



11375

  
Michael Schumacher



Available in English  
Disponible en français  
Disponible en español

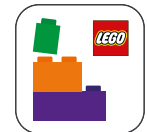

LEGO® Builder

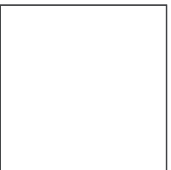



## WE'RE MAKING OUR PACKAGING MORE SUSTAINABLE

We're transitioning from single-use plastic to paper-based packaging. As we progress, you may find a mix of paper and plastic in our boxes.

## NOUS RENDONS NOS EMBALLAGES PLUS DURABLES

Nous passons des emballages en plastique à usage unique aux emballages à base de papier. Durant la transition, vous pourriez trouver un mélange de papier et de plastique dans nos boîtes.

## QUEREMOS HACER MÁS SUSTENTABLES NUESTROS MATERIALES DE EMBALAJE

Estamos cambiando las bolsas de plástico desechables por bolsas con base de papel. Conforme avanzamos en este propósito, puedes encontrar una mezcla de papel y de plástico en nuestras cajas.

[LEGO.com/sustainable-packaging](https://www.lego.com/sustainable-packaging)



# BUILDER



Apple and the Apple logo are trademarks of Apple Inc., registered in the U.S. and other countries and regions. App Store is a service mark of Apple Inc. Google Play and the Google Play logo are trademarks of Google LLC. Tencent and the Tencent logo are trademarks of Tencent Inc.

LEGO.com/devicecheck



LEGO® Builder



## THE FERRARI F2004

// The Ferrari F2004, driven by racing legend Michael Schumacher, dominated the 2004 Formula 1® season. Still widely hailed as one of the greatest F1® cars ever, it famously helped Schumacher claim his seventh, final world title – his fifth in a row. Adding yet another jewel to their crown, Ferrari also clinched their sixth straight Constructors' Championship with the F2004, capping their era of sovereignty on the tracks and delivering unforgettable racing moments for fans worldwide.

## LA FERRARI F2004

// La Ferrari F2004, pilotée par la légende de la course automobile Michael Schumacher, s'est imposée lors de la saison 2004 de Formule 1®. Toujours largement reconnue comme l'une des plus grandes voitures de F1® de tous les temps, elle a notamment aidé Schumacher à remporter son septième et dernier titre mondial – le cinquième consécutif. Ajoutant un nouveau joyau à sa couronne, Ferrari a également remporté son sixième titre consécutif de champion du monde des constructeurs avec la F2004, couronnant ainsi son règne sur les circuits et offrant des moments de course inoubliables aux amateurs du monde entier.

## EL FERRARI F2004

// Con la leyenda de las carreras Michael Schumacher al volante, el Ferrari F2004 dominó la temporada de Formula 1® de 2004. Aún aclamado por muchos como uno de los autos de F1® más grandiosos de la historia, este famoso monoplaza ayudó a Schumacher a conquistar su séptimo título mundial, concluyendo una serie de cinco al hilo. Además de agregar otra joya a su corona, Ferrari también se adjudicó su sexto Campeonato de Constructores consecutivo con el F2004, cerrando con broche de oro la era de su hegemonía en las pistas y regalando inolvidables momentos a fans de todo el mundo.



*M. Schumacher*



## THE RACING LEGEND

// The partnership between Ferrari and Michael Schumacher fostered the kind of unique synergy that arises when stars in their respective fields align perfectly. Joining the team in 1996, Schumacher found an ideal match for his extraordinary talent and deep dedication to collaboration and perfection. Consistently defending Ferrari's world championship status, Schumacher secured 72 Grand Prix wins during his time with the team. With his unwavering commitment to the sport, and his involvement with various charities, he left an indelible mark on the racing world.

## LA LÉGENDE DE LA COURSE

// Le partenariat entre Ferrari et Michael Schumacher a donné naissance à une synergie unique, celle qui naît lorsque des vedettes de leur domaine respectif se rencontrent. En rejoignant l'équipe en 1996, Schumacher a trouvé le partenaire idéal pour son talent extraordinaire et son profond dévouement à la collaboration et à la perfection. Défendant sans relâche le titre de champion du monde de Ferrari, Schumacher a remporté 72 Grands Prix au cours de sa carrière au sein de l'équipe. Grâce à son engagement sans faille envers ce sport et à son implication dans diverses associations caritatives, il a laissé une empreinte indélébile dans le monde de la course automobile.

## LA LEYENDA DE LAS CARRERAS

// La asociación entre Ferrari y Michael Schumacher engendró esa sinergia tan particular que surge cuando las estrellas más brillantes de sus respectivas disciplinas se alinean a la perfección. En la escudería, a la que se incorporó en 1996, Schumacher encontró el entorno ideal para canalizar su talento fuera de serie y su profunda vocación por la colaboración y la excelencia. Defendiendo incansablemente el estatus de Ferrari como campeón del mundo, Schumacher sumó 72 Grandes Premios a lo largo de su etapa con el equipo. Su inquebrantable compromiso con el deporte y su apoyo a numerosas causas benéficas imprimieron una huella imborrable en el mundo de las carreras.





## FROM THE LEGO® ICONS DESIGN TEAM

// Our amazing partners at Scuderia Ferrari helped us get the correct shaping and proportions of the F2004 in LEGO® form, down to each minute detail. We recreated the long, slim 'nose', intricate, aerodynamic shapes and organic design features of the F2004 with different LEGO bow elements and curved pieces. Under the engine cover, you'll see a detailed engine bay, and you might spot a few references to the story of the car, as well as its legendary driver.

## UN MOT DE L'ÉQUIPE DE CONCEPTION LEGO® ICONS

// Nos incroyables partenaires de la Scuderia Ferrari nous ont aidés à reproduire la forme et les proportions de la F2004 en LEGO®, jusque dans les moindres détails. Nous avons recréé le long « nez » effilé, les formes aérodynamiques complexes et les caractéristiques organiques de la F2004 à l'aide de différents éléments LEGO en forme d'arc et de pièces courbées. Sous le capot, vous découvrirez un compartiment moteur détaillé et vous apercevrez peut-être quelques références à l'histoire de la voiture et à son légendaire pilote.

## IMPRESIONES DEL EQUIPO DE DISEÑO DE LEGO® ICONS

// Nuestros increíbles socios de Scuderia Ferrari nos ayudaron a replicar correctamente las formas y proporciones del F2004 en formato LEGO®, cuidando hasta el más mínimo detalle. Recreamos la larga y delgada nariz, las intrincadas líneas aerodinámicas y el diseño orgánico del F2004 mediante una variedad de piezas LEGO curvadas y elementos en arco. La cubierta del motor resguarda un detallado compartimento en el que podrías encontrar algunas referencias a la historia del auto y la trayectoria de su legendario conductor.





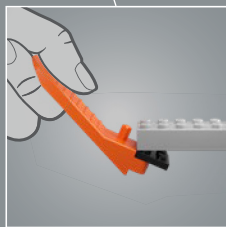
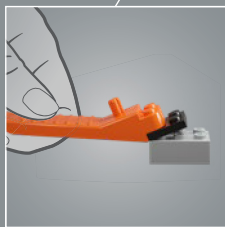
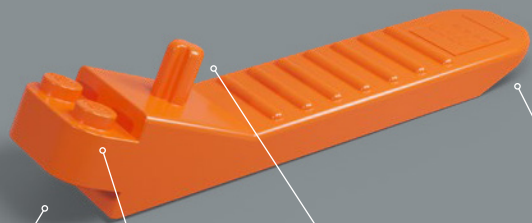



Michael Schumacher expressed a passion for racing early on, starting go-kart racing at the age of four, and winning his first go-kart title just two years later. He drove in a go-kart built by his father from scrap parts.

Michael Schumacher a très tôt manifesté sa passion pour la course automobile. Il a commencé le karting à l'âge de quatre ans et a remporté son premier titre de karting deux ans plus tard. Il pilotait un kart fabriqué à partir de pièces de récupération par son père.

Michael Schumacher hizo notoria su pasión por la velocidad desde temprana edad, iniciándose en las carreras de go-karts con cuatro años y adjudicándose su primer título de esa disciplina solo dos años después. Su padre había construido el vehículo que condujo usando piezas de desecho.

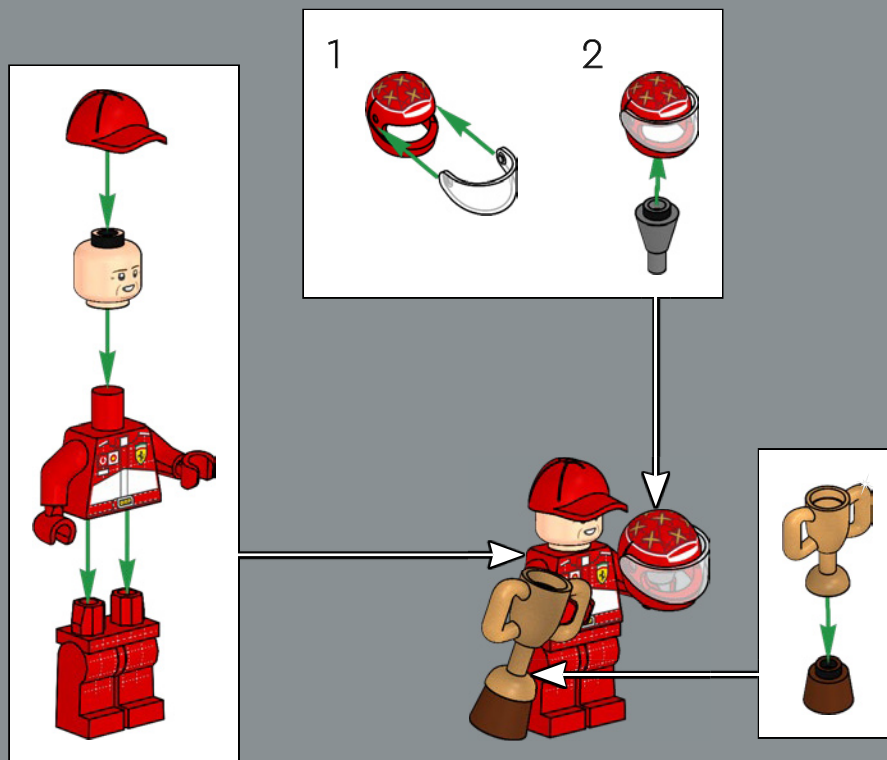

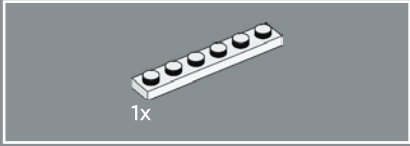

1

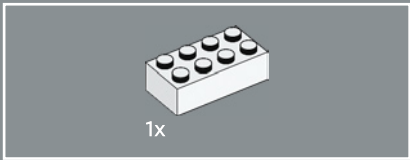
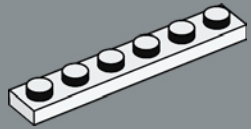

2

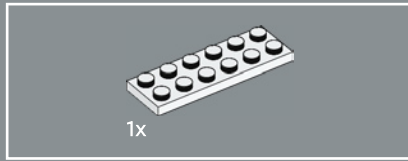
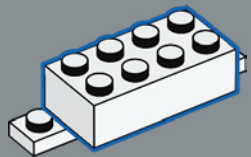

3

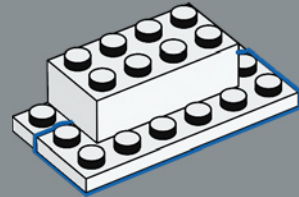

4

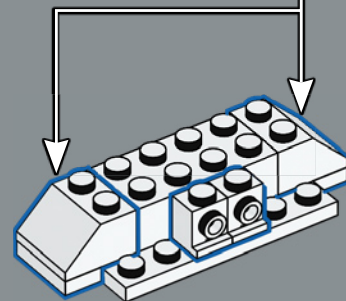
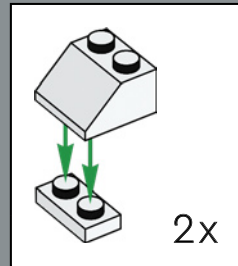

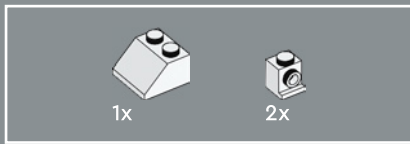

5

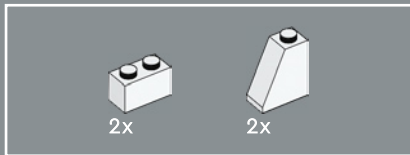
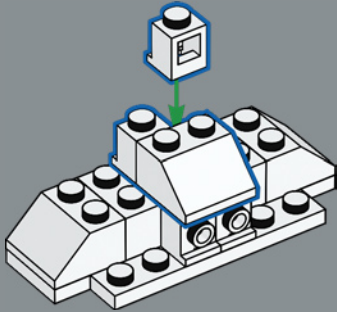

6

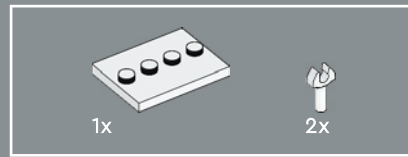
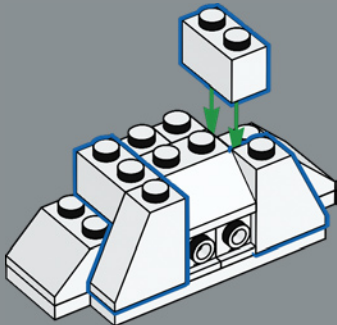

7

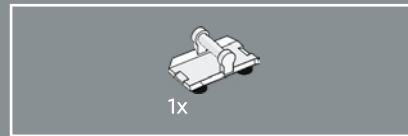
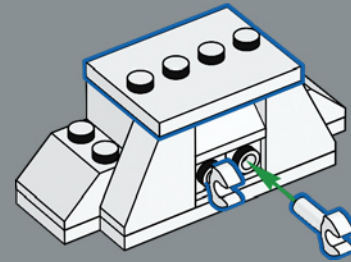

8

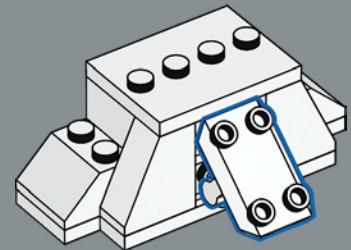

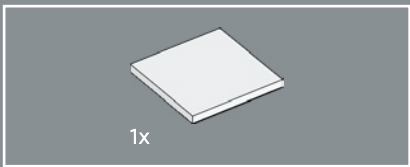

9

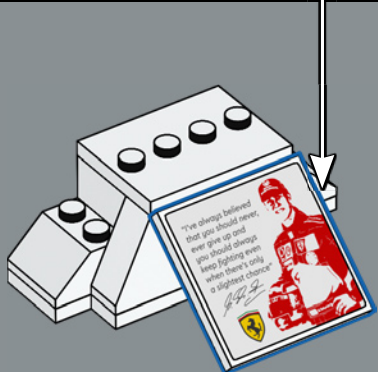
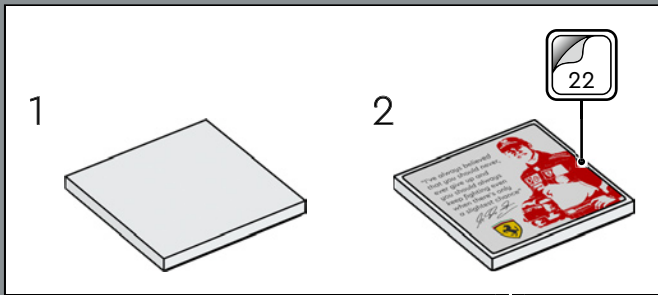

10

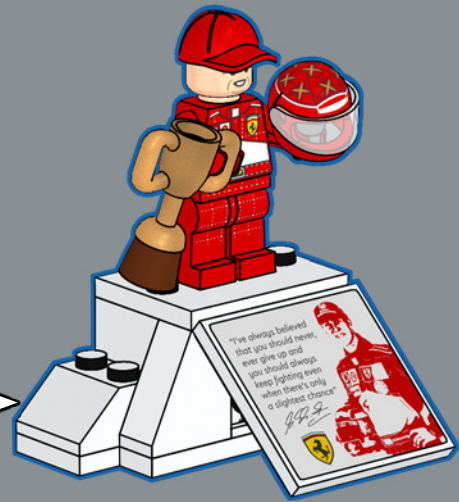

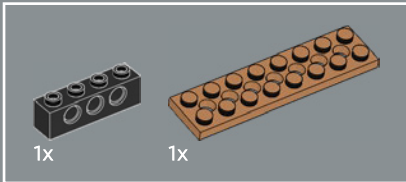
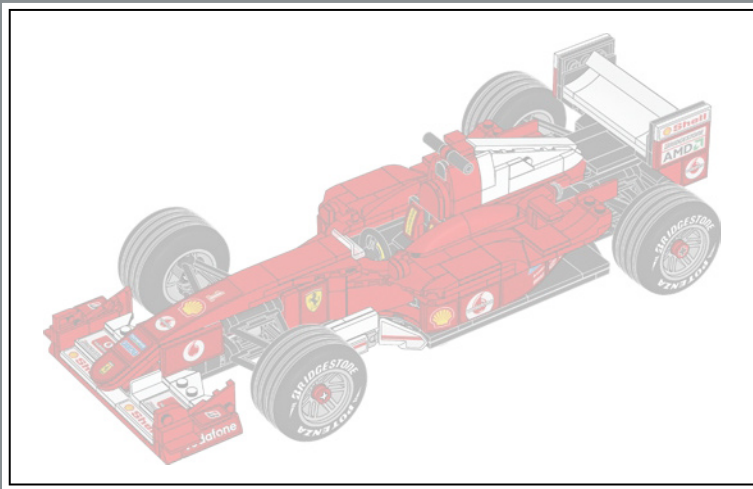

1

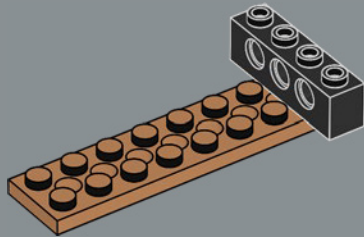

The two 2x8 LEGO® plates with holes, in a medium nougat color, represent the skid block and plank that every F1® car has featured as a safety measure since 1994.

Les deux plaques LEGO® 2x8 perforées, de couleur nougat moyen, représentent le bloc de patinage et la planche dont toutes les voitures de F1® sont équipées depuis 1994 à des fins de sécurité.

Las dos placas LEGO® 2x8 con orificios en color caramelo medio representan el *skid block* que todos los autos de F1® llevan como medida de seguridad desde 1994.

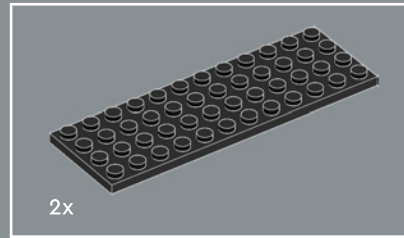

2

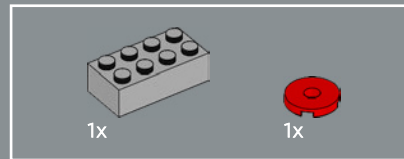
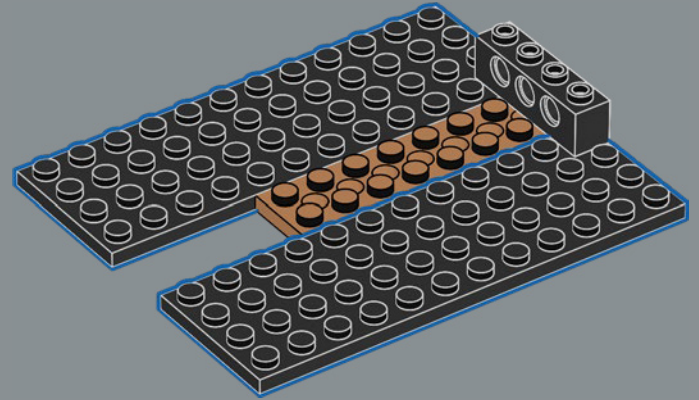

3

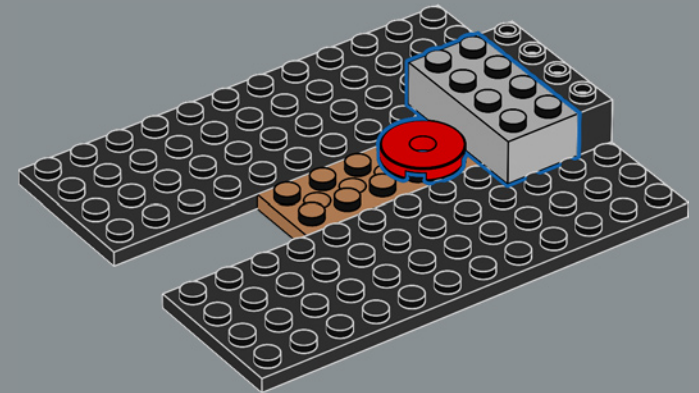

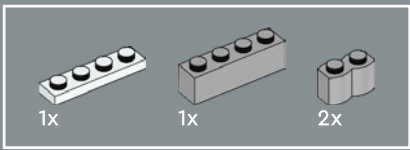

4

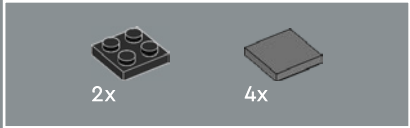
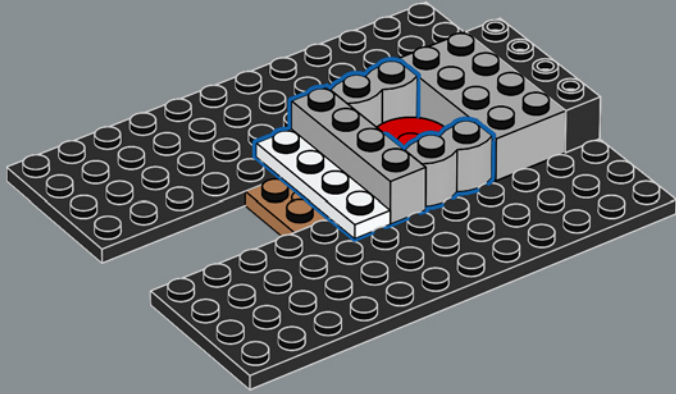

5

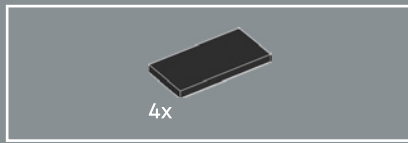
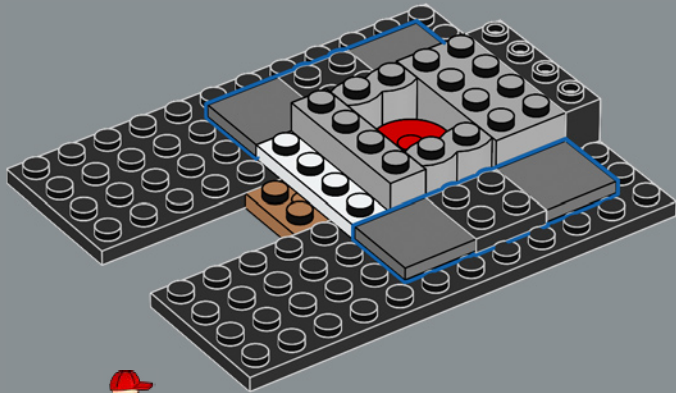

6

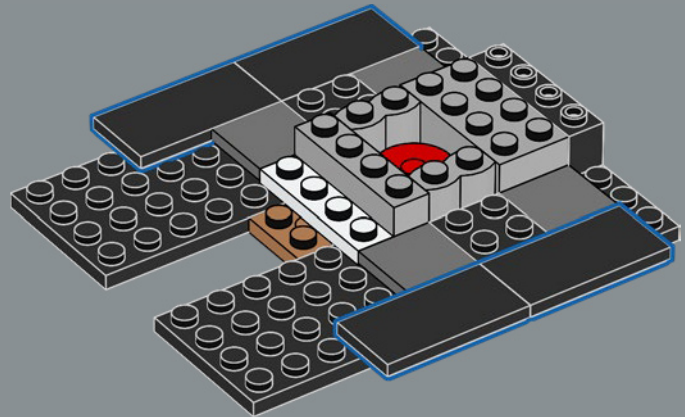

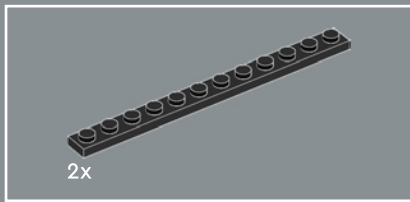

7

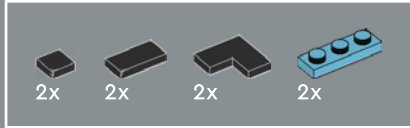
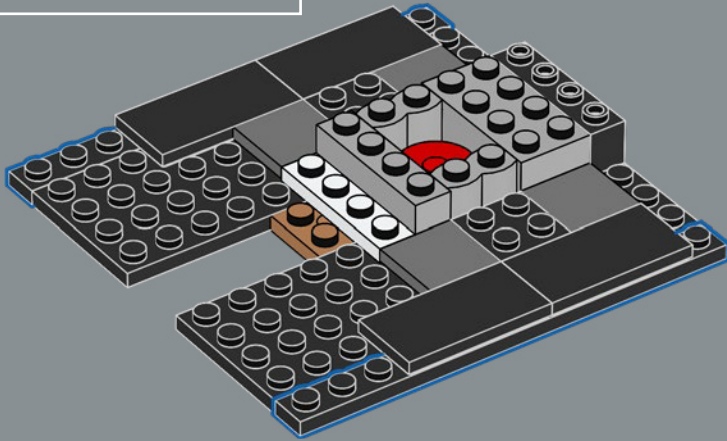

8

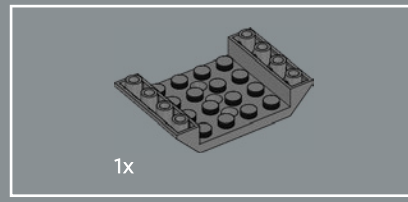
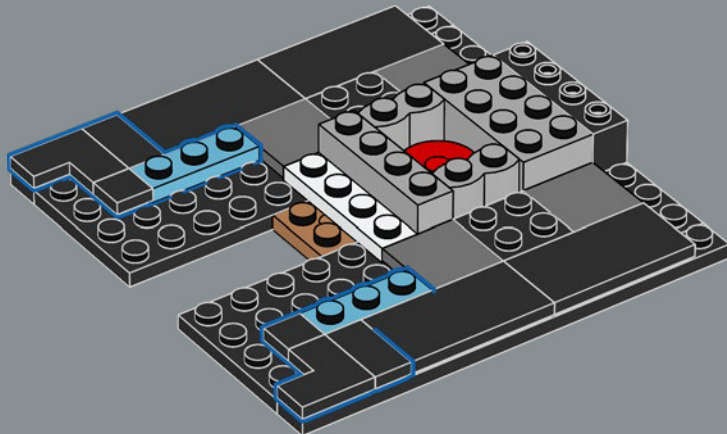

9

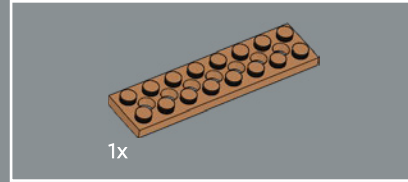
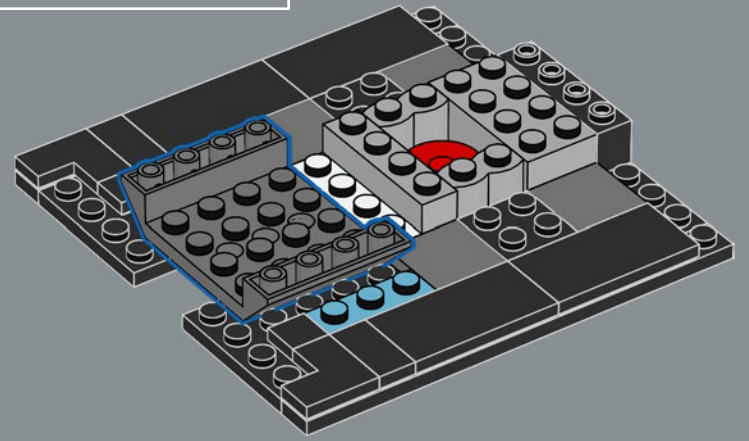

10

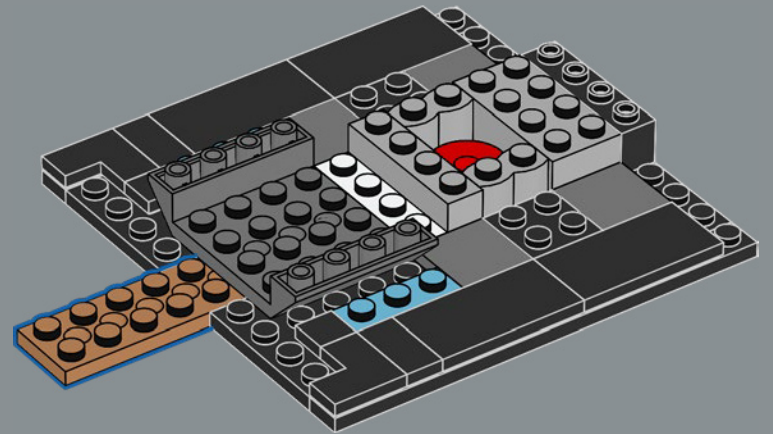

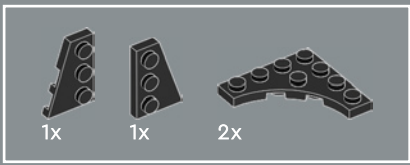

11

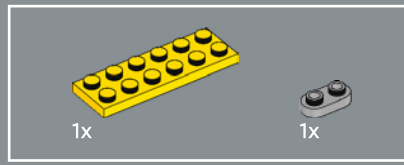
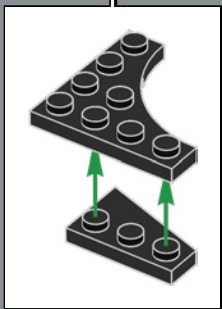
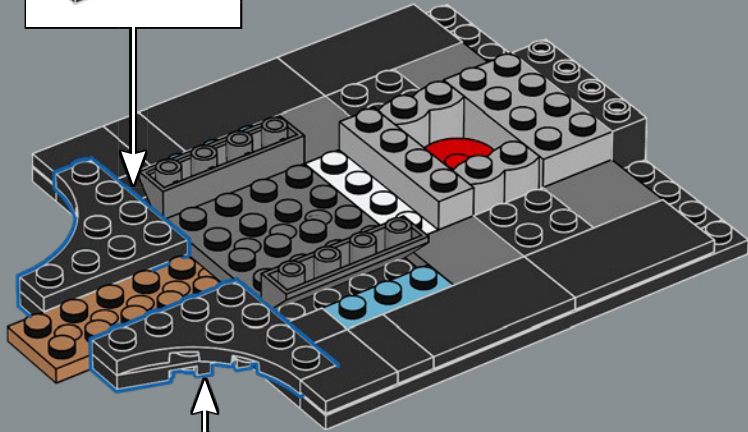
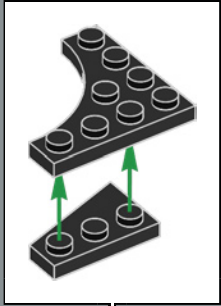

12

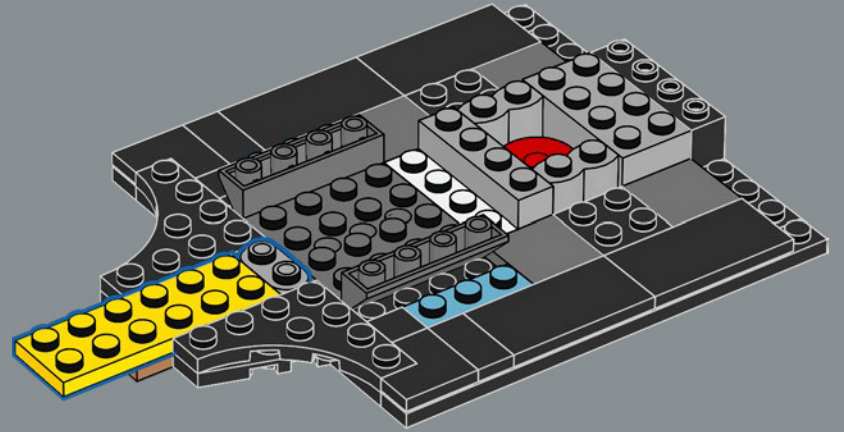

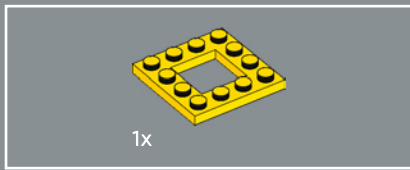

13

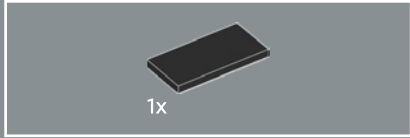
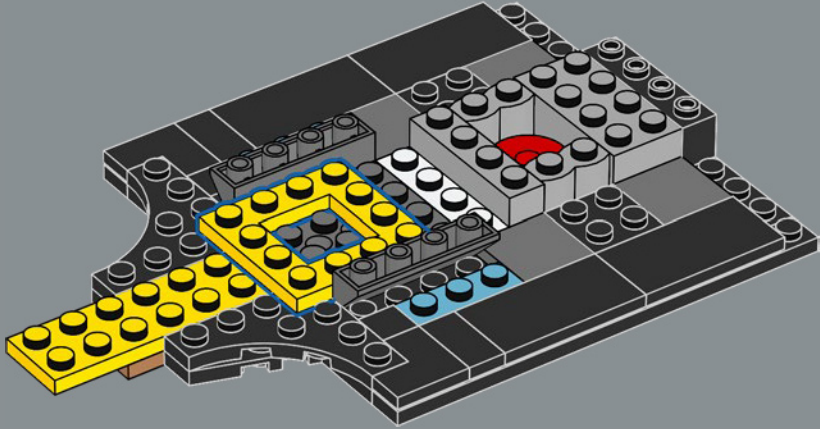

14

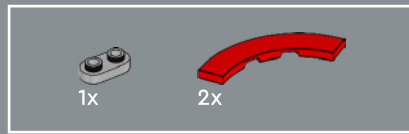
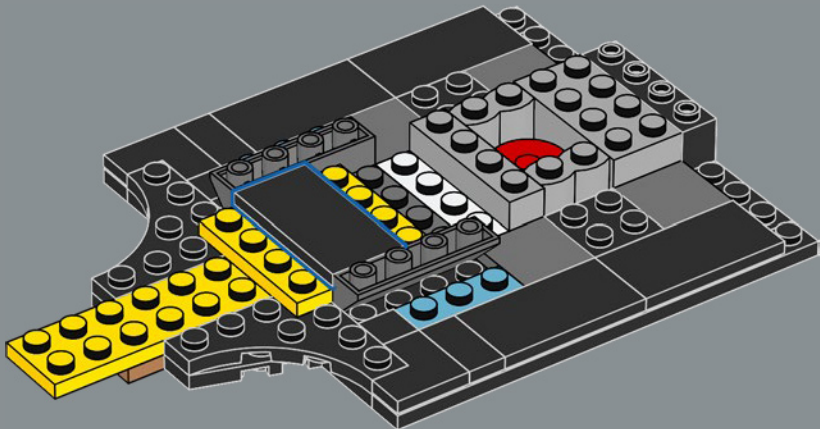

15

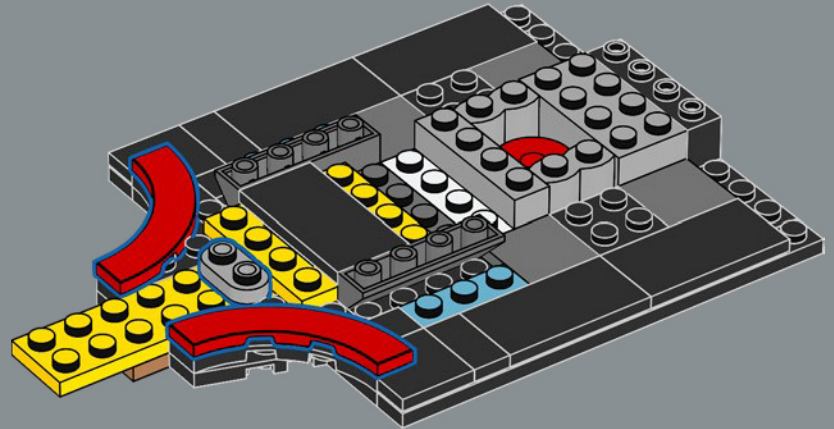



16

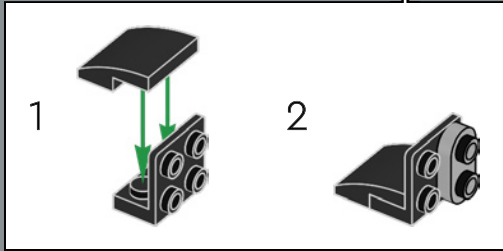
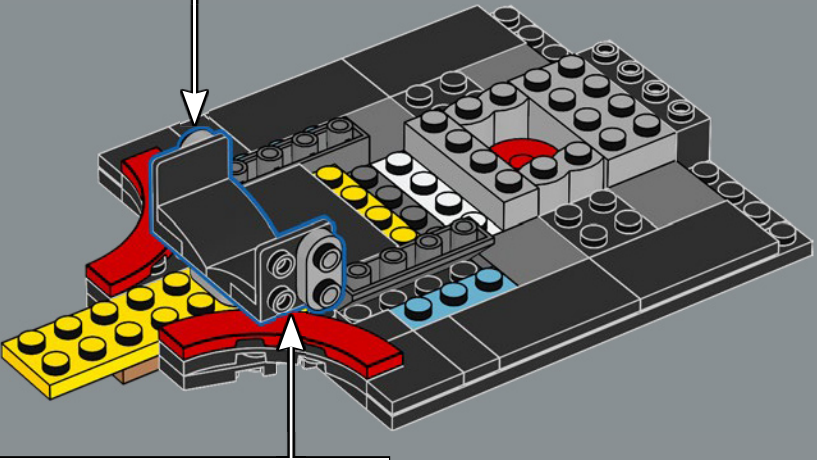
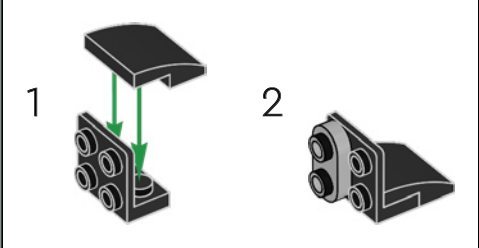

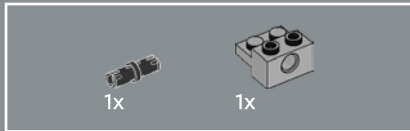
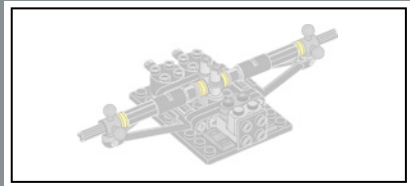

17

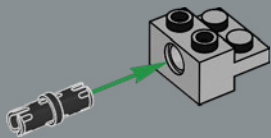

18

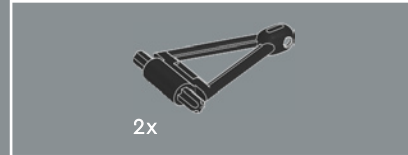
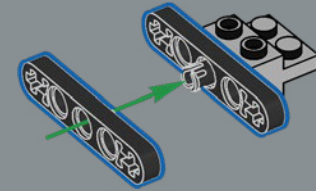

19

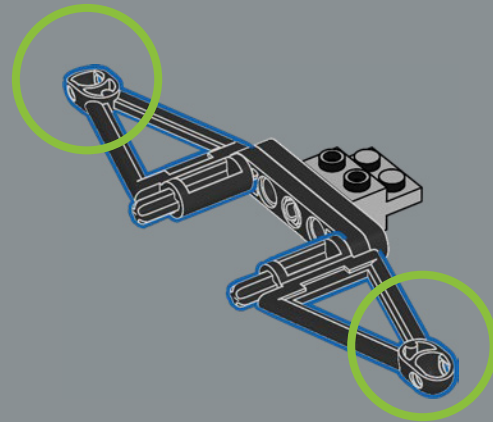



20

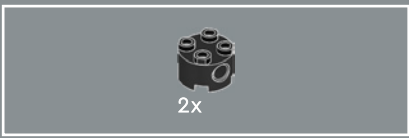
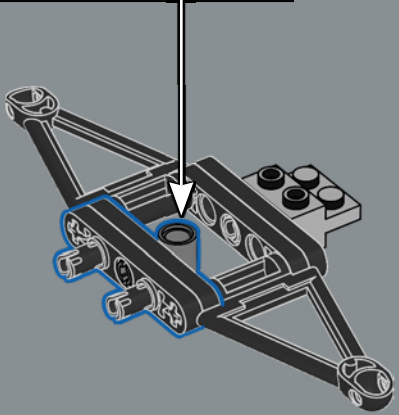
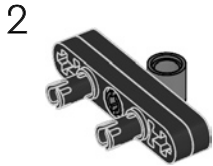
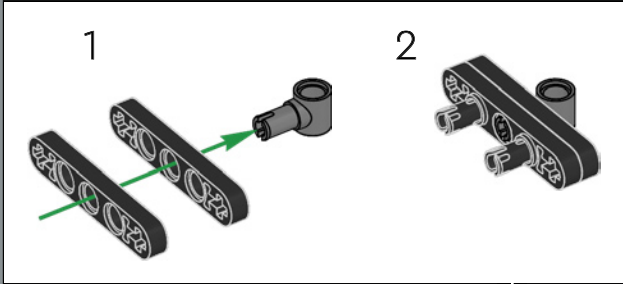

21

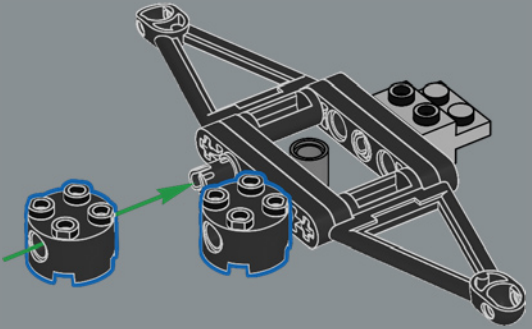

22

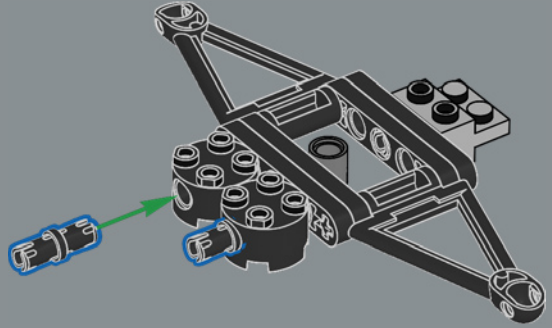

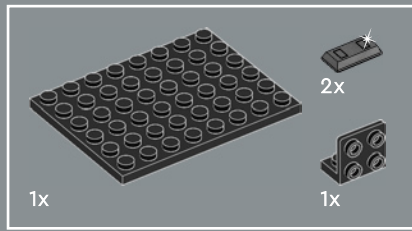

23

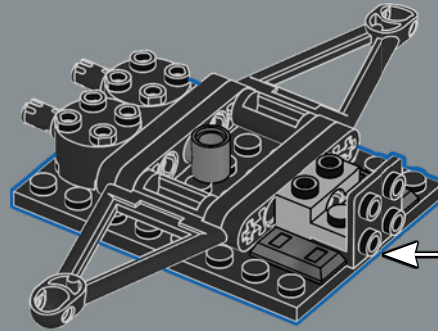
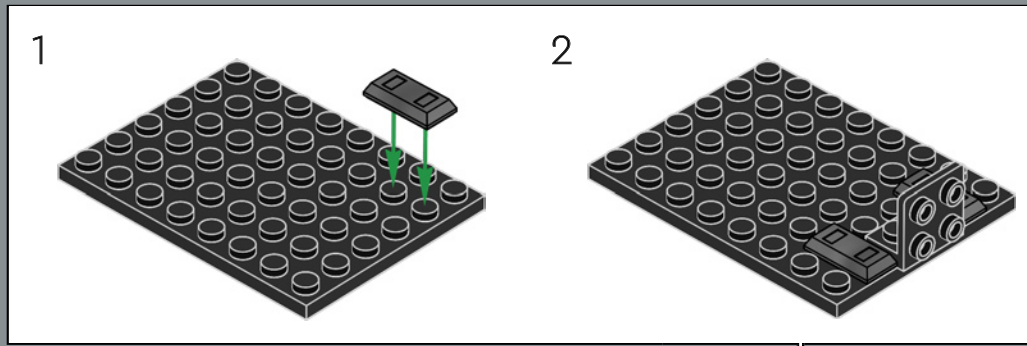

24

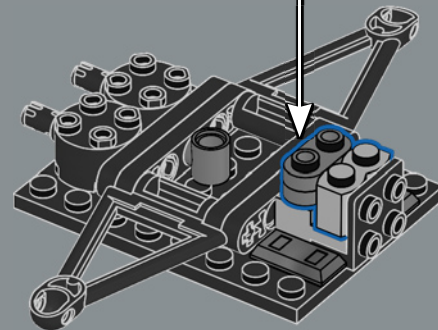
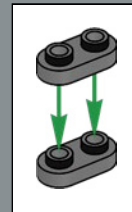

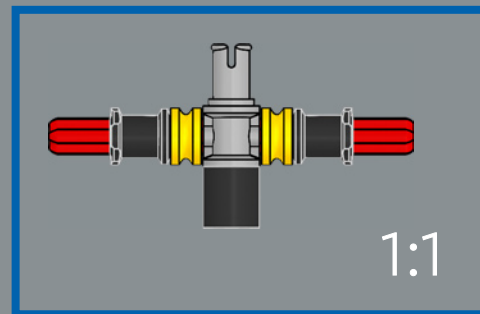
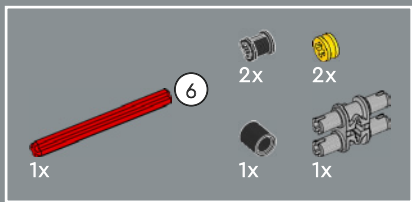

25

1

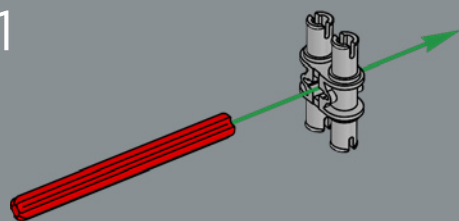

2

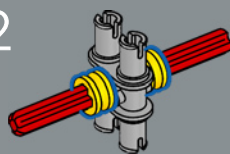

3

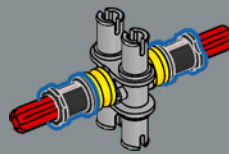

4

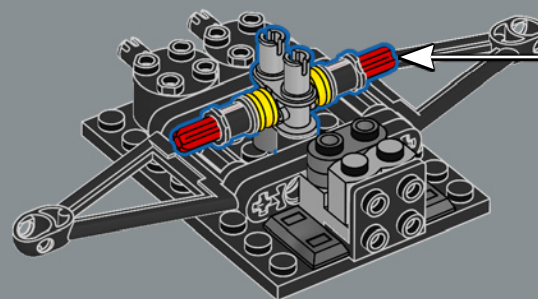
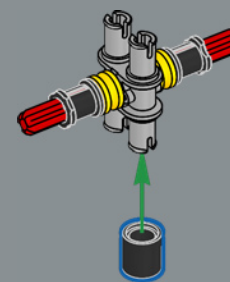

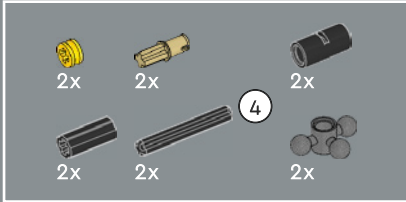
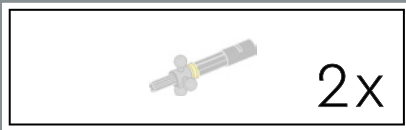

26

1

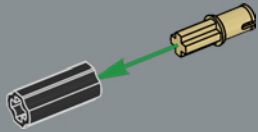

2

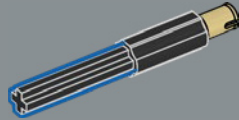

3

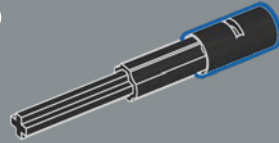

4

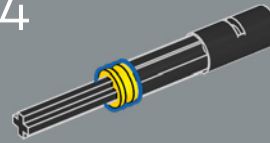

5

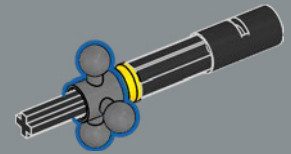

2x

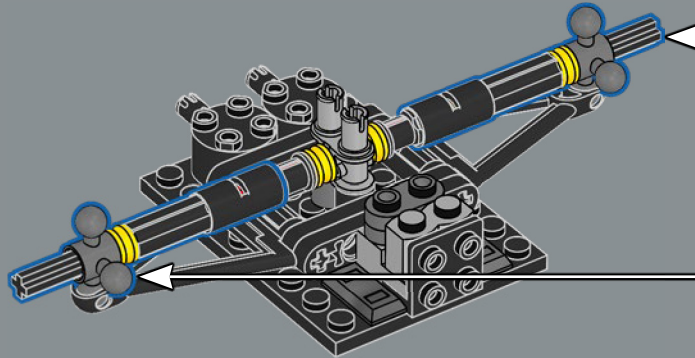

27

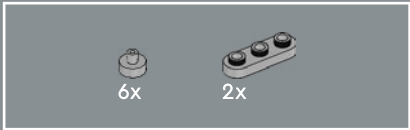
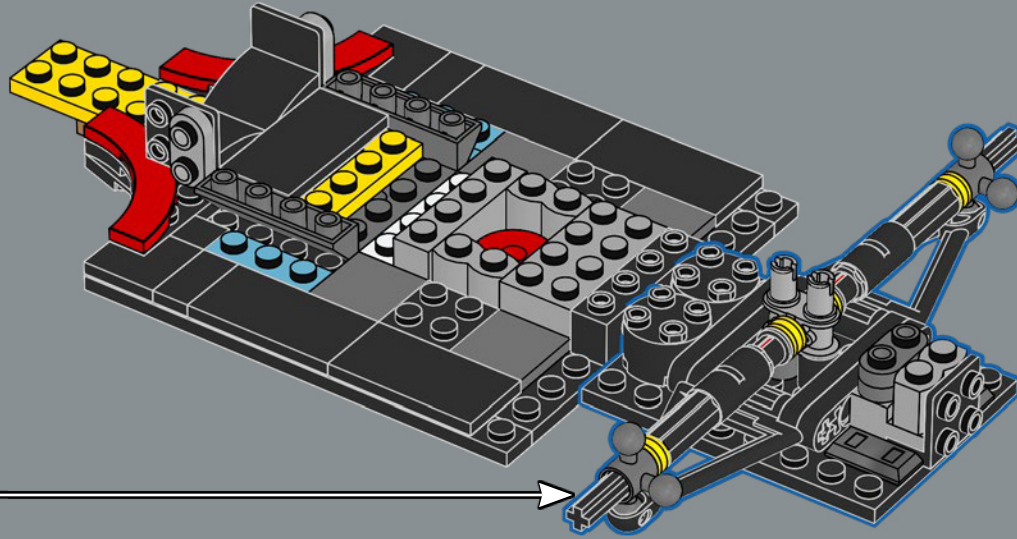

28

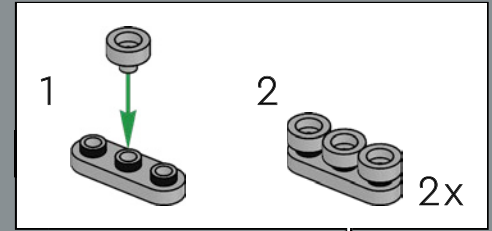
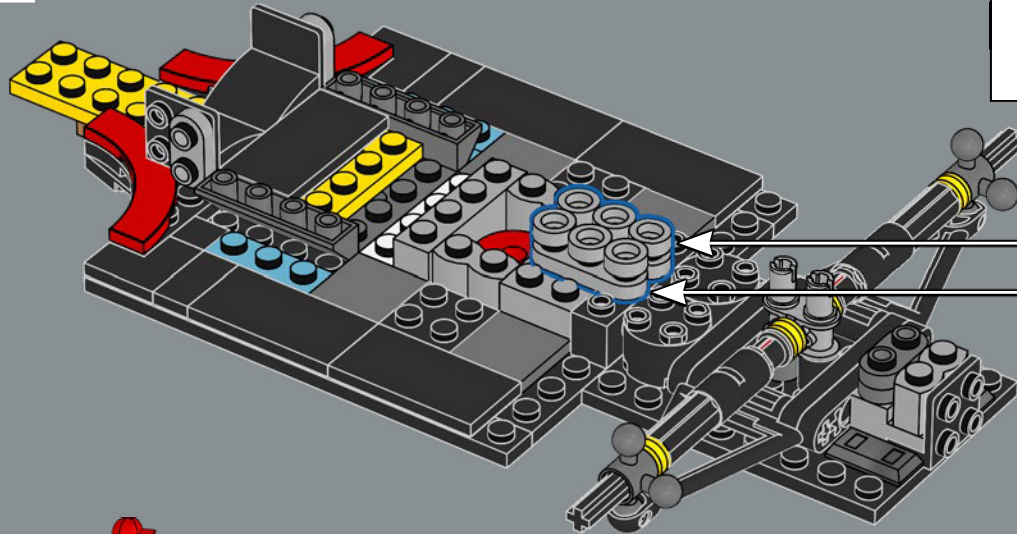

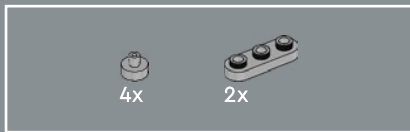

29



The 1x1 round plates with shafts are used here to represent the car's V10 engine. The V10 was used by all F1® teams between 1998 and 2005.

Les plaques rondes 1x1 avec des axes sont utilisées ici pour représenter le moteur V10 de la voiture. Le V10 a été utilisé par toutes les écuries de F1® entre 1998 et 2005.

Aquí, se usan placas redondas 1x1 con ejes para representar el motor V10 del auto. Todos los equipos de F1® usaron motores V10 entre 1998 y 2005.

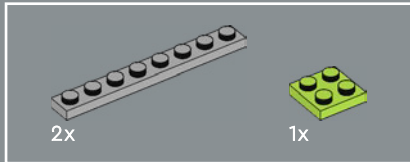
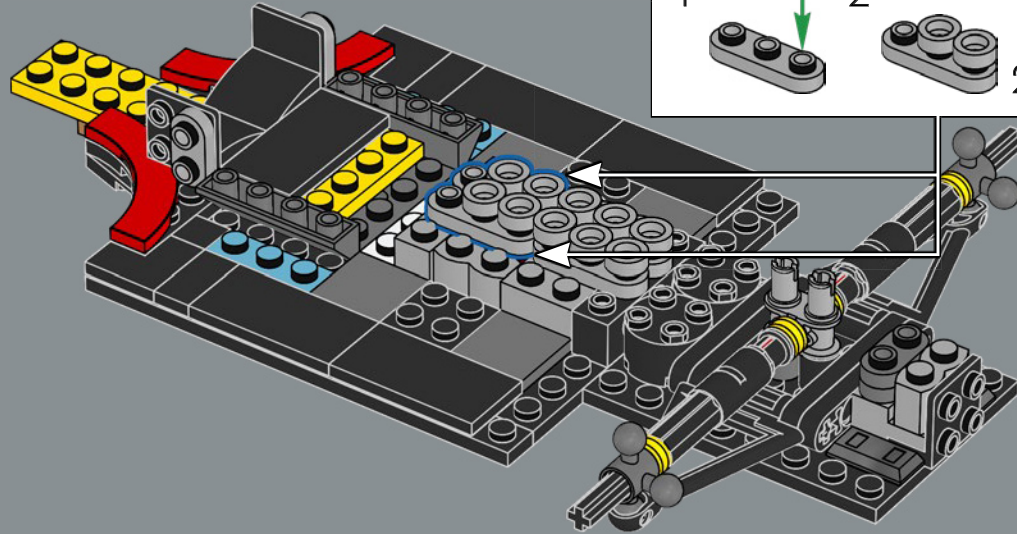
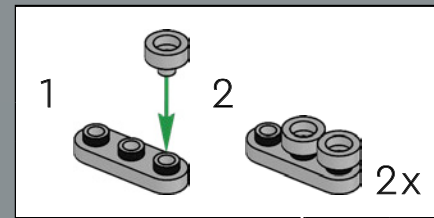

30

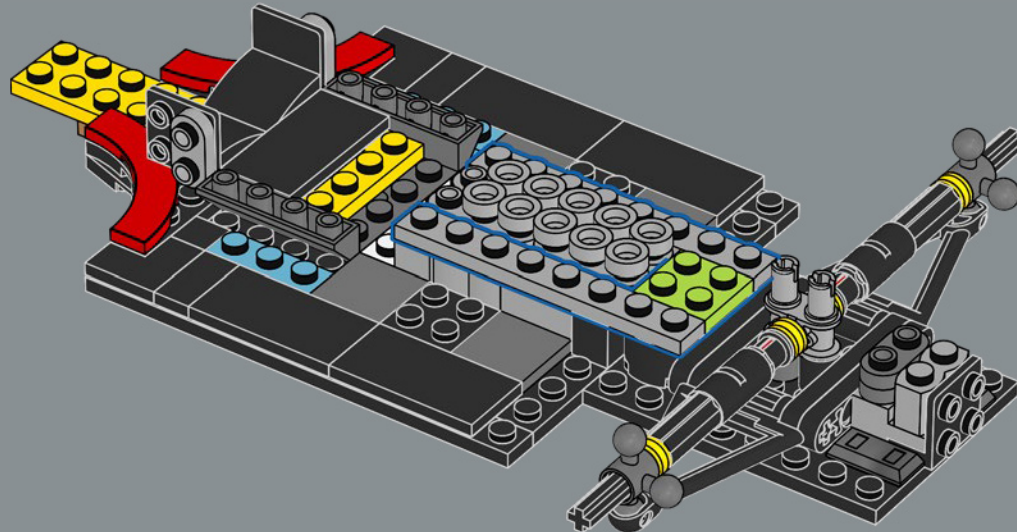

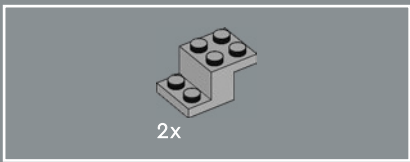

31

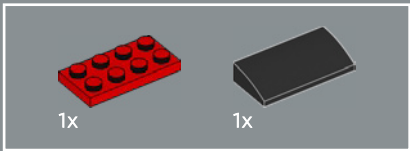
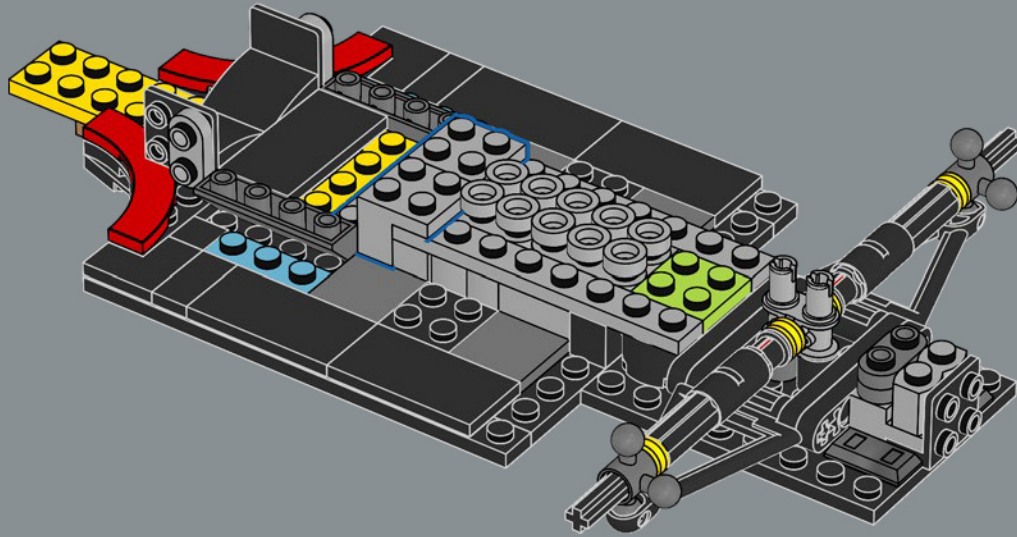

32

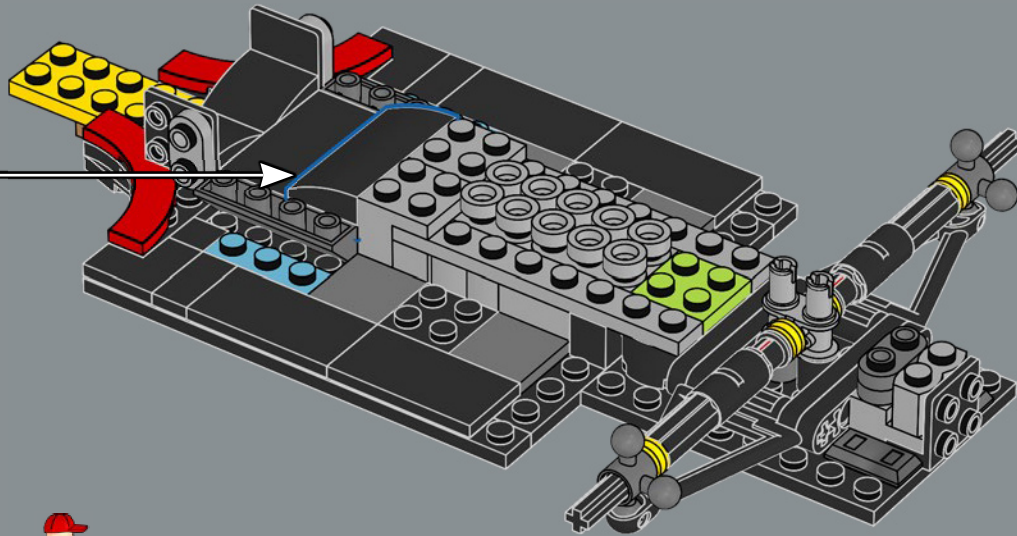
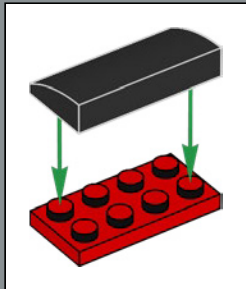

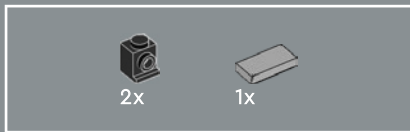

33

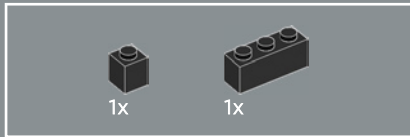
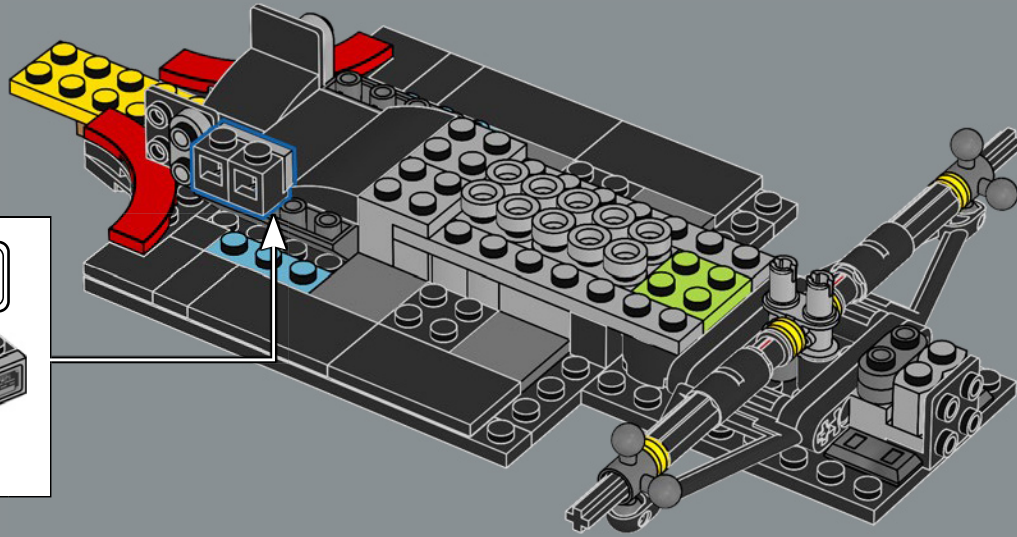
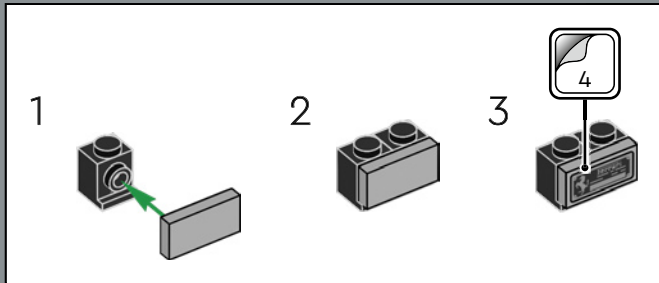

34

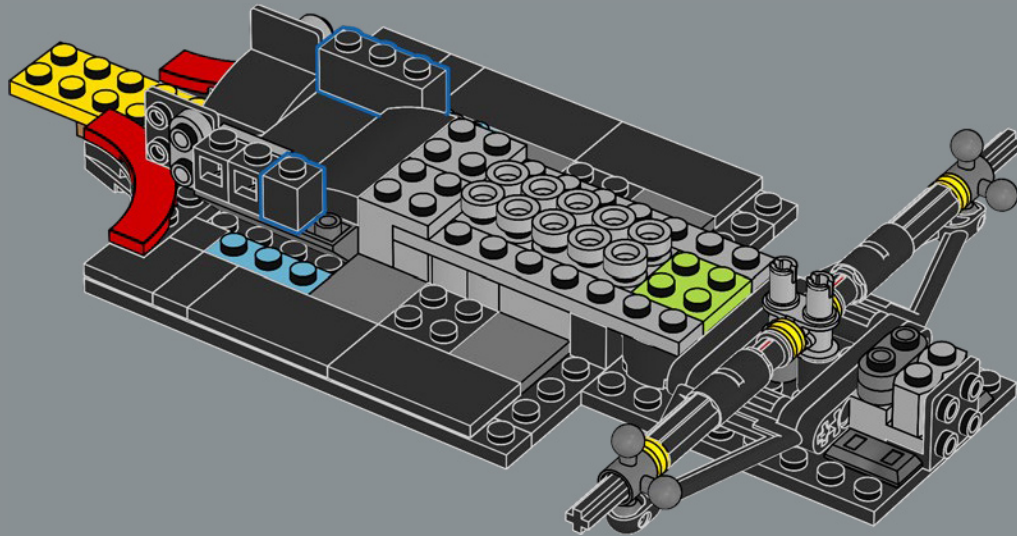

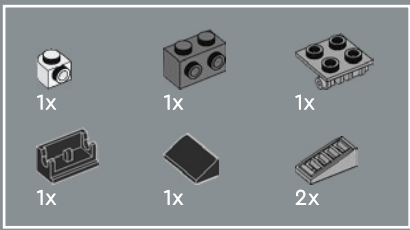

35

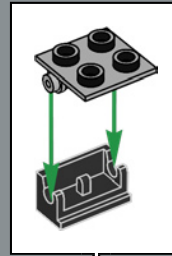

1

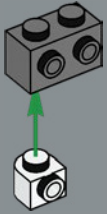

2

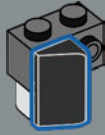

3

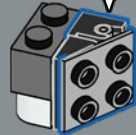

4

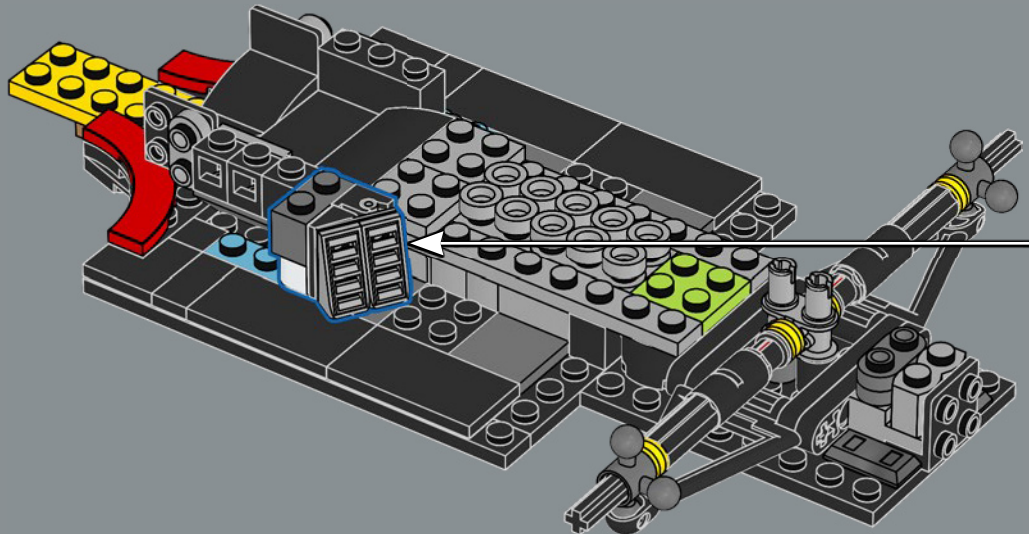
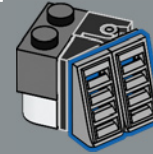

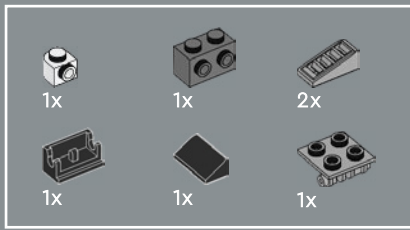

36

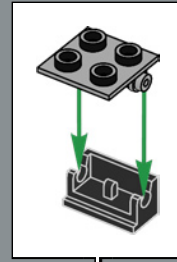

1

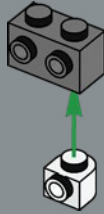

2

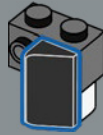

3



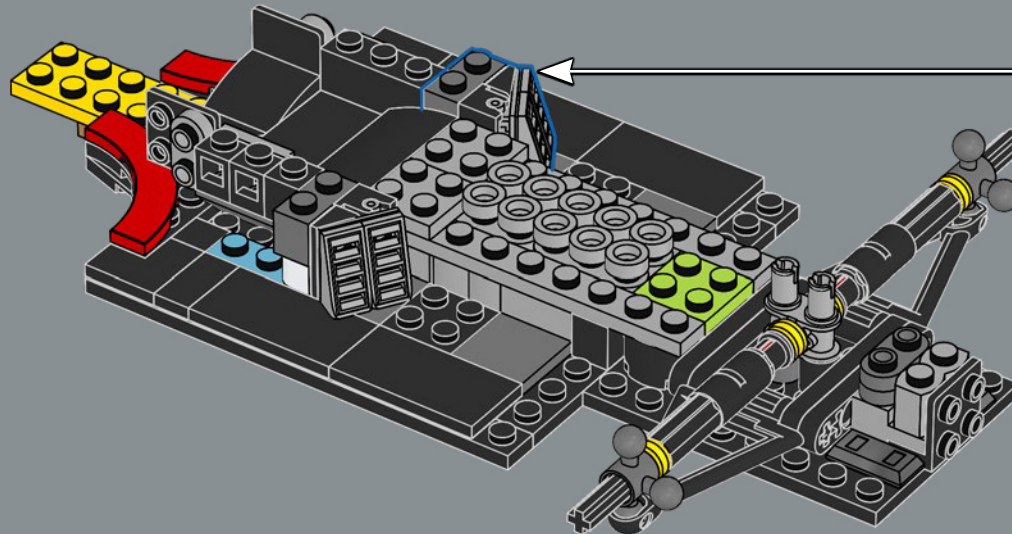

4



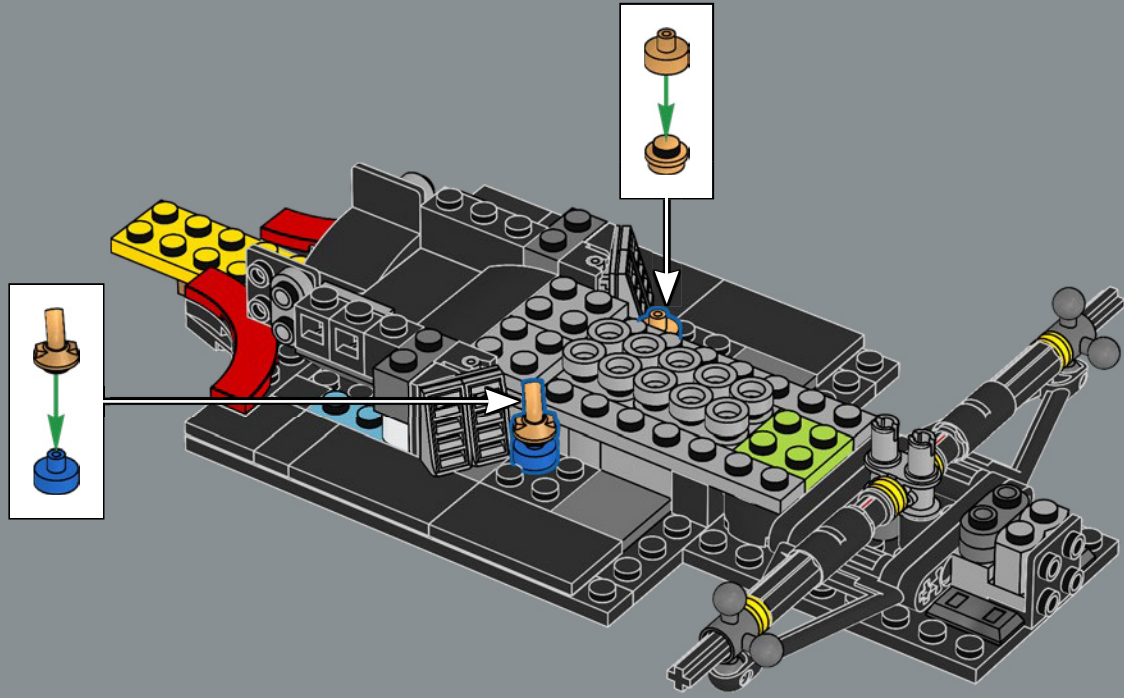

-  1x
-  1x
-  1x
-  1x

37

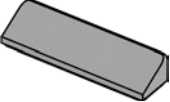

-  2x

38

- 1 
- 2  2x

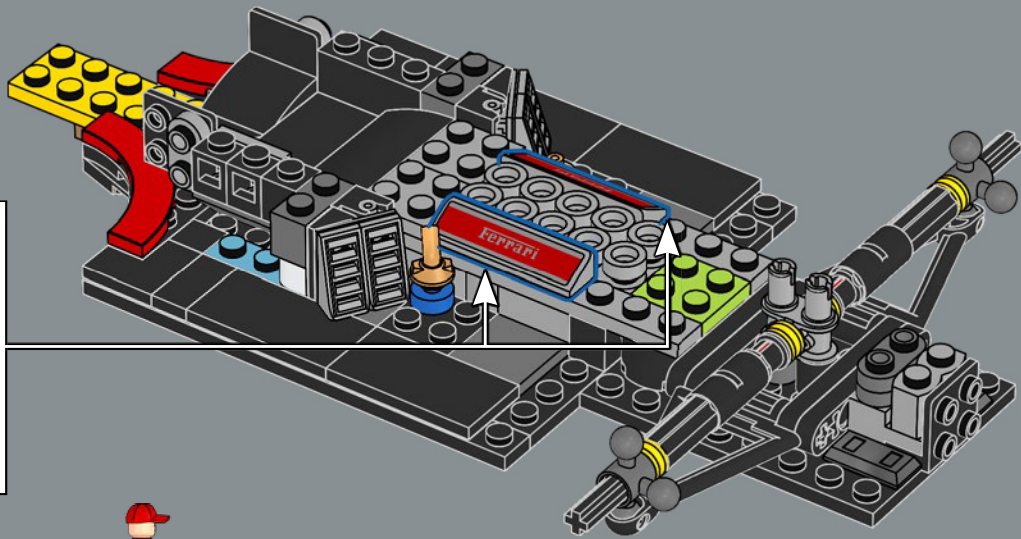

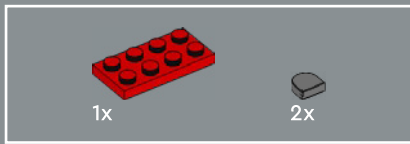

39

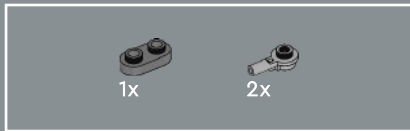
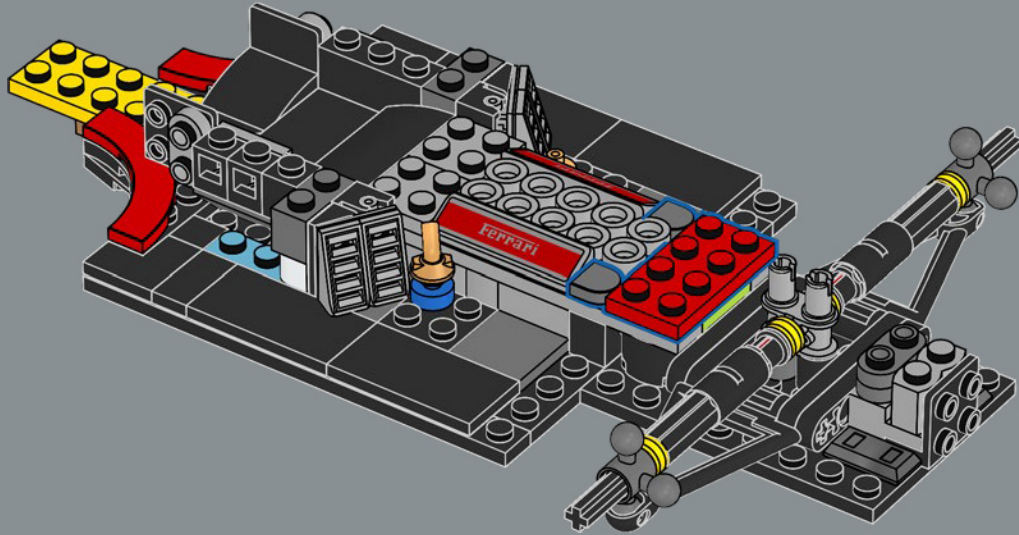

40

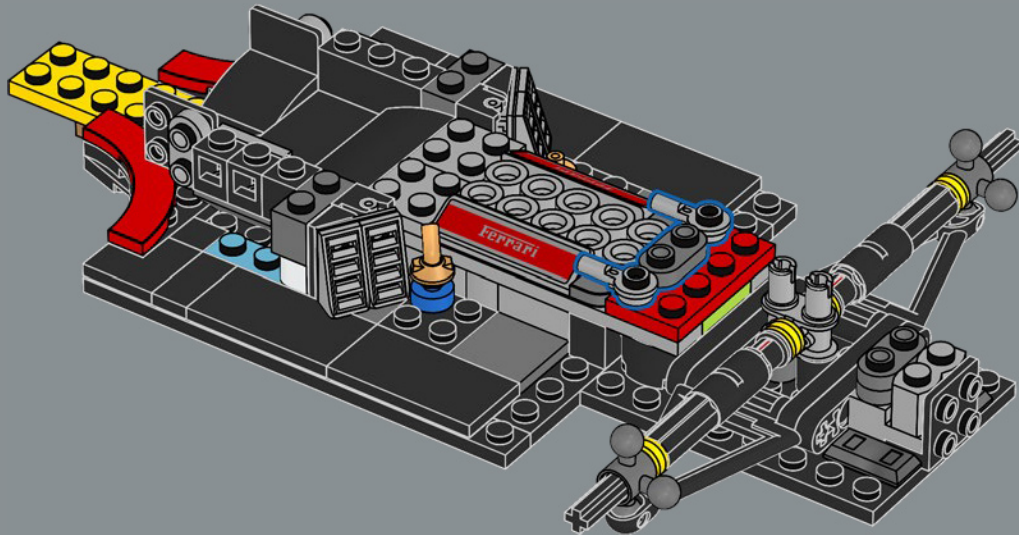



2x

41

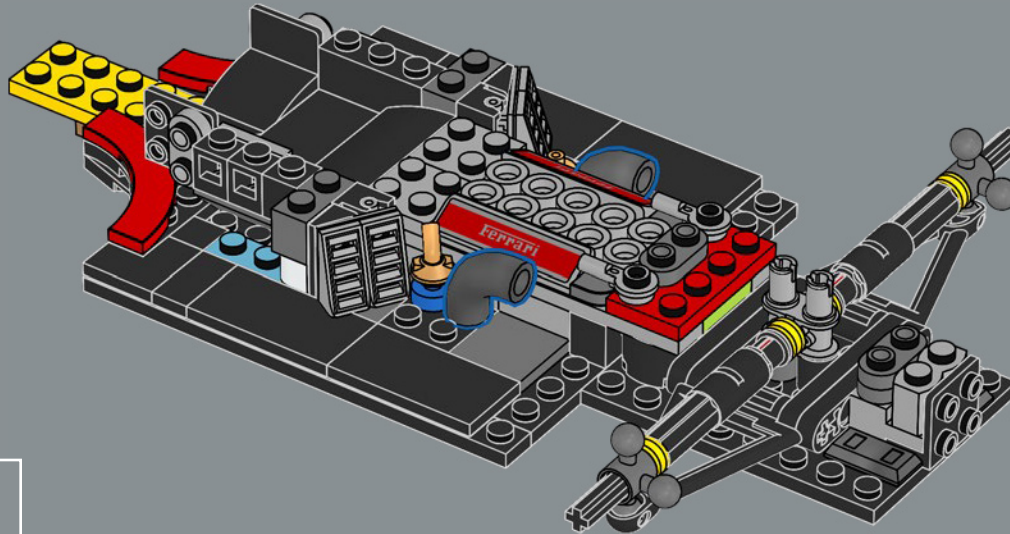

The F2004 engine was developed by Ferrari and had a maximum power of 865 hp (636kW). It was designed to last an entire race weekend.

Le moteur F2004 a été développé par Ferrari et avait une puissance maximale de 865 ch (636 kW). Il était conçu pour durer tout un week-end de course.

Desarrollado por Ferrari, el motor del F2004 tenía una potencia máxima de 865 HP (636 kW). Estaba diseñado para durar todo un fin de semana de carreras.



1x



1x



2x

42

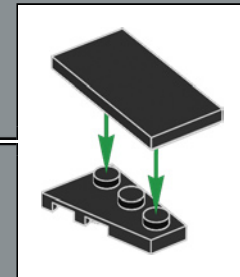
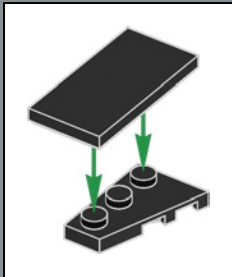
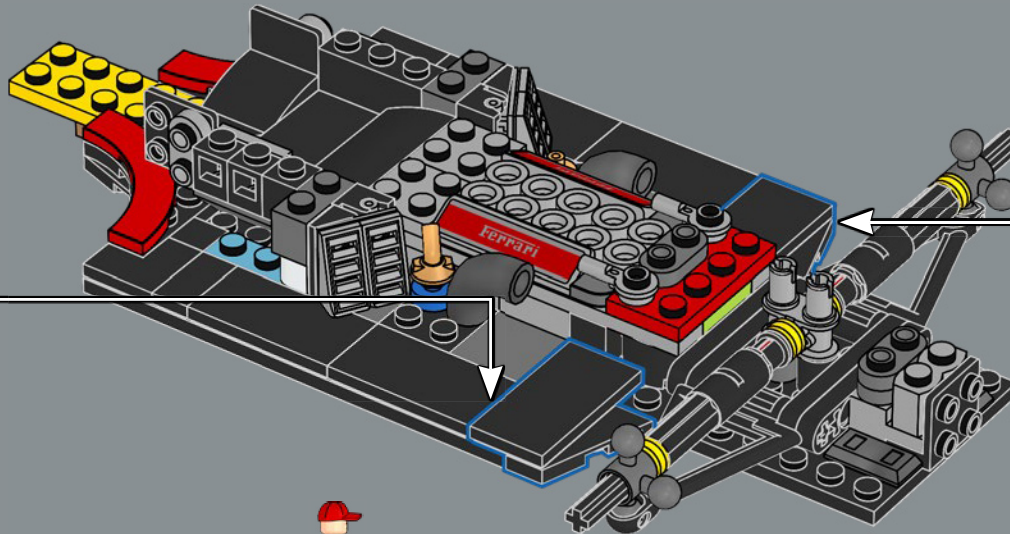

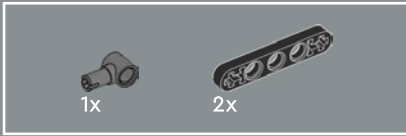
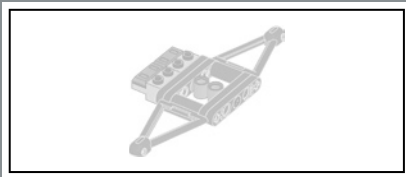

43

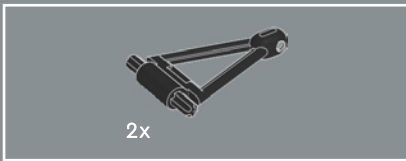
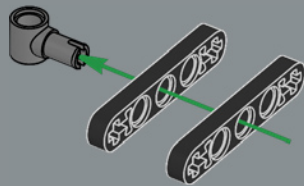

44

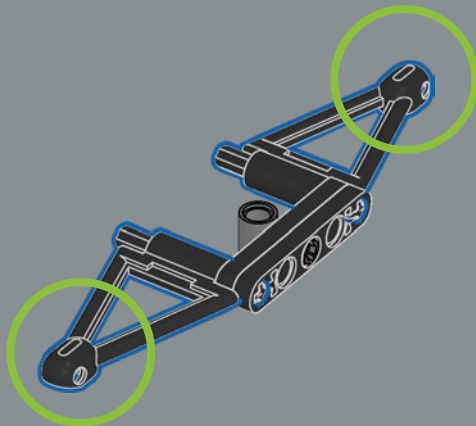

45

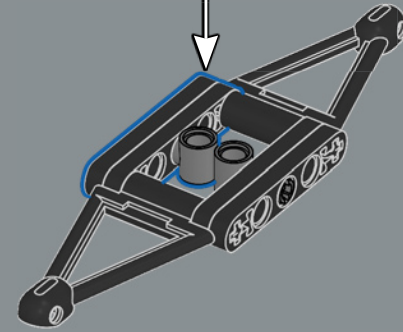
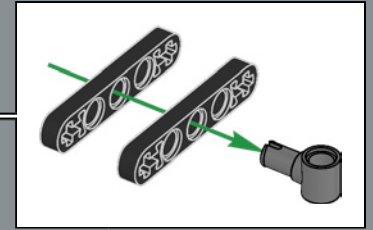

46

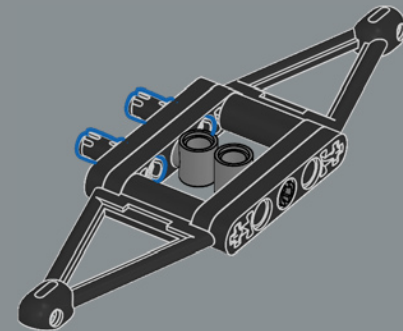

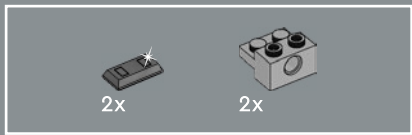

47

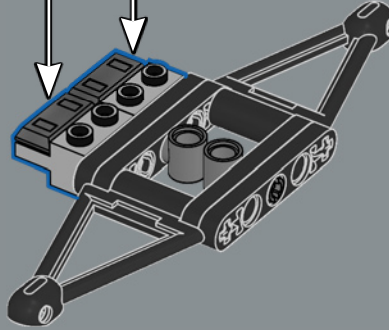
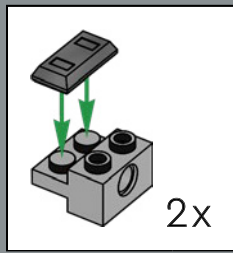

48

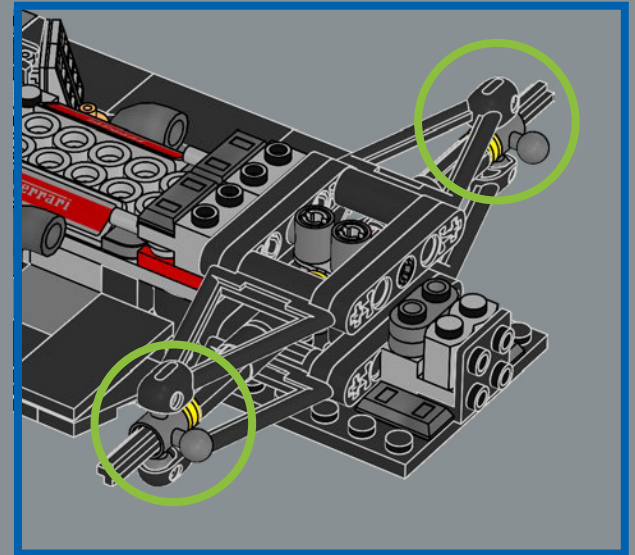
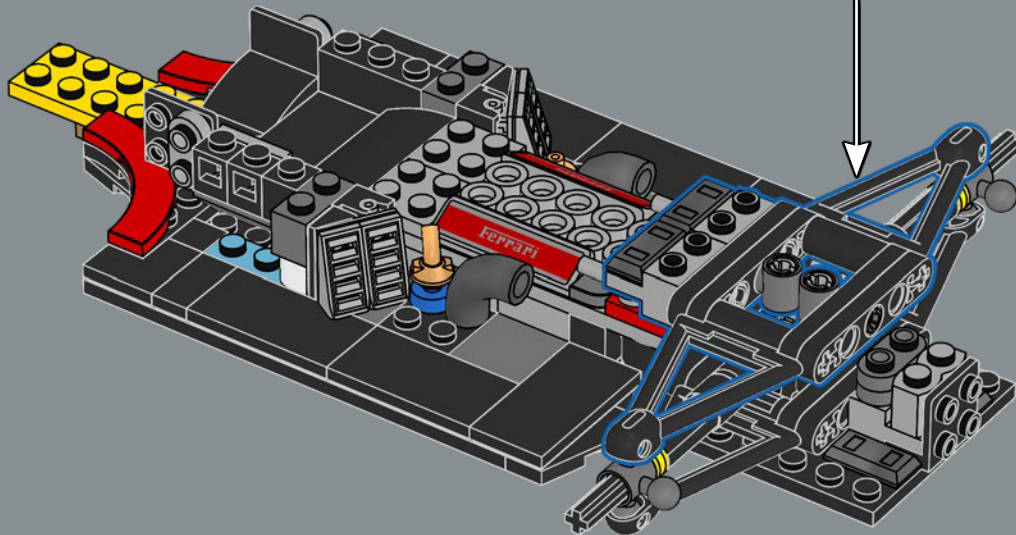

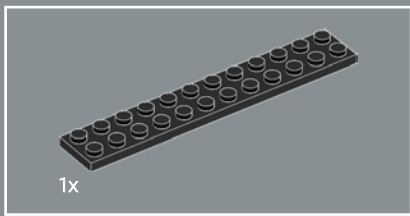

49

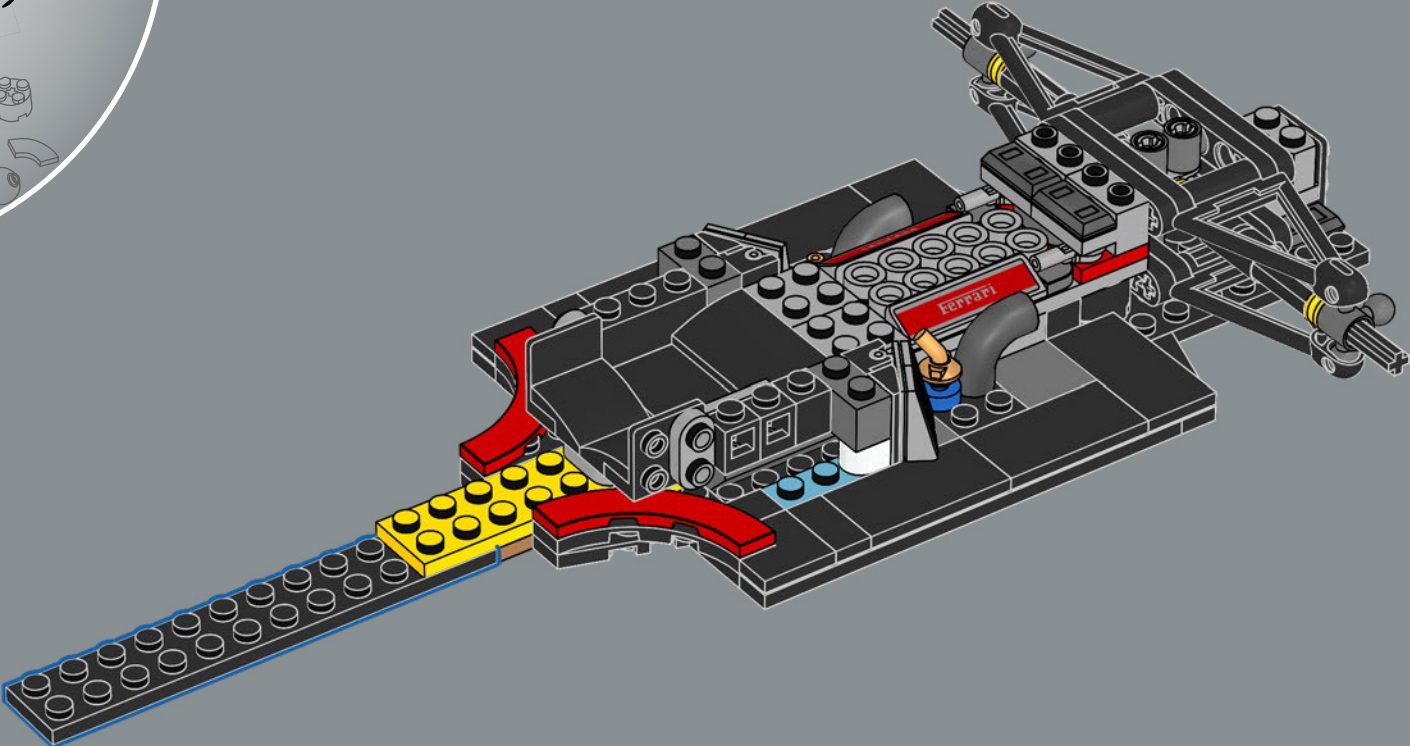

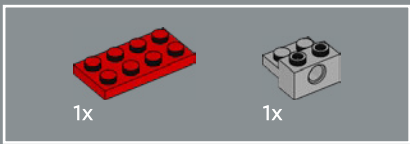

50

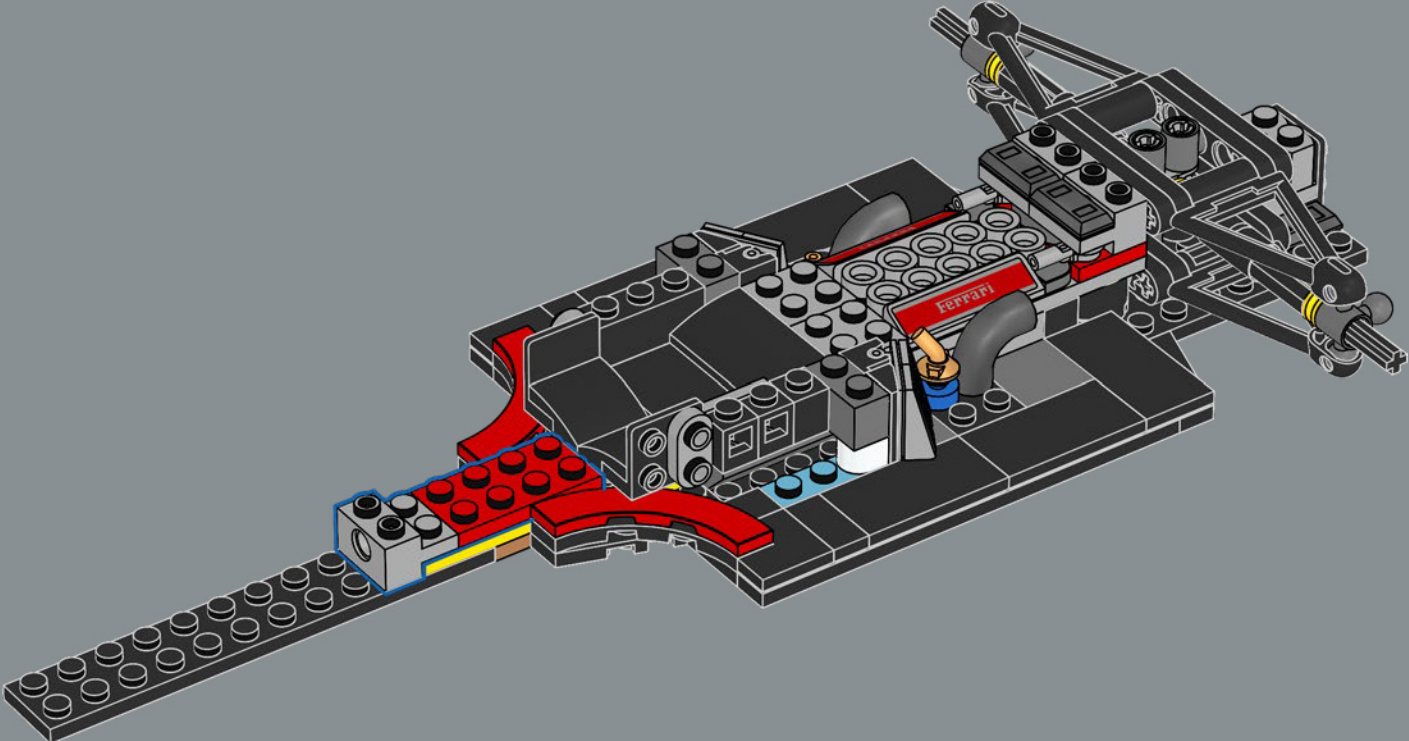



51

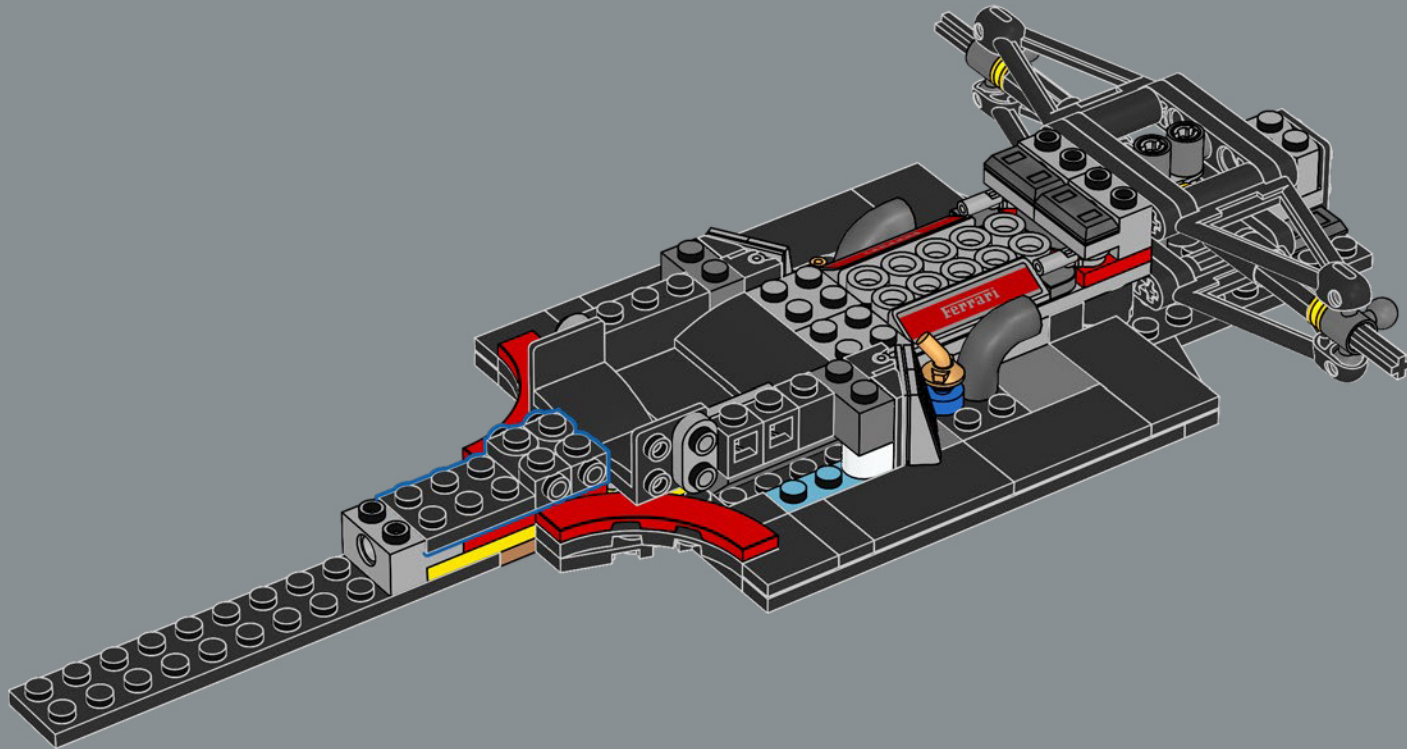

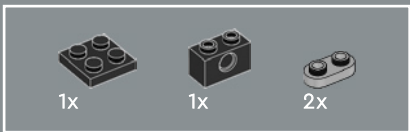

52

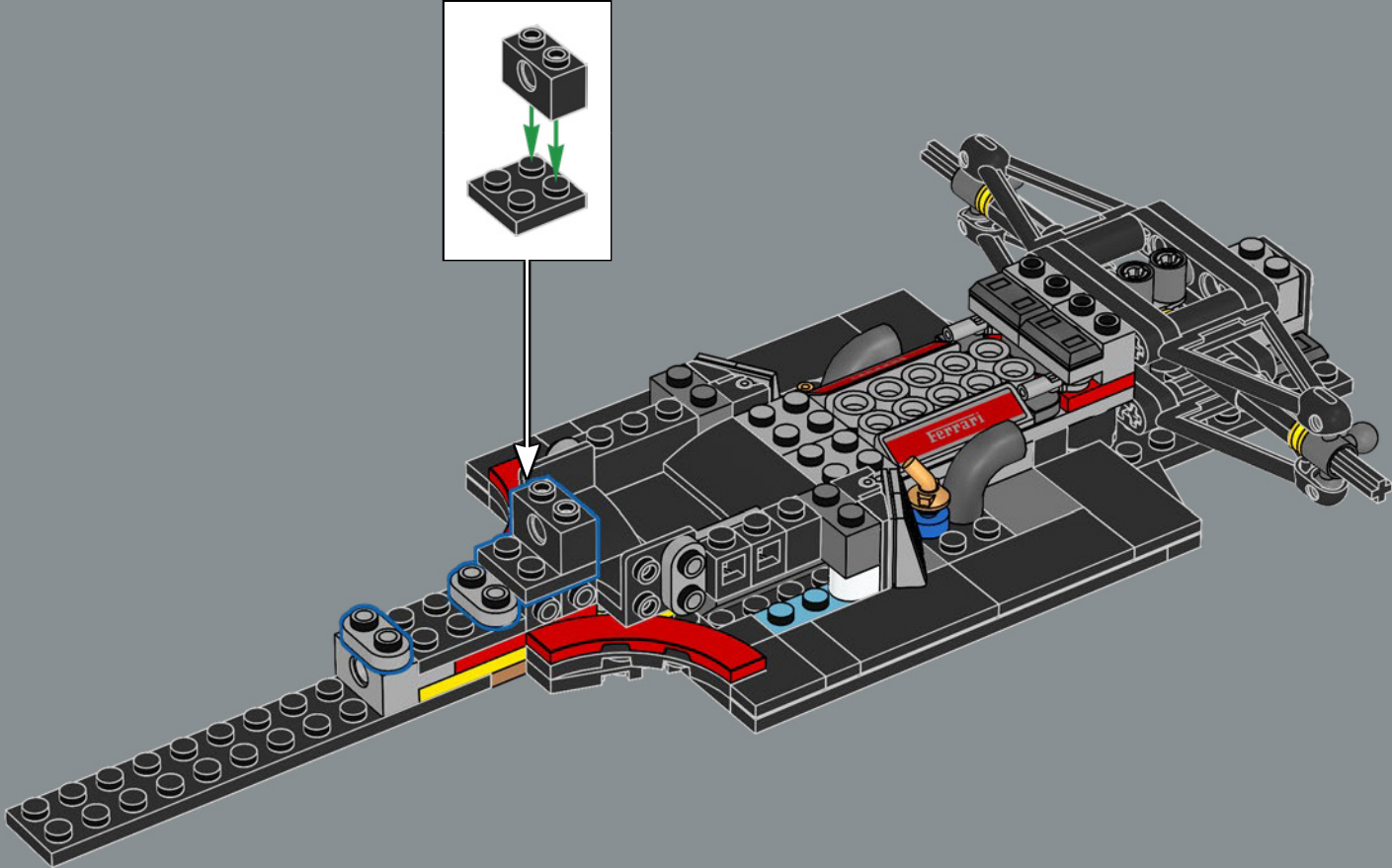

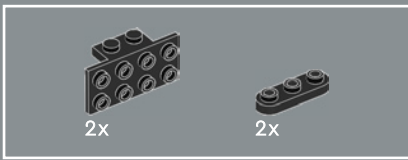

53

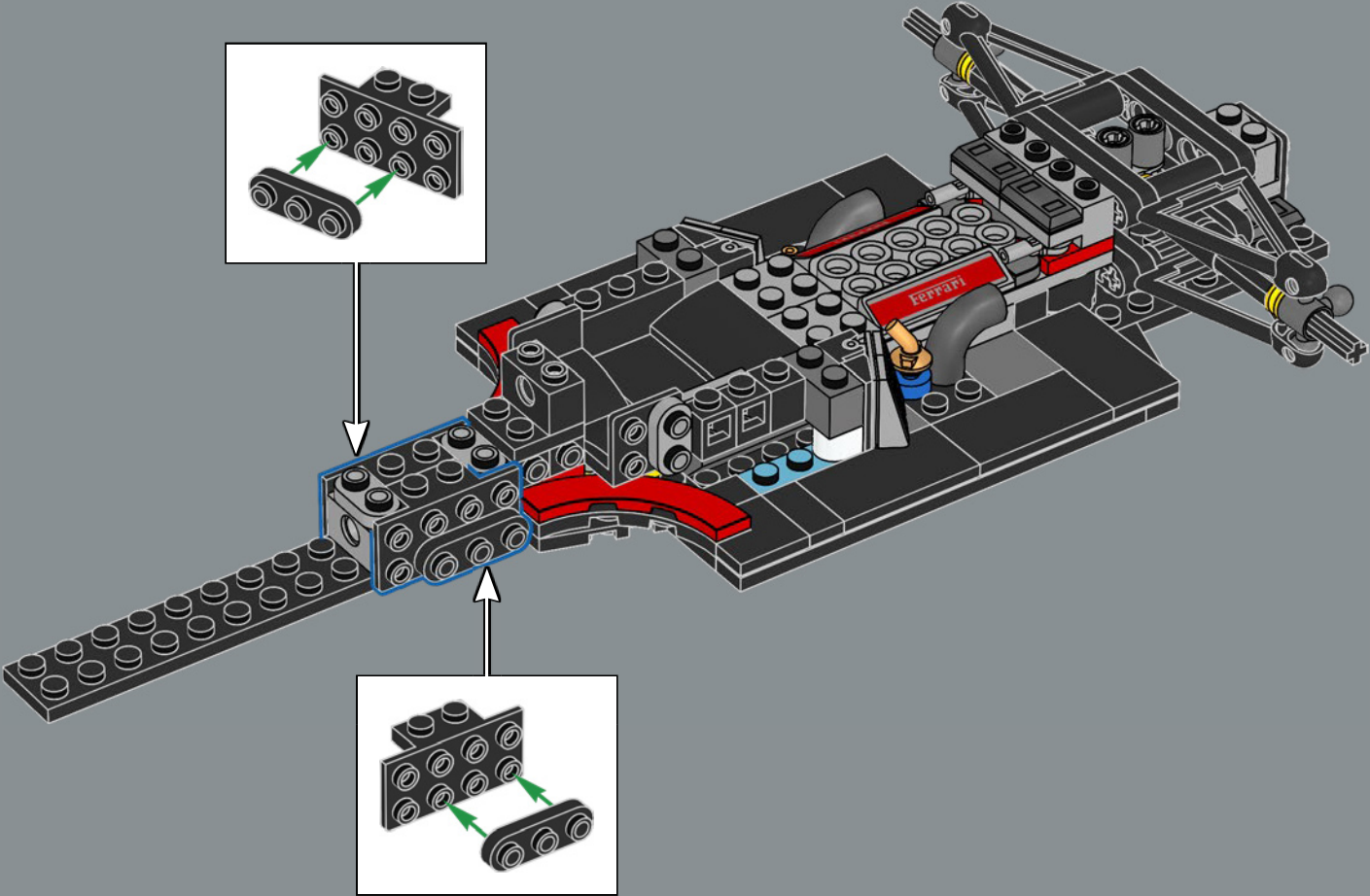



4x

54

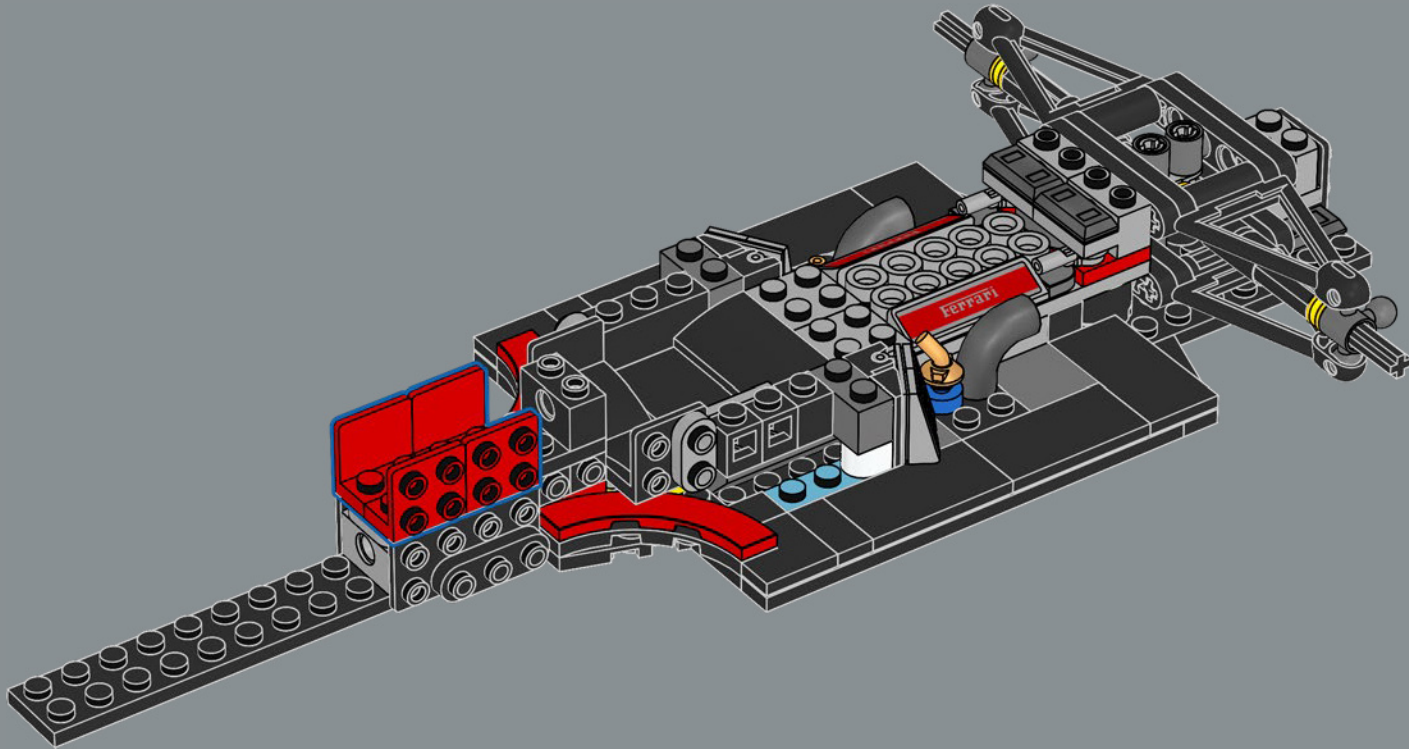

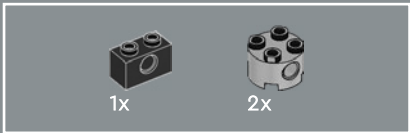

55

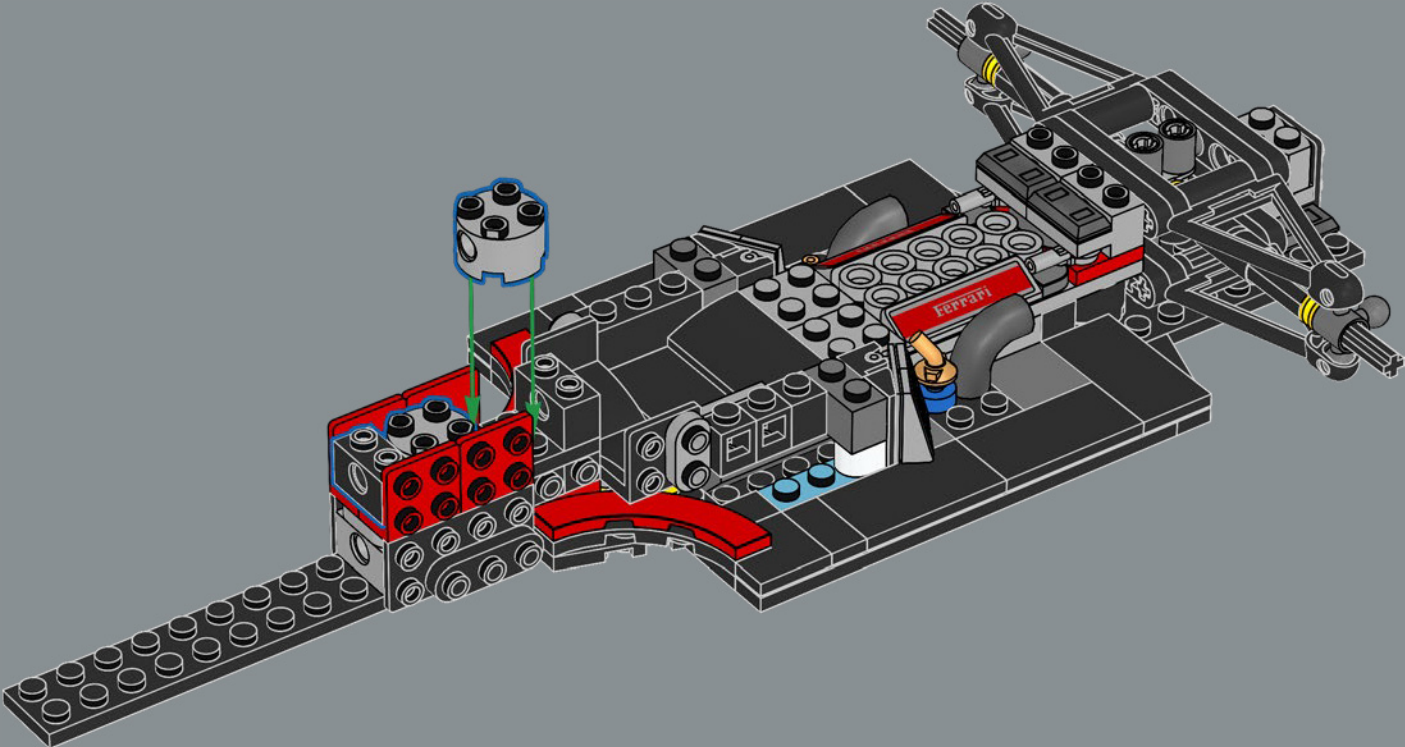

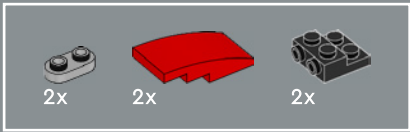

56

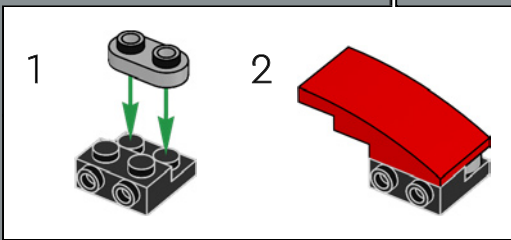
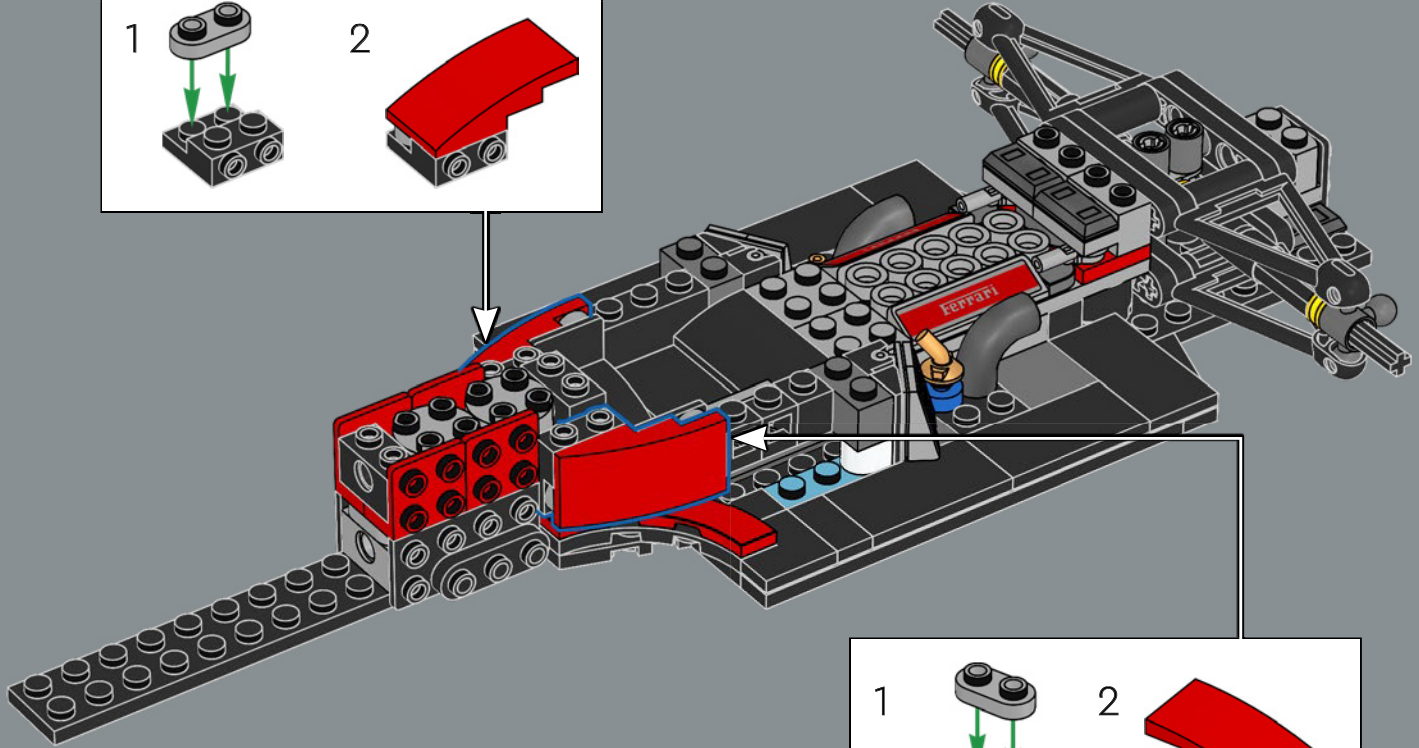
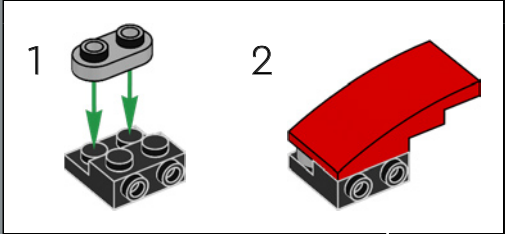



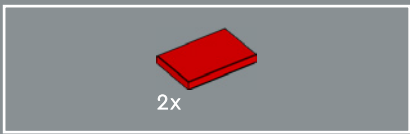

58

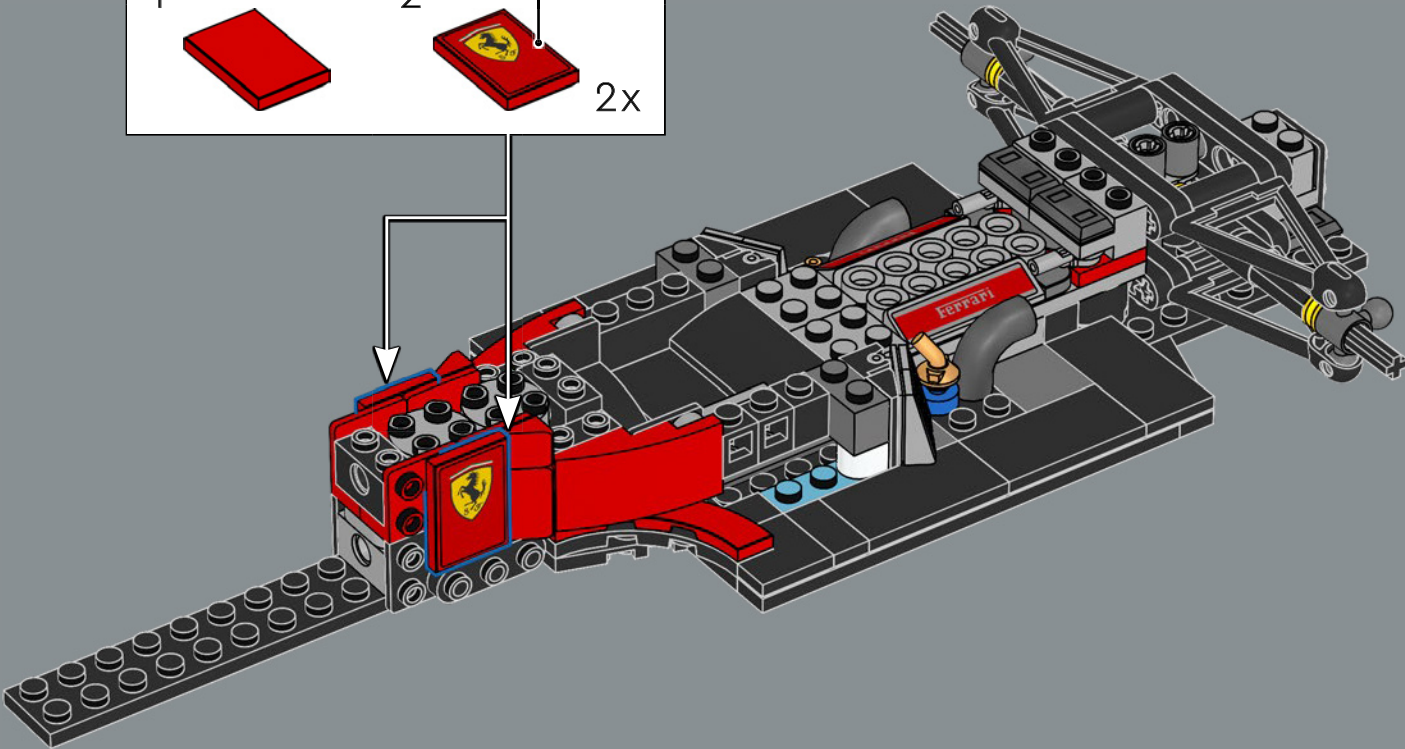
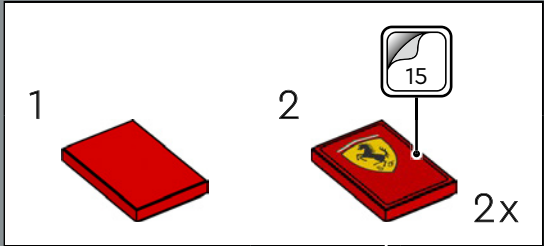

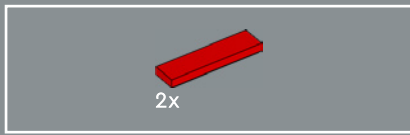

59

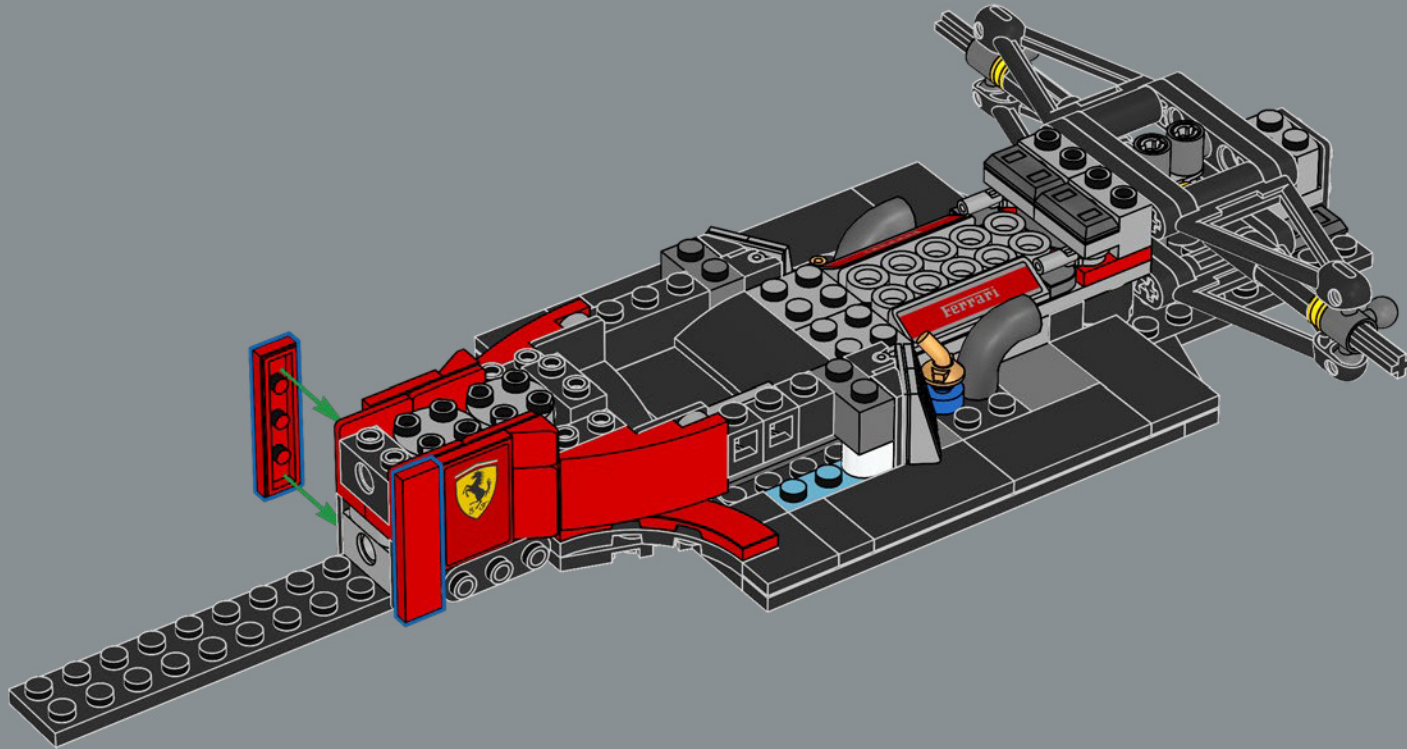

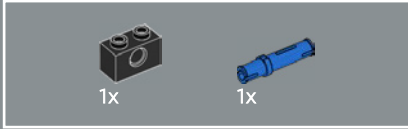
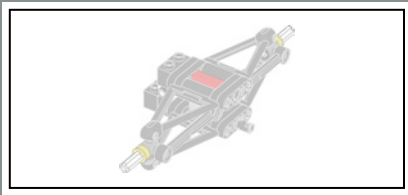

60

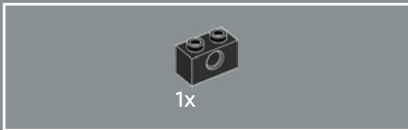
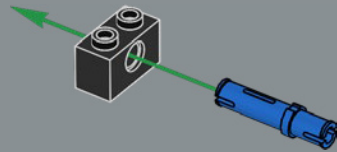

61

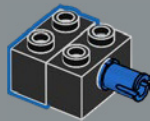

62

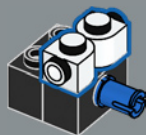

63

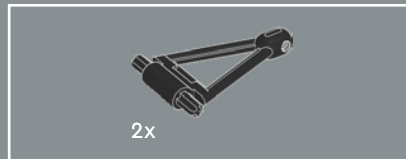
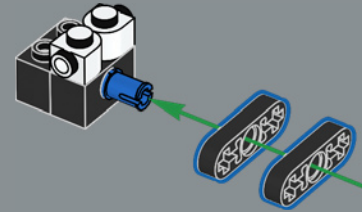

64

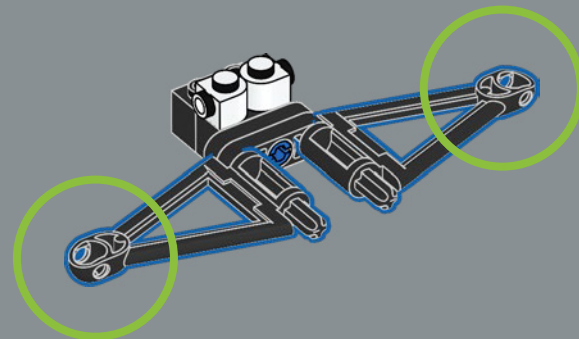



65

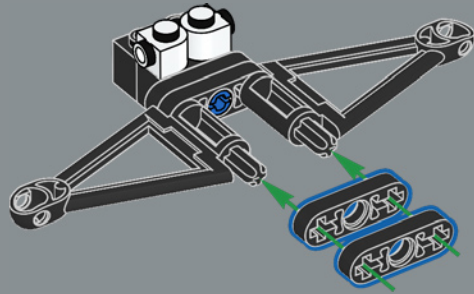

66

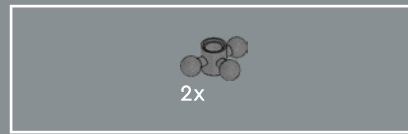
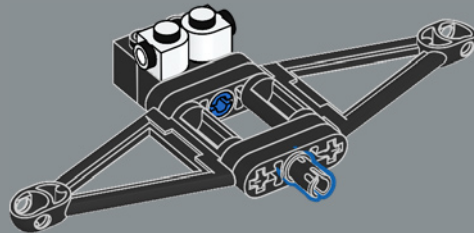

67

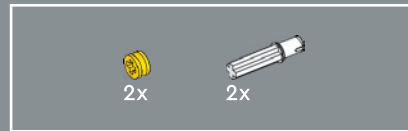
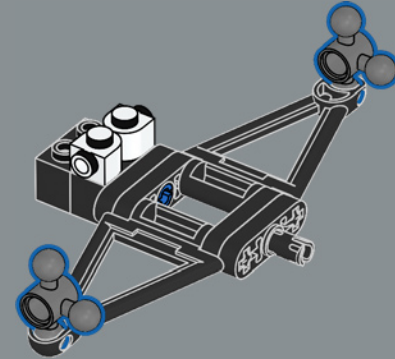

68

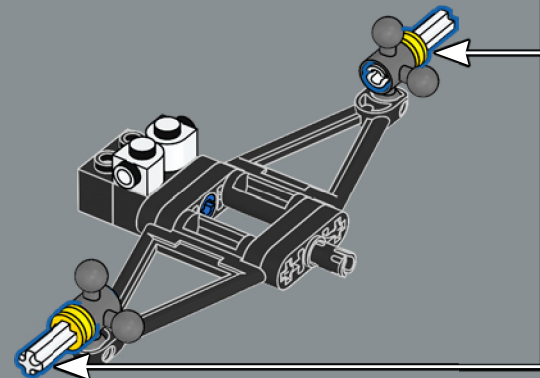
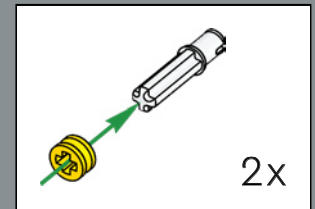

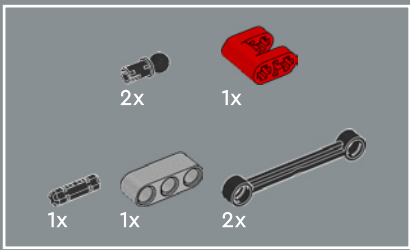

69

1

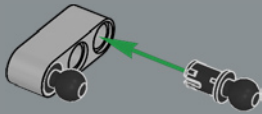

2

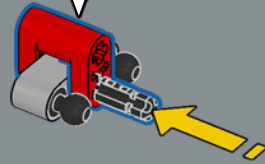

3

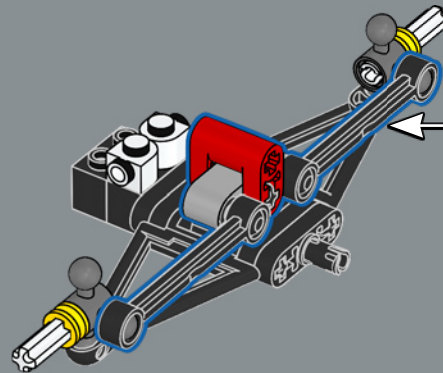
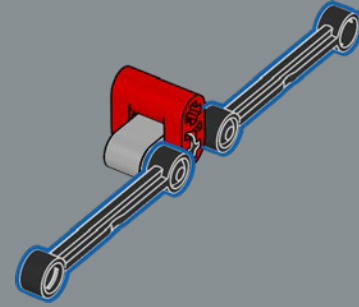

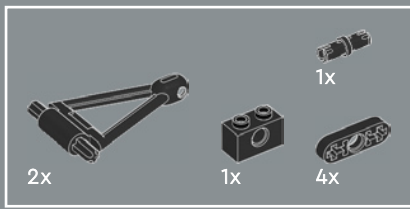

70

1

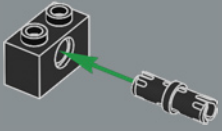

2

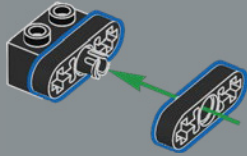

3

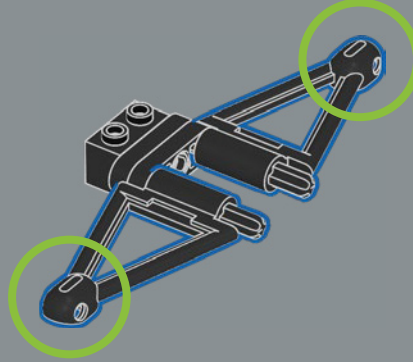

4

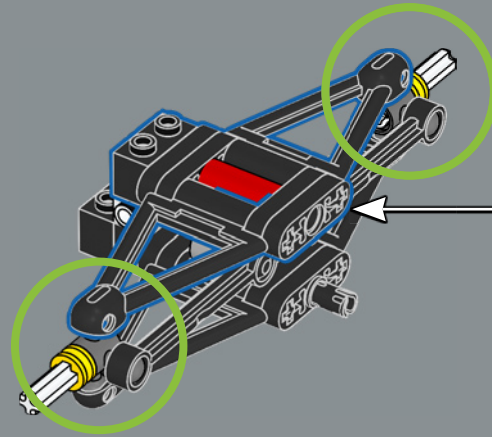
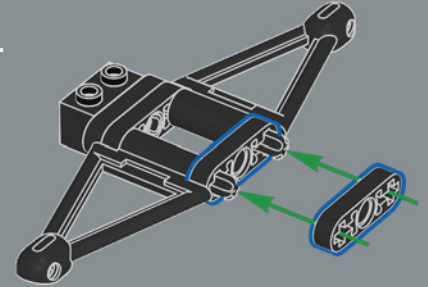



The Ferrari F2004 is an evolution of the previous season's F2003-GA. The main parts of the car were revised to reach maximum levels of performance.

La Ferrari F2004 est une évolution de la F2003-GA de la saison précédente. Les principales pièces de la voiture ont été révisées afin d'atteindre des niveaux de performance maximaux.

El Ferrari F2004 es una evolución del F2003-GA de la temporada anterior. Se revisaron las partes principales del auto para mejorar aún más su desempeño.

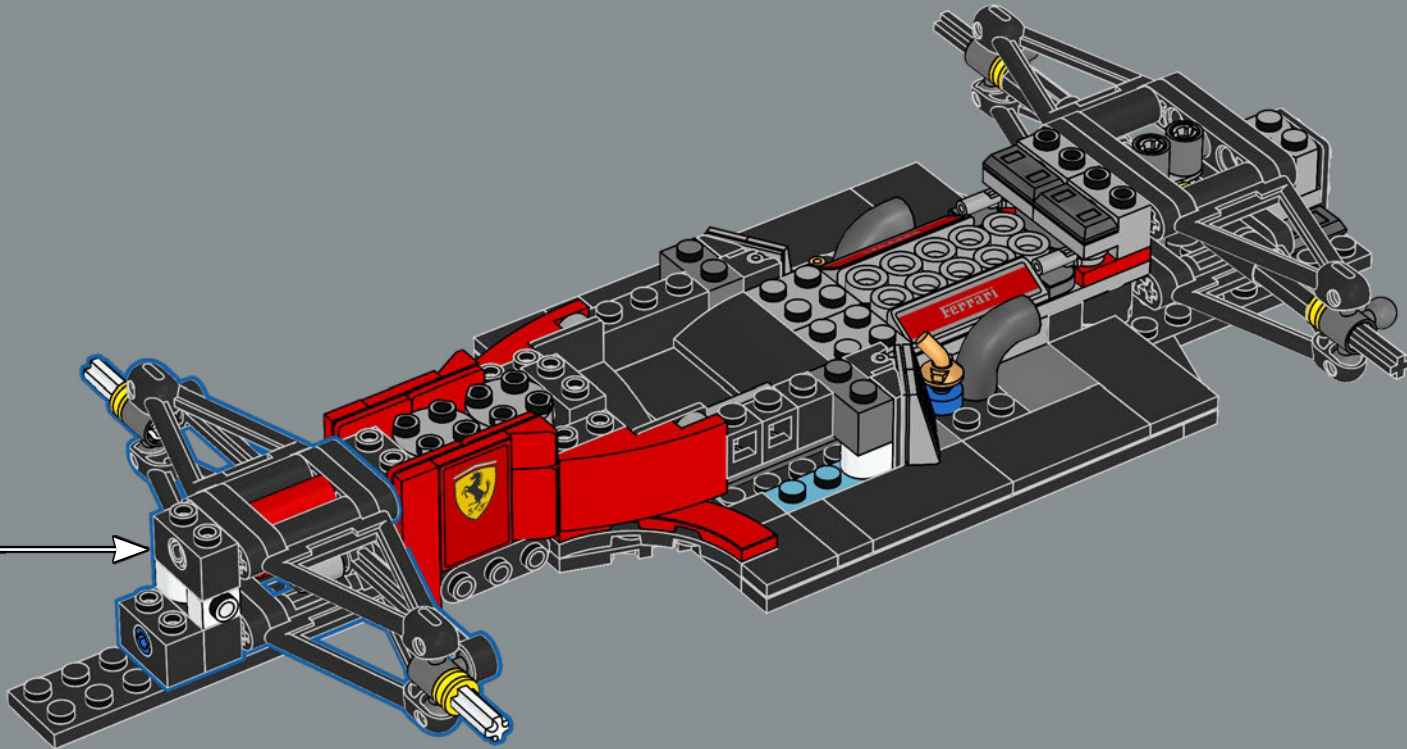

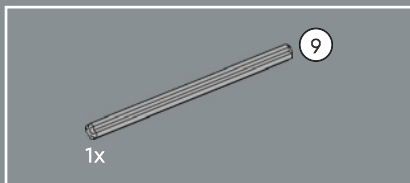

72

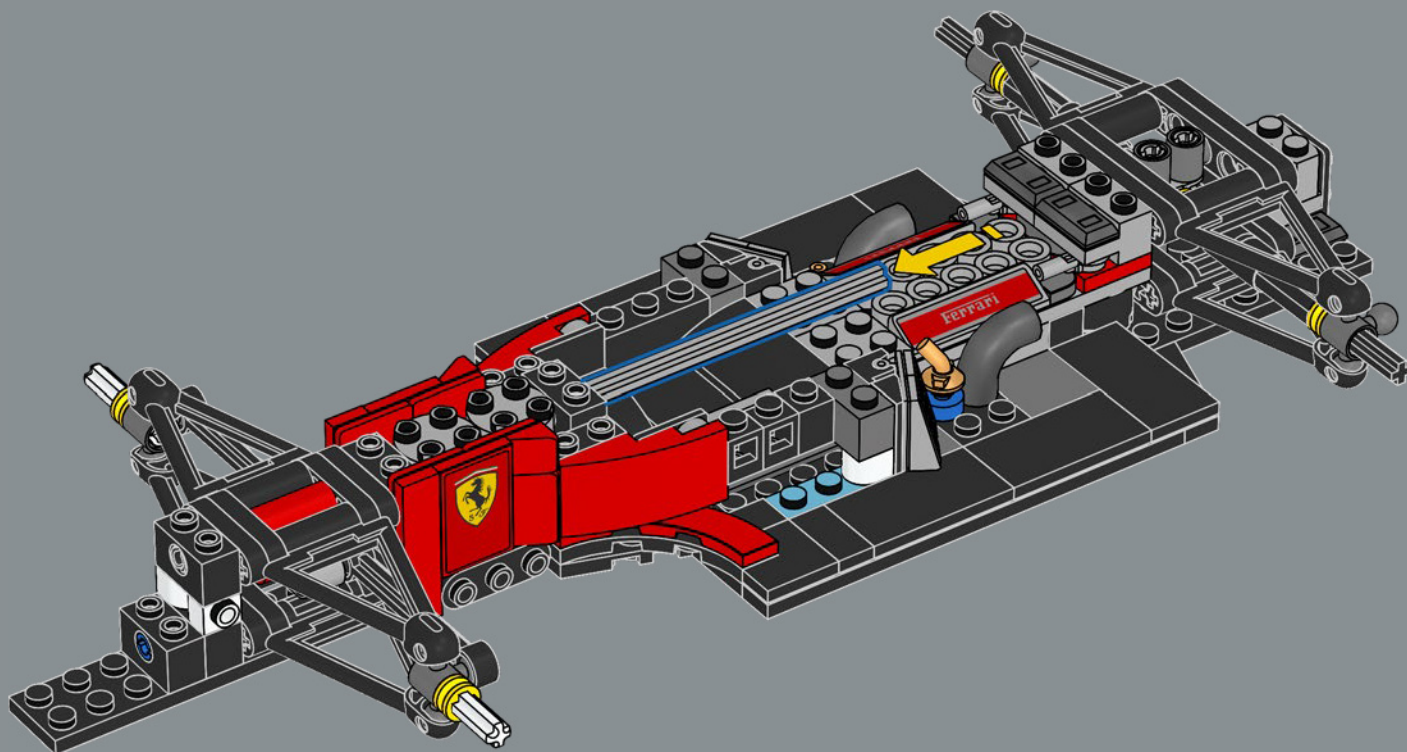



2x

73

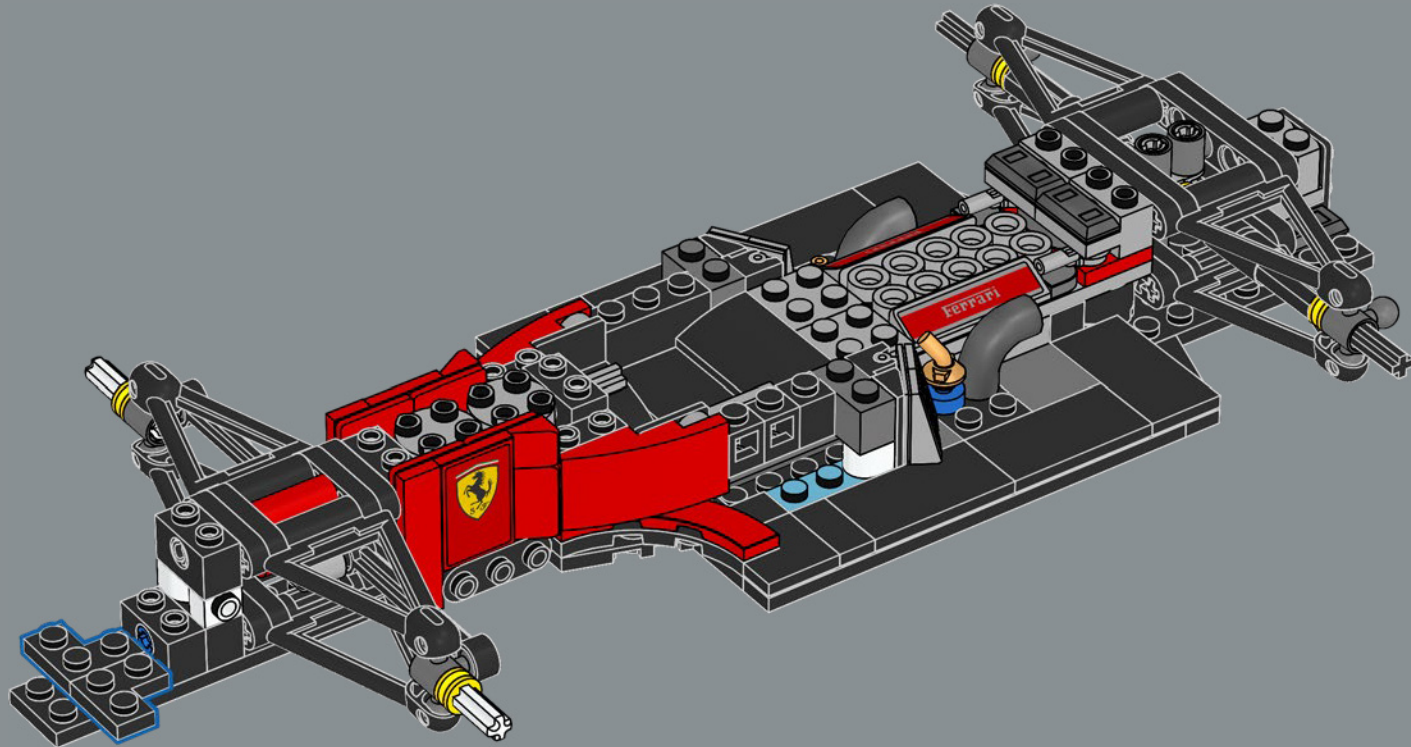

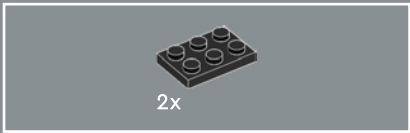

74

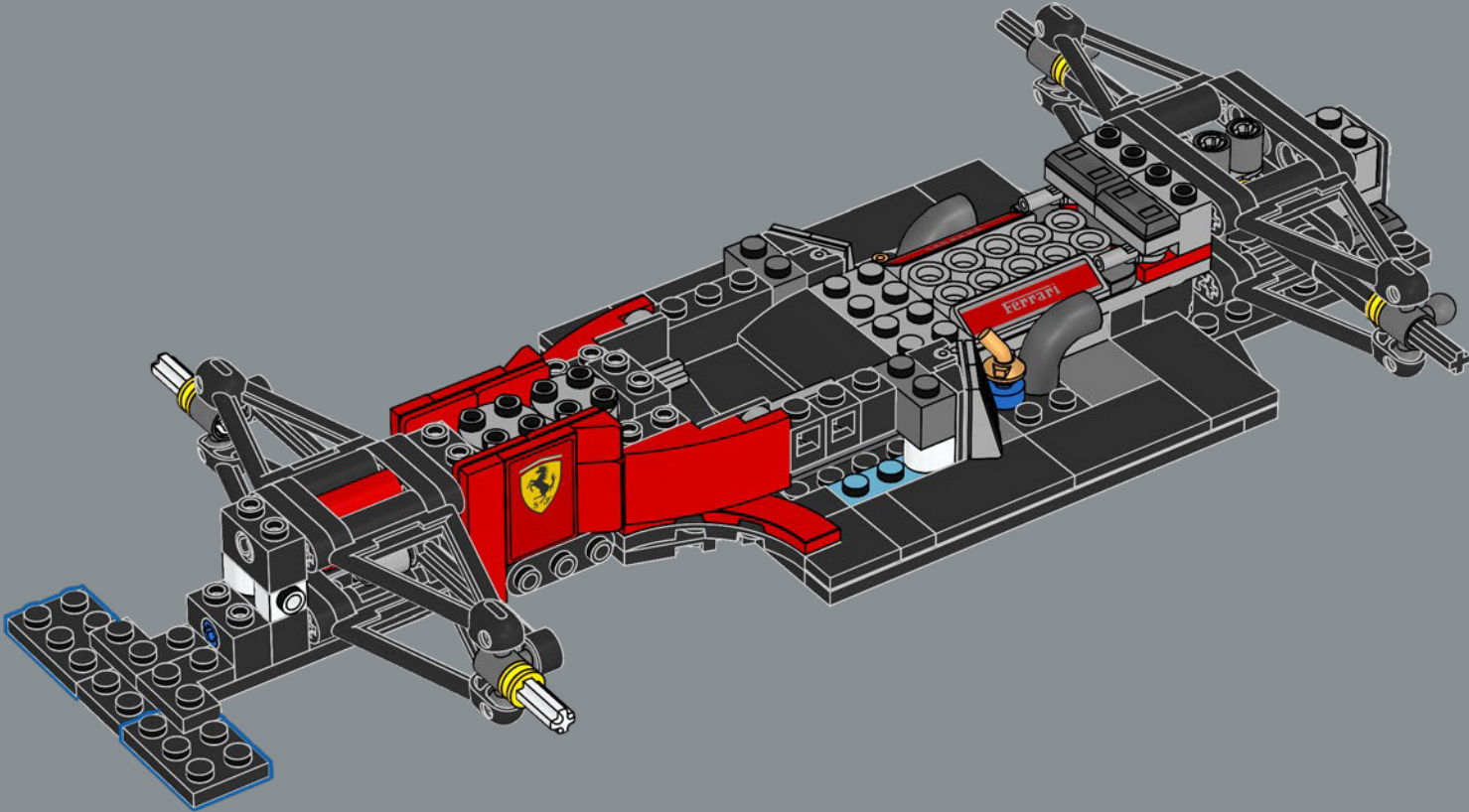

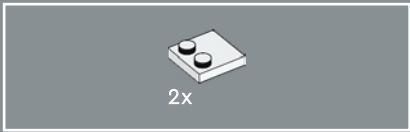

75

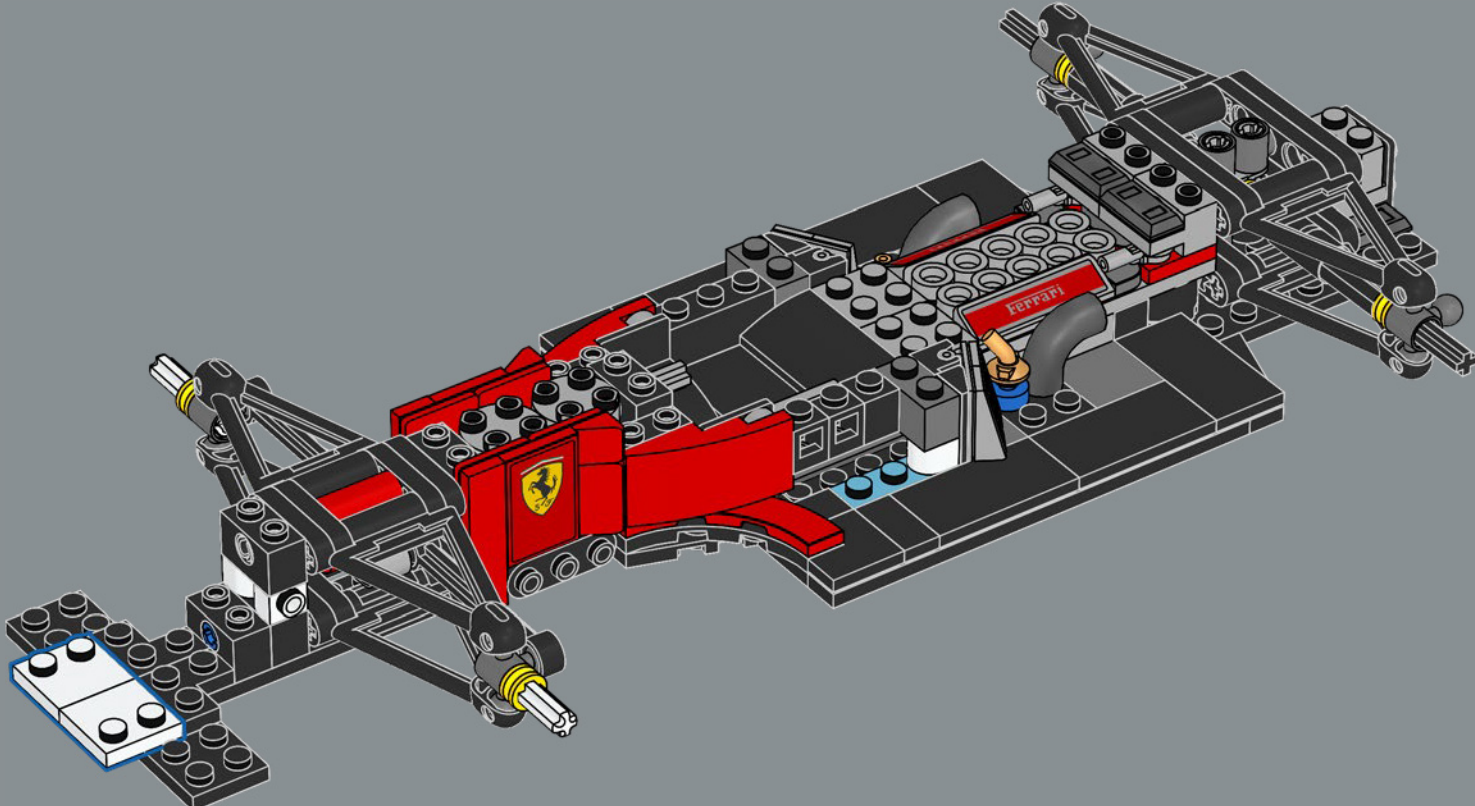

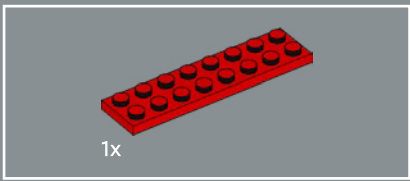

76

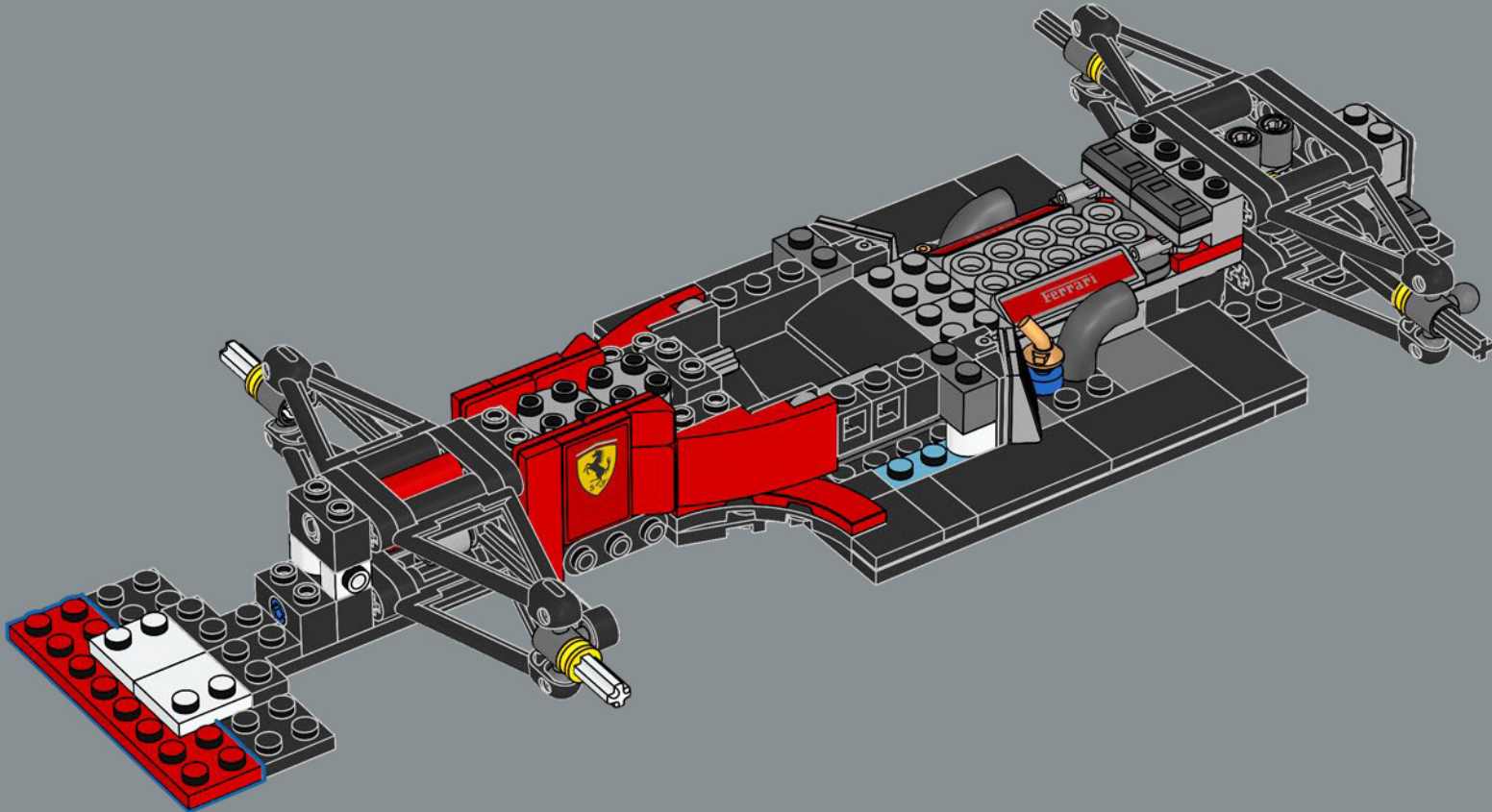

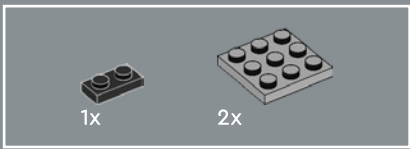

77

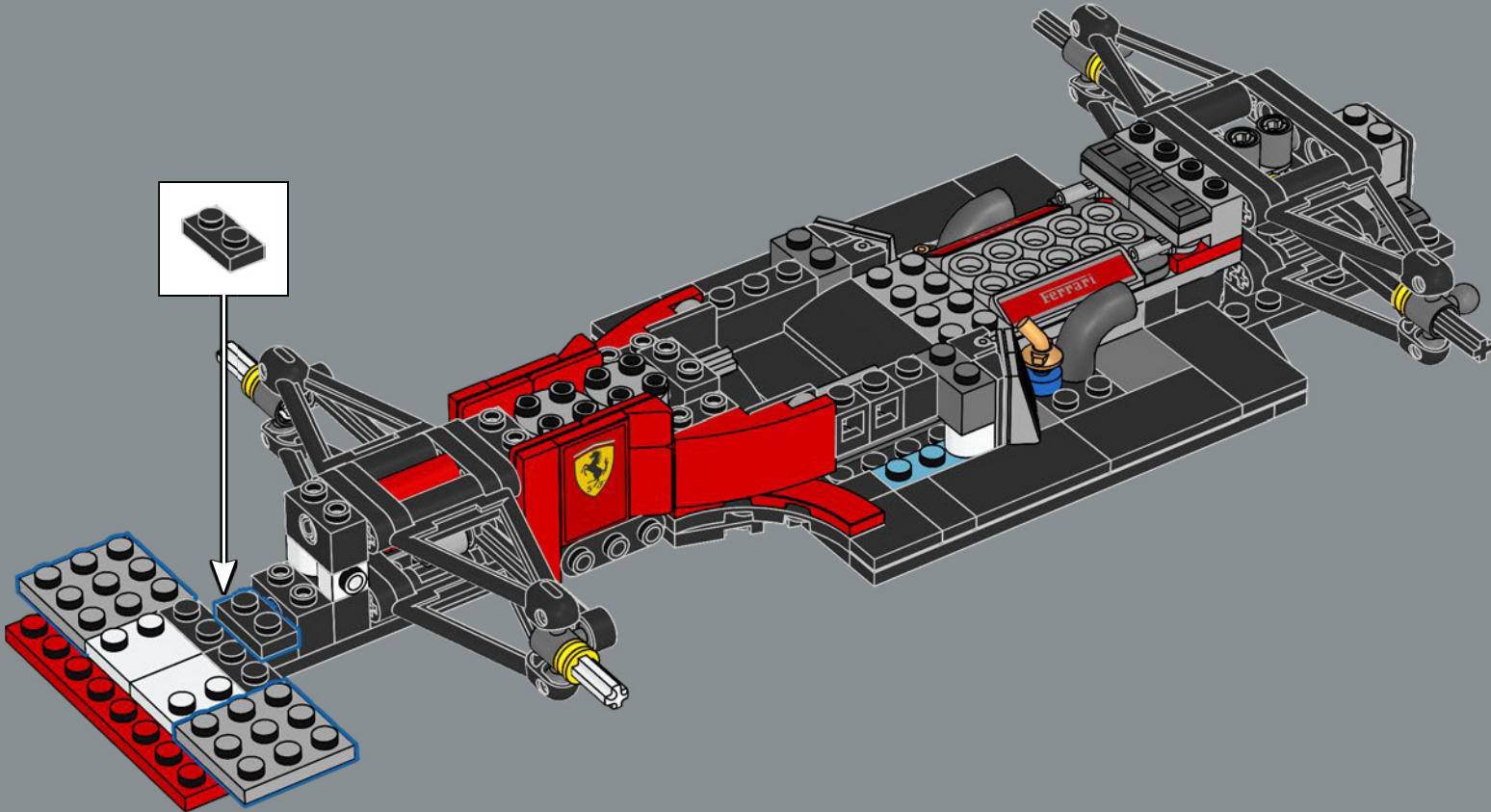



78

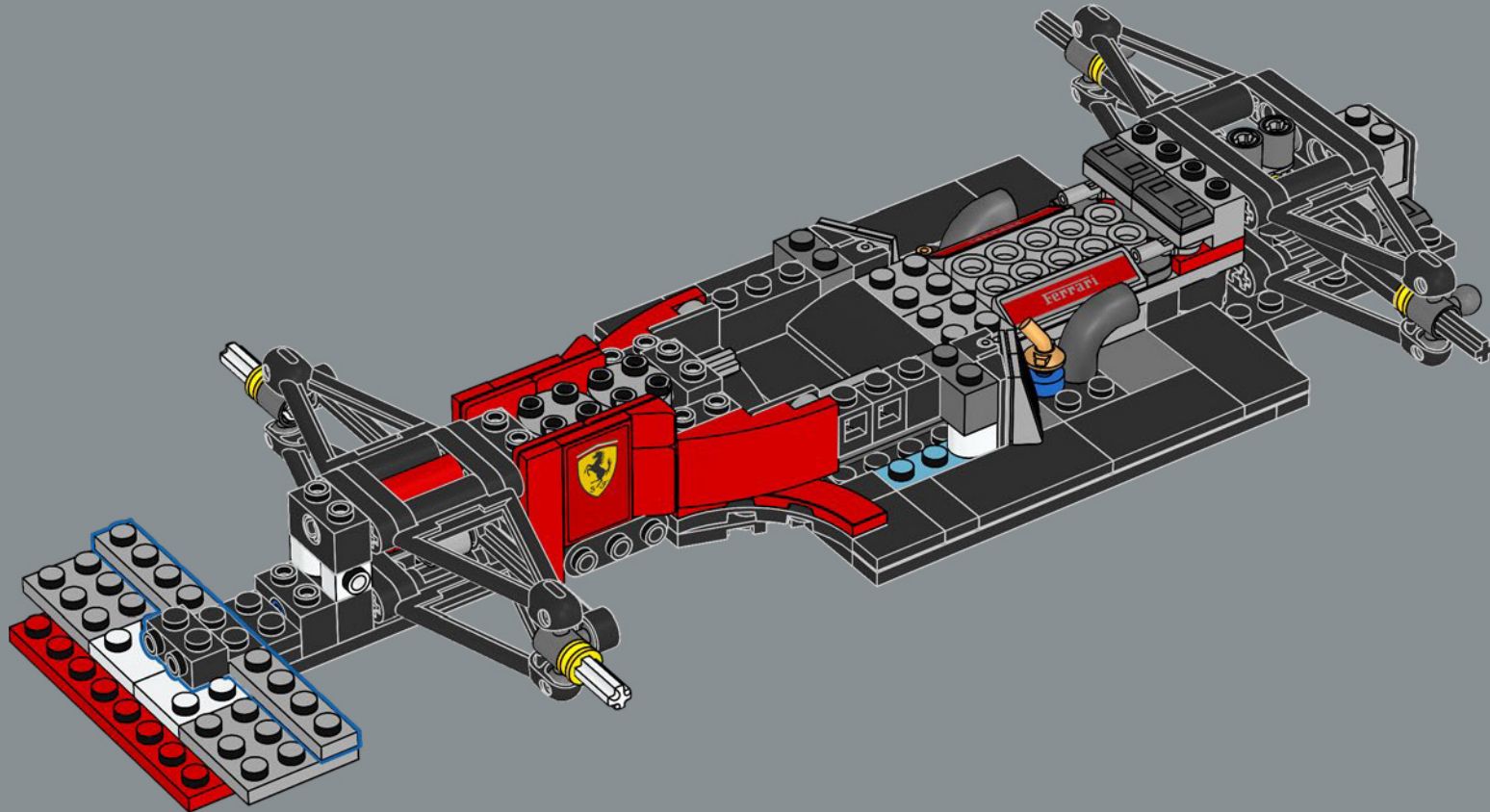

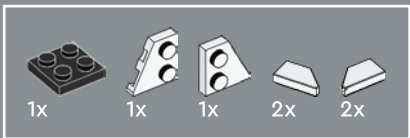

79

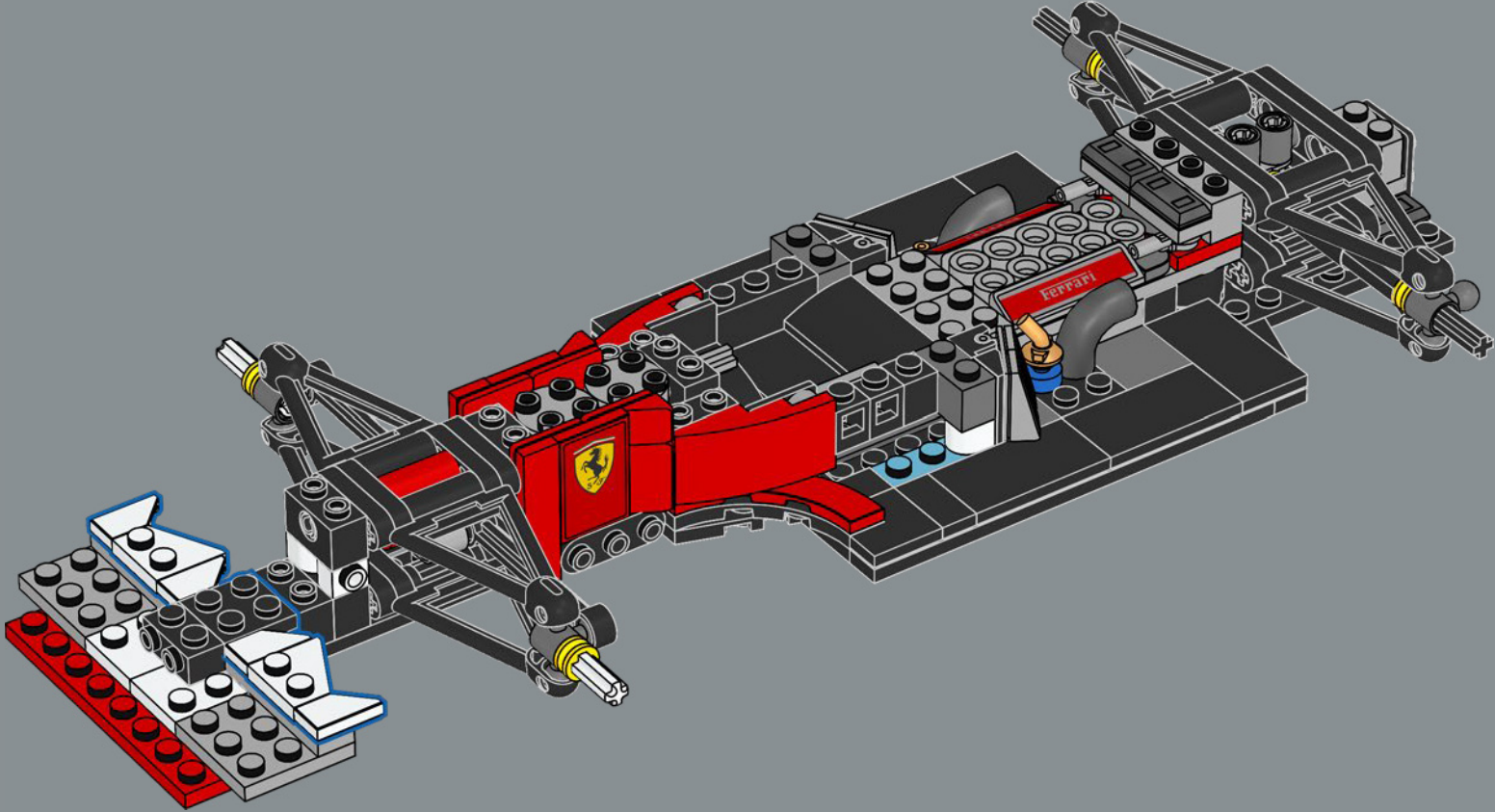

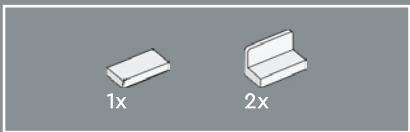

80

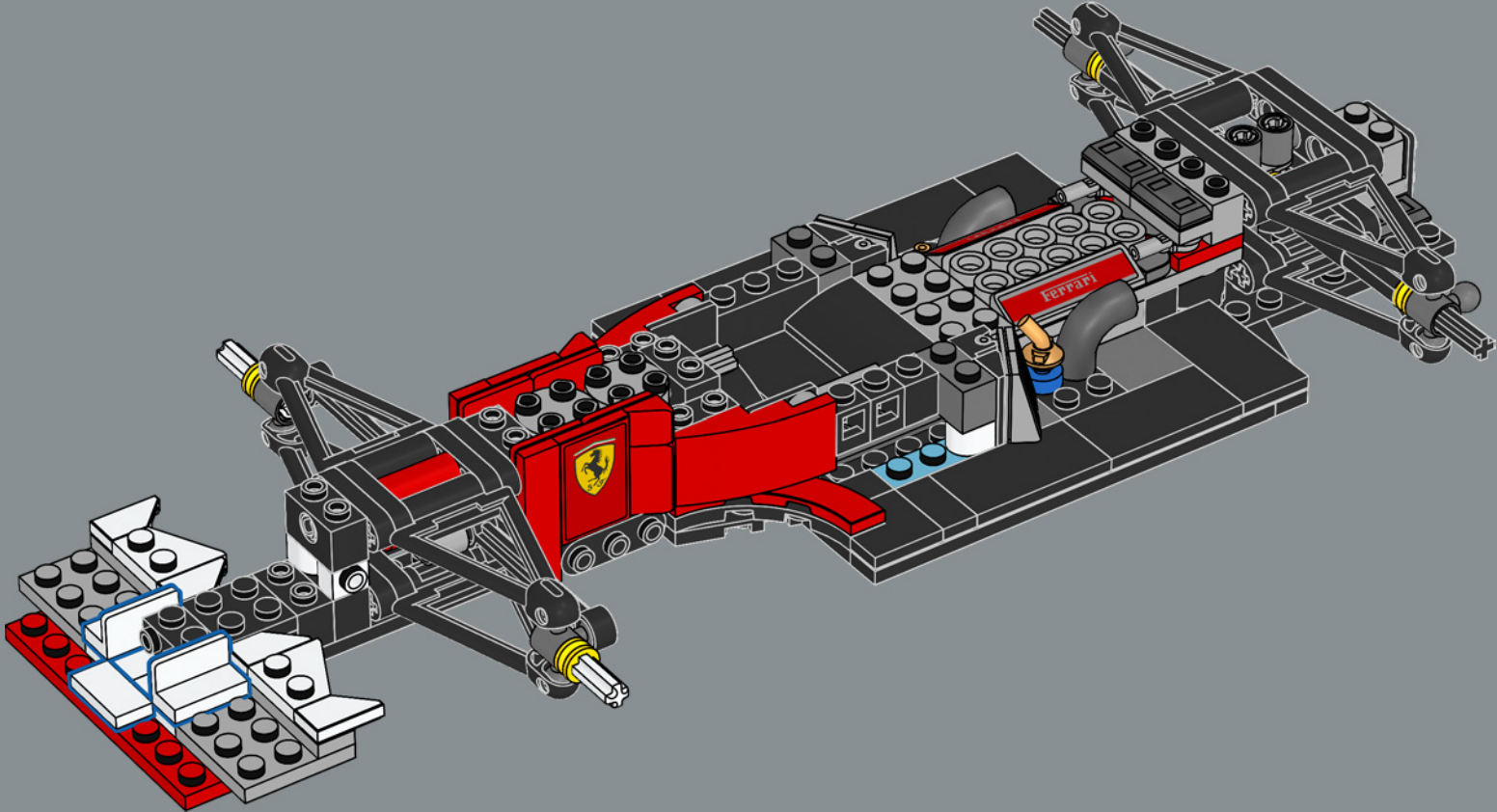

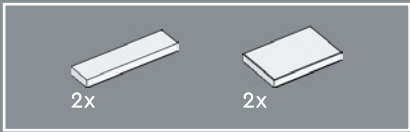

81

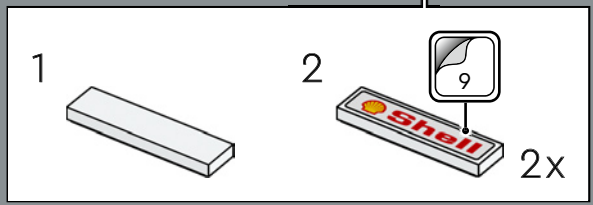
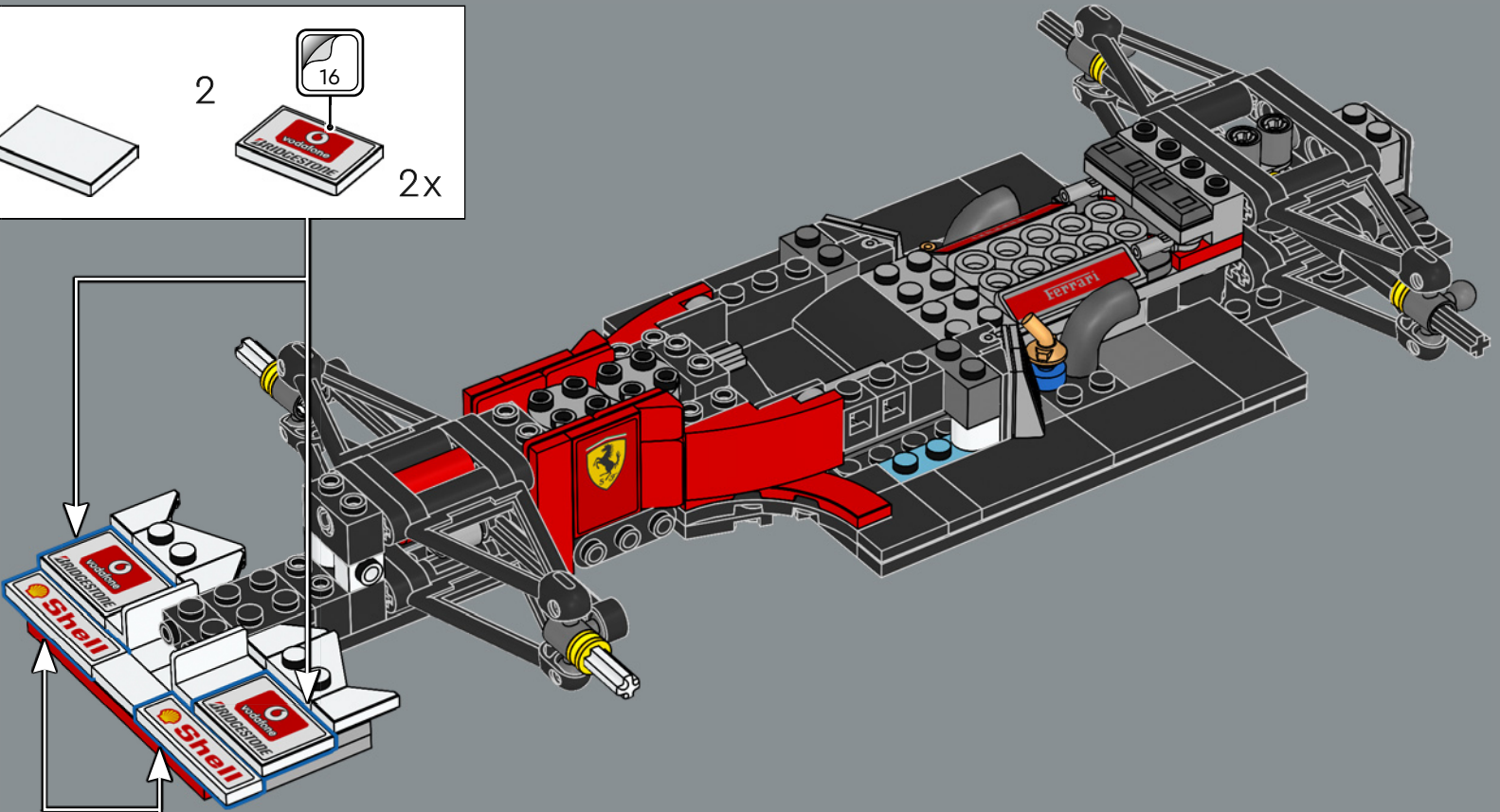
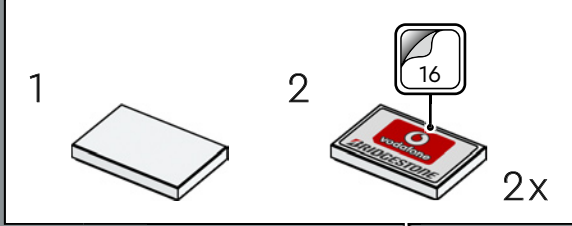

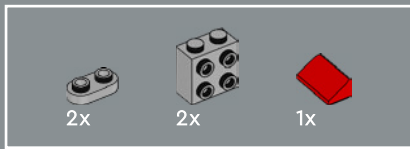

82

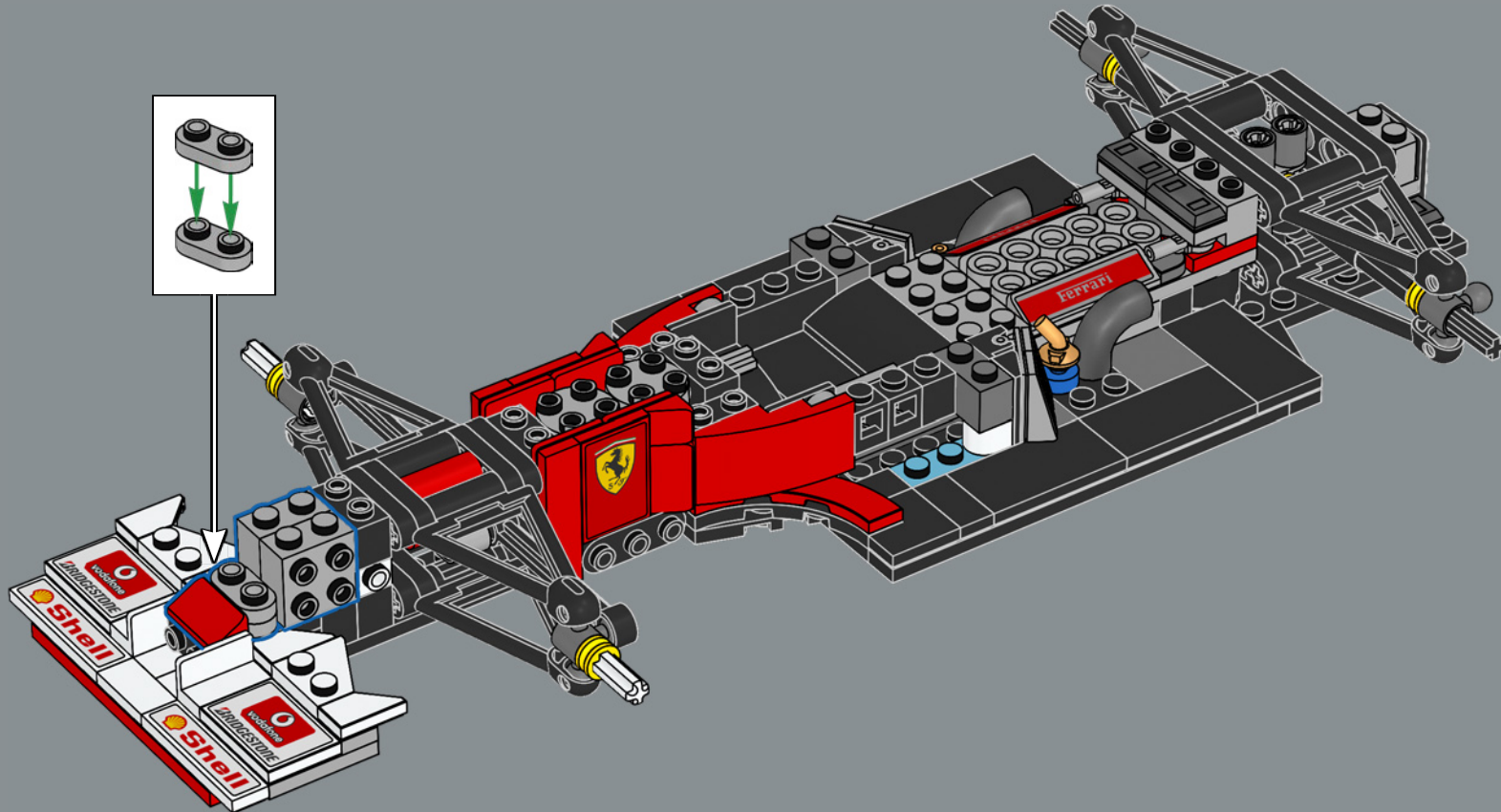



83

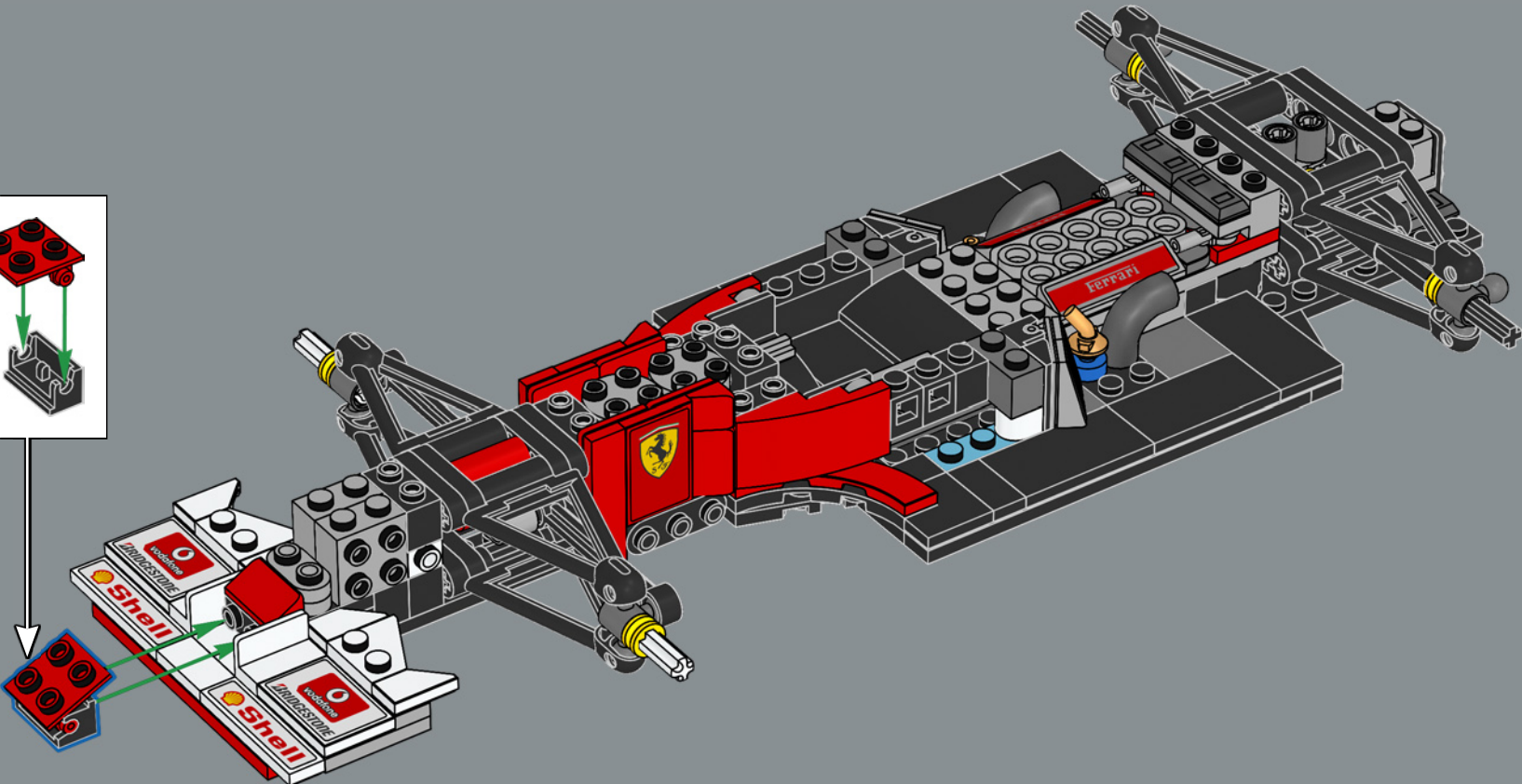
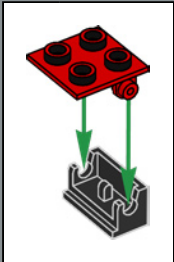

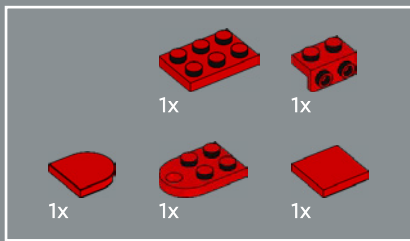

84

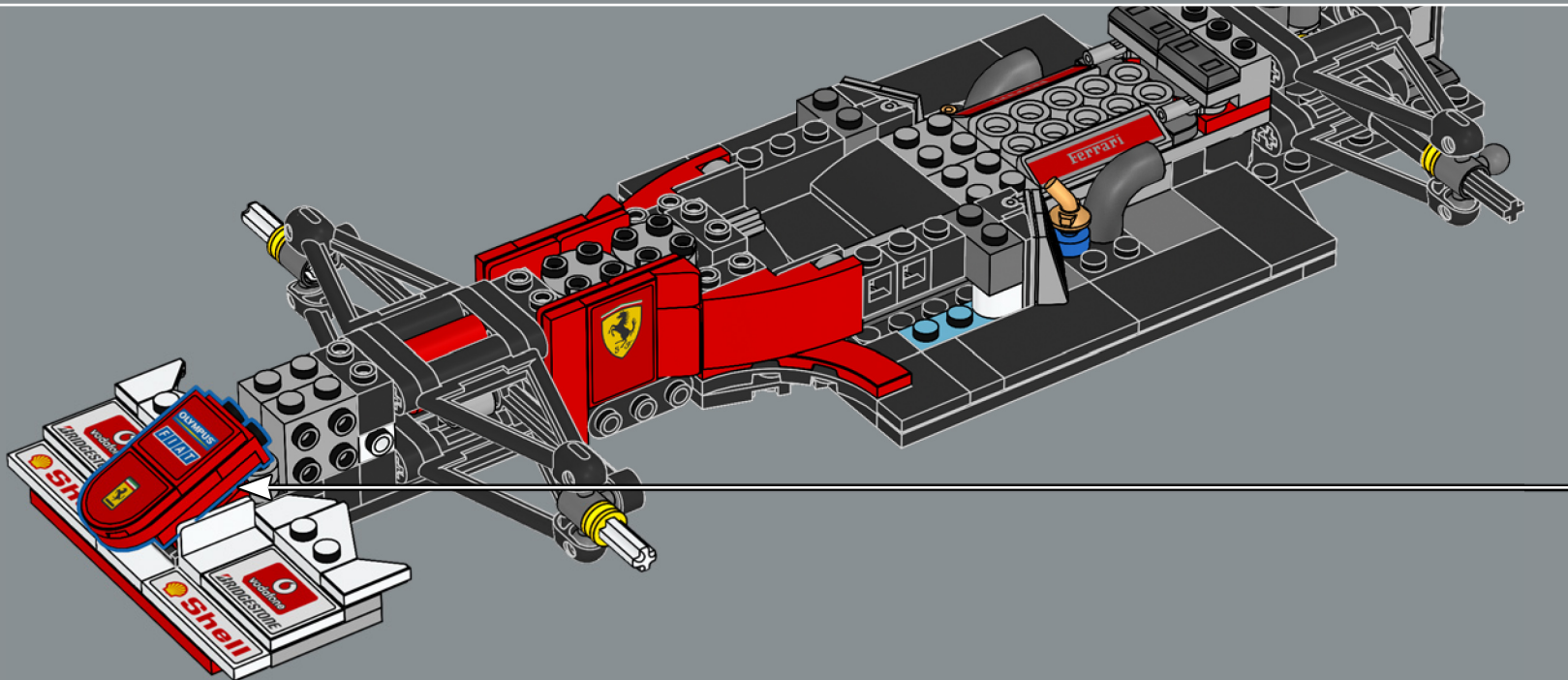
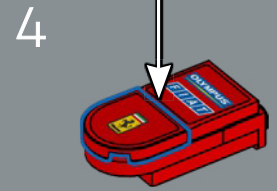
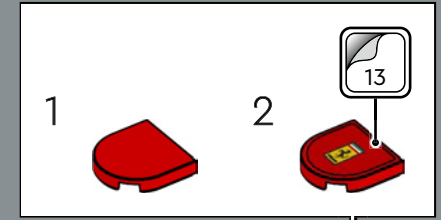
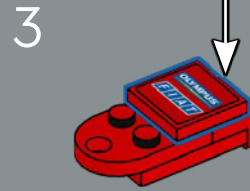
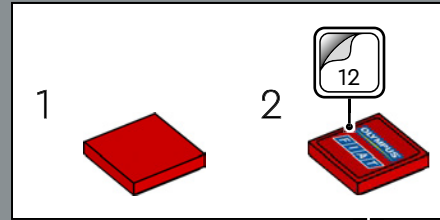
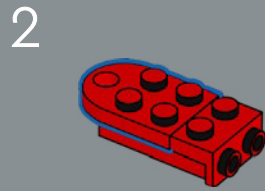
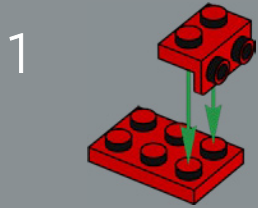

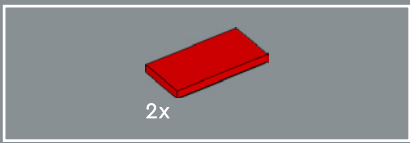

85

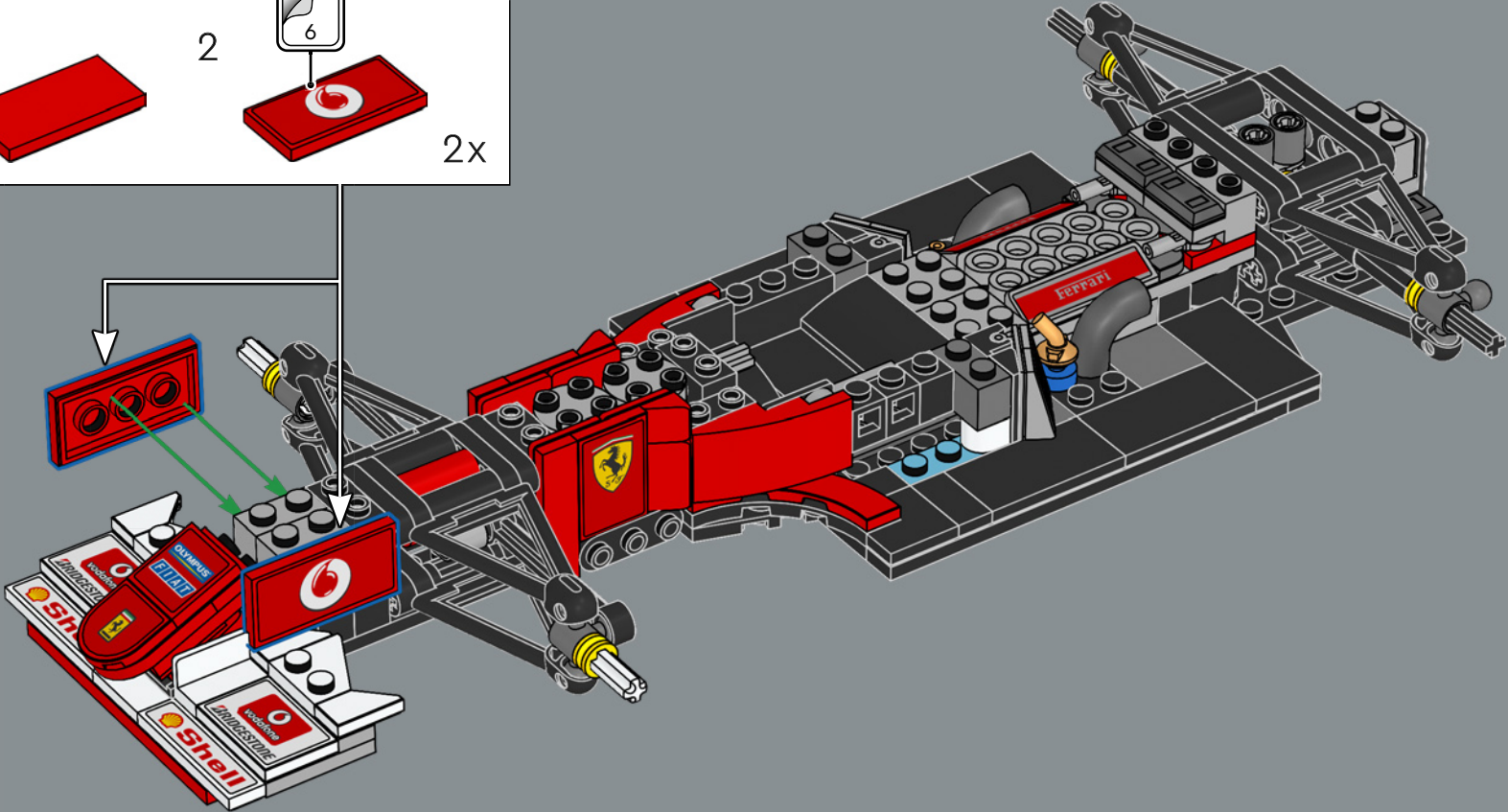
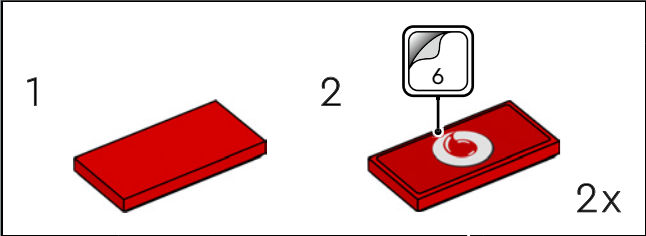



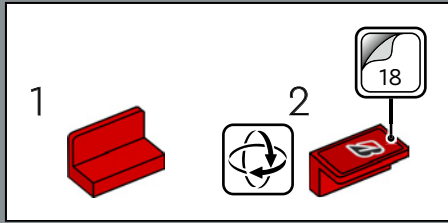

5

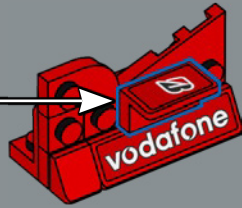

6

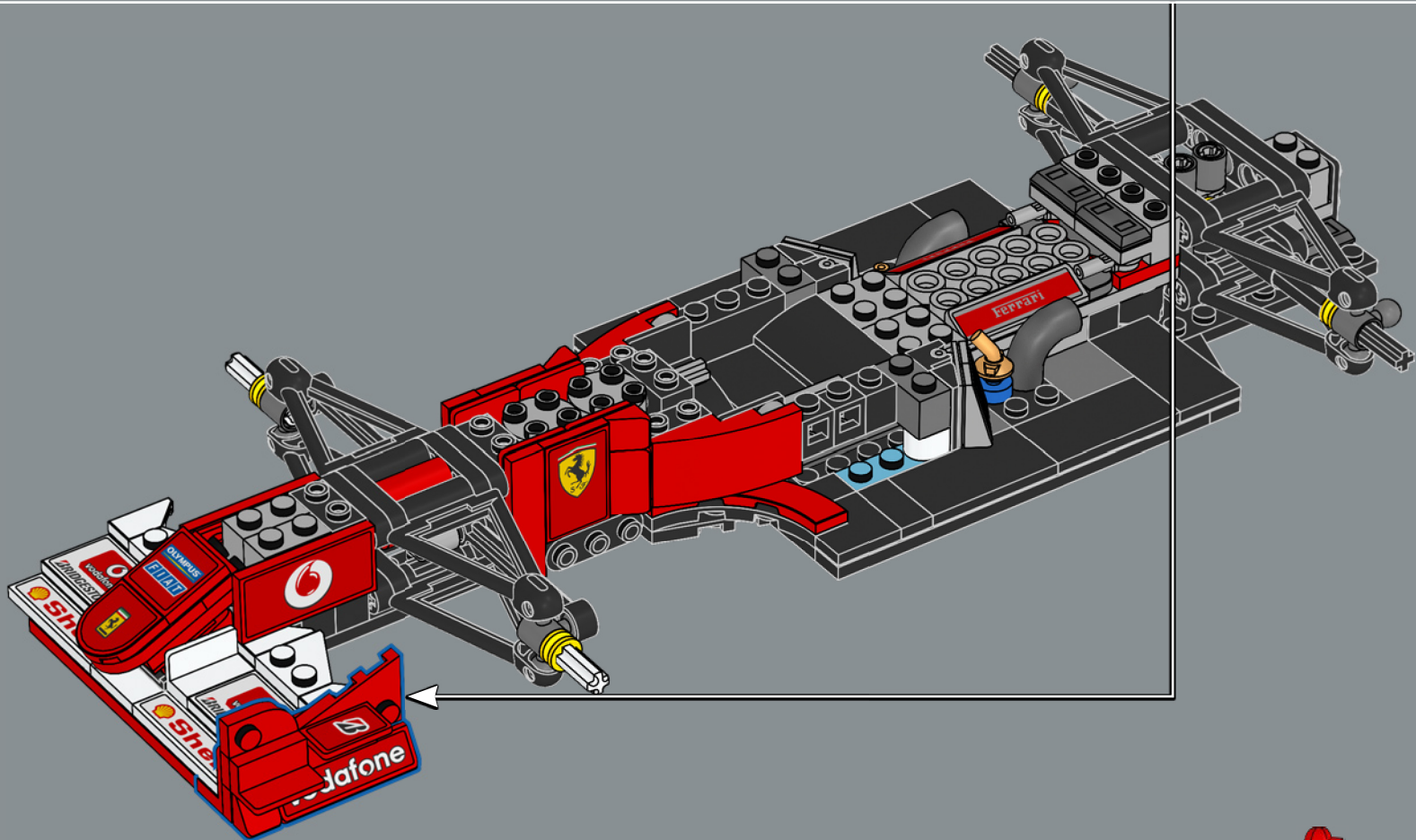
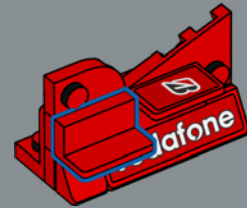

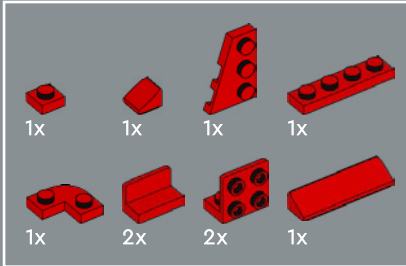
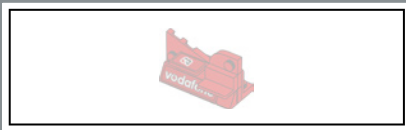

87

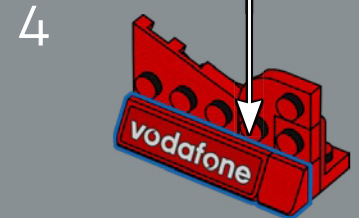
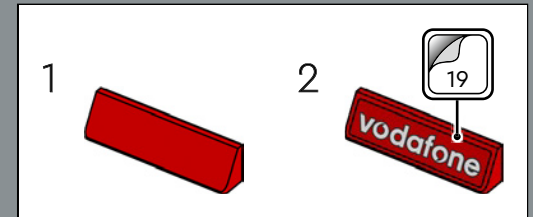
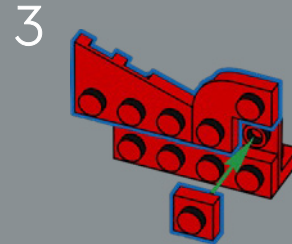
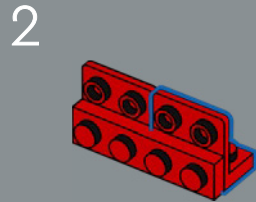
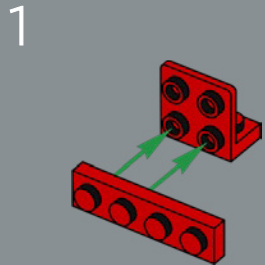

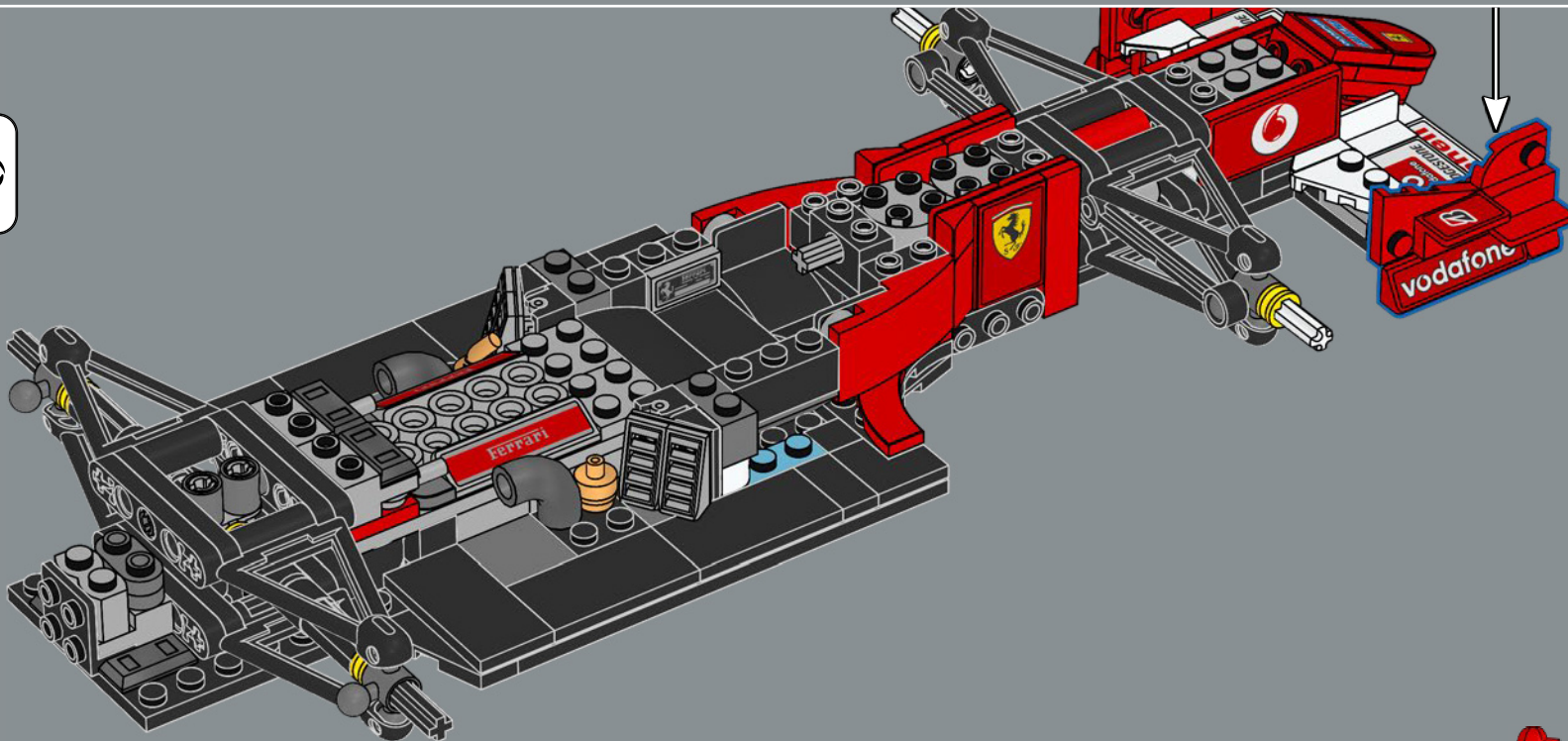
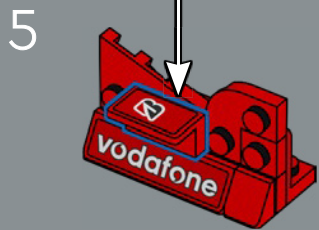
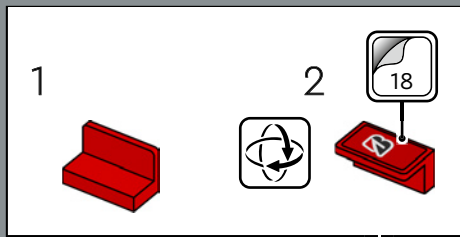



88

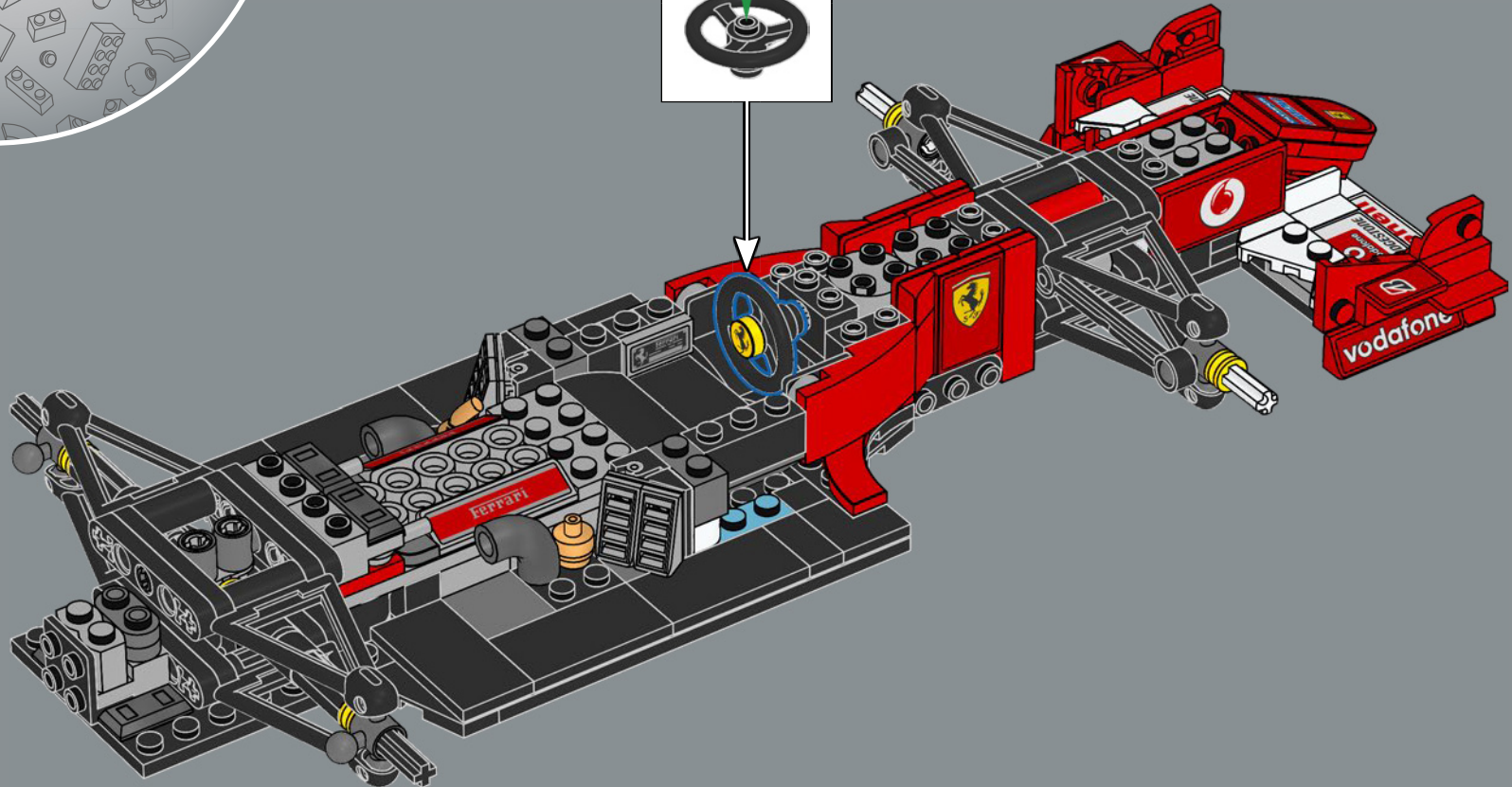
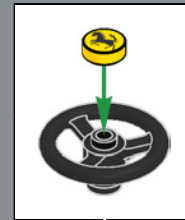

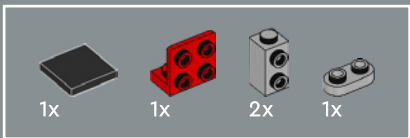

89

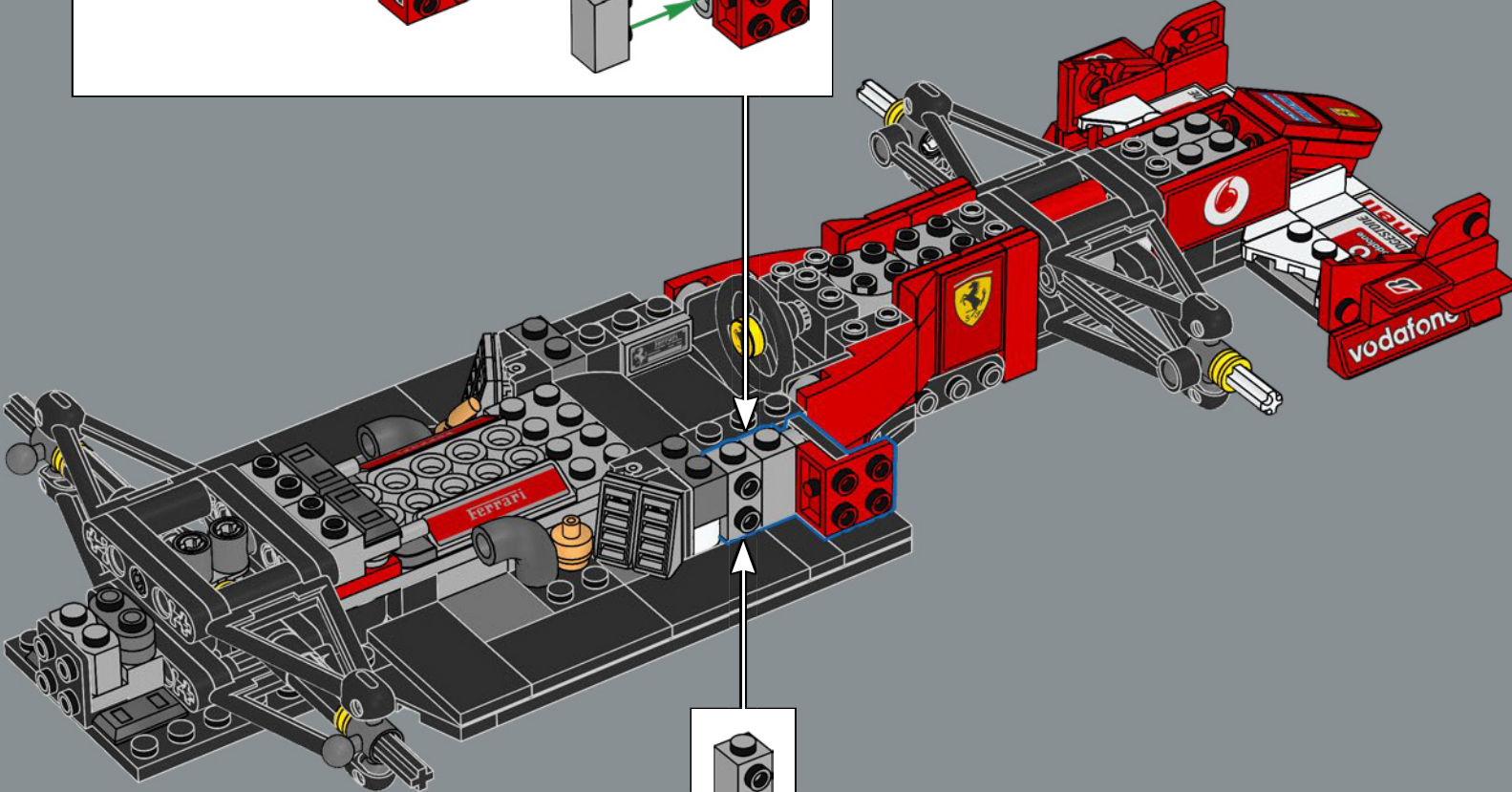
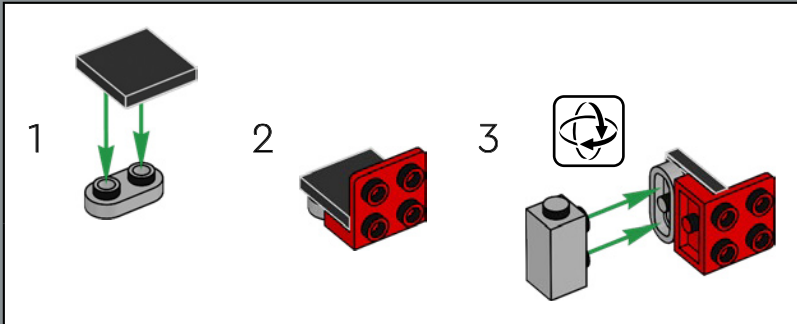

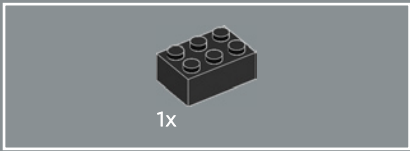

90

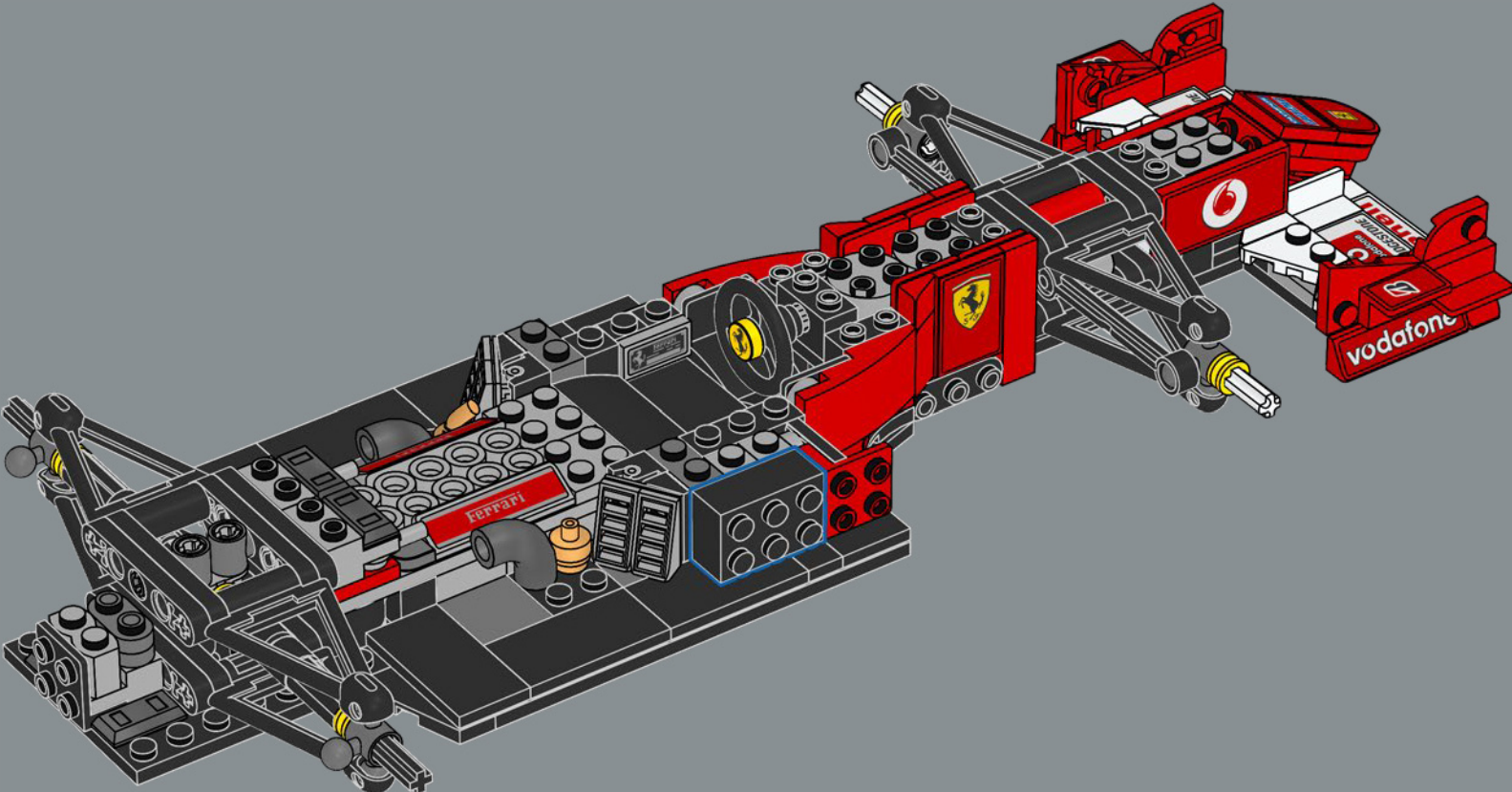

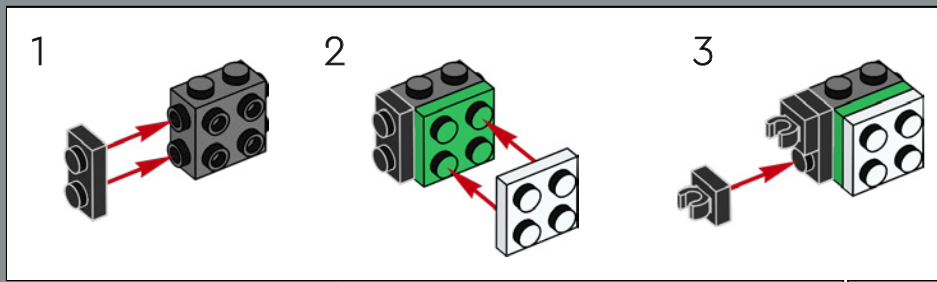
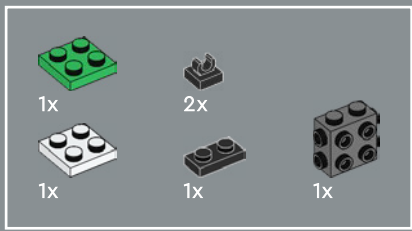

91

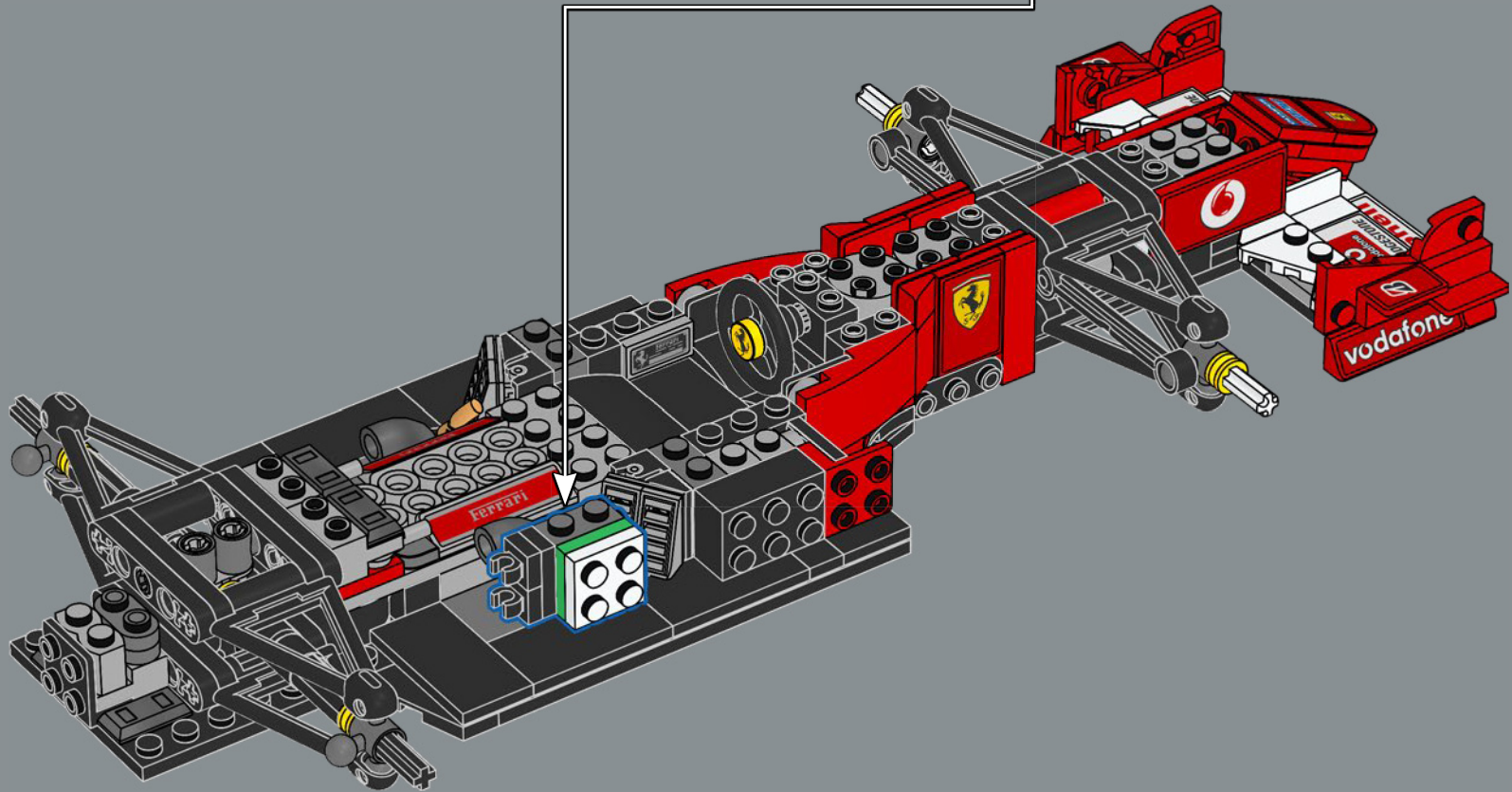

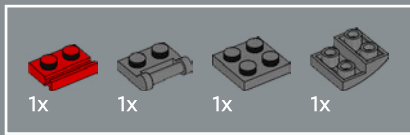

92

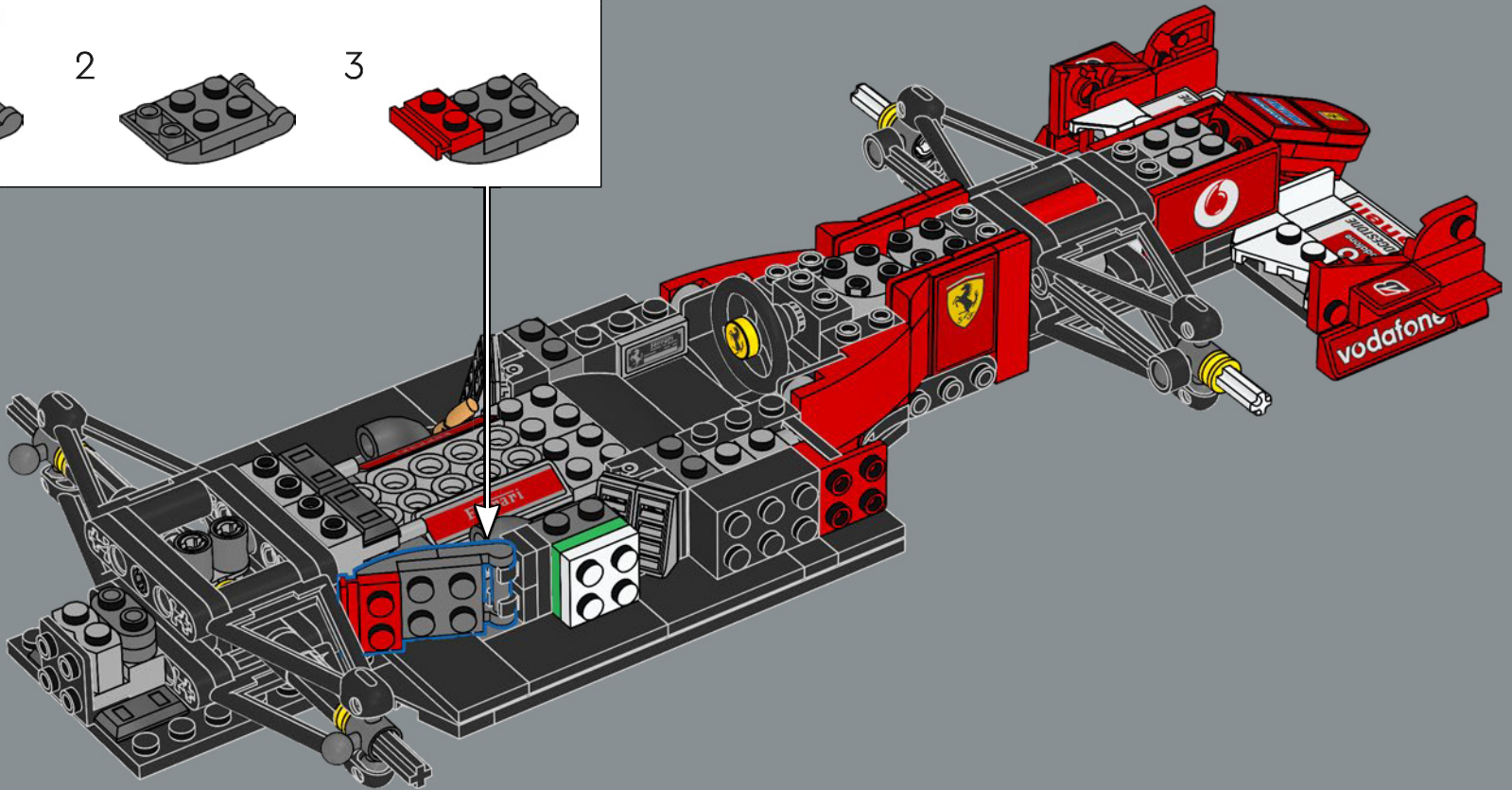

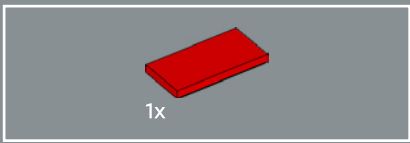

93

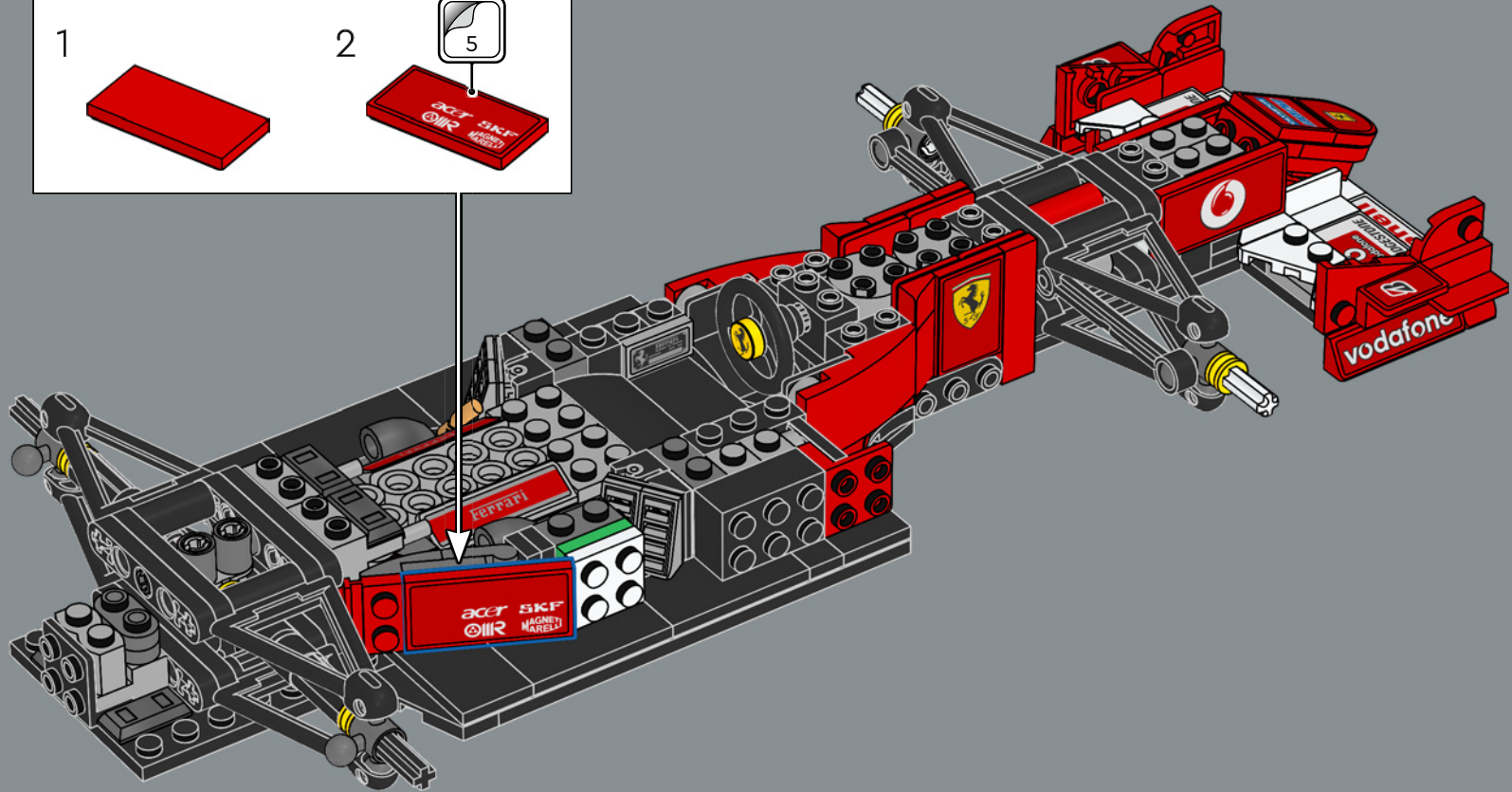
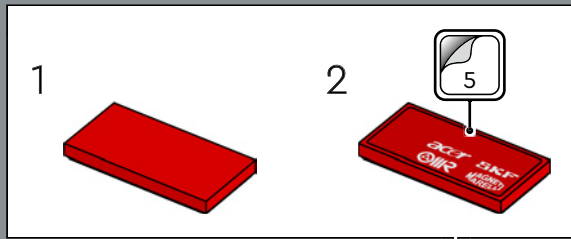

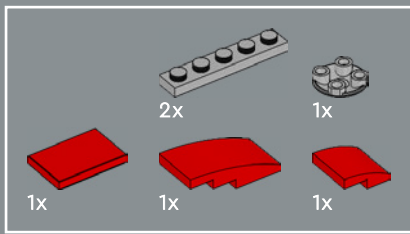

94

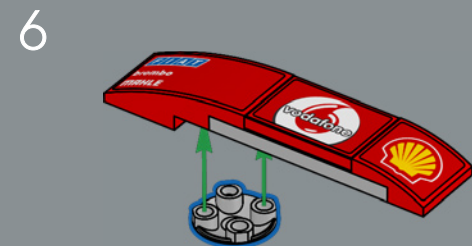
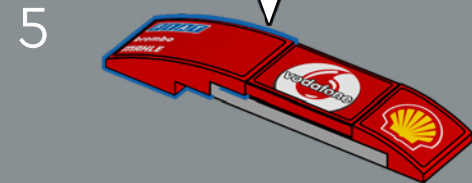
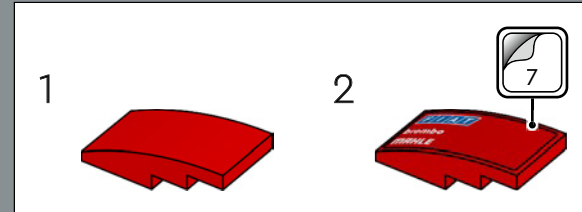
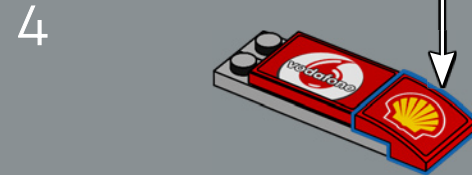
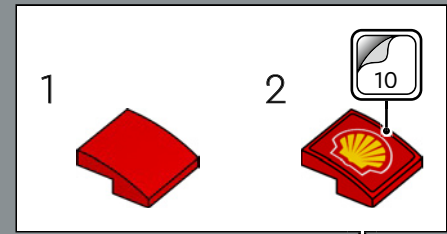
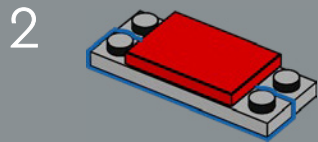
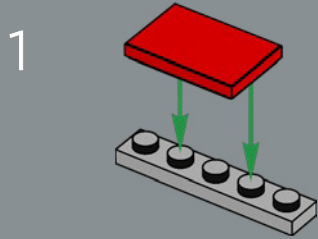



The aerodynamic bodywork of the Ferrari F2004 was designed to maximize the performance of the car by improving the airflow and taking advantage of the grooved tires.

La carrosserie aérodynamique de la Ferrari F2004 a été conçue pour optimiser les performances de la voiture en améliorant l'écoulement de l'air et en tirant parti des pneus rainurés.

El diseño de la aerodinámica carrocería del Ferrari F2004 buscaba maximizar el desempeño del auto mejorando el flujo de aire y aprovechando las llantas ranuradas.

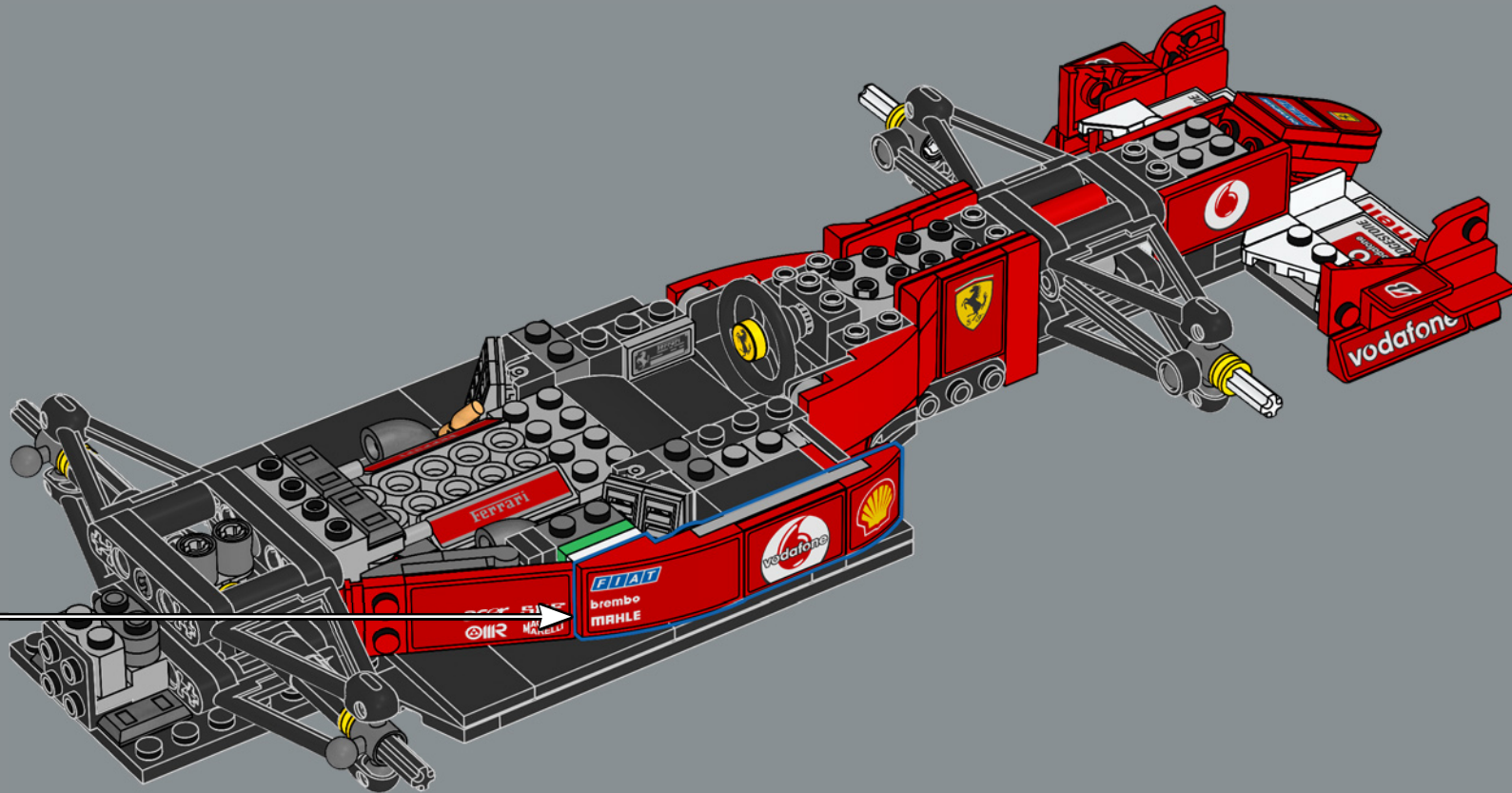

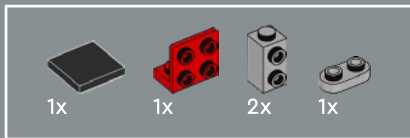

95

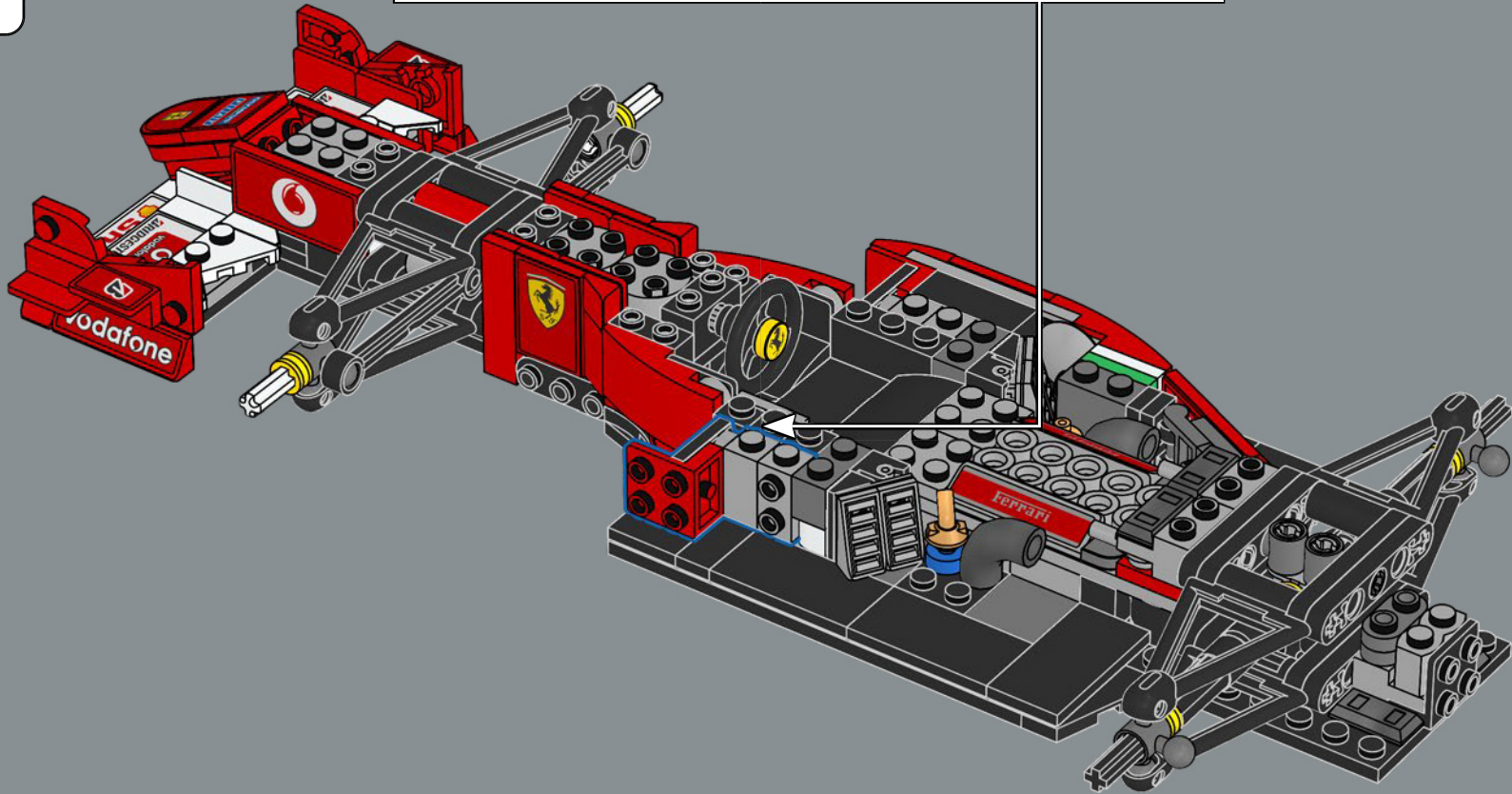
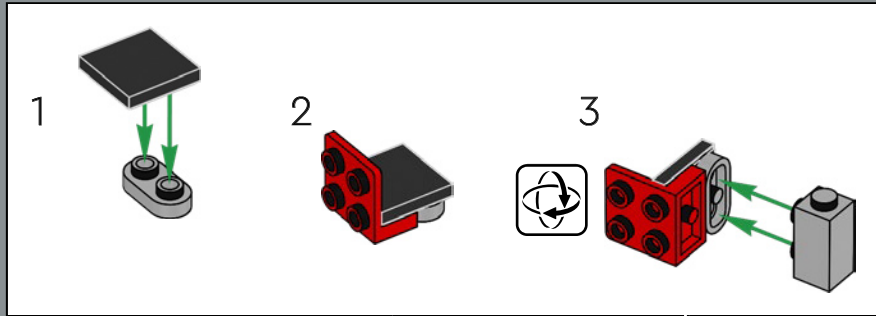

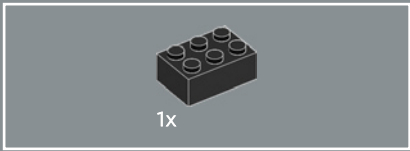

96

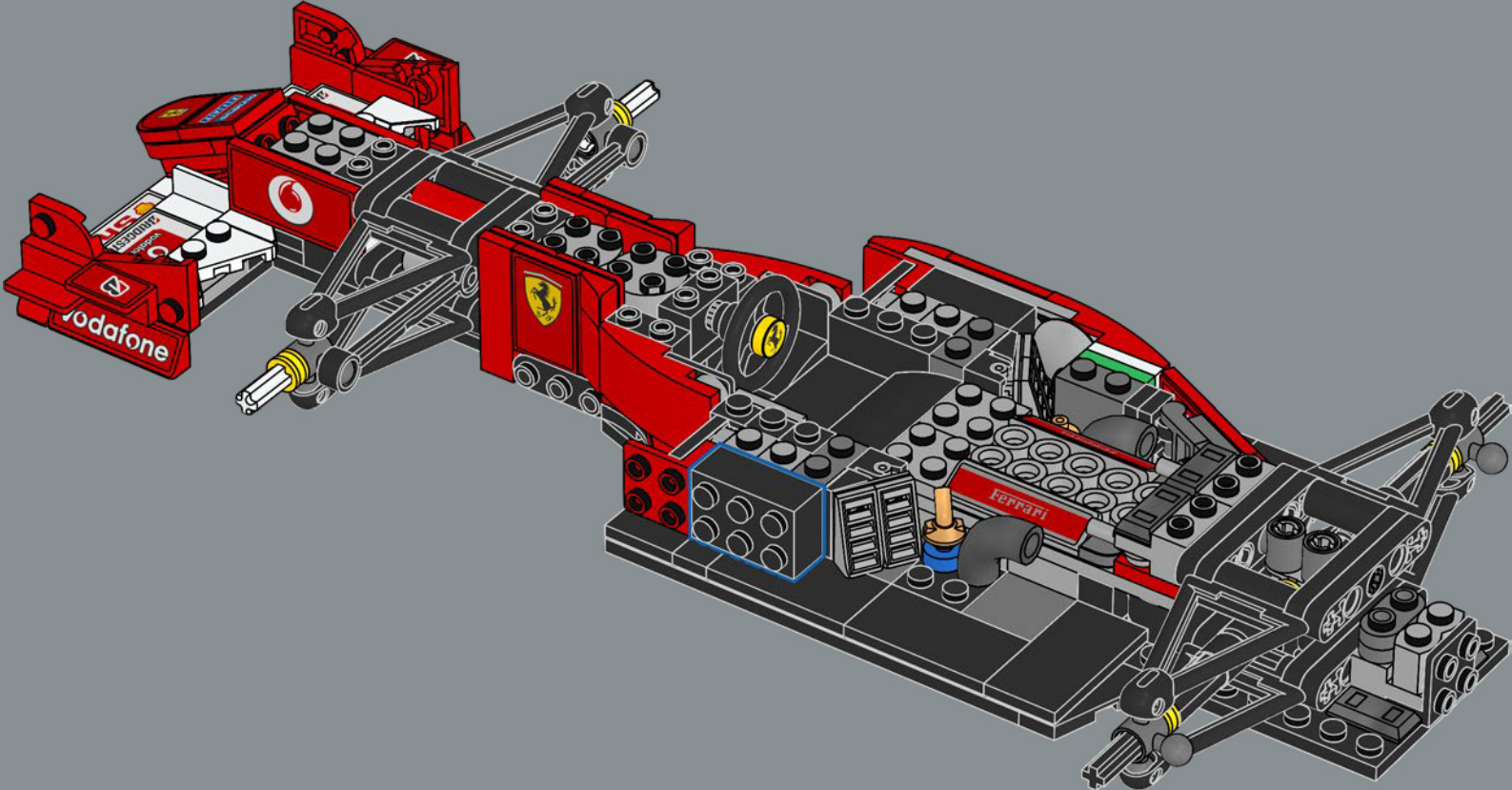

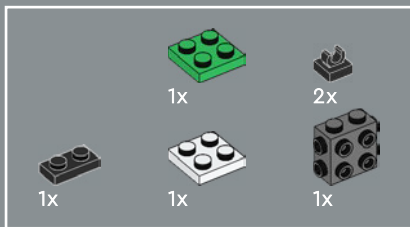

97

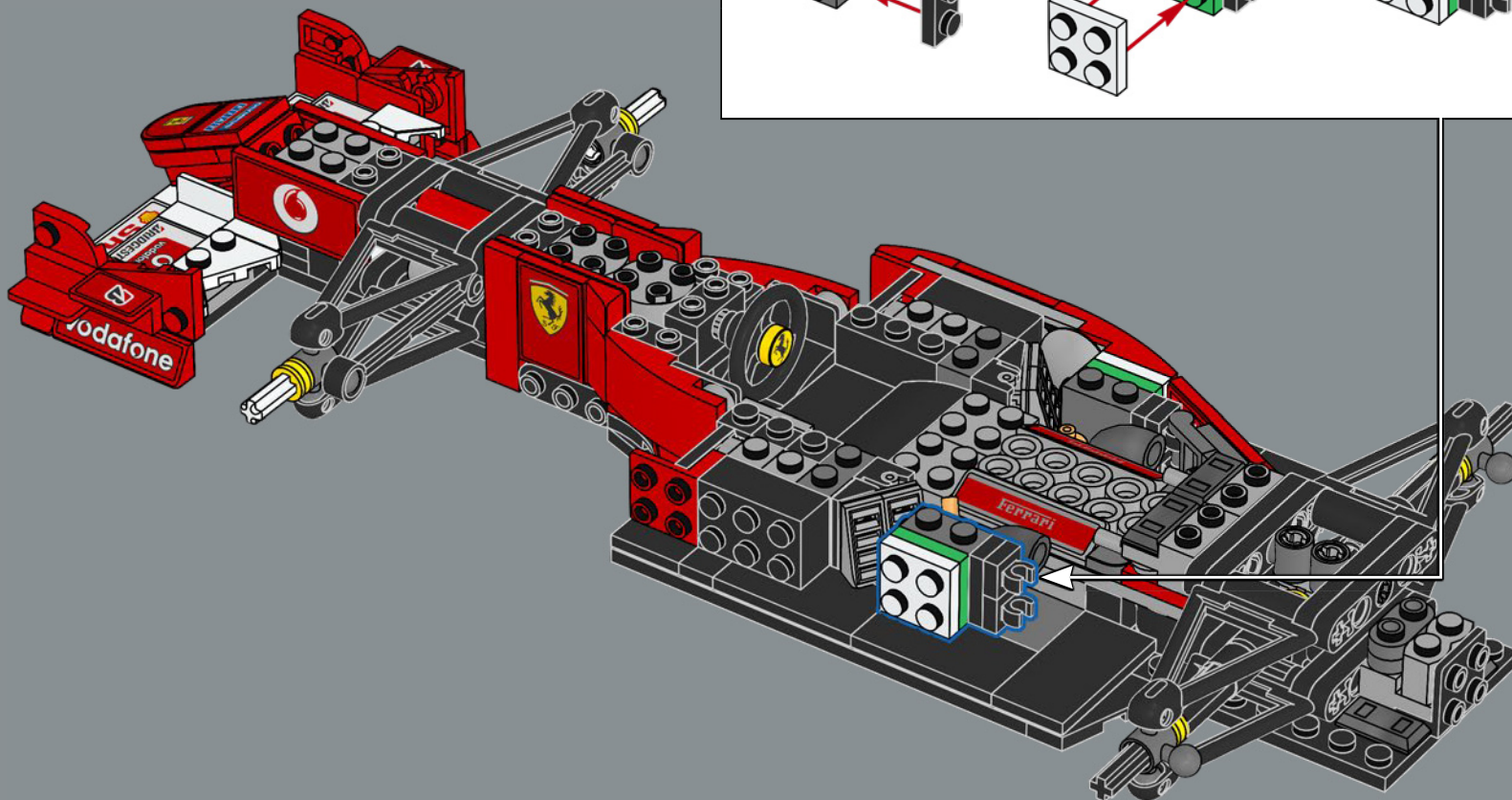
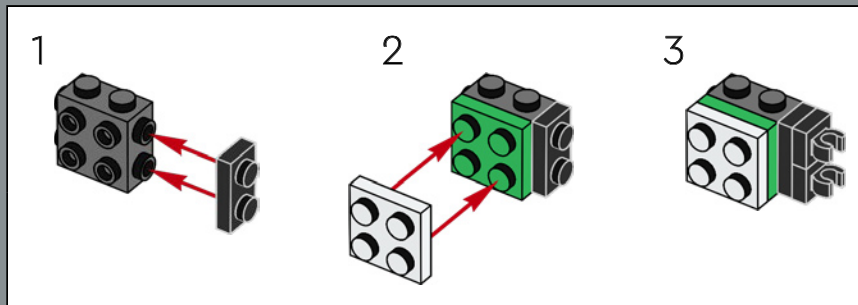

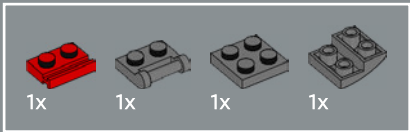

98

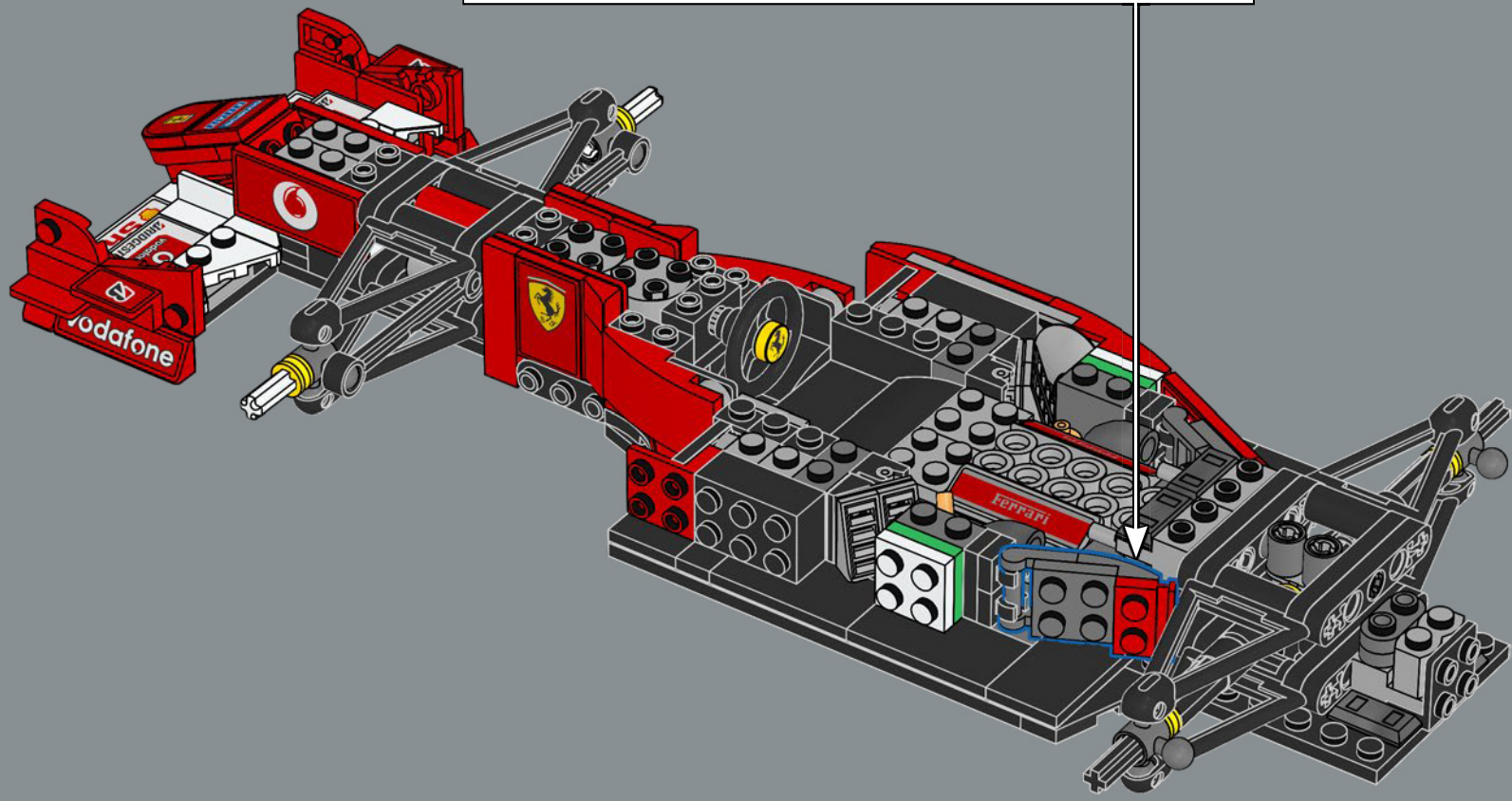
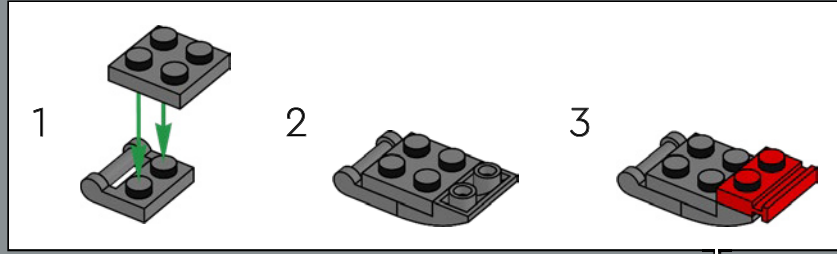

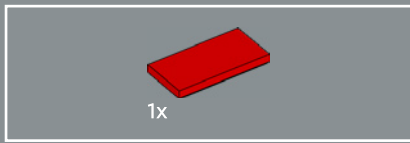

99

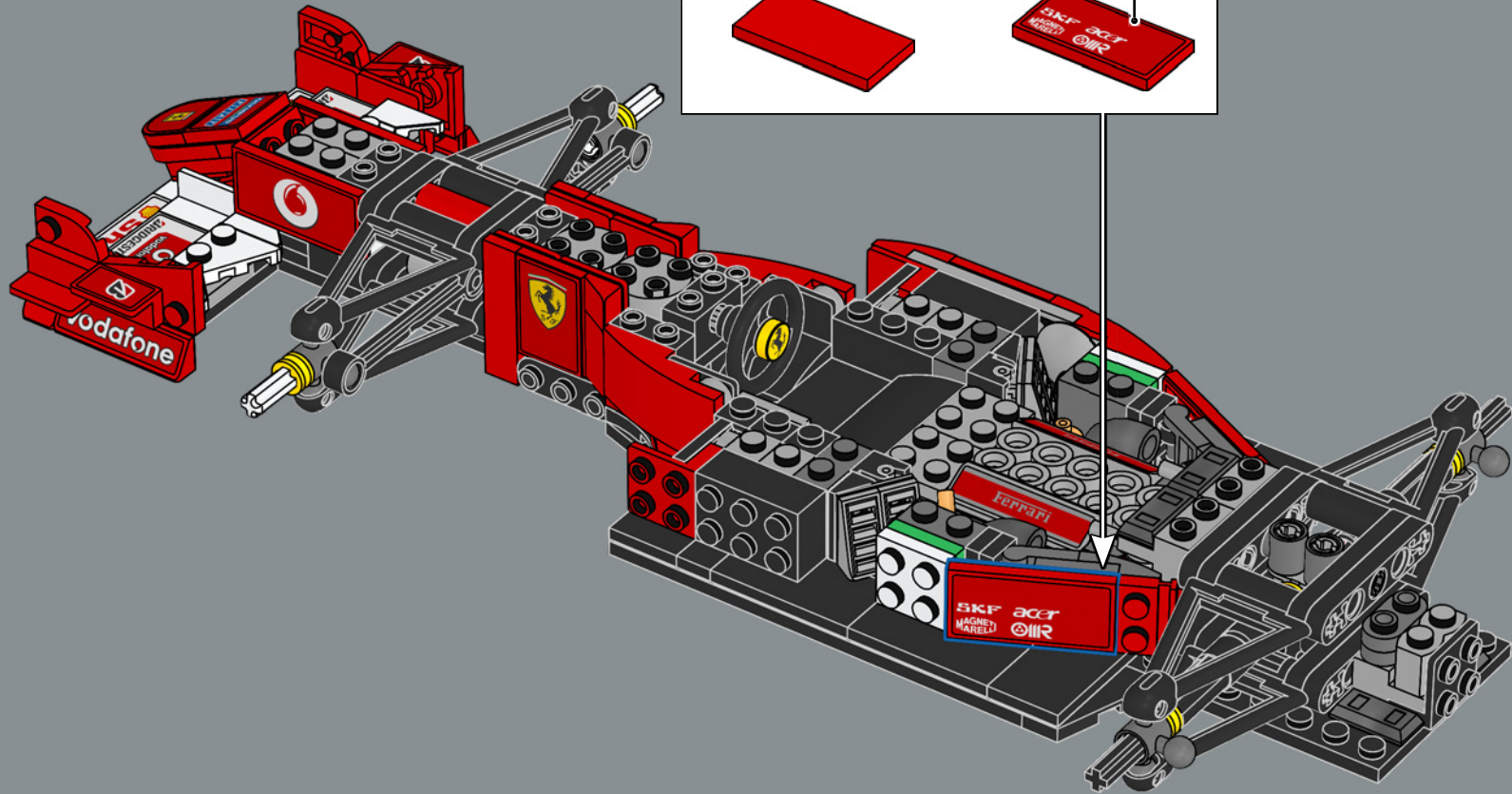
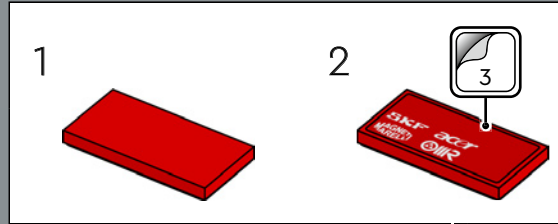

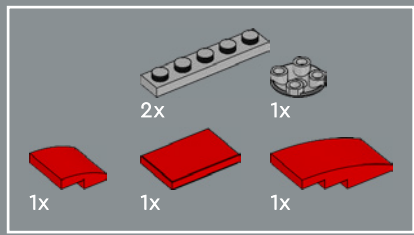

100

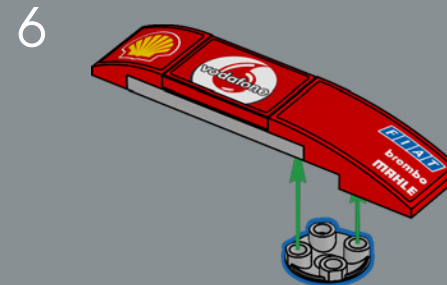
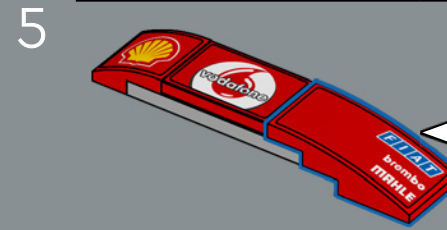
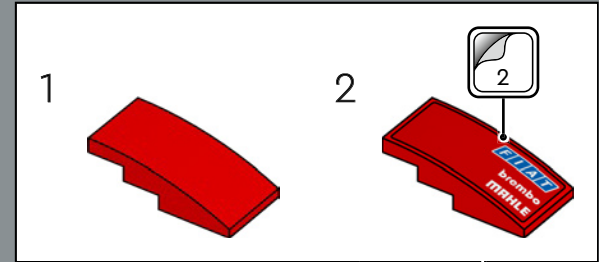
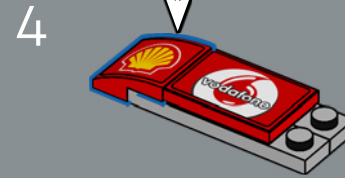
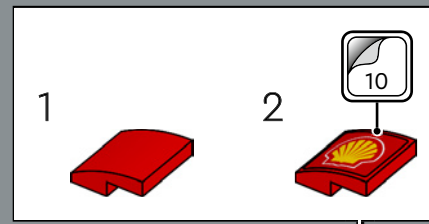
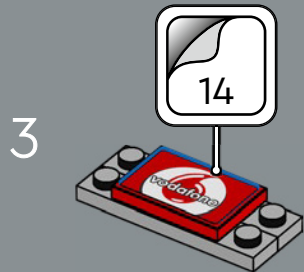
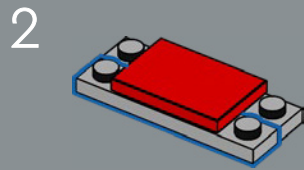
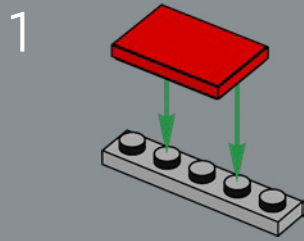

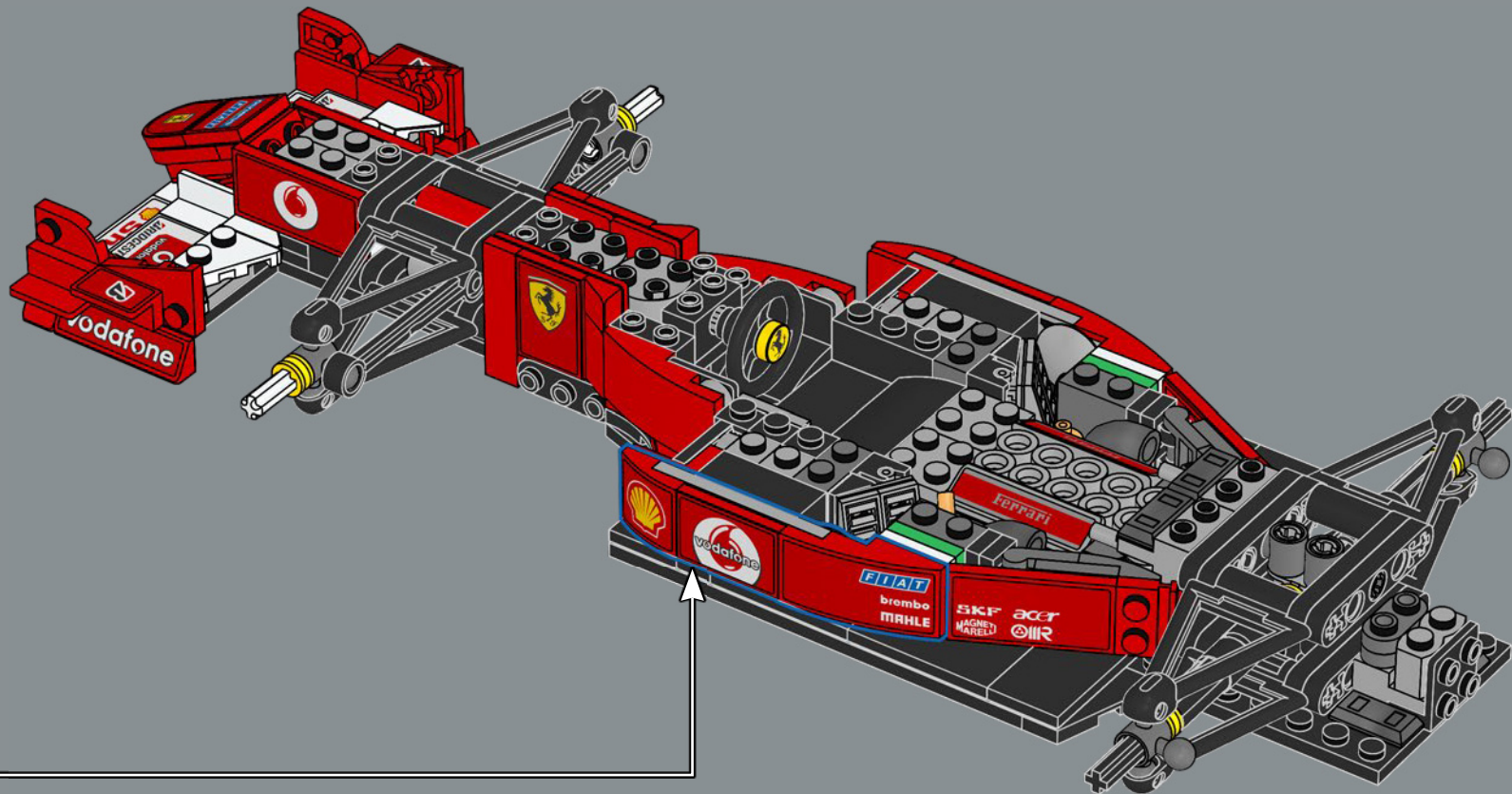

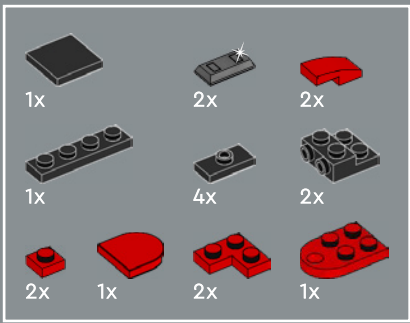

# 101

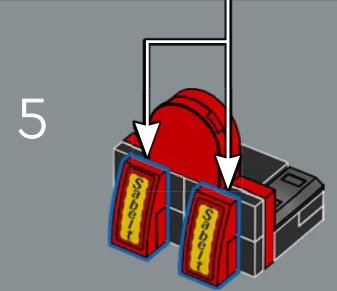
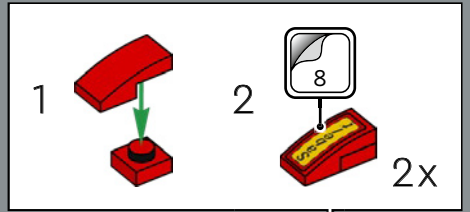
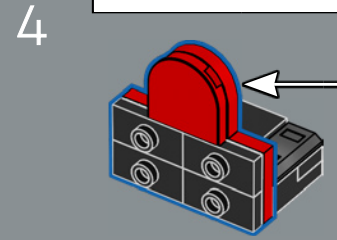
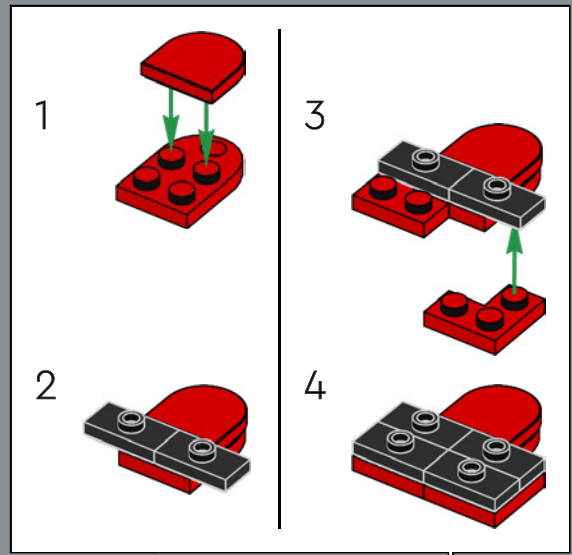
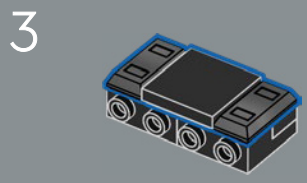
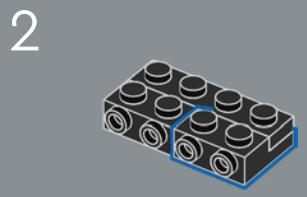
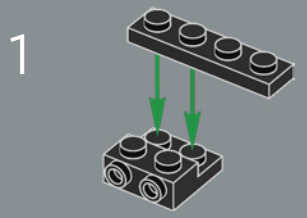

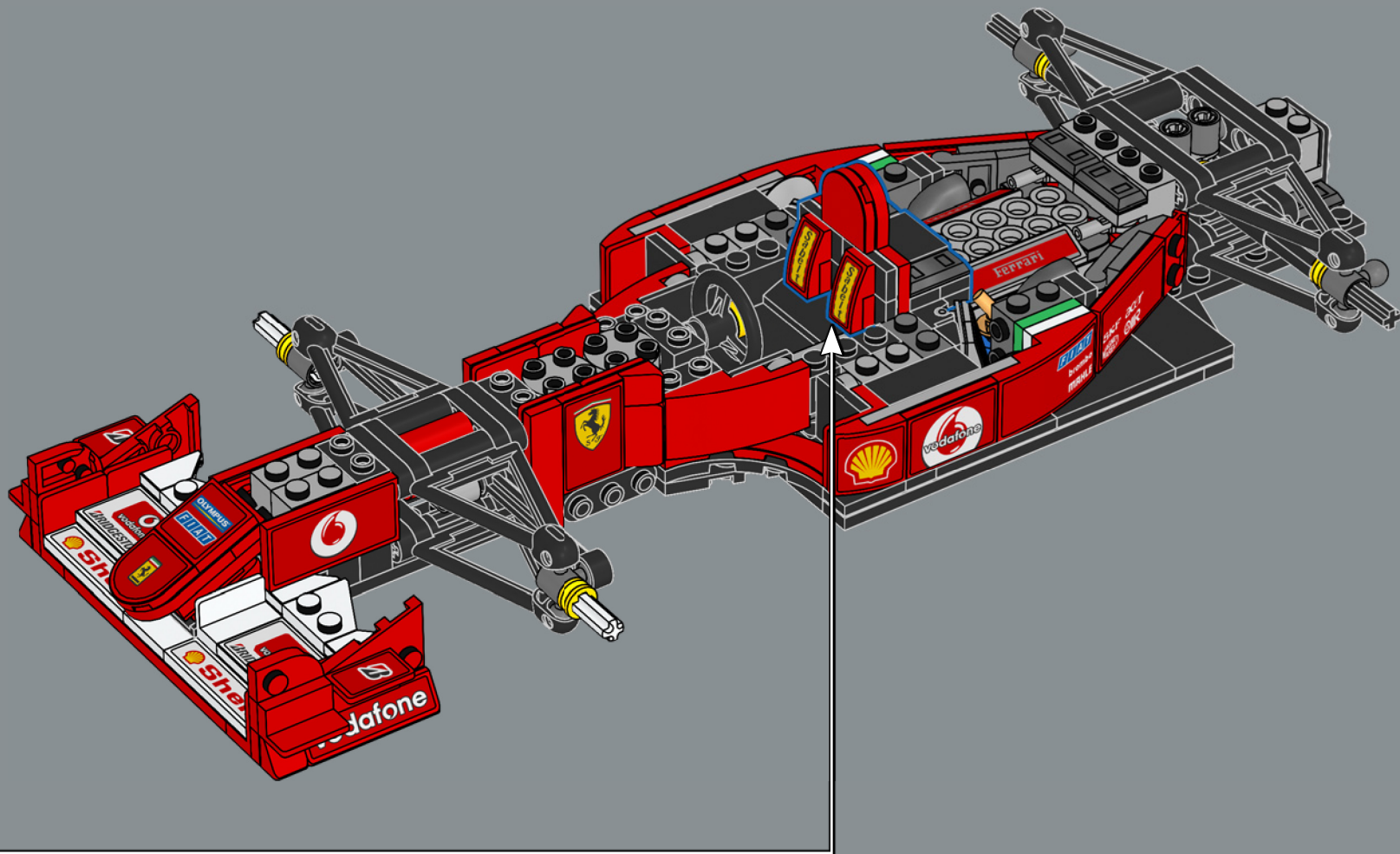

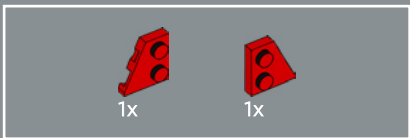

102

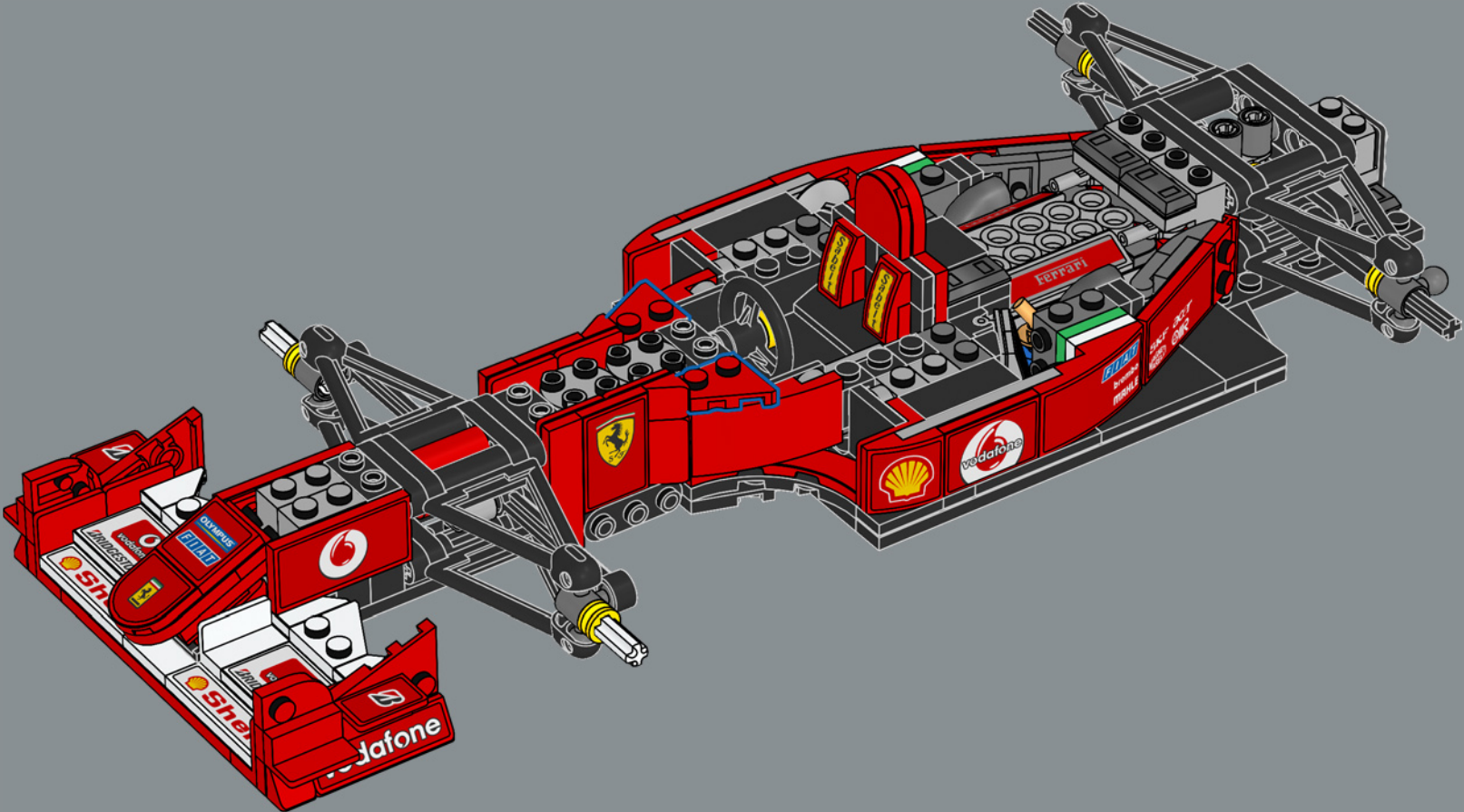

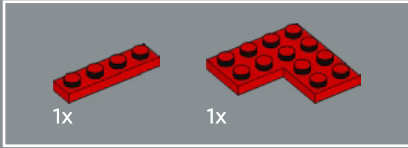
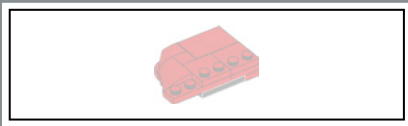

103

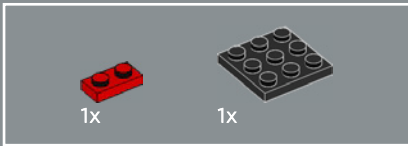
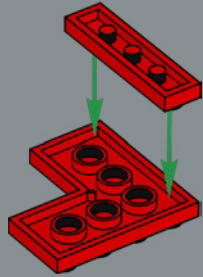

104

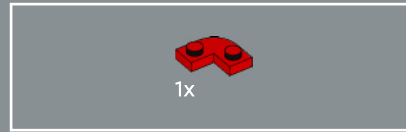
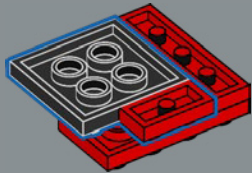

105

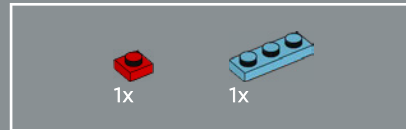
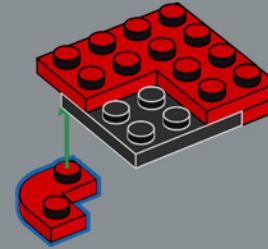

106

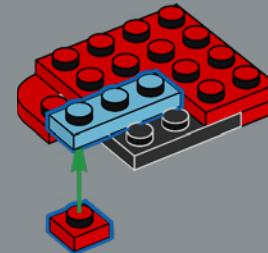

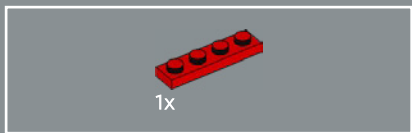

107

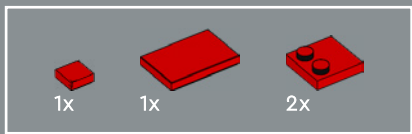
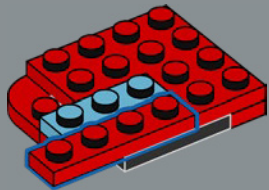

108

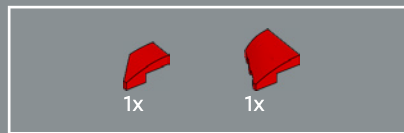
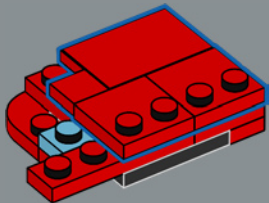

109

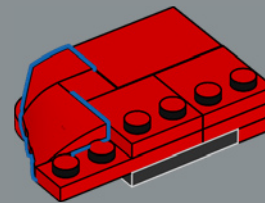

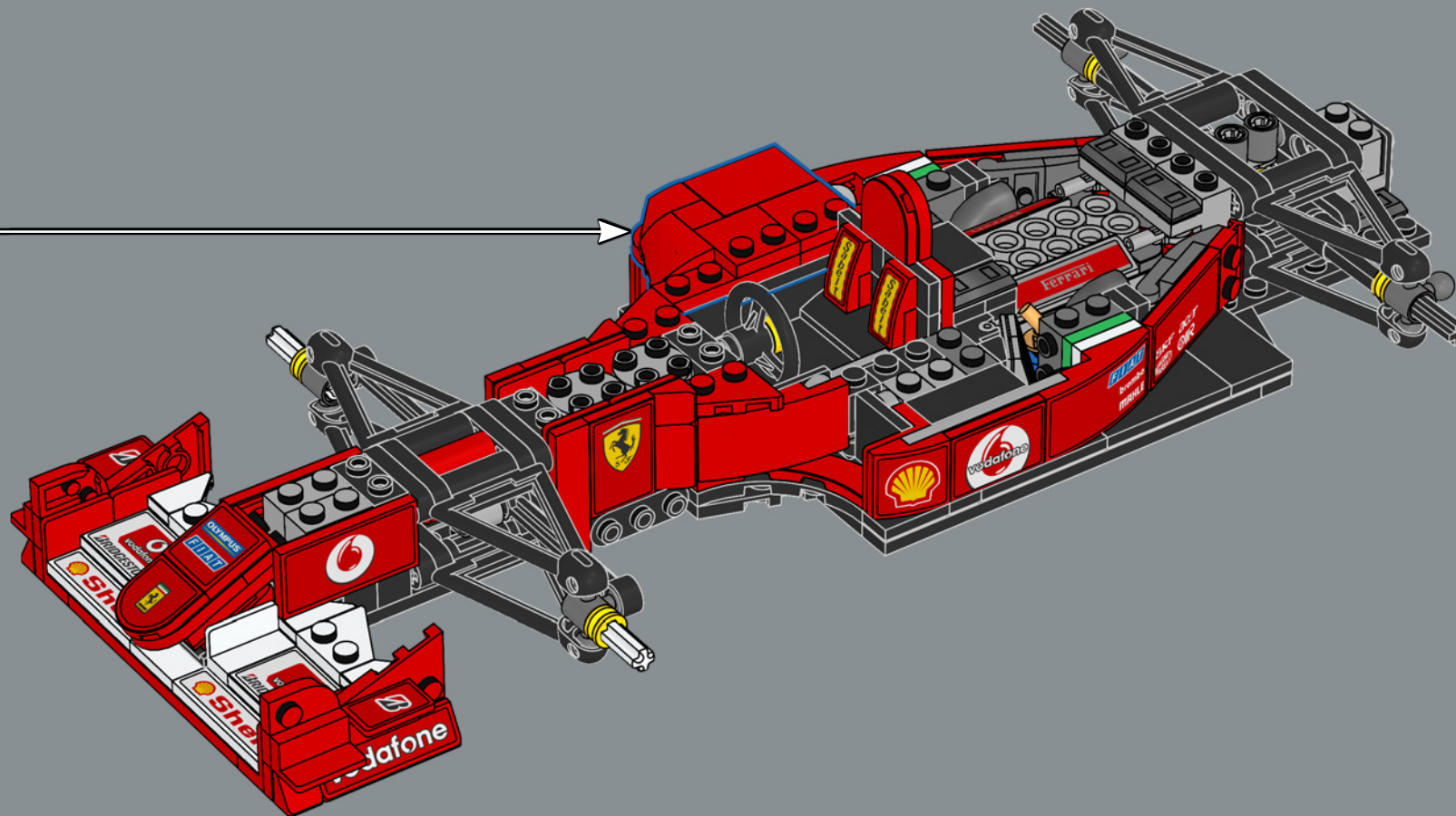

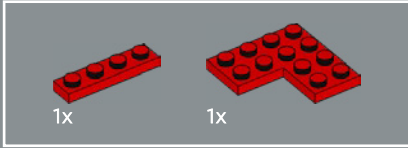
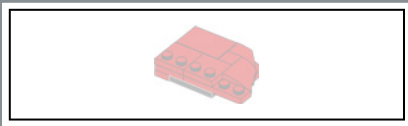

111

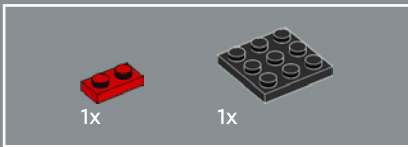
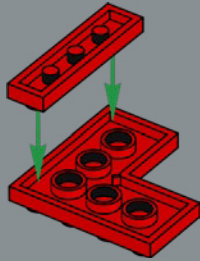

112

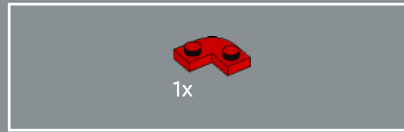
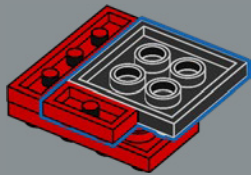

113

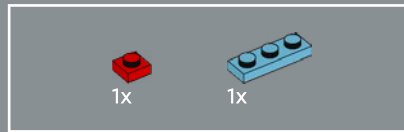
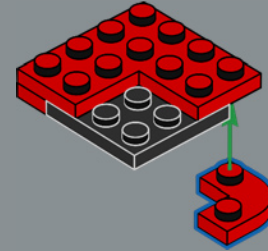

114

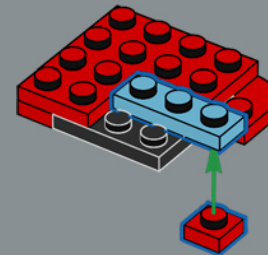

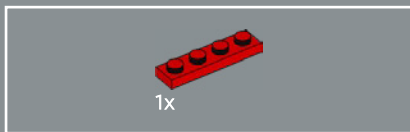

115

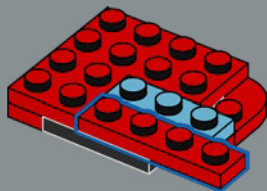

116

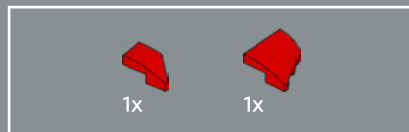
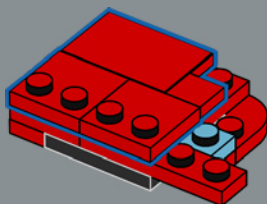

117

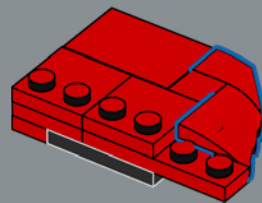

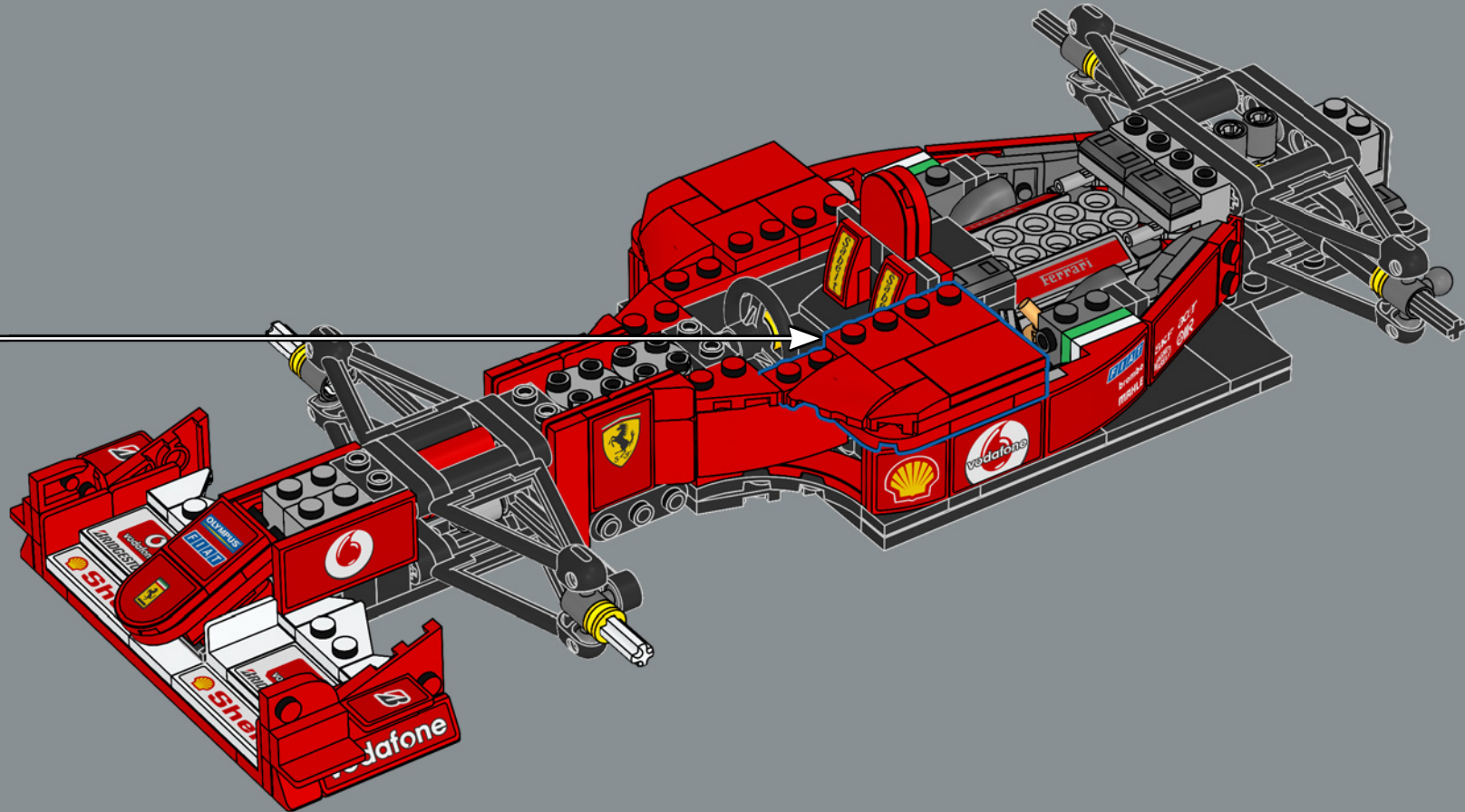

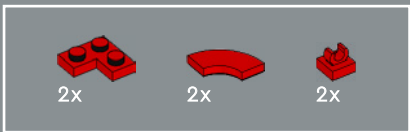

119

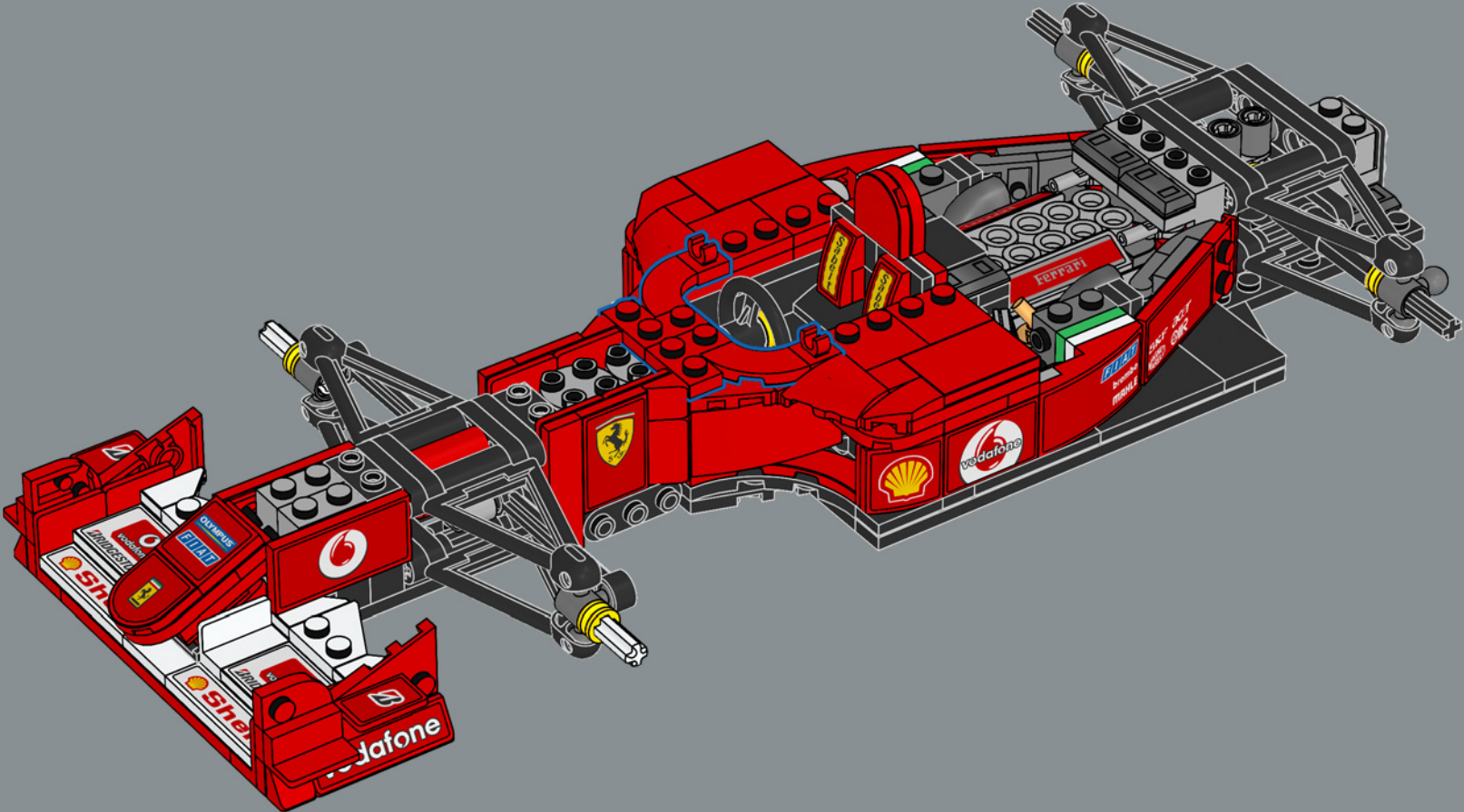

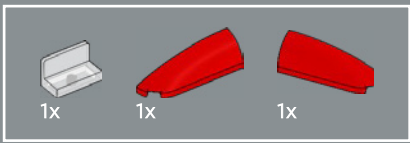

120

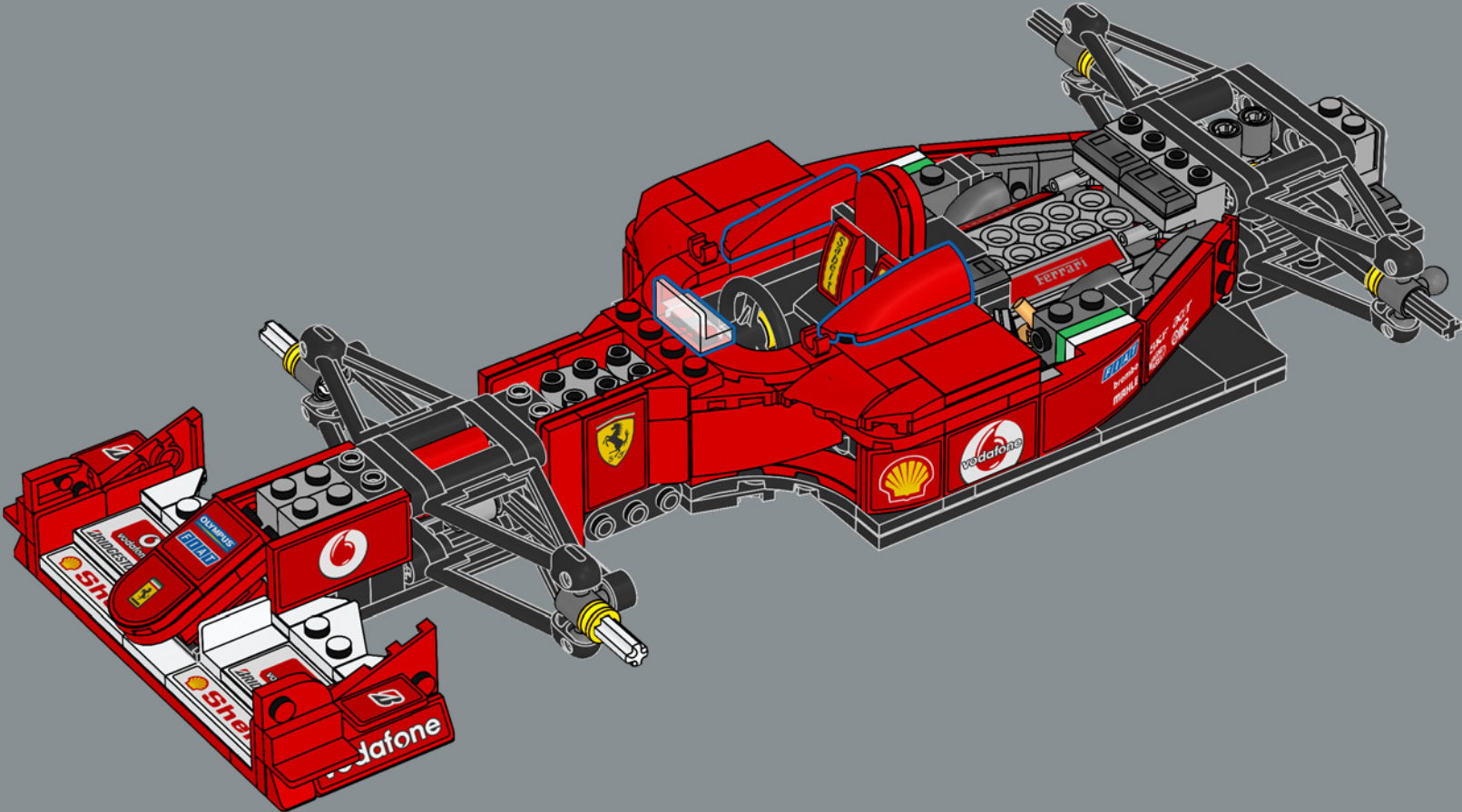



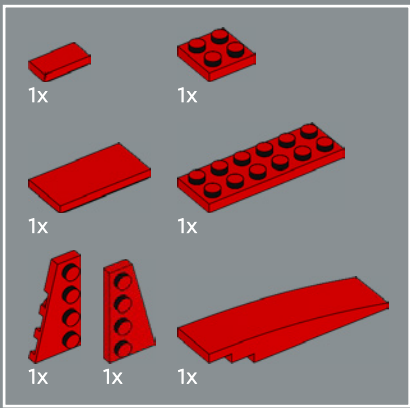

122

1

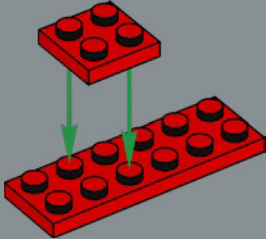

2

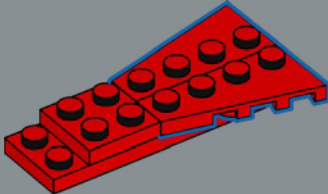

3

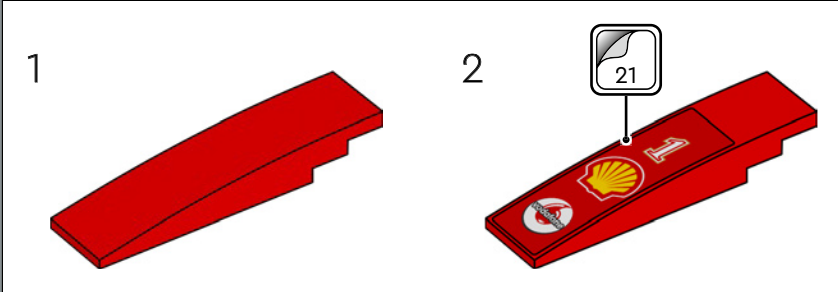
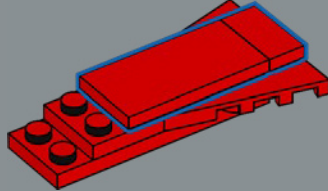

4

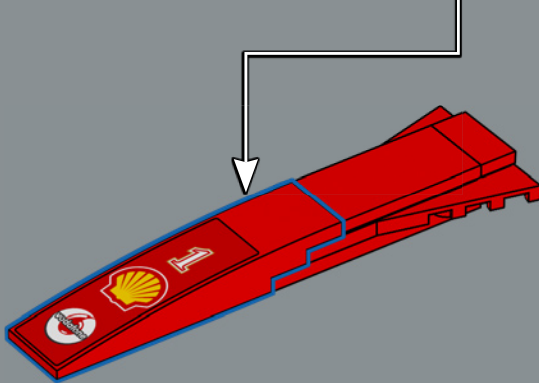

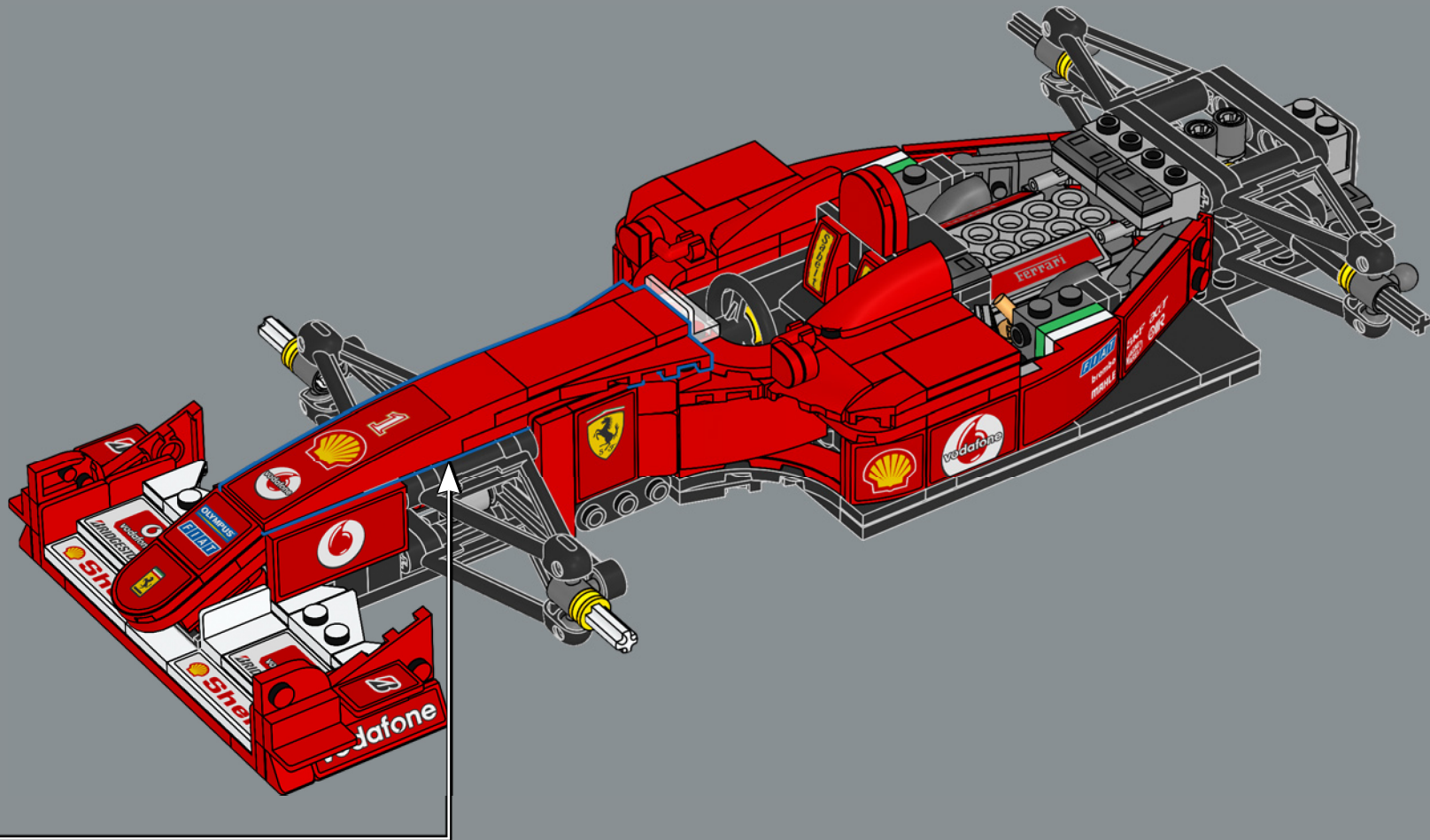

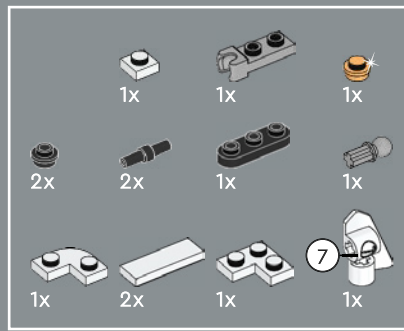

123

1

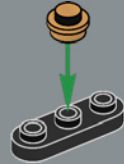

2



3

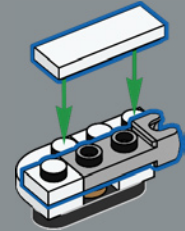

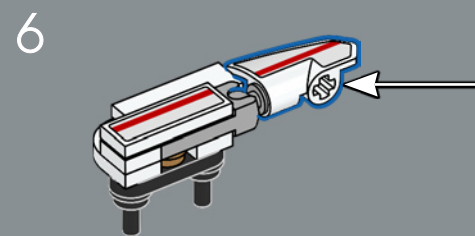
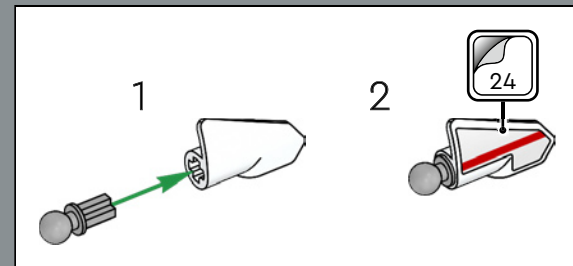
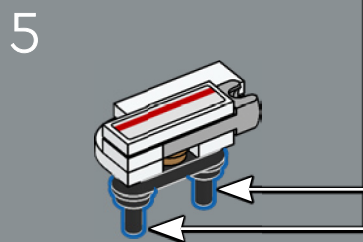
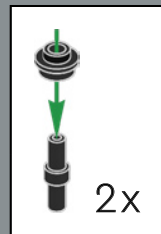
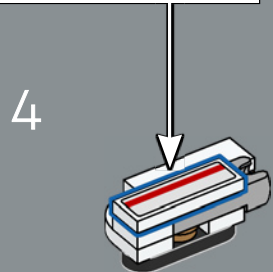
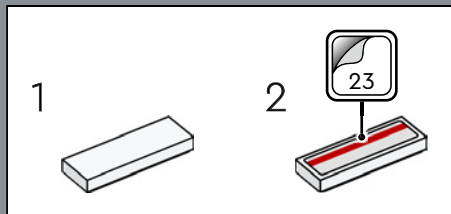

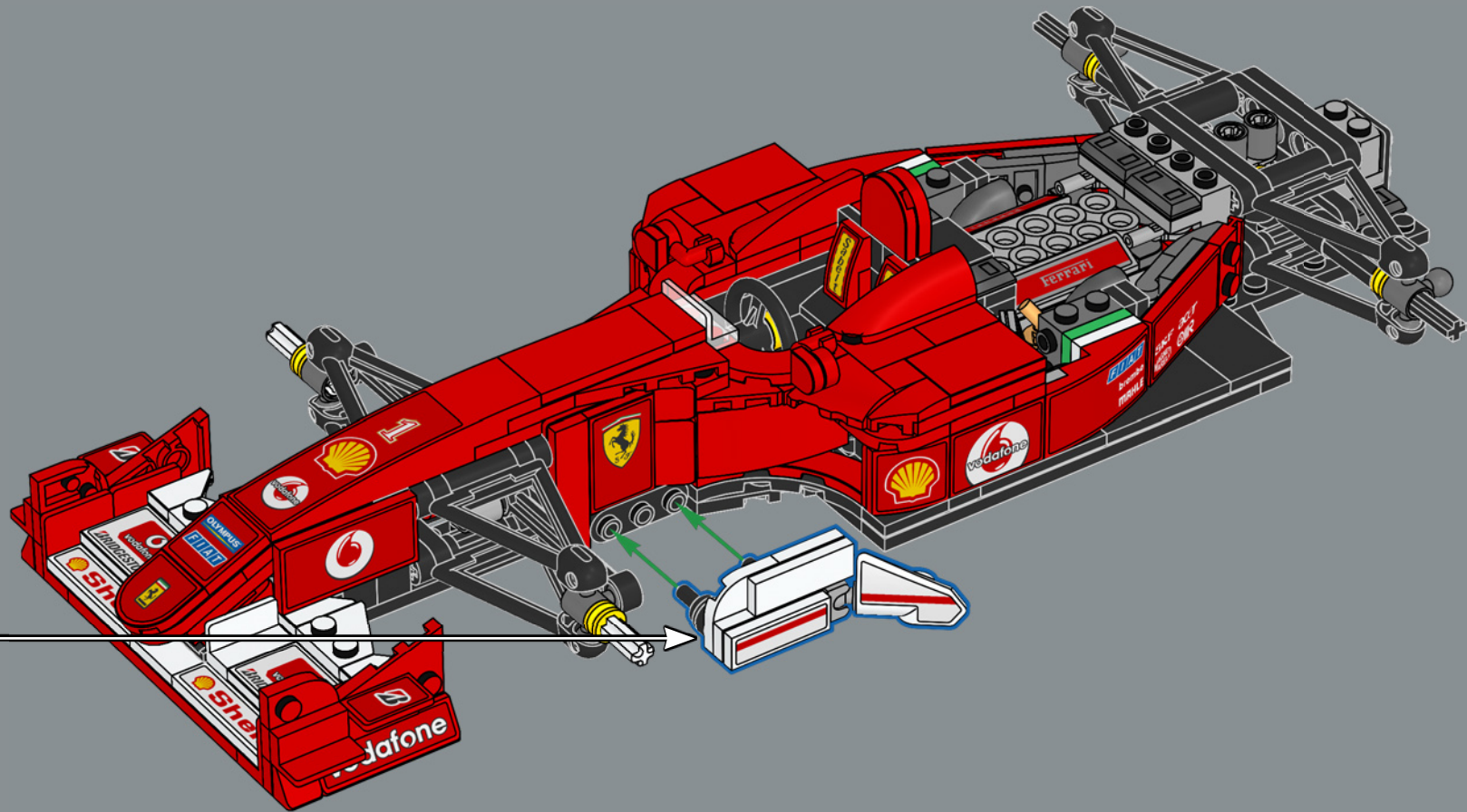

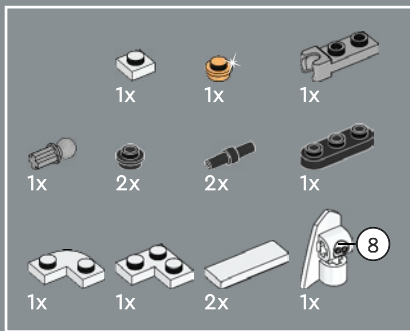

124

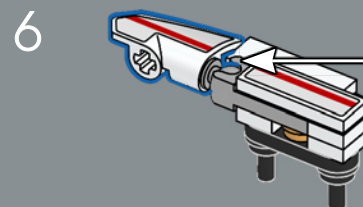
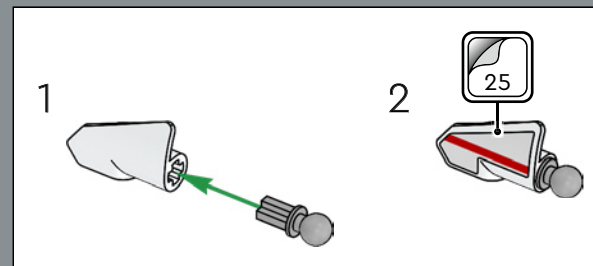
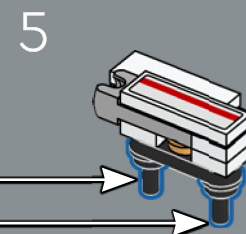
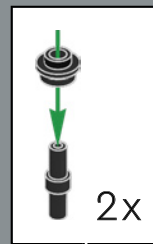
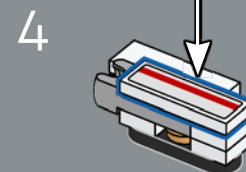
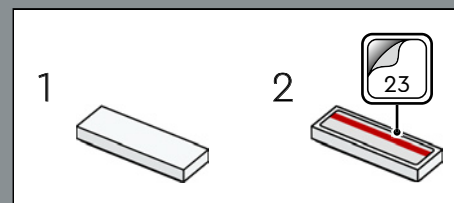
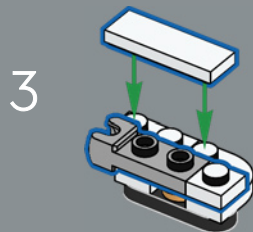
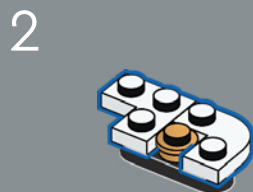
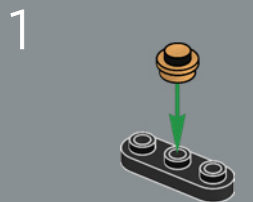

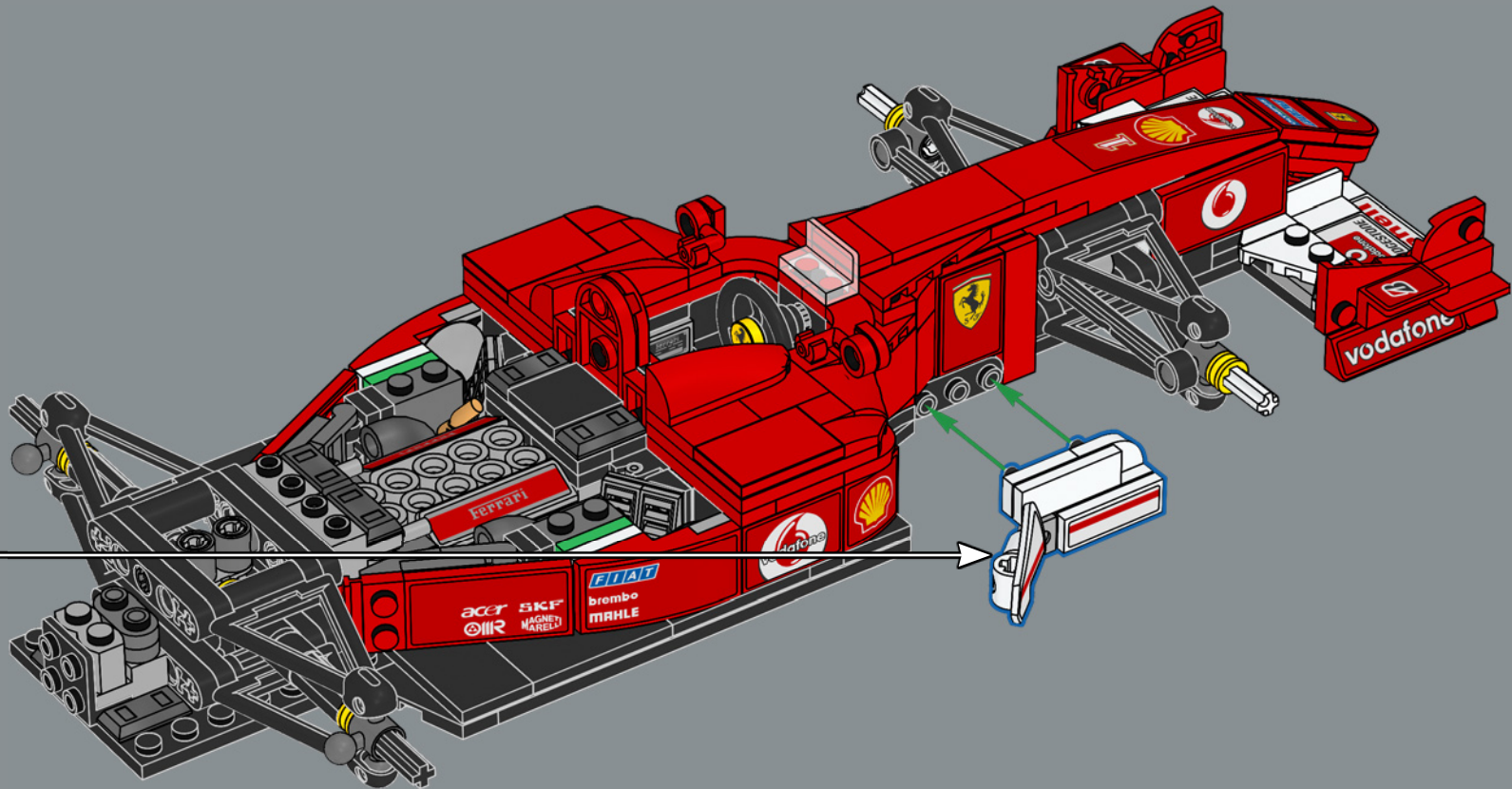

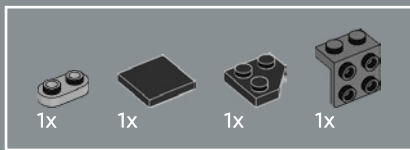

125

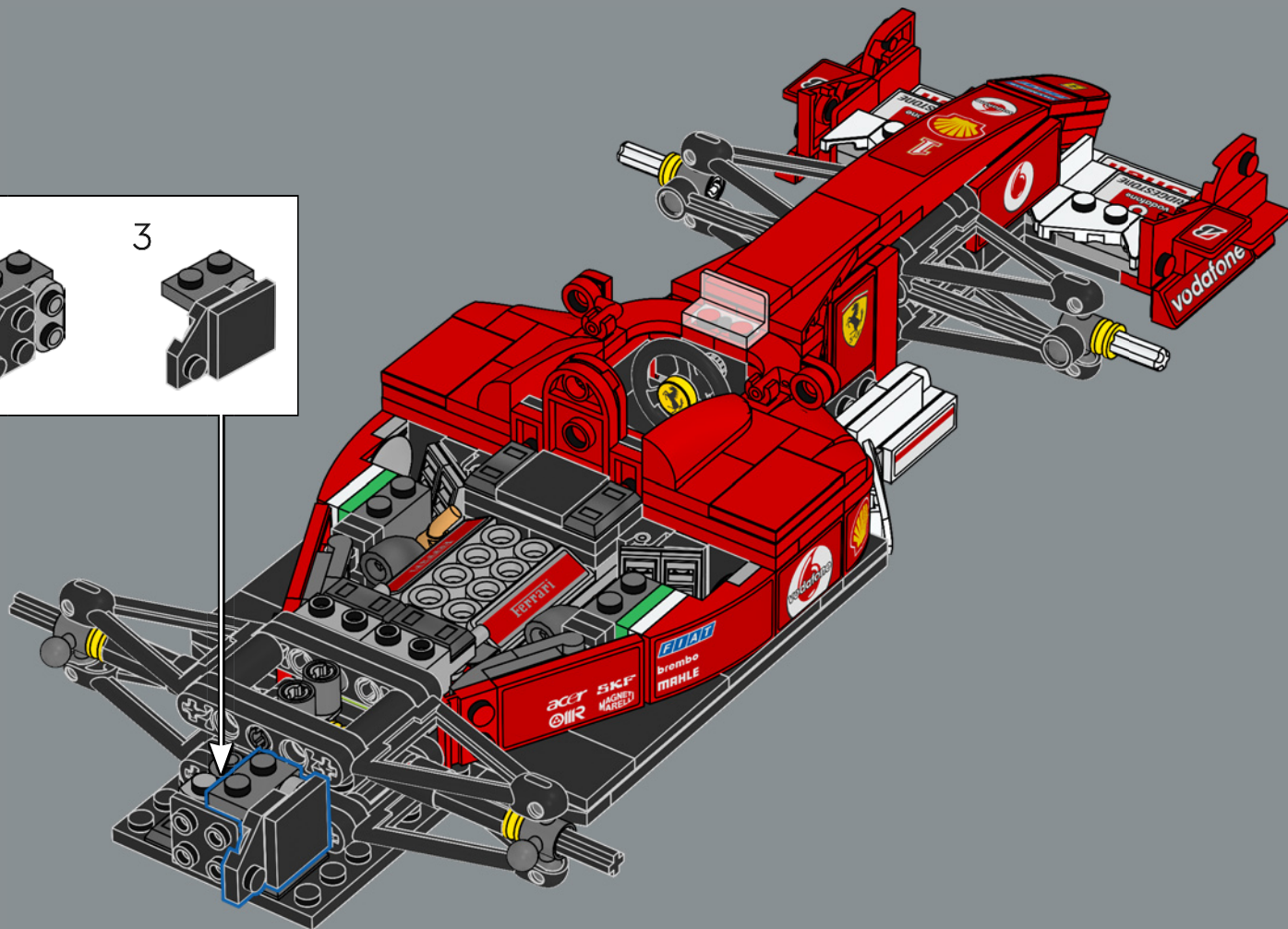
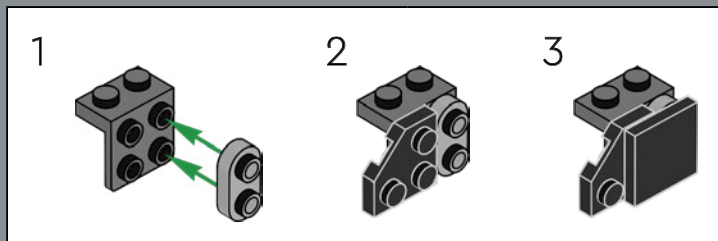

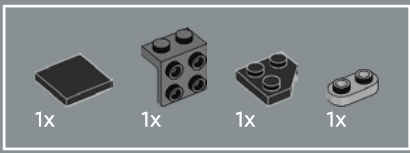

126

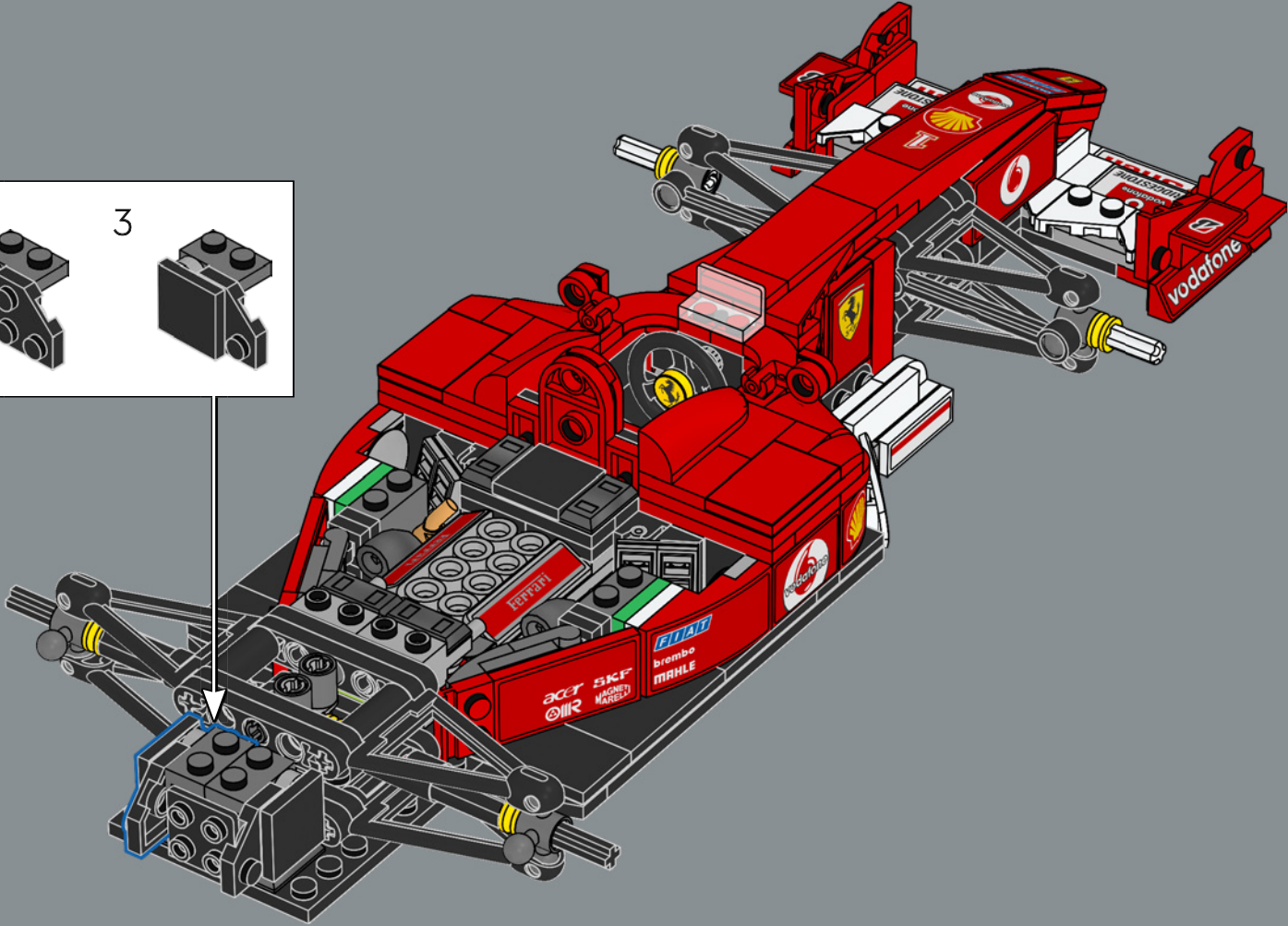
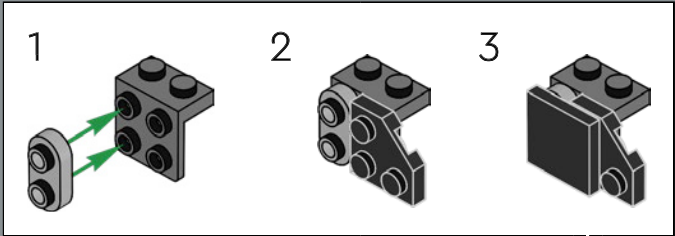

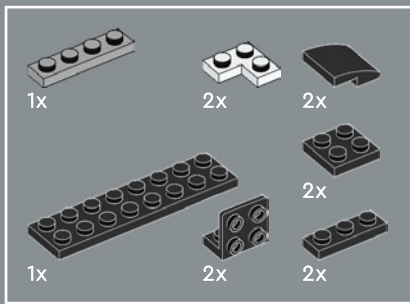

127

1

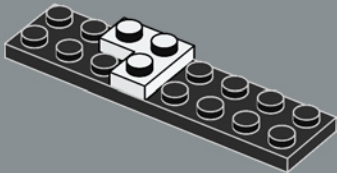

2

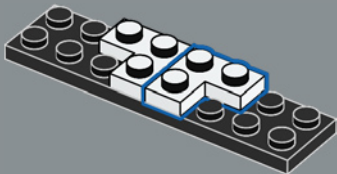

3

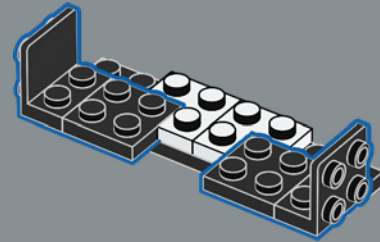

4

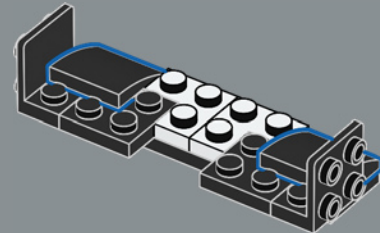

5

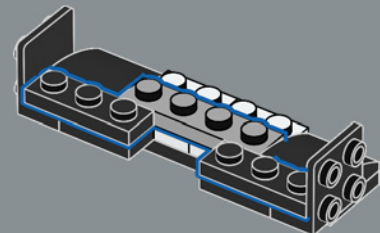

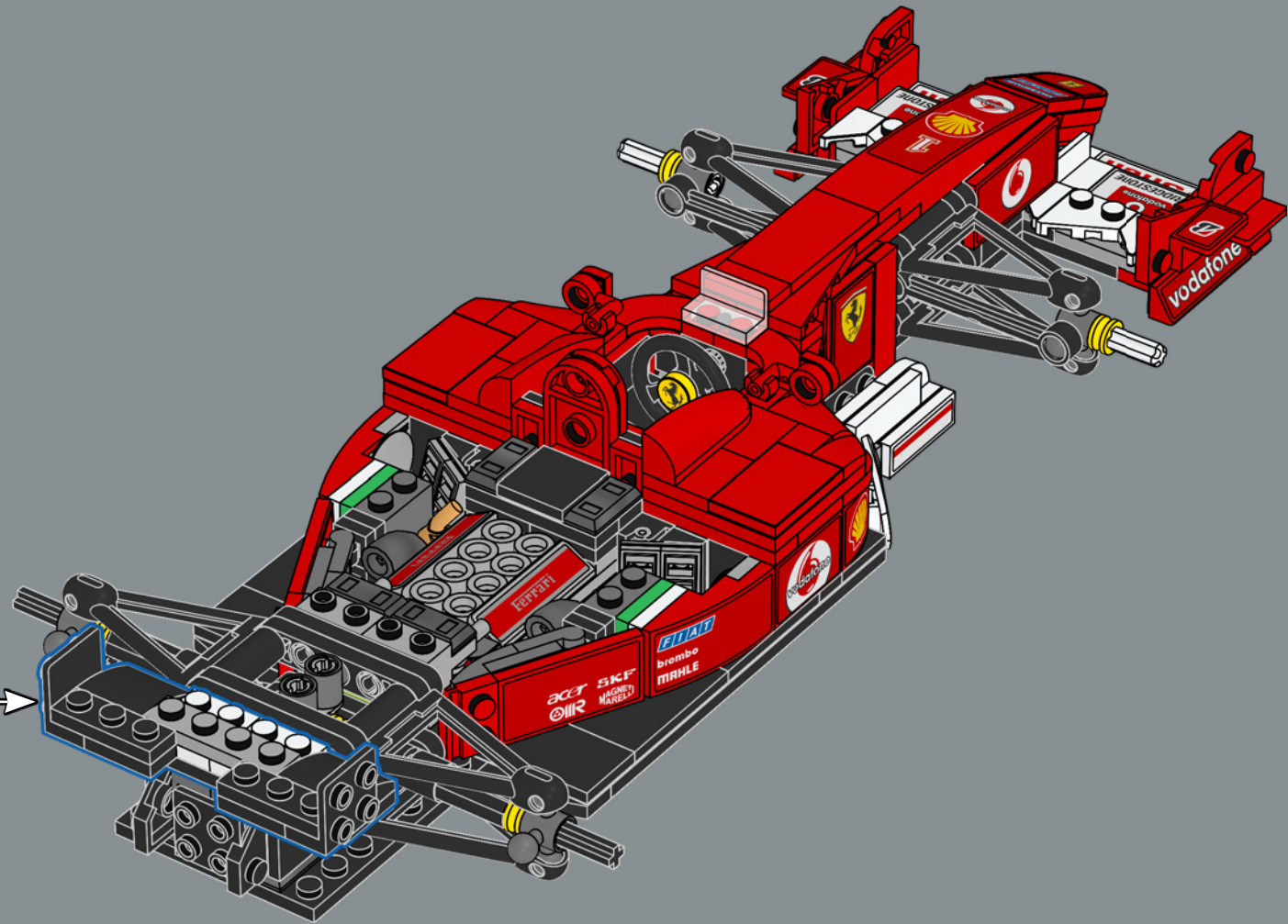

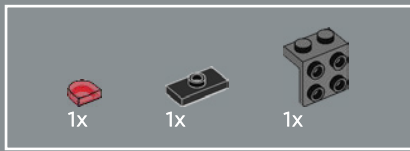

128

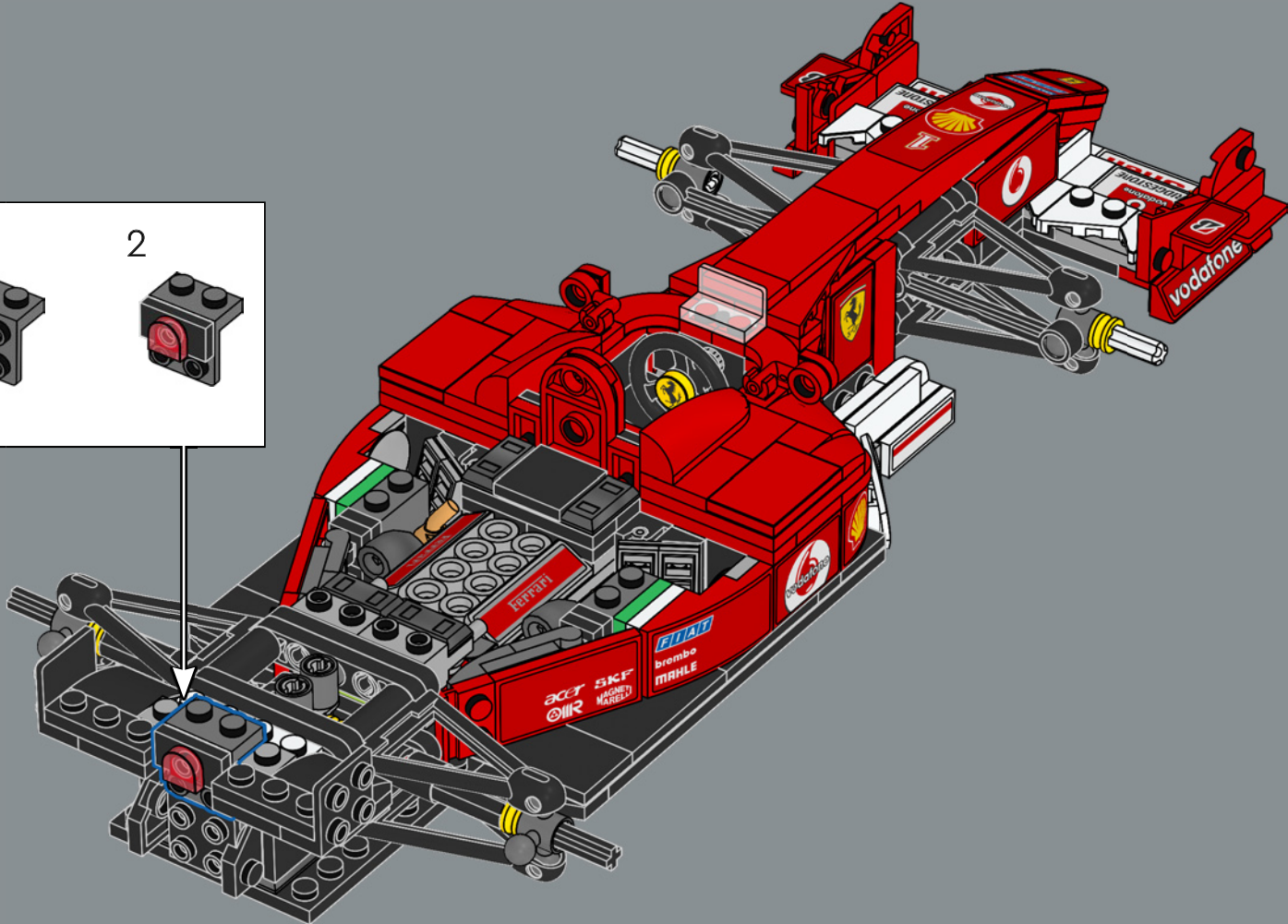
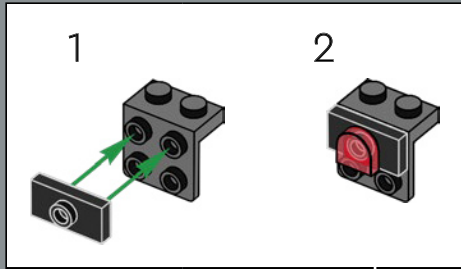

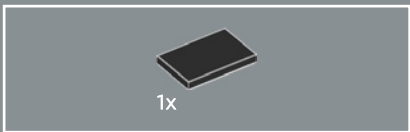

129

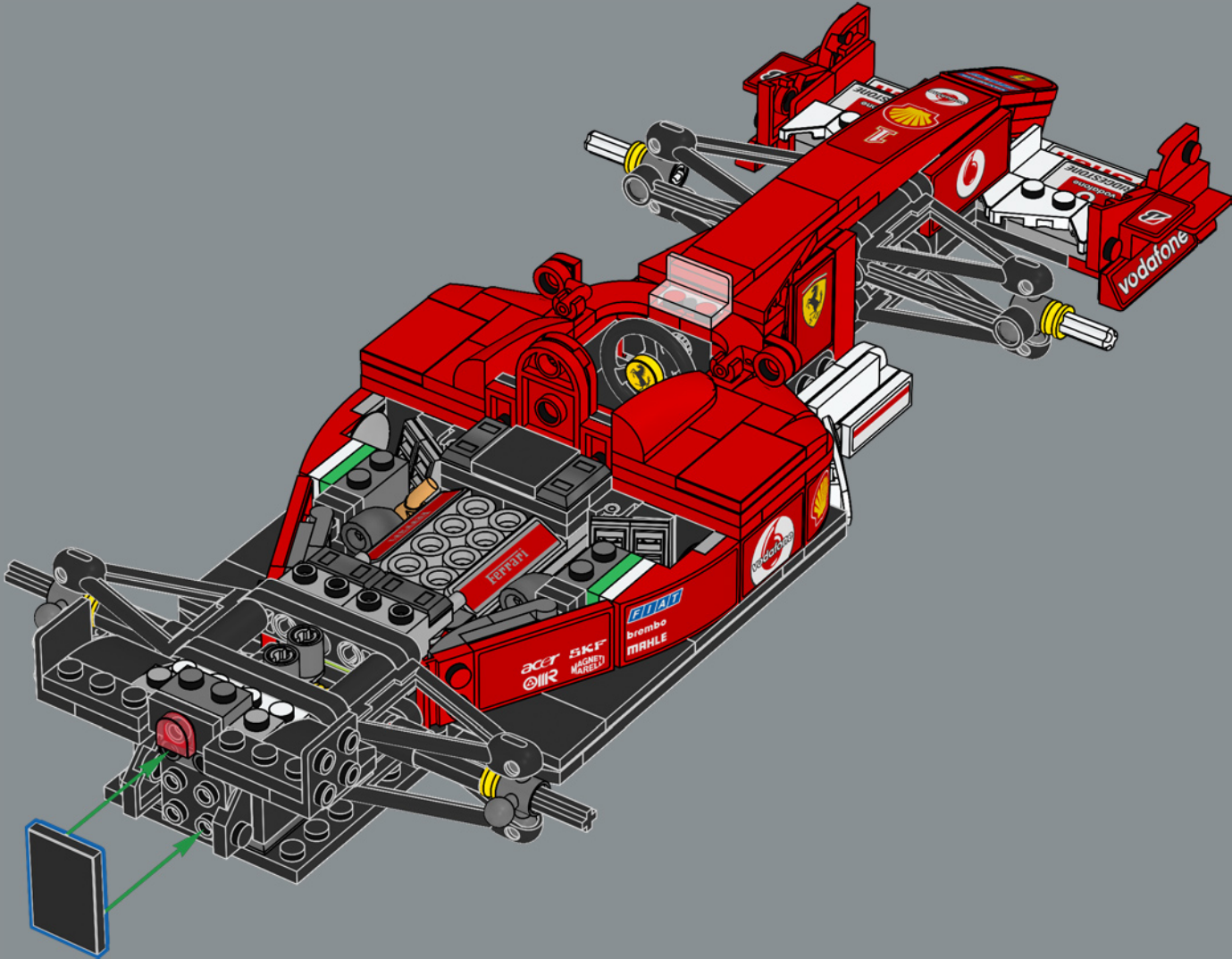

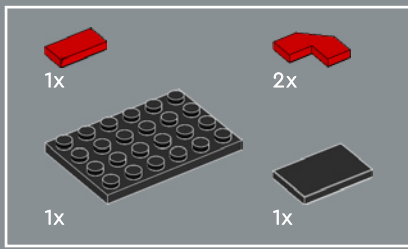

130

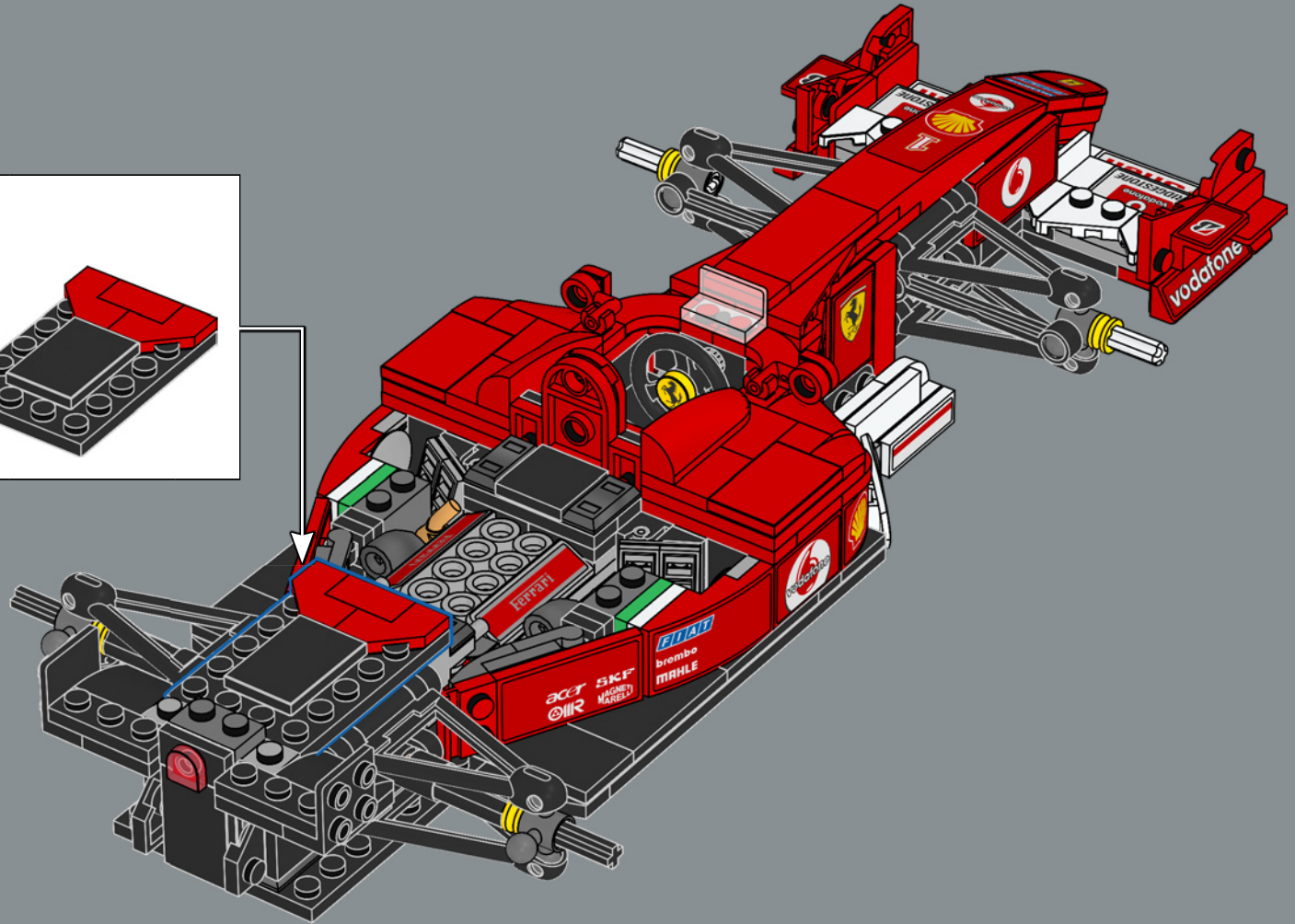
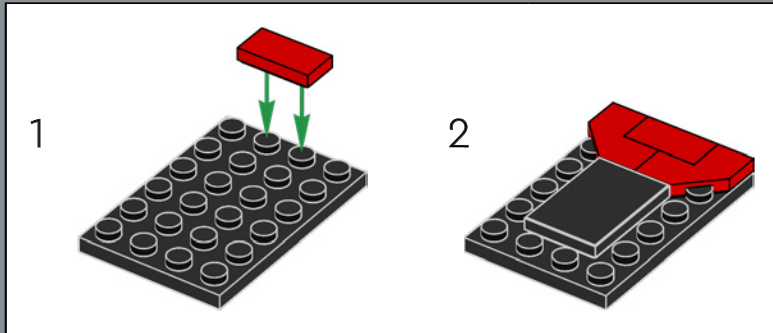

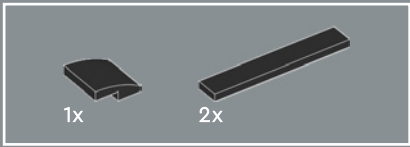

131

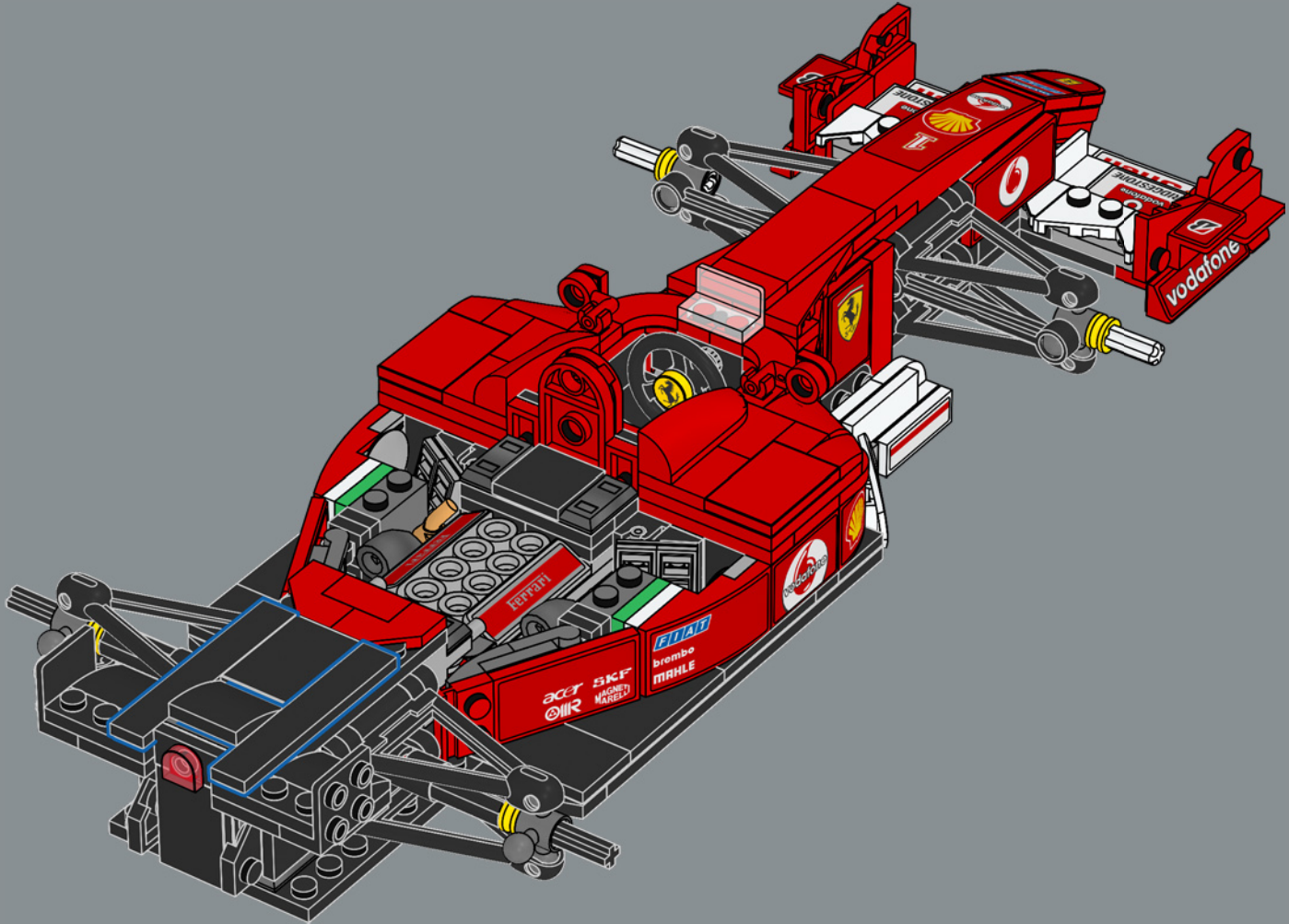

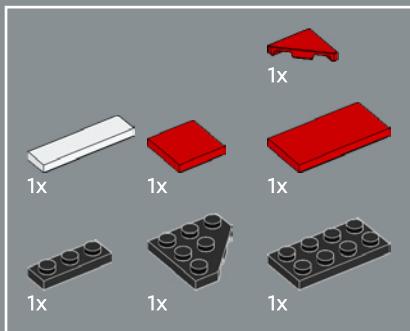

132

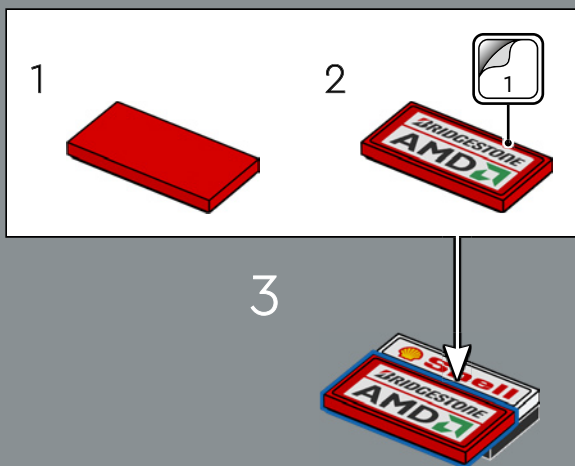
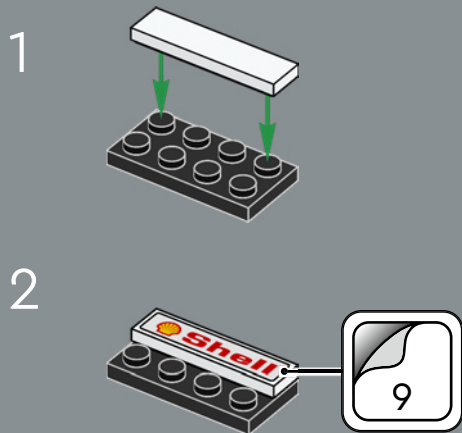

4

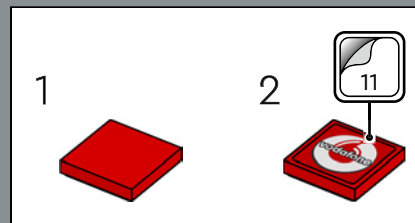

5



6



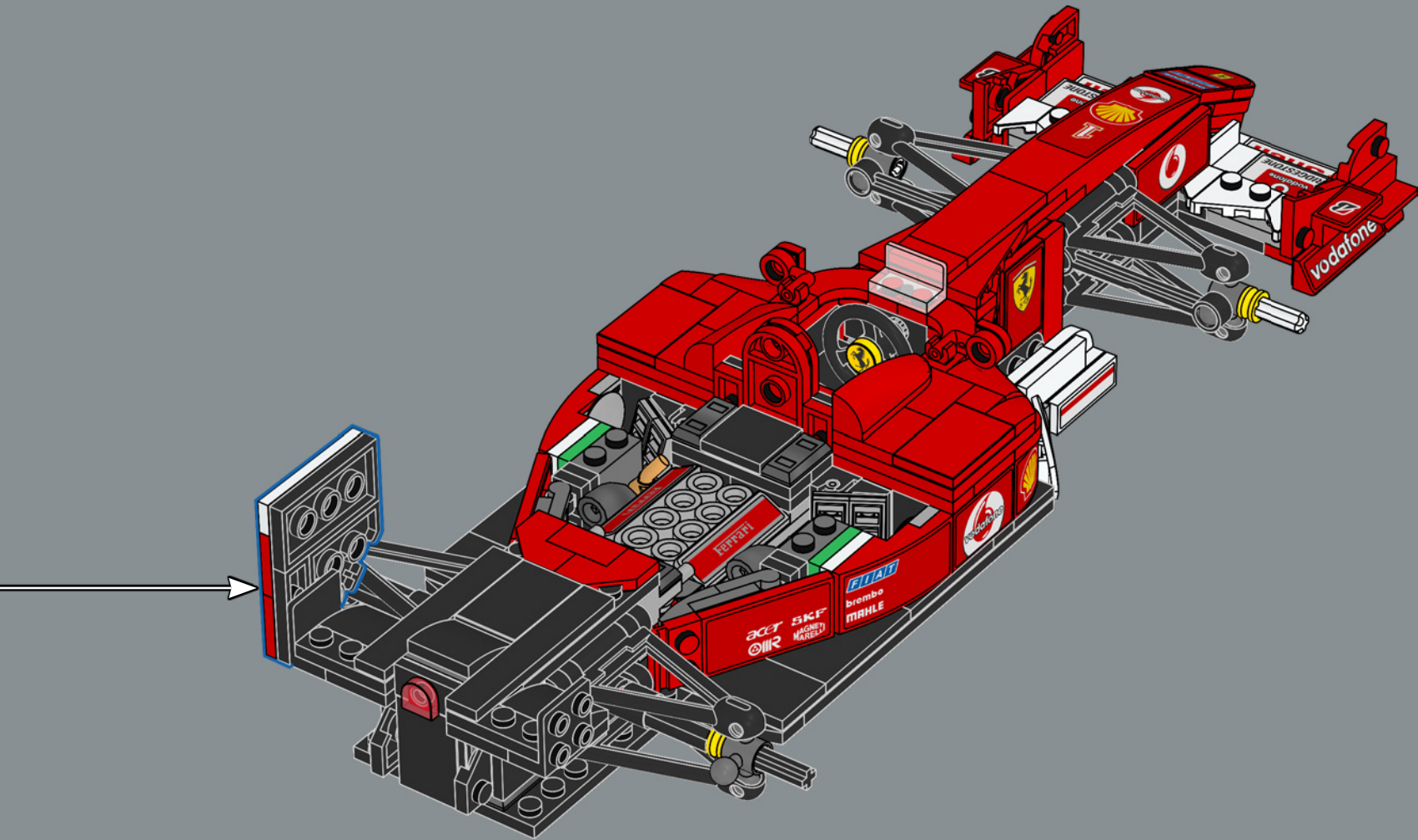

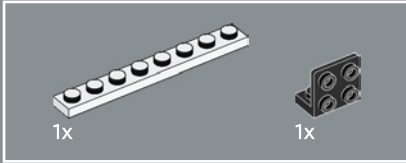
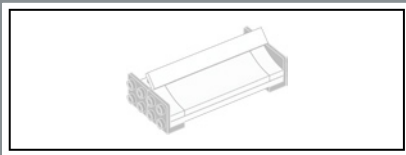

133

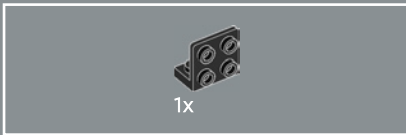
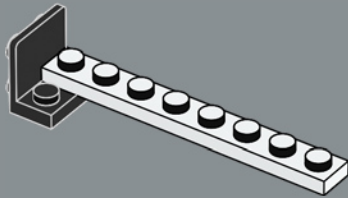

134

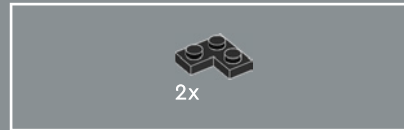
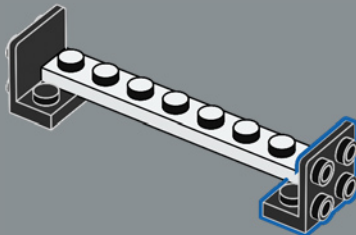

135

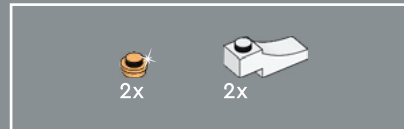
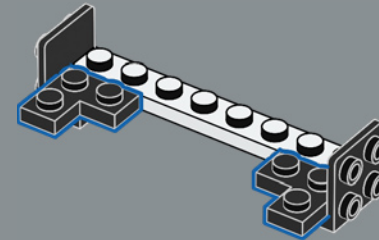

136

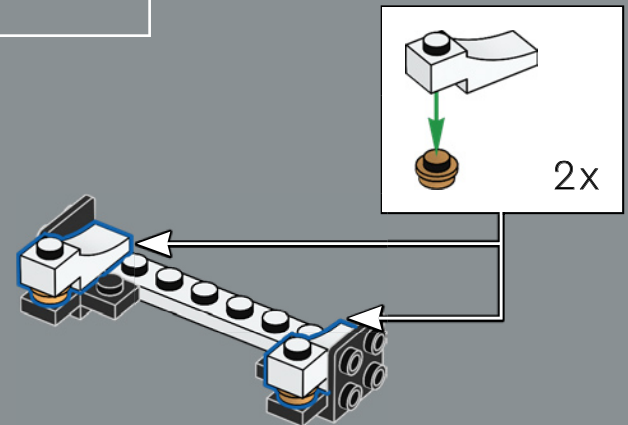

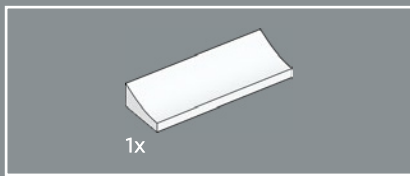

137

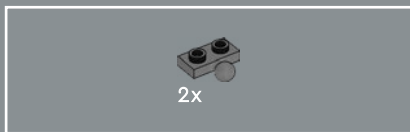
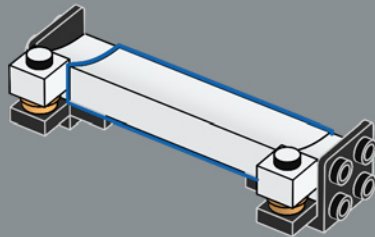

138

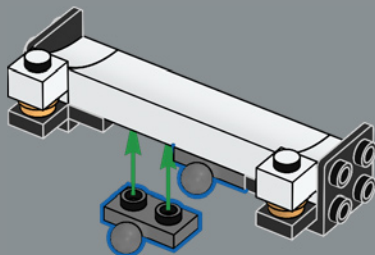

139

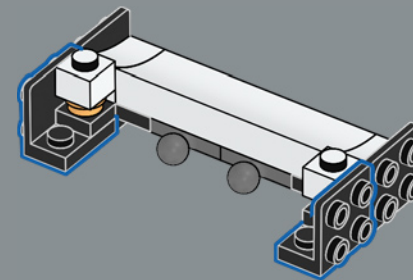

The 2x6 brick with inverted arch was also used in the 2025 LEGO® Speed Champions Formula 1® cars. It's used in white for the first time in this model.

La brique 2x6 avec arche inversée a également été utilisée dans les voitures de Formule 1® LEGO® Speed Champions 2025. Elle est utilisée en blanc pour la première fois dans ce modèle.

El brick 2x6 con arco invertido también se usó en los autos LEGO® Speed Champions de Formula 1® de 2025. En este modelo, aparece por primera vez en blanco.

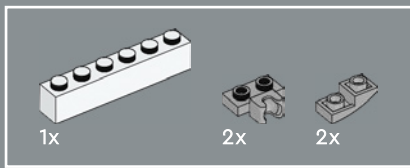

140

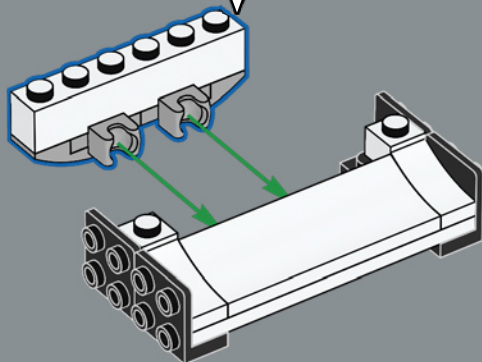
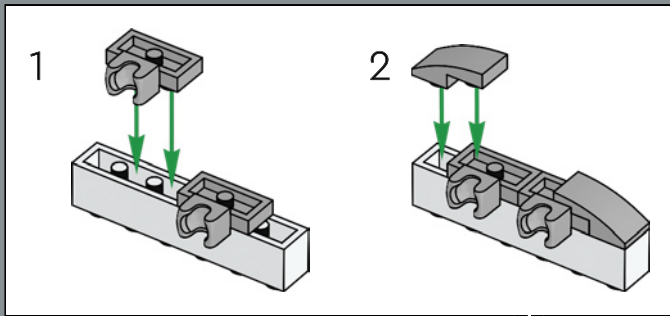

141

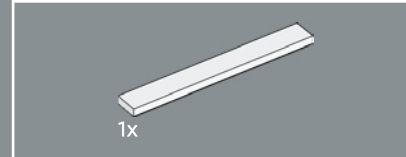
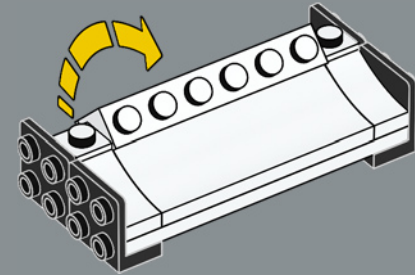

142

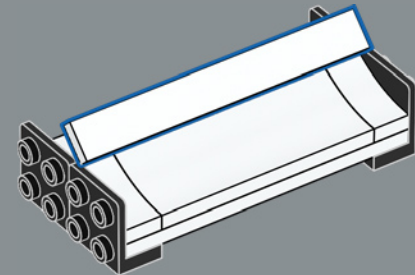

143

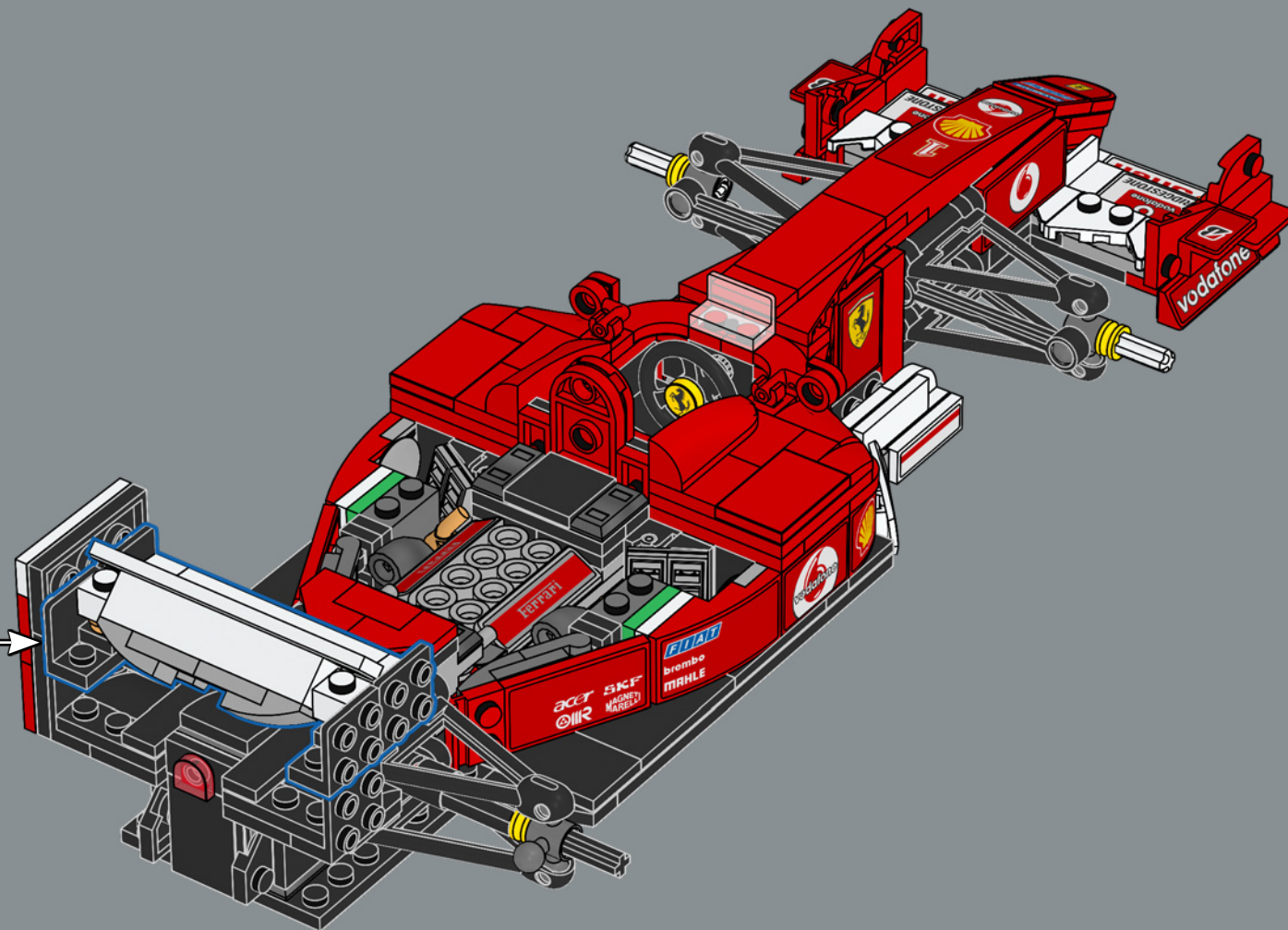

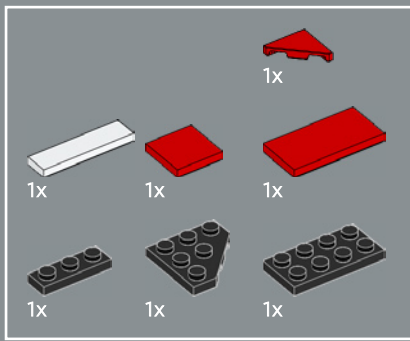

144

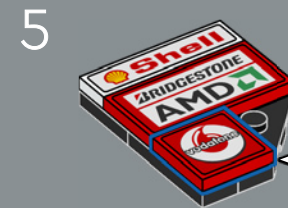
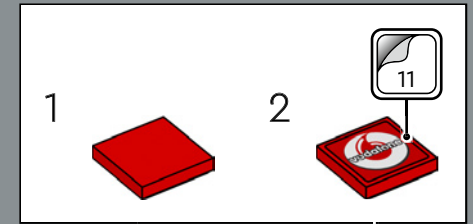
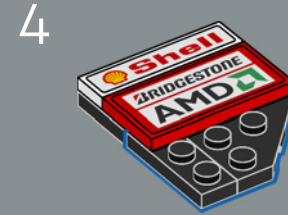
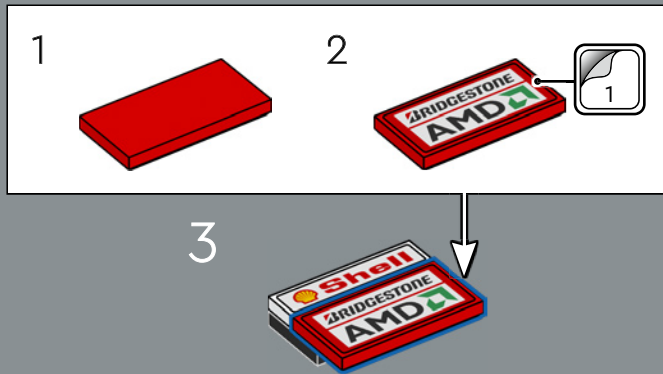
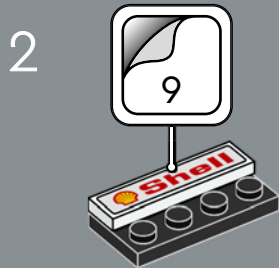
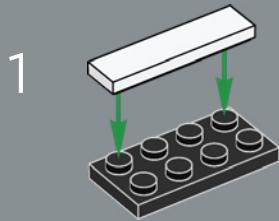



When the Ferrari team tested the F2004 back-to-back with its predecessor, the F2003-GA in Imola, they expected the new car to be at least half a second faster – Schumacher shaved a full 2 seconds off the previous lap time!

Lorsque l'équipe Ferrari a testé la F2004 en comparaison avec son prédécesseur, la F2003-GA, à Imola, elle s'attendait à ce que la nouvelle voiture soit au moins une demi-seconde plus rapide – Schumacher a même amélioré le temps du tour précédent de deux secondes!

Ferrari organizó una prueba comparativa del F2004 frente a su predecesor, el F2003-GA, en Imola. La escudería esperaba que el auto nuevo fuera al menos medio segundo más rápido, ¡pero Schumacher recortó 2 segundos completos al tiempo de vuelta anterior!

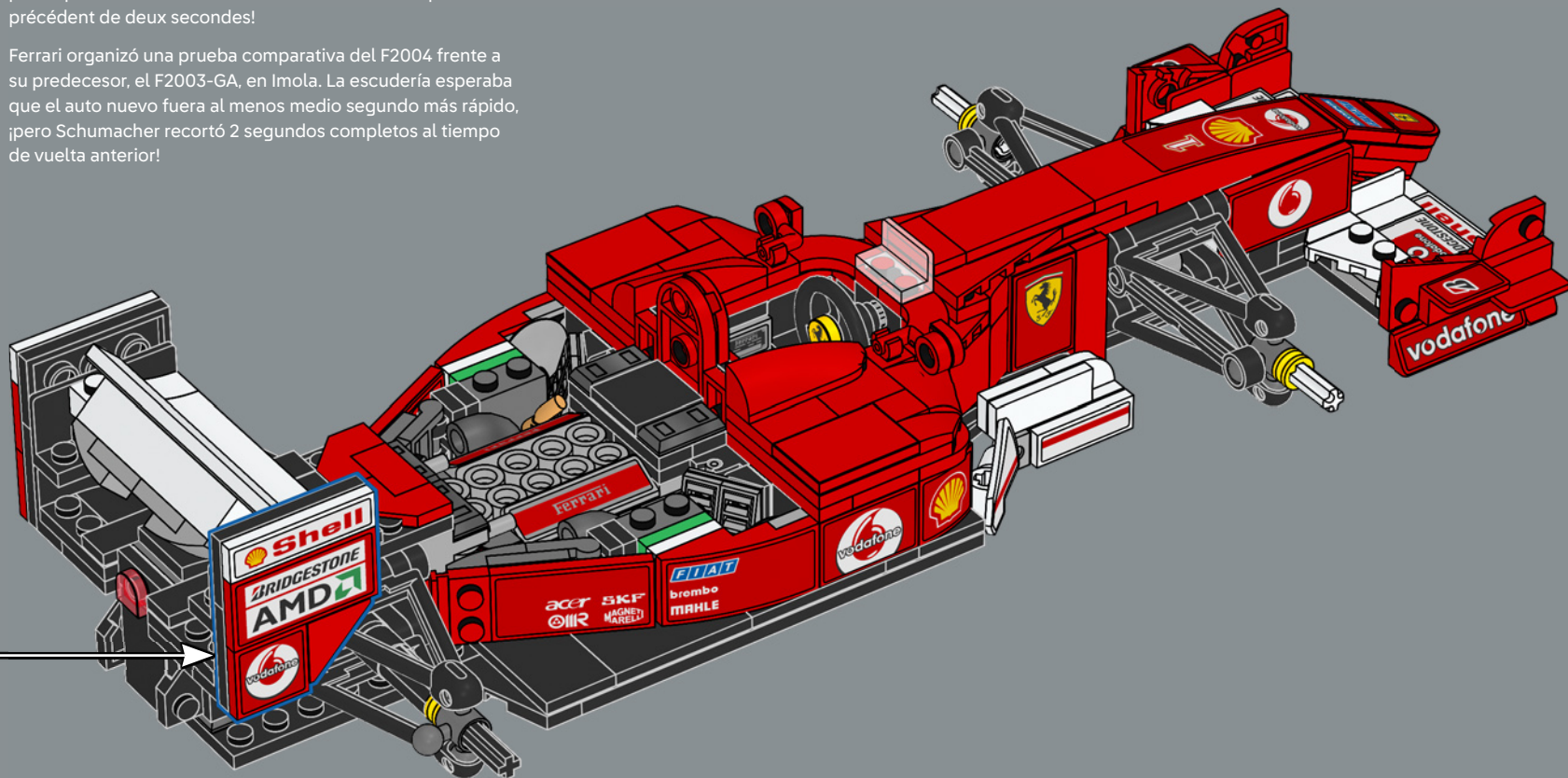

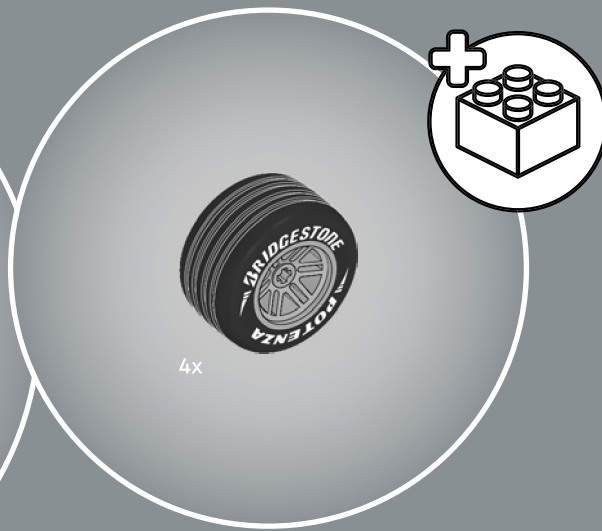

145

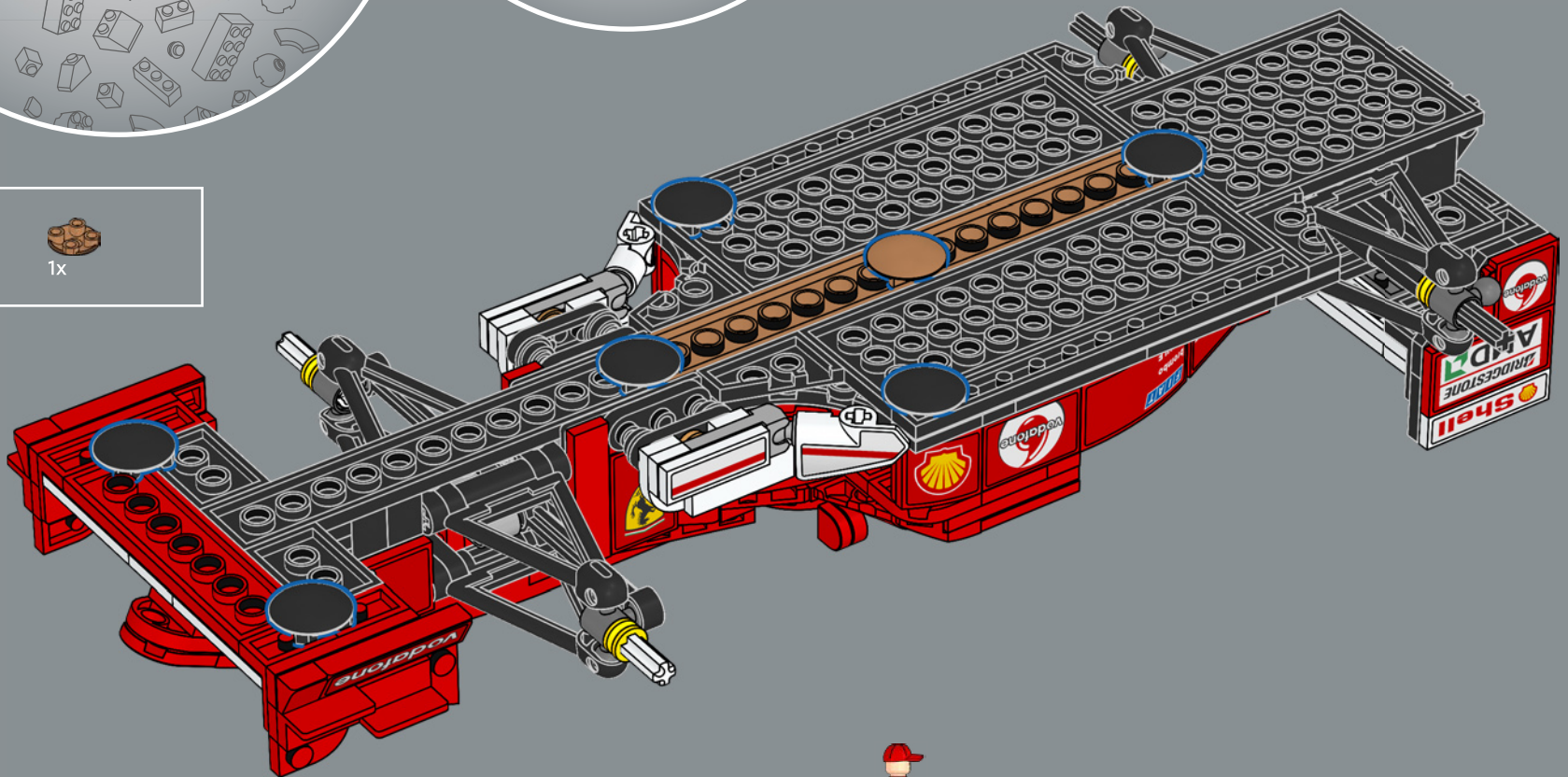

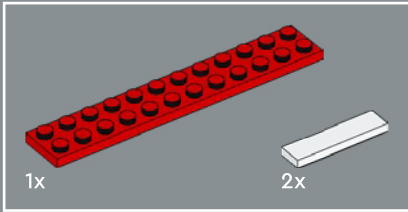
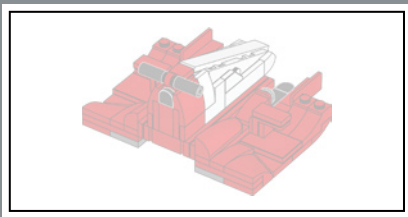

146

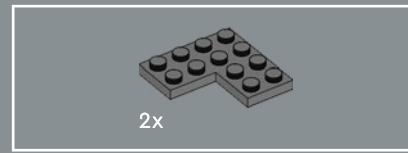
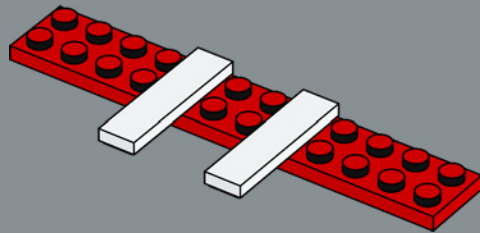

147

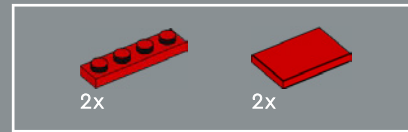
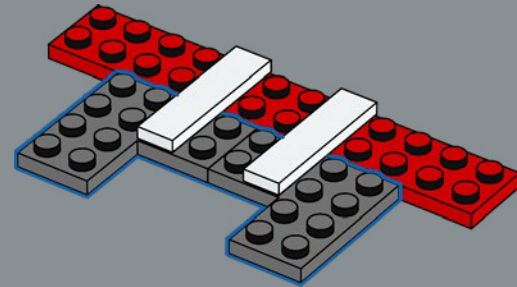

148

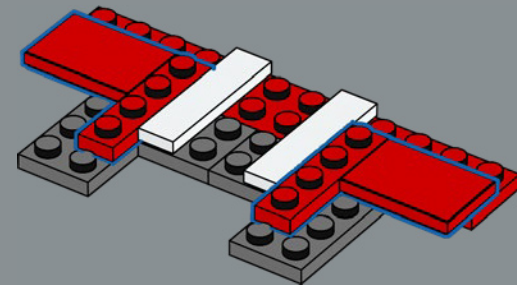

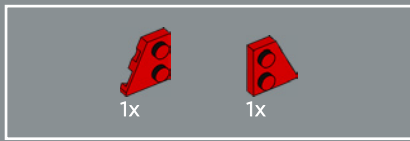

149

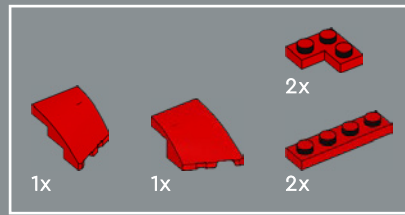
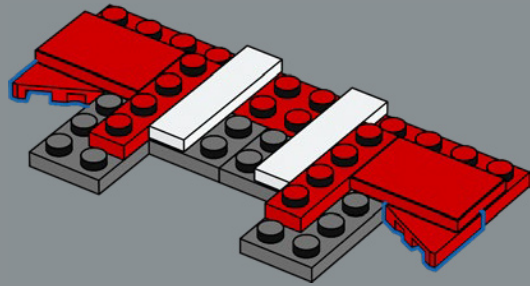

150

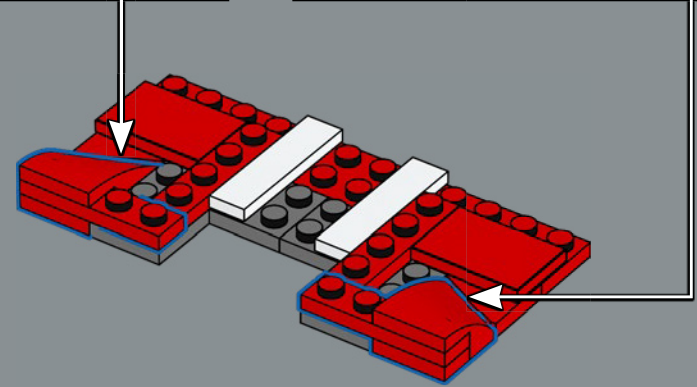
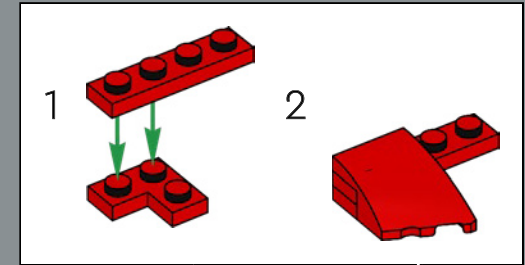
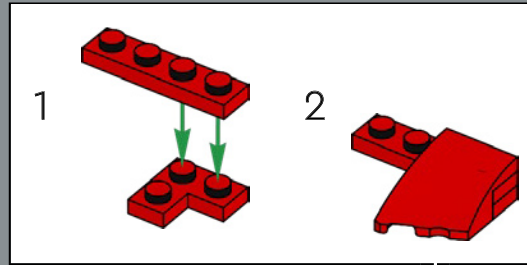

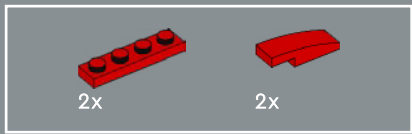

151

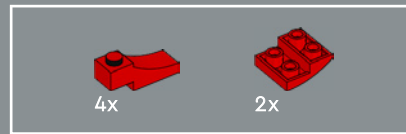
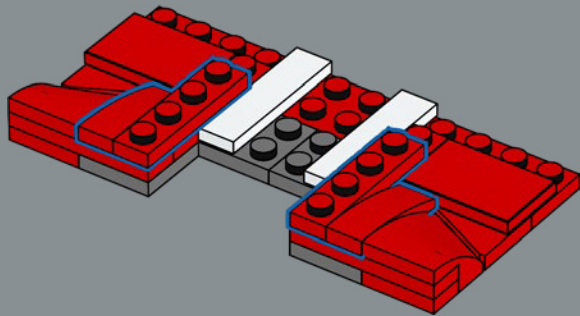

152

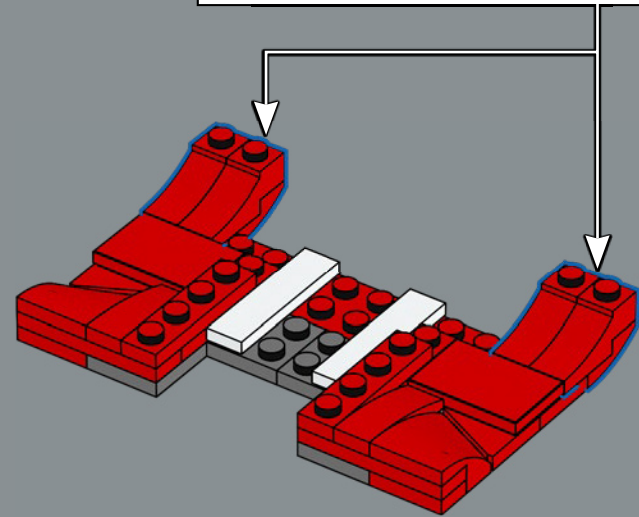
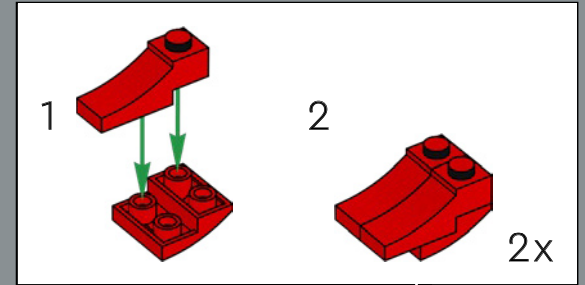

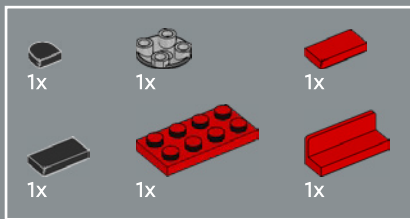

153

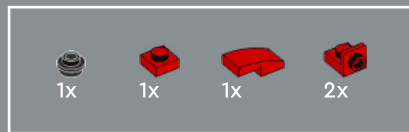
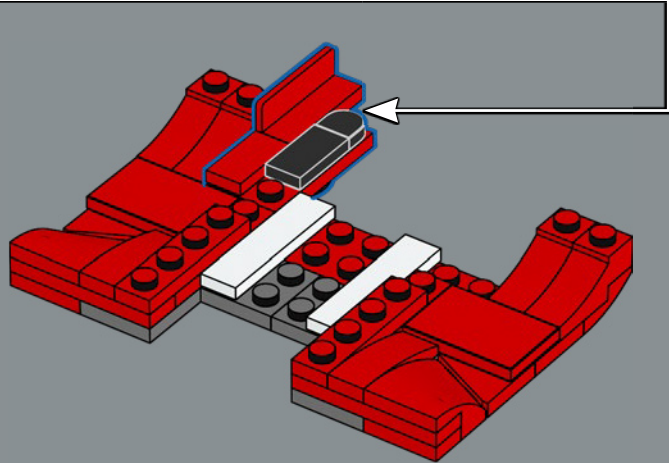
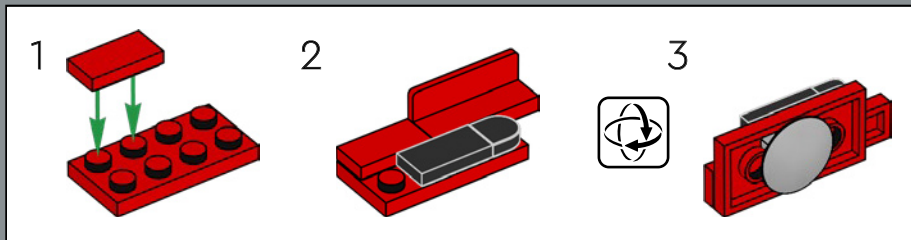

154

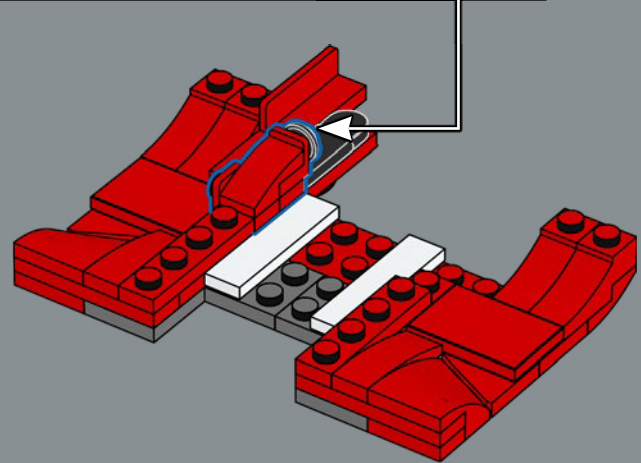
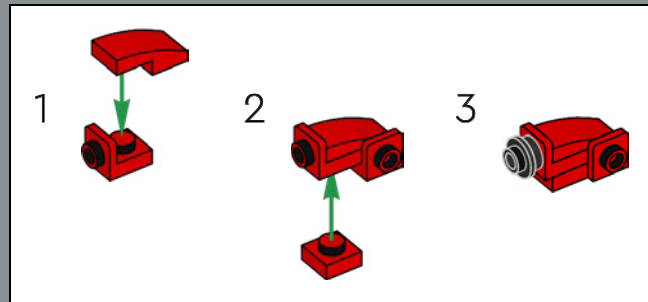

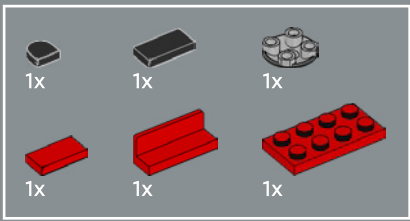

155

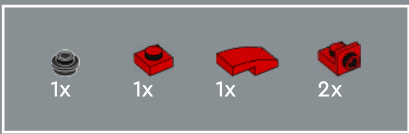
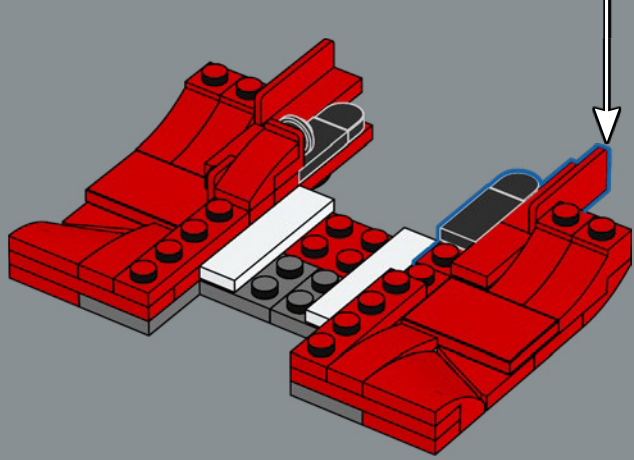
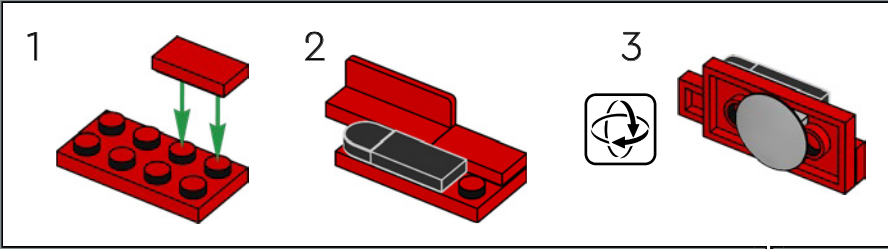

156

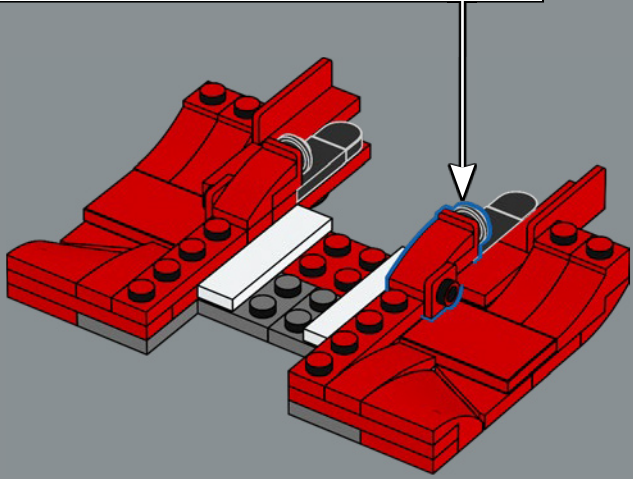
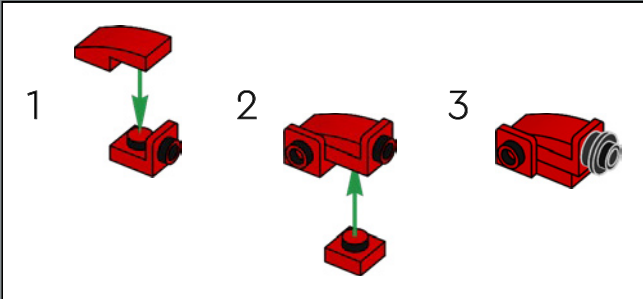

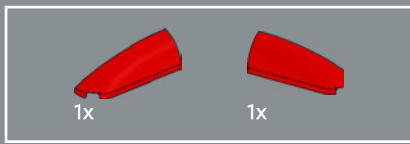

157

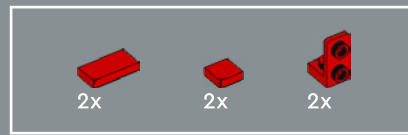
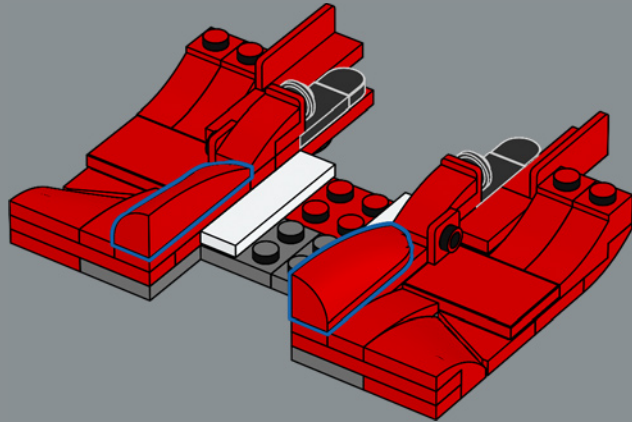

158

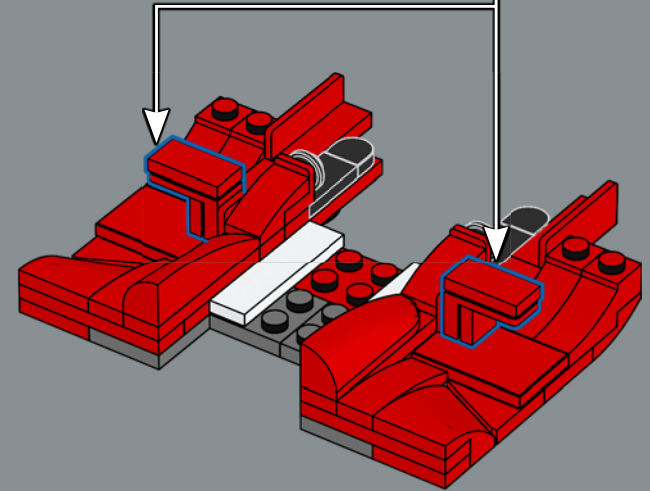
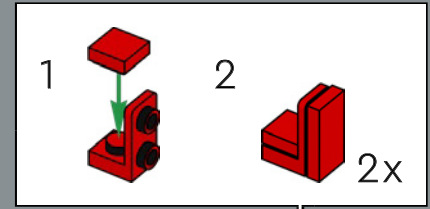

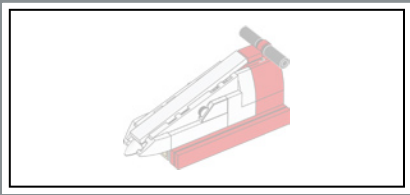

159

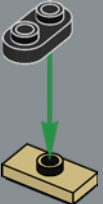

160

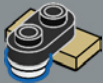

161

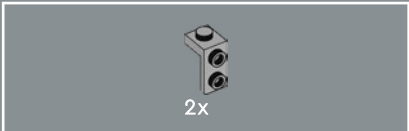
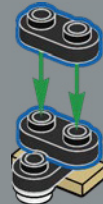

162



163

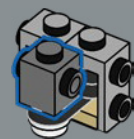

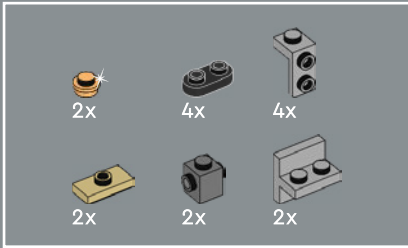

164

1

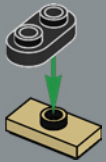

2

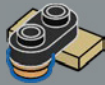

3

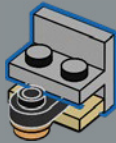

4

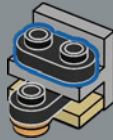

5

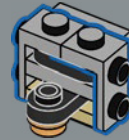

6

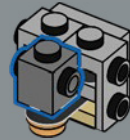

2x

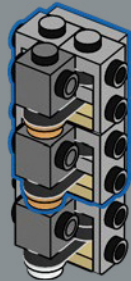

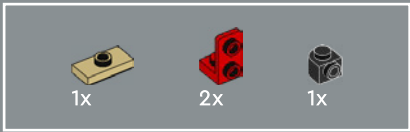

165

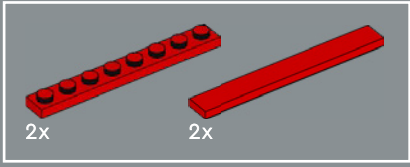
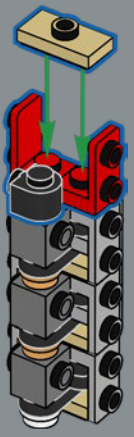

166

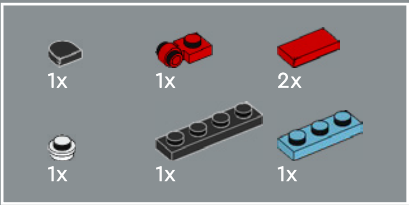
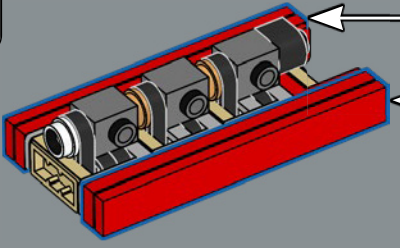
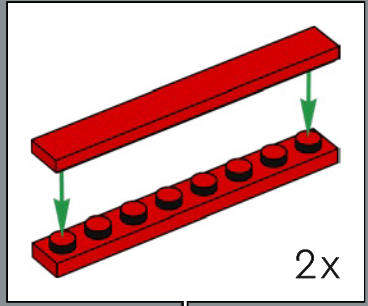

167

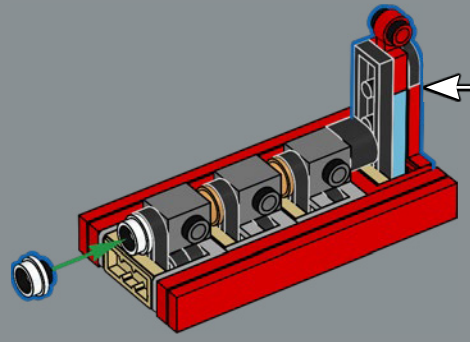
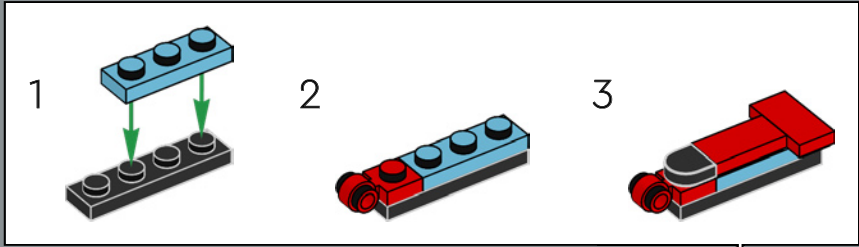

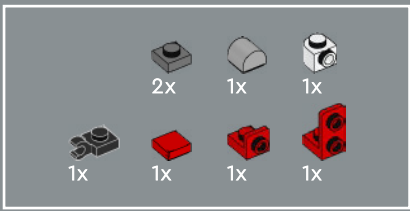

# 168

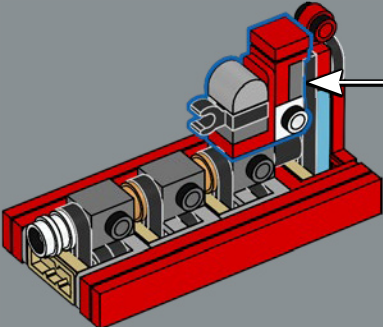
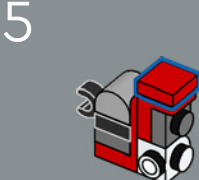
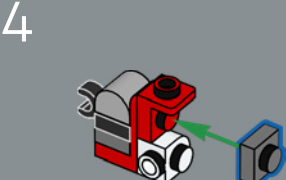
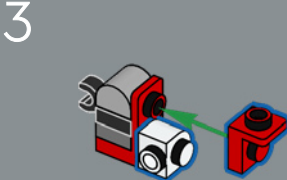
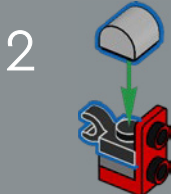
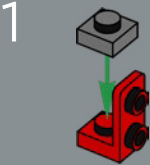

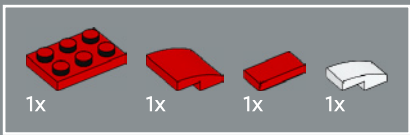

169

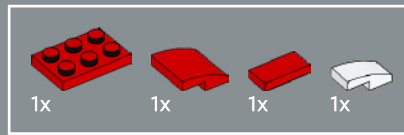
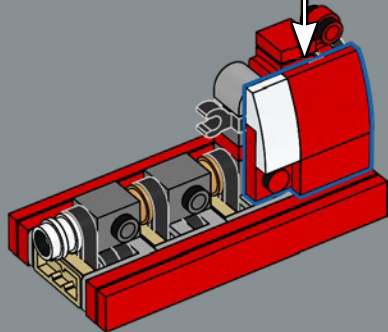
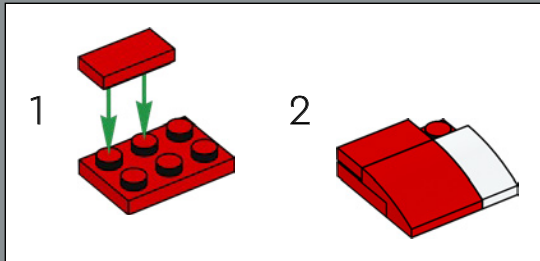

170

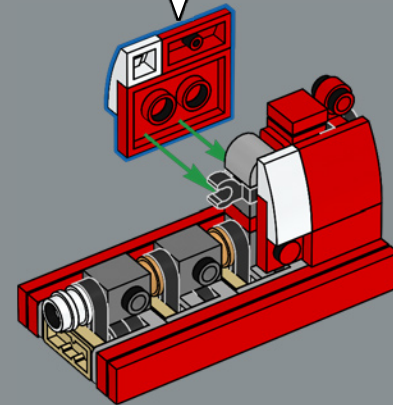
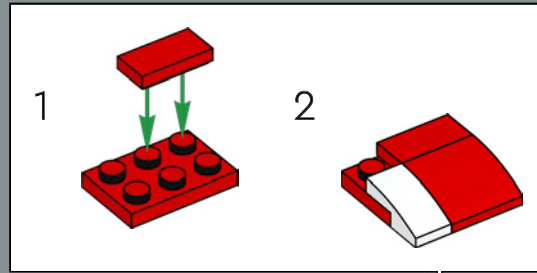

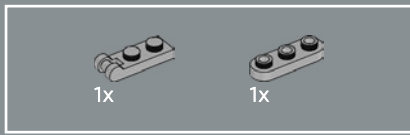

171

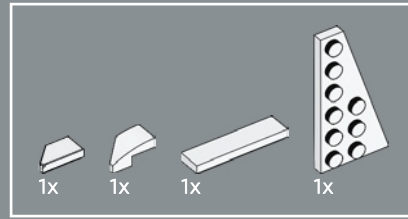
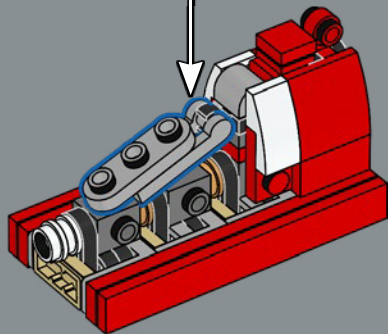
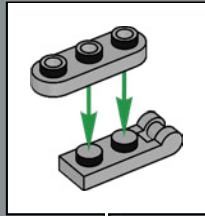

172

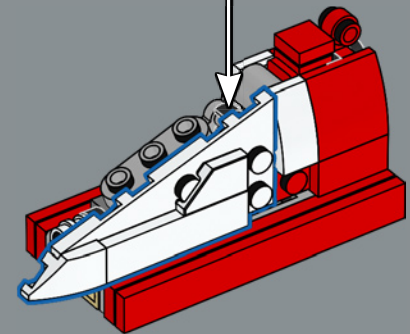
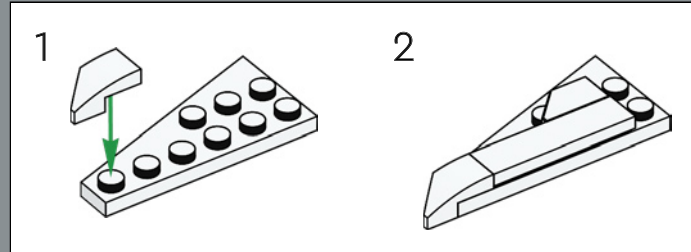

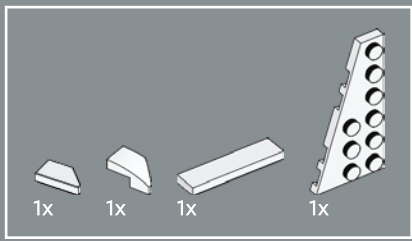

173

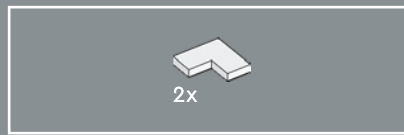
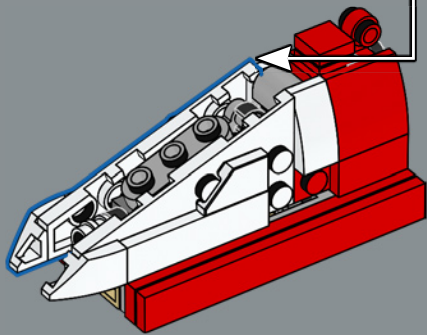
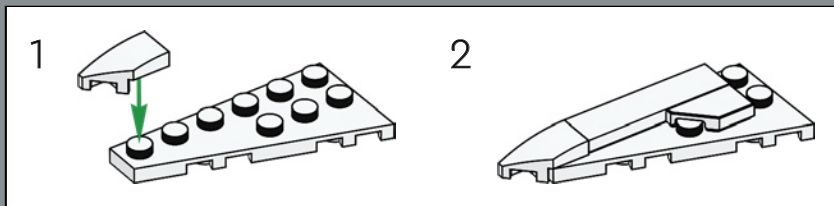

174

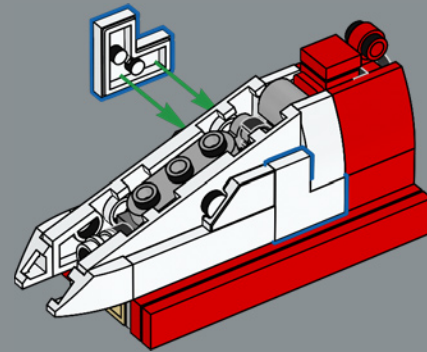

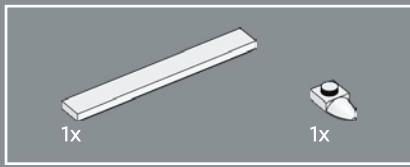

175

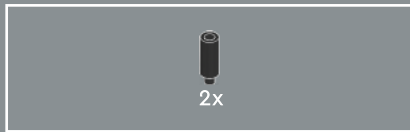
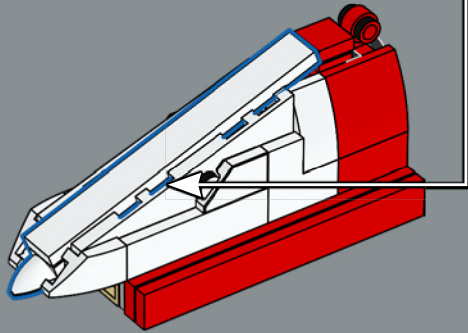
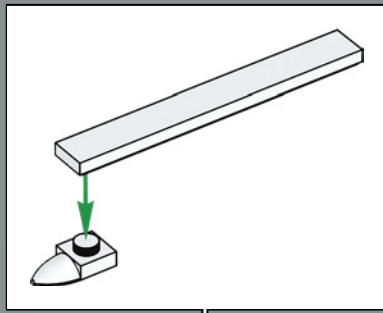

176

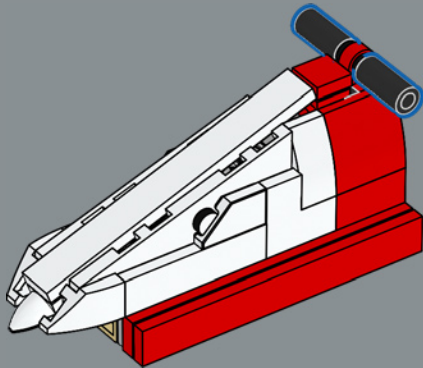

177

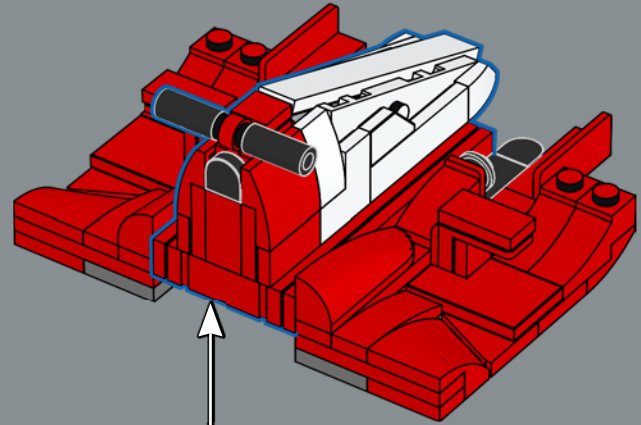

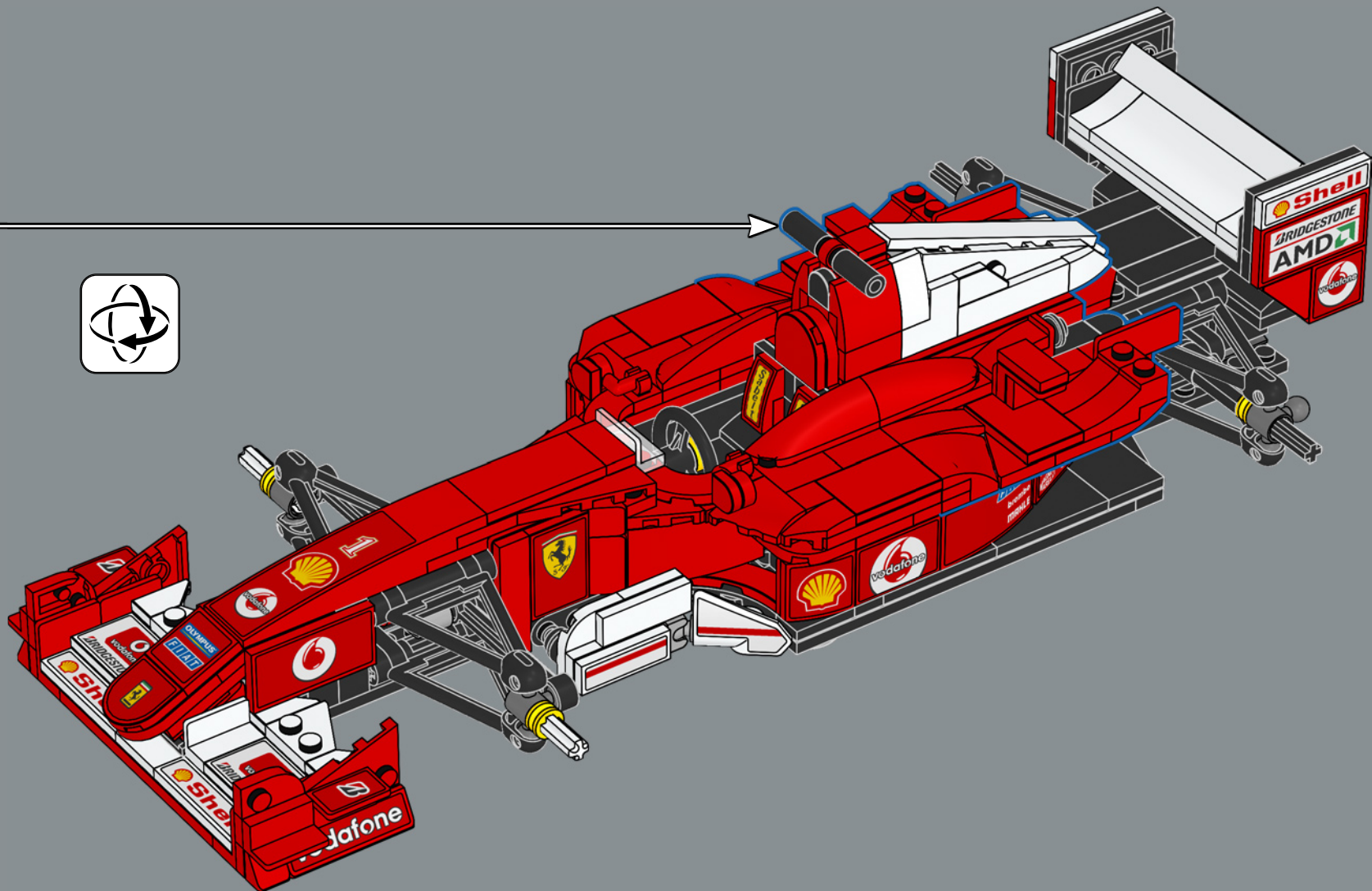

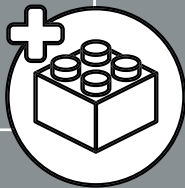

179

We designed a new wheel element to represent the grooved Bridgestone tires used in F1® cars between 1999 and 2008. Every element in a LEGO® Icons set is carefully selected to represent a specific aspect of its real-life counterpart. Did you happen to count the gold-colored elements in this model?

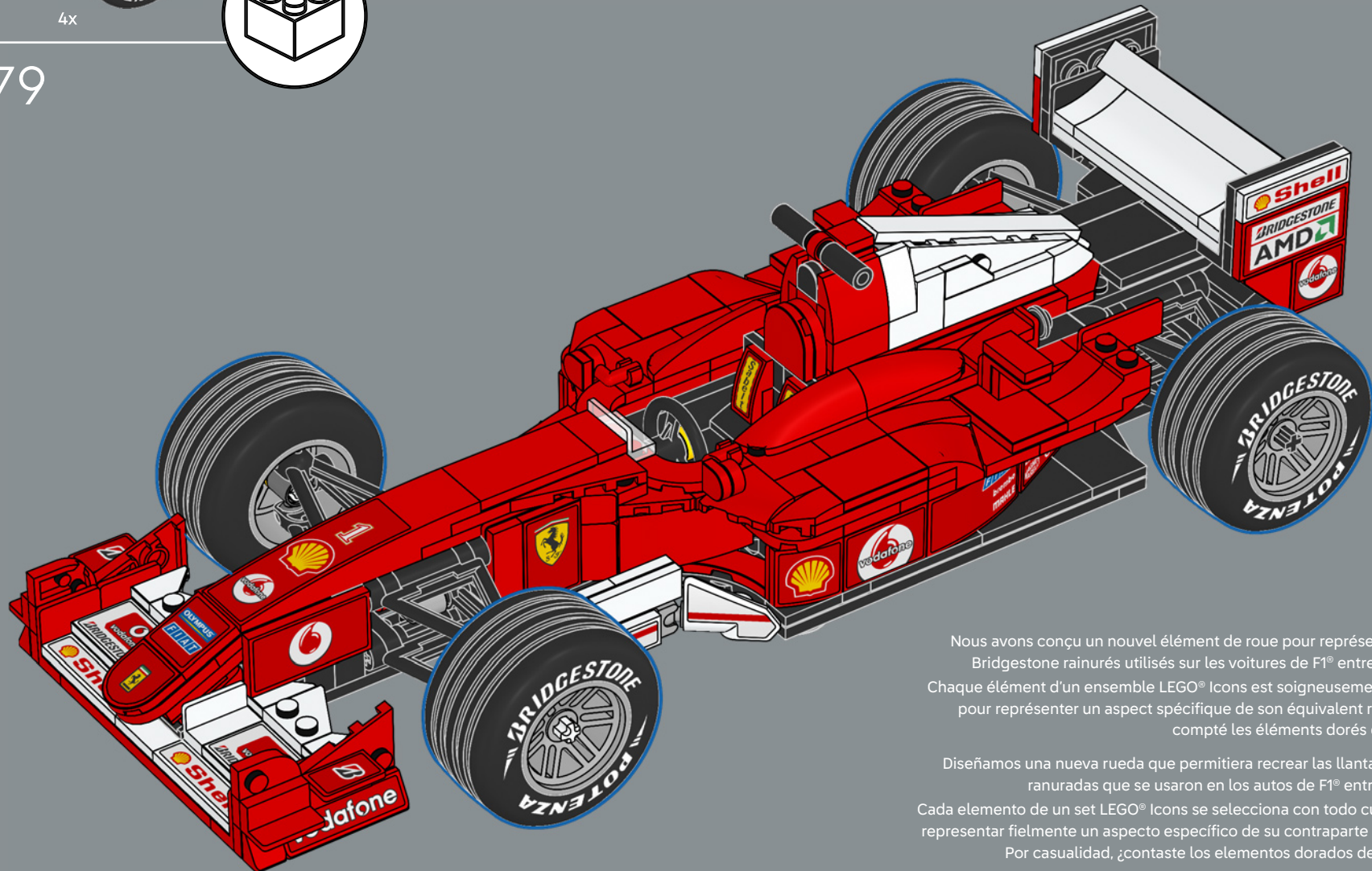

Nous avons conçu un nouvel élément de roue pour représenter les pneus Bridgestone rainurés utilisés sur les voitures de F1® entre 1999 et 2008. Chaque élément d'un ensemble LEGO® Icons est soigneusement sélectionné pour représenter un aspect spécifique de son équivalent réel. Avez-vous compté les éléments dorés de ce modèle?

Diseñamos una nueva rueda que permitiera recrear las llantas Bridgestone ranuradas que se usaron en los autos de F1® entre 1999 y 2008. Cada elemento de un set LEGO® Icons se selecciona con todo cuidado a fin de representar fielmente un aspecto específico de su contraparte de la vida real. Por casualidad, ¿contaste los elementos dorados de este modelo?





2x



2x

# 180

Comme sur le modèle réel, les goupilles centrales des roues sont rouges à gauche et bleues à droite. L'élément LEGO® Technic™ « bush » (bouchon) a été recoloré en rouge pour cet ensemble.

Al igual que en su contraparte de la vida real, los conectores centrales de las ruedas son rojos en el lado izquierdo y azules en el lado derecho. Para este set, el buje LEGO® Technic™ se recoloró en rojo.

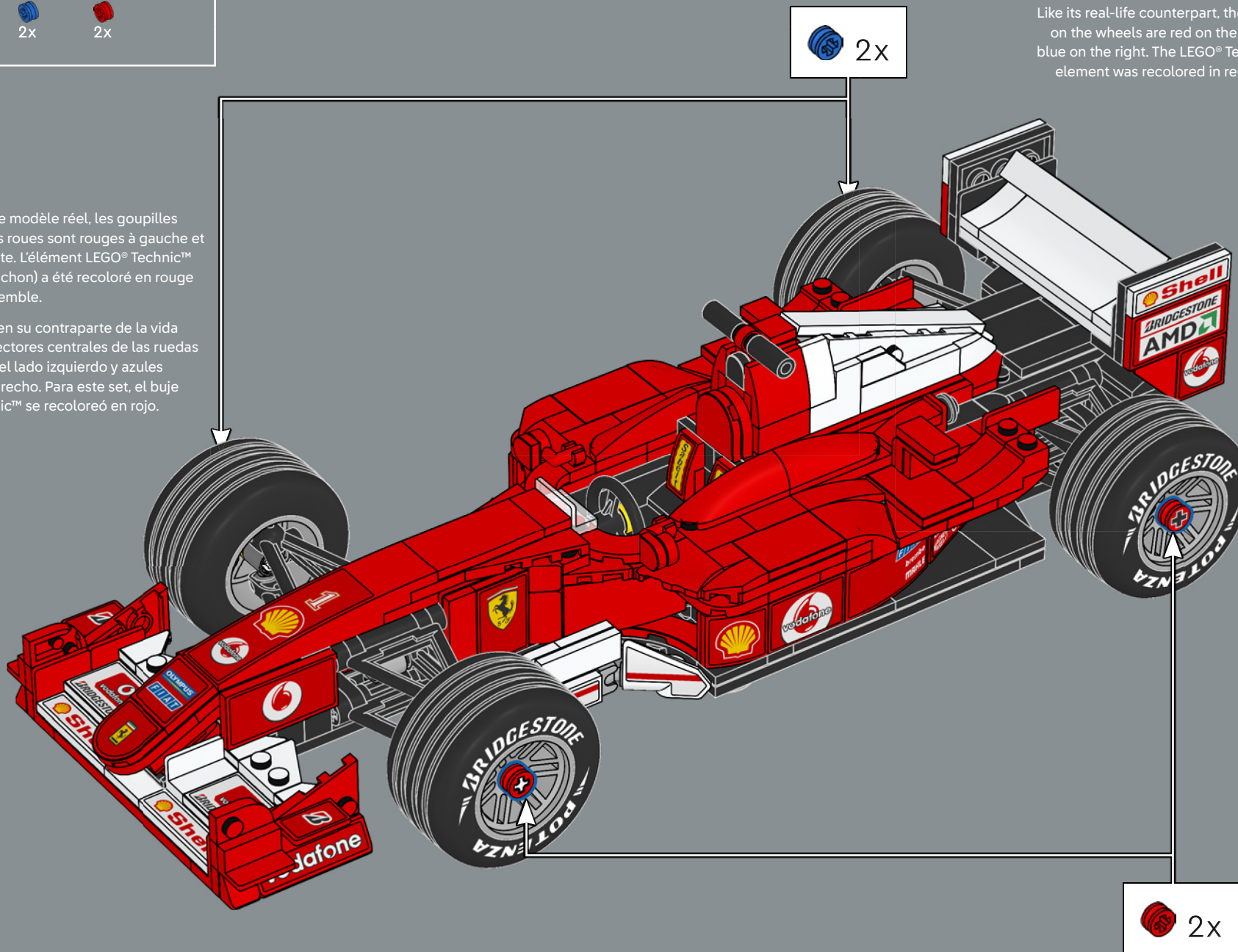

Like its real-life counterpart, the center pins on the wheels are red on the left side and blue on the right. The LEGO® Technic™ bush element was recolored in red for this set.



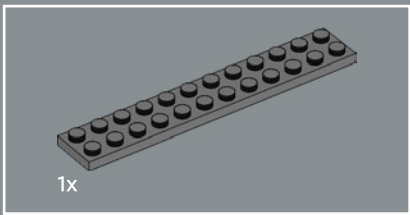

182

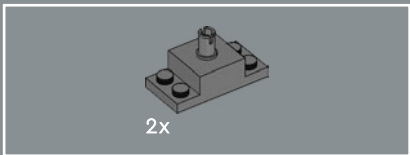
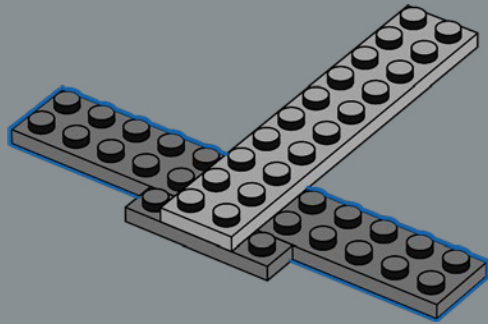

183

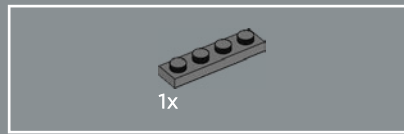
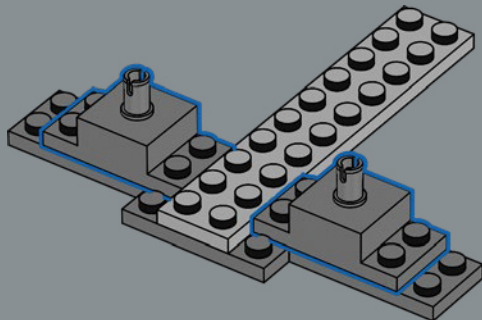

184

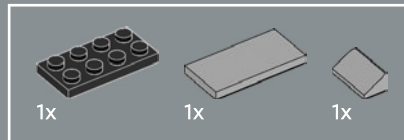
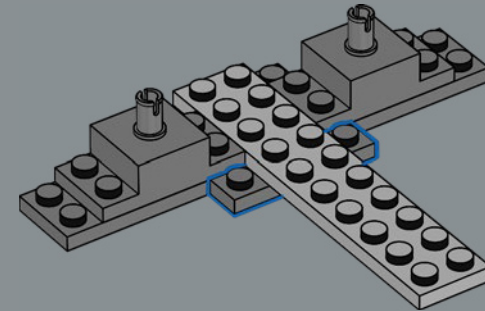

185

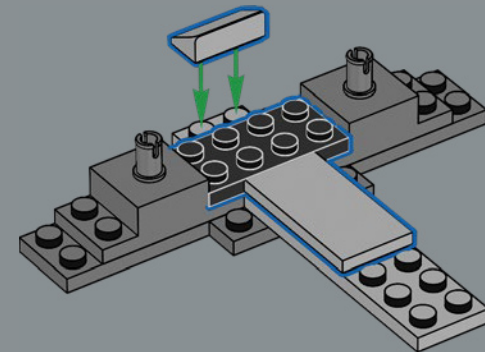

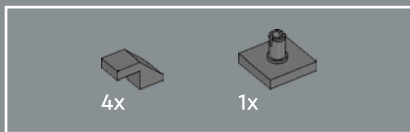

186

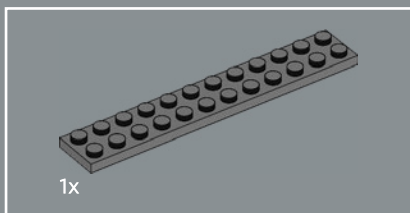
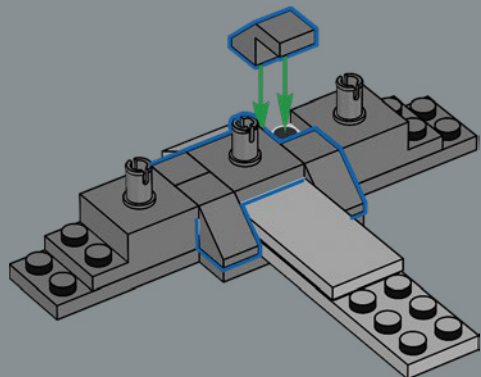

187

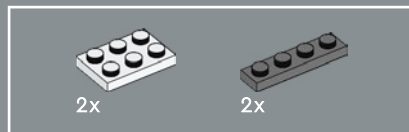
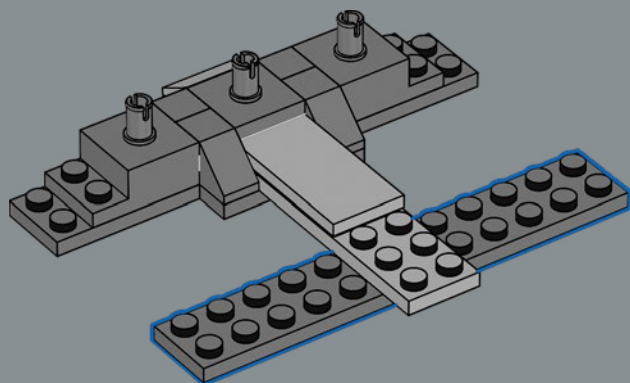

188

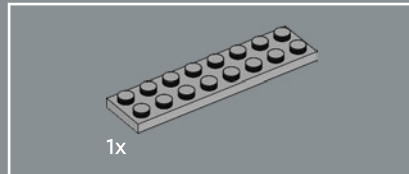
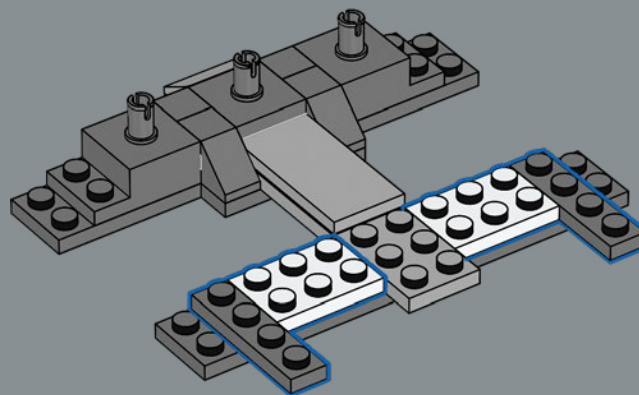

189

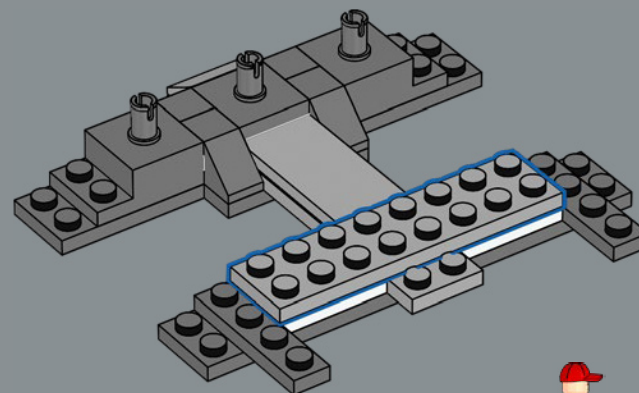

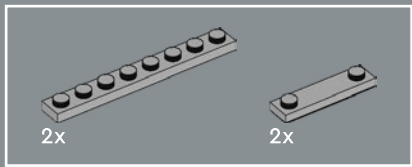

190

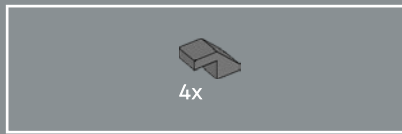
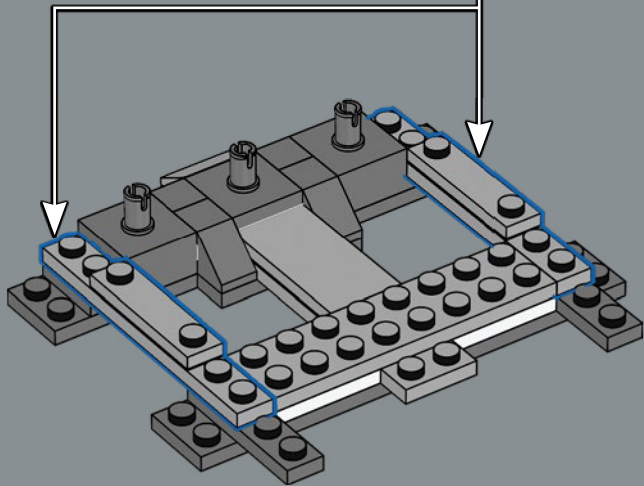
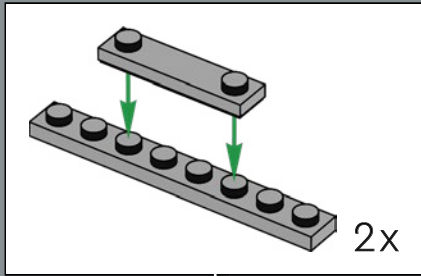

191

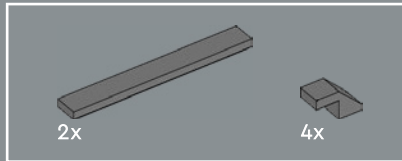
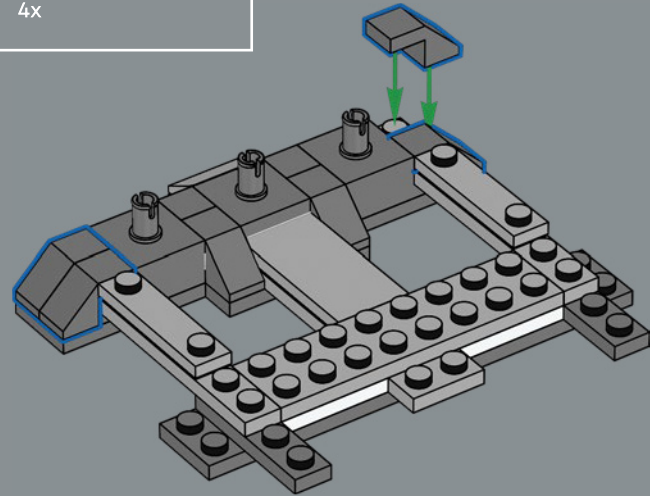

192

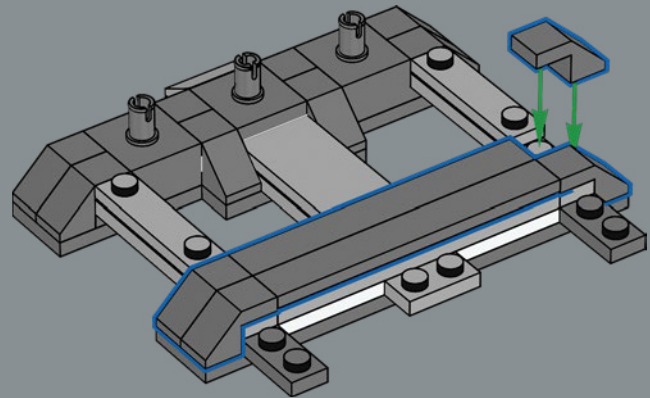

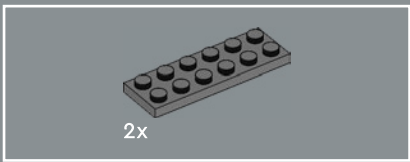

193

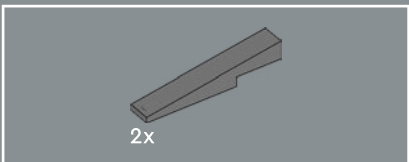
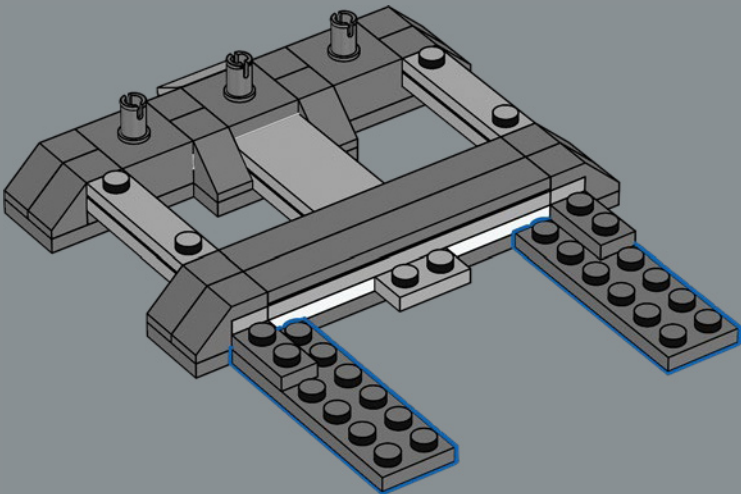

194

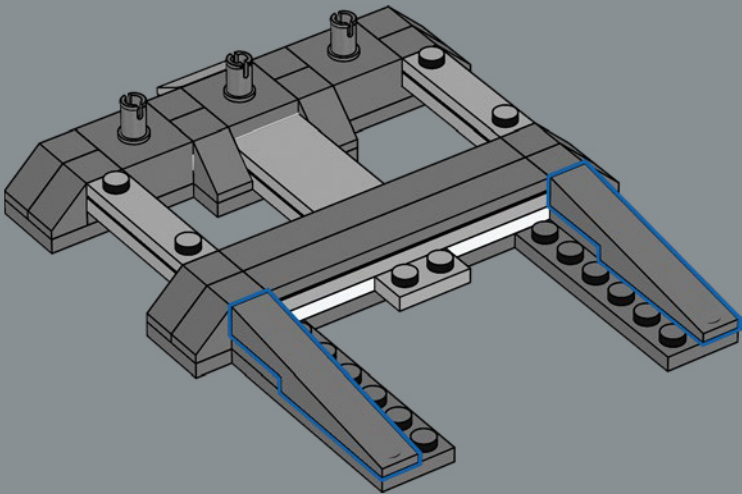

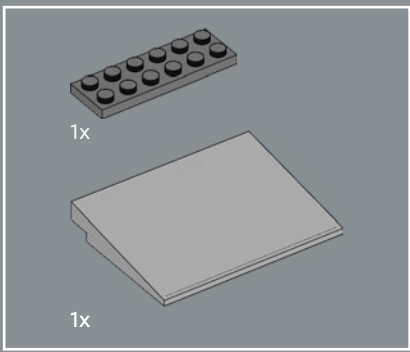

195

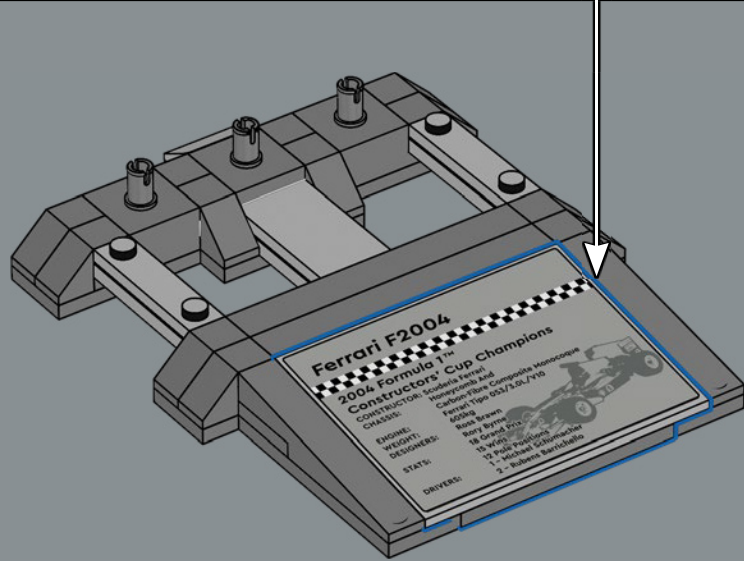
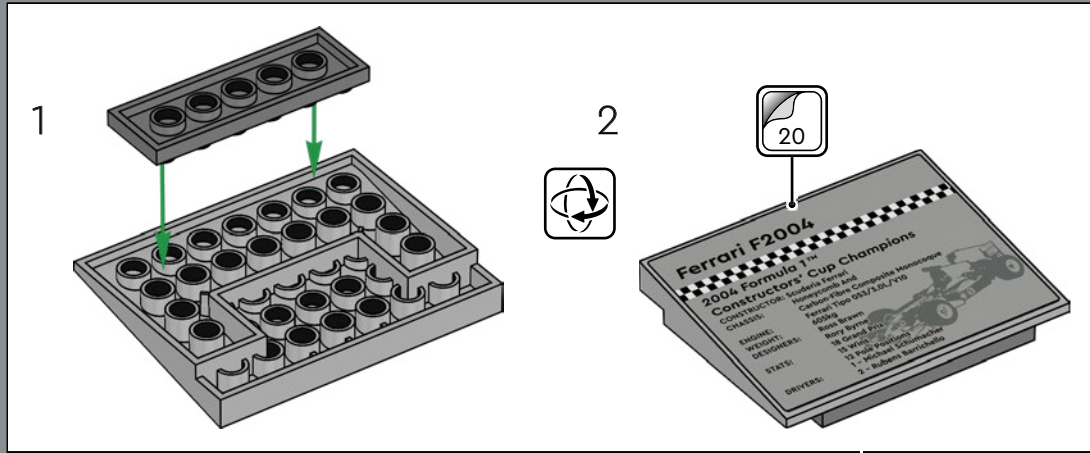

Michael Schumacher won 13 of the 18 races of the 2004 season, breaking his own record of 11 races in the 2002 season.

Michael Schumacher a remporté 13 des 18 courses de la saison 2004, battant son propre record de 11 courses établi lors de la saison 2002.

Michael Schumacher ganó 13 de las 18 carreras de la temporada 2004, rompiendo su propia marca de 11 carreras de la temporada 2002.



196

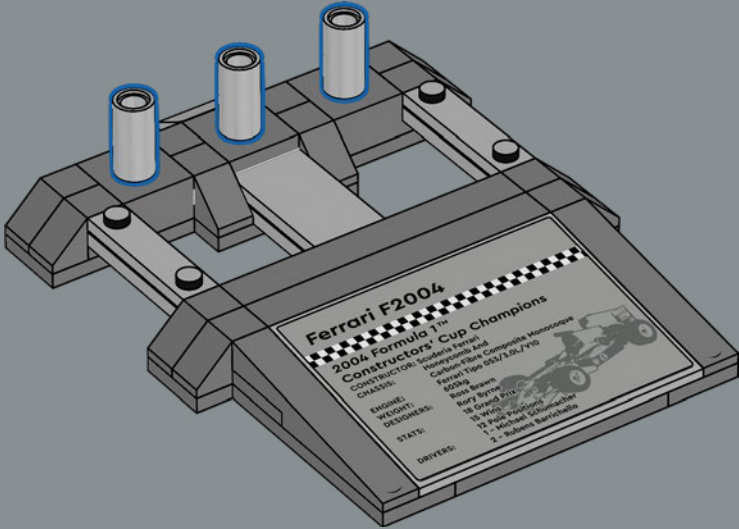

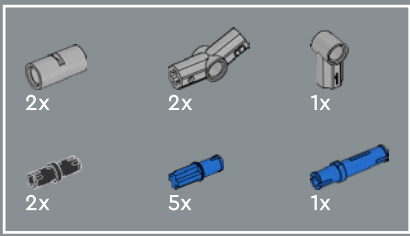

197

1

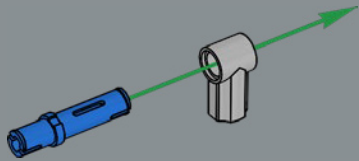

2

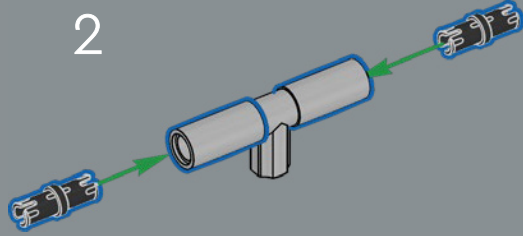

3

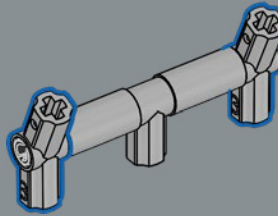

4

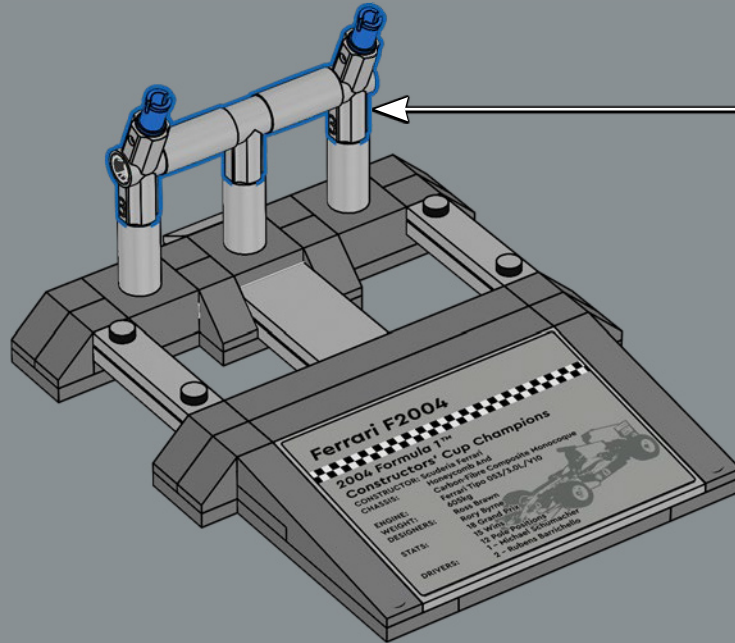
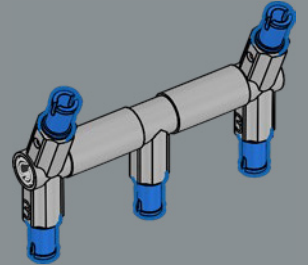











# YOU COULD WIN



## YOU COULD WIN

Your feedback will help shape the future development of this product series.

Visit:

## DU KÖNNTEST GEWINNEN

Dein Feedback trägt zur Weiterentwicklung dieser Produktreihe bei.

Geh auf:

## VOUS POURRIEZ GAGNER

Vos commentaires nous aideront à concevoir les futurs produits de cette gamme.

Visitez :

## POTRESTI VINCERE TU

La tua opinione ci aiuterà a migliorare la creazione futura di questa linea di prodotti.

Visita:

## PUEDES GANAR

Tu opinión contribuirá al futuro de esta serie de productos.

Visita:

## 轻松获奖

您的反馈将有助于我们在今后改进本产品系列。

请访问:

---

# LEGO.com/productfeedback

---

You also have the chance to win a LEGO® set.

Terms and conditions apply.\*

Außerdem hast du die Chance, ein LEGO® Set zu gewinnen.

Es gelten die Teilnahmebedingungen.\*

Vous pourriez également gagner un ensemble LEGO®.

Des conditions s'appliquent.\*

Hai anche la possibilità di vincere un set LEGO®.

Termini e condizioni sono applicabili.\*

También tienes la oportunidad de ganar un set LEGO®.

Aplican términos y condiciones.\*

您还有机会赢取乐高®套装。

条款和条件适用。\*

\*LEGO.com/productfeedback-terms

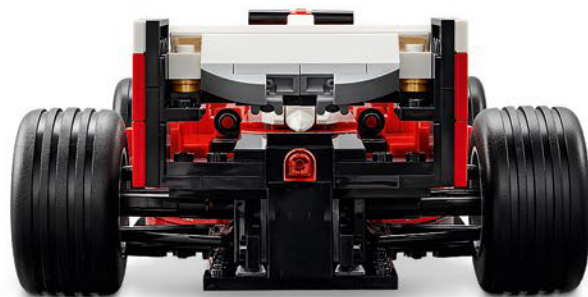

LEGO and the LEGO logo are trademarks of the/son des marques de commerce du/son marcas registradas de LEGO Group. ©2026 The LEGO Group.  
Produced under license of Ferrari S.p.A. The name FERRARI, the PRANCING HORSE device, all associated logos and distinctive designs are property of Ferrari S.p.A.  
The body designs of the Ferrari cars are protected as Ferrari S.p.A. property under design, trademark and trade dress regulations.  
Produced under licence of Michael Schumacher.