



11375



Michael Schumacher

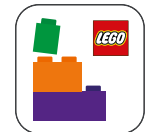

Available in English
In deutscher Sprache verfügbar
Disponibles en français
Disponibile in italiano
Disponible en español
提供中文版本

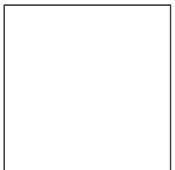

LEGO® Builder





LEGO.com/sustainable-packaging



FR
DONNEZ
OU
RECYCLEZ



OU



OU



ASSOCIATION MAGASIN DÉCHÈTERIE

Adresses sur quefairedemesdechets.fr



BUILDER



Apple and the Apple logo are trademarks of Apple Inc., registered in the U.S. and other countries and regions. App Store is a service mark of Apple Inc. Google Play and the Google Play logo are trademarks of Google LLC. Tencent and the Tencent logo are trademarks of Tencent Inc.

LEGO.com/devicecheck



LEGO® Builder



THE FERRARI F2004

// The Ferrari F2004, driven by racing legend Michael Schumacher, dominated the 2004 Formula 1® season. Still widely hailed as one of the greatest F1® cars ever, it famously helped Schumacher claim his seventh and final world title – his fifth in a row. Adding yet another jewel to their crown, Ferrari also clinched their sixth straight Constructors' Championship with the F2004, capping their era of dominance on the tracks and delivering unforgettable racing moments for fans worldwide.



M. Schumacher



THE RACING LEGEND

// The partnership between Ferrari and Michael Schumacher fostered the kind of unique synergy that arises when stars in their respective fields align perfectly. Joining the team in 1996, Schumacher found an ideal match for his extraordinary talent and deep dedication to collaboration and perfection. Consistently defending Ferrari's world championship status, Schumacher secured 72 Grand Prix wins during his time with the team. With his unwavering commitment to the sport, and his involvement with various charities, he left an indelible mark on the racing world.





FROM THE LEGO® ICONS DESIGN TEAM

// Our amazing partners at Scuderia Ferrari helped us get the correct shaping and proportions of the F2004 in LEGO® form, down to each minute detail. We recreated the long, slim 'nose', intricate, aerodynamic shapes and organic design features of the F2004 with different LEGO bow elements and curved pieces. Under the engine cover, you'll see a detailed engine bay, and you might spot a few references to the story of the car, as well as its legendary driver.





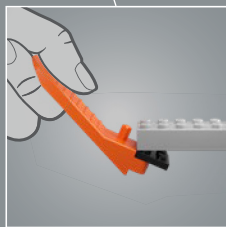
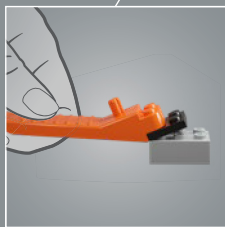
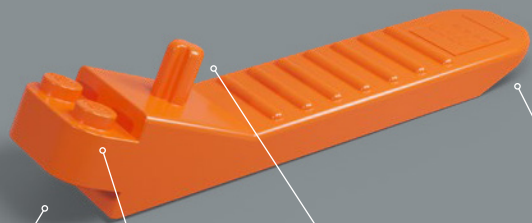



Michael Schumacher expressed a passion for racing early on, starting go-kart racing at the age of four, and winning his first go-kart title just two years later. He drove in a go-kart built by his father from scrap parts.

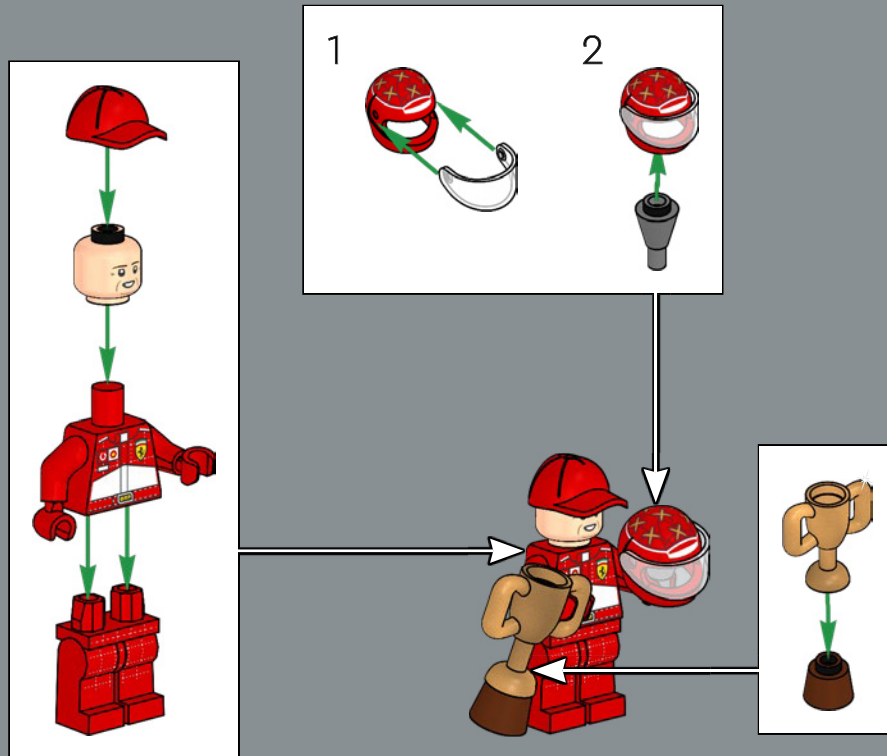

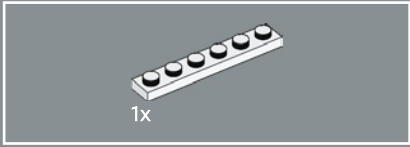

1

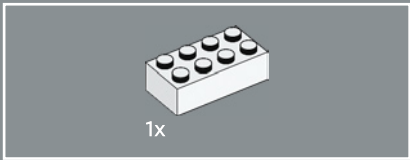
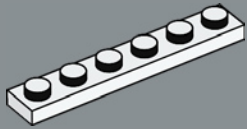

2

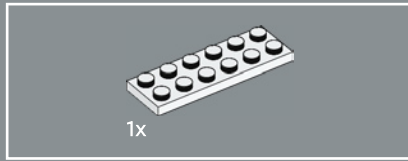
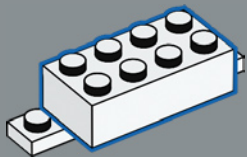

3

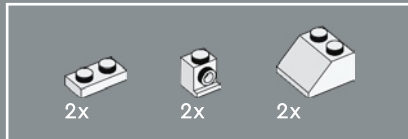
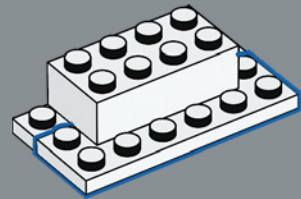

4

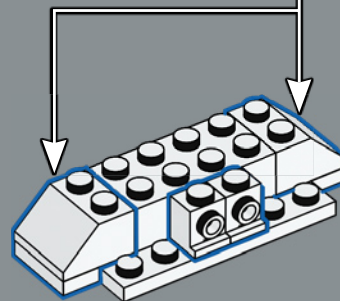
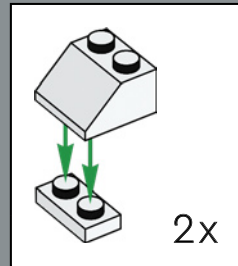

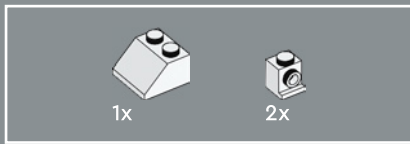

5

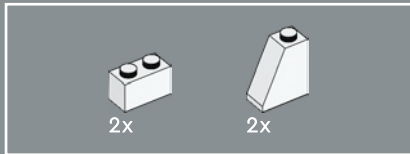
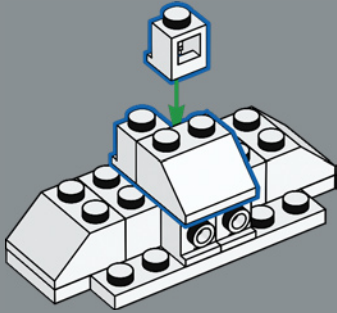

6

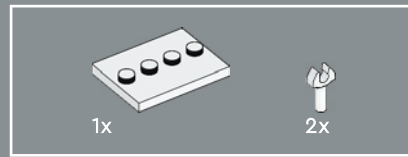
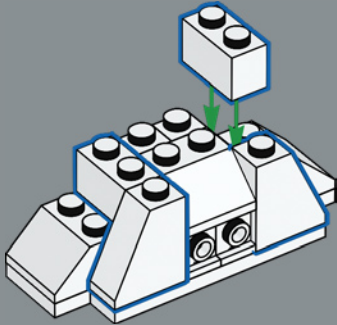

7

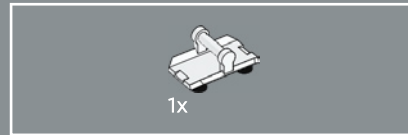
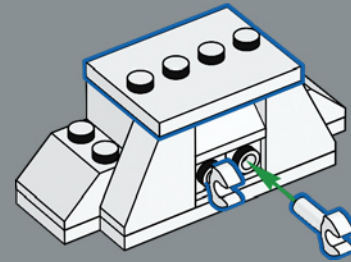

8

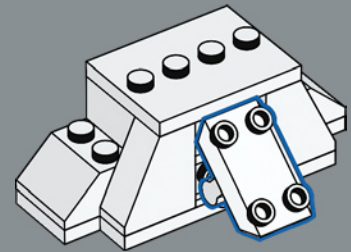

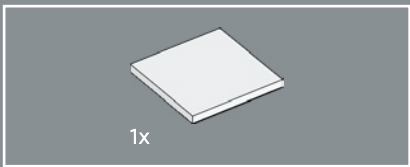

9

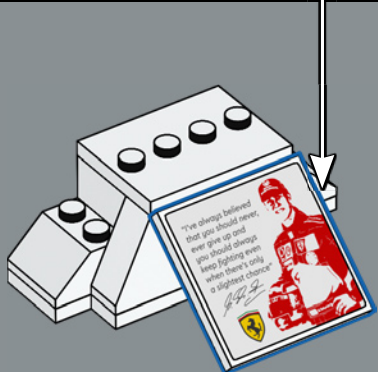
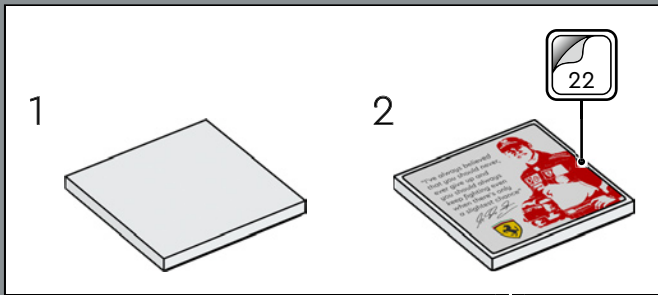

10

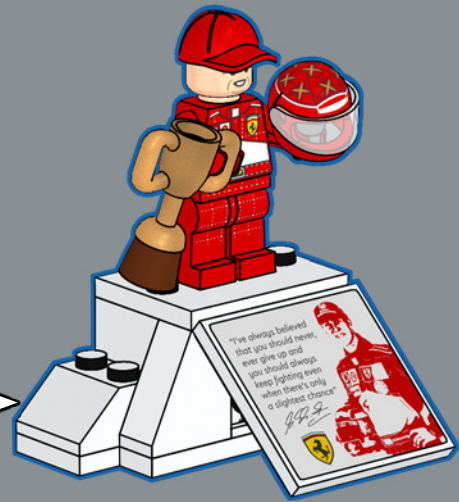

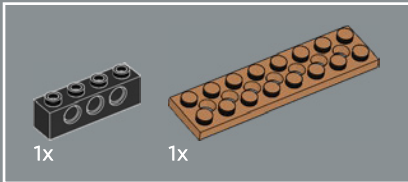
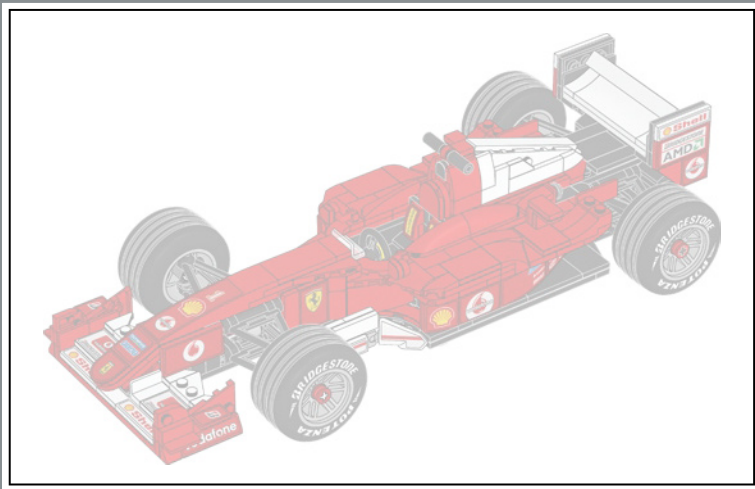

1

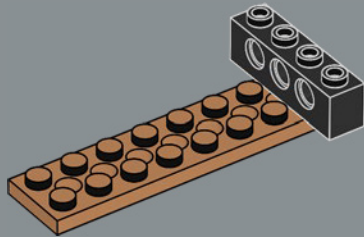

The two 2x8 LEGO® plates with holes, in a medium nougat colour, represent the skid block and plank that every F1® car has featured as a safety measure since 1994.

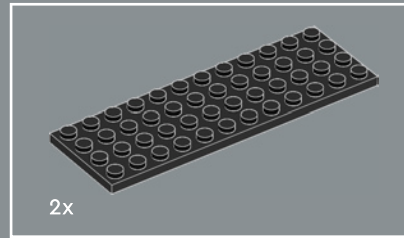

2

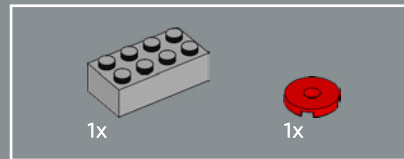
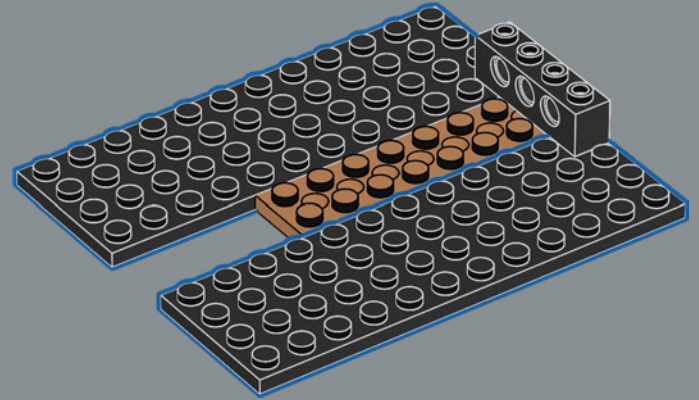

3

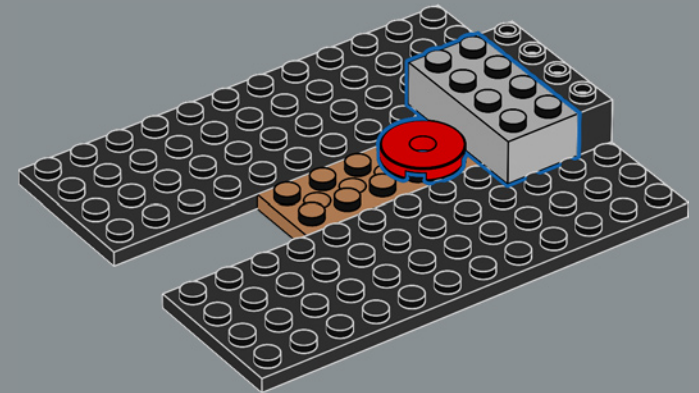

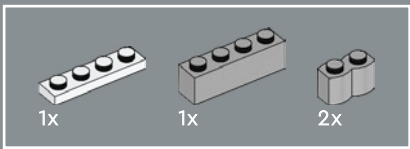

4

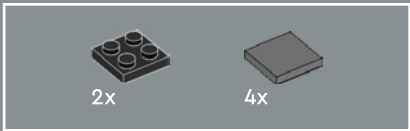
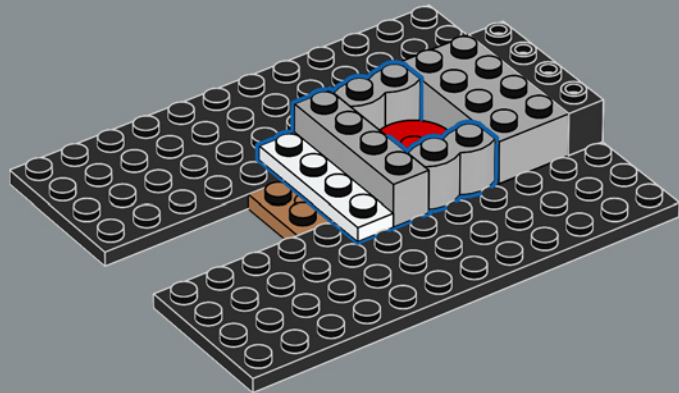

5

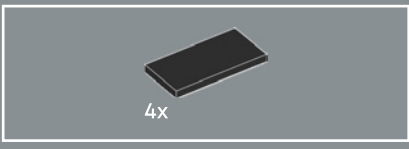
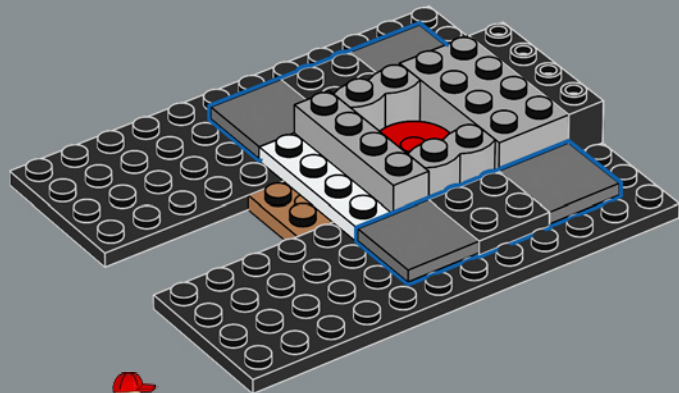

6

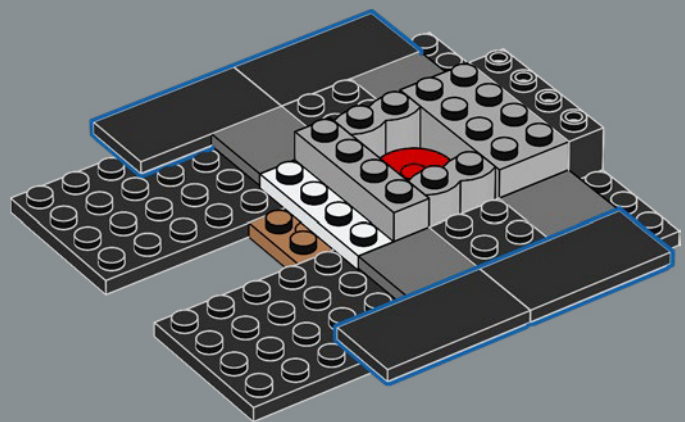

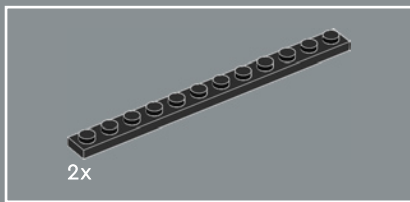

7

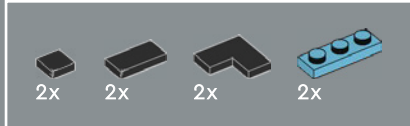
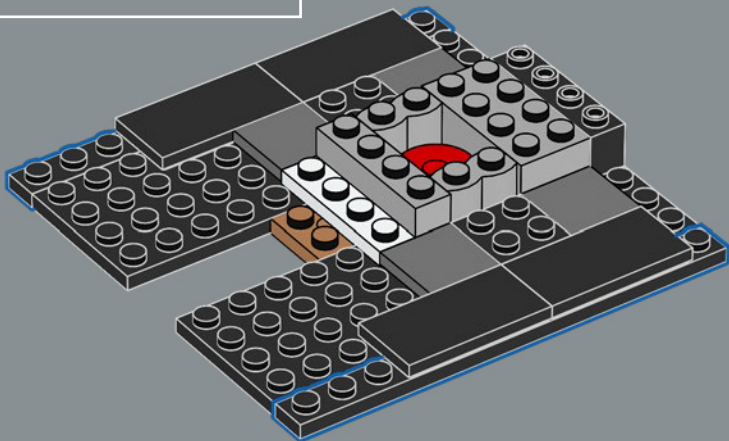

8

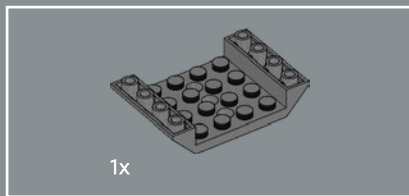
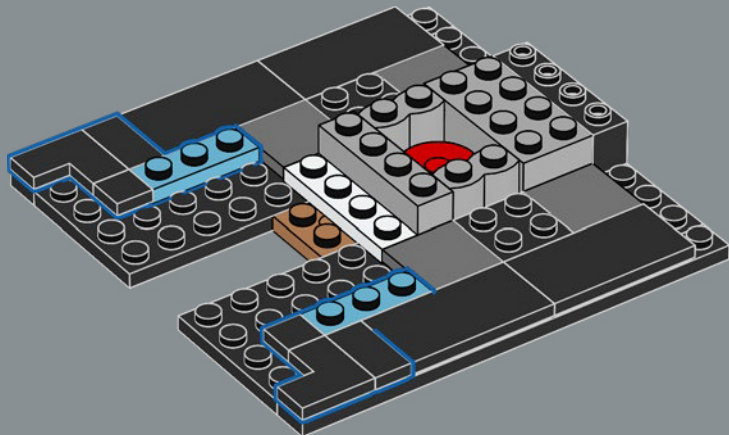

9

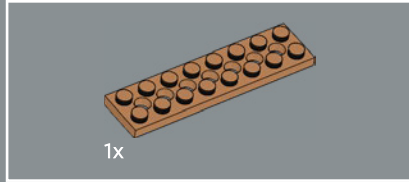
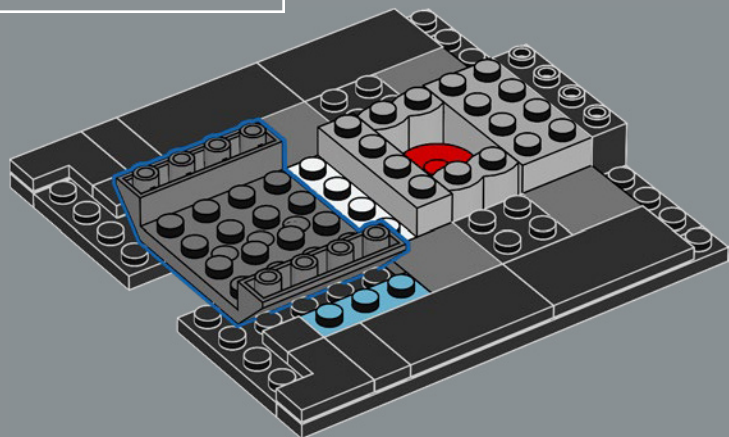

10

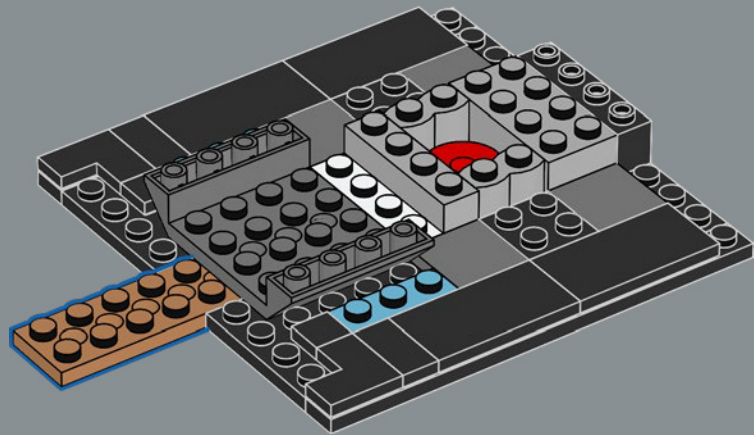

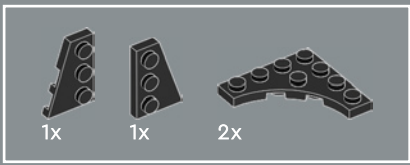

11

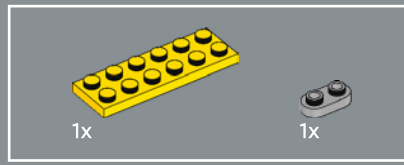
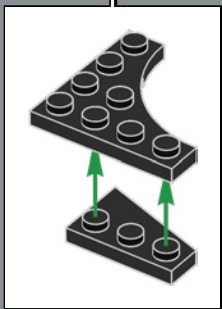
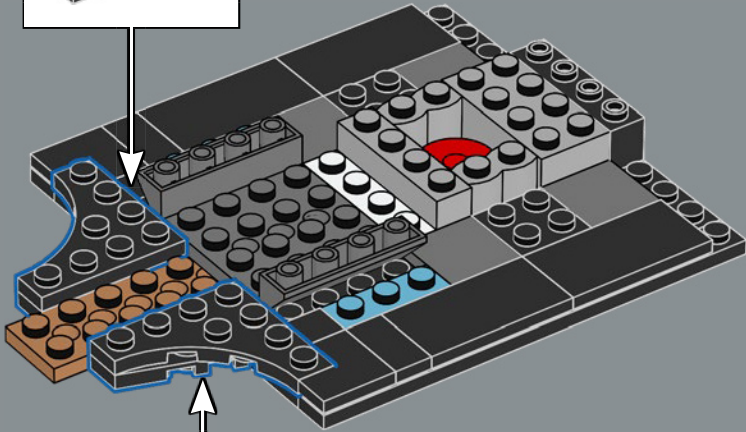
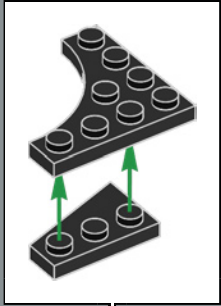

12

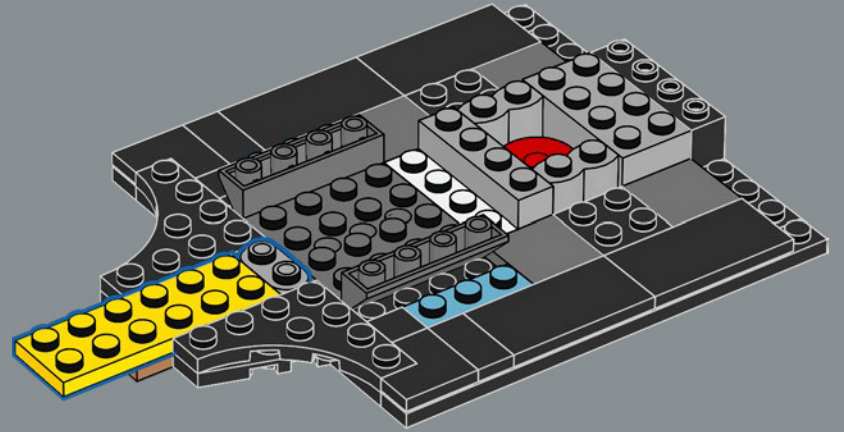

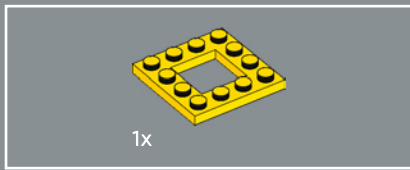

13

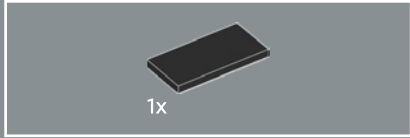
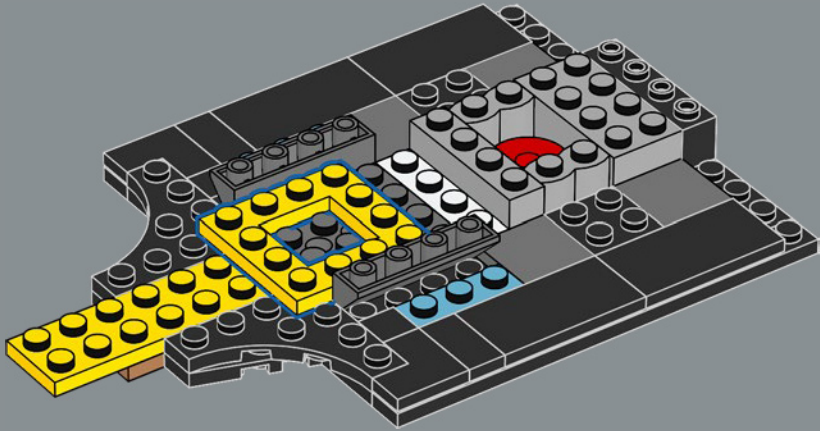

14

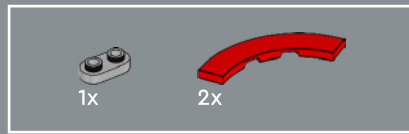
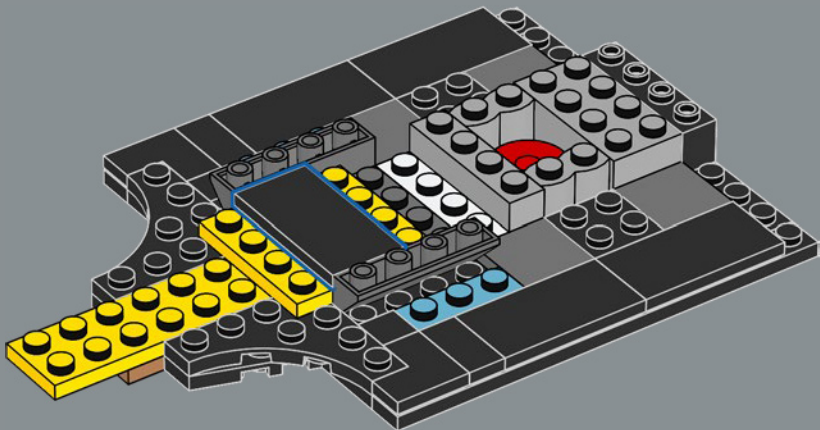

15

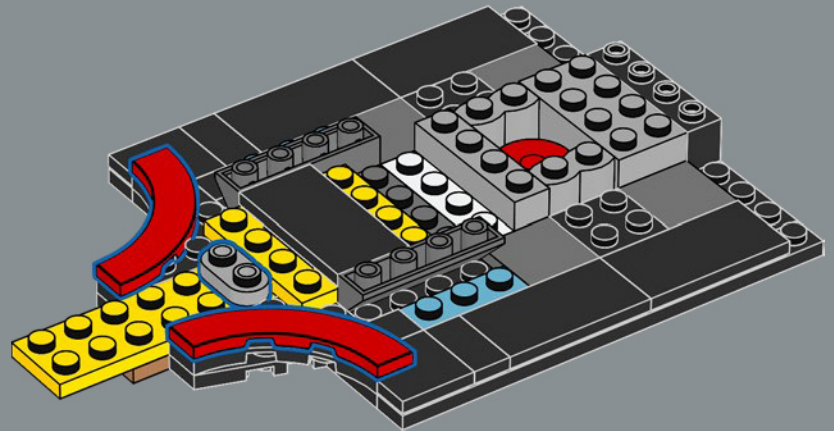



16

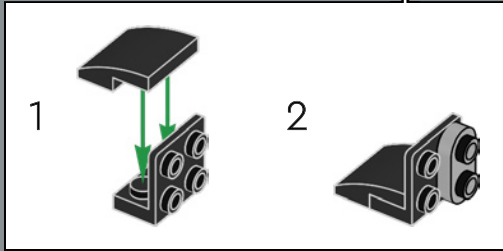
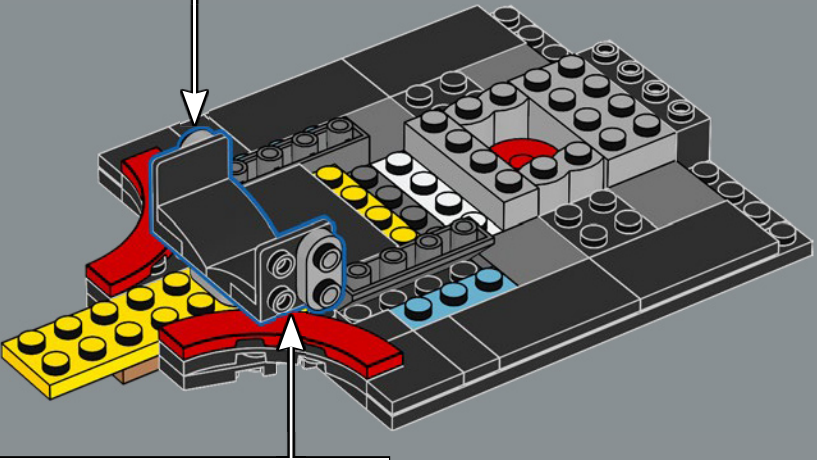
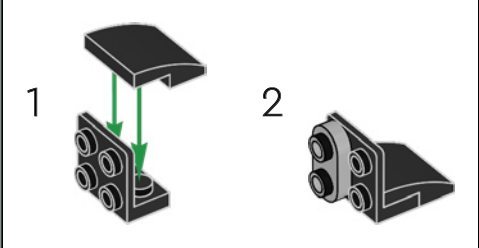

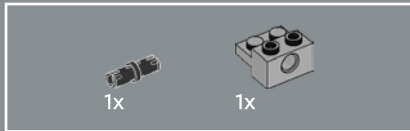
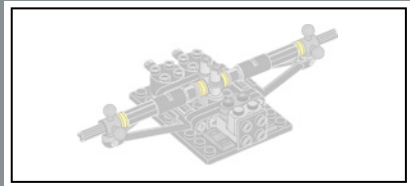

17

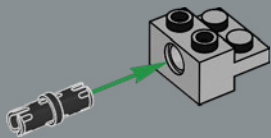

18

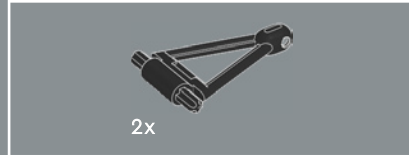
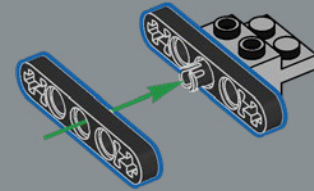

19

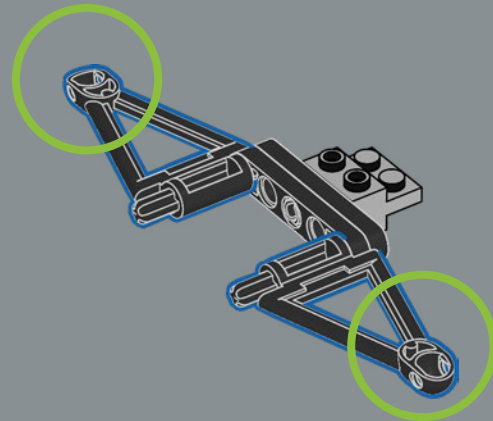



20

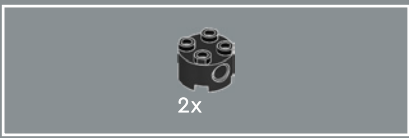
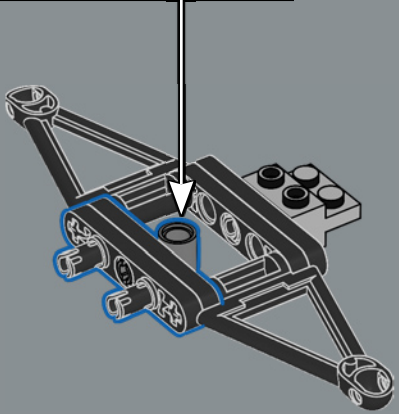
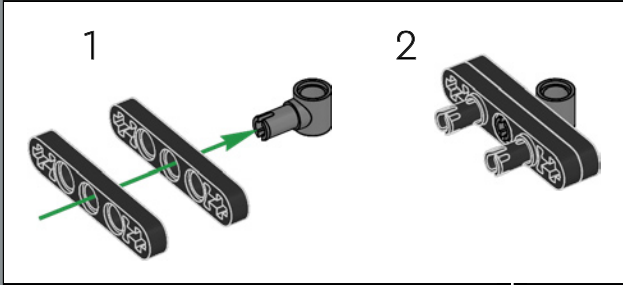

21

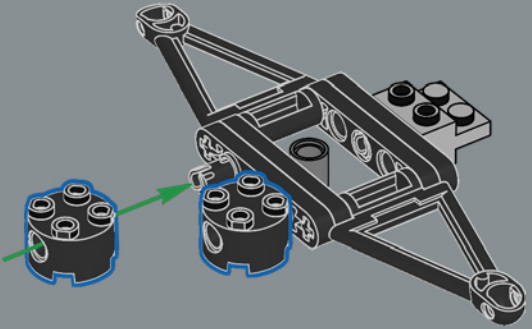

22

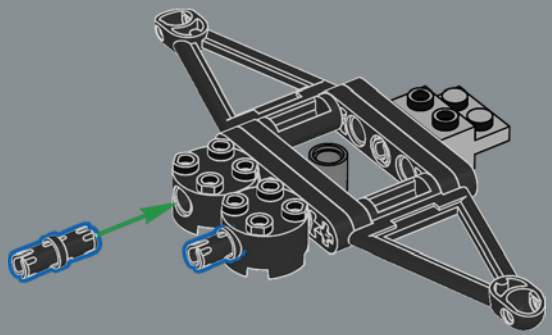

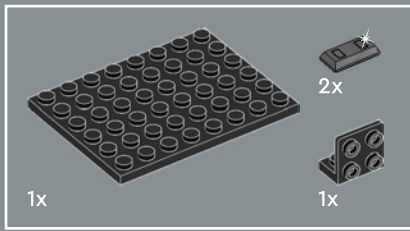

23

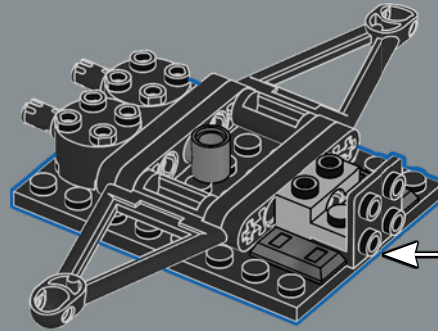
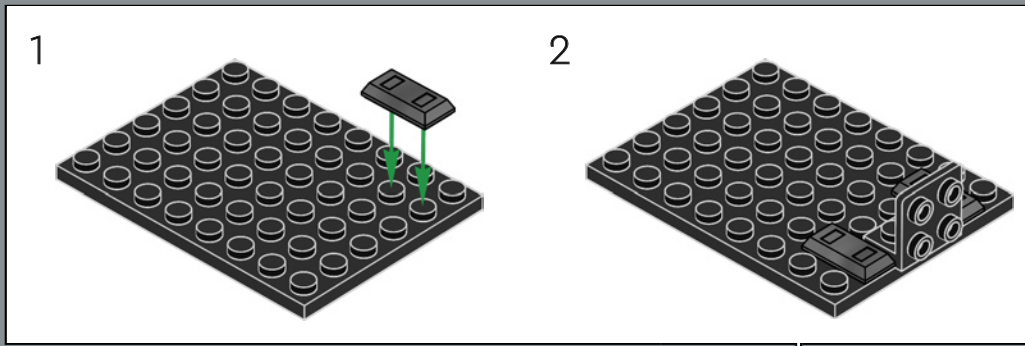

24

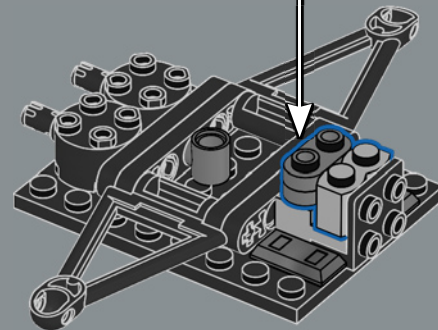
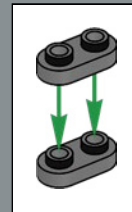

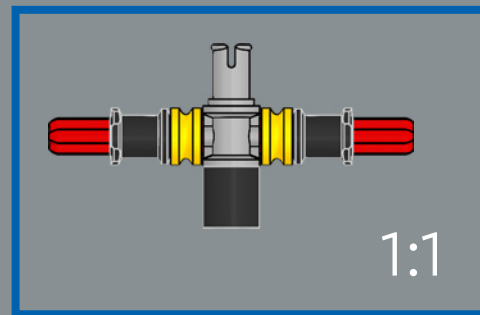
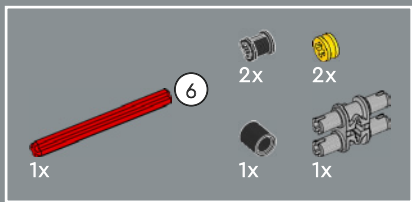

25

1

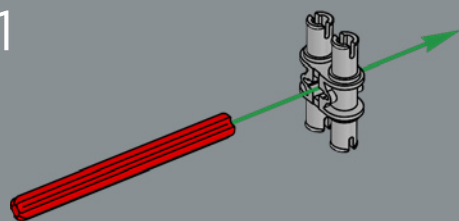

2

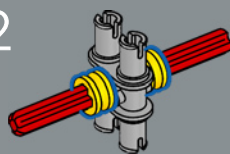

3

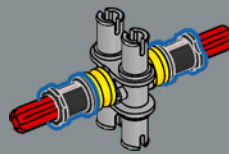

4

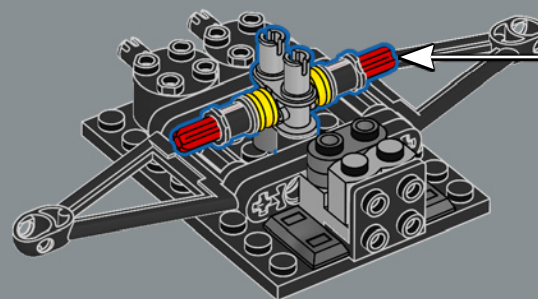
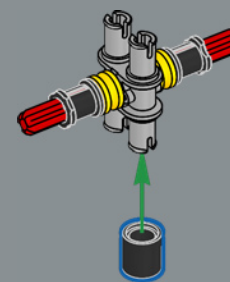

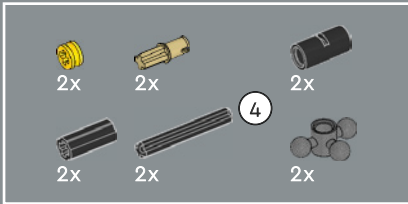
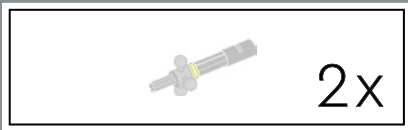

26

1

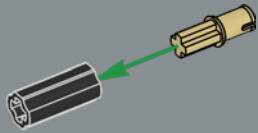

2

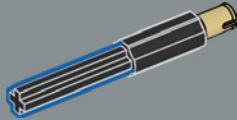

3

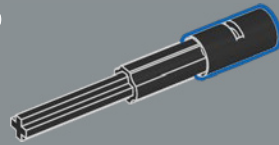

4

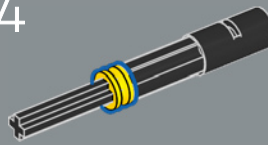

5

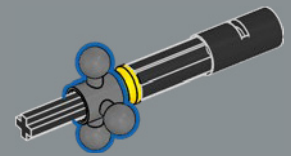

2x

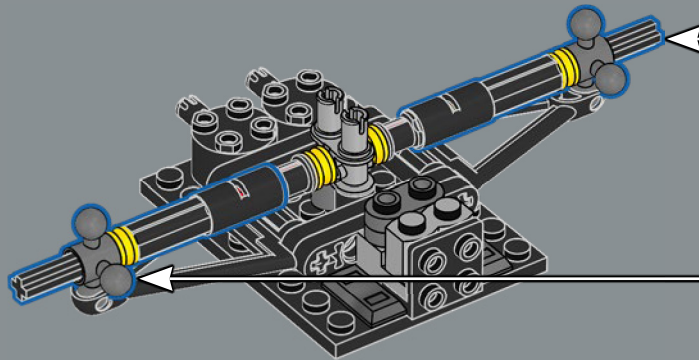

27

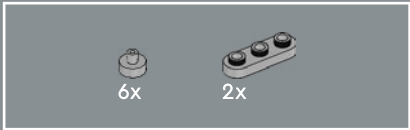
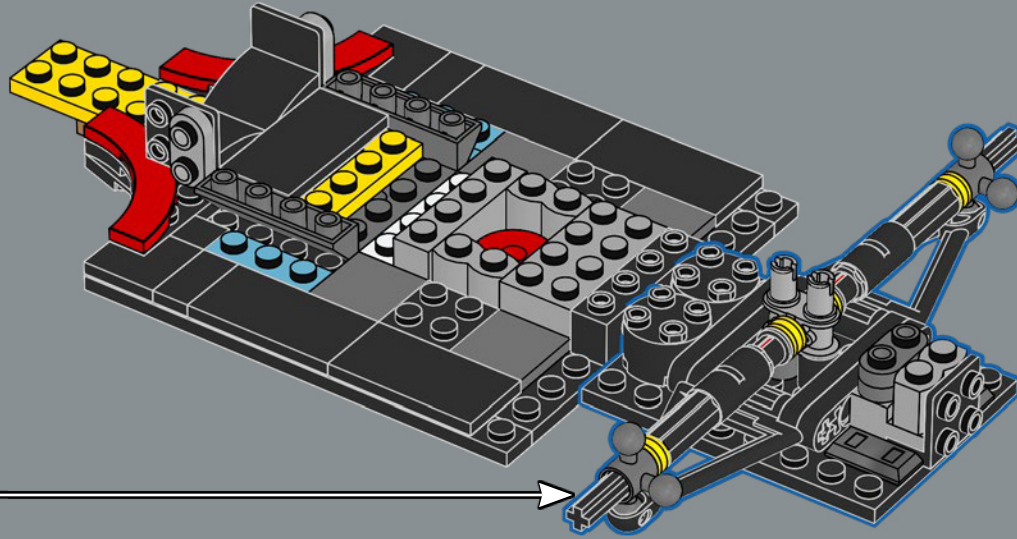

28

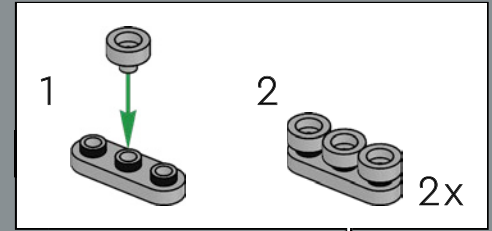
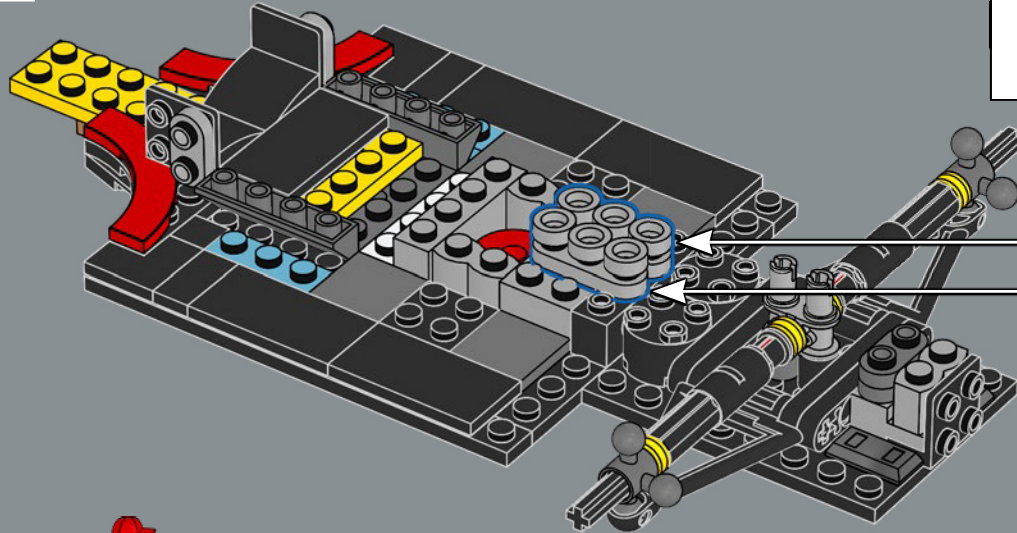

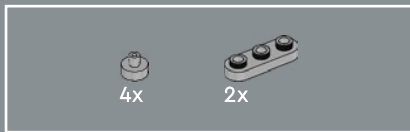

29

The 1x1 round plates with shafts are used here to represent the car's V10 engine. The V10 was used by all F1® teams between 1998 and 2005.

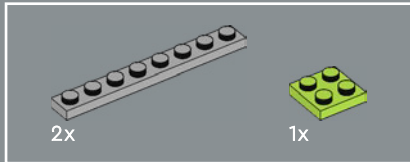
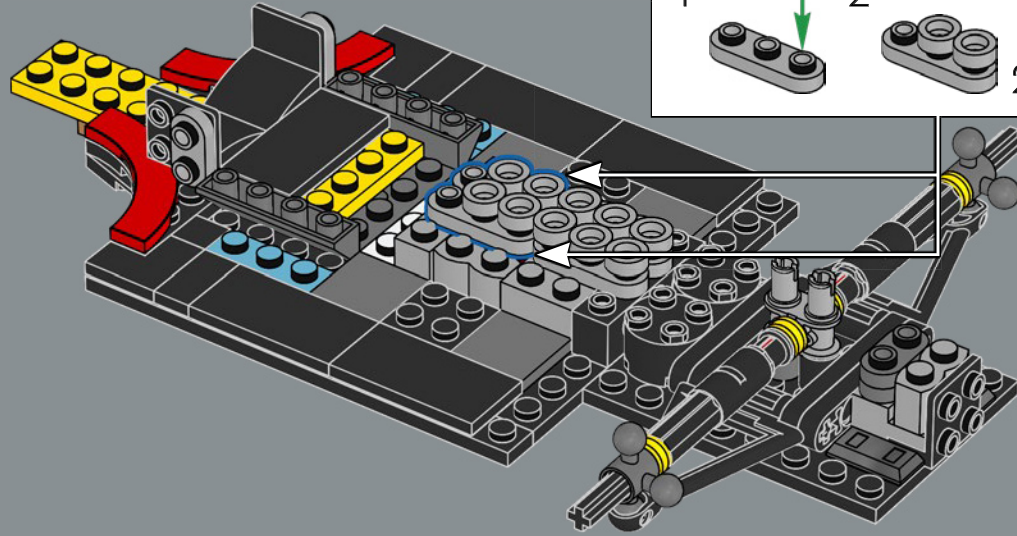
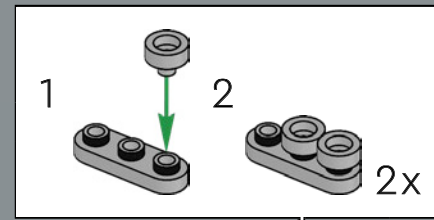

30

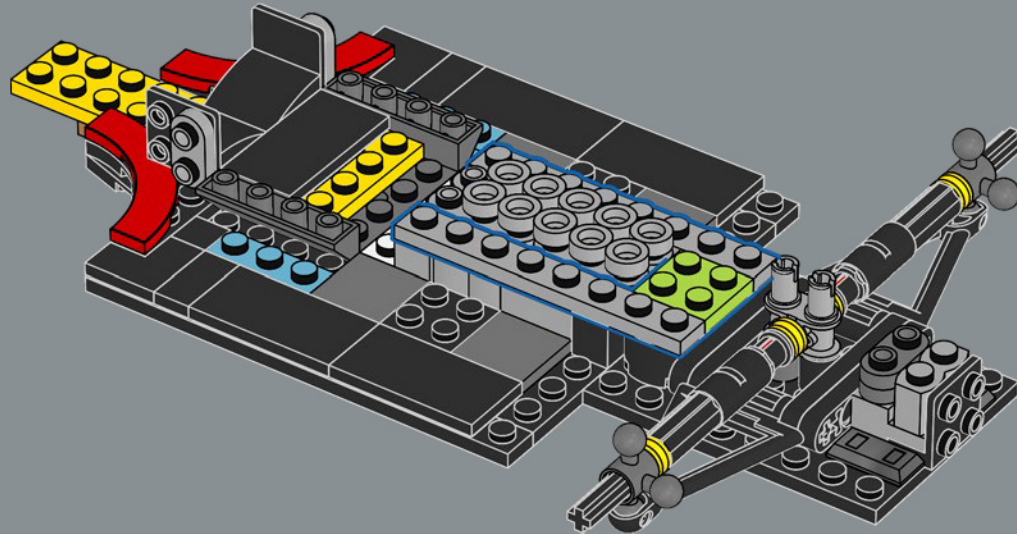

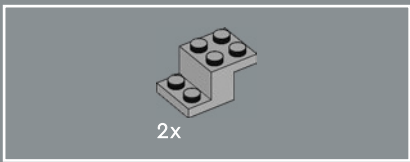

31

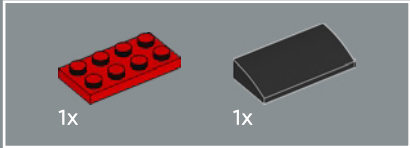
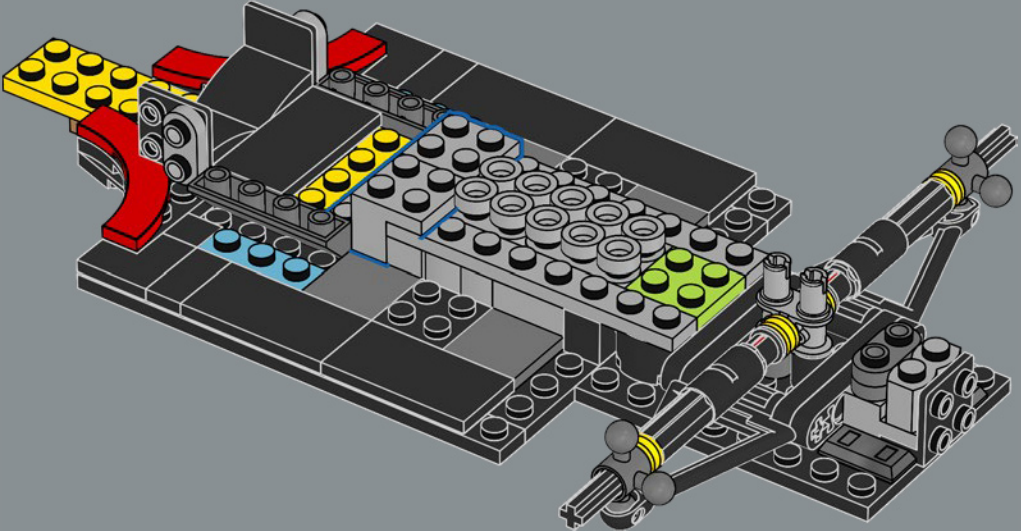

32

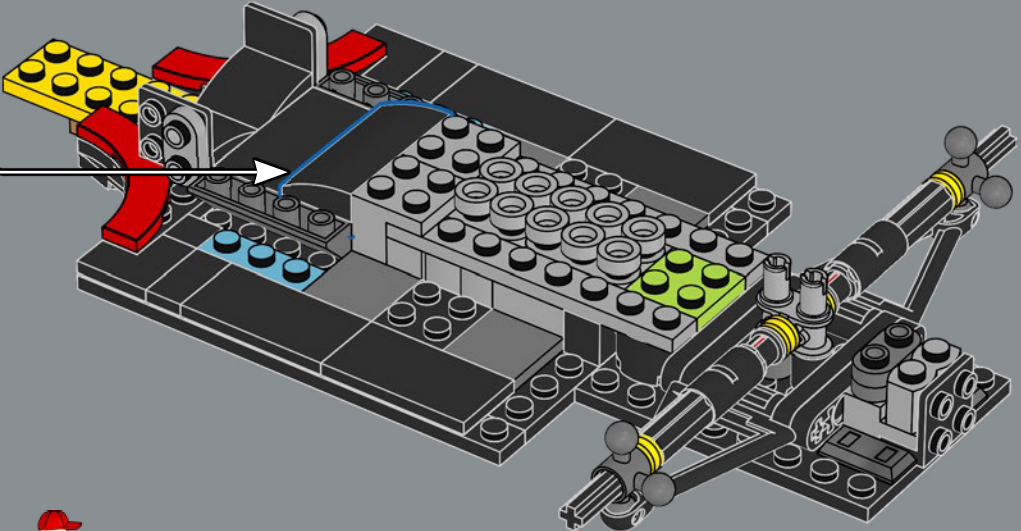
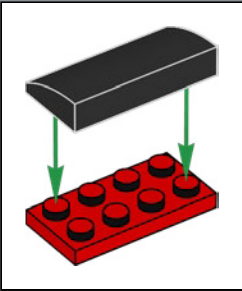

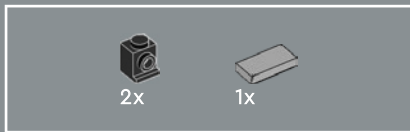

33

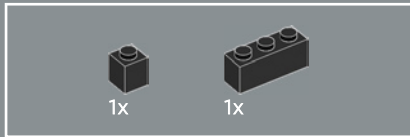
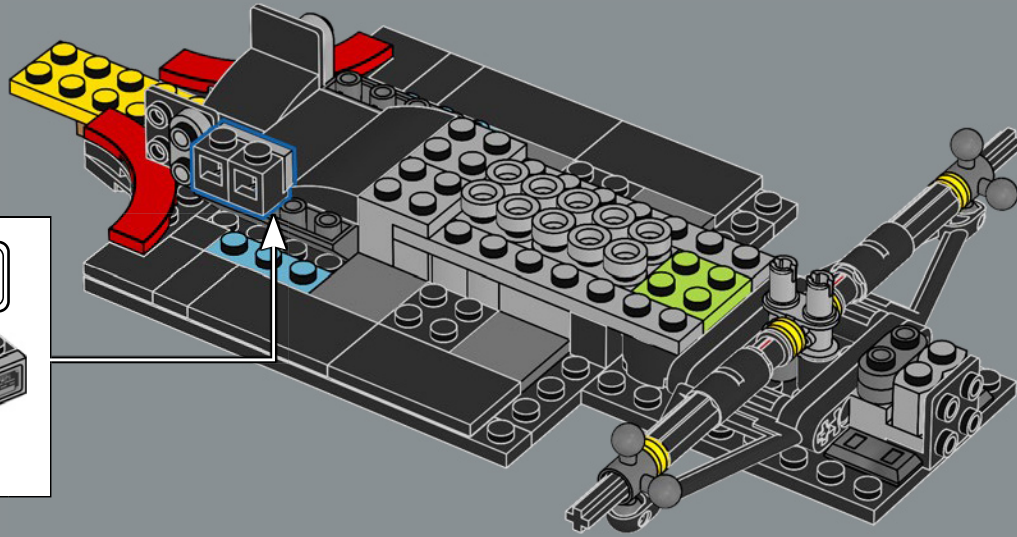
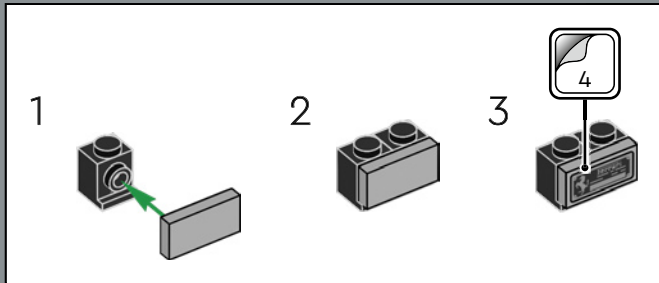

34

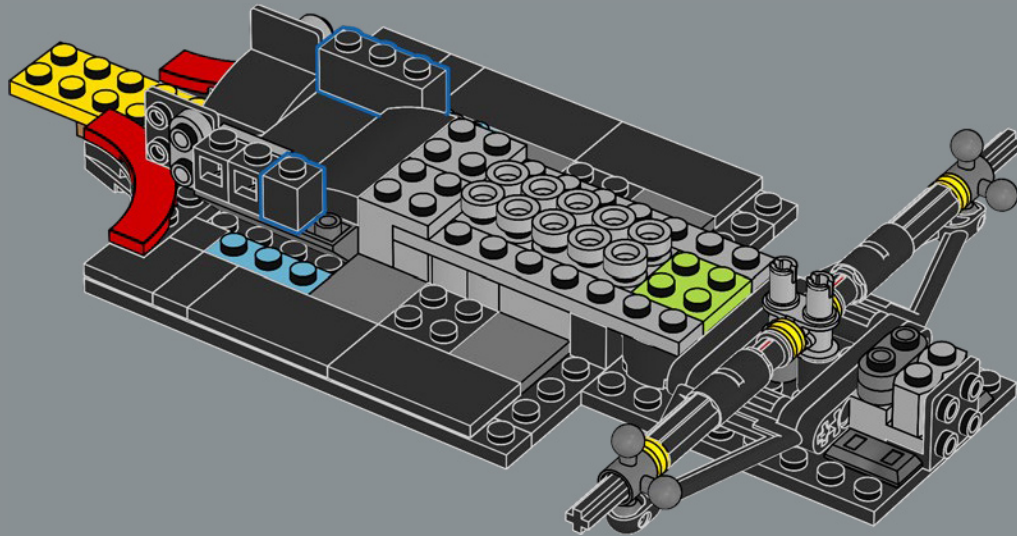

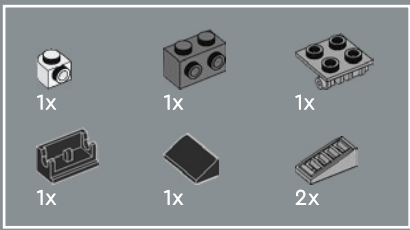

35

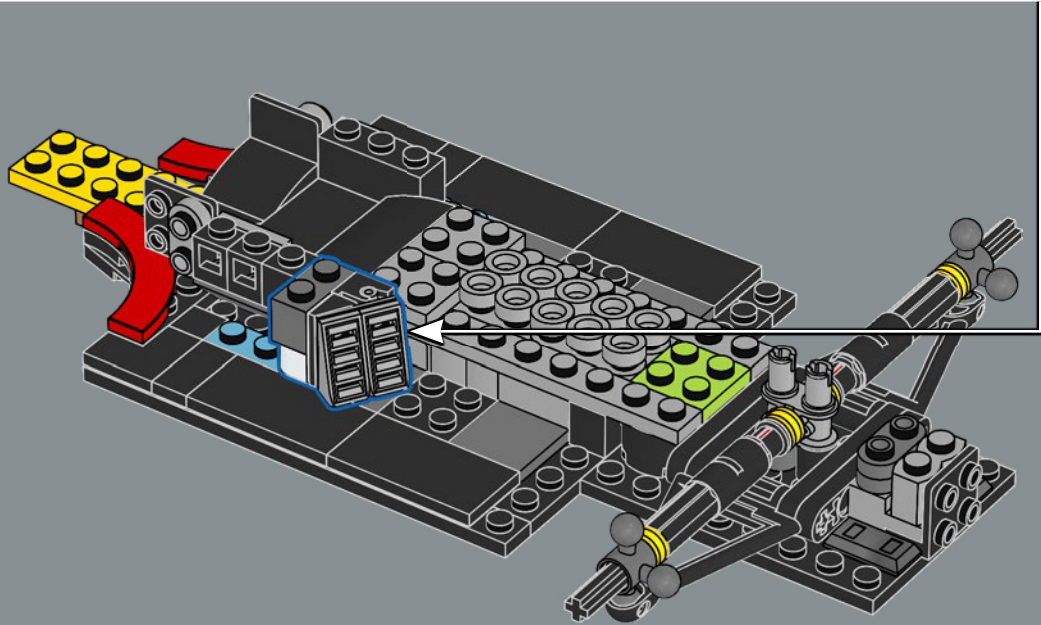
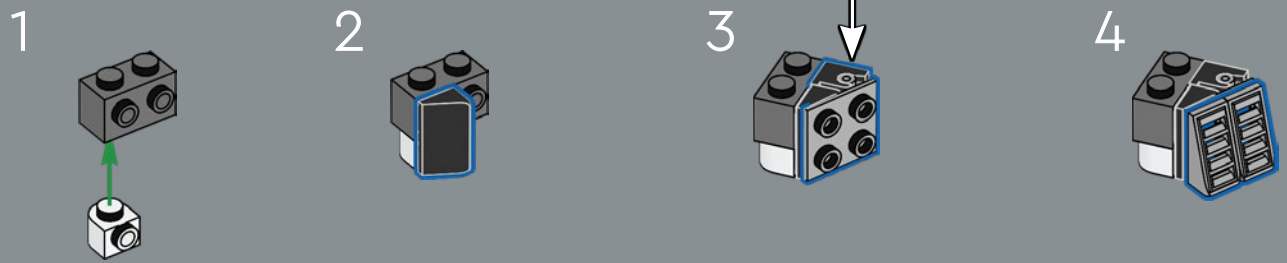
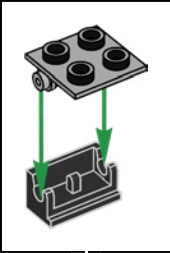

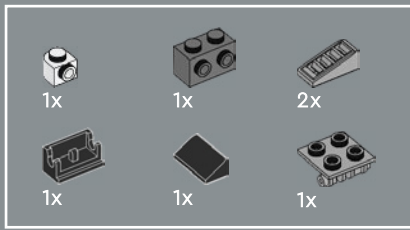

36

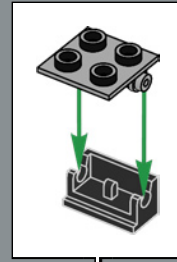

1

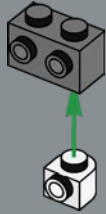

2

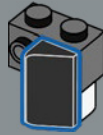

3



4

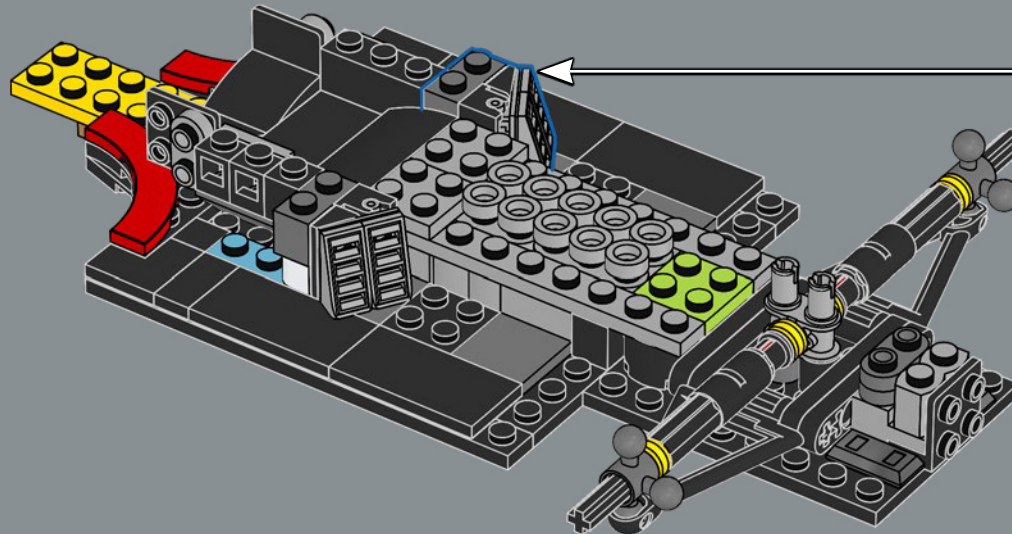

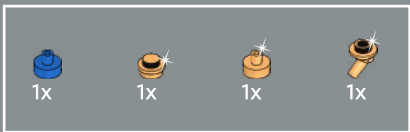

37

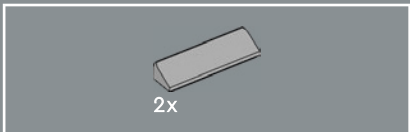
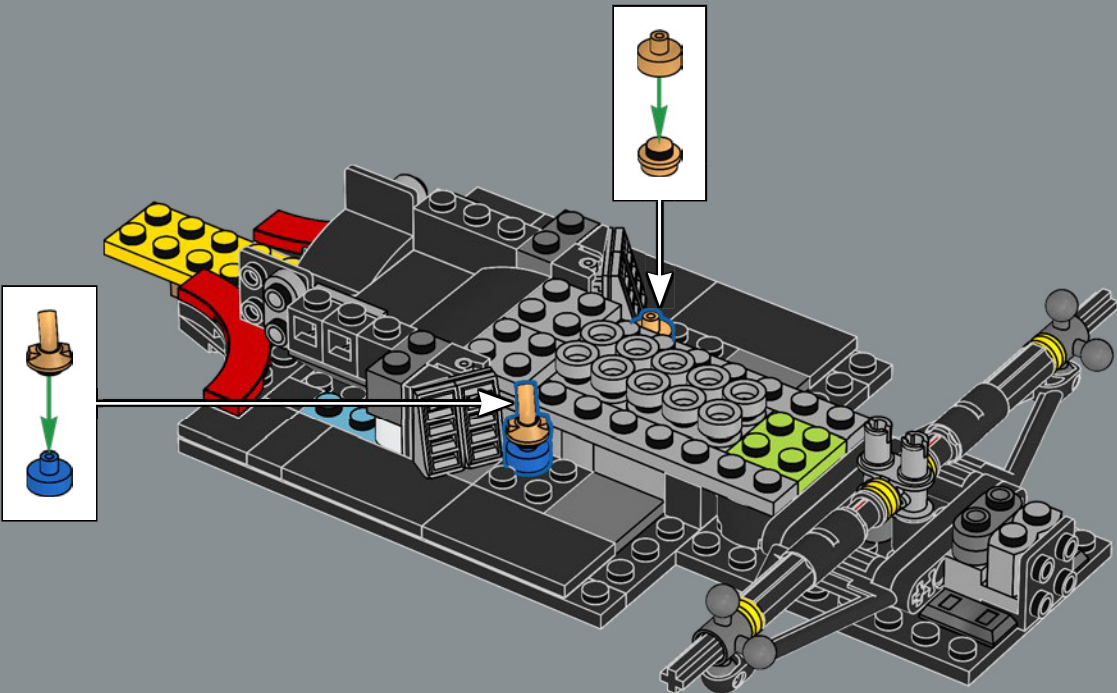

38

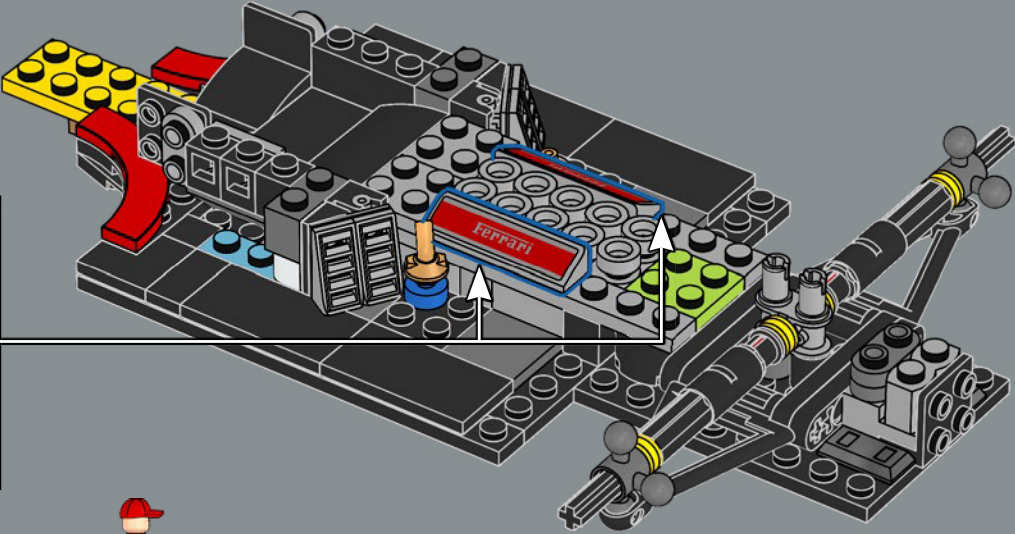
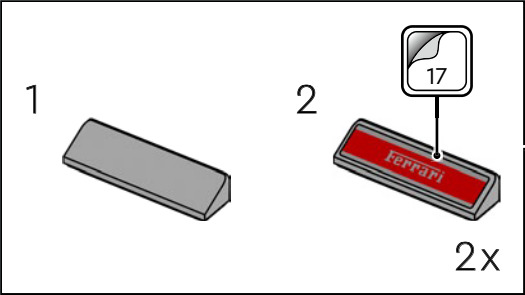

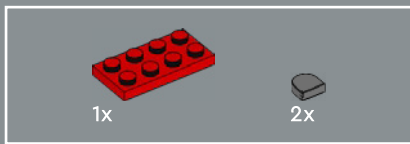

39

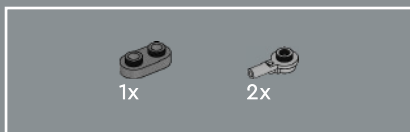
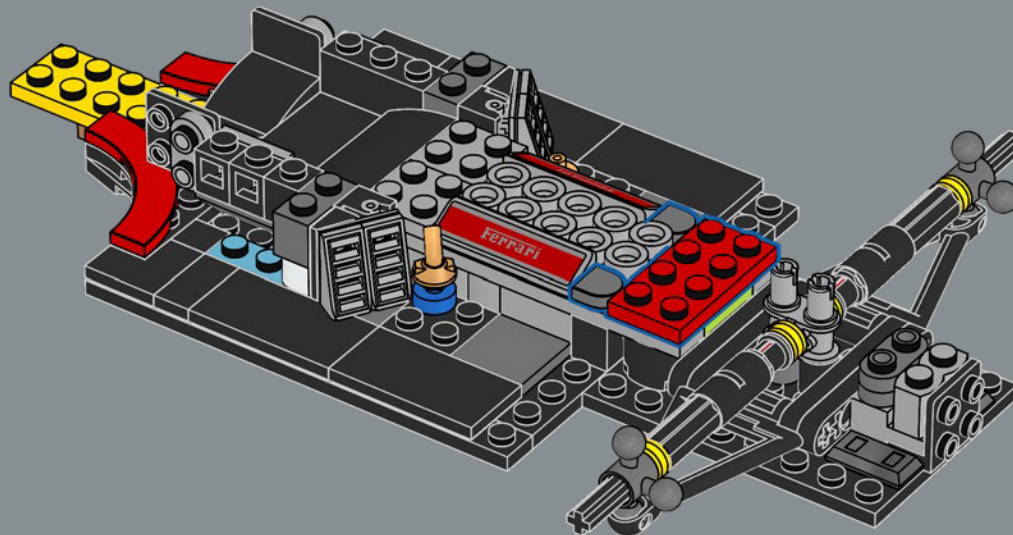

40

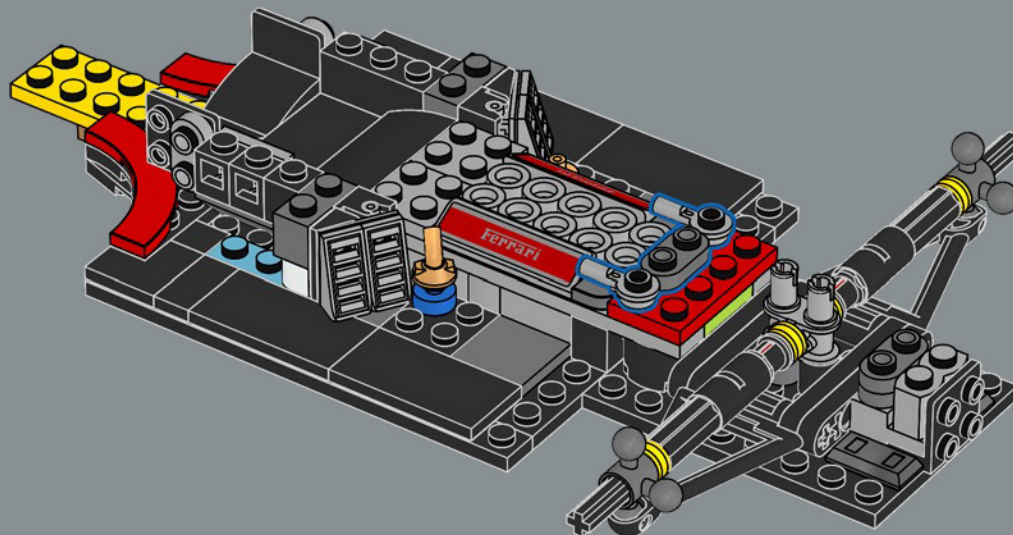



The F2004 engine was developed by Ferrari and had a maximum power of 636 kW (865 hp). It was designed to last an entire race weekend.



2x

41

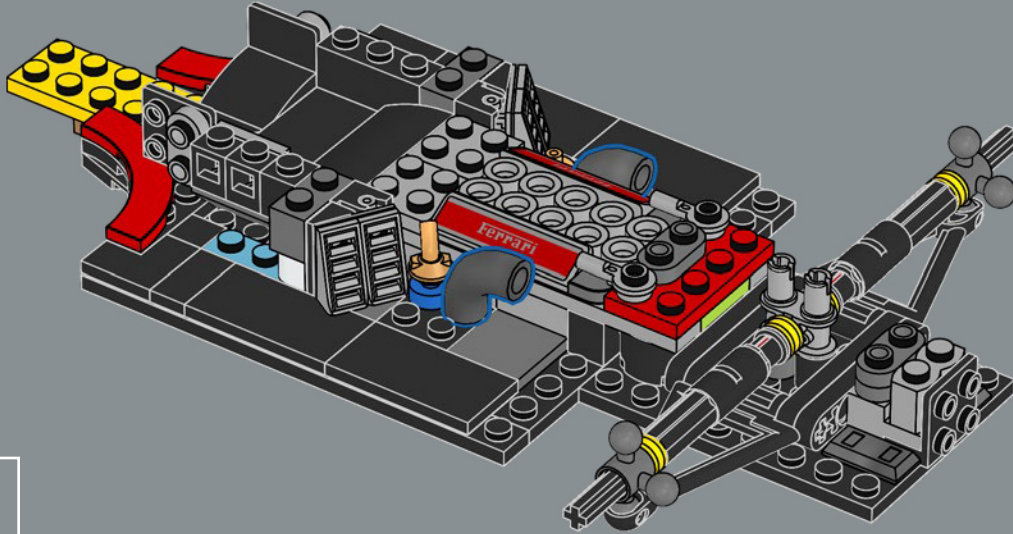

1x



1x

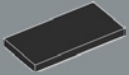

2x

42

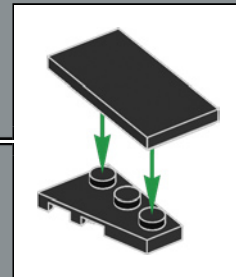
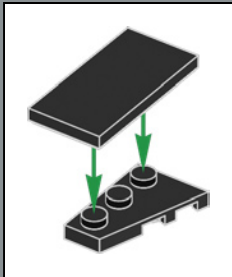
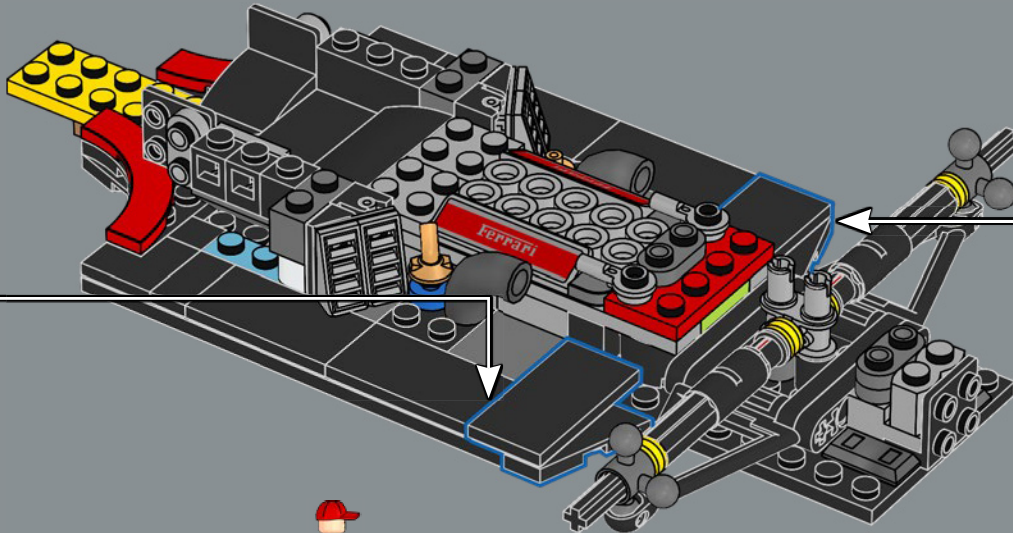

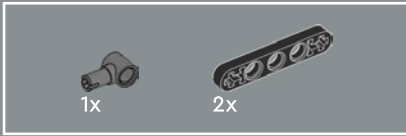
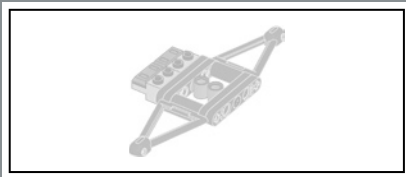

43

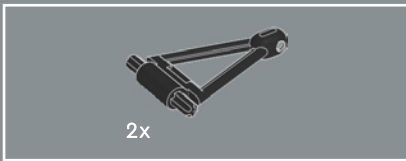
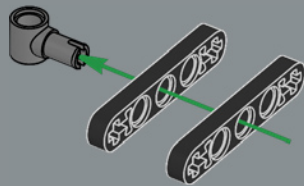

44

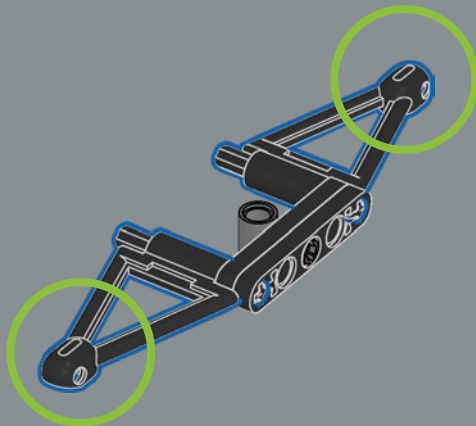

45

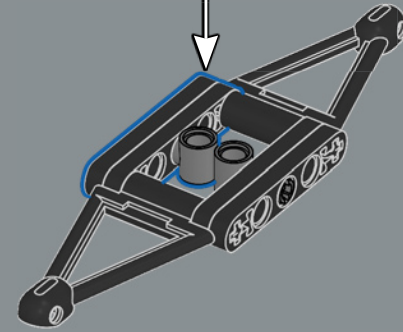
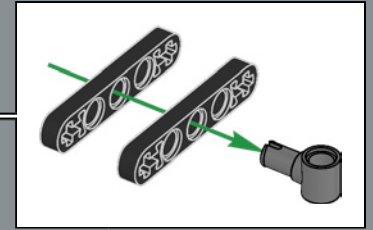

46

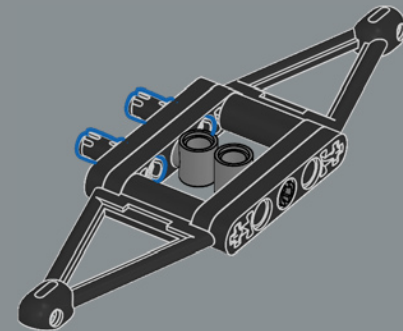

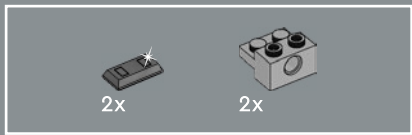

47

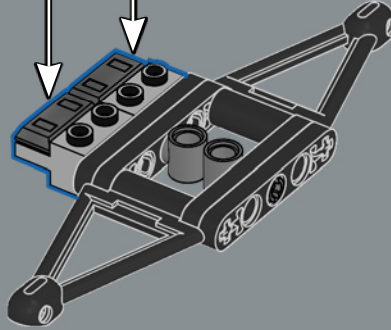
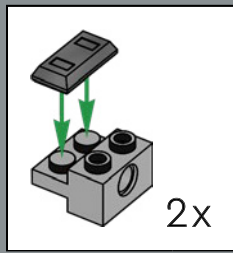

48

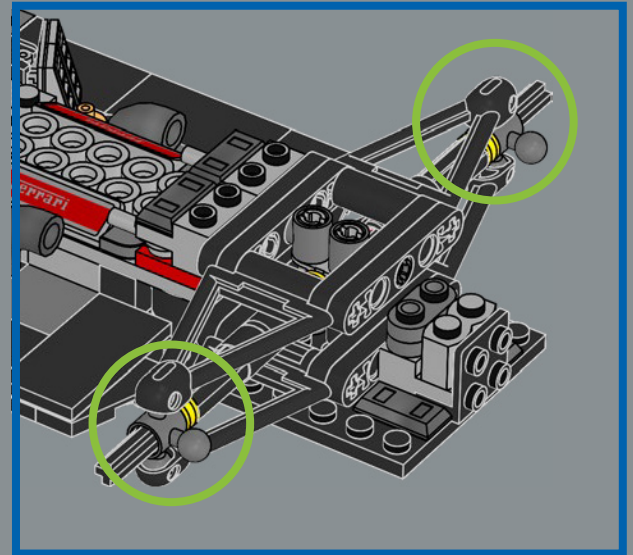
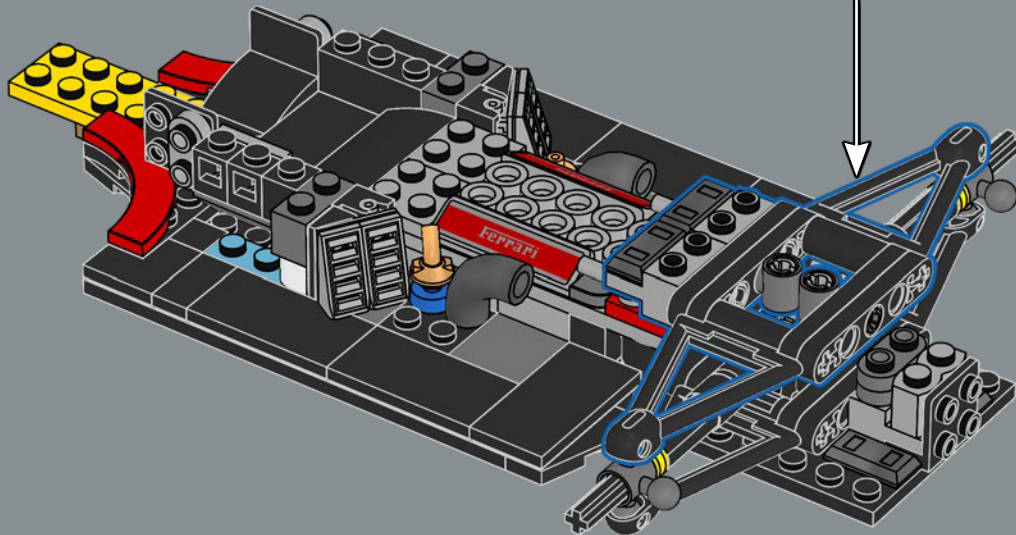

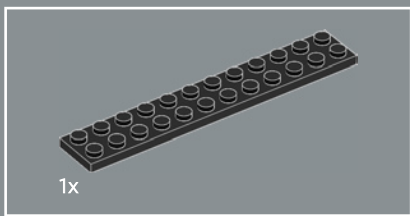

49

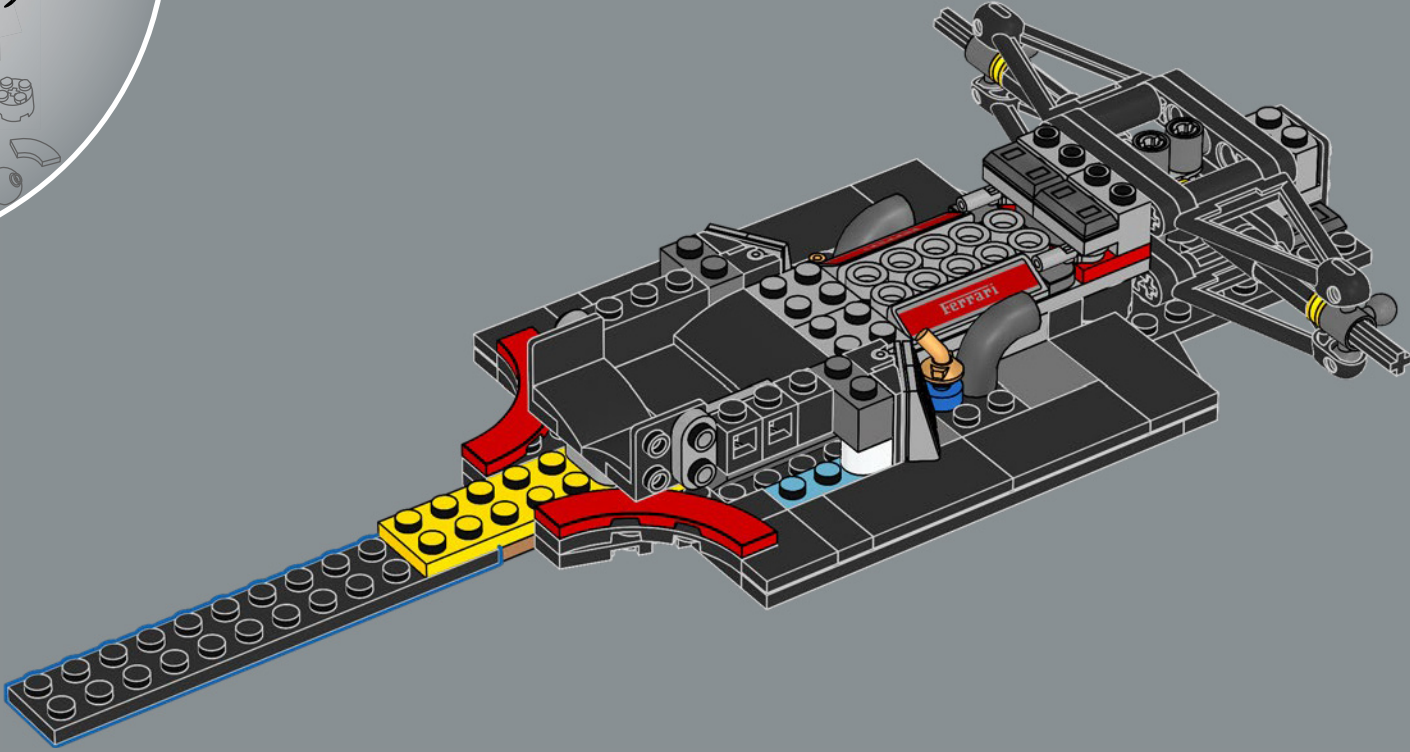

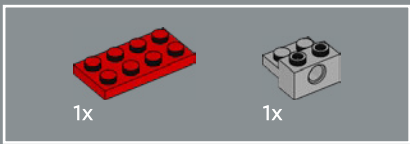

50

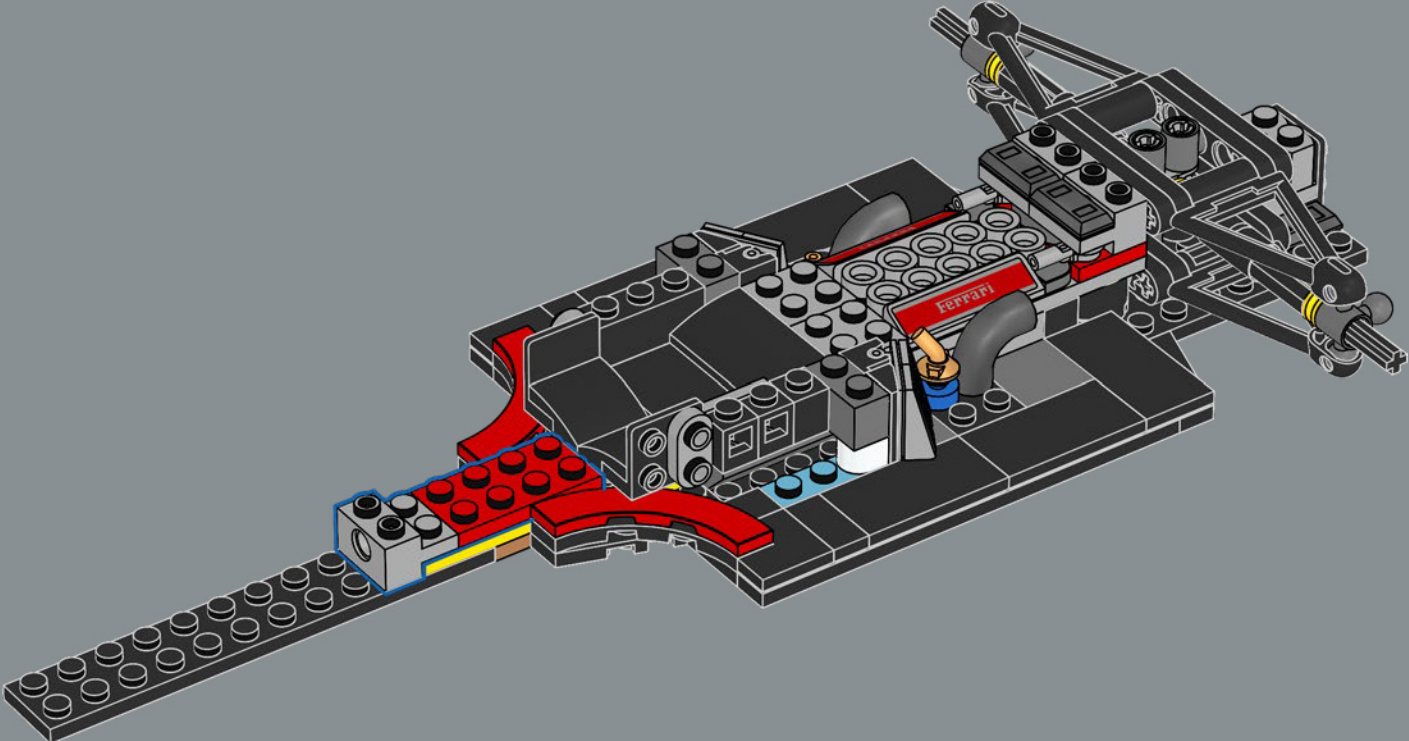



51

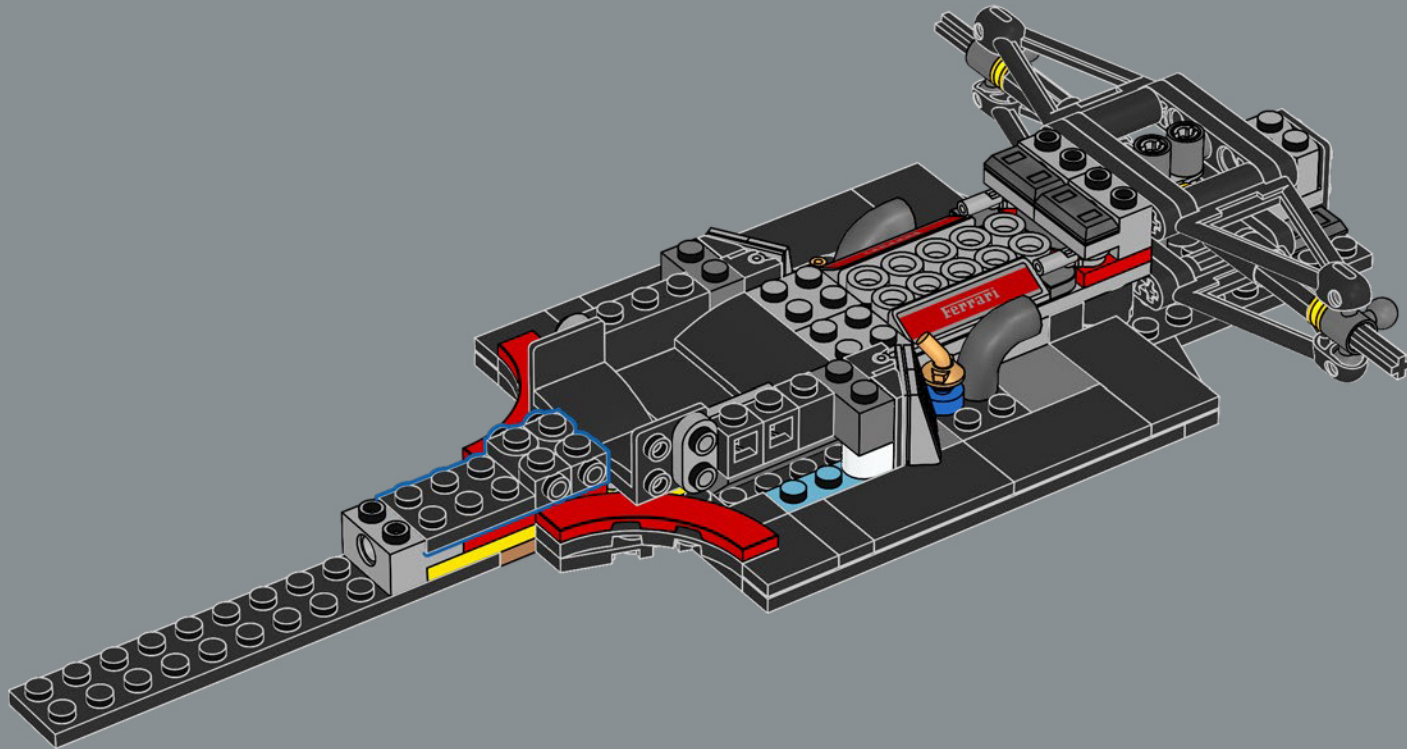

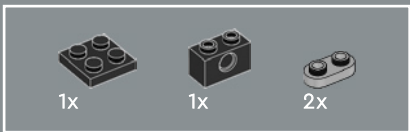

52

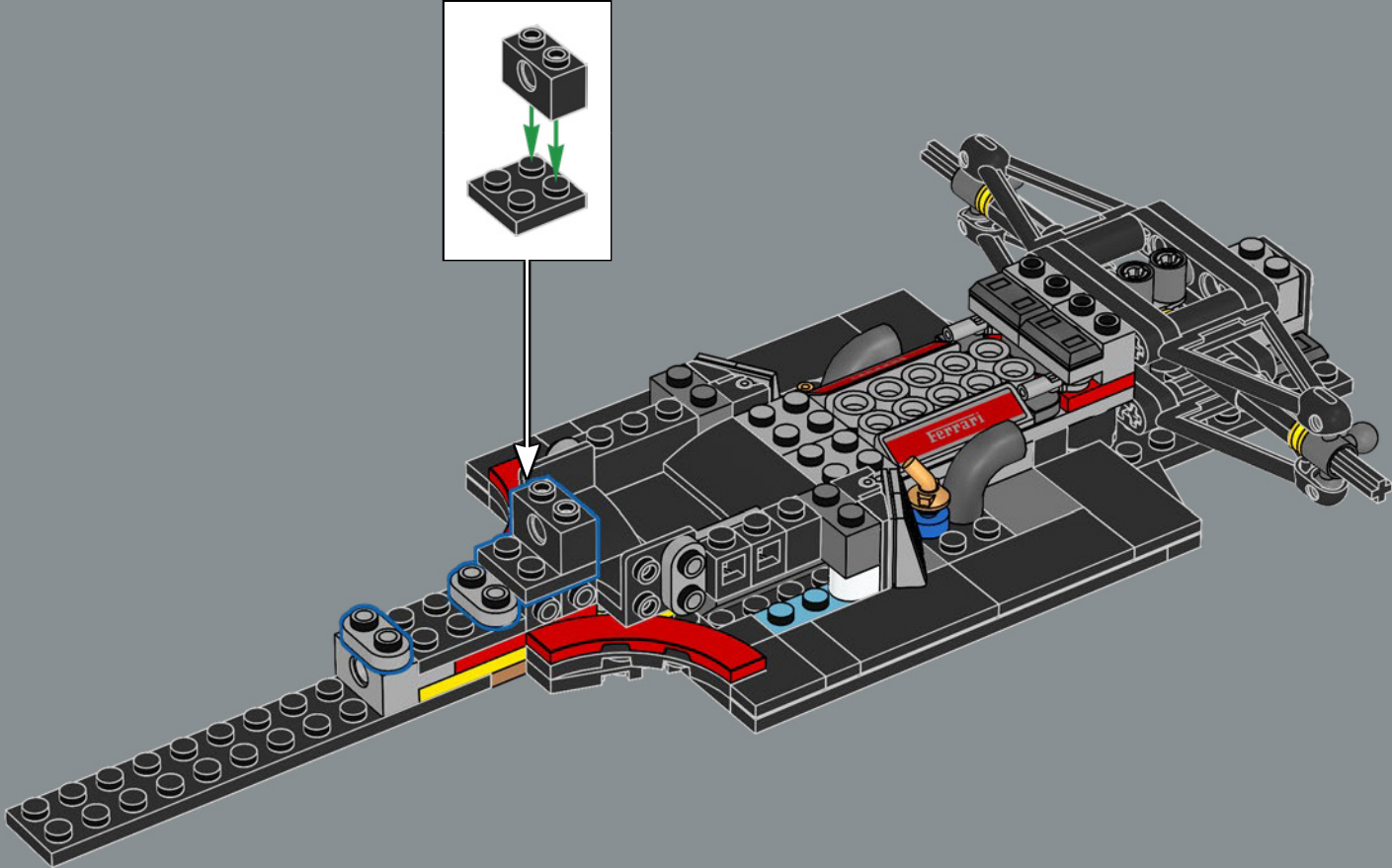

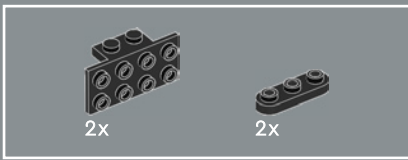

53

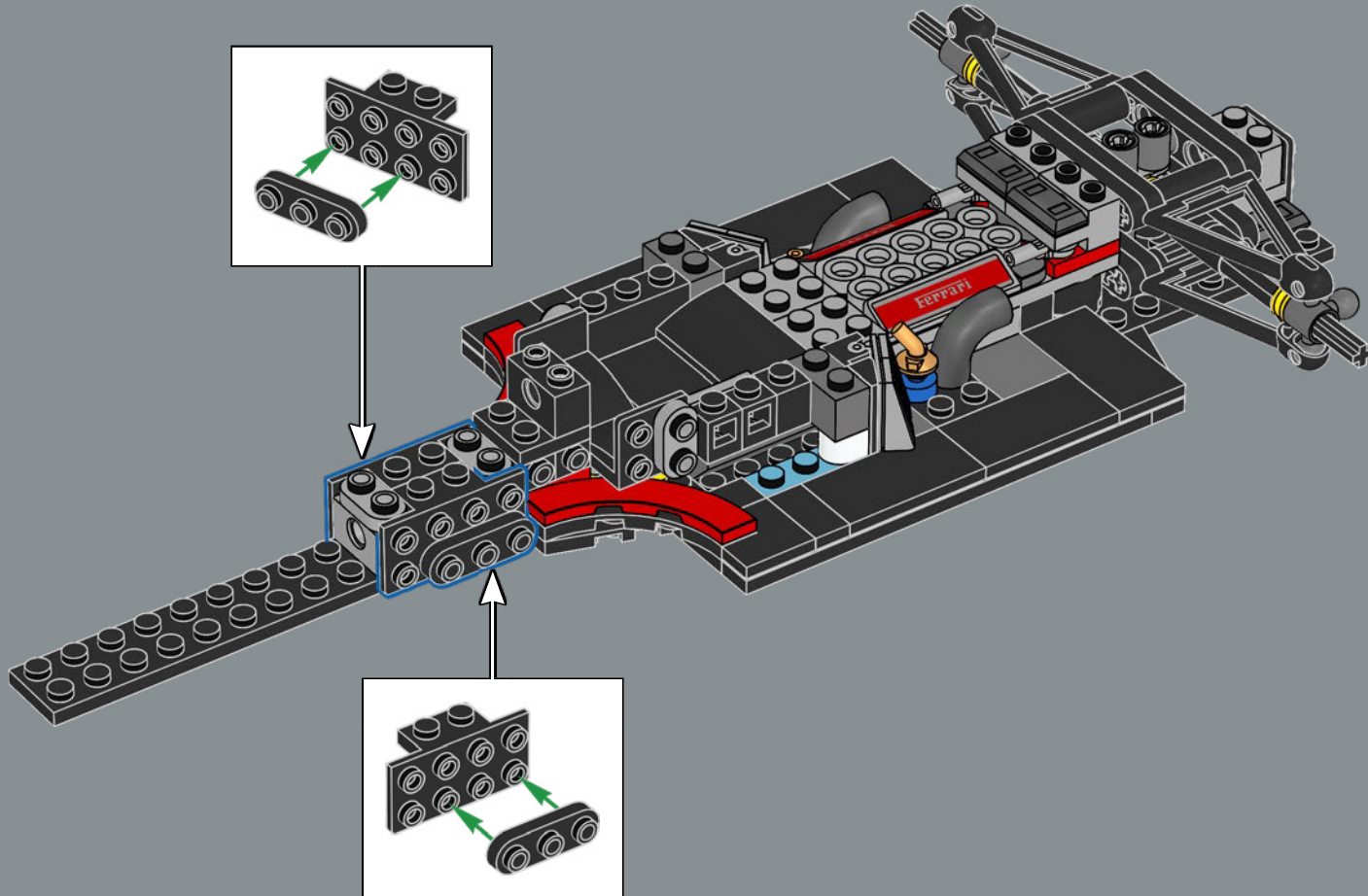



4x

54

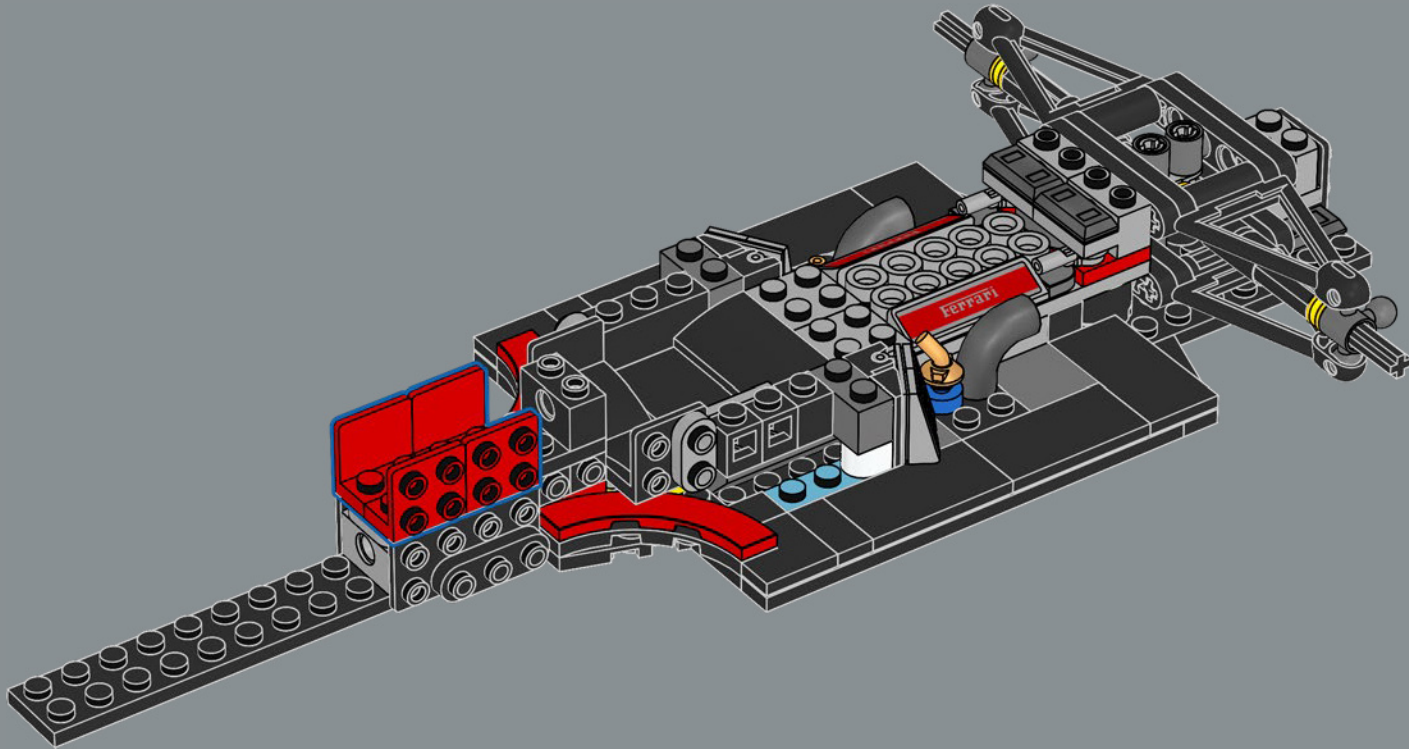

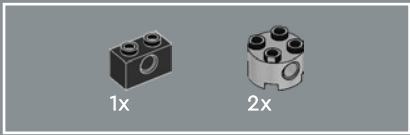

55

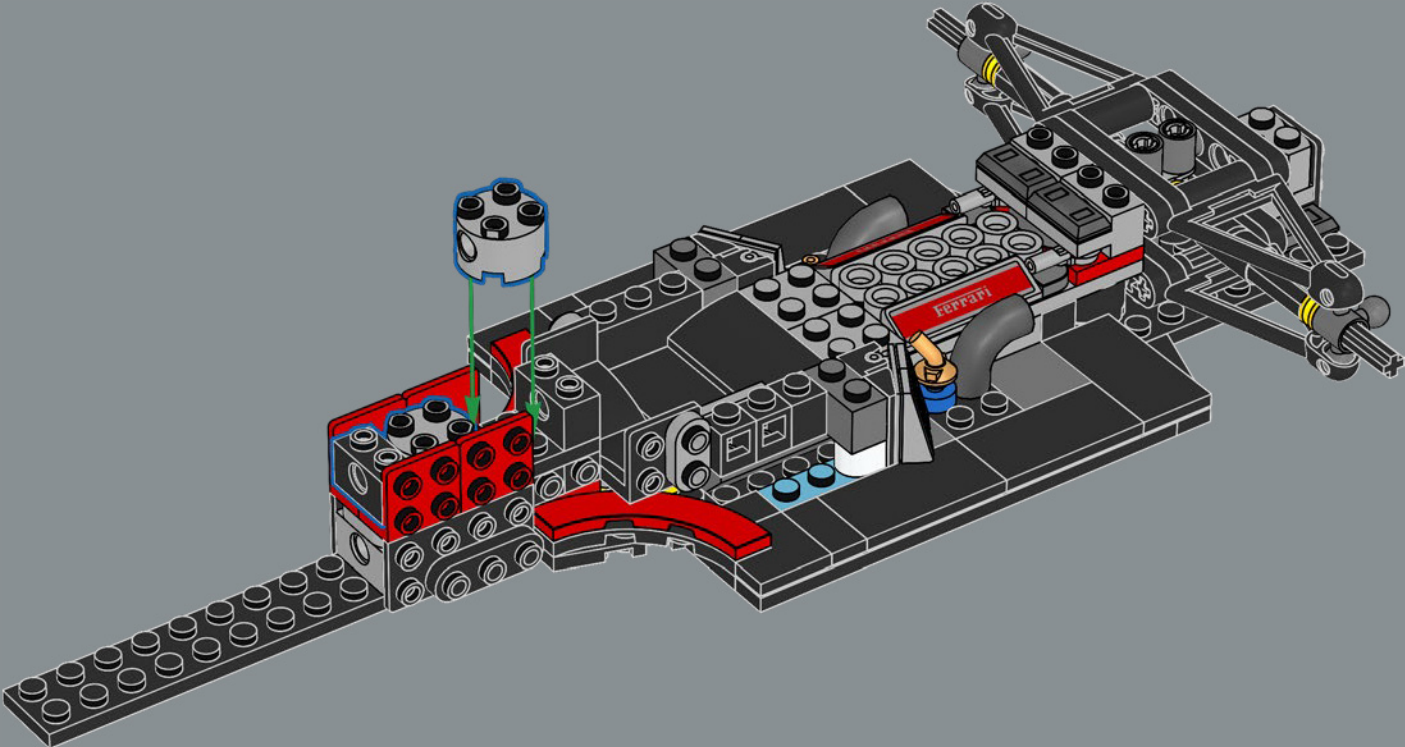

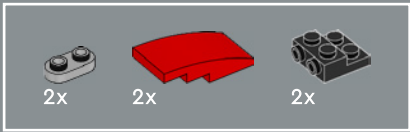

56

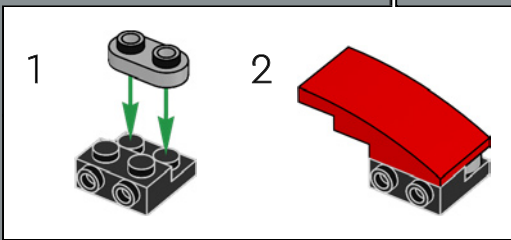
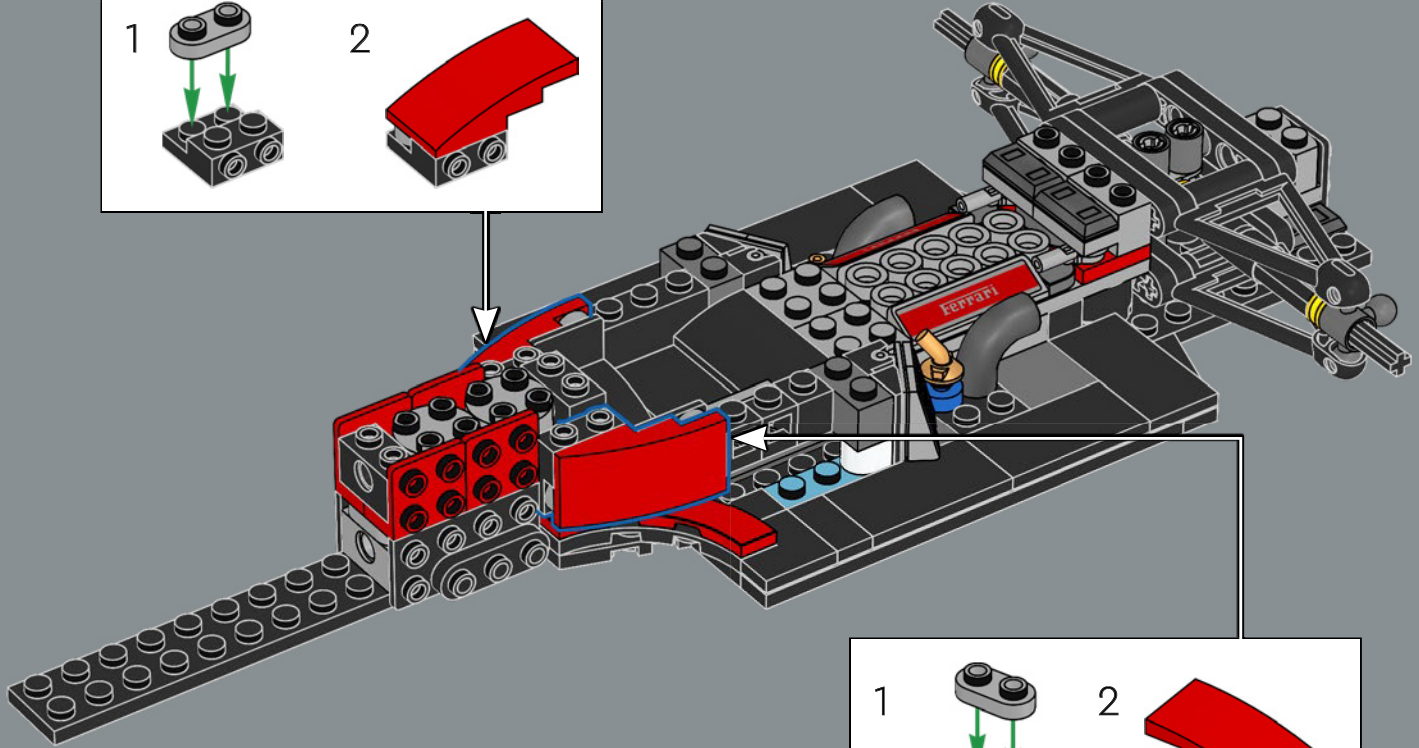
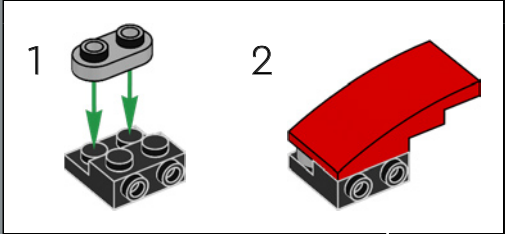

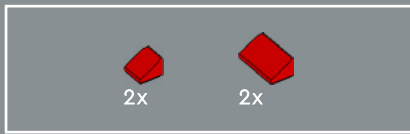

57

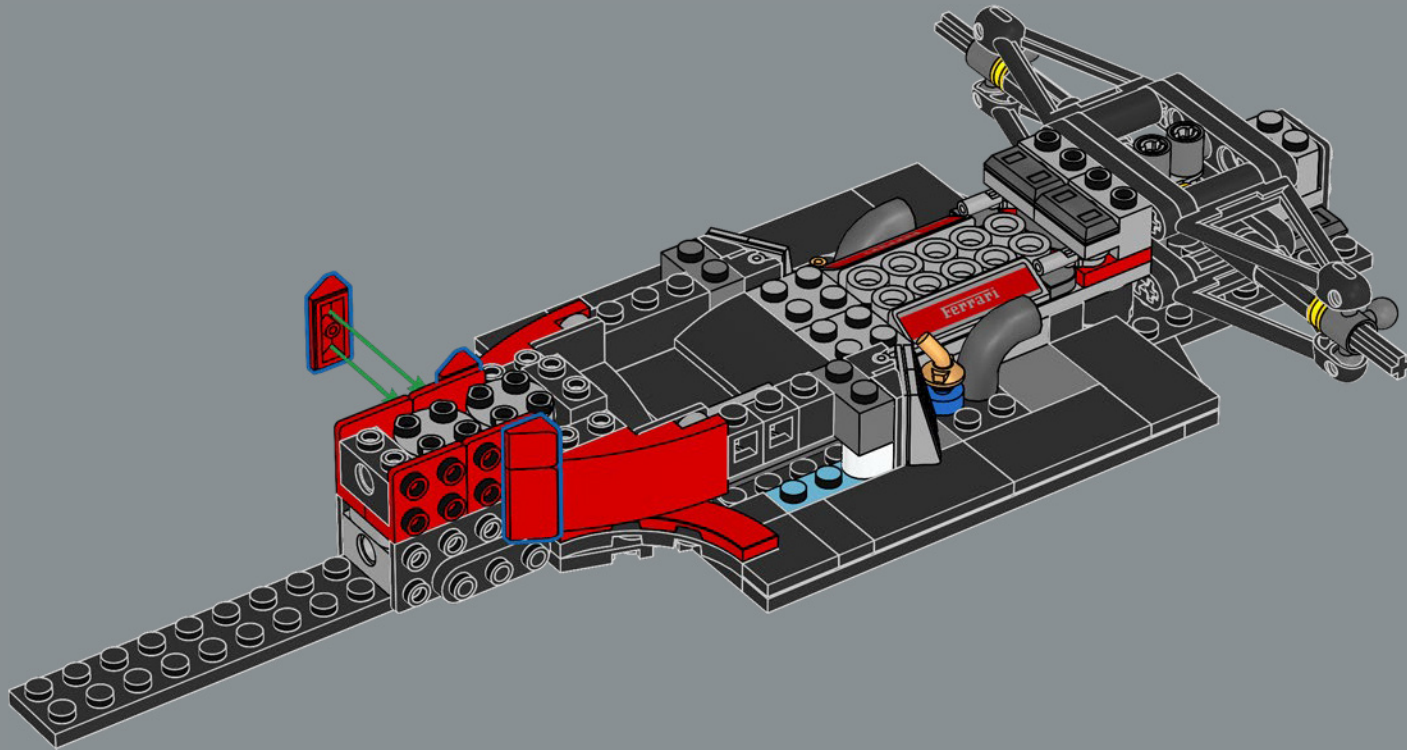

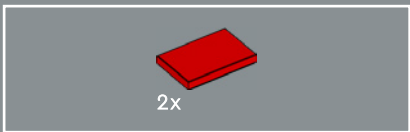

58

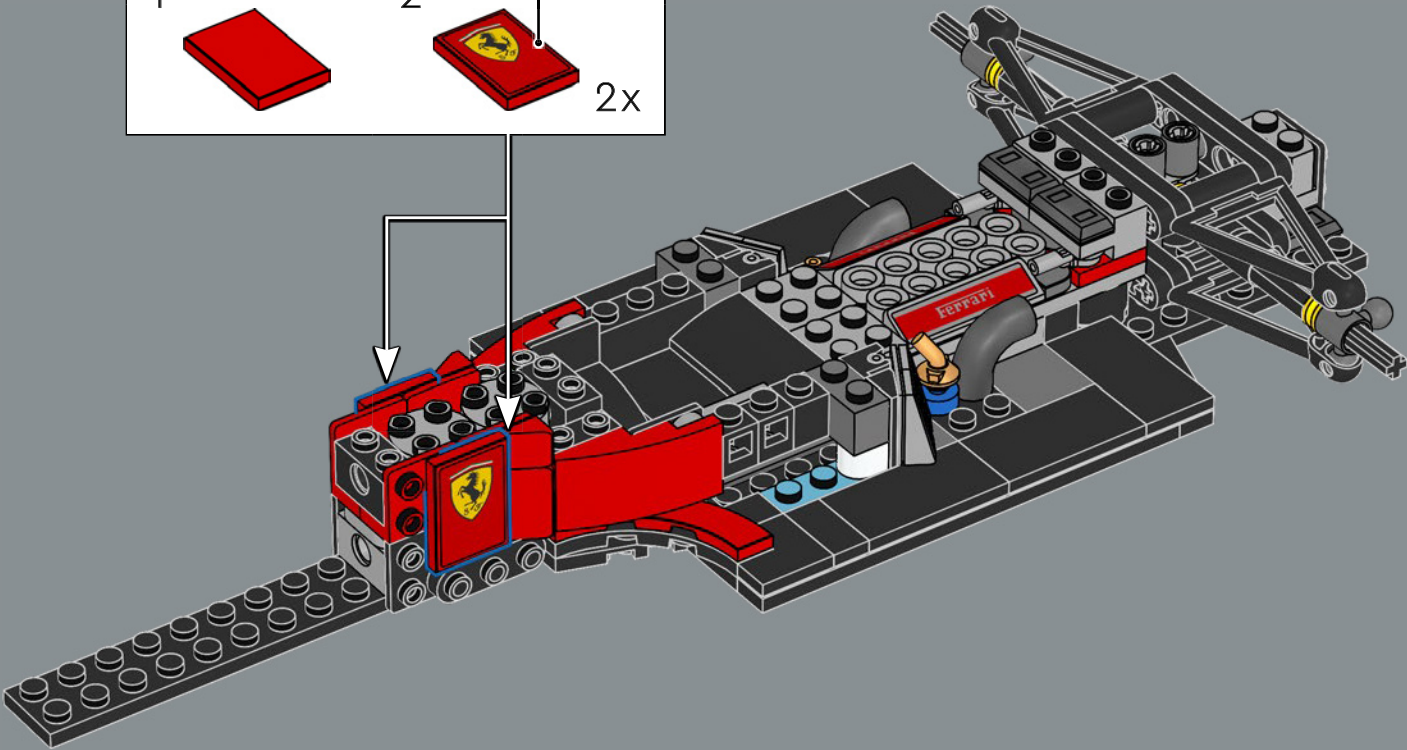
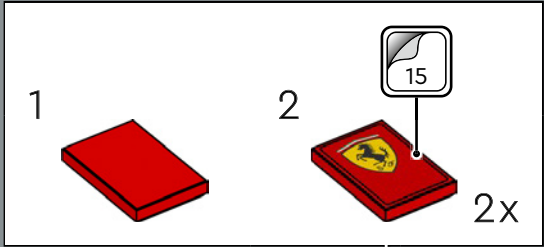

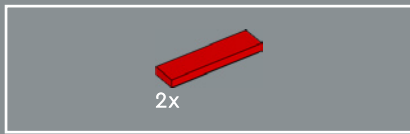

59

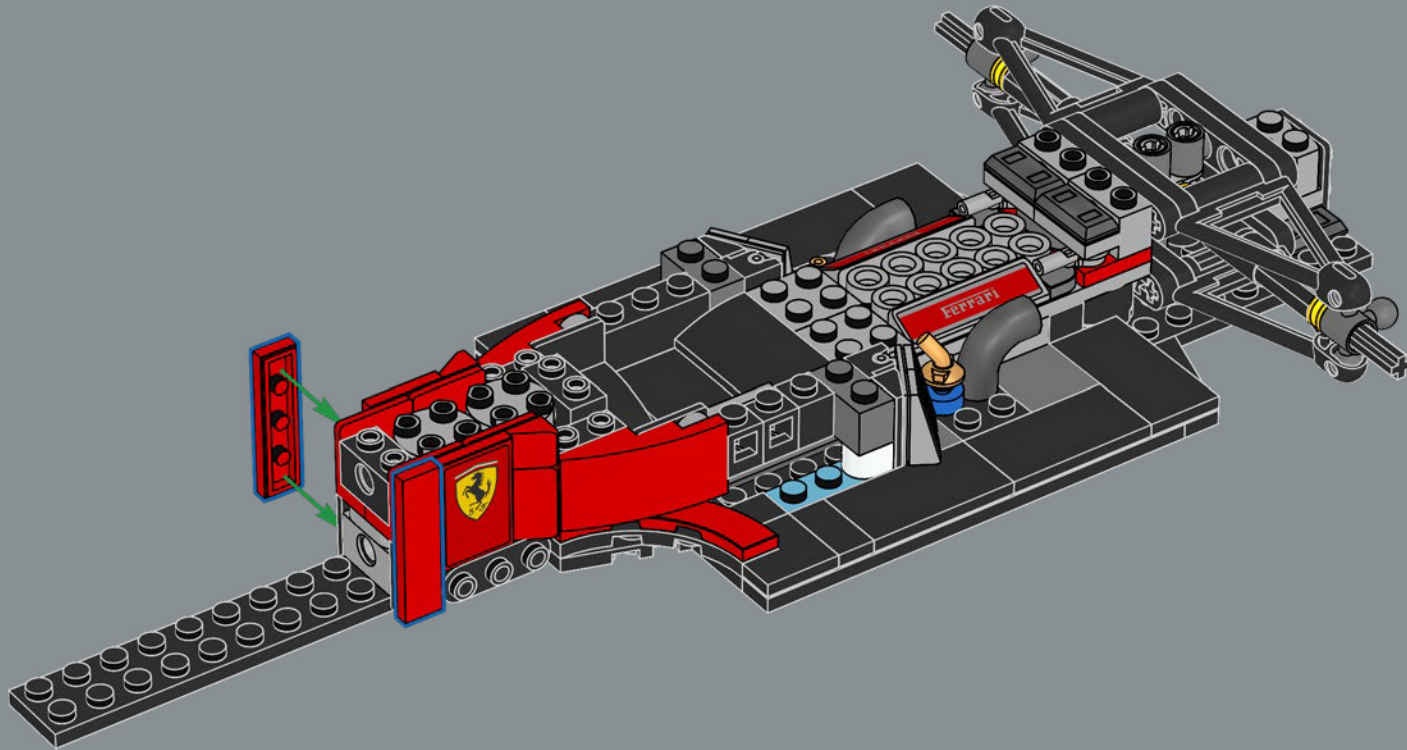

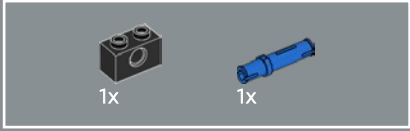
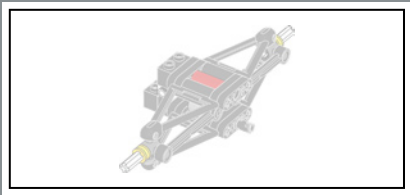

60

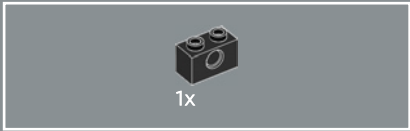
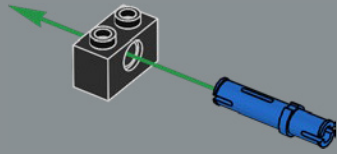

61

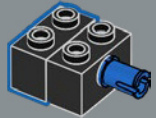

62

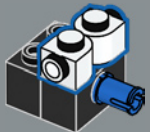

63

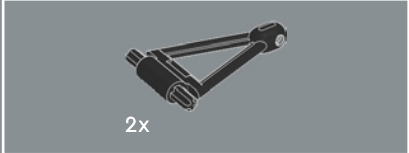
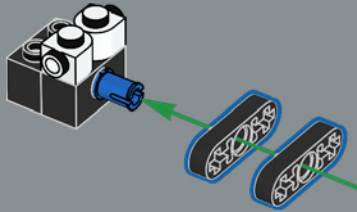

64

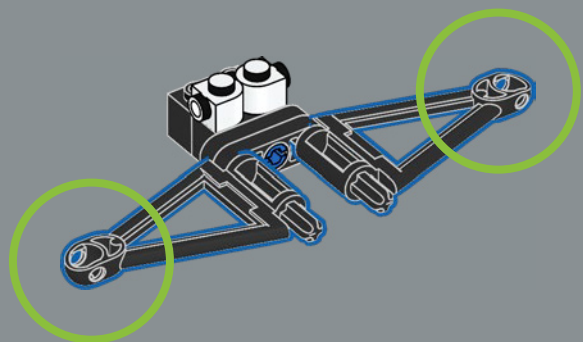



65

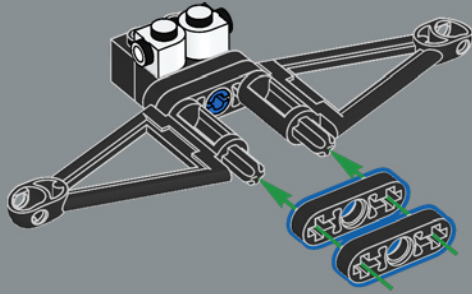

66

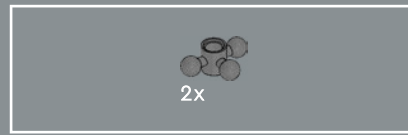
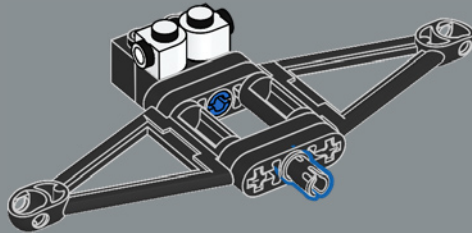

67

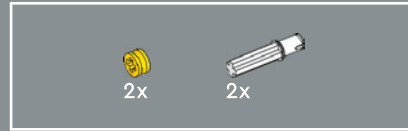
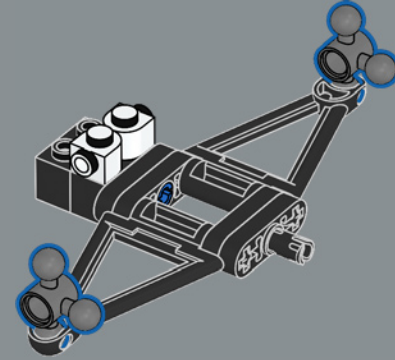

68

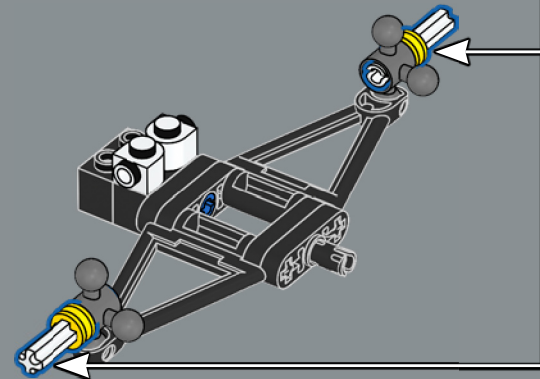
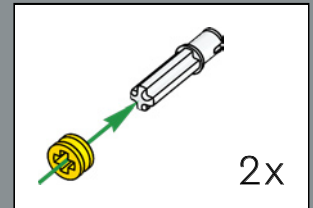

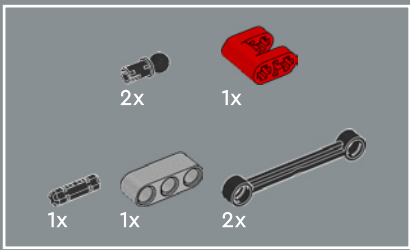

69

1

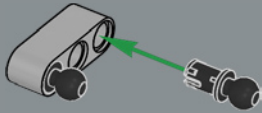

2

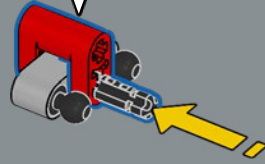

3

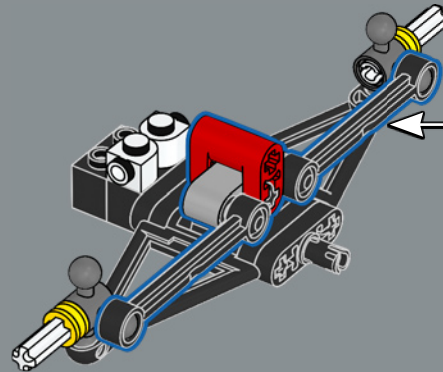
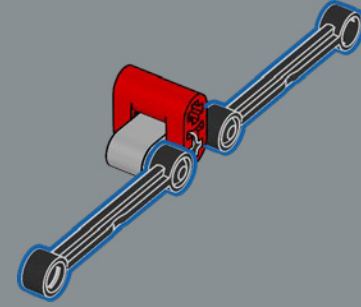

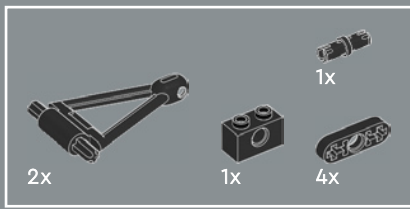

70

1

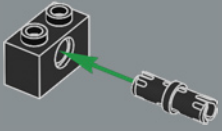

2

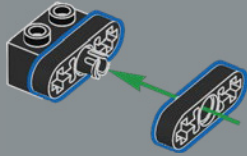

3

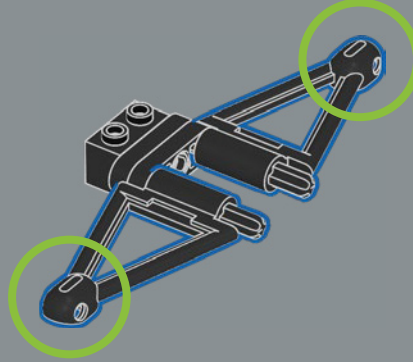

4

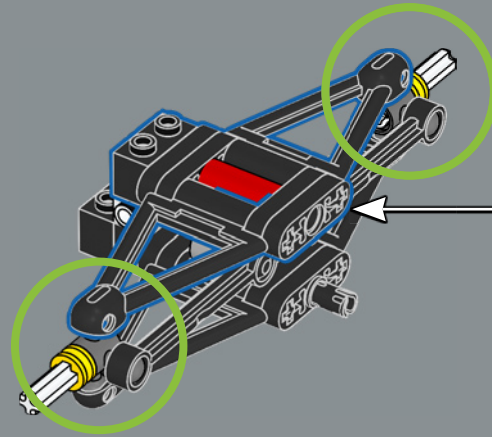
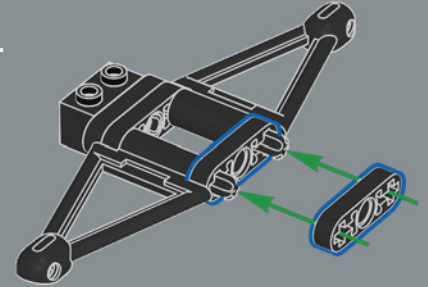



The Ferrari F2004 is an evolution of the previous season's F2003-GA. The main parts of the car were revised to reach maximum levels of performance.

71

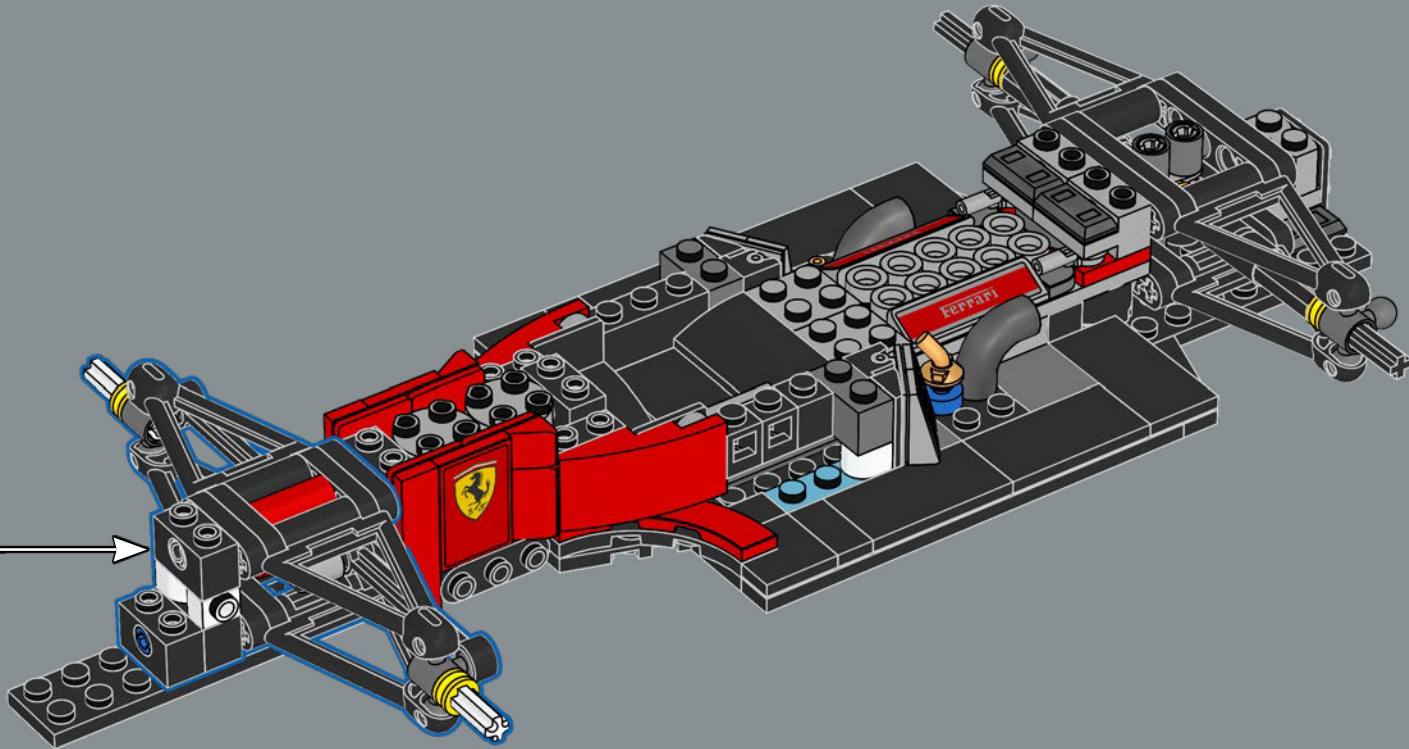

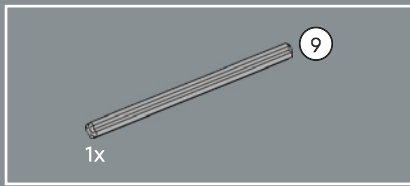

72

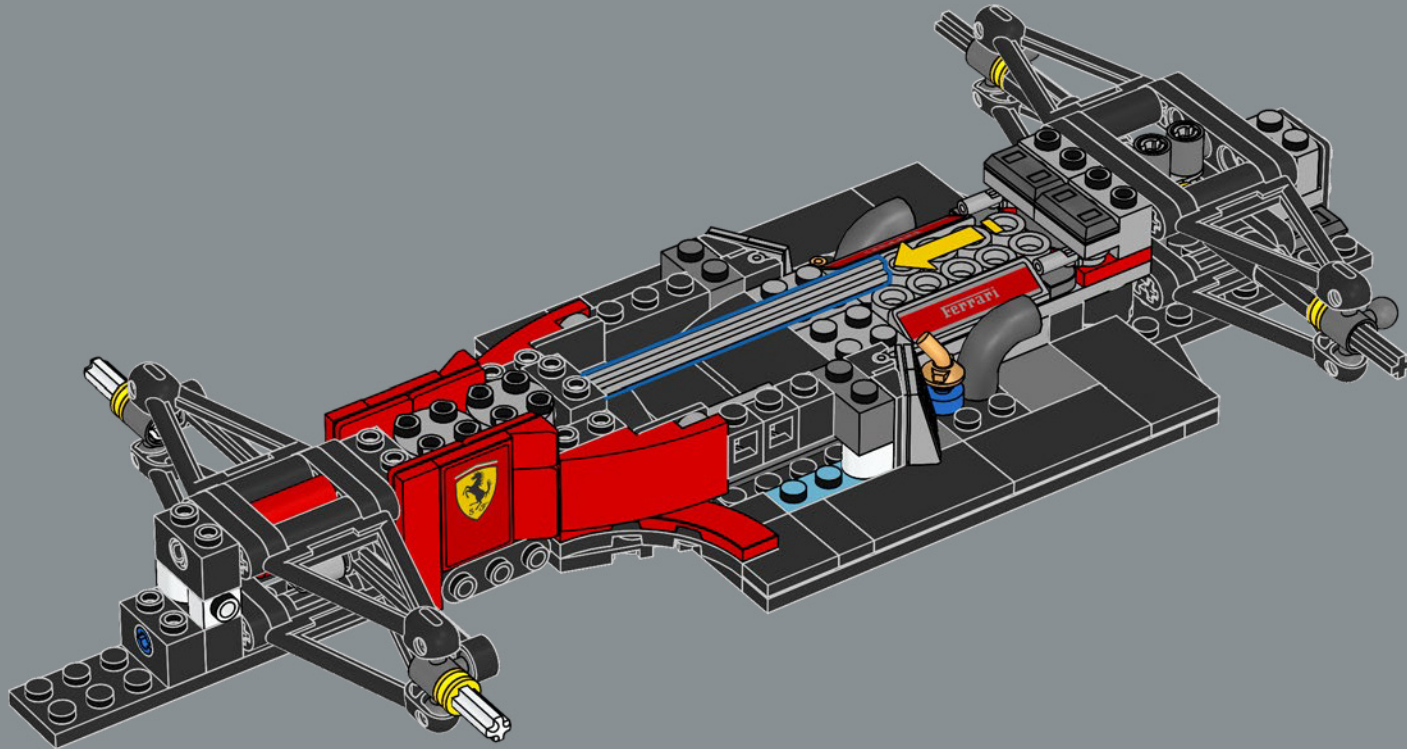



2x

73

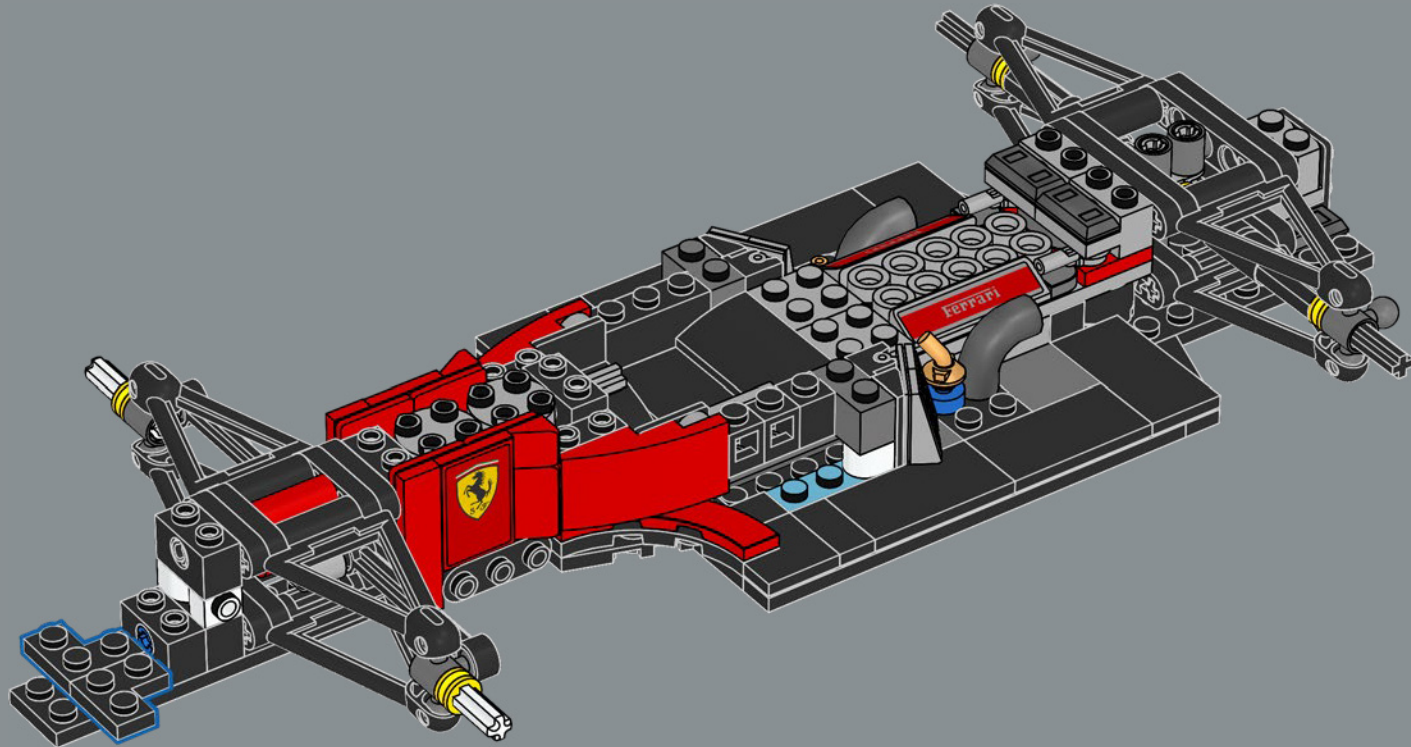

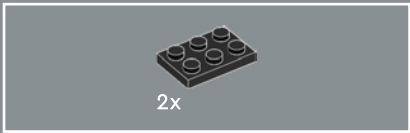

74

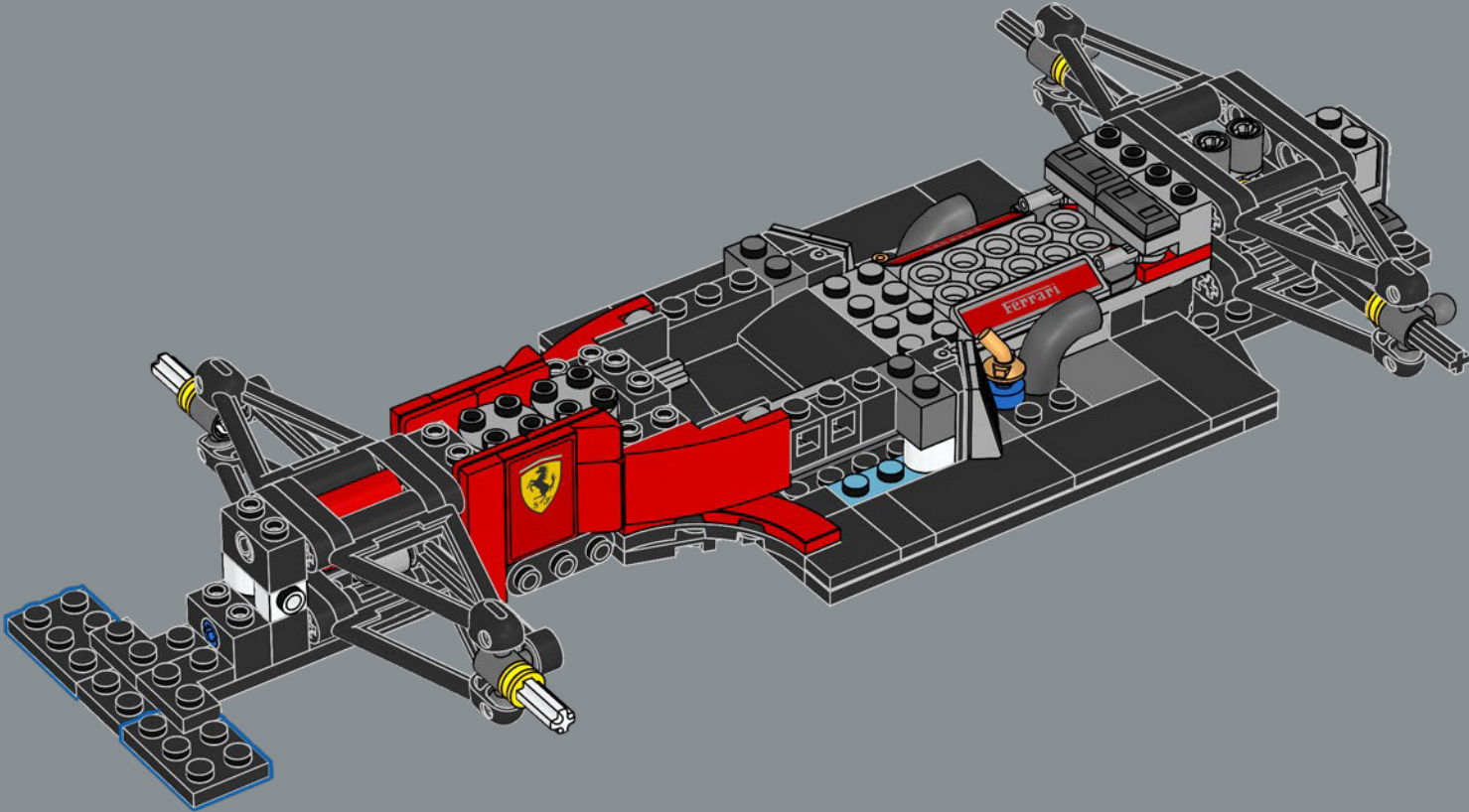

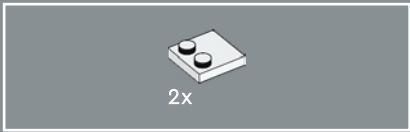

75

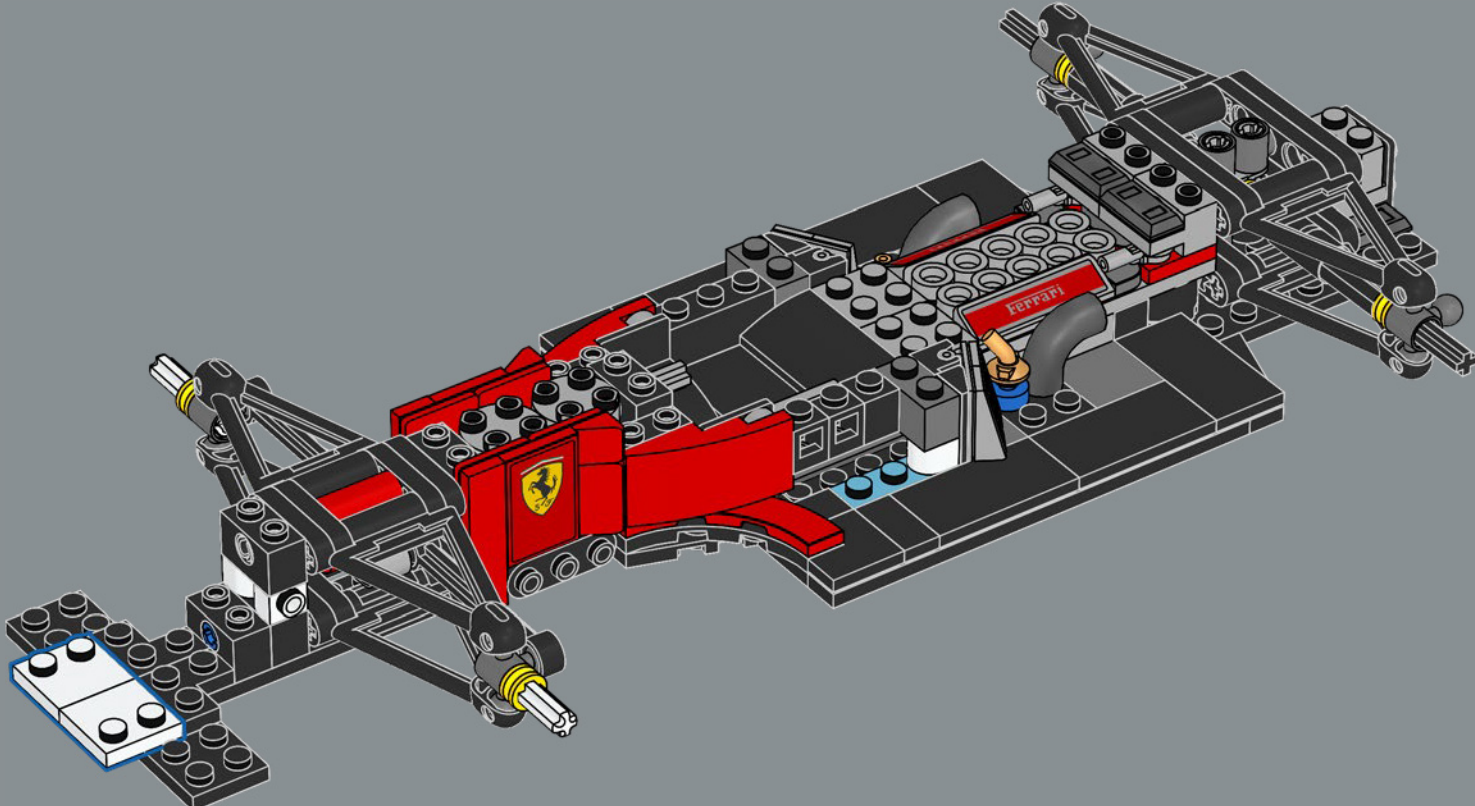

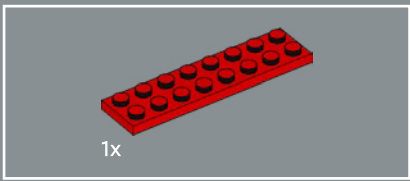

76

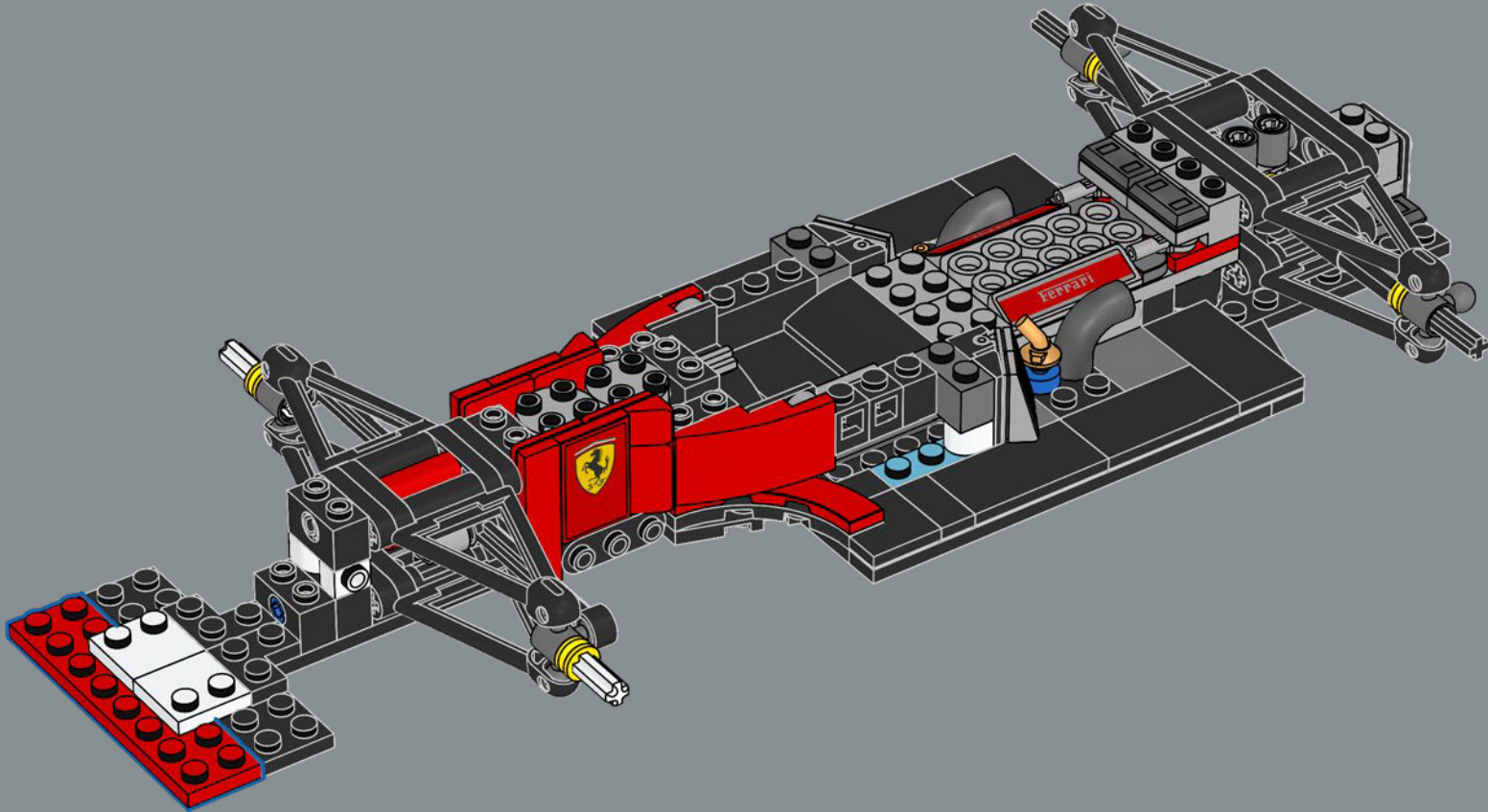

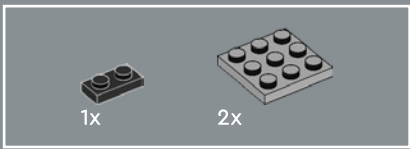

77

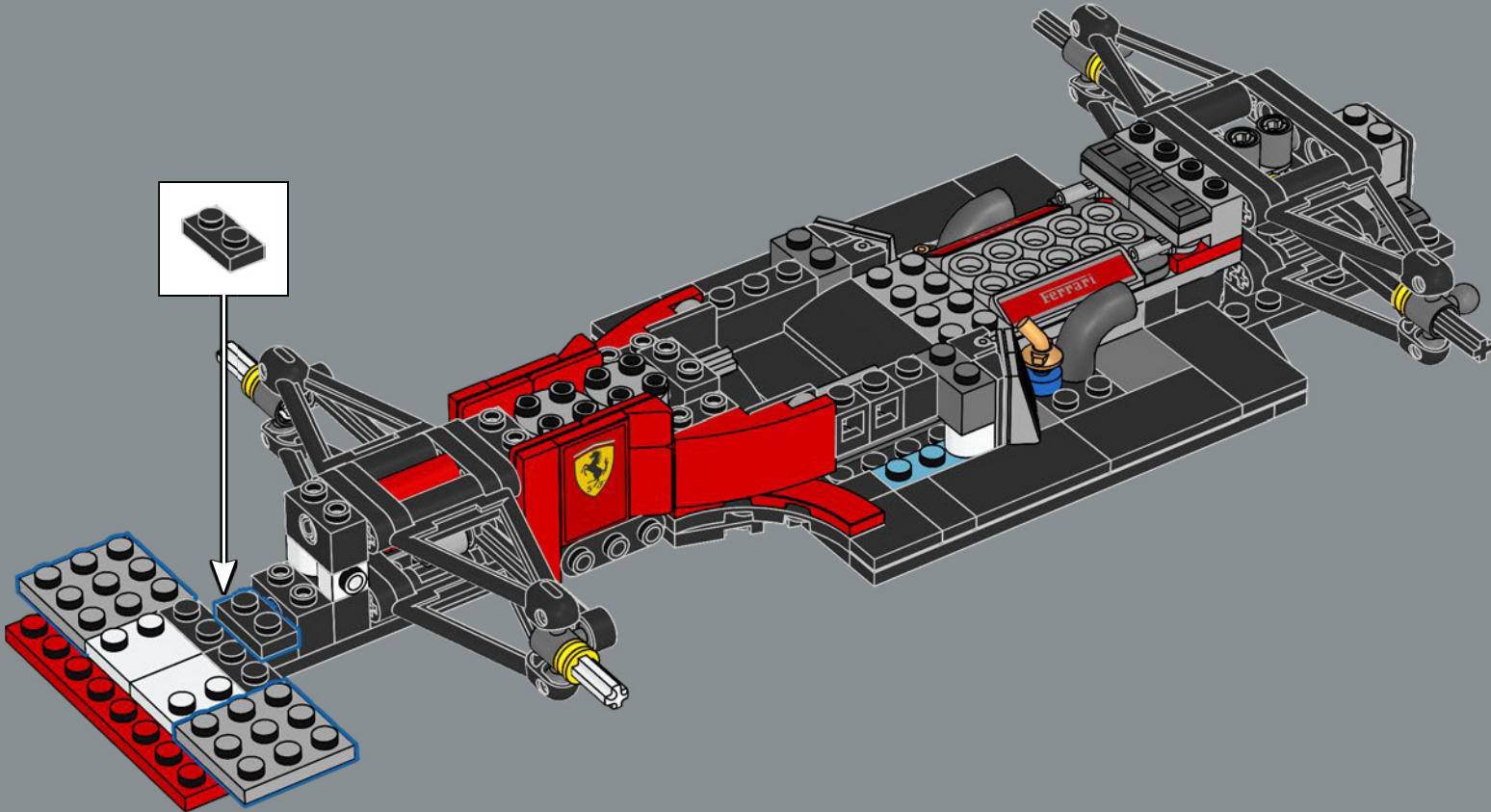



78

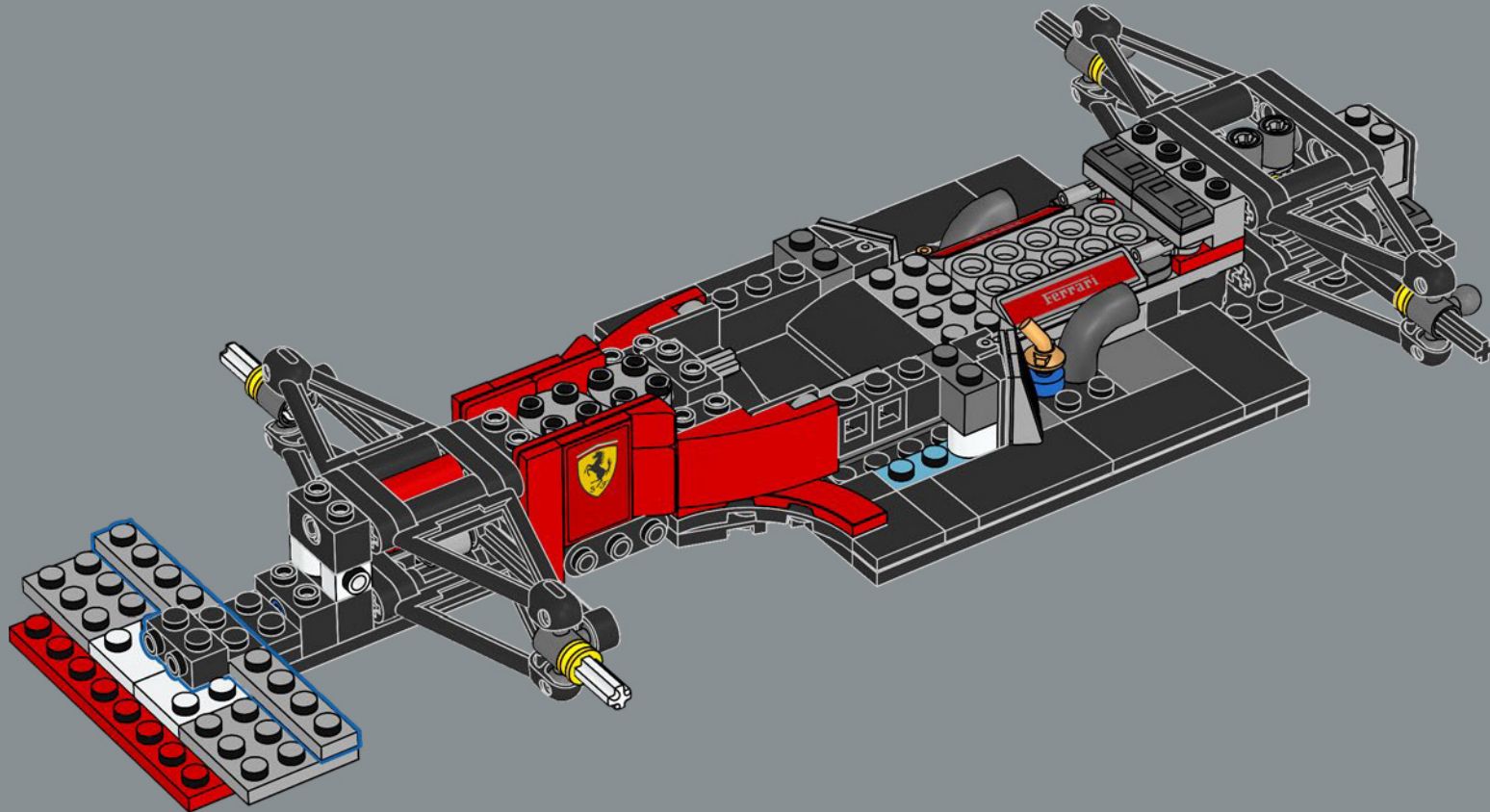

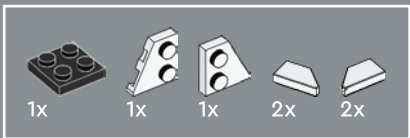

79

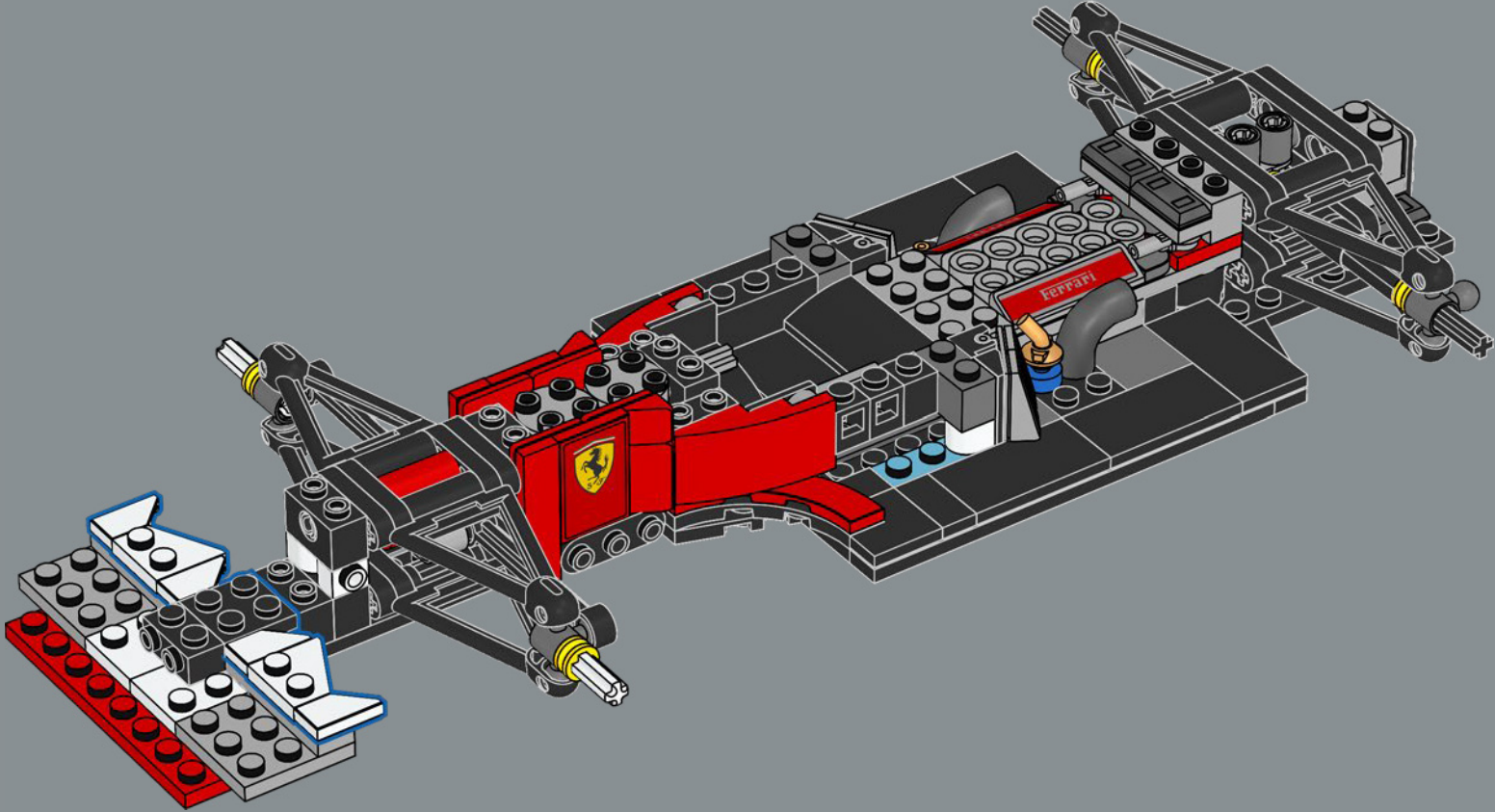

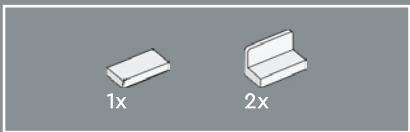

80

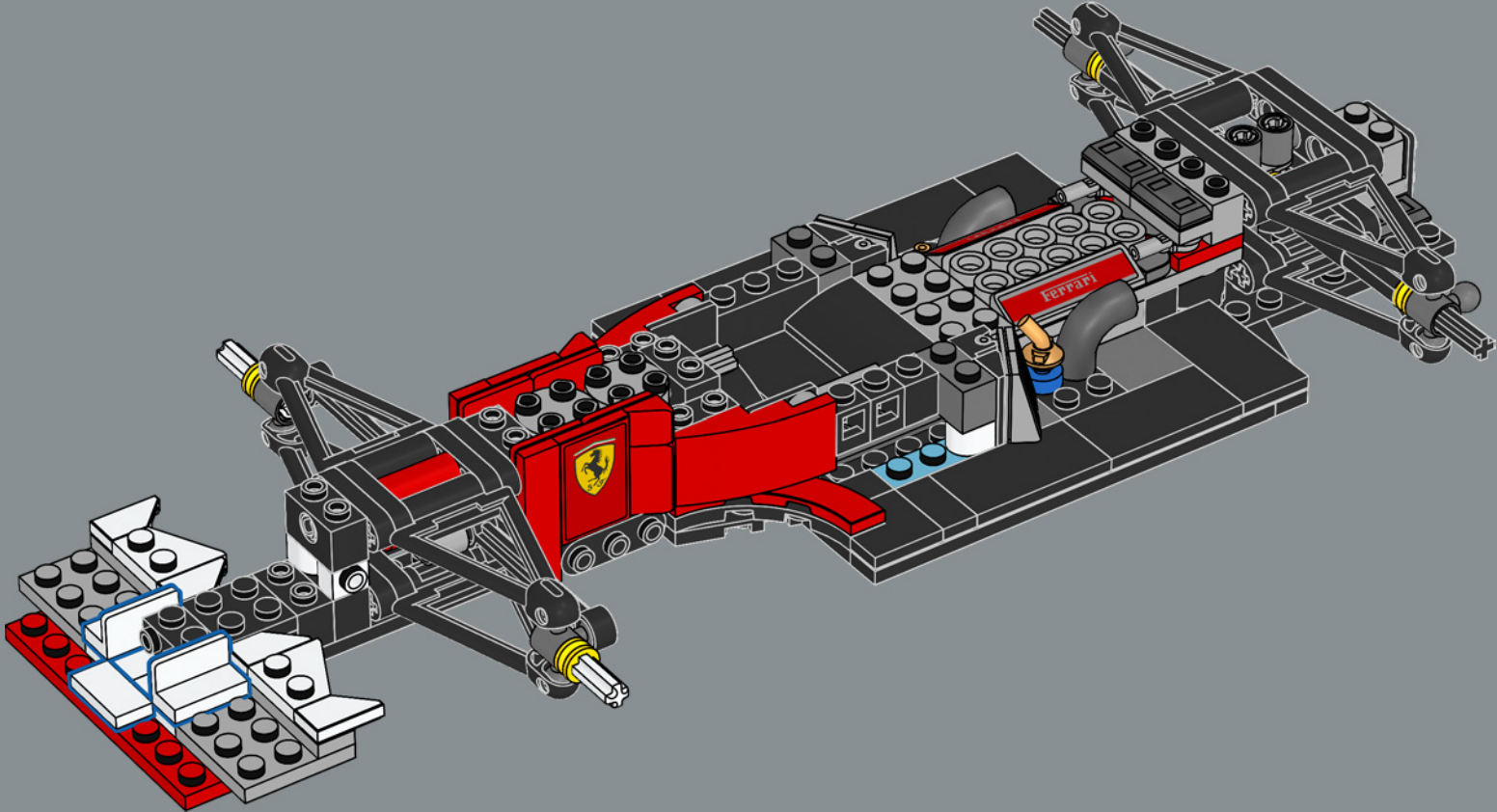

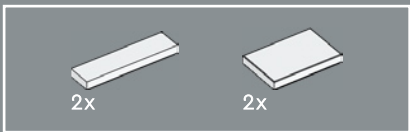

81

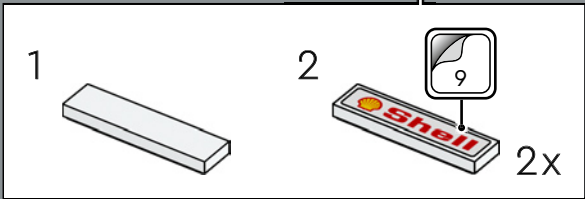
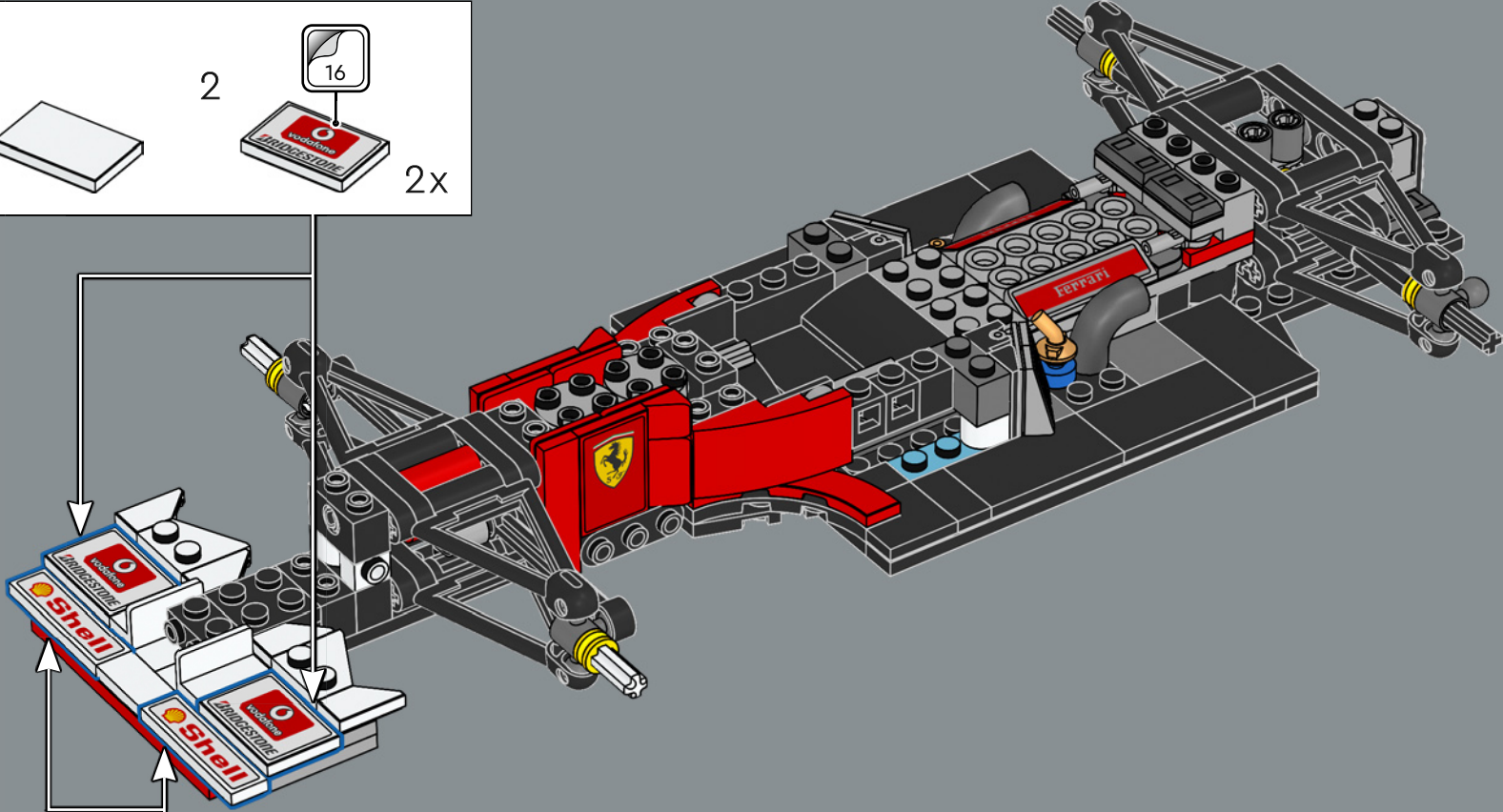
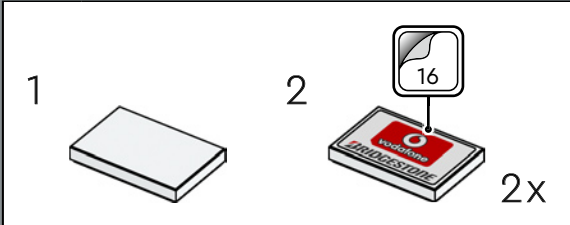

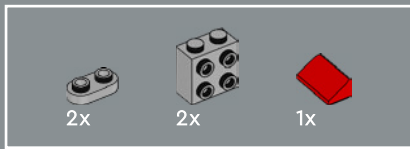

82

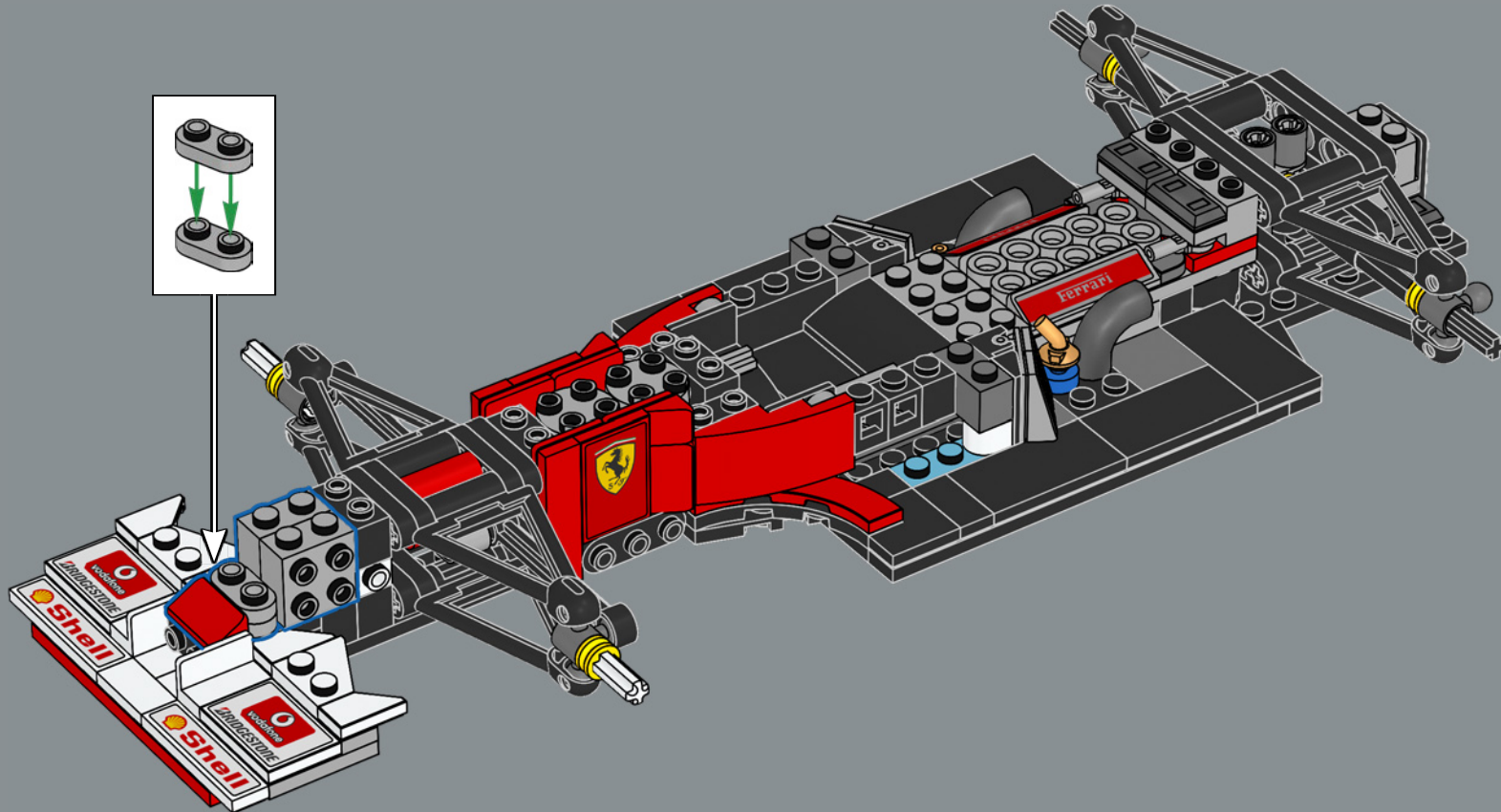



83

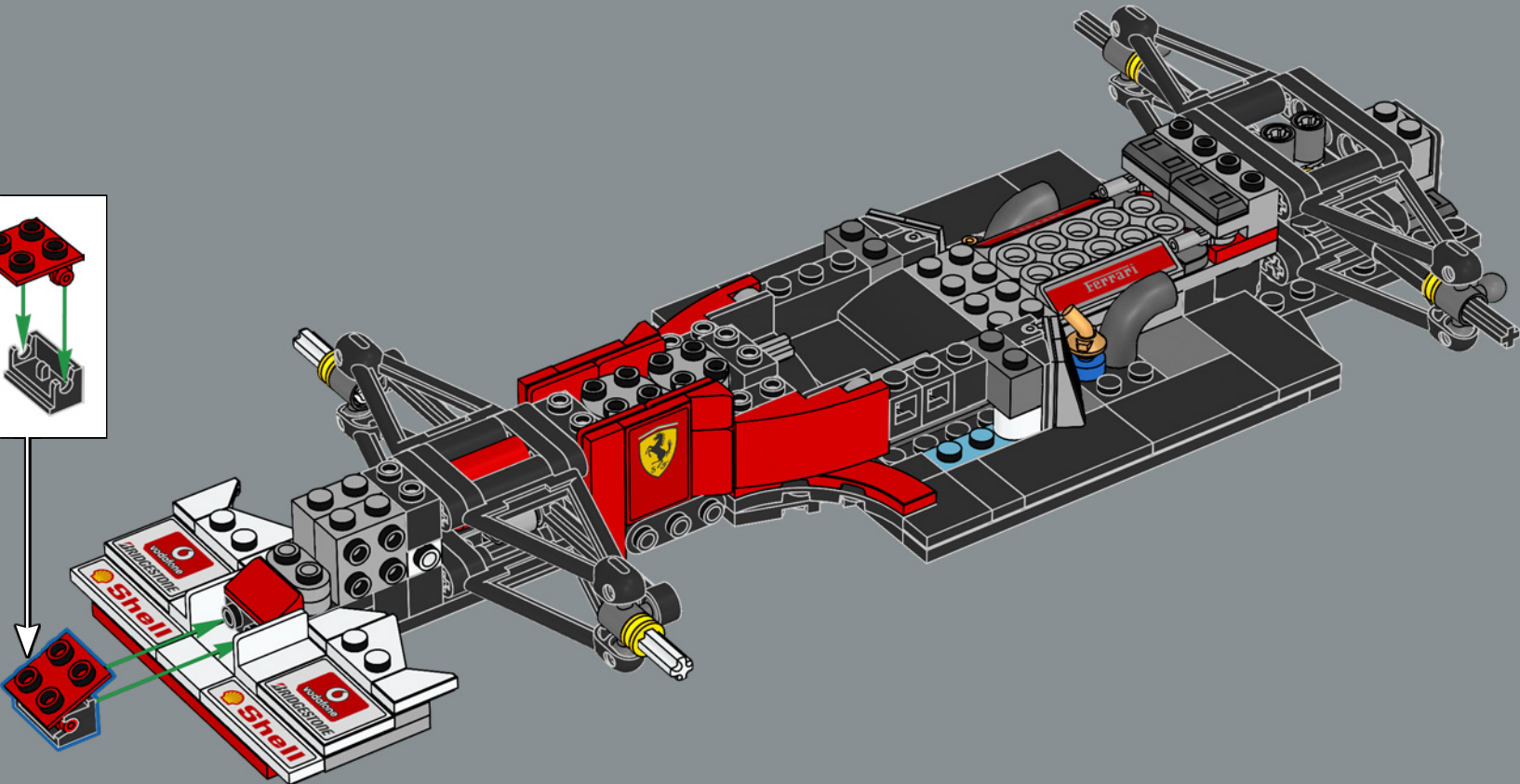
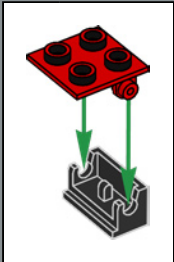

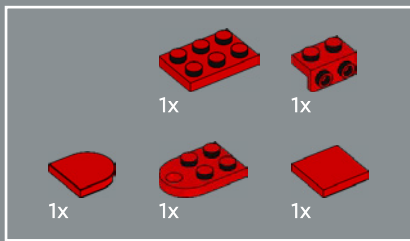

84

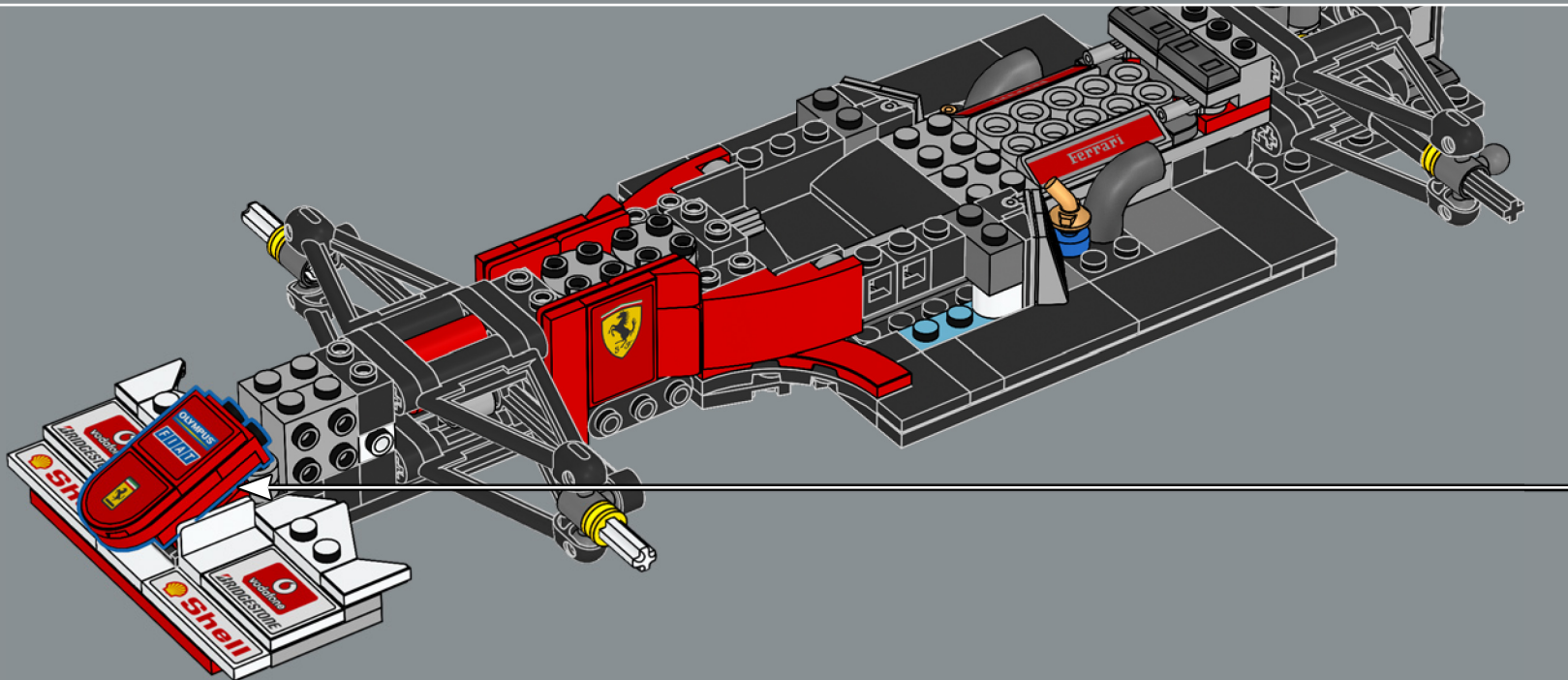
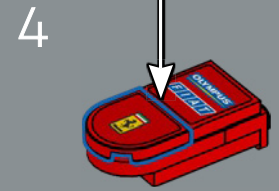
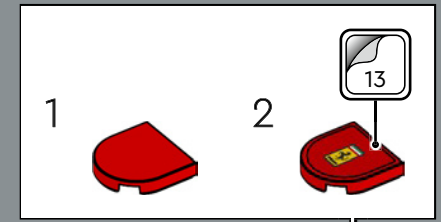
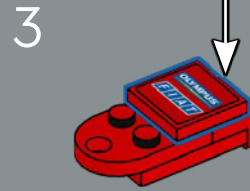
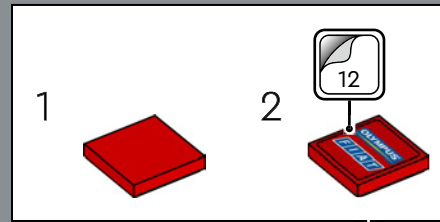
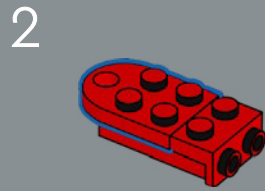
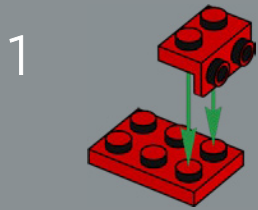

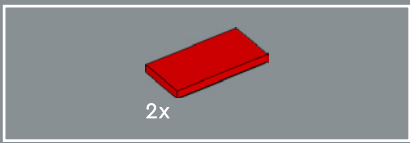

85

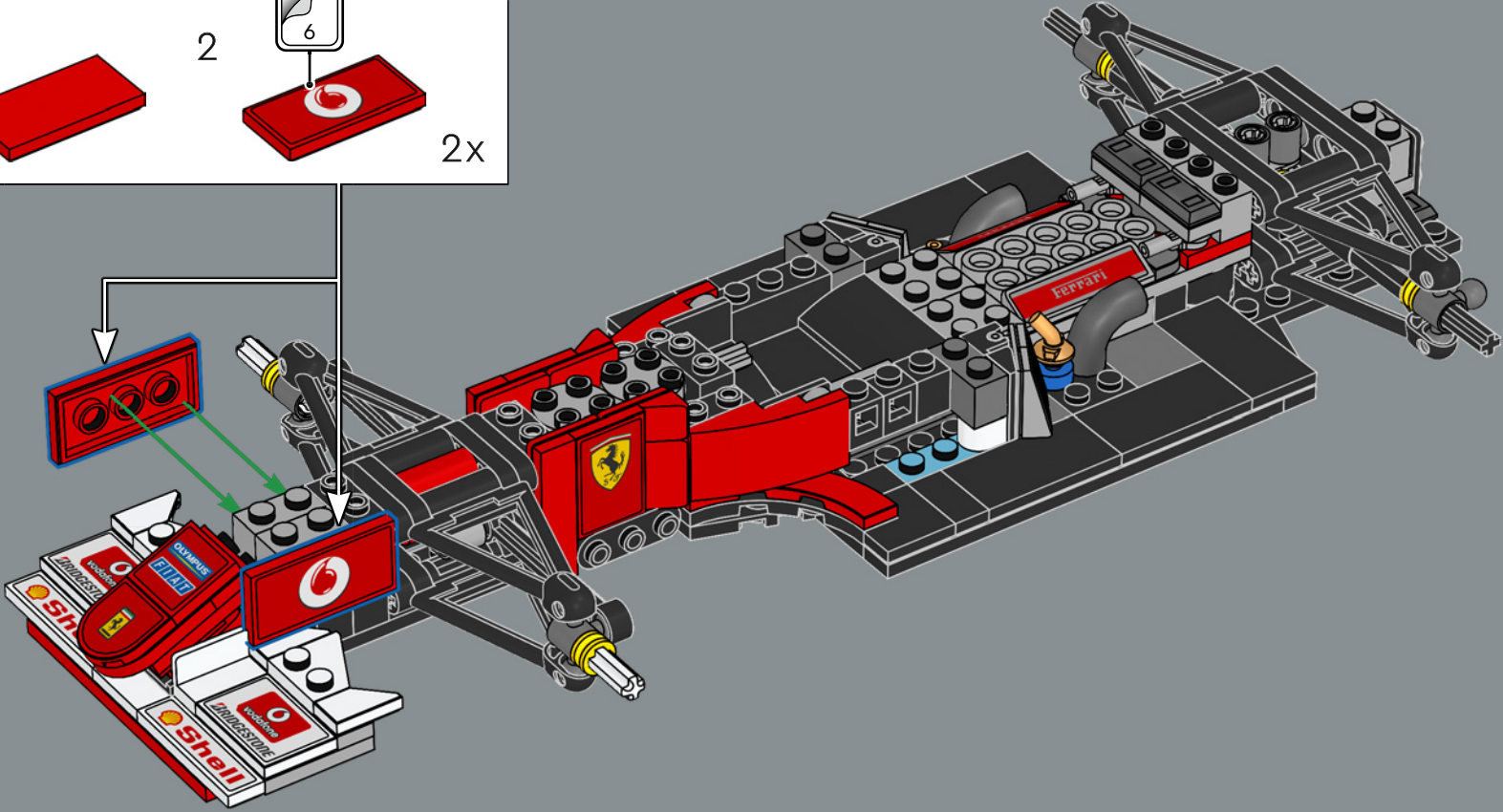
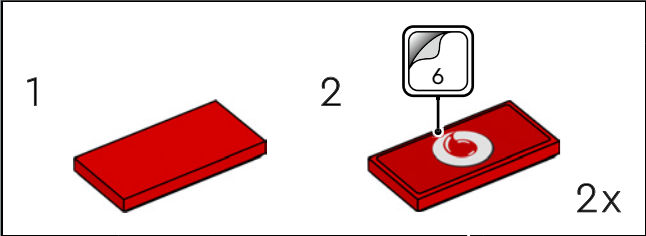

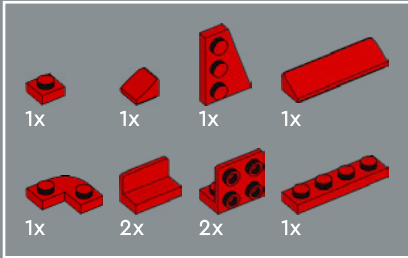
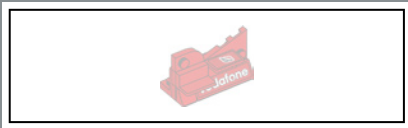

86

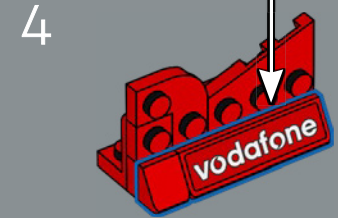
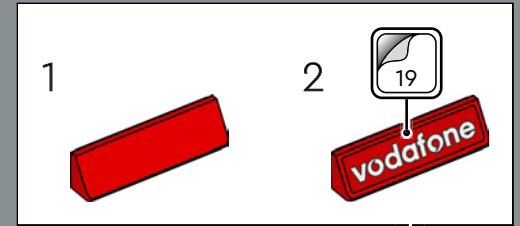
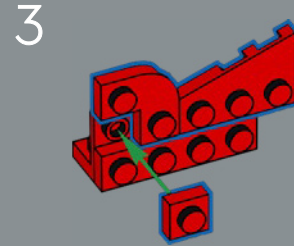
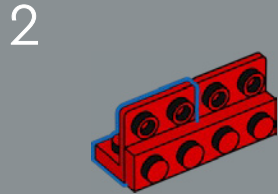
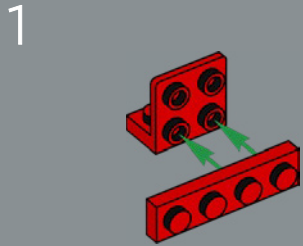

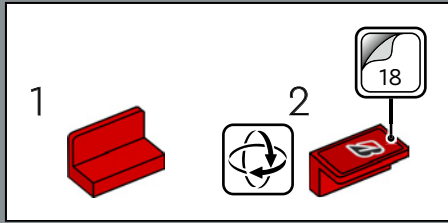

5

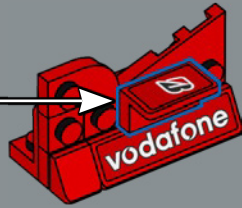

6

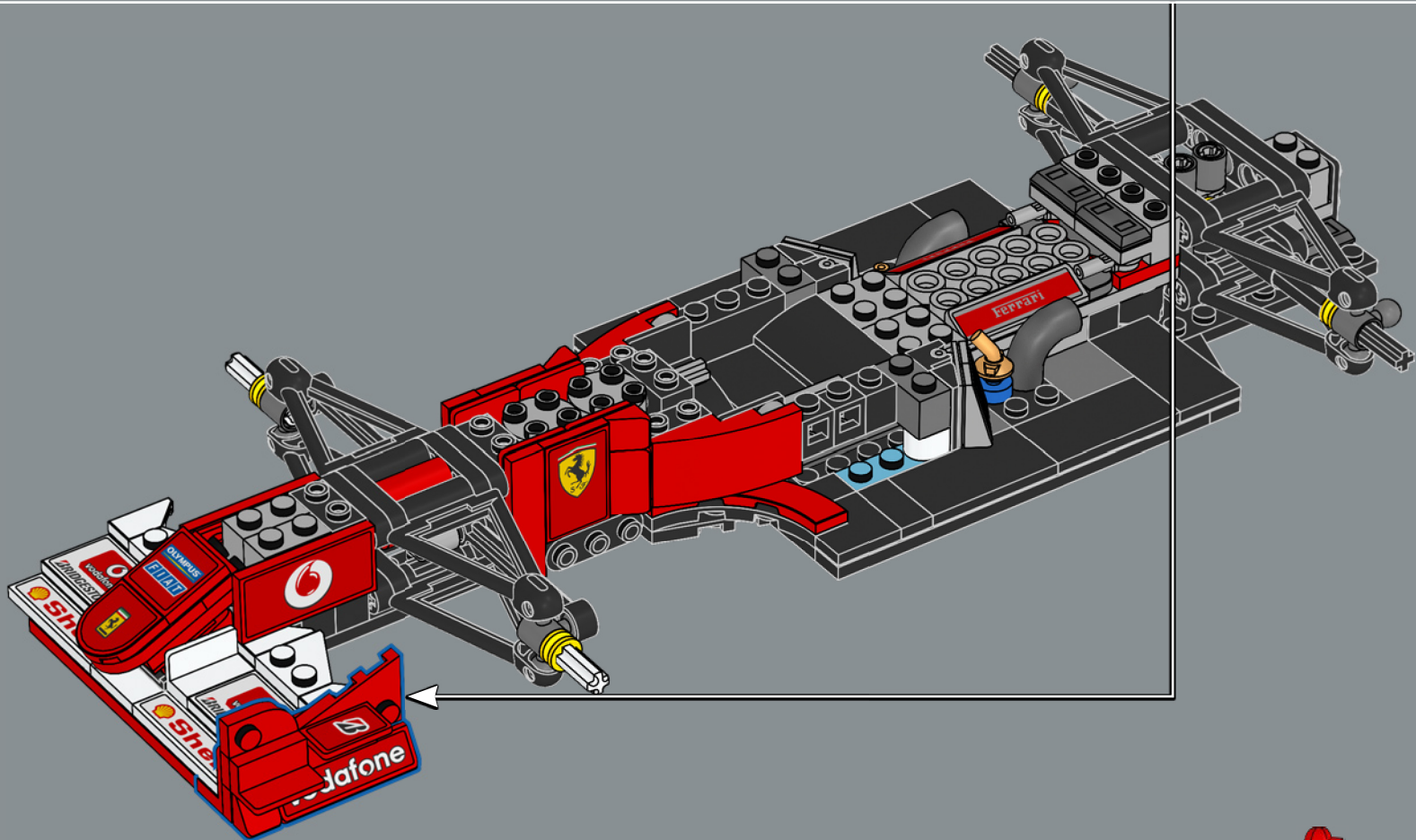
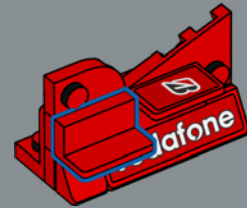

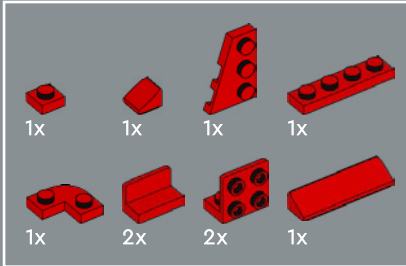
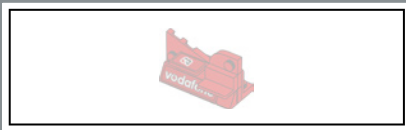

87

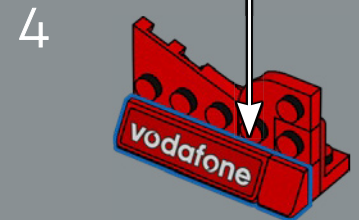
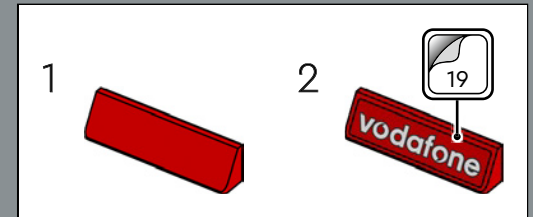
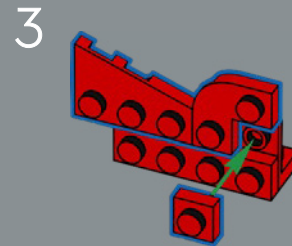
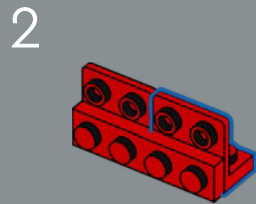
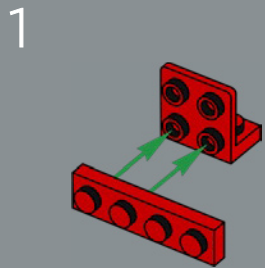

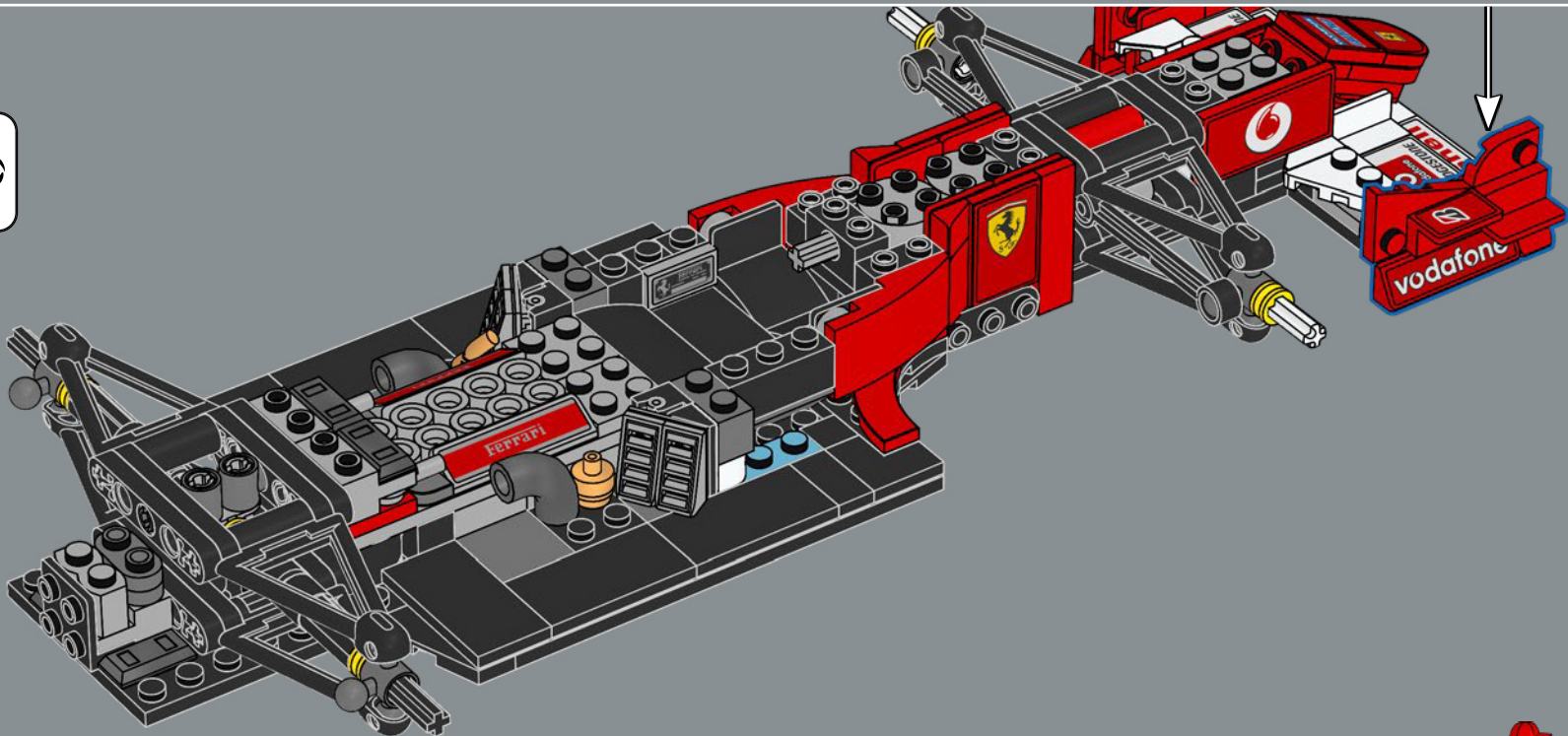
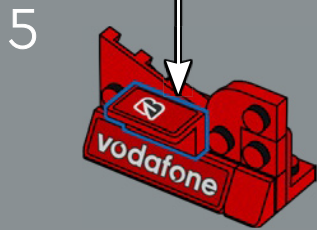
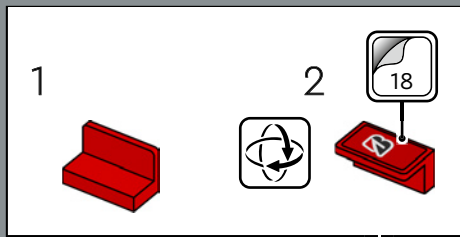



88

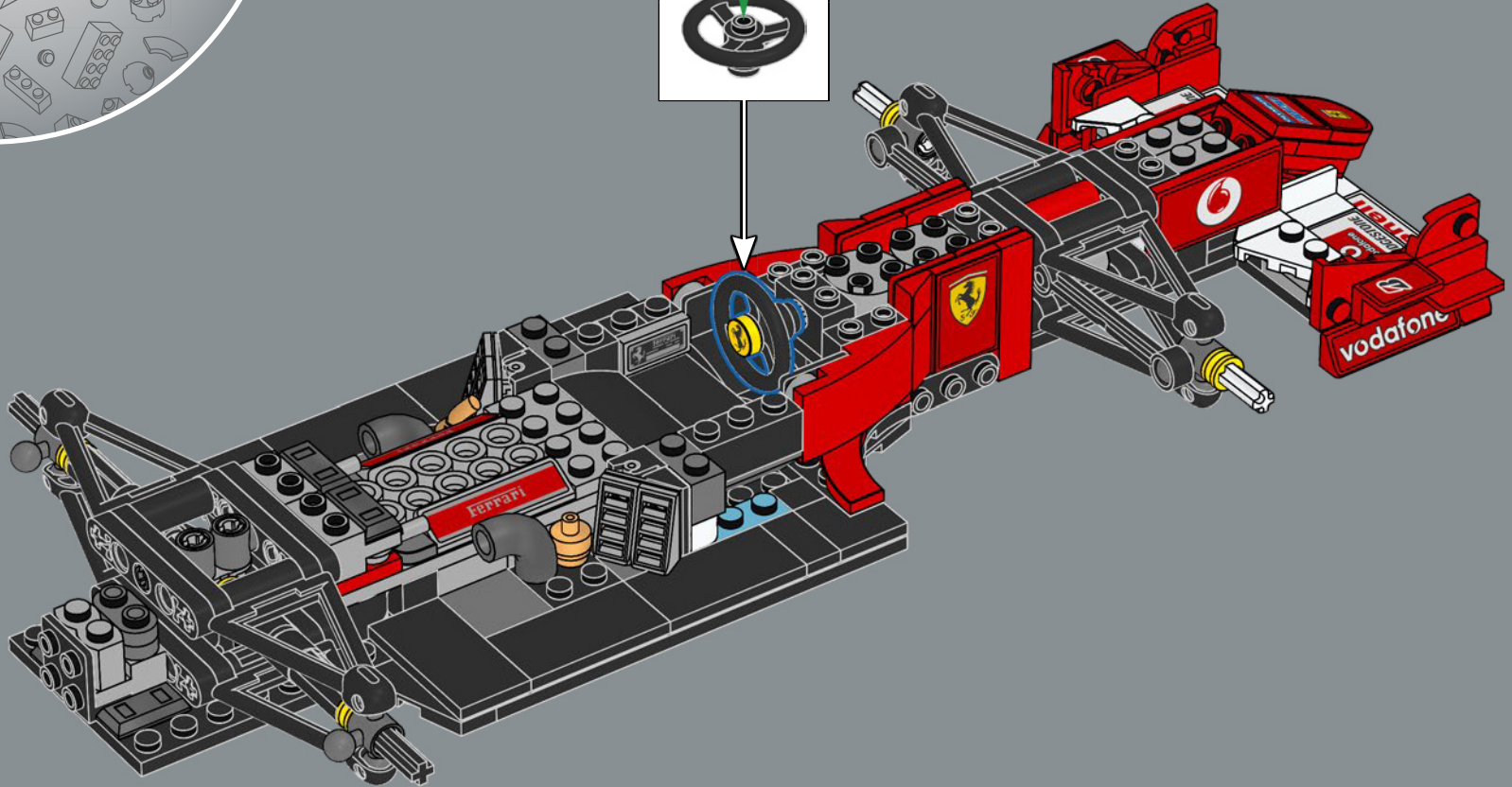
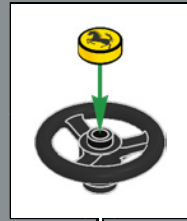

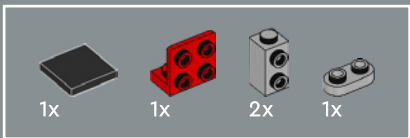

89

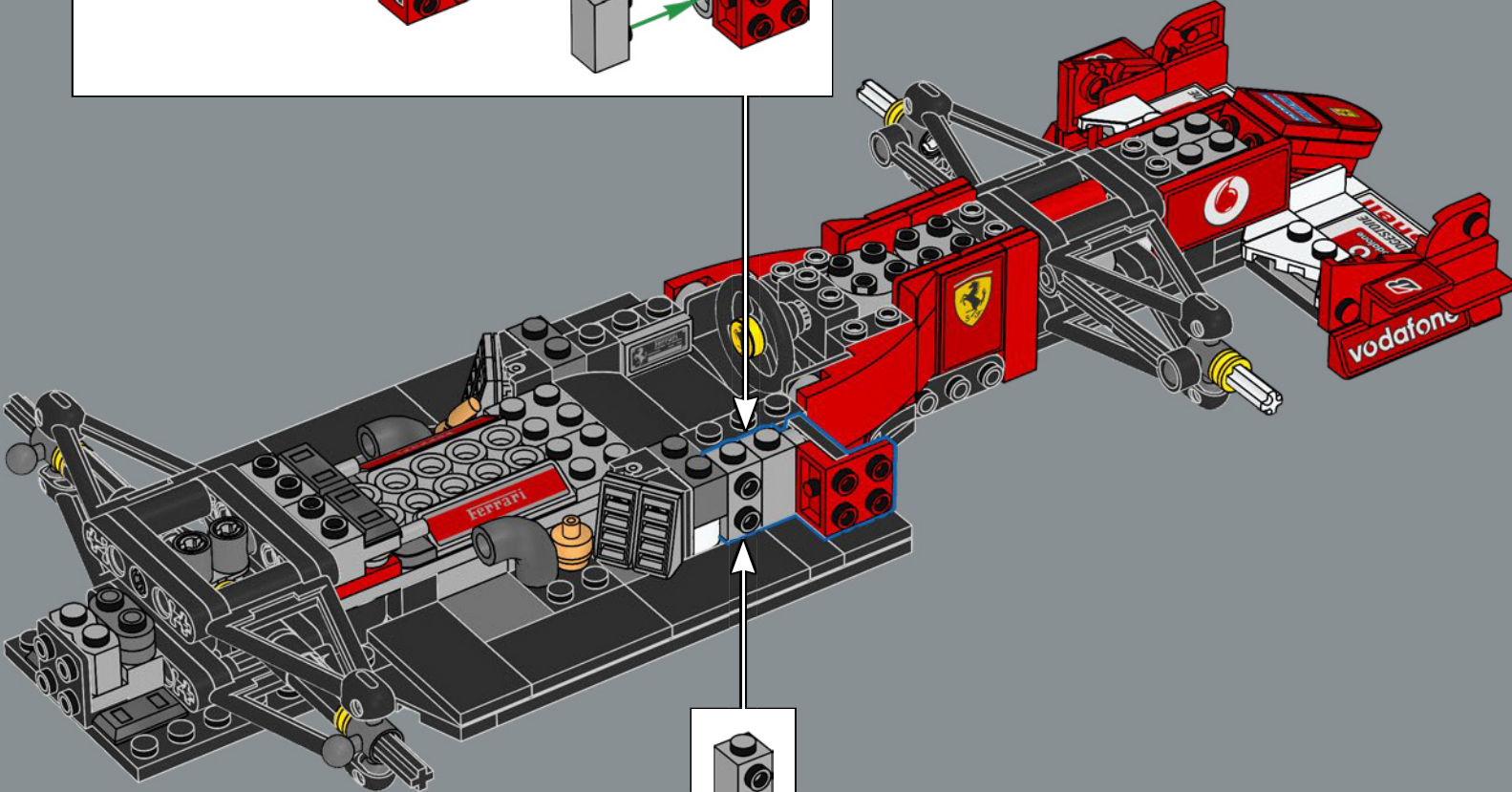
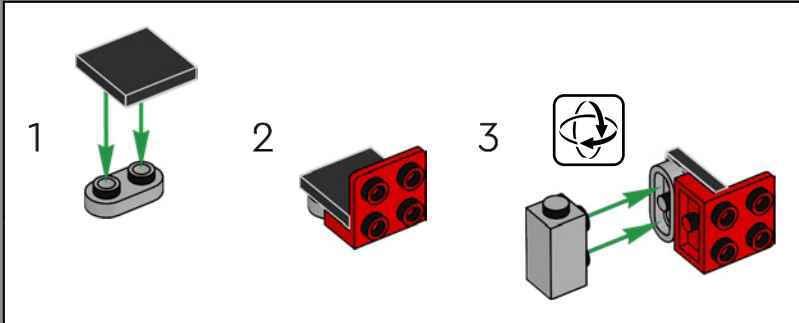

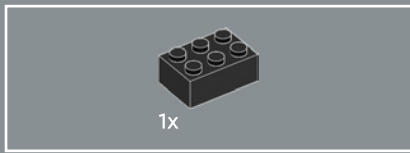

90

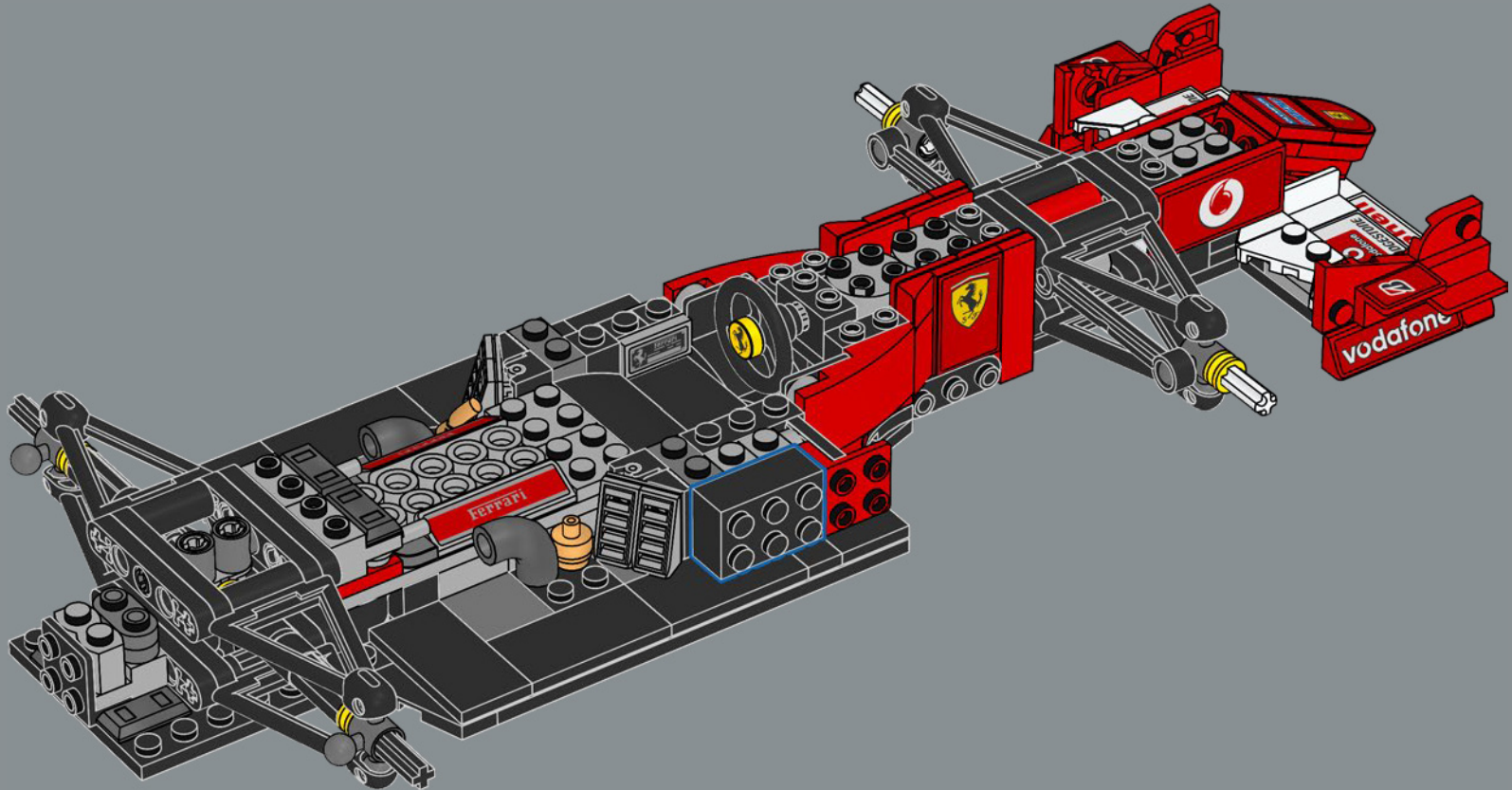

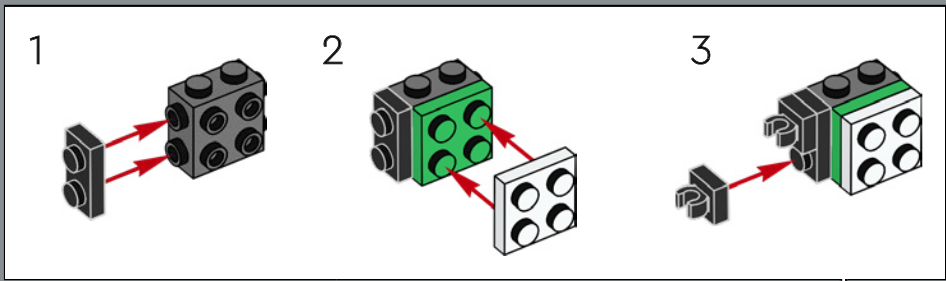
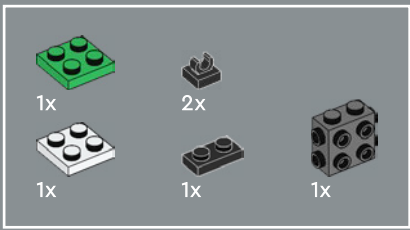

91

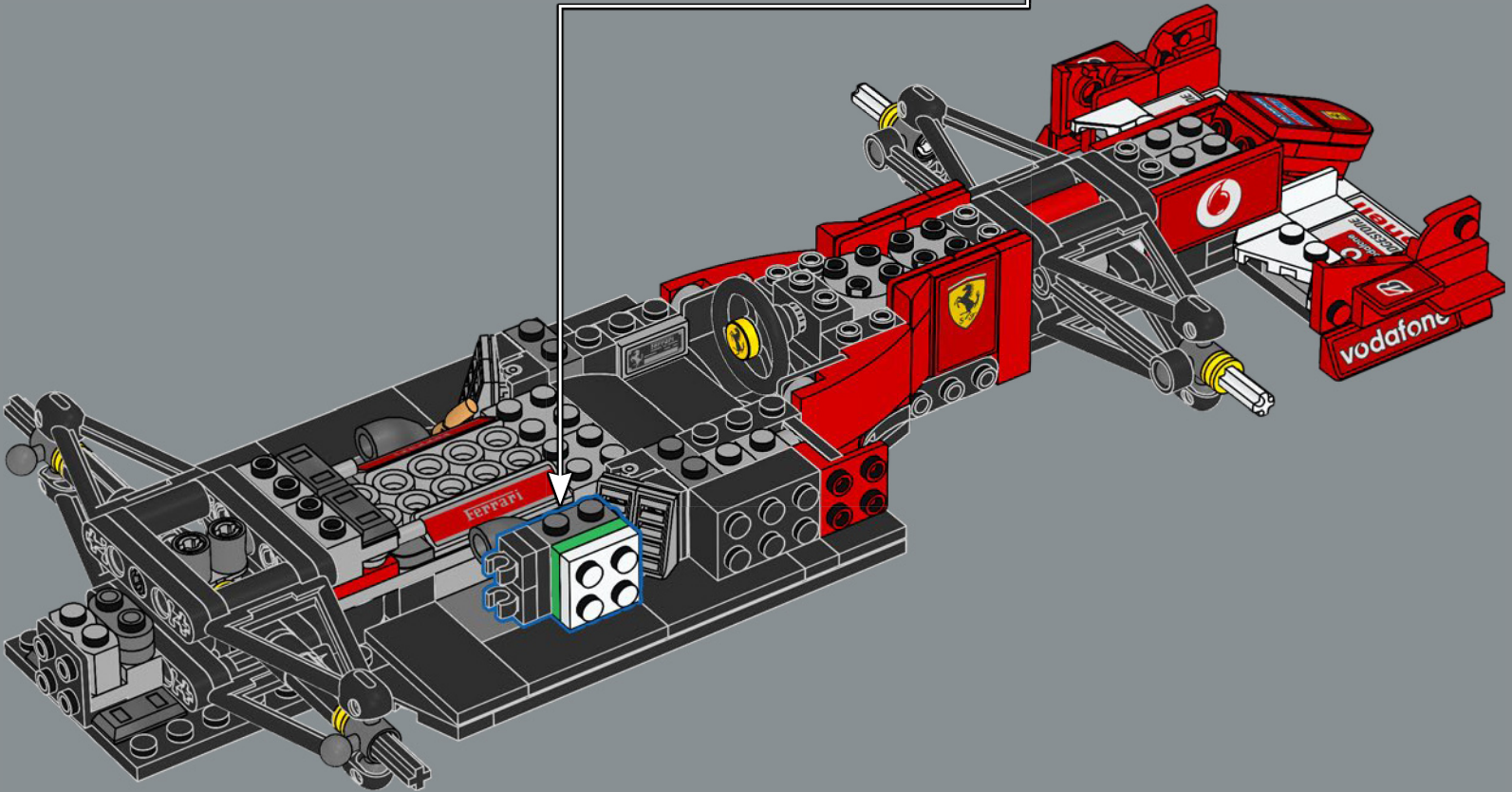

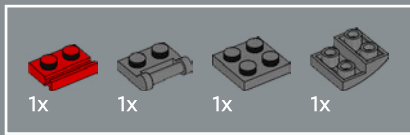

92

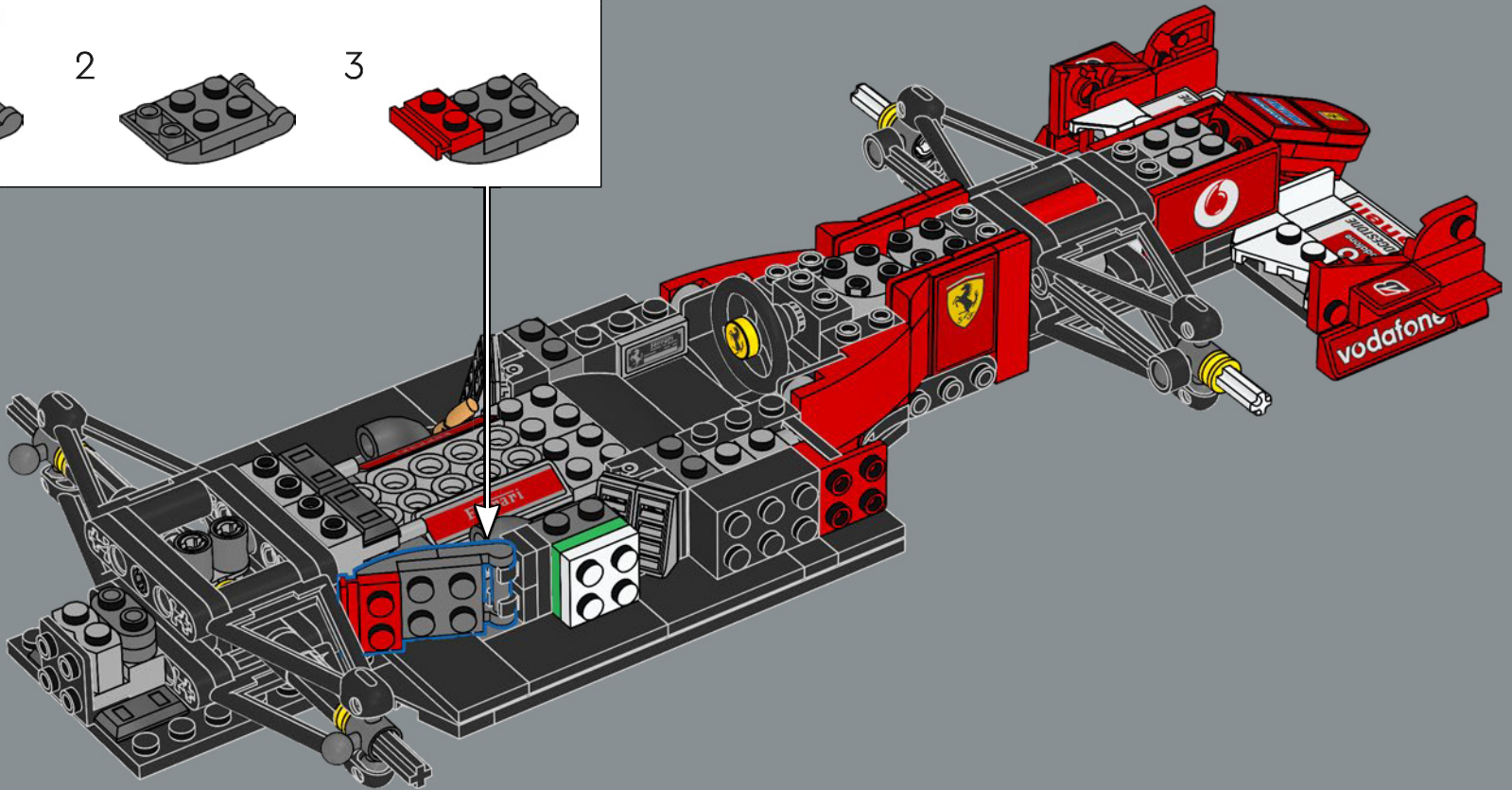

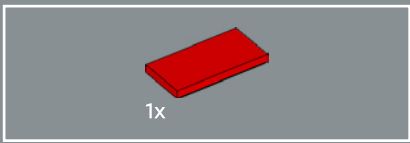

93

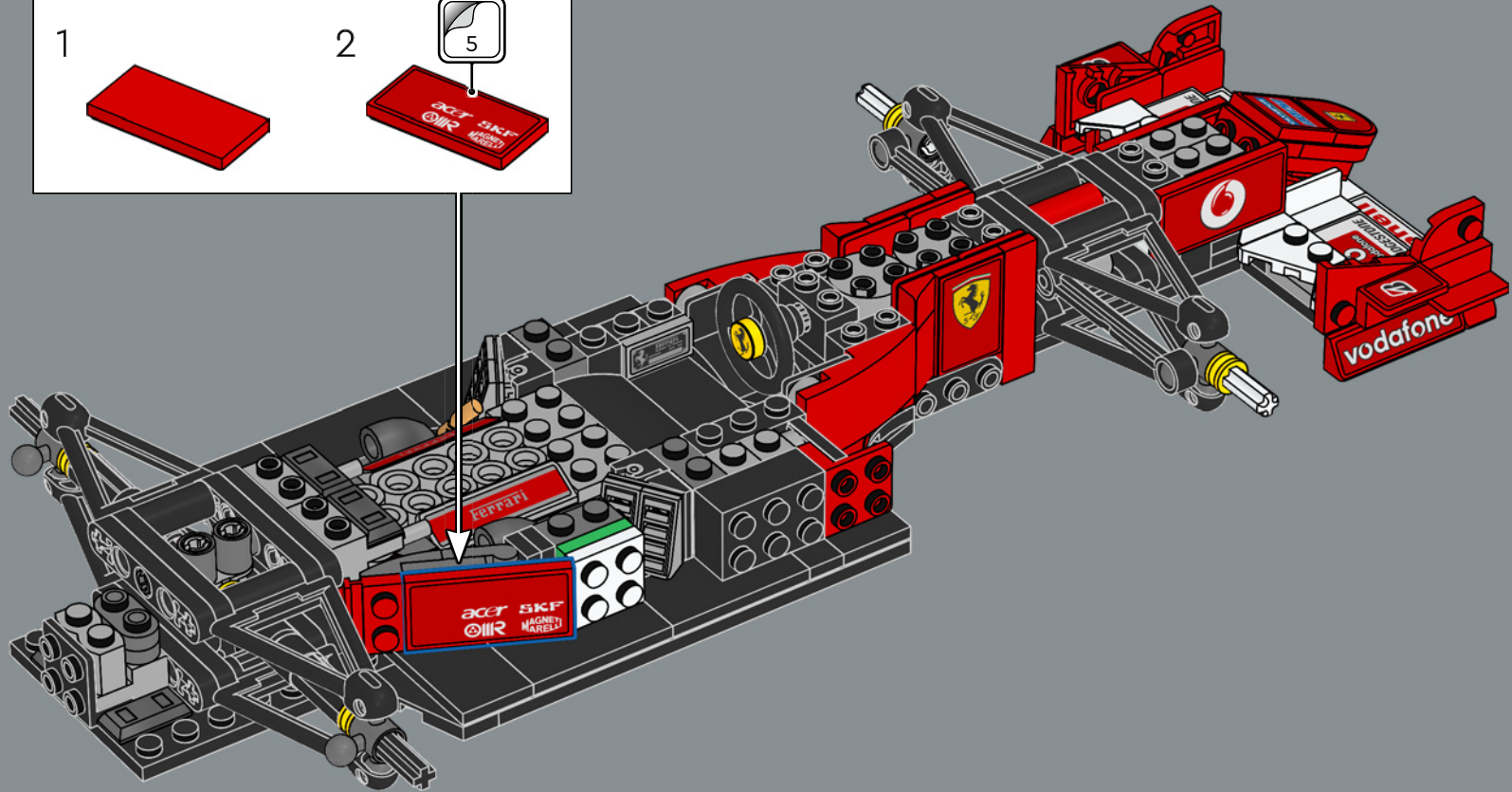
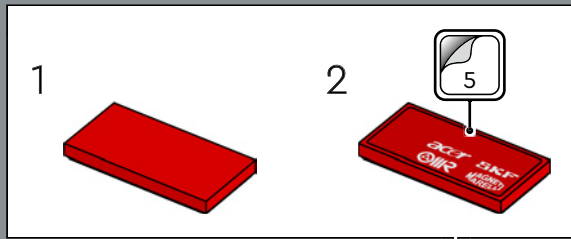

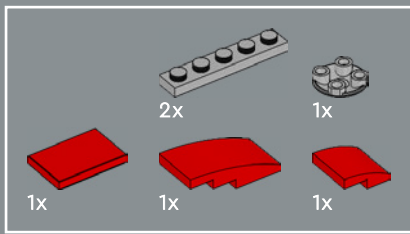

94

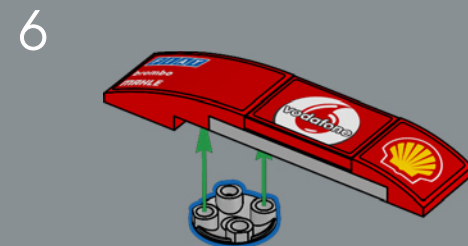
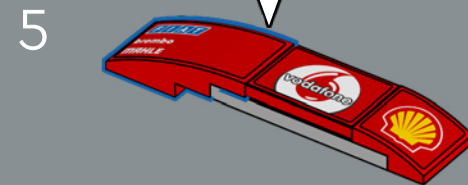
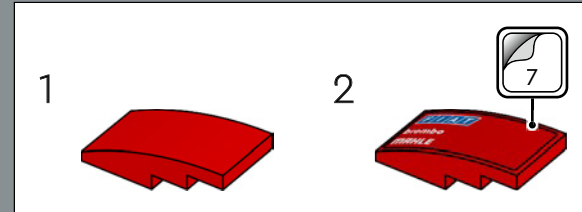
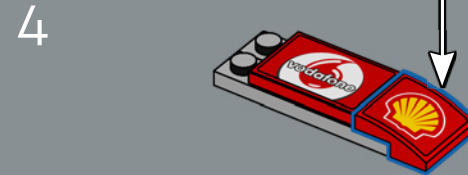
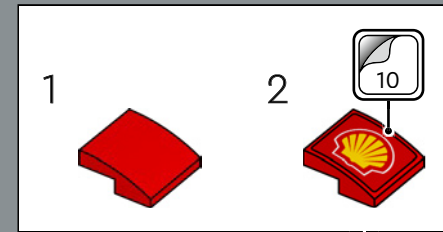
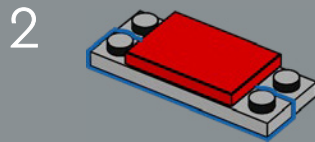
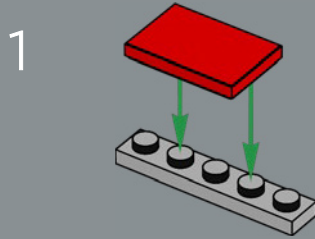



The aerodynamic bodywork of the Ferrari F2004 was designed to maximise the performance of the car by improving the airflow and taking advantage of the grooved tyres.

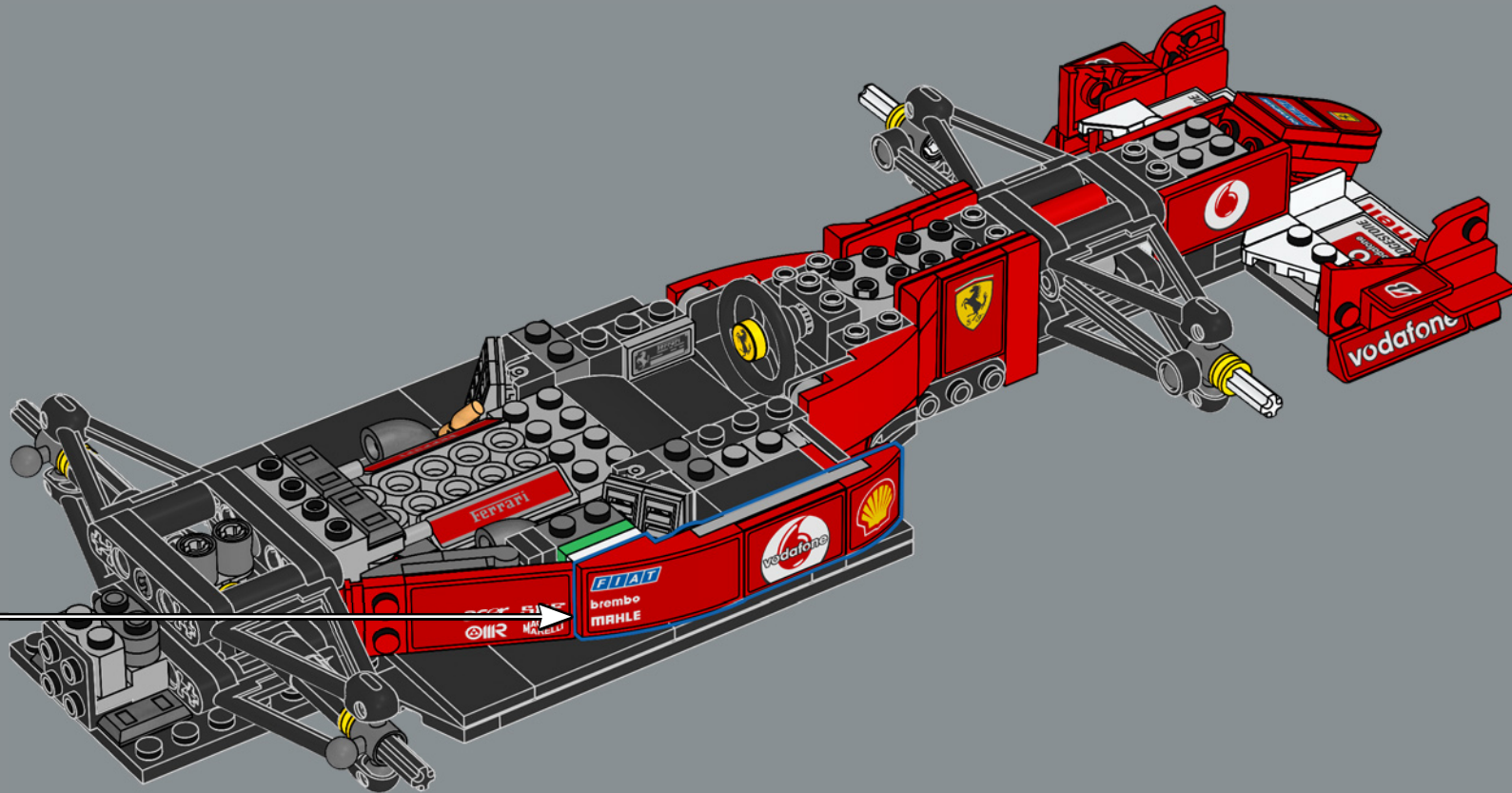

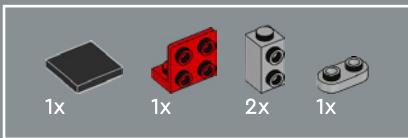

95

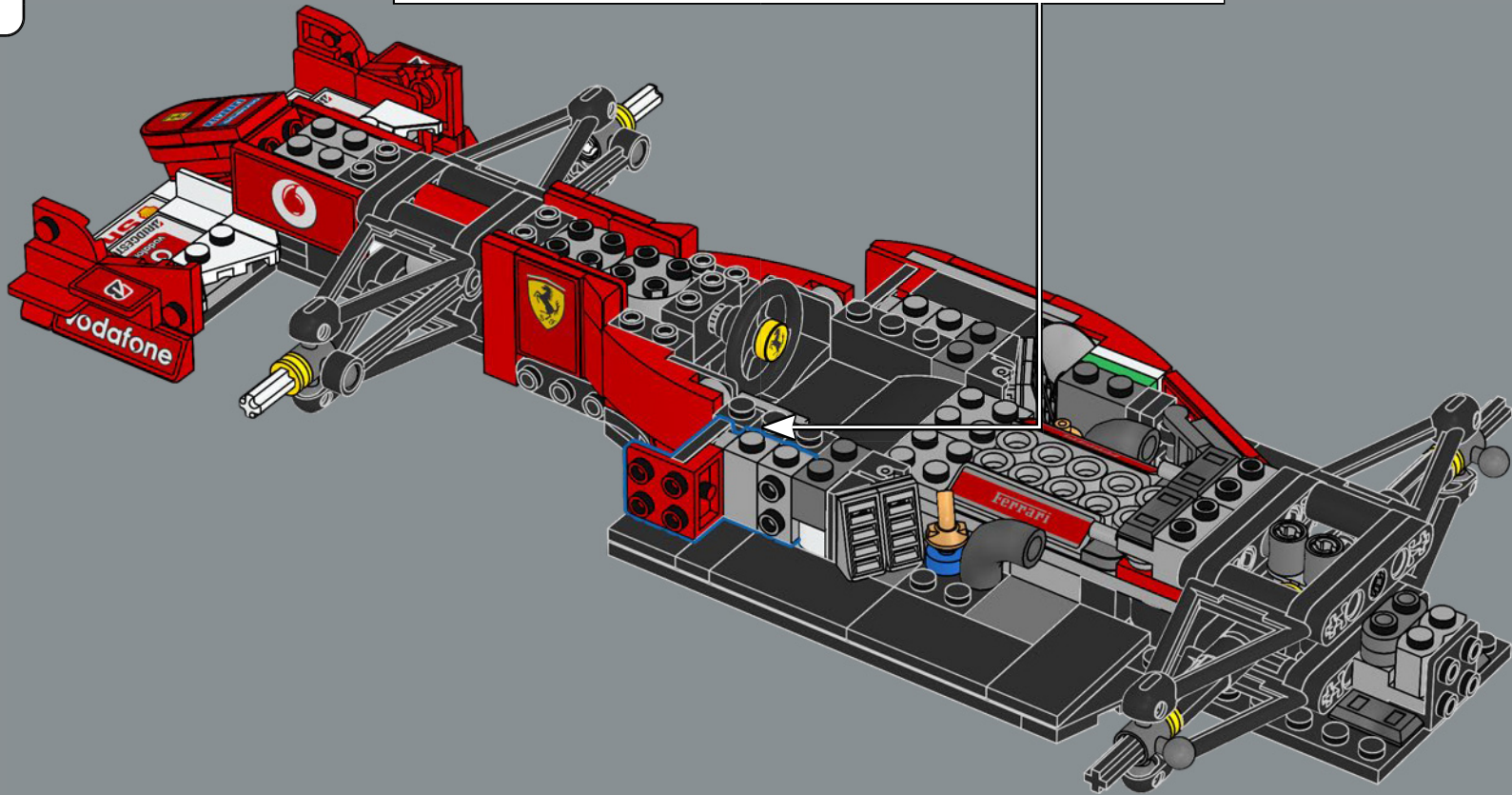
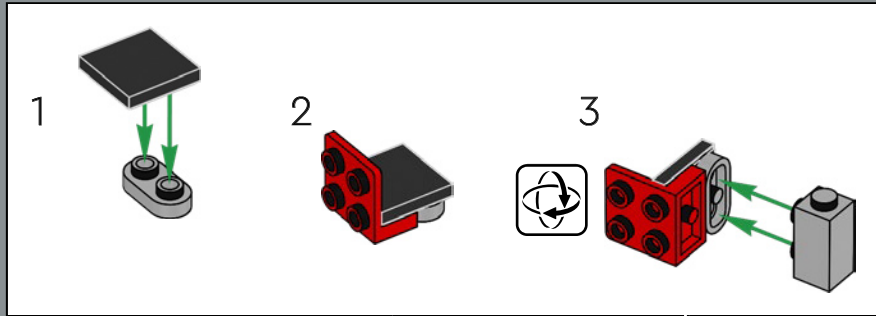

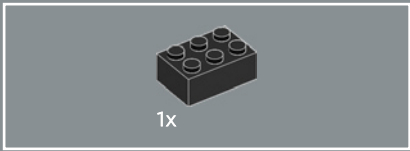

96

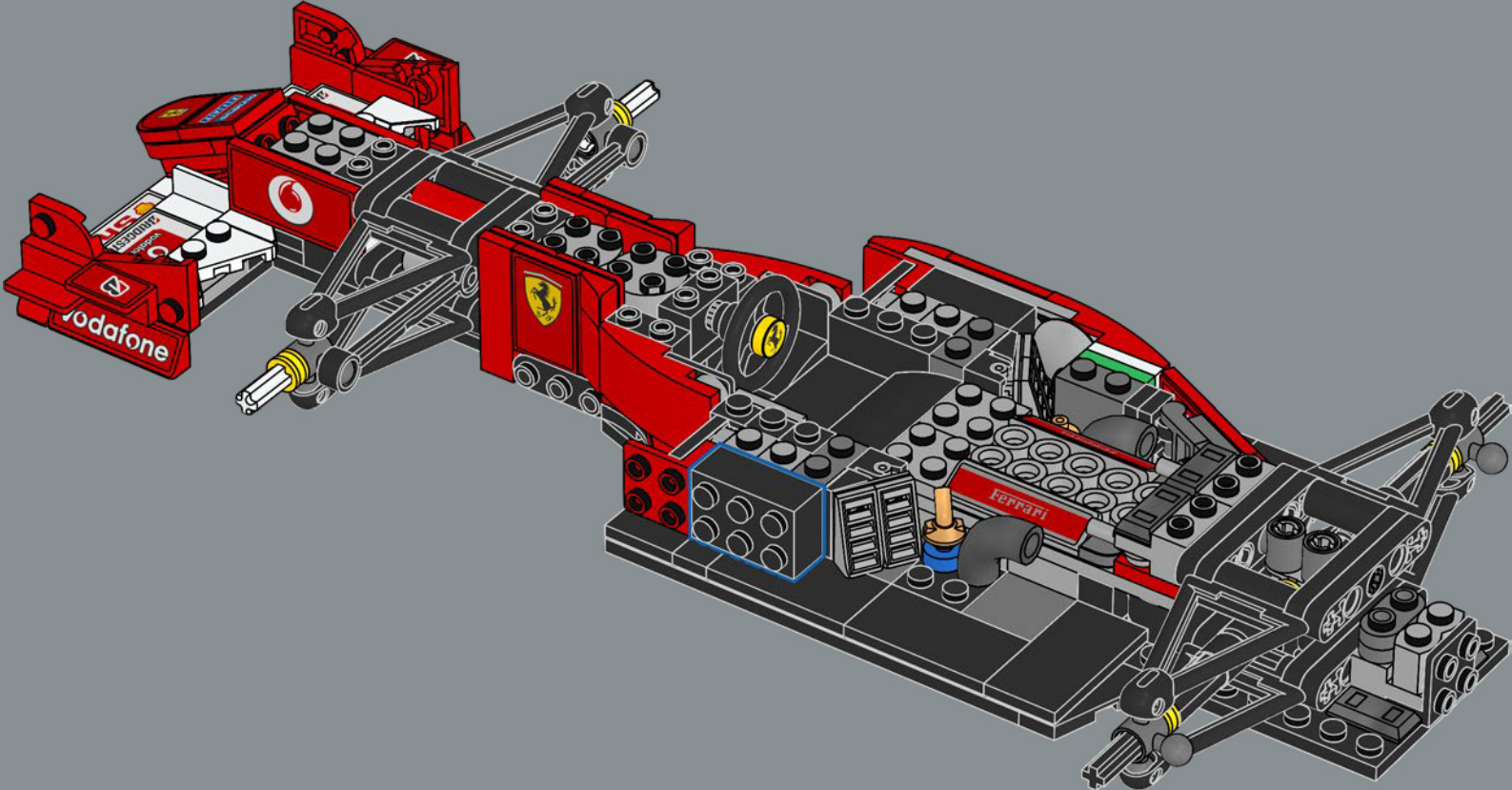

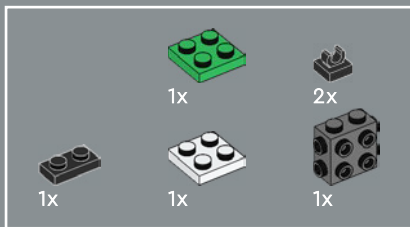

97

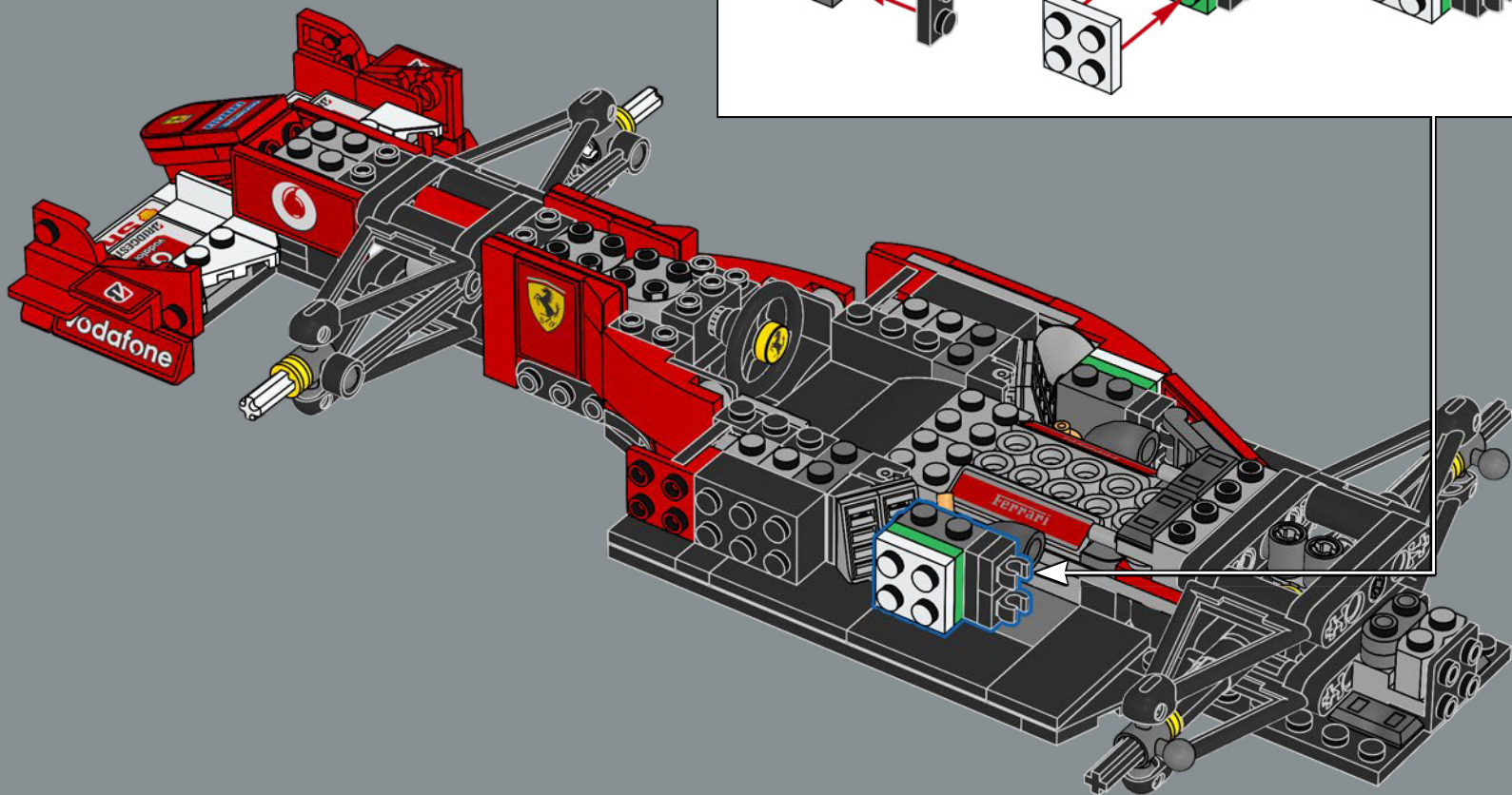
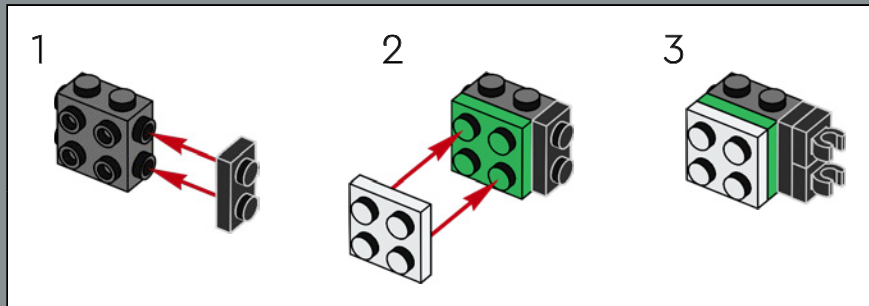

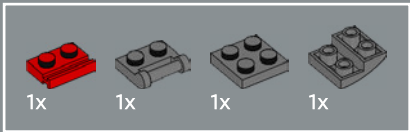

98

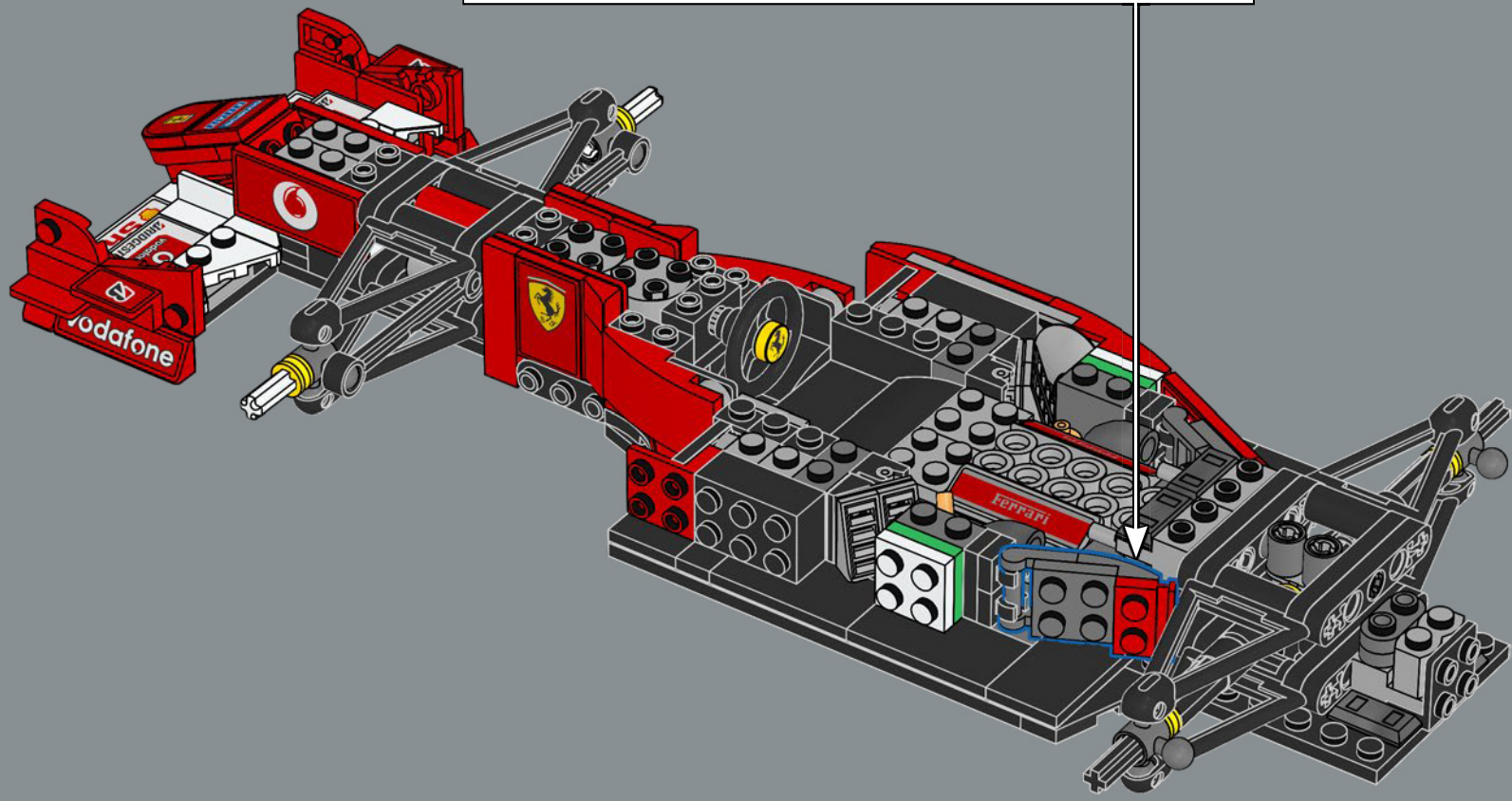
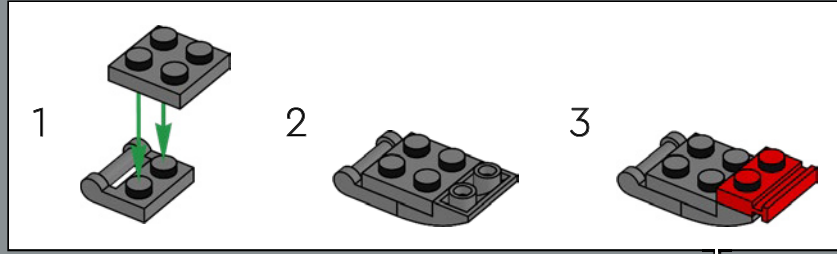

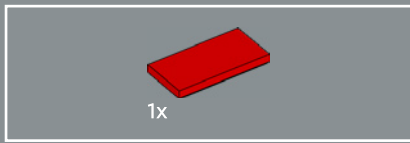

99

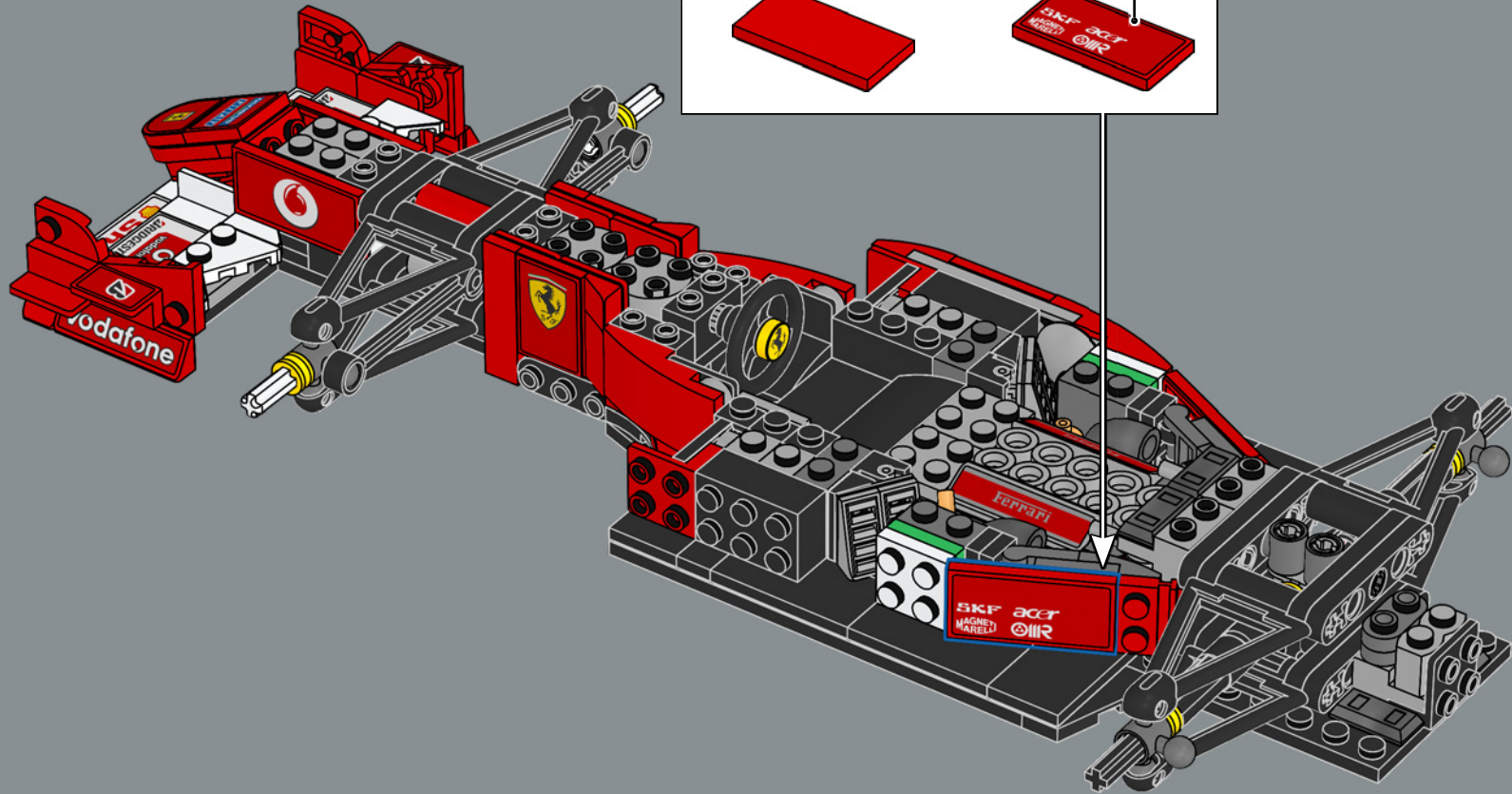
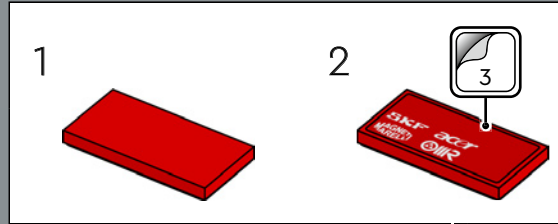

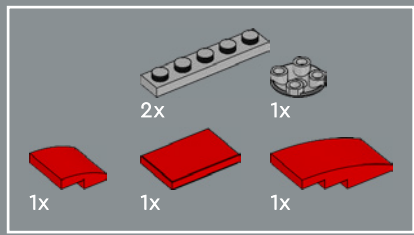

100

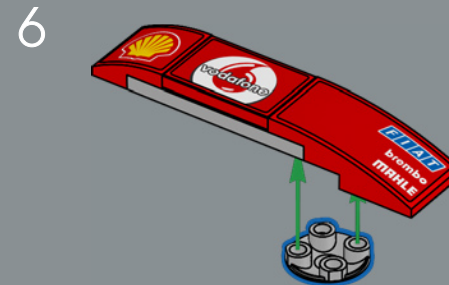
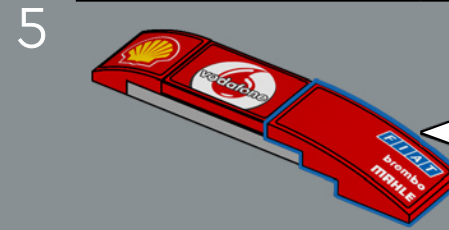
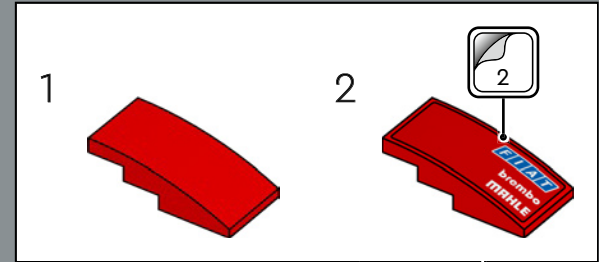
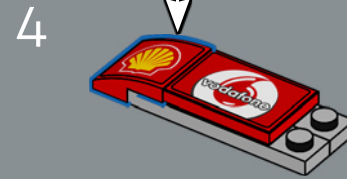
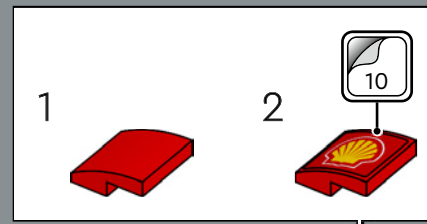
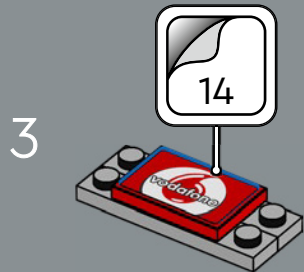
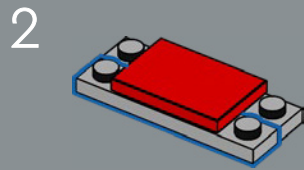
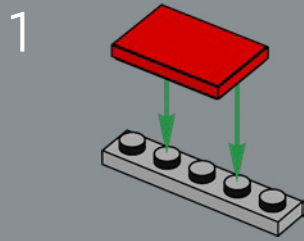

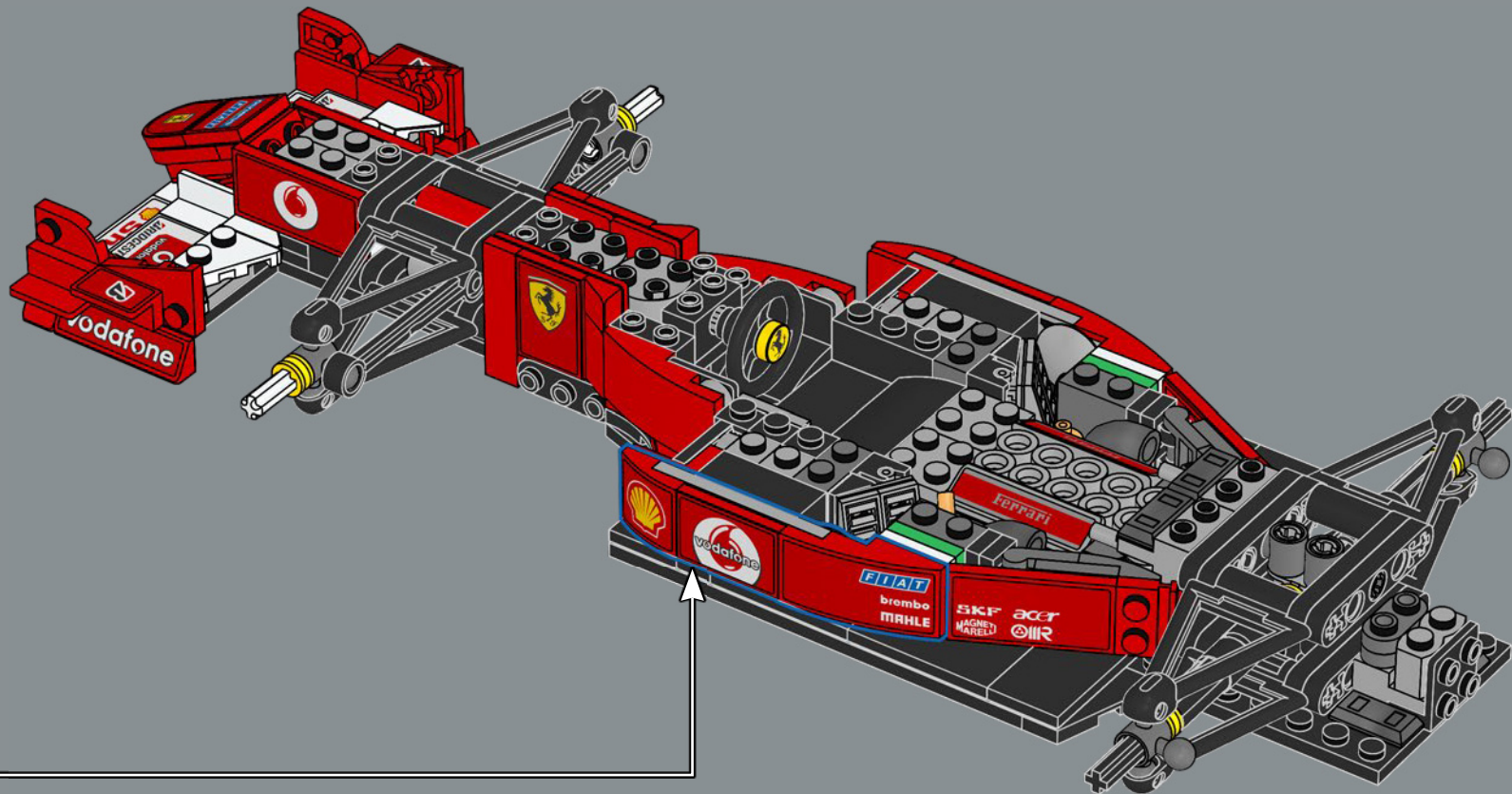

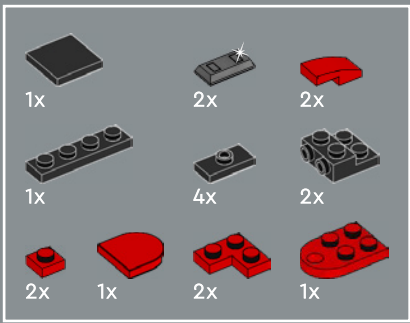

101

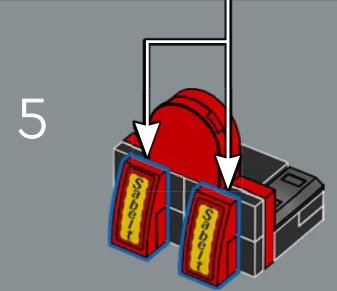
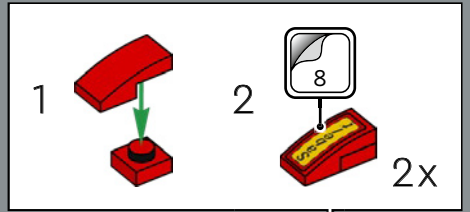
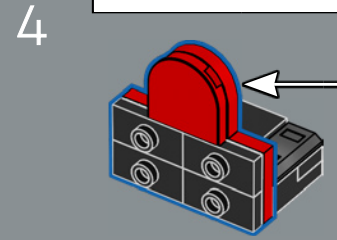
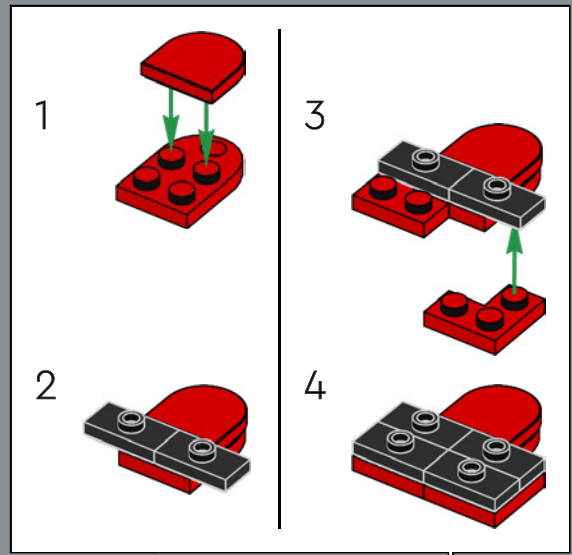
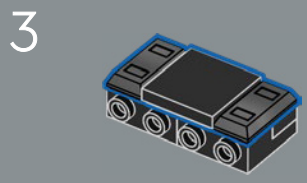
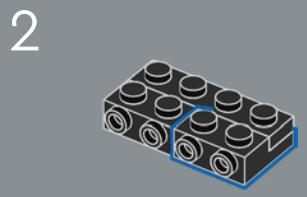
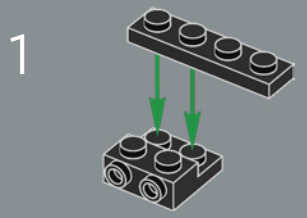

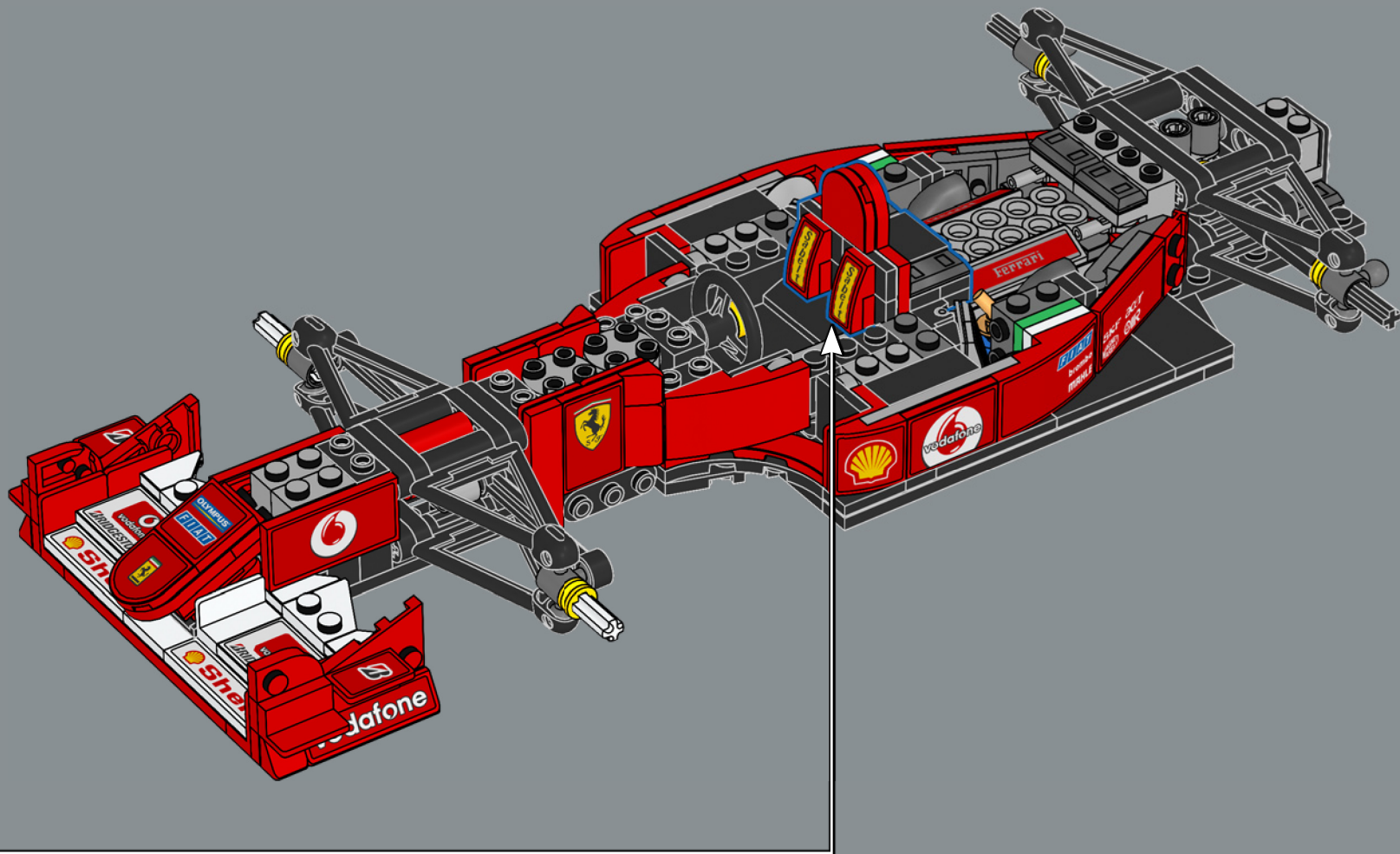

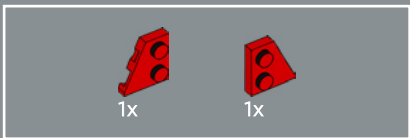

102

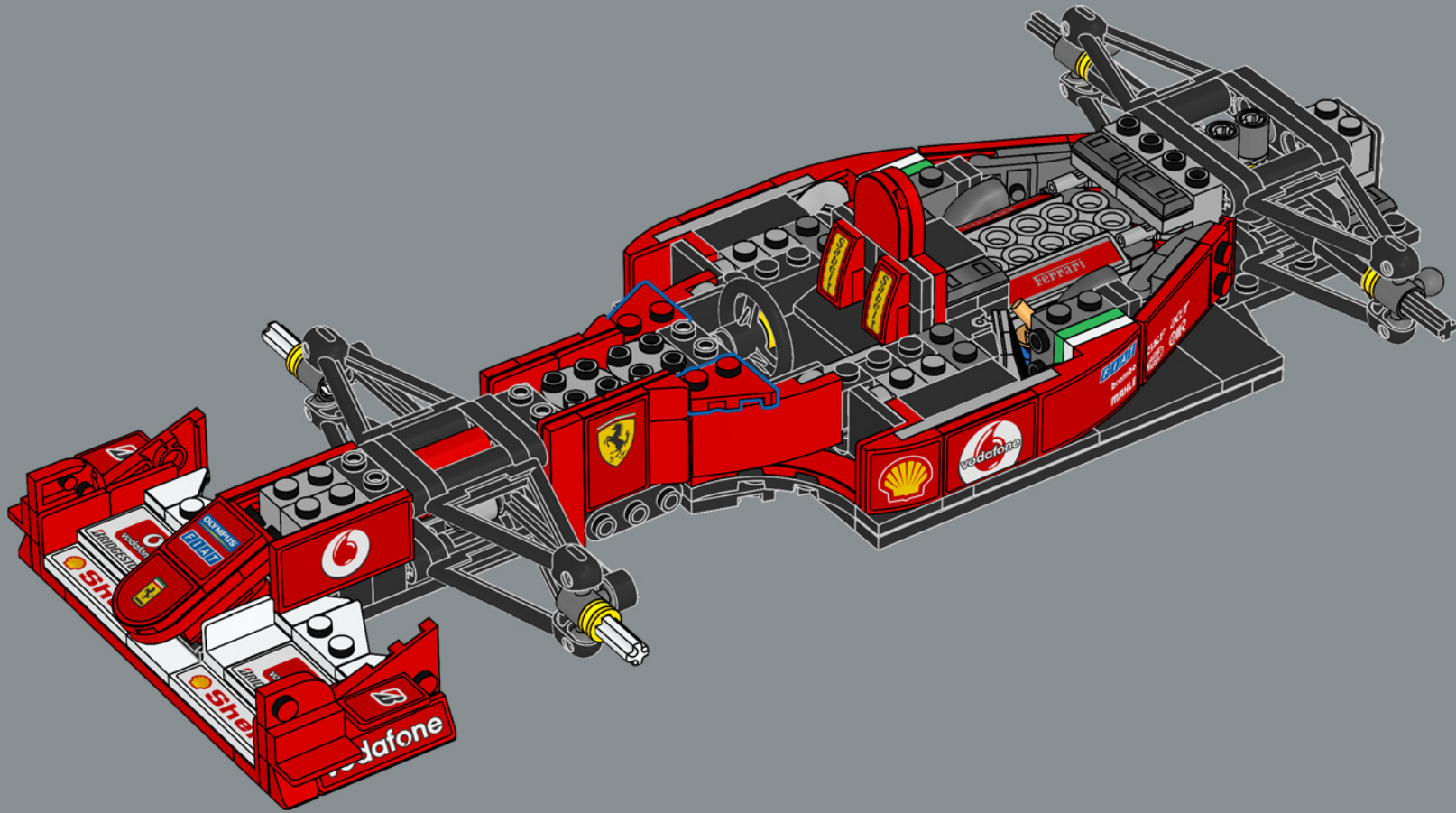

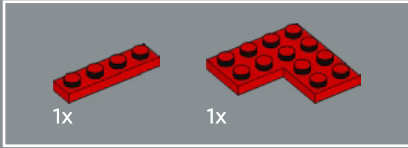
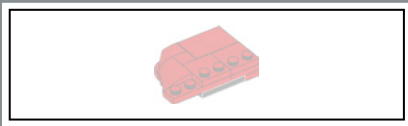

103

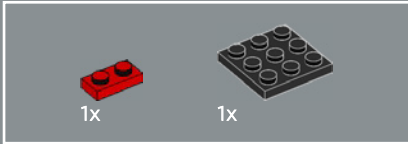
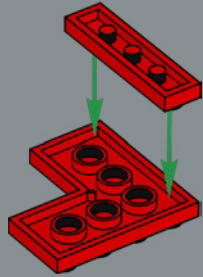

104

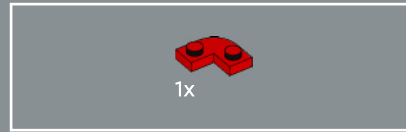
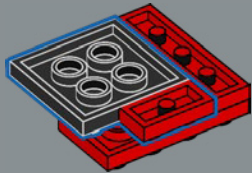

105

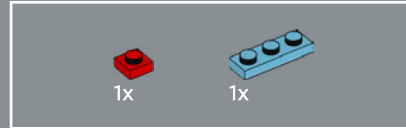
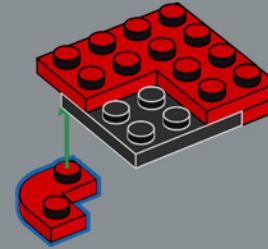

106

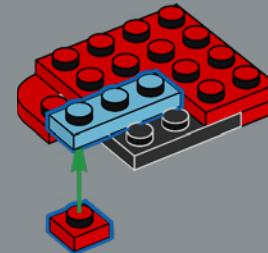

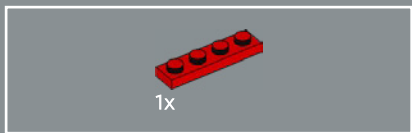

107

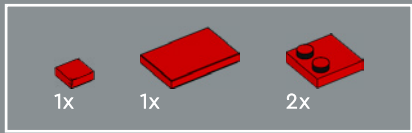
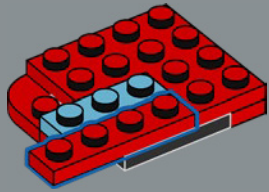

108

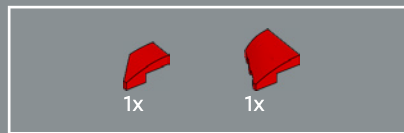
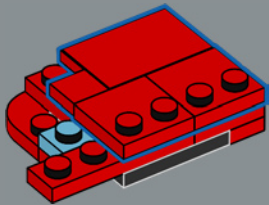

109

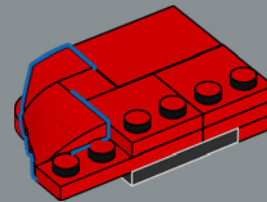

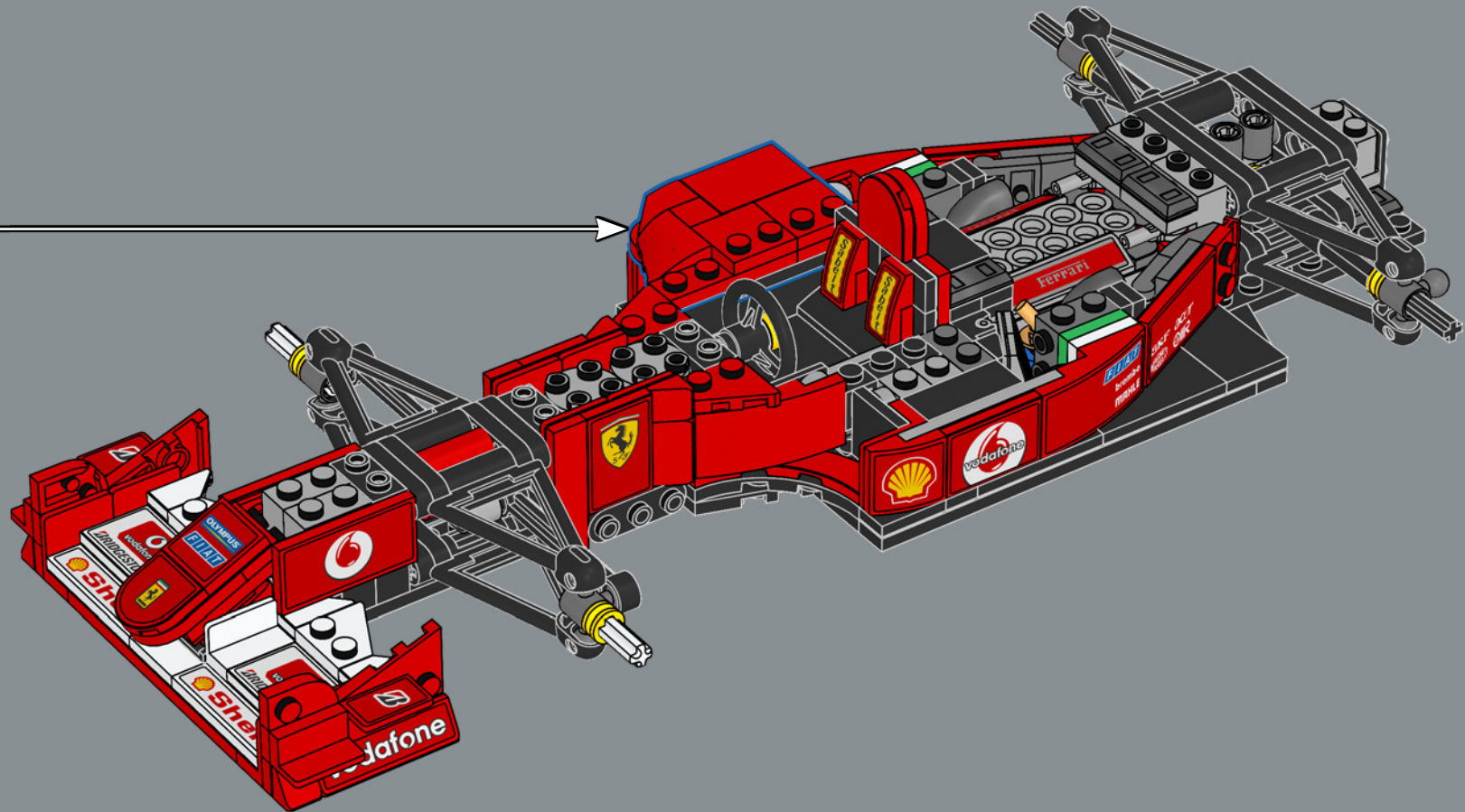

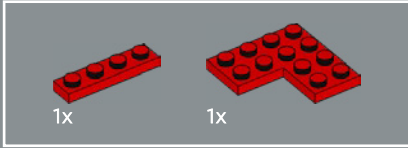
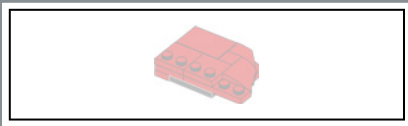

111

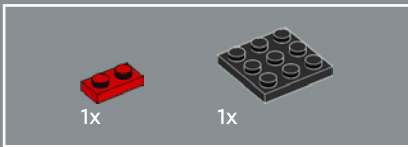
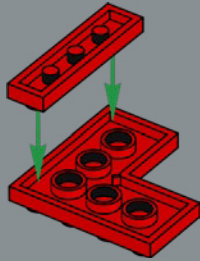

112

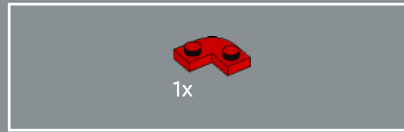
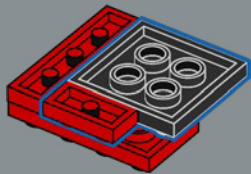

113

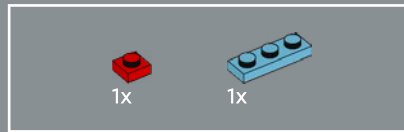
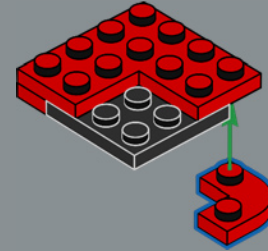

114

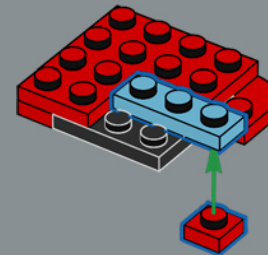

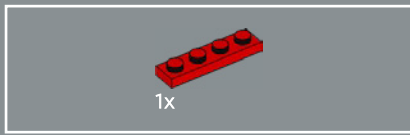

115

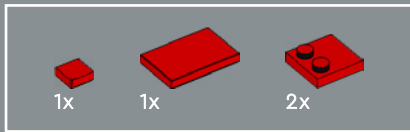
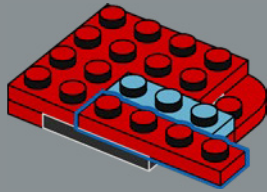

116

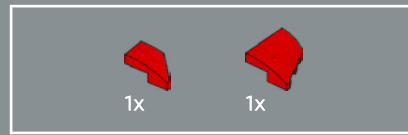
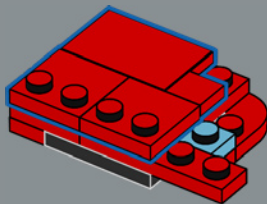

117

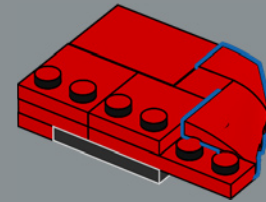

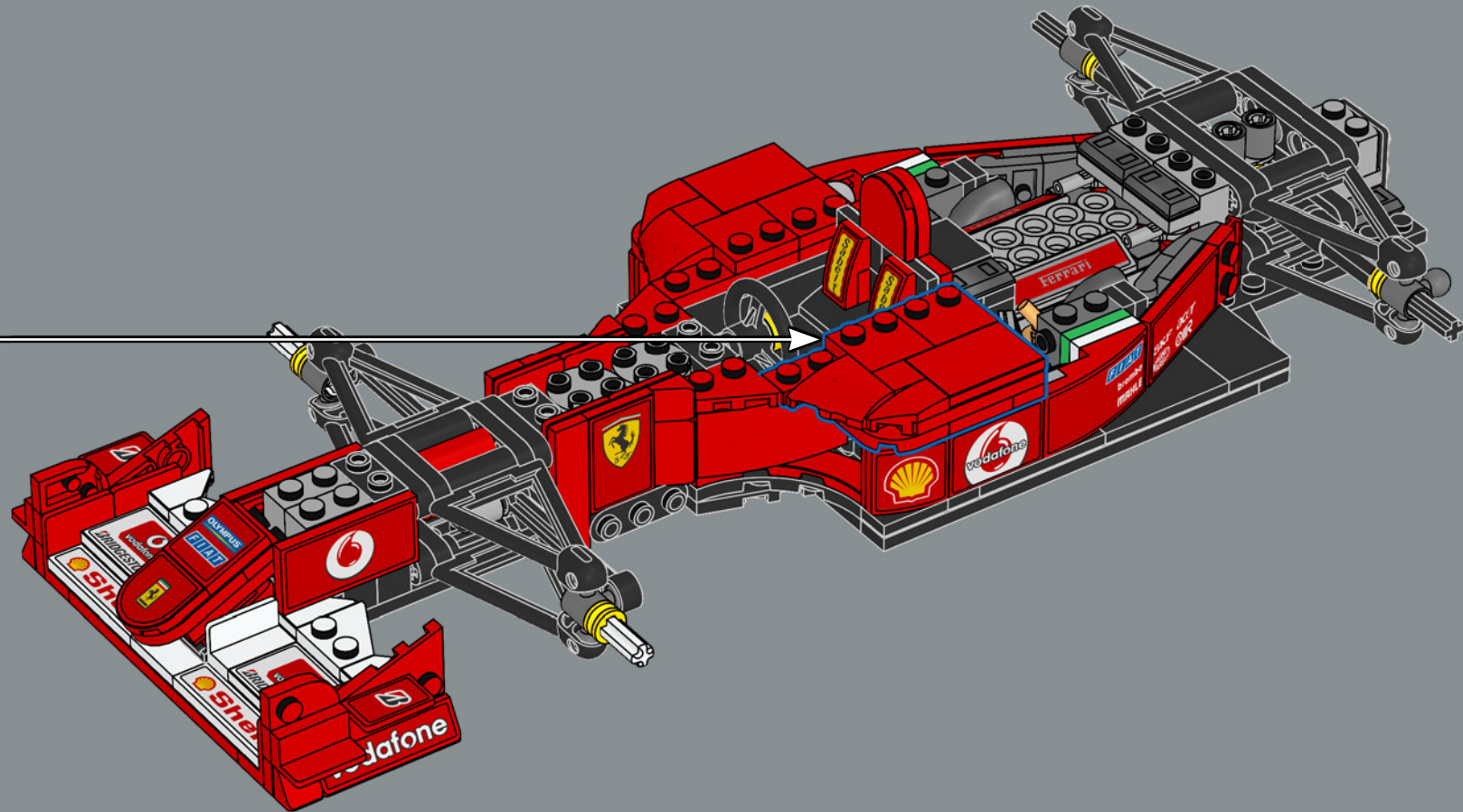

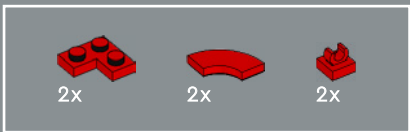

119

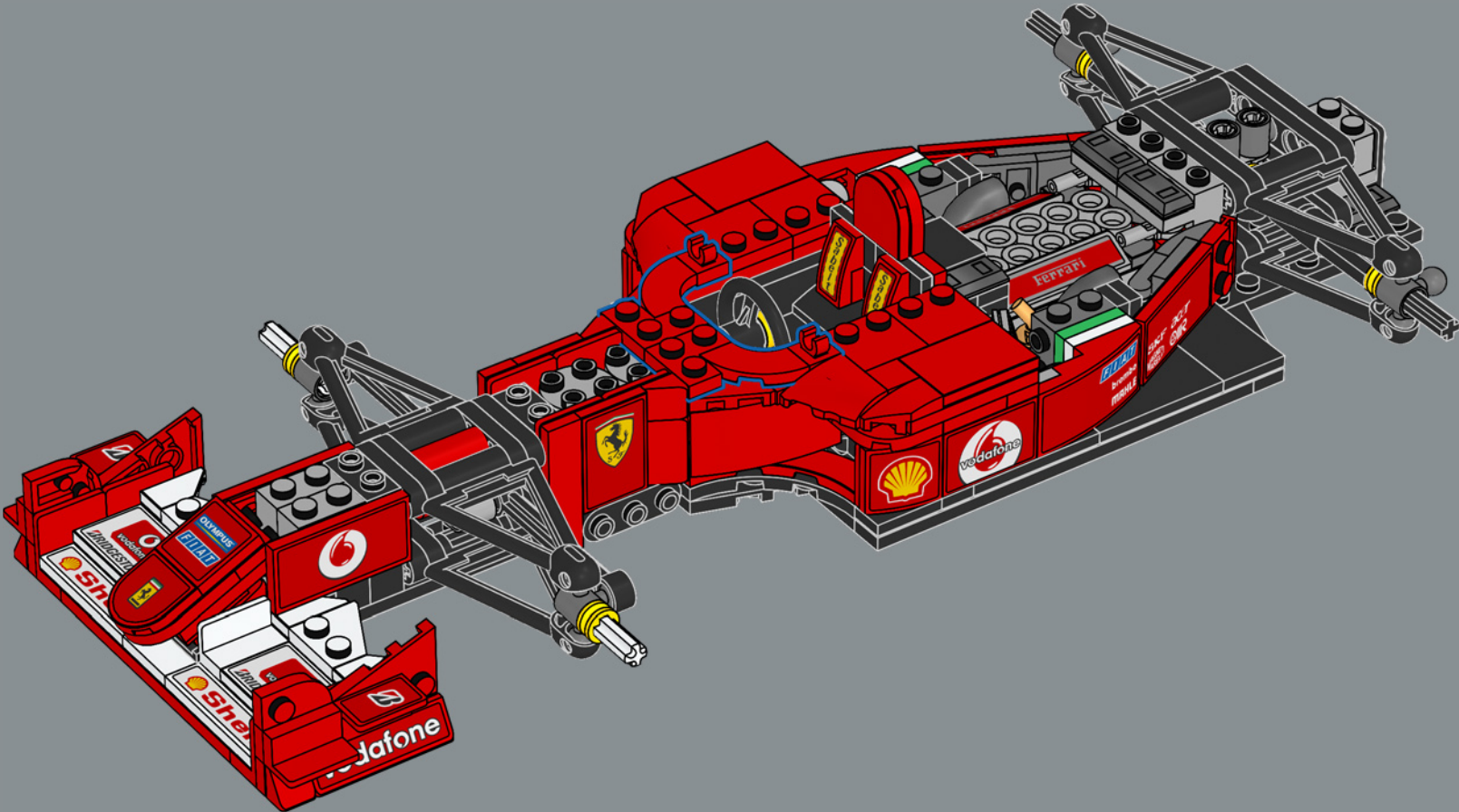

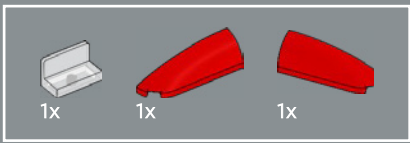

120

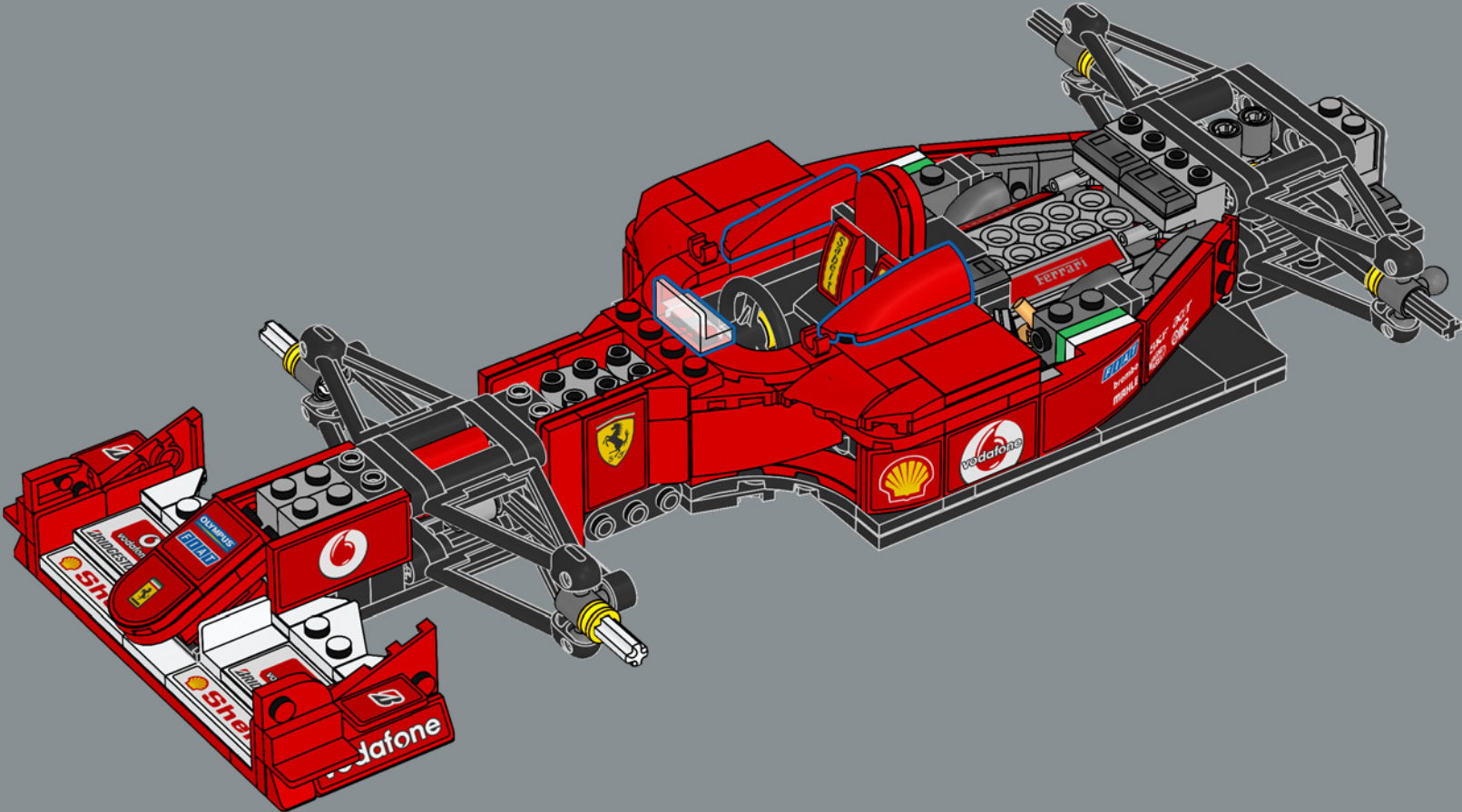

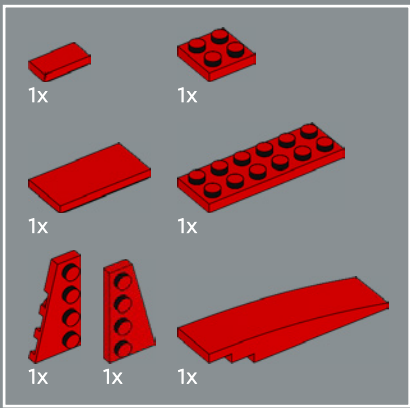

122

1

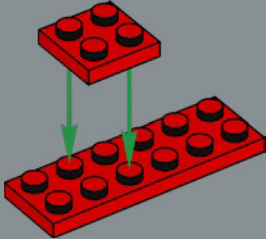

2

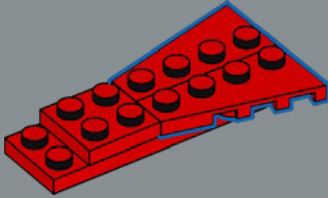

3

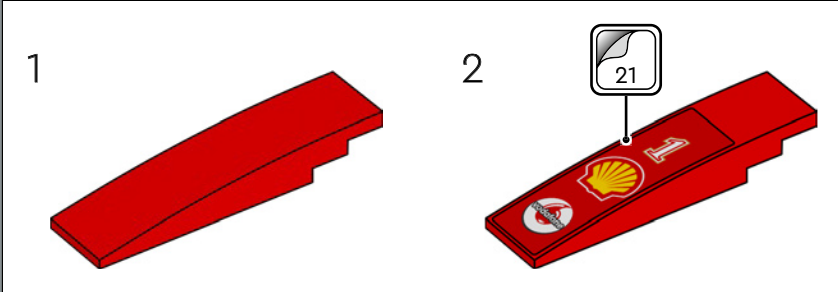
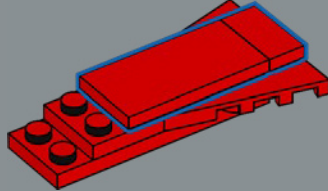

4

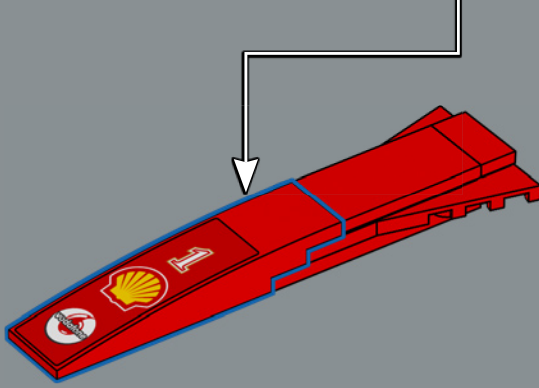

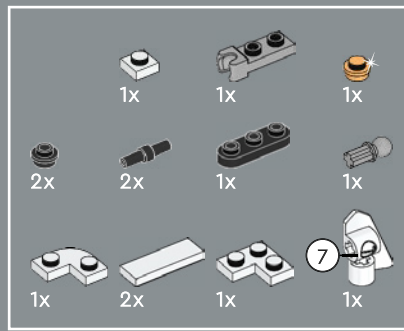

123

1

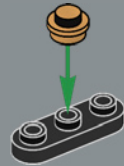

2



3

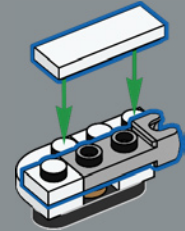

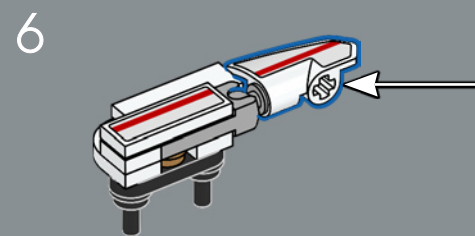
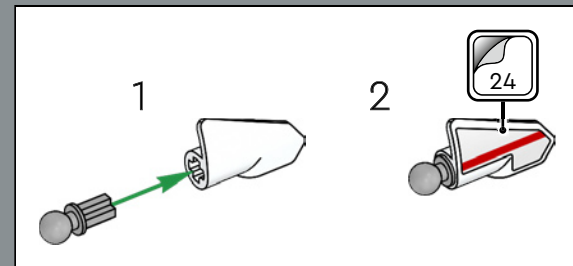
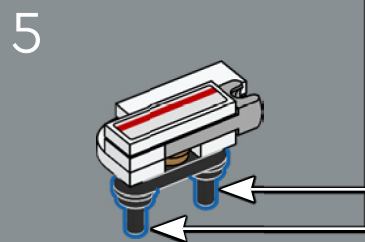
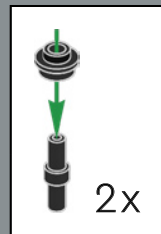
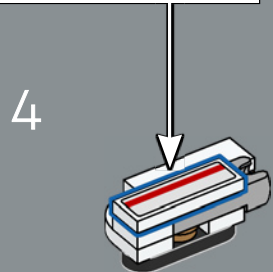
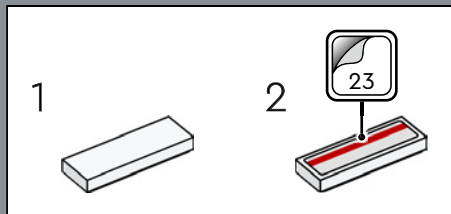

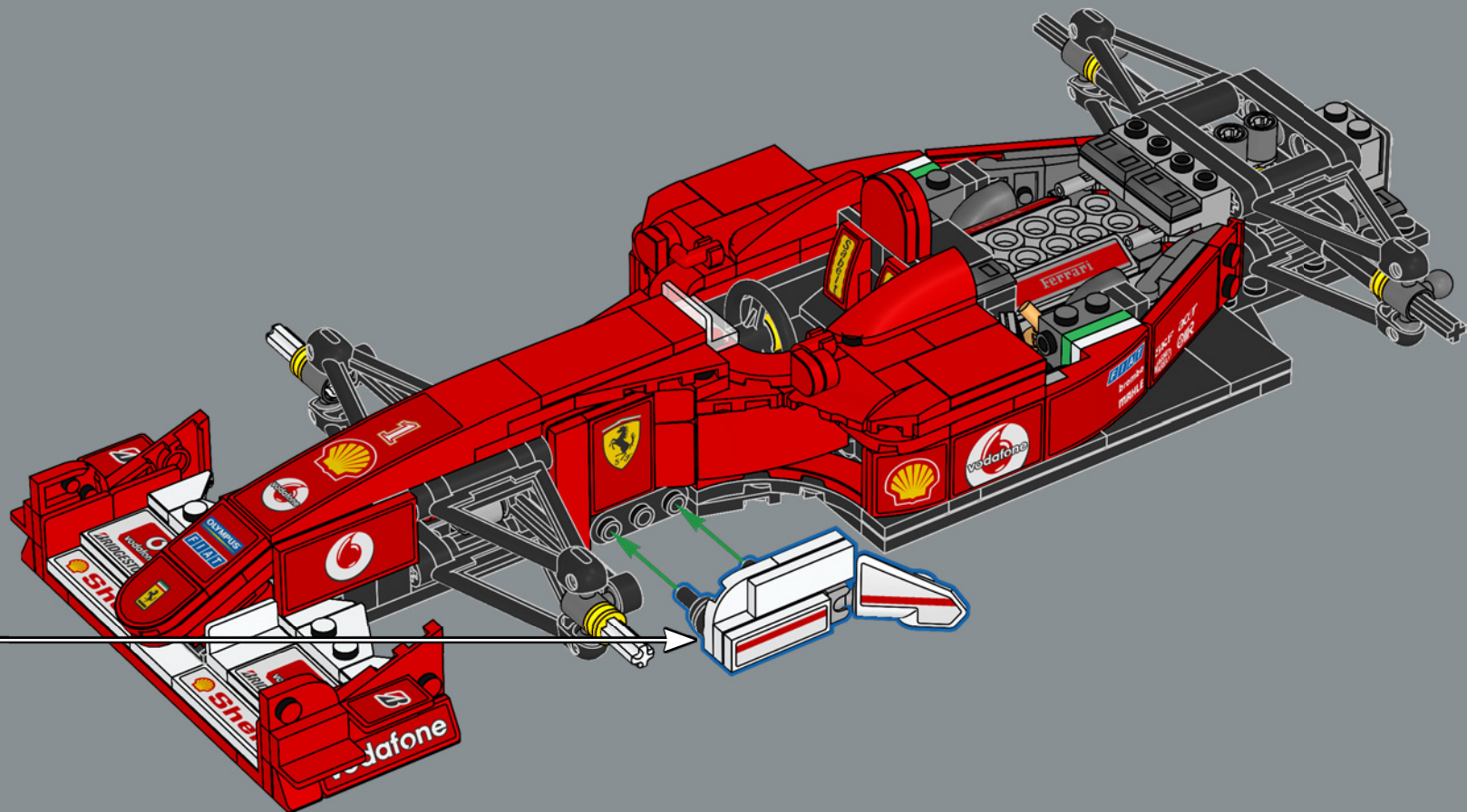

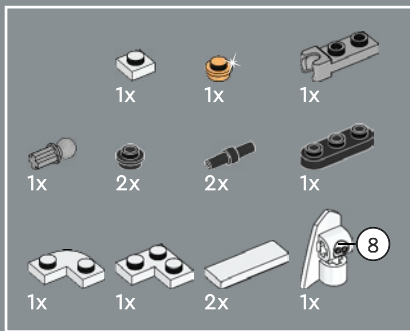

124

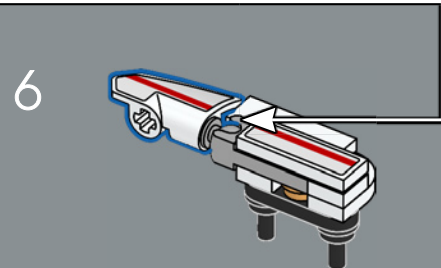
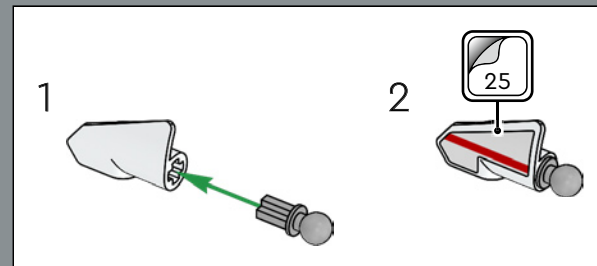
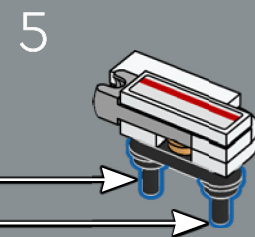
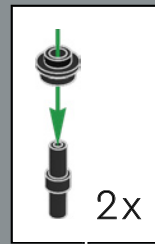
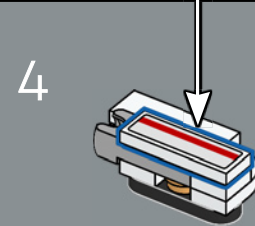
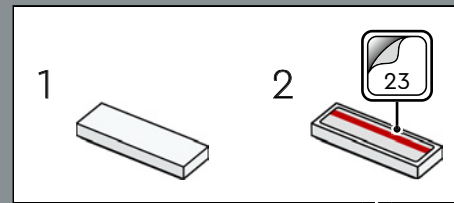
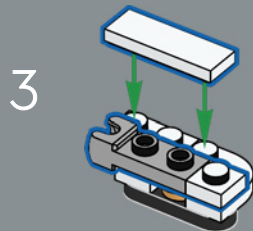
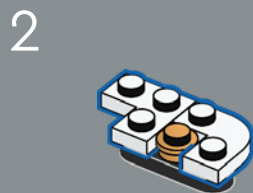
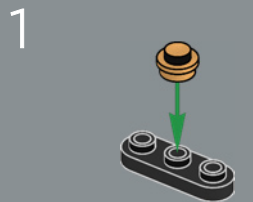

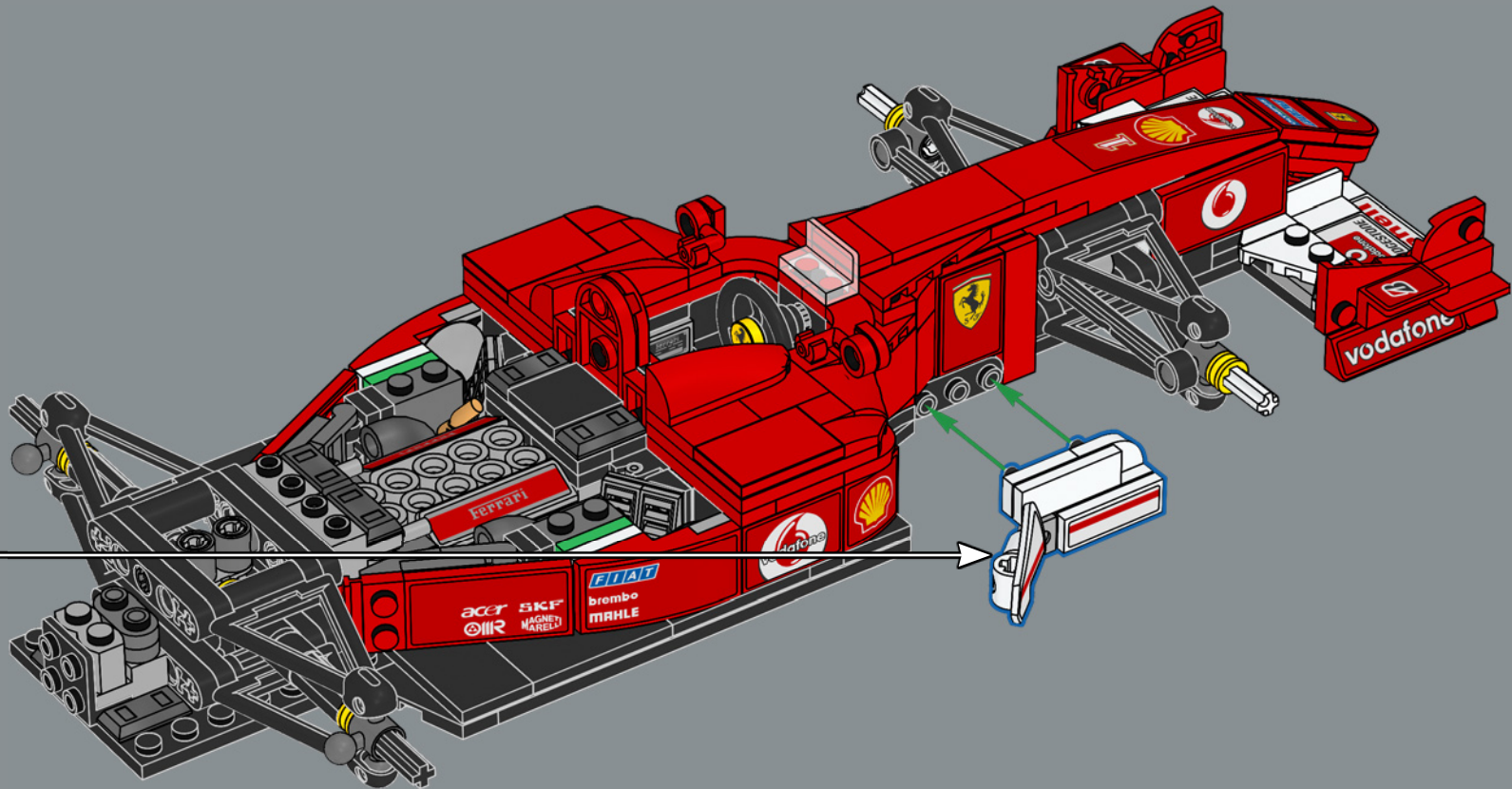

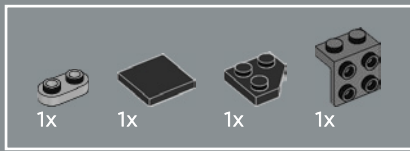

125

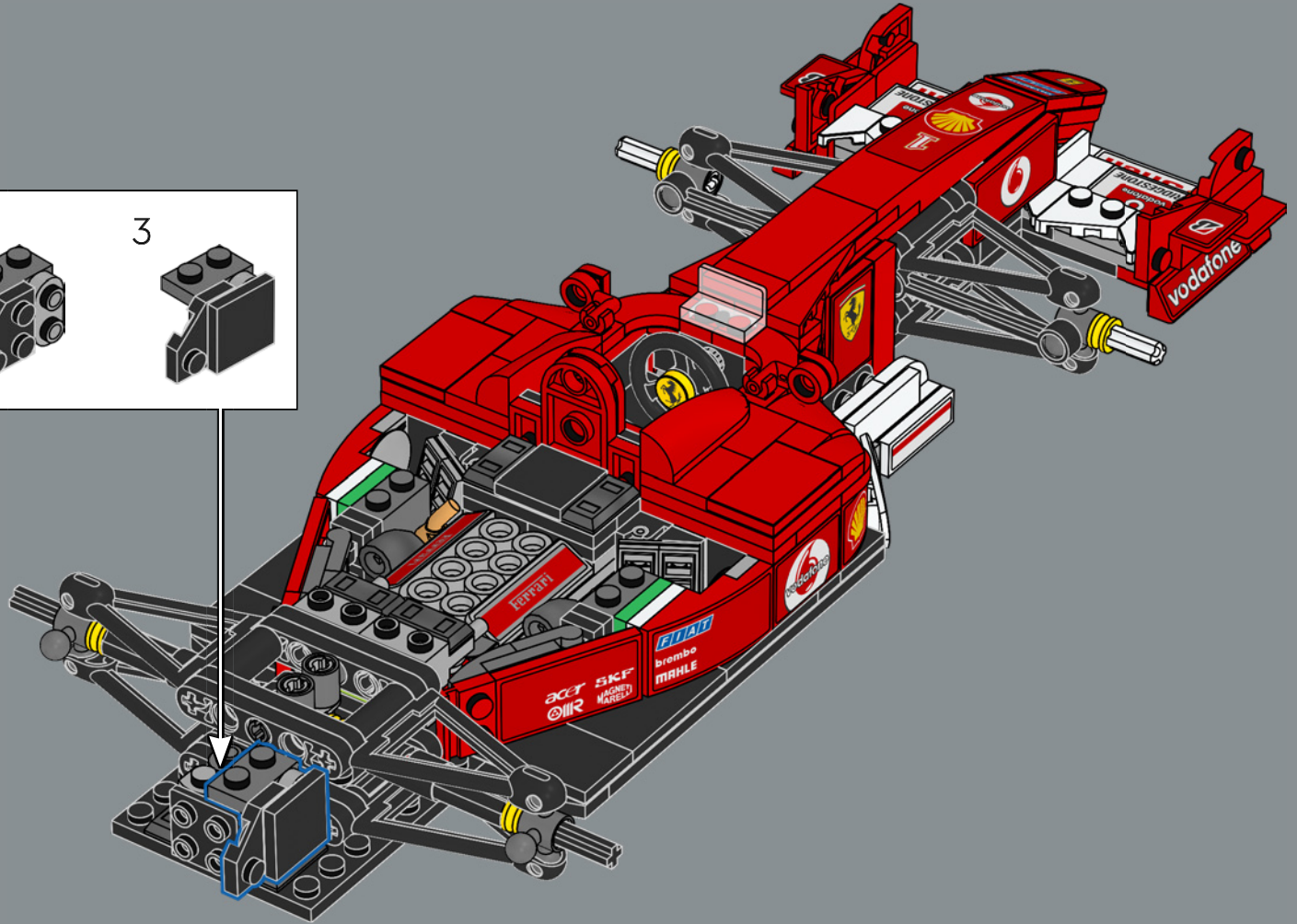
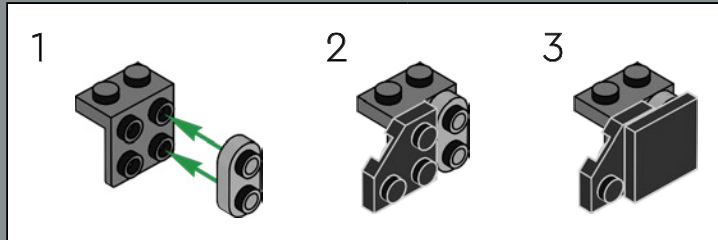

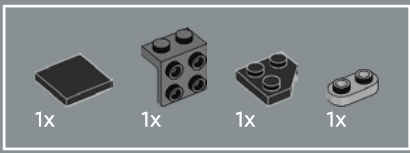

126

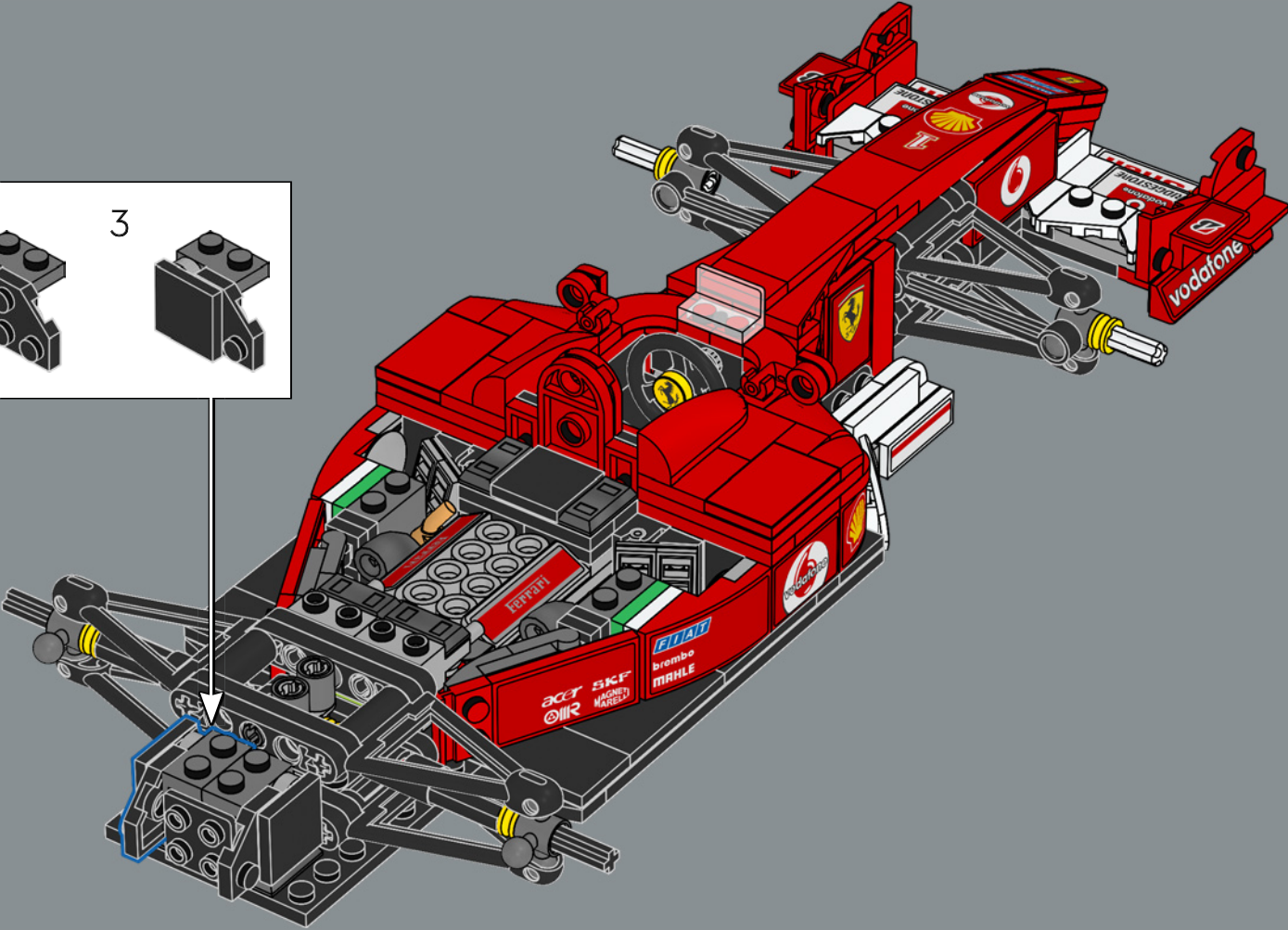
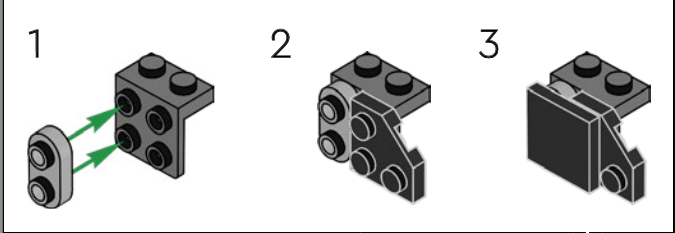

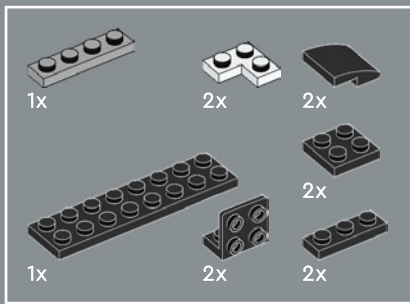

127

1

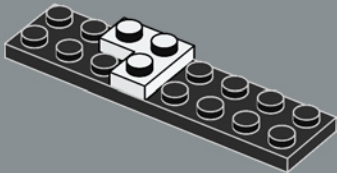

2

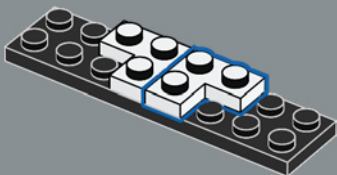

3

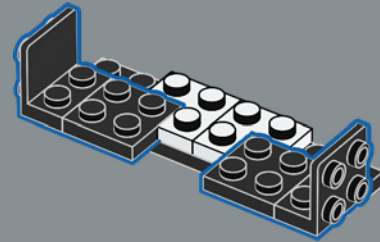

4

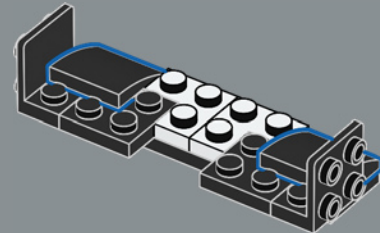

5

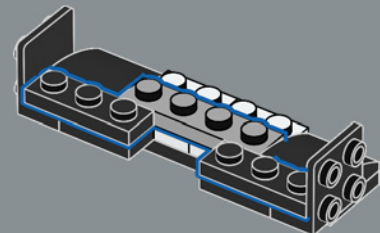

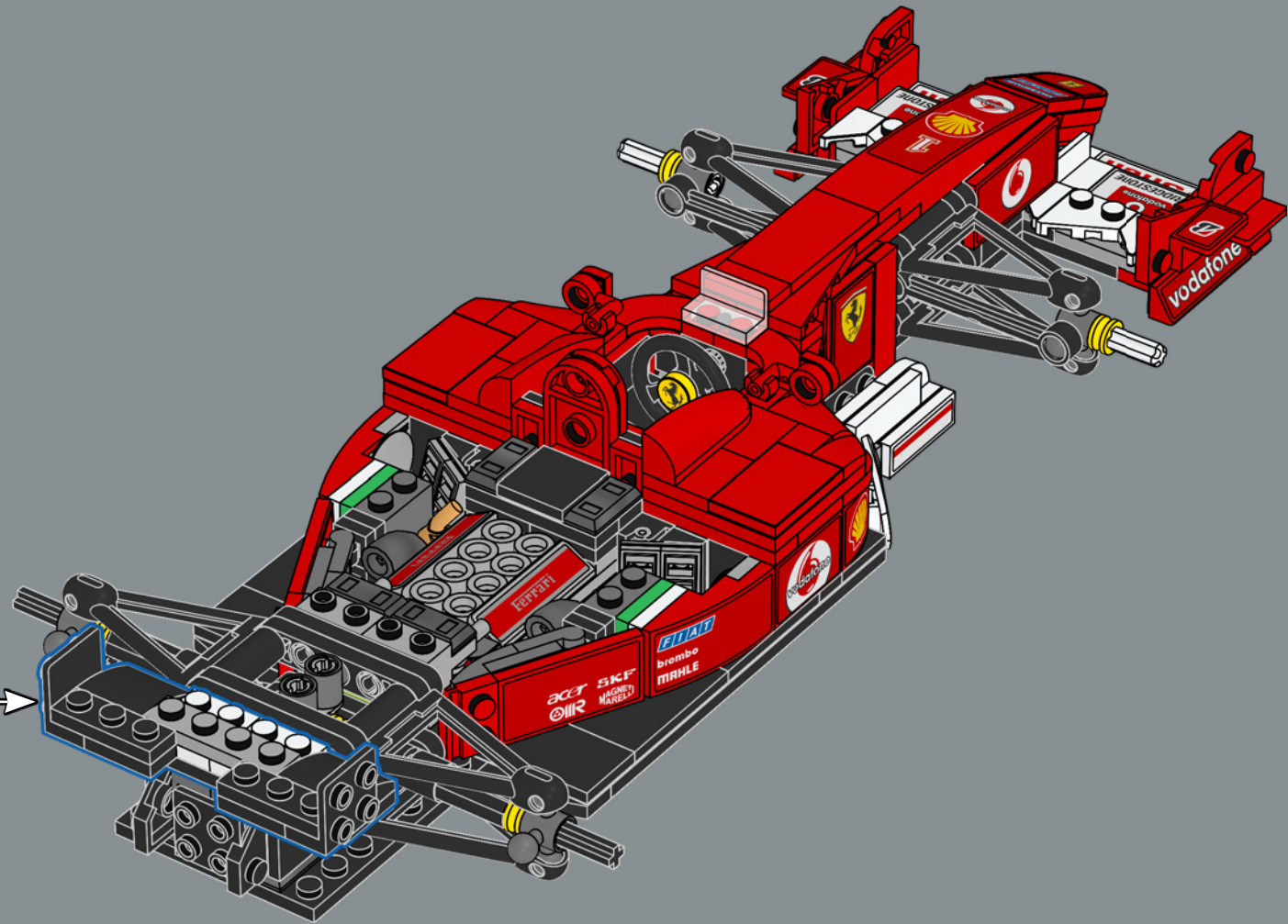

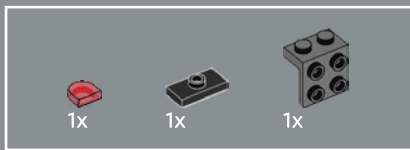

128

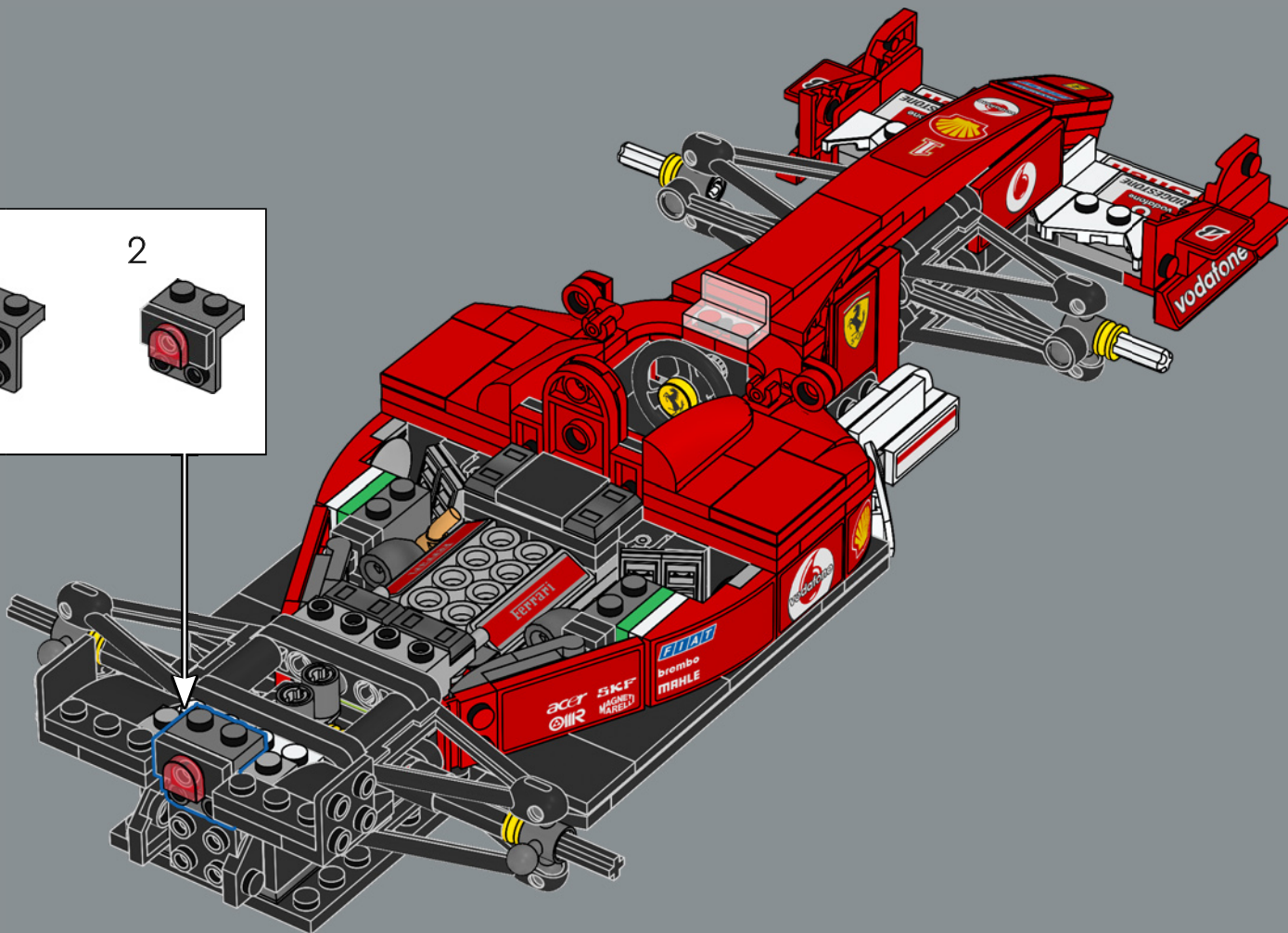
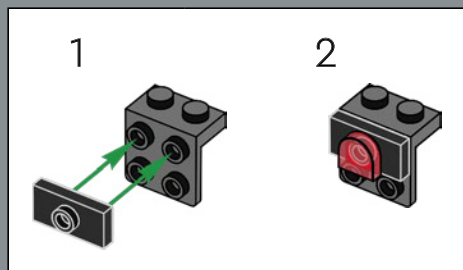

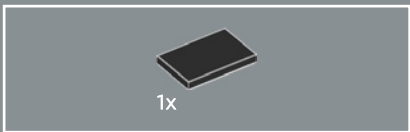

129

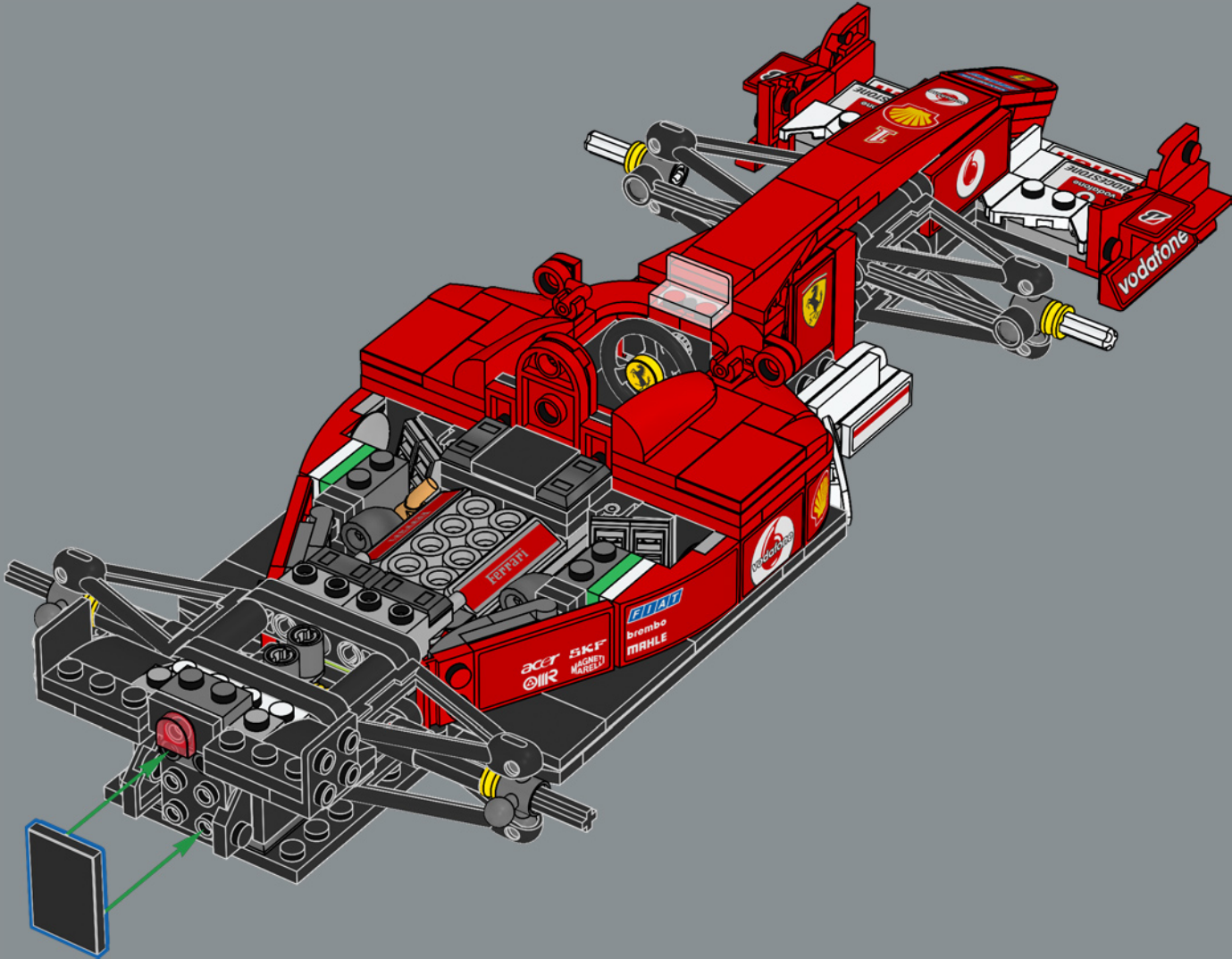

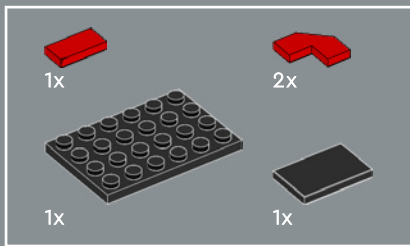

130

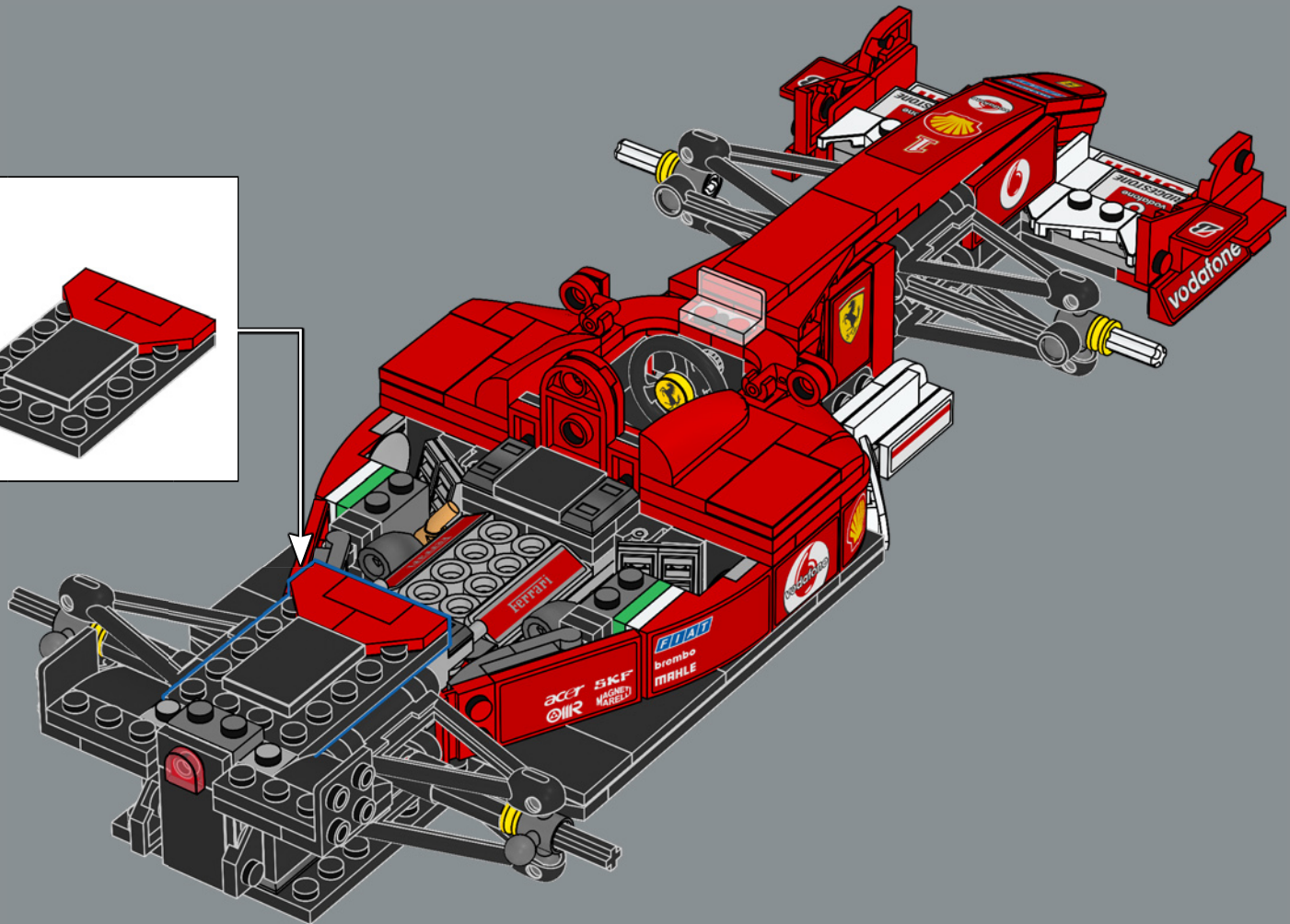
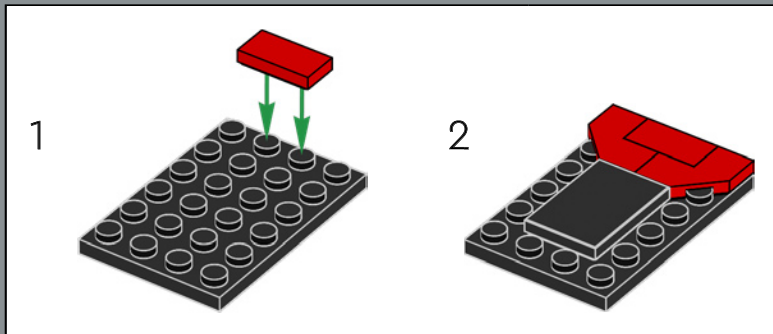

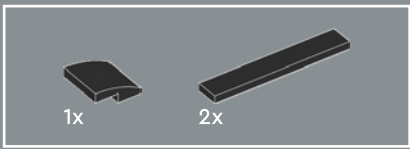

131

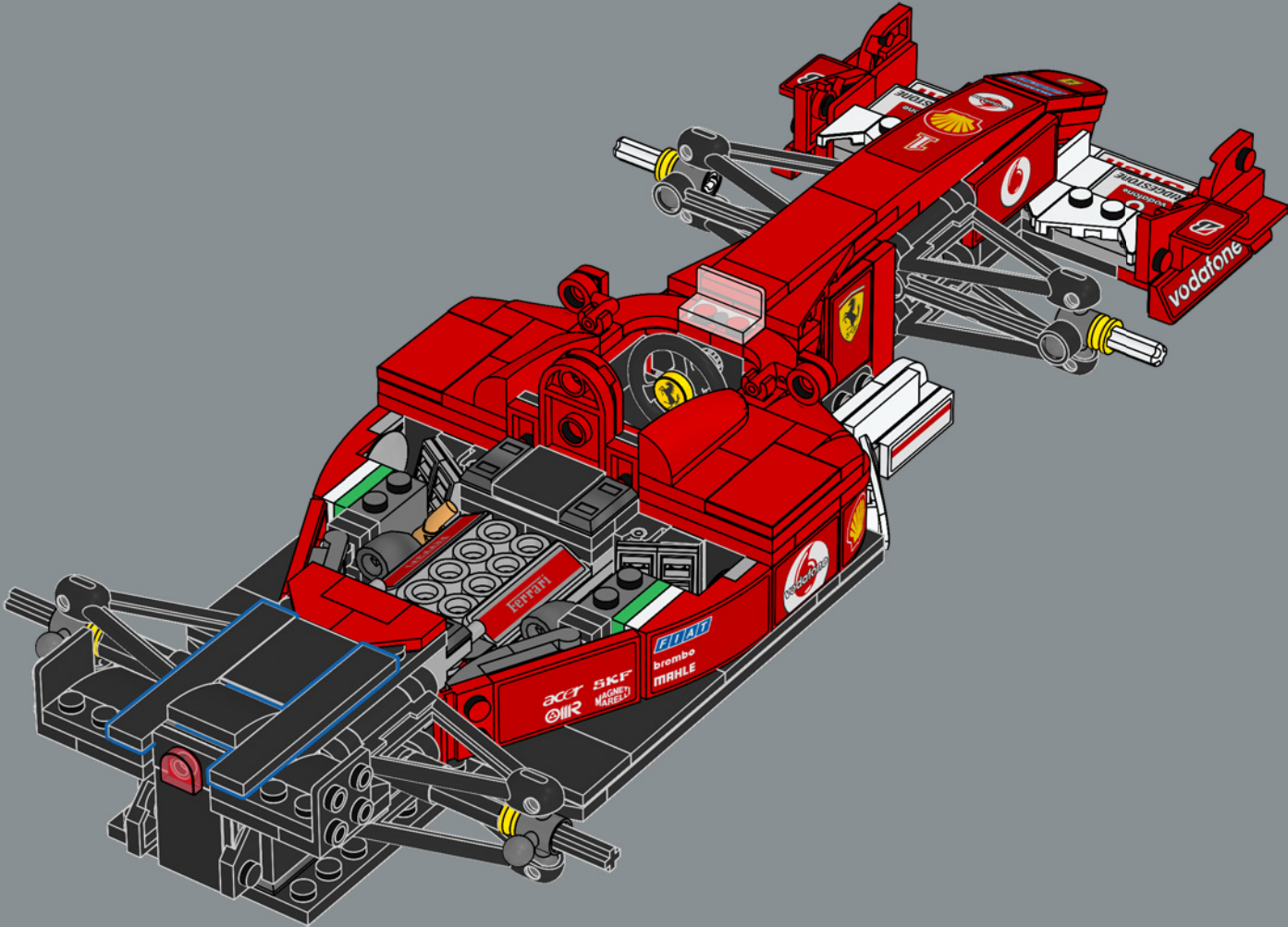

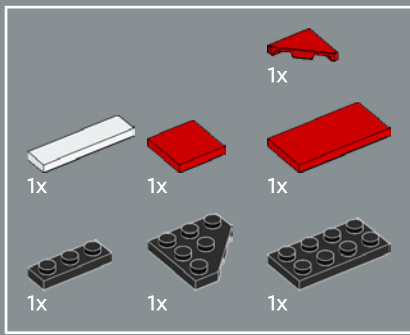

132

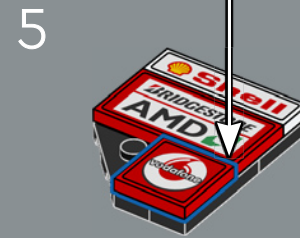
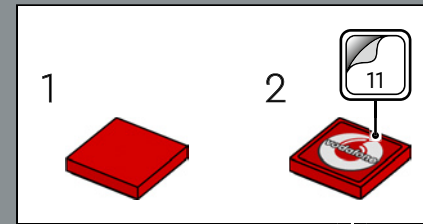
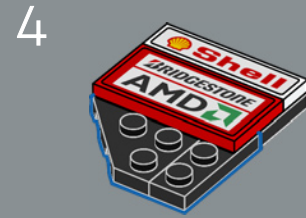
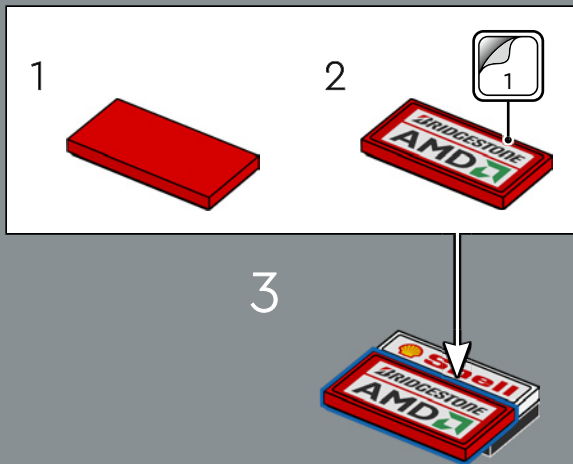
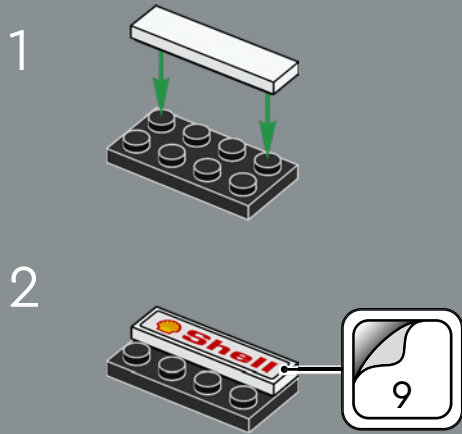

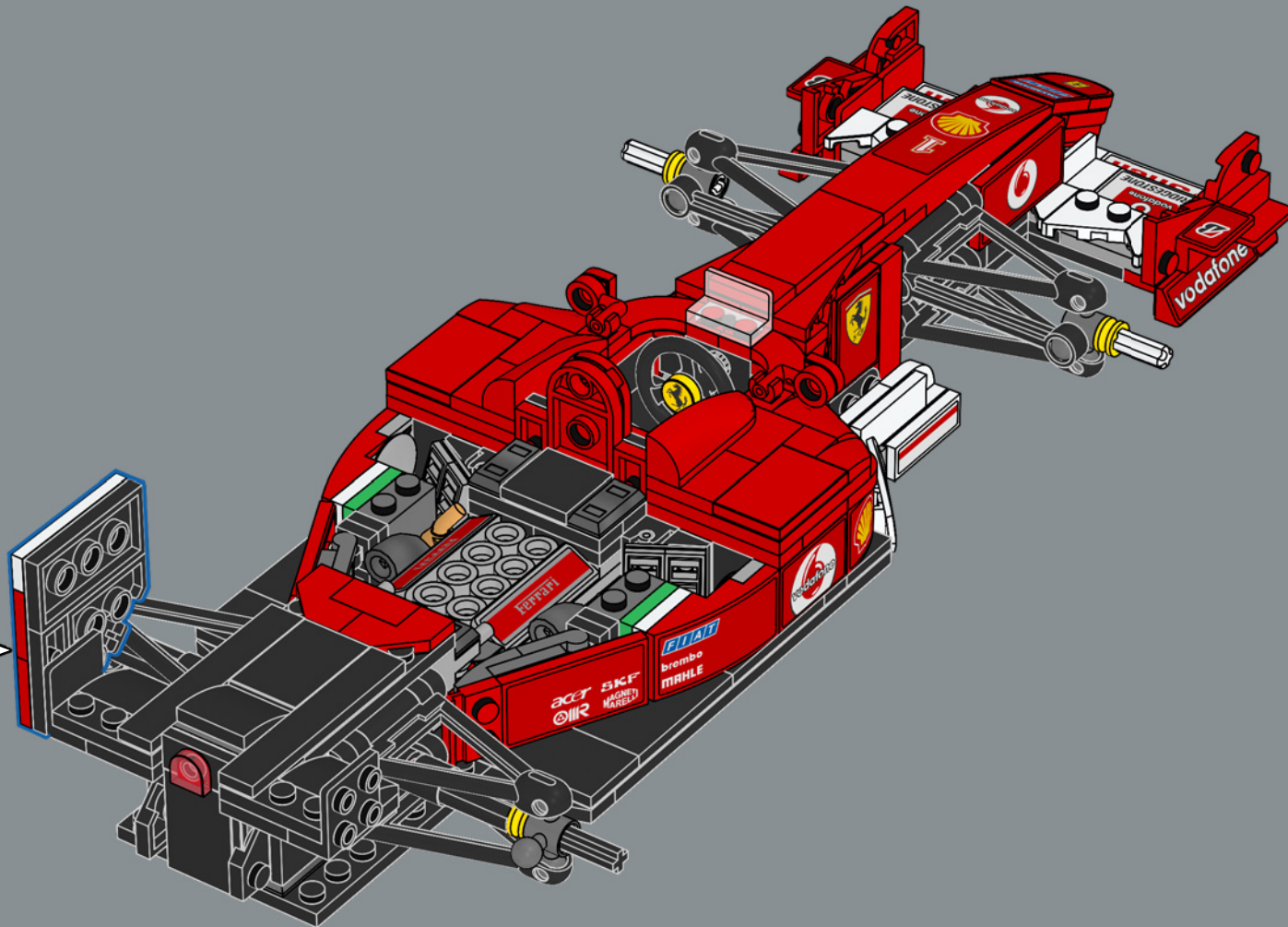

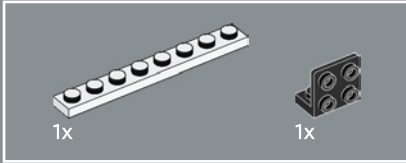
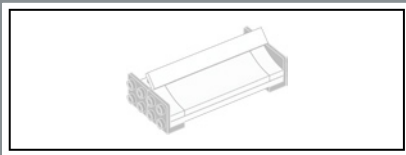

133

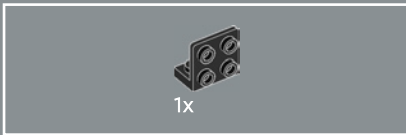
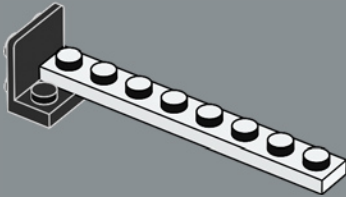

134

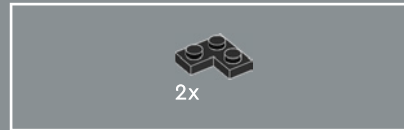
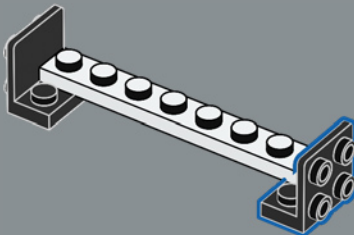

2x

135

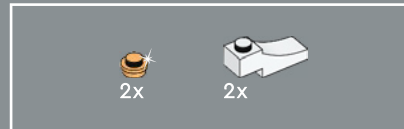
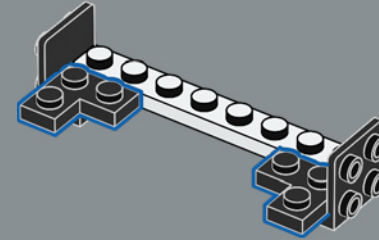

136

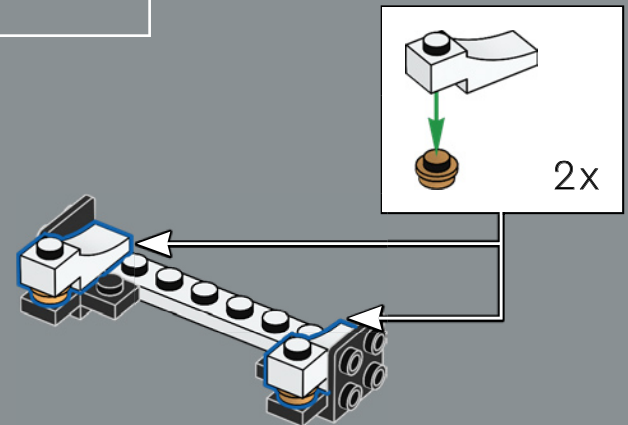

2x



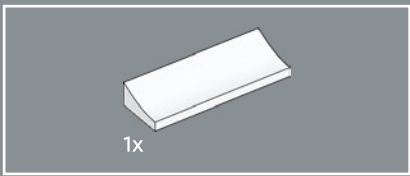

137

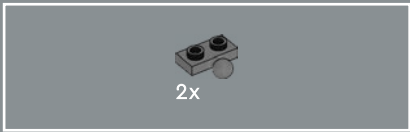
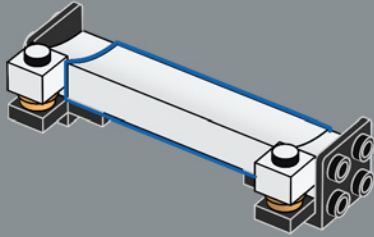

138

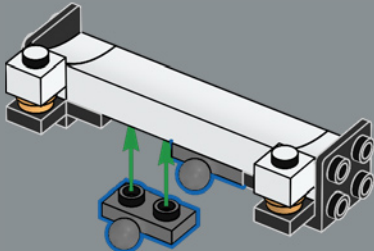

139

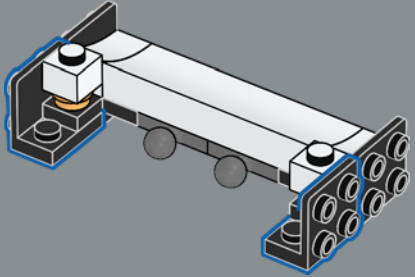

The 2x6 brick with inverted arch was also used in the 2025 LEGO® Speed Champions Formula 1® cars. It's used in white for the first time in this model.

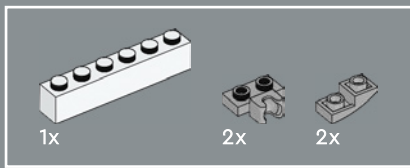

140

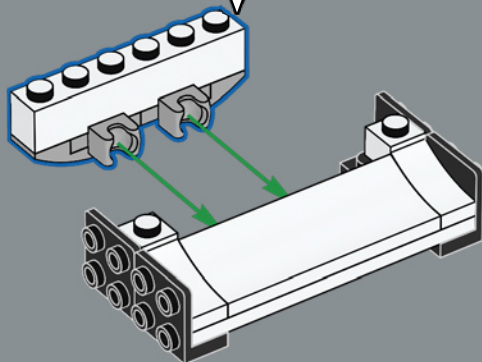
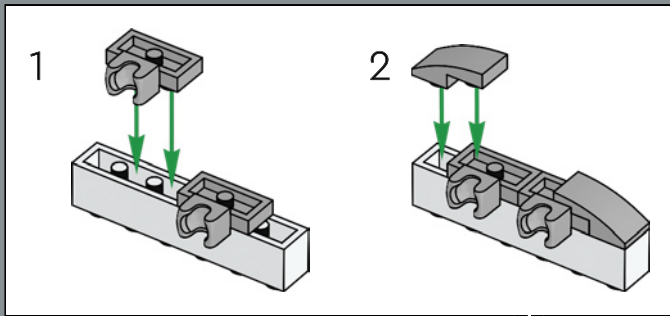

141

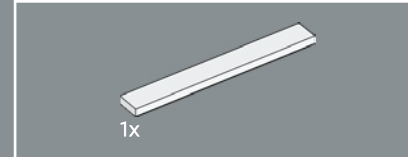
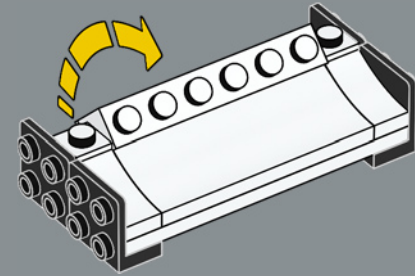

142

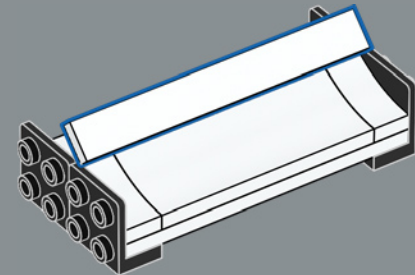

143

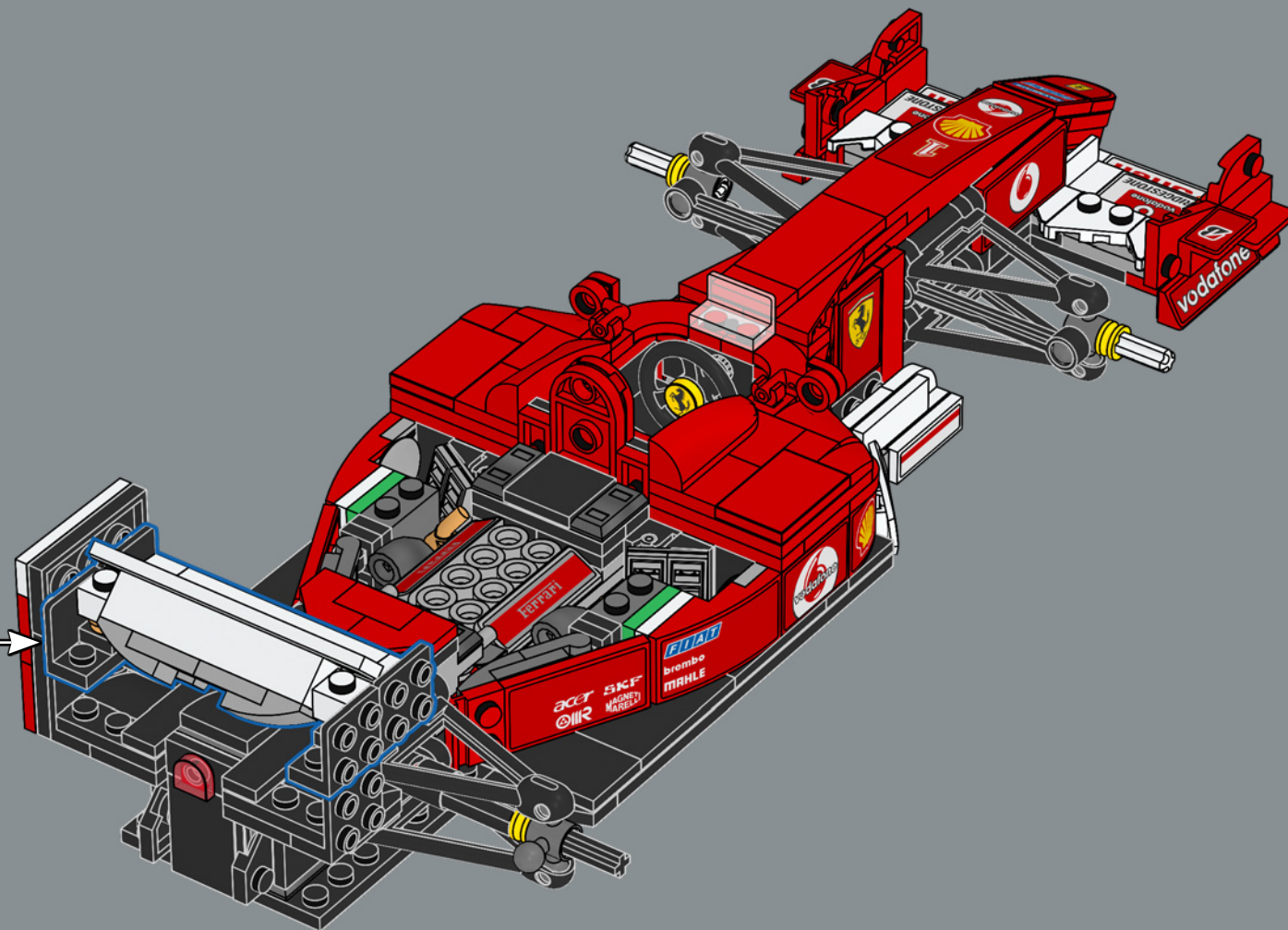

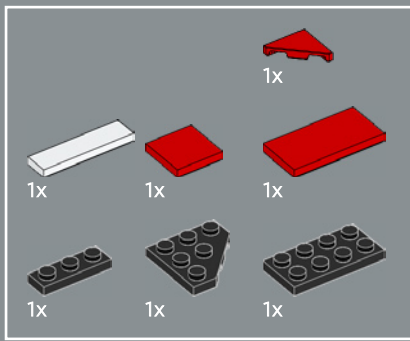

144

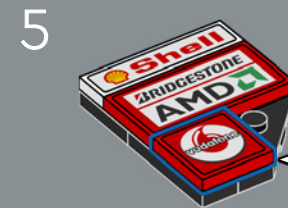
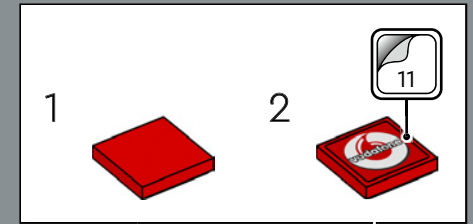
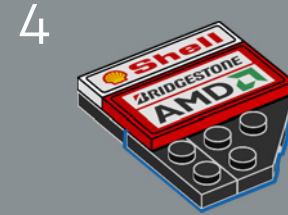
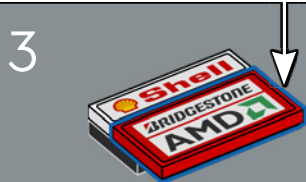
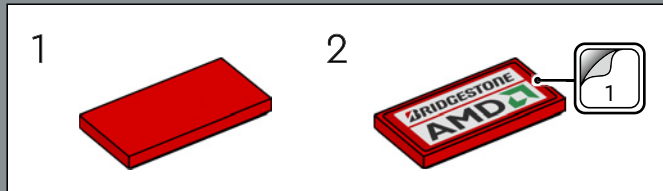
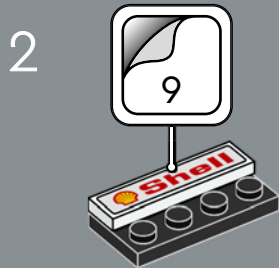
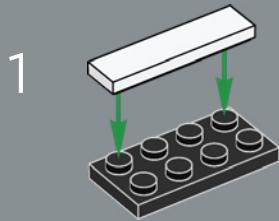



When the Ferrari team tested the F2004 back-to-back with its predecessor, the F2003-GA, in Imola, they expected the new car to be at least half a second faster – Schumacher shaved a full 2 seconds off the previous lap time!

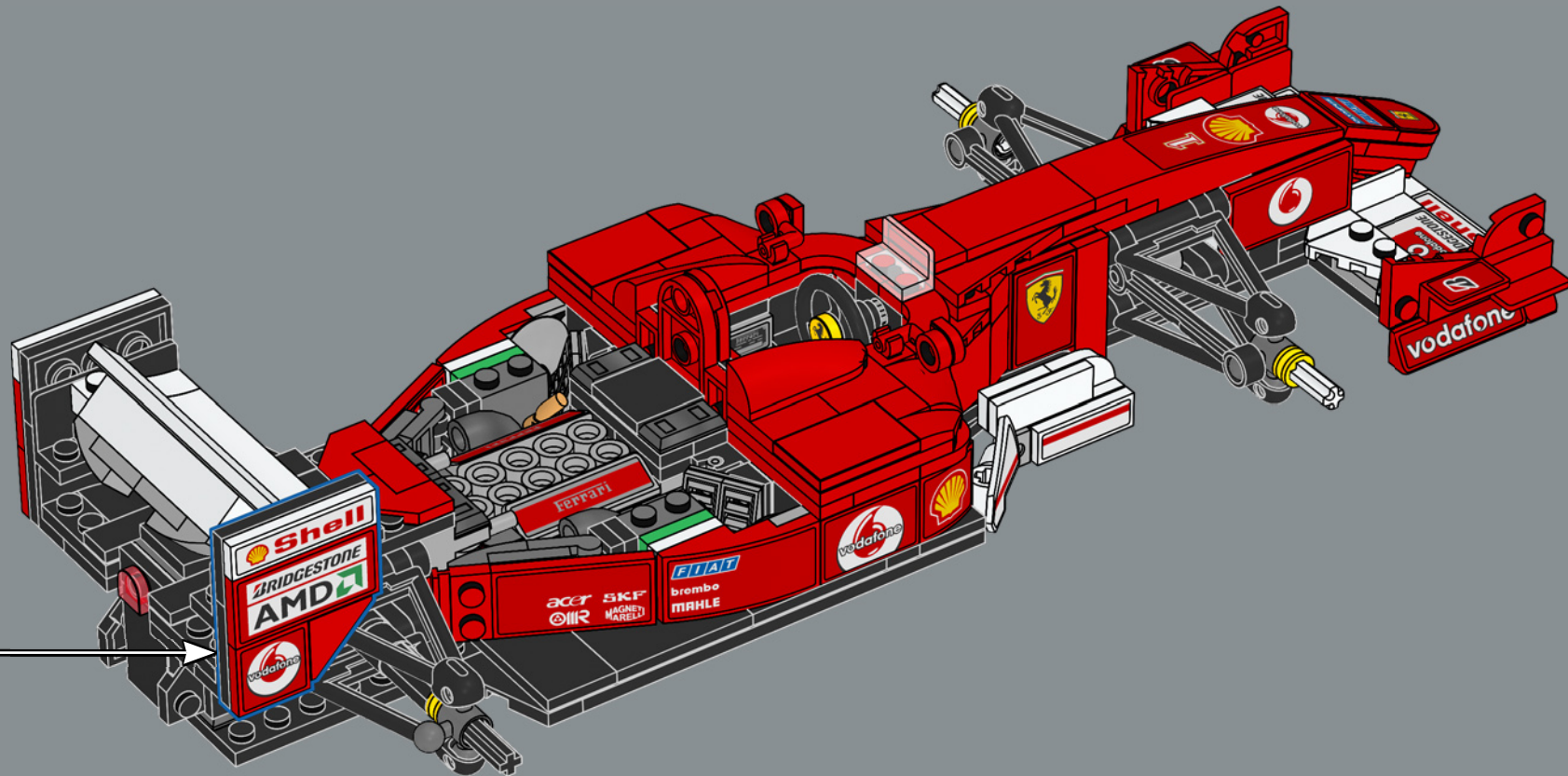

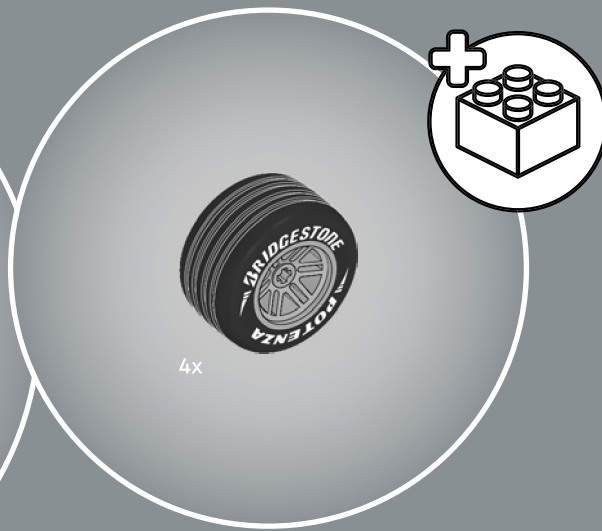

145

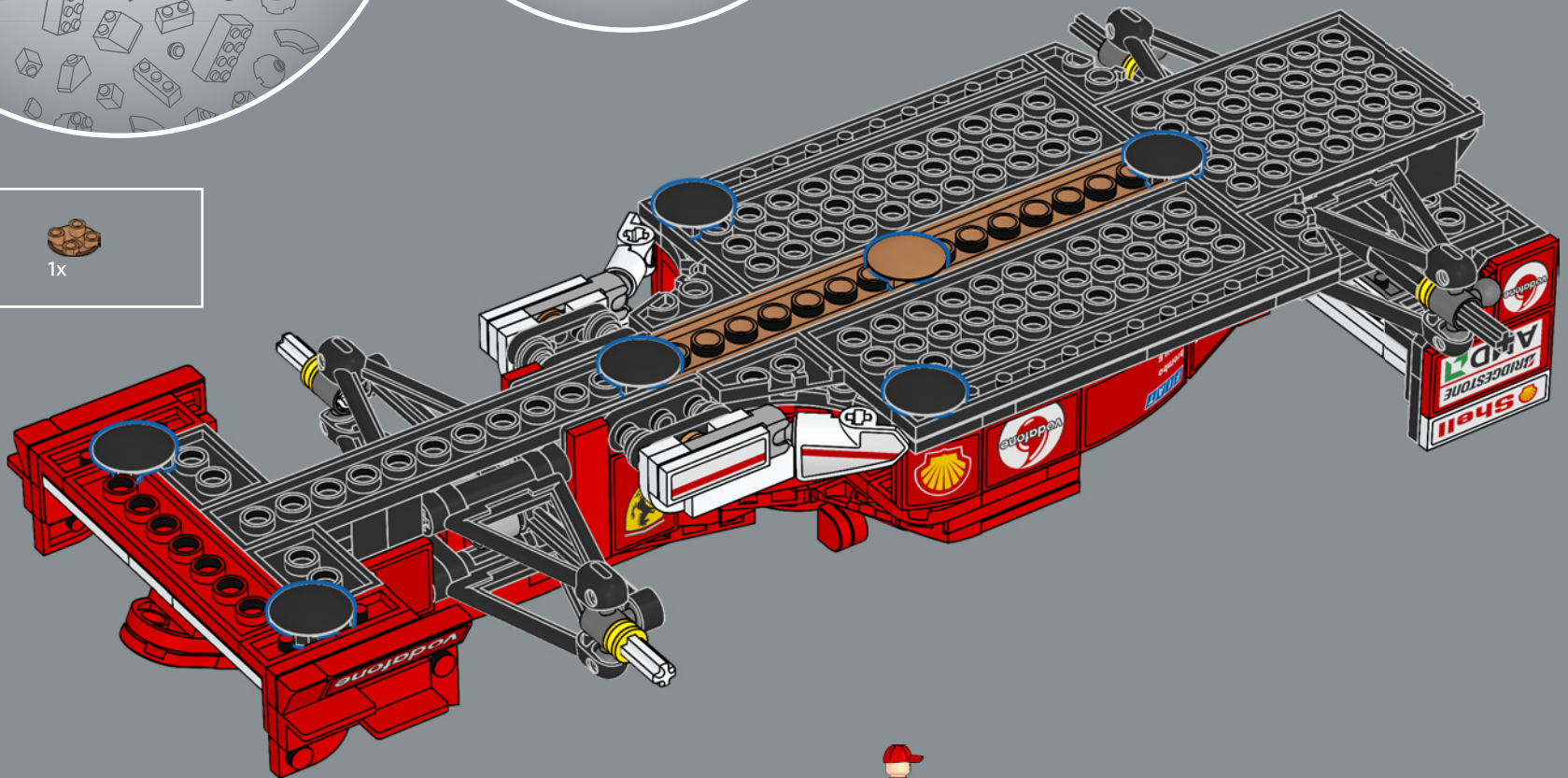

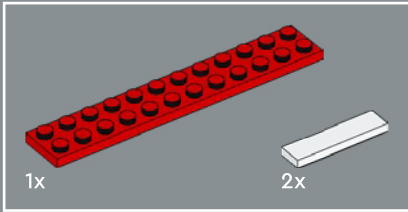
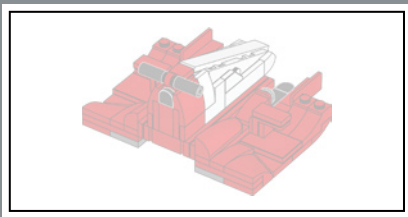

146

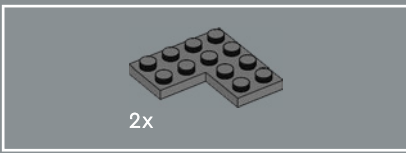
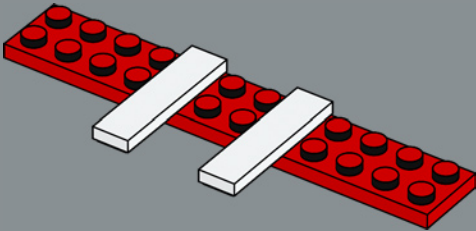

147

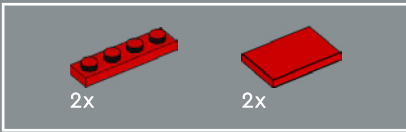
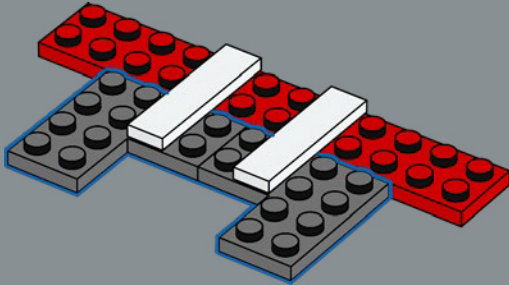

148

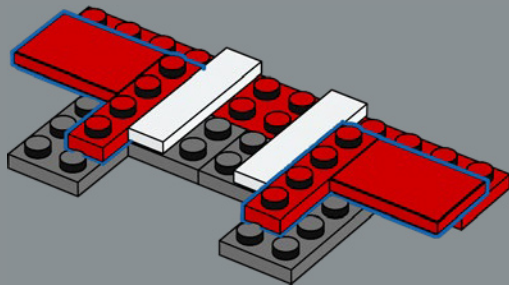

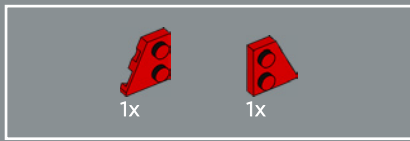

149

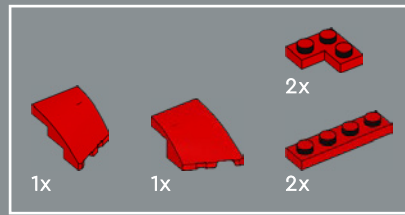
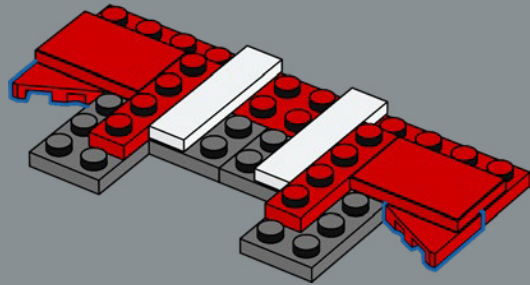

150

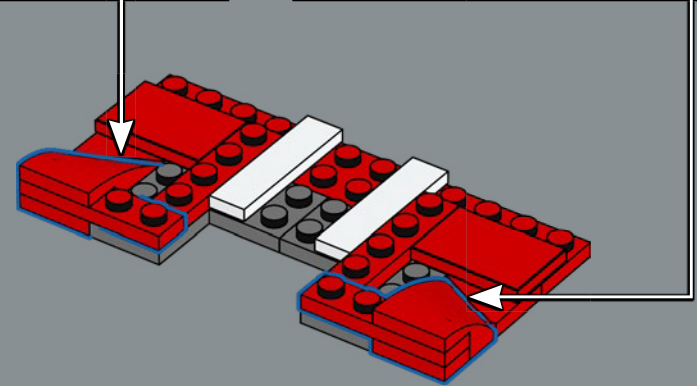
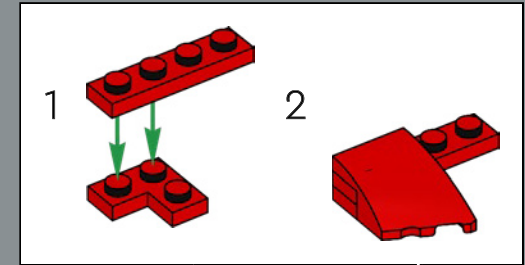
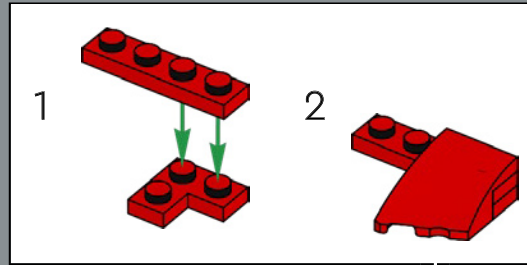

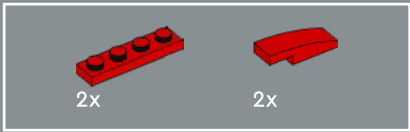

151

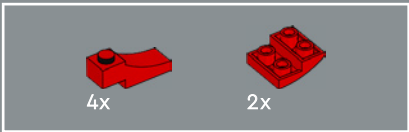
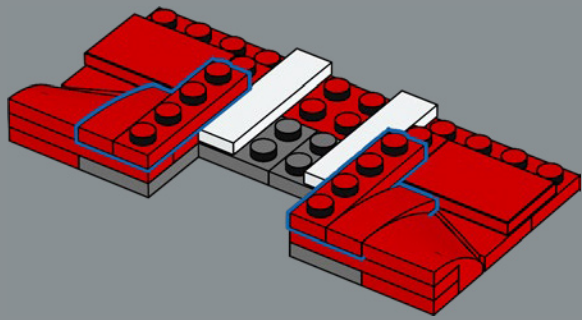

152

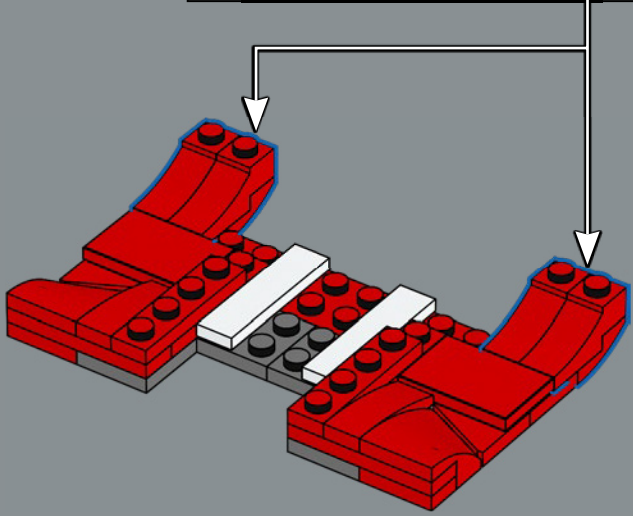
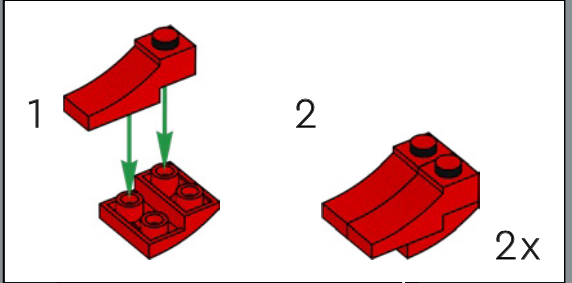

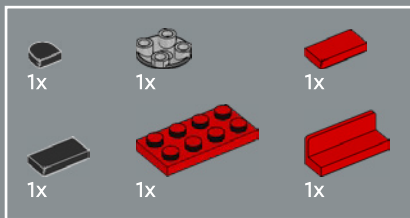

153

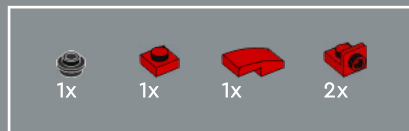
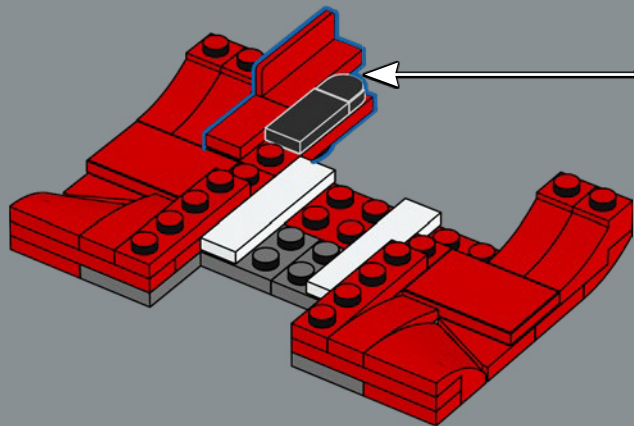
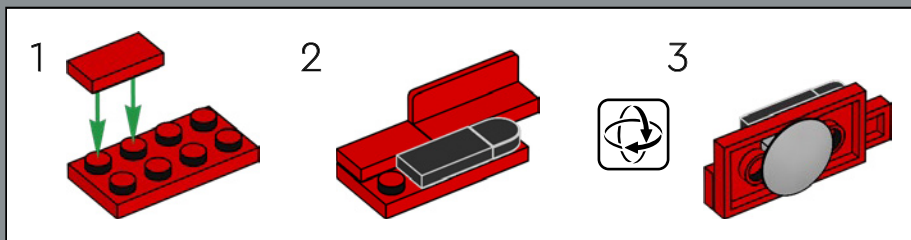

154

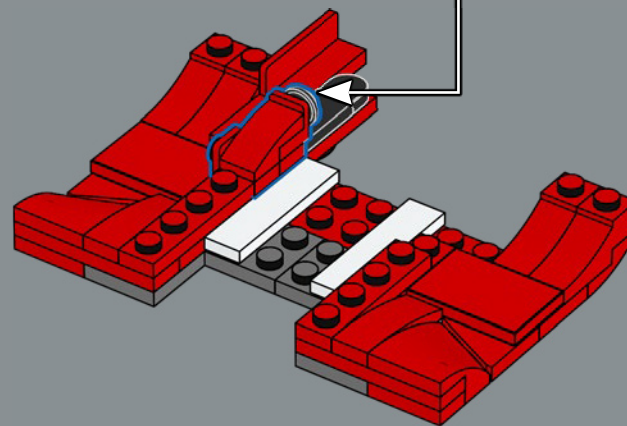
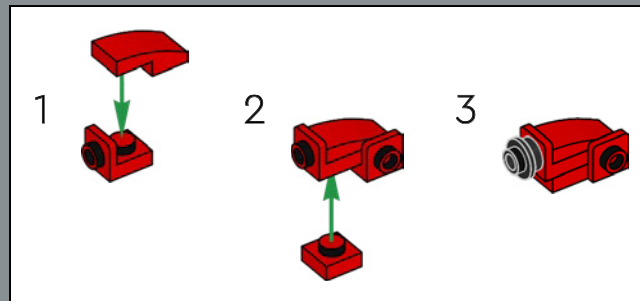

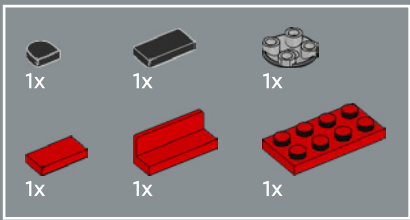

155

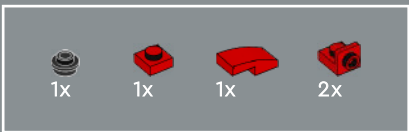
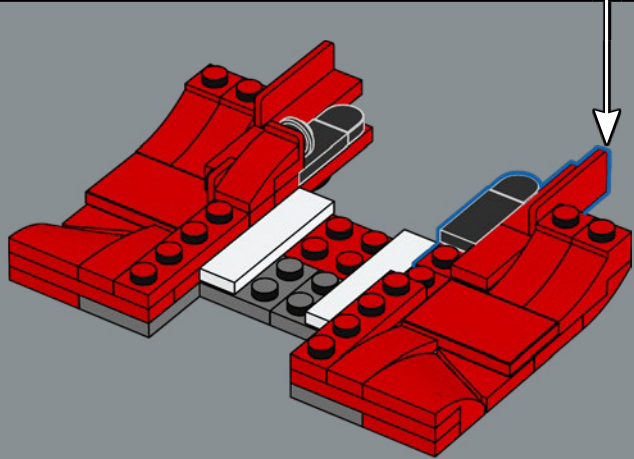
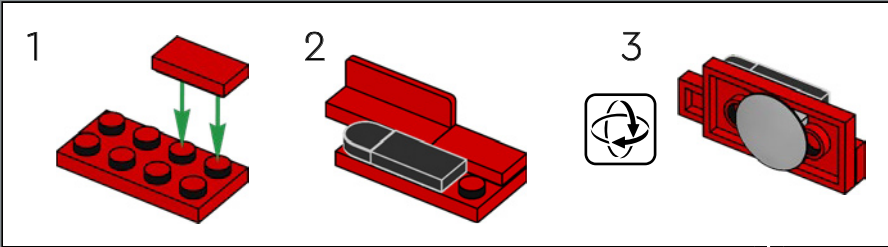

156

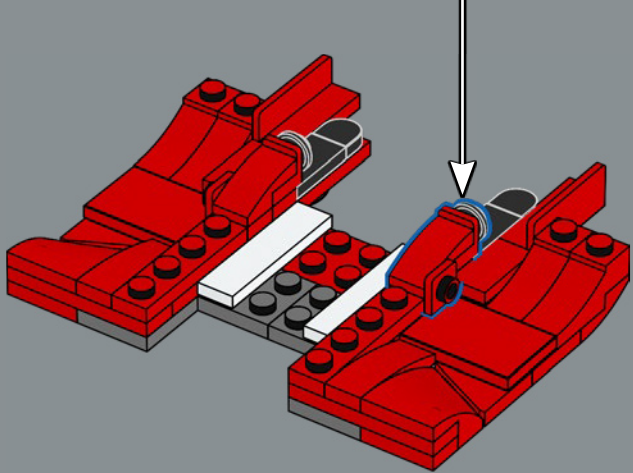
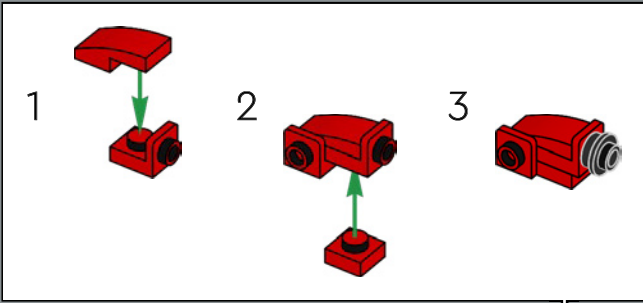

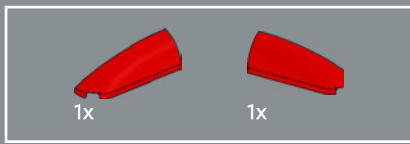

157

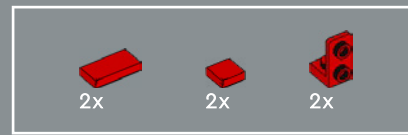
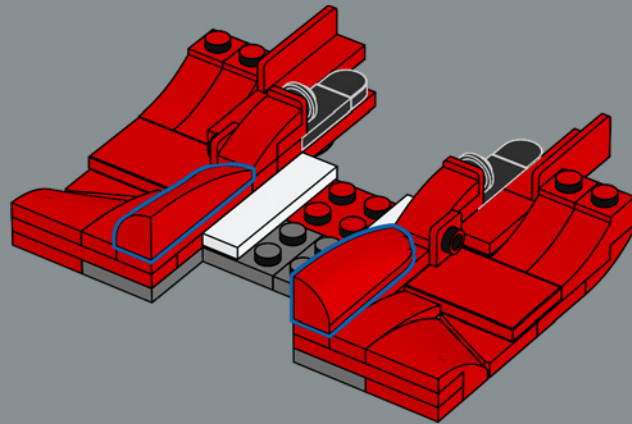

158

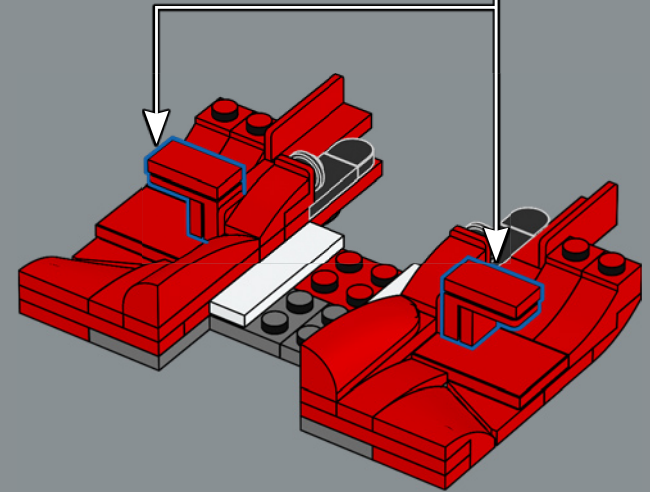
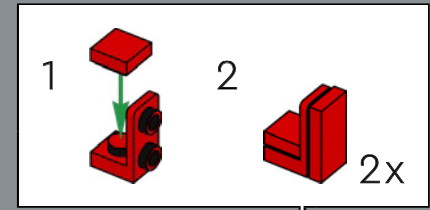

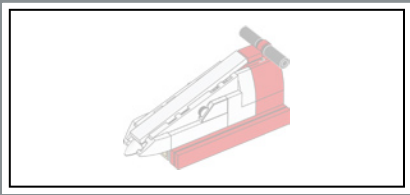

159

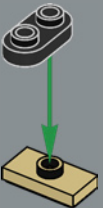

160

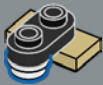

161

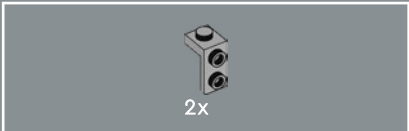
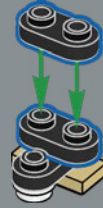

162

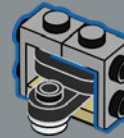

163



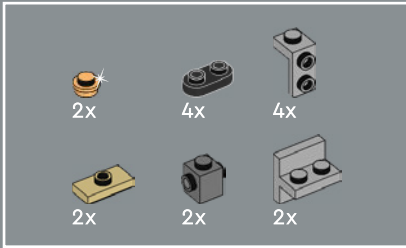

164

1

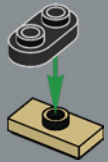

2

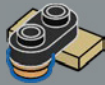

3

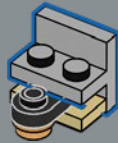

4

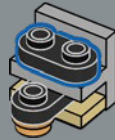

5

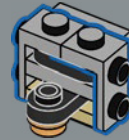

6

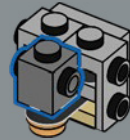

2x

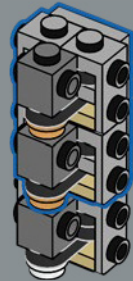

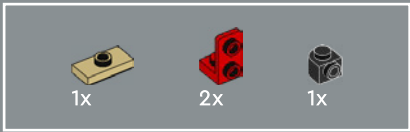

165

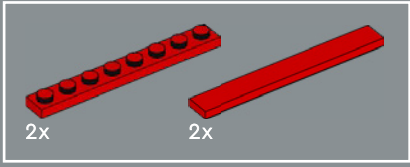
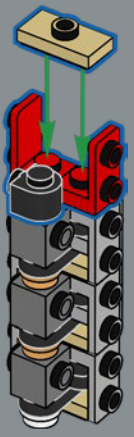

166

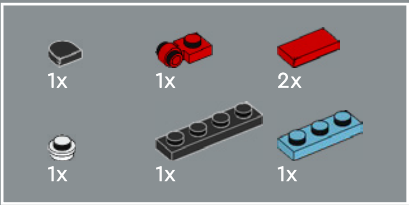
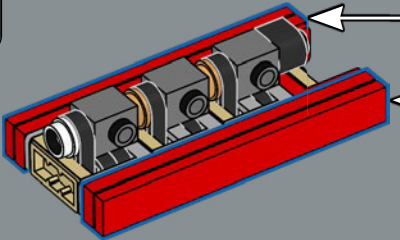
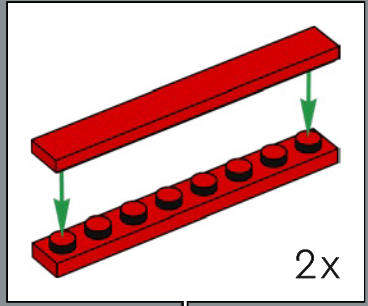

167

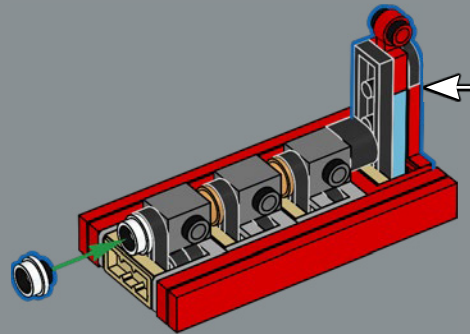
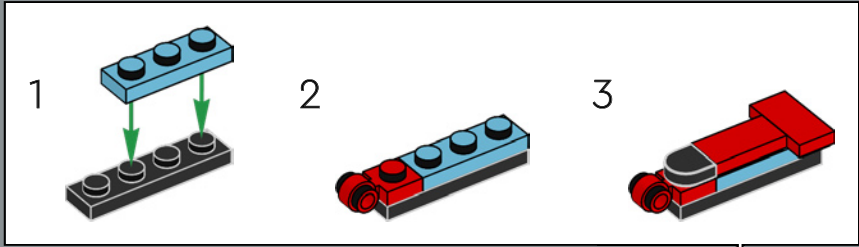

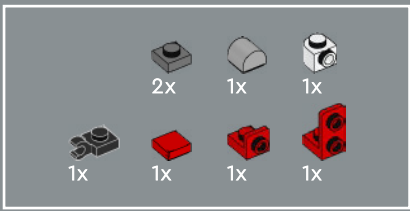

168

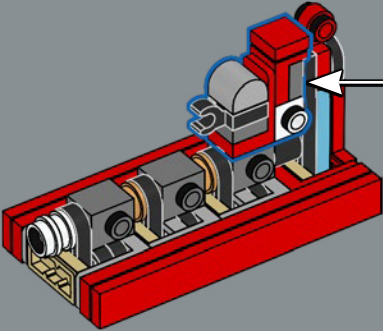
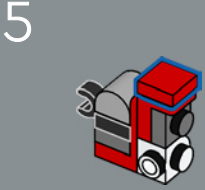
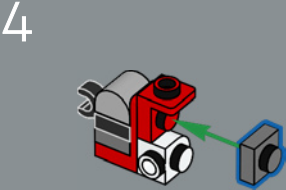
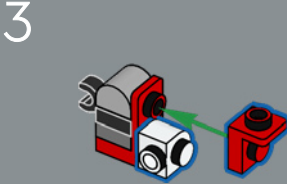
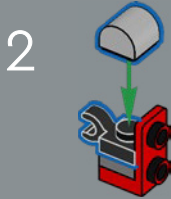
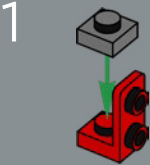

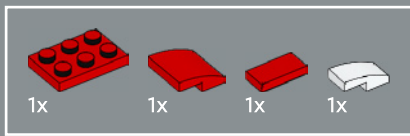

169

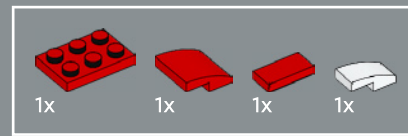
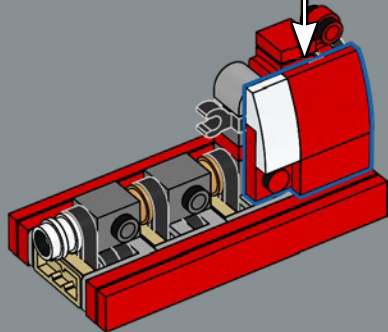
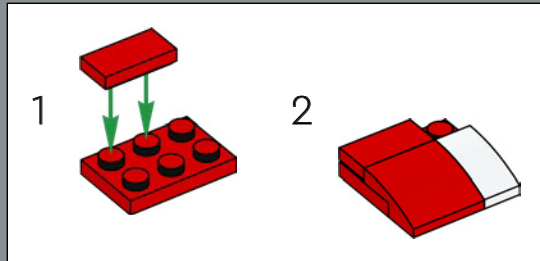

170

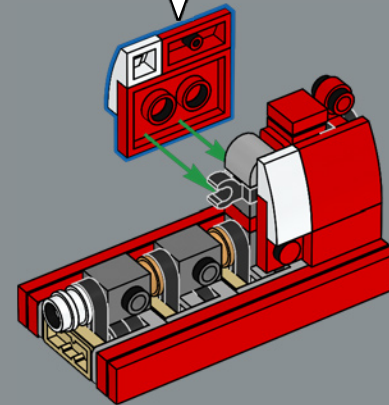
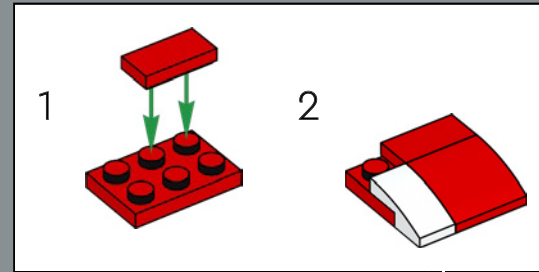

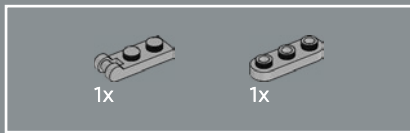

171

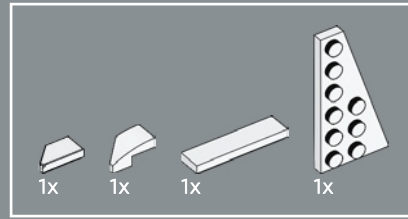
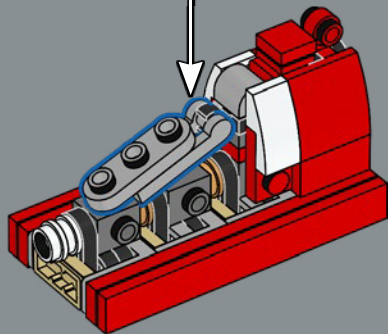
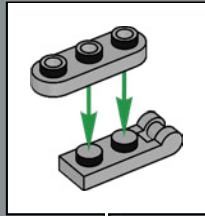

172

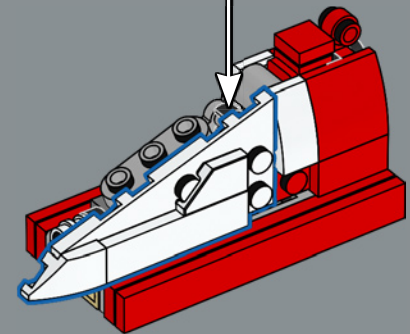
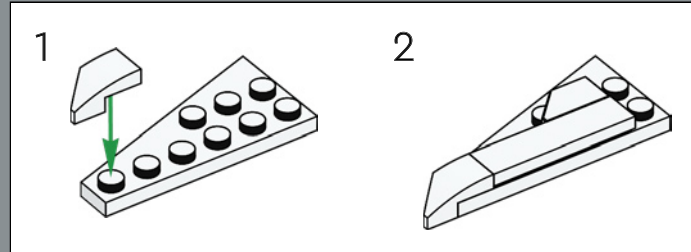

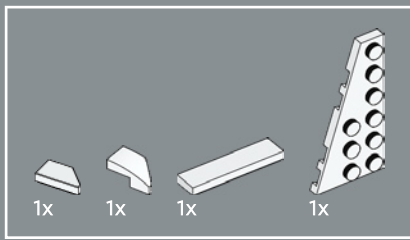

173

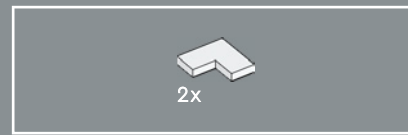
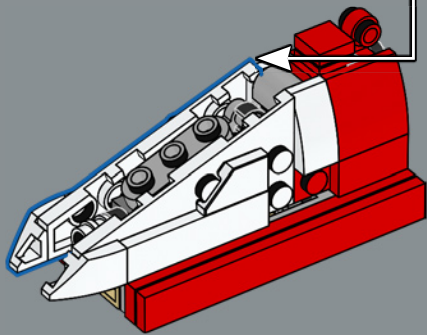
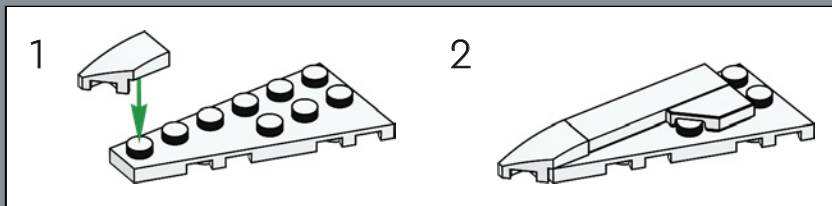

174

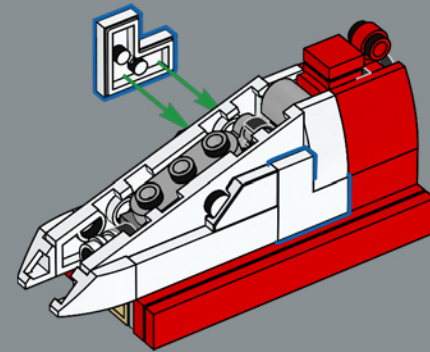

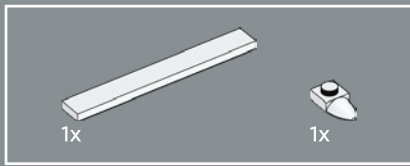

175

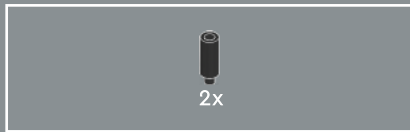
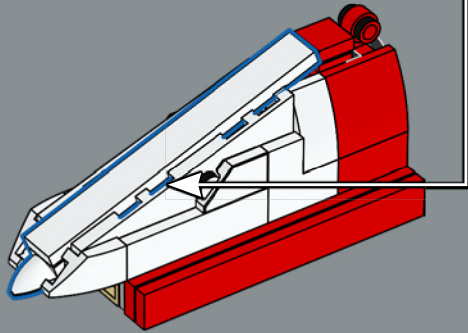
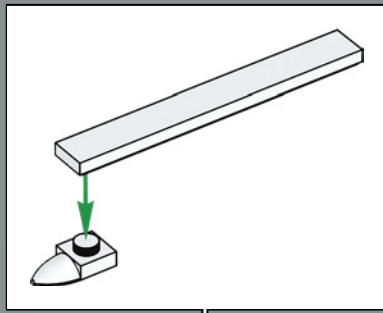

176

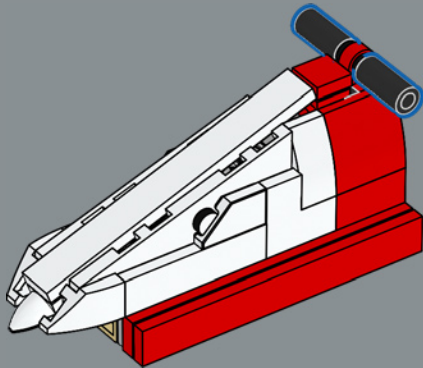

177

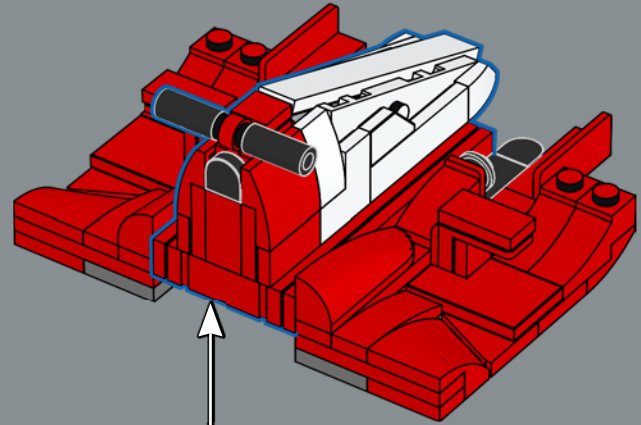

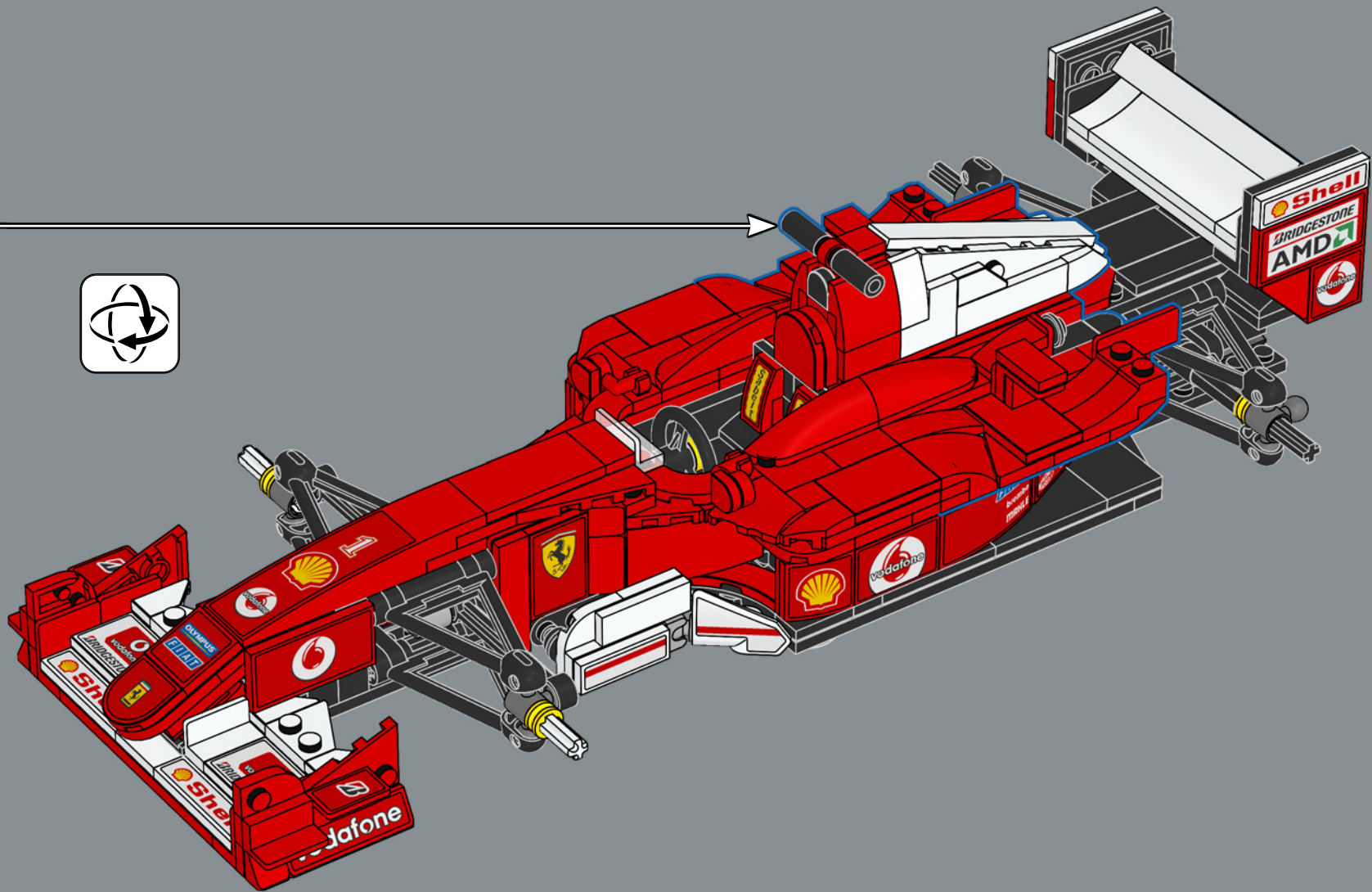



4x

179

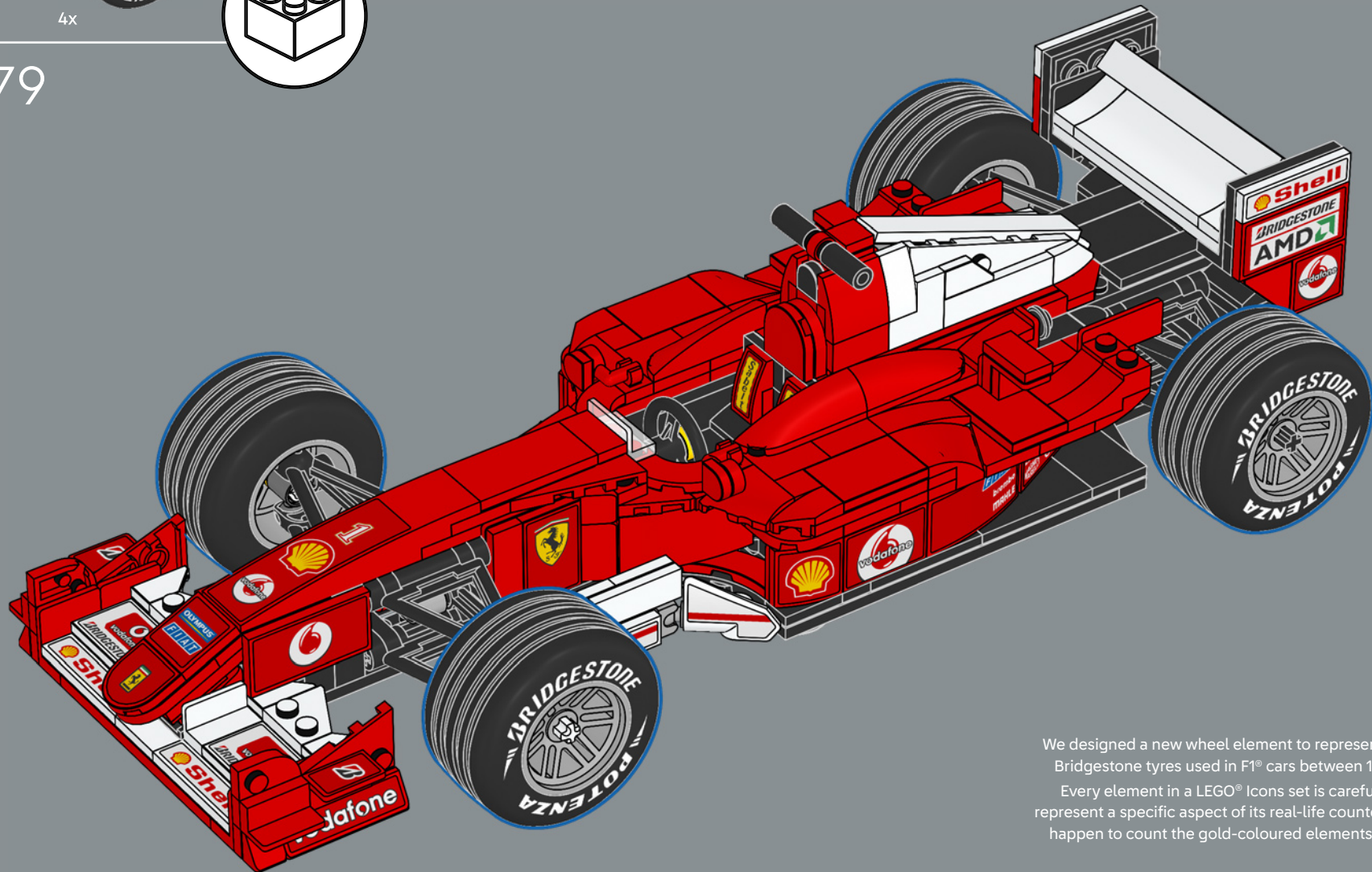
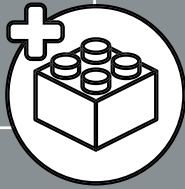

We designed a new wheel element to represent the grooved Bridgestone tyres used in F1® cars between 1999 and 2008. Every element in a LEGO® Icons set is carefully selected to represent a specific aspect of its real-life counterpart. Did you happen to count the gold-coloured elements in this model?





2x



2x

180



2x

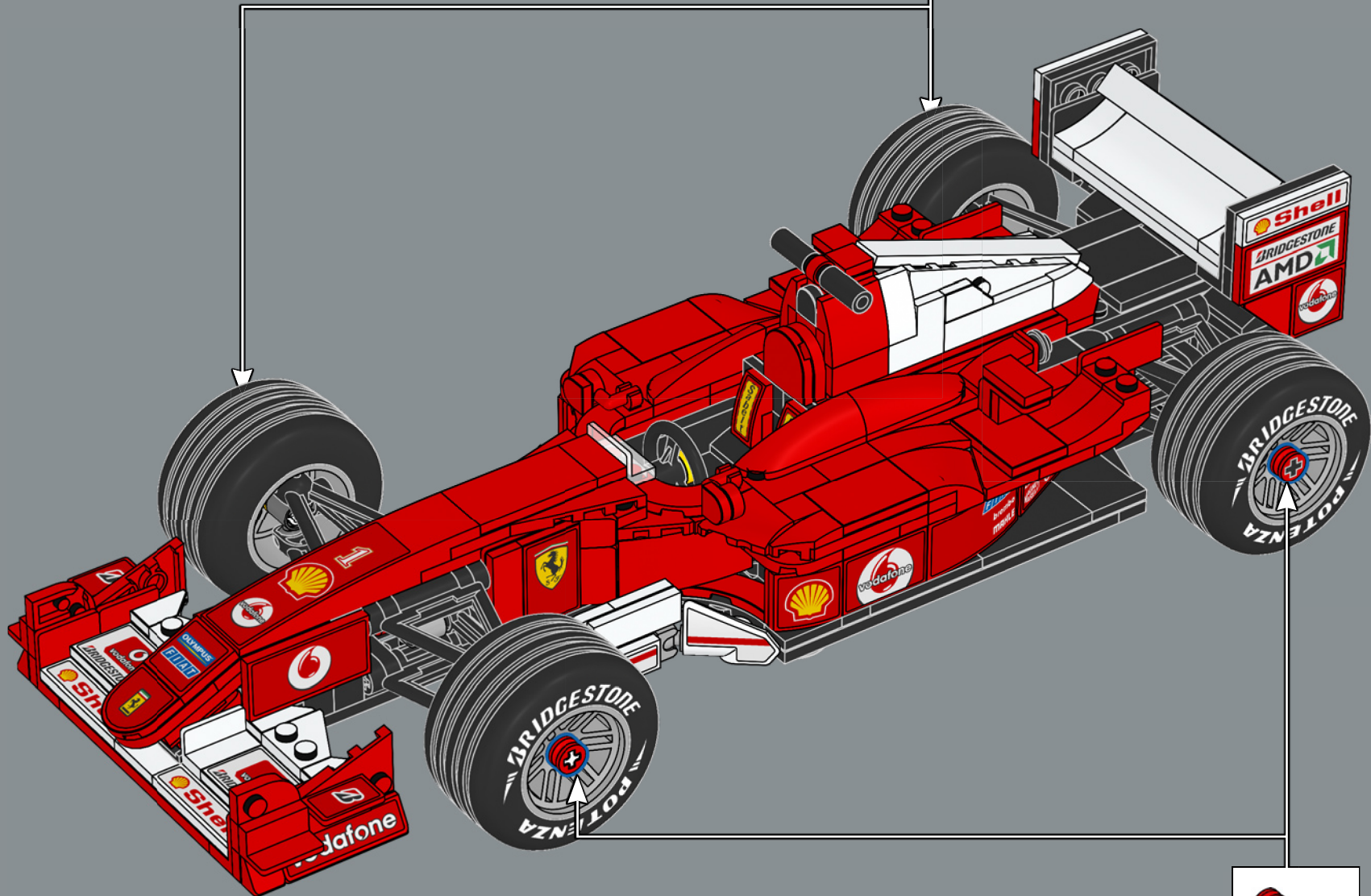

2x

Like its real-life counterpart, the centre pins on the wheels are red on the left side and blue on the right. The LEGO® Technic bush element was recoloured in red for this set.

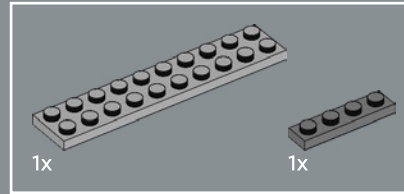
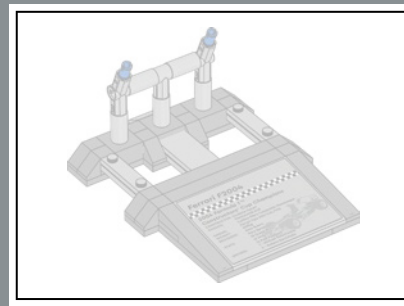

181

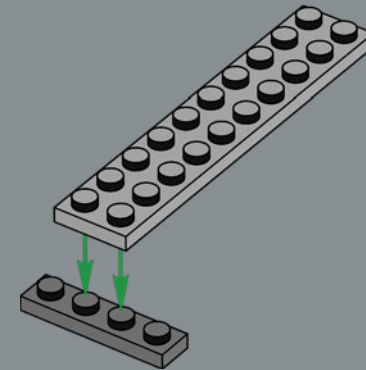

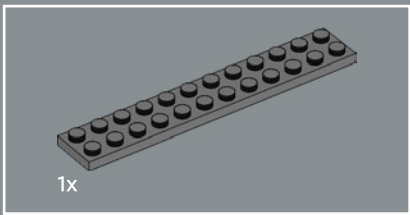

182

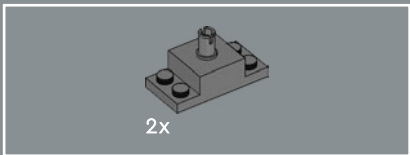
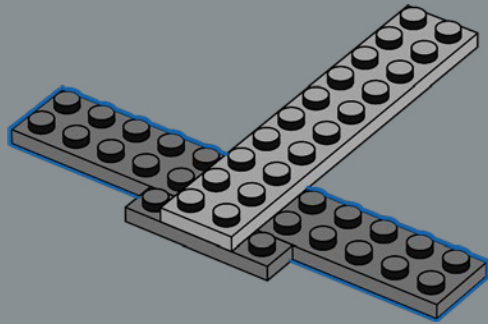

183

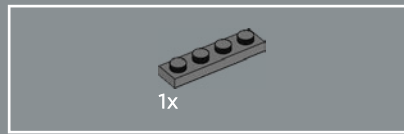
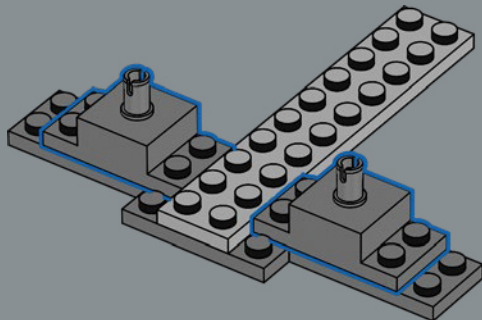

184

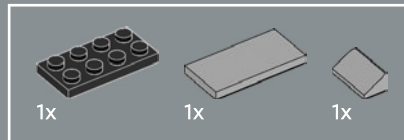
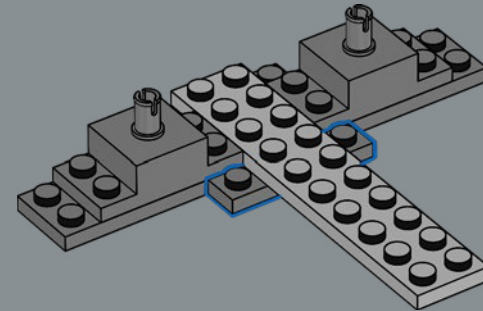

185

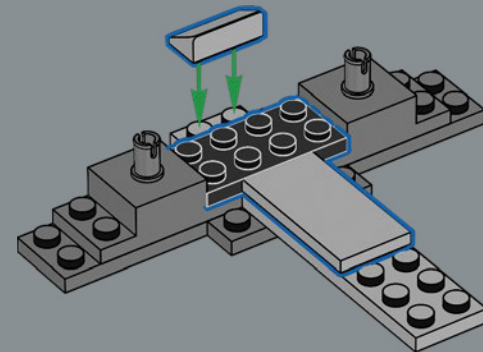

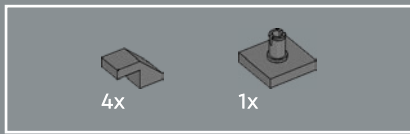

186

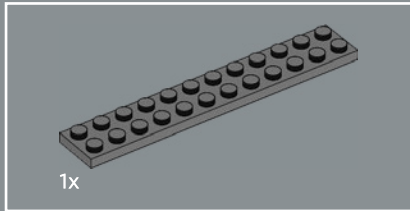
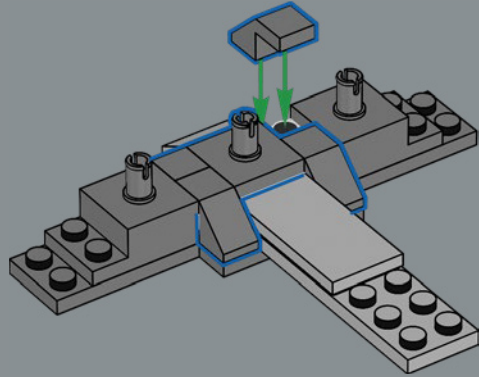

187

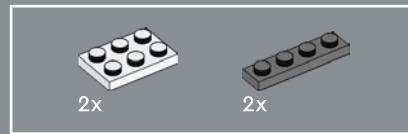
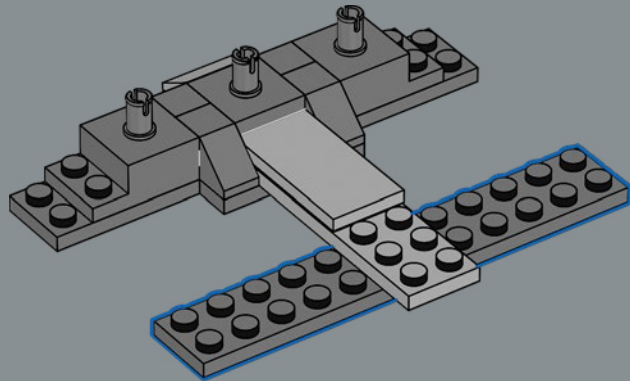

188

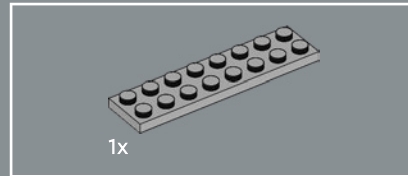
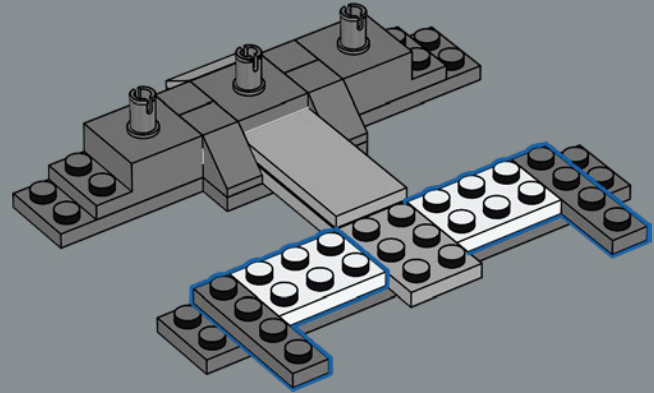

189

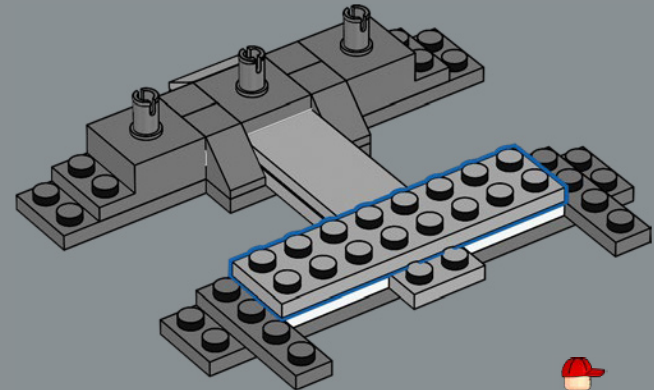

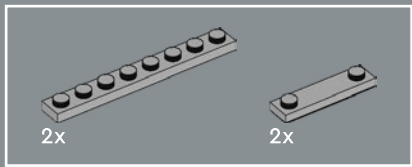

190

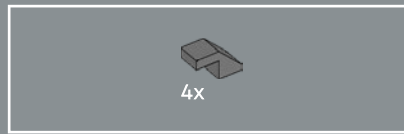
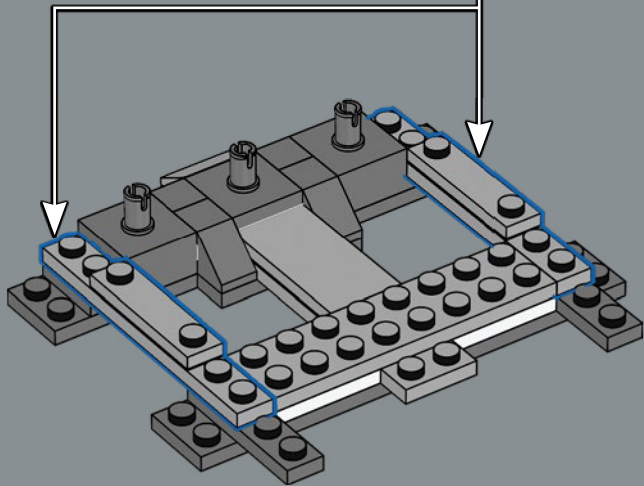
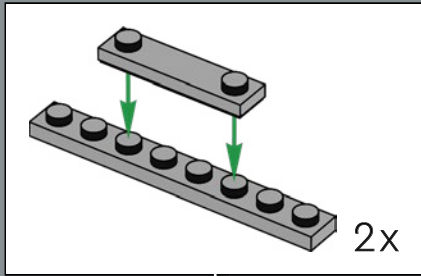

191

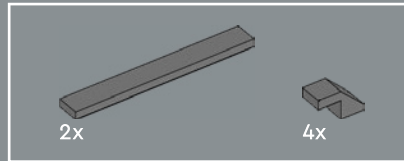
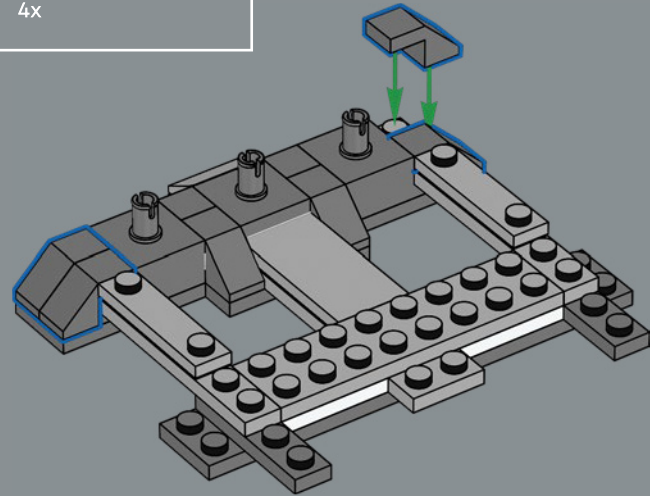

192

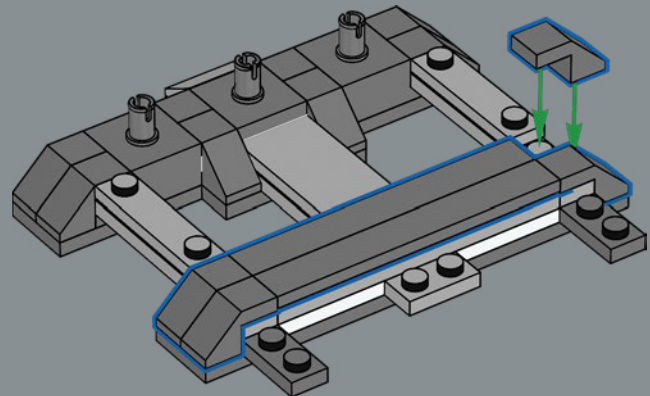

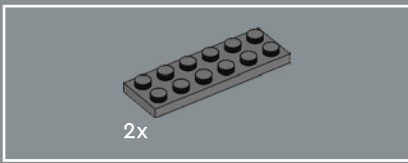

193

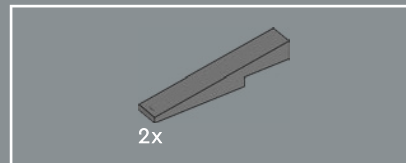
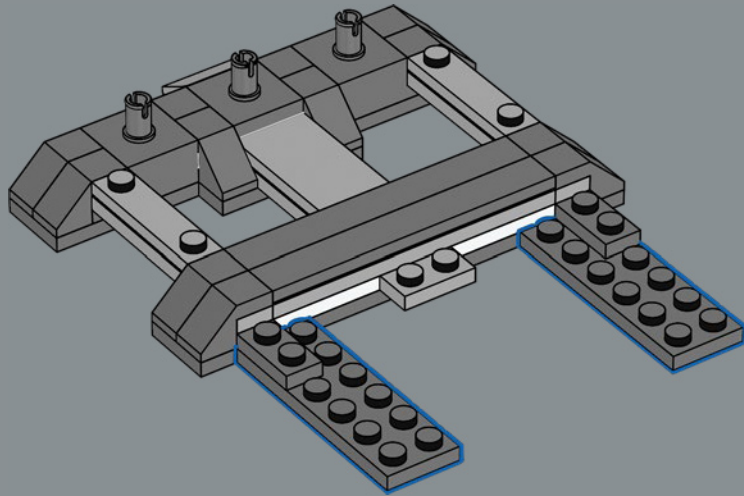

194

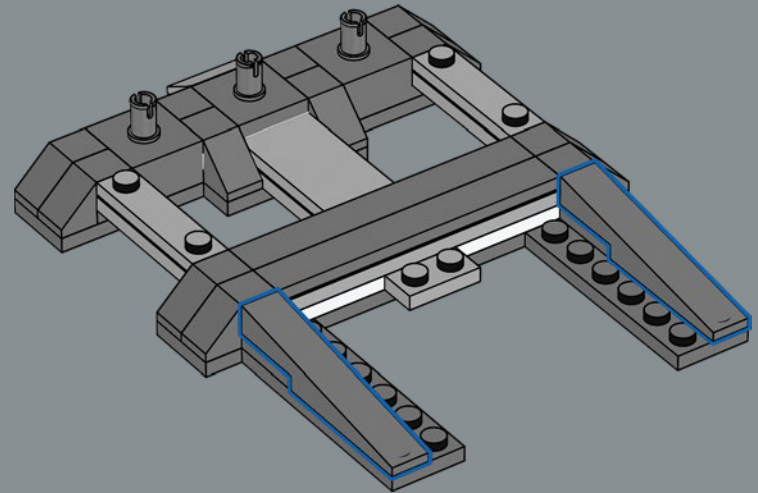

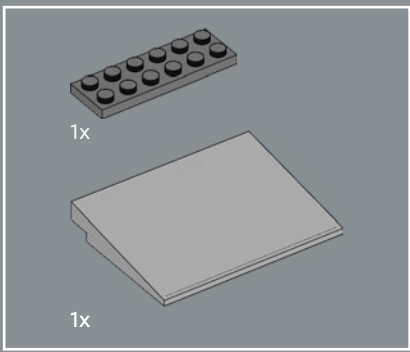

195

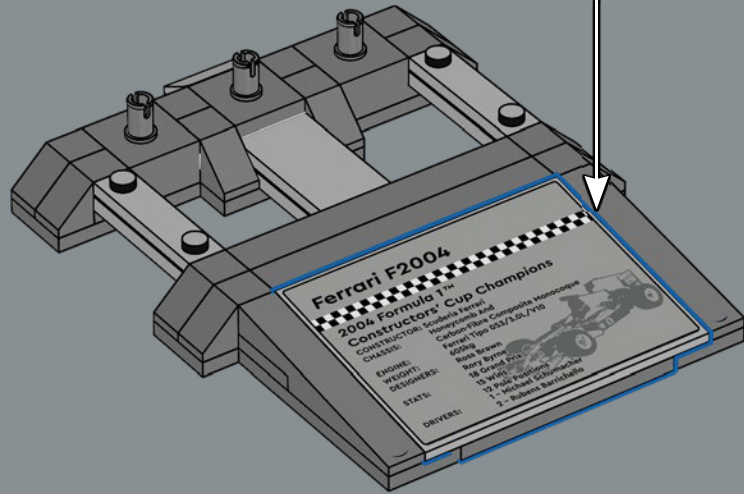
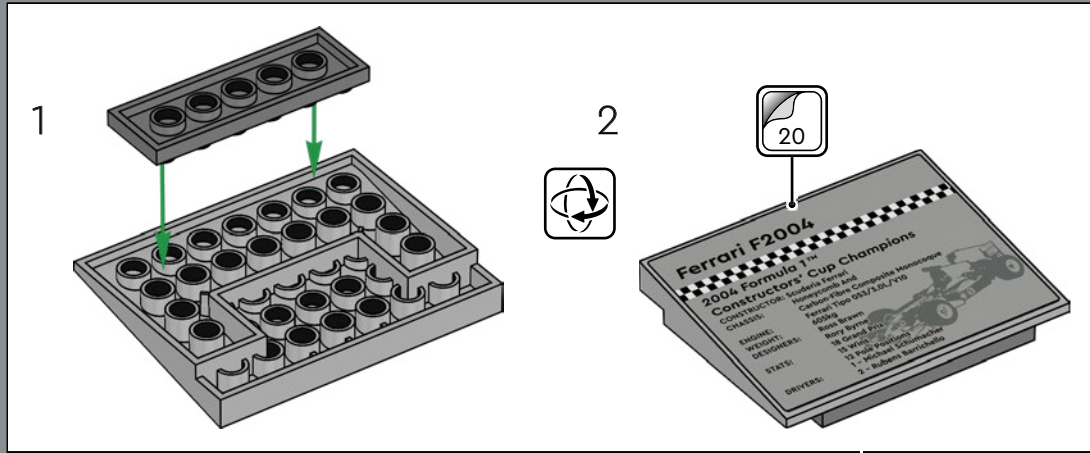

Michael Schumacher won 13 of the 18 races of the 2004 season, breaking his own record of 11 races in the 2002 season.



196

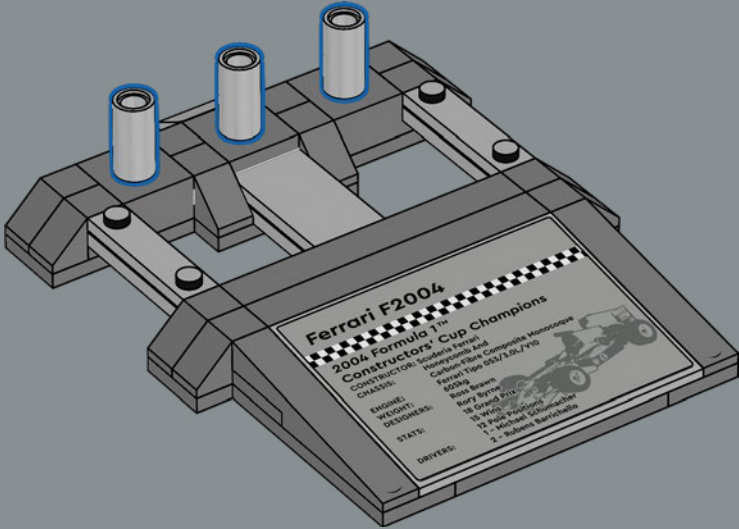

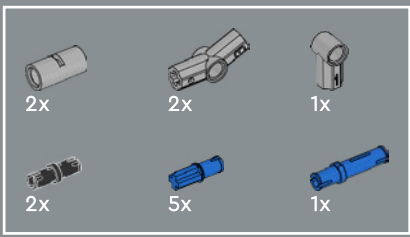

197

1

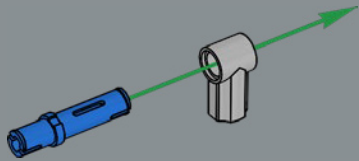

2

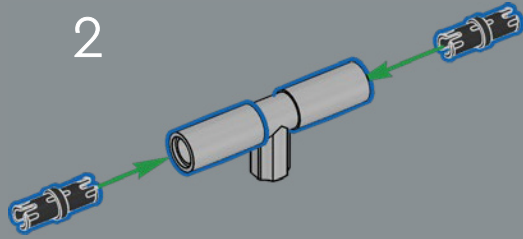

3

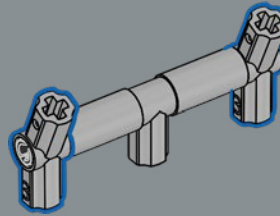

4

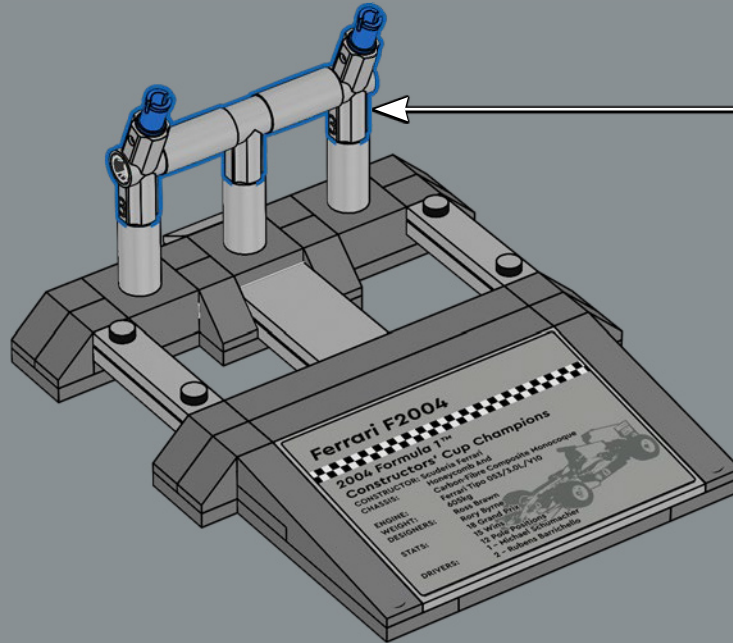
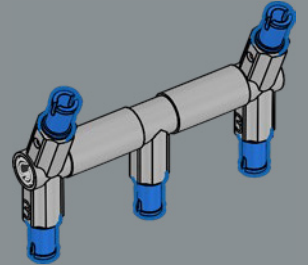





YOU COULD
WIN



**YOU COULD
WIN**

Your feedback will help shape the future development of this product series.

Visit:

**DU KÖNNTEST
GEWINNEN**

Dein Feedback trägt zur Weiterentwicklung dieser Produktreihe bei.

Geh auf:

**VOUS POURRIEZ
GAGNER**

Vos commentaires nous aideront à concevoir les futurs produits de cette gamme.

Visitez :

**POTRESTI
VINCERE TU**

La tua opinione ci aiuterà a migliorare la creazione futura di questa linea di prodotti.

Visita:

**PUEDES
GANAR**

Tu opinión contribuirá al futuro de esta serie de productos.

Visita:

轻松获奖

您的反馈将有助于我们在今后改进本产品系列。

请访问:

LEGO.com/productfeedback

You also have the chance to win a LEGO® set.

Terms and conditions apply.*

Außerdem hast du die Chance, ein LEGO® Set zu gewinnen.

Es gelten die Teilnahmebedingungen.*

Vous pourriez également gagner un ensemble LEGO®.

Des conditions s'appliquent.*

Hai anche la possibilità di vincere un set LEGO®.

Termini e condizioni sono applicabili.*

También tienes la oportunidad de ganar un set LEGO®.

Aplican términos y condiciones.*

您还有机会赢取乐高®套装。

条款和条件适用。*

*LEGO.com/productfeedback-terms

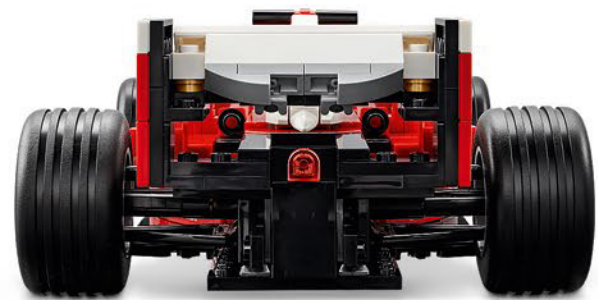

LEGO and the LEGO logo are trademarks of the LEGO Group. ©2026 The LEGO Group.
Produced under license of Ferrari S.p.A. The name FERRARI, the PRANCING HORSE device, all associated logos and distinctive designs are property of Ferrari S.p.A.
The body designs of the Ferrari cars are protected as Ferrari S.p.A. property under design, trademark and trade dress regulations.
Produced under licence of Michael Schumacher.