

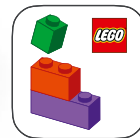

40912



Available in English
In deutscher Sprache verfügbar
Disponibles en français
Disponibile in italiano
Disponibile en español
提供中文版本



LEGO® Builder





[LEGO.com/sustainable-packaging](https://www.lego.com/sustainable-packaging)



 **FR**
DONNEZ
OU
RECYCLEZ

 OU  OU 

ASSOCIATION MAGASIN DÉCHÈTERIE

Adresses sur quefairedemesdechets.fr



BUILDER



Apple and the Apple logo are trademarks of Apple Inc., registered in the U.S. and other countries and regions. App Store is a service mark of Apple Inc. Google Play and the Google Play logo are trademarks of Google LLC. Tencent and the Tencent logo are trademarks of Tencent Inc.

LEGO.com/devicecheck

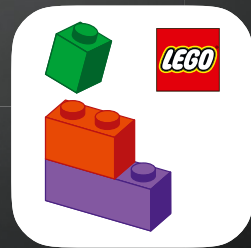

LEGO® Builder



MEET DAMIAN HALLOWELL

LEGO® IDEAS GRAND PRIZE WINNER

Say 'ahoy' to Damian (LEGO® Ideas name HallowedBrick02) and get ready to board his winning model from our *A Twist of Nostalgia* challenge!

"I joined LEGO Ideas because I've always enjoyed seeing what others build, like in the *Cool Creations* section of the old LEGO Club magazines. Turning a bucket full of bricks into different ideas is what makes LEGO building so special.

Supporting other fans and maybe seeing their sets in stores is awesome. Pirates, Castle and City ships are some of the most fun LEGO sets I've built, so the 6057 Sea Serpent (1992) seemed perfect for a remake, and taking part in the design of an official LEGO set is a childhood dream. I'm so thankful to everyone who supported this idea and helped carry out this dream."

*LEGO® Ideas Fan Designer
& Grand Prize Winner
Damian Hallowell*



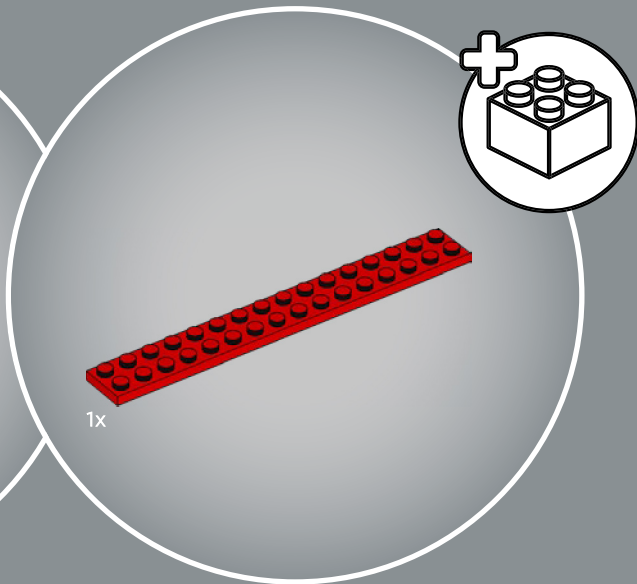

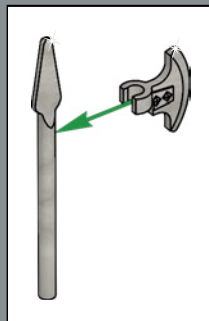
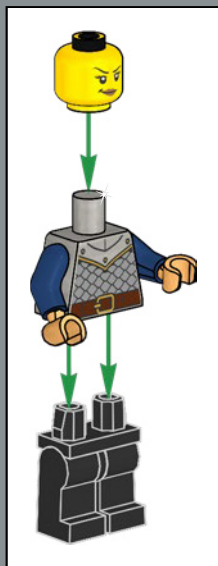

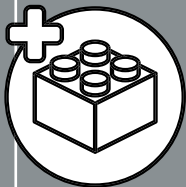
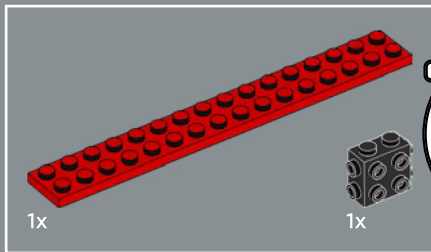

1

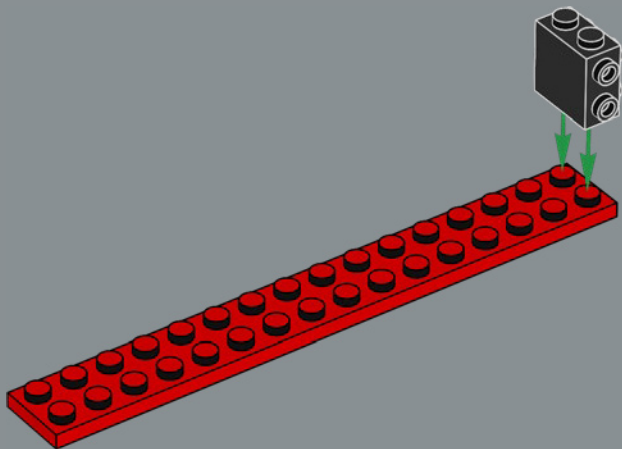

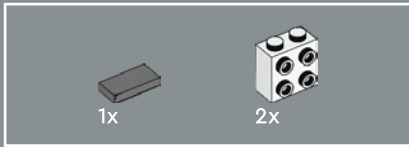

2

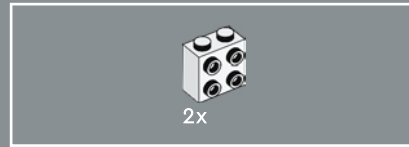
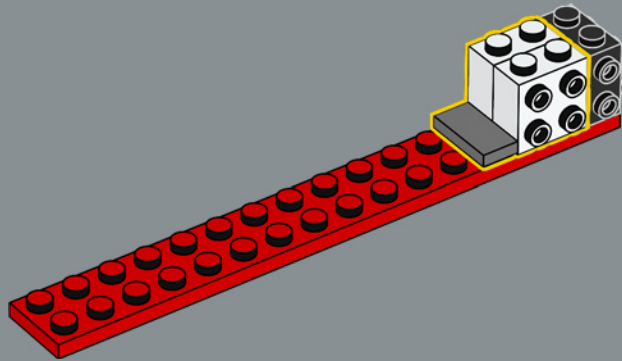

3

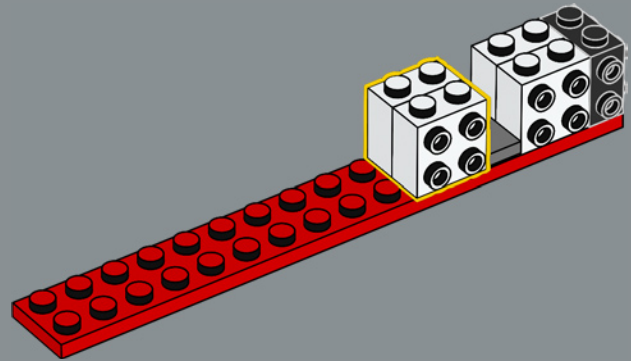

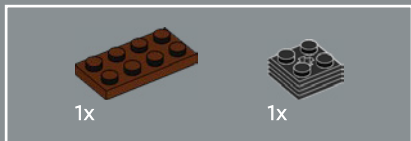

4

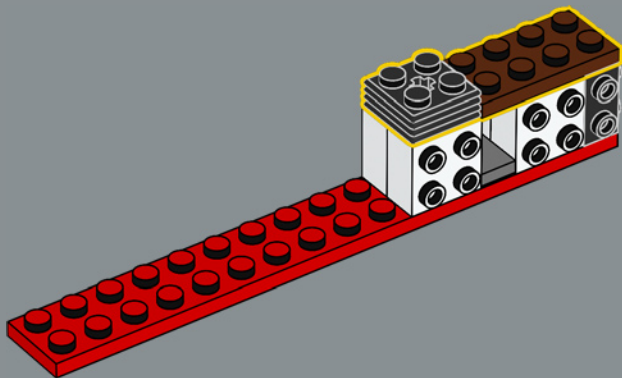

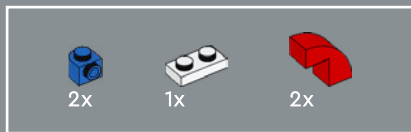

5

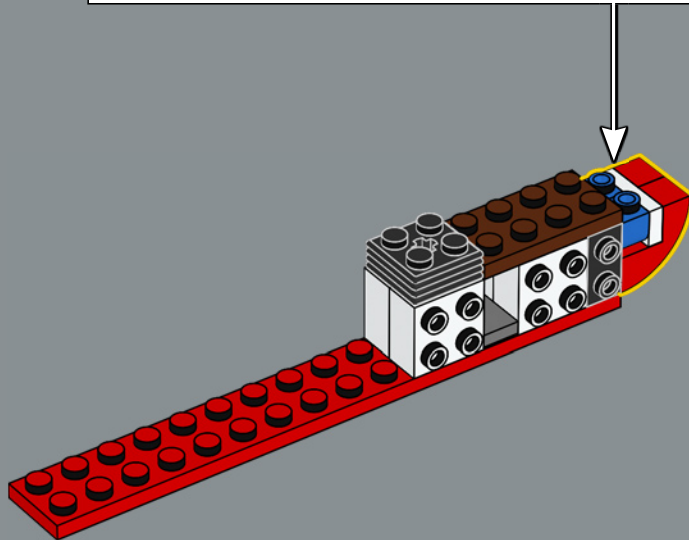
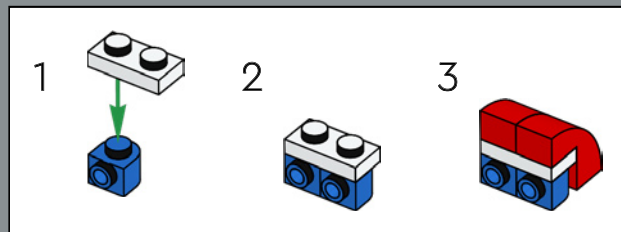

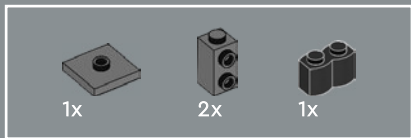

6

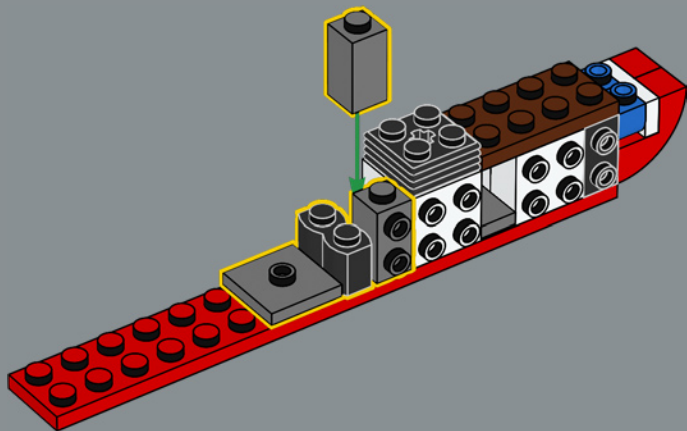

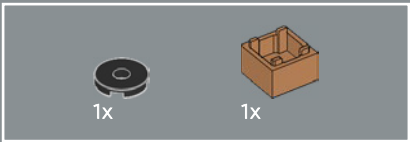

7

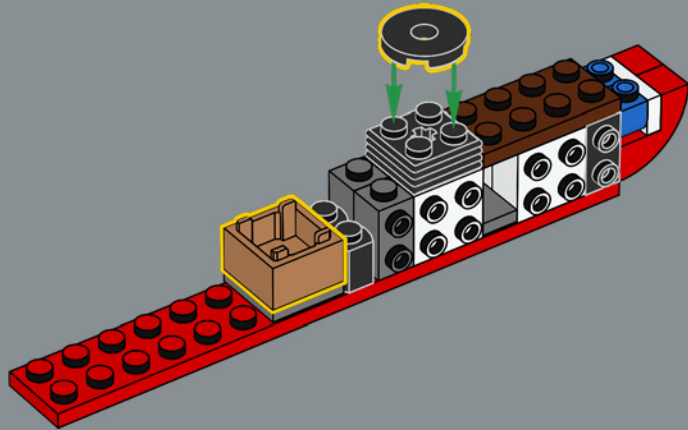

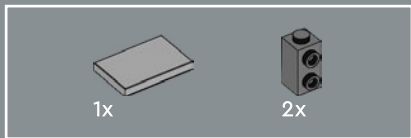

8

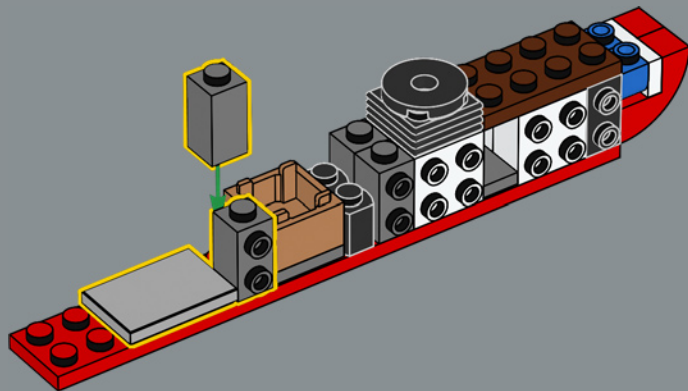

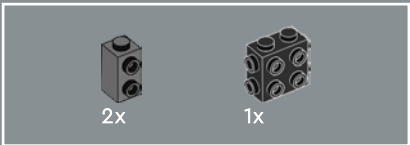

9

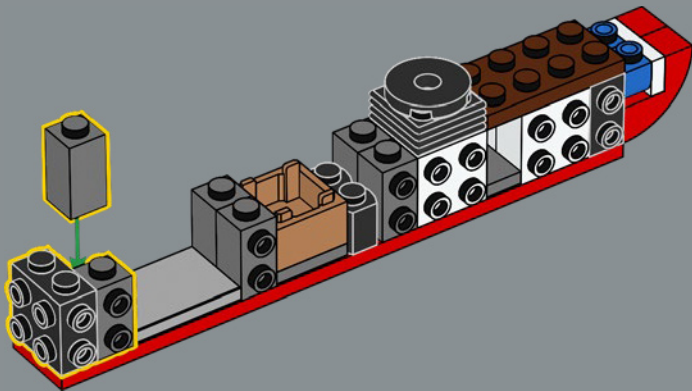

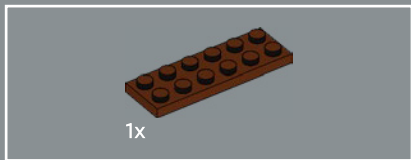

10

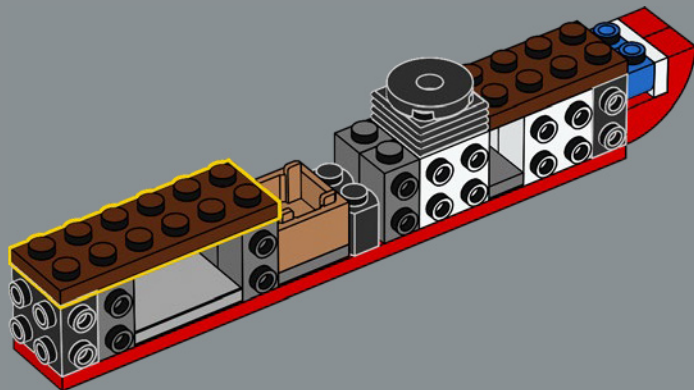

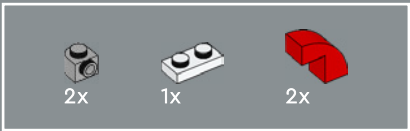

11

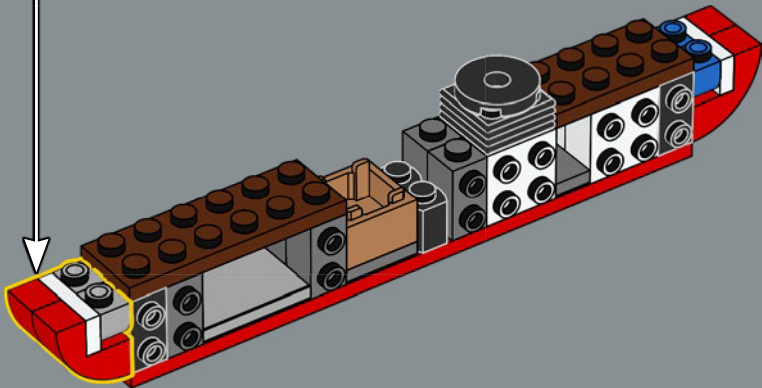
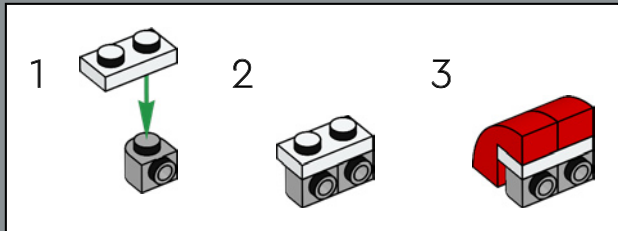

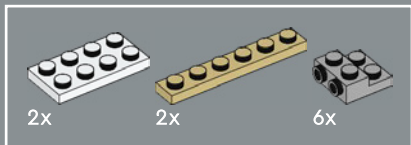

12

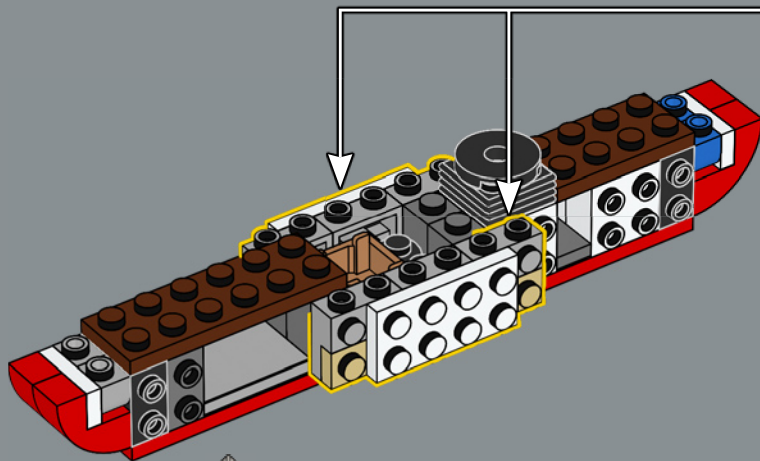
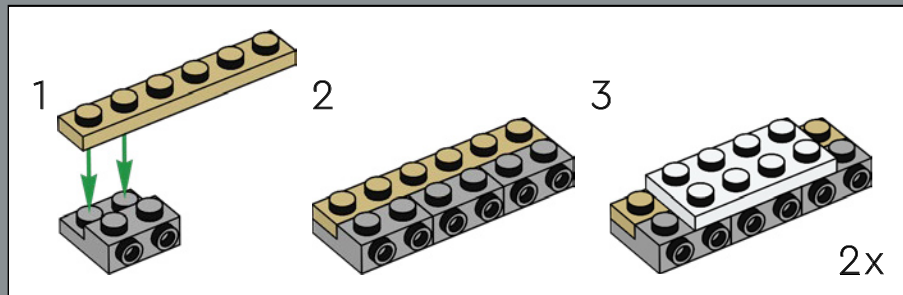

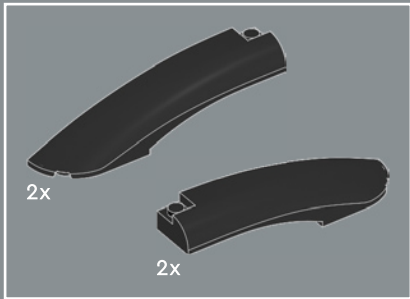

13

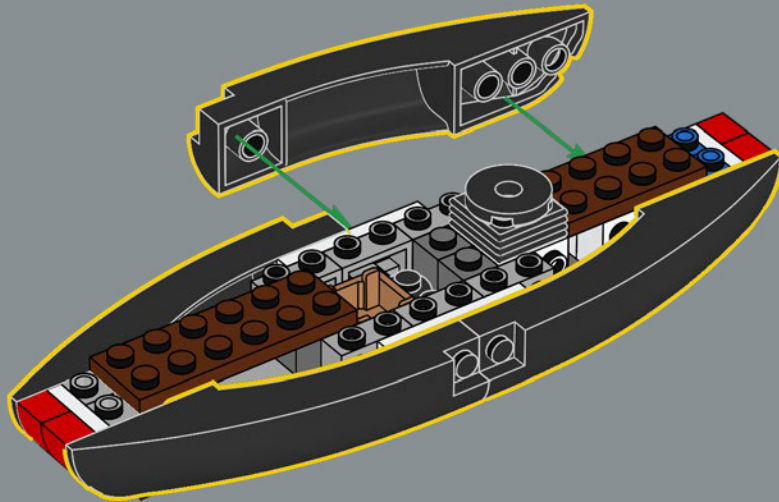



14

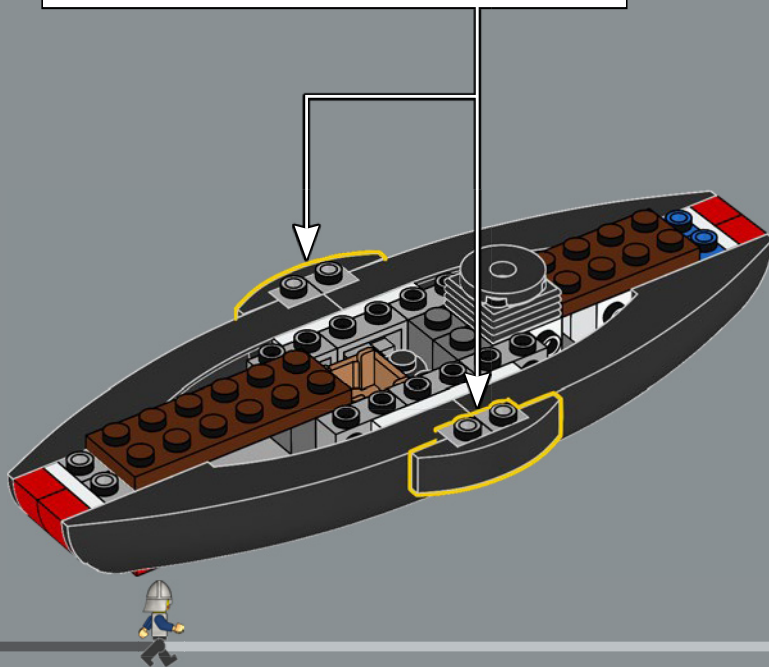
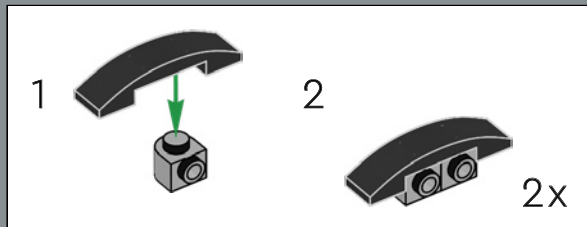

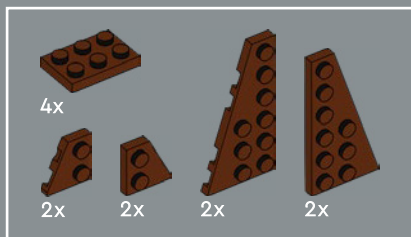

15

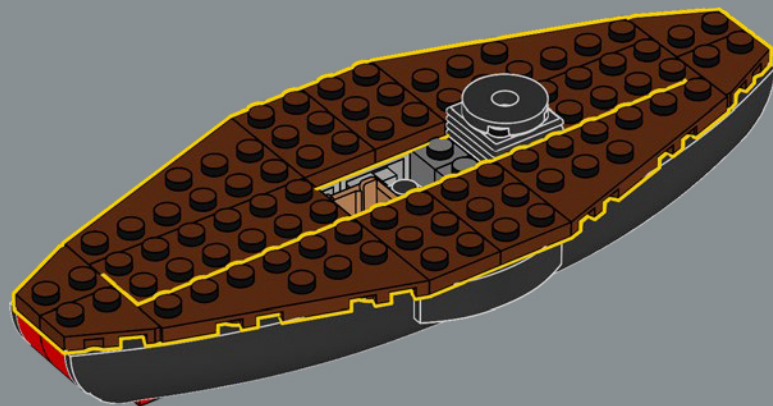

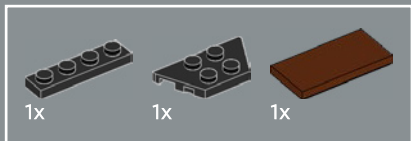

16

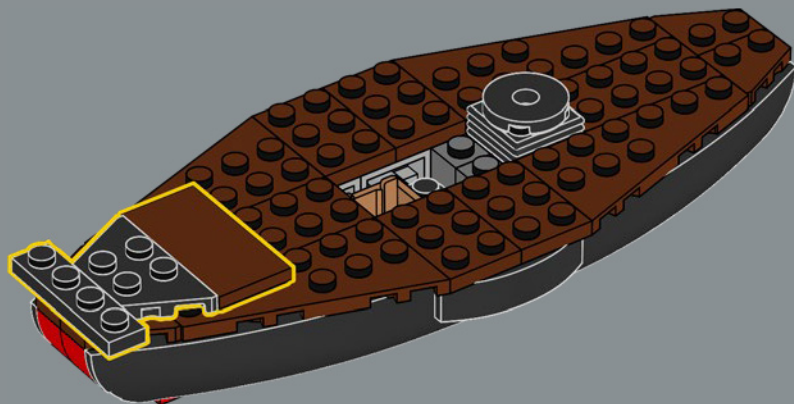



1x

17



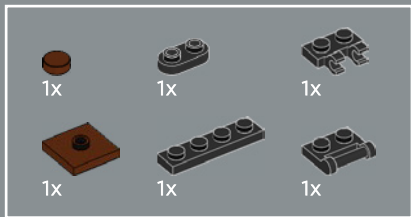

18

1

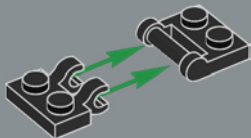

2

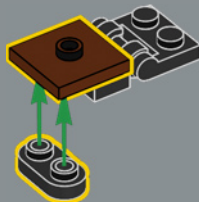

3

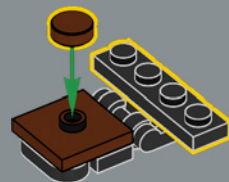

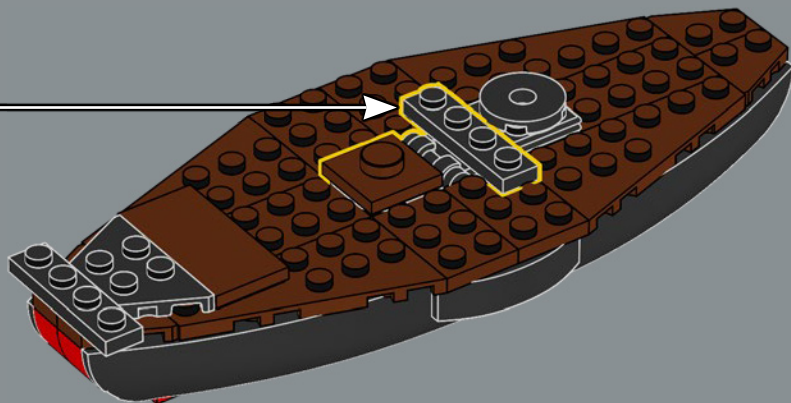



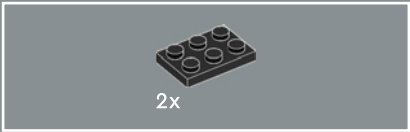

19

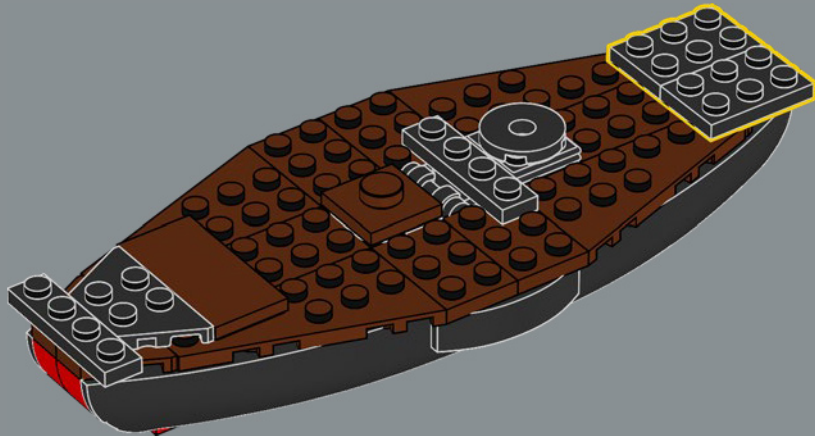

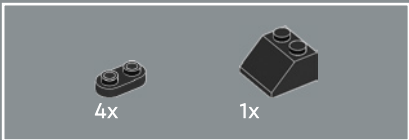

20

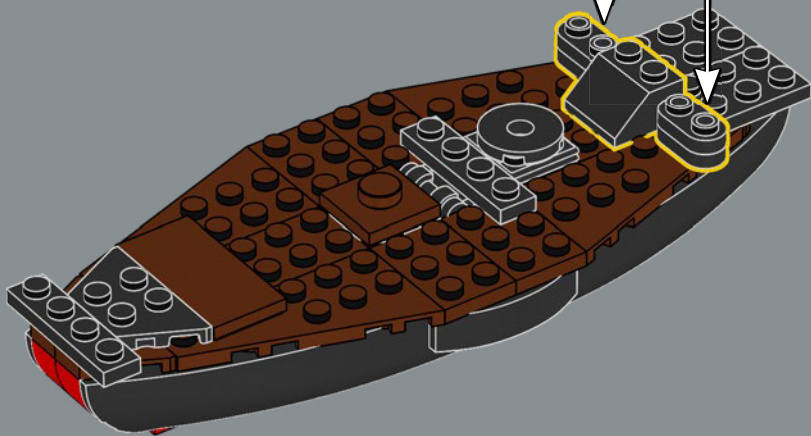
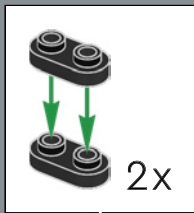



21

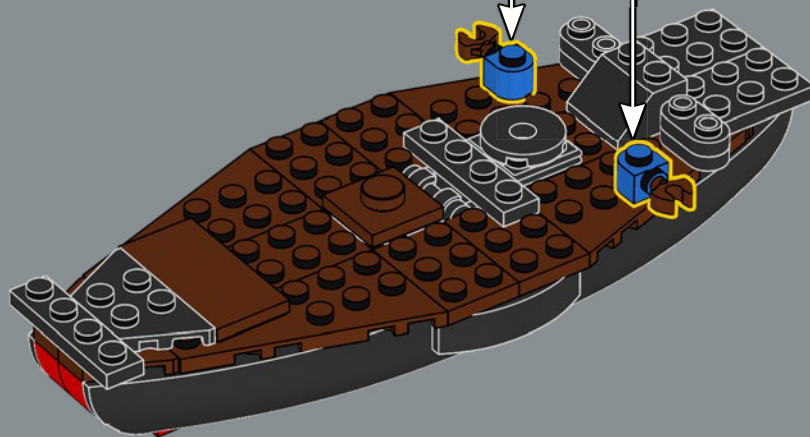
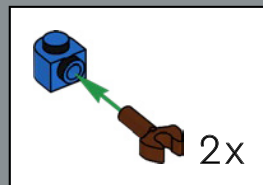



2x

22

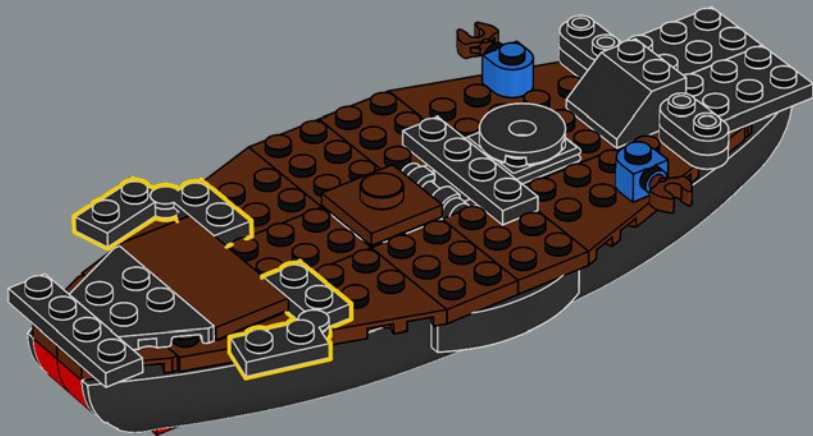



23

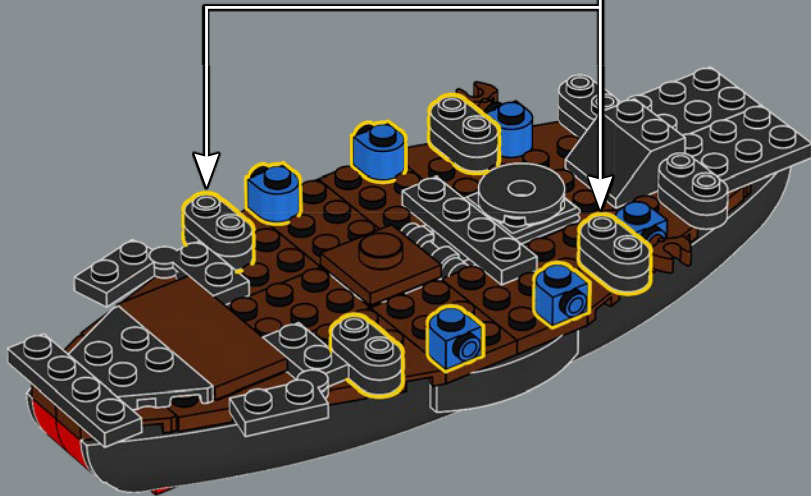
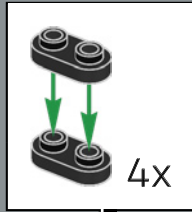

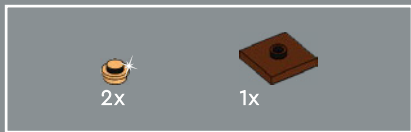

24

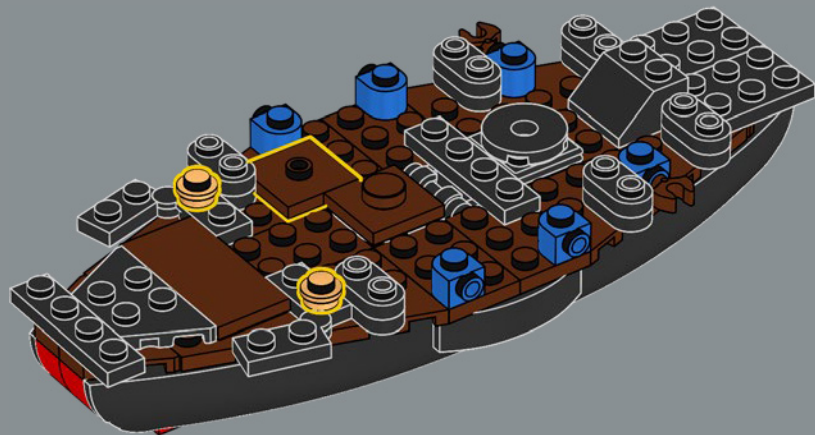

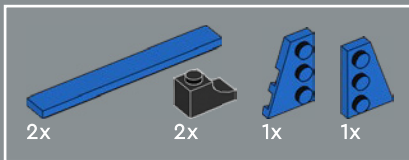

25

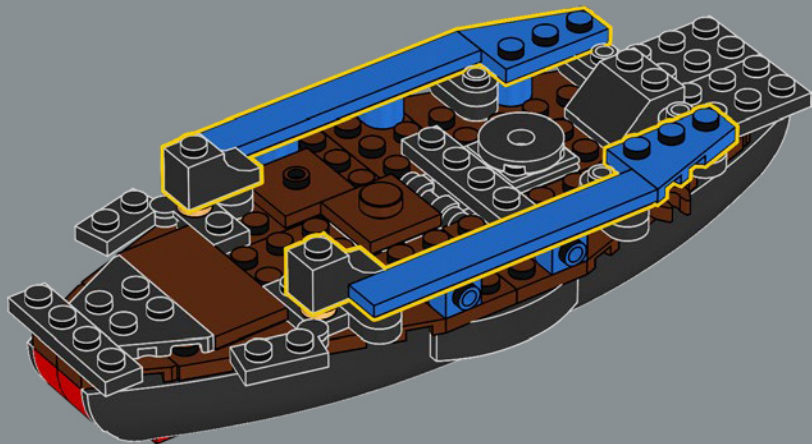

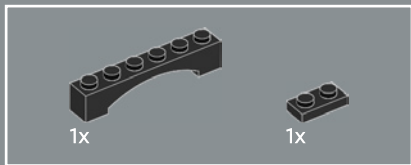

26

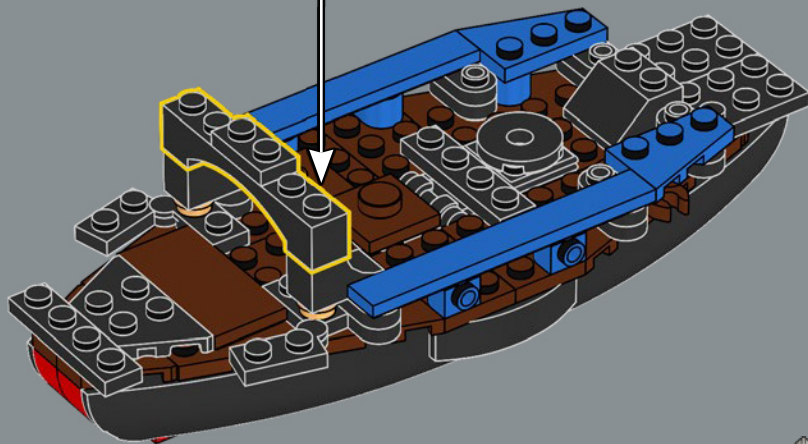
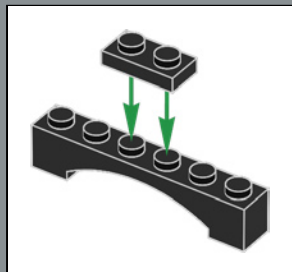



27

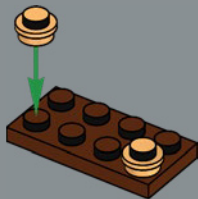

28

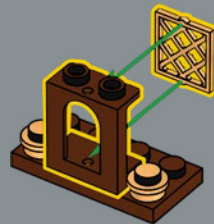



2x

29

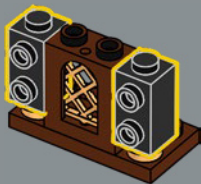

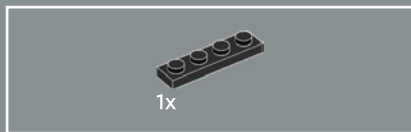

30

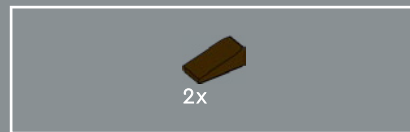

31



32

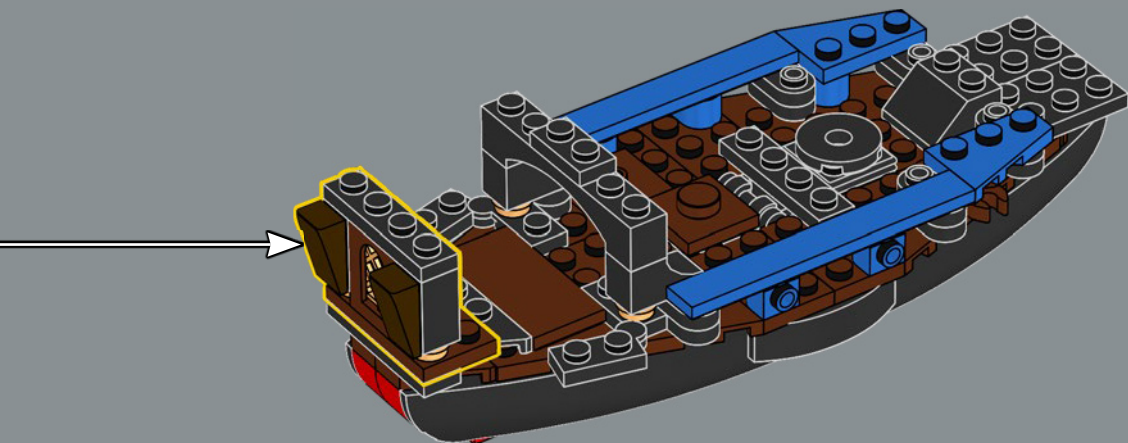

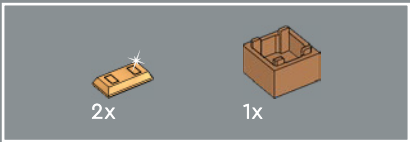

33

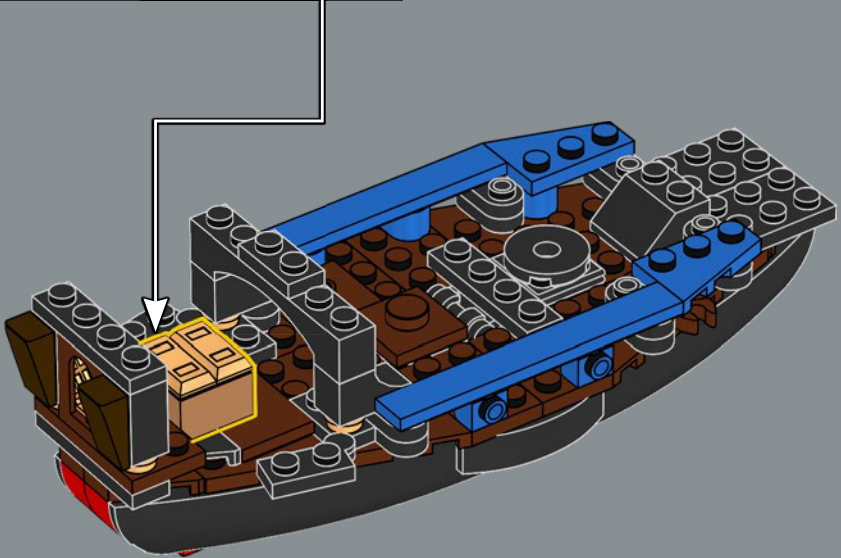
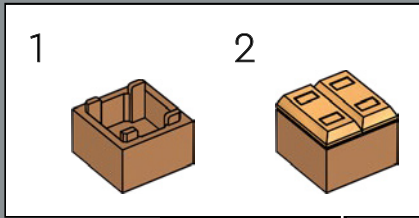



34

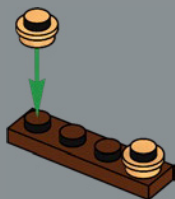

35

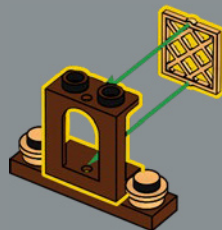

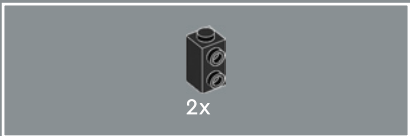

36

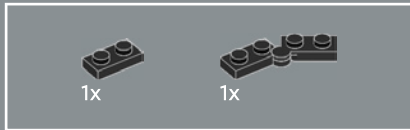

37

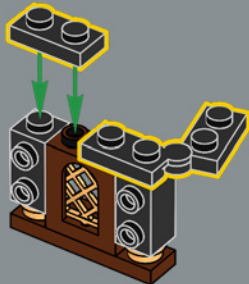

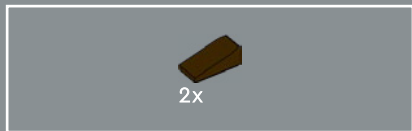

38

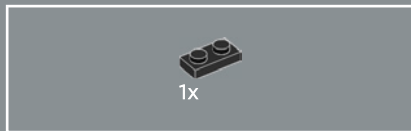
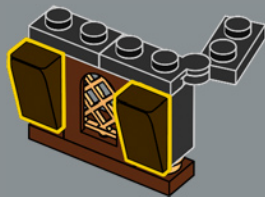

39

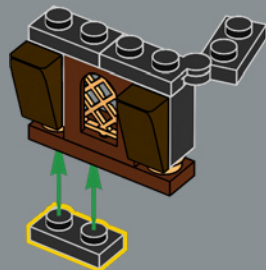

40

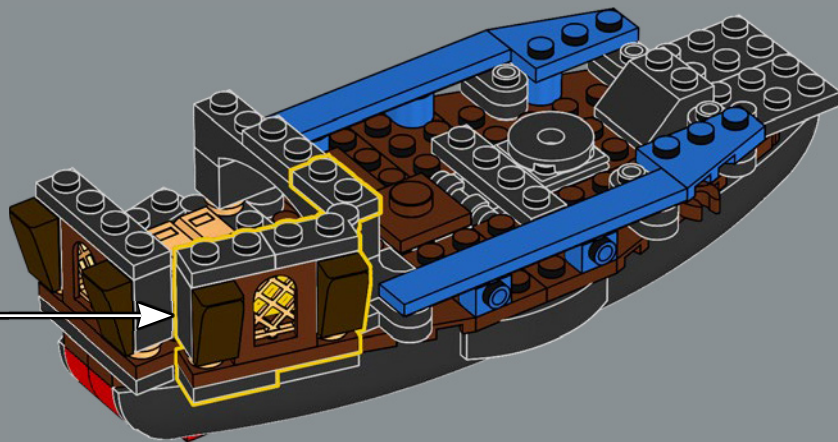

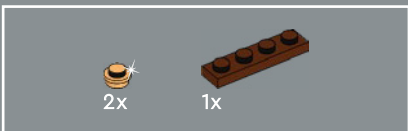

41

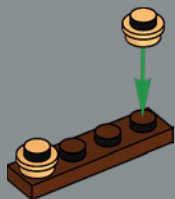

42

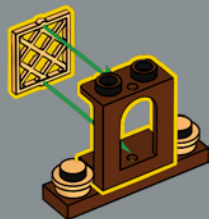

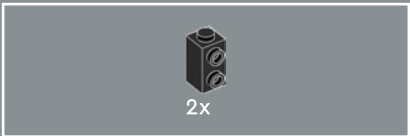

43

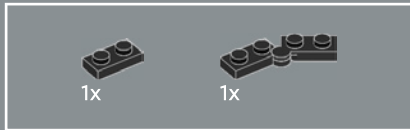
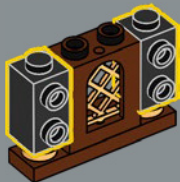

44

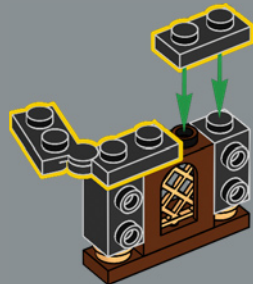

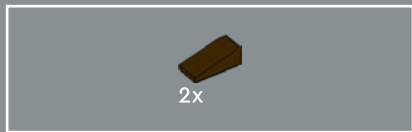

45

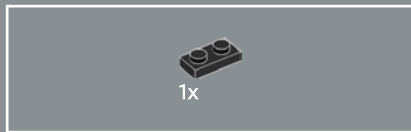
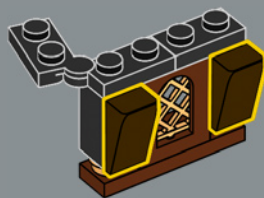

46

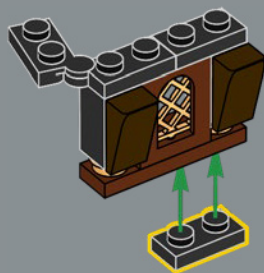

47

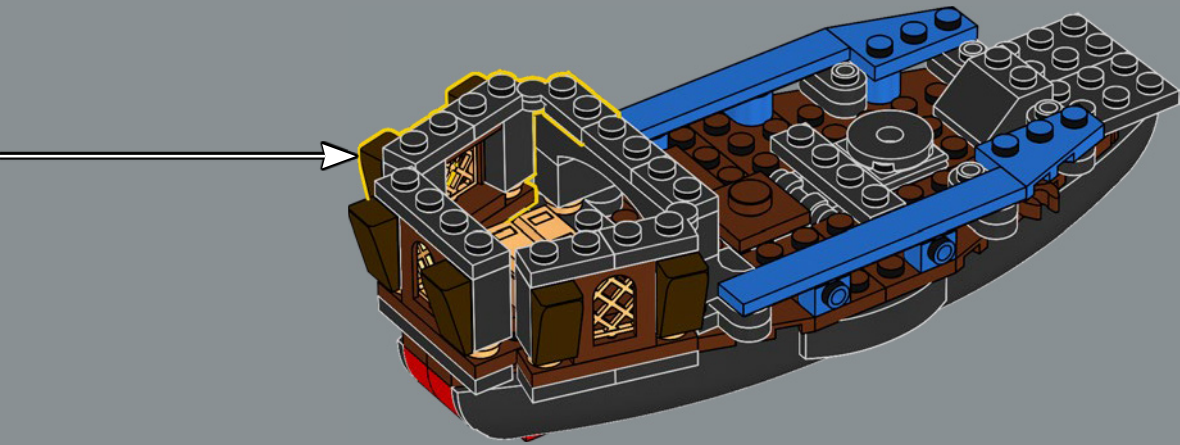



48

1



2



2x

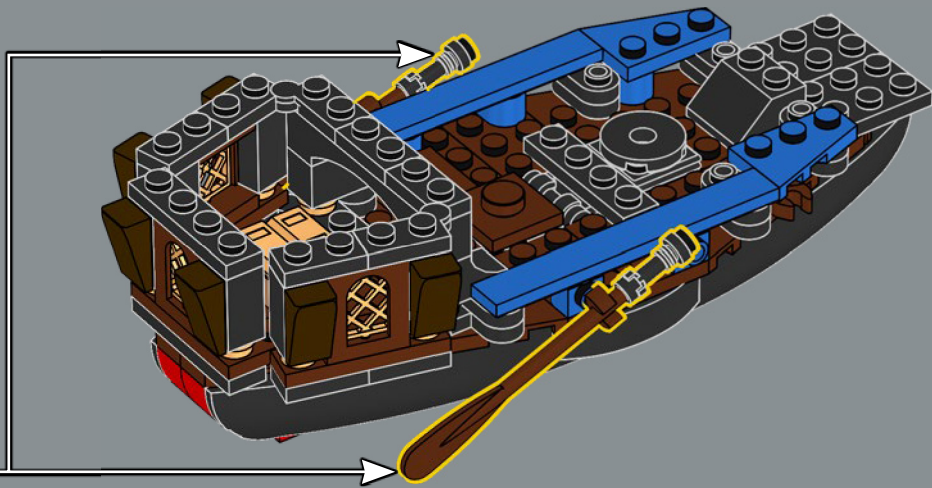

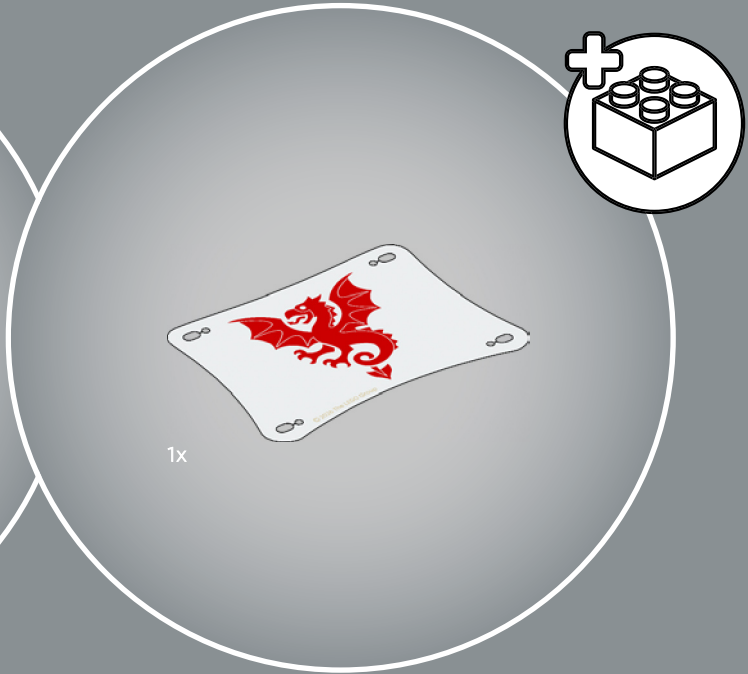

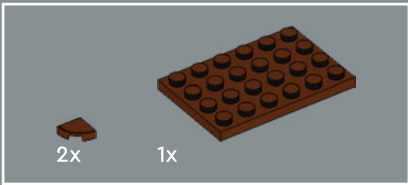

49



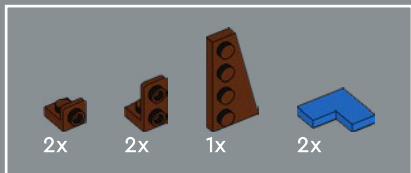

50

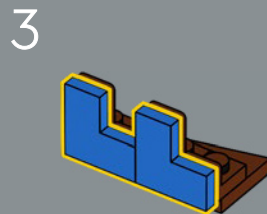
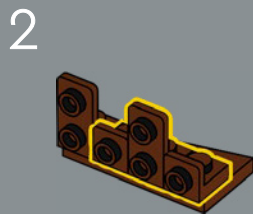
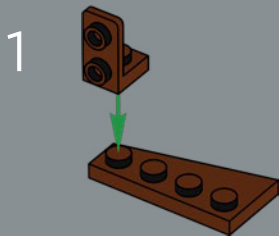

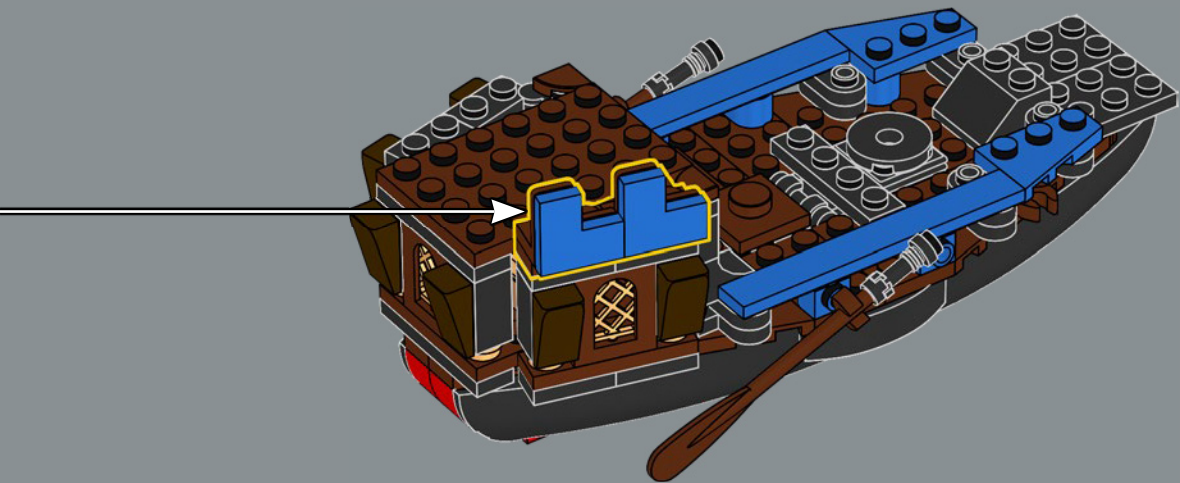

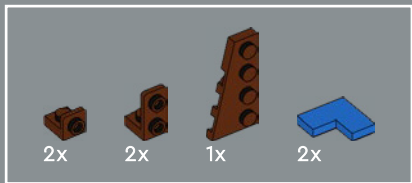

51

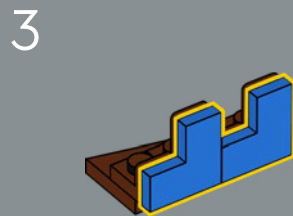
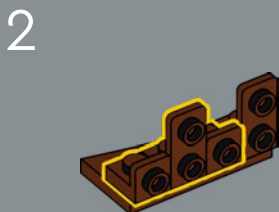
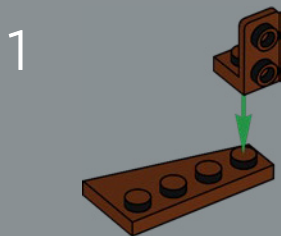

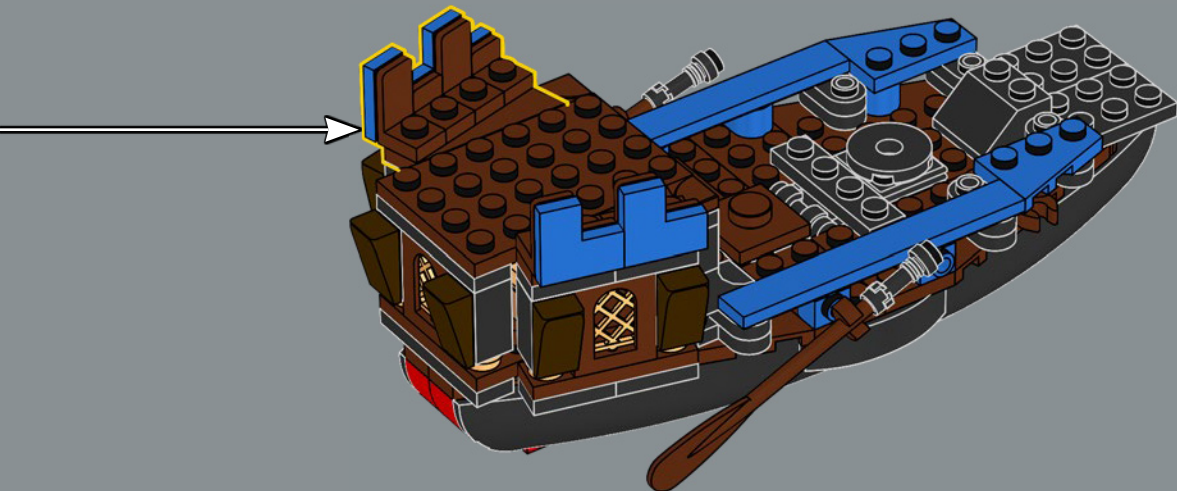

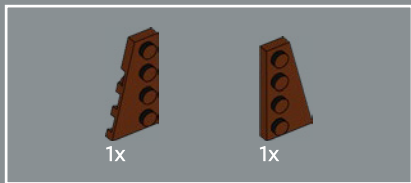

52





1x



2x

53

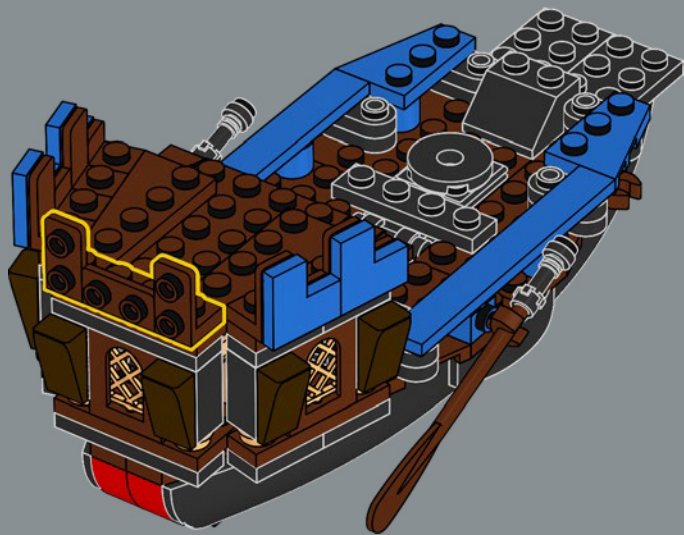



2x

54

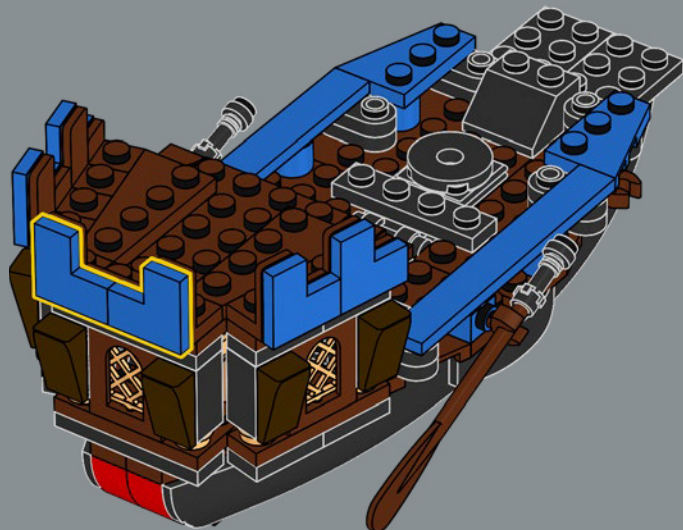

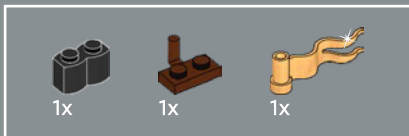

55

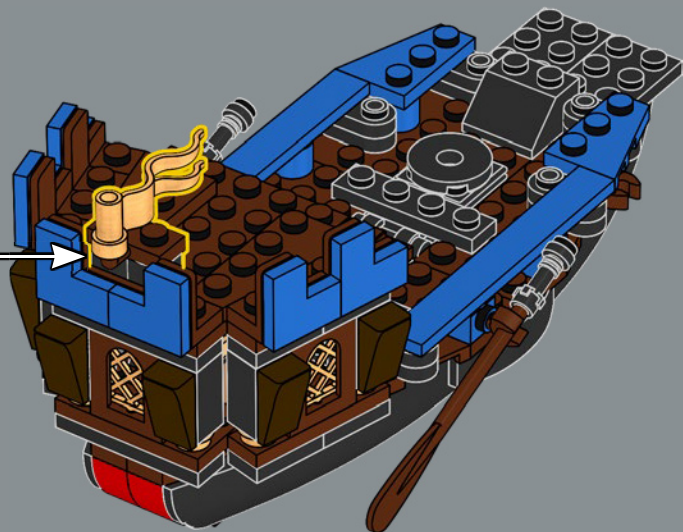
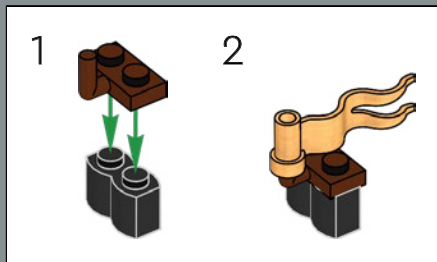



56

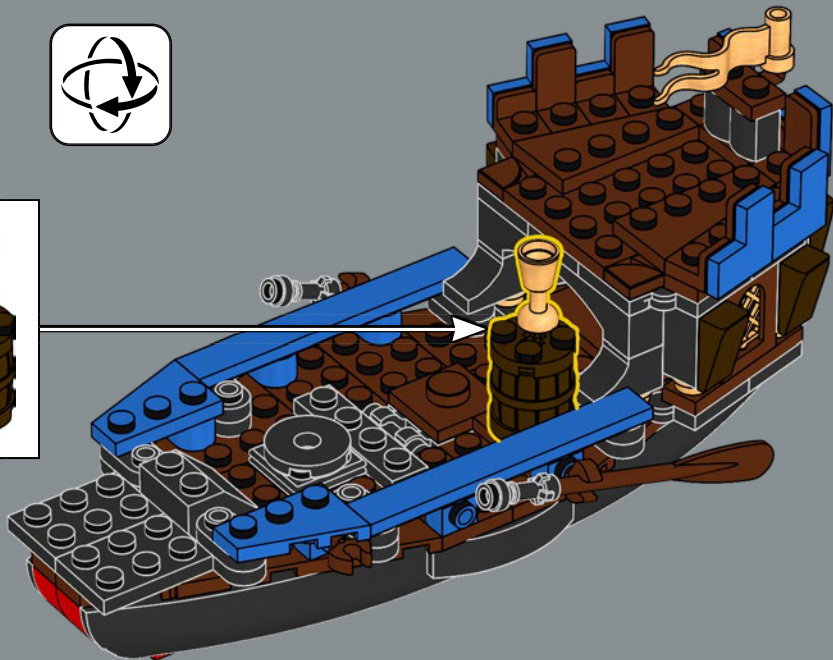



57





2x

58

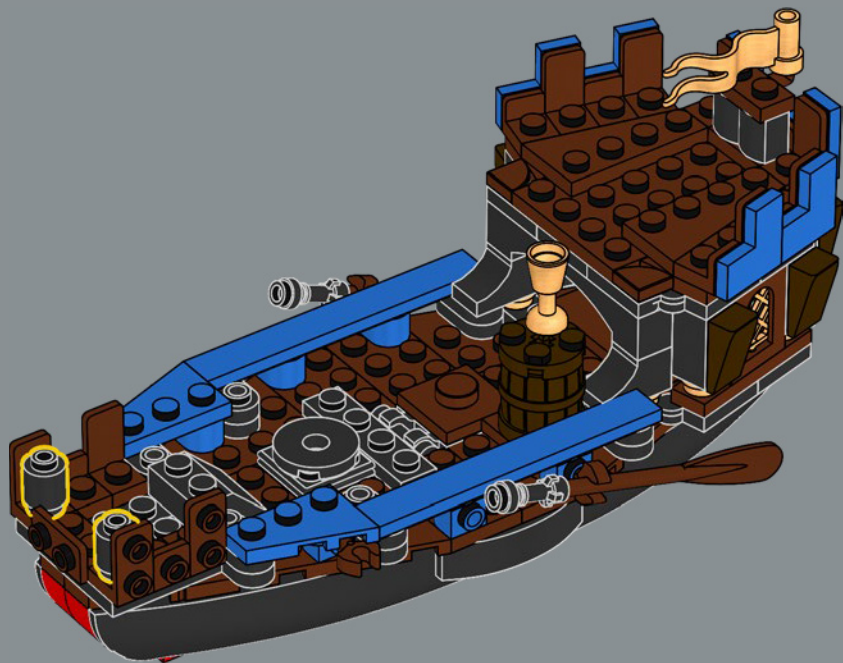



2x

59

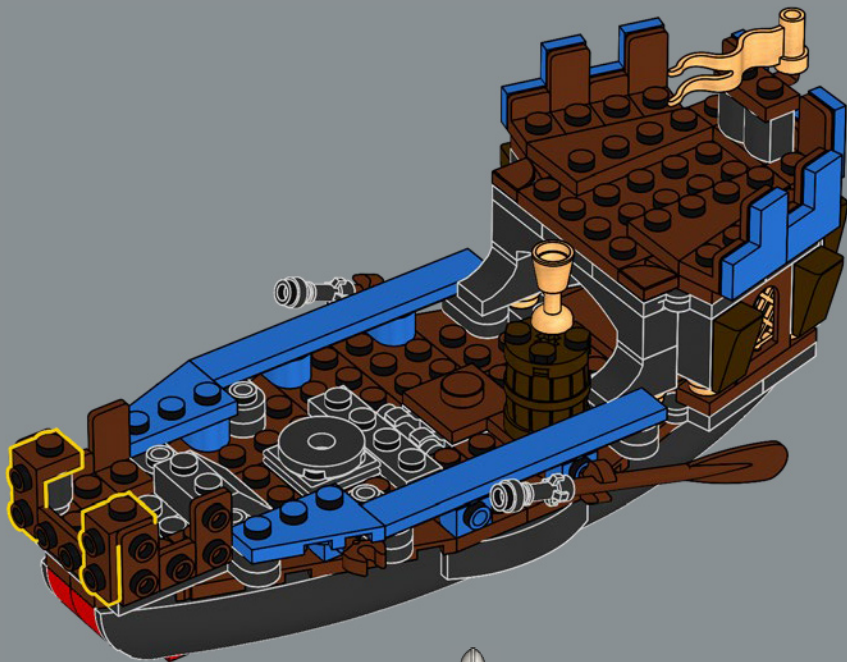

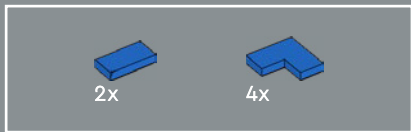

60

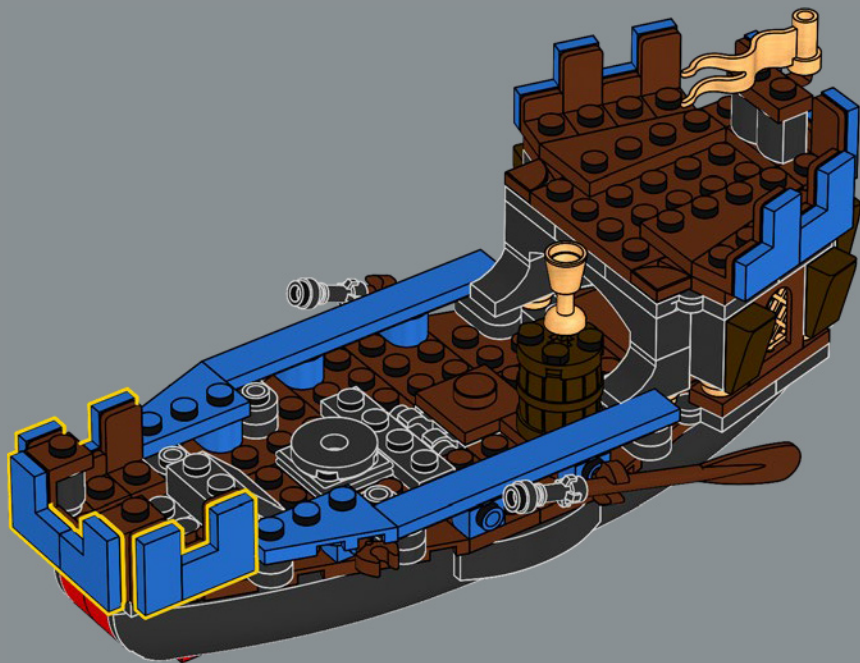

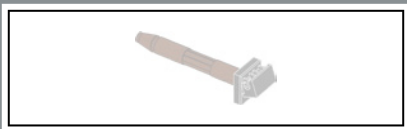

61

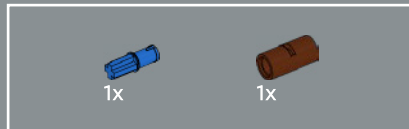
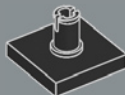

62

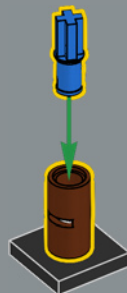



63

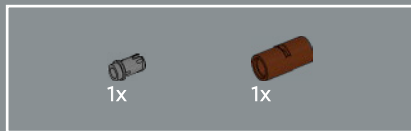

64





1x

65



1x

66

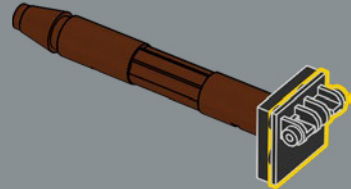



1x

67

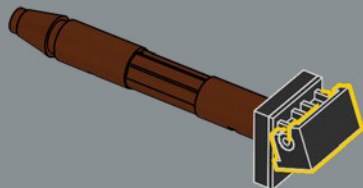

68

68

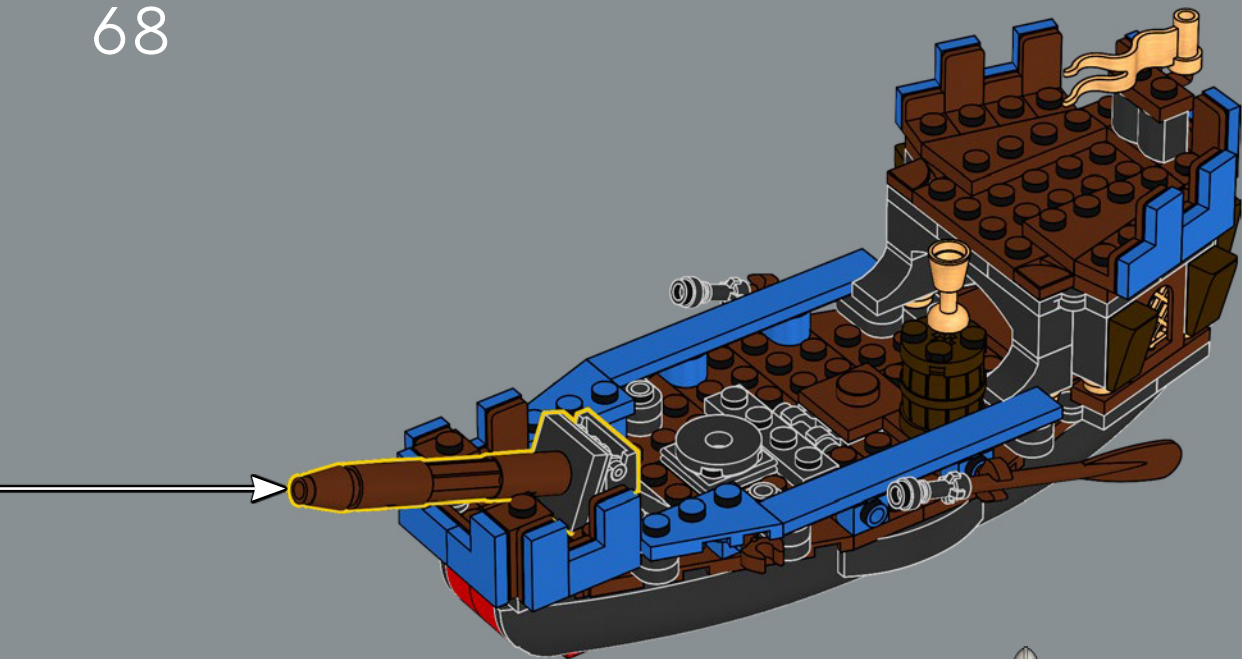

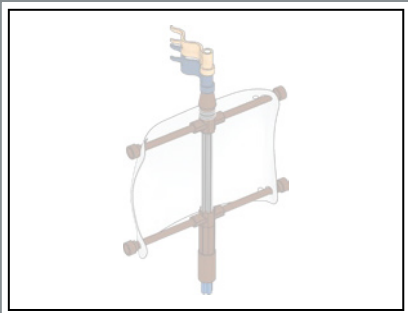

69

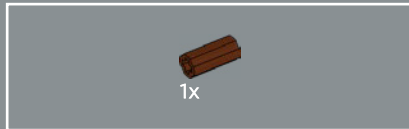

70



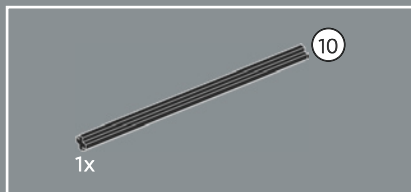

71





1x

72





73

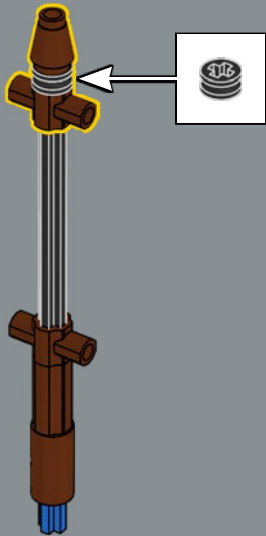

74

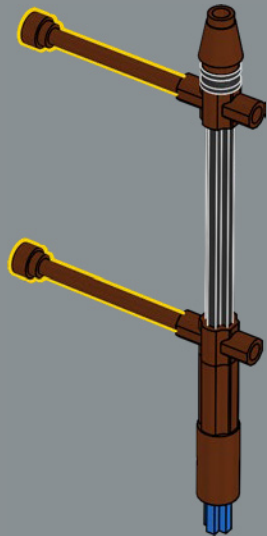

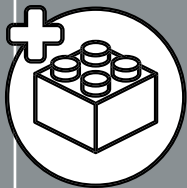

75

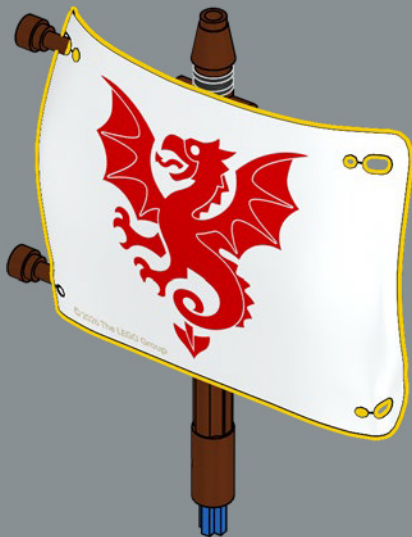



76

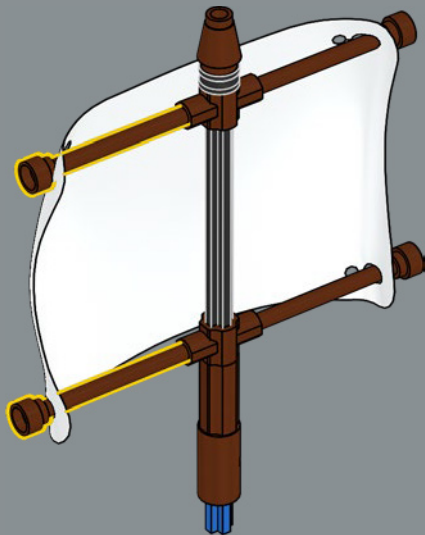

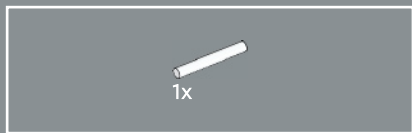

77

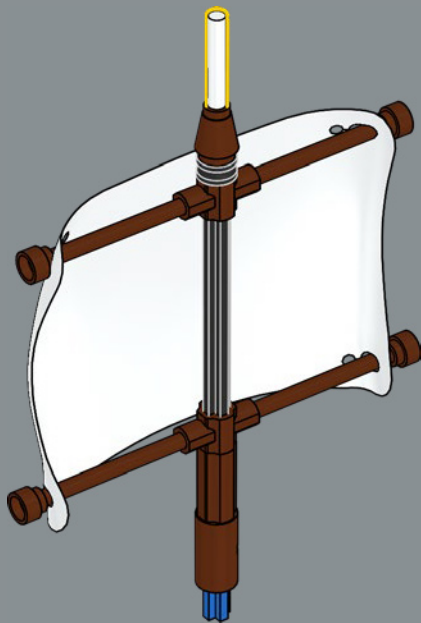



78

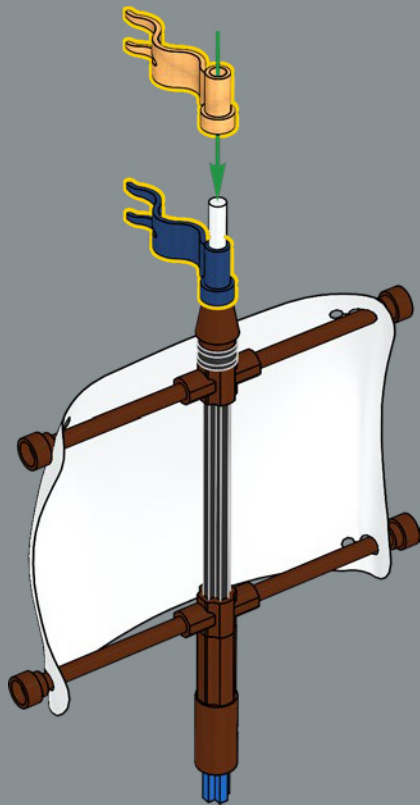

79

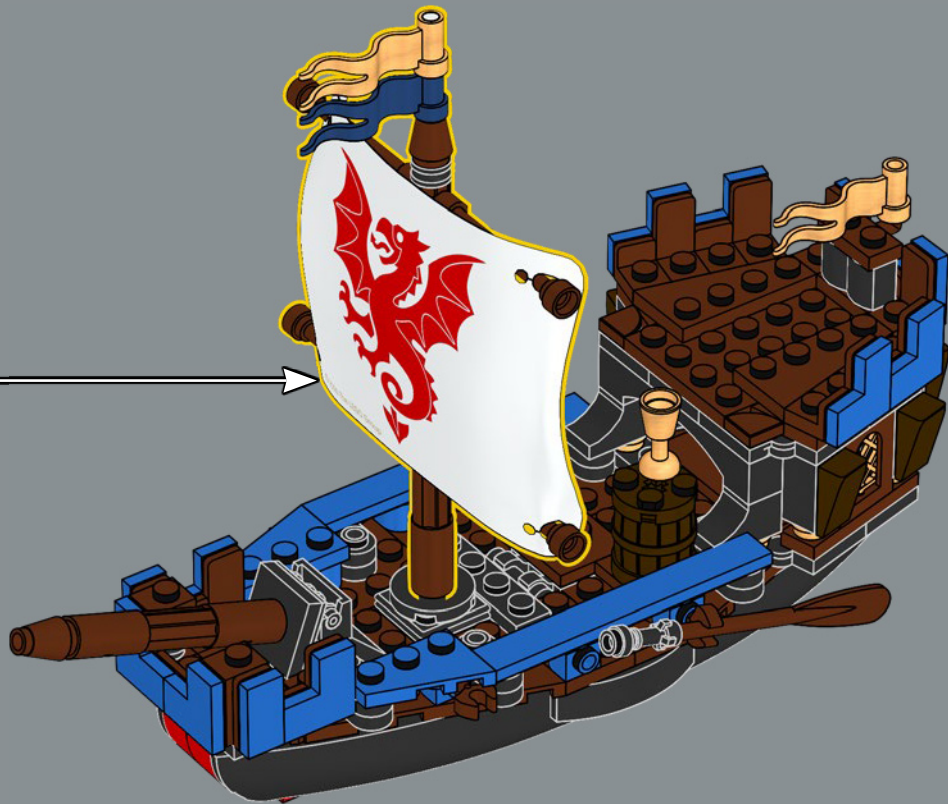

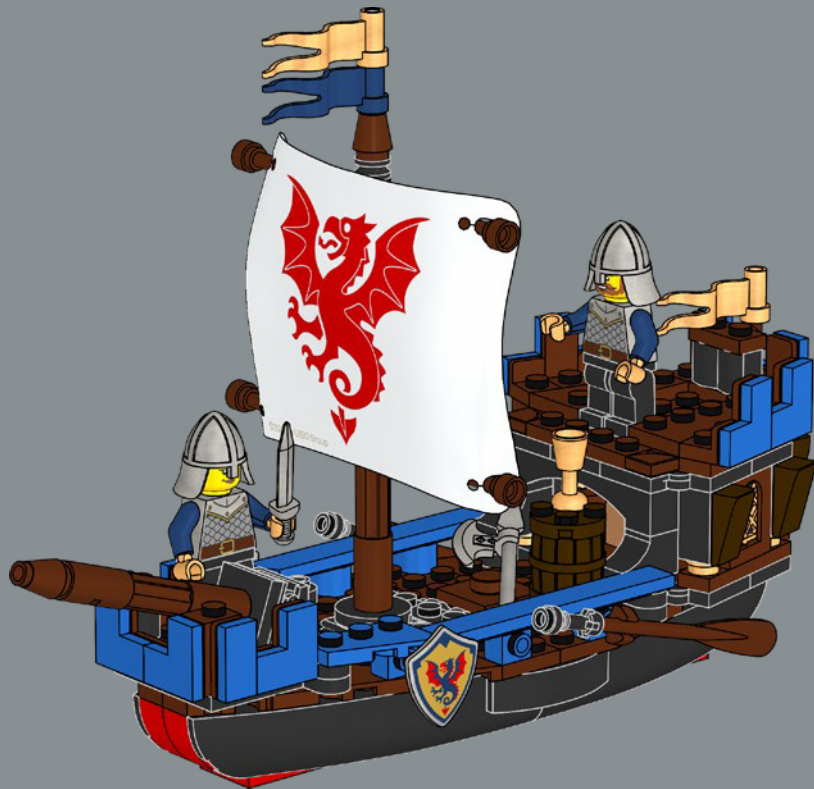



4x
6218823



2x
302301



1x
6428803



2x
302001



1x
6618122



2x
4598897



1x
6600750



2x
306226

80



6x
6228987



13x
6210270



1x
6143850



2x
4644456



2x
9339



5x
302326



2x
6369578



1x
393726



2x
6308883



1x
6310268



1x
4225201



1x
6325254



1x
303926



1x
6313191



1x
4124096



1x
4531412



2x
302126



3x
371026



2x
4613153



4x
6416444



1x
4620763



2x
6523487

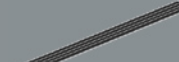

1x
373726



2x
6523486

10



1x
6642352



1x
6434805



1x
6268948



2x
4124067



1x
6284586



2x
4529242



4x
6439053



2x
6149677



10x
6341553



6x
6238874



2x
6472546



2x
6385263



2x
6385262



2x
4205470



2x
4205469



2x
6459423



2x
4531751



3x
6173132



3x
6063447



1x
6261359



2x
6174856



2x
6503731



2x
6503730



2x
4565394



4x
4211189



8x
6482573



1x
4498155



1x
4498156



4x
4206482



2x
306923



10x
6129747



2x
416223



4x
6547136



1x
428221



1x
6287854



2x
6435640



6x
6448793



6x
6469440



1x
6171894



LEGO.com/service



8x
4523159



1x
4505990



1x
6375358



3x
6477142



2x
6207933



2x
6268949



1x
6395635



6x
6228923



1x
4211052



1x
6126083



1x
4623298



1x
6605459



6x
6509391



1x
6363145



2x
6627638



2x
6037507



2x
6627742



1x
6093532



1x
4611883



2x
4211190



4x
4538252



2x
4211186



1x
4579690



2x
4609635



1x
4211247



1x
4271874



YOU COULD WIN



YOU COULD WIN

Your feedback will help shape the future development of this product series.

Visit:

DU KÖNNTEST GEWINNEN

Dein Feedback trägt zur Weiterentwicklung dieser Produktreihe bei.

Geh auf:

VOUS POURRIEZ GAGNER

Vos commentaires nous aideront à concevoir les futurs produits de cette gamme.

Visitez :

POTRESTI VINCERE TU

La tua opinione ci aiuterà a migliorare la creazione futura di questa linea di prodotti.

Visita:

PUEDES GANAR

Tu opinión contribuirá al futuro de esta serie de productos.

Visita:

轻松获奖

您的反馈将有助于我们在今后改进本产品系列。

请访问:

LEGO.com/productfeedback

You also have the chance to win a LEGO® set.

Terms and conditions apply.*

Außerdem hast du die Chance, ein LEGO® Set zu gewinnen.

Es gelten die Teilnahmebedingungen.*

Vous pourriez également gagner un ensemble LEGO®.

Des conditions s'appliquent.*

Hai anche la possibilità di vincere un set LEGO®.

Termini e condizioni sono applicabili.*

También tienes la oportunidad de ganar un set LEGO®.

Aplican términos y condiciones.*

您还有机会赢取乐高®套装。

条款和条件适用。*

*LEGO.com/productfeedback-terms



LEGO and the LEGO logo are trademarks of the LEGO Group.
©2026 The LEGO Group.

