

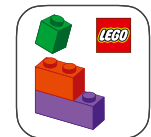

21066



Available in English
Disponible en français
Disponible en español



LEGO® Builder

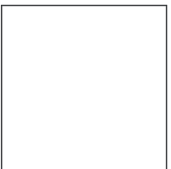



WE'RE MAKING OUR PACKAGING MORE SUSTAINABLE

We're transitioning from single-use plastic to paper-based packaging. As we progress, you may find a mix of paper and plastic in our boxes.

NOUS RENDONS NOS EMBALLAGES PLUS DURABLES

Nous passons des emballages en plastique à usage unique aux emballages à base de papier. Durant la transition, vous pourriez trouver un mélange de papier et de plastique dans nos boîtes.

QUEREMOS HACER MÁS SUSTENTABLES NUESTROS MATERIALES DE EMBALAJE

Estamos cambiando las bolsas de plástico desechables por bolsas con base de papel. Conforme avanzamos en este propósito, puedes encontrar una mezcla de papel y de plástico en nuestras cajas.

LEGO.com/sustainable-packaging



BUILDER



Apple and the Apple logo are trademarks of Apple Inc., registered in the U.S. and other countries and regions. App Store is a service mark of Apple Inc. Google Play and the Google Play logo are trademarks of Google LLC. Tencent and the Tencent logo are trademarks of Tencent Inc.

LEGO.com/devicecheck

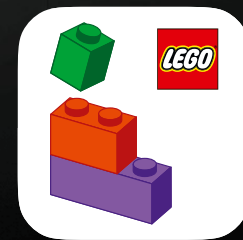

LEGO® Builder





THE BIG APPLE

New York, New York – the city that never sleeps, city of dreams, the Big Apple – the city known by many names as a place of boundless energy and opportunity. Founded in 1624 as 'New Amsterdam', it has evolved into a vibrant beacon of culture, trade, art and innovation. New York City's iconic skyline features instantly recognizable landmarks spread across its five boroughs. From the Statue of Liberty welcoming newcomers to the lively streets that inspire us to chase our dreams, the city's unique pulse captures the hearts of both visitors and residents. The borough of Manhattan alone is home to over 1.5 million people packed into just 23 sq. mi. (59 km²), making it one of the most densely populated places on Earth. Whether you're drawn to its bright lights and buzz, or the peaceful paths of Central Park, the city's spirit, rich history and diversity is guaranteed to leave a lasting impression.

LA GROSSE POMME

New York, New York – la ville qui ne dort jamais, la ville des rêves, la Grosse Pomme... une ville connue sous de nombreux noms et reconnue comme un lieu d'énergie et de possibilités sans limites. Fondée en 1624 sous le nom de Nouvelle-Amsterdam, elle est devenue un phare dynamique de culture, de commerce, d'art et d'innovation. L'horizon emblématique de New York présente des monuments immédiatement reconnaissables répartis dans ses cinq arrondissements. De la statue de la Liberté qui accueille les nouveaux arrivants aux rues animées qui nous inspirent à poursuivre nos rêves, le rythme unique de la ville conquiert le cœur des visiteurs comme des résidents. L'arrondissement de Manhattan à lui seul abrite plus de 1,5 million de personnes entassées dans seulement 59 km², ce qui en fait l'un des endroits les plus densément peuplés de la planète. Que vous soyez attiré par ses lumières vives et son effervescence ou par les sentiers paisibles de Central Park, l'esprit de la ville, la richesse de son histoire et sa diversité vous laisseront à coup sûr une impression durable.

LA GRAN MANZANA

Nueva York: la ciudad que nunca duerme, la ciudad de los sueños, la Gran Manzana..., una metrópoli conocida por muchos nombres y celebrada como un lugar de energía inagotable y oportunidades sin límites. Fundada en 1624 como Nueva Ámsterdam, ha evolucionado hasta convertirse en un vibrante faro de cultura, comercio, arte e innovación. El inconfundible horizonte de la ciudad de Nueva York cuenta con monumentos fácilmente reconocibles repartidos por sus cinco distritos. Desde la Estatua de la Libertad, que da la bienvenida a los recién llegados, hasta las animadas calles que nos inspiran a perseguir nuestros sueños, el ritmo único de la ciudad conquista tanto a visitantes como a residentes. Tan solo Manhattan reúne a más de un millón y medio de personas en apenas 59 km², lo que convierte a este distrito en una de las zonas más densamente pobladas del planeta. Ya sea que te atraigan sus brillantes luces y su bullicio o los tranquilos senderos de Central Park, el espíritu de la ciudad, su nutrida historia y su diversidad te dejarán, sin duda, una impresión imborrable.



EMPIRE STATE BUILDING (1931)

The 102-story New York icon offers stunning views of New York from the heart of Midtown Manhattan.

L'EMPIRE STATE BUILDING (1931)

Avec ses 102 étages, cette icône new-yorkaise offre des vues spectaculaires sur la ville depuis le cœur de Midtown Manhattan.

EMPIRE STATE BUILDING (1931)

Este ícono neoyorquino de 102 pisos ofrece unas vistas espectaculares de Nueva York desde el corazón del Medio Manhattan.



SOLOMON R. GUGGENHEIM MUSEUM (1959)

Since its opening, the museum has been recognized for its spiral architecture and world-class collection of modern and contemporary art.

MUSÉE SOLOMON R. GUGGENHEIM (1959)

Depuis son inauguration, ce musée est reconnu pour son architecture en spirale et sa collection de calibre mondial d'art moderne et contemporain.

MUSEO SOLOMON R. GUGGENHEIM (1959)

Desde su inauguración, el museo goza de reconocimiento tanto por su arquitectura en espiral como por su colección de arte moderno y contemporáneo de prestigio mundial.





ONE WORLD TRADE CENTER (2014)

To date, One World Trade Center is the tallest building in the Western Hemisphere, built as a symbol of unity and resilience.

ONE WORLD TRADE CENTER (2014)

À ce jour, le One World Trade Center est le plus haut bâtiment de l'hémisphère ouest, érigé comme symbole d'unité et de résilience.

ONE WORLD TRADE CENTER (2014)

Hasta hoy, el One World Trade Center es el edificio más alto del hemisferio occidental, erigido como símbolo de unidad y resiliencia.



METROPOLITAN MUSEUM OF ART (1870)

Founded in 1870, The Met is one of the world's largest museums, showcasing over 5,000 years of art history and modern masterpieces.

METROPOLITAN MUSEUM OF ART (1870)

Fondé en 1870, le Met est l'un des plus grands musées du monde, présentant plus de 5 000 ans d'histoire de l'art et des chefs-d'œuvre modernes.

MUSEO METROPOLITANO DE ARTE (1870)

Fundado en 1870, The Met es uno de los museos más grandes del mundo, con una colección que abarca más de 5000 años de historia del arte y obras maestras modernas.

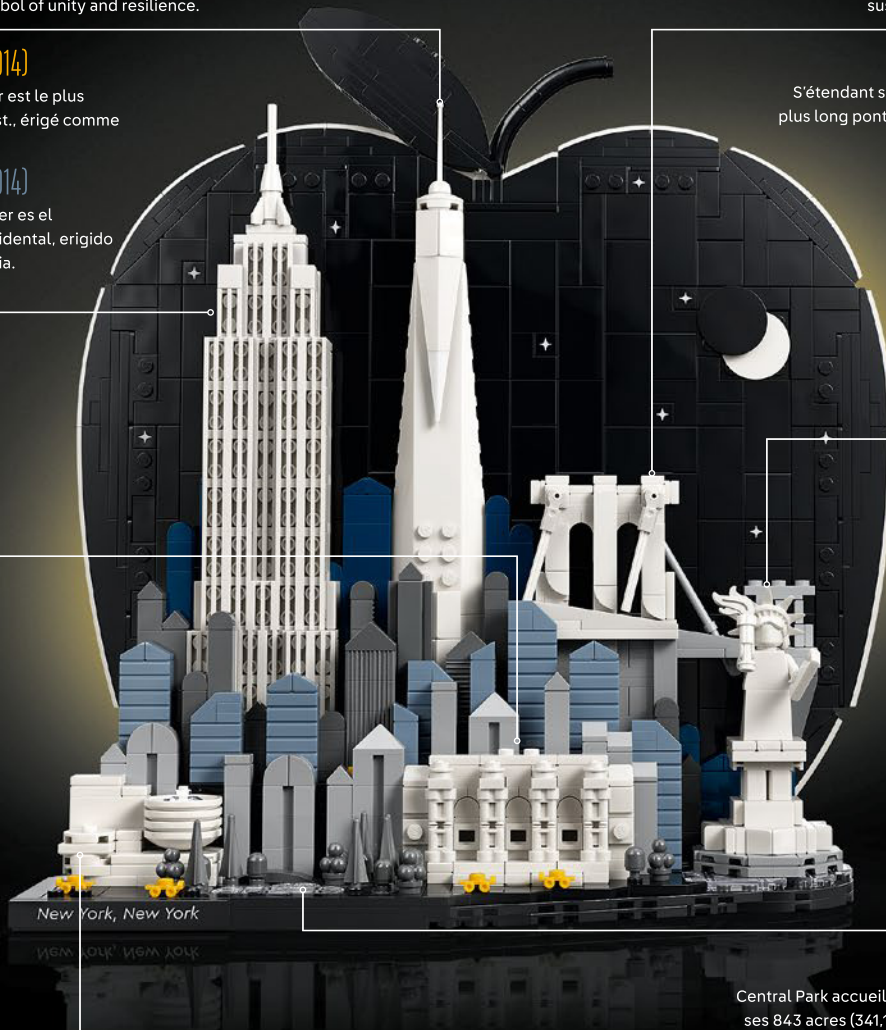

New York, New York

New York, New York

BROOKLYN BRIDGE (1883)

Stretching over a mile, Brooklyn Bridge was the longest suspension bridge in the world when it opened.

PONT DE BROOKLYN (1883)

S'étendant sur plus d'un mille, le pont de Brooklyn était le plus long pont suspendu du monde lorsqu'il a été inauguré.

PUENTE DE BROOKLYN (1883)

Con más de 1,5 km de extensión, el Puente de Brooklyn fue el puente colgante más largo del mundo cuando se inauguró.

STATUE OF LIBERTY (1886)

The grand neoclassical statue stands on Liberty Island in New York Harbor, originally the most famed port of entry to the U.S.

LA STATUE DE LA LIBERTÉ (1886)

La grande statue néoclassique se dresse sur Liberty Island, dans le port de New York, autrefois la plus célèbre porte d'entrée des États-Unis.

ESTATUA DE LA LIBERTAD (1886)

La imponente estatua neoclásica se encuentra en la isla de la Libertad, en el puerto de Nueva York, que fue durante décadas la entrada más famosa a los Estados Unidos.

CENTRAL PARK (1858)

Central Park welcomes 42 million visitors a year to its 843 ac. (341.1 ha) of meadows, trails and lakes.

CENTRAL PARK (1858)

Central Park accueille 42 millions de visiteurs chaque année dans ses 843 acres (341,1 ha) d'étendues vertes, de sentiers et de lacs.

CENTRAL PARK (1858)

Central Park recibe 42 millones de visitantes al año en sus 341,1 ha de césped, senderos y lagos.

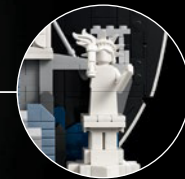
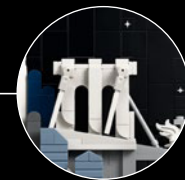

FROM THE LEGO® ARCHITECTURE DESIGN TEAM

2026 marks the 250th anniversary of the signing of the United States Declaration of Independence AND the 10th anniversary of our first LEGO® Architecture New York City Skyline set! That inspired us to celebrate both occasions, with famous New York landmarks reinterpreted against a 'Big Apple' backdrop depicting a night sky. We used faceted elements to replicate the intricate geometry of One World Trade Center as it rests on the 'shoulders' of the Empire State Building and tapers as it rises. LEGO grille plates make up the windows and long upward Art Deco lines on the Empire State Building. The build of the Brooklyn Bridge plays with a forced perspective effect, by drastically changing the size, adding color variations in both towers and adding a slight angle to the road. With other iconic details, like 'Lady Liberty' as a minifigure, we hope you have fun building and exploring this magnificent city!

UN MOT DE L'ÉQUIPE DE CONCEPTION LEGO® ARCHITECTURE

L'année 2026 marquera le 250^e anniversaire de la signature de la Déclaration d'indépendance des États-Unis et le 10^e anniversaire de notre tout premier ensemble LEGO® Architecture New York City Skyline! Cela nous a inspirés à célébrer ces deux occasions, en réinterprétant les monuments emblématiques de New York contre une toile de fond de la « Grosse Pomme » représentant un ciel nocturne. Nous avons utilisé des éléments facetés pour reproduire la géométrie complexe du One World Trade Center, posé sur les « épaules » de l'Empire State Building et s'affinant vers le sommet. Les plaques LEGO en grille forment les fenêtres et la longue ligne Art déco ascendante de l'Empire State Building. La construction du pont de Brooklyn joue avec un effet de perspective forcée en modifiant drastiquement les dimensions, en ajoutant des variations de couleur aux deux tours et en inclinant légèrement la route. Avec d'autres détails emblématiques, comme « Lady Liberty » sous forme de minipoupée, nous espérons que vous prendrez plaisir à construire et à explorer cette magnifique ville!

IMPRESIONES DEL EQUIPO DE DISEÑO DE LEGO® ARCHITECTURE

El año 2026 marcará el 250 aniversario de la firma de la Declaración de Independencia de los Estados Unidos Y TAMBIÉN el 10 aniversario del set LEGO® Architecture Skyline Nueva York, ¡el primero de la colección! Esa coincidencia nos inspiró a celebrar ambas ocasiones con una reinterpretación de los monumentos más famosos de Nueva York, presentados ante un fondo en forma de gran manzana que sugiere un cielo nocturno. Para reproducir la compleja geometría del One World Trade Center utilizamos elementos facetados que evocan la forma en la que parece apoyarse sobre los *hombros* del Empire State Building y cómo se va estrechando al ganar altura. Las placas de rejilla LEGO conforman las ventanas y las largas líneas ascendentes de estilo *art déco* del Empire State Building. El modelo del Puente de Brooklyn juega con un efecto de perspectiva forzada: se modifican drásticamente las proporciones, se incorporan variaciones de color en las dos torres y se agrega una ligera inclinación al tramo de carretera. Y, con otros detalles icónicos, como la minifigura de la Dama de la Libertad, ¡esperamos que disfrutes construyendo y explorando esta magnífica ciudad!



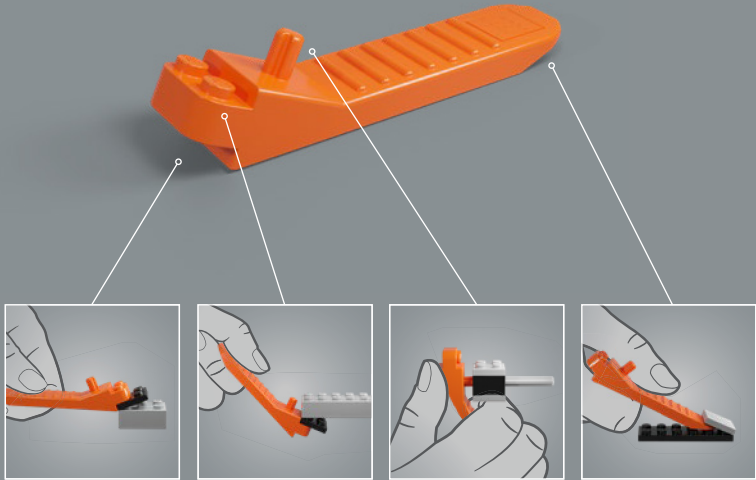

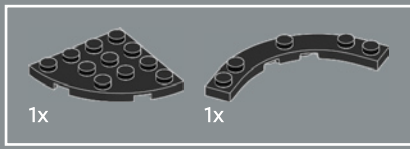

1

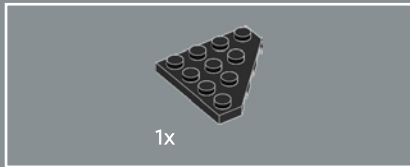
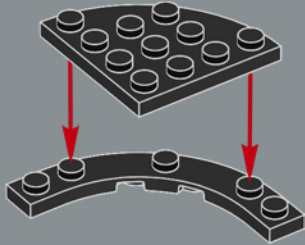

2

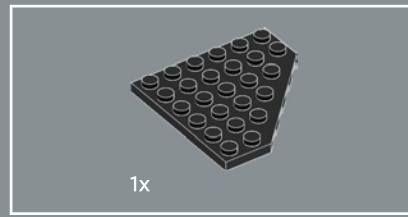
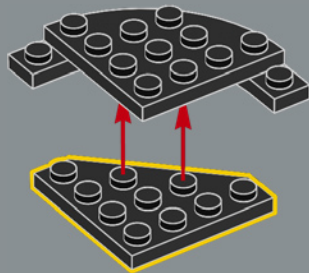

3

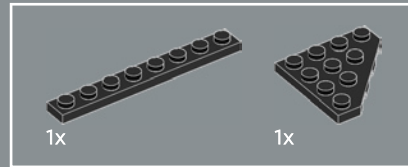
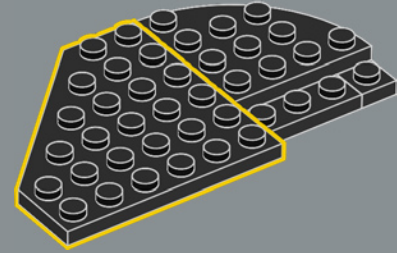

4

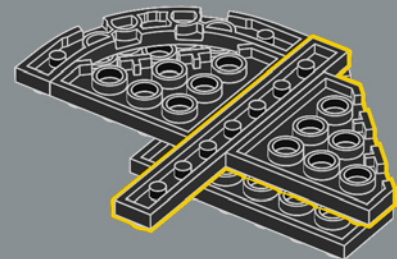

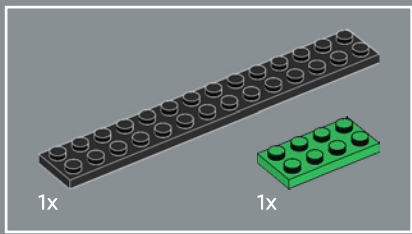

5

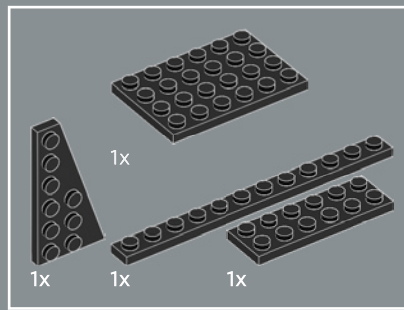
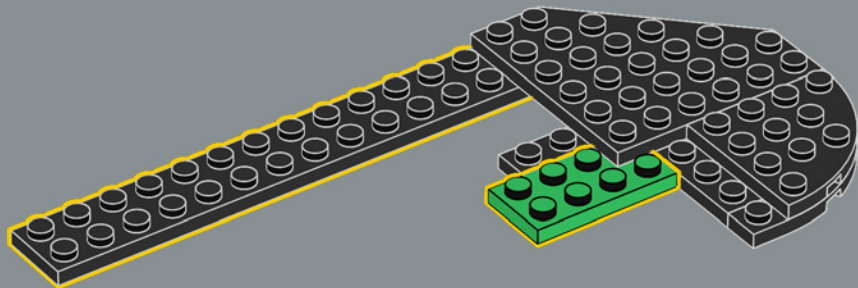

6

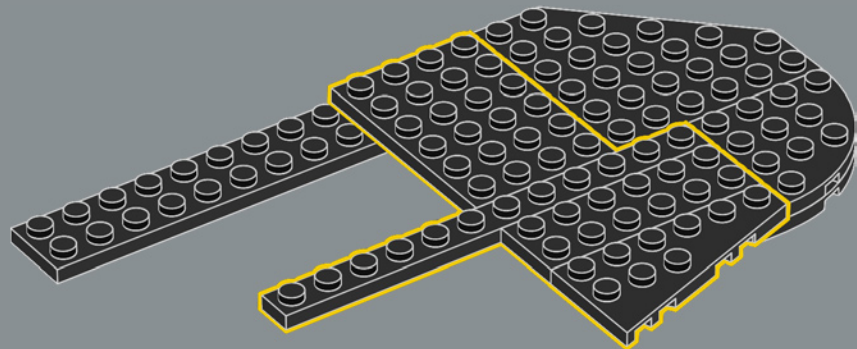

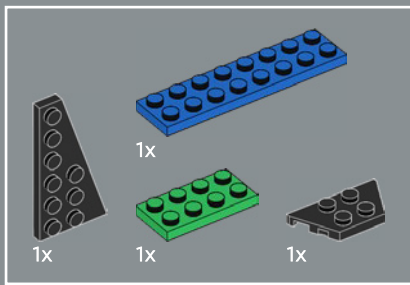

7

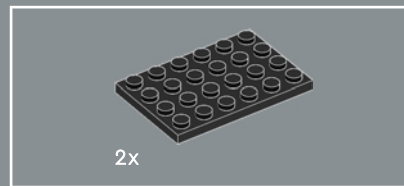
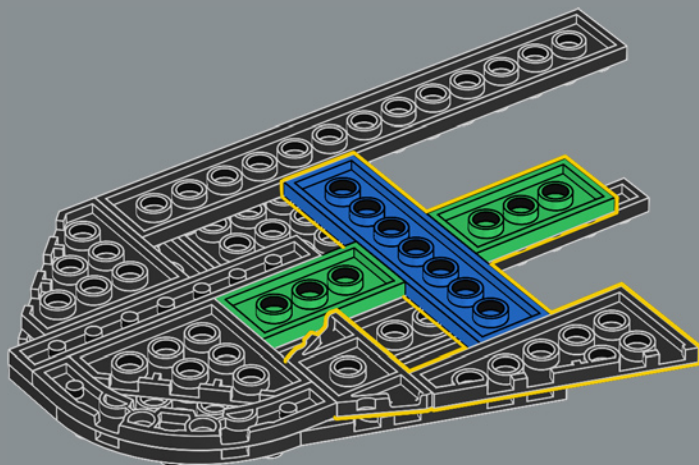

8

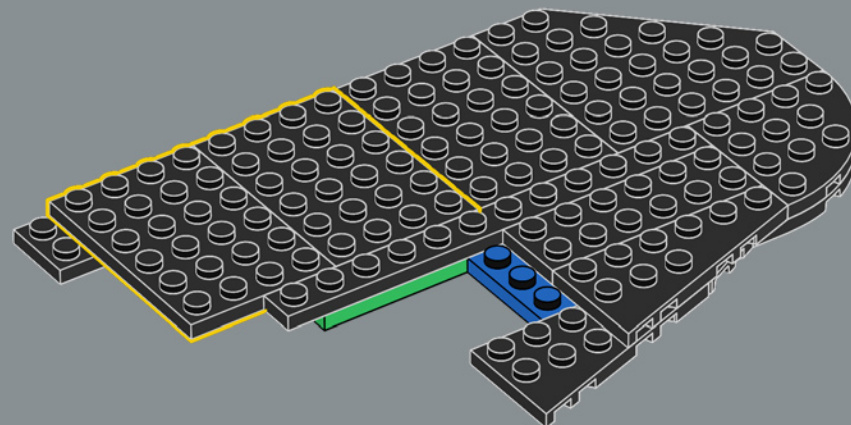

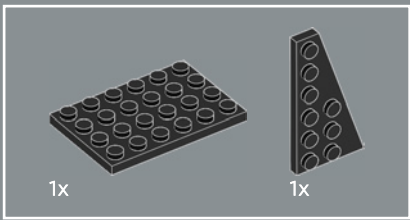

9

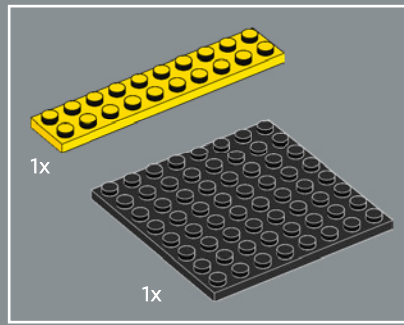
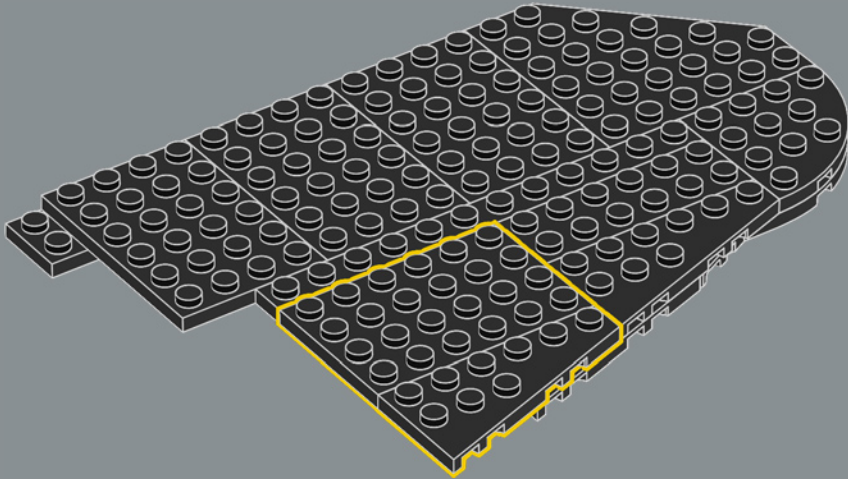

10

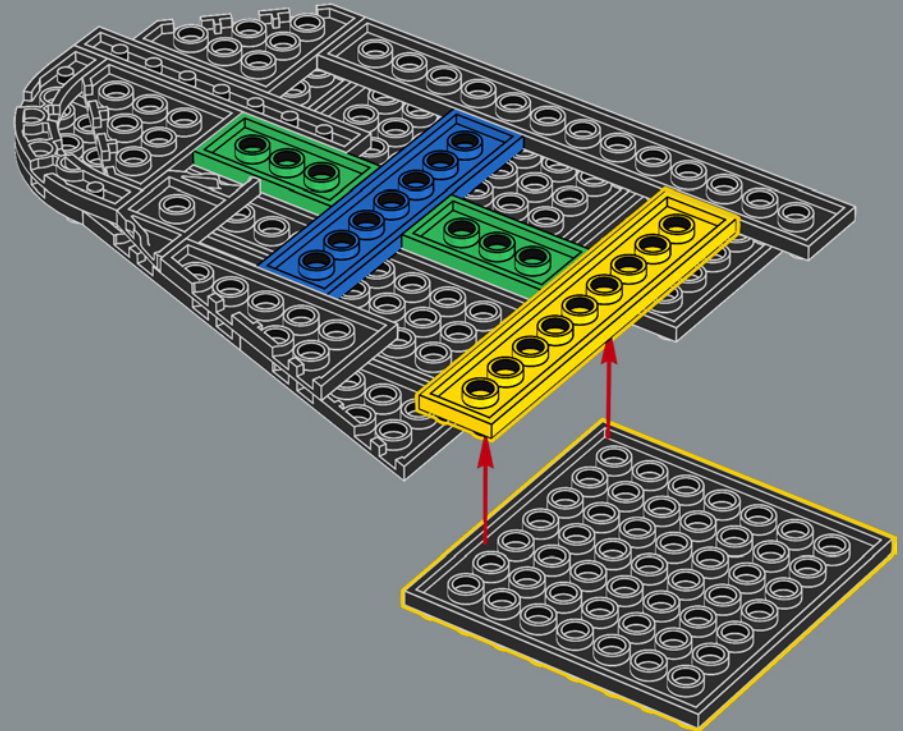

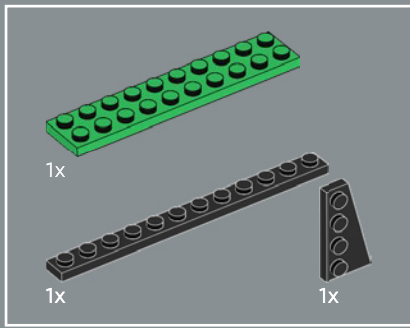

11

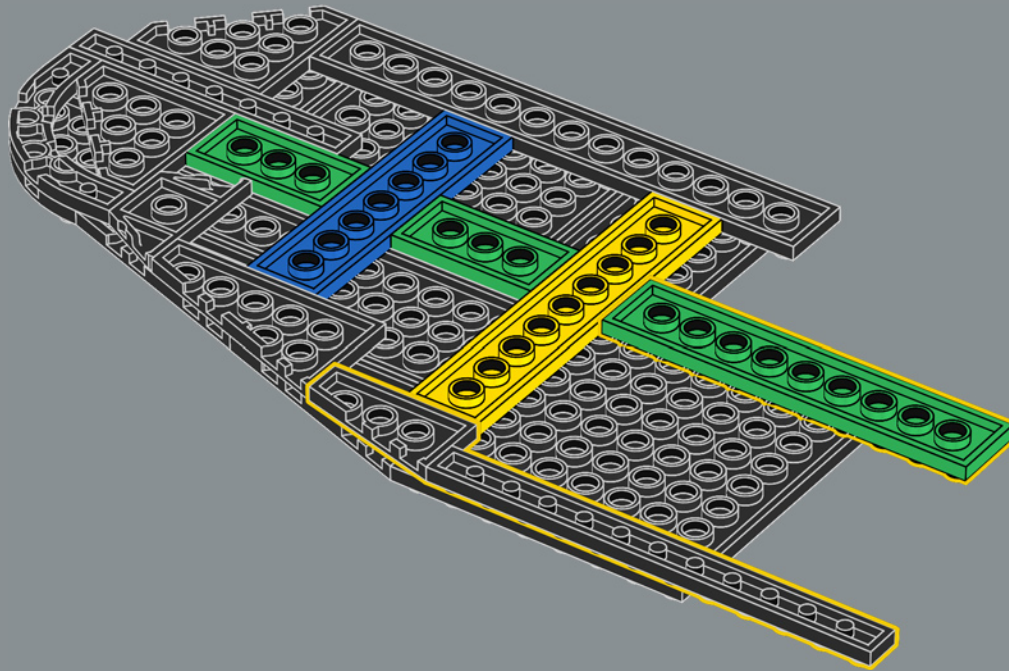

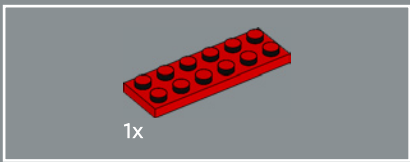

12

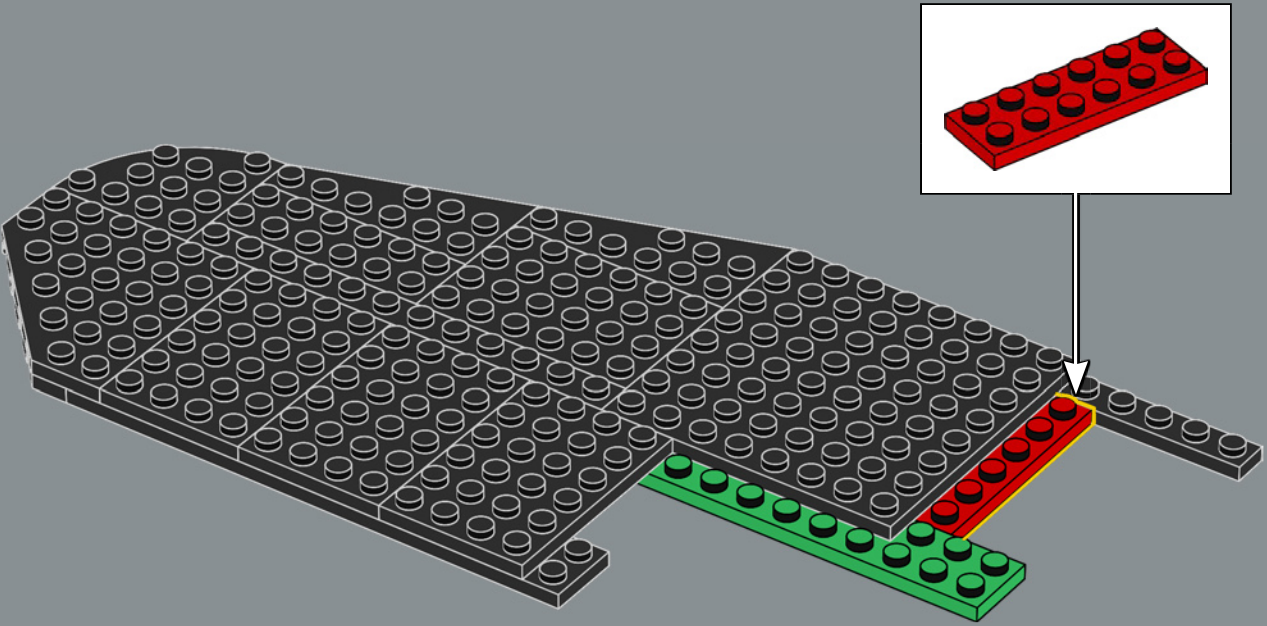

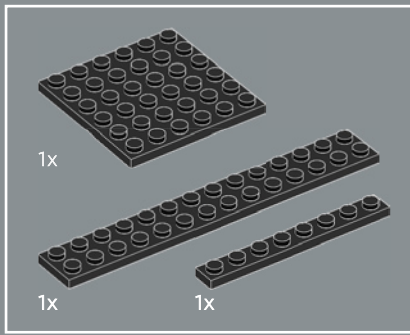

13

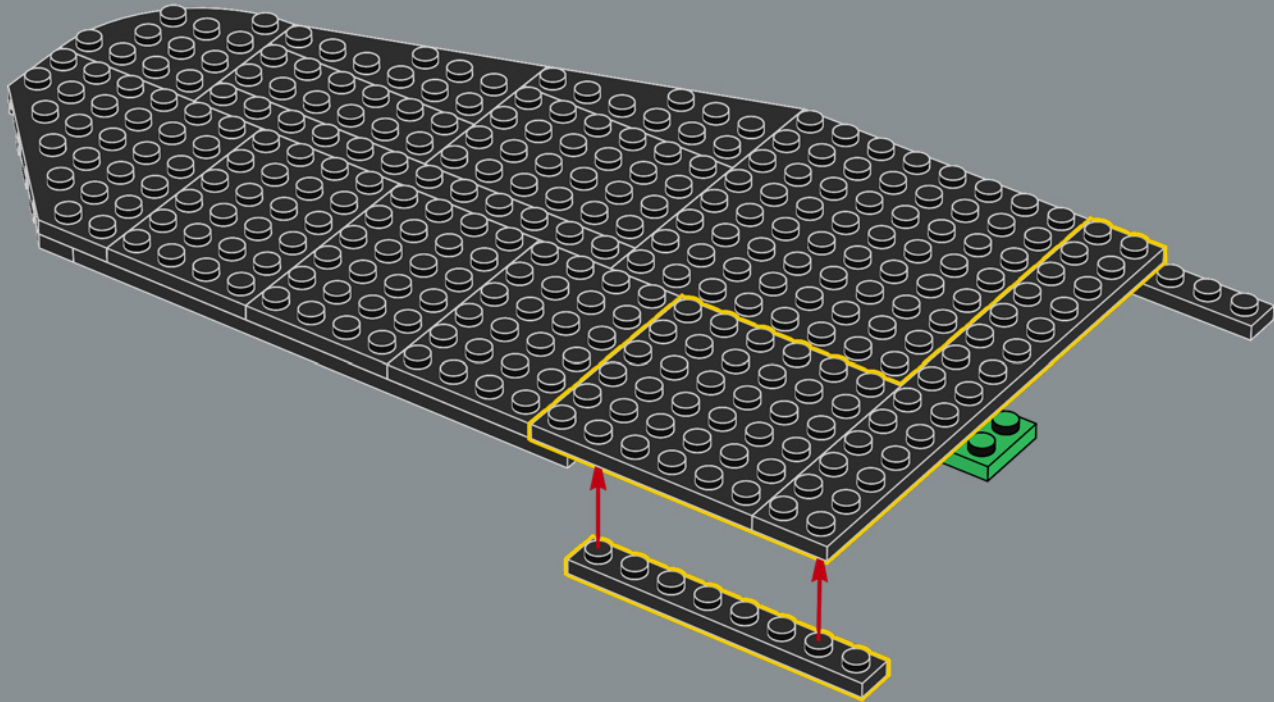

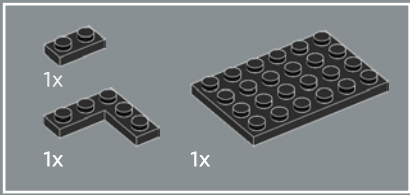

14

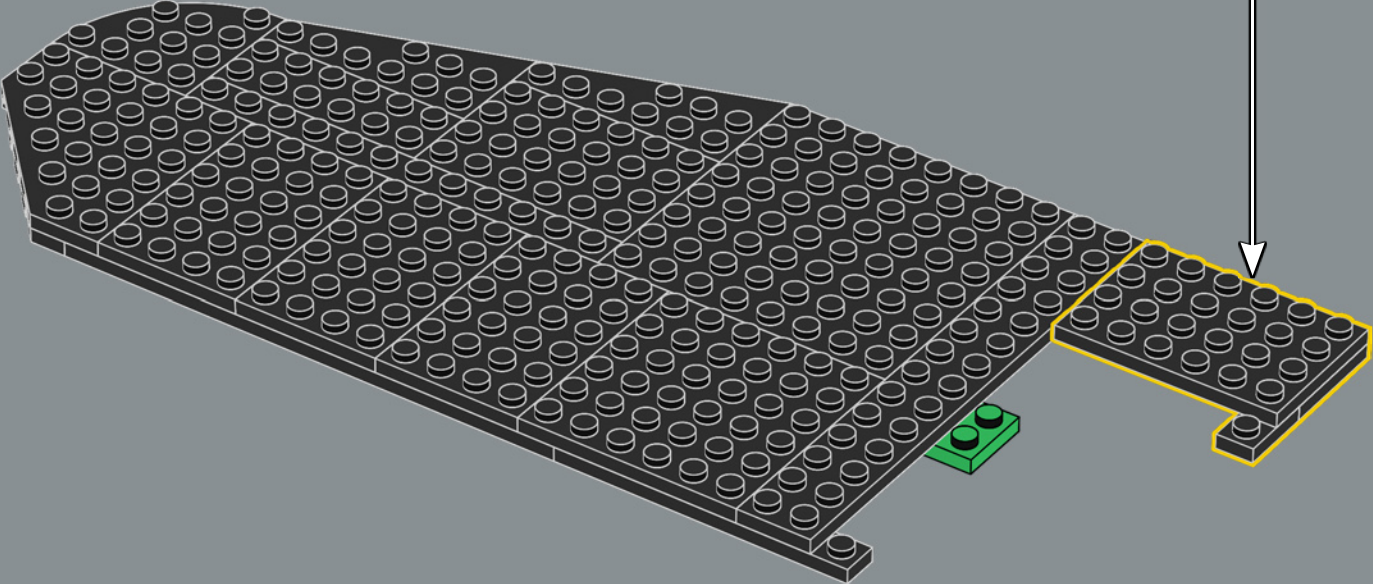
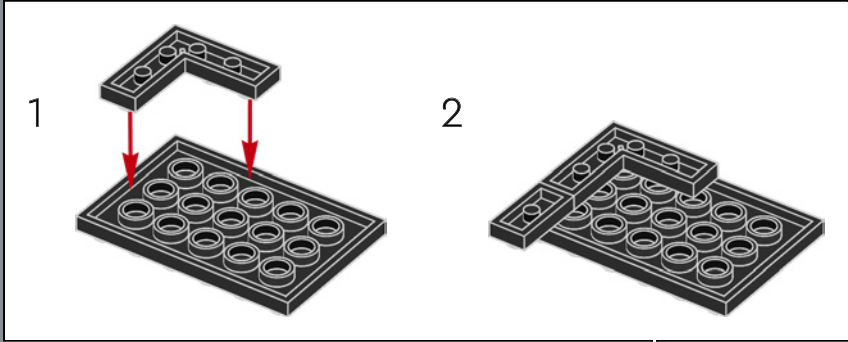

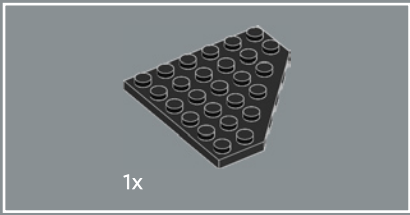

15

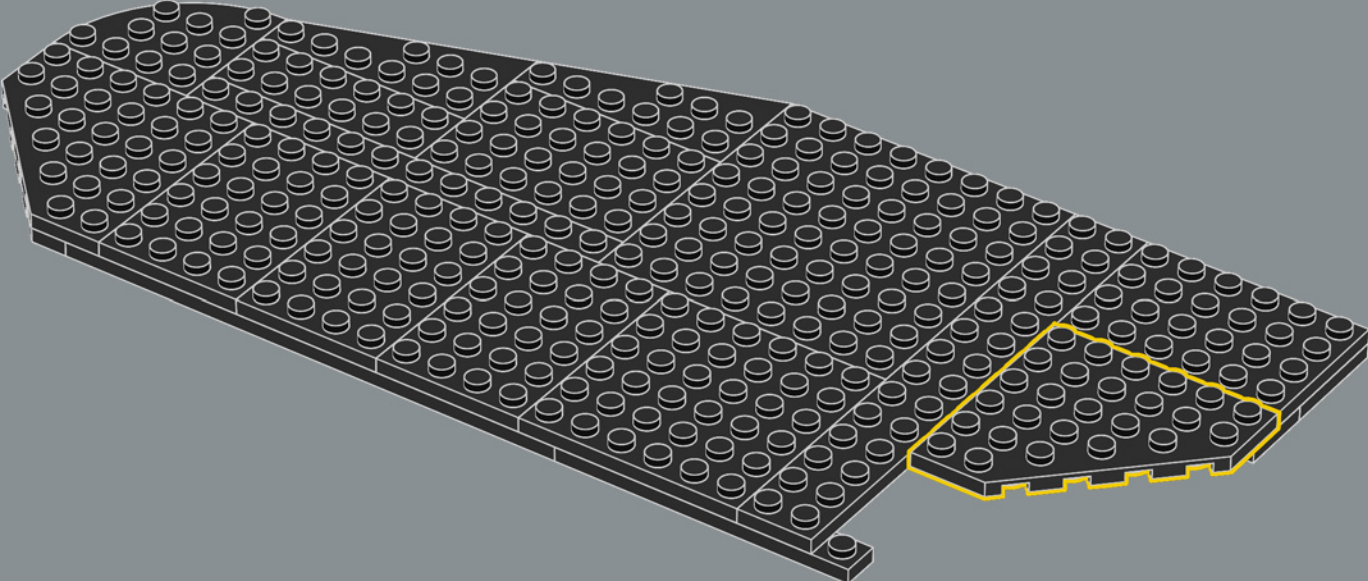

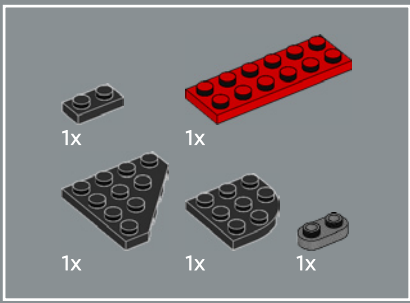

The colorful LEGO® plates within the base are inspired by a few of the 36 subway lines that connect the city.

Les plaques LEGO® colorées à la base s'inspirent de quelques-unes des 36 lignes de métro qui relient la ville.

Las coloridas placas LEGO® de la base se inspiran en algunas de las 36 líneas de metro que conectan la ciudad.

16

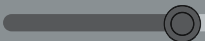
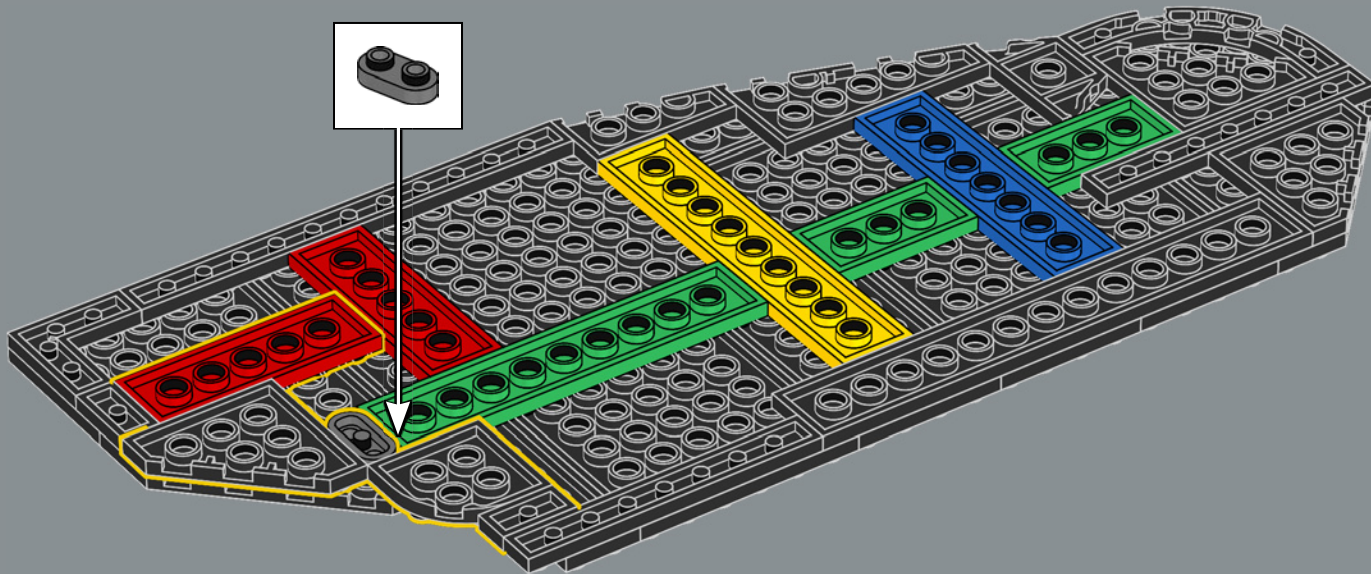

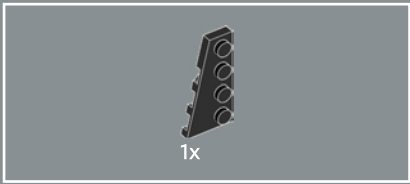

17

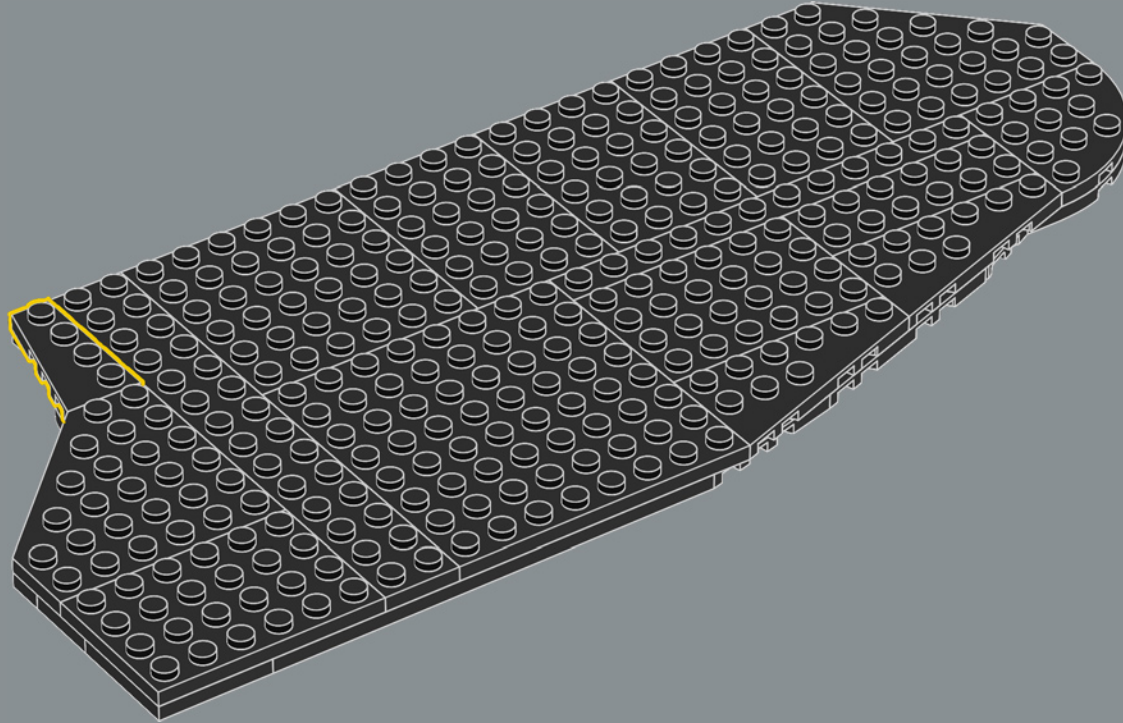

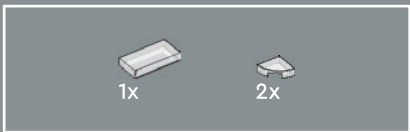

18



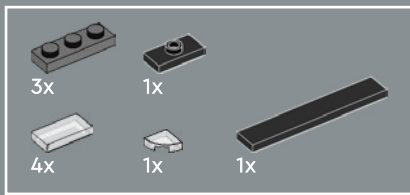

19

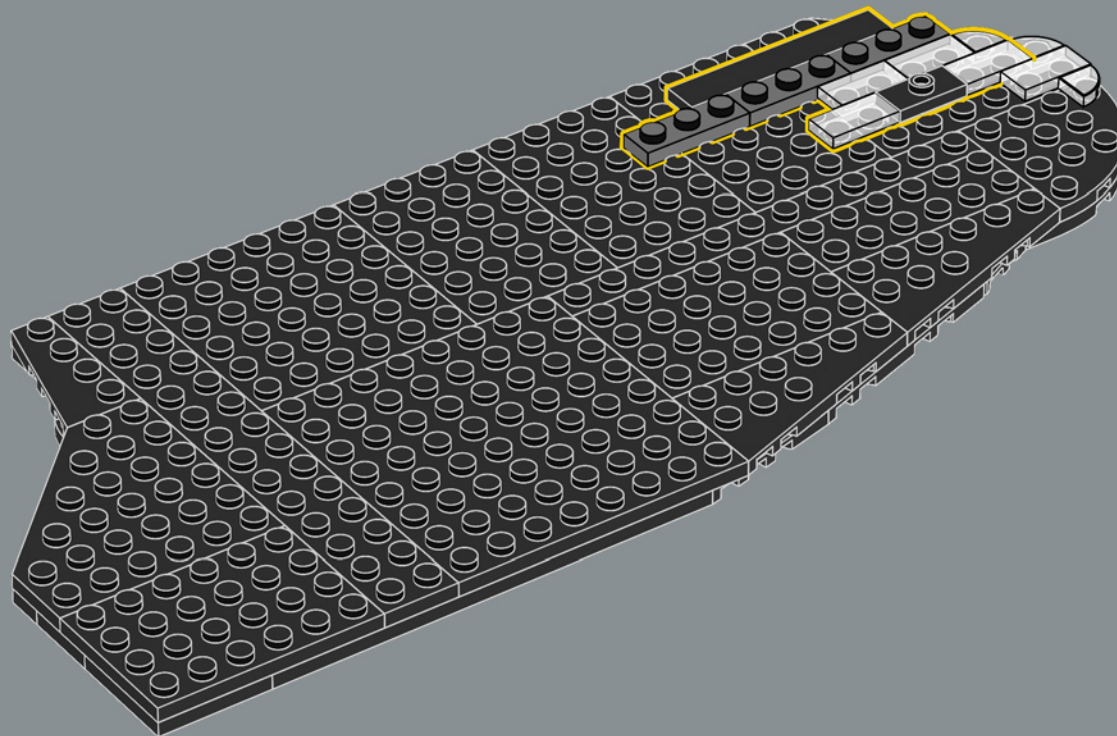

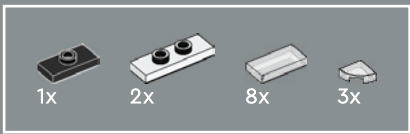

20

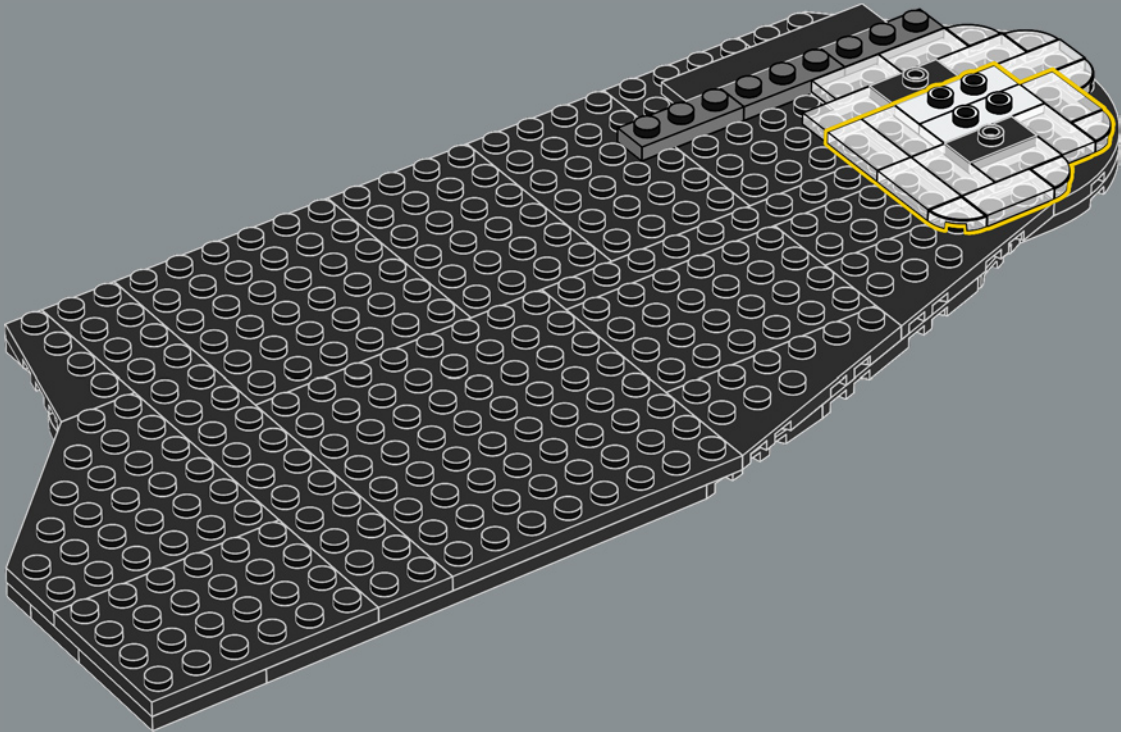

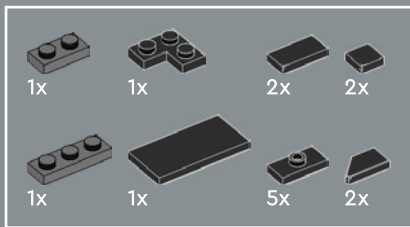

21

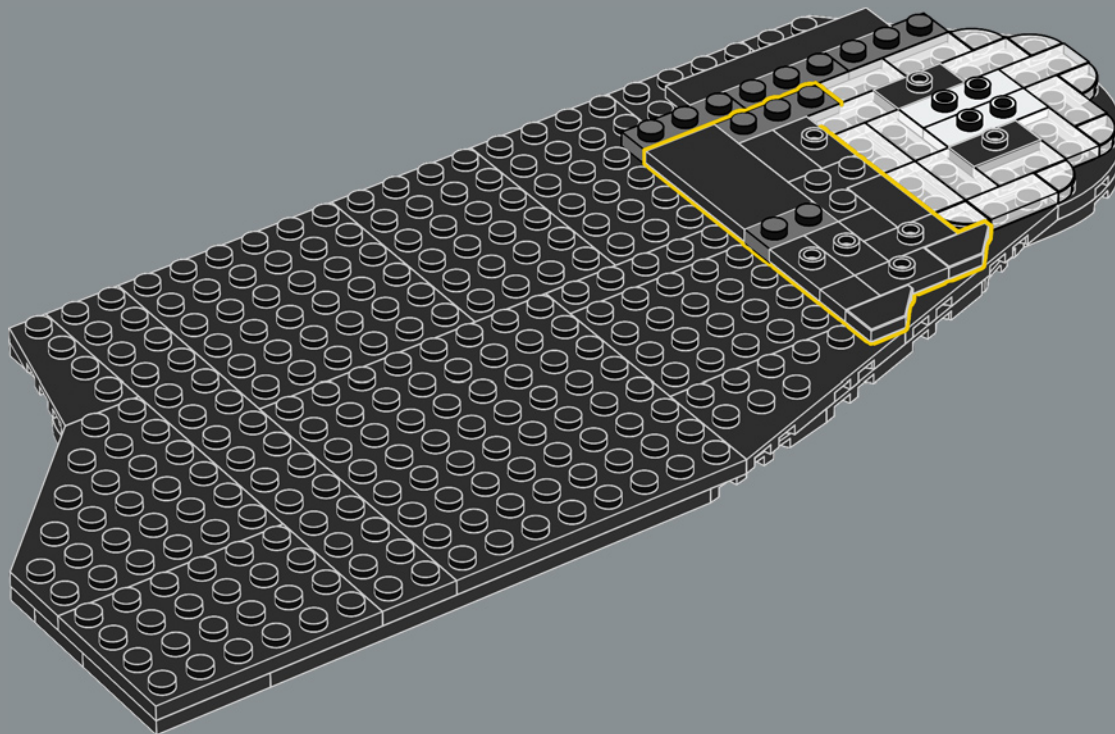

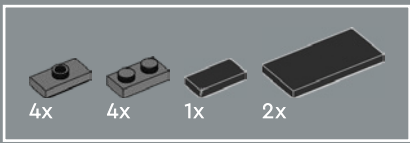

22

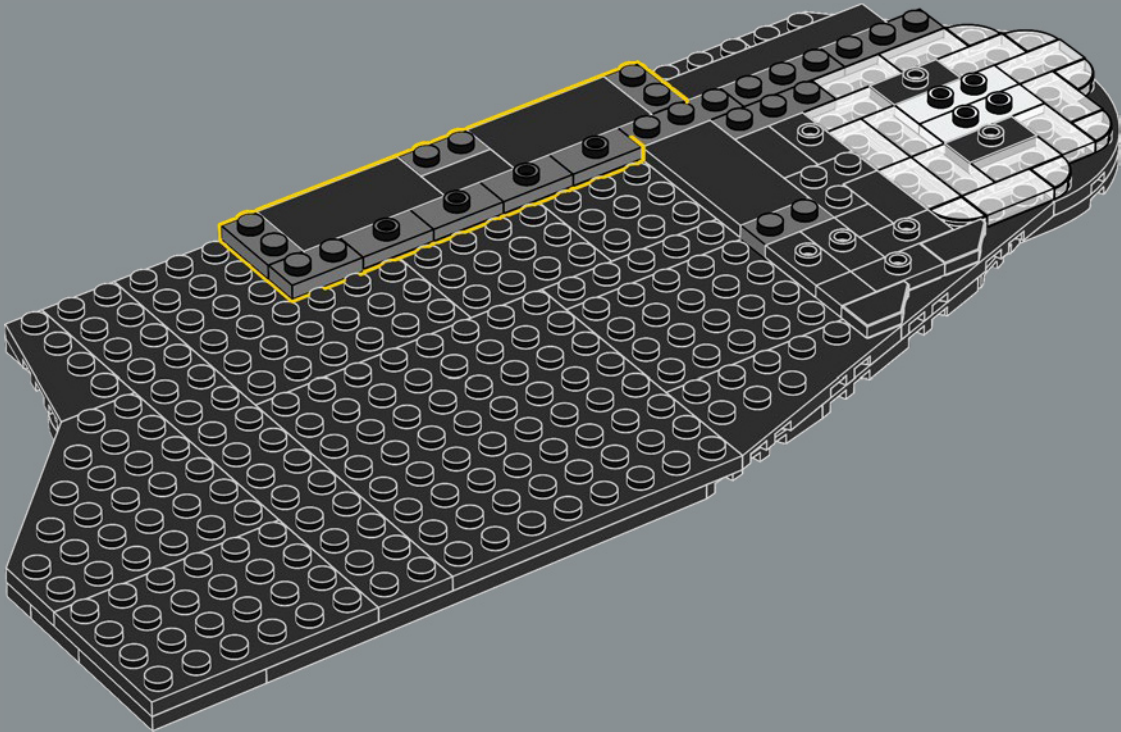

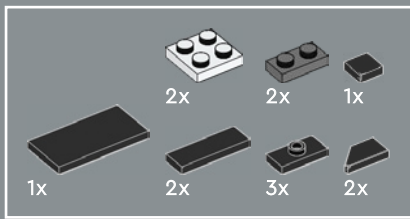

23

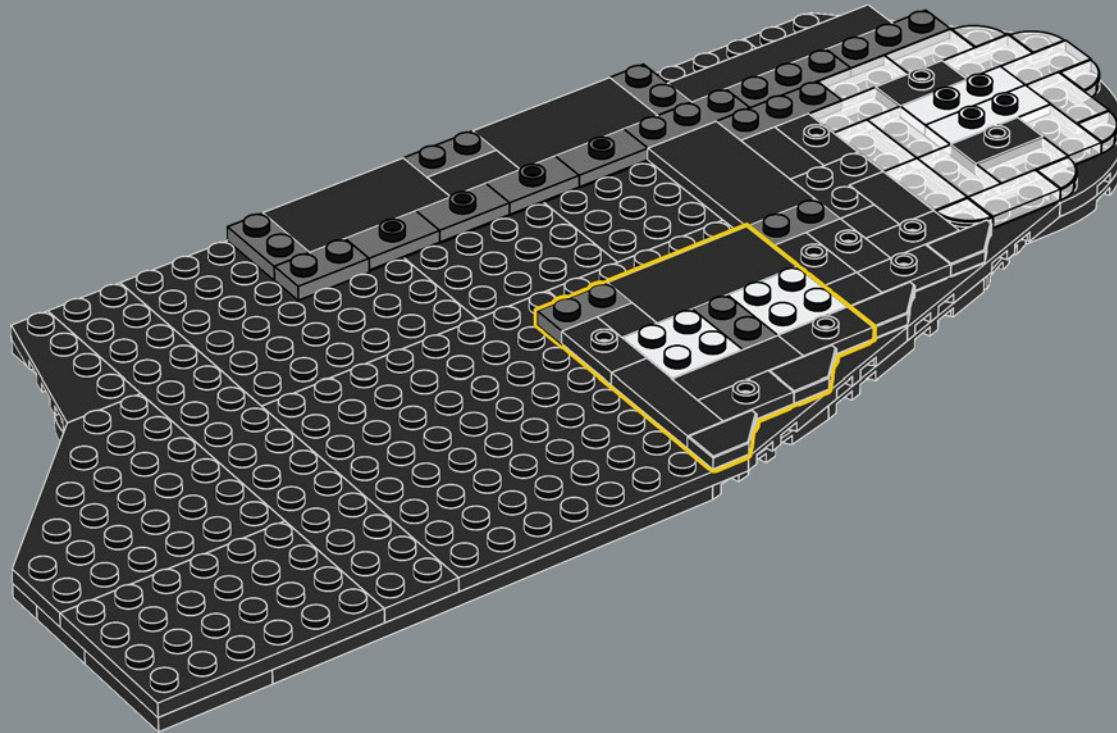

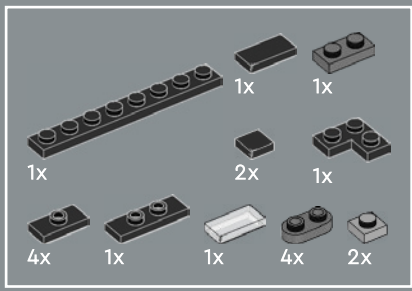

24

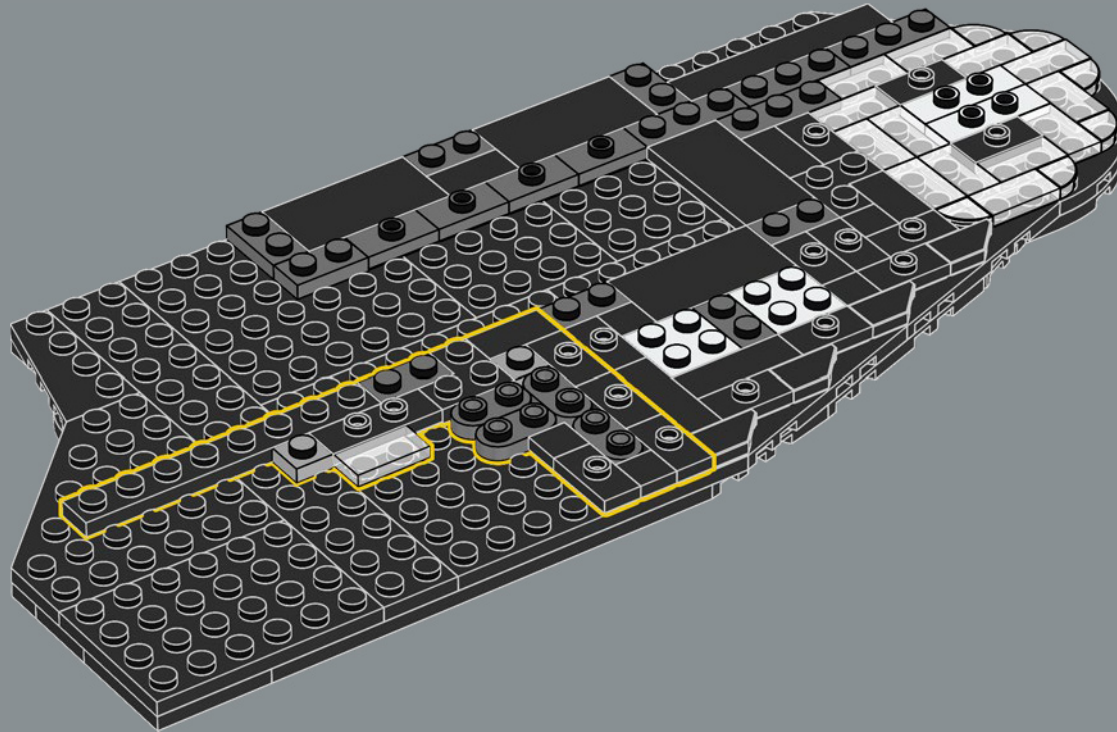

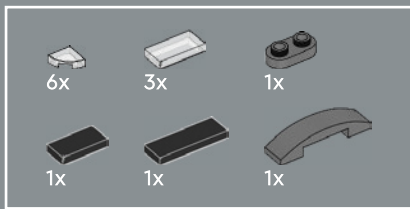

25

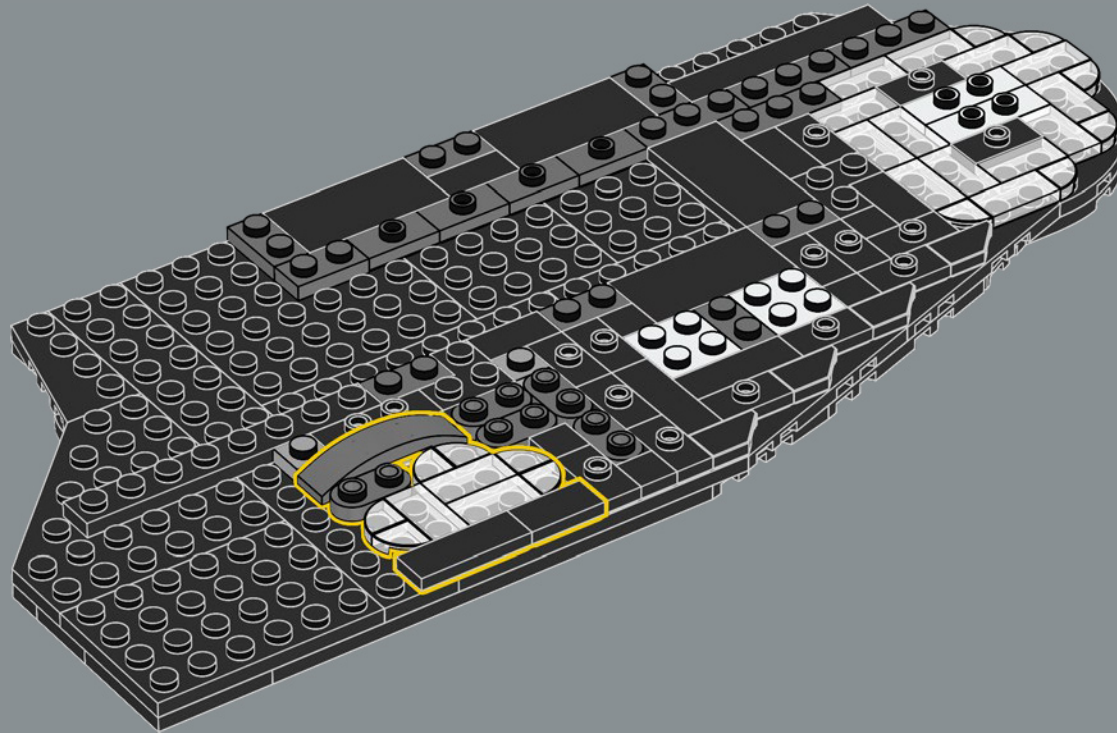

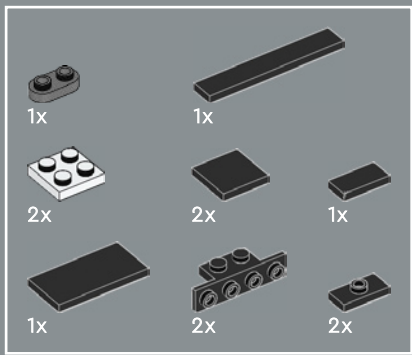

26

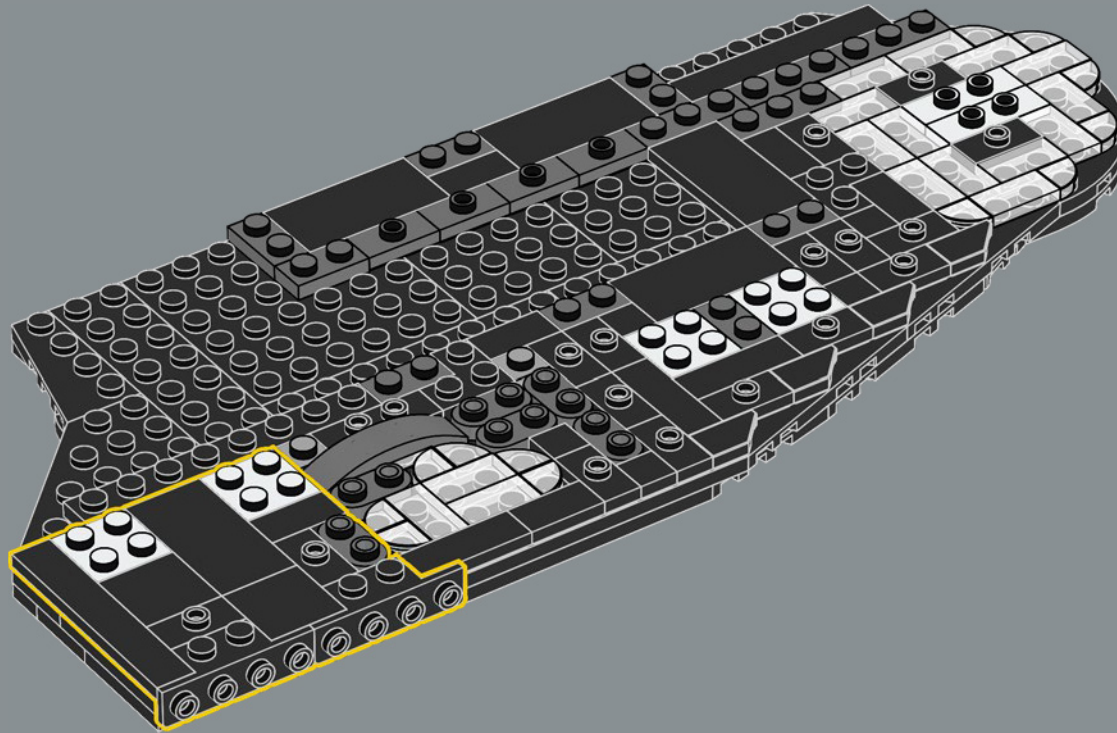

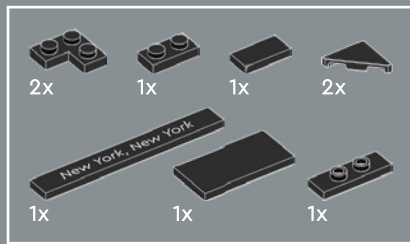

27

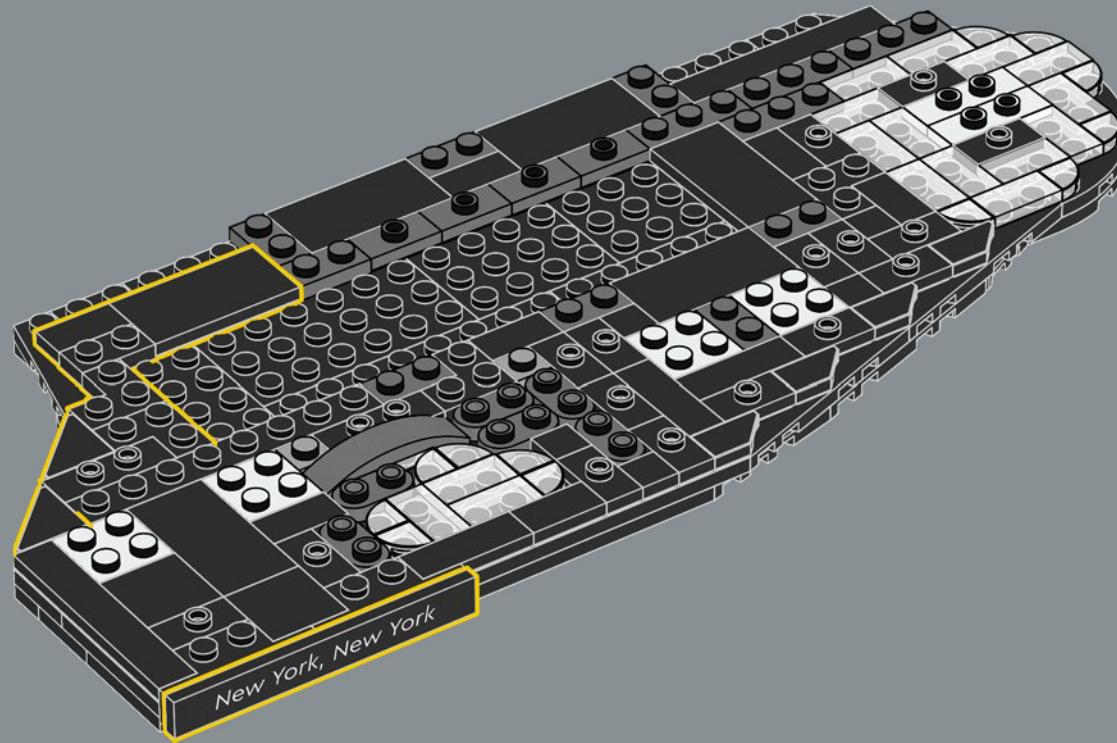

The base of the model is inspired by the largest New York borough, the Island of Manhattan.

La base du modèle s'inspire du plus grand arrondissement de New York, l'île de Manhattan.

La base del modelo toma como referencia el distrito más grande de Nueva York, la isla de Manhattan.

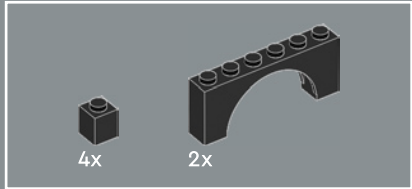

28

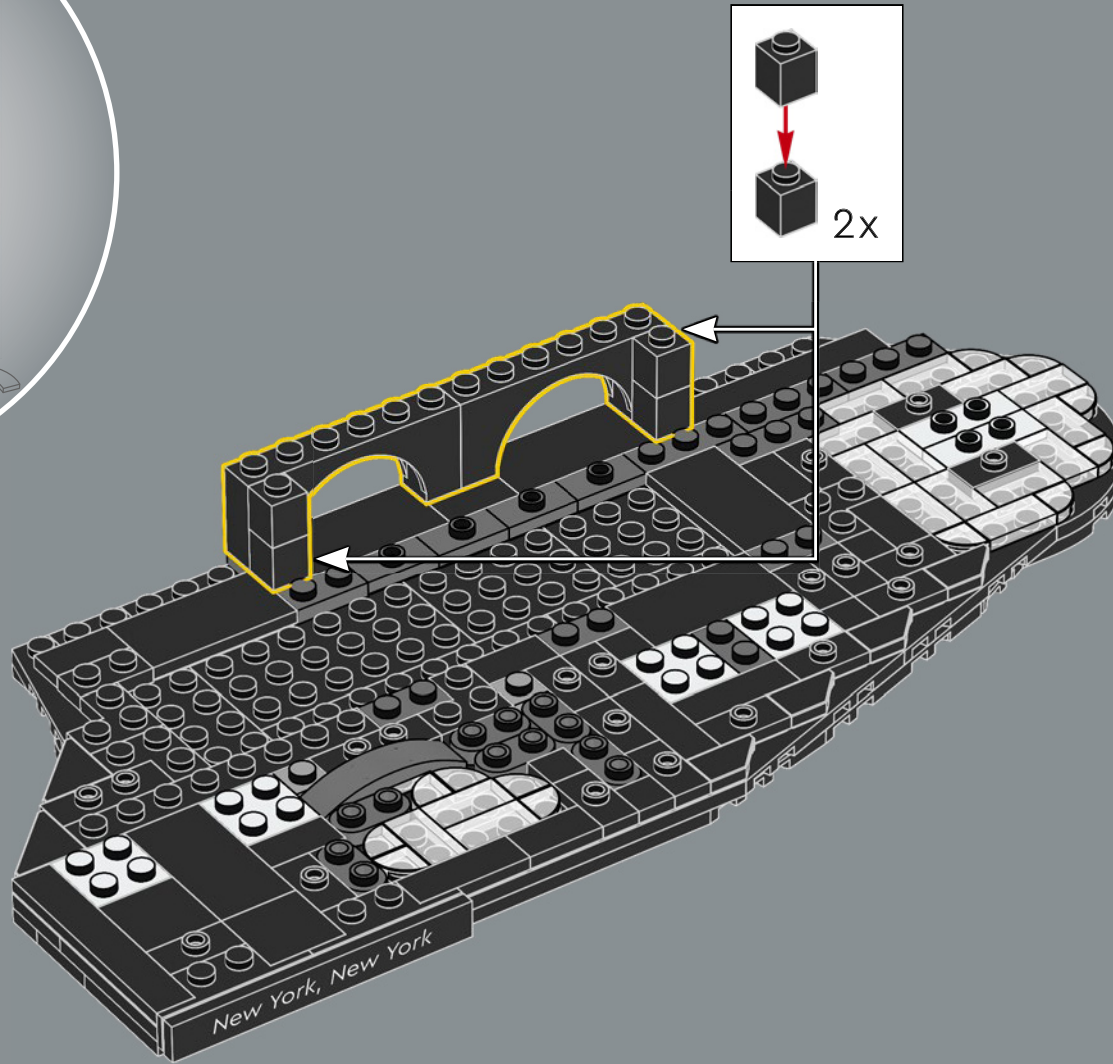

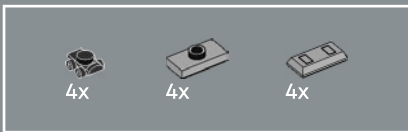

29

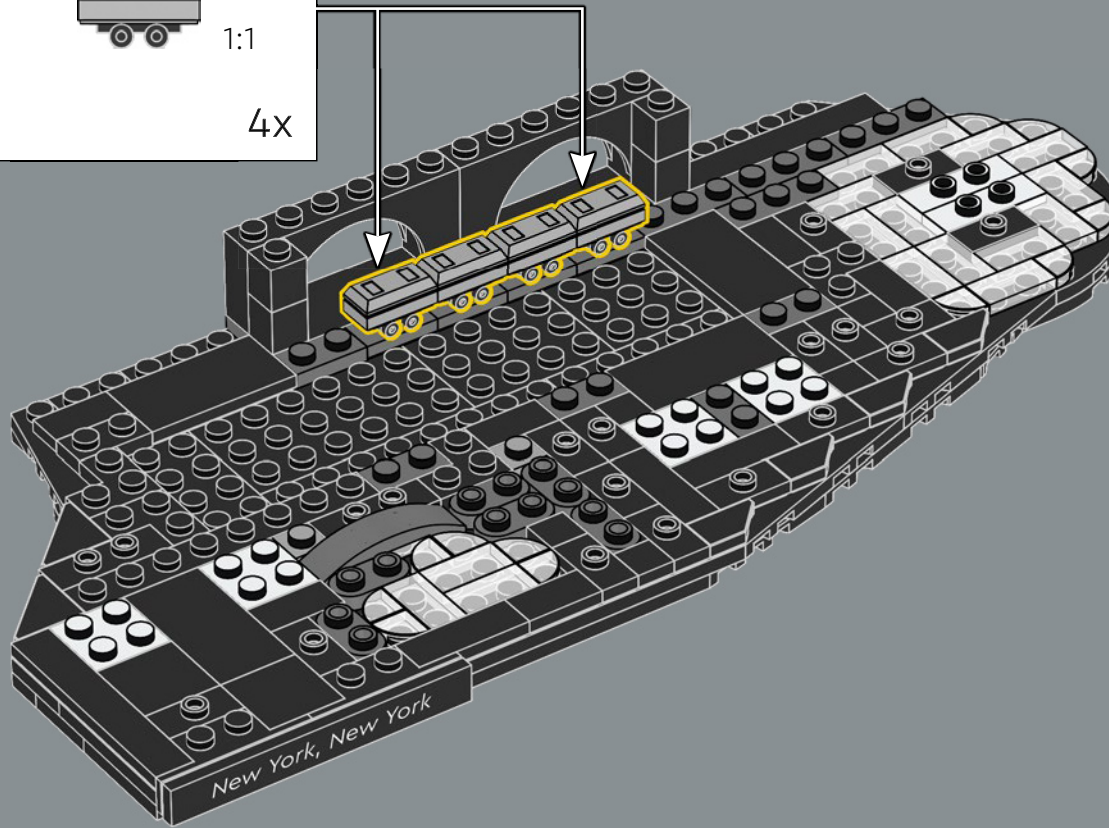
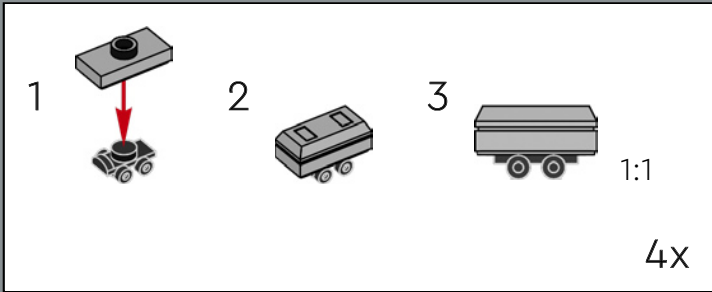

If you placed all 842 mi. (1,355 km) of track in the New York subway system in a straight line, they would reach all the way from New York City to Chicago.

Si vous placiez bout à bout les 1355 km de voies du métro de New York en une ligne droite, ils atteindraient Chicago depuis New York.

Si se colocaran en línea recta los 1355 km de vía del metro neoyorquino, cubrirían la distancia que separa la ciudad de Nueva York de Chicago.

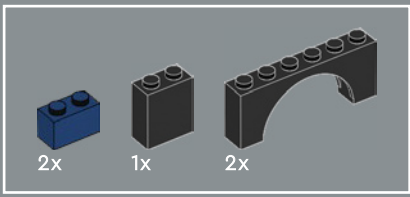

30

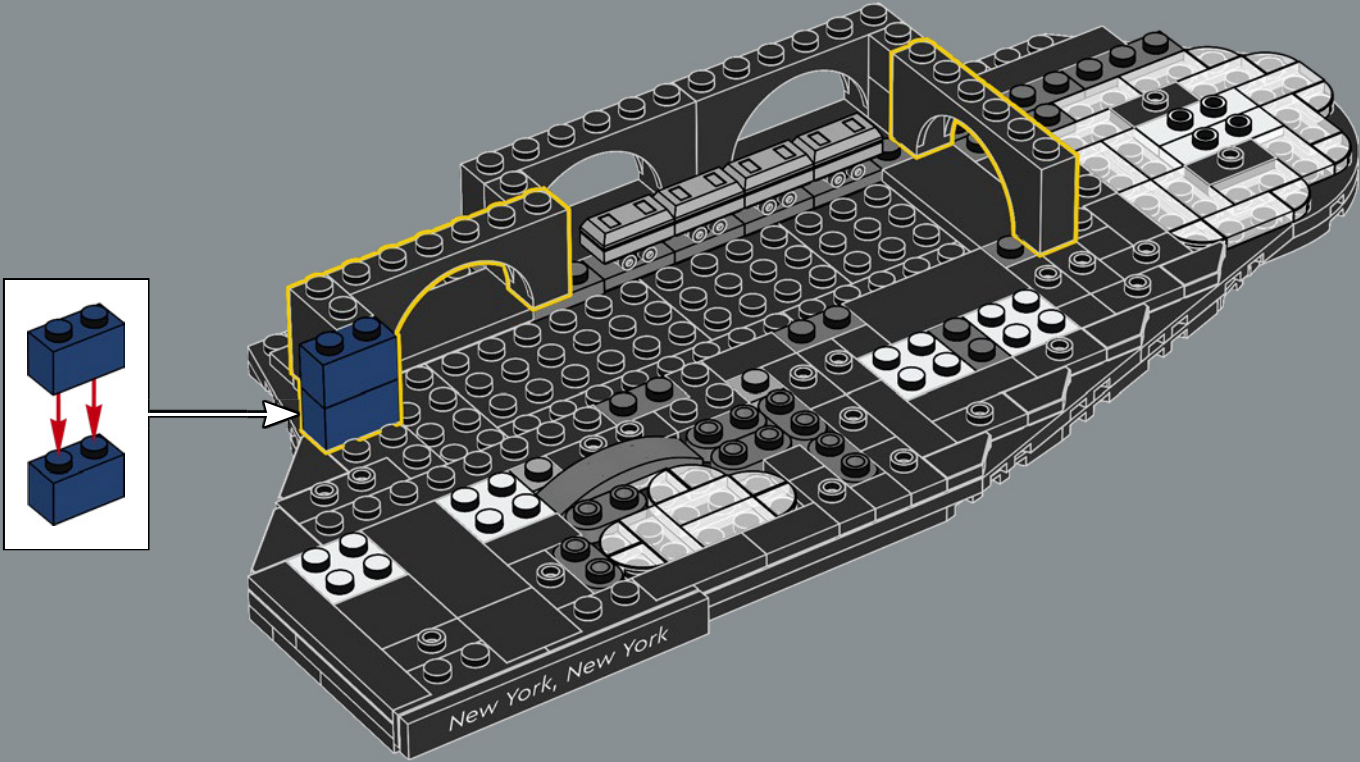

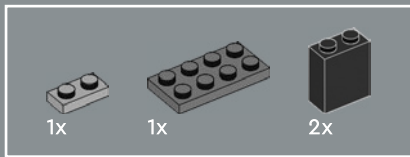

31

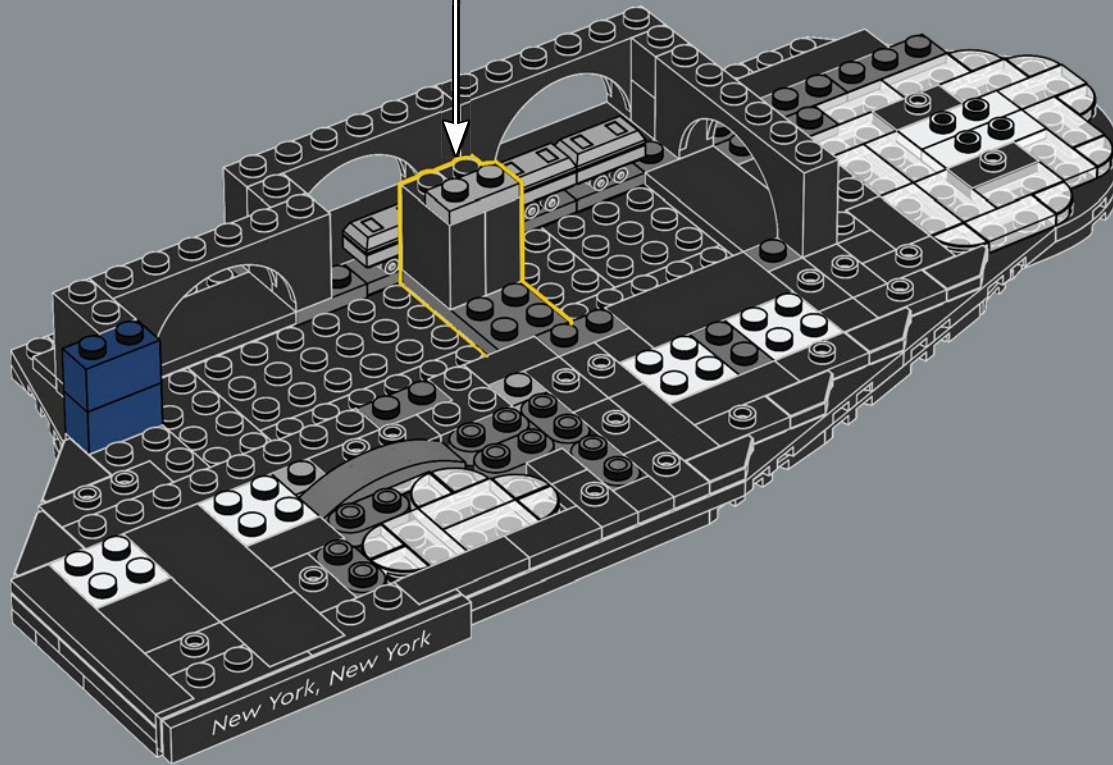
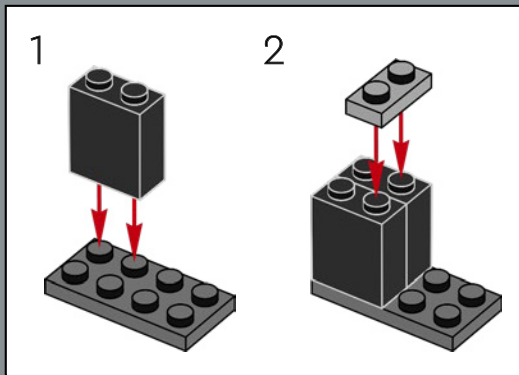

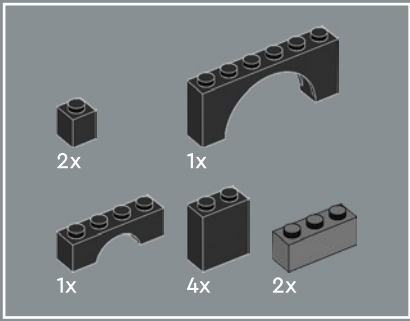

32

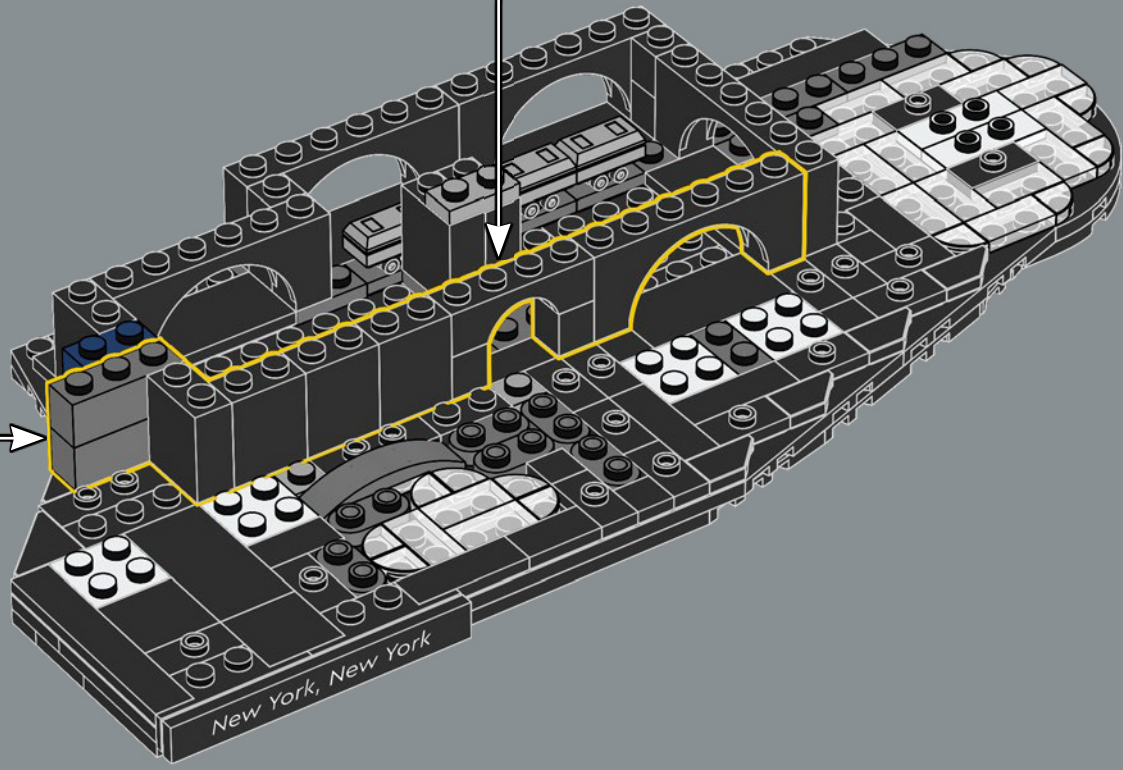
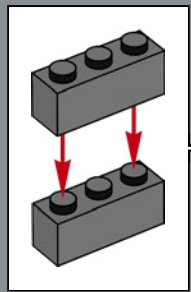
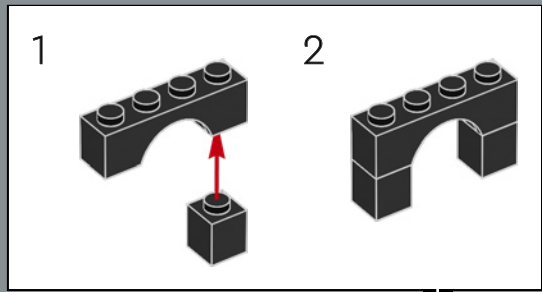

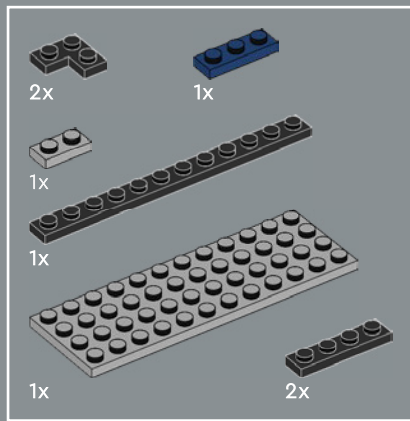

33

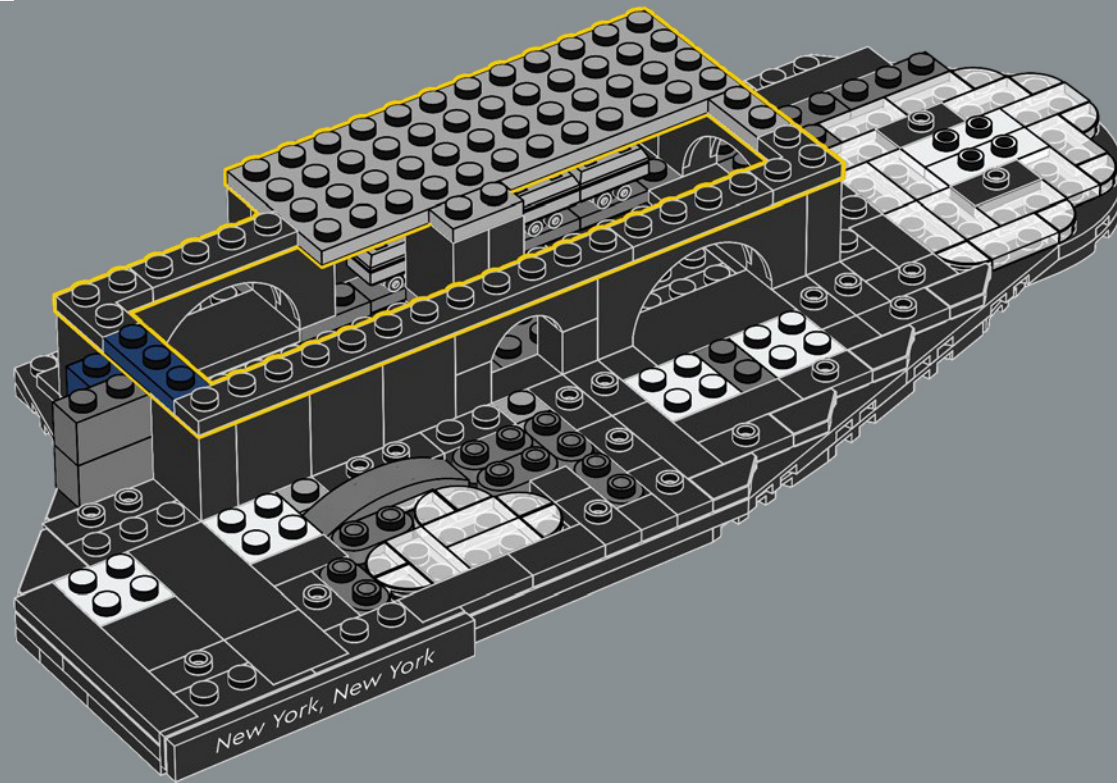

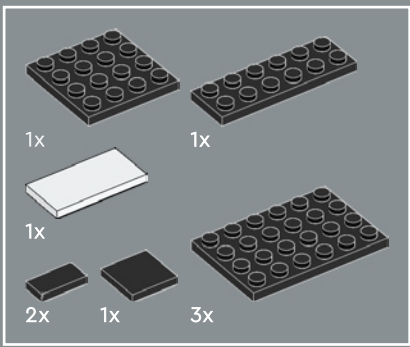

34

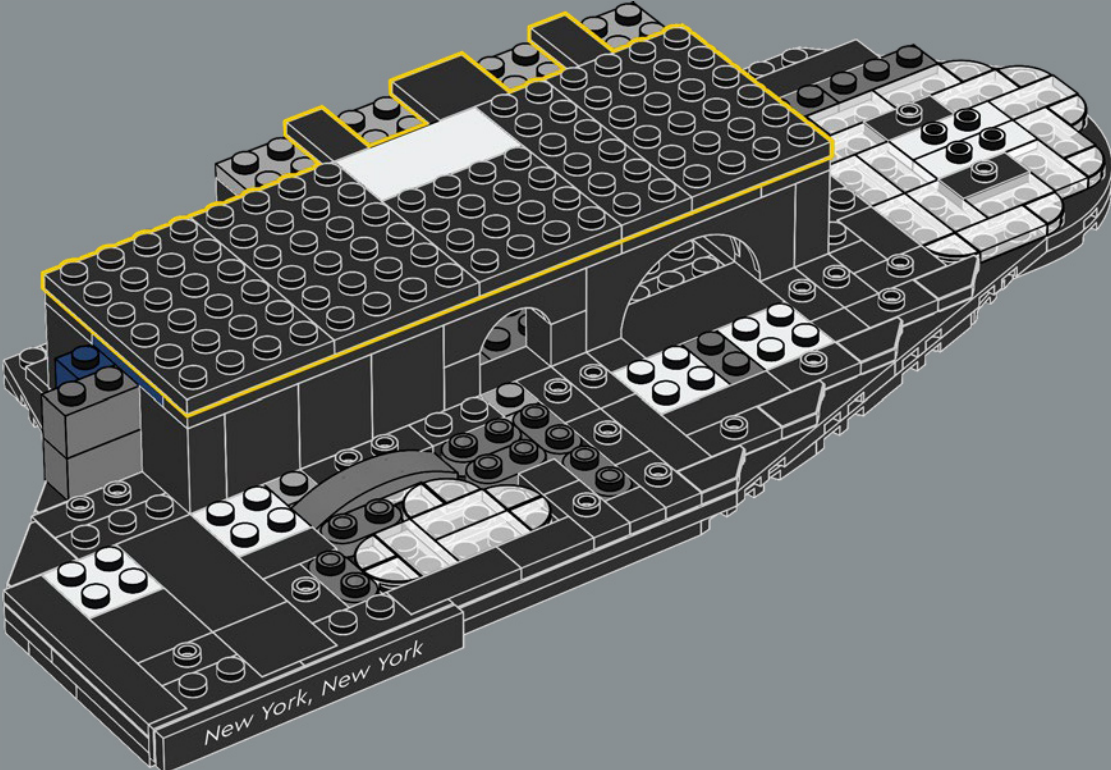

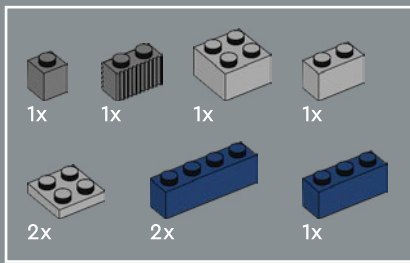

35

1

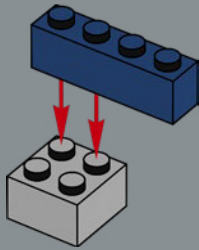

2

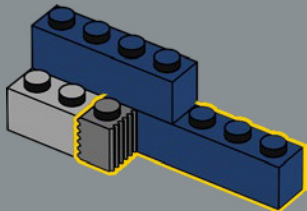

3

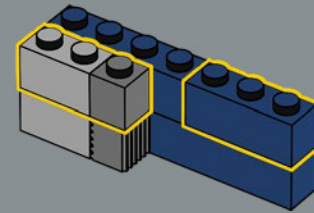

4

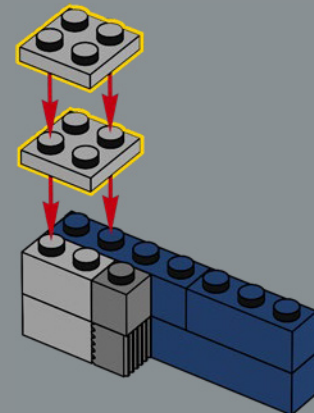

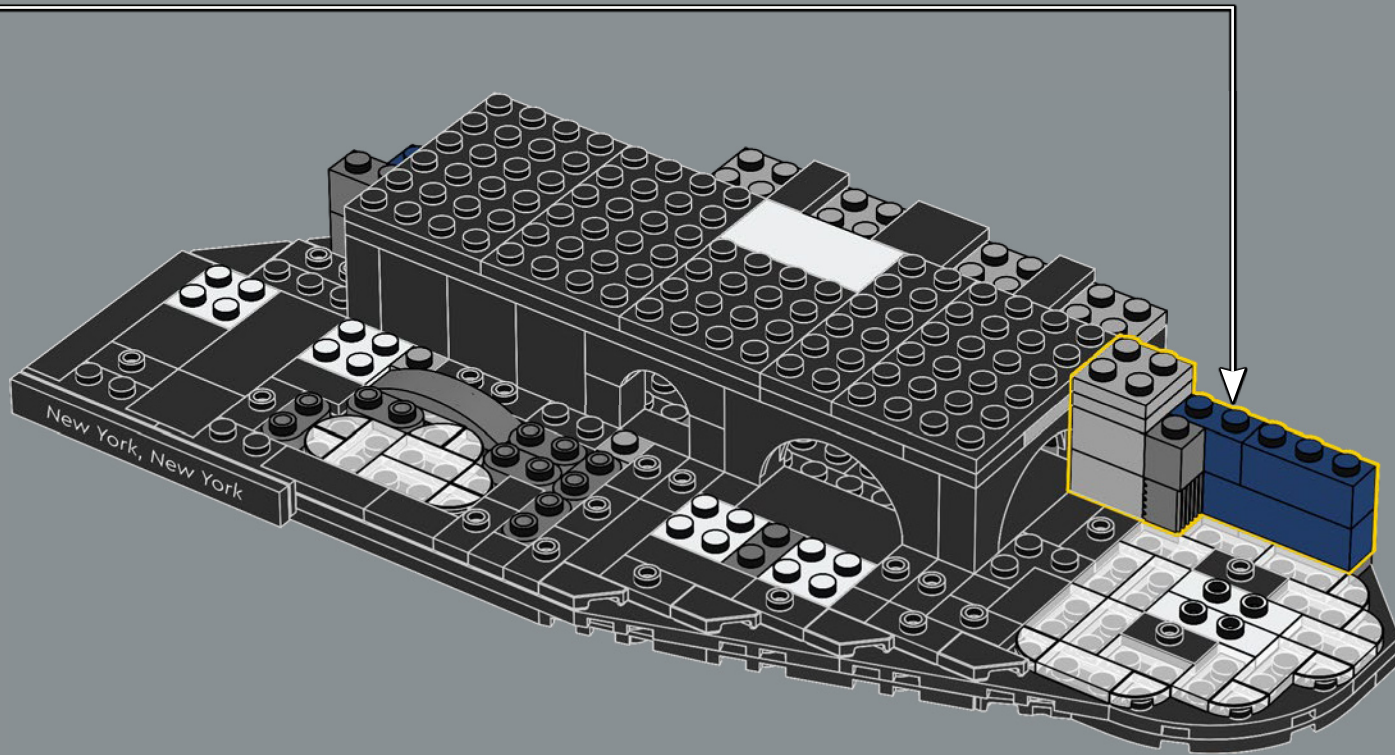

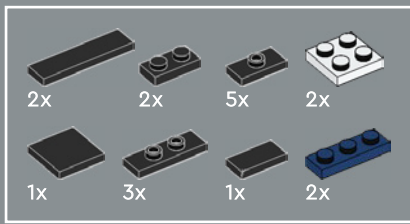

36

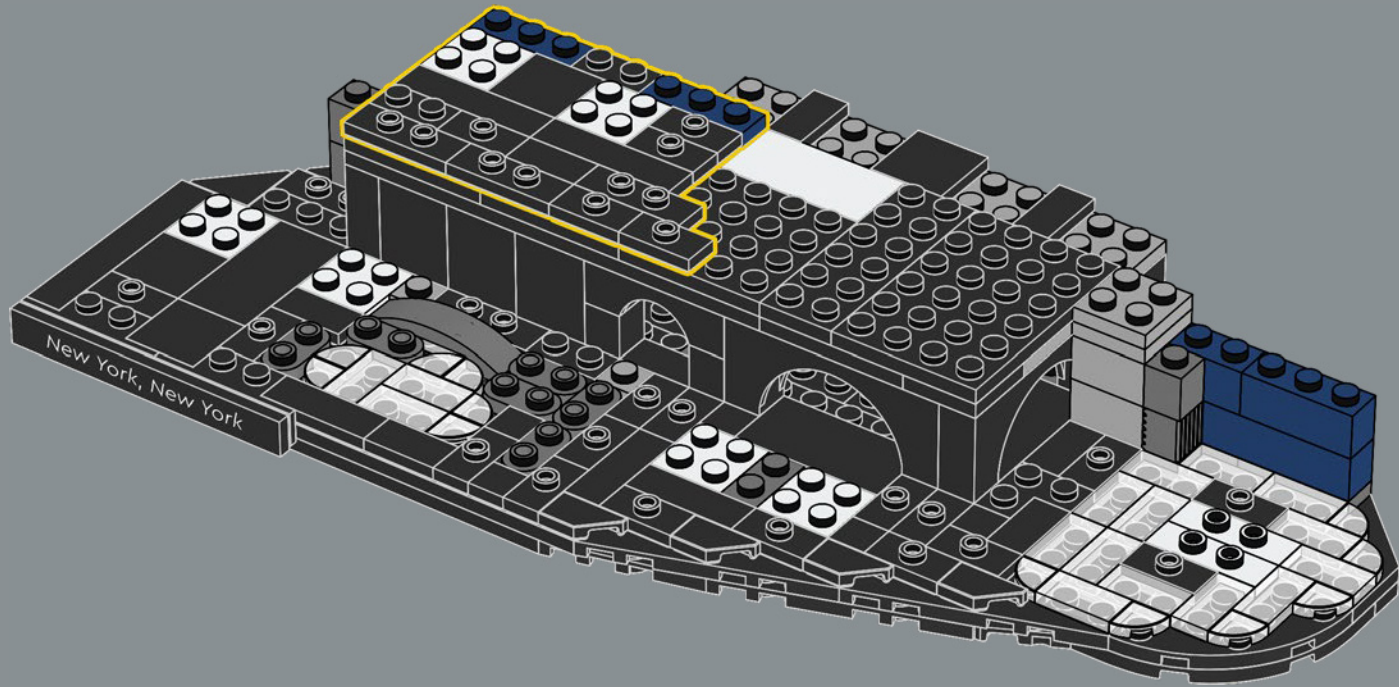

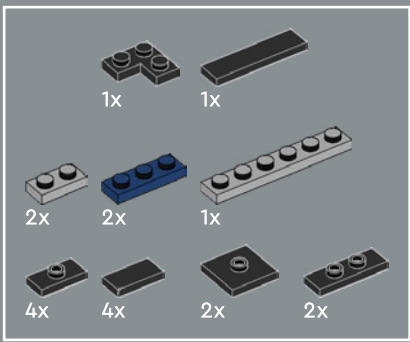

37

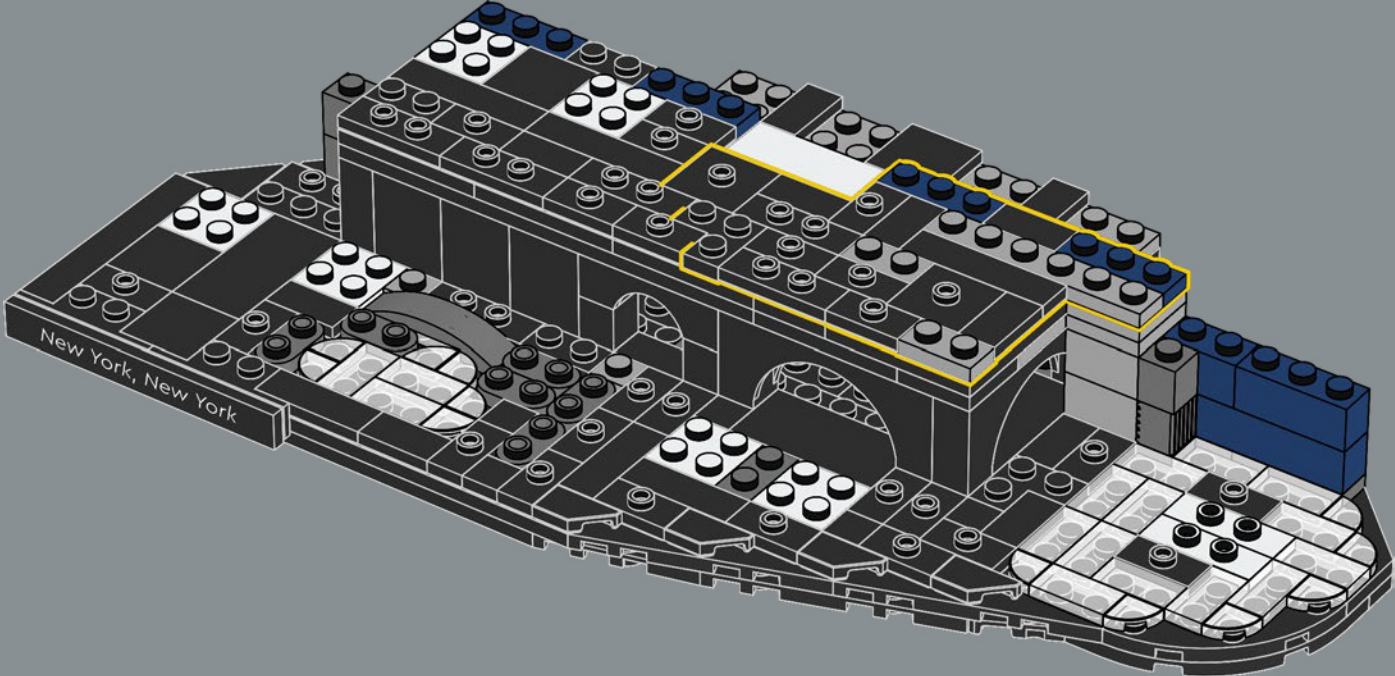

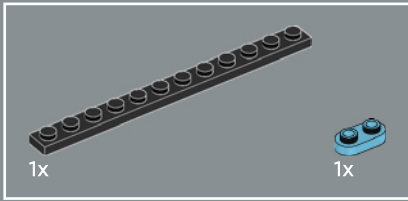
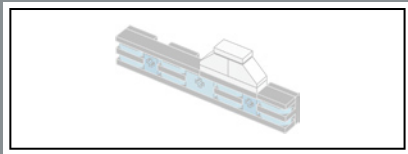

38

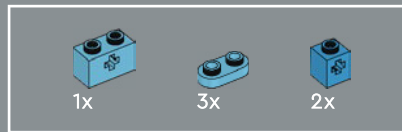
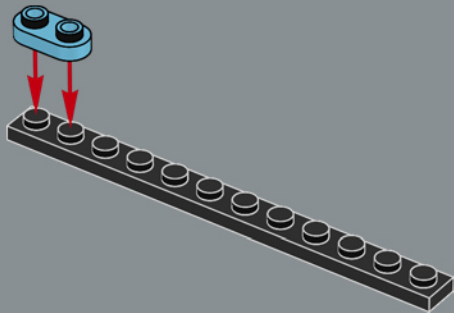

39

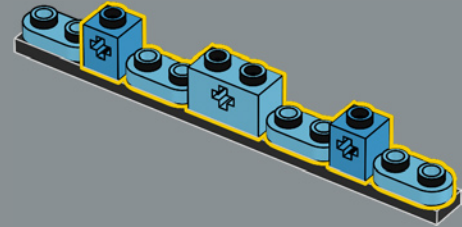

40

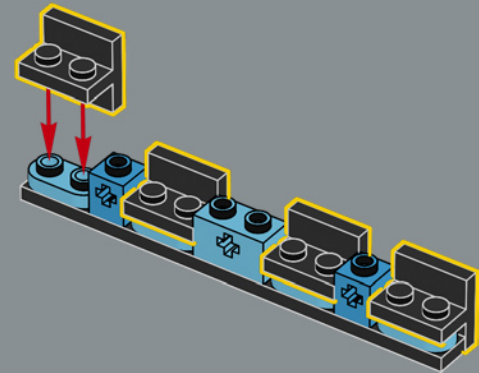

4x

41

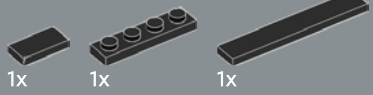
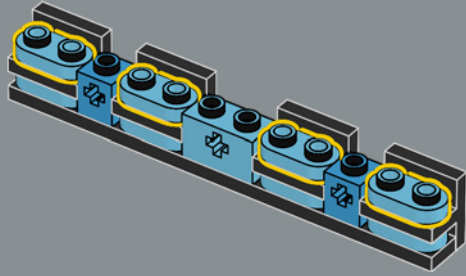

42

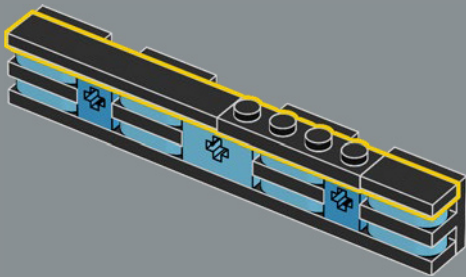

1x

1x

2x

43

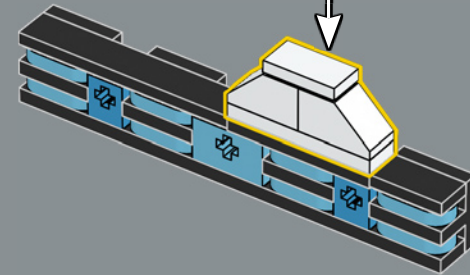
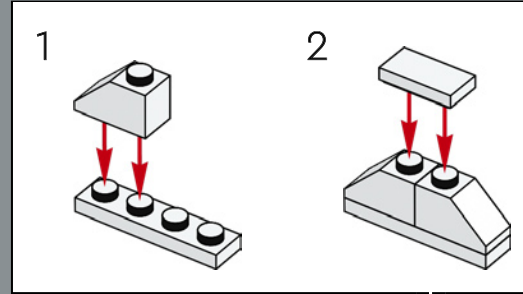

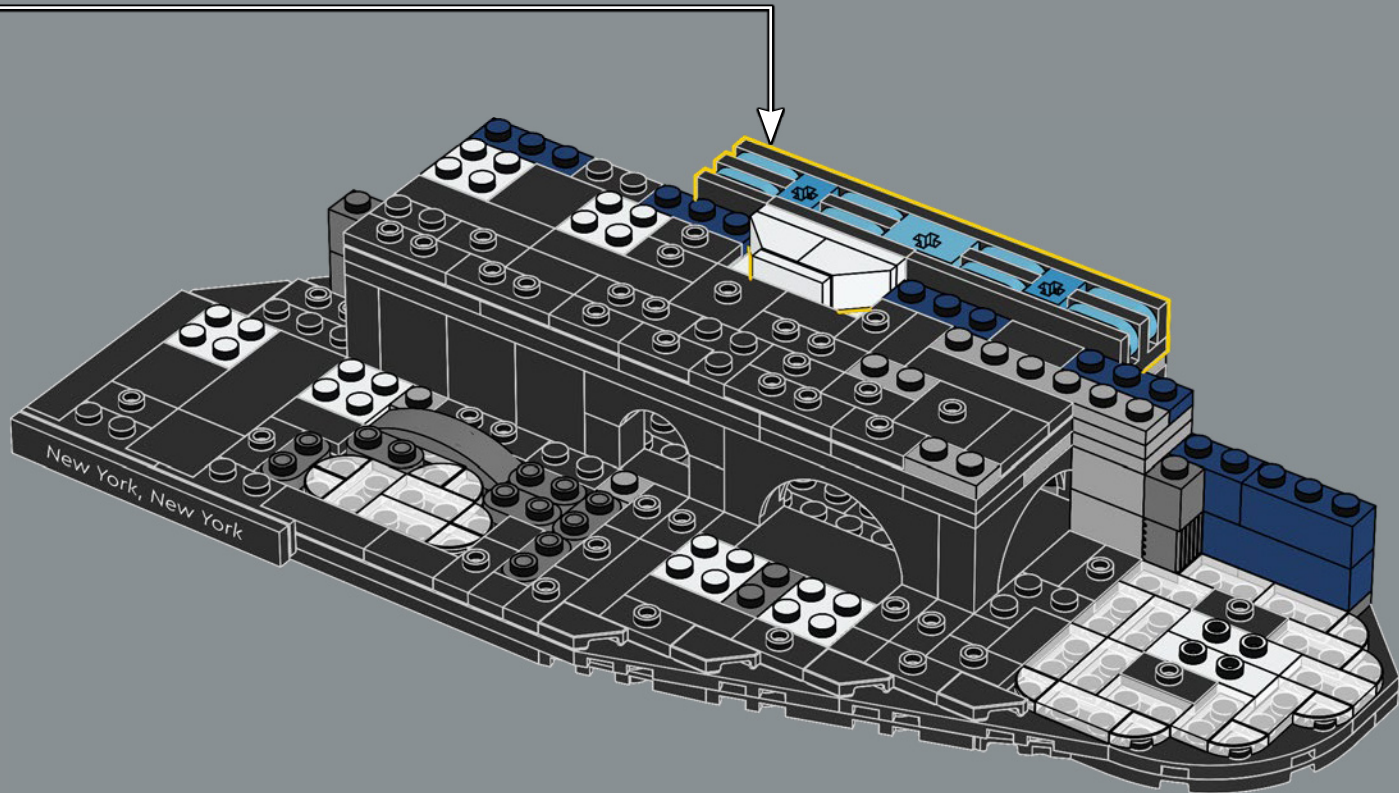

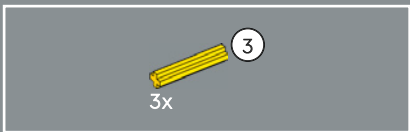

45

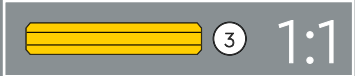
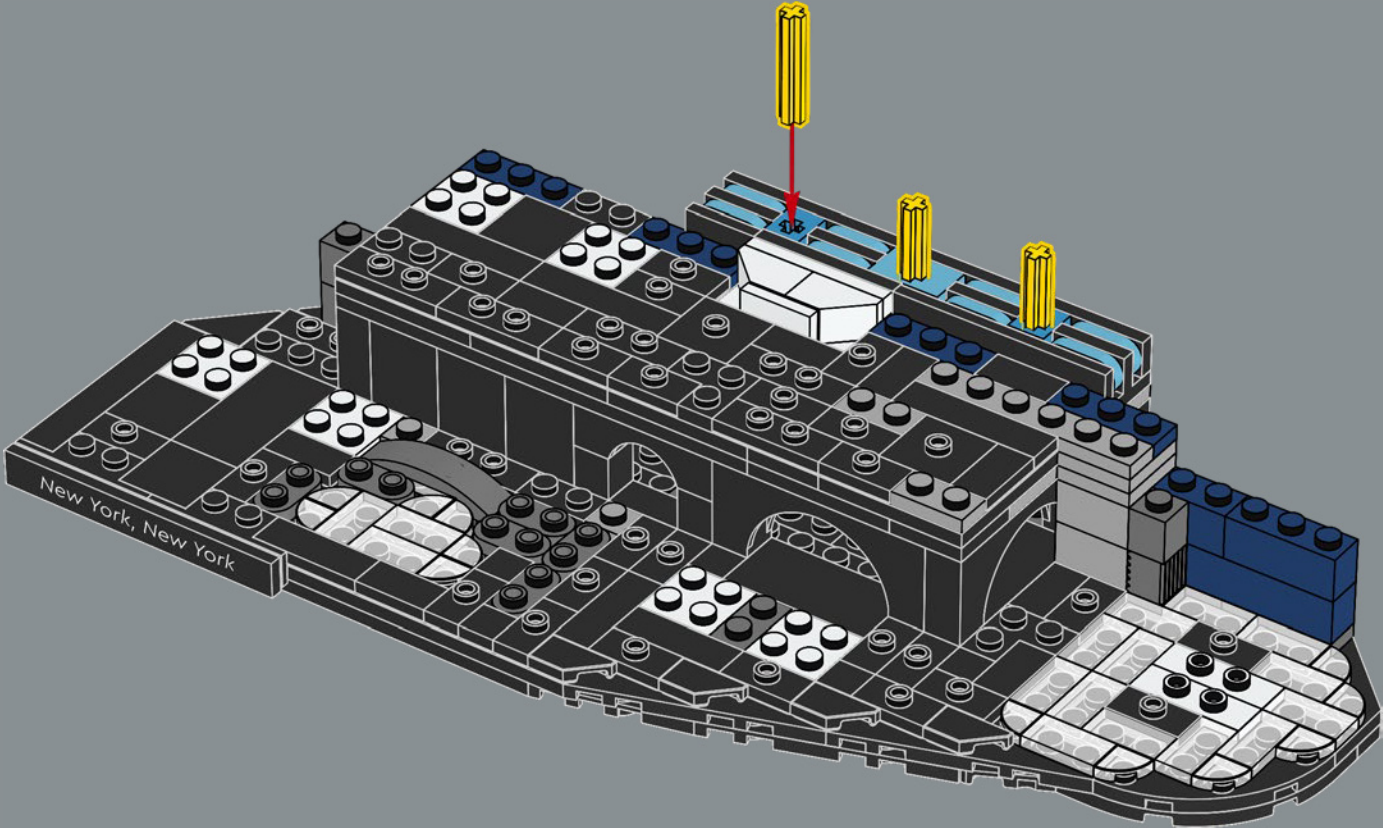

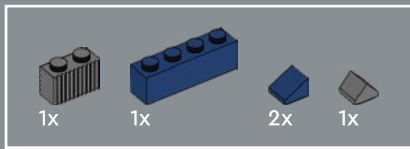

46

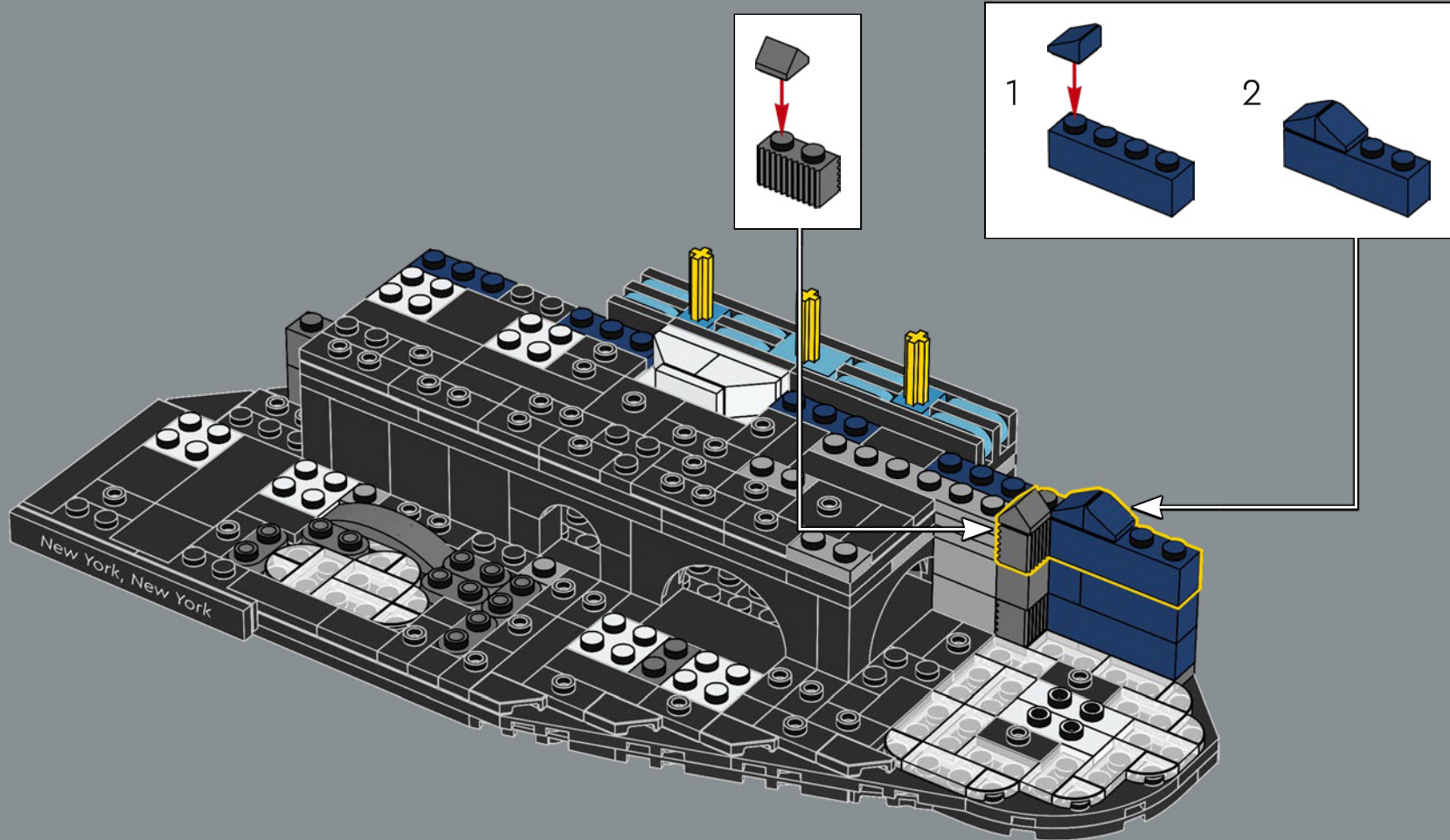

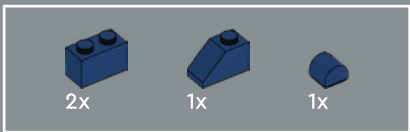

47

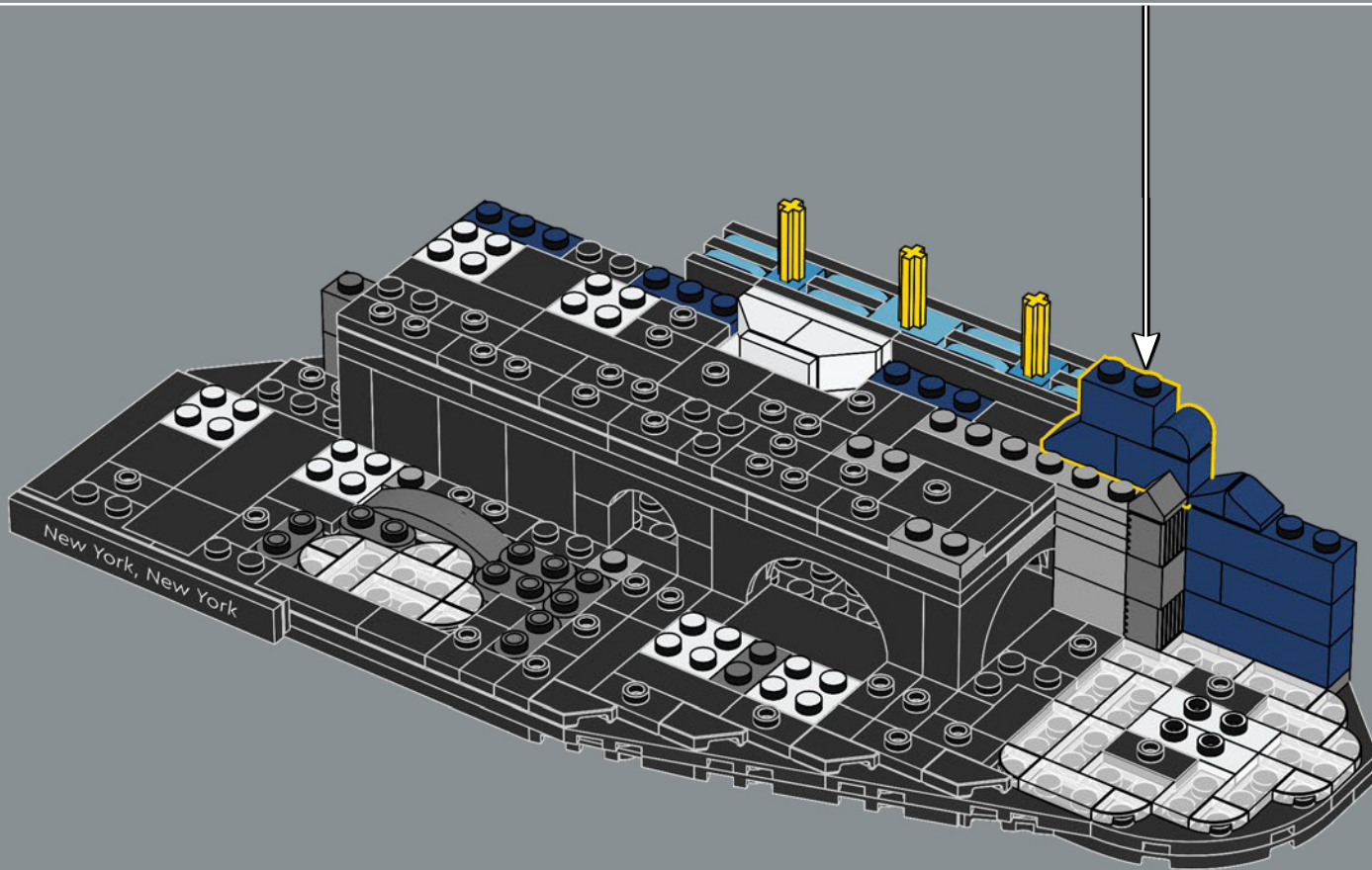
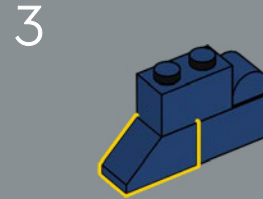
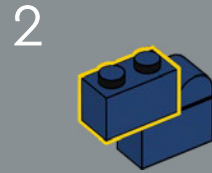
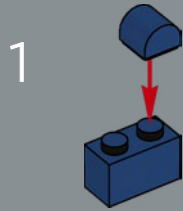

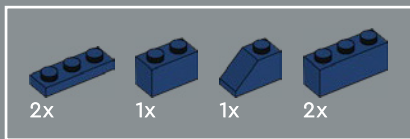

48

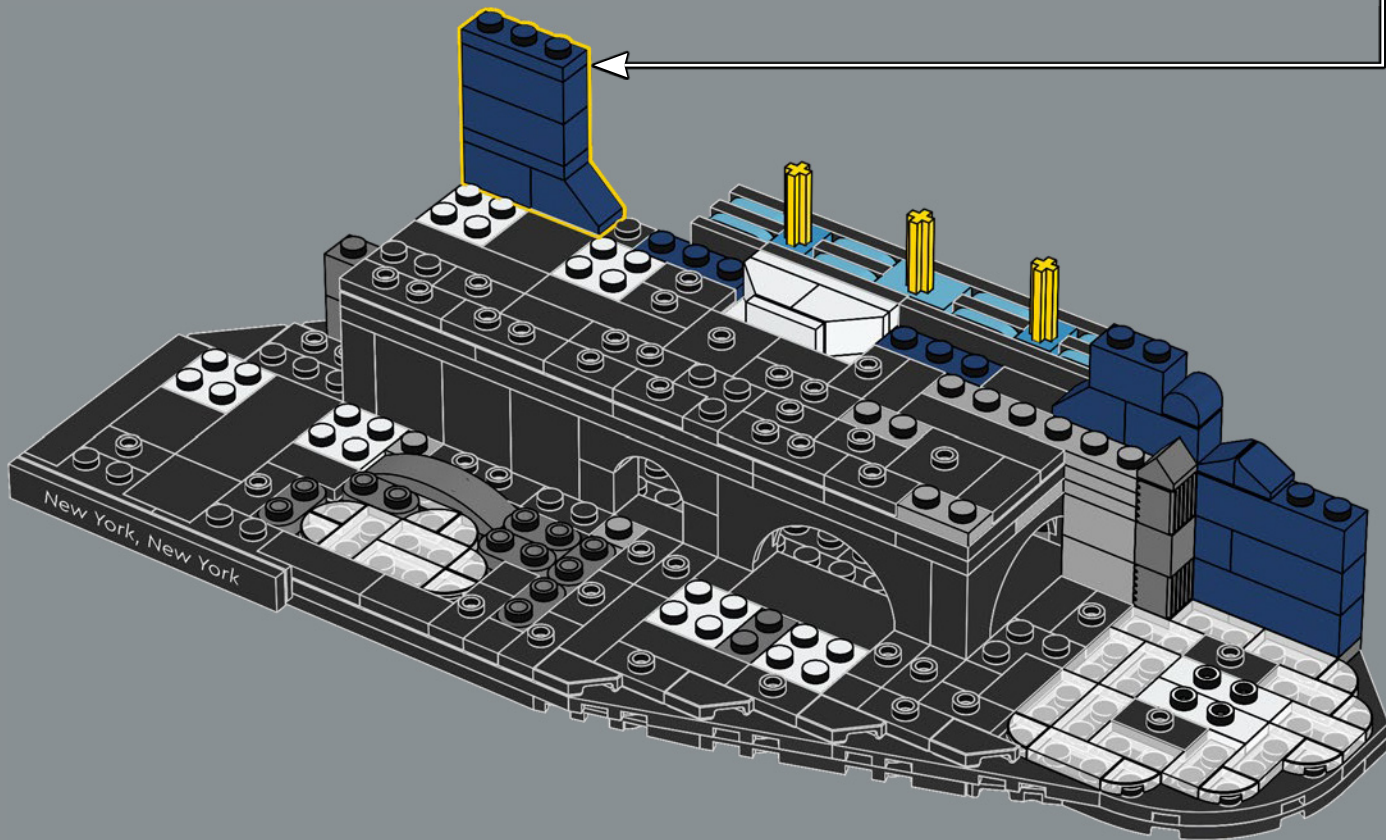

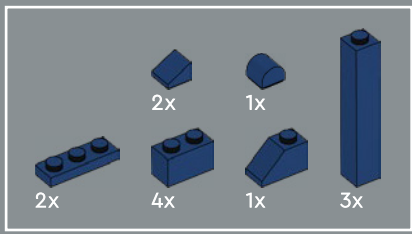

49

1

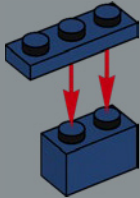

2

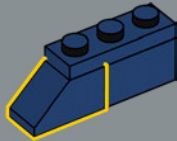

3

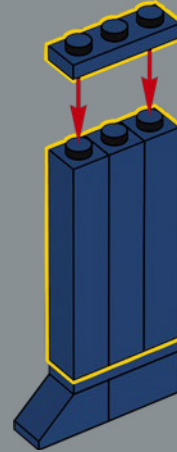

4

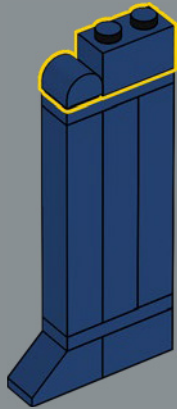

5

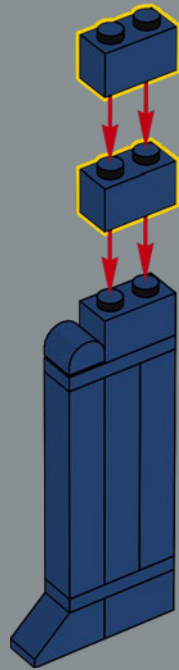

6

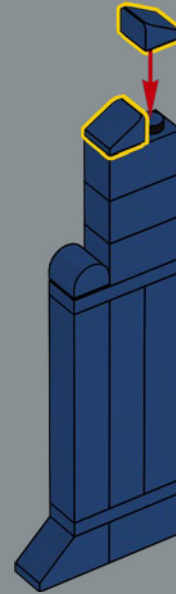

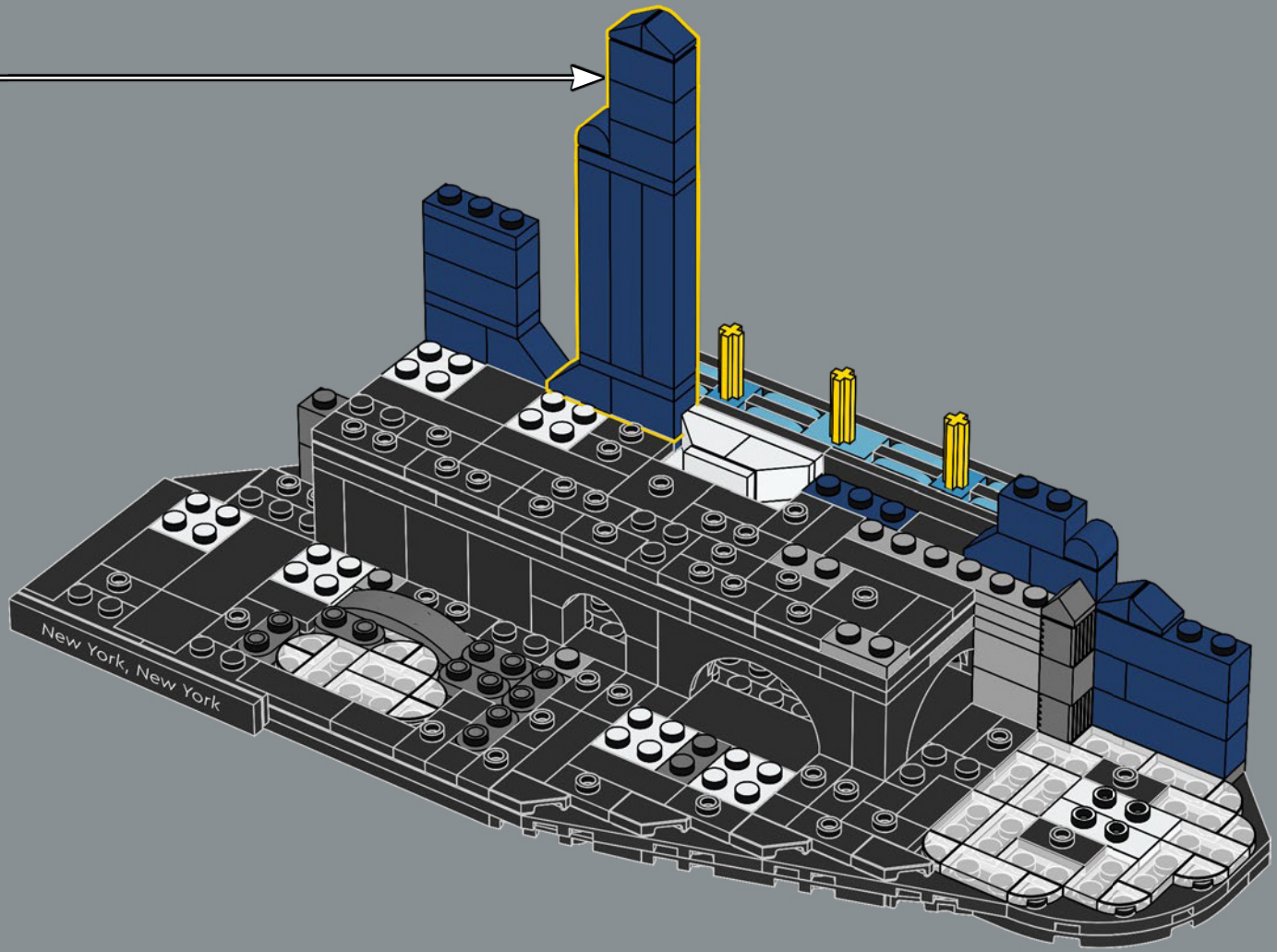

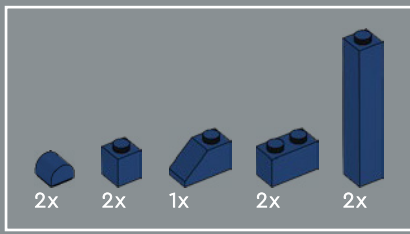

50

1

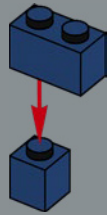

2

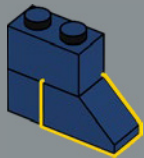

3

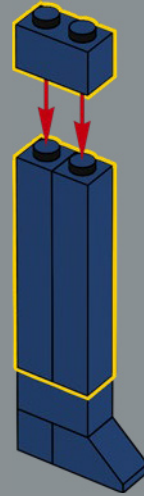

4

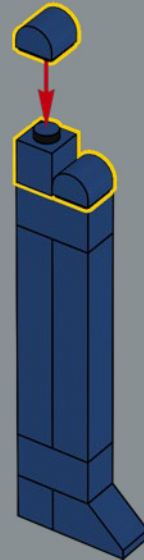

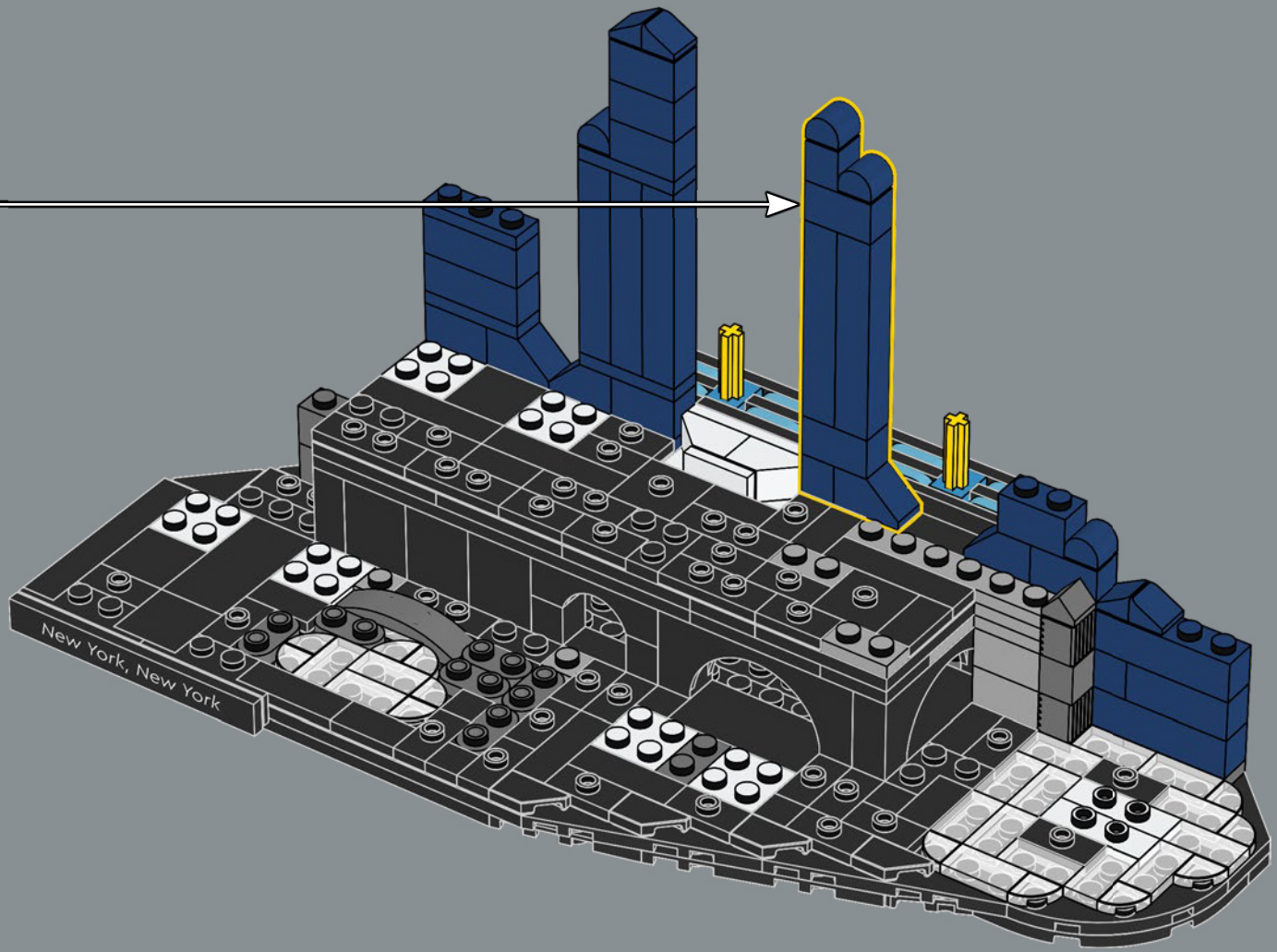

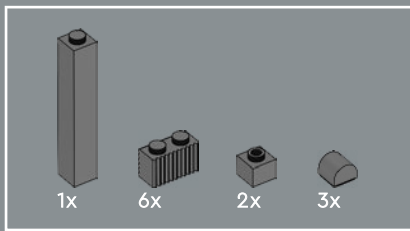

51

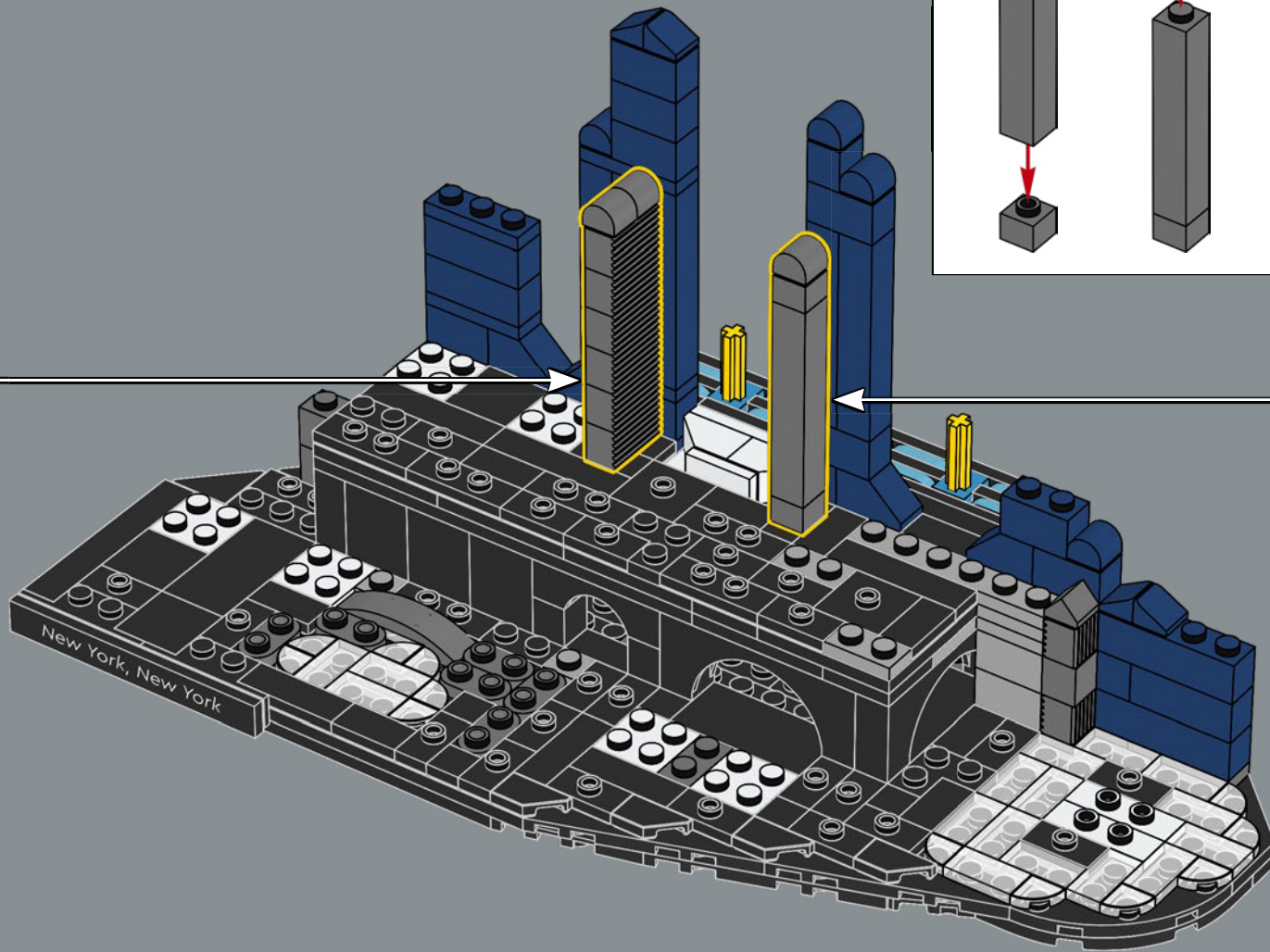
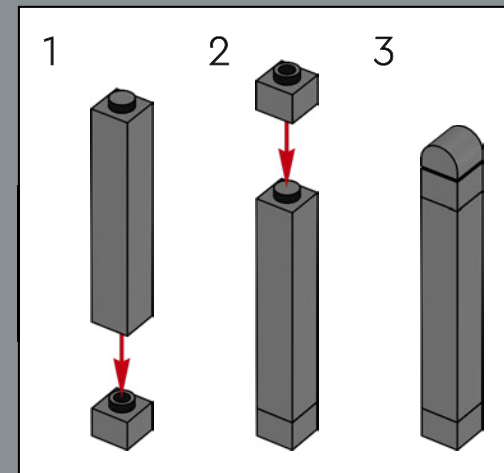
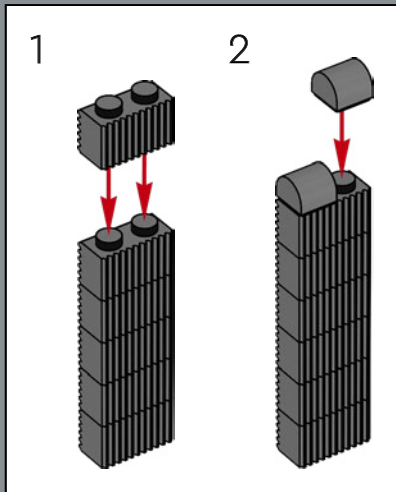

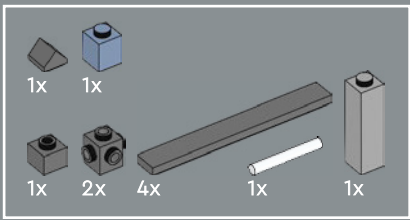

52

1

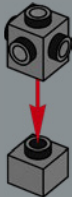

2



3



4



5

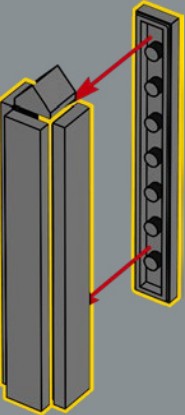

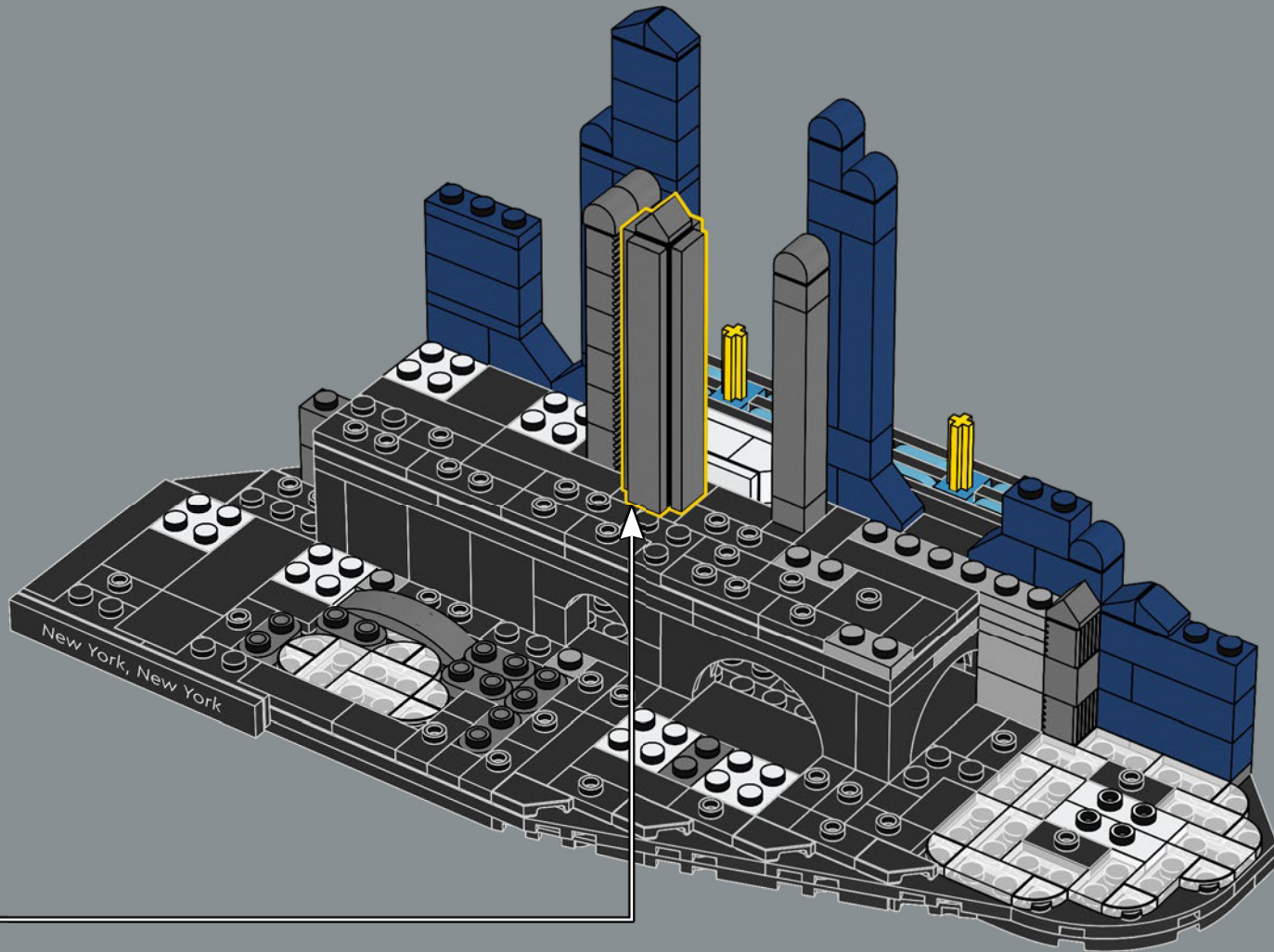

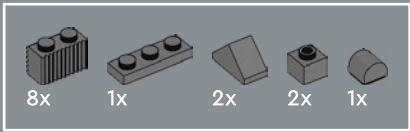

53

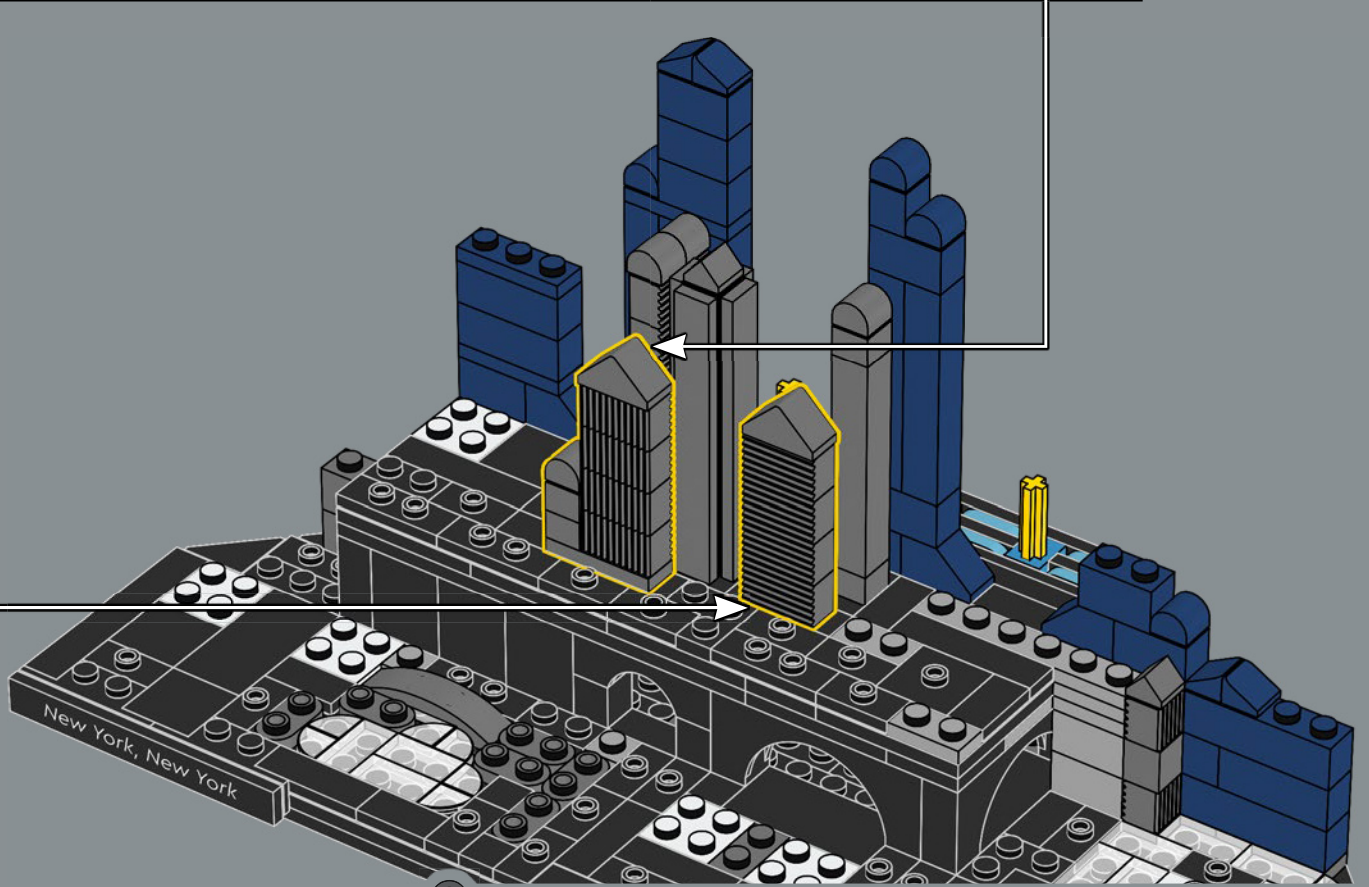
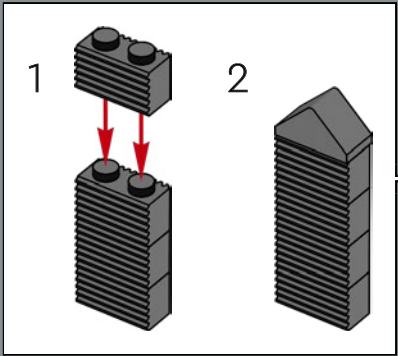
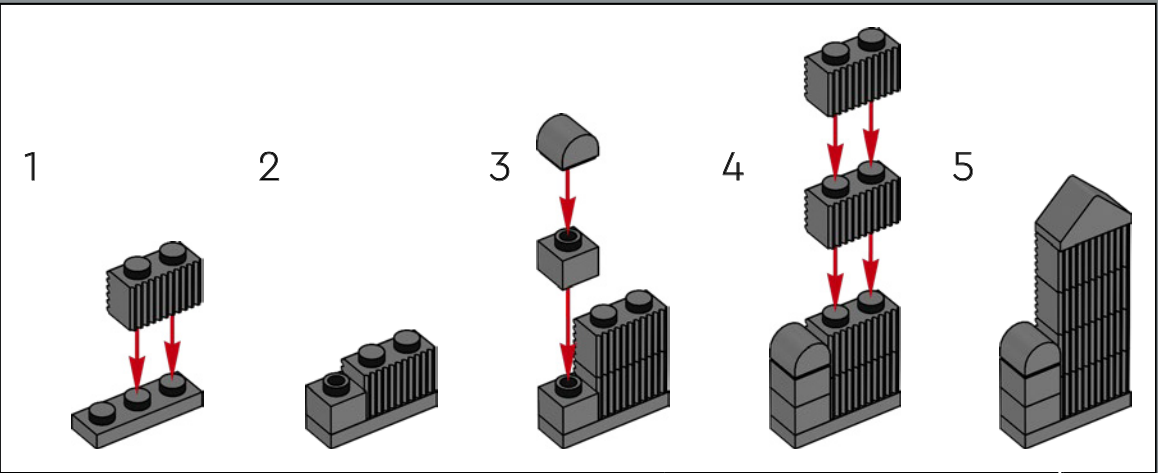

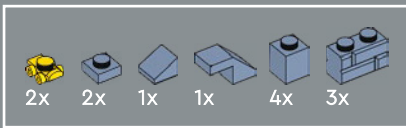

54

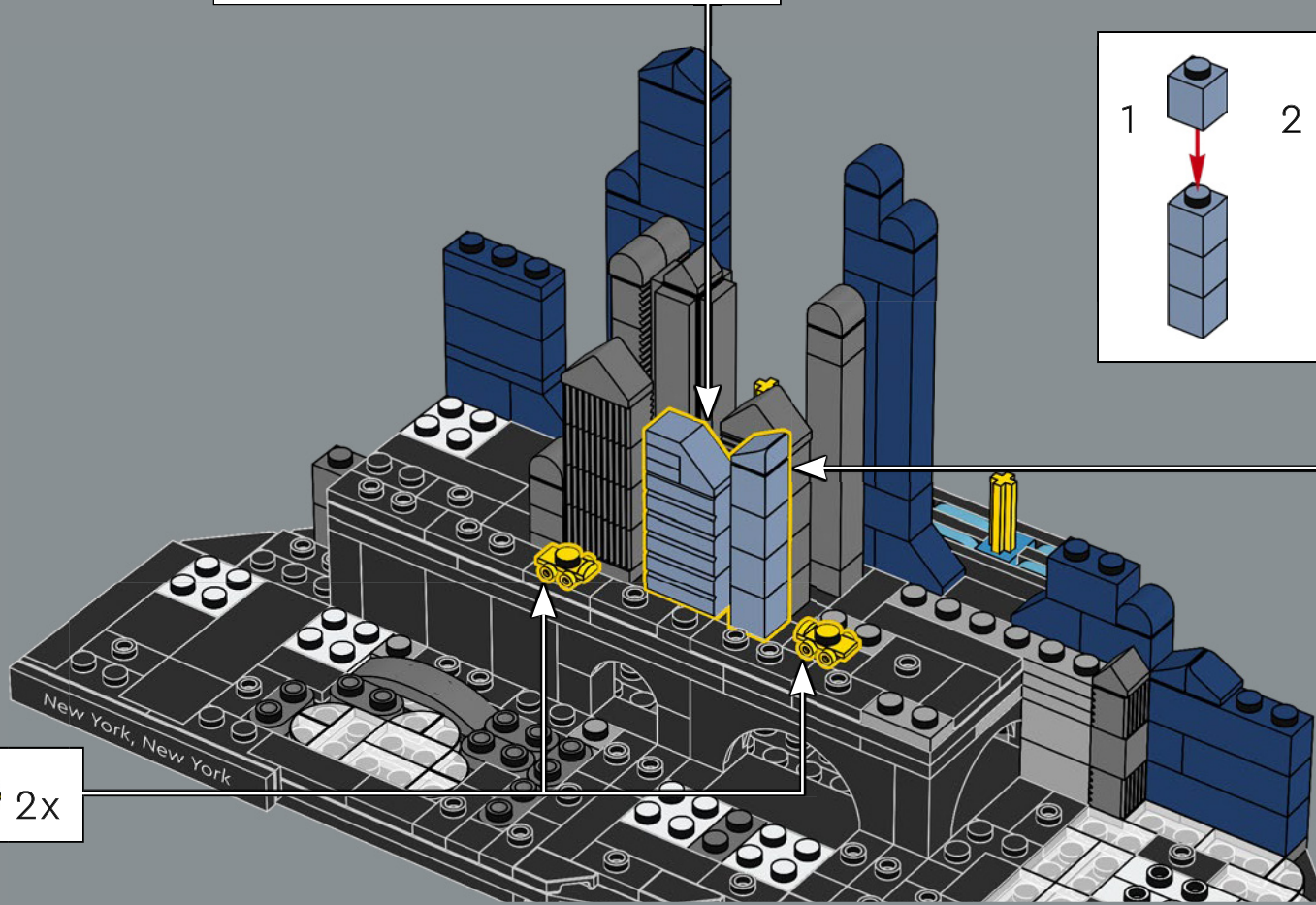
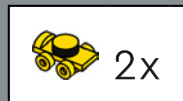
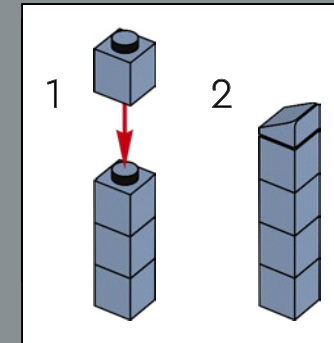
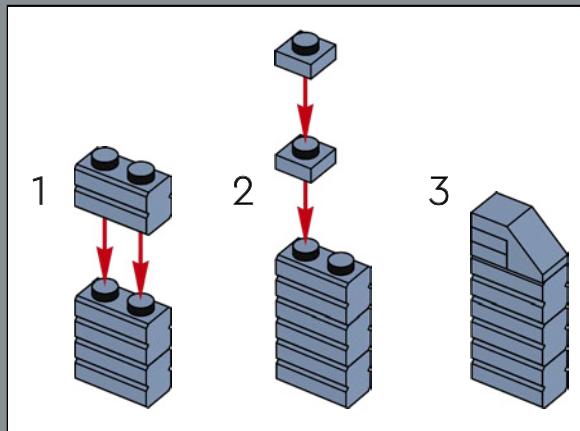

These yellow LEGO® minifigure roller skate elements represent some of the over 13,000 characteristic taxis in New York City.
 Ces éléments LEGO® jaunes en patins à roulettes de figurines représentent certains des plus de 13 000 taxis caractéristiques de New York.
 Estos elementos LEGO® amarillos, usados originalmente como patines para minifiguras, representan algunos de los más de 13.000 taxis característicos de la ciudad de Nueva York.

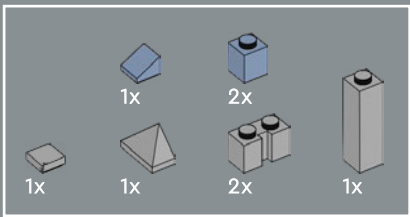

55

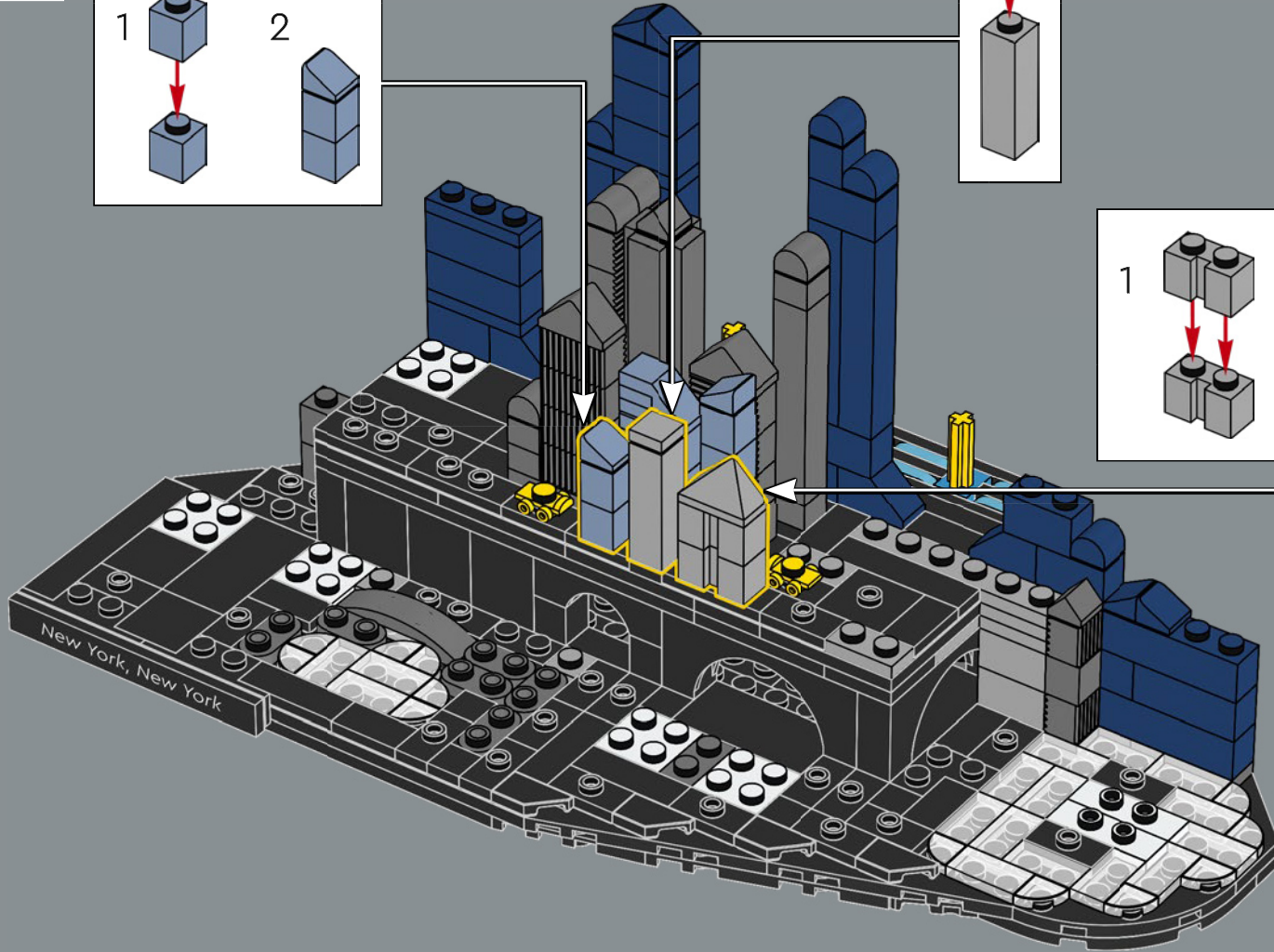
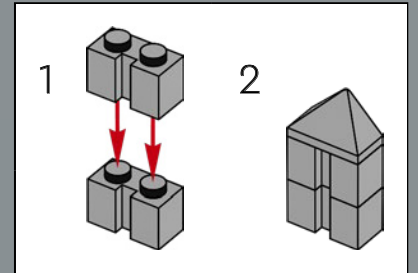
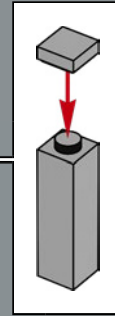
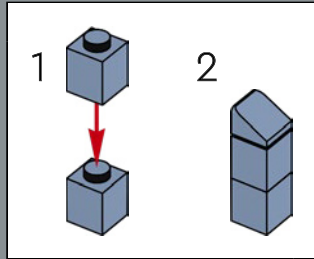

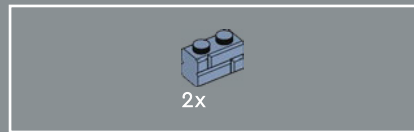

56

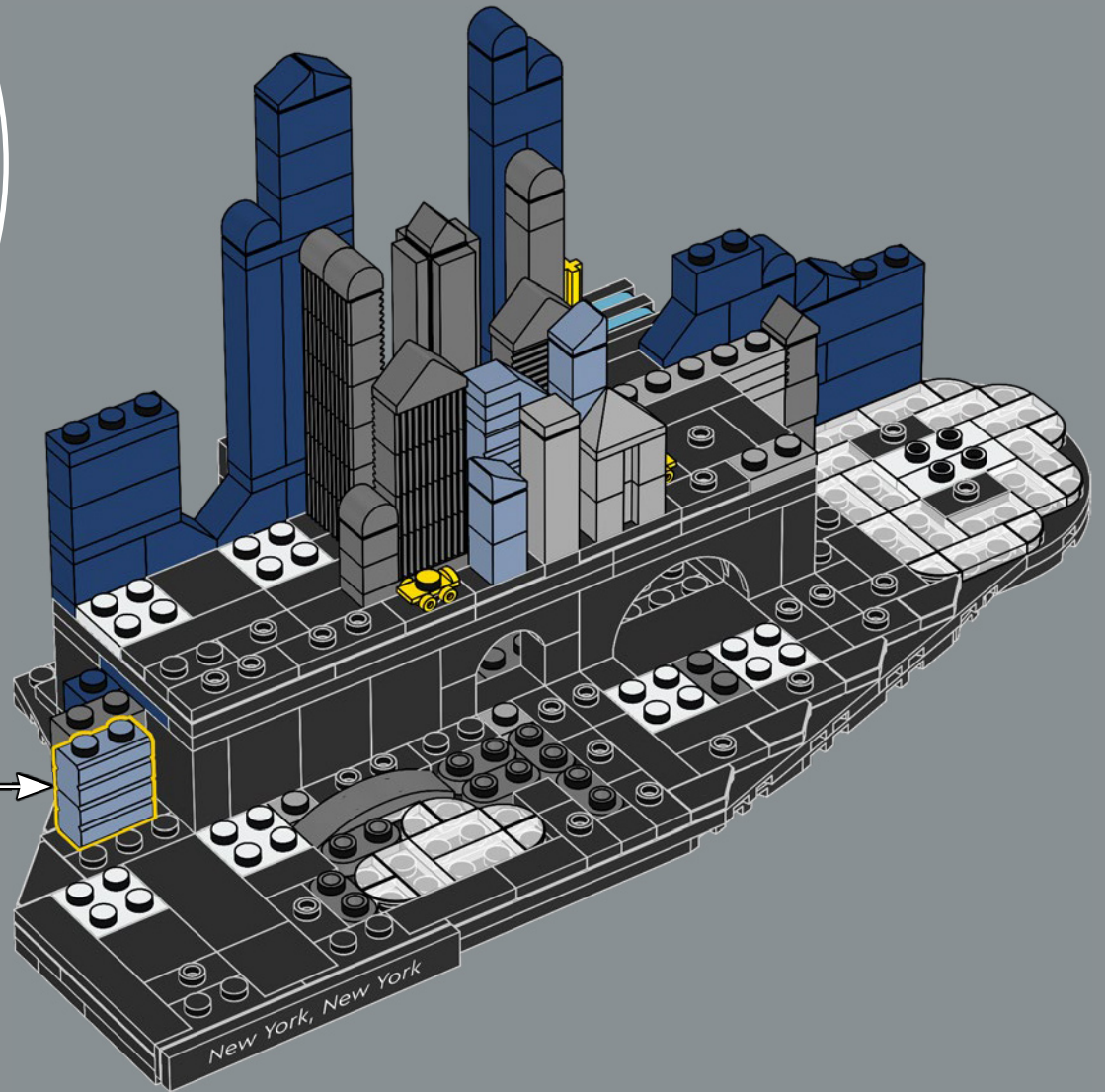
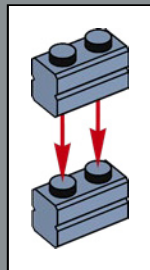

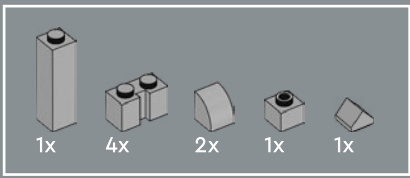

57

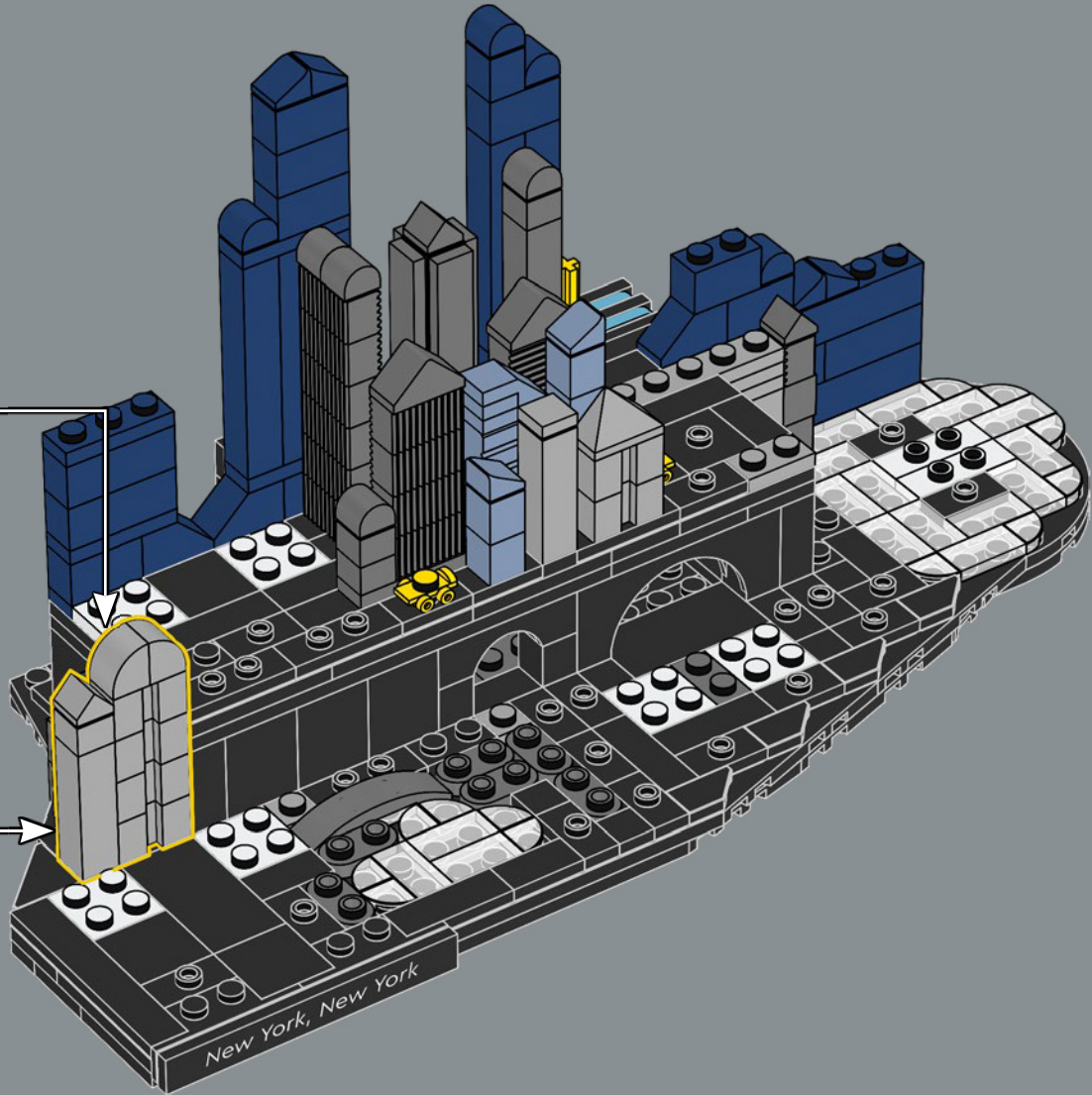
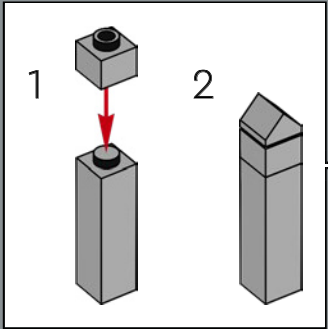
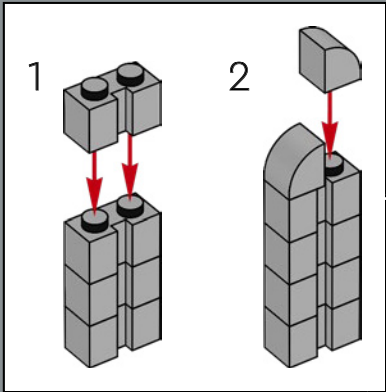

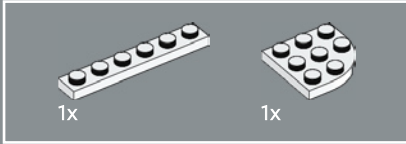
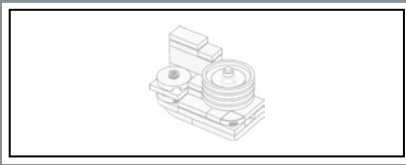

58

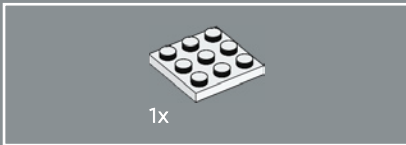
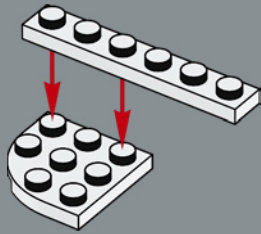

59

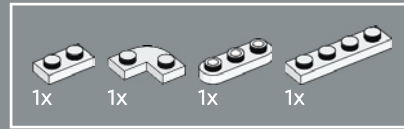
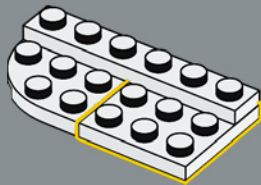

60

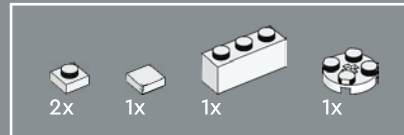
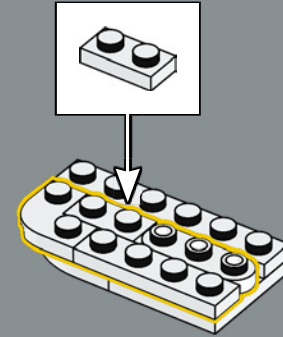

61

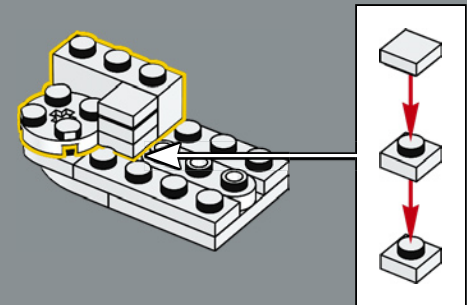



62

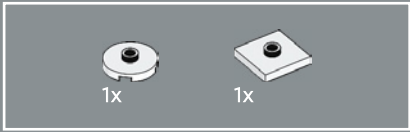
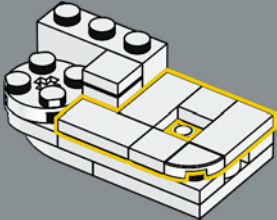

63

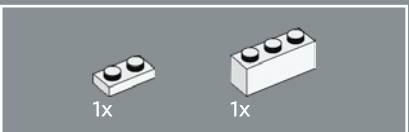
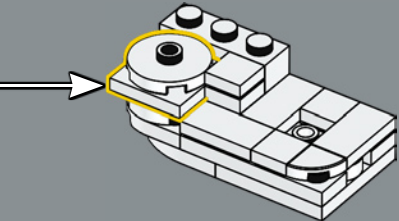
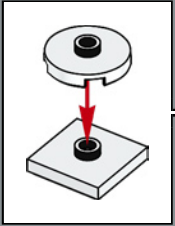

64

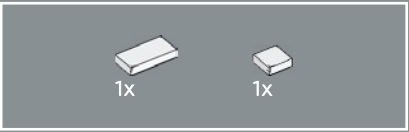
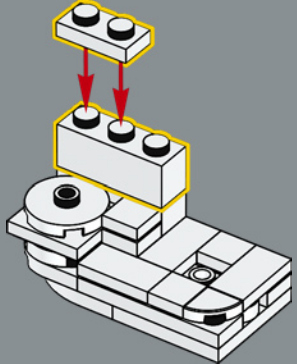

65

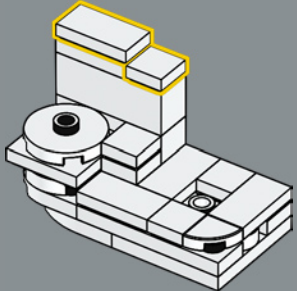

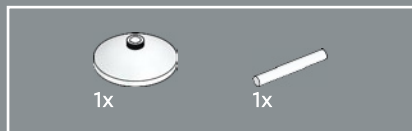

66

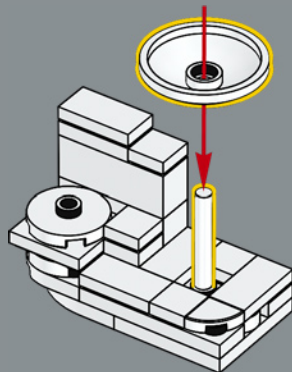

67

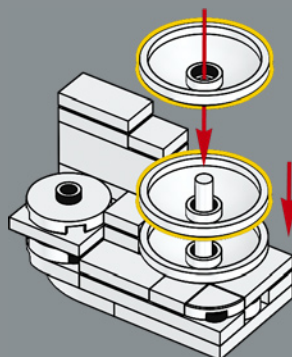

68

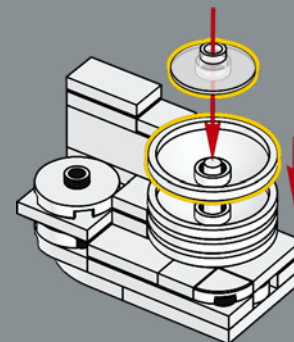

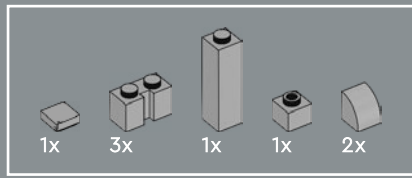

70

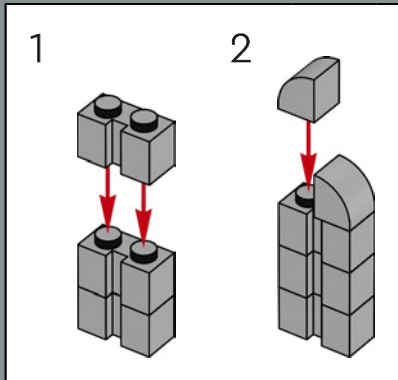
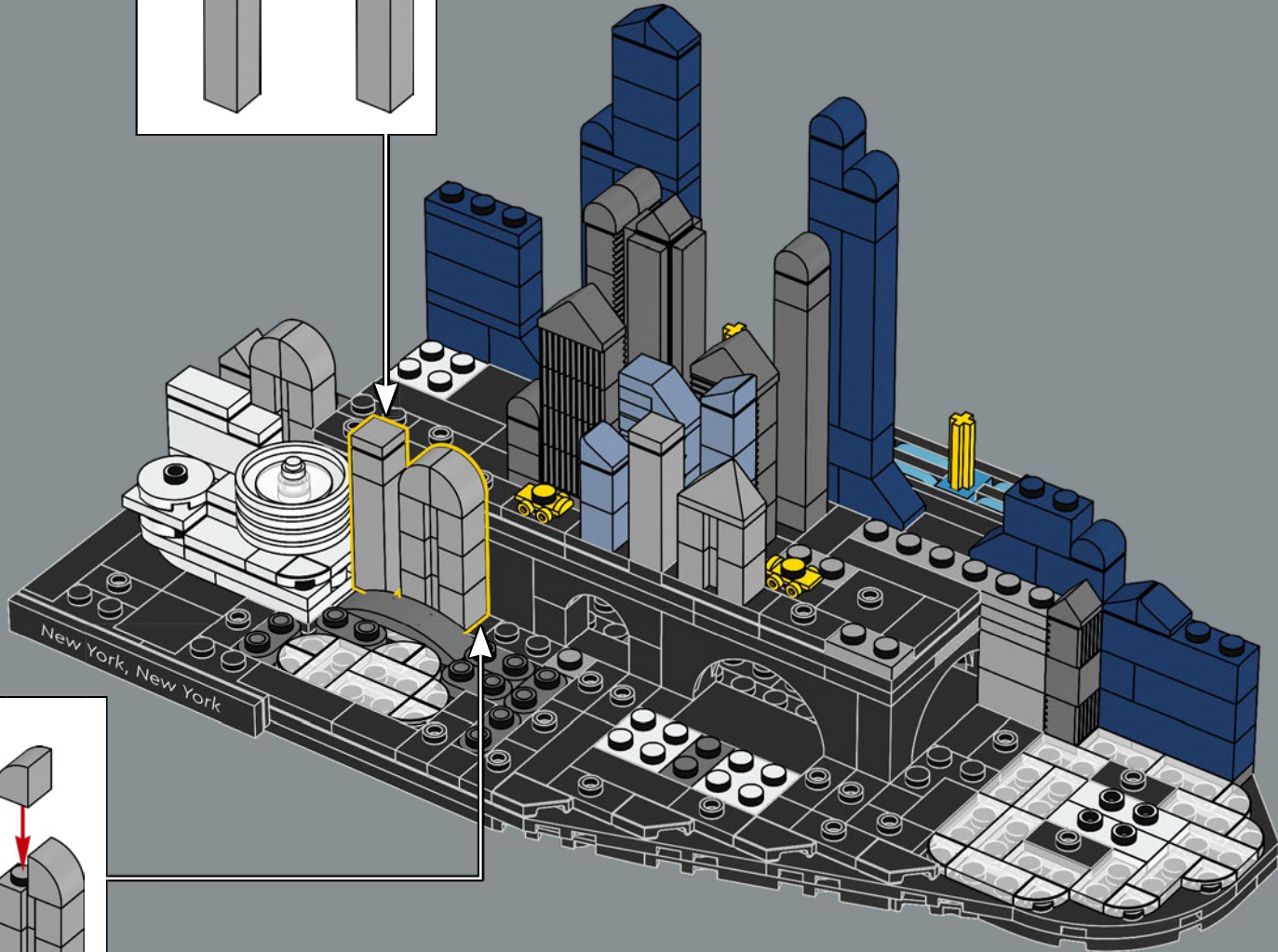
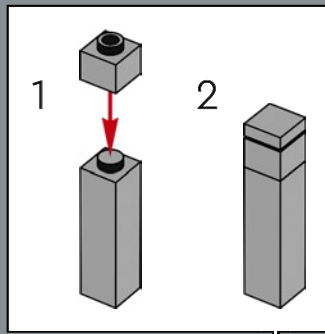

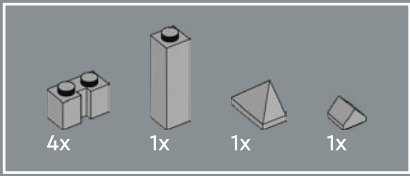

71

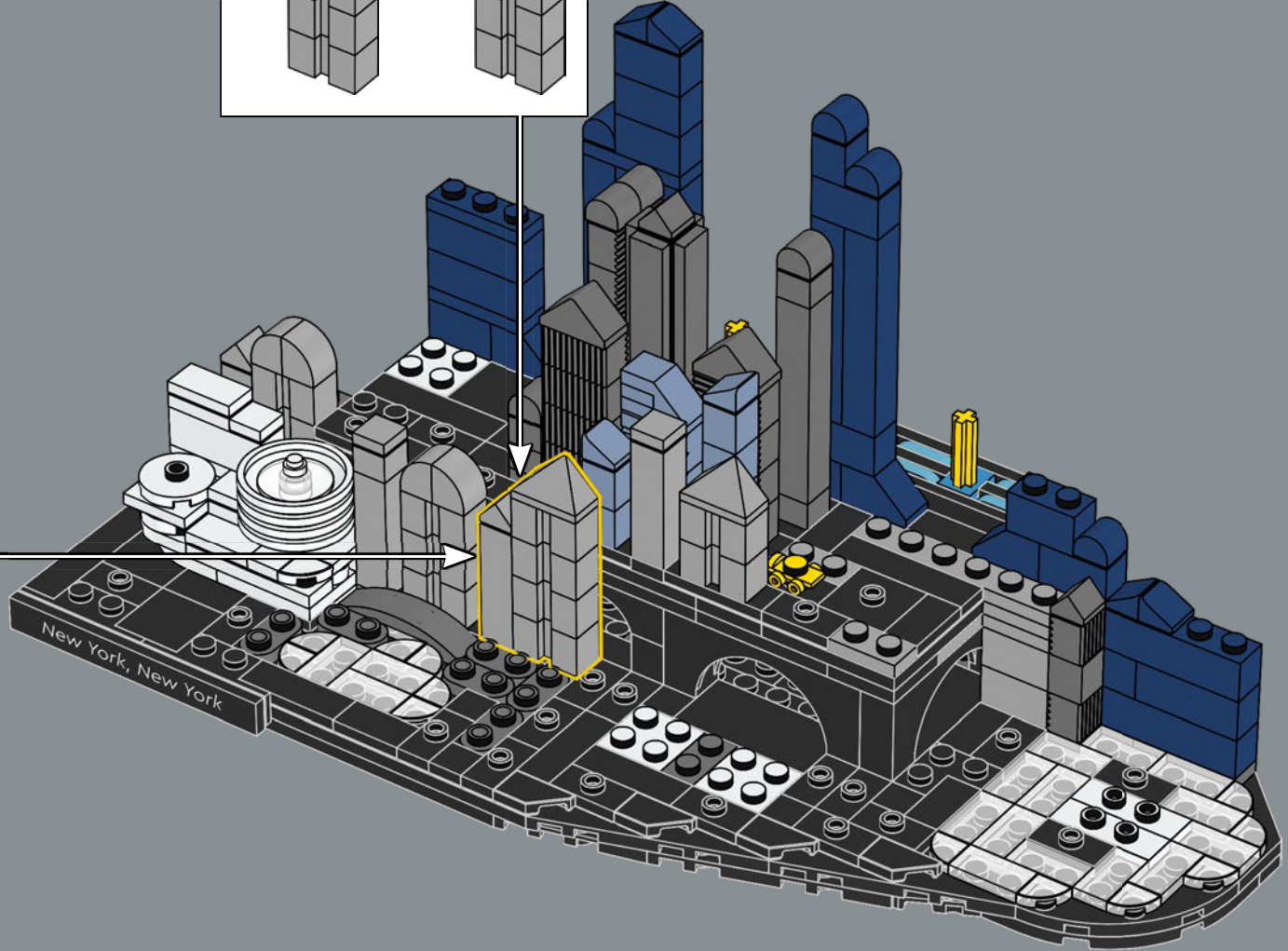
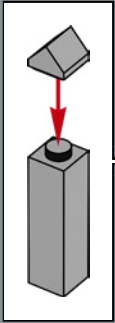
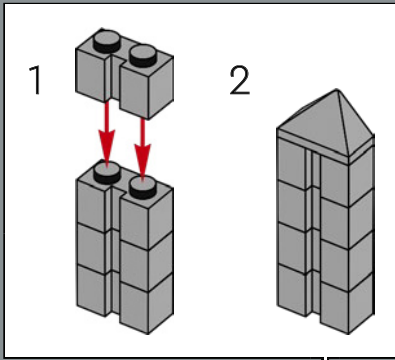



7x



3x

72

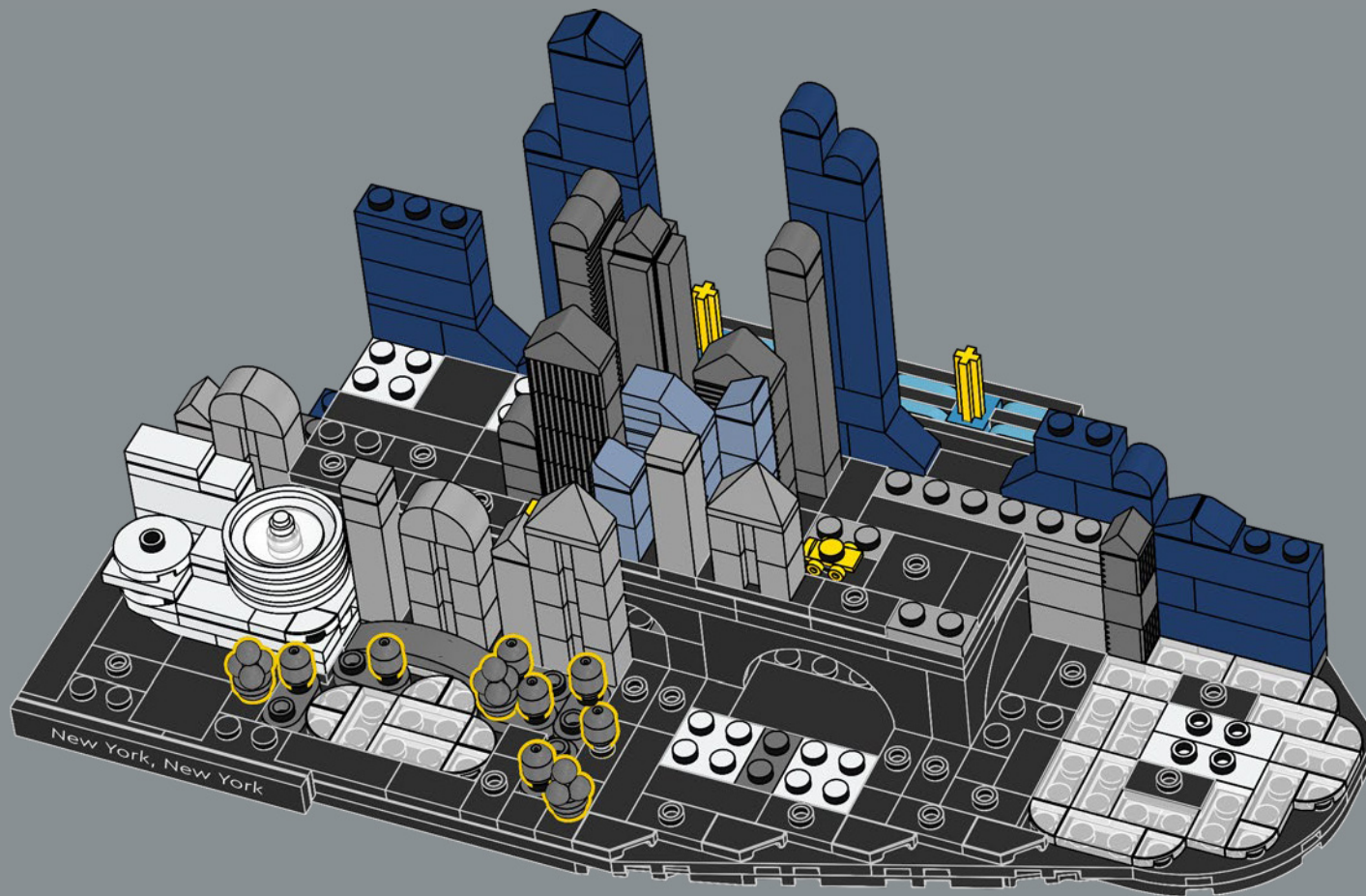



73

LEGO® ice cream elements, blades and globes are used here to make up some of the estimated 18,000 trees in Central Park.

Des éléments LEGO® en crème glacée, lames et globes sont utilisés ici pour représenter une partie des quelque 18 000 arbres estimés de Central Park.

Aquí se utilizan helados, espadas y globos LEGO® para dar forma a algunos de los aproximadamente 18.000 árboles de Central Park.

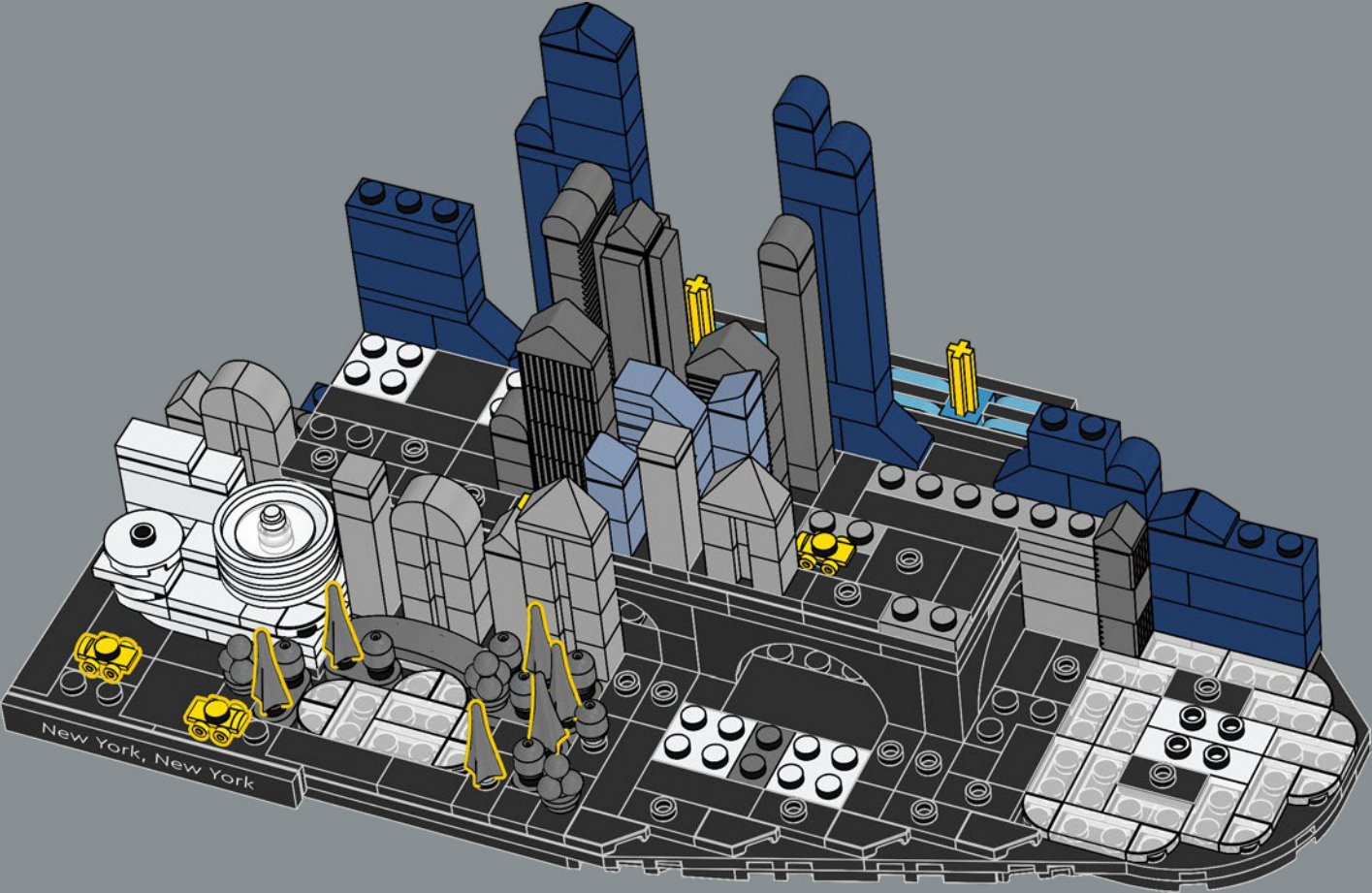

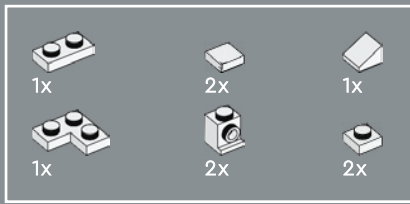

74

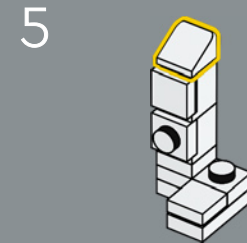
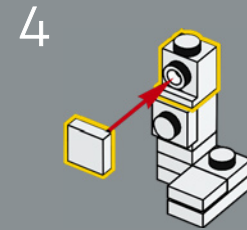
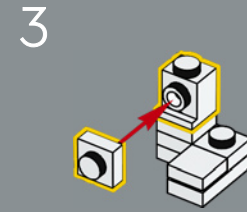
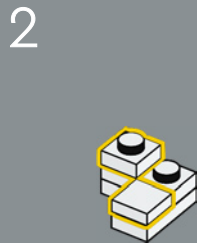
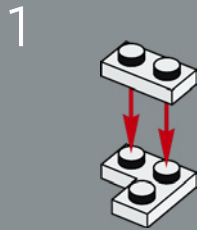

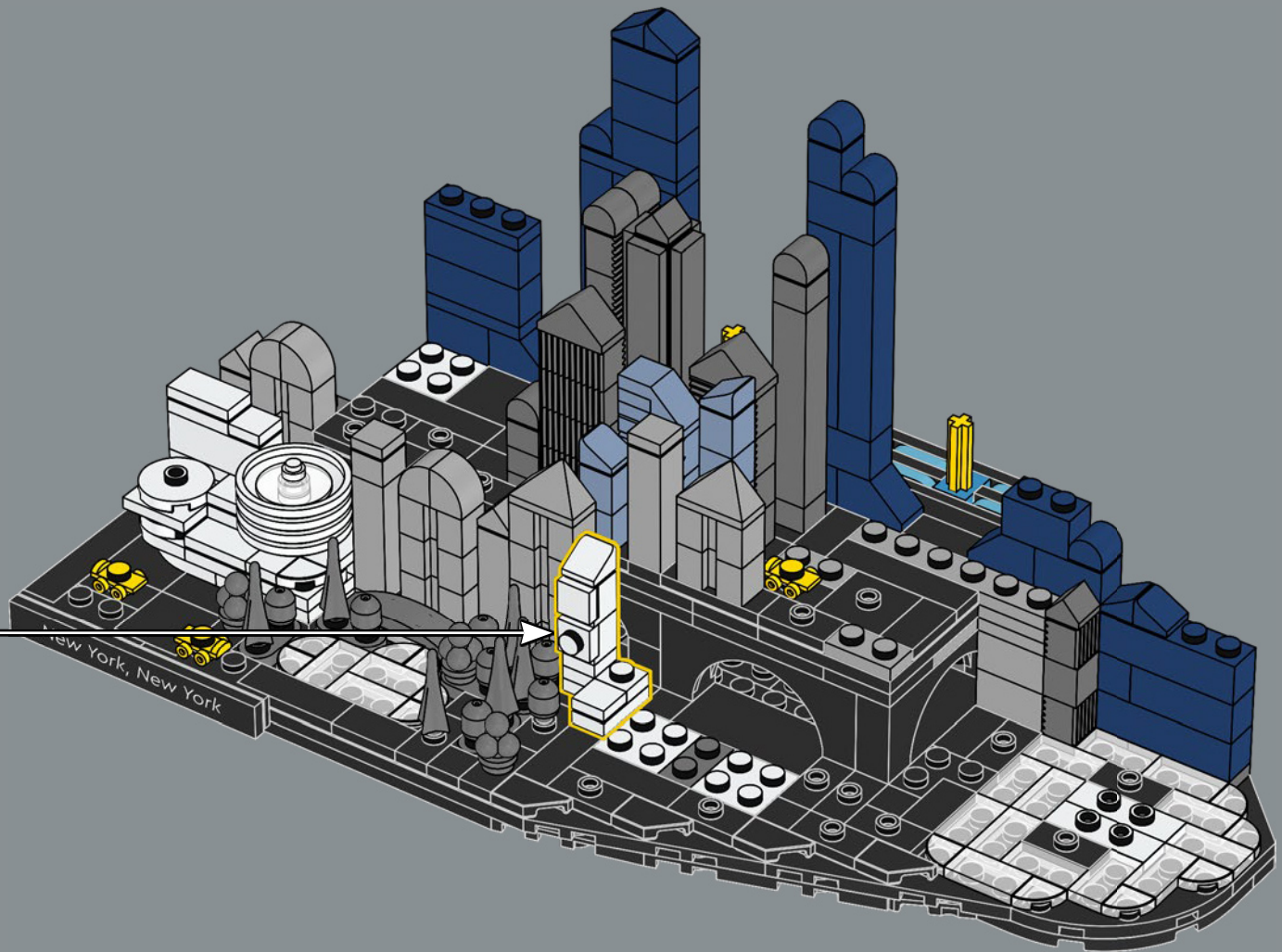

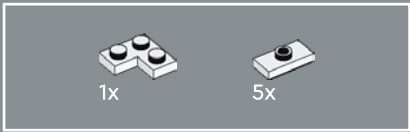

75

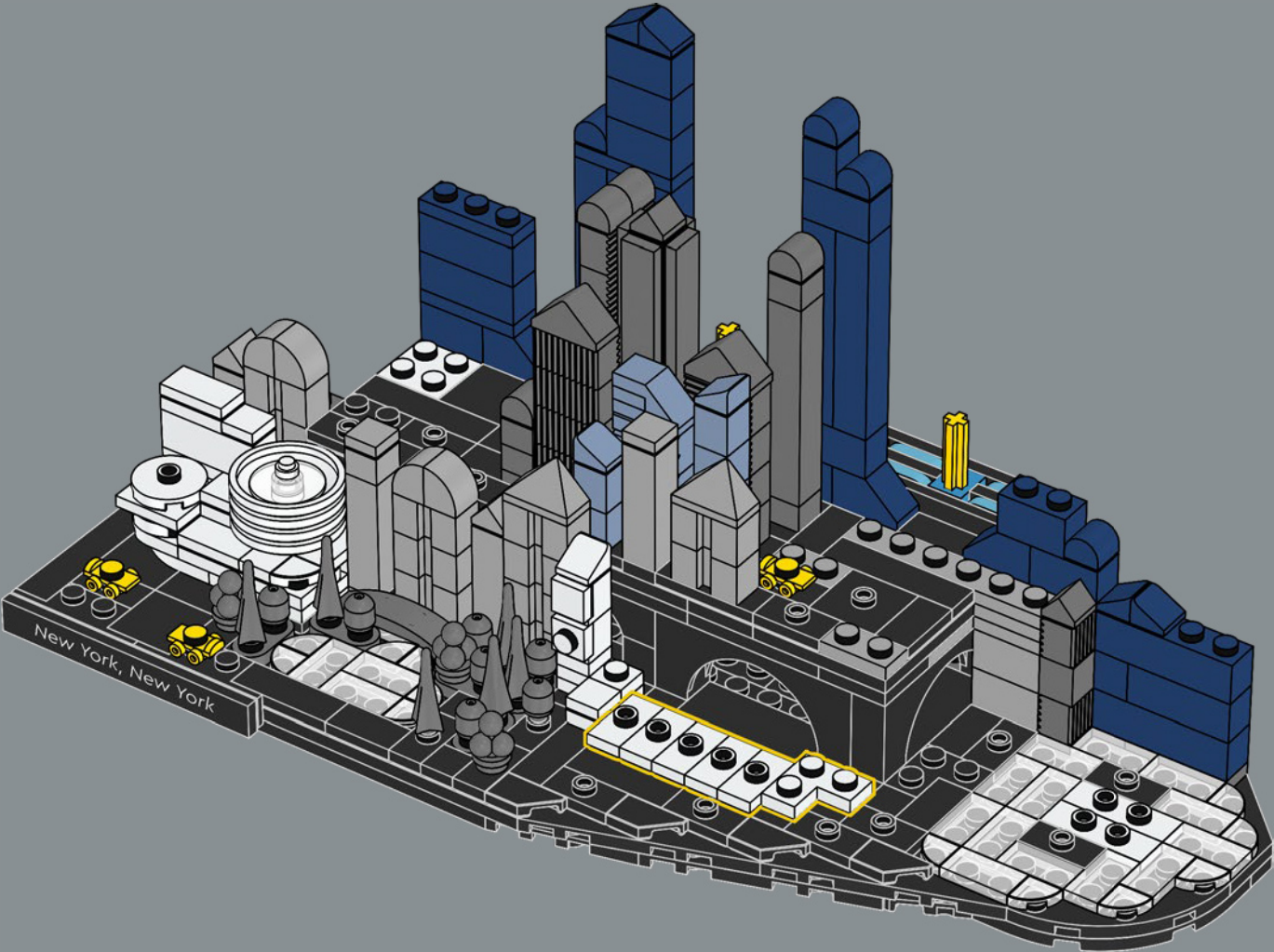

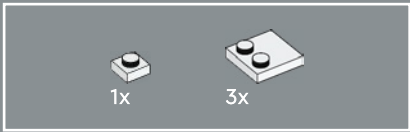

76

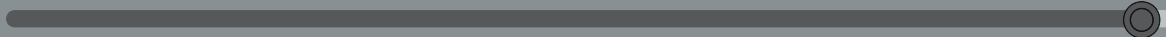
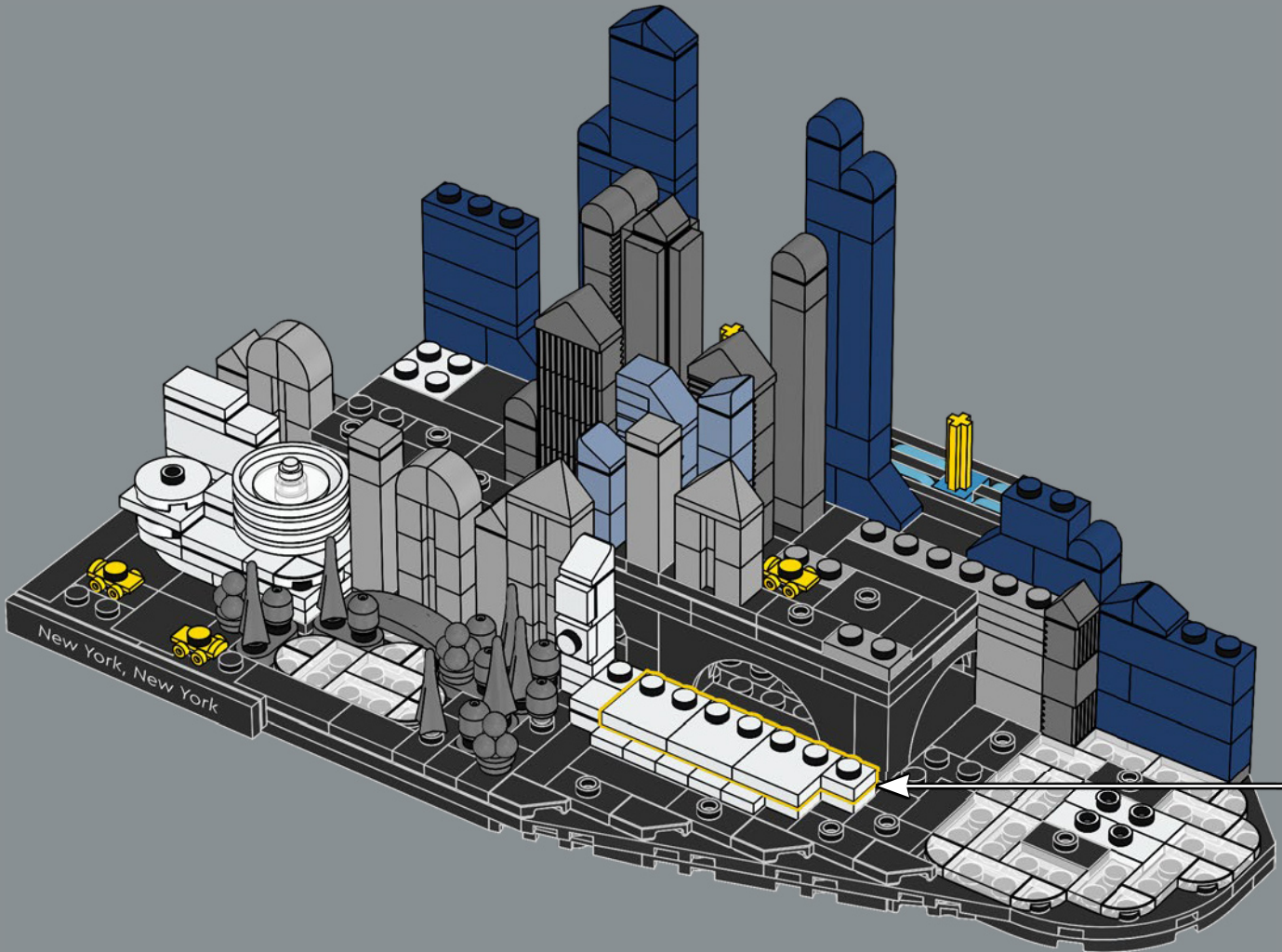

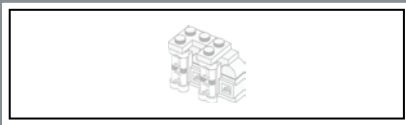

77

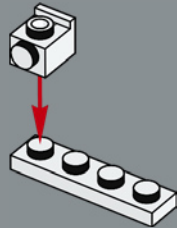

78

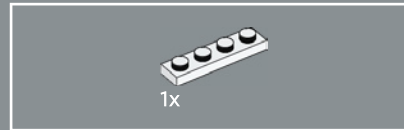
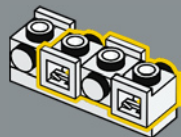

79

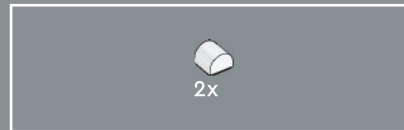
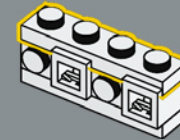

80

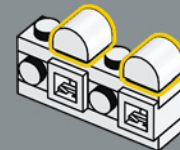

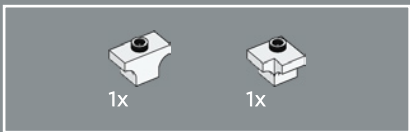

81

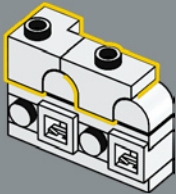

82

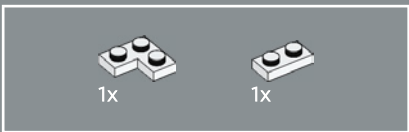
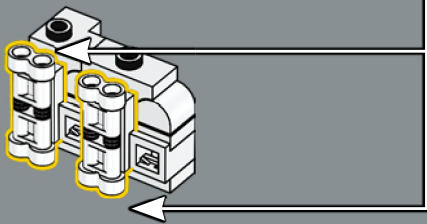
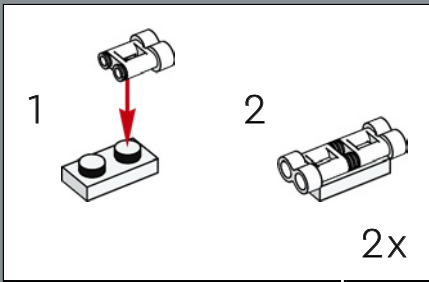

83

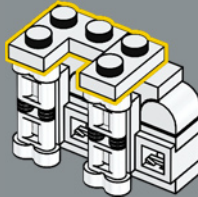

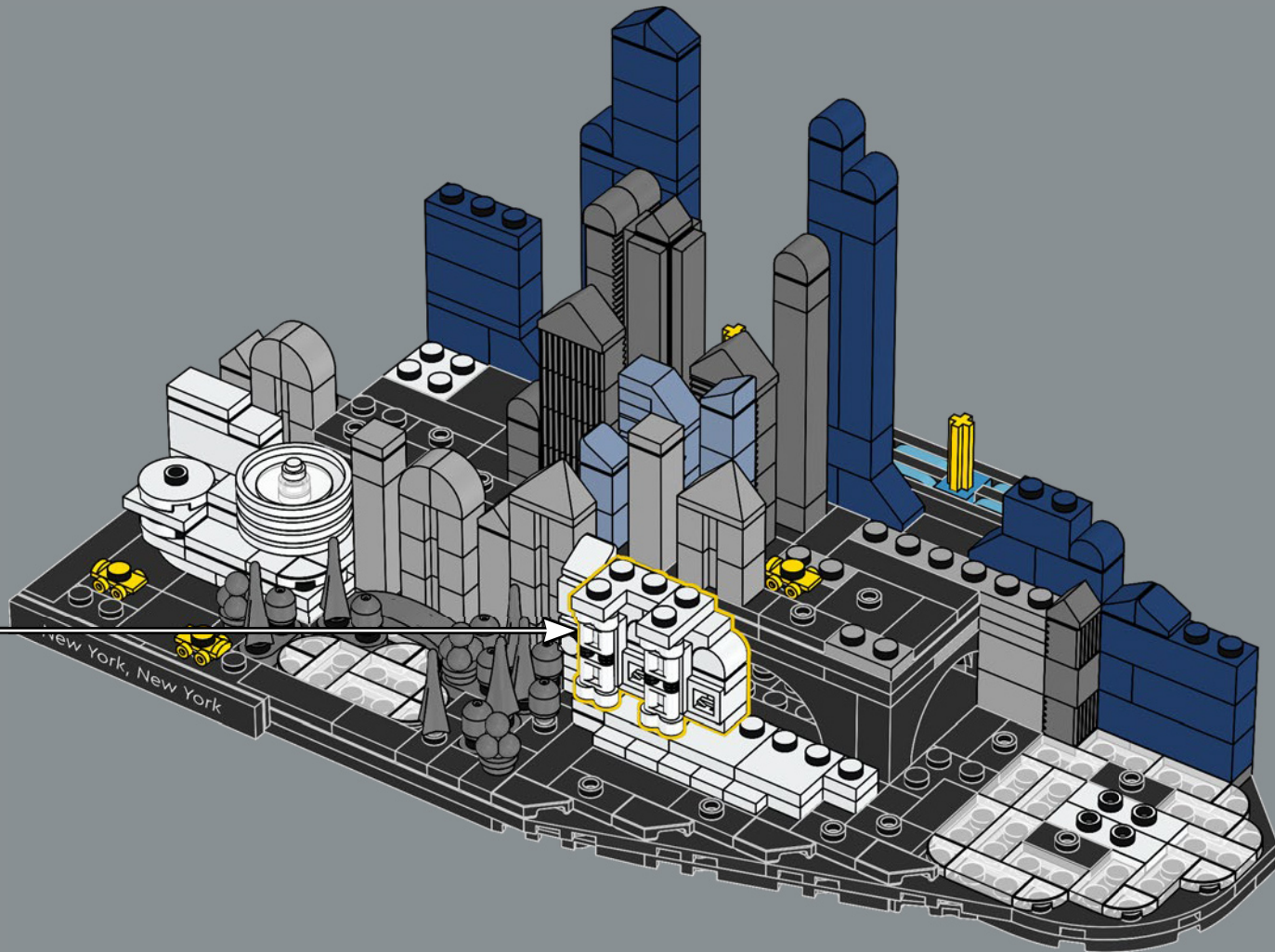

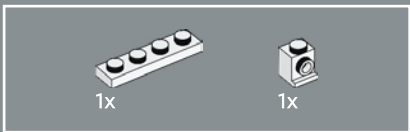

85

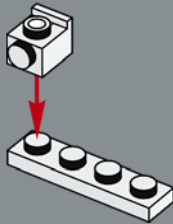

86

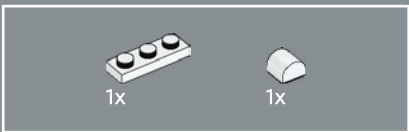
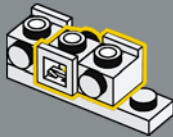

87

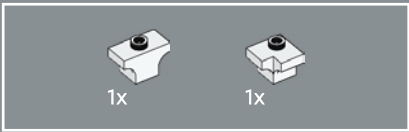
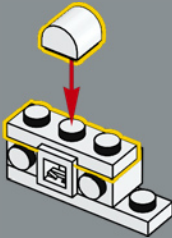

88

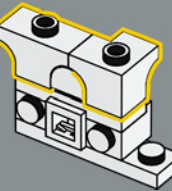

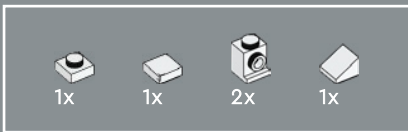

89

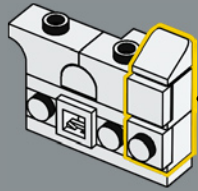
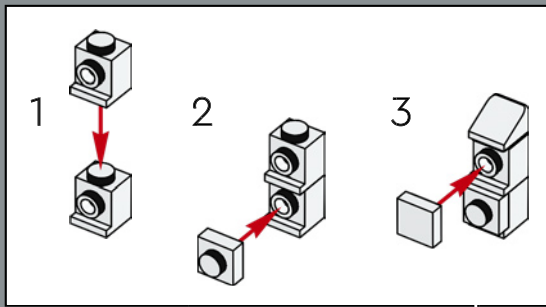

90

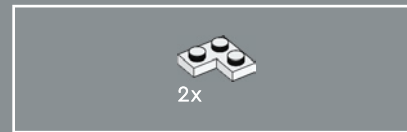
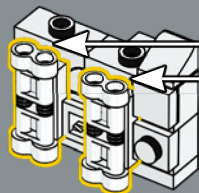
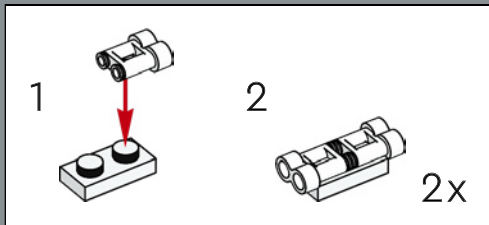

91

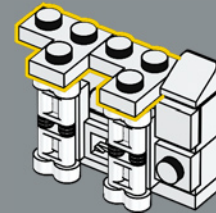

LEGO® binoculars create tiny pairs of columns that decorate the main entrance of the Metropolitan Museum of Art.

Les jumelles LEGO® créent de petites paires de colonnes qui décorent l'entrée principale du Metropolitan Museum of Art.

Los binoculares LEGO® se transforman en pares de columnitas que decoran la entrada principal del Museo Metropolitano de Arte.

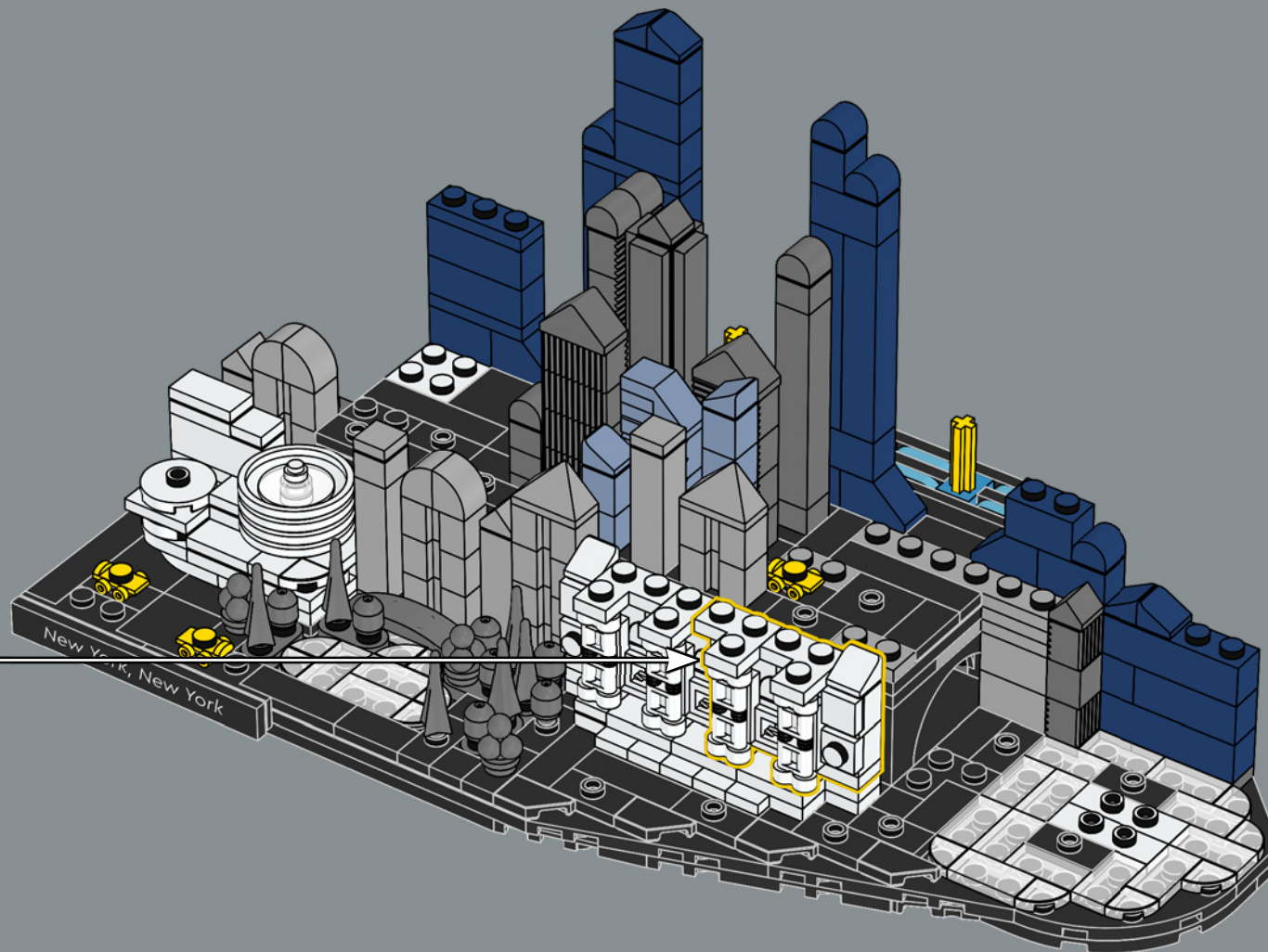

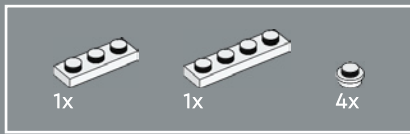

93

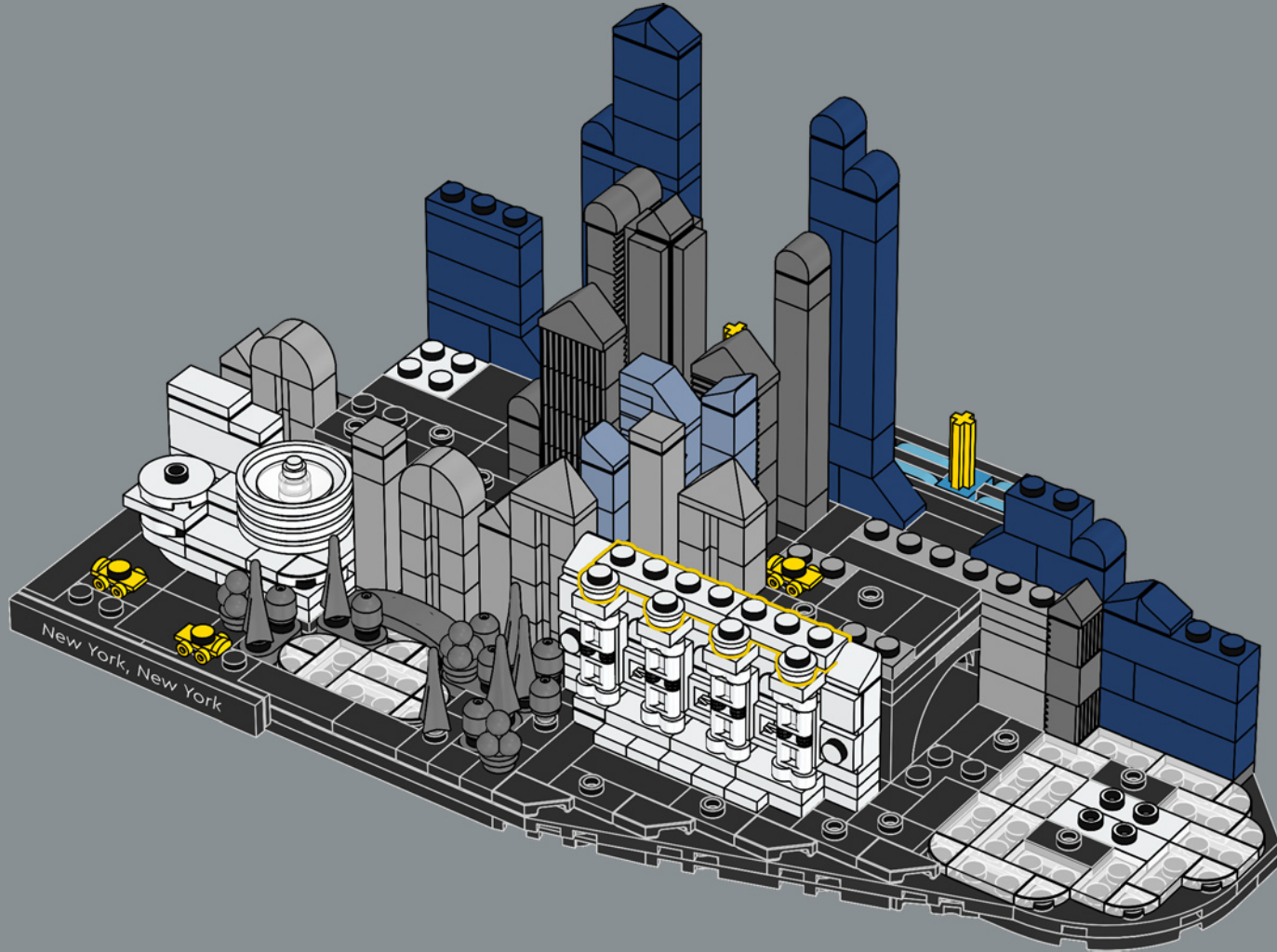

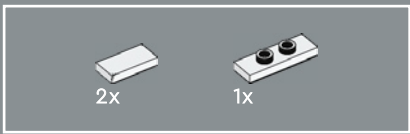

94

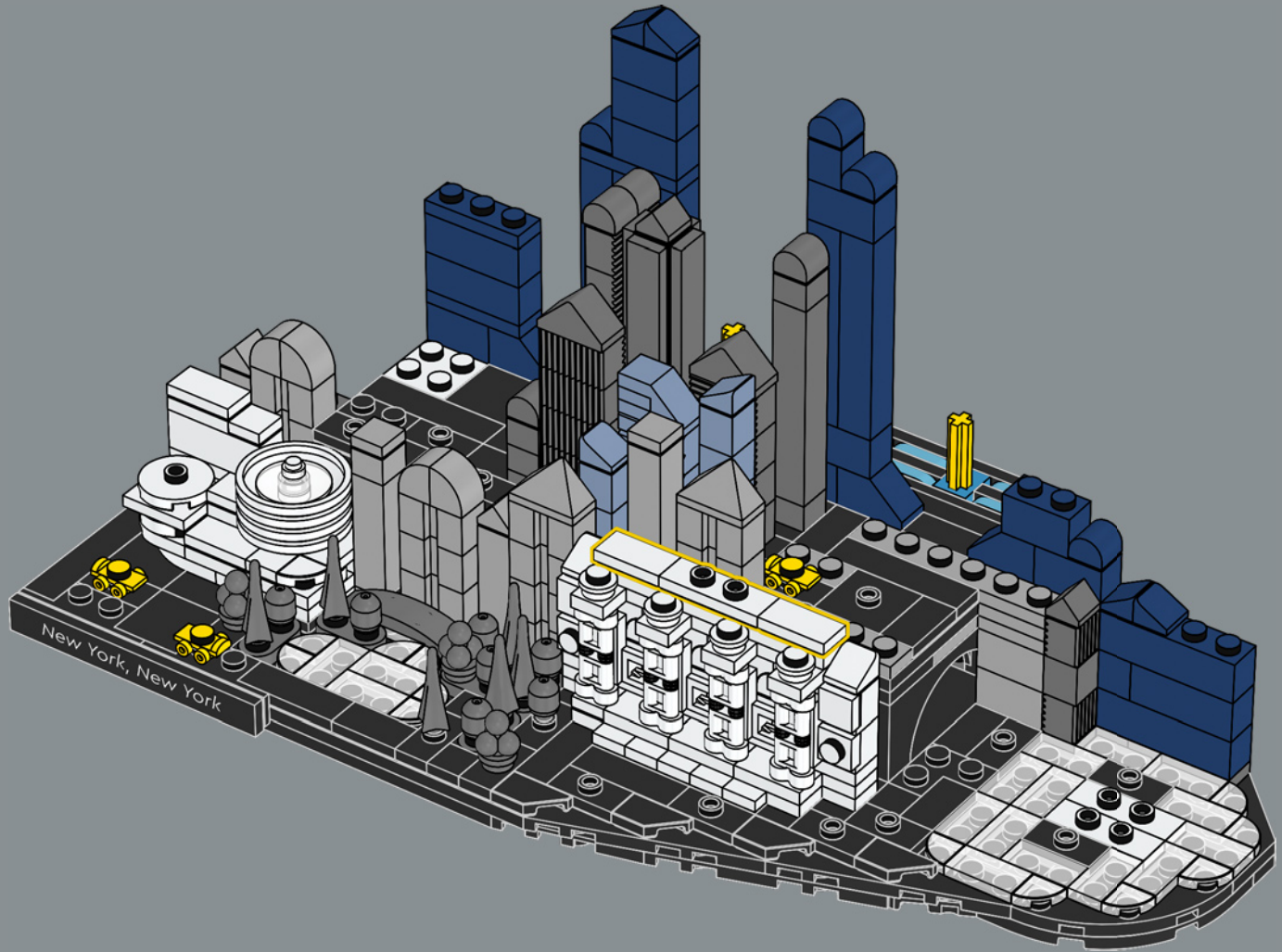

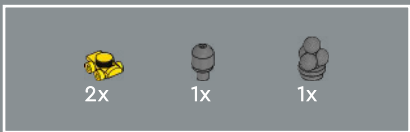

95

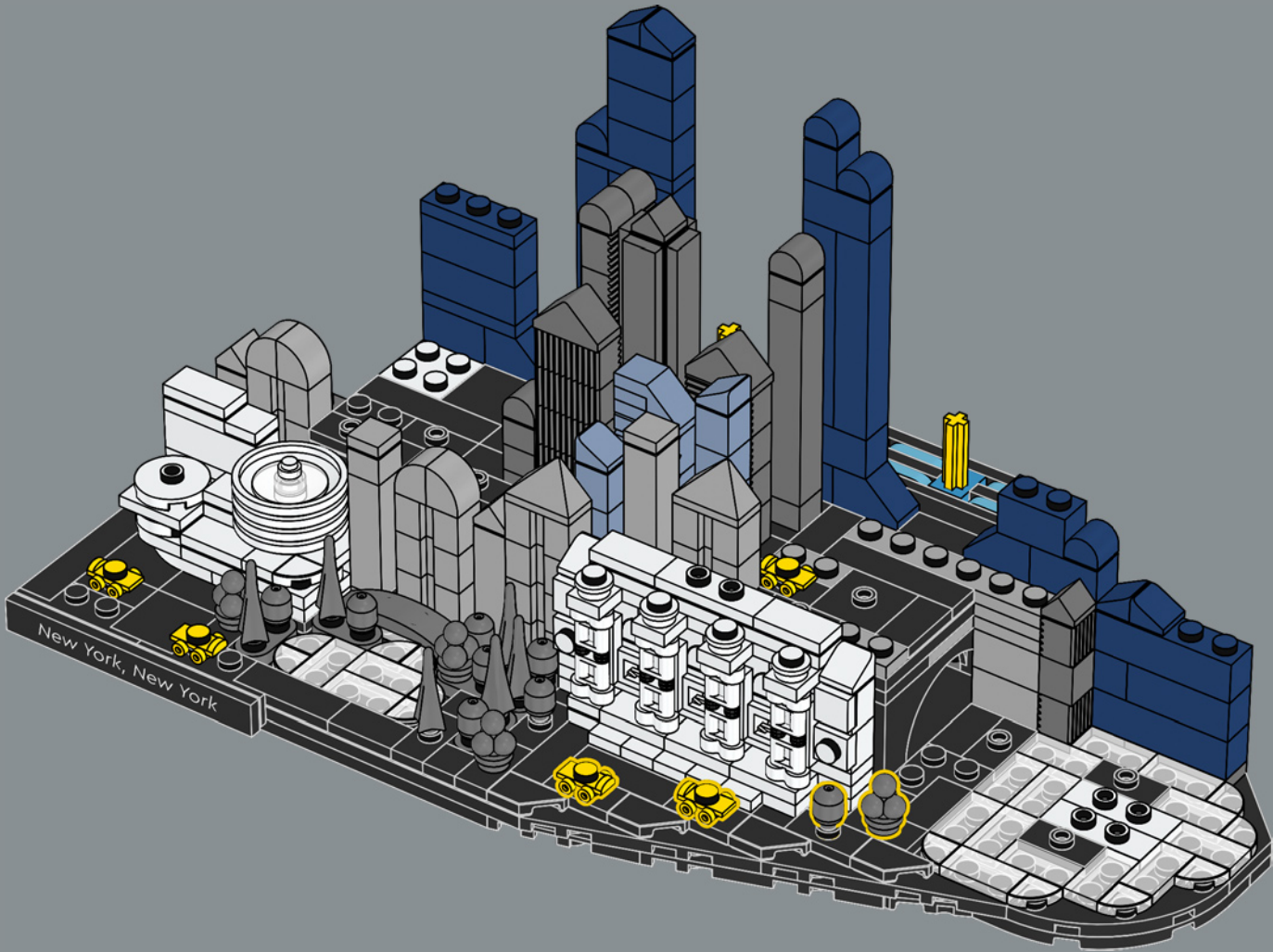

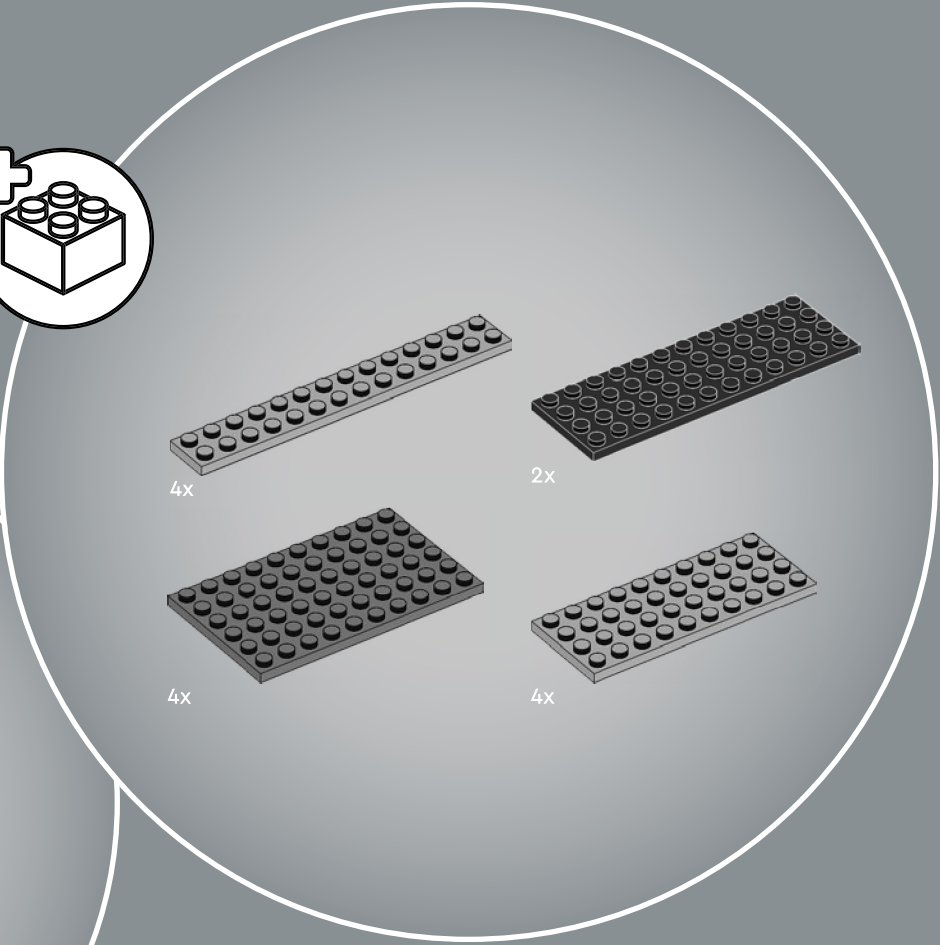
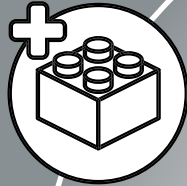

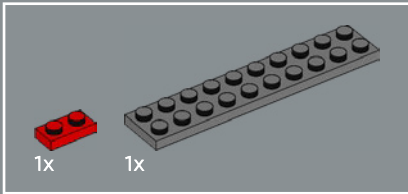
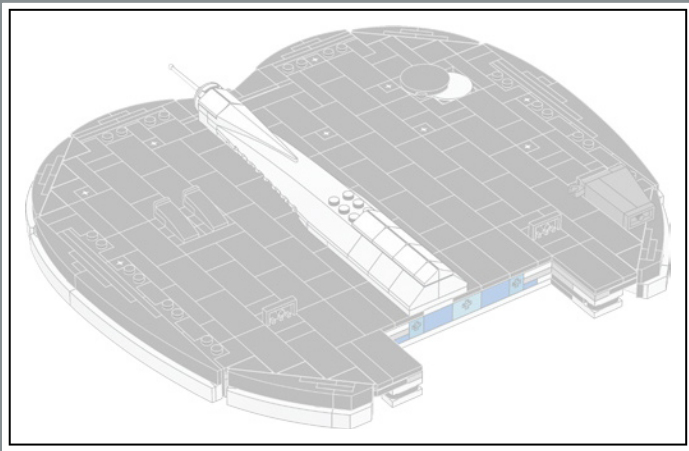

96

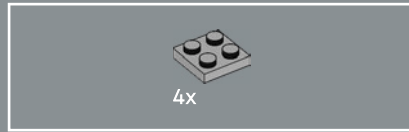
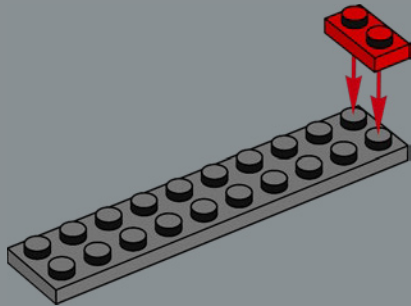

97

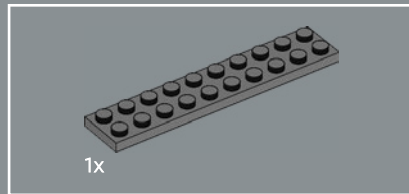
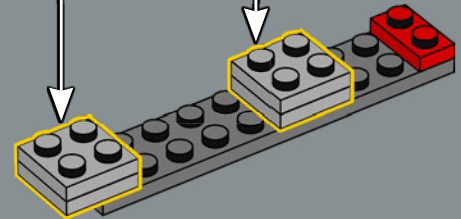
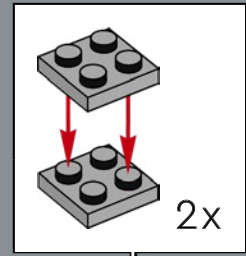

98

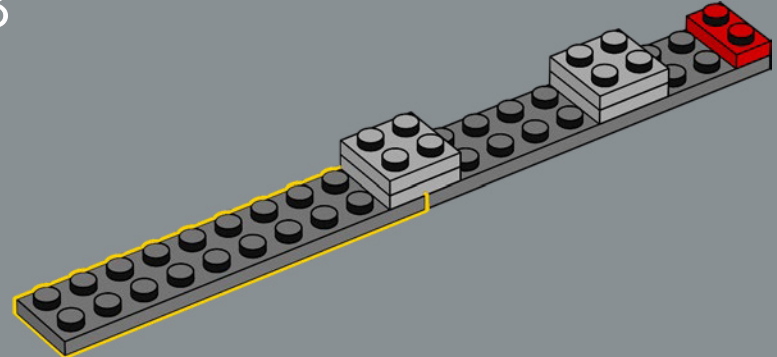

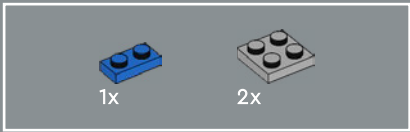

99

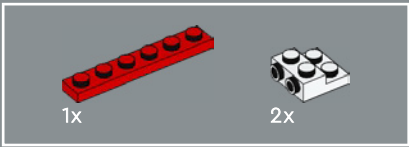
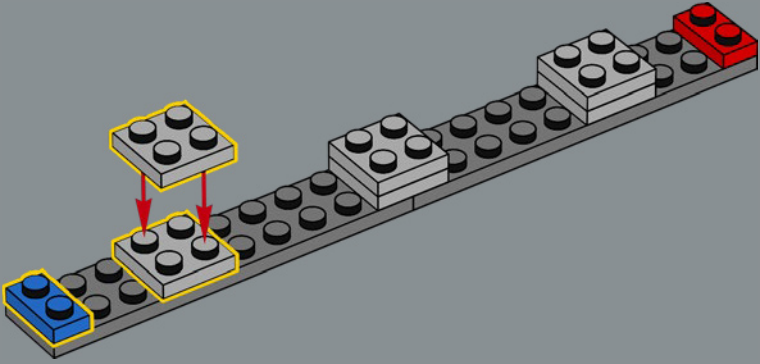

100

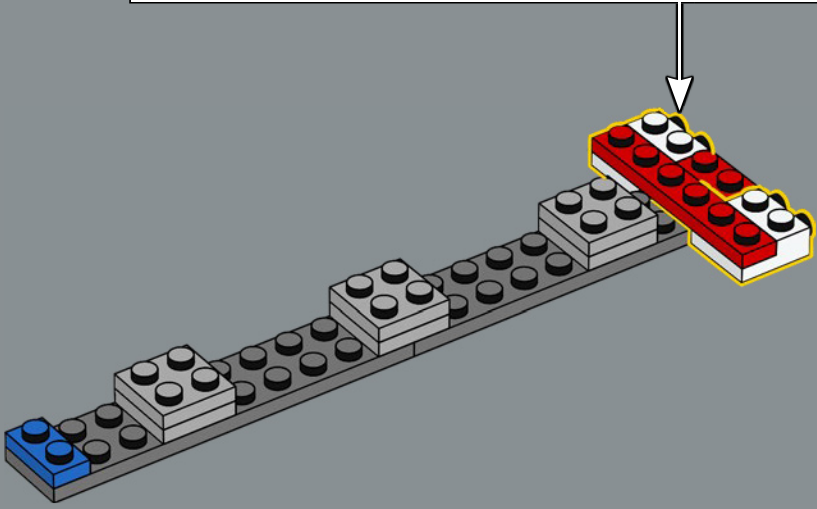
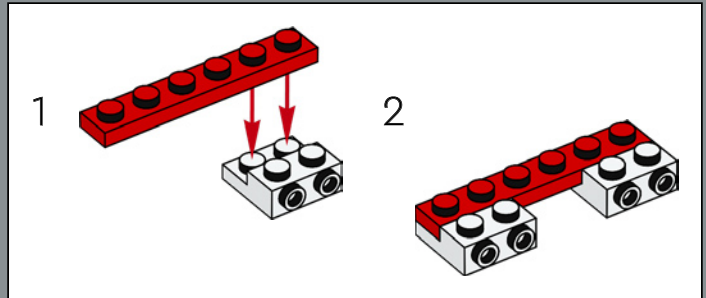

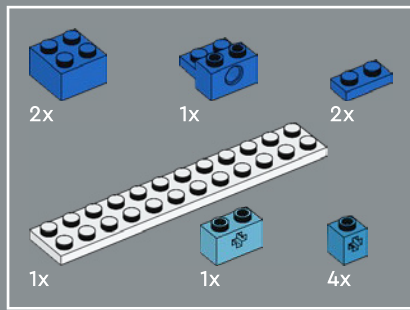

101

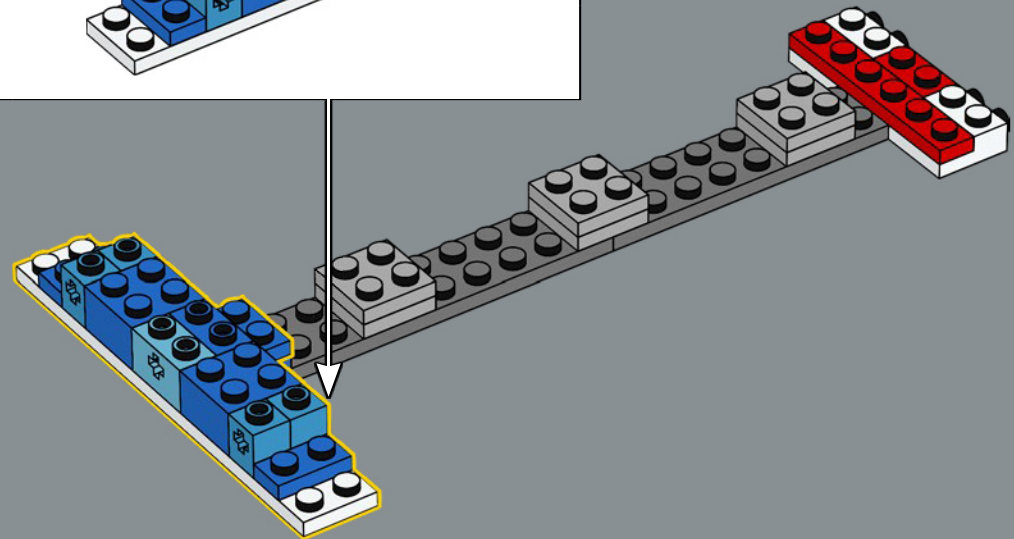
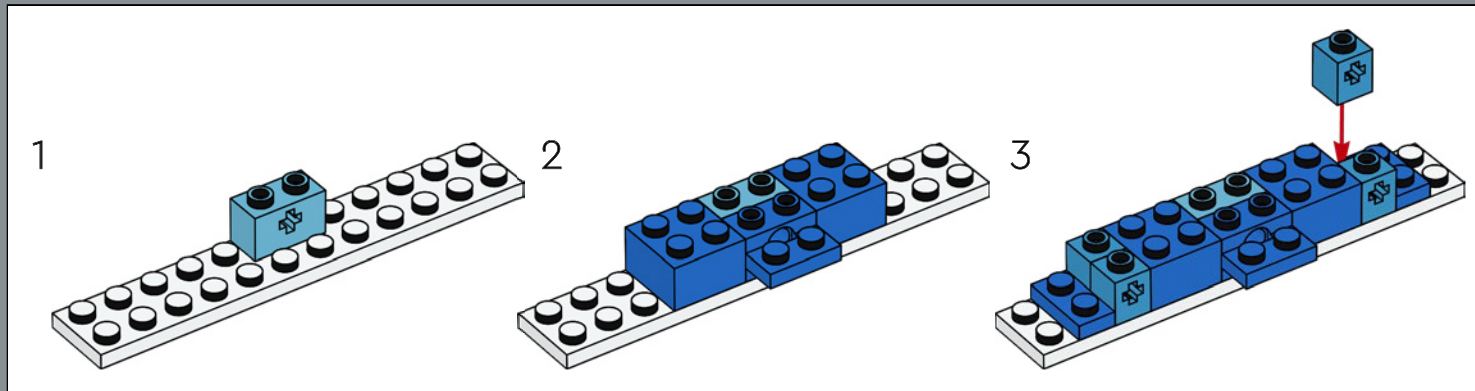

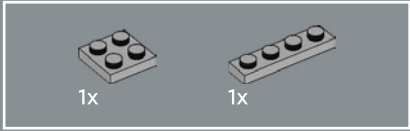
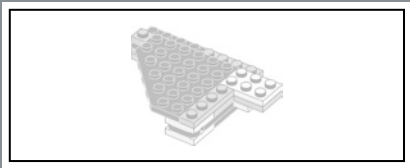

102

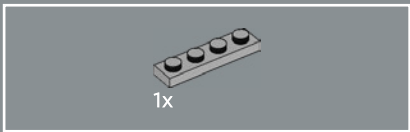
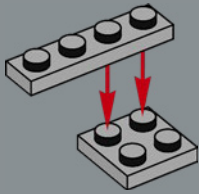

103

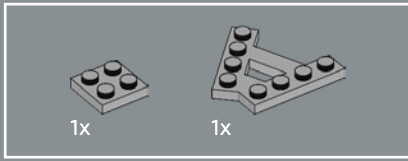
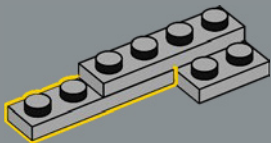

104

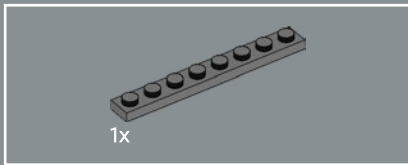
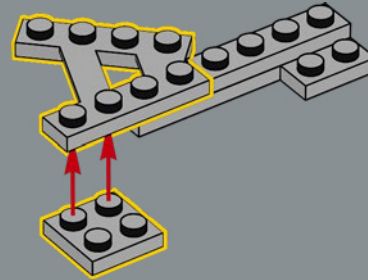

105

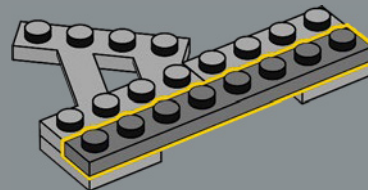



106

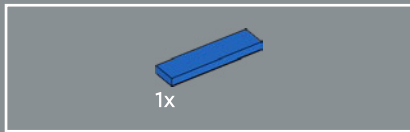
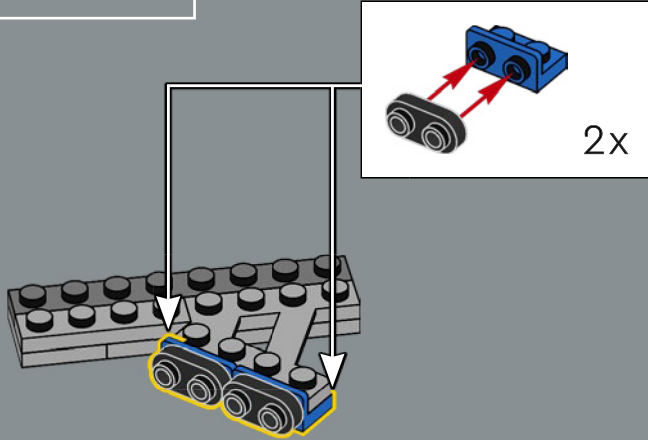

107

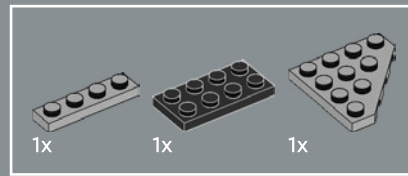
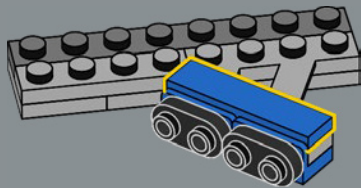

108

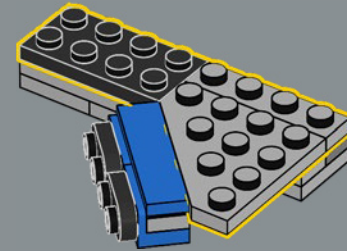

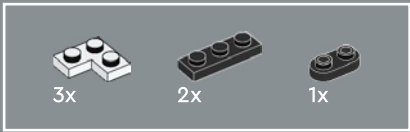

109

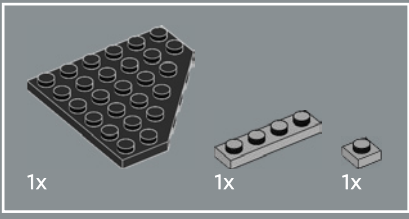
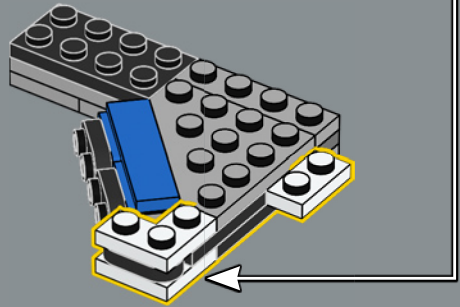
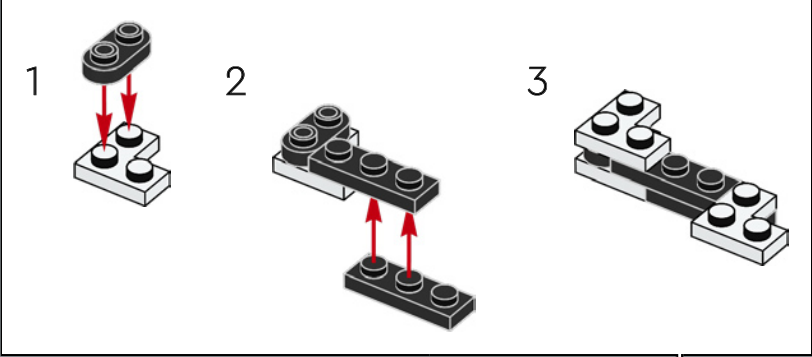

110

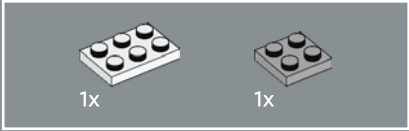
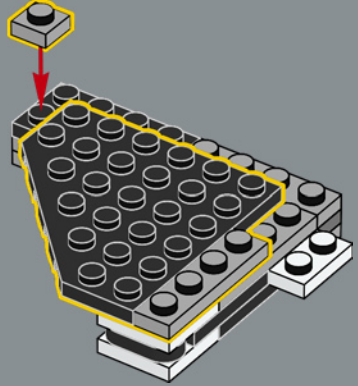

111

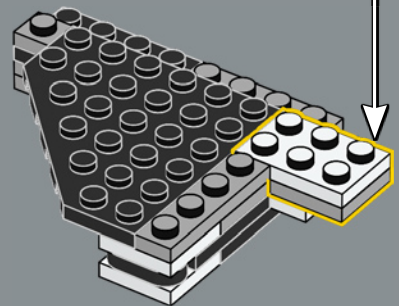
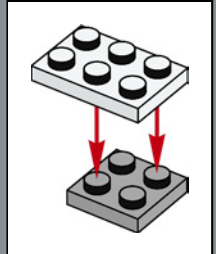

112

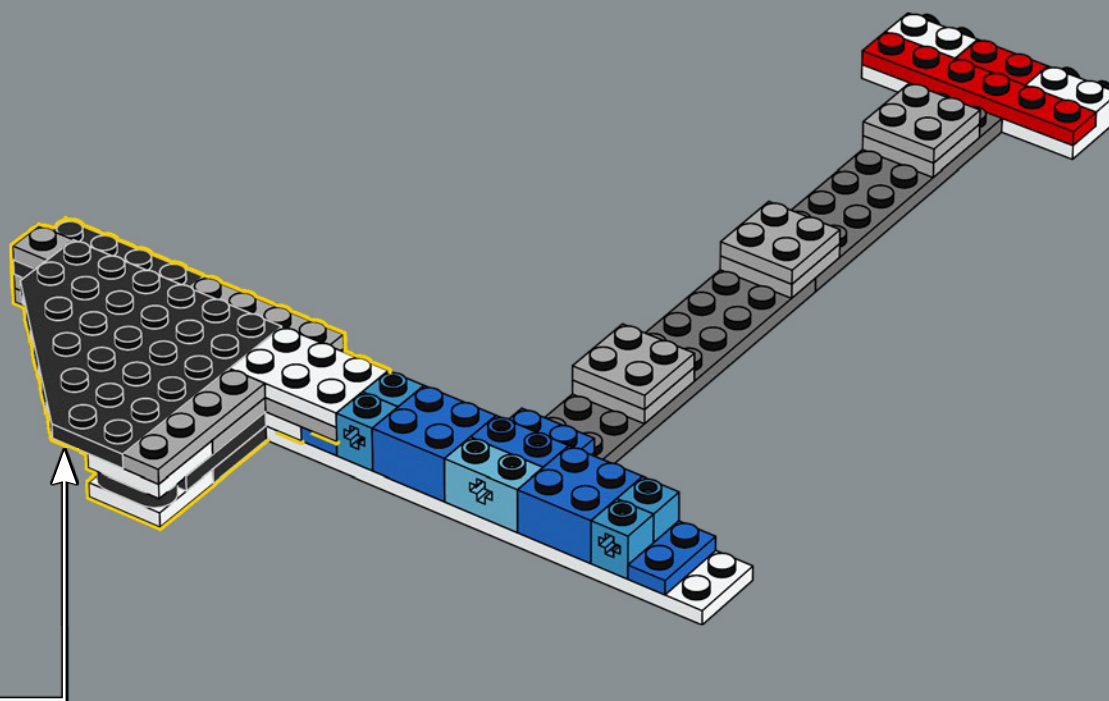

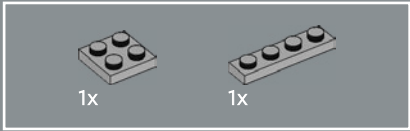
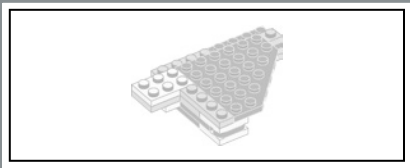

113

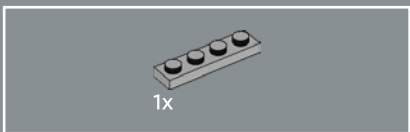
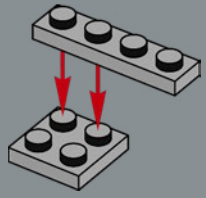

114

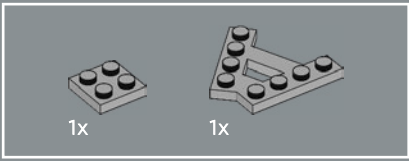
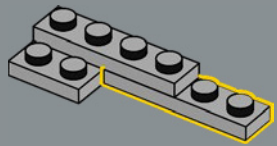

115

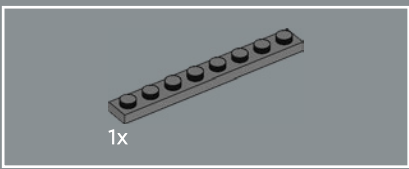
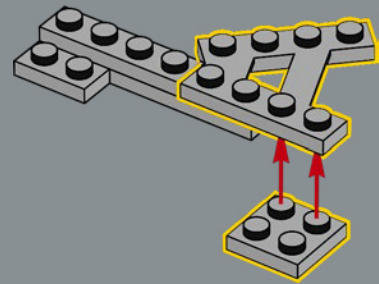

116

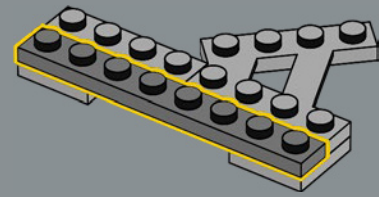



117

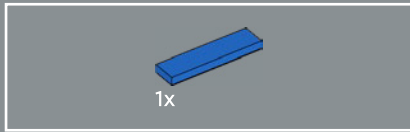
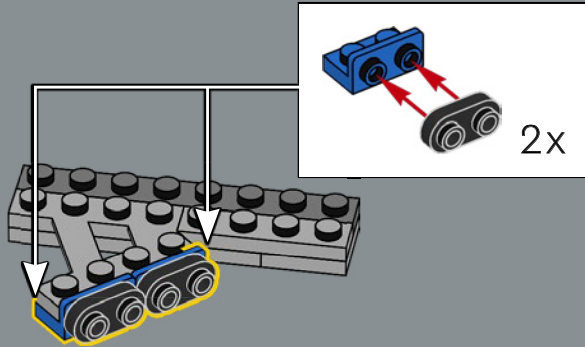

118

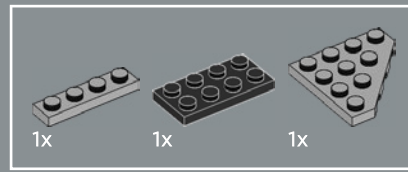
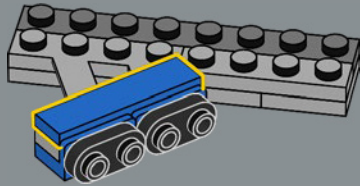

119

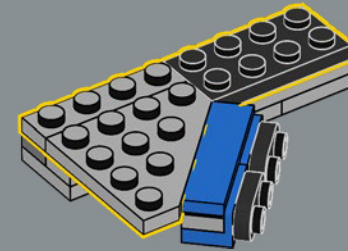

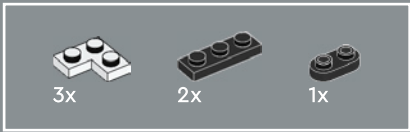

120

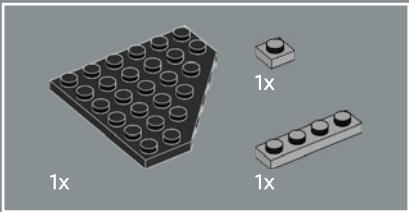
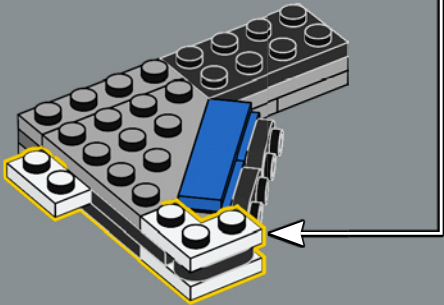
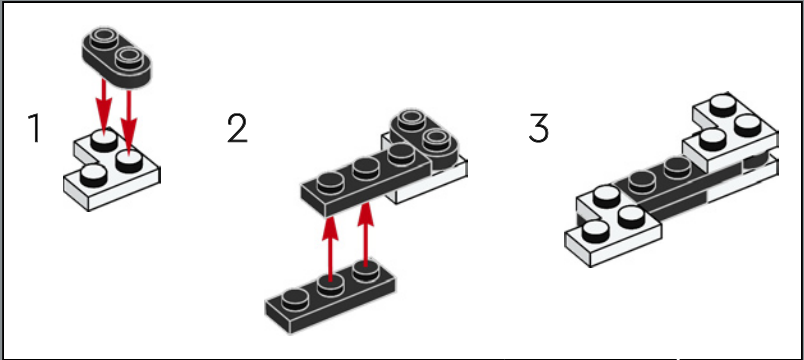

121

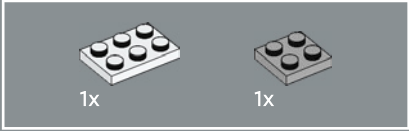
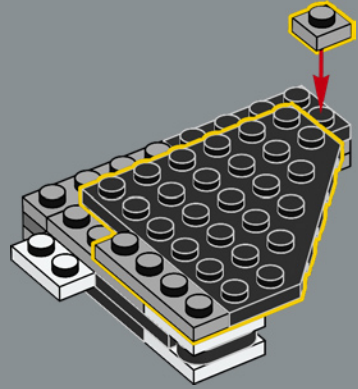

122

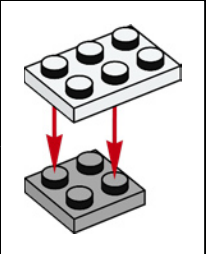
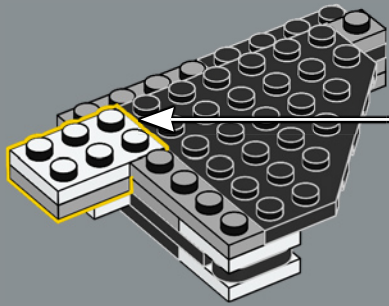

123

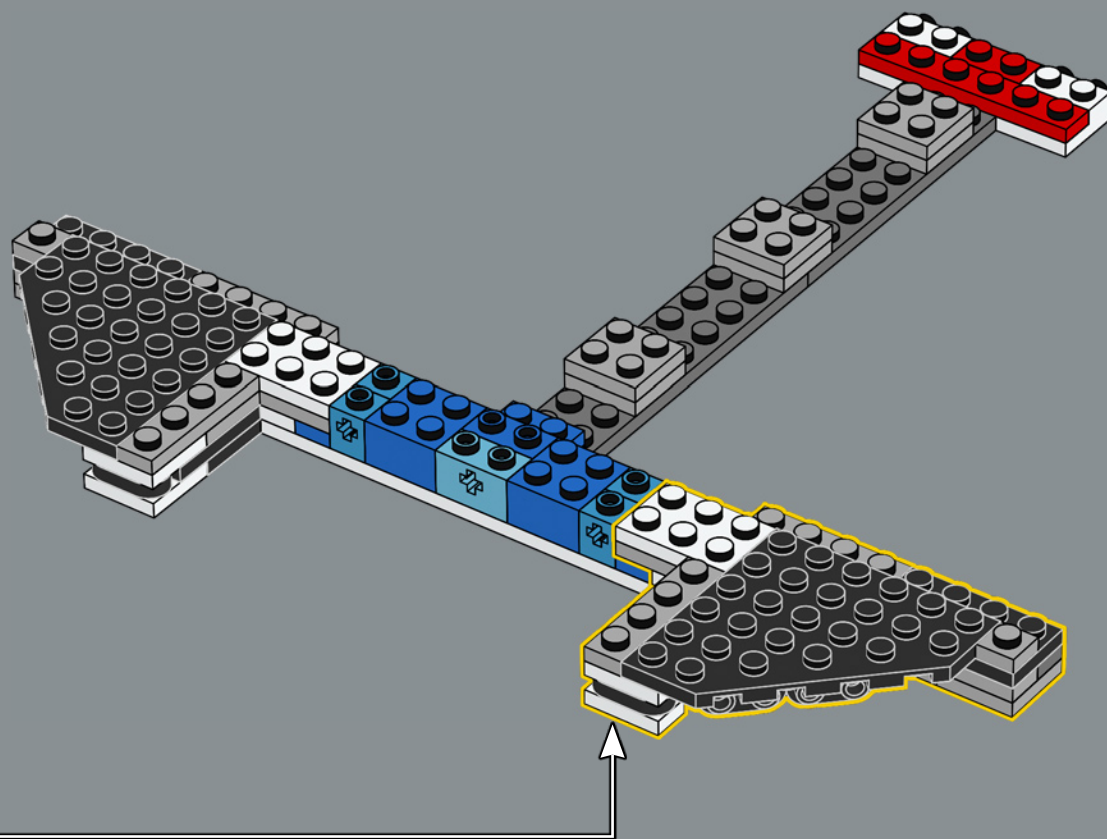

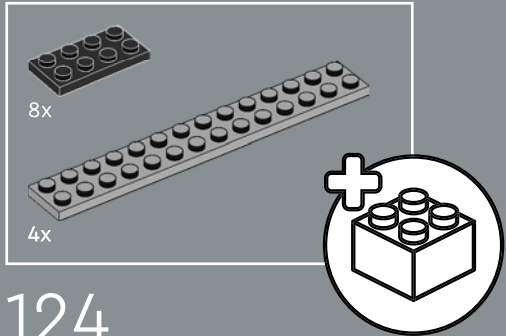
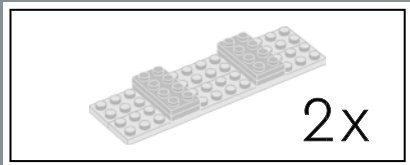

124

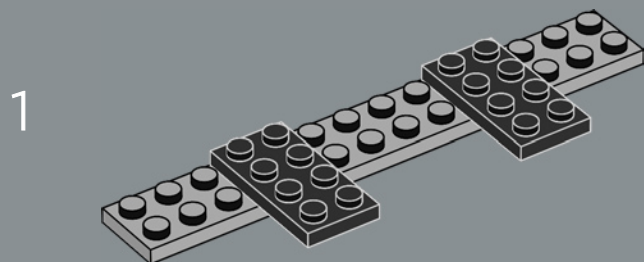

2

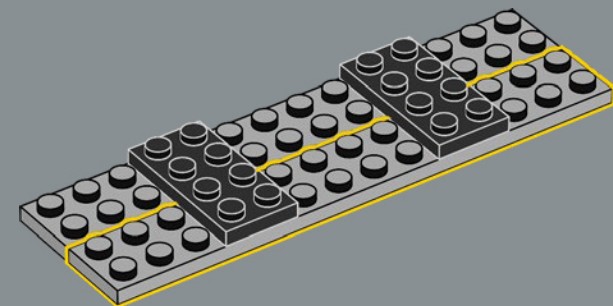

3

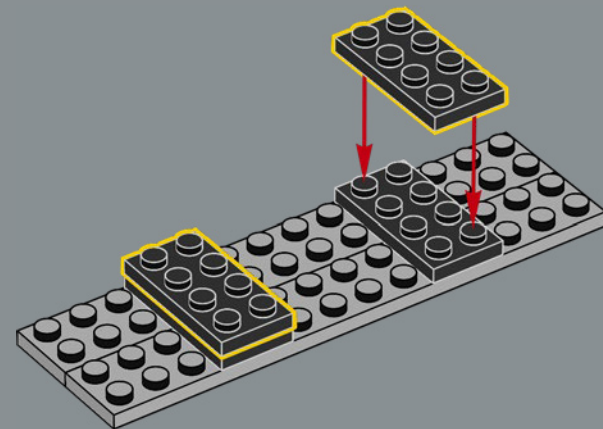

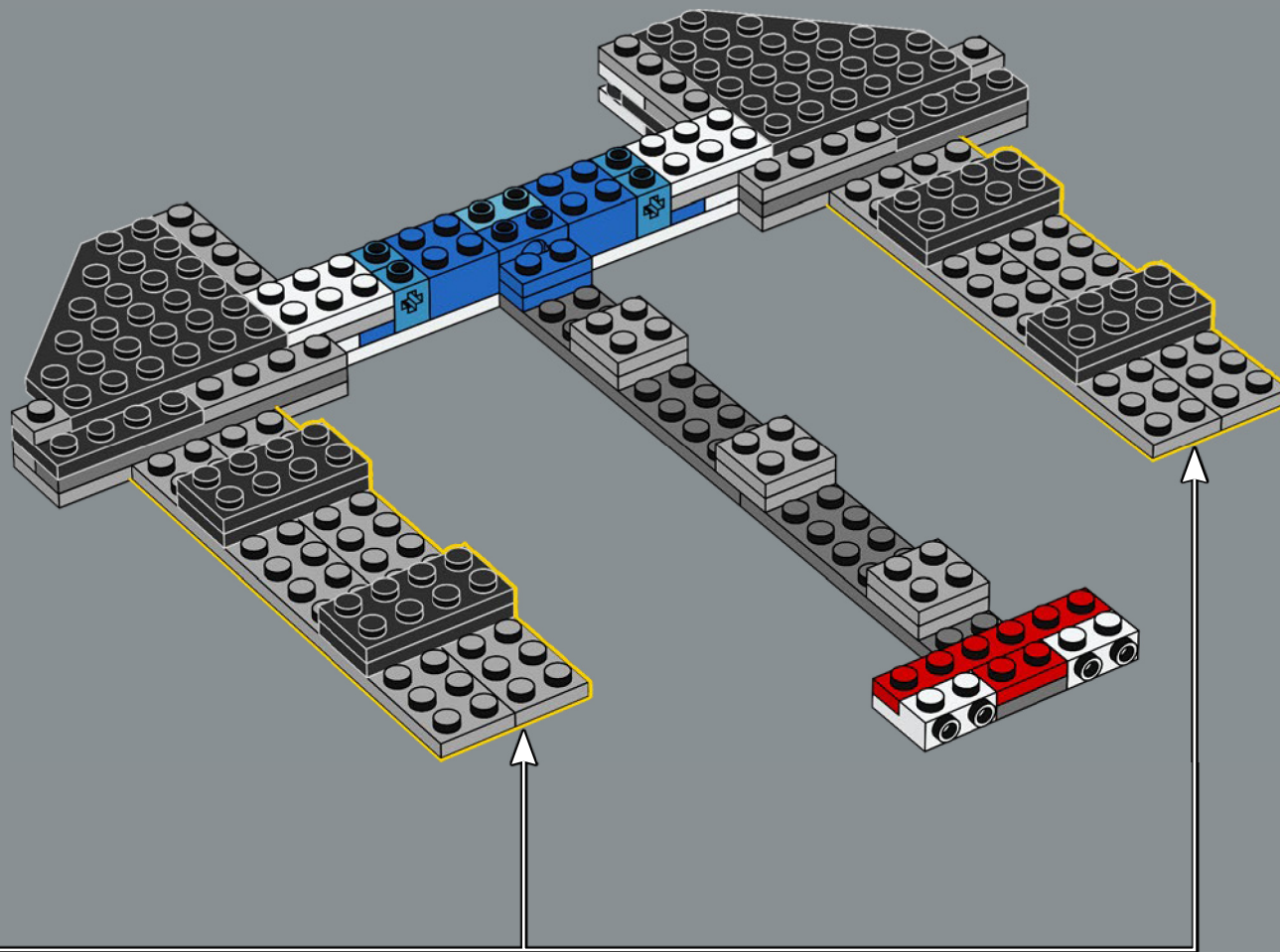

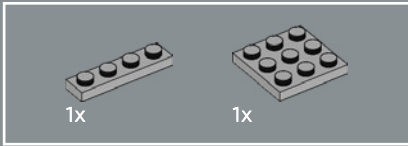
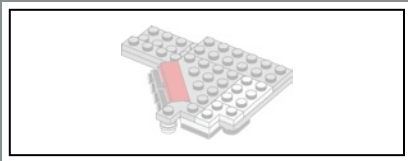

125

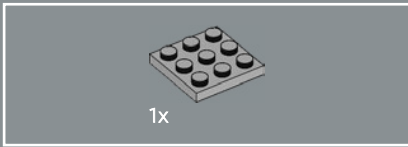
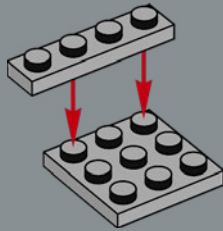

126

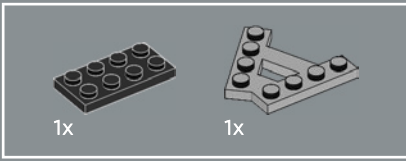
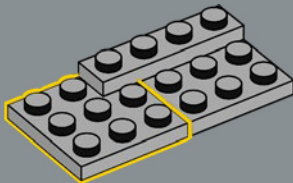

127

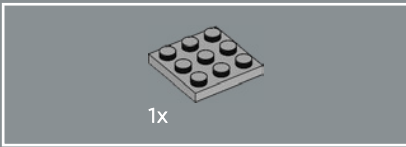
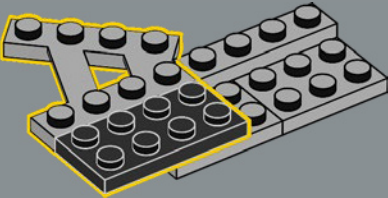

128

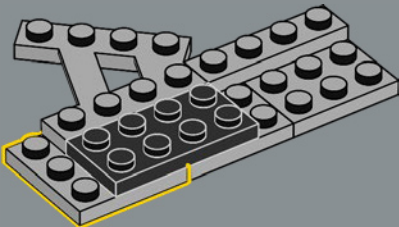



129

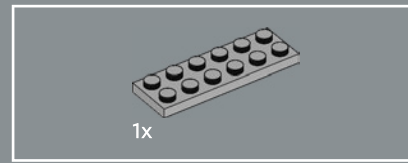
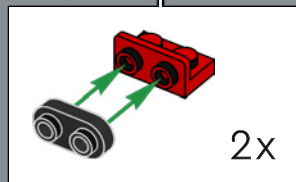
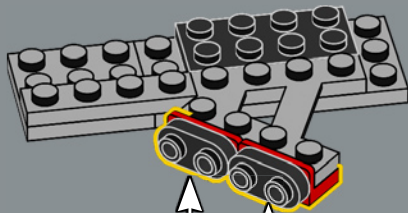

130

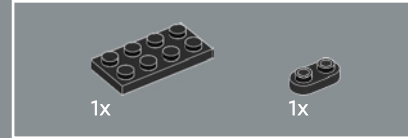
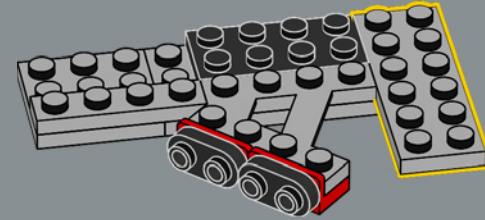

131

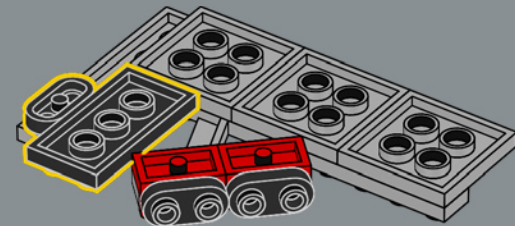

135

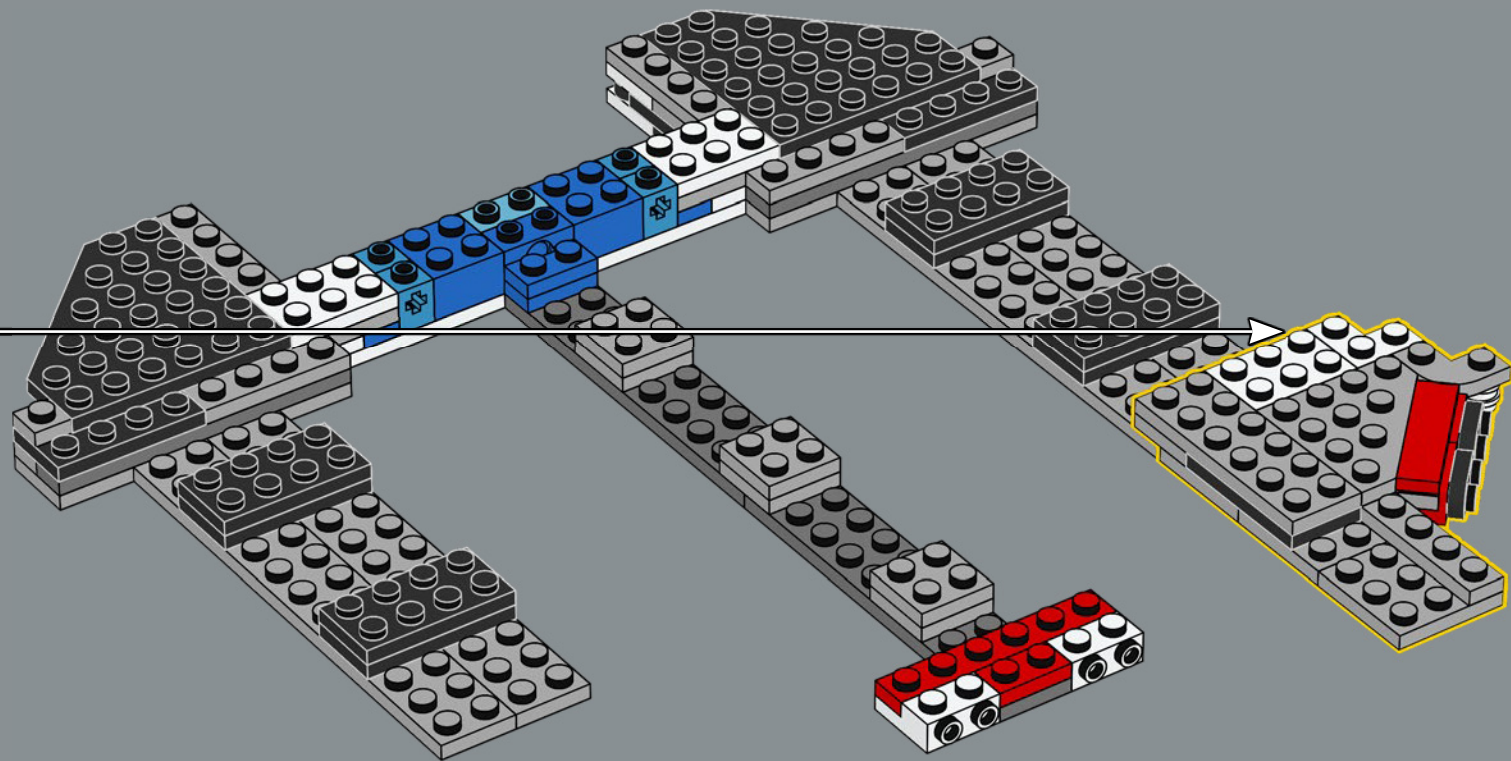

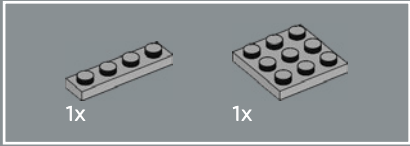
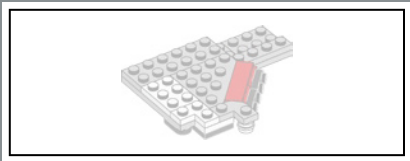

136

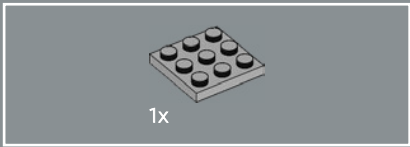
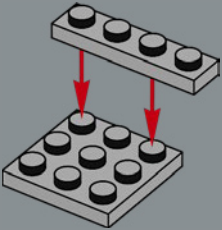

137

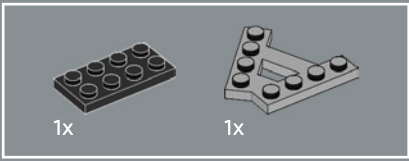
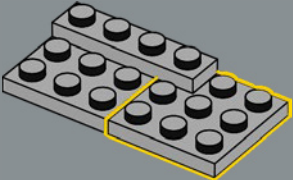

138

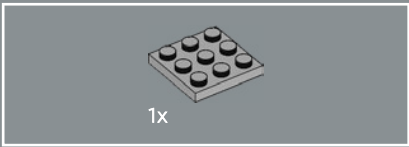
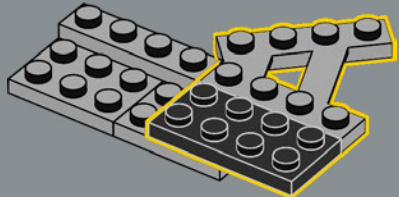

139

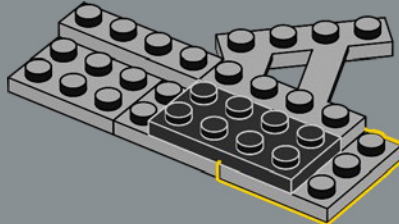



140

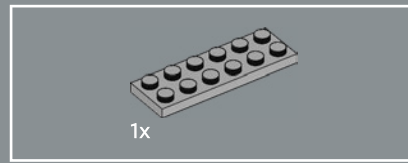
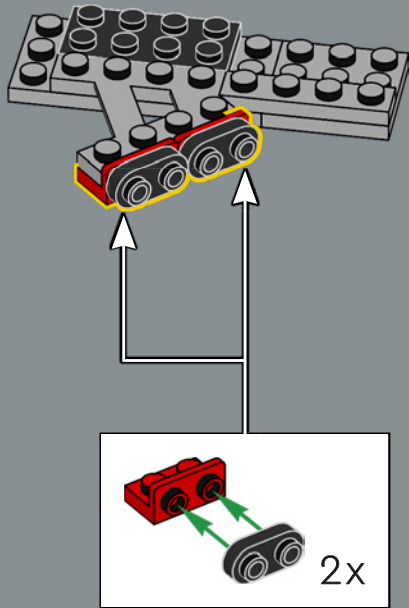

141

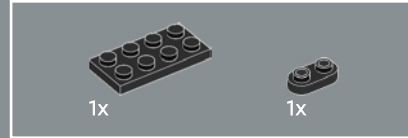
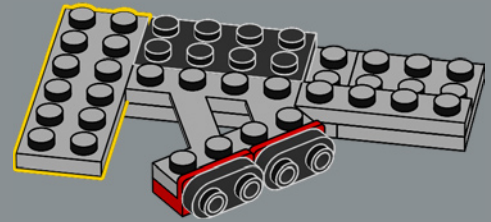

142

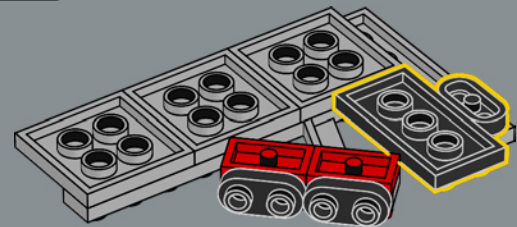



143

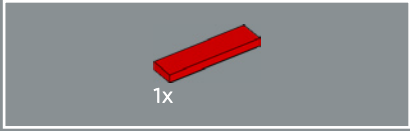
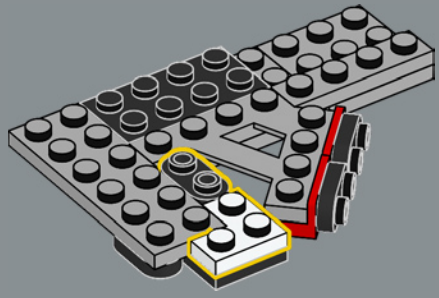

144

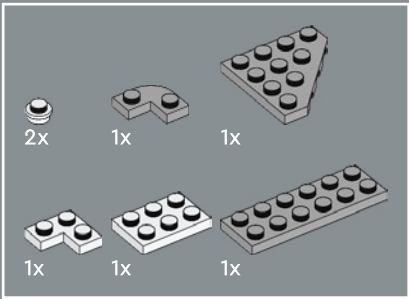
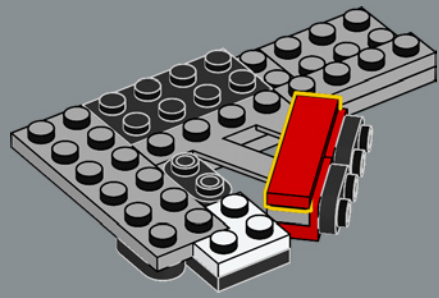

145

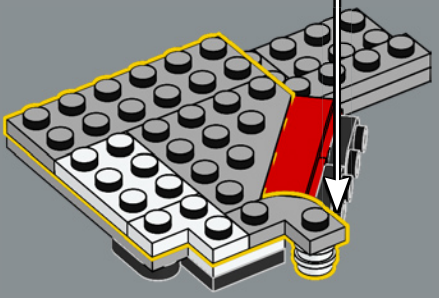
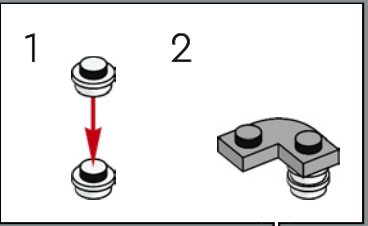

146

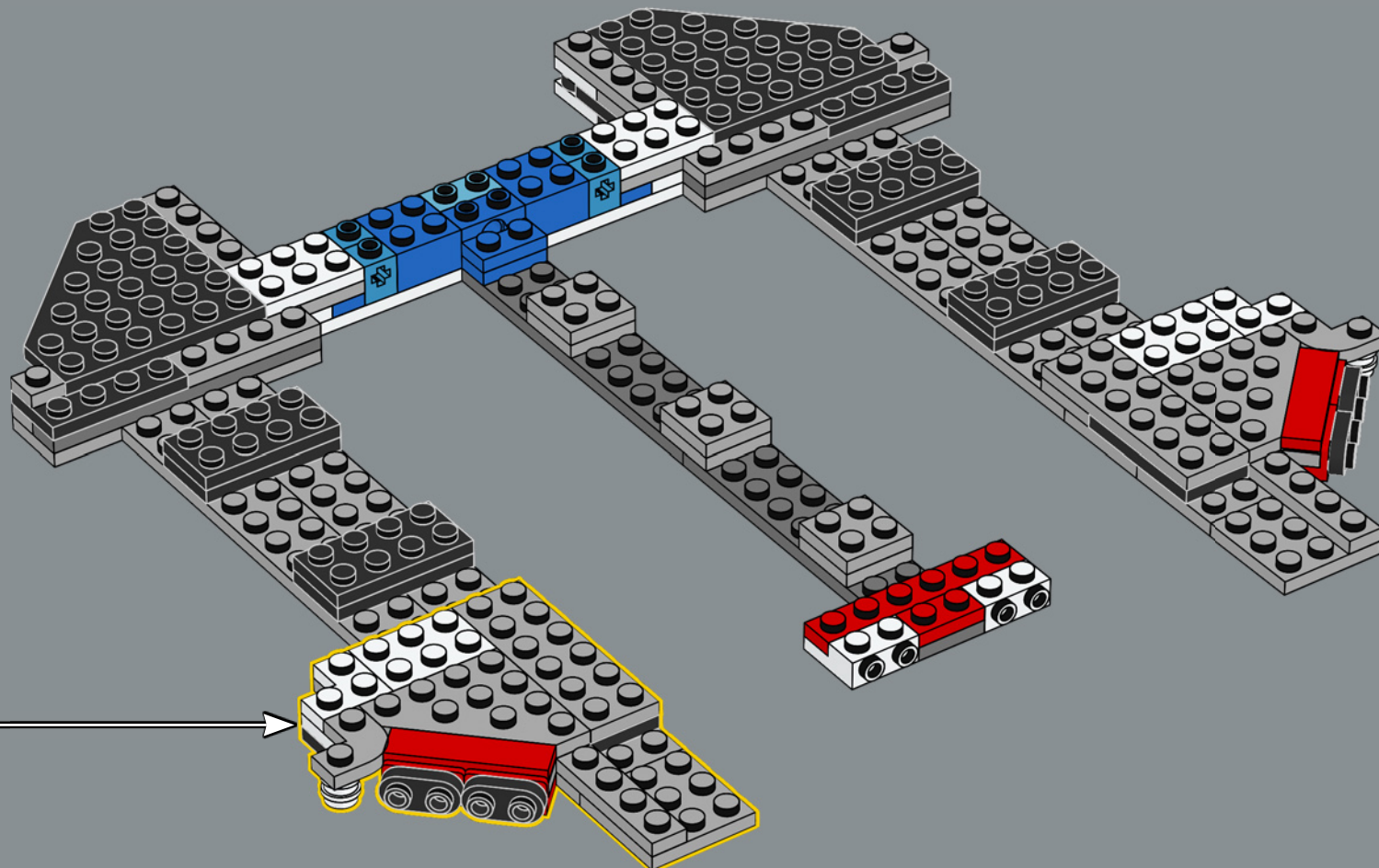

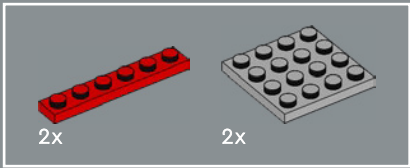

147

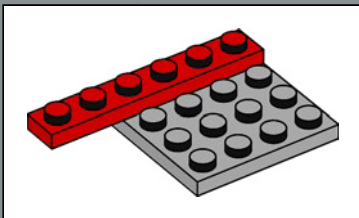
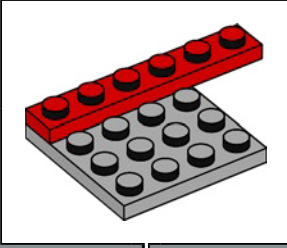
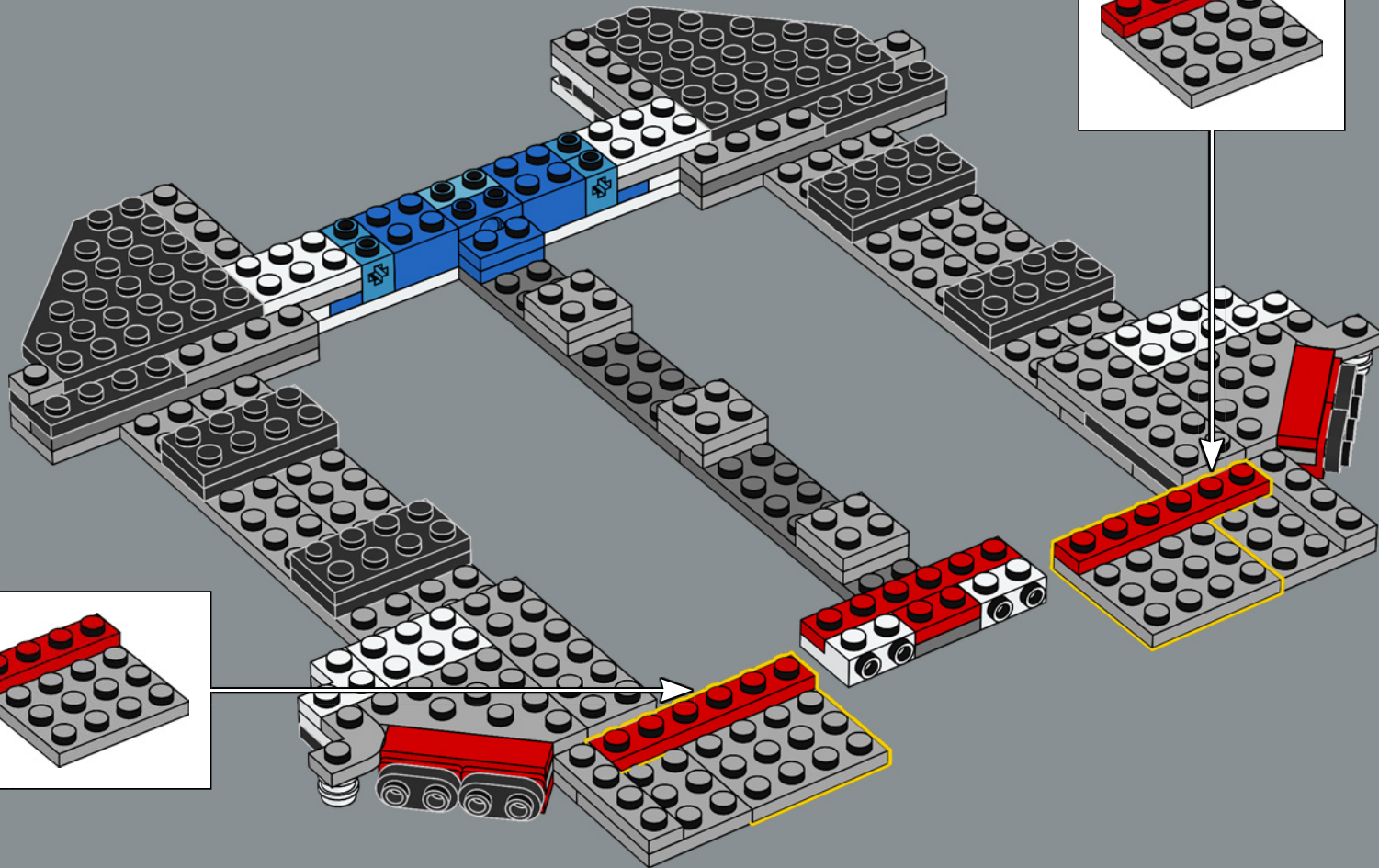

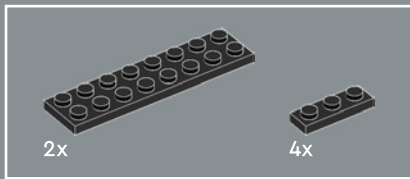

148

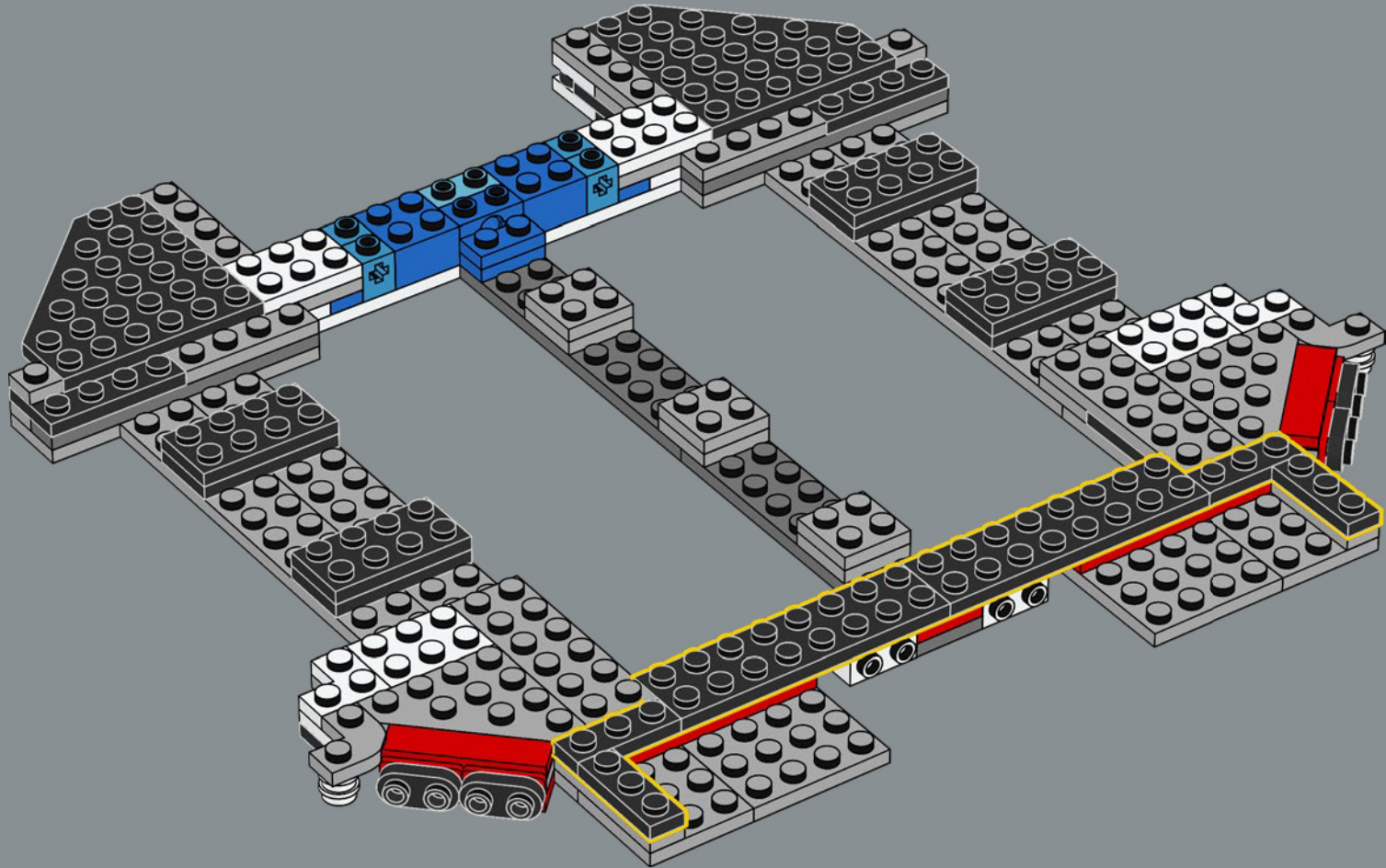

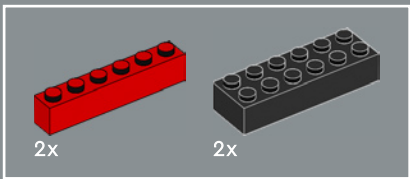

149

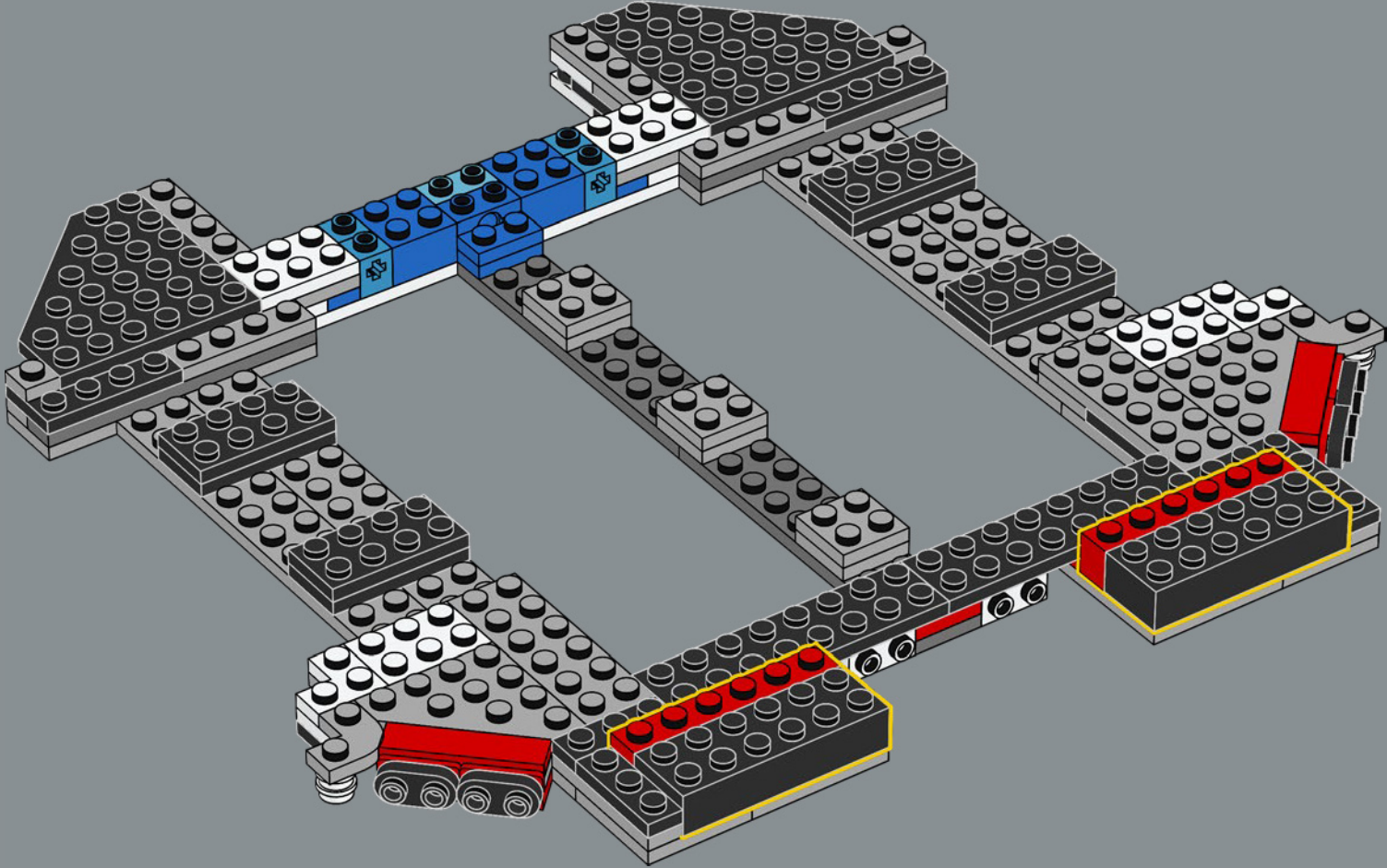

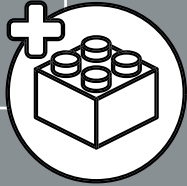
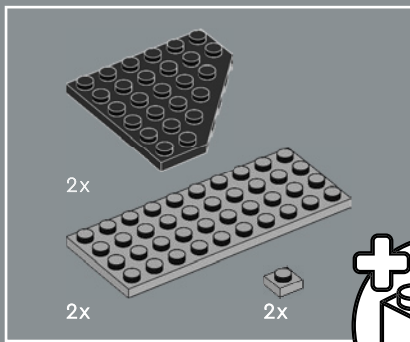

150

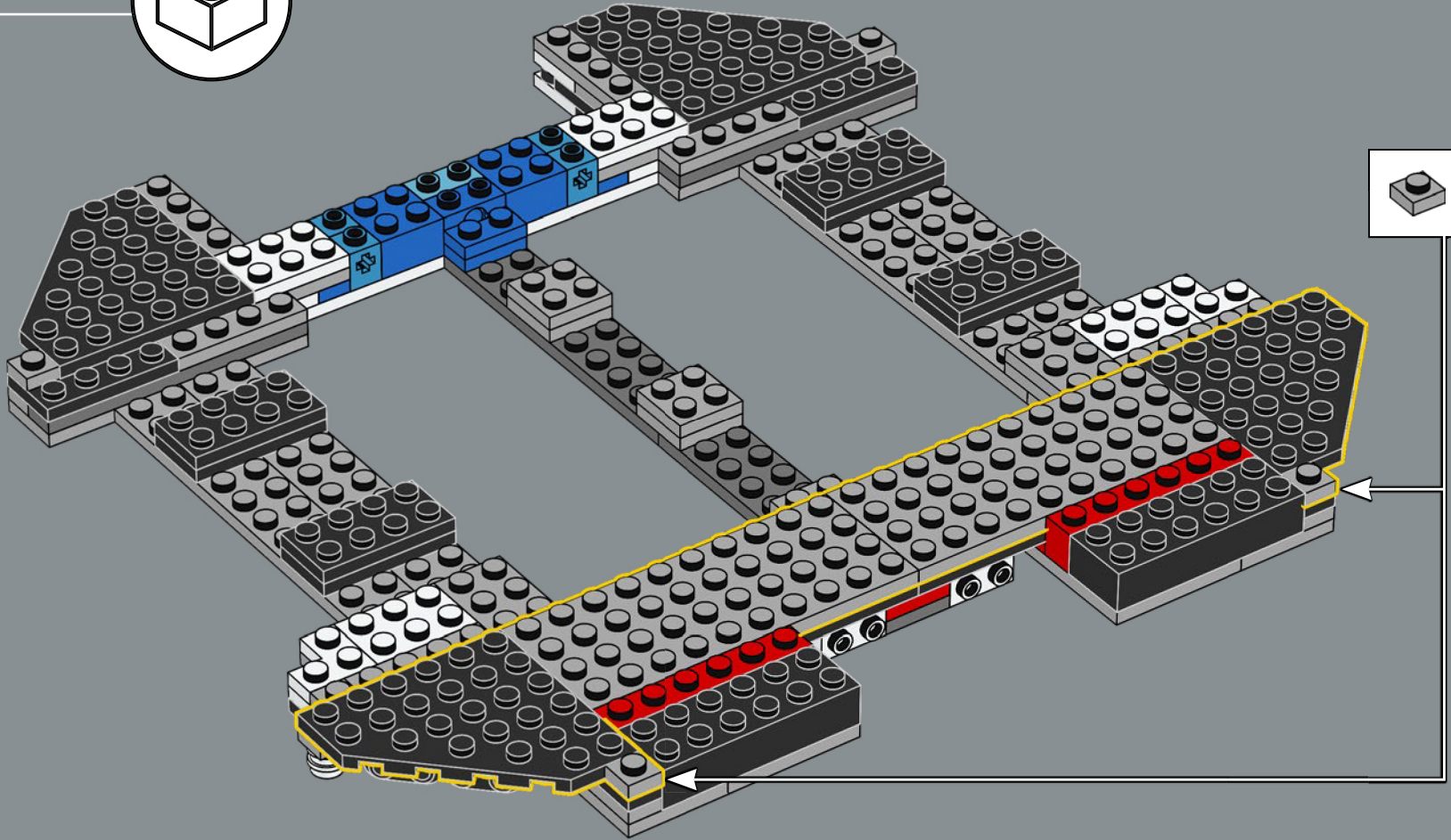

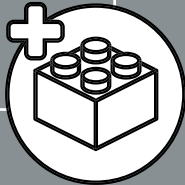
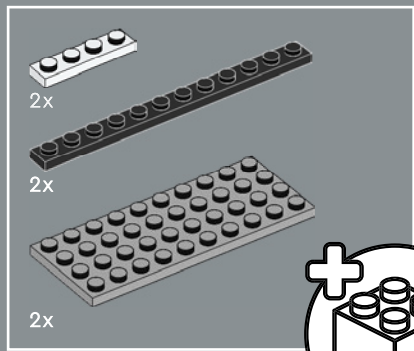

151

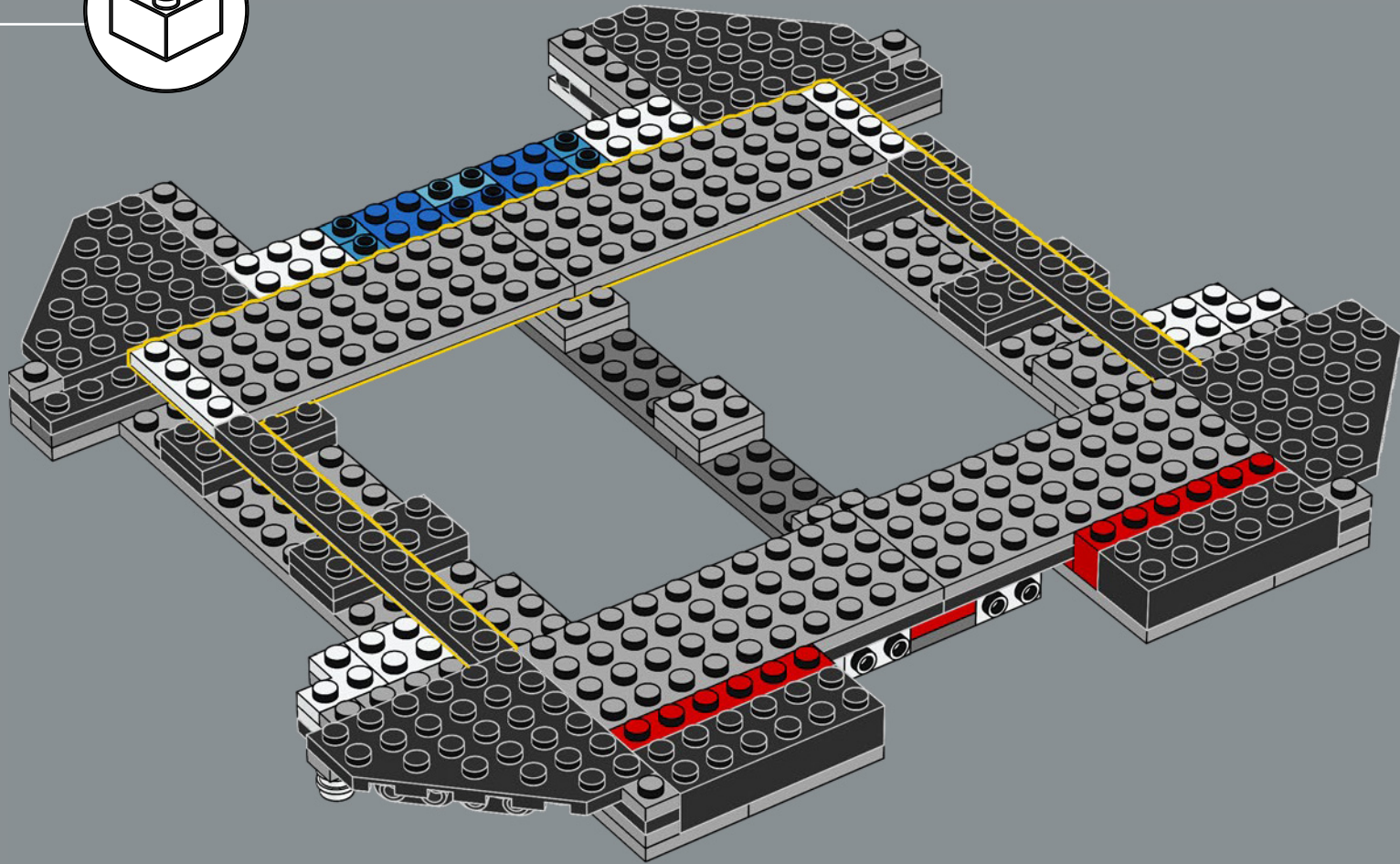

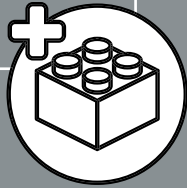
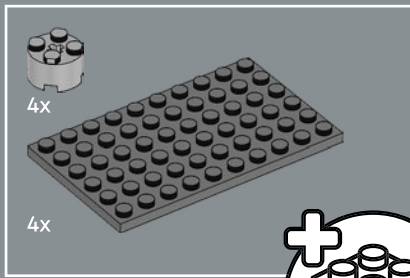

152

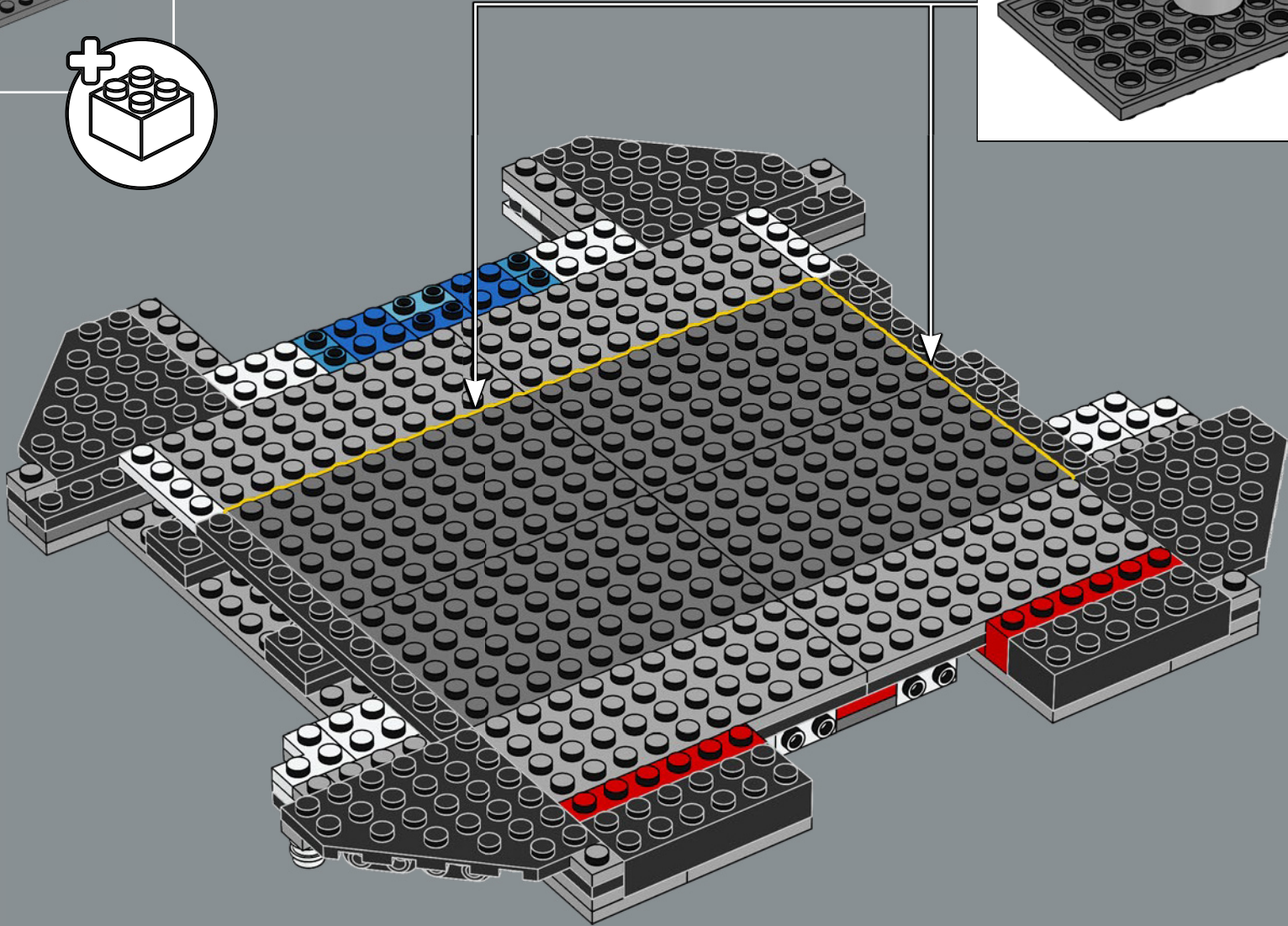
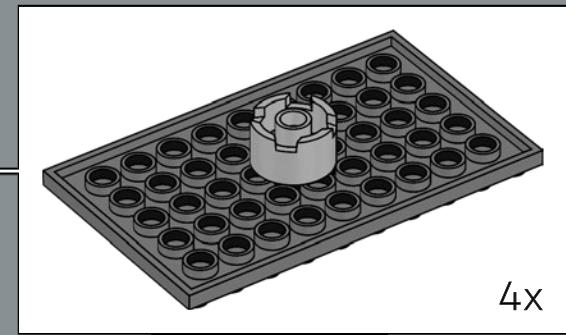

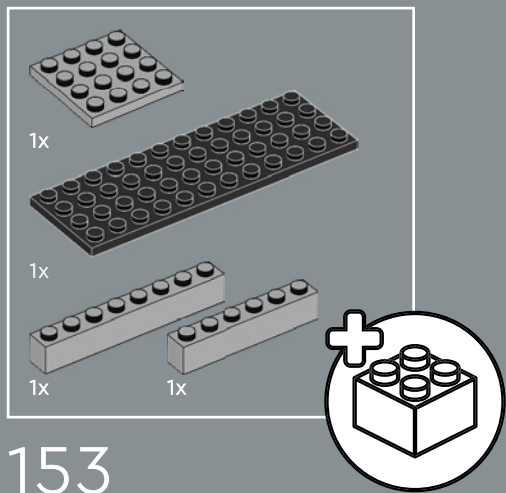

153

1

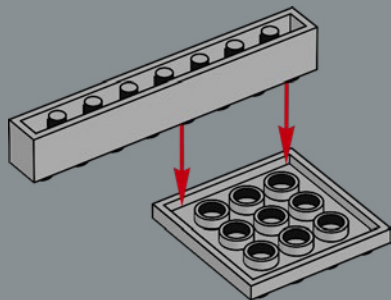

2

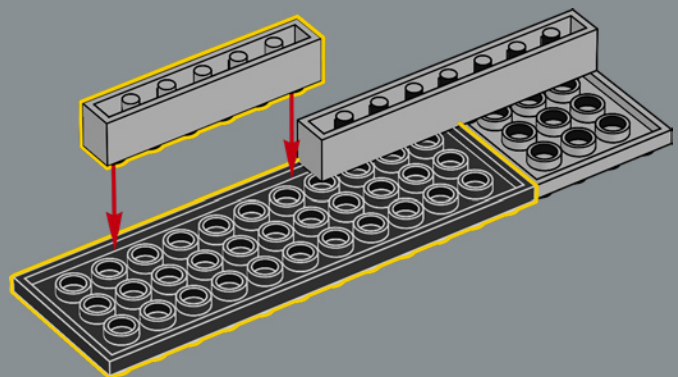

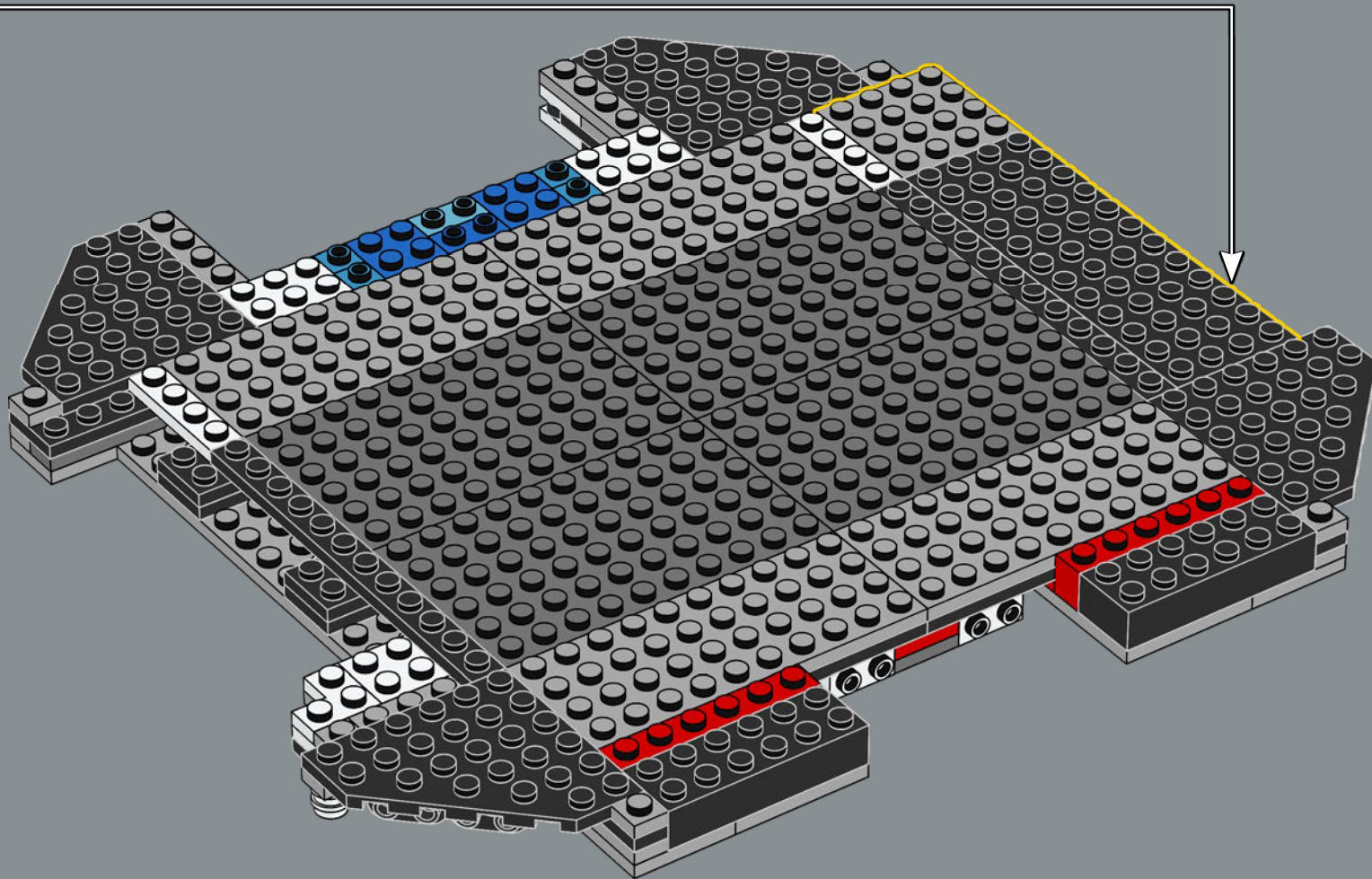

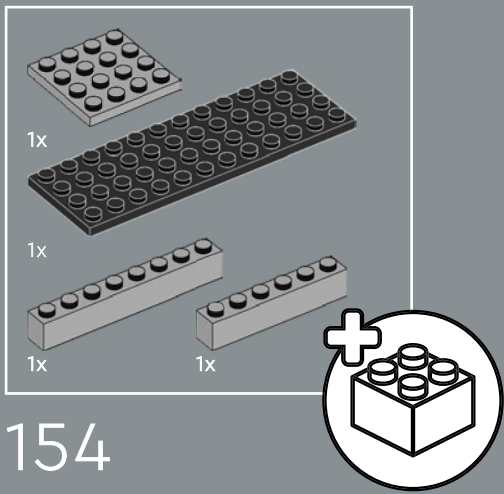

1

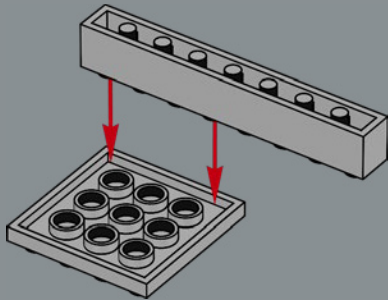

2

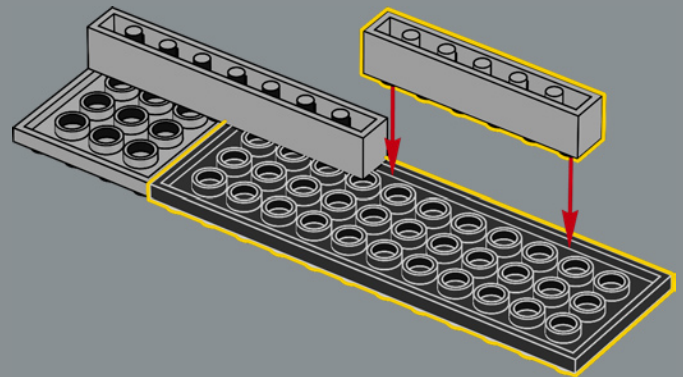

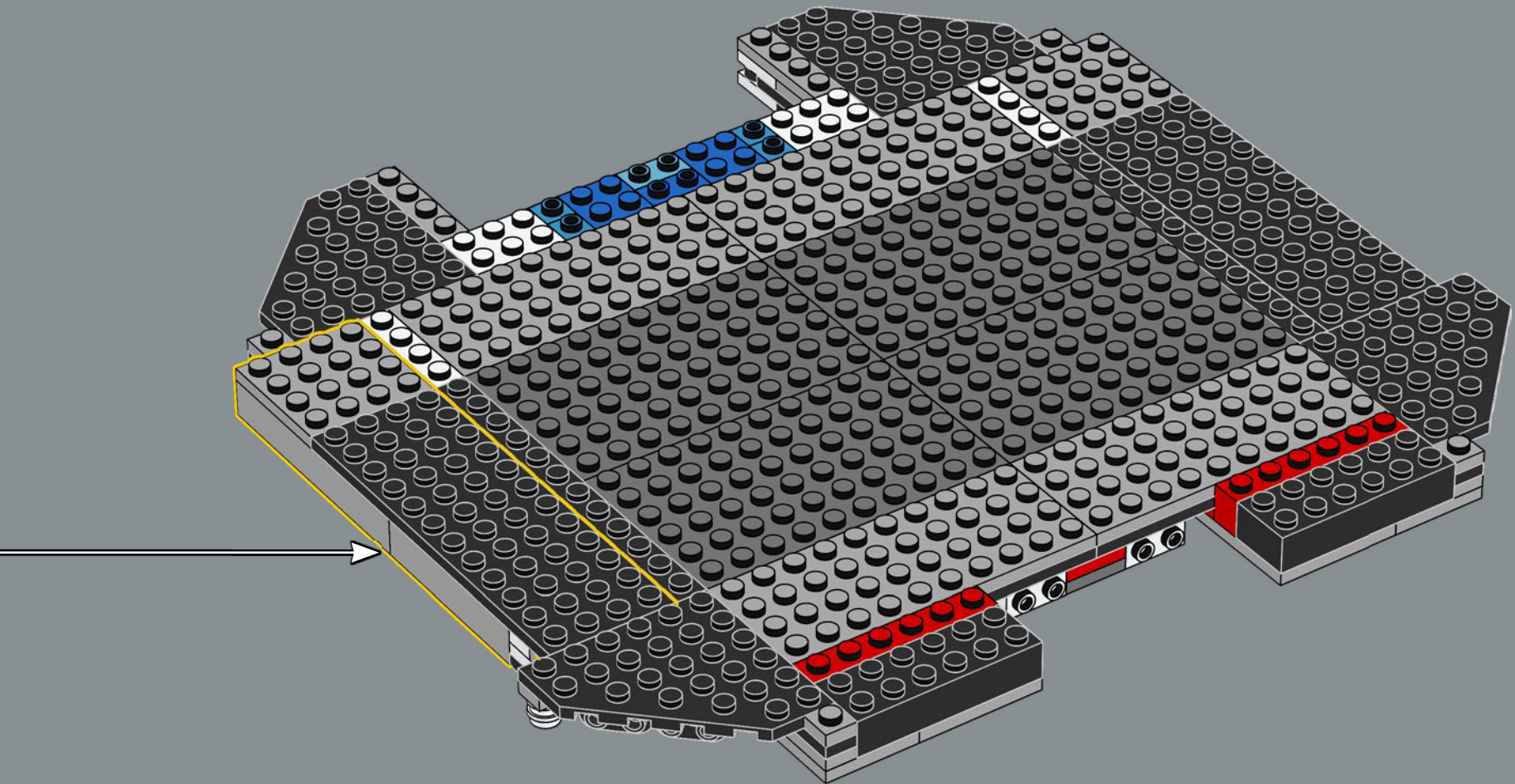

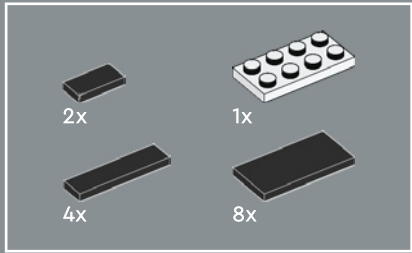

155

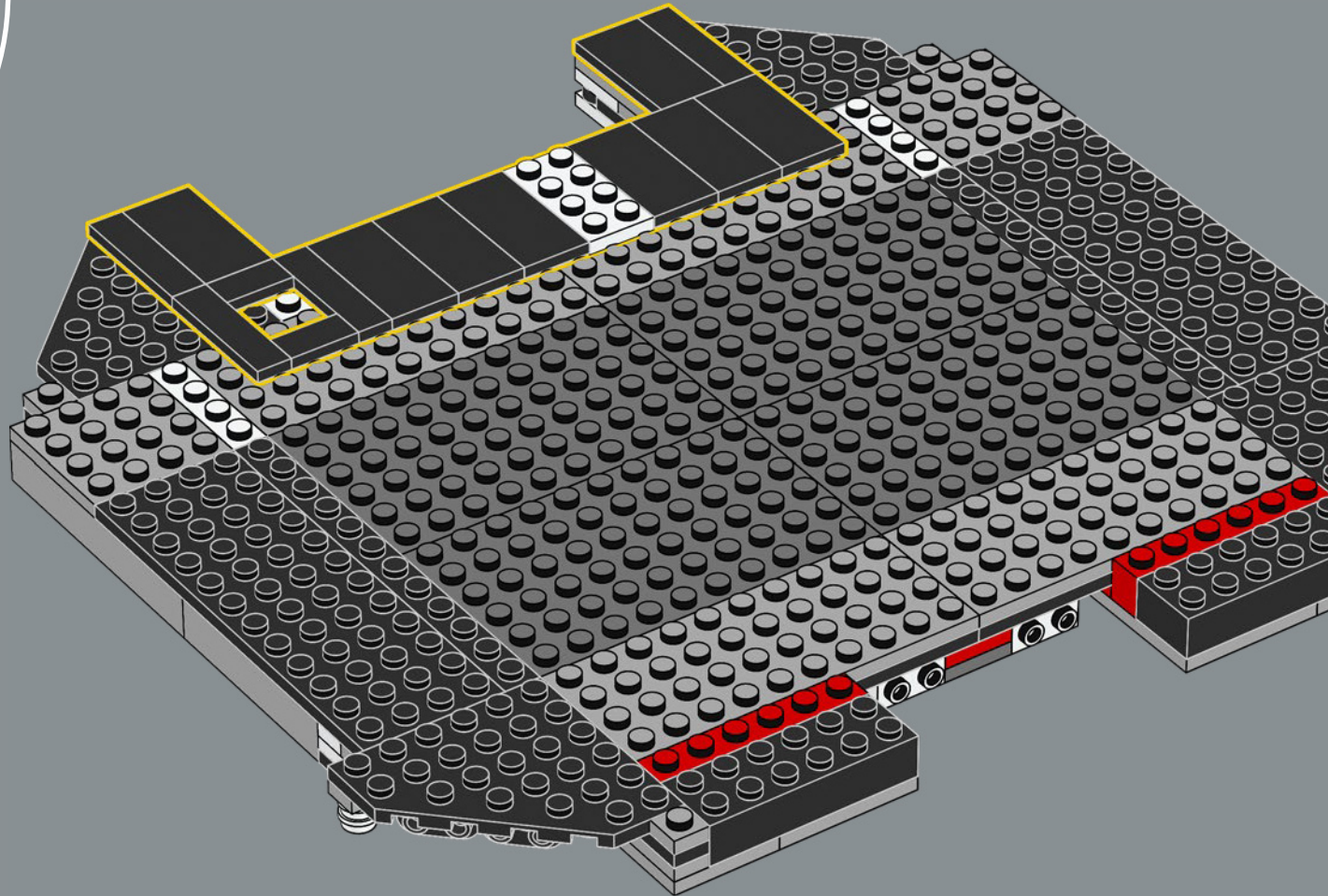

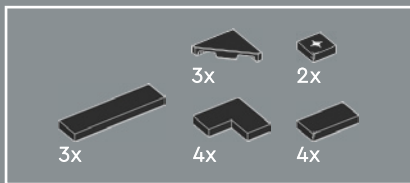

156

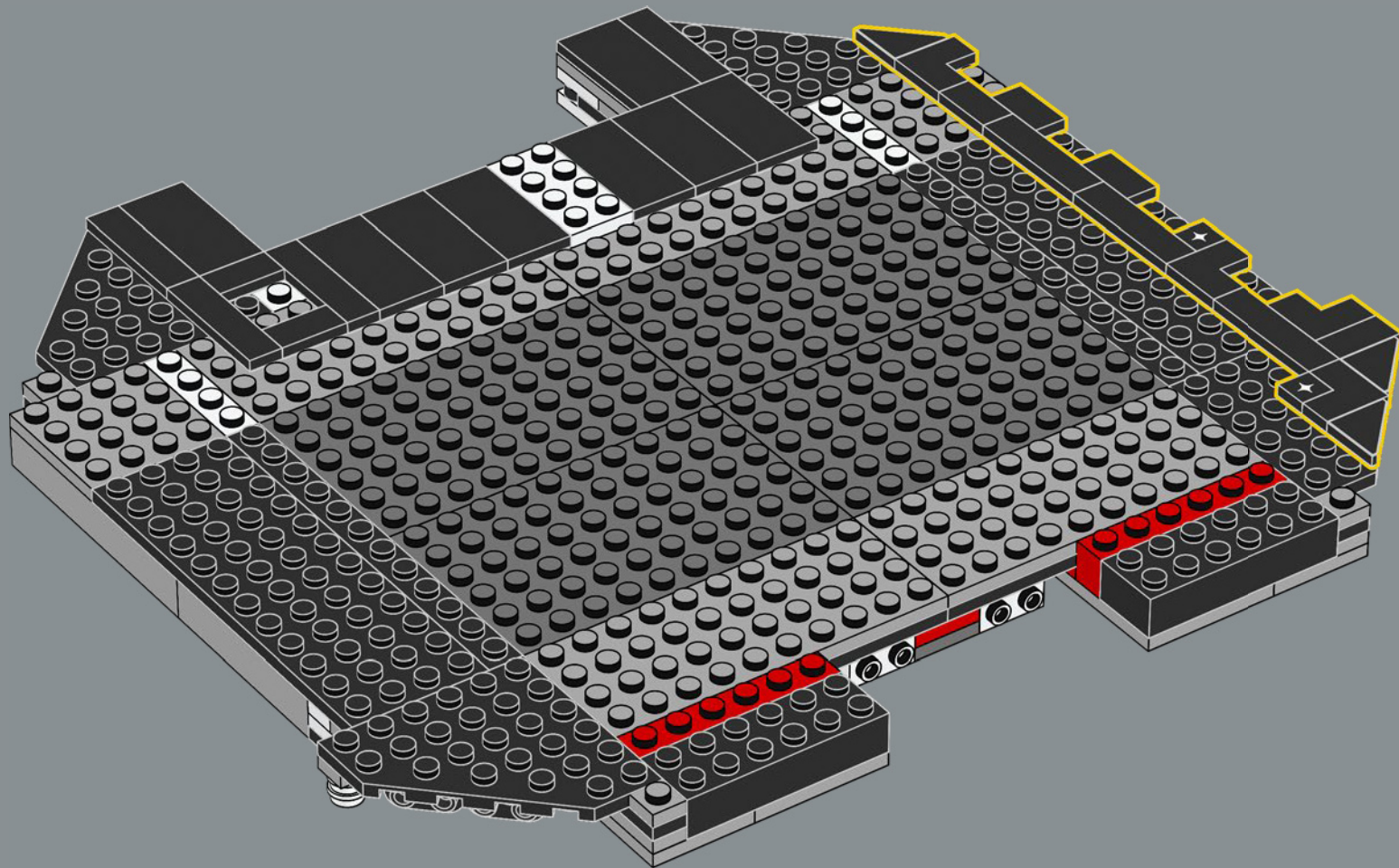

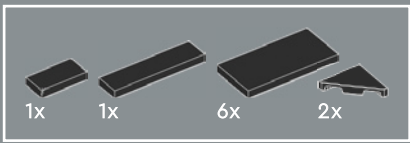

157

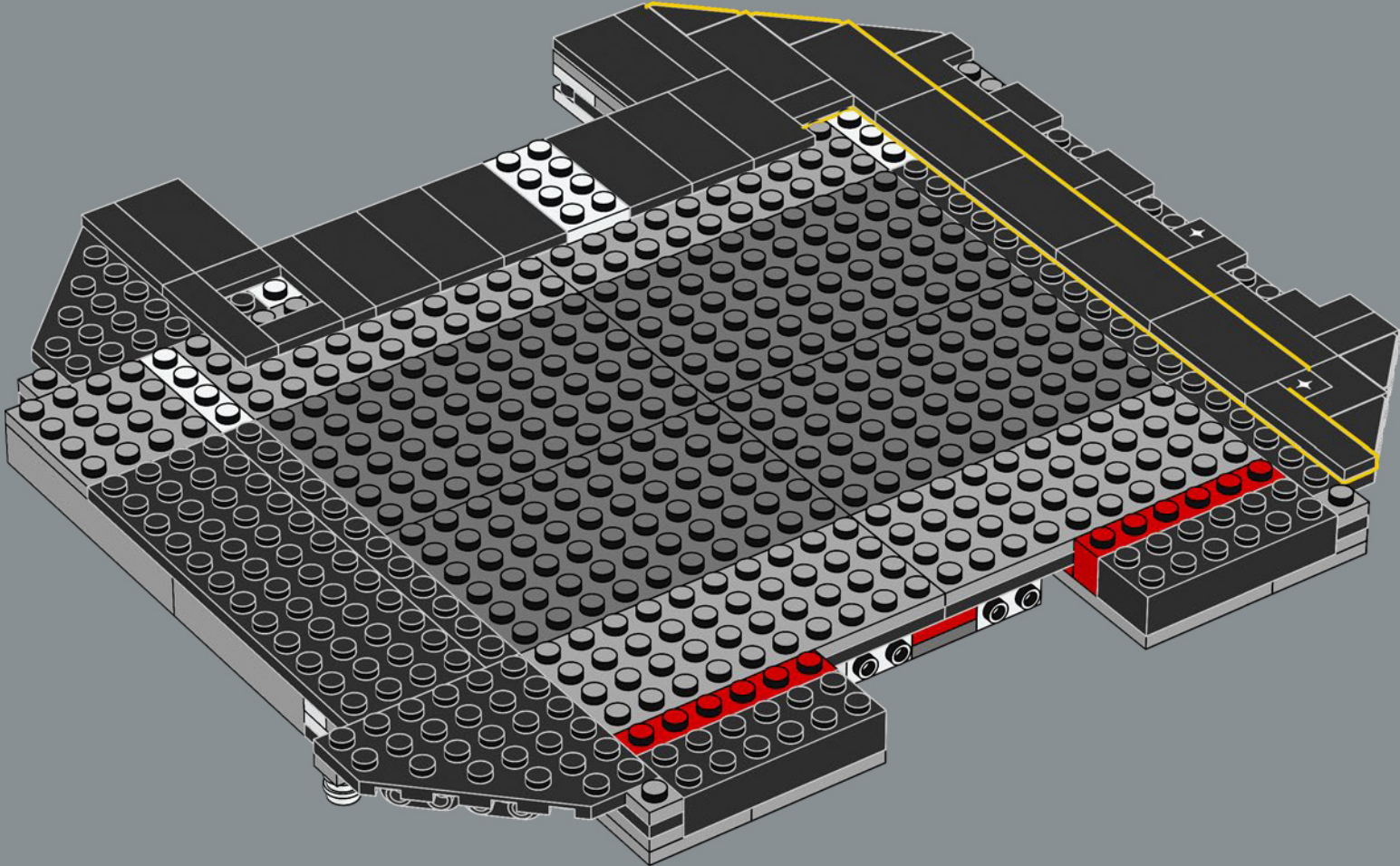

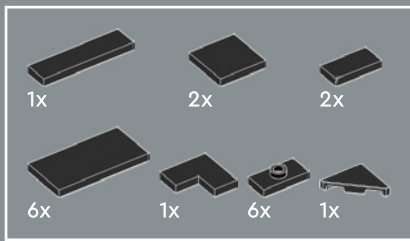

158

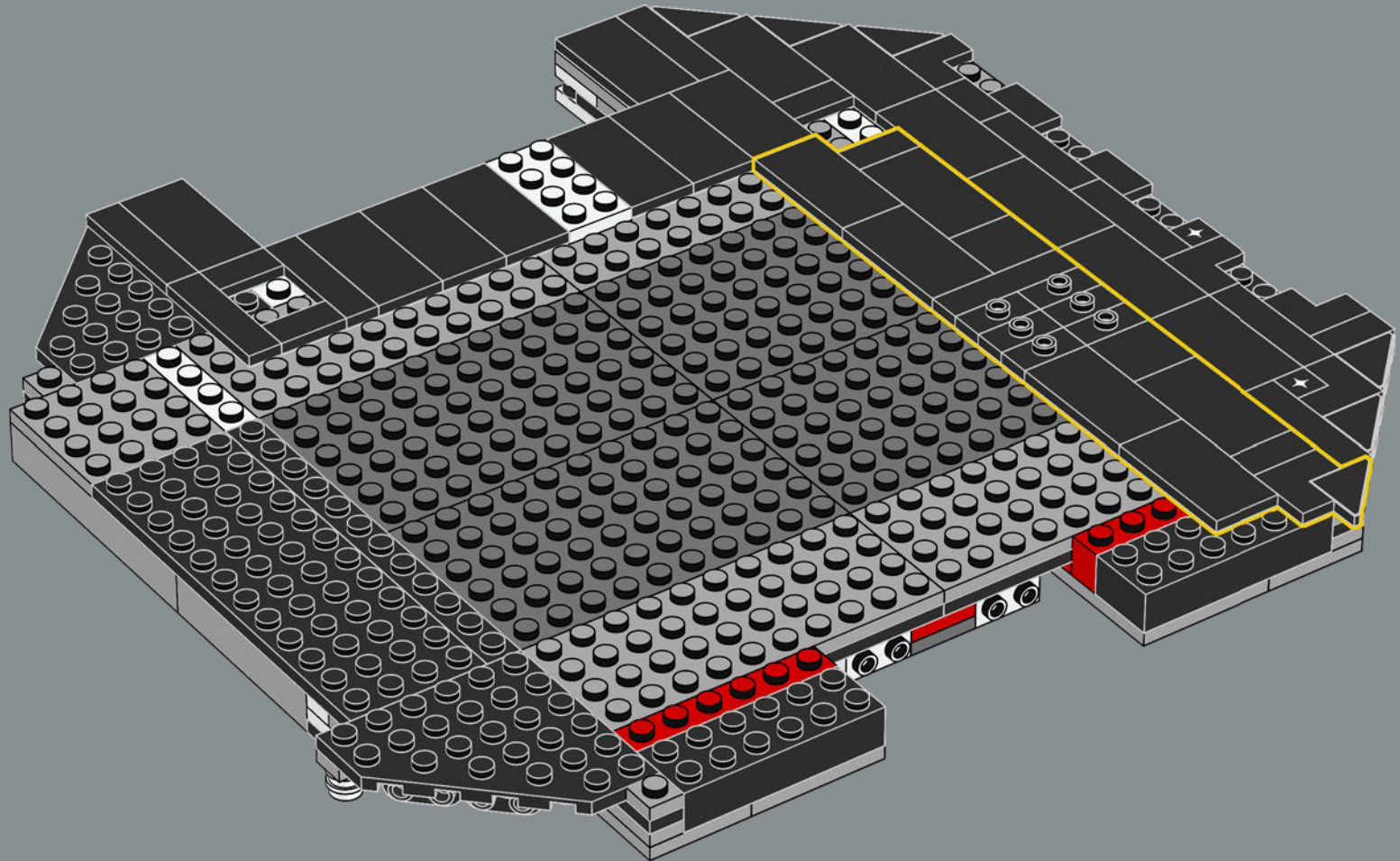

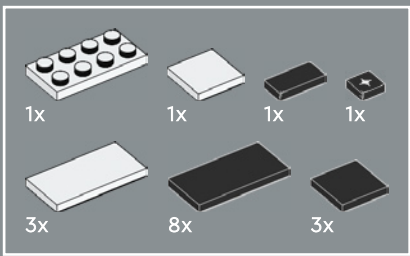

159

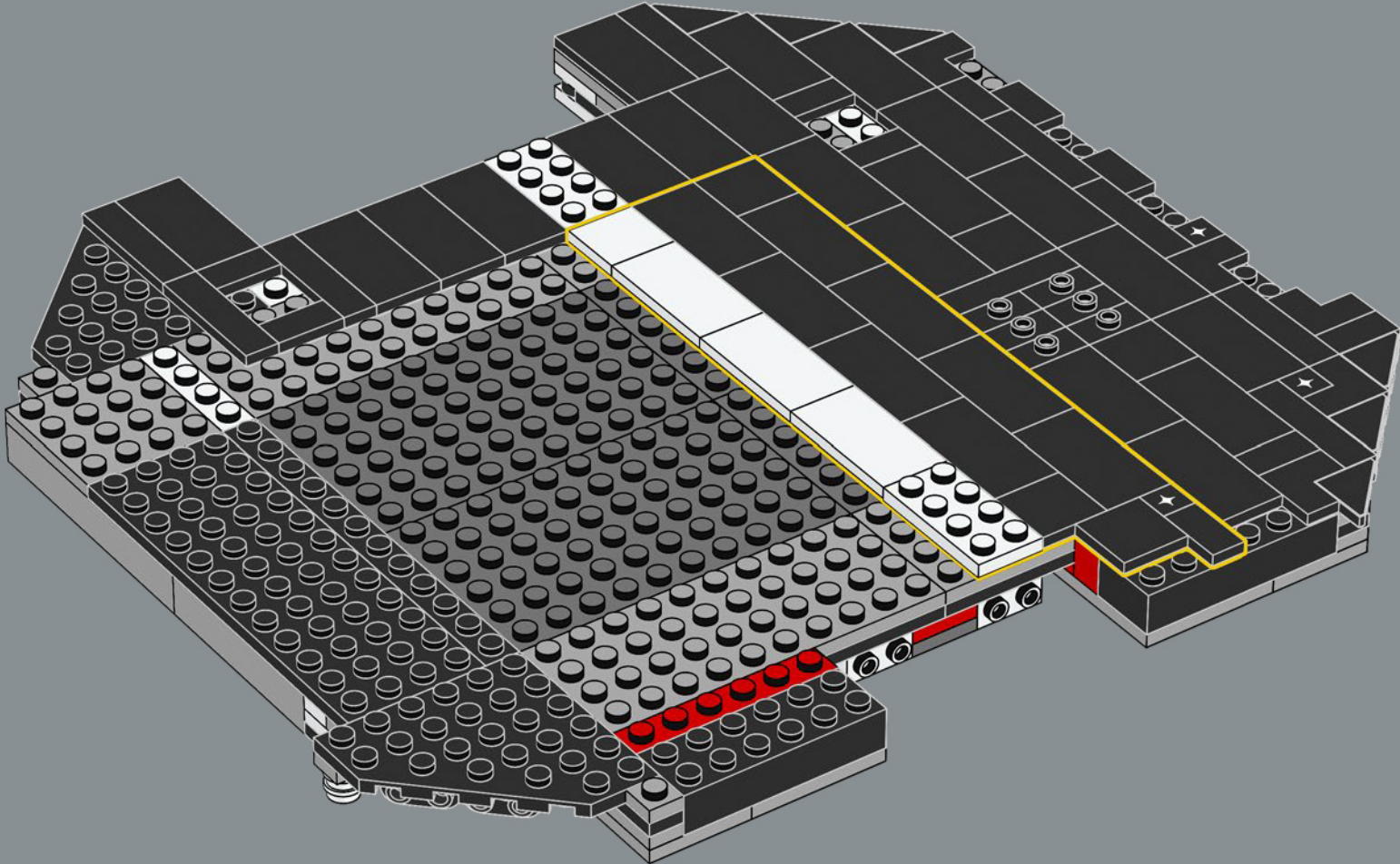

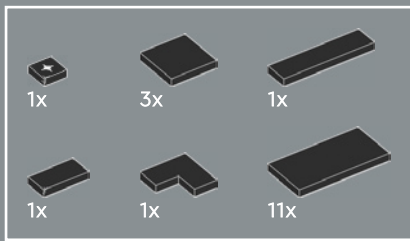

160

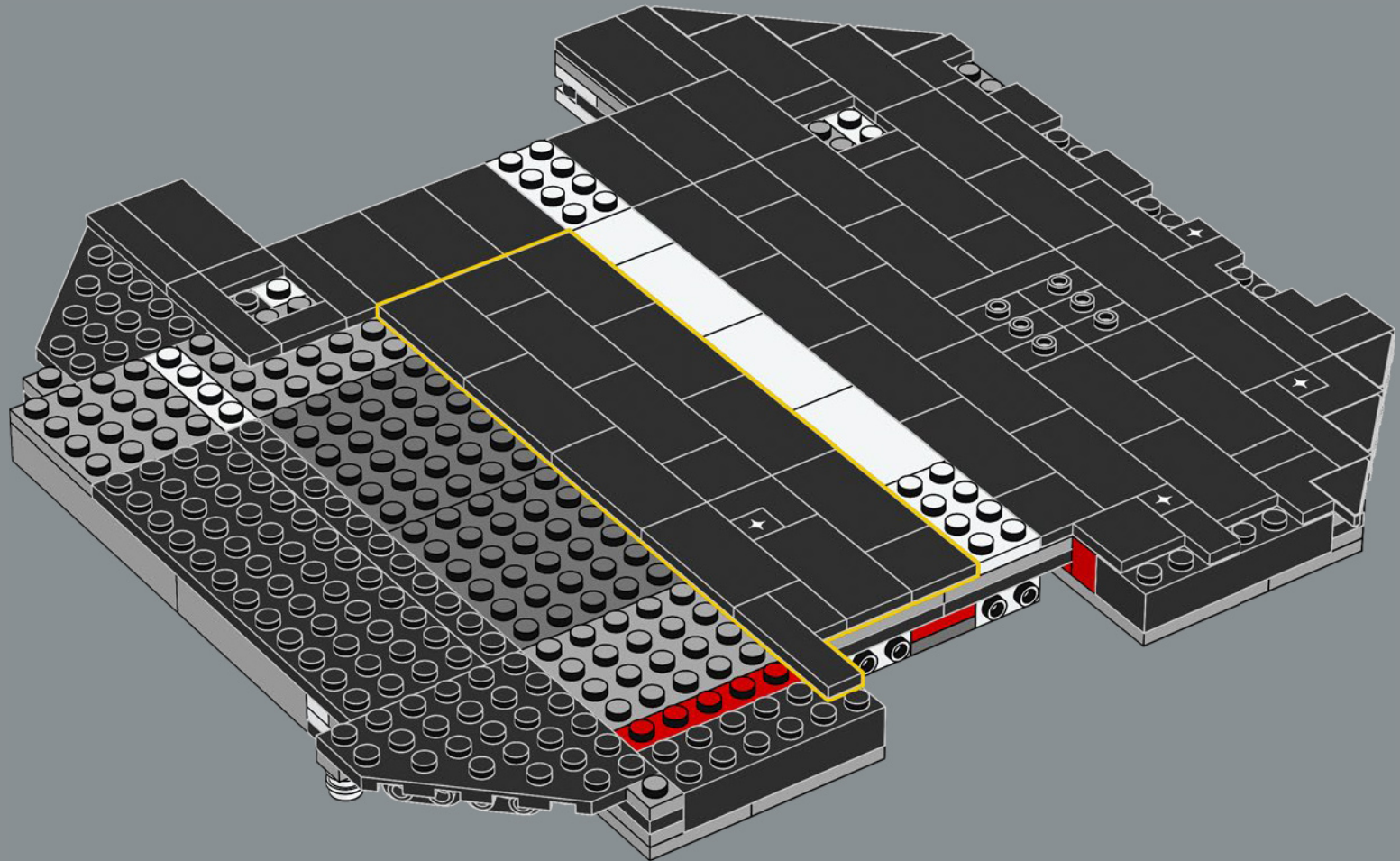

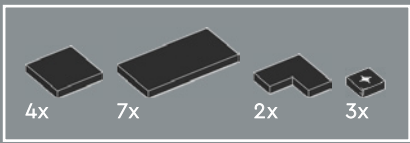

161

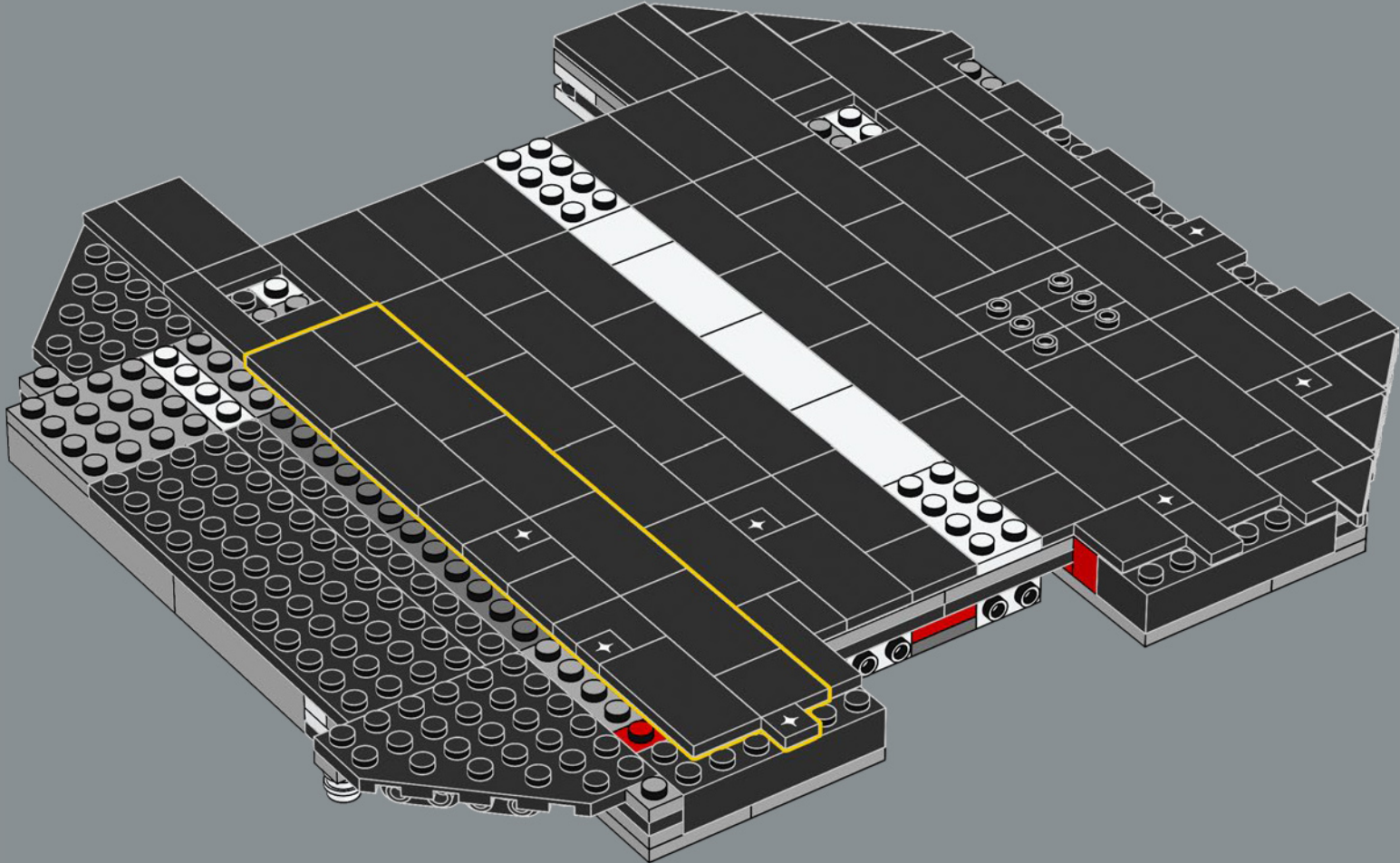

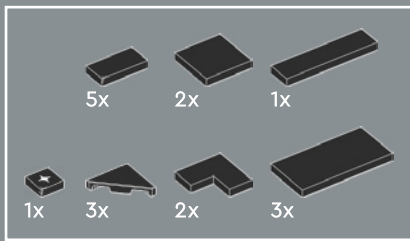

162

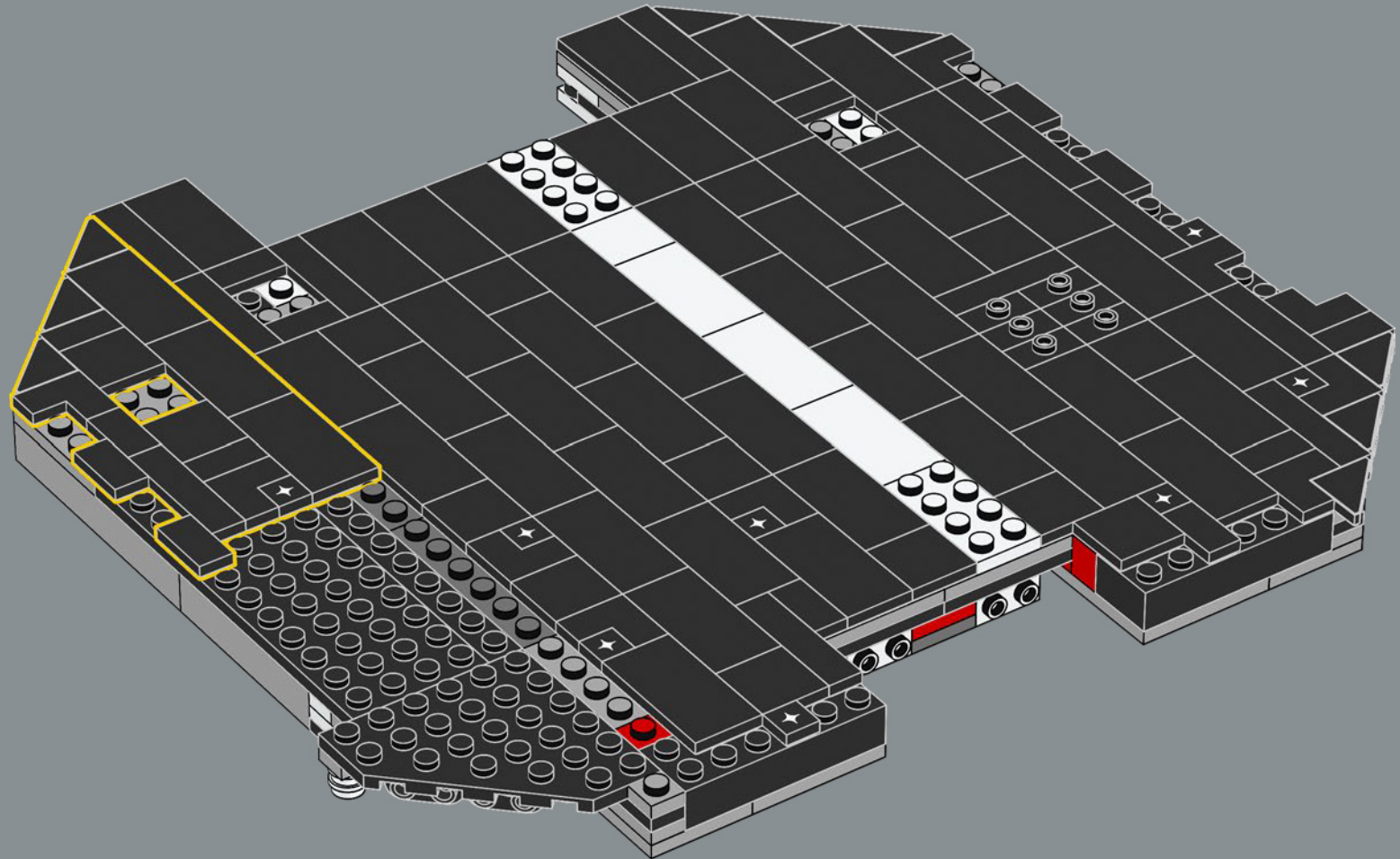

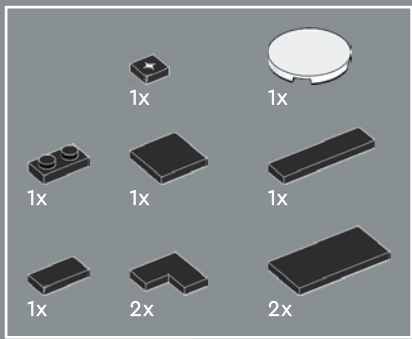

163

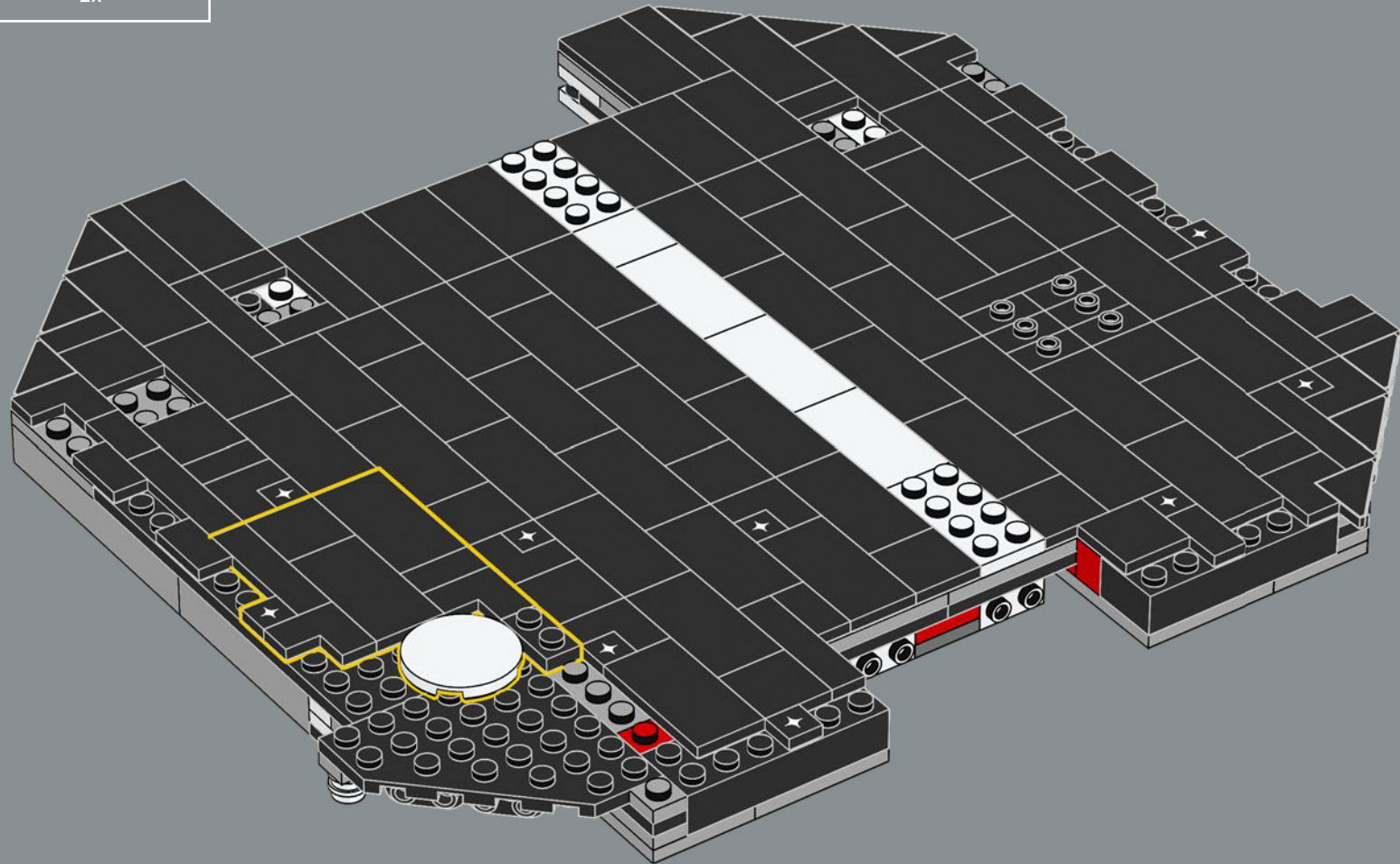

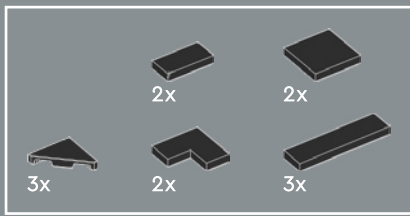

164

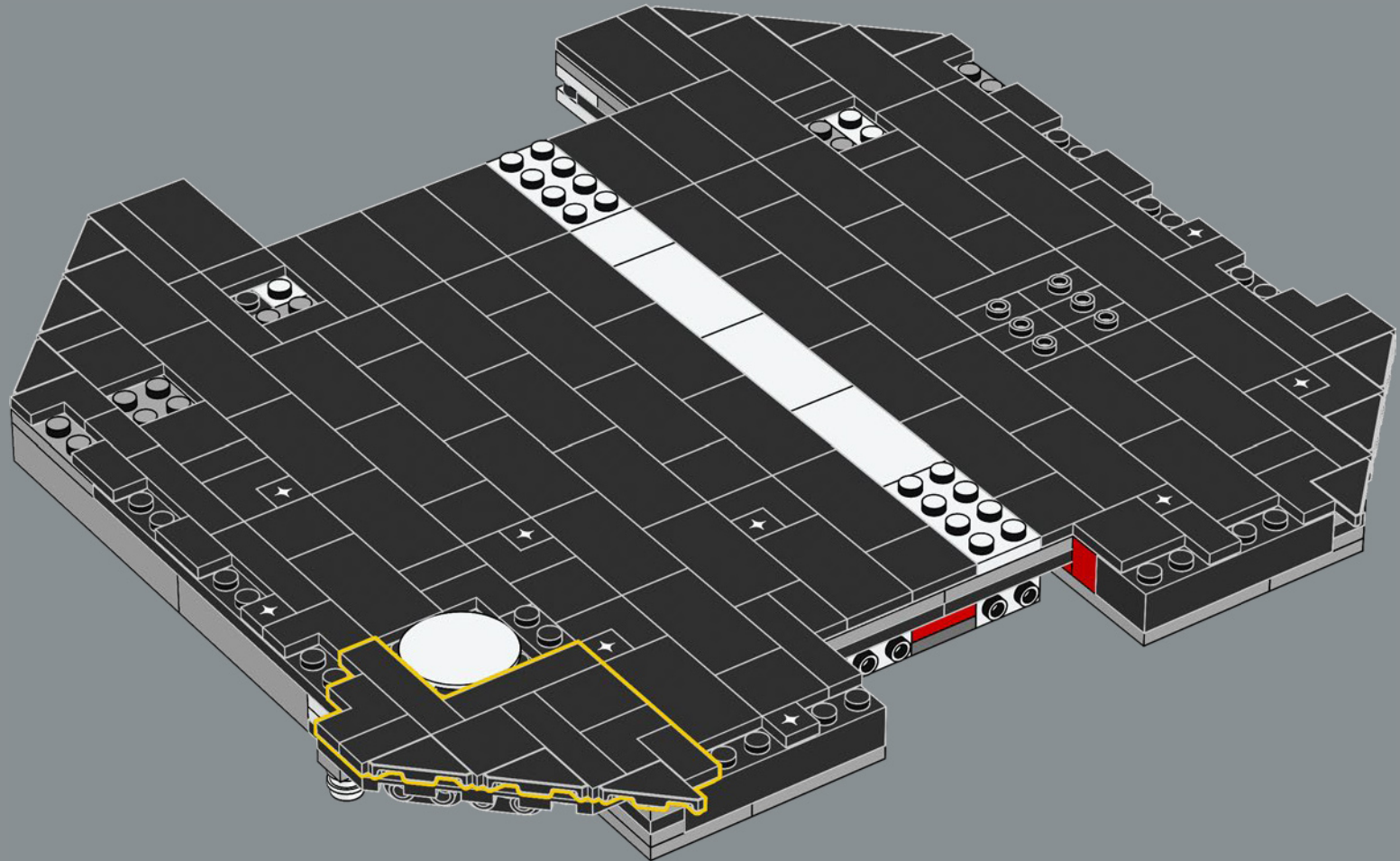

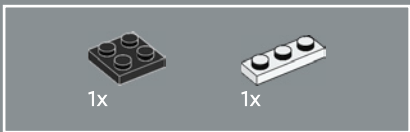

165

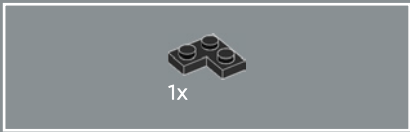
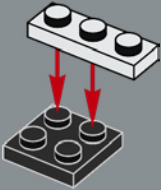

166

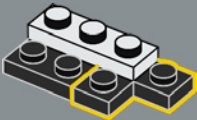

167

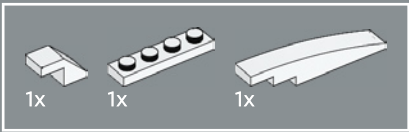
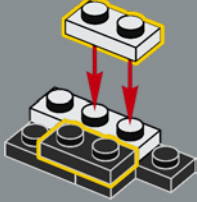

168

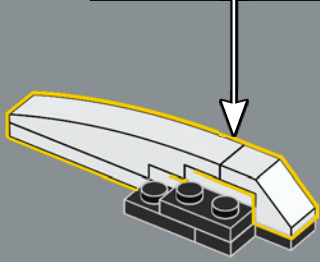
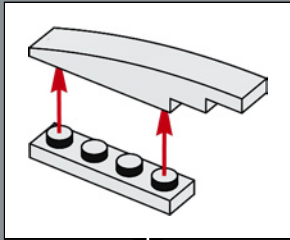

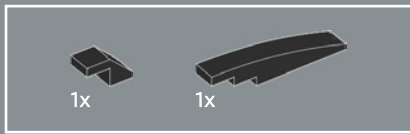

169

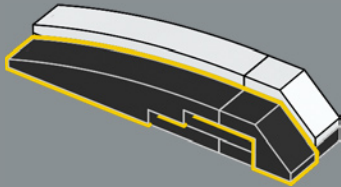

170

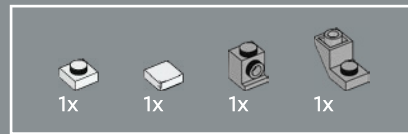
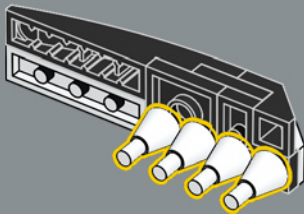

171

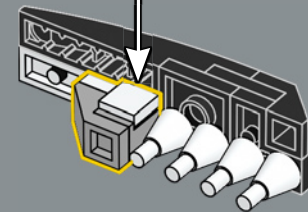
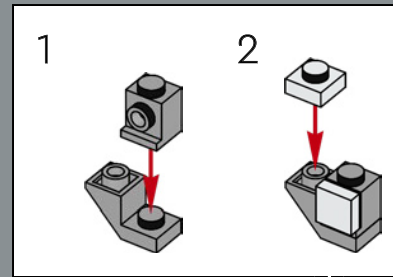

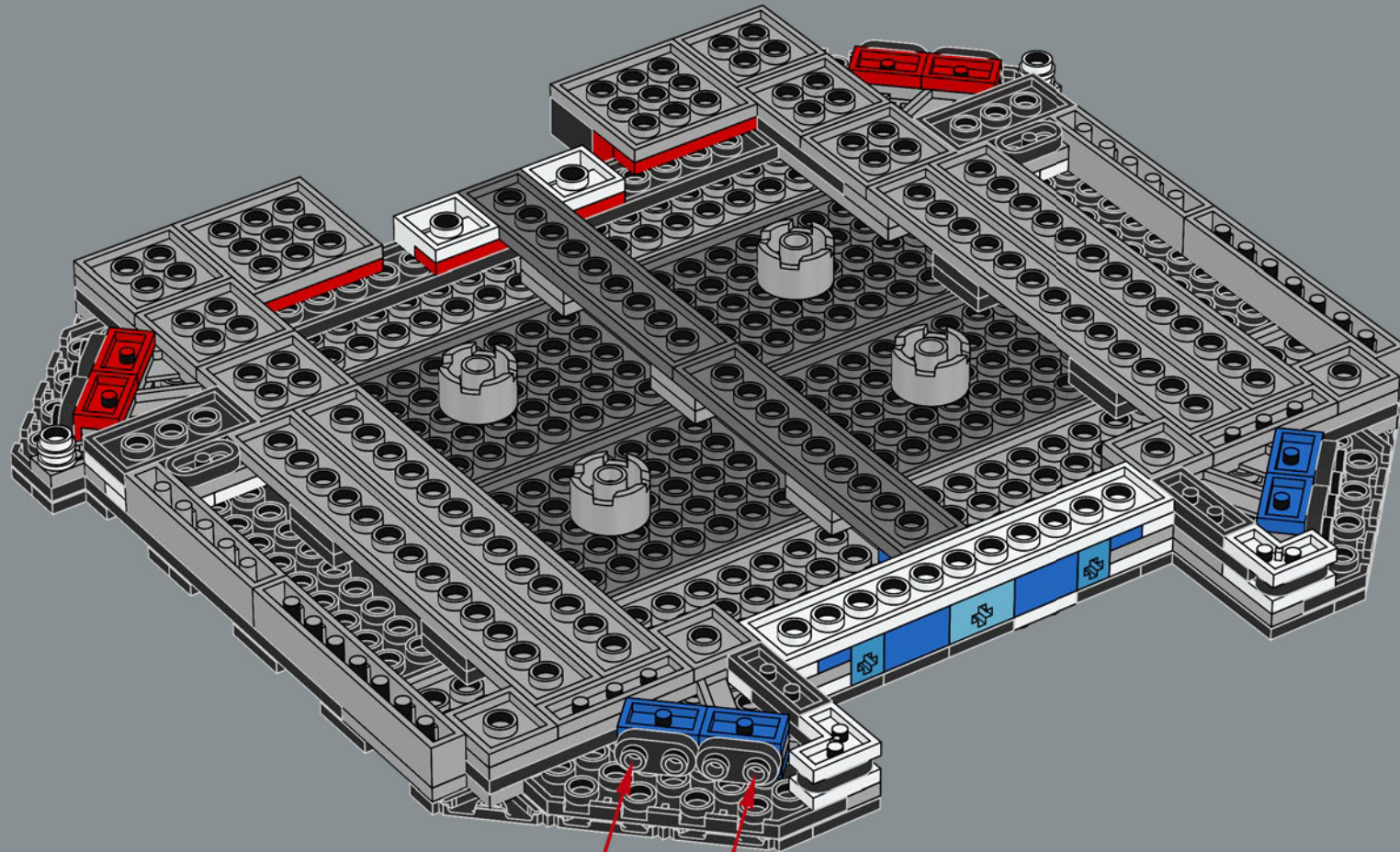

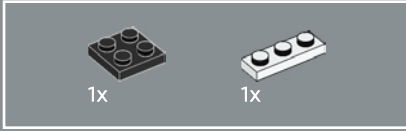
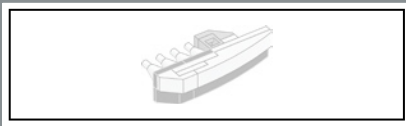

173

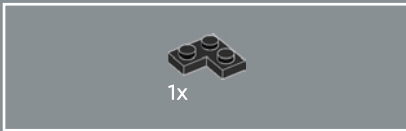
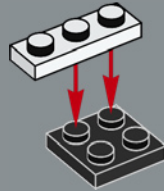

174

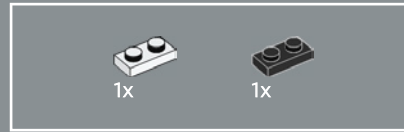
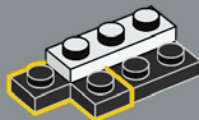

175

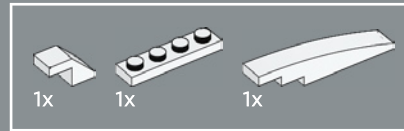
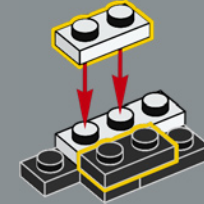

176

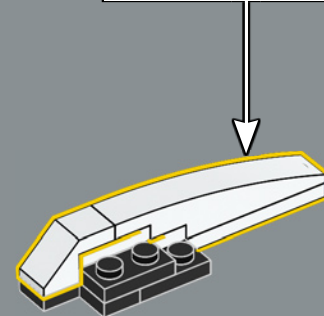
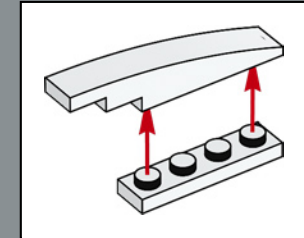

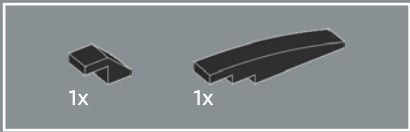

177

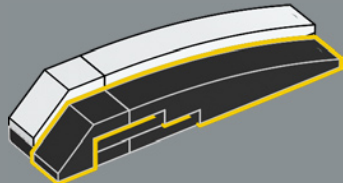

178

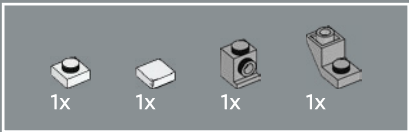
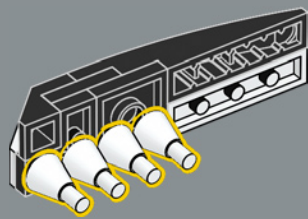

179

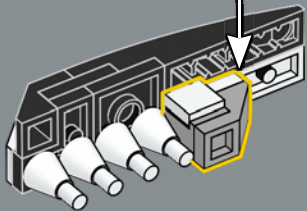
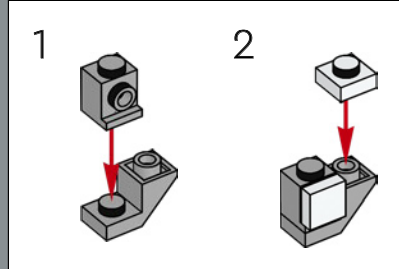

180

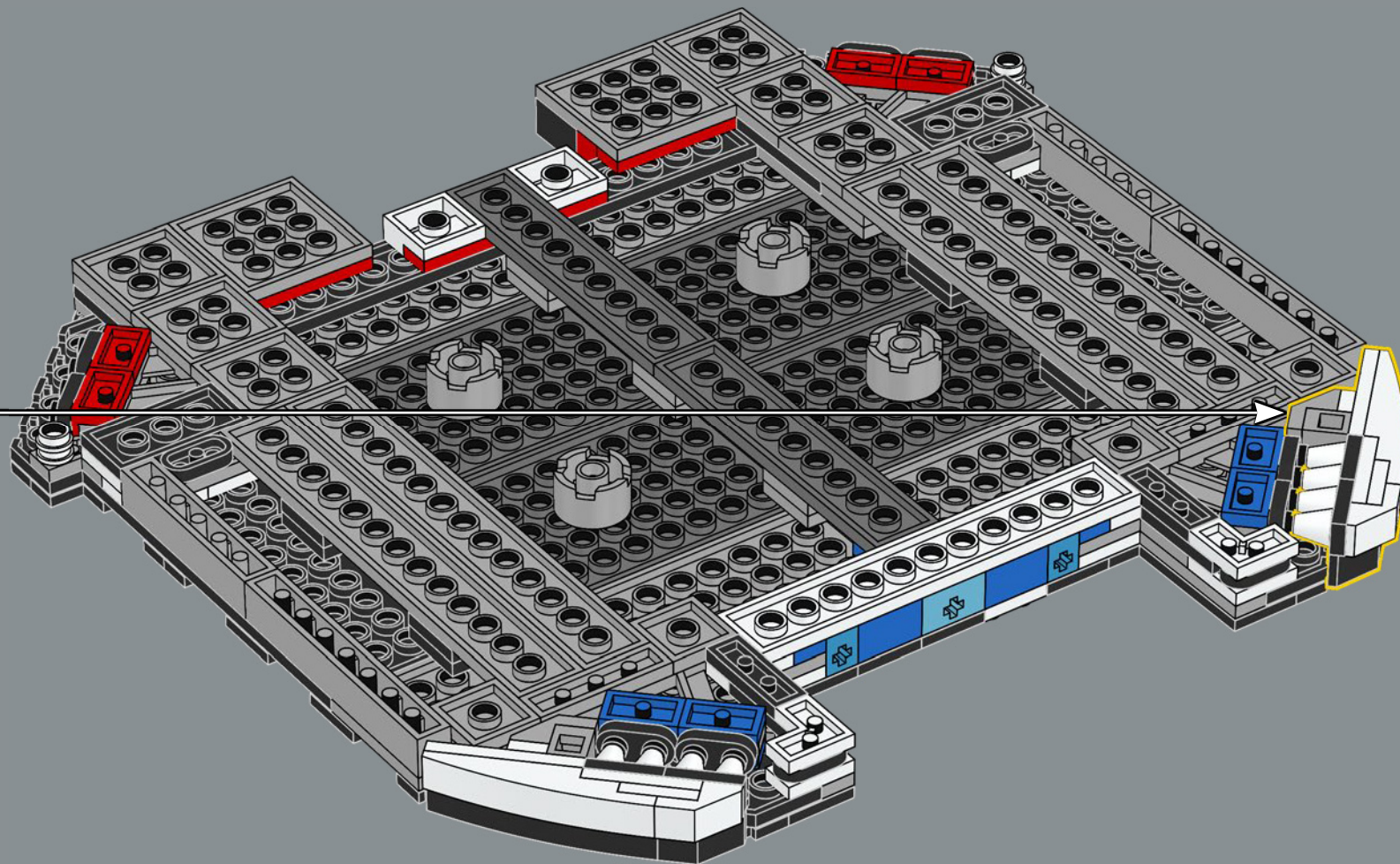

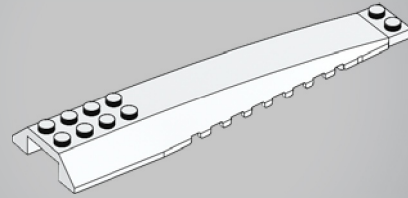
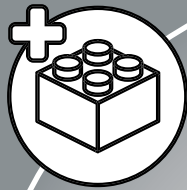

1x

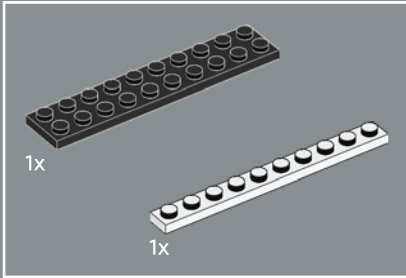
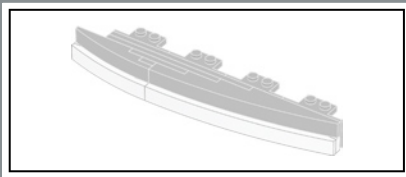

181

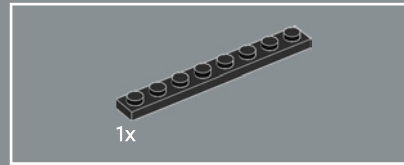
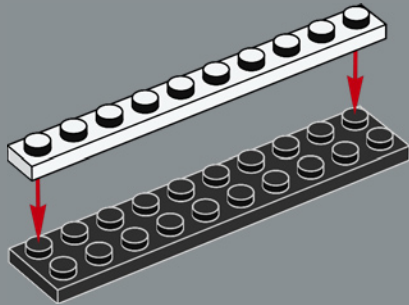

182

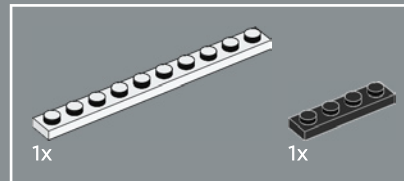
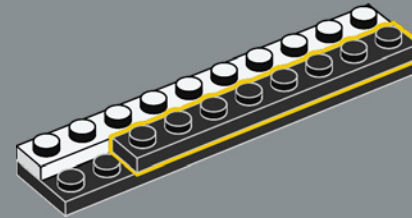

183

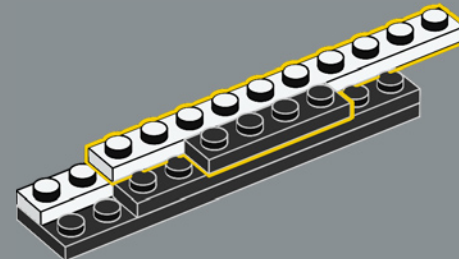

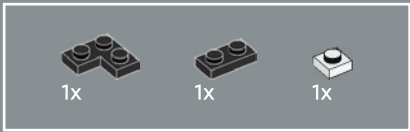

184

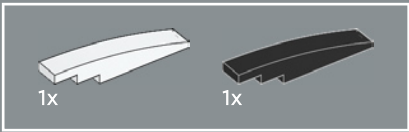
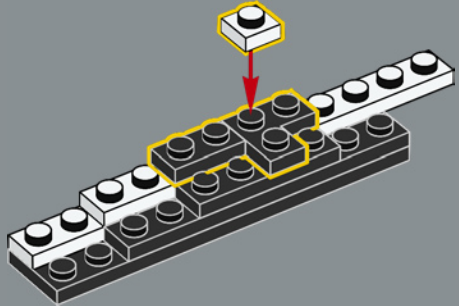

185

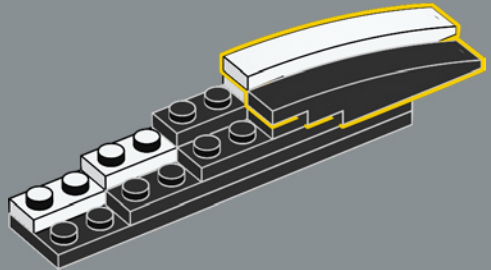

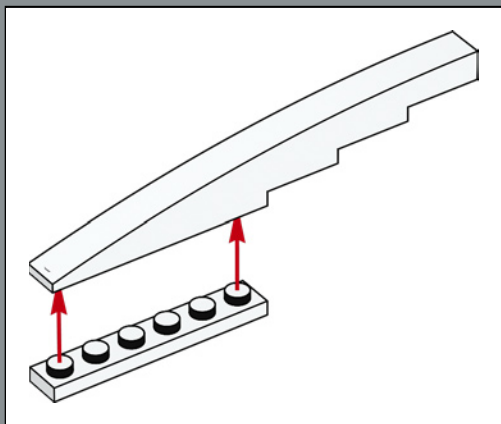
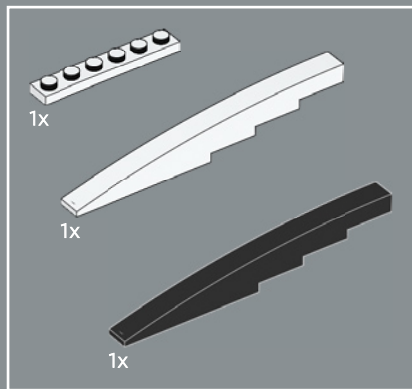

186

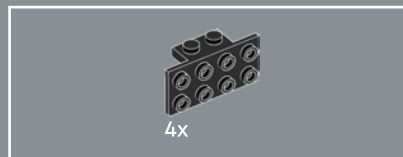
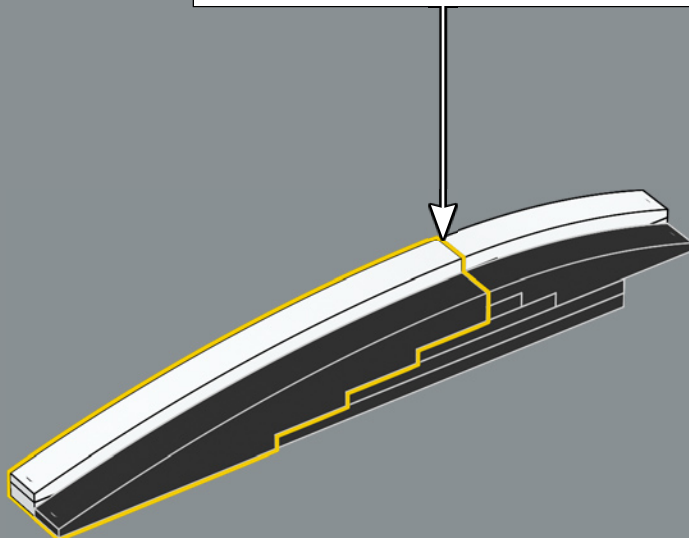

187

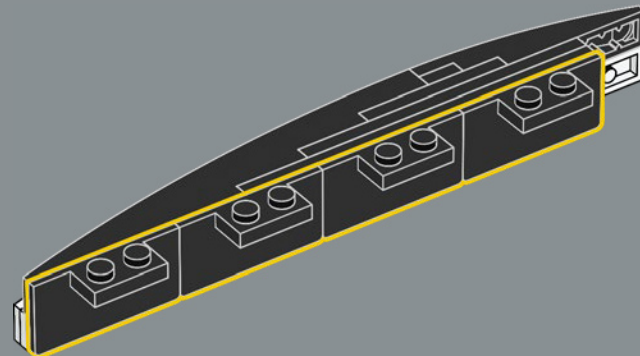

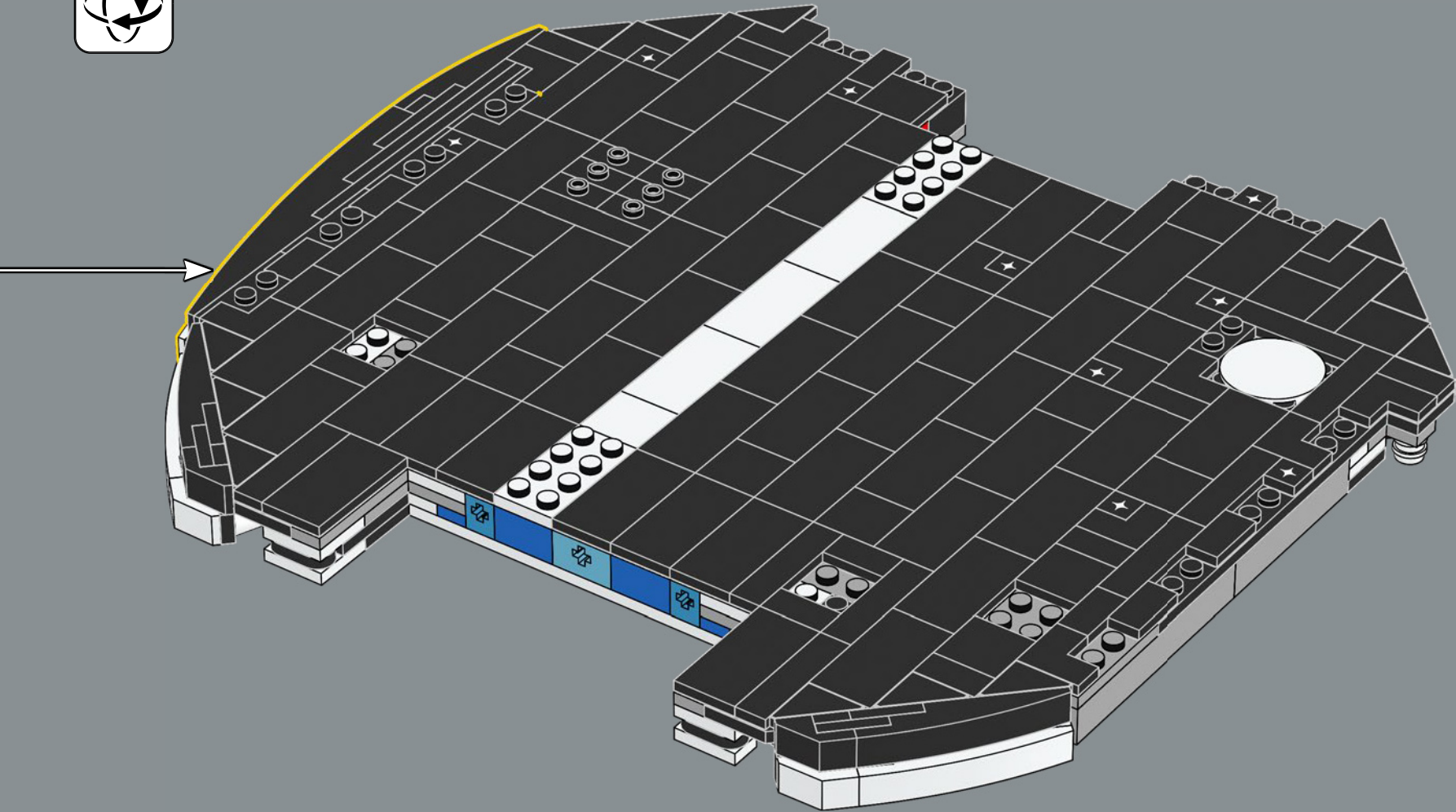

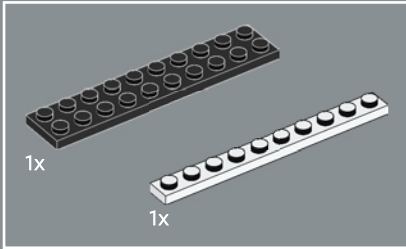
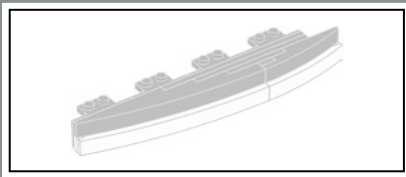

189

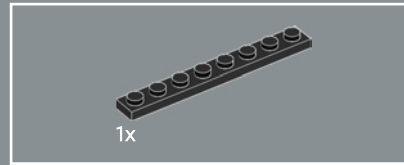
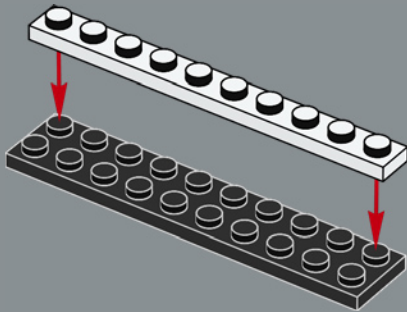

190

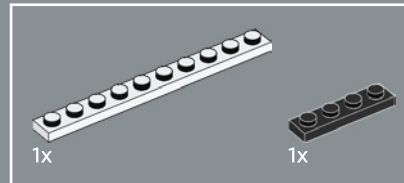
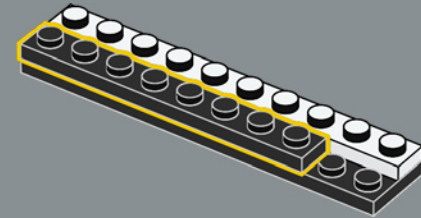

191

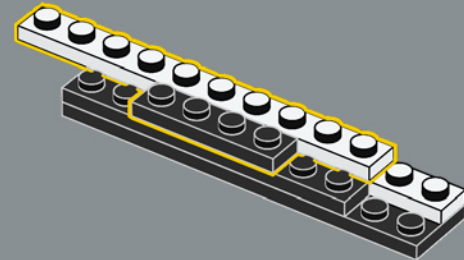

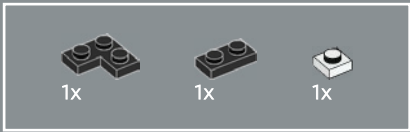

192

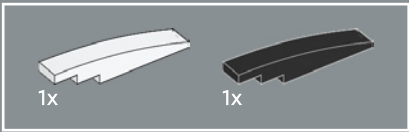
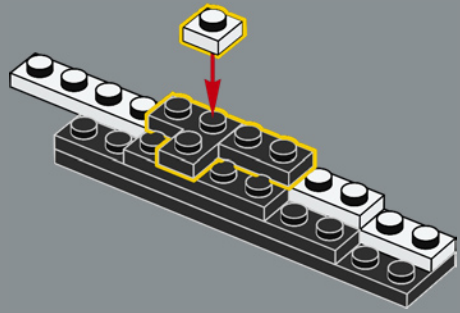

193

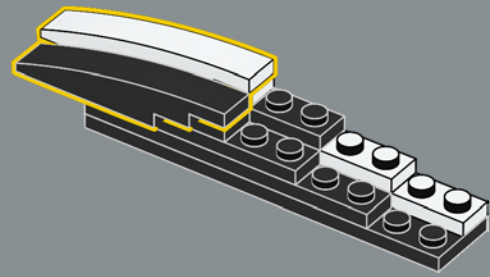

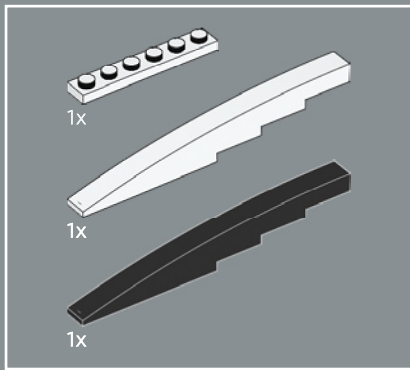

194

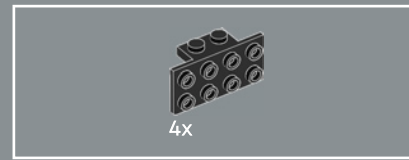
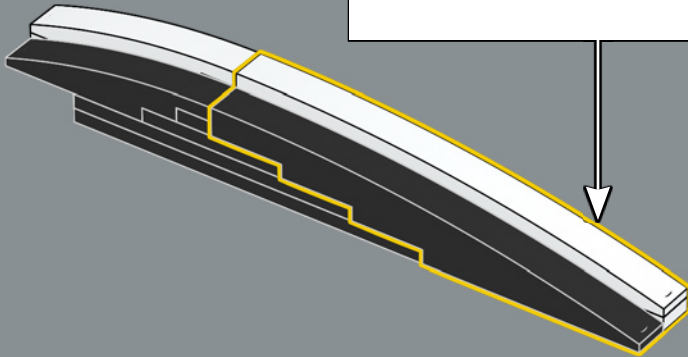
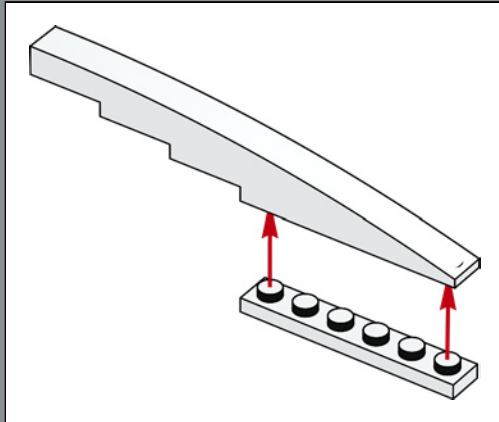

195

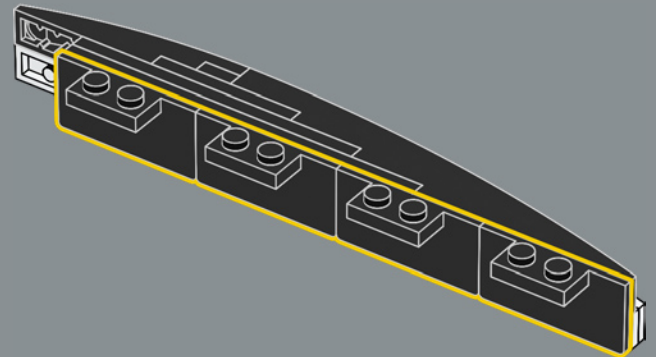

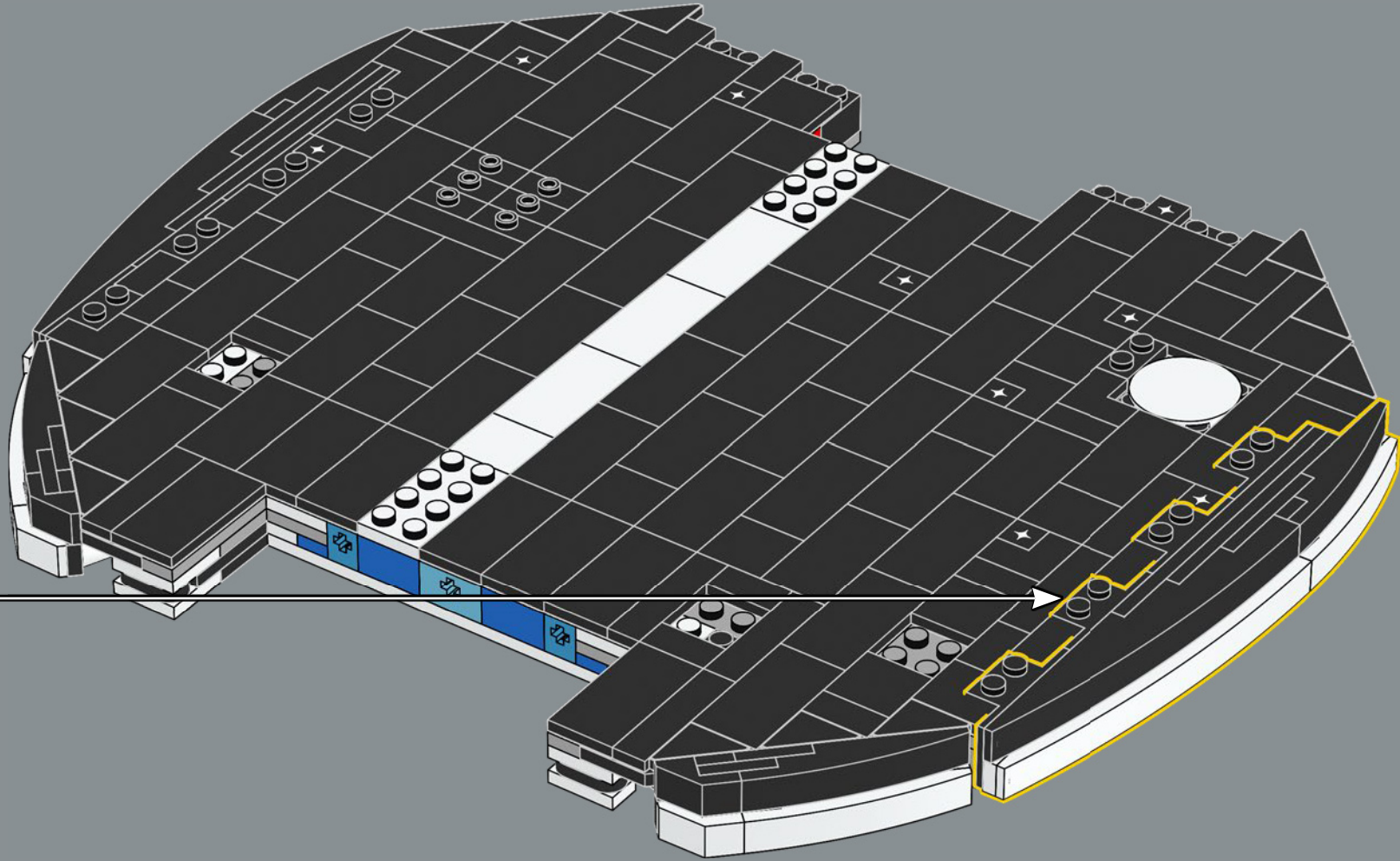

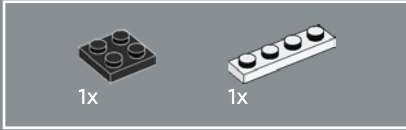
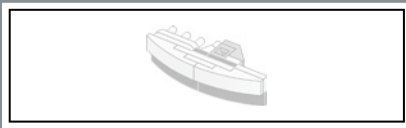

197

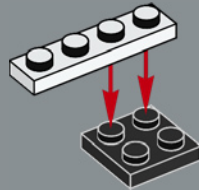

198

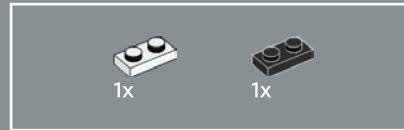
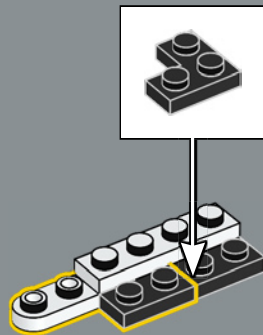

199

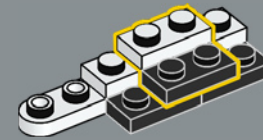

200

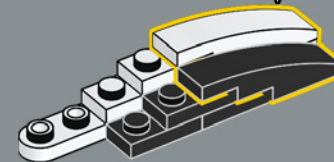
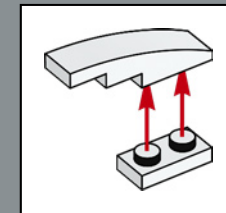

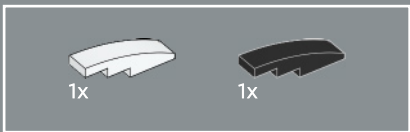

201

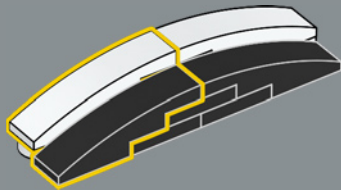

202

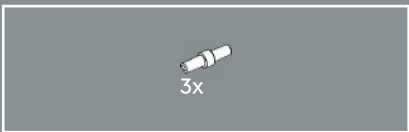
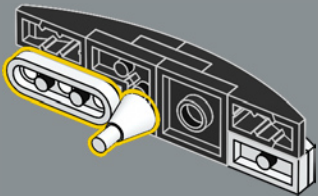

203

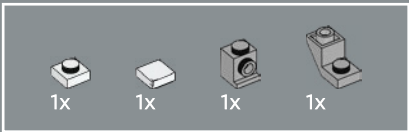
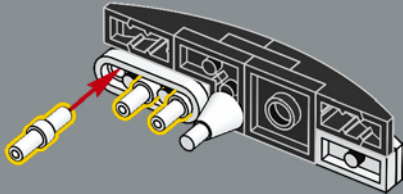

204

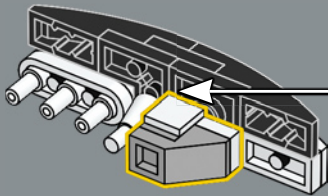
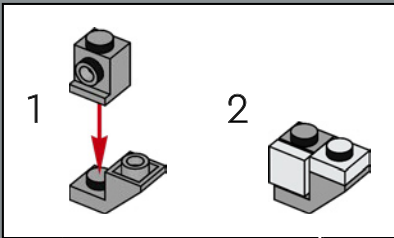

205

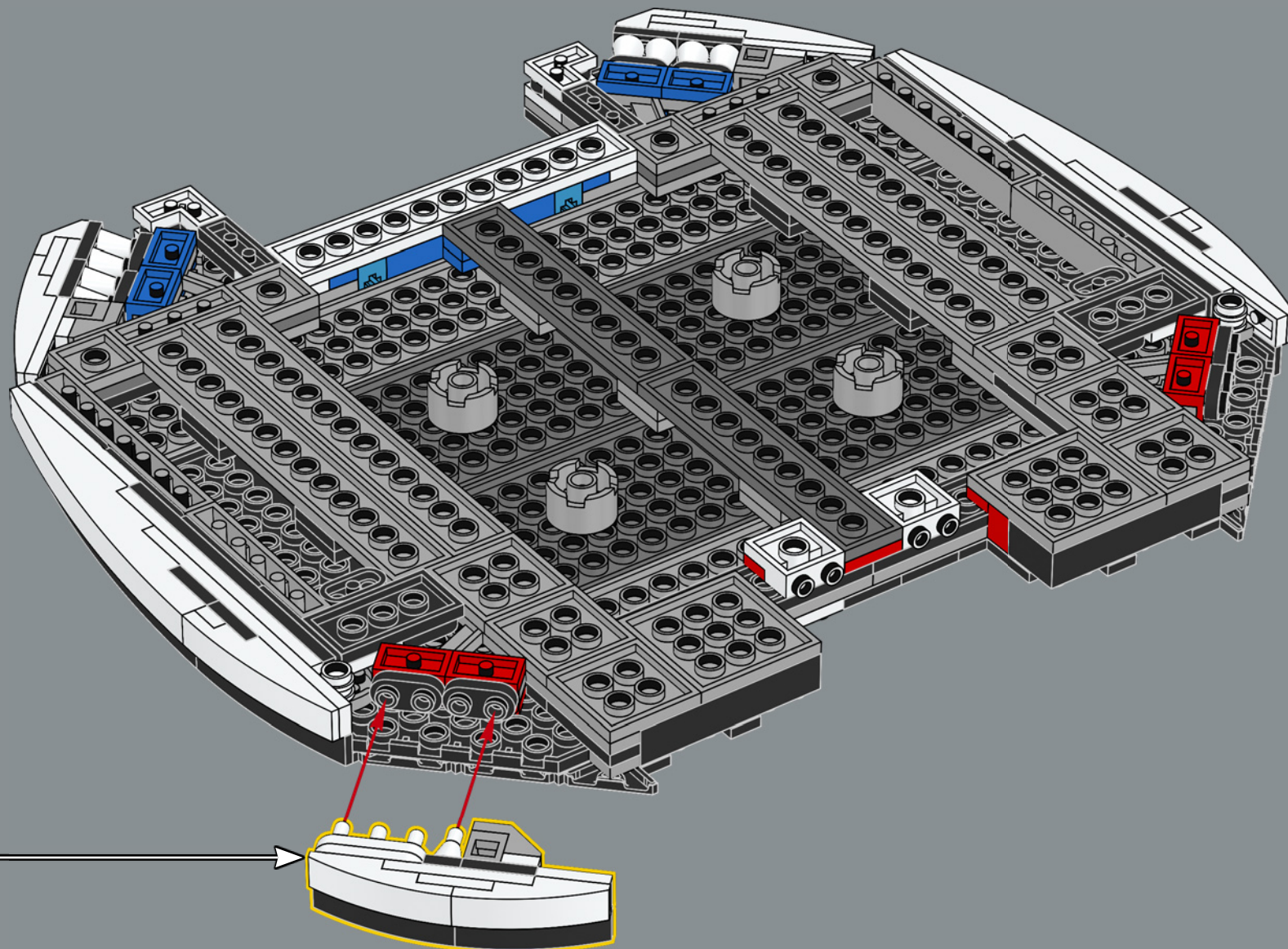

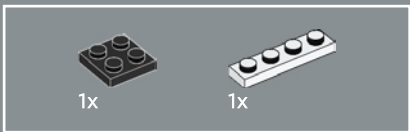

206

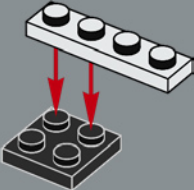

207

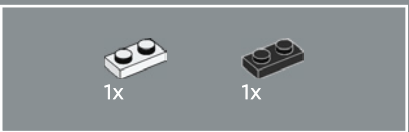
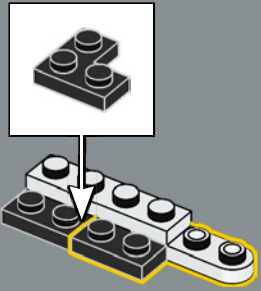

208

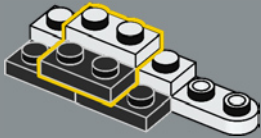

209

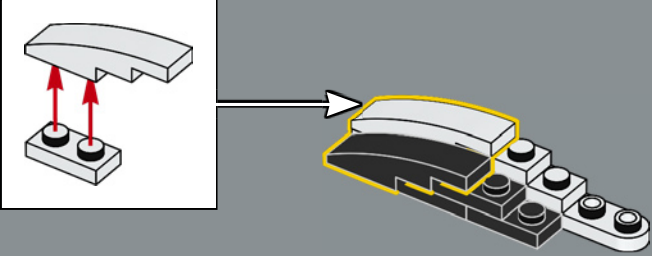

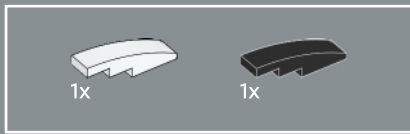

210

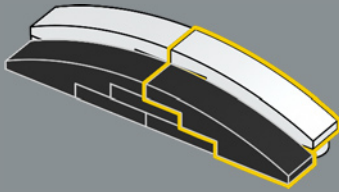

211

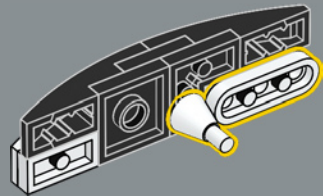

212

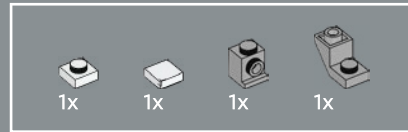
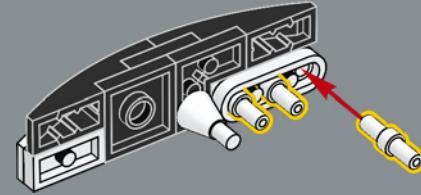

213

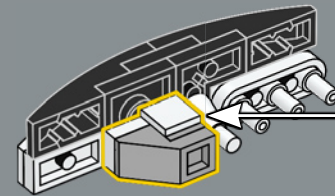
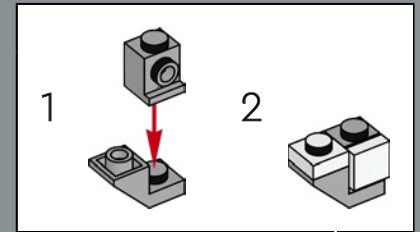

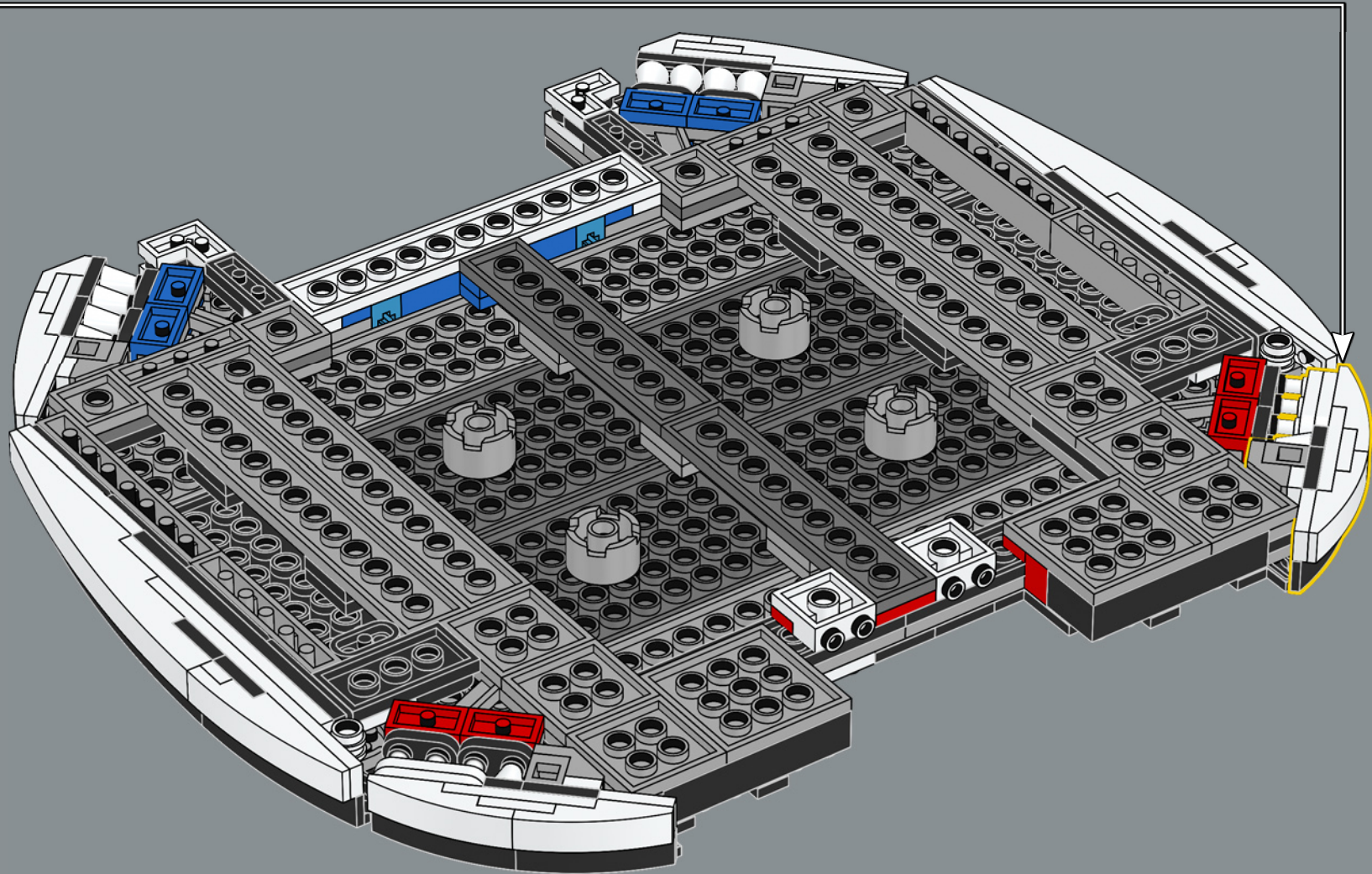

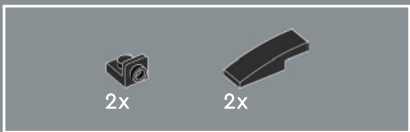

215

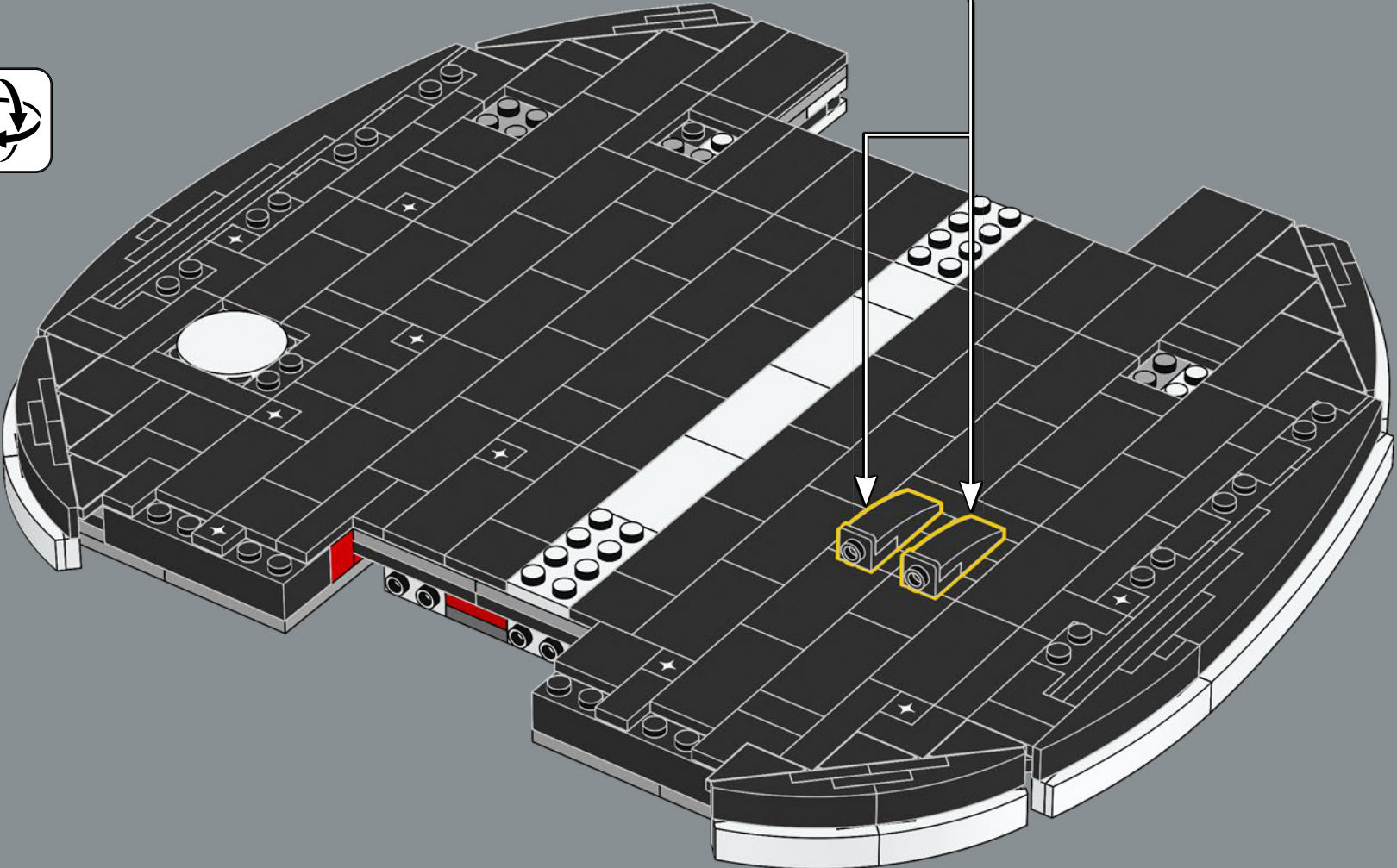
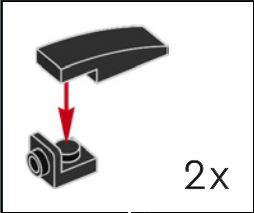

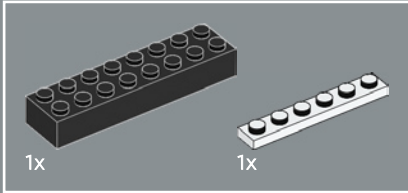
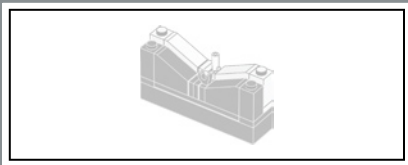

216

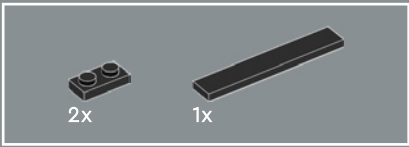
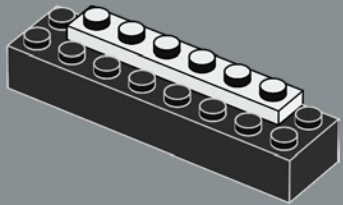

217

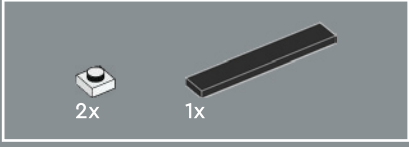
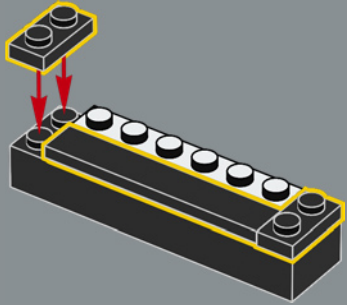

218

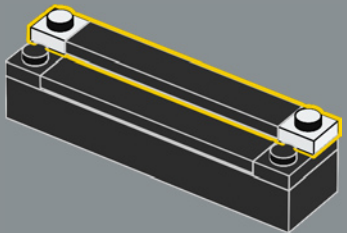



219

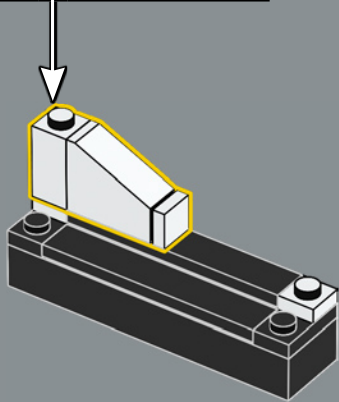
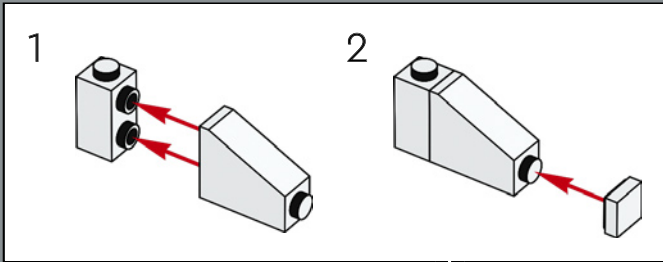

220

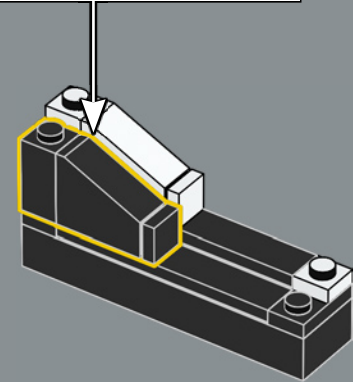
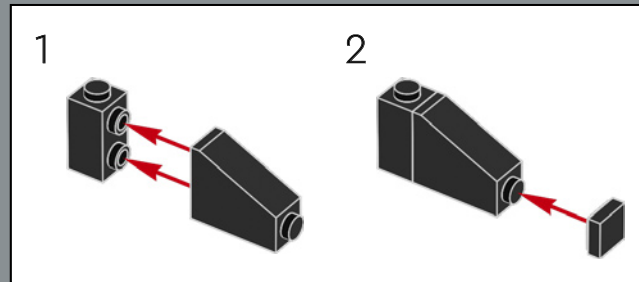

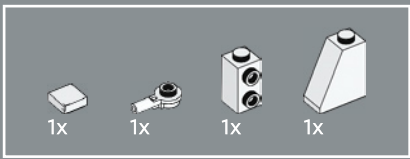

221

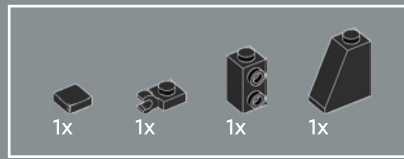
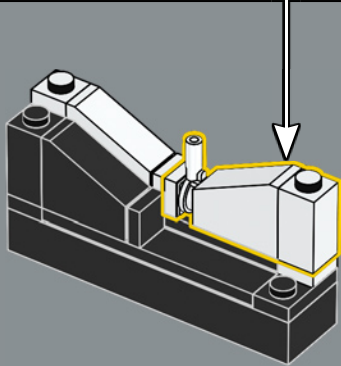
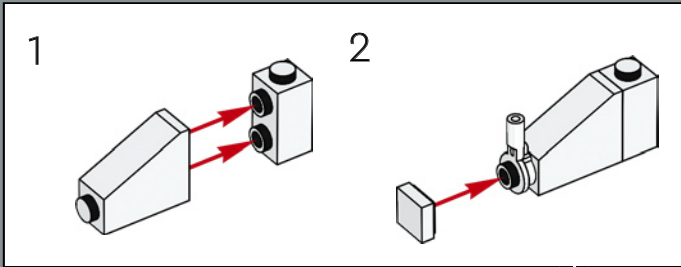

222

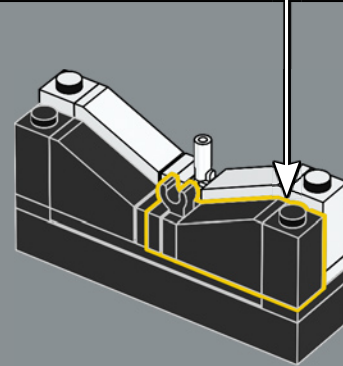
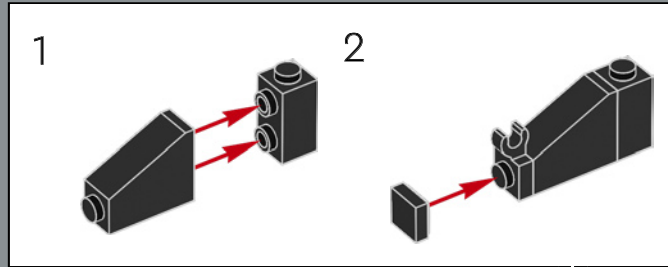

223

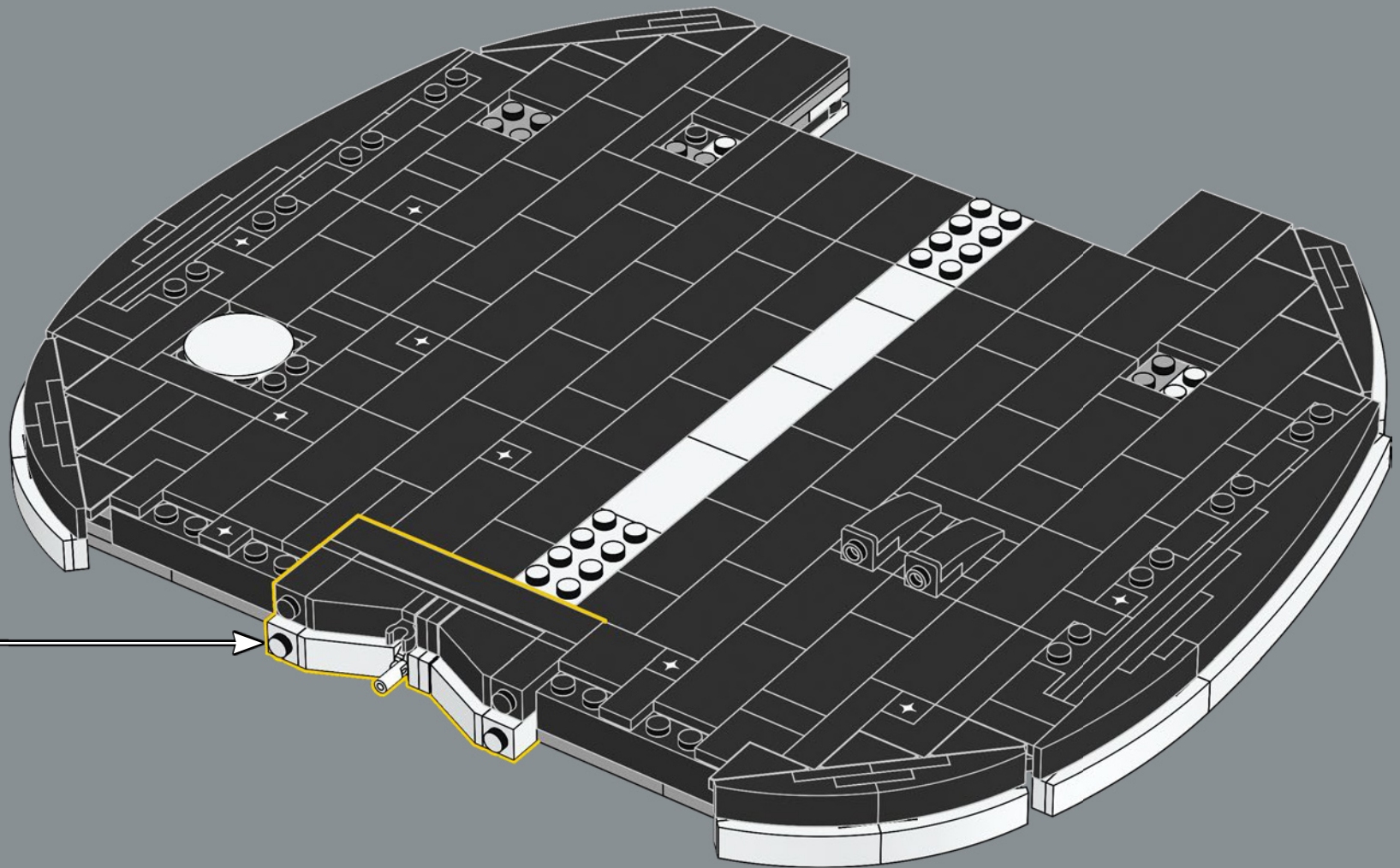

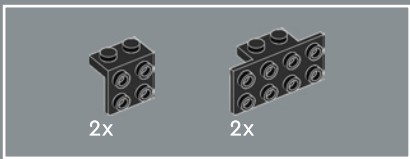

224

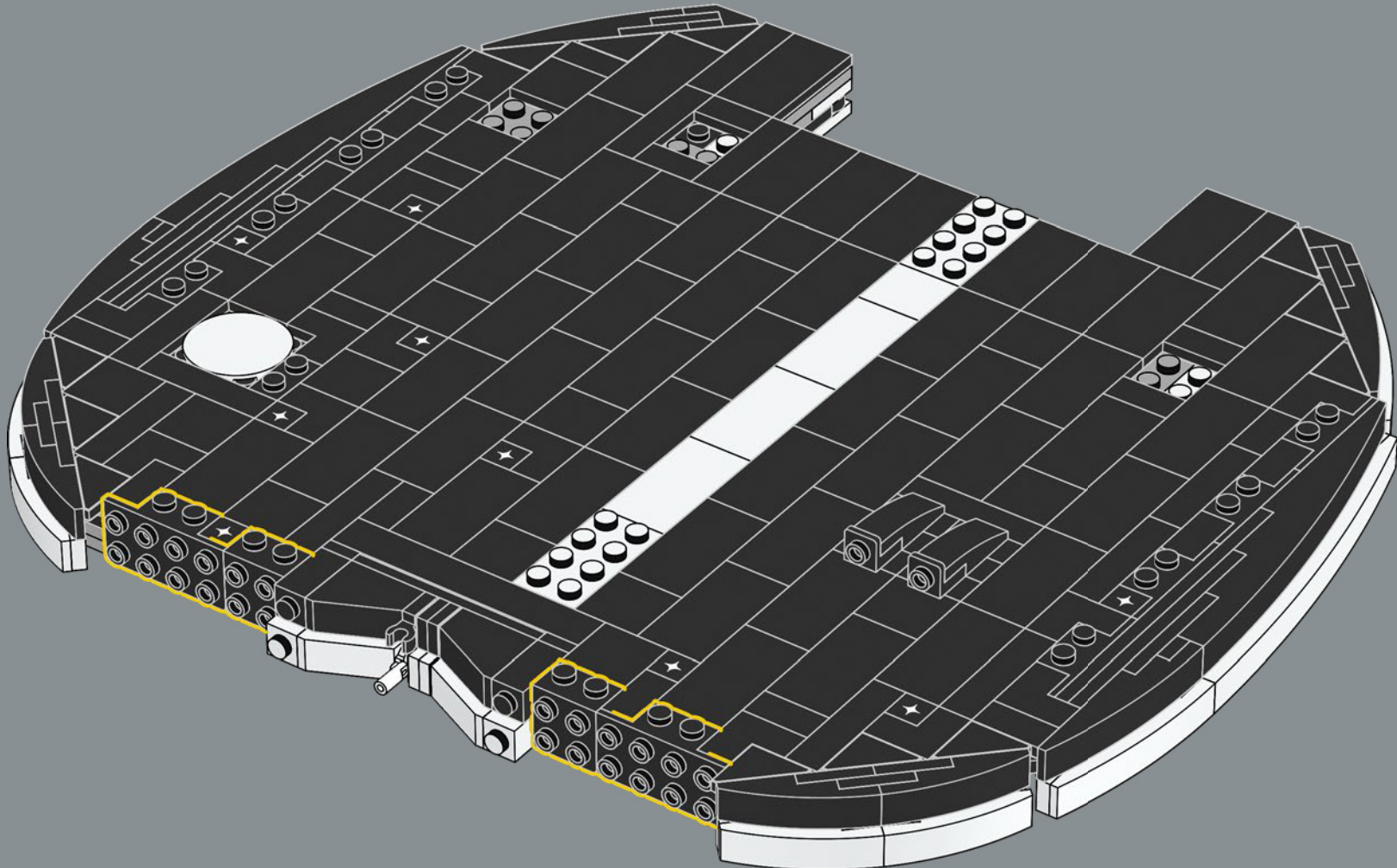

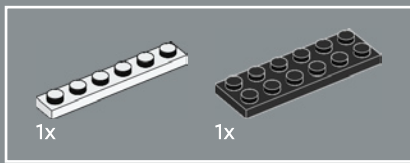

225

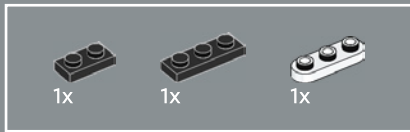
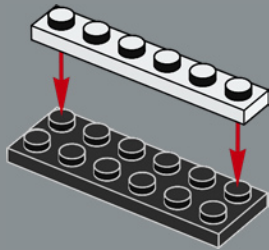

226

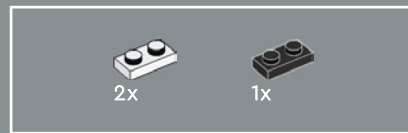
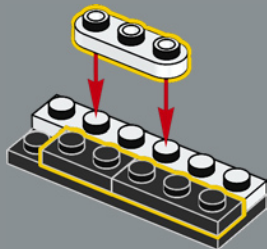

227

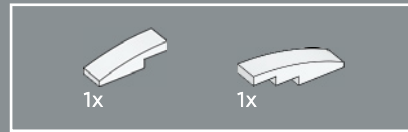
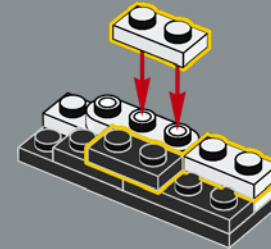

228

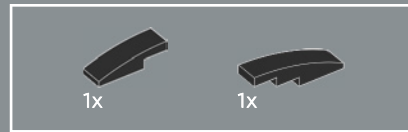
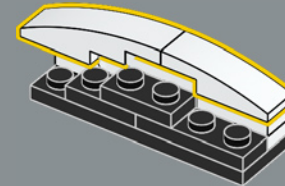

229

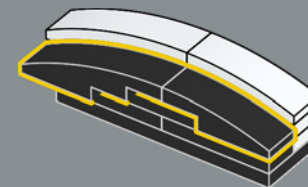

230

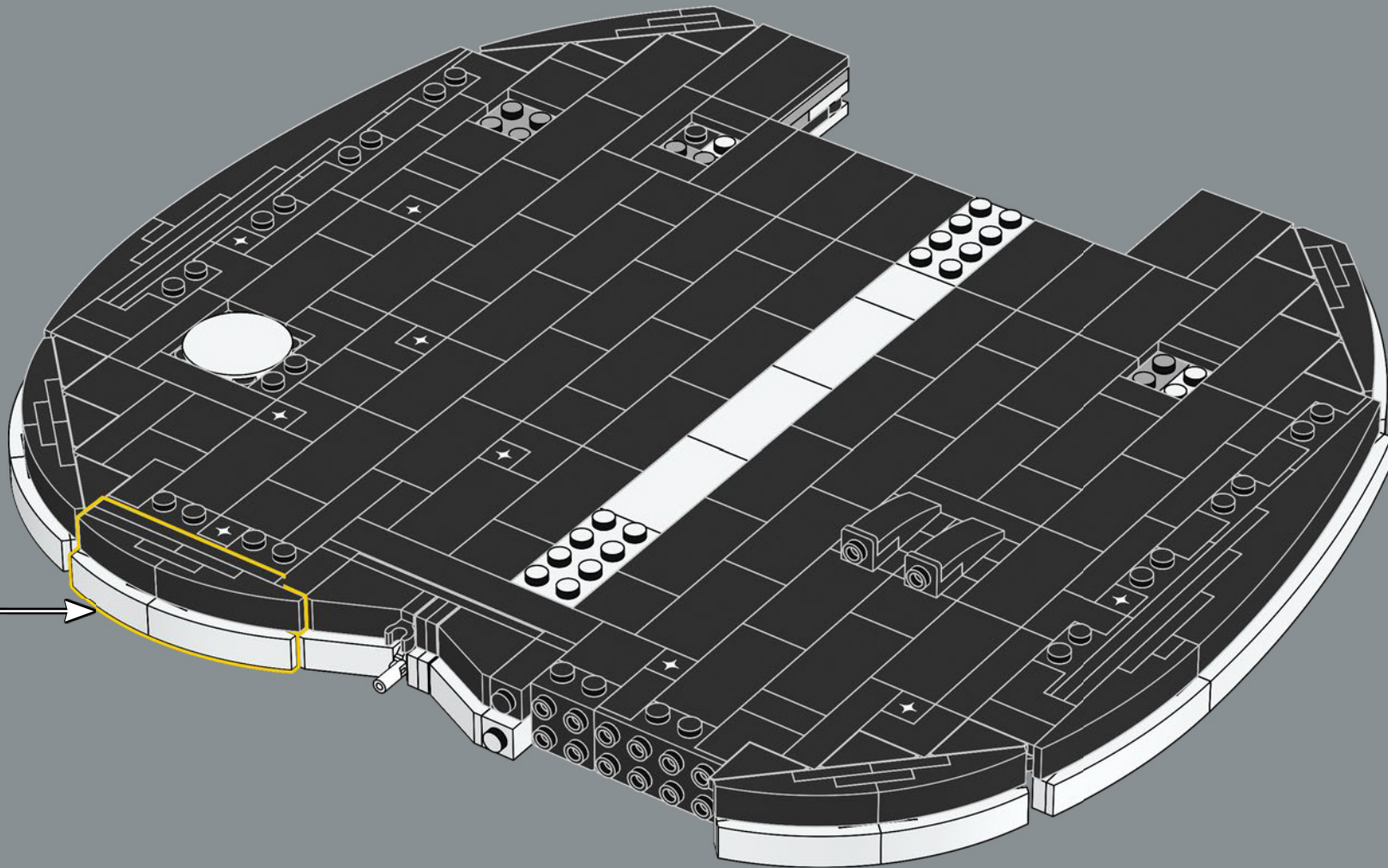

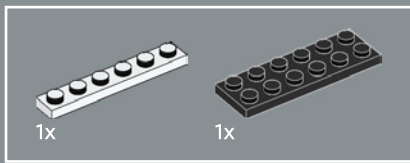

231

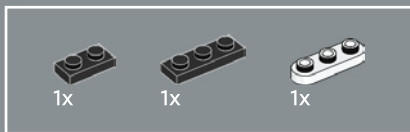
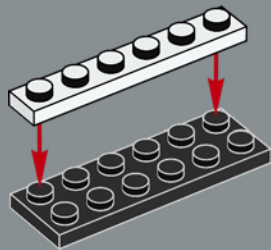

232

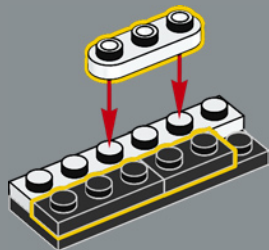

233

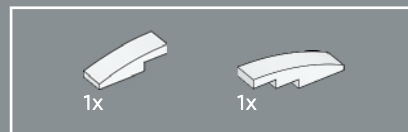
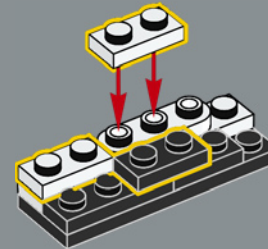

234

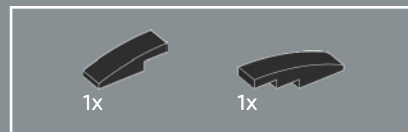
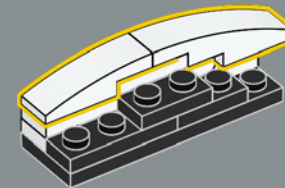

235

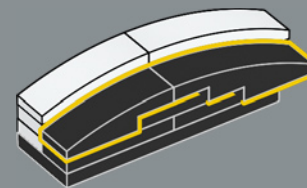

236

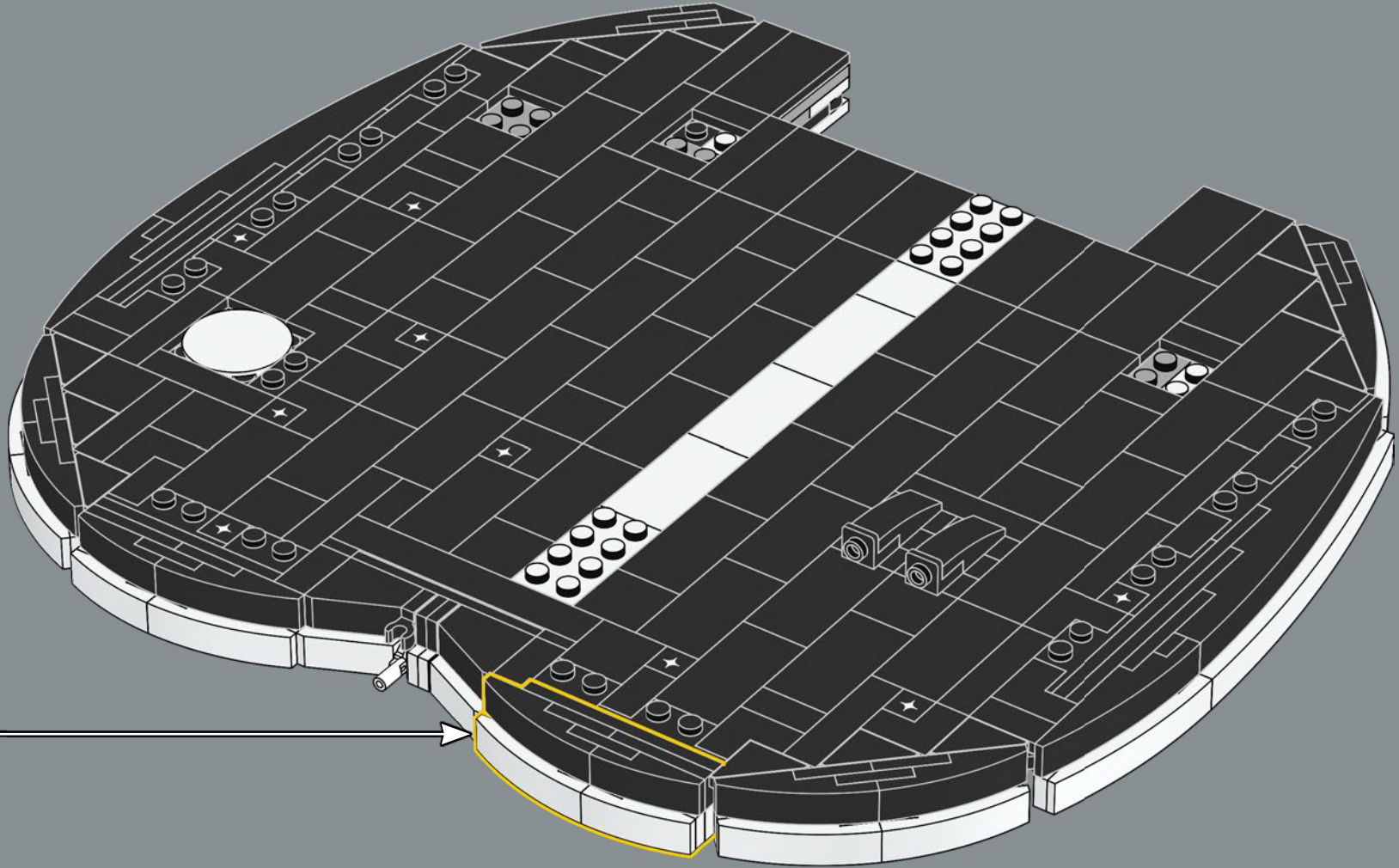



237

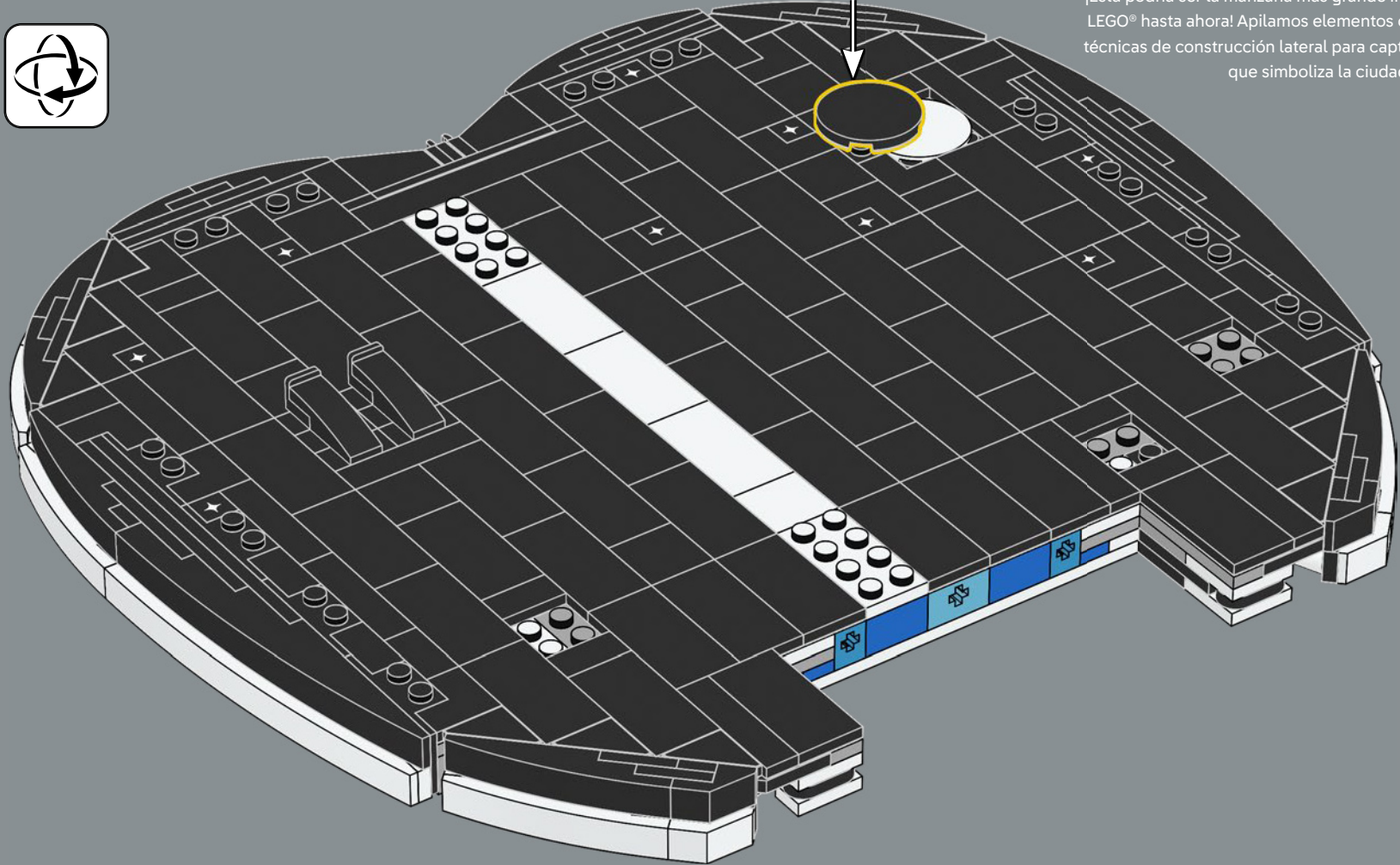

This might be the biggest apple in a LEGO® set to date!
We stacked curved elements and used sideways building techniques to capture this silhouette symbol of New York City.

C'est peut-être la plus grosse pomme jamais vue dans un ensemble LEGO®! Nous avons empilé des éléments courbés et utilisé des techniques de construction latérales pour capturer cette silhouette emblématique de New York.

¡Esta podría ser la manzana más grande incluida en un set LEGO® hasta ahora! Apilamos elementos curvos y usamos técnicas de construcción lateral para capturar esta silueta que simboliza la ciudad de Nueva York.



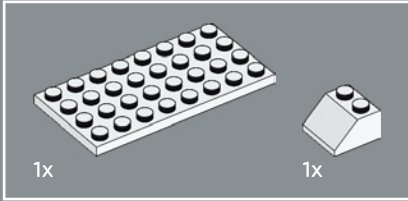
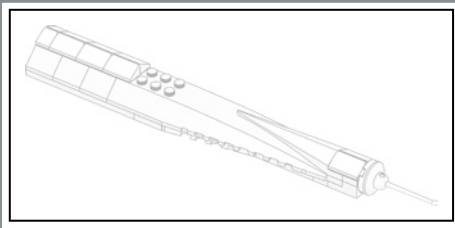

238

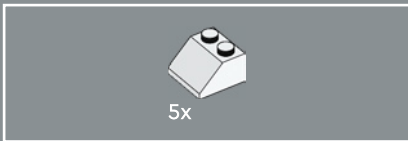
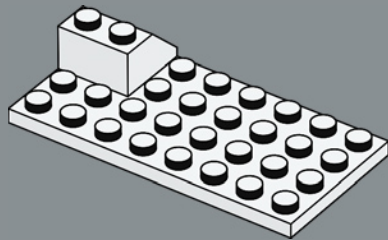

239

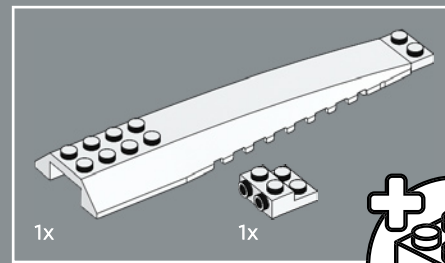
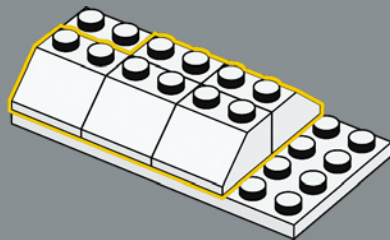

240

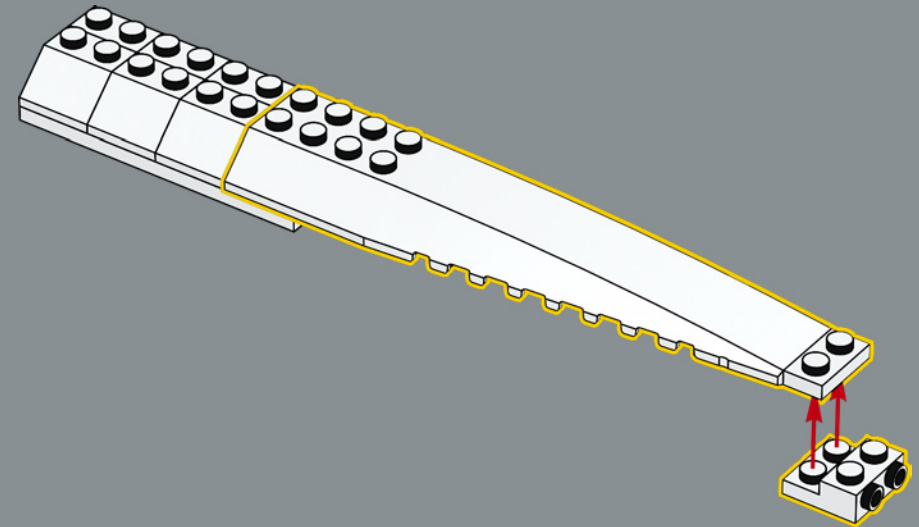
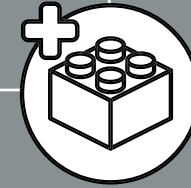

The height of One World Trade Center is 1,776 ft. (541.3 m)
– a nod to the signing of the U.S. Declaration of Independence.

La hauteur du One World Trade Center est de 541,3 m – un clin d'œil
à la signature de la Déclaration d'indépendance des États-Unis.

El One World Trade Center tiene una altura de 541,3 m; en pies,
1776: una referencia a la fecha de la firma de la Declaración de
Independencia de los Estados Unidos.

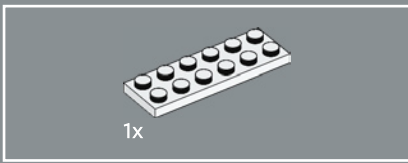

241

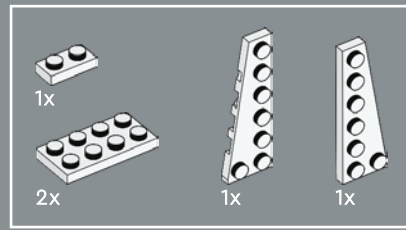
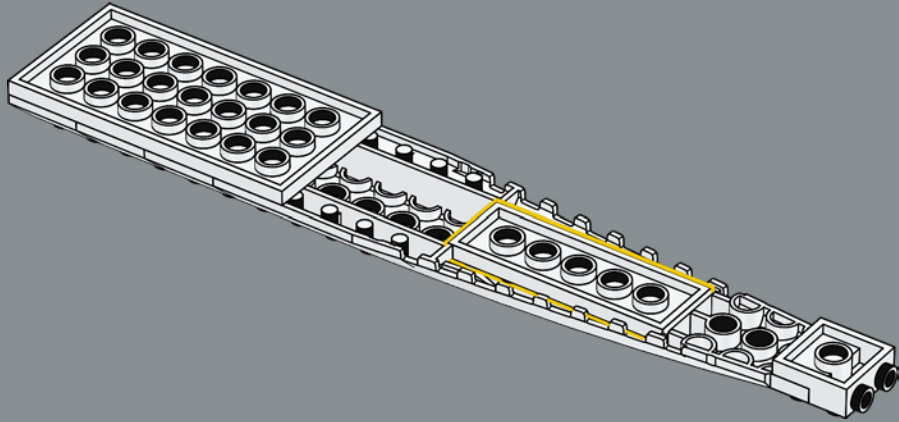

242

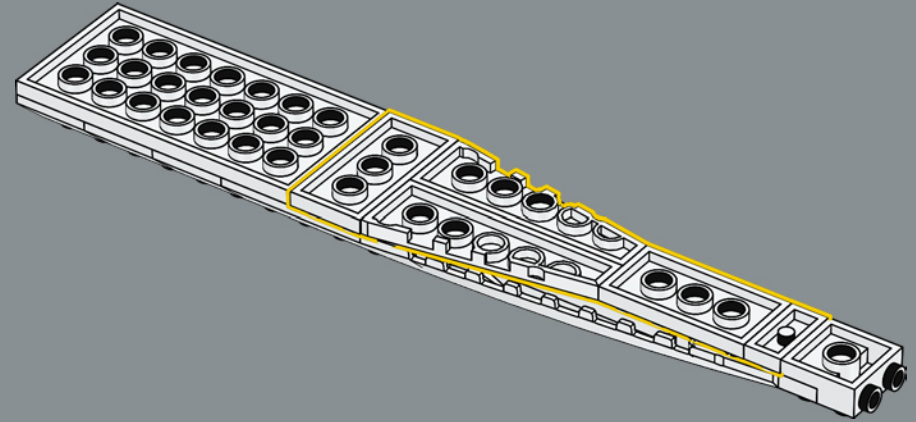

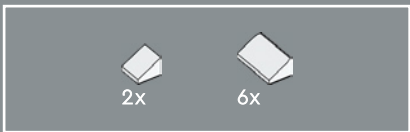

243

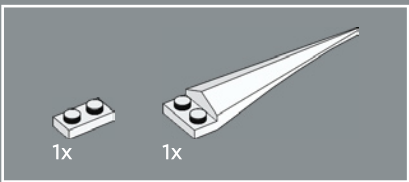
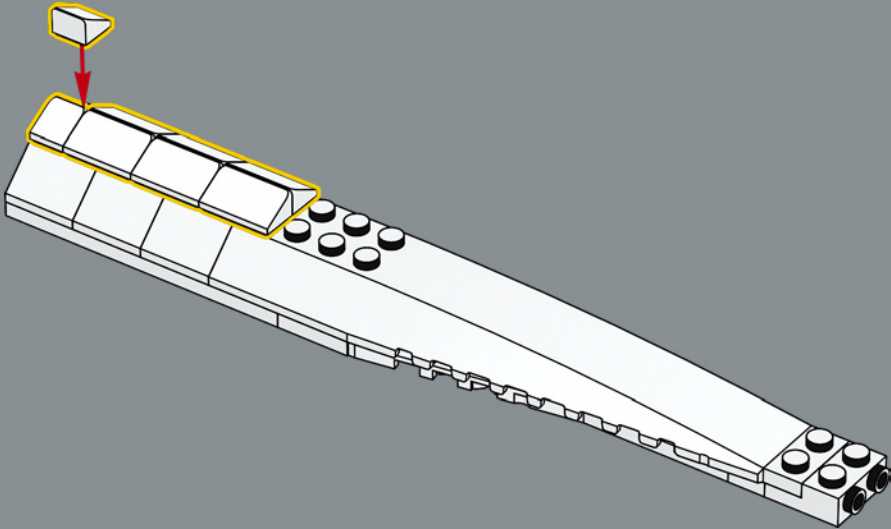

244

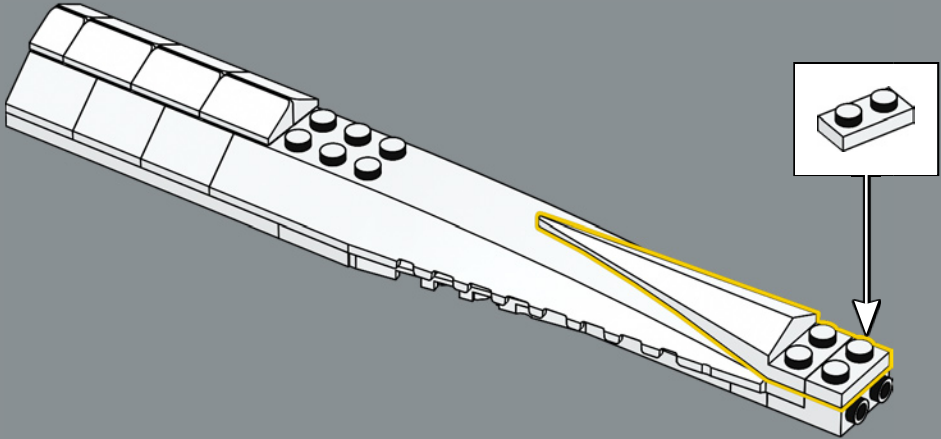



245

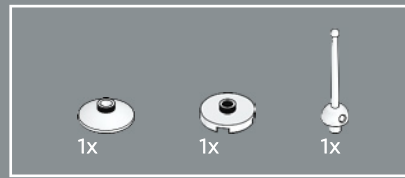
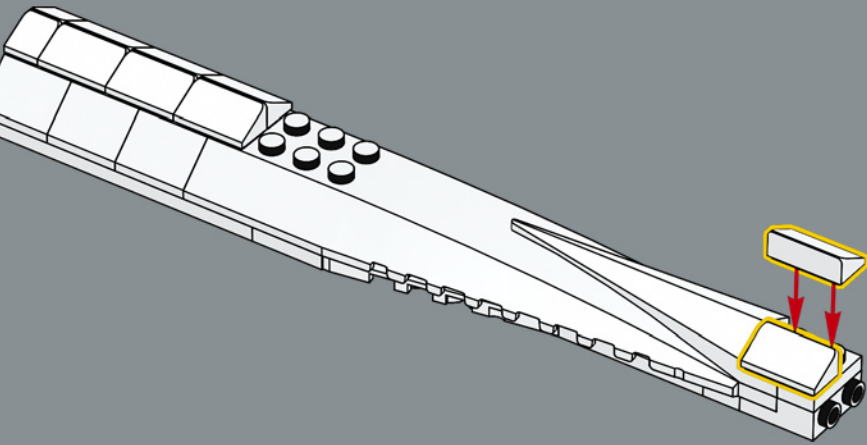

246

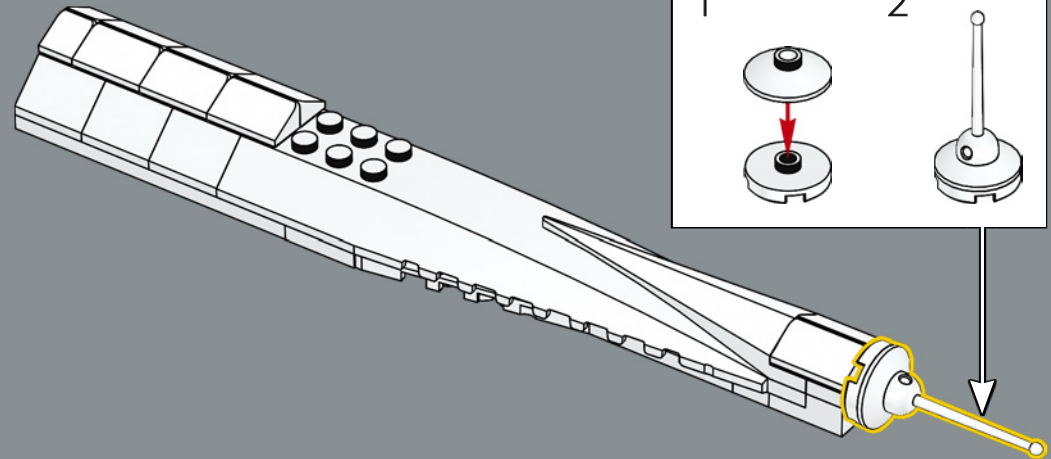

A LEGO® epee sword element creates the antenna on the tallest building in NYC, the One World Trade Center. In real life, the antenna alone is 407.9 ft. (124.3 m) tall.

Un élément LEGO® en forme d'épée est utilisé pour créer l'antenne de l'édifice le plus haut de New York, le One World Trade Center. En réalité, l'antenne à elle seule mesure 124,3 m.

Un elemento LEGO® que representa una espada de esgrima recrea la antena del rascacielos más alto de la ciudad de Nueva York, el One World Trade Center. En la vida real, solo la antena mide 124,3 m de altura.

247

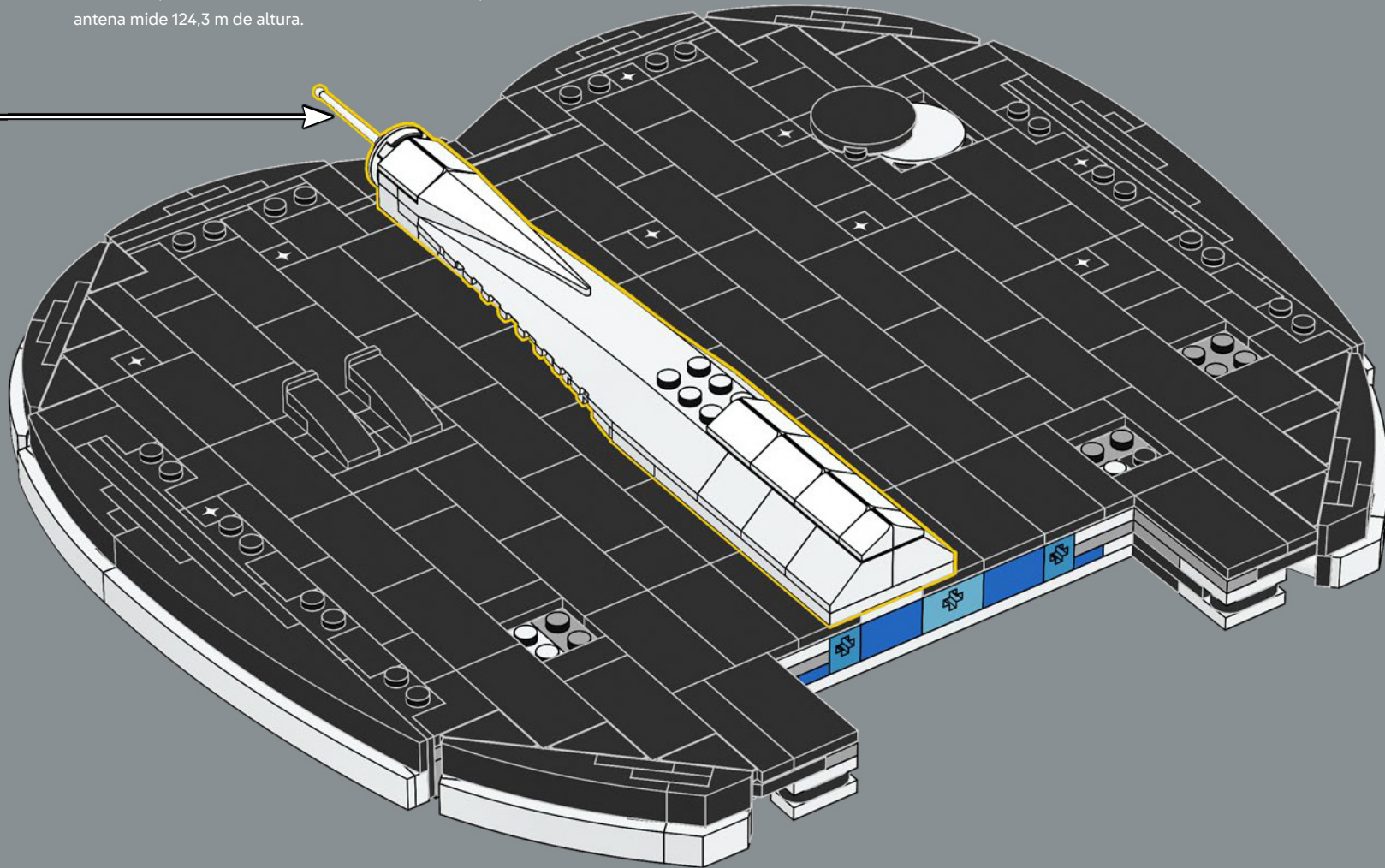

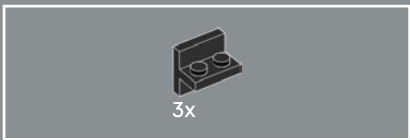

248

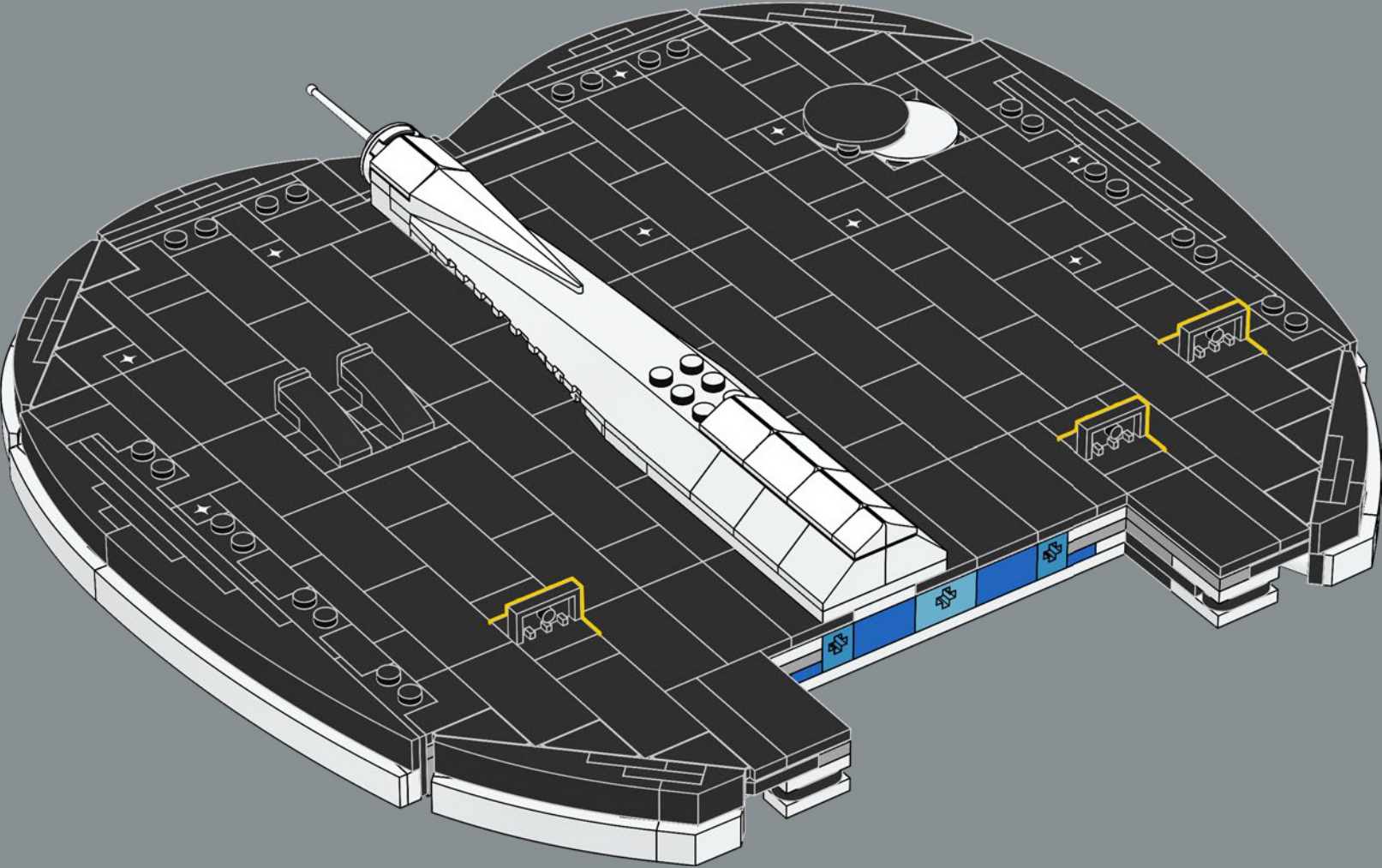

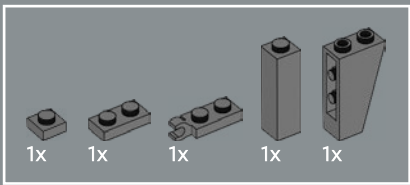

249

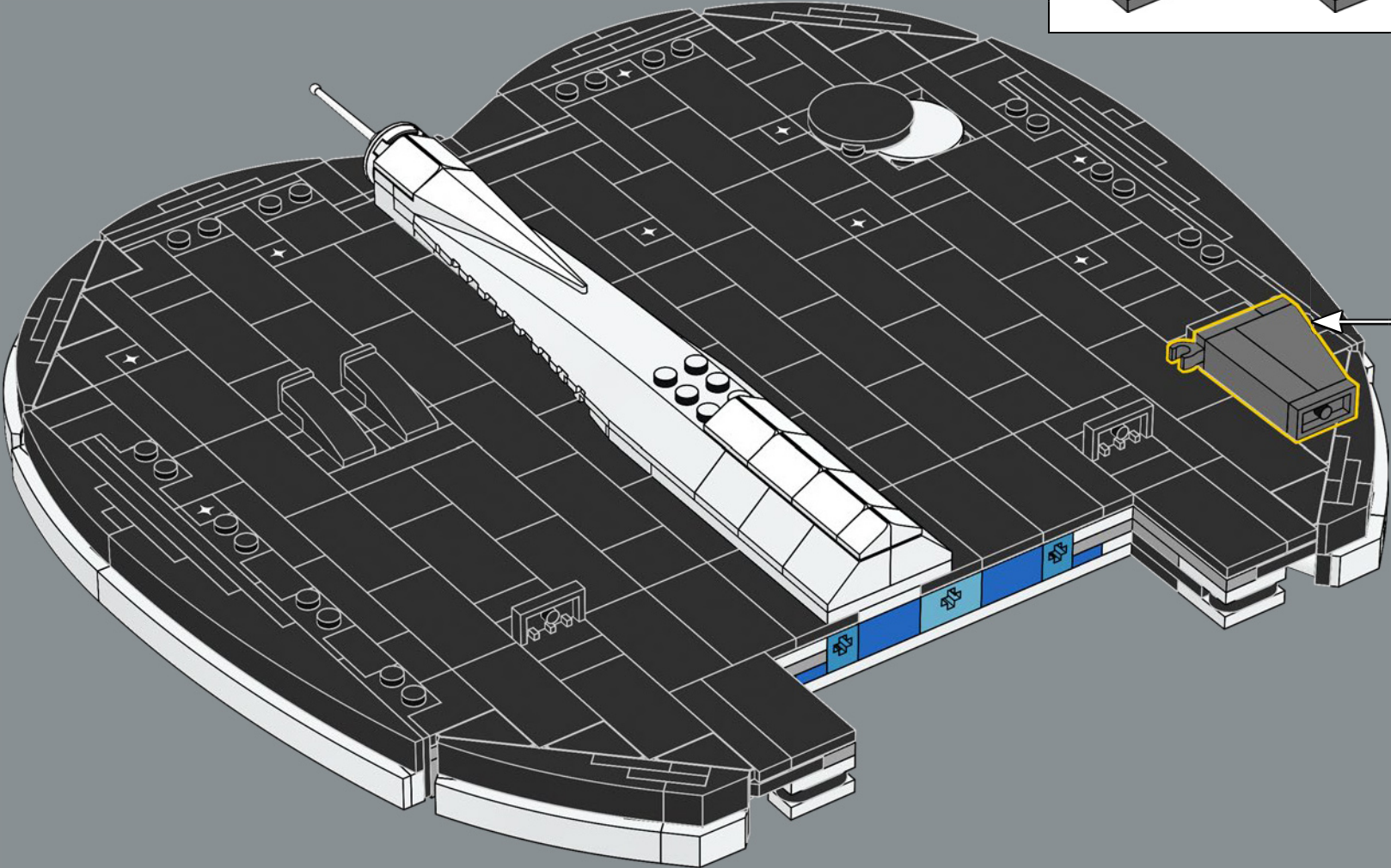
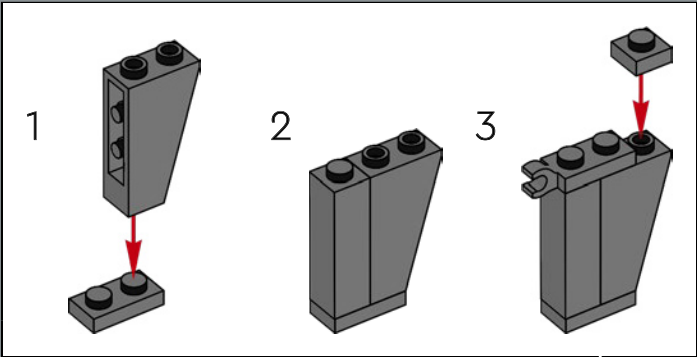

250

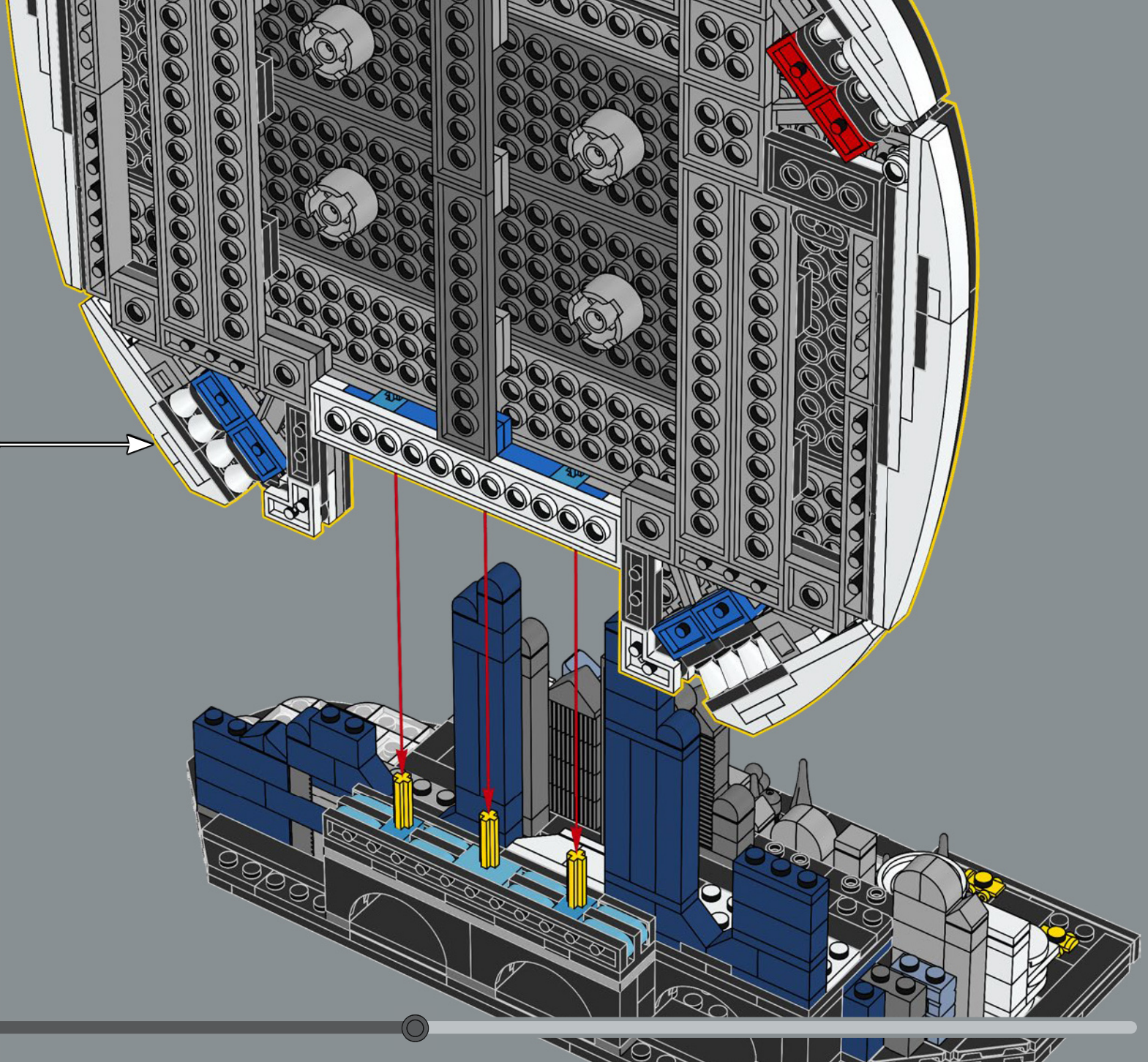

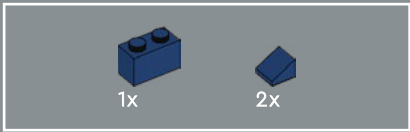

251

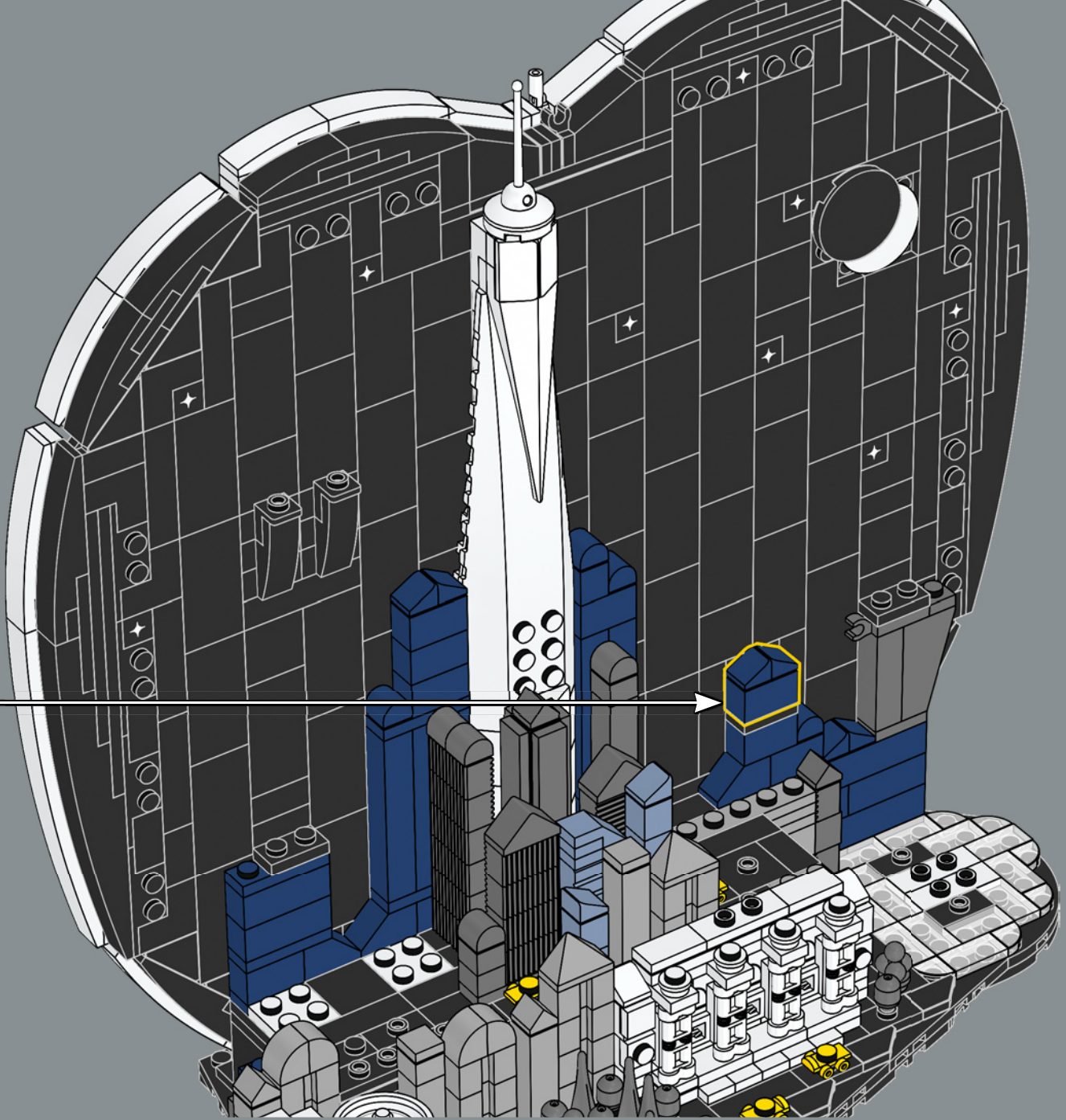
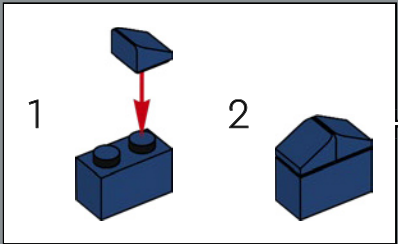

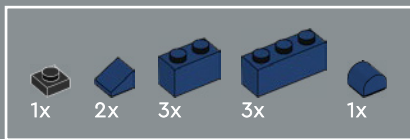

252

1

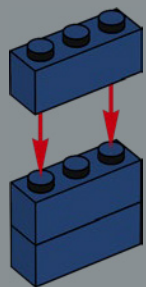

2

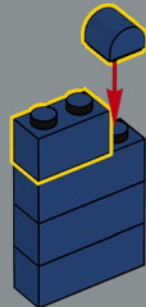

3

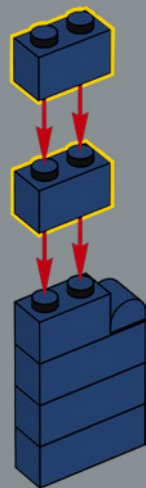

4

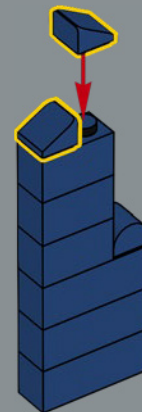

5



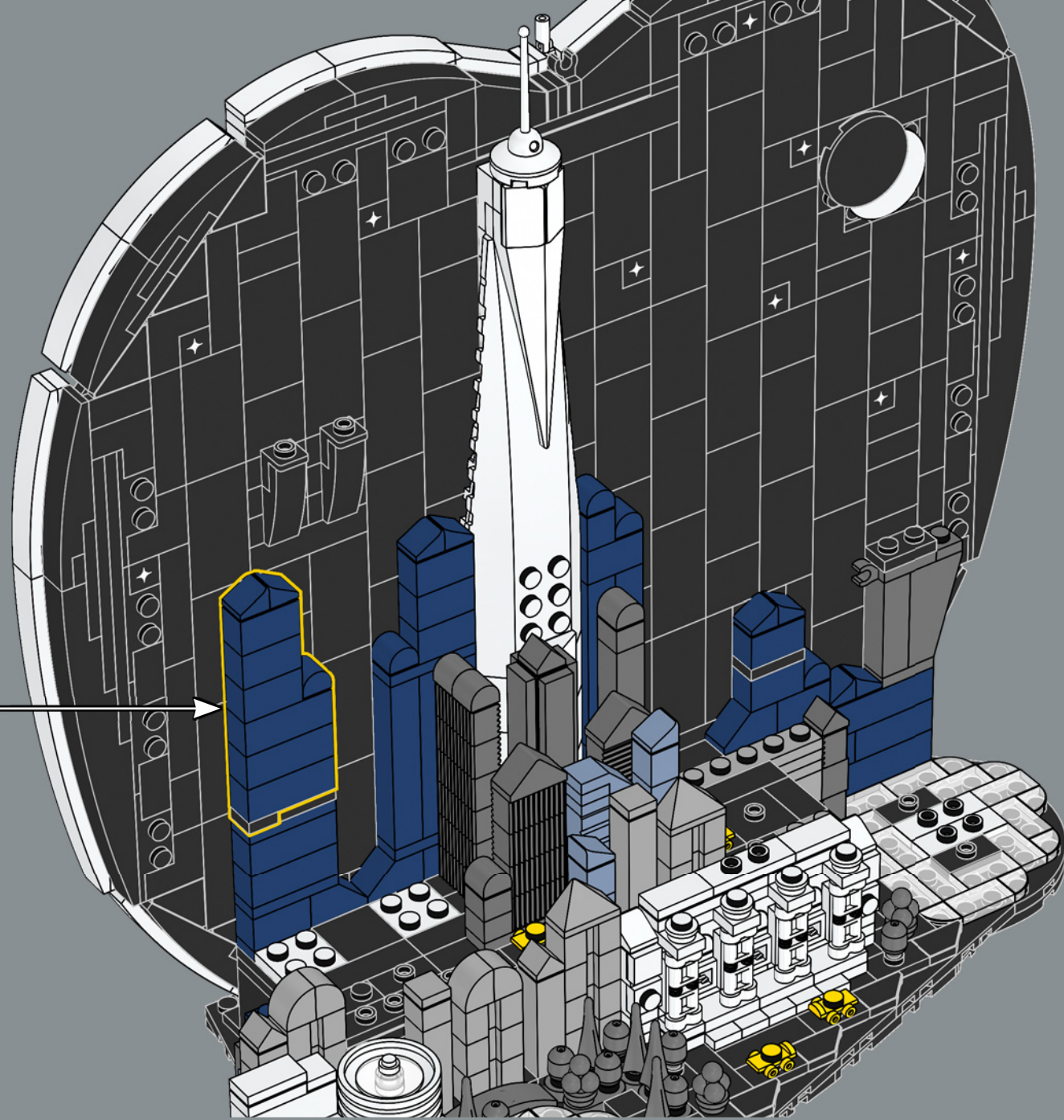

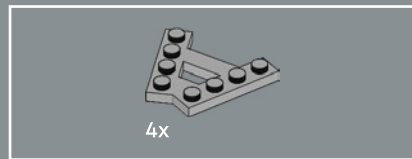

253

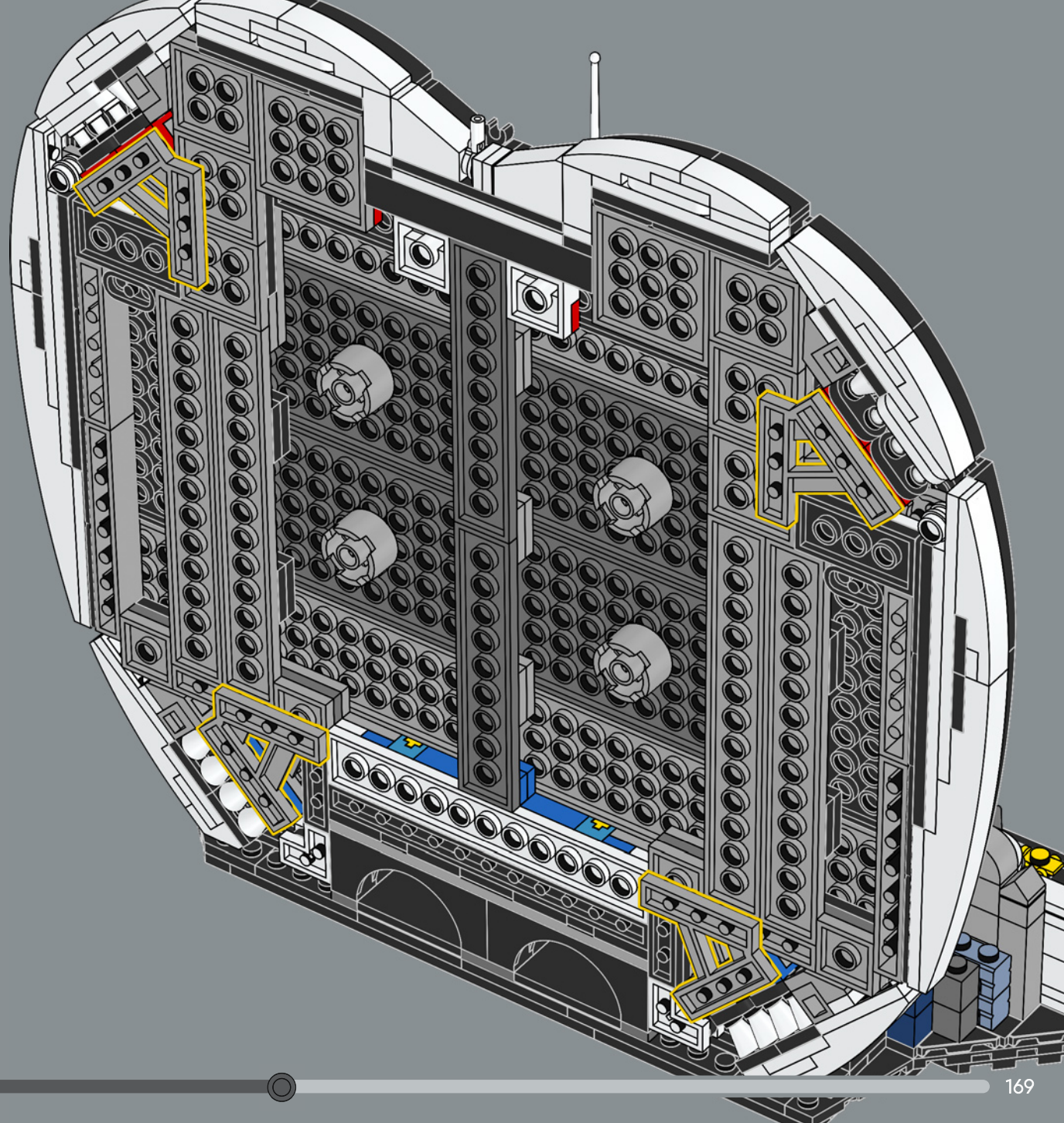

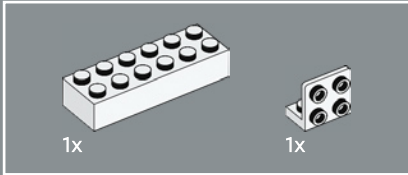
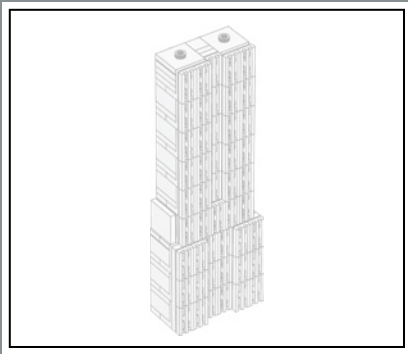

254

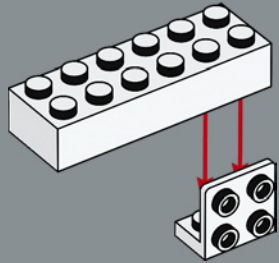

Opened in 1931, the Empire State Building remains an Art Deco icon. As the world's first ever steel-frame building with over 100 floors, it ruled the New York skyline as the world's tallest for nearly 40 years.

Inauguré en 1931, l'Empire State Building demeure une icône Art déco. En tant que tout premier gratte-ciel à ossature d'acier de plus de 100 étages, il a dominé l'horizon de New York en tant que plus haut bâtiment du monde pendant près de 40 ans.

Inaugurado en 1931, el Empire State Building sigue siendo un ícono del *art déco*. Fue el primer edificio jamás construido con estructura de acero y más de 100 pisos, y dominó el horizonte urbano de Nueva York como el más alto del mundo durante casi 40 años.

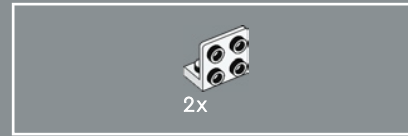

255

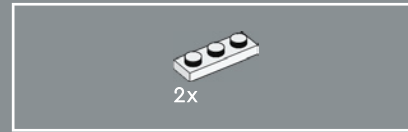
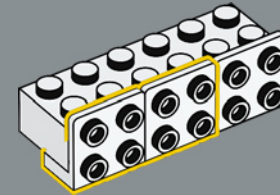

256

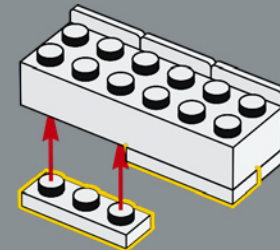

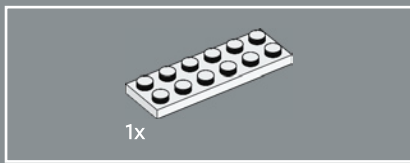

257

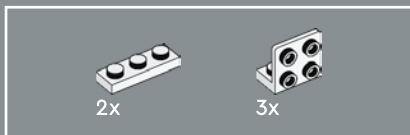
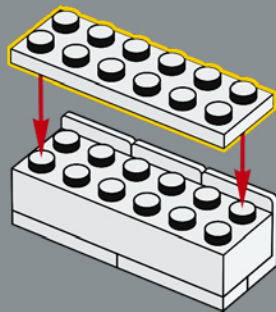

258

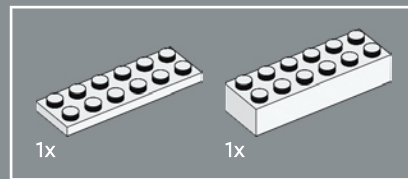
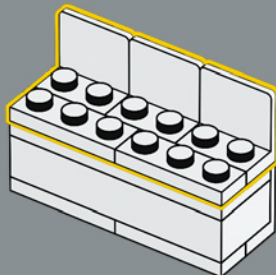

259

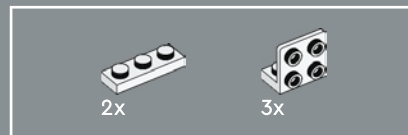
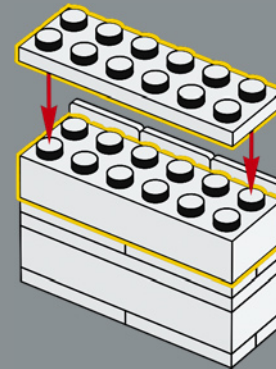

260

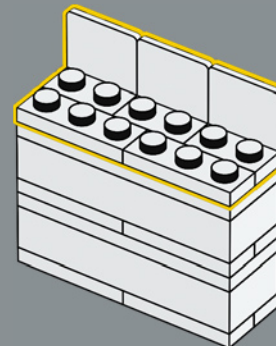

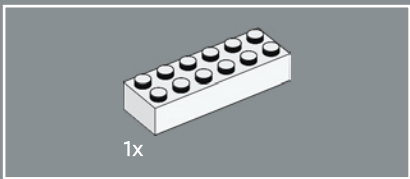

261

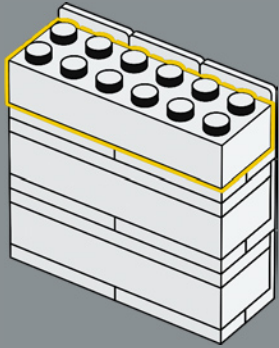

262

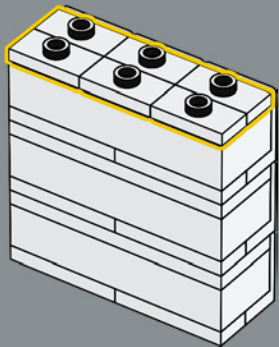

263

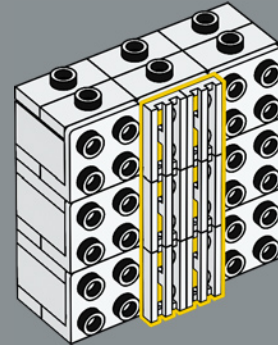

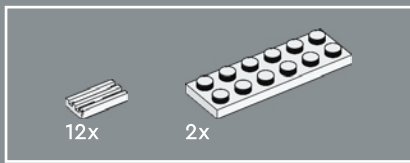

264

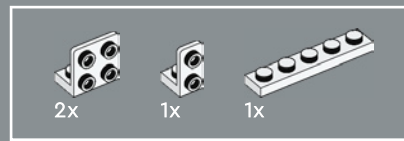
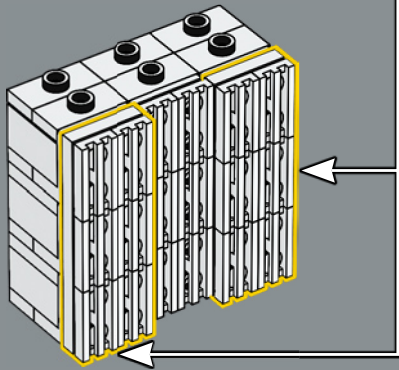
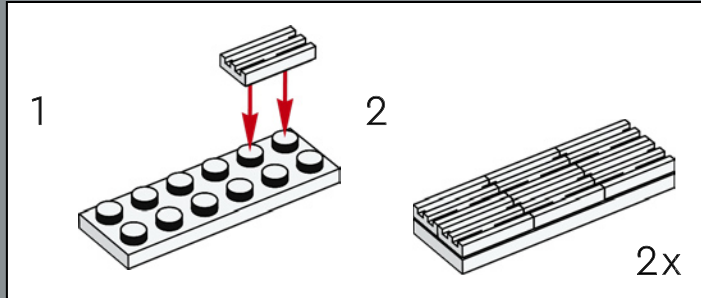

265

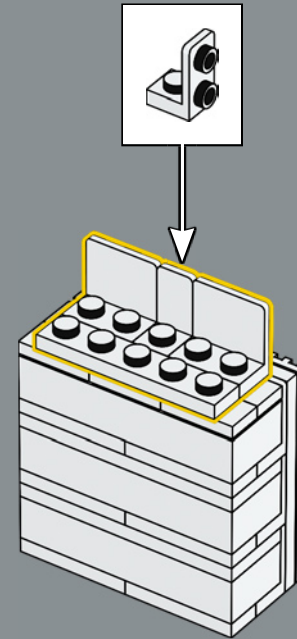

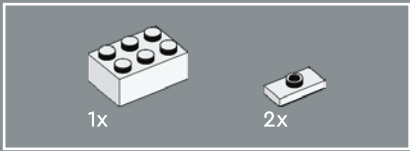

266

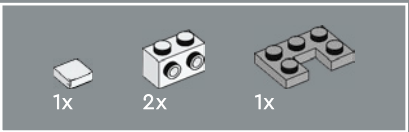
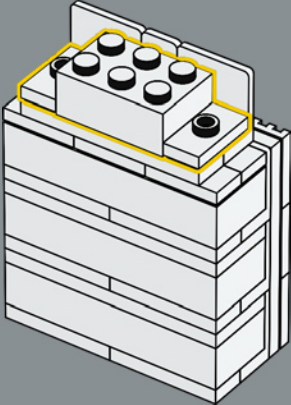

267

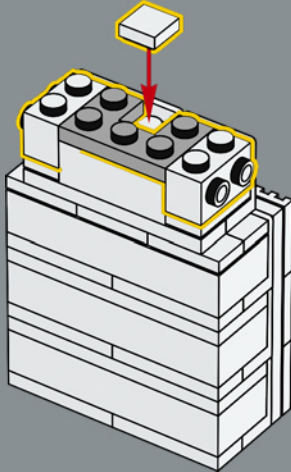

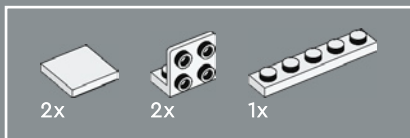

268

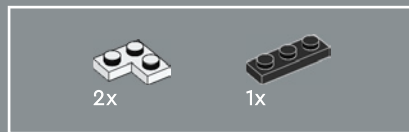
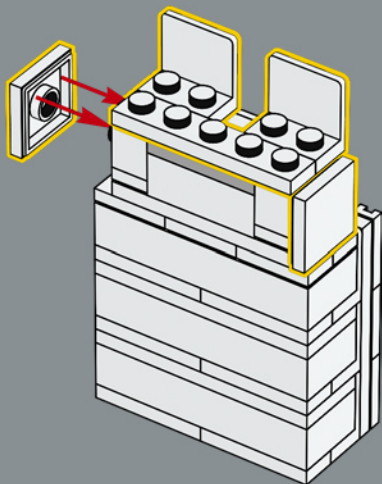

269

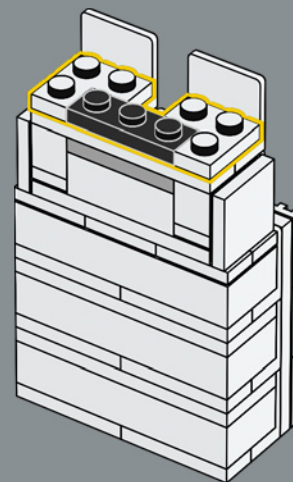

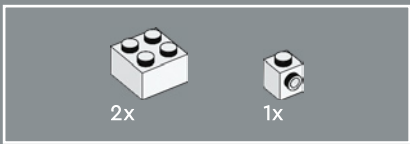

270

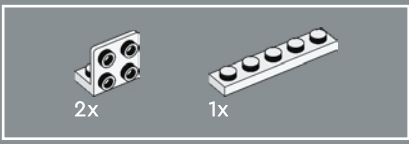
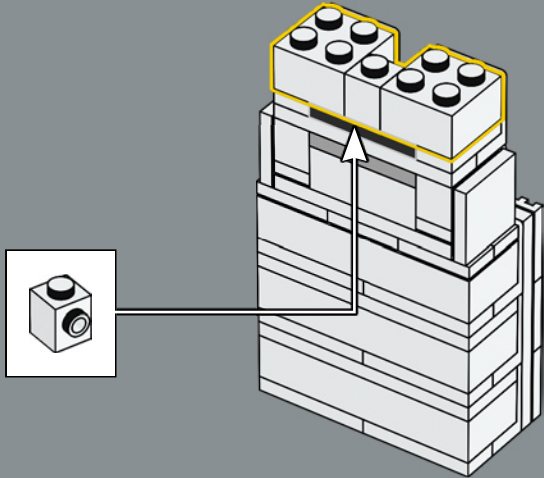

271

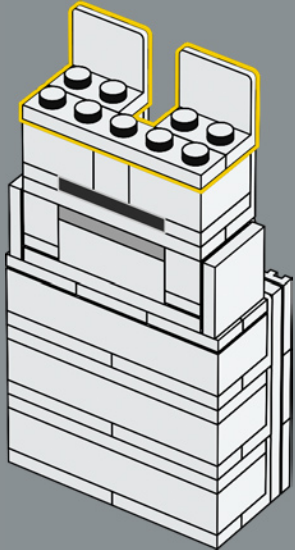

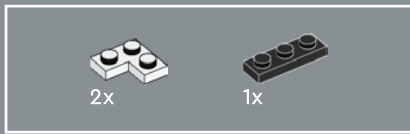

272

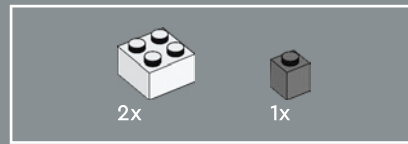
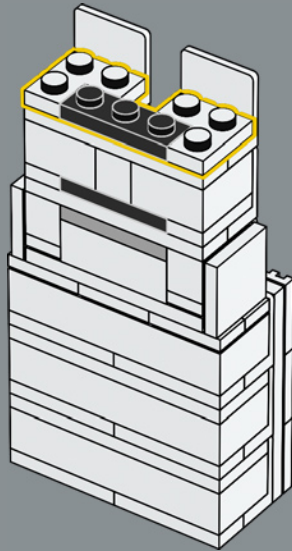

273

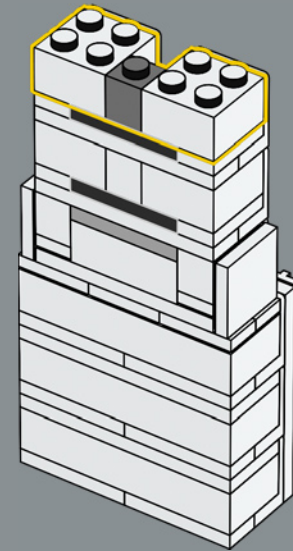

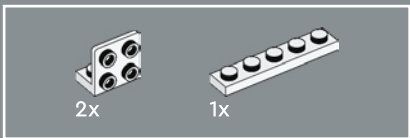

274

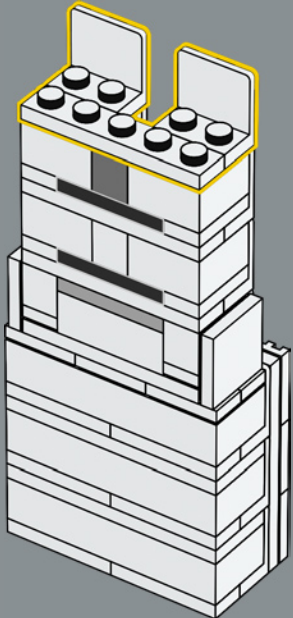

275

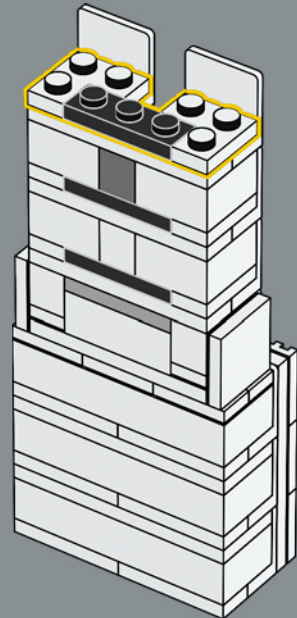

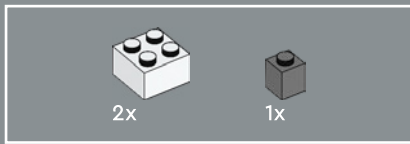

276

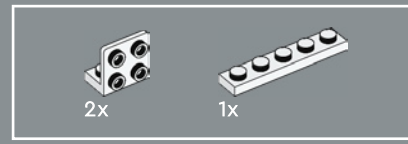
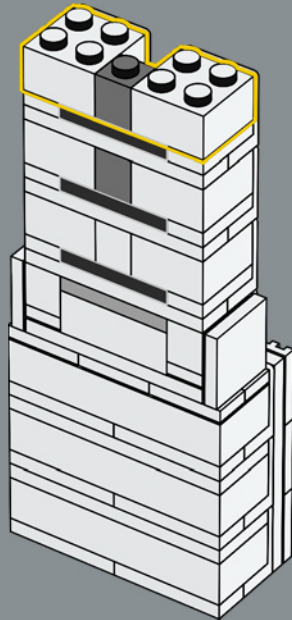

277

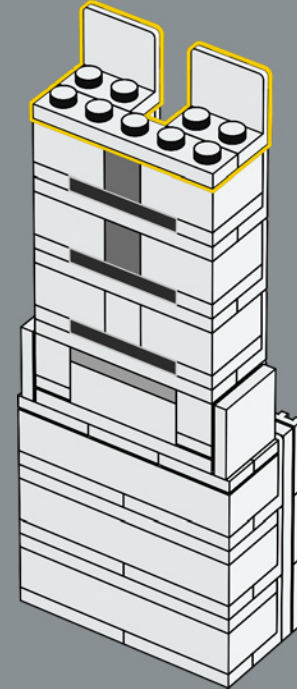

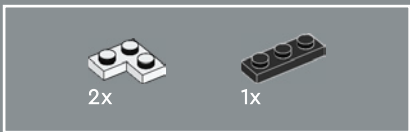

278

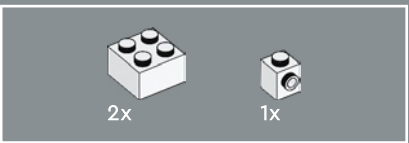
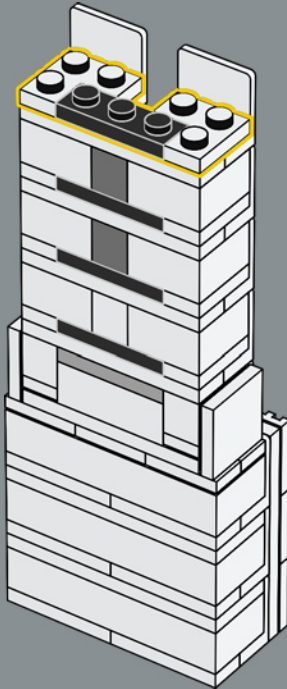

279

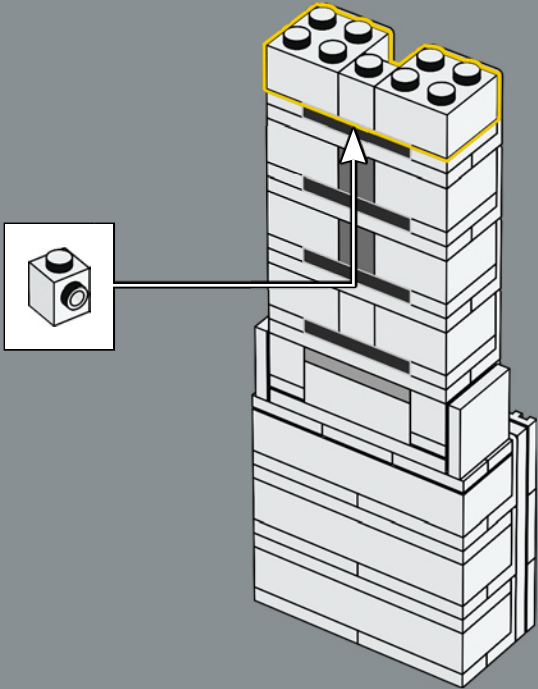

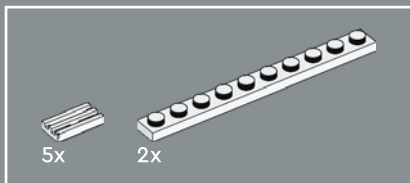

280

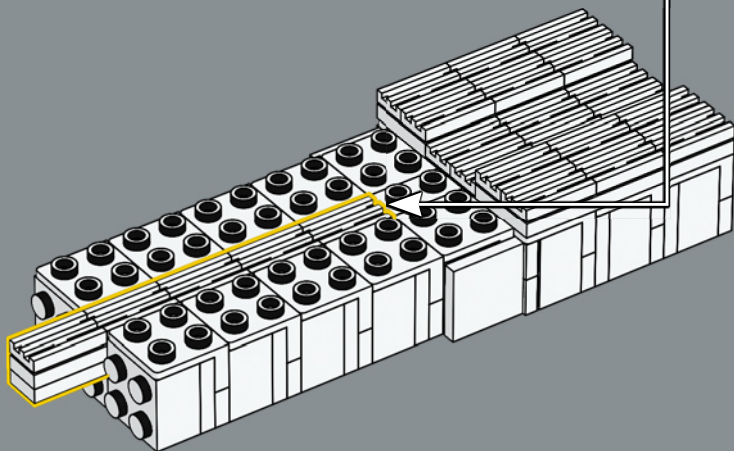
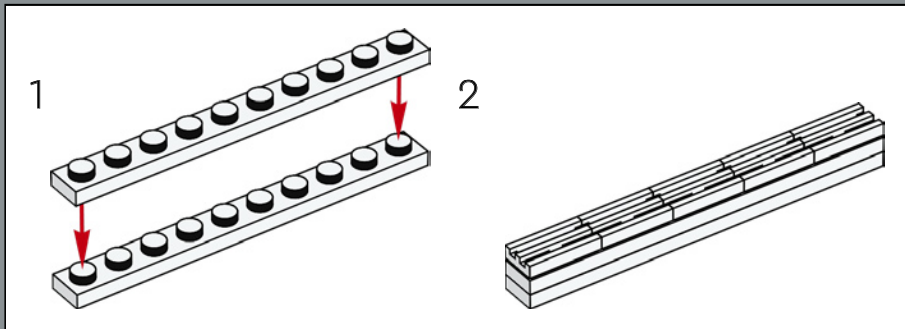

281

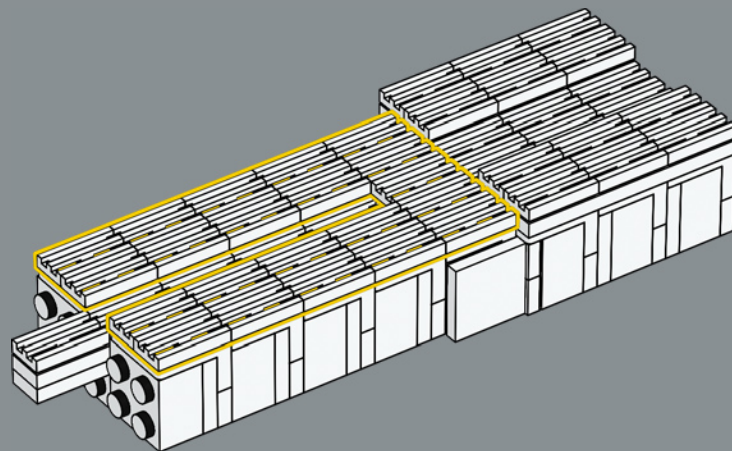

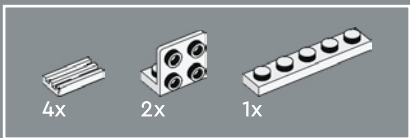

282

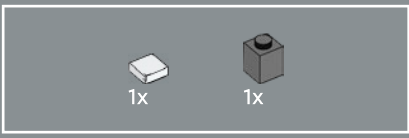
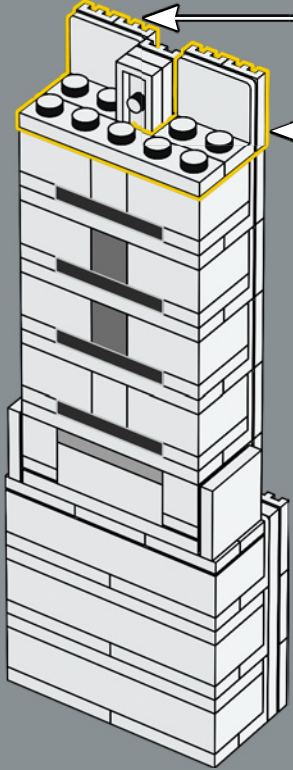
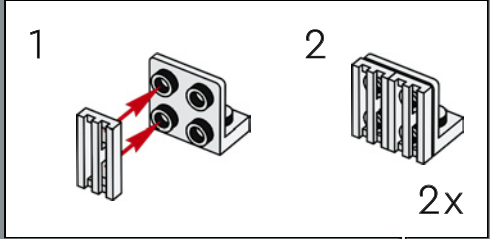

283

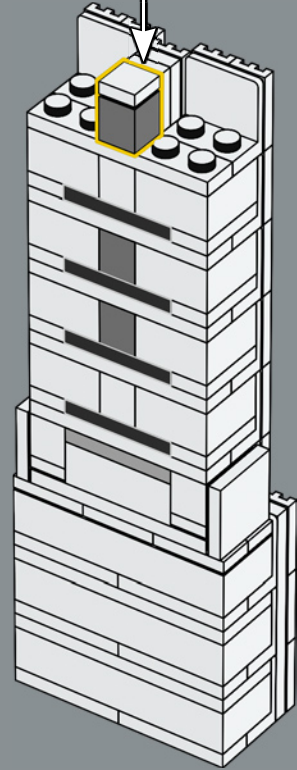
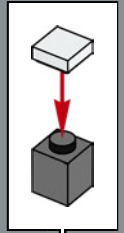

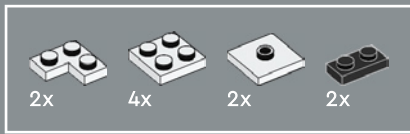

284

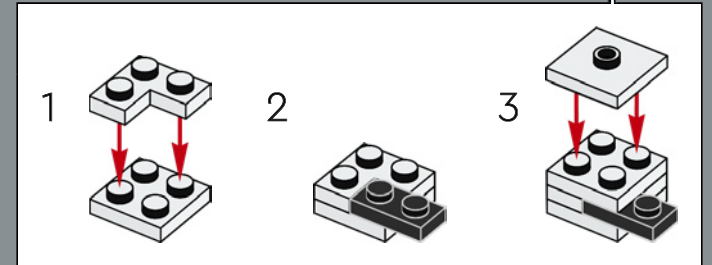
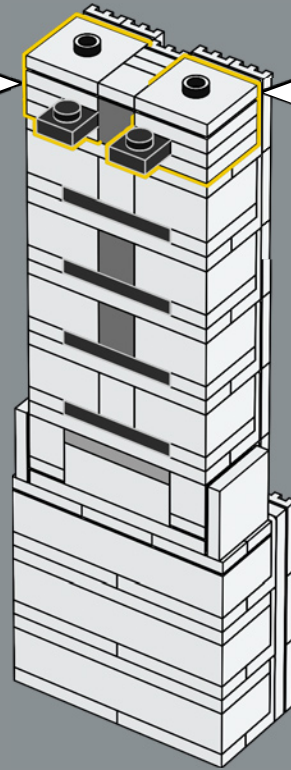
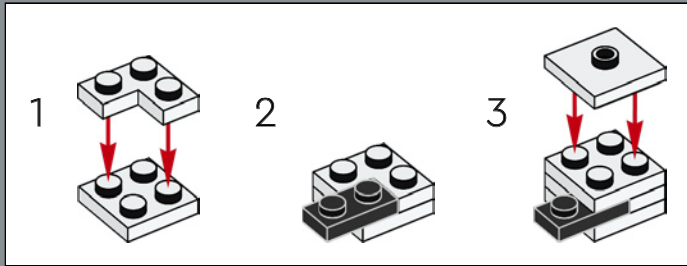

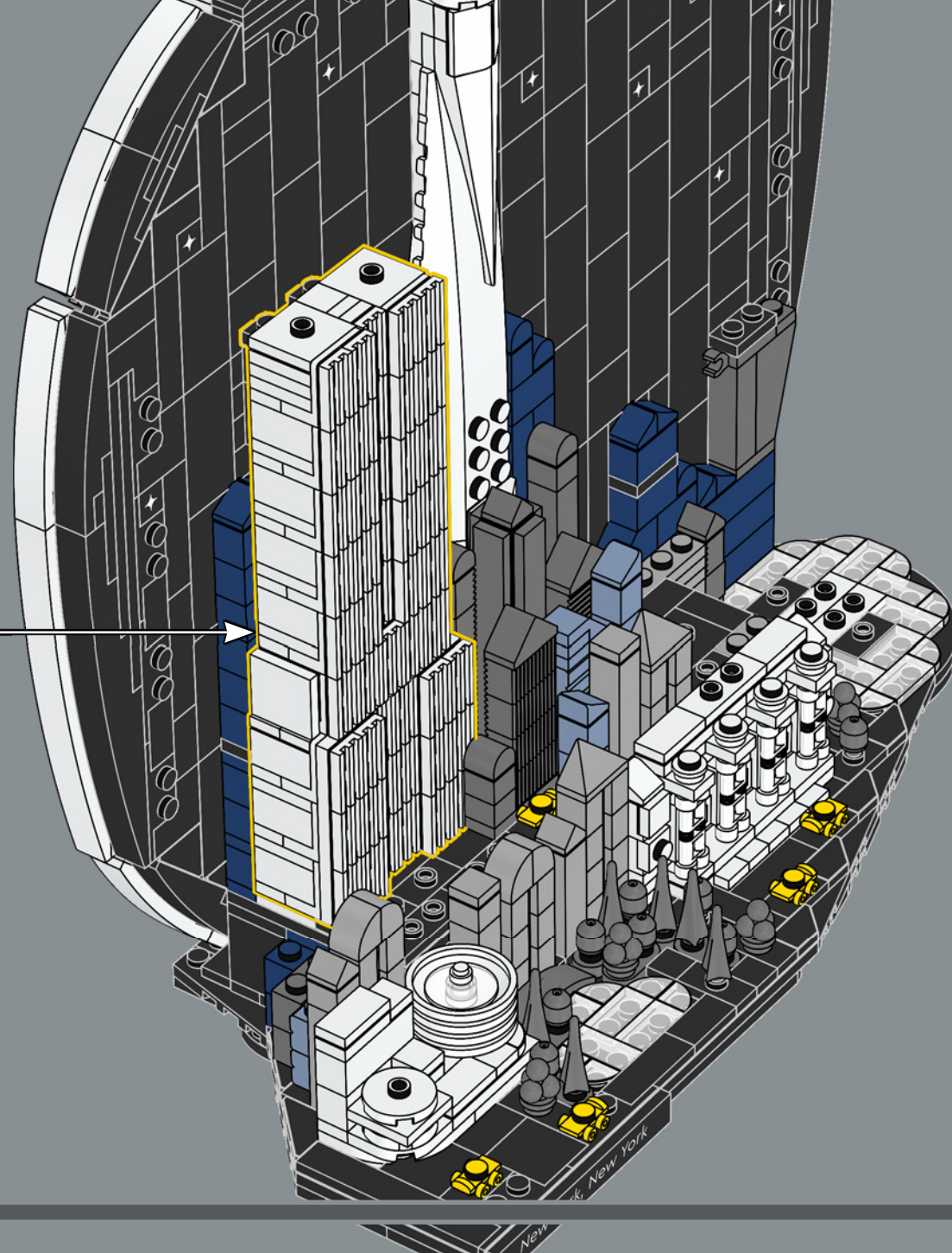

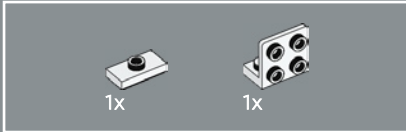
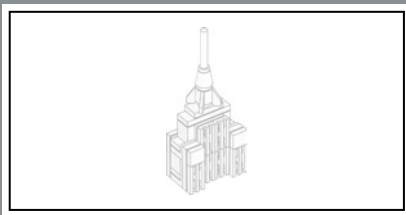

286

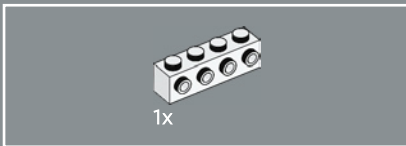
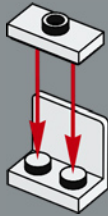

287

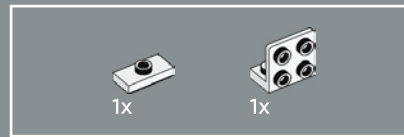
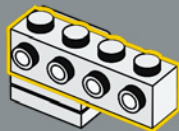

288

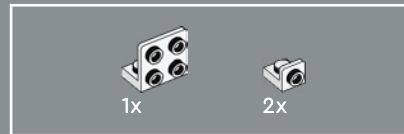
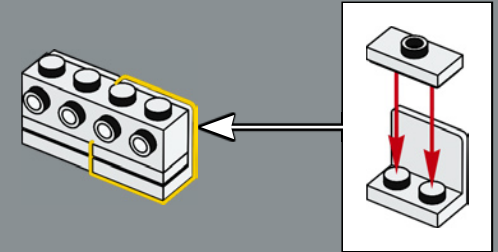

289

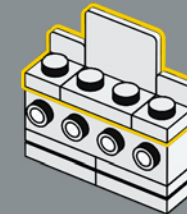



2x

290

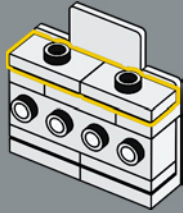

1x



1x

291

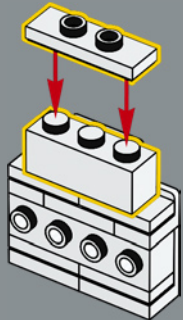

2x

292

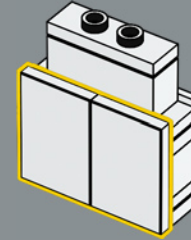

4x

293

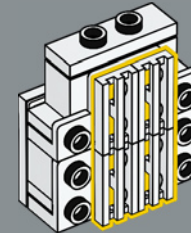



294

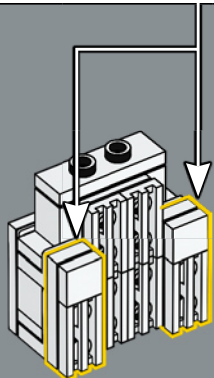
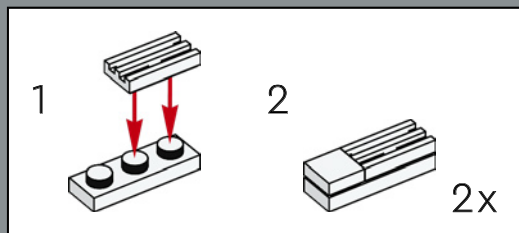

In recent years, the Empire State Building has been through meticulous restorations to preserve its original design and the building's history for generations to come.

Ces dernières années, l'Empire State Building a fait l'objet de restaurations méticuleuses afin de préserver son design d'origine et son histoire pour les générations futures.

En los últimos años, el Empire State Building ha sido objeto de minuciosas restauraciones para preservar su diseño original y su historia para las generaciones futuras.



295

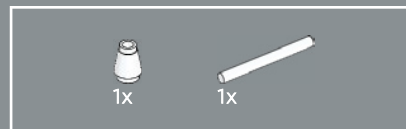
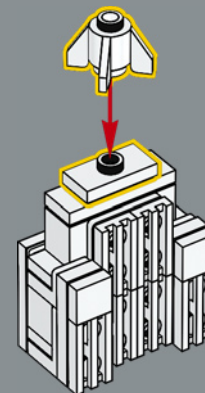

296

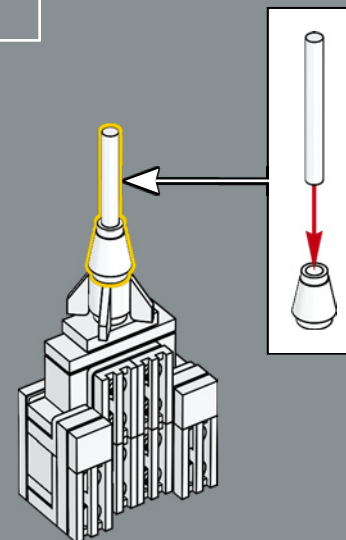

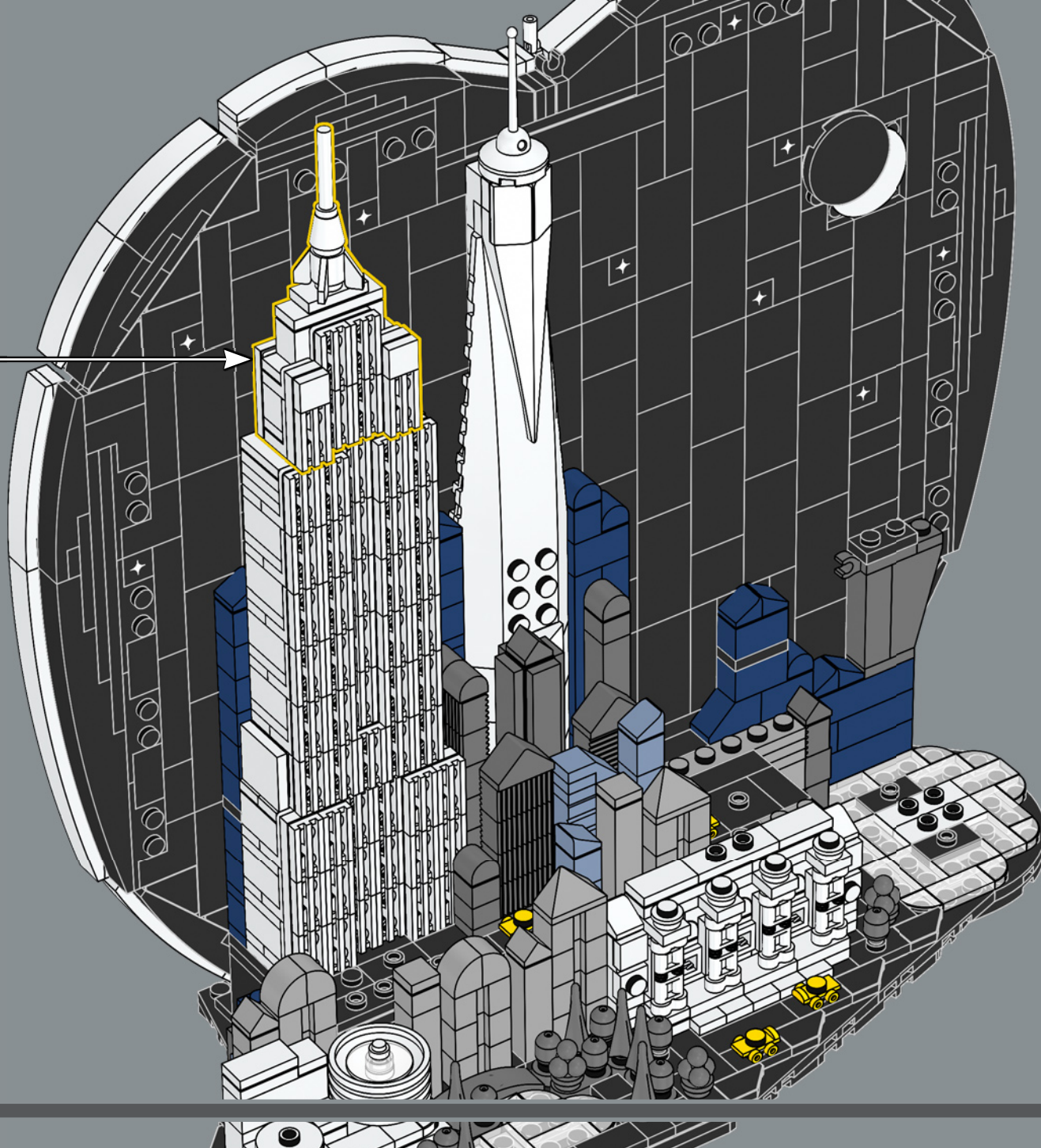

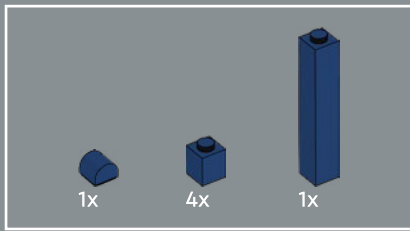

298

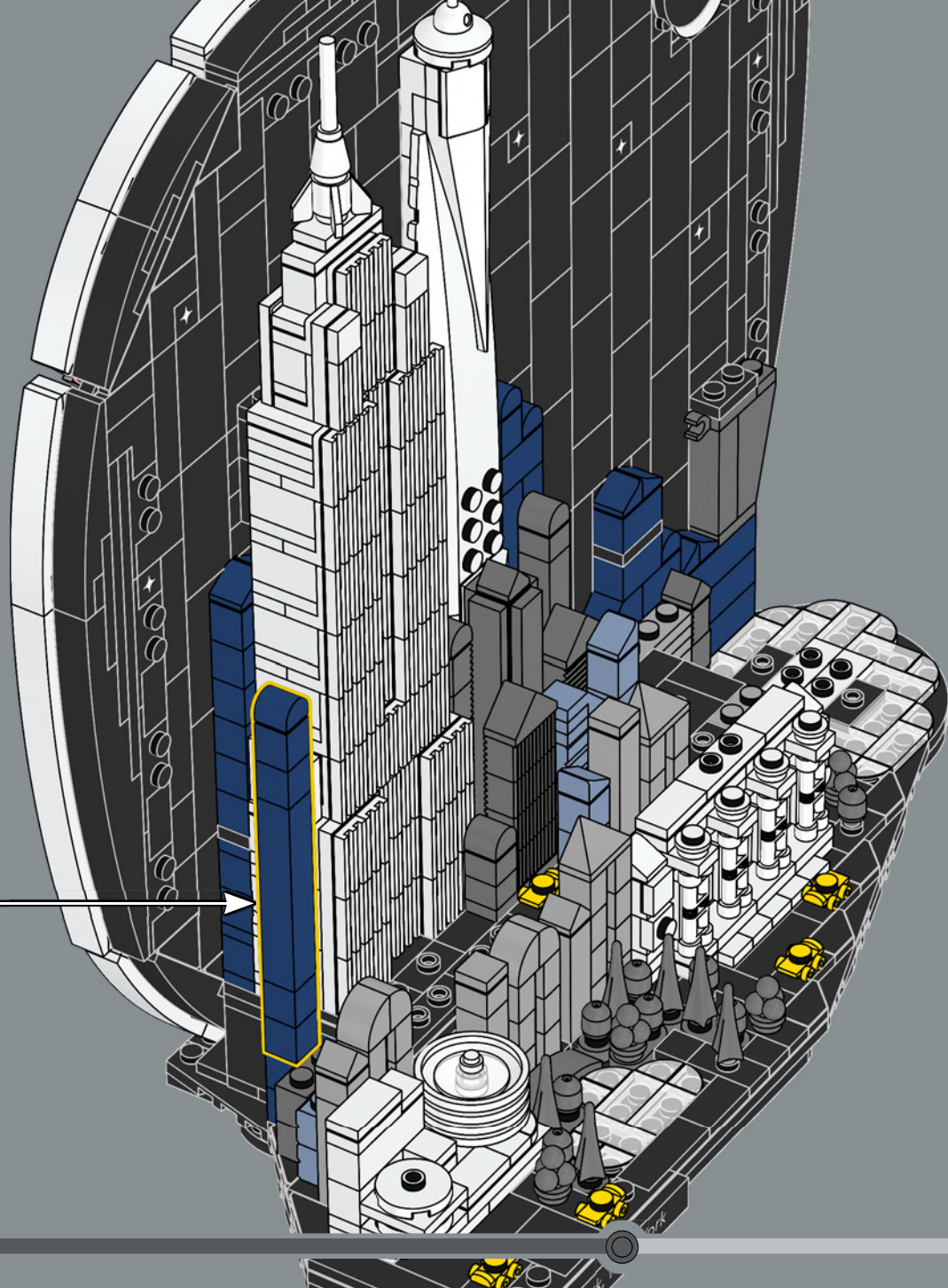
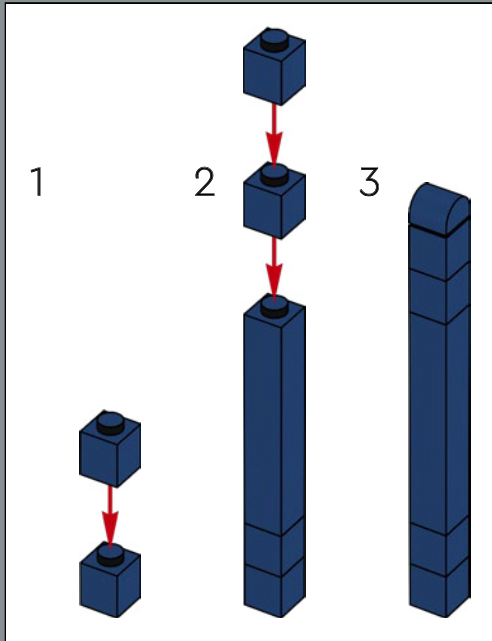

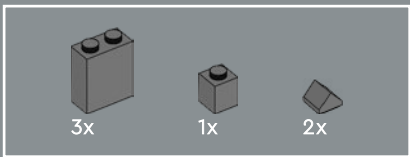

299

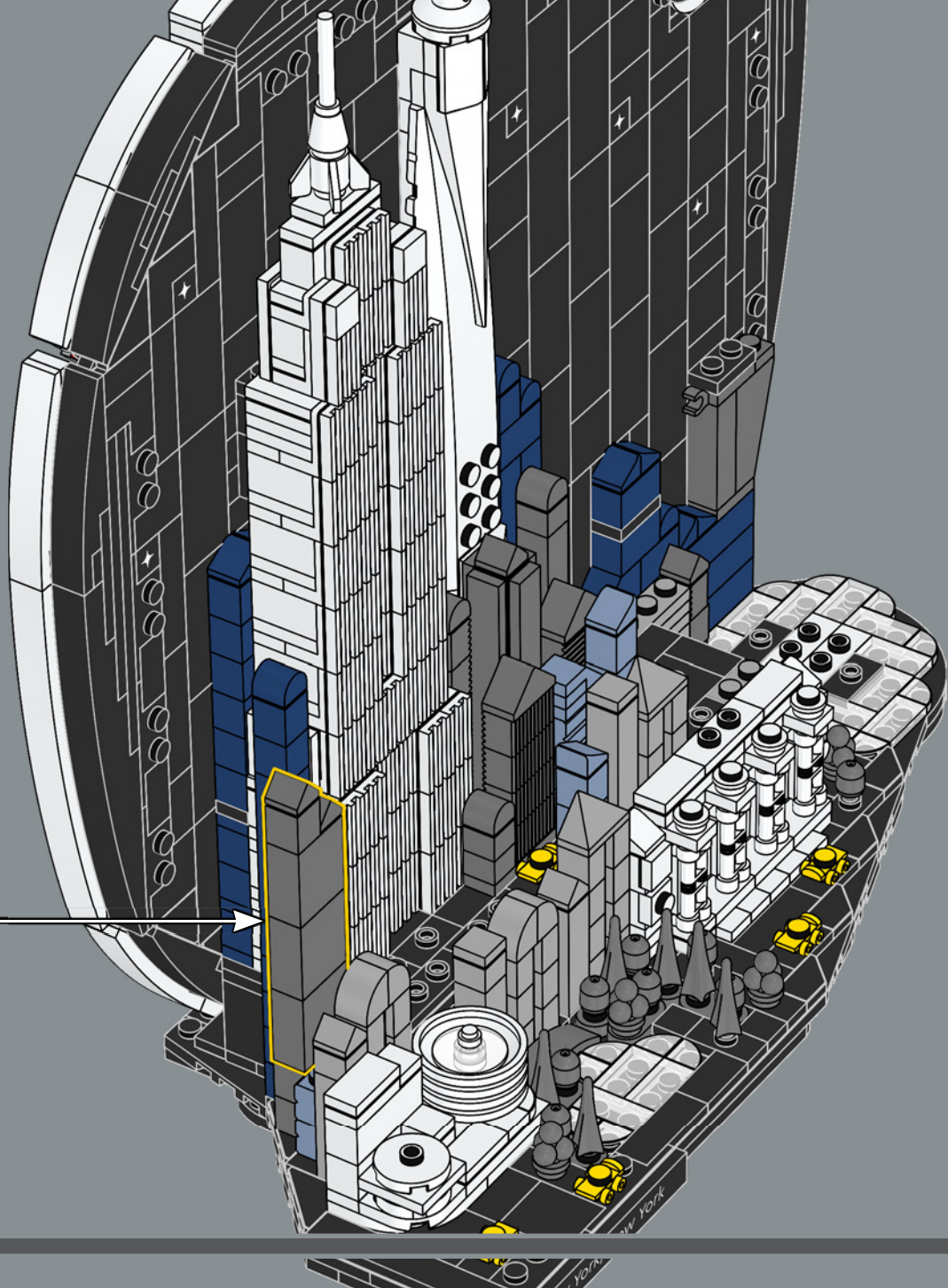
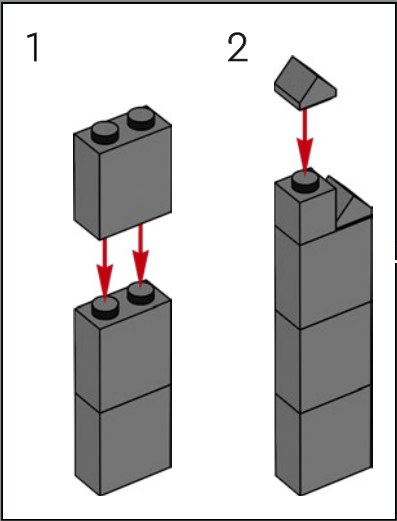

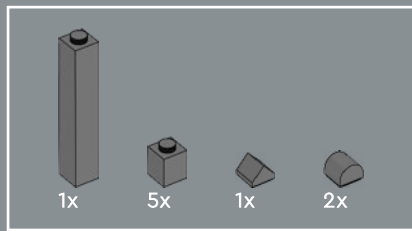

300

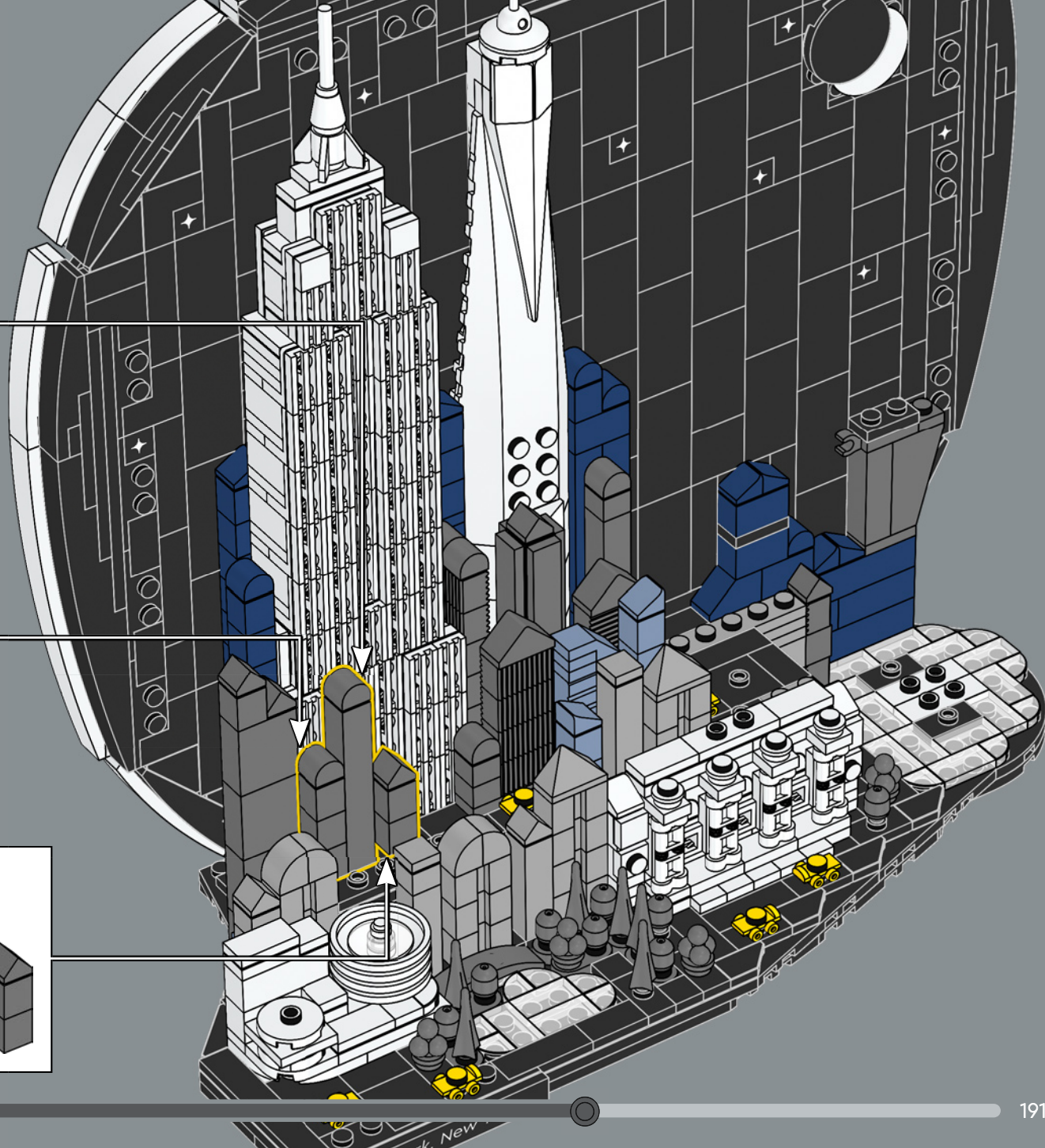
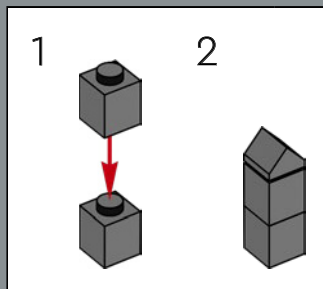
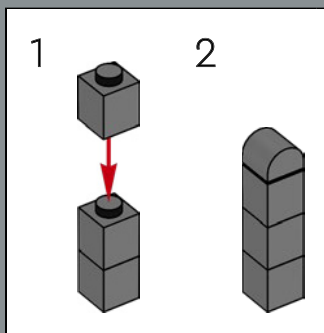
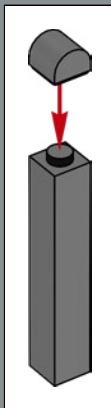



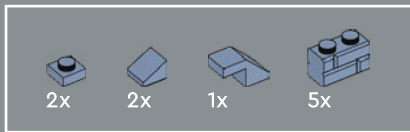

301

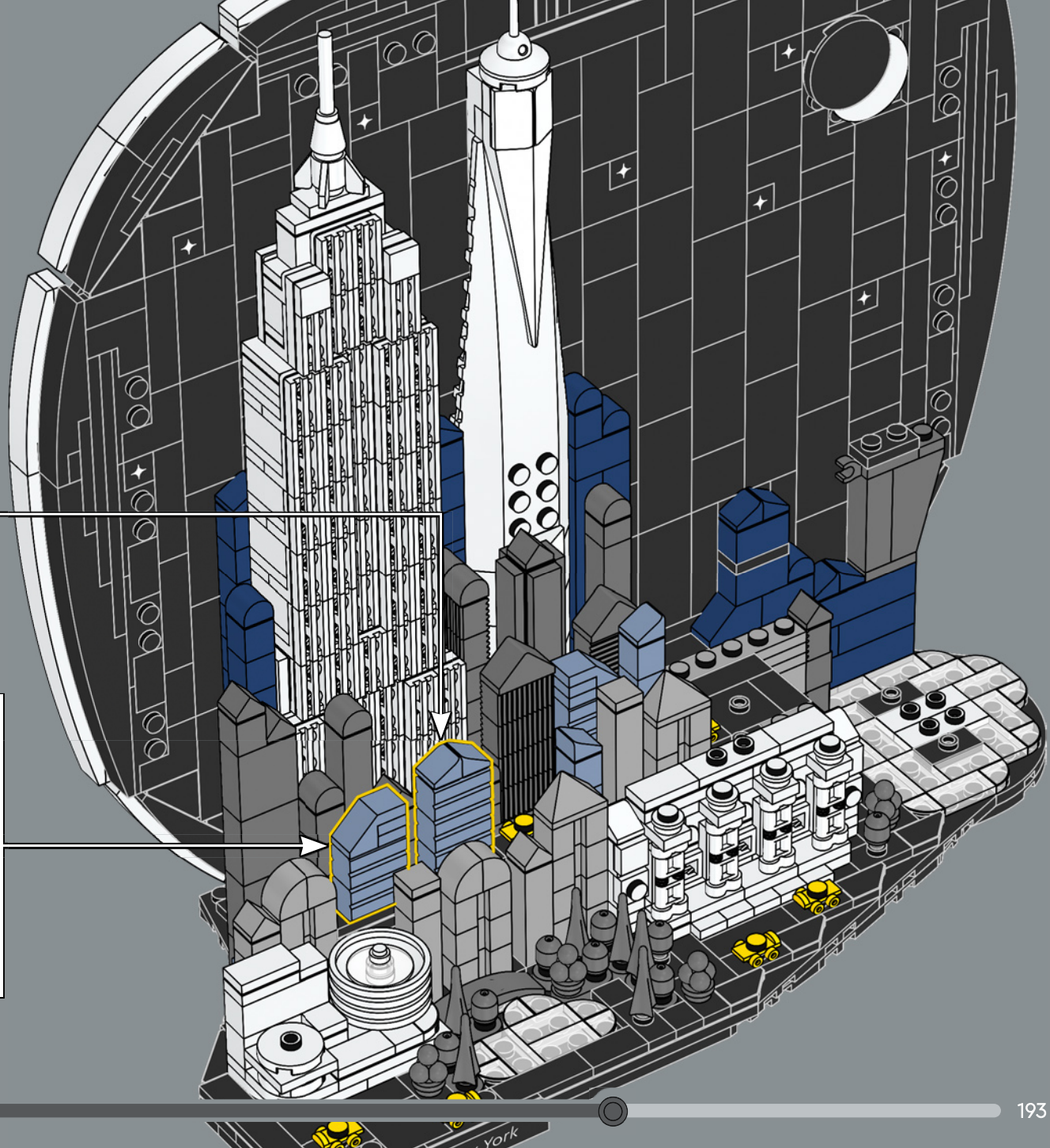
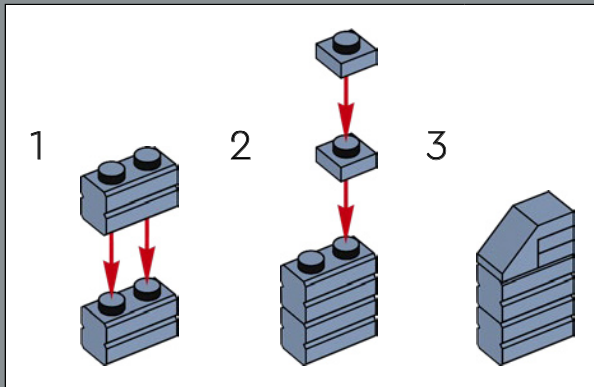
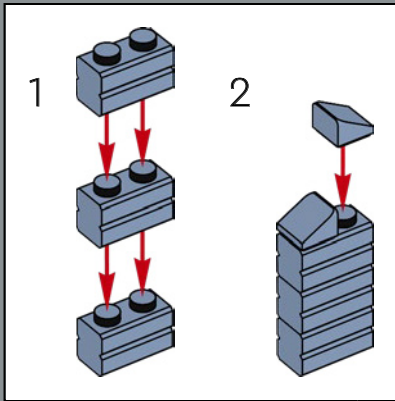

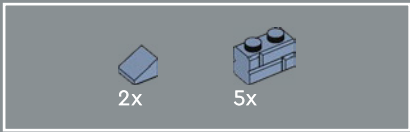

302

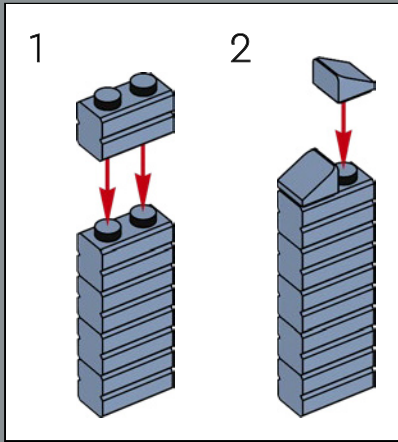
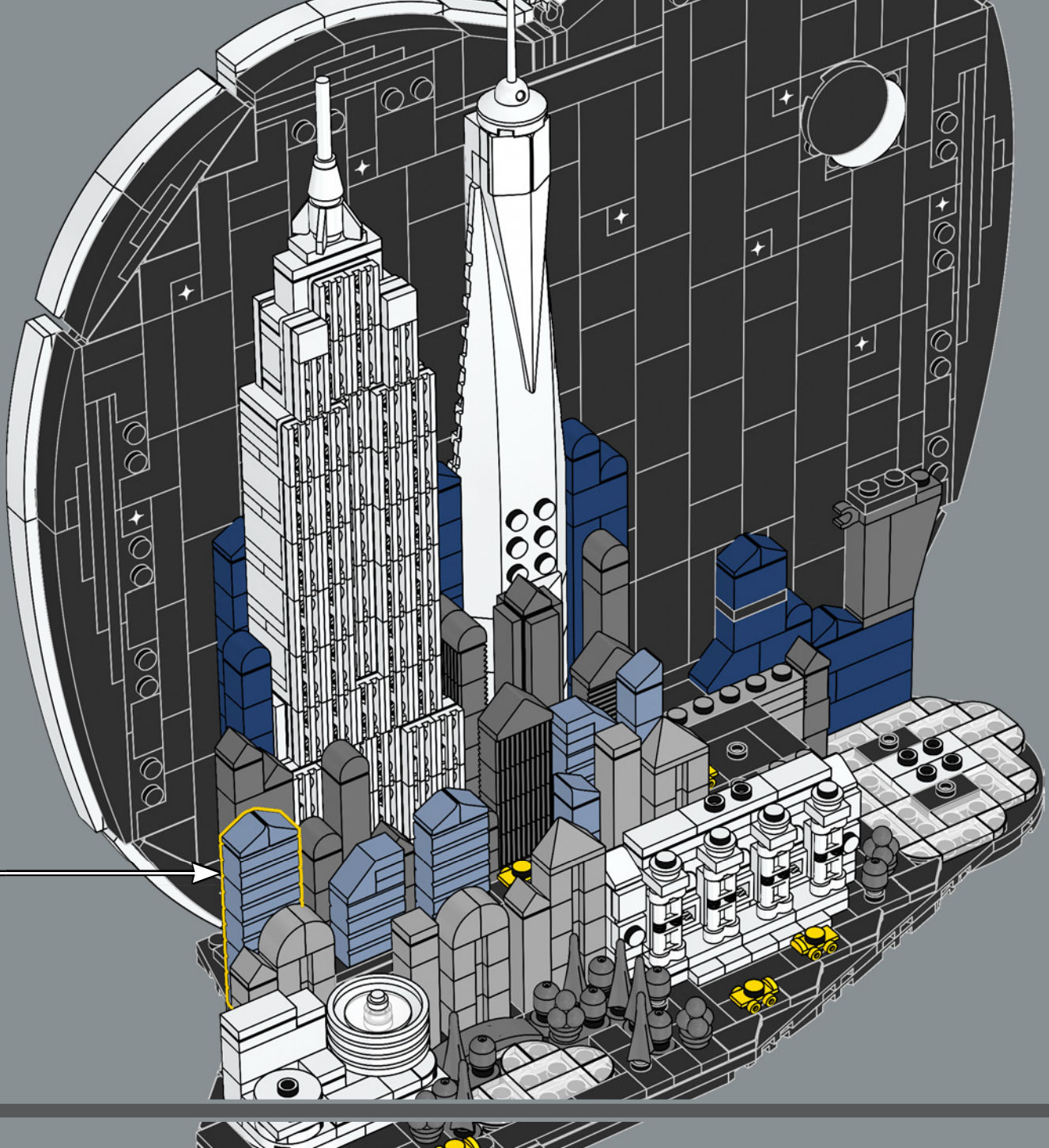



303

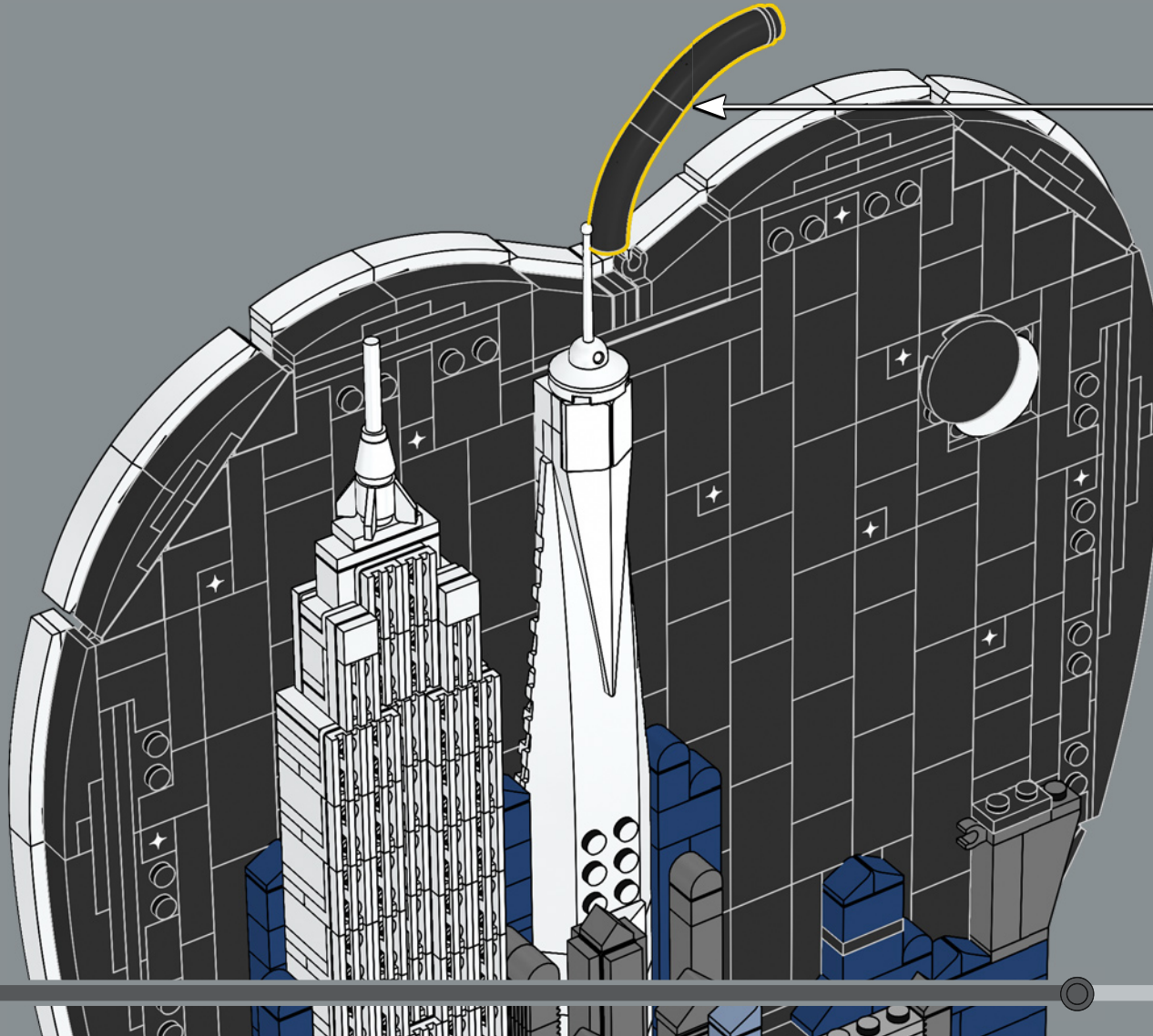
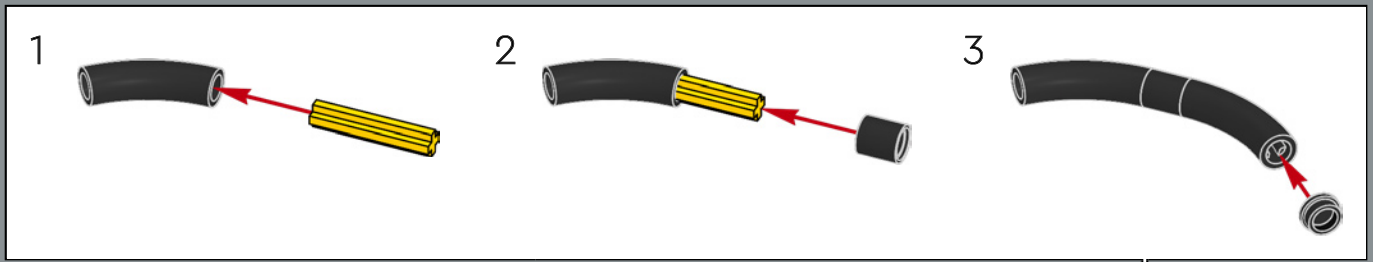

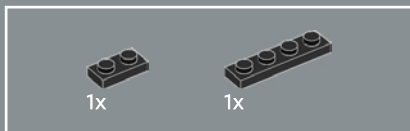

304

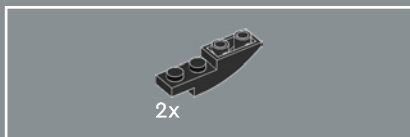
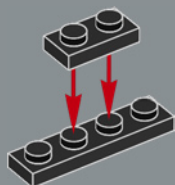

305

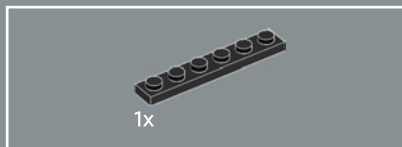
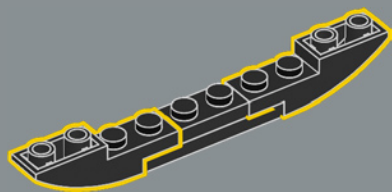

306

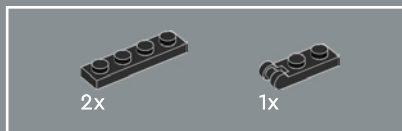
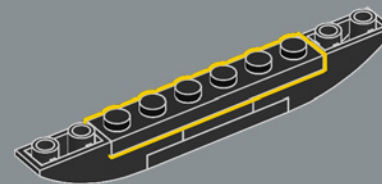

307

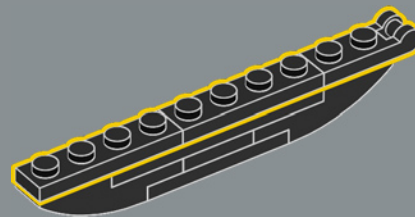

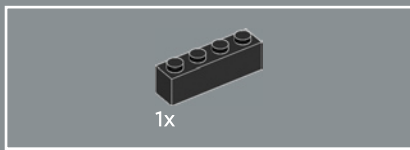

308

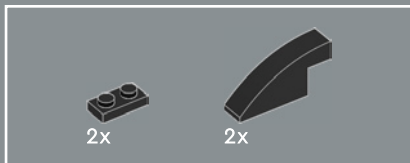
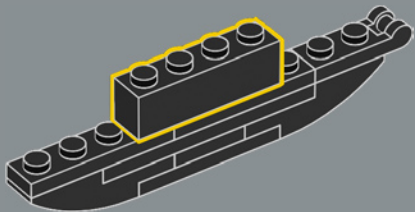

309

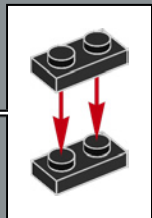
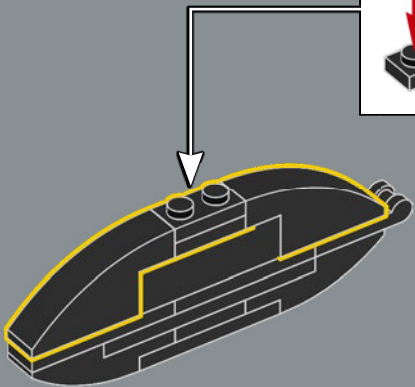

310

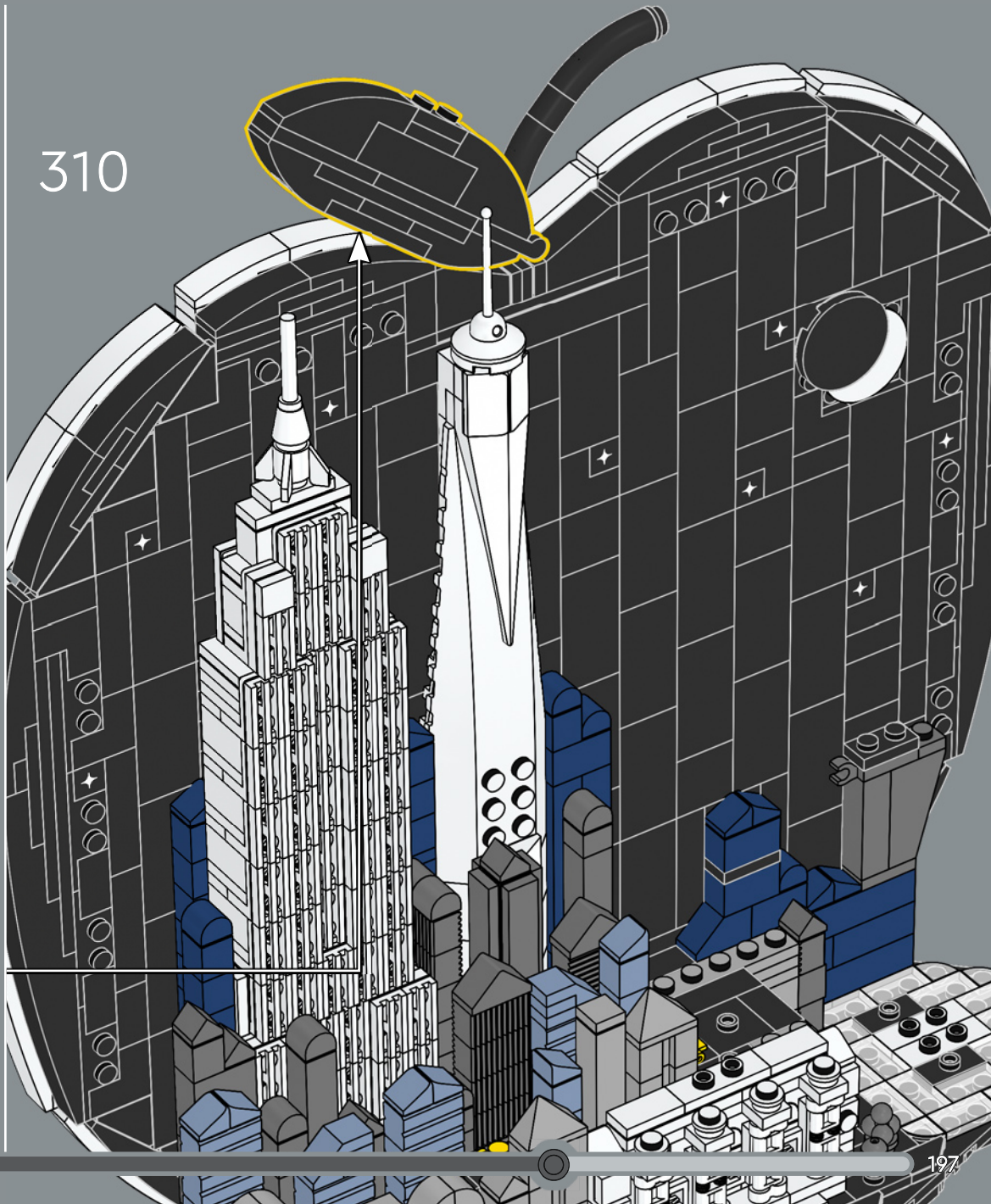

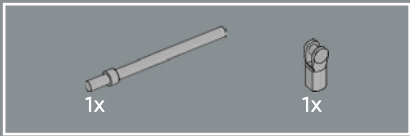

311

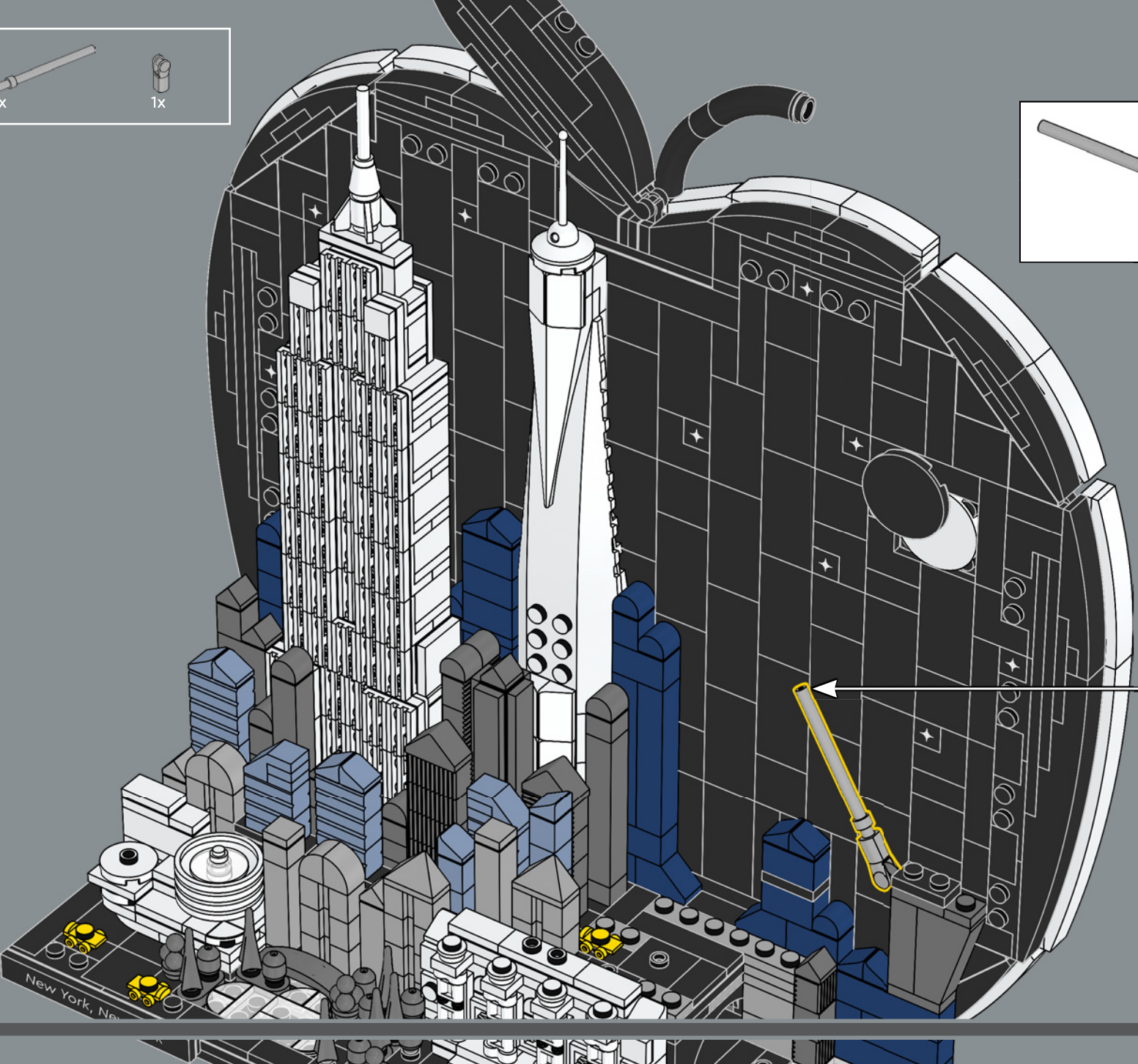
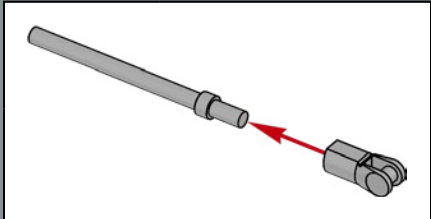

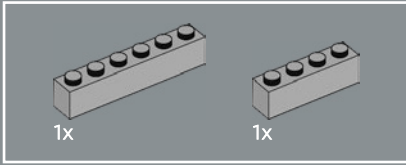
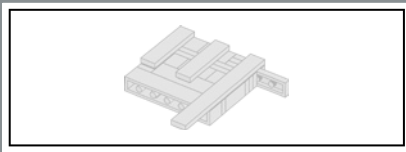

312

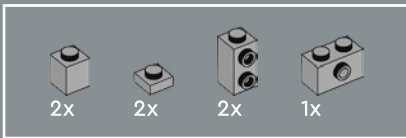
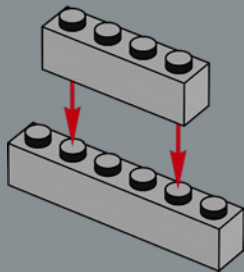

313

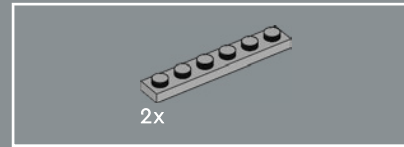
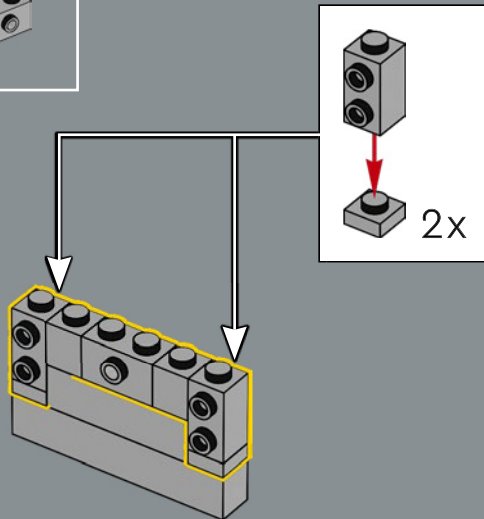

314

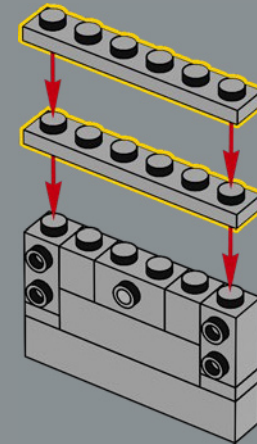

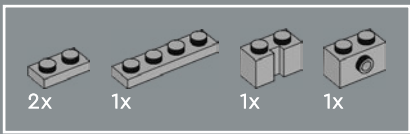

315

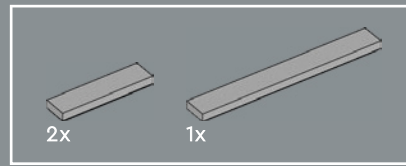
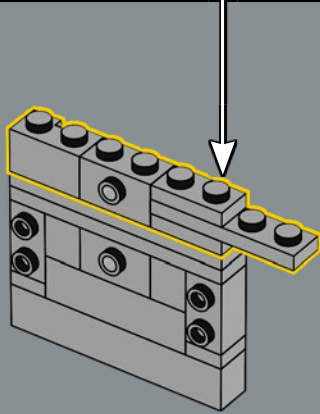
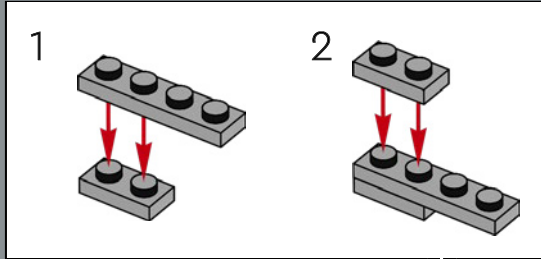

316

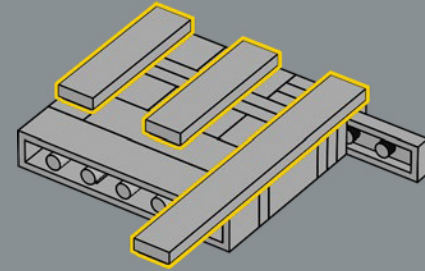

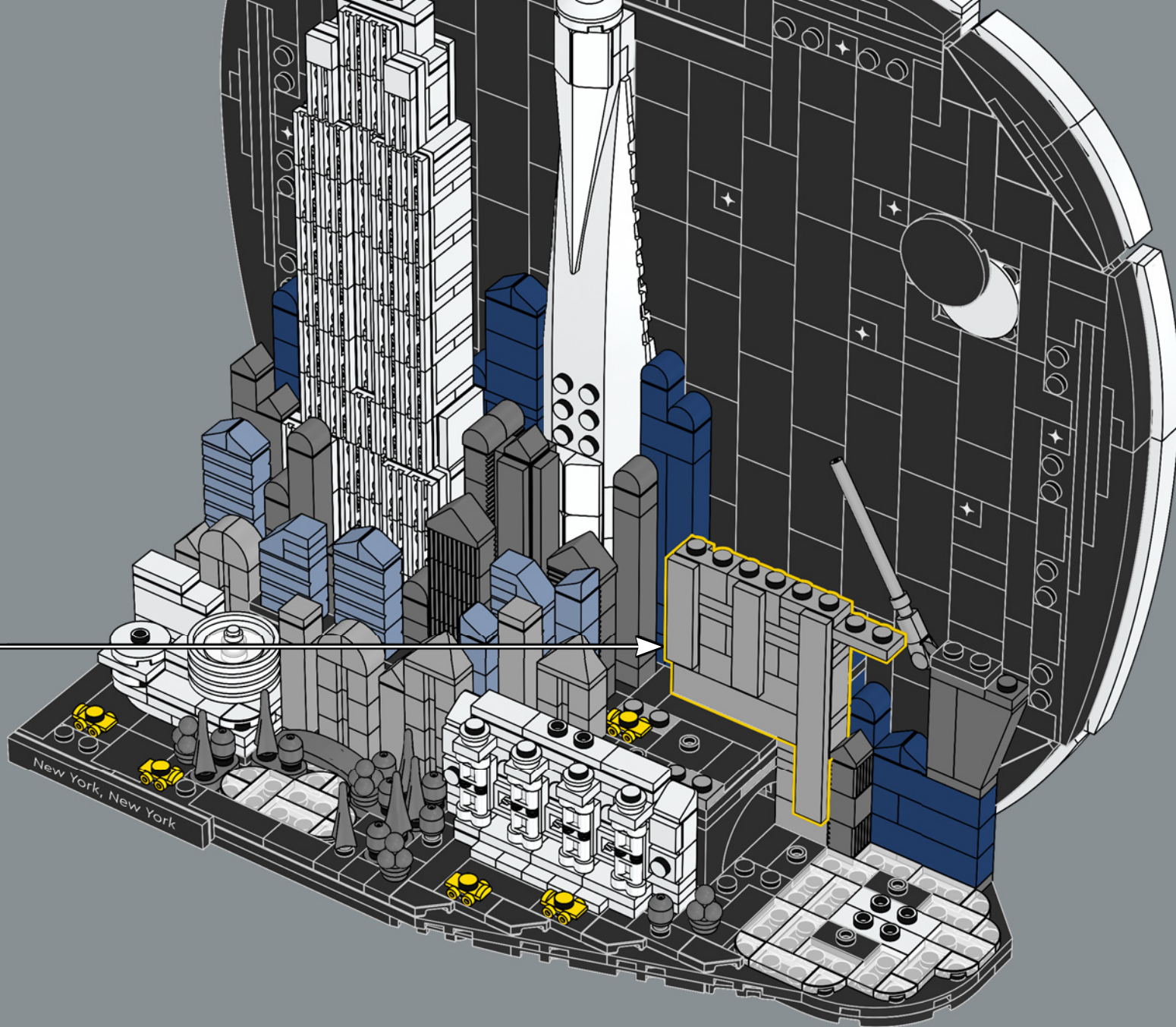

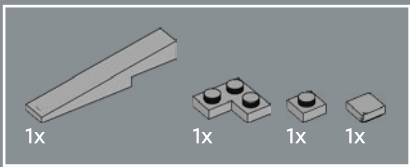

318

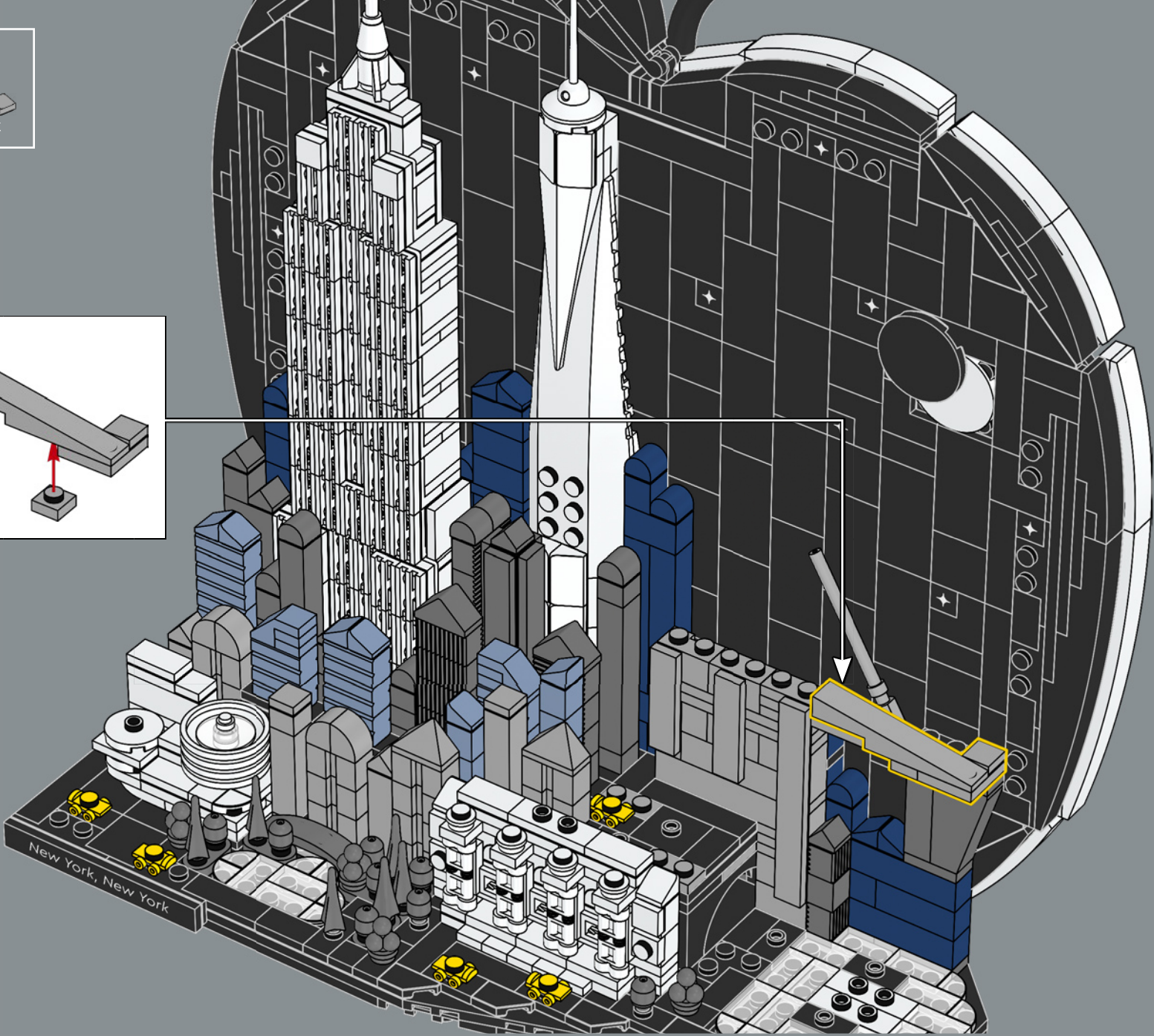
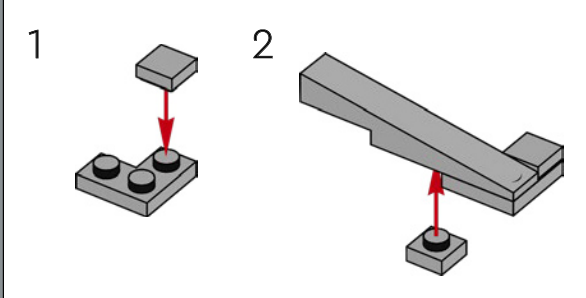



319

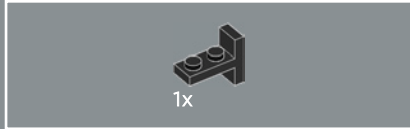

320



321

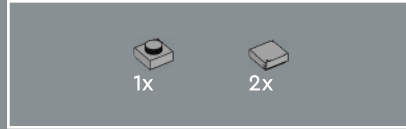
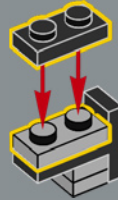

322

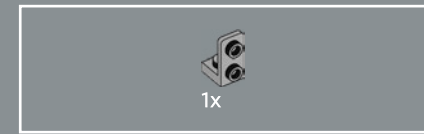
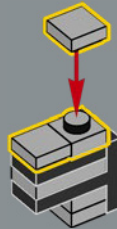

323

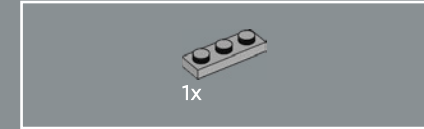
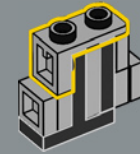

324

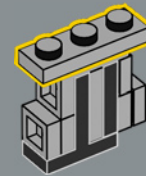

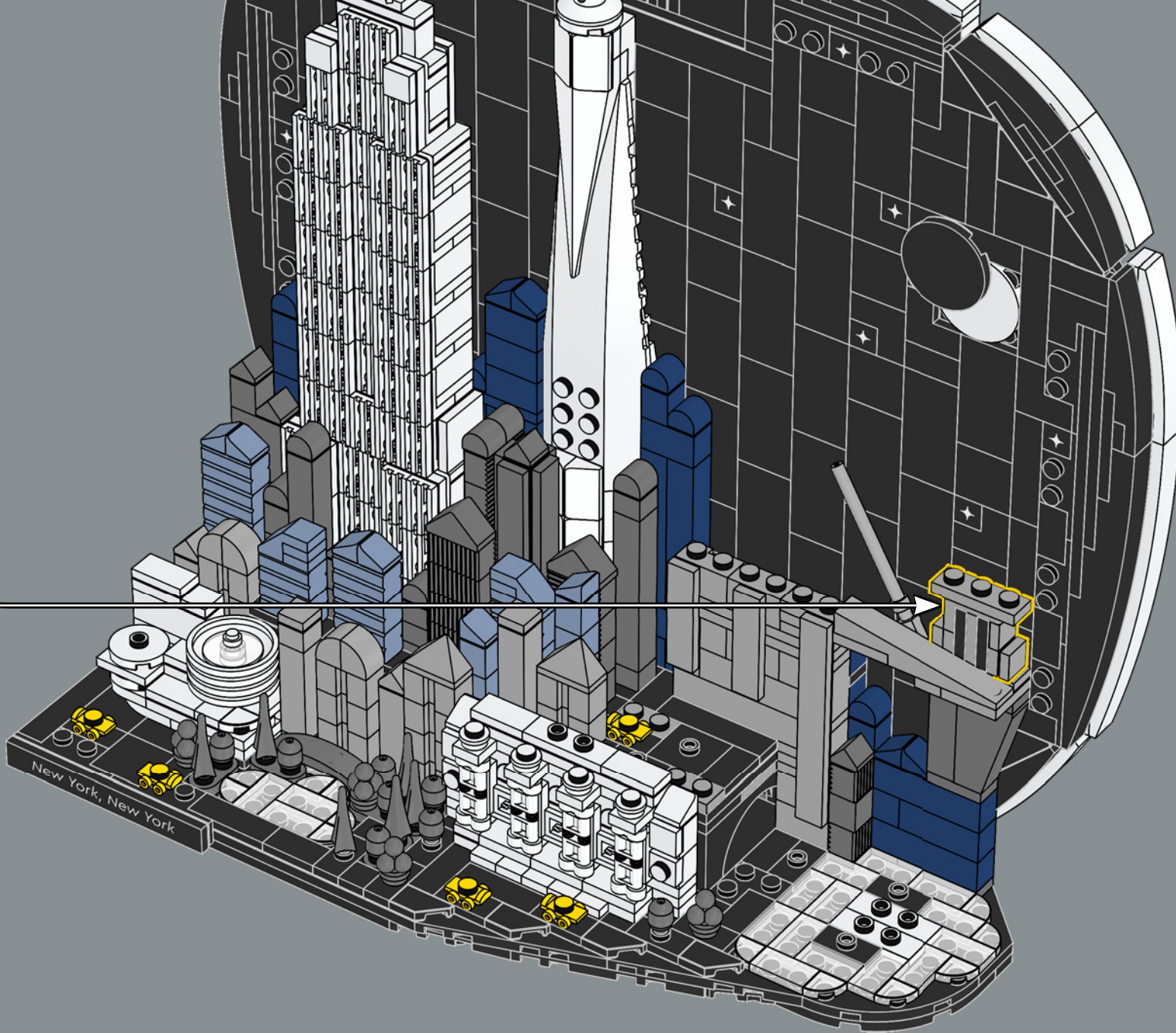

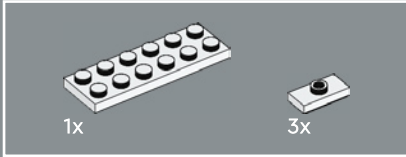
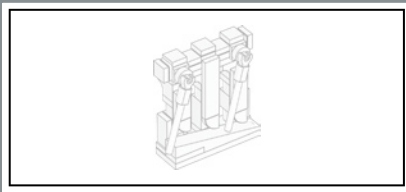

326

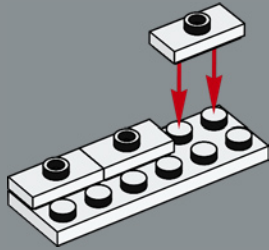

327

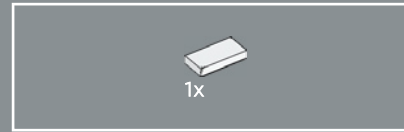
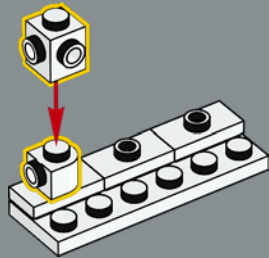

328

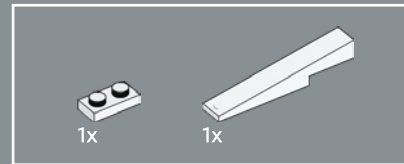
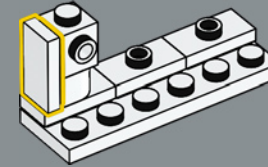

329

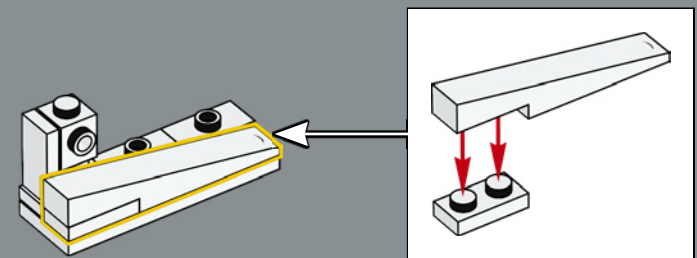

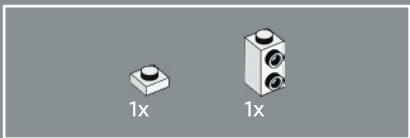

330

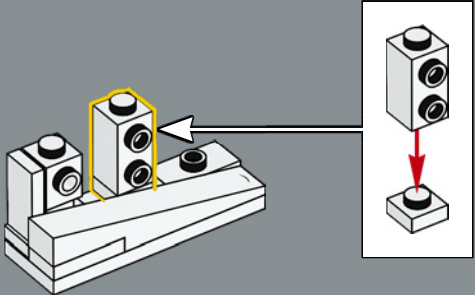

331

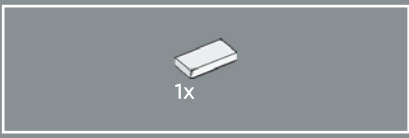
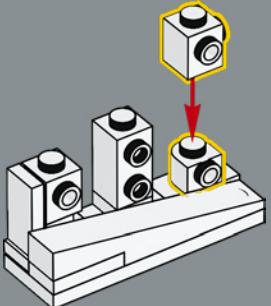

332

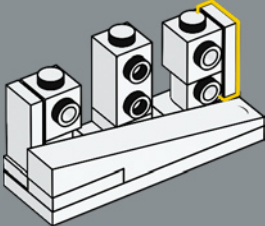

333

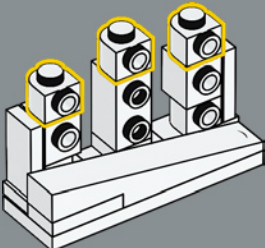



334

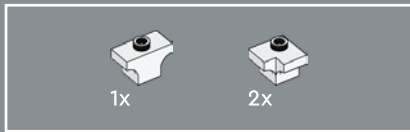
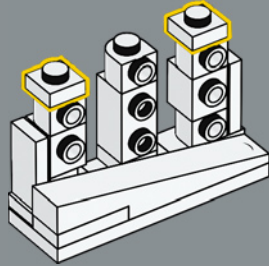

335

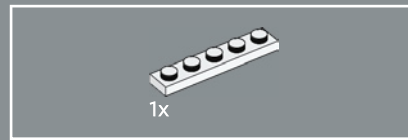
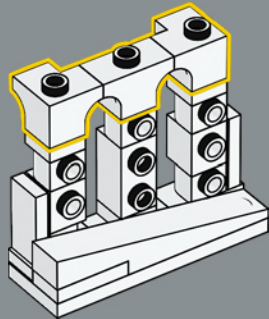

336

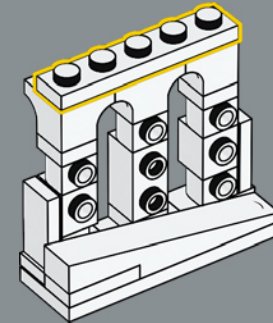

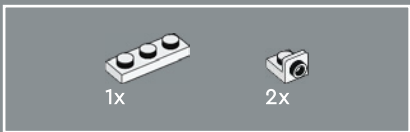

337

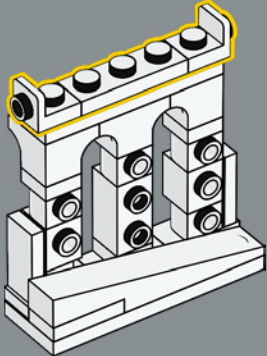

338

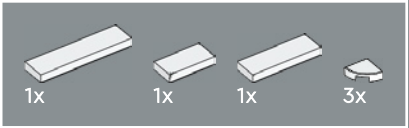
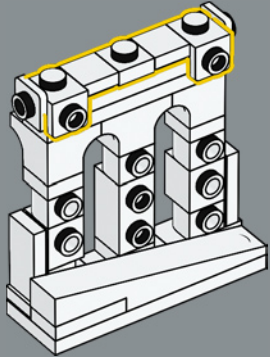

339

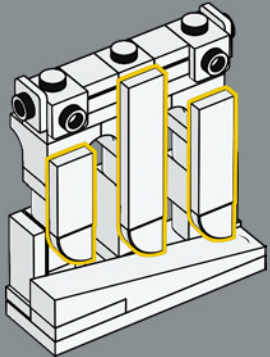



2x

340

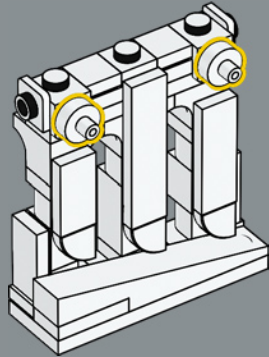

5x

341

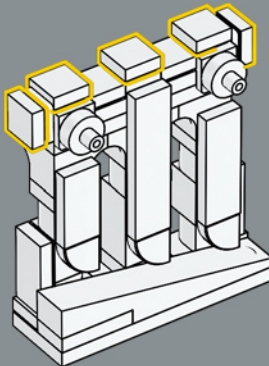

2x



2x

342

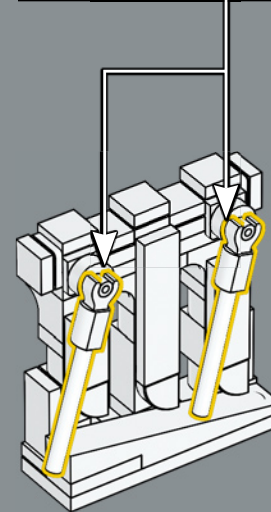
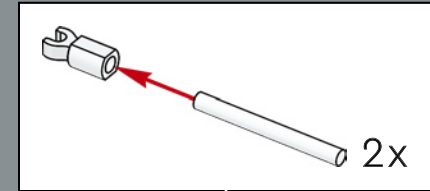

Over 137,000 people cross the Brooklyn Bridge daily by car, foot or bike. (Trucks are not allowed on the bridge.)

Plus de 137 000 personnes traversent chaque jour le pont de Brooklyn en voiture, à pied ou à vélo. (Les camions ne sont pas autorisés sur le pont.)

Más de 137.000 personas cruzan cada día el Puente de Brooklyn en auto, a pie o en bicicleta. (Los camiones tienen prohibido el paso).



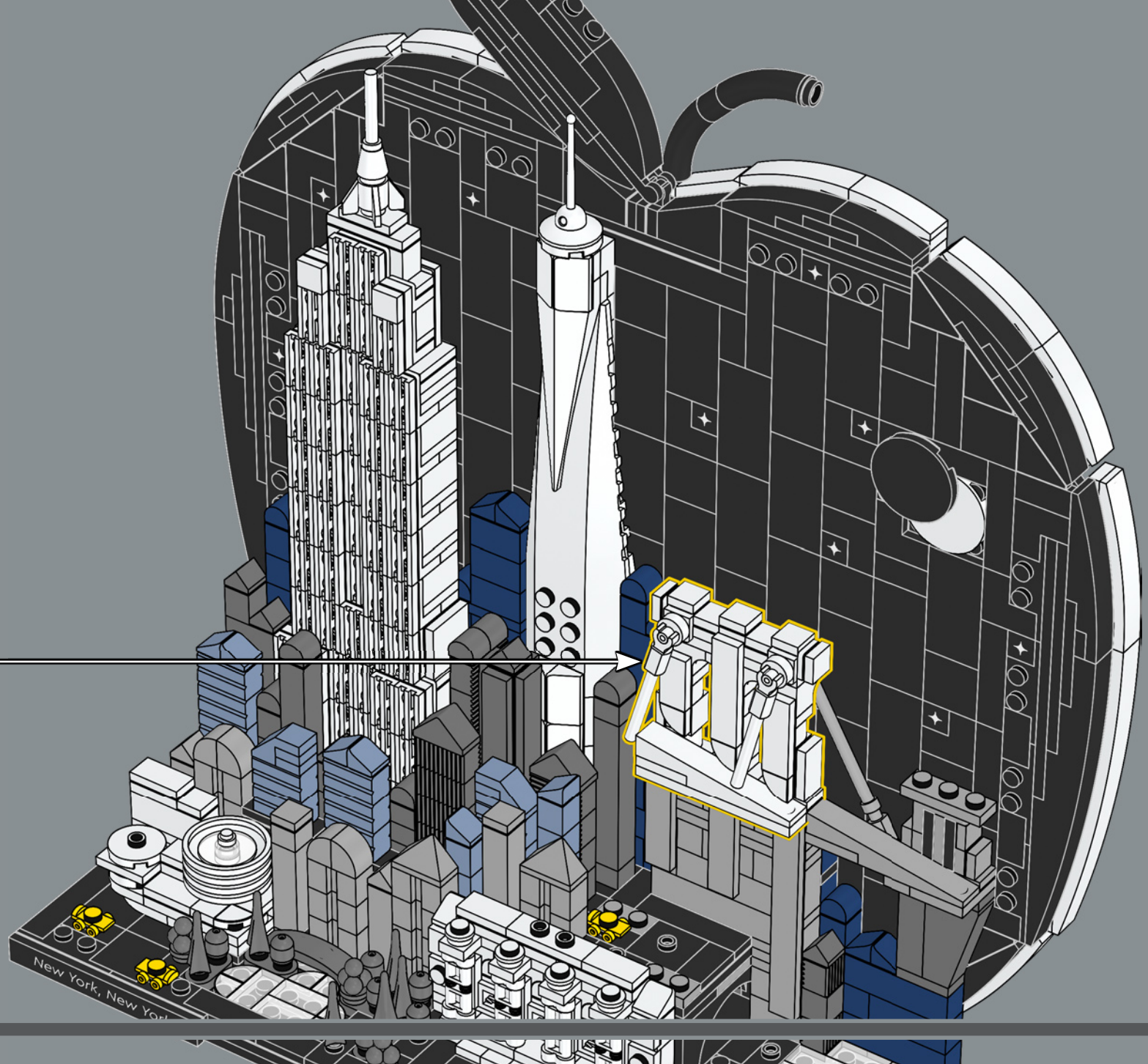

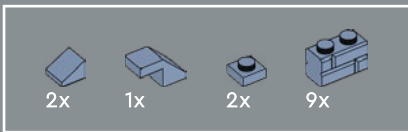

344

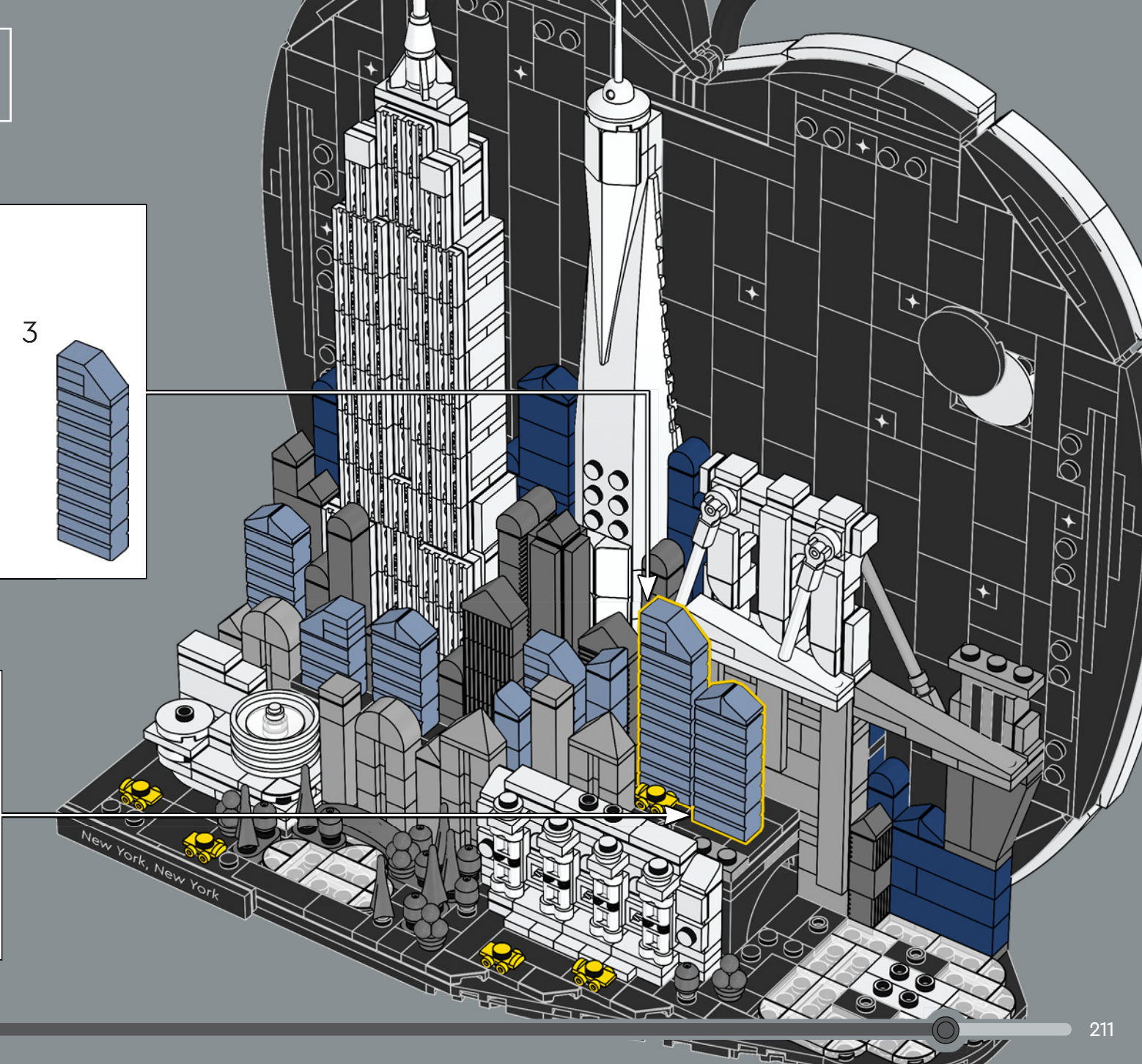
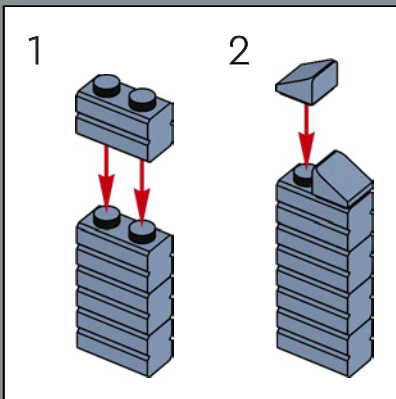
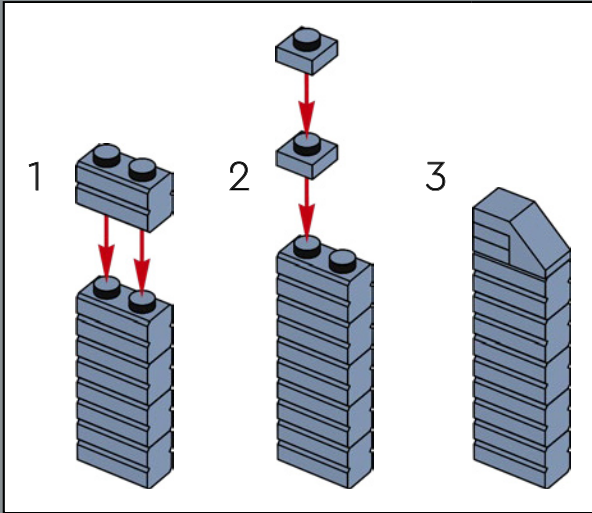

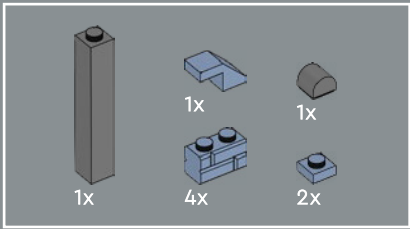

345

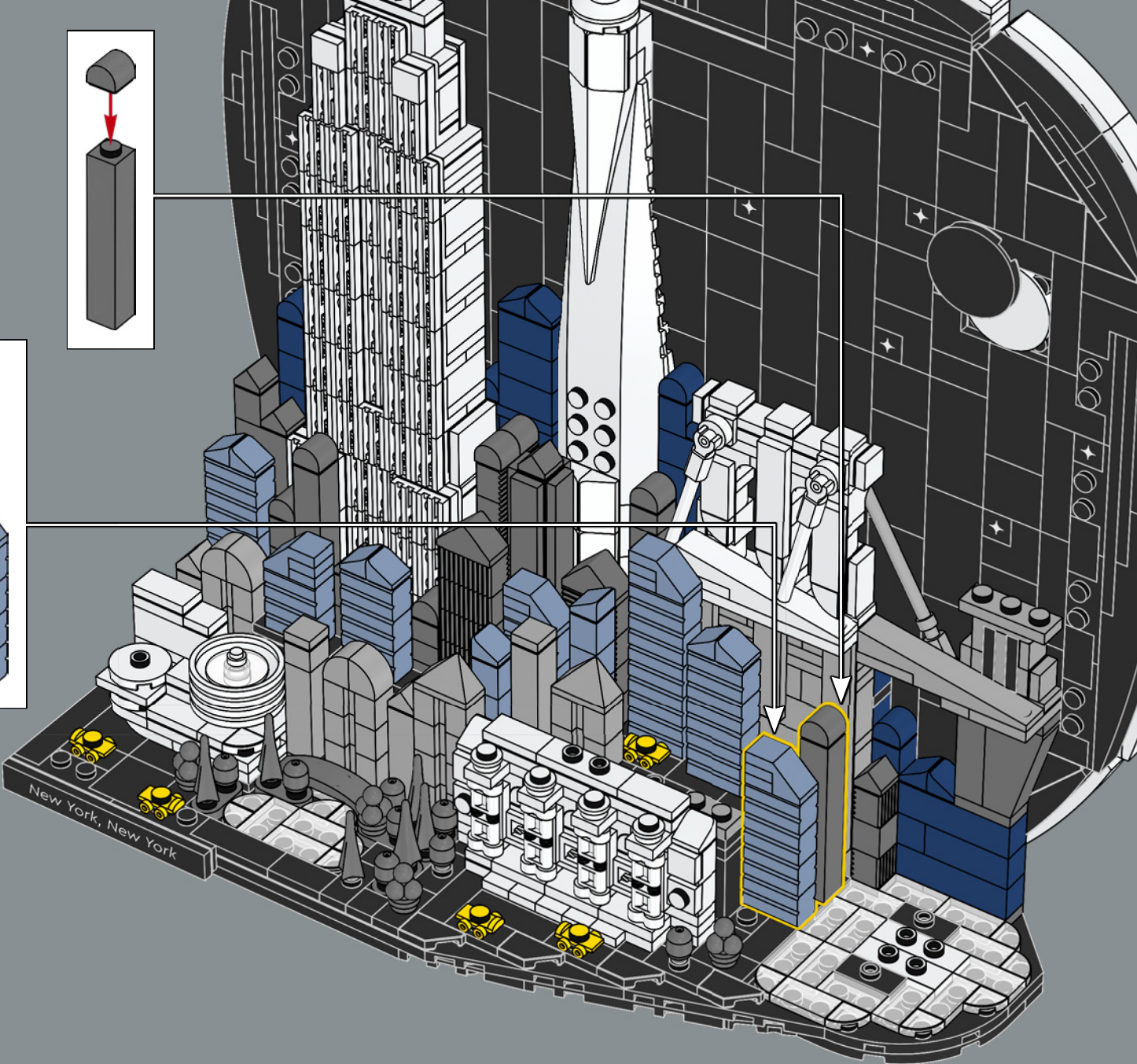
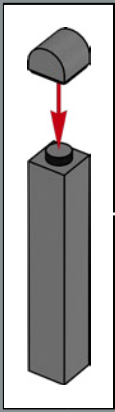
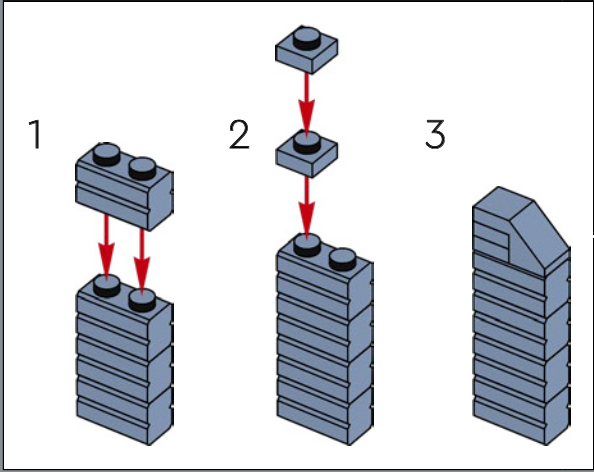

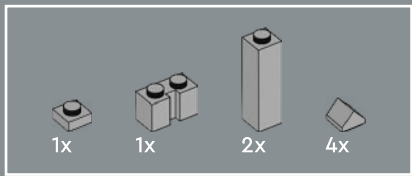

346

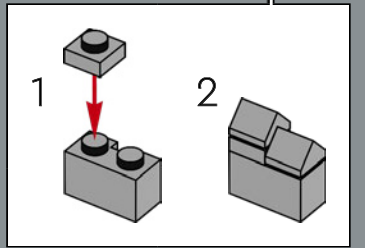
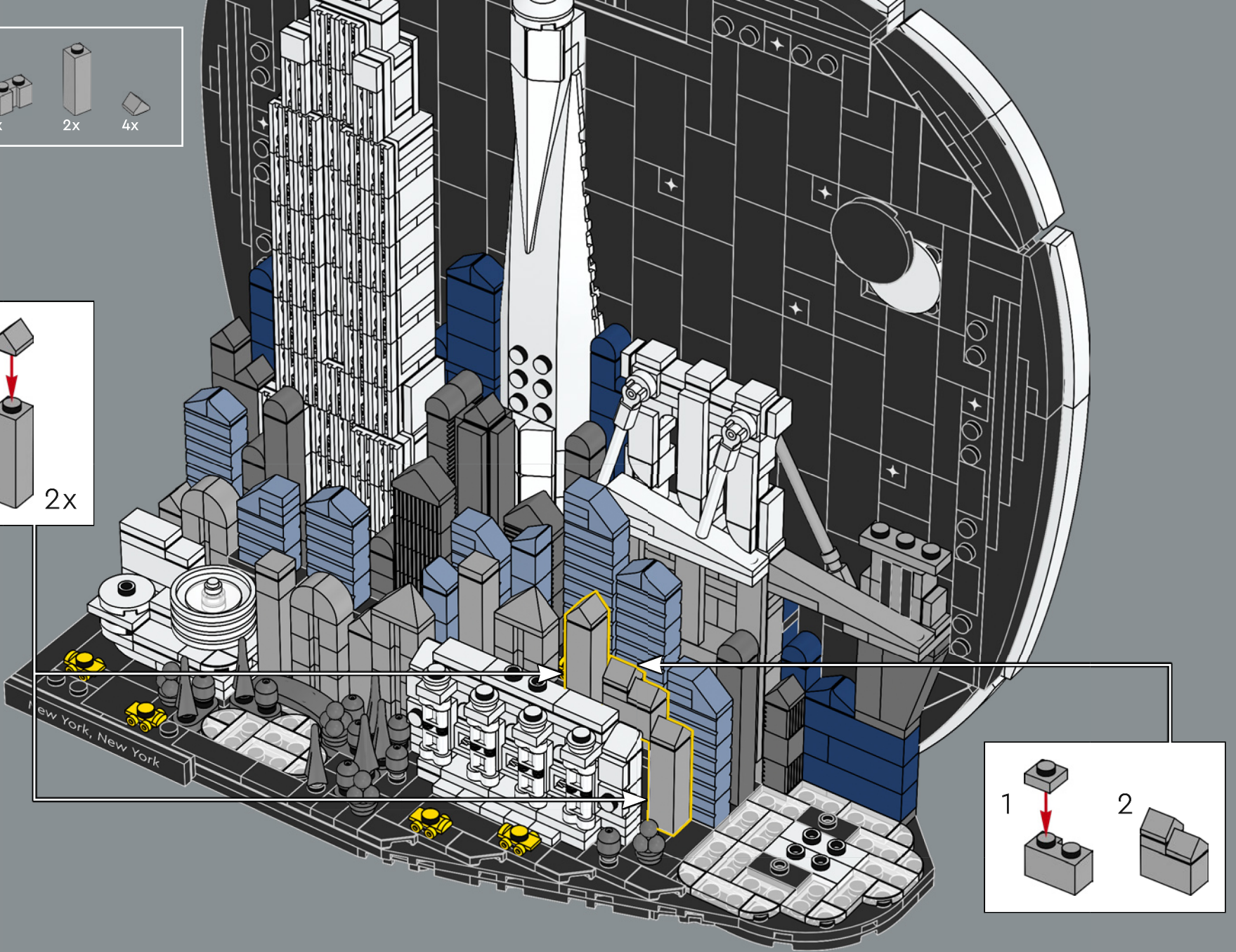
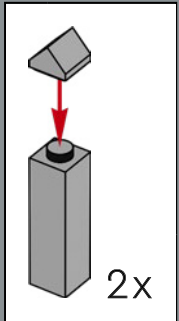

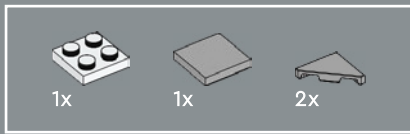

351

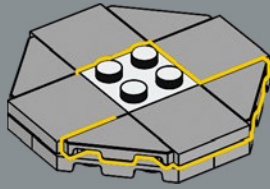

352

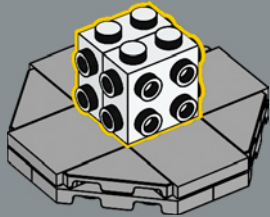

353

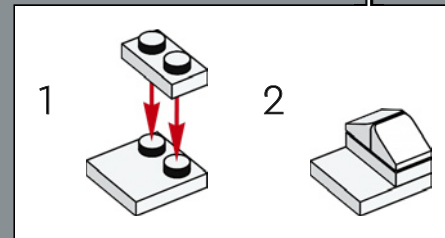
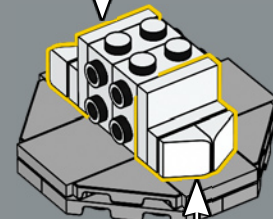
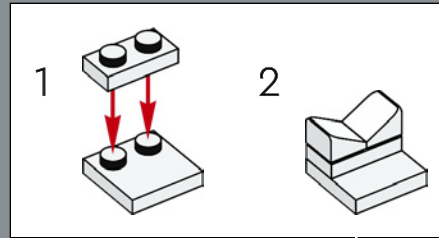



354

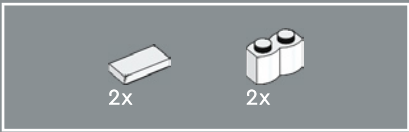
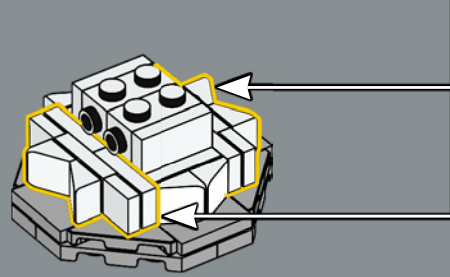
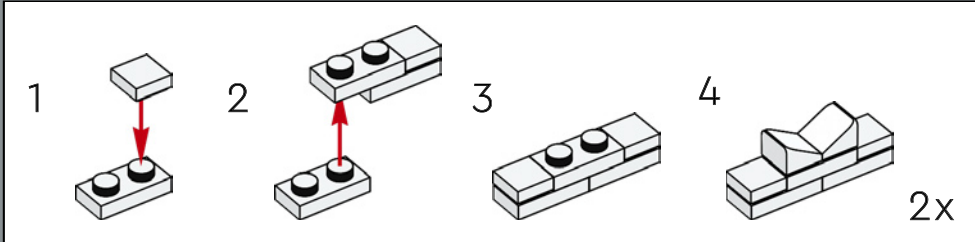

355

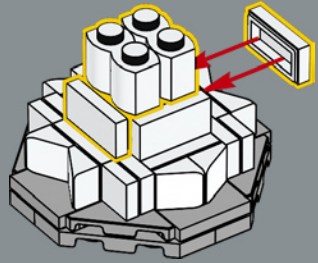



356

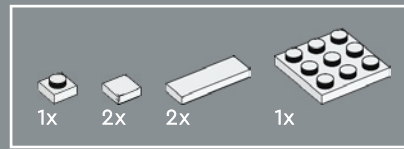
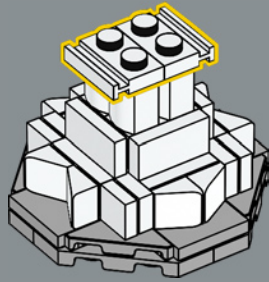

357

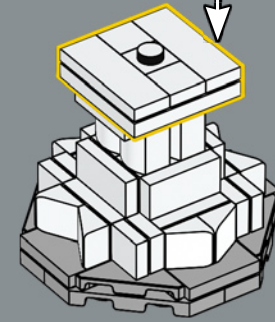
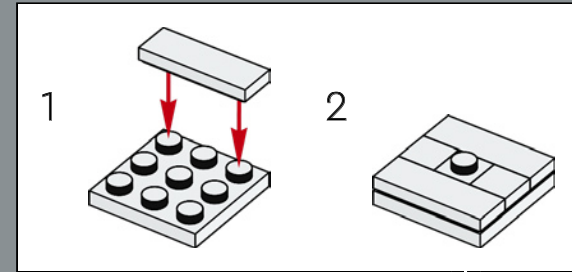

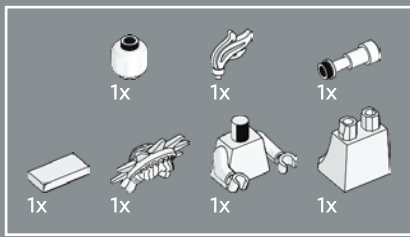

358

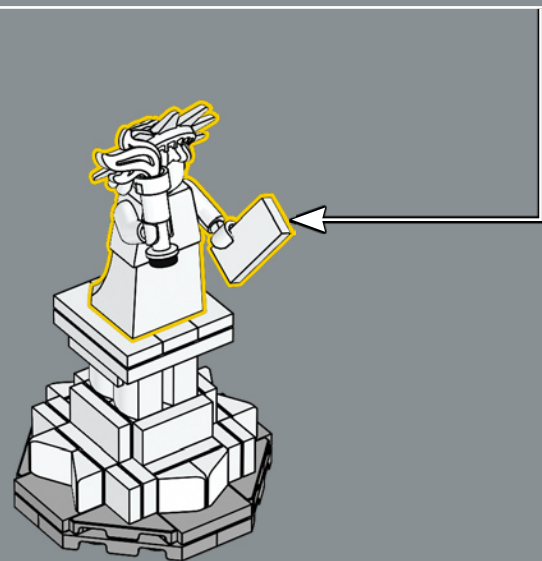
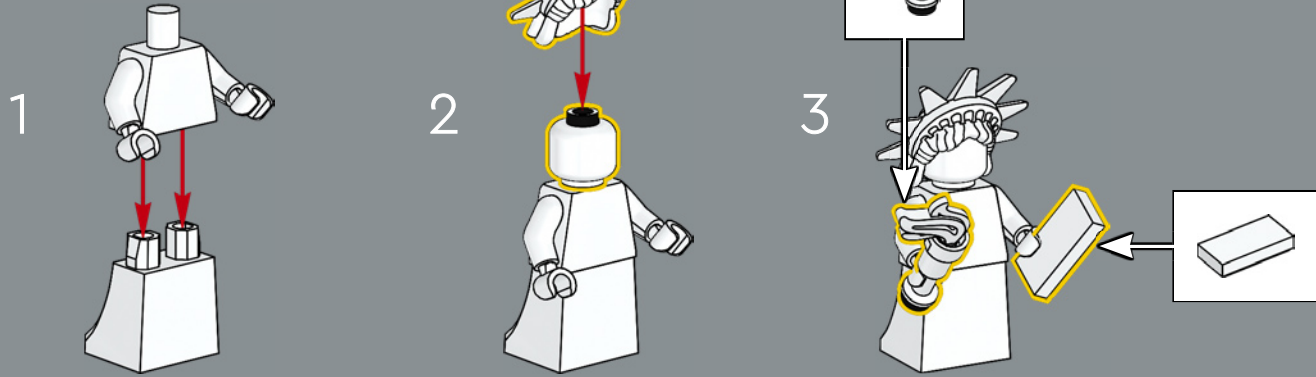

'Lady Liberty' has appeared in LEGO® minifigure form a few times before – the first one was released in 2012.

« Lady Liberty » est déjà apparue sous forme de figurine LEGO® à quelques reprises, la première ayant fait son apparition en 2012.

La Dama de la Libertad ha aparecido en formato de minifigura LEGO® en varias ocasiones; la primera se lanzó en 2012.

359

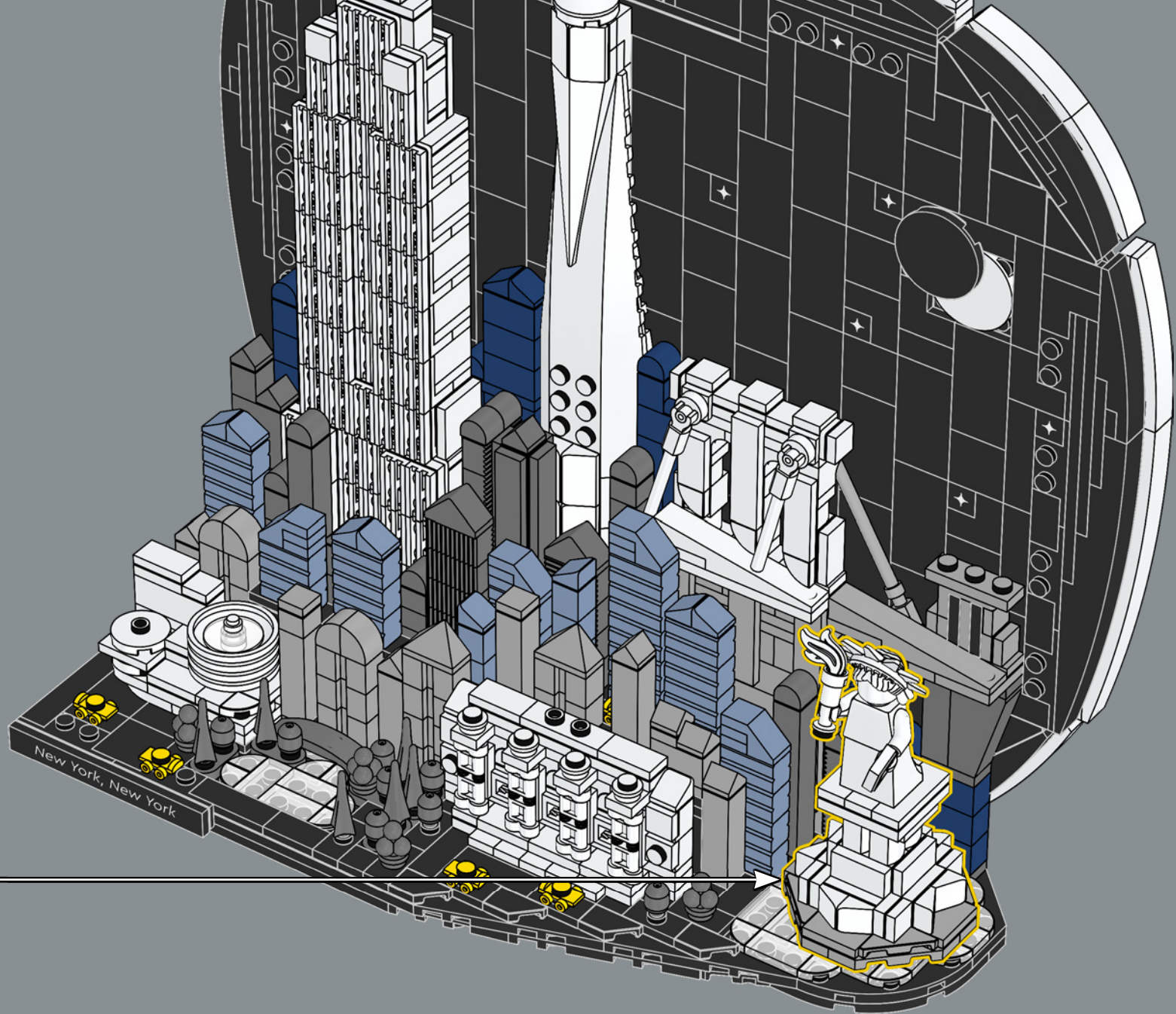

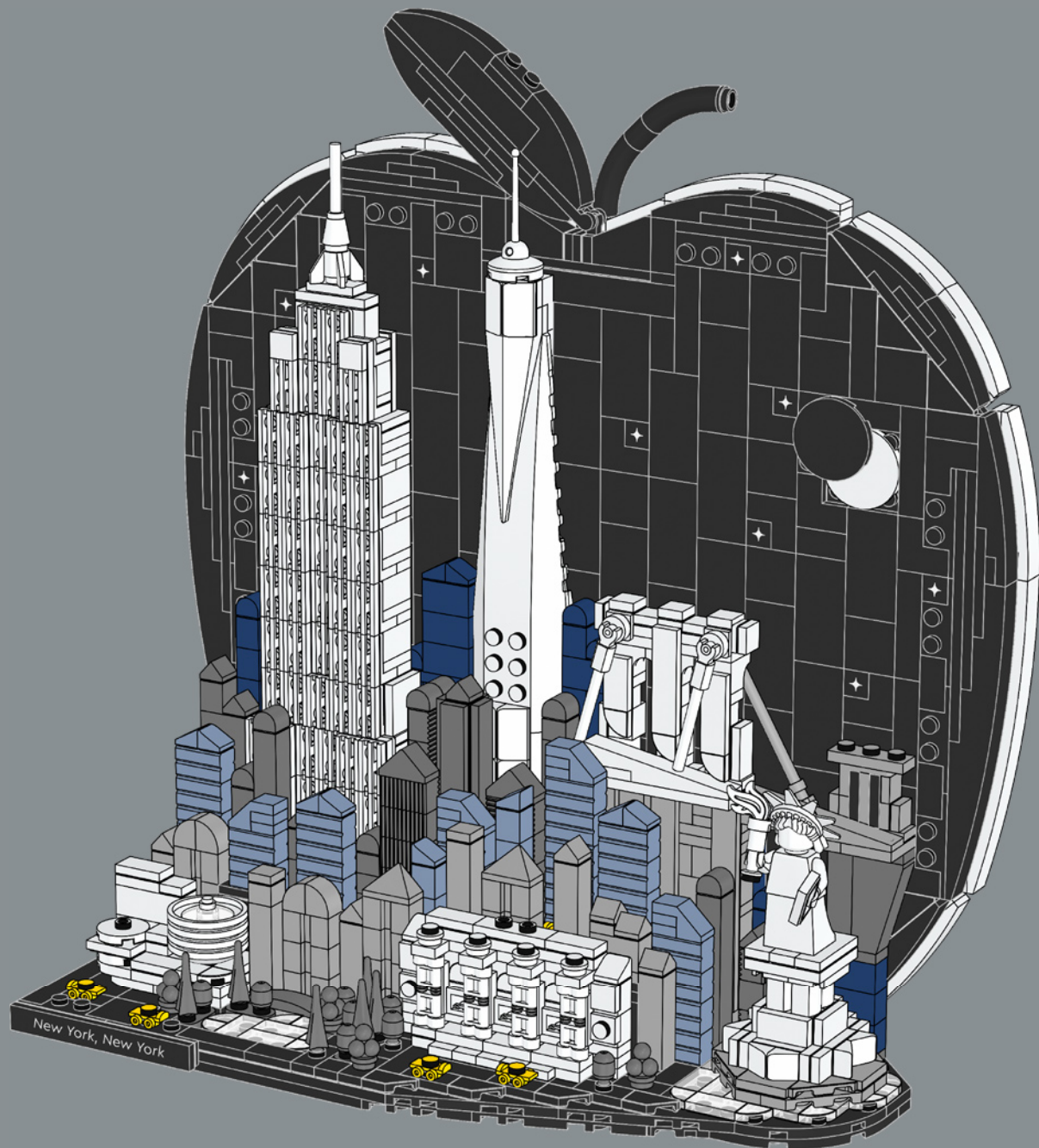

- 10x 6118829
- 2x 6168620
- 1x 4531412
- 6x 6580394
- 18x 243126
- 8x 371026
- 3x 4160025
- 1x 365926
- 1x 301026
- 2x 6039869
- 14x 302026
- 5x 663626
- 4x 6535144
- 5x 6184876
- 1x 366626
- 1x 4243819
- 1x 6101857
- 2x 4181144
- 57x 4560182
- 1x 6585142
- 8x 303226
- 2x 303426
- 1x 6037390
- 1x 395826
- 2x 383226
- 6x 4514845
- 2x 302926
- 2x 6001494
- 2x 6601431
- 1x 4166619
- 1x 6372045
- 5x 346026
- 4x 379526
- 6x 4106977
- 2x 6509390
- 1x 6439175
- 8x 4504374
- 6x 6403899
- 6x 4255413
- 6x 6595205
- 15x 4249891
- 4x 6103405
- 6x 6233955
- 9x 4177735
- 3x 4264569
- 1x 6343976
- 13x 4211399
- 6x 6253436
- 2x 6401023
- 2x 6225242
- 2x 4211389
- 5x 4211415
- 4x 4211476
- 4x 6522869
- 7x 6061702
- 1x 6345639
- 2x 6075075
- 4x 6407767
- 4x 4211526
- 15x 4617170
- 2x 6383177
- 7x 4211398
- 1x 4211388
- 4x 6066097
- 4x 6134378
- 4x 6217876
- 14x 4211397
- 1x 4211387
- 1x 4211353
- 4x 4211413
- 2x 6569357
- 1x 4211429
- 4x 4211361
- 1x 6421522
- 4x 4160560
- 11x 4211445
- 1x 4211394
- 2x 4211356
- 6x 6015347
- 8x 6442144
- 1x 6170418
- 3x 4211393
- 3x 4211438
- 1x 6508016
- 4x 4243797
- 4x 4211452
- 2x 4211392
- 1x 4211481
- 4x 4211402
- 1x 4211401
- 4x 4662161
- 3x 4210690
- 2x 4210700
- 7x 6221607
- 2x 4226221
- 12x 6514469
- 1x 6514246
- 17x 6514223
- 8x 6062686
- 7x 4620077
- 8x 6257079
- 4x 6248952
- 28x 6417947
- 1x 383228
- 2x 302028
- 8x 6344216
- 16x 4210636
- 6x 6269969
- 9x 4211063
- 4x 6601435
- 3x 4210978
- 1x 6396489
- 10x 4211098
- 5x 6262021
- 7x 6333129
- 1x 4210719
- 5x 6388133
- 8x 6062686
- 1x 4648256
- 1x 4500975
- 1x 6336990
- 2x 4211104
- 5x 4211133
- 1x 4648256
- 1x 6240515



 [LEGO.com/service](https://www.LEGO.com/service)



YOU COULD
WIN



**YOU COULD
WIN**

Your feedback will help shape the future development of this product series.

Visit:

**DU KÖNNTEST
GEWINNEN**

Dein Feedback trägt zur Weiterentwicklung dieser Produktreihe bei.

Geh auf:

**VOUS POURRIEZ
GAGNER**

Vos commentaires nous aideront à concevoir les futurs produits de cette gamme.

Visitez :

**POTRESTI
VINCERE TU**

La tua opinione ci aiuterà a migliorare la creazione futura di questa linea di prodotti.

Visita:

**PUEDES
GANAR**

Tu opinión contribuirá al futuro de esta serie de productos.

Visita:

轻松获奖

您的反馈将有助于我们在今后改进本产品系列。

请访问:

LEGO.com/productfeedback

You also have the chance to win a LEGO® set.

Terms and conditions apply.*

Außerdem hast du die Chance, ein LEGO® Set zu gewinnen.

Es gelten die Teilnahmebedingungen.*

Vous pourriez également gagner un ensemble LEGO®.

Des conditions s'appliquent.*

Hai anche la possibilità di vincere un set LEGO®.

Termini e condizioni sono applicabili.*

También tienes la oportunidad de ganar un set LEGO®.

Aplican términos y condiciones.*

您还有机会赢取乐高®套装。

条款和条件适用。*

*LEGO.com/productfeedback-terms

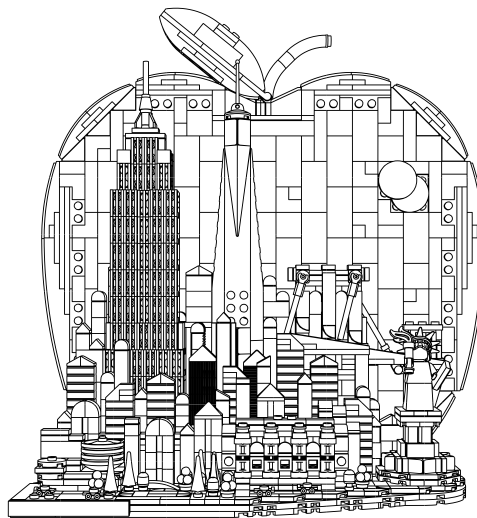

LEGO and the LEGO logo are trademarks of the/son des marques de commerce du/son marcas registradas de LEGO Group. ©2026 The LEGO Group.

The EMPIRE STATE BUILDING name and image are registered trademarks and used with permission.

The name and building image of the Solomon R. Guggenheim Museum are trademarks of the Solomon R. Guggenheim Foundation. Used with permission.

® /™ /© Frank Lloyd Wright Foundation. All Rights Reserved.

One World Trade Center building design is a copyright of WTC Tower 1 LLC. Used under license.

Adam Reed Tucker is the co-developer of the LEGO® Architecture product line.
Adam Reed Tucker est le codéveloppeur de la gamme de produits LEGO® Architecture.
Adam Reed Tucker es el codesarrollador de la línea de productos LEGO® Architecture.