

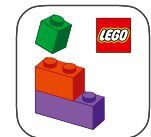

11505



Available in English  
Disponible en français  
Disponible en español



LEGO® Builder

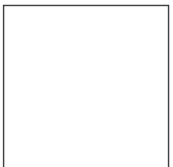



## WE'RE MAKING OUR PACKAGING MORE SUSTAINABLE

We're transitioning from single-use plastic to paper-based packaging. As we progress, you may find a mix of paper and plastic in our boxes.

## NOUS RENDONS NOS EMBALLAGES PLUS DURABLES

Nous passons des emballages en plastique à usage unique aux emballages à base de papier. Durant la transition, vous pourriez trouver un mélange de papier et de plastique dans nos boîtes.

## QUEREMOS HACER MÁS SUSTENTABLES NUESTROS MATERIALES DE EMBALAJE

Estamos cambiando las bolsas de plástico desechables por bolsas con base de papel. Conforme avanzamos en este propósito, puedes encontrar una mezcla de papel y de plástico en nuestras cajas.

[LEGO.com/sustainable-packaging](https://LEGO.com/sustainable-packaging)



# BUILDER



Apple and the Apple logo are trademarks of Apple Inc., registered in the U.S. and other countries and regions. App Store is a service mark of Apple Inc. Google Play and the Google Play logo are trademarks of Google LLC. Tencent and the Tencent logo are trademarks of Tencent Inc.

[LEGO.com/devicecheck](https://LEGO.com/devicecheck)



LEGO® Builder



## SIMPLE, WILD EXISTENCE

When you explore nature with a curious mindset, you inevitably feel a sense of duality in the change of seasons. Decay coexists in perfect harmony with new life. This LEGO® built ecosystem captures a magical slice of a forest floor at the edge of a Northern European woodland, at the transition from summer to fall. Imagine a bountiful foraging trip, where you get to explore a rich variety of fungi and autumn crocuses. While such a dense collection of species might be improbable in nature, we wanted to create a visually captivating – and theoretically plausible – scene. Every element is designed with care to balance realism with a whimsical charm.

The LEGO® Botanicals Design Team

## UNE EXISTENCE SIMPLE ET SAUVAGE

Lorsque l'on explore la nature avec un esprit curieux, on ressent inévitablement un sentiment de dualité dans le changement des saisons. La décomposition coexiste en parfaite harmonie avec la nouvelle vie. Cet écosystème construit par LEGO® capture une tranche magique d'un sol forestier à la lisière d'une forêt d'Europe du Nord, lors de la transition entre l'été et l'automne. Imaginez une excursion fructueuse, au cours de laquelle vous pourrez explorer une riche variété de champignons et de crocus d'automne. Bien qu'une collection aussi dense d'espèces soit improbable dans la nature, nous avons voulu créer une scène visuellement captivante – et théoriquement plausible. Chaque élément est conçu avec soin afin d'équilibrer le réalisme avec un charme fantaisiste.

L'équipe de conception de LEGO® Botanicals

## UNA EXISTENCIA TAN SENCILLA COMO SALVAJE

Cuando exploras la naturaleza con una mentalidad curiosa, es inevitable que percibas una sensación de dualidad durante el cambio de estaciones. La decadencia coexiste en perfecta armonía con la vida nueva. Este ecosistema construido con LEGO® captura una mágica porción de suelo de los bordes de un bosque del norte de Europa cuando tiene lugar la transición del verano al otoño. Imagina una fructífera excursión de búsqueda de alimentos silvestres que te permita explorar una amplia variedad de hongos y colchicos de otoño. Aunque una concentración tan densa de especies podría ser improbable en la naturaleza, queríamos dar forma a una escena visualmente cautivadora y, al menos en teoría, plausible. Cada elemento está diseñado con todo cuidado para equilibrar el realismo con un encanto caprichoso.

El equipo de diseño de LEGO® Botanicals





*Colchicum autumnale*

## AUTUMN CROCUS

Unlike its spring cousin, this pink and purple crocus belongs to the Colchicaceae family and blooms in the fall. Elegant and graceful, yet toxic, it thrives in grasslands and woodlands in Europe and Asia.

## CROCUS D'AUTOMNE

Contrairement à son cousin printanier, ce crocus rose et violet appartient à la famille des Colchicaceae et fleurit à l'automne. Élégant et gracieux, mais toxique, il pousse dans les prairies et les forêts d'Europe et d'Asie.

## COLCHICO DE OTOÑO

A diferencia de su primo primaveral, este colchico rosa y morado pertenece a la familia de las colchicáceas y florece durante el otoño. Elegante y delicado, aunque también tóxico, crece en praderas y bosques de Europa y Asia.



*Pteridium aquilinum*

## BRACKEN

One of the most common plants in the world, it thrives in sun or shade, grasslands or busy areas. With fronds that grow up to 3 ft. (1 m), it's a popular and decorative garden display.

## FOUGÈRE-AIGLE

C'est l'une des plantes les plus répandues dans le monde. Elle prospère au soleil ou à l'ombre, dans les prairies ou dans les zones très fréquentées. Avec des frondes pouvant atteindre un mètre, il s'agit d'une plante décorative très appréciée dans les jardins.

## HELECHO

Una de las plantas más comunes del mundo, crece tanto al sol como a la sombra, y tanto en praderas como en zonas concurridas. Con frondas que se extienden hasta 1 m, es una planta muy popular para decorar jardines.



*Mycena galericulata*

## COMMON BONNET

This delicate, bell-capped clusterer is found on fallen logs and stumps in damp areas and mixed woods. Known for its beautiful, enchanting appearance, it has inspired artists for ages.

## MYCÈNE EN CASQUE

Cette délicate grappe à chapeau en forme de cloche se trouve dans les zones humides et les bois mixtes, sur les troncs et les souches tombés au sol. Connue pour sa beauté et son aspect enchanteur, elle inspire les artistes depuis des lustres.

## HONGO BONETE

Es común encontrar este delicado hongo con forma de campana en áreas húmedas, donde forma pequeños grupos sobre troncos caídos y árboles muertos. Conocido por su belleza encantadora, ha inspirado a artistas durante siglos.



*Pleurotus ostreatus*

## OYSTER MUSHROOM

Look for these popular shell-like caps with decurrent gills and short – or absent – stems on decaying wood in forests or even urban areas. They are typically white or gray and can grow up to 9.8 in. (25 cm) wide.

## PLEUROTE

Recherchez ces populaires capsules ressemblant à des coquillages avec des lamelles décurrentes et des tiges courtes – ou absentes – sur le bois en décomposition des forêts, ou même dans les zones urbaines. Elles sont généralement blanches ou grises et peuvent atteindre 25 cm de large.

## SETA

Estos populares hongos con forma de concha, láminas decurrentes y tallos cortos (o ausentes) crecen sobre la madera en descomposición, tanto en los bosques como en zonas urbanas. Suelen ser blancos o grises y pueden alcanzar una anchura de hasta 25 cm.



*Cantharellus cibarius*

## GOLDEN CHANTERELLE

Chanterelles flare their golden trumpets with blunt, forked ridges in place of gills. Notoriously elusive, foragers often carefully guard their locations and treasure them as an exquisite delicacy.

## CHANTERELLE

Les chanterelles déploient leurs trompettes dorées avec des crêtes émousées et fourchues à la place des lamelles. Les cueilleurs de champignon protègent souvent soigneusement les lieux de cueillette des chanterelles, réputées pour leur rareté, et les considèrent comme un mets raffiné.

## HONGO CHANTERELLE

Los hongos chanterelle exhiben unas trompetas doradas con pliegues gruesos y ramificados en lugar de láminas. Tienen fama de ser difíciles de encontrar, por lo que los recolectores suelen proteger cuidadosamente sus ubicaciones, atesorándolas como fuentes de un manjar exquisito.



*Amanita muscaria*

## FLY AGARIC

With a glossy red-orange cap flecked with white, the fly agaric adds a vibrant splash of color in European winters, often found beneath birch, pine and spruce. When seen in the wild, handle with care!

## AMANITE TUE-MOUCHES

Avec son chapeau rouge-orange brillant moucheté de blanc, l'amanite tue-mouches ajoute une touche de couleur vibrante aux hivers européens. On la trouve souvent sous les bouleaux, les pins et les épinettes. Lorsqu'elle est observée dans la nature, à manipuler avec précaution!

## HONGO MATAMOSCAS

Con su brillante sombrero de color rojo anaranjado y salpicado de manchas blancas, el hongo matamoscas aporta una vibrante pincelada de color a los inviernos europeos y suele encontrarse debajo de abedules, pinos y abetos. Si lo ves en la naturaleza, ¡manéjalo con cuidado!



*Inocybe hirtella*

## MARZIPAN FIBRECAP

Despite its name and a fibrous cap with an almond-like scent, this mushroom is best when admired from a safe distance! Found in grassy areas, it provides sugars and nutrients to surrounding trees.

## INOCYBE HIRSUTE

Malgré son nom et son chapeau fibreux à l'odeur d'amande, ce champignon gagne à être admiré à bonne distance! Présent dans les zones herbeuses, il fournit des sucres et des nutriments aux arbres environnants.

## PARAGÜITAS MALO

Su nombre lo advierte y, a pesar de que su sombrero fibroso despide un irresistible aroma parecido al de las almendras, ¡es mejor admirar este hongo desde una distancia segura! Podrás encontrarlo en zonas cubiertas de hierba, donde proporciona azúcares y nutrientes a los árboles circundantes.



*Geastrum triplex*

## COLLARED EARTHSTAR

Look for this spectacular mushroom in woods and grasslands. From a round, spore-filled body, it opens its star-shaped arms to release its spores in a veritable miniature fireworks display!

## GÉASTRE À TROIS PLIS

Cherchez ce champignon spectaculaire dans les bois et les prairies. À partir d'un corps rond rempli de spores, il ouvre ses bras en forme d'étoile pour libérer ses spores dans un véritable feu d'artifice miniature!

## ESTRELLA DE TIERRA

Busca este espectacular hongo en bosques y praderas. Desde un cuerpo redondo lleno de esporas, ¡extiende sus brazos en forma de estrella para liberarlas en lo que podría considerarse un auténtico espectáculo de pirotecnia en miniatura!



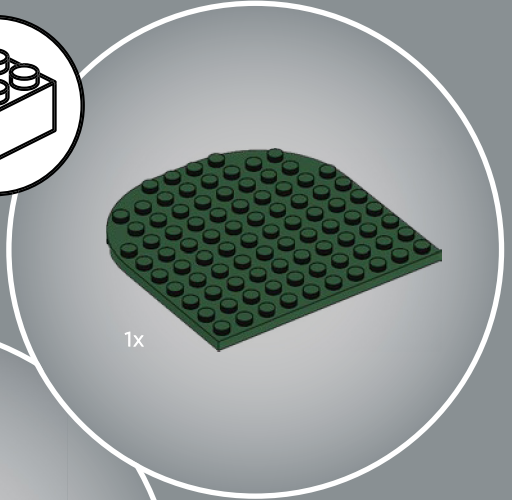
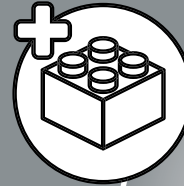
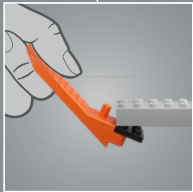
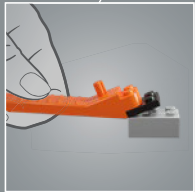
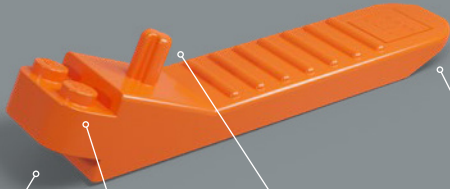

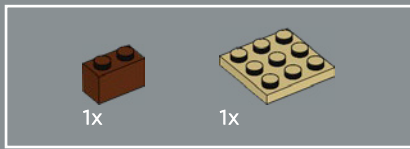

1

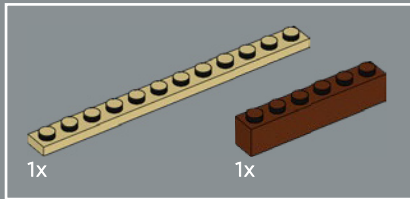
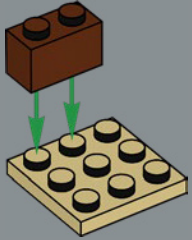

2

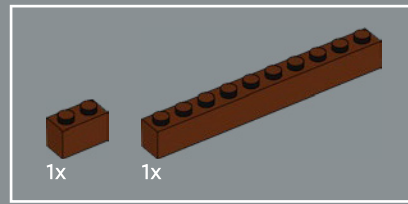
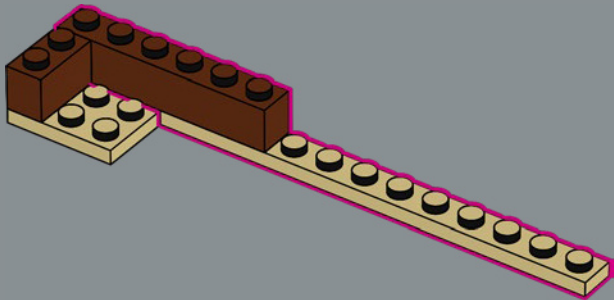

3

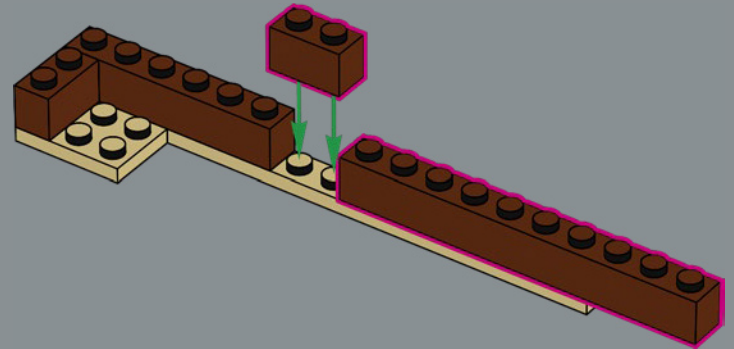

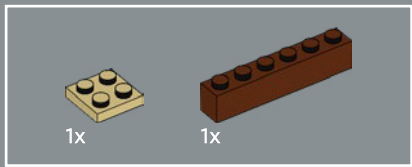

4

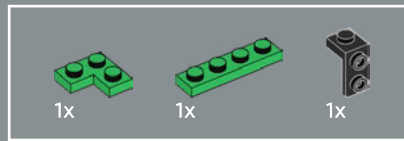
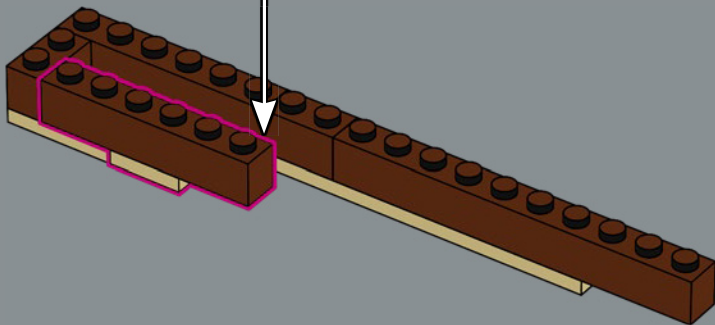
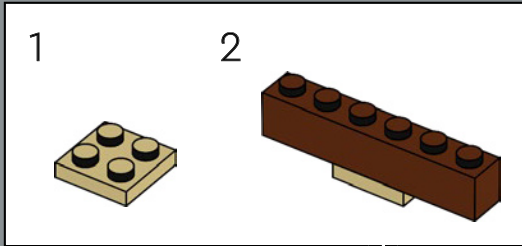

5

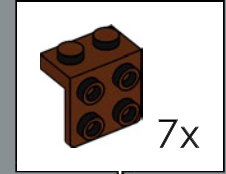
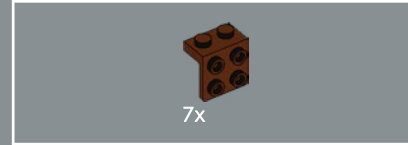
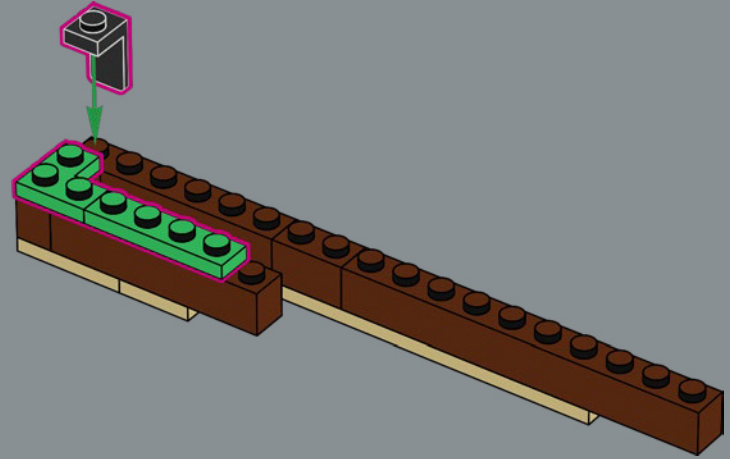

6

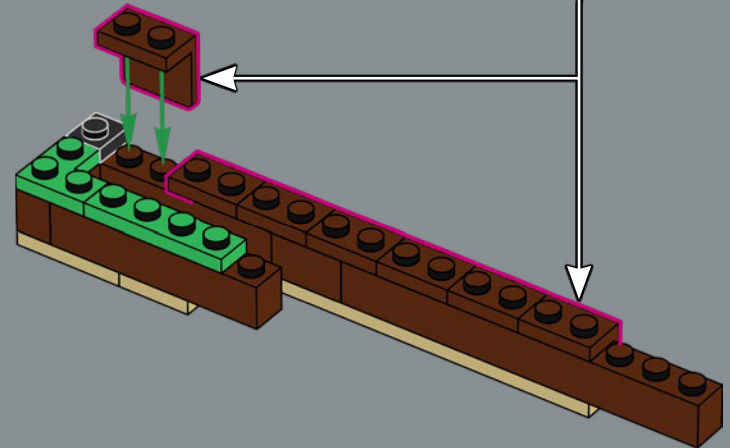



5

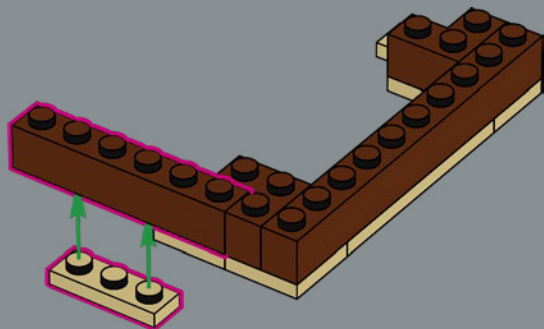

6

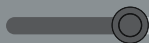
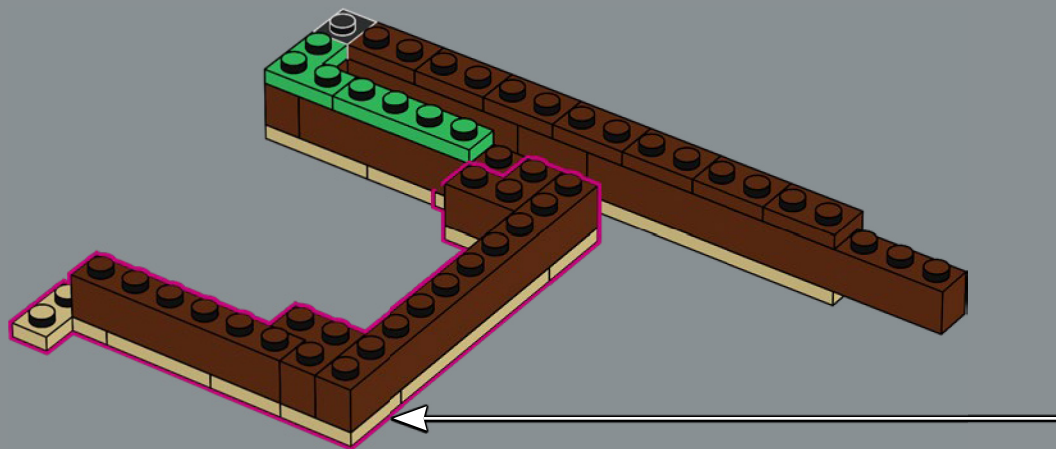
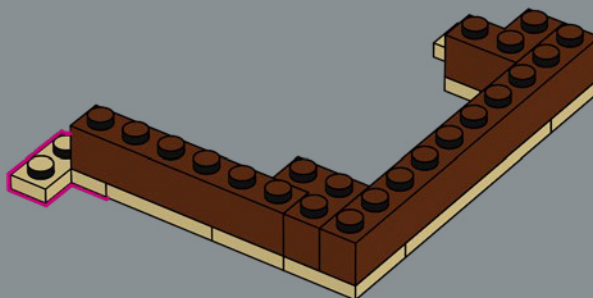

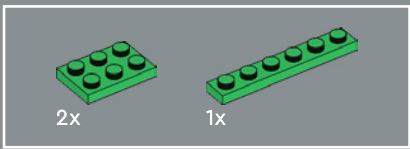

8

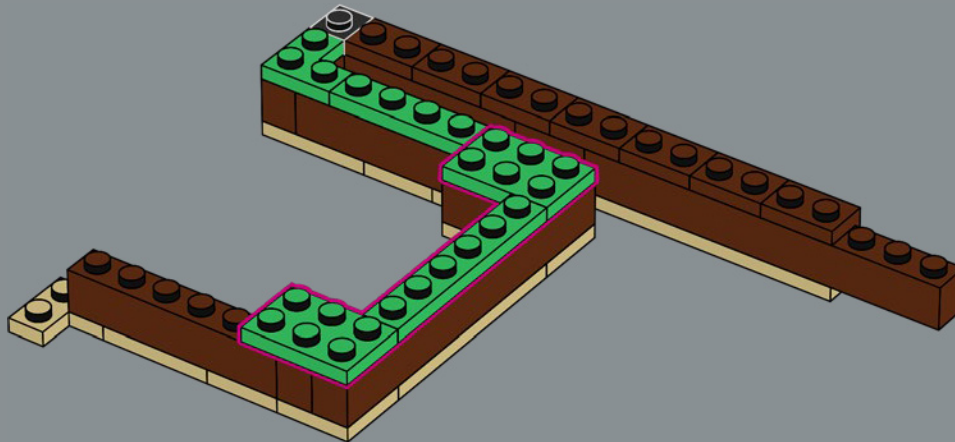

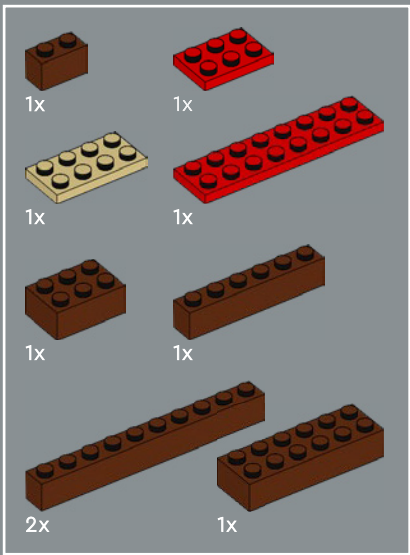

9

1

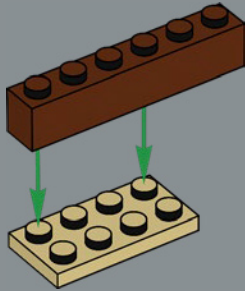

2

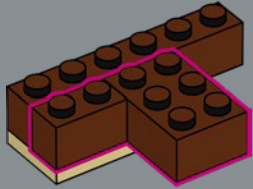

3

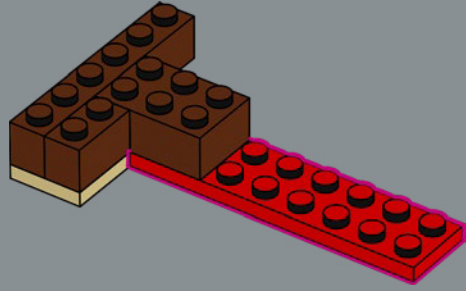

4

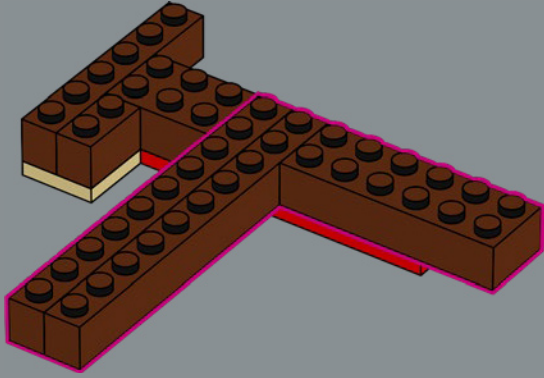

5

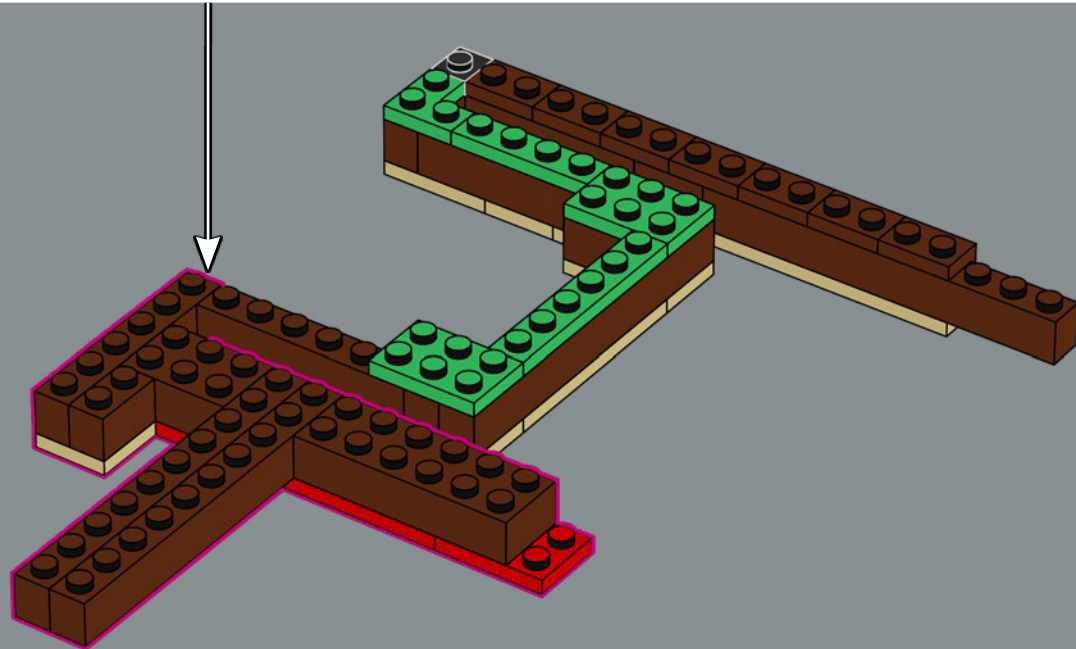
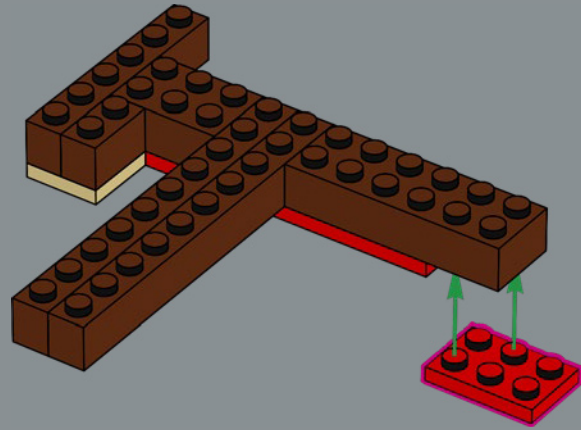

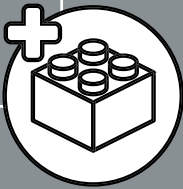
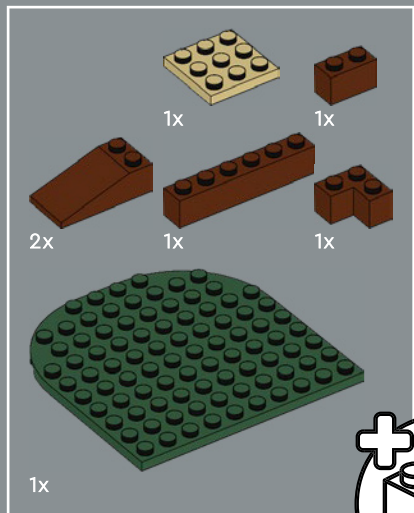

10

1

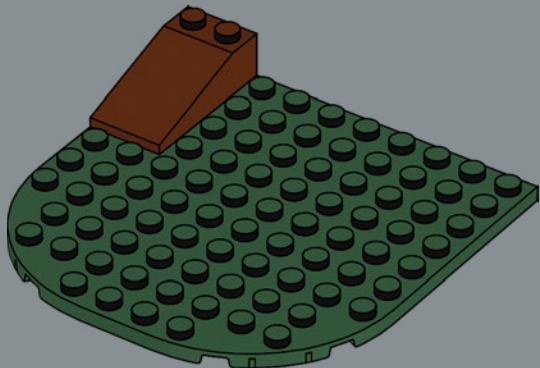

2

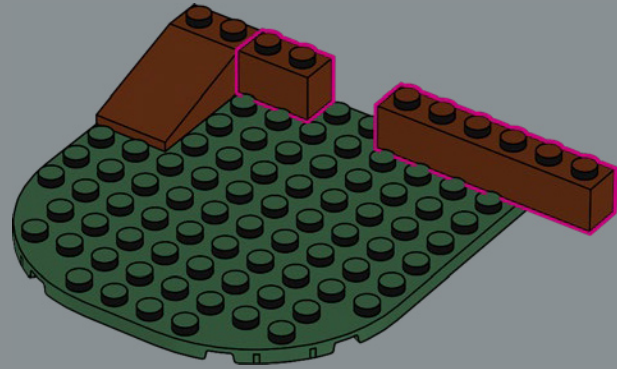

3

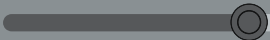
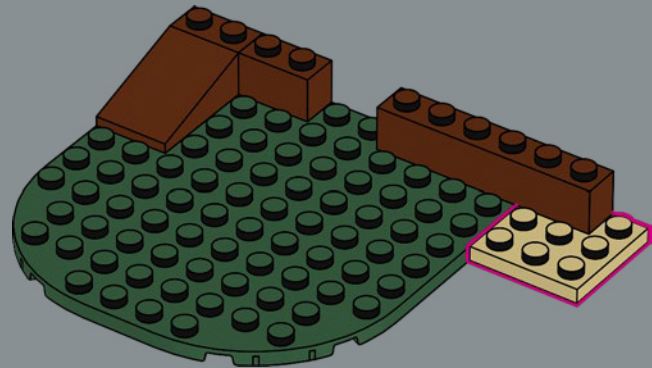

4

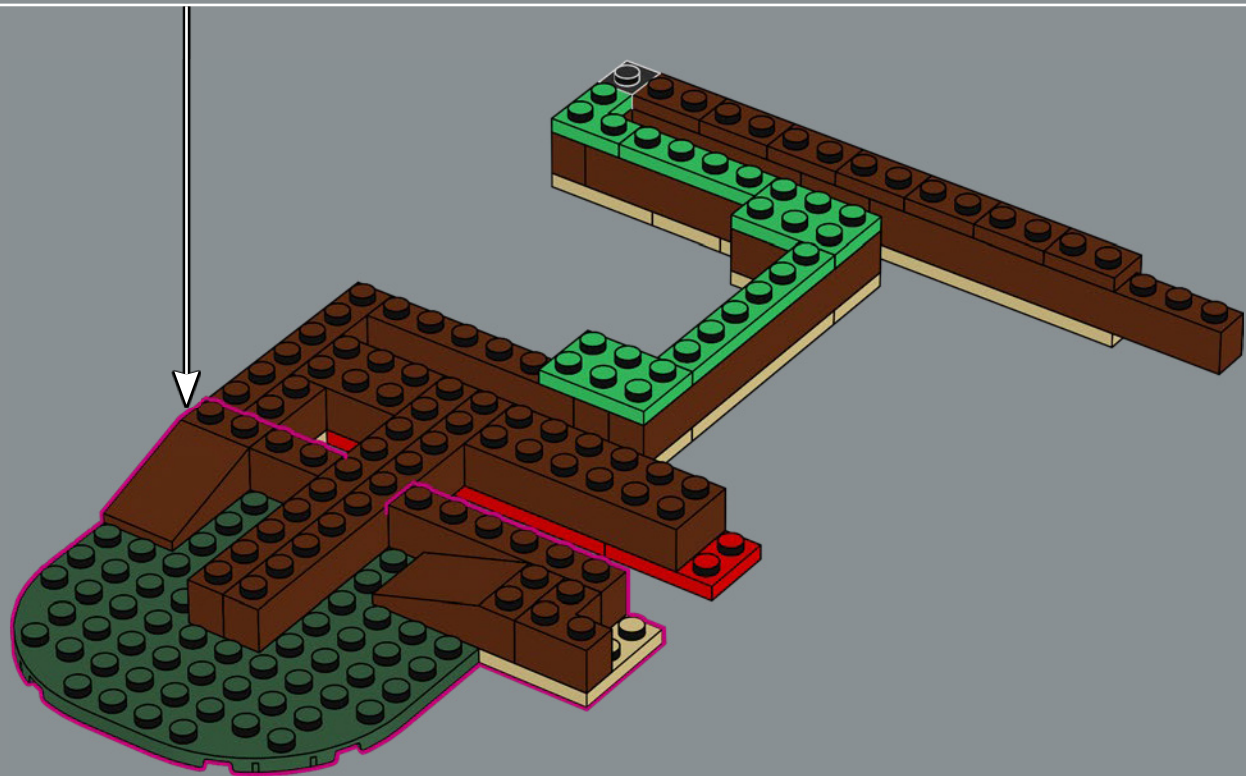
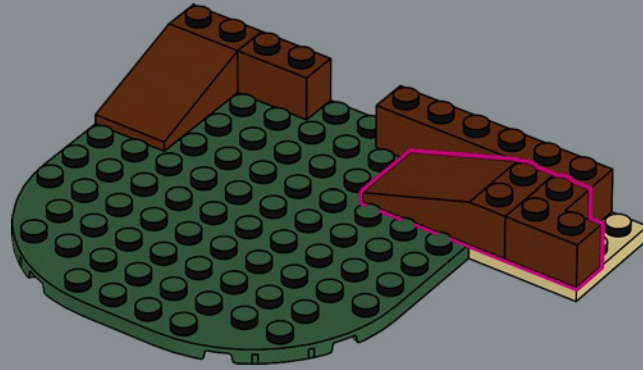

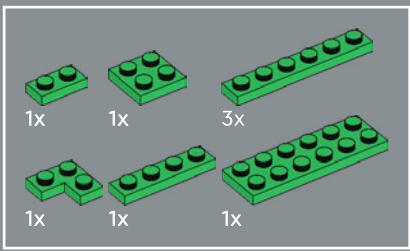

11

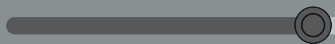
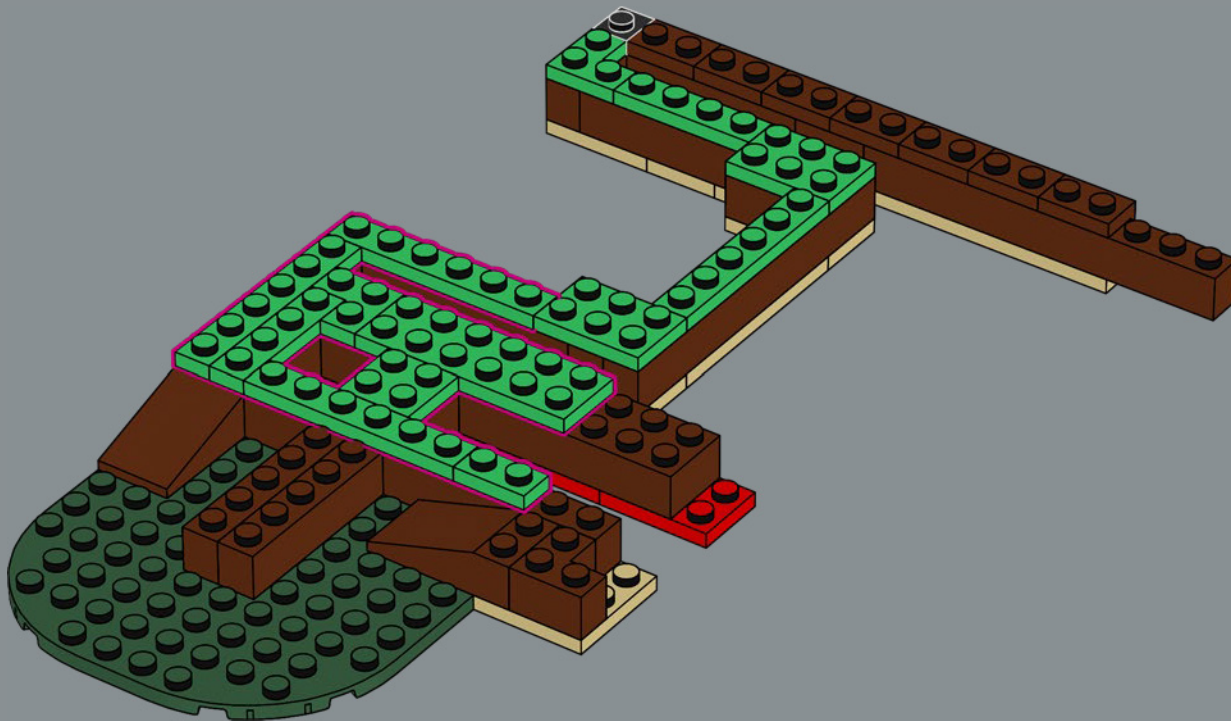

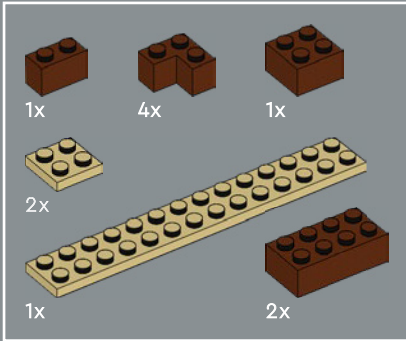
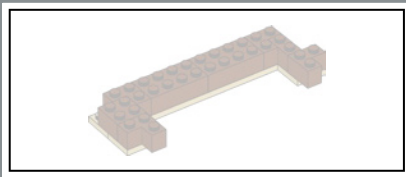

12

1

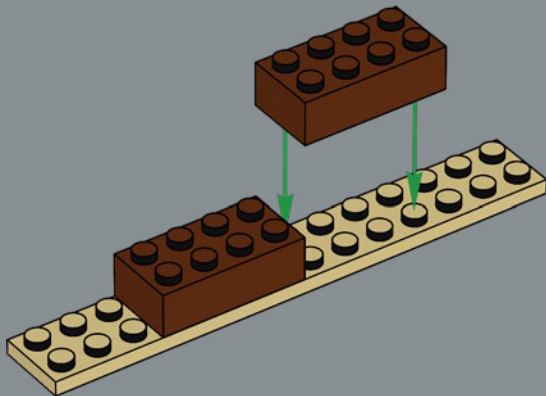

2

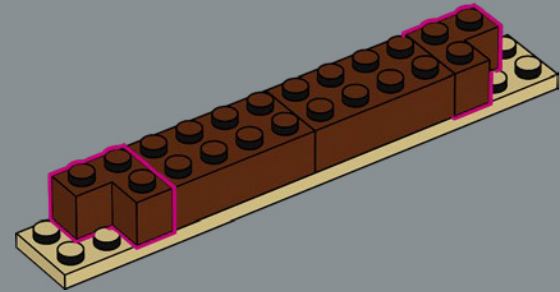

3

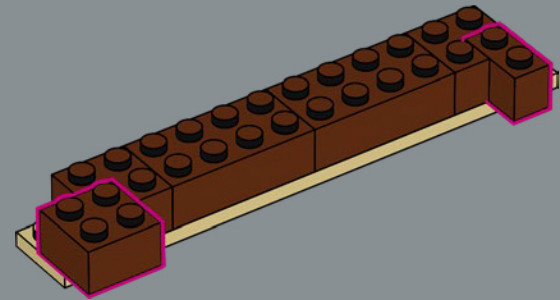

4

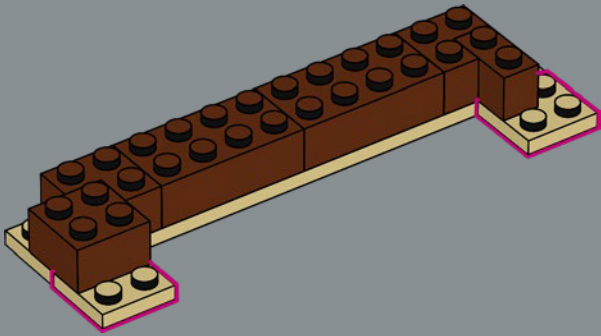

5

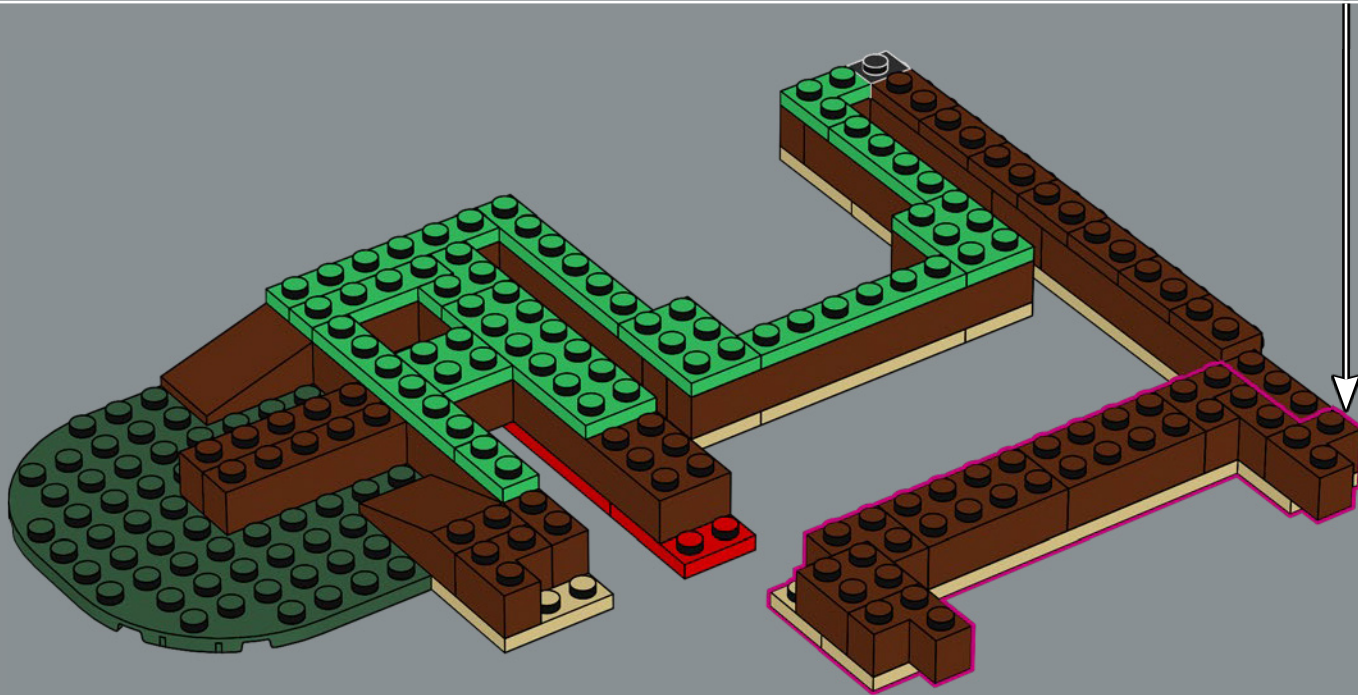
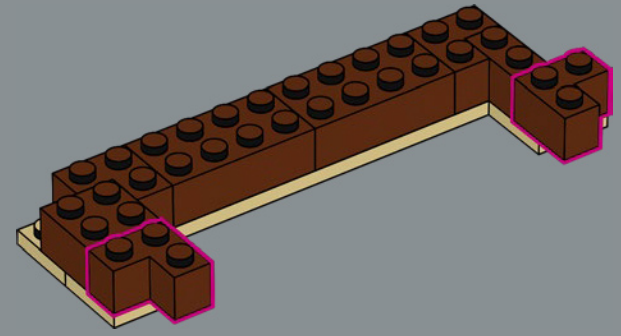

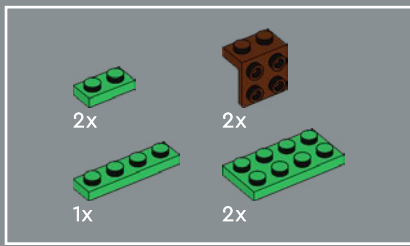

13

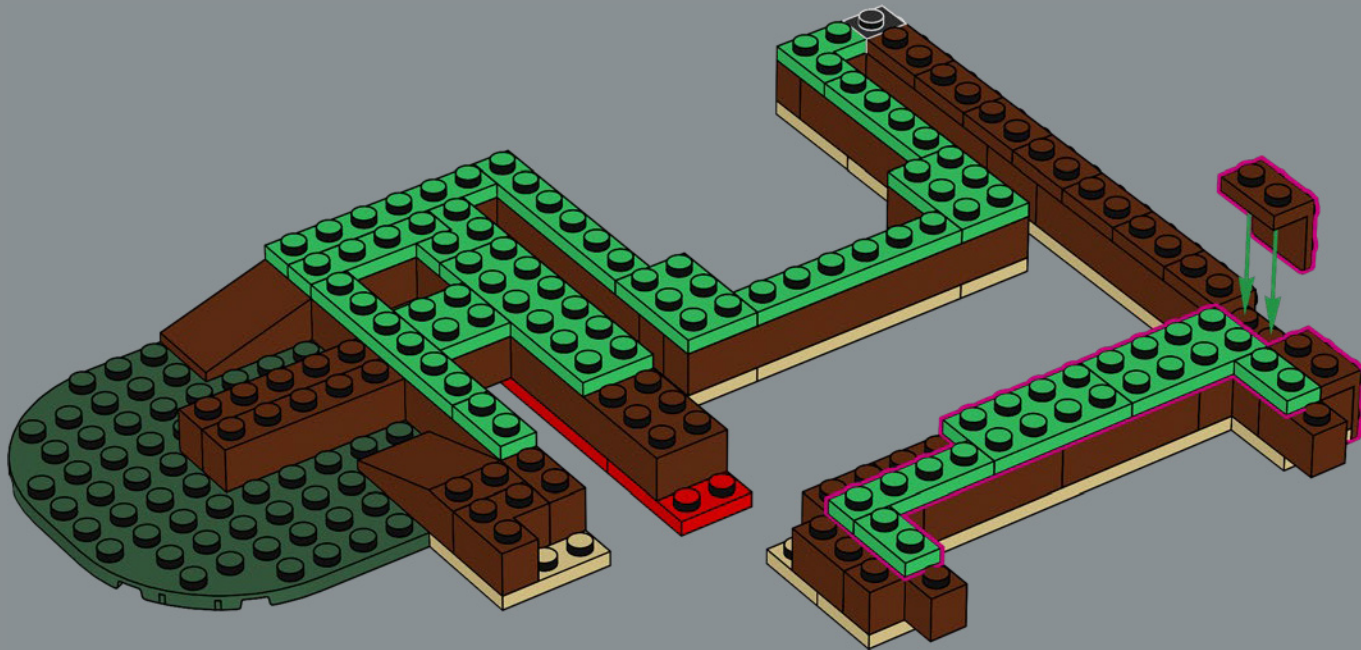

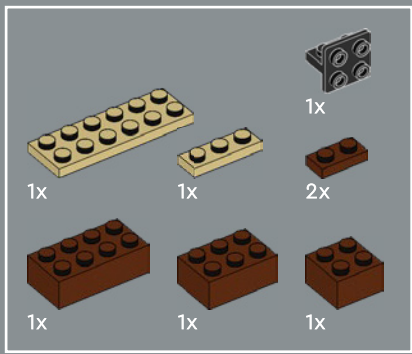

14

1

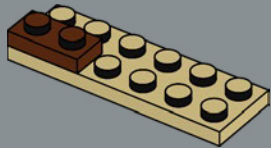

2

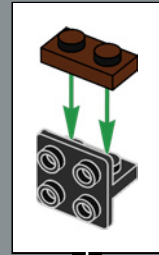
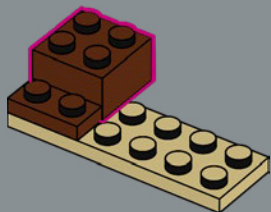

3

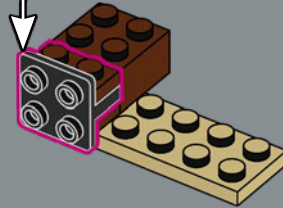

4

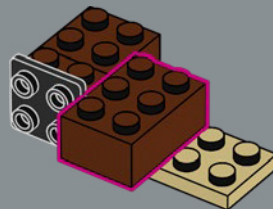

5

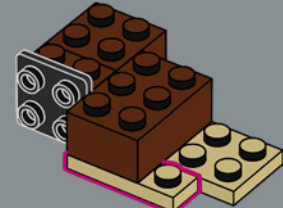

6

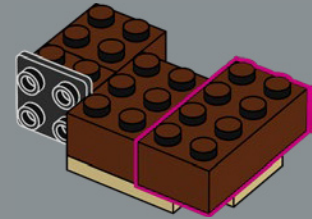

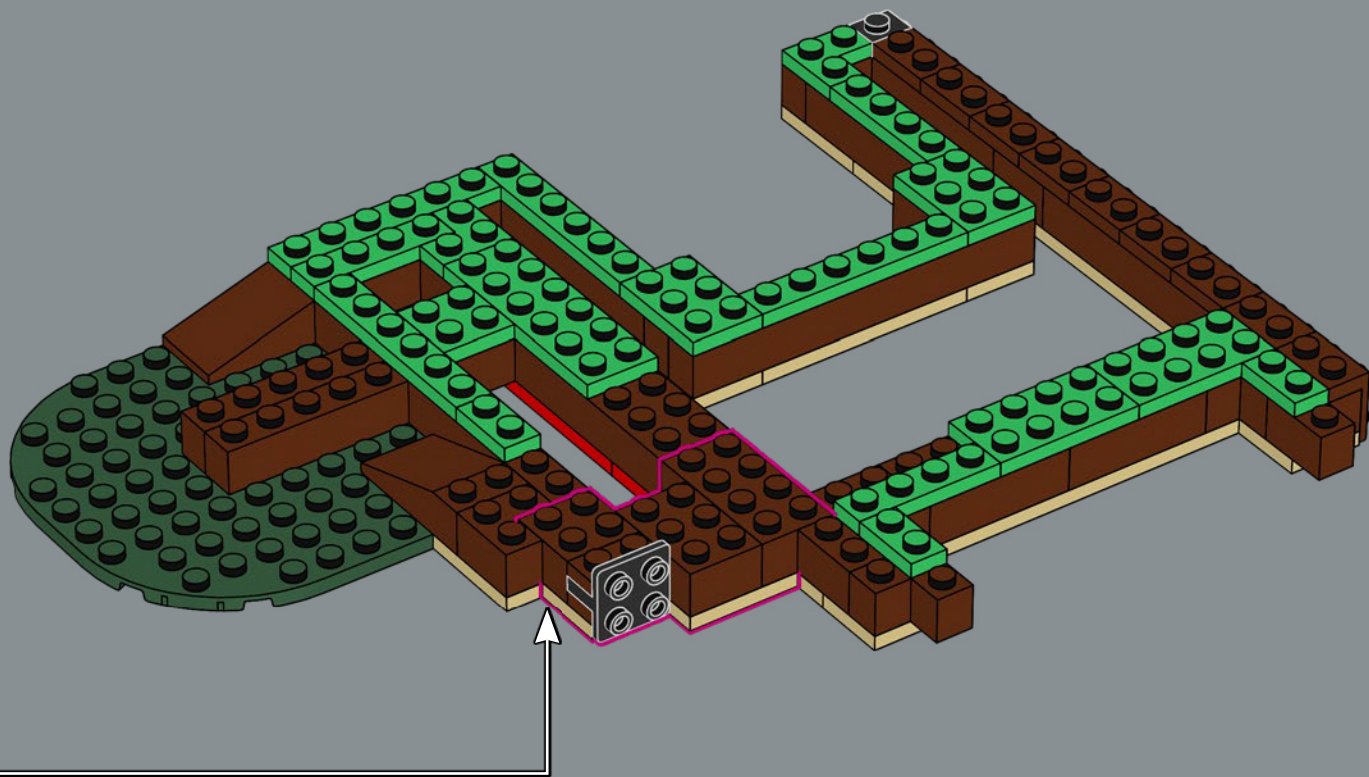

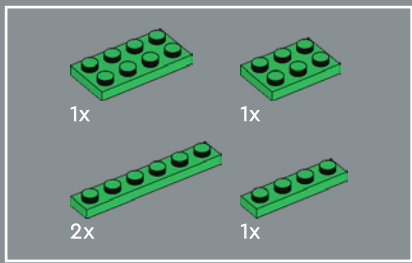

15

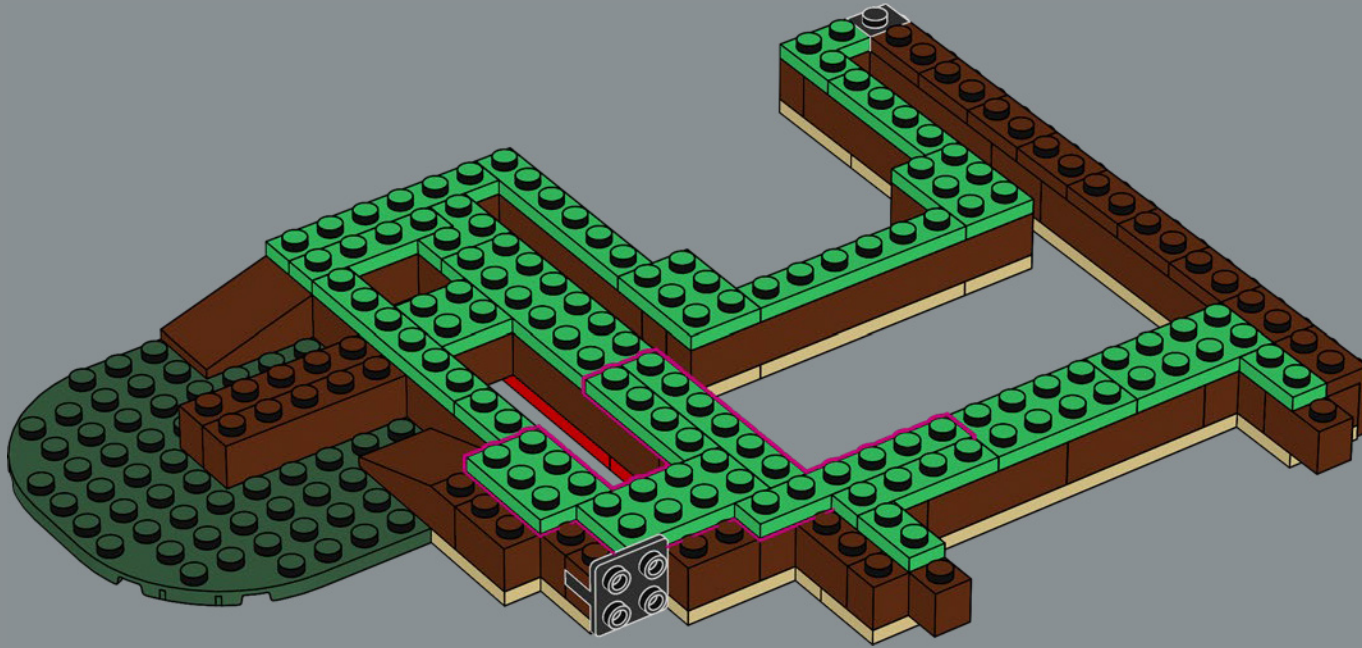

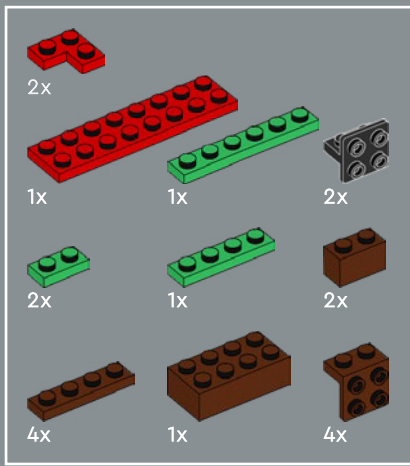

16

1

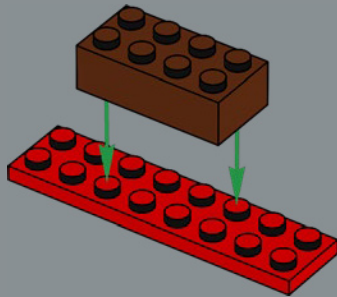

2

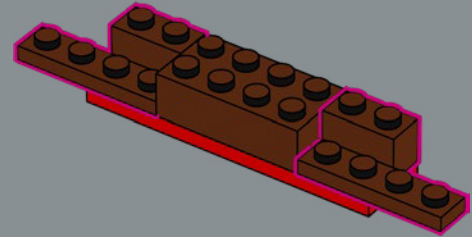

3

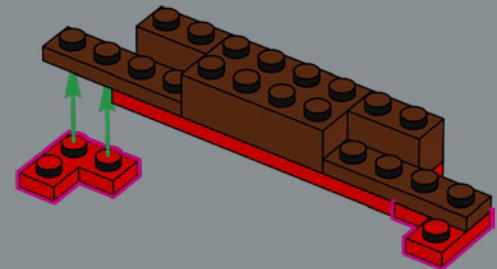

4

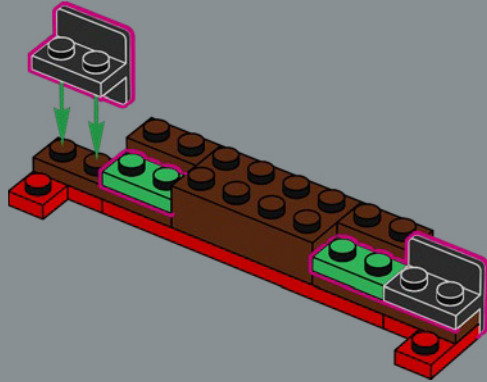

5

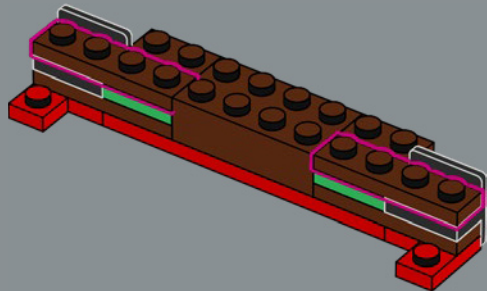

6

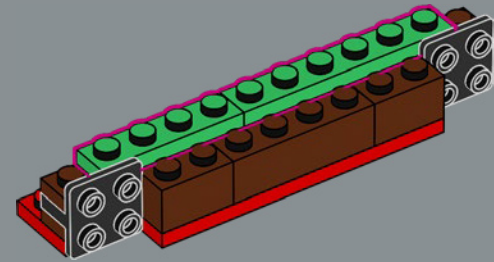

7

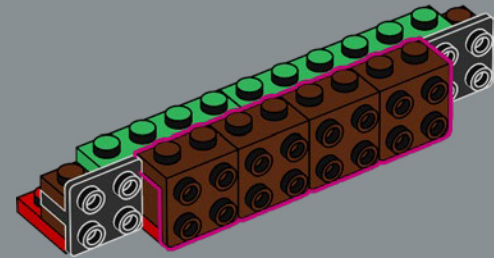

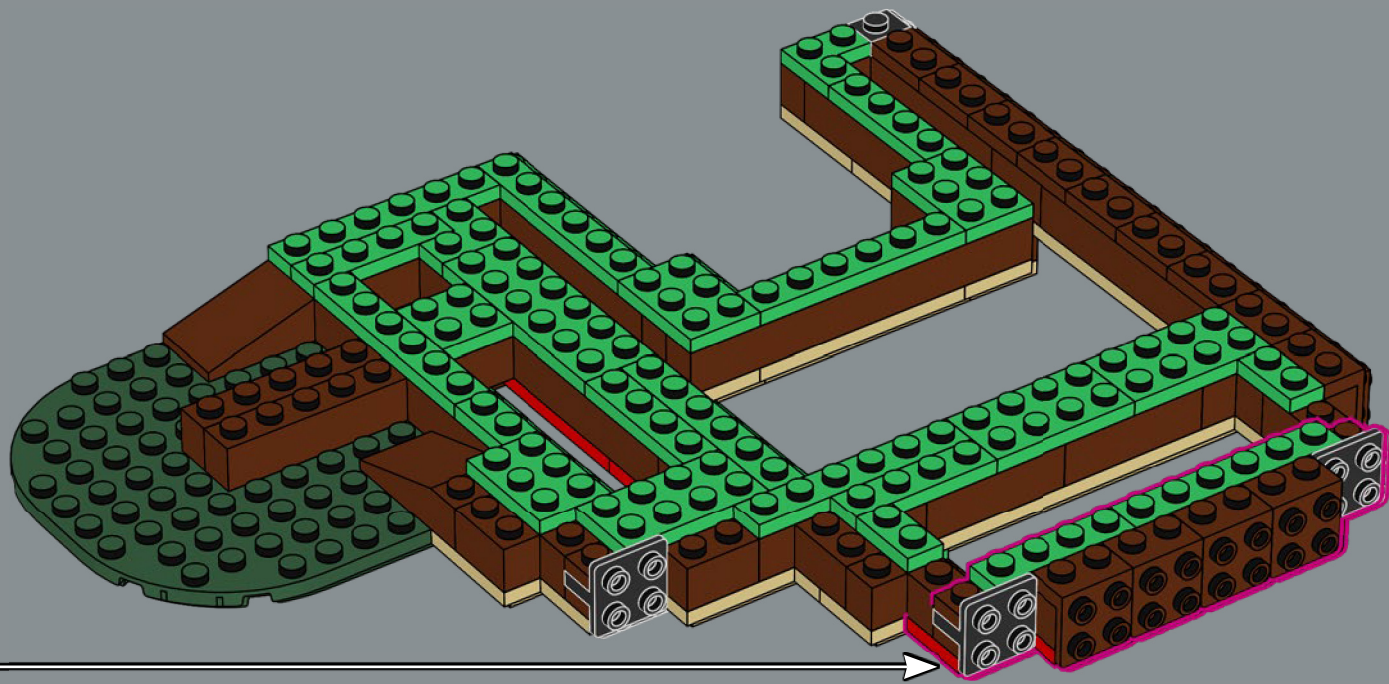



17

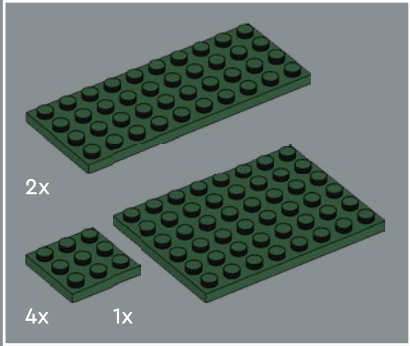
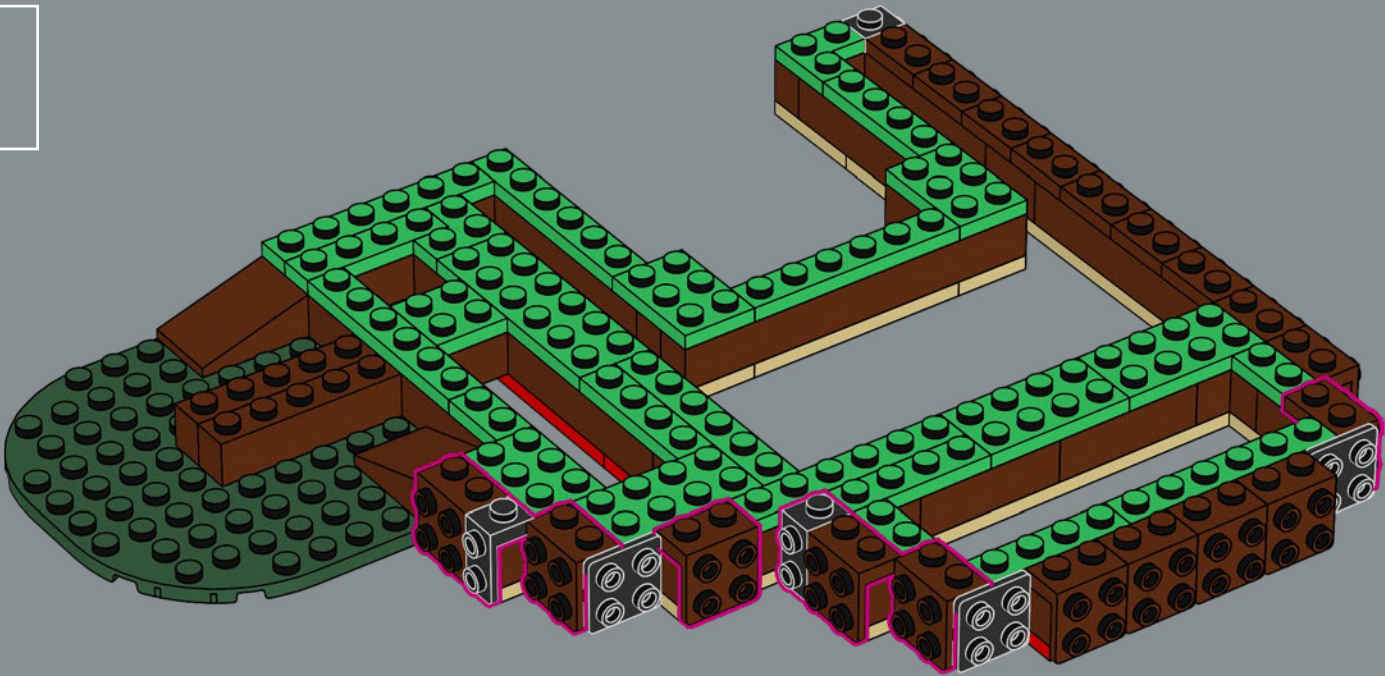

18

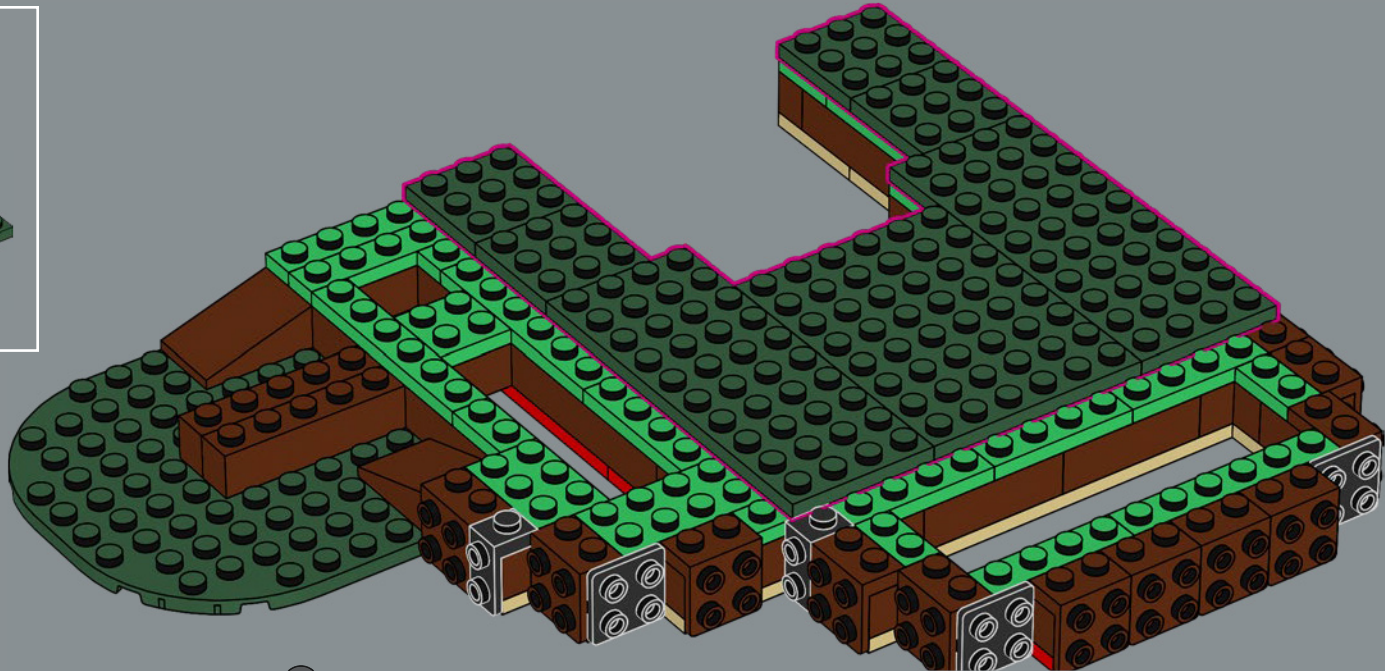

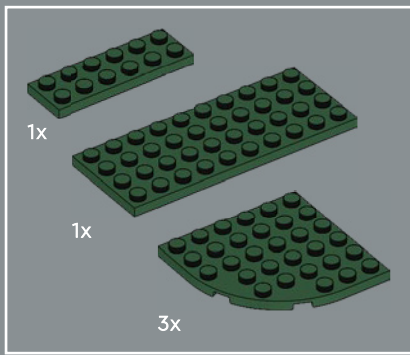

19

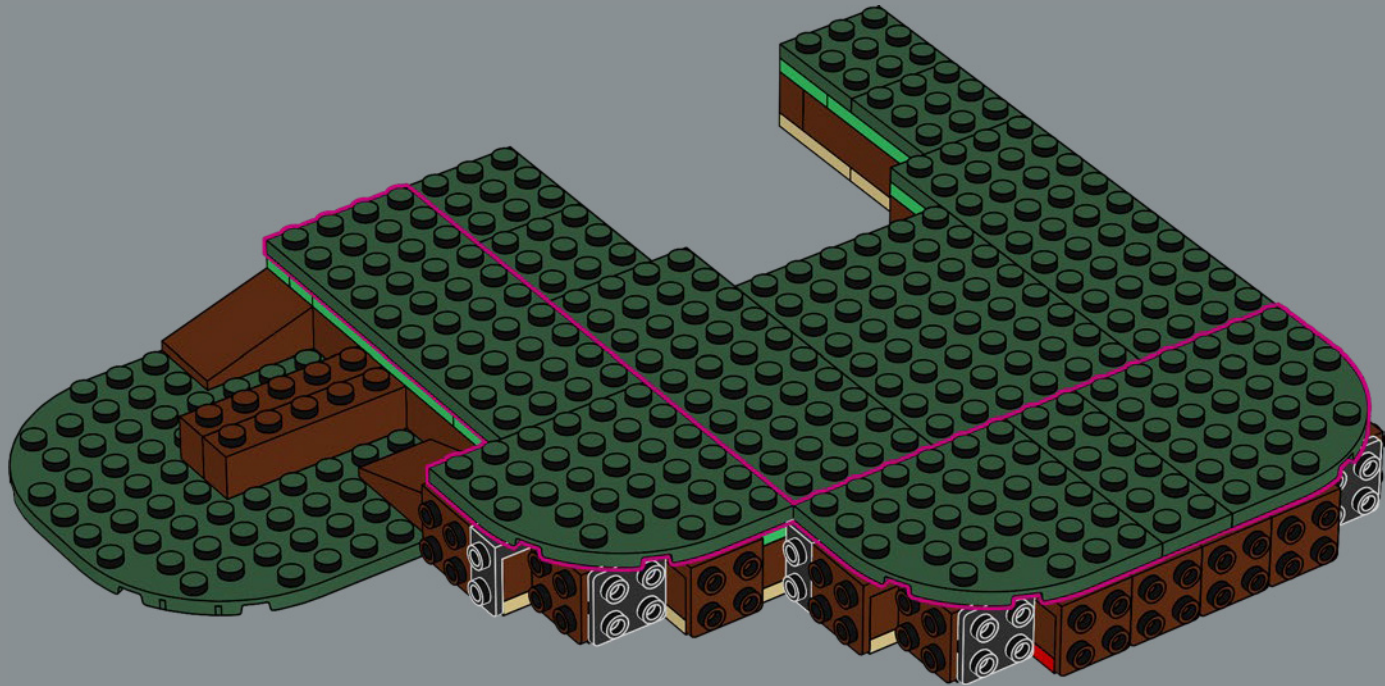

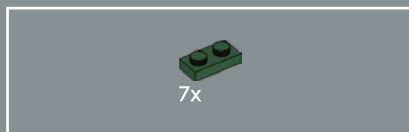

20

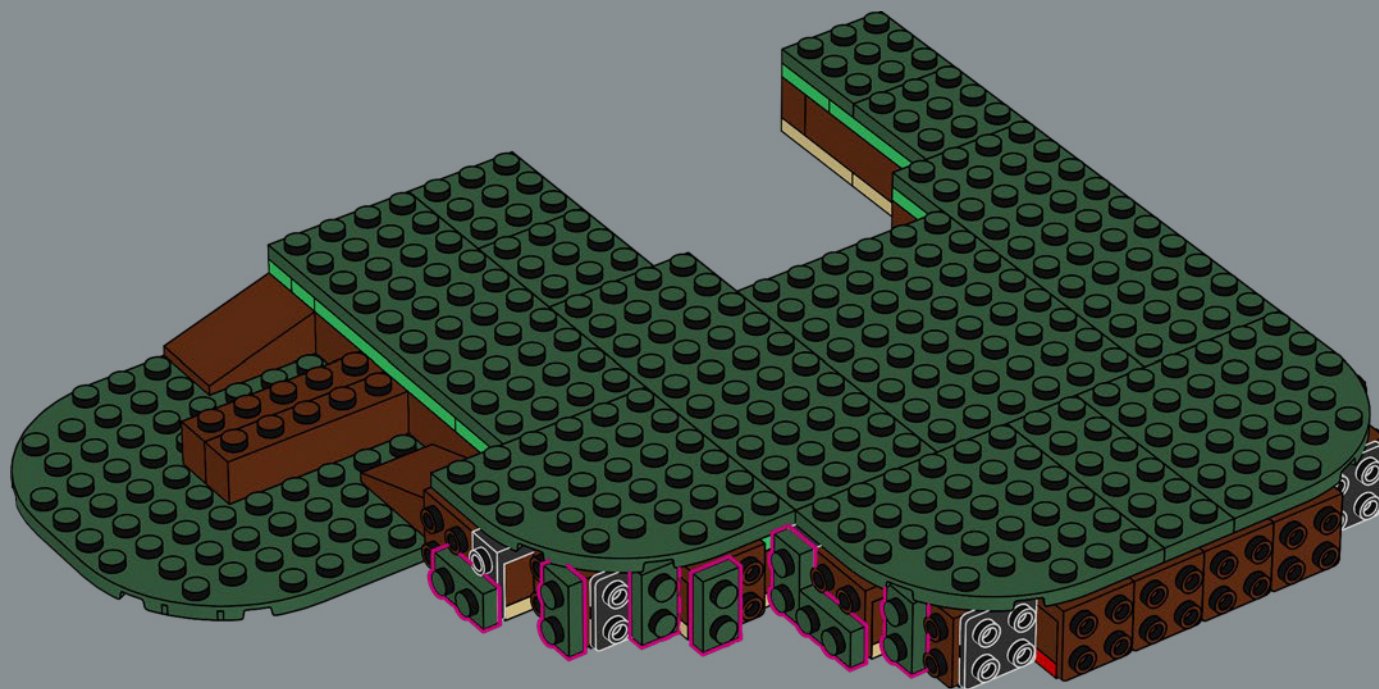



21

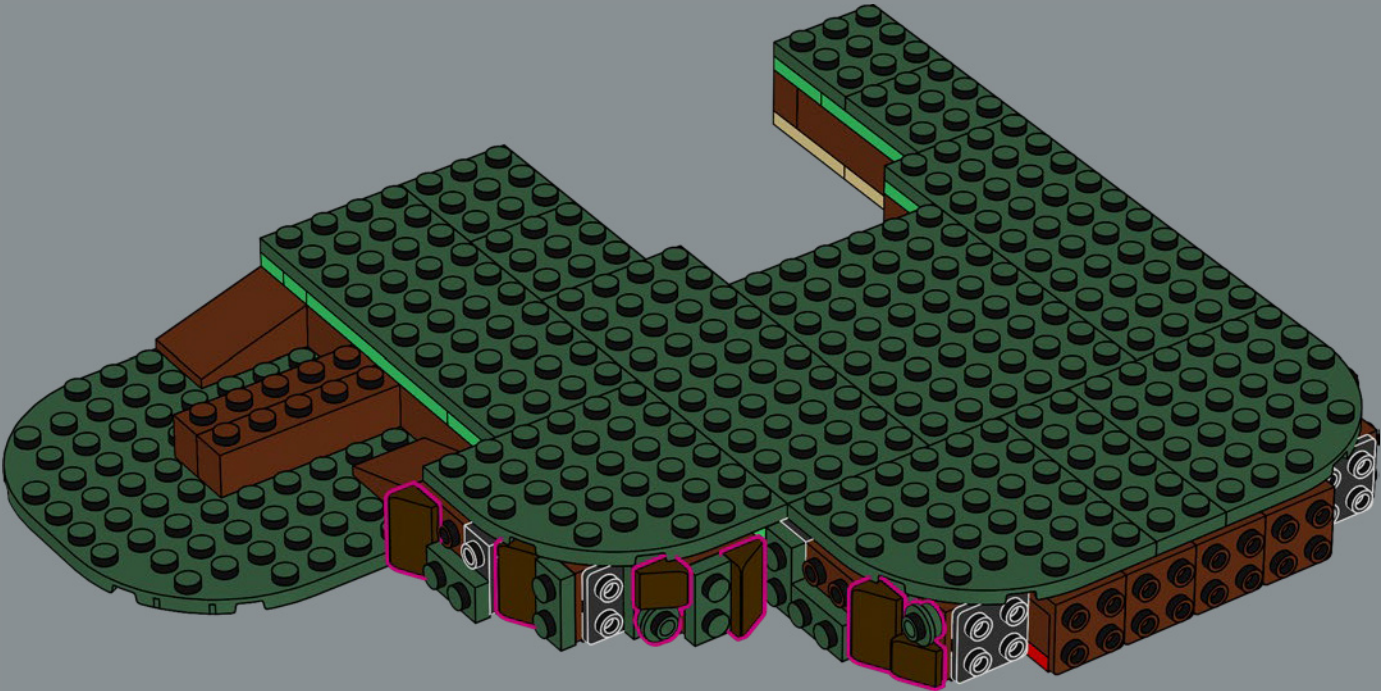



22

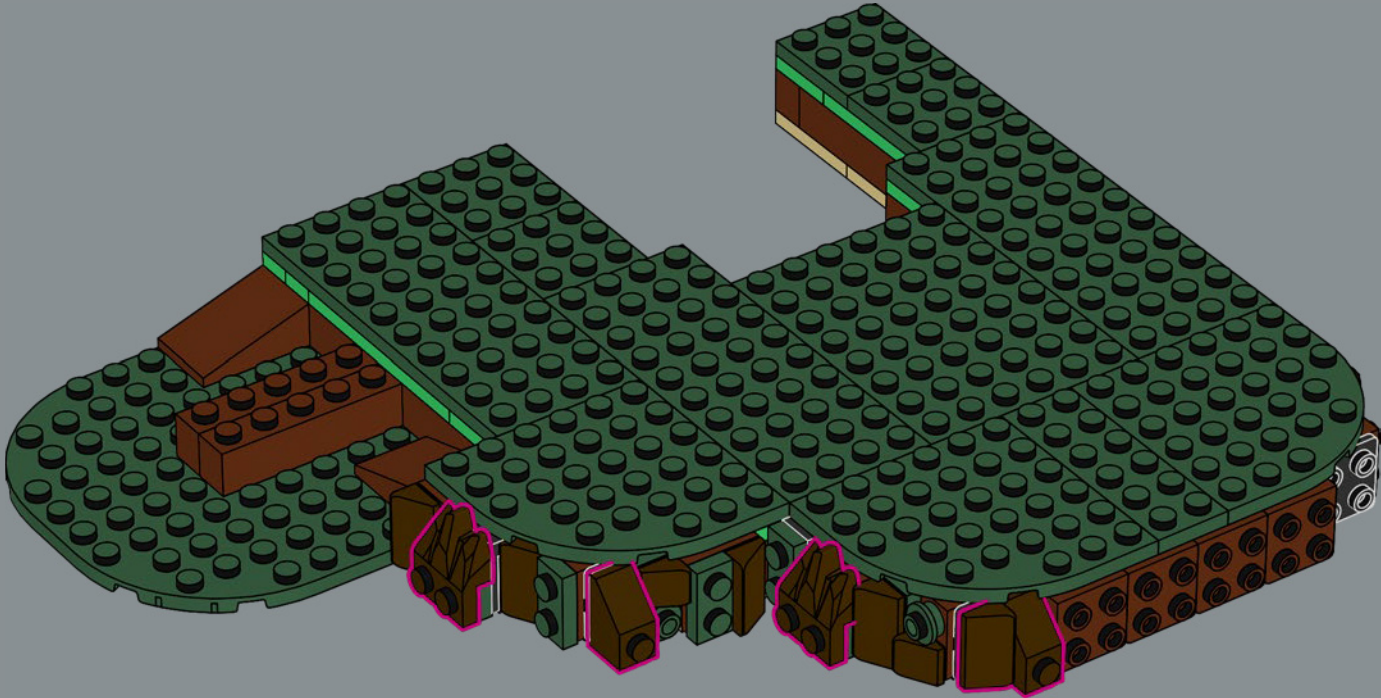

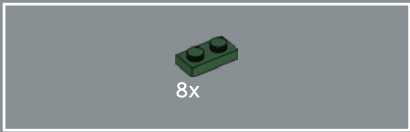

23

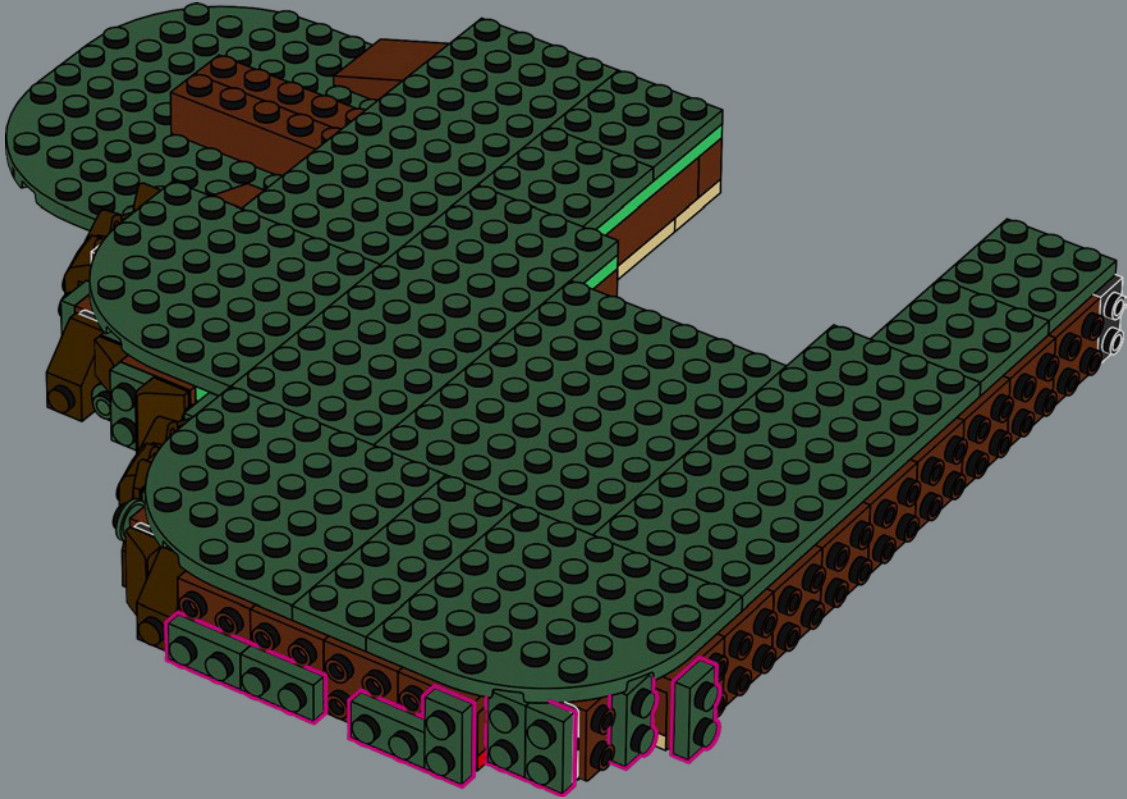

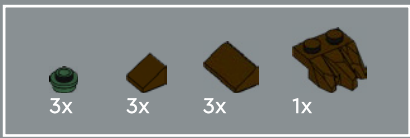

24

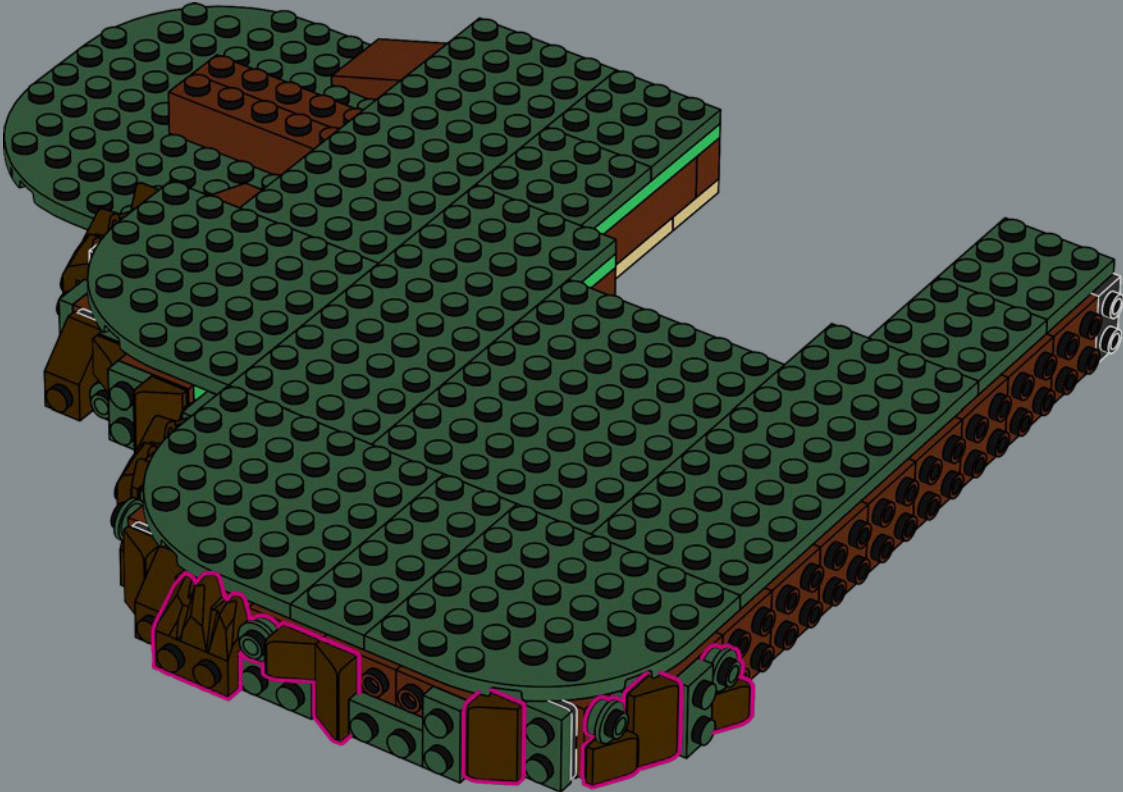



25

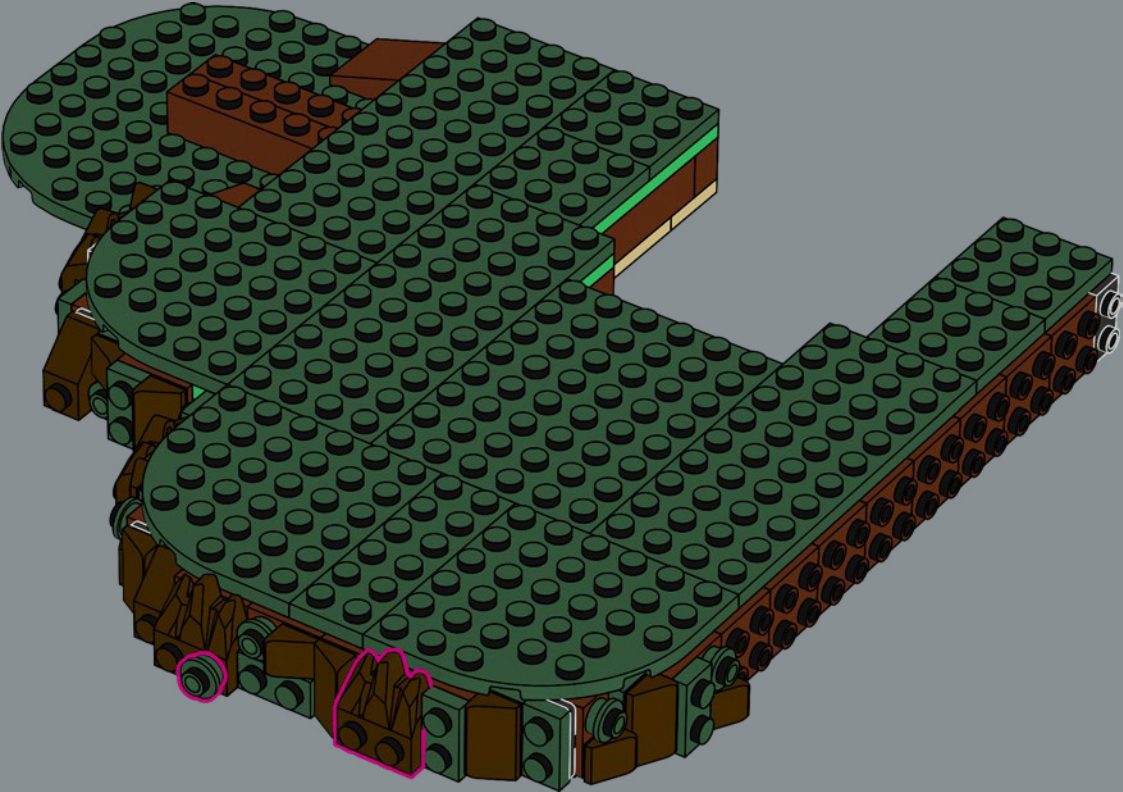

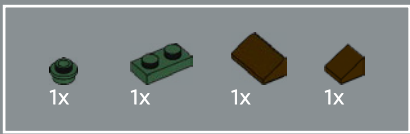

26

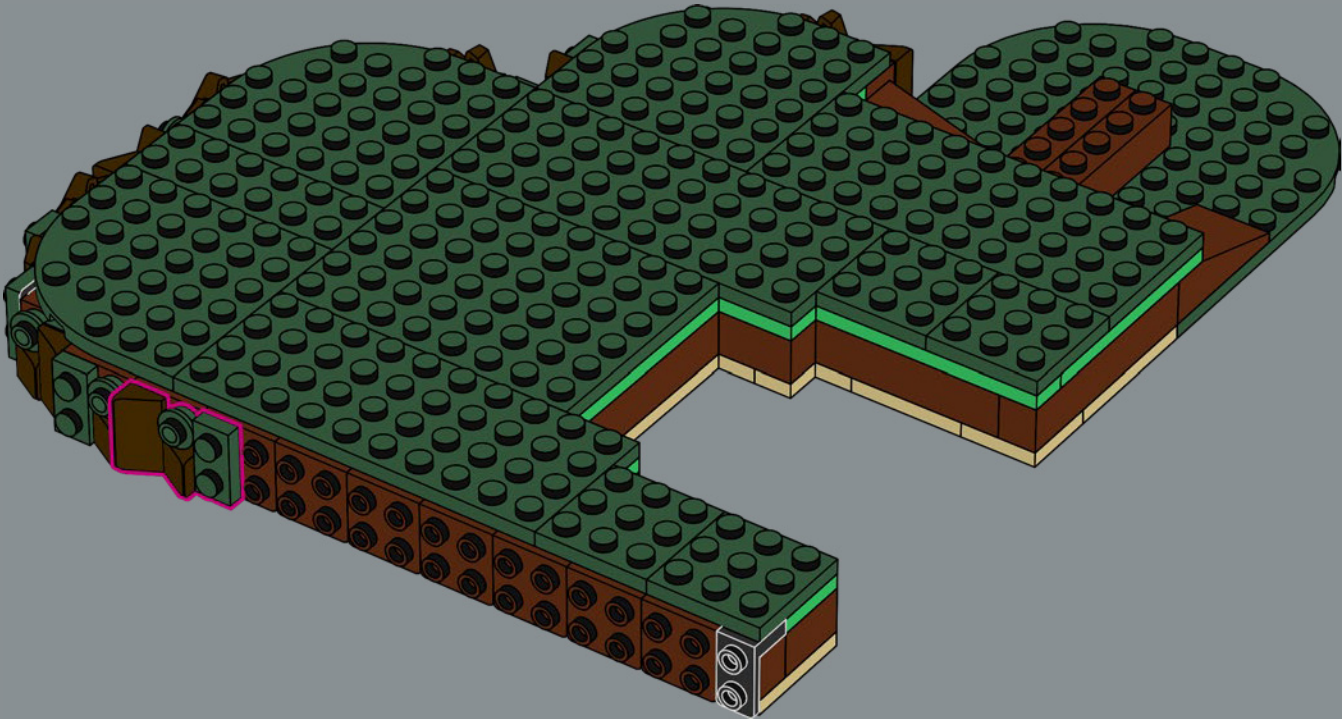

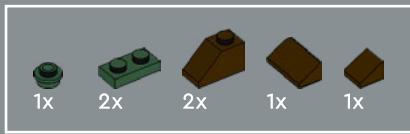

27



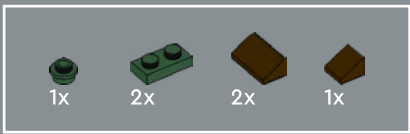

28

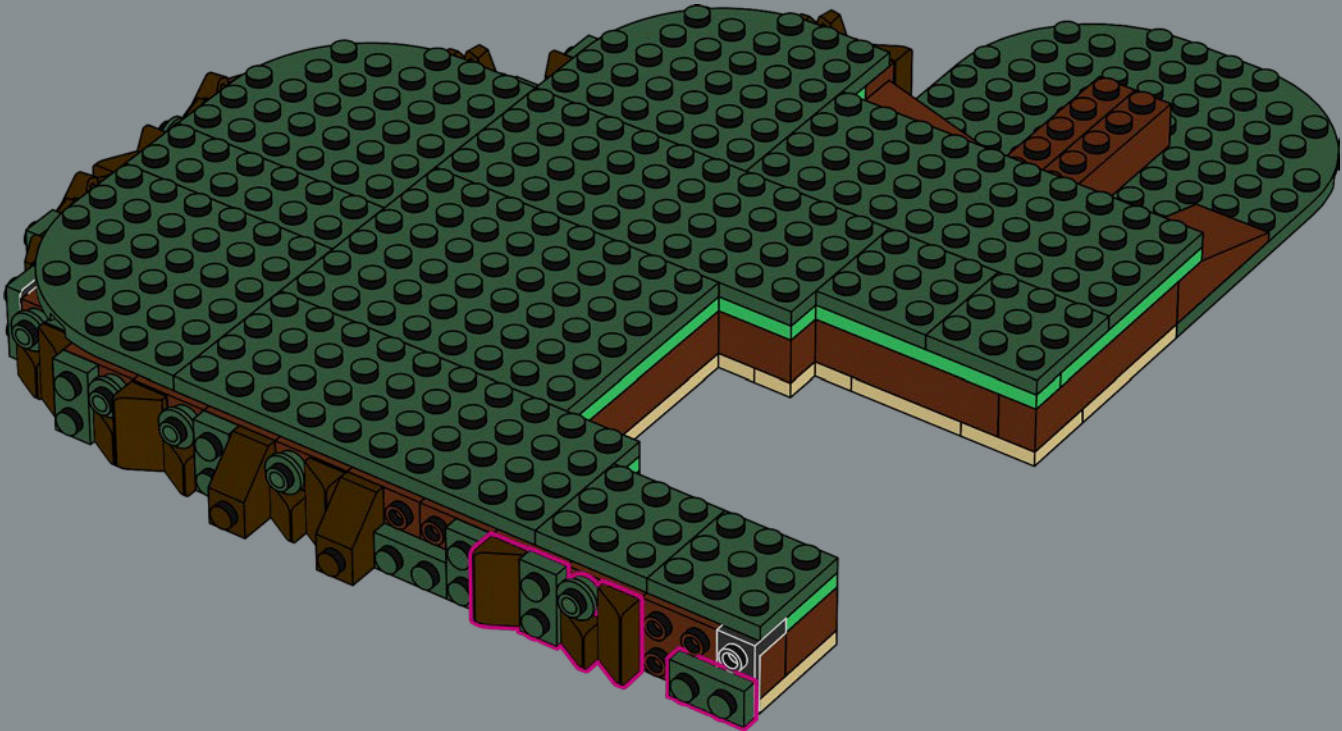

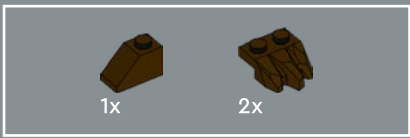

29

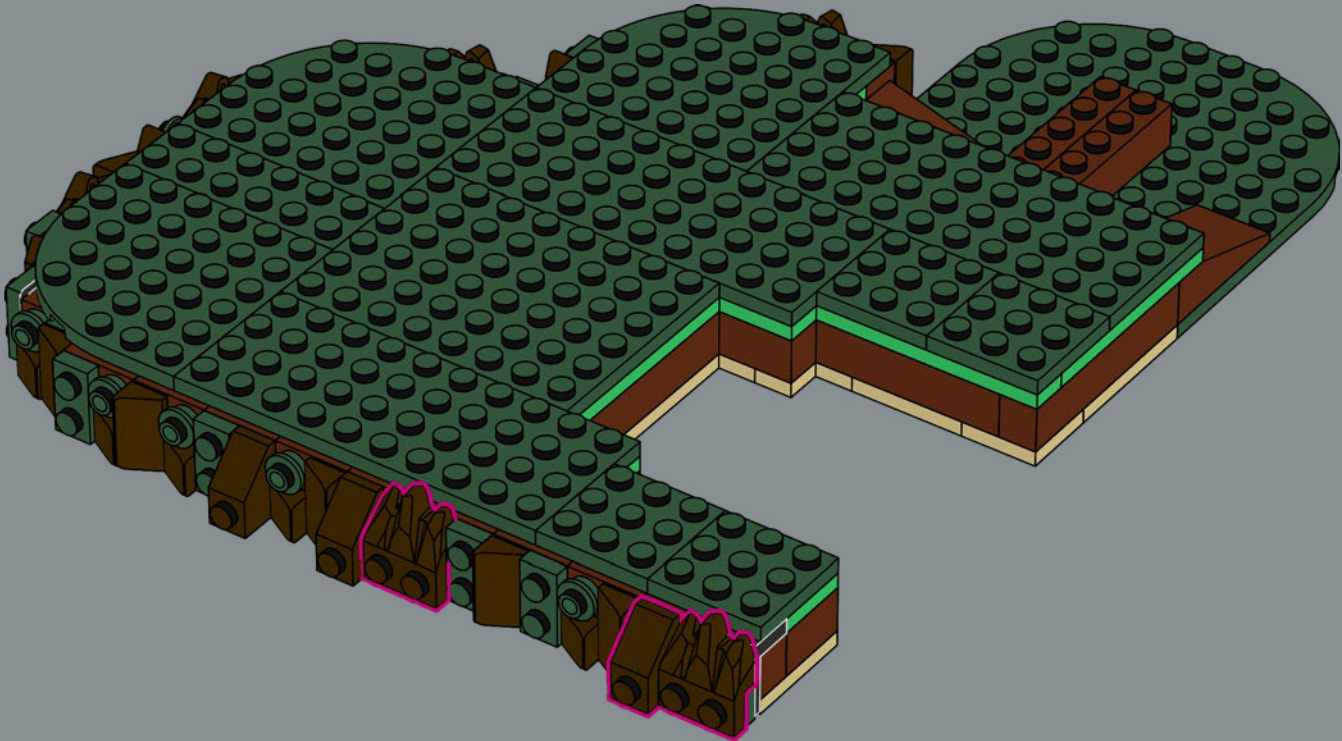





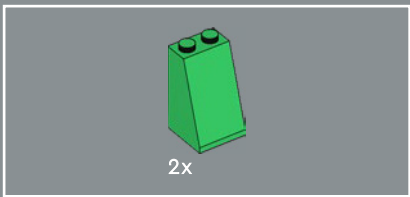

32

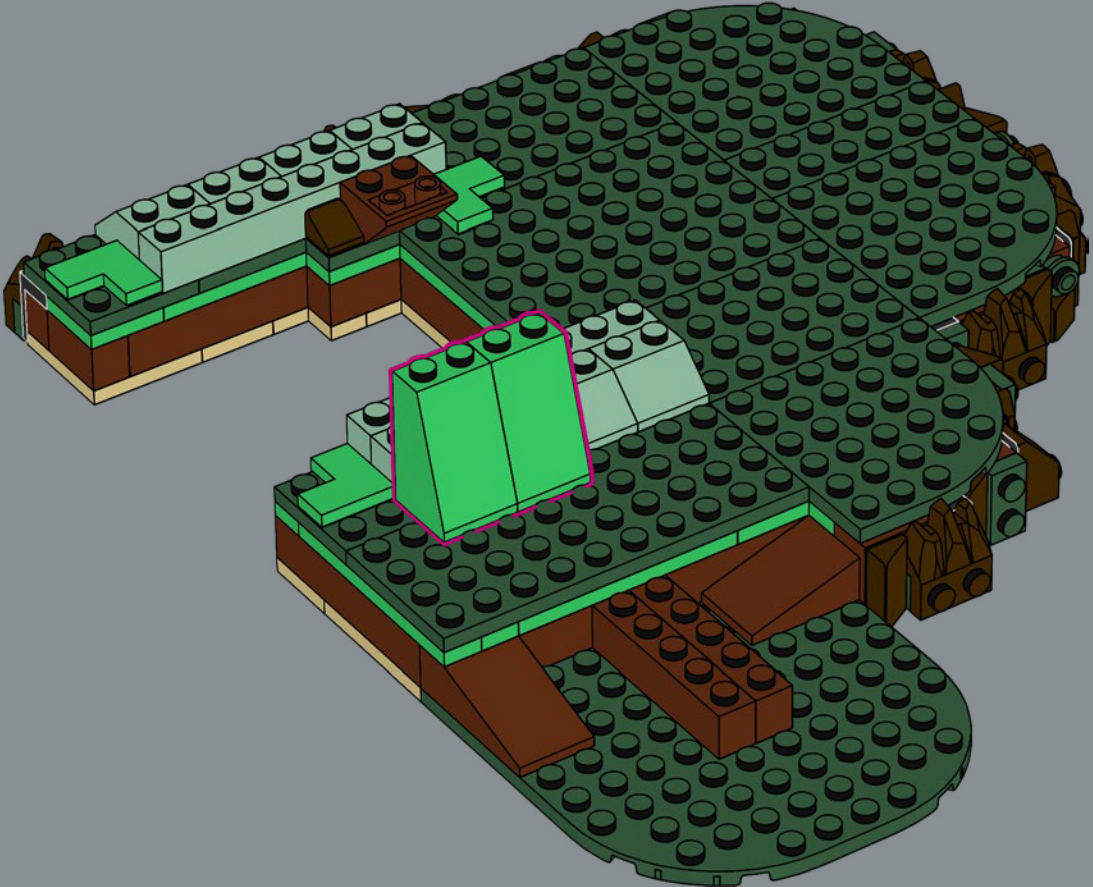

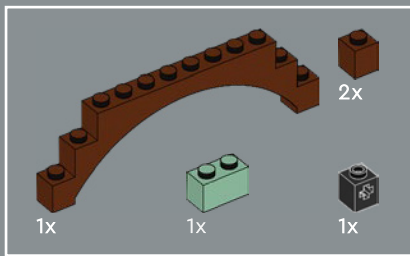

33

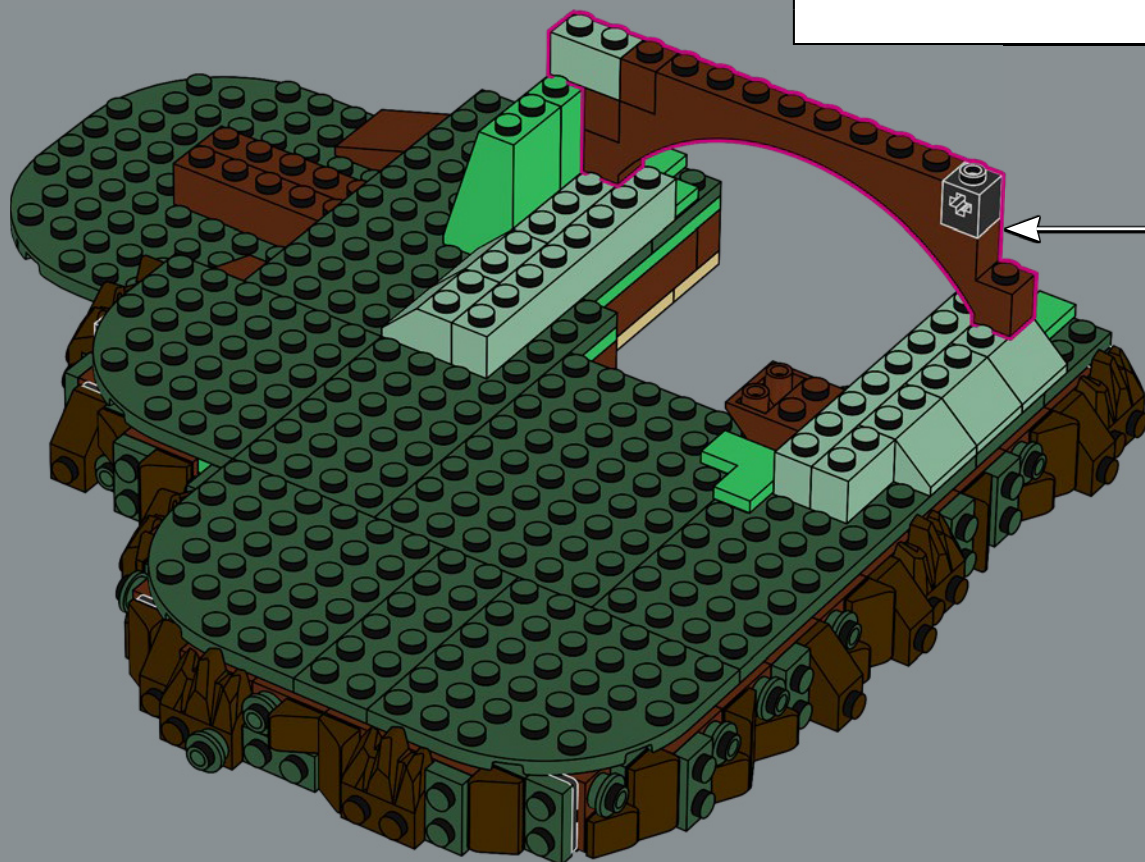
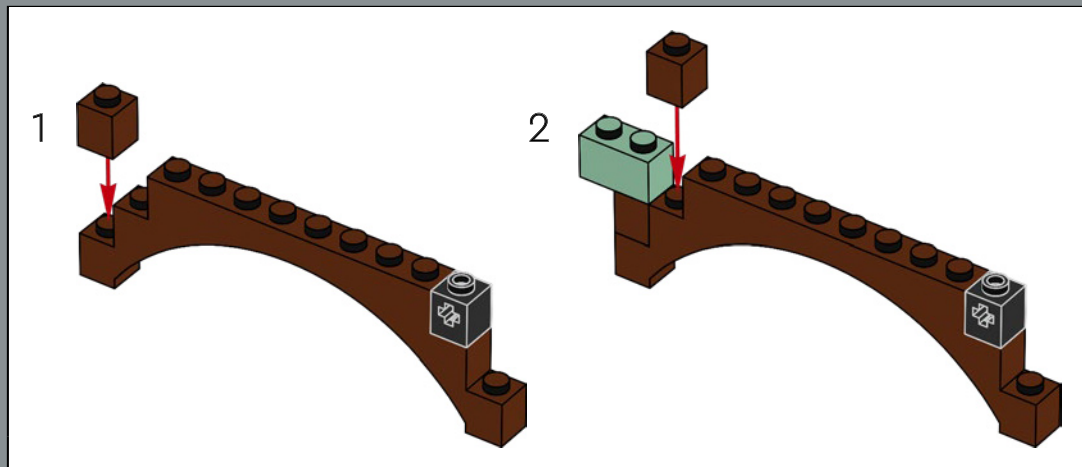

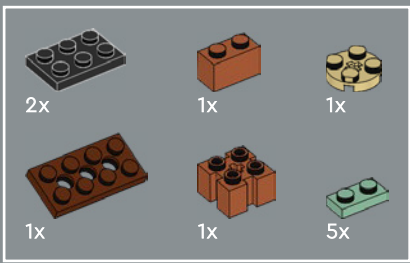

34

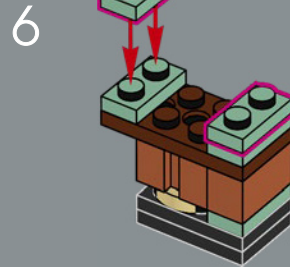
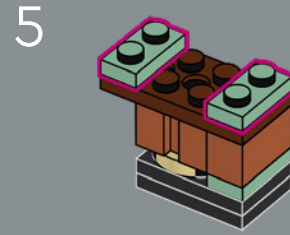
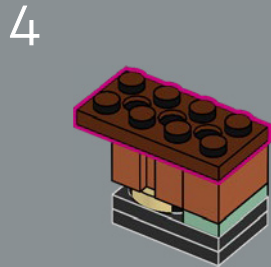
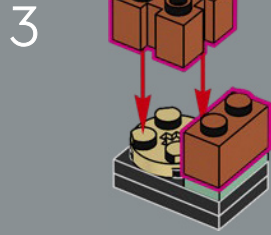
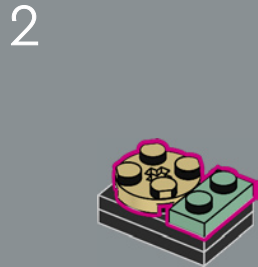
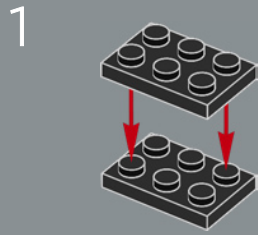



35

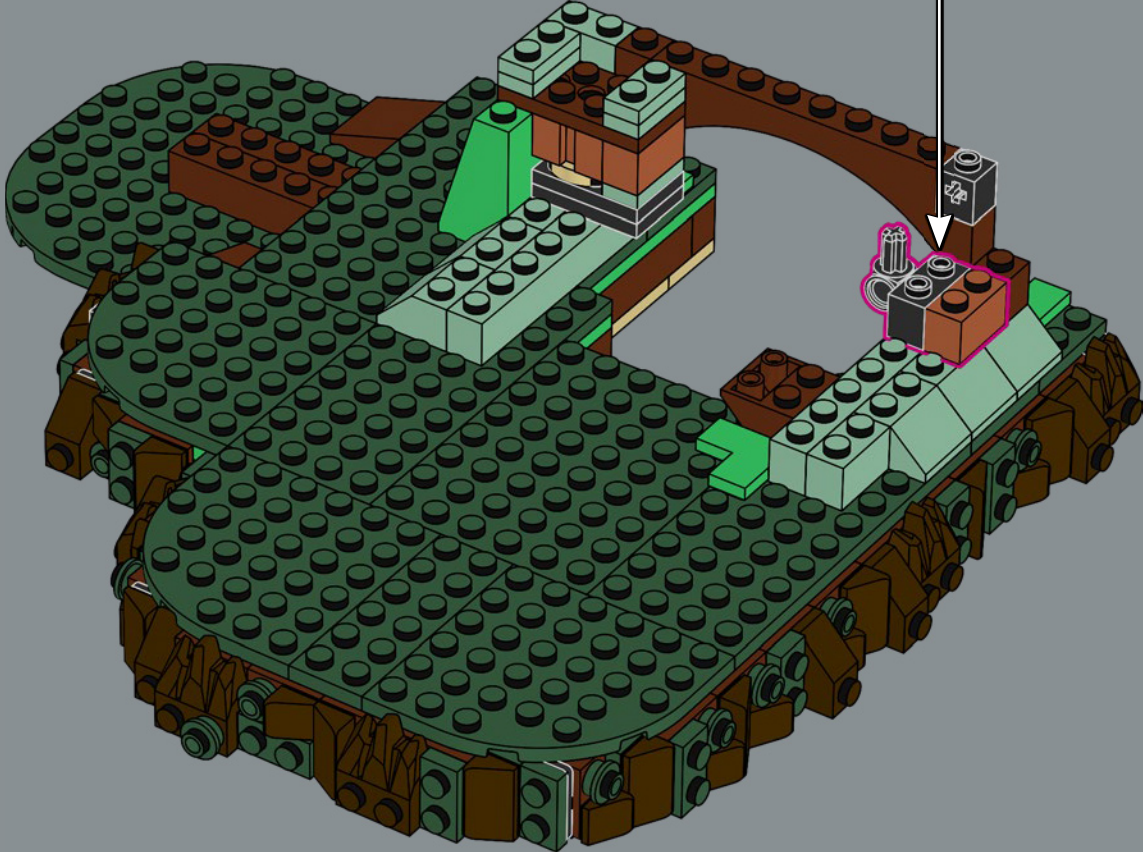
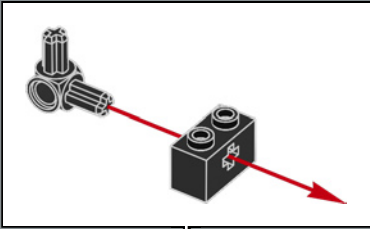



36

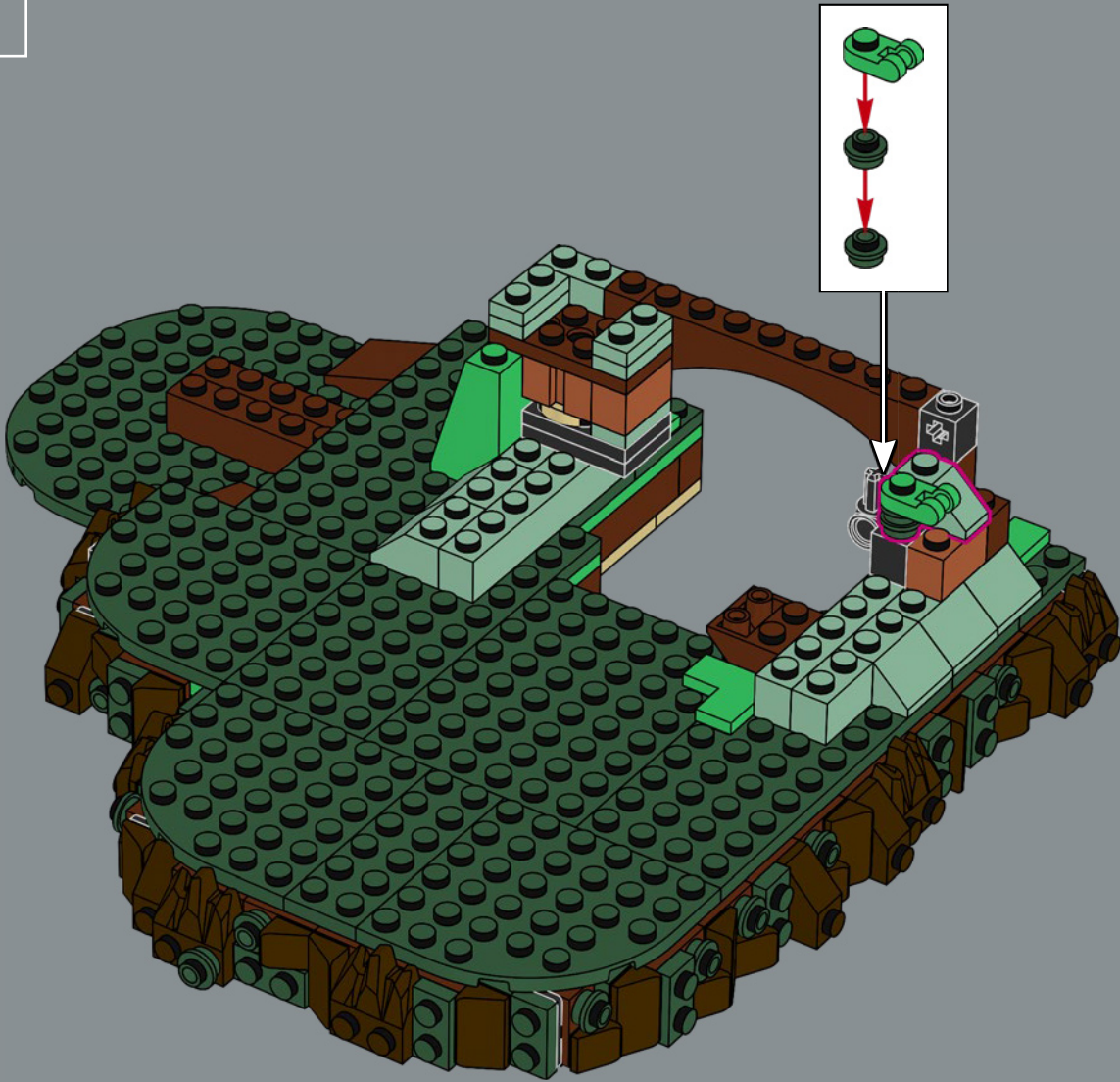

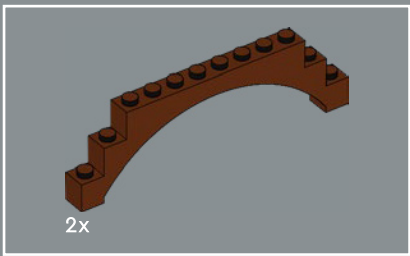

37

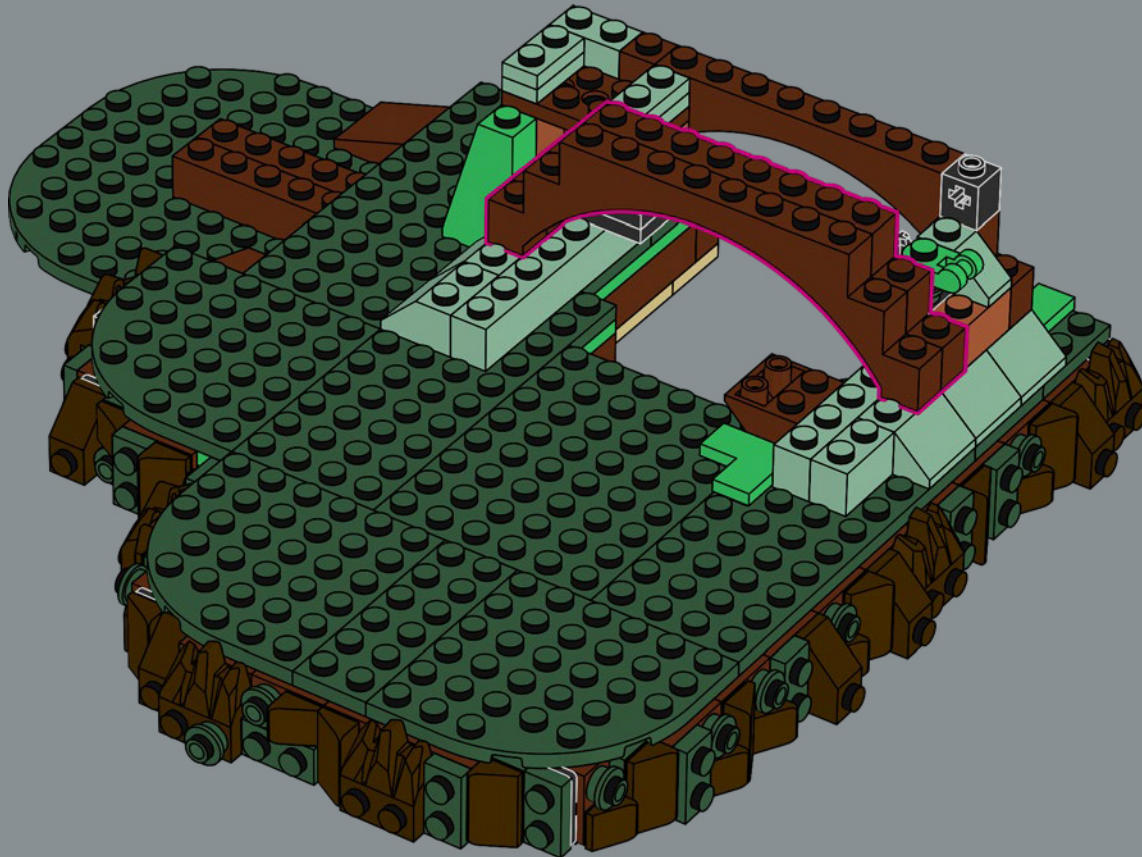



2x

38

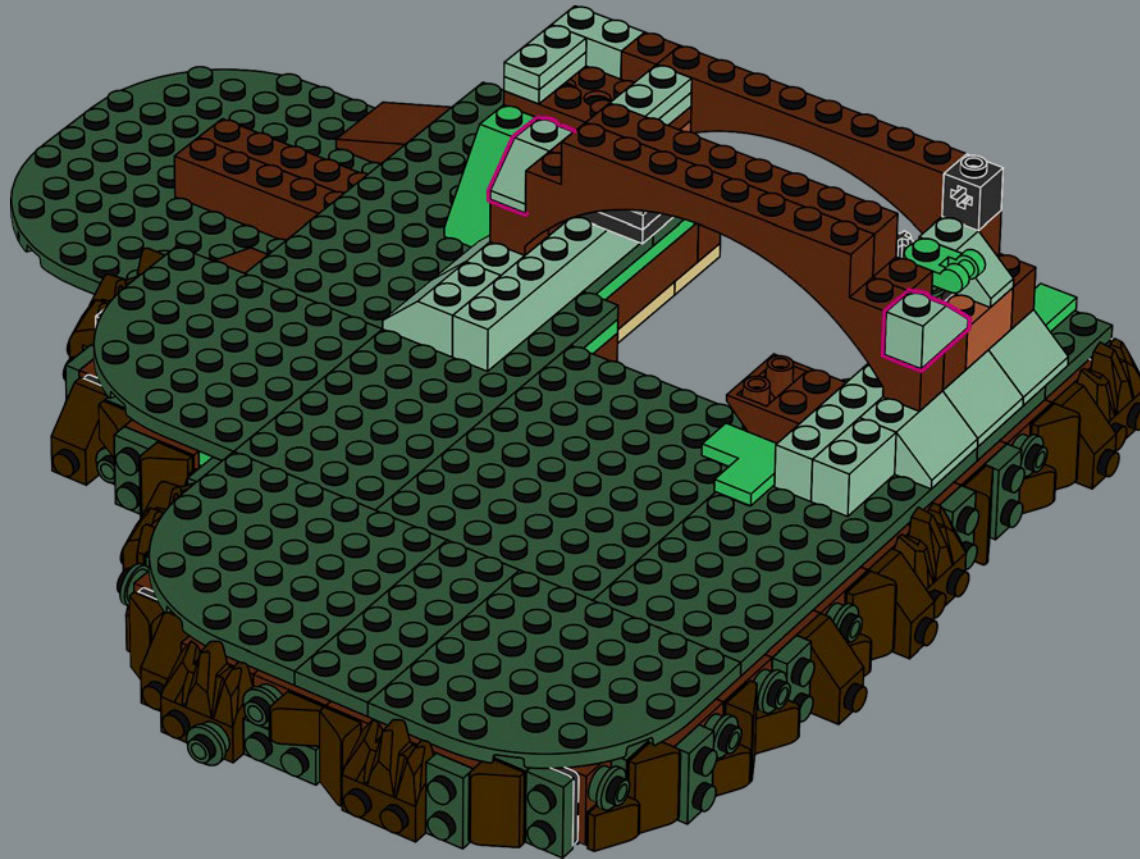

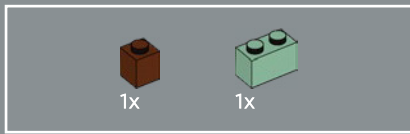

39

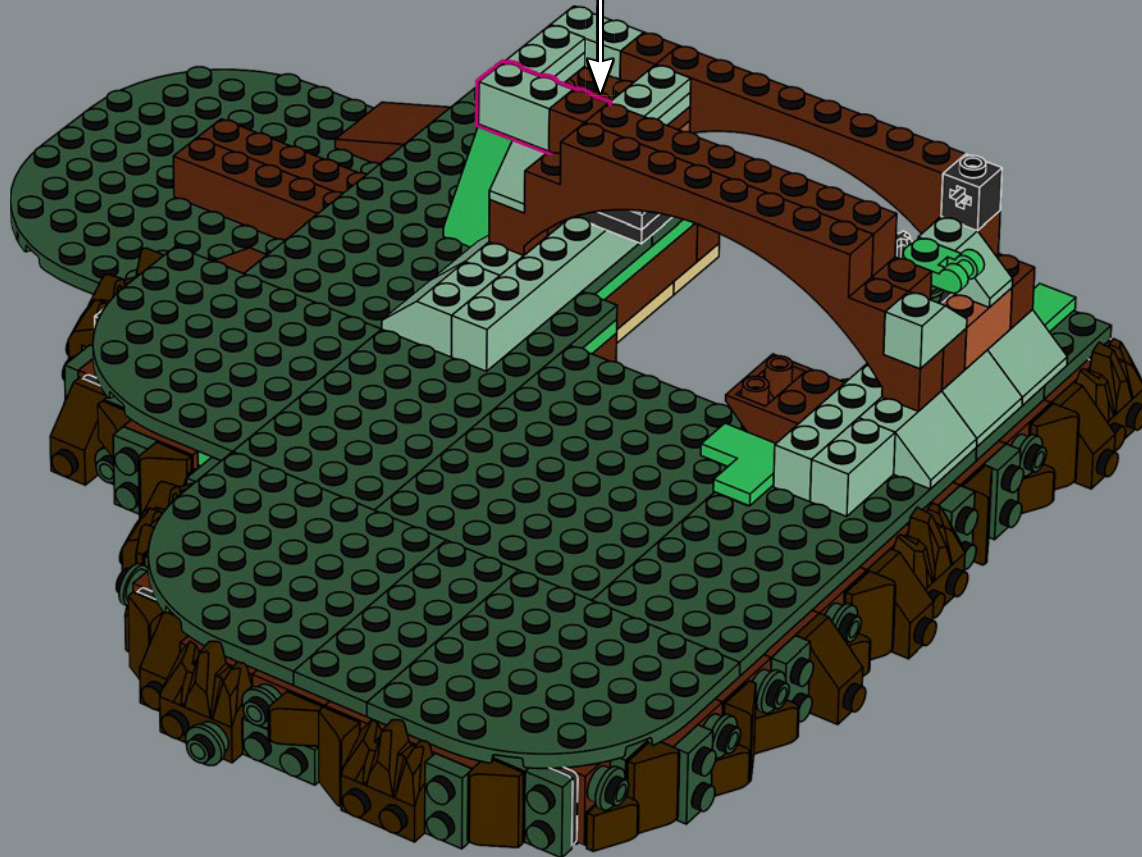
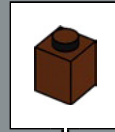

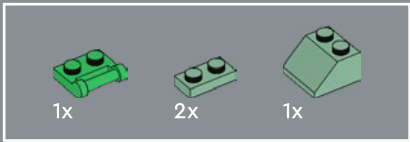

40

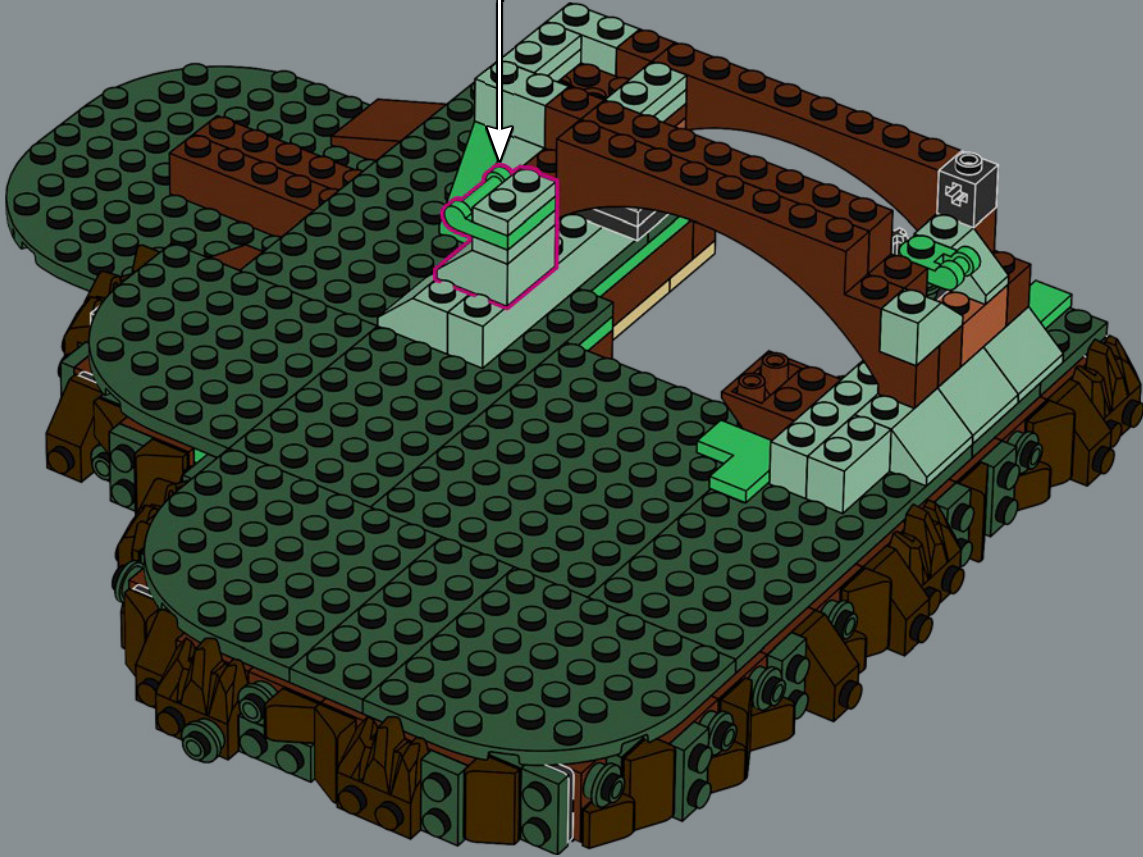
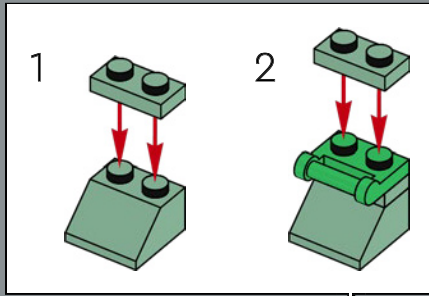

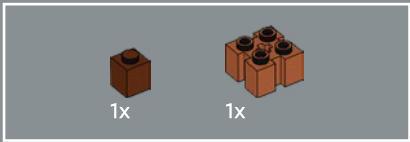

41

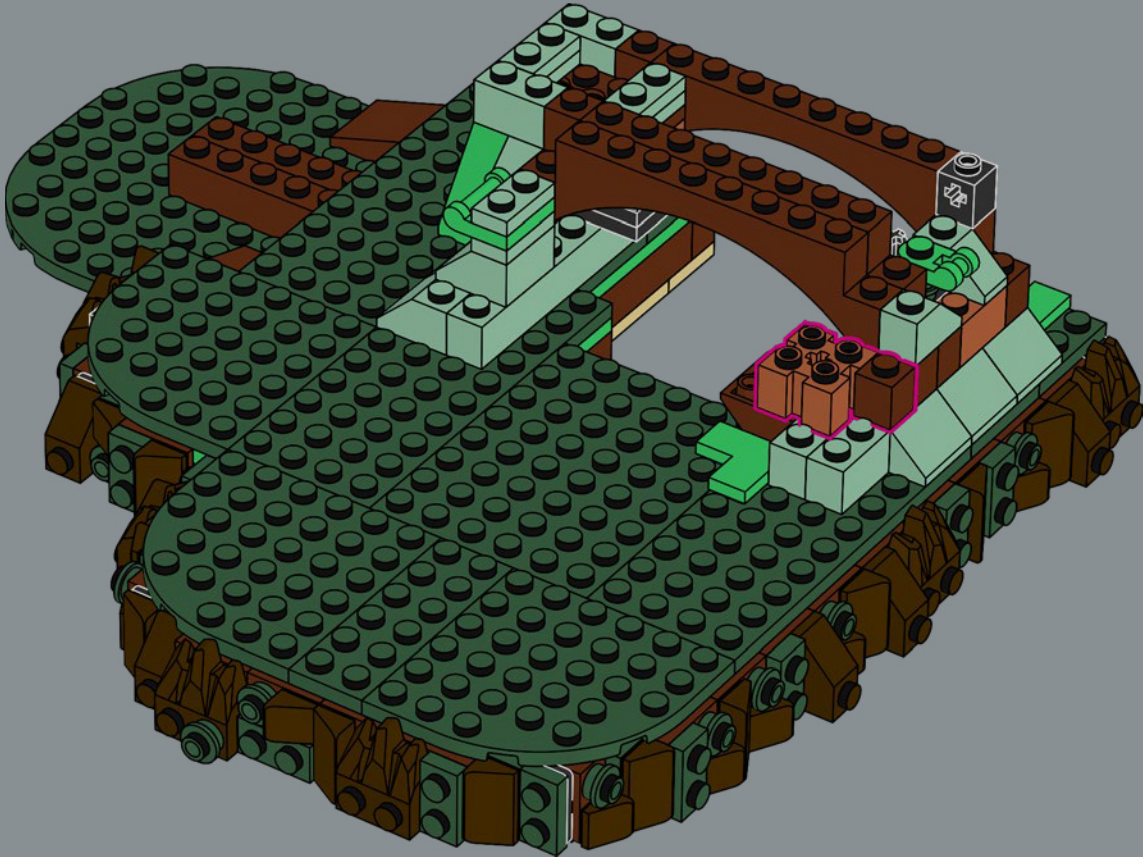

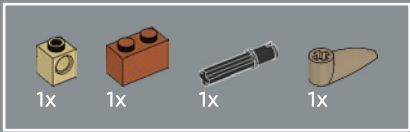

42

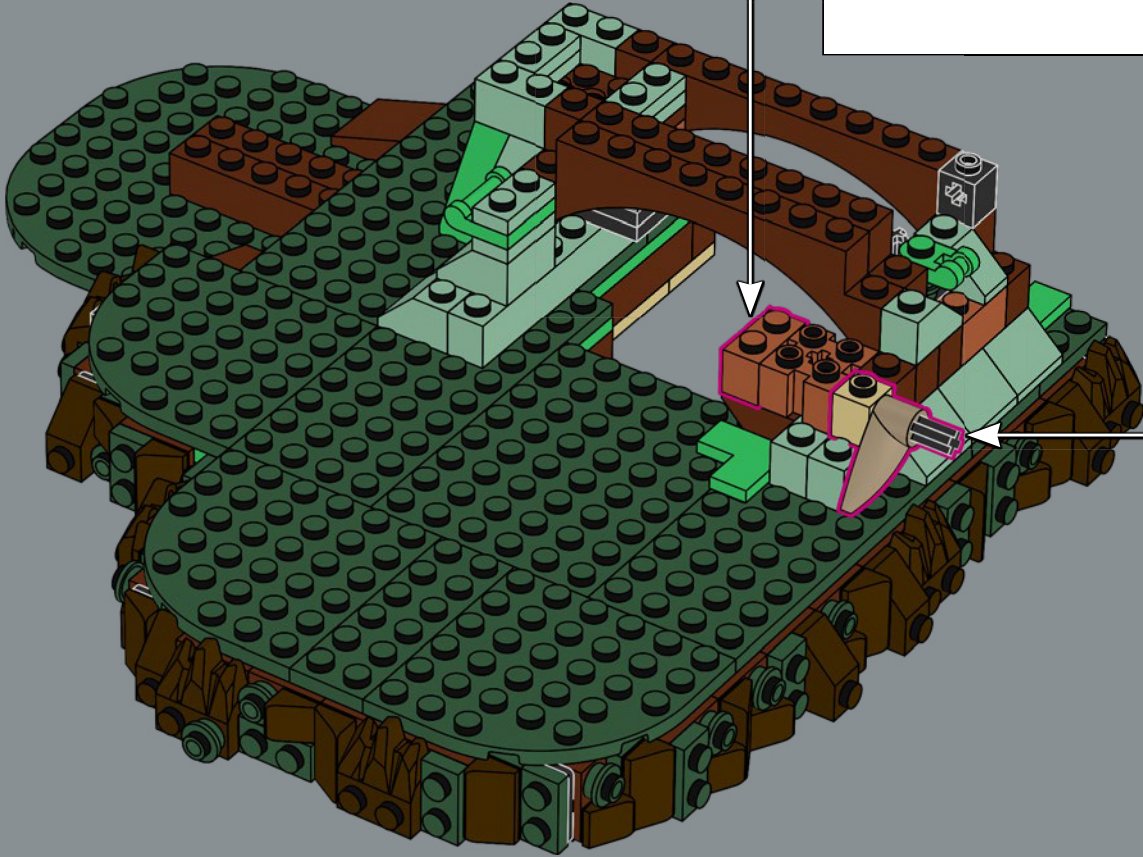
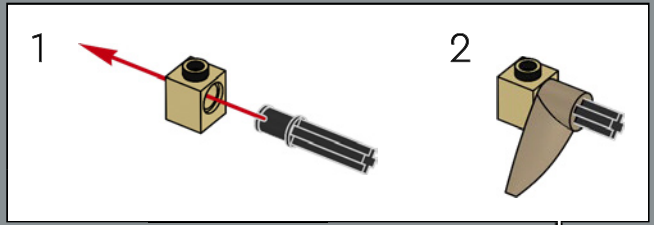
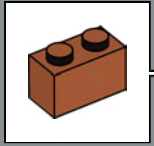

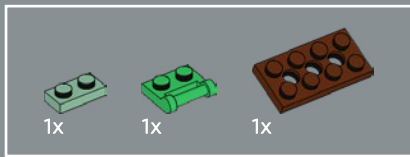

43

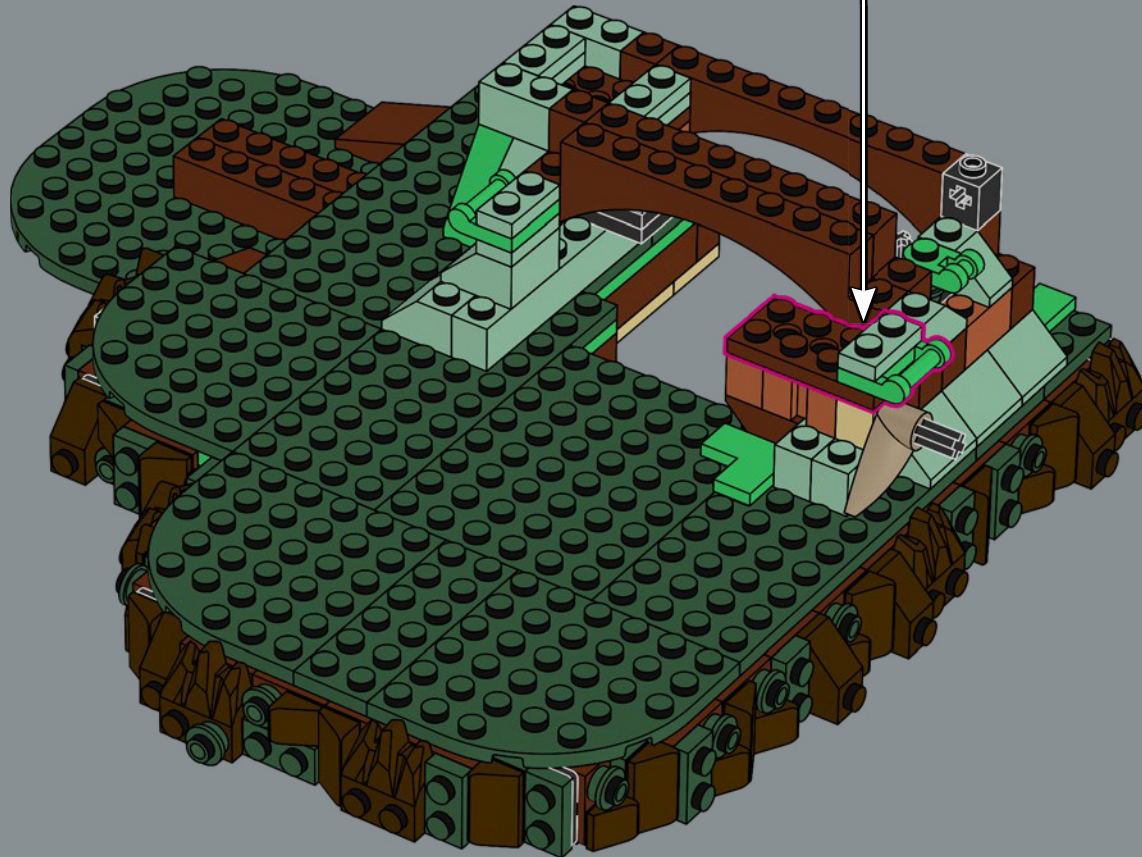
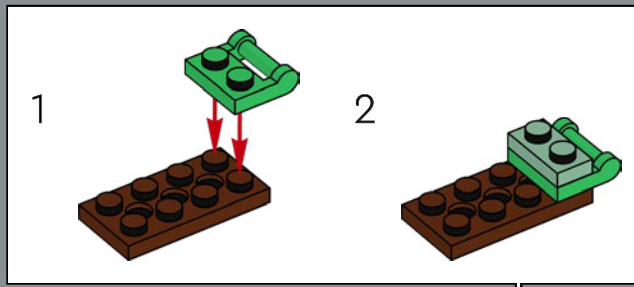

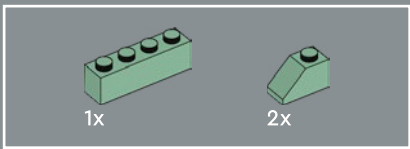

44

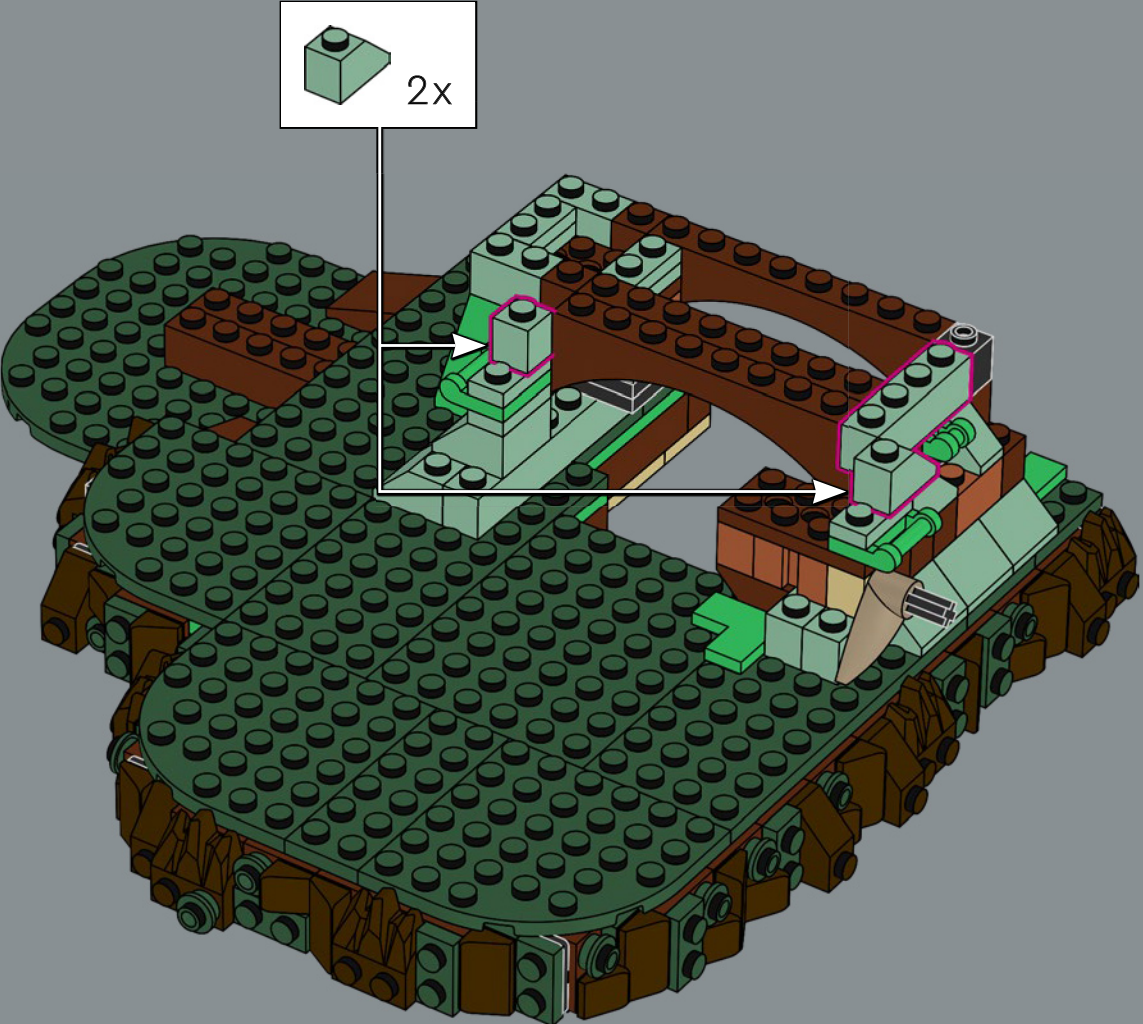

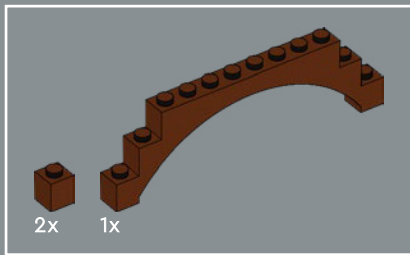

45

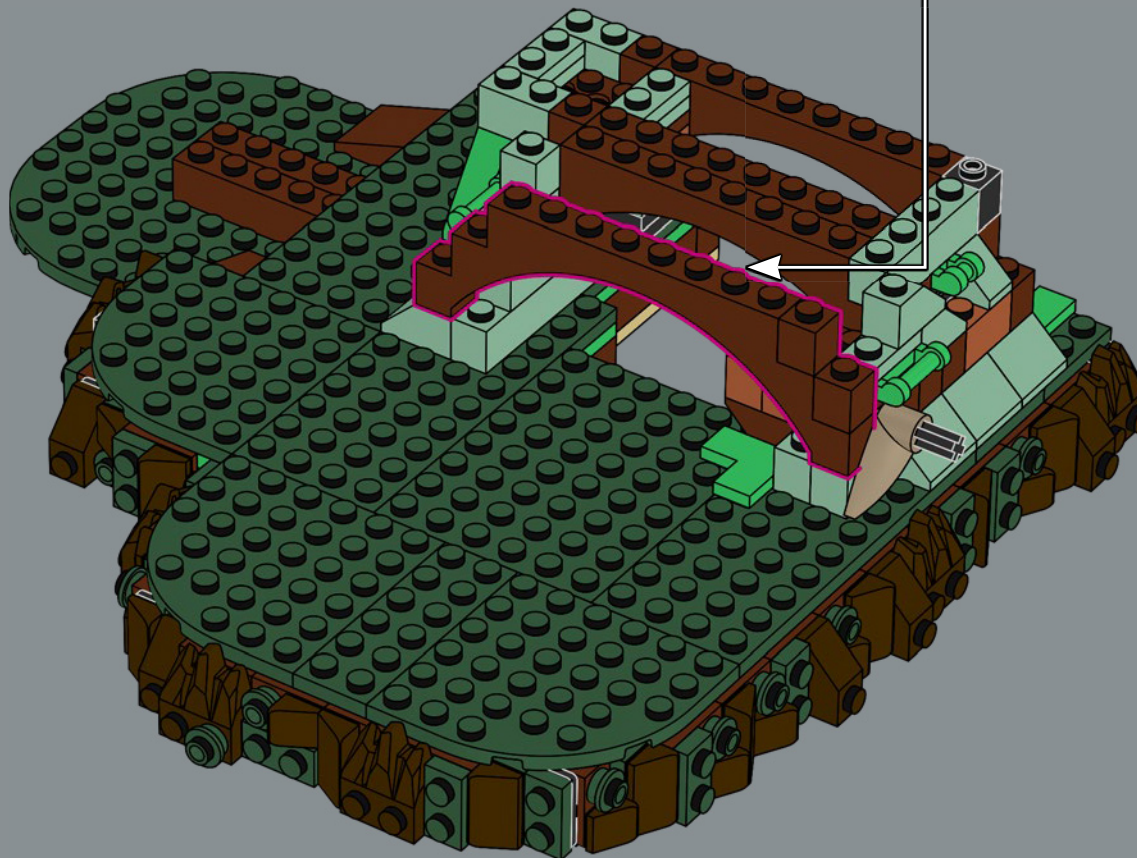
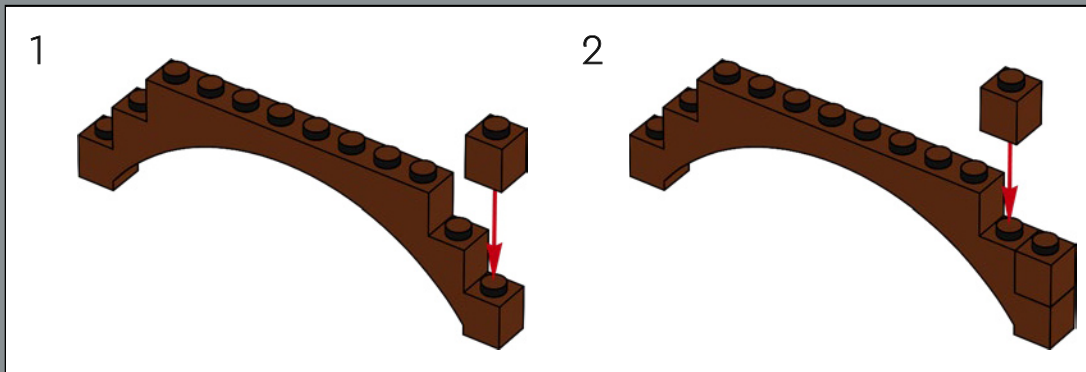



2x

46

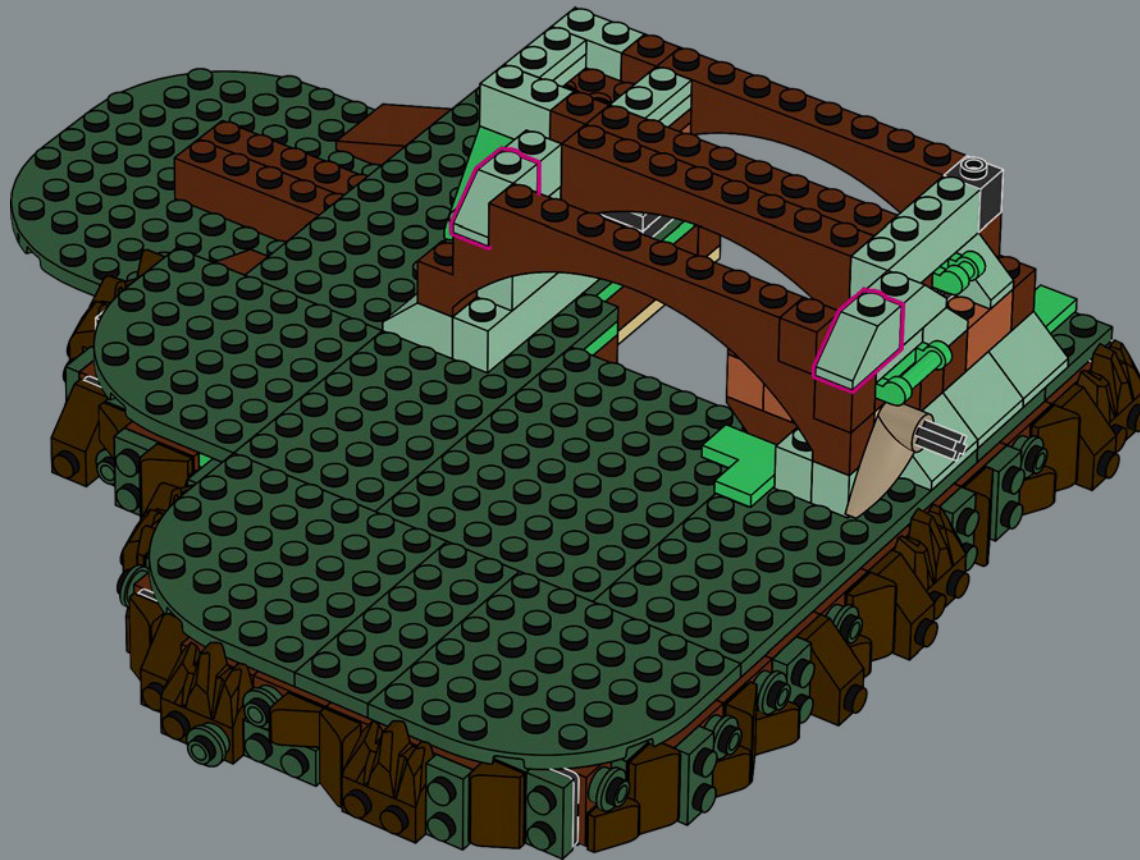

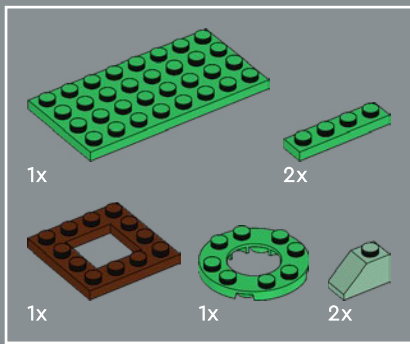

47



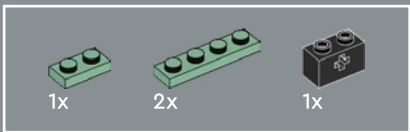

48



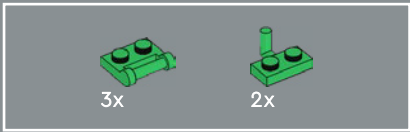

49

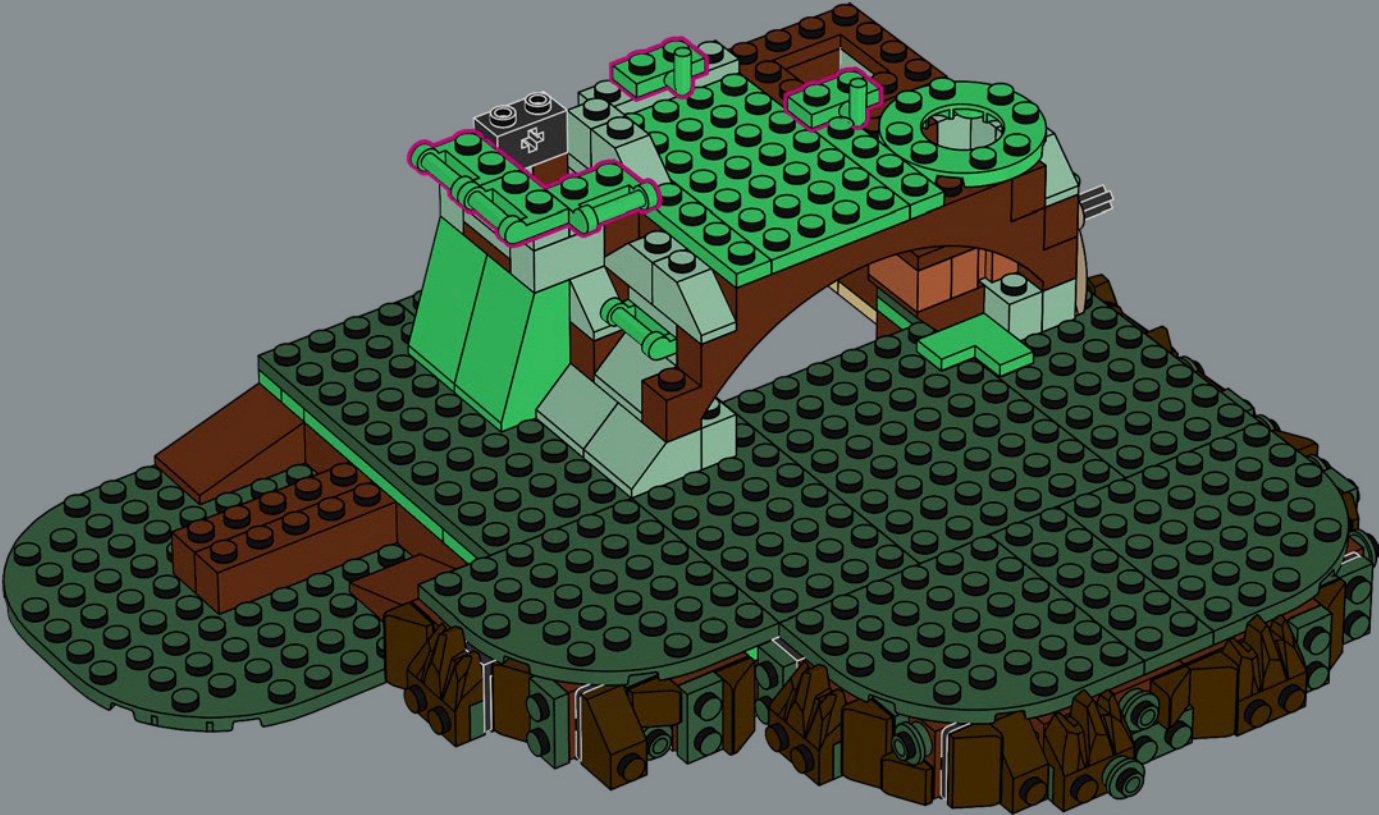

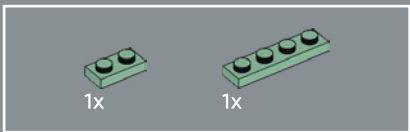

50



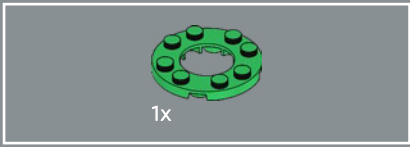

51



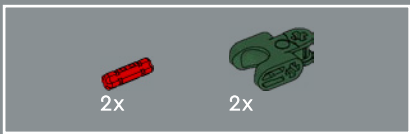

52

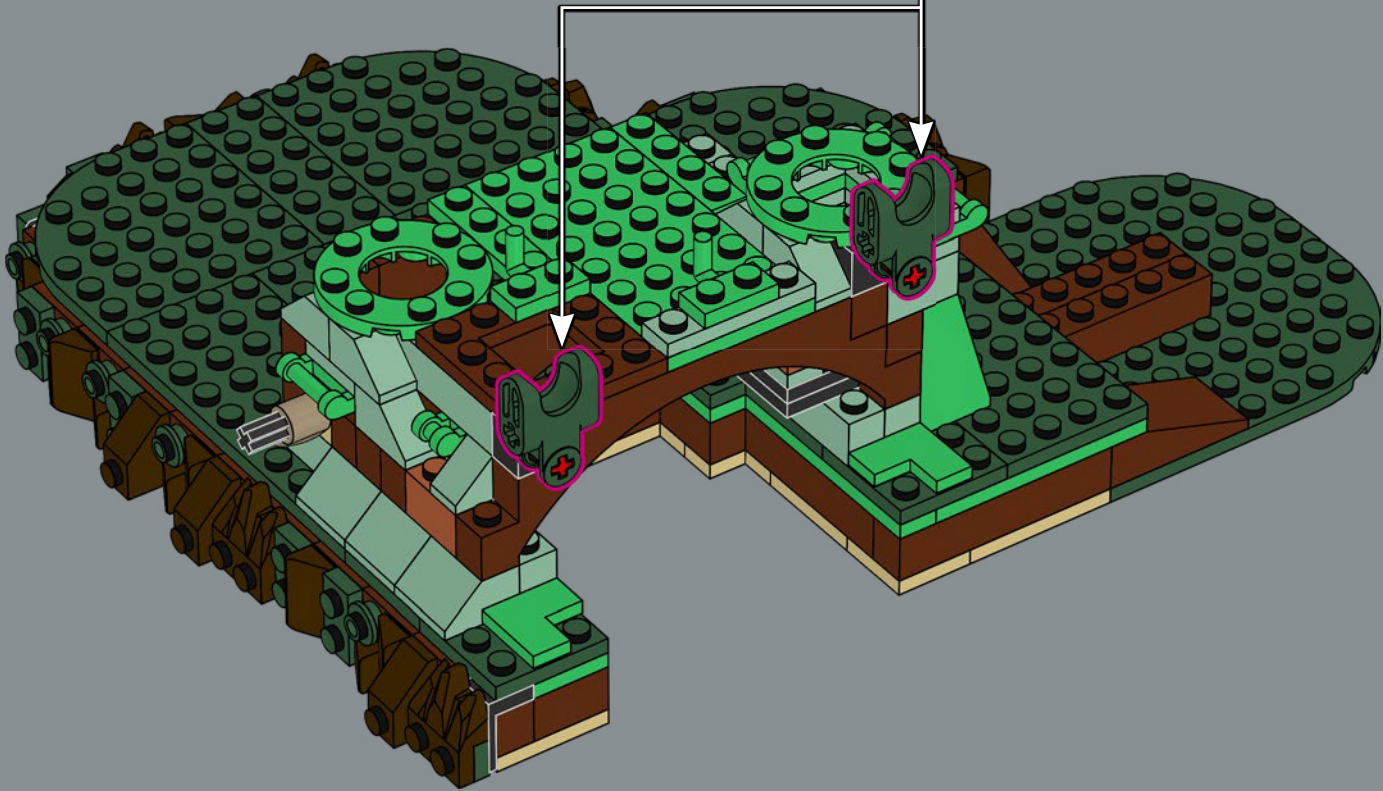
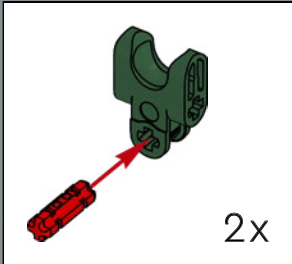

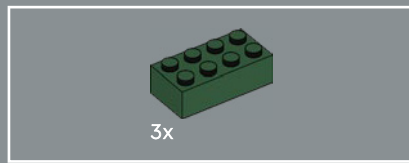

53

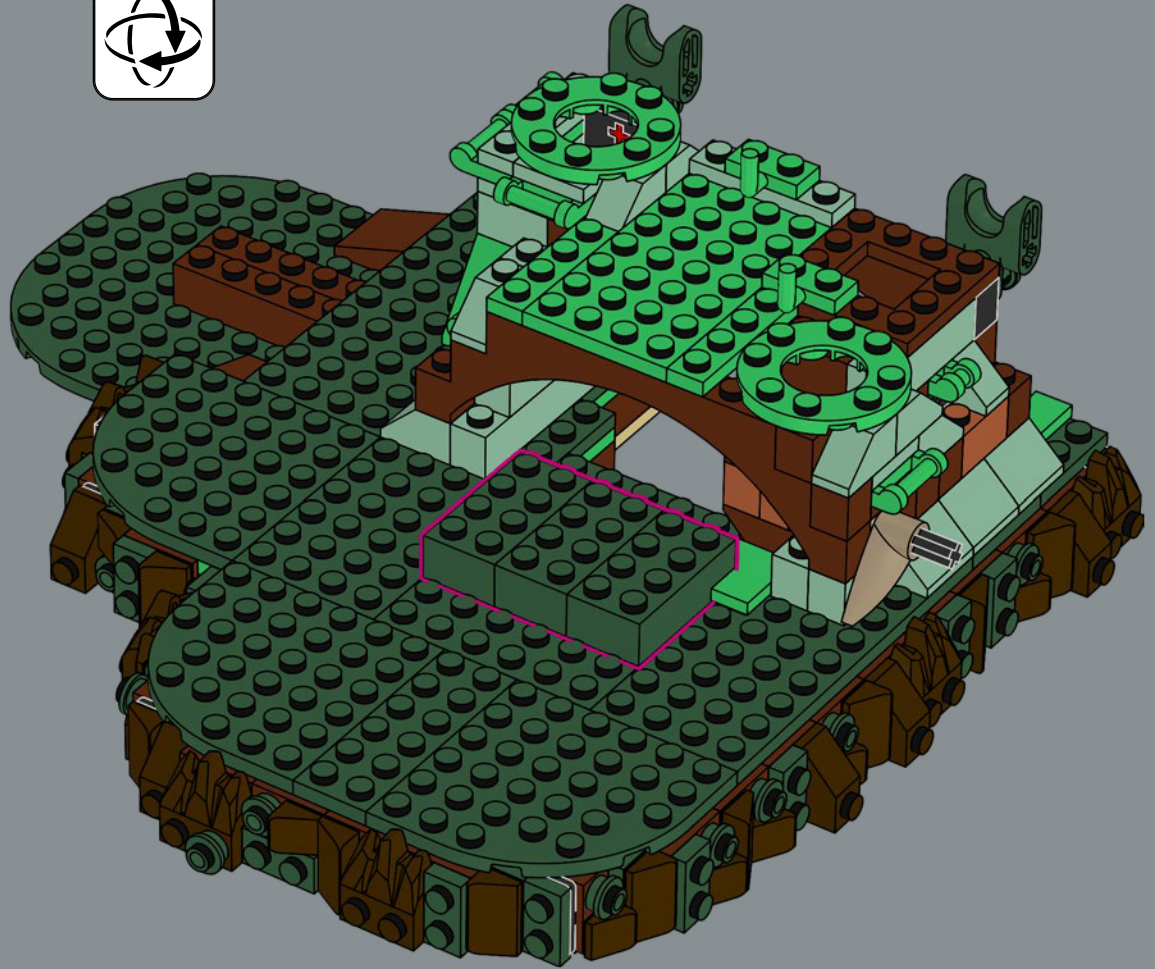

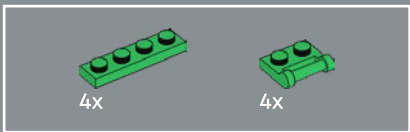

54



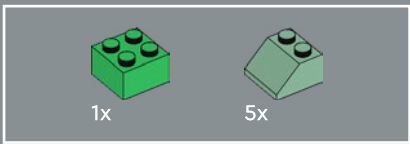

55

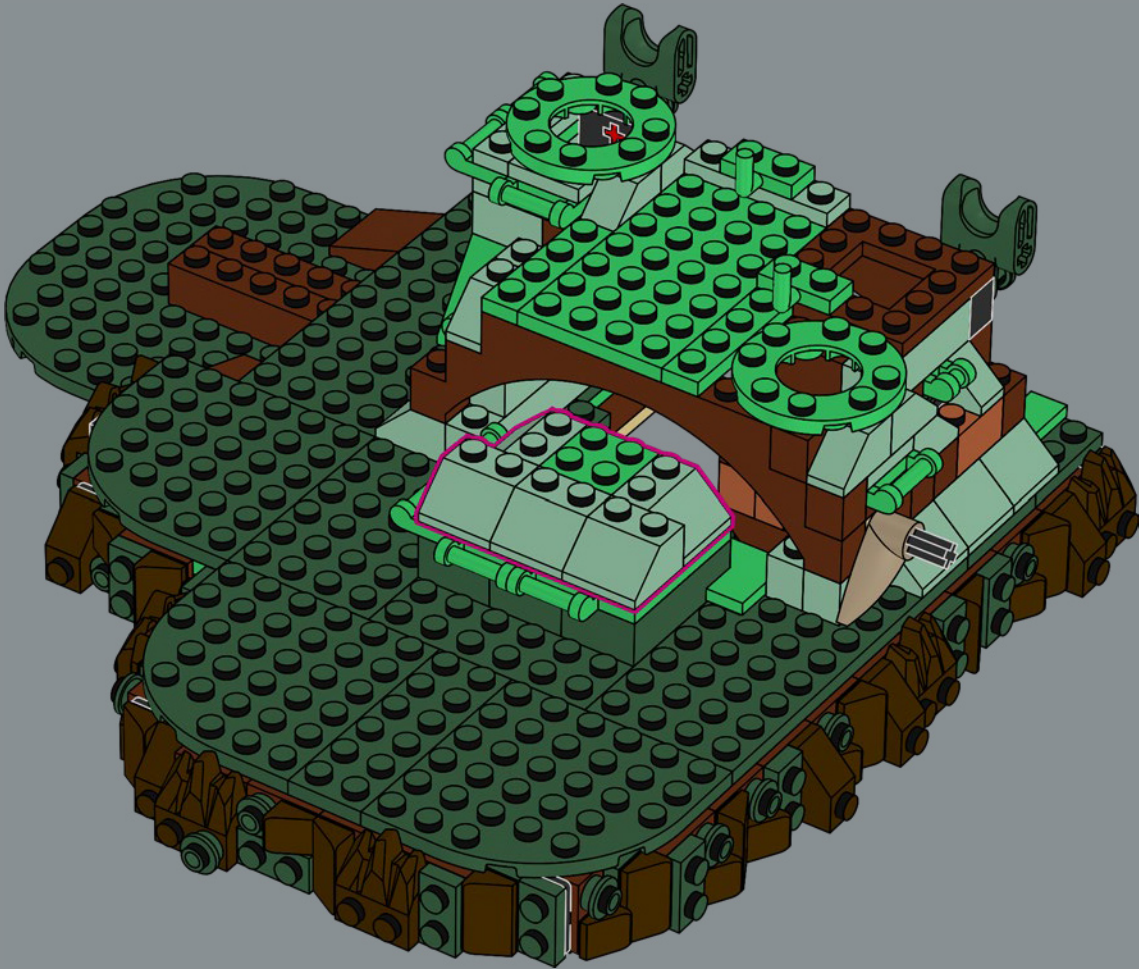

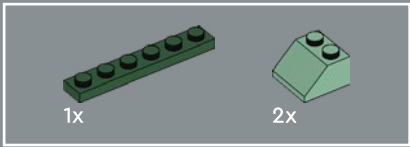

56

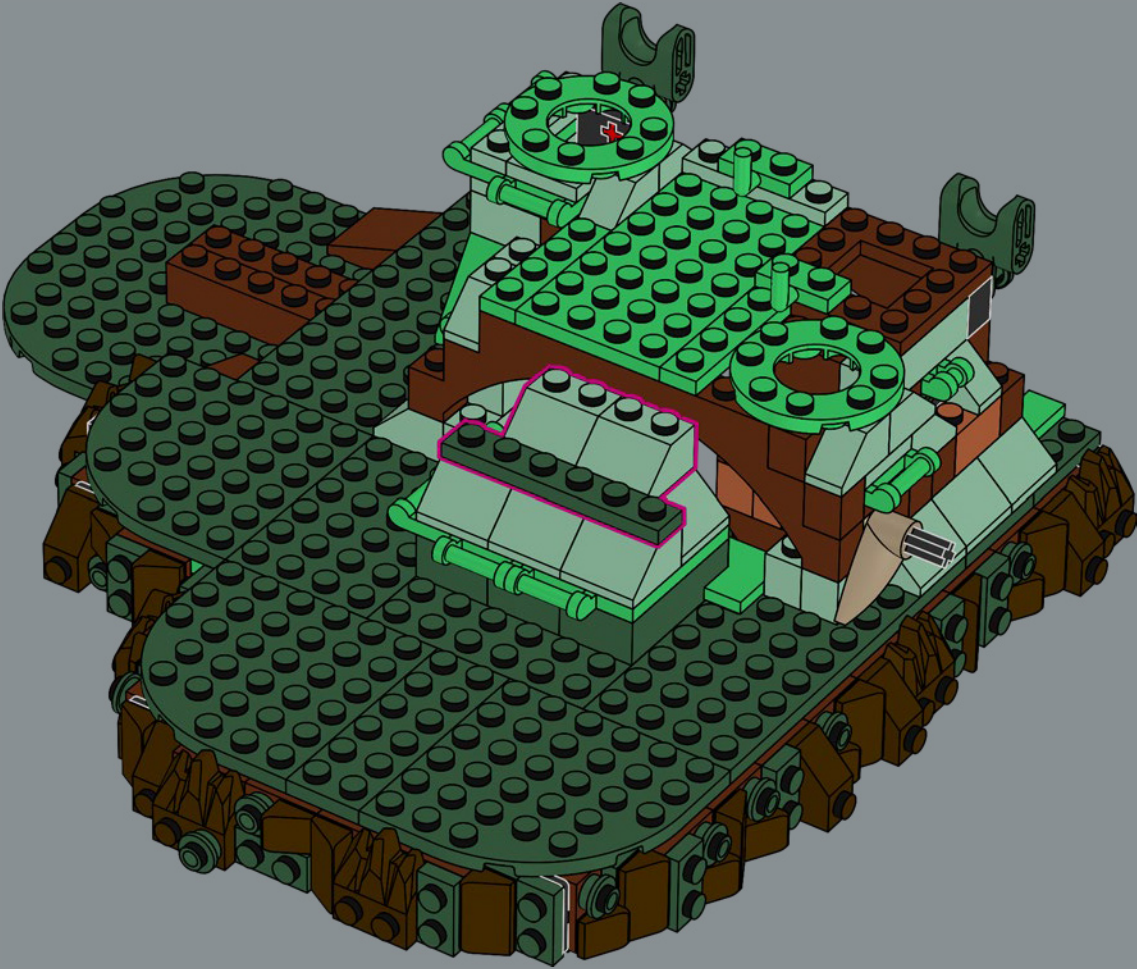

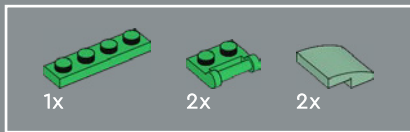

57

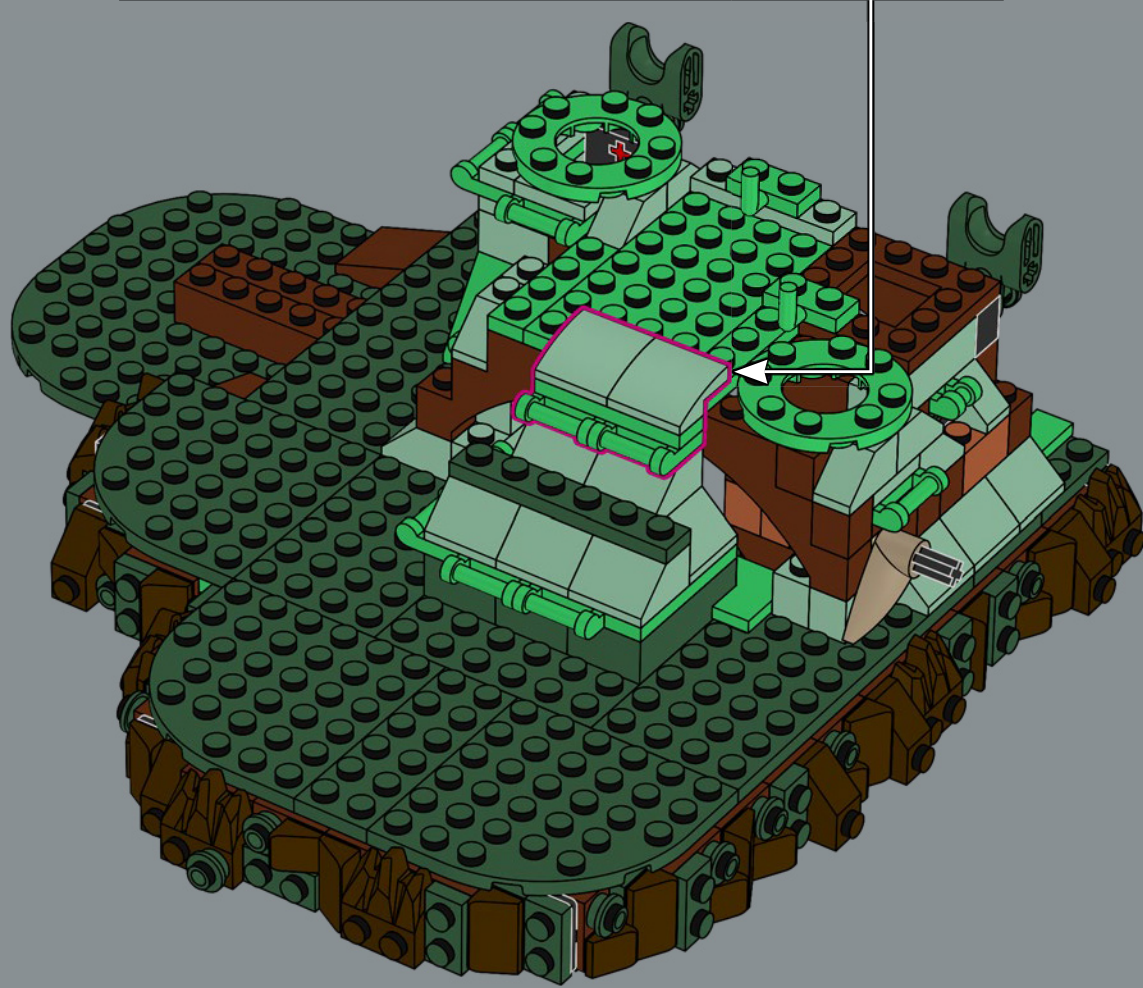
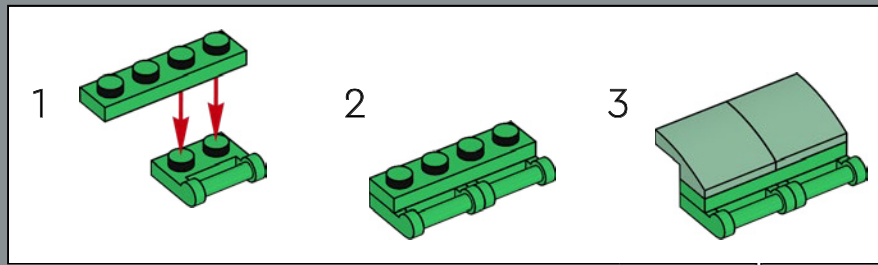



5x

58

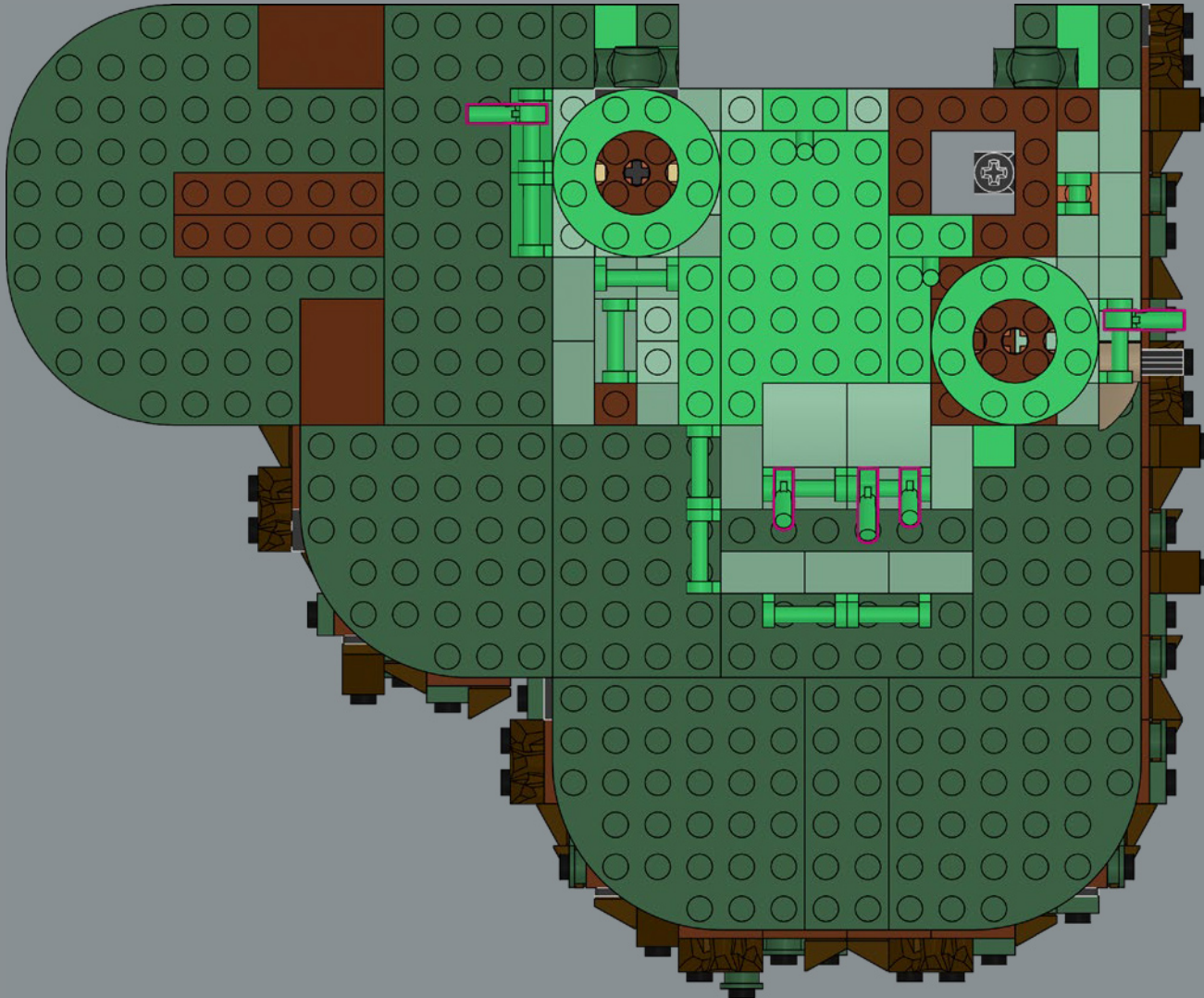



59

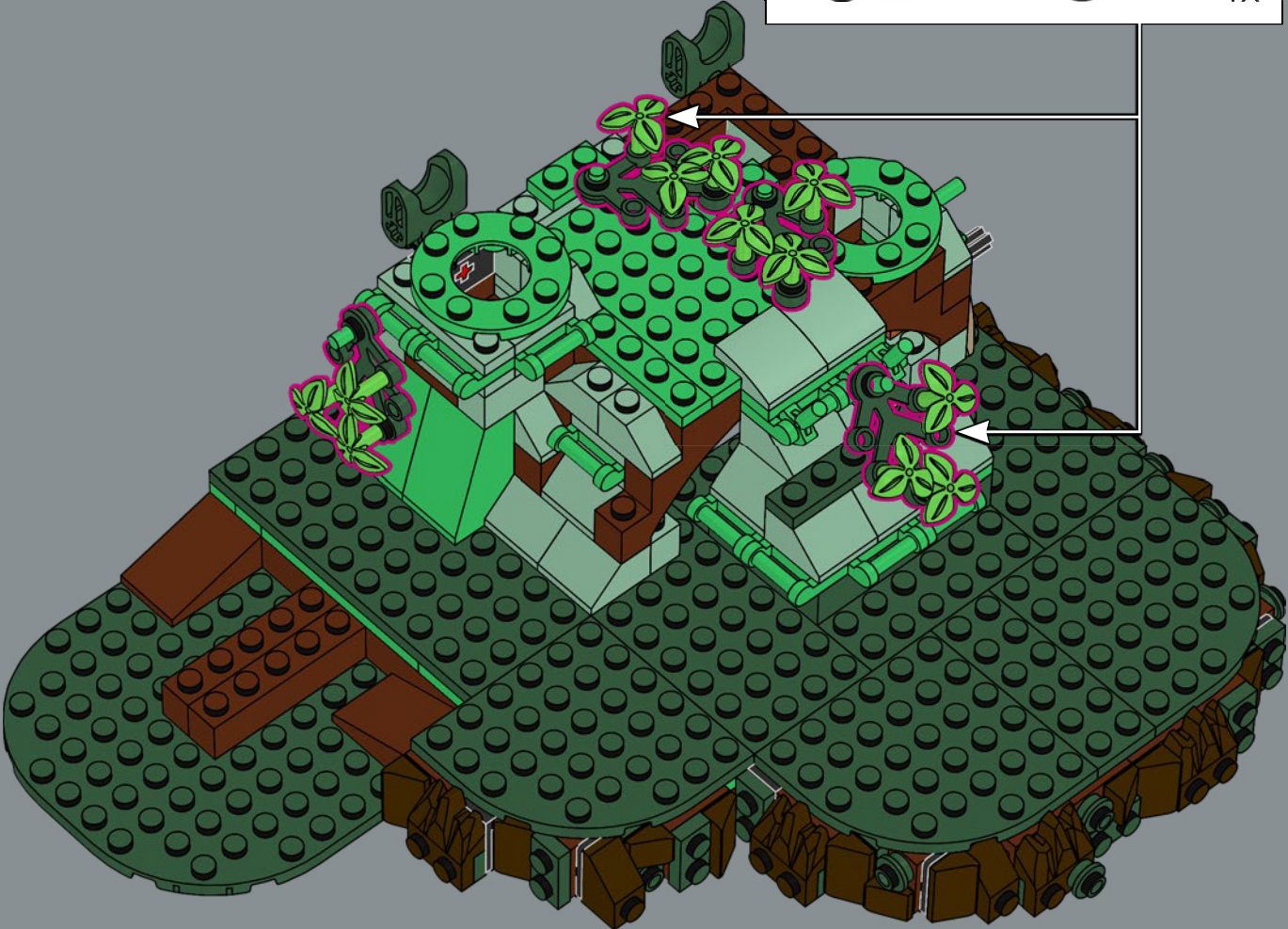
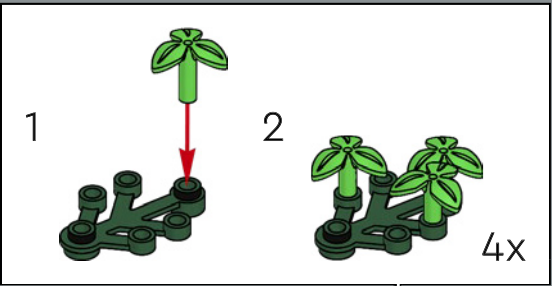



60

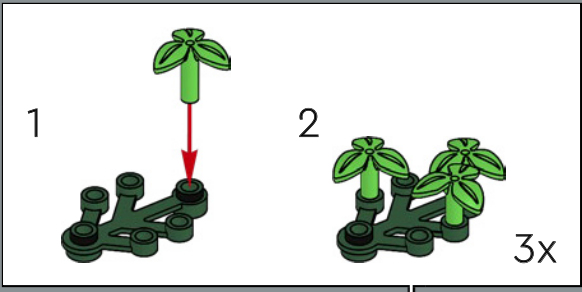



5x

61

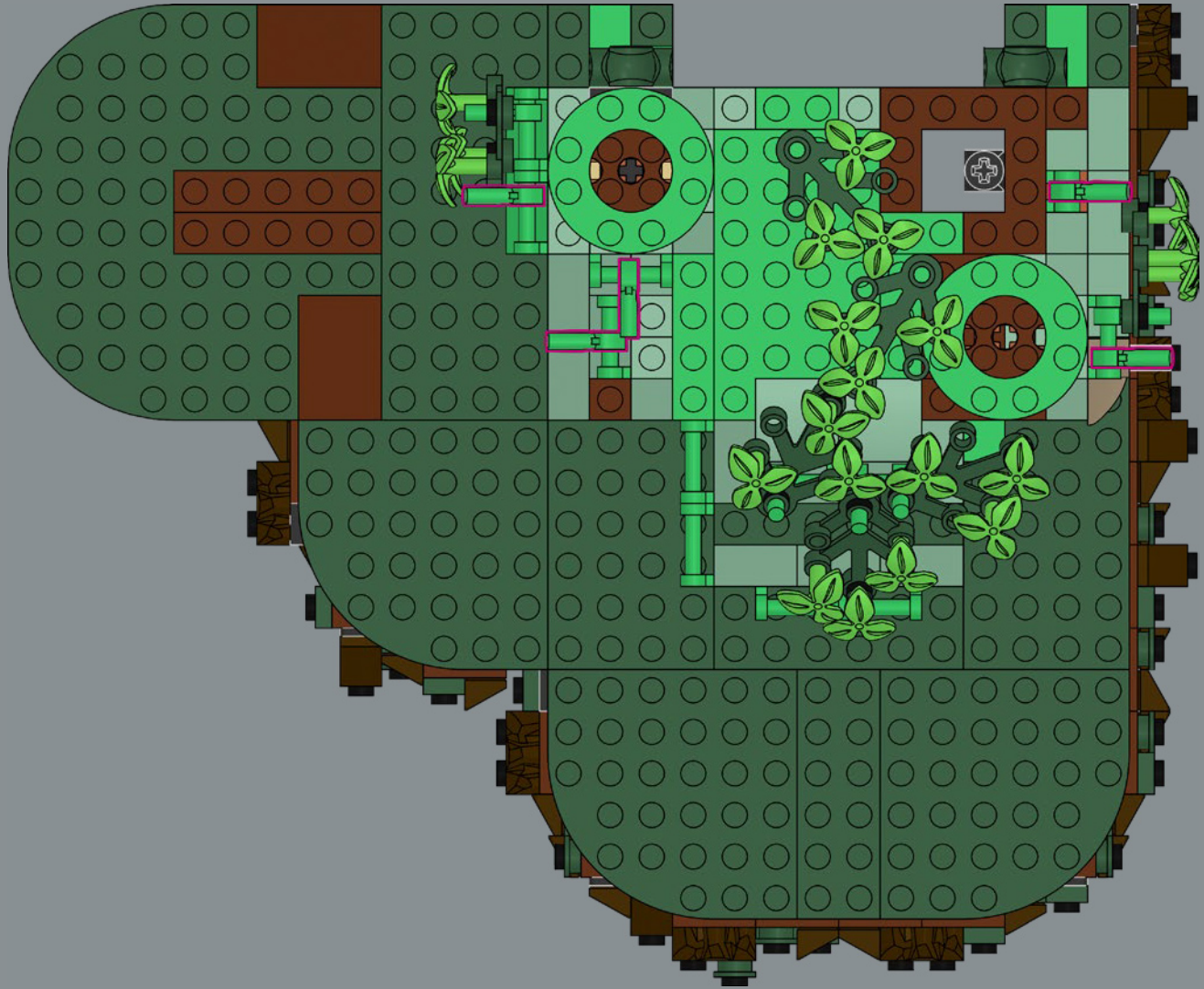



62

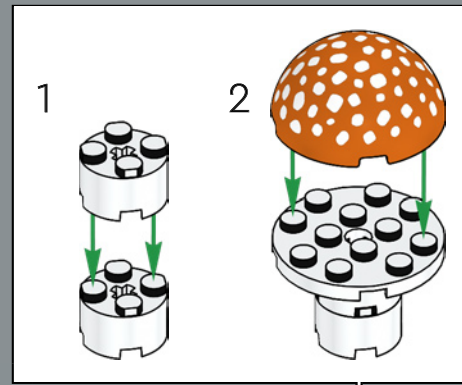



63



A new decoration makes the fly agaric tops shine with bright bursts of color.

Une nouvelle décoration fait briller les cimes de l'amanite tue-mouches de couleurs éclatantes.

Una nueva decoración hace que los sombreros de los hongos matamoscas brillen con estallidos de color.

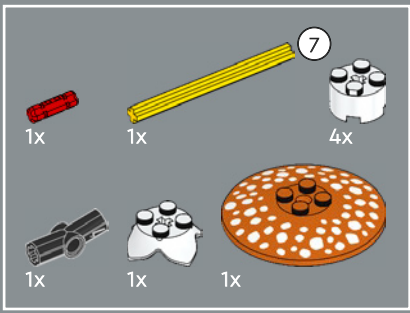

64

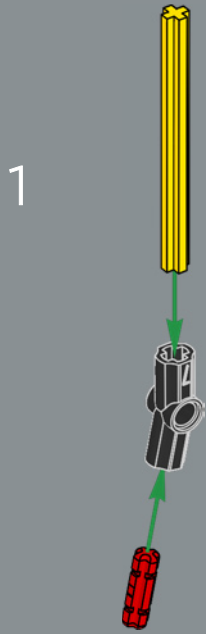

2



3

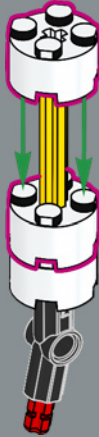

4



5





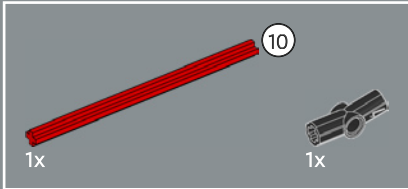
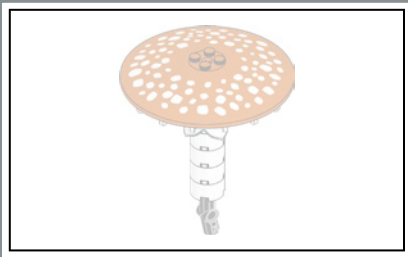

65

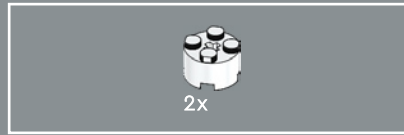

66

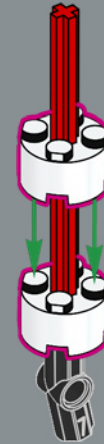

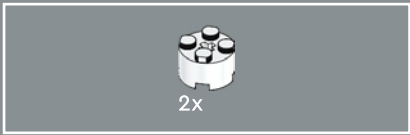

67

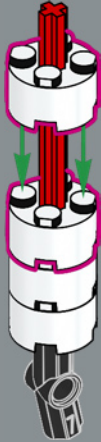

68

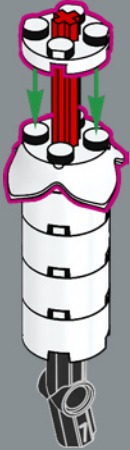

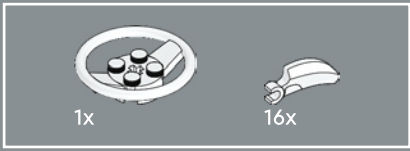

69

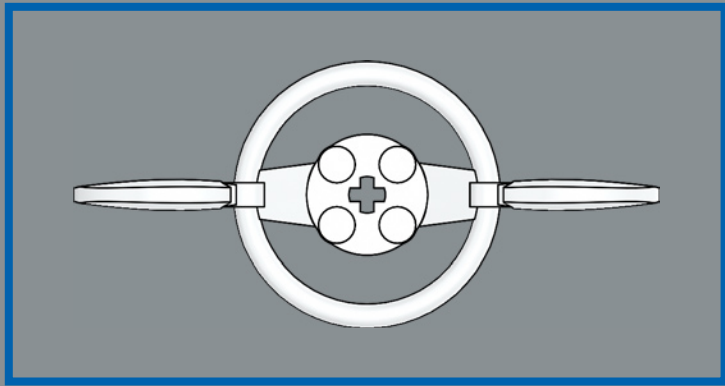

1

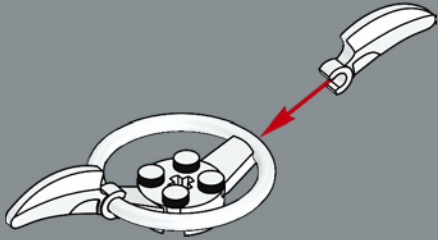

2

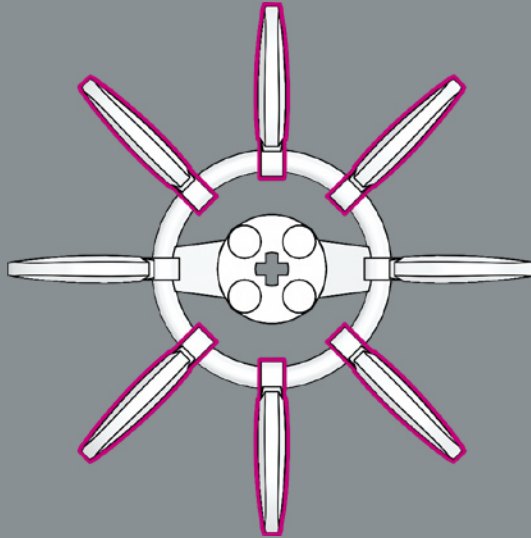

3

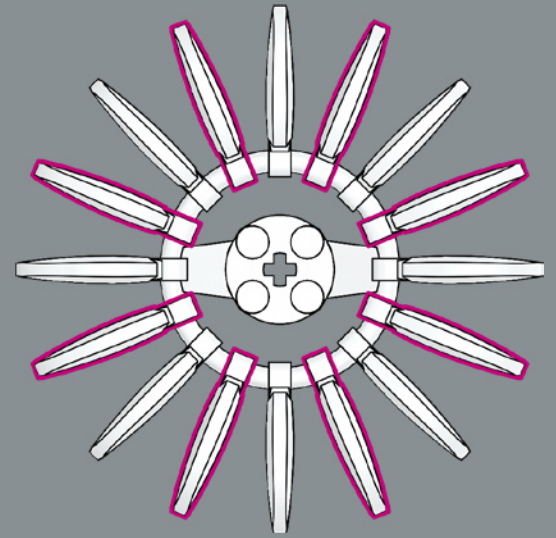

Claw elements can be used for much more than LEGO® animals and creatures. Here, they make up the gills under the large fly agaric mushrooms.

Les éléments de griffes peuvent être utilisés pour bien plus que les animaux et créatures LEGO®. Ici, ils composent les lamelles sous les gros champignons de l'amanite tue-mouches.

Los elementos que representan garras pueden usarse para mucho más que animales y criaturas LEGO®. Aquí, forman las láminas de debajo de los grandes hongos matamoscas.

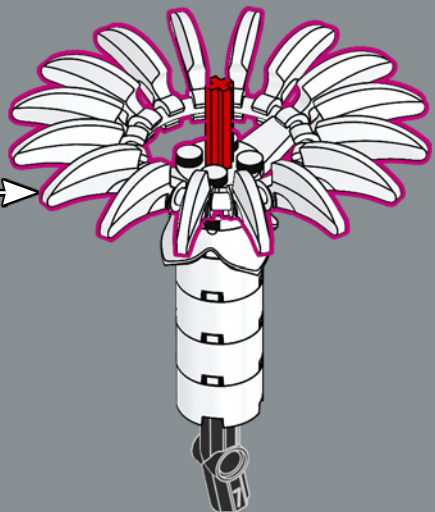

70

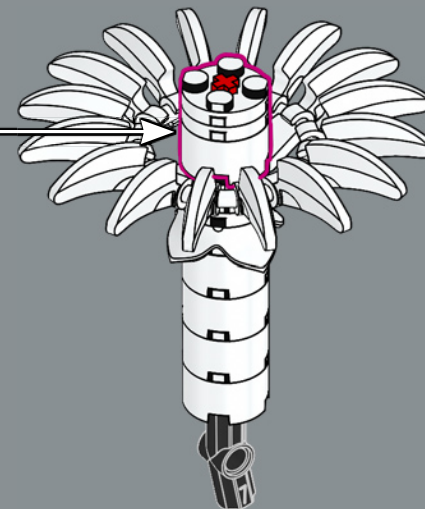
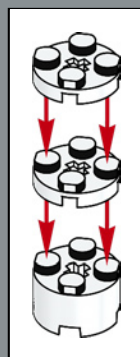

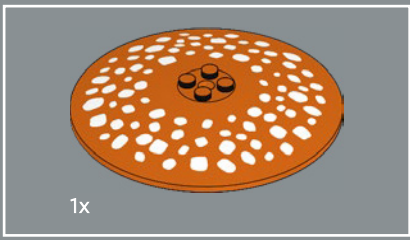

71



72





73



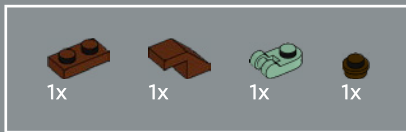

74

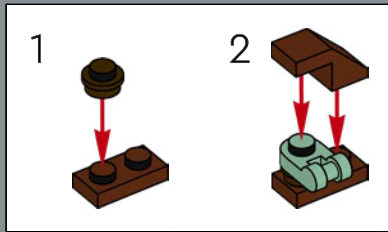



4x

75





76

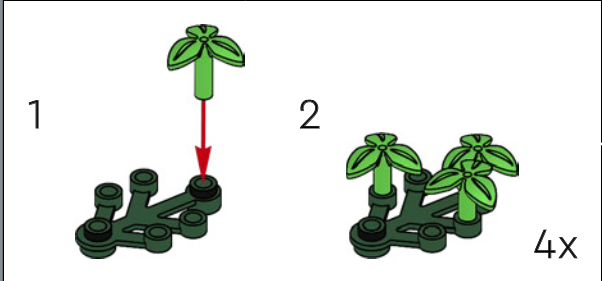



77

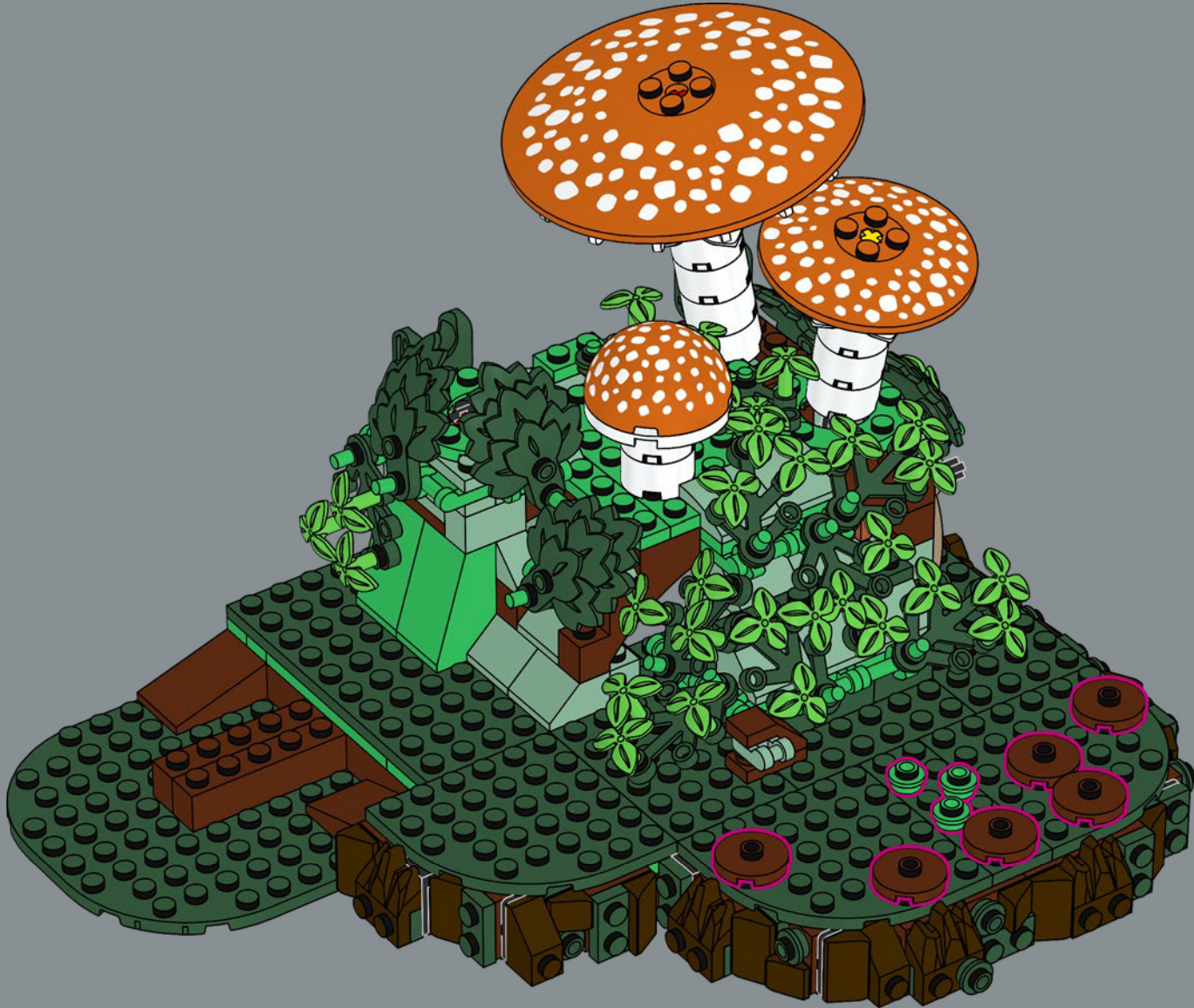

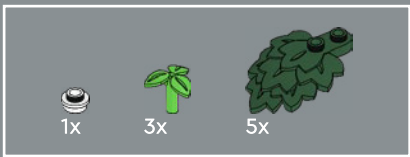

78



3x  2x 

79



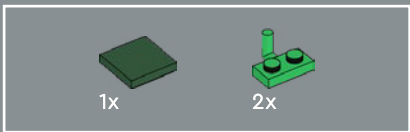

80

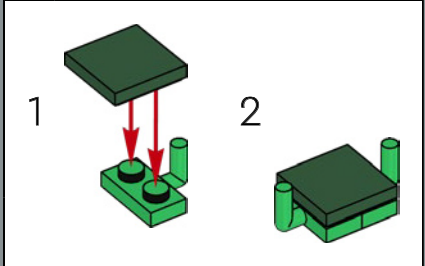

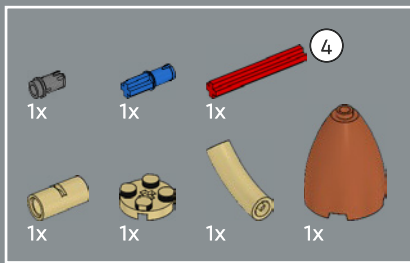

81

1



2

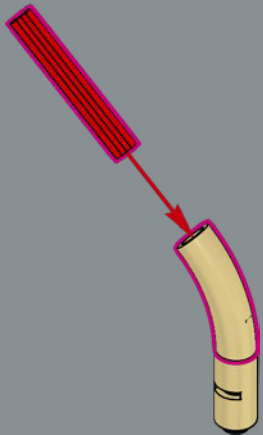

3

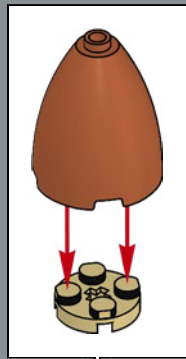

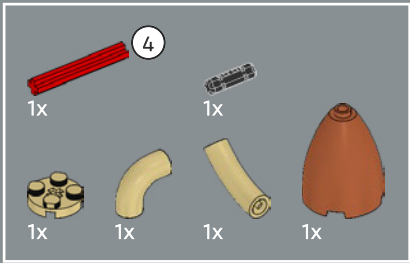

82

1

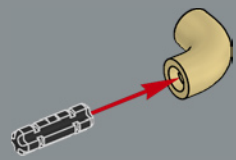

2

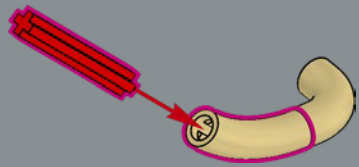

3

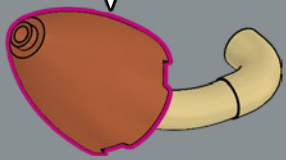
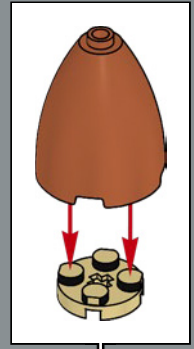

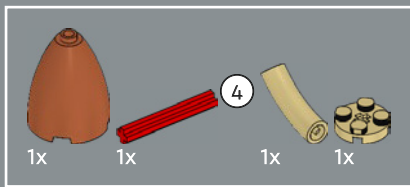

83

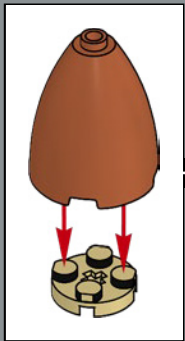
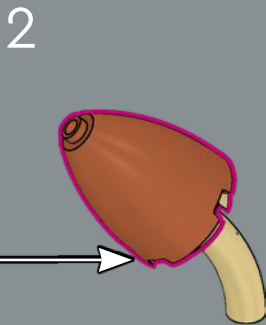
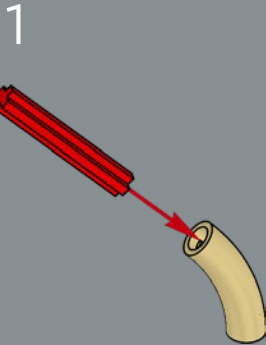

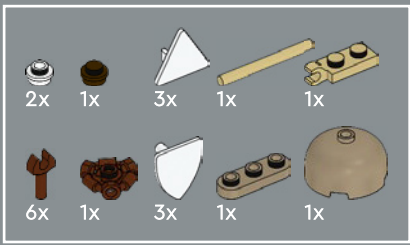

84

1

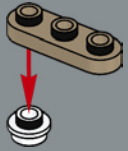

2

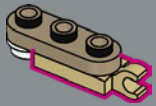

3

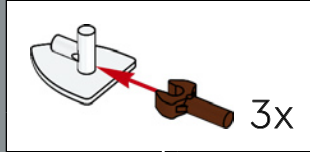
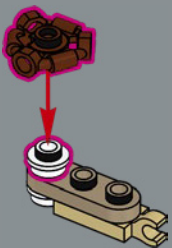

4

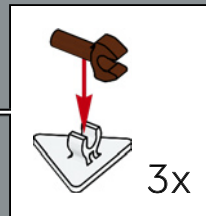
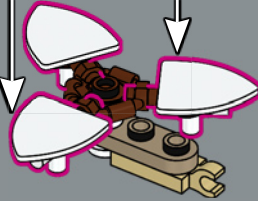

5

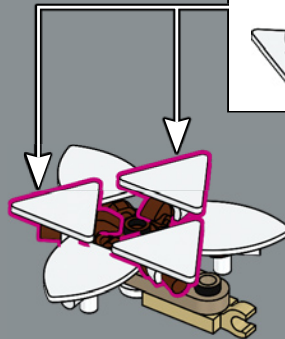

When recreating whimsical shapes, all sorts of LEGO® elements come into play. For the collared earthstar's characteristic form, we combined triangular street signs with minifigure shield elements.

Pour recréer des formes fantaisistes, toutes sortes d'éléments LEGO® entrent en jeu. Pour la forme caractéristique du géastre à trois plis, nous avons combiné des panneaux de signalisation triangulaires avec des éléments de bouclier de figurine.

A la hora de recrear formas caprichosas, entran en juego todo tipo de elementos LEGO®. Para recrear la forma característica de la estrella de tierra con collar, combinamos señales de tráfico triangulares con escudos de minifiguras.

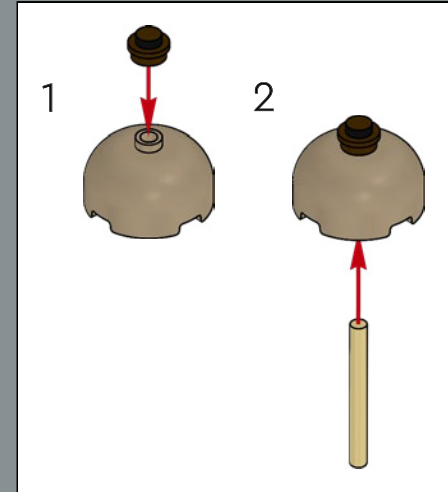

6

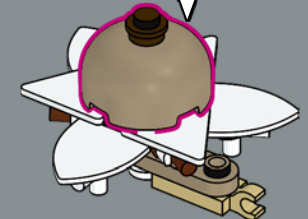



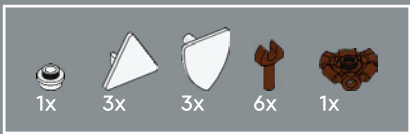

85

1

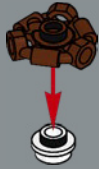

2

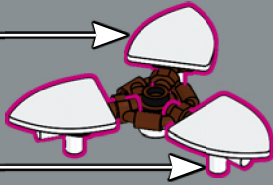
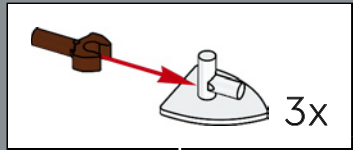

3

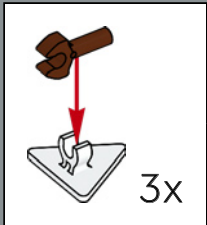



86

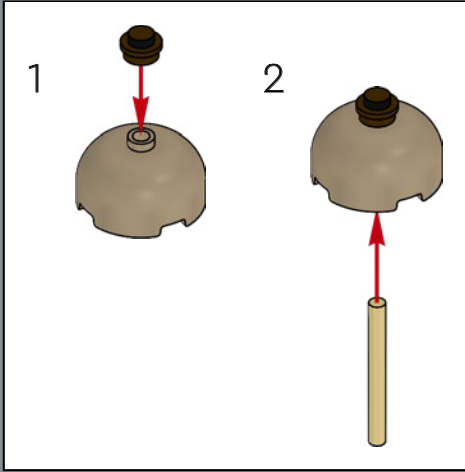

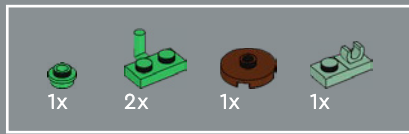

87



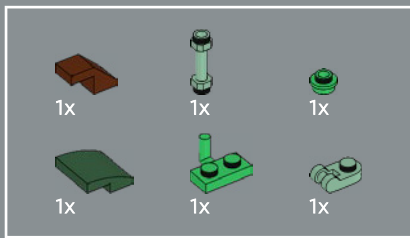

88

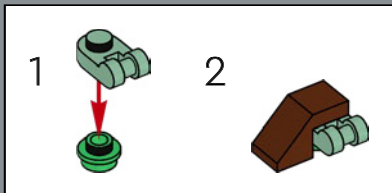
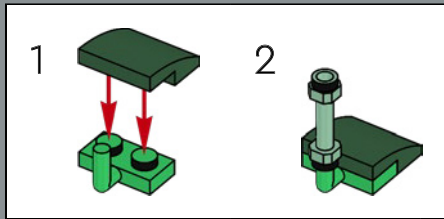

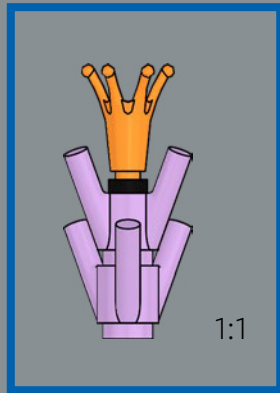
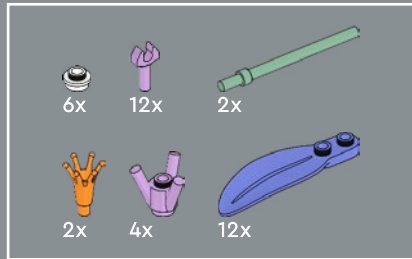
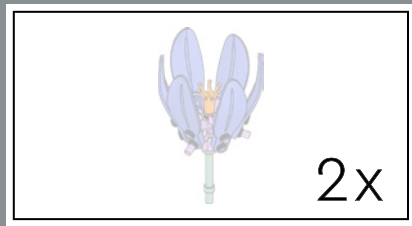

89

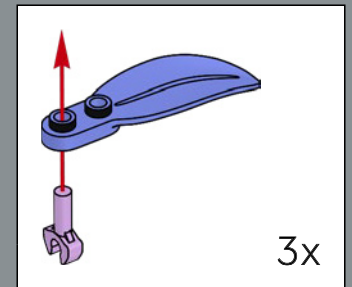
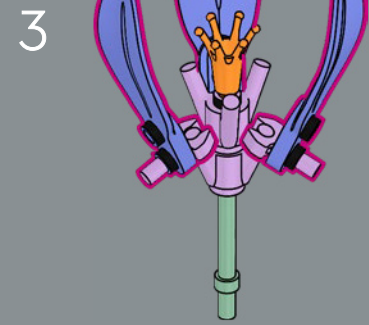
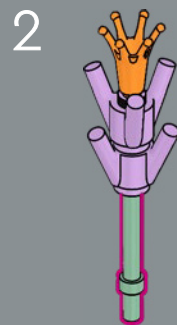
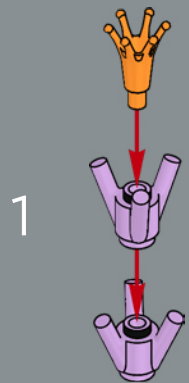

The stamens in the crocuses get an almost regal glow with these LEGO® minifigure crowns.

Les étamines des crocus ont un éclat presque royal grâce à ces couronnes de figurines LEGO®.

Los estambres de los colchicos adquieren un brillo casi regio con estas coronas de minifiguras LEGO®.

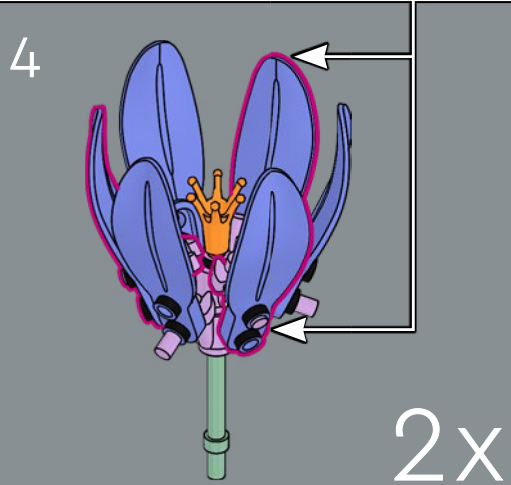
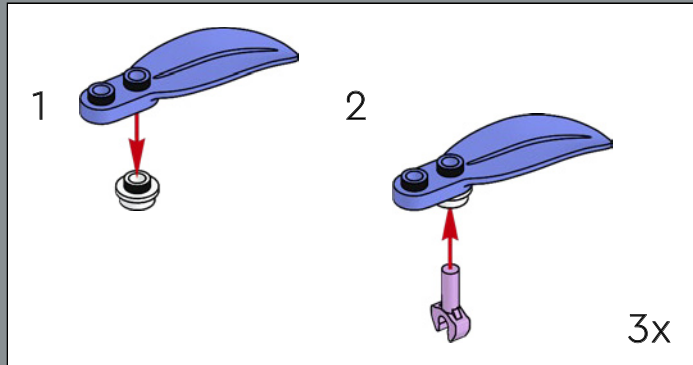

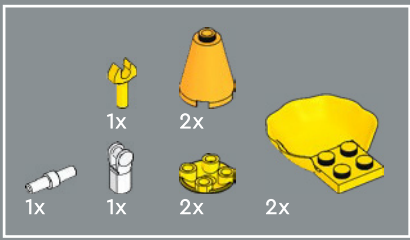

90

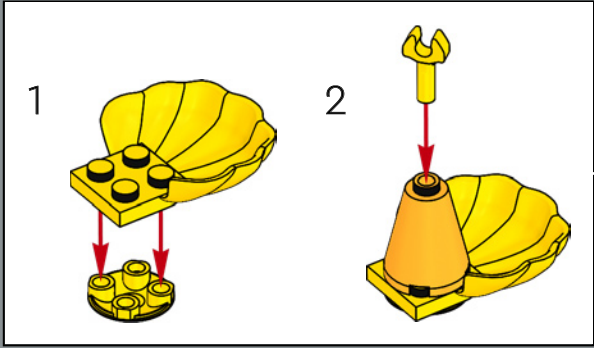
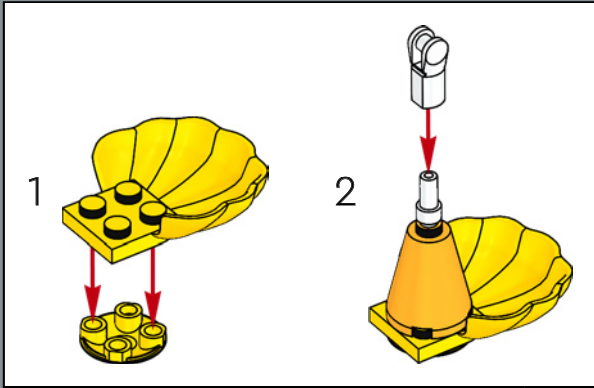

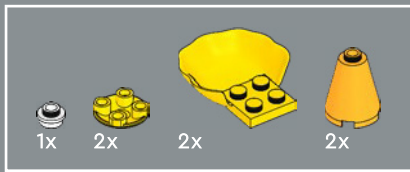

91

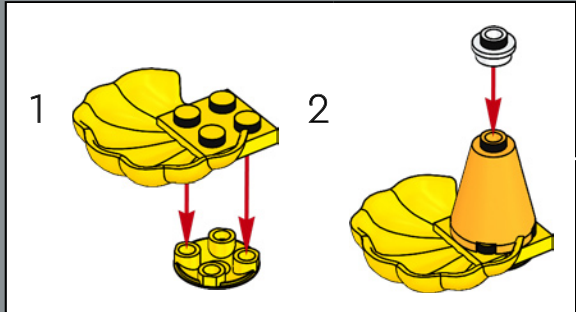
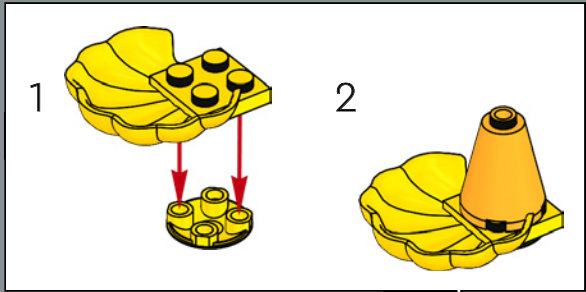

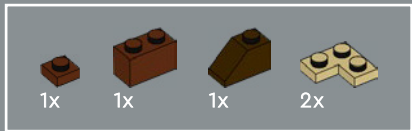

92





93





94



1x  2x 

95





96



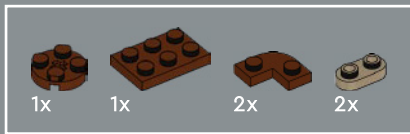

97



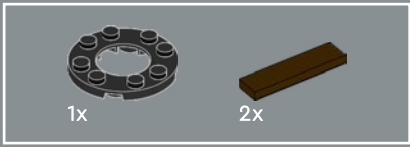

98



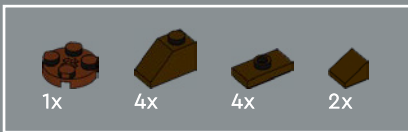

99

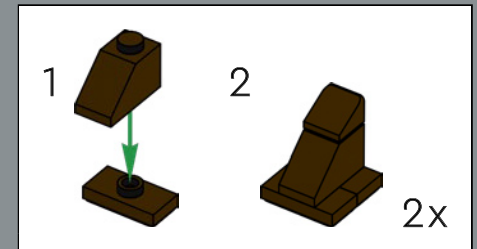



1x

100



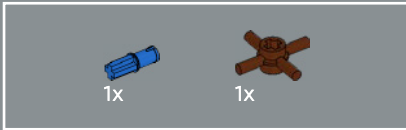

101

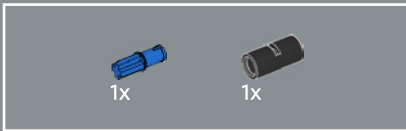
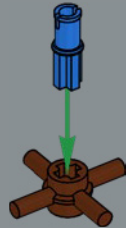

102

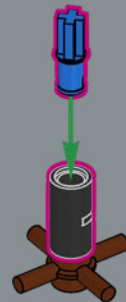

103

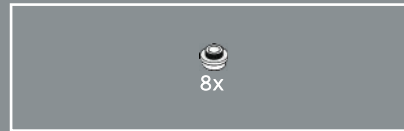

104

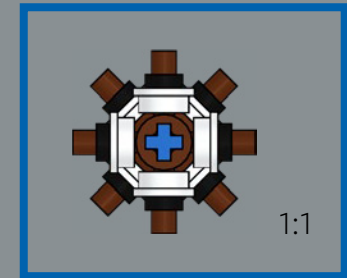



105

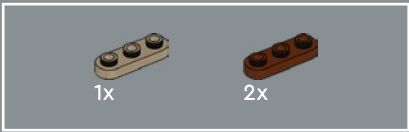
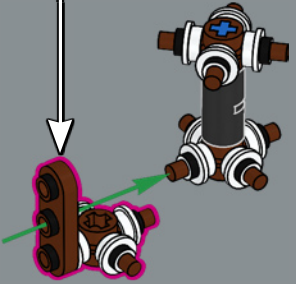
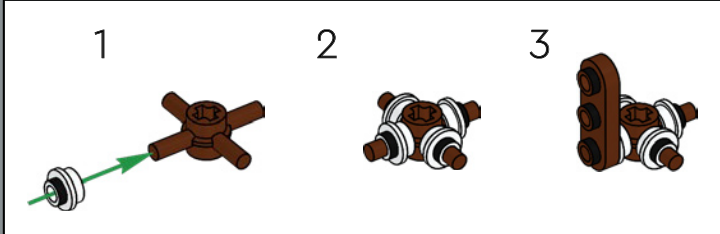

106

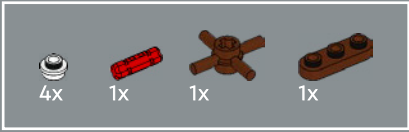
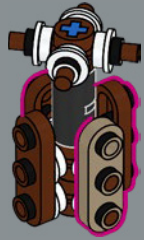

107

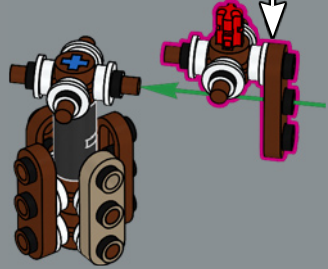
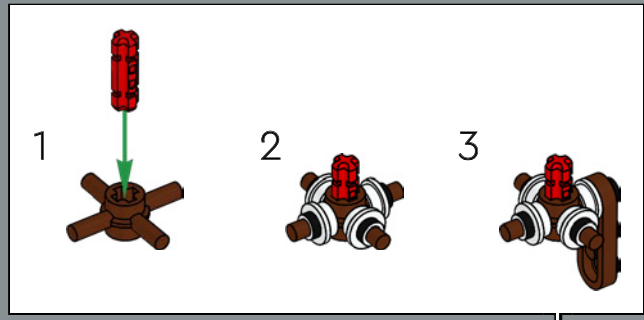



108

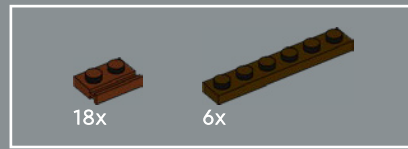
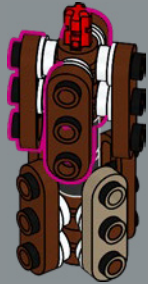

109

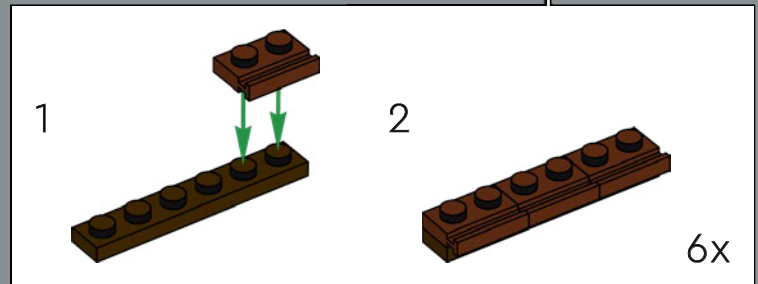
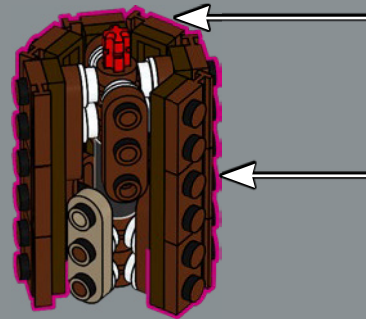
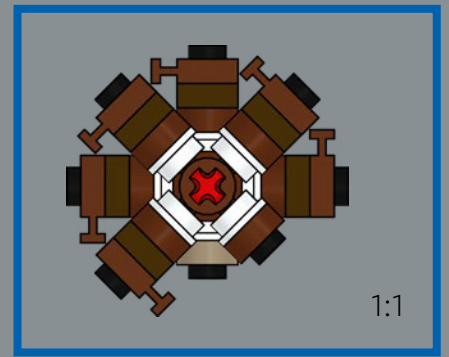

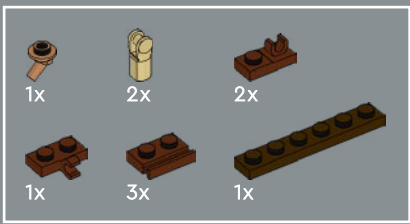

110

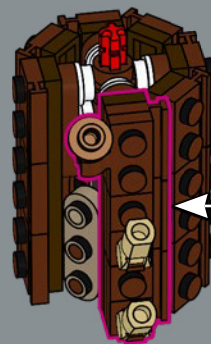
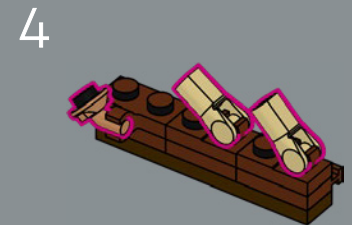
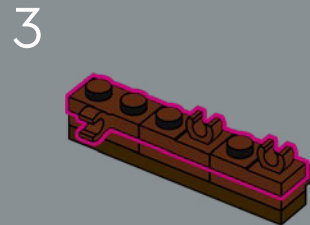
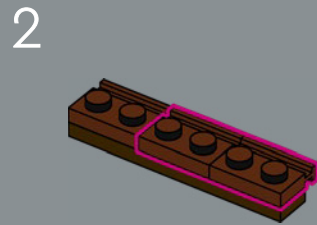
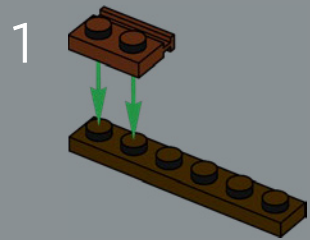

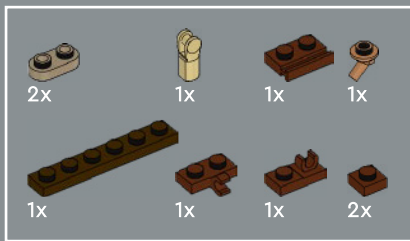

111

1

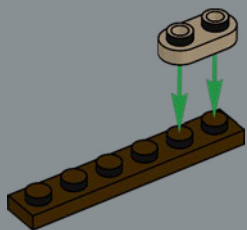

2

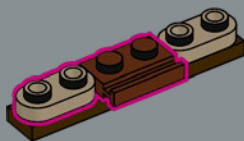

3

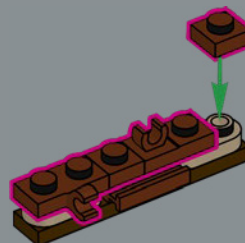

4

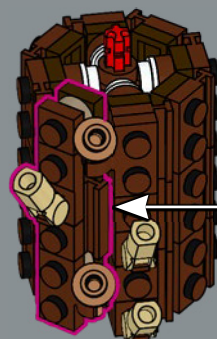
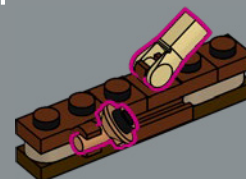



112

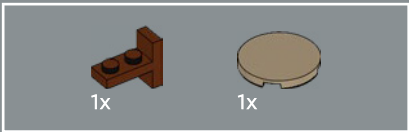
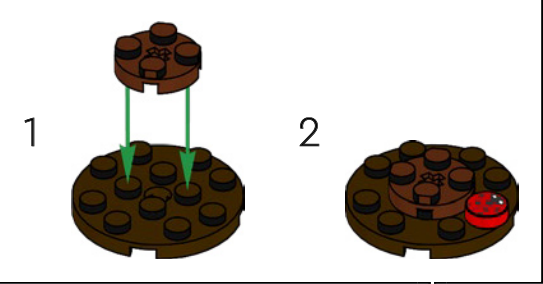

113

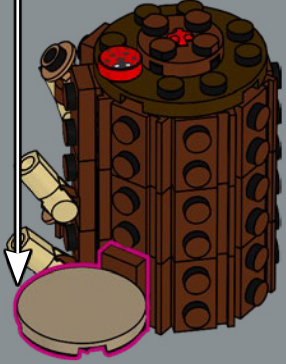
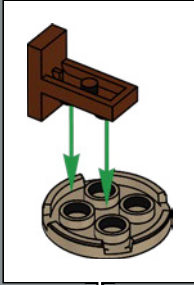



114

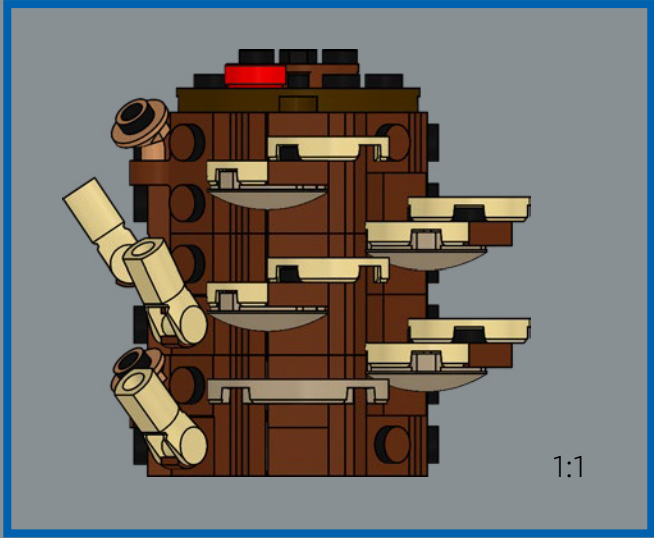
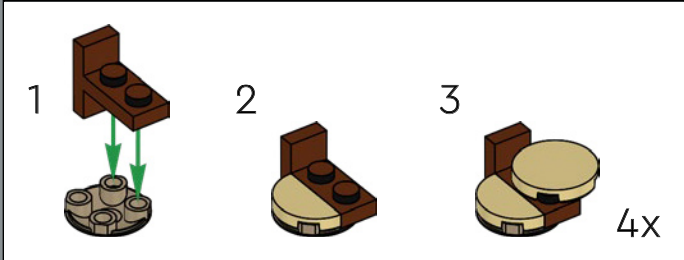





116

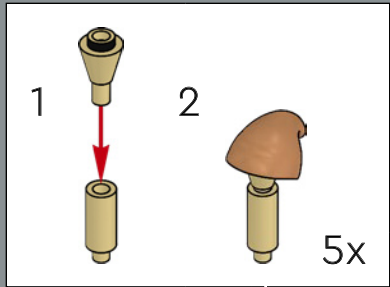

The common bonnet, with its delicate cap and slender stem, looks like it's been plucked straight from the pages of a fairytale – their tops are made with LEGO® dwarf minifigure hats.

Le mycène en casque, avec sa délicate coiffe et sa tige élancée, semble tout droit sorti des pages d'un conte de fées. Son sommet est fait de chapeaux de figurines de nains LEGO®.

El hongo bonete, con su delicada copa y su esbelto tallo, parece sacado directamente de las páginas de un cuento de hadas. El sombrero de esta versión es, en realidad, un sombrero de minifiguras LEGO® de enanos.



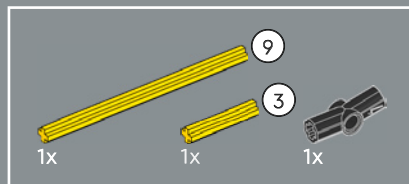
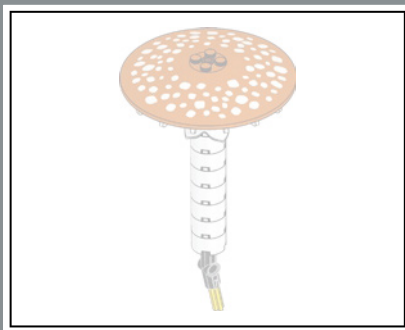

117

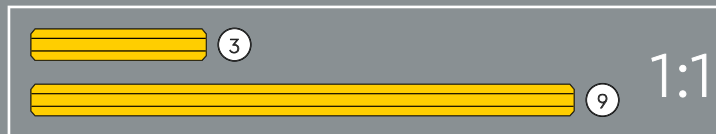
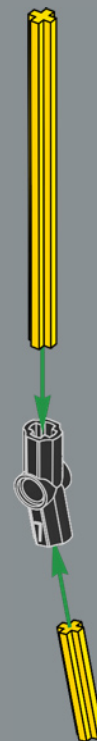

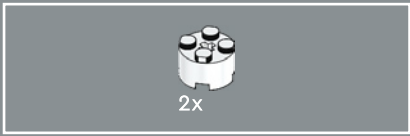

118

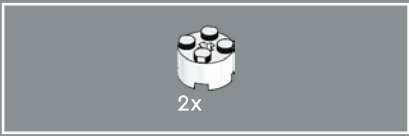
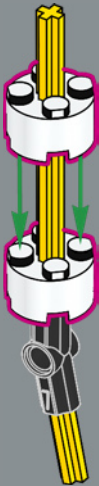

119

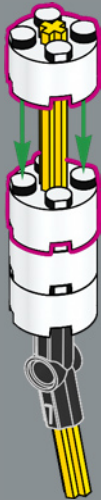



2x

120

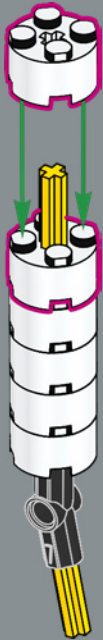

1x



1x



1x

121

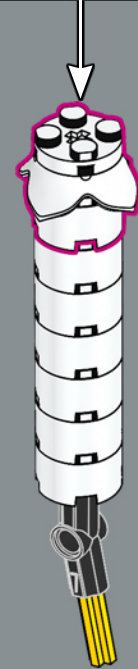
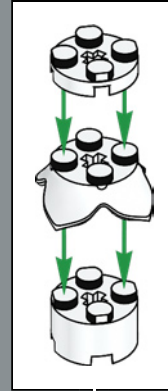

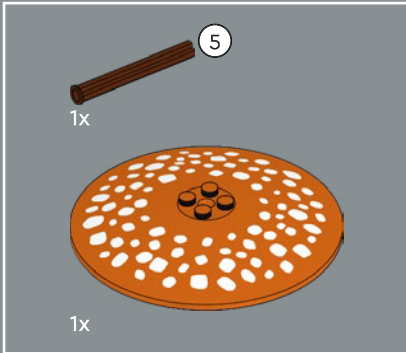
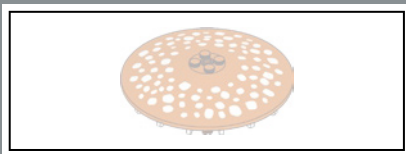

122

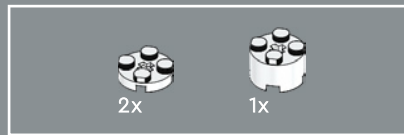
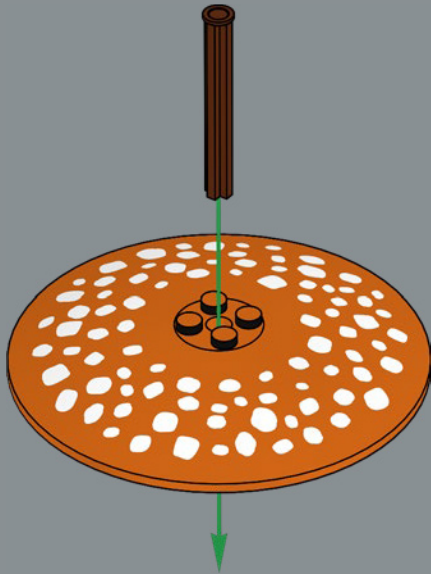

123

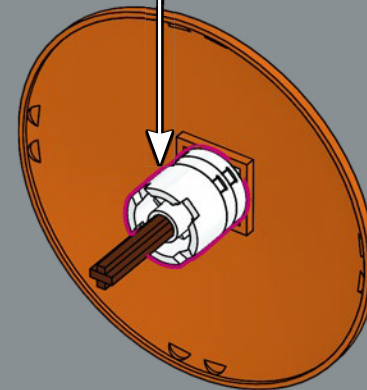
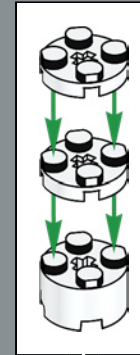

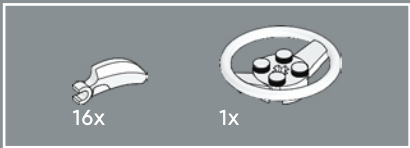
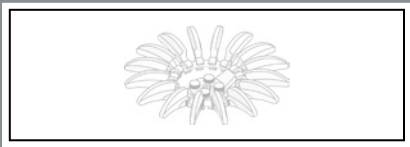

124

1

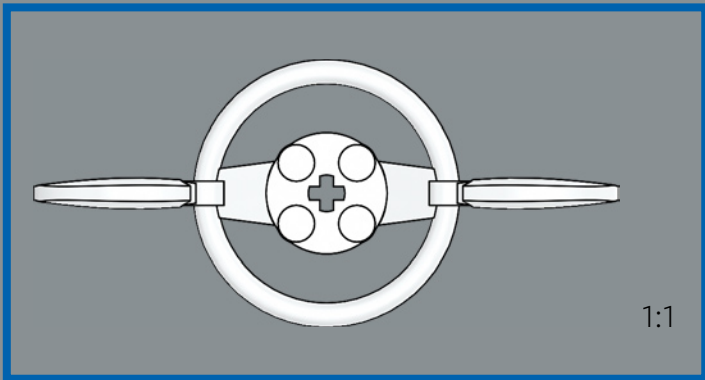
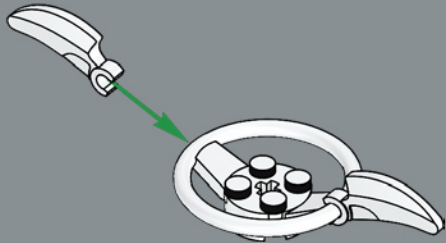

1:1

2

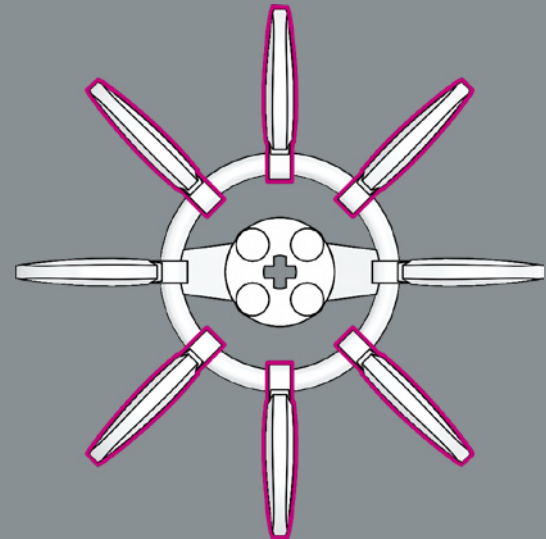

3

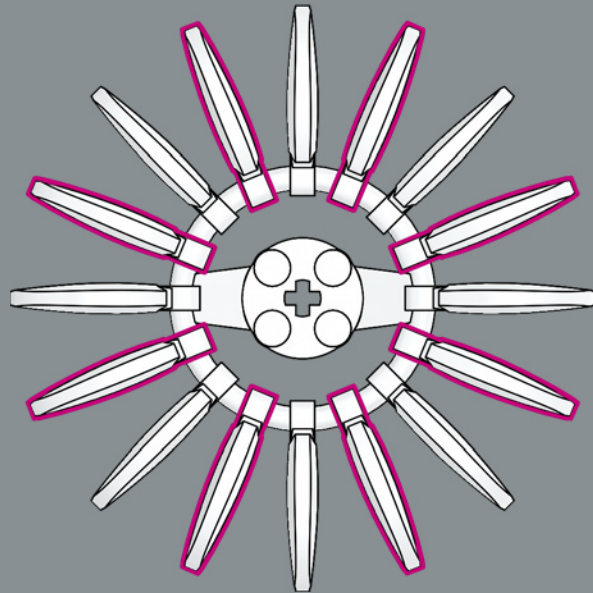

125

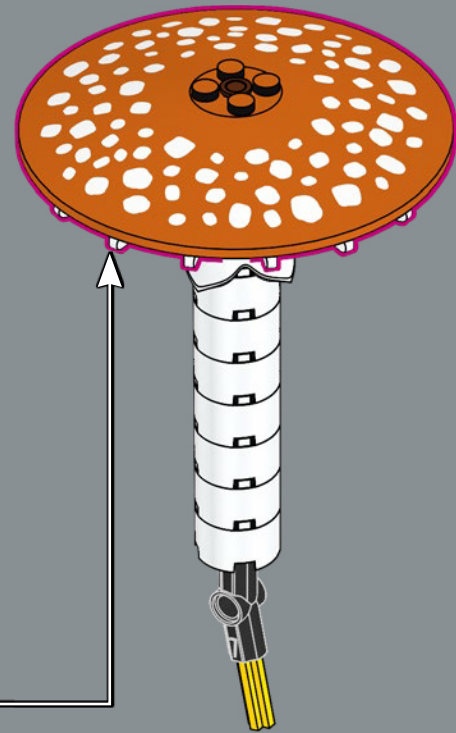



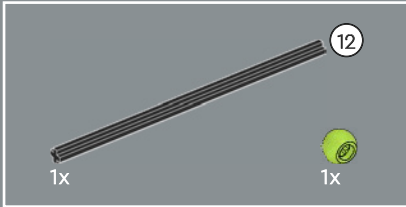
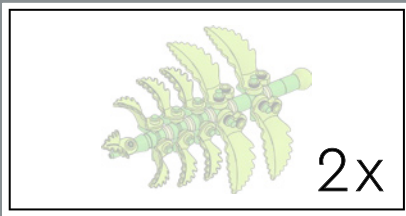

127

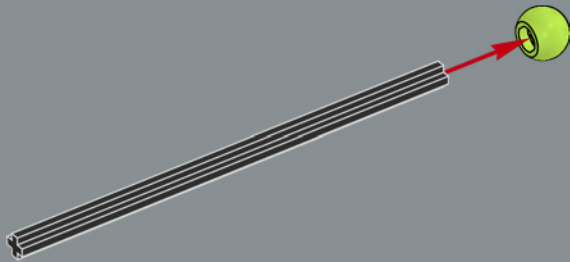

128

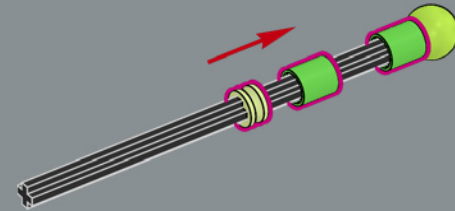

129

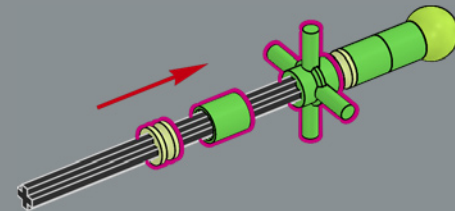



130

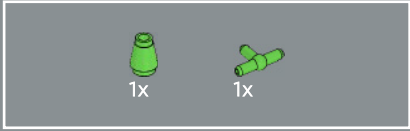
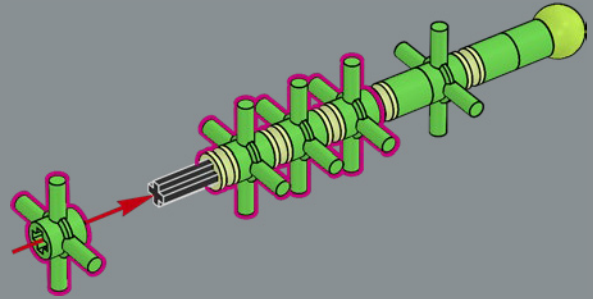

131

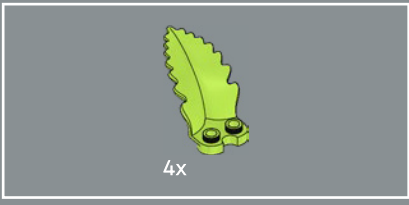
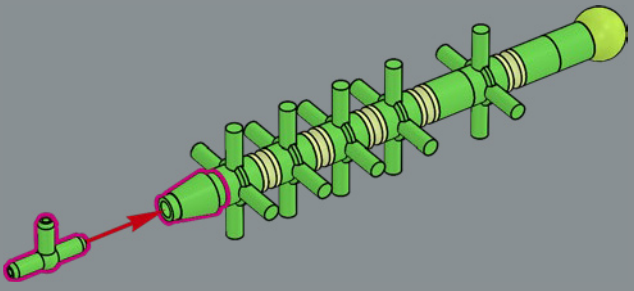

132

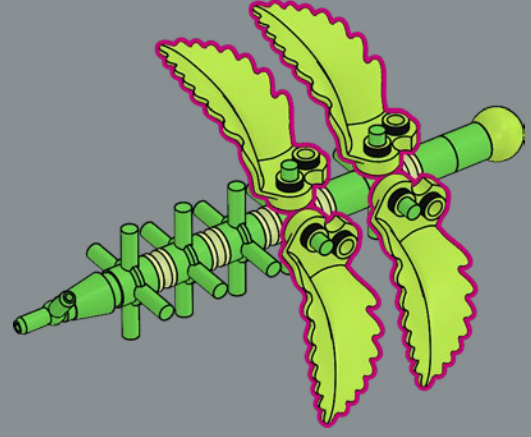

133

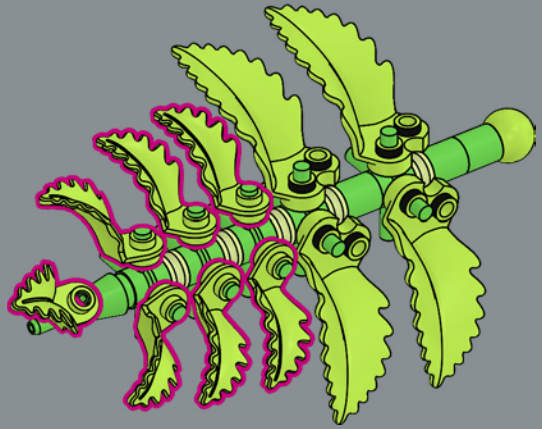

2x





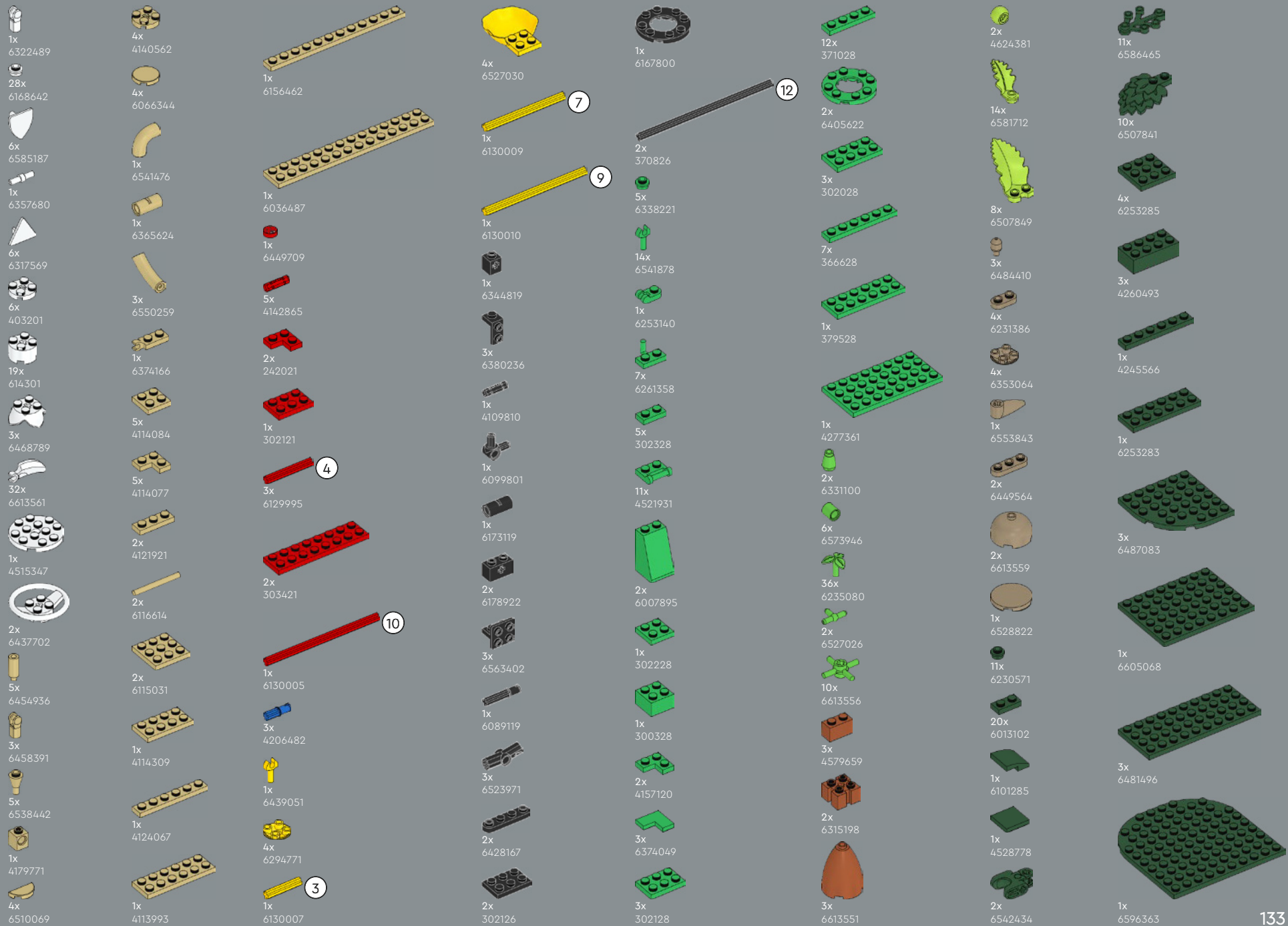



2x  
6527031

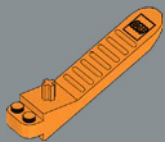

1x  
6240515



2x  
6510192



5x  
6613562



4x  
6613560



10x  
6553342



1x  
6474604



2x  
6278550



1x  
6360075



10x  
4655080



[LEGO.com/service](https://www.LEGO.com/service)



9x  
6083976



3x  
4616581



13x  
6083972



2x  
4521947



2x  
6080431



3x  
6100234

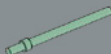

2x  
6474602

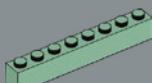

2x  
6577789

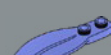

12x  
6614067



2x  
6551408



4x  
6559515



12x  
6439053



6x  
4211242



4x  
4221744



3x  
4211159



7x  
6102360



3x  
4211150



2x  
6313124



3x  
6608792



19x  
6117976



2x  
6226436



22x  
4645103



2x  
6273865



5x  
6502370



9x  
6551600



4x  
6316697



7x  
4211200



2x  
4211210



1x  
6425510



2x  
6492629



2x  
6248854



4x  
6526059



8x  
4211149



2x  
4216668



3x  
4211189



4x  
4211190



2x  
6574769



4x  
4211201



2x  
4225869



1x  
6159763



5x  
4211193



1x  
6070442

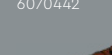

1x  
4216615

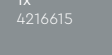

4x  
6469351



4x  
6246843



1x  
6395635



3x  
6315780



11x  
6259071

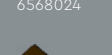

6x  
6568024

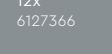

12x  
6127366



10x  
4518557



4x  
6404033



6x  
6353396



2x  
6179803



2x  
6313874



1x  
6005030



8x  
6223039



12x  
6439052



1x  
6623718



1x  
6623717



2x  
6623716



2x  
6623716



**YOU** COULD  
**WIN**



**YOU COULD  
WIN**

Your feedback will help shape the future development of this product series.

Visit:

**DU KÖNNTEST  
GEWINNEN**

Dein Feedback trägt zur Weiterentwicklung dieser Produktreihe bei.

Geh auf:

**VOUS POURRIEZ  
GAGNER**

Vos commentaires nous aideront à concevoir les futurs produits de cette gamme.

Visitez :

**POTRESTI  
VINCERE TU**

La tua opinione ci aiuterà a migliorare la creazione futura di questa linea di prodotti.

Visita:

**PUEDES  
GANAR**

Tu opinión contribuirá al futuro de esta serie de productos.

Visita:

**轻松获奖**

您的反馈将有助于我们在今后改进本产品系列。

请访问:

---

**LEGO.com/productfeedback**

---

You also have the chance to win a LEGO® set.

Terms and conditions apply.\*

Außerdem hast du die Chance, ein LEGO® Set zu gewinnen.

Es gelten die Teilnahmebedingungen.\*

Vous pourriez également gagner un ensemble LEGO®.

Des conditions s'appliquent.\*

Hai anche la possibilità di vincere un set LEGO®.

Termini e condizioni sono applicabili.\*

También tienes la oportunidad de ganar un set LEGO®.

Aplican términos y condiciones.\*

您还有机会赢取乐高®套装。

条款和条件适用。\*

\*LEGO.com/productfeedback-terms

LEGO and the LEGO logo are trademarks of the/sont des marques de commerce du/son marcas registradas de LEGO Group.  
©2026 The LEGO Group. All rights reserved/Tous droits réservés/Todos los derechos reservados.

 6650754

