



11377 | 1

THE
LORD OF THE RINGS



Available in English
Disponible en français
Disponible en español

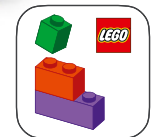

LEGO® Builder

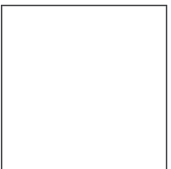



WE'RE MAKING OUR PACKAGING MORE SUSTAINABLE

We're transitioning from single-use plastic to paper-based packaging. As we progress, you may find a mix of paper and plastic in our boxes.

NOUS RENDONS NOS EMBALLAGES PLUS DURABLES

Nous passons des emballages en plastique à usage unique aux emballages à base de papier. Durant la transition, vous pourriez trouver un mélange de papier et de plastique dans nos boîtes.

QUEREMOS HACER MÁS SUSTENTABLES NUESTROS MATERIALES DE EMBALAJE

Estamos cambiando las bolsas de plástico desechables por bolsas con base de papel. Conforme avanzamos en este propósito, puedes encontrar una mezcla de papel y de plástico en nuestras cajas.

LEGO.com/sustainable-packaging



BUILDER



Apple and the Apple logo are trademarks of Apple Inc., registered in the U.S. and other countries and regions. App Store is a service mark of Apple Inc. Google Play and the Google Play logo are trademarks of Google LLC. Tencent and the Tencent logo are trademarks of Tencent Inc.

LEGO.com/devicecheck

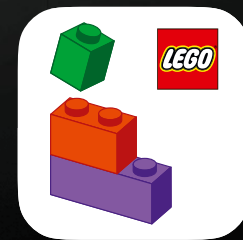

LEGO® Builder



MINAS TIRITH™ – CITY OF KINGS

The role of Minas Tirith™ in the conclusive battle for Middle-earth™ sometimes overshadows its glorious, thousand-year-old history. When Pippin and Gandalf™ first arrive, the once so noble realm has fallen into dire disrepair under the stewardship of the fatalistic Denethor™. Driven by an impending sense of doom and self-pity, he gorges himself on grotesque meals rather than fulfilling his duties. Even so, neither the Nazgûl™ nor Sauron™ himself can diminish its architectural splendor. Solidly built into the White Mountains, Minas Tirith soars with its seven concentric levels of stone, crowned by the Tower of Ecthelion, a 300-foot beacon whose pinnacle reaches 1,000 feet above the plain. After the War of the Ring ends, Minas Tirith once again stands as a symbol of hope and prosperity.

MINAS TIRITH™ – LA CITÉ DES ROIS

Le rôle de Minas Tirith™ dans l'ultime bataille pour la Terre du Milieu™ éclipse parfois son histoire millénaire et glorieuse. Lorsque Pippin et Gandalf™ y arrivent pour la première fois, ce royaume jadis noble est en plein déclin sous la gouverne du fataliste Denethor™ qui, rongé par un sentiment de fatalité et d'apitoiement, s'empiffre de repas grotesques plutôt que de s'acquitter de ses responsabilités. Malgré tout, ni les Nazgûl™ ni même Sauron™ ne peuvent ternir sa splendeur architecturale. Solidement ancrée dans les Montagnes Blanches, Minas Tirith s'élève en sept niveaux concentriques de pierre, dominés par la Tour d'Ecthelion, un phare de 300 pieds dont le sommet culmine à 1 000 pieds au-dessus de la plaine. Après la fin de la Guerre de l'Anneau, Minas Tirith redevient un symbole d'espoir et de prospérité.

MINAS TIRITH™ : LA CIUDAD DE LOS REYES

No en pocas ocasiones el papel de Minas Tirith™ en la decisiva batalla por la Tierra Media opaca su gloriosa y milenaria historia. Cuando Pippin y Gandalf™ llegan allí por primera vez, este reino, en otro tiempo tan noble, ha caído en un estado de profundo deterioro bajo la senescalía del fatalista Denethor™. Dominado por una sensación de inminente perdición y absoluta desesperanza, pasa los días atiborrándose de grotescas comidas en vez de cumplir con sus obligaciones. Aun así, empañar el esplendor arquitectónico de este lugar es algo que no está al alcance de los Nazgûl™, y ni siquiera del mismísimo Sauron™. Cimentada en las Montañas Blancas, Minas Tirith está edificada en siete niveles concéntricos de piedra sólida coronados por la Torre de Ecthelion, una baliza con una altura de 300 pies cuyo pináculo se eleva 1000 pies por encima de la llanura. Luego del fin de la Guerra del Anillo, Minas Tirith vuelve a erigirse como símbolo de esperanza y prosperidad.



“Here, the hammer stroke
will fall hardest.”

- Gandalf

« C'est ici que le coup de
marteau s'abattra le plus fort. »

- Gandalf

“Aquí el martillo caerá con
la mayor energía”.

- Gandalf



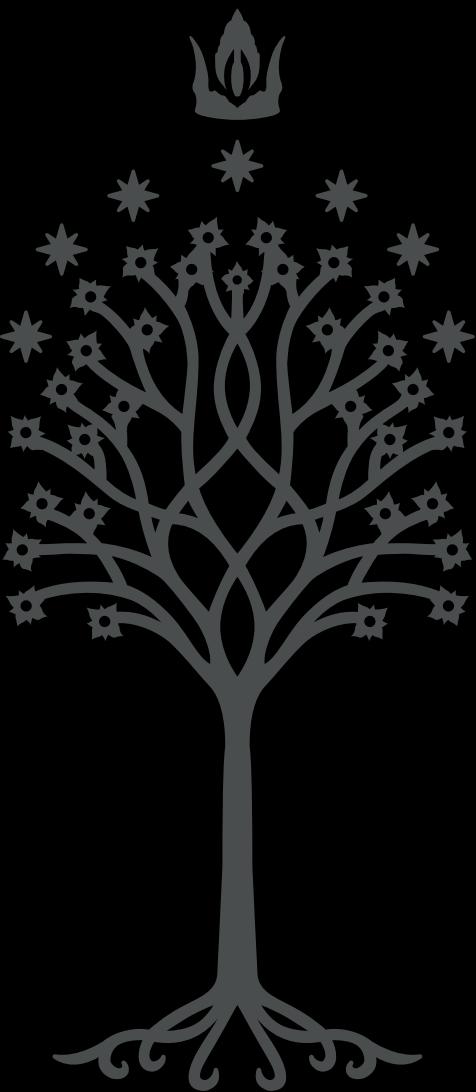

FROM THE LEGO® ICONS DESIGN TEAM

It's always with a sense of awe that we start working on models based on popular themes – including the vast realms in *The Lord of the Rings™* film trilogy. Inspired by the 'bigature' model created for *The Return of the King™*, we stayed close to the movie version's storytelling and the structural details. We created a hybrid-scale model by using a forced perspective building technique. The outer wall is built for LEGO® minifigures to interact with, while the six upper walls are built progressively smaller for dramatic effect. You can place the characters into the iconic scenes both at the top layer and inside. However you display it, there are myriad details everywhere, and you can remove sections of the model for even more versatile display options. You're about to pass into the Realm of Gondor™. The board is set. The pieces are moving. Let the building adventure begin!



DE L'ÉQUIPE DE CONCEPTION LEGO® ICONS

C'est toujours avec un profond sentiment d'émerveillement que nous entamons la création de modèles inspirés de thèmes populaires, comme les vastes royaumes de la trilogie cinématographique *Le Seigneur des anneaux™*. Inspirés par la « bigature » créée pour *Le Retour du roi™*, nous avons respecté de près la narration du film ainsi que ses détails architecturaux. Nous avons conçu un modèle à échelle hybride en utilisant une technique de construction en perspective forcée.

Le mur extérieur est conçu pour que les figurines LEGO® puissent interagir avec lui, tandis que les six niveaux supérieurs sont construits de plus en plus petits pour accentuer l'effet dramatique. Vous pouvez placer les personnages dans les scènes emblématiques, autant au sommet qu'à l'intérieur. Peu importe comment vous l'exposez, une foule de détails se dévoilent partout. De plus, certaines sections peuvent être retirées pour multiplier les options d'exposition. Vous êtes sur le point d'entrer dans le royaume de Gondor™. Le jeu est en place. Les pièces sont en mouvement. Que l'aventure de construction commence!

IMPRESIONES DEL EQUIPO DE DISEÑO DE LEGO® ICONS

Empezar a trabajar en modelos que recrean pasajes de temas populares siempre enciende nuestro asombro. Eso incluye los vastos reinos de la trilogía cinematográfica de *El señor de los anillos*. Al inspirarnos en el modelo "bigature" (miniatura a gran escala) creado para *El retorno del rey*, nuestra versión se mantiene fiel a los detalles estructurales y narrativos de la que vimos en la pantalla. Usar una técnica de construcción de perspectiva forzada nos permitió crear un modelo a escala híbrida. Diseñamos la muralla exterior para que las minifiguras LEGO® interactuaran con ella, y las de los seis niveles escalonados del interior son cada vez más pequeñas para aumentar el efecto dramático. También puedes recrear escenas icónicas con los personajes tanto en la capa superior como adentro del modelo. Sin importar desde qué ángulo lo mires, encontrarás innumerables detalles por todas partes. Además, algunas secciones son removibles, lo que lo hace más versátil a la hora de exhibirlo. Estás a punto de entrar al corazón de Gondor™. El tablero está listo. Las piezas se mueven. ¡Que empiece la aventura de la construcción!





THE GATES OF MINAS TIRITH™

The Great Gate on the first wall faces east and serves as the city's only gateway. It opens into a paved courtyard, the meeting point of the North-way, South Road and the route to Osgiliath. Each of the seven levels is protected by its own wall and gate. These gates are placed at angles to one another, creating a zigzagging path upward through the city rather than a straight ascent – a hallmark of Minas Tirith's defensive architecture. In this model, the gate can be detached so newly designed minifigure characters of Gandalf™, Pippin and Shadowfax can make a dramatic entrance through the gate and alert Denethor™ of Sauron's threat.



LES PORTES DE MINAS TIRITH™

La Grande Porte, située sur le premier mur et orientée vers l'est, est l'unique accès à la cité. Elle s'ouvre sur une cour pavée, point de jonction de la Route du Nord, de la Route du Sud et du chemin menant à Osgiliath. Chacun des sept niveaux est protégé par son propre mur et sa propre porte. Les portes sont disposées en angle les unes par rapport aux autres, formant un chemin en zigzag à travers la cité plutôt qu'une montée directe — une caractéristique clé de l'architecture défensive de Minas Tirith. Dans ce modèle, la porte peut être retirée pour permettre aux nouvelles figurines de Gandalf™, Pippin et Gripoil d'effectuer une entrée spectaculaire et d'avertir Denethor™ de la menace de Sauron.

LAS PUERTAS DE MINAS TIRITH™

Instalada en la primera muralla, la Gran Puerta está orientada al este y es la única forma de entrar a la ciudad. Se abre hacia una explanada pavimentada donde confluyen el Camino del Norte, el Camino del Sur y el sendero que conduce a Osgiliath. Cada uno de los siete niveles está protegido por su propia muralla y puerta. Las puertas están colocadas en ángulo unas con respecto de otras, creando un camino que asciende por la ciudad en zigzag en vez de subir en línea recta, lo que constituye un sello distintivo de la arquitectura defensiva de Minas Tirith. La puerta del modelo es removible para que las nuevas minifiguras de Gandalf™, Pippin y Sombragrís puedan hacer una dramática entrada con la intención de alertar a Denethor™ de la amenaza de Sauron.



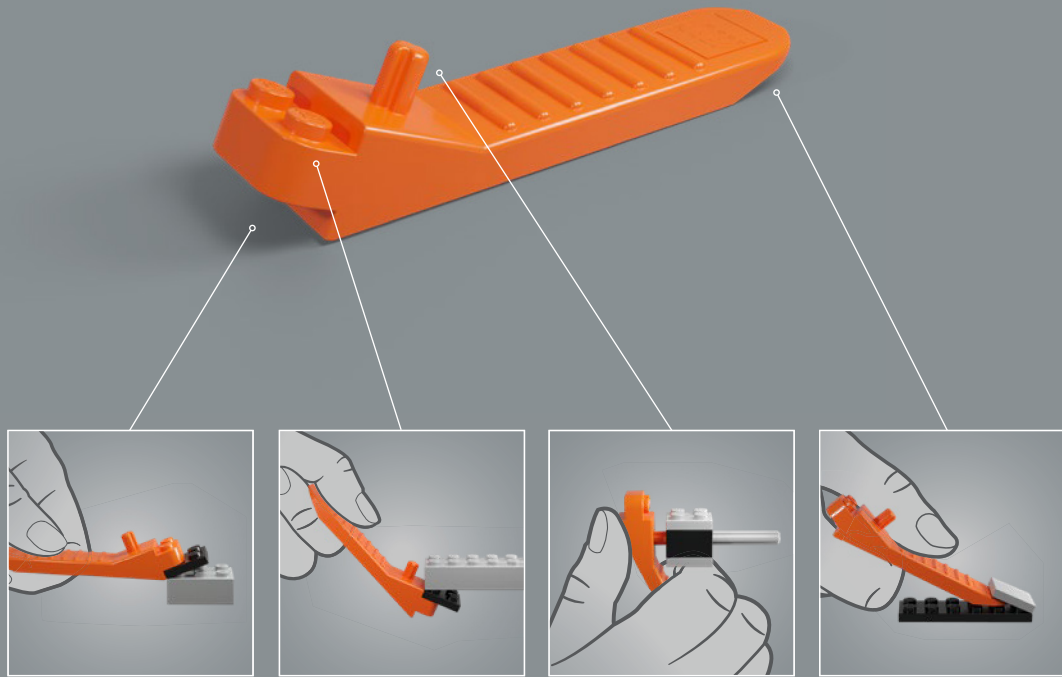

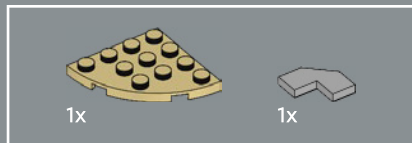

1

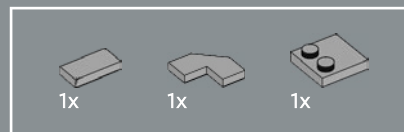
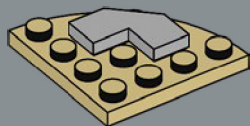

2

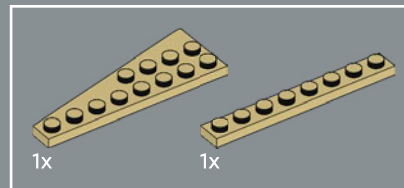
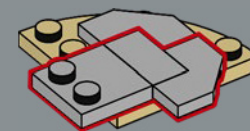

3

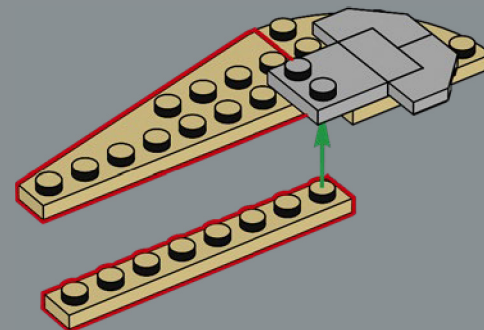

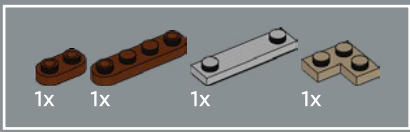

4

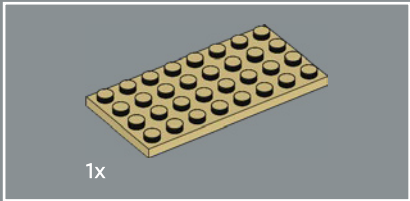
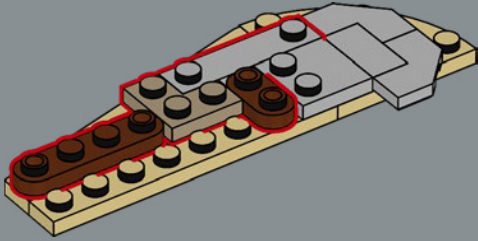

5

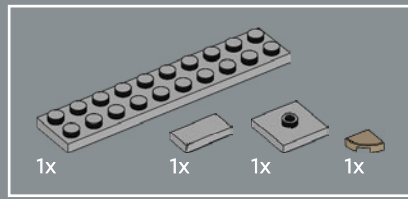
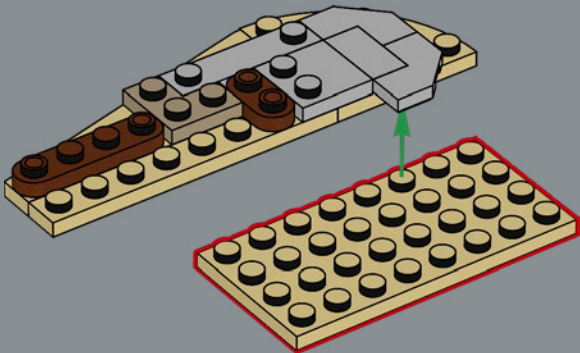

6

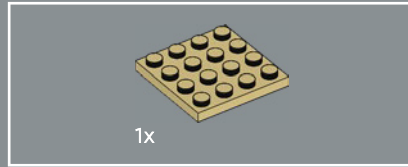
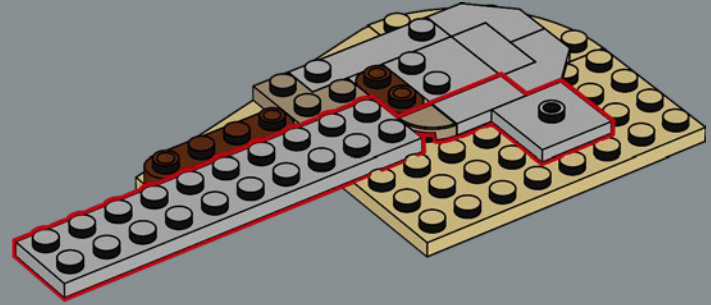

7

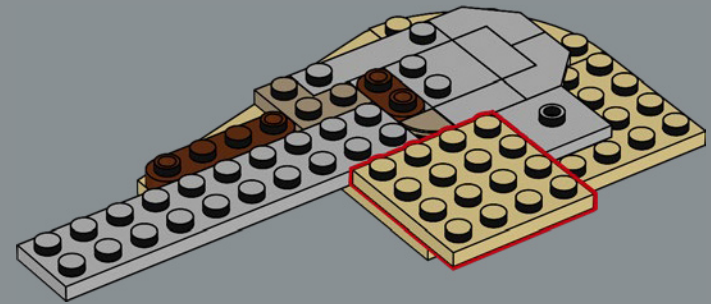

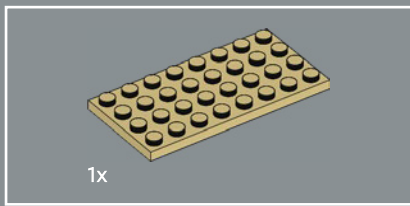

8

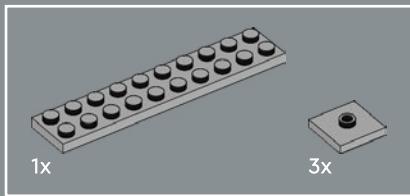
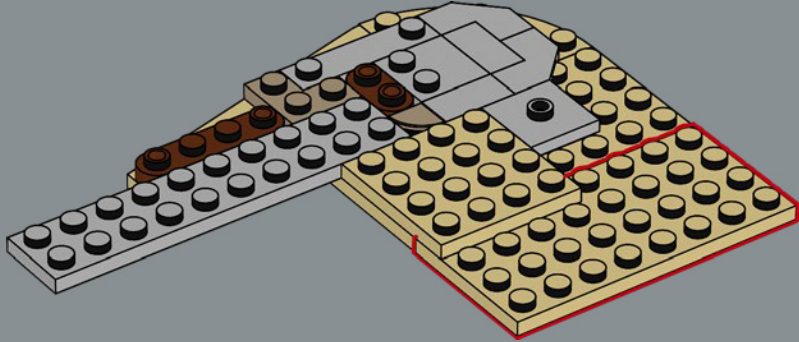

9

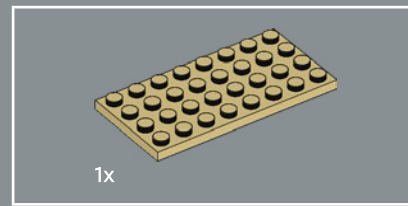
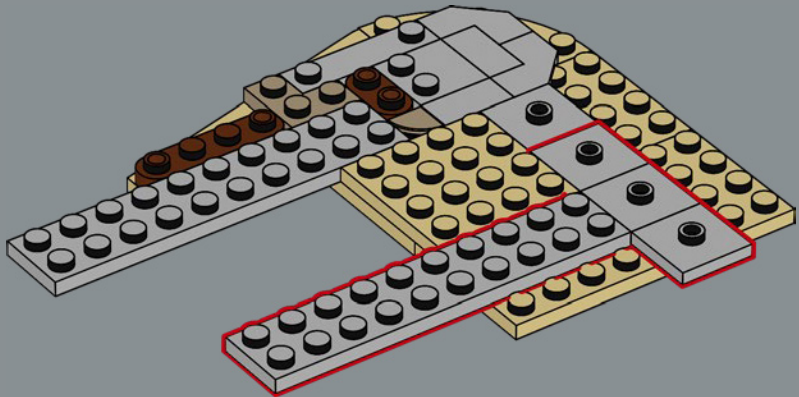

10

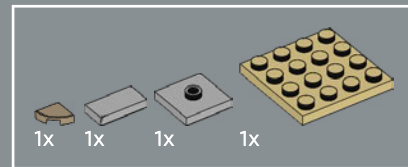
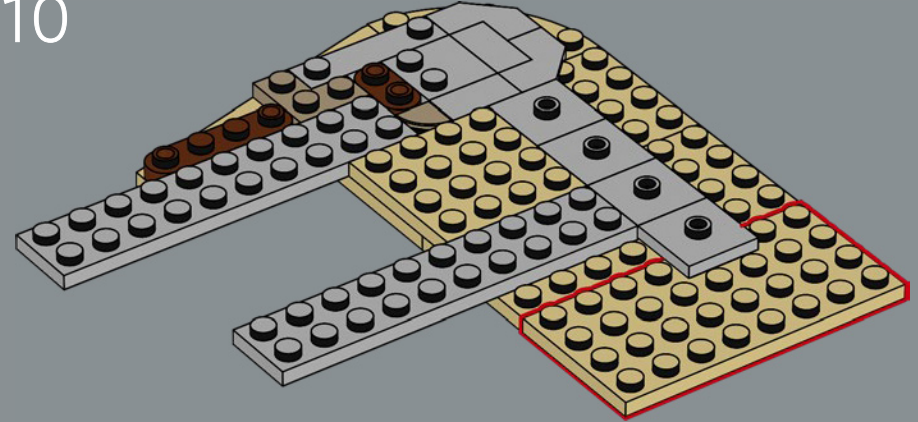

11

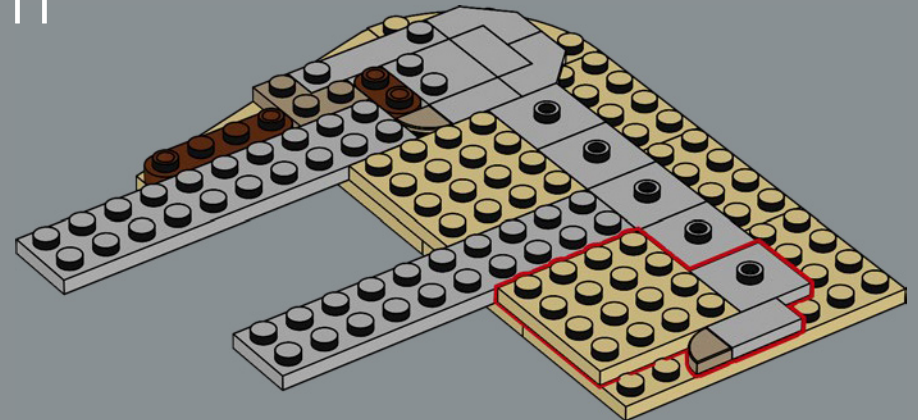

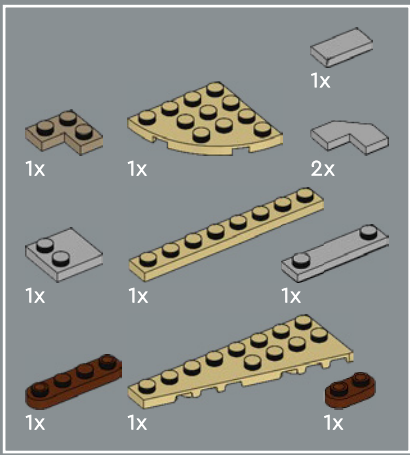

12

1

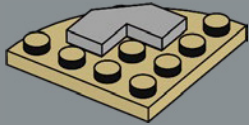

2

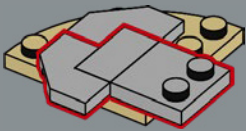

3

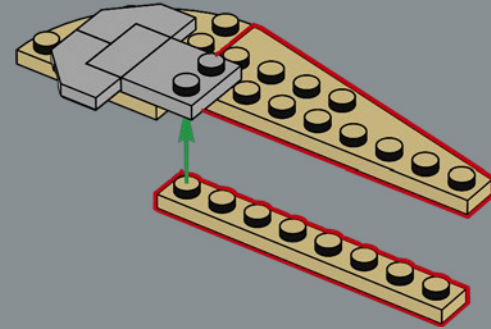

4

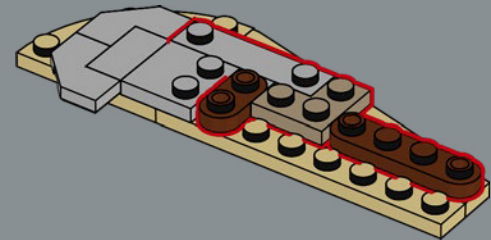

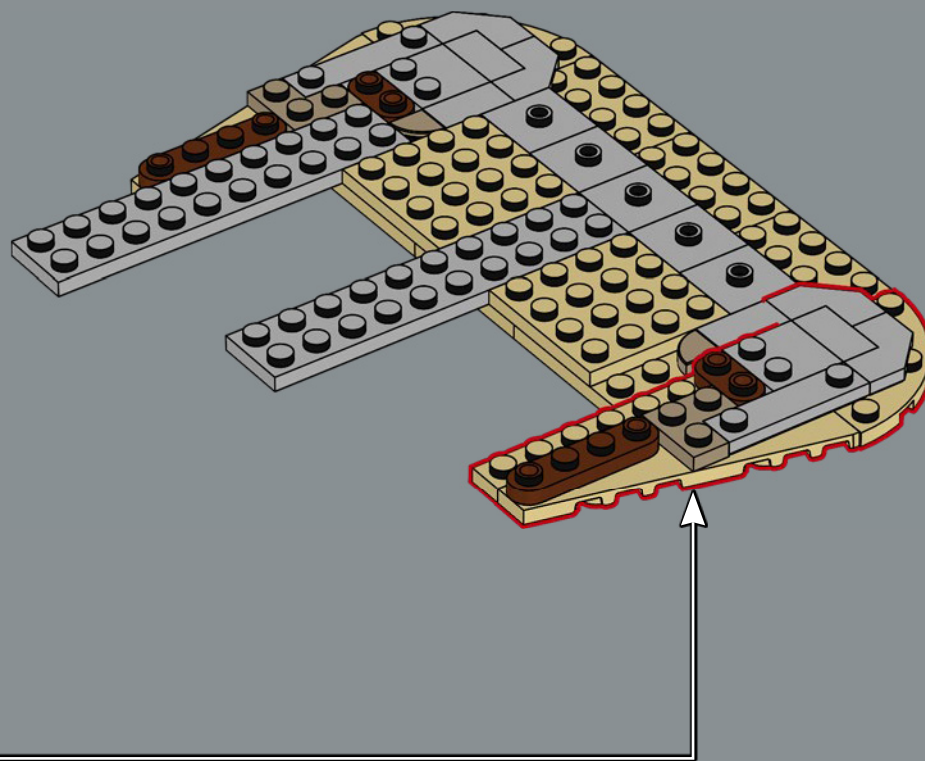

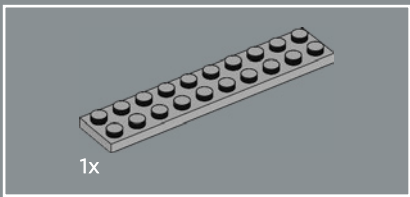

13

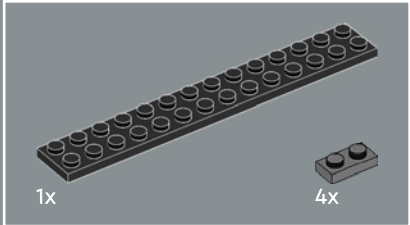
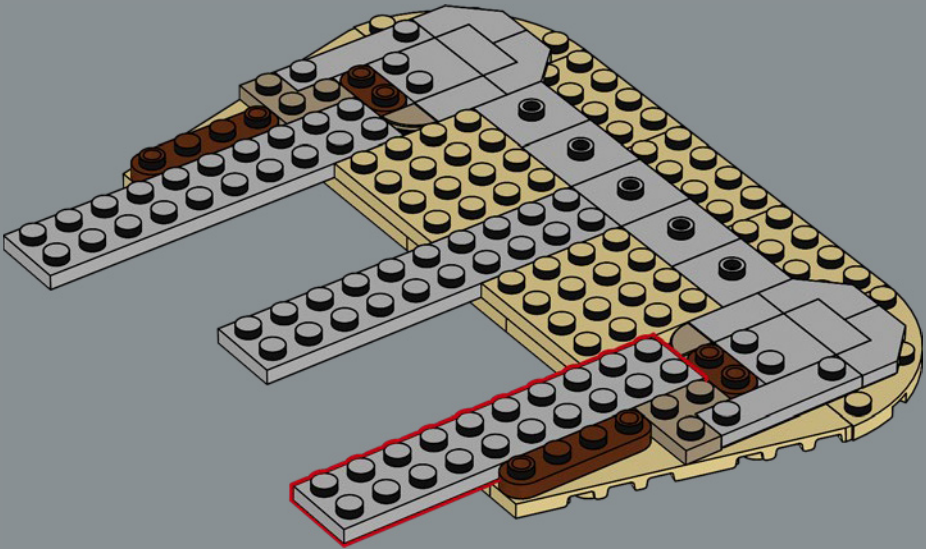

14

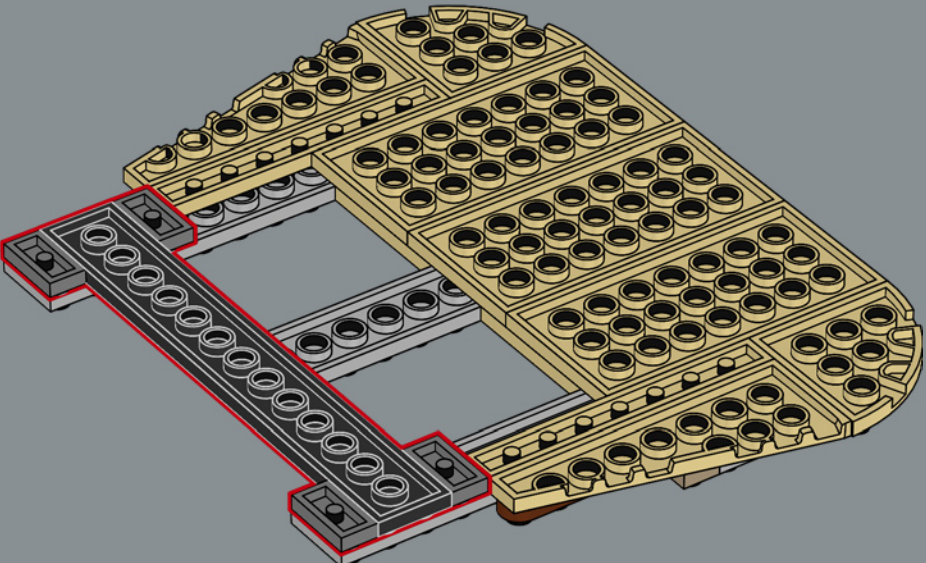

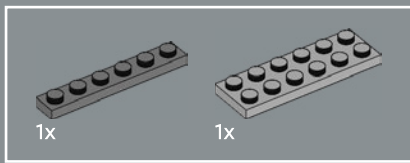

15

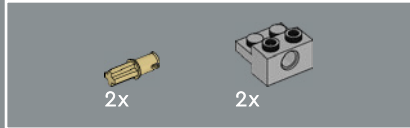
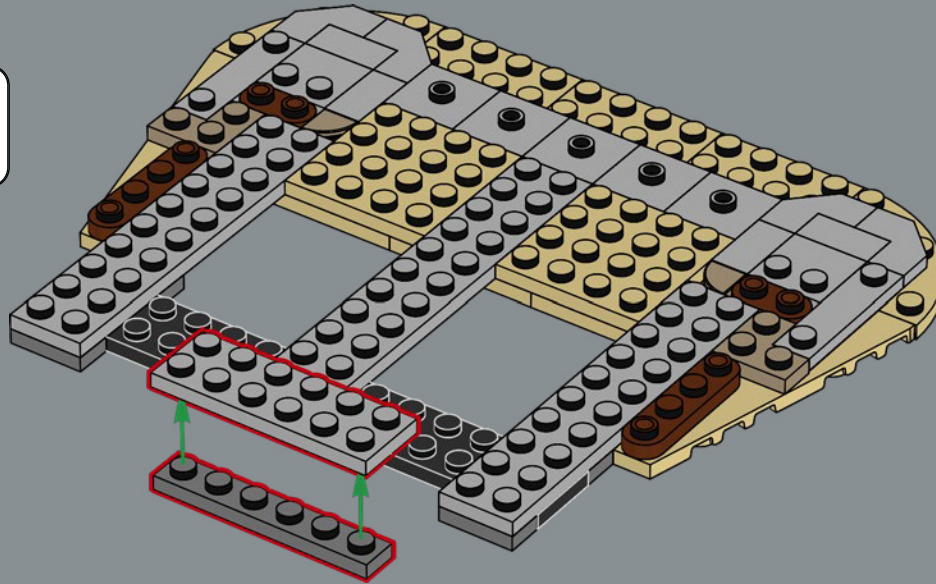

16

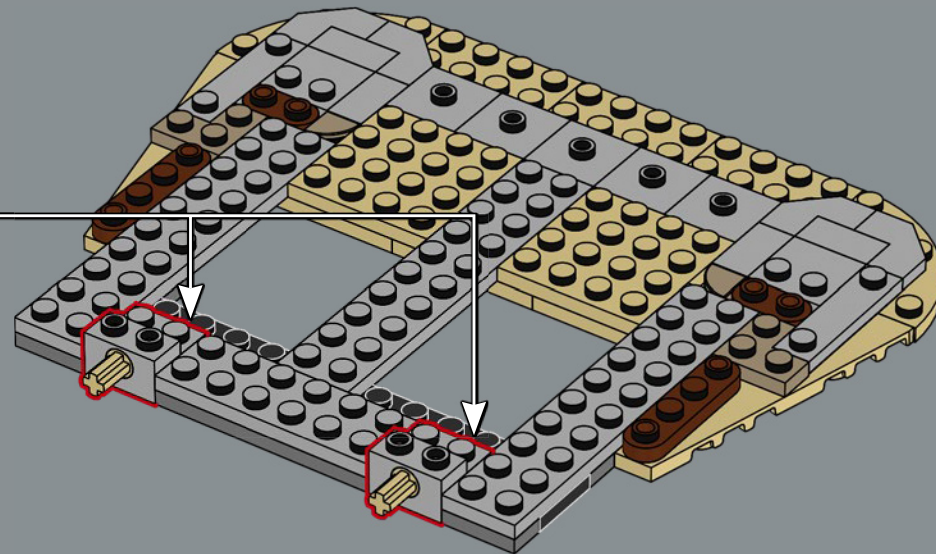
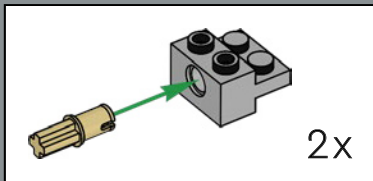

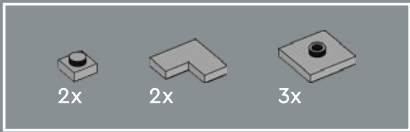

17

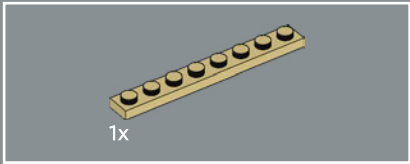
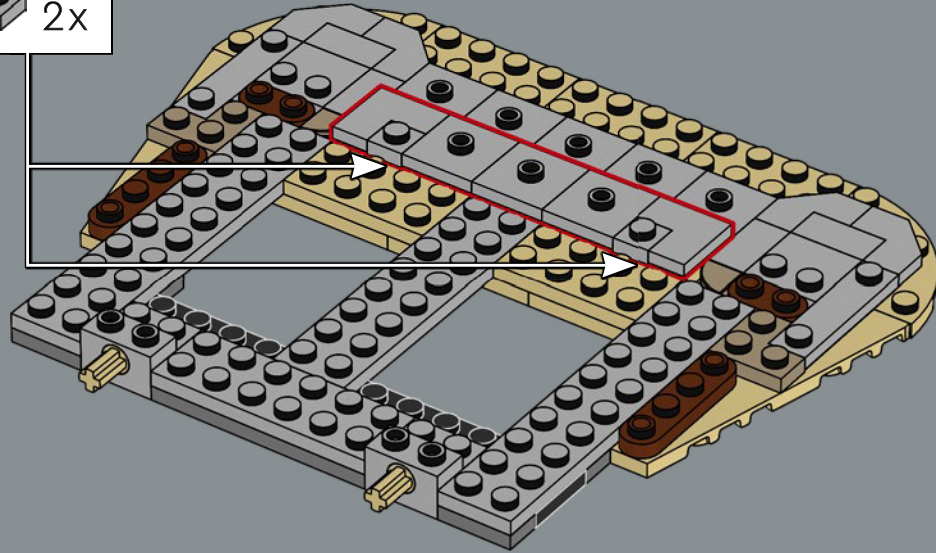
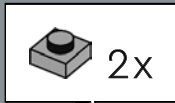

18

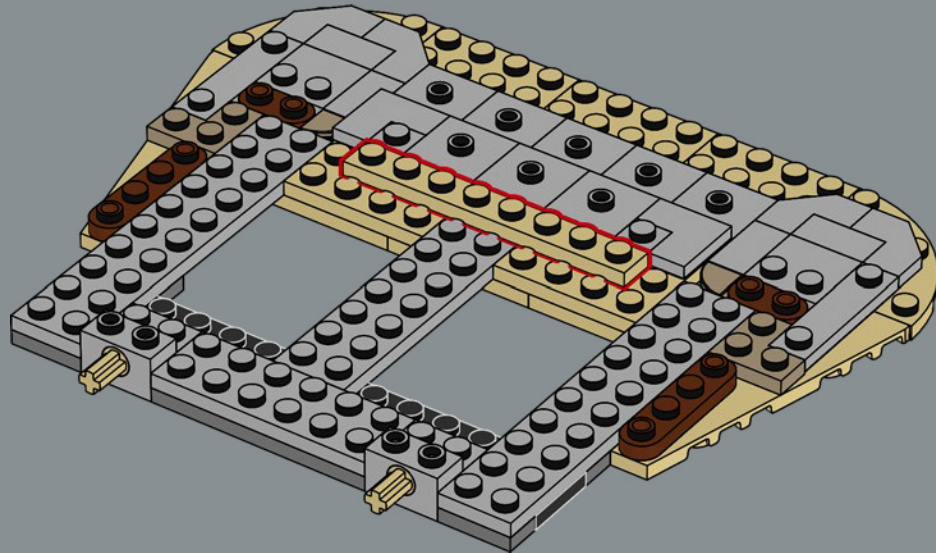

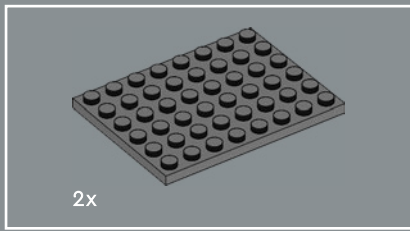

19

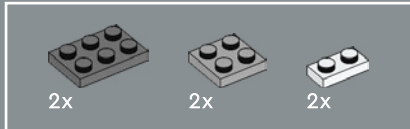
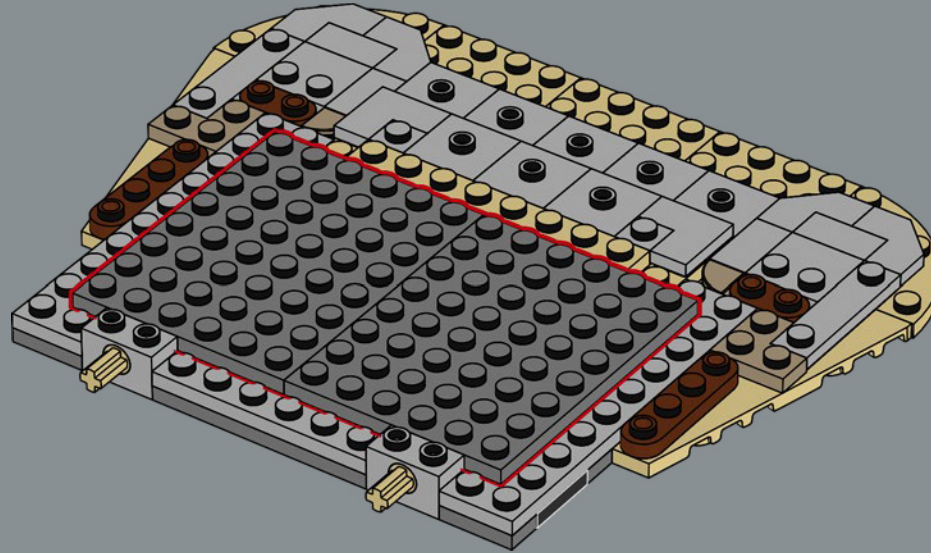

20

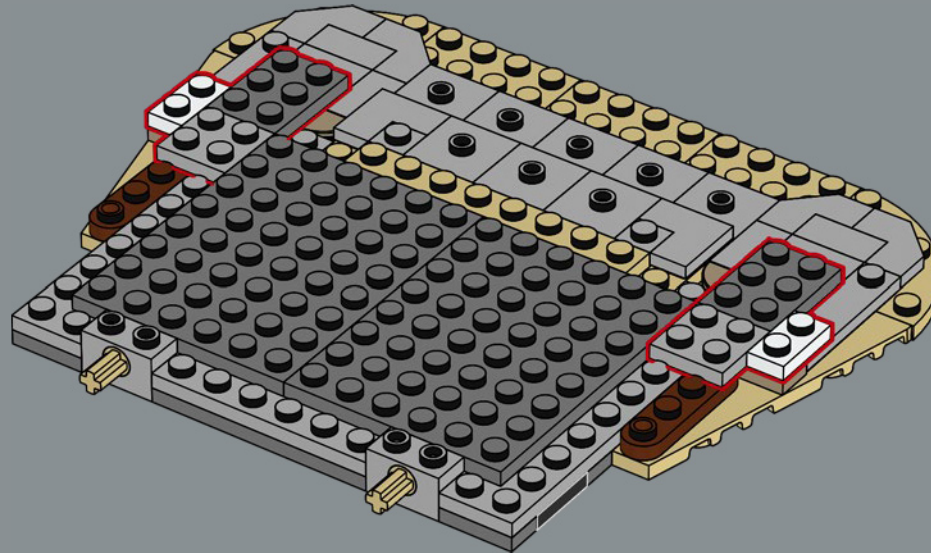

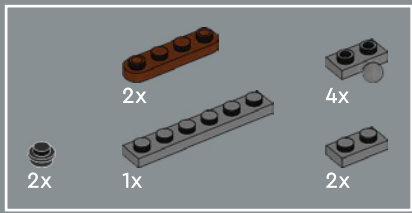

21

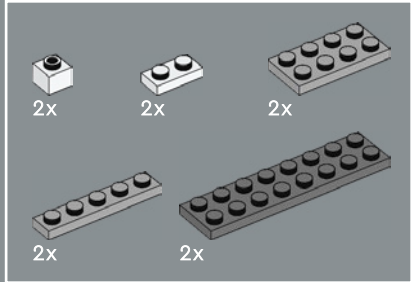
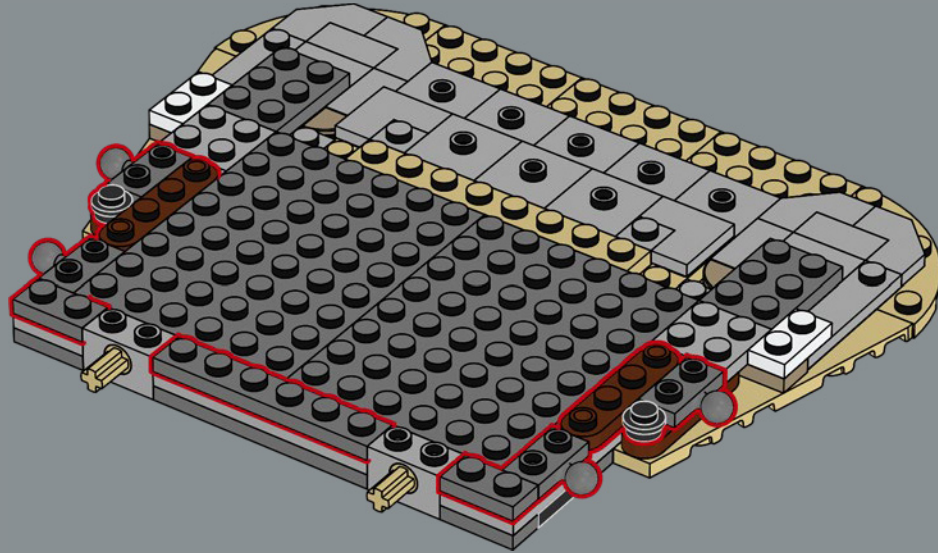

22

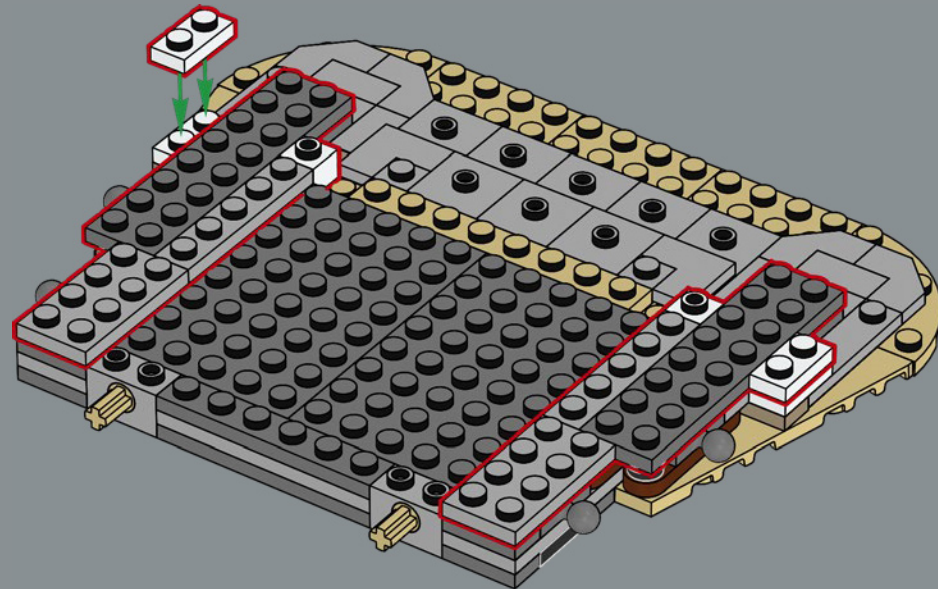

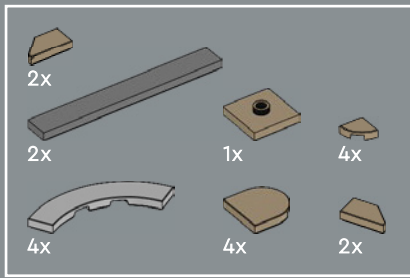

23

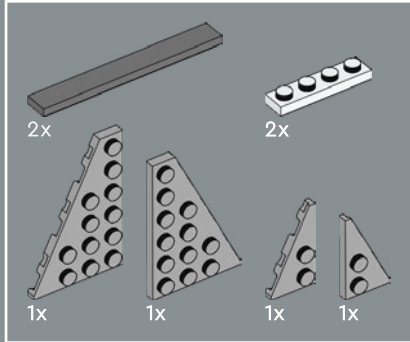
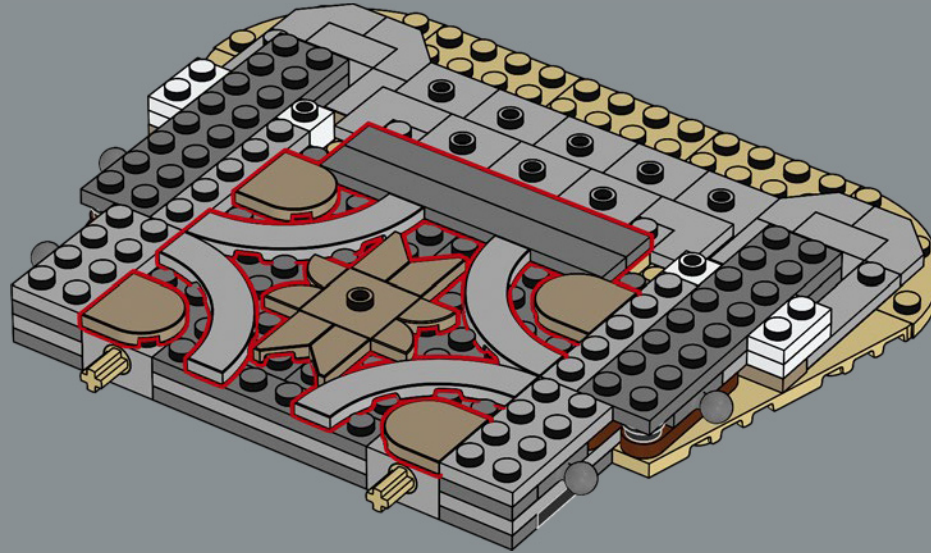

24

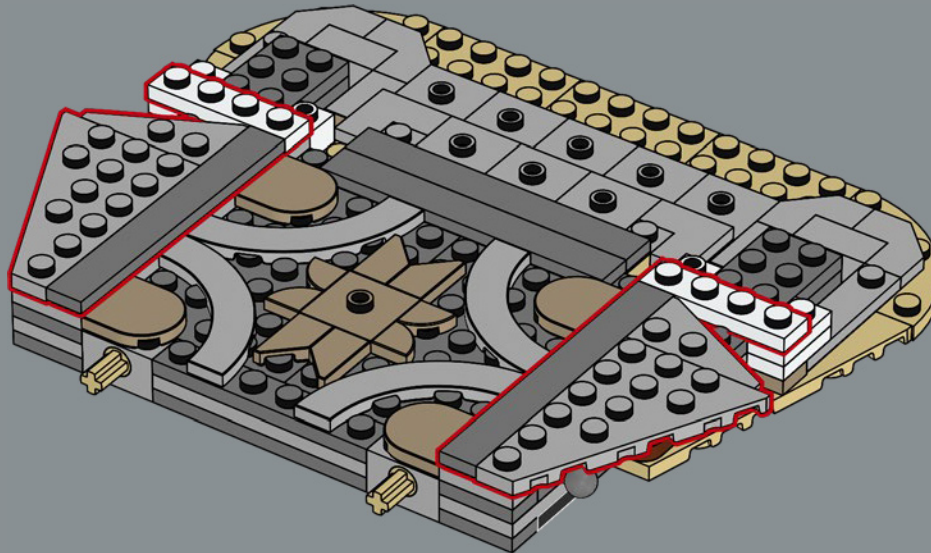

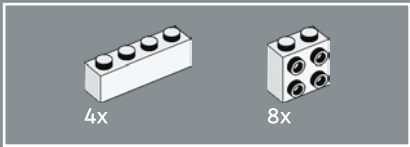

25

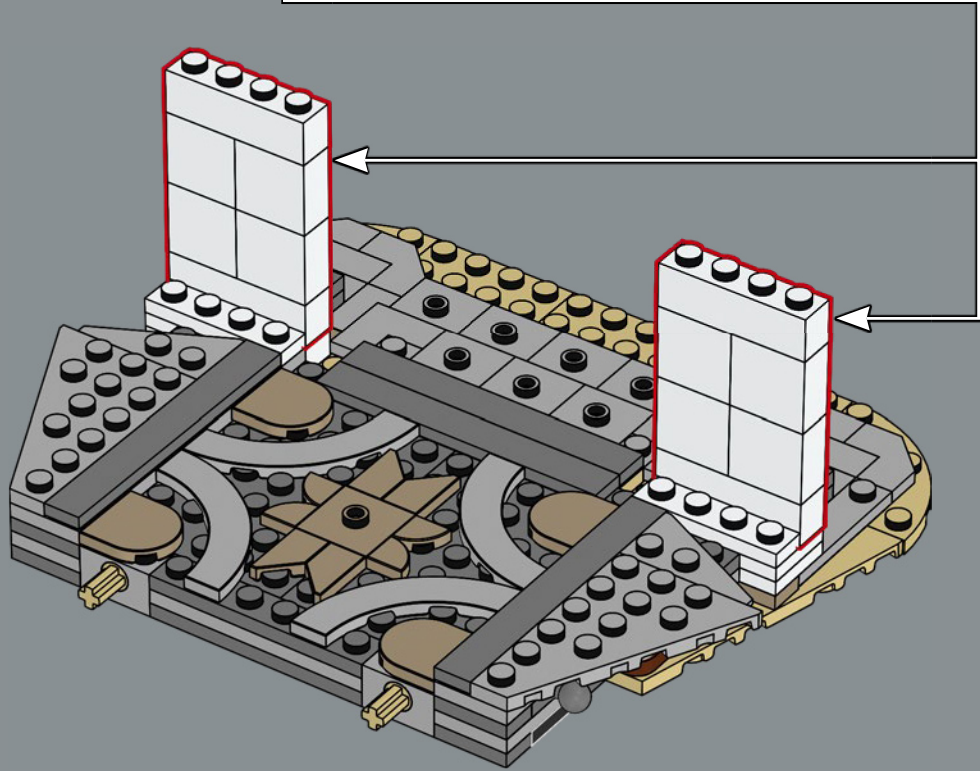
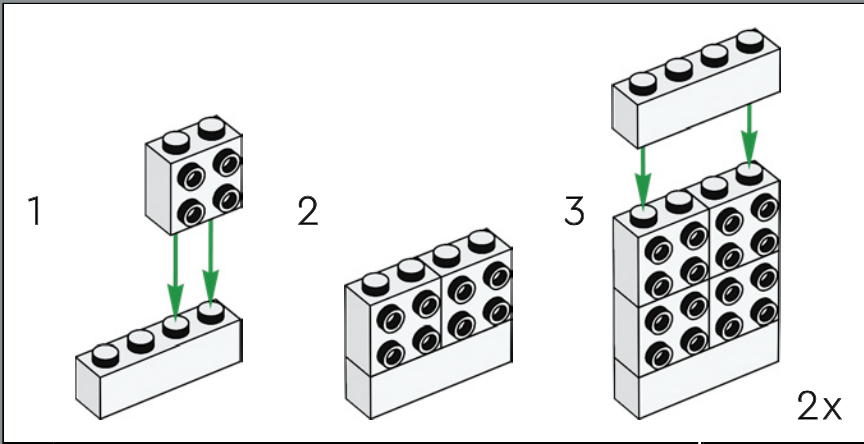

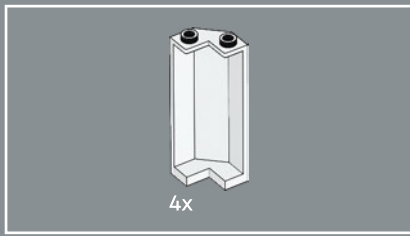

26

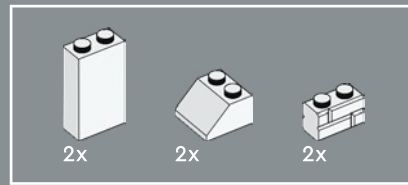
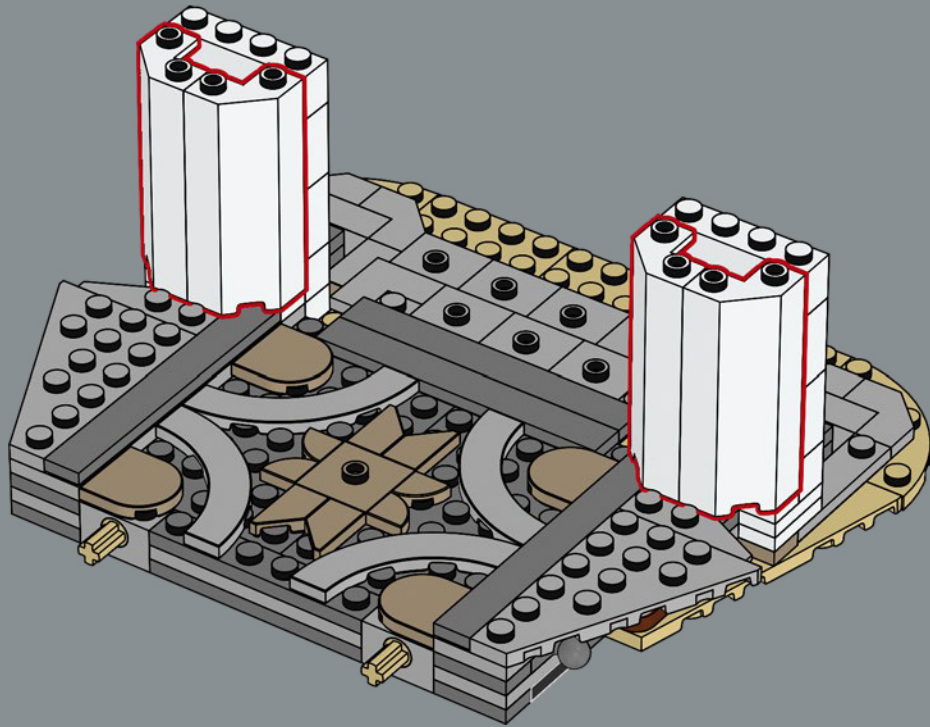

27

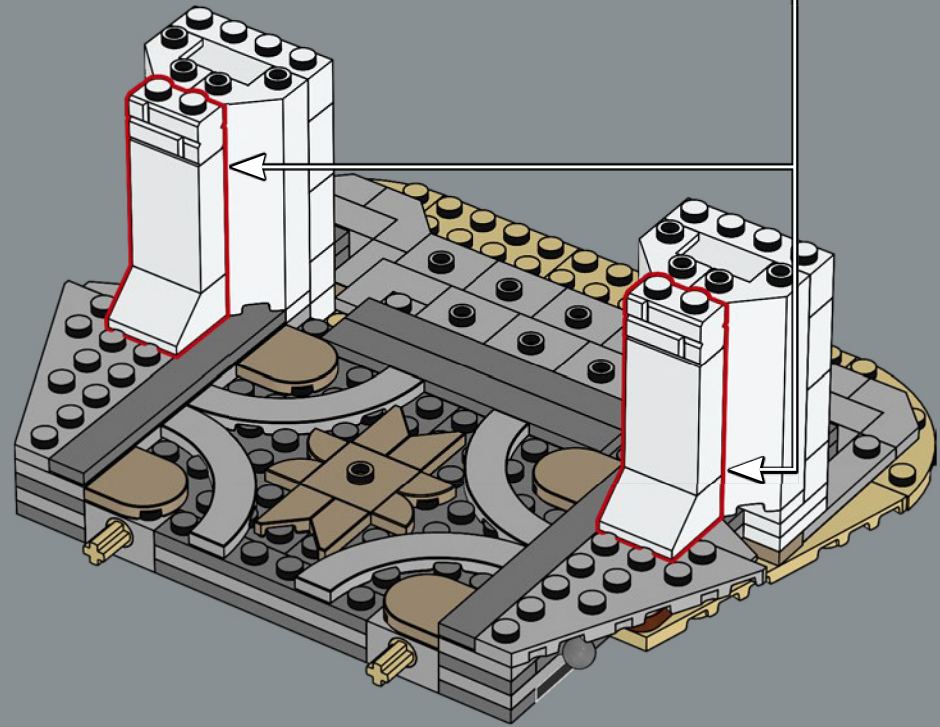
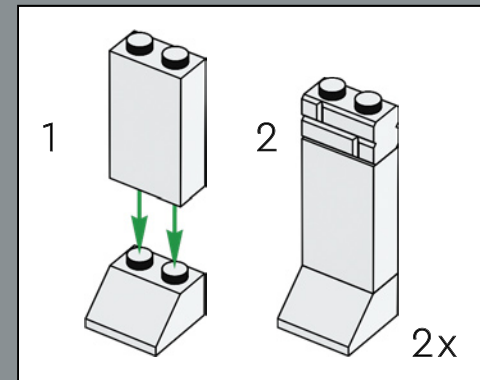

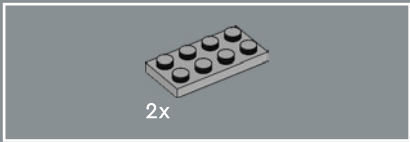

28

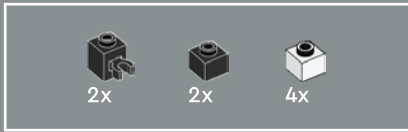
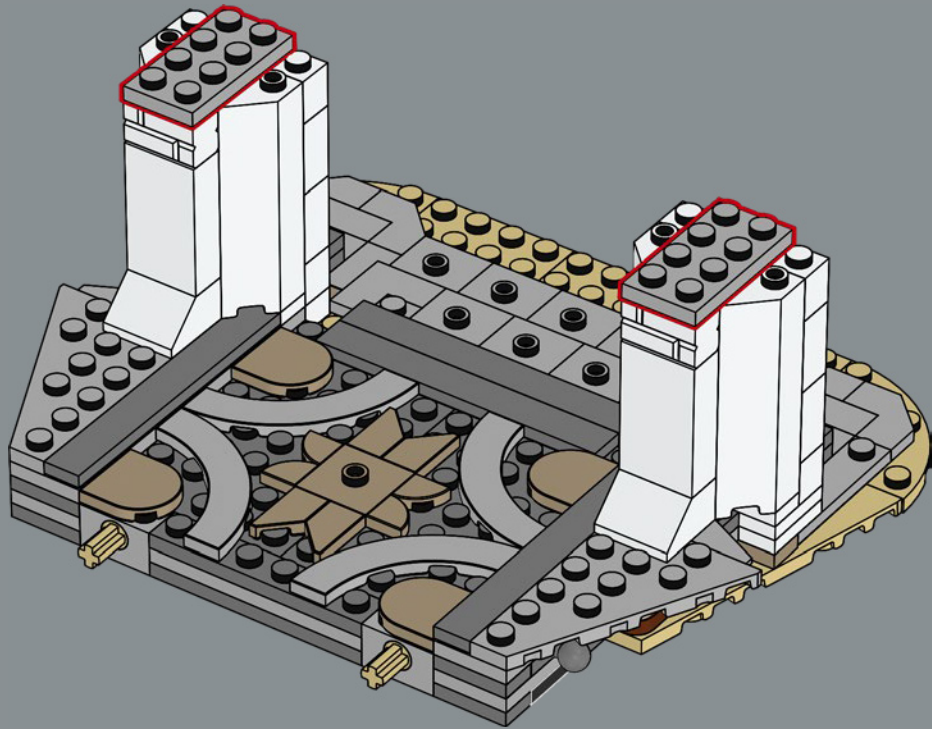

29

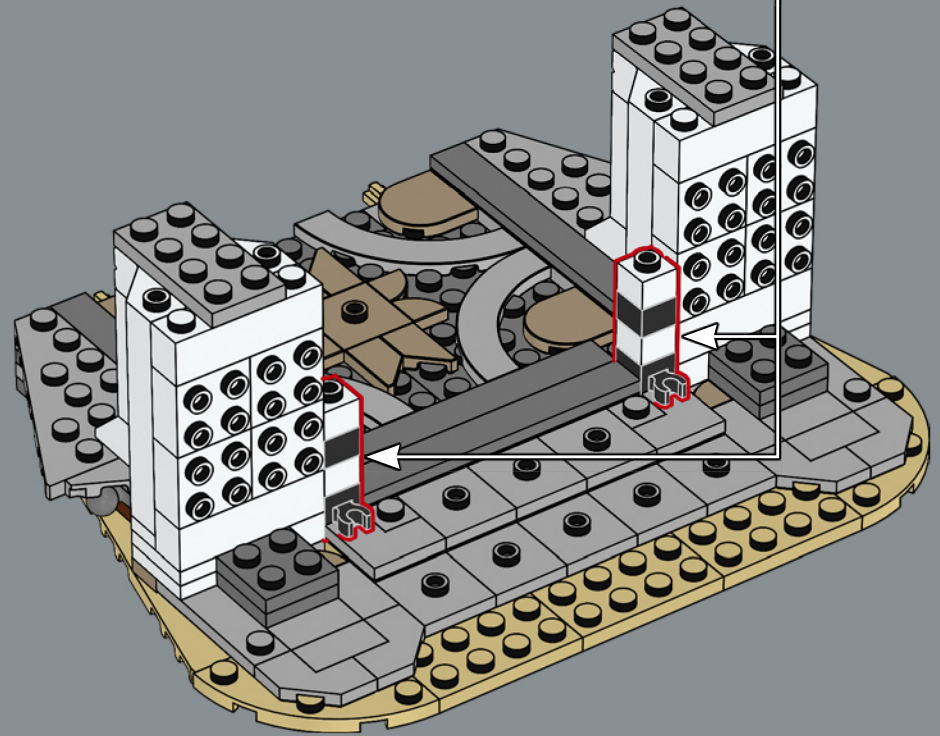
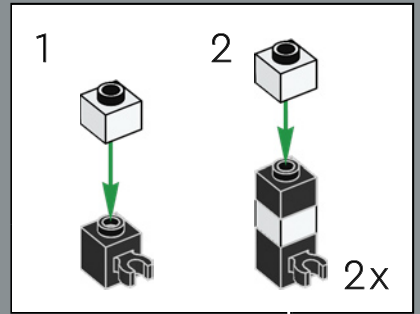

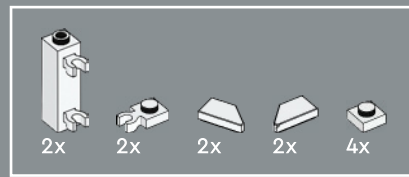

30

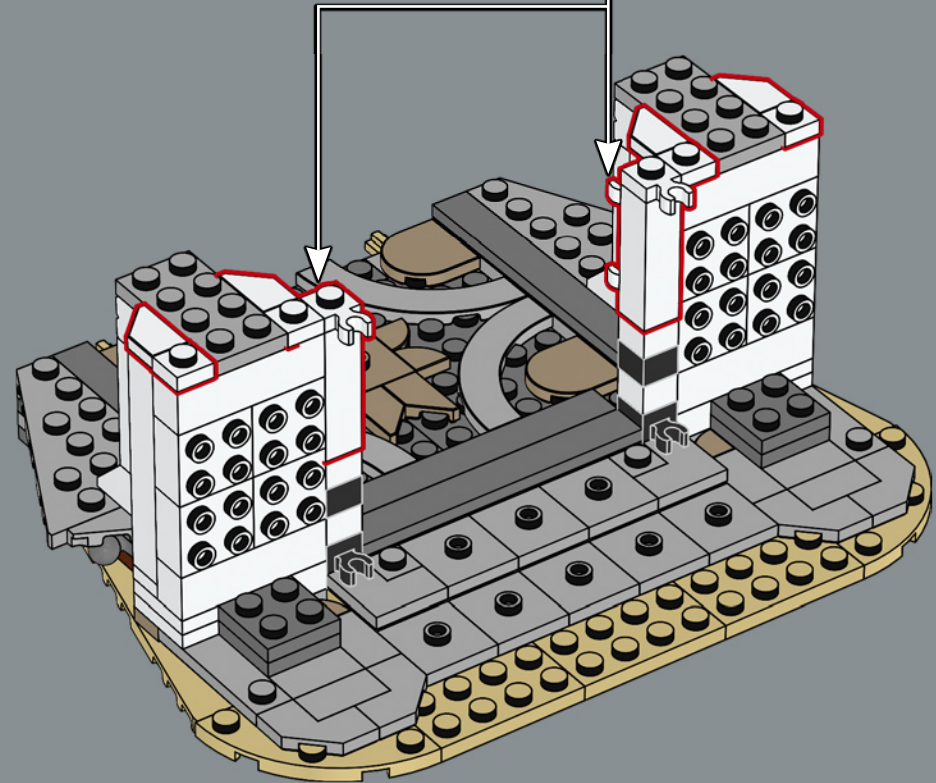
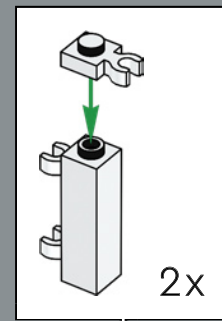

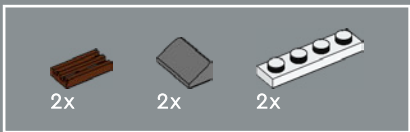

31

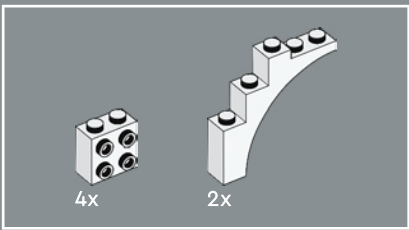
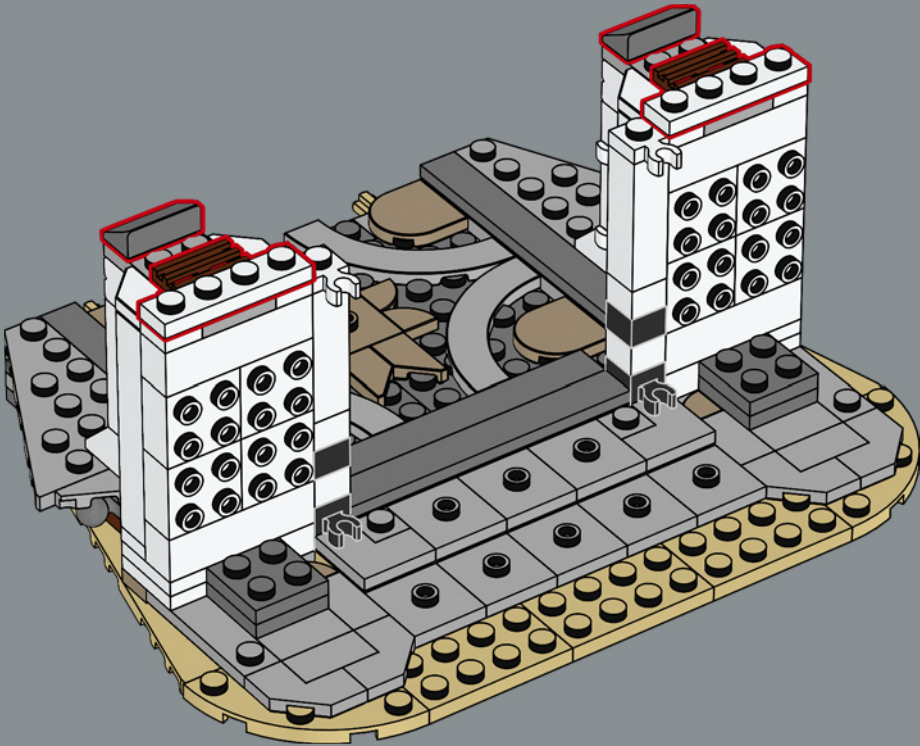

32

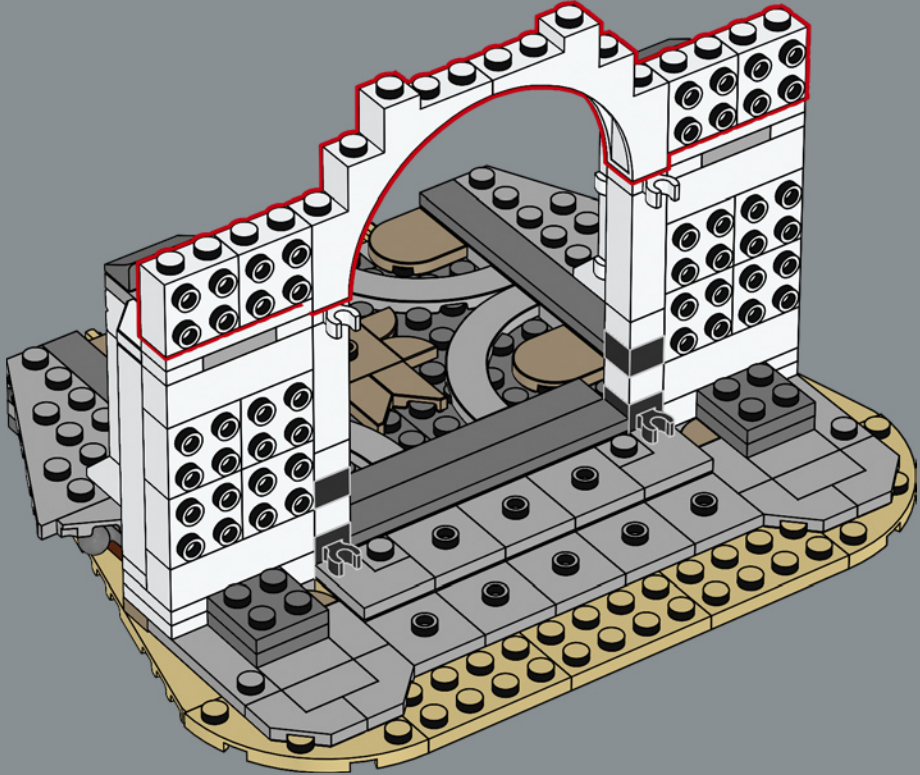

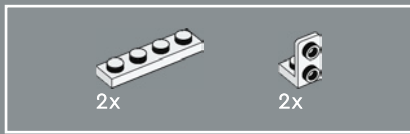

33

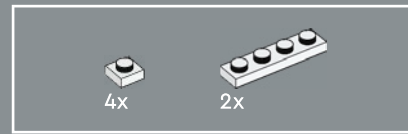
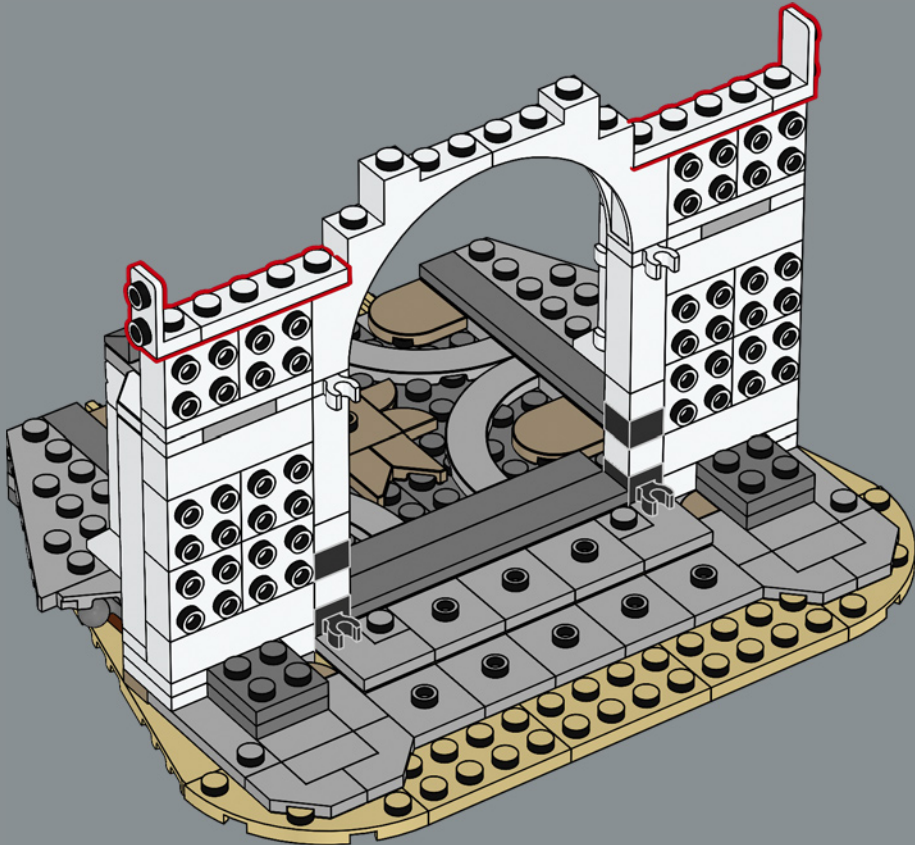

34

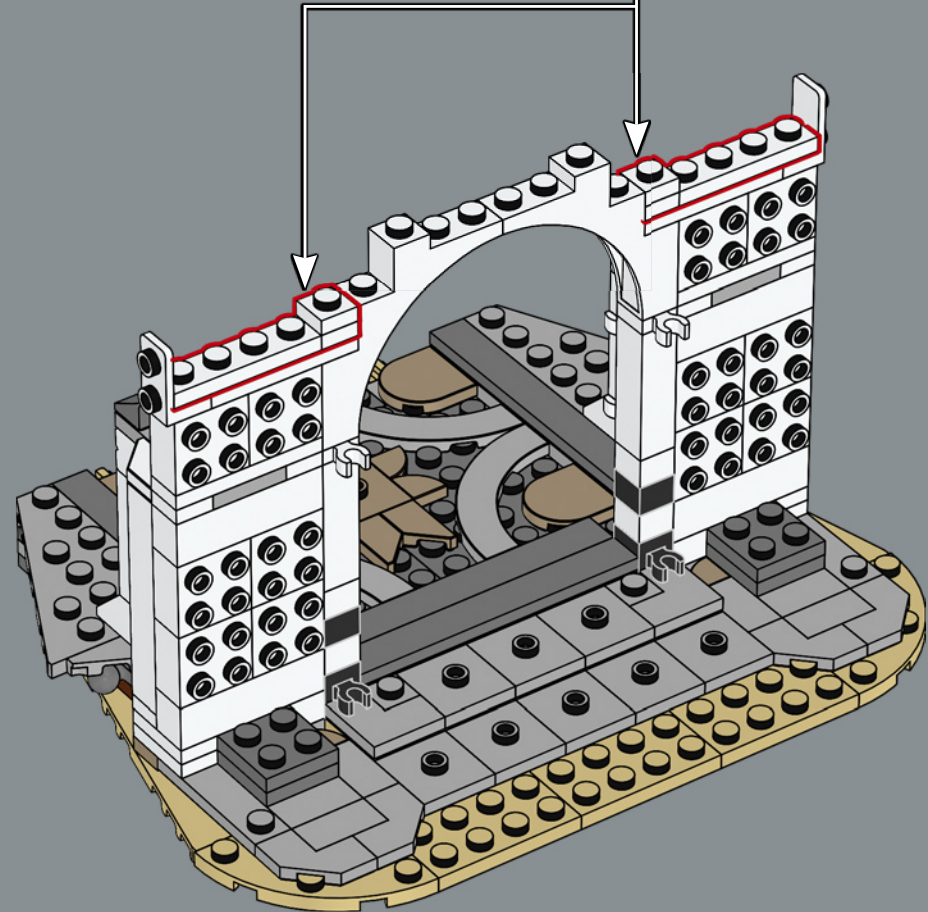
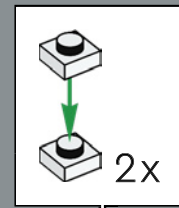

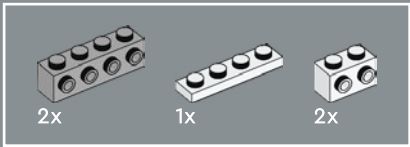

35

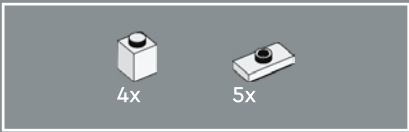
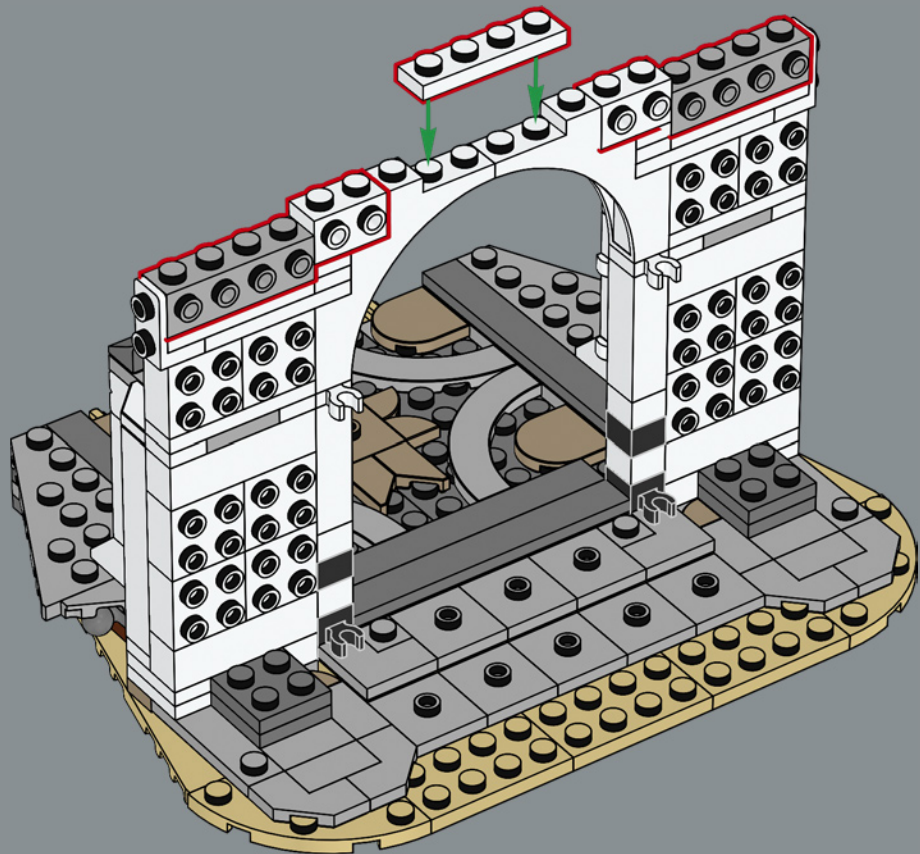

36

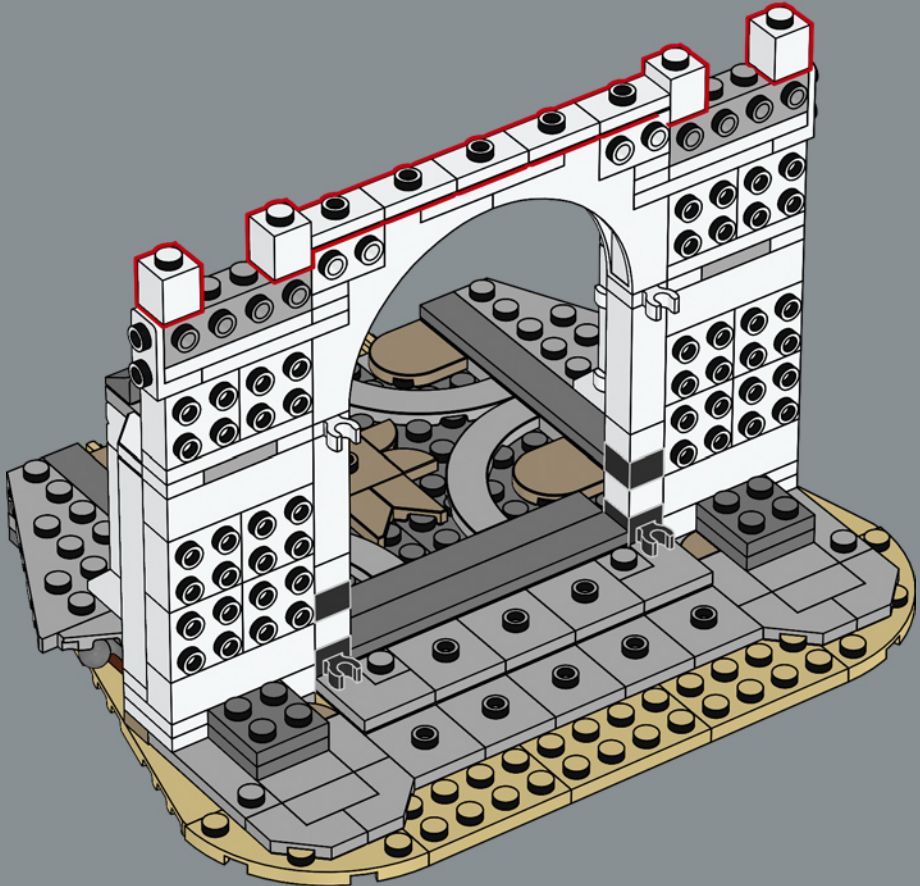



37

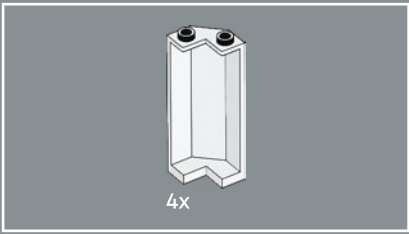
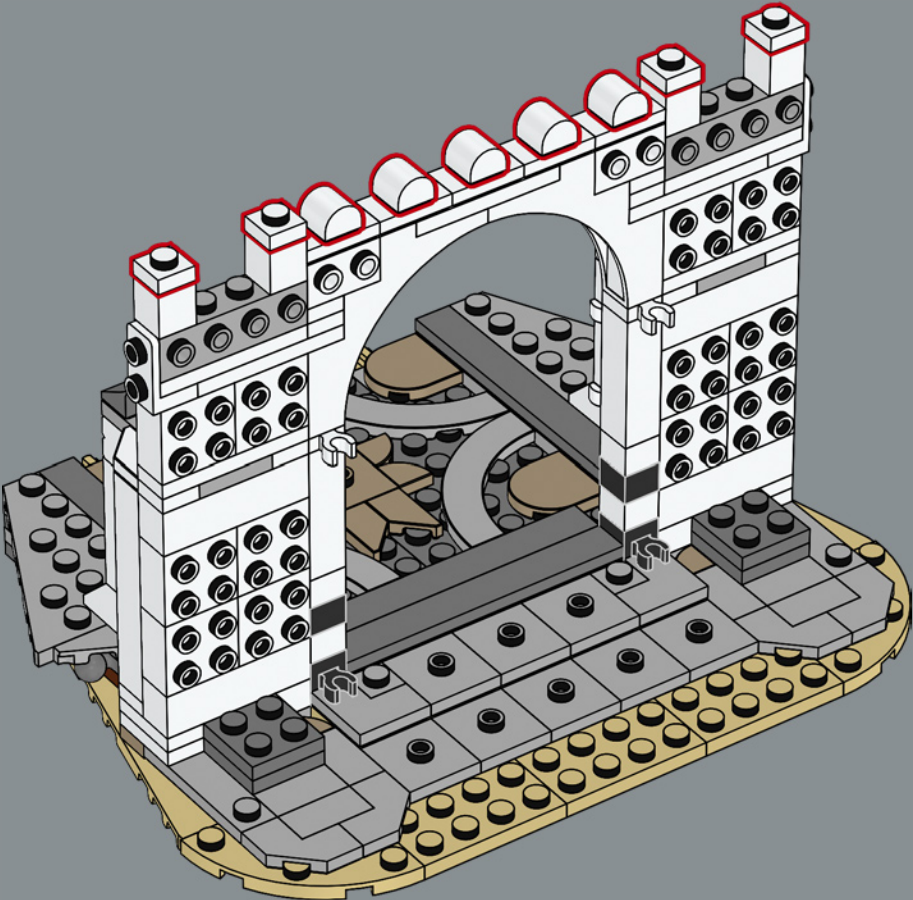

38

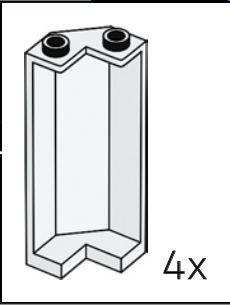
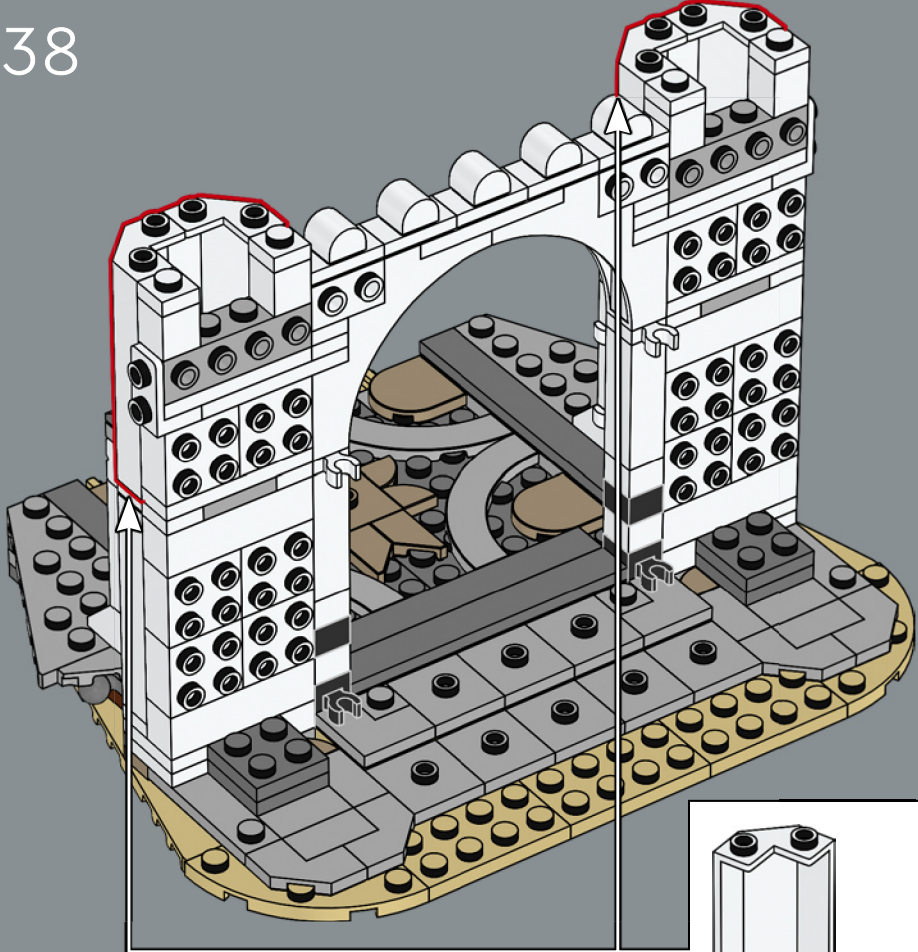



39

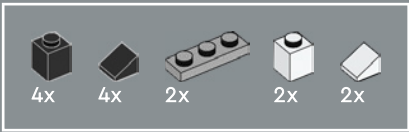
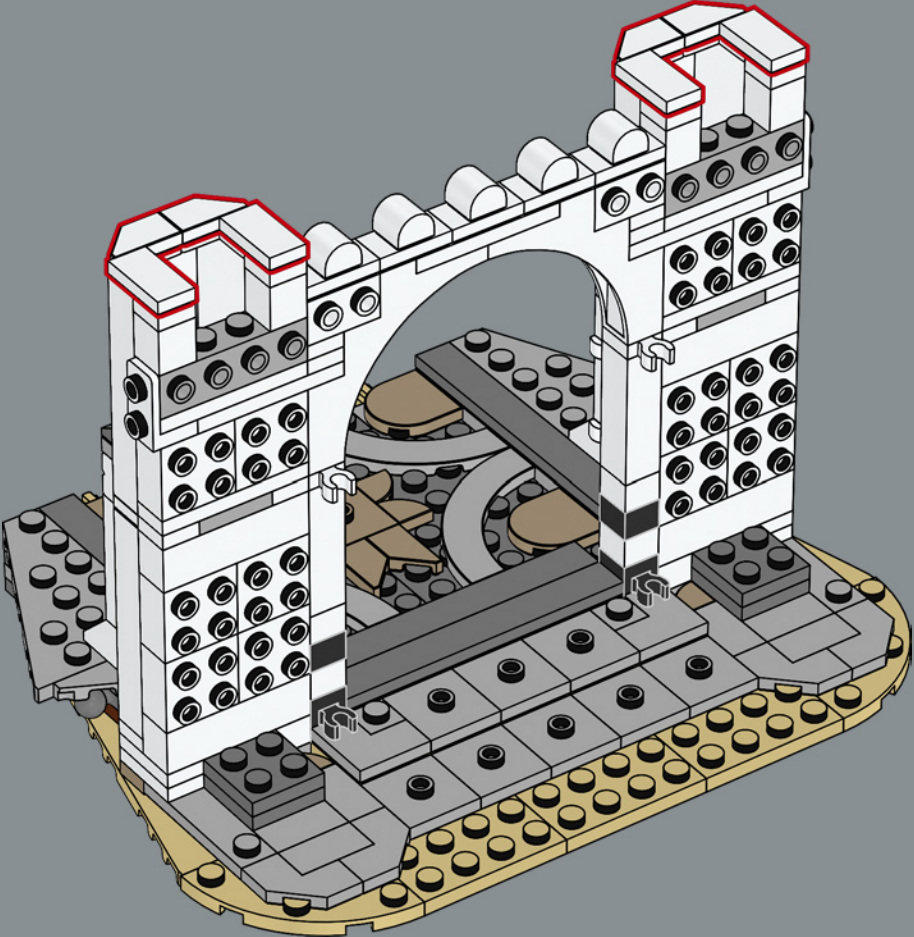

40

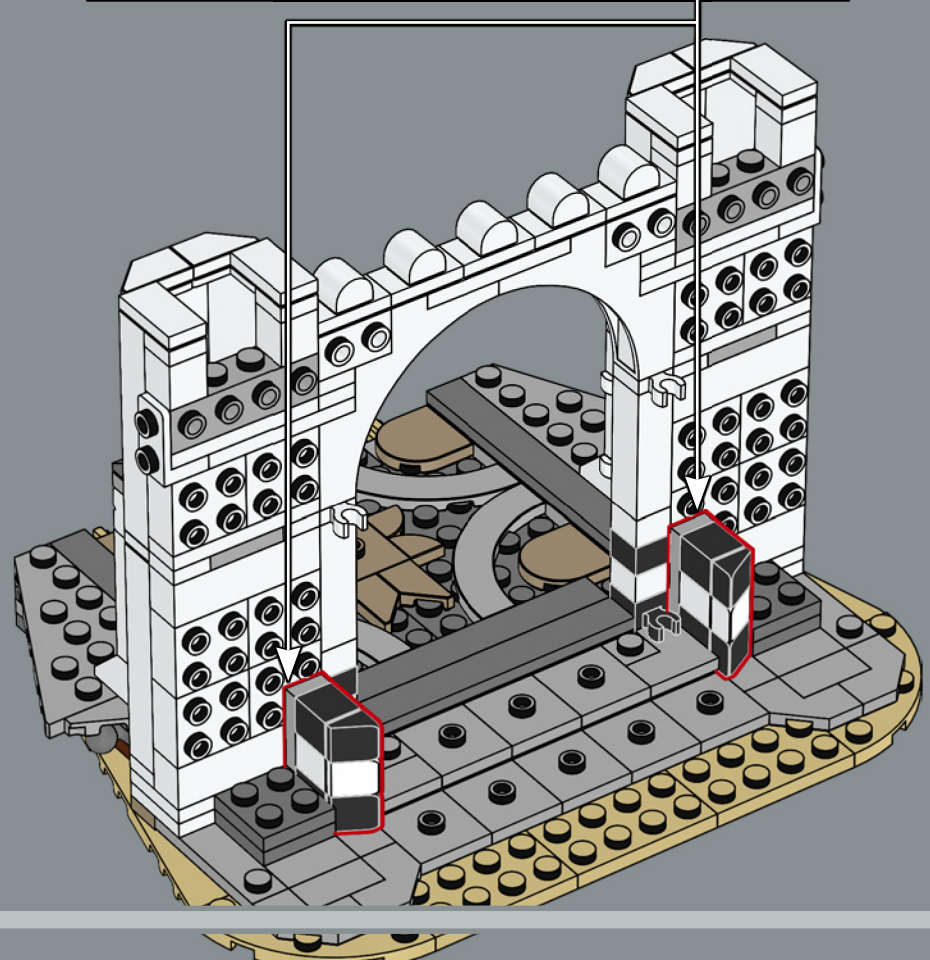
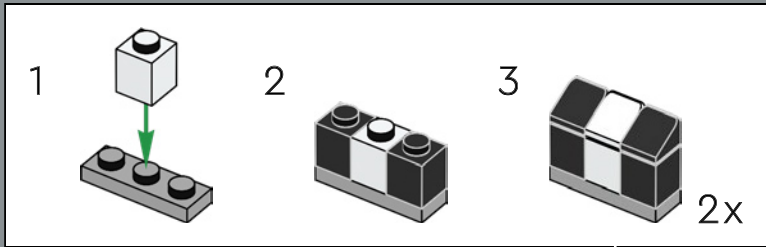

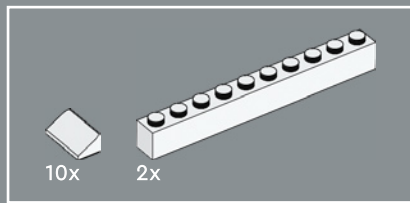

41

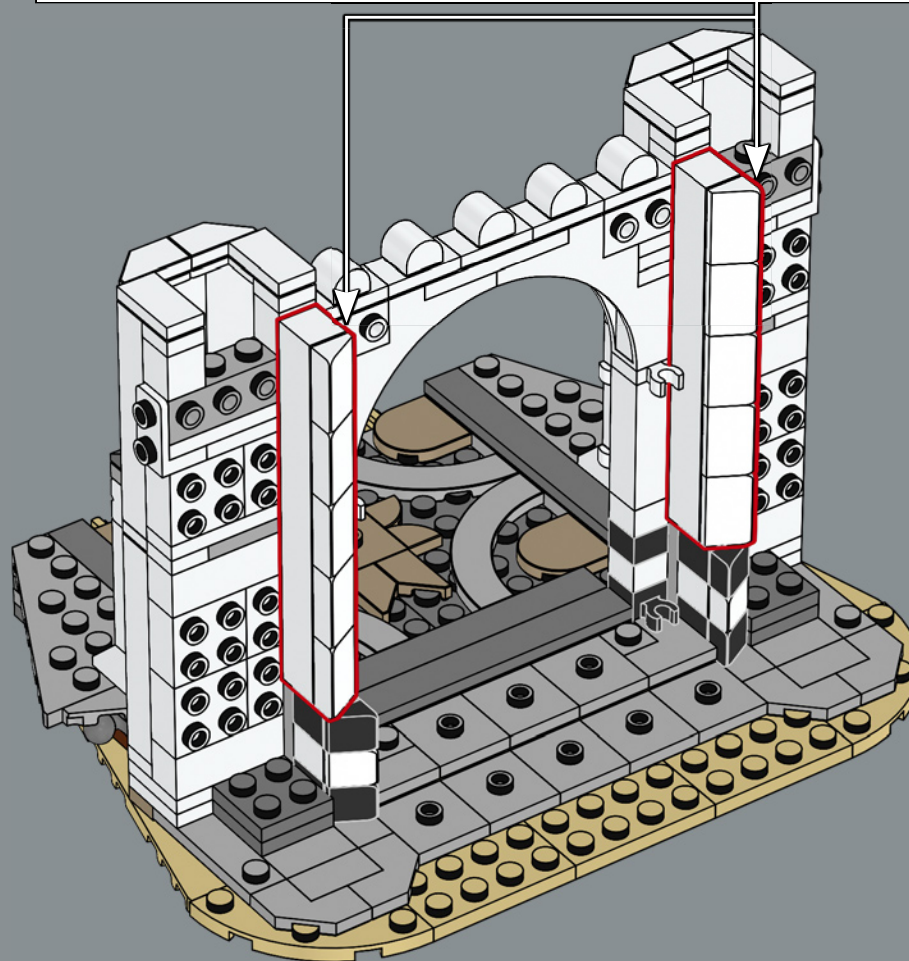
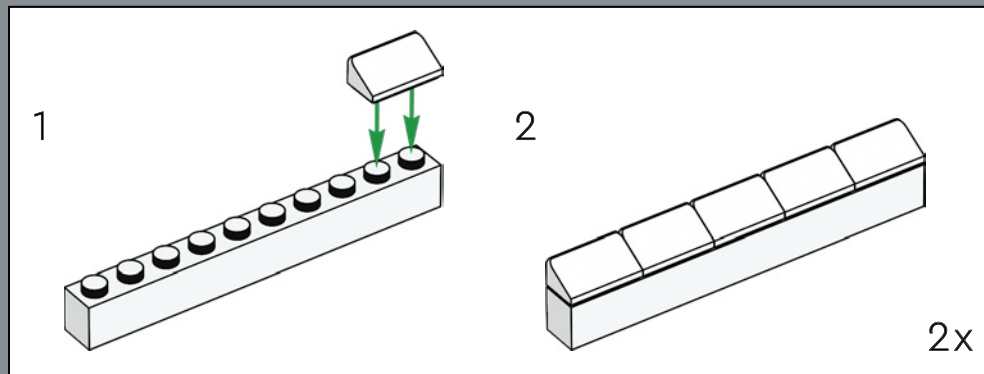

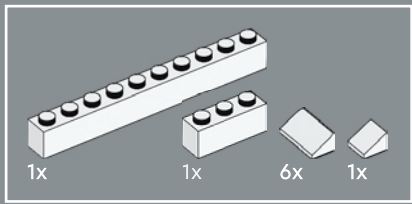

42

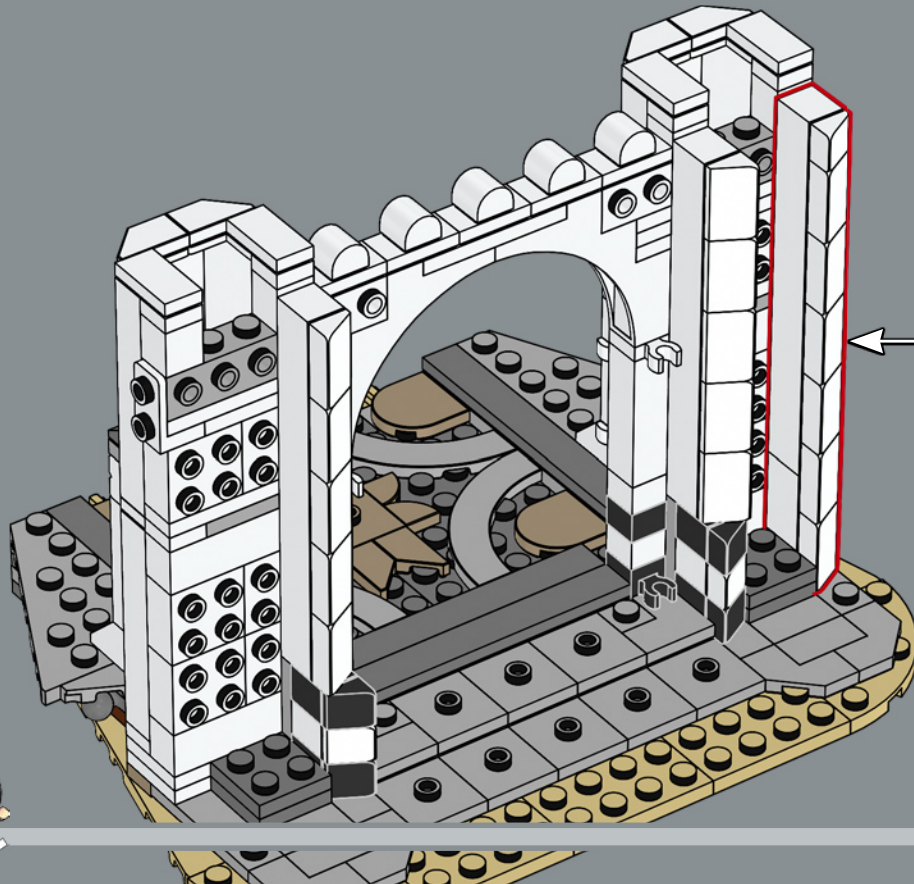
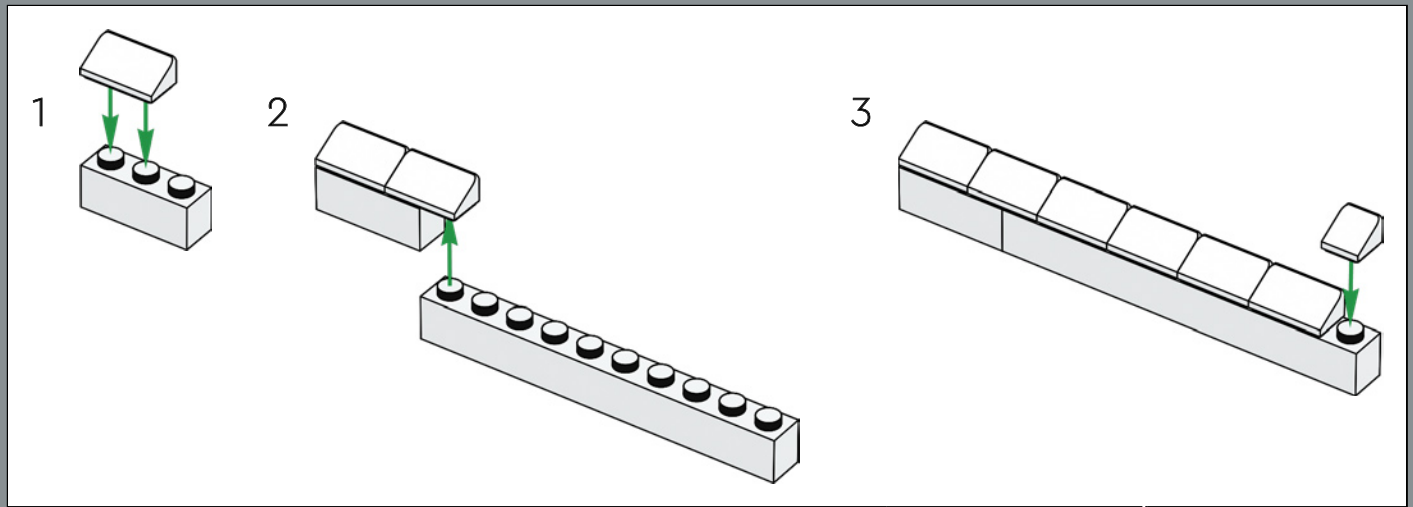

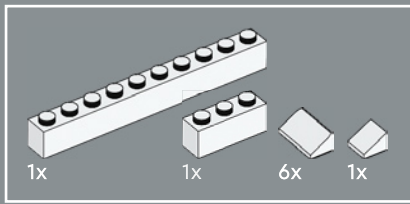

43

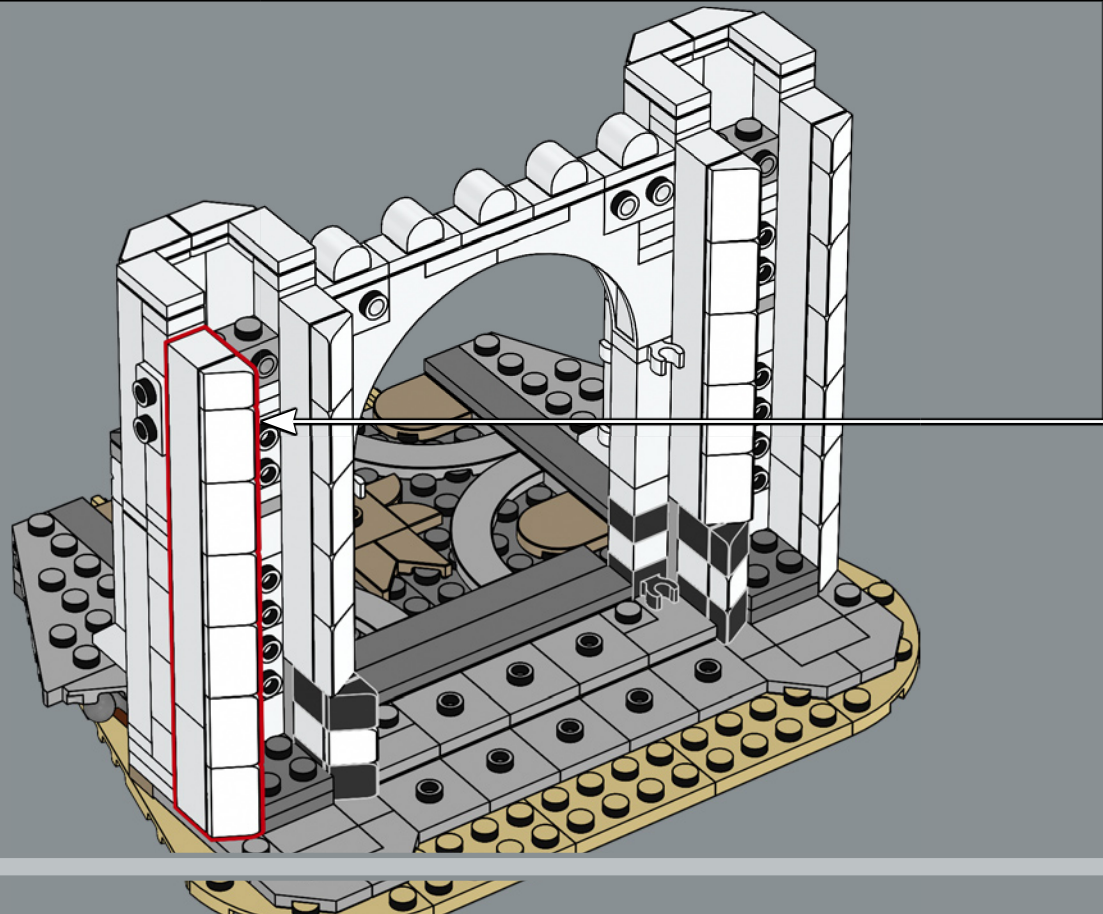
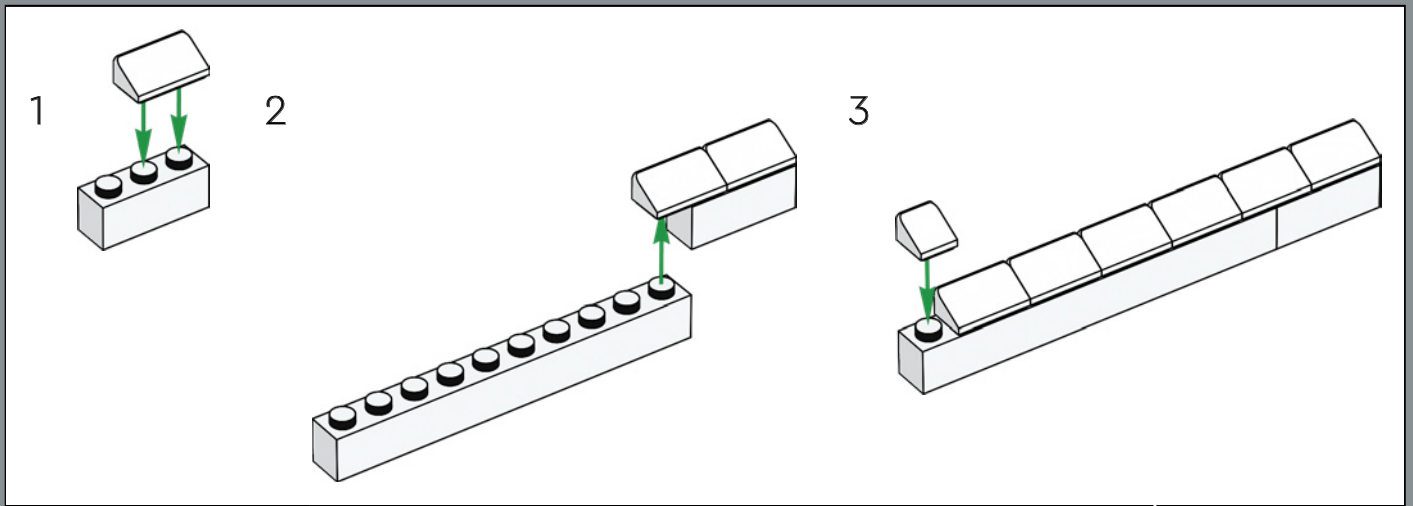

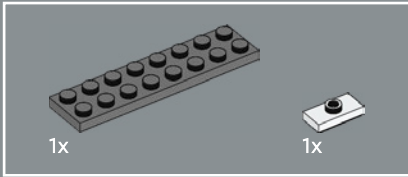
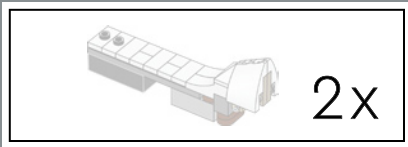

44

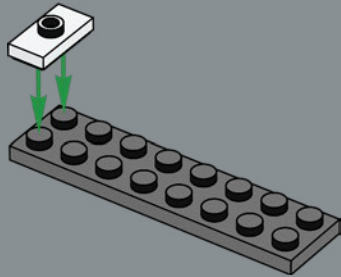

45

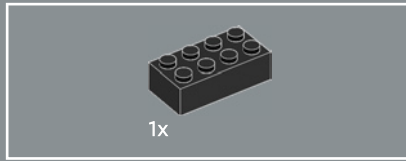
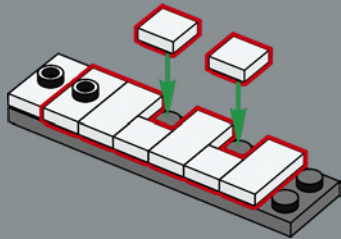

46

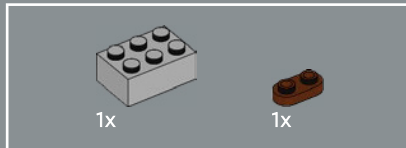
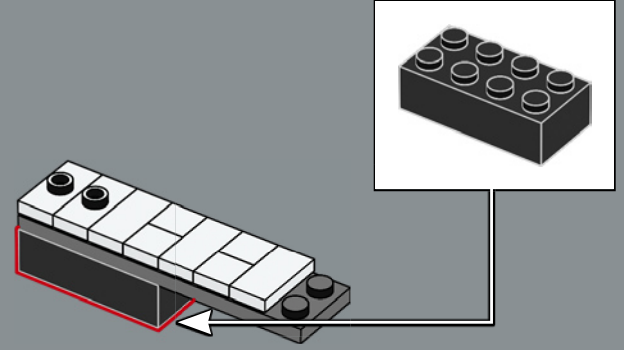

47

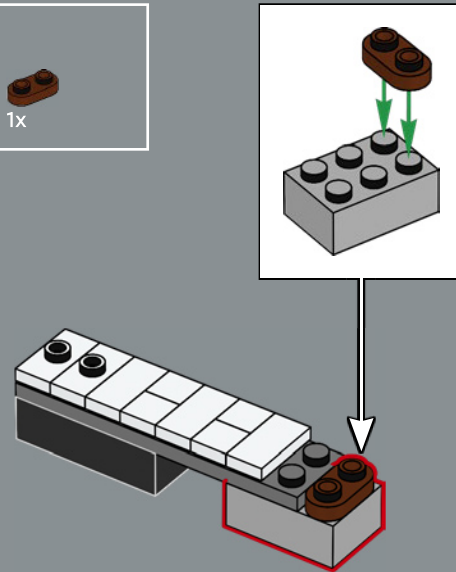



48

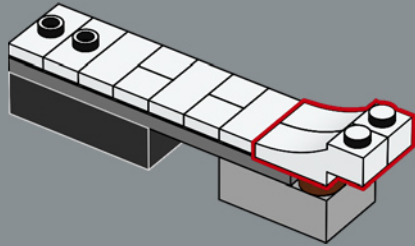

49

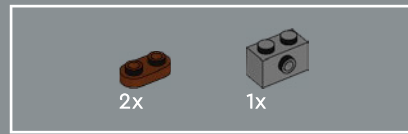
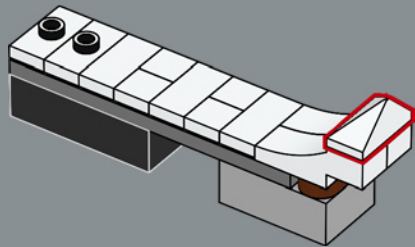

50

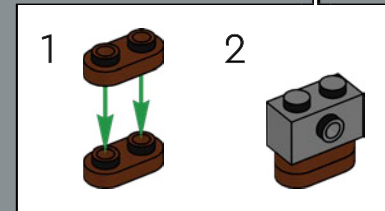
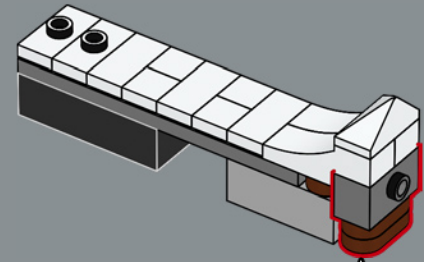

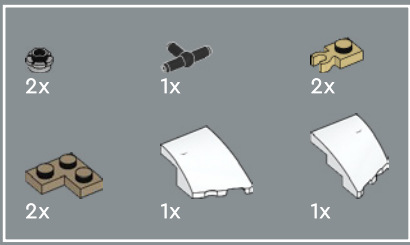

51

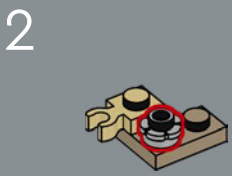
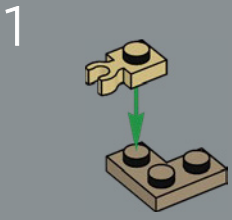

4

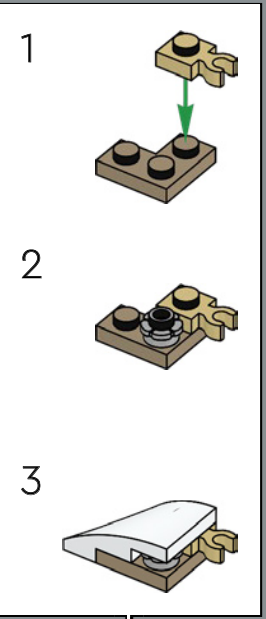
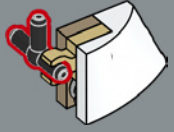

5

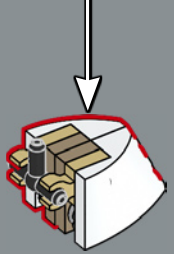

52

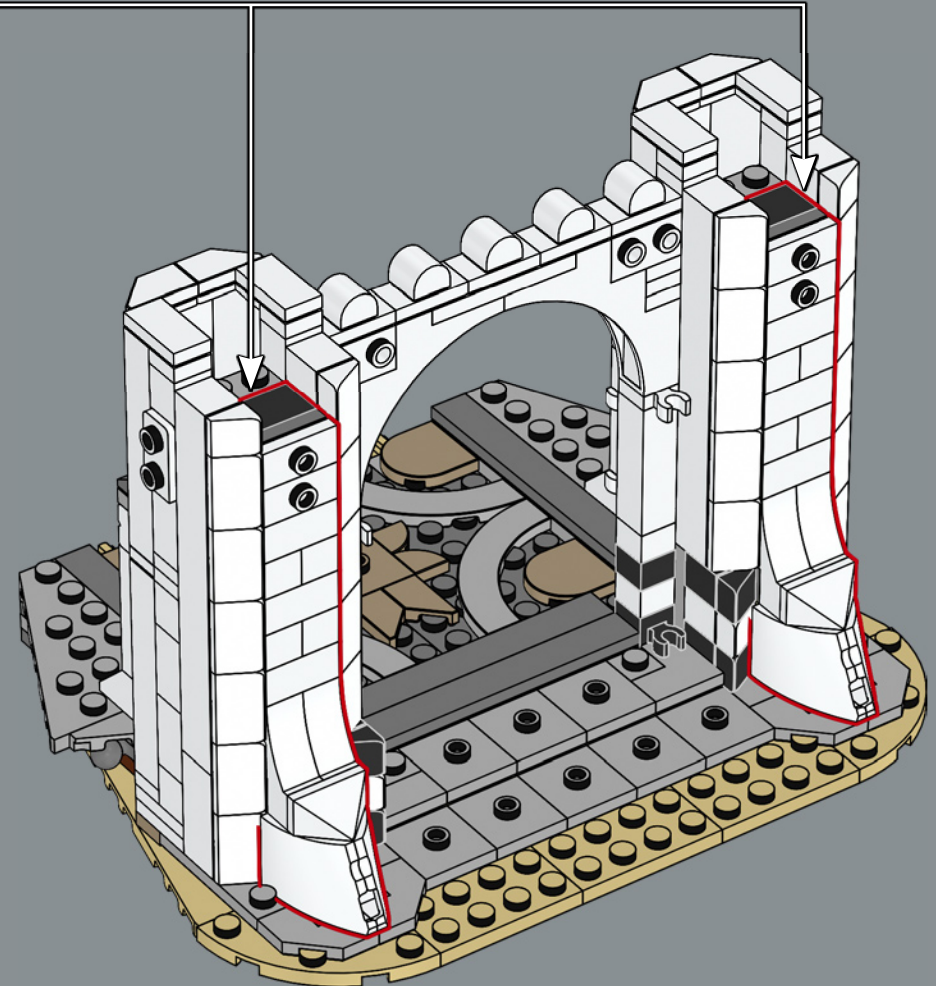
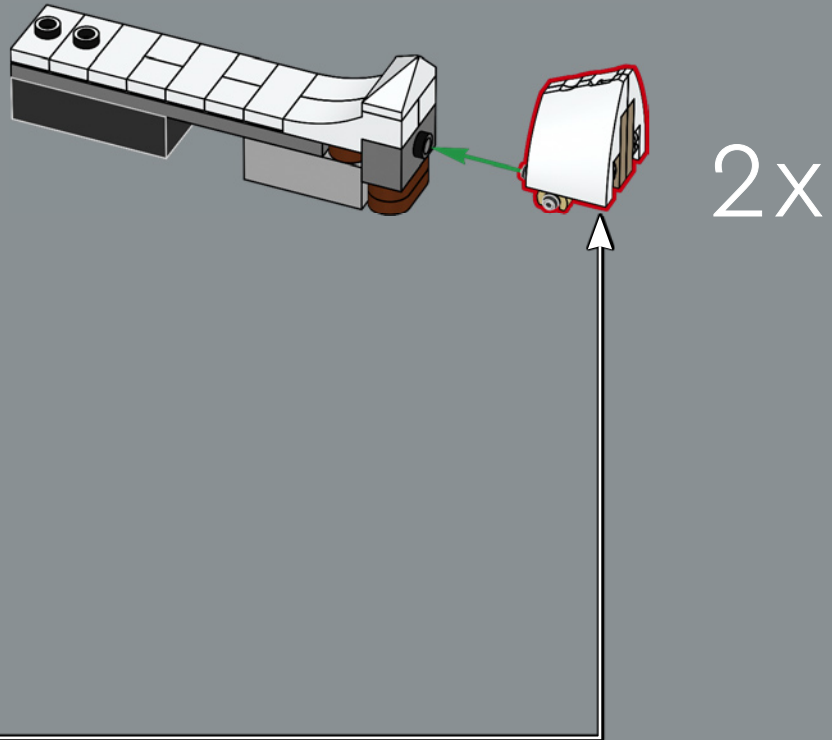



53

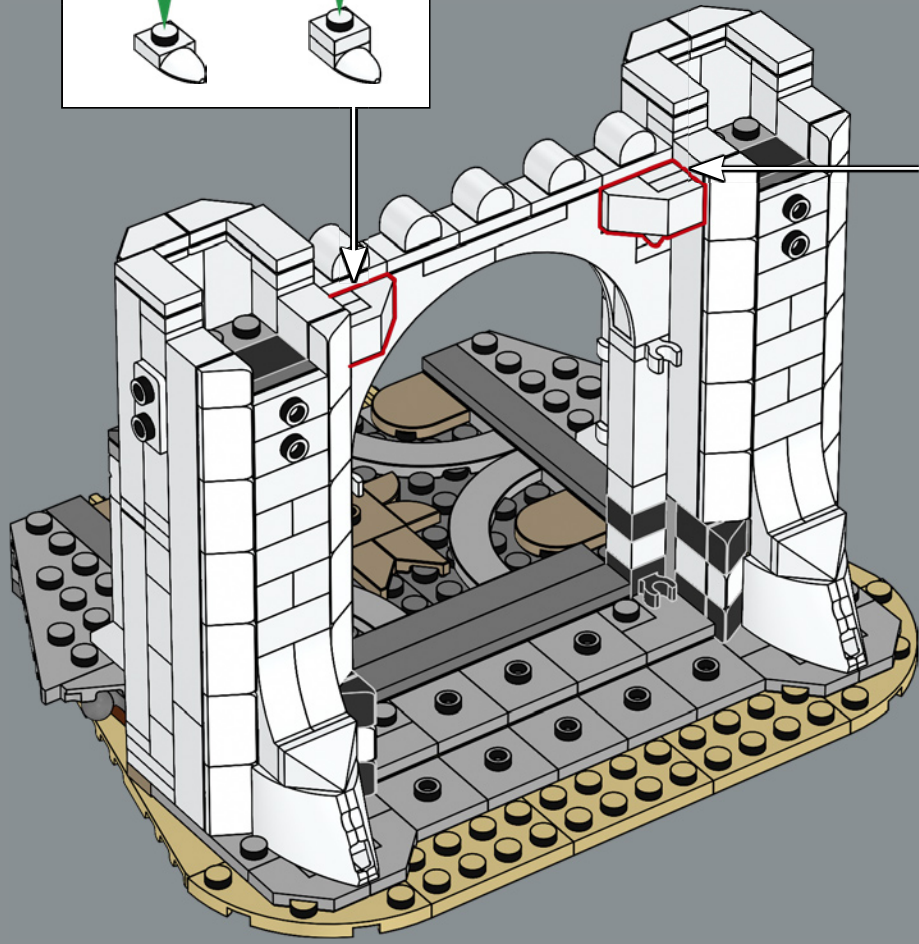
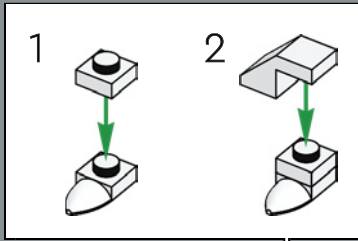
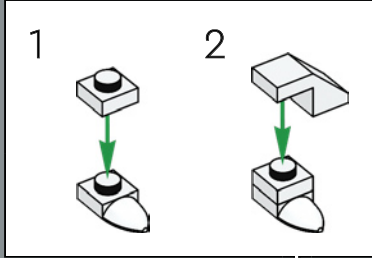

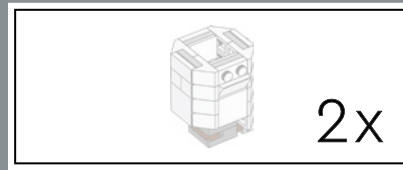

54

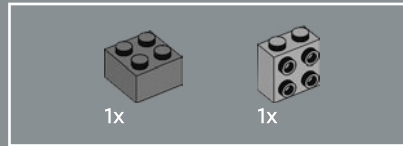
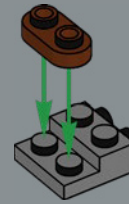

55

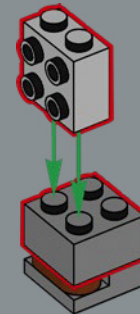

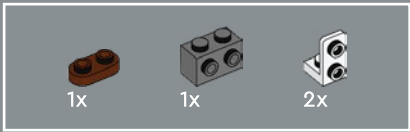

56

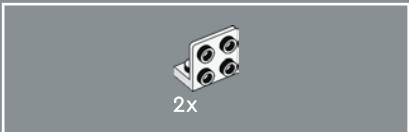
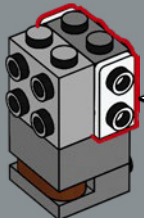
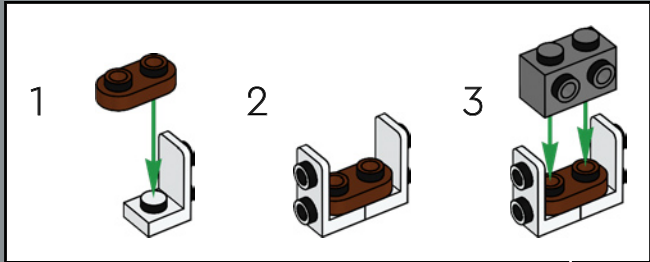

57

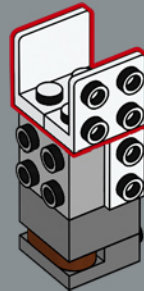

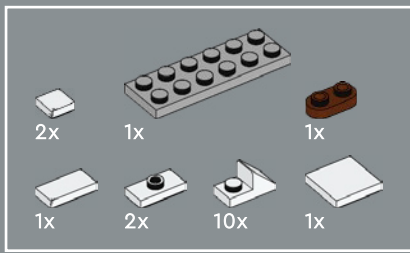

58

1

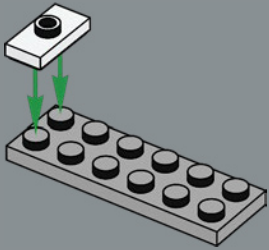

2

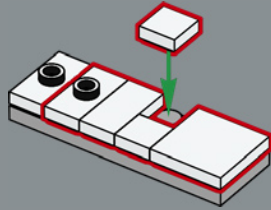

3

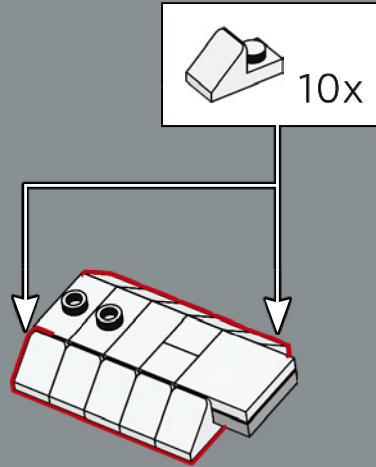

4

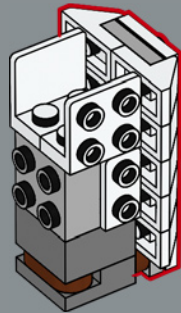
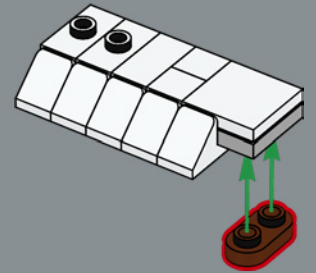

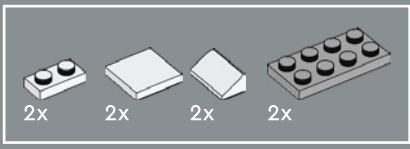

59

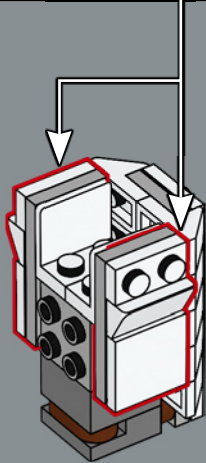
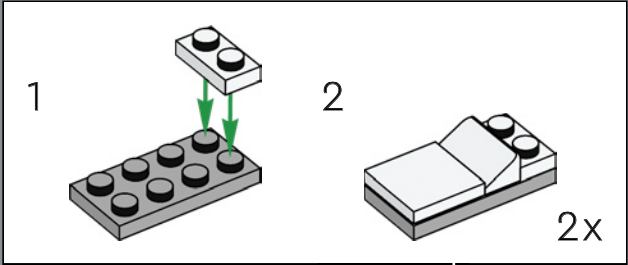

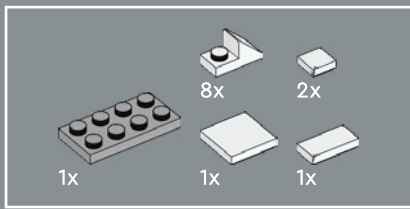

60

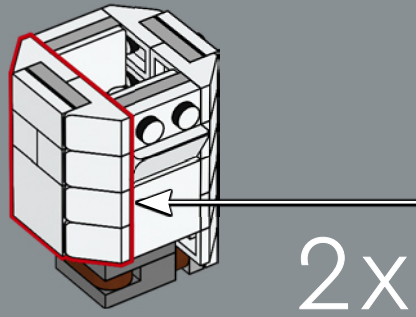
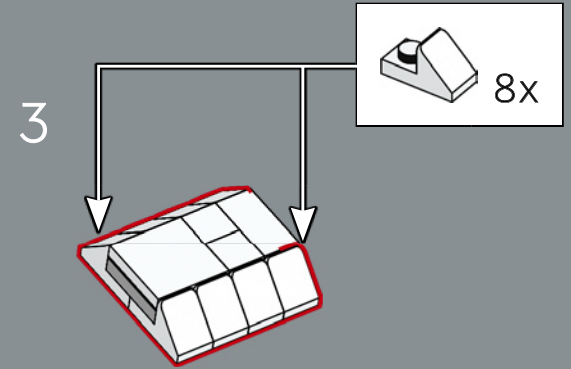
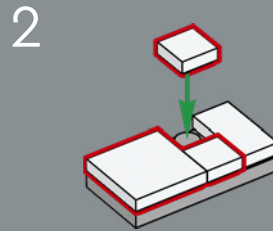
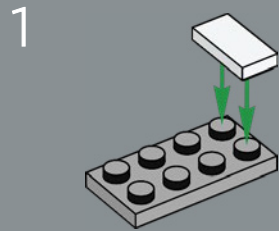

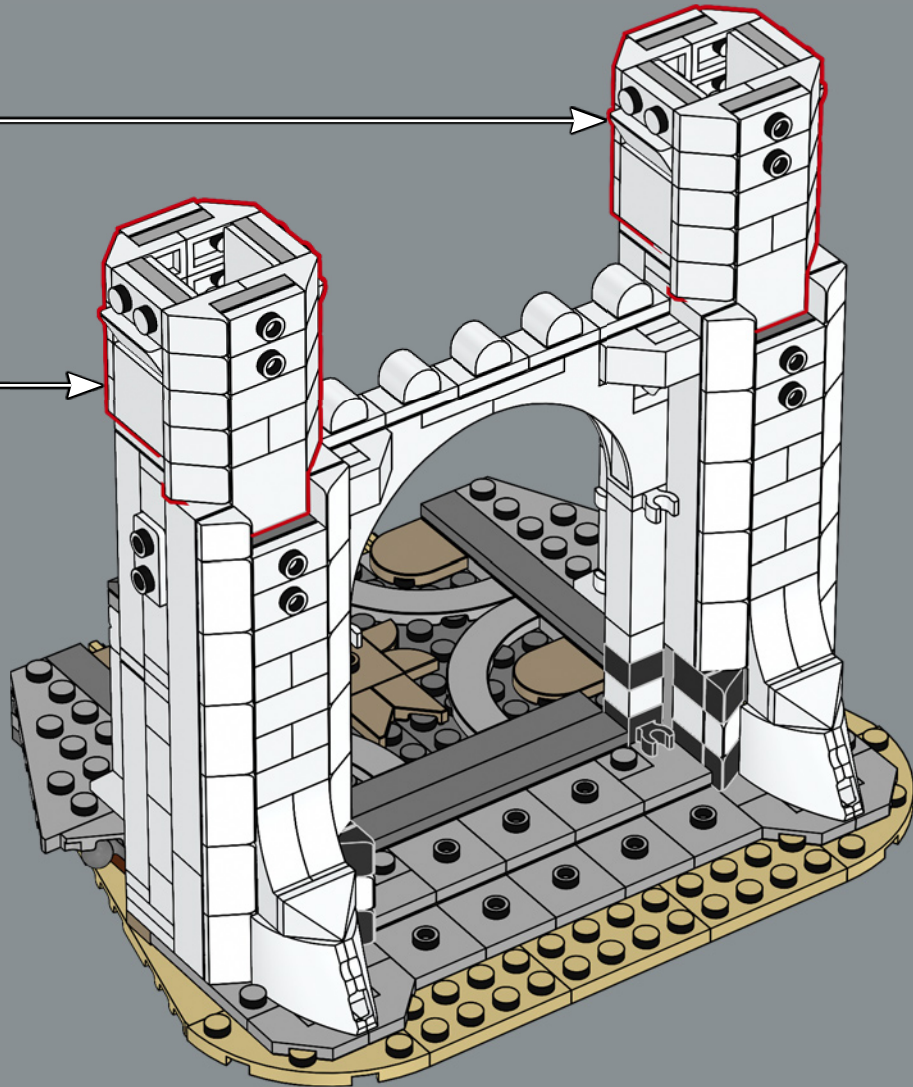

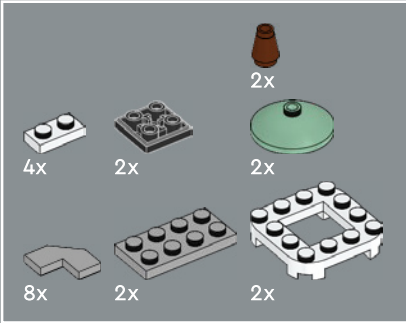
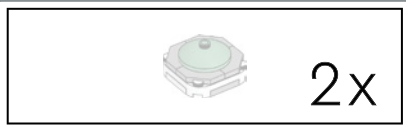

62

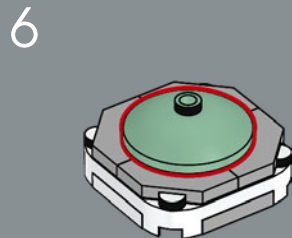
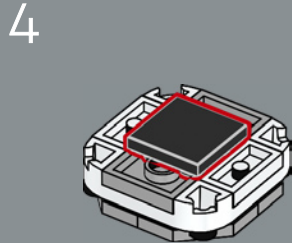
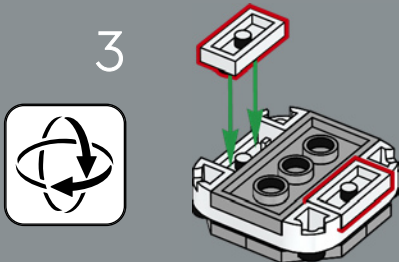
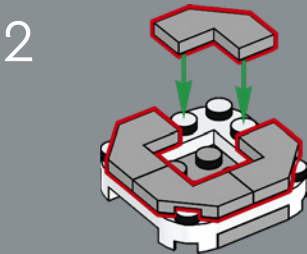
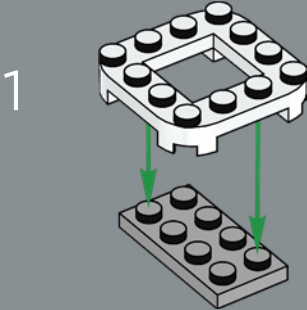

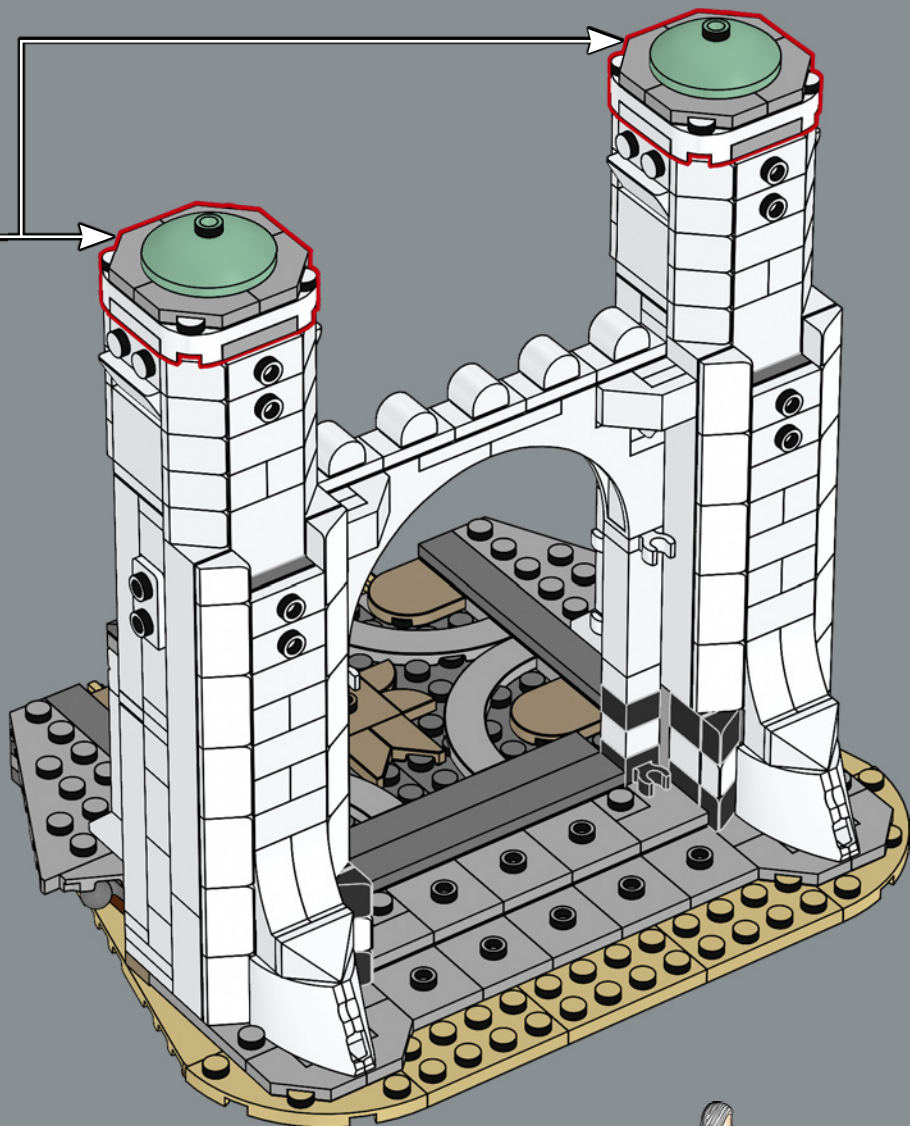

63

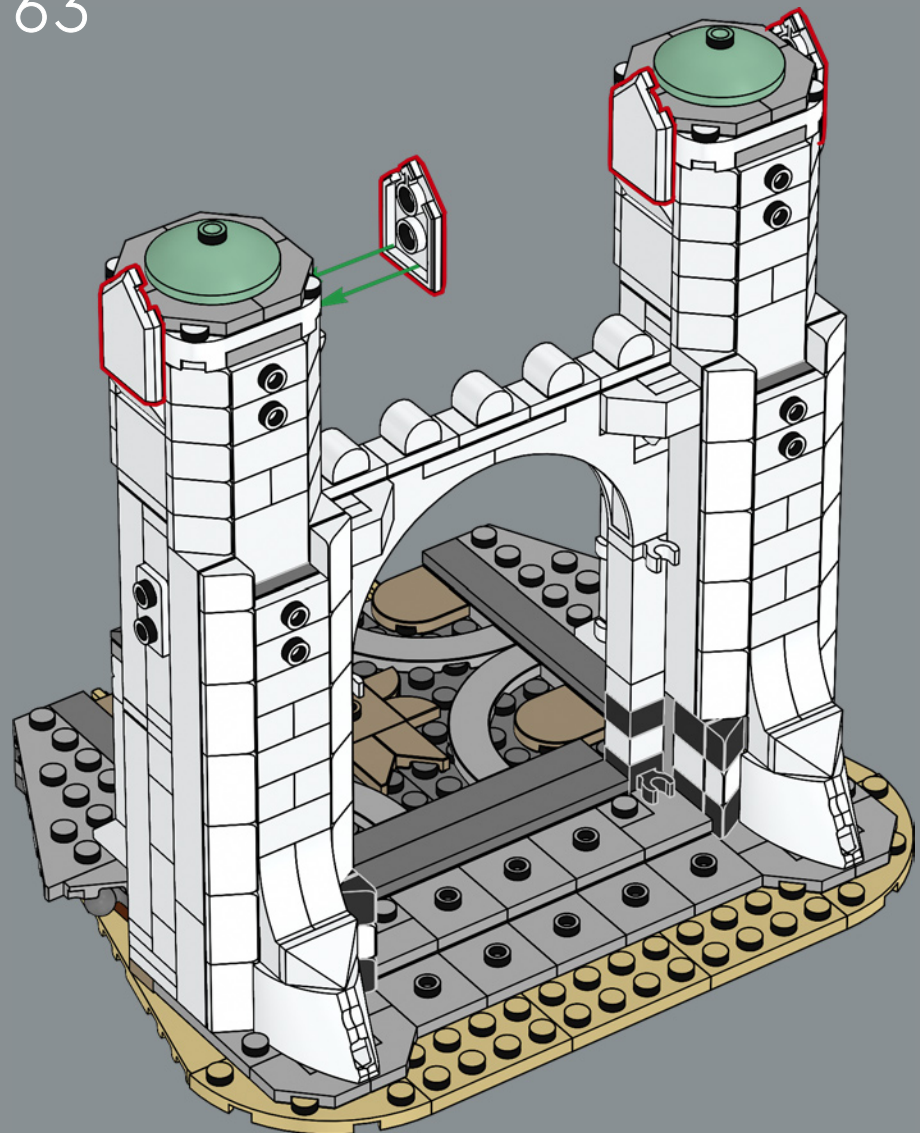

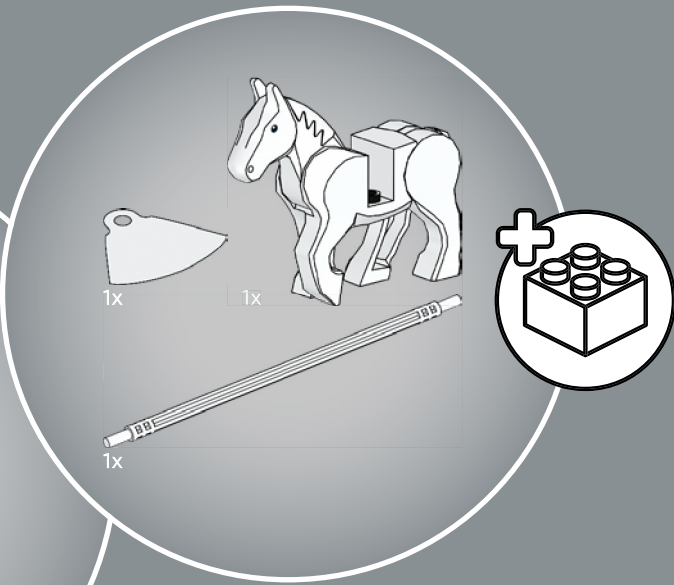

1

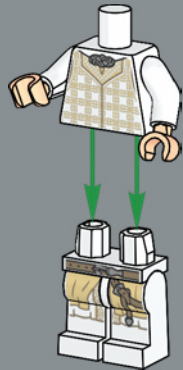

2

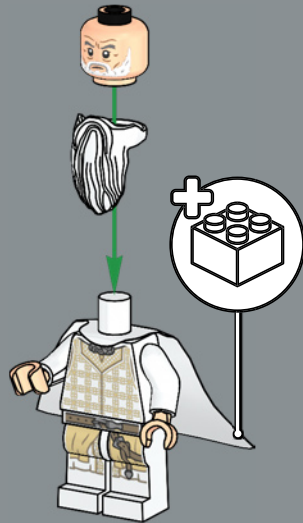

3

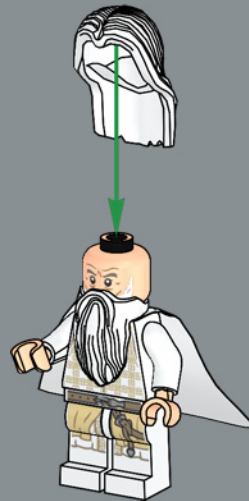

4



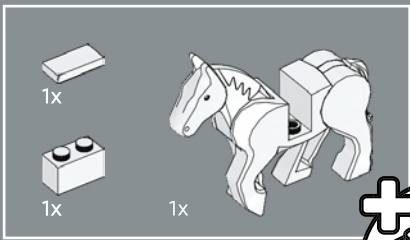

64

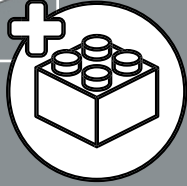

1

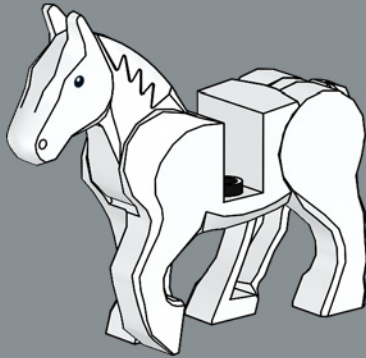

2

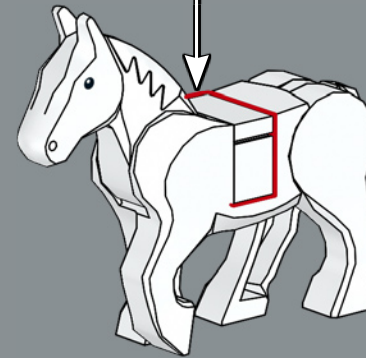
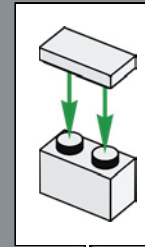

Shadowfax, the Lord of the Horses,
answers only to Gandalf™.

Gripoil, seigneur des chevaux,
n'obéit qu'à Gandalf™.

Sombragrís, Señor de los Caballos,
solo obedece a Gandalf™.





65

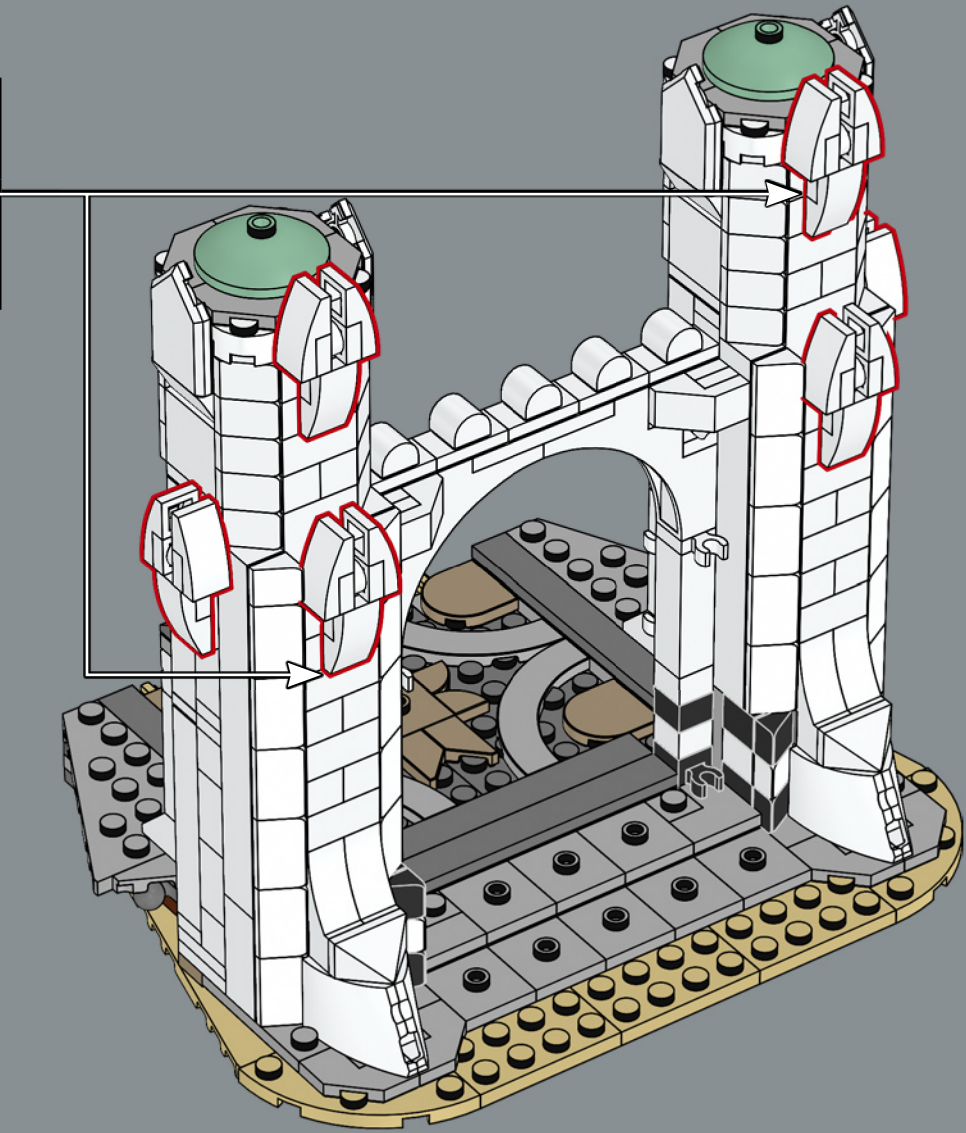
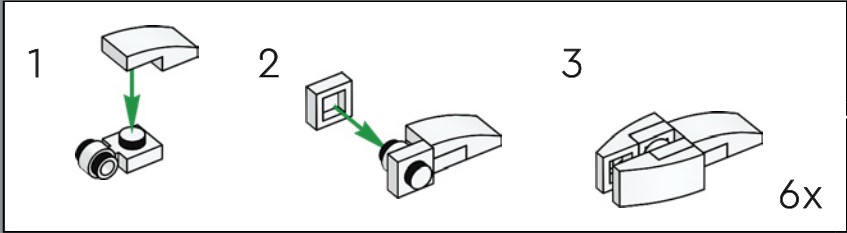

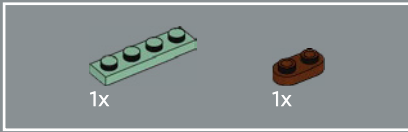
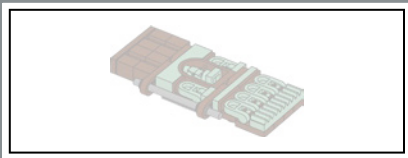

66

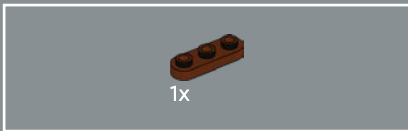
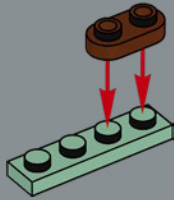

67

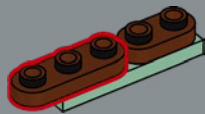

68

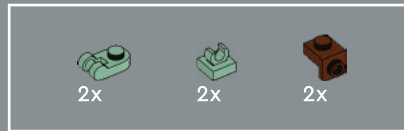
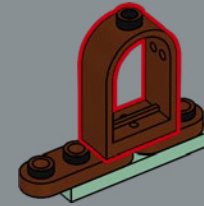

69

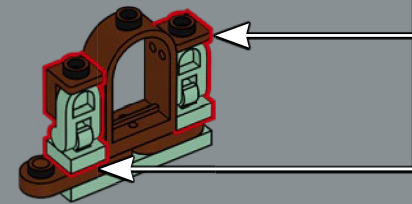
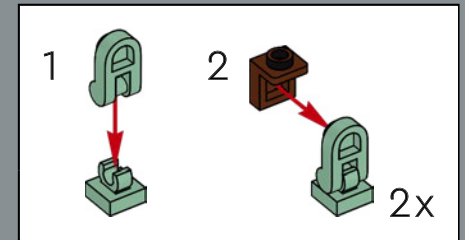

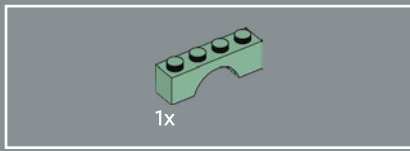

70

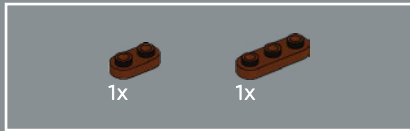
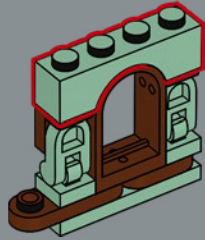

71

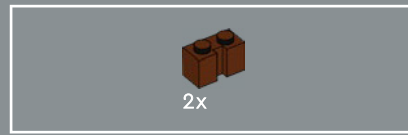
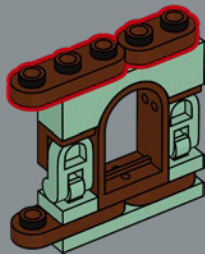

72

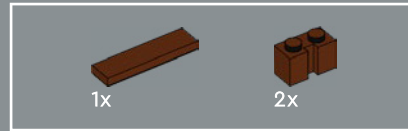
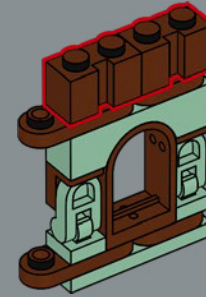

73

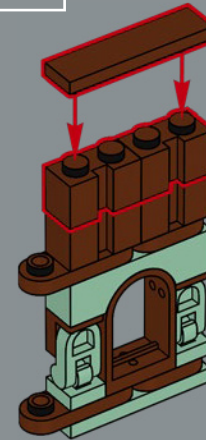

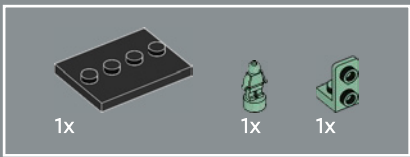

74

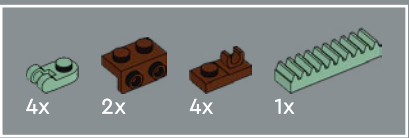
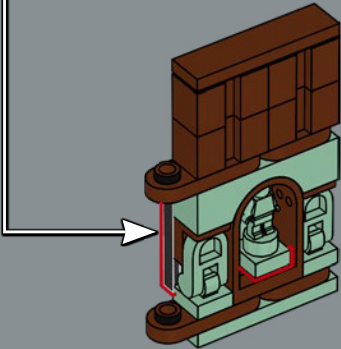
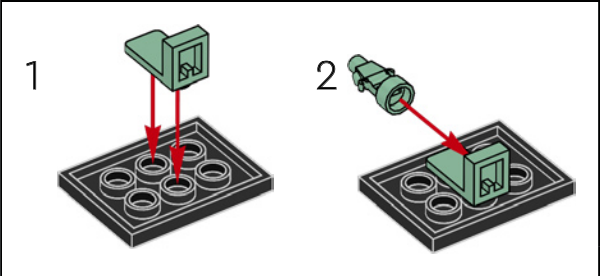

75

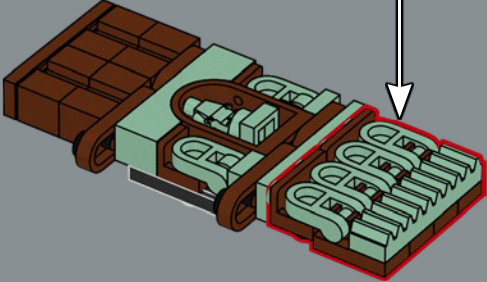
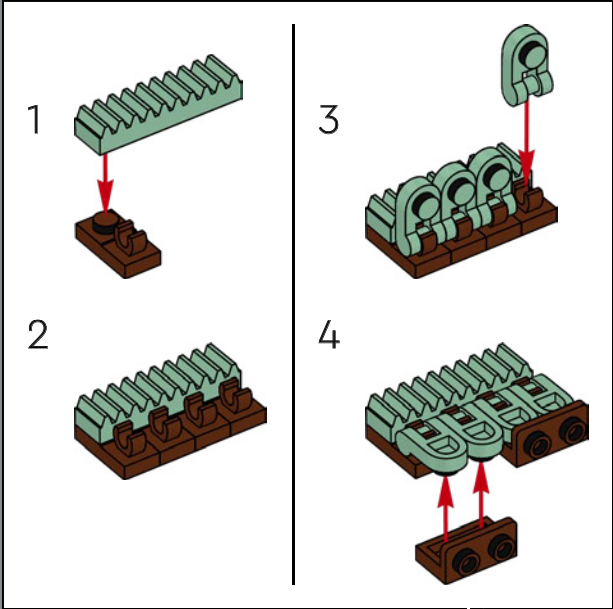

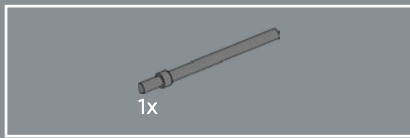

76

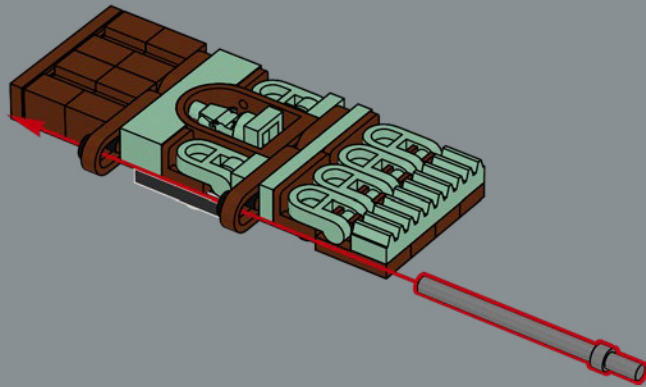

La brique LEGO® 1x4 dentelée utilisée pour représenter les détails cuivrés de la porte principale a été introduite pour la première fois en 1977 comme crémaillère de direction dans LEGO Technic™.

La placa LEGO® dentada 1x4 utilizada para representar los detalles de cobre de la puerta principal se introdujo en 1977 como cremallera de dirección para sets LEGO Technic™.

The 1x4 toothed LEGO® plate used to represent copper detailing on the main gate was first introduced in 1977 as a steering rack for LEGO Technic™.



77

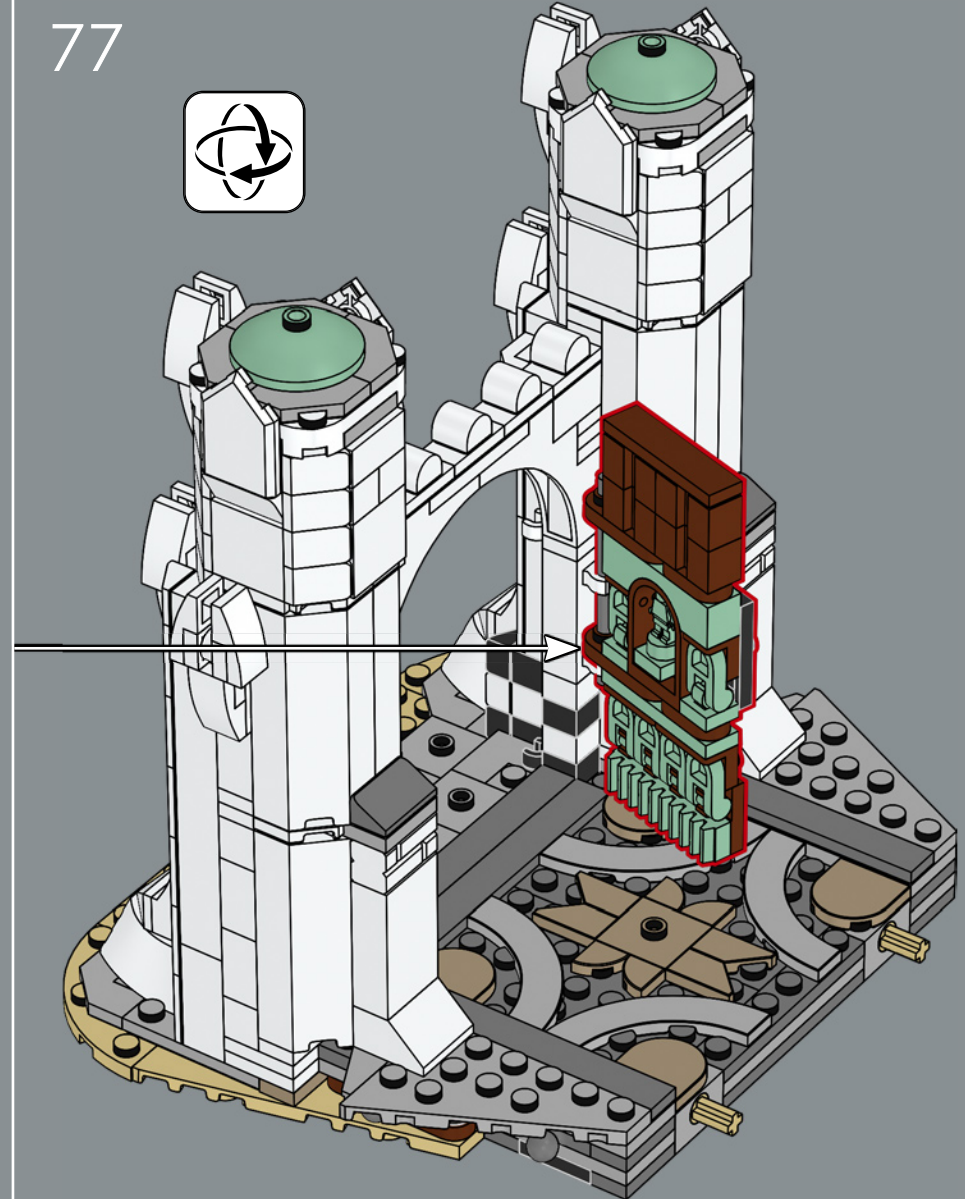

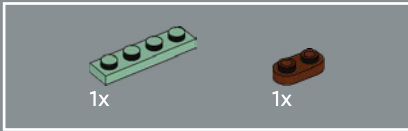
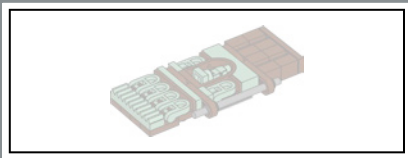

78

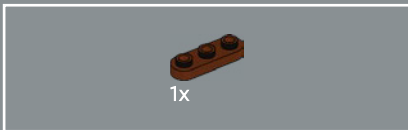
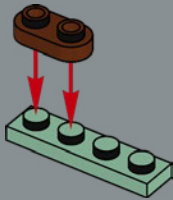

79

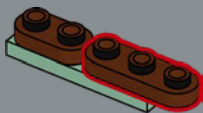

80

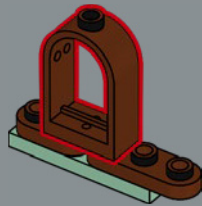

81

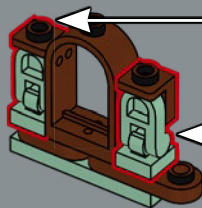
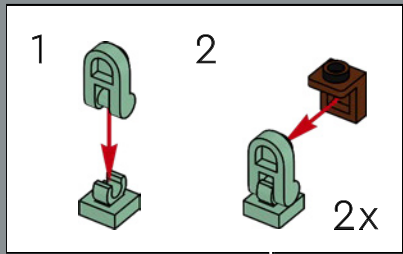

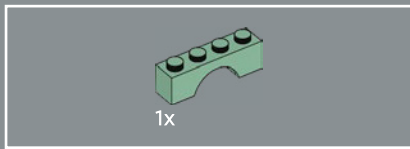

82

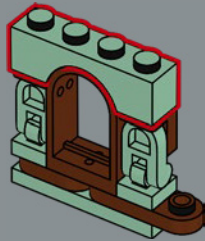

83

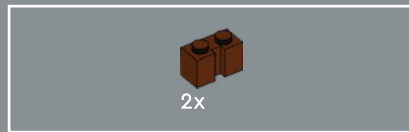
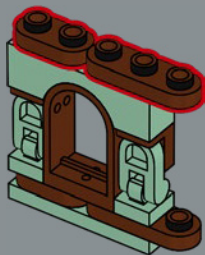

84

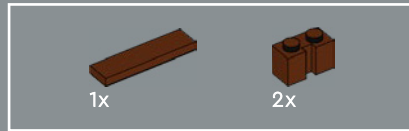
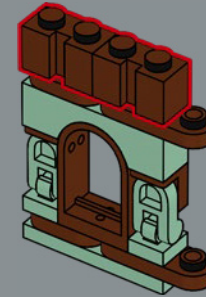

85

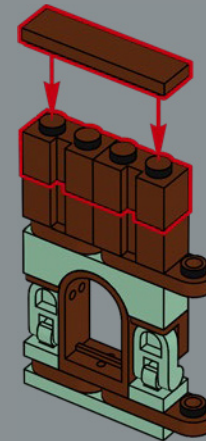

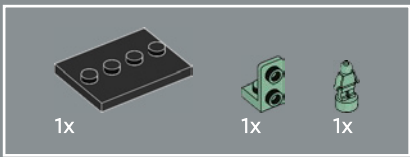

86

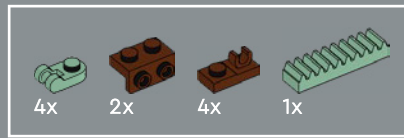
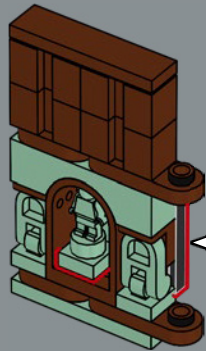
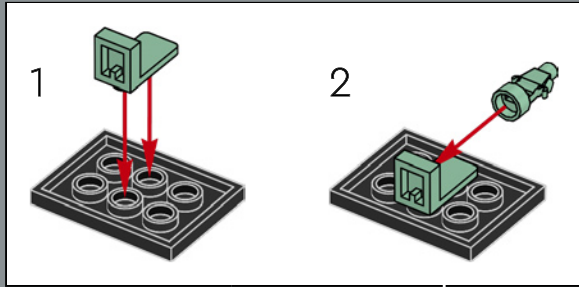

87

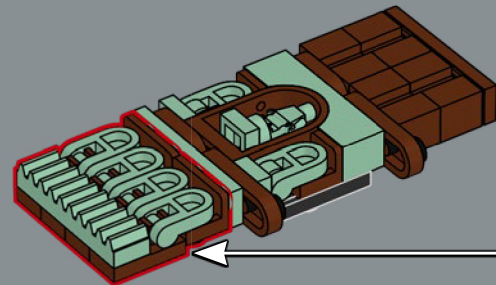
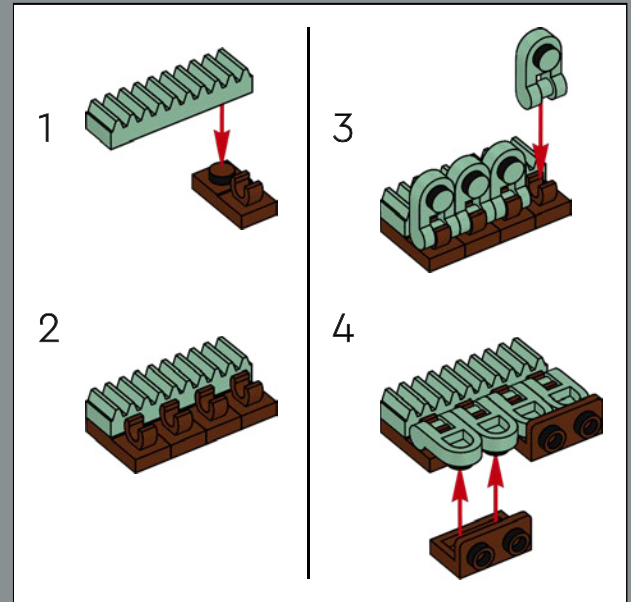

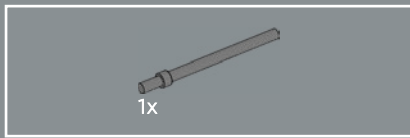

88

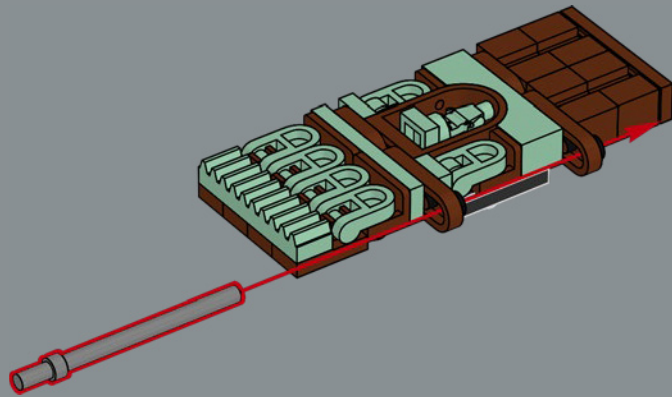

89

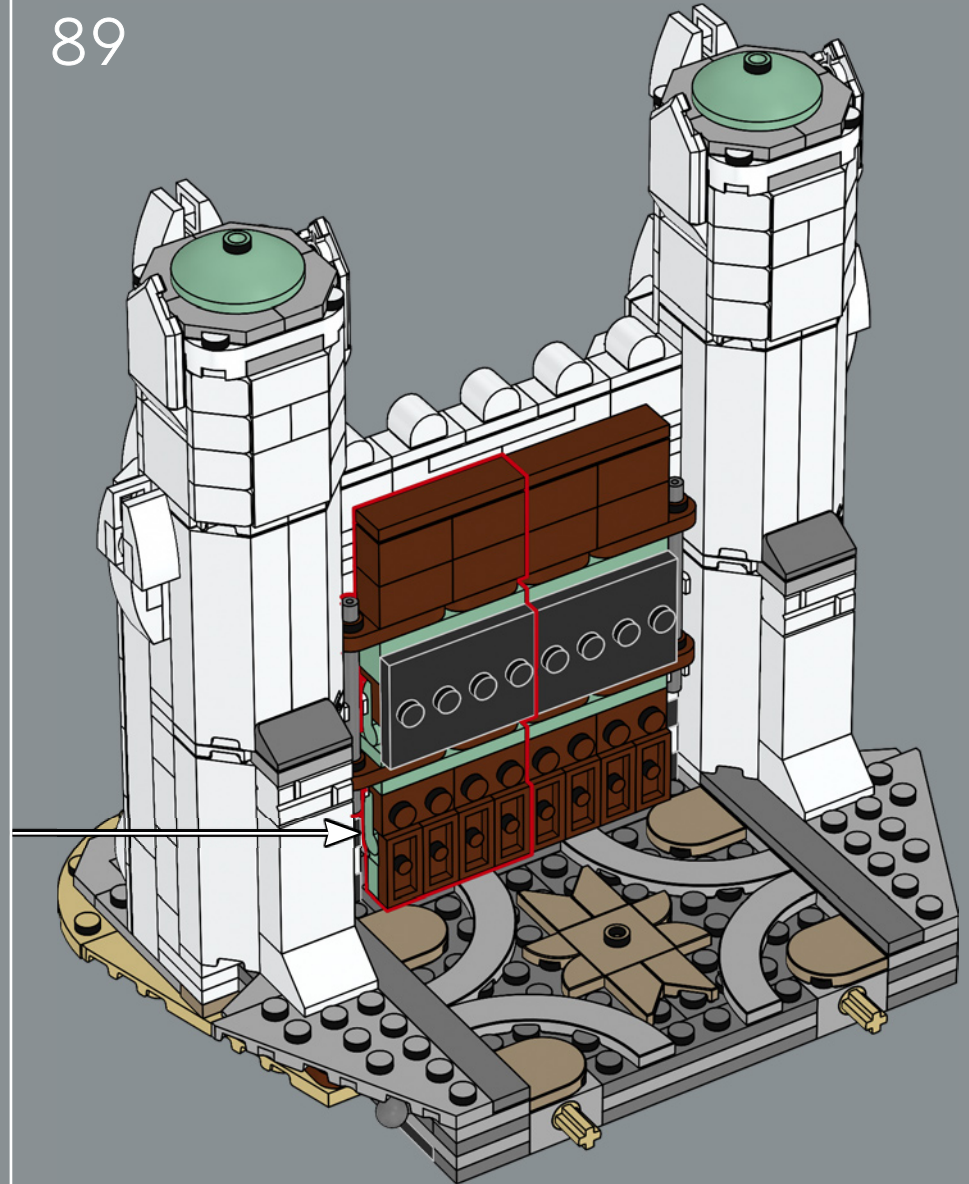

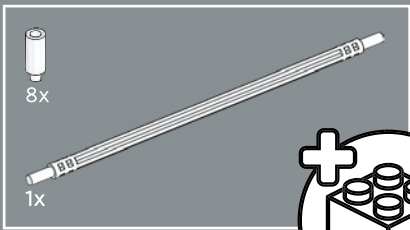

90

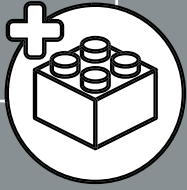

1



2



3

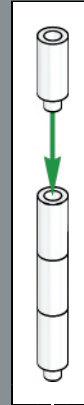
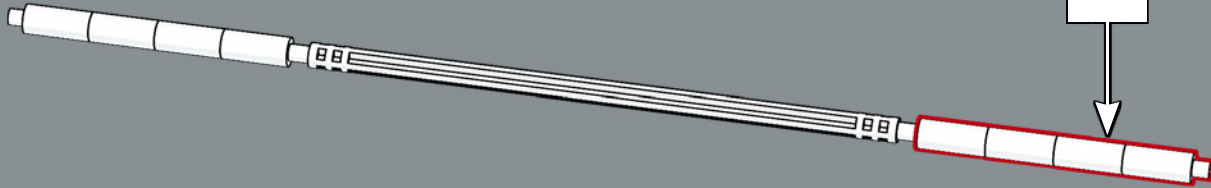

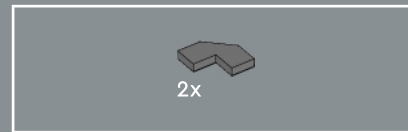
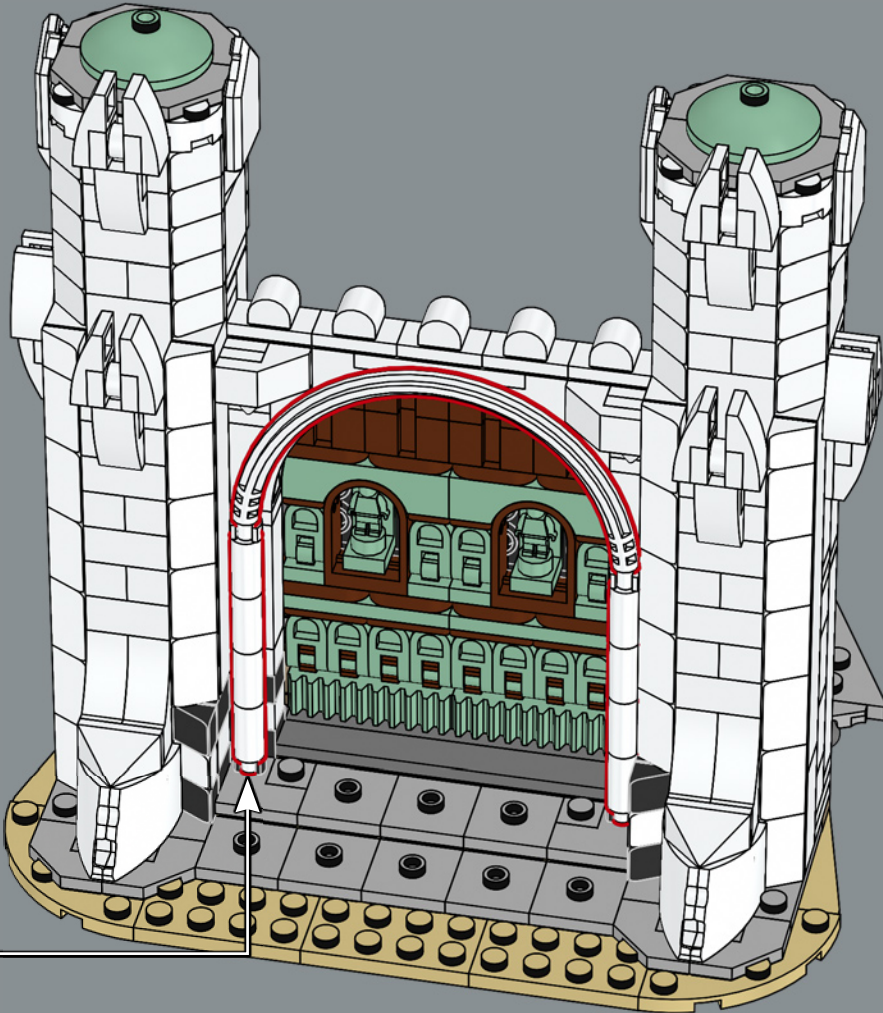

91

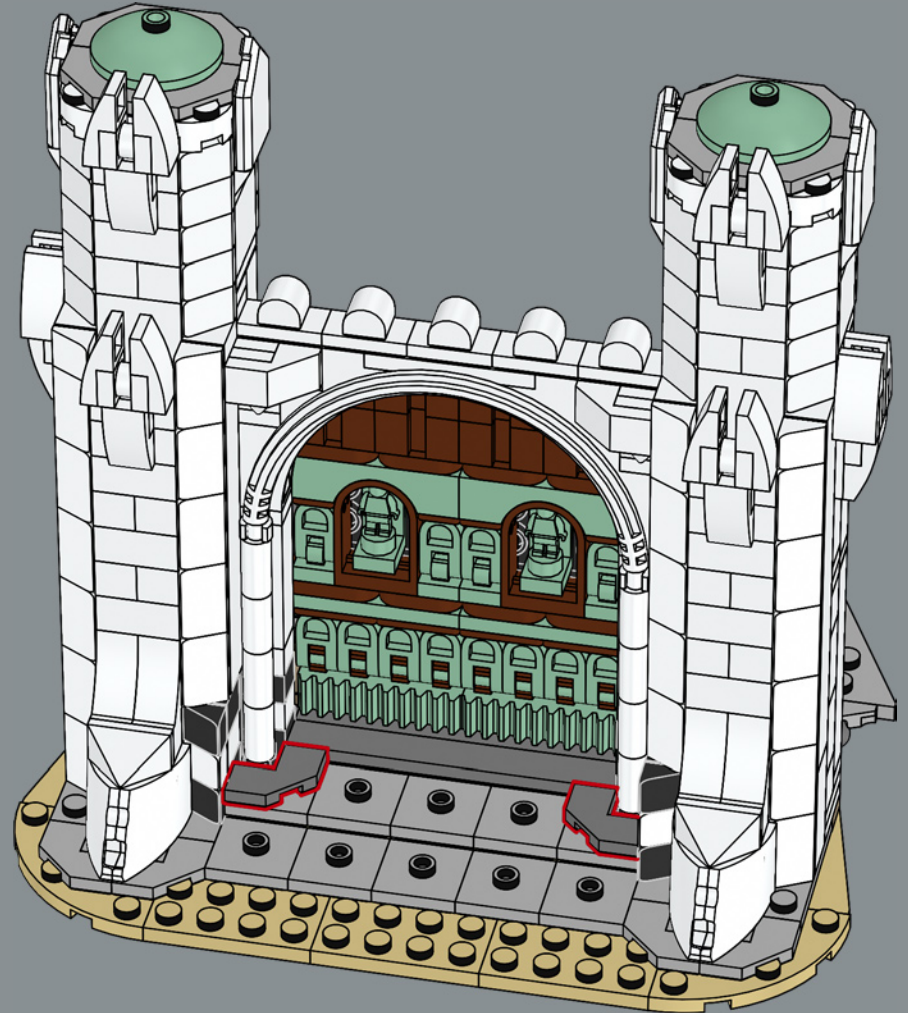

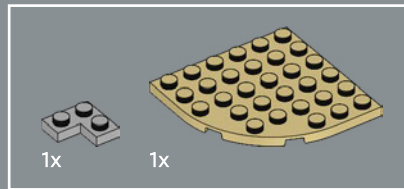
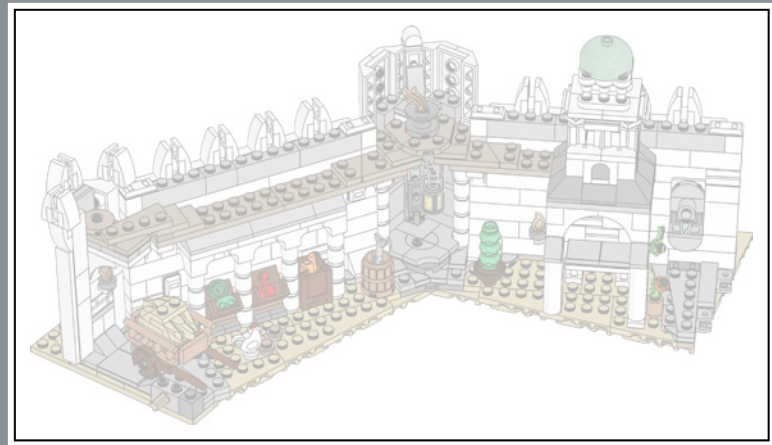

92

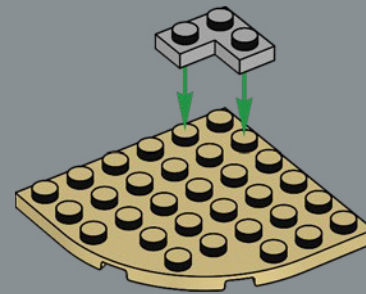

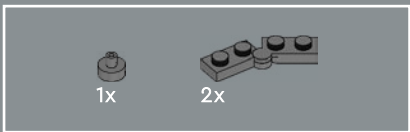

93

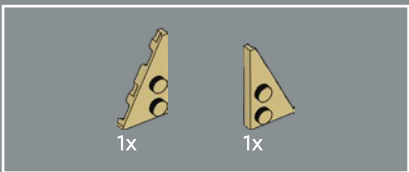
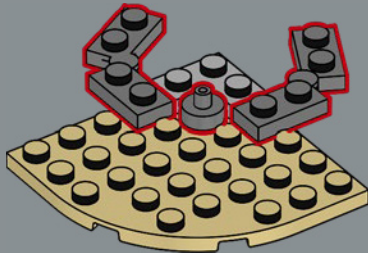

94

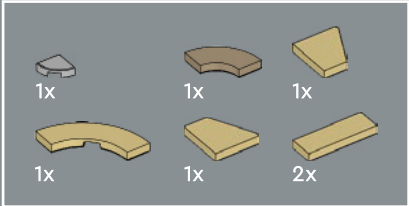
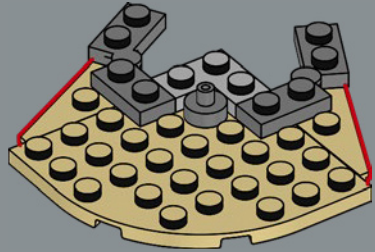

95

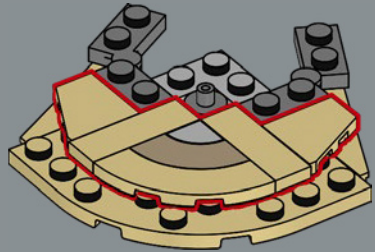

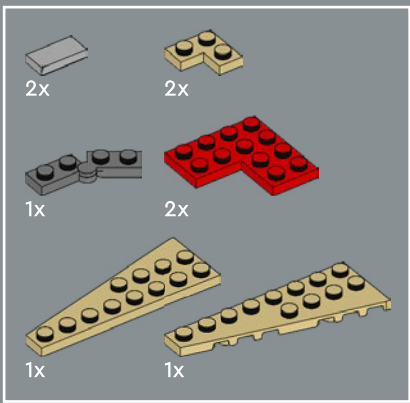

96

1

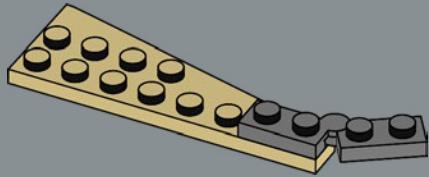

2

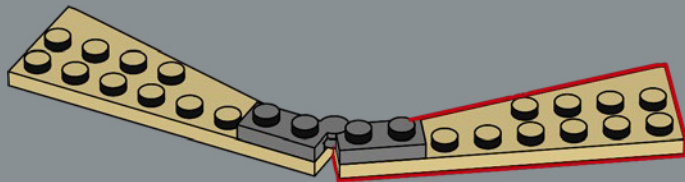

3

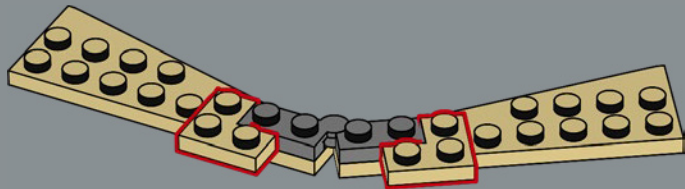

4

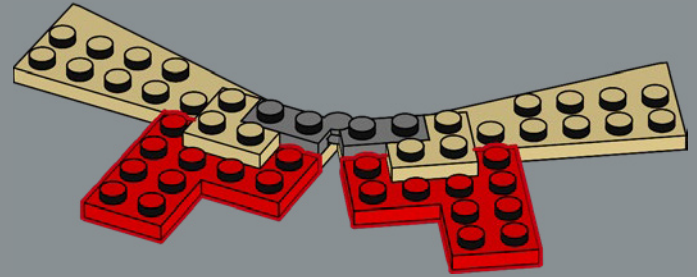

5

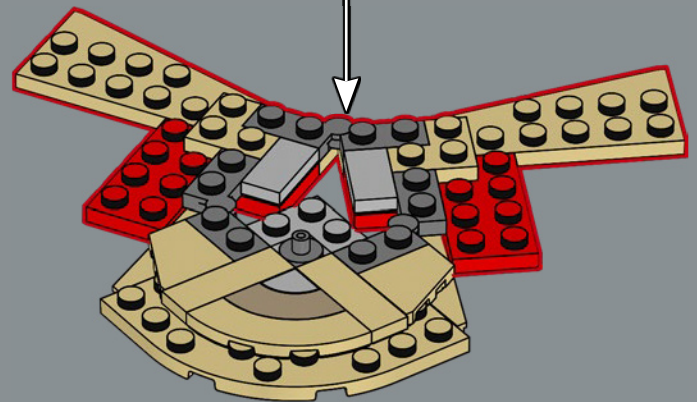
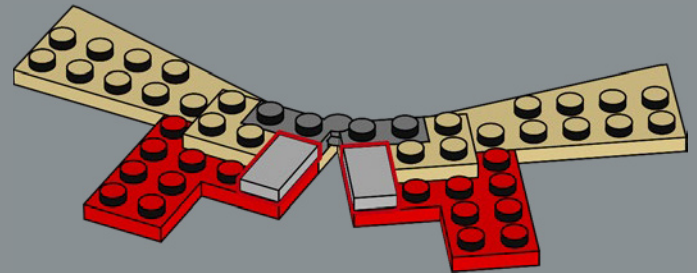

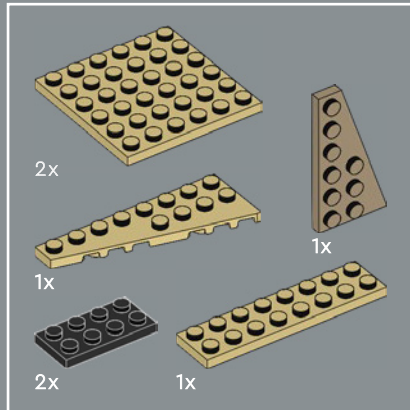
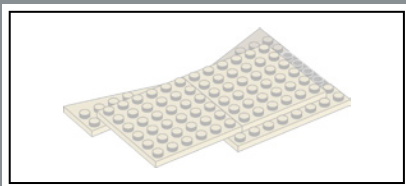

97

1

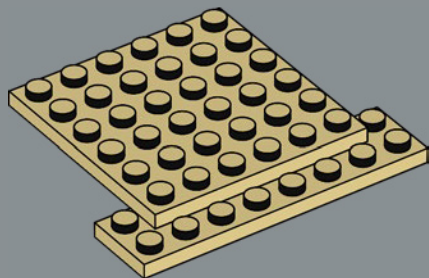

2

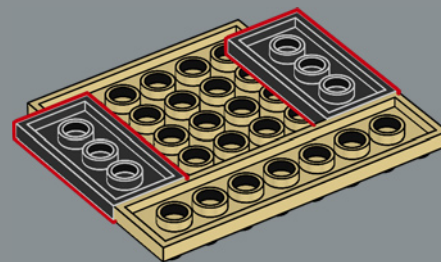

3

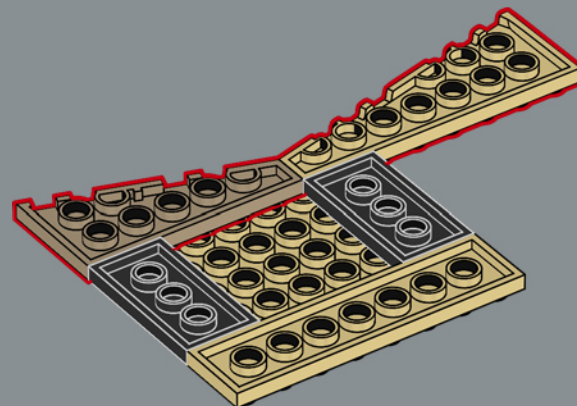

4

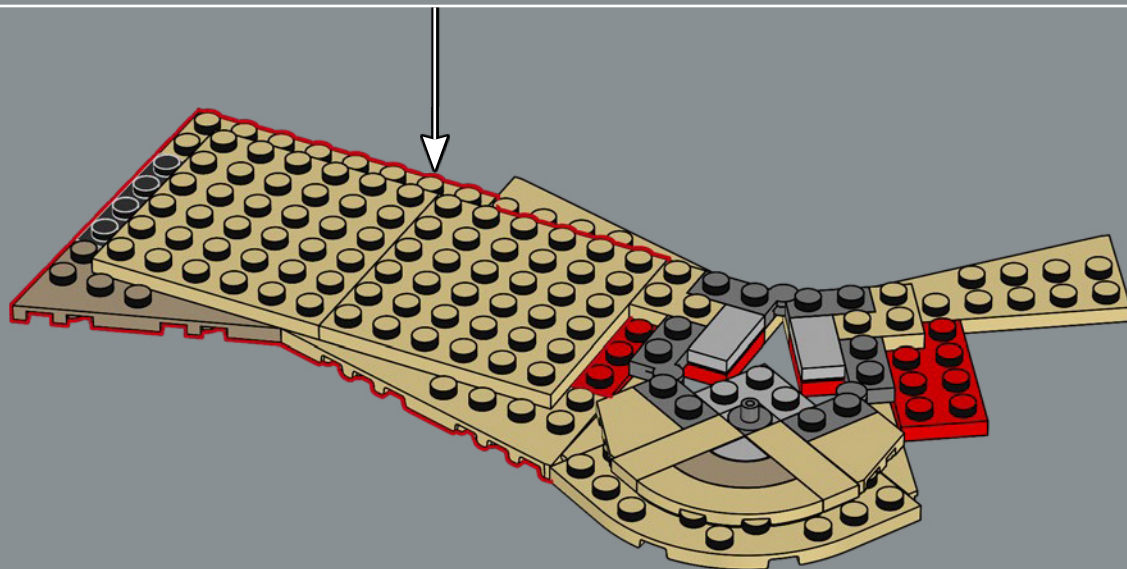
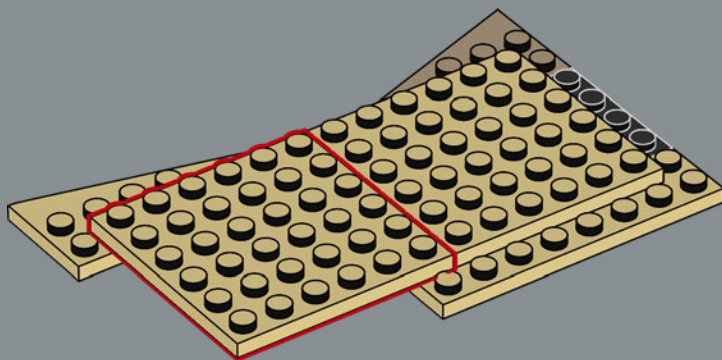

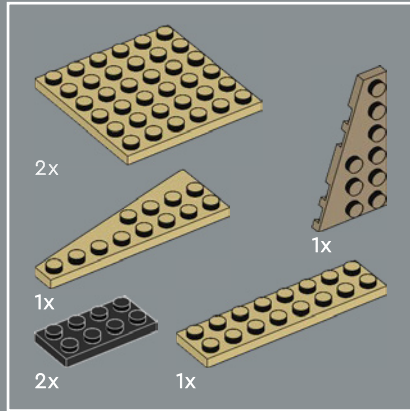
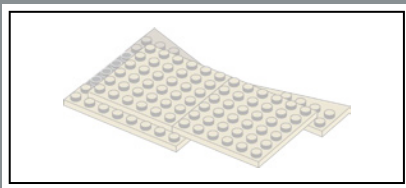

98

1

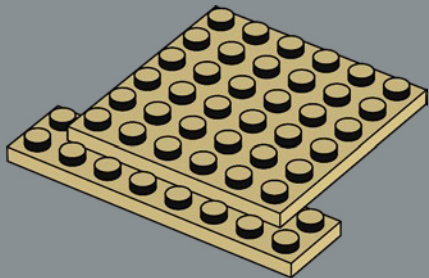

2

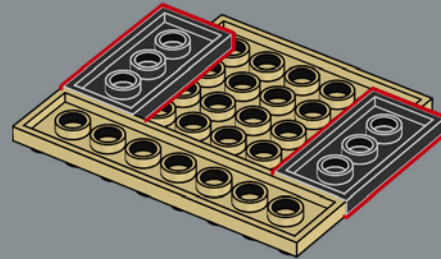

3

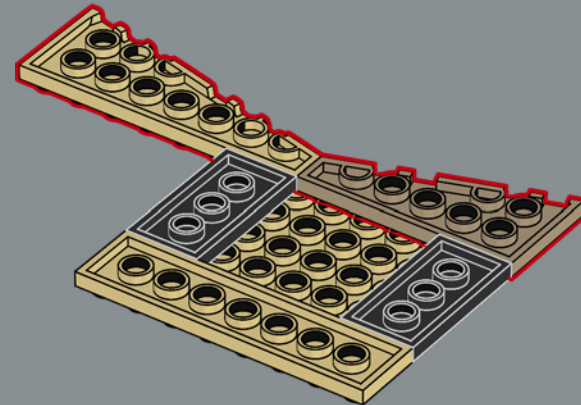

4

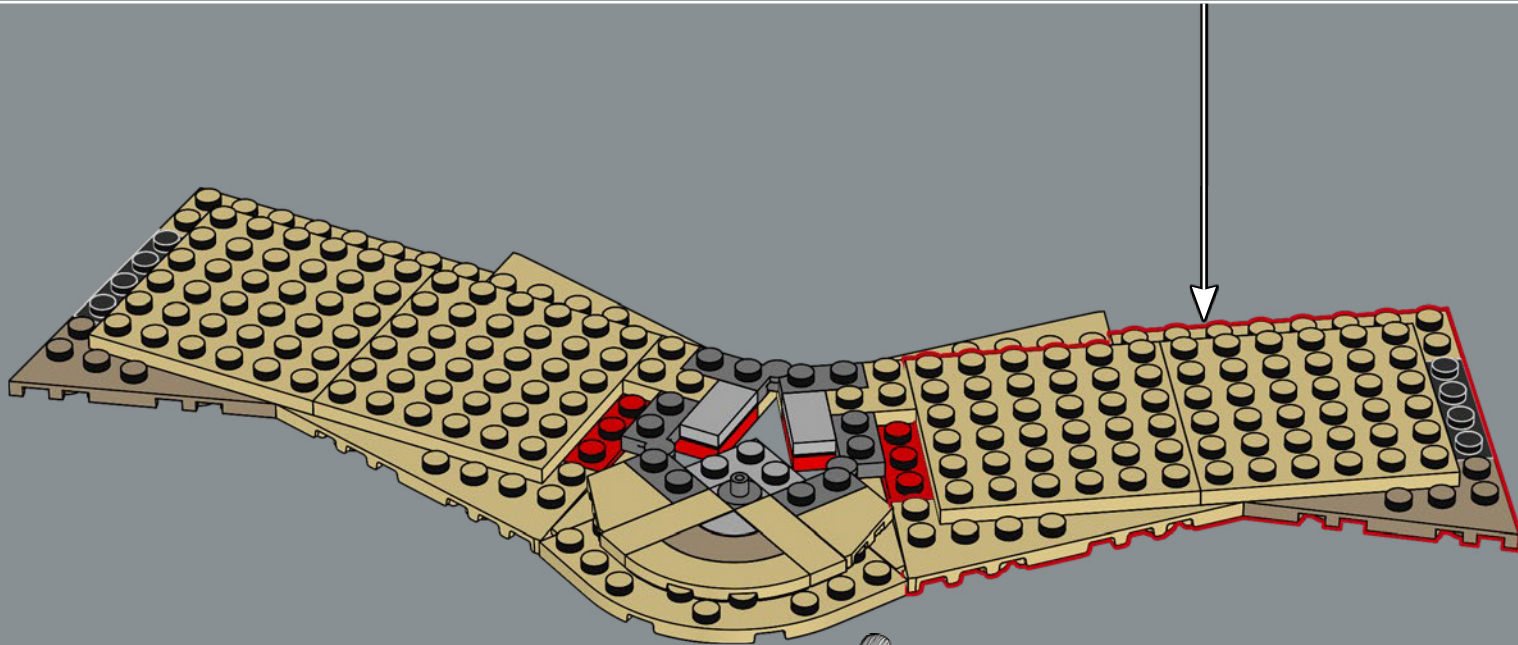
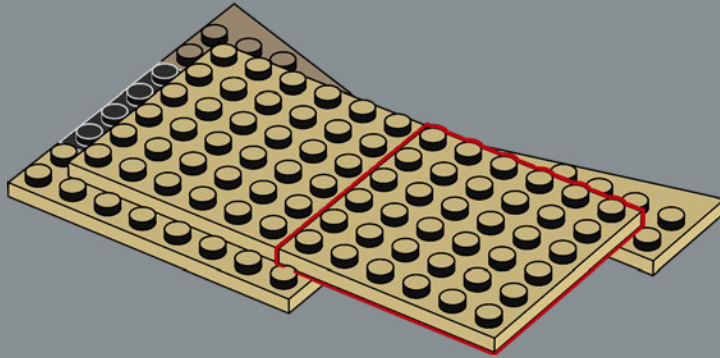

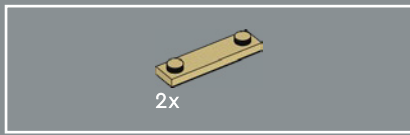

99

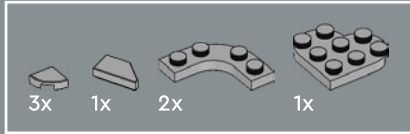
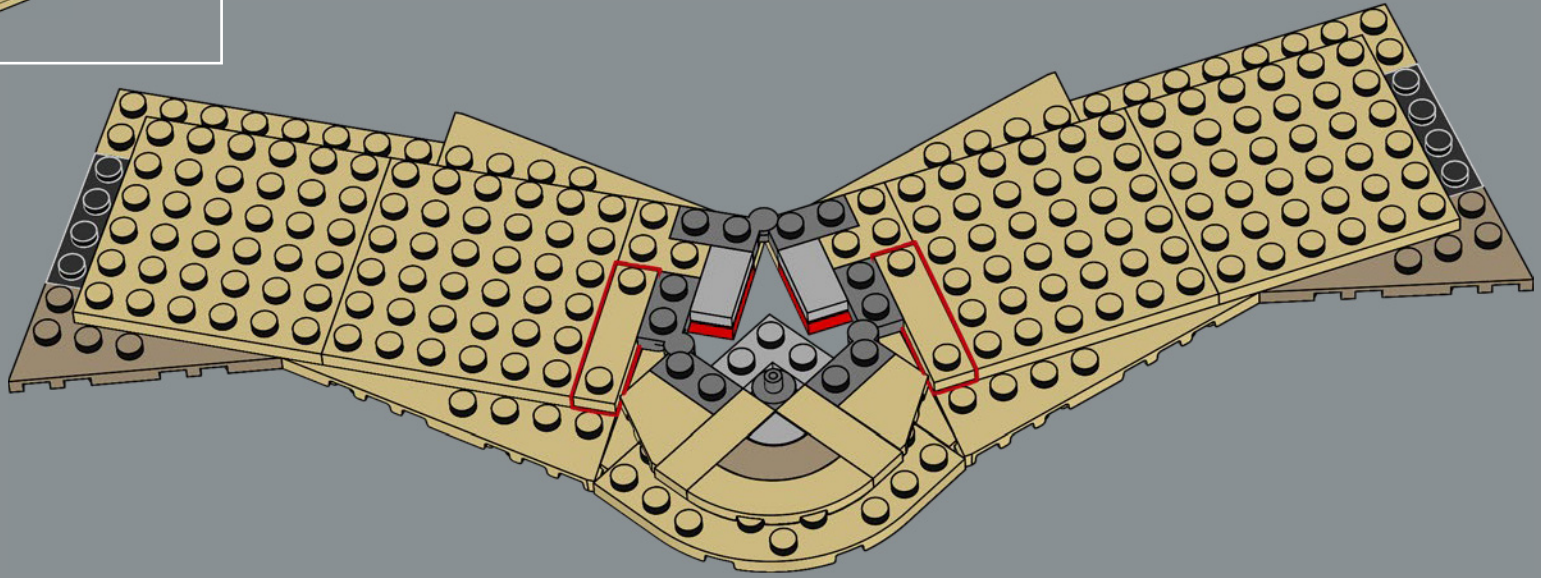

100

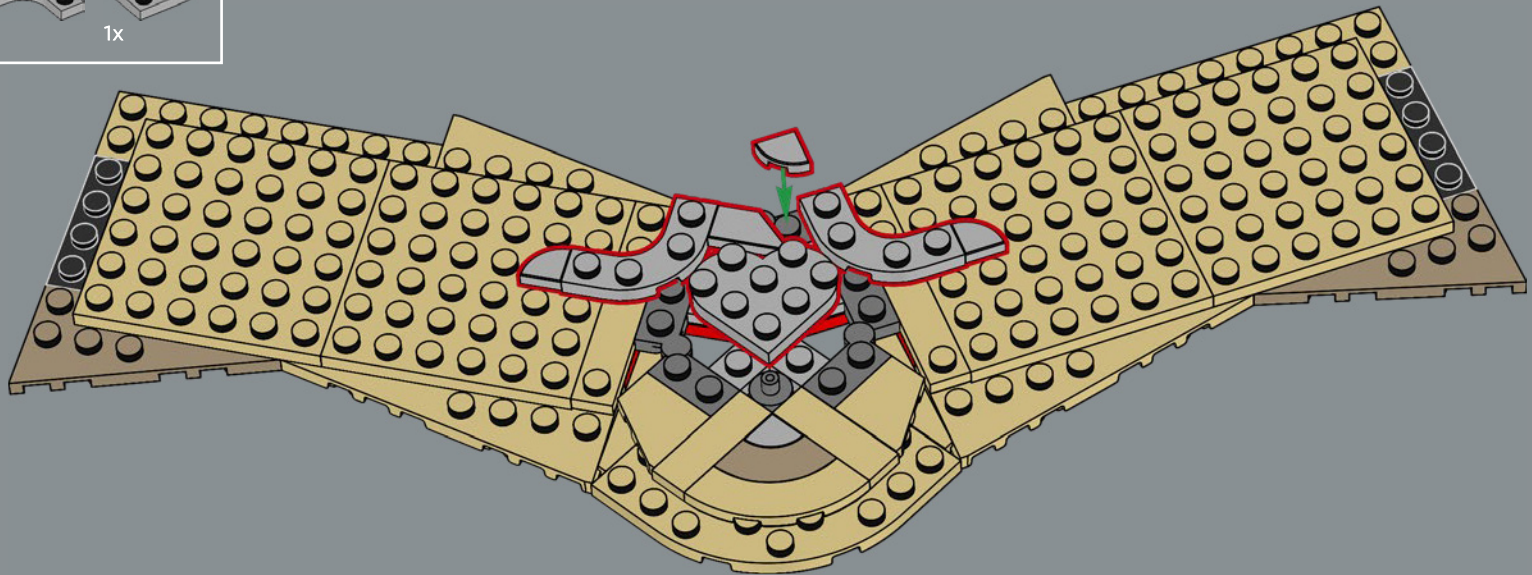

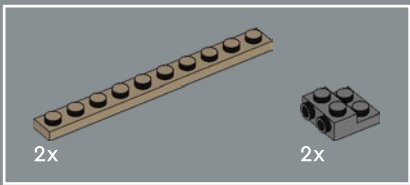

101

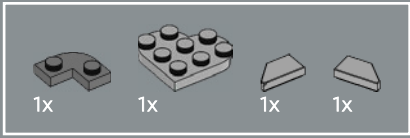
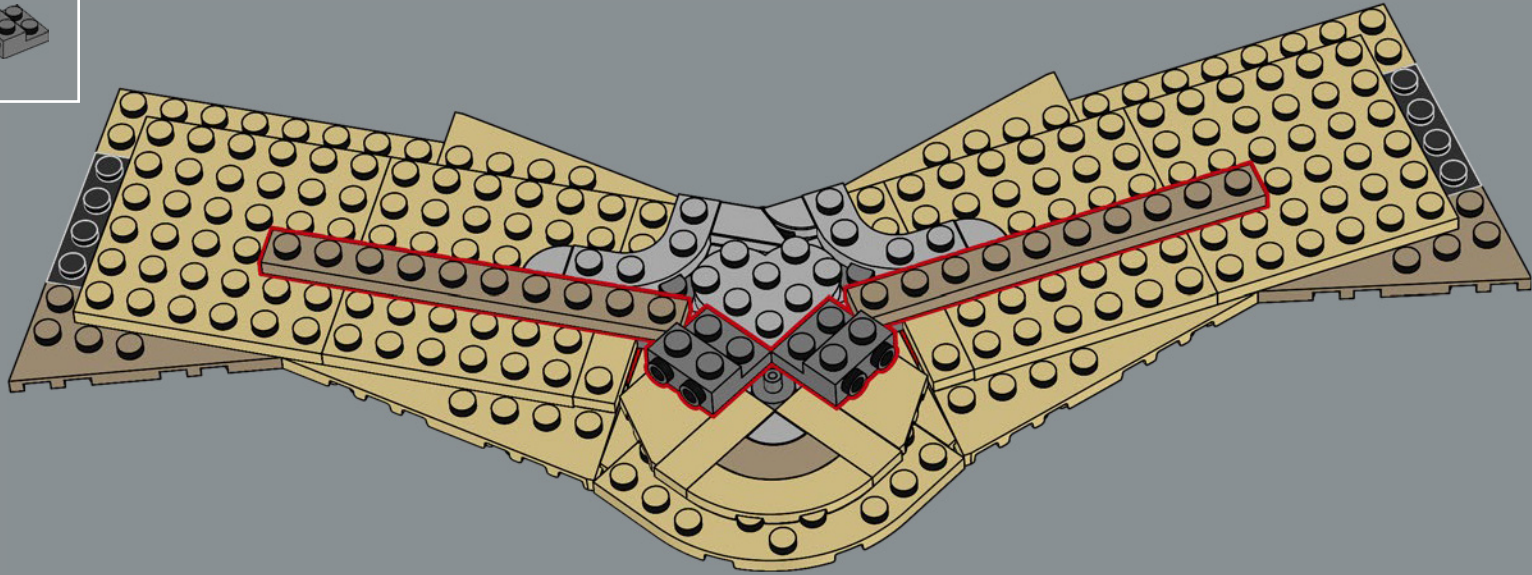

102

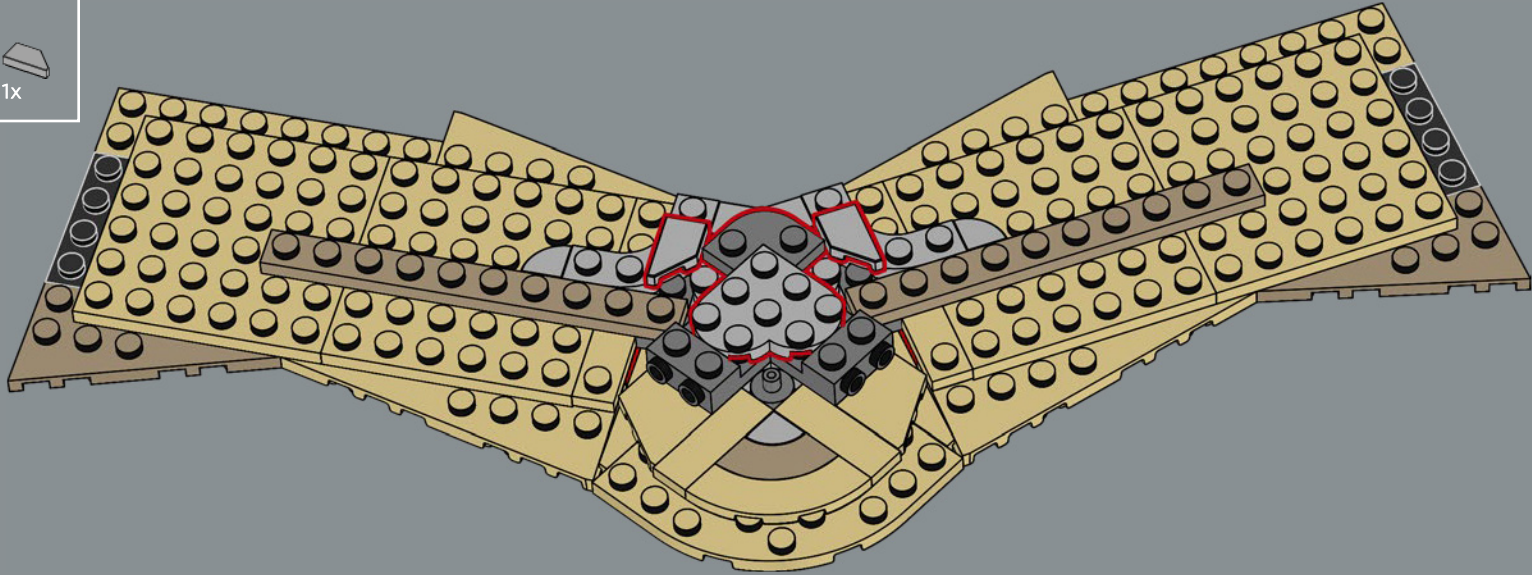

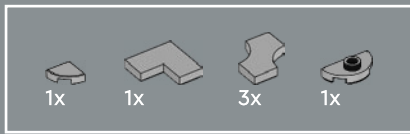

103

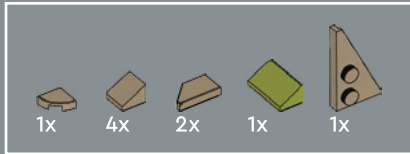
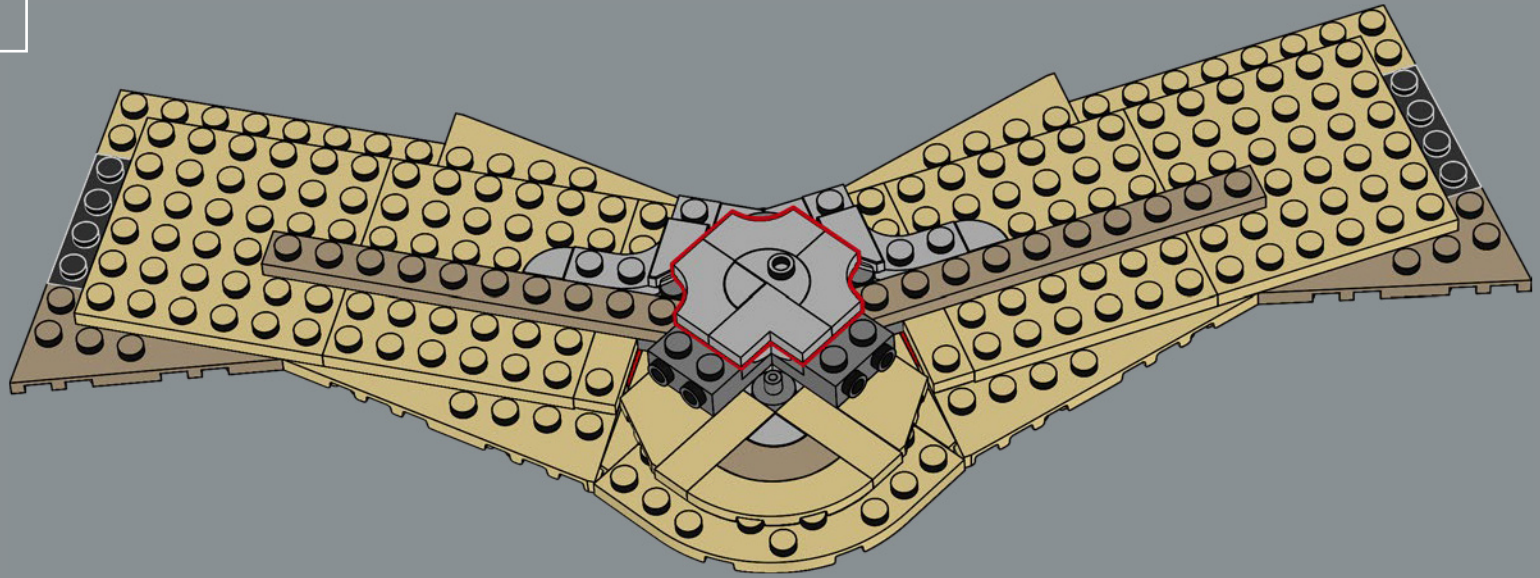

104

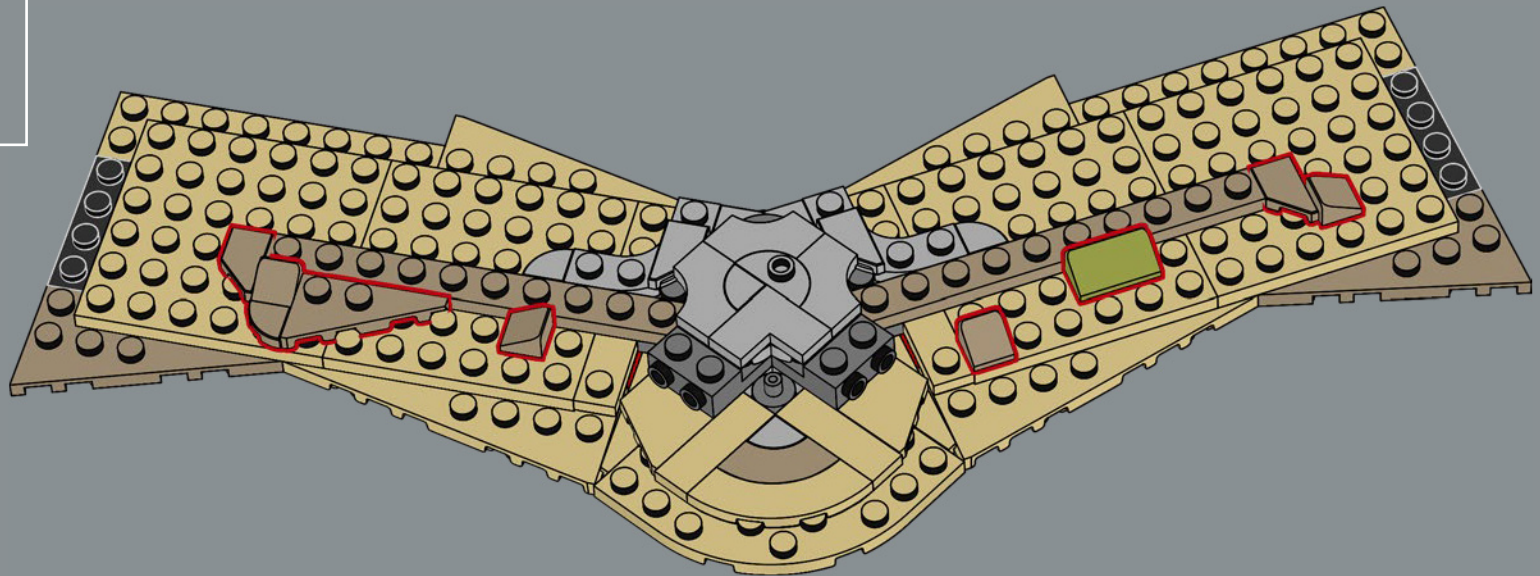

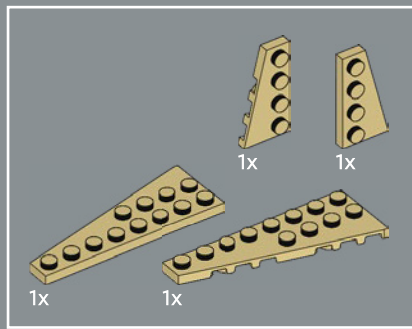

107

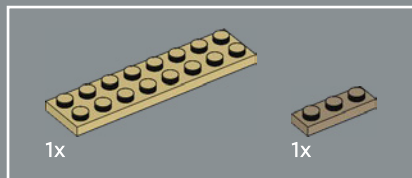
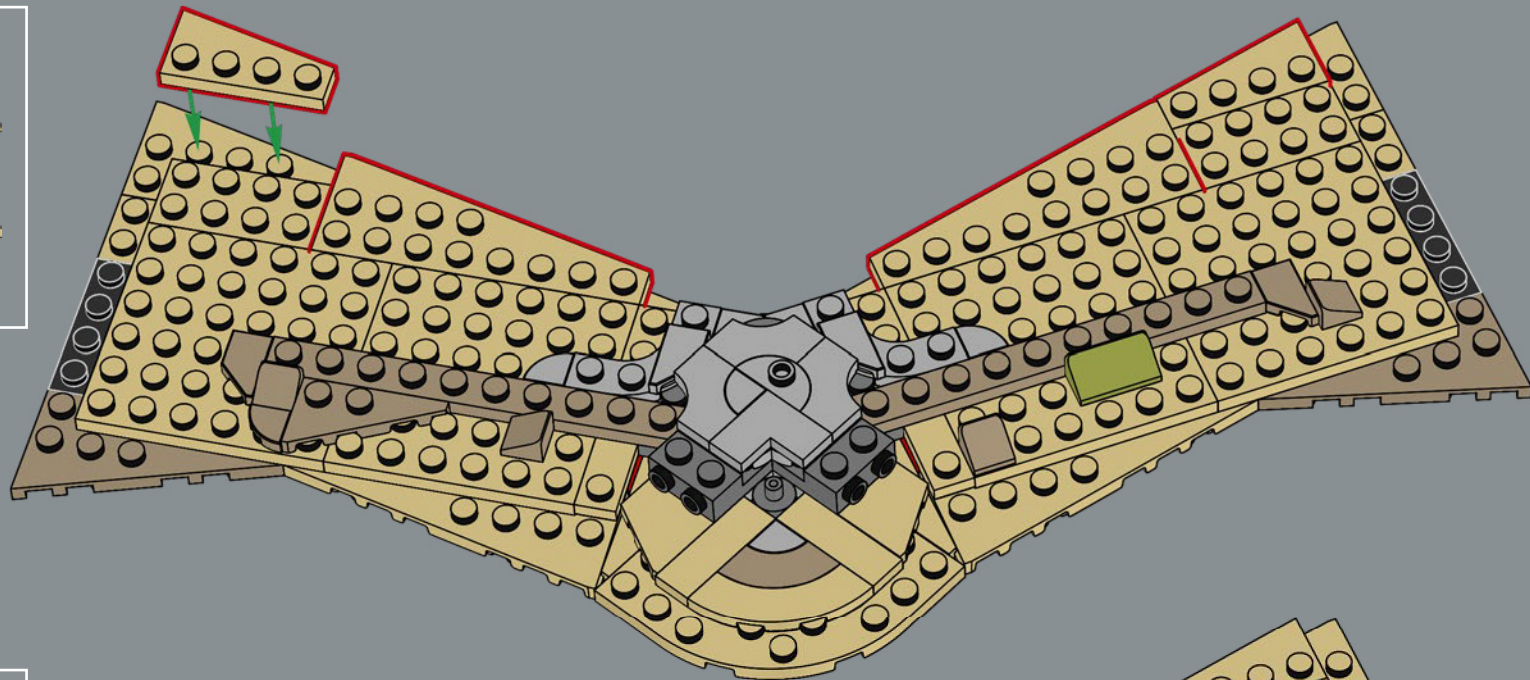

108

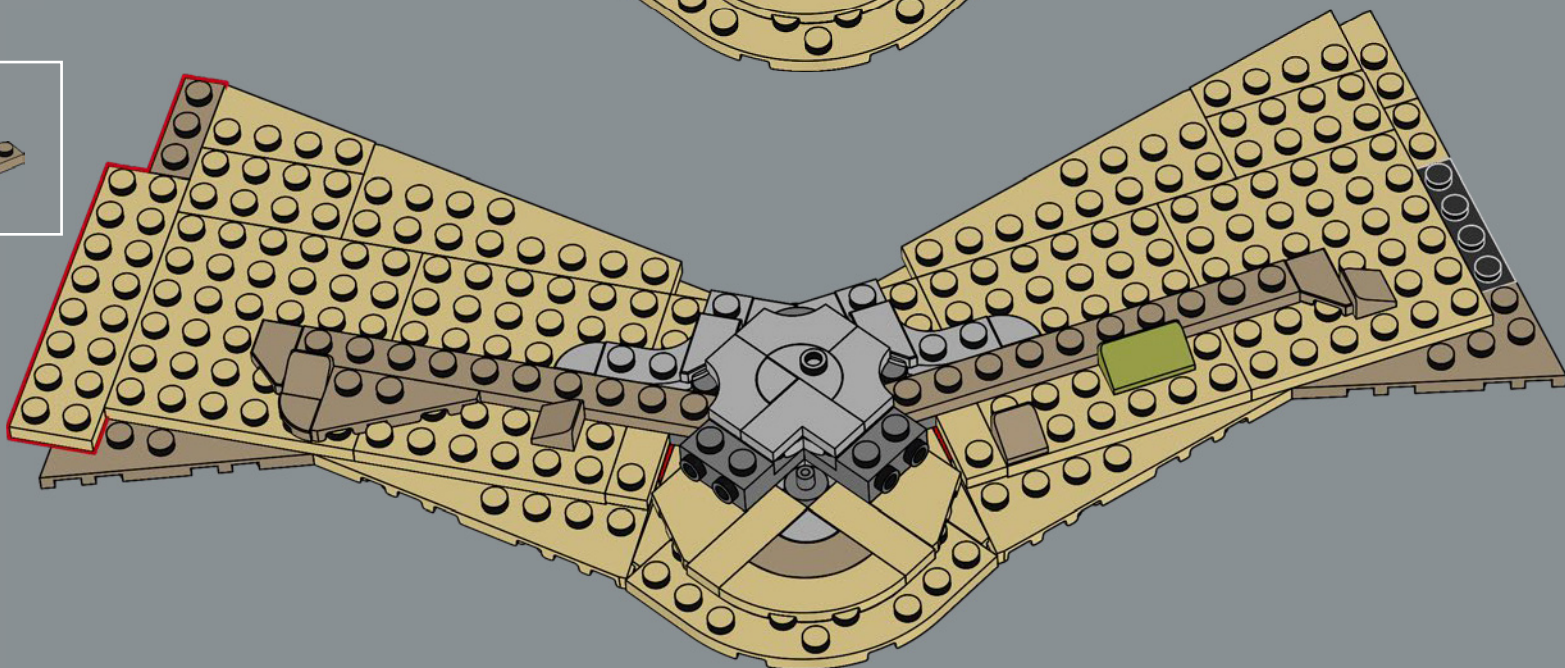

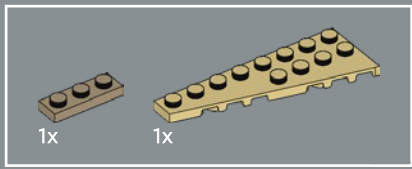

109

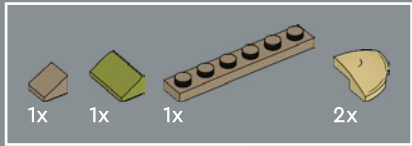
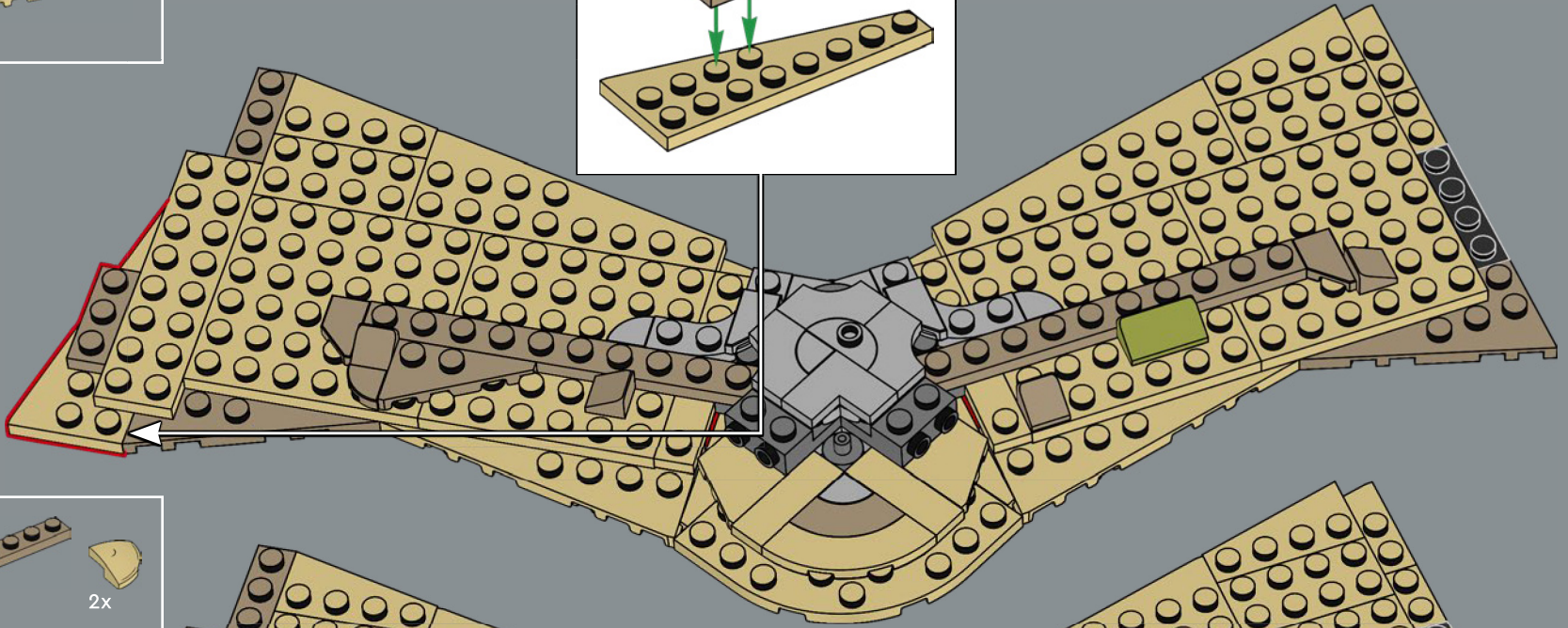
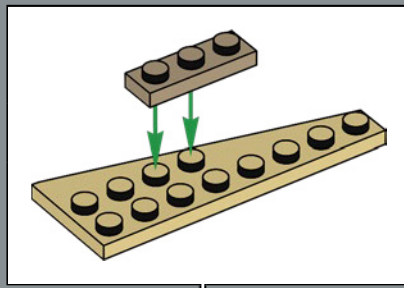

110

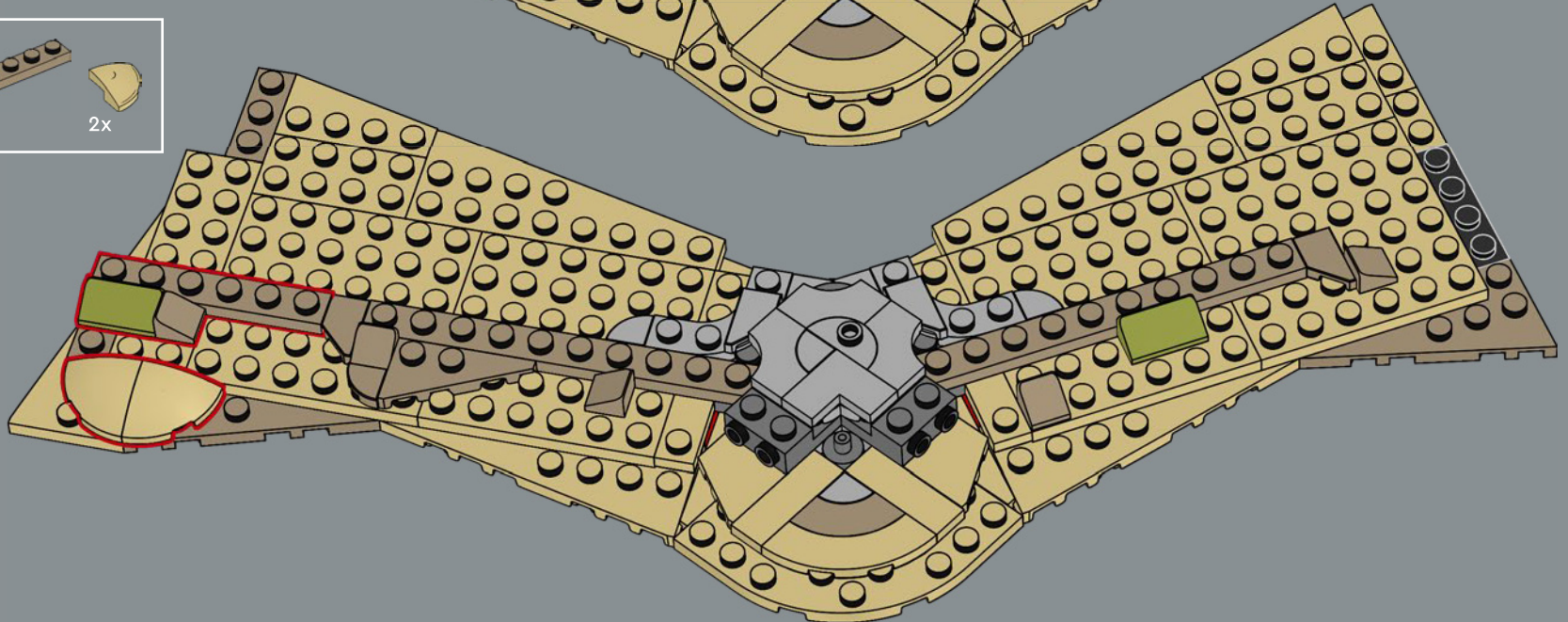

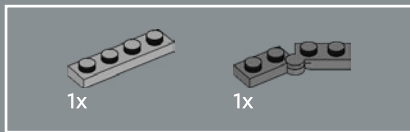

111

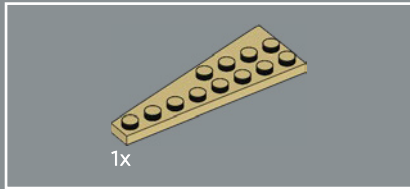
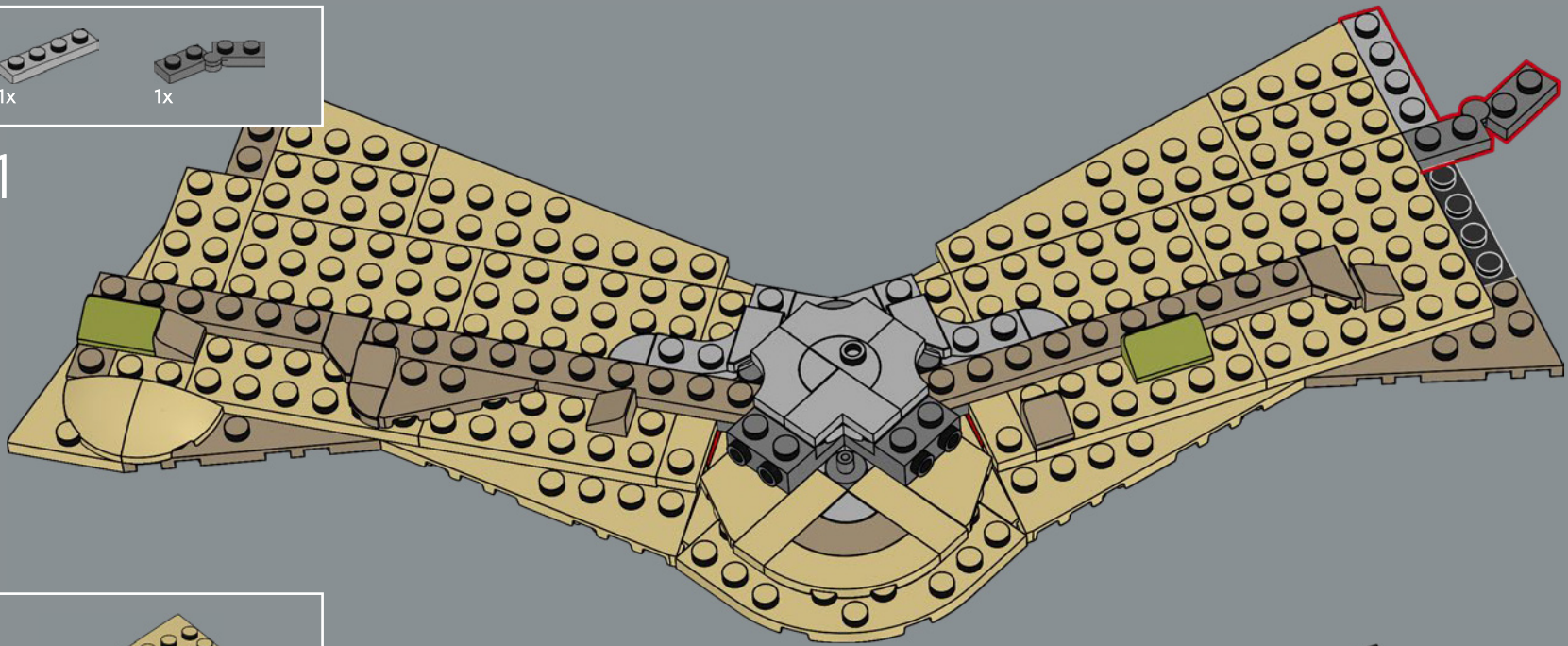

112

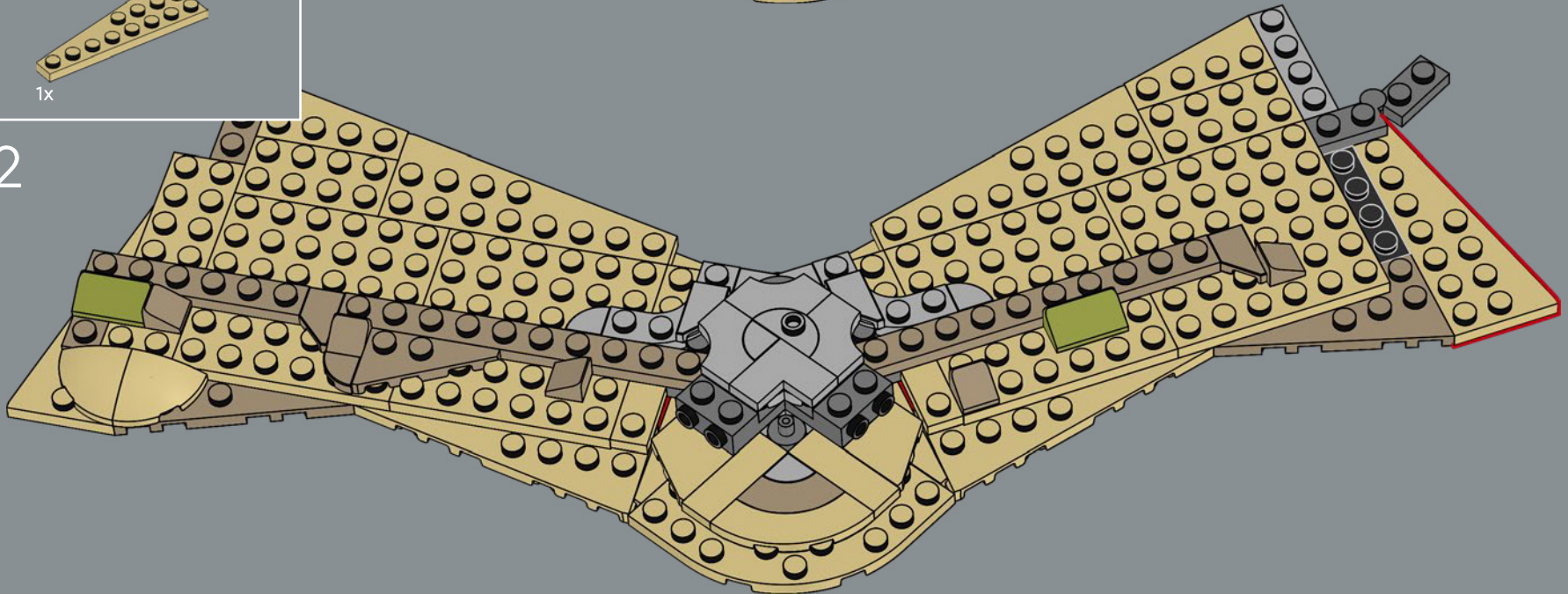

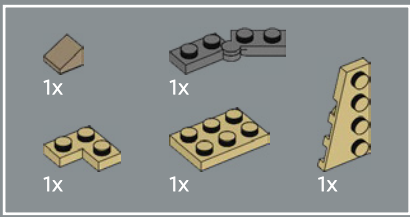

113

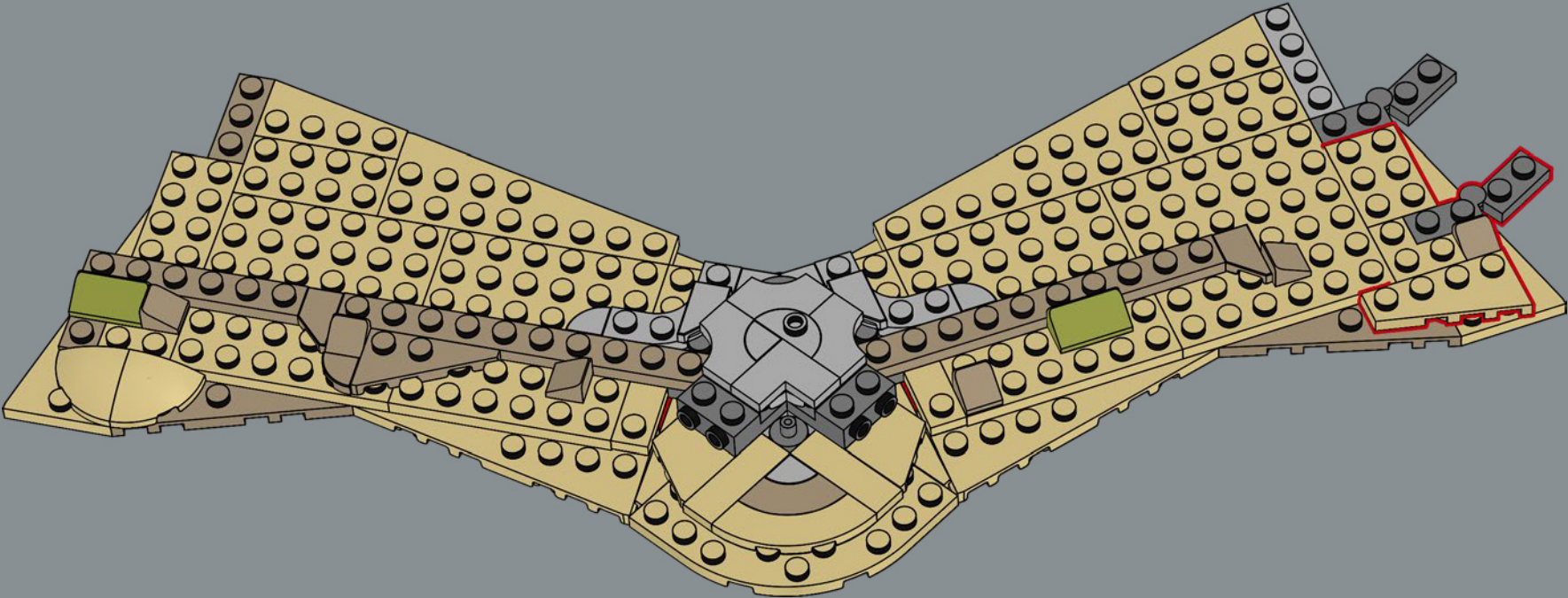

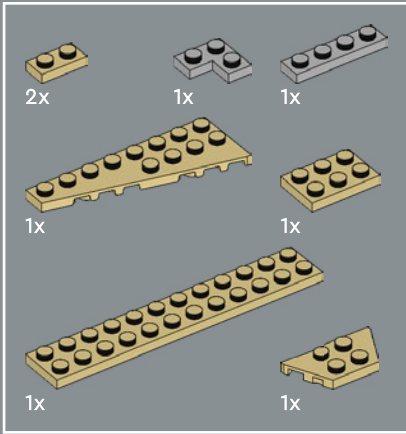
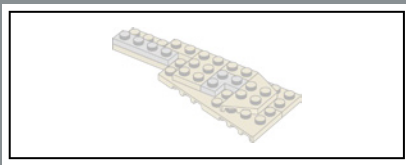

114

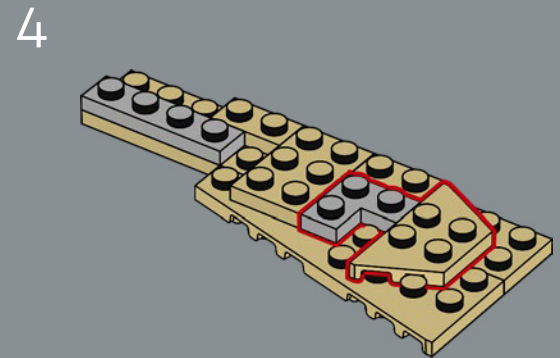
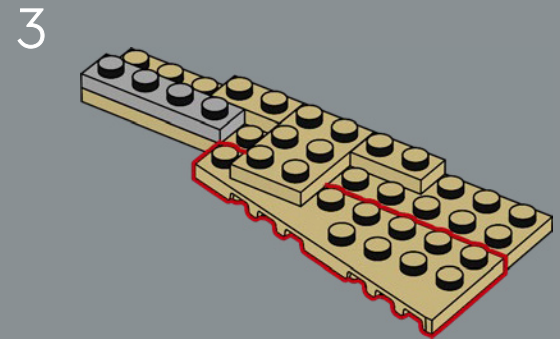
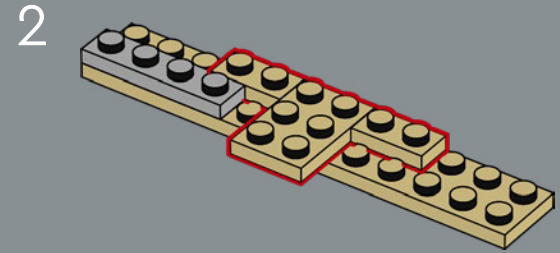
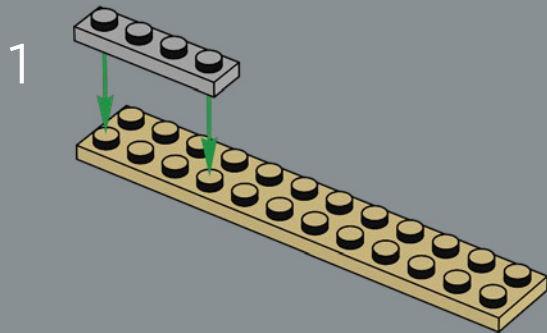

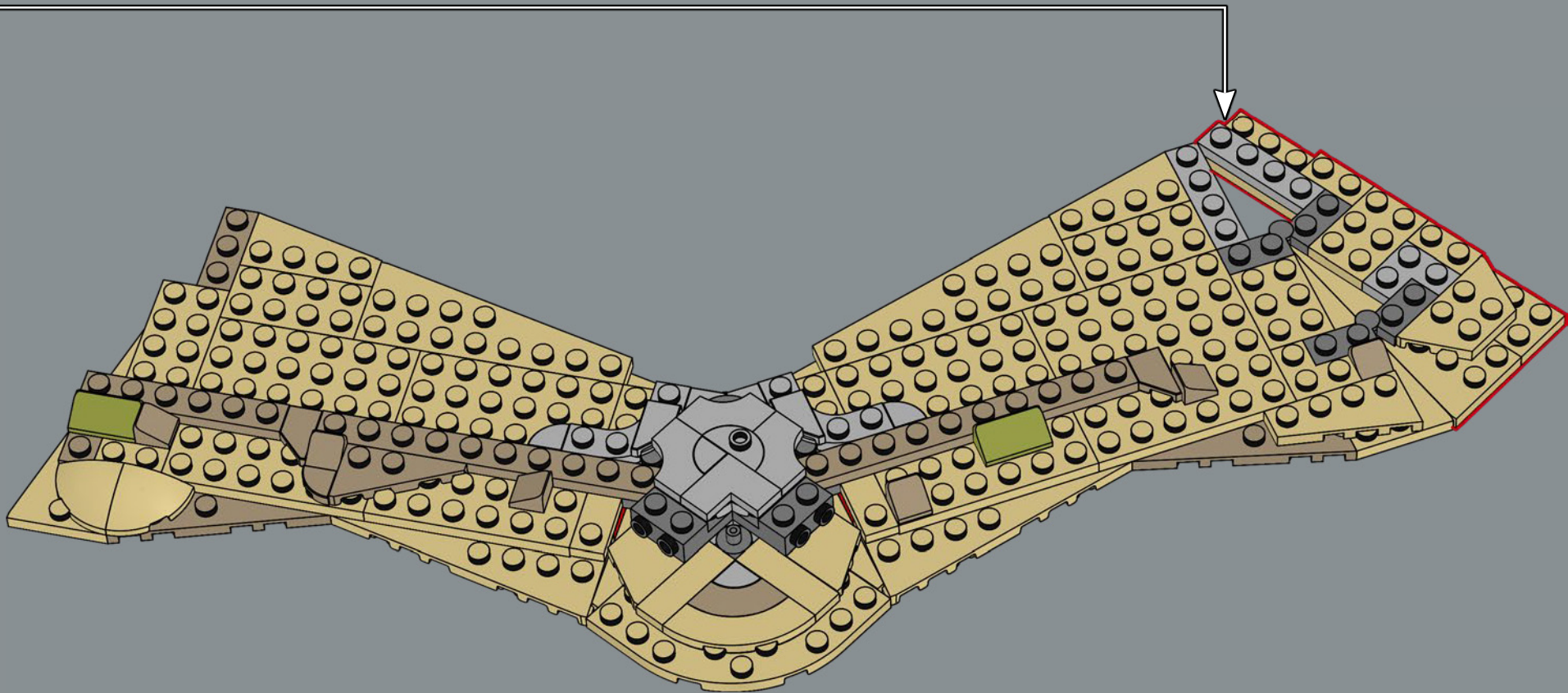

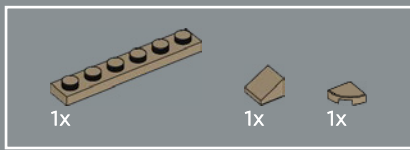

115

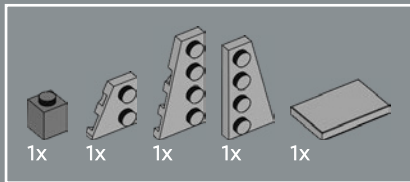
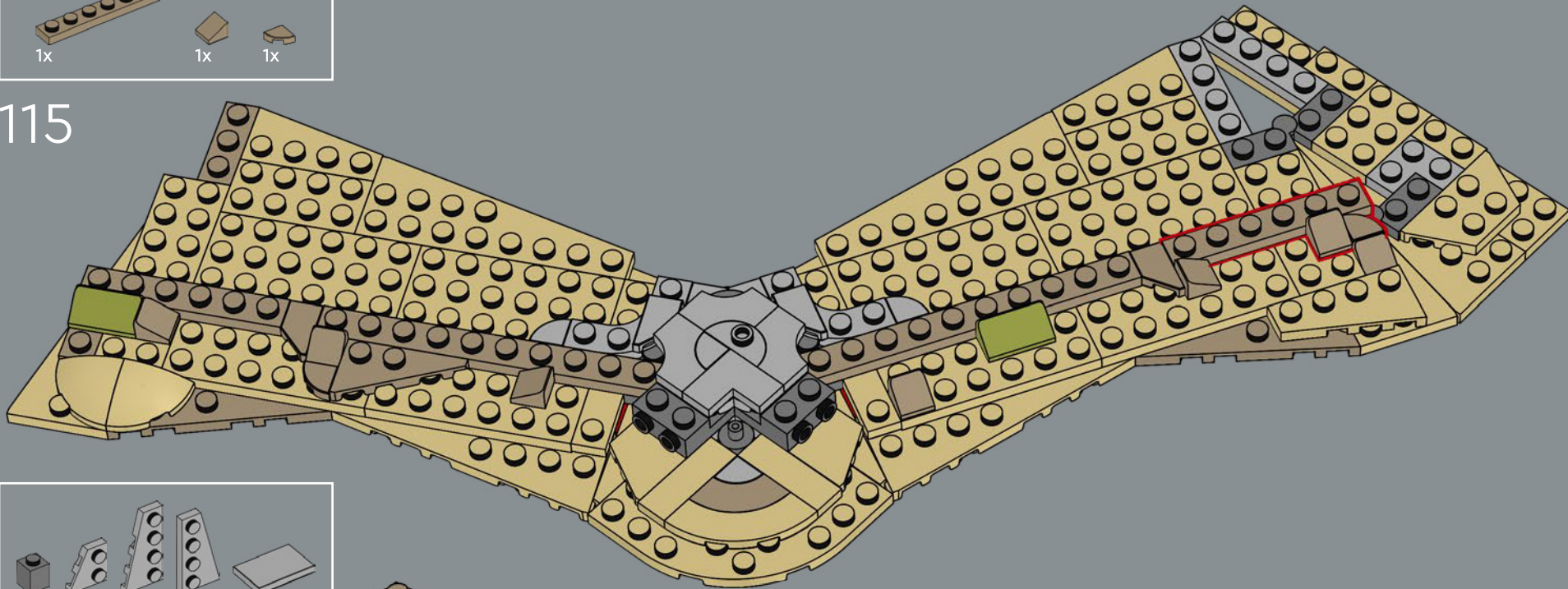

116

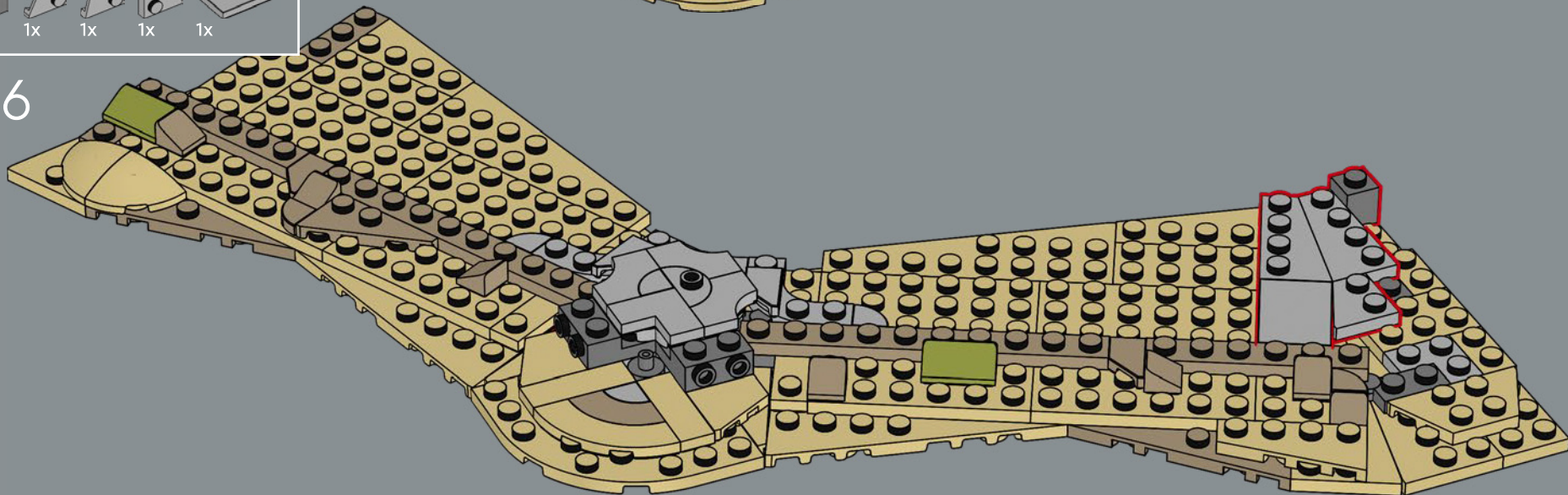

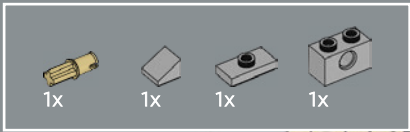

117

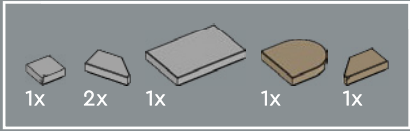
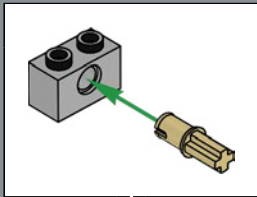
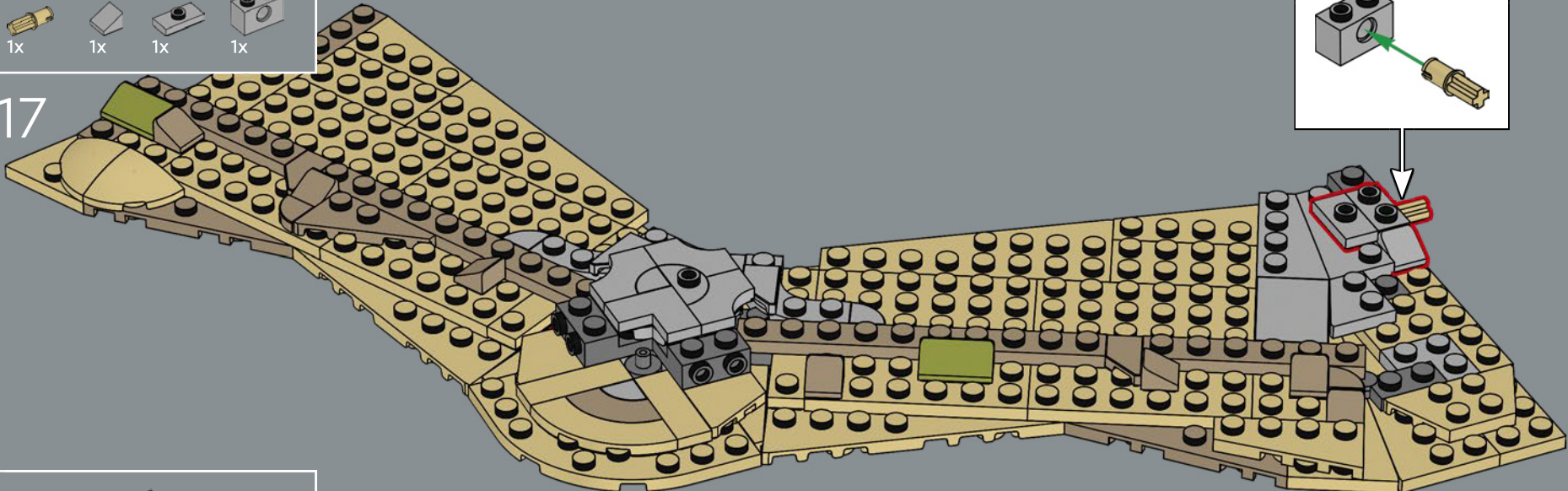

118

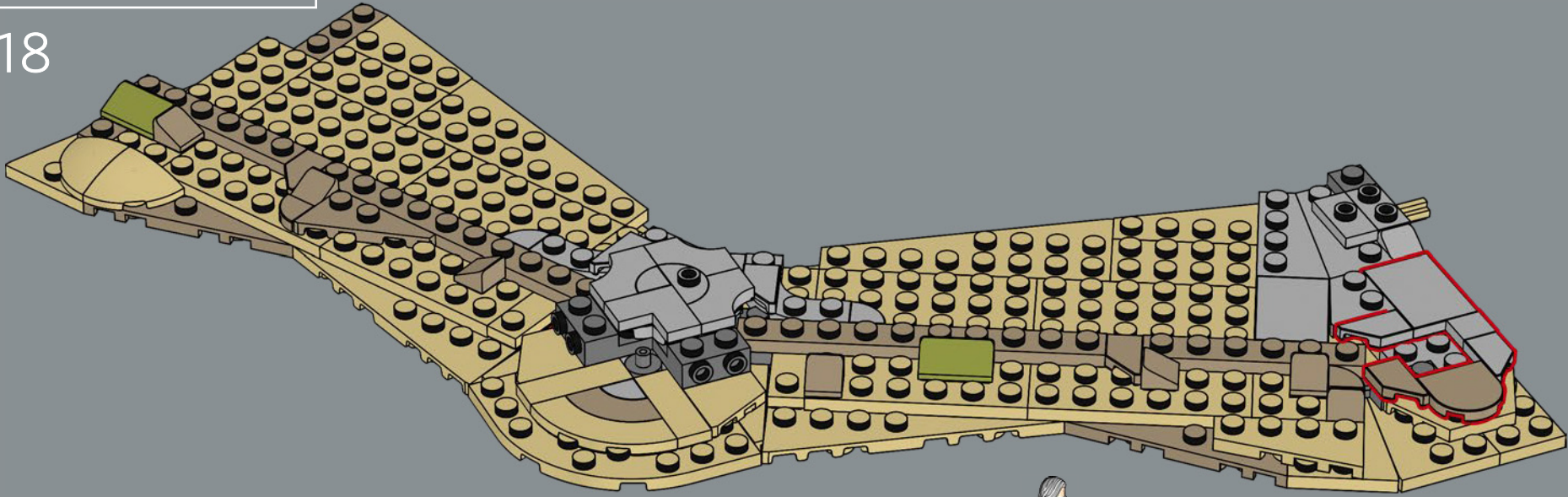

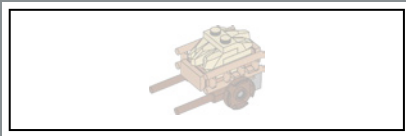

119

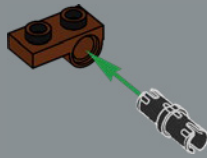

120

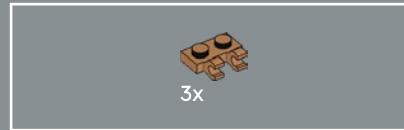

121

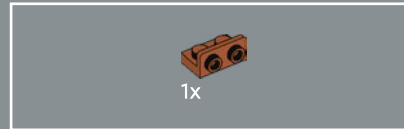
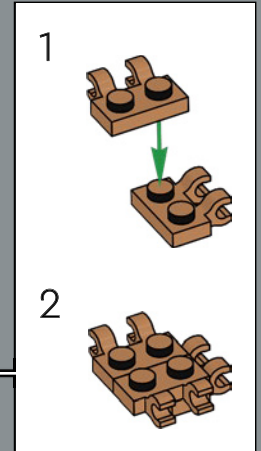
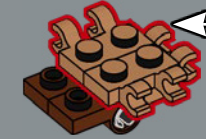

122

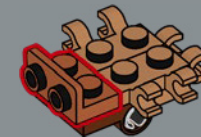

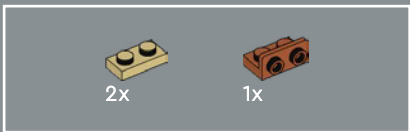

123

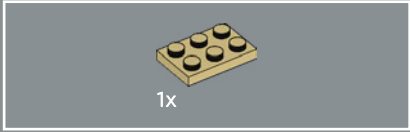

124

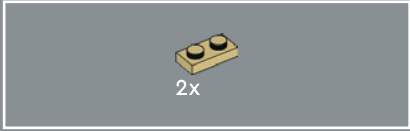

125

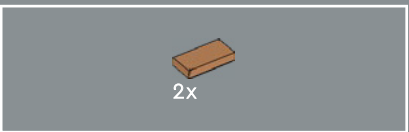
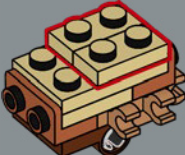

126

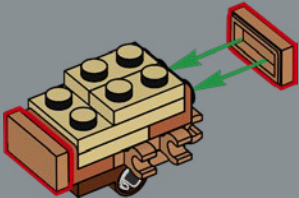

127

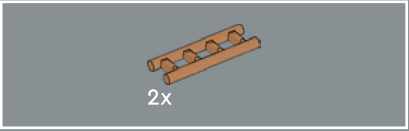
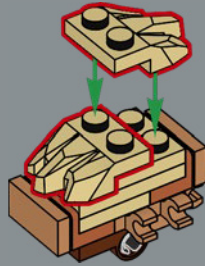

128

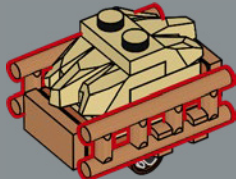

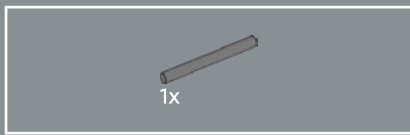

129

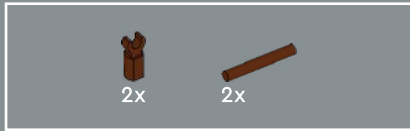
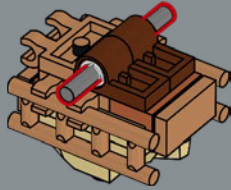

130

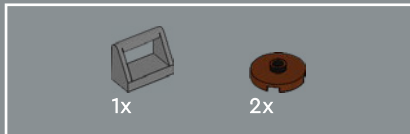
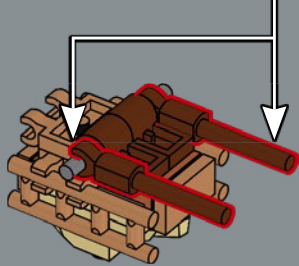
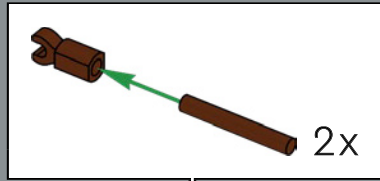

131

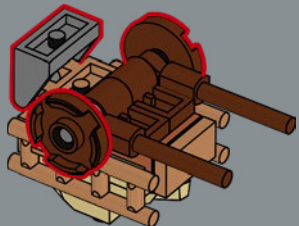

132

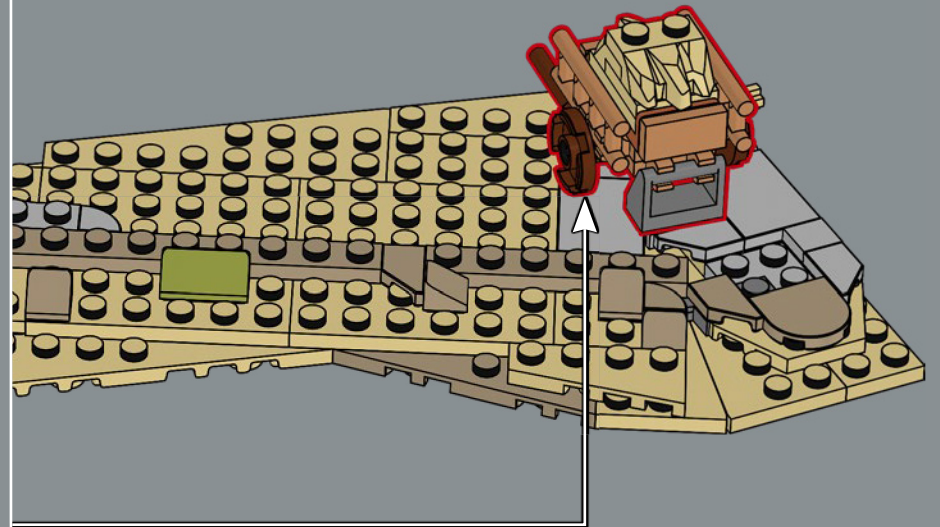

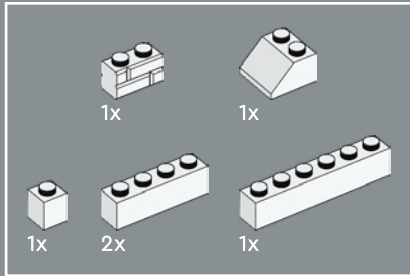
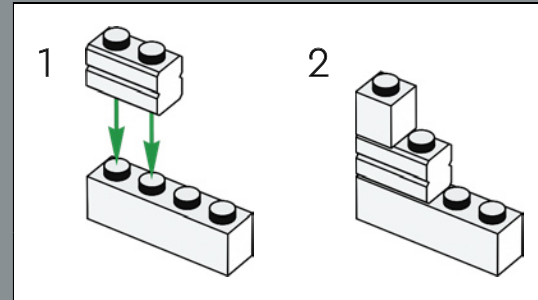

133

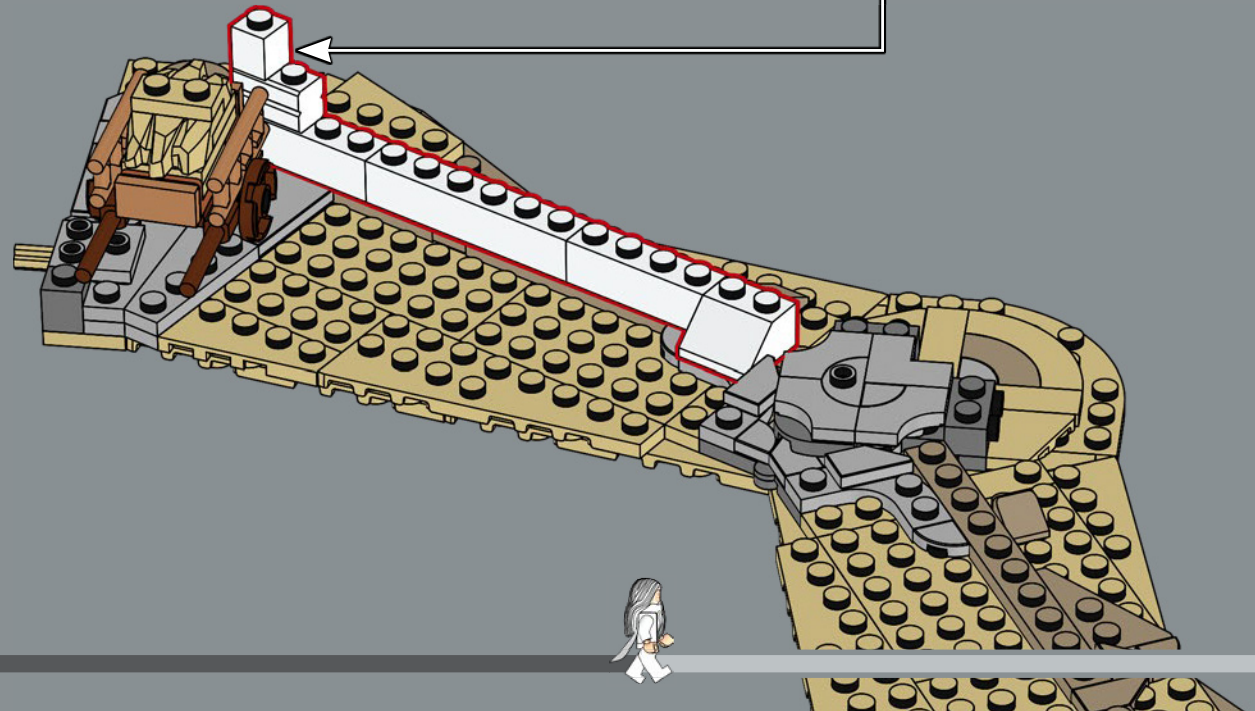

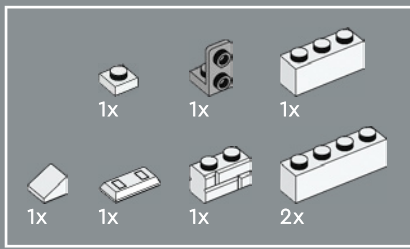

134

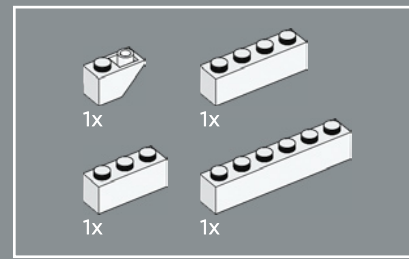
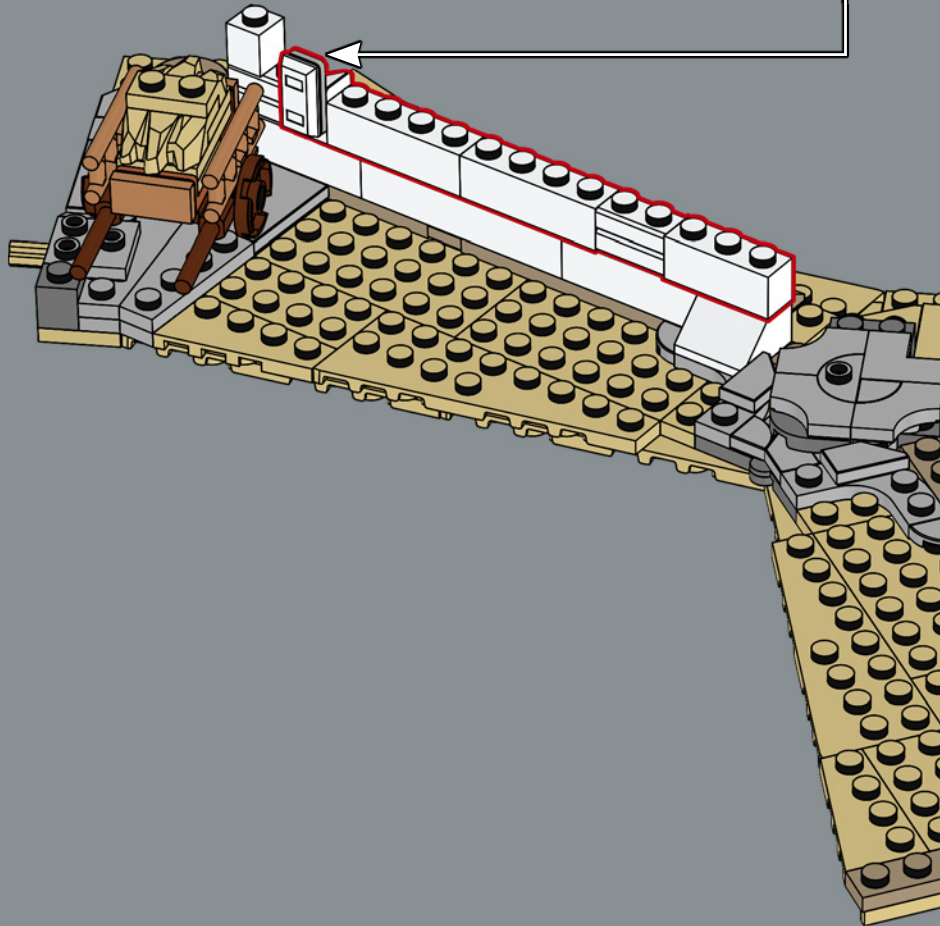
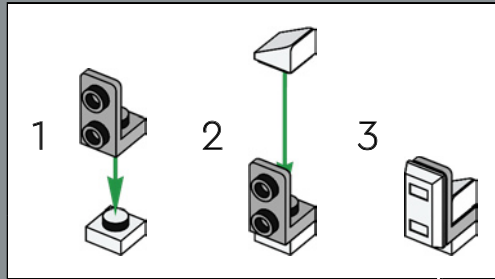

135

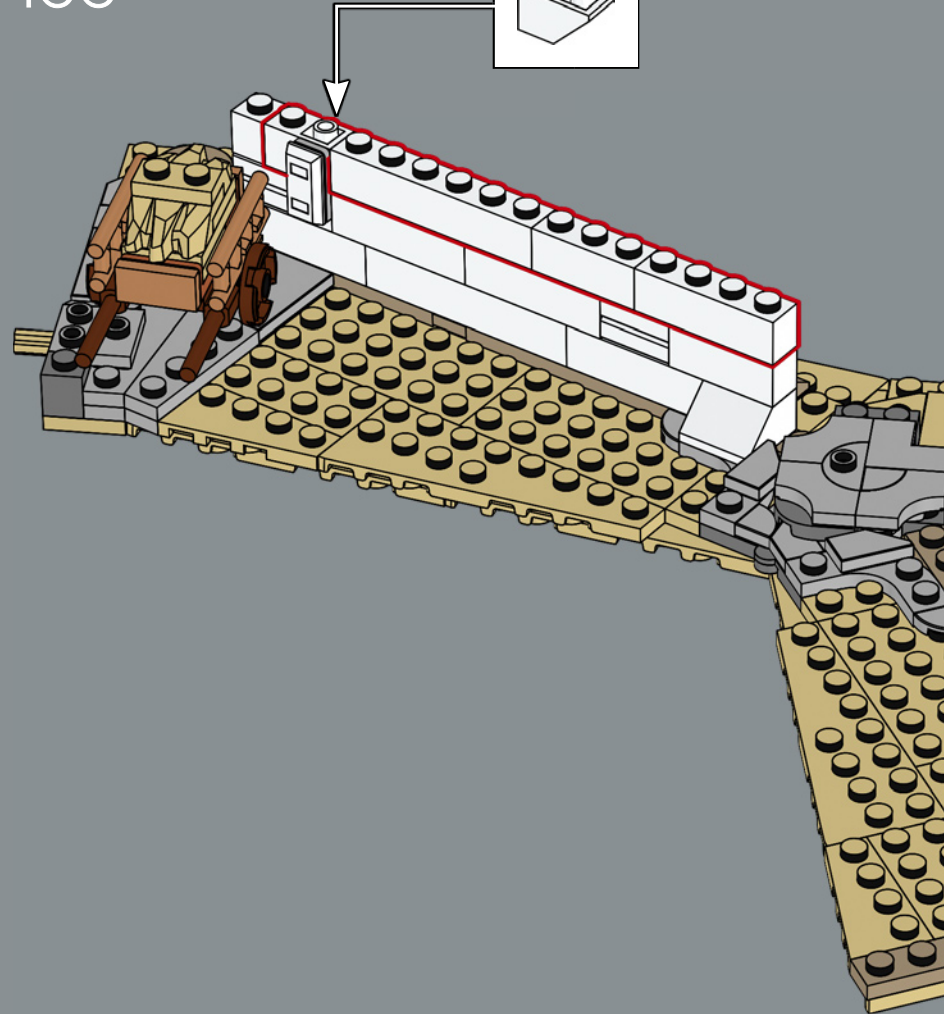
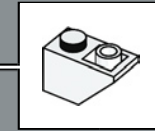

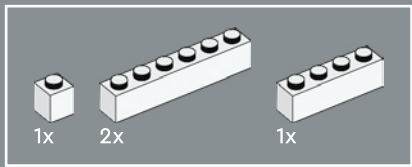

136

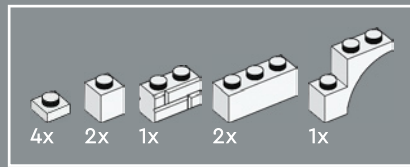
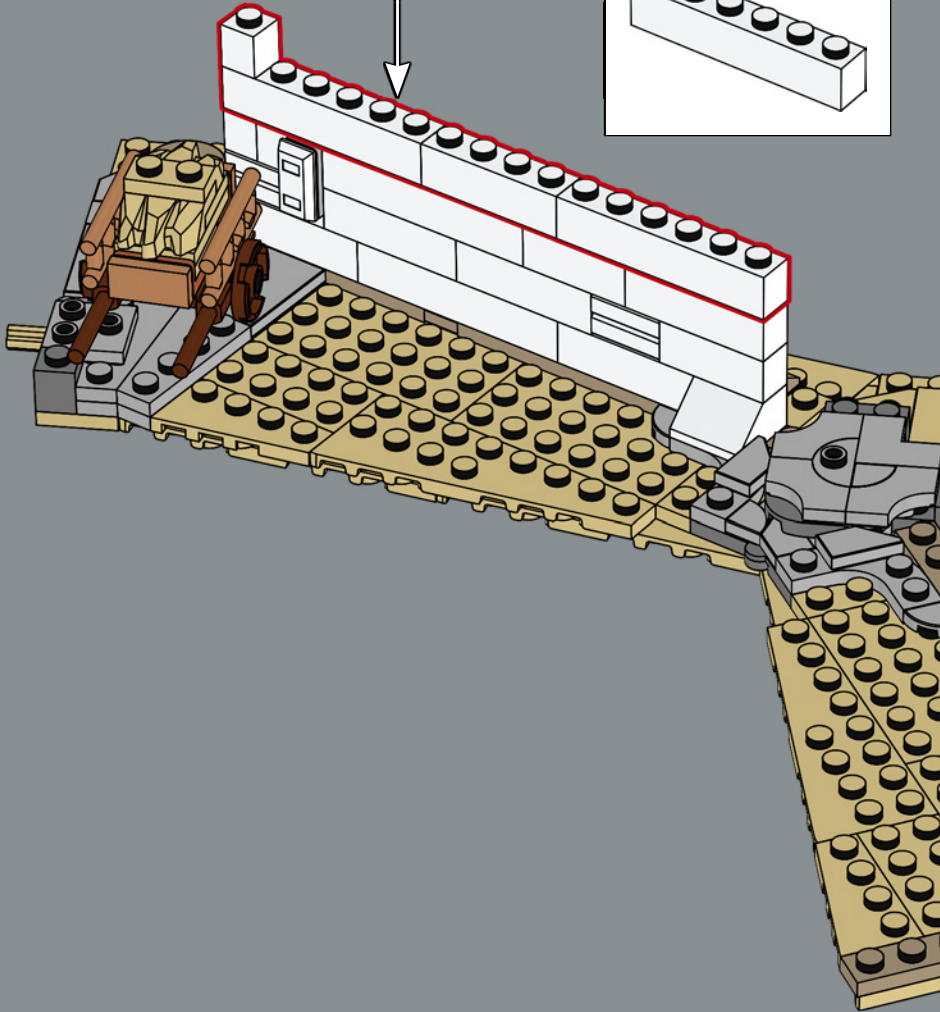
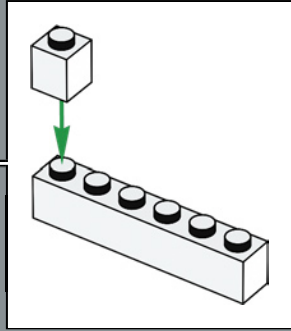

137

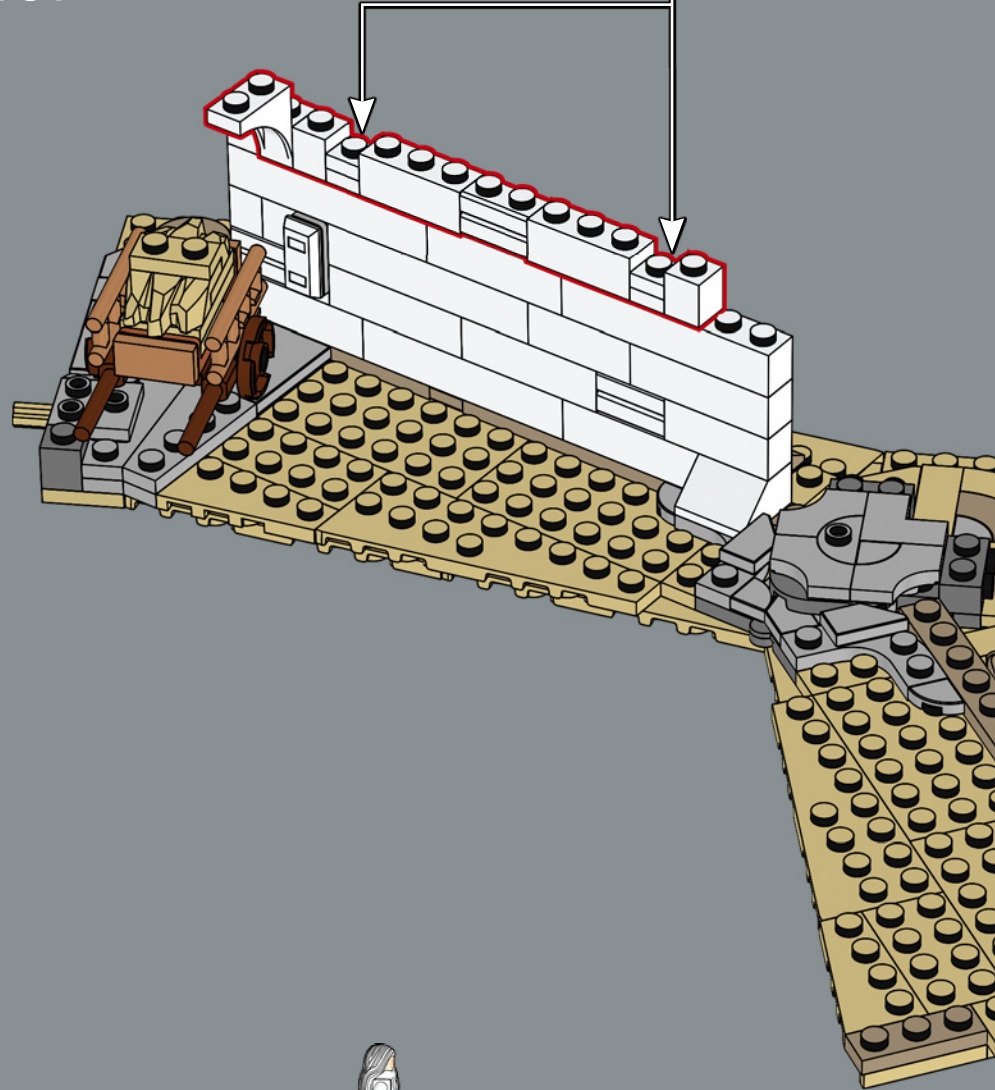
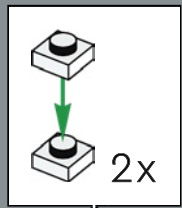



138

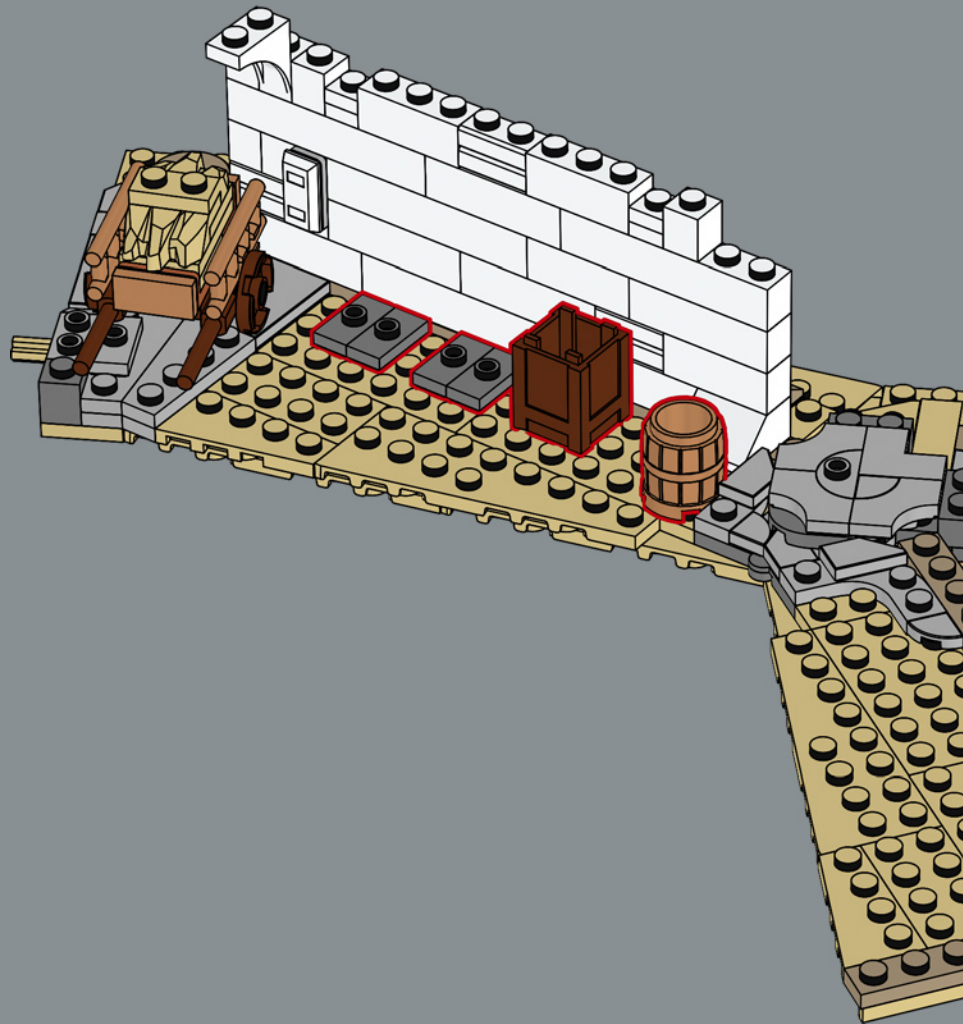

139

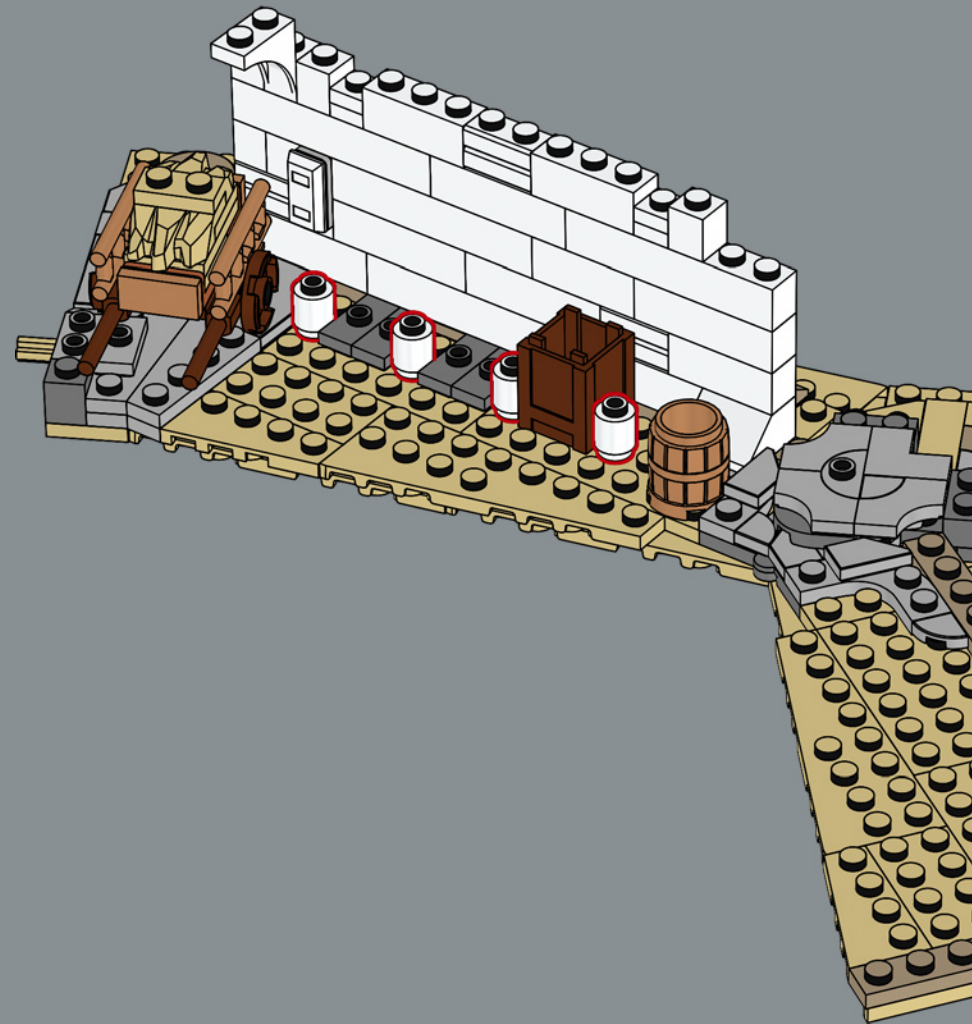

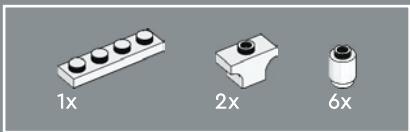

140

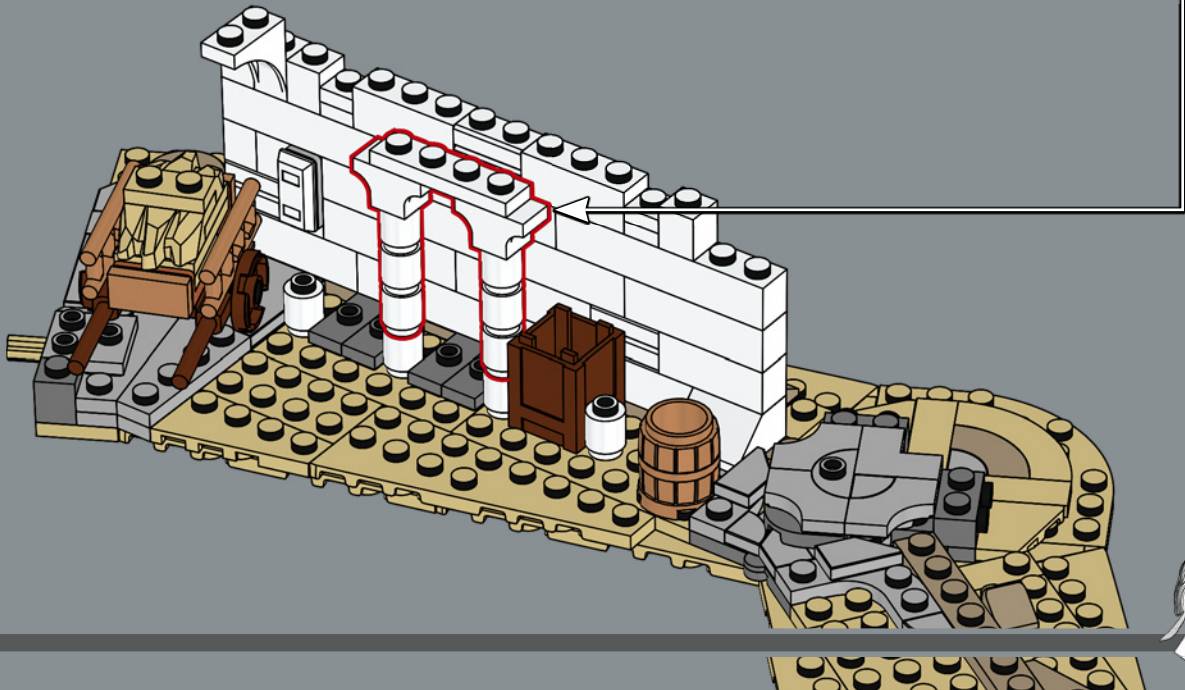
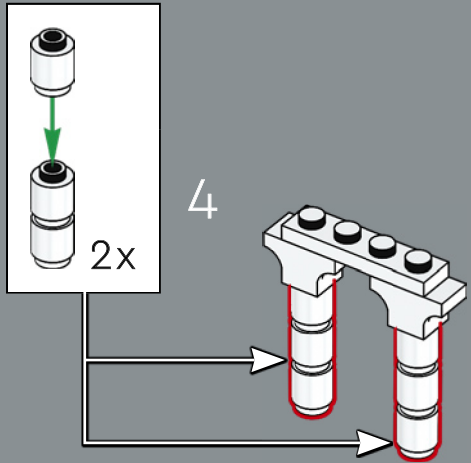
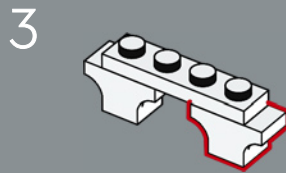
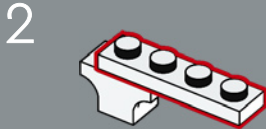
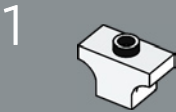

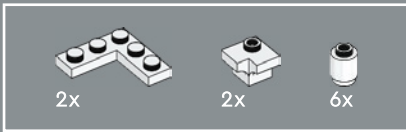
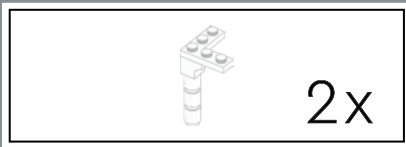

141

1



2

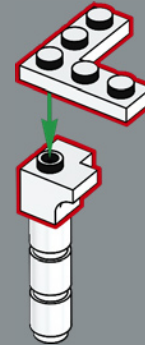

2x

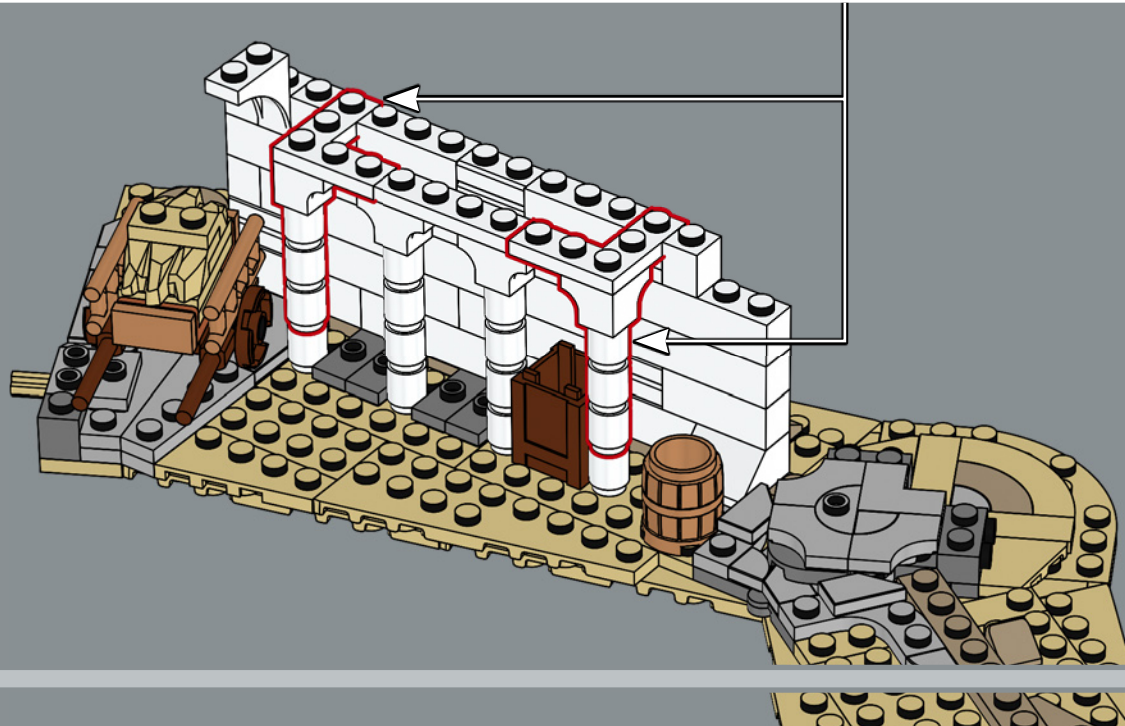

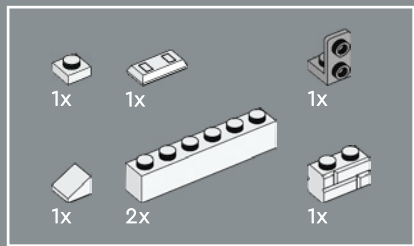

142

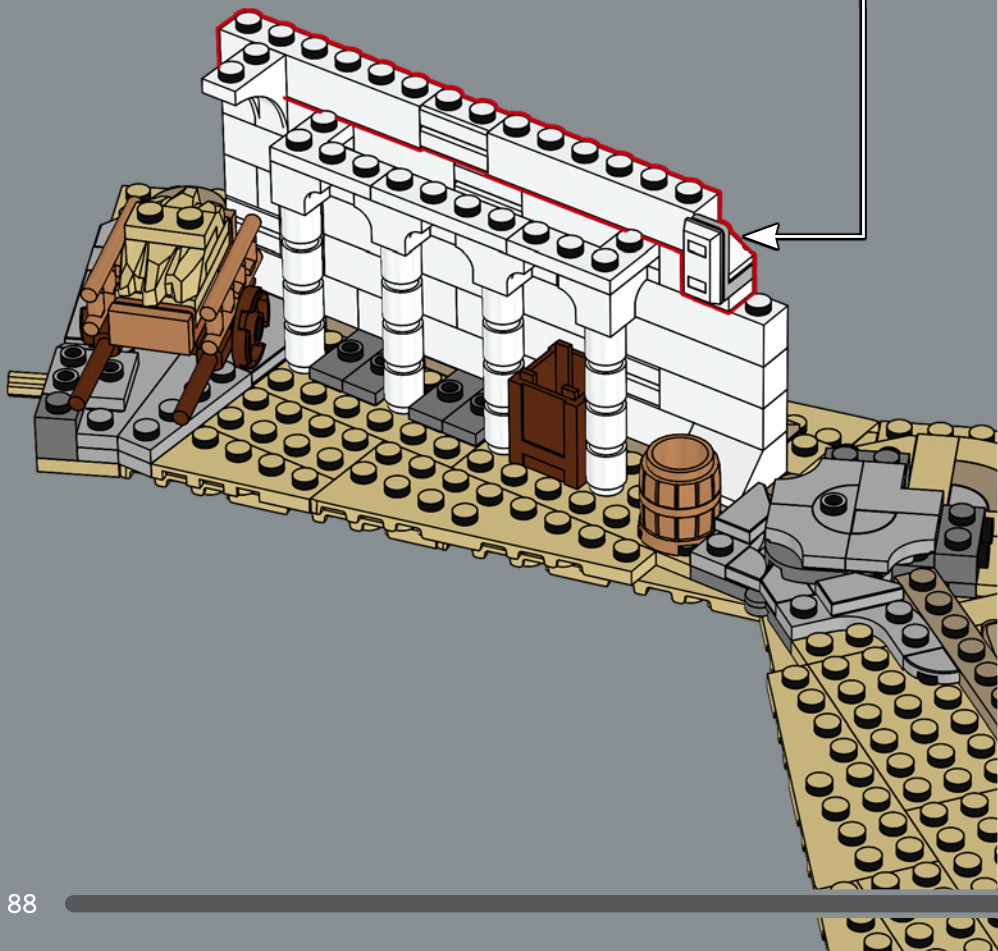
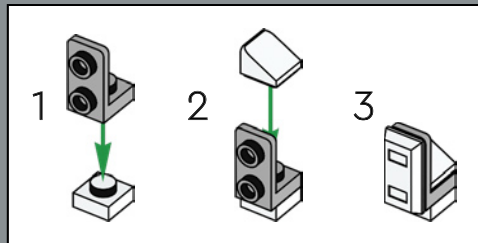

143

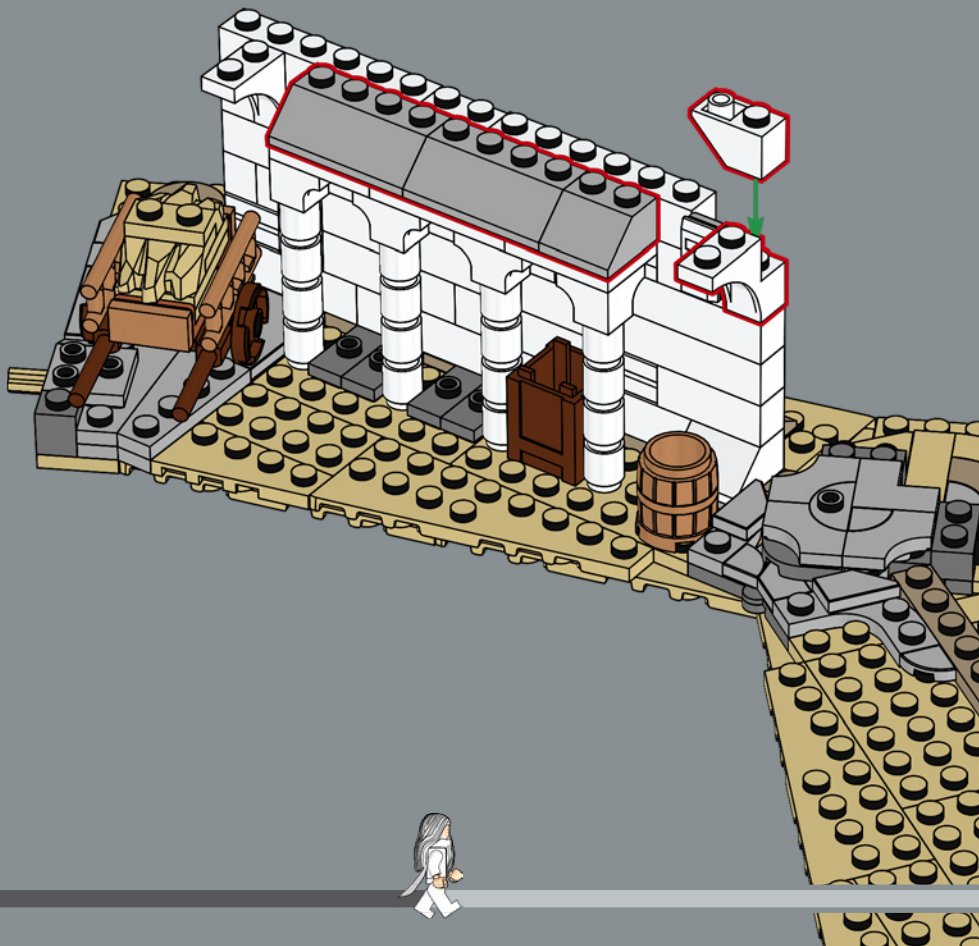



144

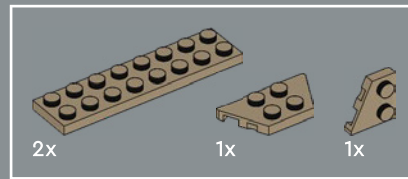
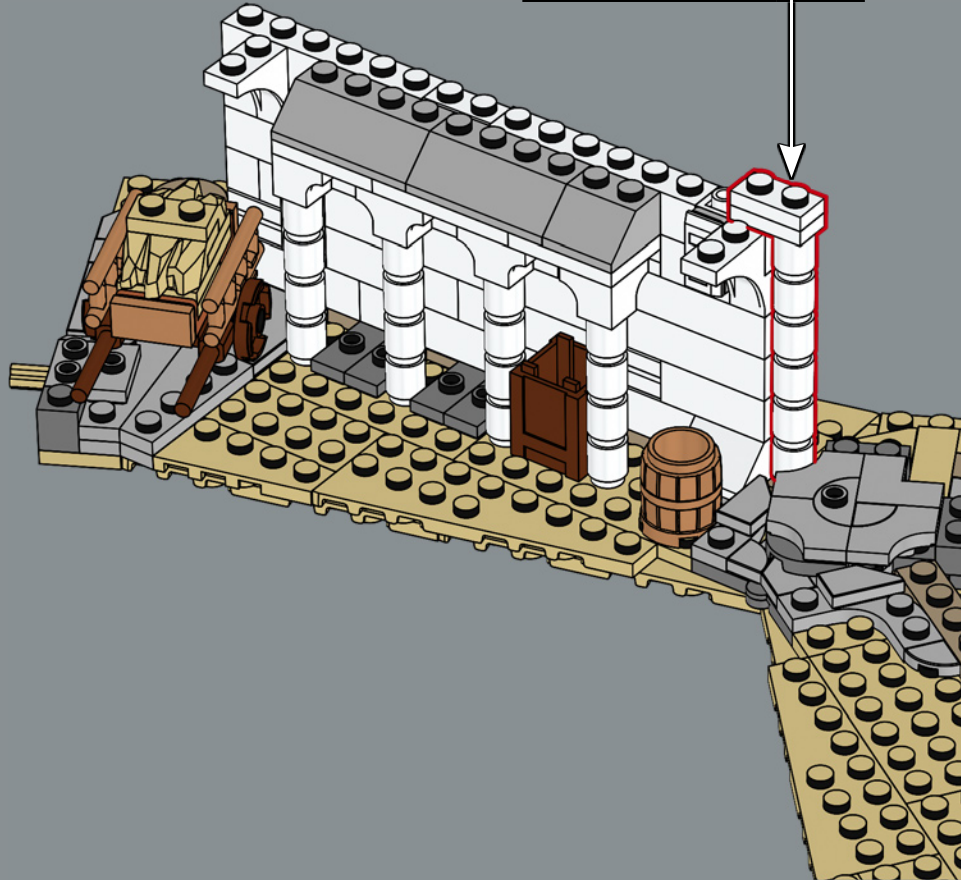
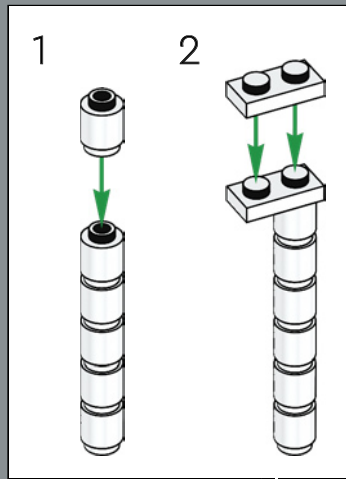

145

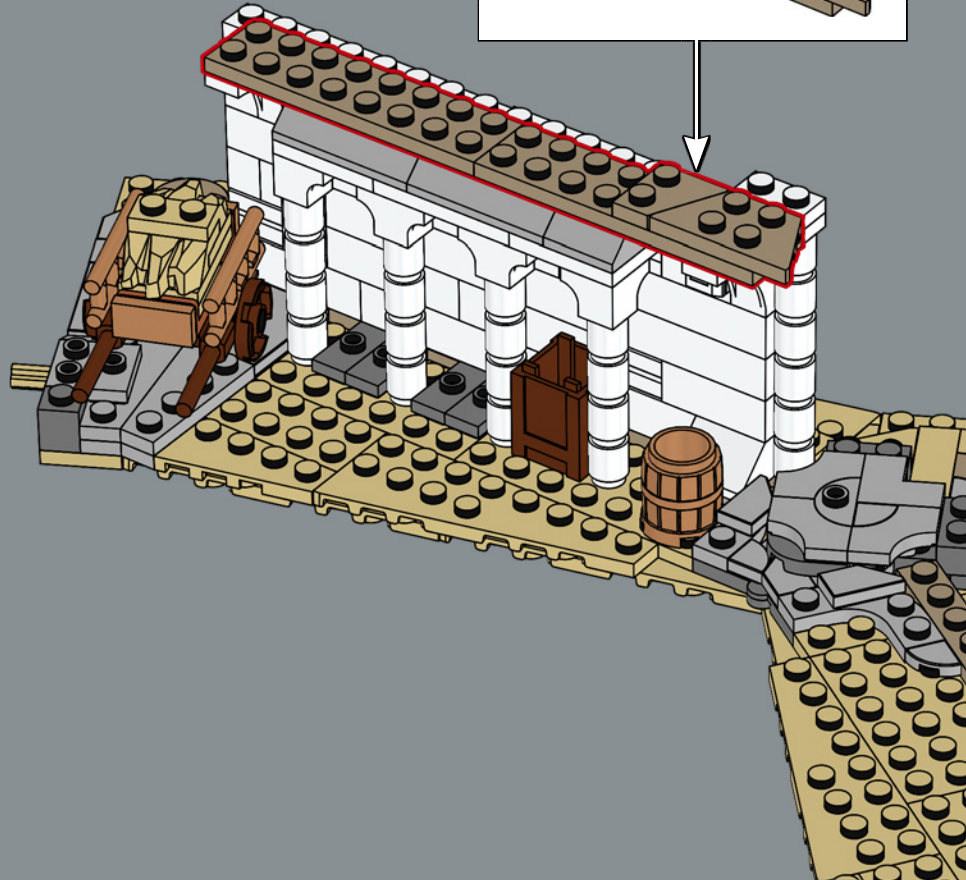
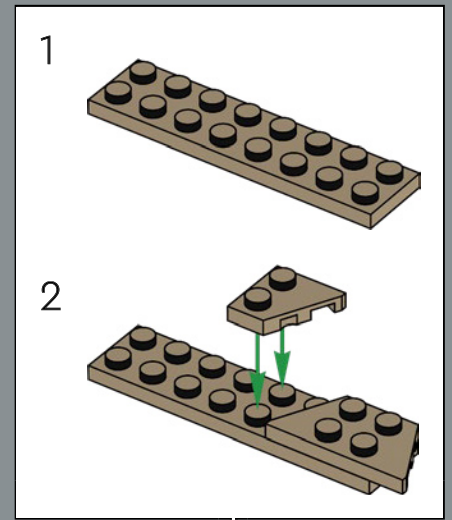

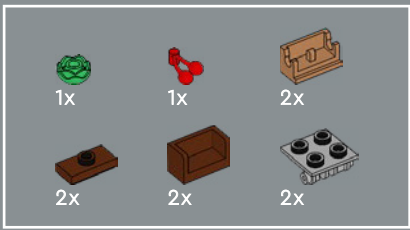

146

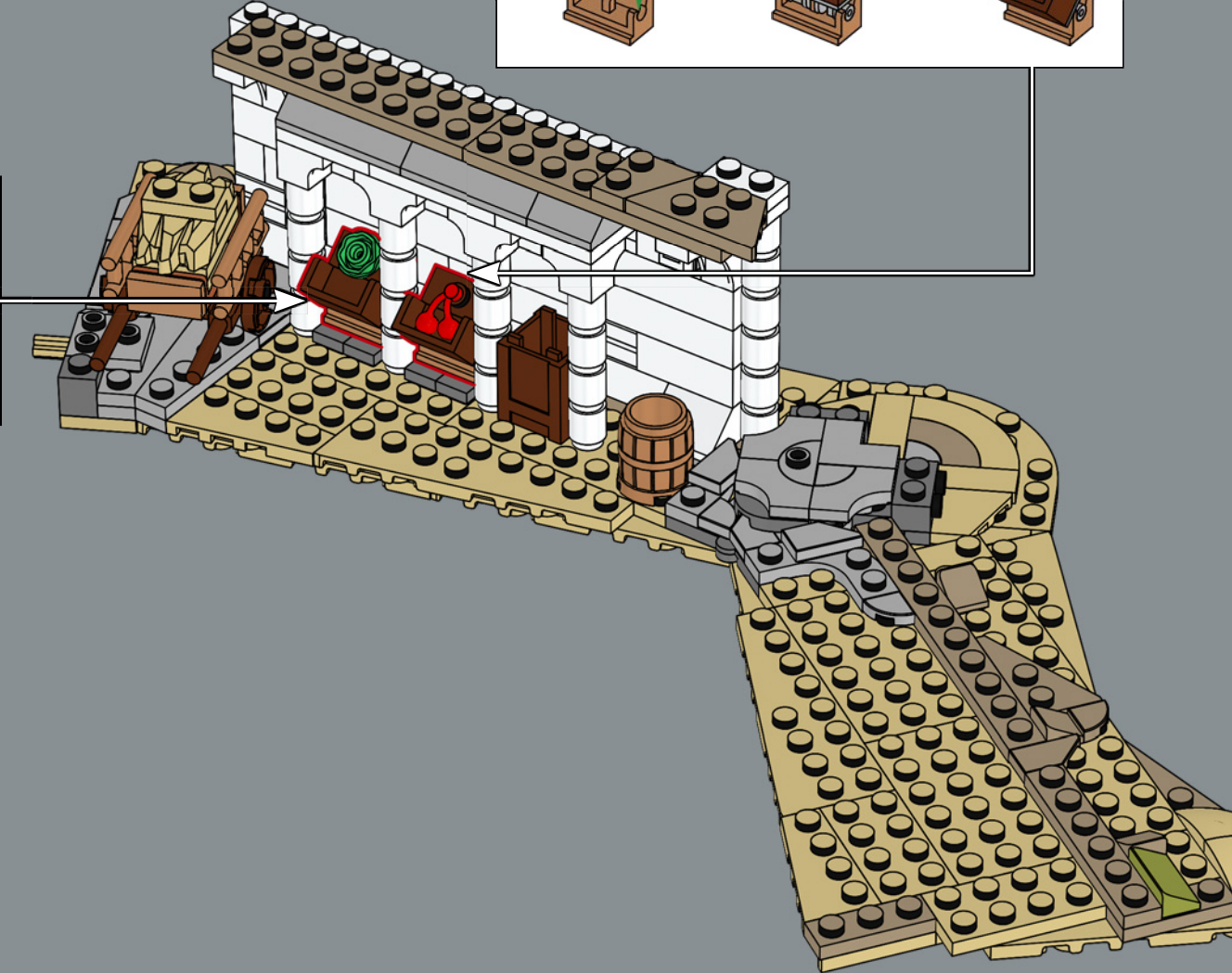
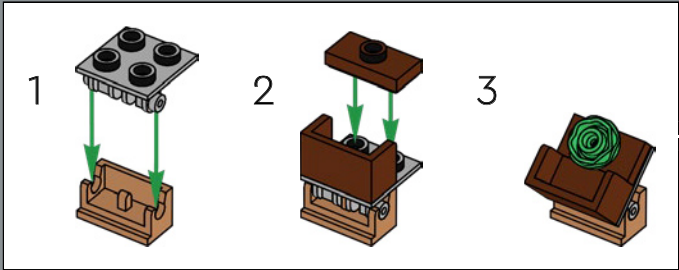
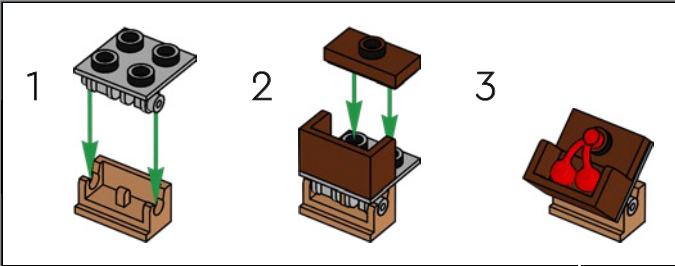

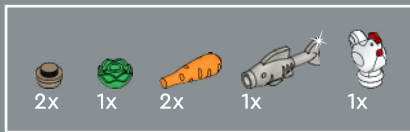

147

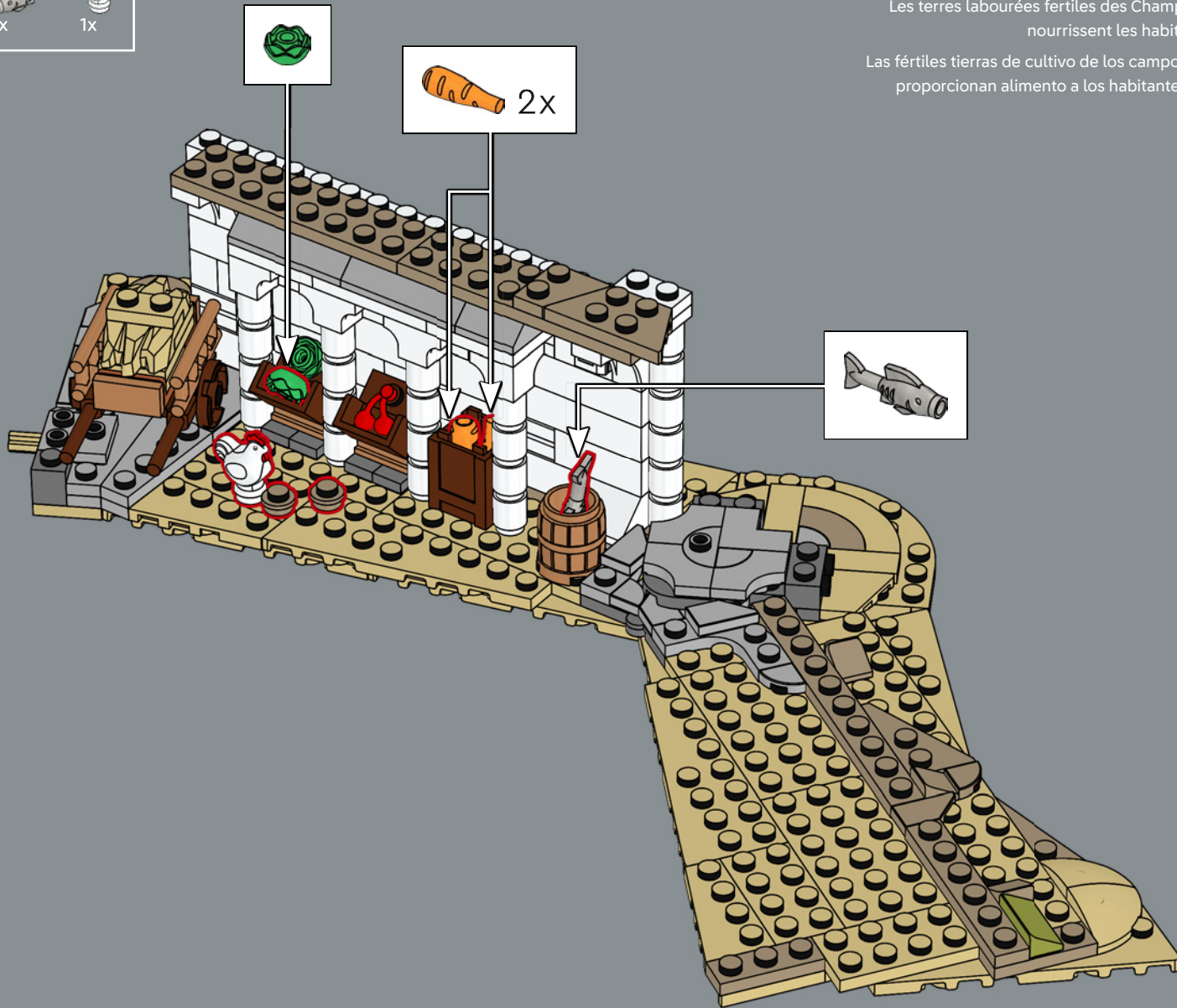

The fertile farmland of the Pelennor Fields provides food for the city's inhabitants.

Les terres labourées fertiles des Champs du Pelennor nourrissent les habitants de la cité.

Las fértiles tierras de cultivo de los campos del Pelennor proporcionan alimento a los habitantes de la ciudad.



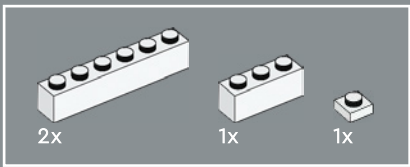

148

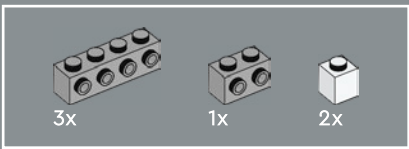
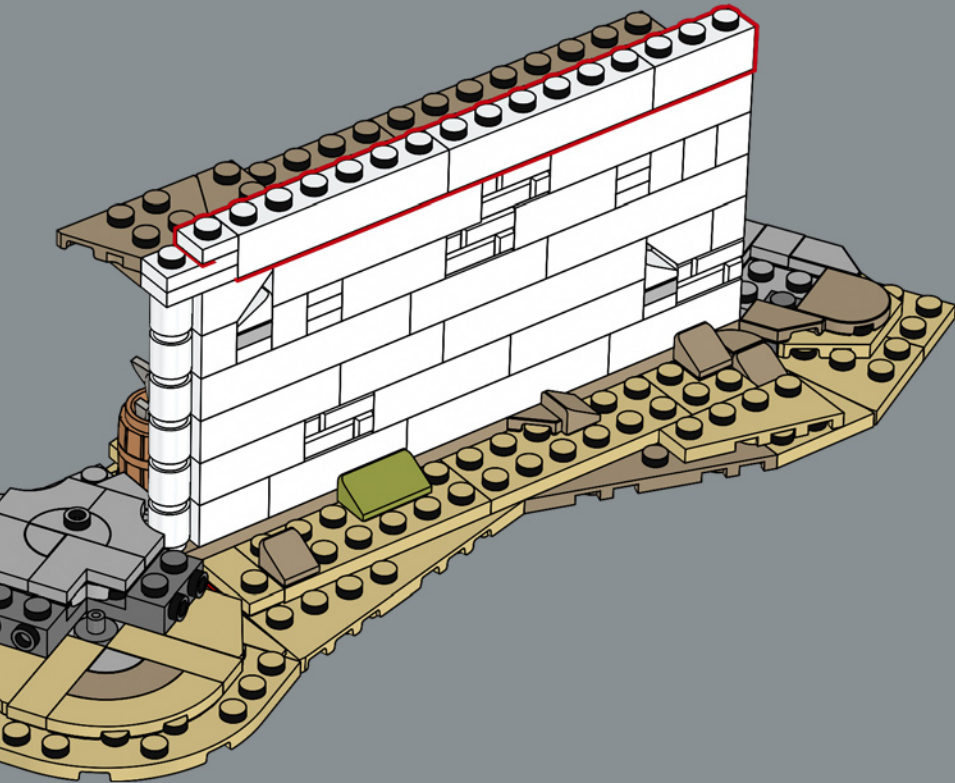

149

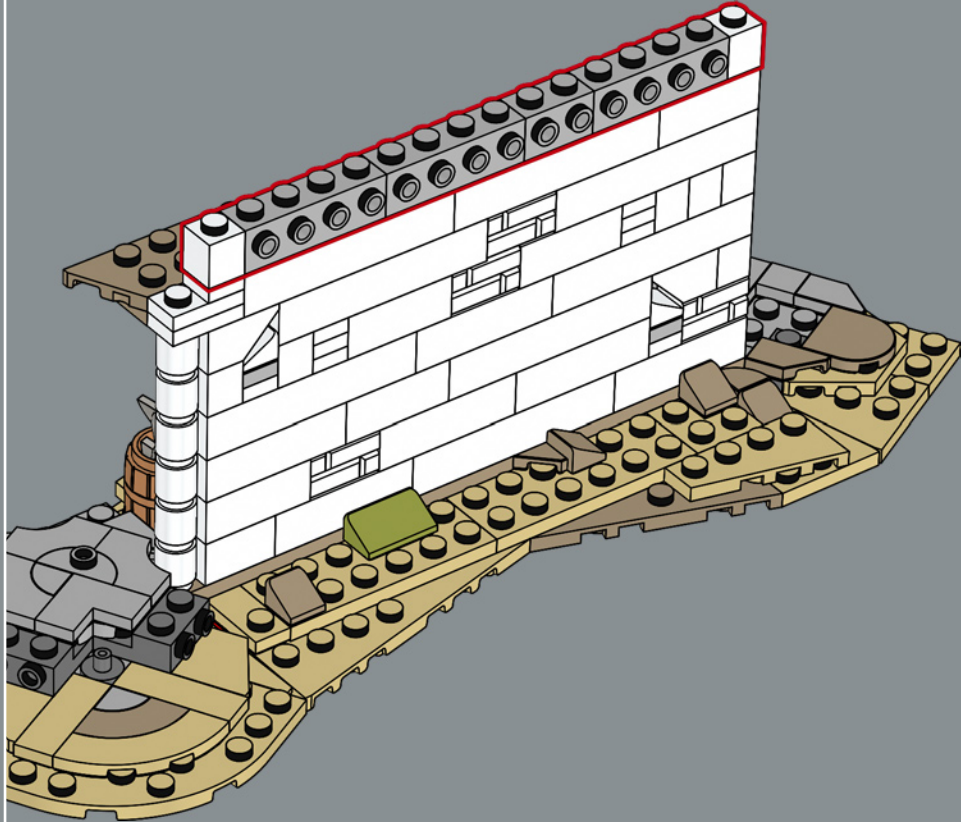

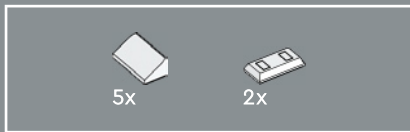

150

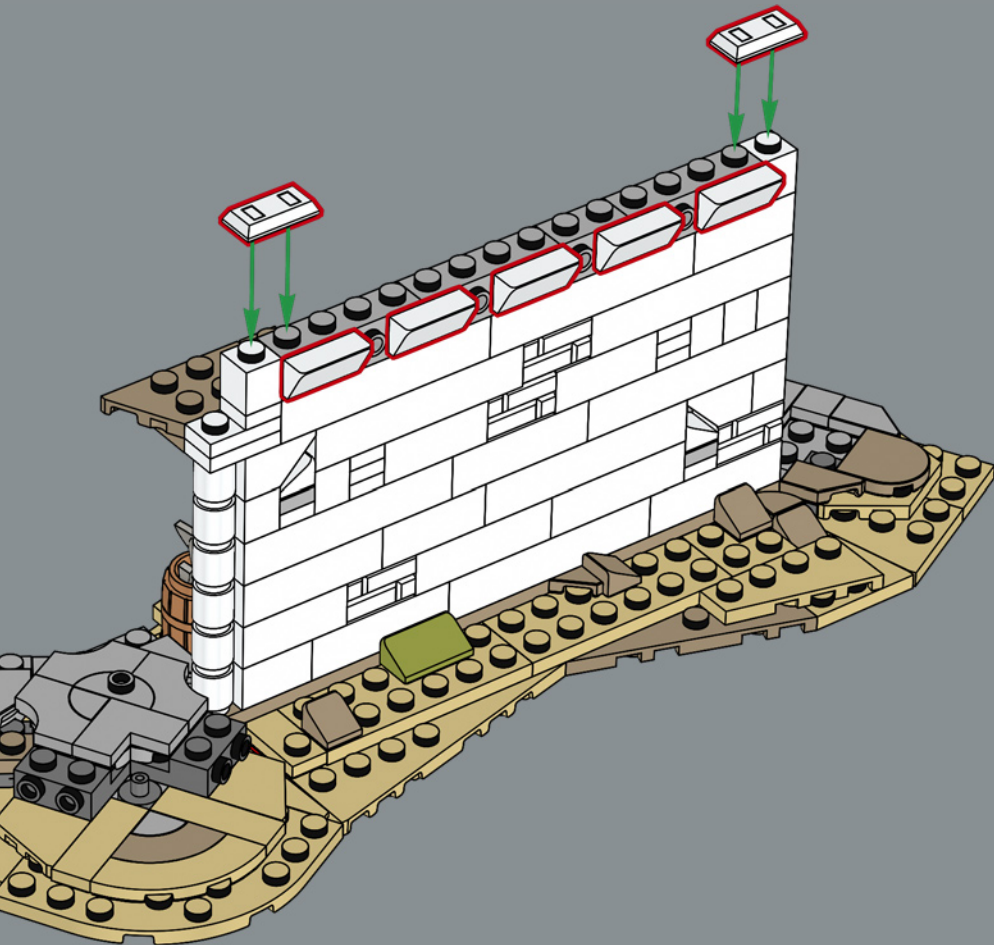

151

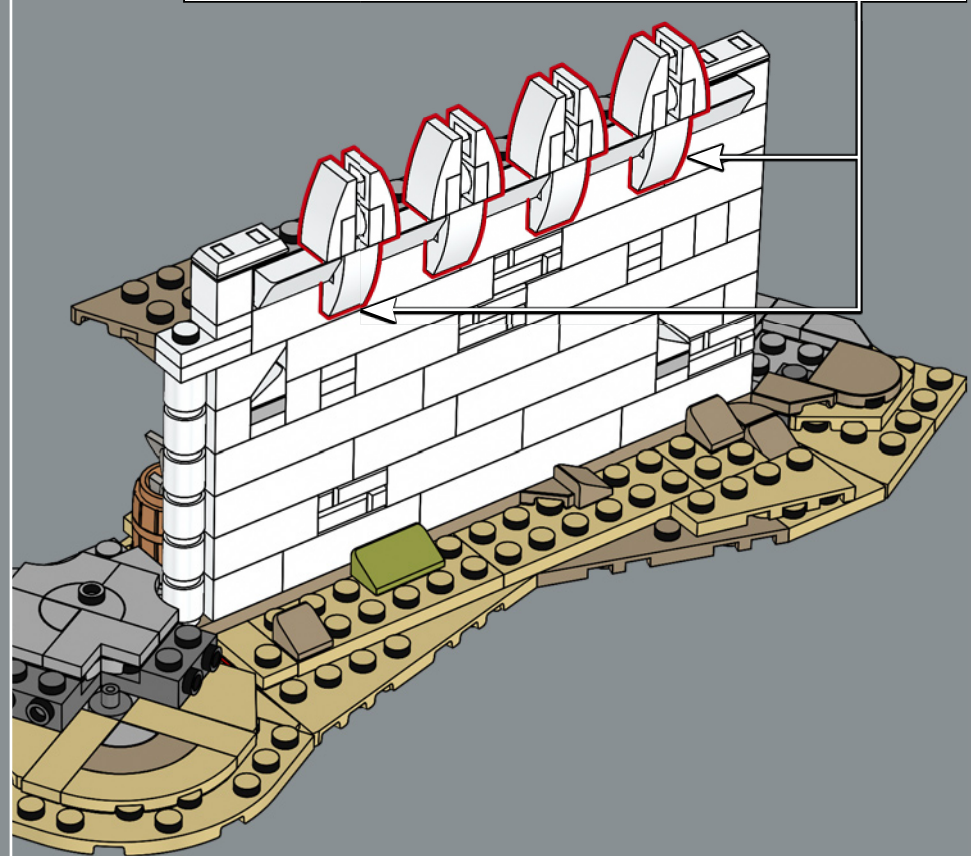
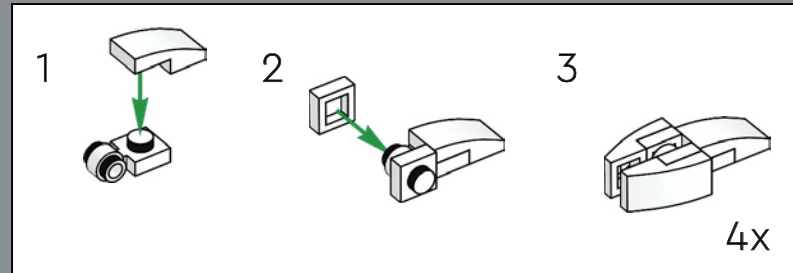

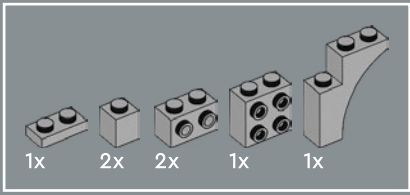

152

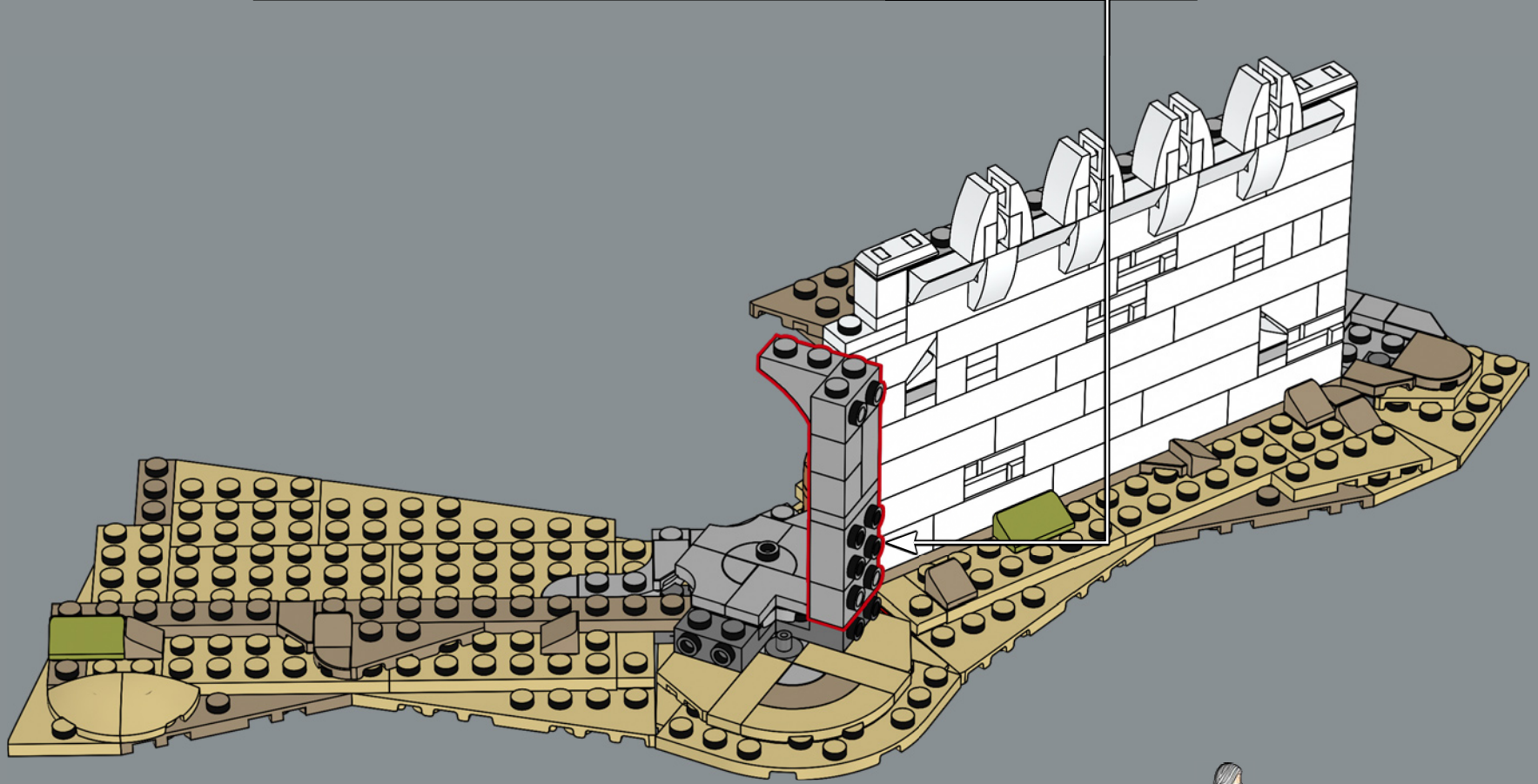
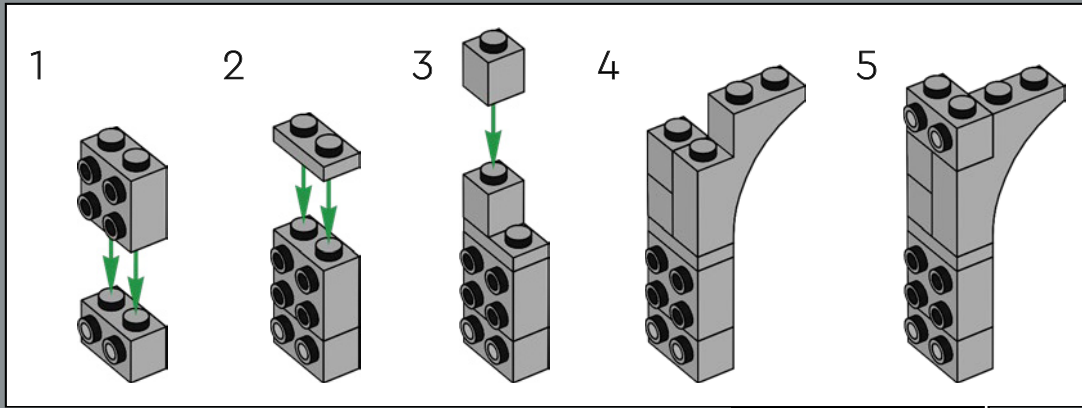

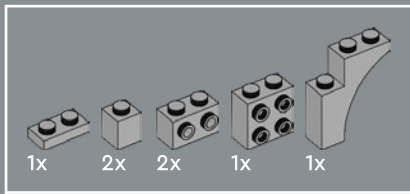

153

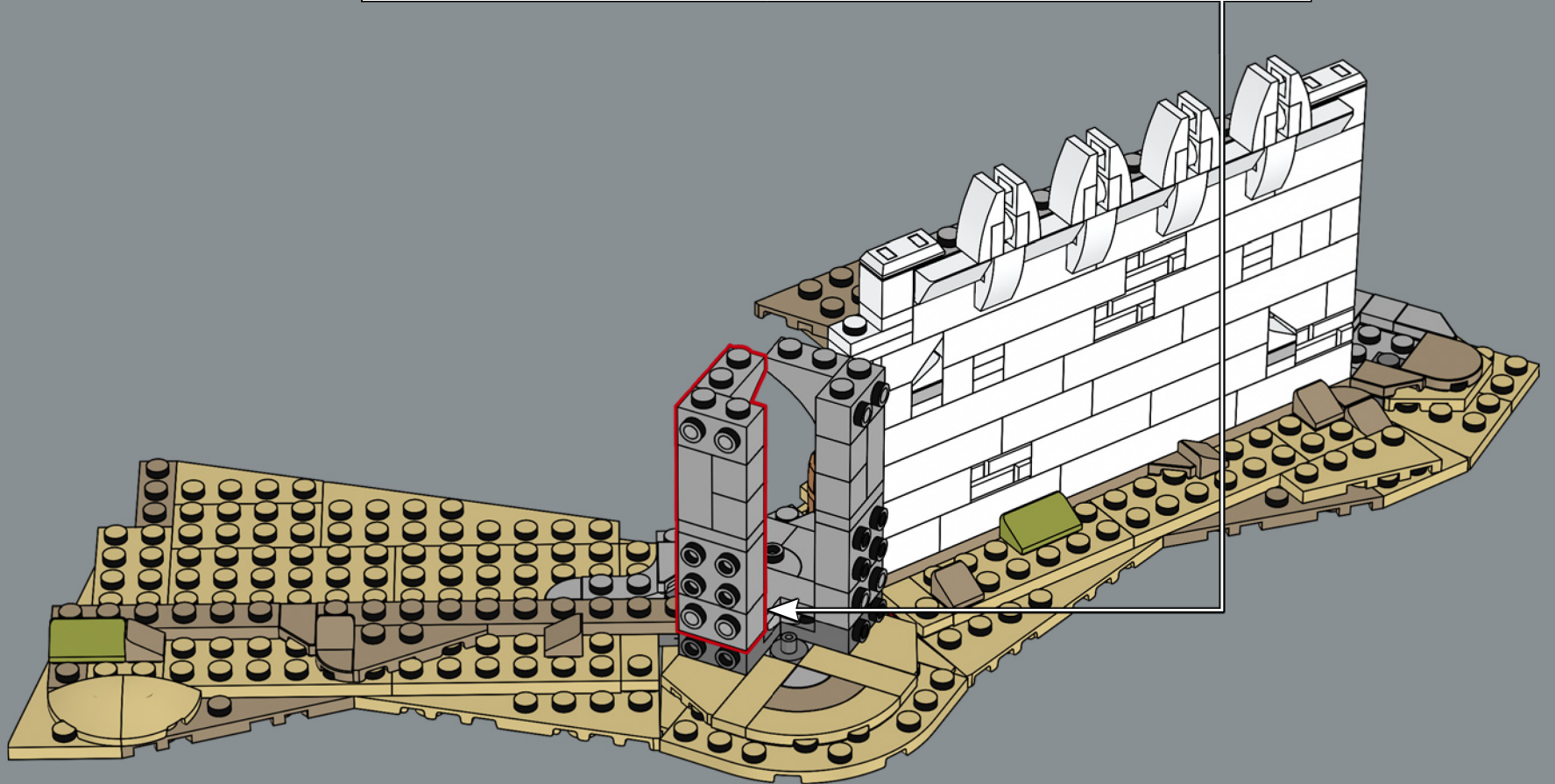
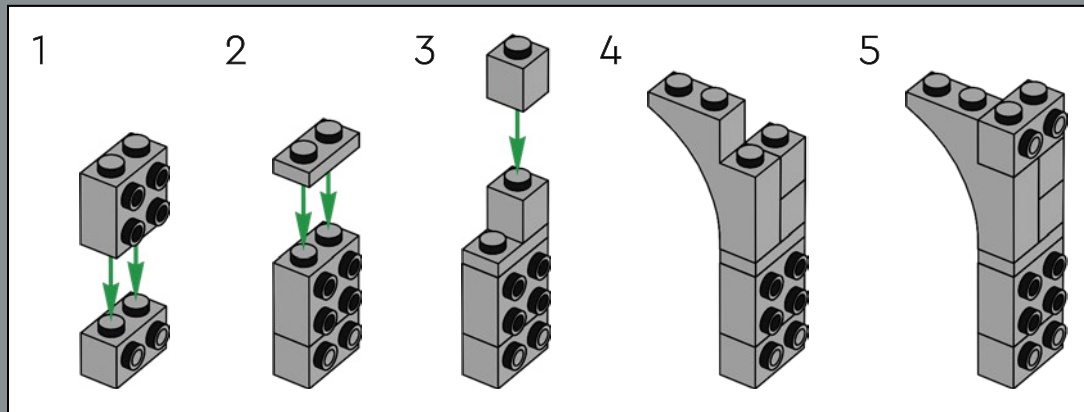

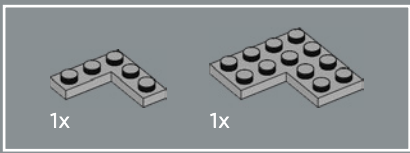

154

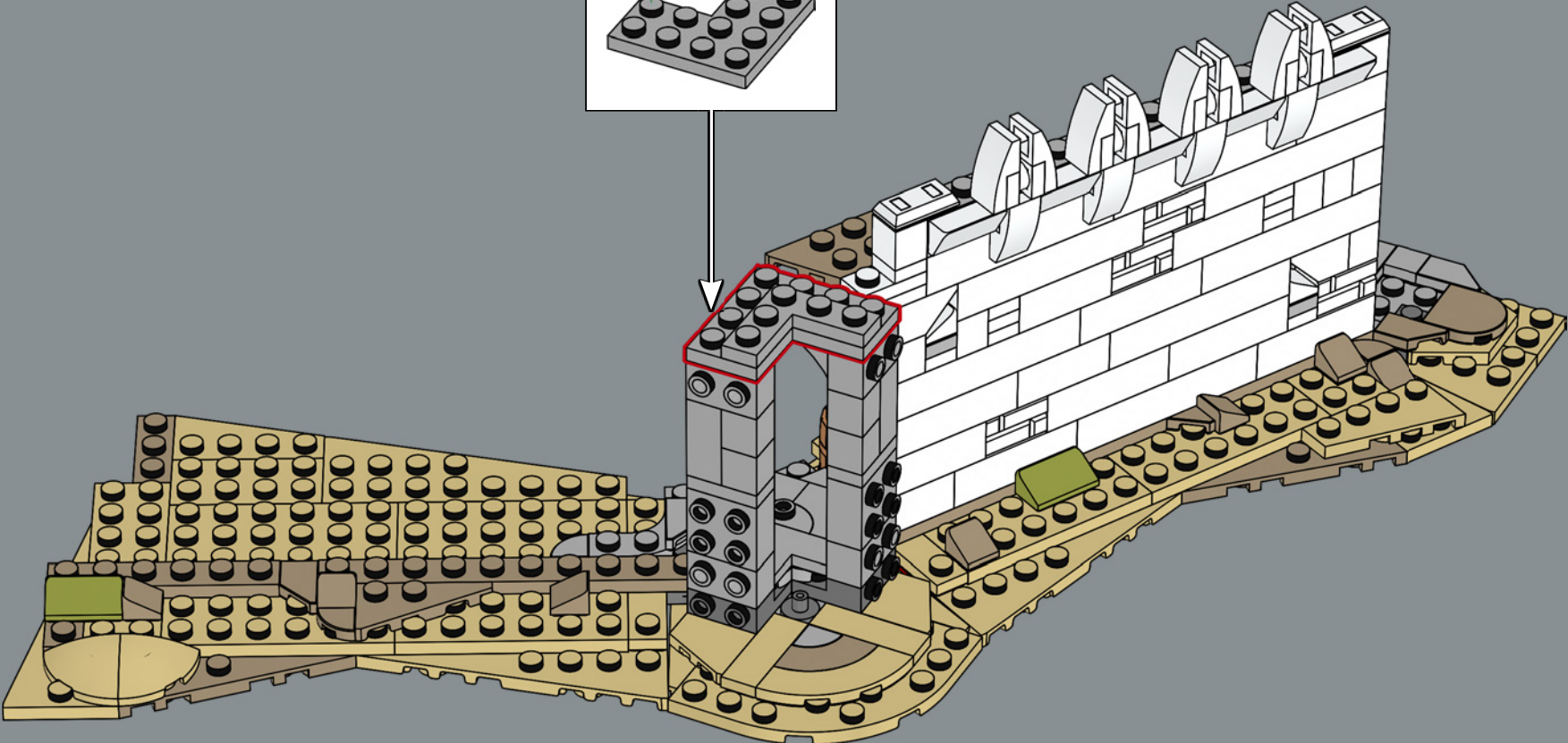
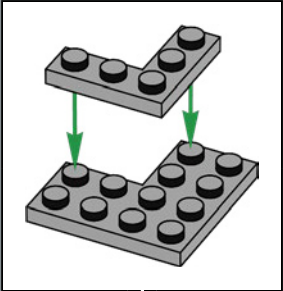

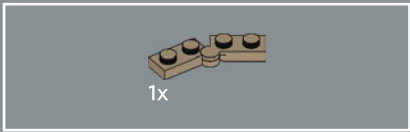

155

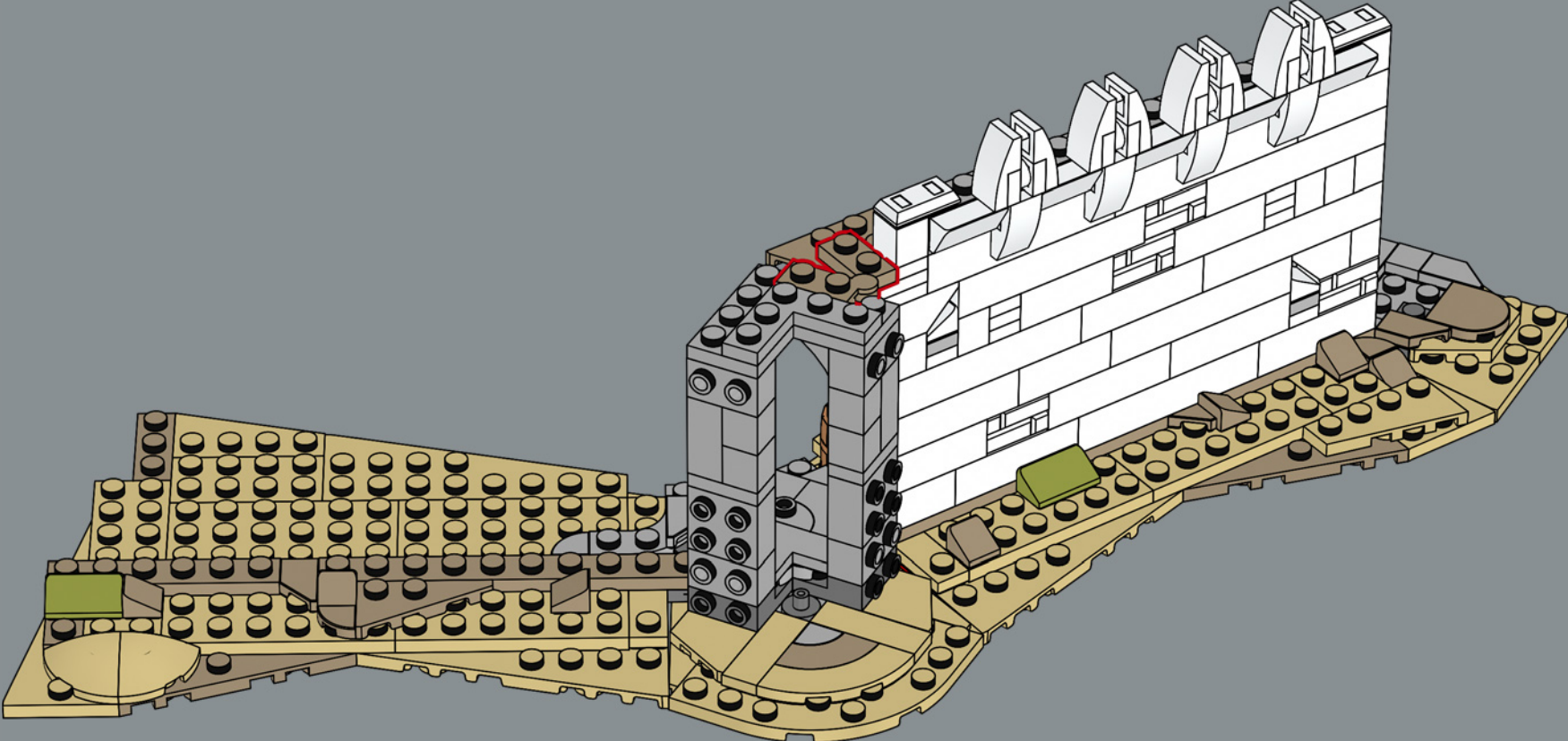

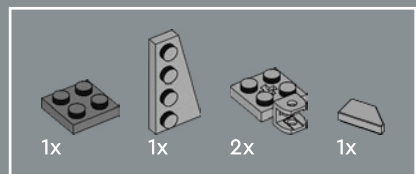

156

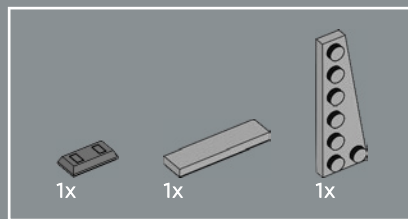
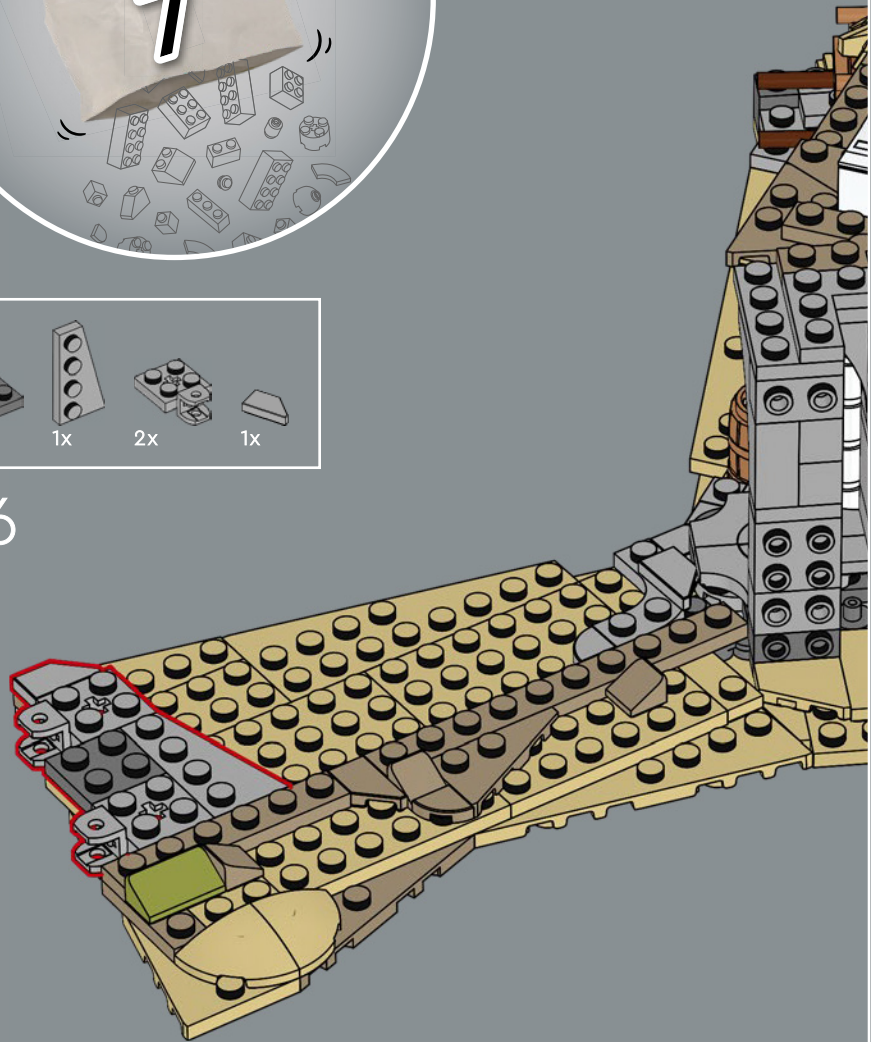

157

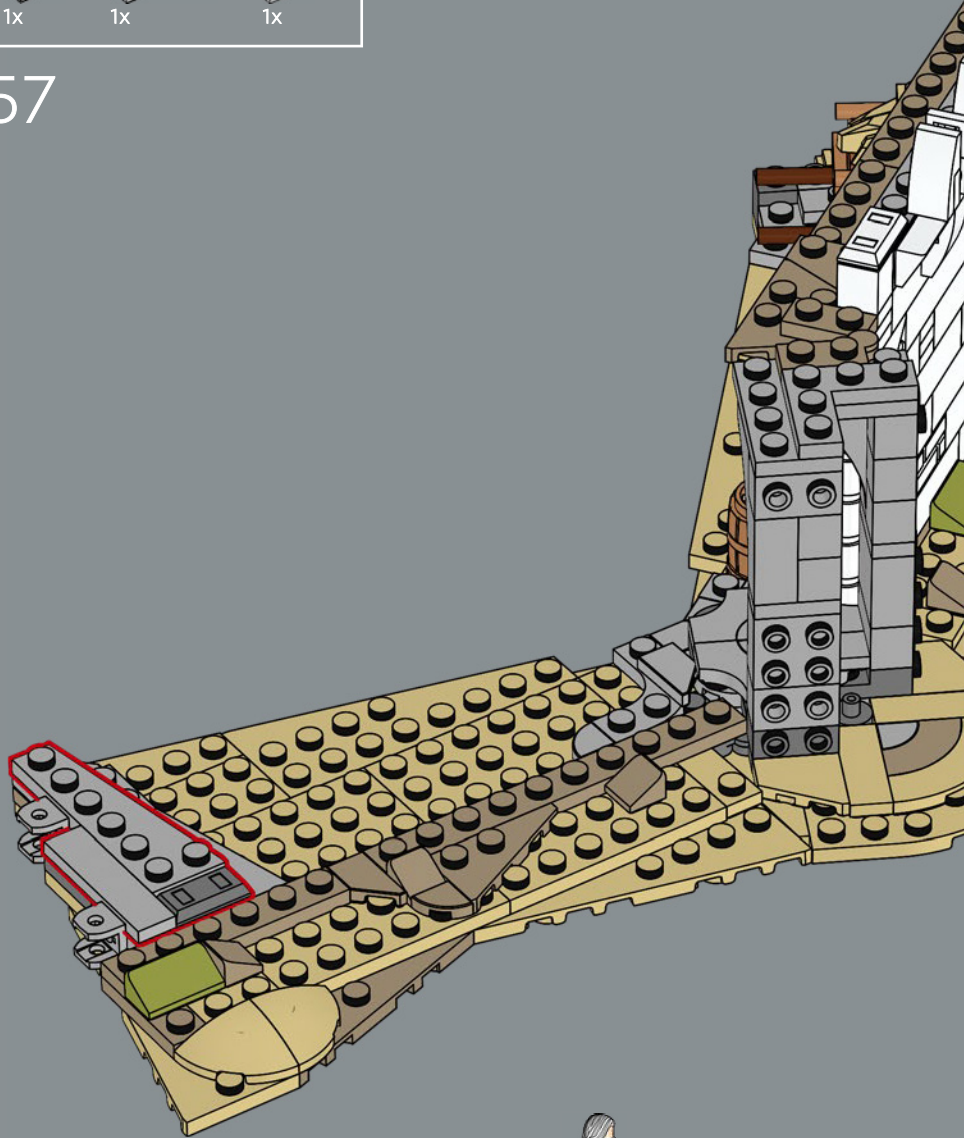

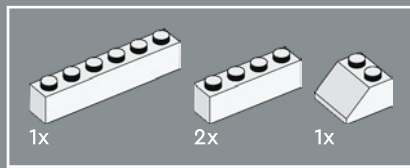

158

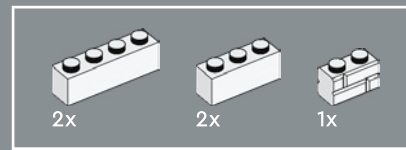
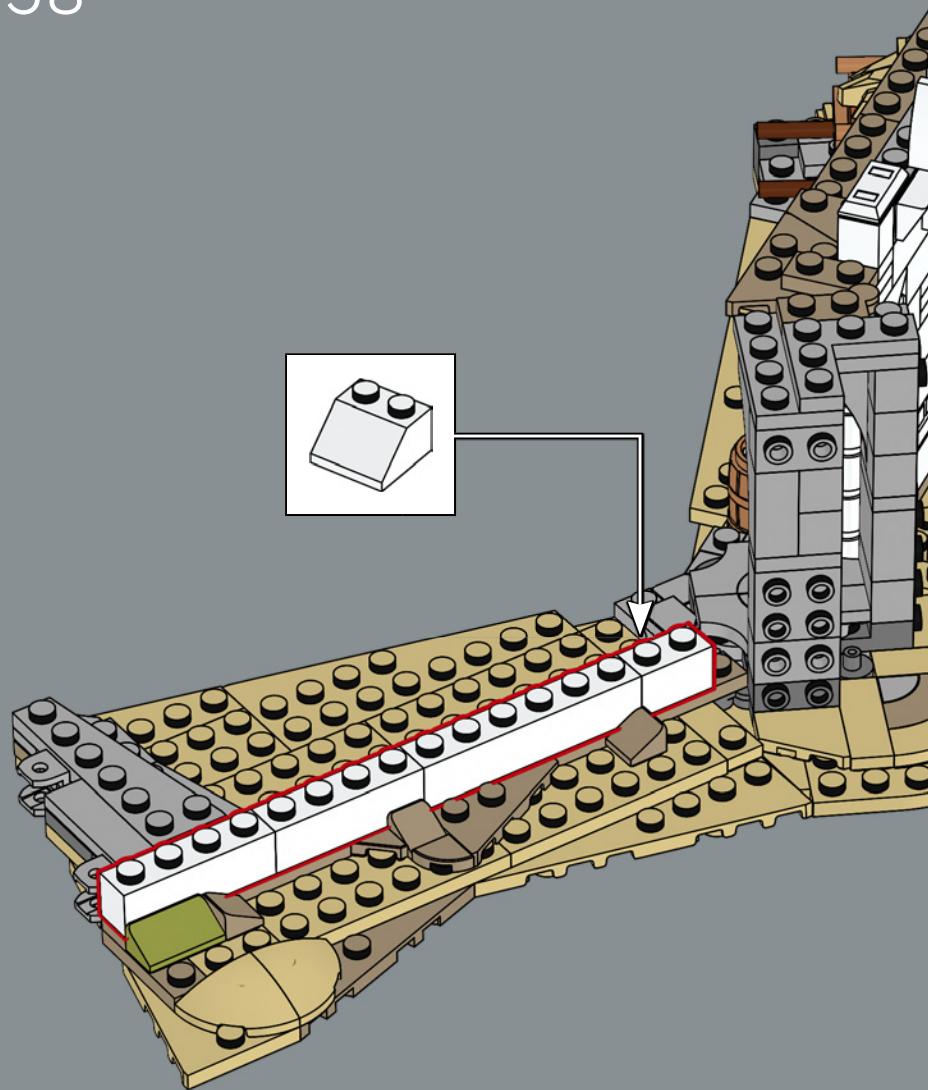

159

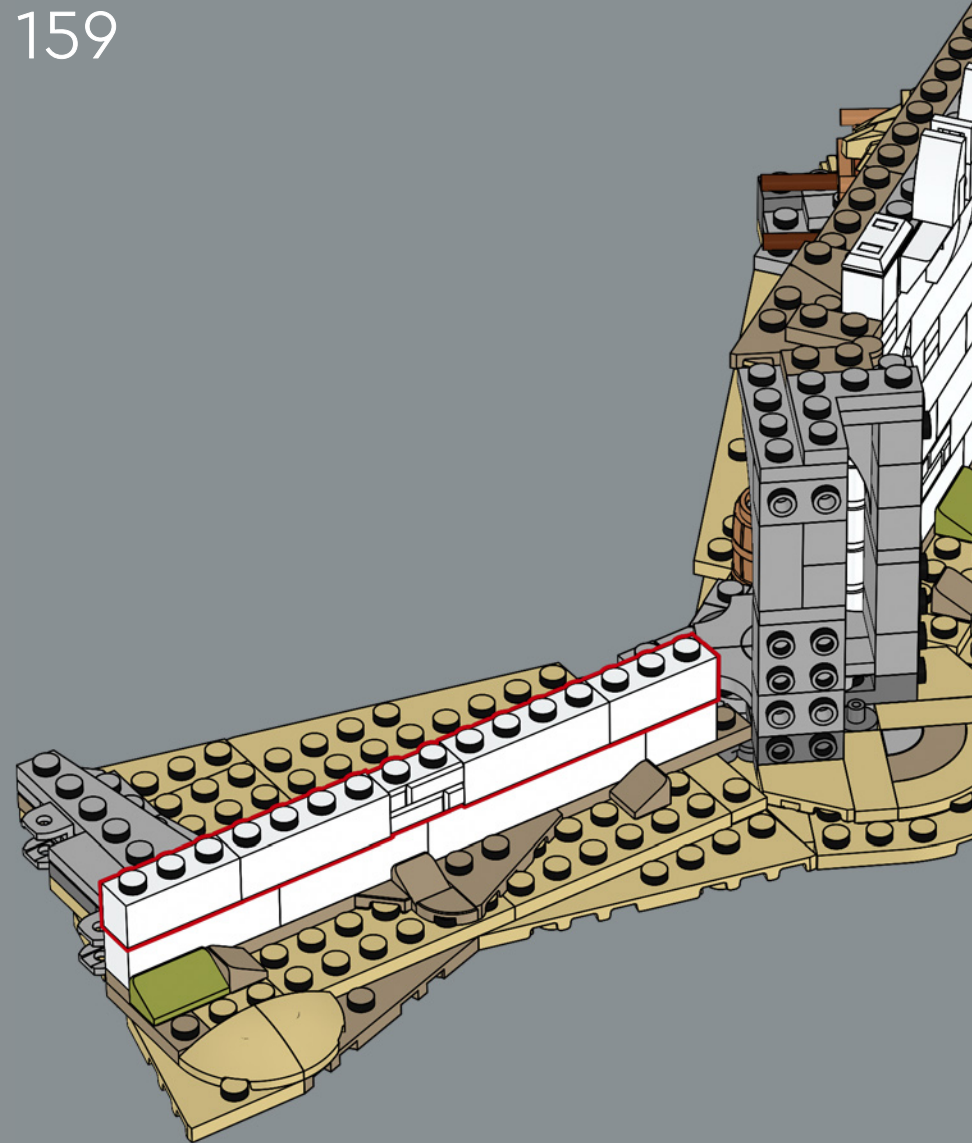

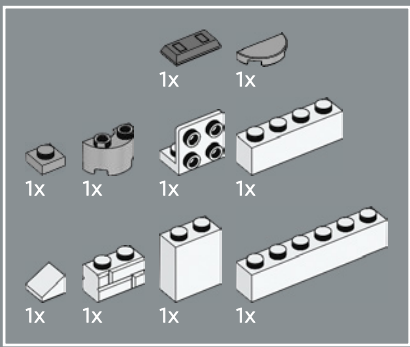

160

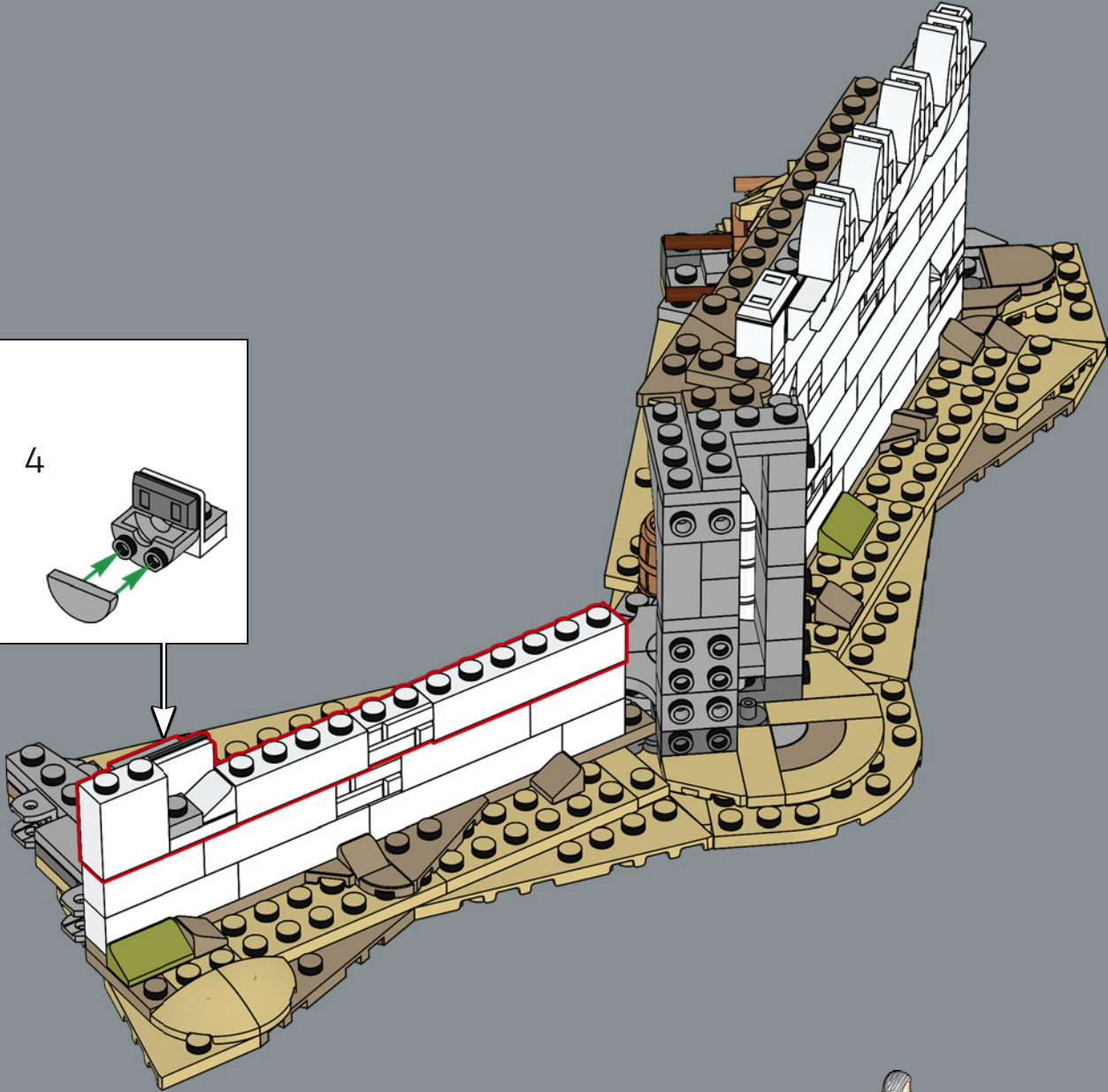
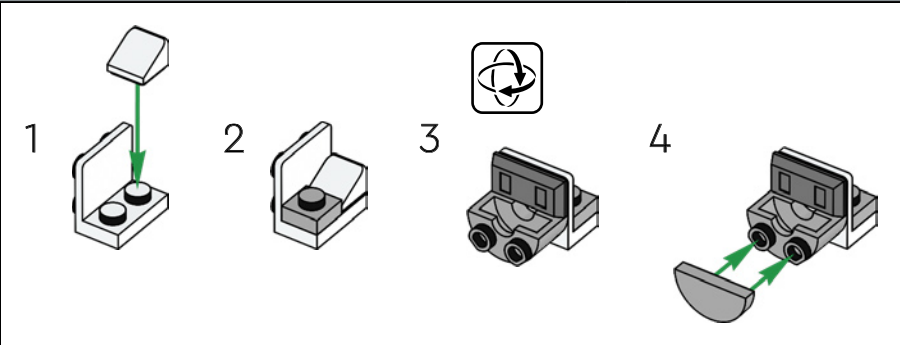

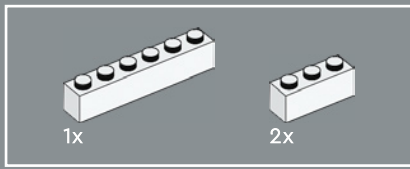

161

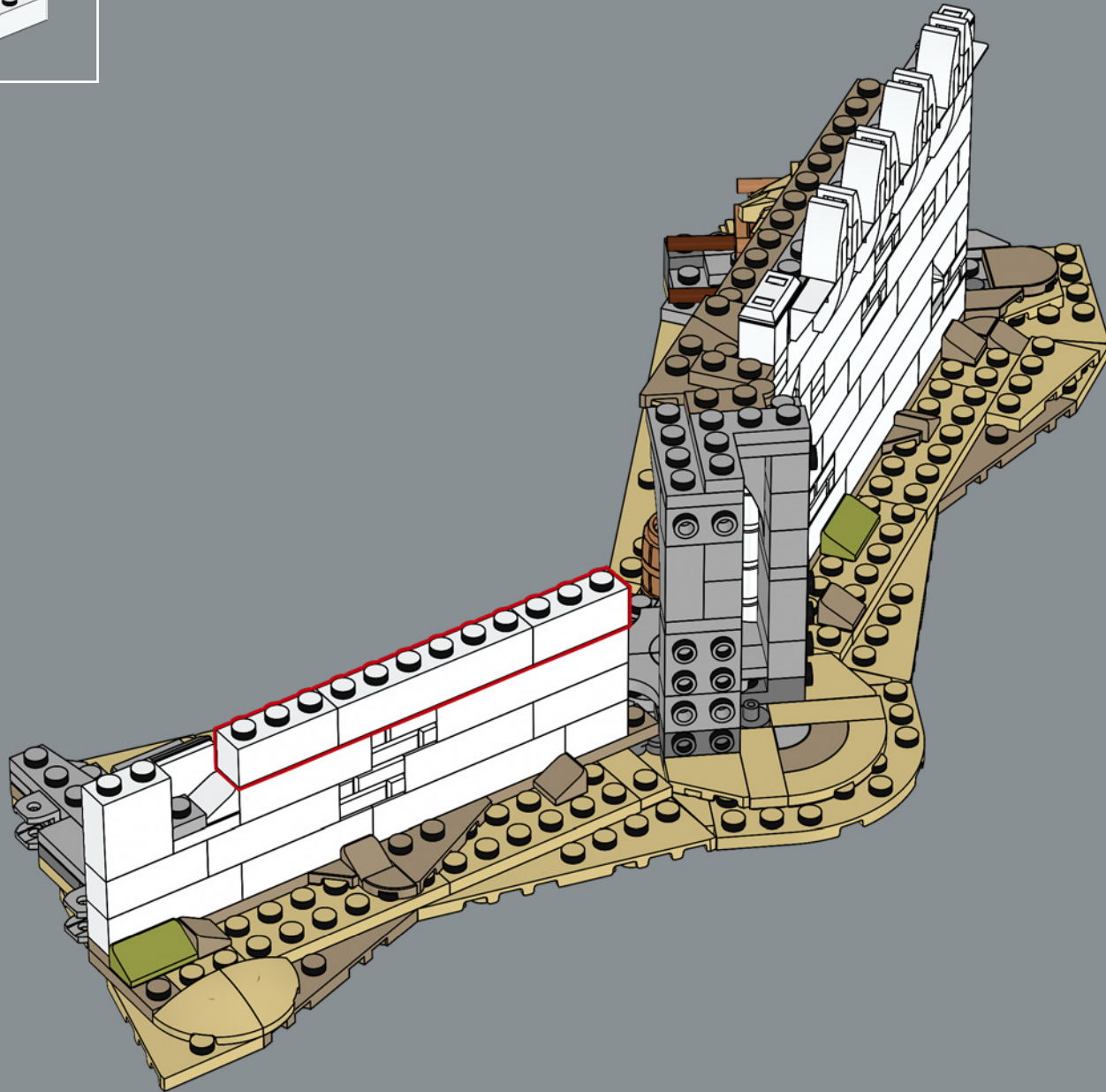

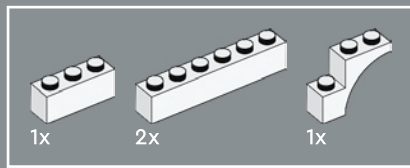

163

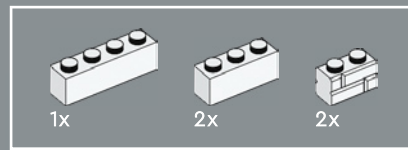
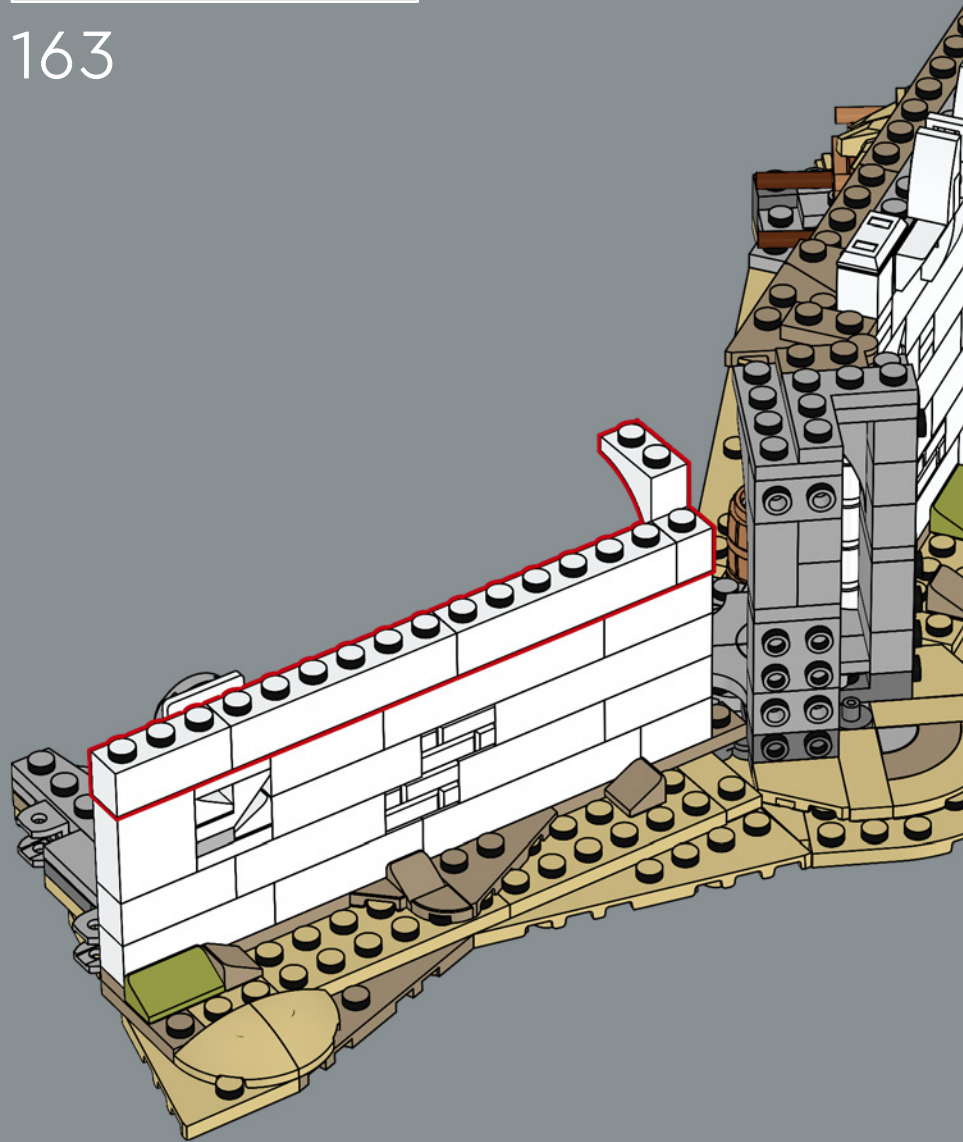

164

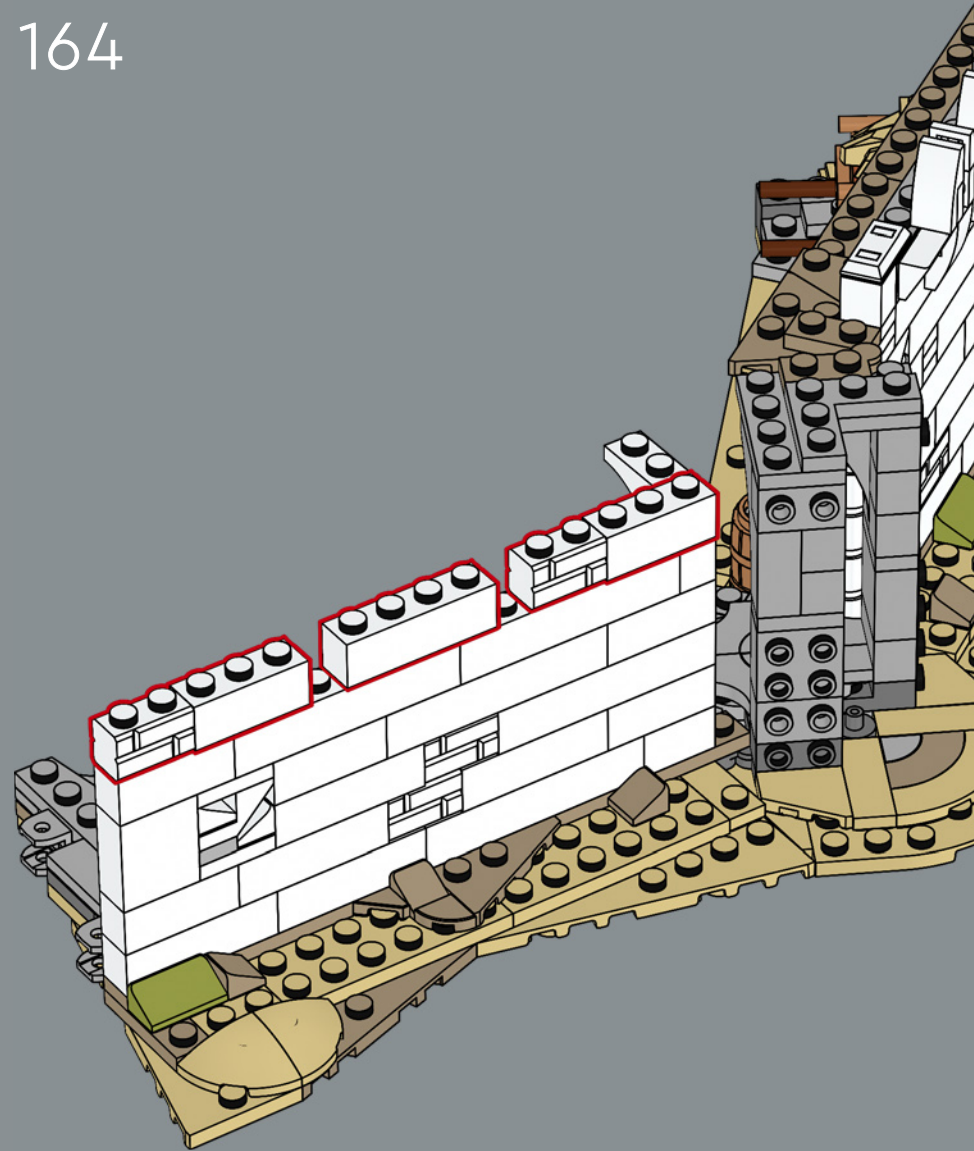

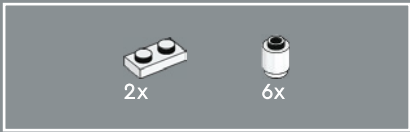

165

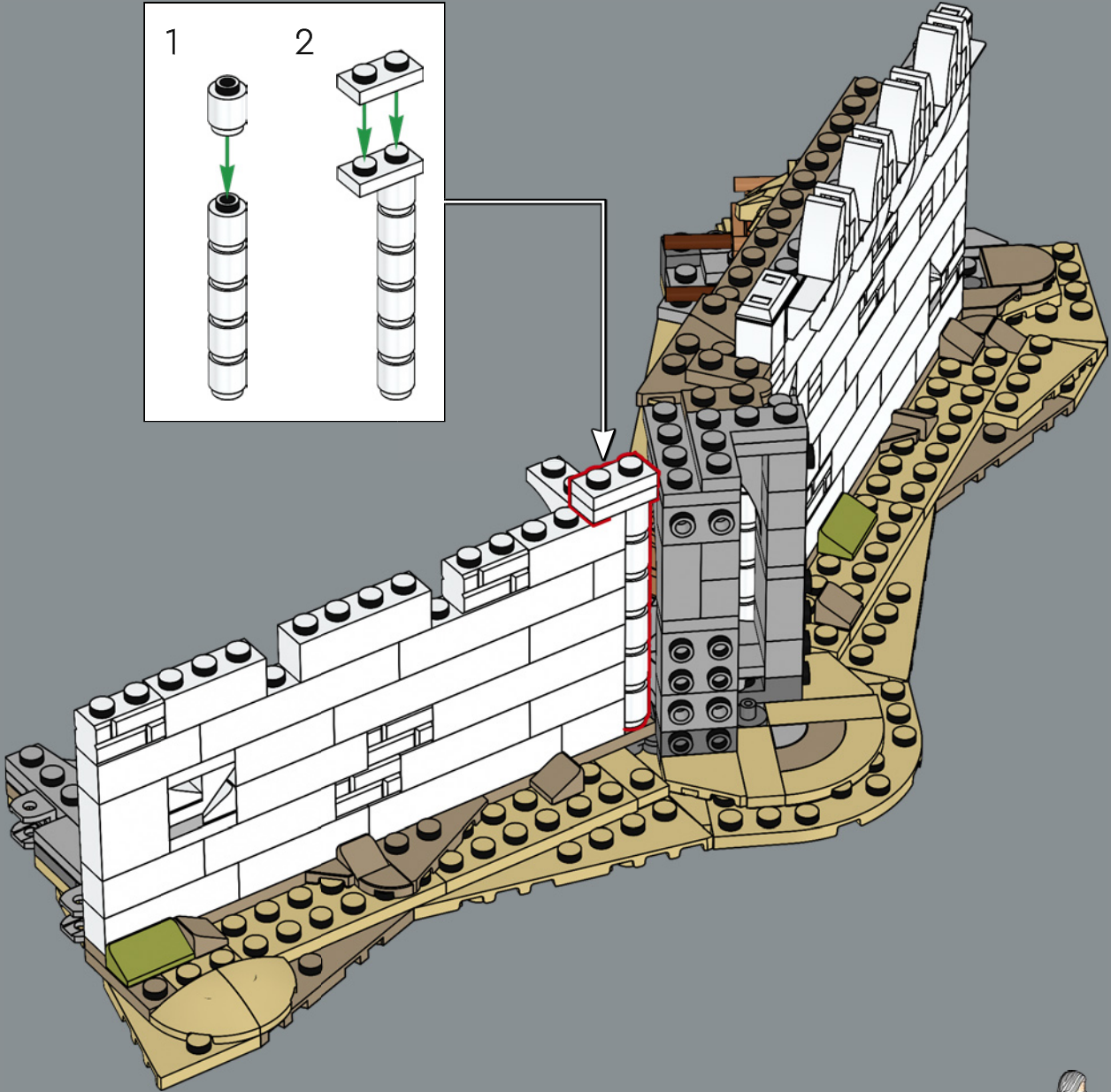
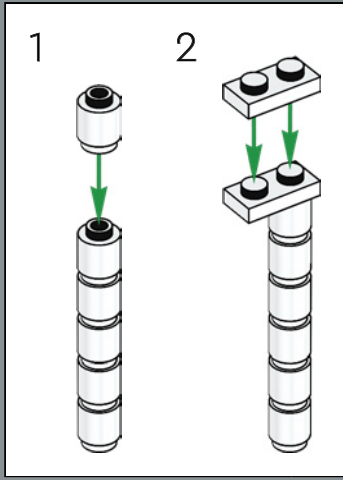

 2x	 2x	 3x
--	--	--

166

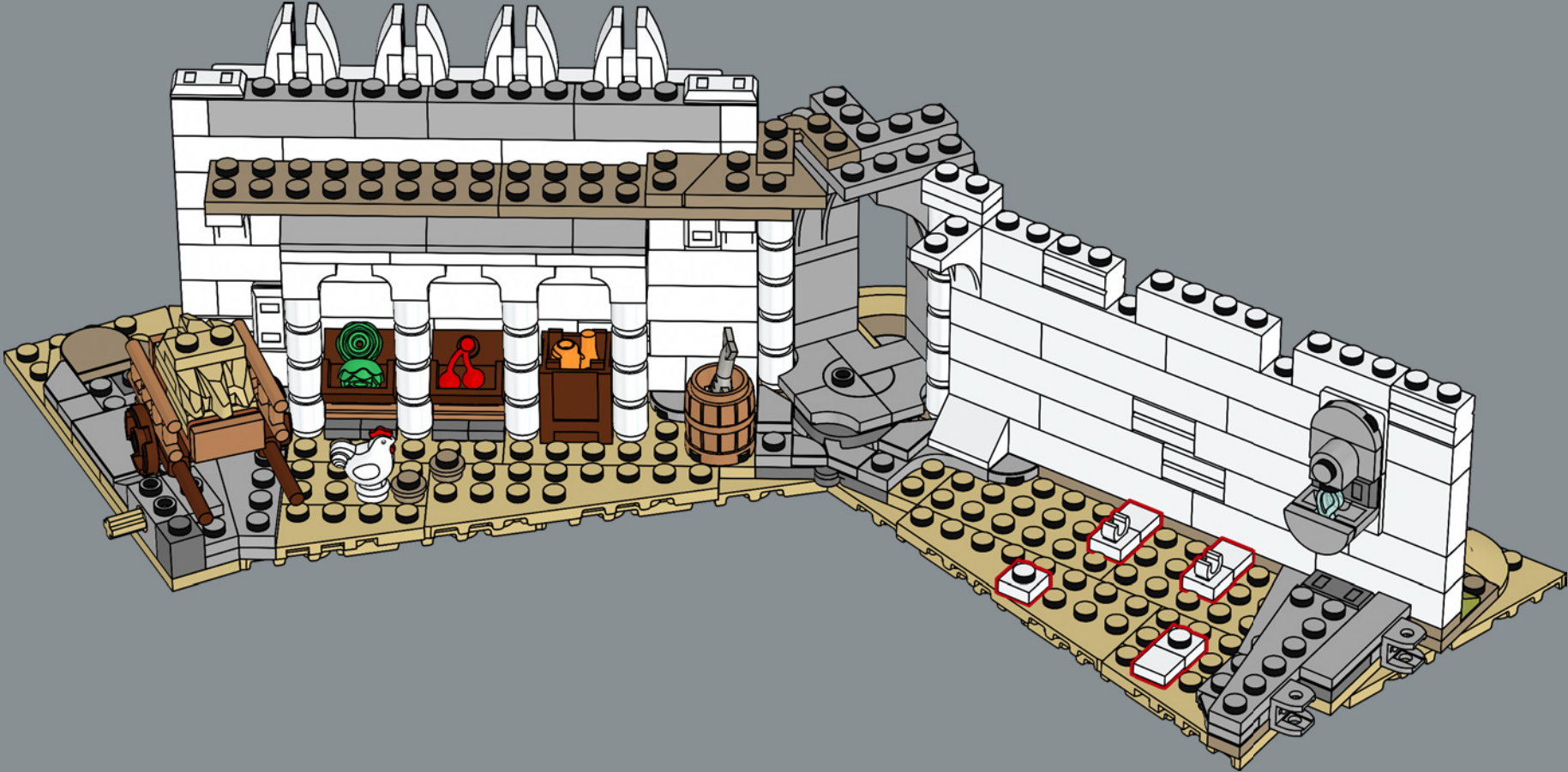

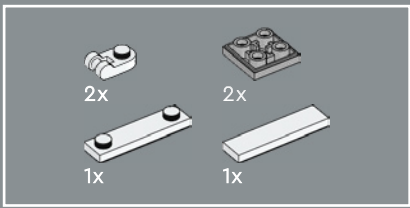

167

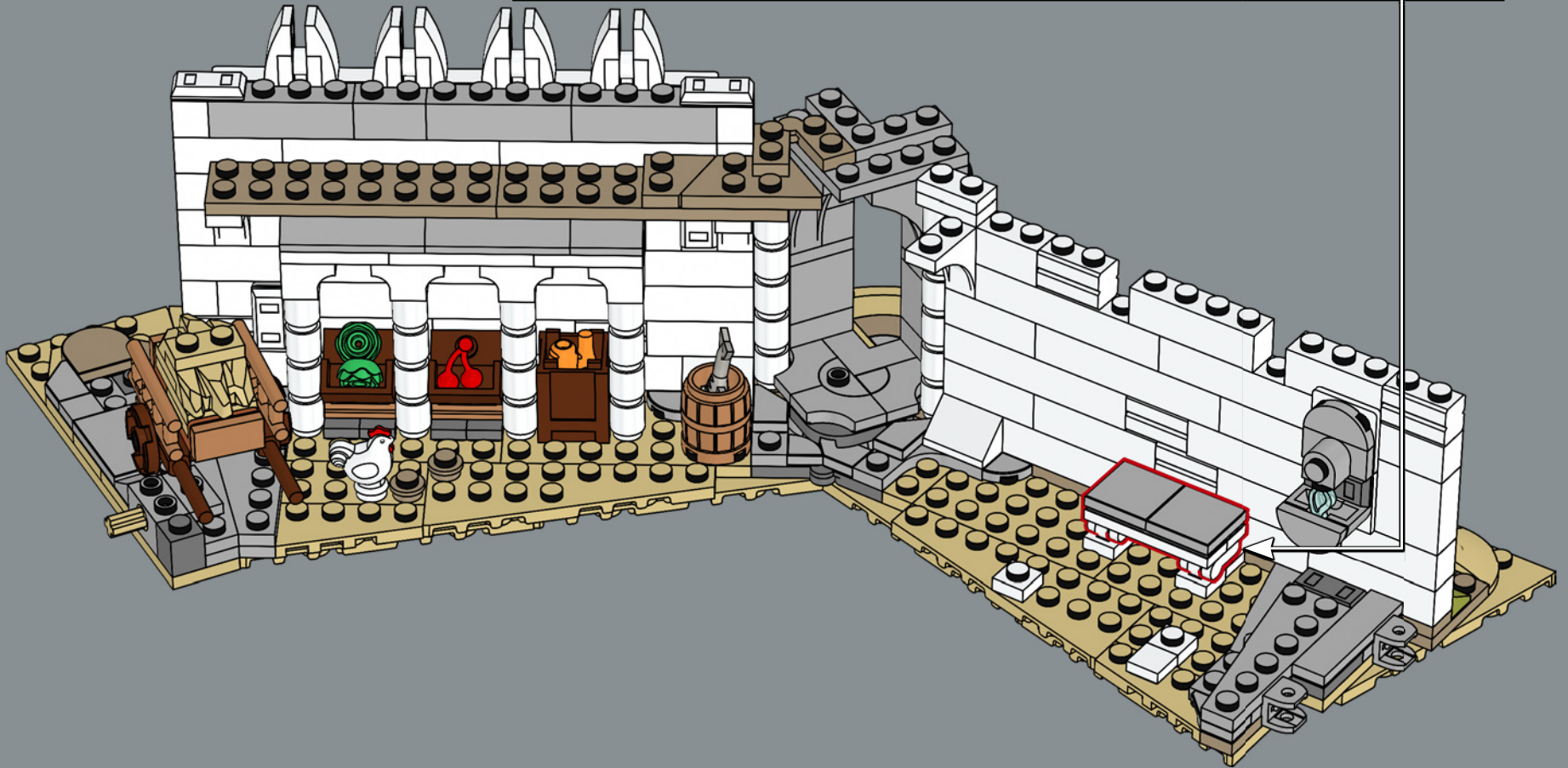
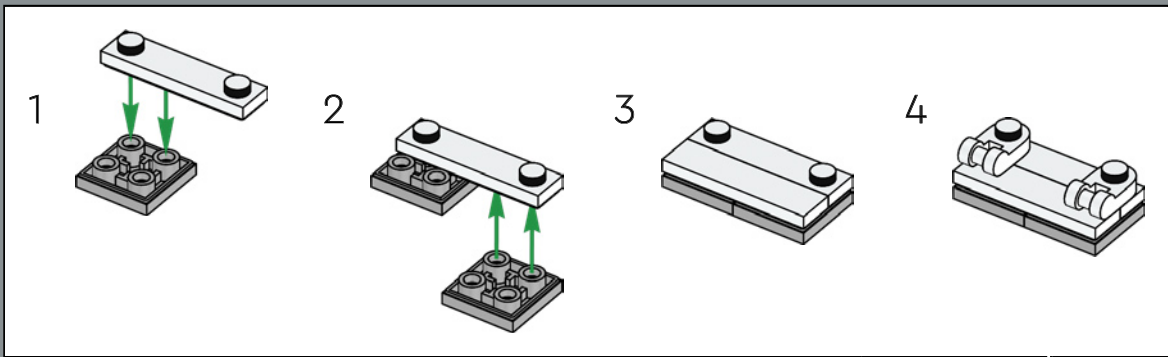

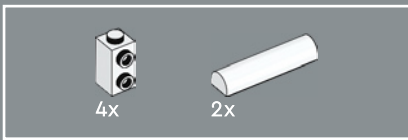

168

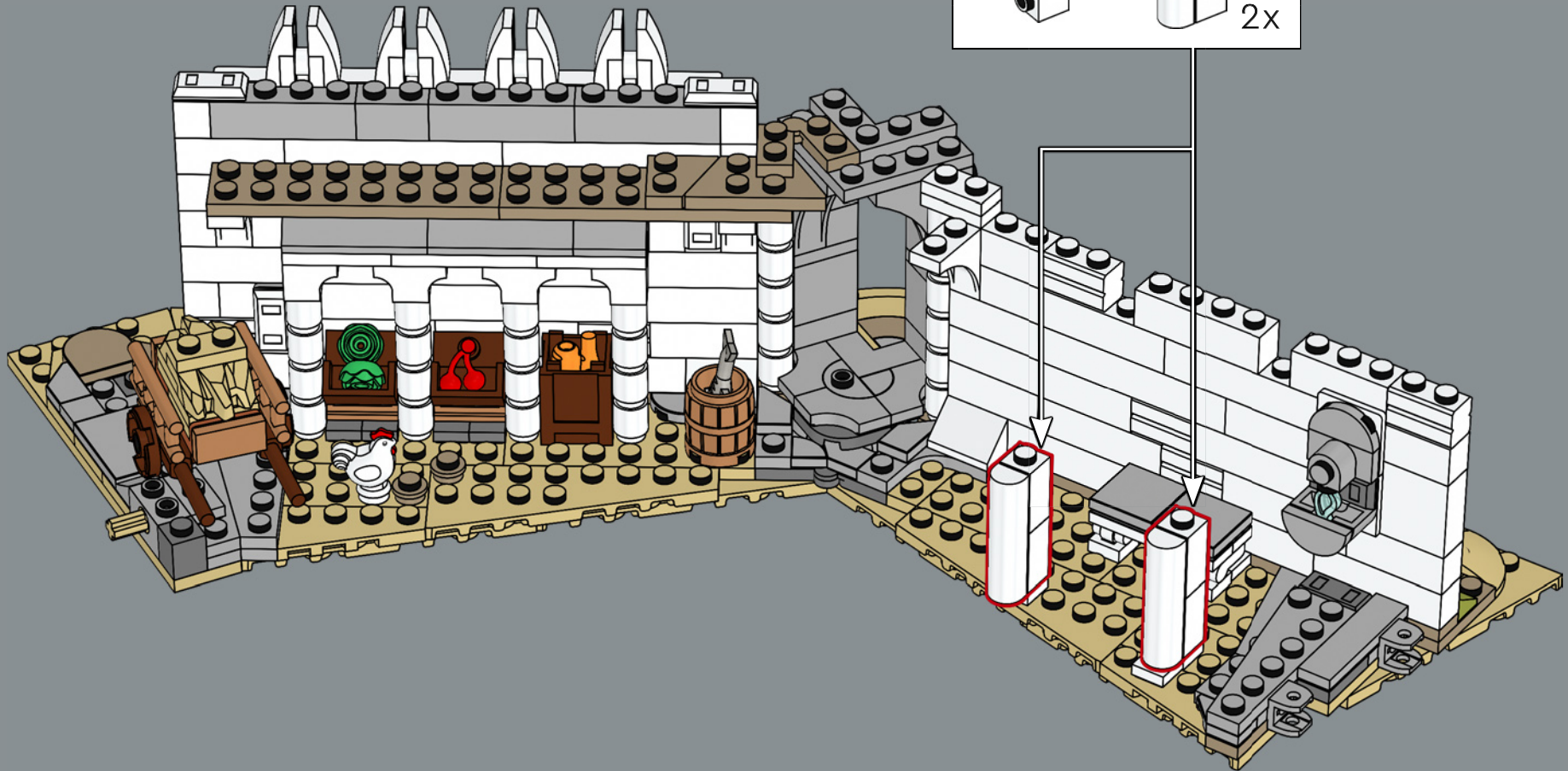
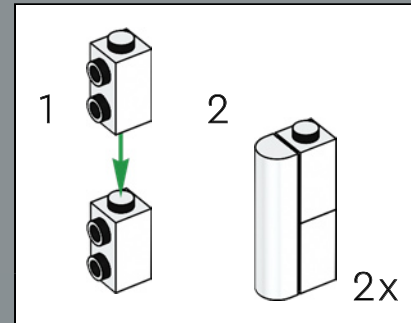

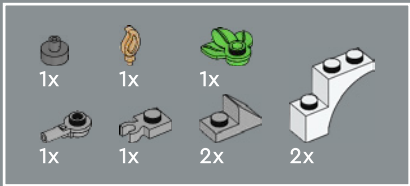

169

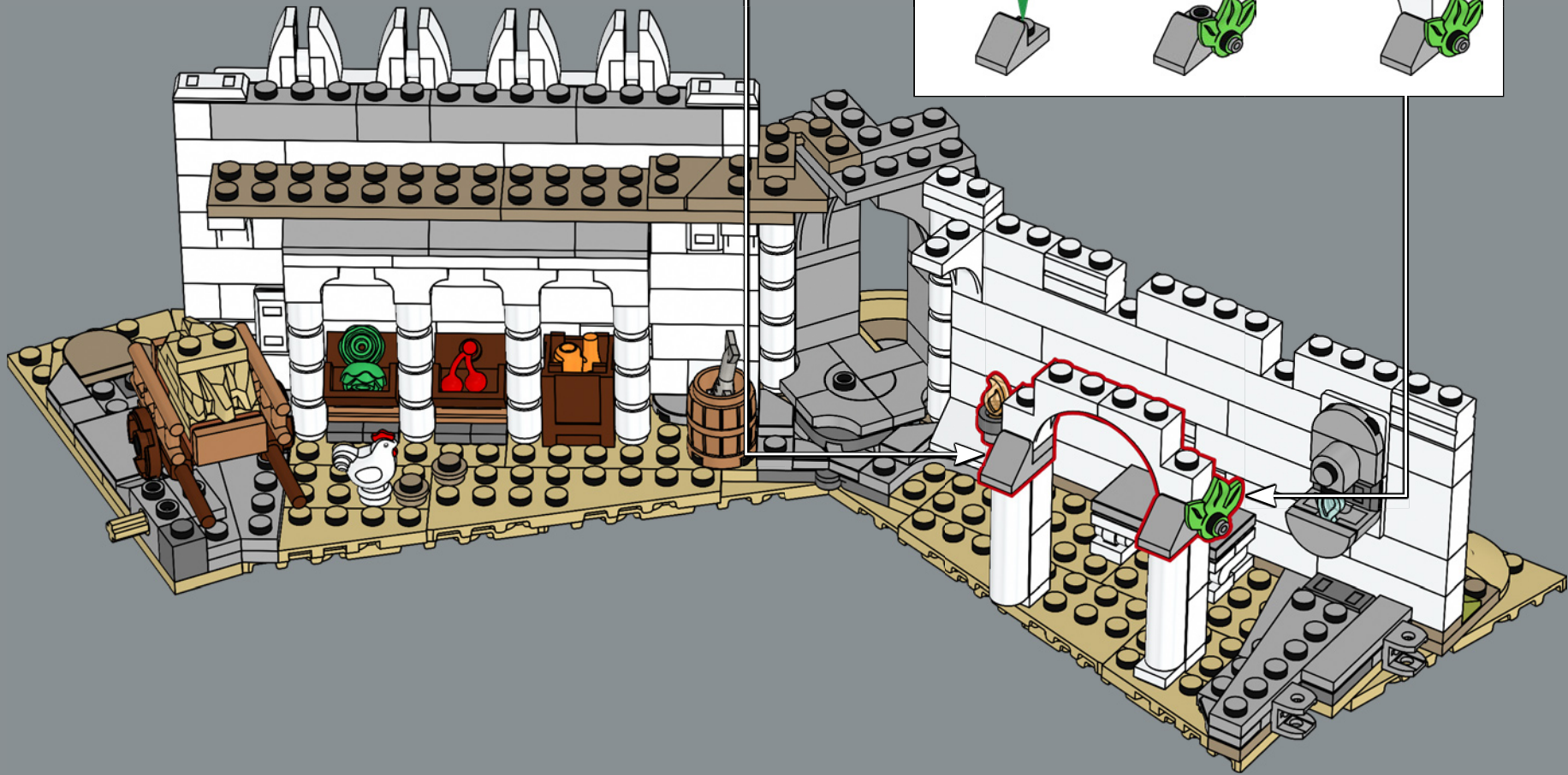
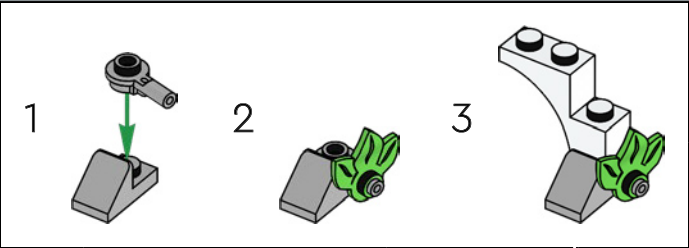
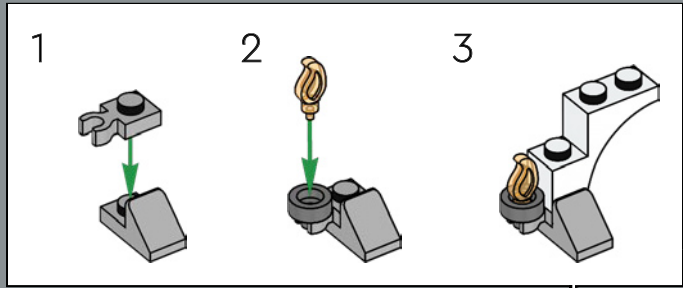

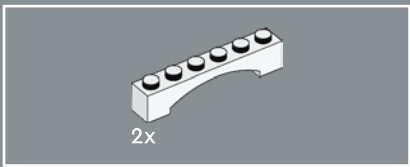

170

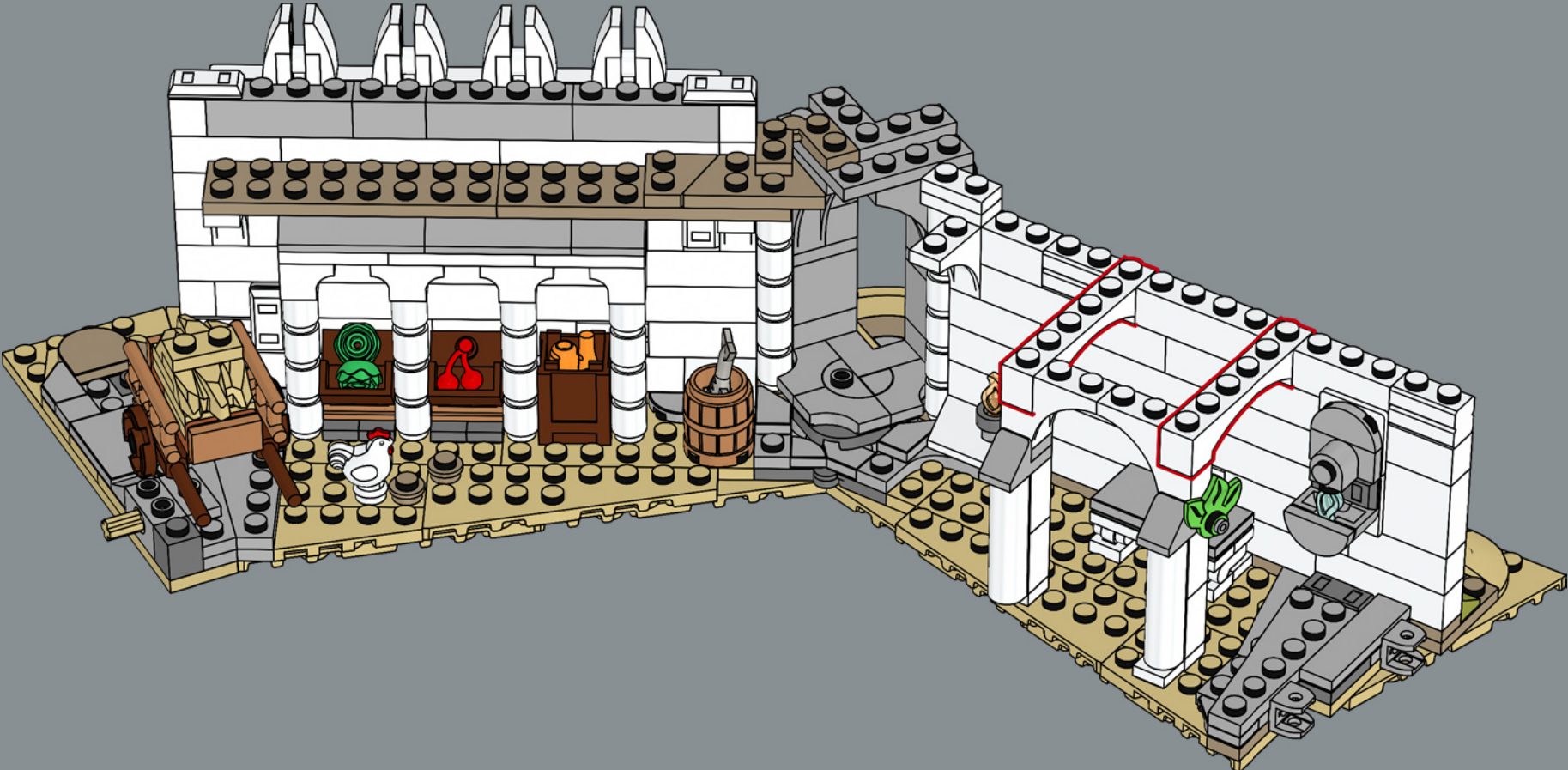

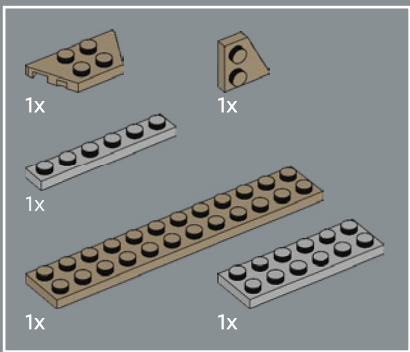

171

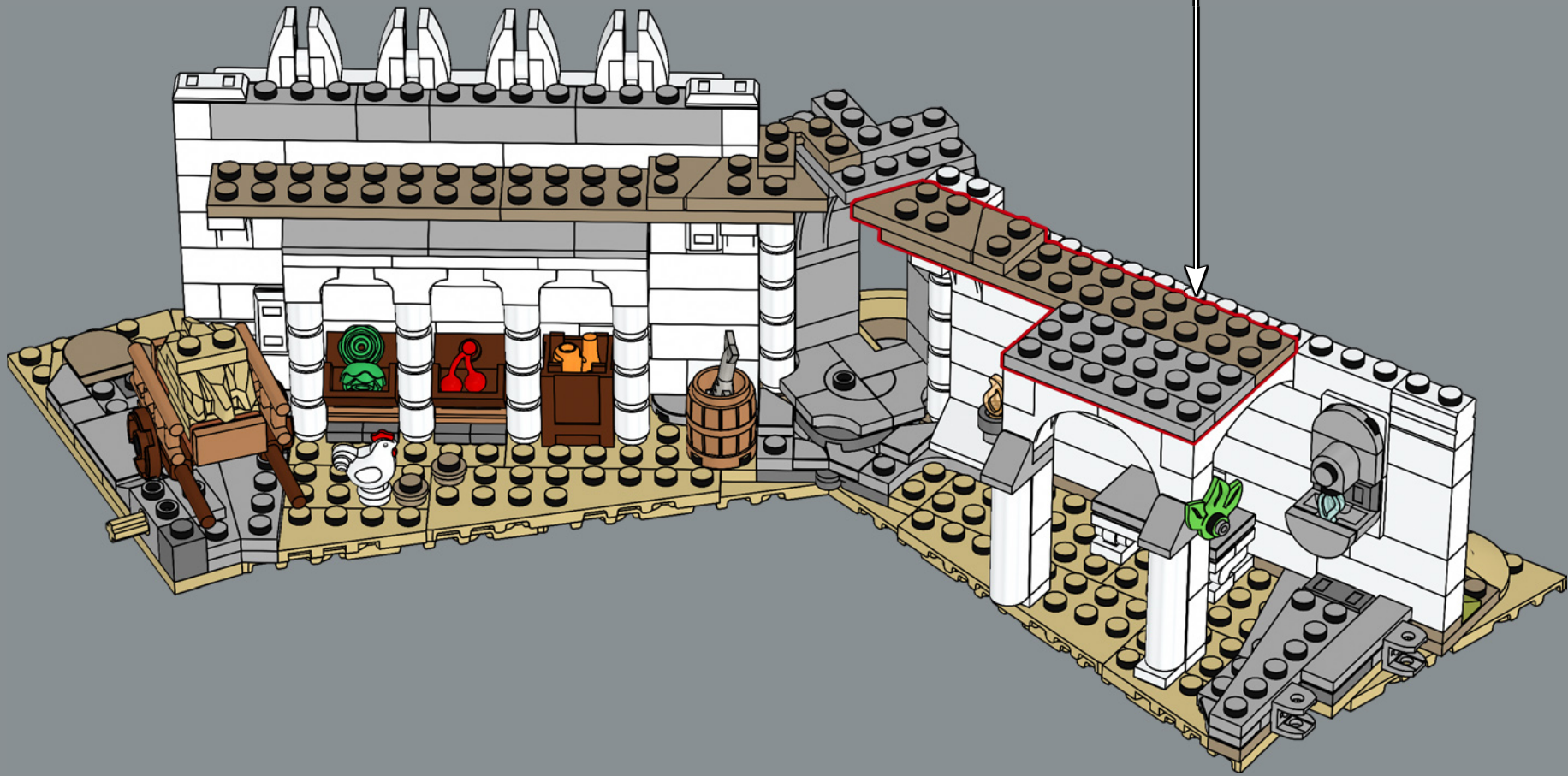
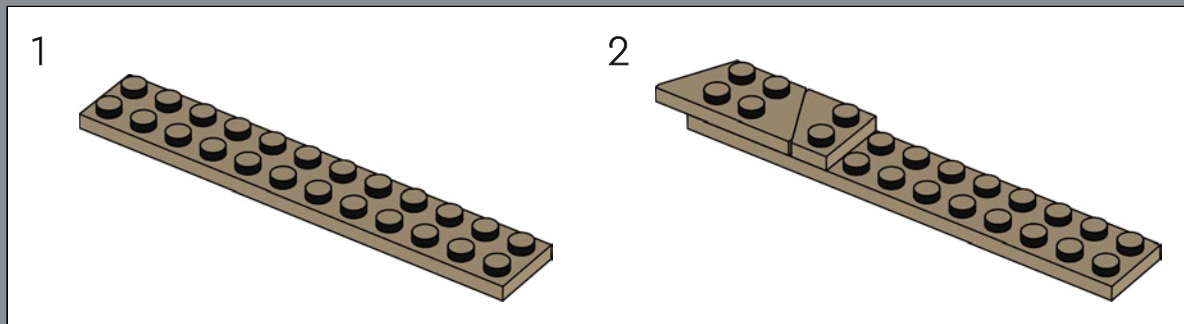

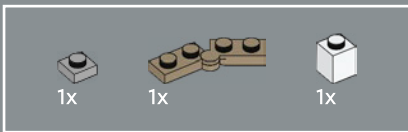

172

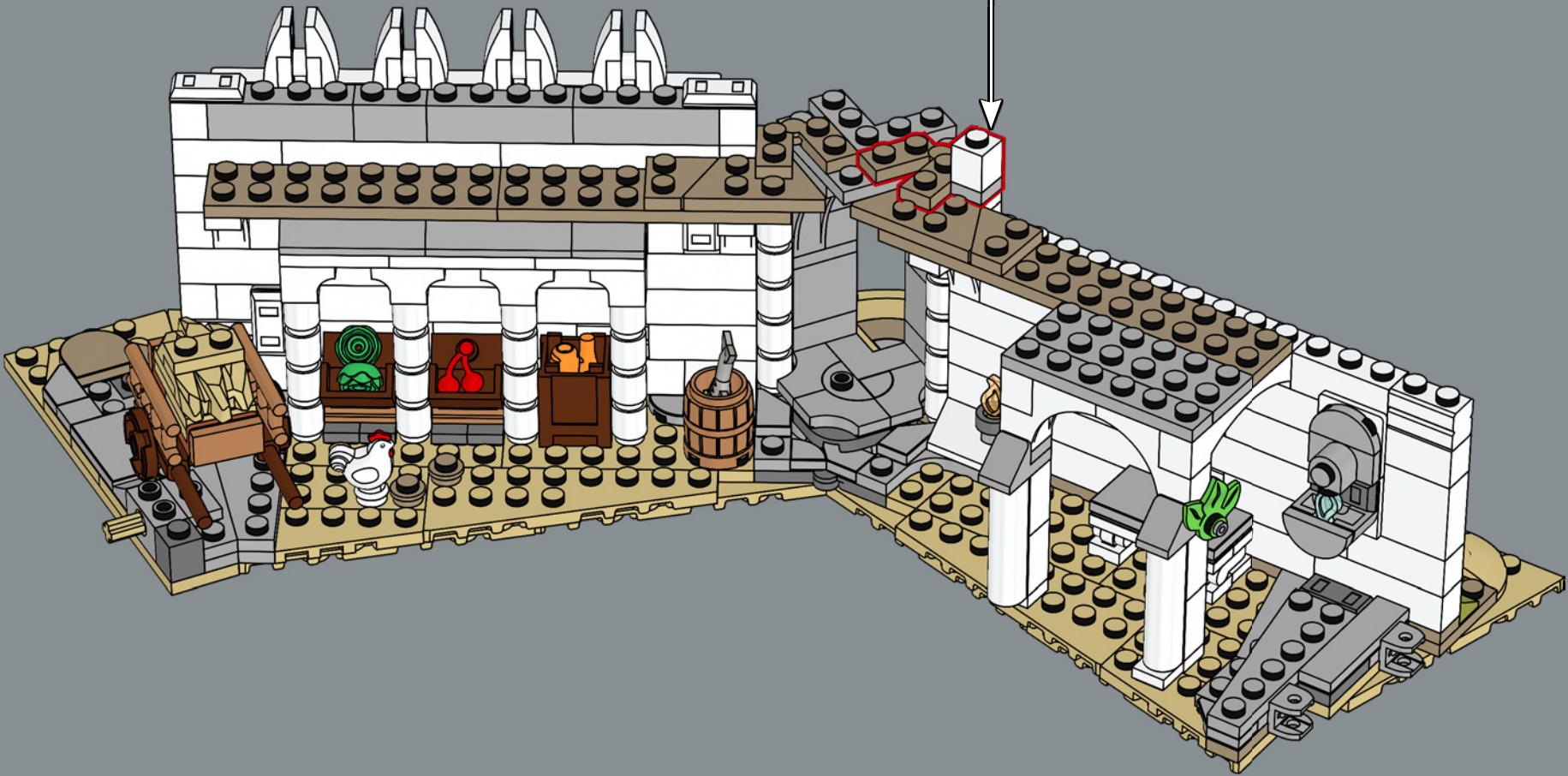
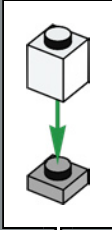

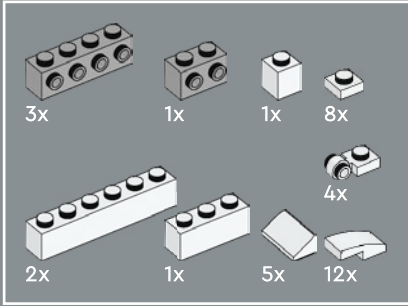
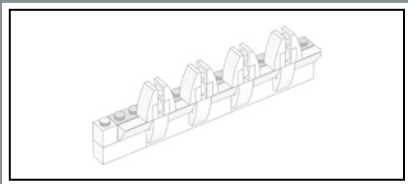

173

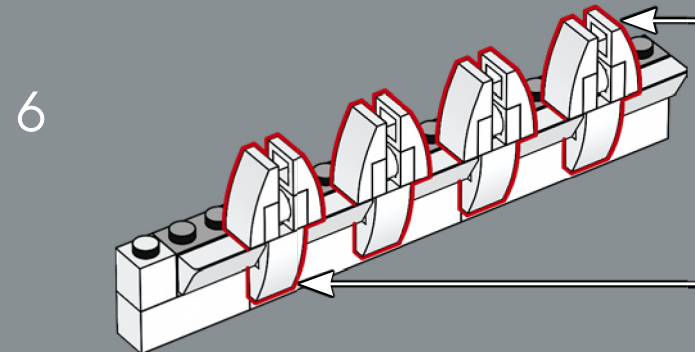
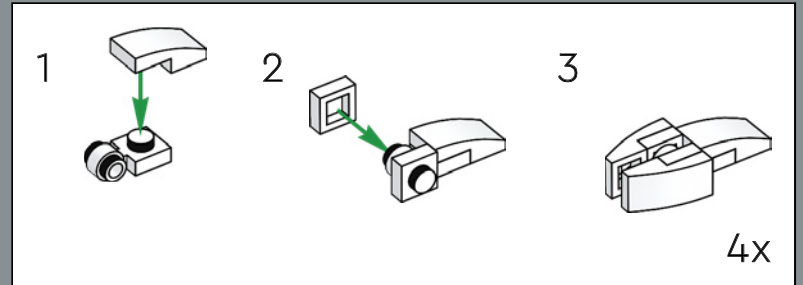
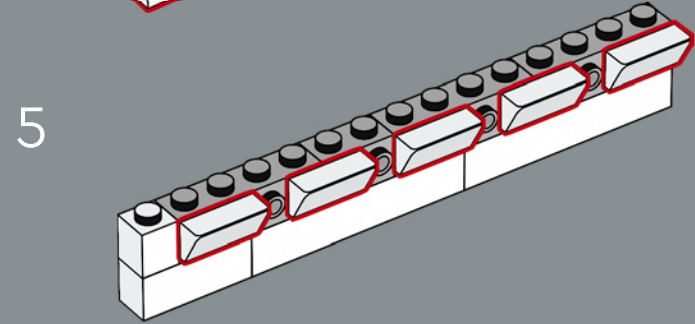
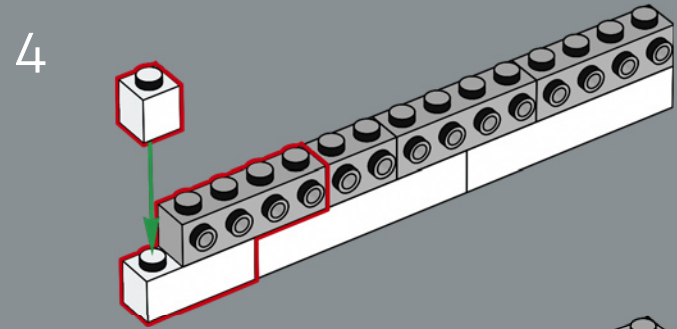
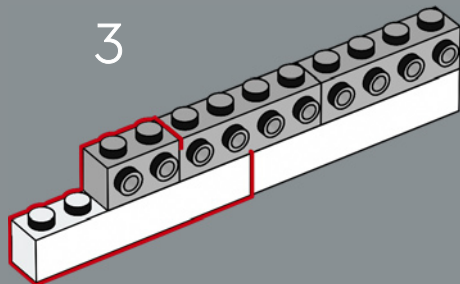
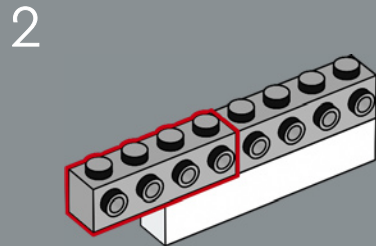
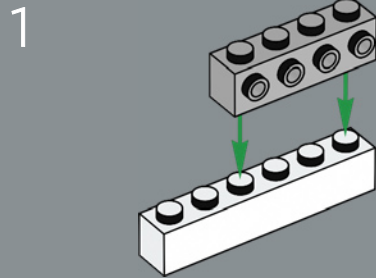

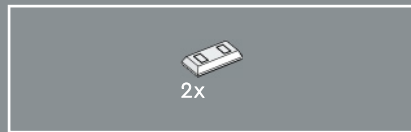
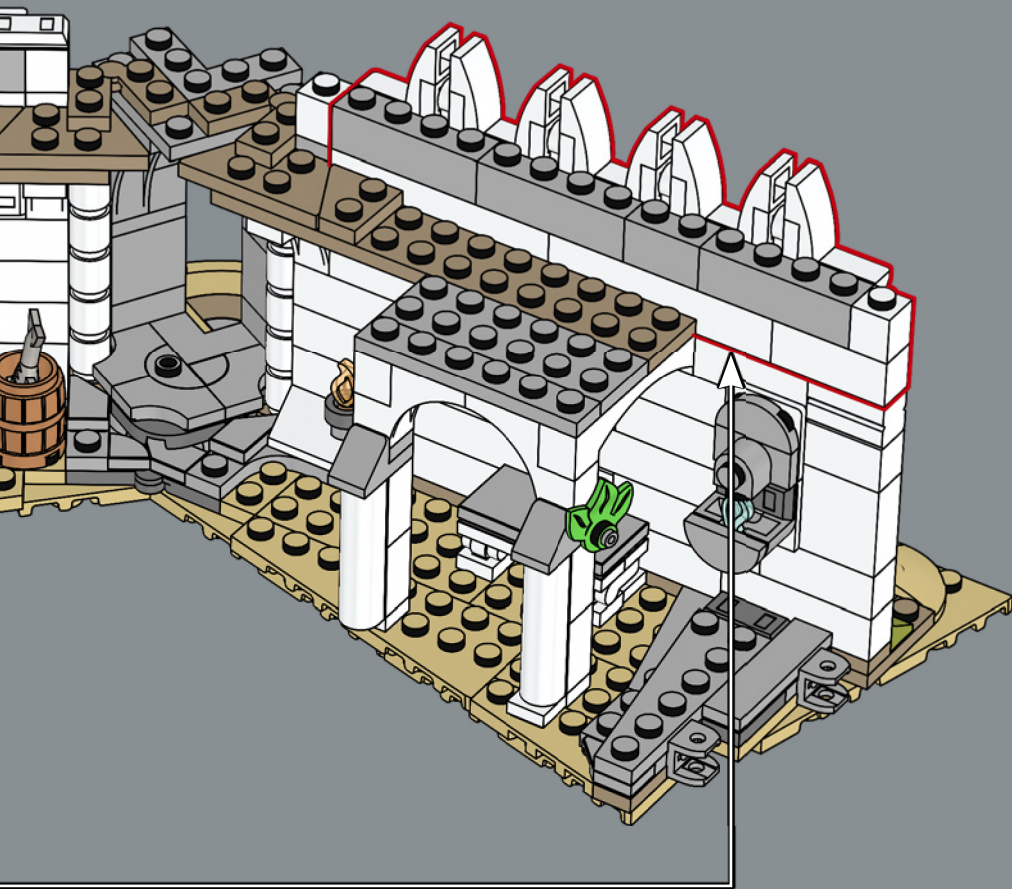

174

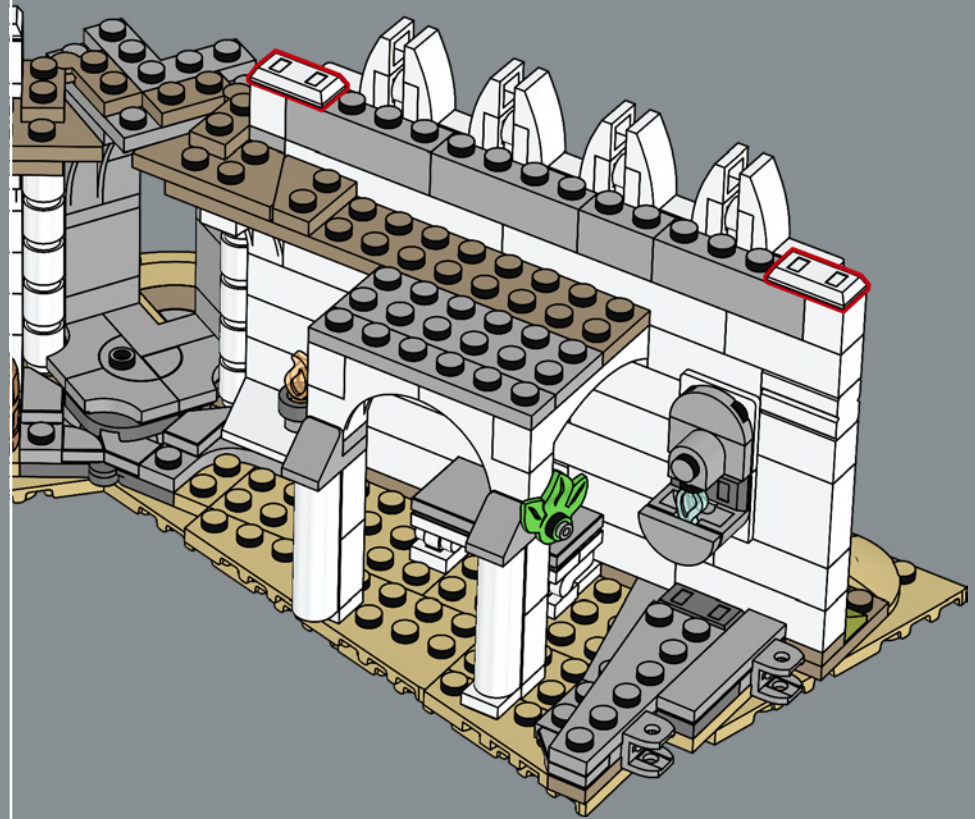



175

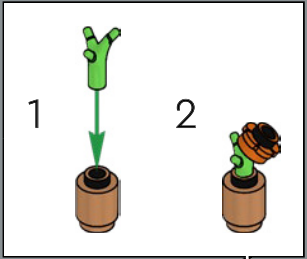
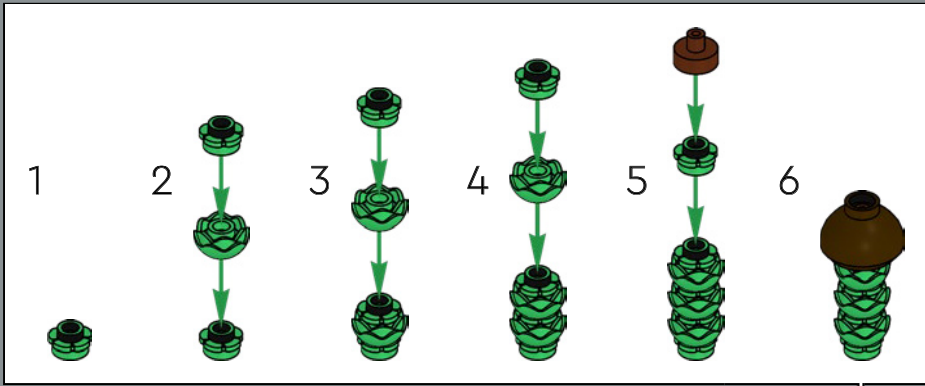

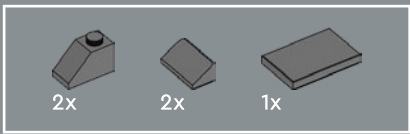

176

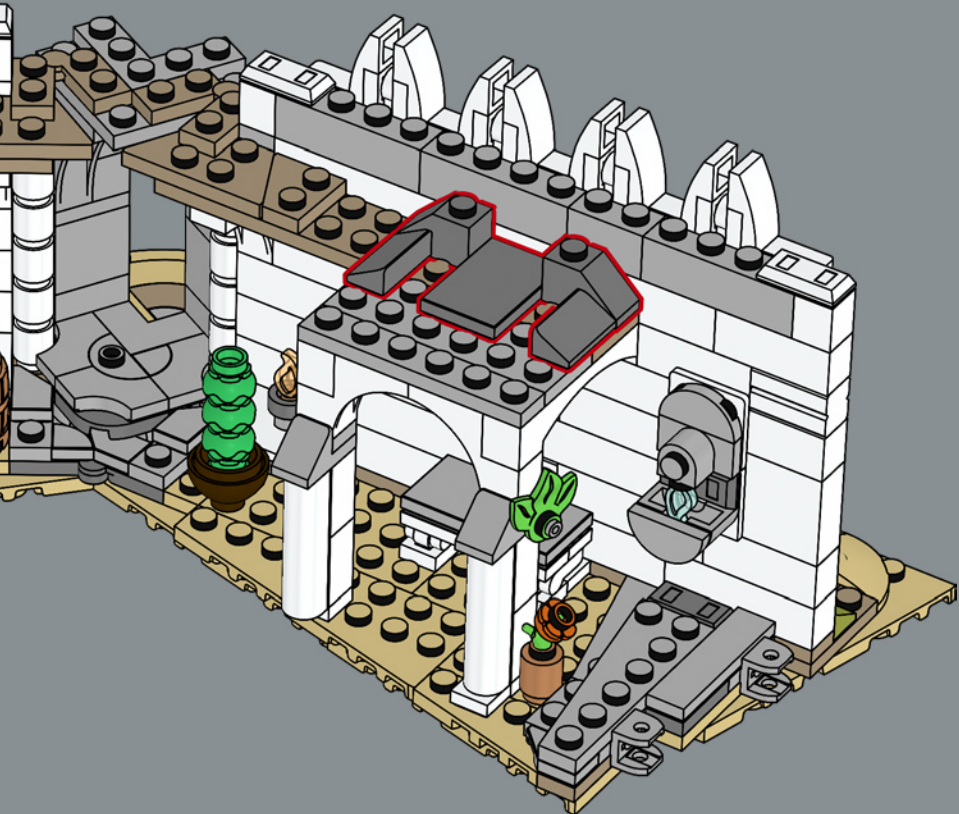

177

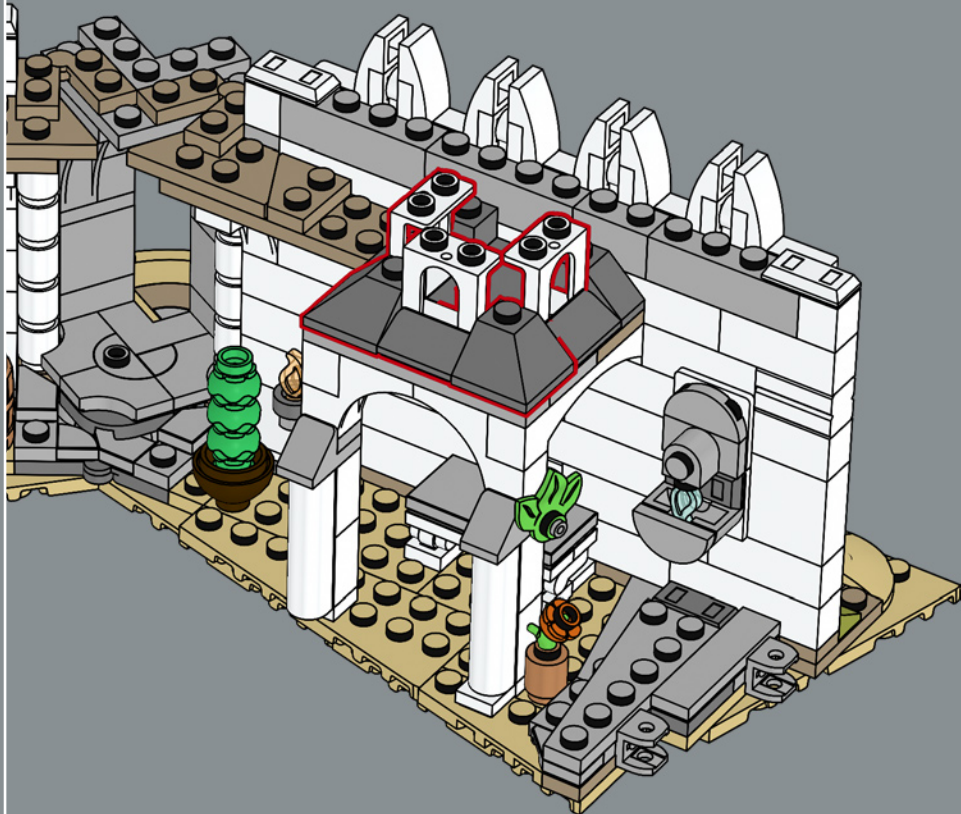

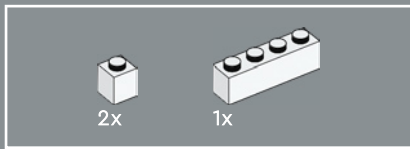

178

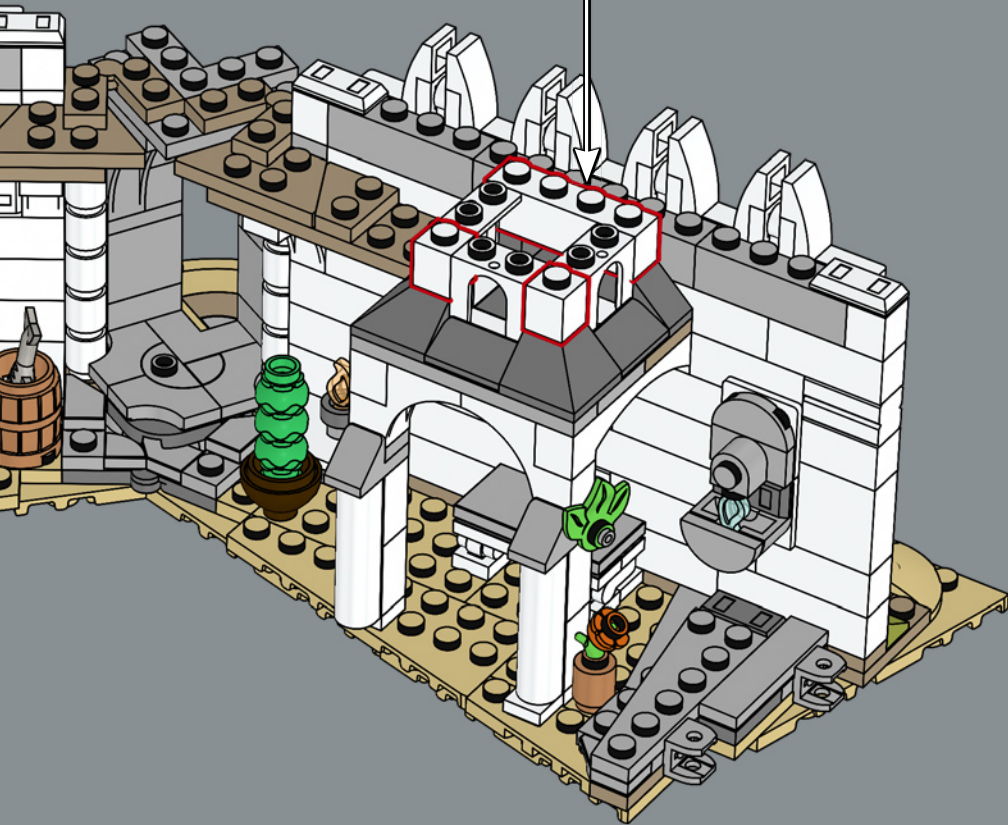
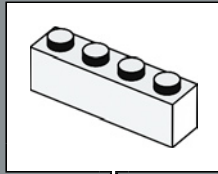

179

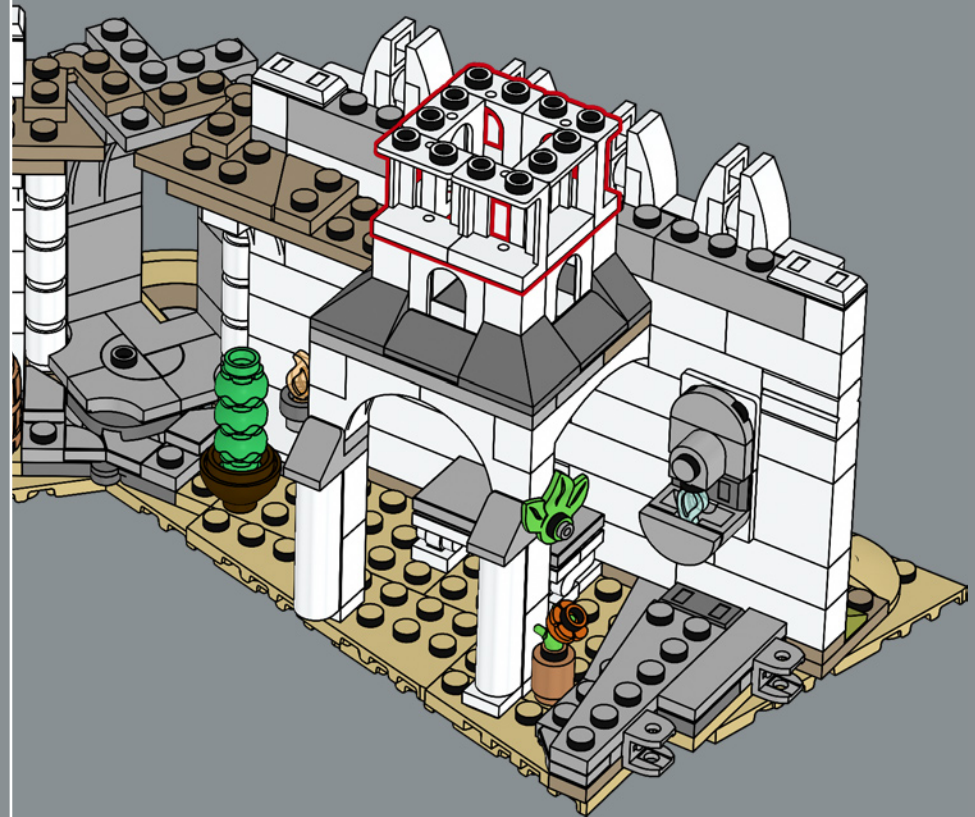

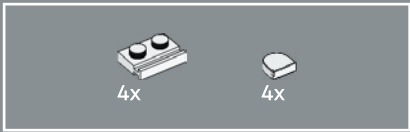

180

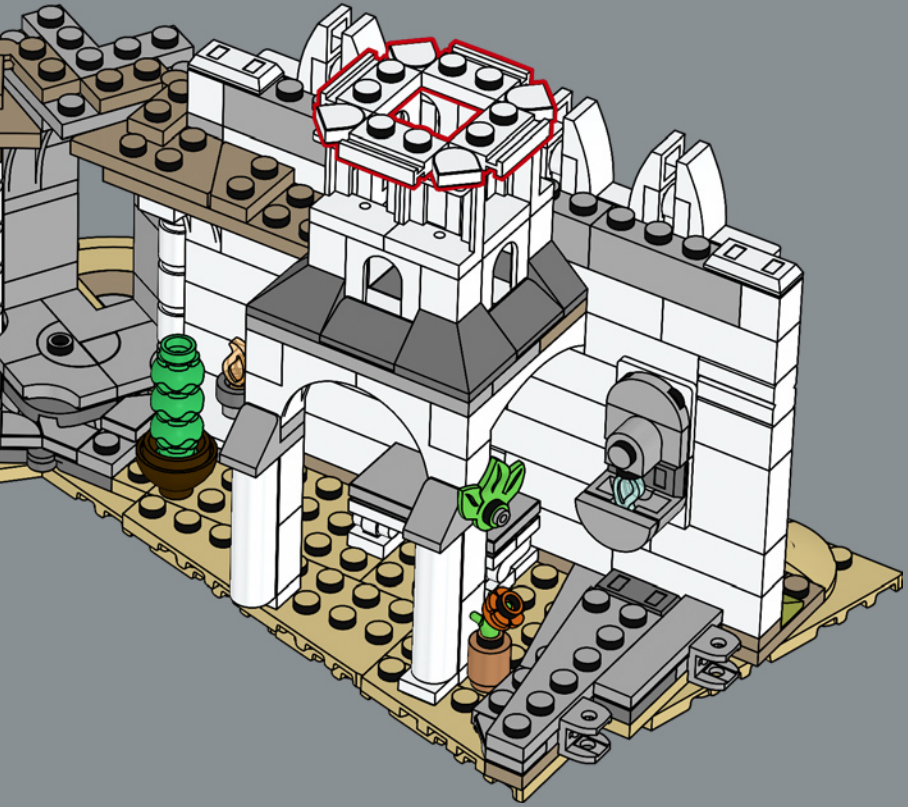

181

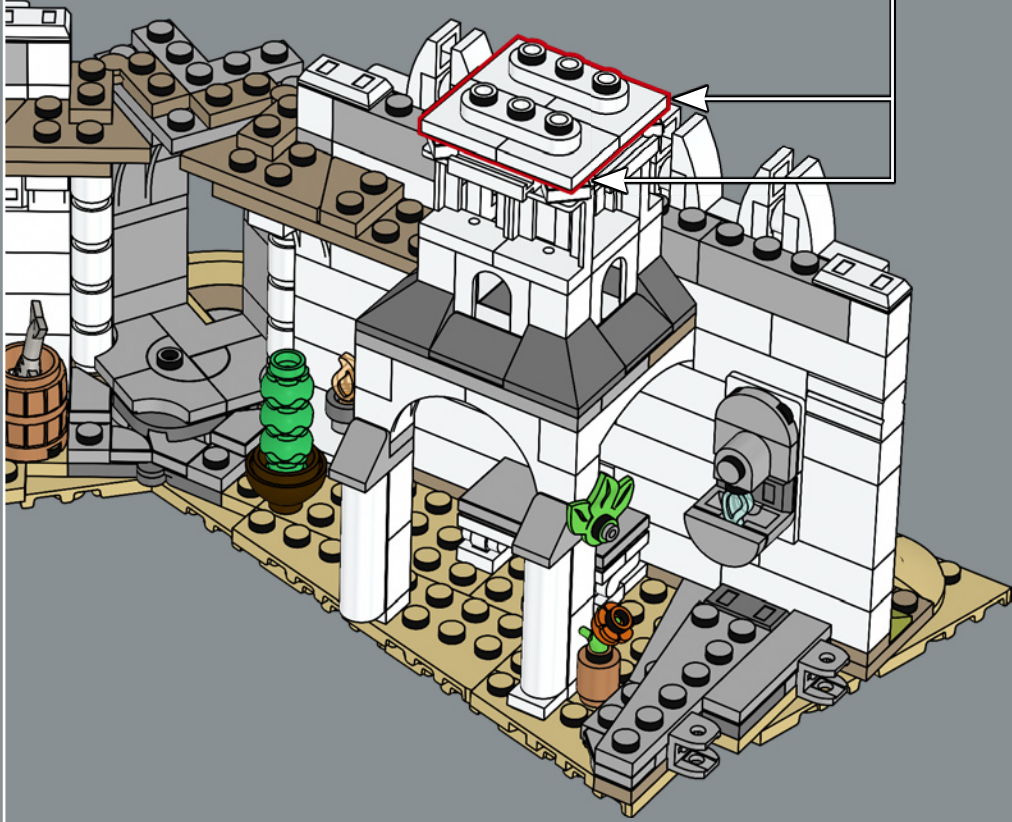
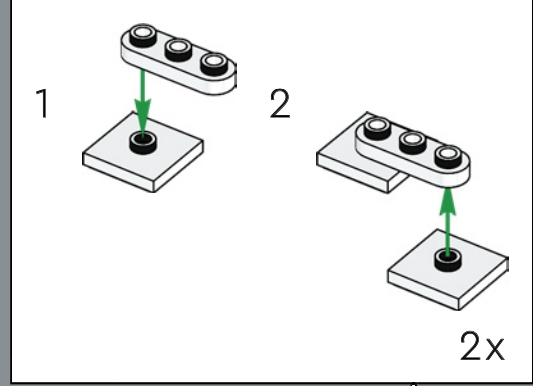

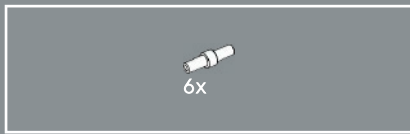

182



183

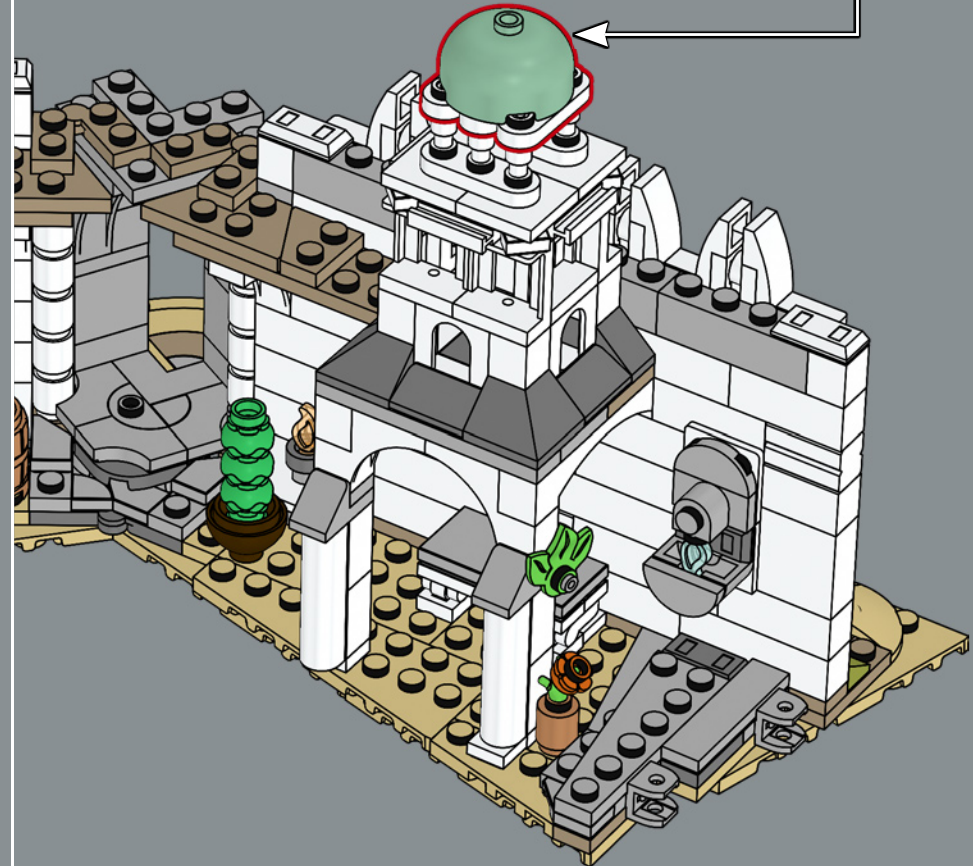
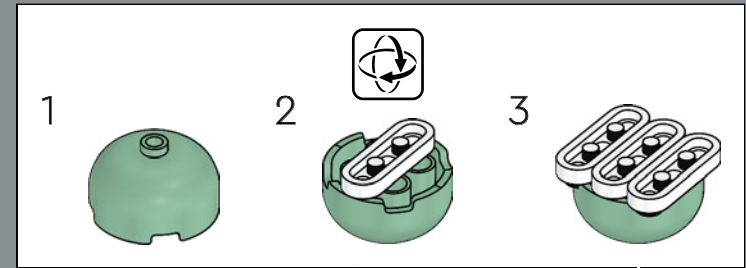



184



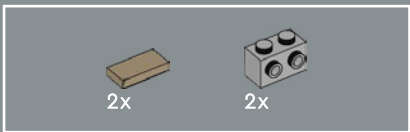

185

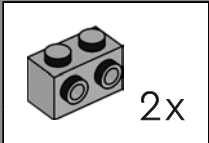

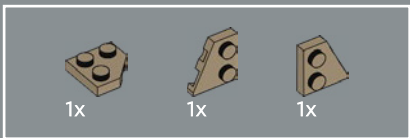

186



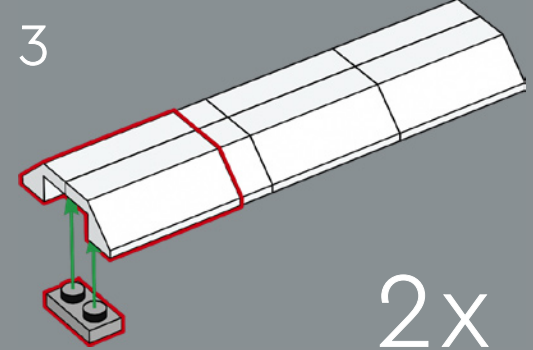
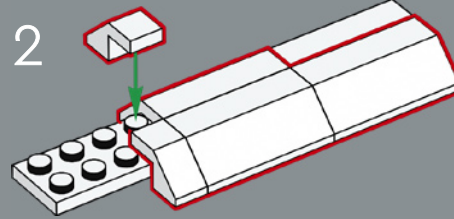
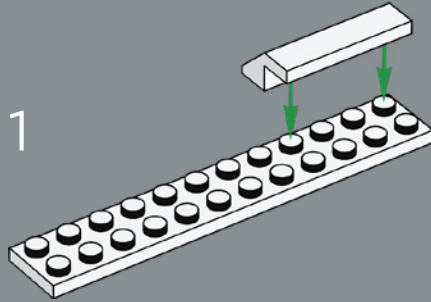
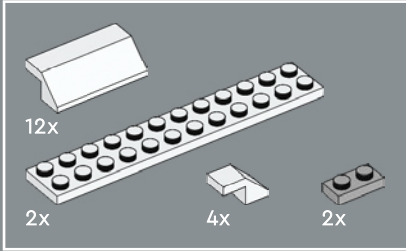
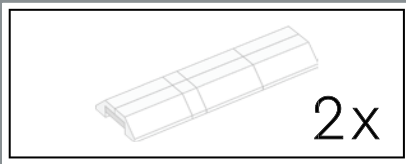

187

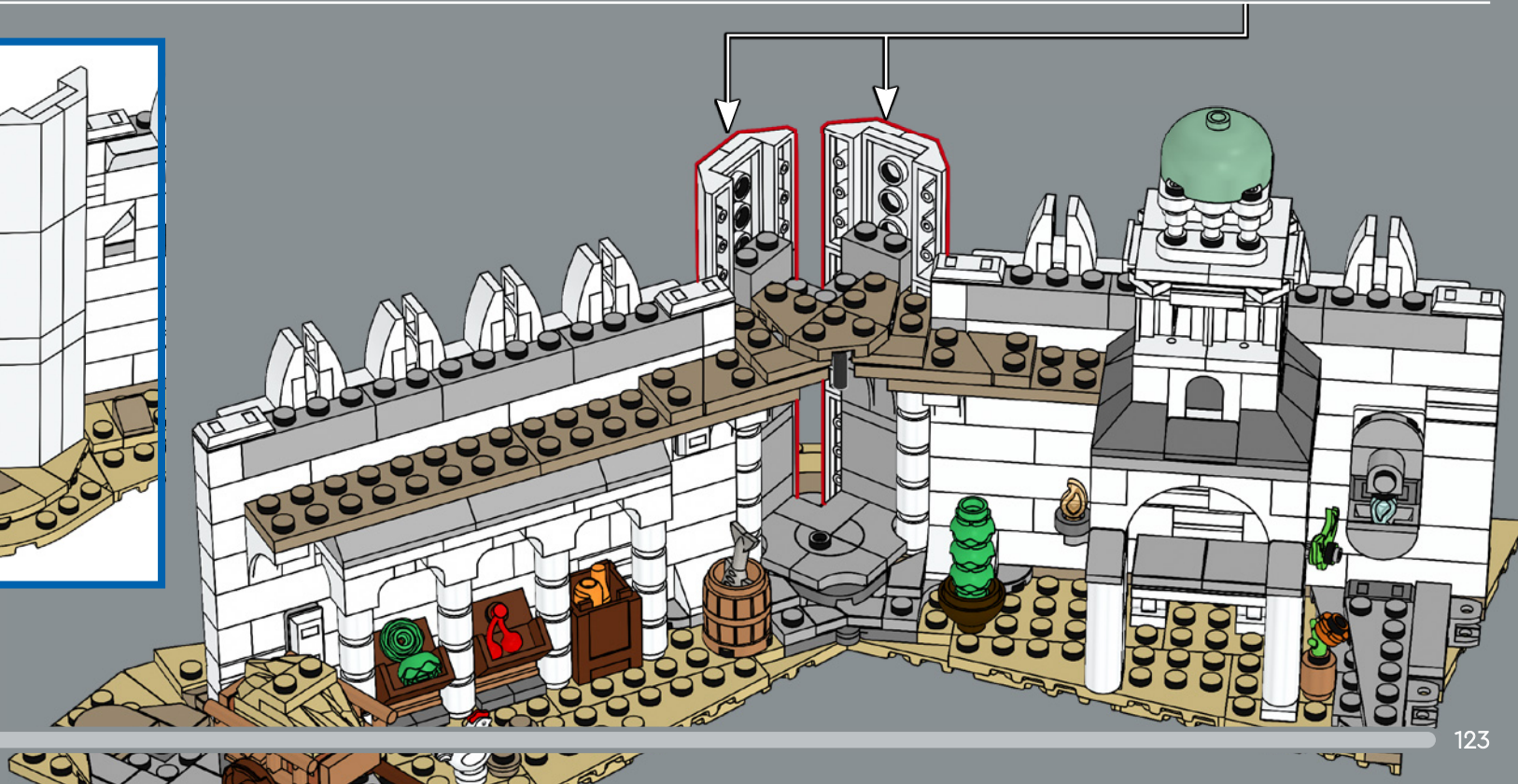
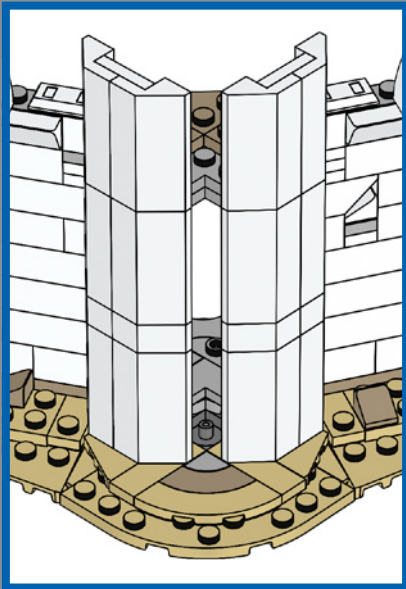

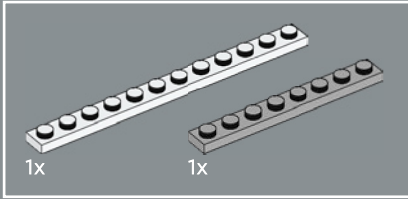
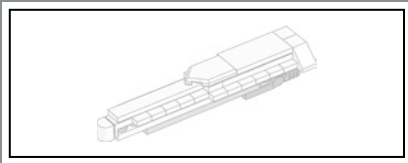

188

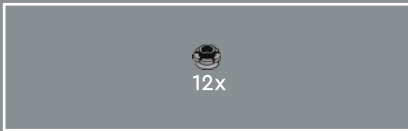
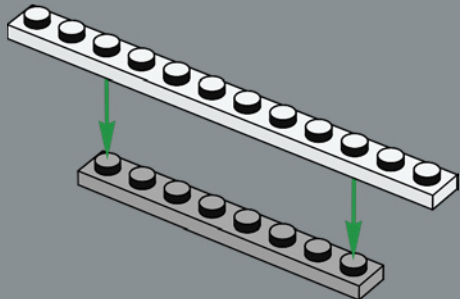

189

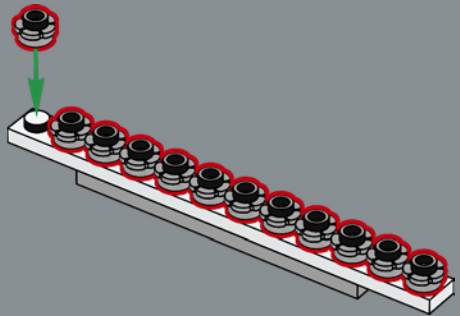

190

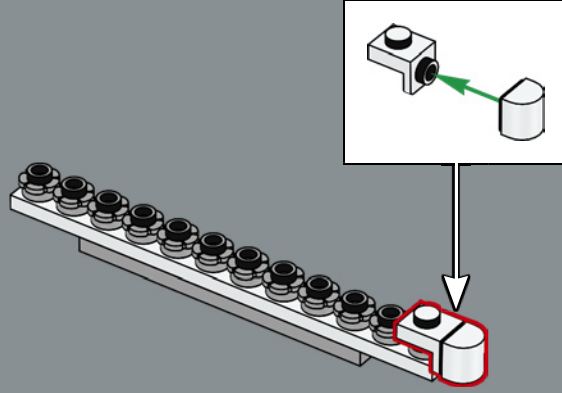

191

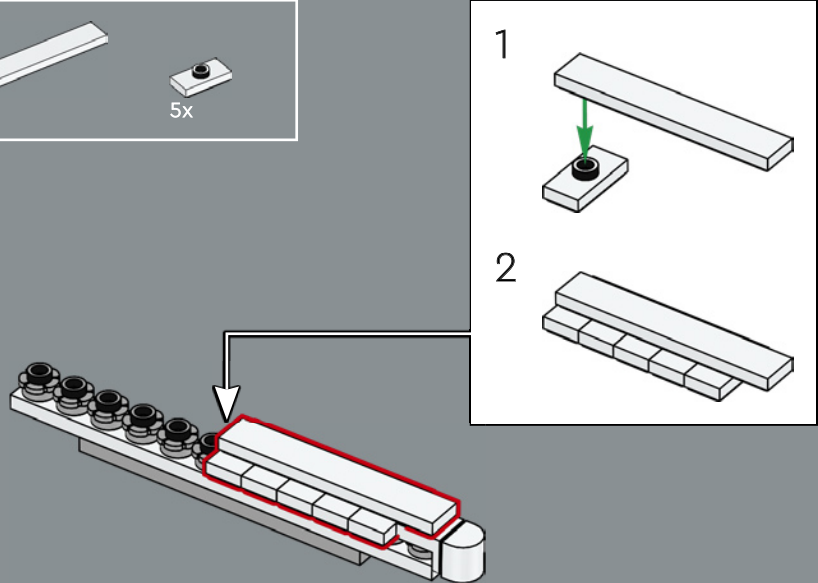

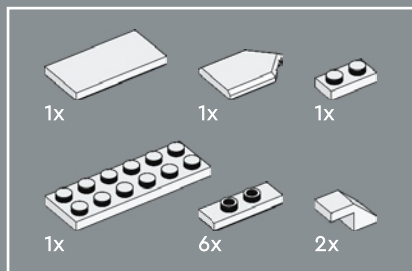

192

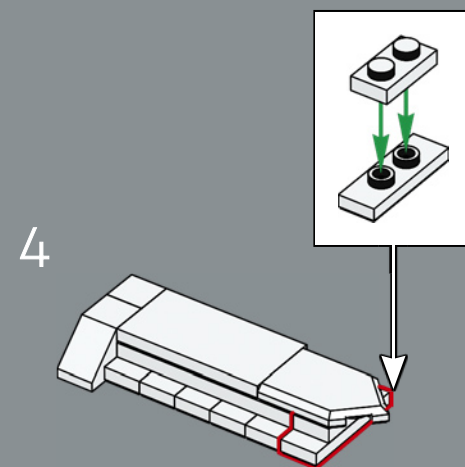
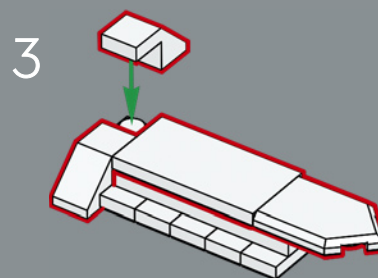
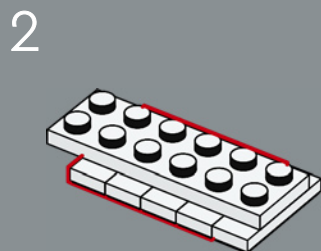
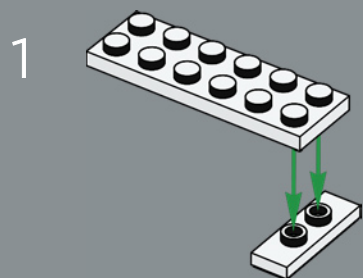

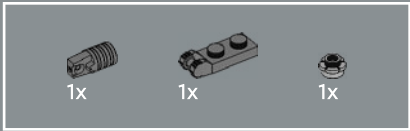
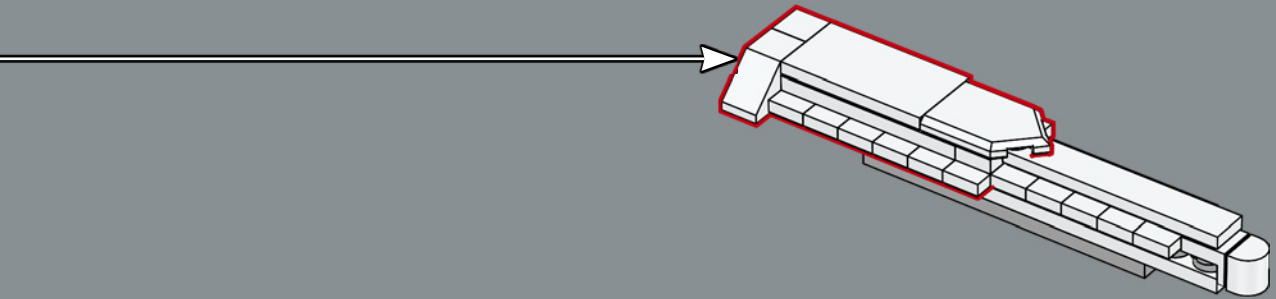

193

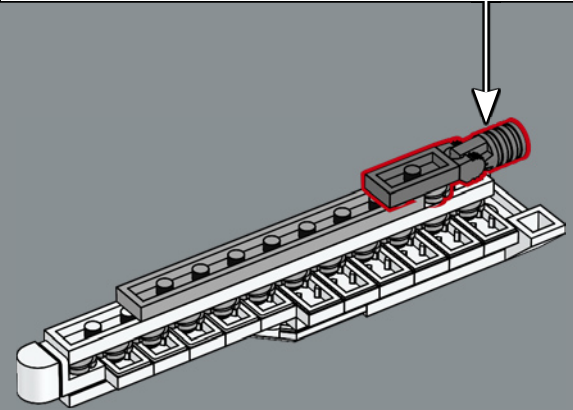
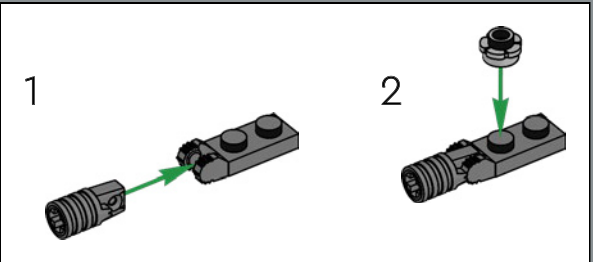

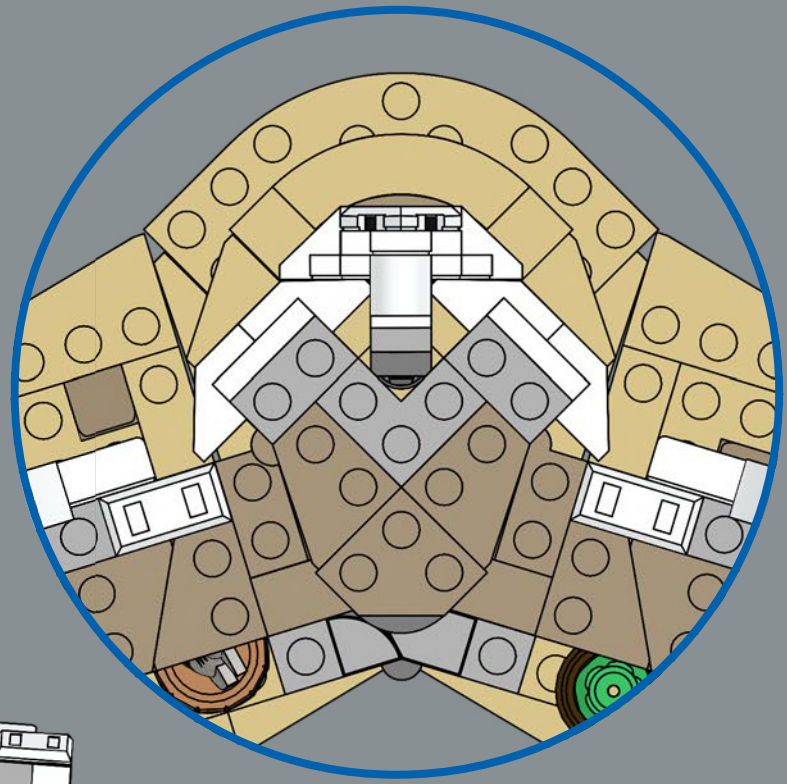
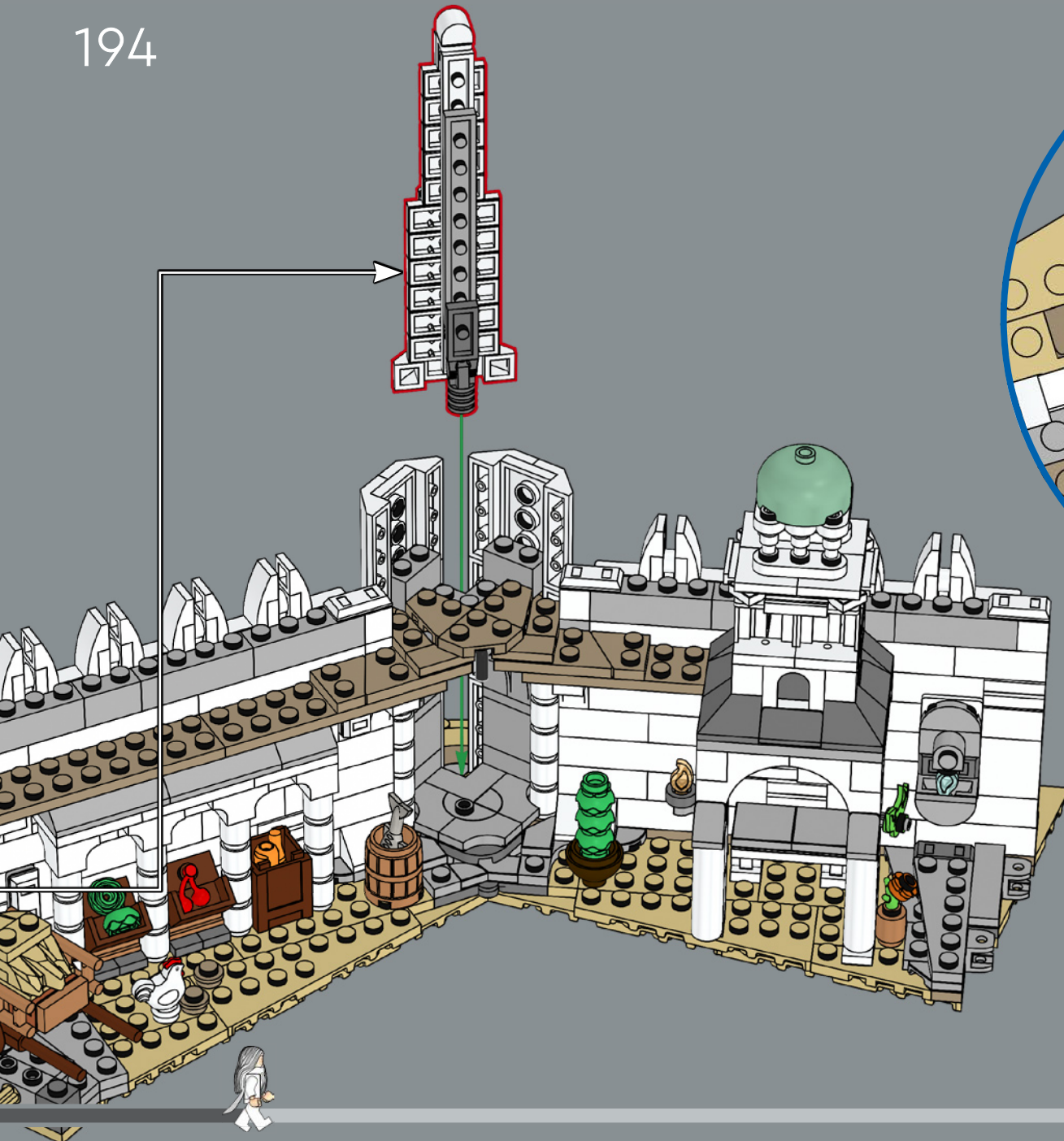

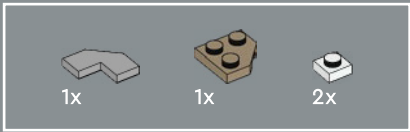

195

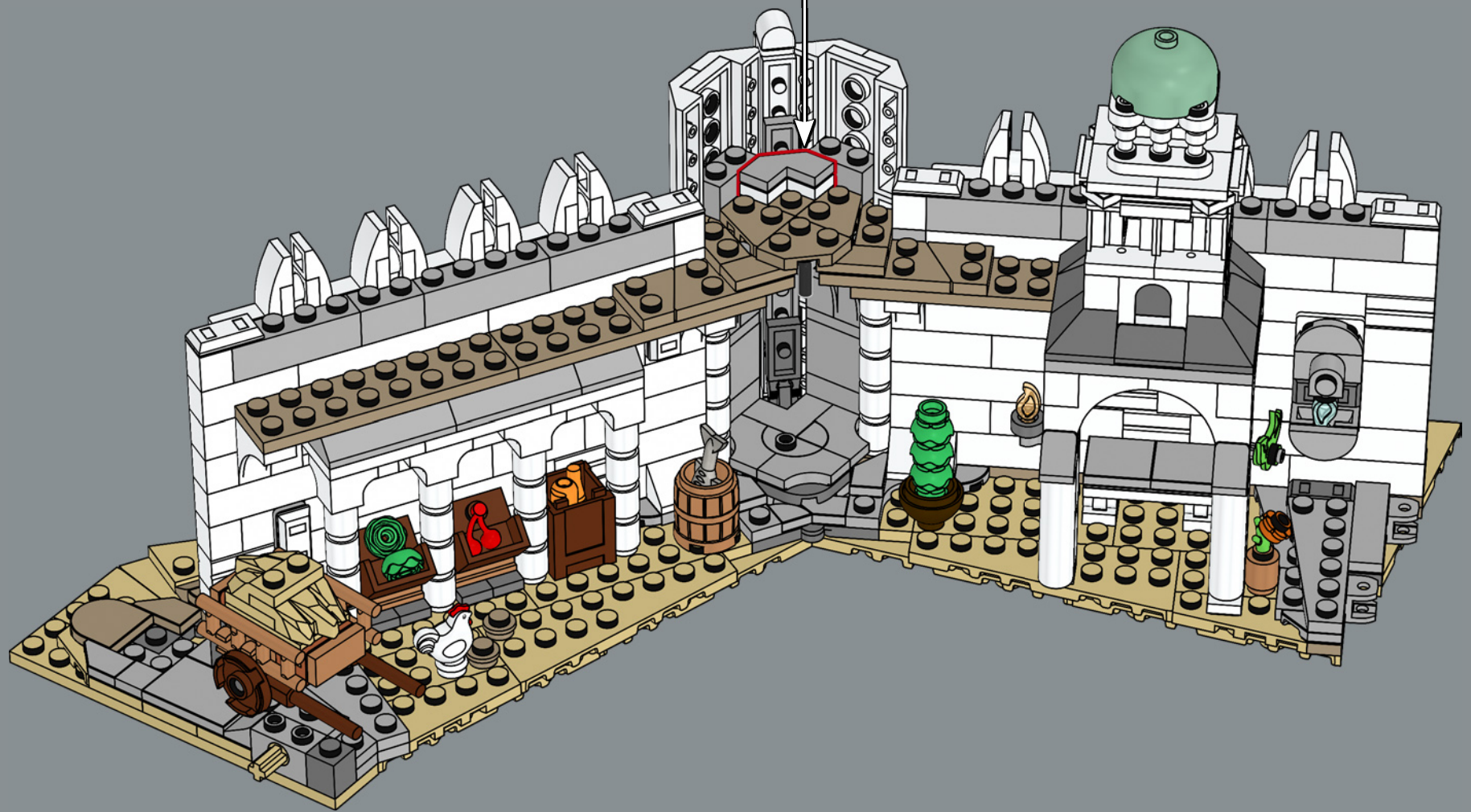
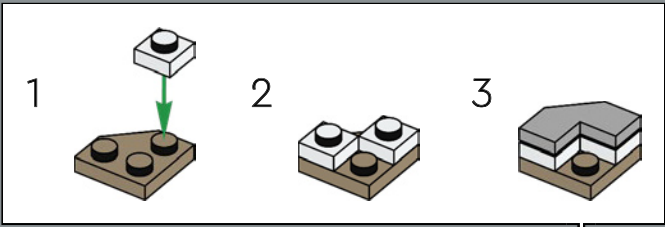

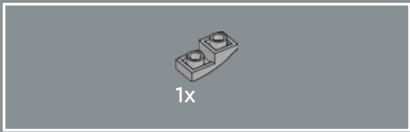

196

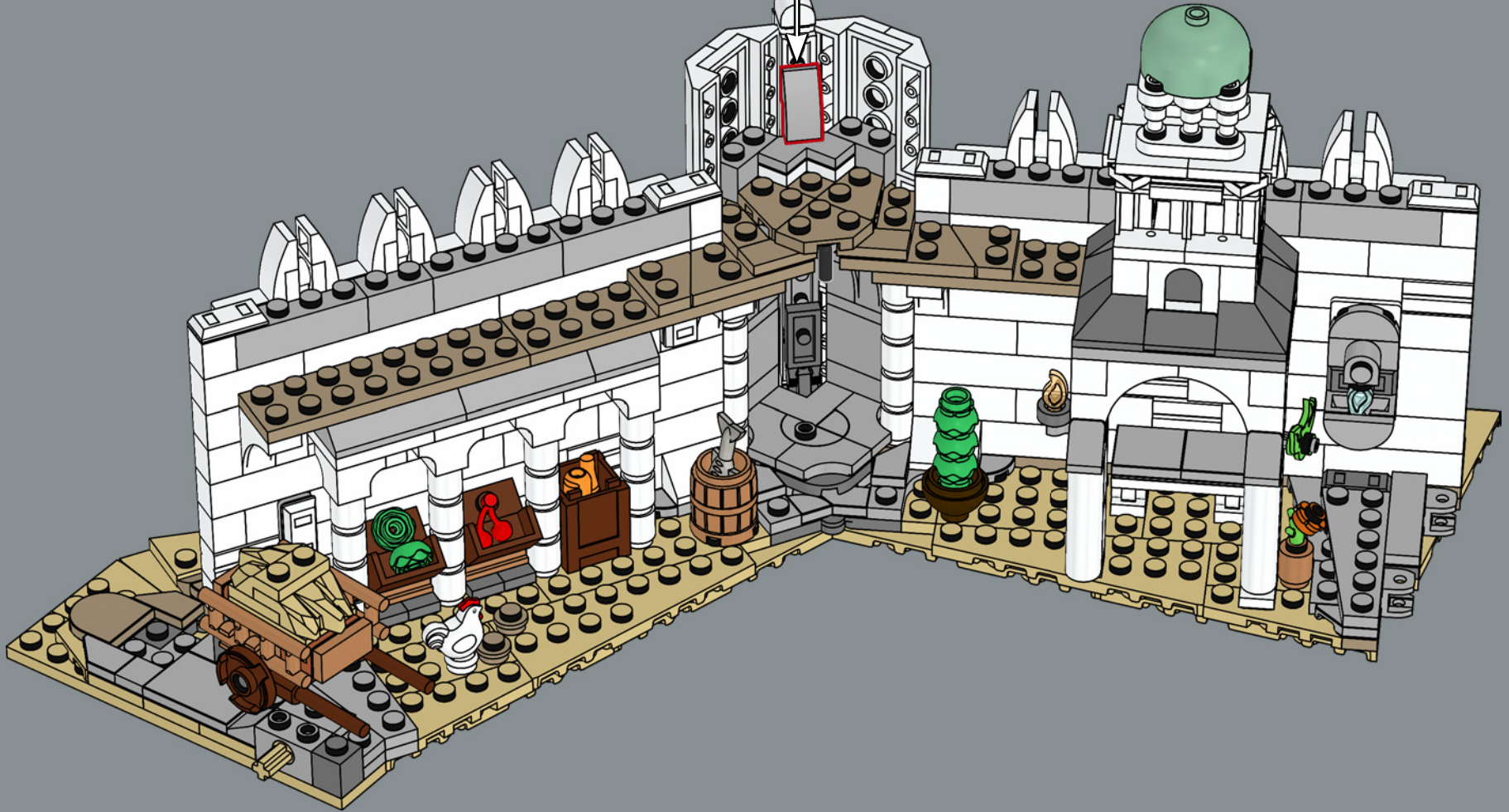
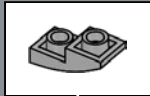

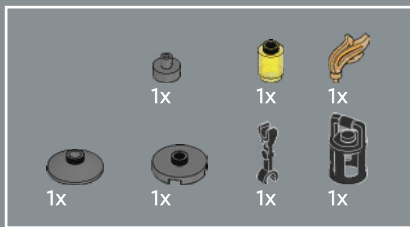

197

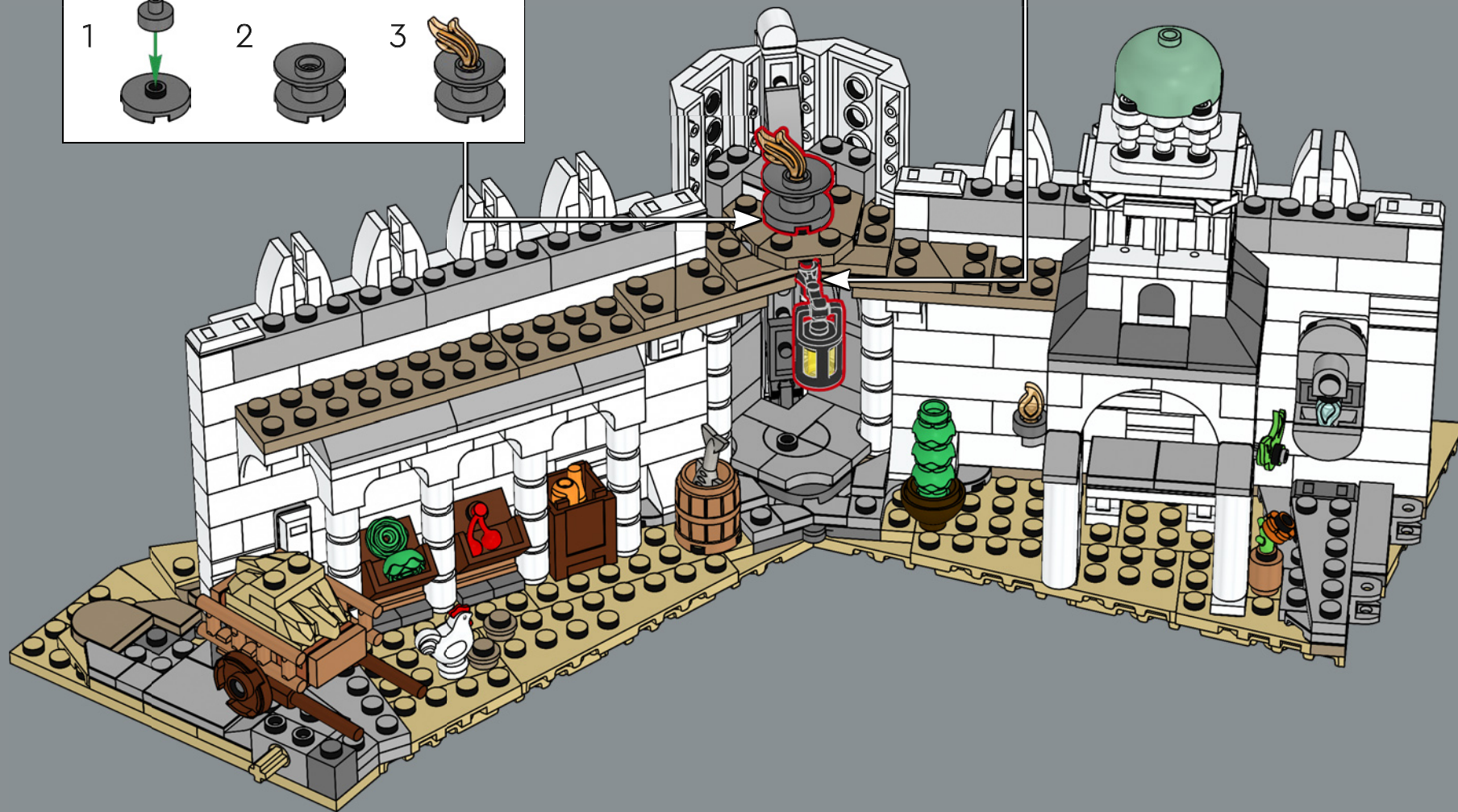
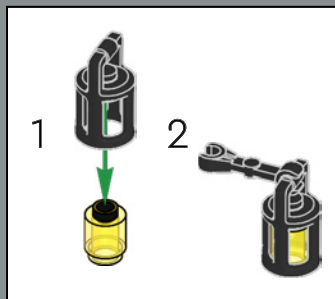
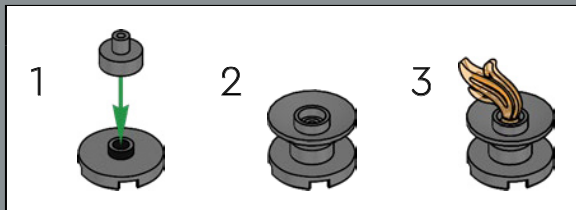

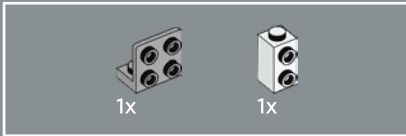
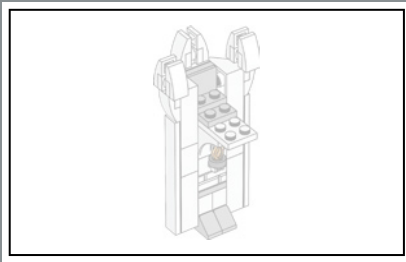

198

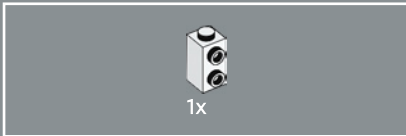
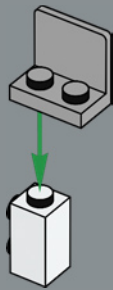

199

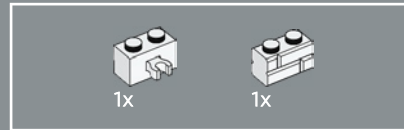
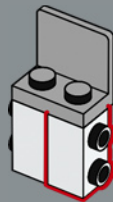

200

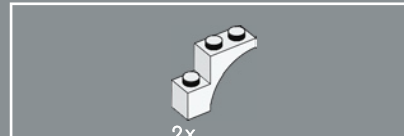
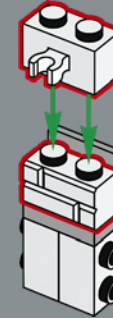

201

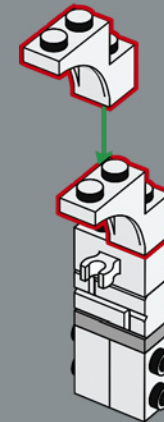

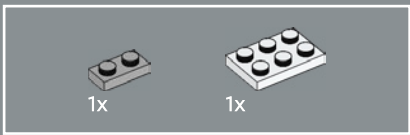

202

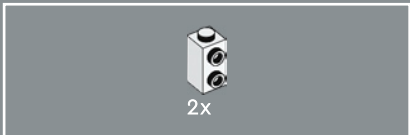
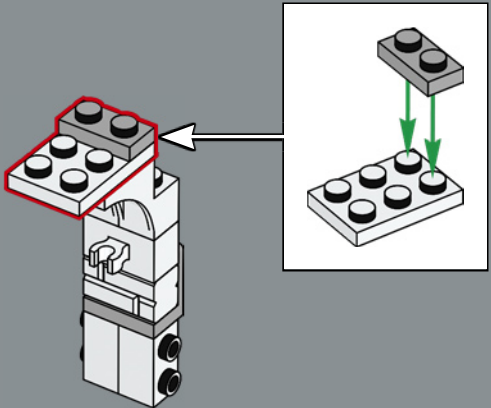

203

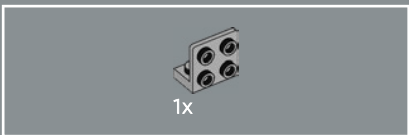
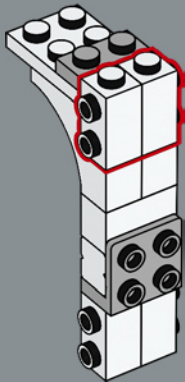

204

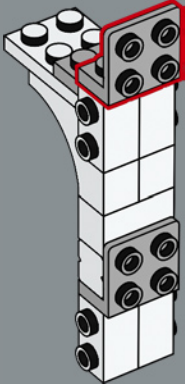

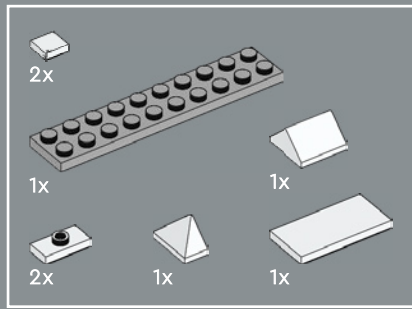

205

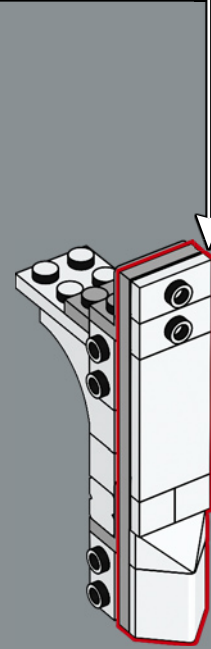
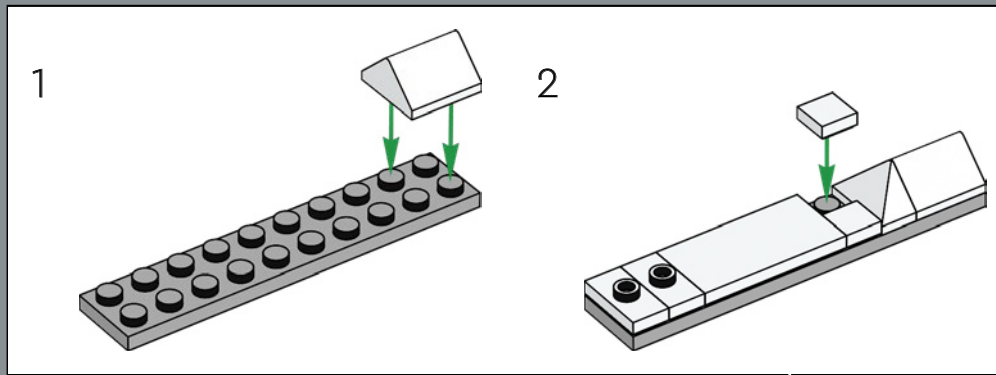

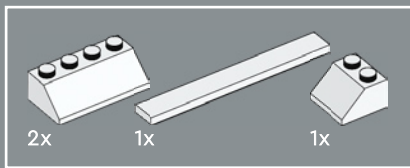

206

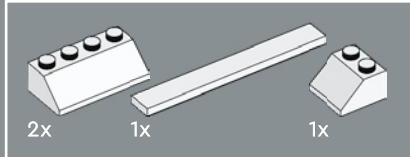
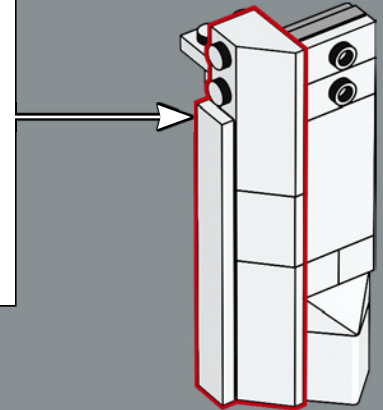
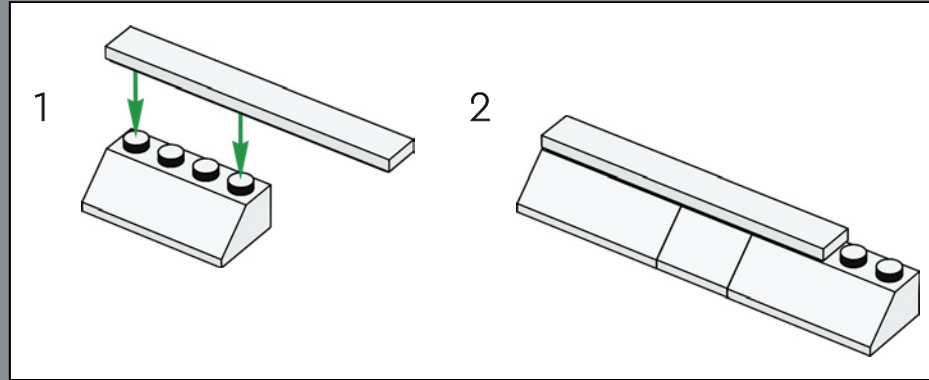

207

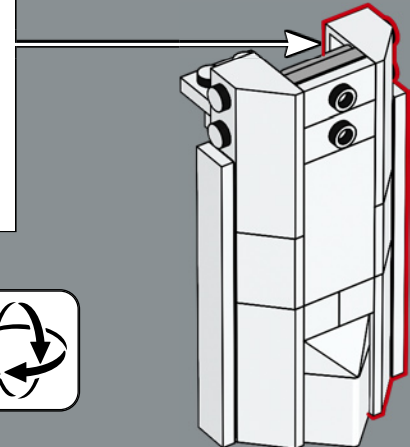
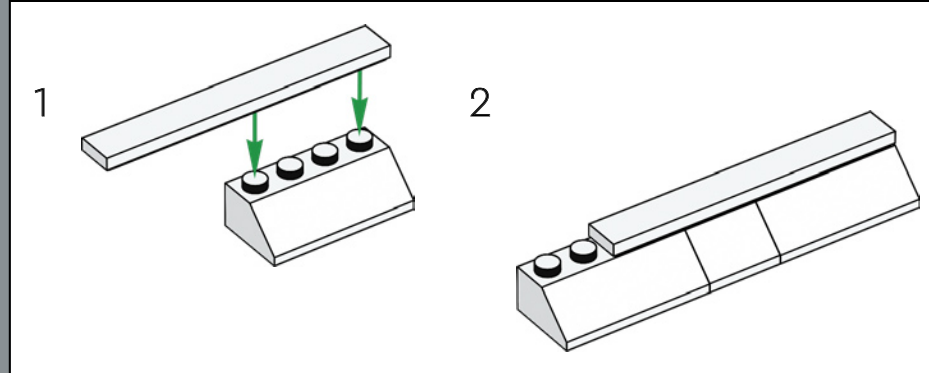



208

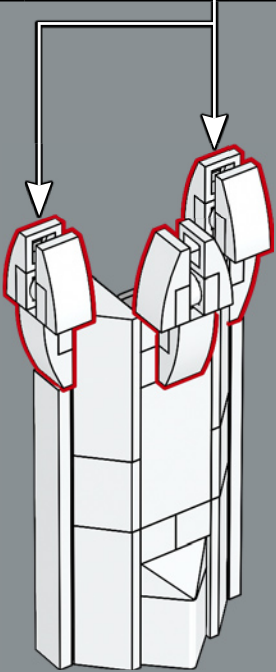
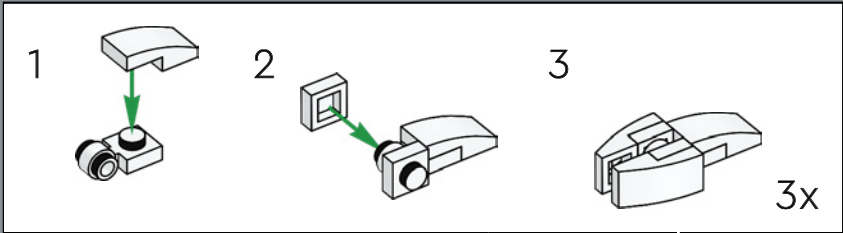

209

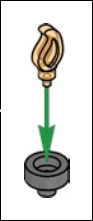
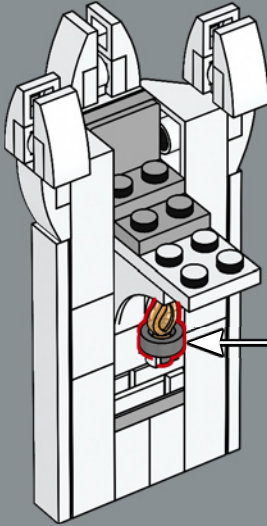



2x

210

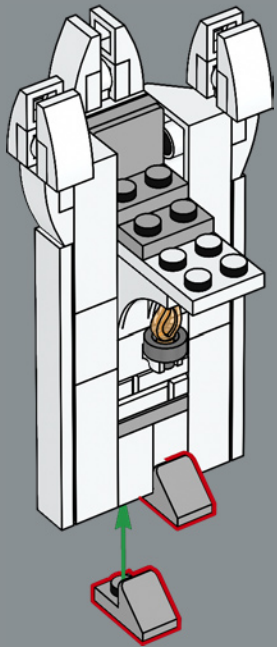

211

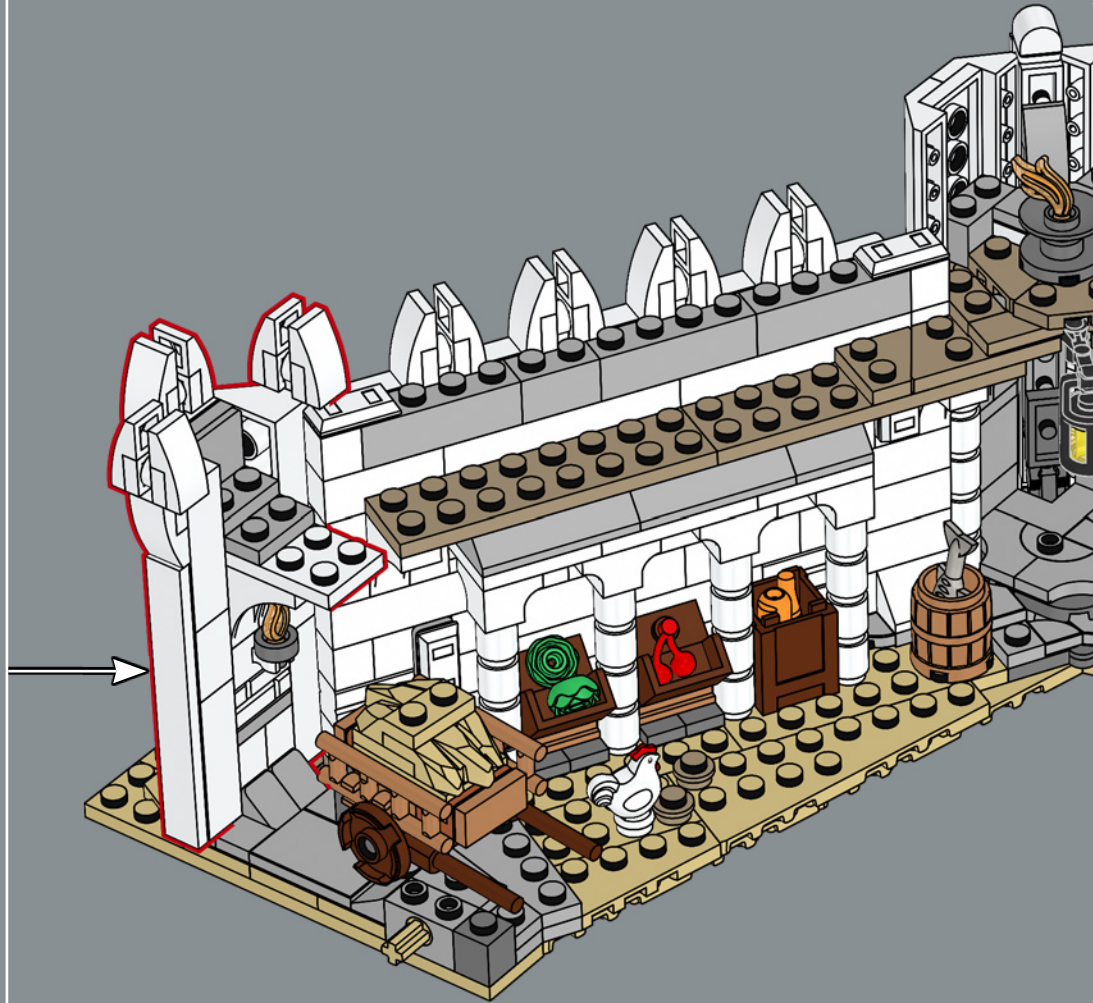

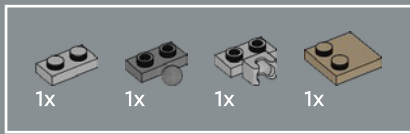

212

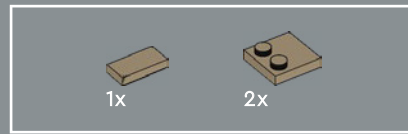
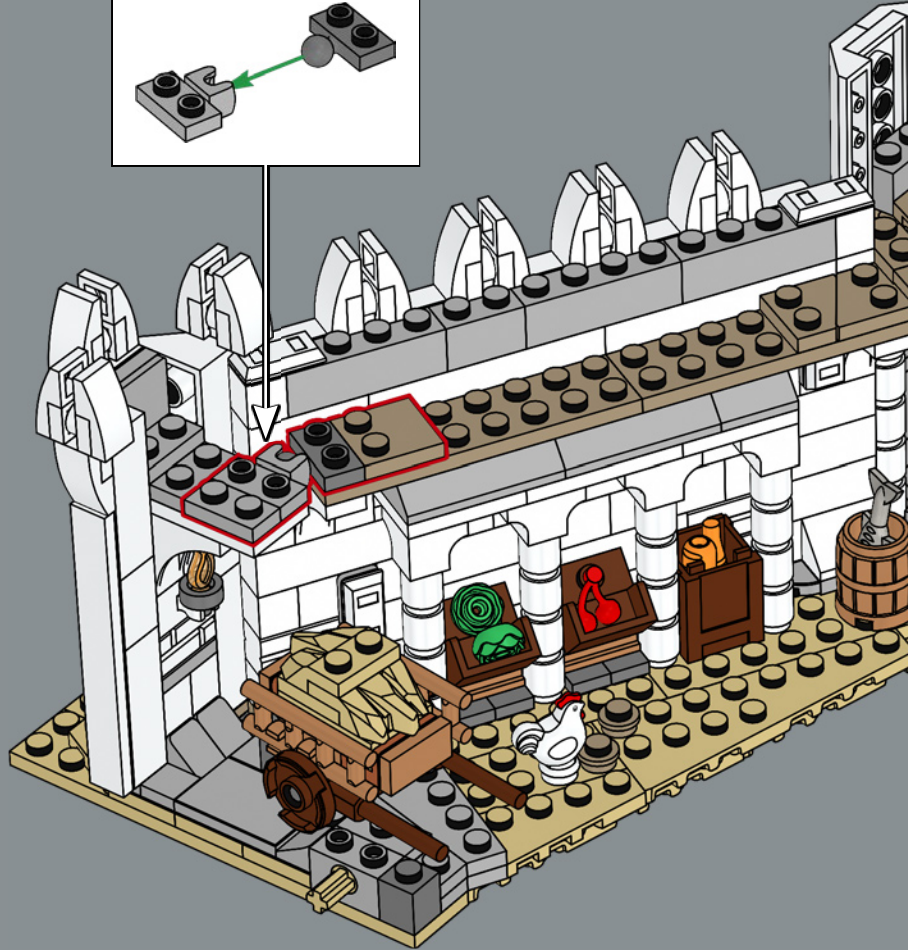
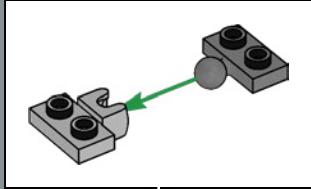

213

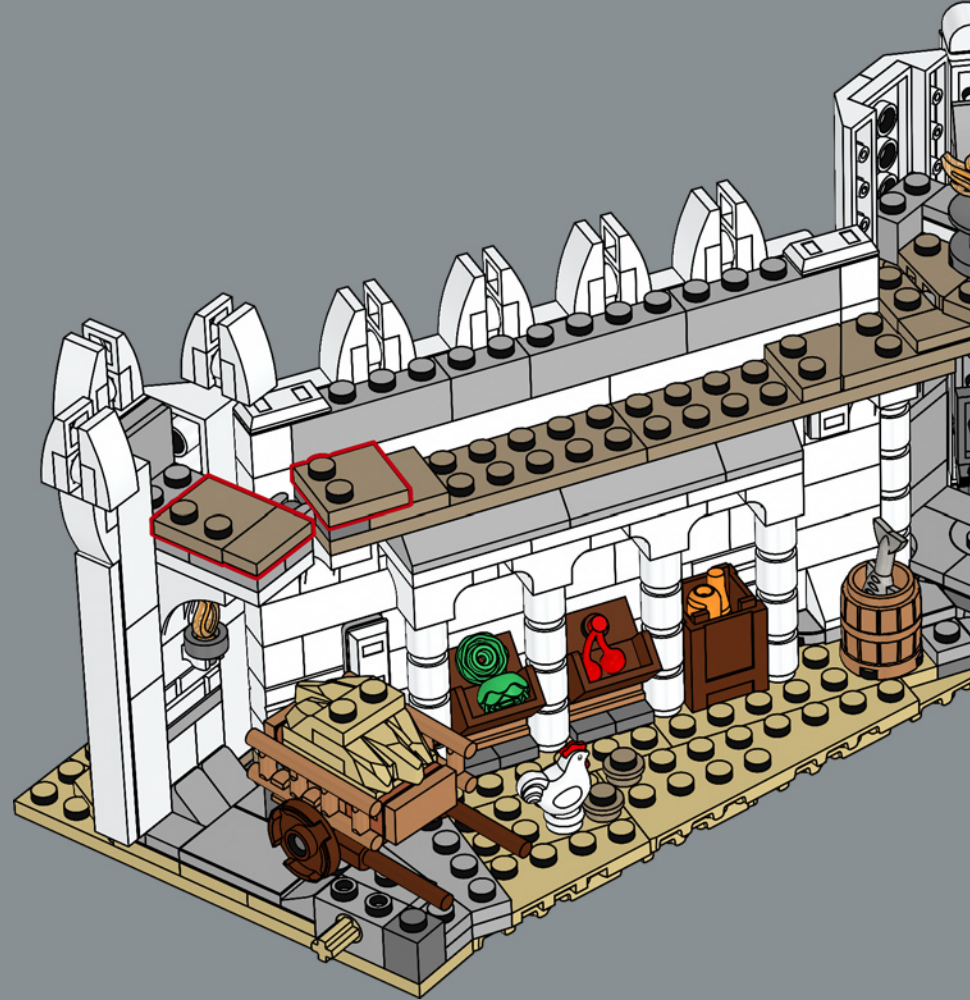

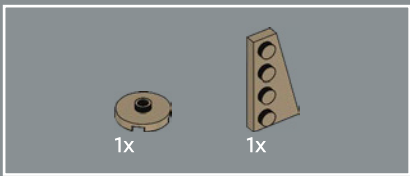

214

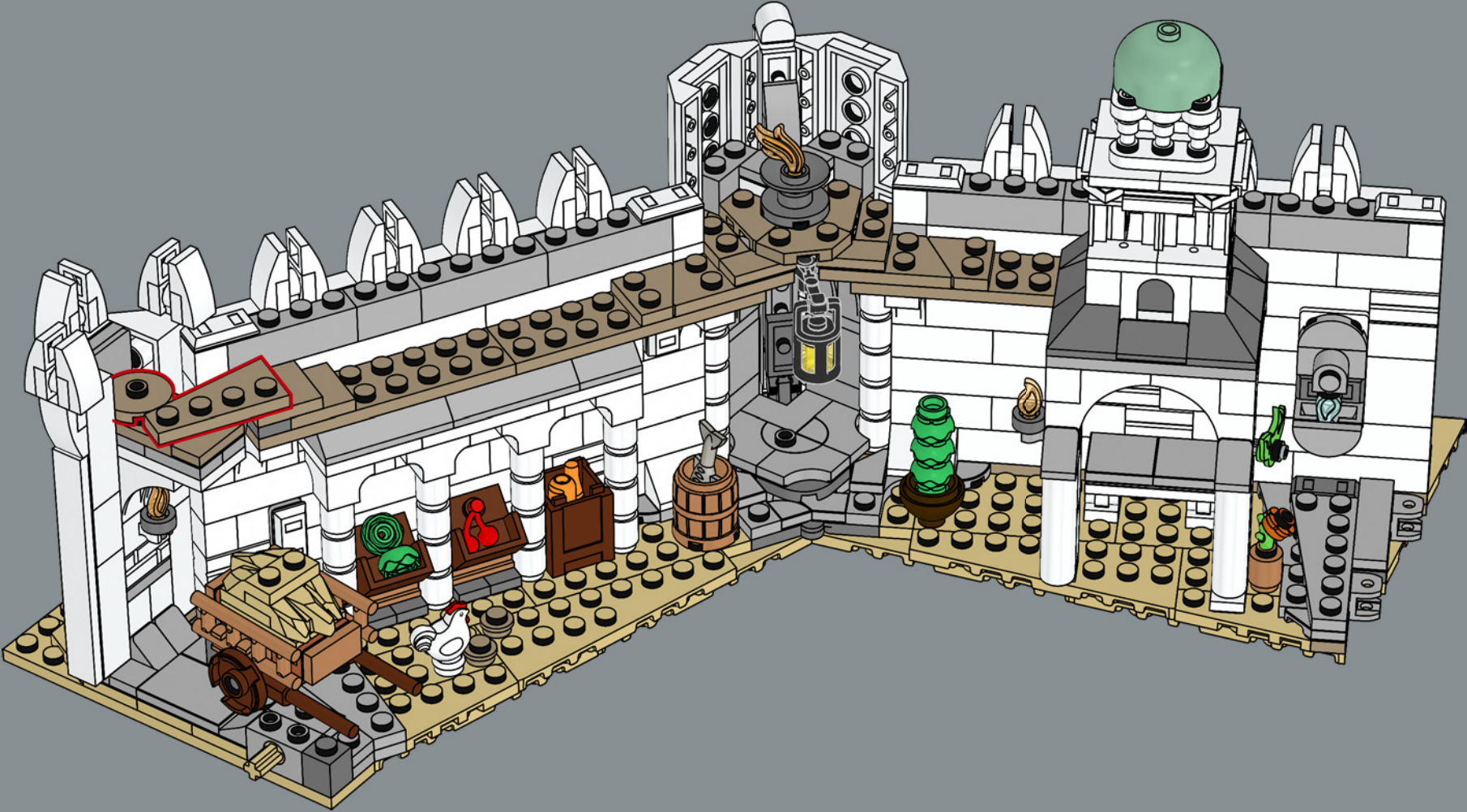

215

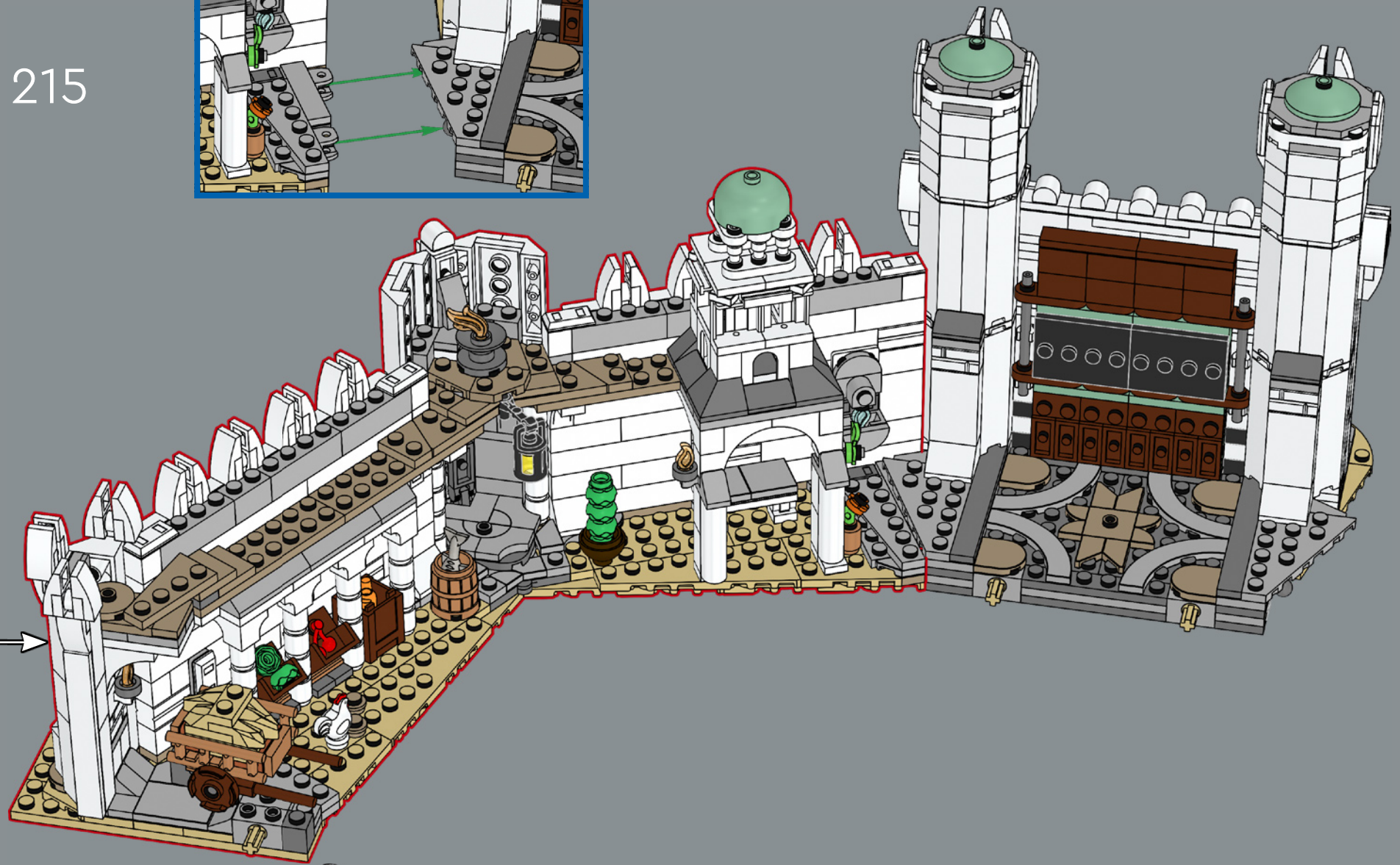
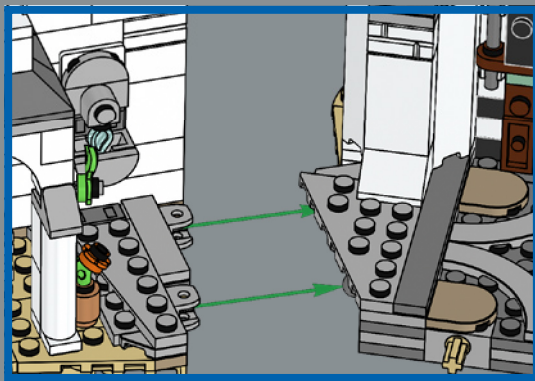

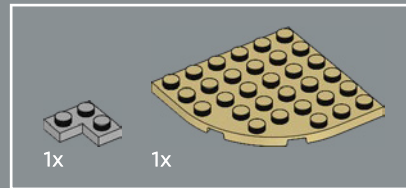
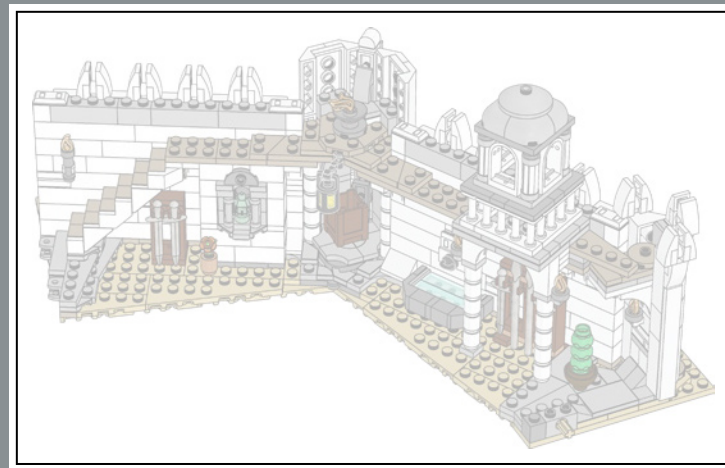

216

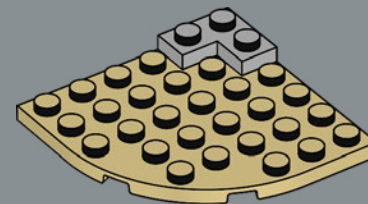

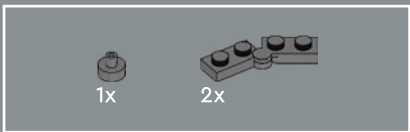

217

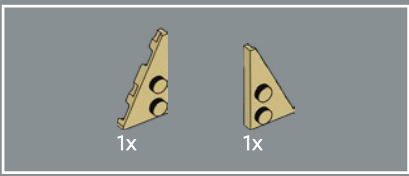
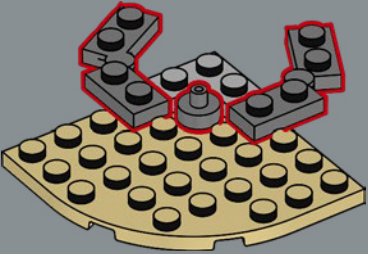

218

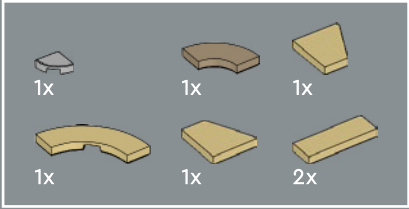
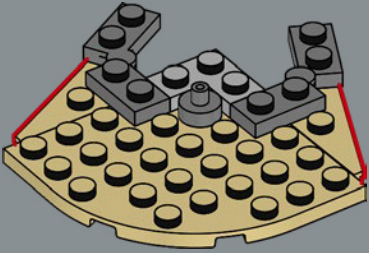

219

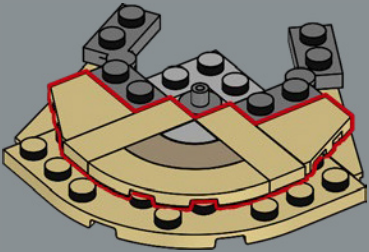

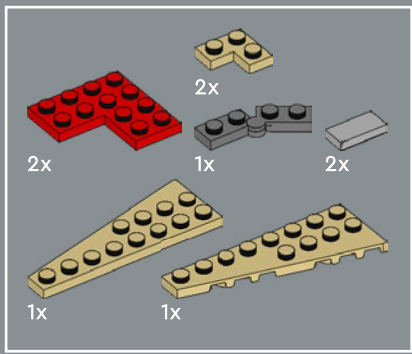

220

1

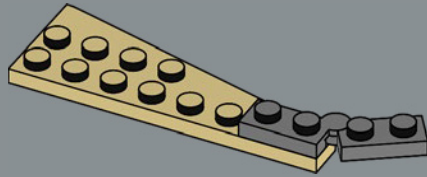

2

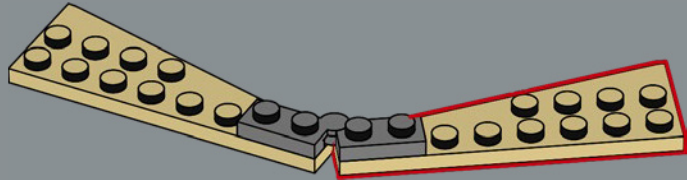

3

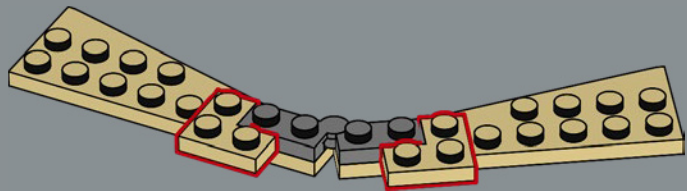

4

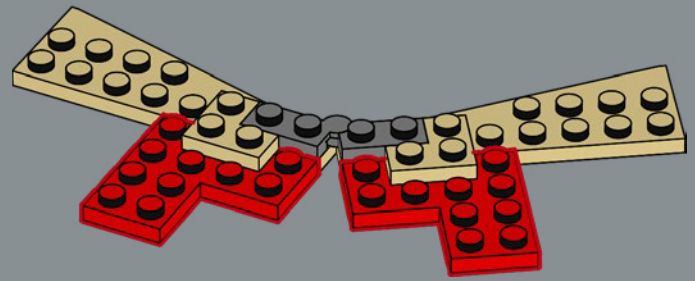

5

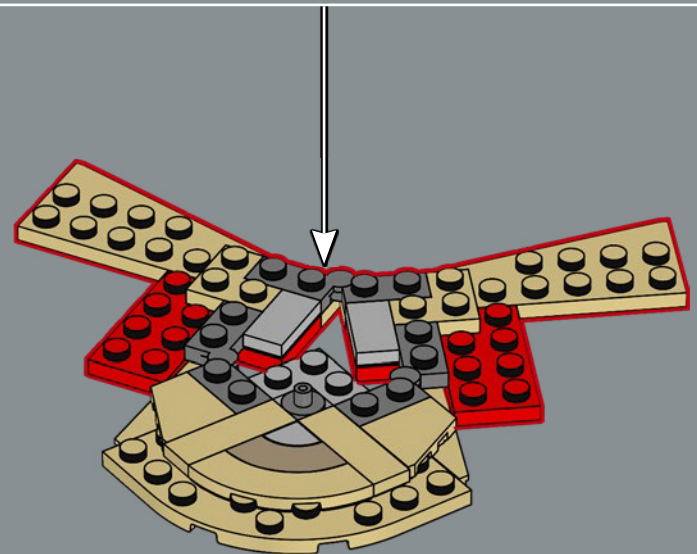
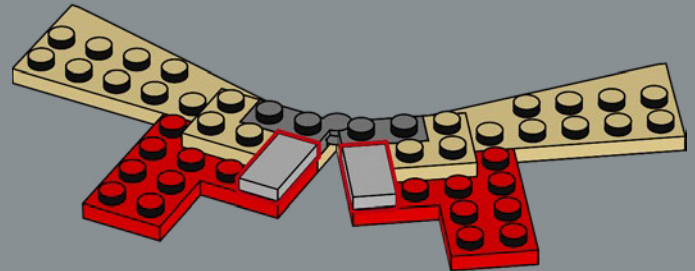

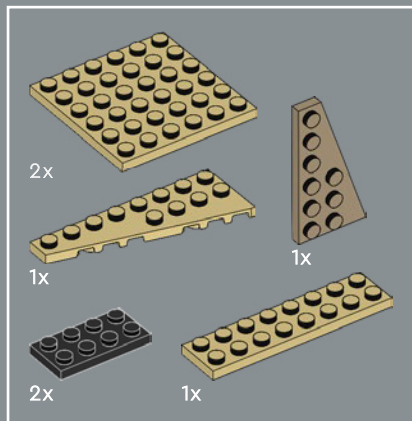

221

1

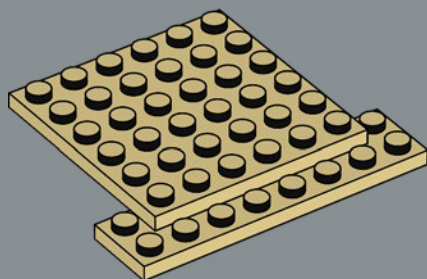

2

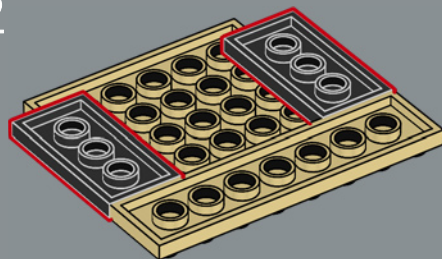

3

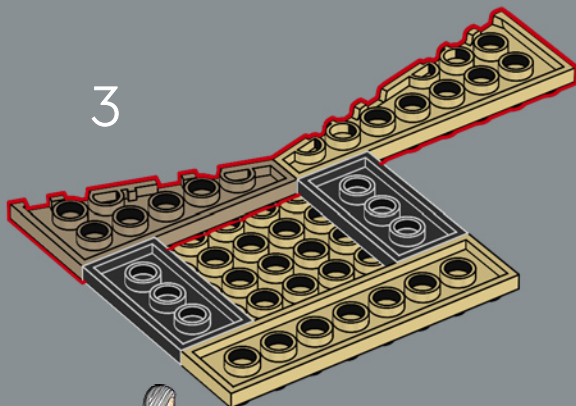

4

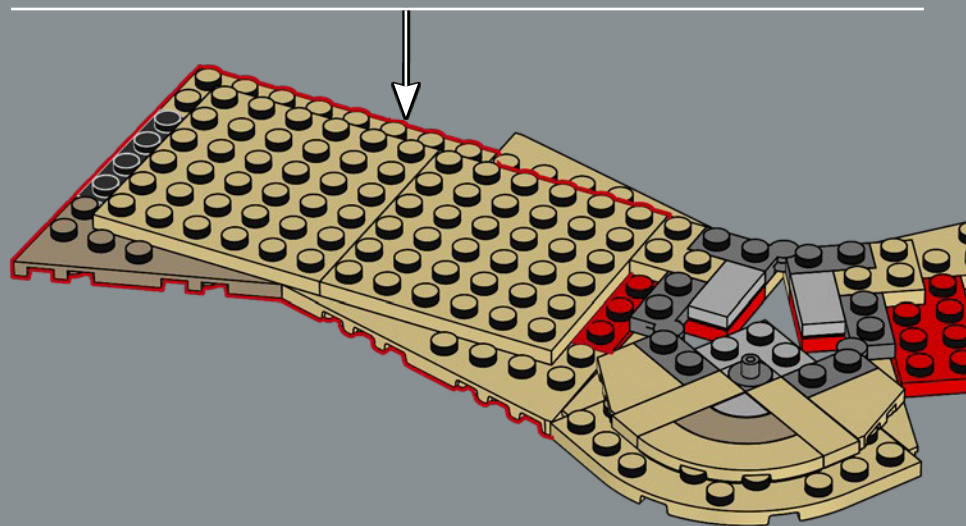
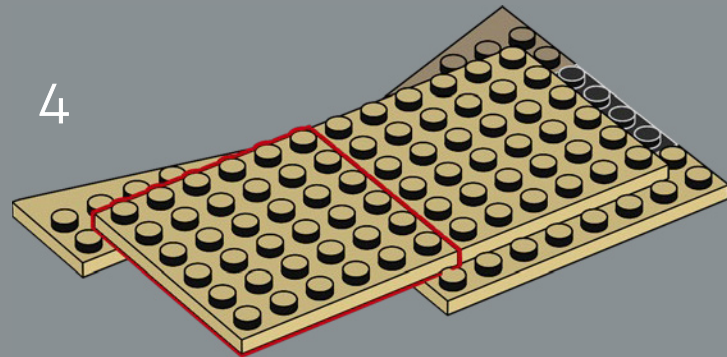

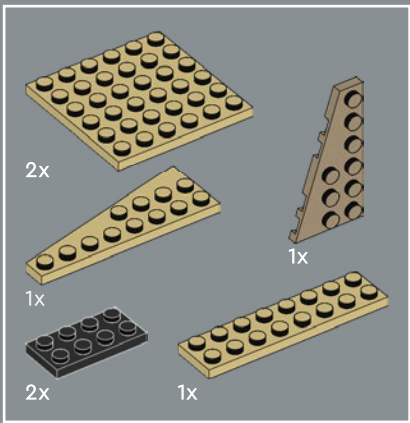

222

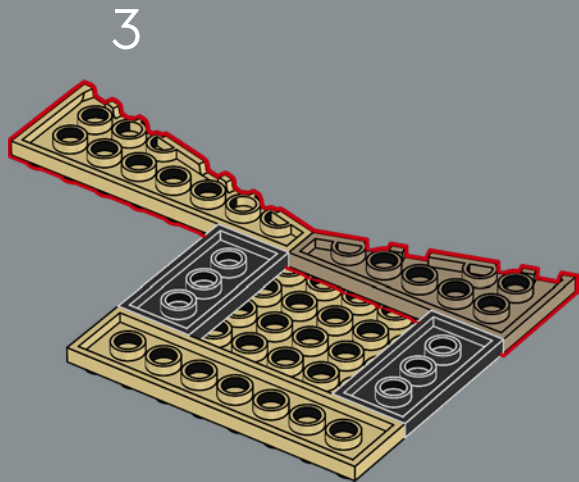
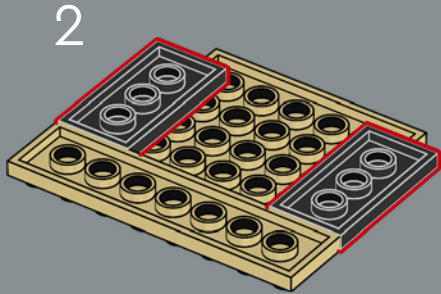
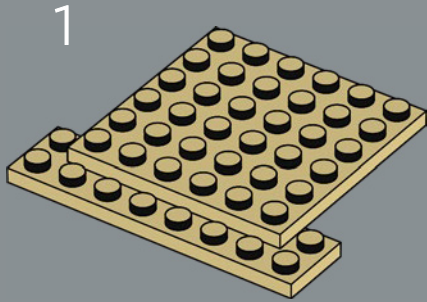

4

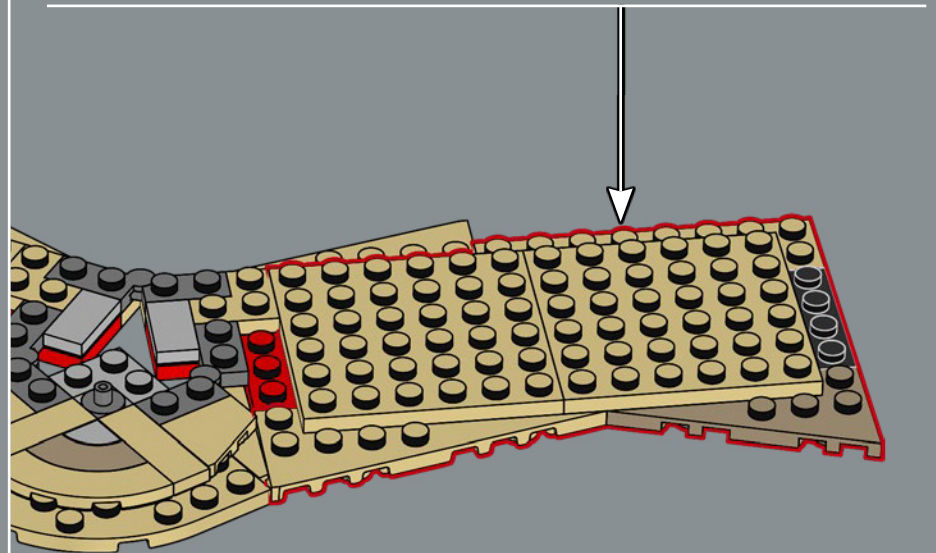
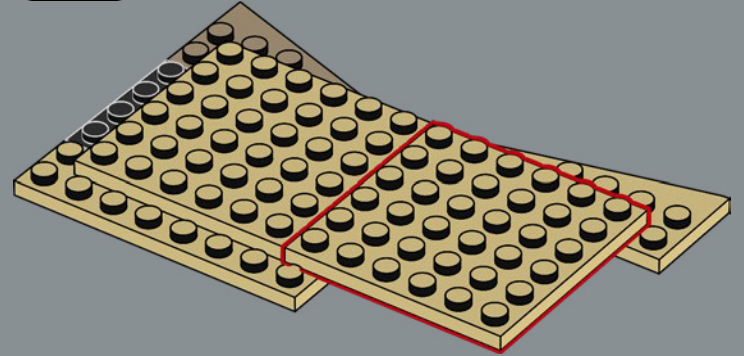



223

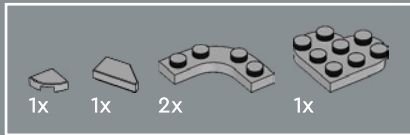
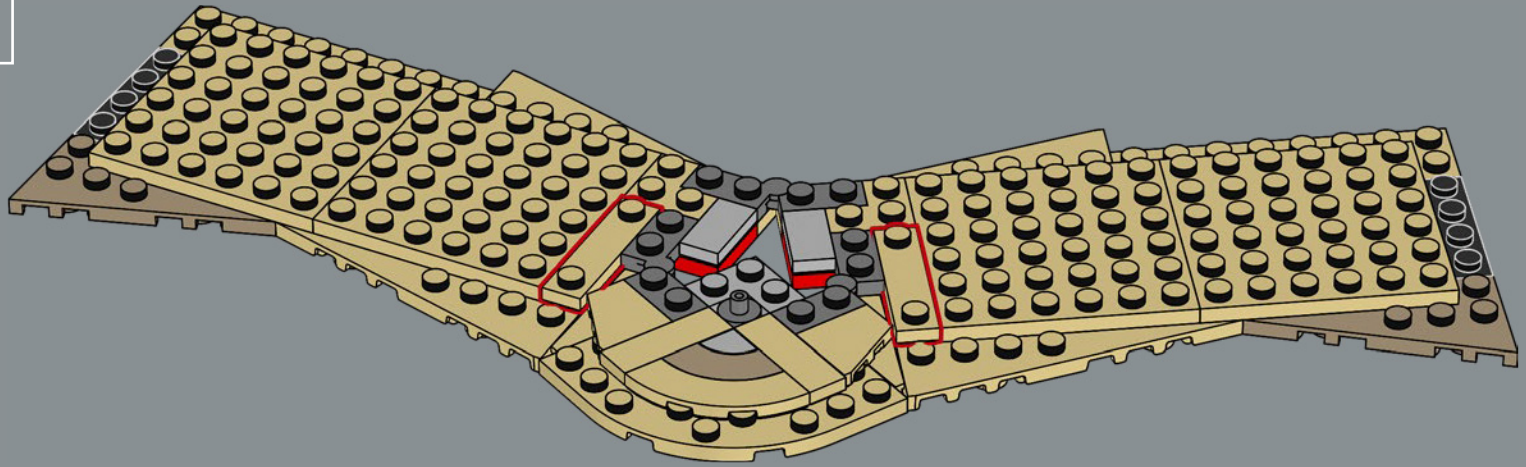

224

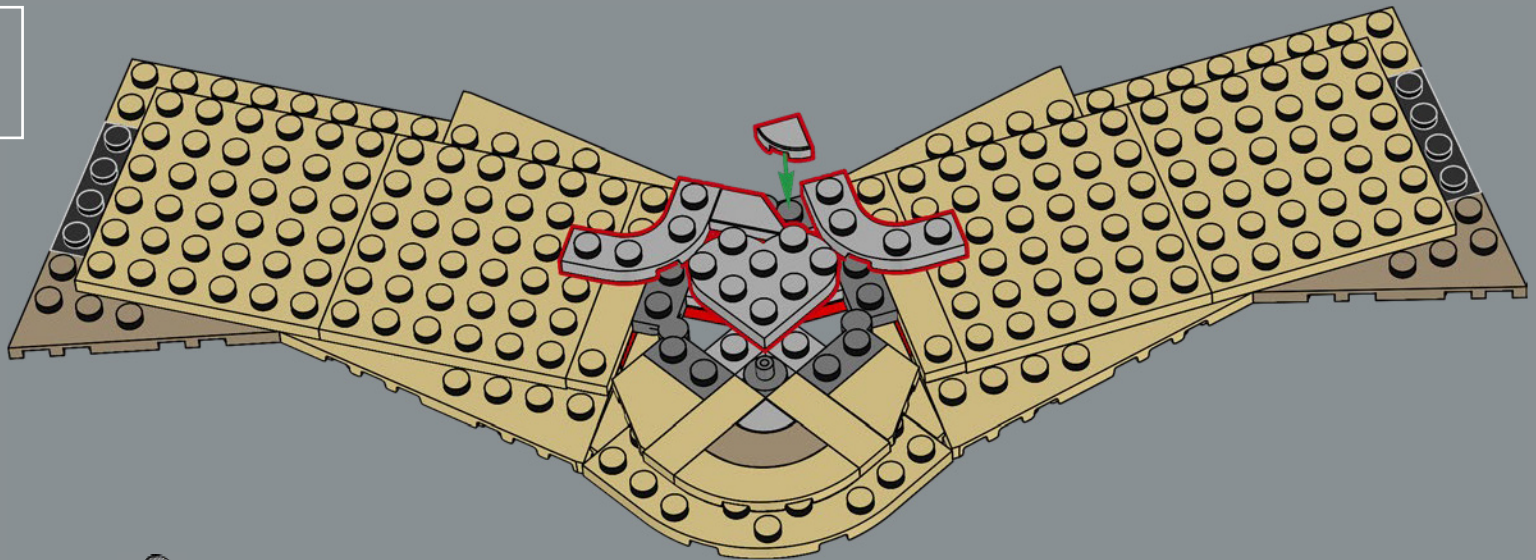

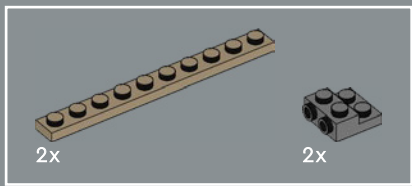

225

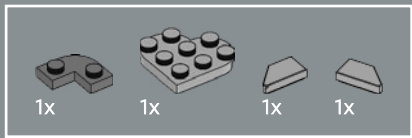
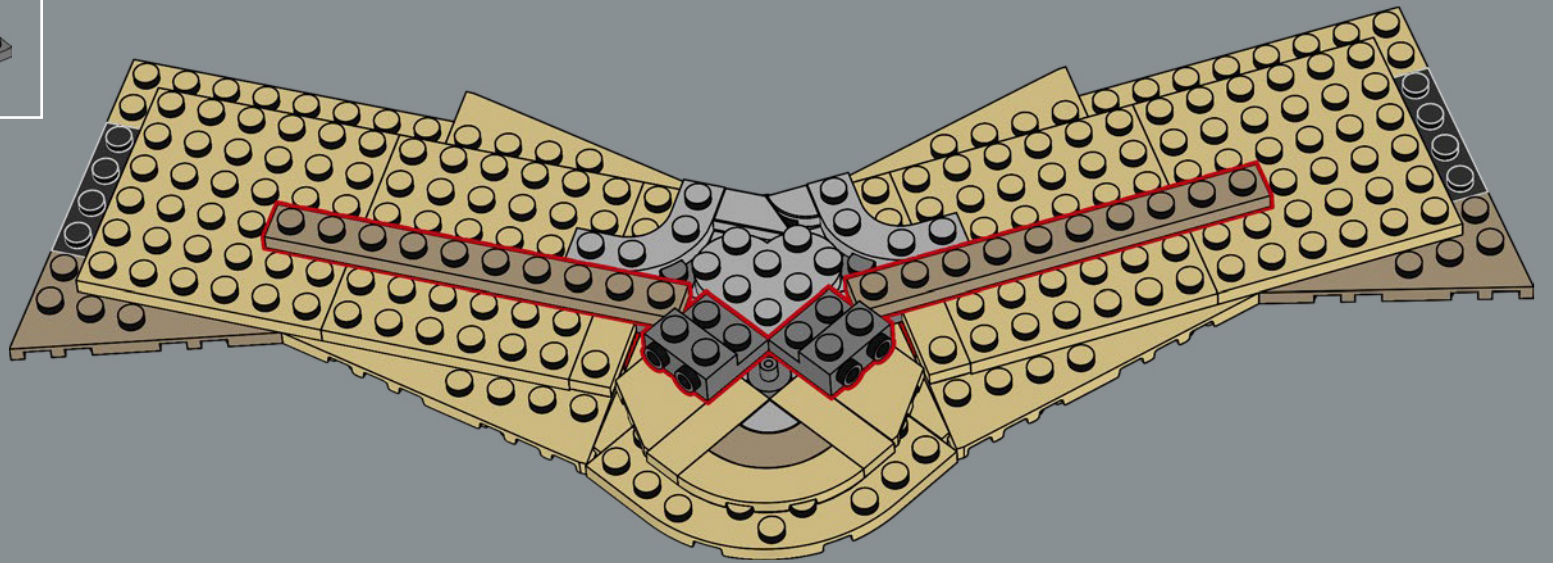

226

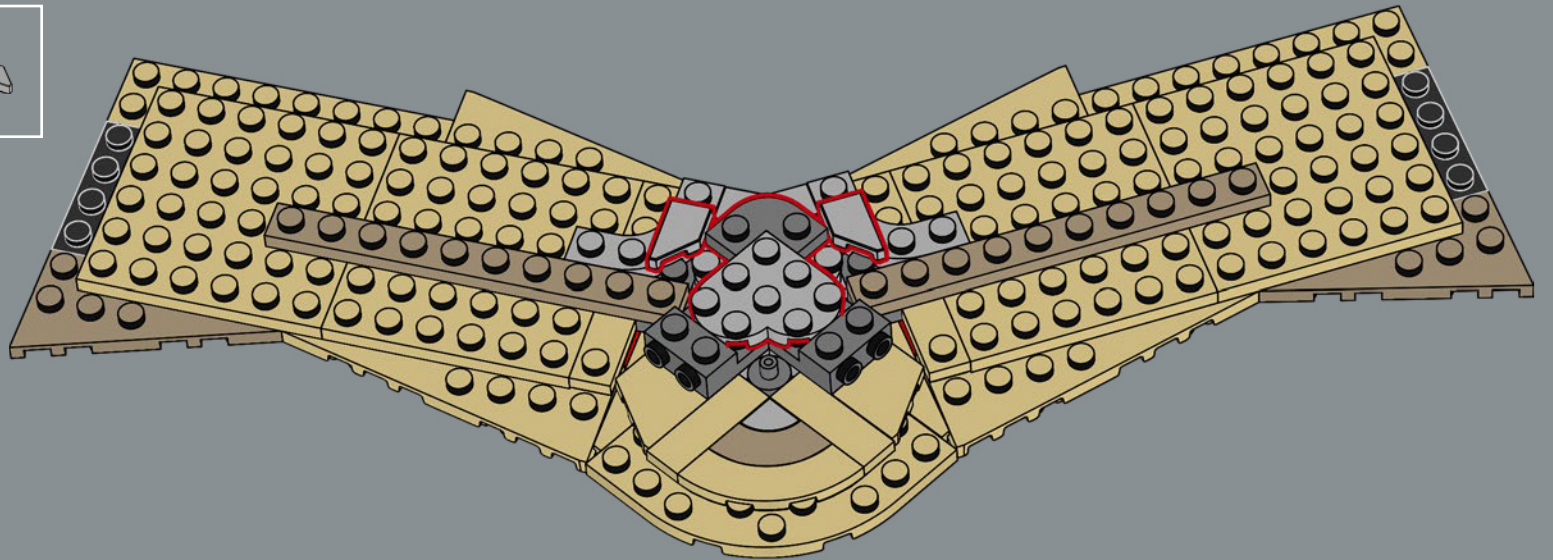

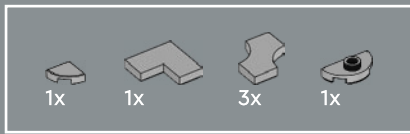

227

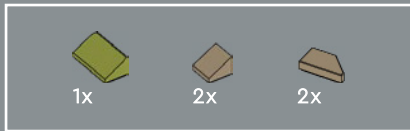
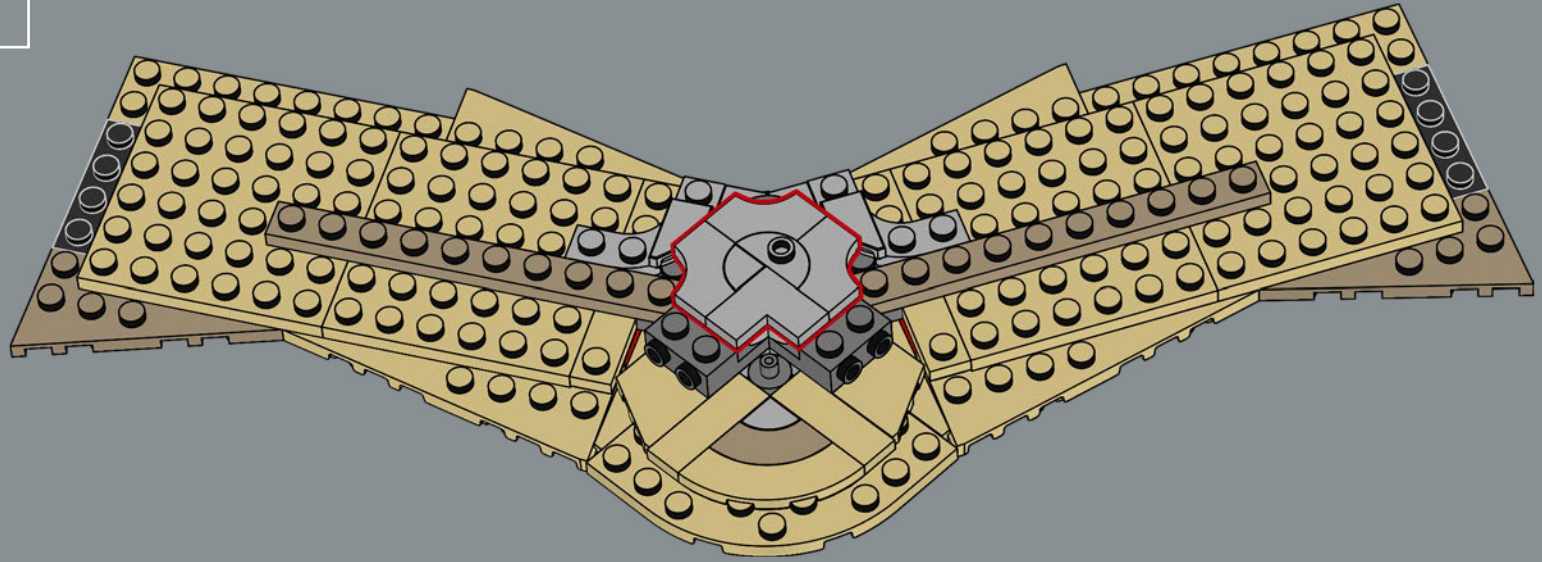

228

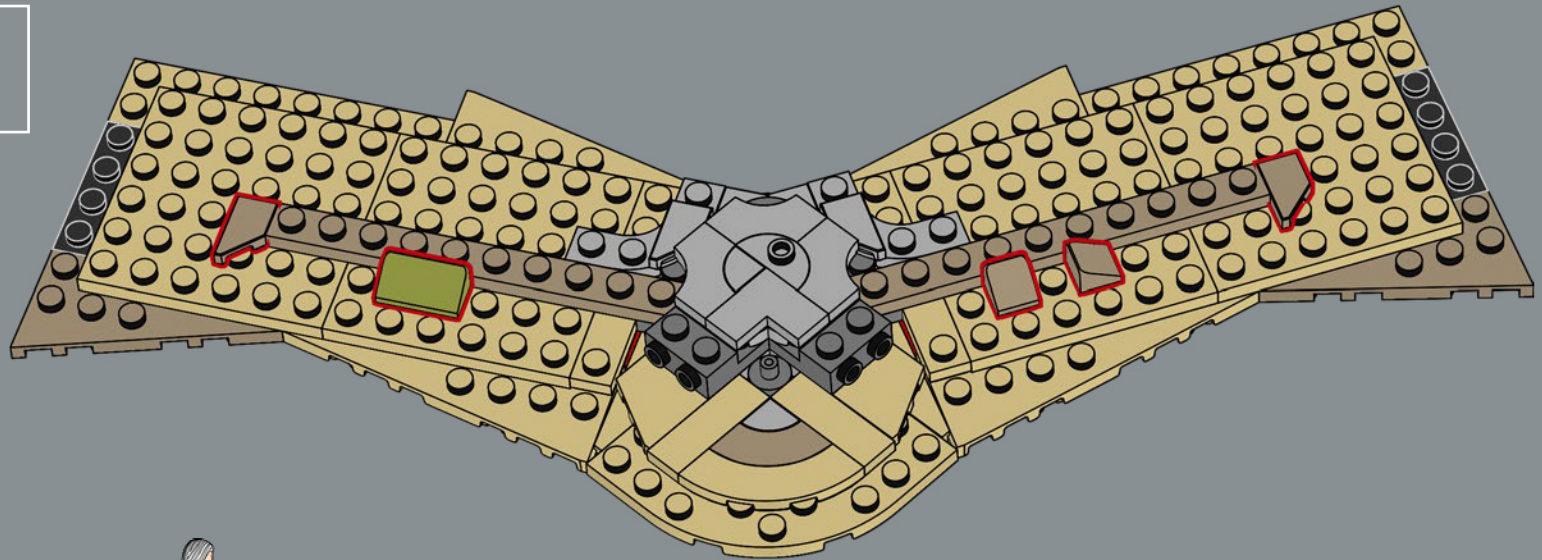

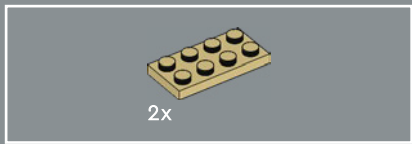

229

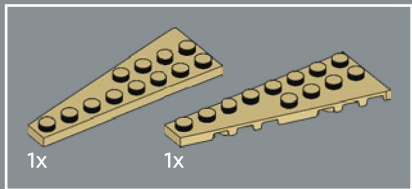
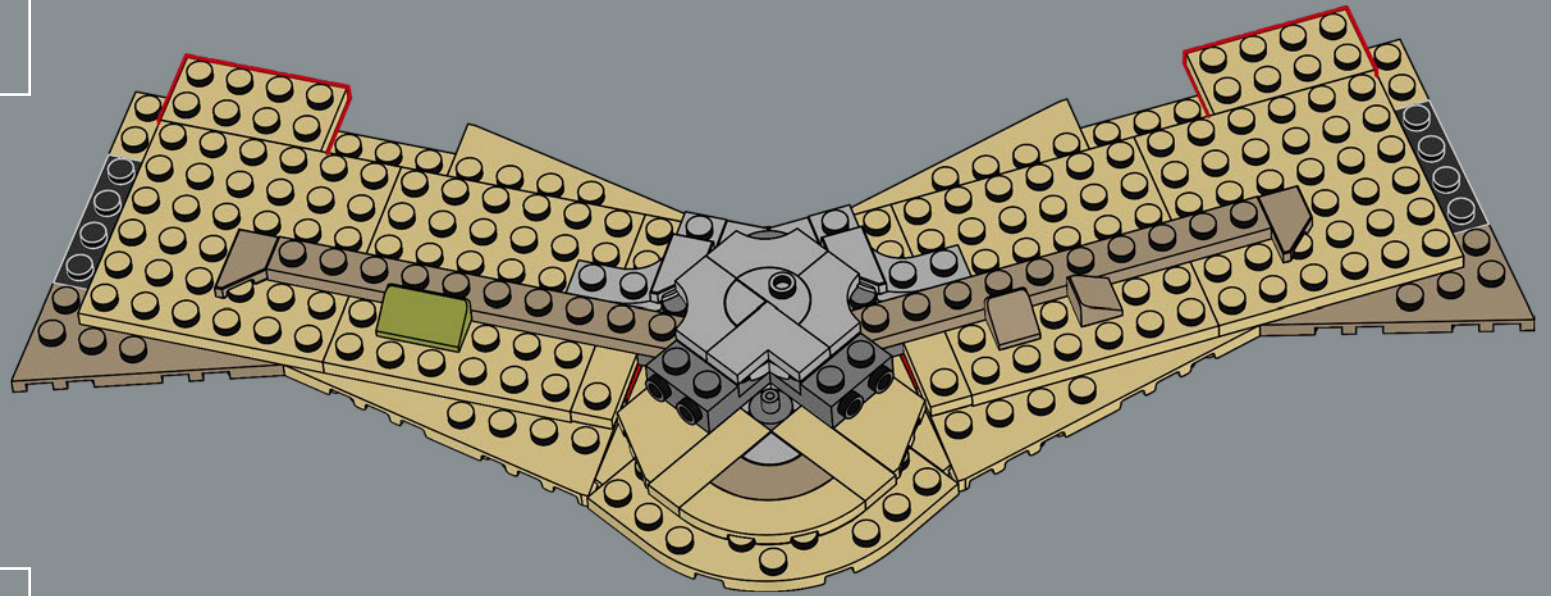

230

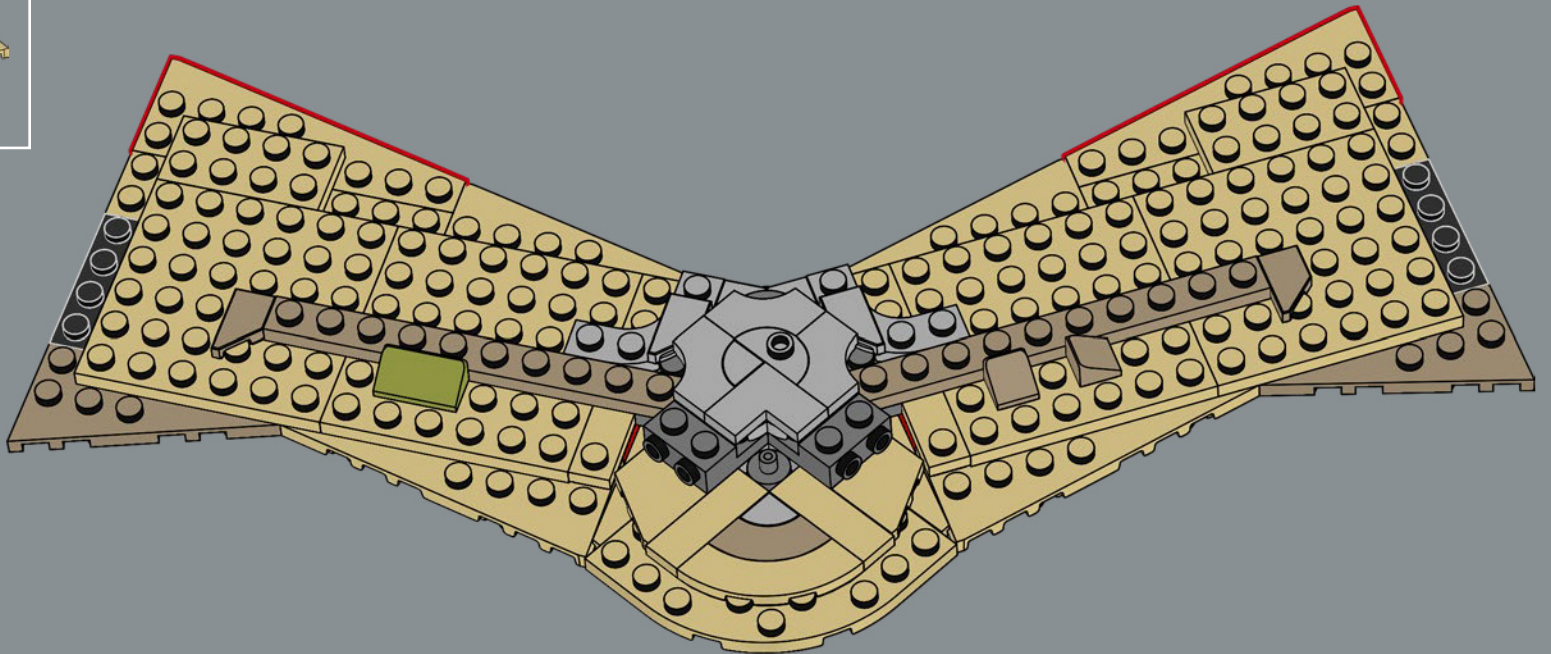

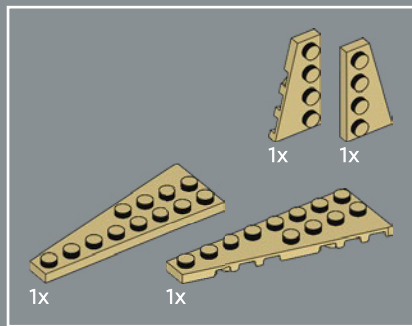

231

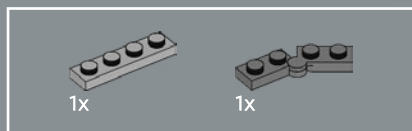
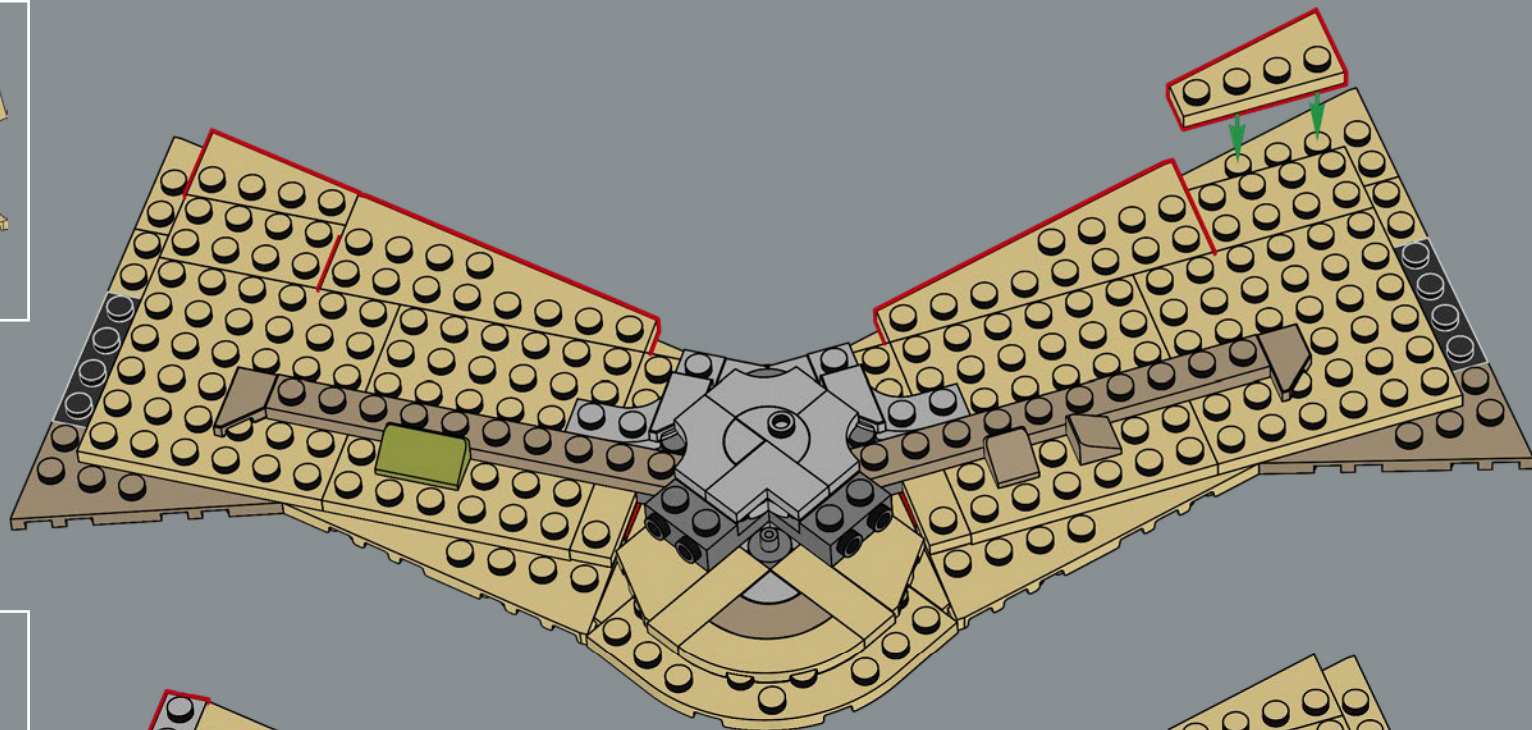

232

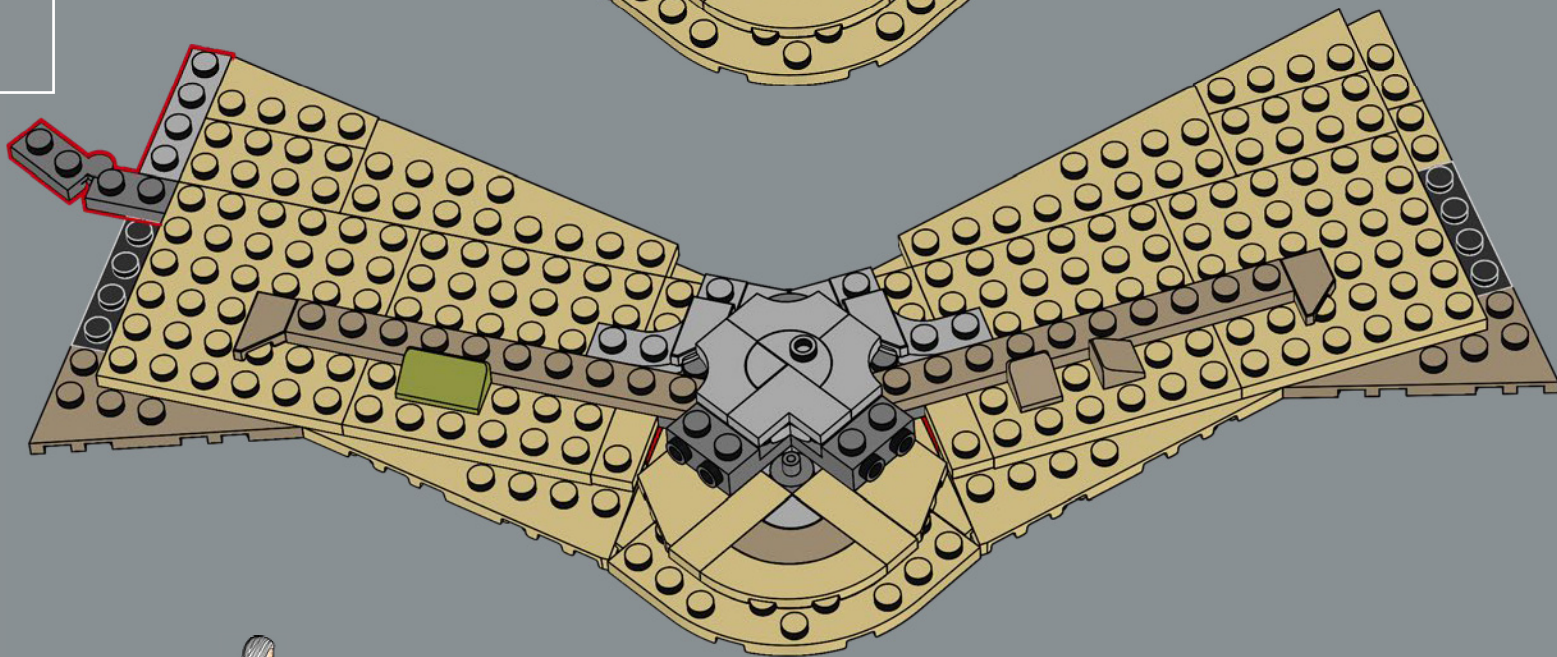

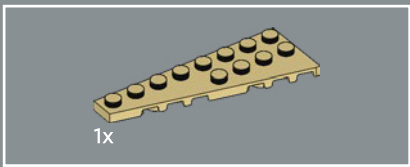

233

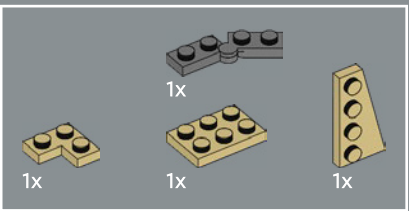
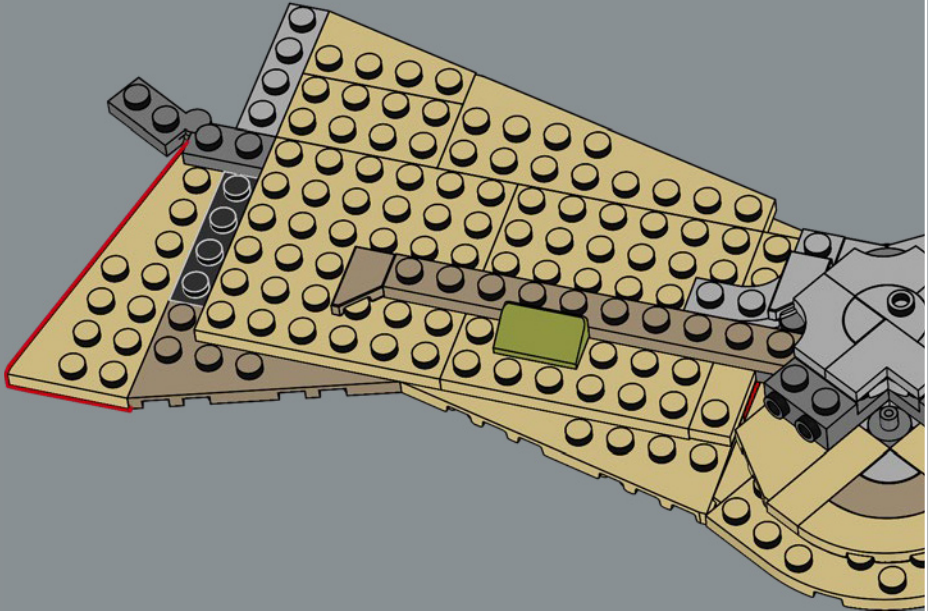

234

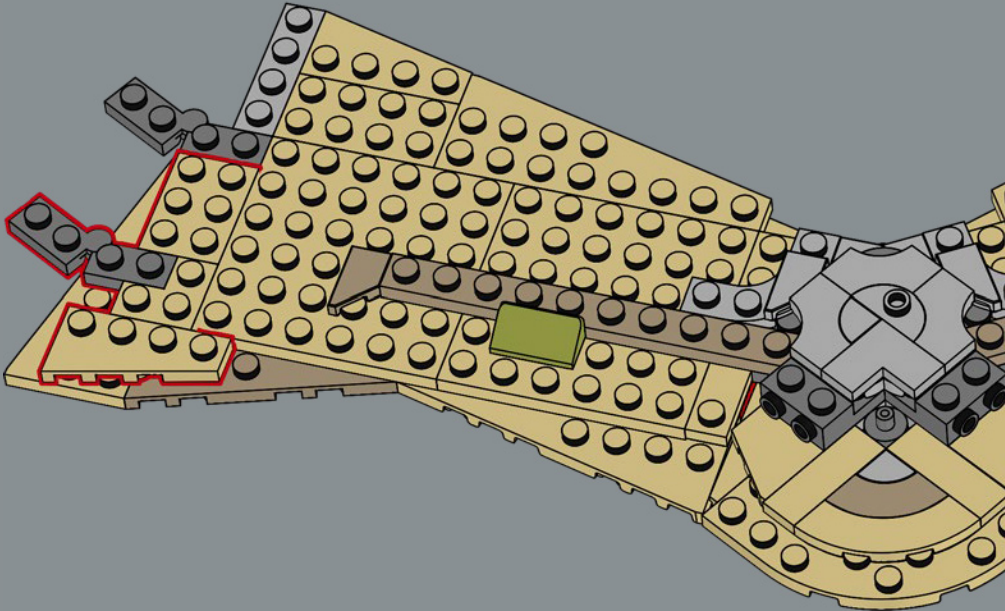

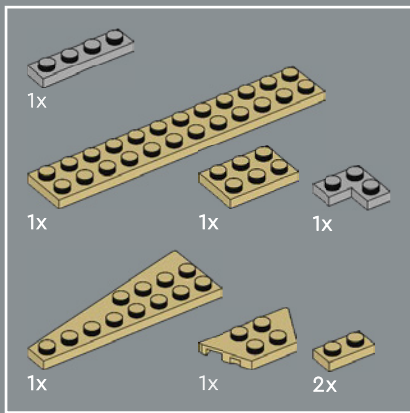

235

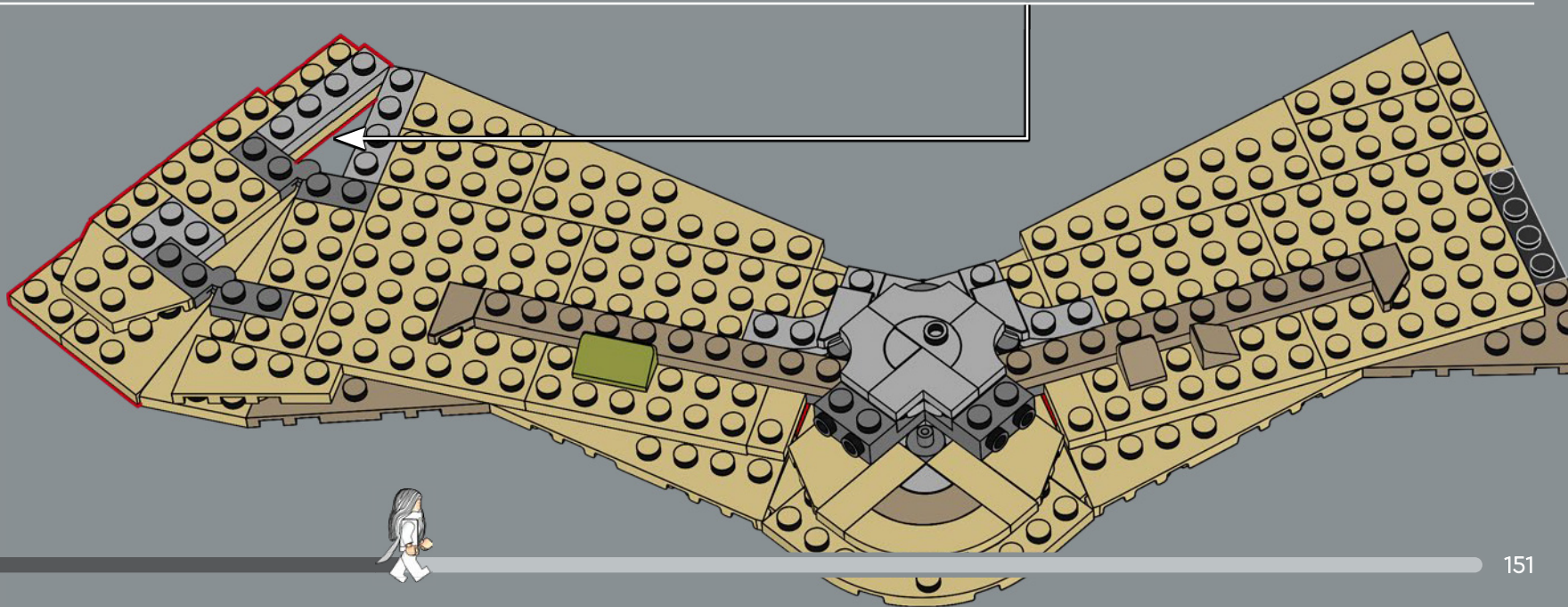
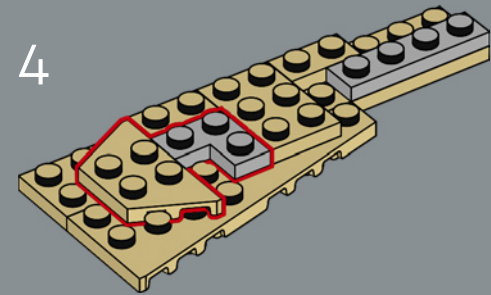
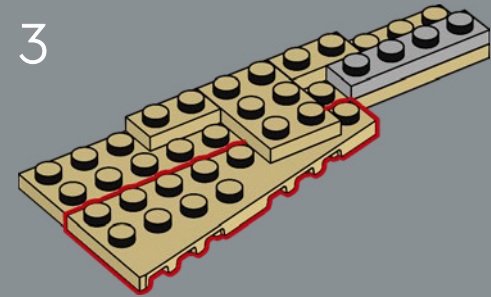
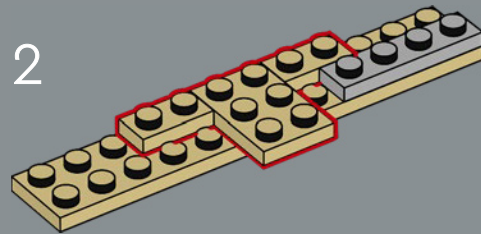
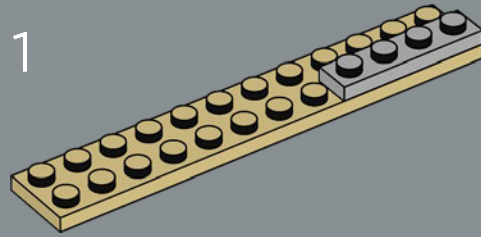

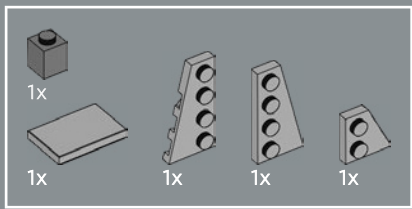

236

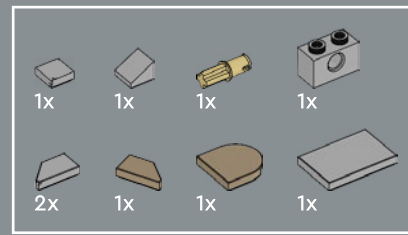
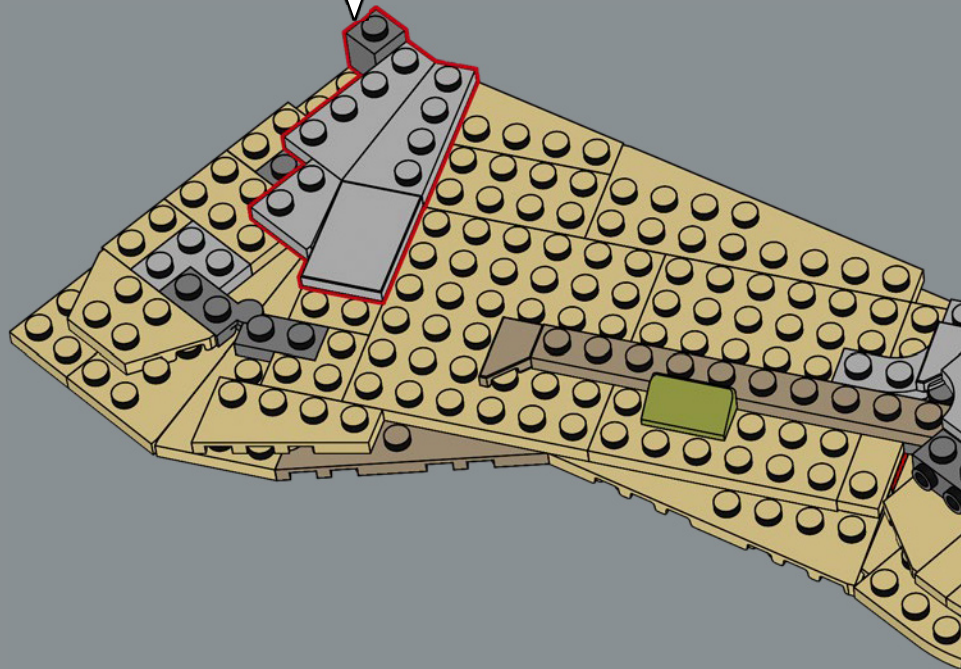
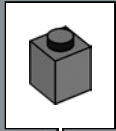

237

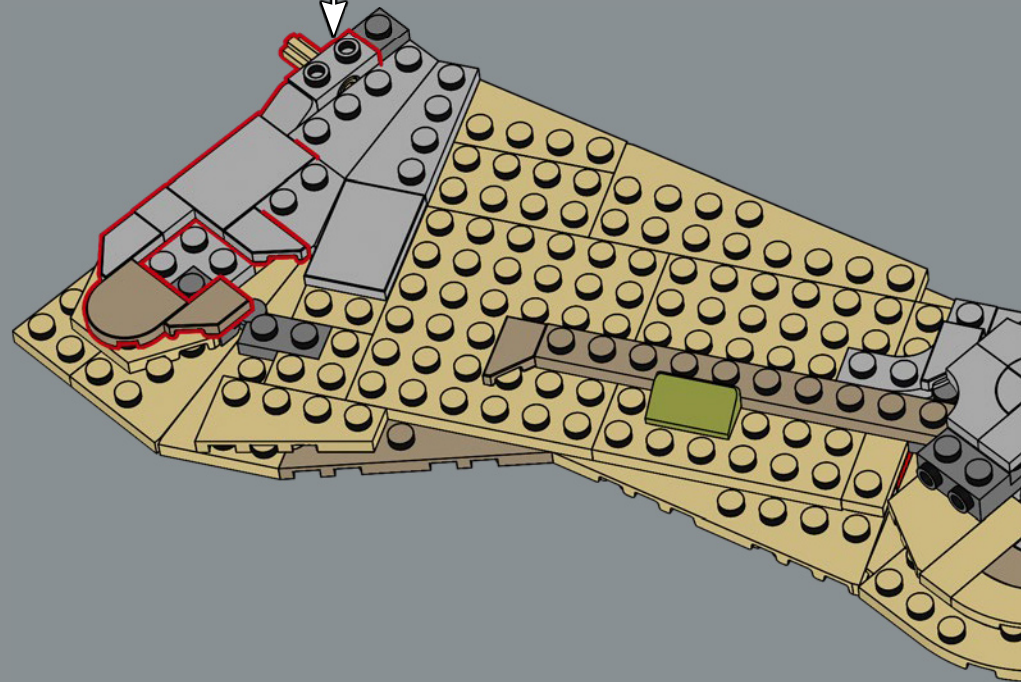
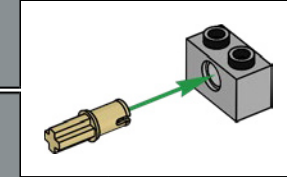

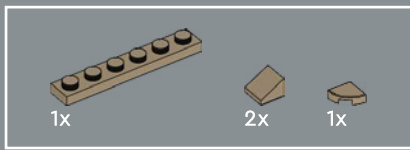

238

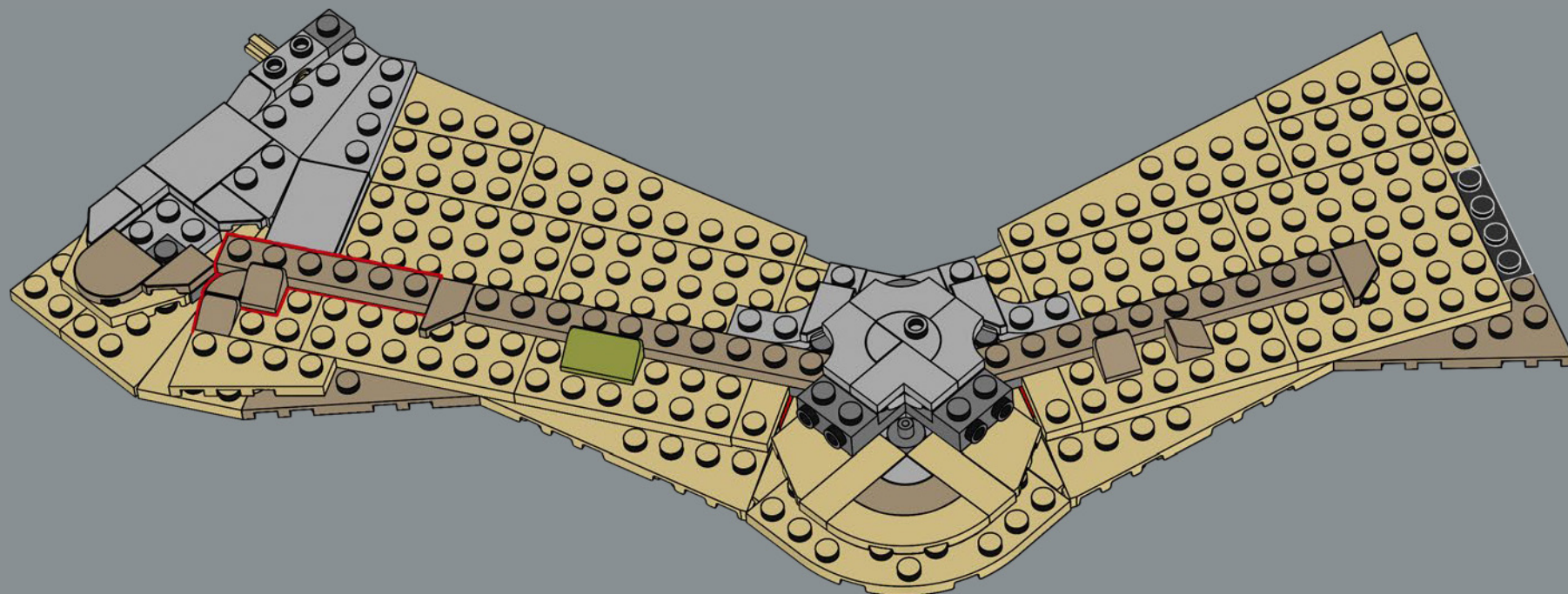

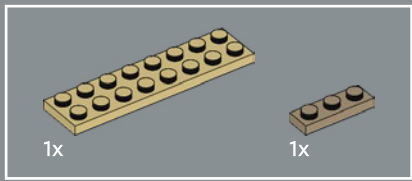

239

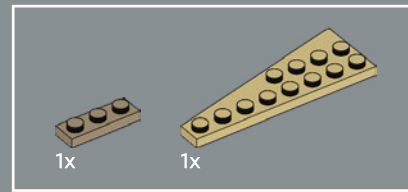
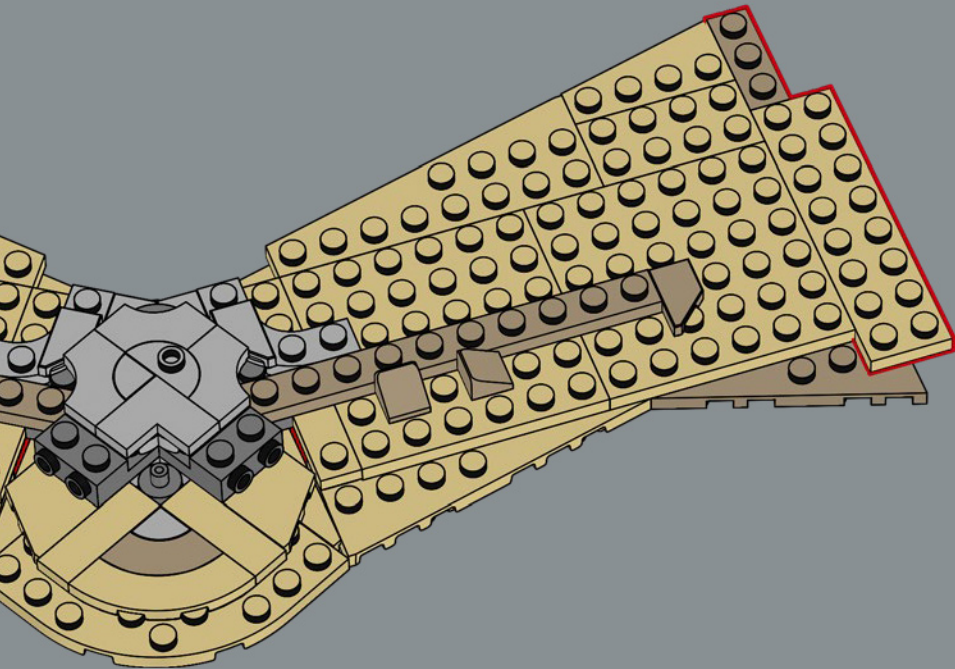

240

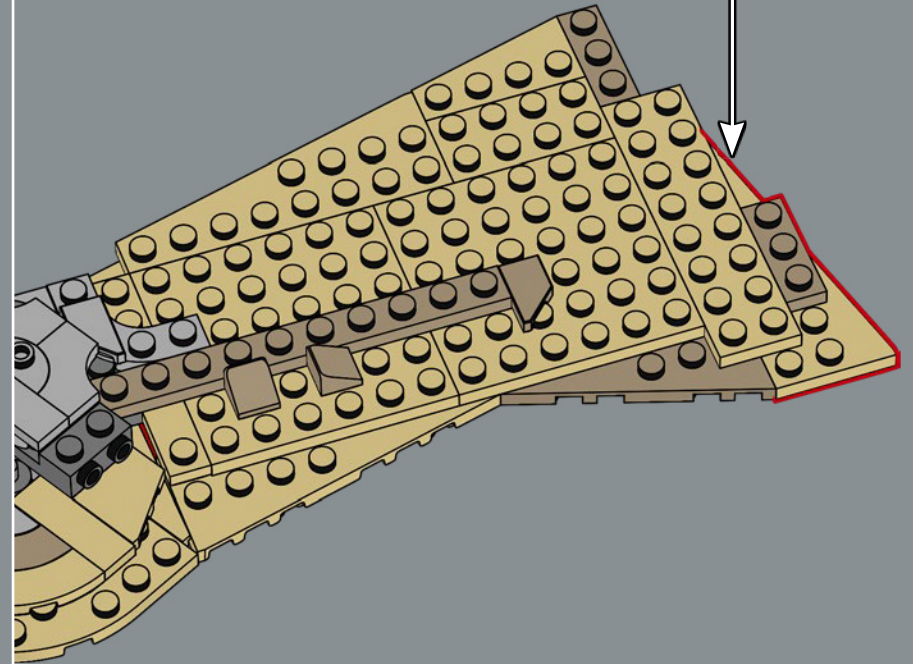
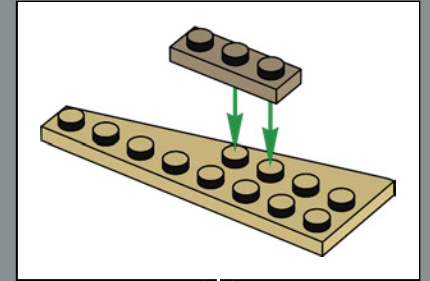

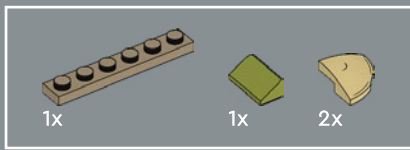

241

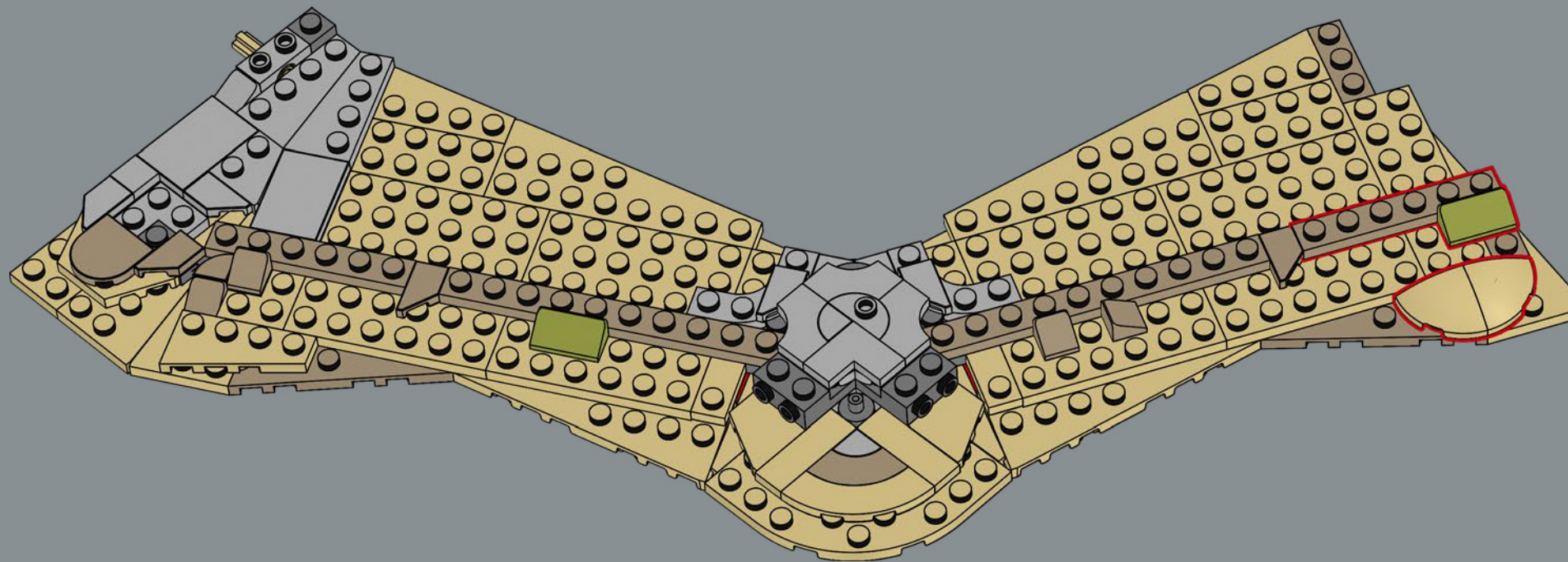

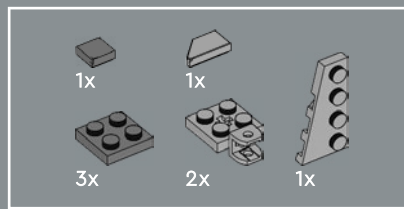

242

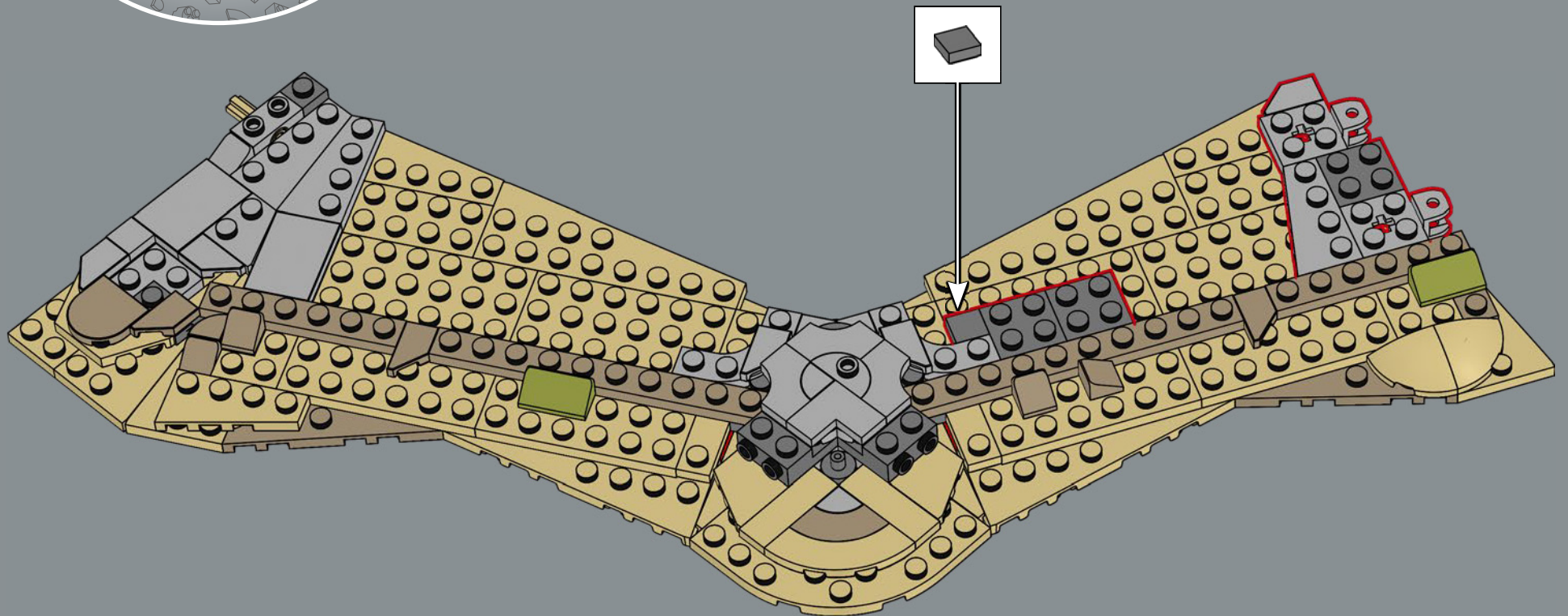

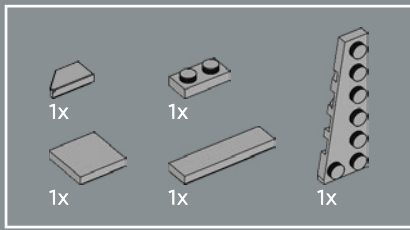

243

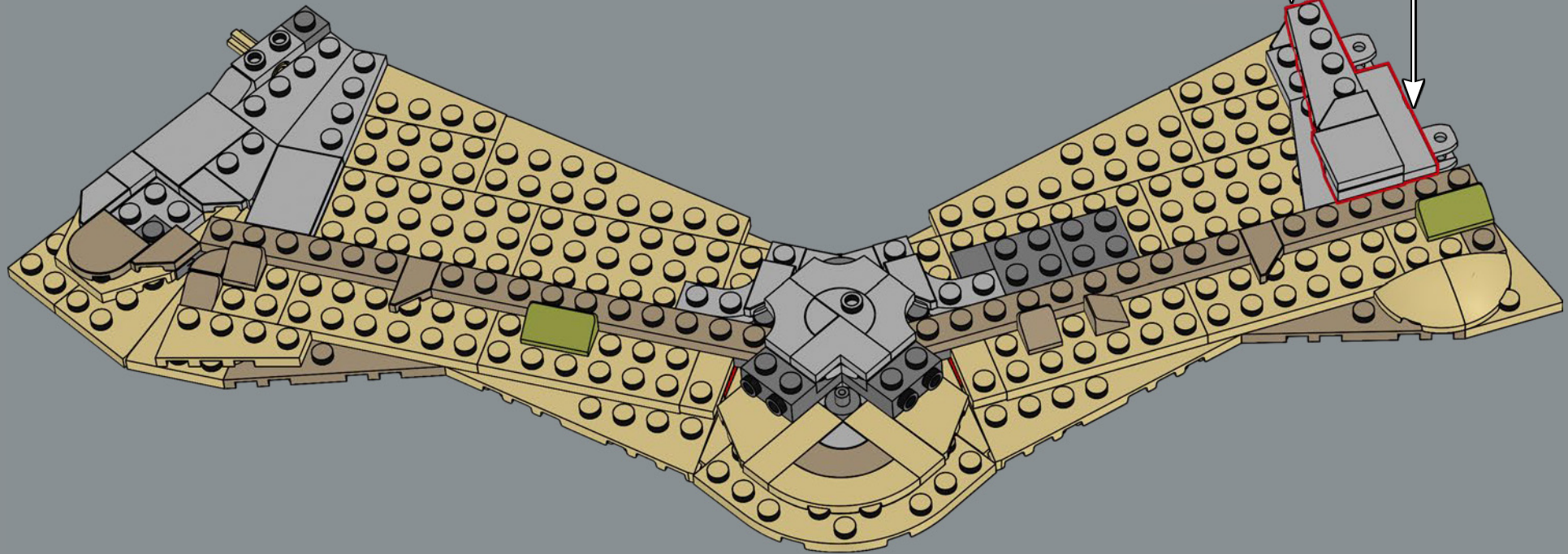
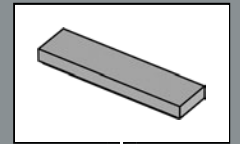
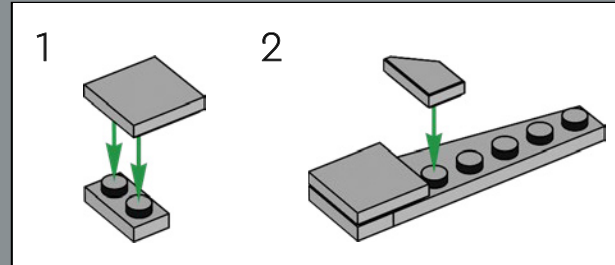

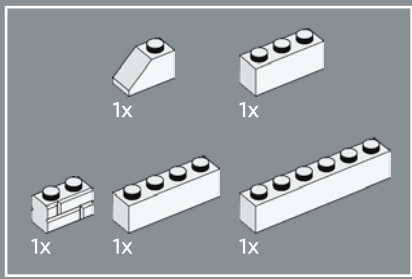

244

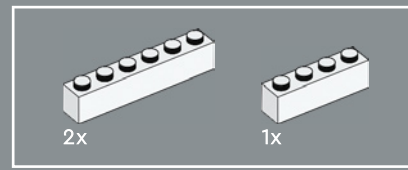
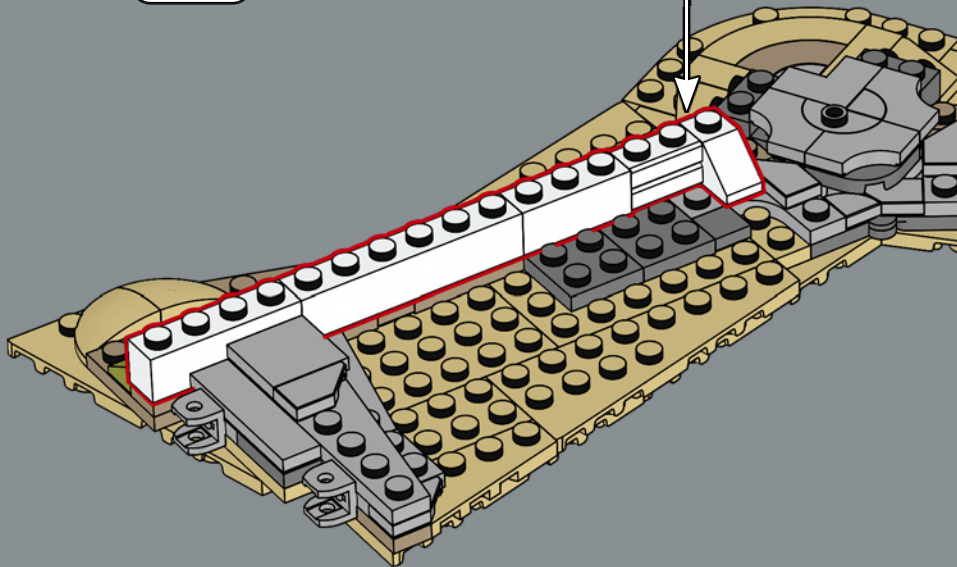
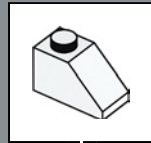

245

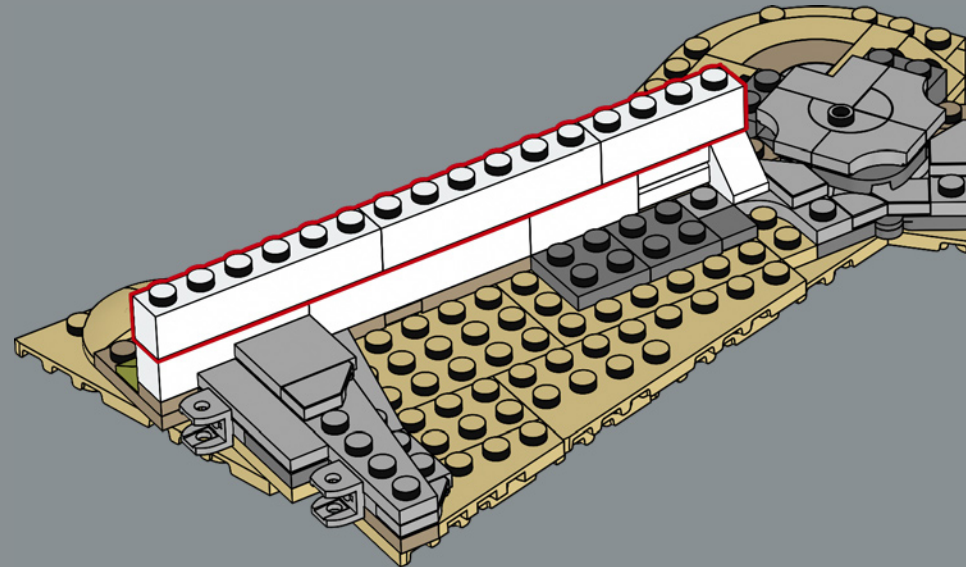

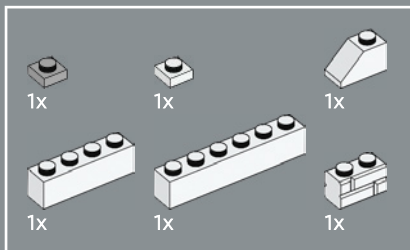

246

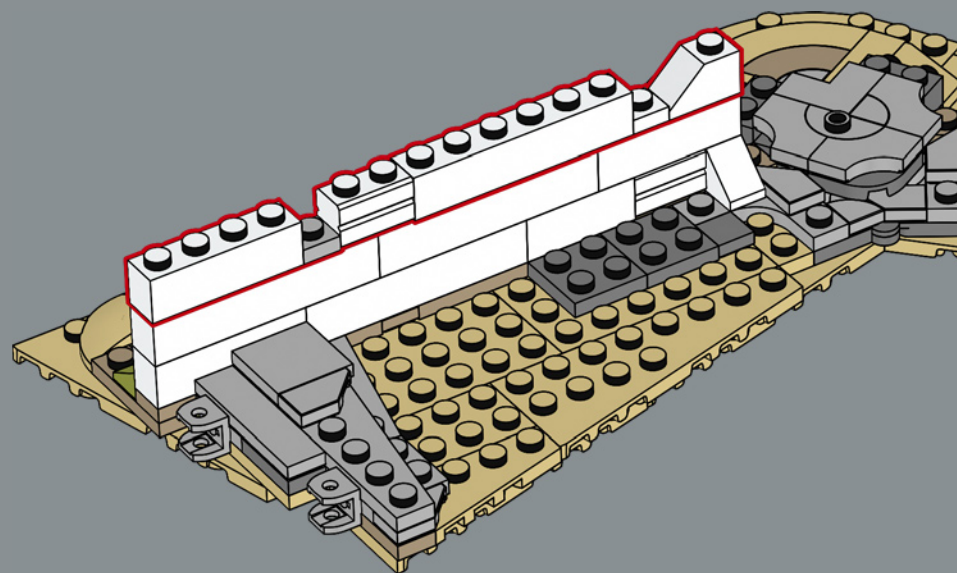

247

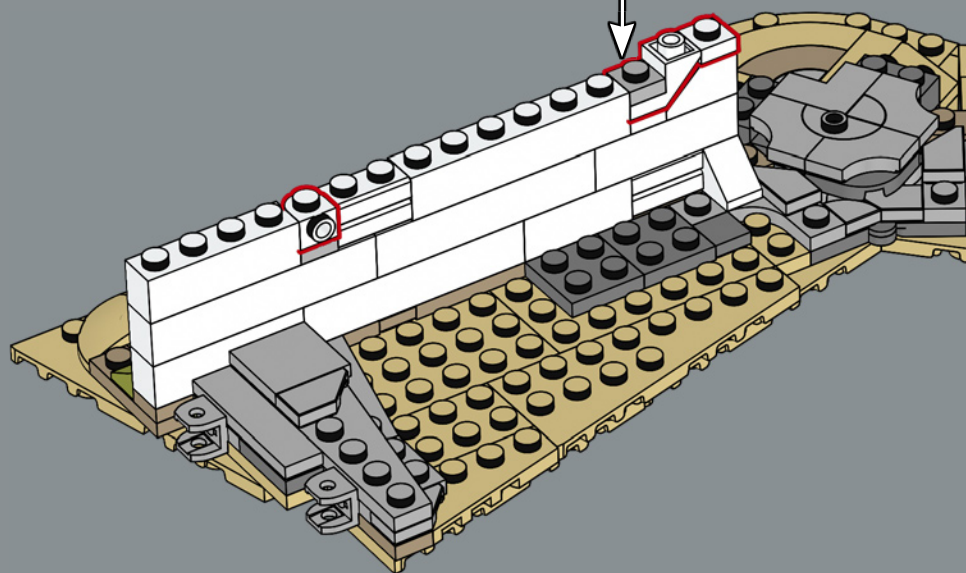
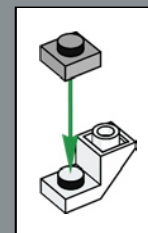

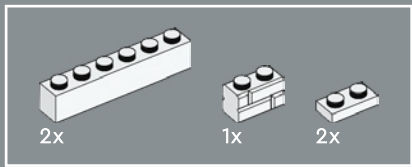

248

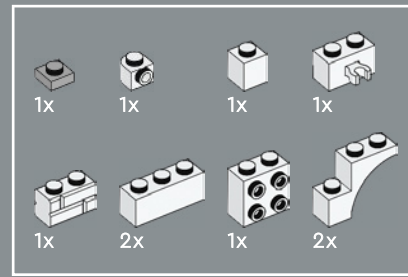
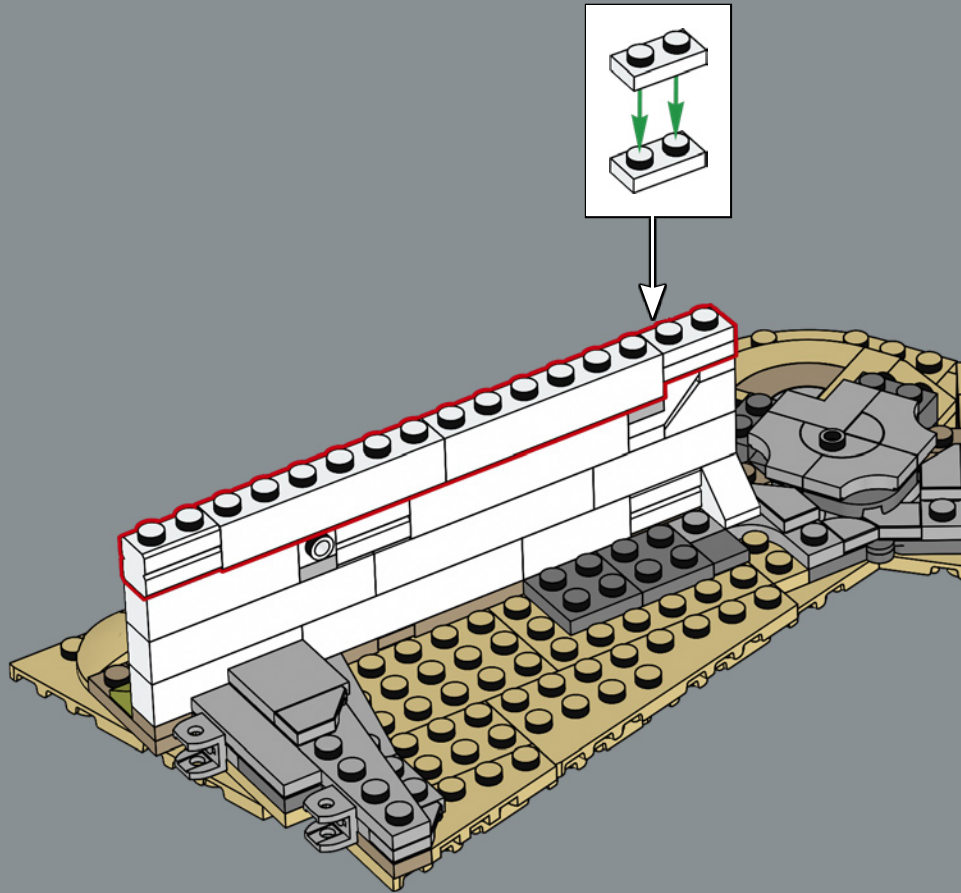

249

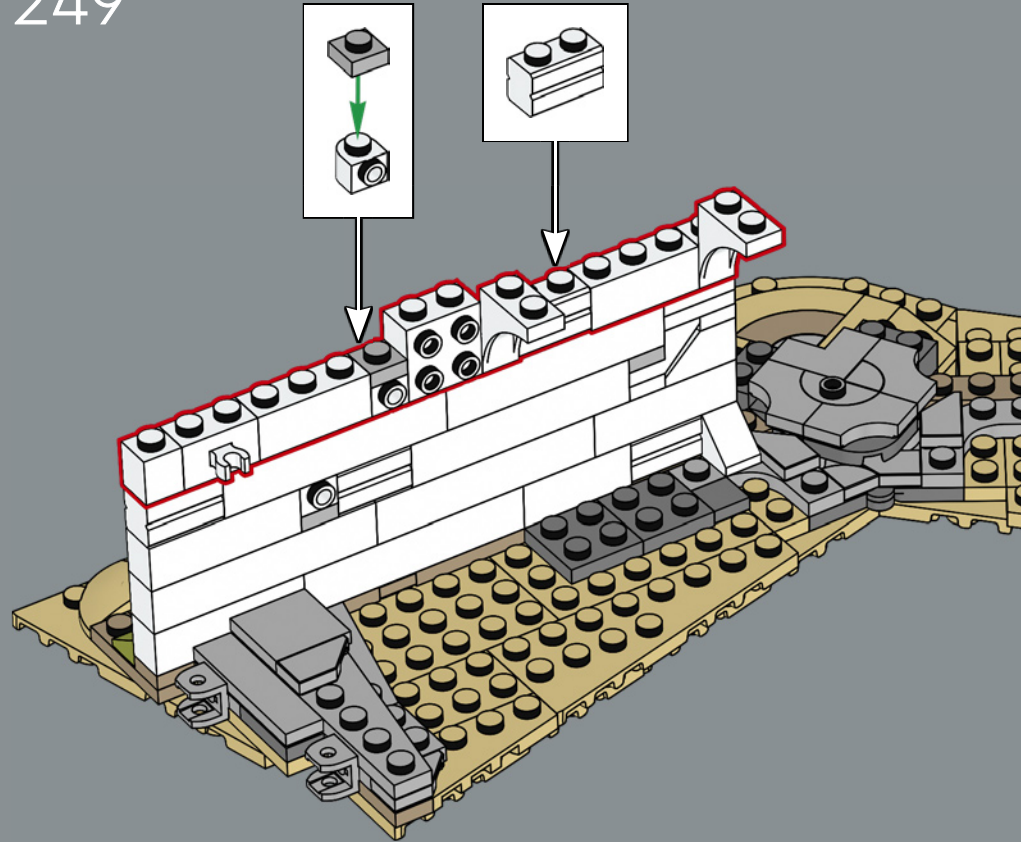

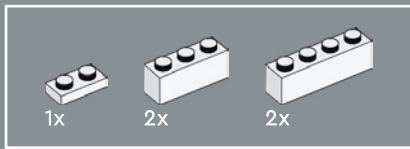

250

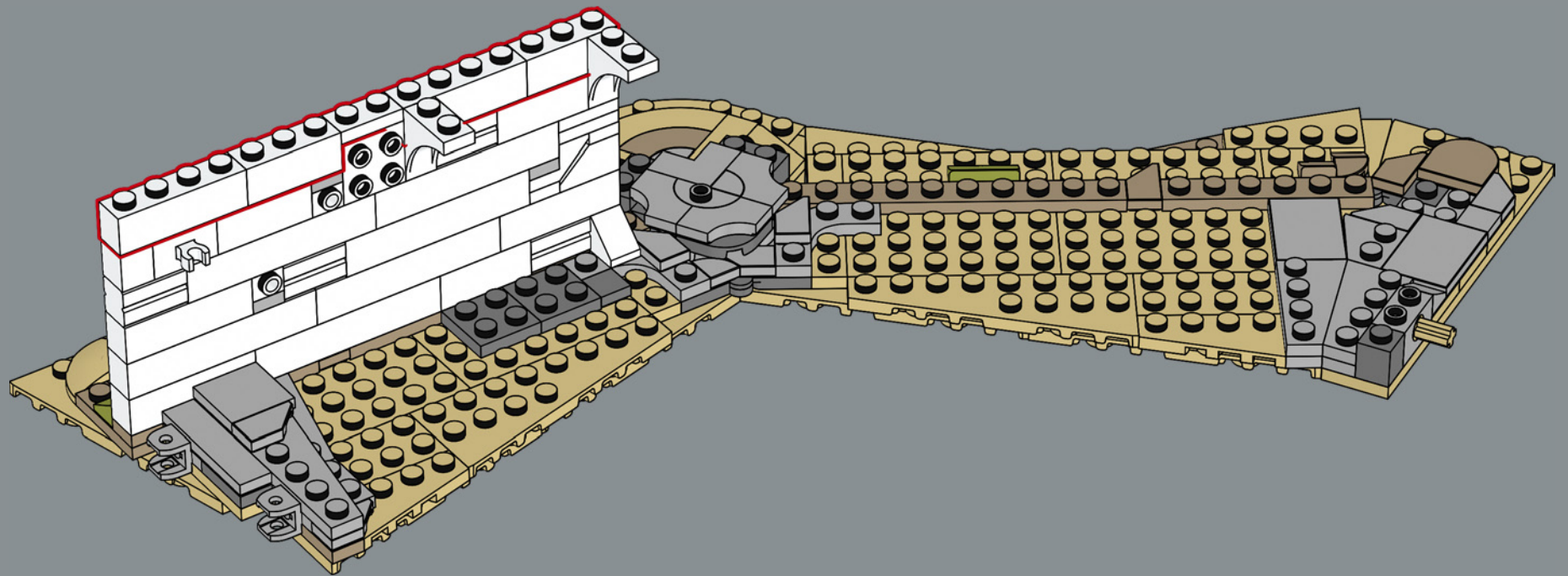

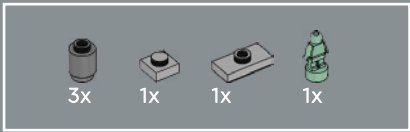

255

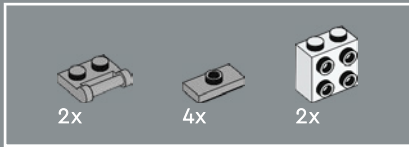
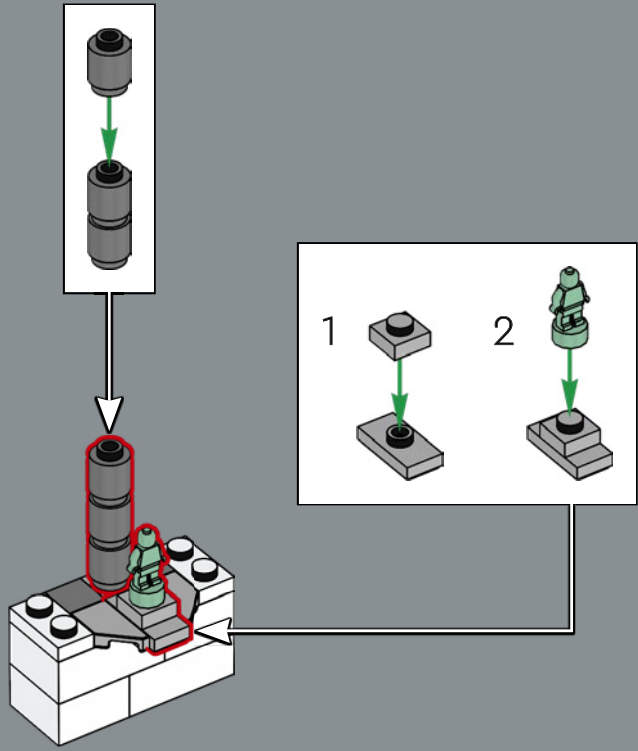

256

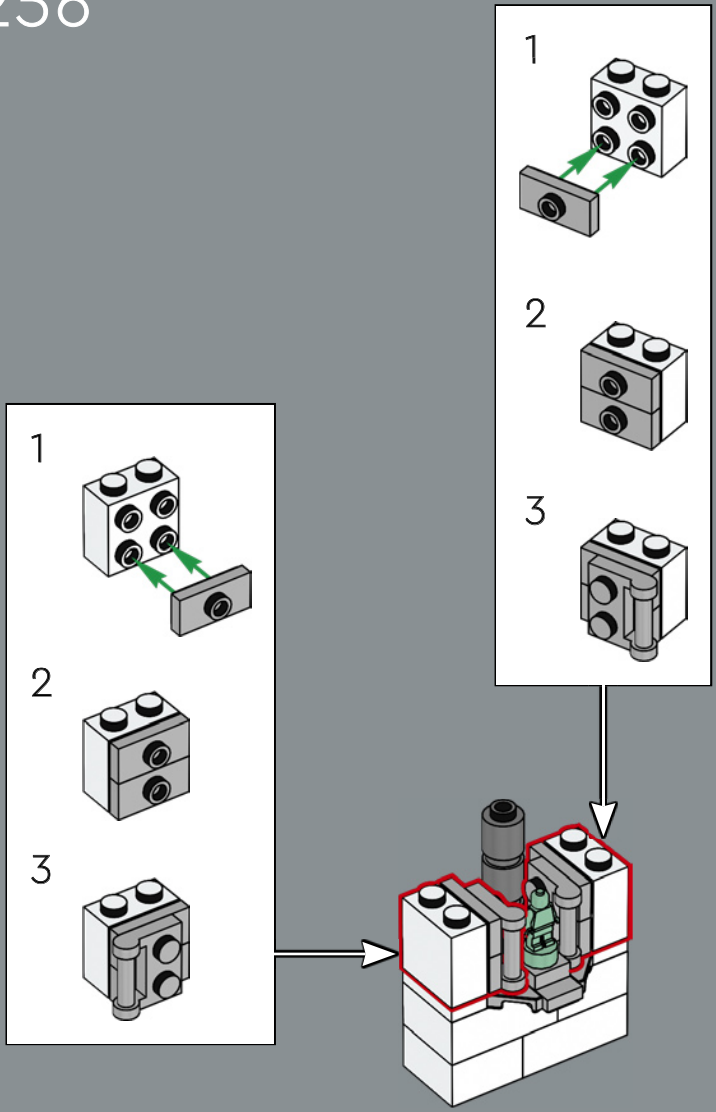

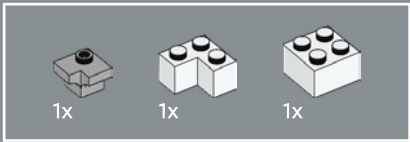

257

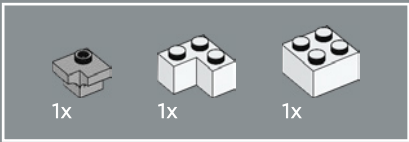
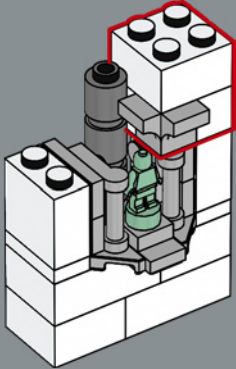
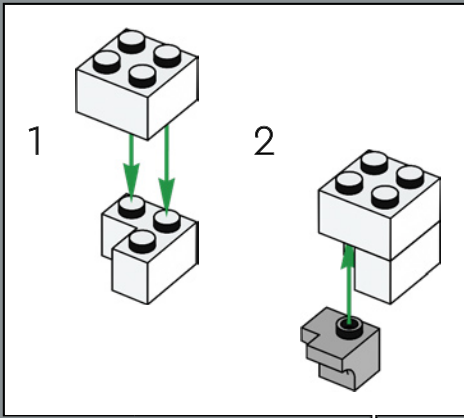

258

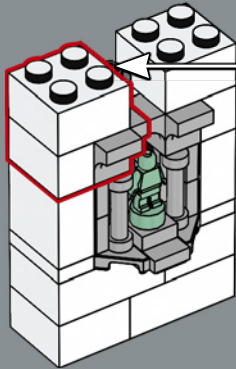
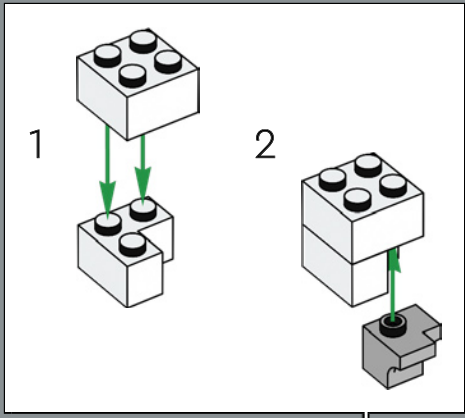

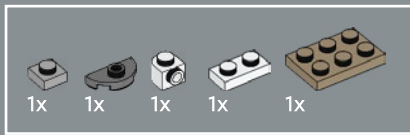

259

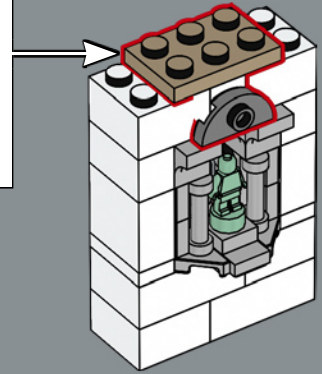
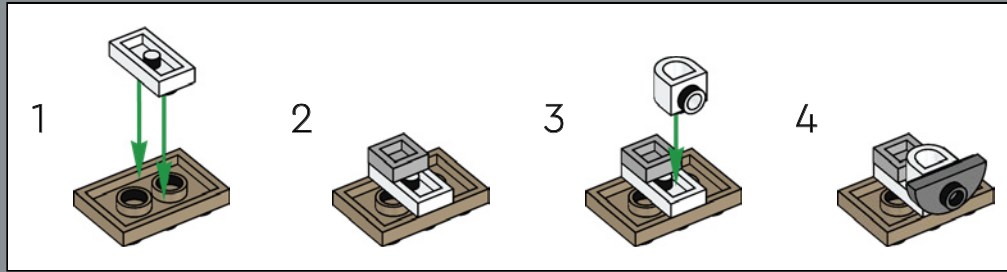

260

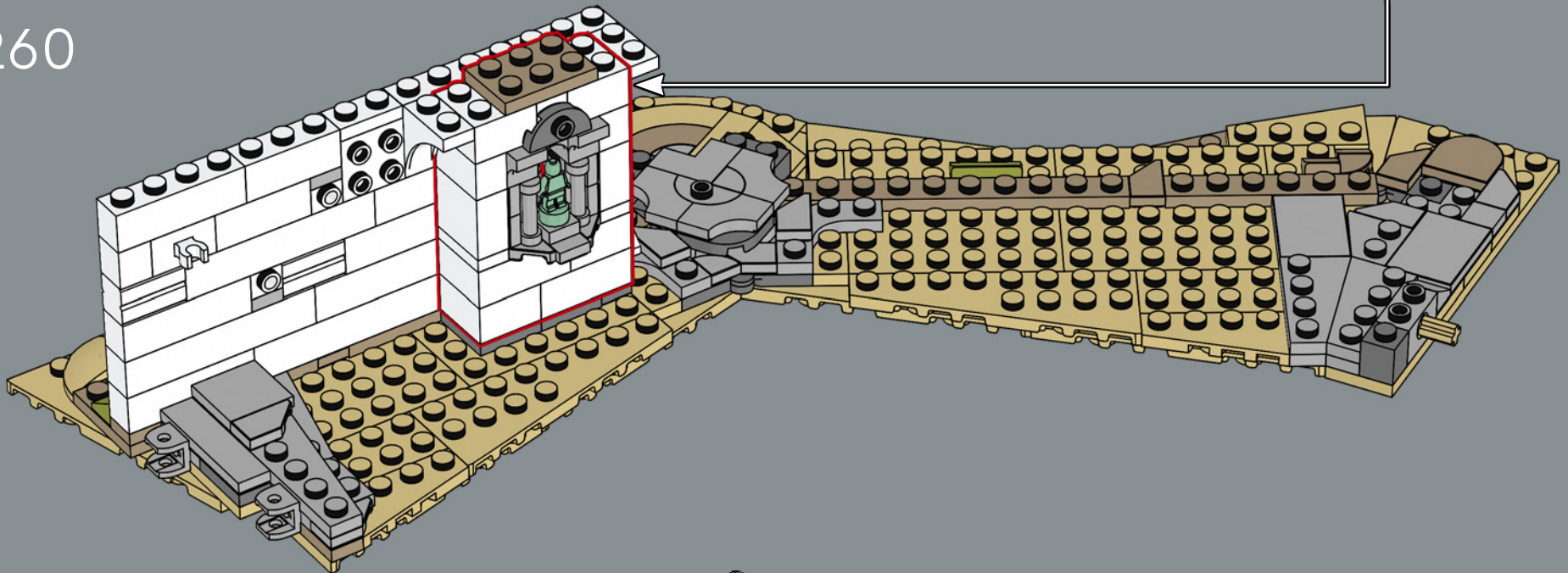

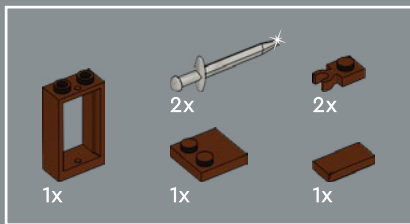

Although the spear is the weapon of choice for most soldiers of Gondor™, they are also fierce sword fighters.

Même si la lance est l'arme de prédilection des soldats du Gondor™, ils manient aussi l'épée avec une redoutable maîtrise.

Aunque la lanza es el arma preferida por la mayoría de los soldados de Gondor™, estos también son feroces con la espada.



261

1

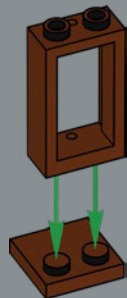

2

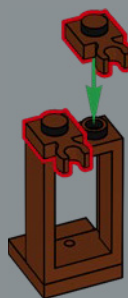

3

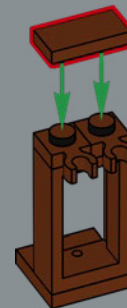

4

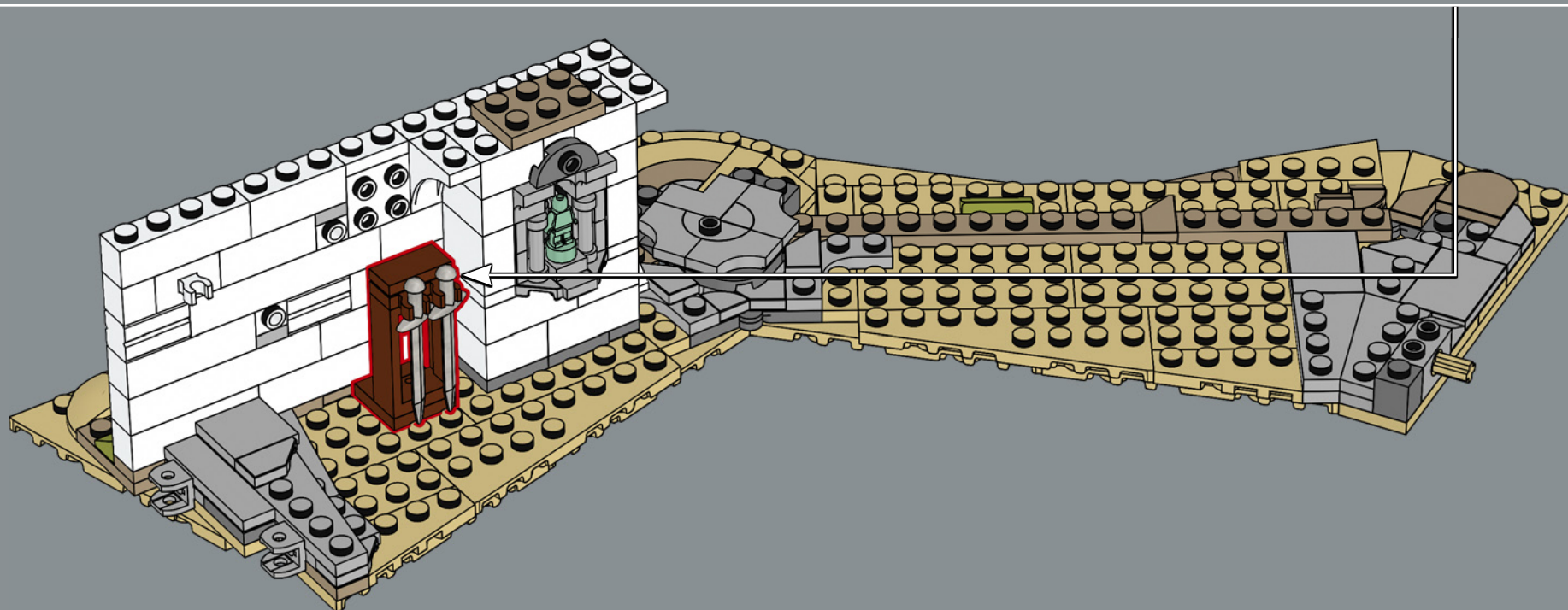
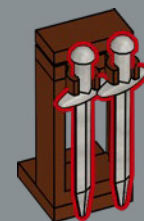

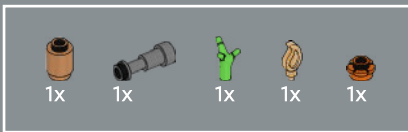

262

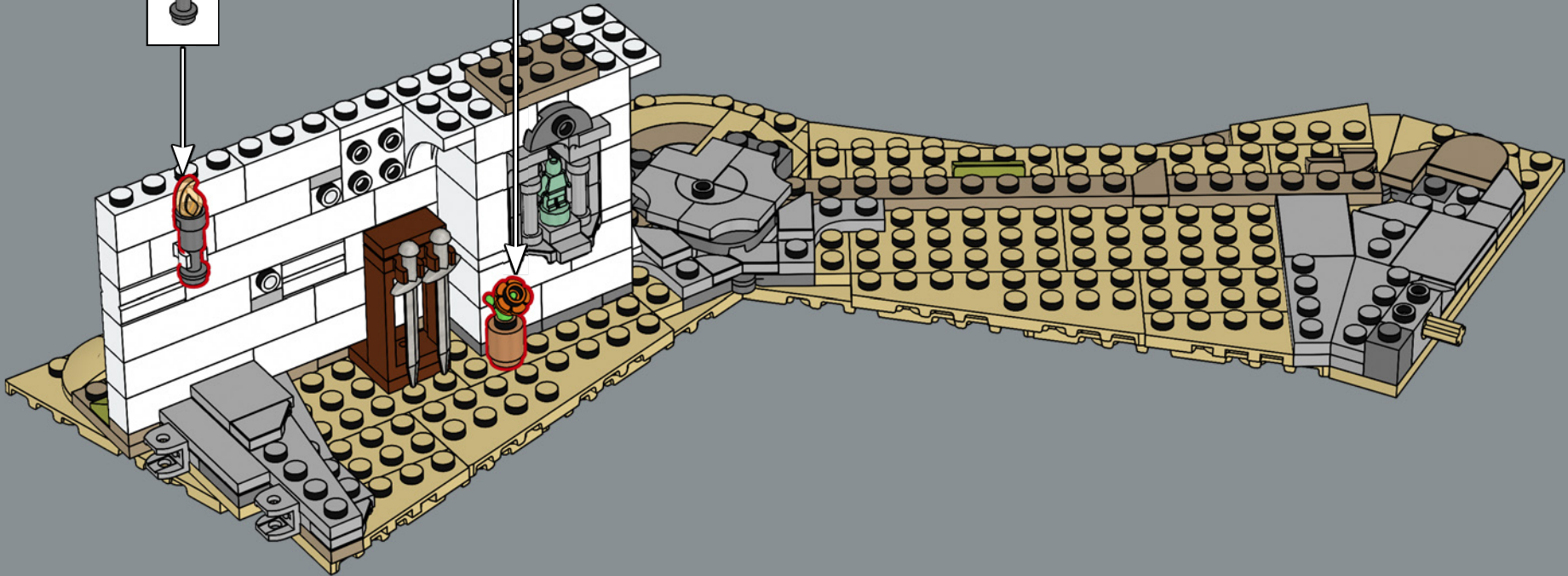
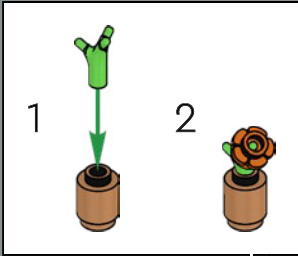
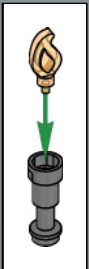

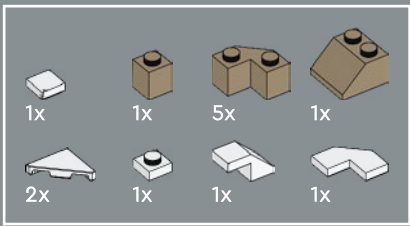

263

1

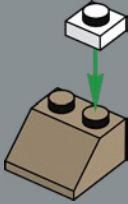

2

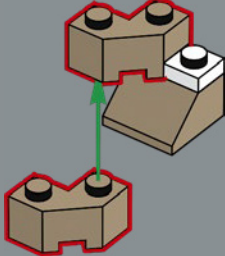

3

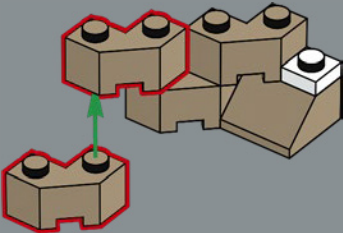

4

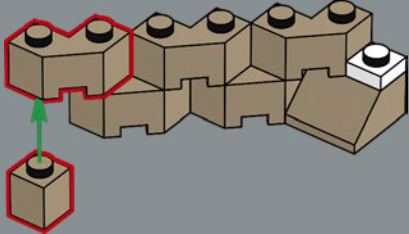

5

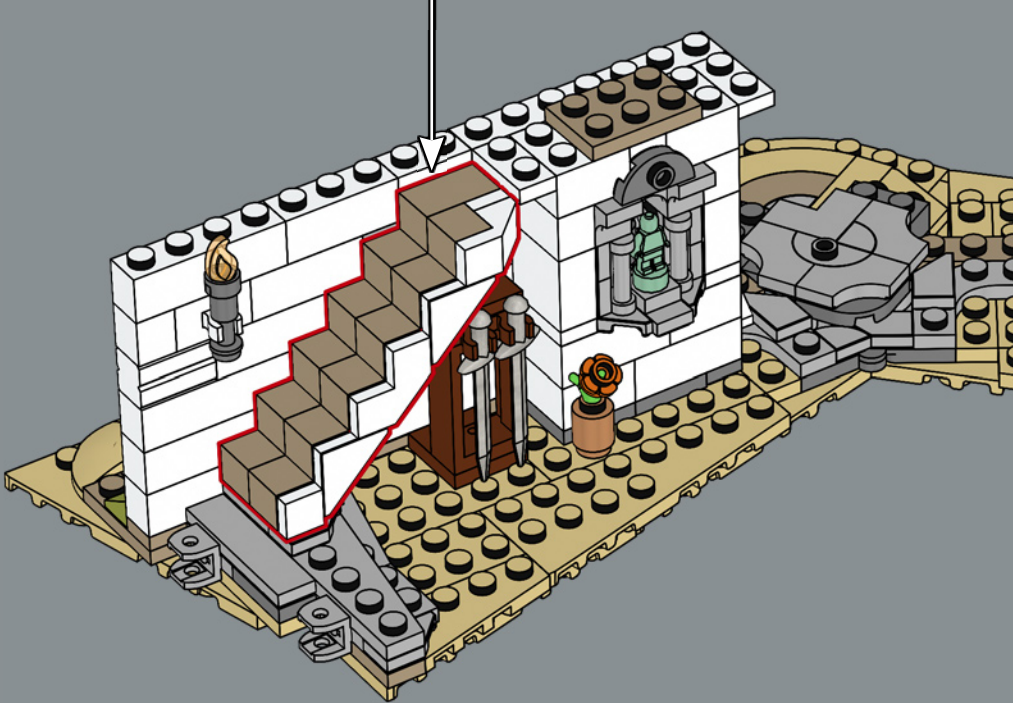
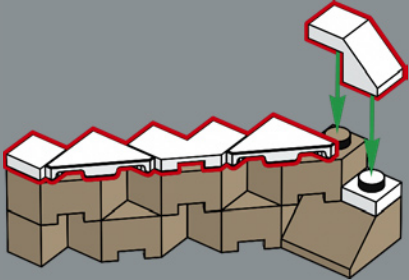

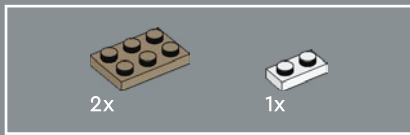

264

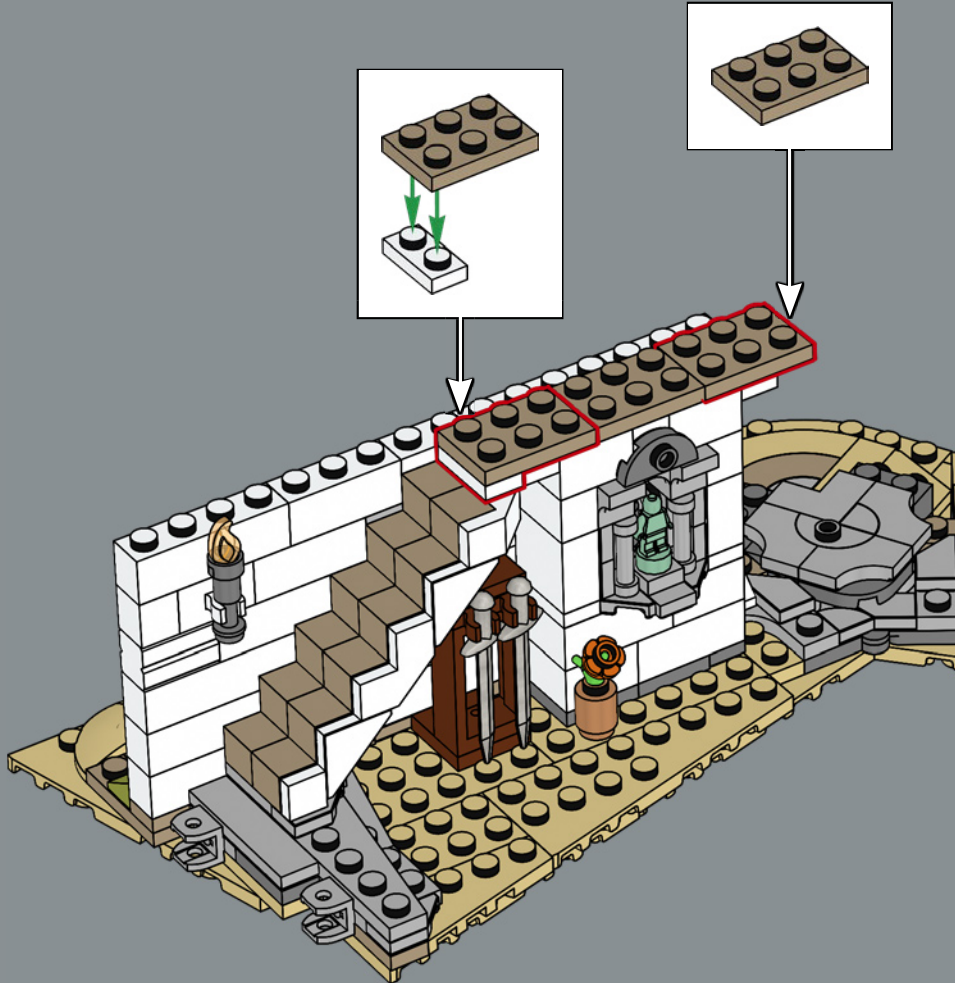

265

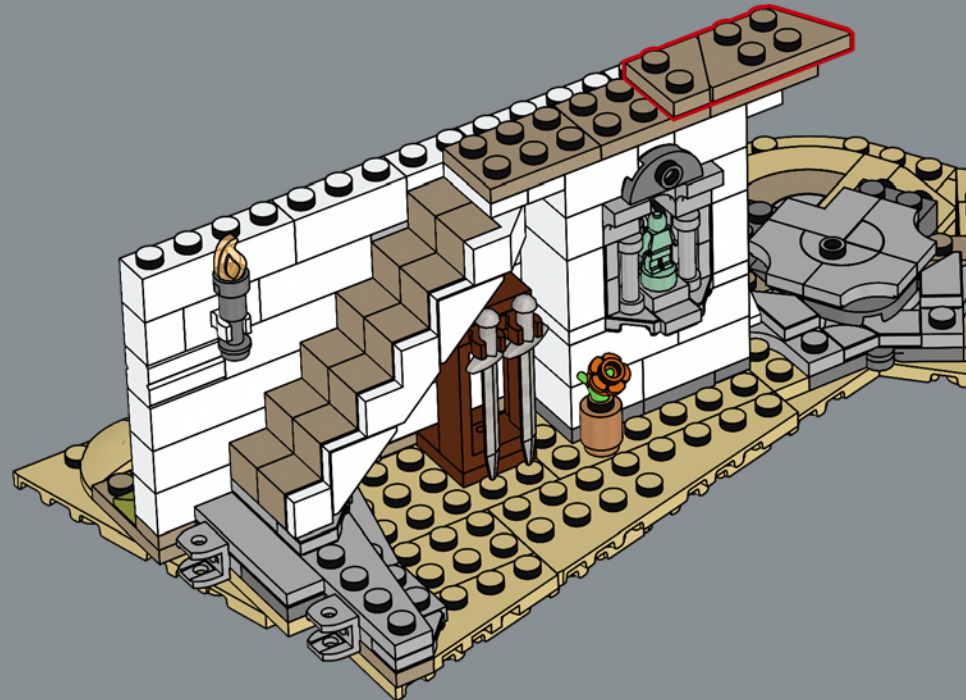

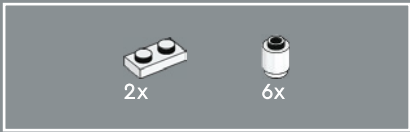

266

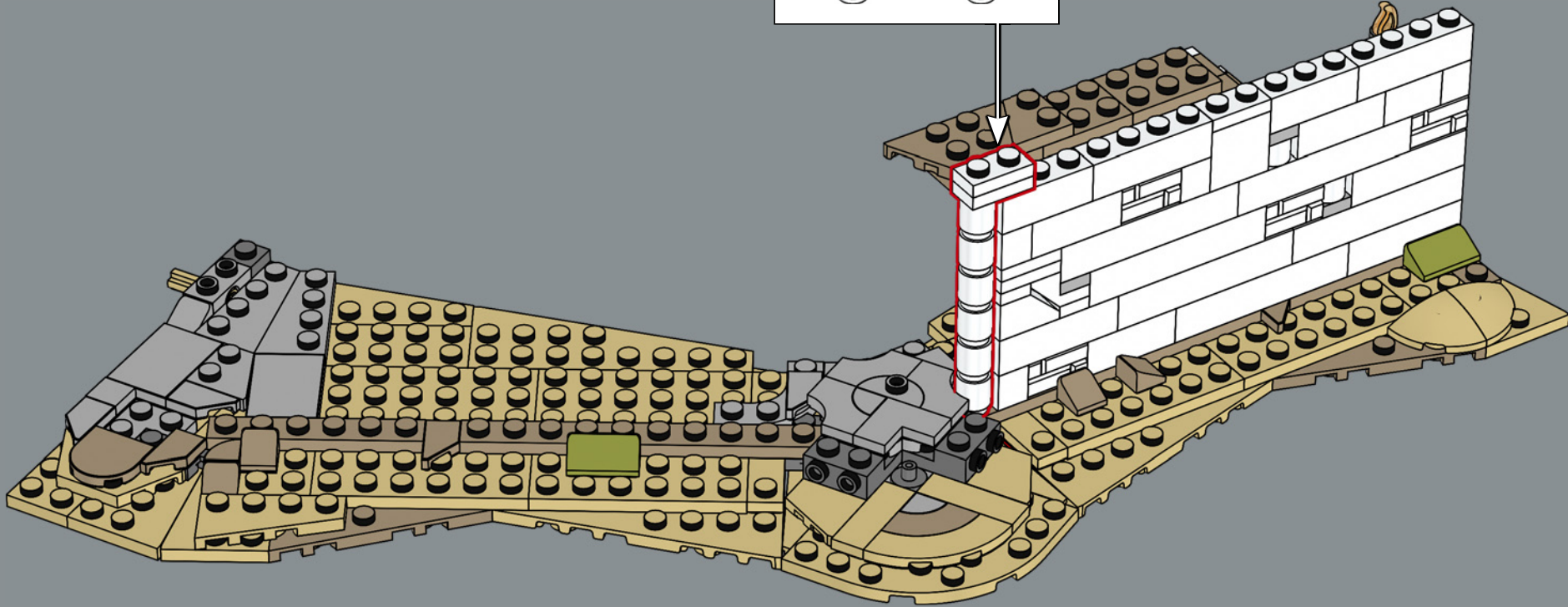
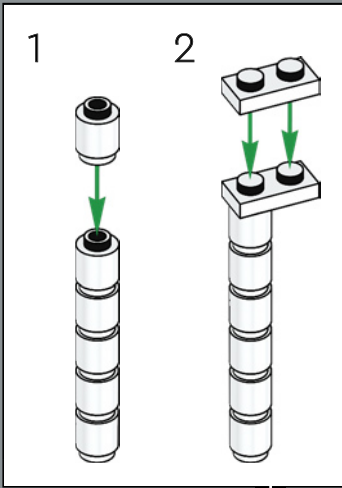

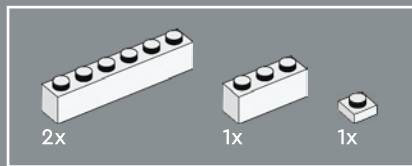

267

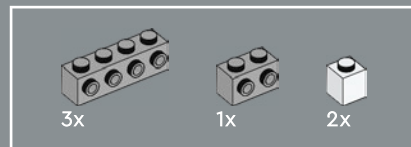
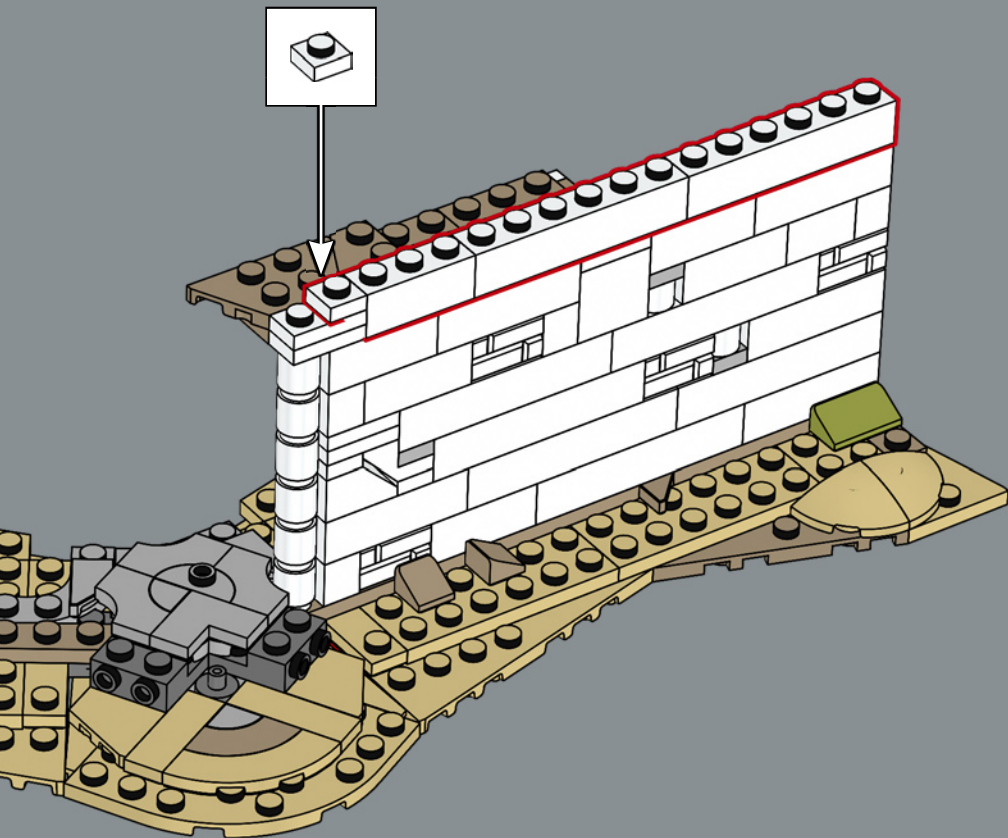

268

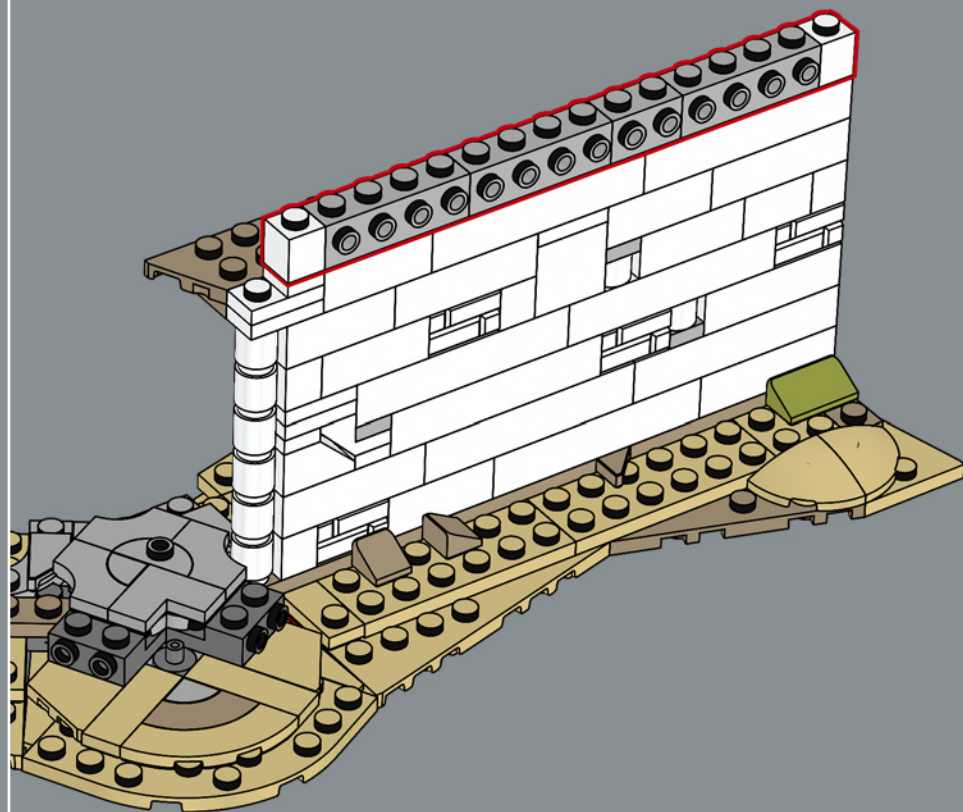

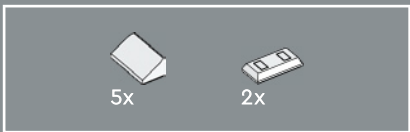

269

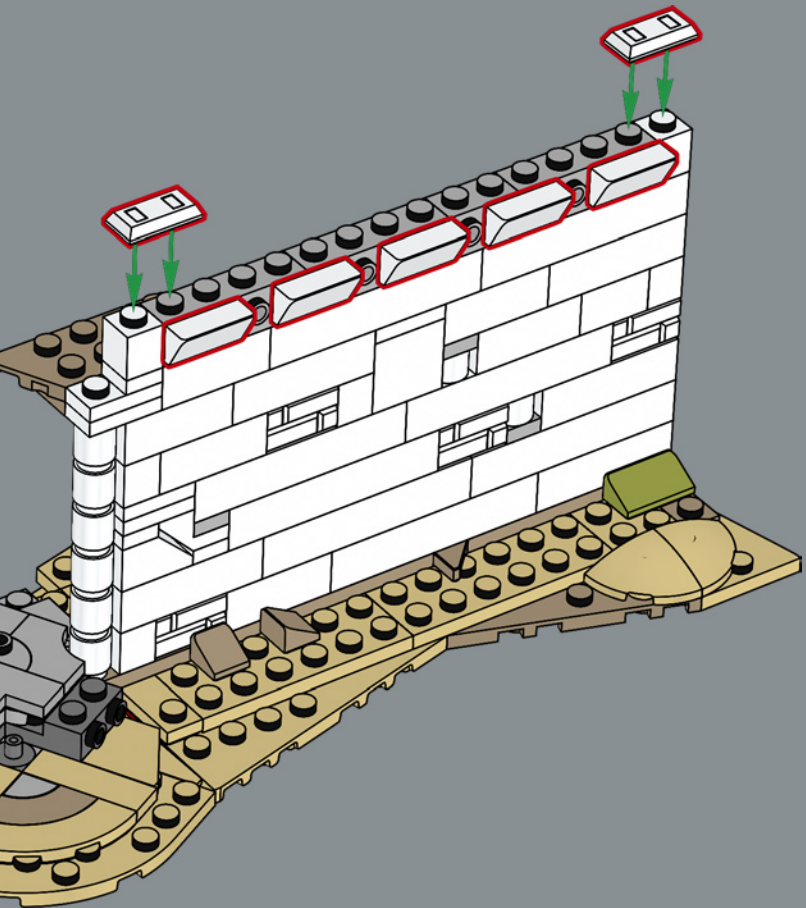

270

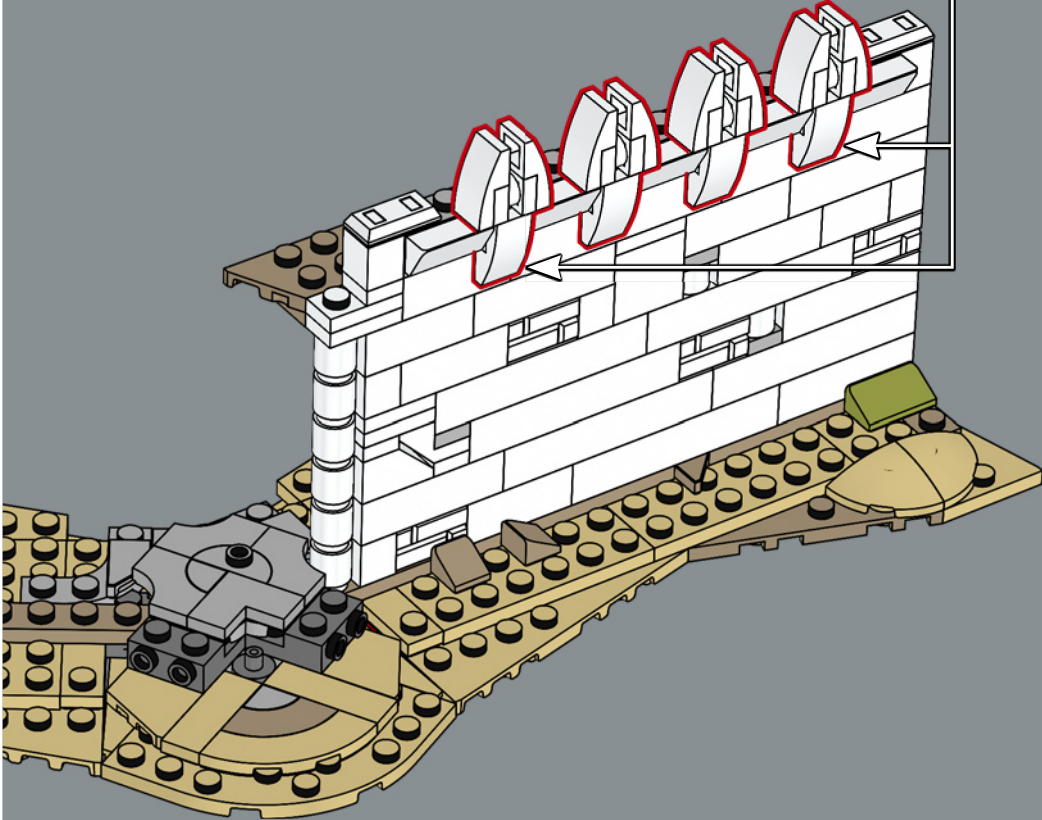
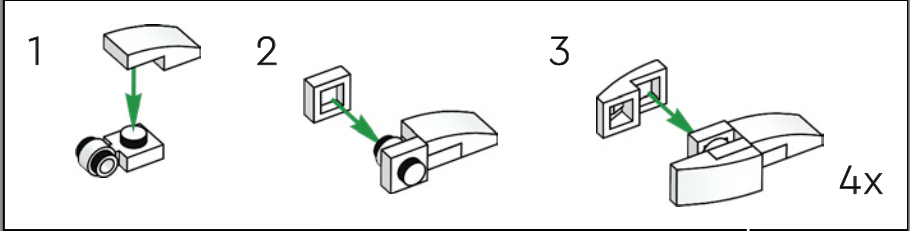

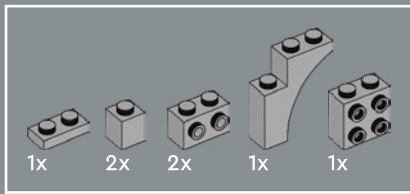

271

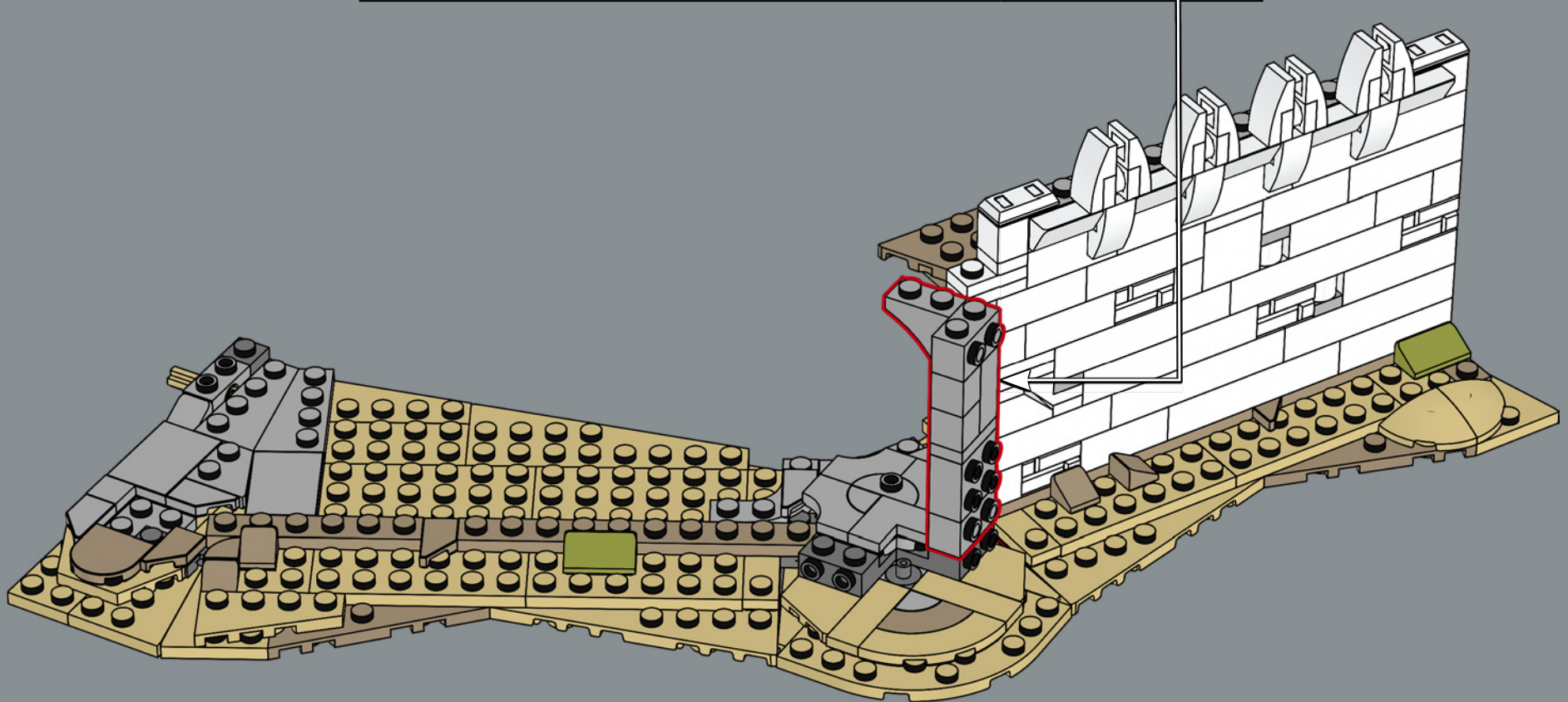
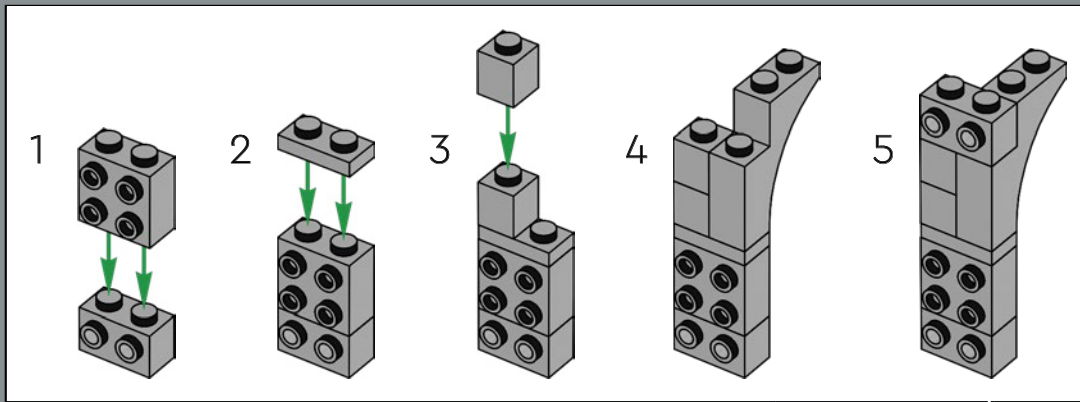

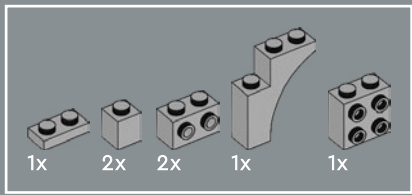

272

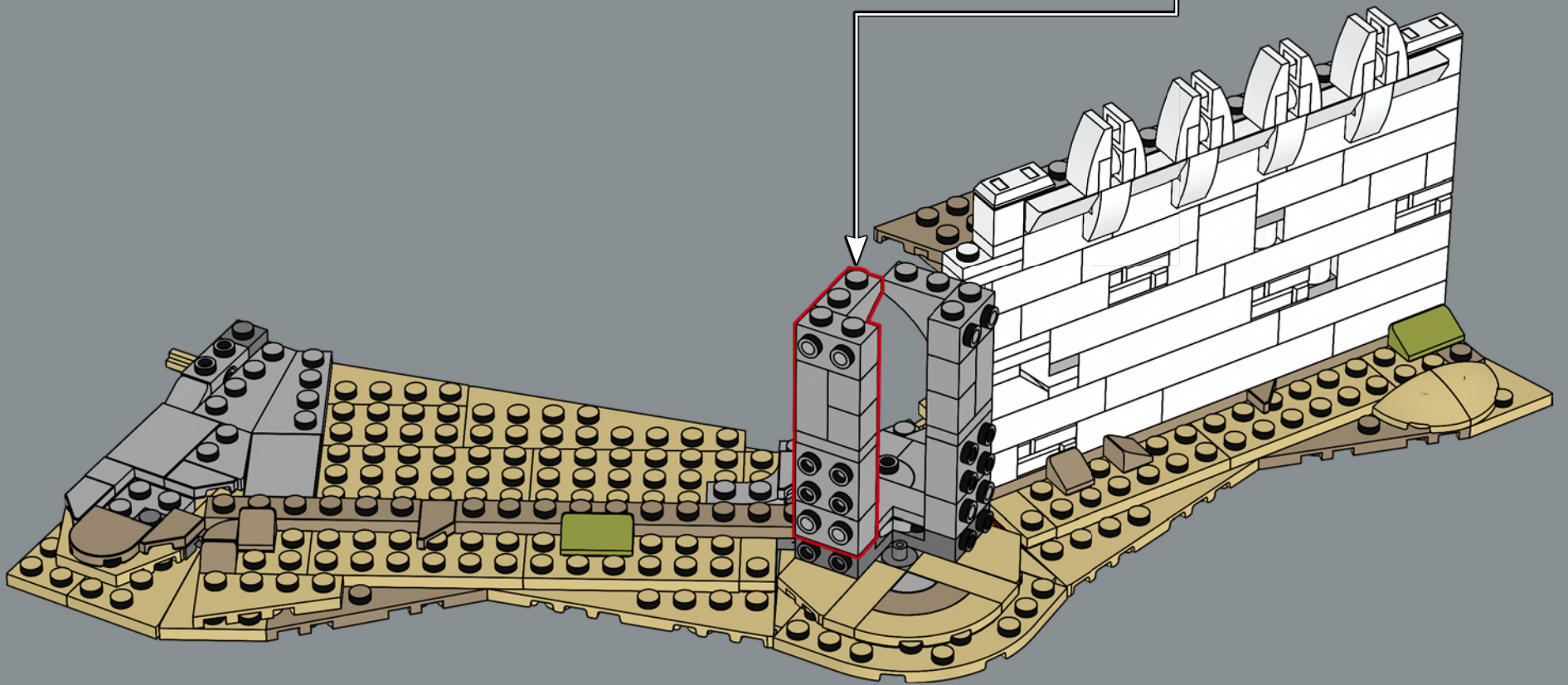
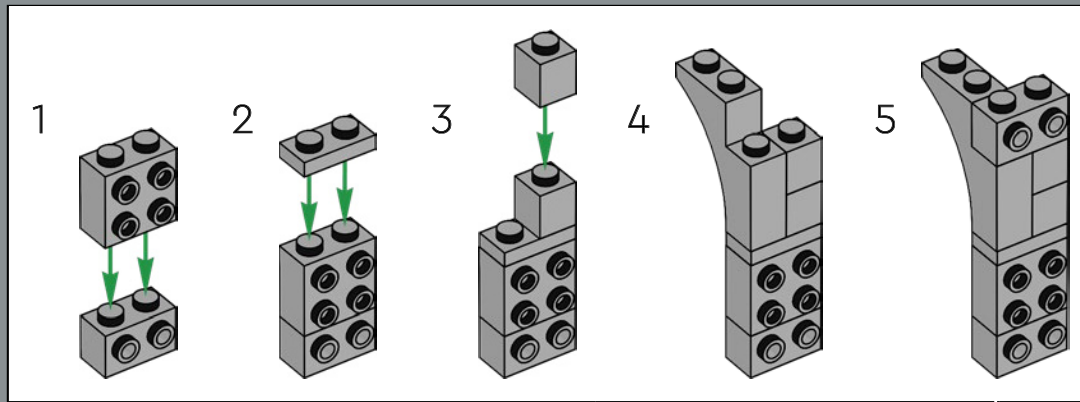

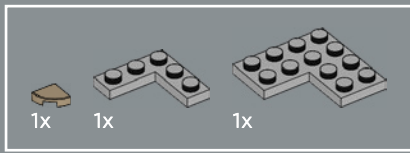

273

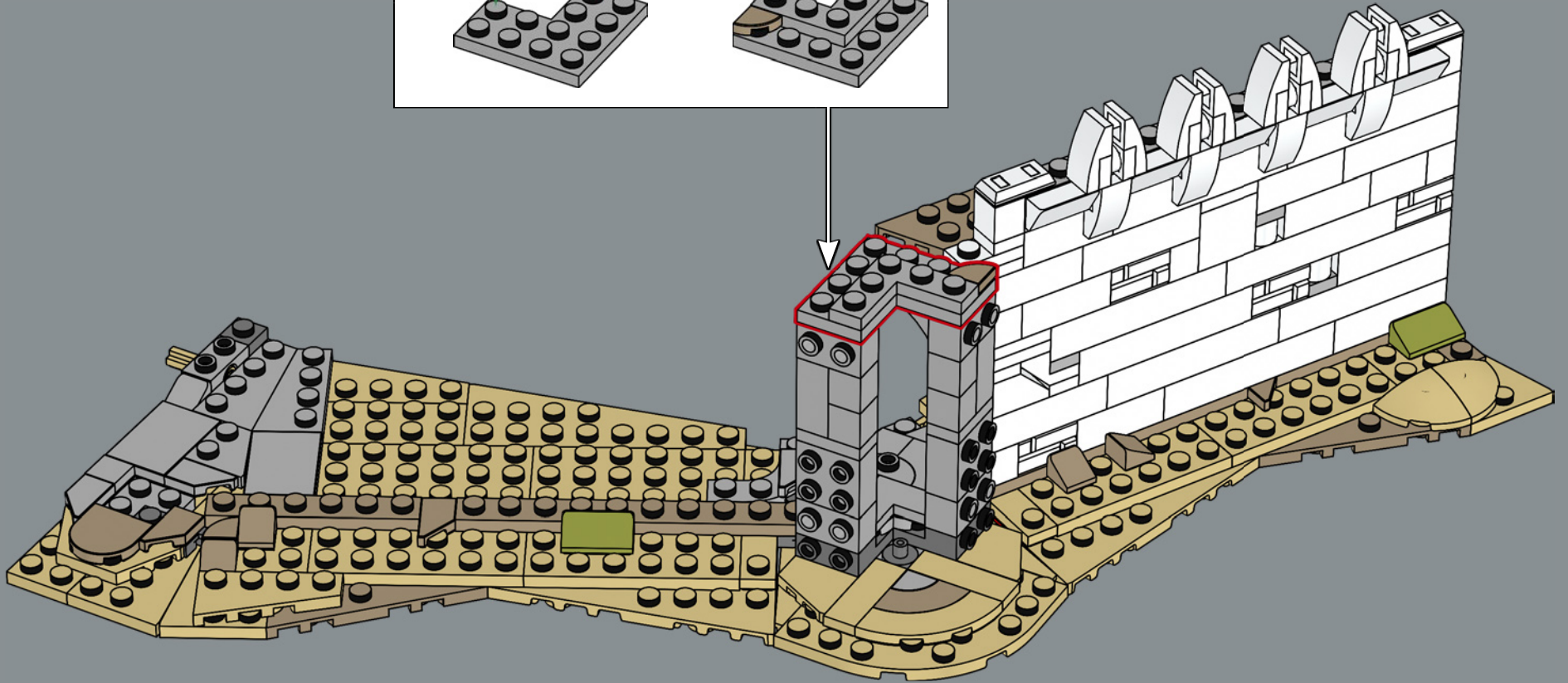
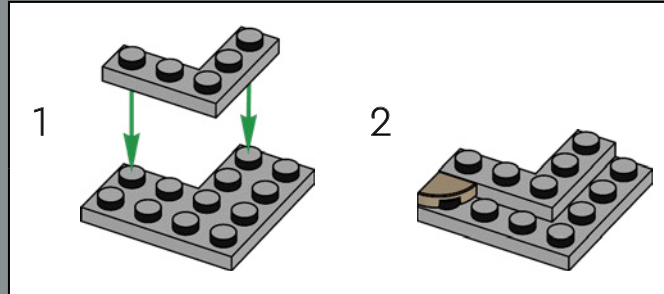

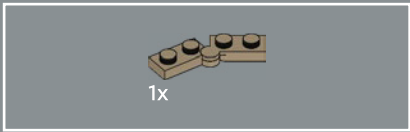

274

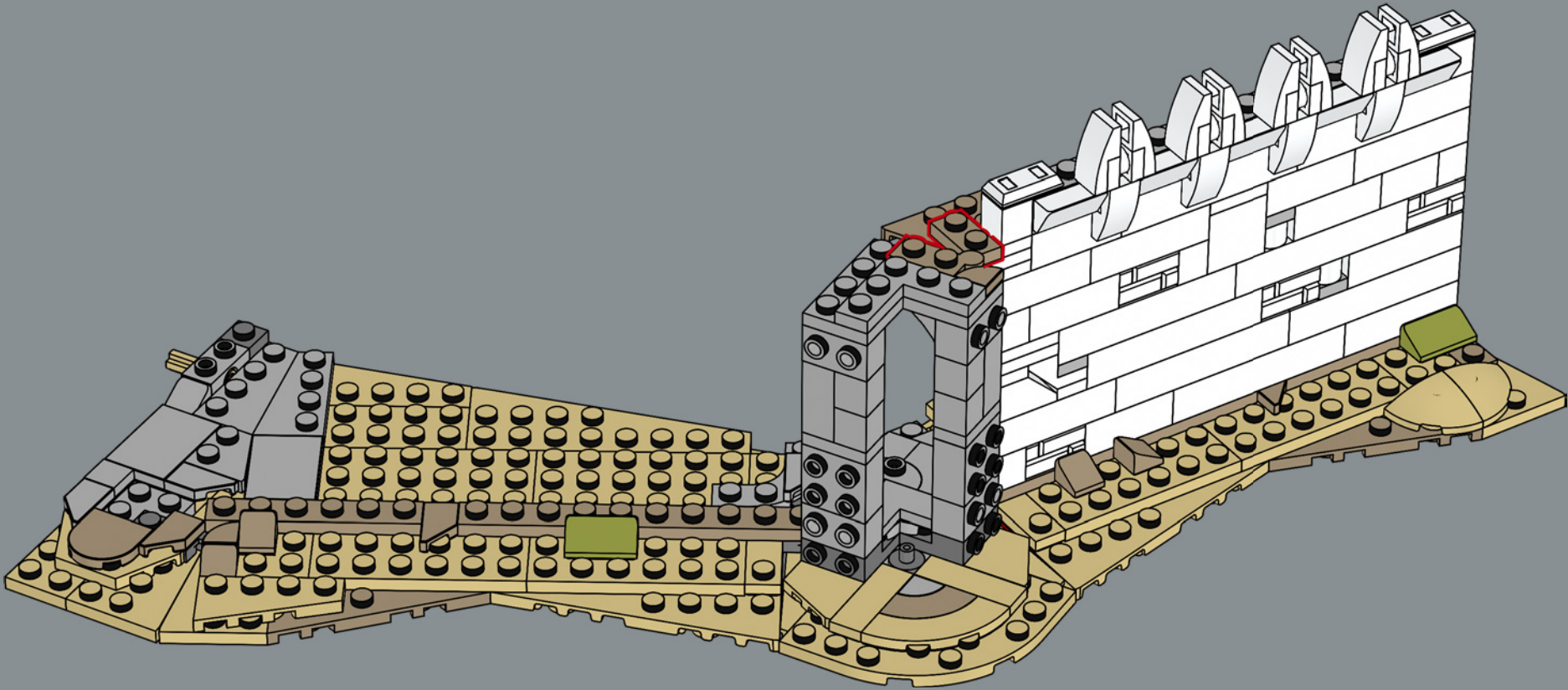

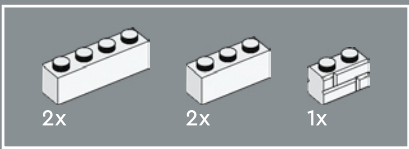

276

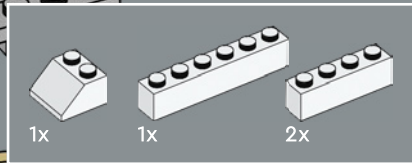

275

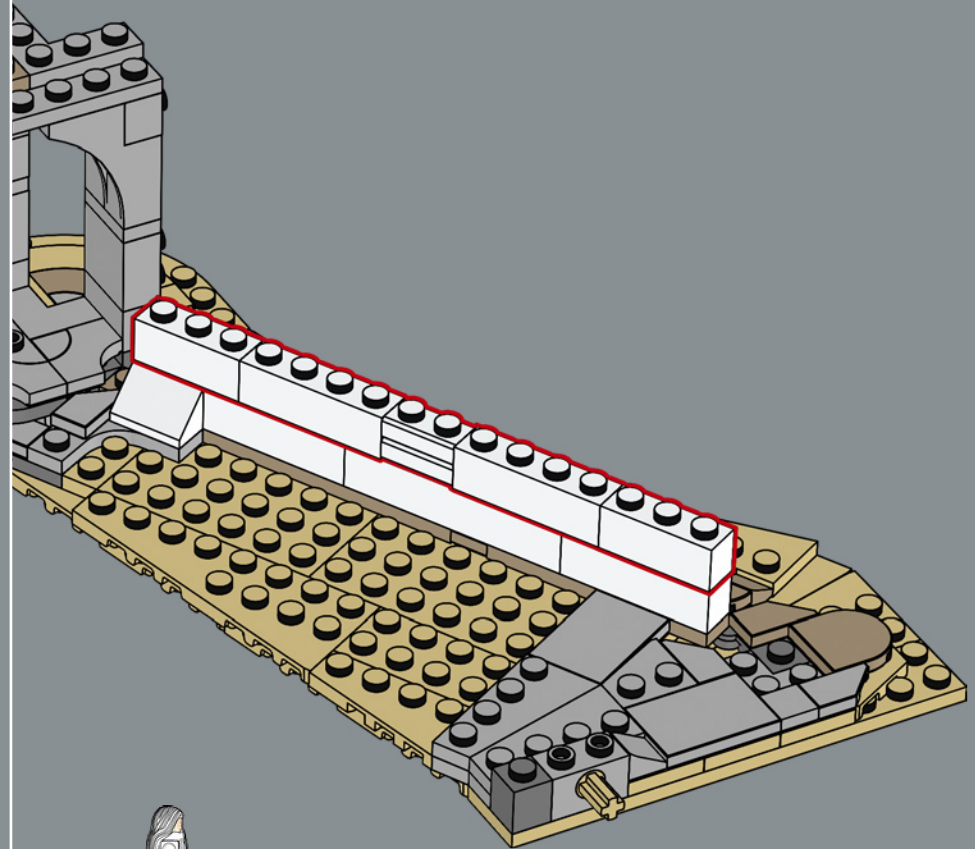
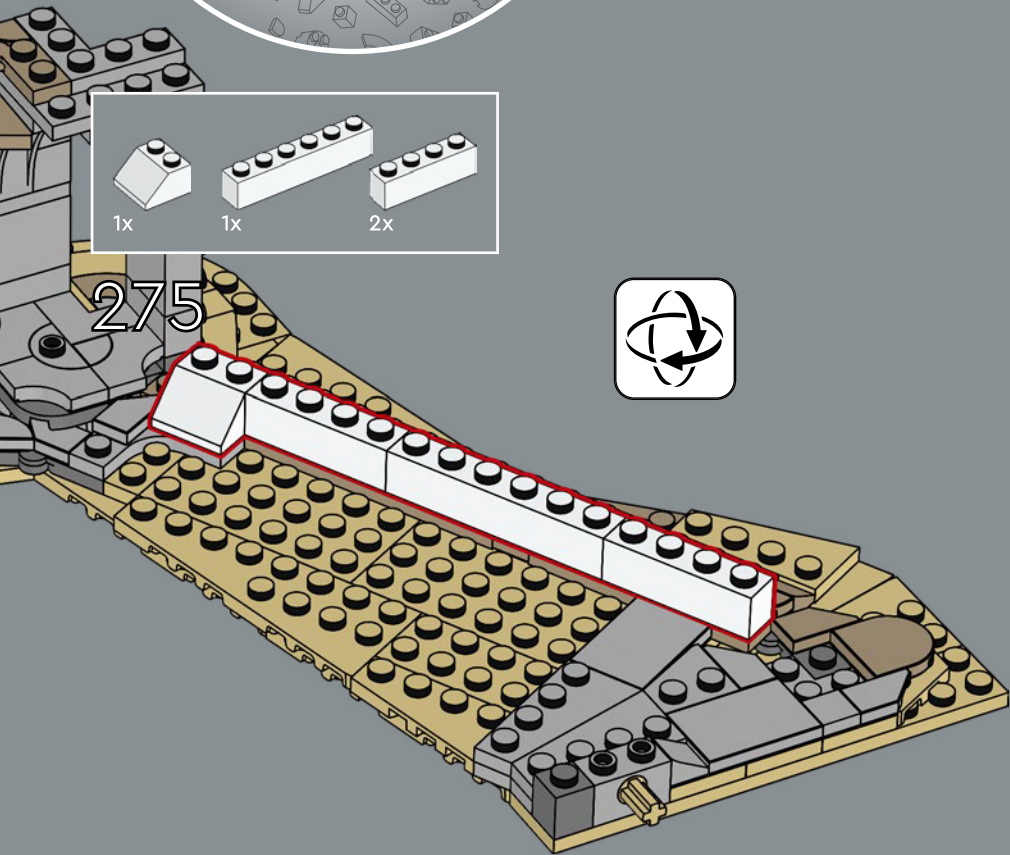

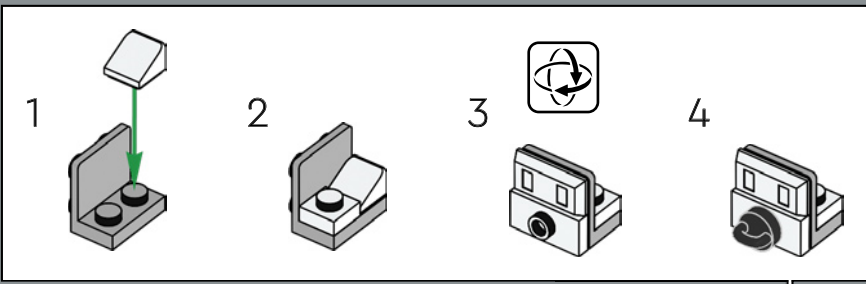
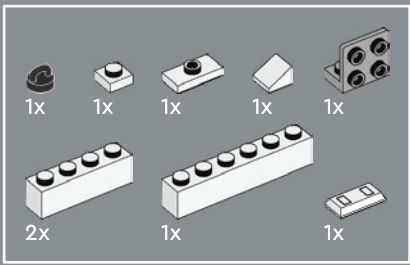

277

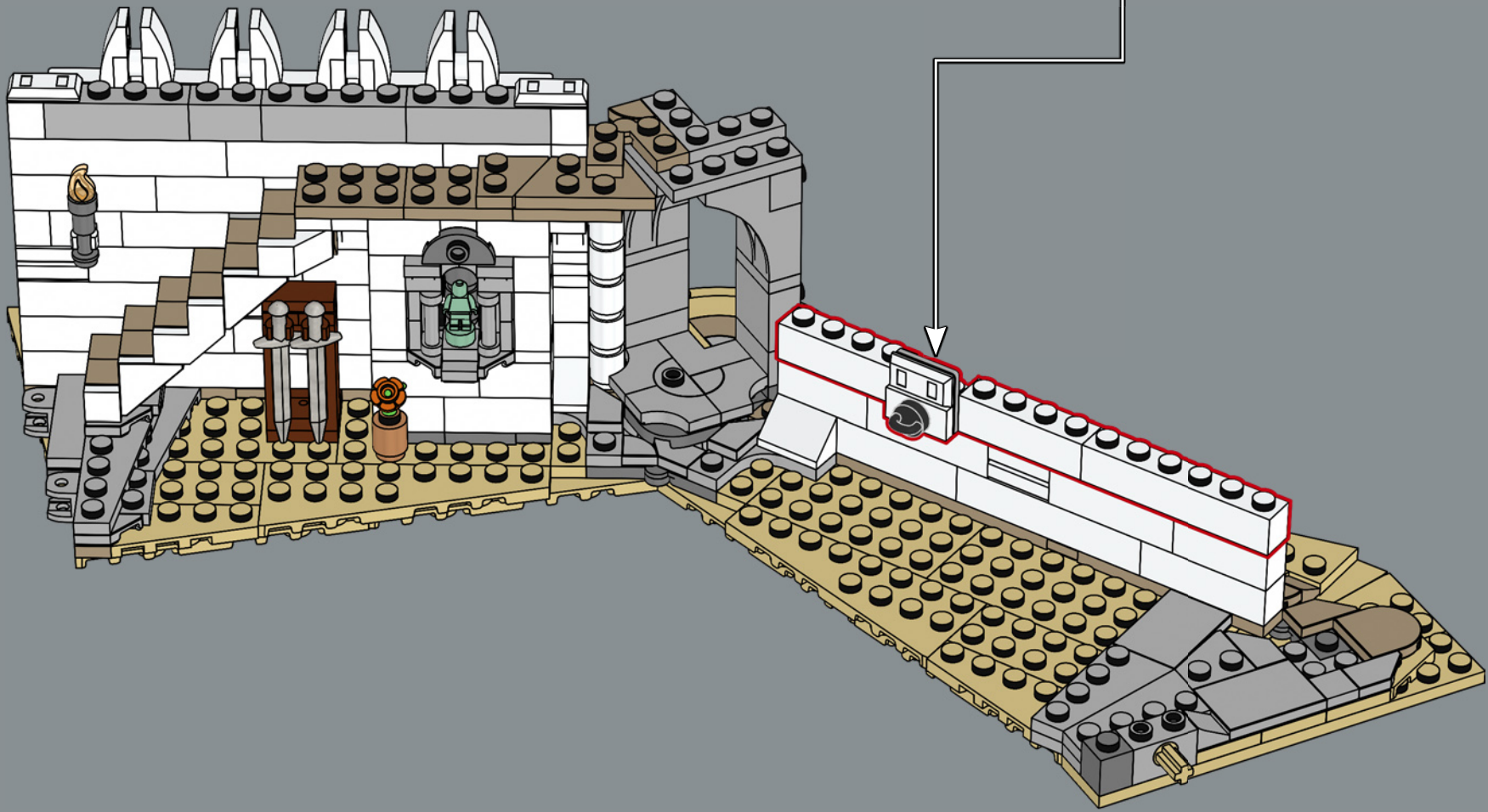

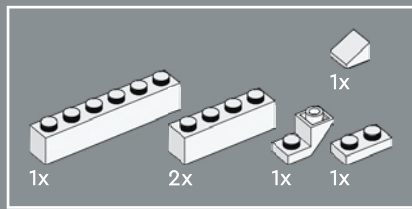

278

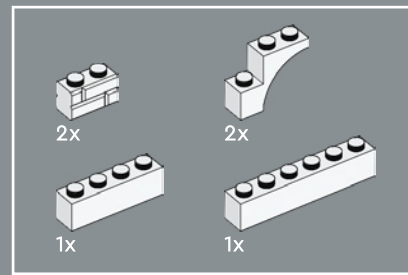
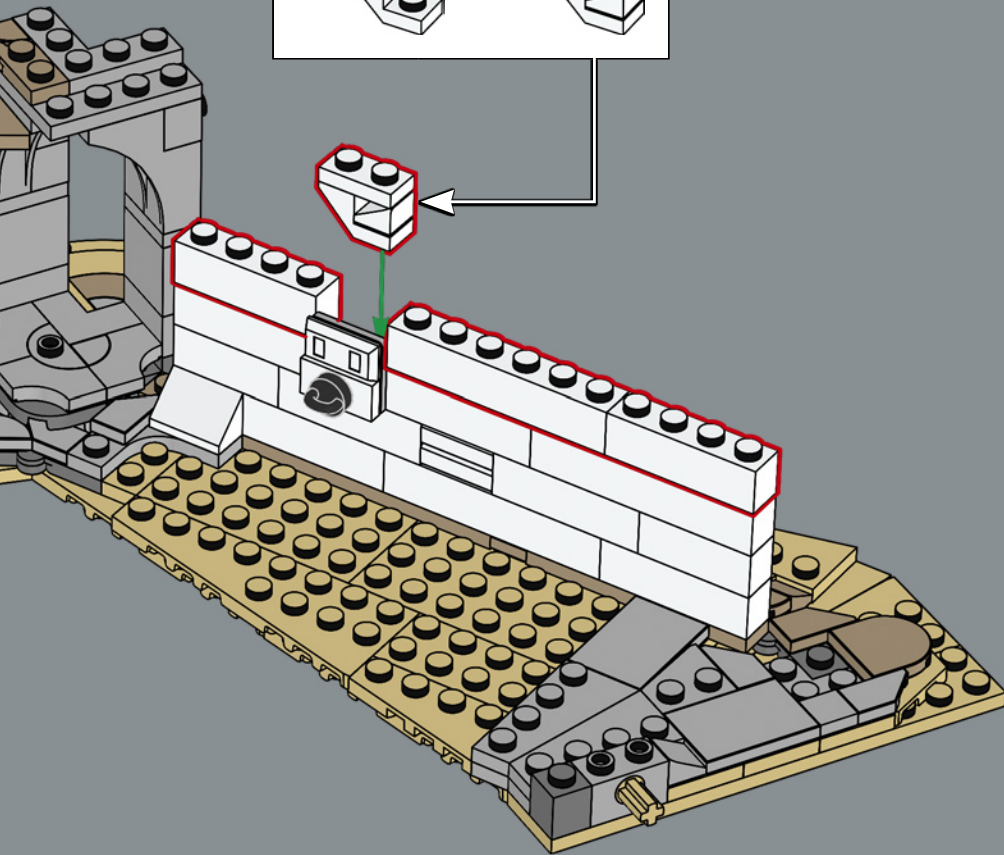
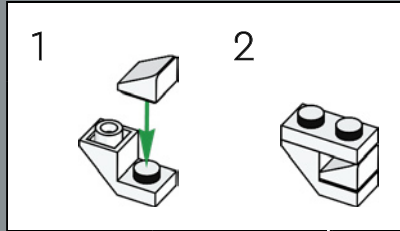

279

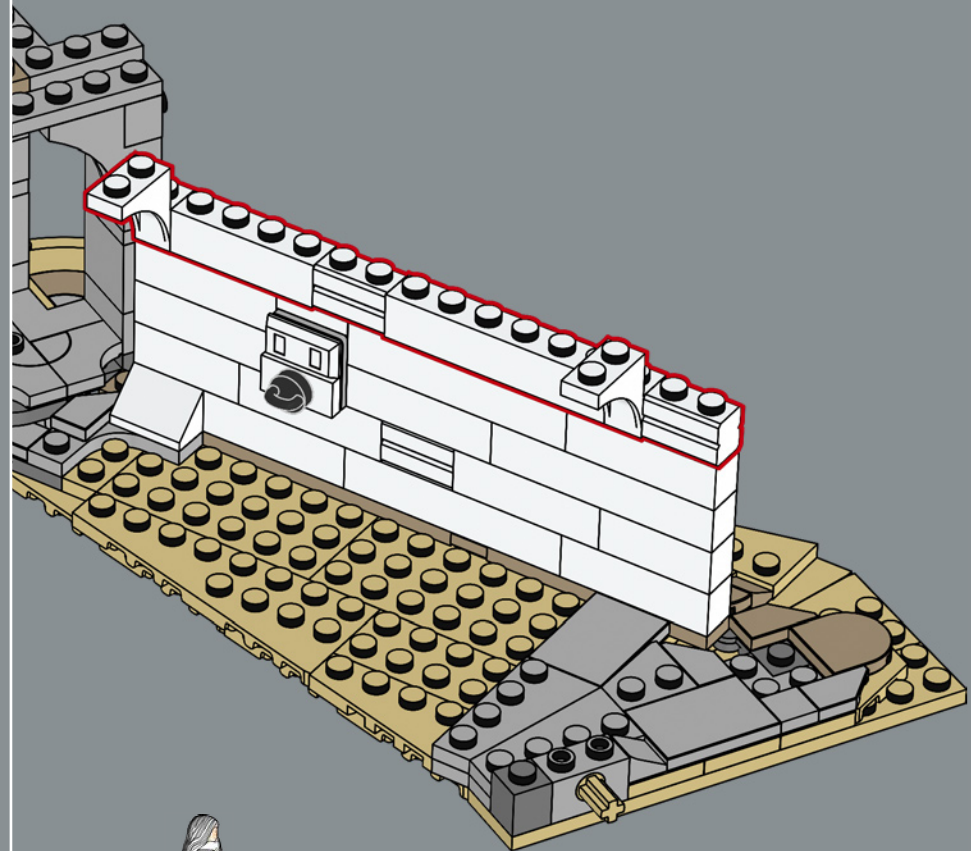

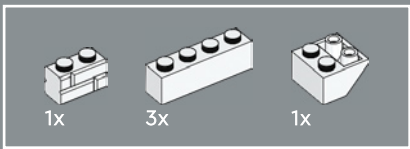

280

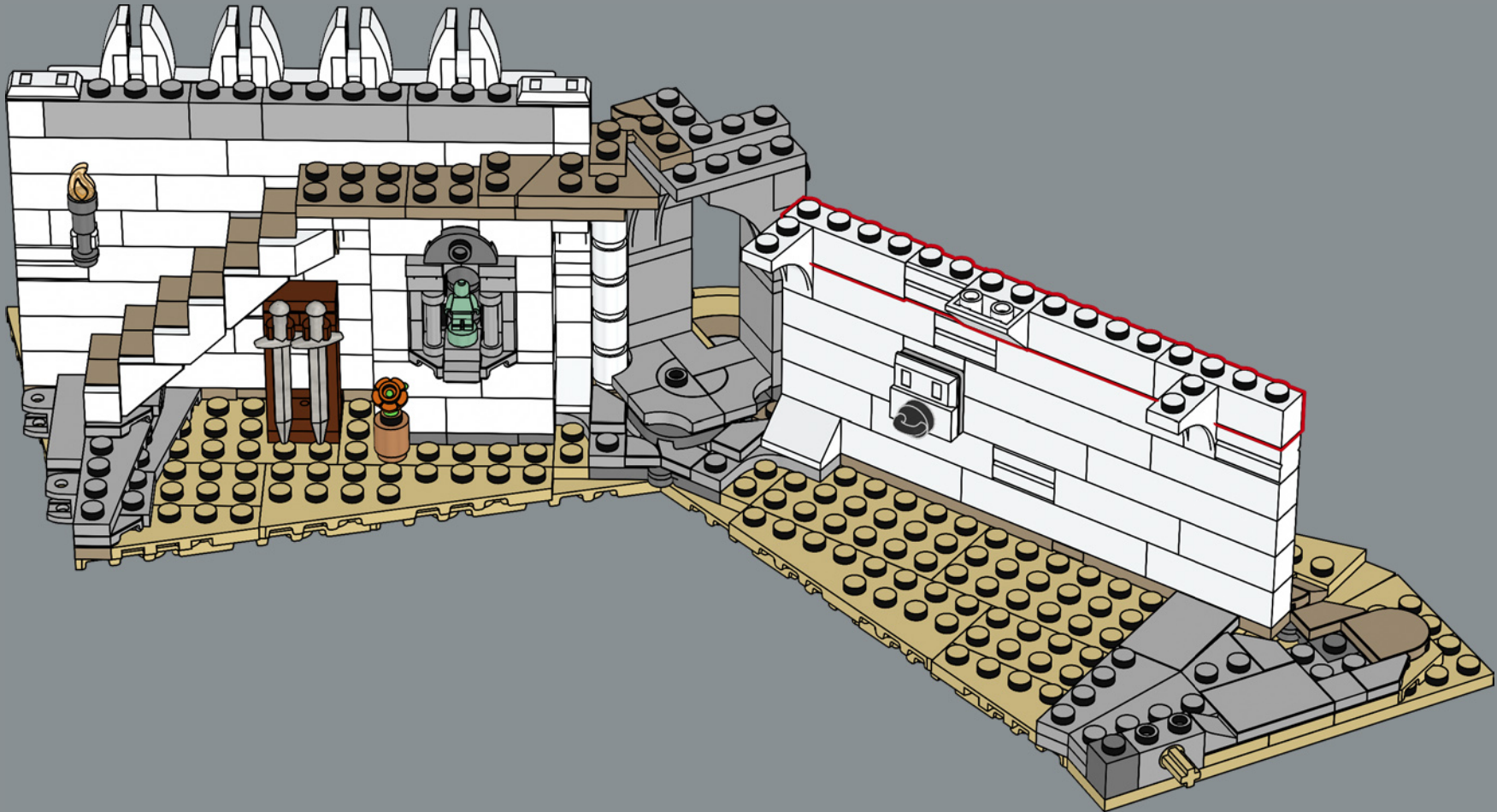

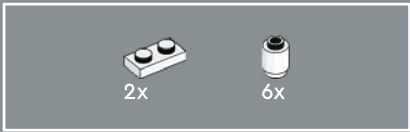

281

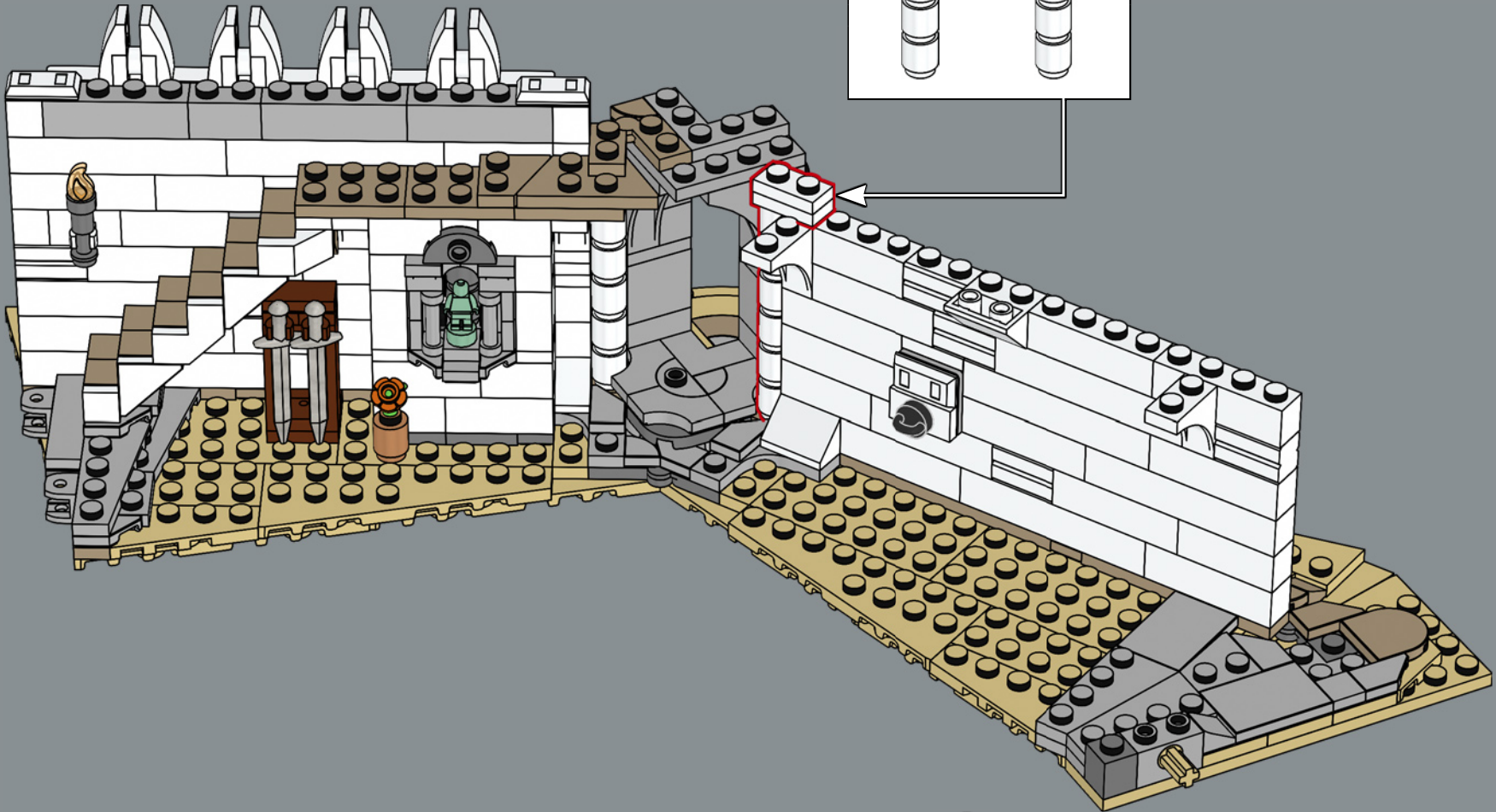
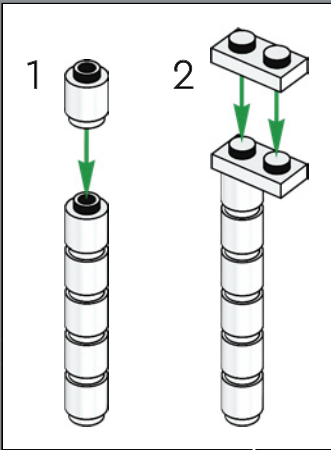

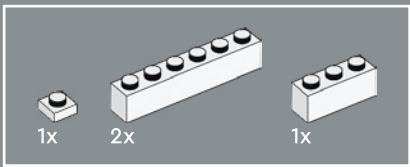

282

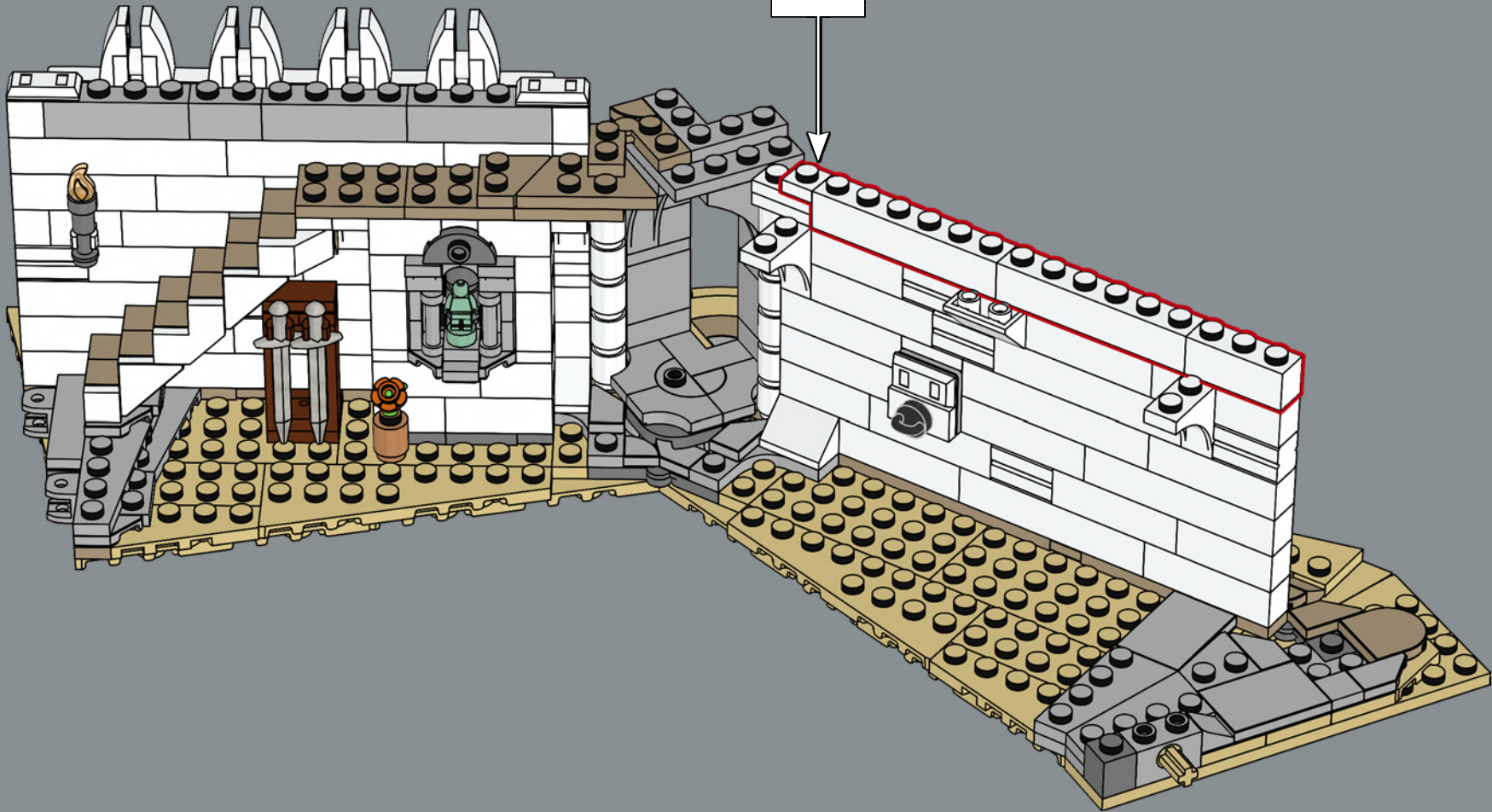
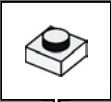

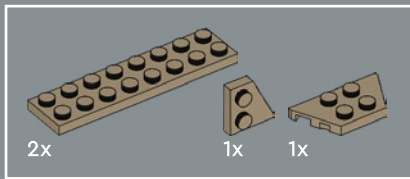

283

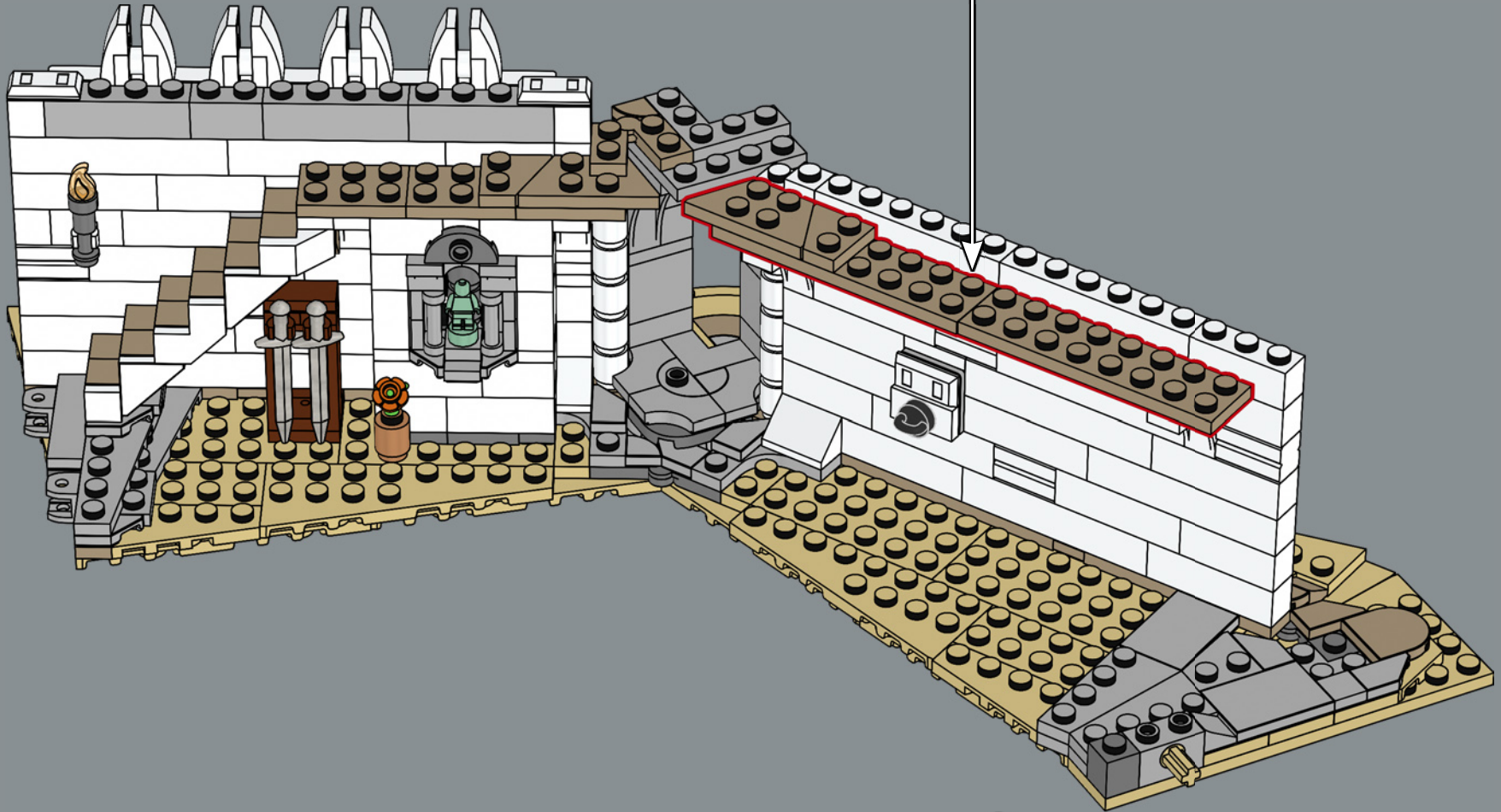
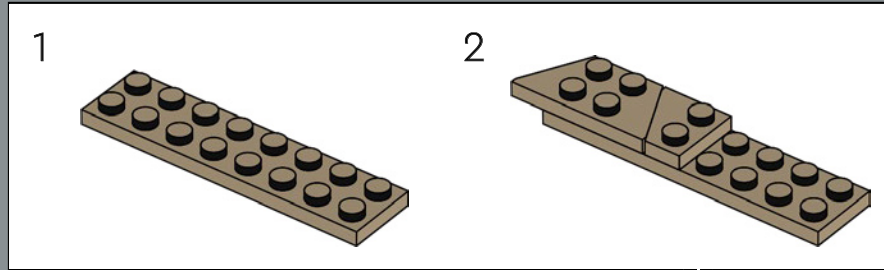

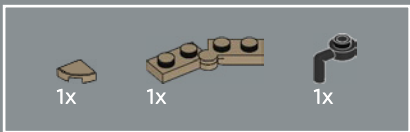

284

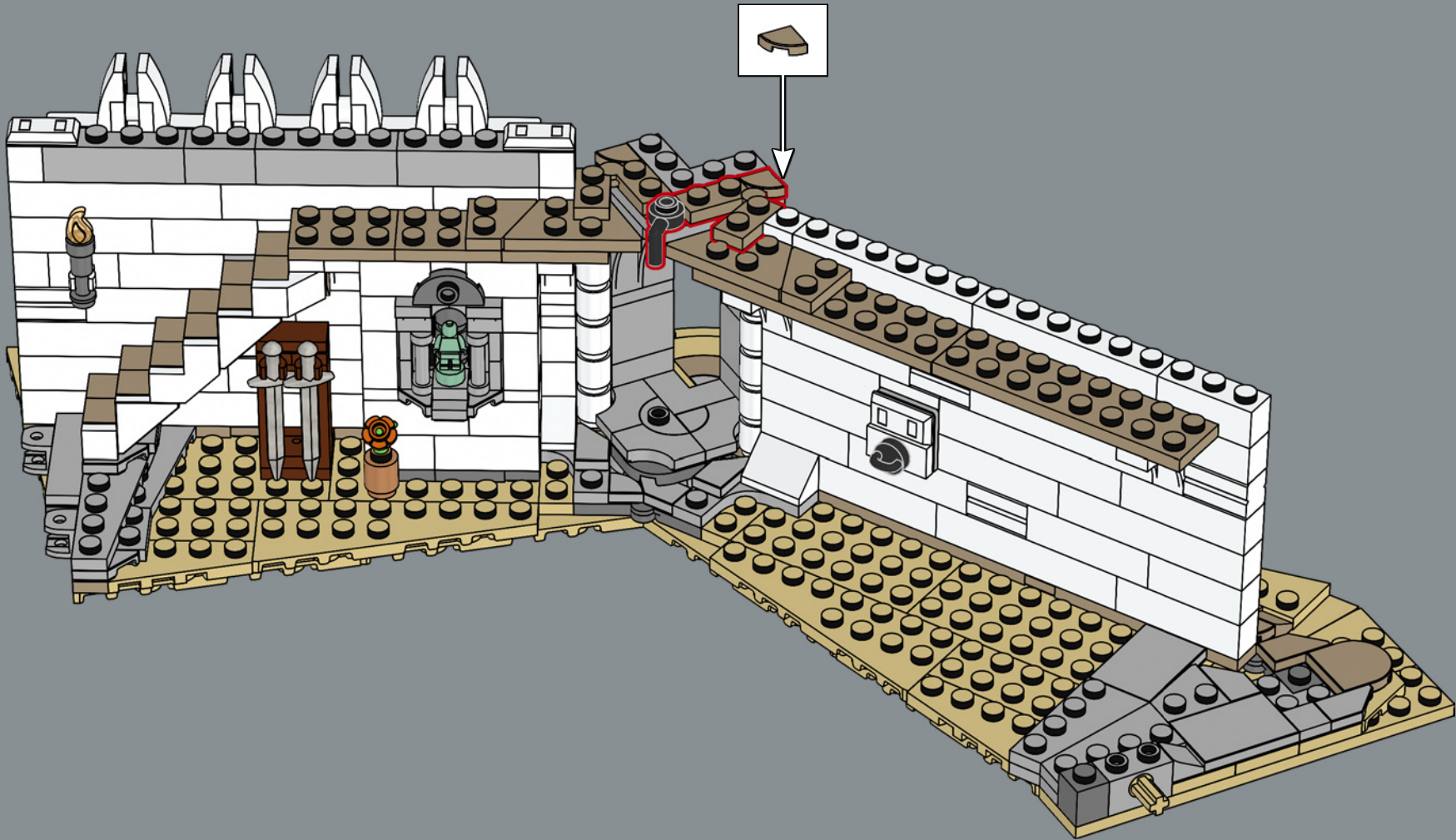

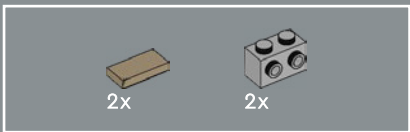

285

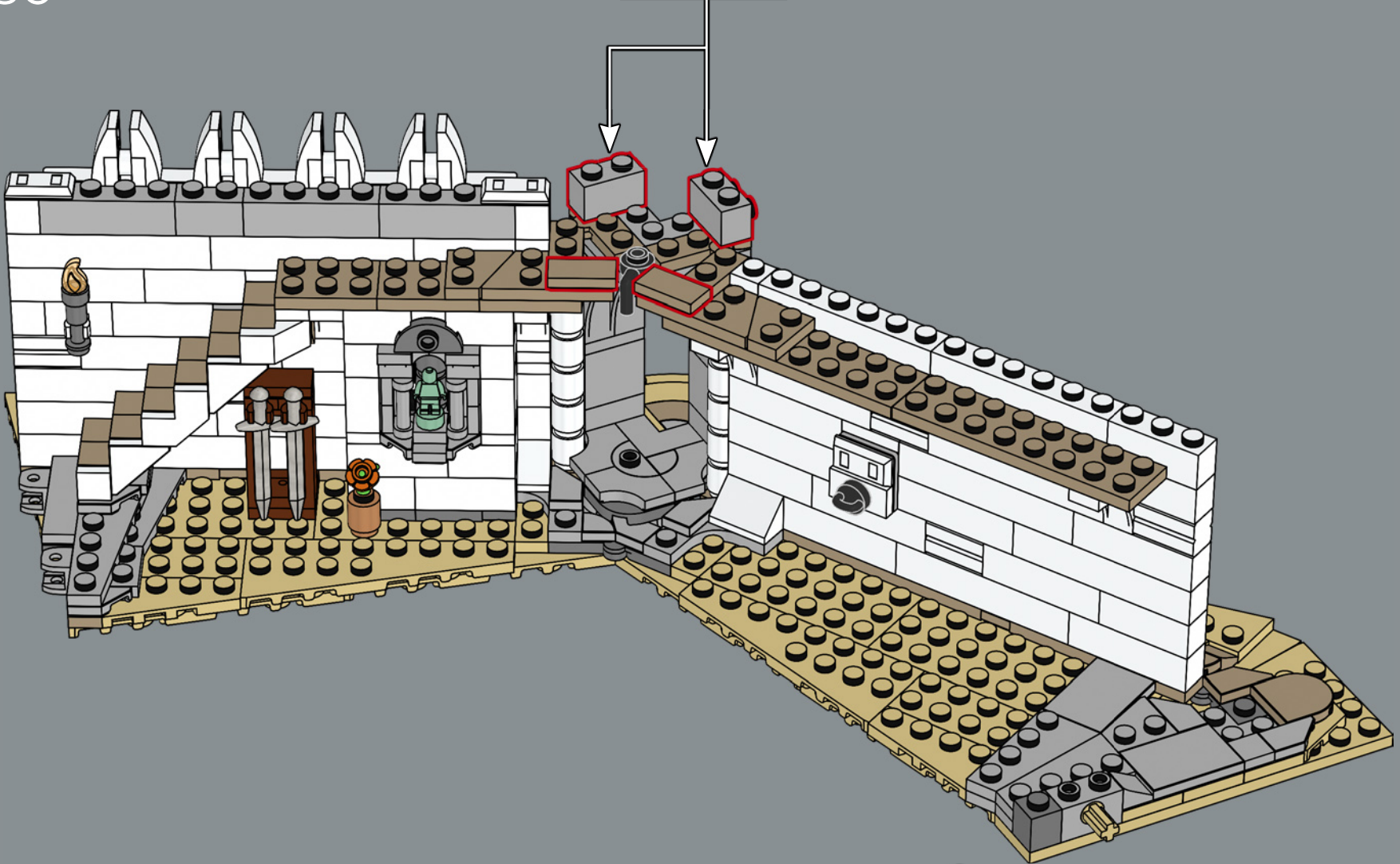
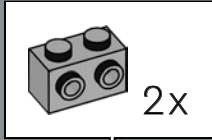

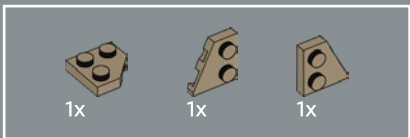

286

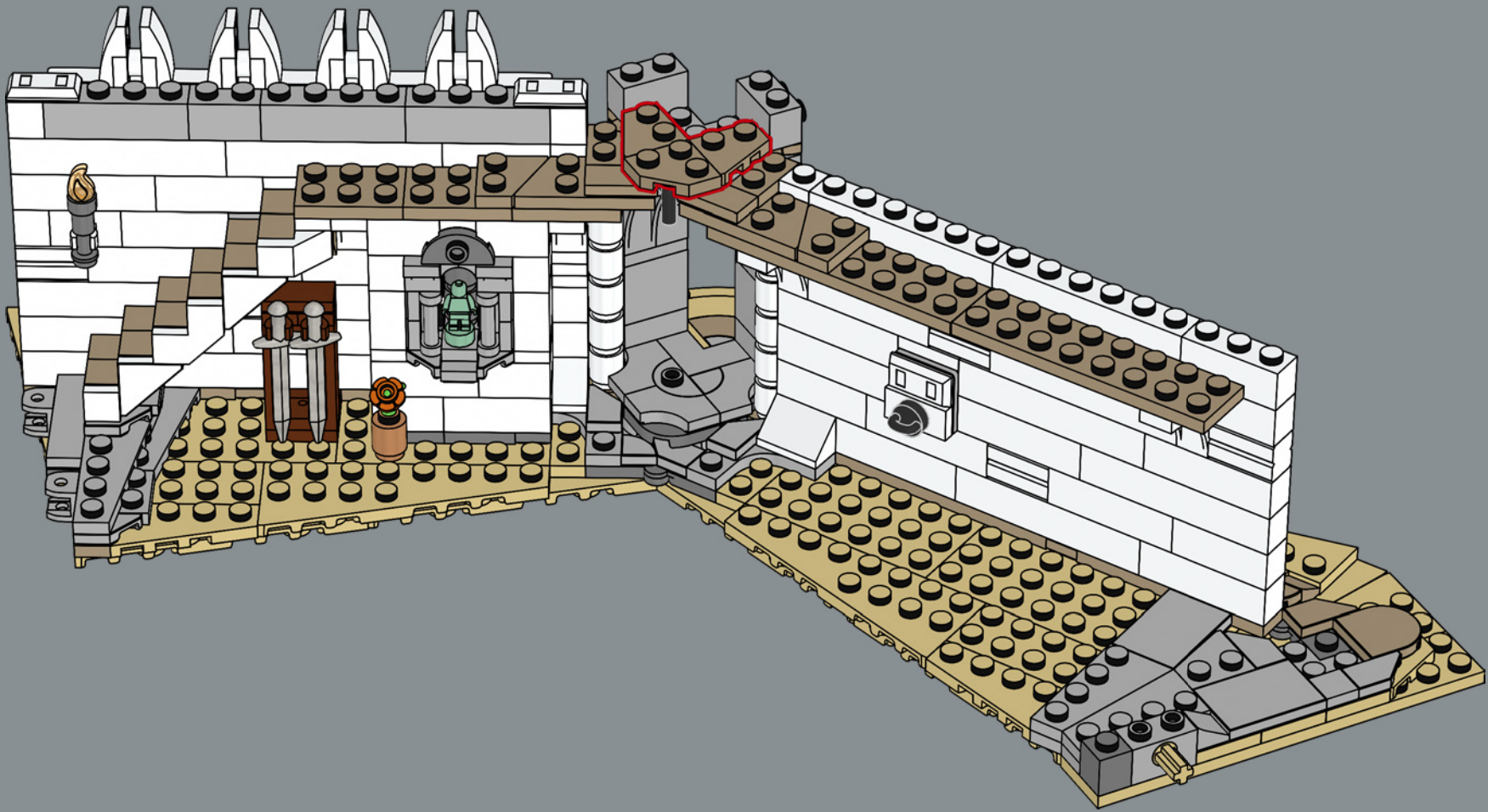

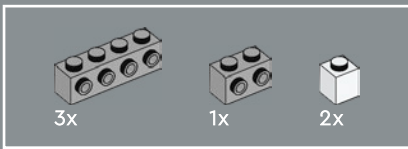

287

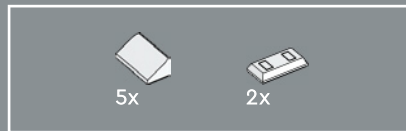
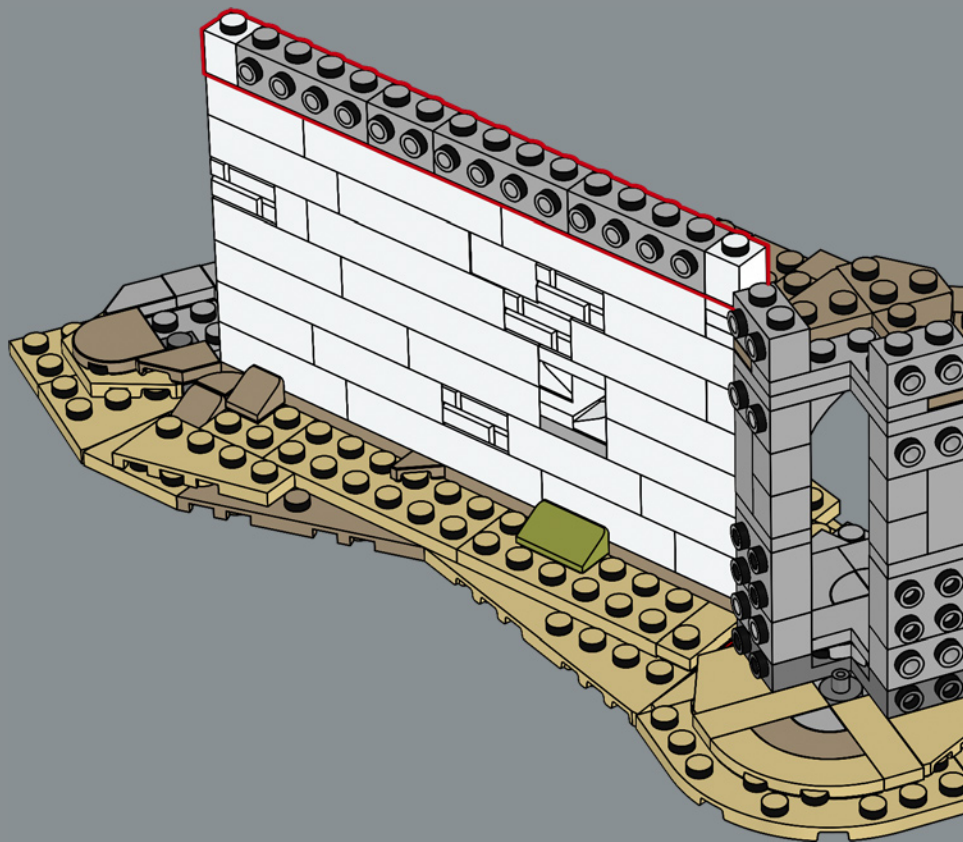

288

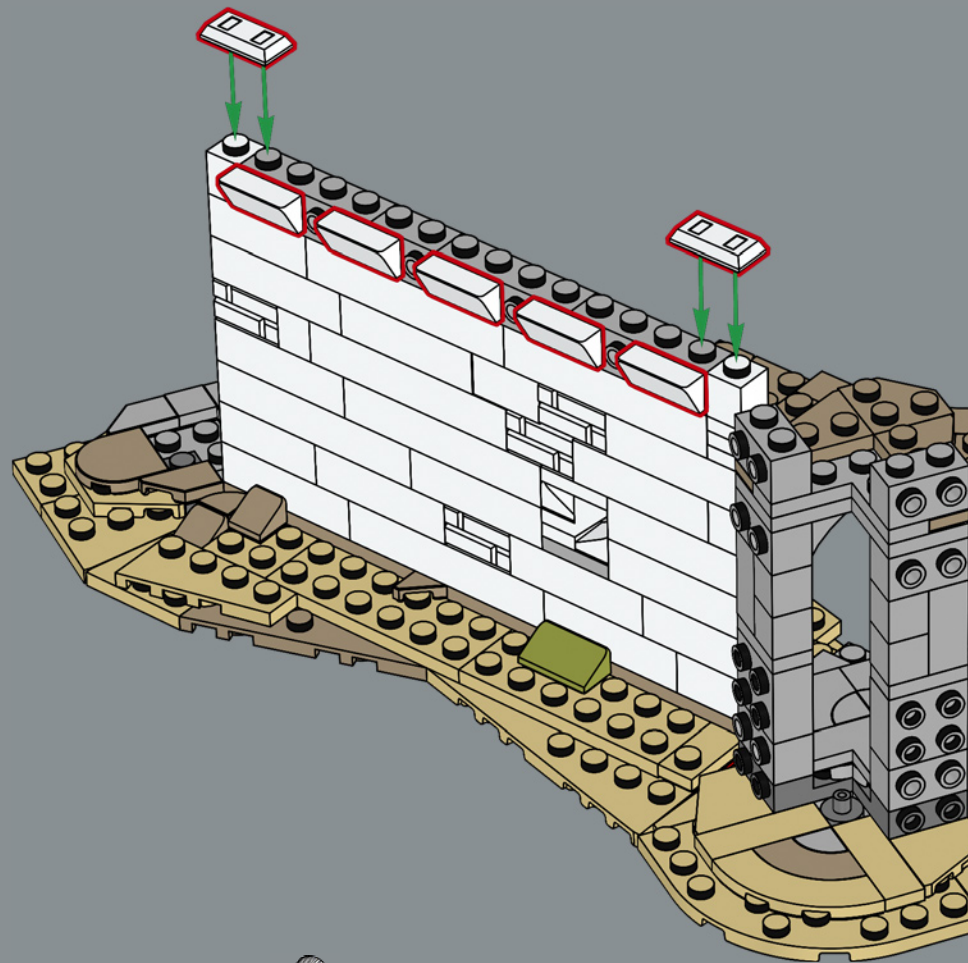



289

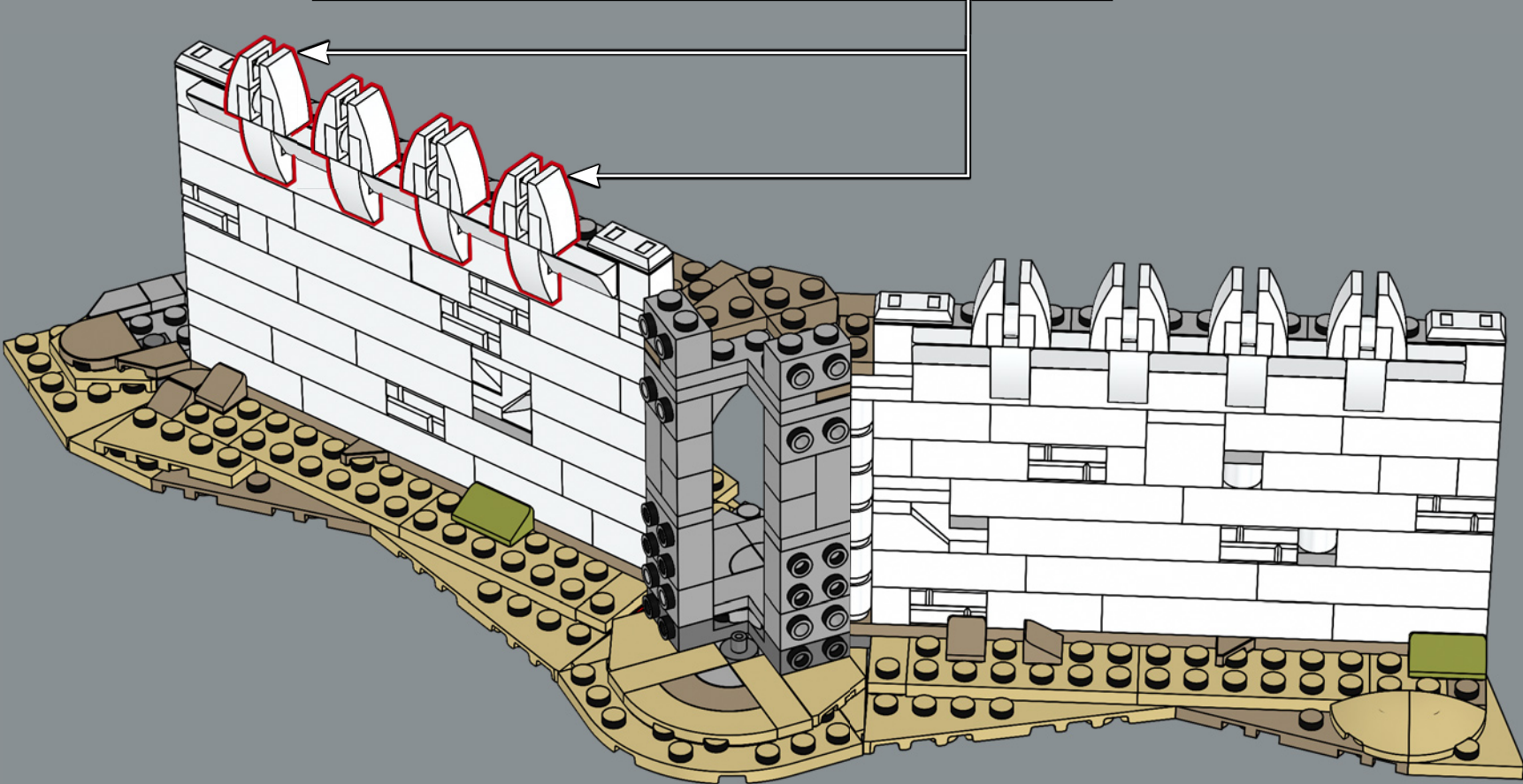
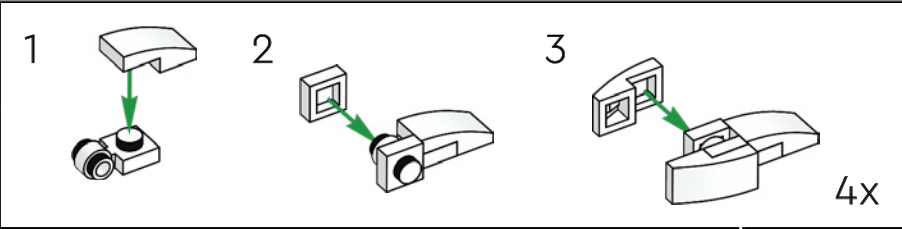

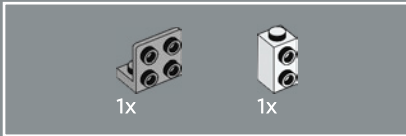
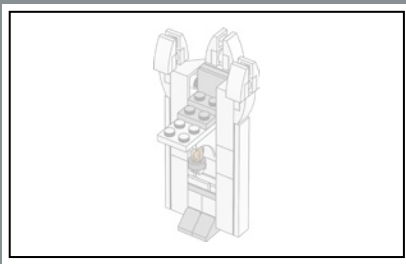

290

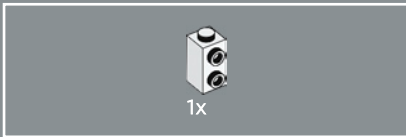
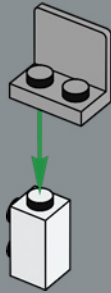

291

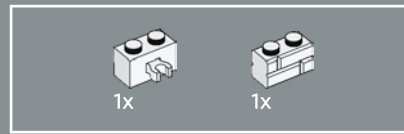
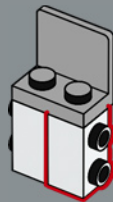

292

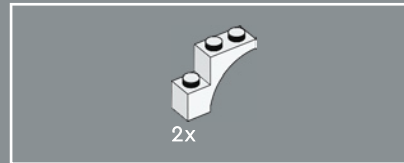
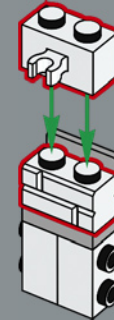

293

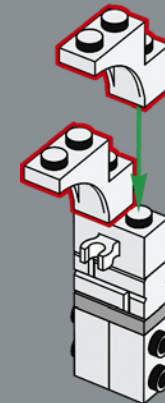

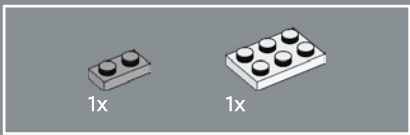

294

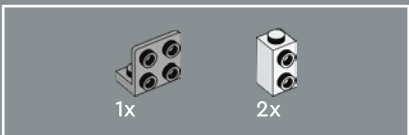
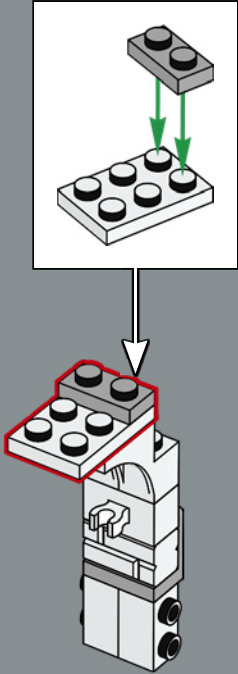

295

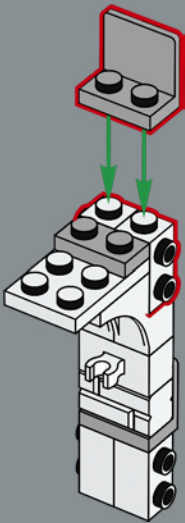

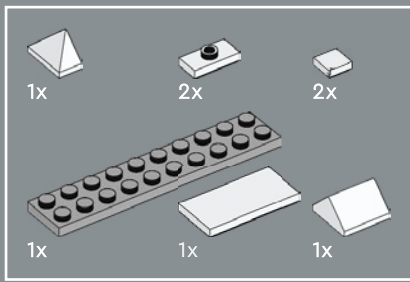

296

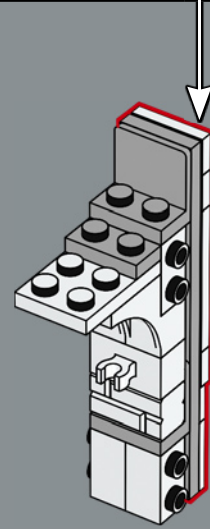
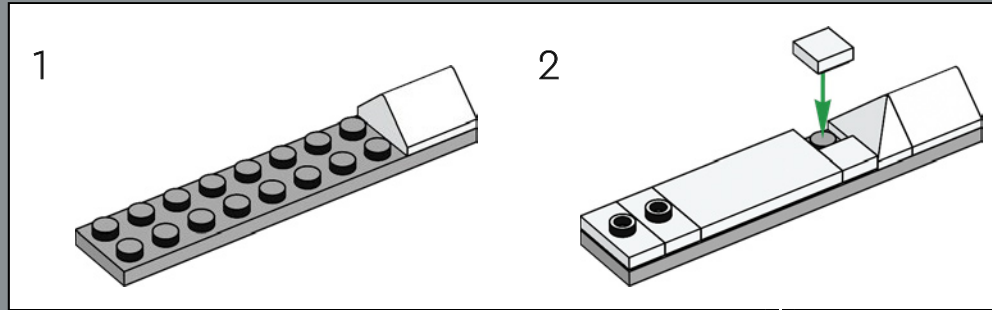

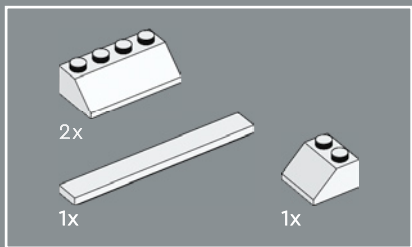

297

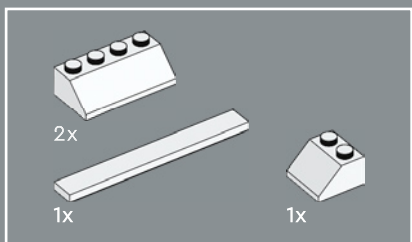
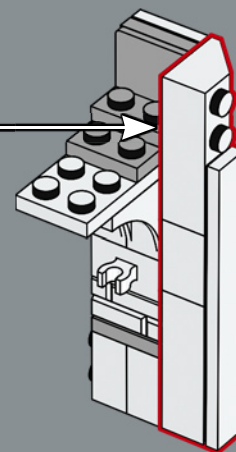
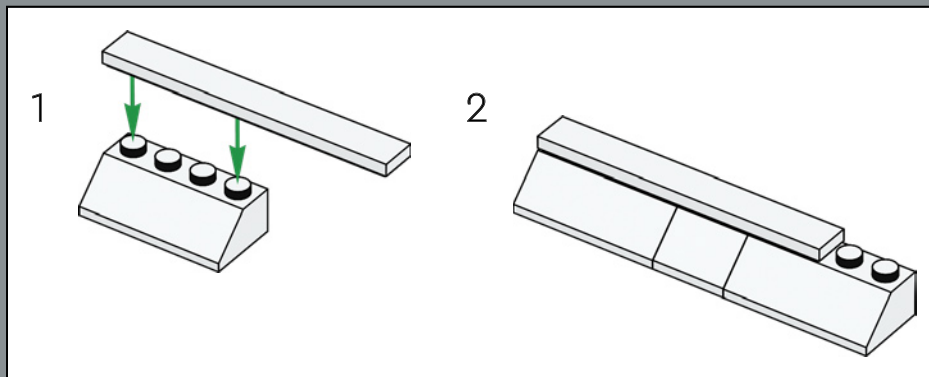

298

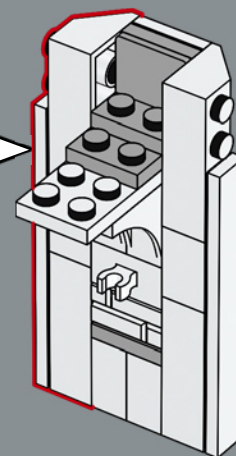
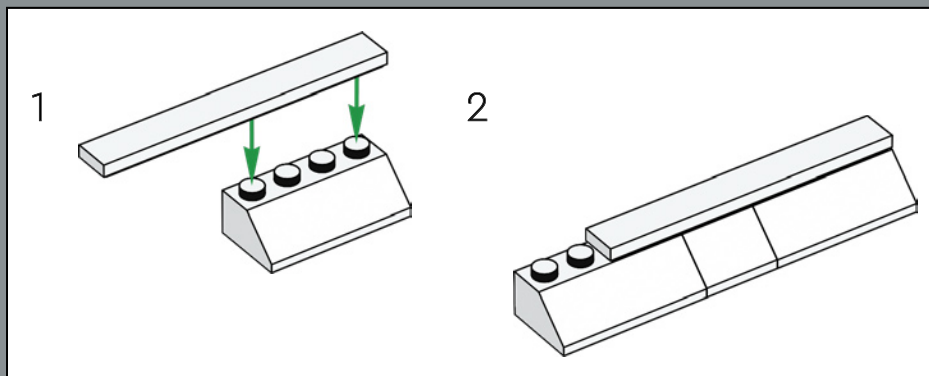



299

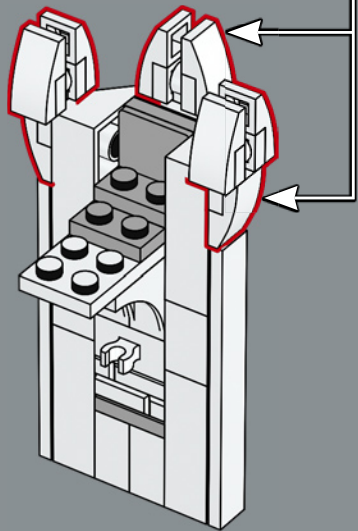
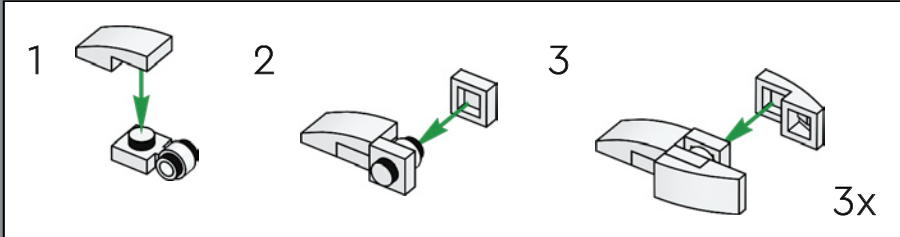

300

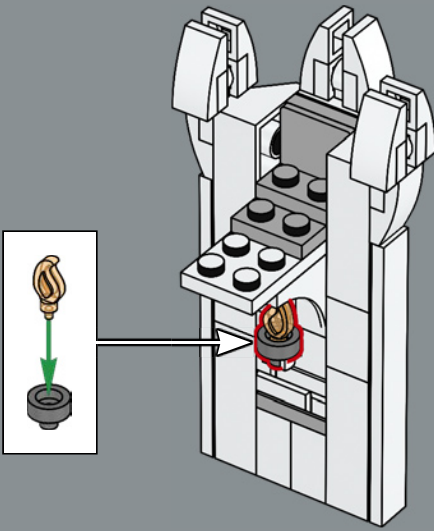



2x

301

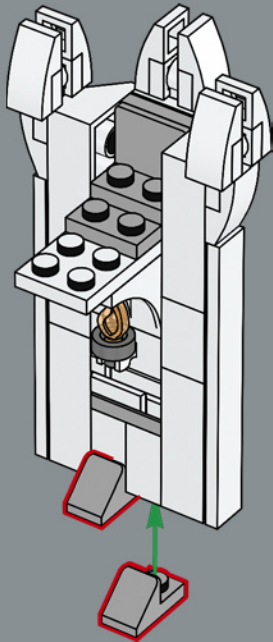

302

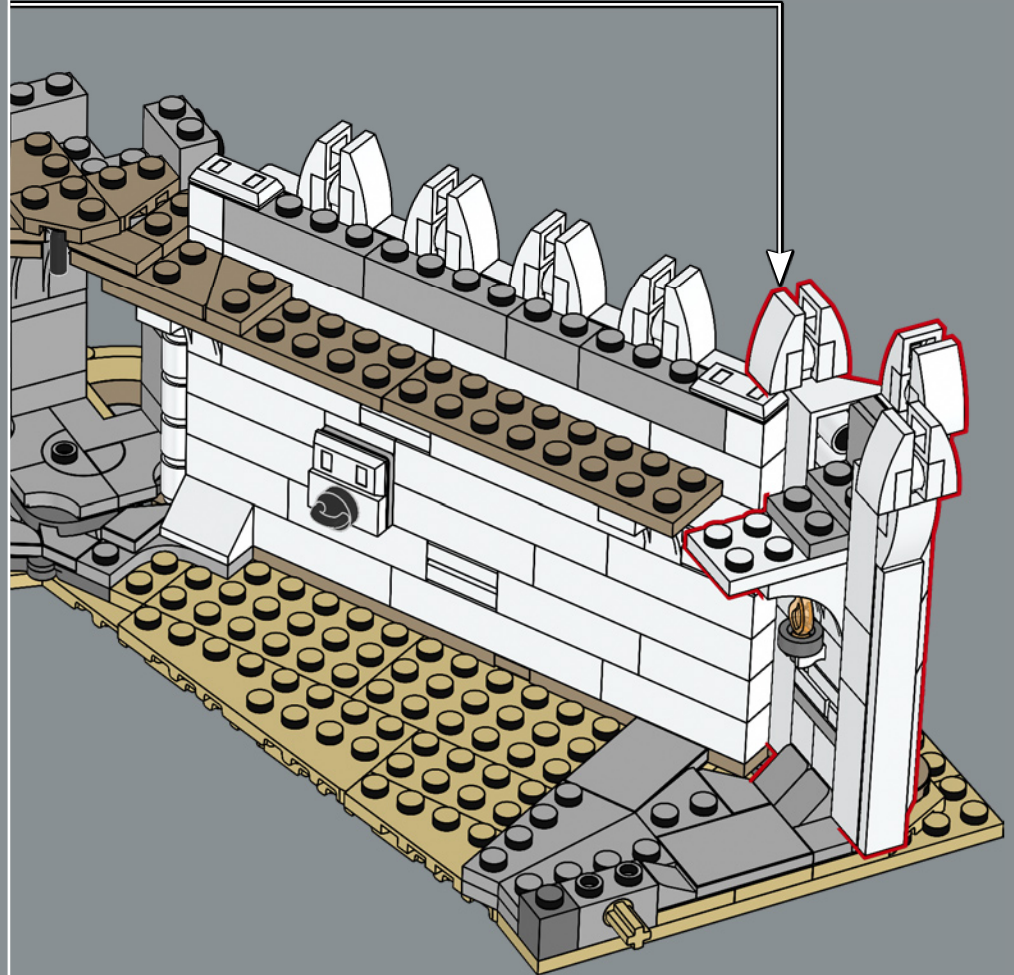

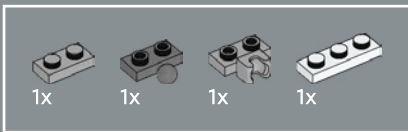

303

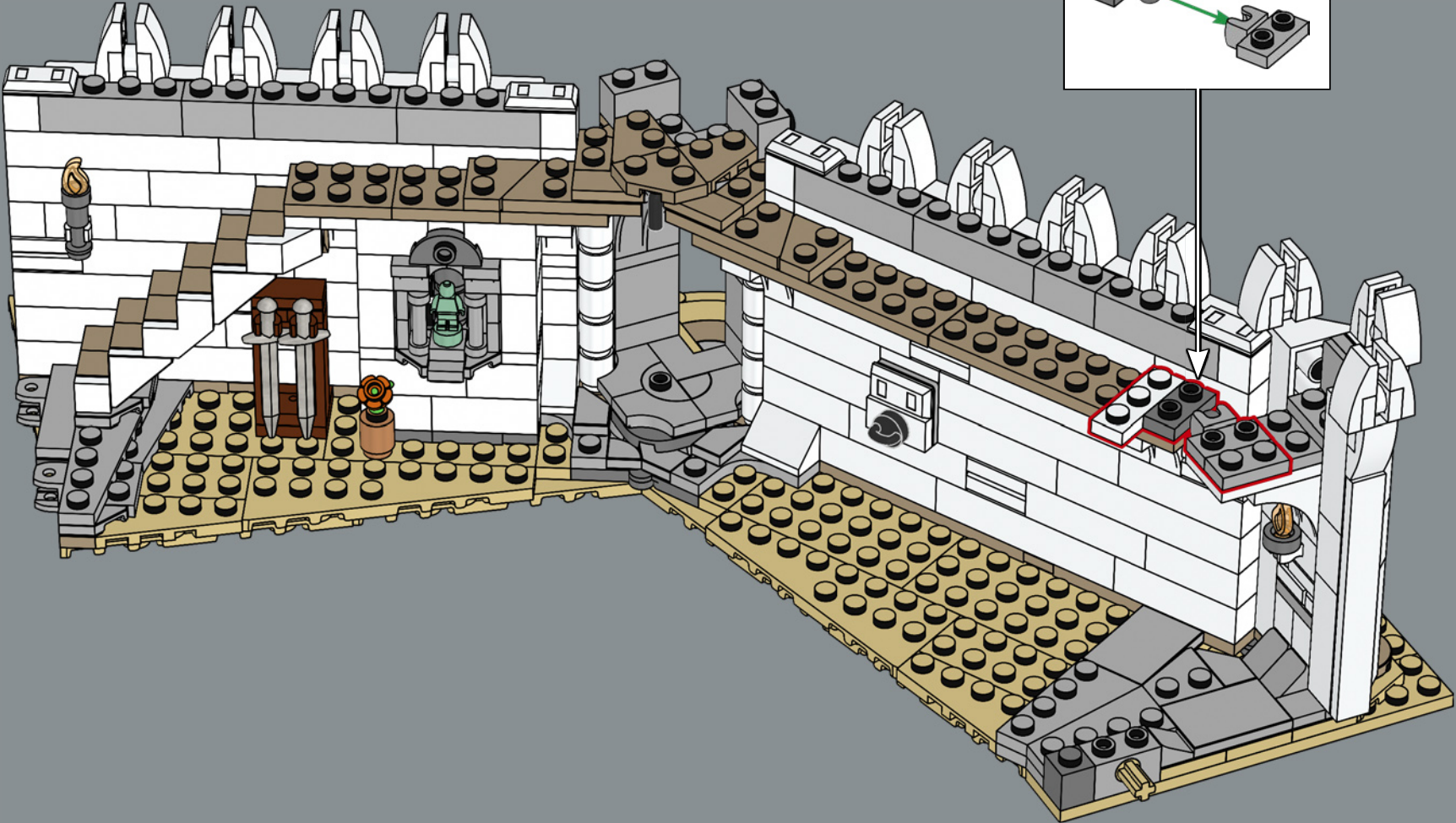
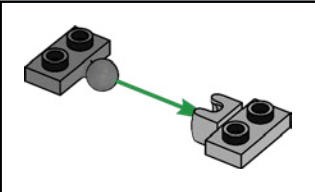

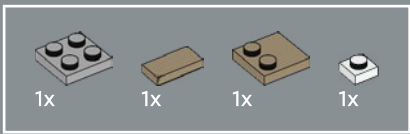

304

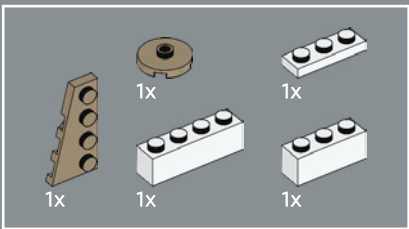
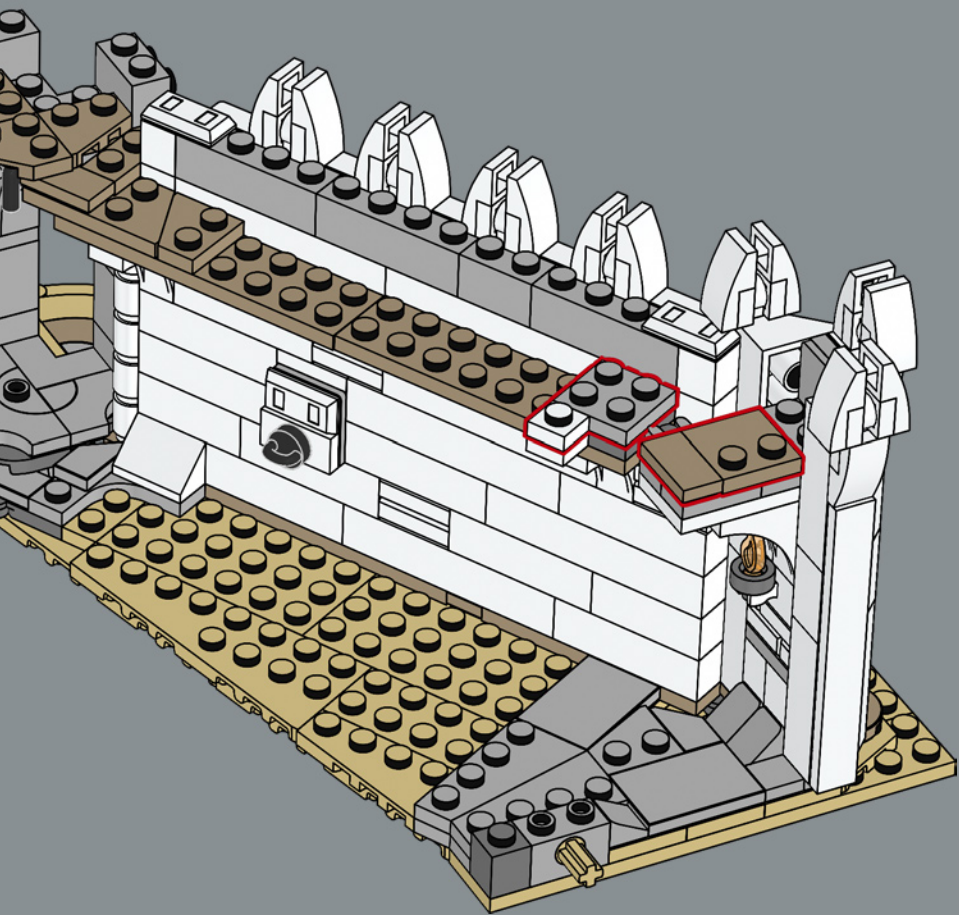

305

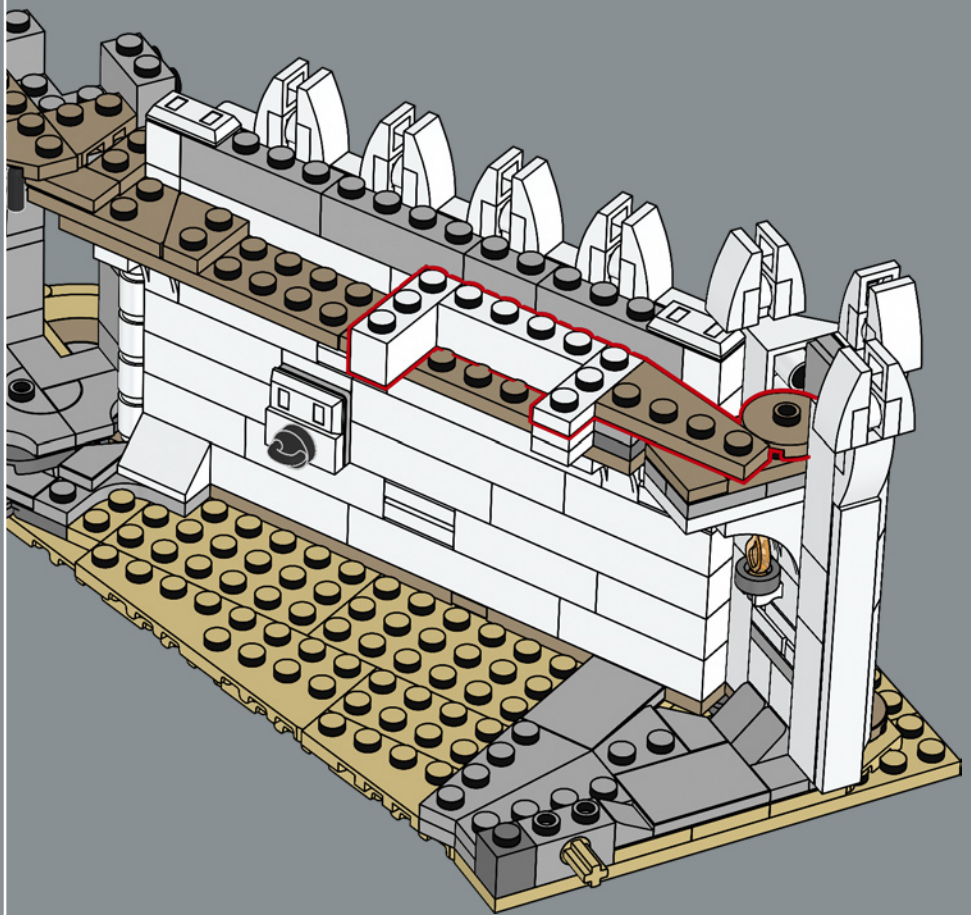

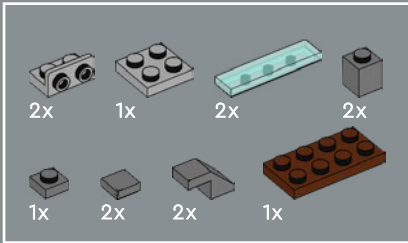
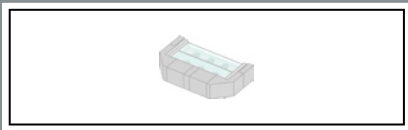

306

1



2



3

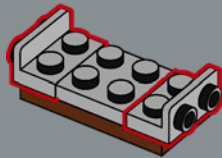

4

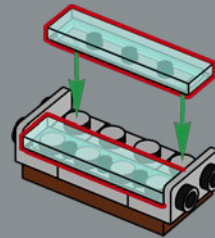

5

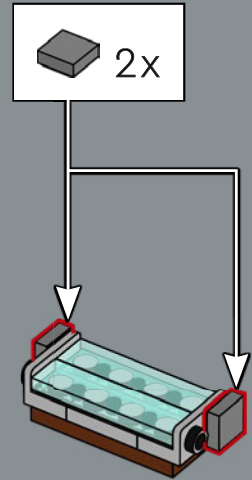

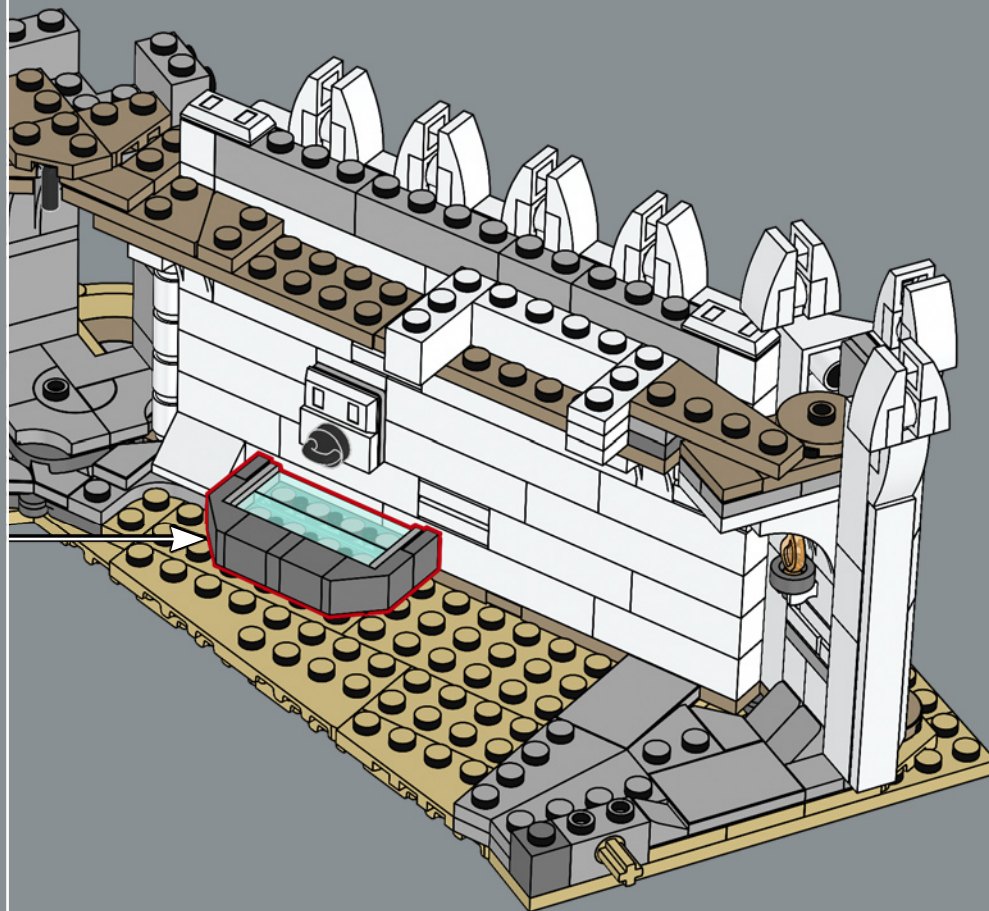
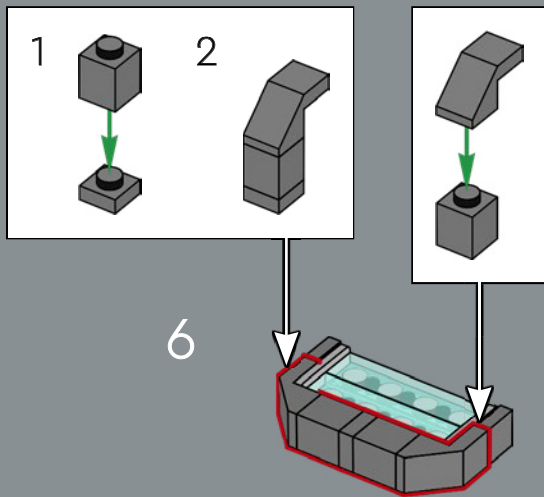

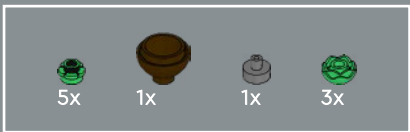

307

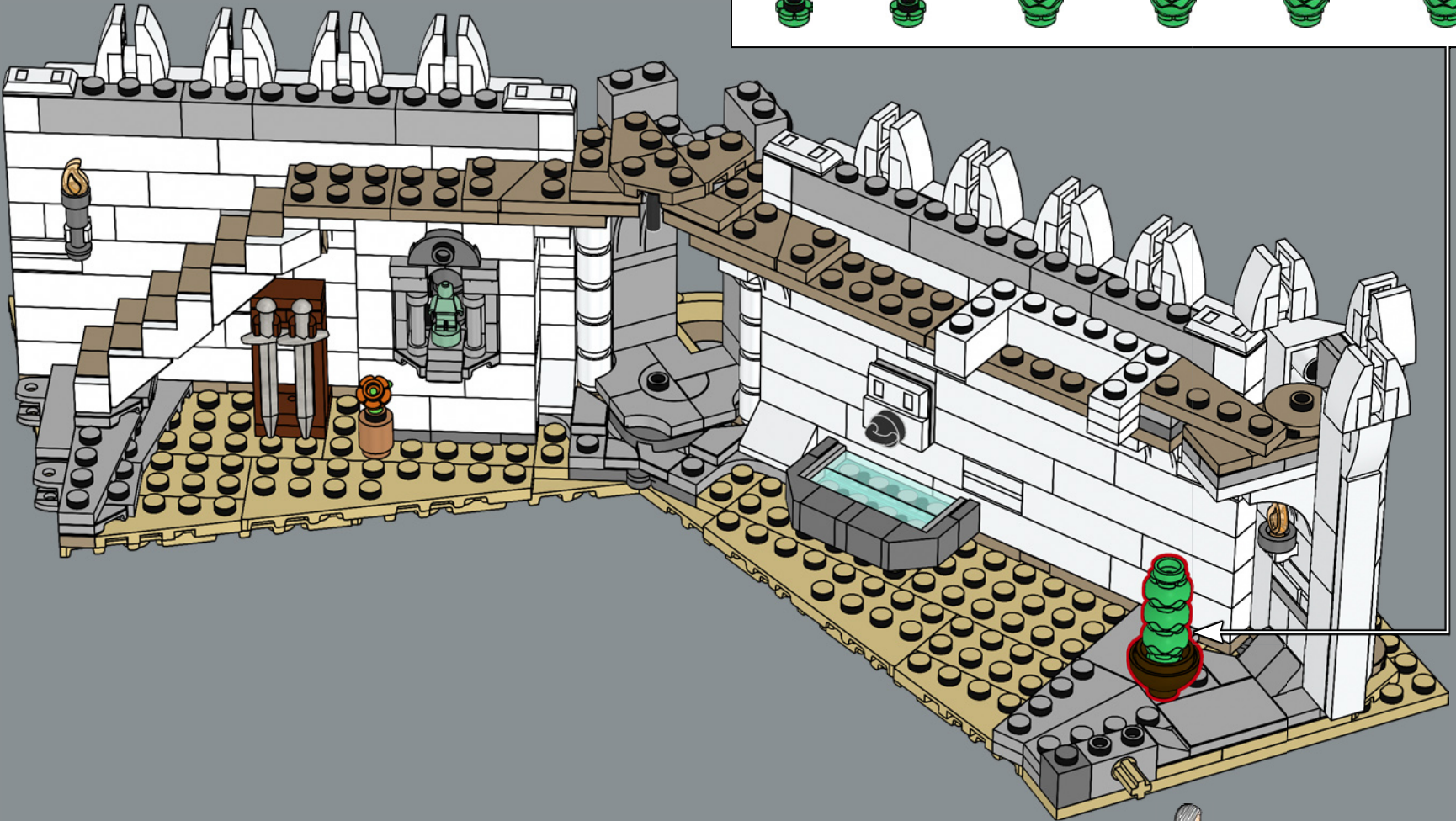
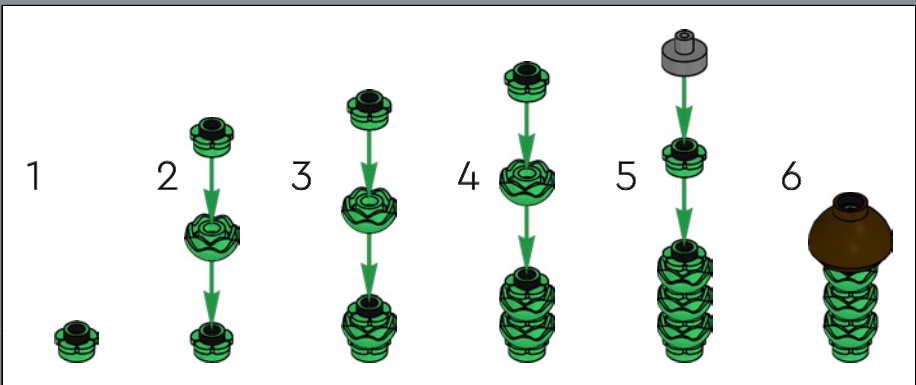



1

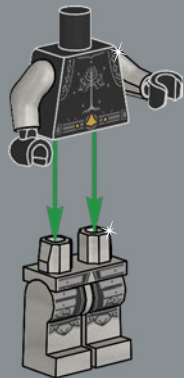

2

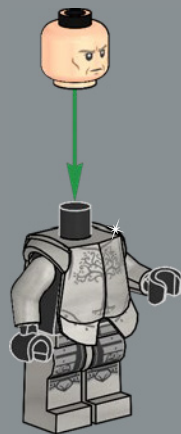

3



4



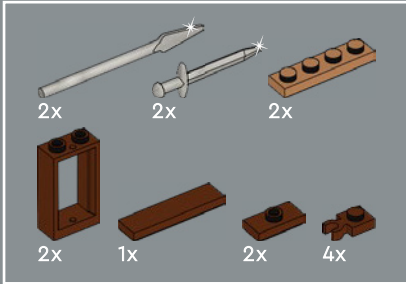
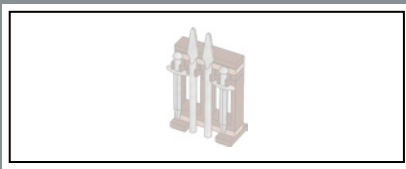

308

1

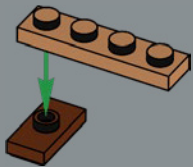

2

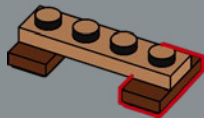

3

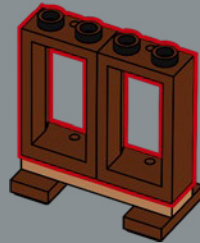

4

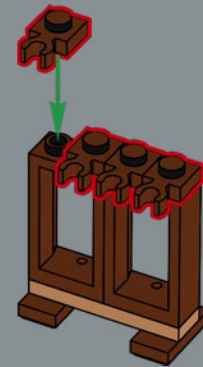

5

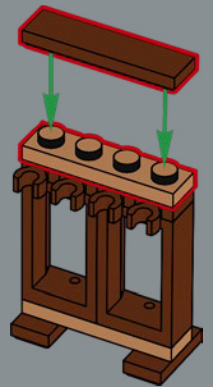

309

6

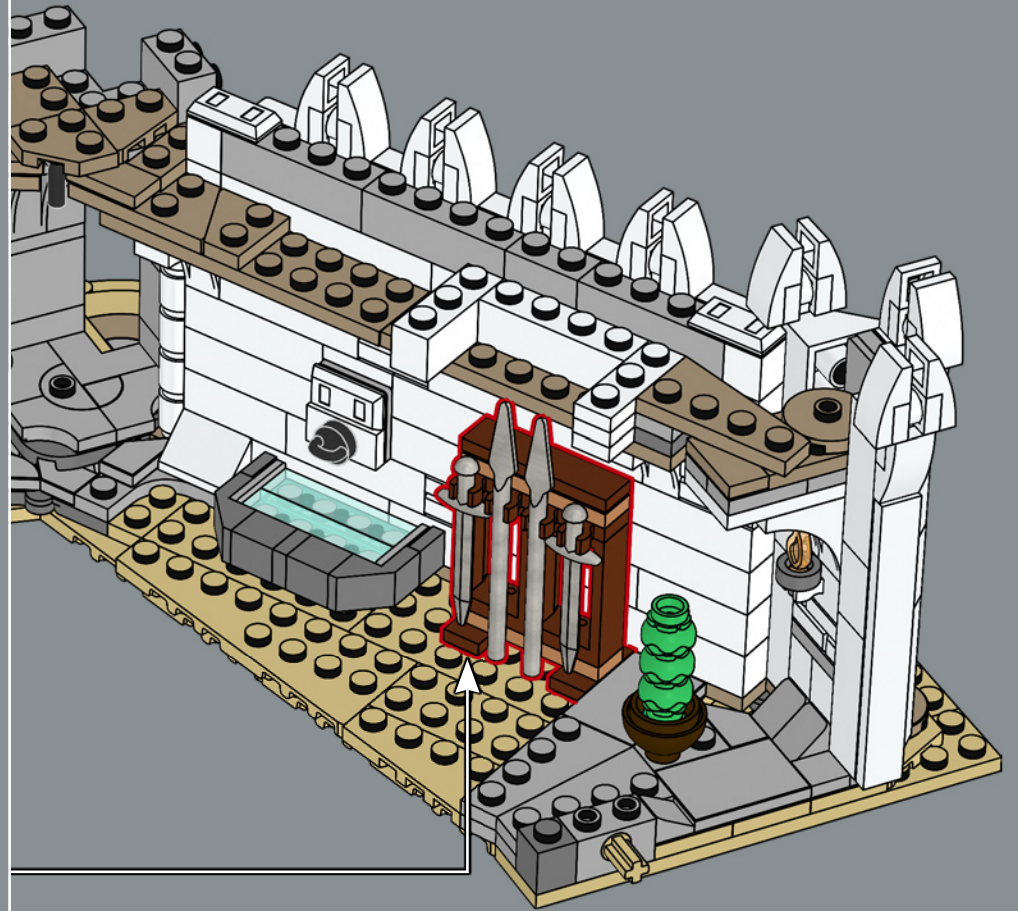
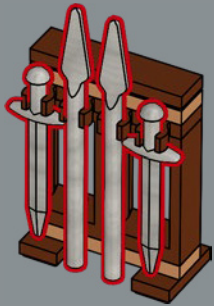

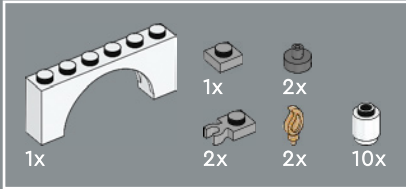
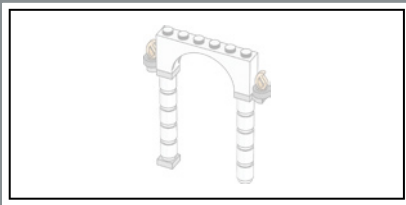

310

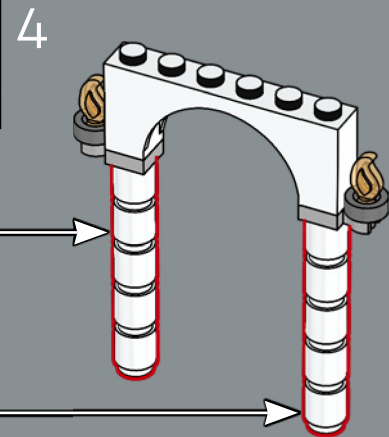
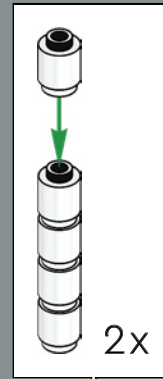
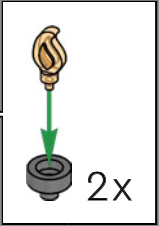
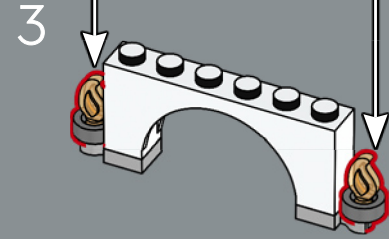
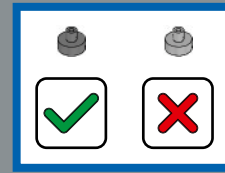
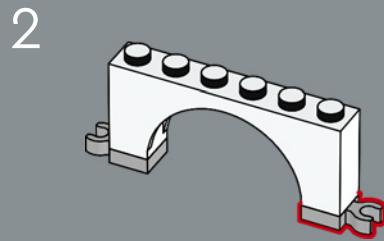
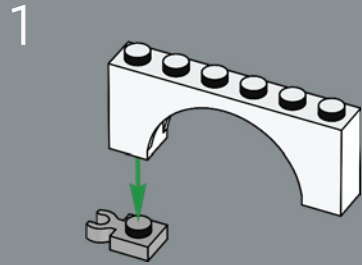

5

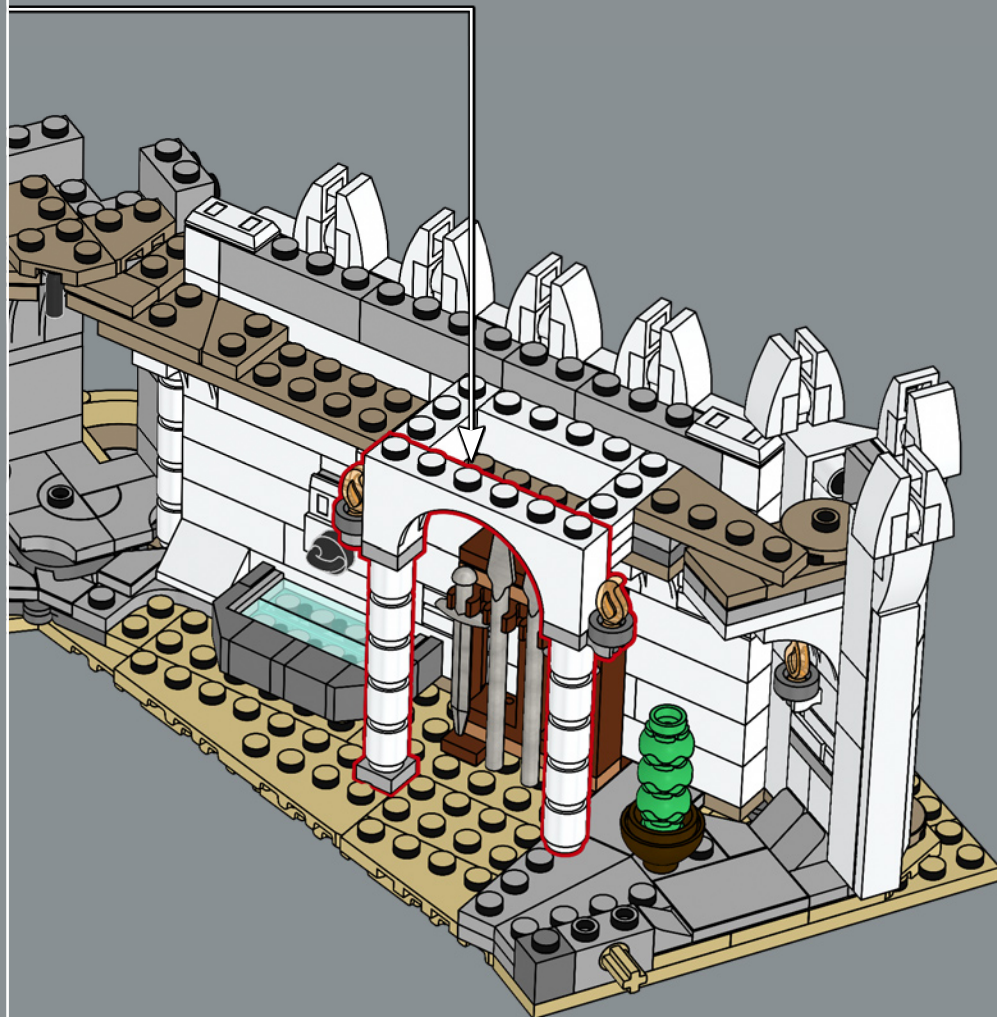
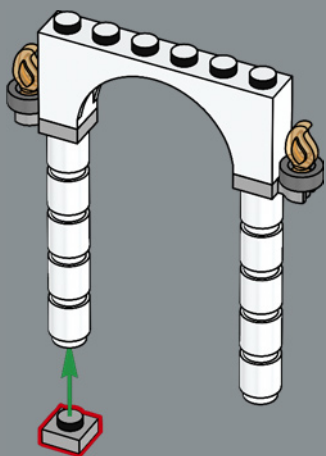

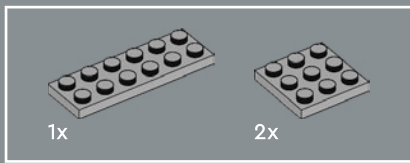

311

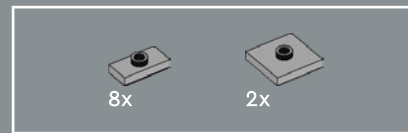
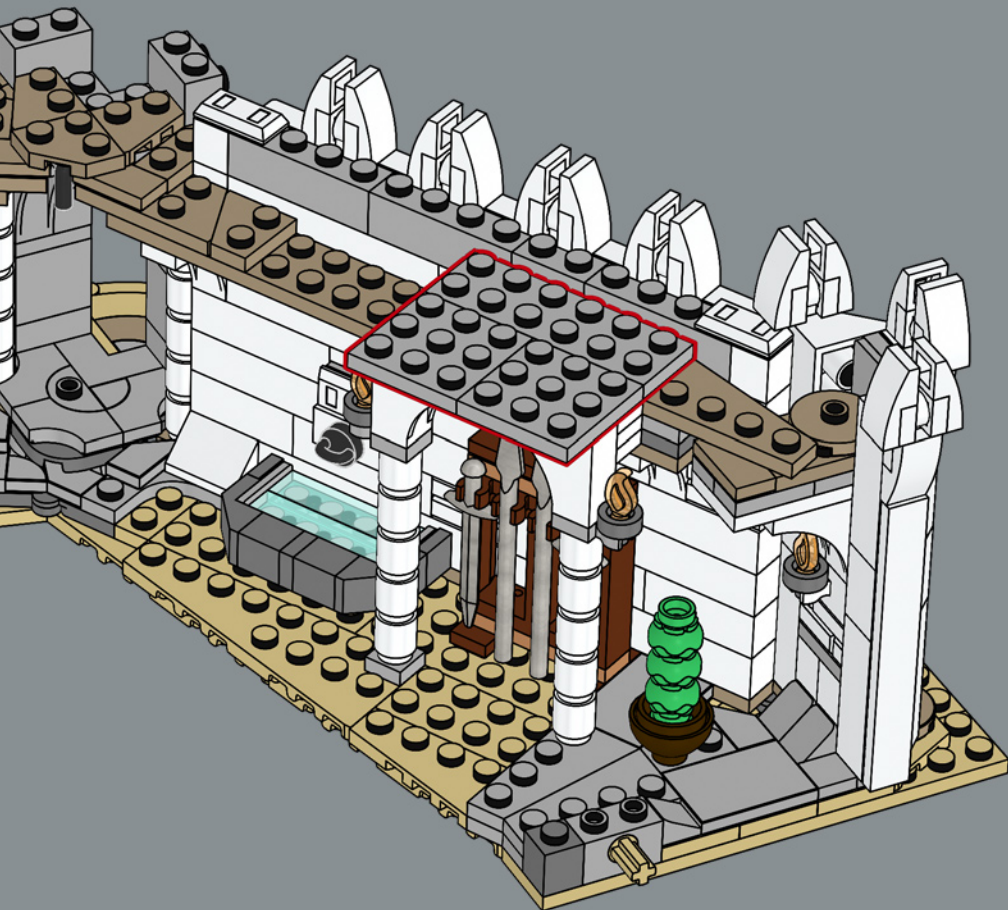

312

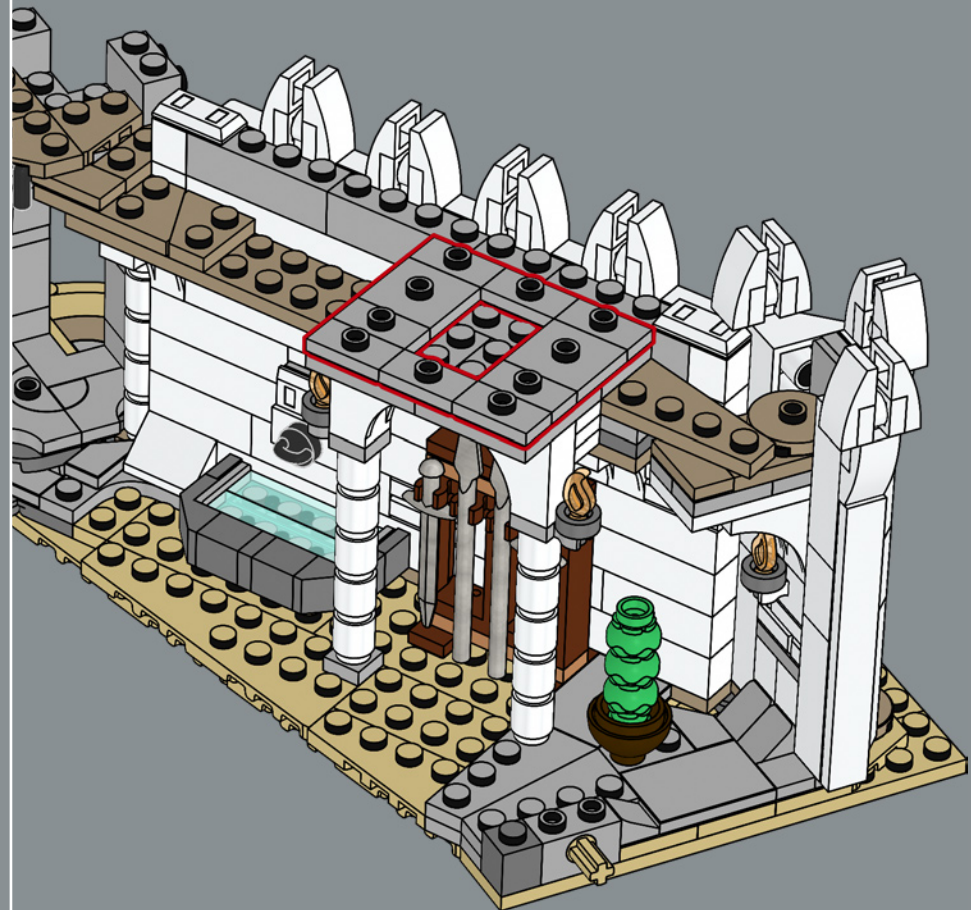

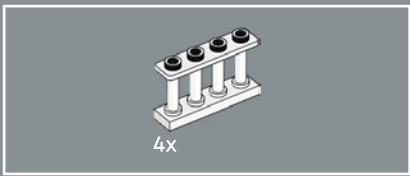

313

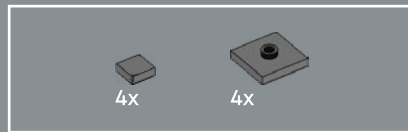
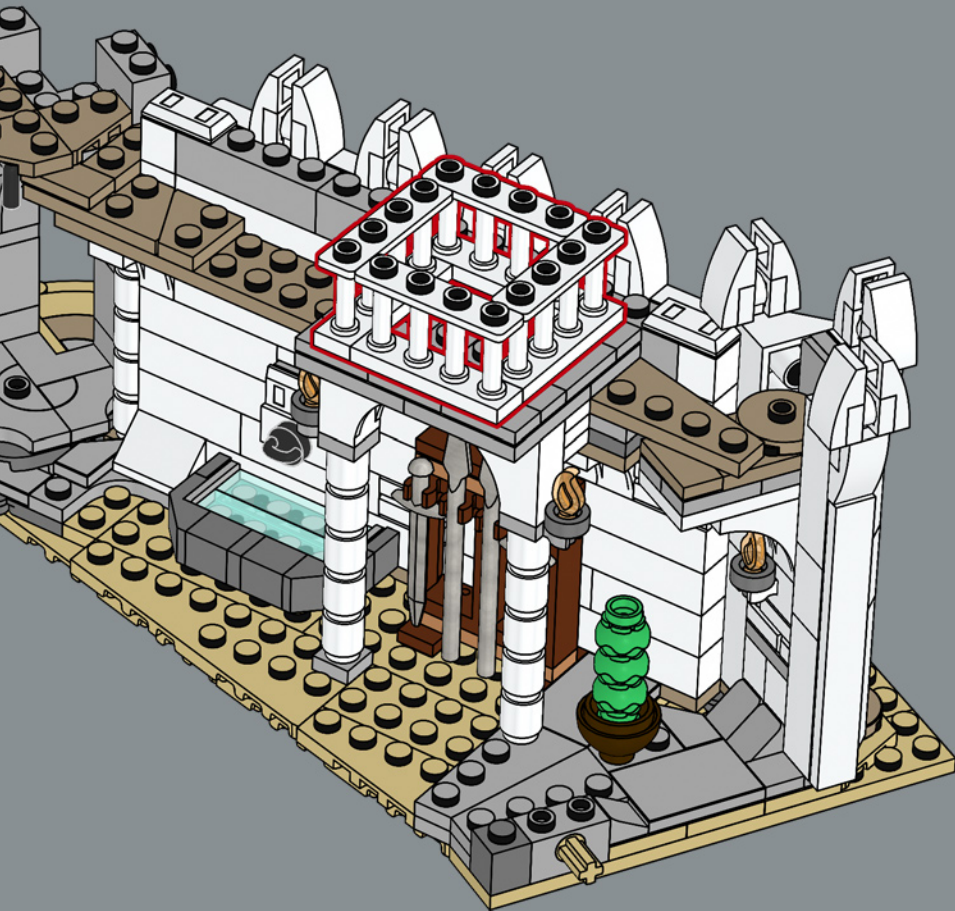

314

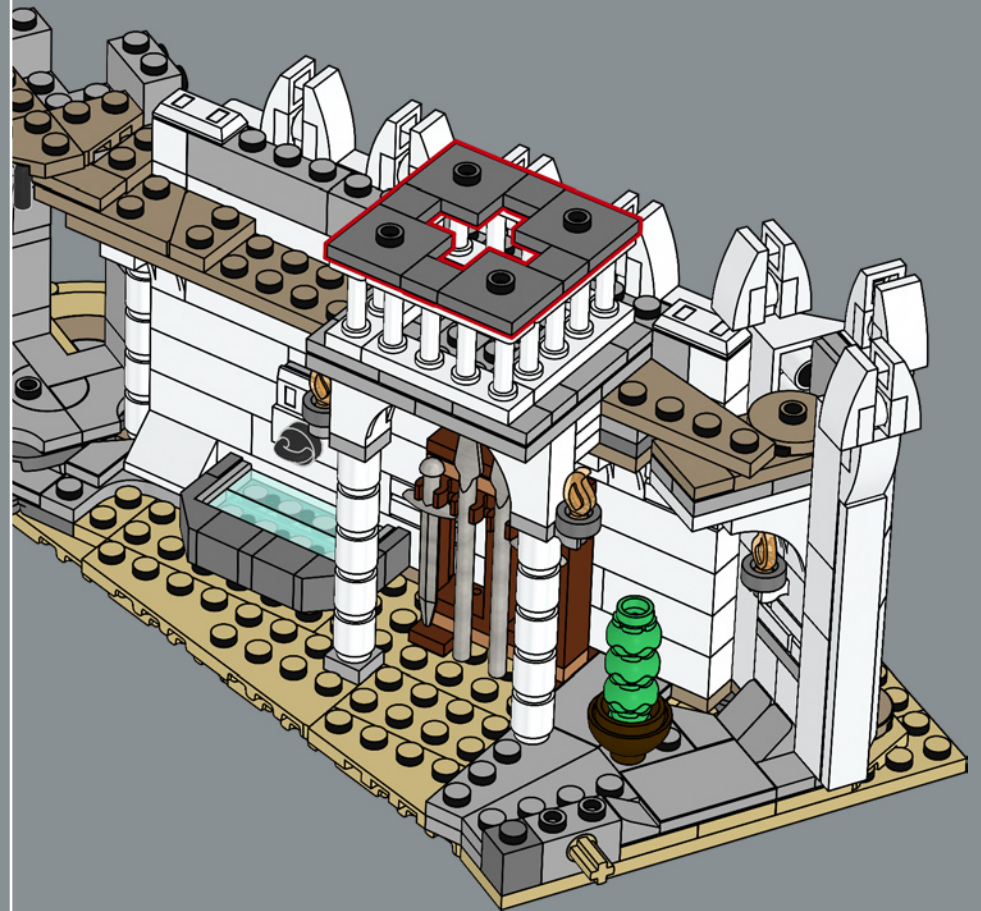

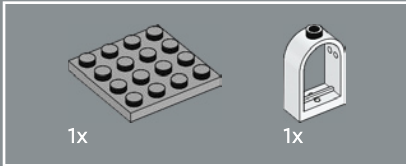

315

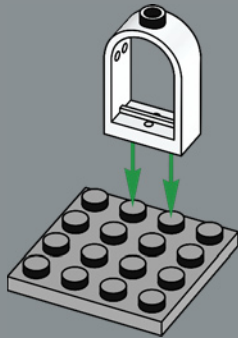

3x

316

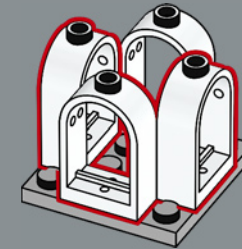

4x

8x

317

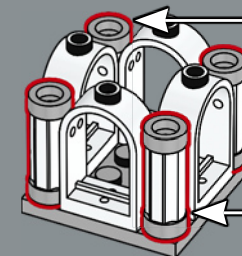
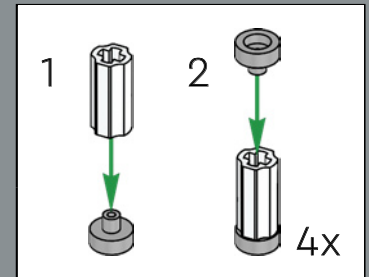

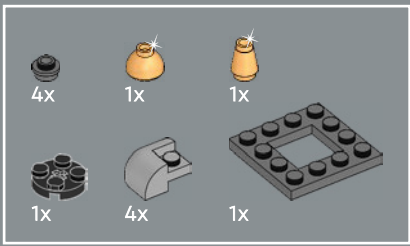

318

1

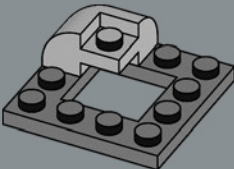

2

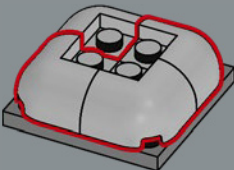

3

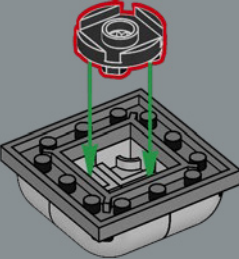

4

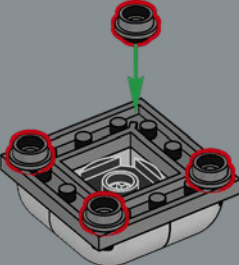

5

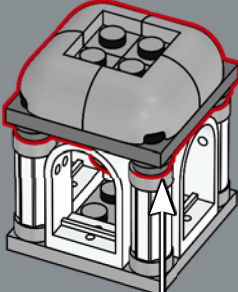
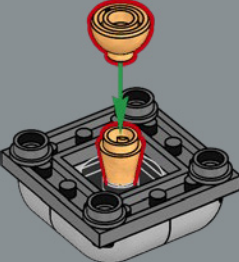

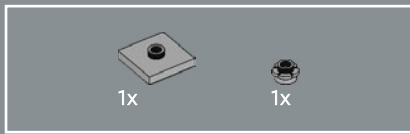

319

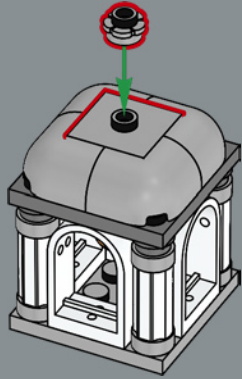

320

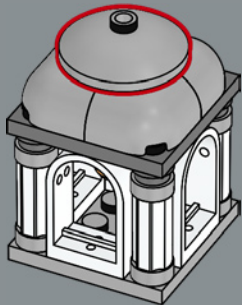

321

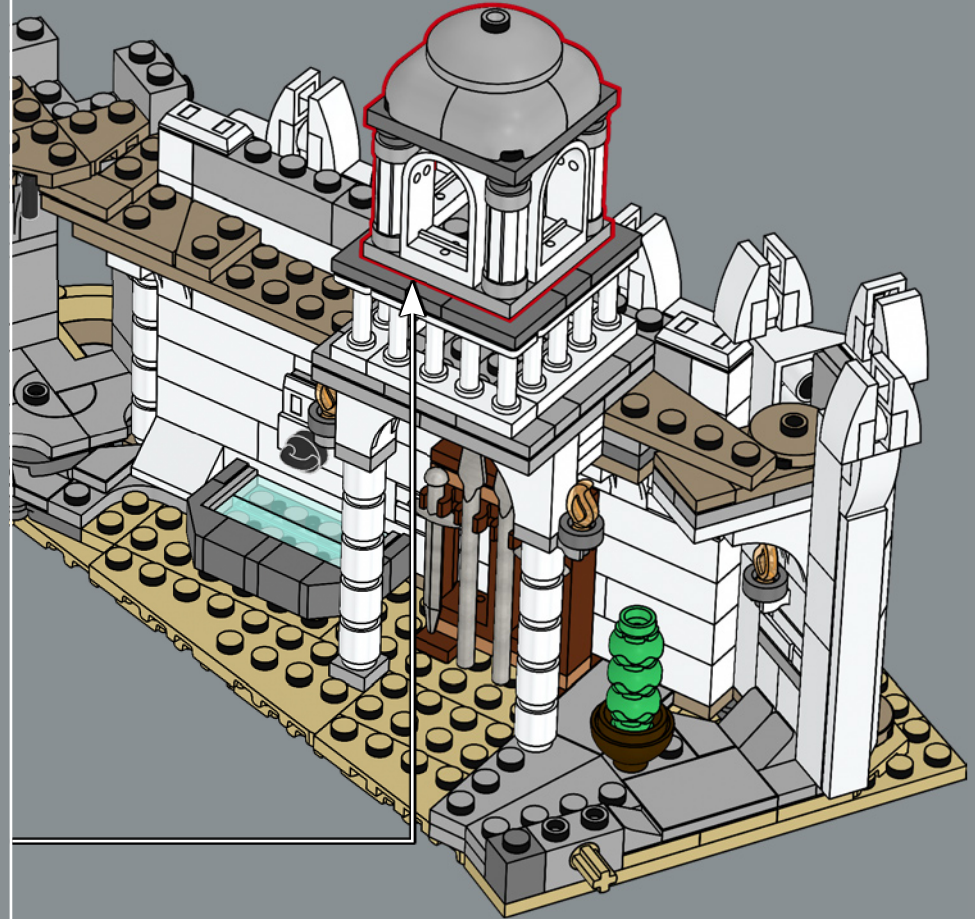

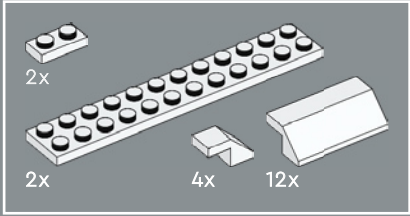
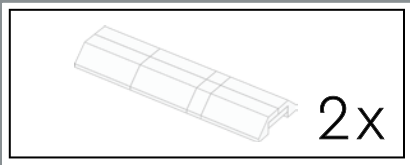

322

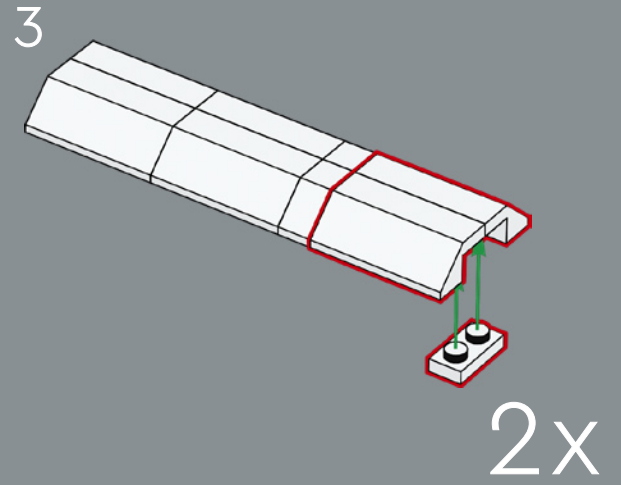
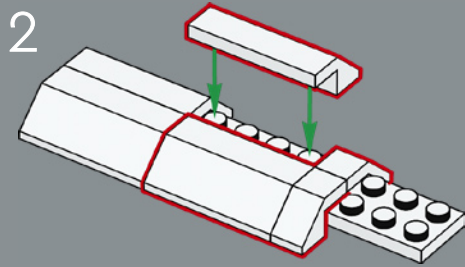
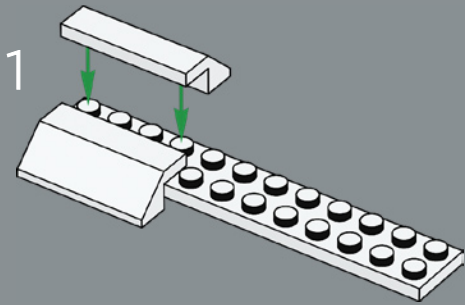

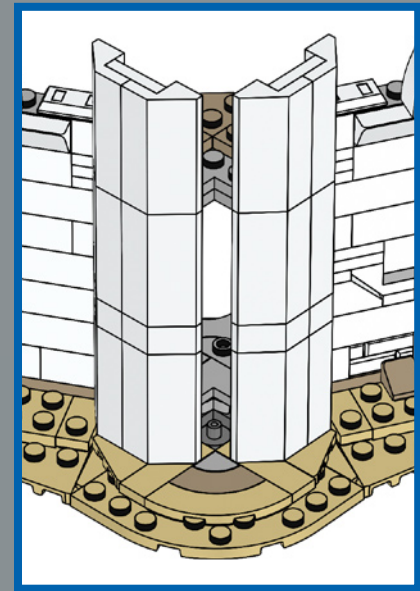

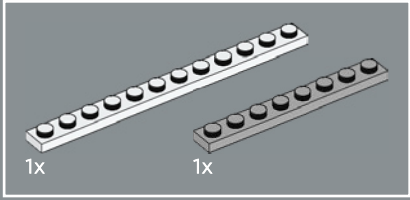
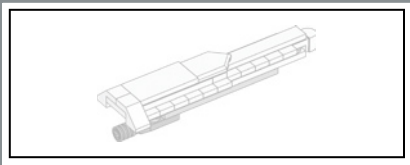

323

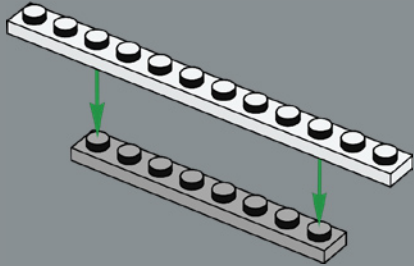

324

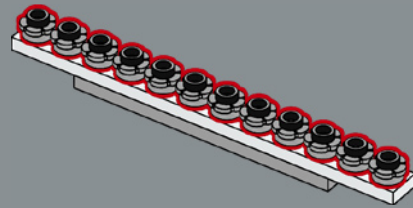



325

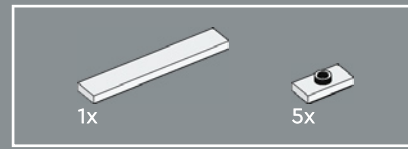
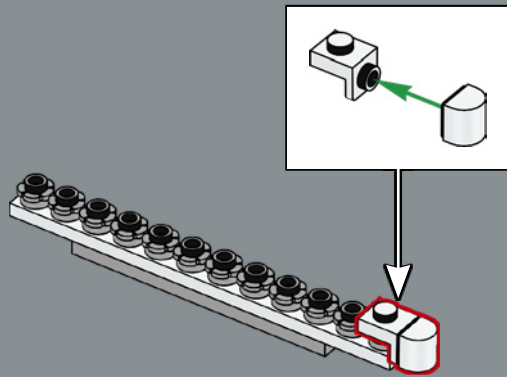

326

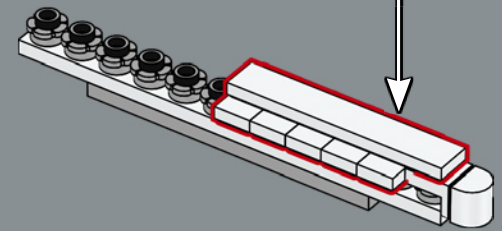
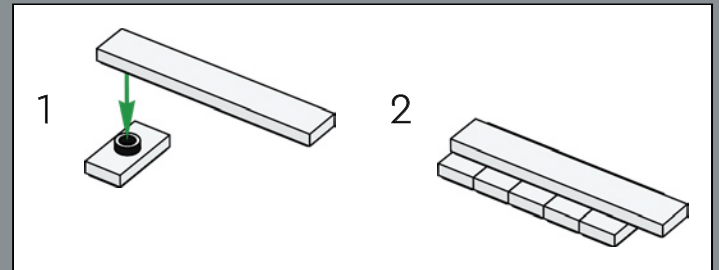

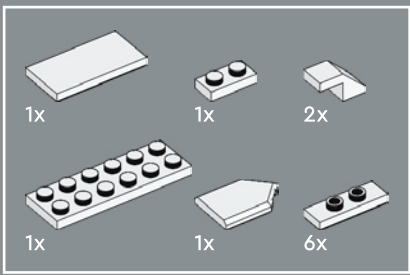

327

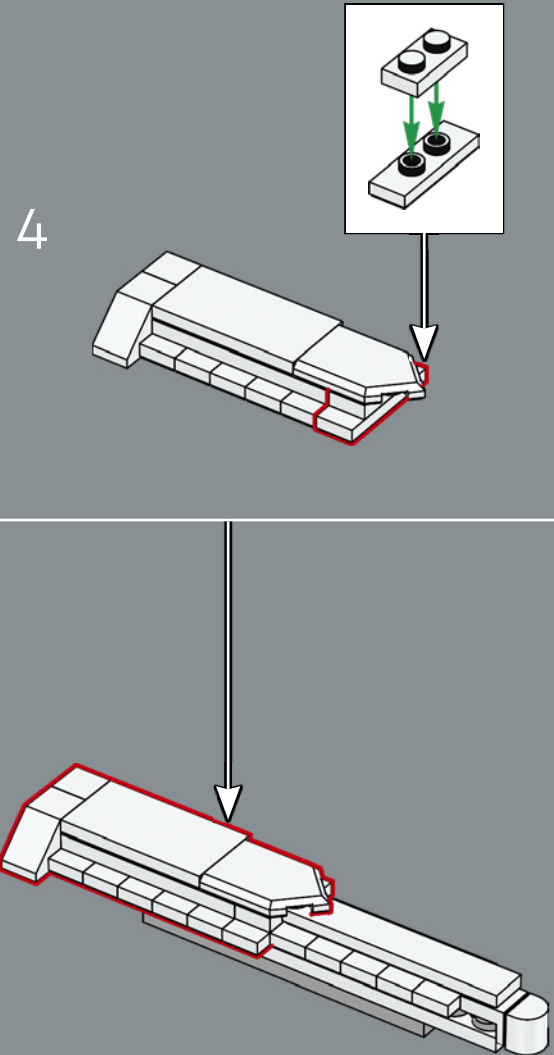
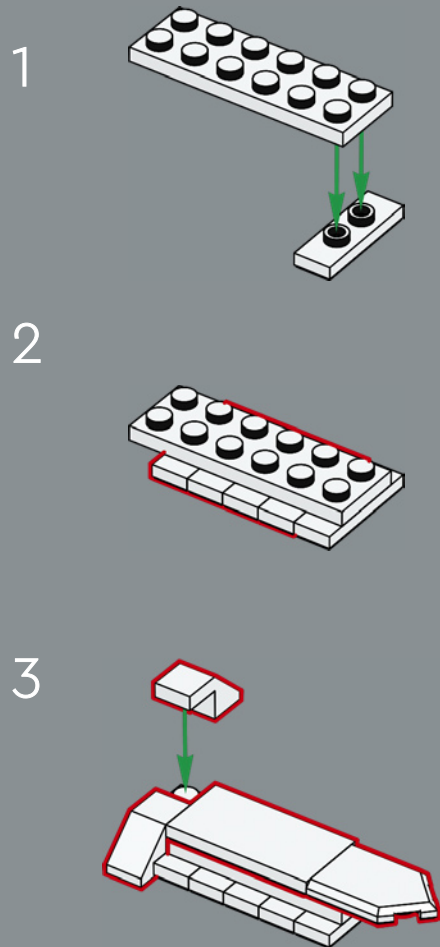

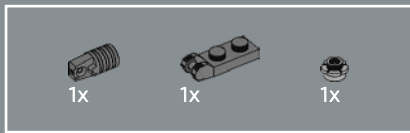

328

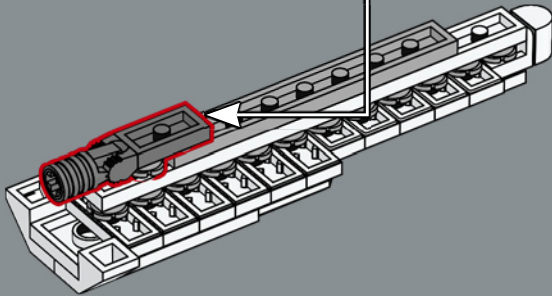
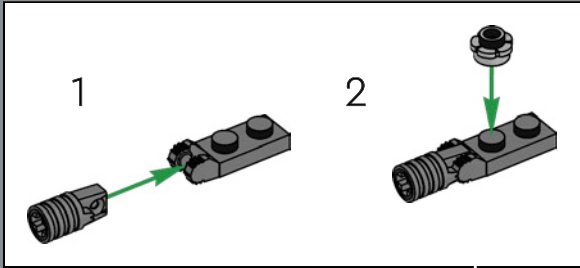

329

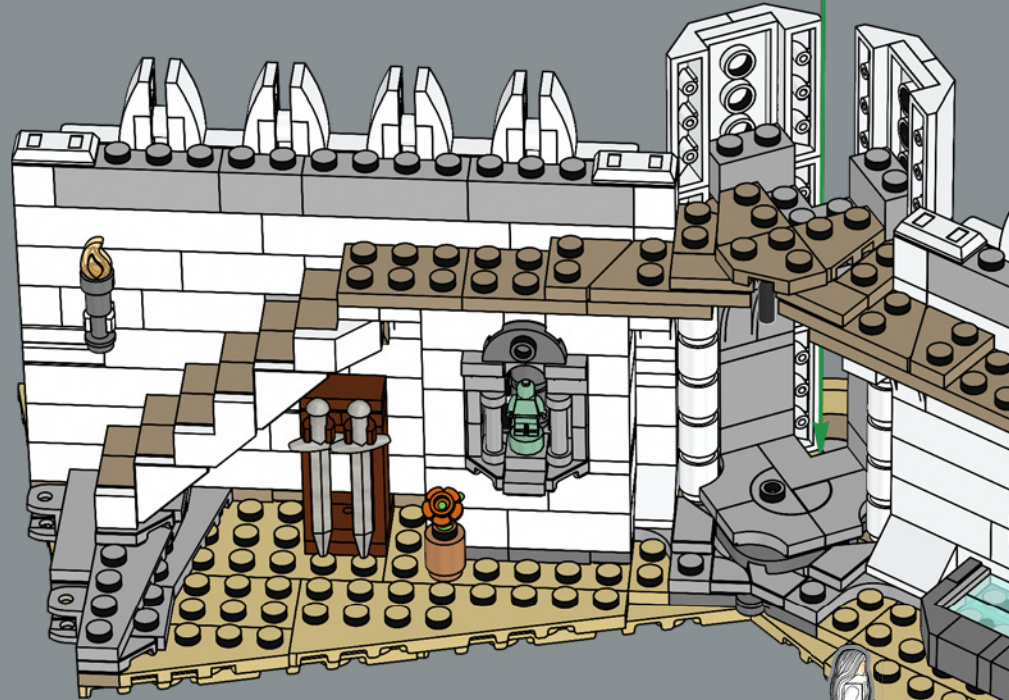
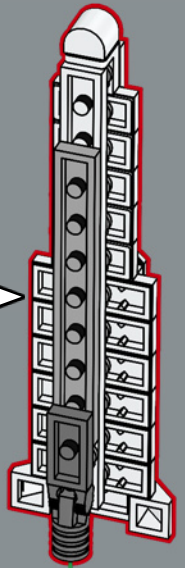

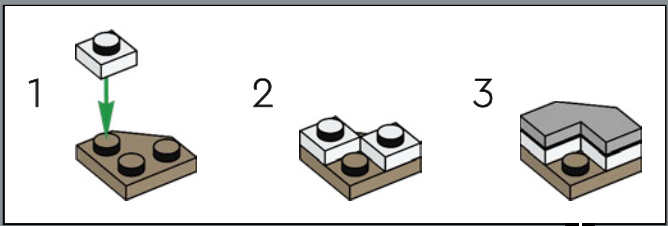
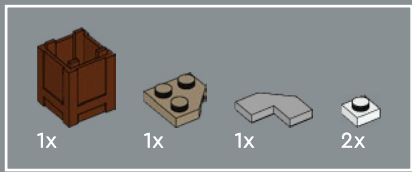

330



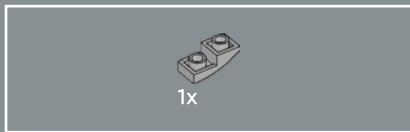

331



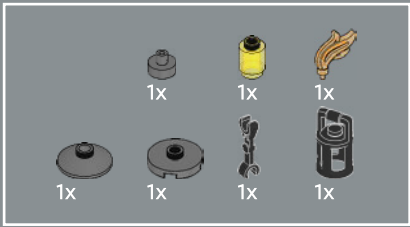

332

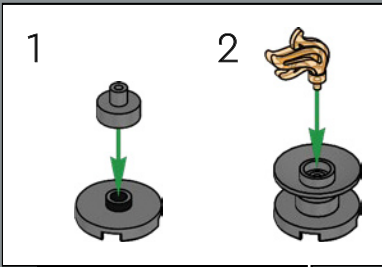
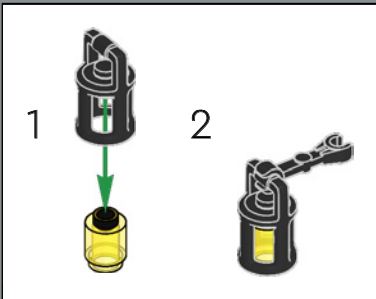

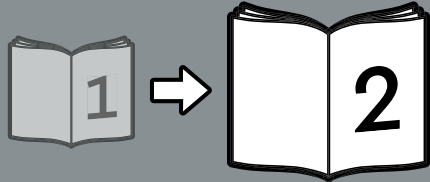
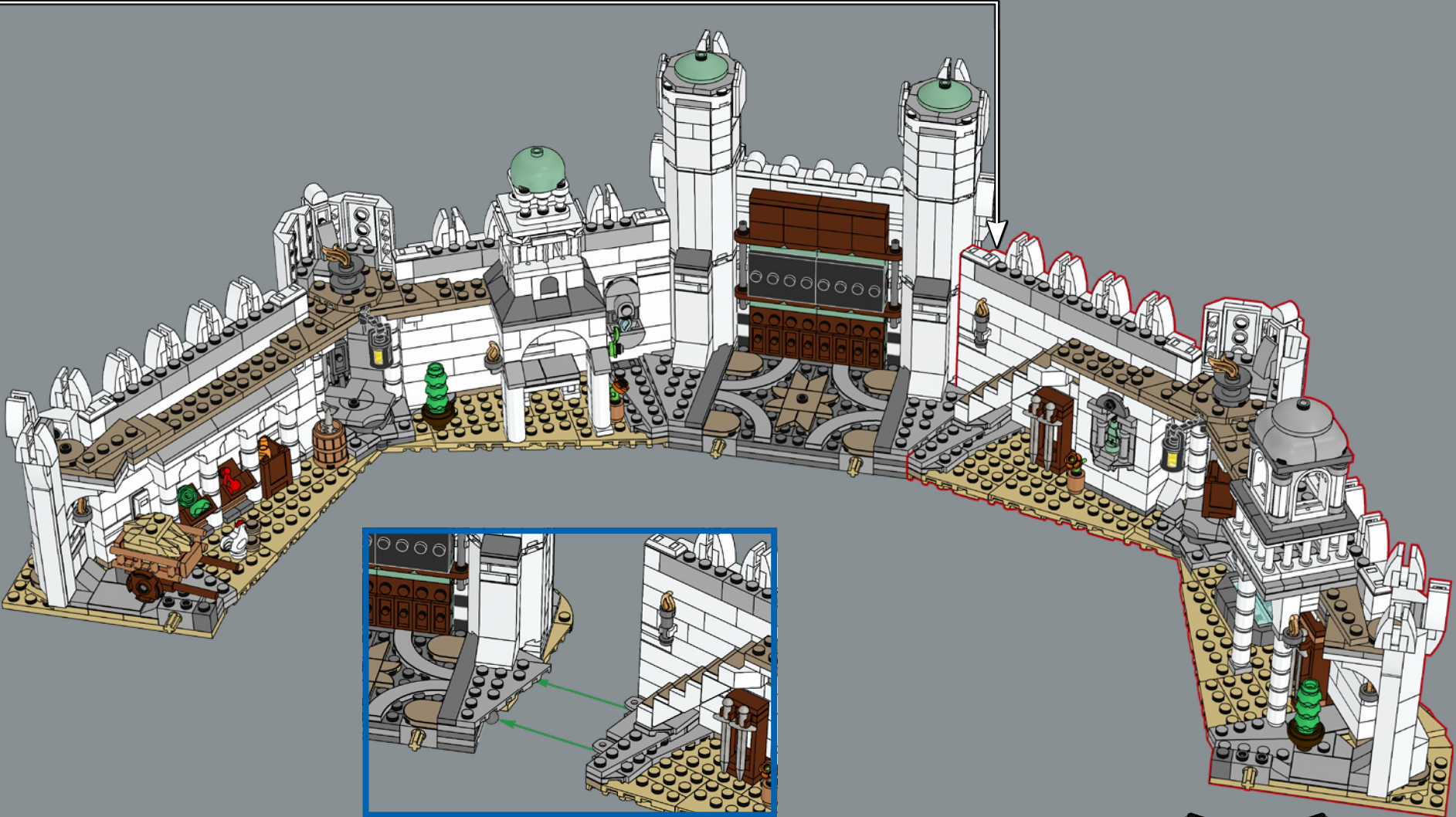

- 1x 6582567
- 1x 6582582
- 1x 6582572
- 1x 6541256
- 1x 6541258
- 1x 6582569
- 1x 6582576
- 1x 6582564
- 1x 6003147
- 8x 6378168
- 4x 4523159
- 4x 6262138
- 11x 6186672
- 2x 6592500
- 3x 4529247
- 4x 4505990
- 2x 6066345
- 2x 6326425
- 7x 6619003
- 1x 6436101
- 1x 6602339
- 2x 6174246
- 1x 6509391
- 1x 6501057
- 2x 6347604
- 1x 6582574
- 1x 6382784
- 4x 6167641
- 2x 6300103
- 3x 6296061
- 1x 6433634
- 1x 6365629
- 4x 6618654
- 2x 6218360
- 2x 6167642
- 3x 6292154
- 2x 6021997
- 3x 6347306
- 1x 6546483
- 3x 6167700
- 2x 6535361
- 2x 6107389
- 4x 6575787
- 4x 6582575
- 4x 6613809
- 1x 4611885
- 1x 6093532
- 5x 6078442
- 2x 6295400
- 6x 4611883
- 1x 6582581
- 7x 4161734
- 2x 6458390
- 1x 6212758
- 3x 6177890
- 3x 6177891
- 6x 6352222
- 2x 6618910
- 8x 4666579
- 1x 4140562
- 2x 6066344
- 2x 6281995
- 1x 4617765
- 2x 6429062
- 4x 6525416
- 25x 4113917
- 1x 6219794
- 1x 6335307
- 13x 6024495
- 1x 4159196
- 3x 4114026
- 2x 6092587
- 12x 6175968
- 4x 6374151
- 10x 6337525
- 2x 6421618
- 2x 4117070
- 2x 6458392
- 4x 6587444
- 1x 4112980
- 2x 6358290
- 1x 6608949
- 2x 6358289
- 1x 6481741
- 2x 6480280
- 2x 6618909
- 6x 4114084
- 9x 4114077
- 3x 4185177
- 2x 6622621
- 1x 4114306
- 3x 4565387
- 4x 6517736
- 4x 6131896
- 2x 4543858
- 2x 6274685
- 19x 4118790
- 6x 4113233
- 4x 6257600
- 2x 6115031
- 2x 6547395
- 2x 6122047
- 4x 4114309
- 2x 4243824
- 4x 4570516
- 3x 4113993
- 7x 4114324
- 16x 6647546
- 3x 4114001
- 10x 4113988
- 3x 6037398
- 16x 6648002
- 8x 4125217
- 2x 6056484
- 5x 4509897
- 1x 4249019
- 3x 6070501
- 3x 6093864
- 2x 6100565
- 6x 6271820
- 32x 6378120
- 19x 4142865
- 2x 403221



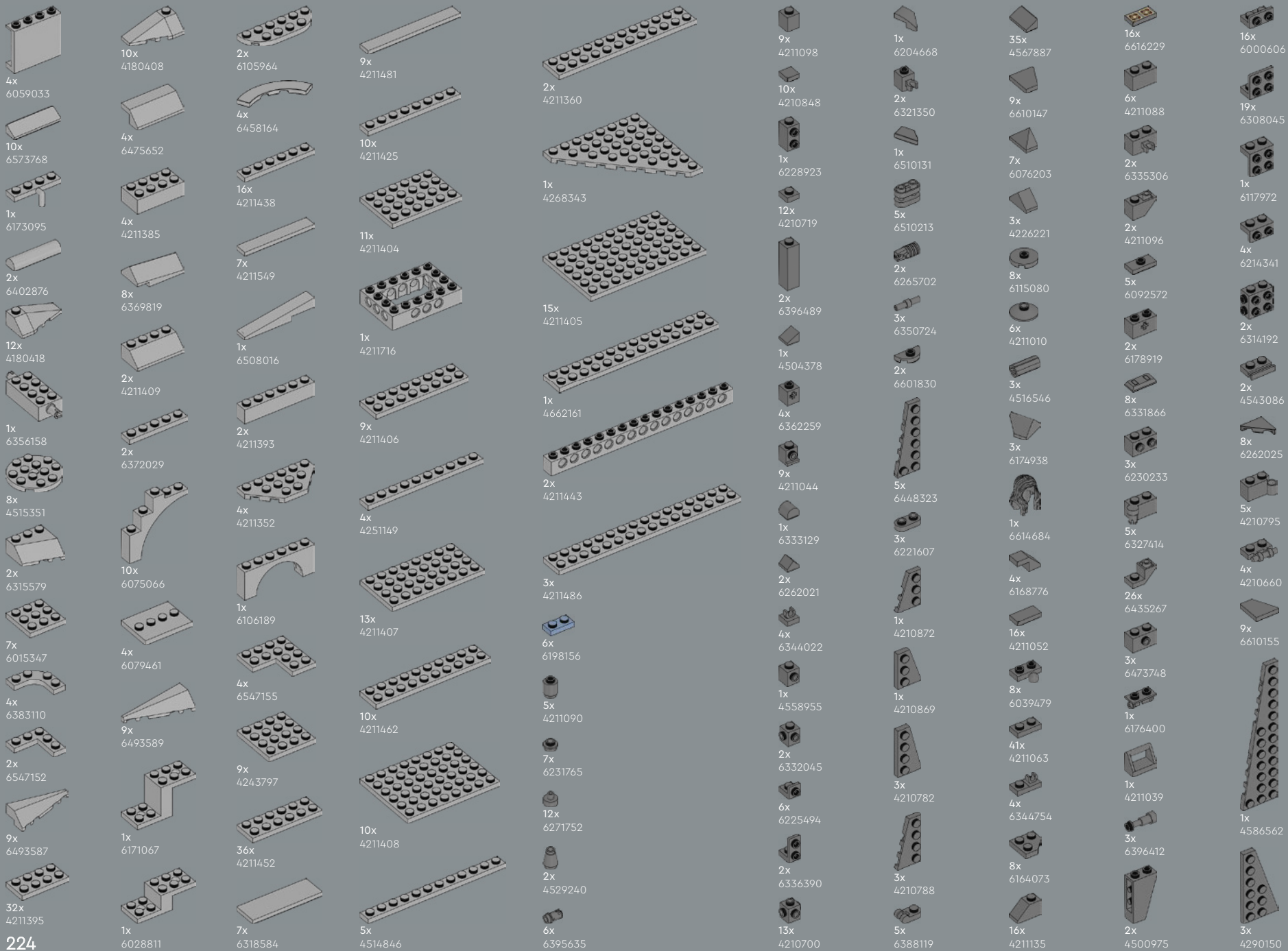

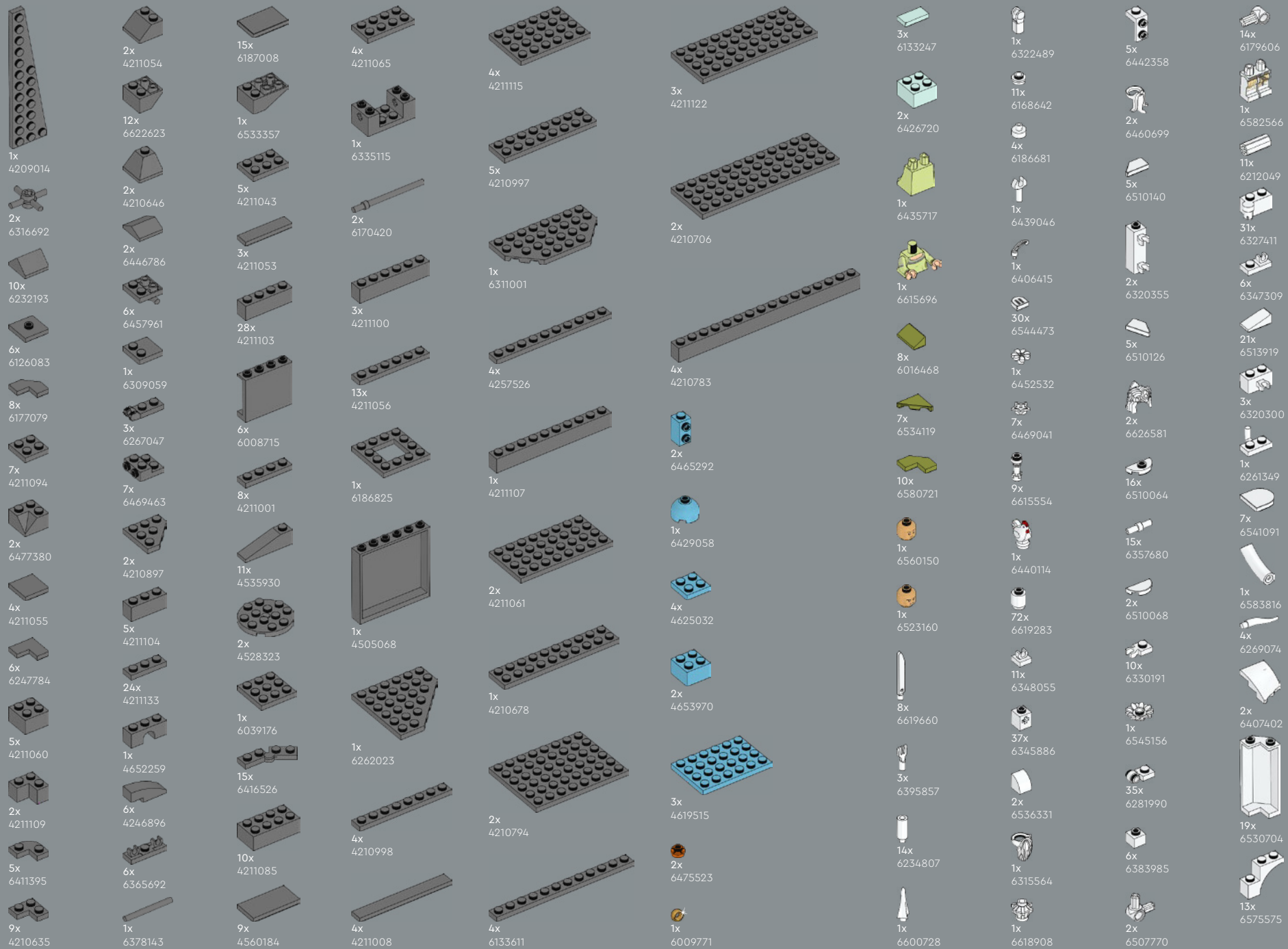





[LEGO.com/service](https://www.LEGO.com/service)



NEW LINE CINEMA



LEGO and the LEGO logo are trademarks of the/son des marques de commerce du/son marcas registradas de LEGO Group. ©2026 The LEGO Group.
© New Line Productions Inc. All rights reserved. THE LORD OF THE RINGS TRILOGY and all names of the characters, items,
events, and places therein are ™ of Middle-earth Enterprises, LLC under license to New Line Productions, Inc. (s26)

 6650284