



SPEED
CHAMPIONS

77261



LEGO® Builder



Get excited about our new packaging!

We're switching from plastic to paper-based packaging. That's why you might find a mix of paper and plastic in our boxes!

Nos nouveaux emballages vous emballeront !

Nous passons des emballages en plastique aux emballages à base de papier. C'est pourquoi vous pourriez trouver un mélange de papier et de plastique dans nos boîtes !

¡Te presentamos nuestros nuevos empaques!

Estamos sustituyendo las bolsas de plástico por bolsas con base de papel. ¡Por eso, puedes encontrar una mezcla de papel y de plástico en nuestras cajas!

[LEGO.com/sustainable-packaging](https://www.lego.com/sustainable-packaging)

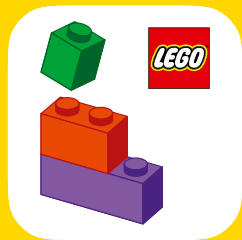

LEGO® Builder



BUILDER



Apple and the Apple logo are trademarks of Apple Inc., registered in the U.S. and other countries and regions. App Store is a service mark of Apple Inc. Google Play and the Google Play logo are trademarks of Google LLC. Tencent and the Tencent logo are trademarks of Tencent Inc.

[LEGO.com/devicecheck](https://www.lego.com/devicecheck)

EN Ask parents' permission before going online | DE Eltern um Erlaubnis bitten, bevor du online gehst | FR Demande l'autorisation d'un parent avant d'aller en ligne | IT Chiedi il permesso ai tuoi genitori prima di andare online | ES Pídeles permiso a tus papás antes de conectarte a Internet | PT Pede autorização aos teus pais antes de ficares online | ZH 上网前应先征得父母的同意 | PL Poproś rodziców o zgodę, zanim wejdiesz do Internetu | CS Než půjdeš na internet, požádej rodiče o svolení | SK Skôr než pôjdeš na internet, vypýtaj si povolenie od rodičov | HU Kérj szülői engedélyt, mielőtt online csatlakoznál! | UA Запитуйте дозволу батьків, перш ніж користуватися інтернетом | RO cere permisiunea părinților înainte de a te conecta online | BG Поискайте разрешение от родител, преди да влезете онлайн | LV Pirms došanās tiešsaistē palūdz atļauju vecākiem | ET Enne Interneti kasutamist küsi vanematelt luba | LT Prieš prisijungdami prie interneto, atsiklauskite tėvų | TR İnternete girmeden önce anne babandan izin iste



Designed for show, not for go!
Conçue pour en mettre plein la vue, pas pour la course!
¡Para presumir, no para conducir!



Redefining hyper racing!
La course extrême, redéfinie!
¡Reinventando la hipervelocidad!

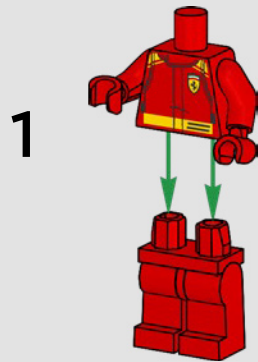

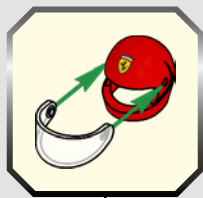

2

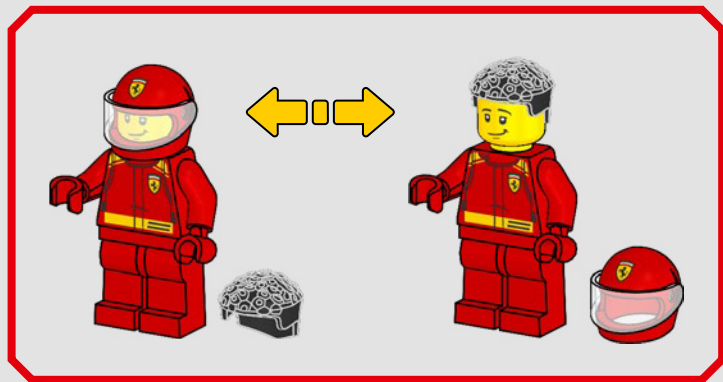
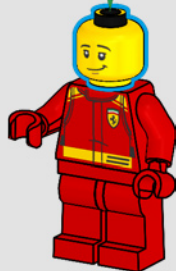

3

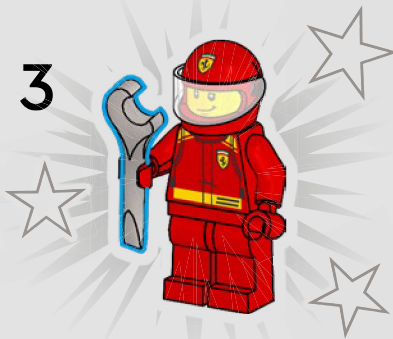

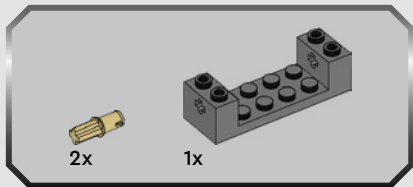

1

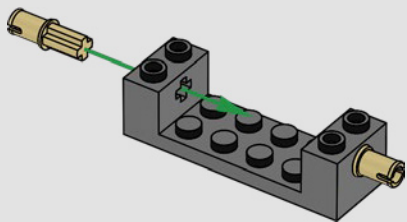

2

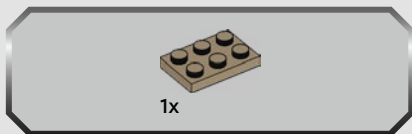
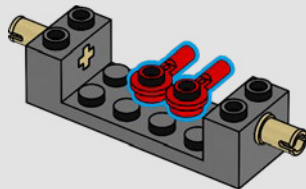

3

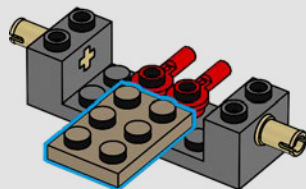

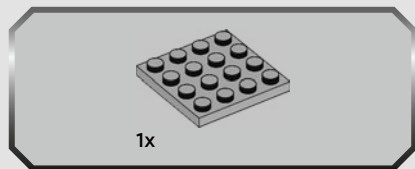

4

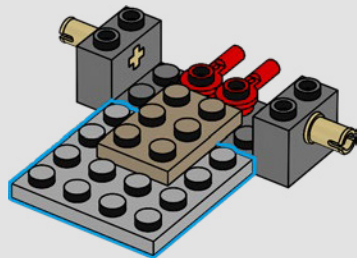

5

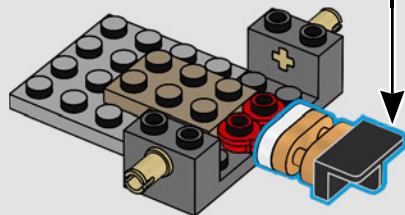
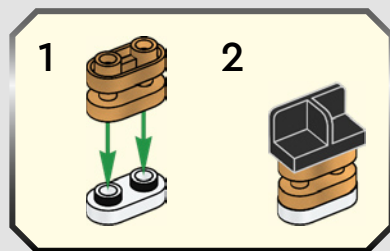



6

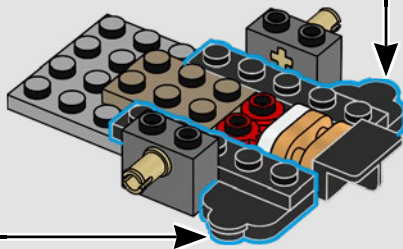
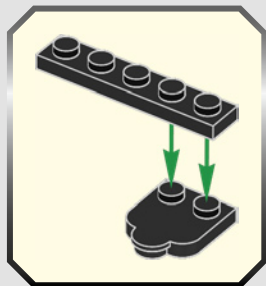
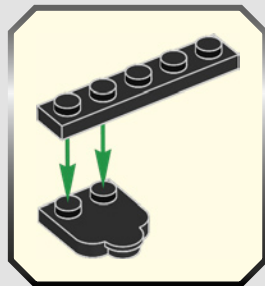

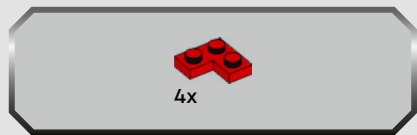

7

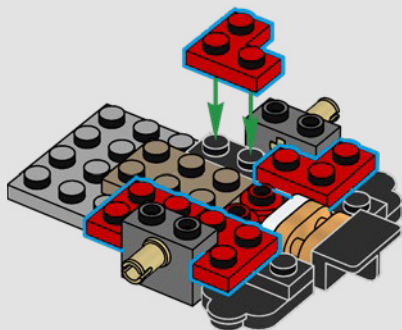

8

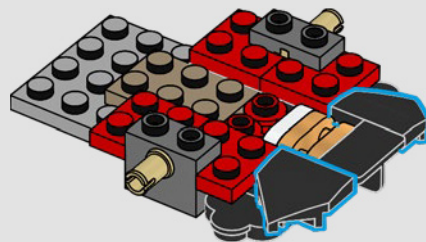

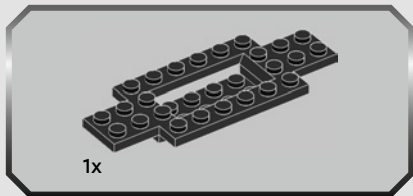

9

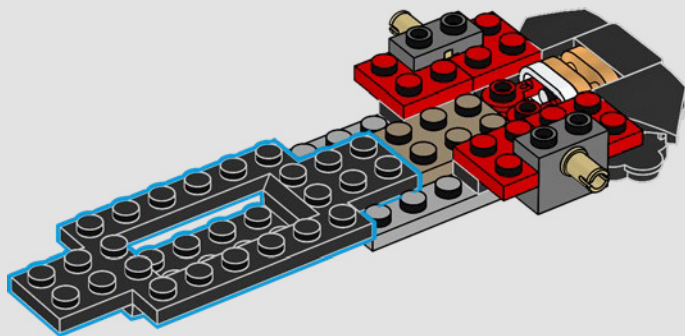

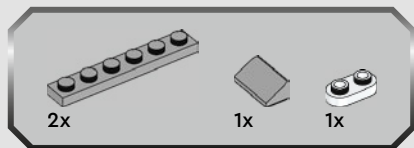

10

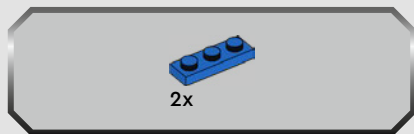
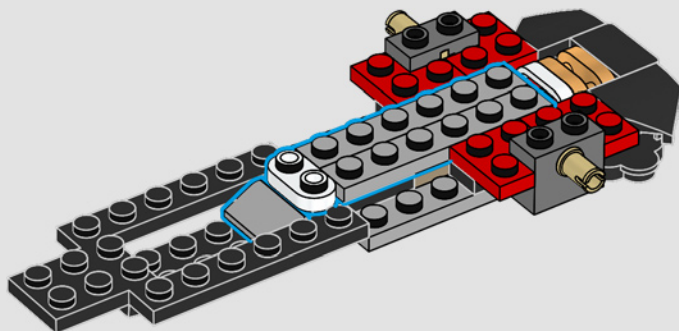

11

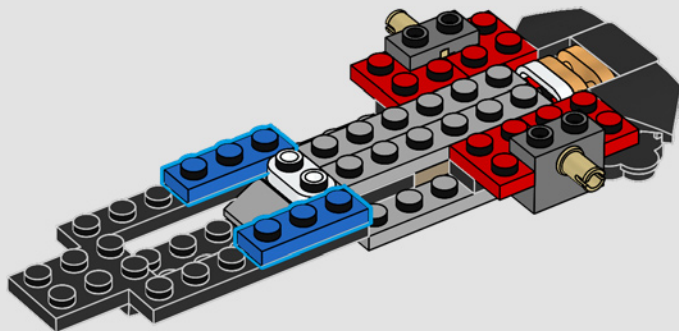



6x

12

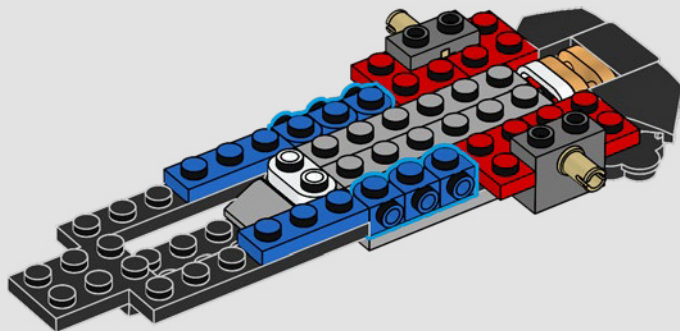

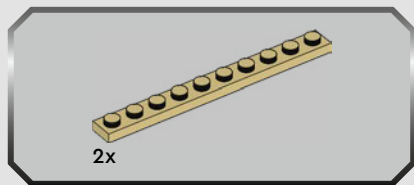

13

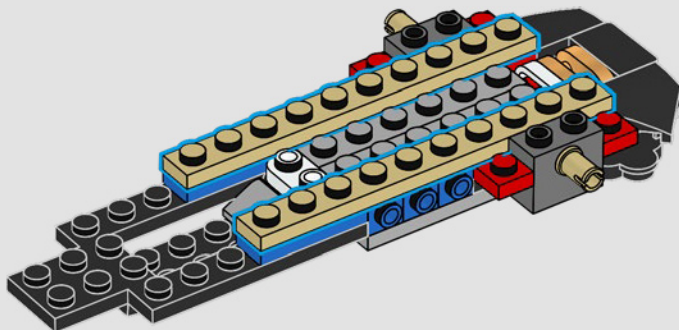

14

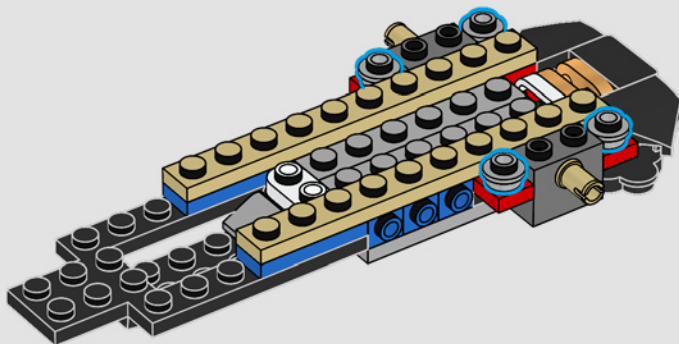



15

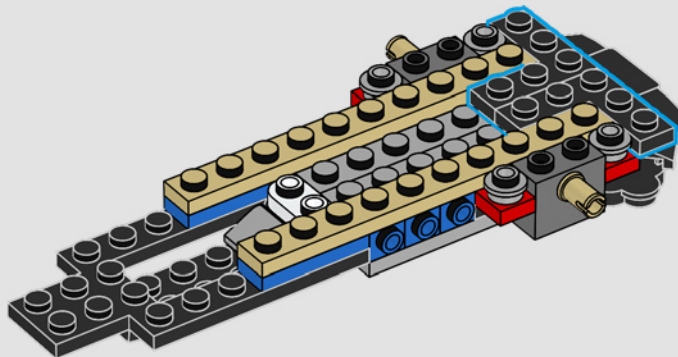



16

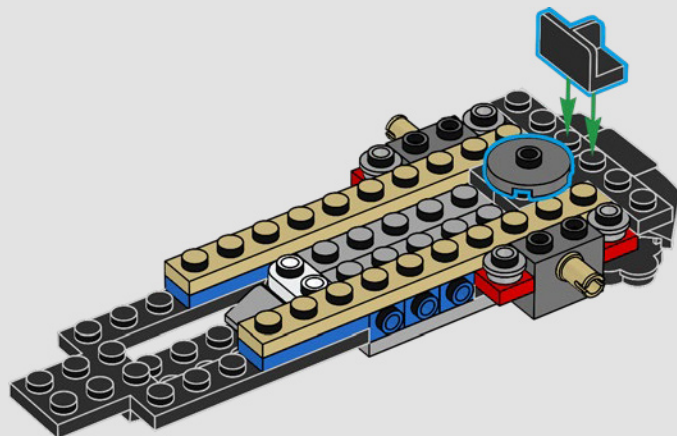



17

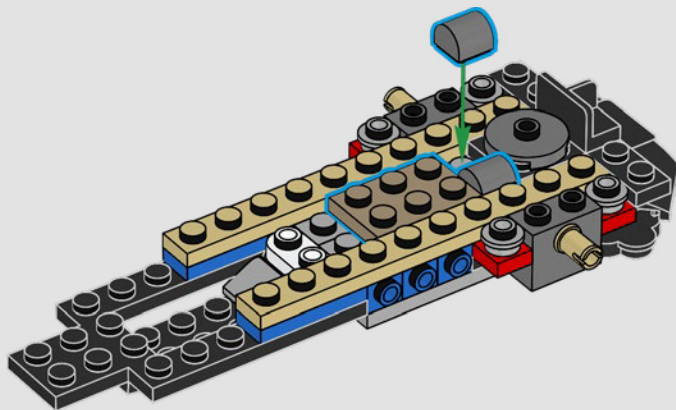

18



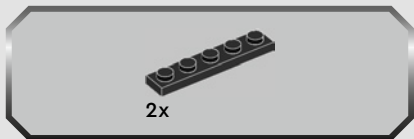

18

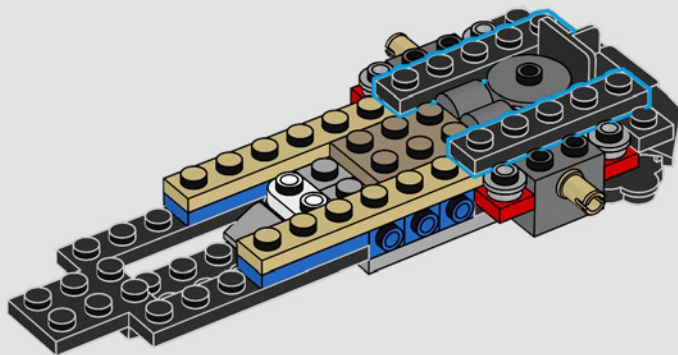

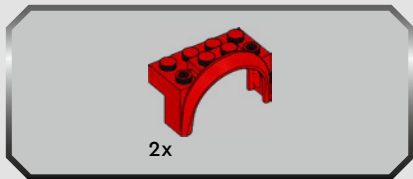

19

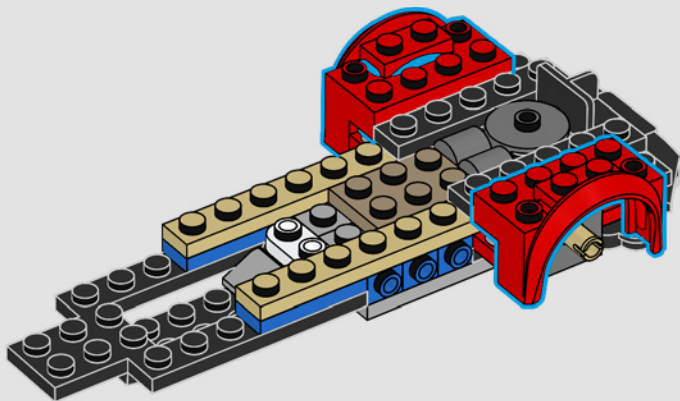

20







20

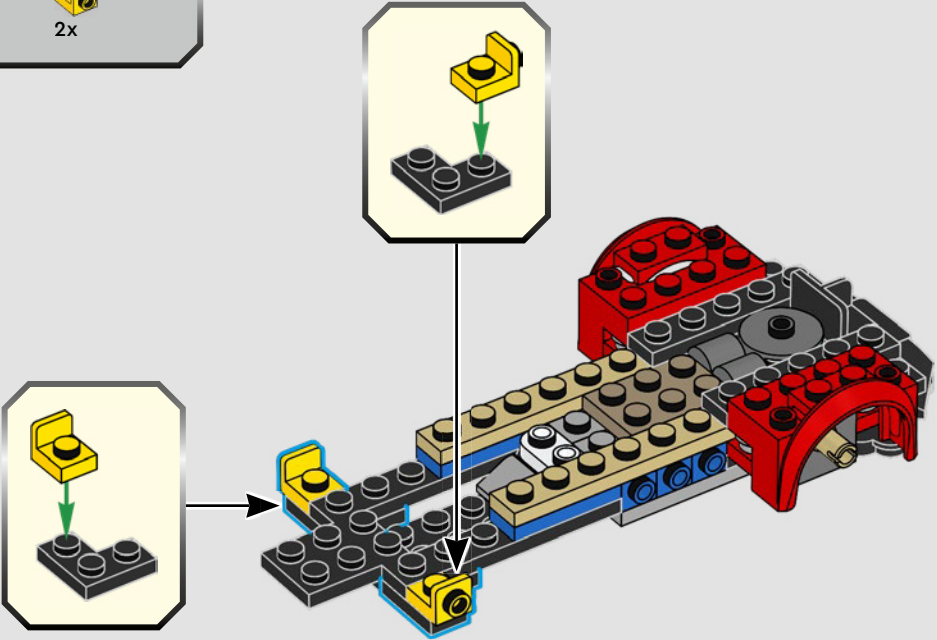

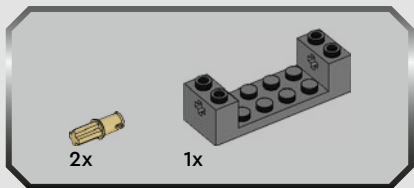
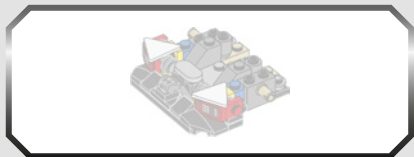

21

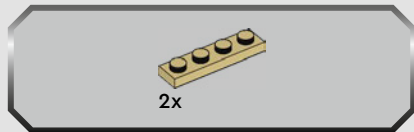
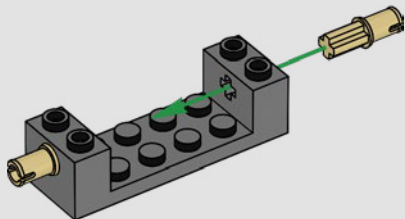

22

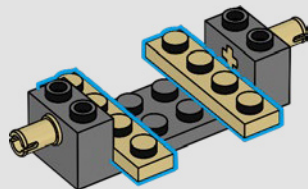

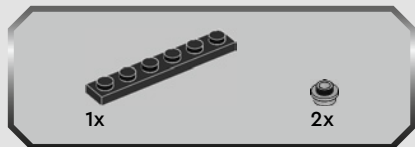

23

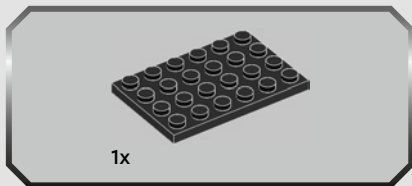
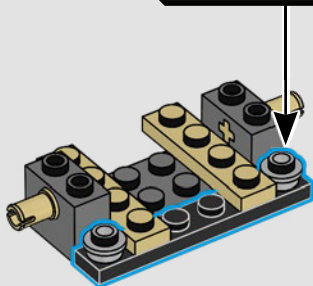
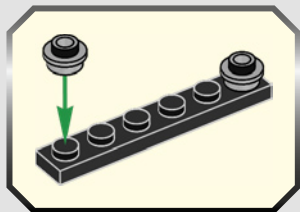

24

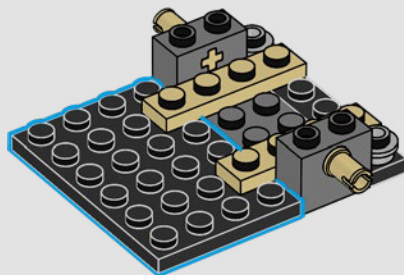

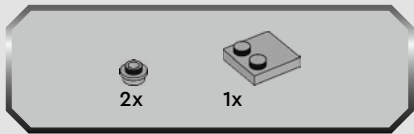

25

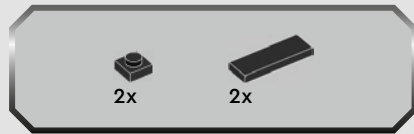
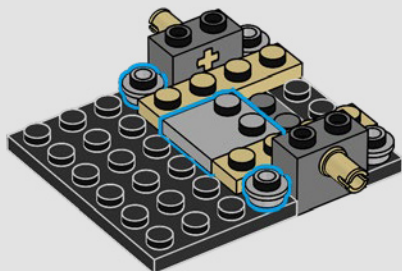

26

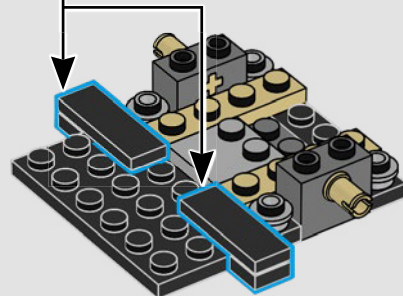
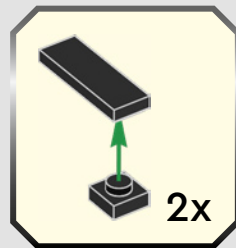



2x



2x

27

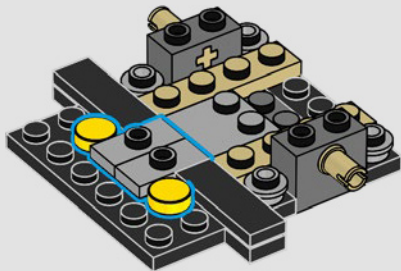

2x



1x



1x

28

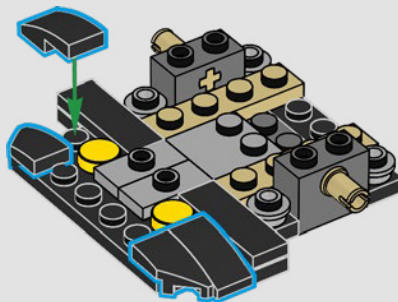



29

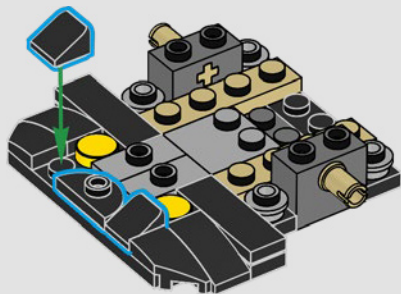

30

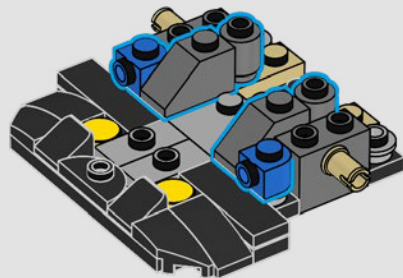



31

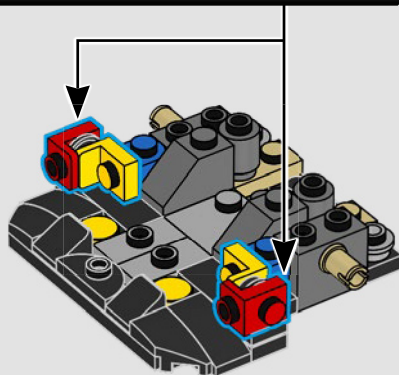



32

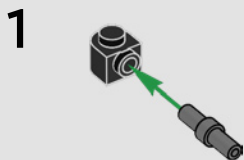

2x

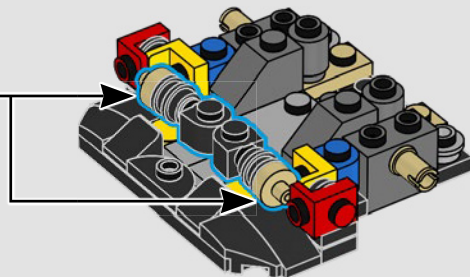
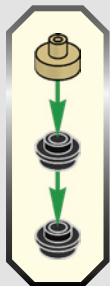

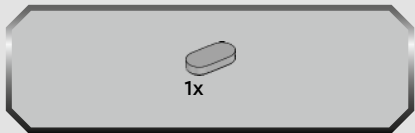

33

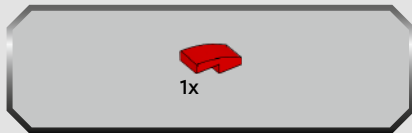
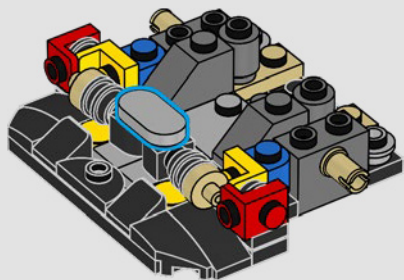

34

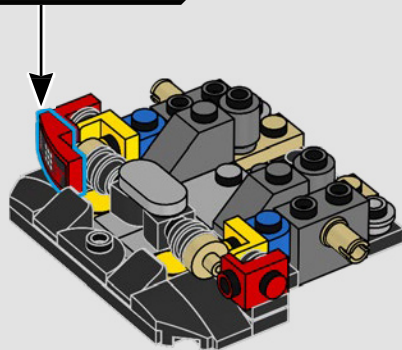
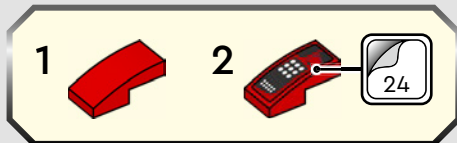



35

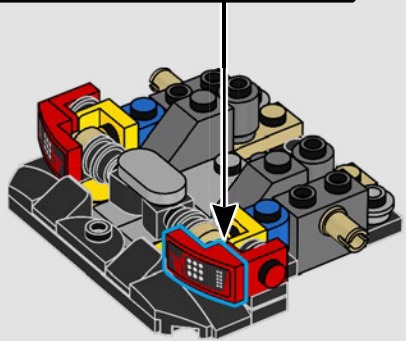
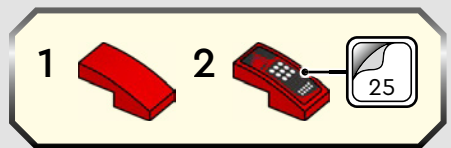

36

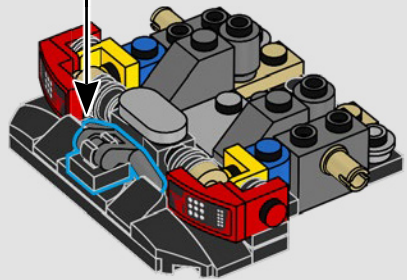
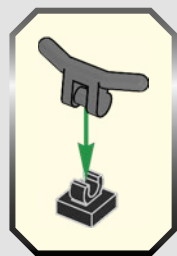



37

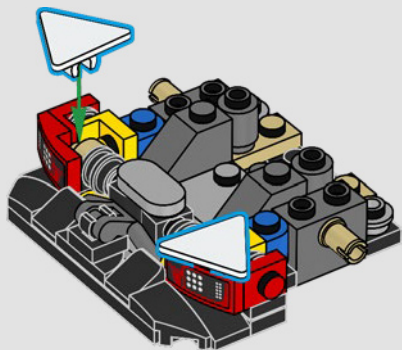

38

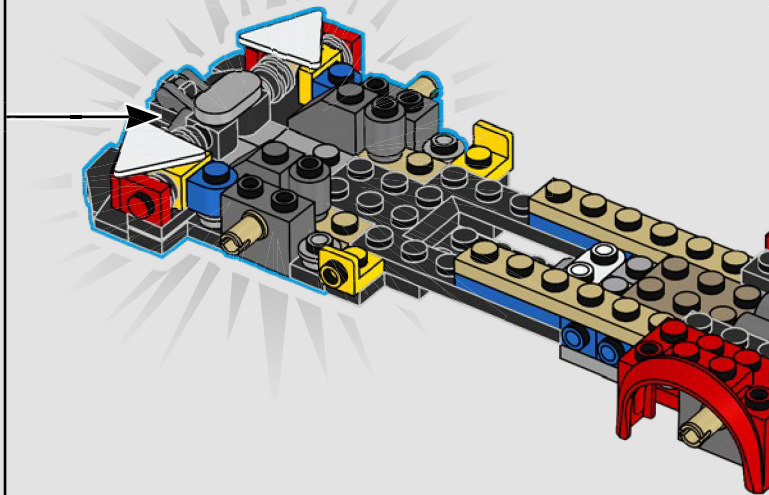

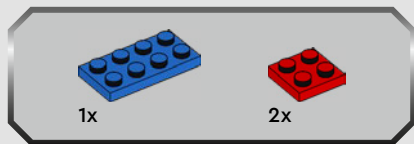

39

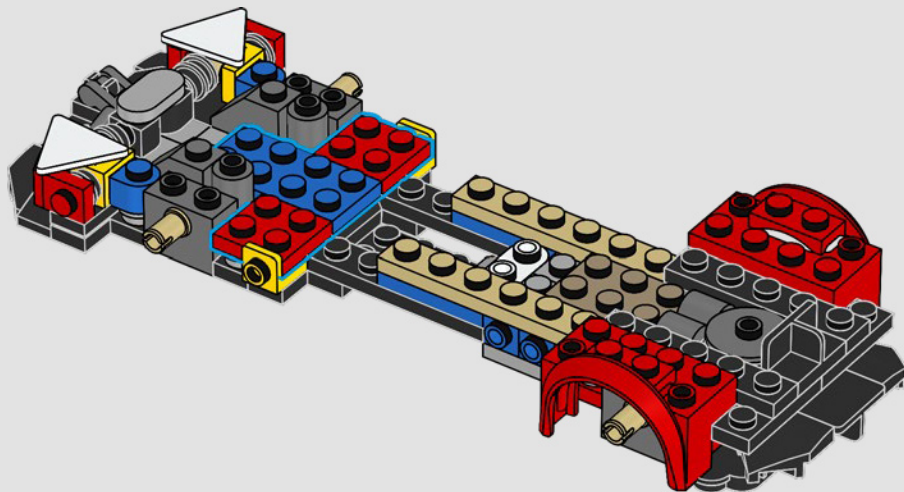



4x

40

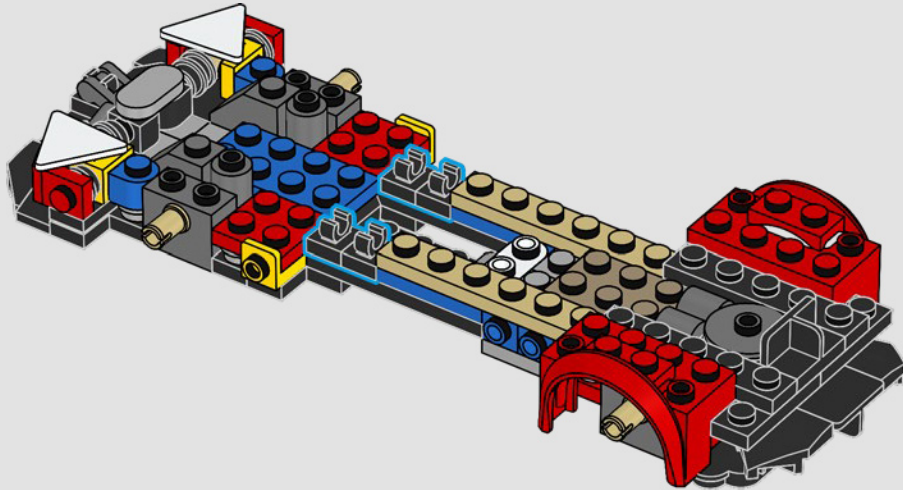

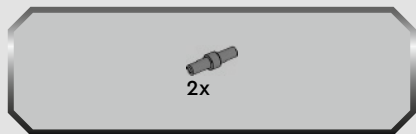

41

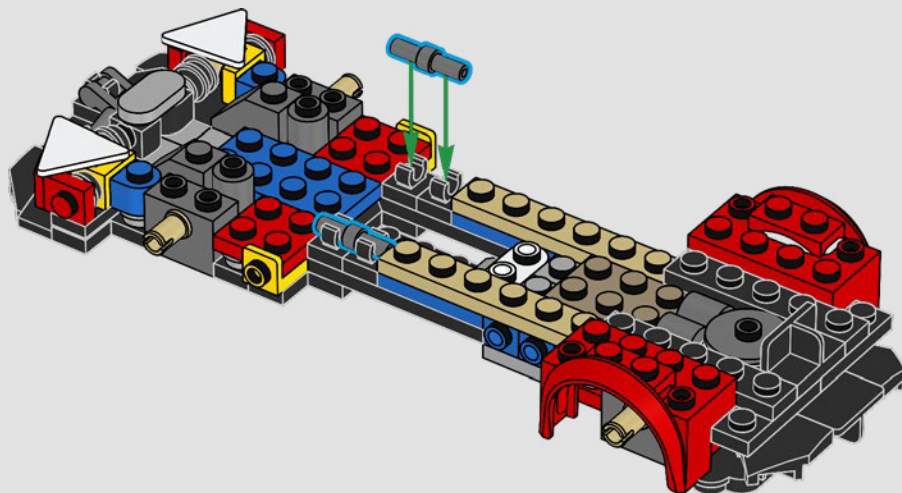

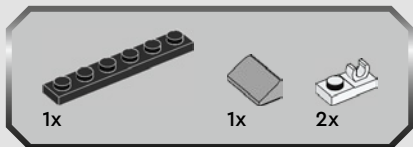

42

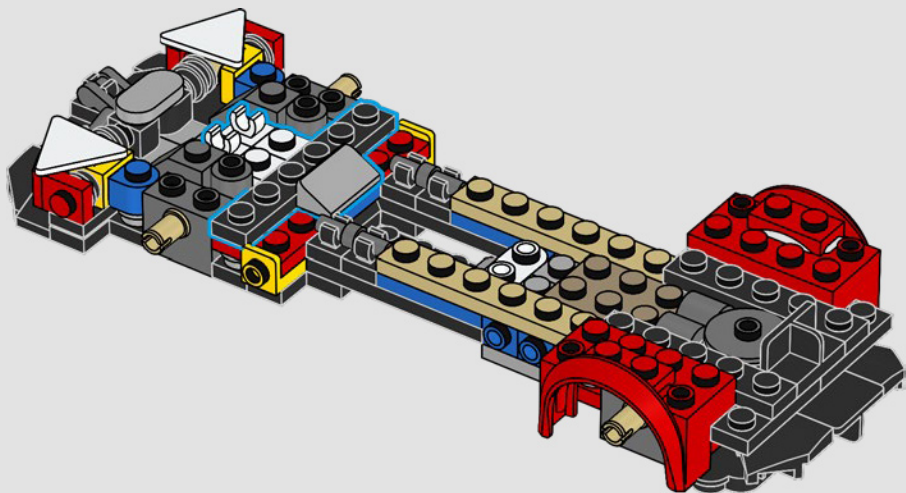

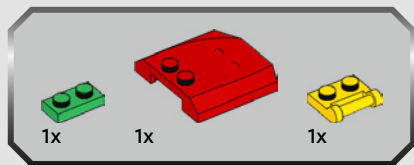

43

1

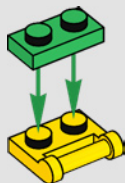

2

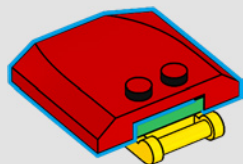

3

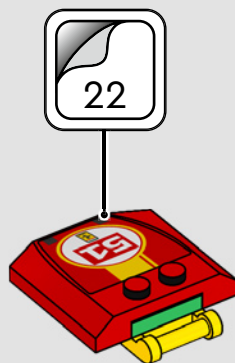

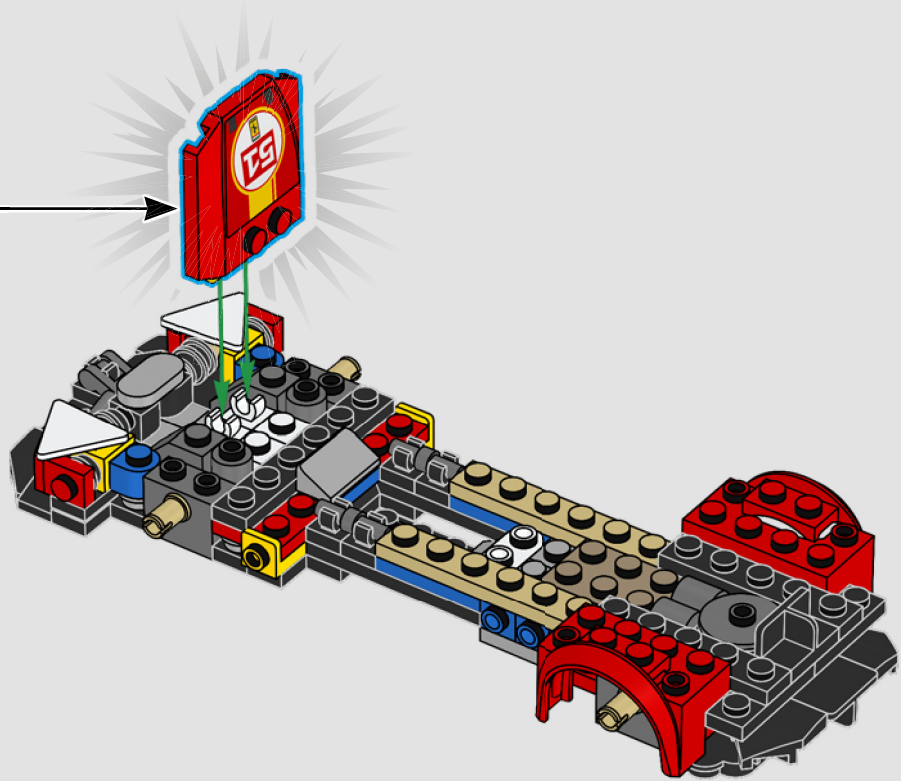

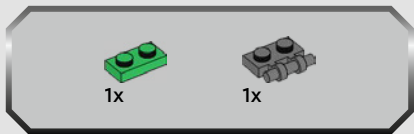

44

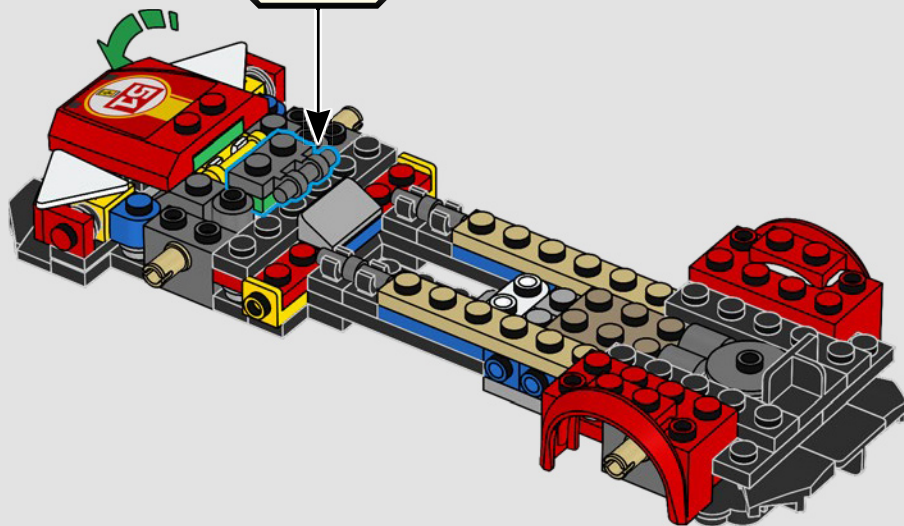
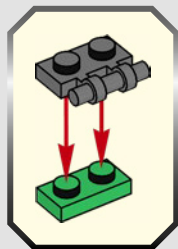

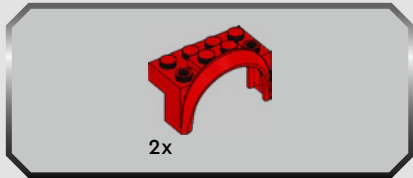

45

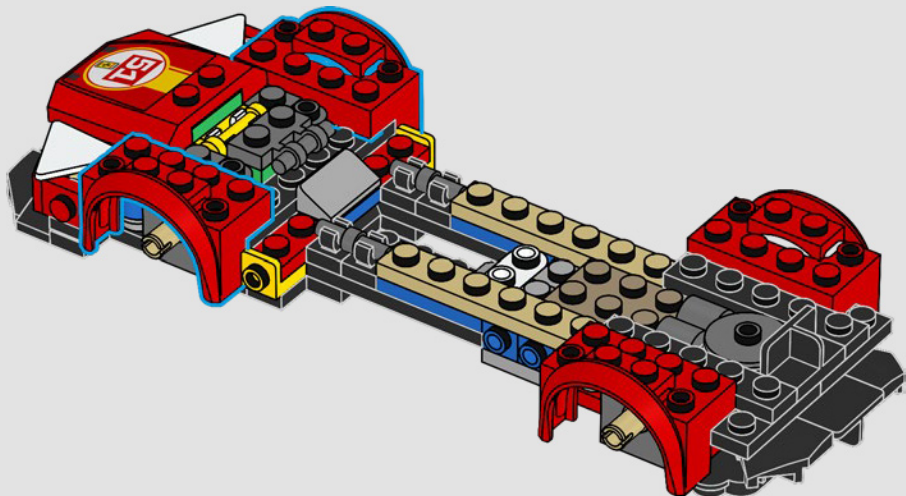

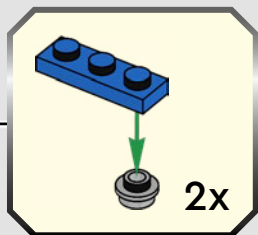
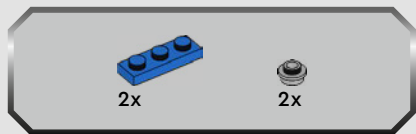

46

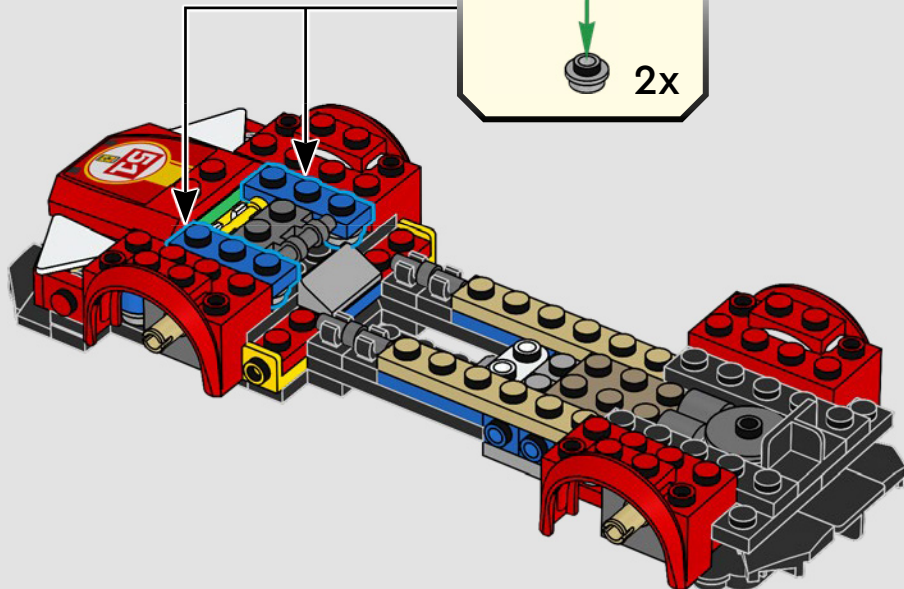



47

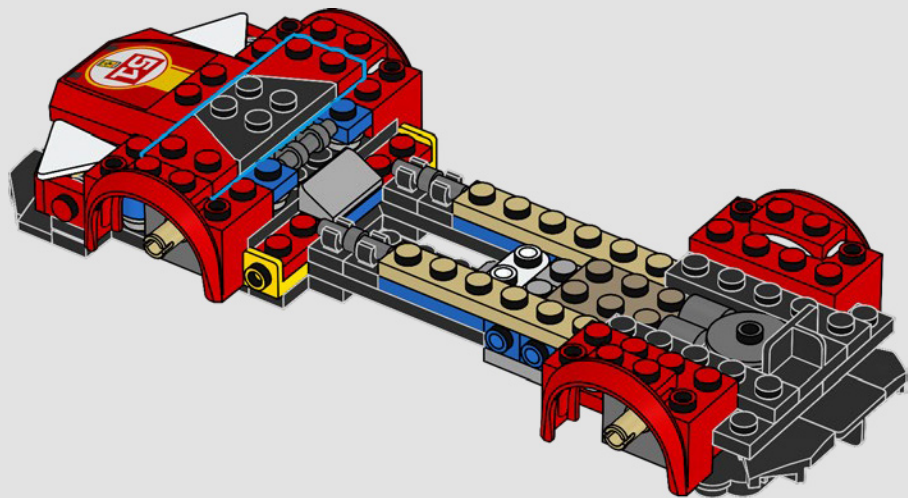



48

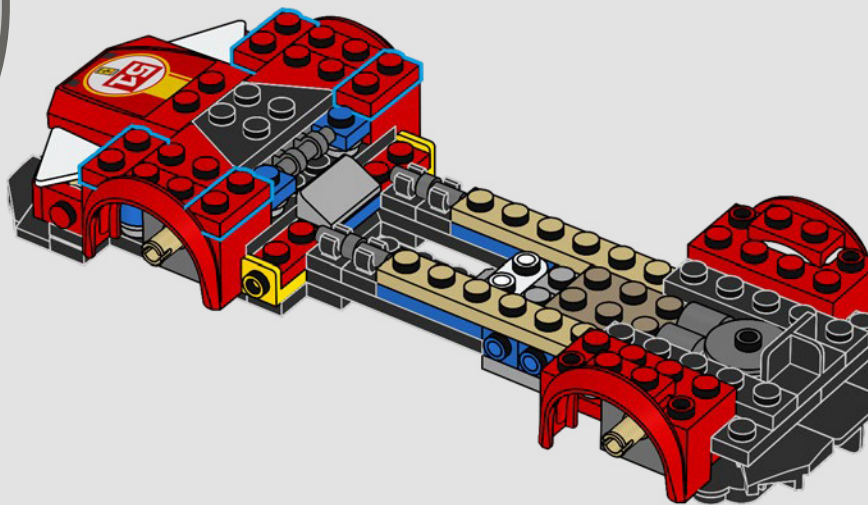



49

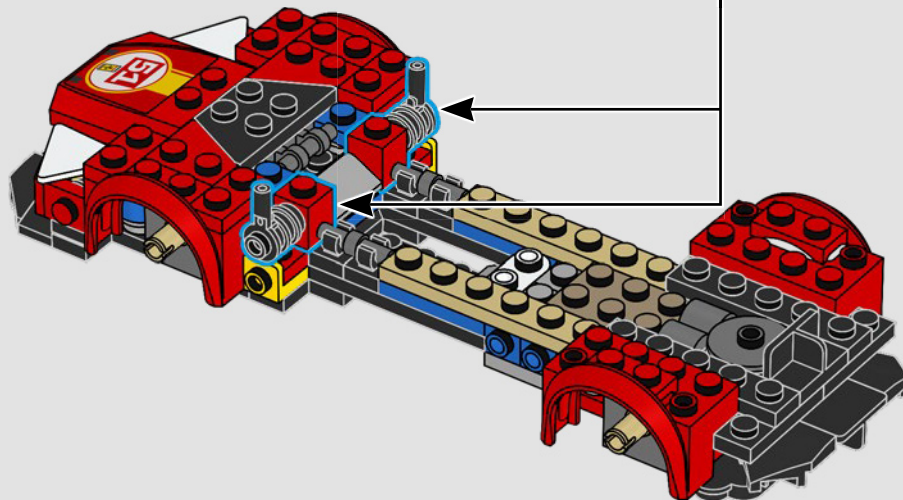
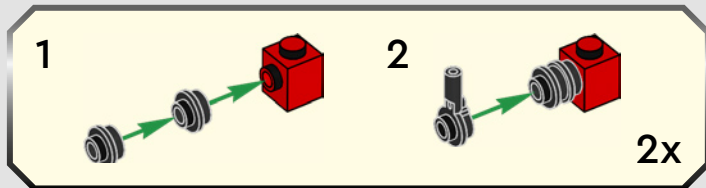



50

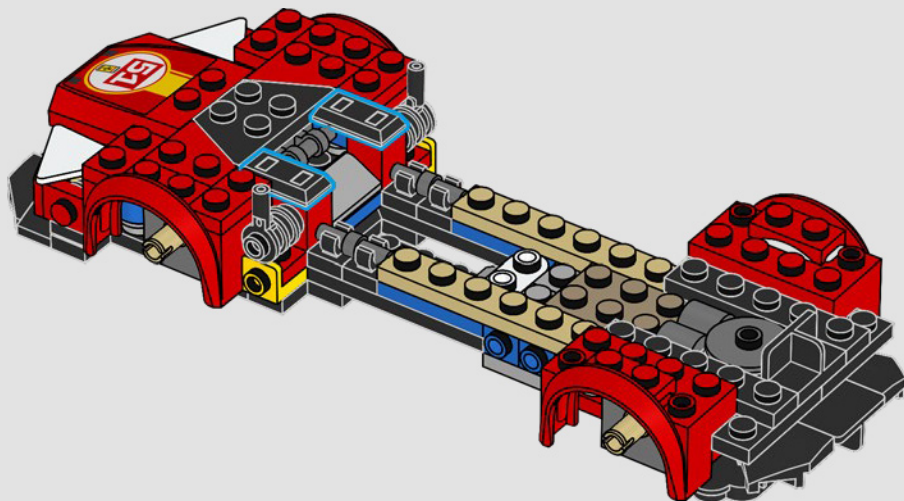

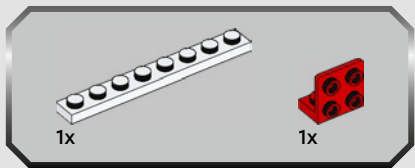

51

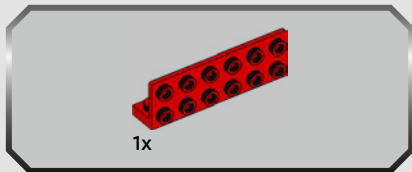
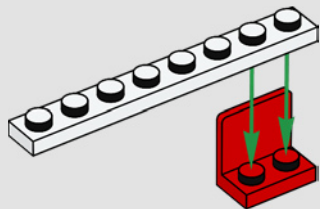

52

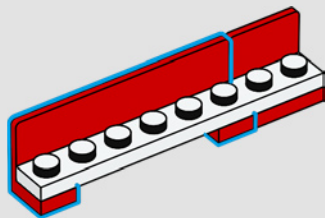



53

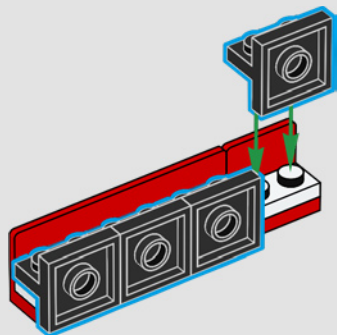

54

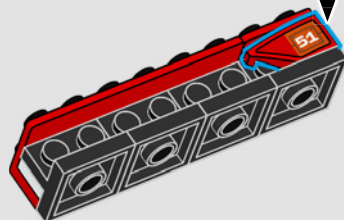
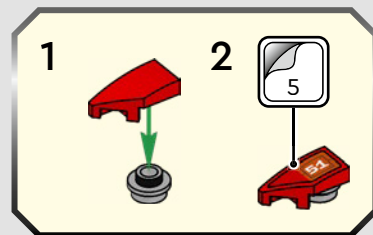

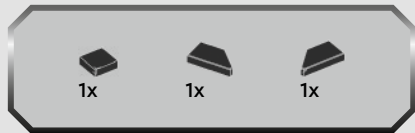

55

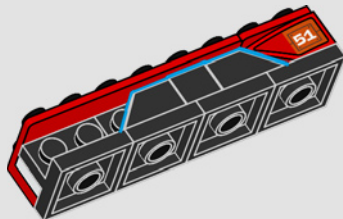

56

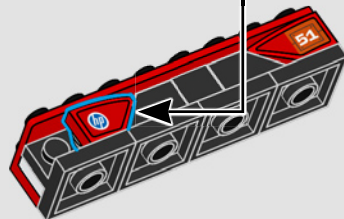
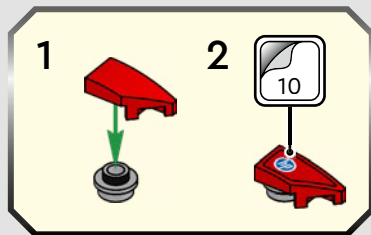

57

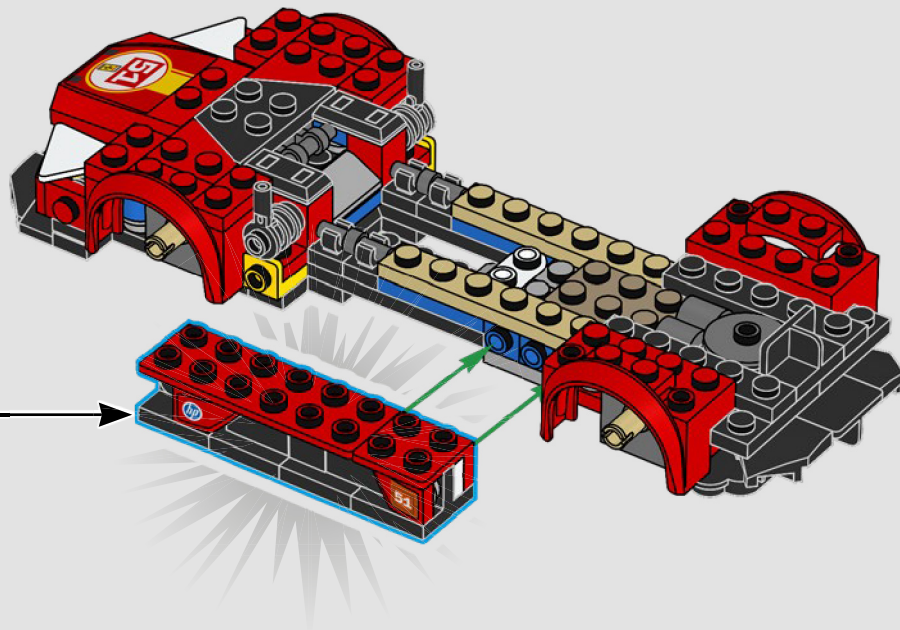

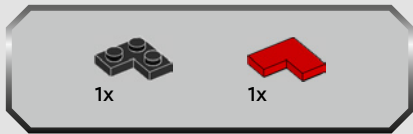

58

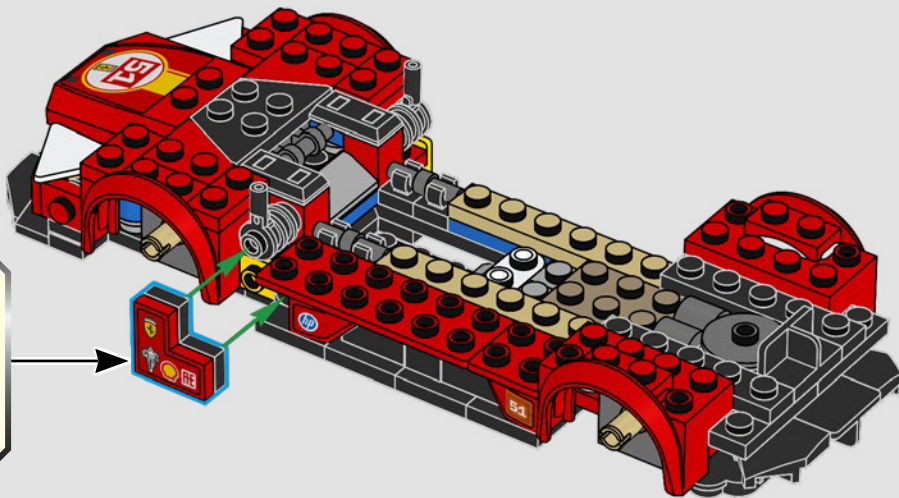
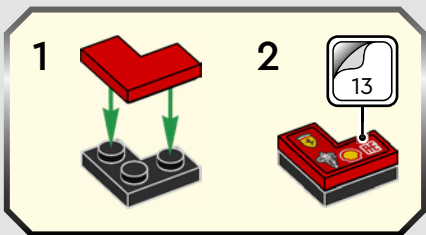

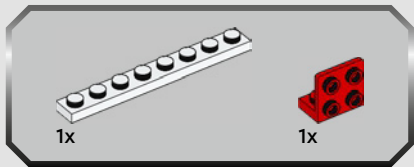

59

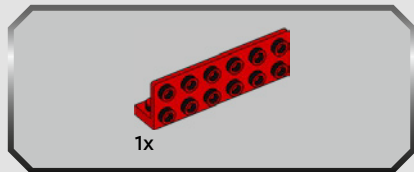
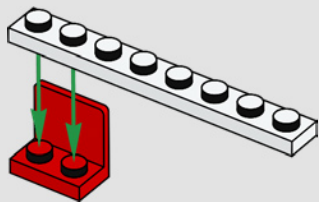

60

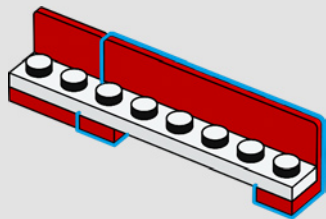



61

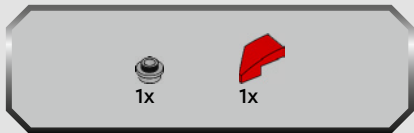
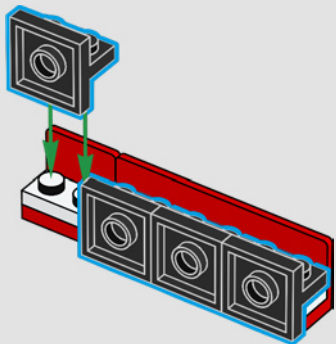

62

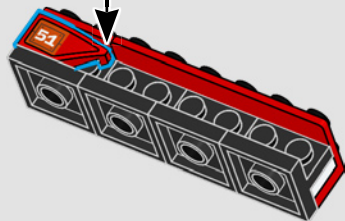
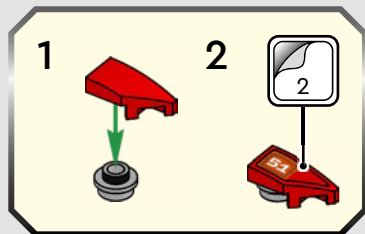

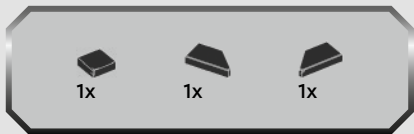

63

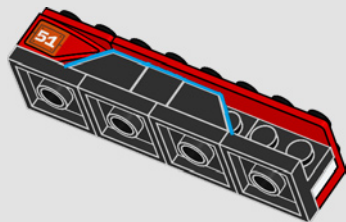

64

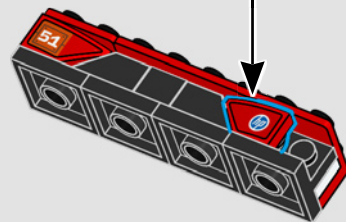
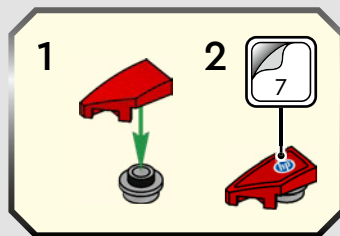

65

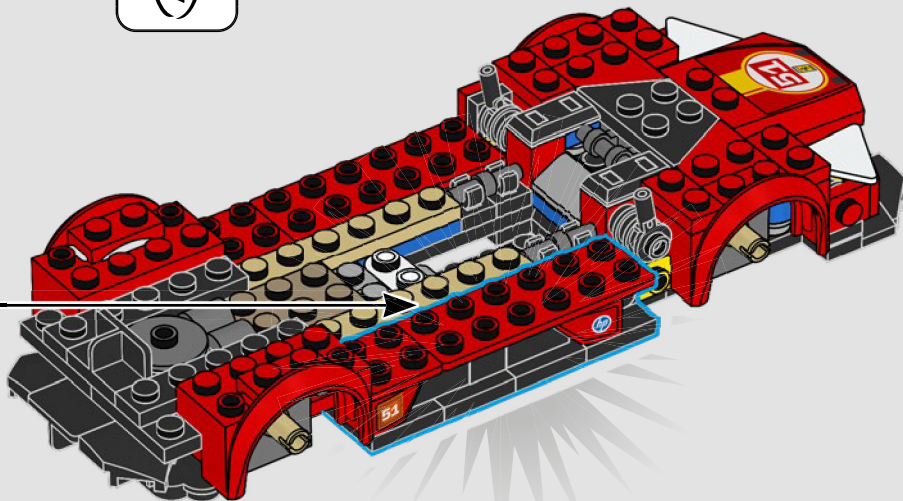

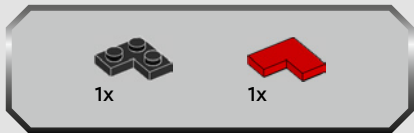

66

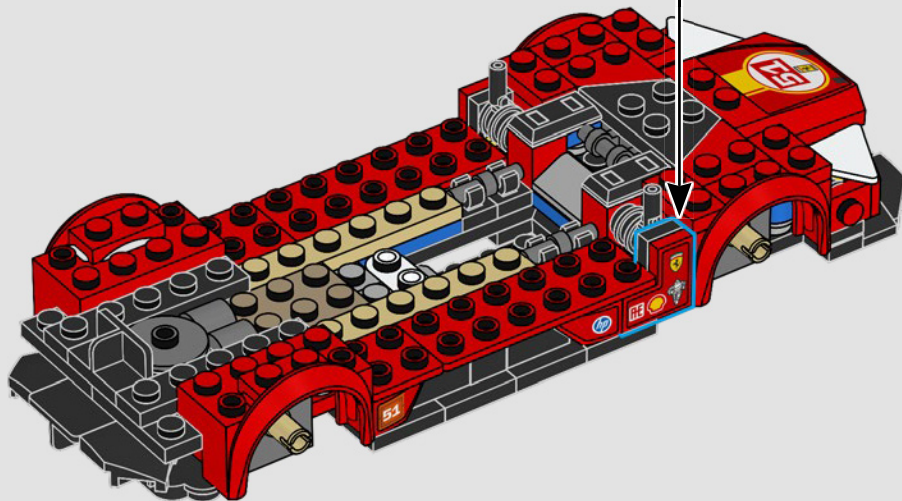
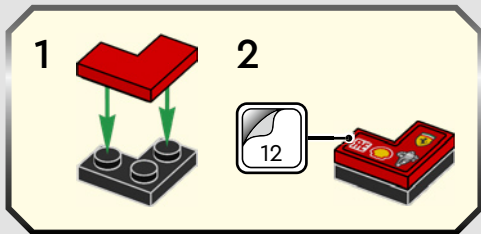

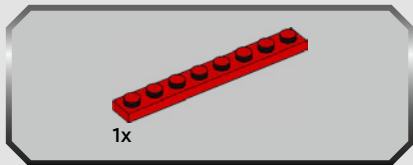

67

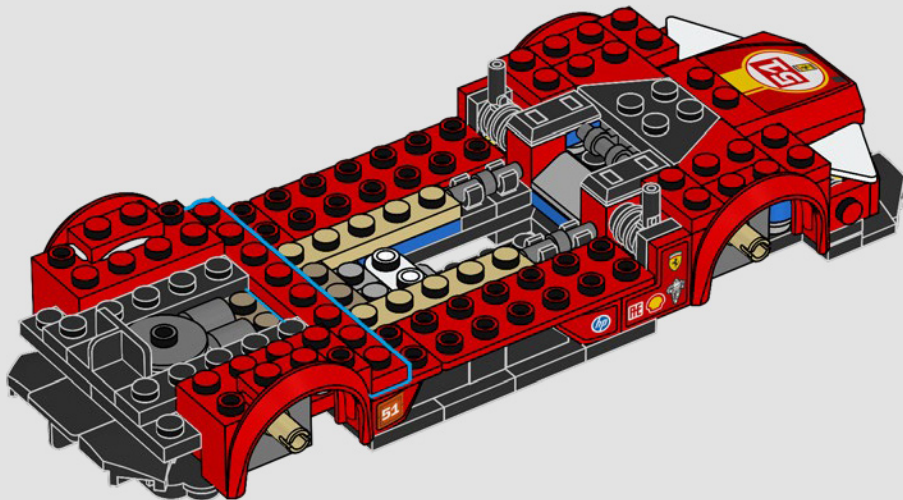

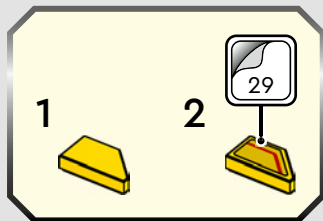
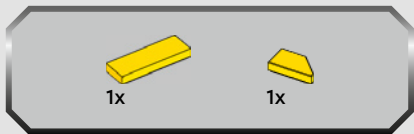

68

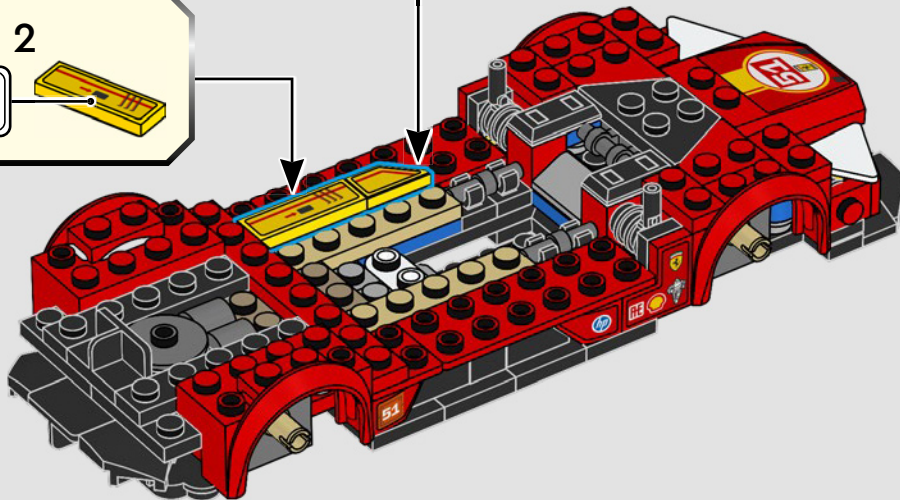
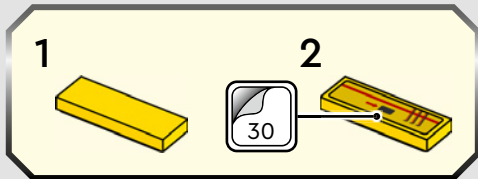

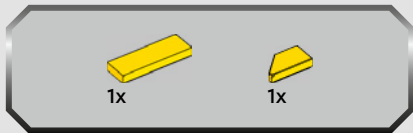

69

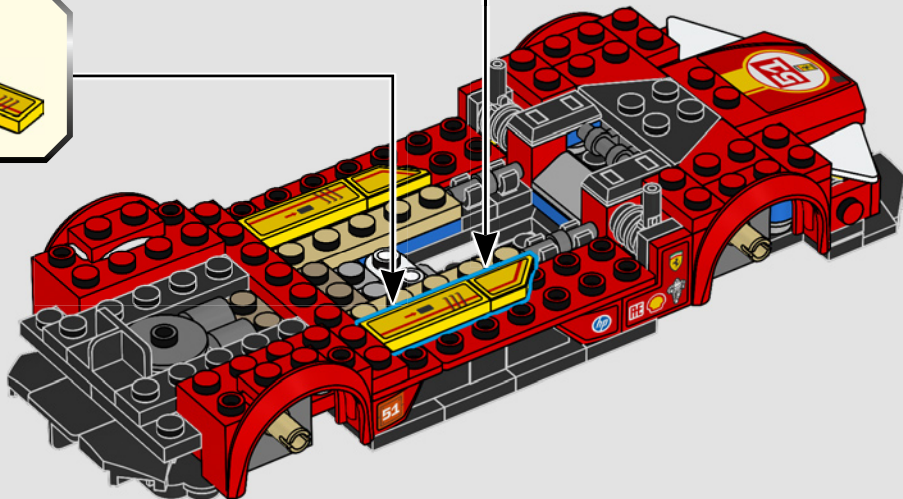
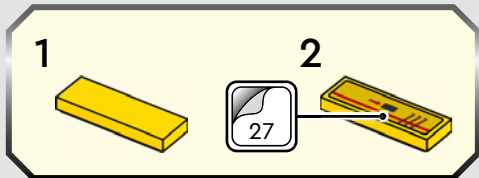
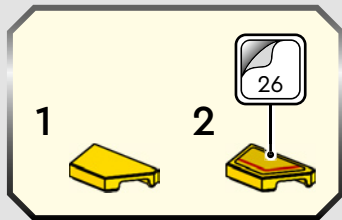

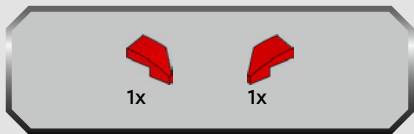

70

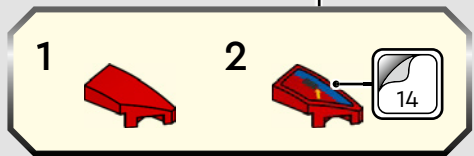
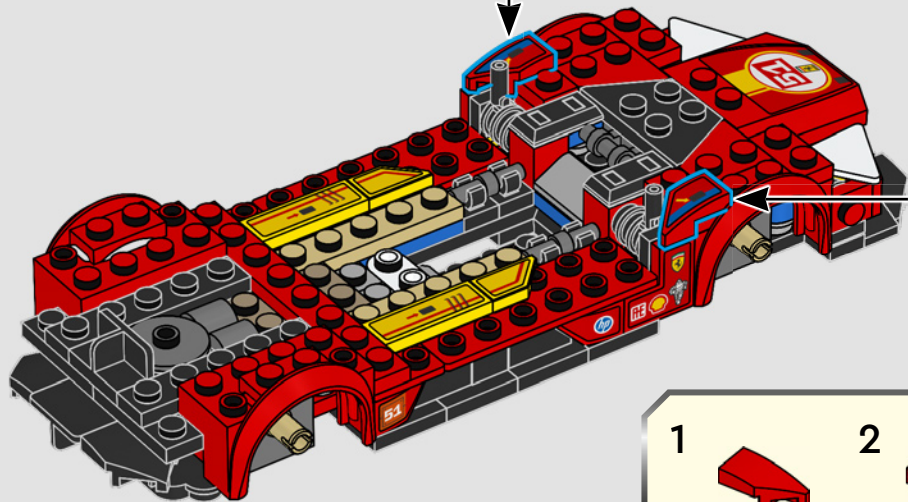
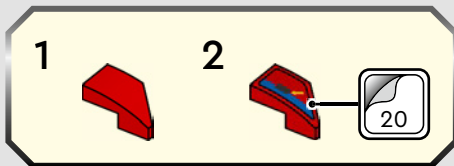



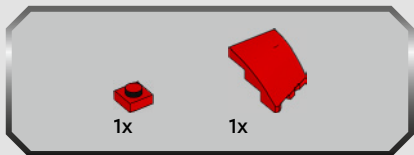

71

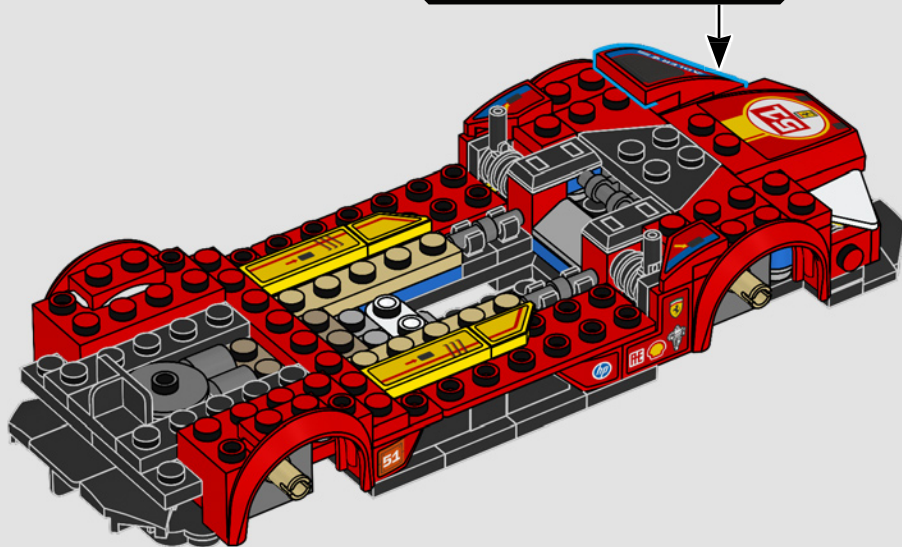
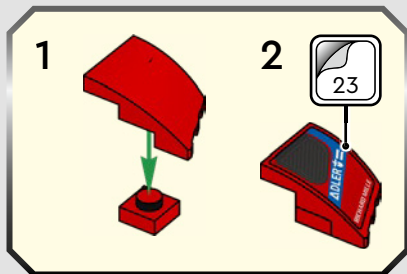

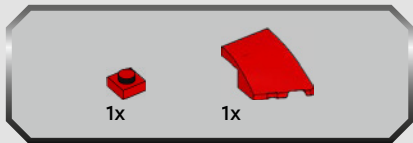

72

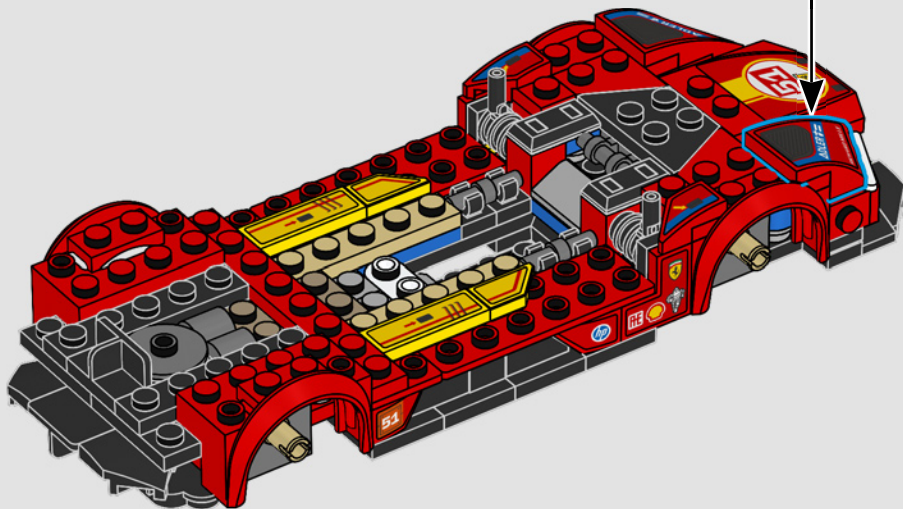
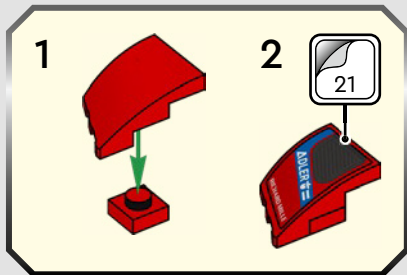



73

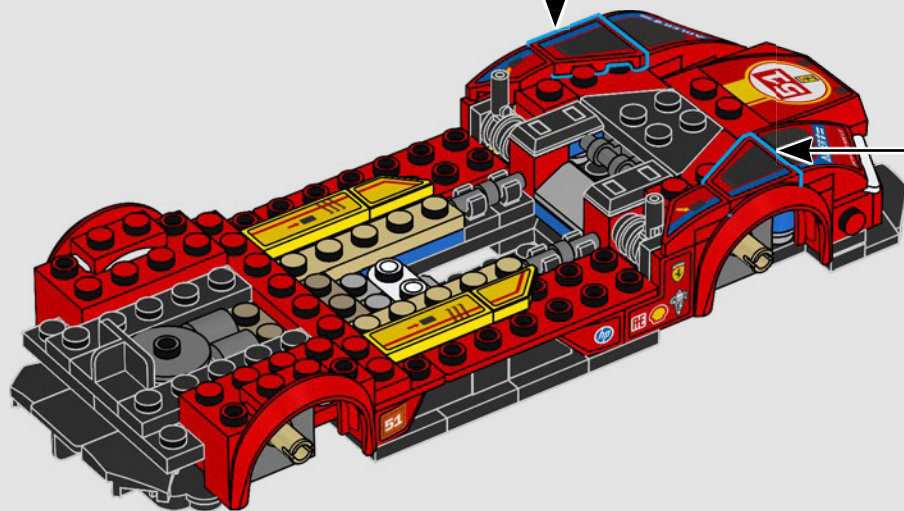
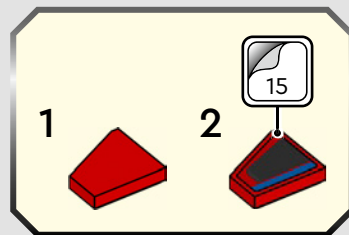
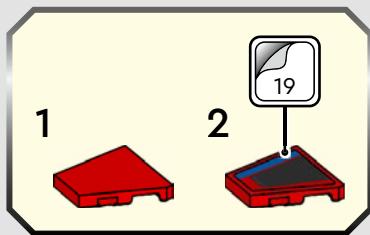

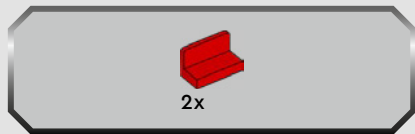

74

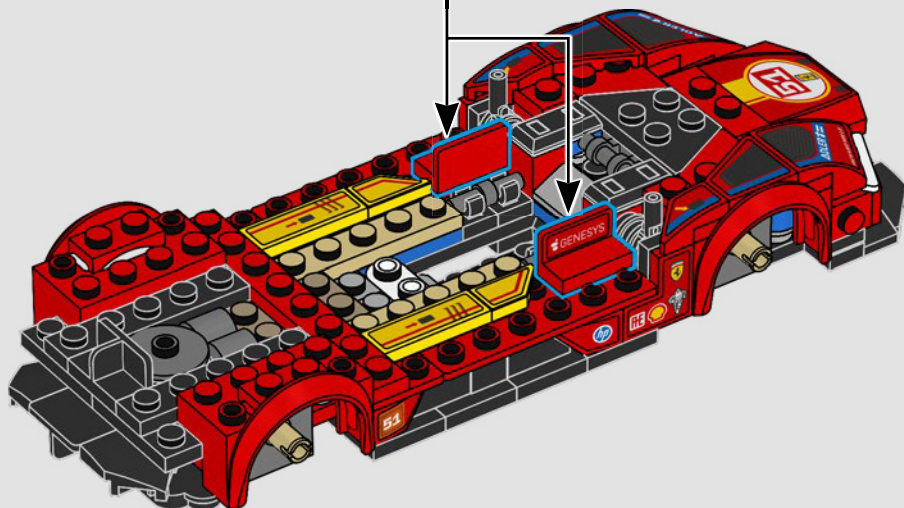
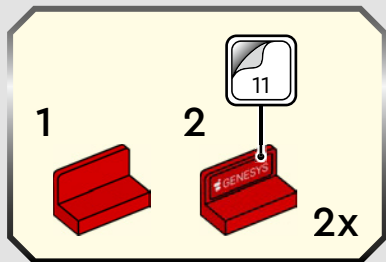



75

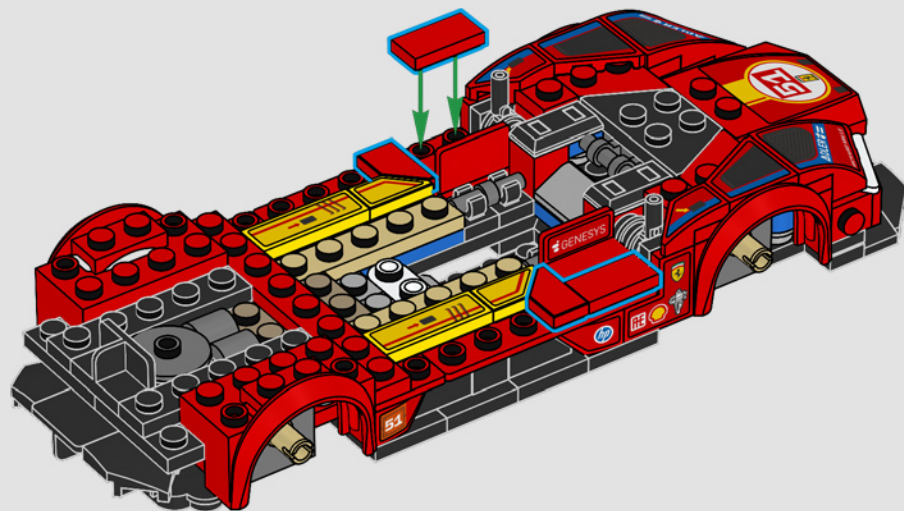

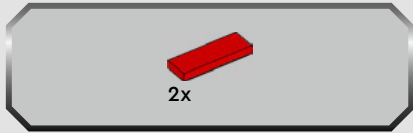

76

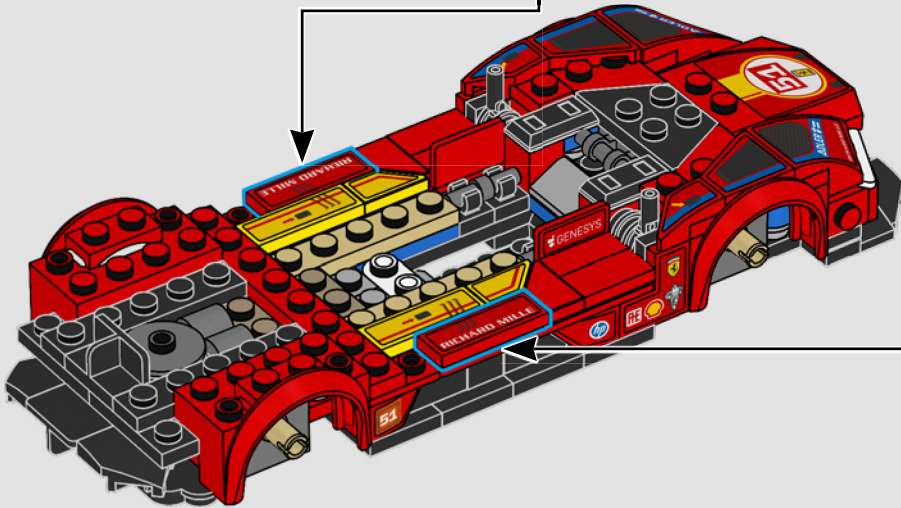
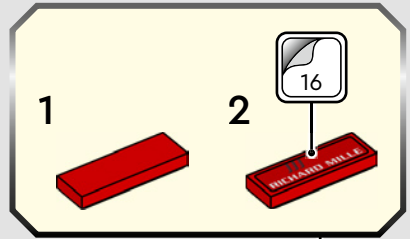
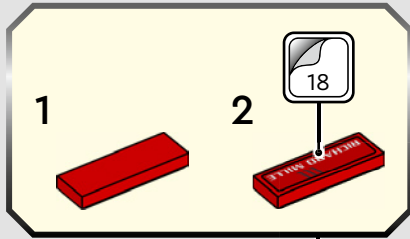



77

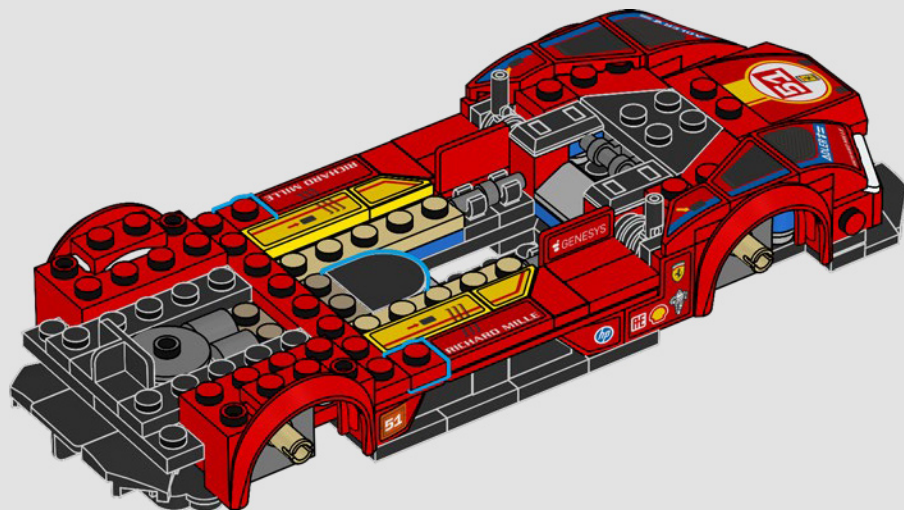

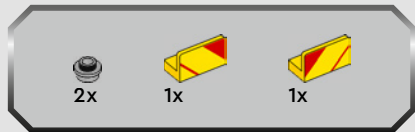

78

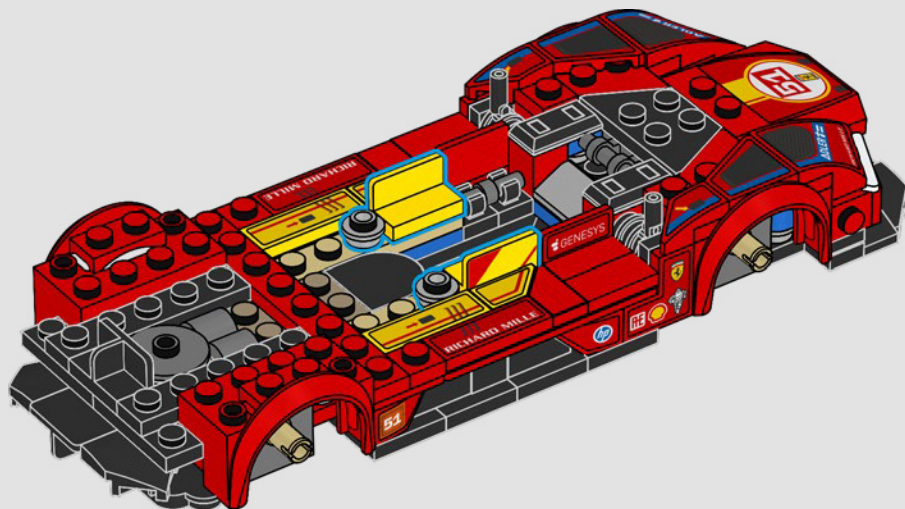



79

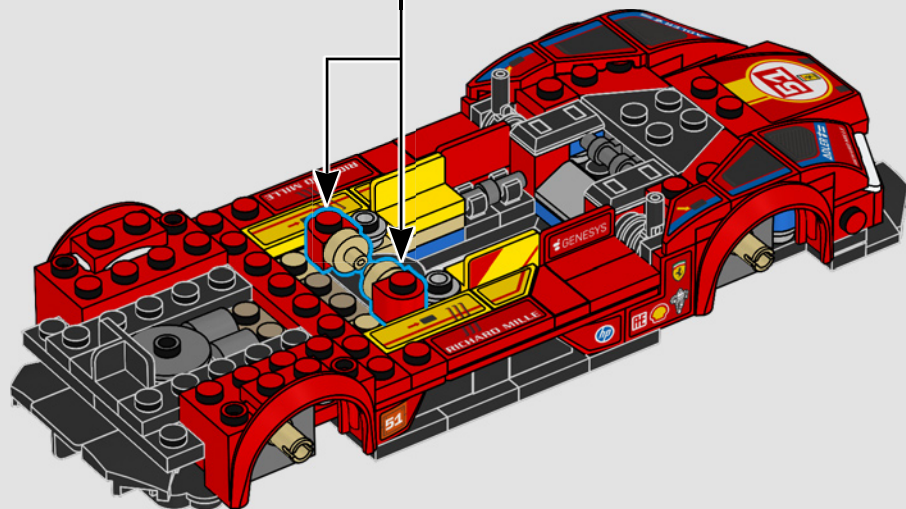
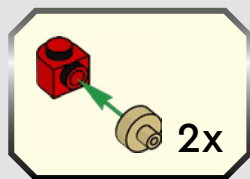

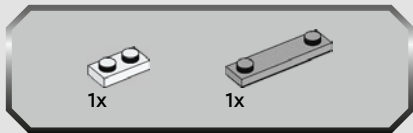

80

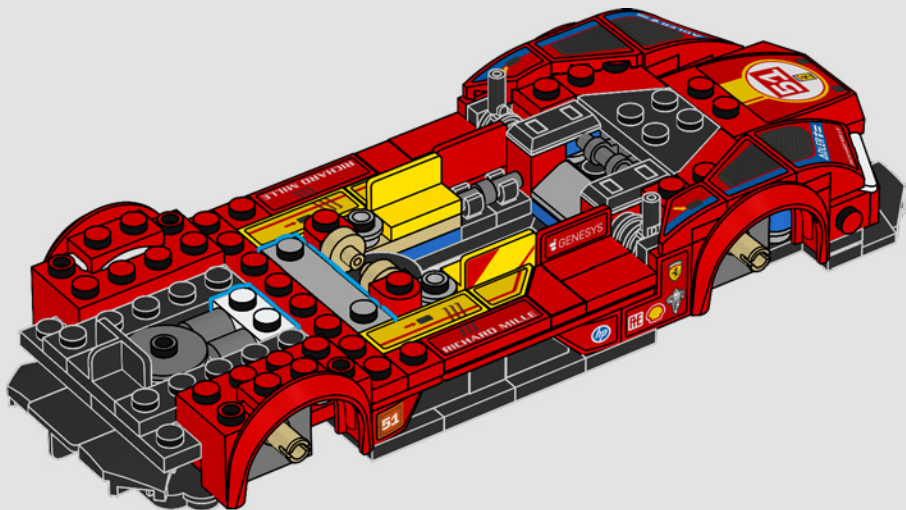



2x



2x

81

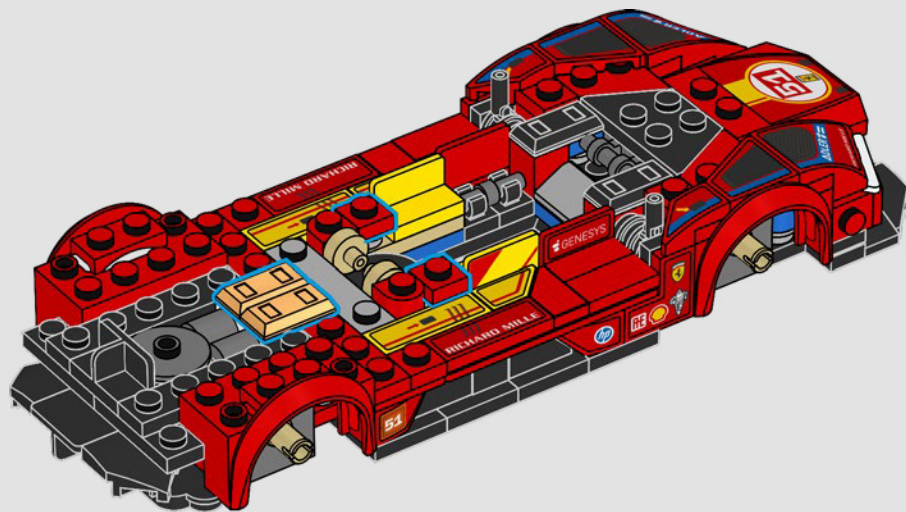



82

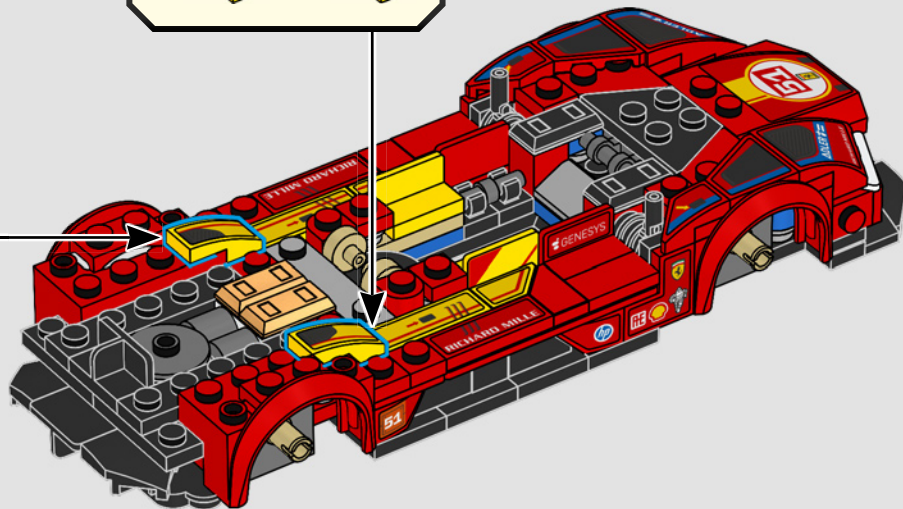
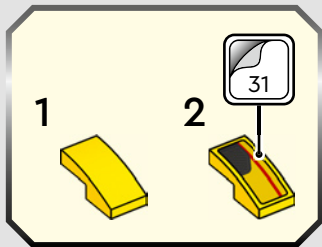
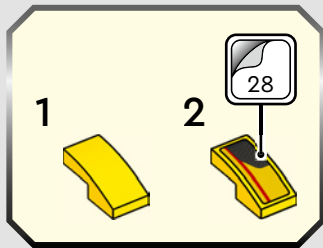

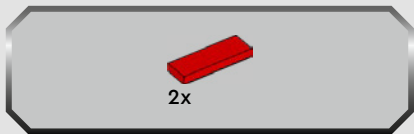

83

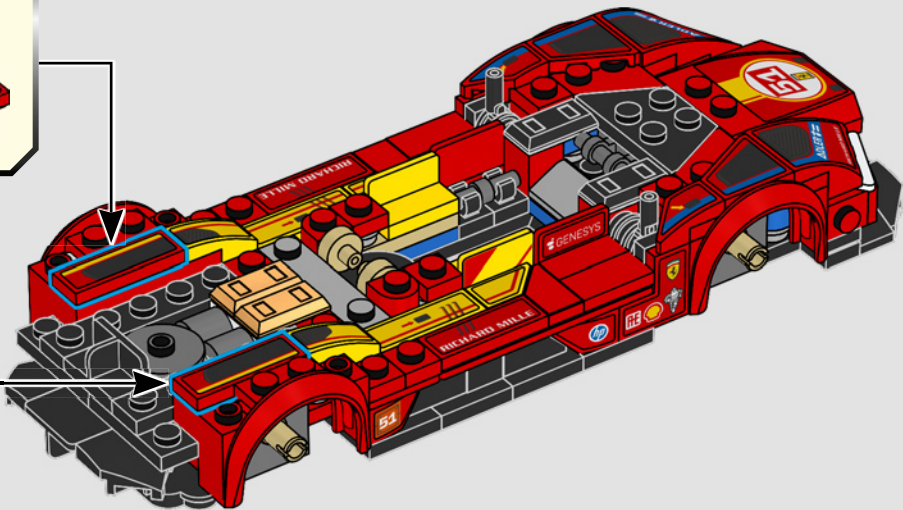
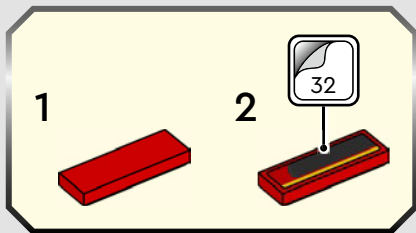
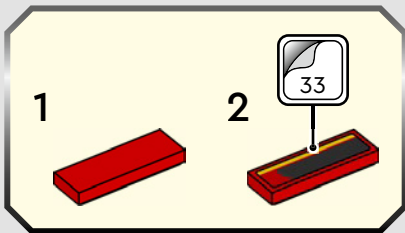

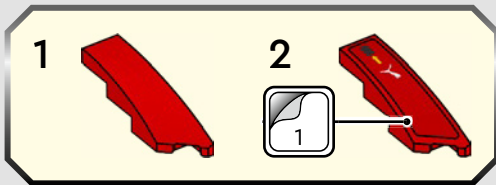
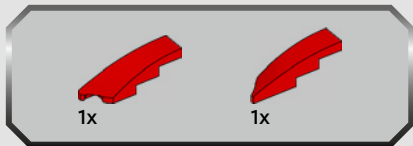

84

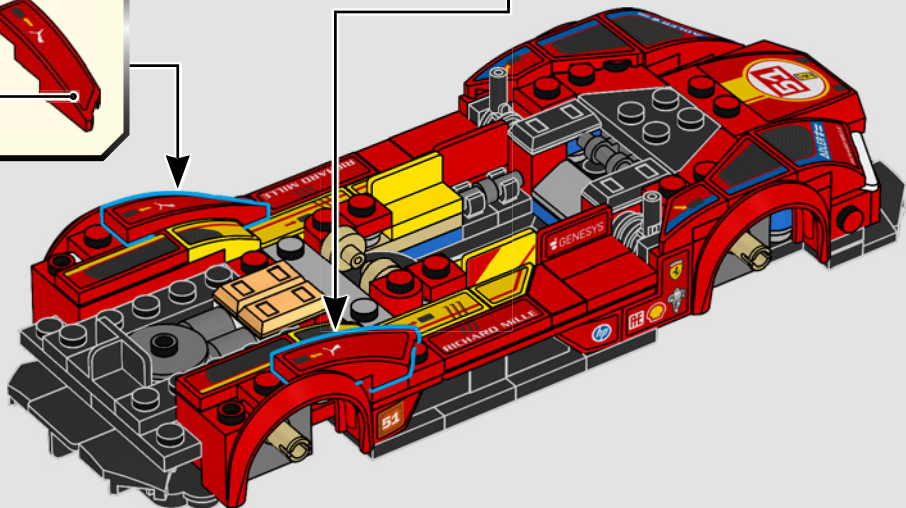
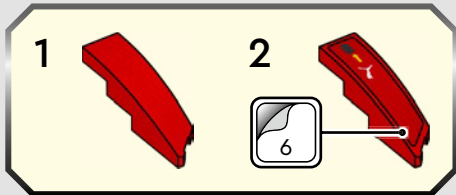

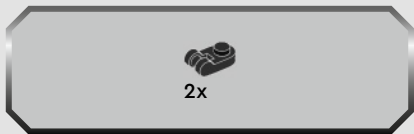

85

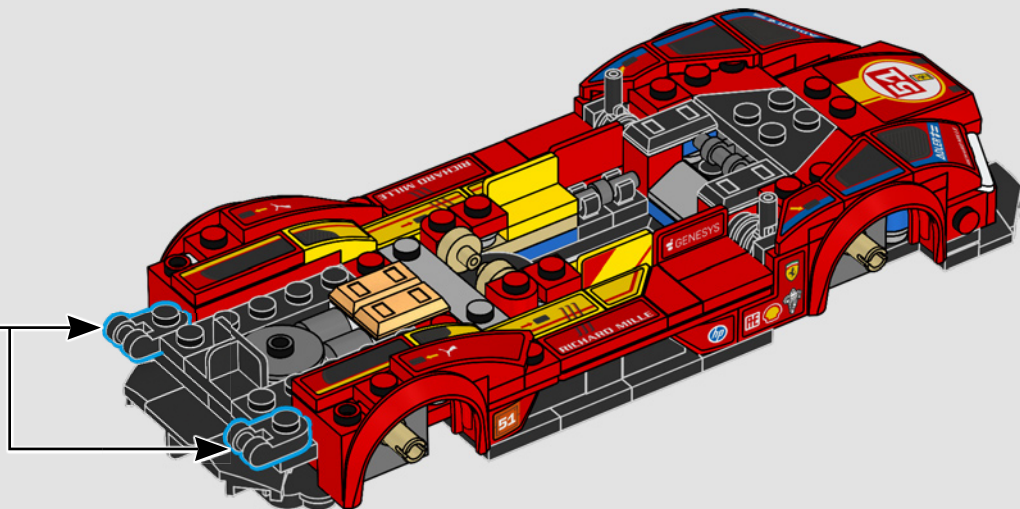

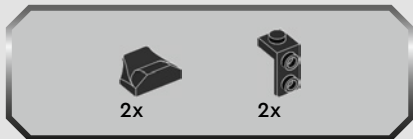

86

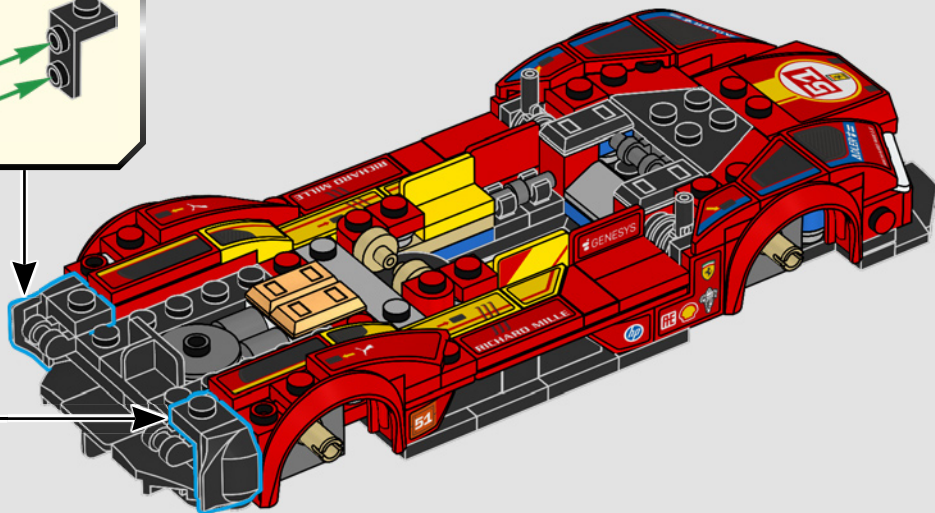
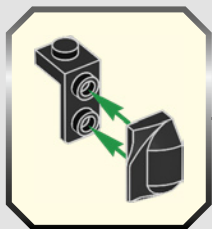
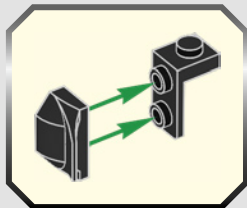



2x

87

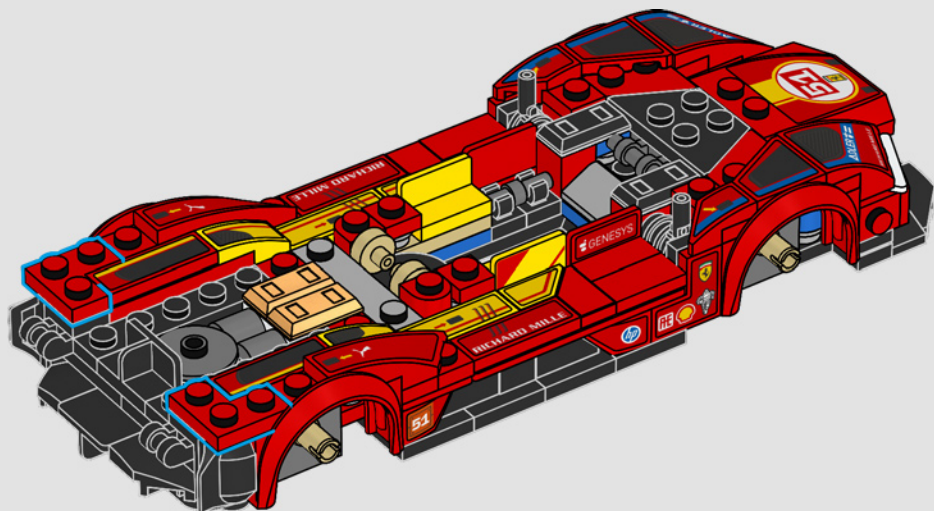

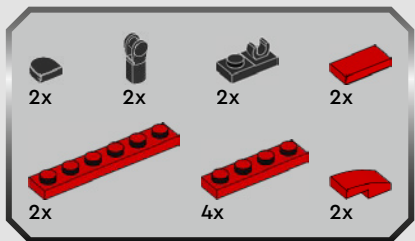
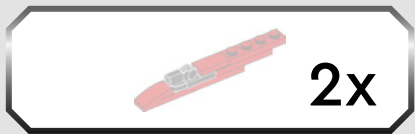

88

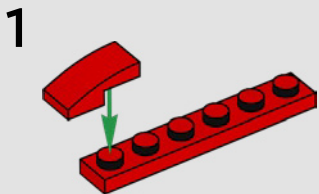

2

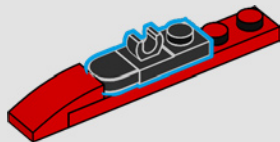

3

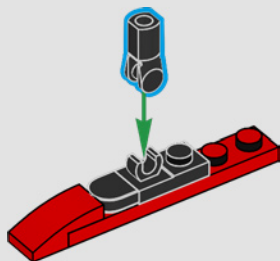

4

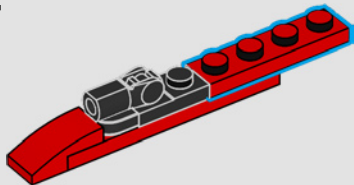

5

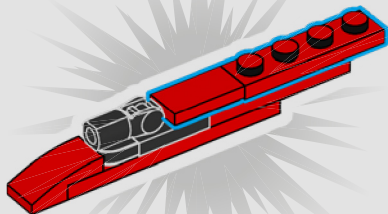

2x

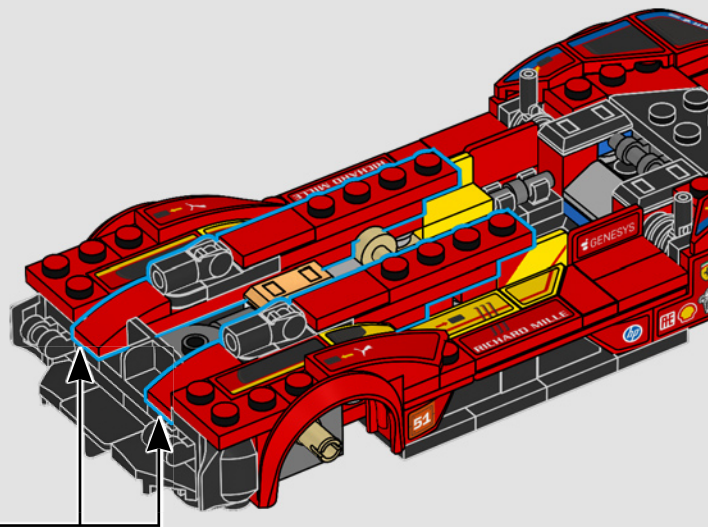



2x



2x

89

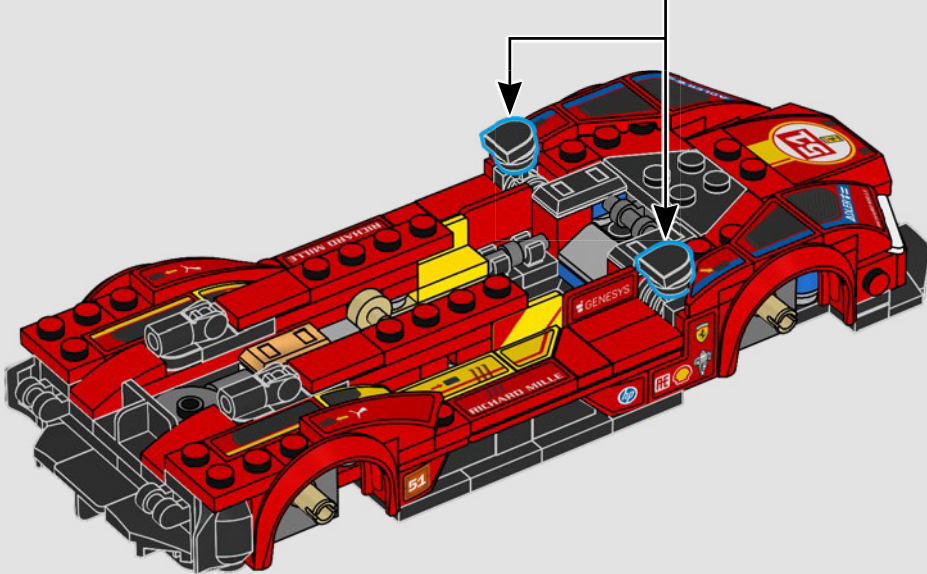
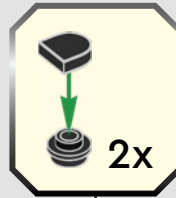



90

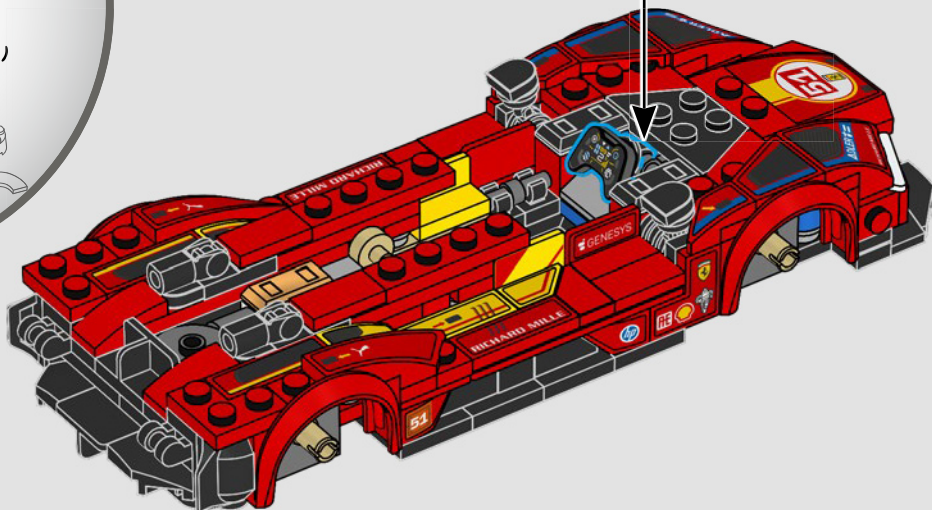
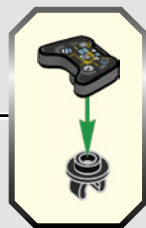



2x

91

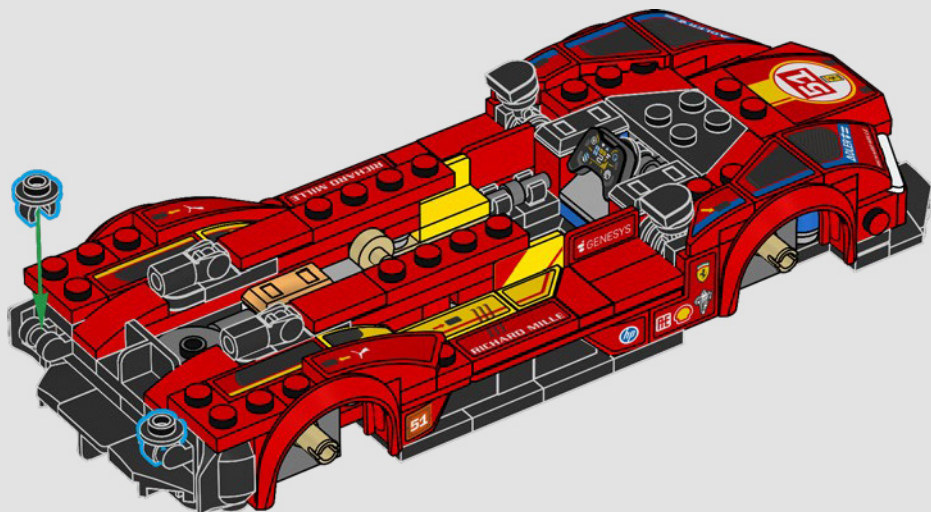

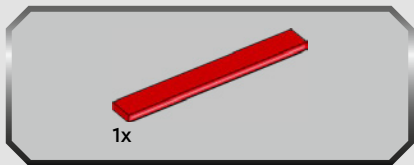

92

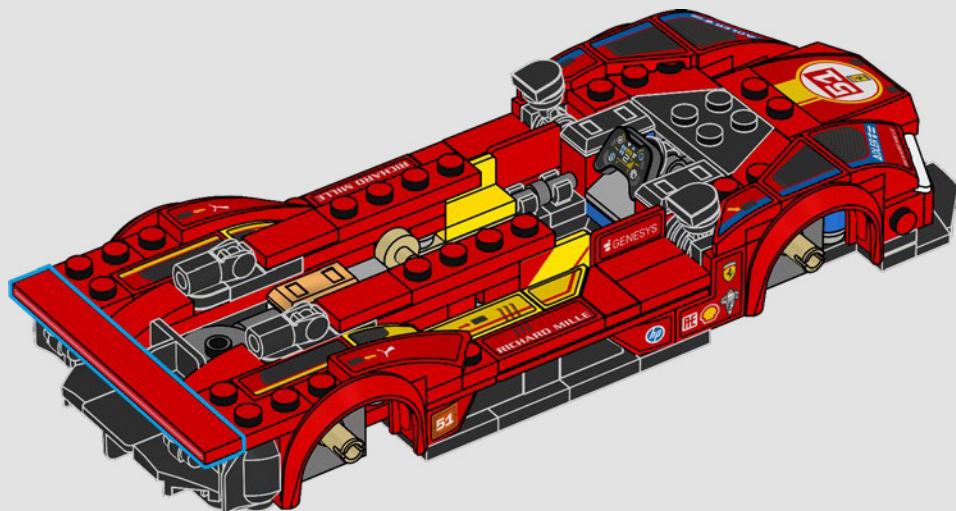

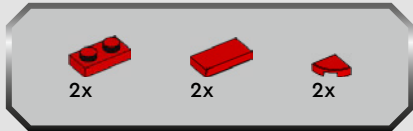

93

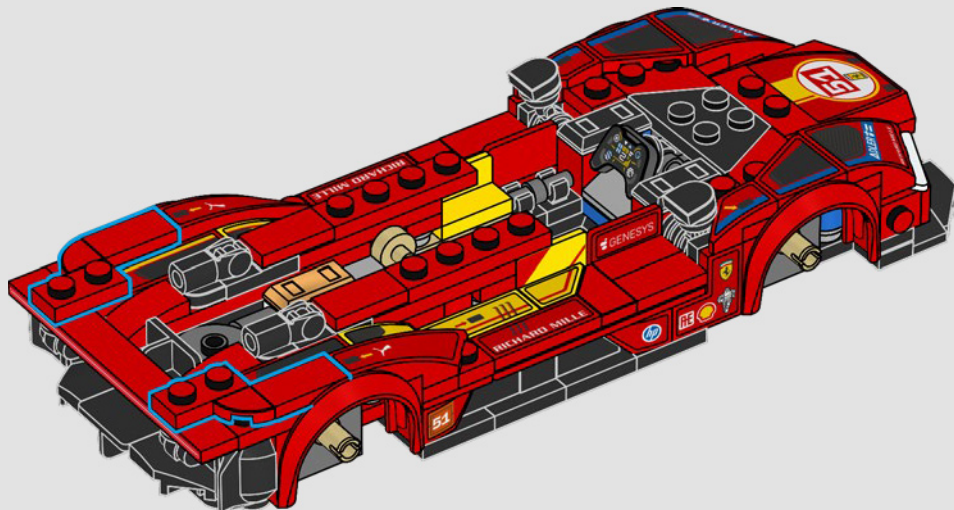

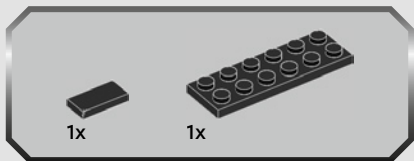
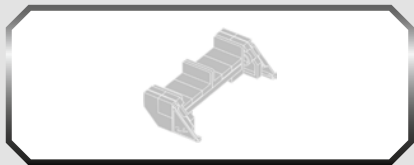

94

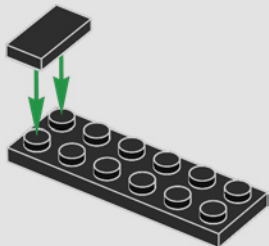

95

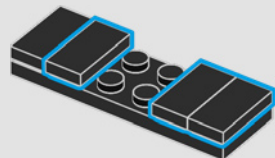

96

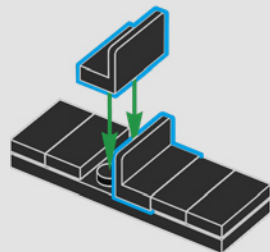



2x

97

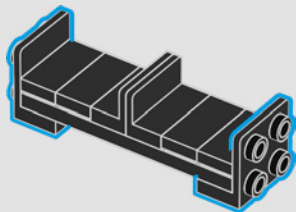

1x



1x

98

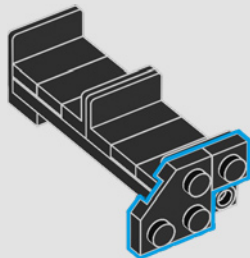

1x



1x

99

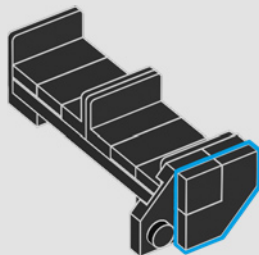



100

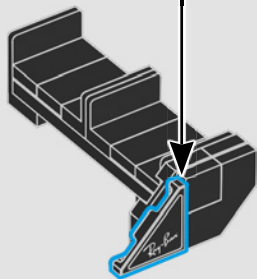
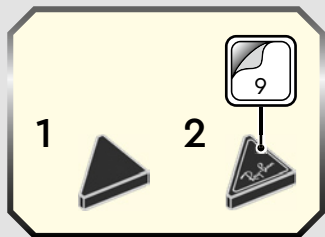

101

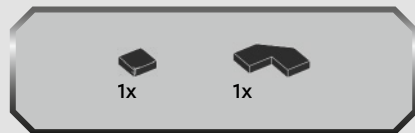
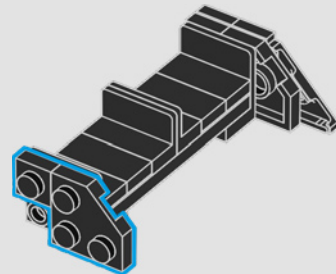

102

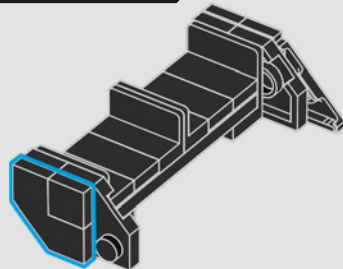



103

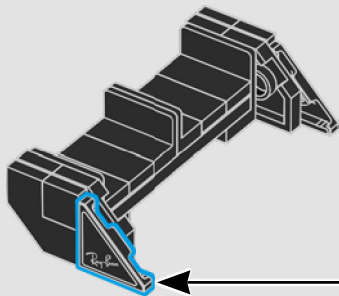
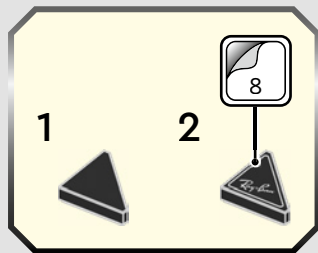

104

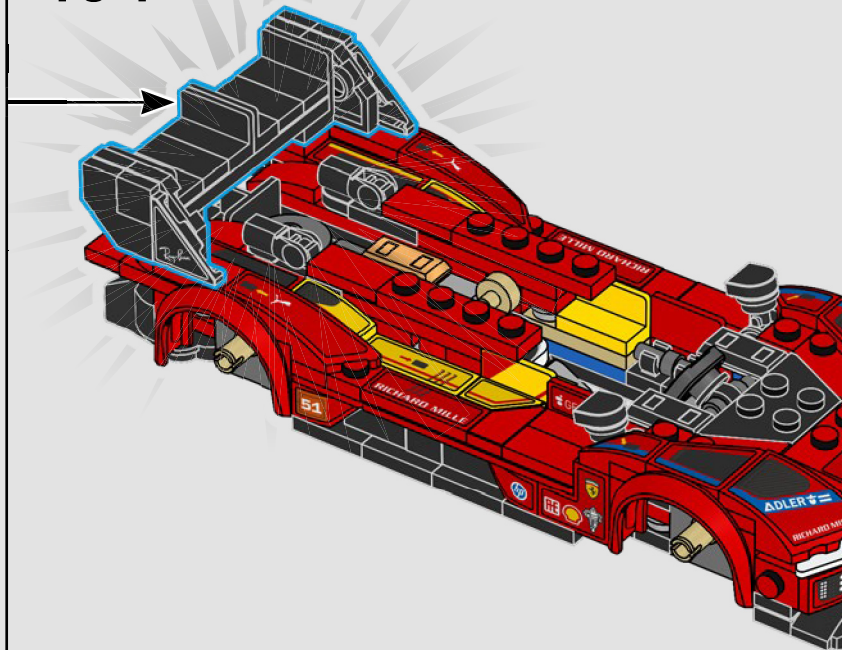

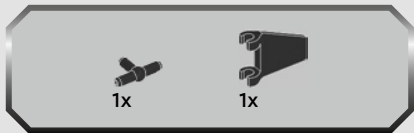

105

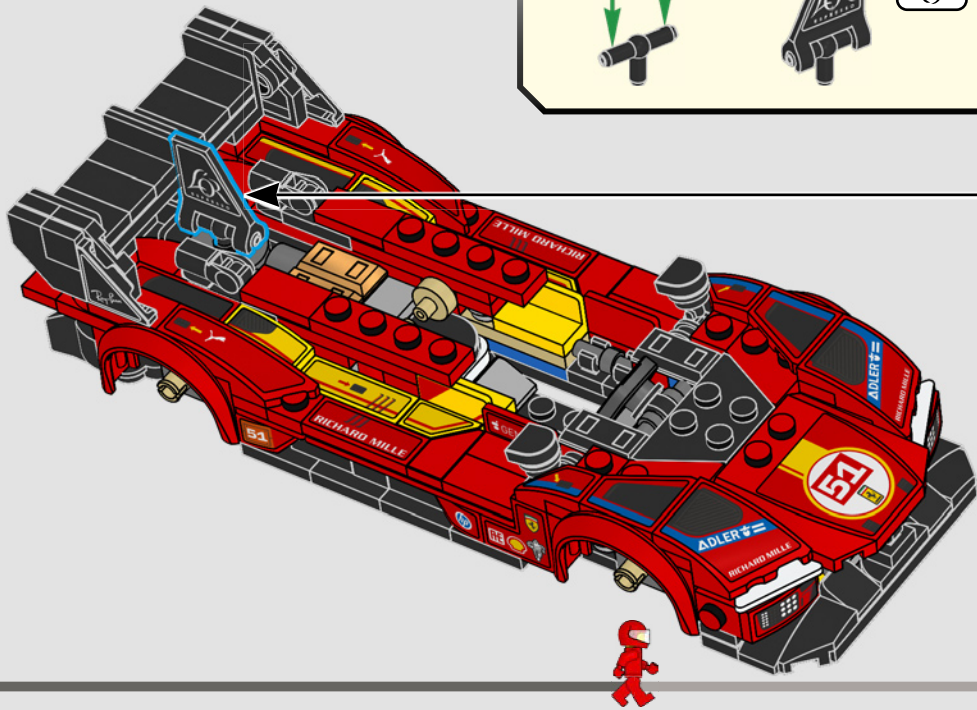
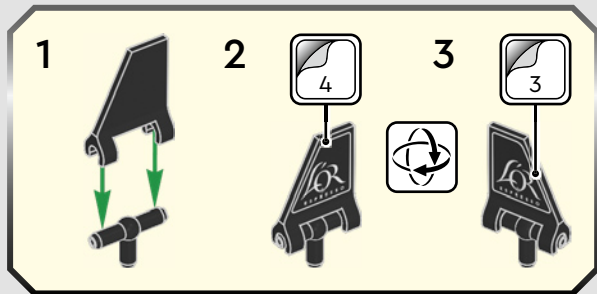

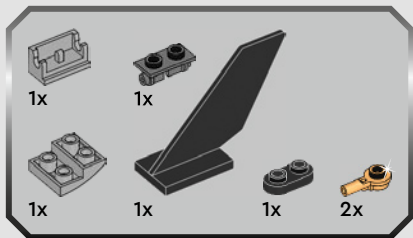

106

1

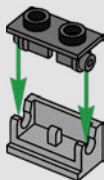

2

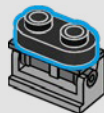

3

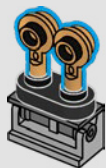

4

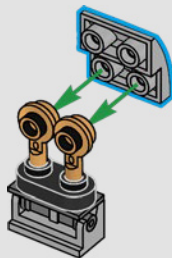

5

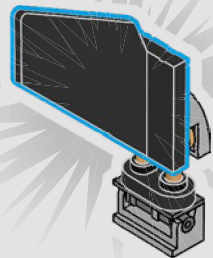

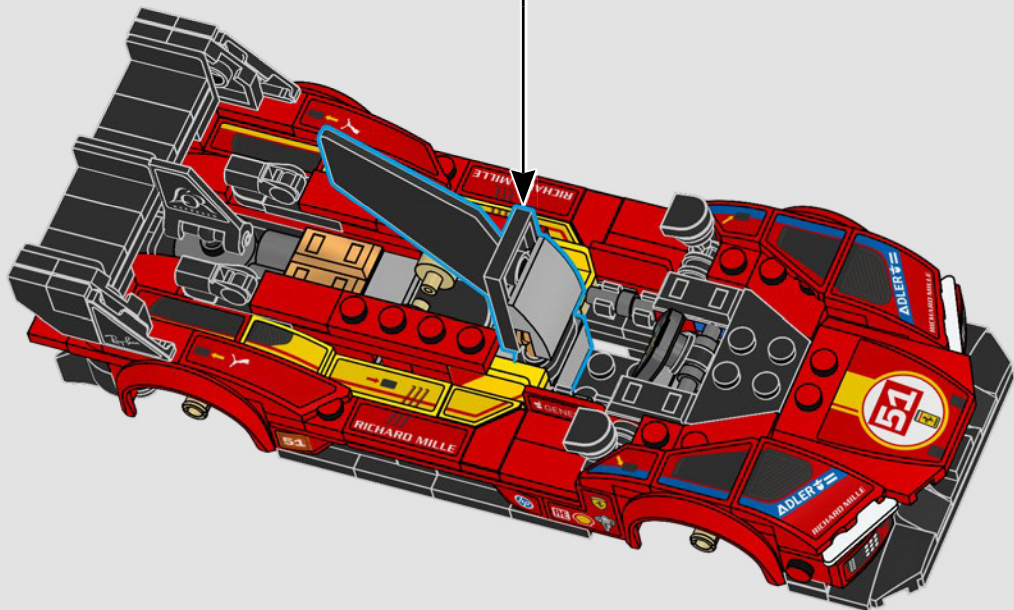

107

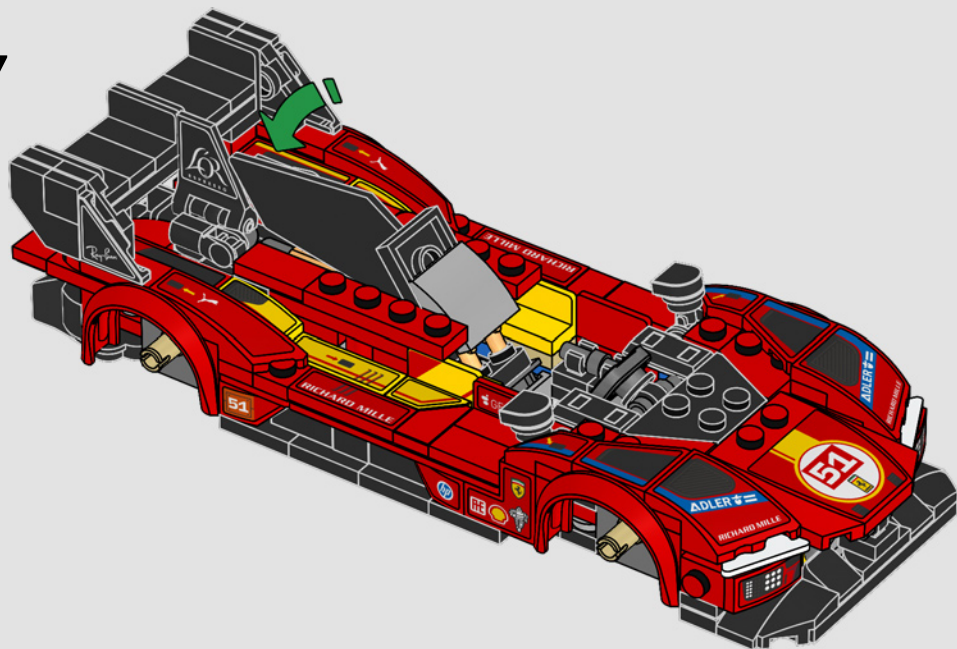

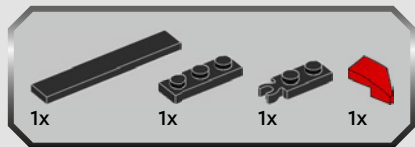

108

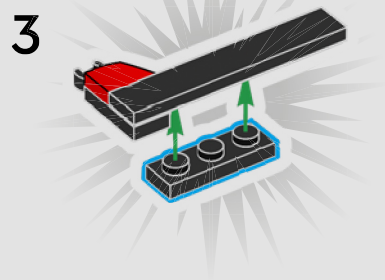
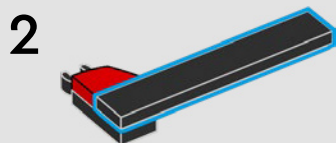
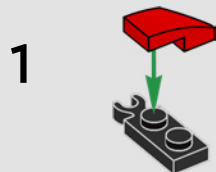

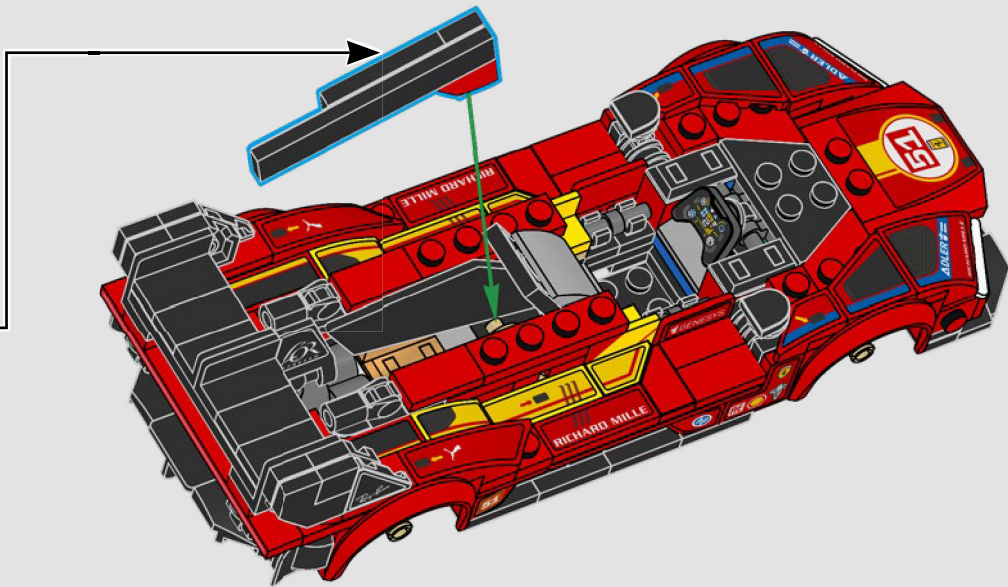

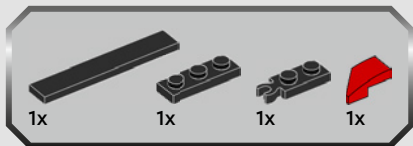

109

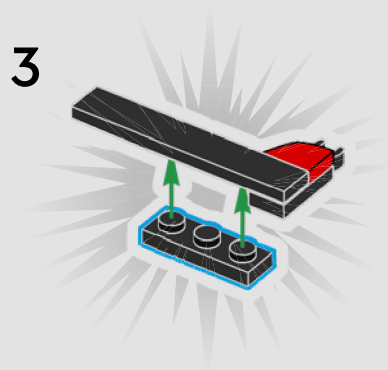
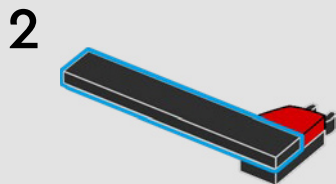
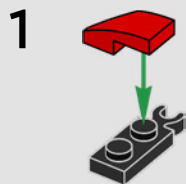

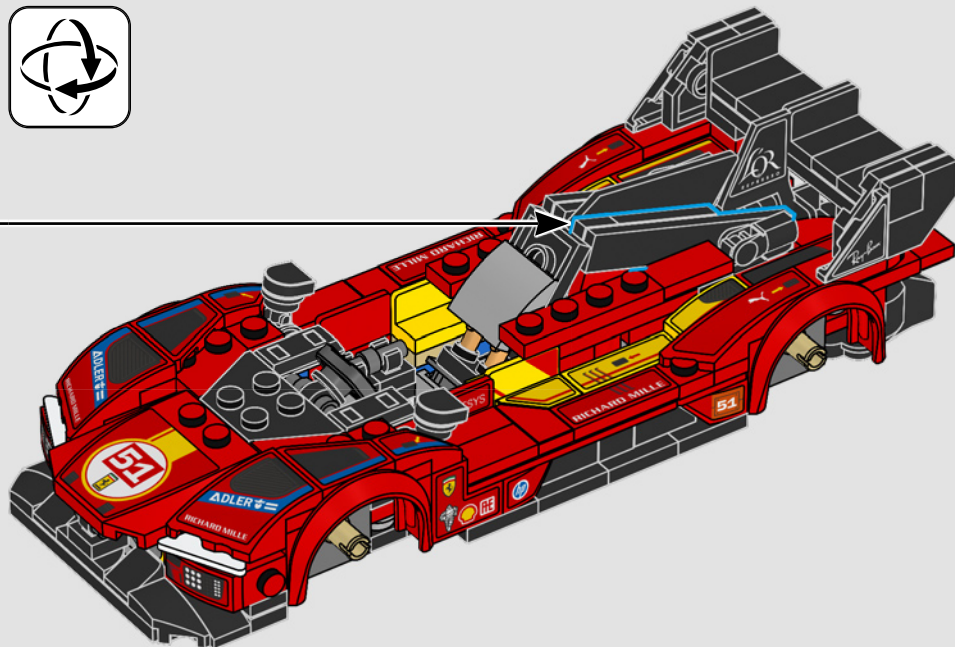



110

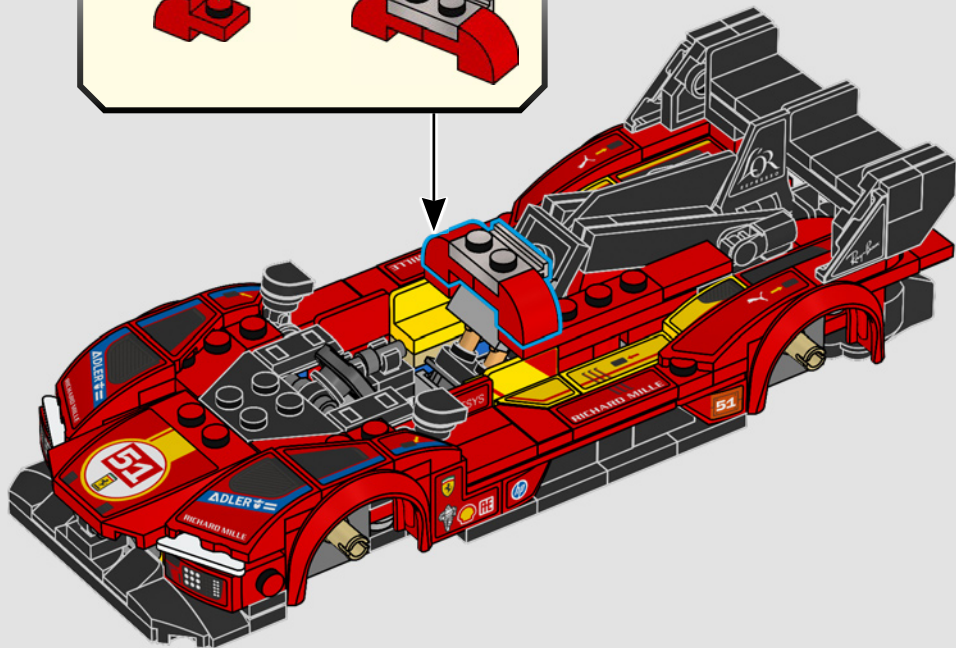
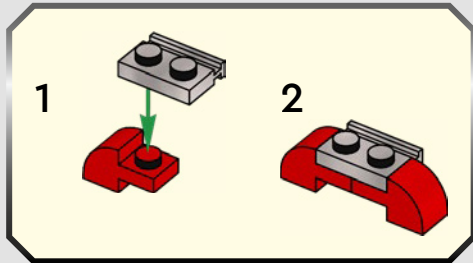

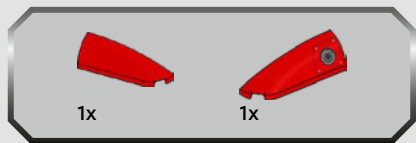

111

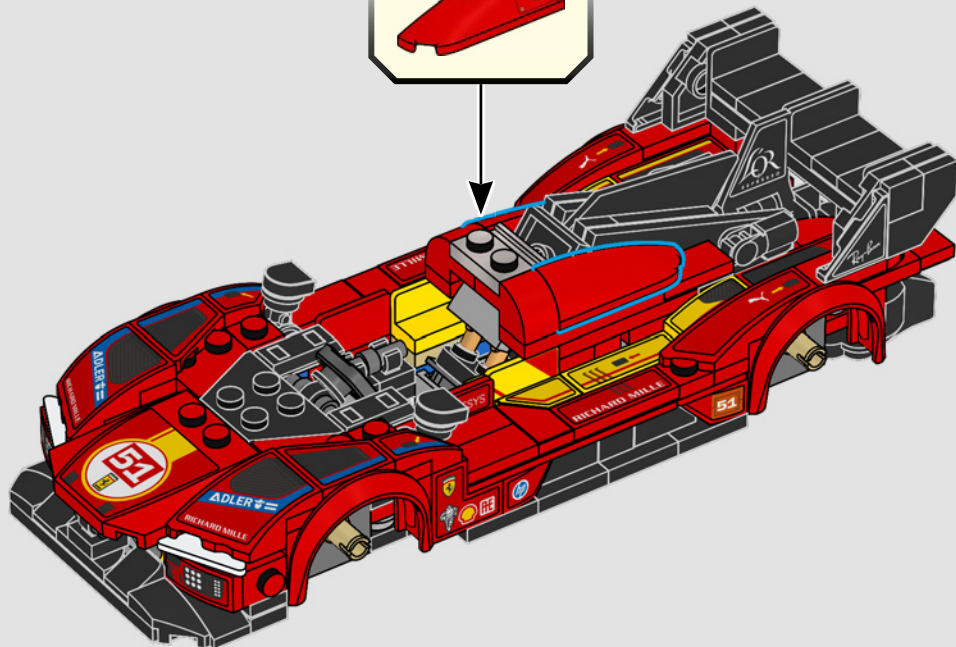

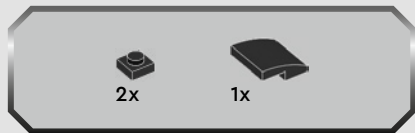

112

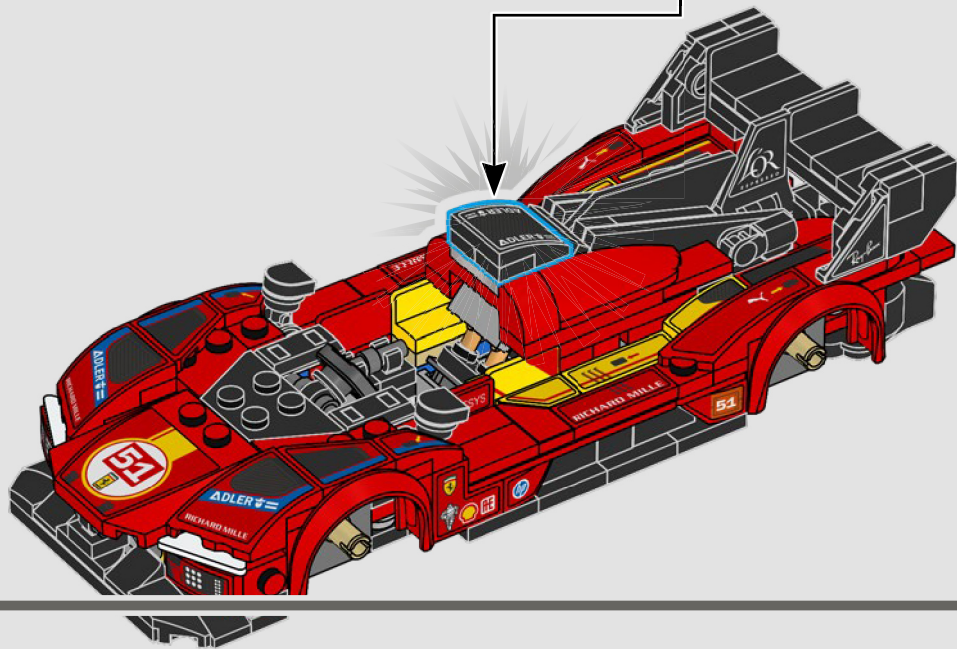
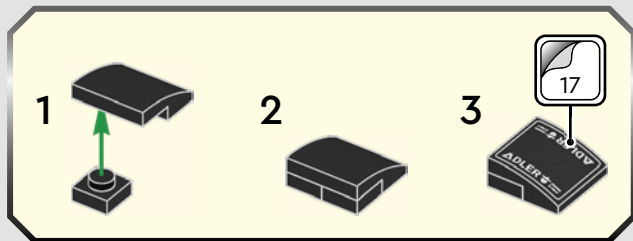



113

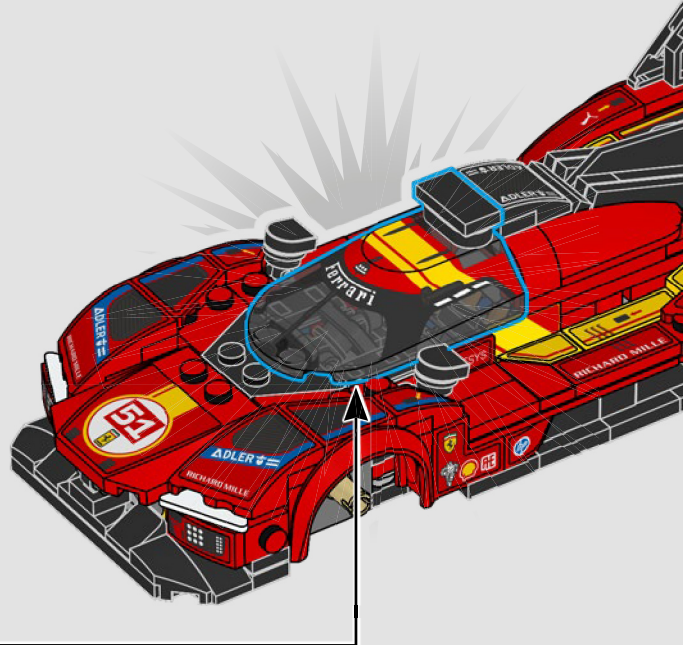
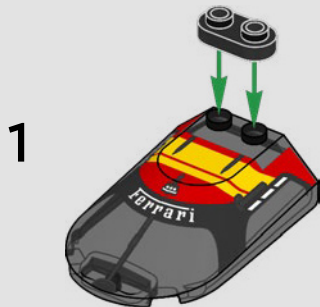

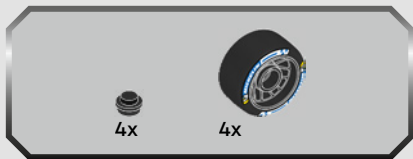

114

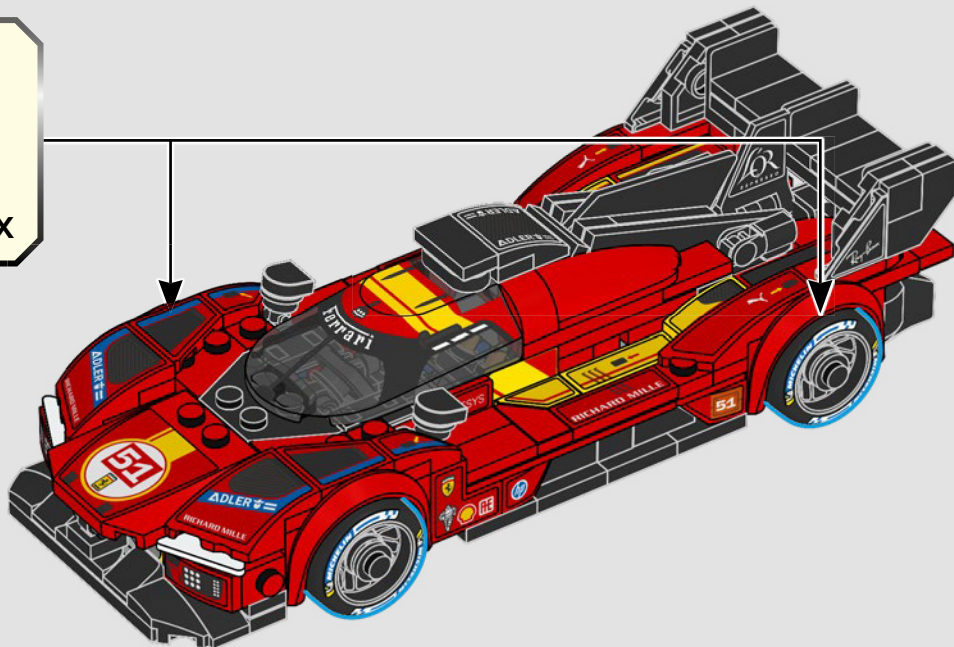
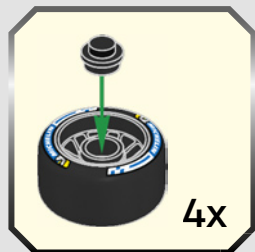

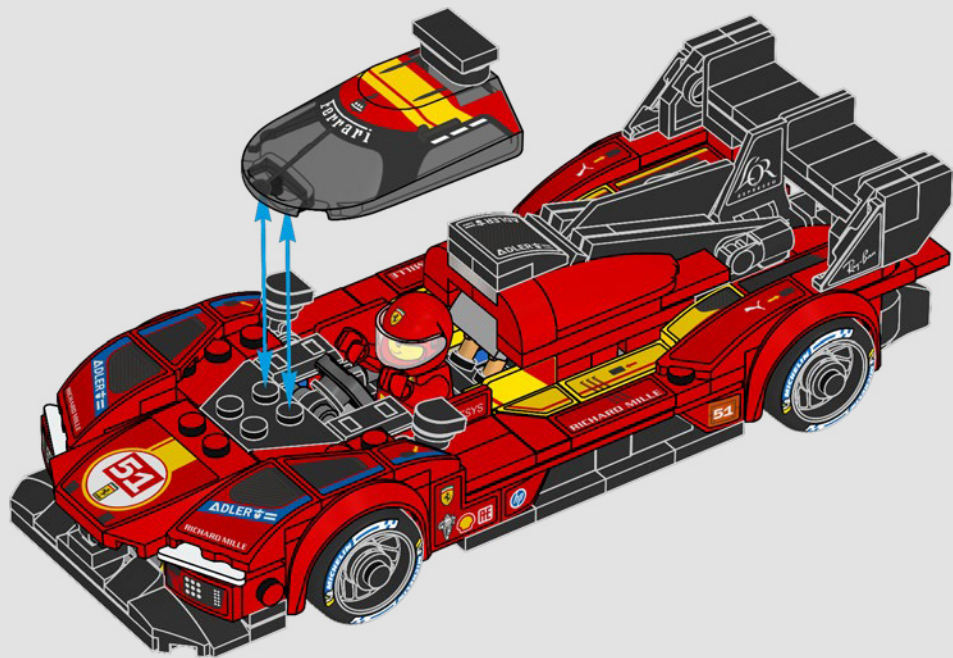

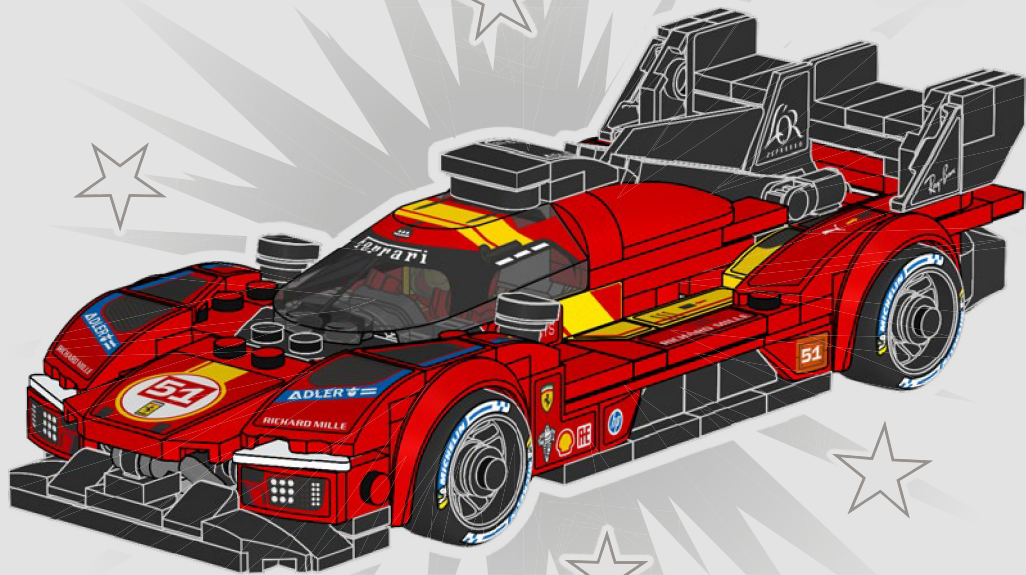



© Universal City Studios LLC. All Rights Reserved.

Designs of Toyota cars and all other associated marks, emblems and designs are intellectual property rights of Toyota Motor Corporation and used with permission.

Produced under license of Ferrari S.p.A. The name FERRARI, the PRANCING HORSE device, all associated logos and distinctive designs, including the design of the Ferrari cars, are property of Ferrari S.p.A.

APXGP is a trademark of Apple.

The F1 logo, FORMULA 1, F1, GRAND PRIX and related marks are trademarks of Formula One Licensing BV, a Formula 1 company. All rights reserved.
OFFICIAL LICENSEE OF FORMULA 1®

HOONIGAN® and HOONICORN® are registered trademarks of Wheel Pros, LLC © 2026 Wheel Pros, LLC All rights reserved.

The 43, Skull logos, and KEN BLOCK are trademarks of KP8 Trust and are used with permission from KP8 Trust and in partnership with Building the Blocks, LLC.

RTR trademarks and designs used under permission from Vaughn Gittin Jr. Motorsports, LLC.

Ford Motor Company Trademarks and Trade Dress used under license to the LEGO Group.

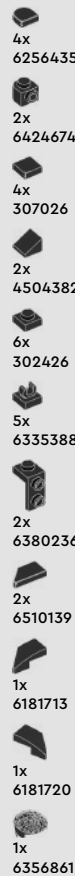
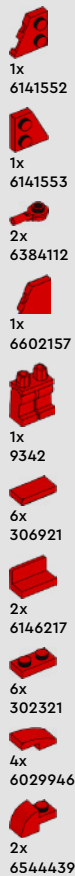

2x
6510125

1x
6510061

1x
6104209

2x
6210270

2x
6196548

2x
6157554

2x
6347310

2x
6156991

5x
306926

2x
6640376

2x
6375706

2x
6174243

2x
6146220

2x
6308912

2x
6047276

2x
6000650

1x
6517779

8x
6250020

1x
6363033

2x
6214807

2x
6350725

2x
6593250

4x
242026

2x
6166859

1x
6053077

2x
4558170

2x
362326

4x
6614270

1x
4531412

2x
6439175

4x
6350415

2x
366626

2x
663626

1x
6093011

1x
379526

1x
303226

1x
4656764

16x
6168647

1x
6507791

2x
4568637

2x
6066097

1x
4211469

1x
6212077

1x
6185676

1x
6257593

2x
4211438

1x
4243797

2x
6454959

2x
4211090

2x
6333129

4x
6350724

1x
6115080

2x
4211135

1x
6176400

1x
4261908

1x
4210660

1x
6614264

1x
6472255

1x
6132264

1x
6167576

1x
6244787

2x
6035540

2x
302328

1x
6510211

2x
6335111

2x
6207933

 [LEGO.com/service](https://www.LEGO.com/service)

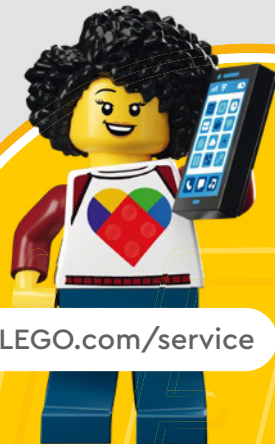

YOU COULD
WIN

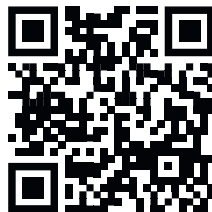

Scan this QR code or go to
LEGO.COM/PRODUCTFEEDBACK and give us
your short feedback about this LEGO® set
for a chance to win a cool LEGO prize.

Terms and Conditions apply*



EN: YOU COULD WIN. Terms and Conditions apply* **DE: Du könntest GEWINNEN.** Es gelten die Teilnahmebedingungen* **FR: TU POURRAIS GAGNER.** Des conditions s'appliquent* **IT: Potresti VINCERE tu.** Termini e condizioni sono applicabili* **ES: PUEDES GANAR.** Aplican términos y condiciones* **PT: PODERÁ GANHAR.** Aplicam-se Termos e Condições* **ZH: 轻松获奖.** 条款和条件适用* **PL: Szansa na WYGRANĄ.** Obowiązuje regulamin* **CS: Máte šanci VYHRÁT.** Platí všeobecné smluvní podmínky* **SK: Máte šancu VYHRAŤ.** Platia všeobecné zmluvné podmienky* **HU: TE IS NYERHETSZ!** Felhasználási feltételek érvényesek* **UA: ВИ МОЖЕТЕ ВИГРАТИ.** Застосовуються загальні положення та умови* **RO: Ai putea CÂȘTIGA.** Se aplică termenii și condiții* **BG: Можете да СПЕЧЕЛИТЕ.** Има определени правила и условия* **LV: Tu vari LAIMĒT.** Ir spēkā noteikumi un nosacījumi.* **ET: Sul on võimalus VÕITA.** Kehtivad tingimused* **LT: Jūs galite LAIMĖTI.** Taikomos sąlygos* **TR: KAZANABİLİRSİN.** Şartlar ve Koşullar geçerlidir*

*[LEGO.com/productfeedback-terms](https://www.lego.com/productfeedback-terms)

LEGO and the LEGO logo are trademarks of the/son des marques de commerce du/son marcas registradas de LEGO Group. ©2026 The LEGO Group.

Produced under license of Ferrari S.p.A. The name FERRARI, the PRANCING HORSE device, all associated logos and distinctive designs, including the design of the Ferrari cars, are property of Ferrari S.p.A.



6649375