



43302

Disney



Available in English
Disponible en français
Disponible en español

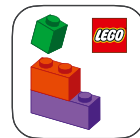

LEGO® Builder





WE'RE MAKING OUR PACKAGING MORE SUSTAINABLE

We're transitioning from single-use plastic to paper-based packaging. As we progress, you may find a mix of paper and plastic in our boxes.

NOUS RENDONS NOS EMBALLAGES PLUS DURABLES

Nous passons des emballages en plastique à usage unique aux emballages à base de papier. Durant la transition, vous pourriez trouver un mélange de papier et de plastique dans nos boîtes.

QUEREMOS HACER MÁS SUSTENTABLES NUESTROS MATERIALES DE EMBALAJE

Estamos cambiando las bolsas de plástico desechables por bolsas con base de papel. Conforme avanzamos en este propósito, puedes encontrar una mezcla de papel y de plástico en nuestras cajas.

LEGO.com/sustainable-packaging



Build Together

1-5 Builders

Construire Ensemble
1-5 constructeurs

Construye En Compañía
1-5 constructores

[LEGO.com/devicecheck](https://www.lego.com/devicecheck)



Apple and the Apple logo are trademarks of Apple Inc., registered in the U.S. and other countries and regions. App Store is a service mark of Apple Inc. Google Play and the Google Play logo are trademarks of Google LLC. Tencent and the Tencent logo are trademarks of Tencent Inc.



LEGO® Builder





WELCOME TO MAIN STREET, U.S.A.

Remember the first time you stepped onto Main Street, U.S.A.? Since 1955, guests have been swept up in Walt Disney's dream of a warm, welcoming, small-town America. Its cheerful architecture and nostalgic charm invigorate the imagination and inspire playful adventures.

BIENVENUE SUR LA MAIN STREET U.S.A.

Vous vous souvenez de la première fois où vous avez mis les pieds sur la Main Street U.S.A.? Depuis 1955, les visiteurs sont transportés dans le rêve de Walt Disney : une petite ville américaine chaleureuse et accueillante. Son architecture joyeuse et son charme d'antan éveillent l'imagination et inspirent des aventures ludiques.

TE DAMOS LA BIENVENIDA A MAIN STREET, U.S.A.

¿Recuerdas la primera vez que pisaste Main Street, U.S.A.? Desde 1955, este pequeño, cálido y acogedor pueblo estadounidense soñado por Walt Disney ha cautivado a los visitantes. Su alegre arquitectura y nostálgico encanto potencian la imaginación e inspiran divertidas aventuras.



EVERYONE IS WELCOME

Now you can recreate and celebrate this timeless location in a model brimming with all the Disney details the heart desires. This set invites everyone to build together and relive special moments and memories of the lively spirit of the famous street, its shops and characters.

UN LIEU POUR TOUS

Vous pouvez maintenant recréer et célébrer cet endroit emblématique grâce à une maquette remplie de tous les détails Disney que l'on peut souhaiter. Cet ensemble invite tout le monde à construire ensemble et à revivre des moments précieux, dans l'esprit vivant de cette rue mythique, de ses boutiques et de ses personnages.

TODOS SON BIENVENIDOS

Ahora puedes recrear y celebrar este intemporal lugar con un modelo repleto de todos los detalles Disney que tu corazón pueda desear. Este set invita a todos a construir juntos y revivir momentos y recuerdos especiales del animado espíritu, las tiendas y los personajes del famoso pasaje.

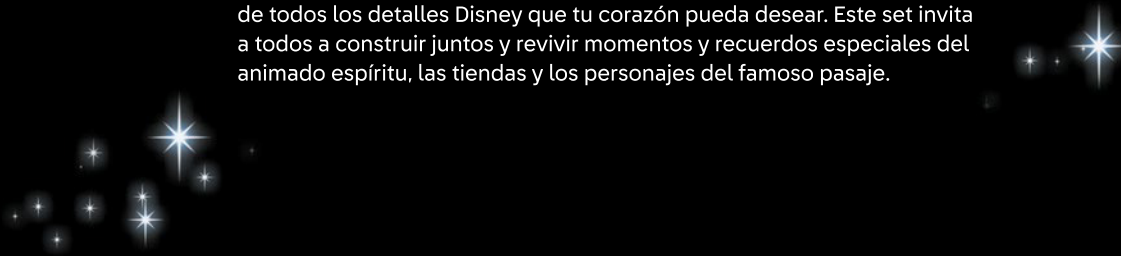



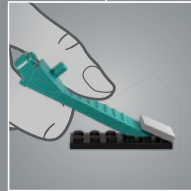
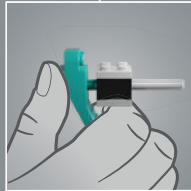
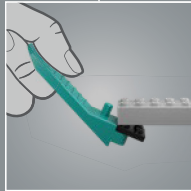
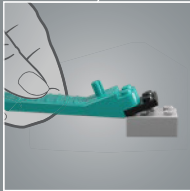
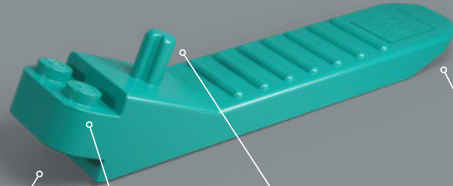

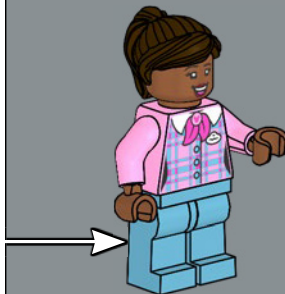

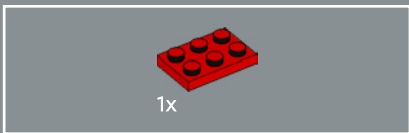

1x

1

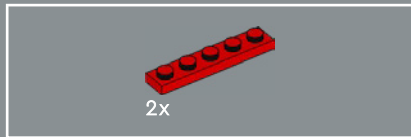

2x

2

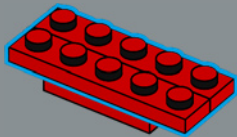

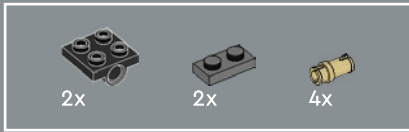

3

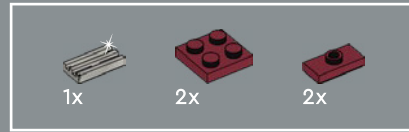
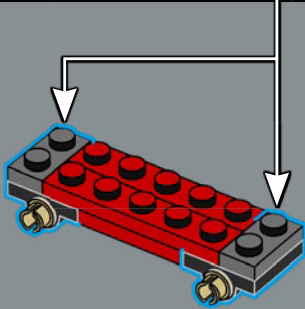
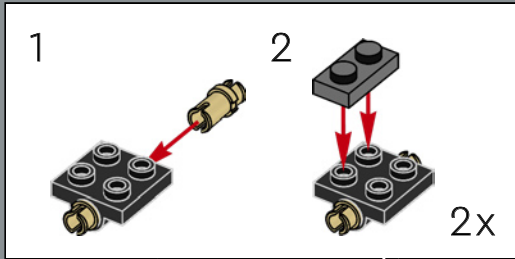

4

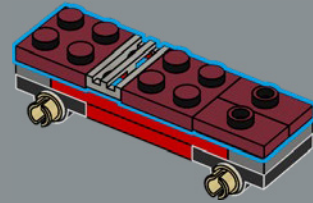

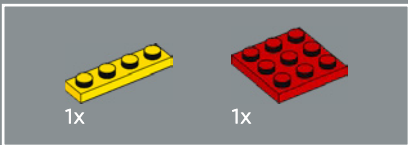
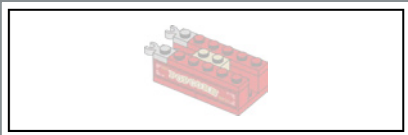

5

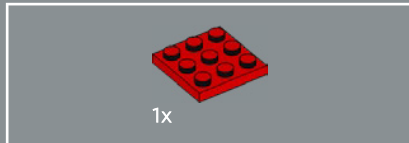

6

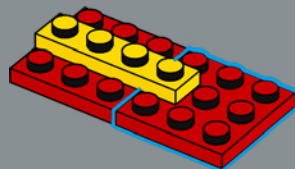

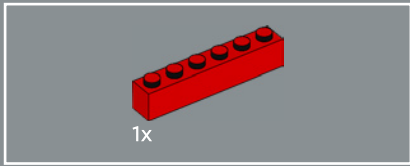

7

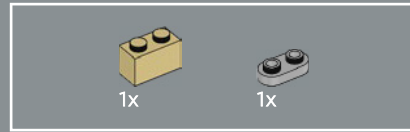
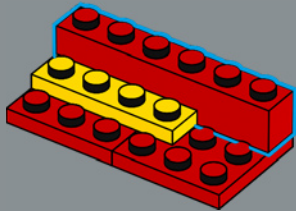

8

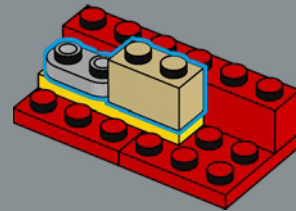

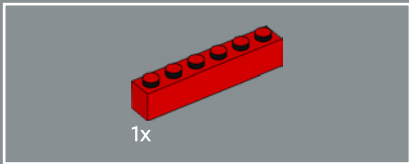

9



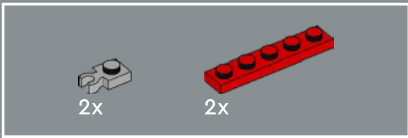

10

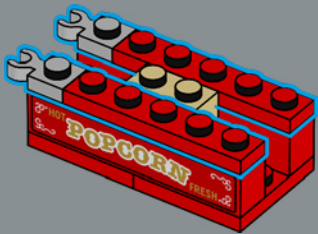

11

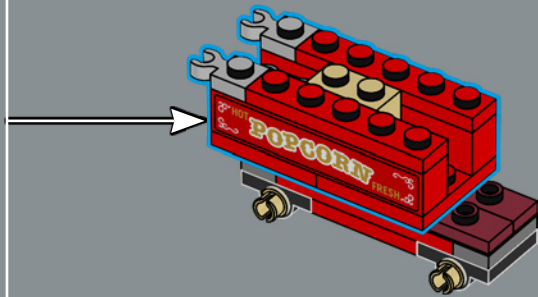

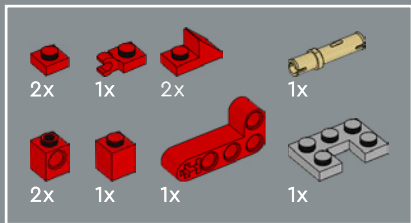

12

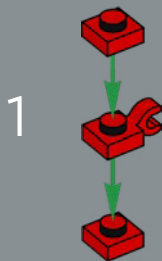

2

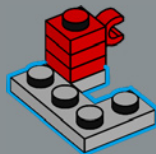

3

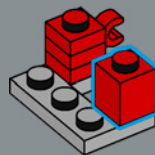

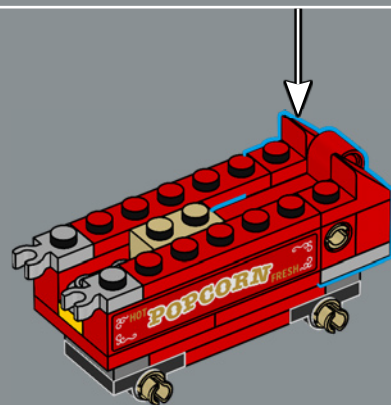
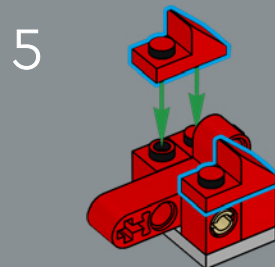
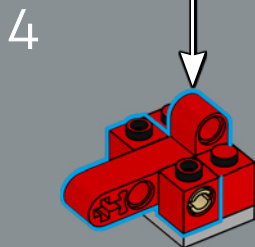
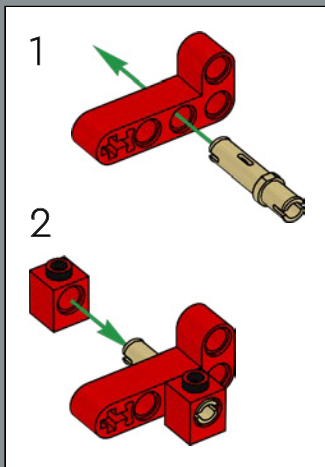

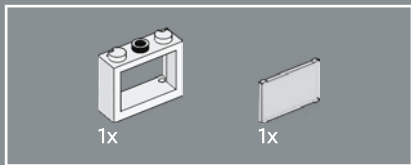

13

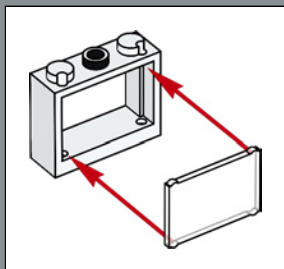

14

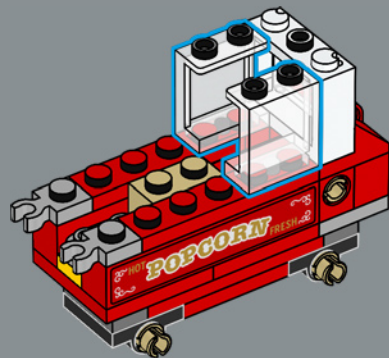

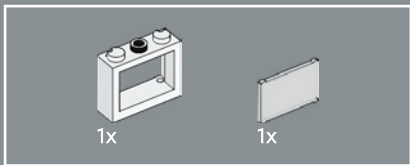

15

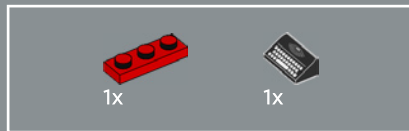
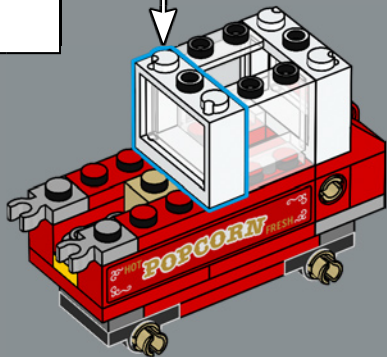
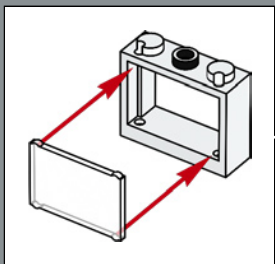

16

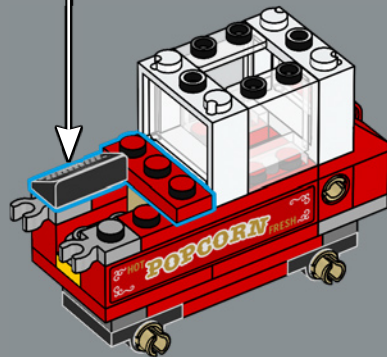

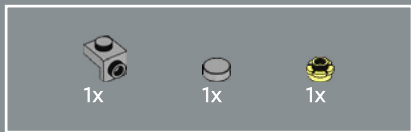

17

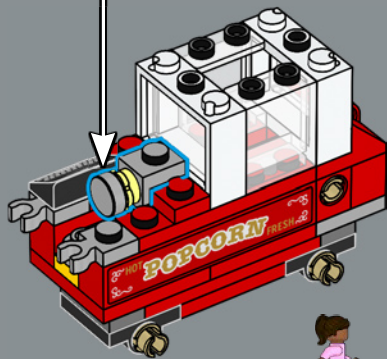
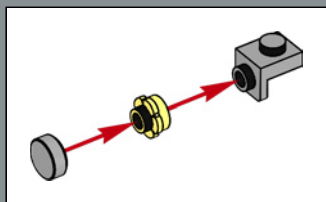

18

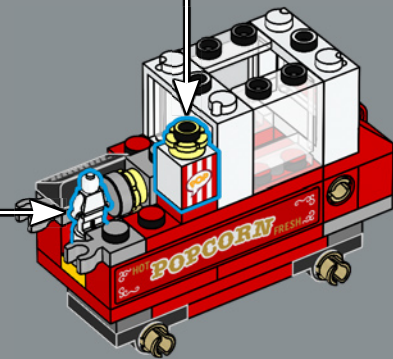
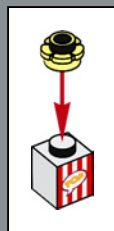



1x

19

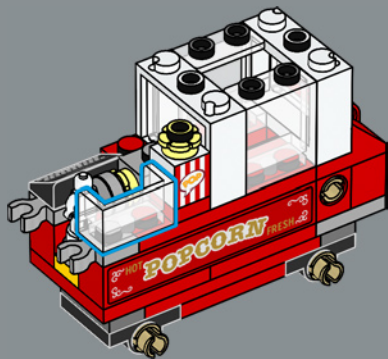

4x



4x

20



4x



4x



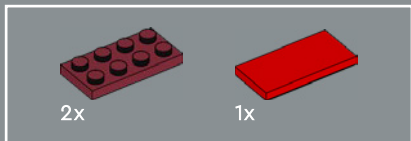

21

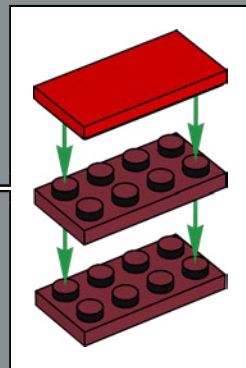

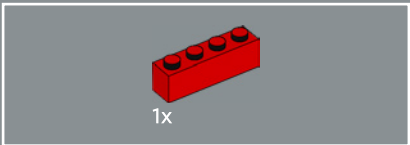

22

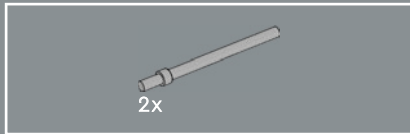
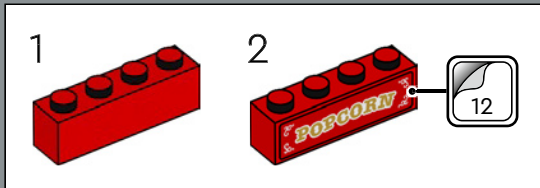

23

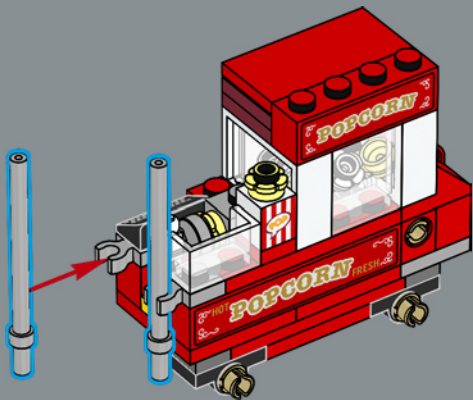

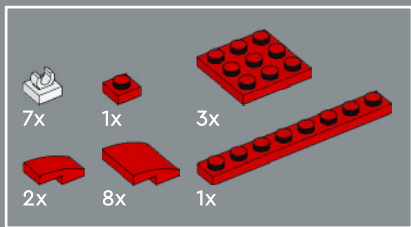

24

1

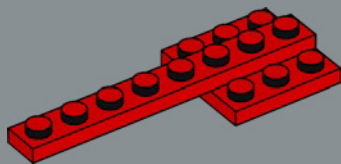

2

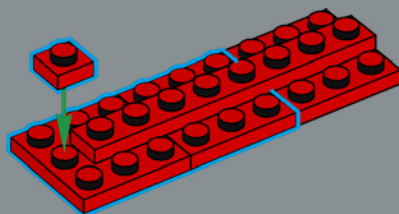

3

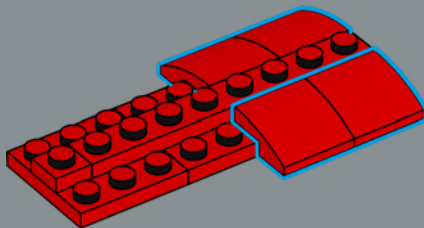

4

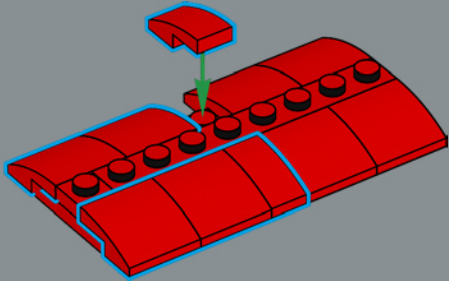

5

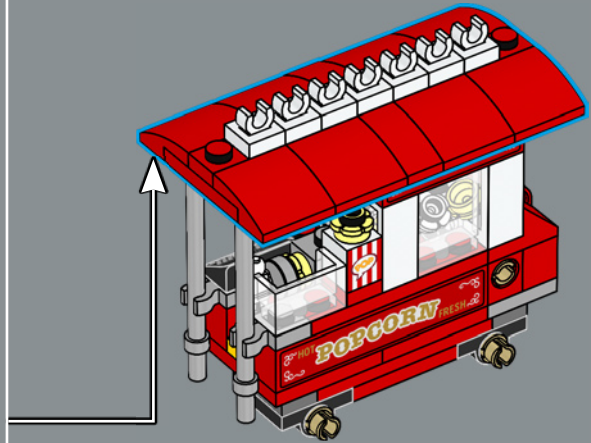
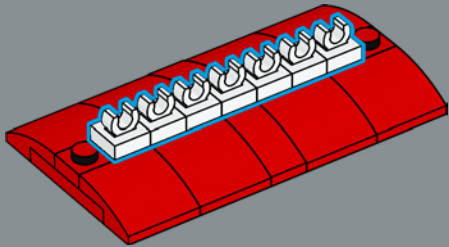



25

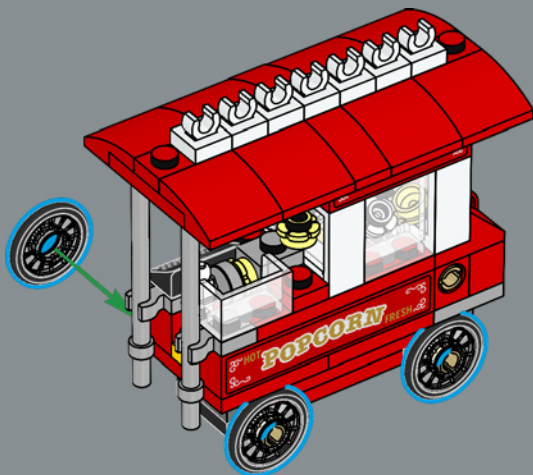

White and yellow LEGO® flower pieces represent popcorn kernels. Tap the lever on the side of the cart to pop the popcorn!

Les petites fleurs LEGO® blanches et jaunes représentent des grains de maïs soufflé. Appuyez sur le levier situé sur le côté du chariot pour faire « éclater » le maïs!

Contiene elementos de flores LEGO® en blanco y amarillo que representan palomitas de maíz. ¡Toca la palanca que lleva el carrito por un lado para que aparezcan las palomitas recién cocinadas!





26

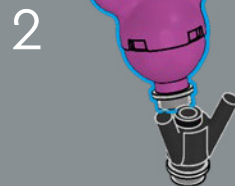
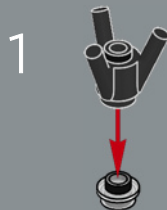
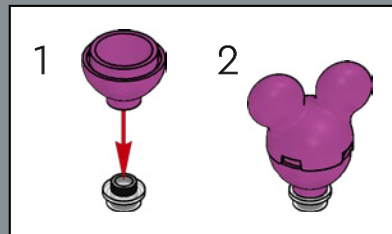

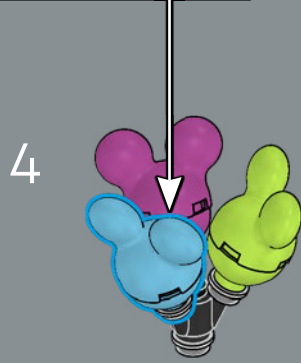
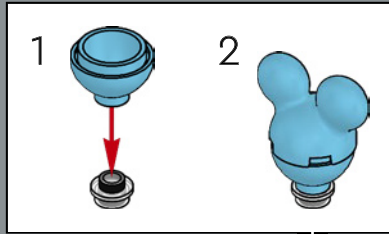
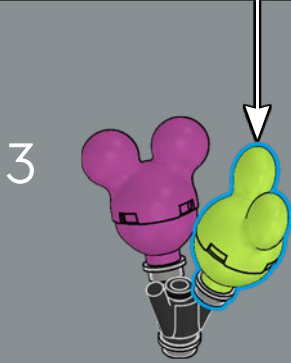
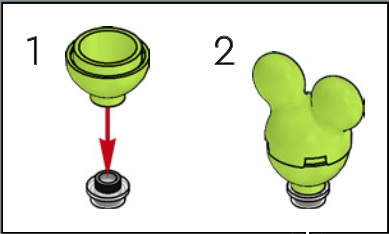

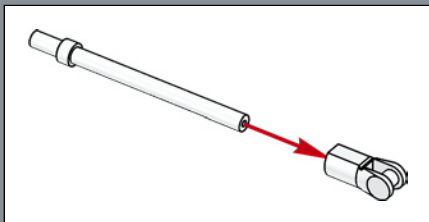

5

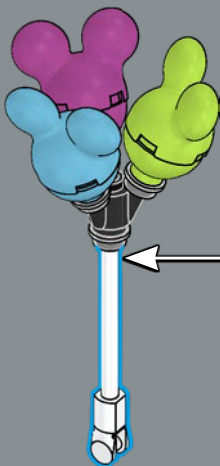

Many popcorn carts around the park feature small, animated dolls – unique to each land – cranking a drum of popcorn. The LEGO® version uses a tiny minifigure trophy element to recreate them.

Dans les parcs, plusieurs chariots à maïs soufflé sont décorés de petites poupées animées – propres à chaque section du parc – qui font tourner le tambour de maïs soufflé. La version LEGO® recrée cette animation à l'aide d'un minuscule trophée de figurine.

Muchos carritos de palomitas distribuidos por el parque presentan pequeños muñecos a tono con la temática de la zona haciendo girar grandes recipientes con palomitas. En la versión LEGO®, se recrean mediante pequeños elementos de trofeos para minifiguras.



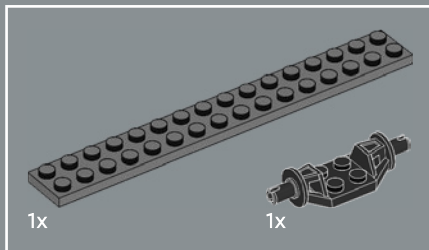
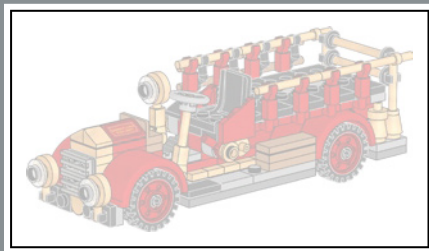

1

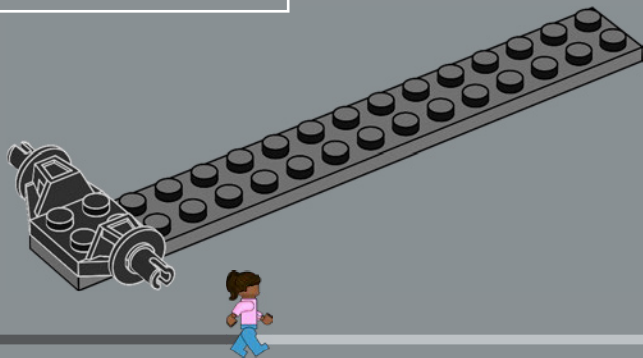



2

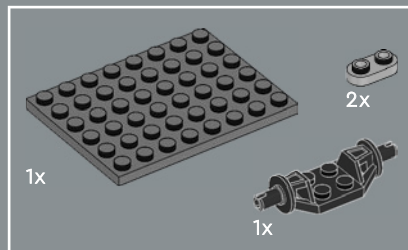
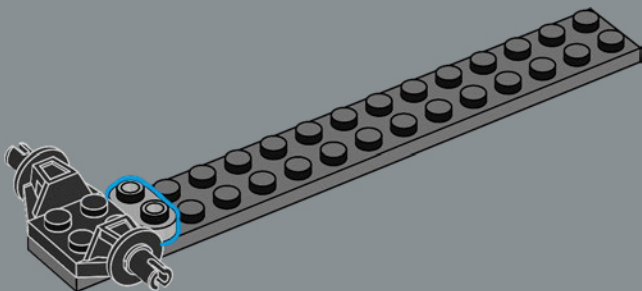

3

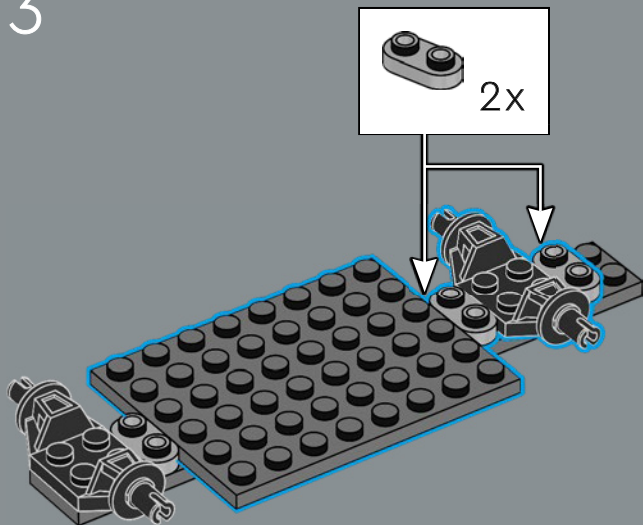

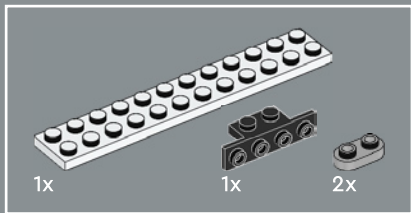

4

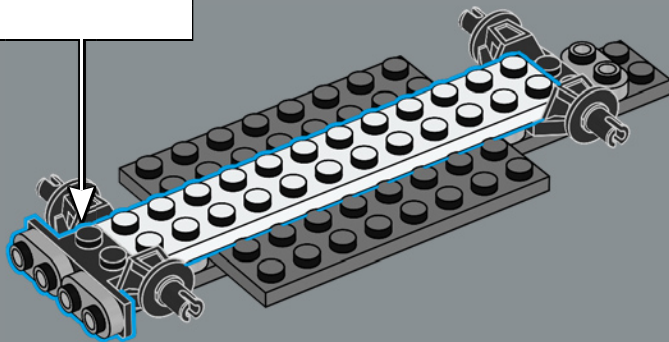
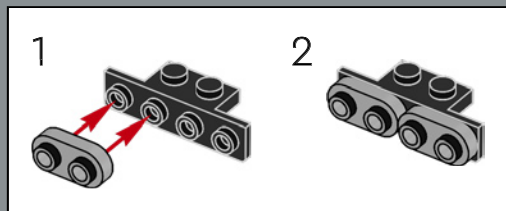

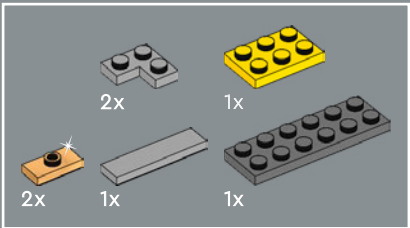

5

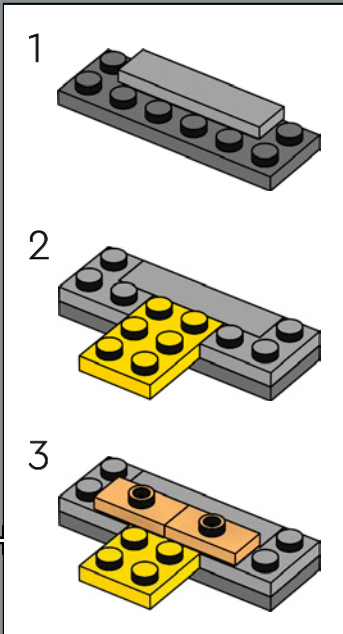
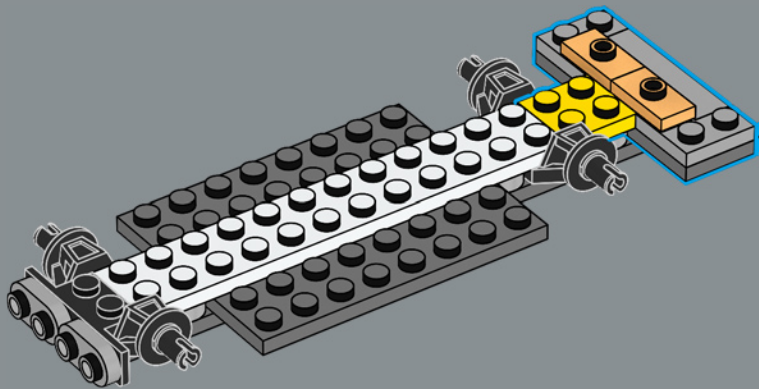



7

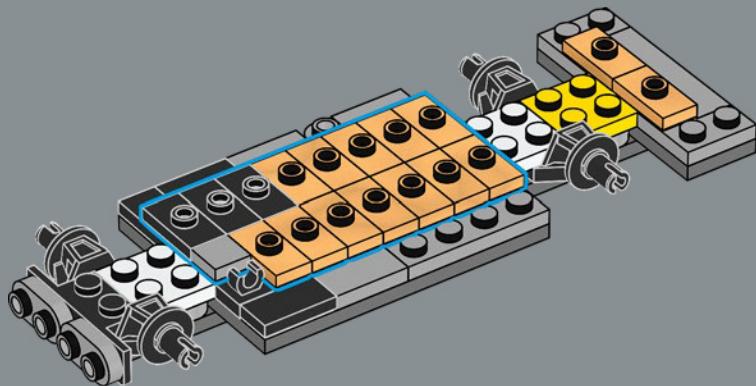

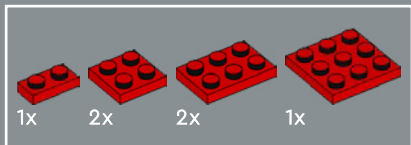

8

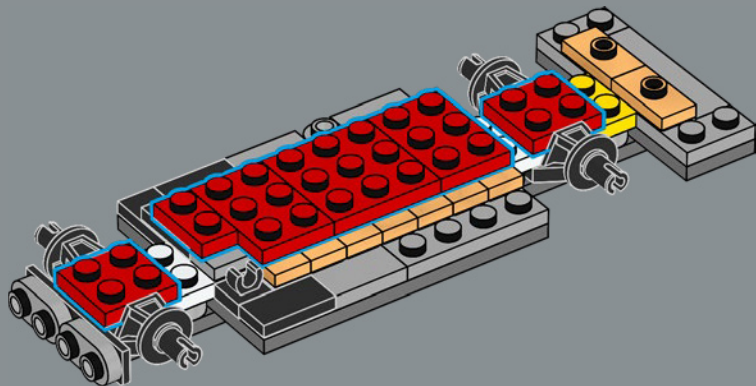

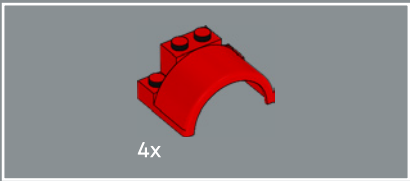

9

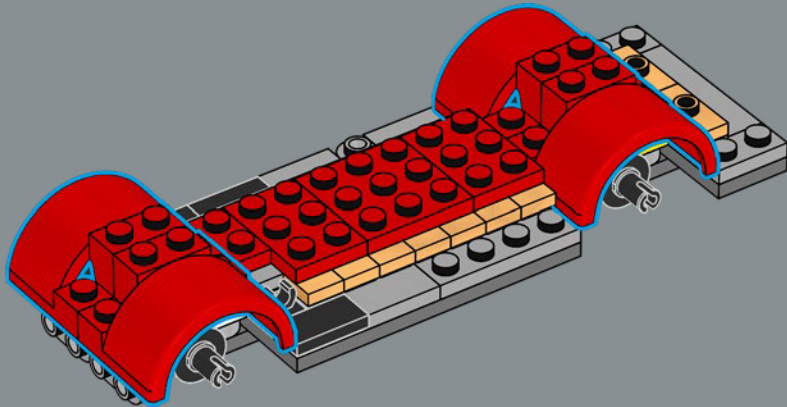



10

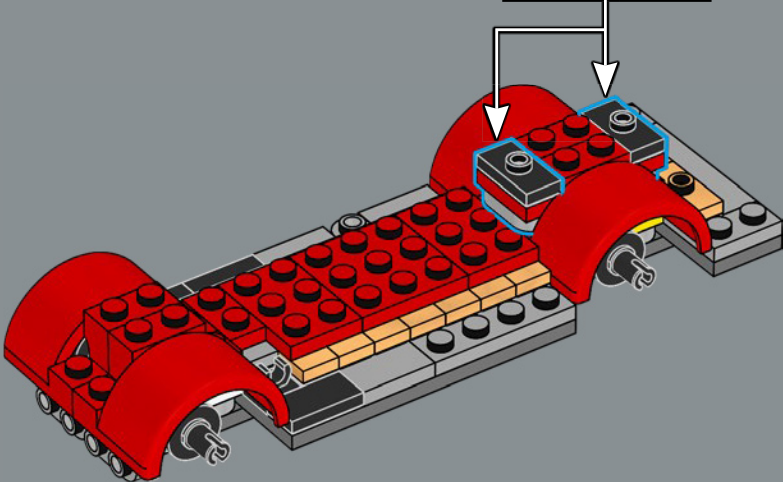
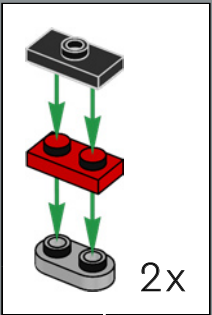

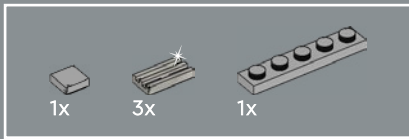

11

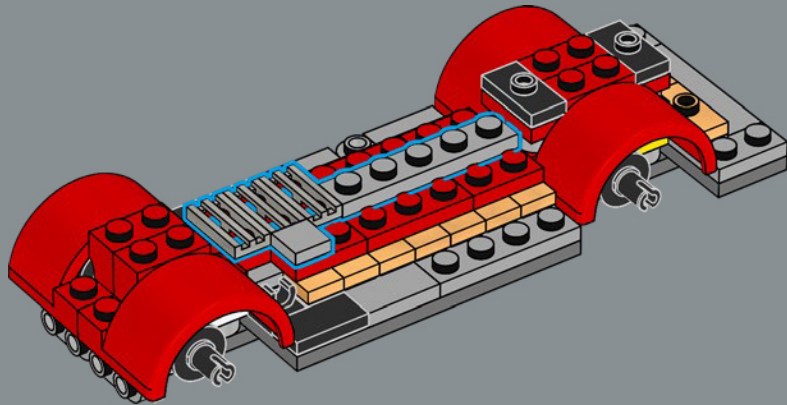

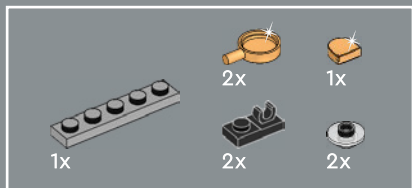

12

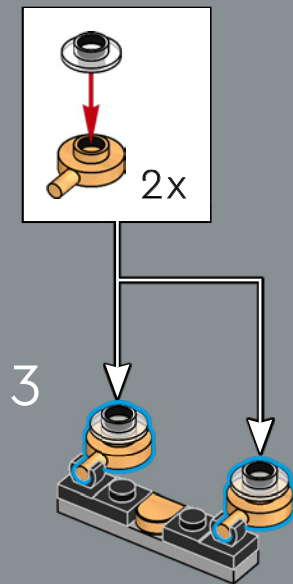
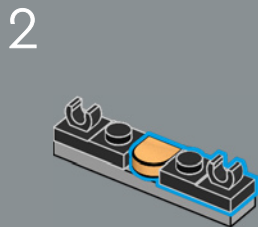
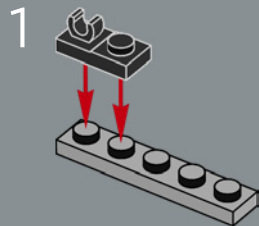

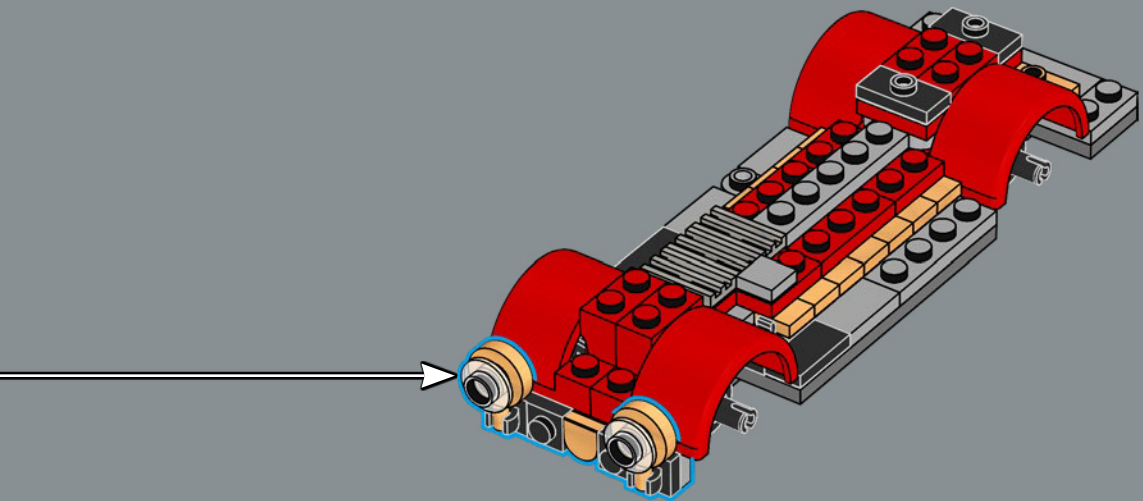

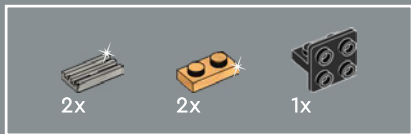

13

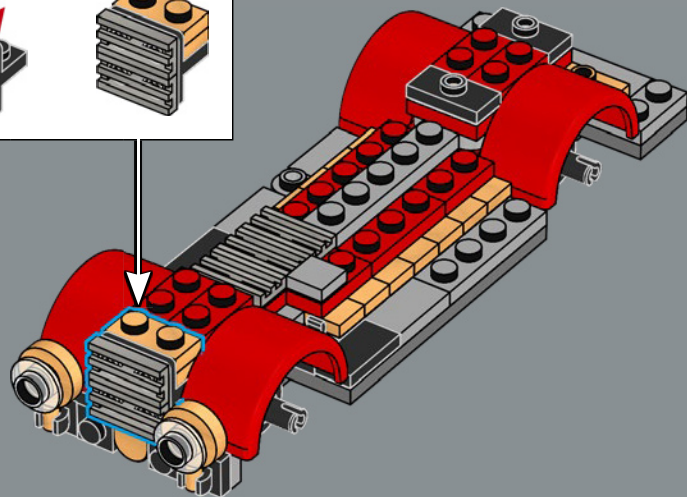
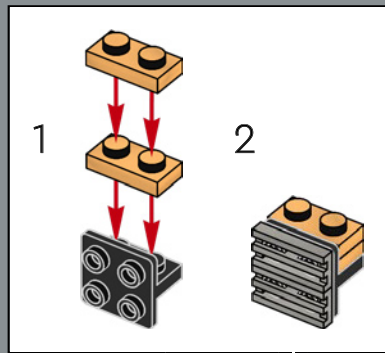



Introduced to the park in 1958, the Main Street Fire Engine was based on the 1916 American LaFrance Fire Truck, and was designed by Bob Gurr, who famously created many iconic attractions within the park.

Introduit au parc en 1958, le camion de pompiers de Main Street est inspiré du modèle American LaFrance de 1916 et a été conçu par Bob Gurr, célèbre pour avoir imaginé de nombreuses attractions emblématiques du parc.

Introducido en el parque en 1958, el camión de bomberos de Main Street, U.S.A. estaba inspirado en el camión de bomberos American LaFrance de 1916 y fue diseñado por Bob Gurr, famoso por haber creado muchos juegos mecánicos icónicos del parque.

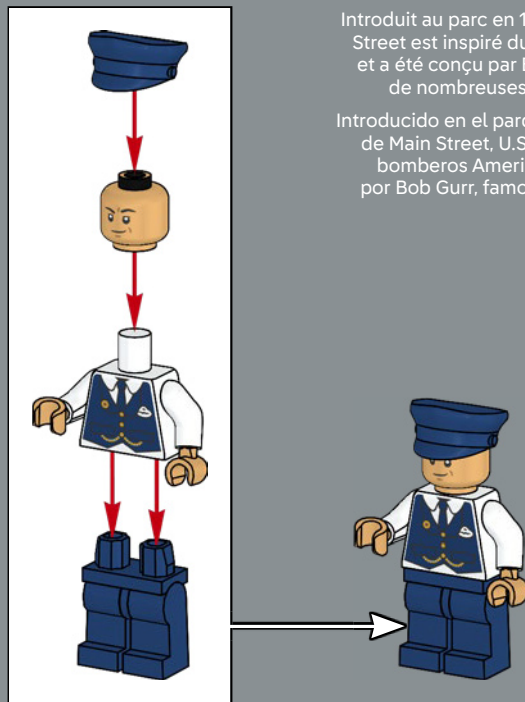

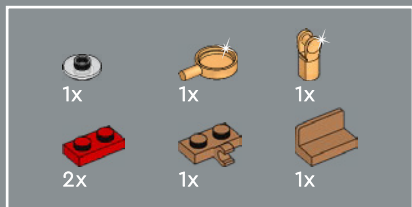

14

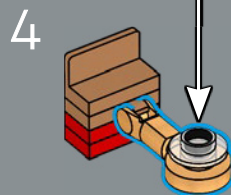
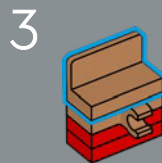
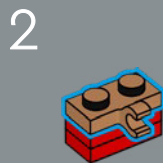
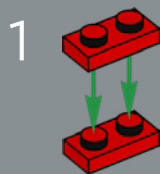
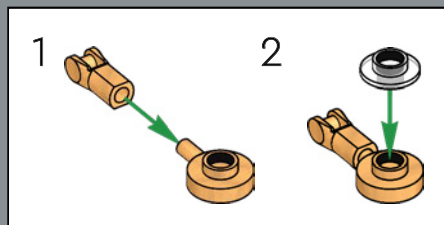



5

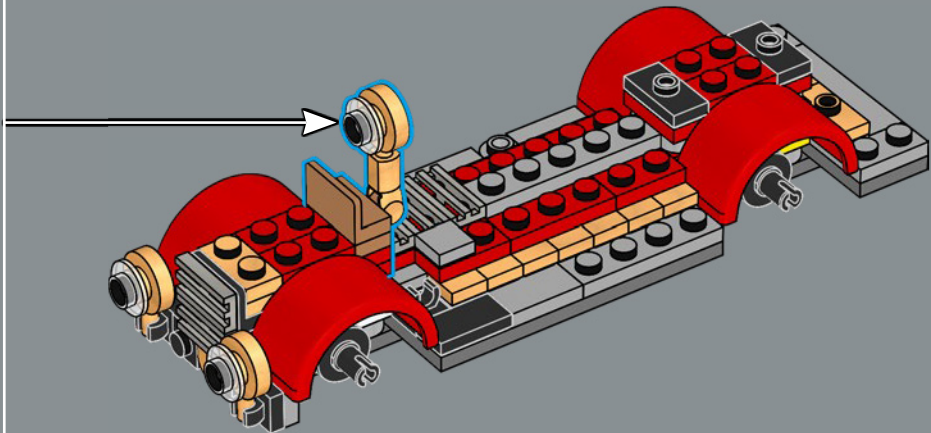

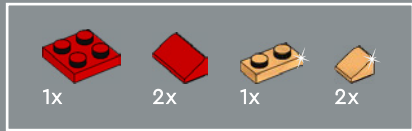

15

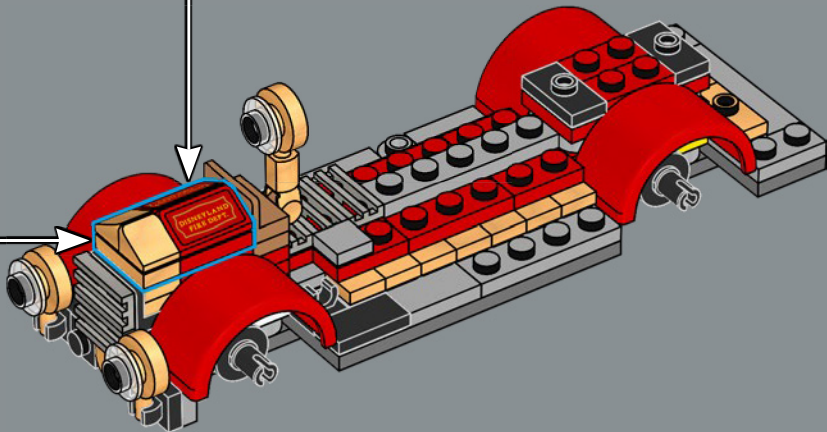
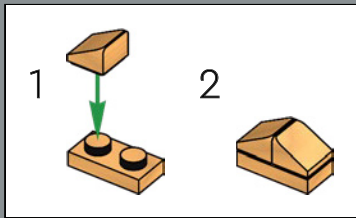
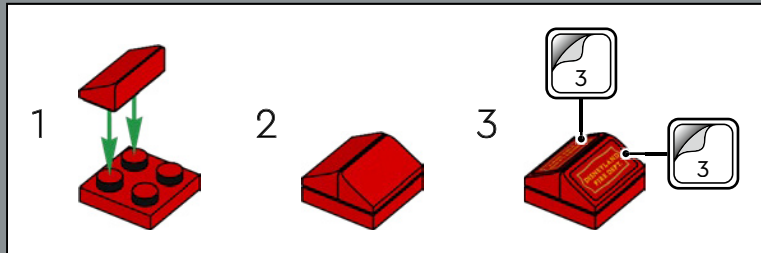

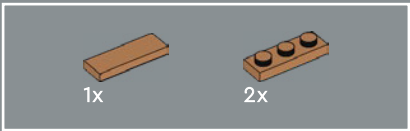

16

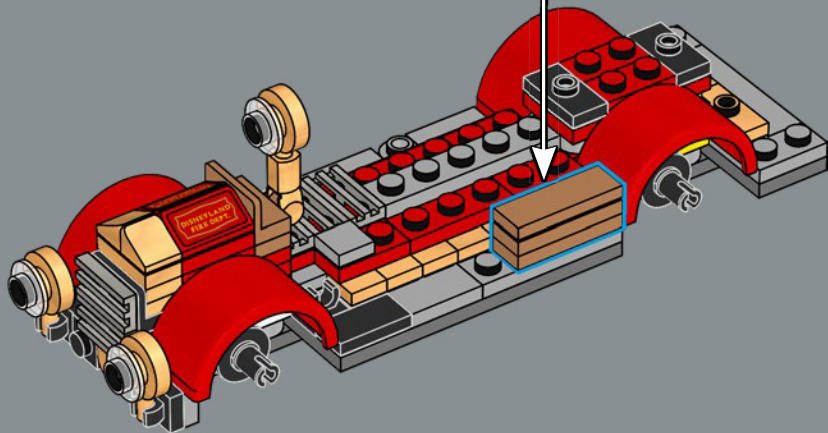
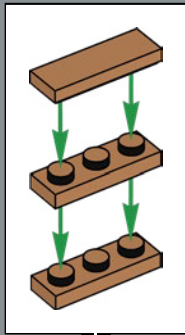

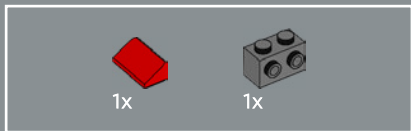

17

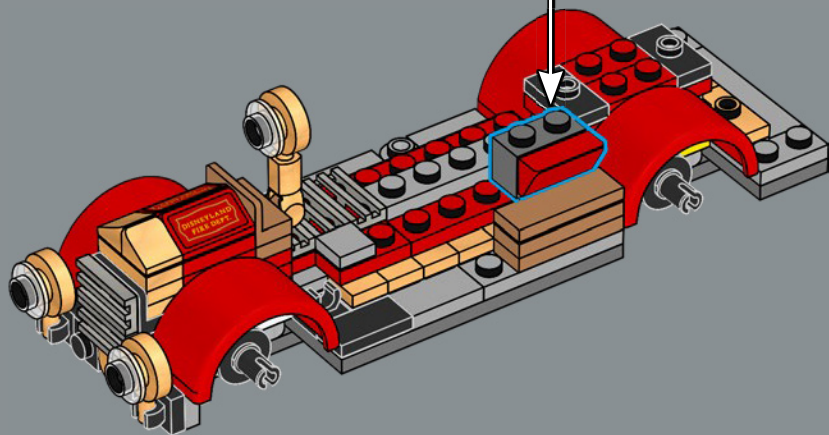
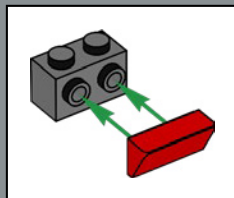

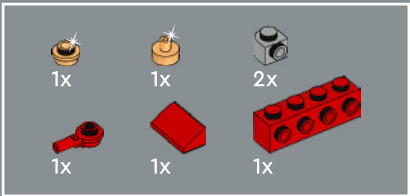

18

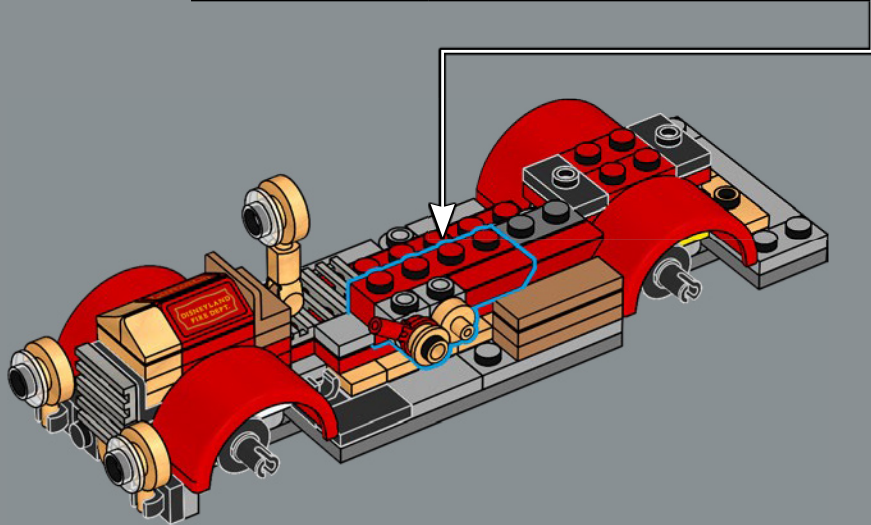
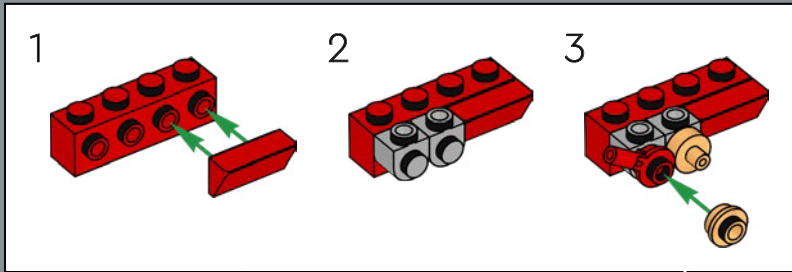

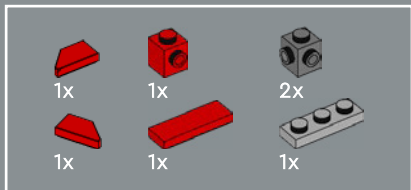

19

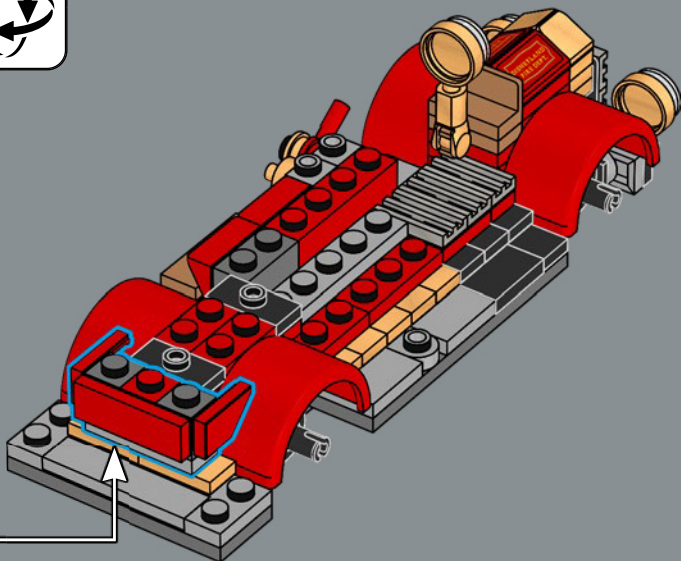
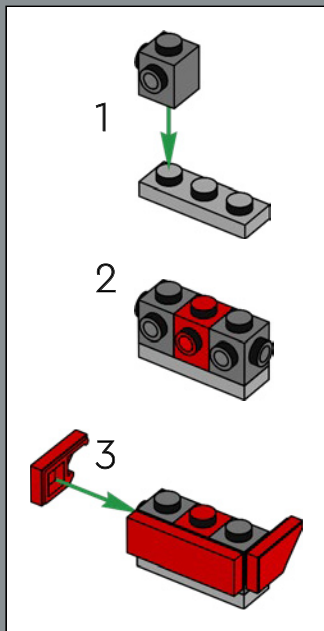



20

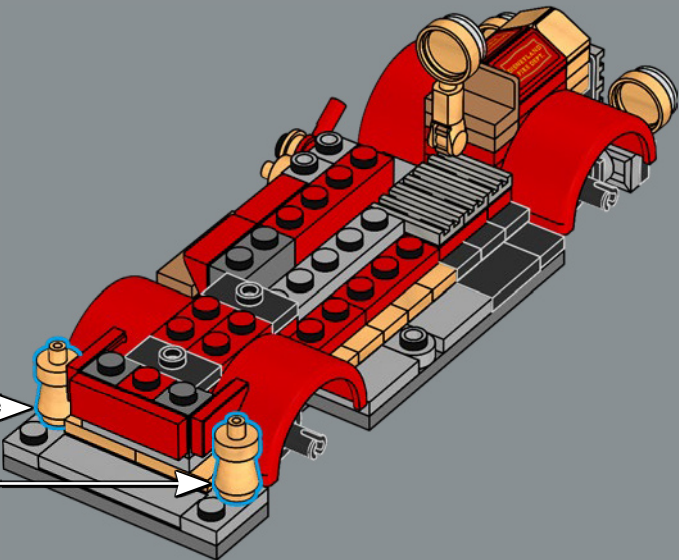
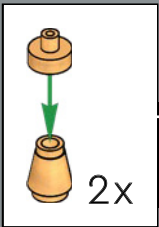

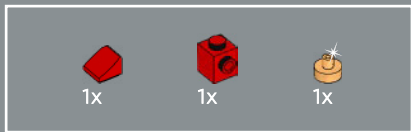

21

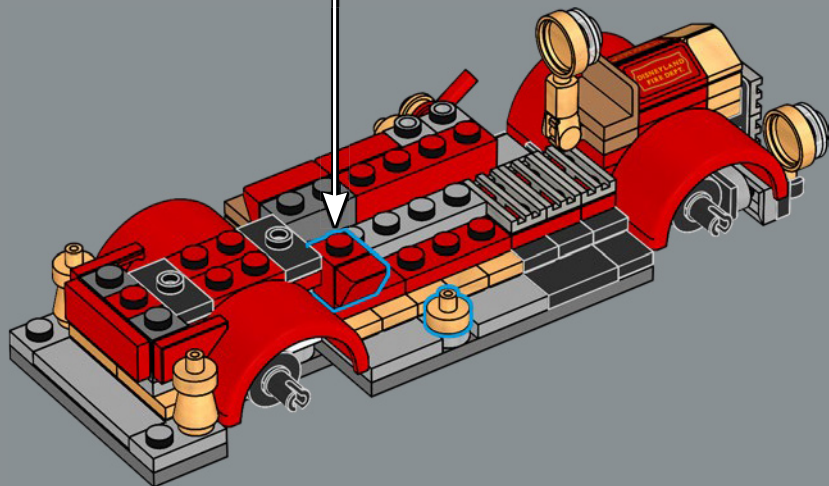
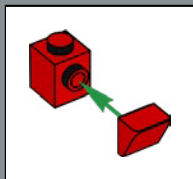

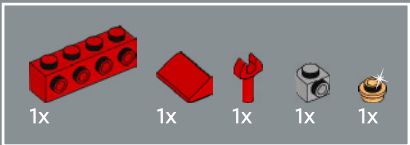

22

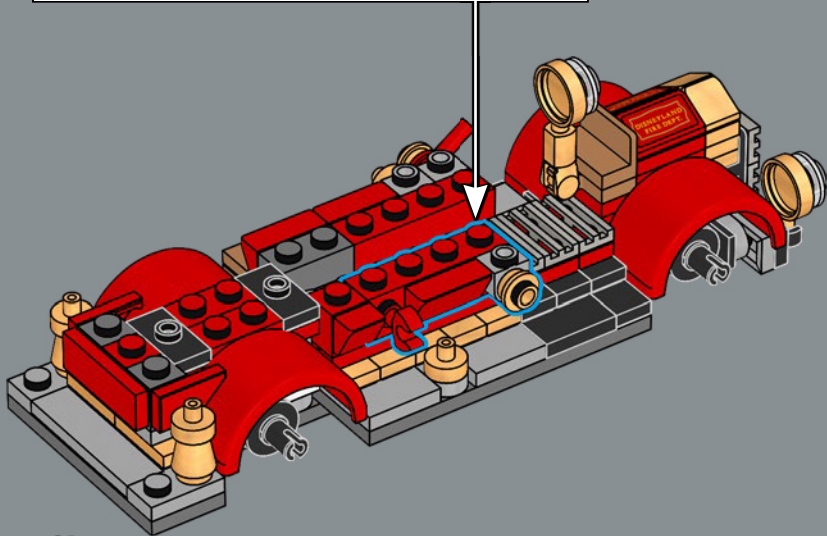
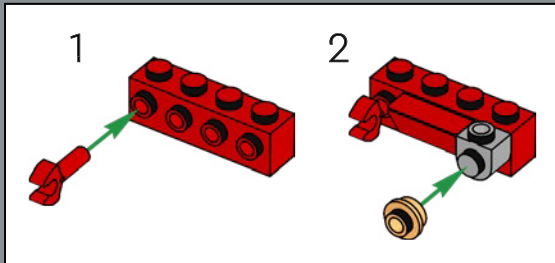

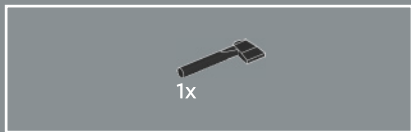

23

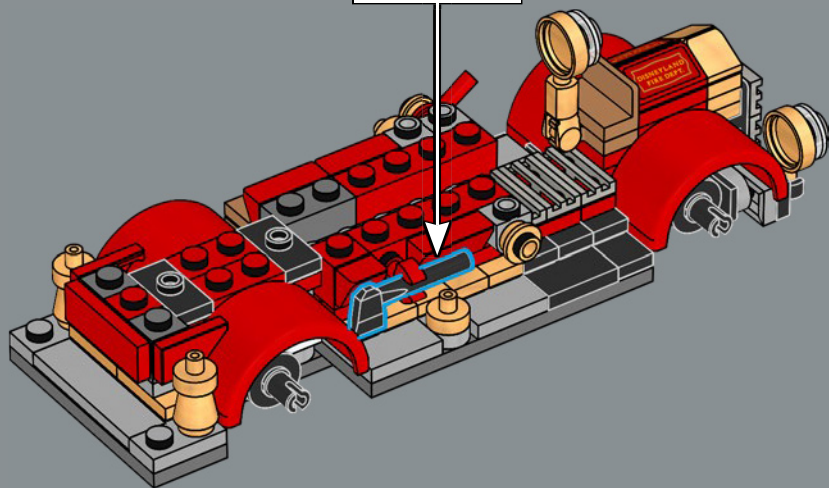

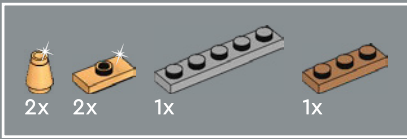

24

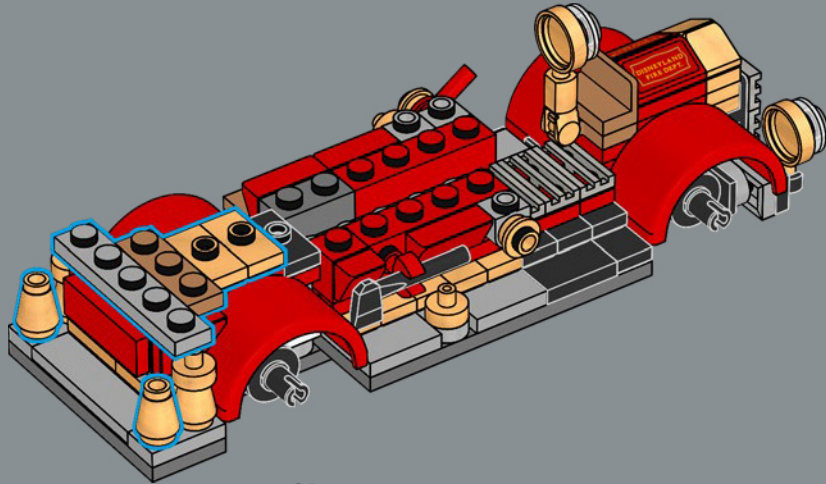



1x



1x



1x

25

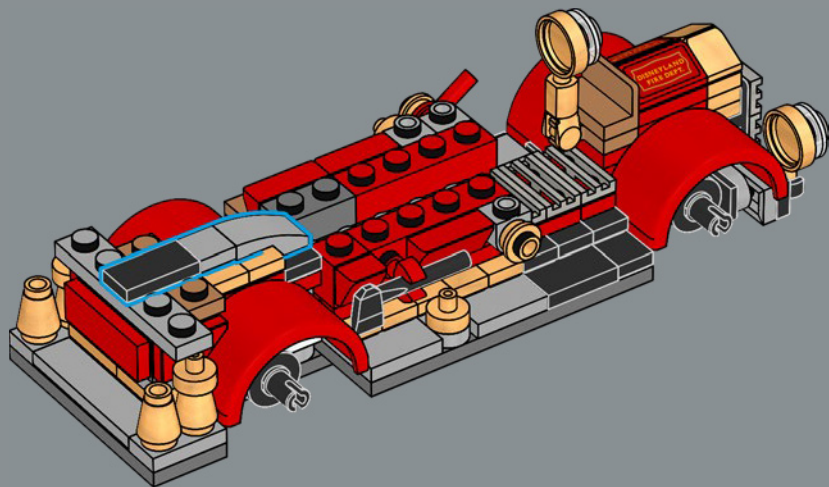

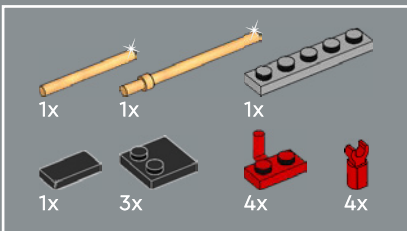
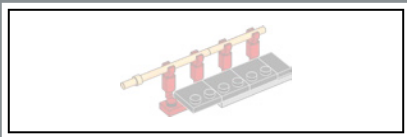

26

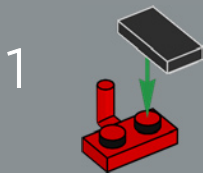

2

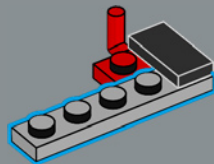

3

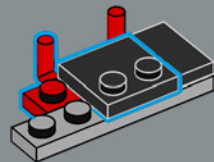

4

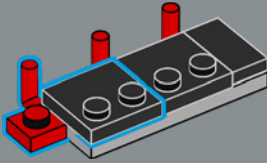

5

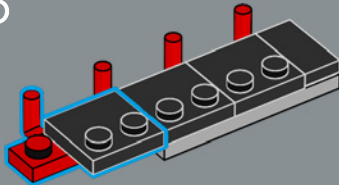

6

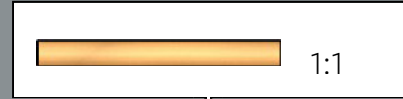
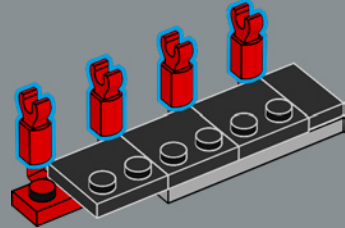

7

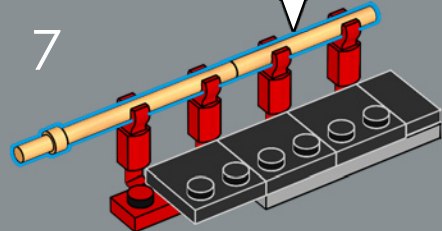

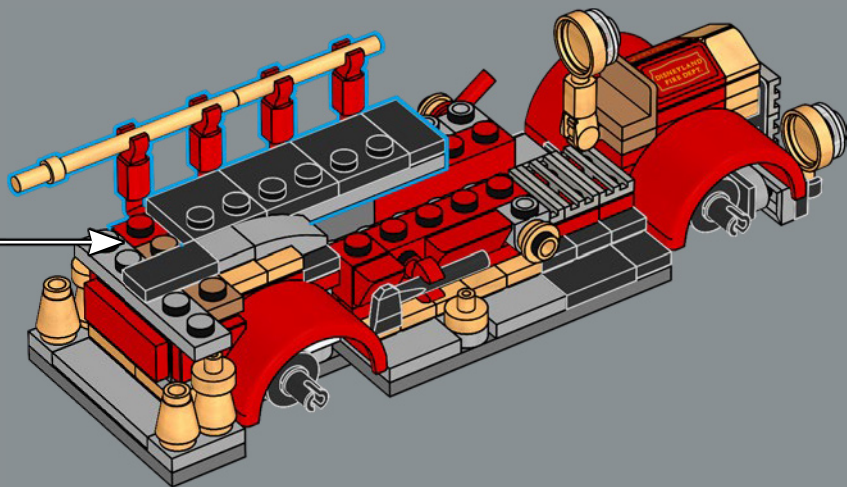

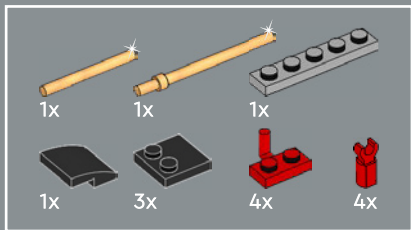
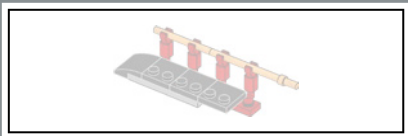

27

1

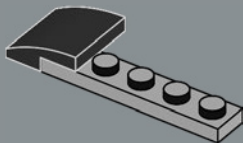

2

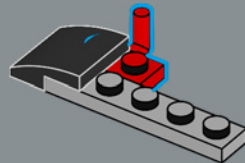

3

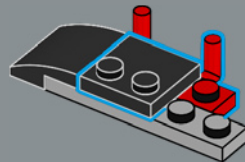

4

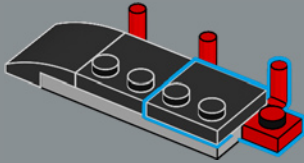

5

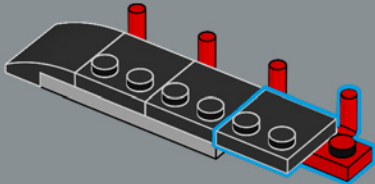

6

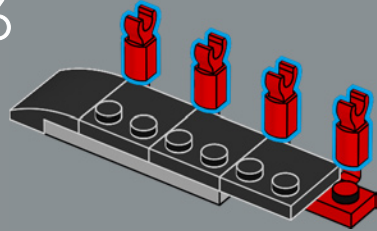

7

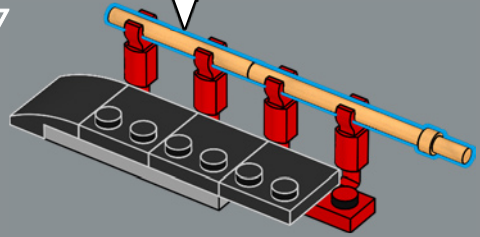

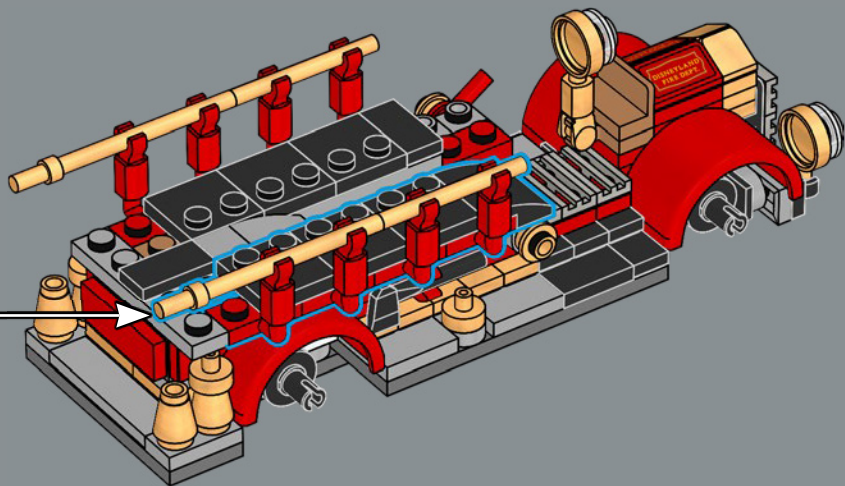



2x

28

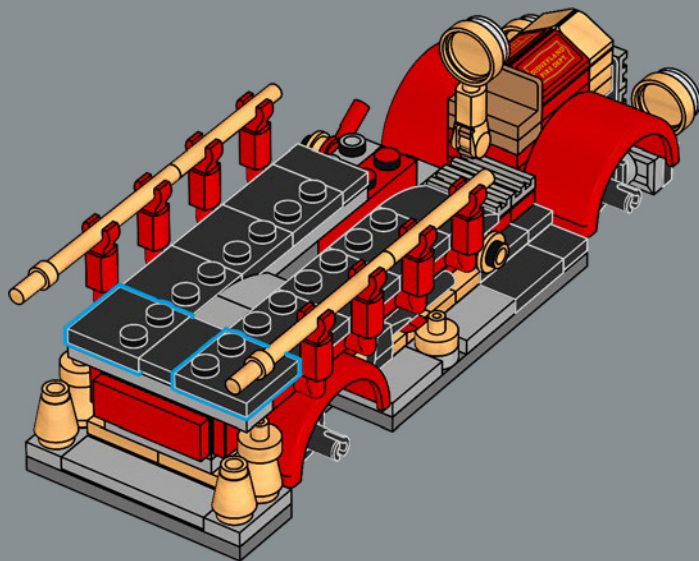

Park guests today can still ride the fire truck along Main Street.

Les visiteurs peuvent encore aujourd'hui monter à bord du camion de pompiers pour une balade sur Main Street.

Los visitantes todavía pueden subirse al camión de bomberos y recorrer Main Street, U.S.A.





29

1

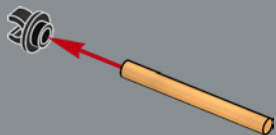

2



3

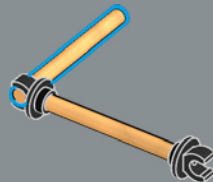

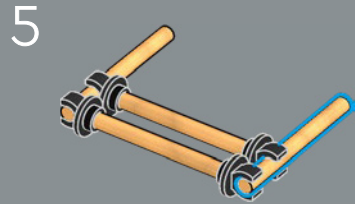
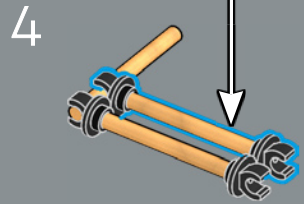
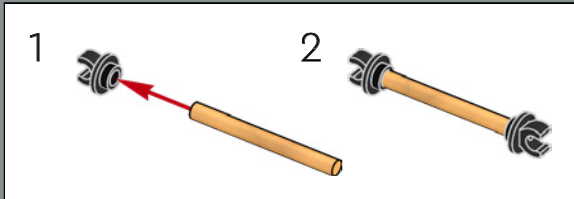

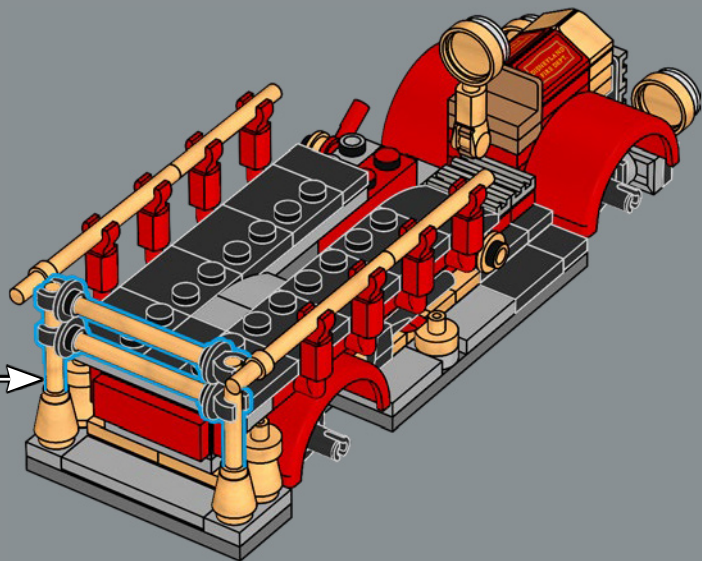

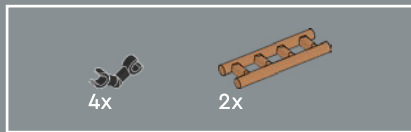

30

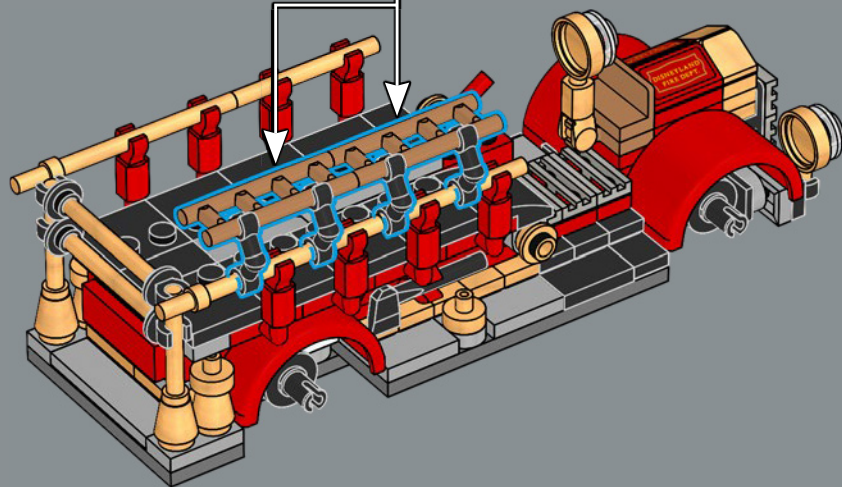
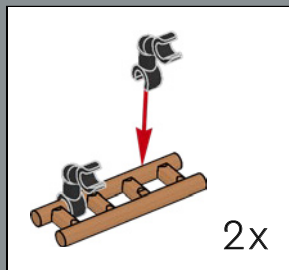

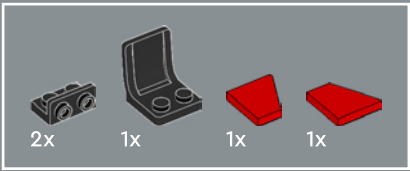

32

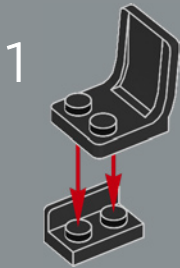

2

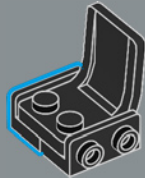

3

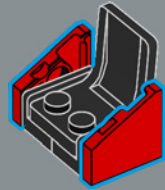

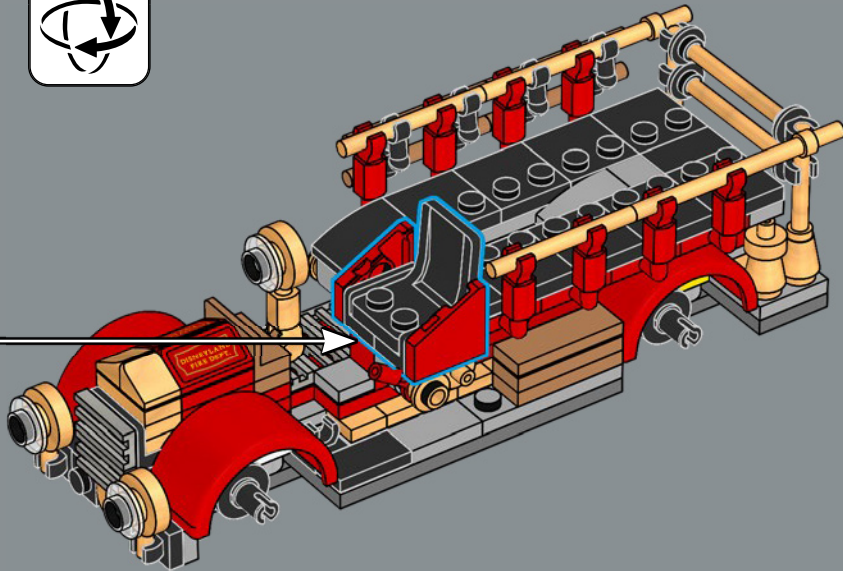



33

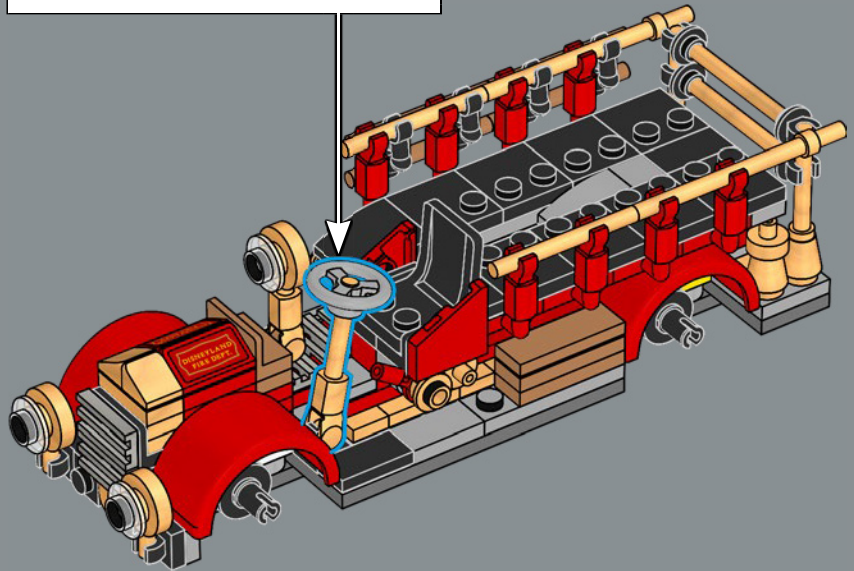
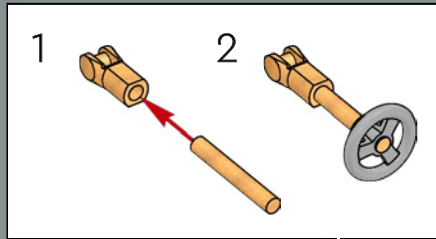

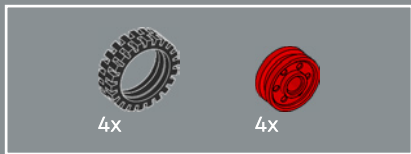

34

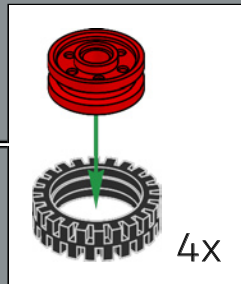
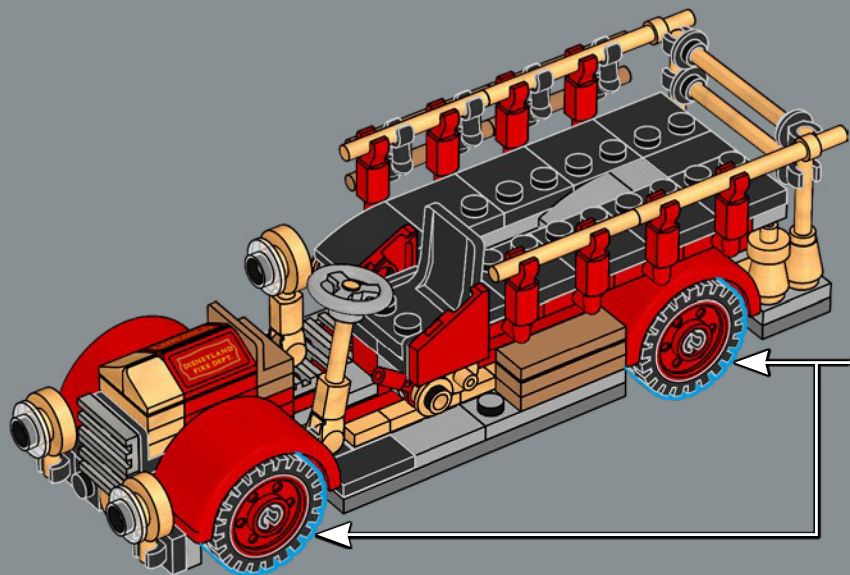

Walt Disney was known to drive the fire truck around the park from time to time.

Walt Disney lui-même aimait parfois le conduire dans le parc.

Era un hecho conocido que Walt Disney conducía el camión de bomberos por el parque de vez en cuando.





LEGO and the LEGO logo are trademarks of the/son des marques de commerce du/son marcas registradas de LEGO Group. ©2026 The LEGO Group.

© Disney © Disney/Pixar © & TM Lucasfilm Ltd © 2026 MARVEL



6649253