



75442

**STAR
WARS**



Disney

Available in English
Disponible en français
Disponible en español

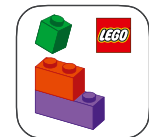

LEGO® Builder

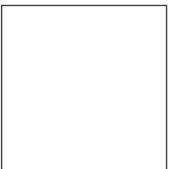



WE'RE MAKING OUR PACKAGING MORE SUSTAINABLE

We're transitioning from single-use plastic to paper-based packaging. As we progress, you may find a mix of paper and plastic in our boxes.

NOUS RENDONS NOS EMBALLAGES PLUS DURABLES

Nous passons des emballages en plastique à usage unique aux emballages à base de papier. Durant la transition, vous pourriez trouver un mélange de papier et de plastique dans nos boîtes.

QUEREMOS HACER MÁS SUSTENTABLES NUESTROS MATERIALES DE EMBALAJE

Estamos cambiando las bolsas de plástico desechables por bolsas con base de papel. Conforme avanzamos en este propósito, puedes encontrar una mezcla de papel y de plástico en nuestras cajas.

LEGO.com/sustainable-packaging



BUILDER



Apple and the Apple logo are trademarks of Apple Inc., registered in the U.S. and other countries and regions. App Store is a service mark of Apple Inc. Google Play and the Google Play logo are trademarks of Google LLC. Tencent and the Tencent logo are trademarks of Tencent Inc.

LEGO.com/devicecheck

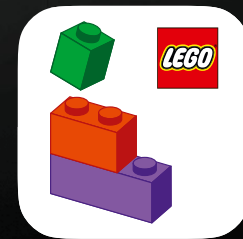

LEGO® Builder



ANYTHING BUT A PILE OF JUNK!

We're pretty sure we weren't the only *Star Wars* fans who let out a gasp of excitement when Peli Motto revealed the Naboo N-1 Starfighter to The Mandalorian in *The Book of Boba Fett*. After all, our passion is to build (and rebuild) starships. And we couldn't wait to see what tricks the renowned Mos Eisley mechanical genius/parts peddler had up her sleeve to replace the notorious *Razor Crest*. Of course, we had to make a LEGO® *Star Wars*™ version – and it's now ready to leave the ~~garage~~ box. A large-scale build-to-display model, it joins our extensive Ultimate Collector Series – guaranteed scurrer-free and will fly under almost any radar.

Enjoy building!
The LEGO® *Star Wars*™ Team



TOUT SAUF UN TAS DE FERRAILLE!

Nous sommes sûrs de ne pas être les seuls amateurs de *Star Wars* à avoir poussé un soupir d'excitation lorsque Peli Motto a révélé le chasseur Naboo N-1 au Mandalorien dans *Le Livre de Boba Fett*. Après tout, notre passion est de construire (et de reconstruire) des vaisseaux spatiaux. Et nous étions impatients de voir quels trucs la célèbre mécanicienne de génie et vendeuse de pièces détachées de Mos Eisley avait dans sa manche pour remplacer le fameux *Razor Crest*. Bien sûr, nous devons faire une version LEGO® *Star Wars*™ – et elle est maintenant prête à quitter le garage la boîte. Ce modèle à grande échelle, conçu pour être exposé, vient s'ajouter à notre vaste Série de collection suprême, qui garantit l'absence d'éraflures et qui passera inaperçue.

Bonne construction!
L'équipe LEGO® *Star Wars*™

¡TODO MENOS UN PEDAZO DE BASURA!

Estamos convencidos de que no fuimos los únicos fans de *Star Wars* que soltamos un grito de emoción cuando Peli Motto le mostró el caza estelar Naboo N-1 al Mandaloriano en *El libro de Boba Fett*. Después de todo, nuestra pasión es construir (y reconstruir) naves espaciales. Y estábamos impacientes por ver qué trucos tenía bajo la manga la renombrada genio mecánica y vendedora de refacciones para naves de Mos Eisley para reemplazar la famosa *Razor Crest*. Naturalmente, teníamos que hacer una versión LEGO® *Star Wars*™ que ahora está lista para abandonar el taller de su caja. Se trata de un modelo de exhibición a gran escala que se une a nuestra extensa colección Ultimate Collector Series, con garantía de estar libre de *scurriers* y volar debajo de casi cualquier radar.

¡Que disfrutes construyendo!
El equipo de diseño de LEGO® *Star Wars*™

A PRE-EMPIRE CLASSIC

When you build a starship that performs well, it doesn't have to be at the expense of a beautiful exterior. The Naboo N-1 starfighter is one of the most striking designs by the Theed Palace Space Vessel Engineering Corps. Its polished chromium nose, sculpted lines and curves, and custom-tuned twin-ion engines are classic examples of a Naboo tradition that fuses elegance with high performance. Originally commissioned by the Royal Naboo Security Forces, the N-1 is a sleek single-seater with a bite: its twin laser cannons and proton torpedoes are backed by scorching speed and precision. The signature 'rat-tail' finials serve as heat sinks for optimal engine cooling, which in turn helps reduce pollution.



UN CLASSIQUE D'AVANT L'EMPIRE

Lorsque vous construisez un vaisseau spatial performant, cela ne doit pas se faire au détriment d'un bel extérieur. Le chasseur Naboo N-1 est l'un des modèles les plus remarquables conçus par le Corps d'ingénierie des vaisseaux spatiaux du Palais Theed. Son nez en chrome poli, ses lignes et ses courbes sculptées et ses moteurs bioniques réglés sur mesure sont des exemples classiques de la tradition Naboo qui allie élégance et hautes performances. Commandé à l'origine par les forces de sécurité royales de Naboo, le N-1 est un monoplace élégant qui ne manque pas de mordant : ses deux canons laser et ses torpilles à protons s'accompagnent d'une vitesse et d'une précision redoutables. Les embouts « queue de rat » caractéristiques servent de puits de chaleur pour un refroidissement optimal du moteur, ce qui contribue à réduire la pollution.

UN CLÁSICO PREIMPERIAL

Cuando construyes una nave espacial, no tienes que sacrificar un exterior vistoso para que funcione bien. El caza estelar Naboo N-1 es uno de los diseños más llamativos del Cuerpo de Ingenieros de Naves Estelares del Palacio de Theed. Su nariz cromada con acabado pulido, sus líneas y curvas esculpidas, y sus motores iónicos dobles adaptados son ejemplos clásicos de la tradición de Naboo, que fusiona la elegancia con el alto desempeño. Encargado originalmente por las Fuerzas de Seguridad Reales de Naboo, el N-1 es un elegante monoplace con capacidad real de noquear, sumando una velocidad vertiginosa y precisión quirúrgica a la potencia de sus cañones láser gemelos y torpedos de protones. Los característicos tapones de tobera sirven como disipadores de calor para enfriar los motores con eficiencia, lo que, a su vez, reduce la contaminación.

THE FASTEST SHIP IN THE OUTER RIM

Decades after its original heyday with Anakin Skywalker at the helm, the iconic starship finds its way to a new pilot. After losing the *Razor Crest*, the Mandalorian Din Djarin is on the hunt for its worthy successor. He first sets his eyes on the battered remains of the N-1 in Peli Motto's garage, although first impressions are not exactly favorable. From there, Motto's resourceful Jawa contractors scrounge the finest scrap the desert world can offer (no questions asked), and Motto's vision begins to take shape. Outfitted with a turbonic venturi power assimilator, cryogenic density booster and custom induction intake, the ship boasts blistering thrust, hyperspace capability without a docking ring and snappy controls and maneuvering tuned for dogfights.

"Dank farrik, she's fast."

– The Mandalorian



© & ™ Lucasfilm Ltd.

LE VAISSEAU LE PLUS RAPIDE DE LA BORDURE EXTÉRIÈRE

Des décennies après son apogée avec Anakin Skywalker aux commandes, le vaisseau emblématique est confié à un nouveau pilote. Après avoir perdu le *Razor Crest*, le mandalorien Din Djarin est à la recherche d'un digne successeur. Il pose d'abord les yeux sur les restes abîmés du N-1 dans le garage de Peli Motto, mais sa première impression n'est pas vraiment favorable. À partir de là, les entrepreneurs Jawa de Motto, pleins de ressources, récupèrent les meilleures pièces que le monde désertique peut offrir (sans poser de questions), et la vision de Motto commence à prendre forme. Équipé d'un assimilateur de puissance à venturi turbonique, d'un amplificateur de densité cryogénique et d'un système d'admission personnalisé, le vaisseau offre une poussée fulgurante, une capacité hyperspatiale sans anneau d'amarrage, des commandes rapides et des manœuvres adaptées aux combats de chiens.

« Dank farrik, elle est rapide. »

– Le Mandalorien.

LA NAVE MÁS RÁPIDA DEL BORDE EXTERIOR

Décadas después de su apogeo original con Anakin Skywalker al mando, la icónica nave espacial encuentra un nuevo piloto. Luego de perder la *Razor Crest*, el Mandaloriano Din Djarin se lanza a la búsqueda de un sucesor digno. Lo primero que ve son los restos destrozados del N-1 en el taller de Peli Motto, llevándose una primera impresión que no era precisamente favorable. Pero luego, los resolutivos Jawas que suministran partes a Motto le consiguen los mejores desechos que el mundo desértico puede ofrecer (sin hacer preguntas, claro está), y la visión de Motto empieza a tomar forma. Equipada con un asimilador de energía turbónico Venturi, un propulsor de combustión criogénico de densidad y un cargador de entrada de inducción, la nave cuenta con un formidable empuje, capacidad de saltar al hiperespacio sin anillo de hiperpropulsión, controles concisos y maniobrabilidad ajustada para el combate contra otras naves.

"Dank farrik, es rápida".

– El Mandaloriano

FROM THE LEGO® STAR WARS™ DESIGN TEAM

Our partners at Lucasfilm Ltd. shared lots of reference images of the N-1 from their archives, and we had hundreds of pictures of a life-size version. The organic shape of the starship has a major design appeal but recreating the bulbous bottom of the N-1 caught us by surprise – it was a real challenge. The same goes for the subtle angle of the wings. We didn't have any existing elements that allowed us to create the correct angle, so it took some creative experiments to get it right. The engines are full of little parts, tubes and bits – it's by far the most intricate part of the model – and we had to capture that while maintaining the stability and build flow. One thing we're really excited about is the number of drum-lacquered elements we were able to add to the exterior. The shiny chromium look adds an extra layer of authenticity to the model as it's seen in the series. Yellow markings hint at its origin story, balancing the rugged edge-look with the sleek design. Overall, it's such an interesting vehicle and we hope you'll be proud to display it.

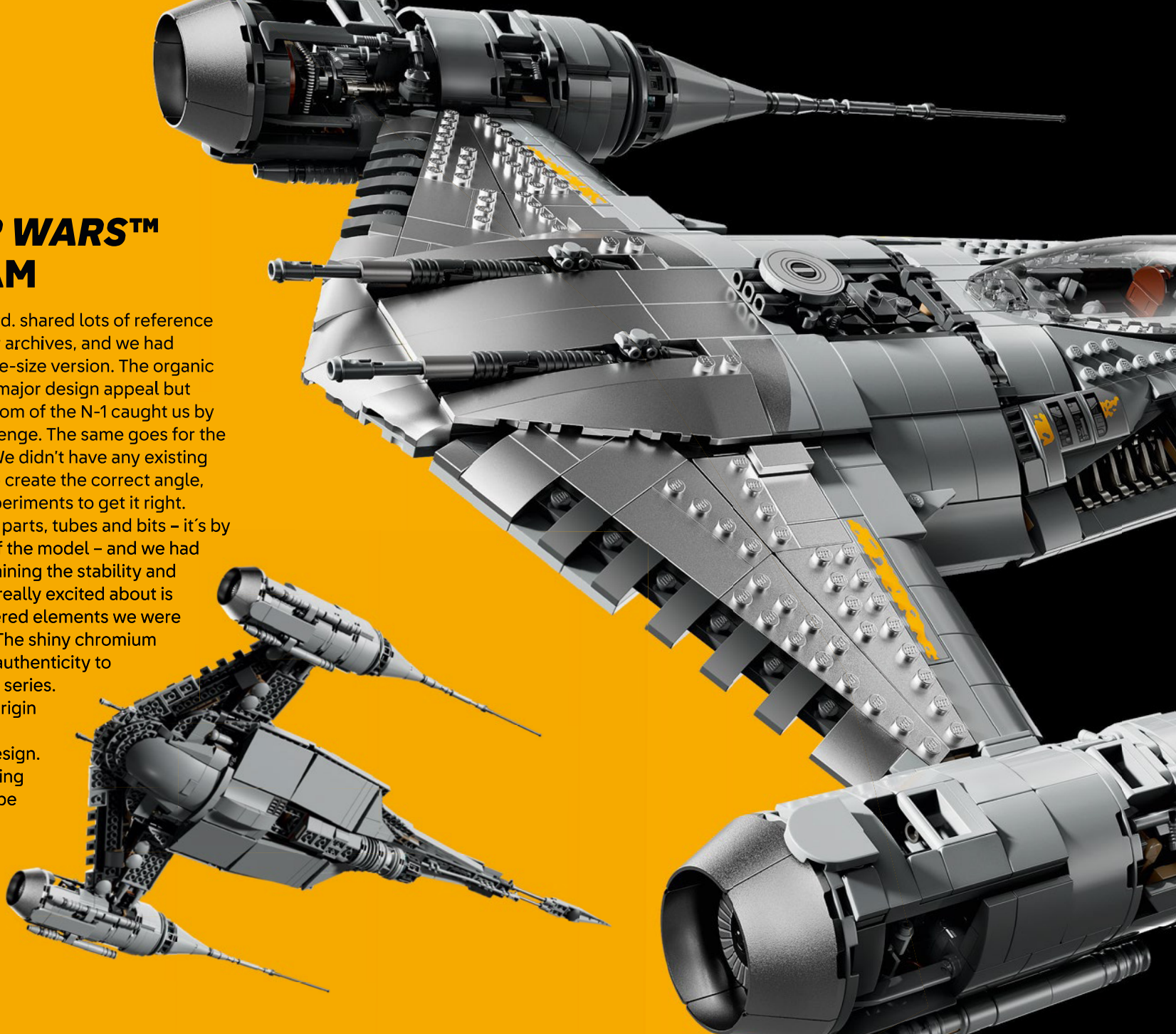



UN MOT DE L'ÉQUIPE DE CONCEPTION LEGO® STAR WARS™

Nos partenaires de Lucasfilm Ltd. ont partagé de nombreuses images de référence du N-1 provenant de leurs archives, et nous avons des centaines de photos d'une version grandeur nature. La forme organique du vaisseau a un attrait majeur pour le design, mais recréer le fond bulbeux du N-1 nous a pris par surprise – c'était un véritable défi. Il en va de même pour l'angle subtil des ailes. Nous n'avions pas d'éléments existants qui nous permettaient de créer l'angle correct, il a donc fallu des expériences créatives pour y parvenir. Les moteurs sont pleins de petites pièces, de tubes et de morceaux – c'est de loin la partie la plus complexe du modèle – et nous devons capturer cela tout en maintenant la stabilité et la fluidité de la construction. Nous sommes très heureux du nombre d'éléments laqués au tambour que nous avons pu ajouter à l'extérieur. L'aspect chromé brillant ajoute une couche supplémentaire d'authenticité au modèle tel qu'il apparaît dans la série. Des marques jaunes indiquent son origine, équilibrant l'aspect robuste et le design épuré. Dans l'ensemble, il s'agit d'un véhicule très intéressant, et nous espérons que vous serez fier de l'exposer.

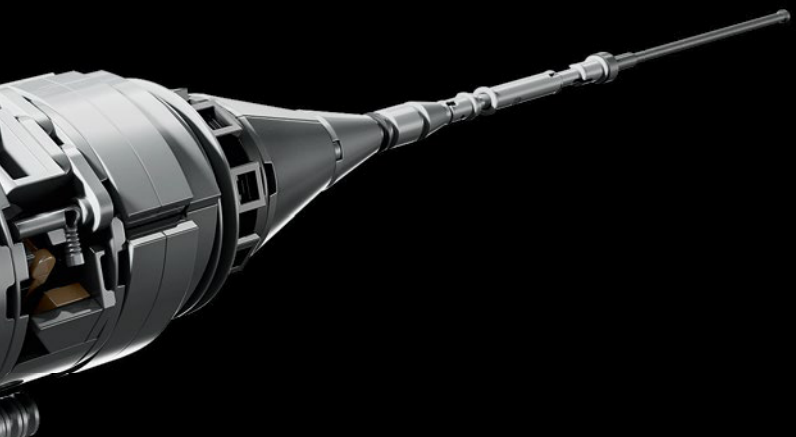

IMPRESIONES DEL EQUIPO DE DISEÑO DE LEGO® STAR WARS™

Nuestros colaboradores de Lucasfilm Ltd. nos compartieron muchas imágenes de referencia del N-1 de sus archivos, y nosotros teníamos cientos de fotos de una versión a tamaño real. La forma orgánica de esta nave espacial es muy interesante desde el punto de vista del diseño, pero recrear su redondeada parte inferior fue un gran desafío que nos tomó verdaderamente por sorpresa. Lo mismo sucedió con el sutil ángulo de las alas. Ninguno de los elementos existentes nos permitía recrear el ángulo correcto, por lo que tuvimos que hacer algunos experimentos creativos para que quedara perfecto. Los motores están repletos de piezas, tubos y componentes pequeños; son, por mucho, la parte más compleja del modelo. Además, tuvimos que considerar la estabilidad y el flujo del proceso de construcción a la hora de capturar su estética. Algo que nos entusiasma es la cantidad de elementos lacados en tambor que logramos agregar al exterior. El brillante acabado cromado aporta un toque extra de autenticidad al modelo, haciéndolo verse tal y como aparece en la serie. Además de revelar su origen e historia, las marcas amarillas crean un equilibrio entre la robustez y la elegancia en su aspecto. En general, es un vehículo muy interesante y esperamos que te sientas orgulloso de exhibirlo.









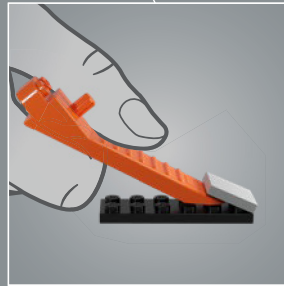
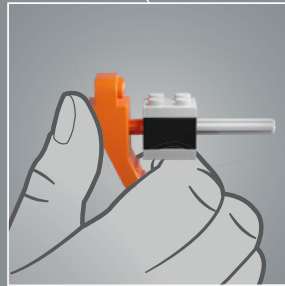
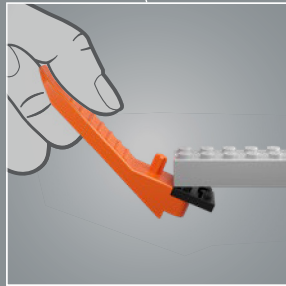
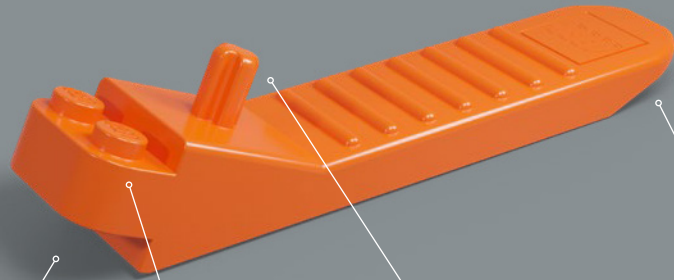

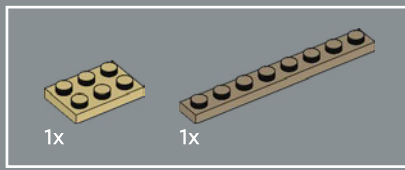

1

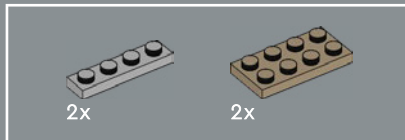
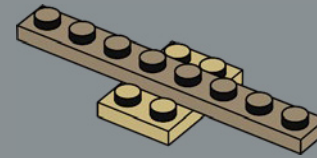

2

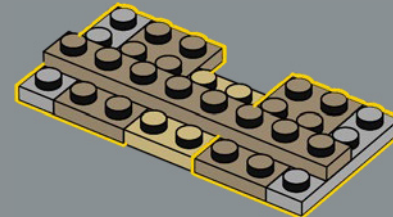

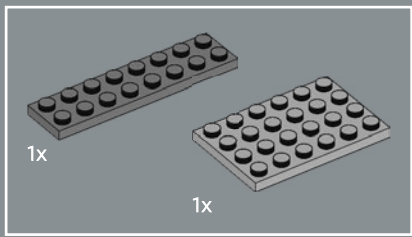

3

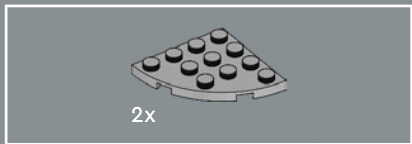
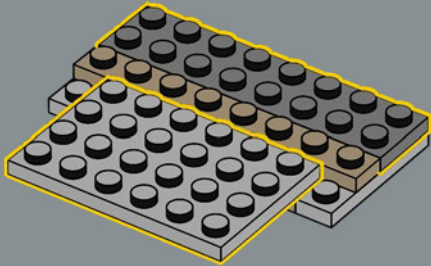

4

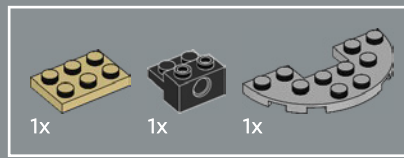
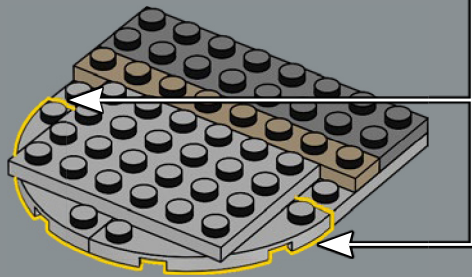
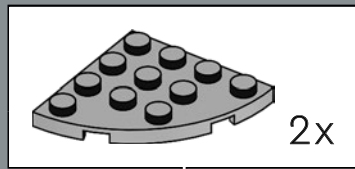

5

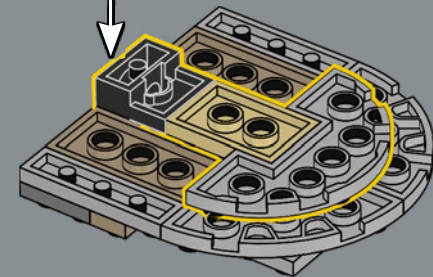
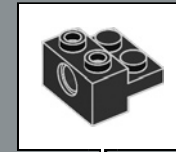

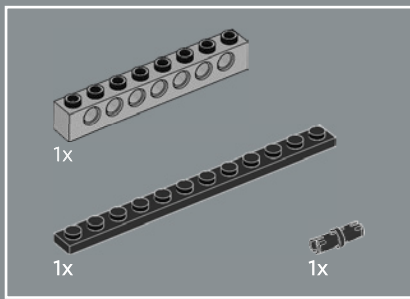

6

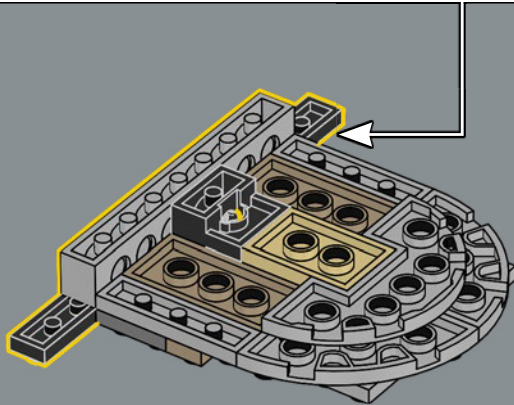
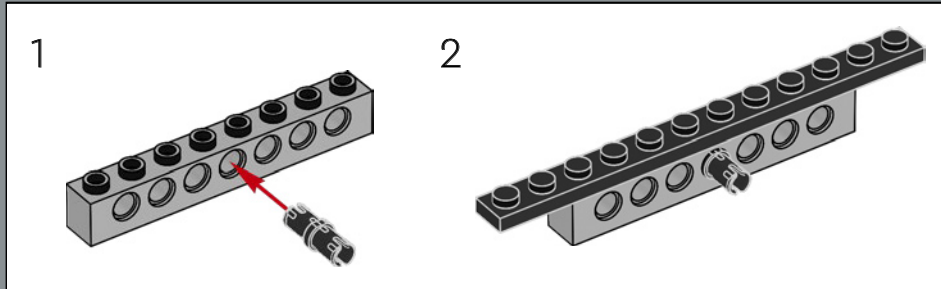

7

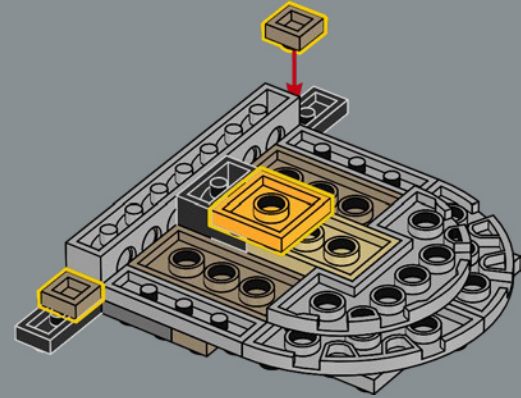

8

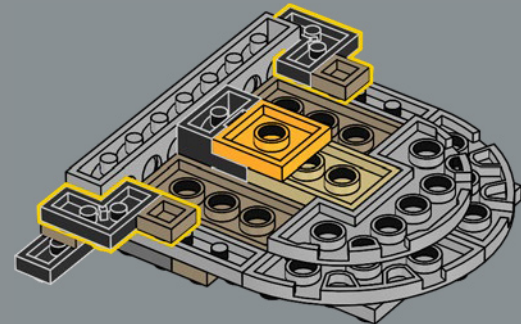

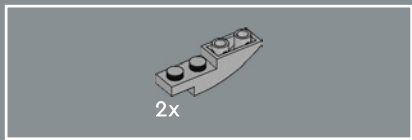

9

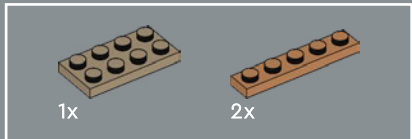
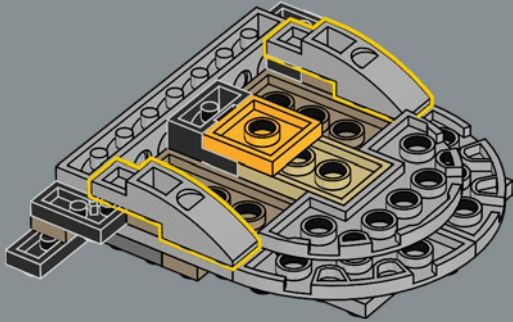

10

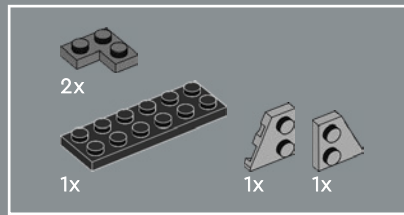
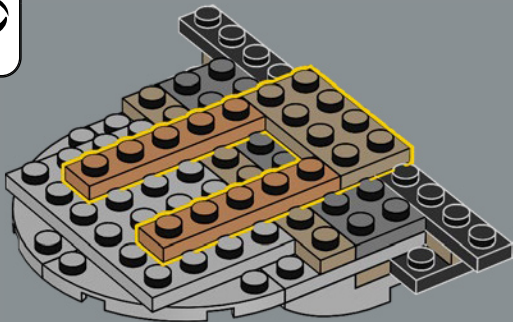

11

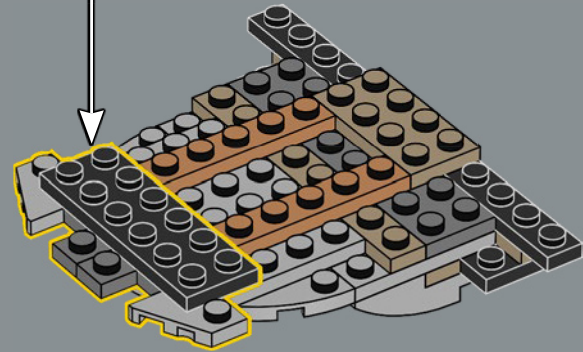
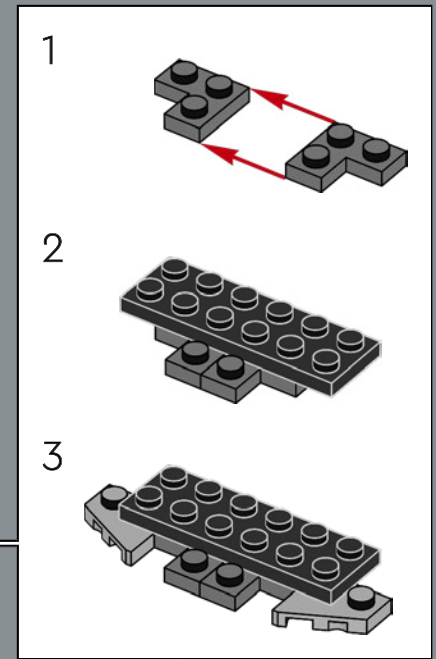



12

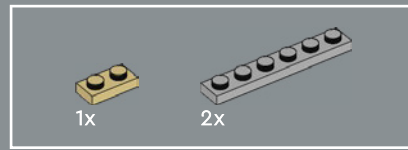
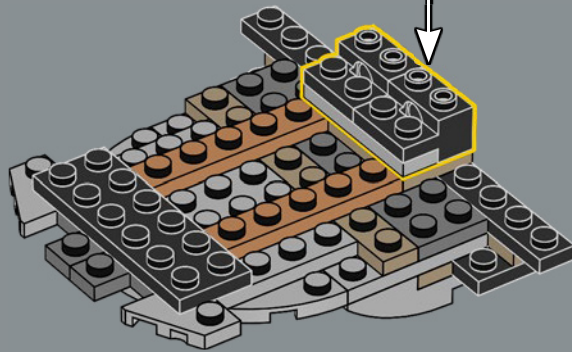
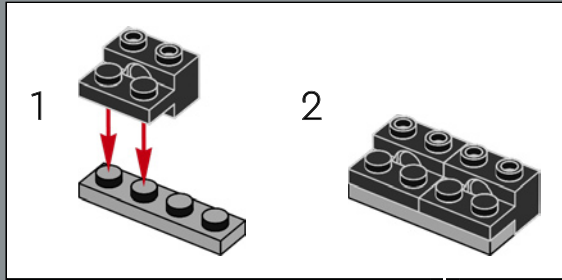

13

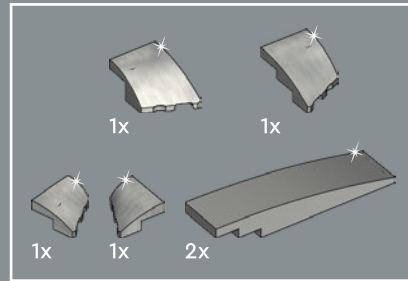
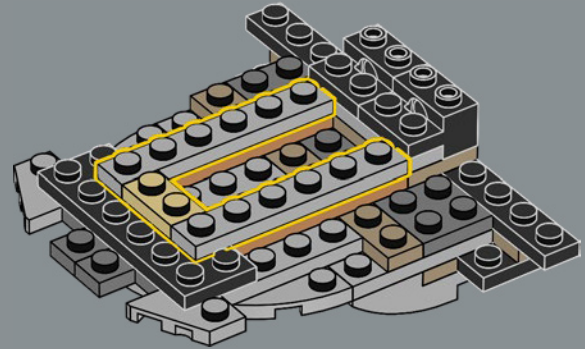

14

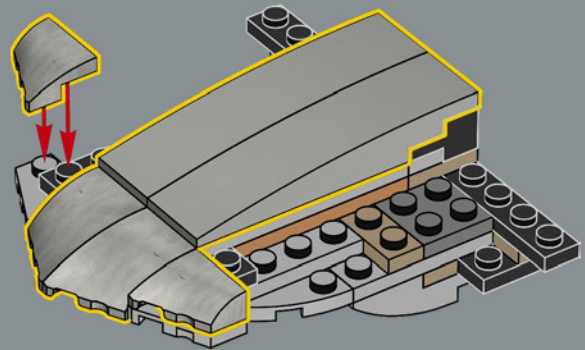

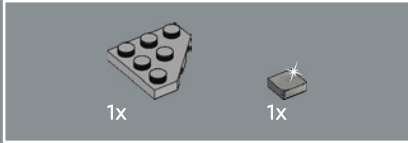
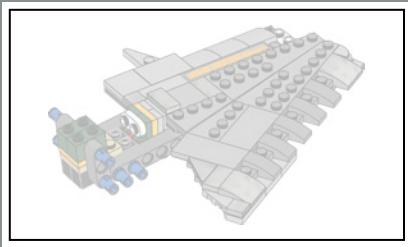

15

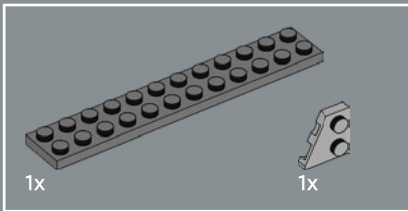
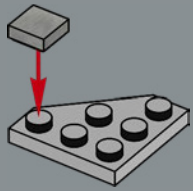

16

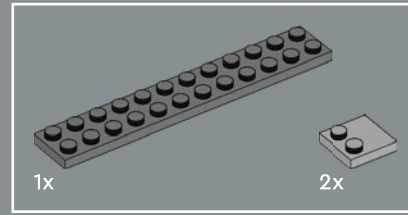
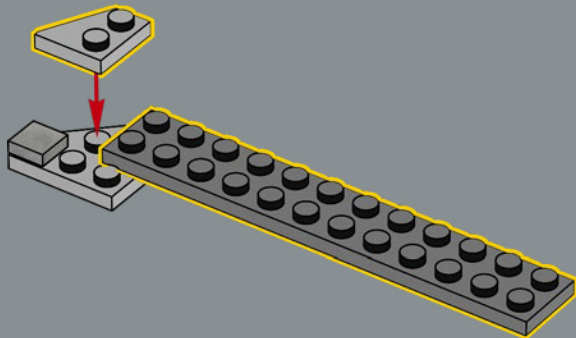

17

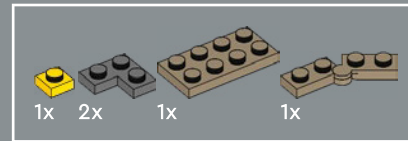
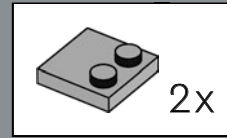
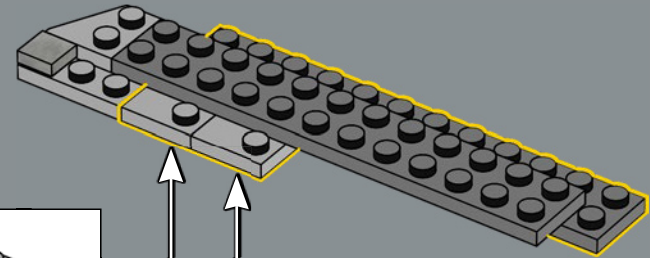

18

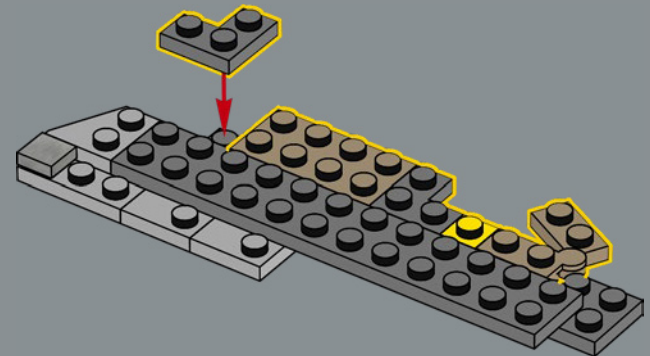

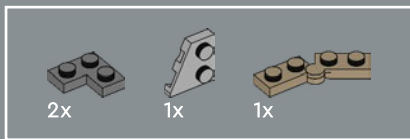

19

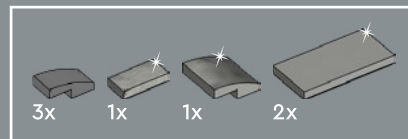
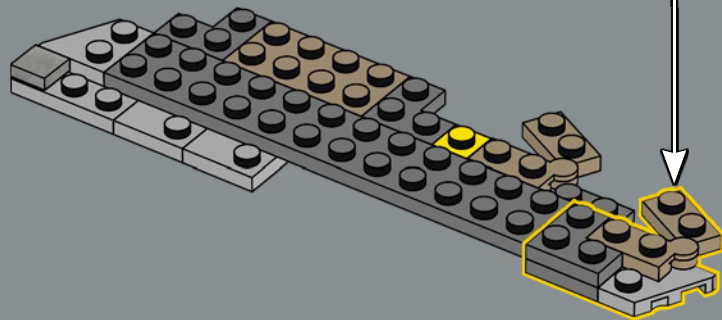
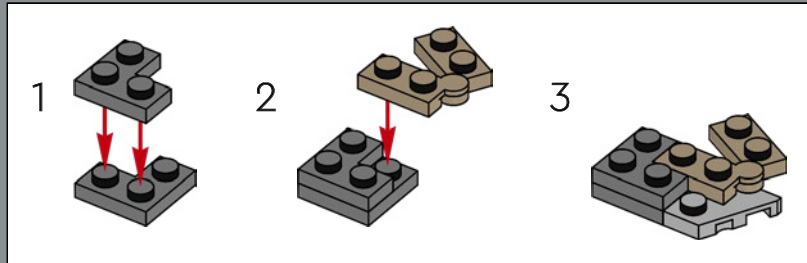

20

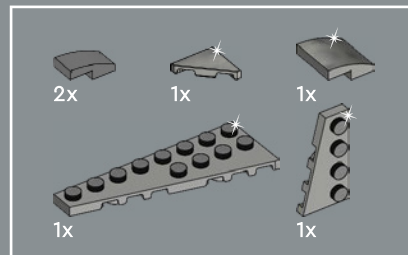
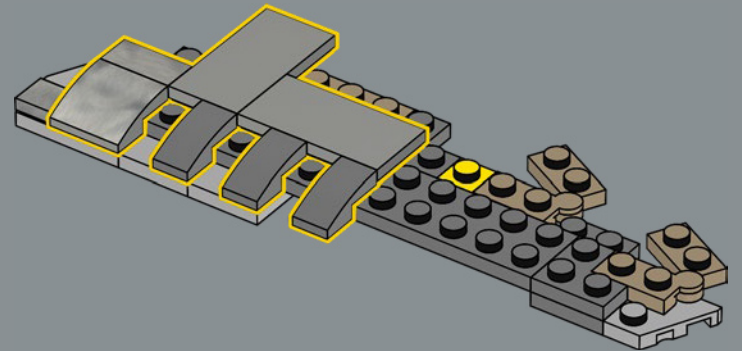

21

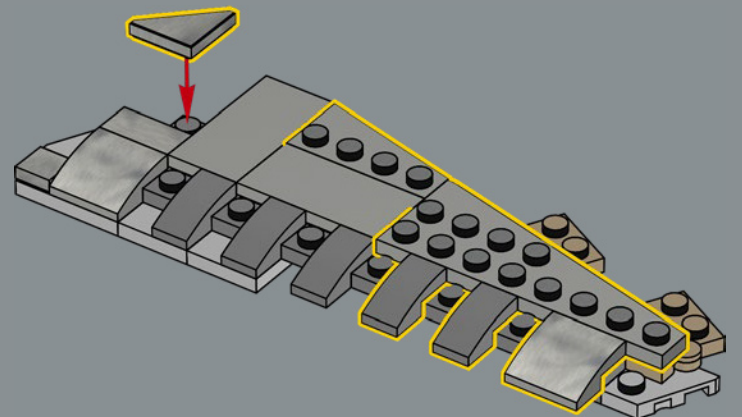

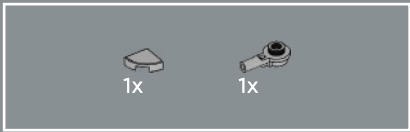

22

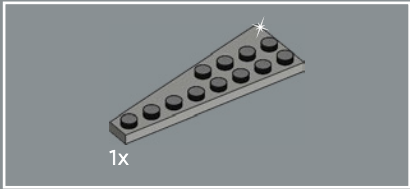
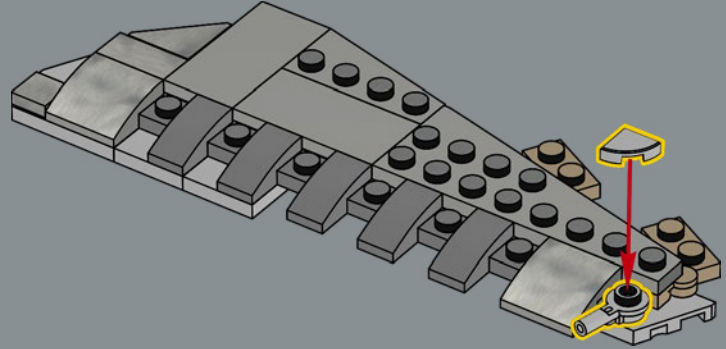

23

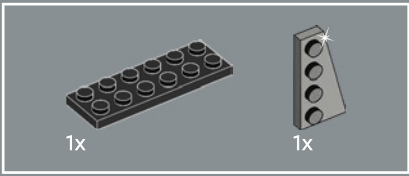
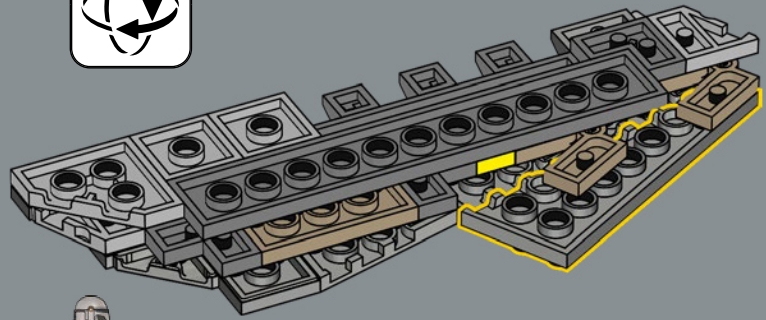

24

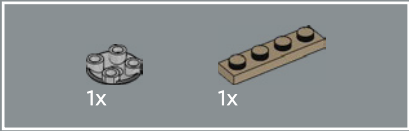
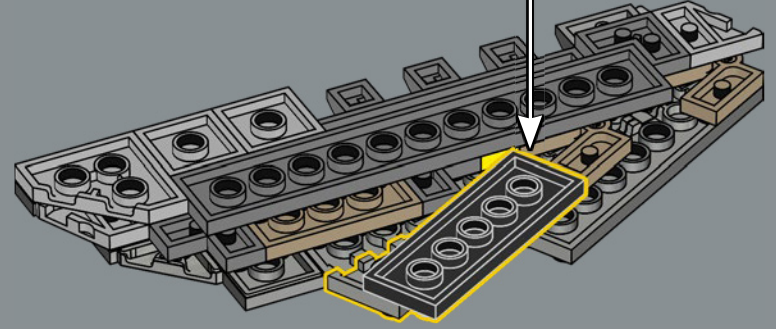
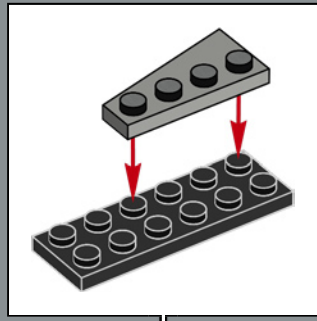

25

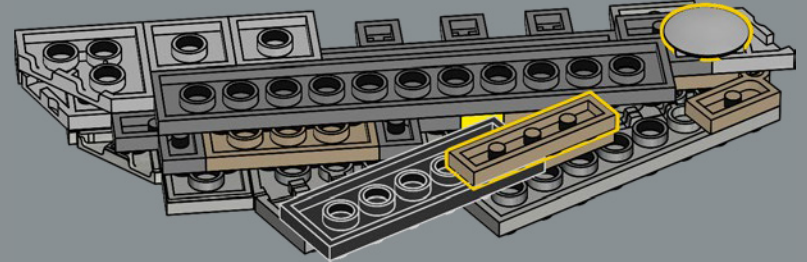

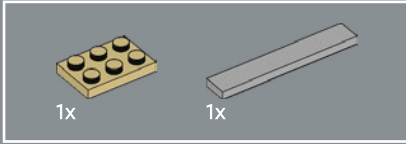
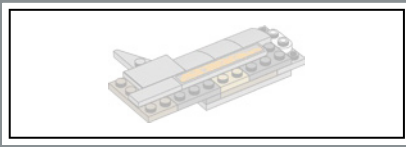

26

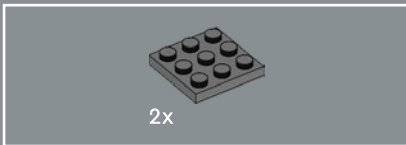
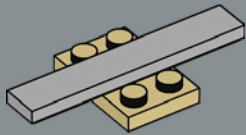

27

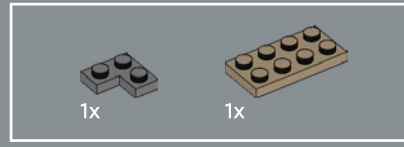
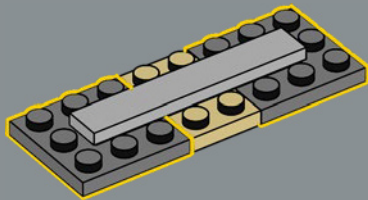

28

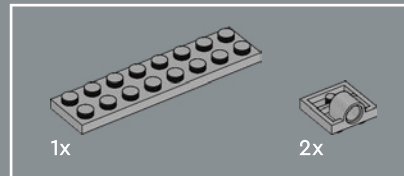
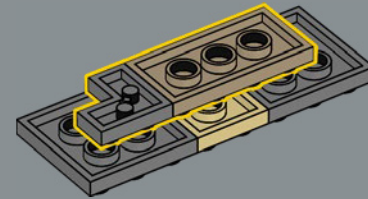

29

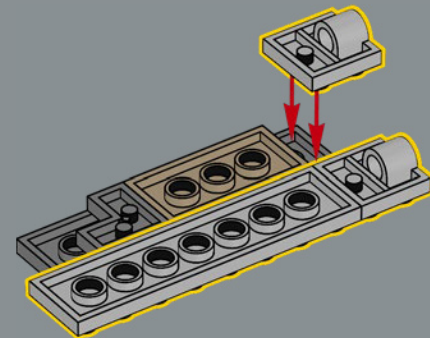

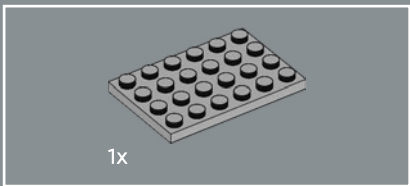

30

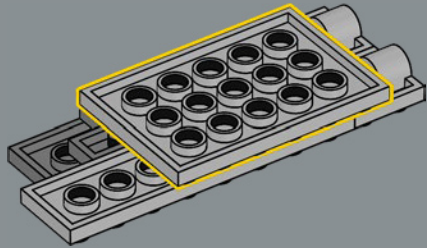

31

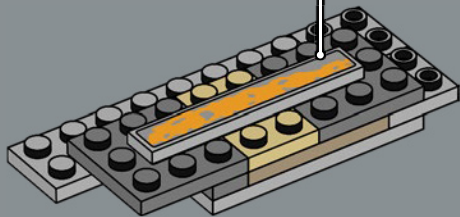

32

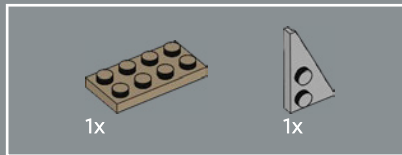
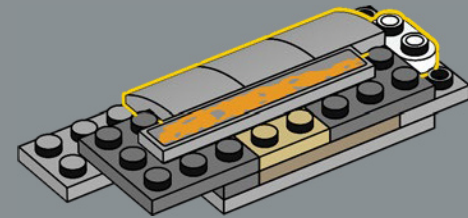

33

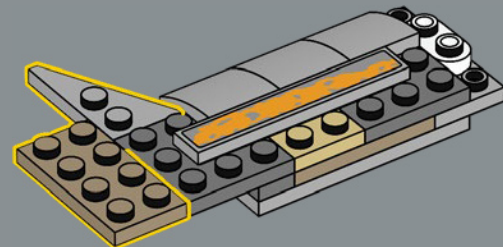

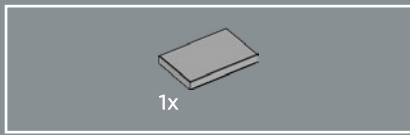

34

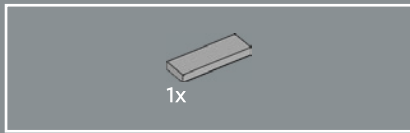
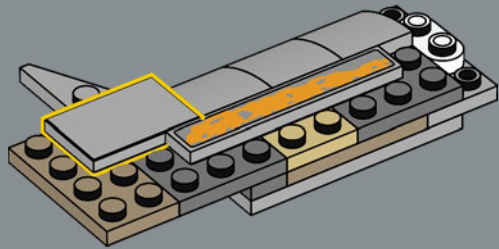

35

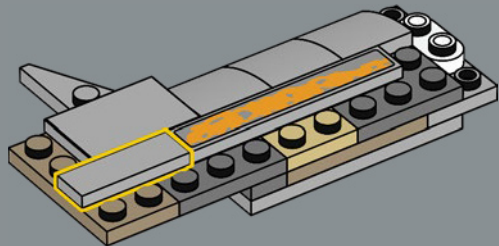

36

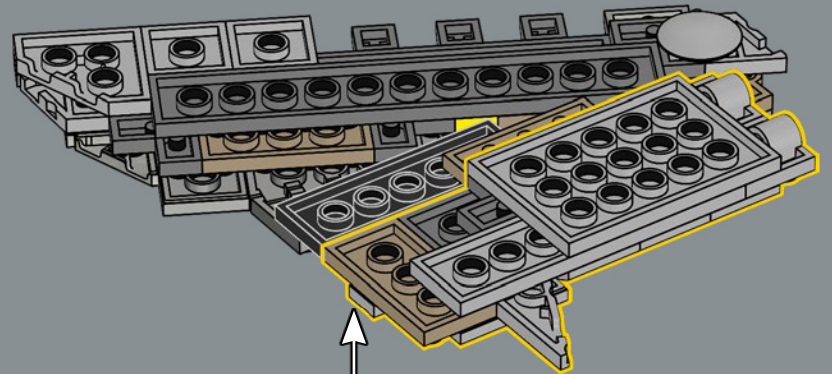

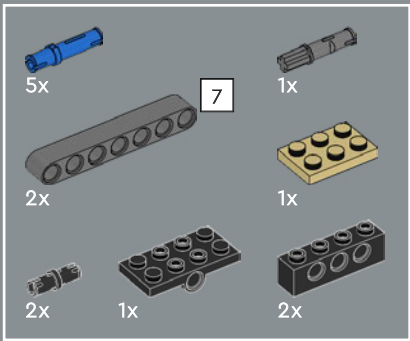
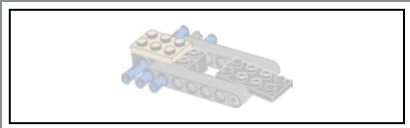

37

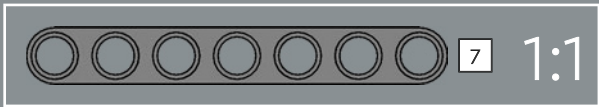
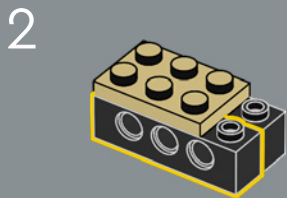
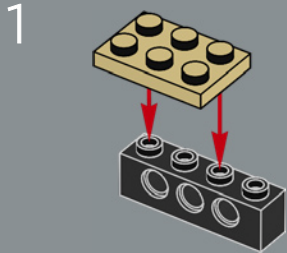

3

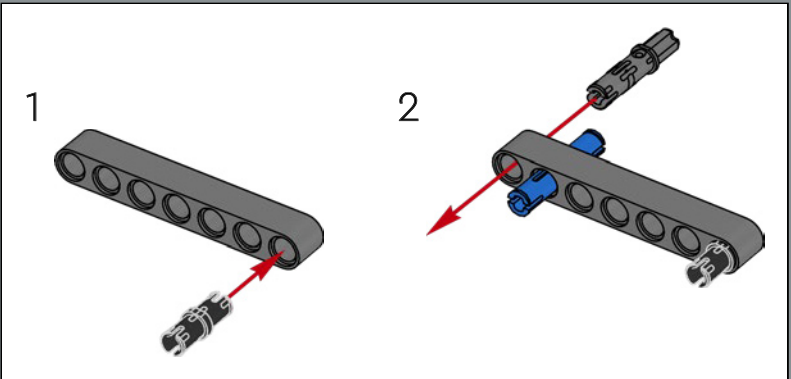
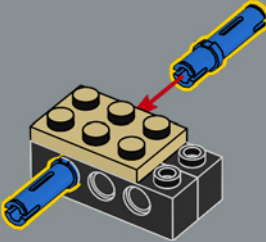

4

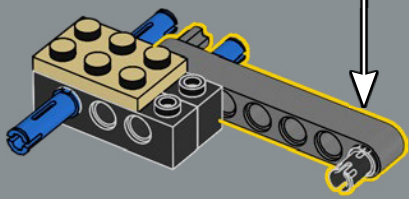

5

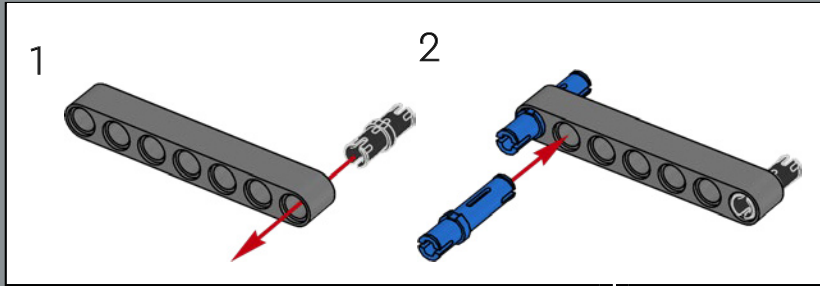
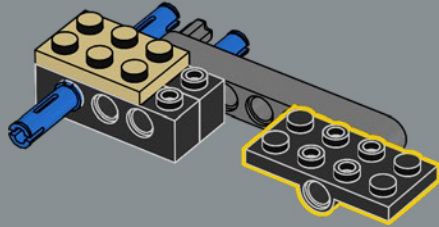

6

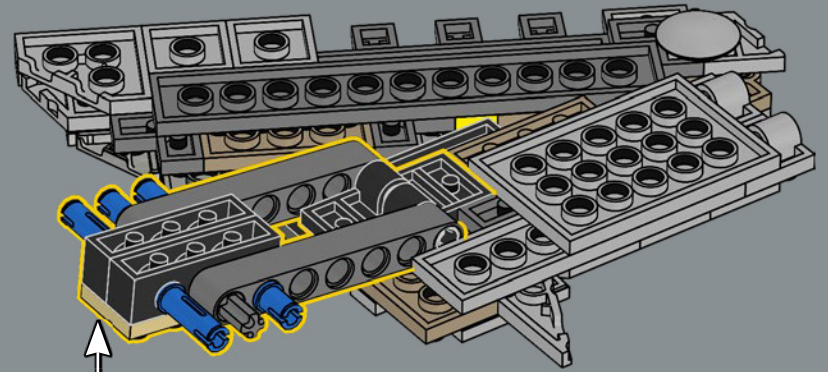
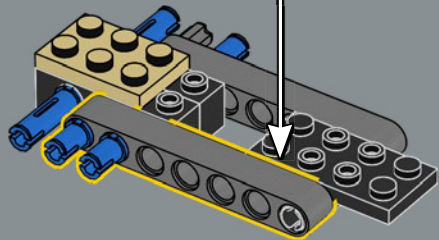

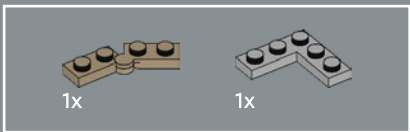

38

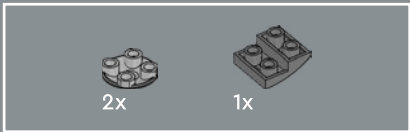
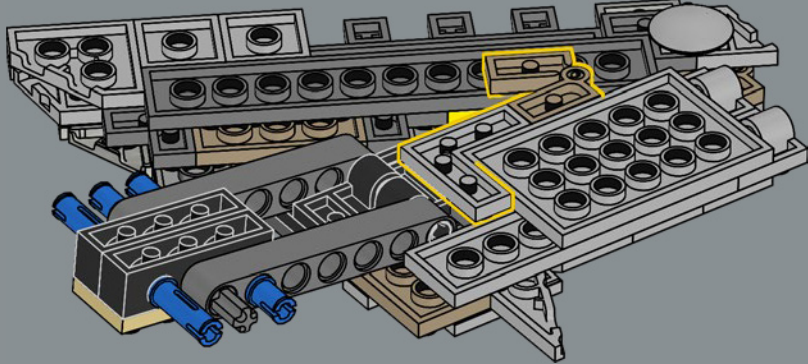

39

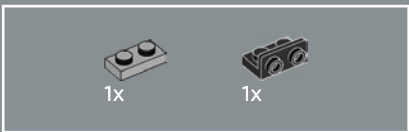
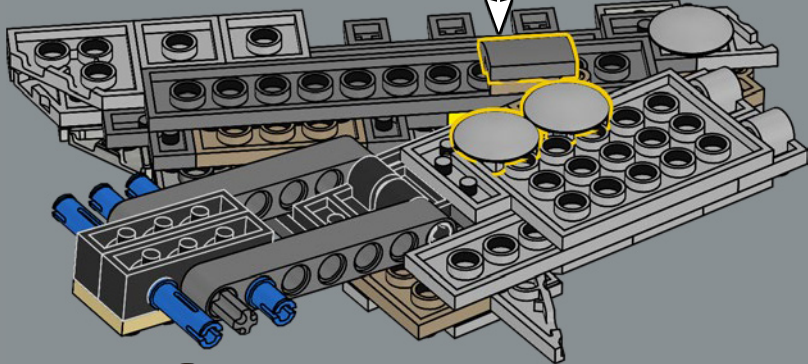
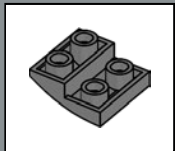

40

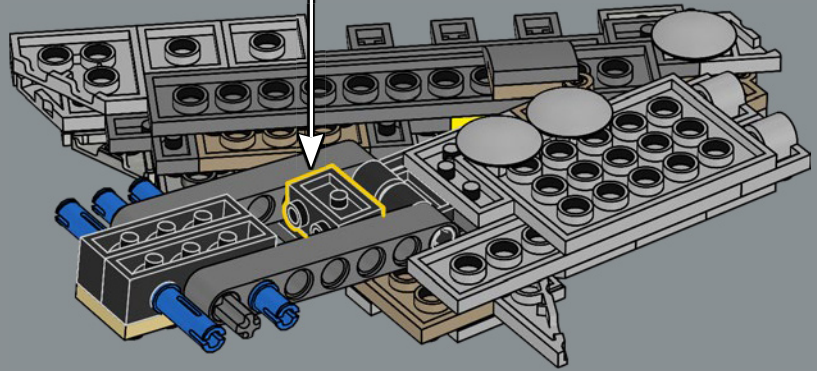
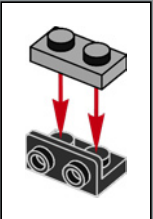



41

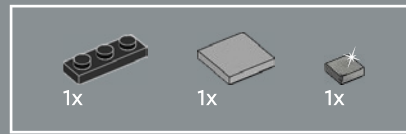
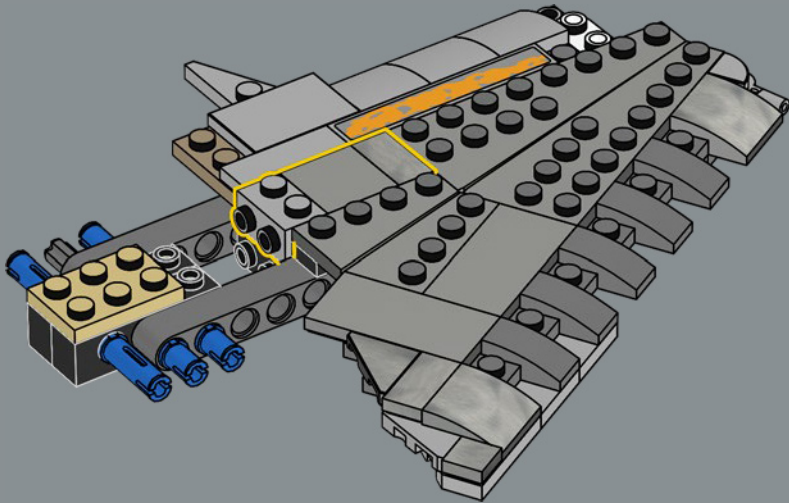

42

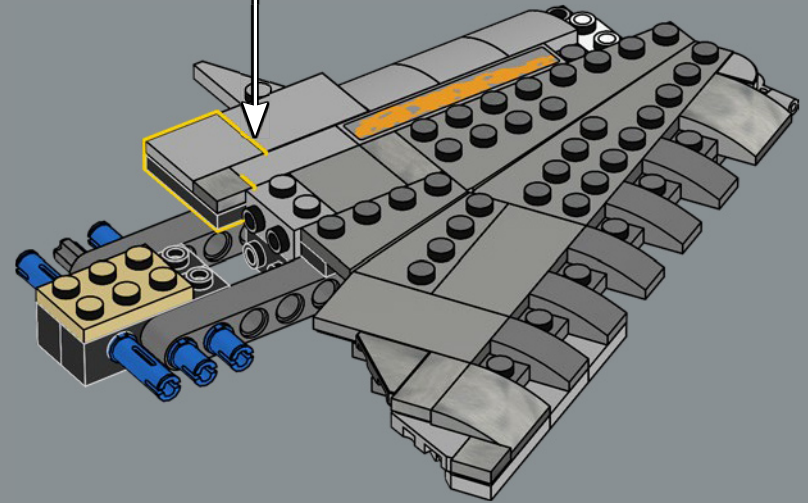
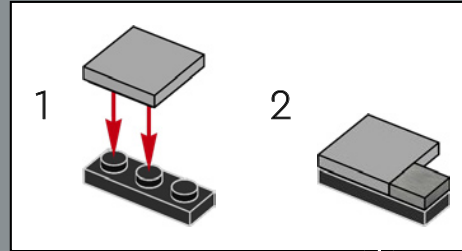



43

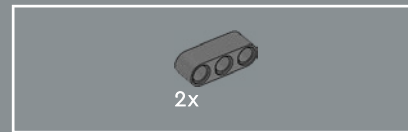
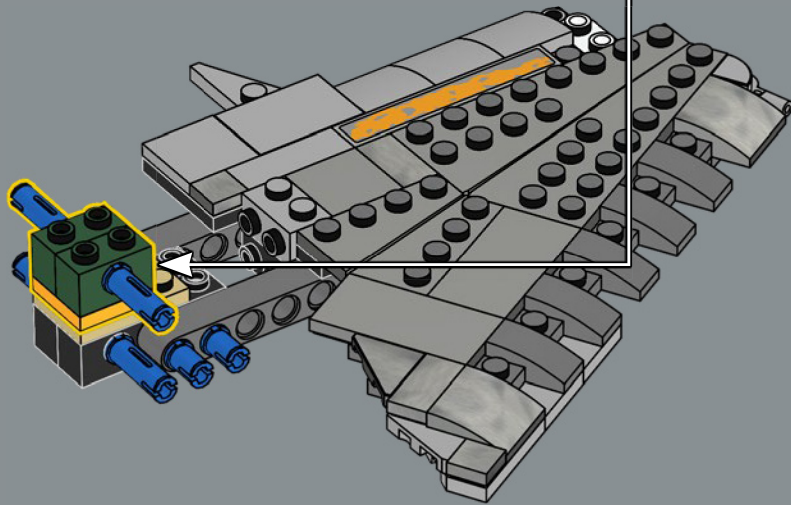
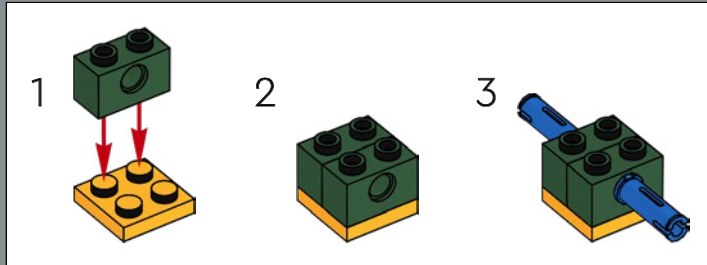

44

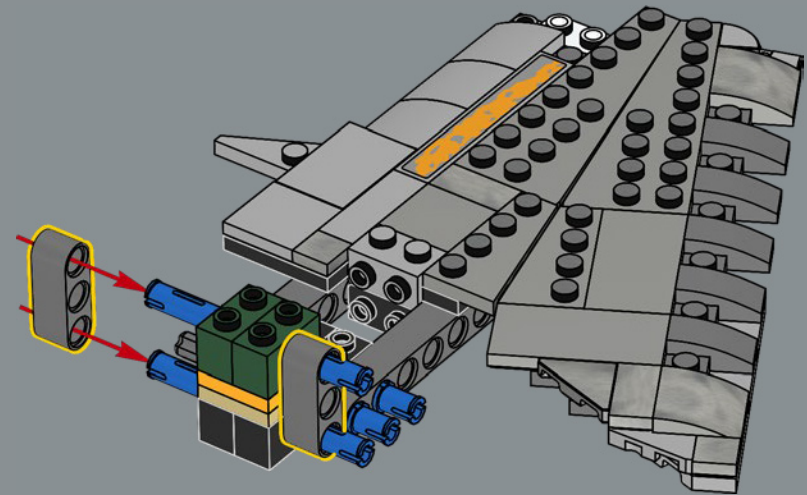

45

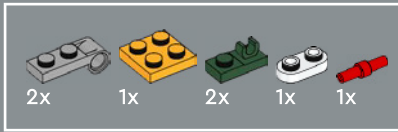
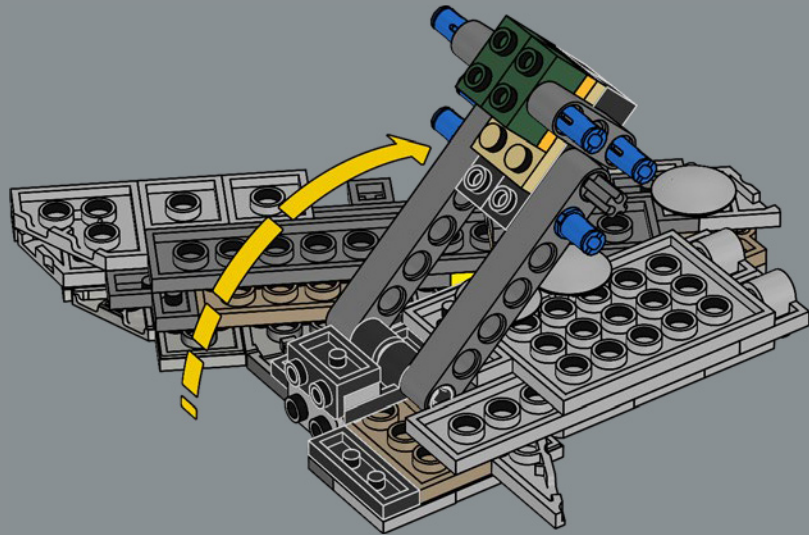

46

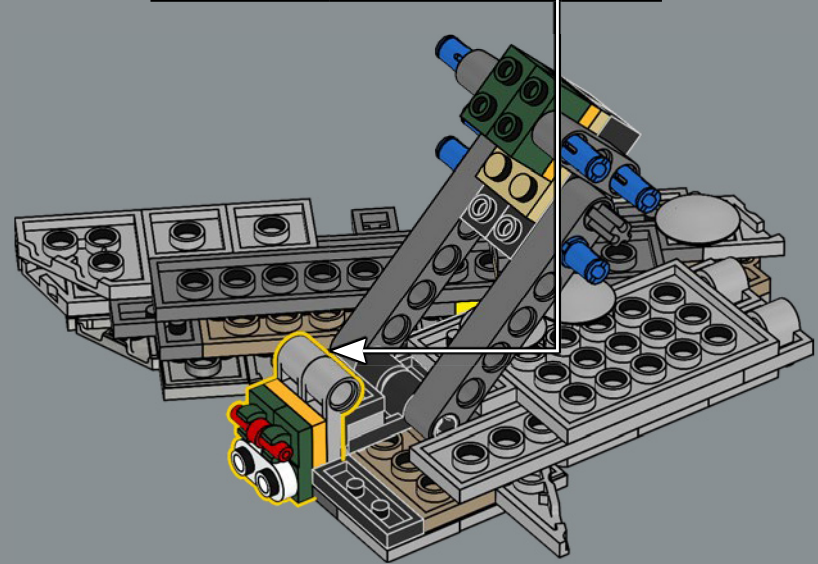
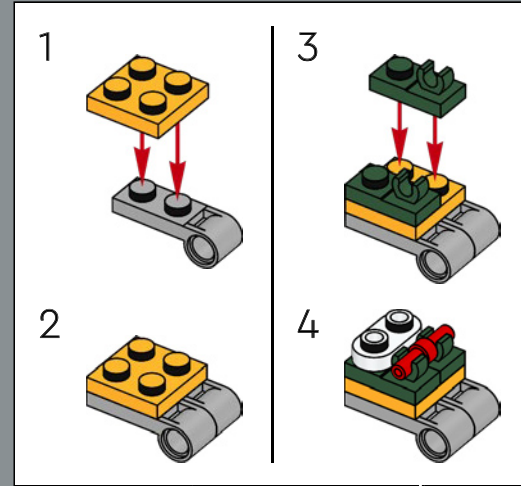

47

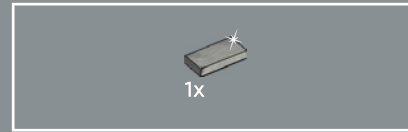
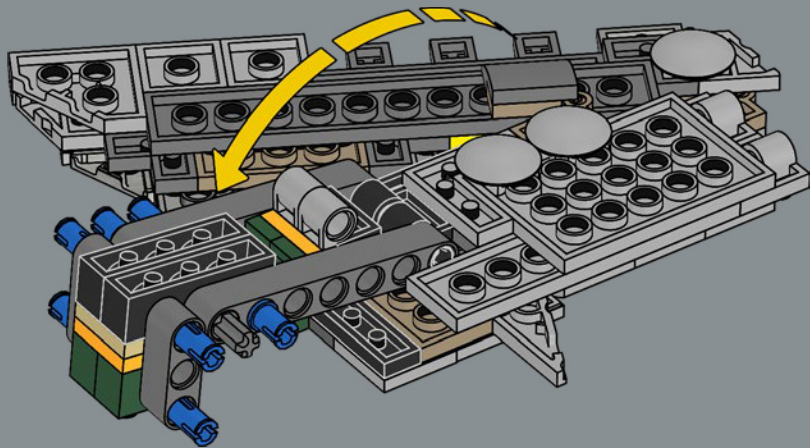

48

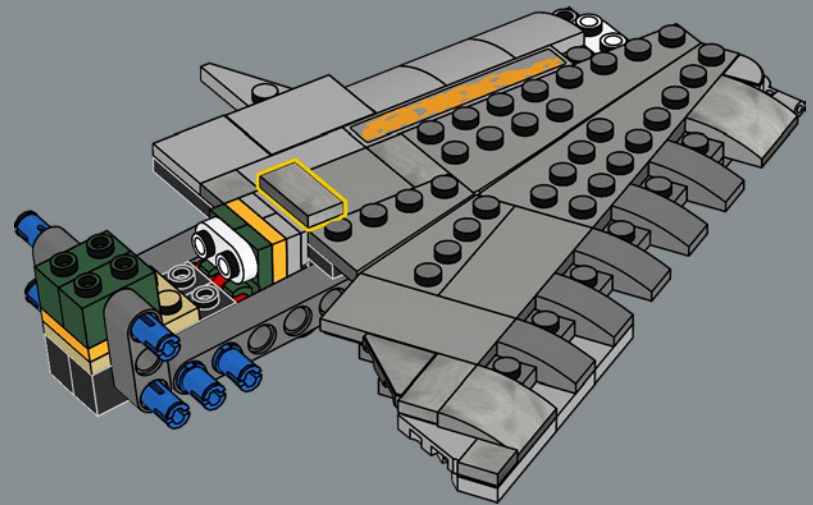

49

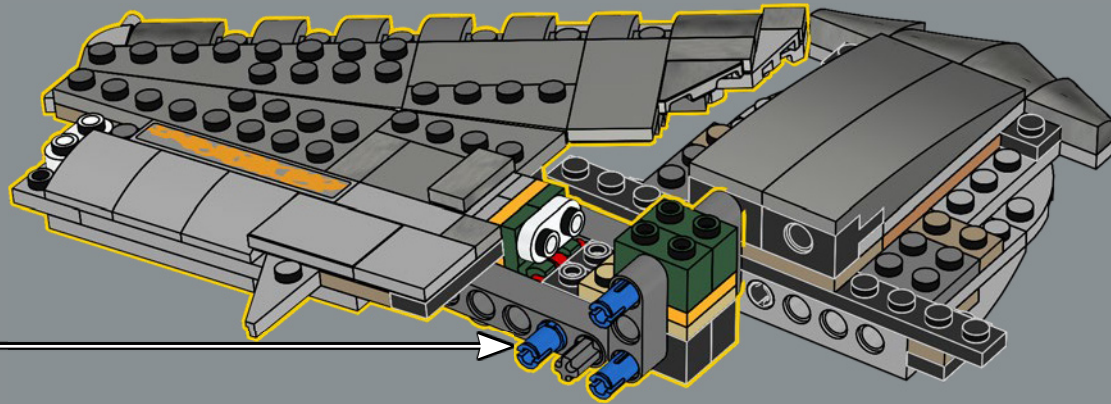

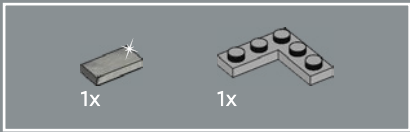

50

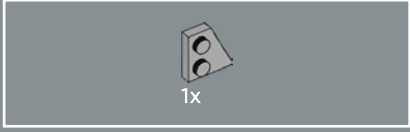
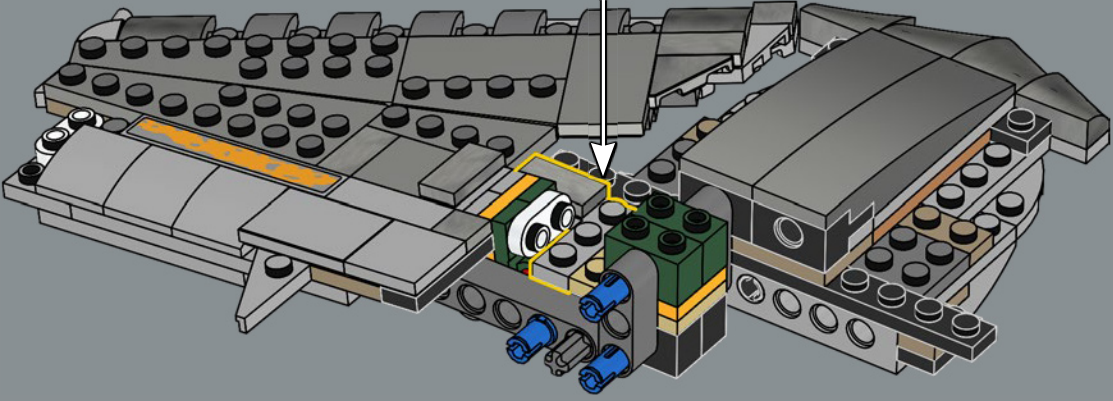
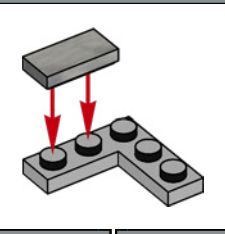

51

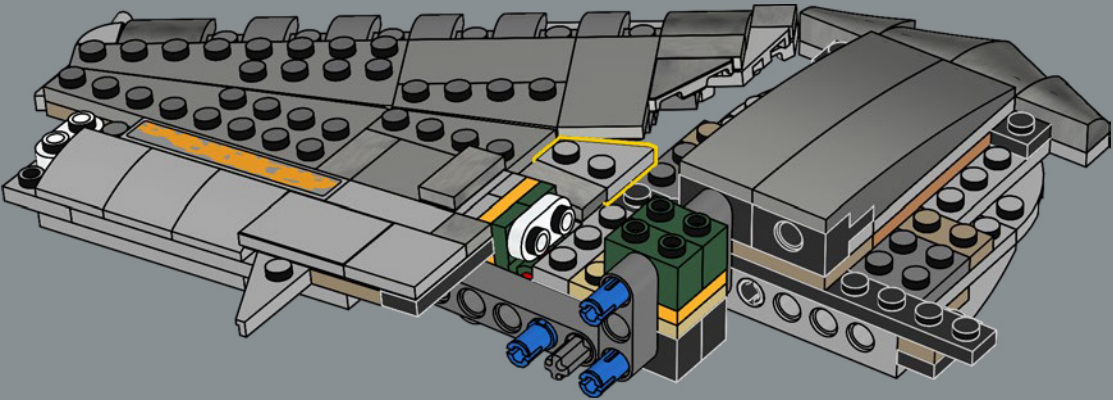



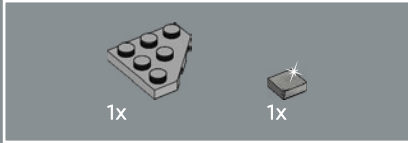
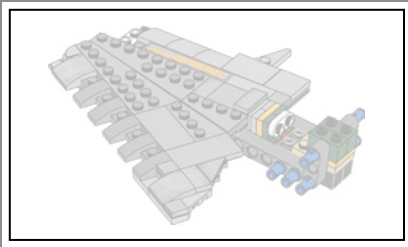

52

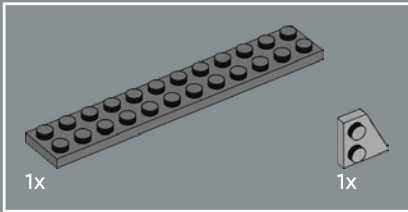
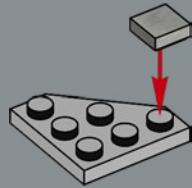

53

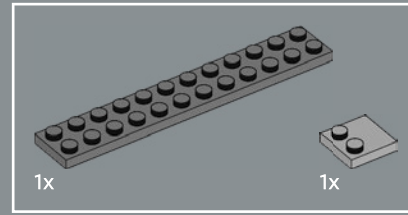
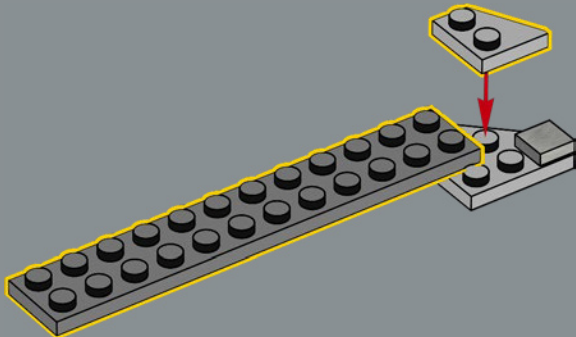

54

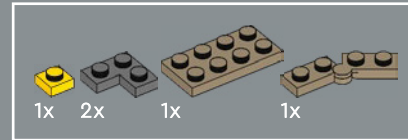
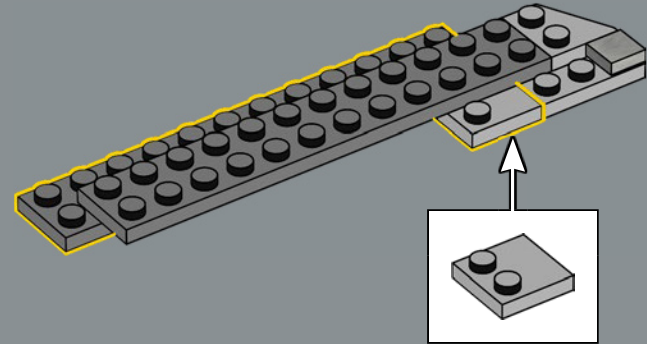

55

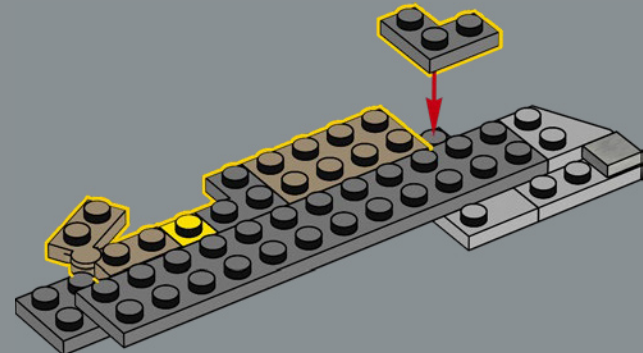

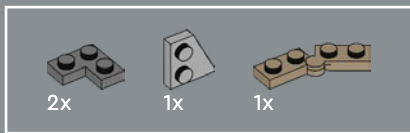

56

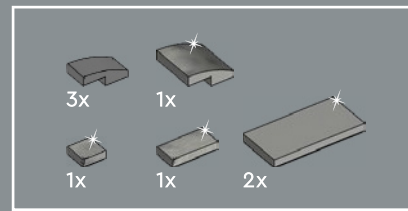
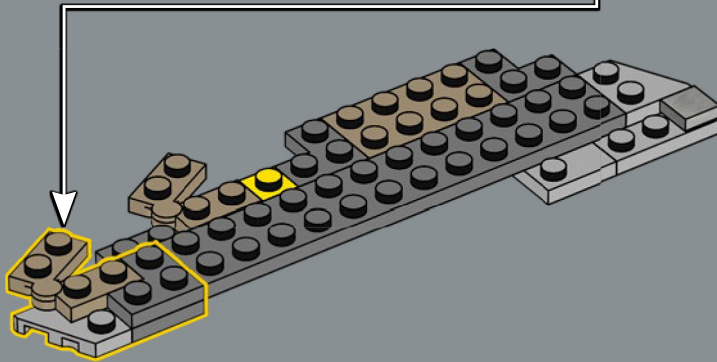
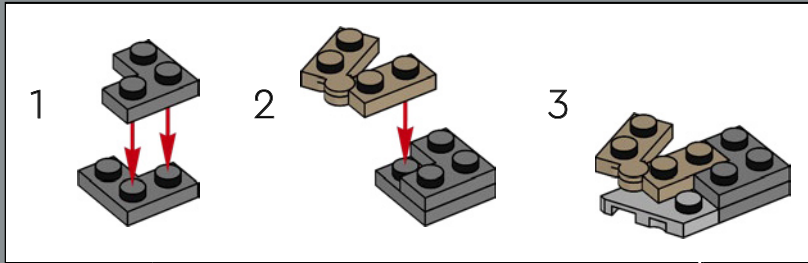

57

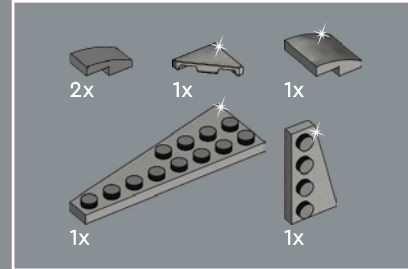
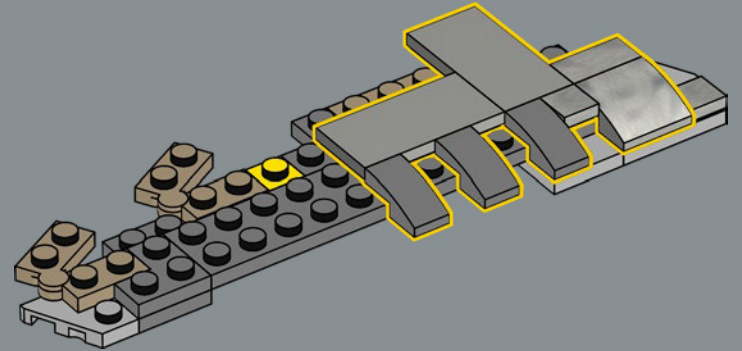

58

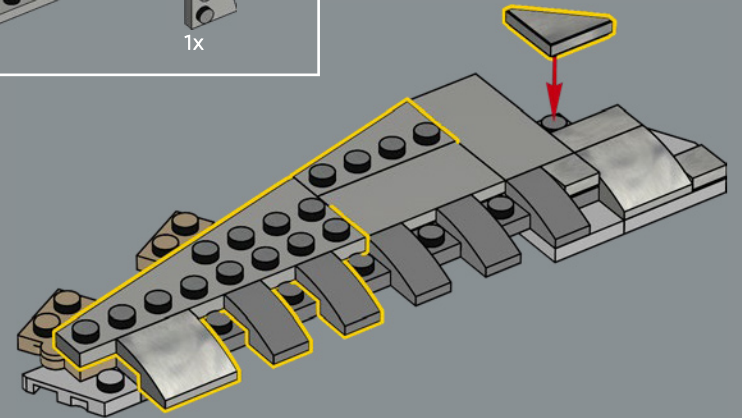

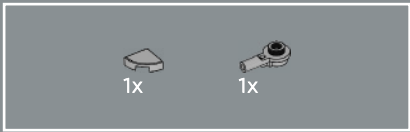

59

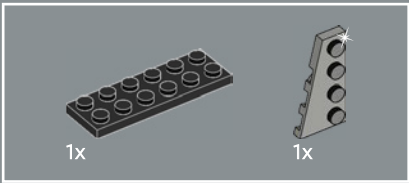
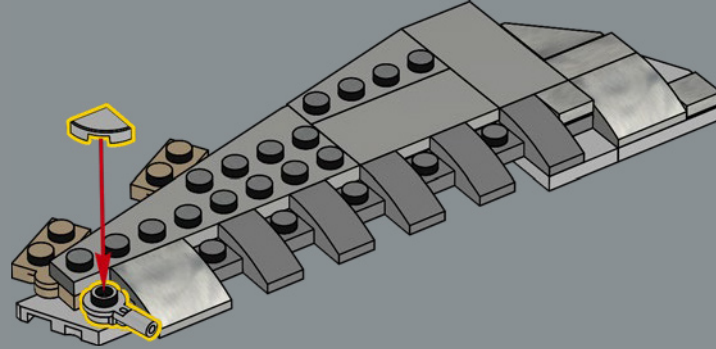

61

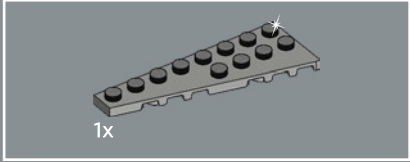
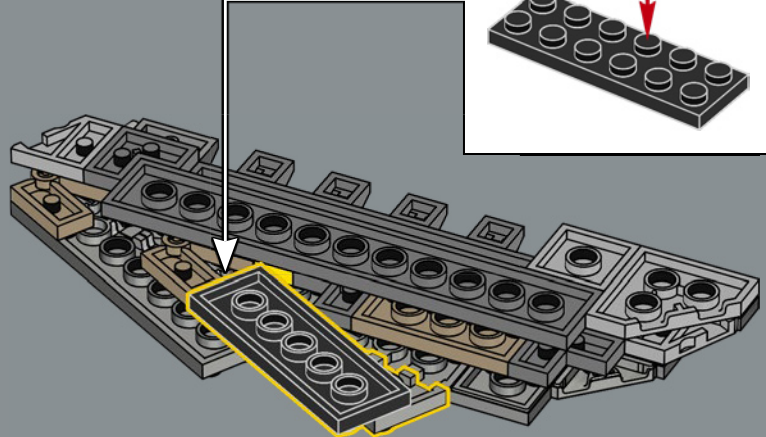

60

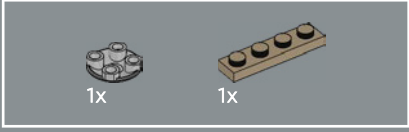
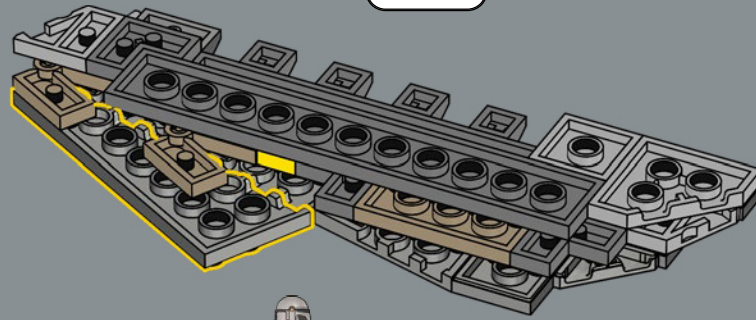

62

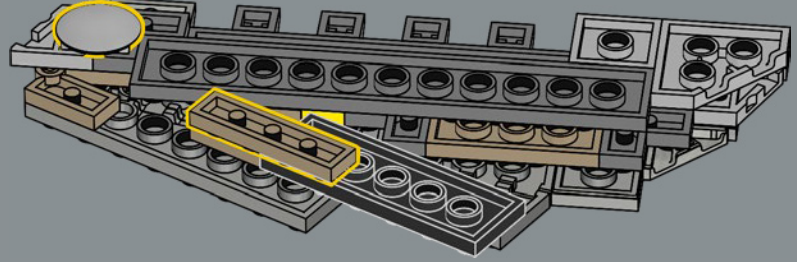

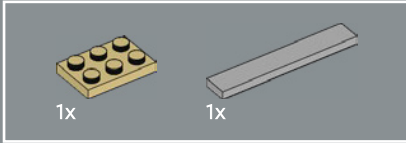
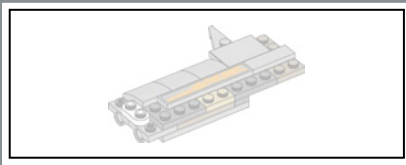

63

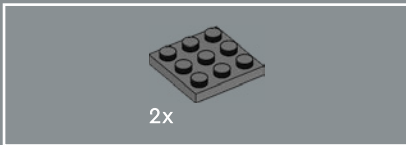
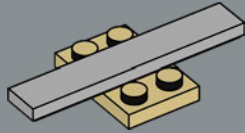

64

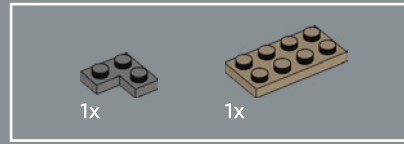
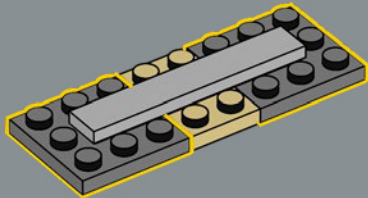

65

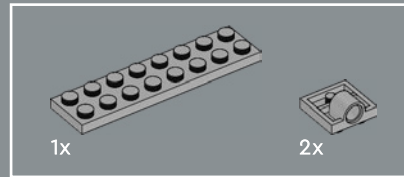

66

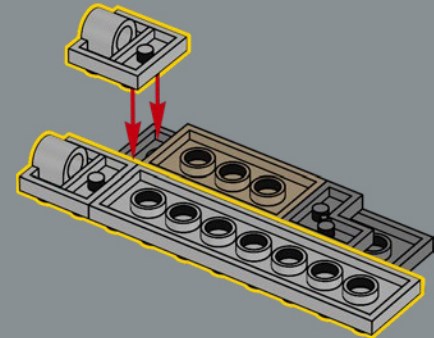

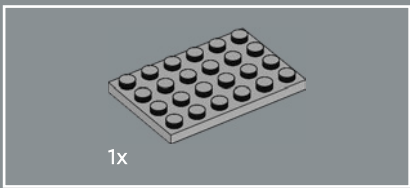

67

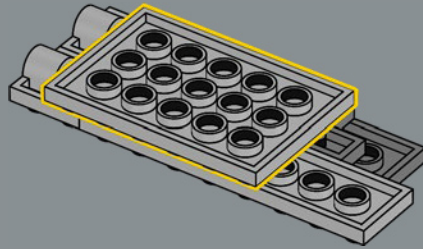

69

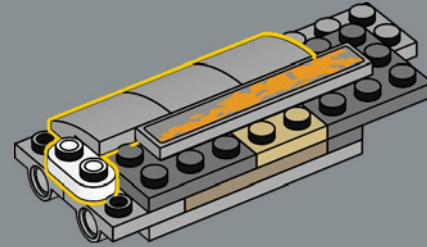

68

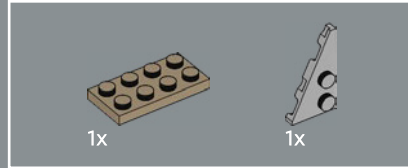
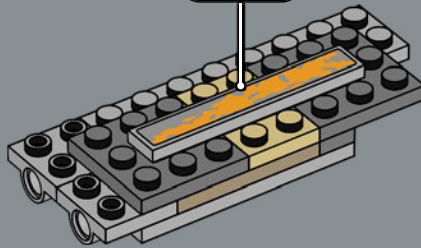

70

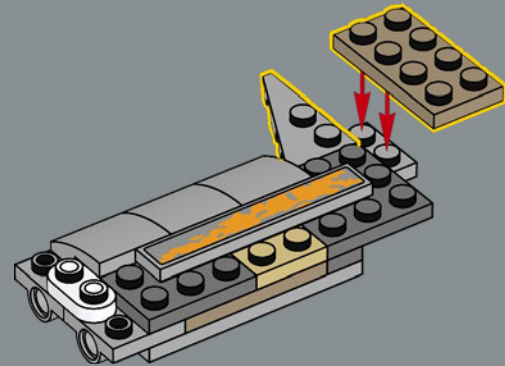

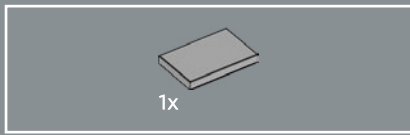

71

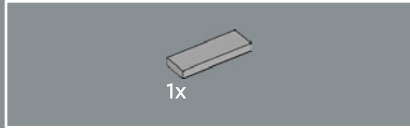
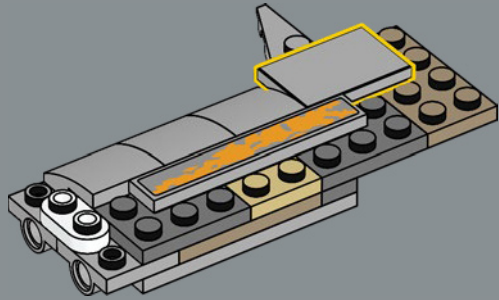

72

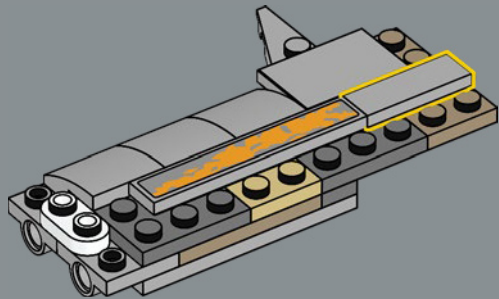

73

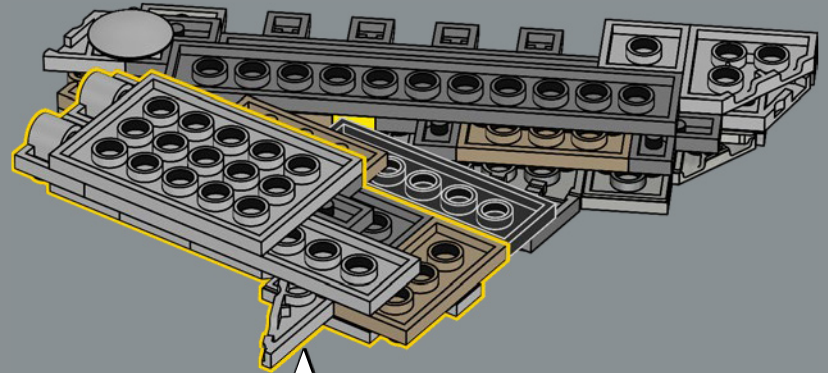

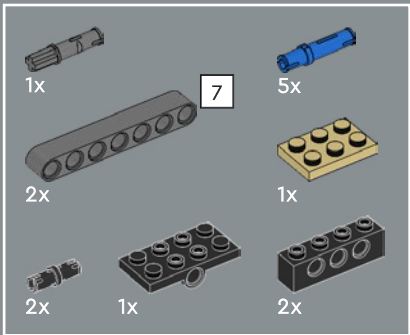
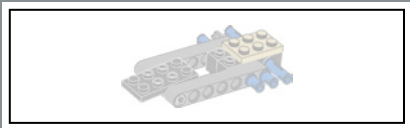

74

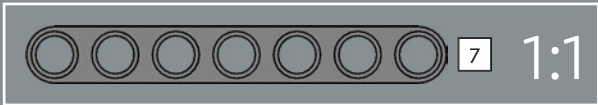
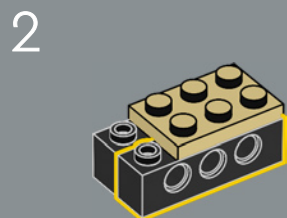
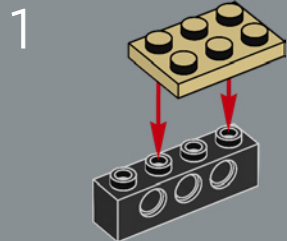

3

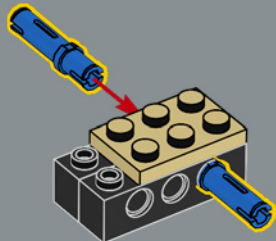

1

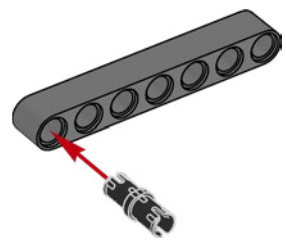

2

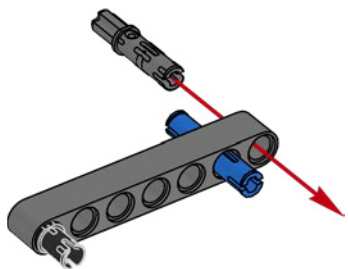

4

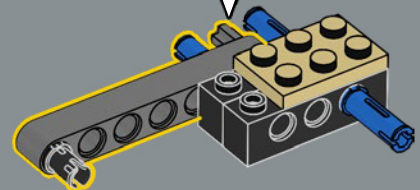

5

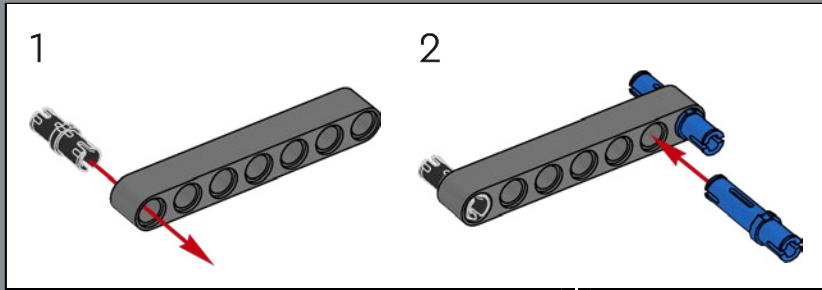
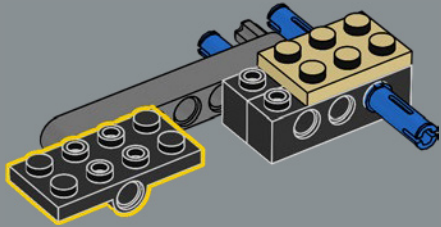

6

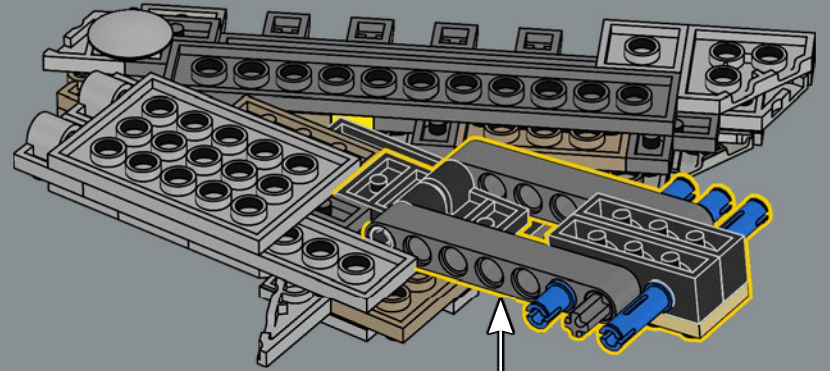
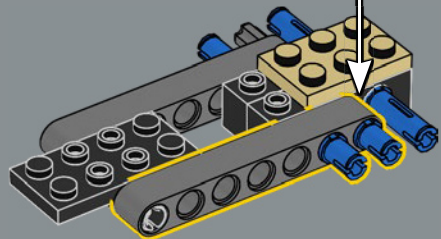

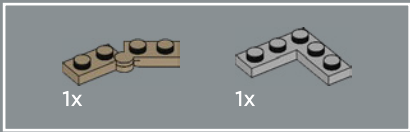

75

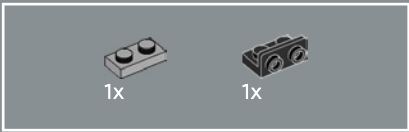
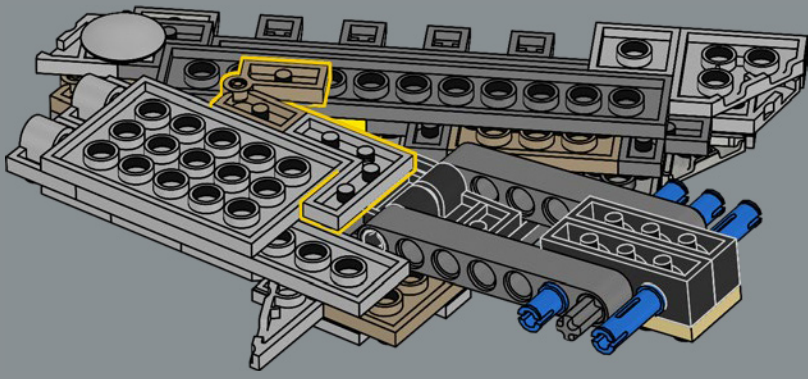

77

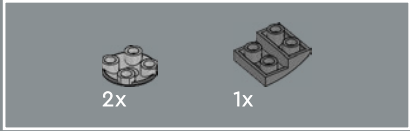
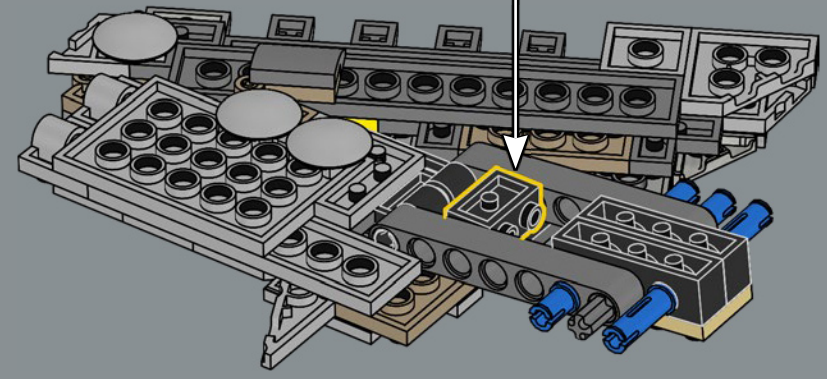
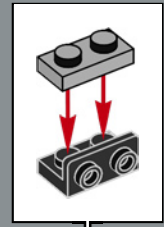

76

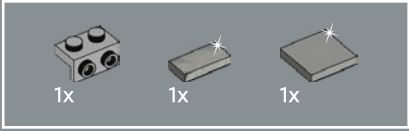
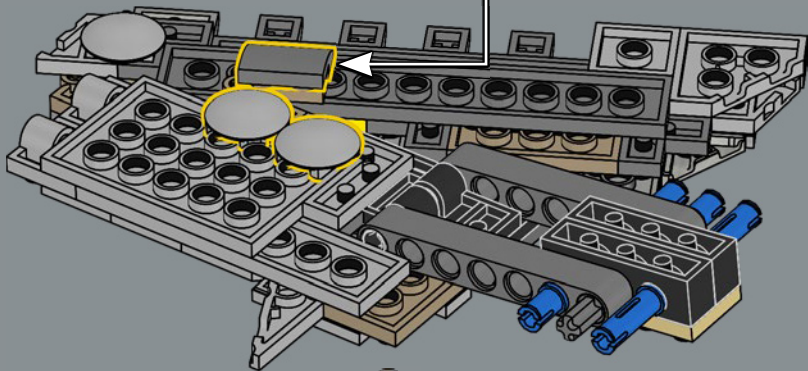
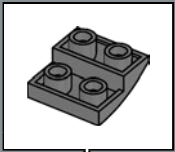

78

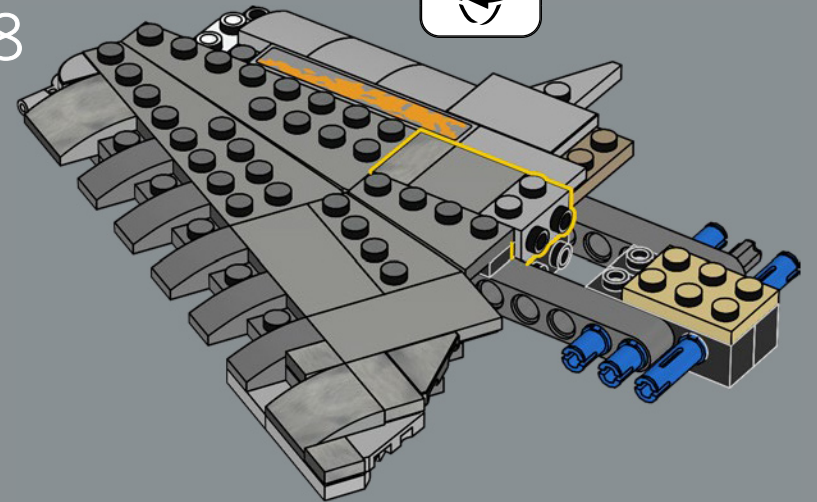

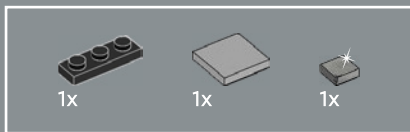

79

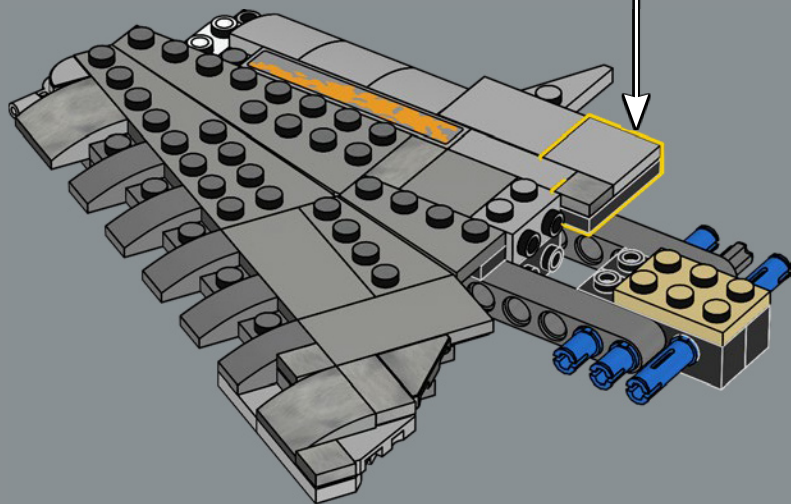
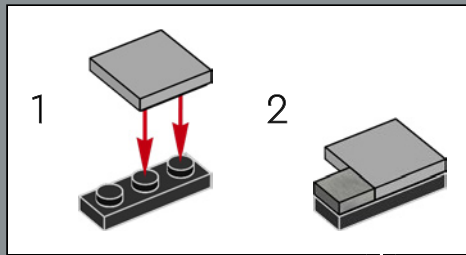

80

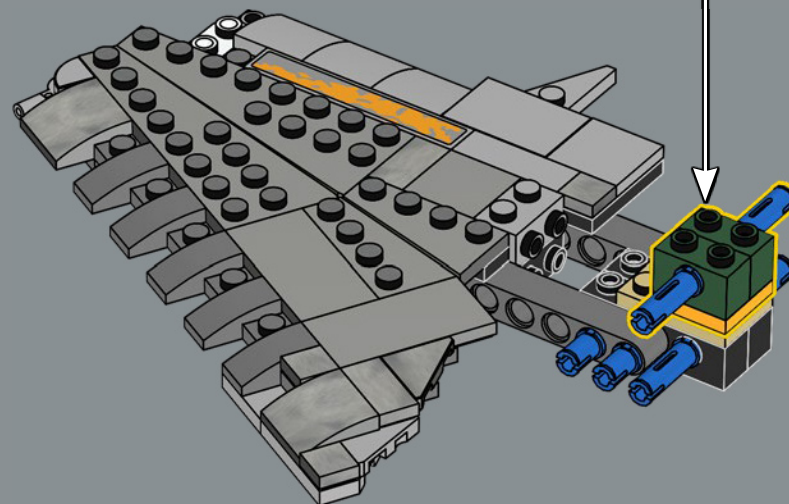
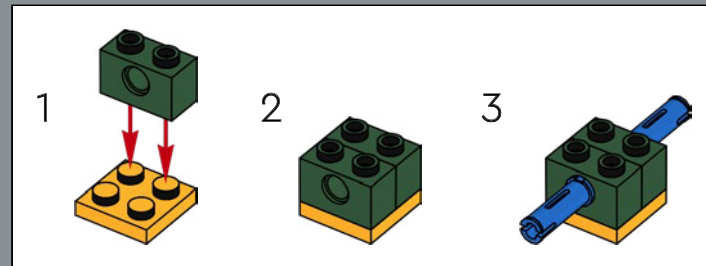

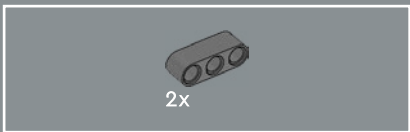

81

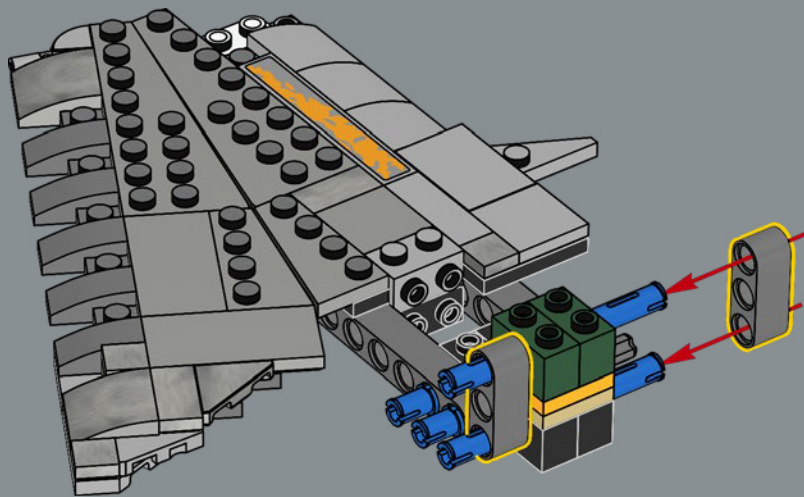

82

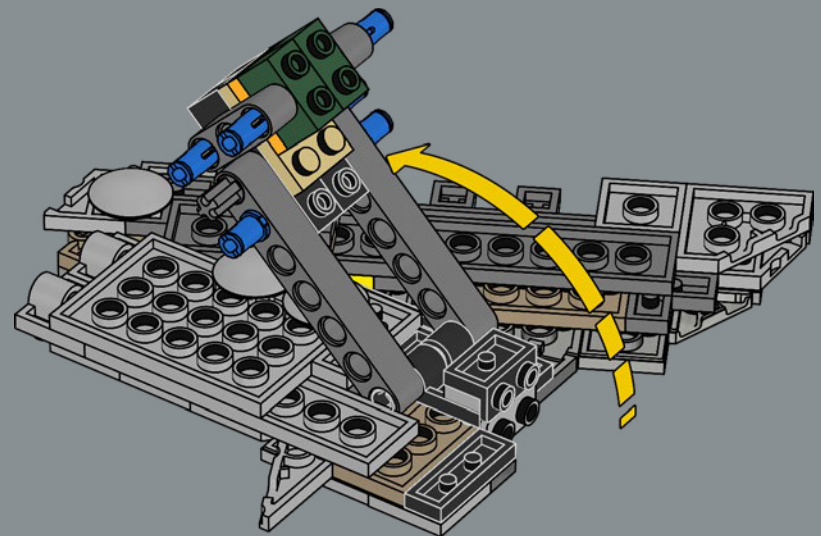

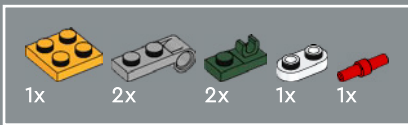

83

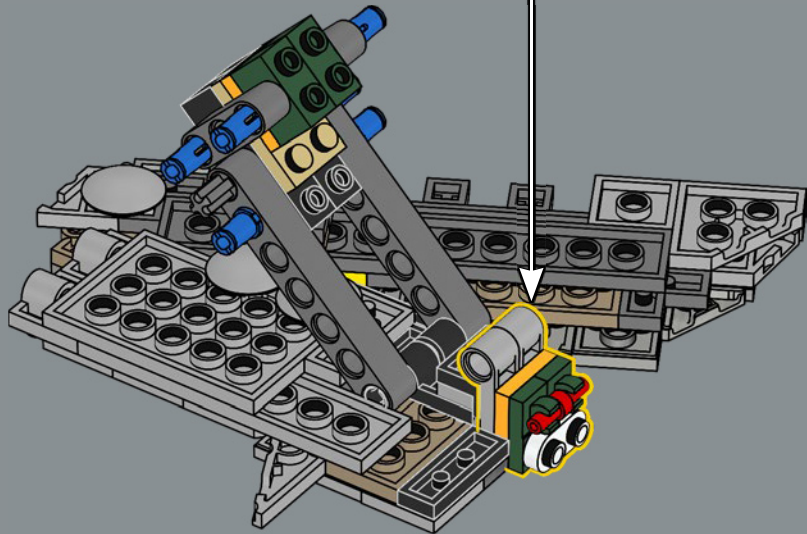
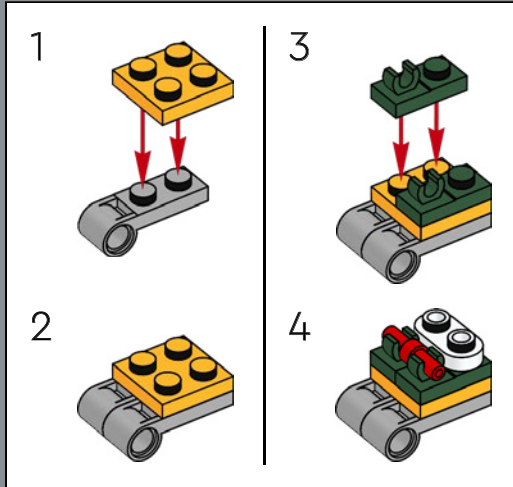

84

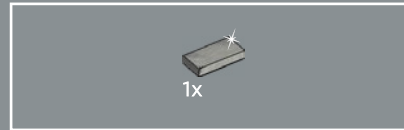
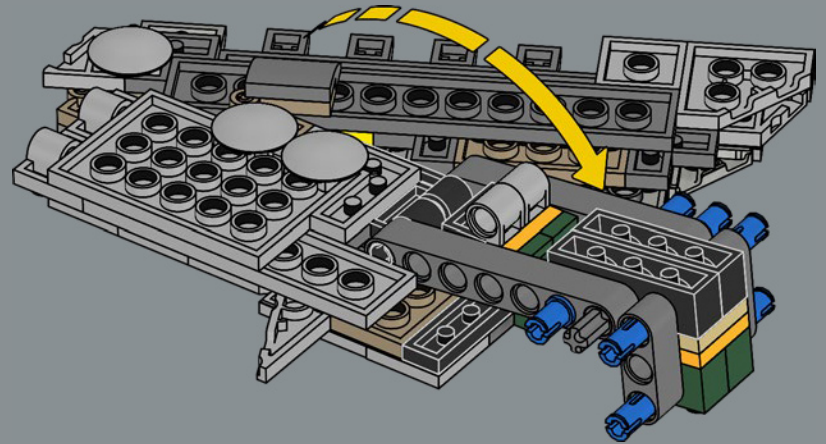

85

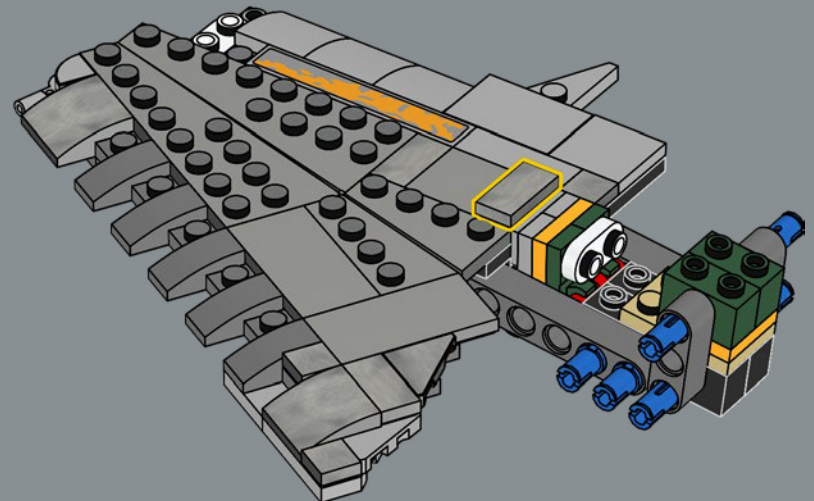

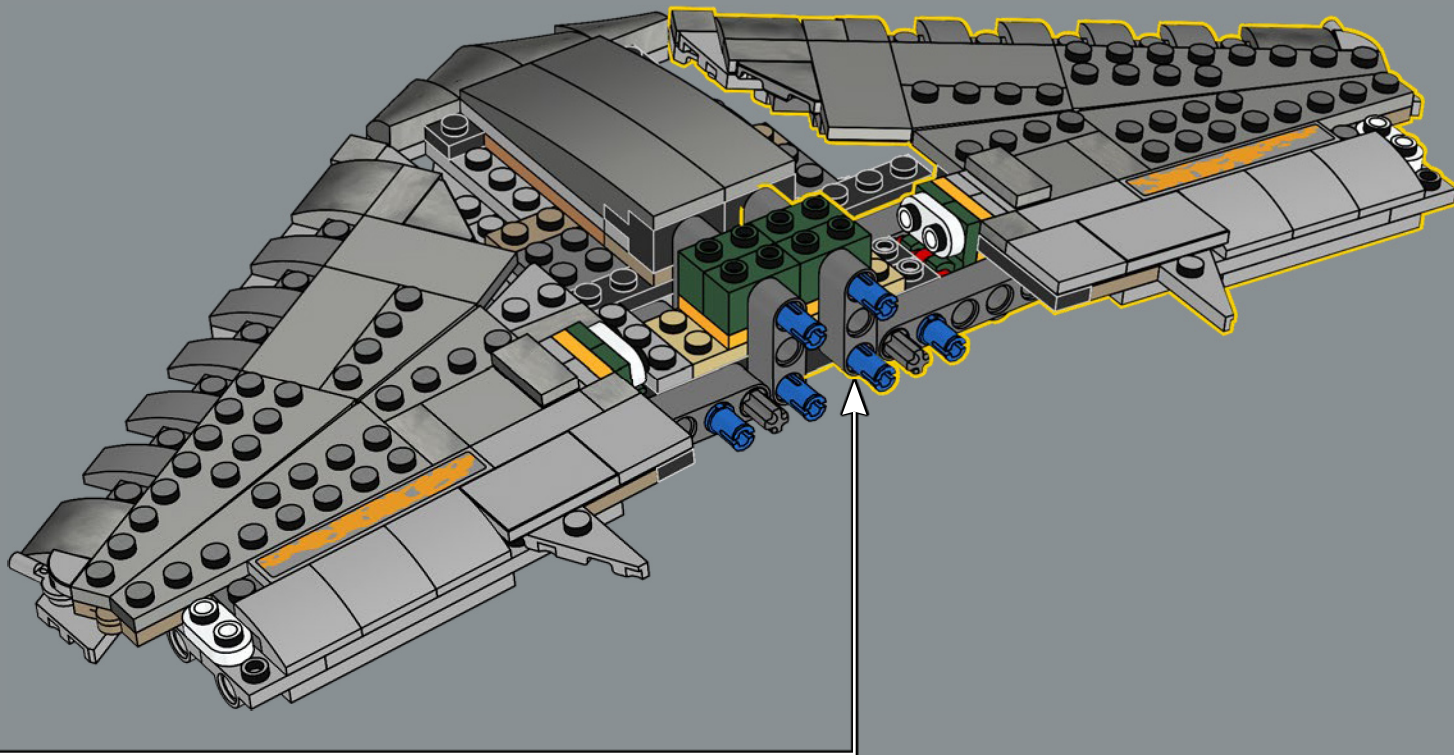

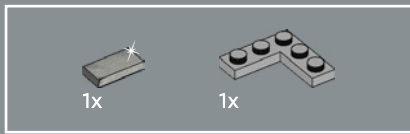

87

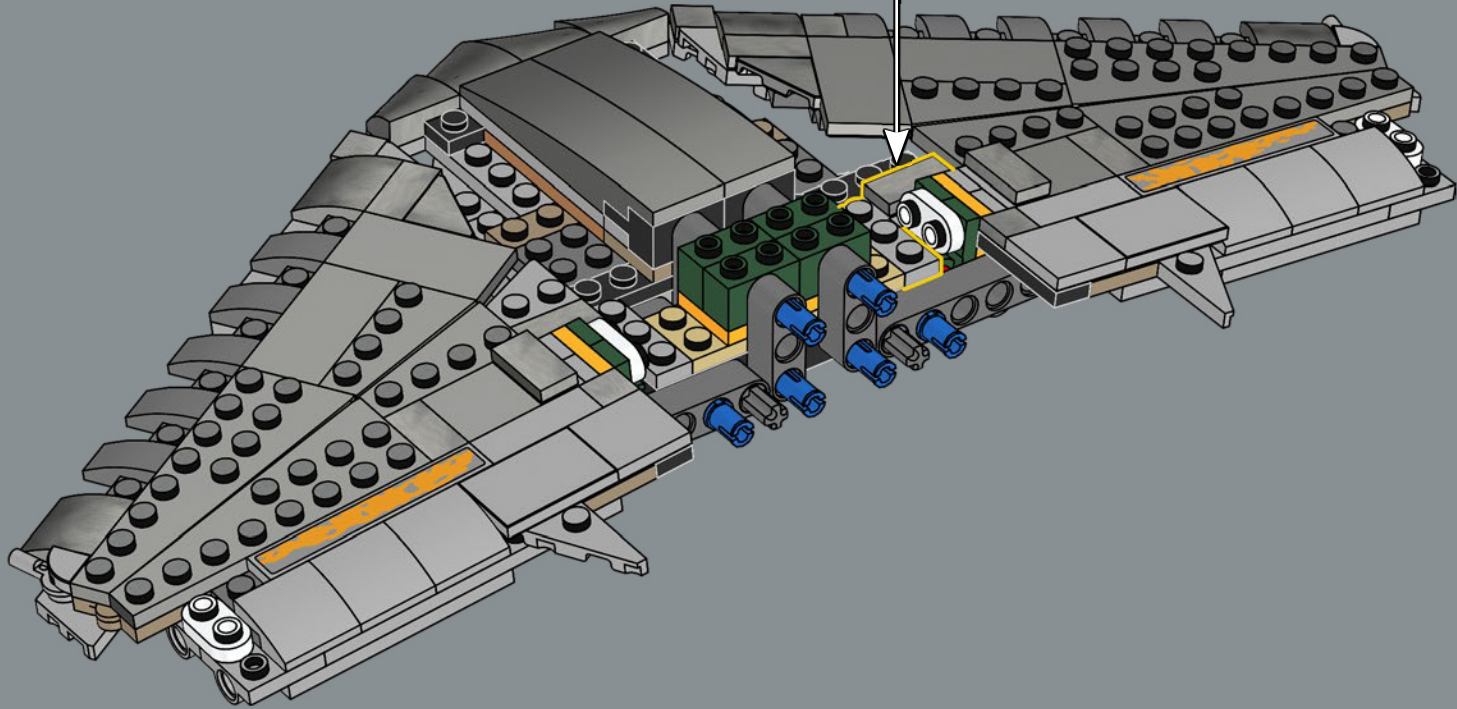
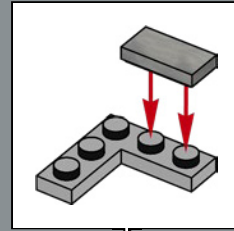



1x

88

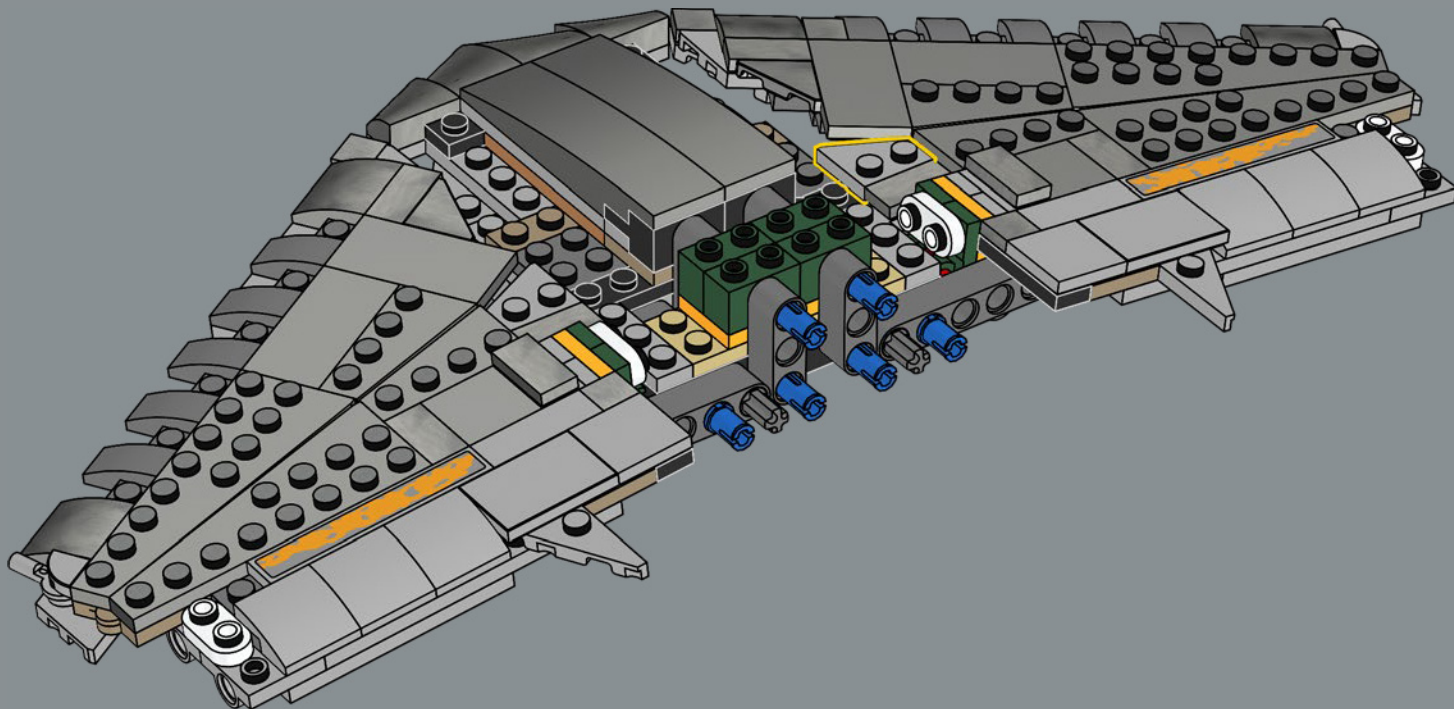

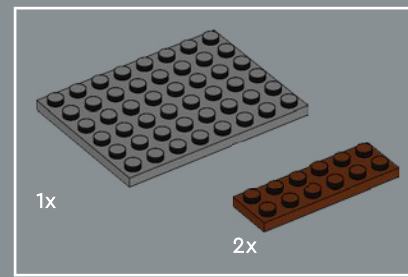
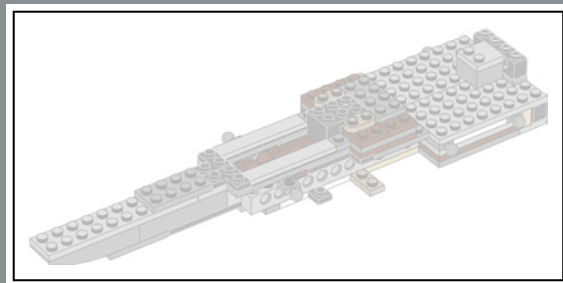

89

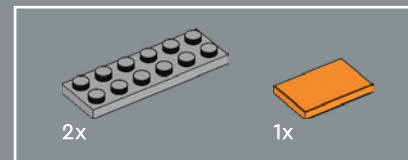
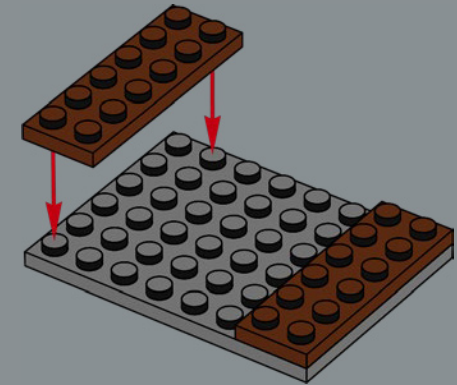

90

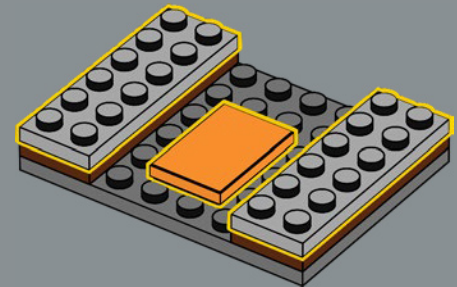

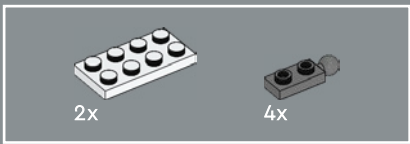

91

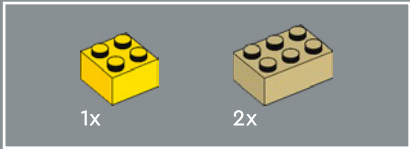
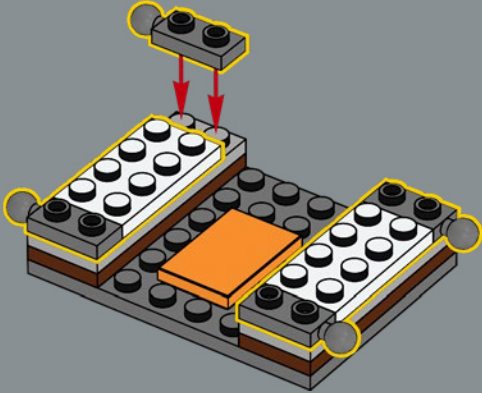

92

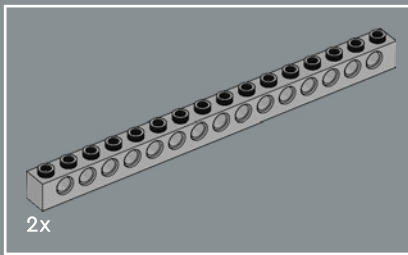
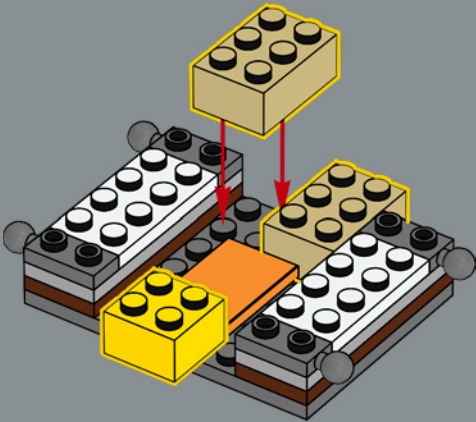

93

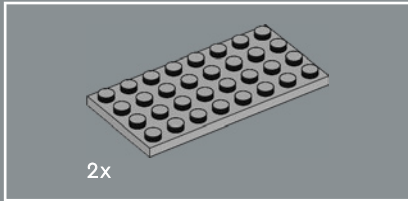
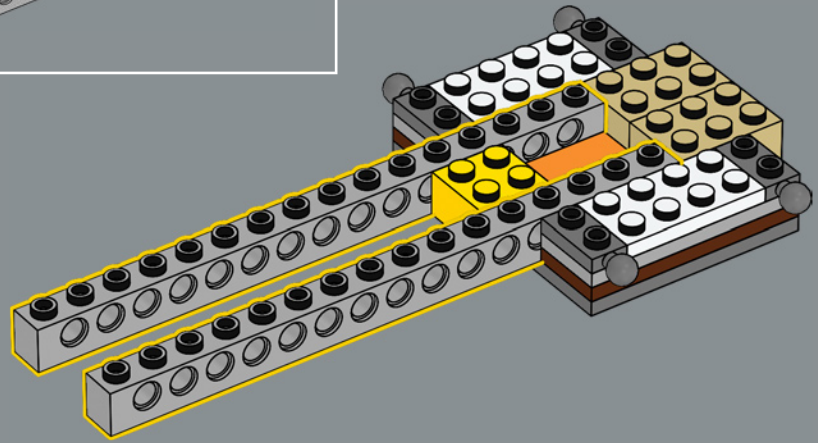

94

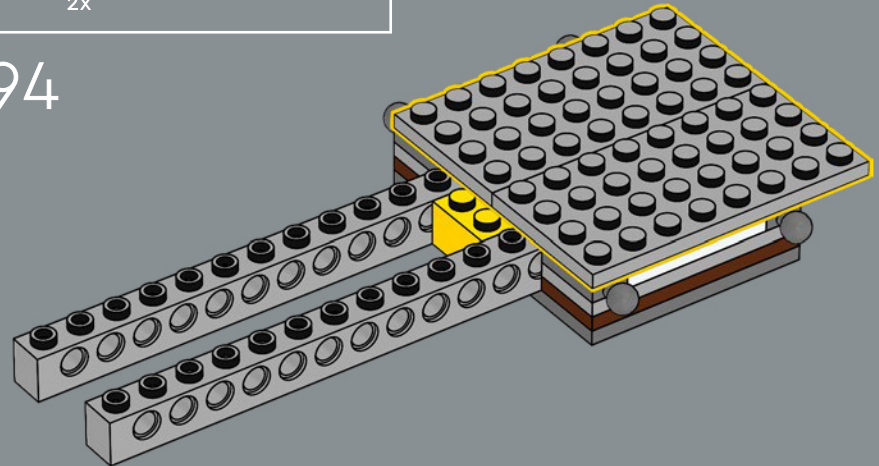



95

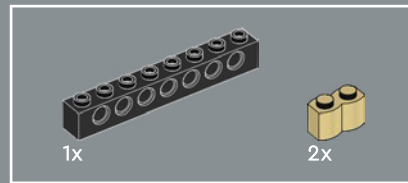
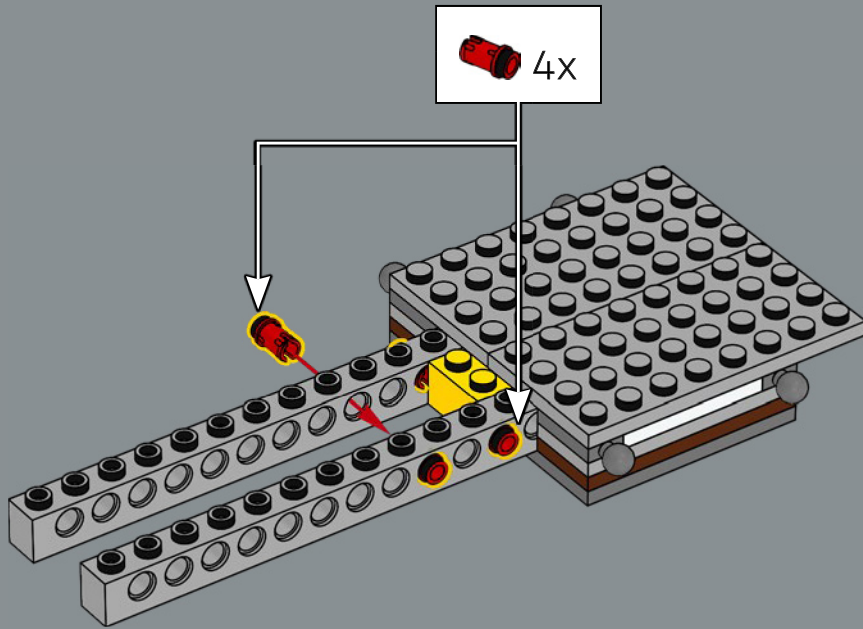

96

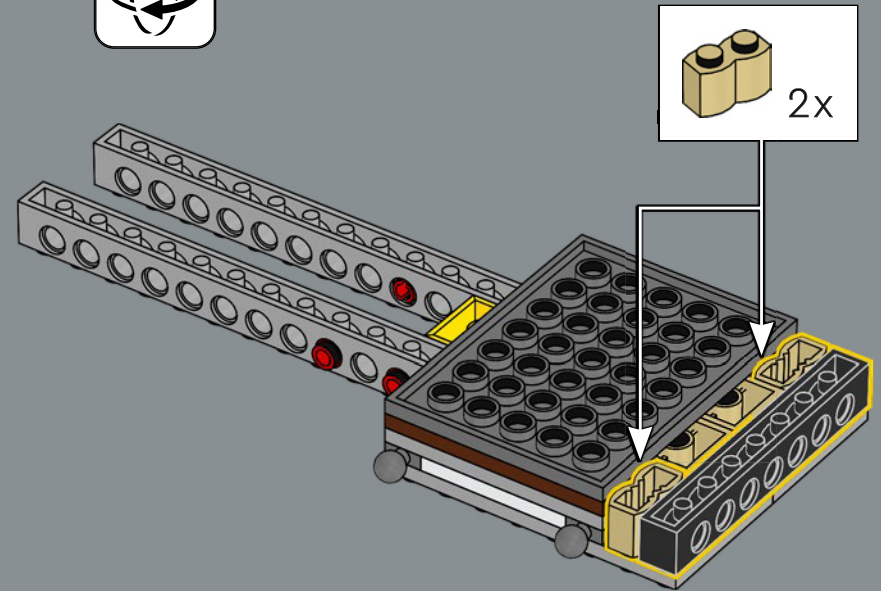

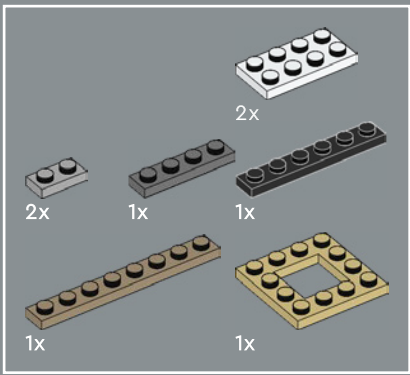

97

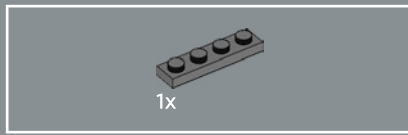
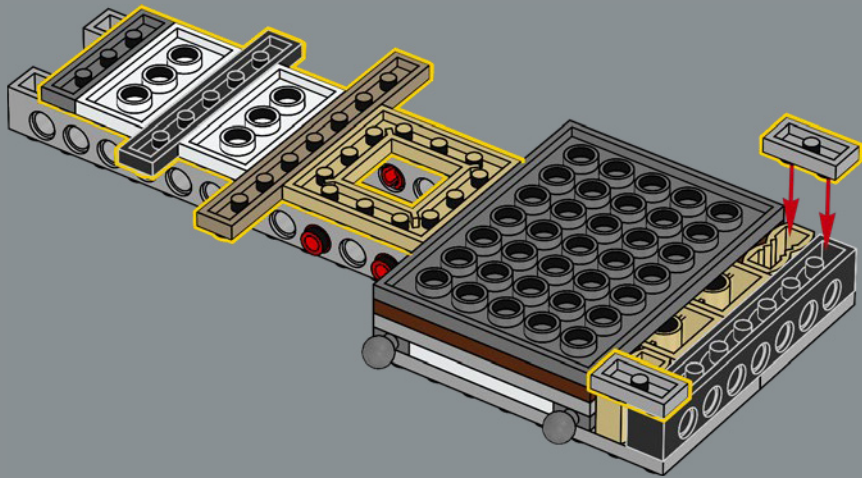

98

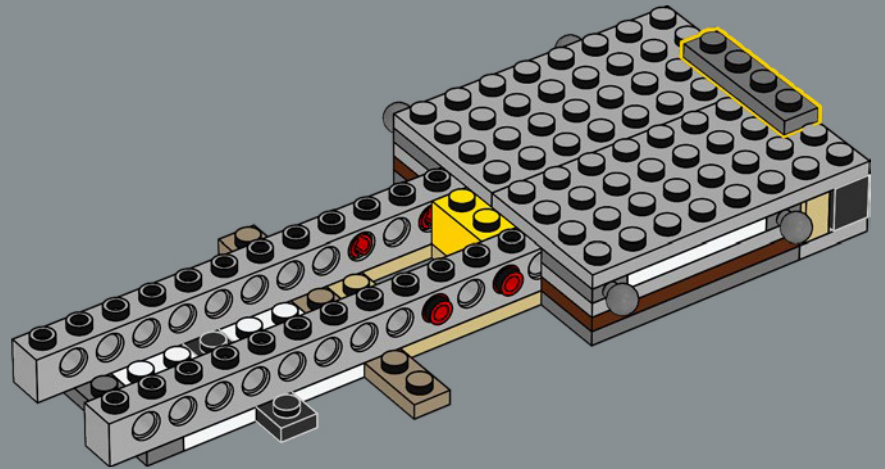

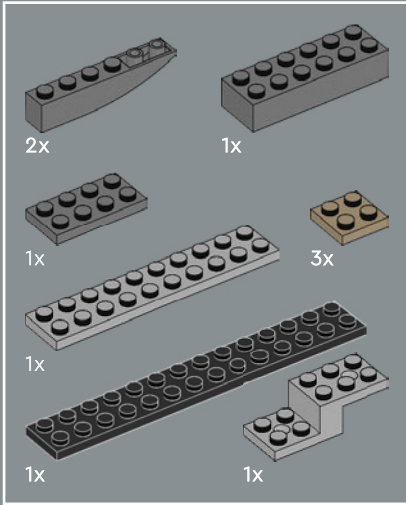
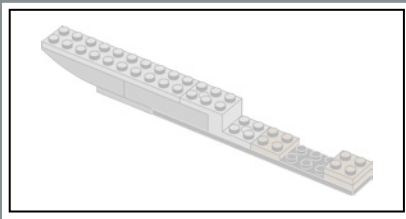

99

1

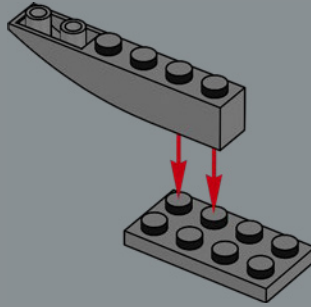

2

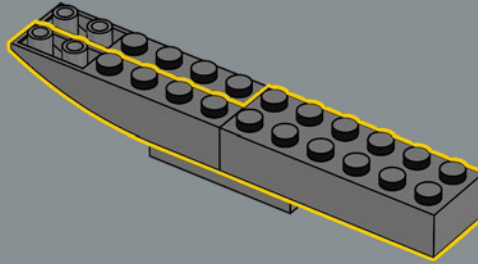

3

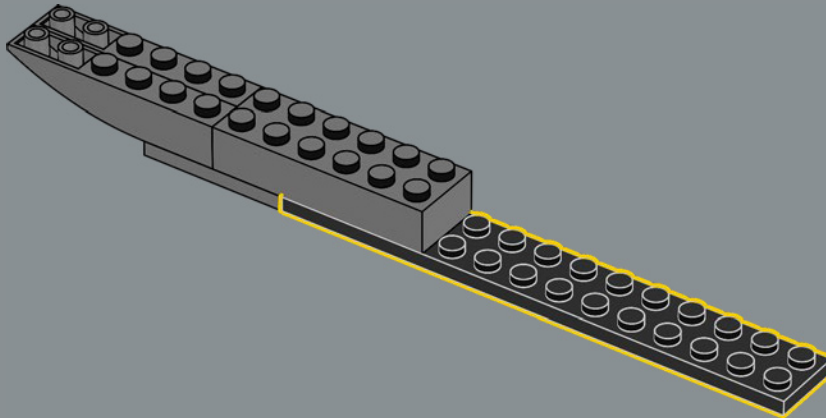

4

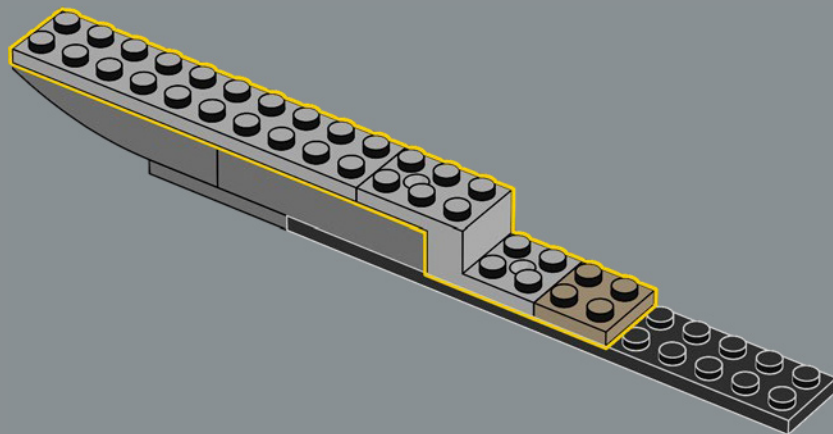

5

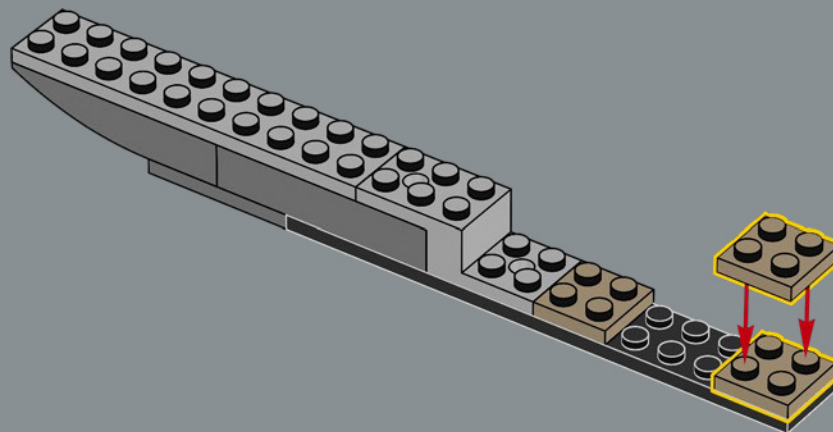

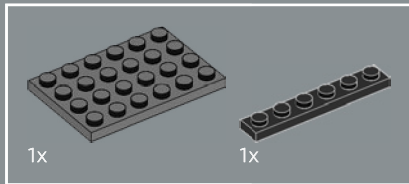
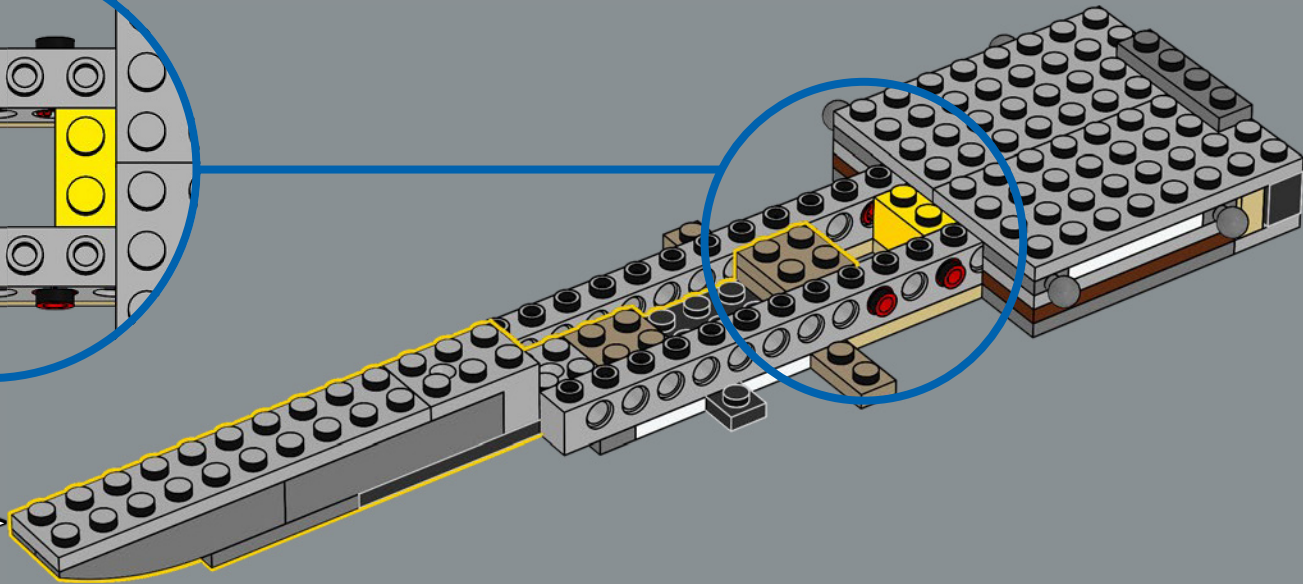
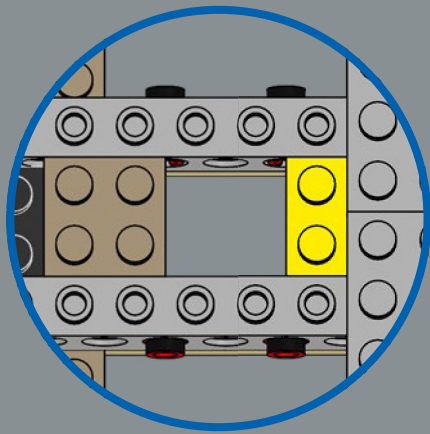

100

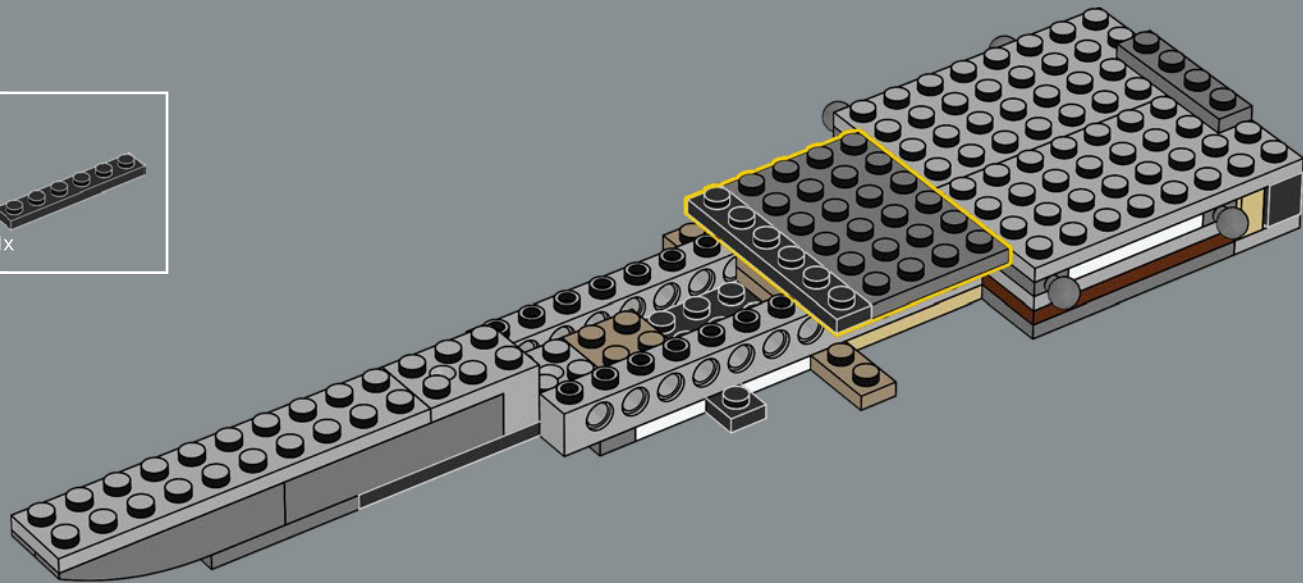

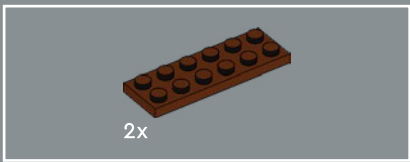

101

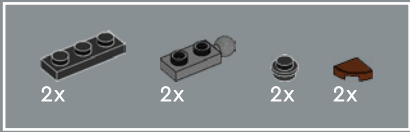
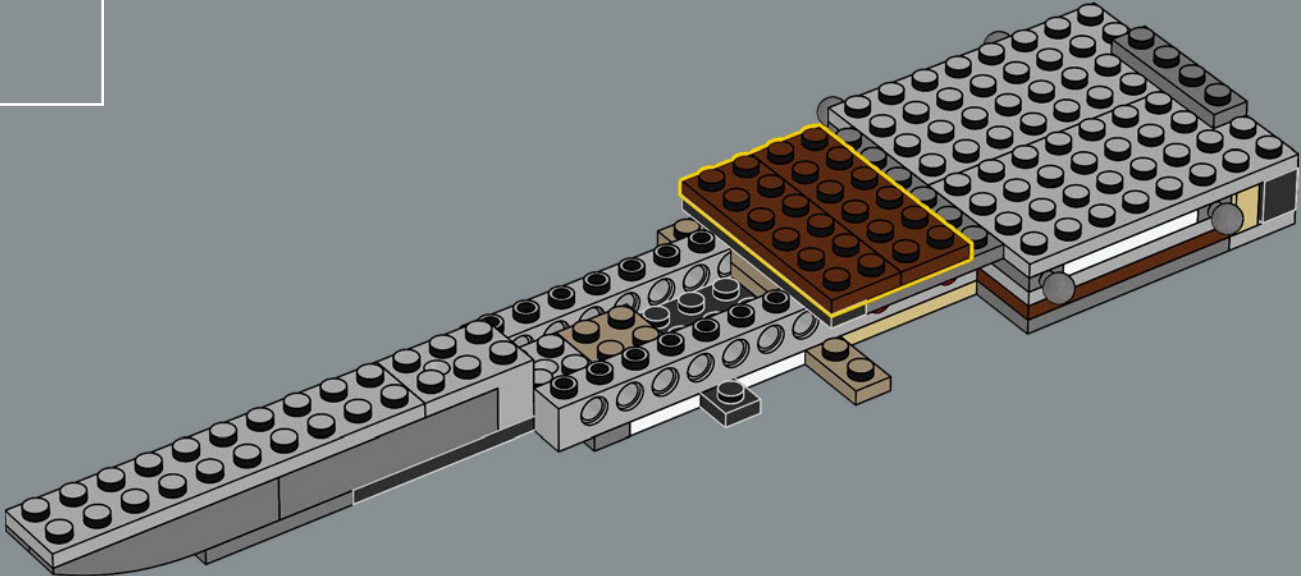

102

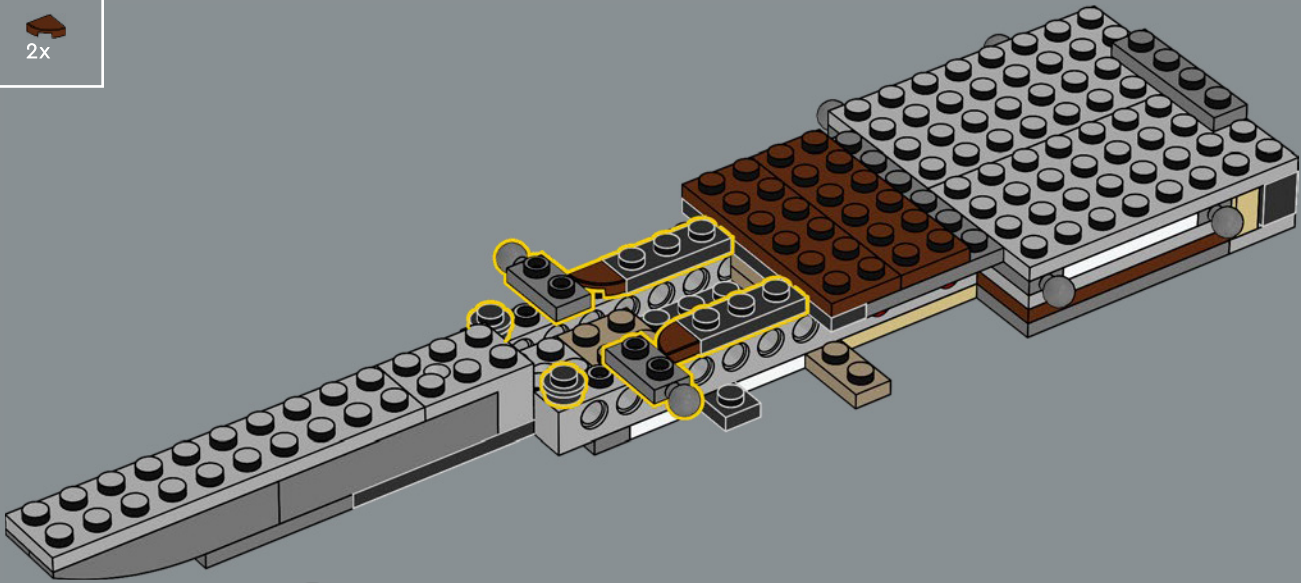

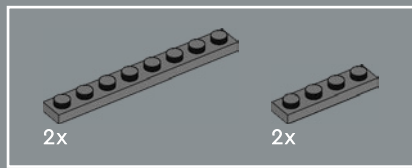

103

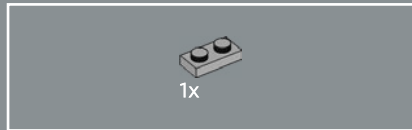
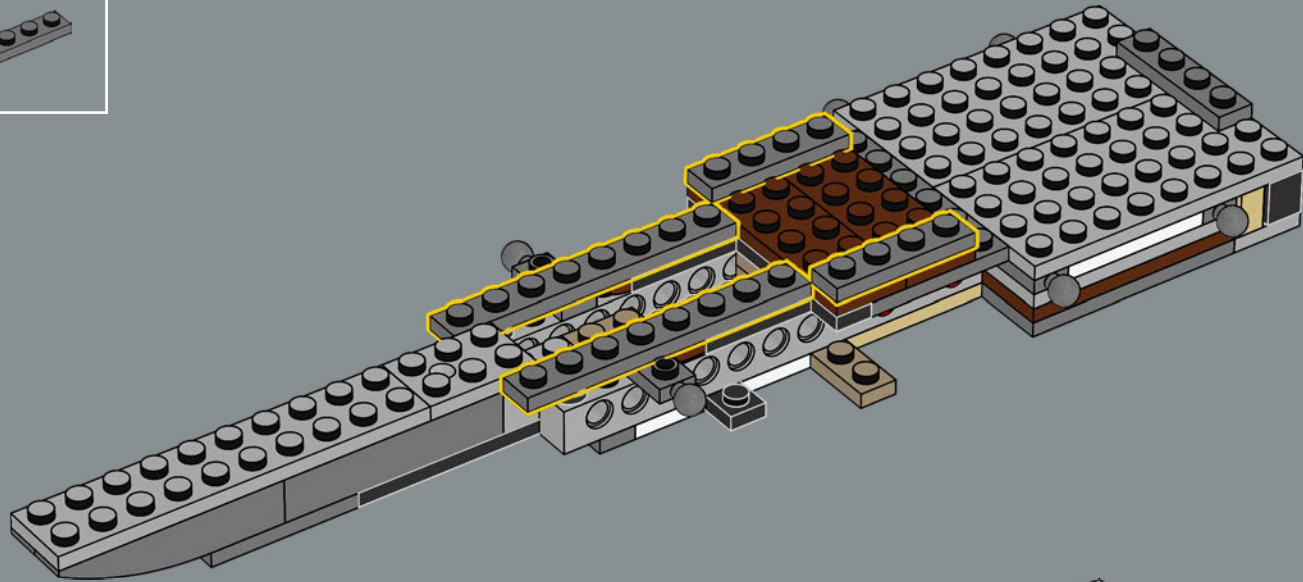

104

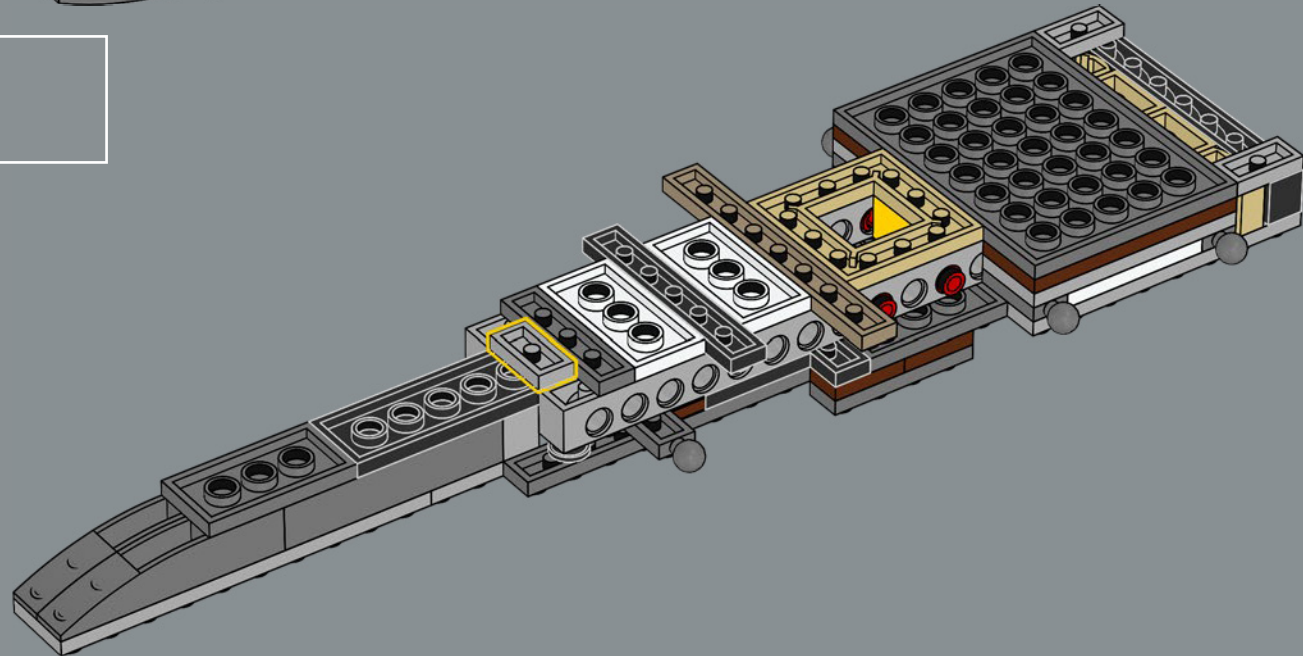

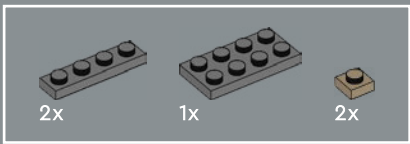

105

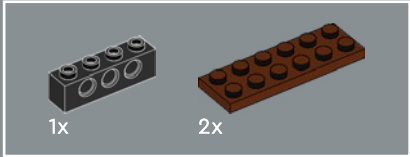
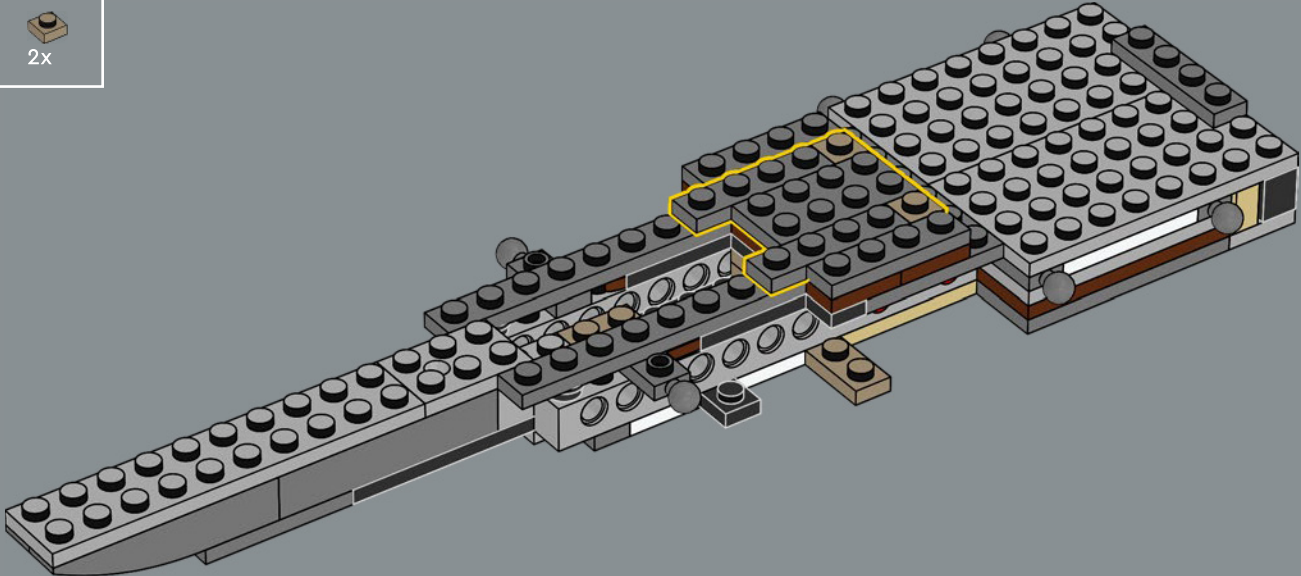

106

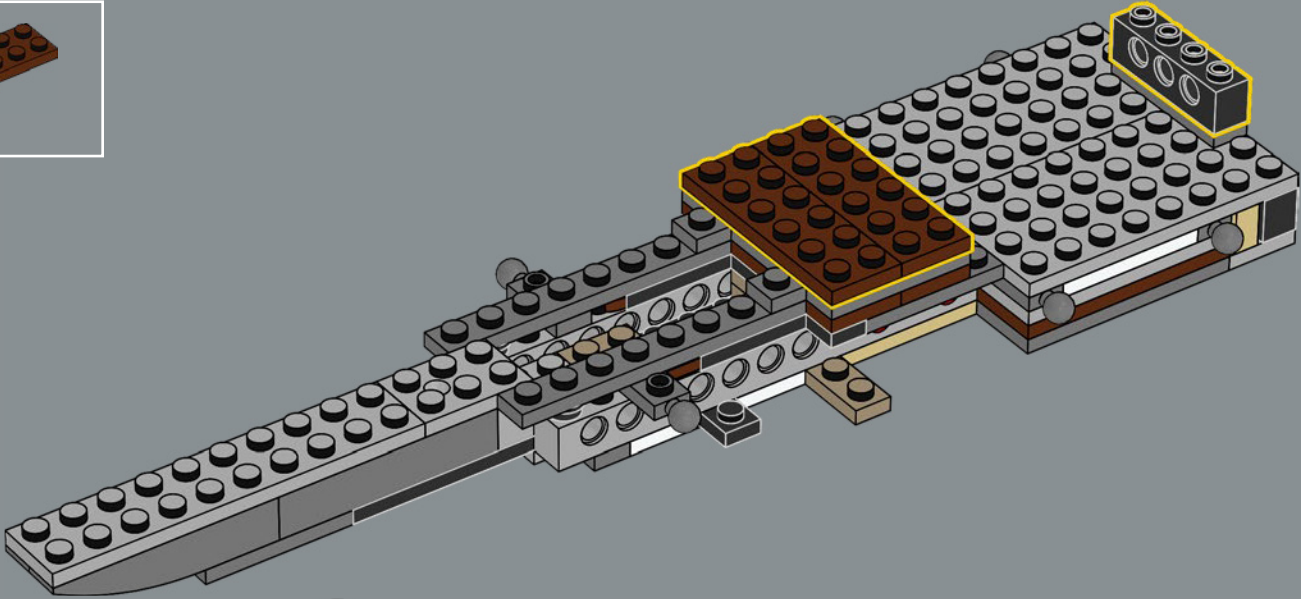

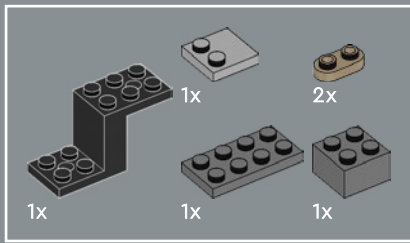

107

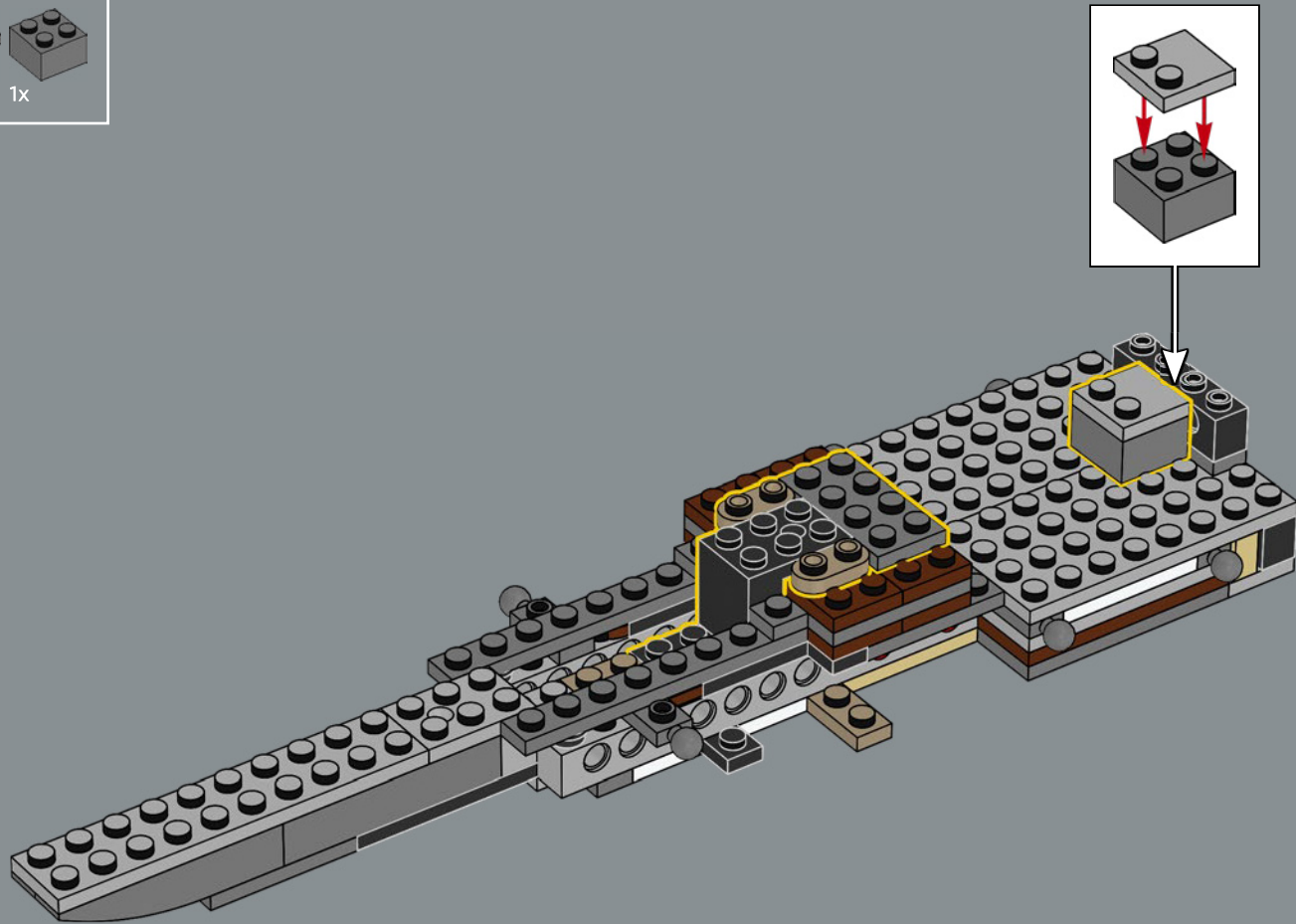

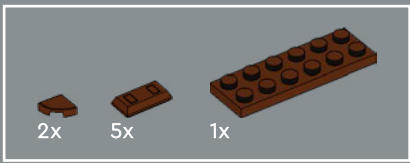

108

1

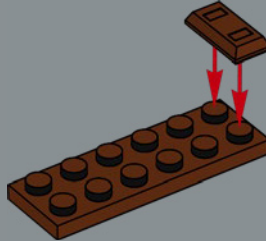

2

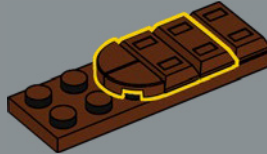

3

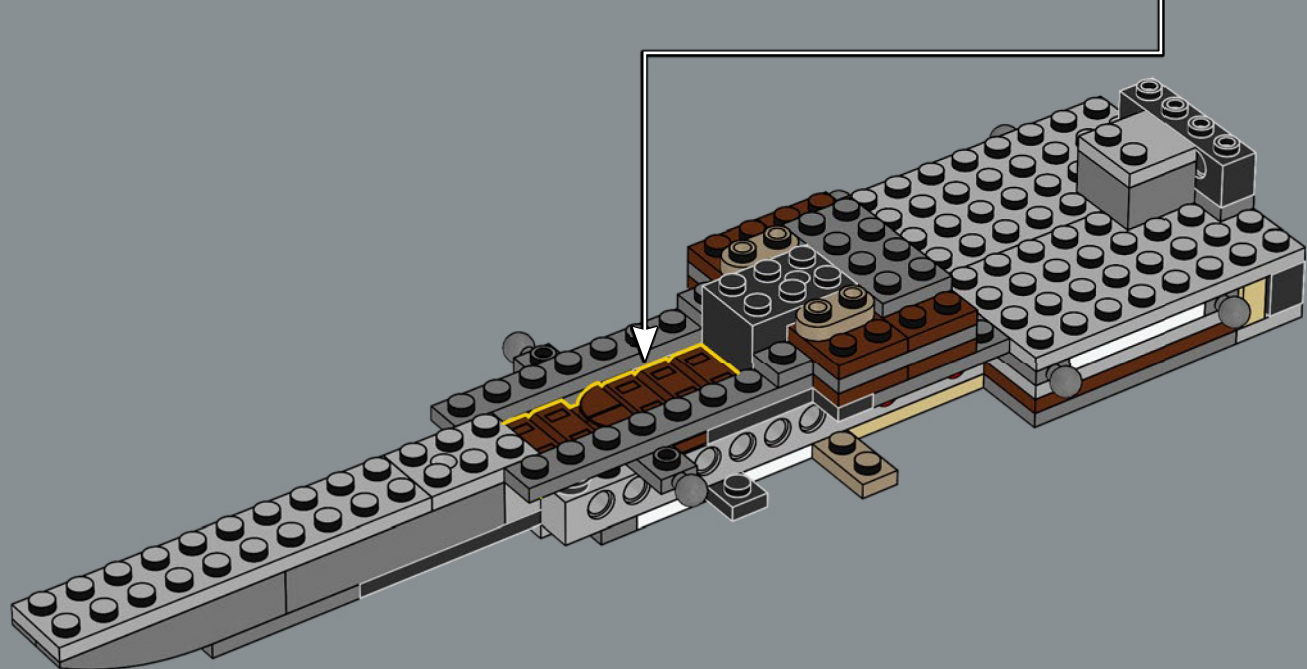
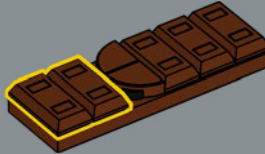

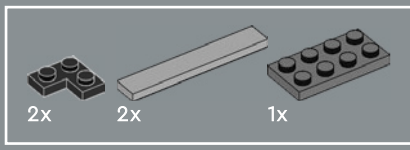

109

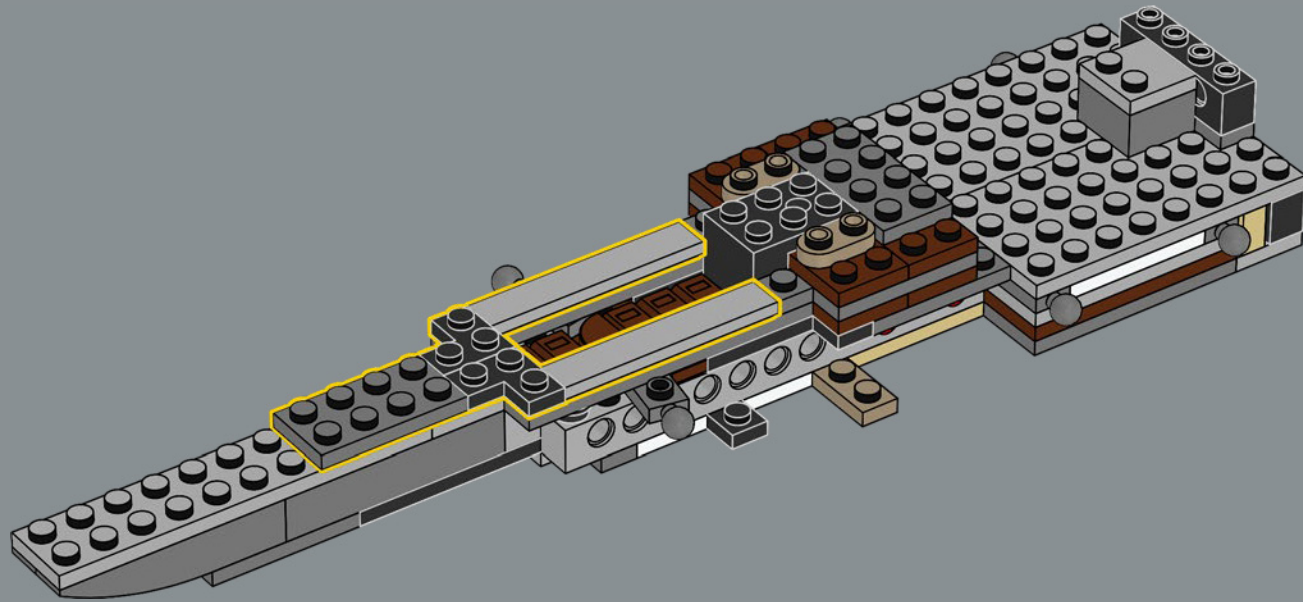

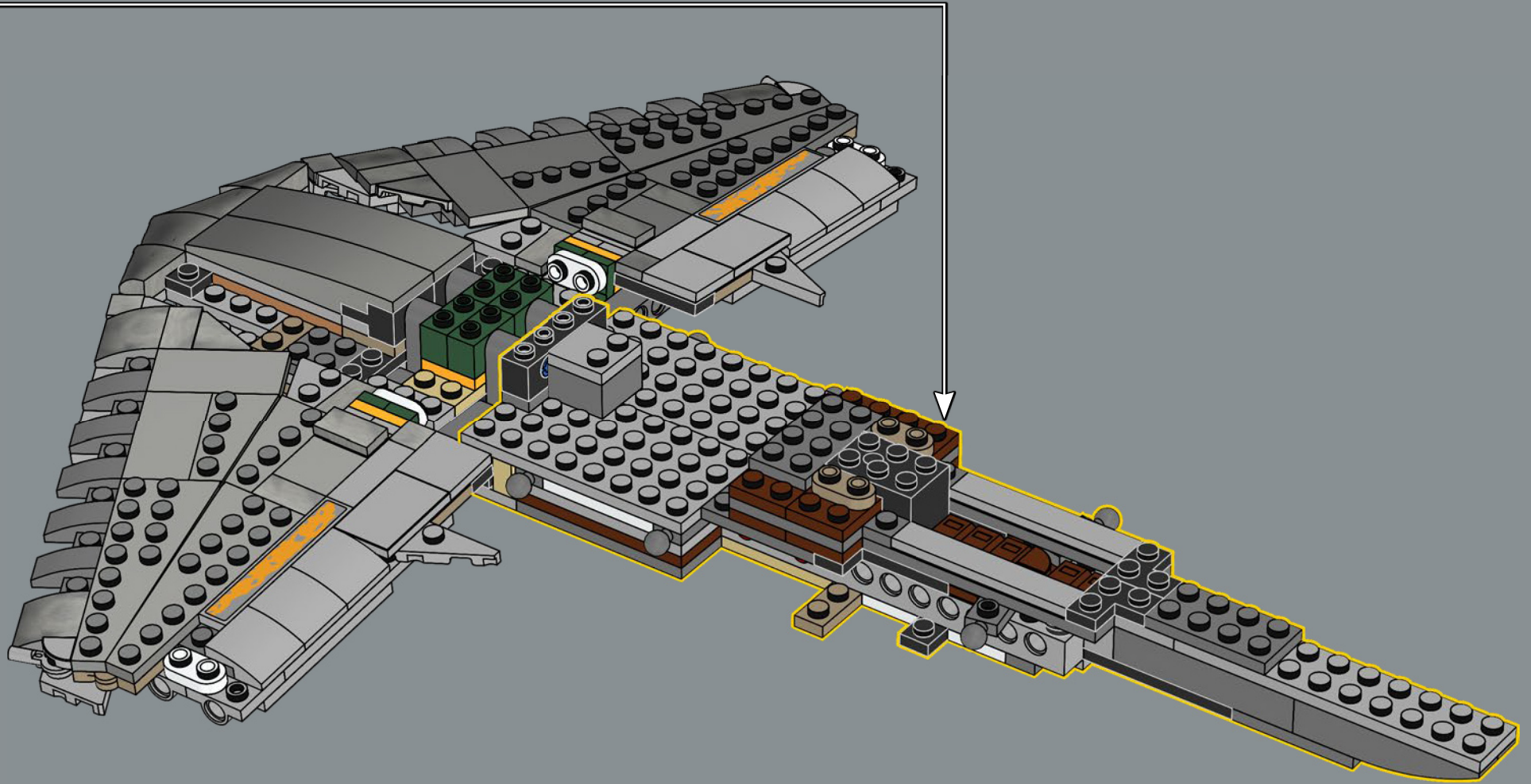



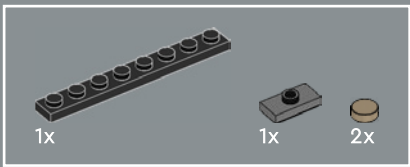

111

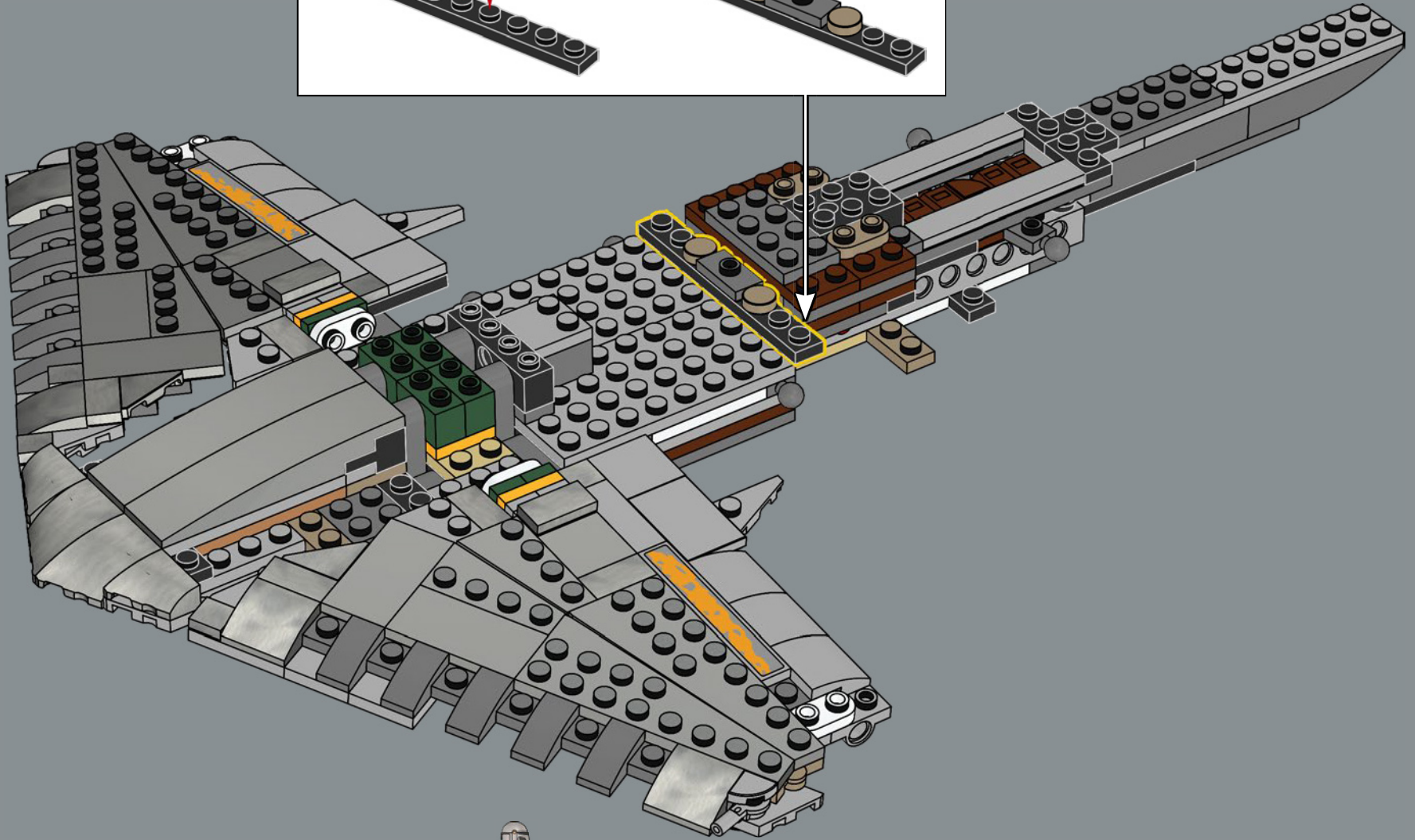
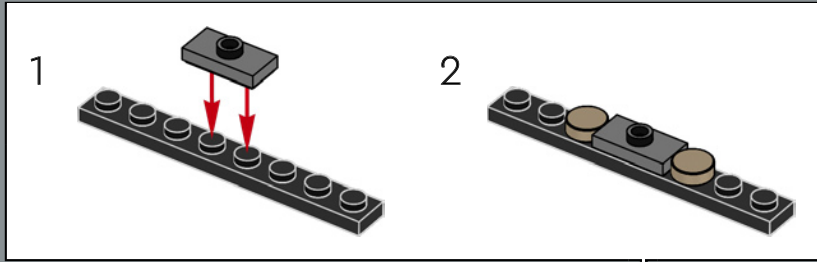

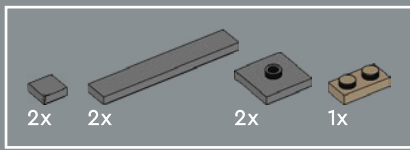

112

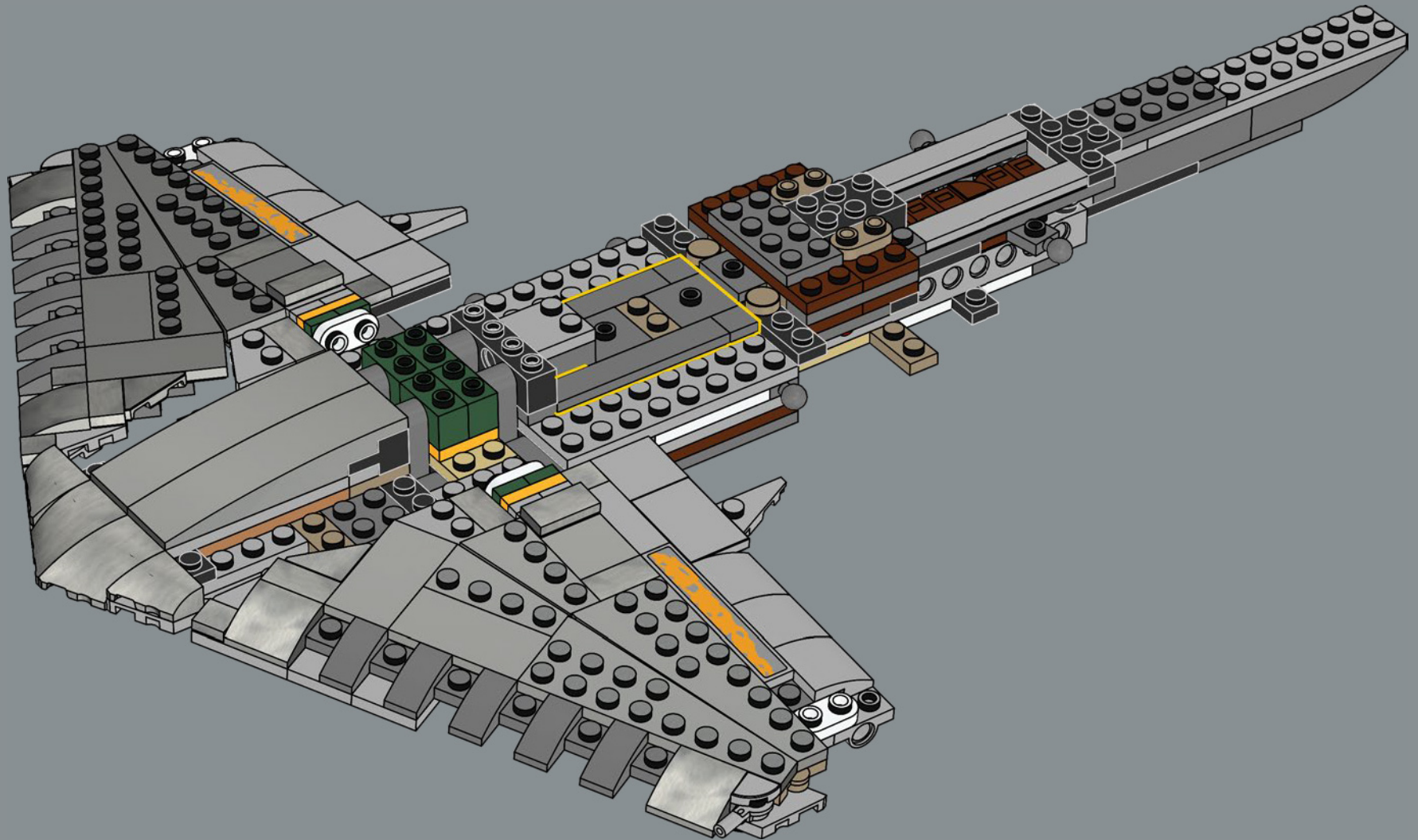

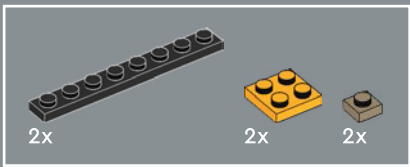

113

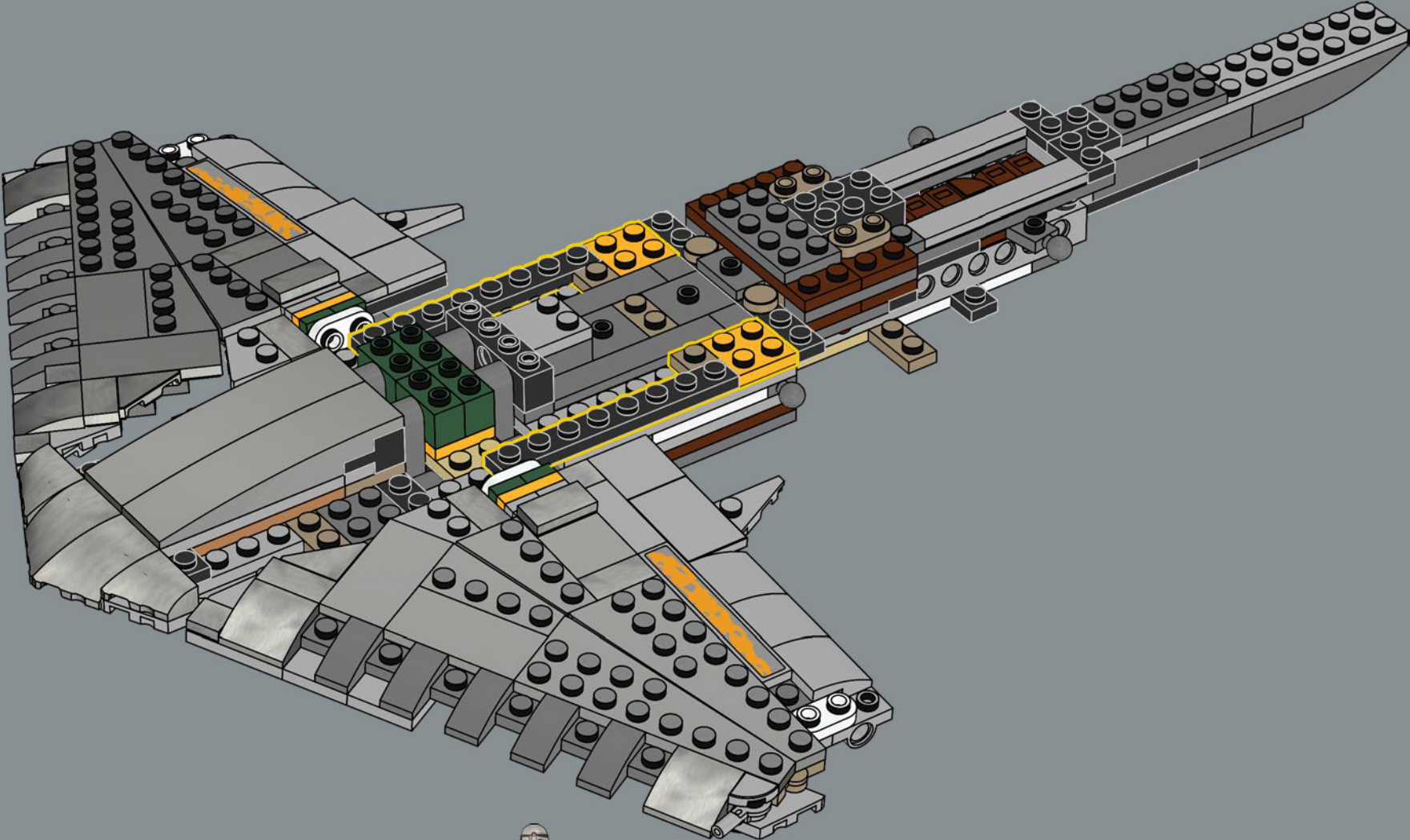

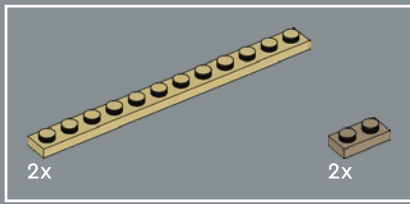

114

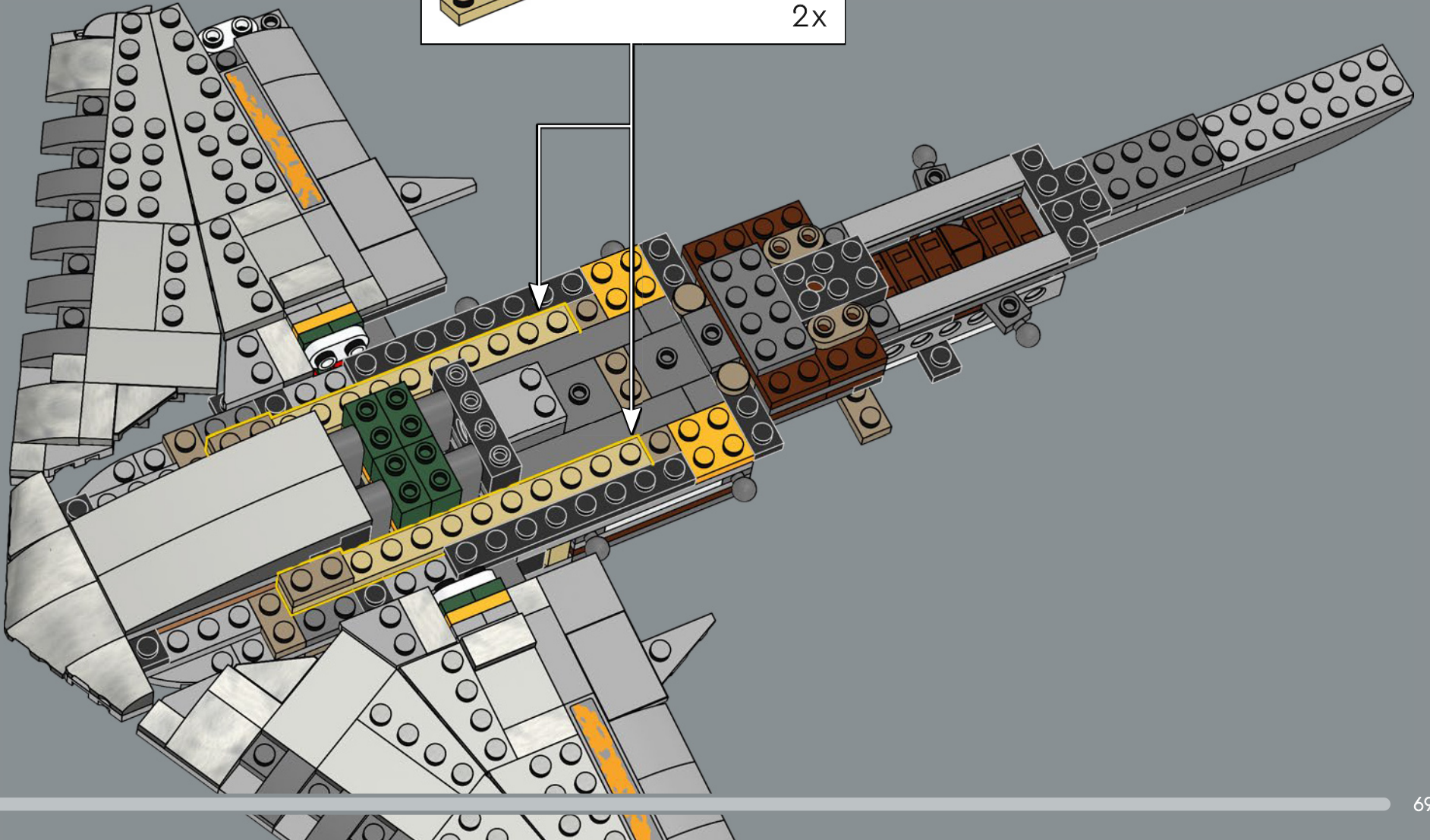
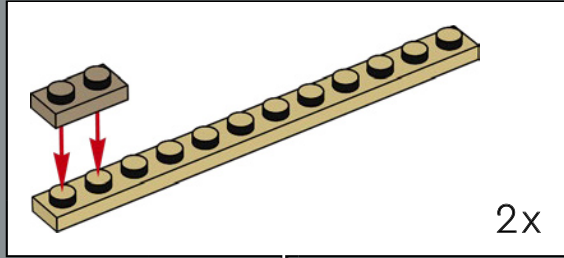



115

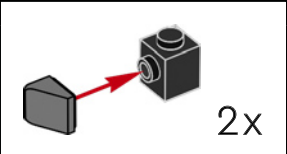
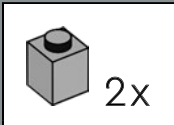
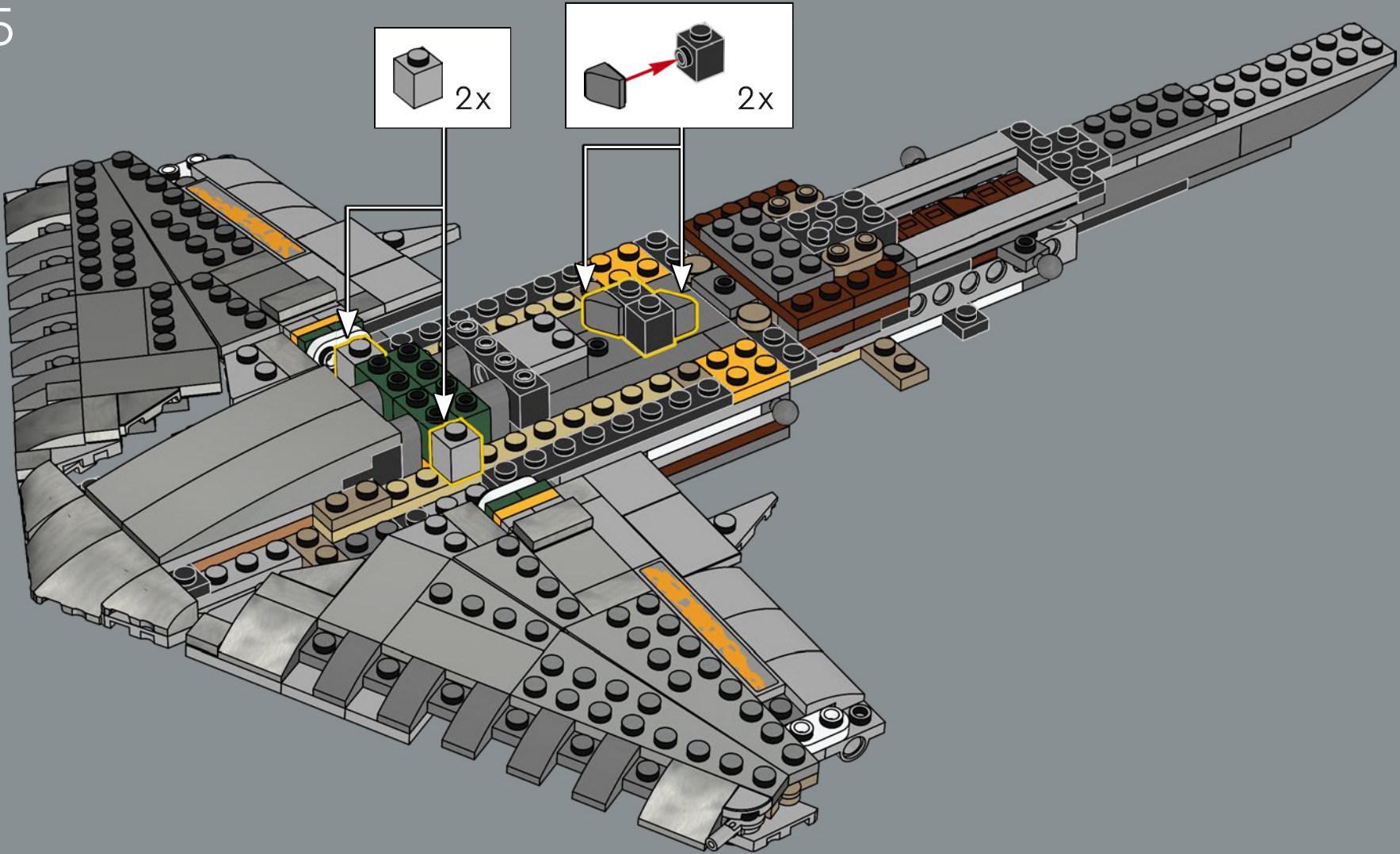

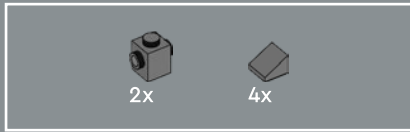

116

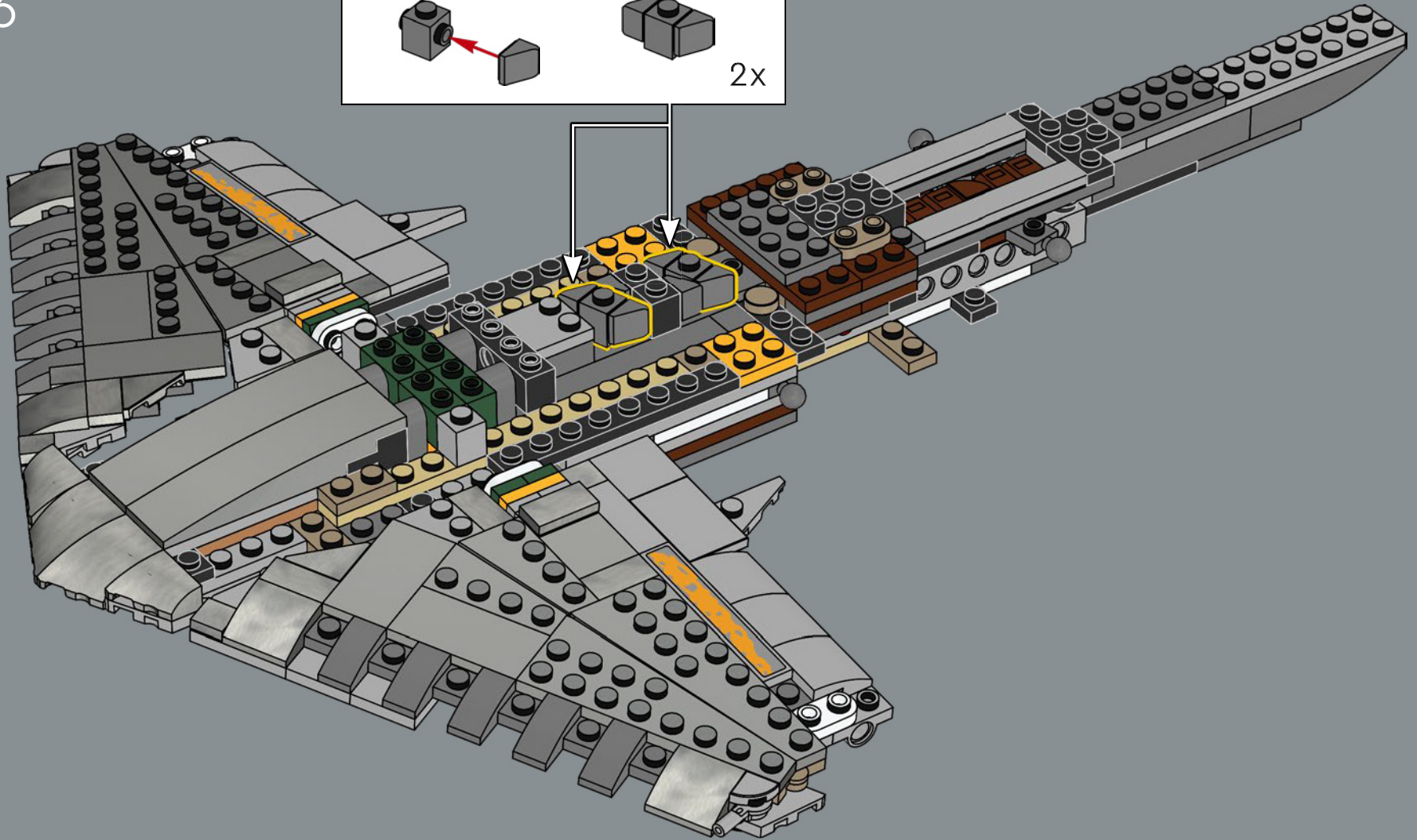
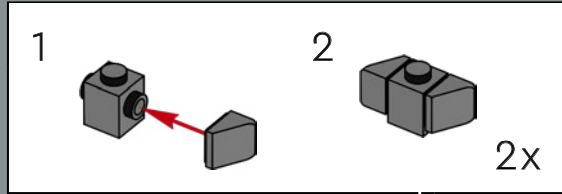

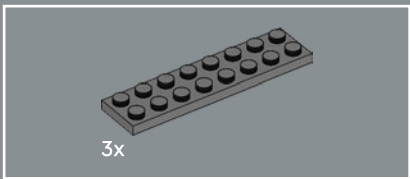

117

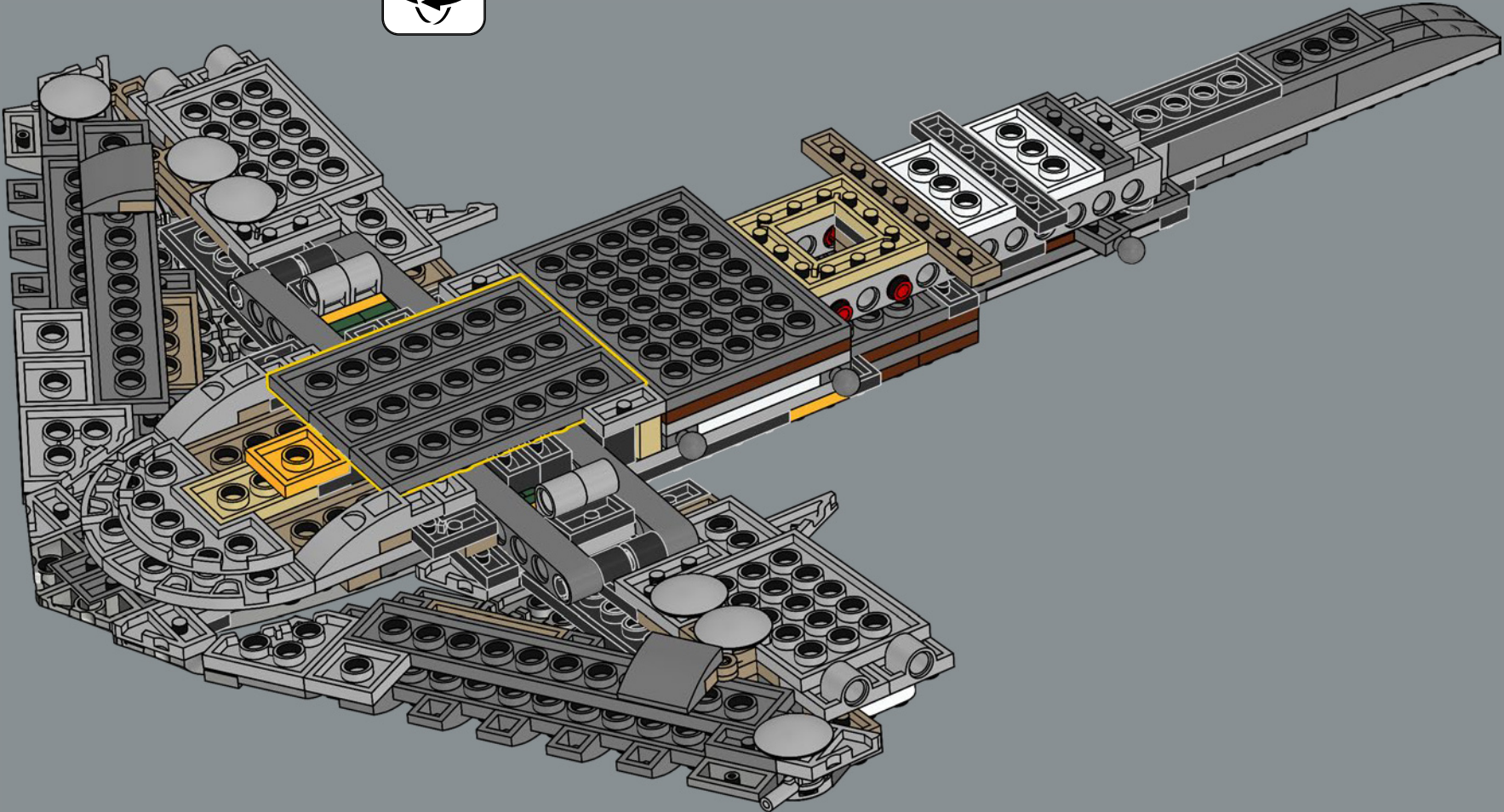

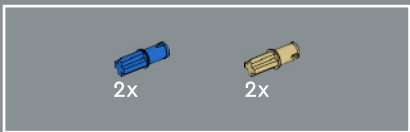

118

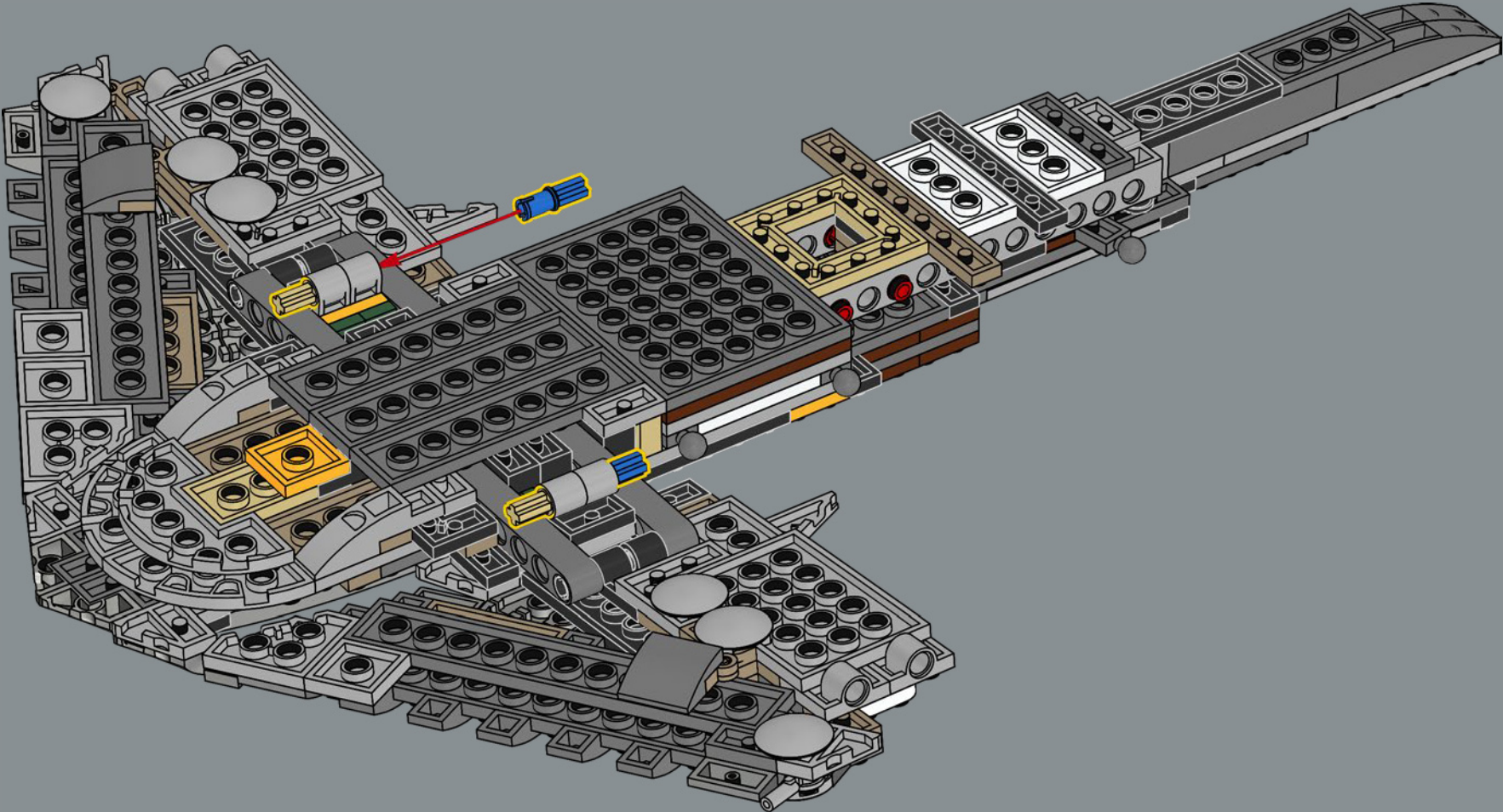



4x

119

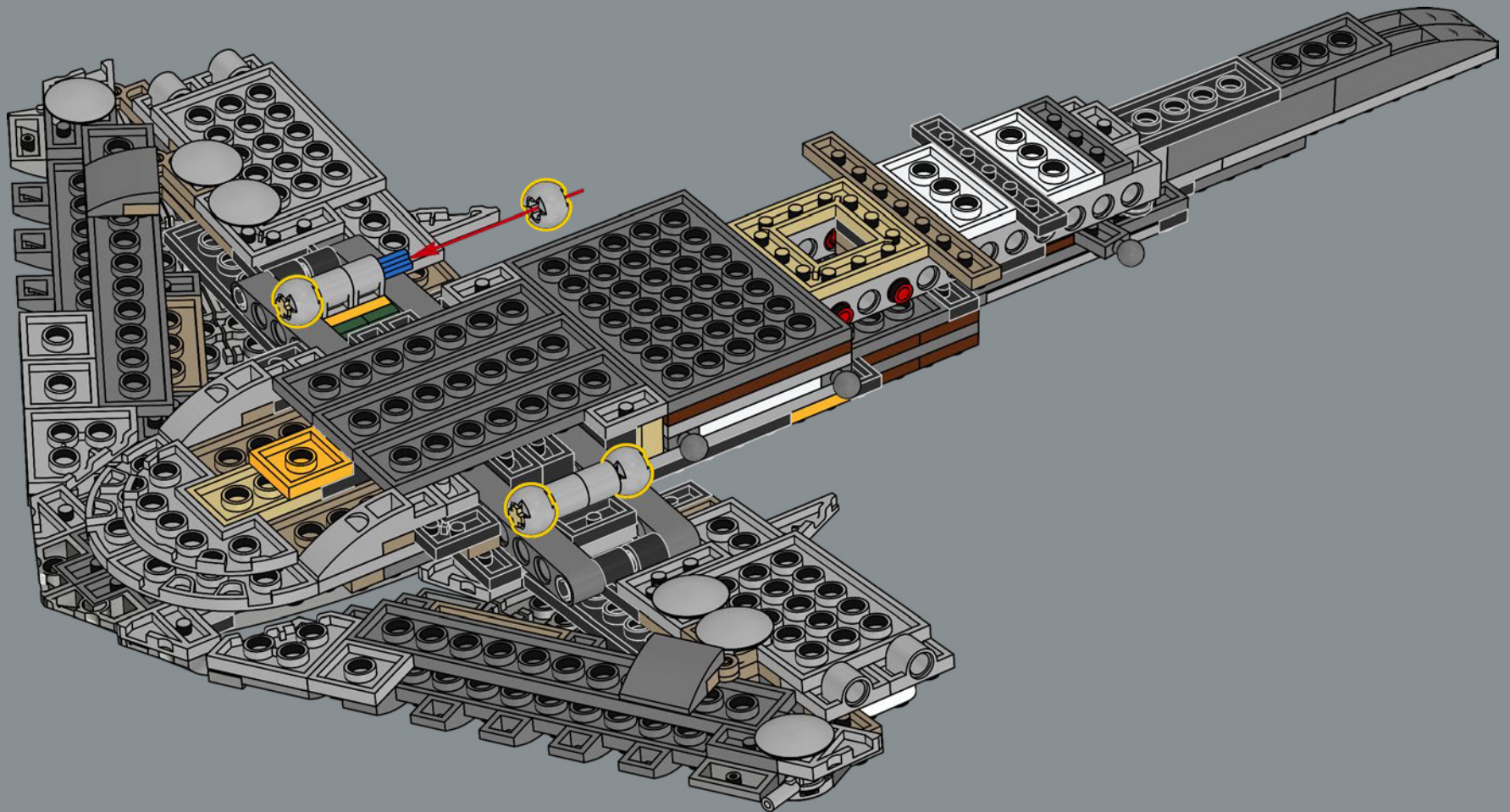

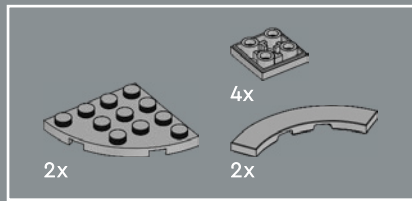

120

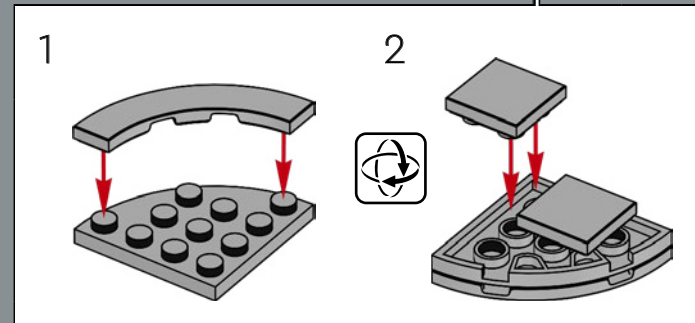
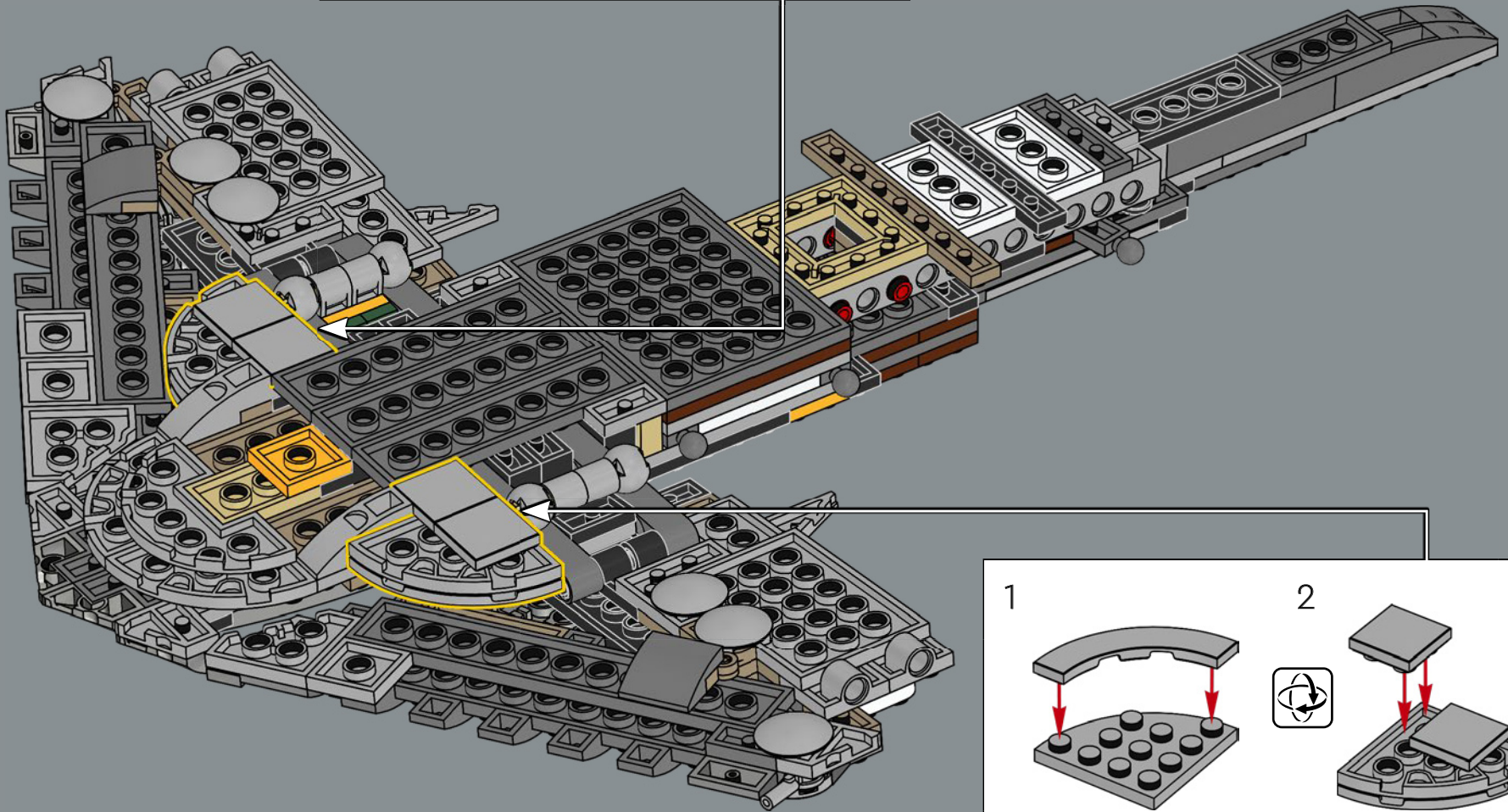
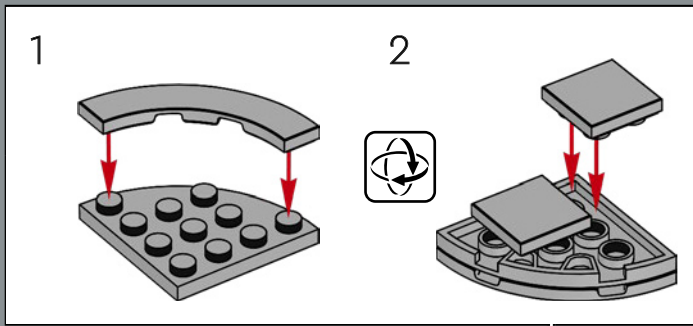

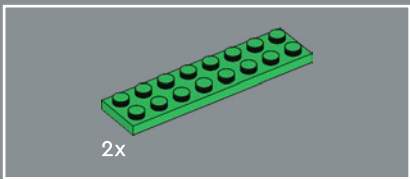

121

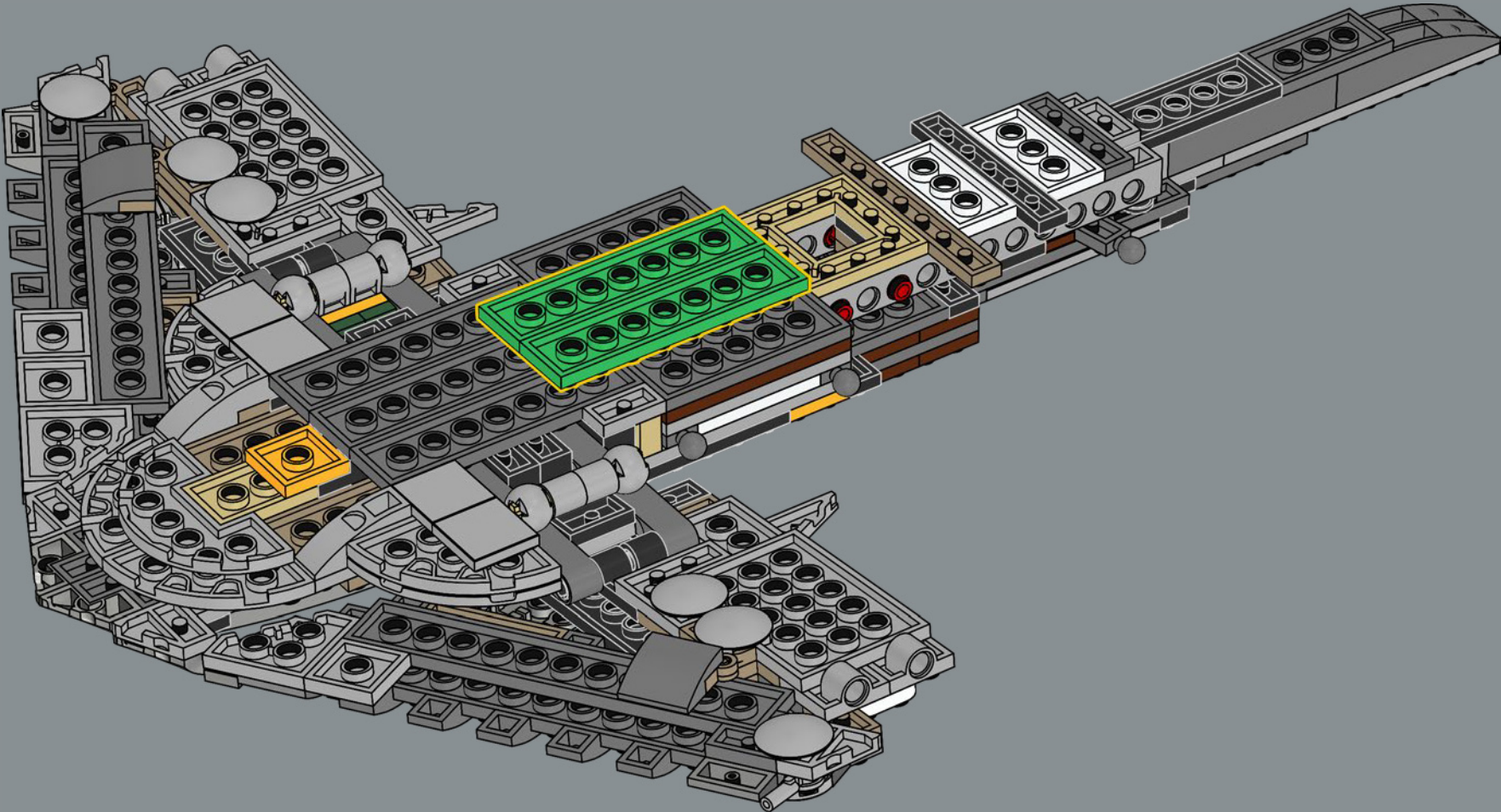

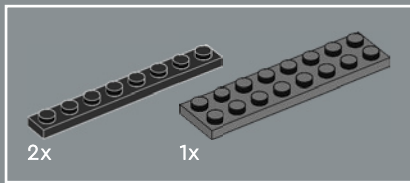

122

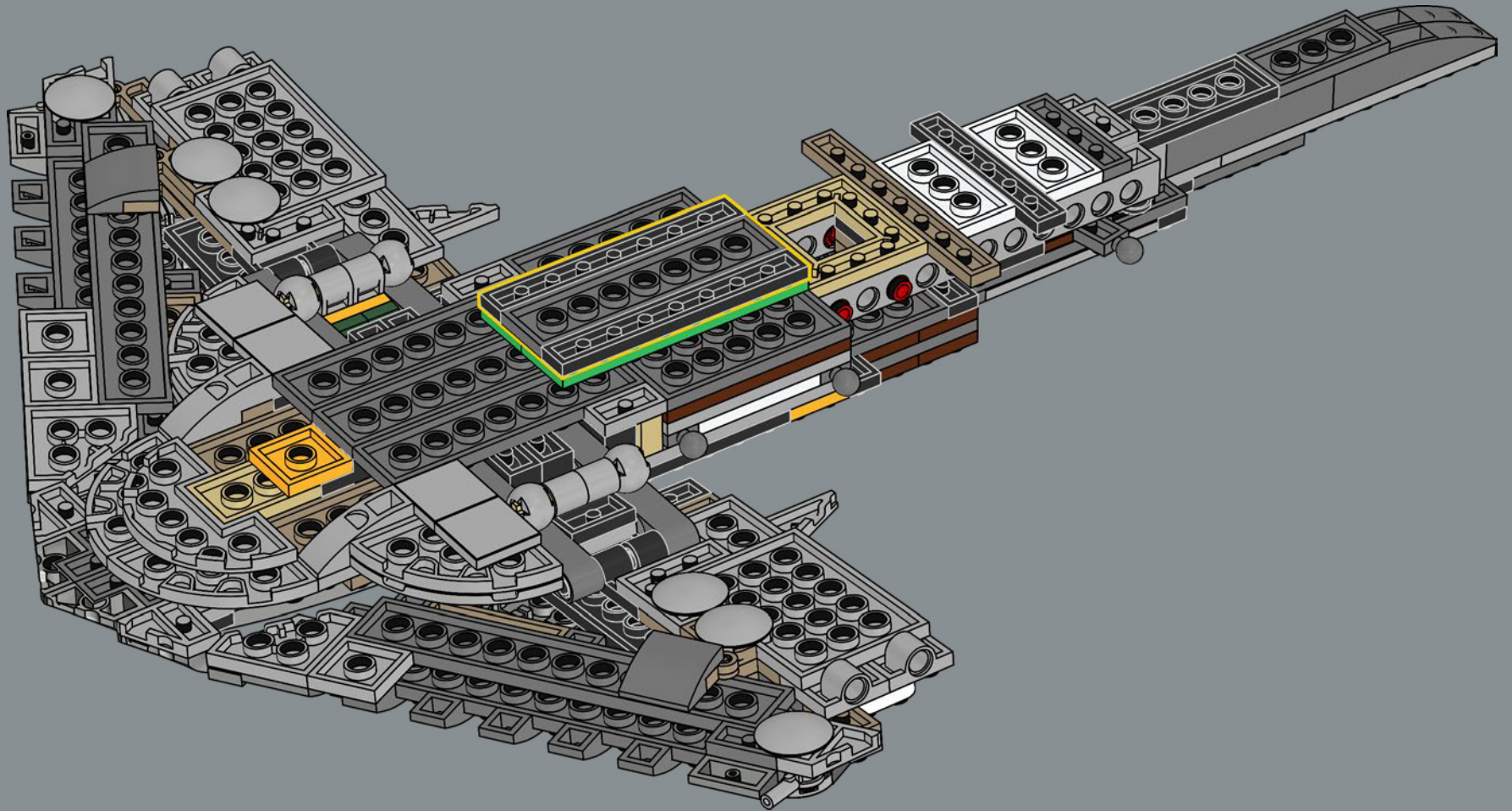

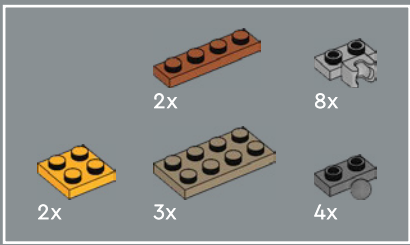

123

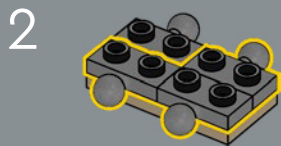
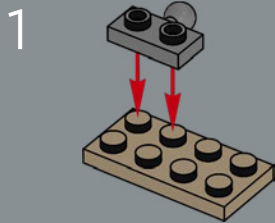

3

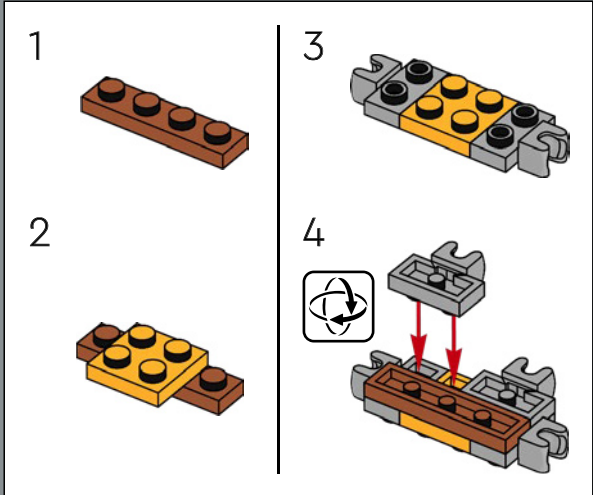
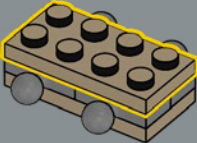

4

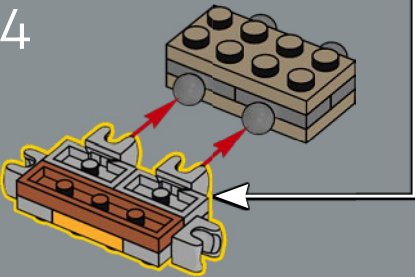

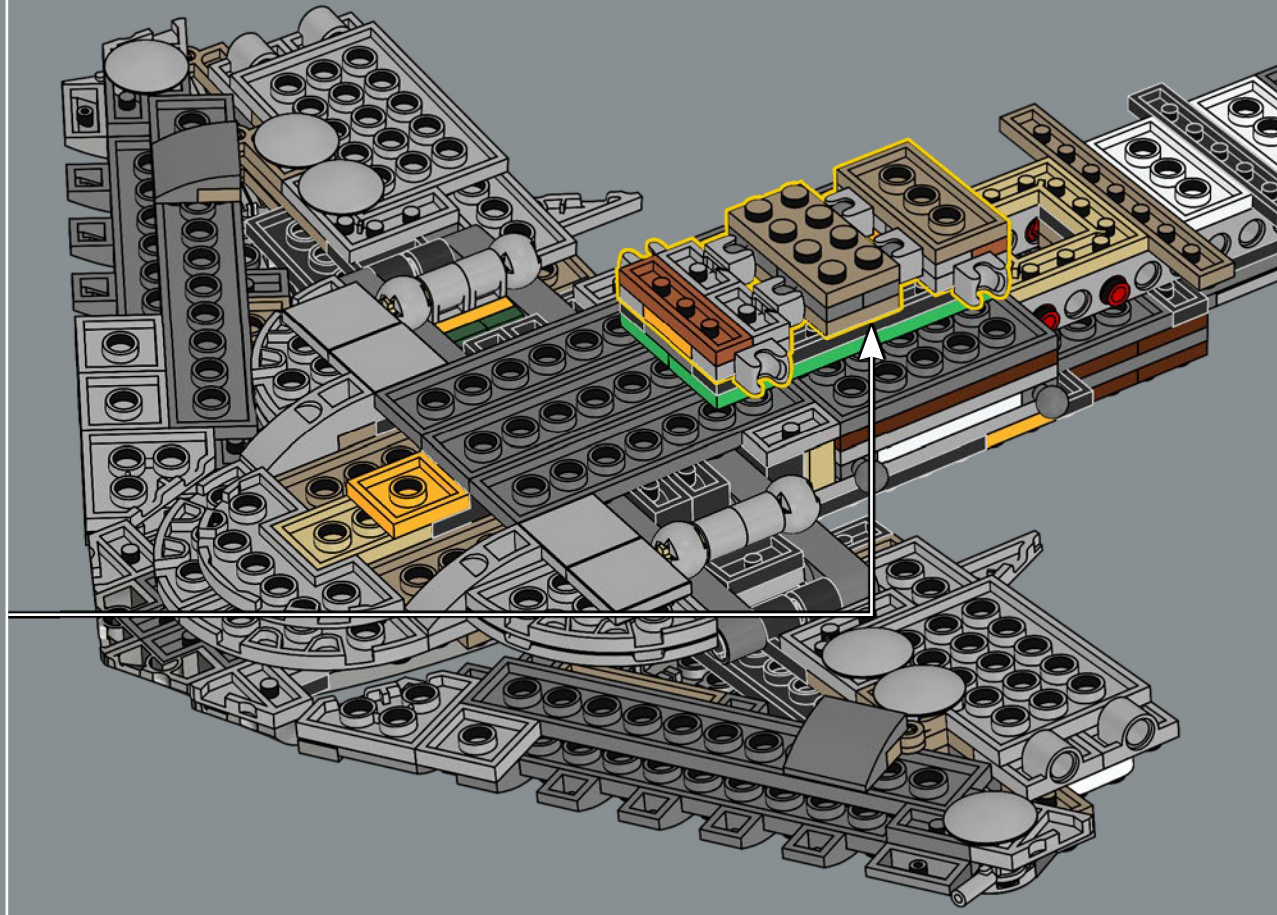
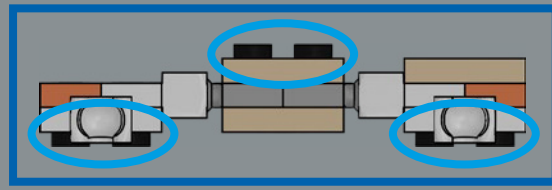
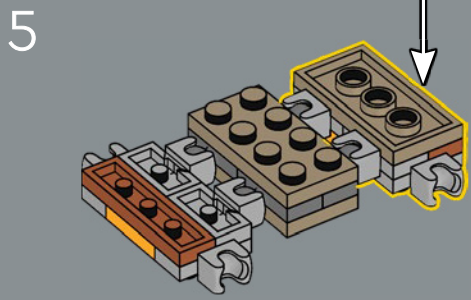
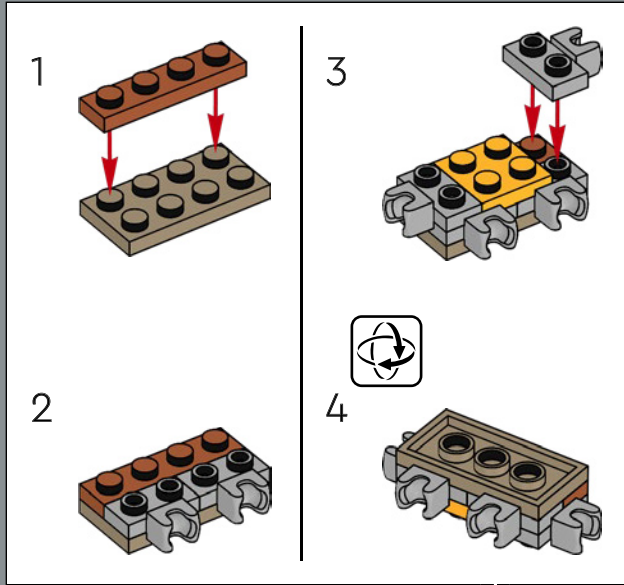

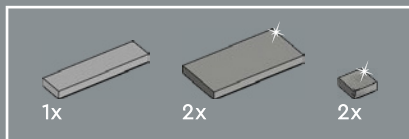

124

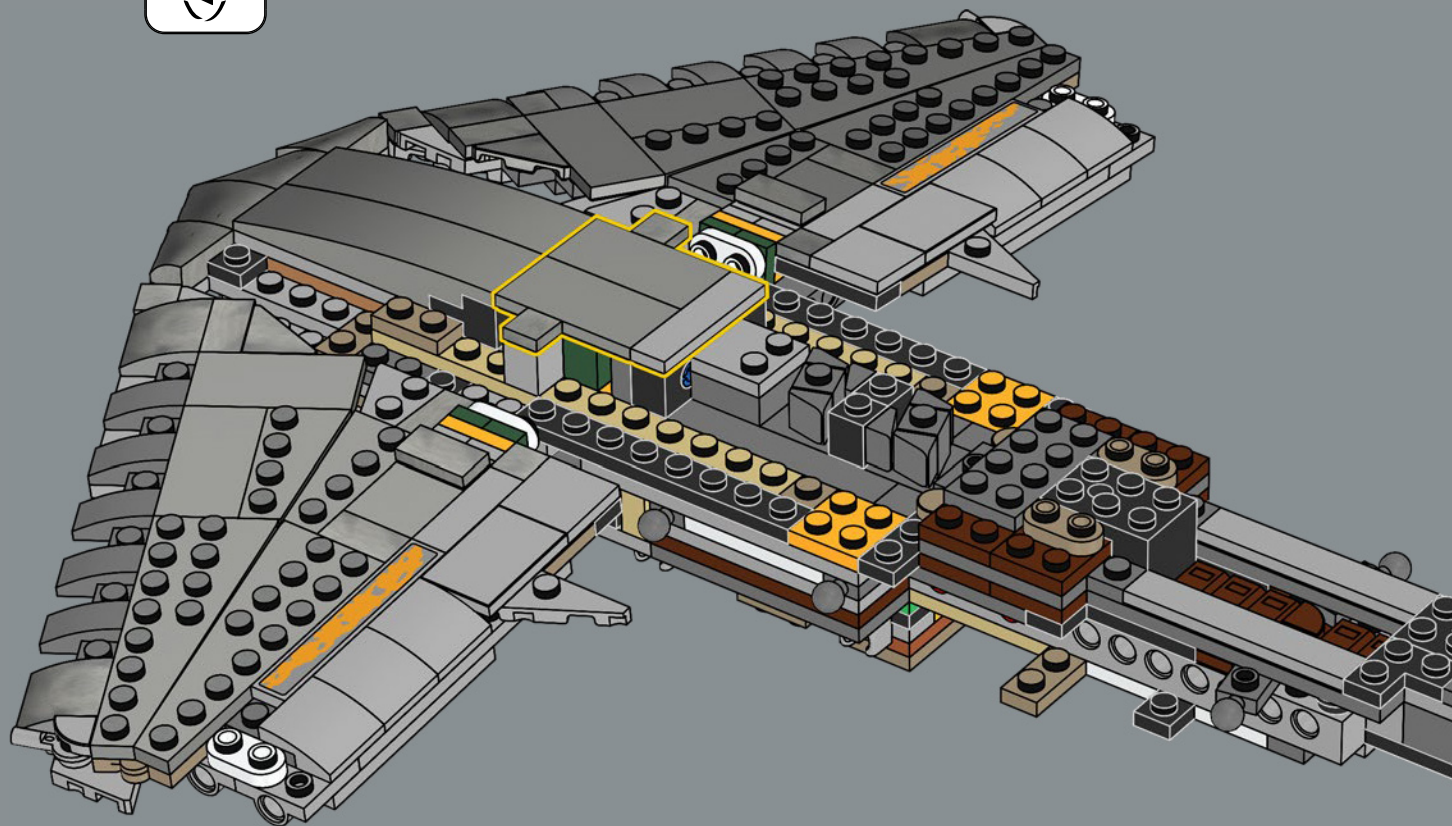



125

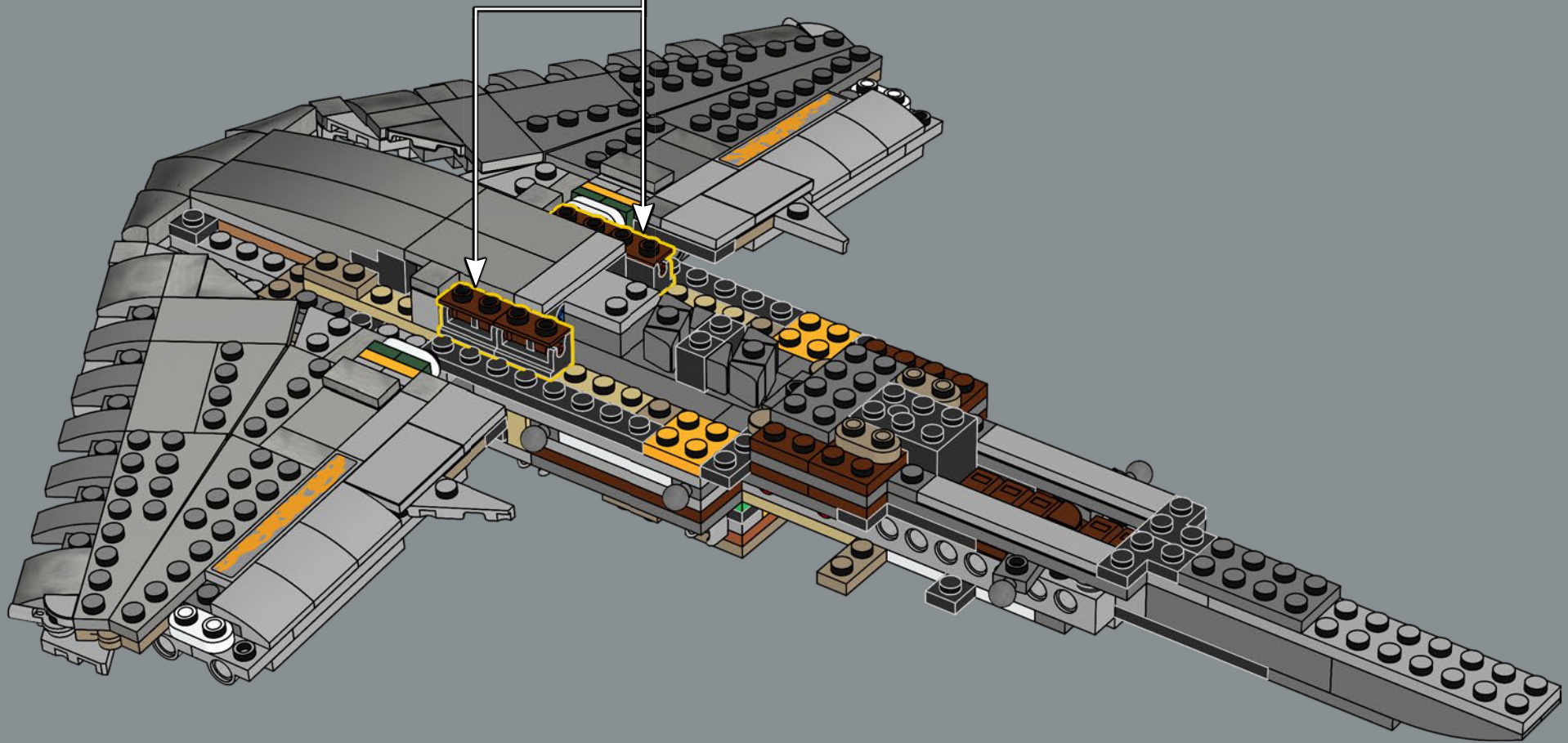
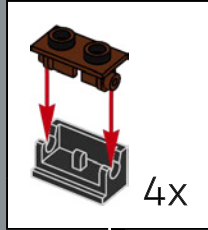

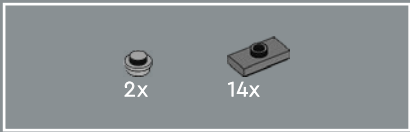

126

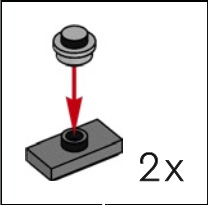
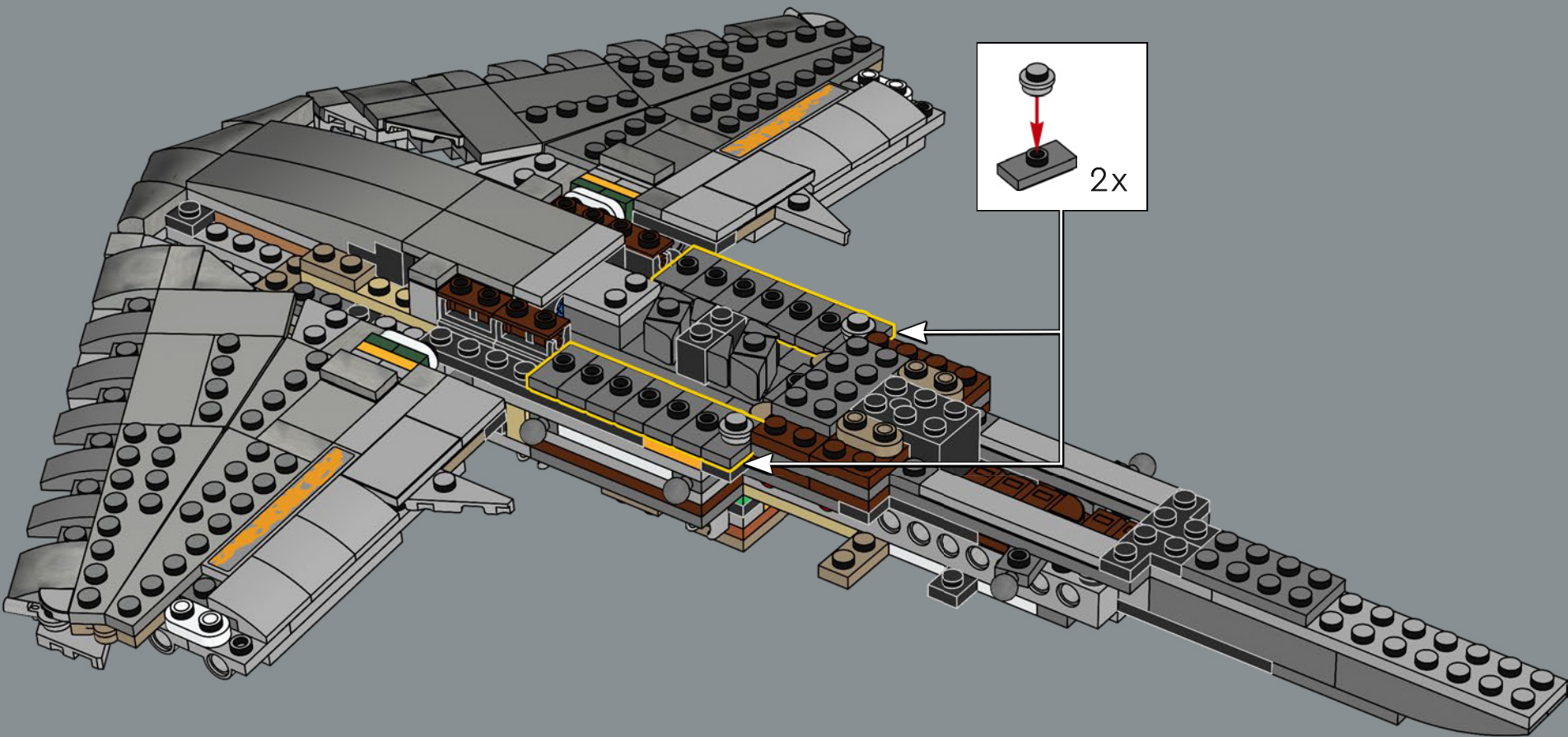

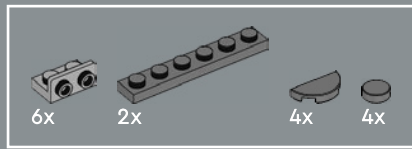

127

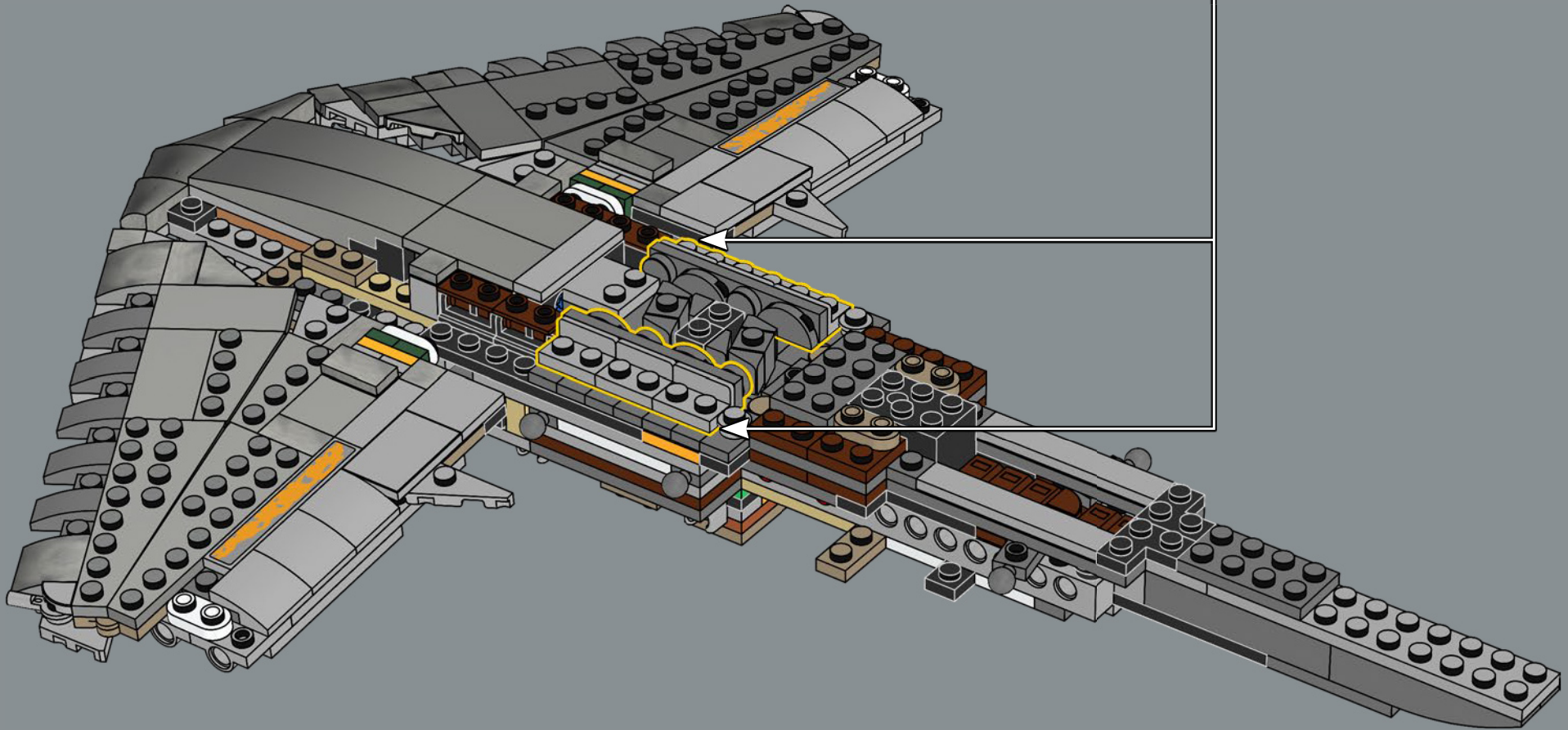
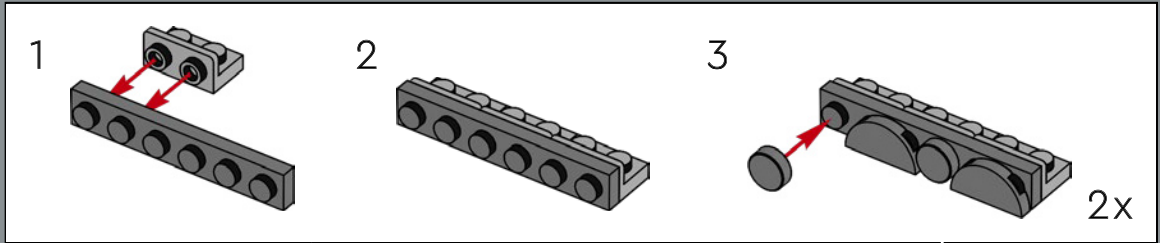

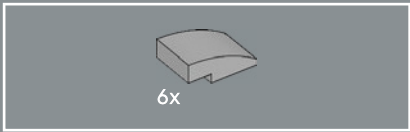

128

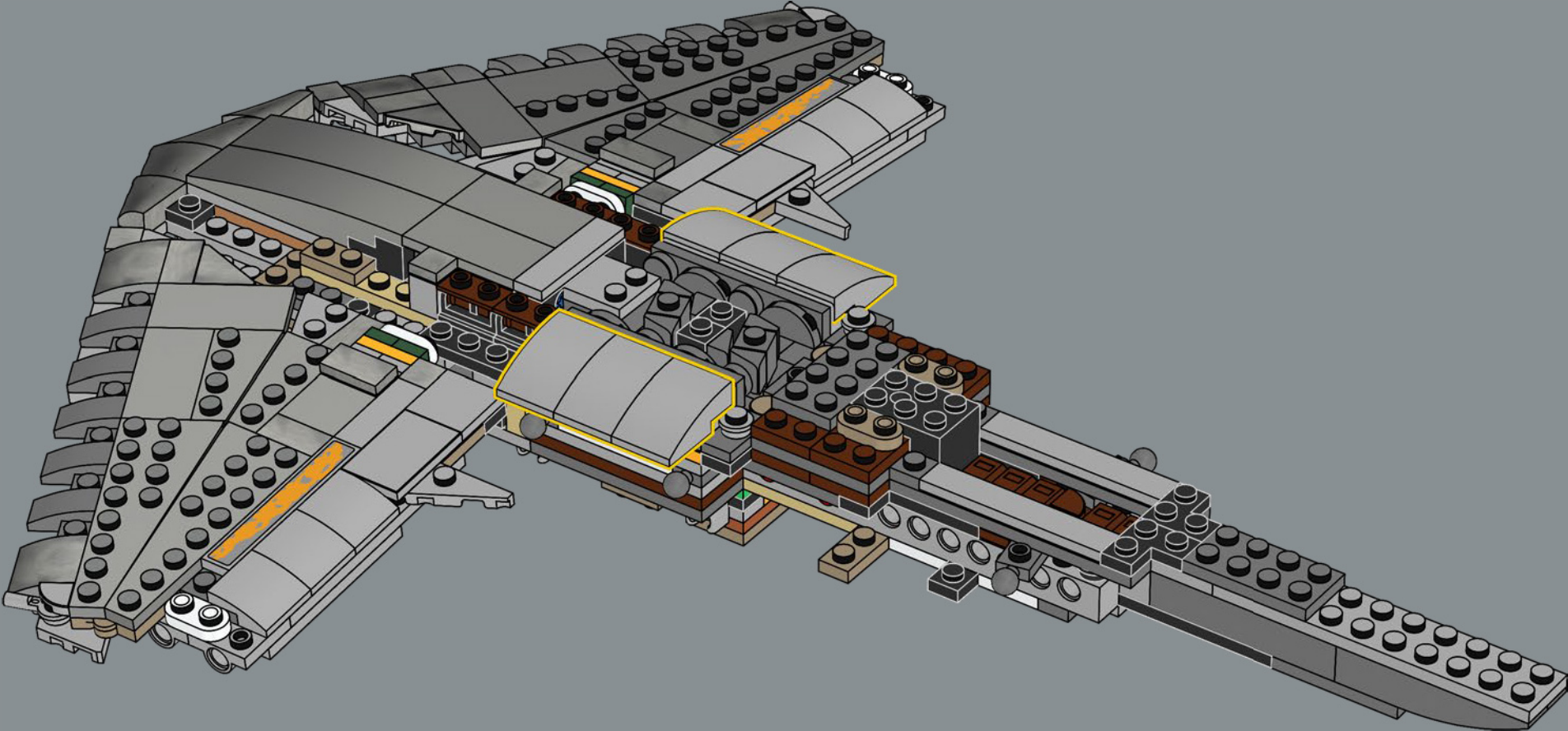

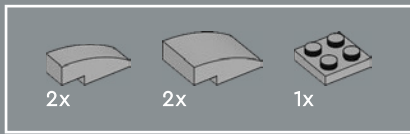

129

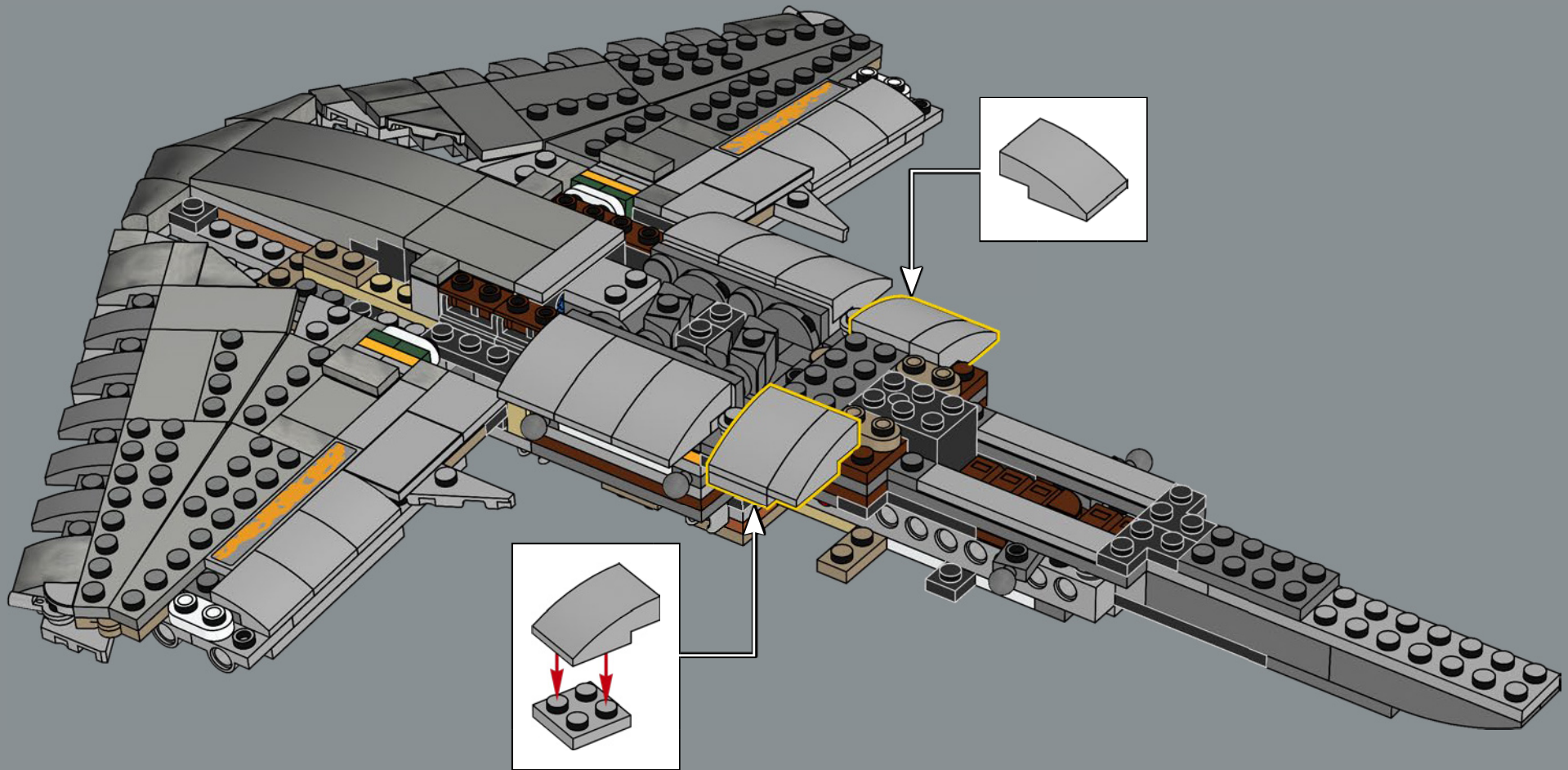

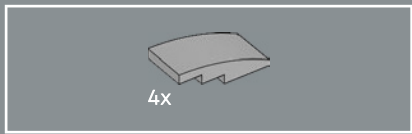

130

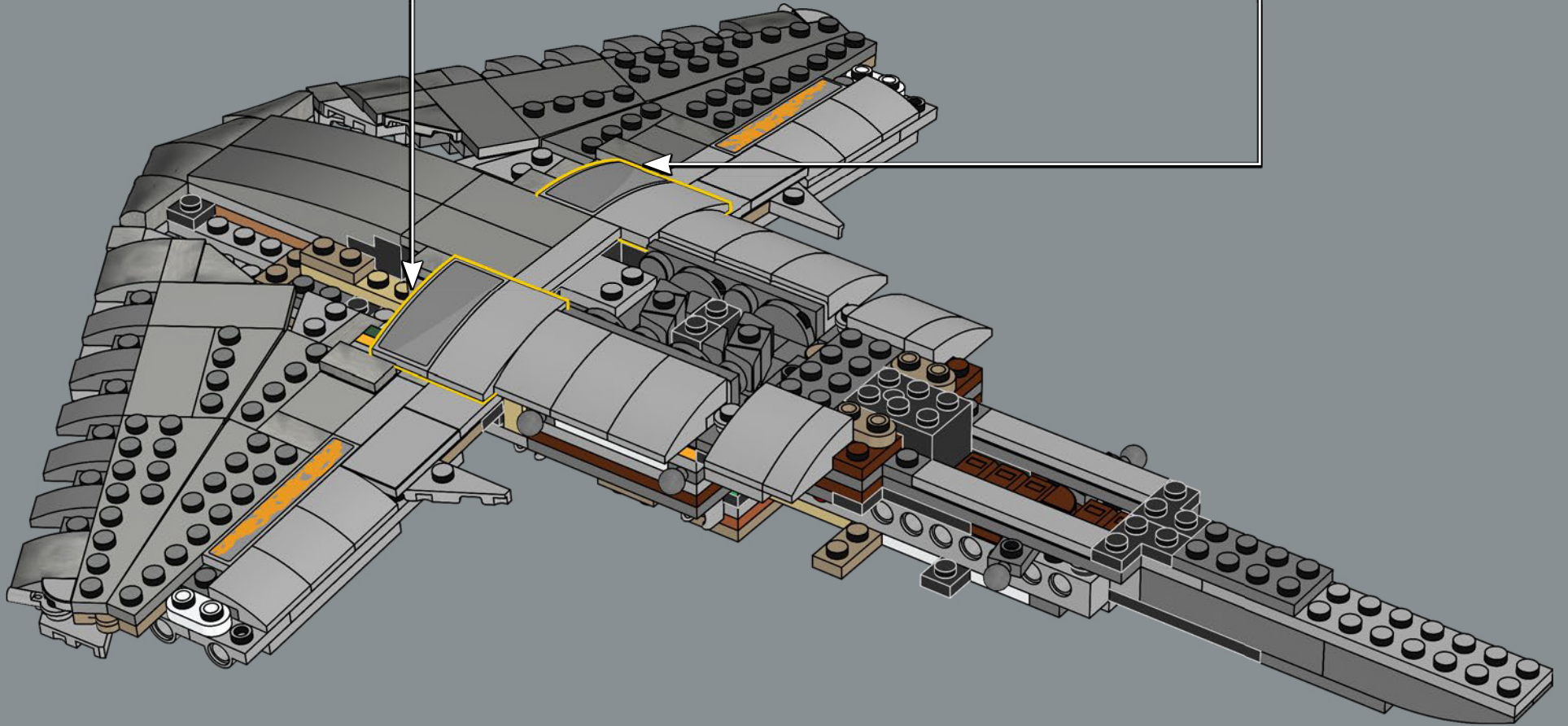
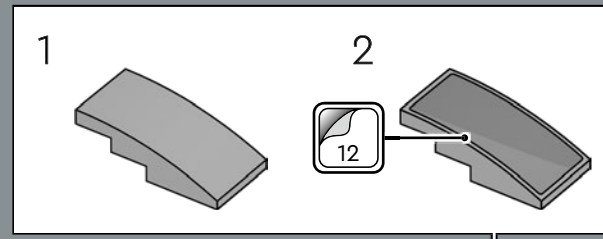
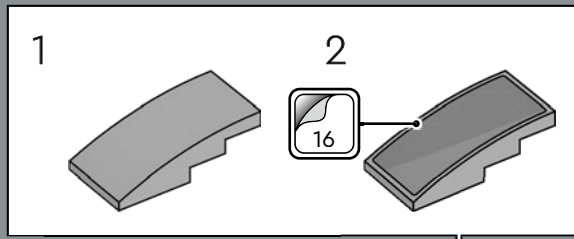

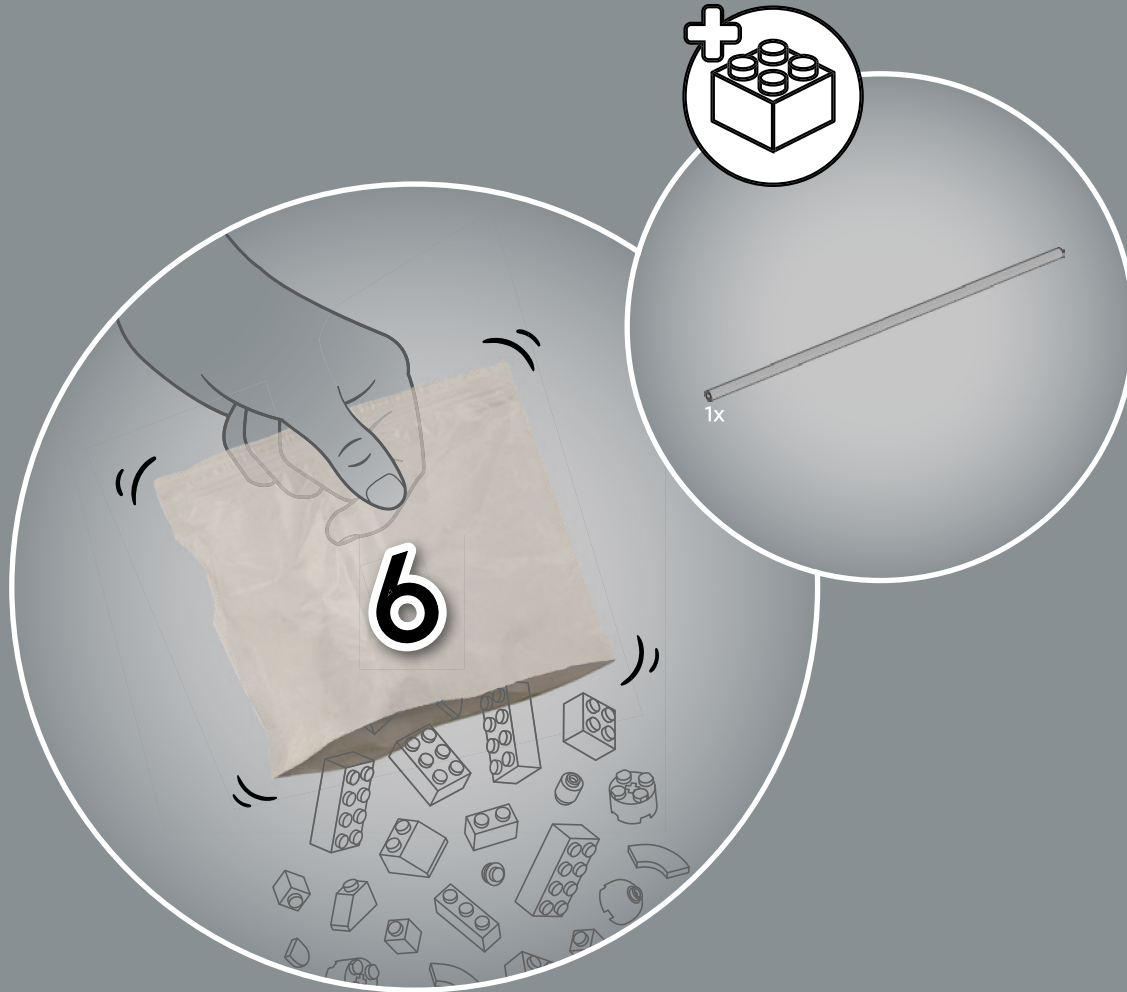

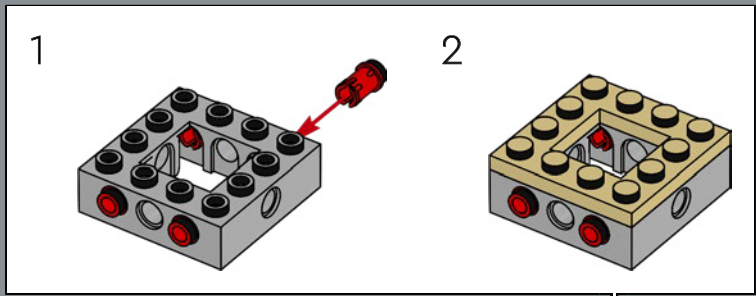
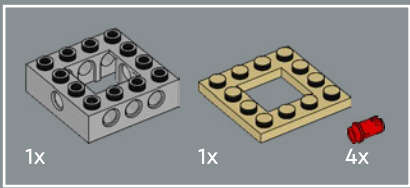

131

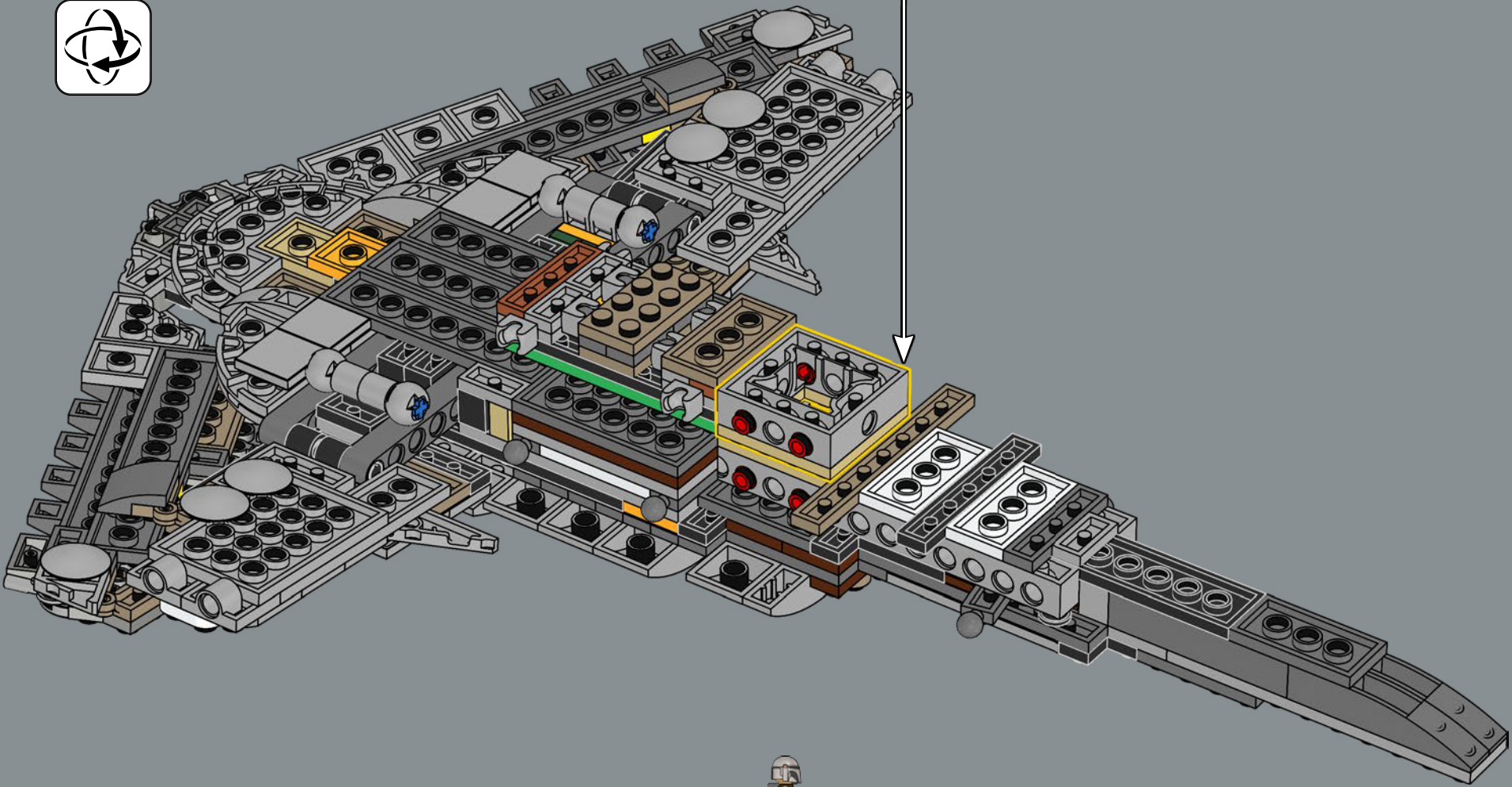

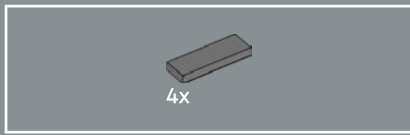

132

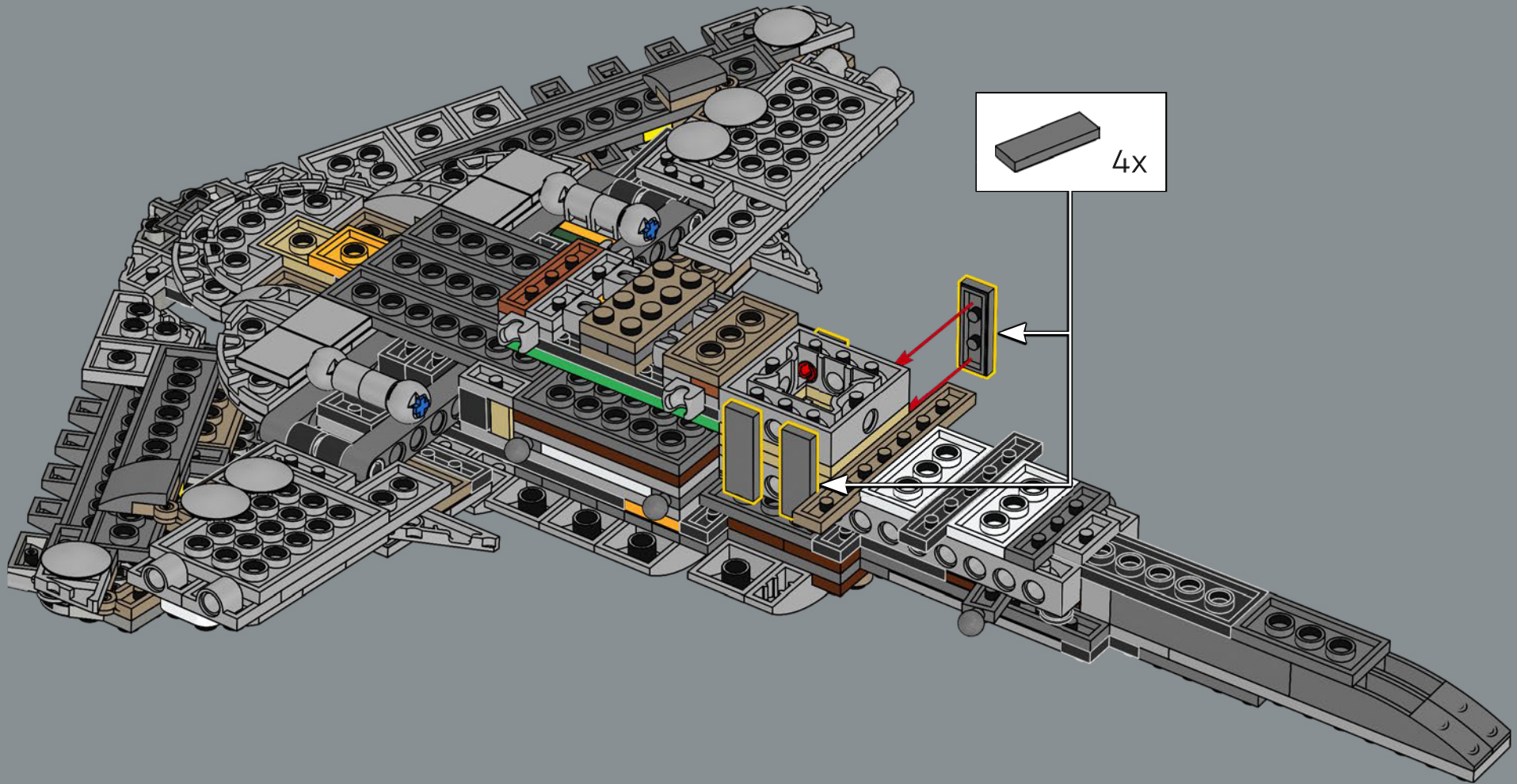

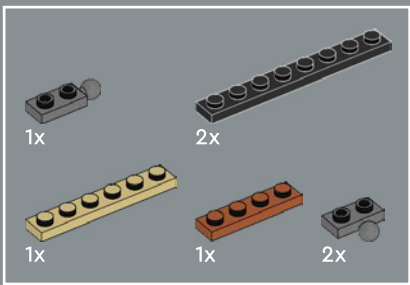

133

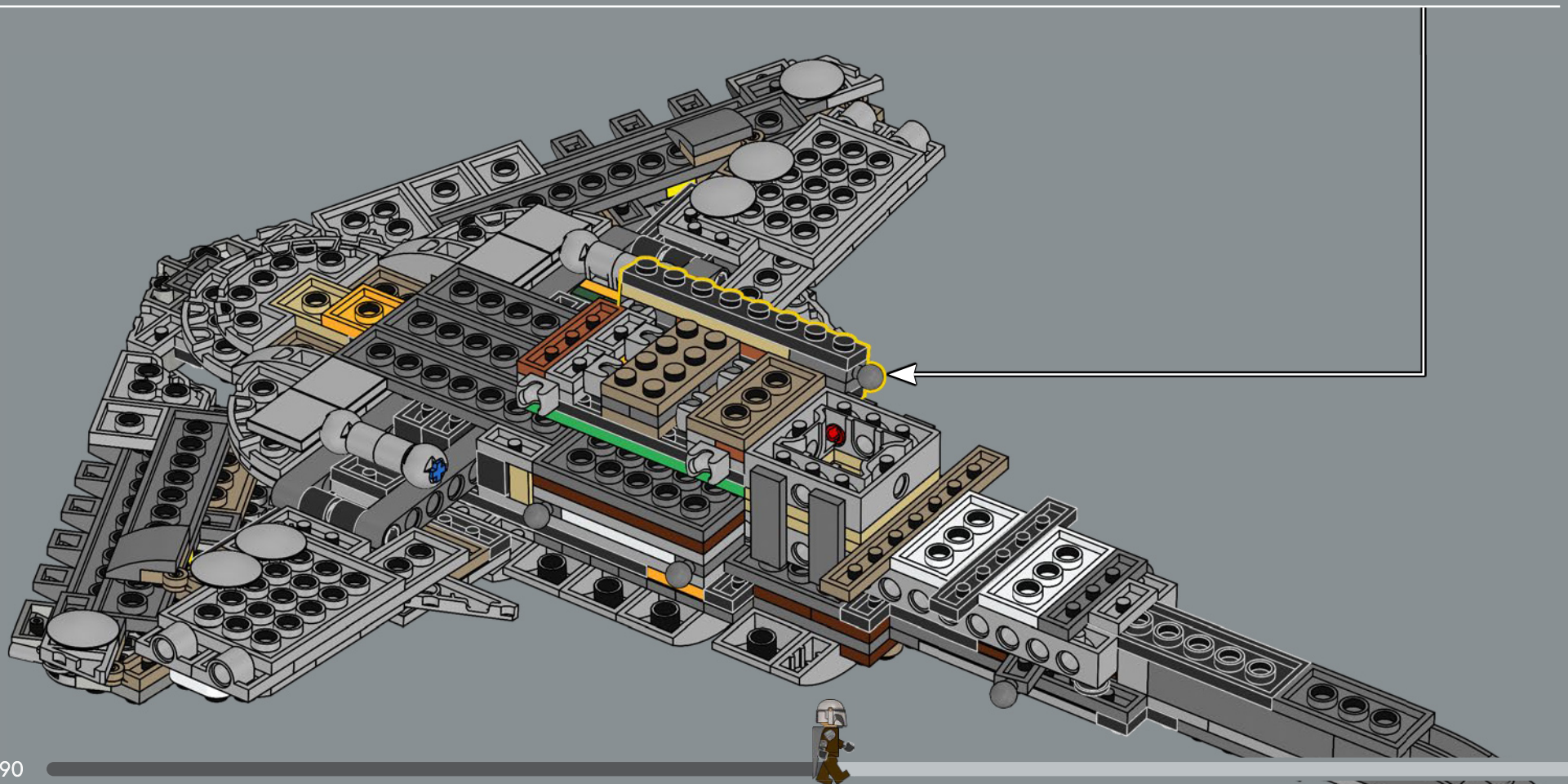
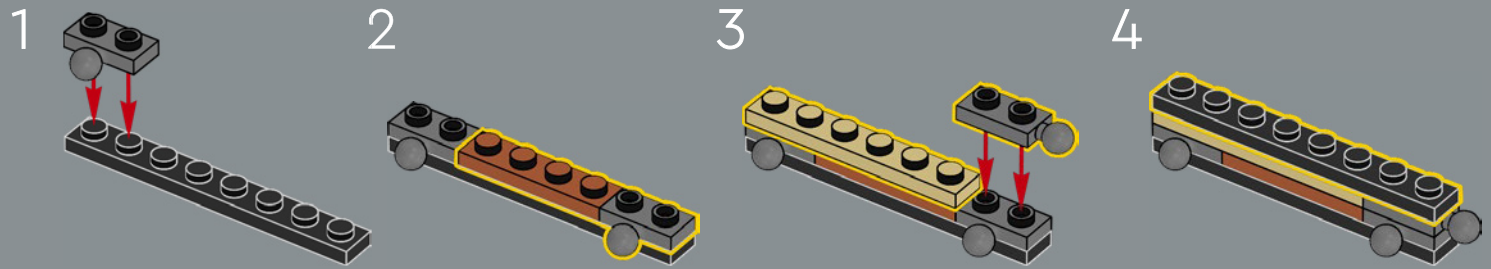

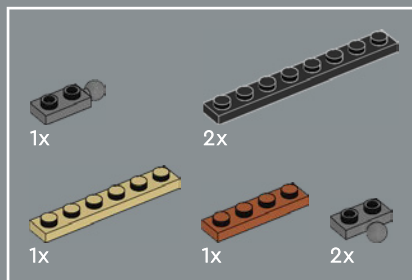

134

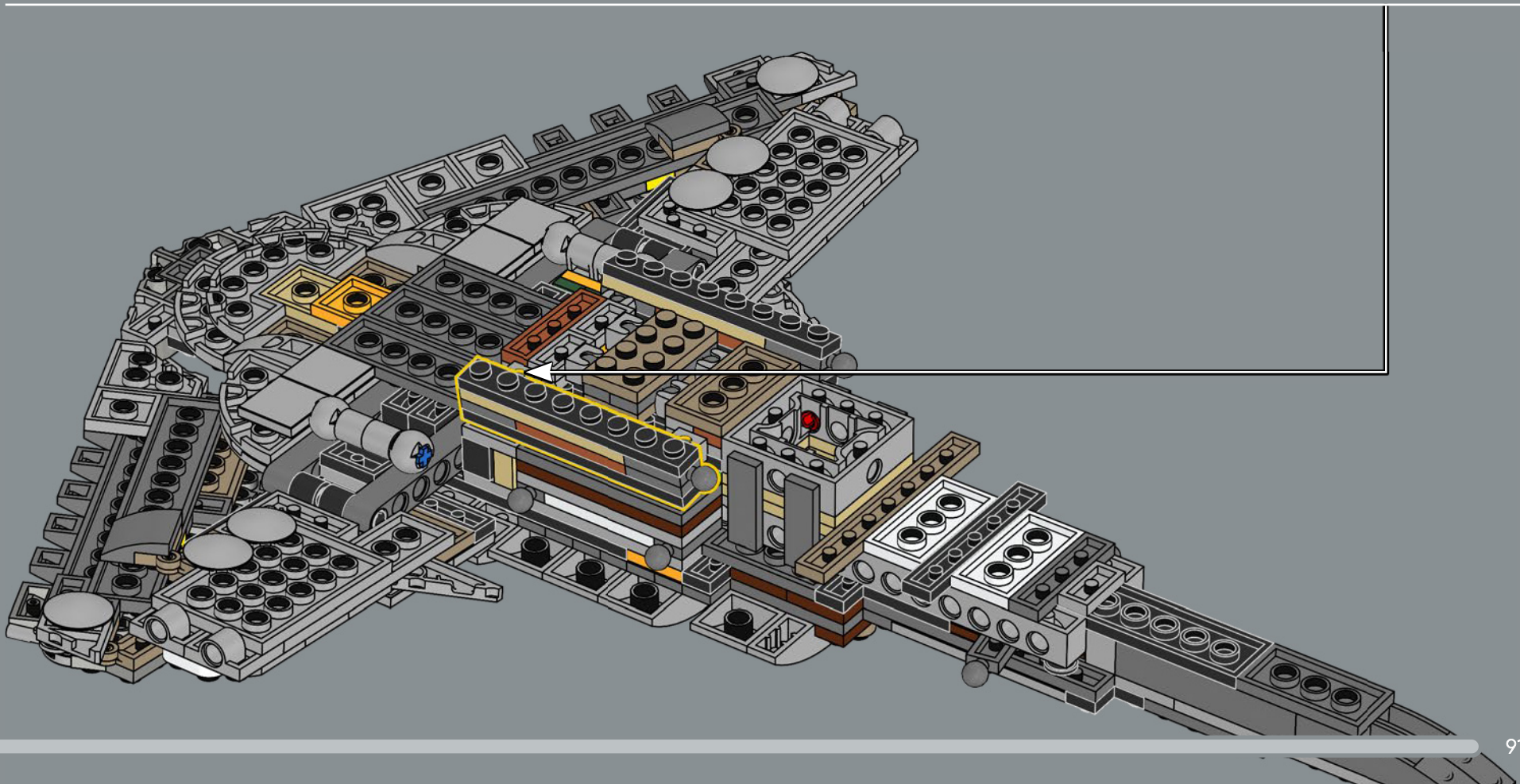
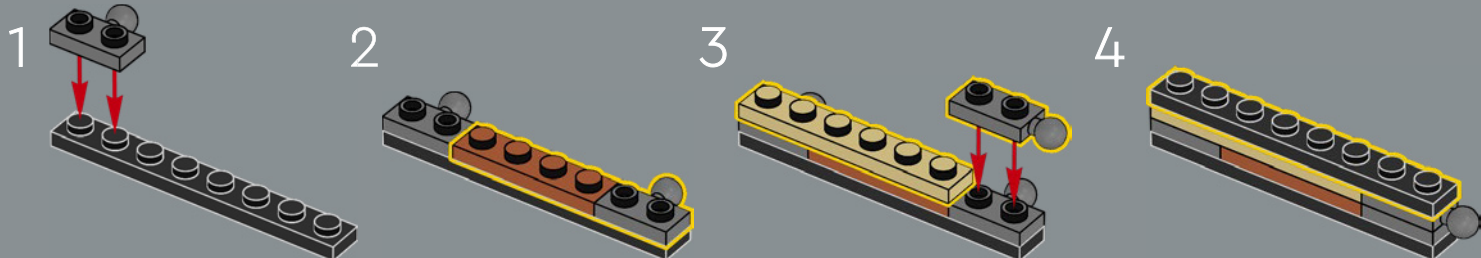

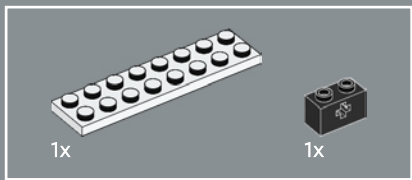

135

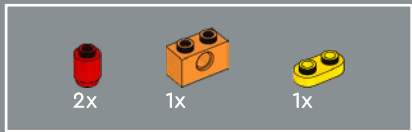
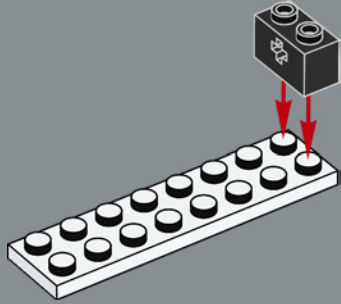

136

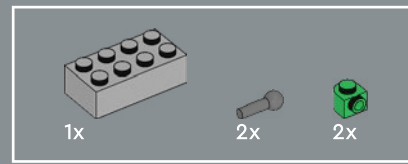
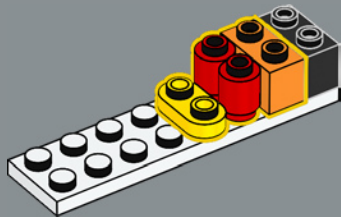

137

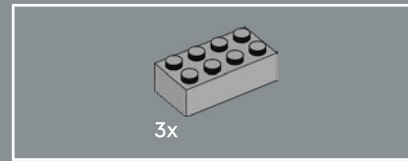
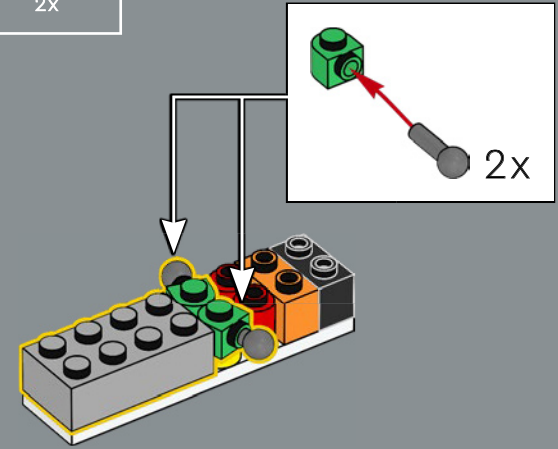

138

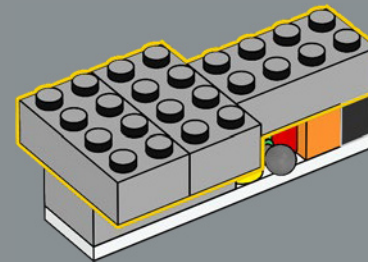

139

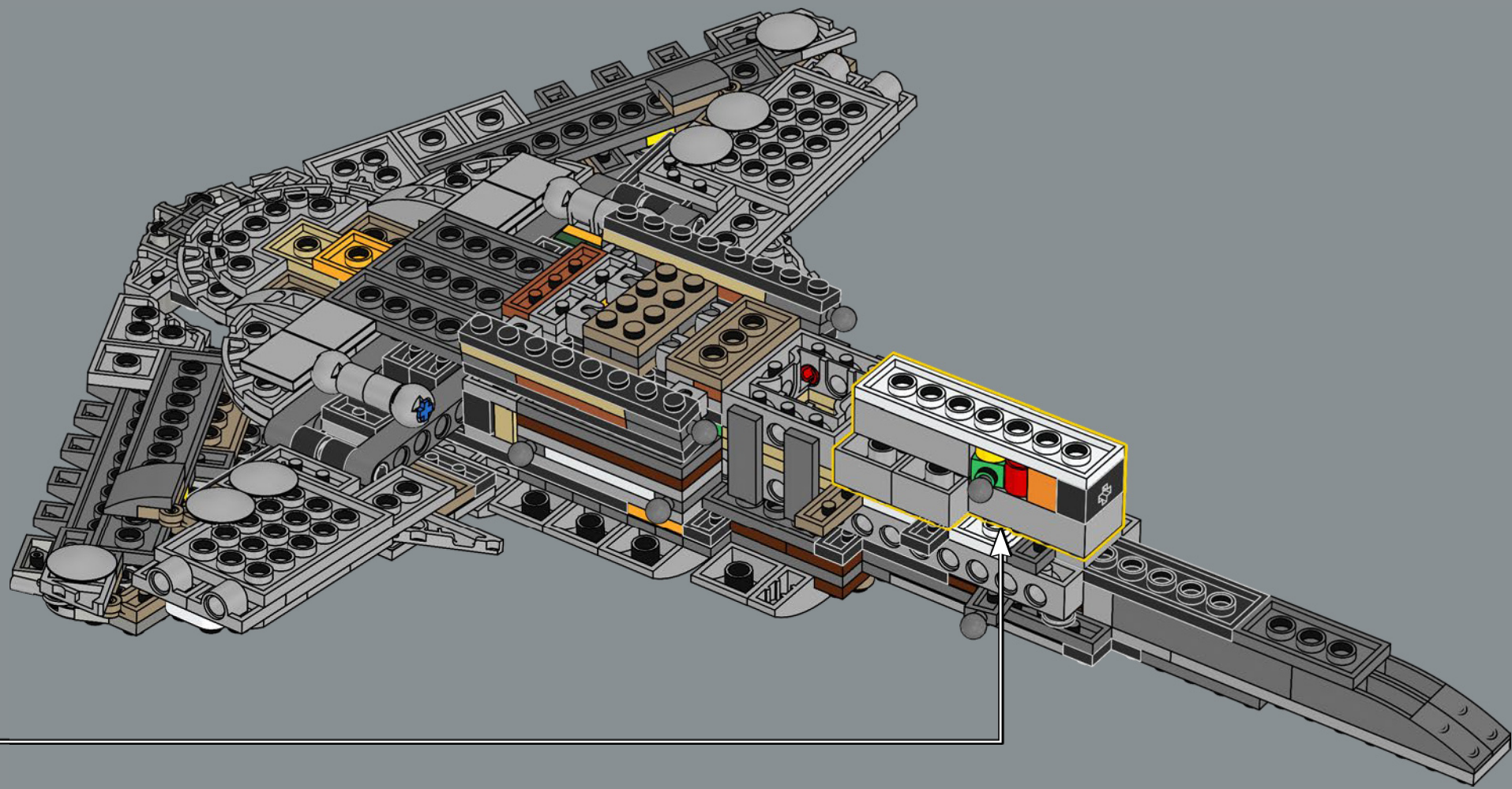

2x  2x 

140

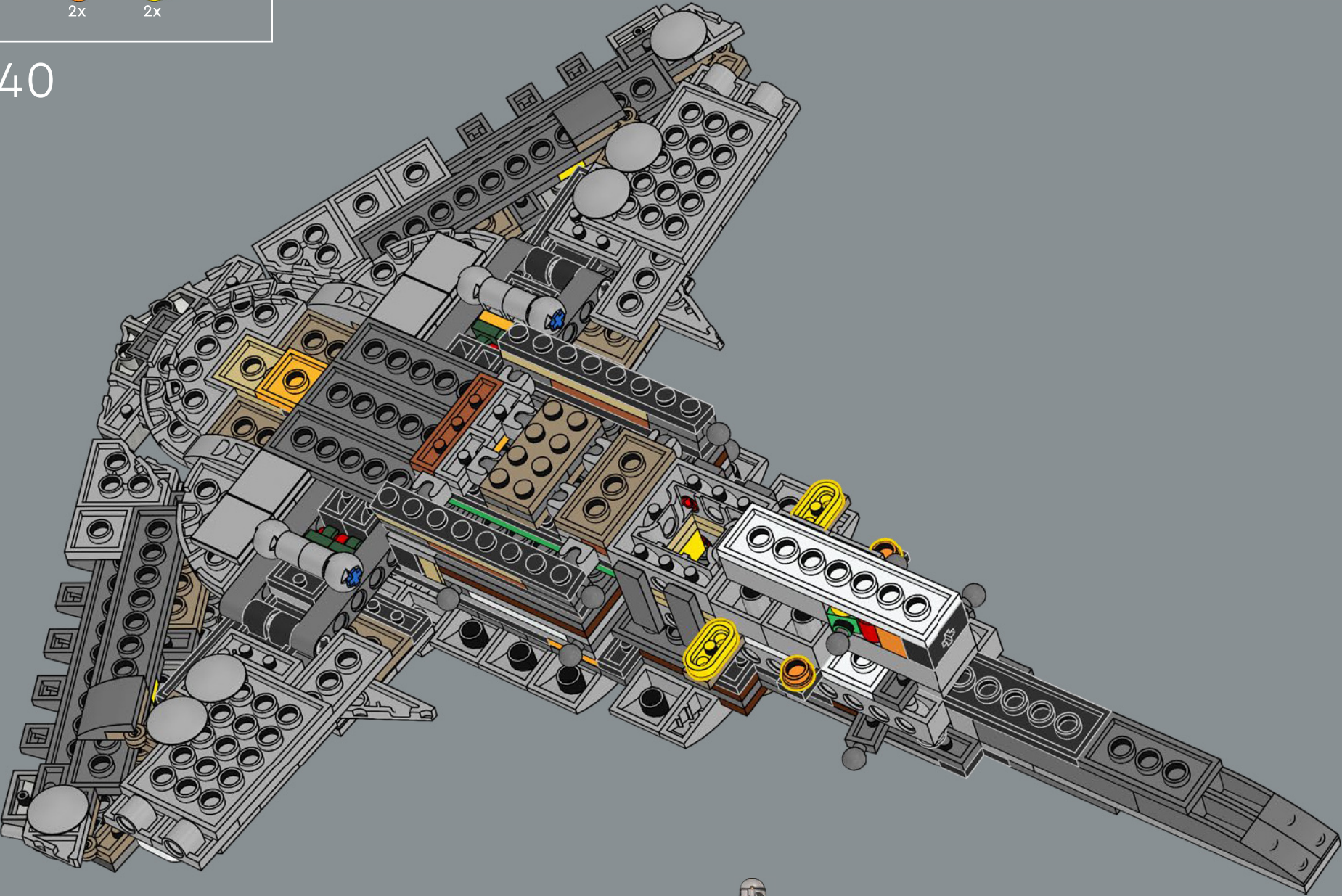

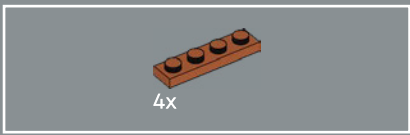

141

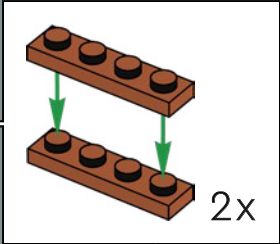
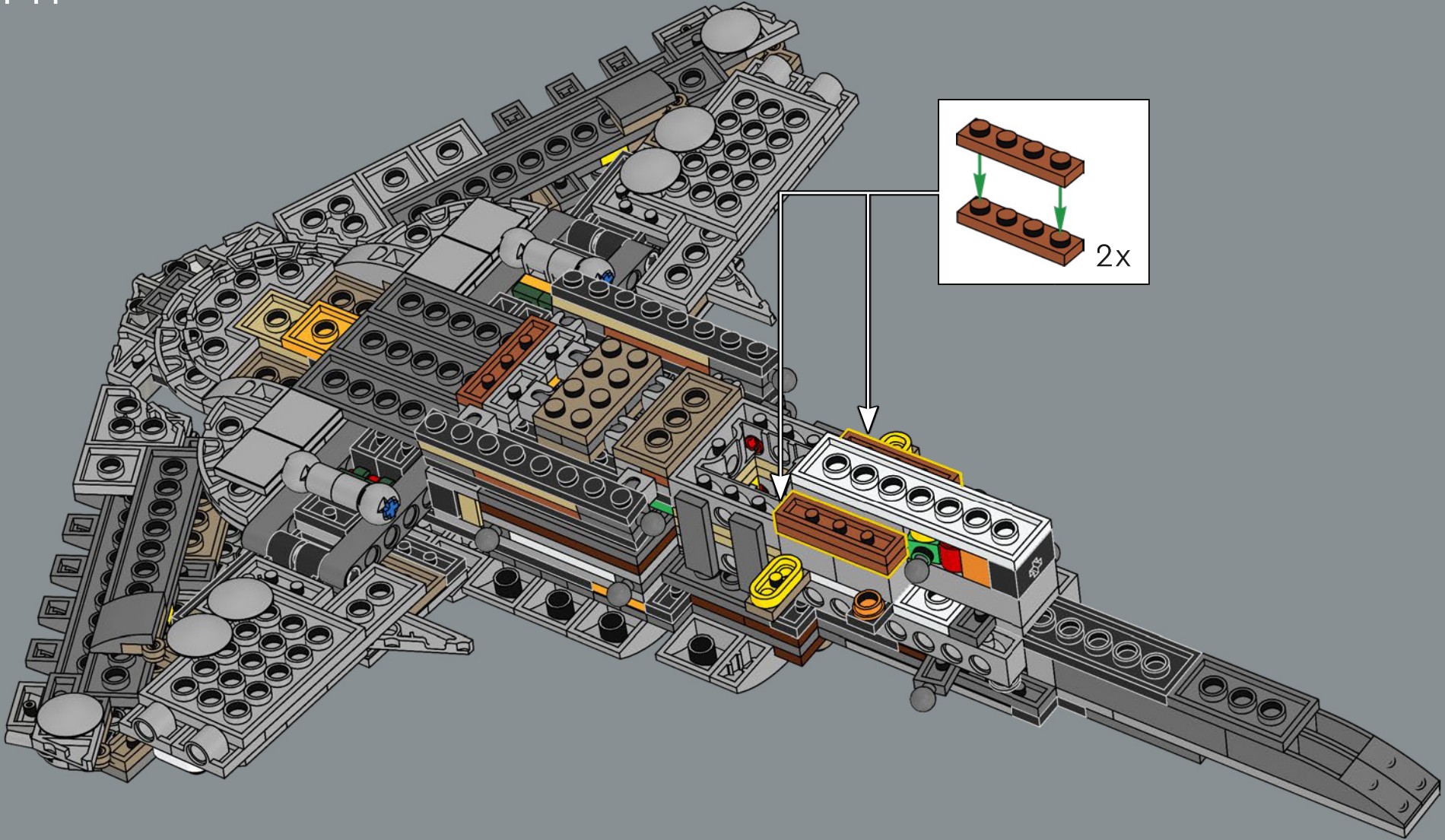

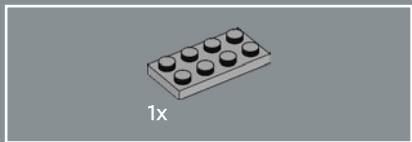
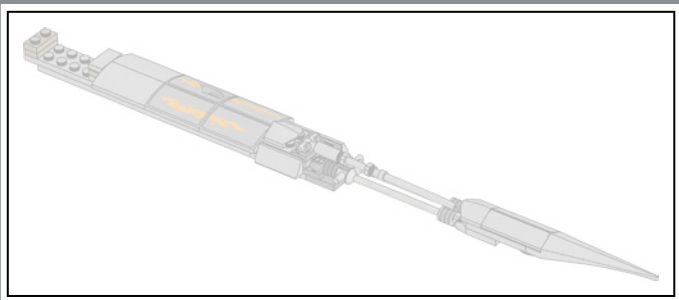

1x

142

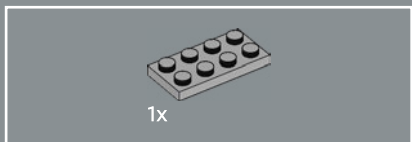
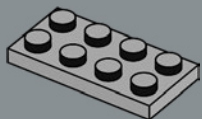

1x

143

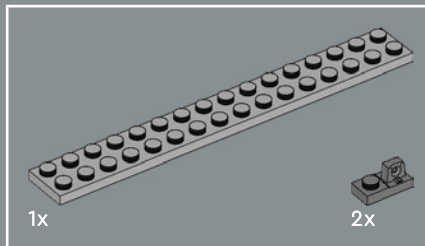
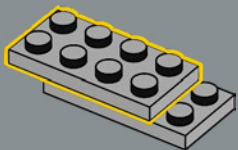

1x

2x

144

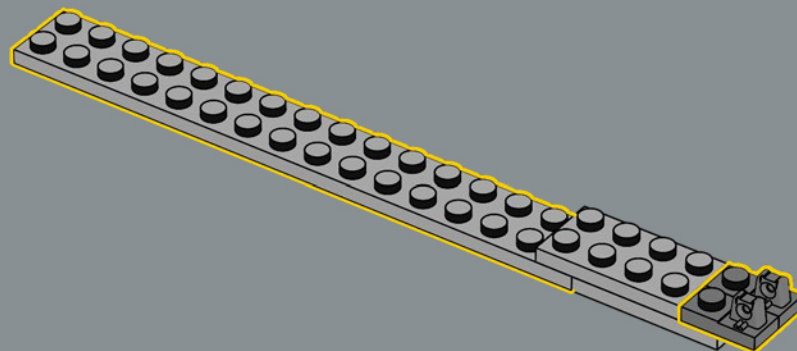

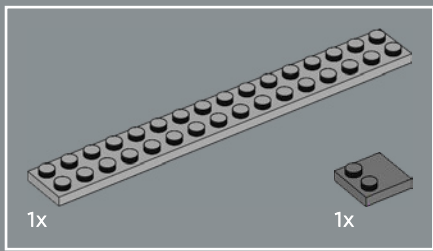

145

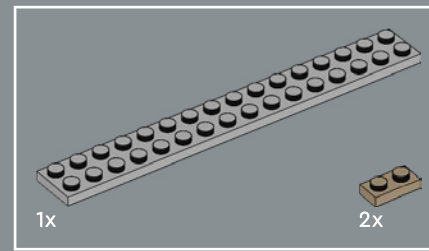
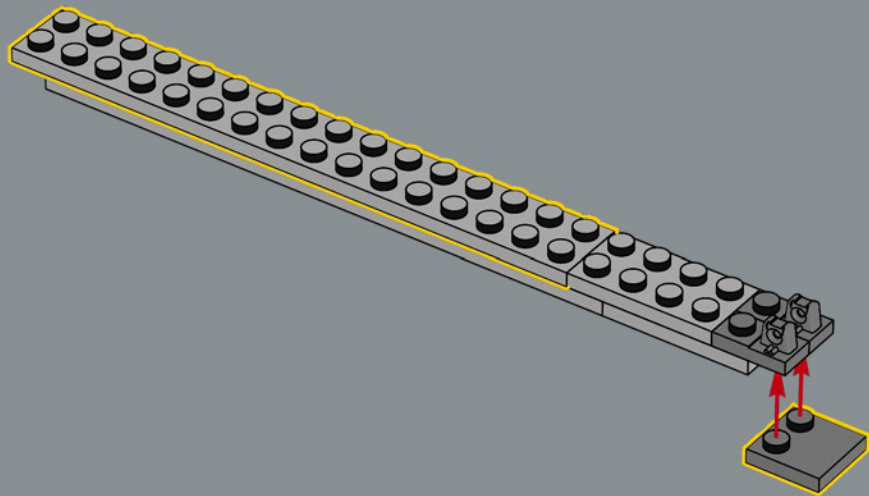

146

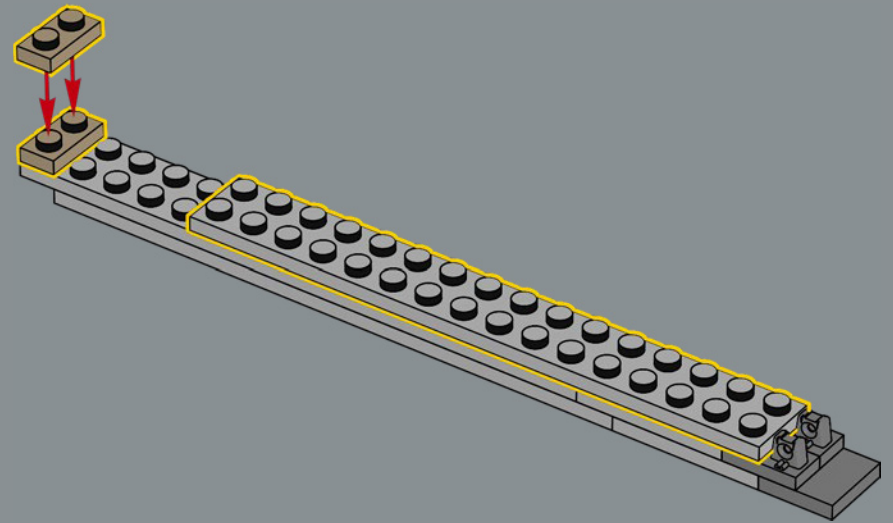

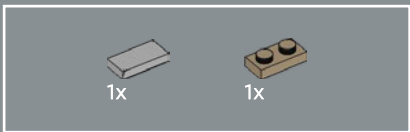

147

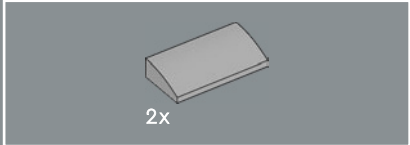
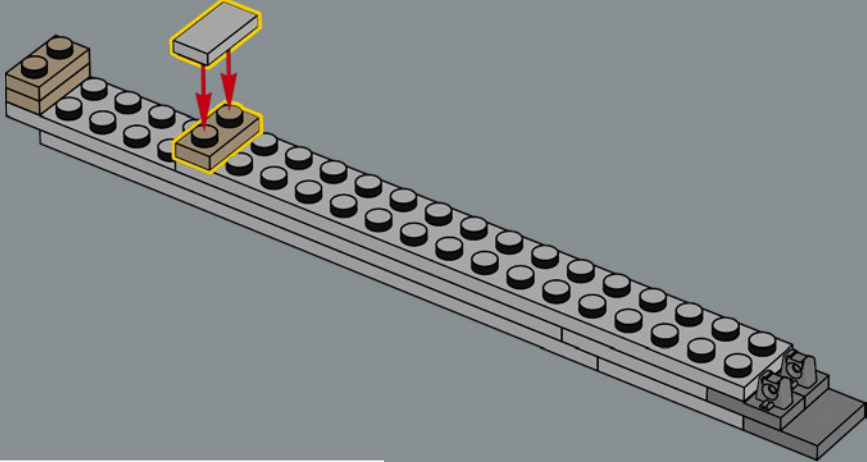

148

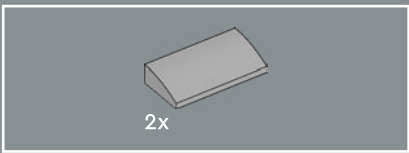
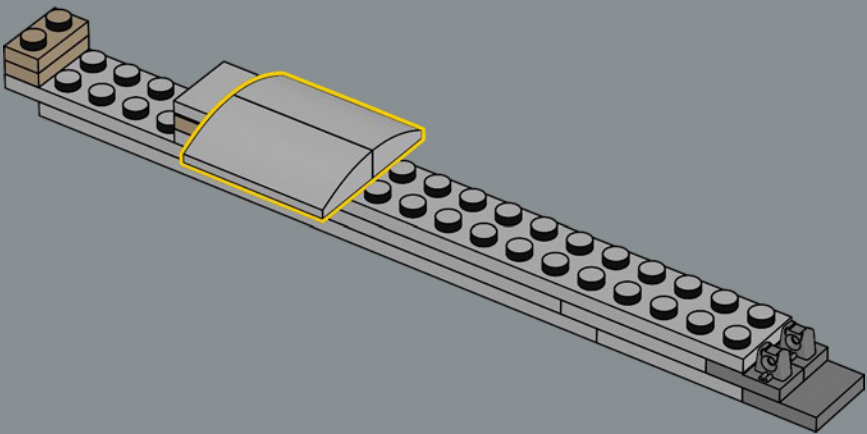

149

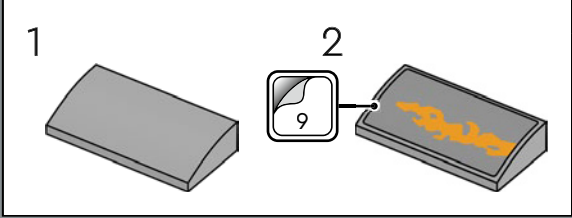
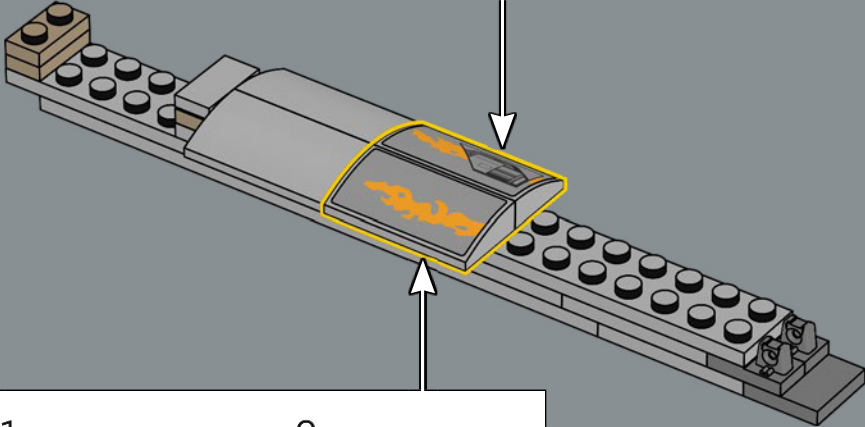
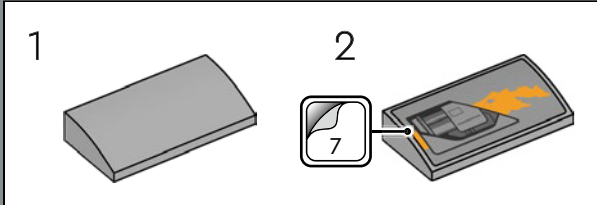

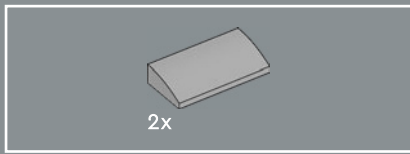

150

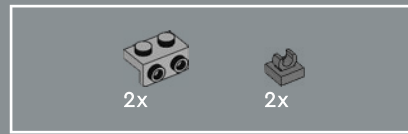
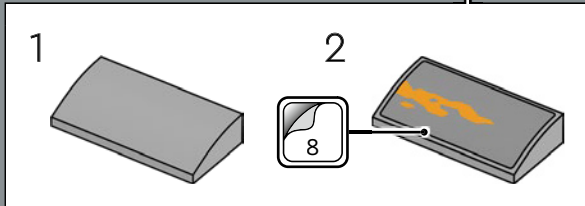
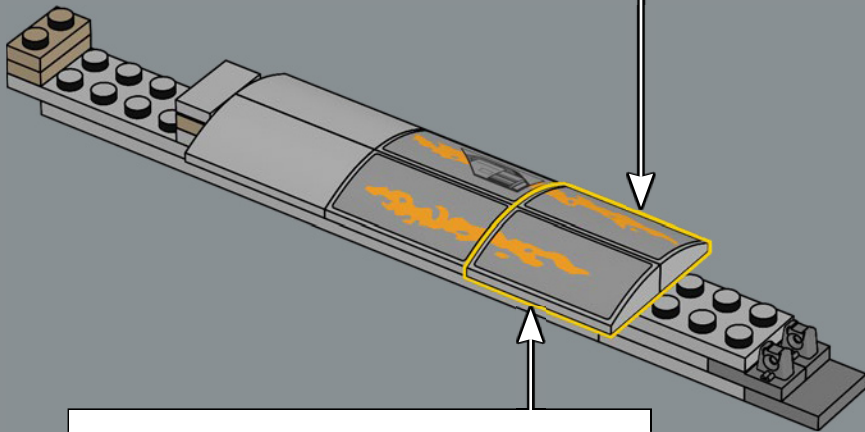
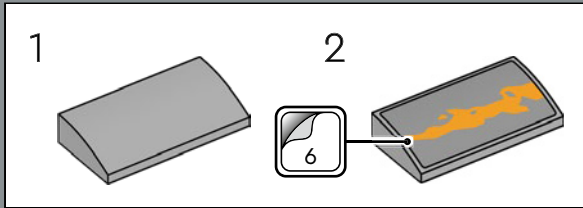

151

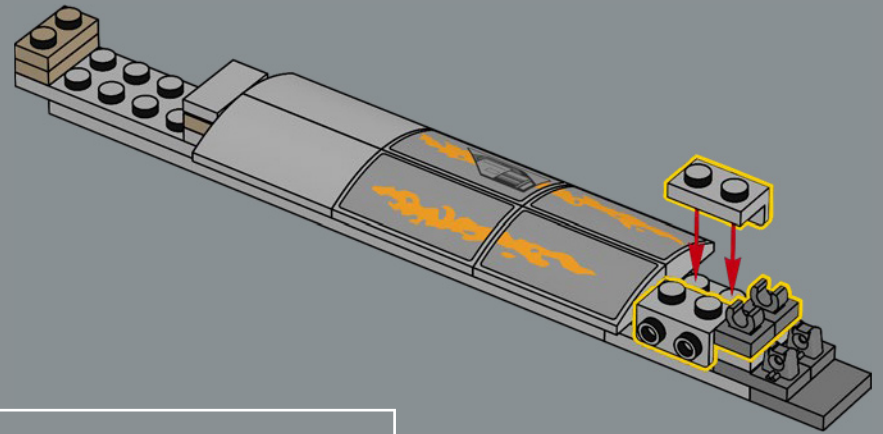

152

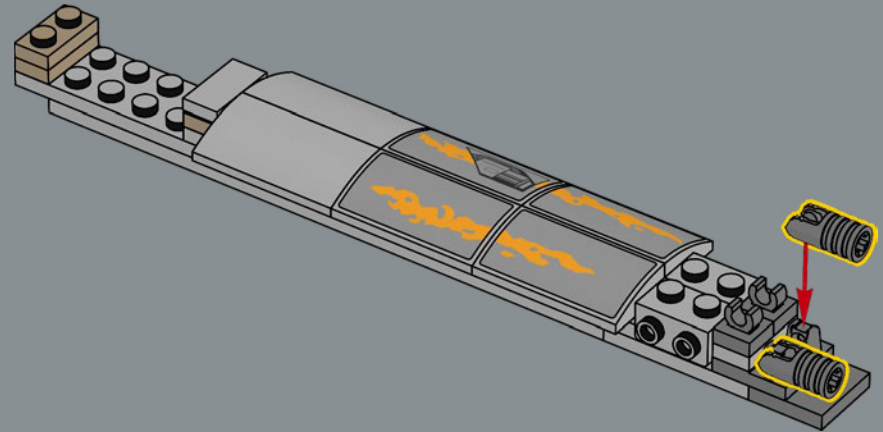

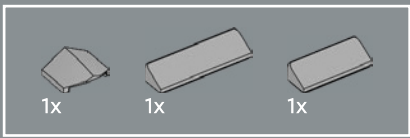

153

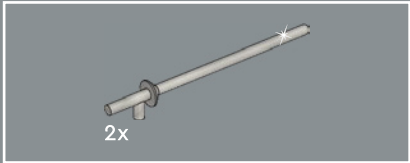
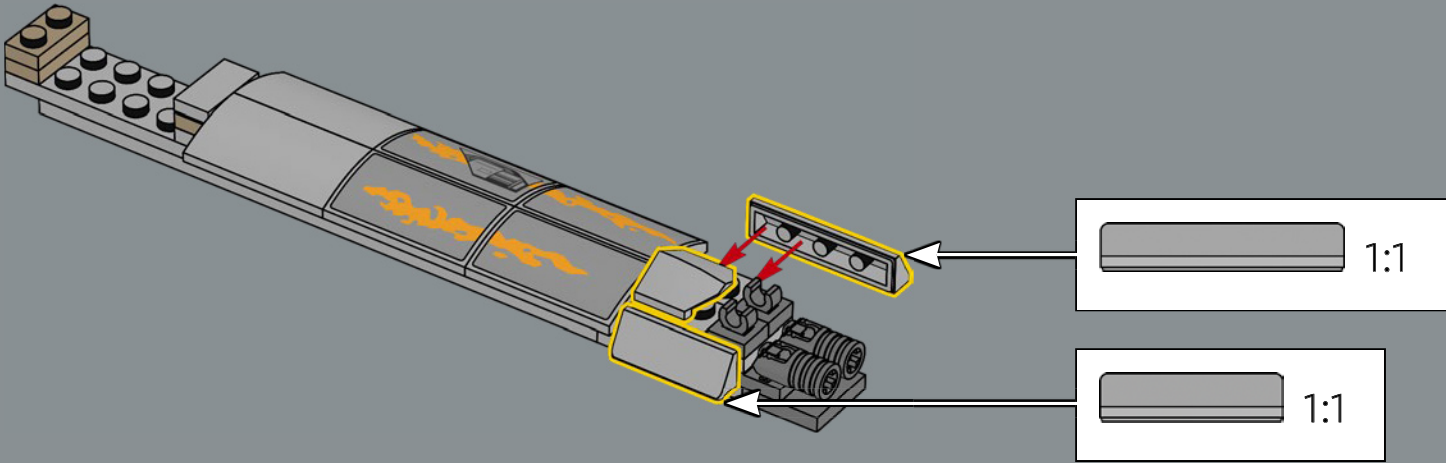

154

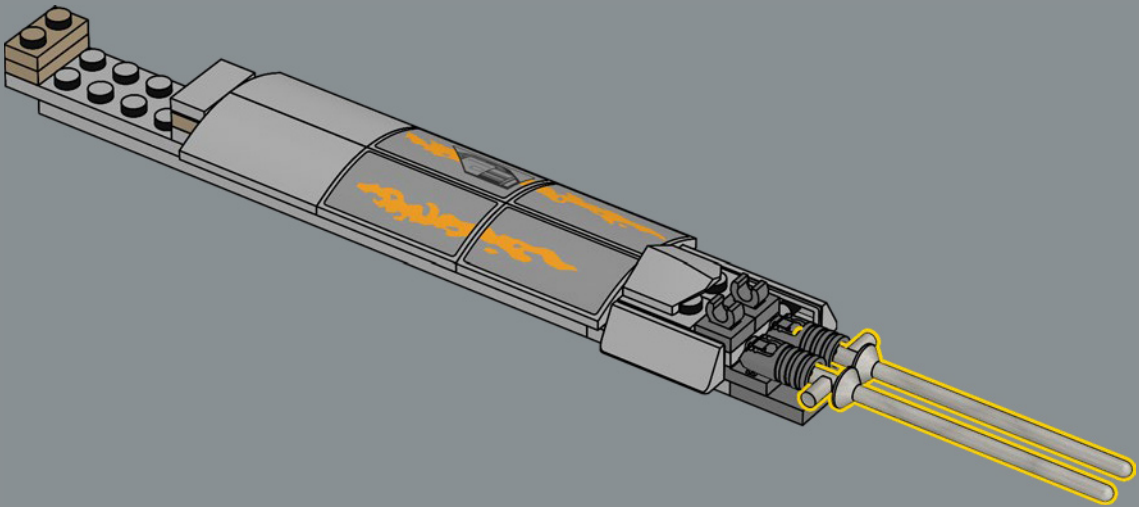

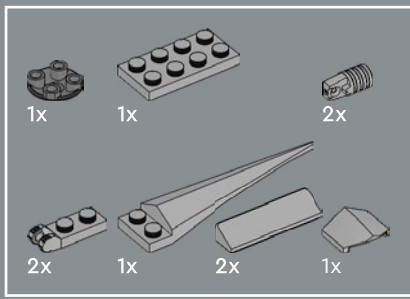

155

1

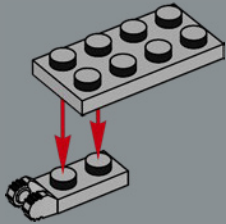

2

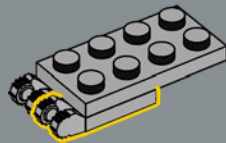

3

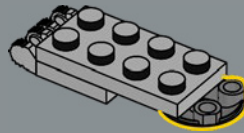

4

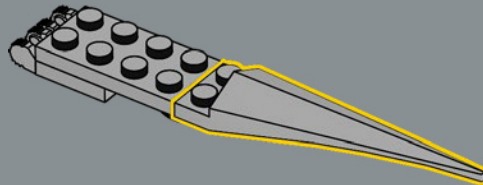

5

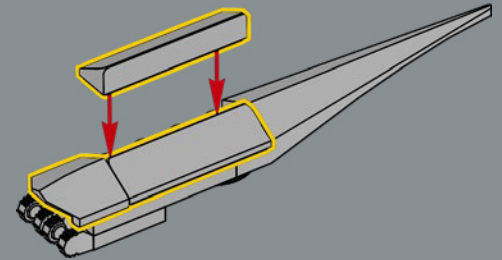

6

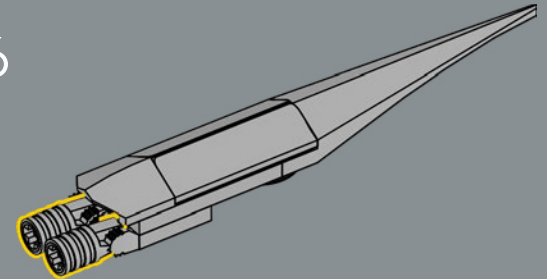

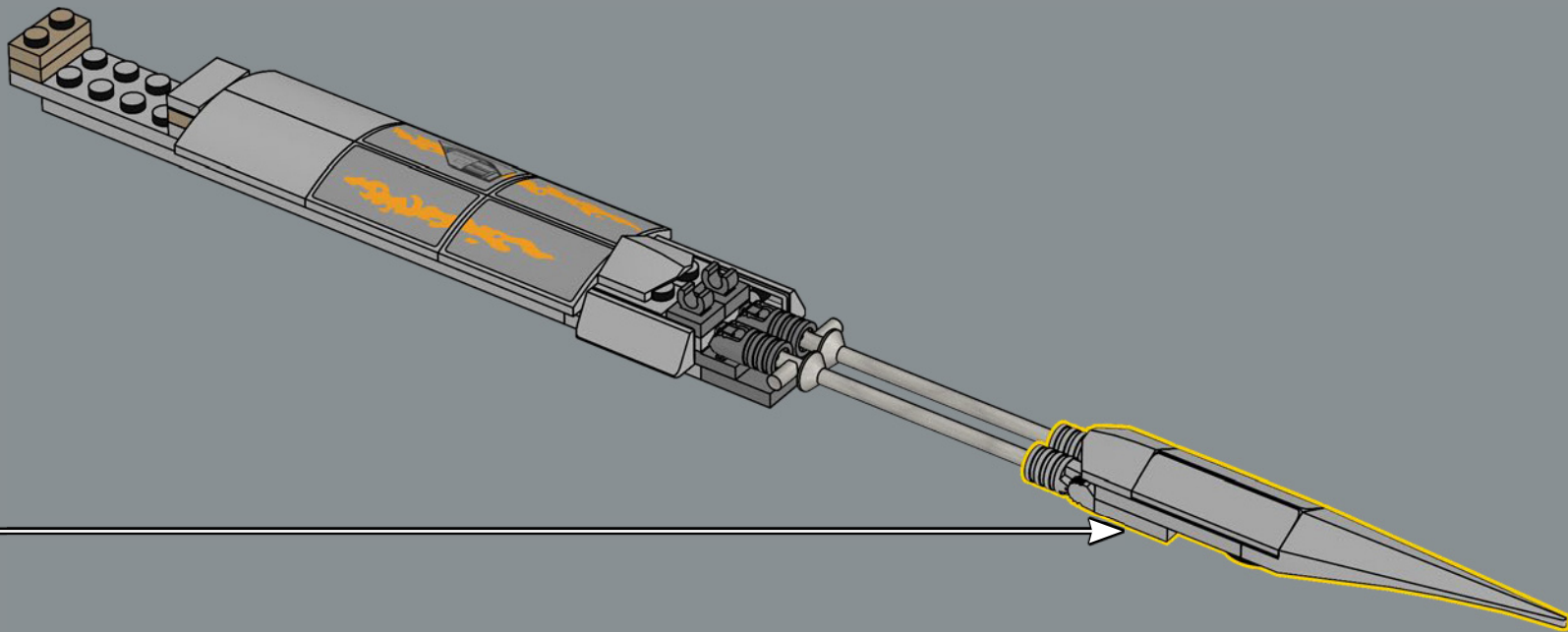



156

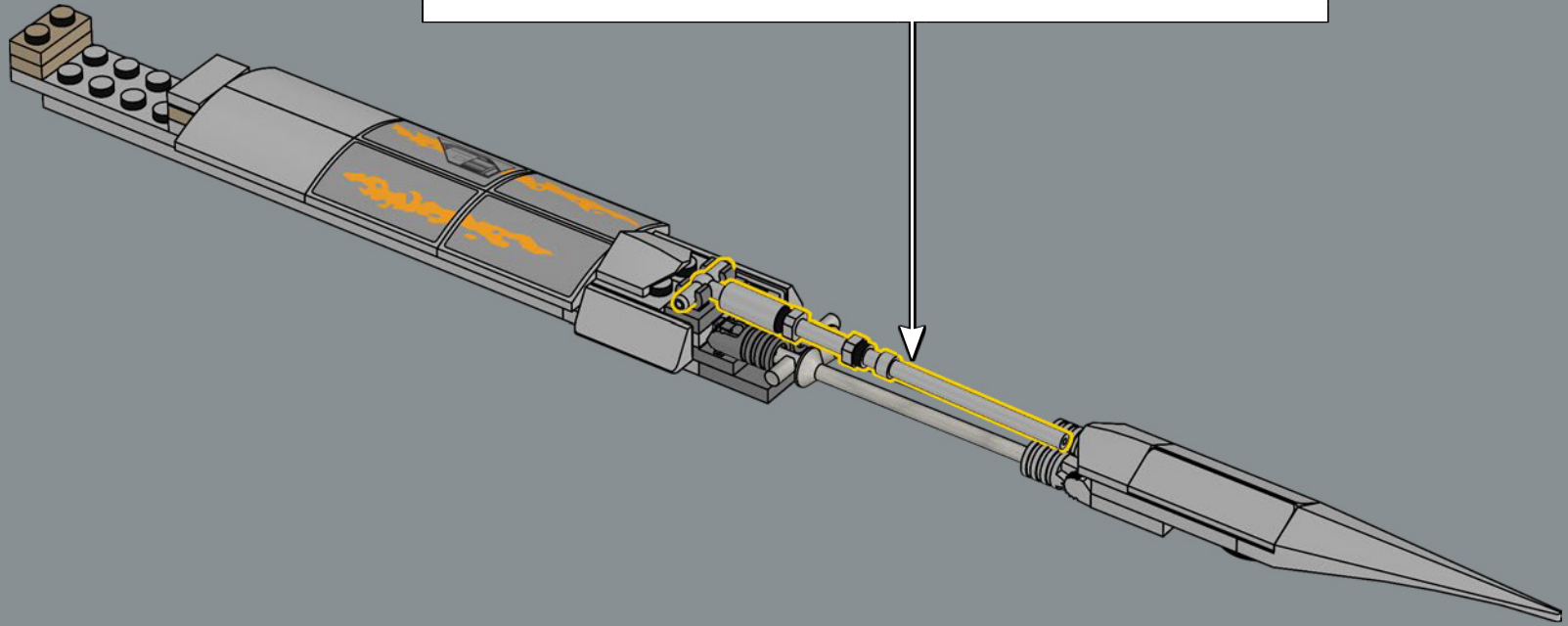
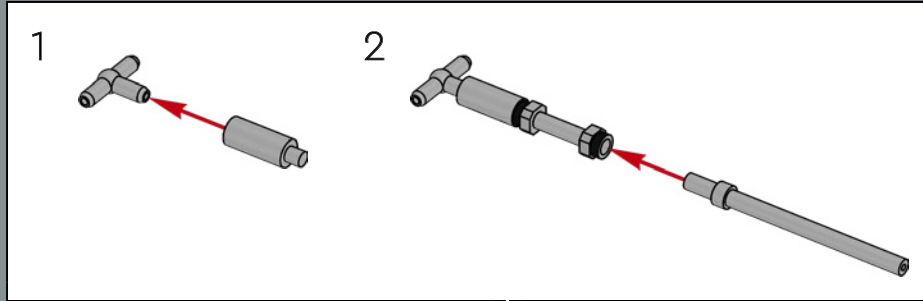

157

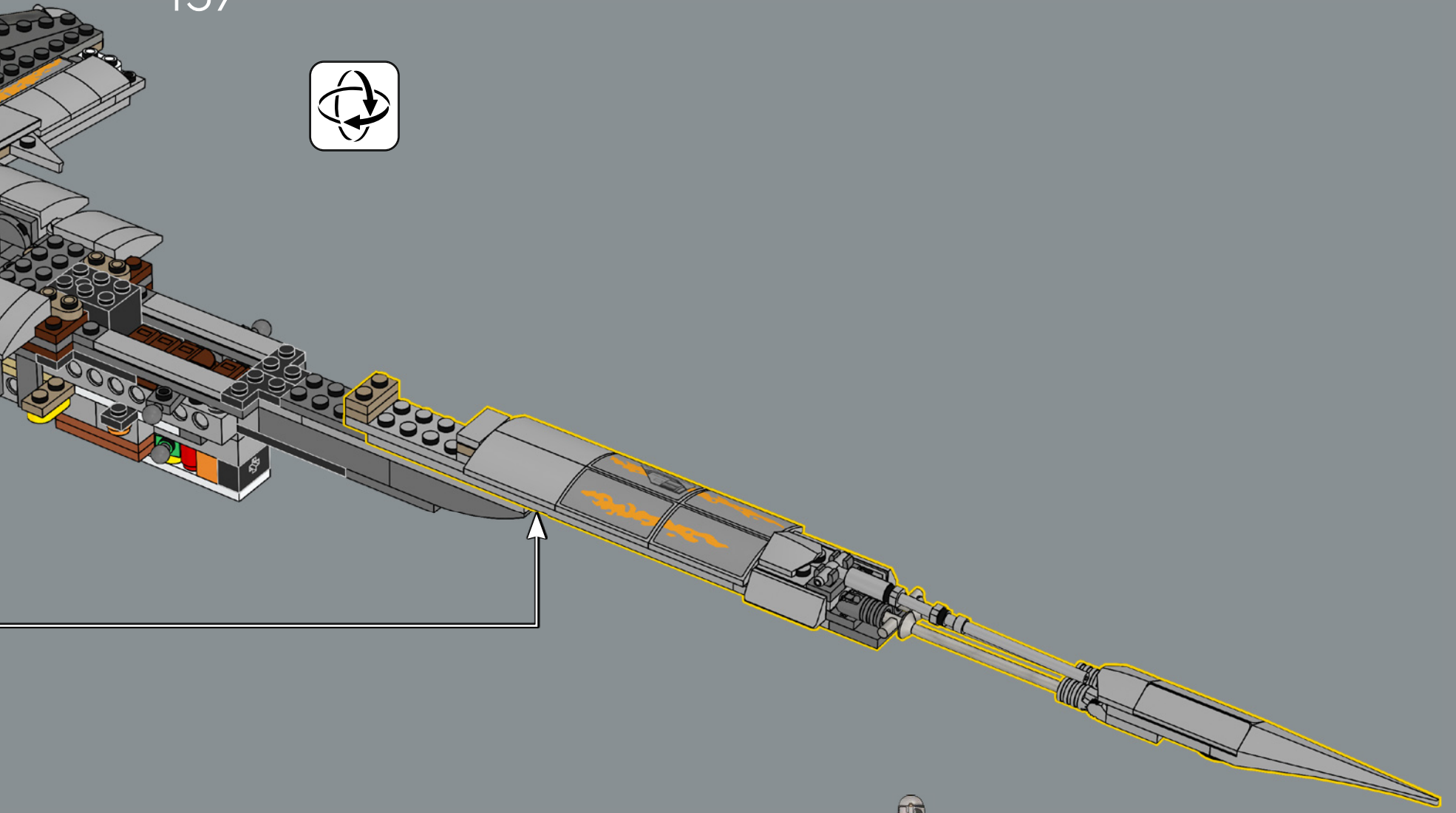

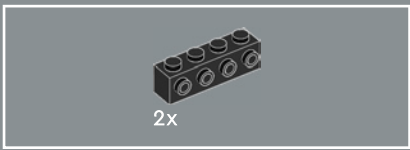

158

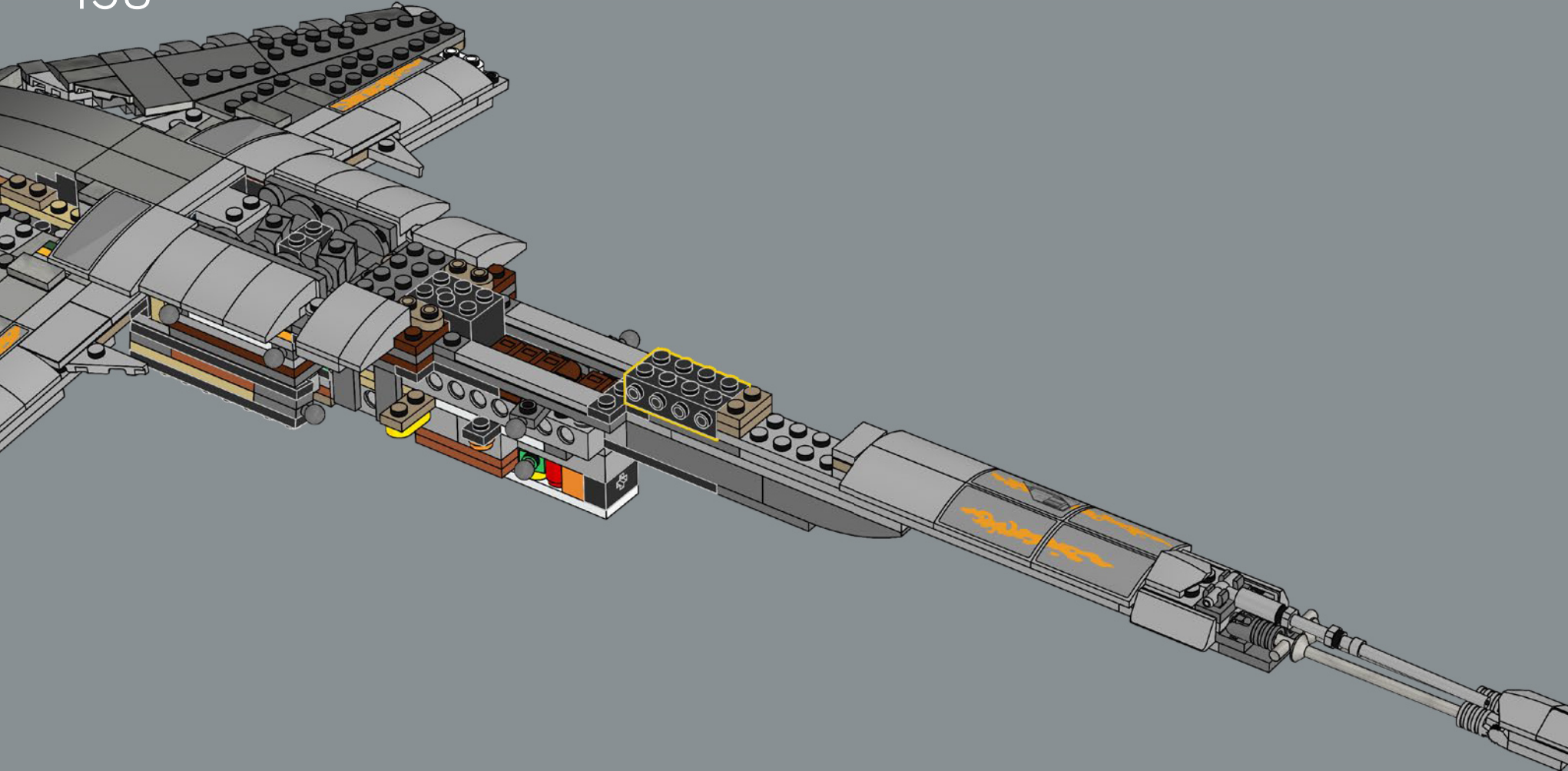

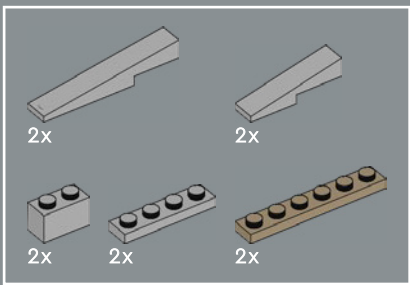

159

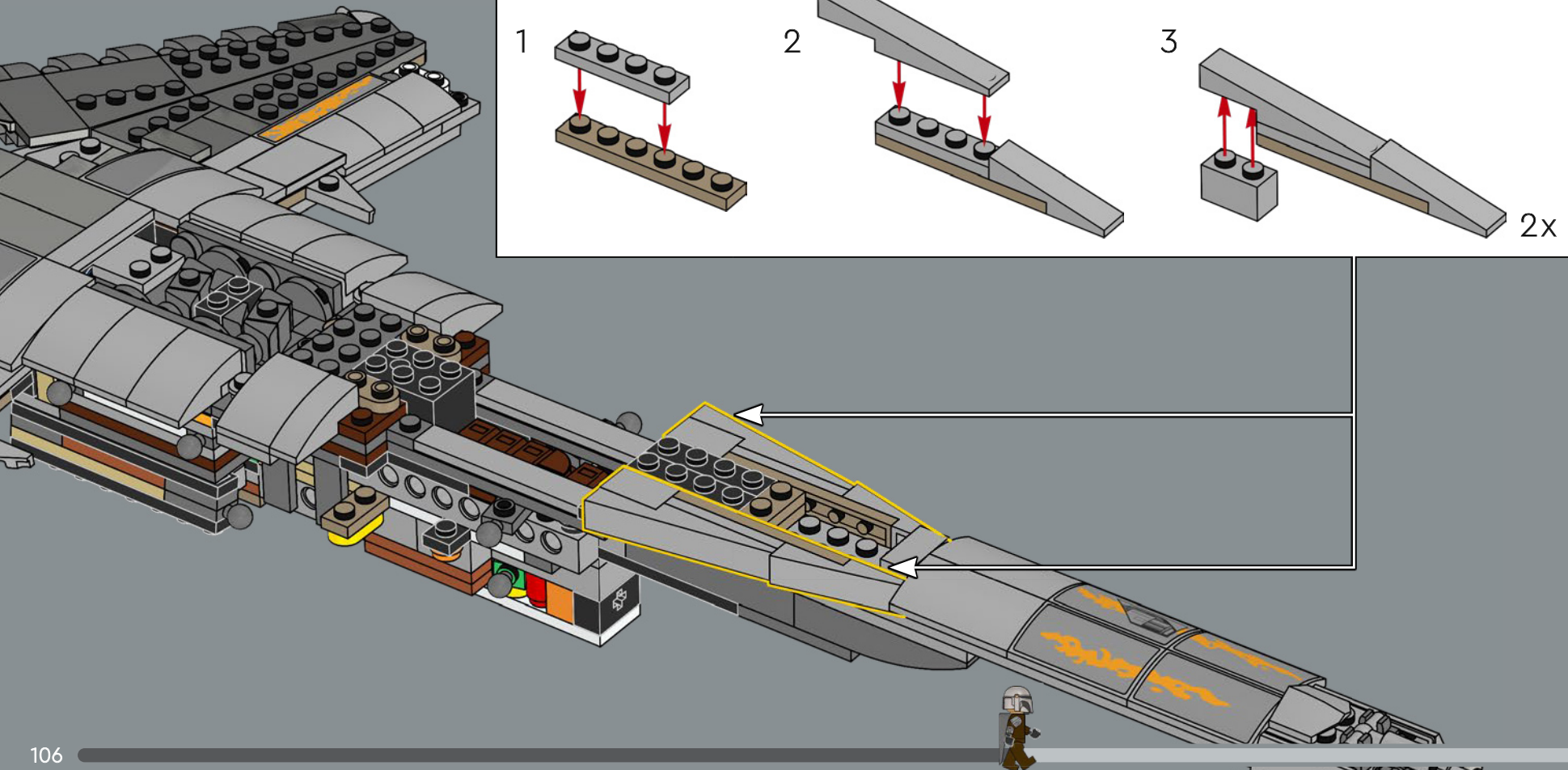

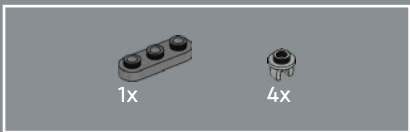

160

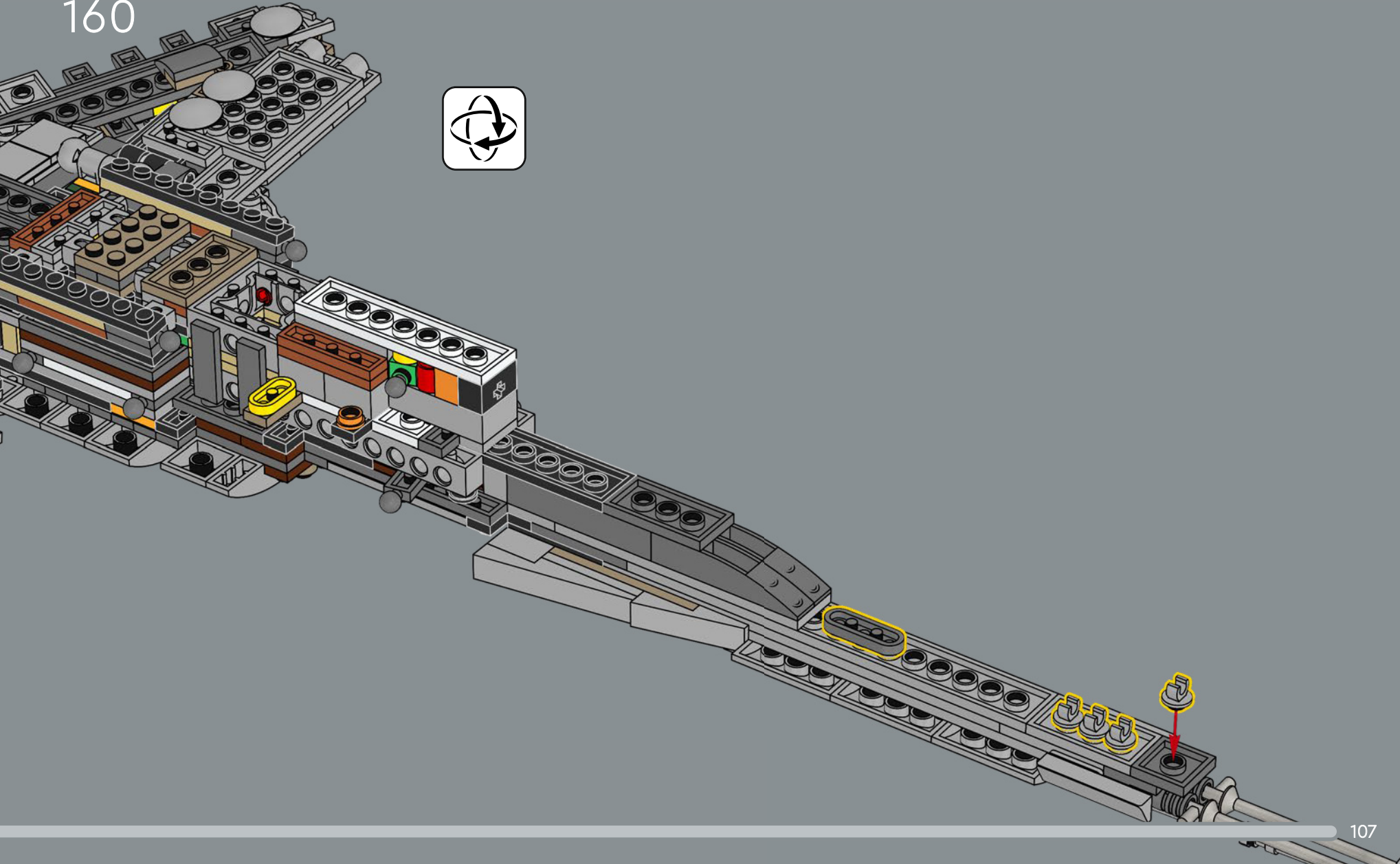



161

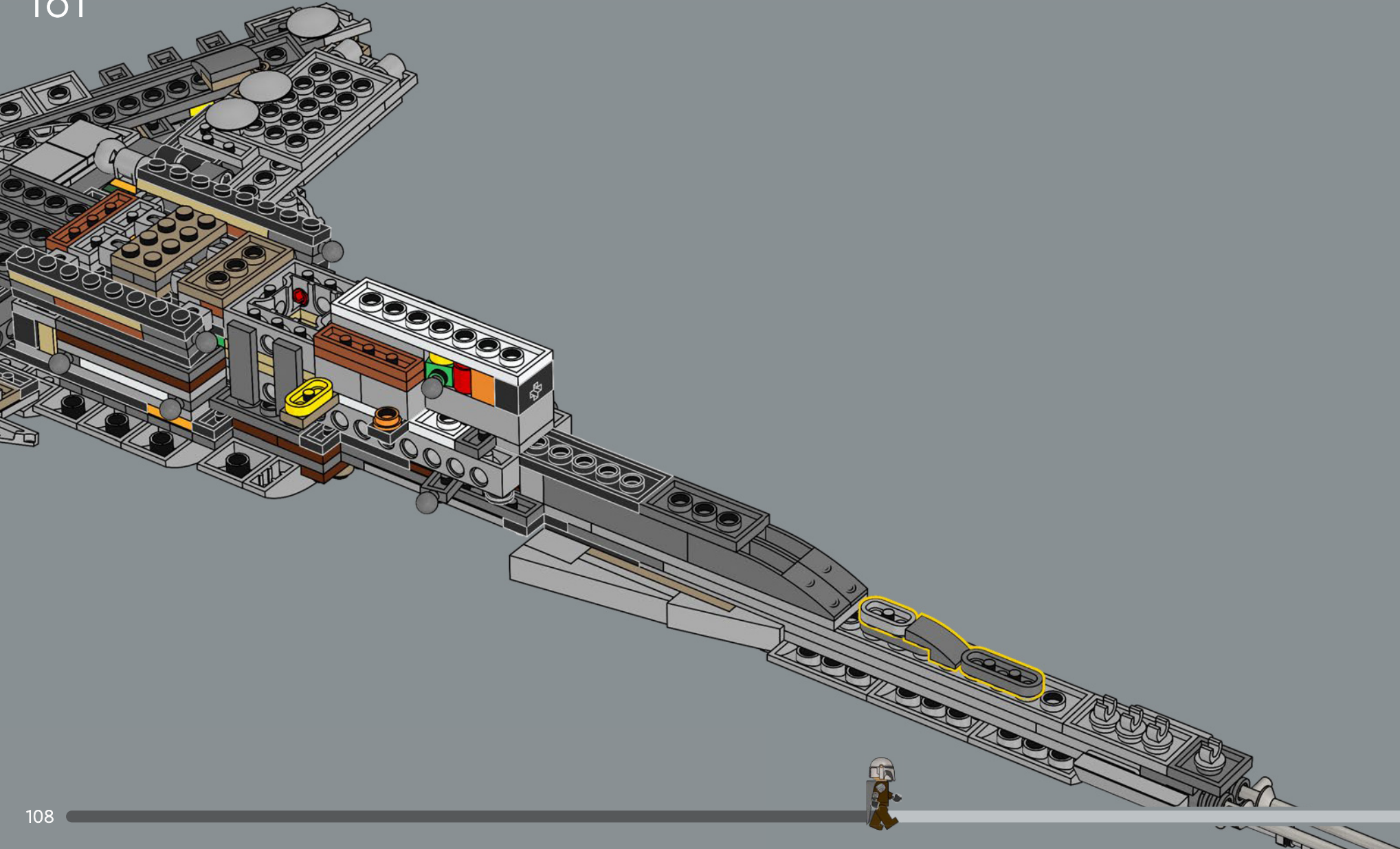



162

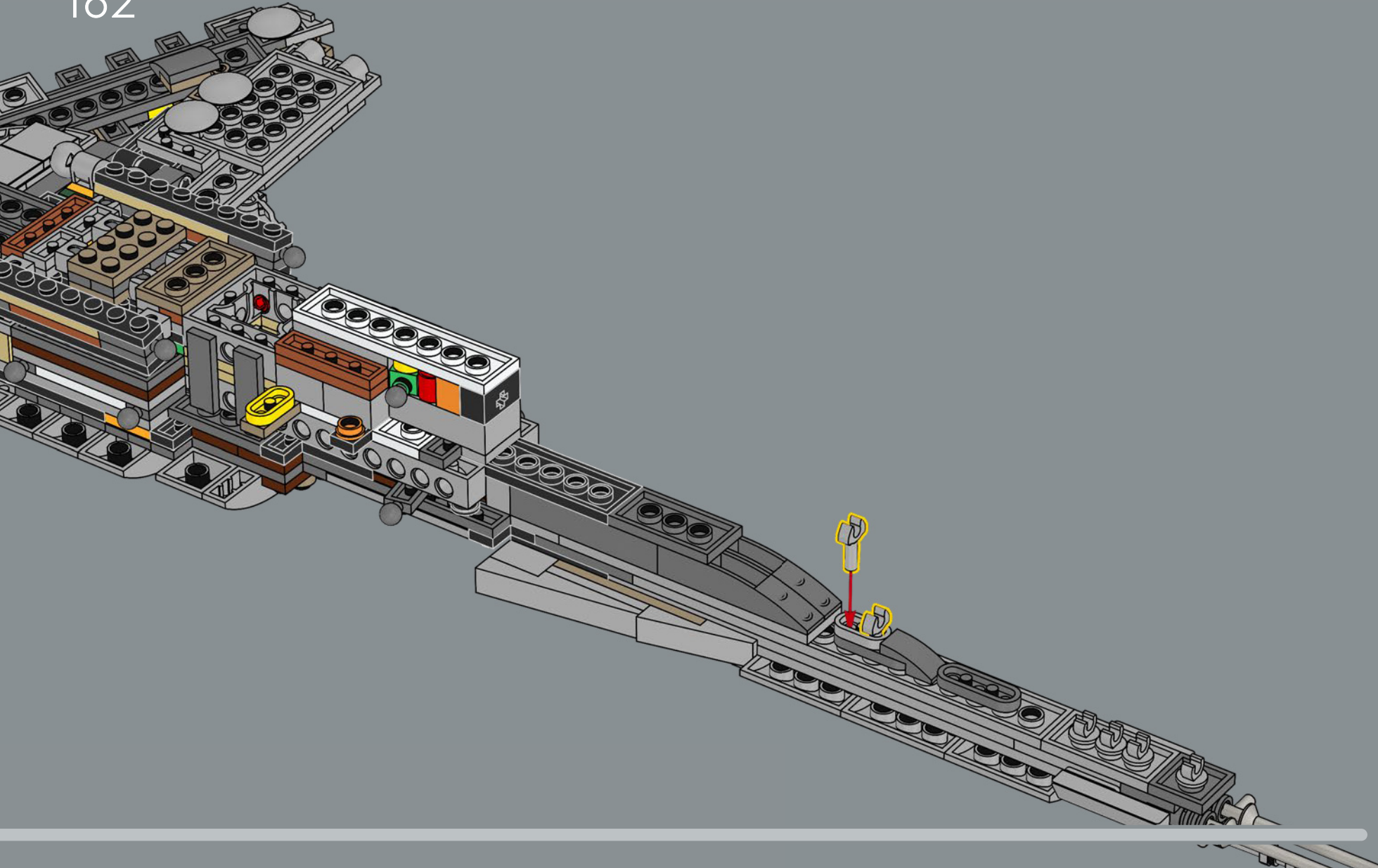

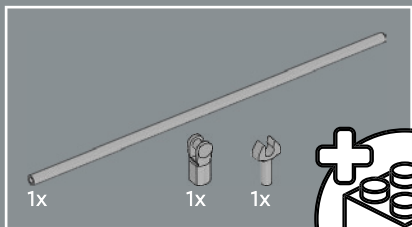

163

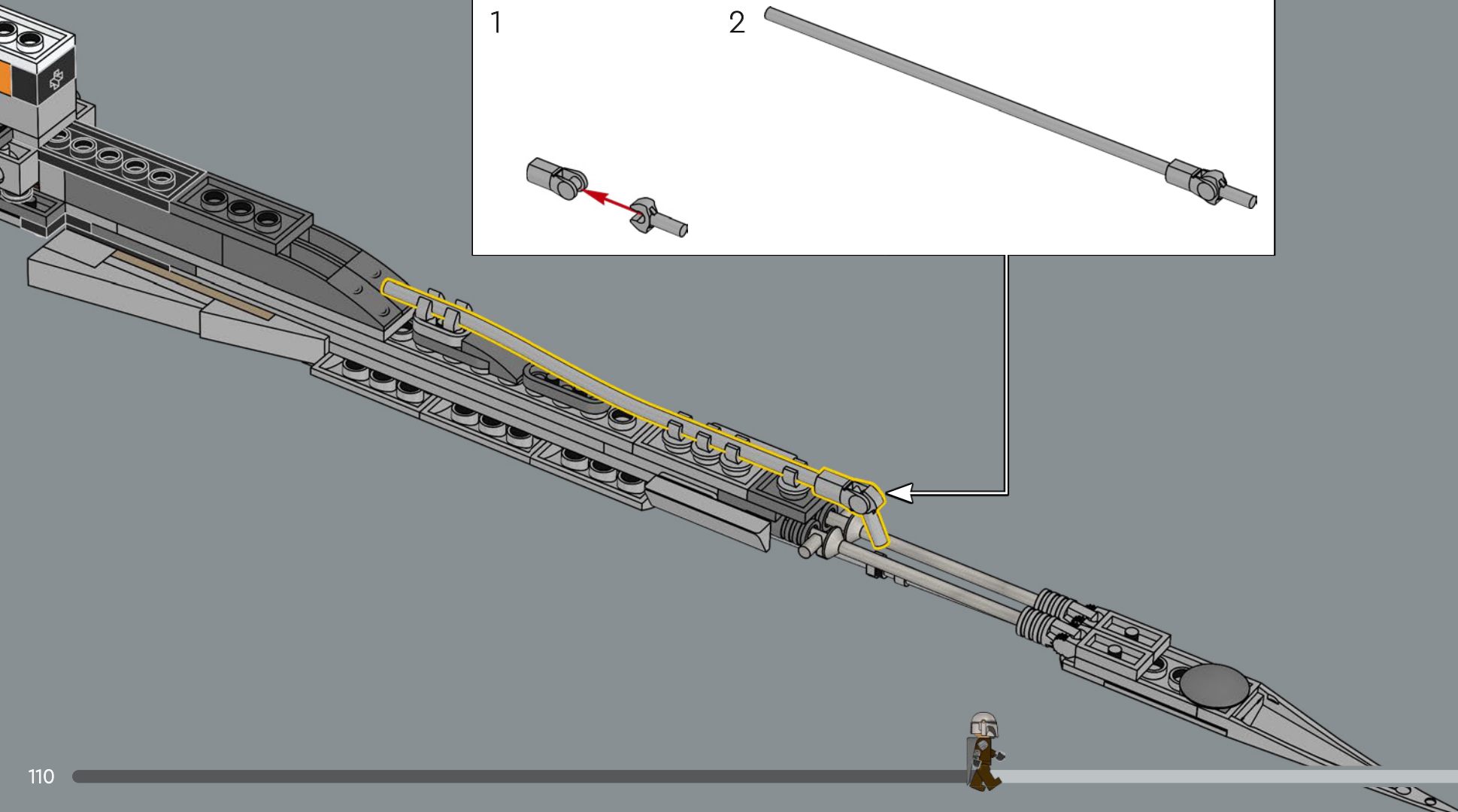
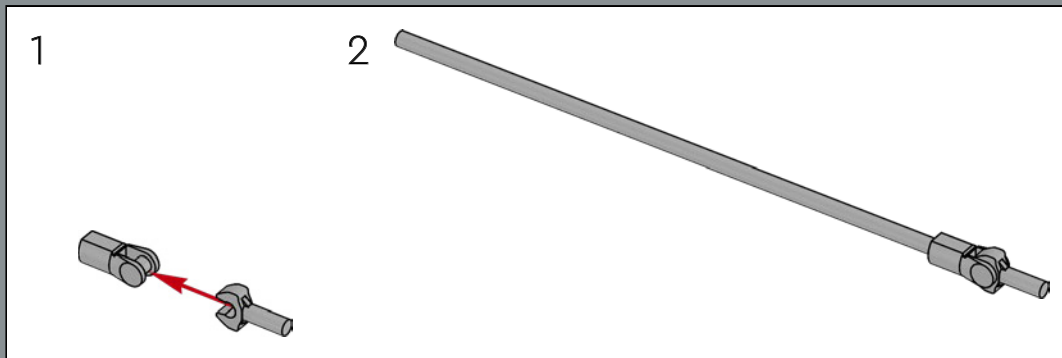

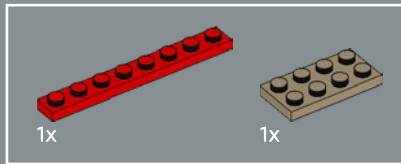
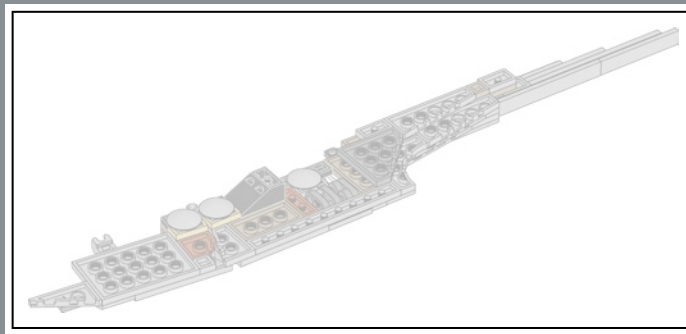

164

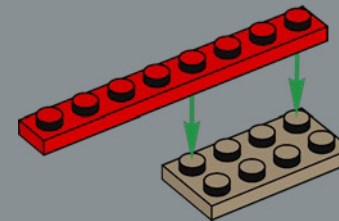

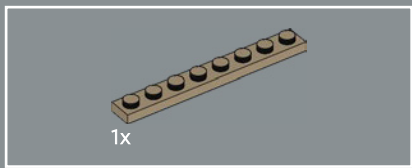

165

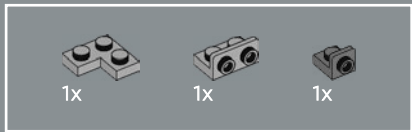
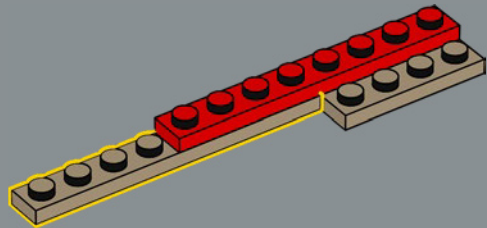

166

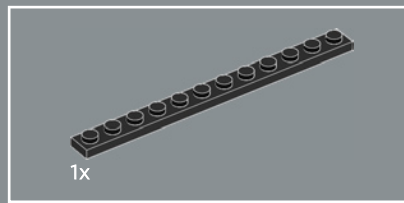
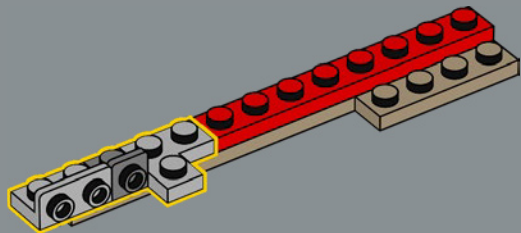

167

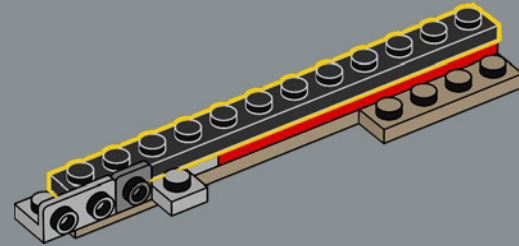

168

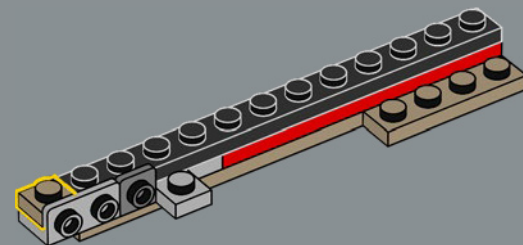

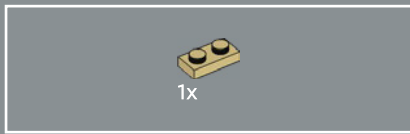

169

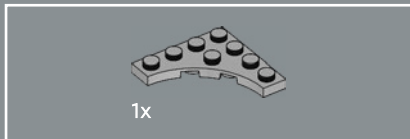
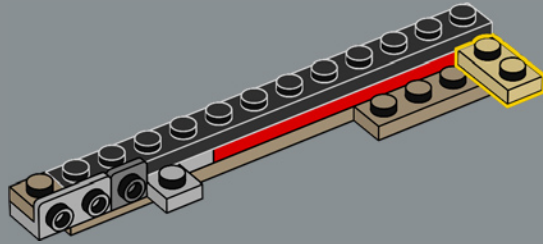

170

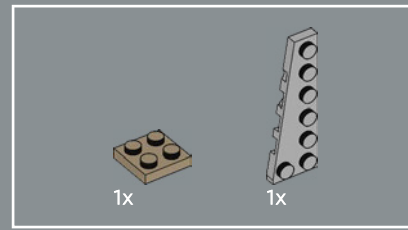
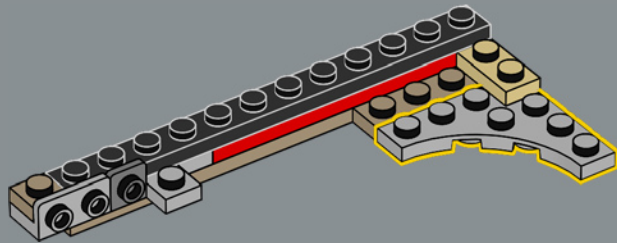

171

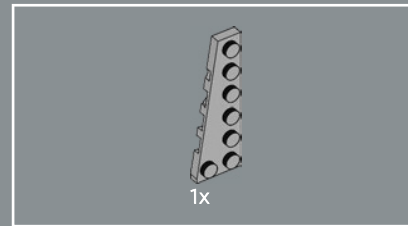
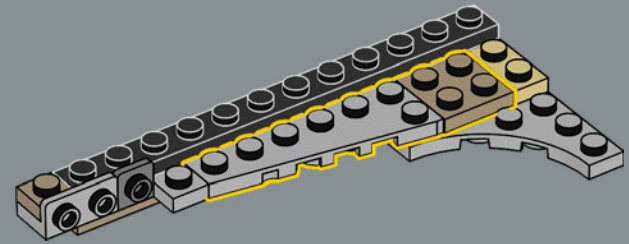

172

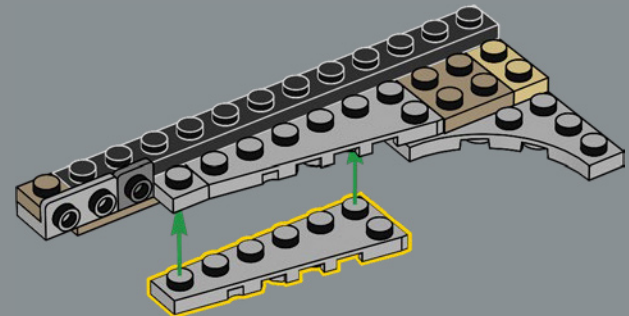

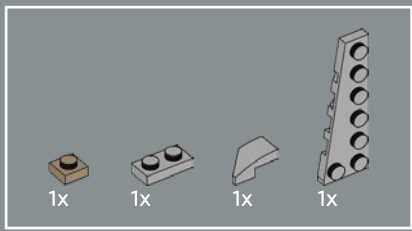

173

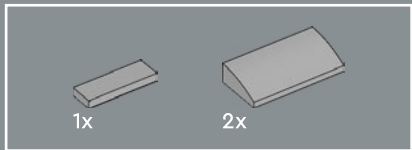
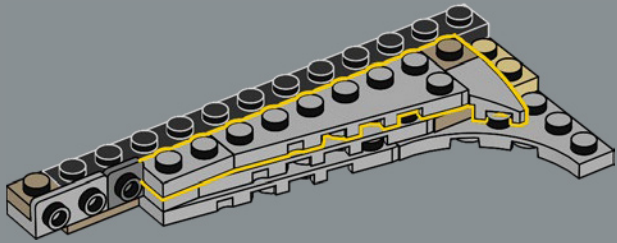

174

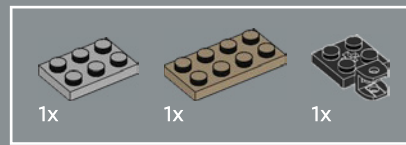
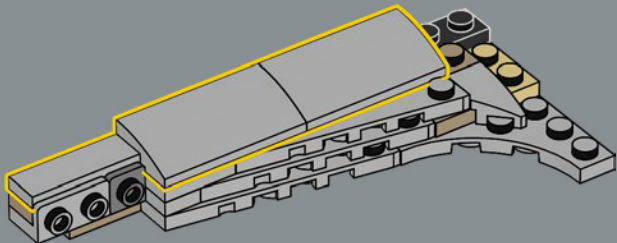

175

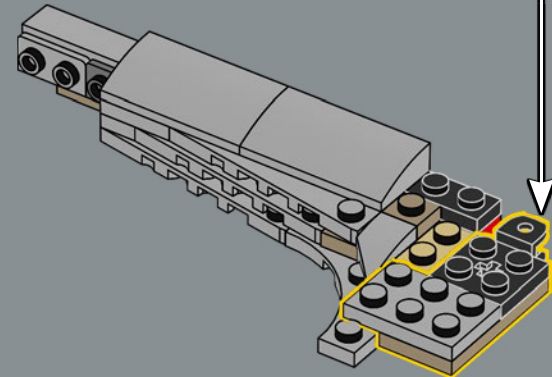
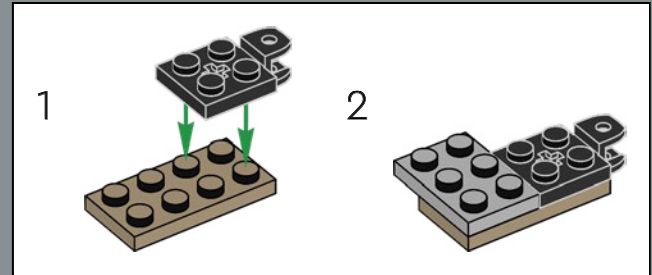

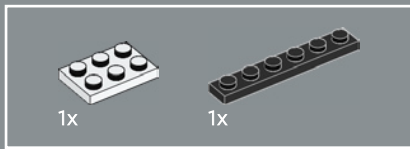

176

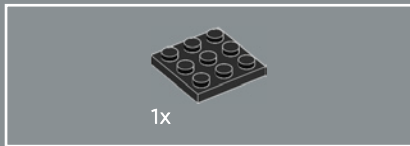
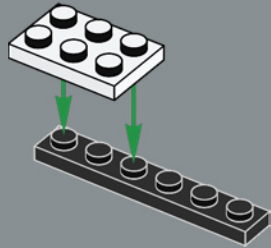

177

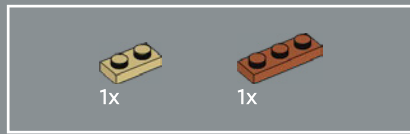
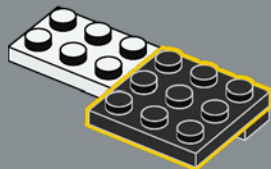

178

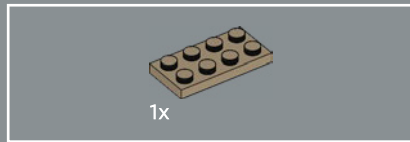
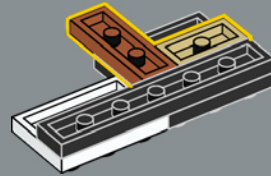

179

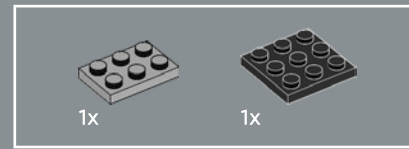
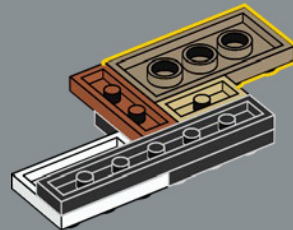

180

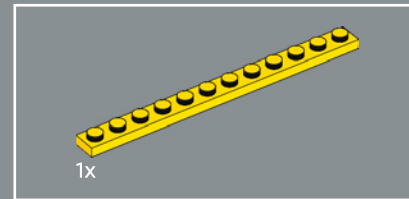
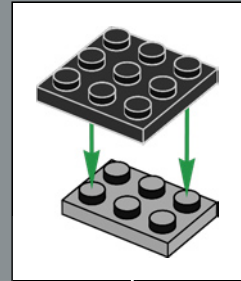
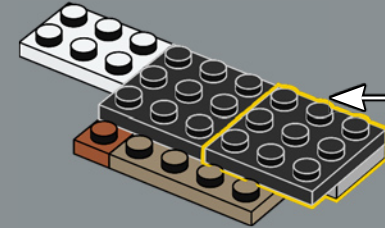

181

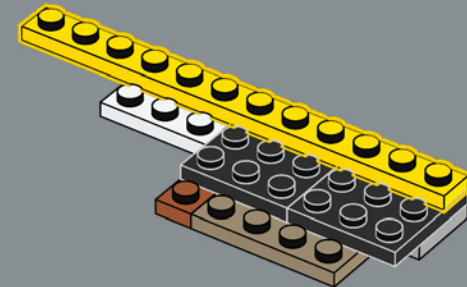

182

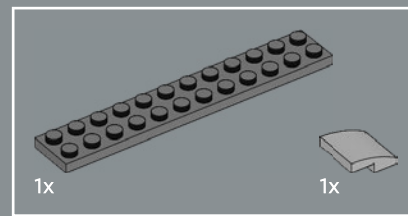
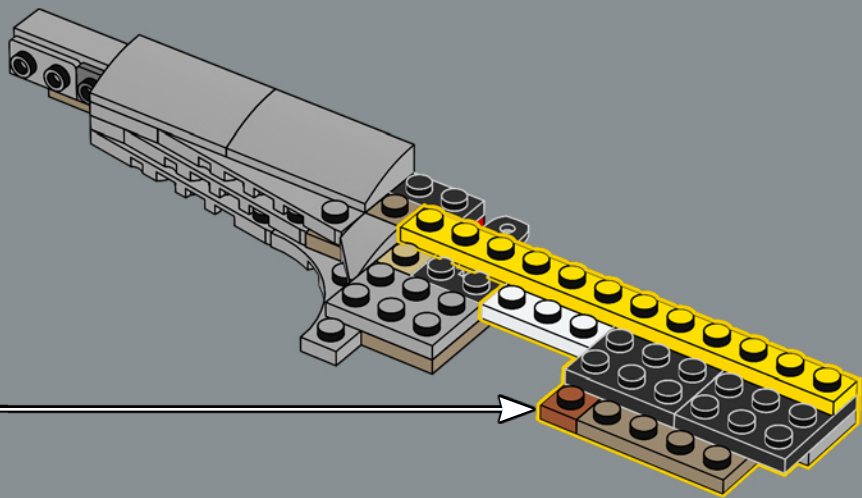

183

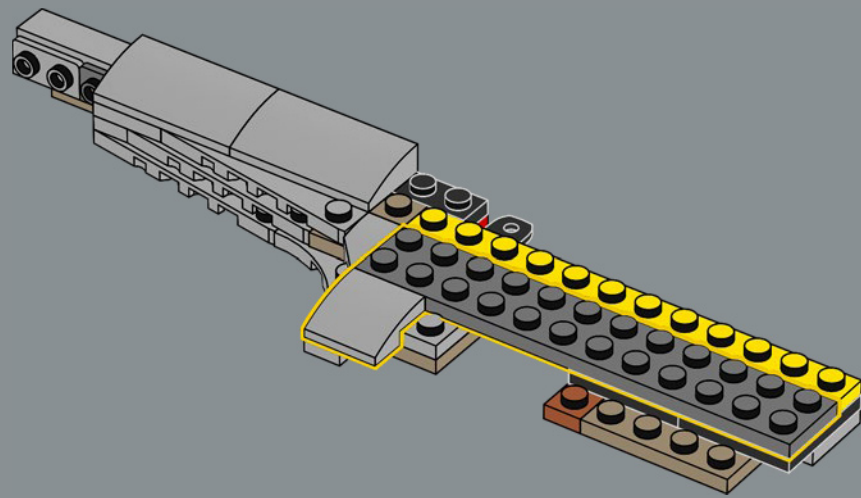

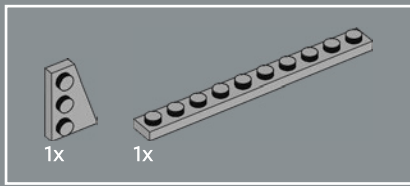

184

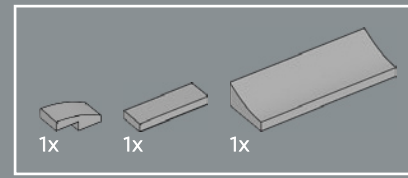

185

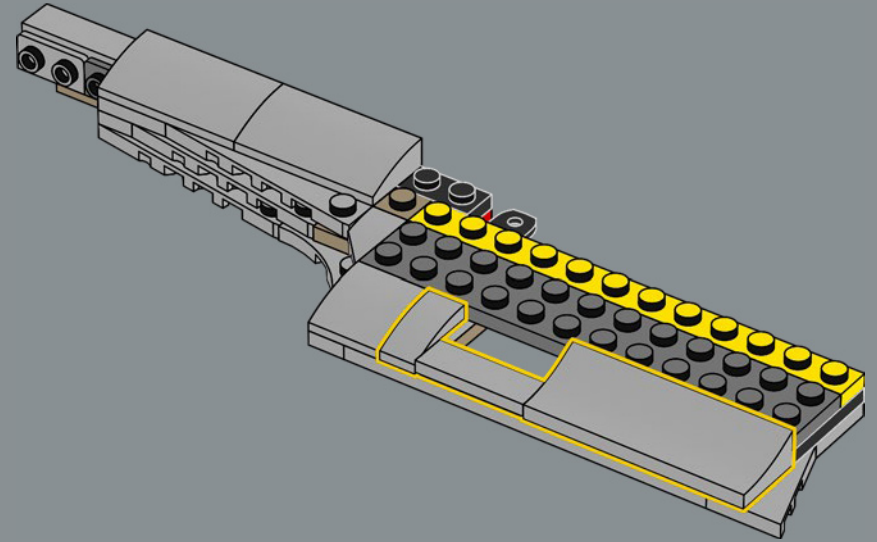
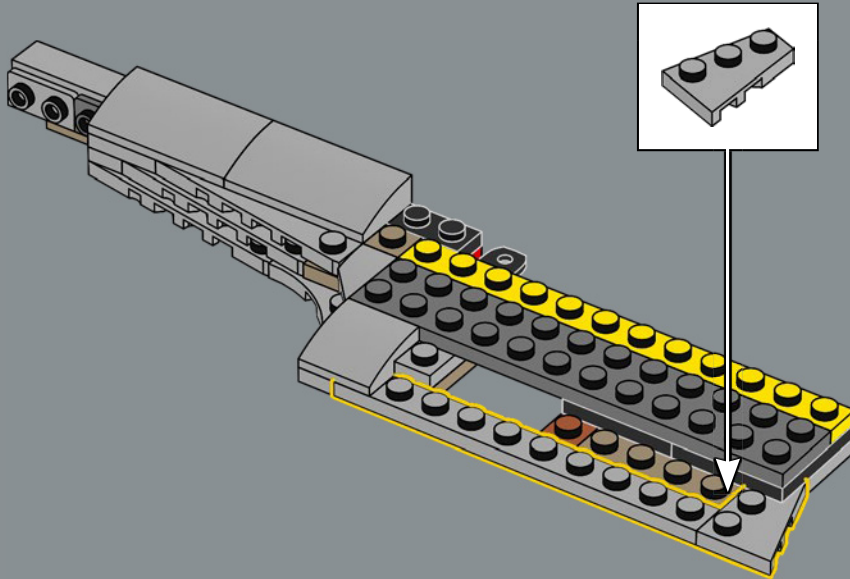

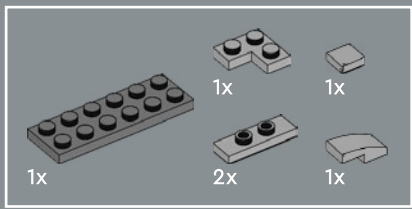

186

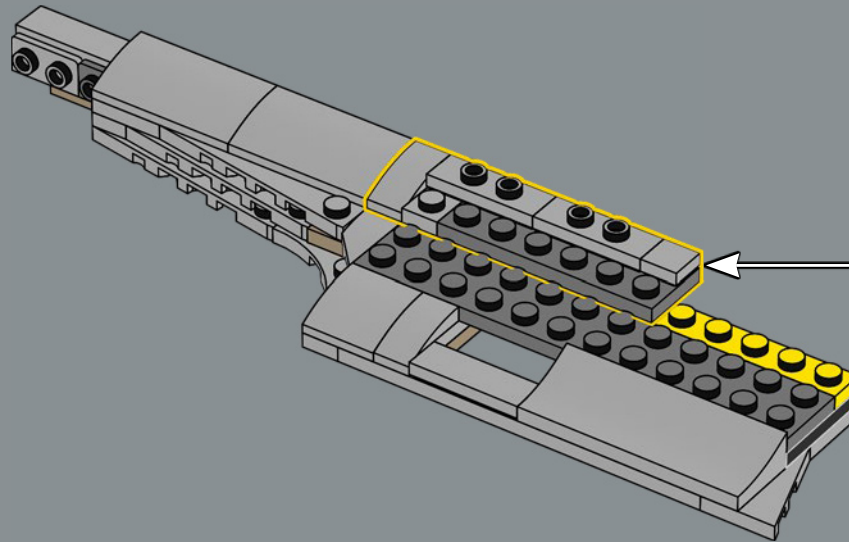
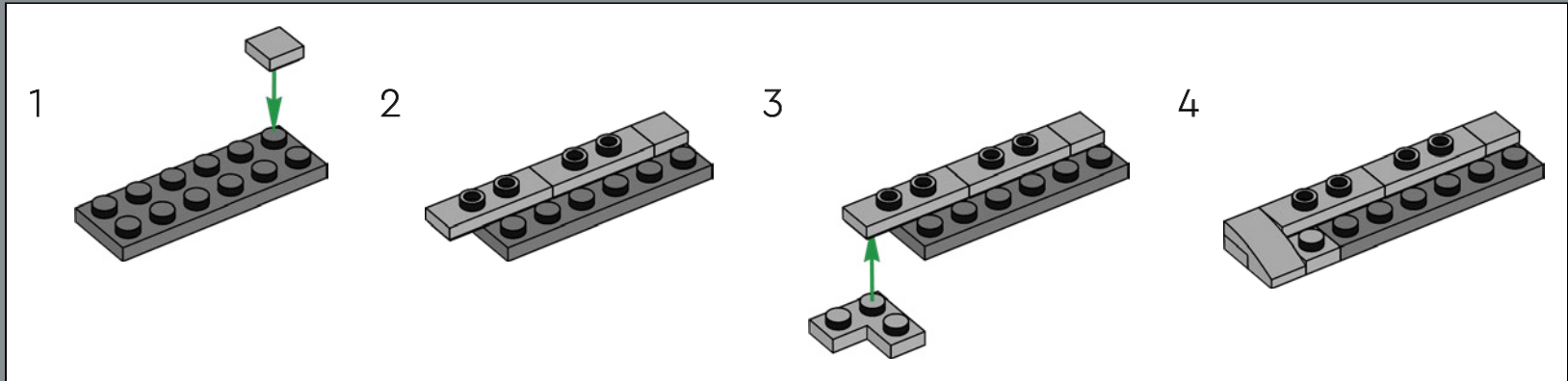

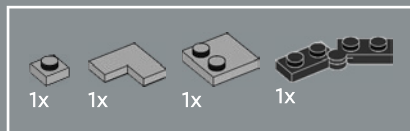

187

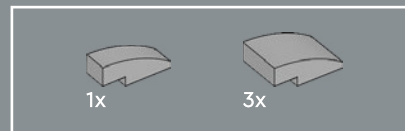
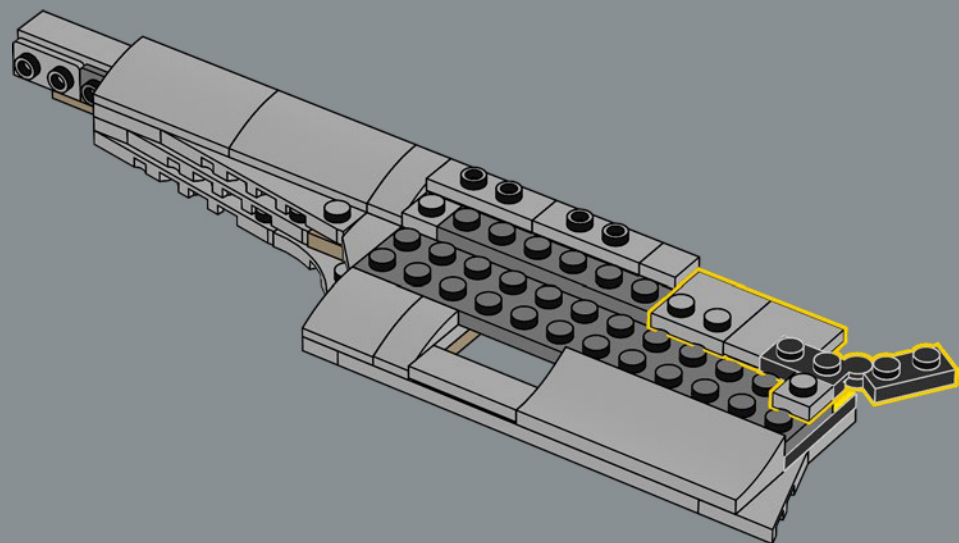

188

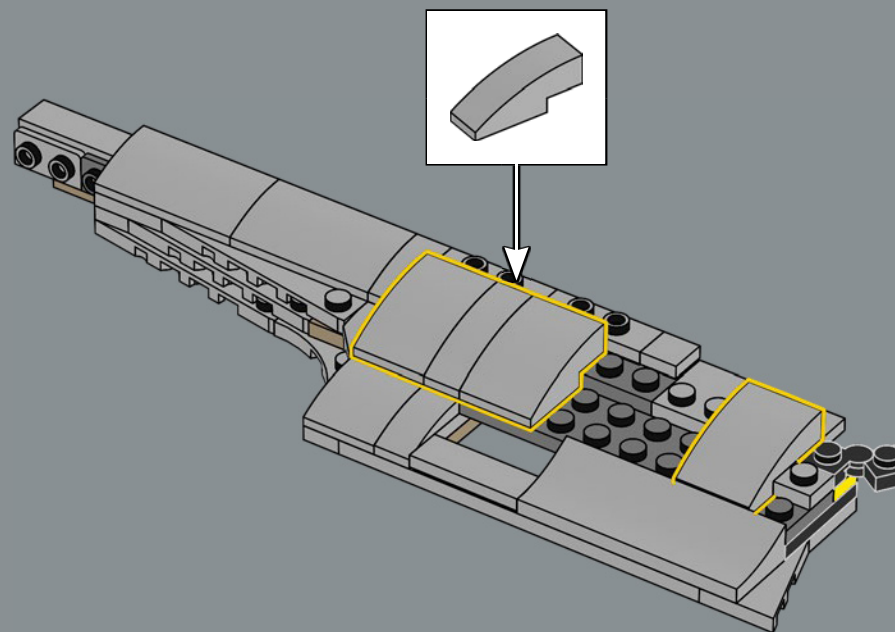

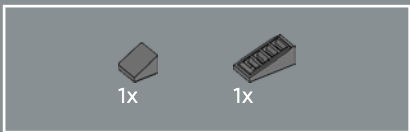

189

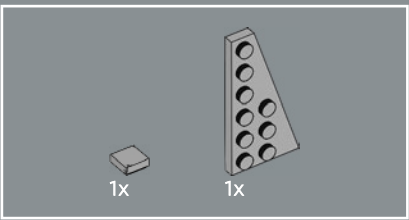
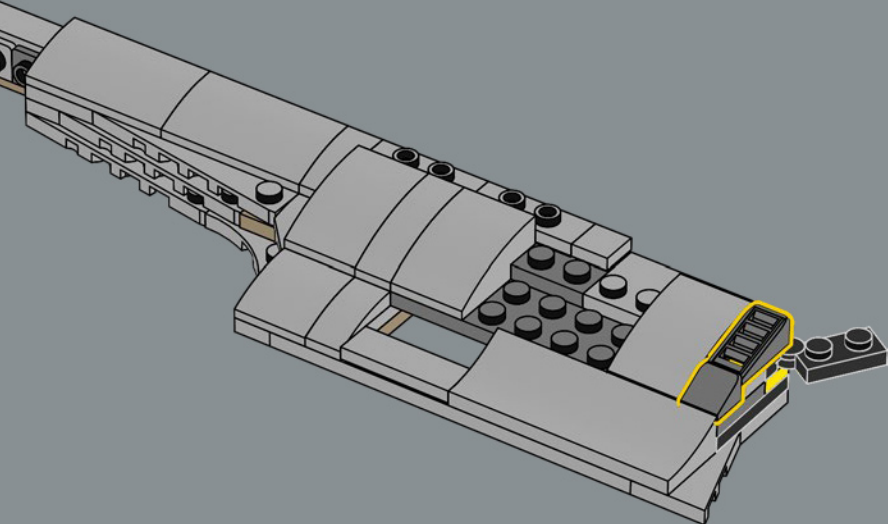

190

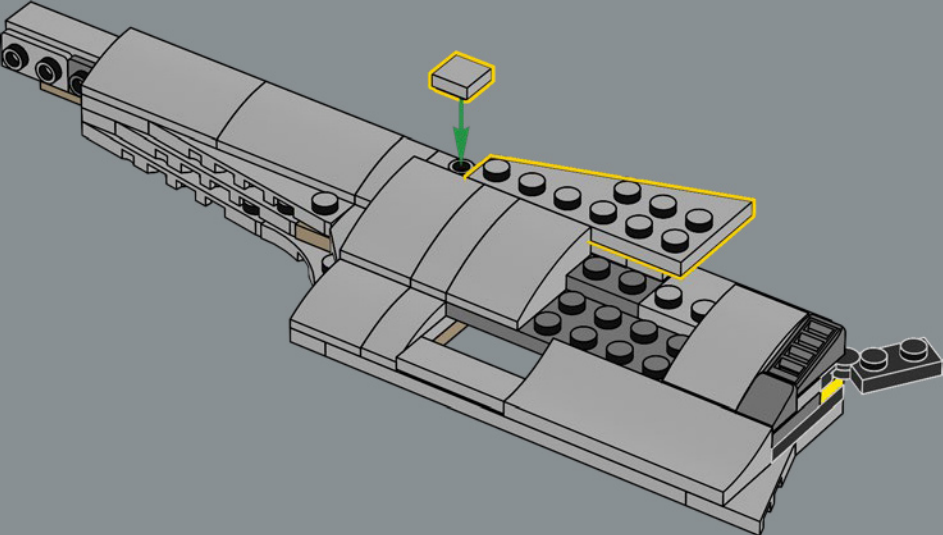

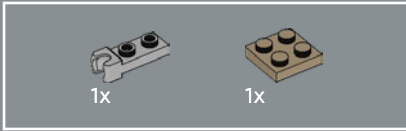
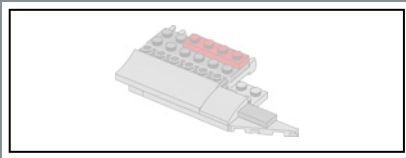

191

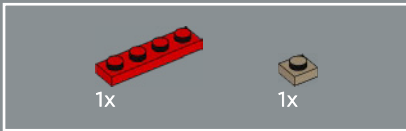
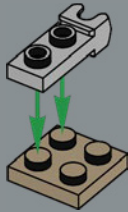

192

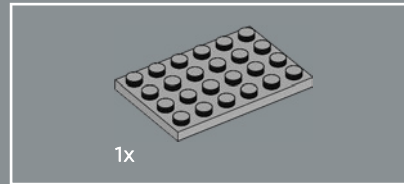
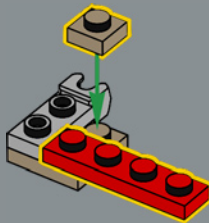

193

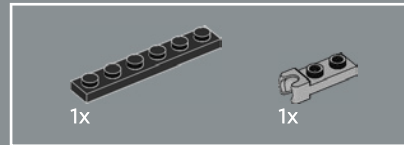
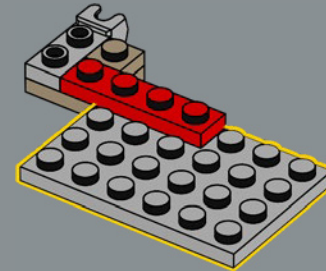

194

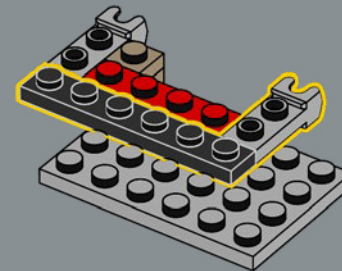



1x

195

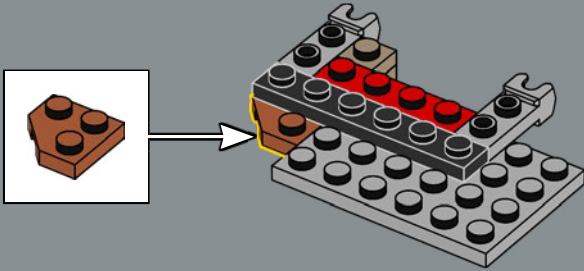

1x

197

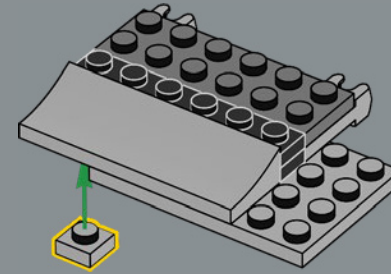

1x

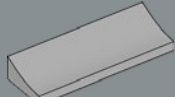

1x



1x

196

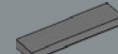
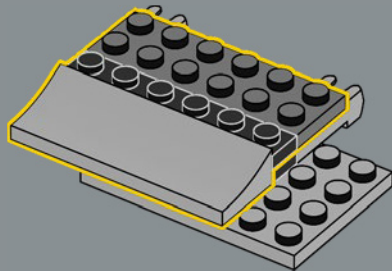

1x



1x

198

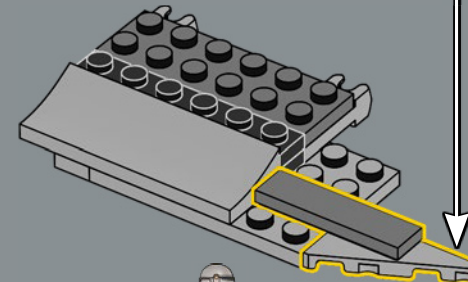
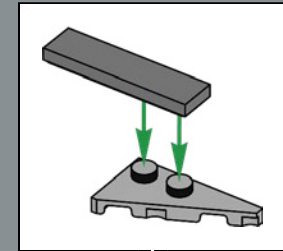

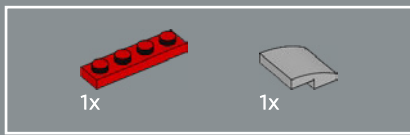

199

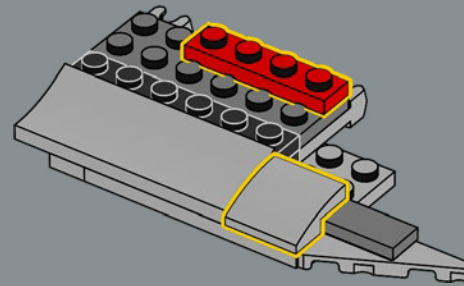

200

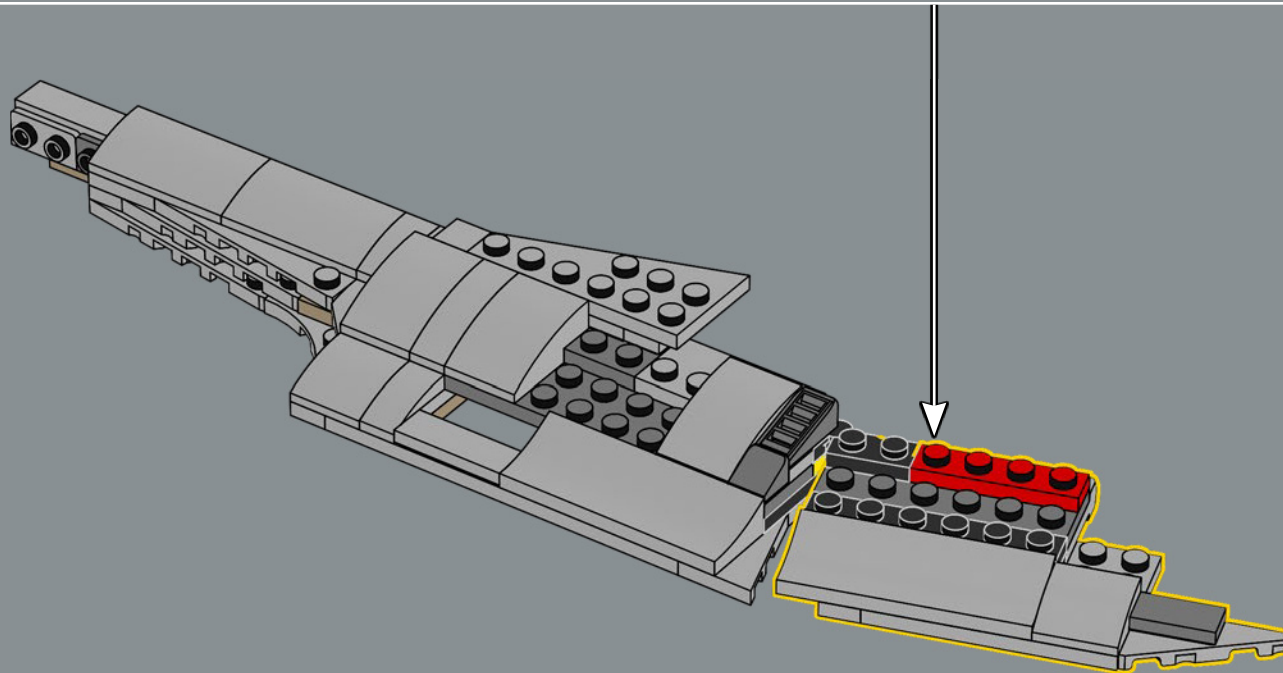

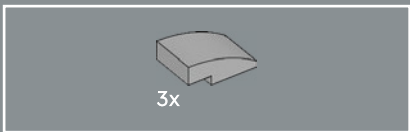

201

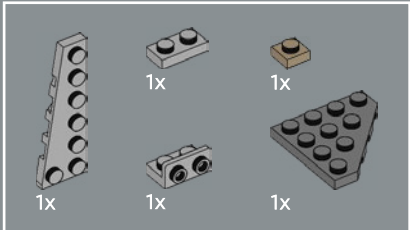
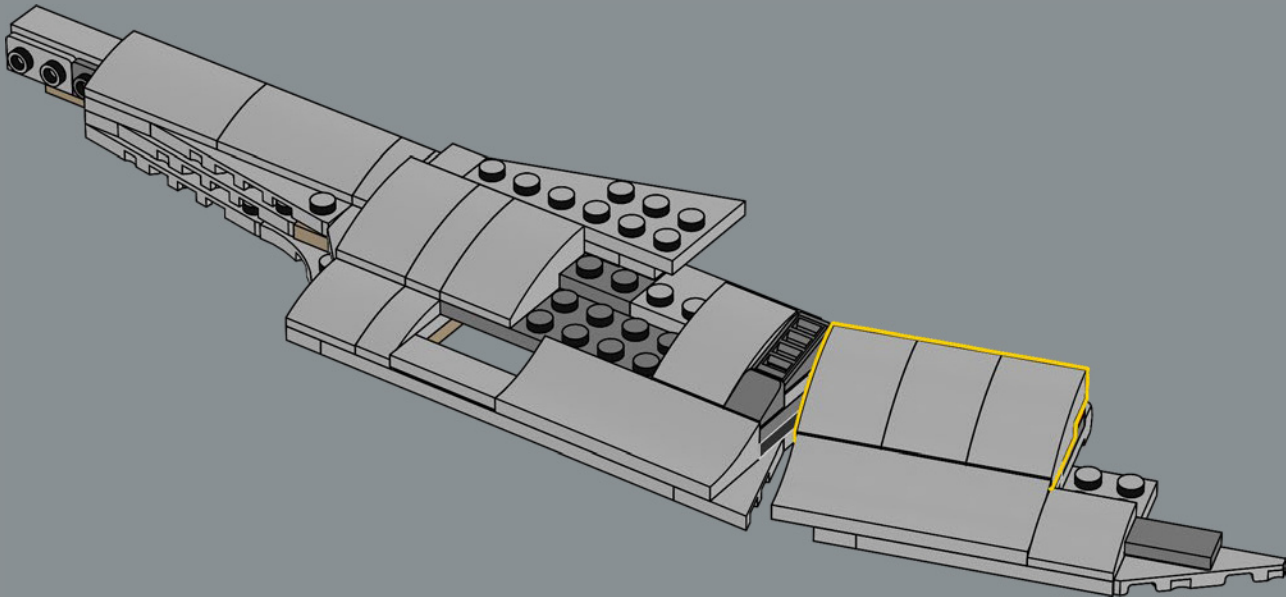

202

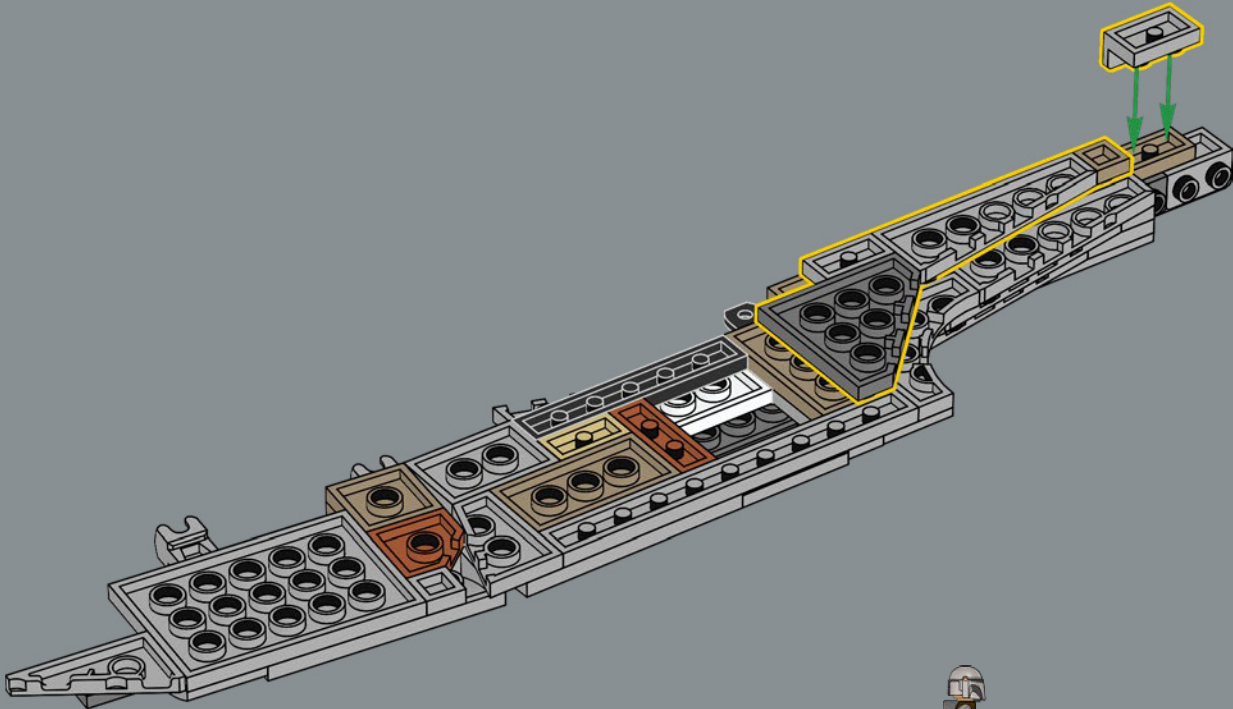

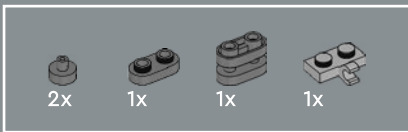

203

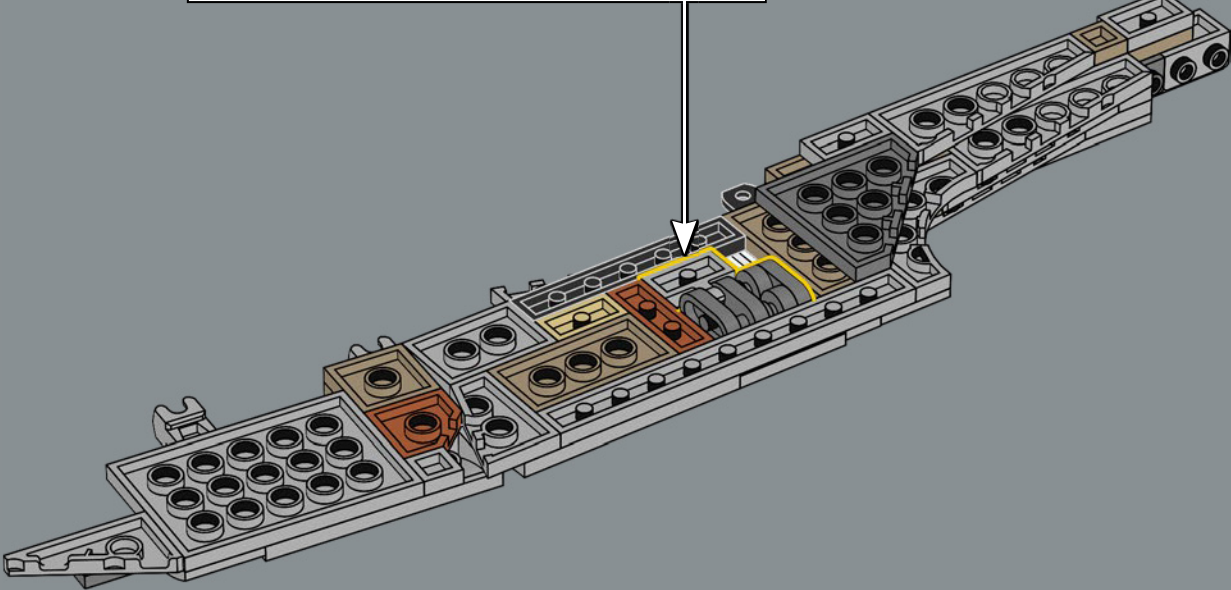
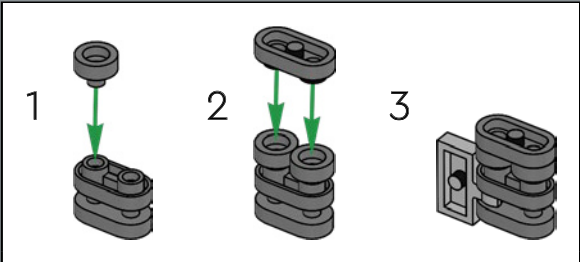



204

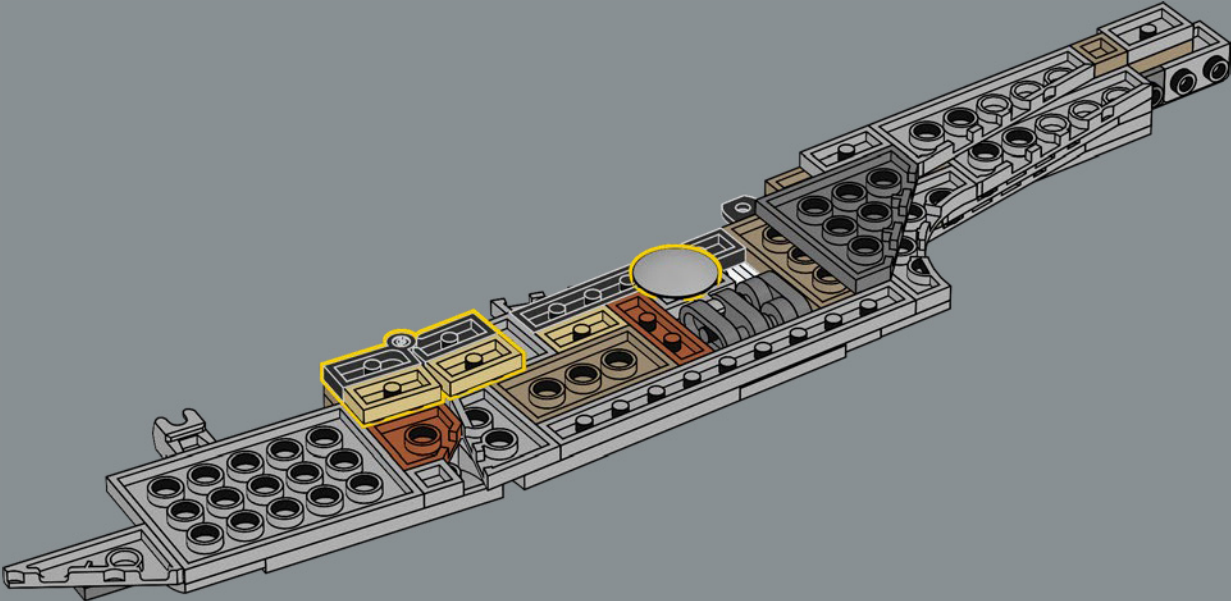

205

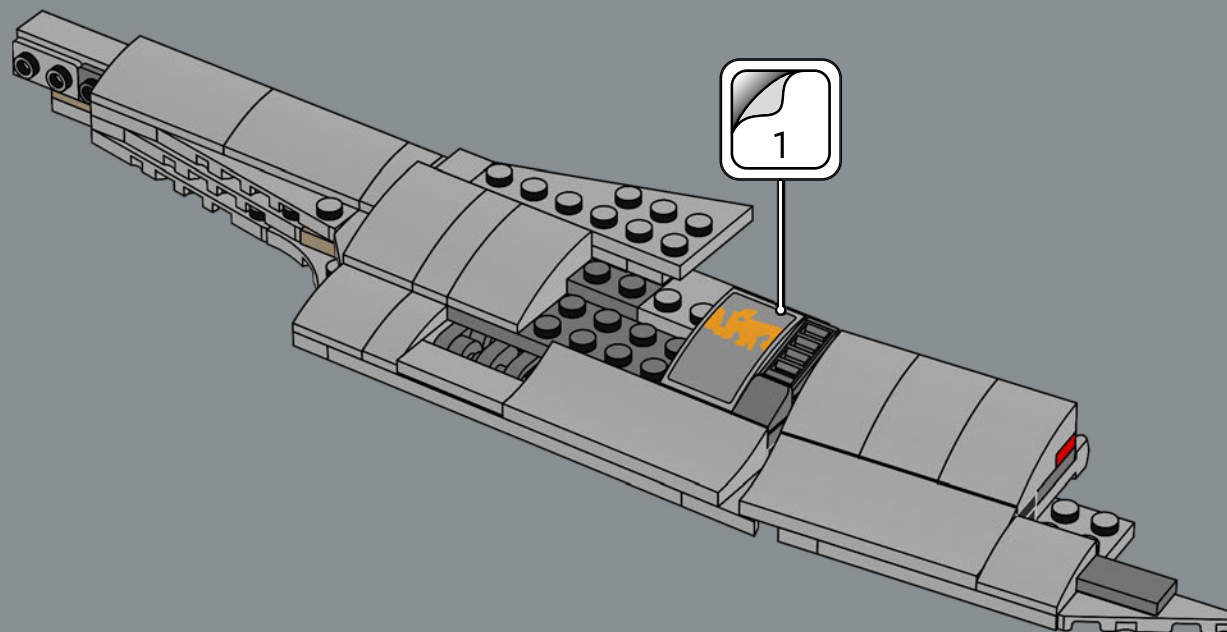

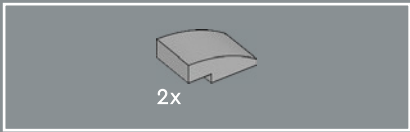

206

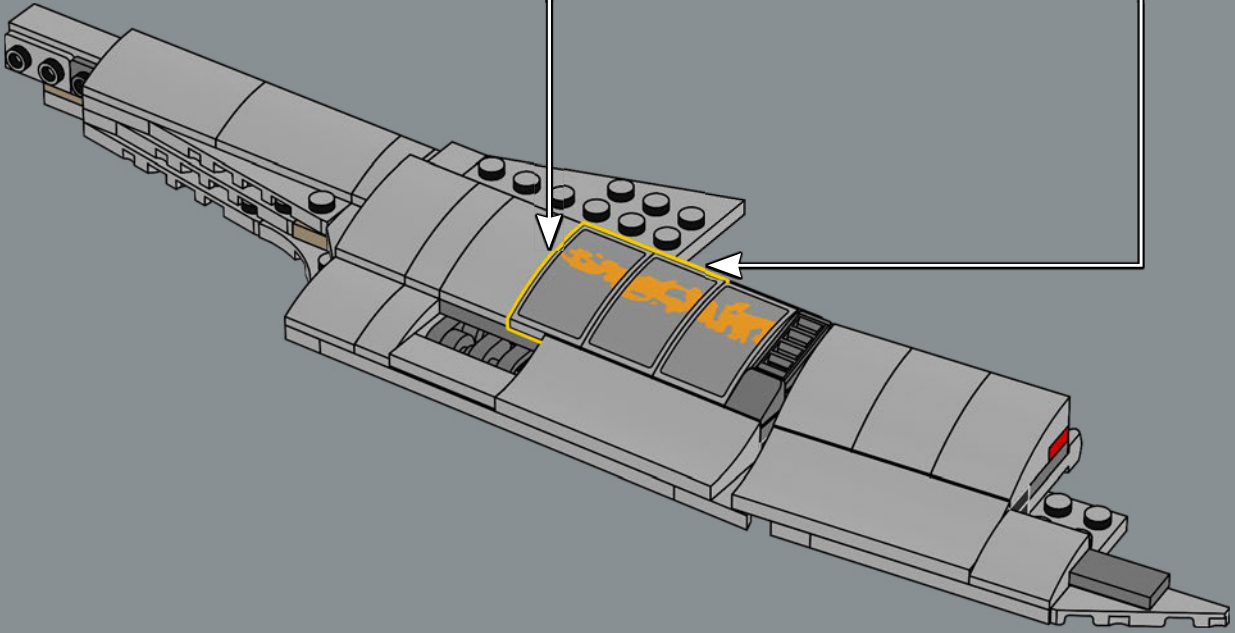
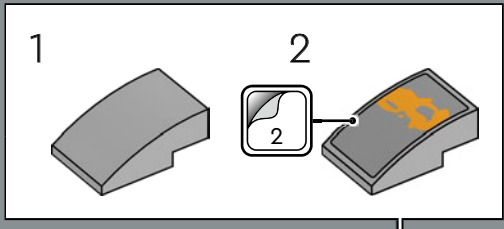
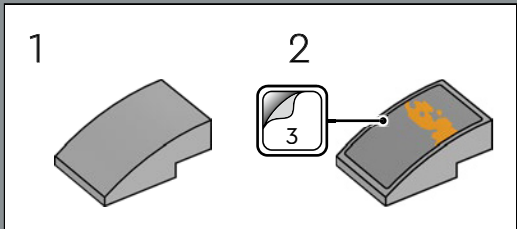

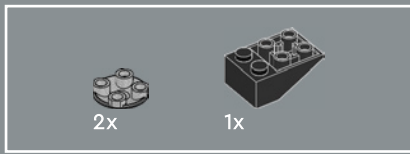

207

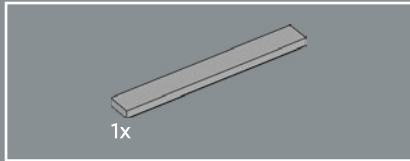
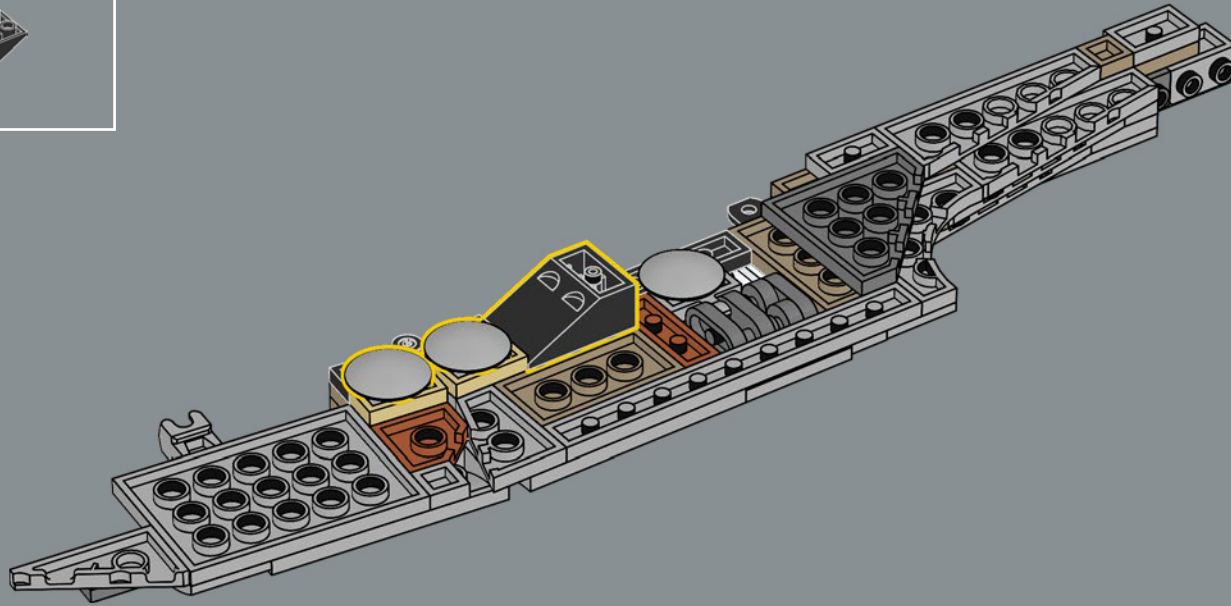

208

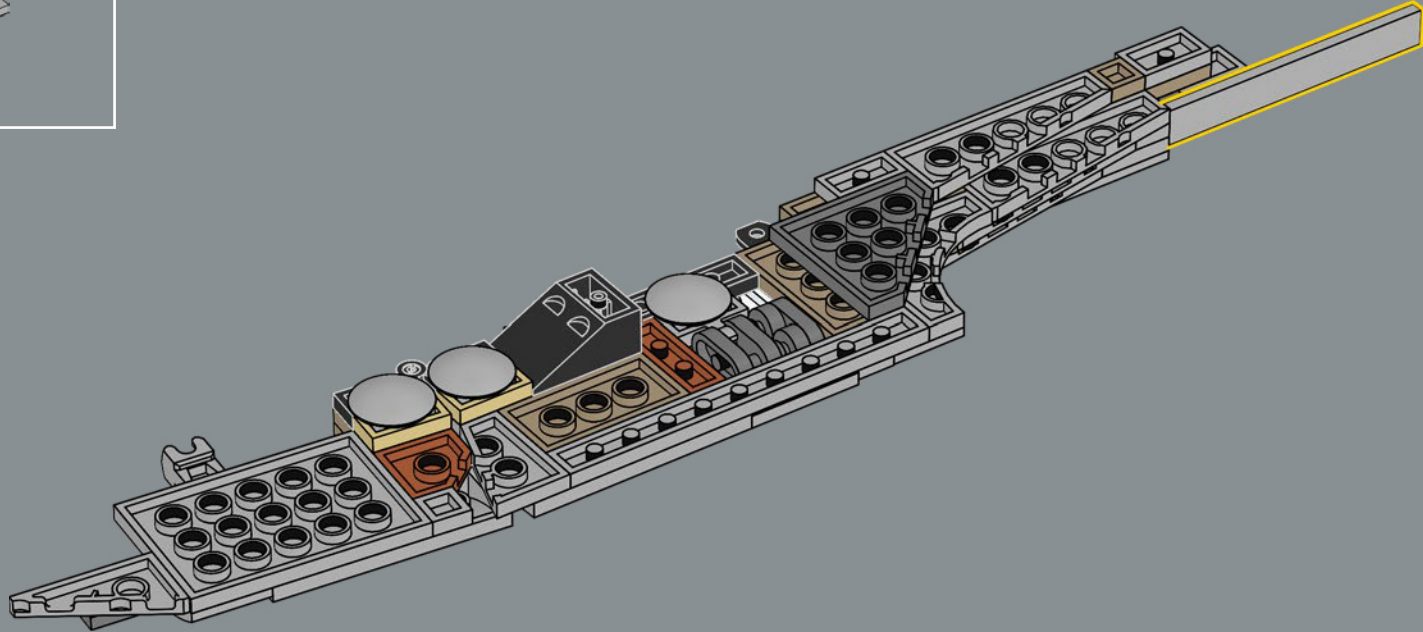

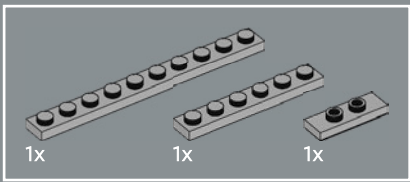

209

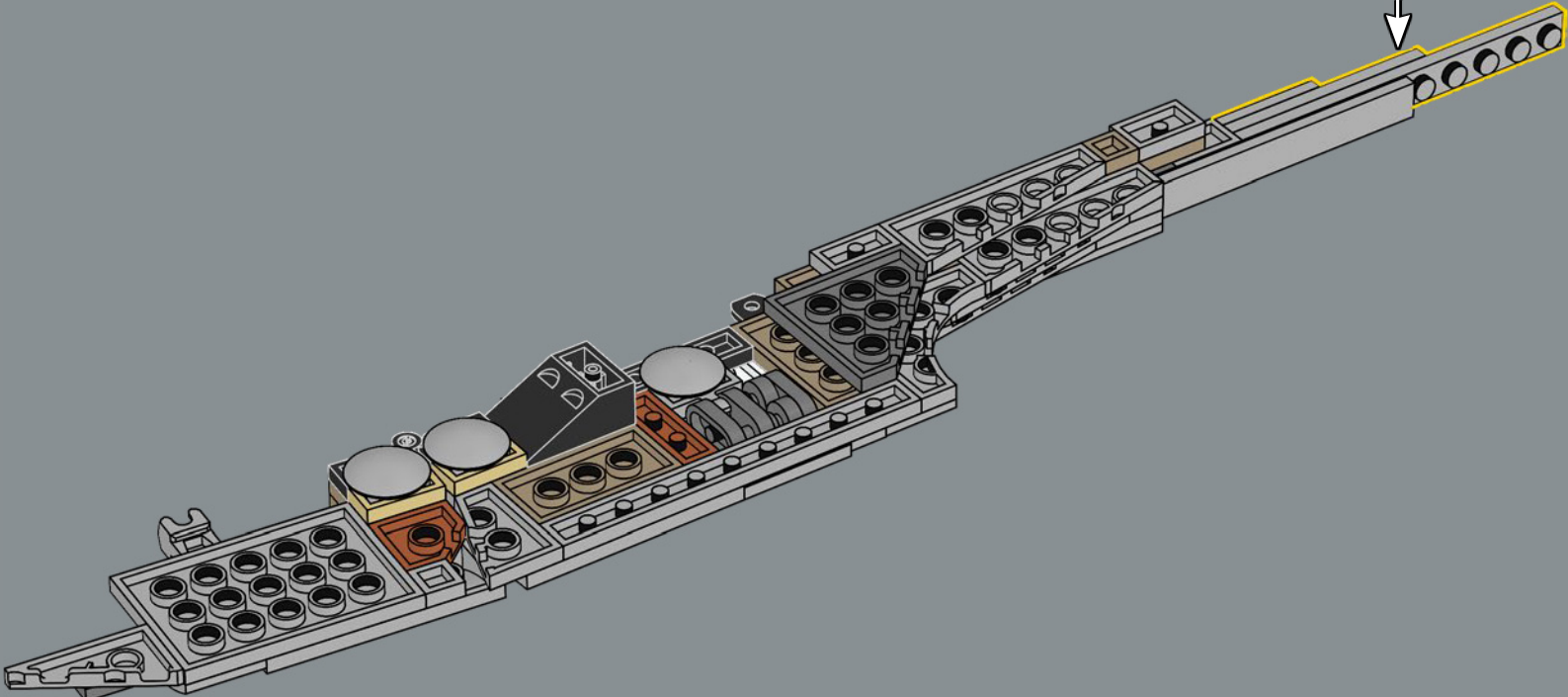
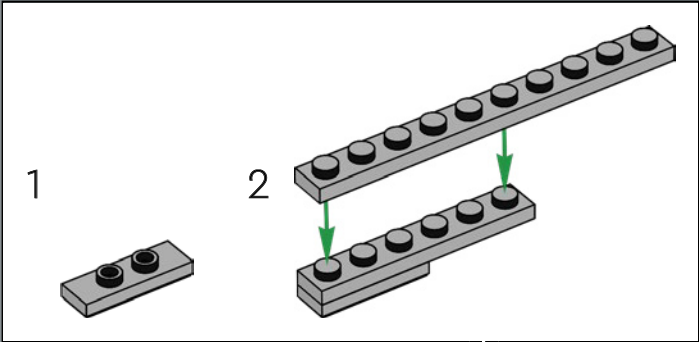

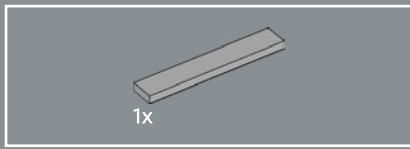

210

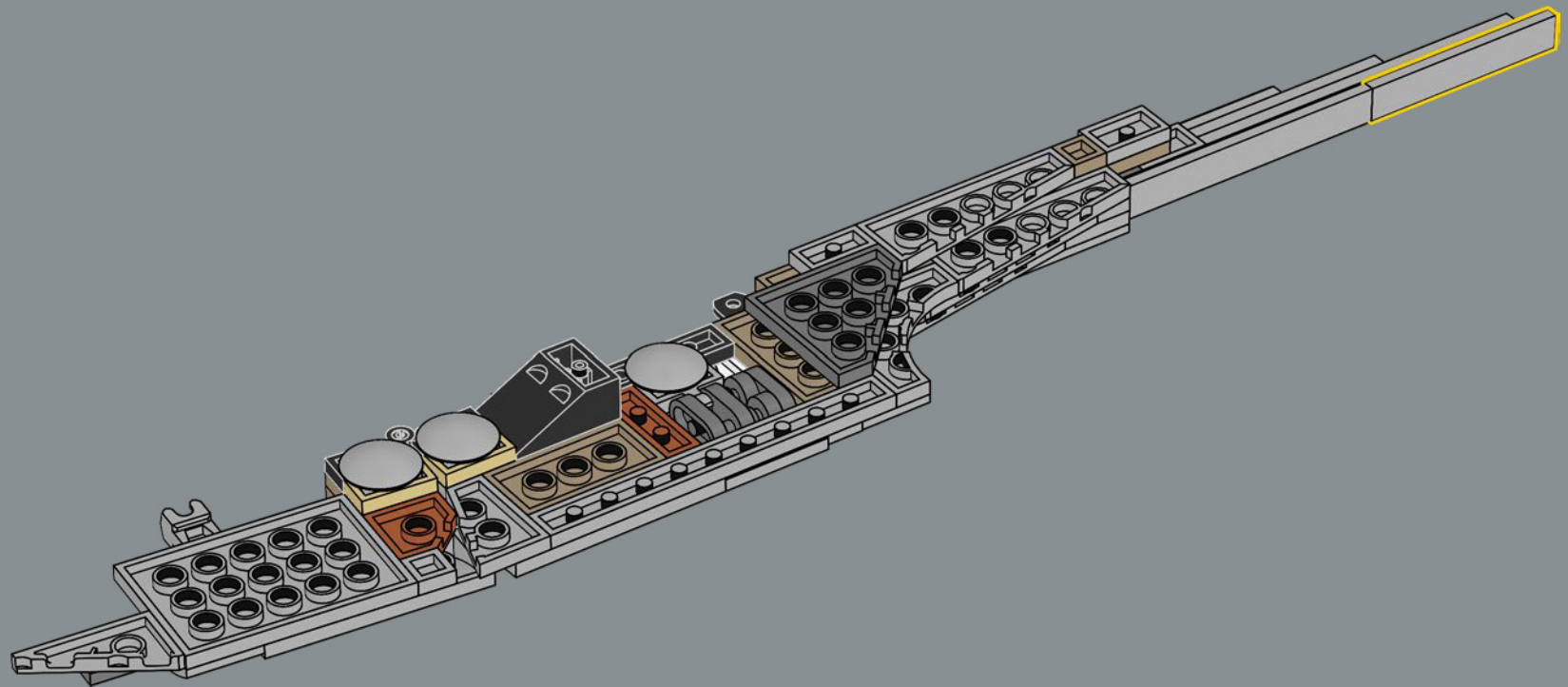

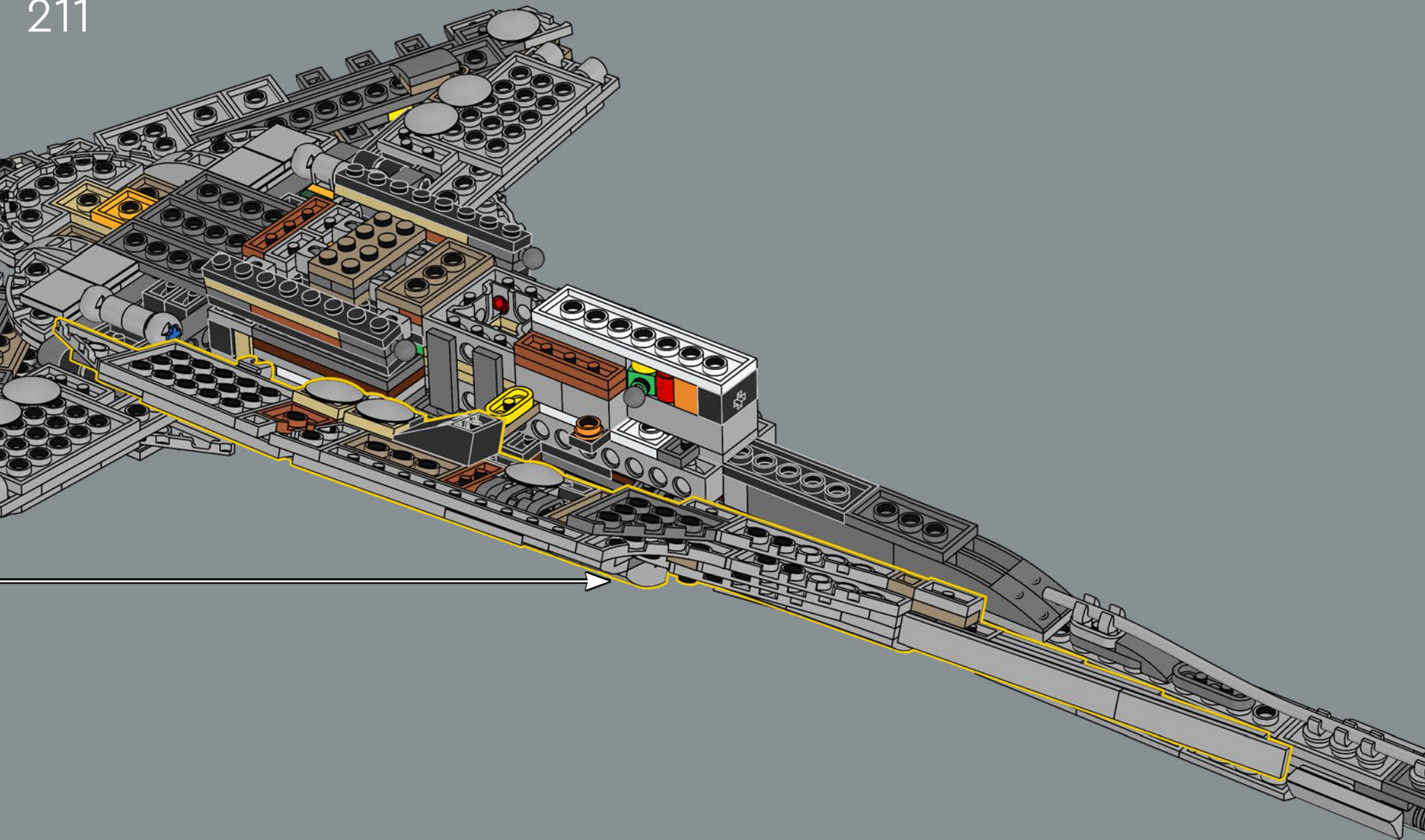

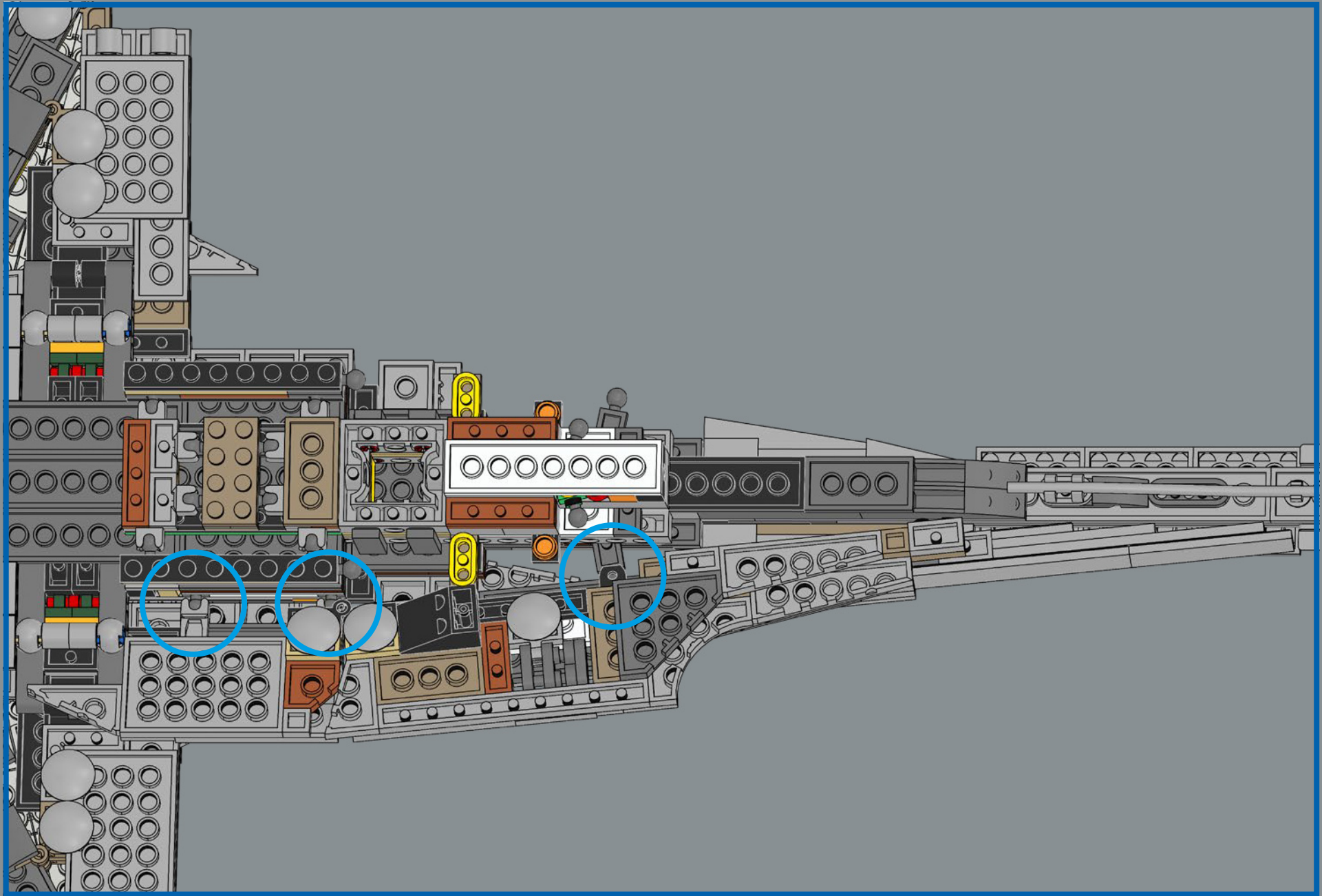

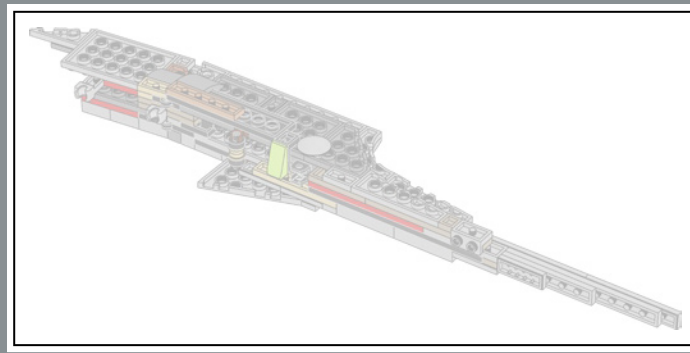

212

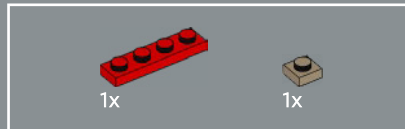
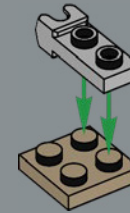

213

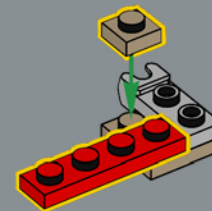

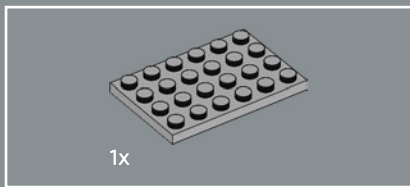

214

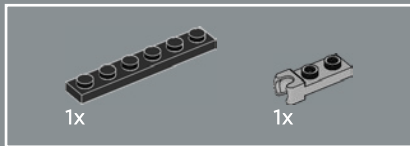
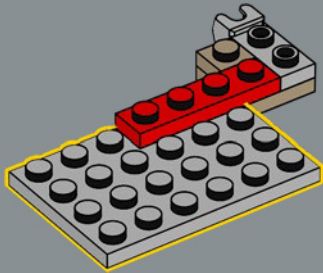

215

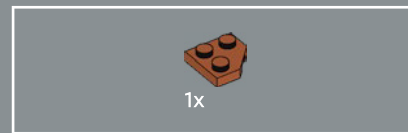
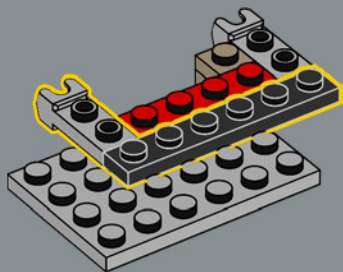

216

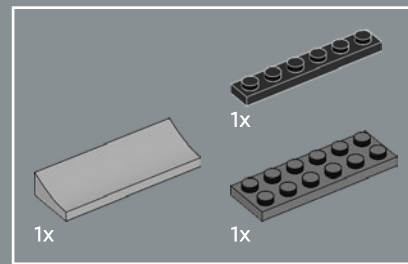
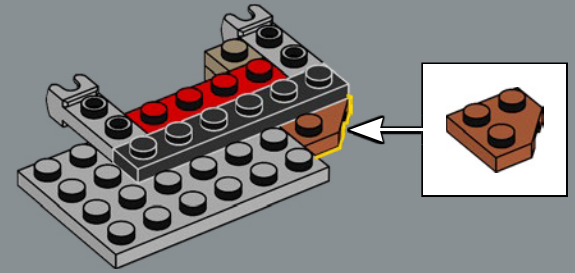

217

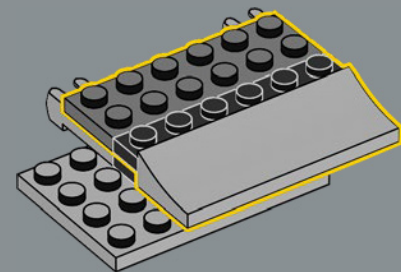



1x

218

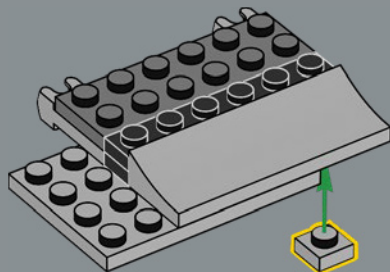

1x



1x



1x

220

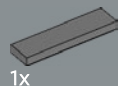
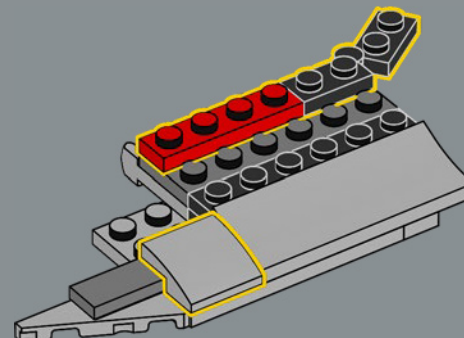

1x



1x

219

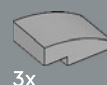
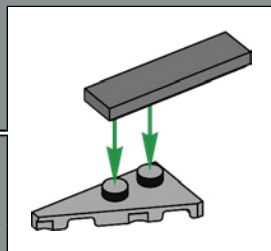
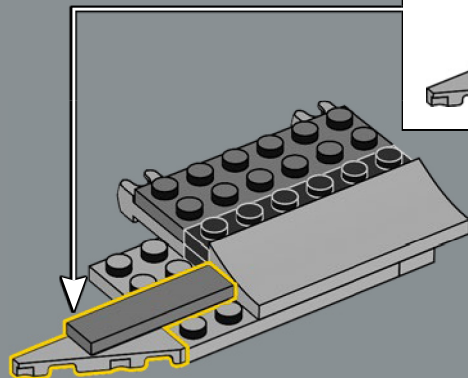

3x

221

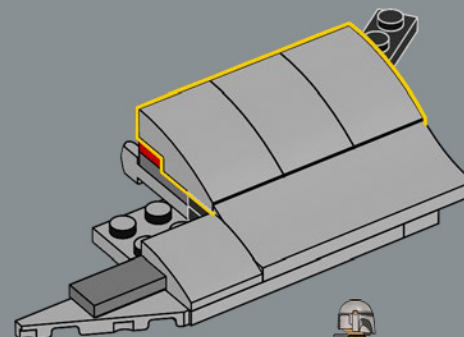

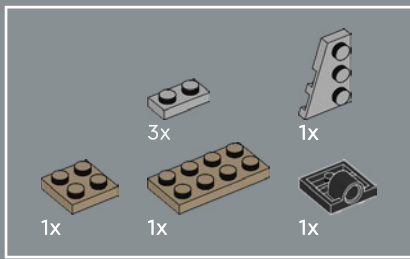

222

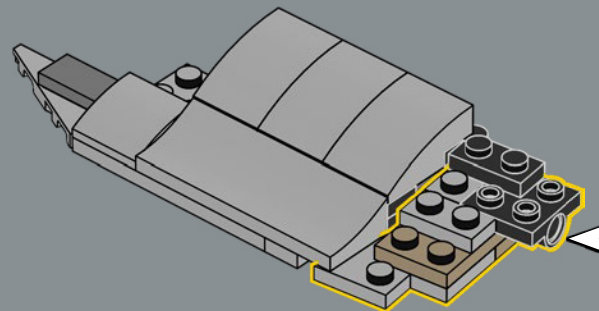
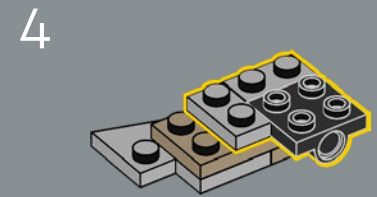
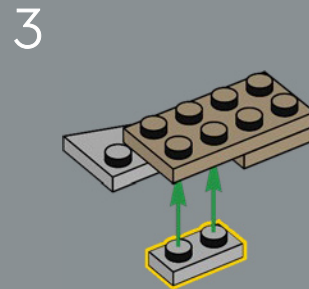
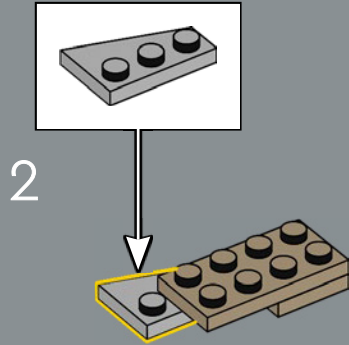
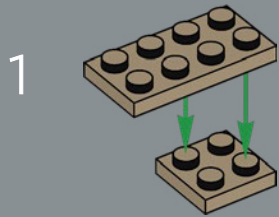

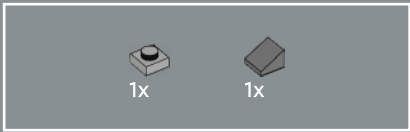

223

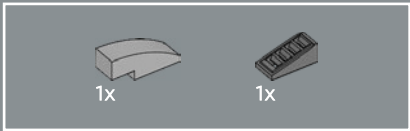
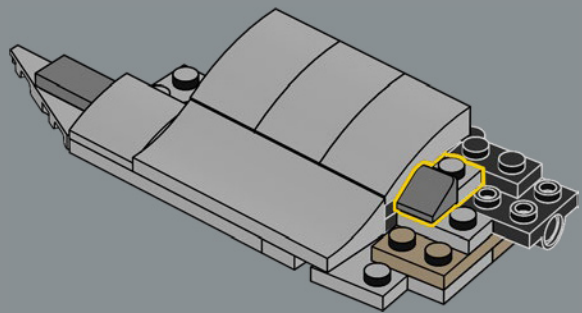

224

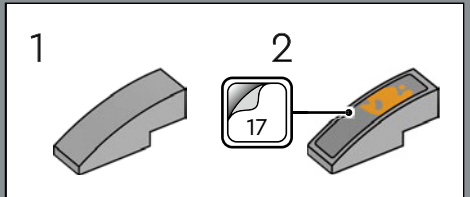
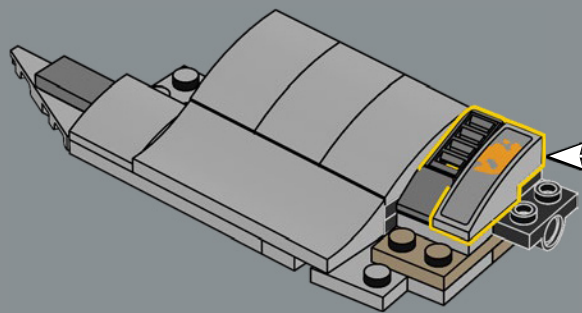

225

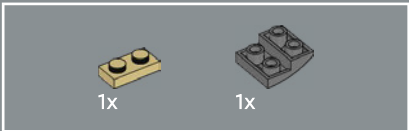
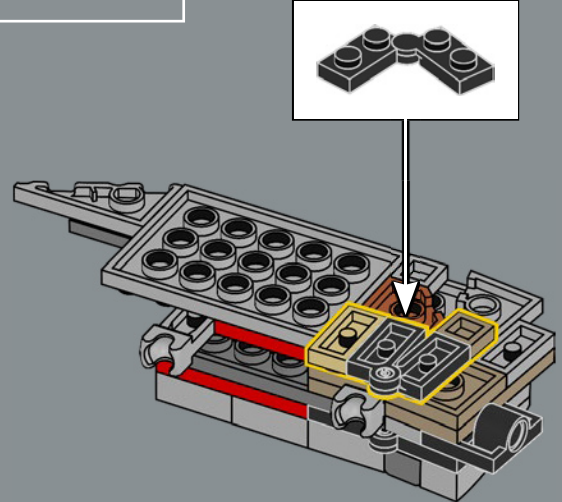

226

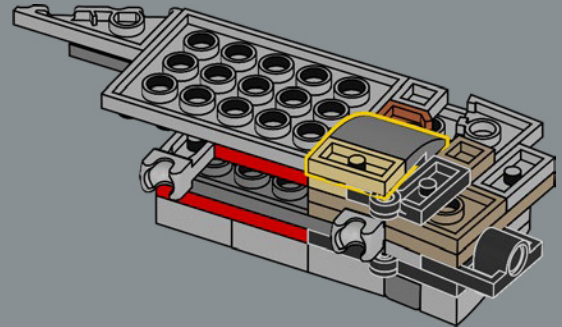

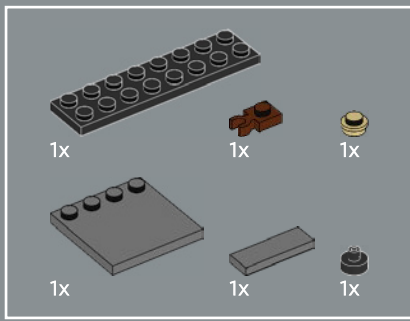

227

1

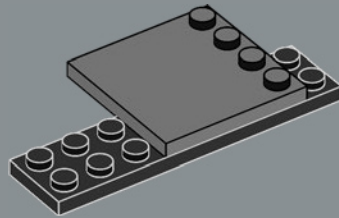

2

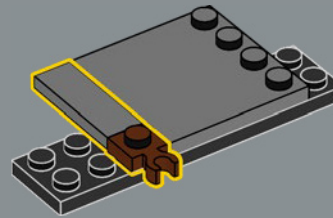

3

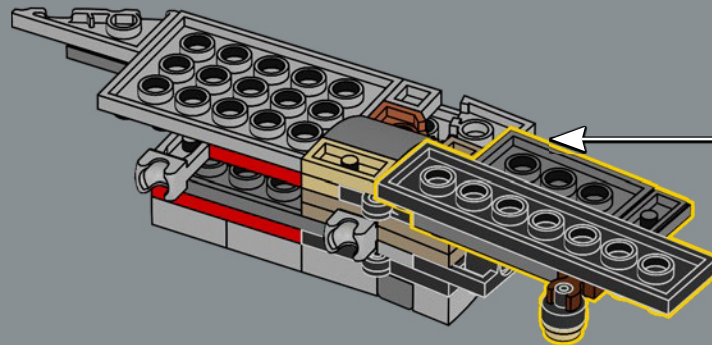
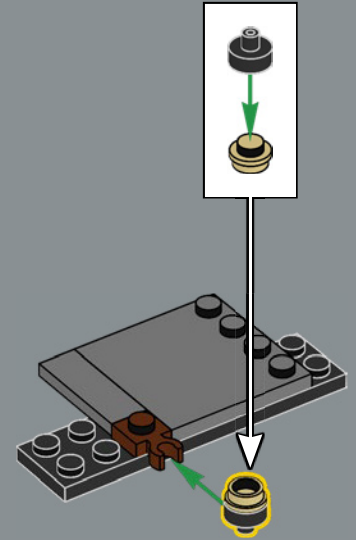

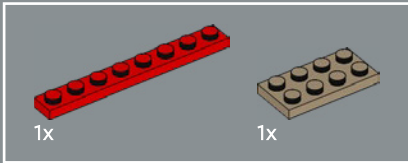
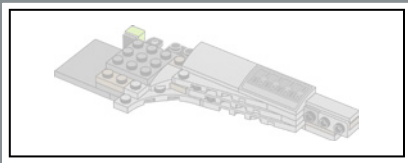

228

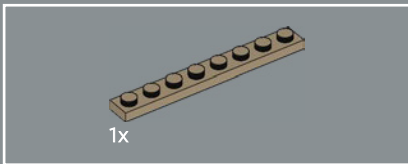
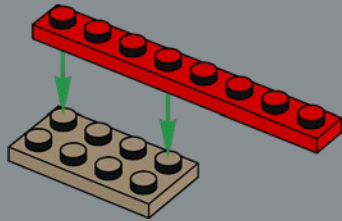

229

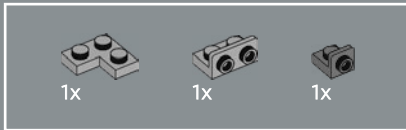
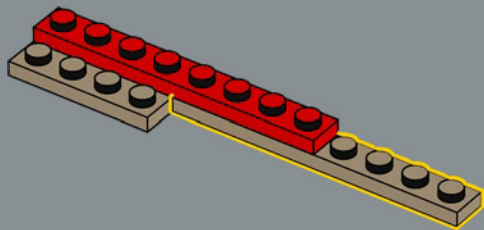

230

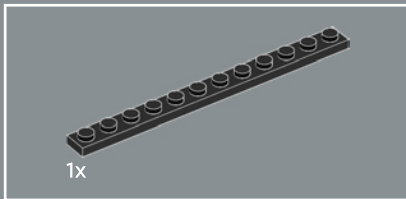
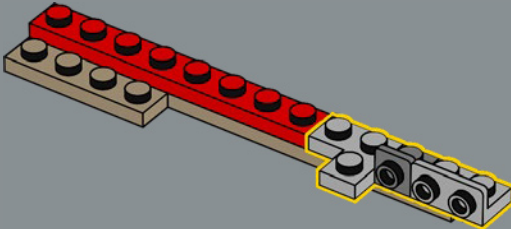

231

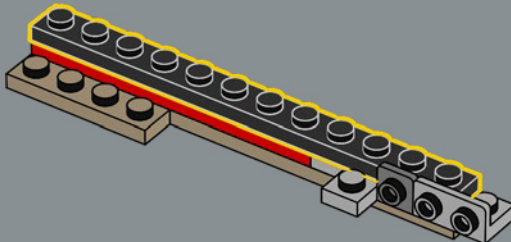



232

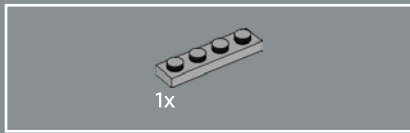
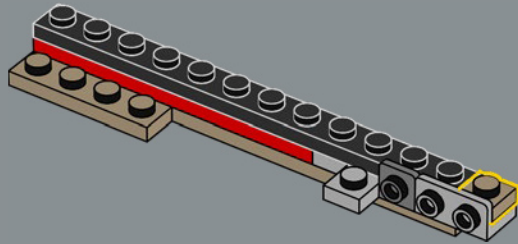

233

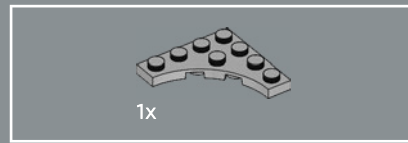
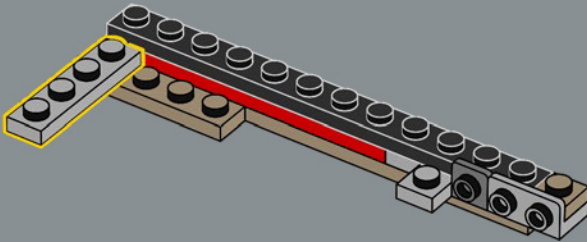

234

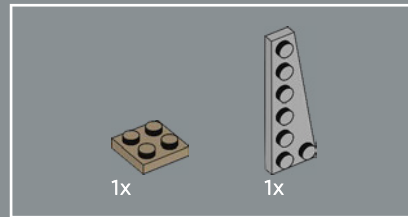
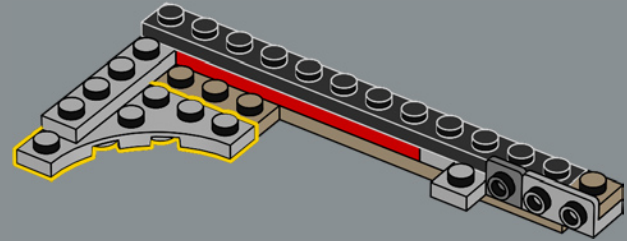

235

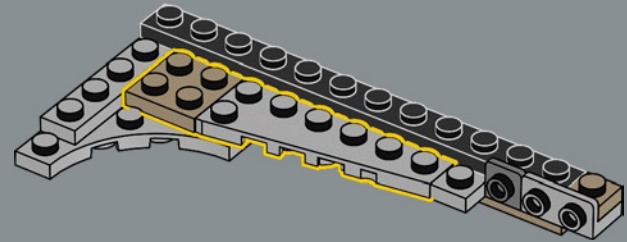

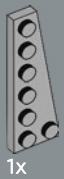

1x

236

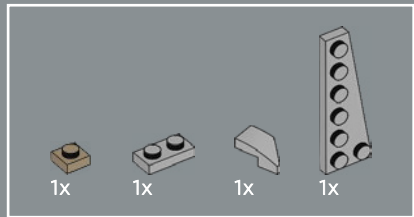
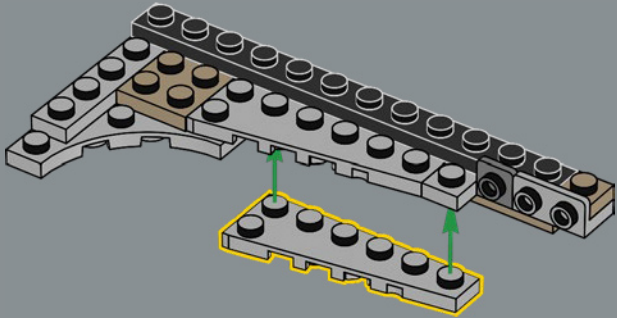

1x

1x

1x

1x

237

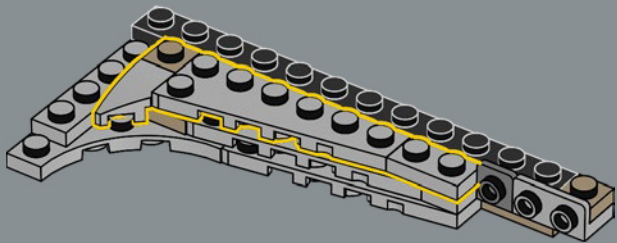

1x

238

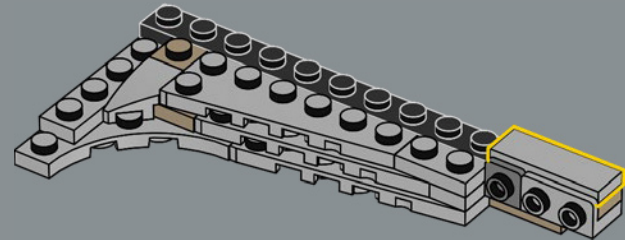

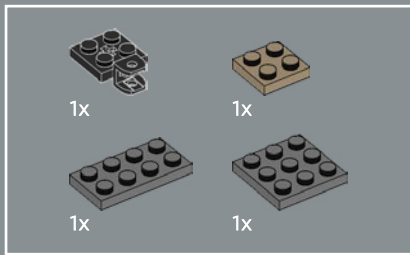

239

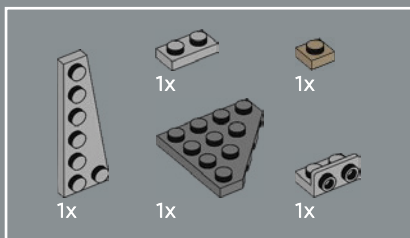
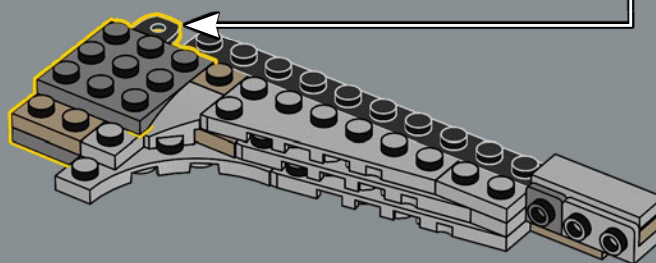
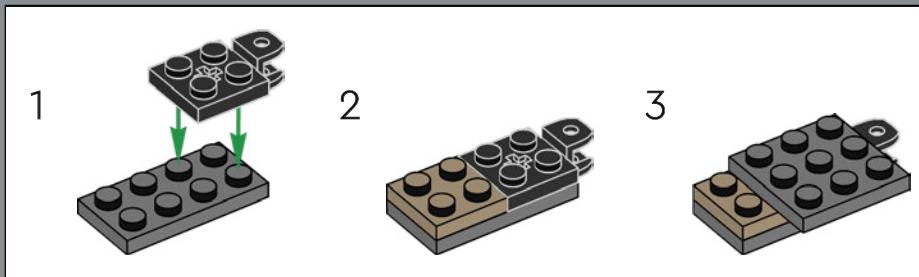

240

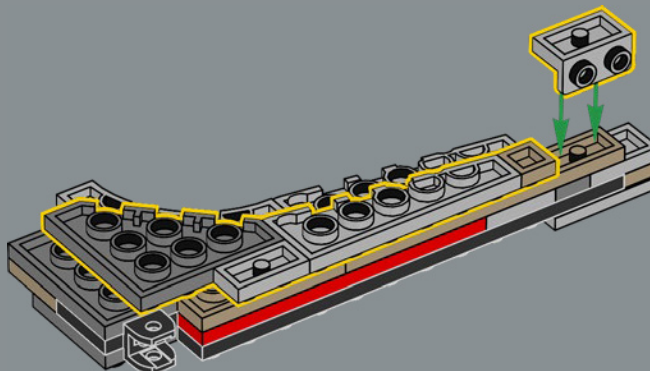

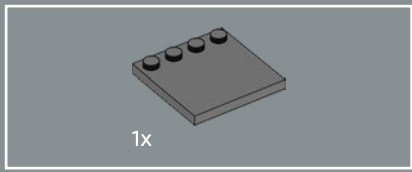

241

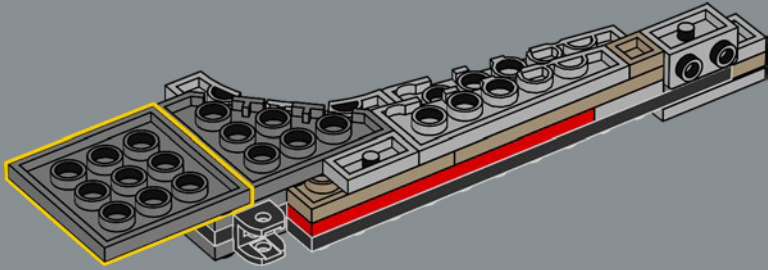

242

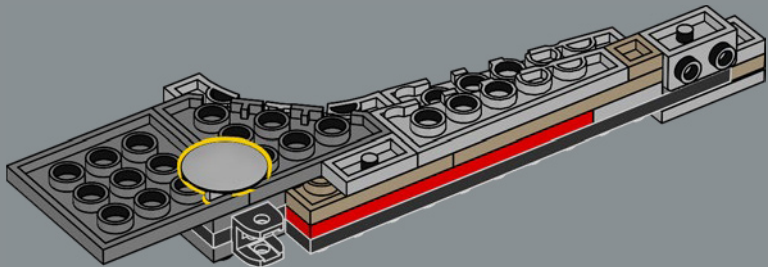

243

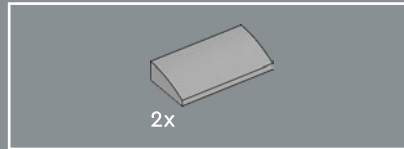
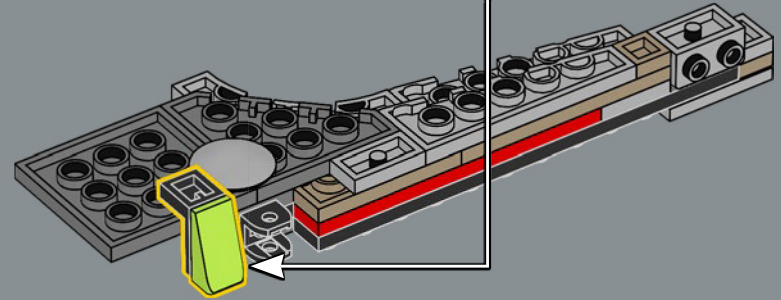
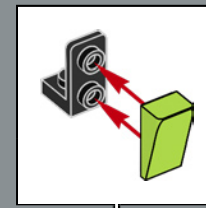

244

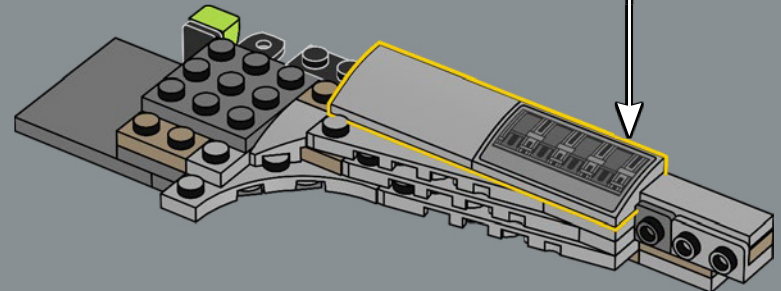
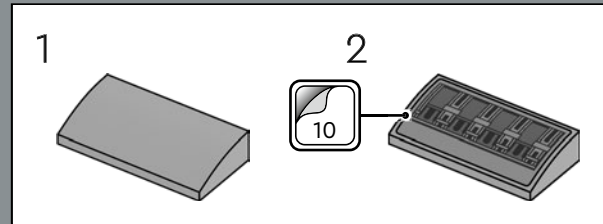

245

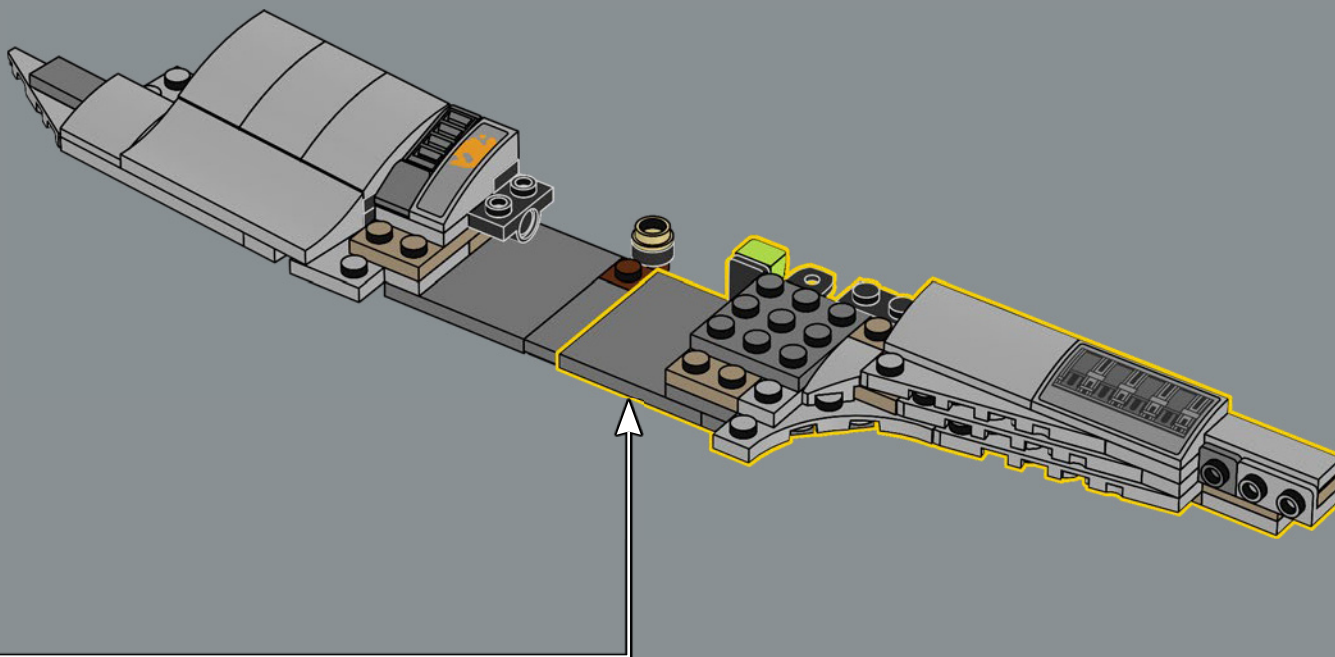

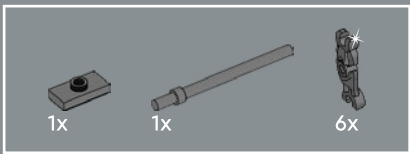

246

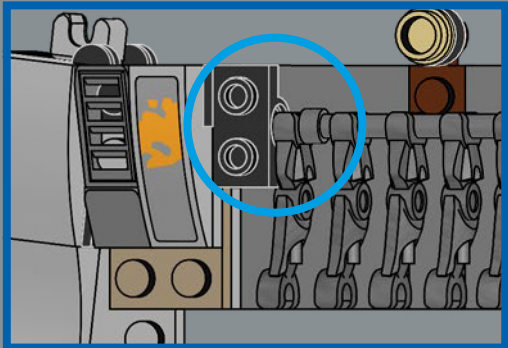
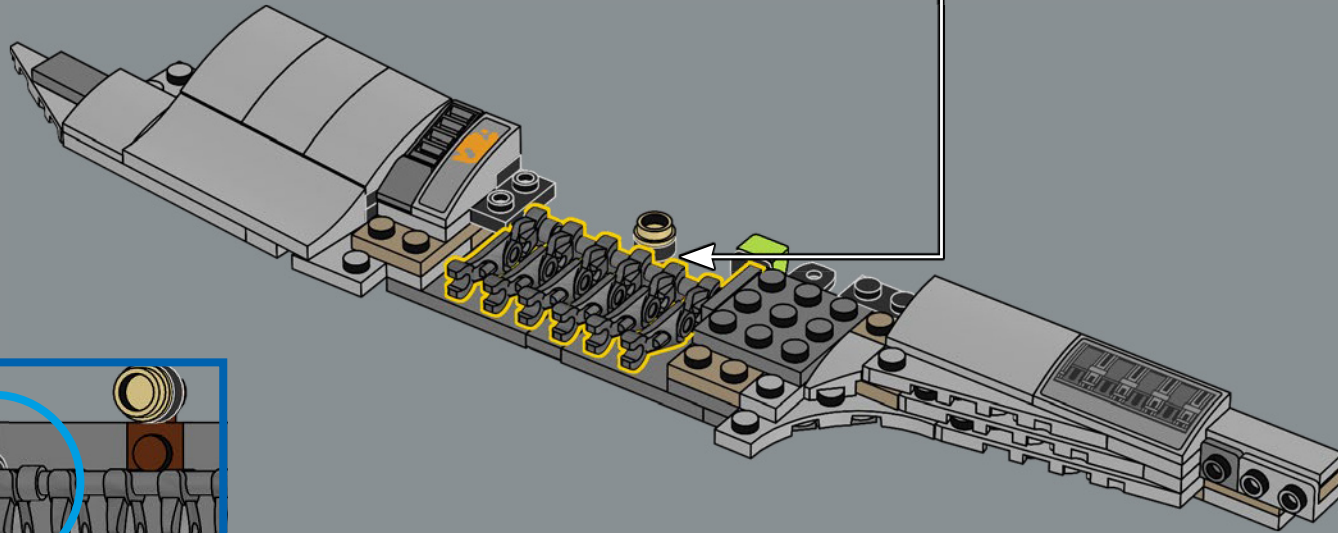
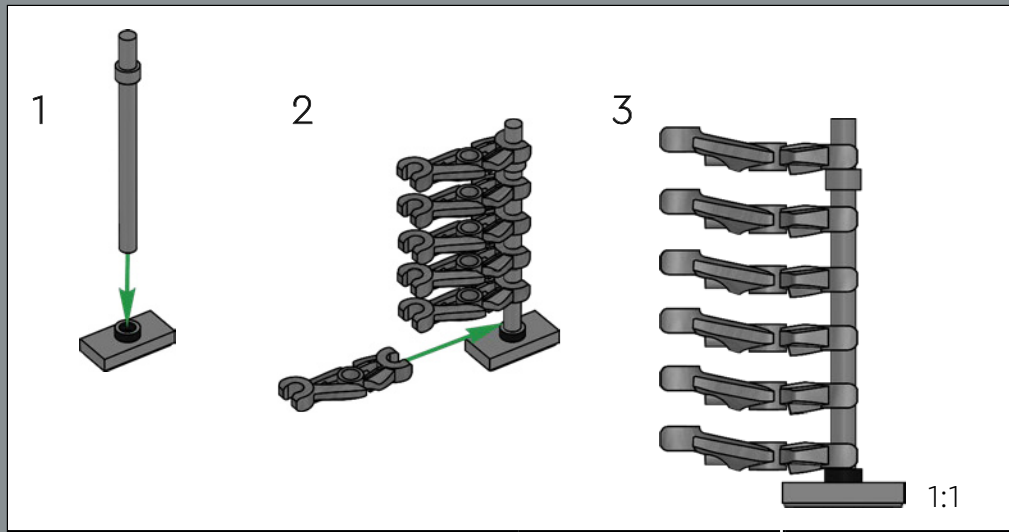

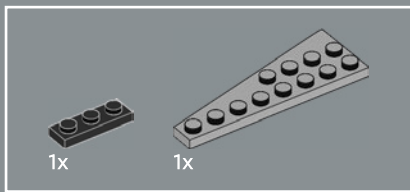

247

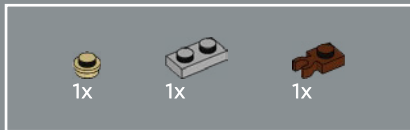
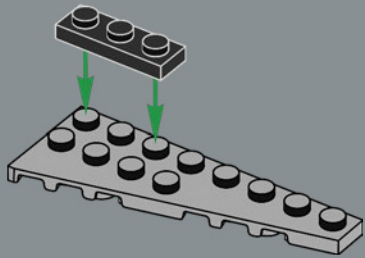

248

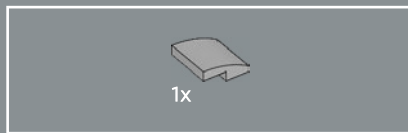
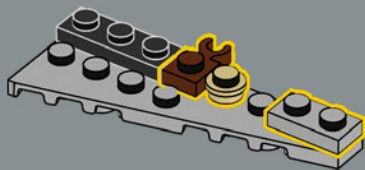

249

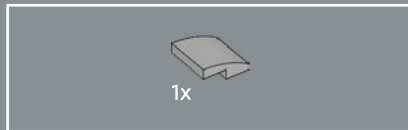
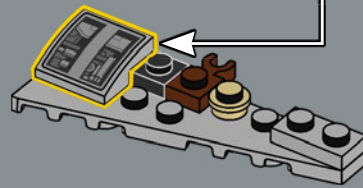
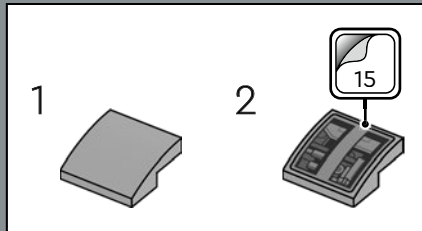

250

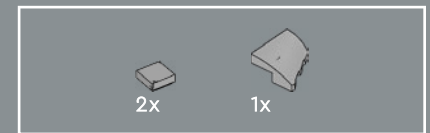
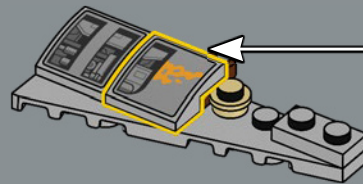
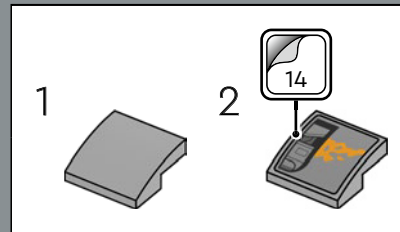

251

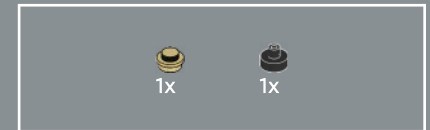
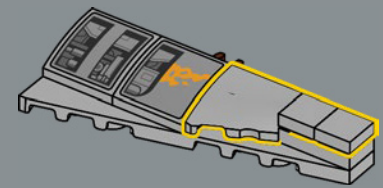

252

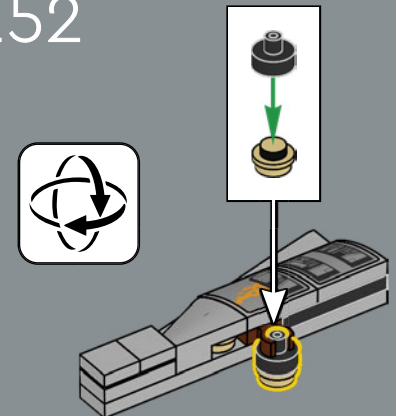

253

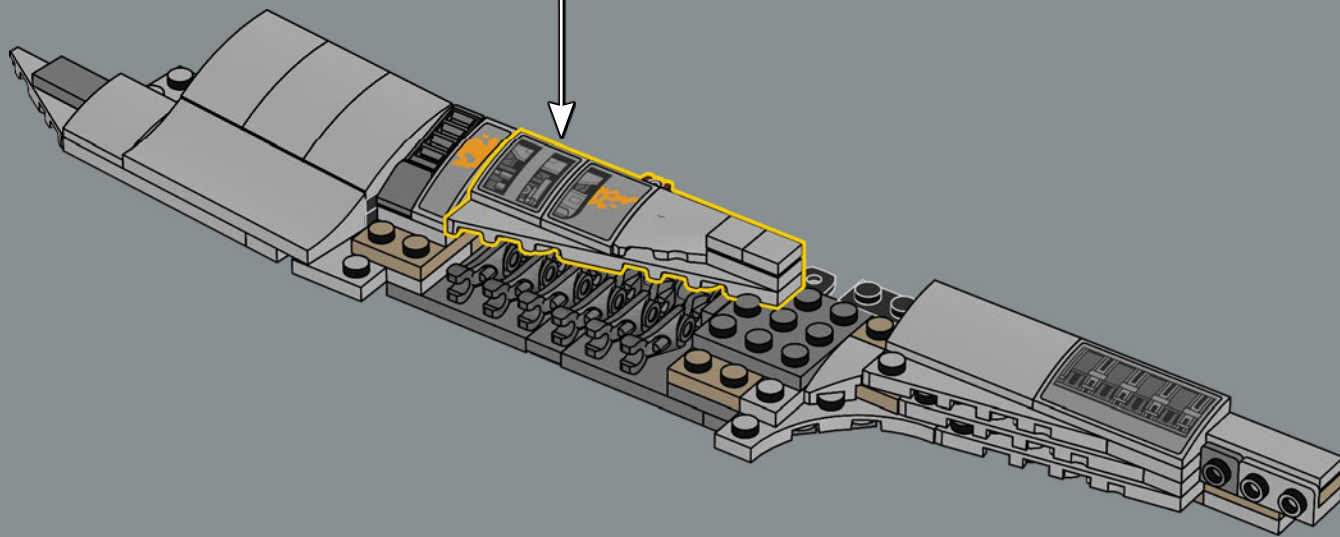

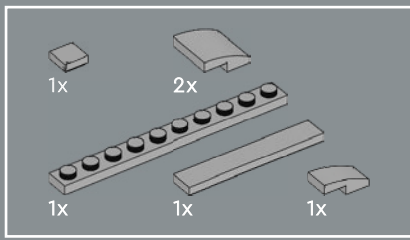

254

1

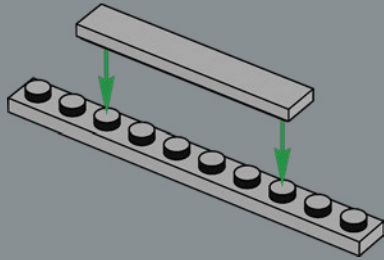

2

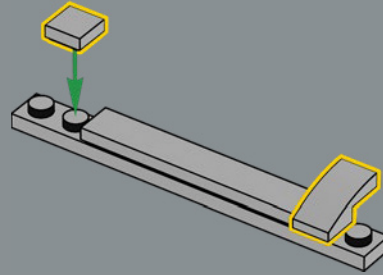

3

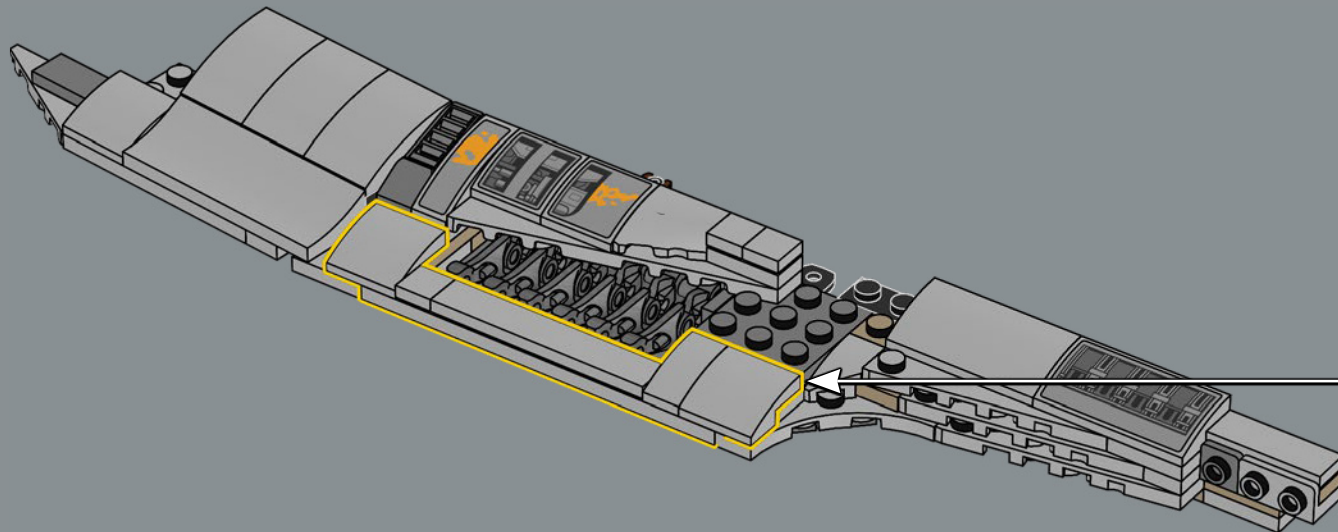
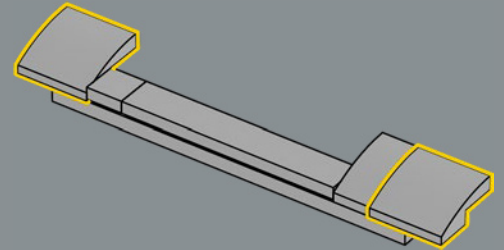

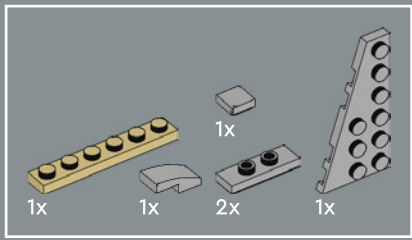

255

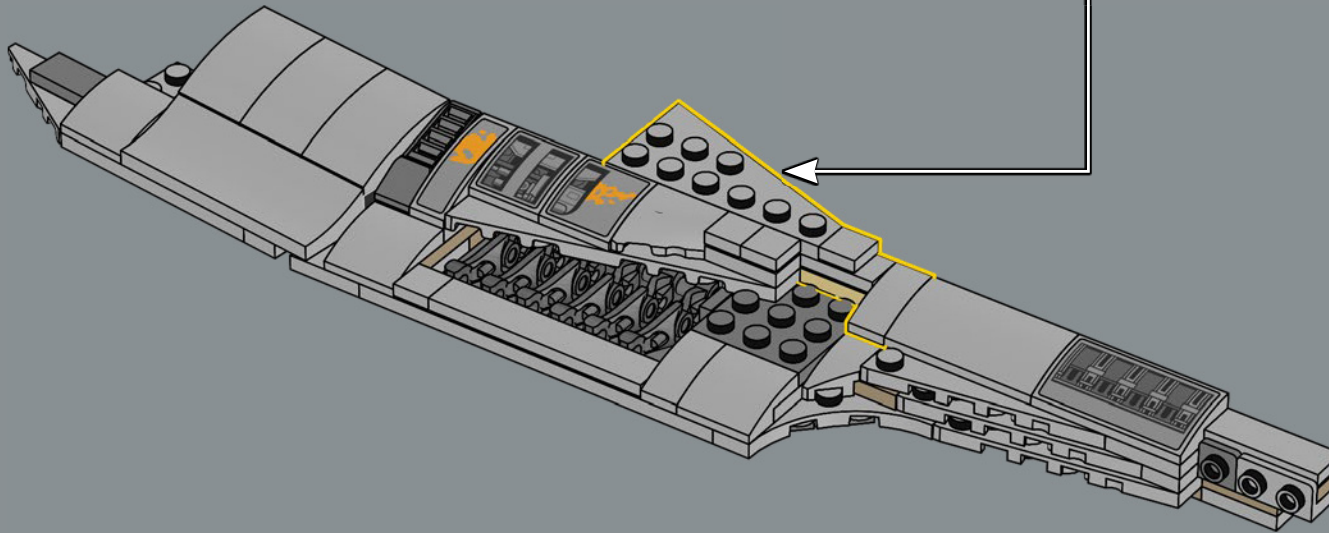
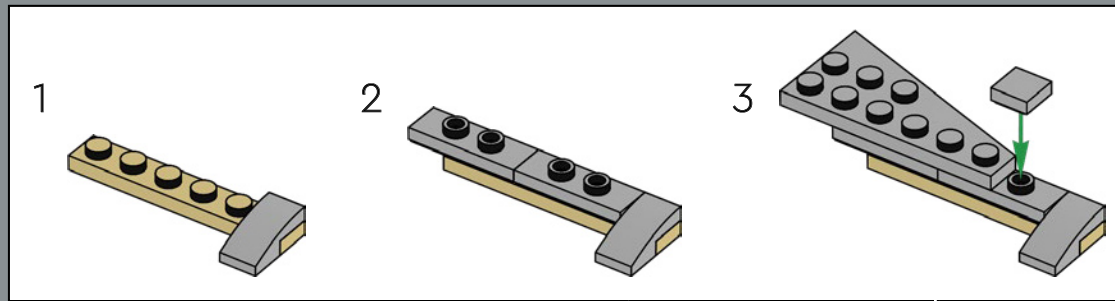

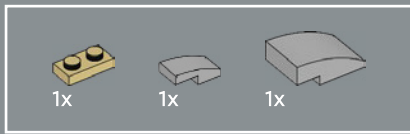

256

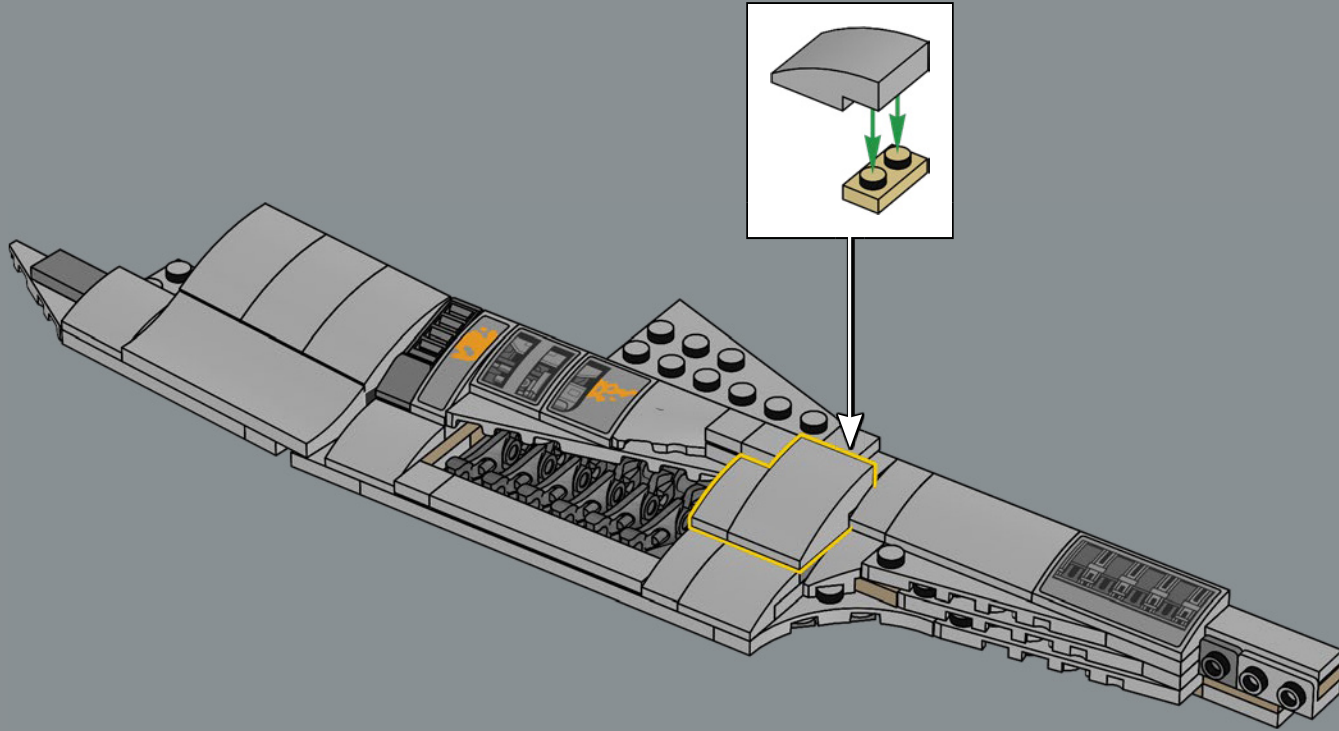

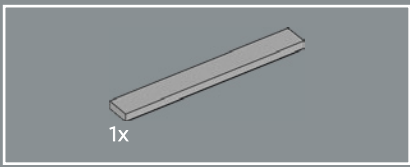

257

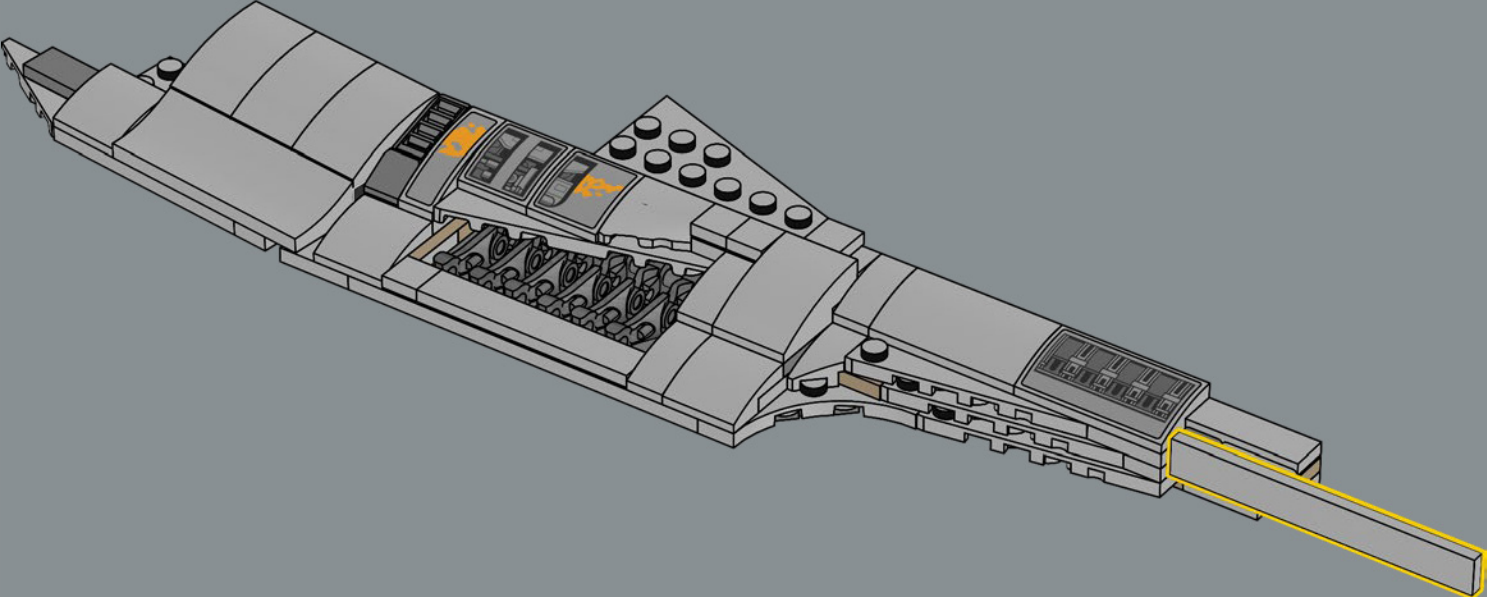

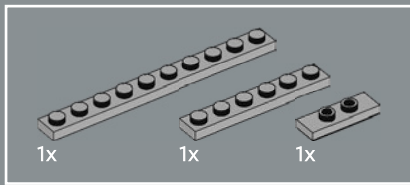

258

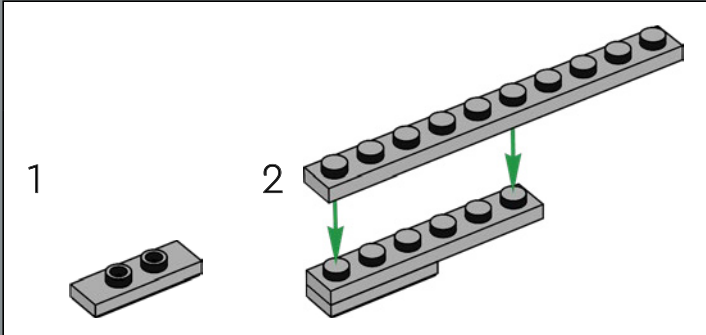
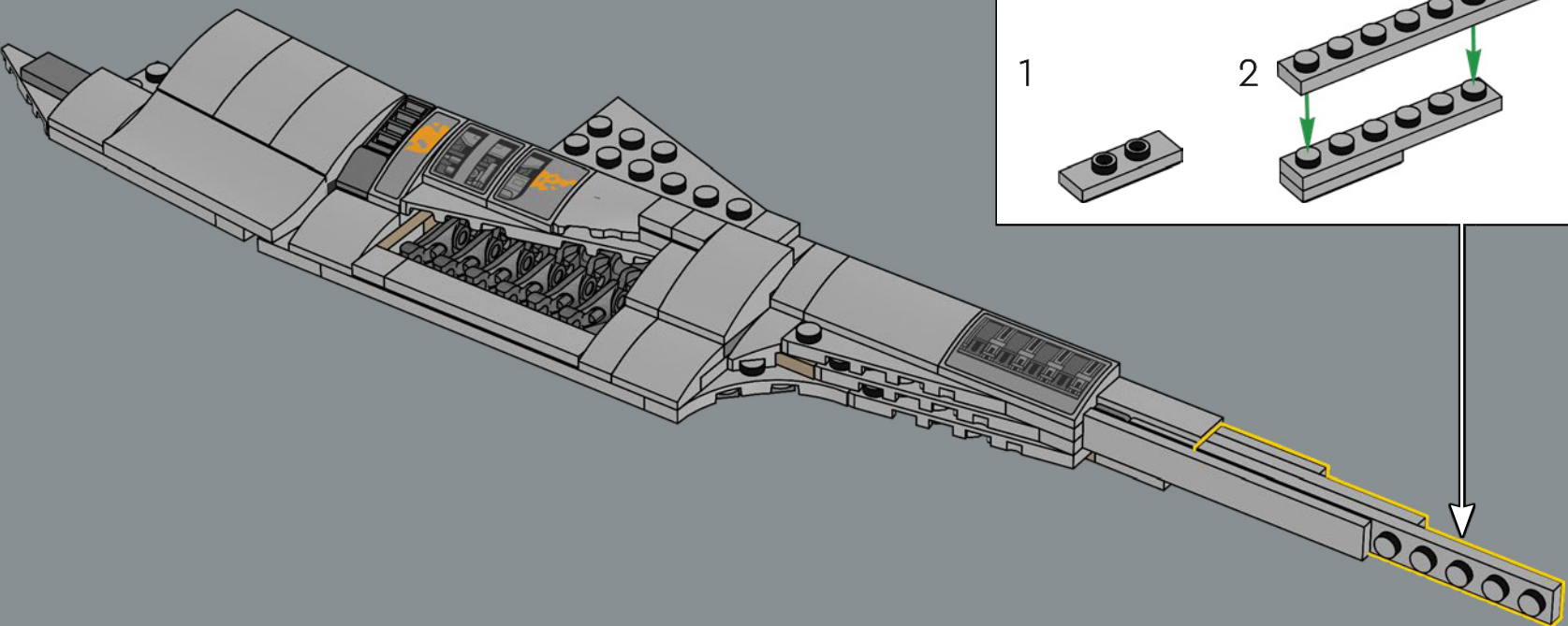

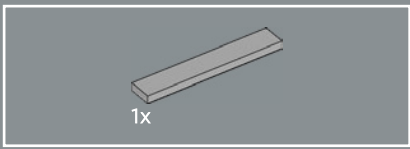

259

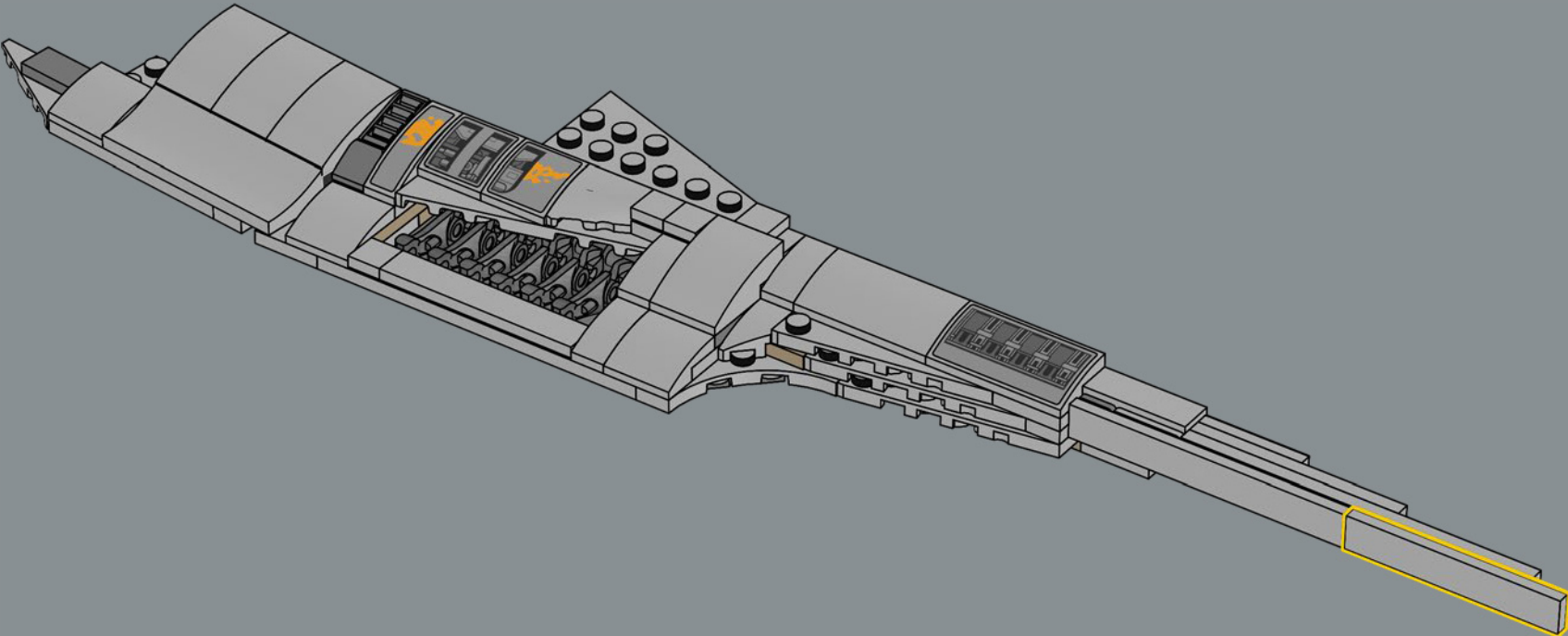

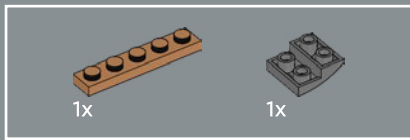

260

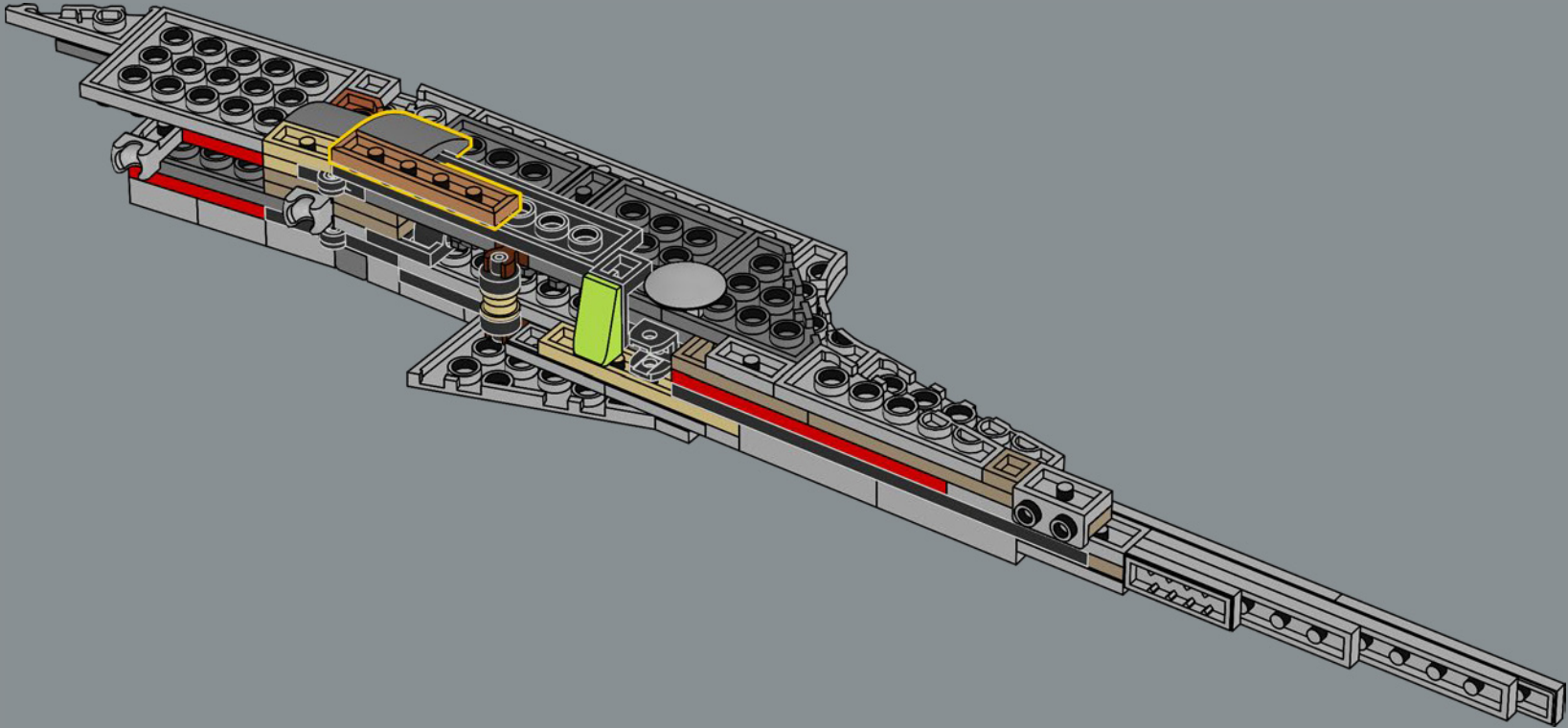

261

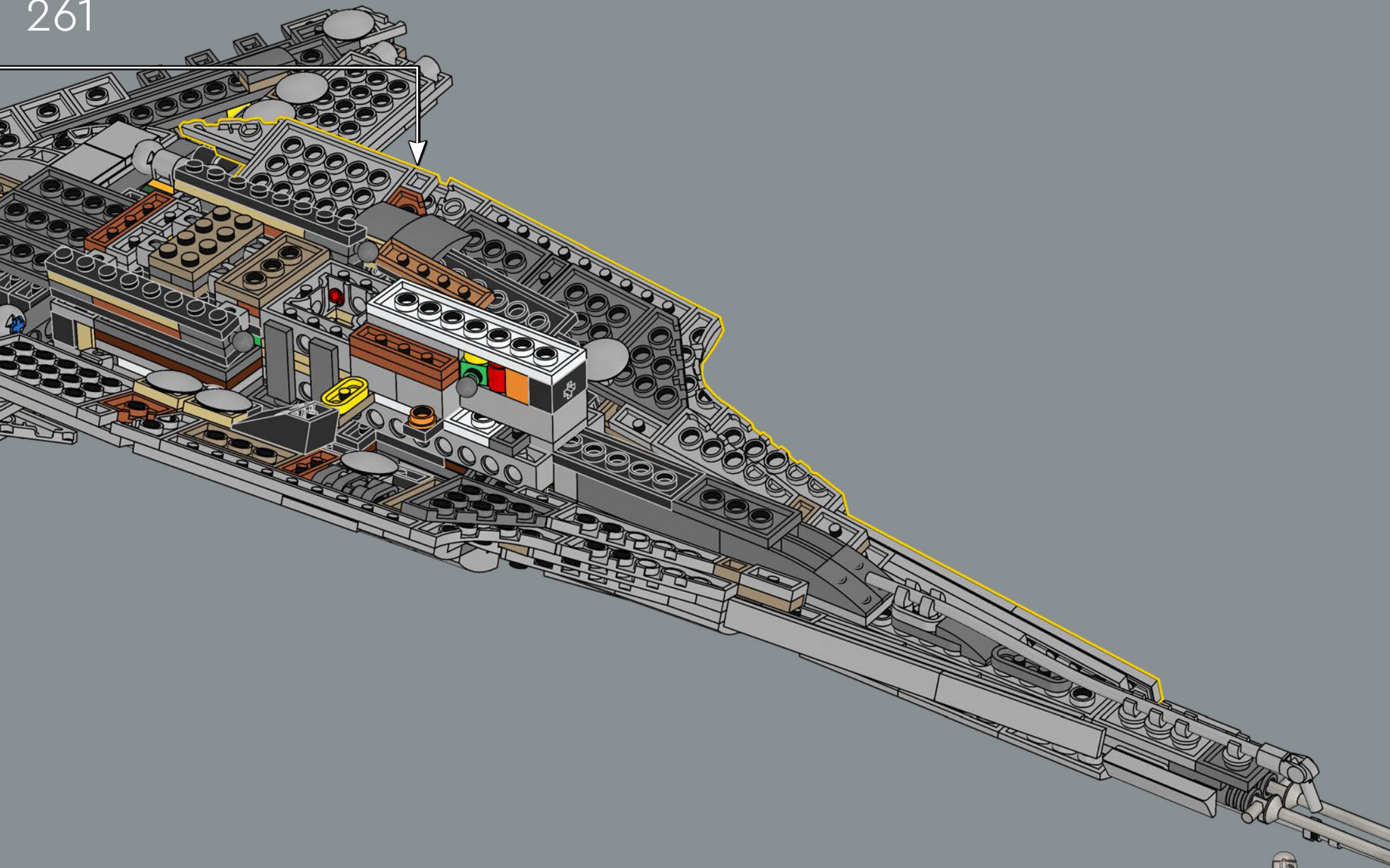

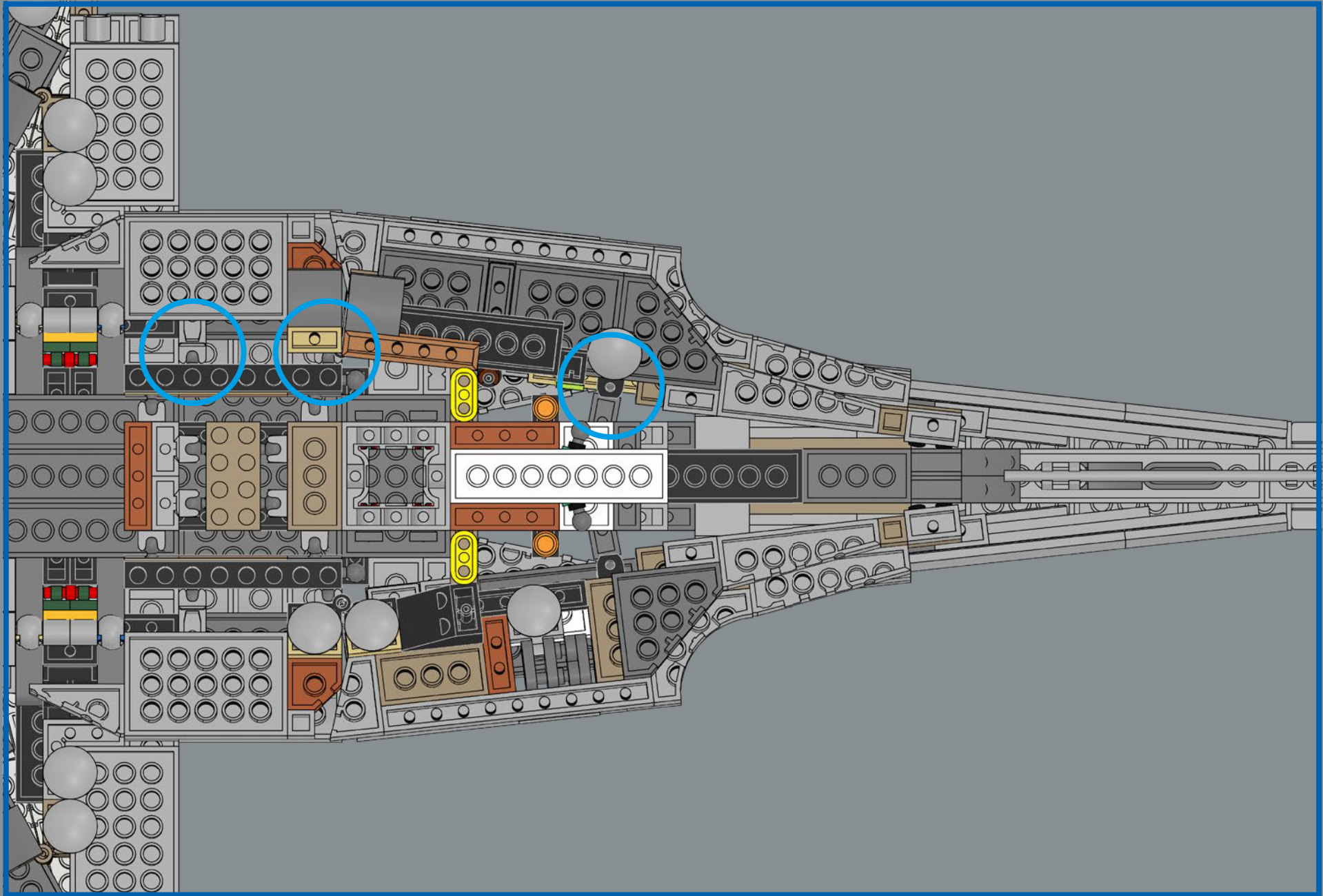



262

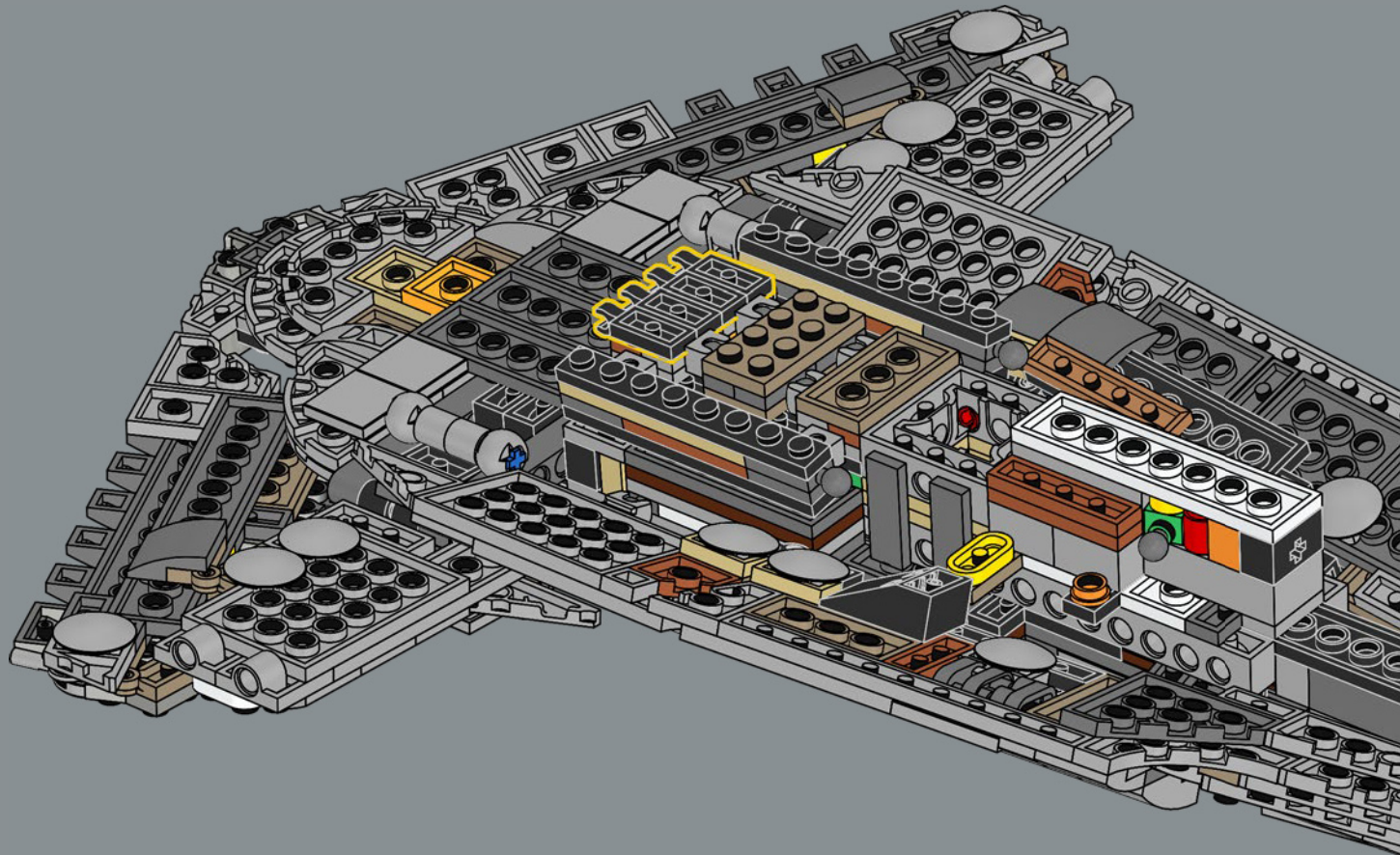

263

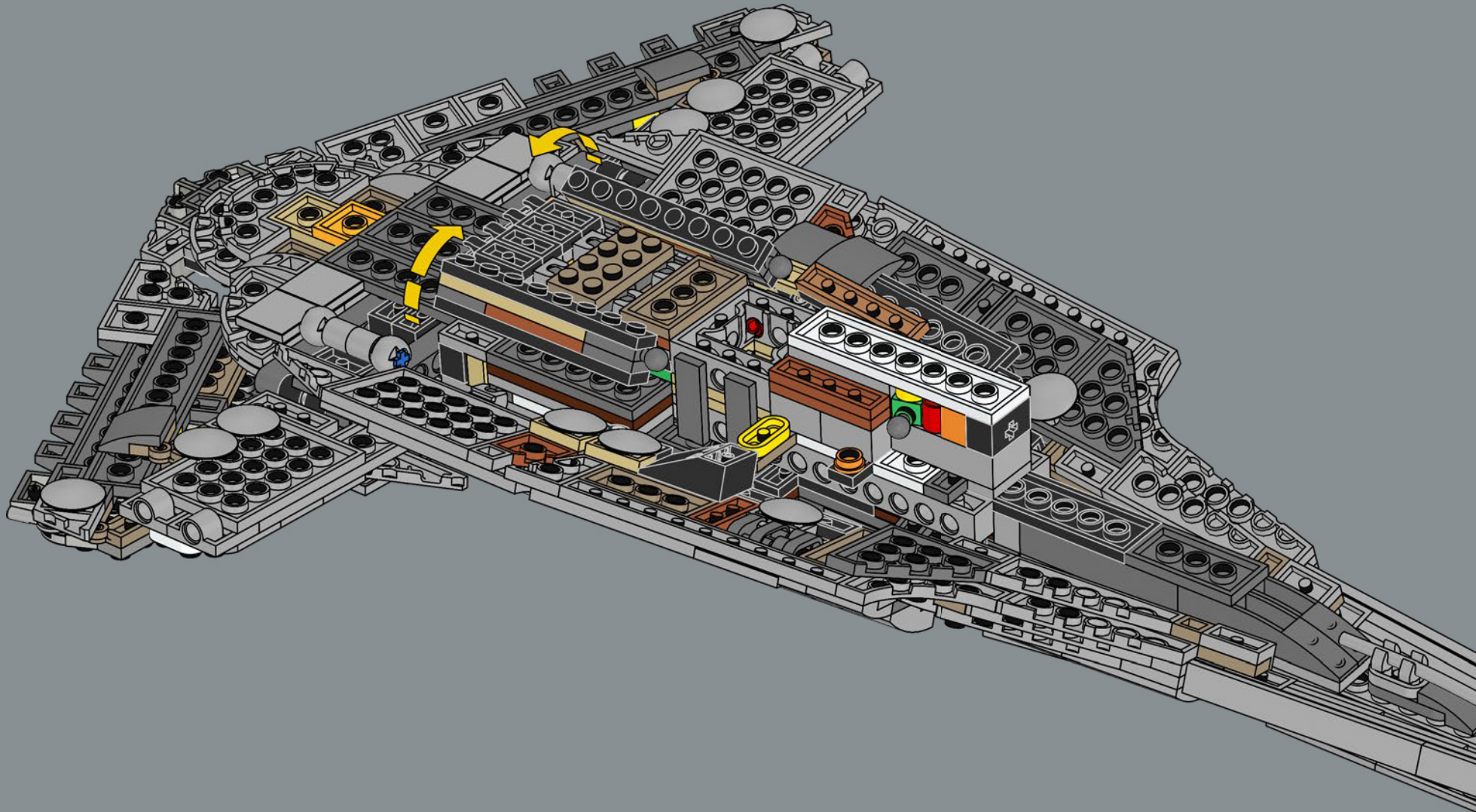

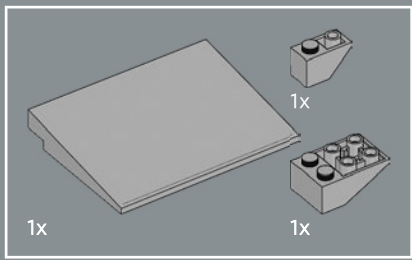

264

1

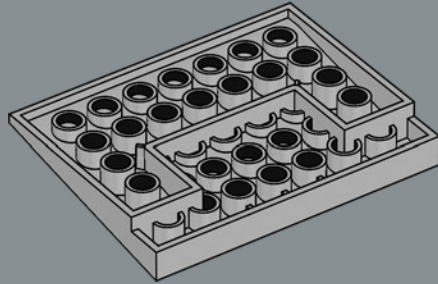

2

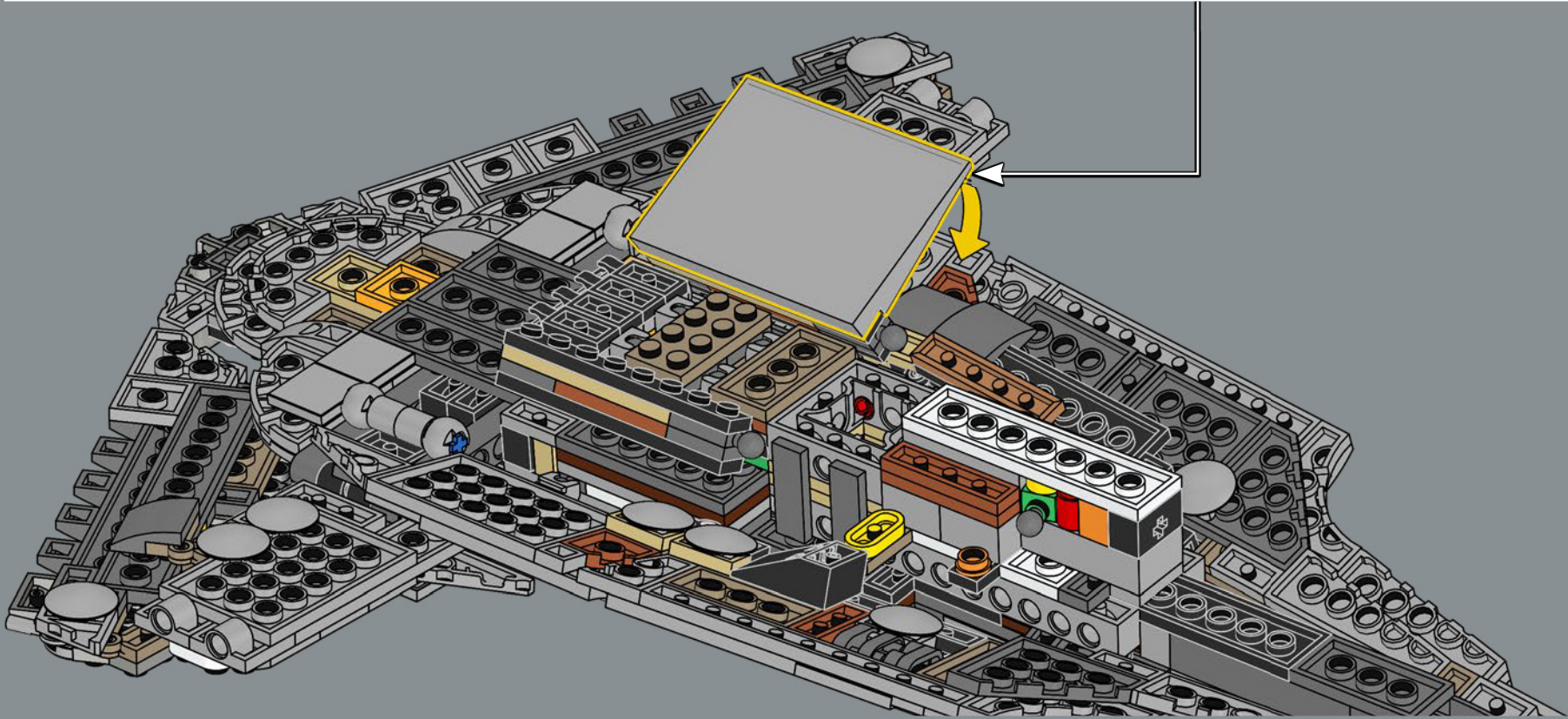
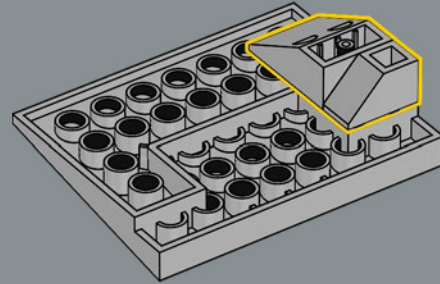

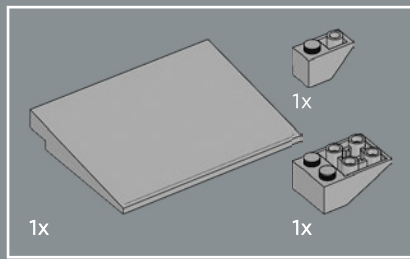

265

1

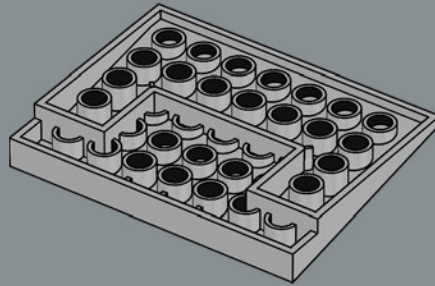

2

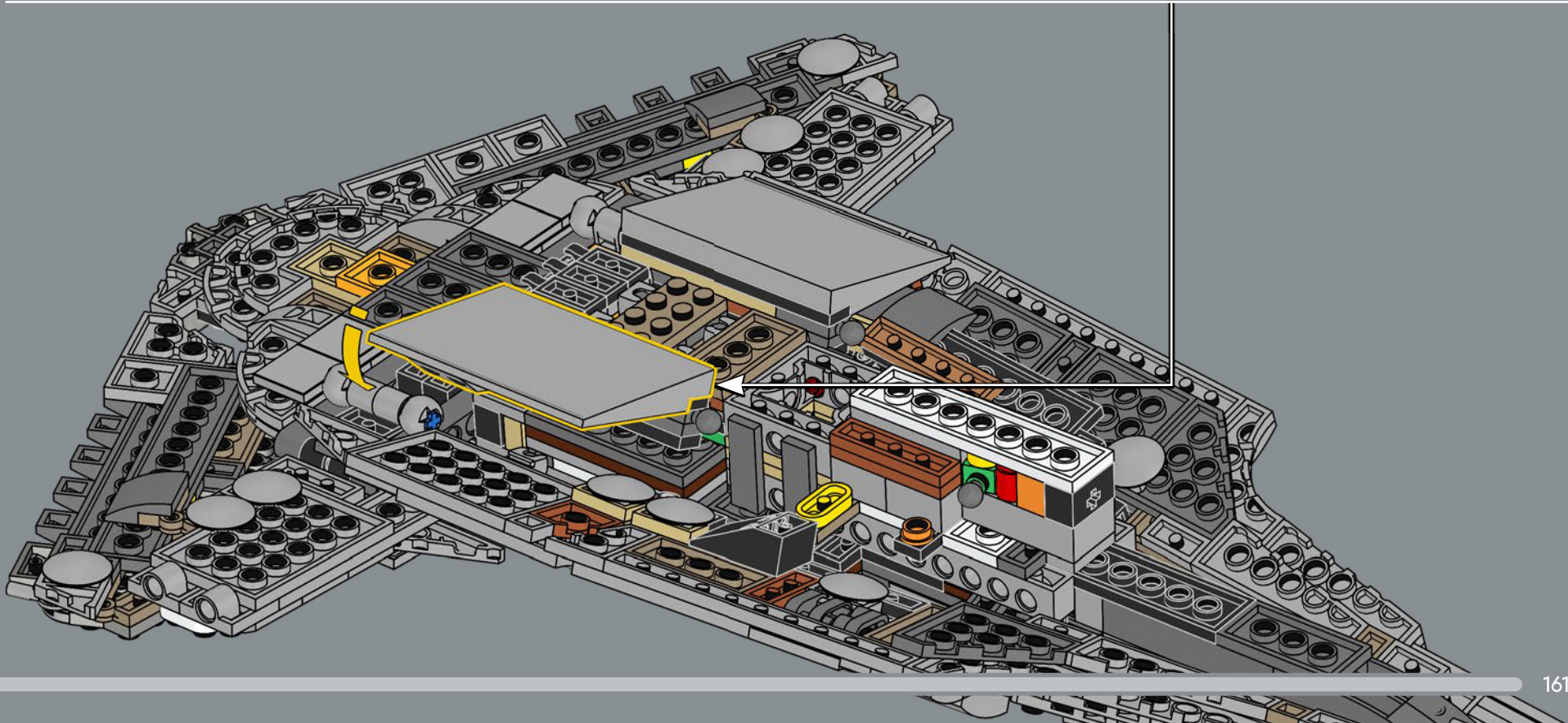
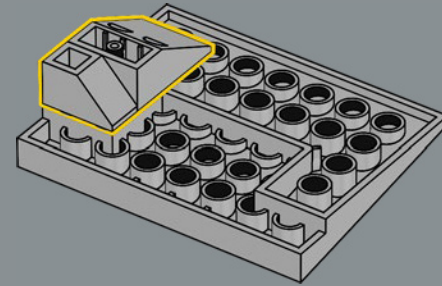

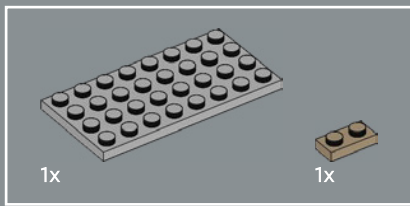

266

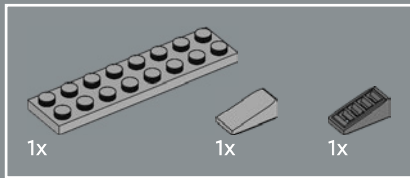
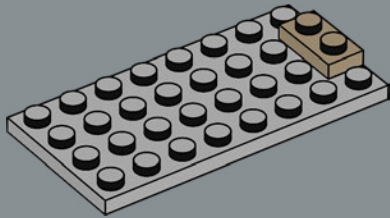

267

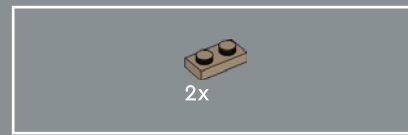
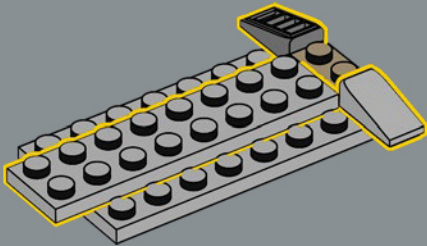

268

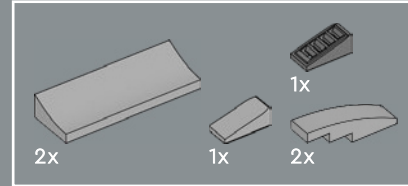
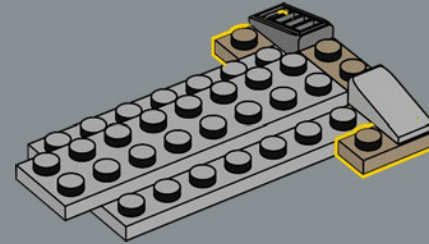

269

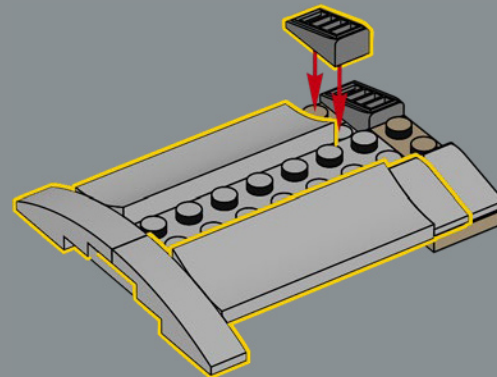

270

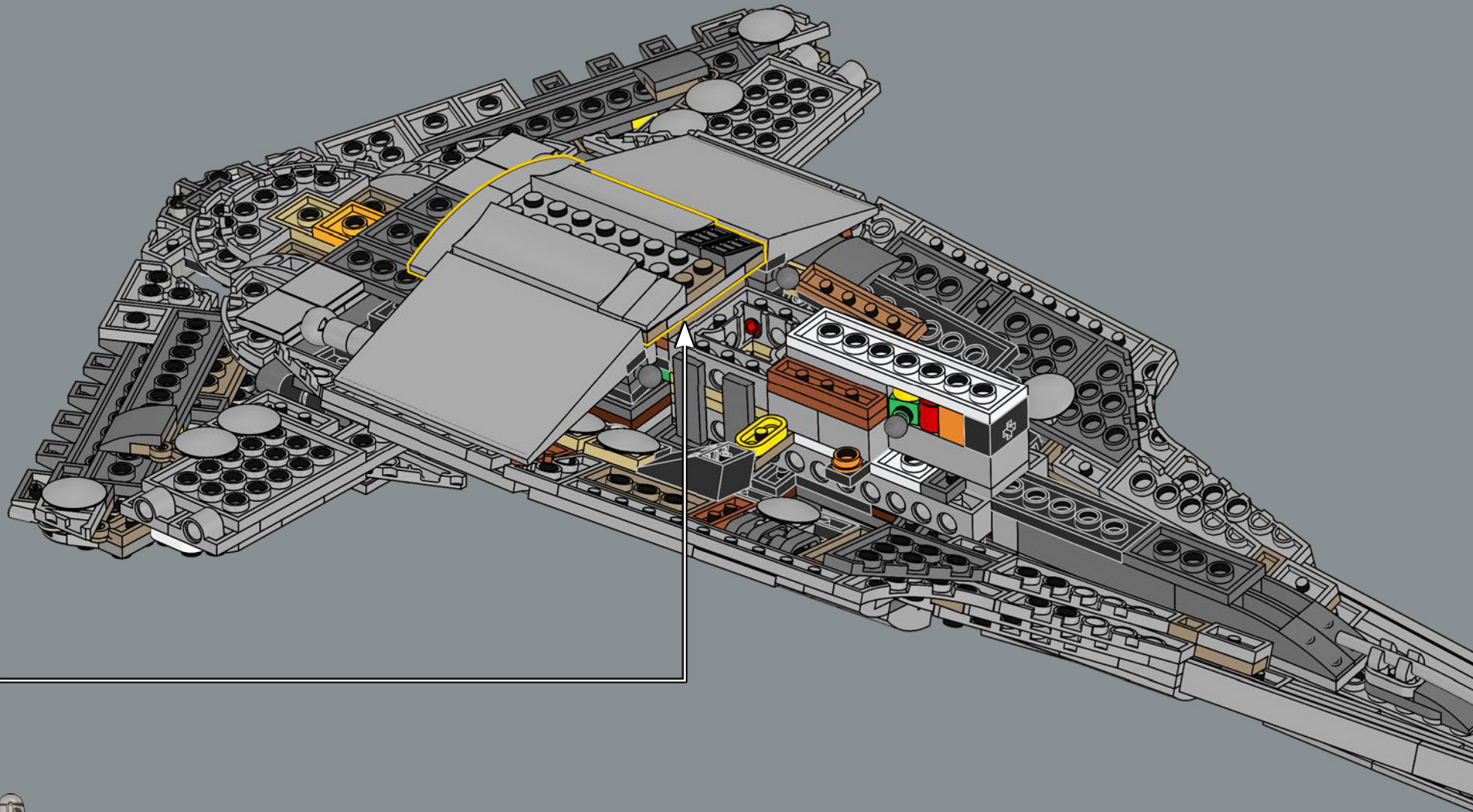

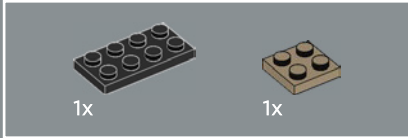
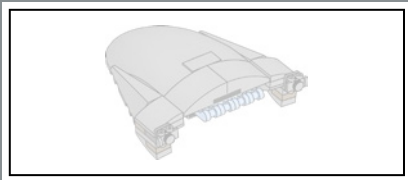

271

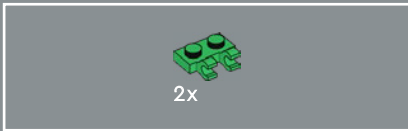
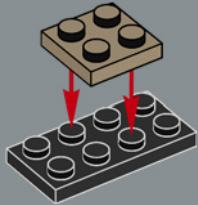

272

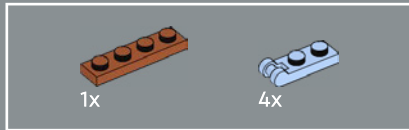
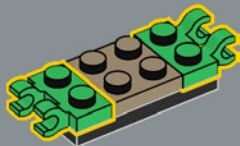

273

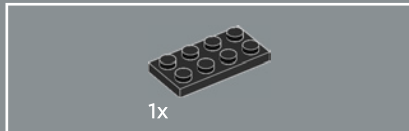
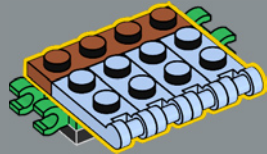

274

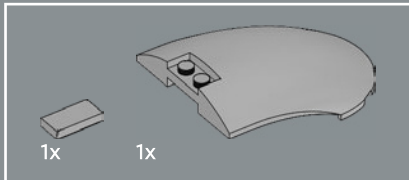
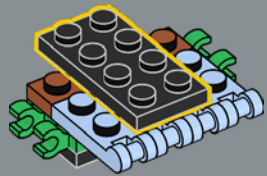

275

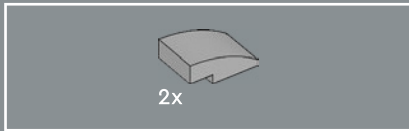
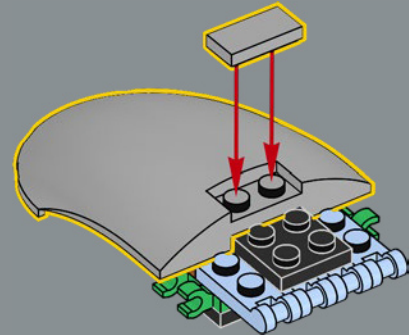

276

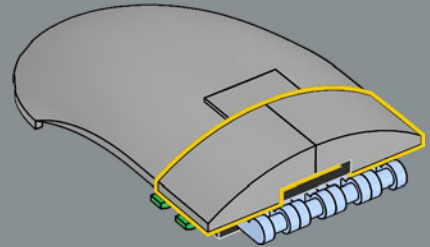



277

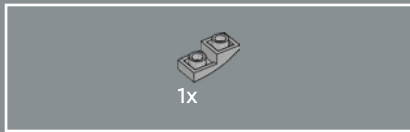
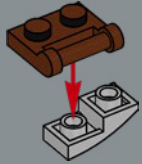

278

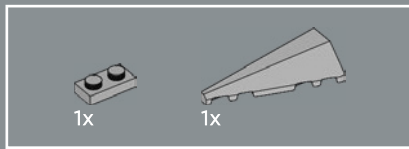
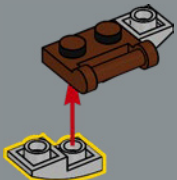

279

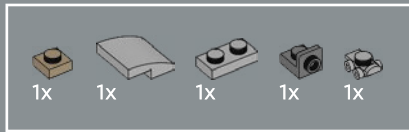
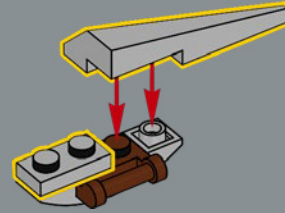

280

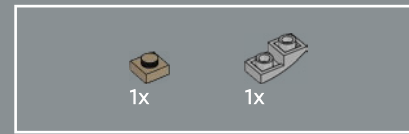
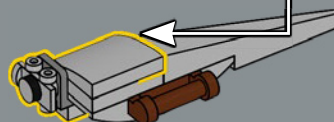
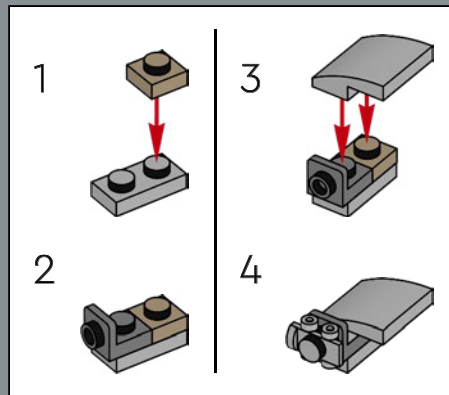

281

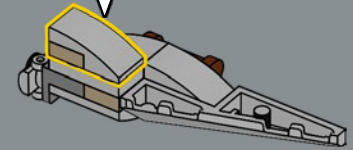
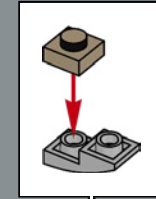

282

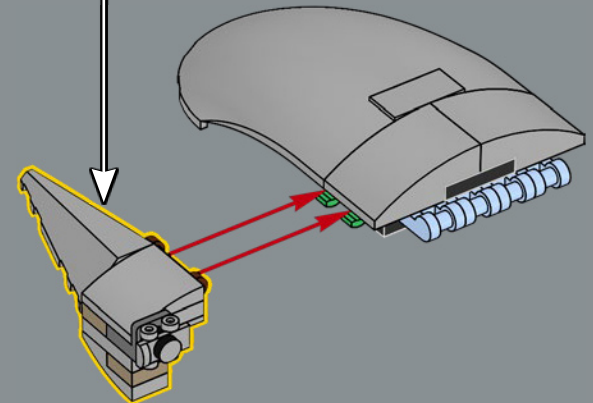



283

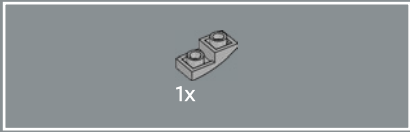
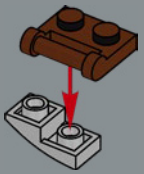

284

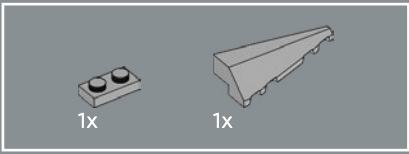
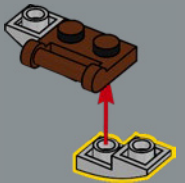

285

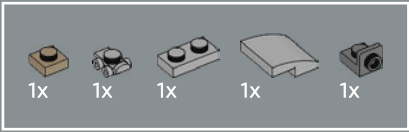
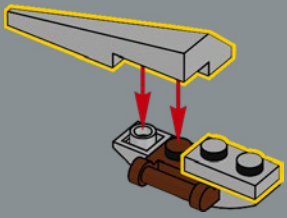

286

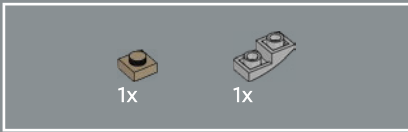
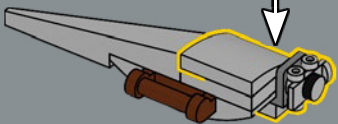
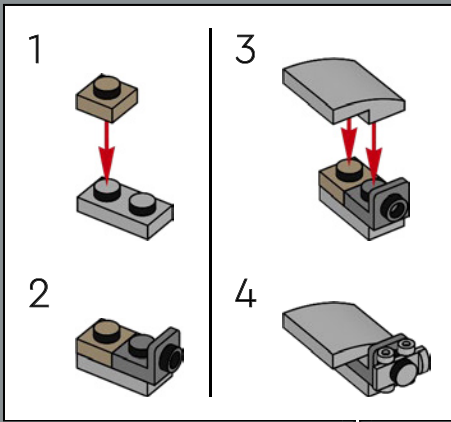

287

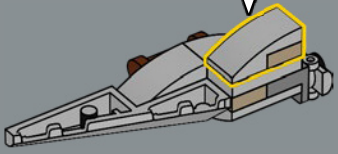
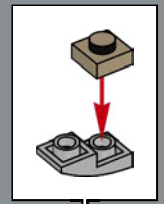

288

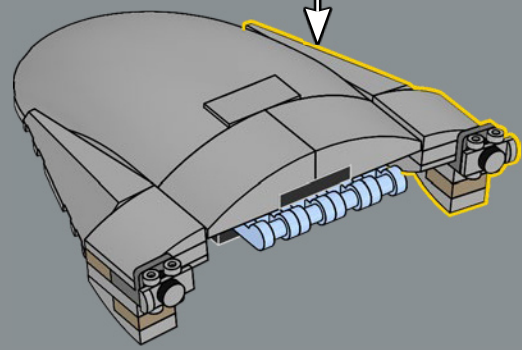

289

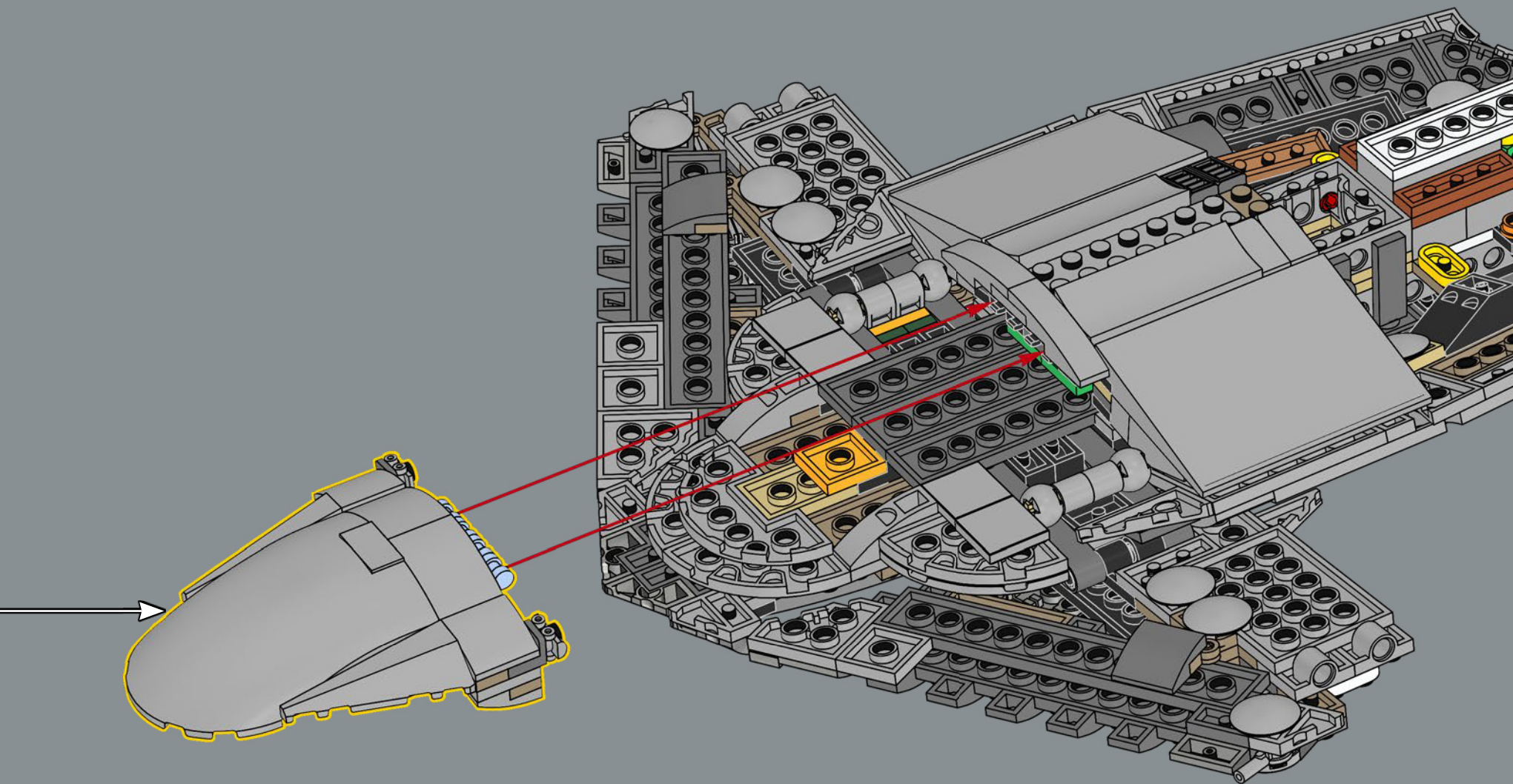

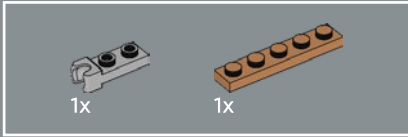
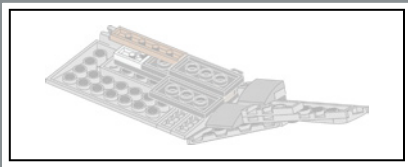

290

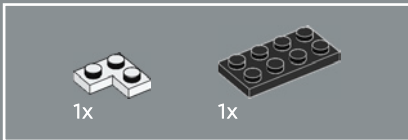
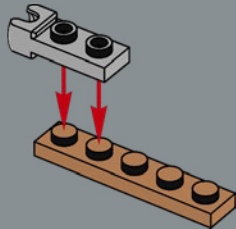

291

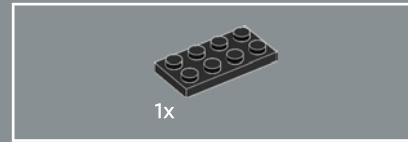
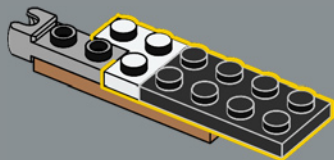

292

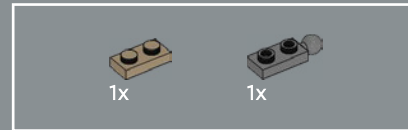
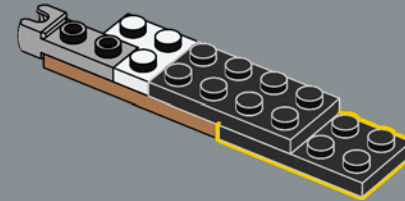

293

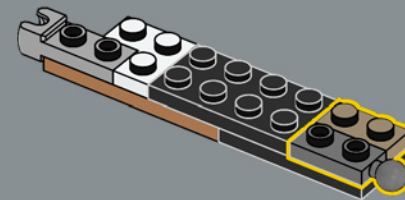

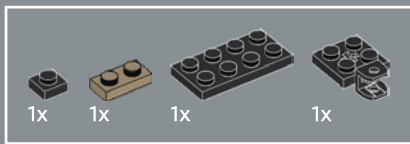

294

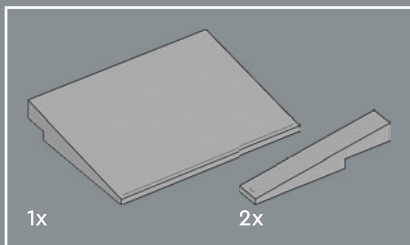
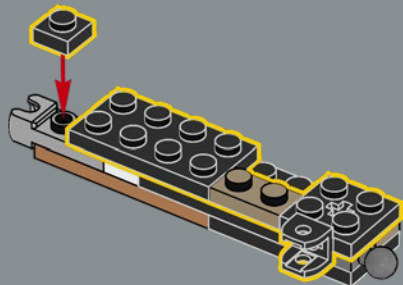

295

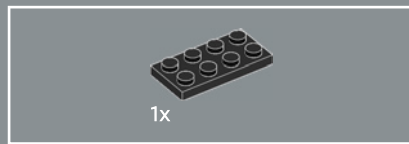
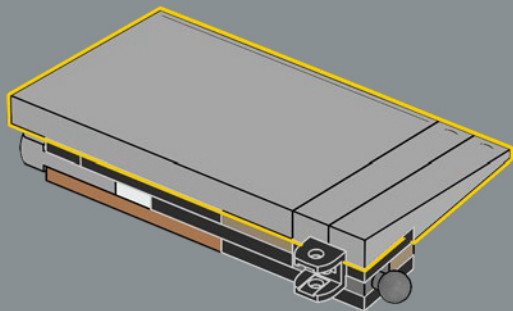

296

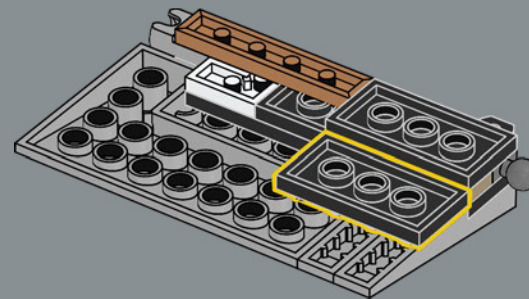

298

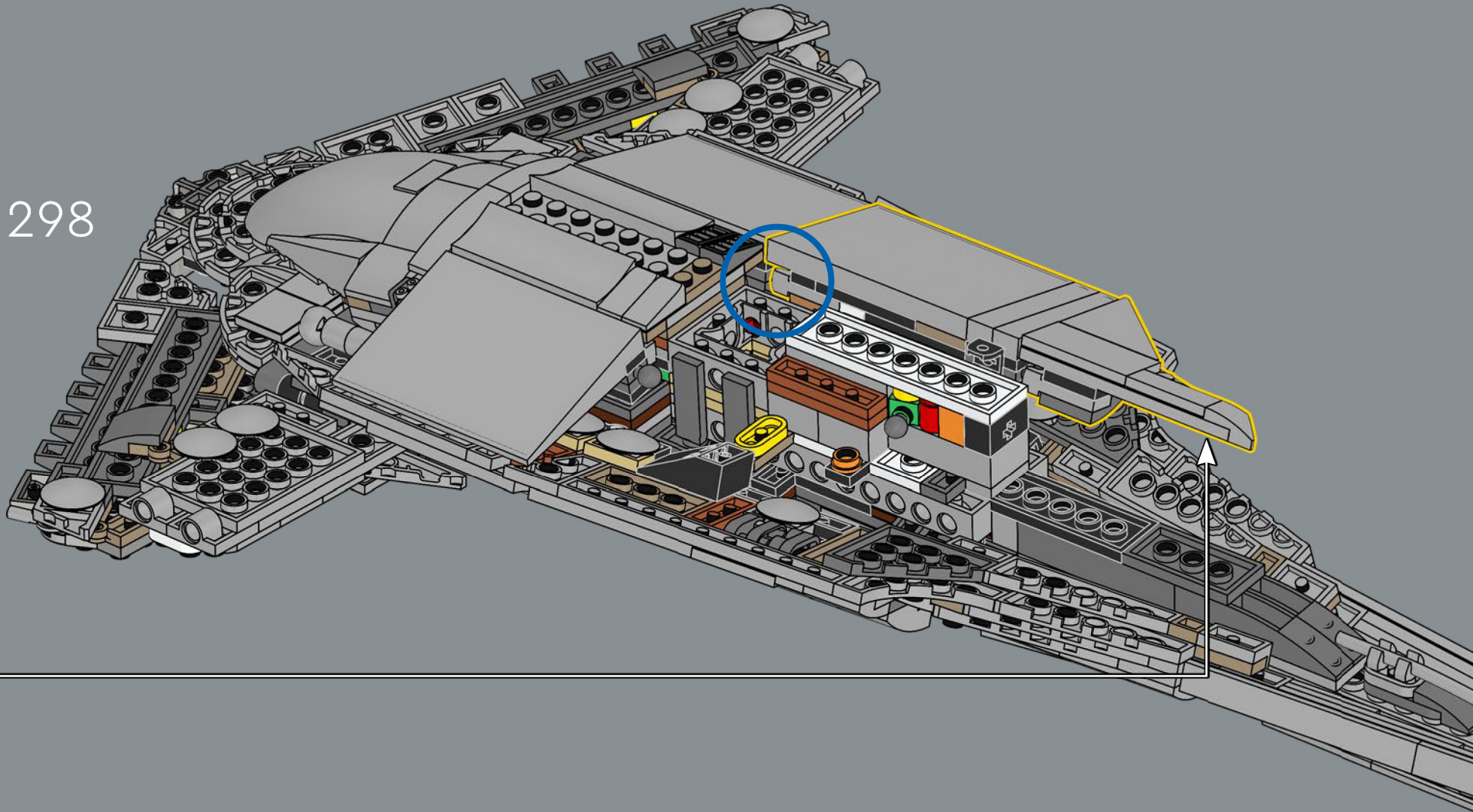

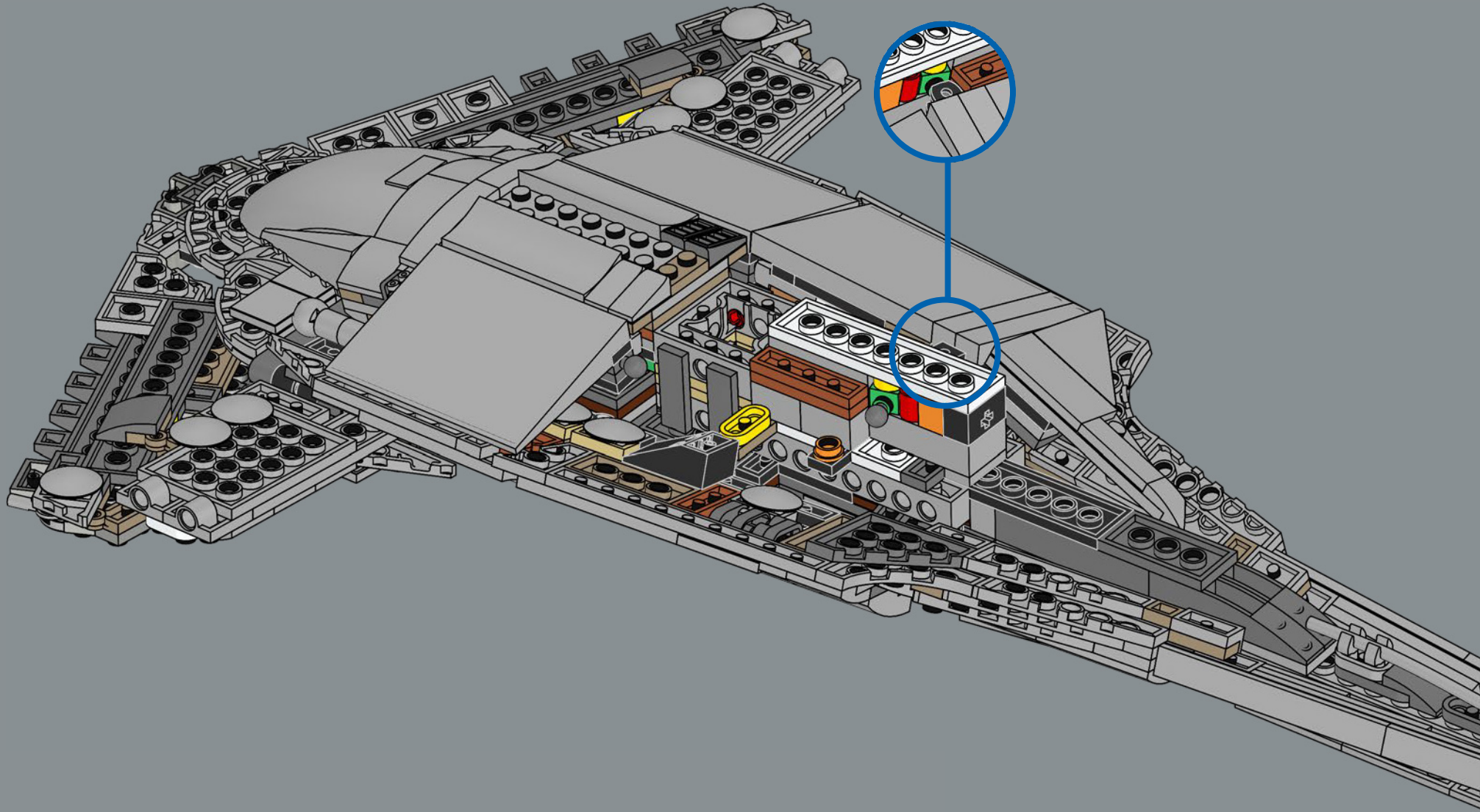

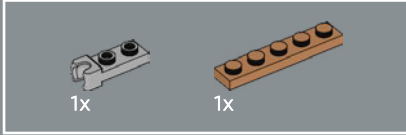
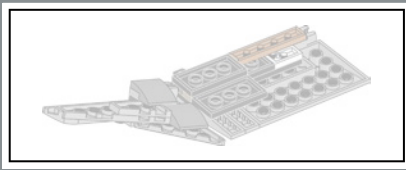

300

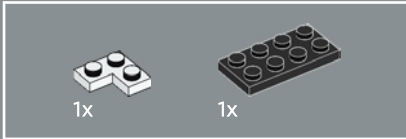
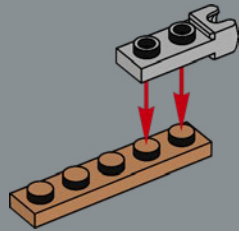

301

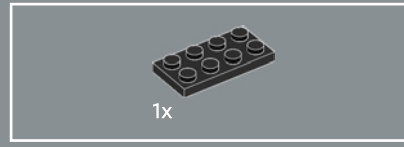
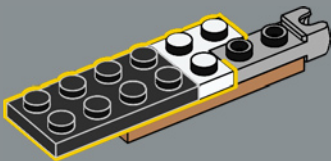

302

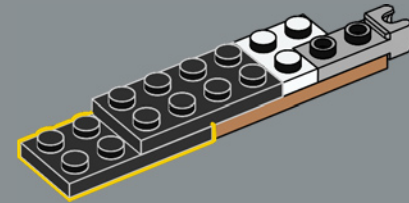

303

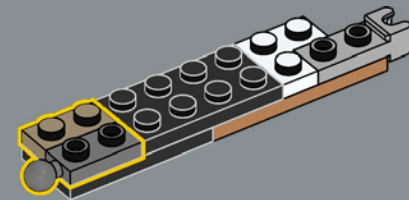

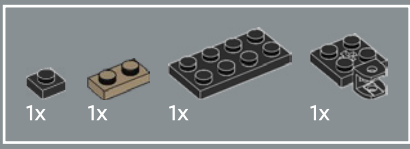

304

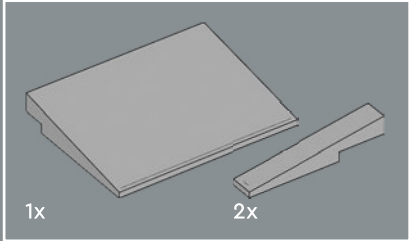
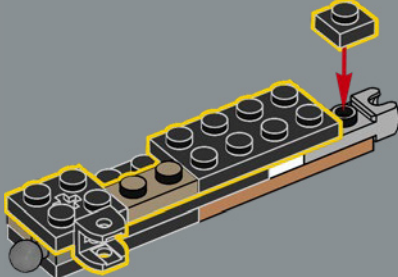

305

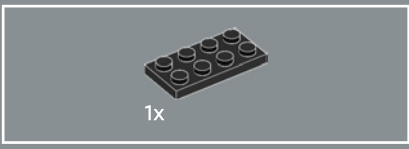
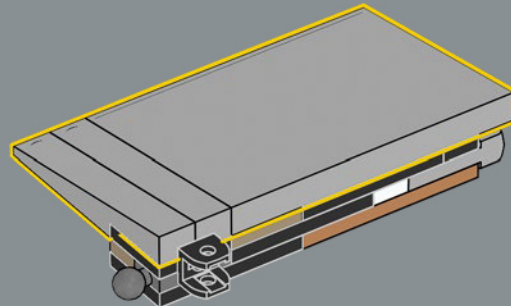

306

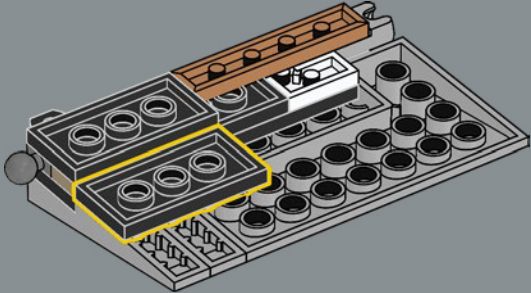

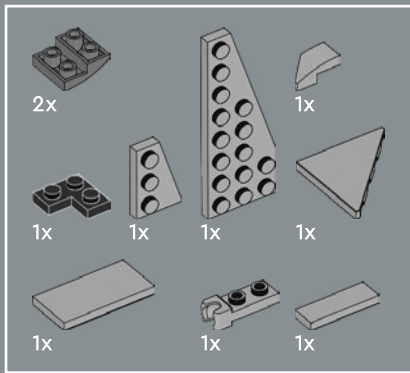

307

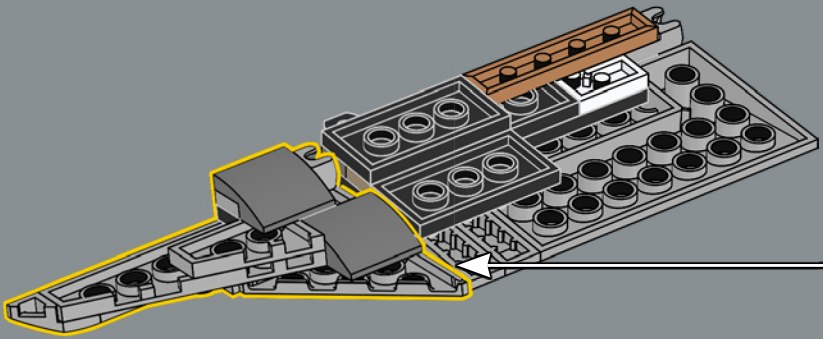
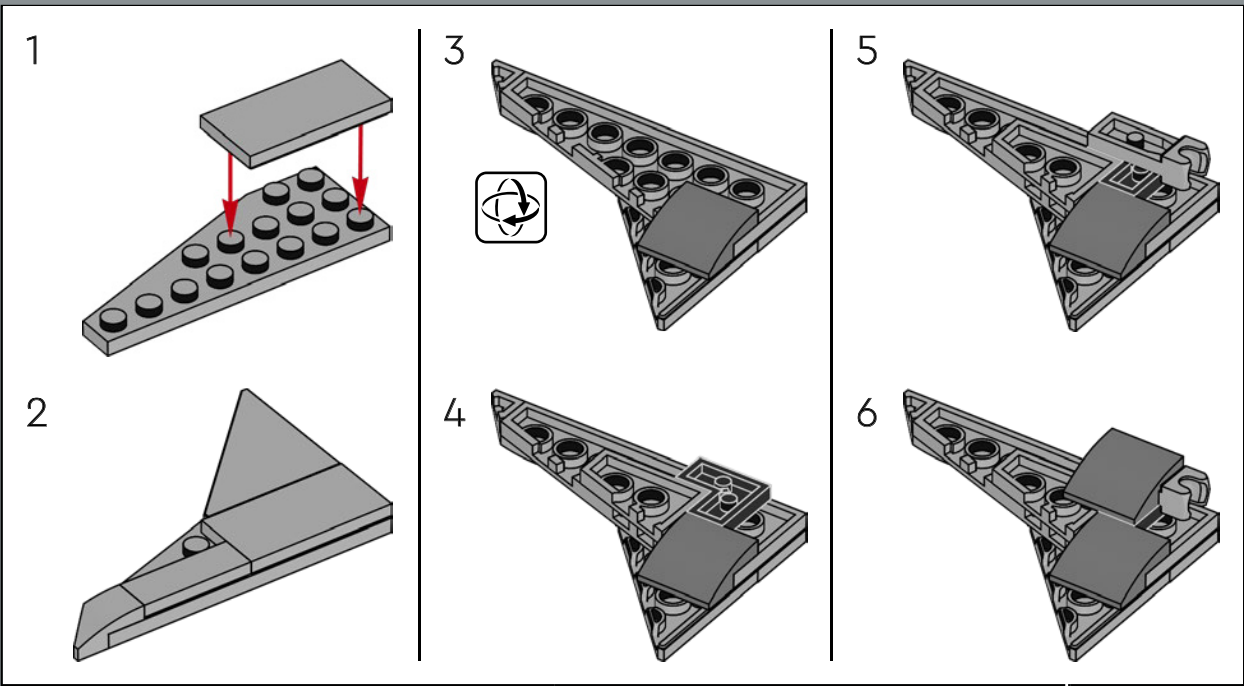

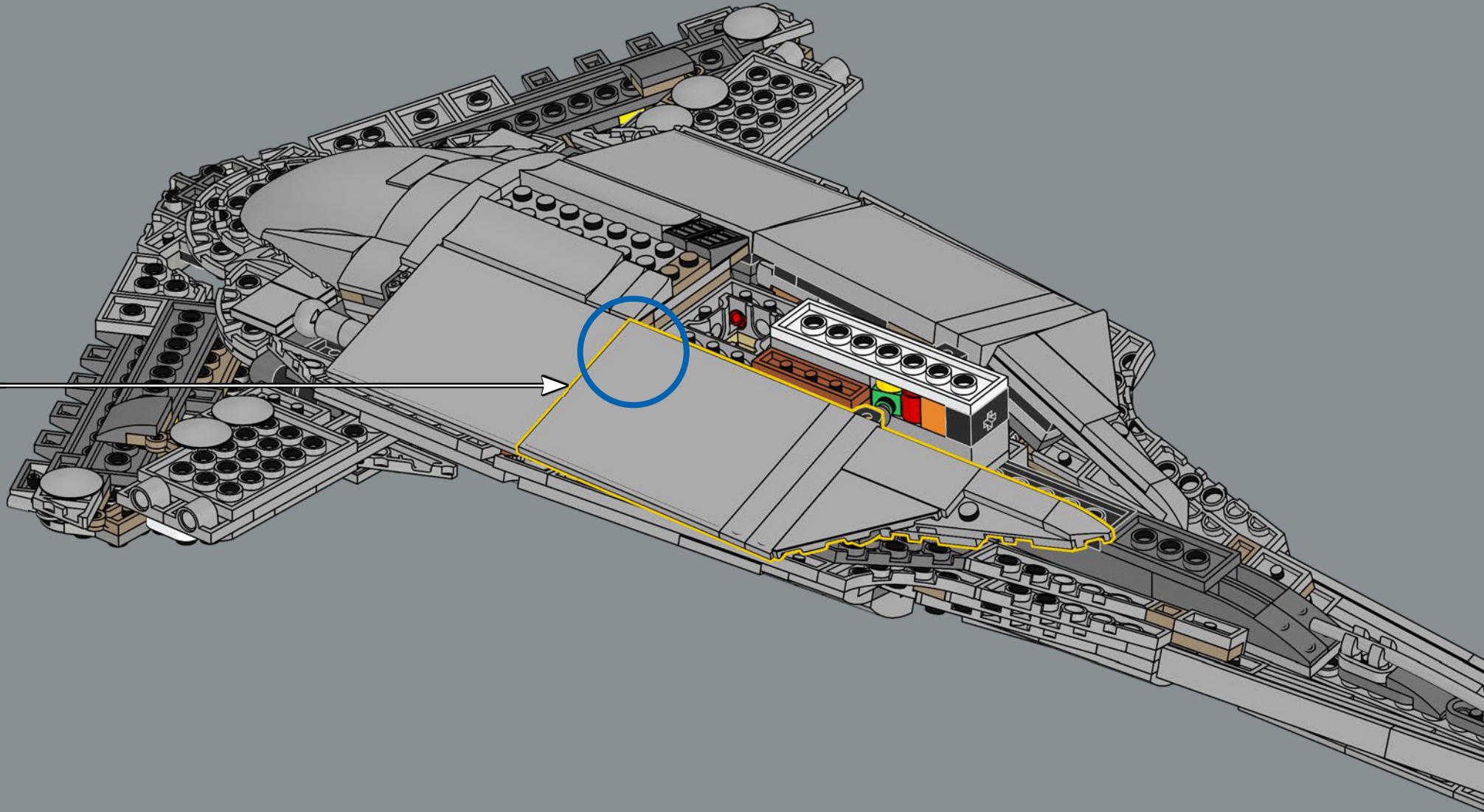

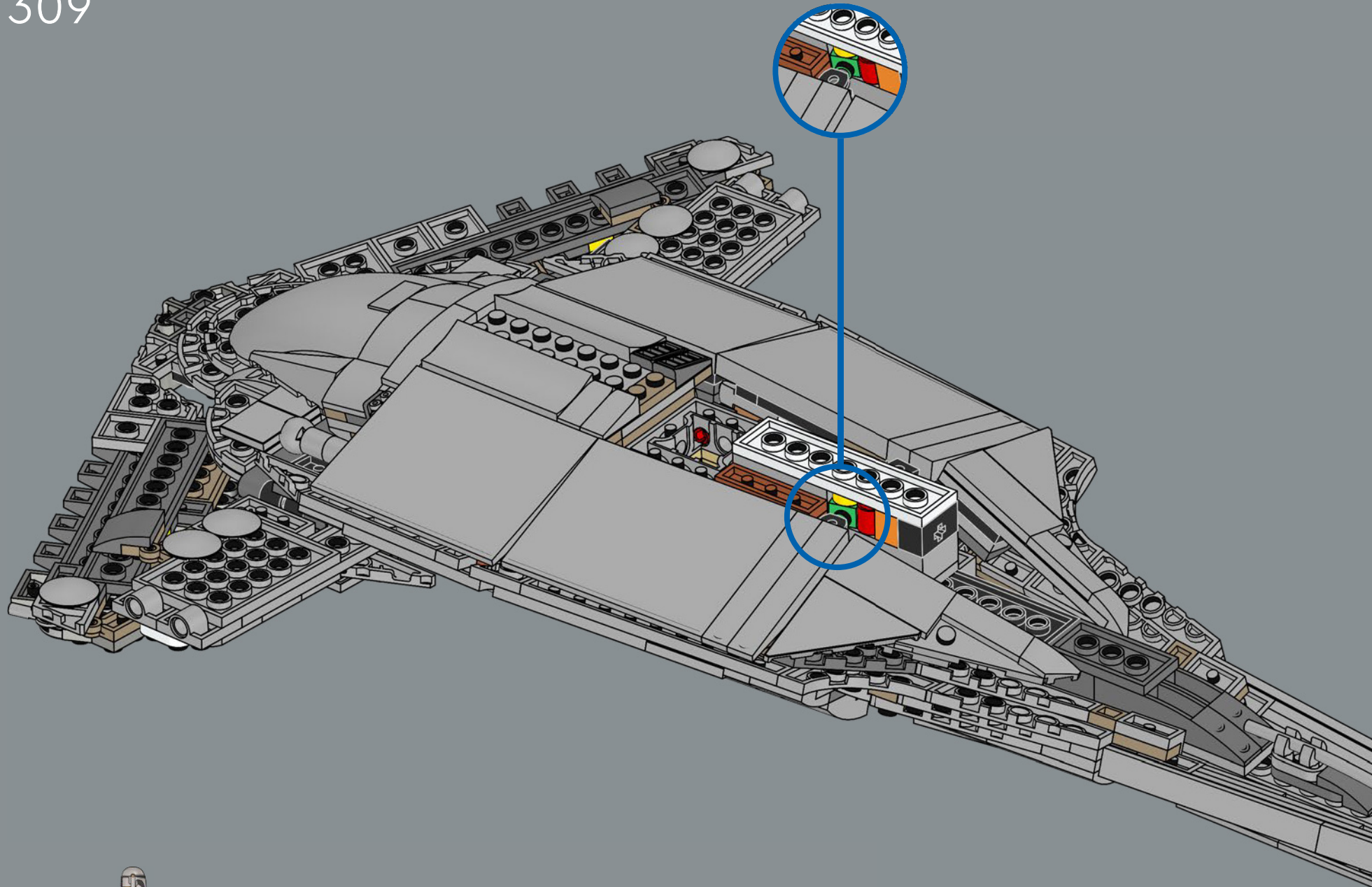

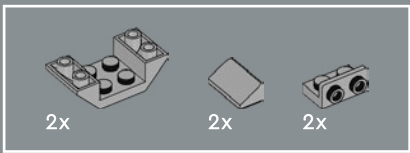

310

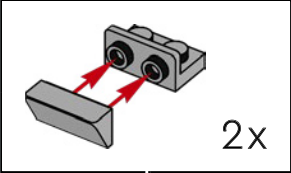
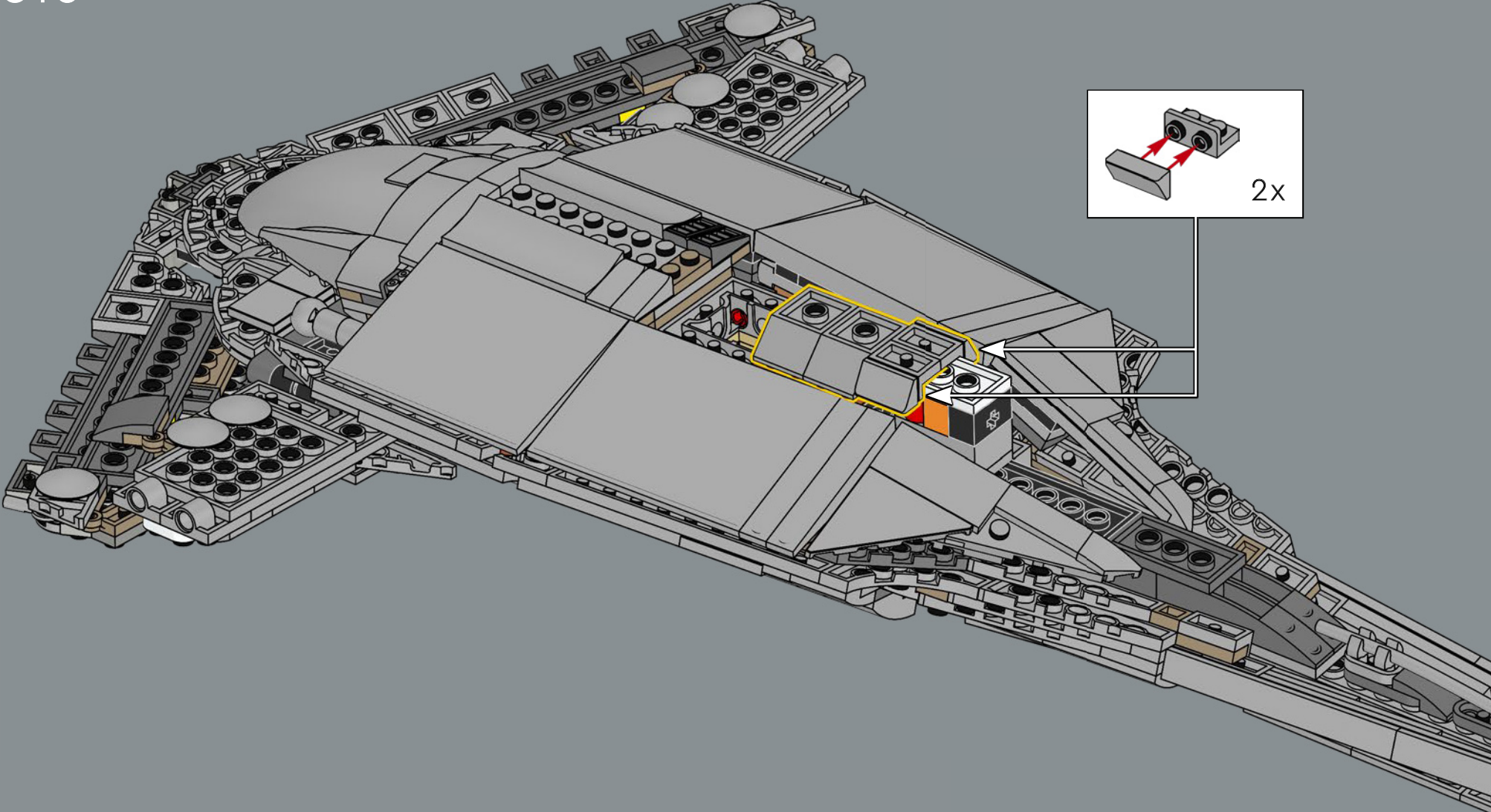

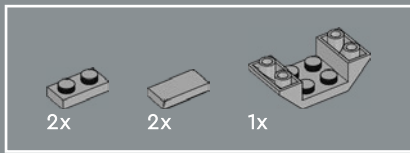

311

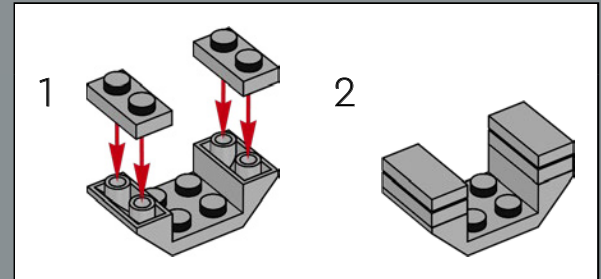
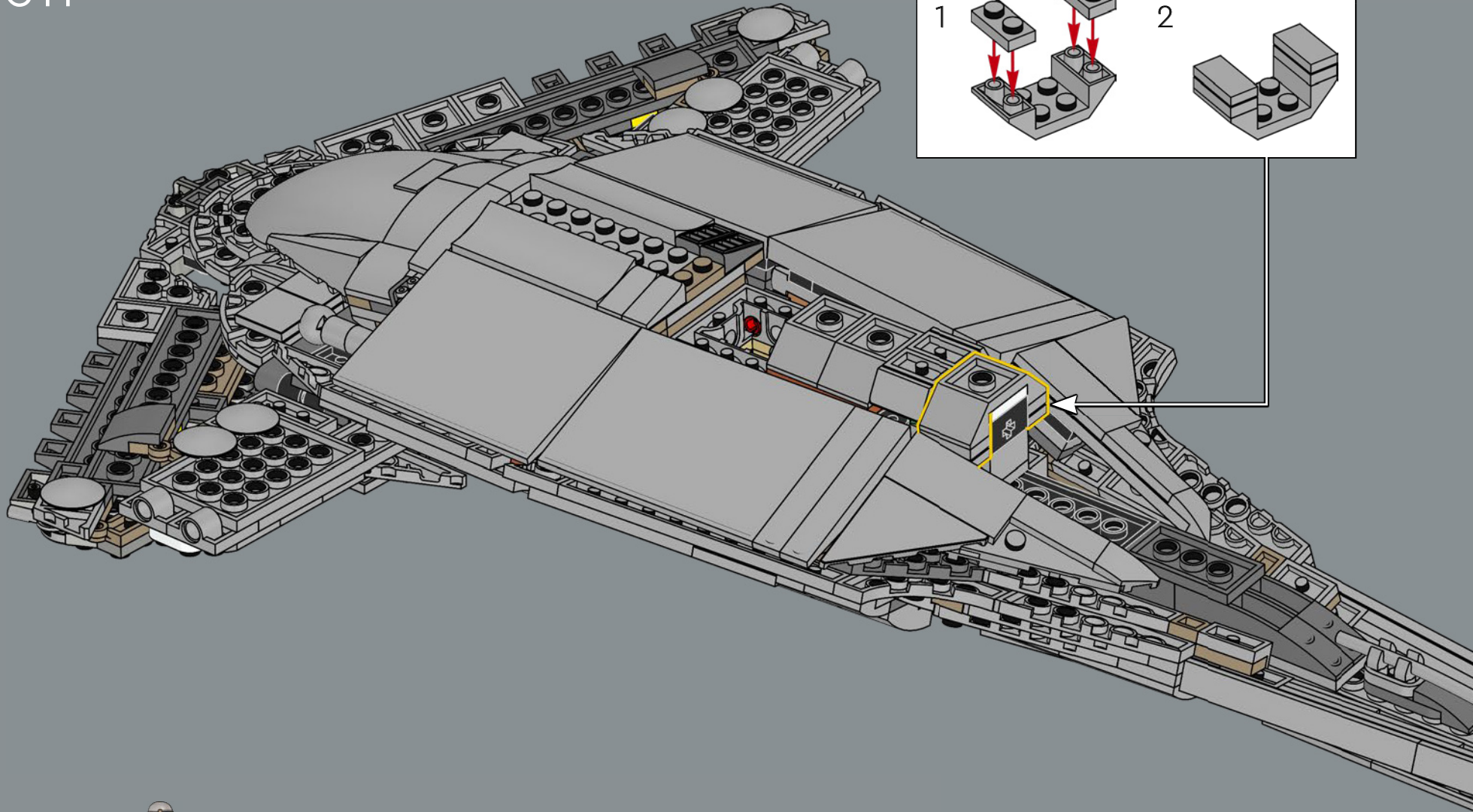

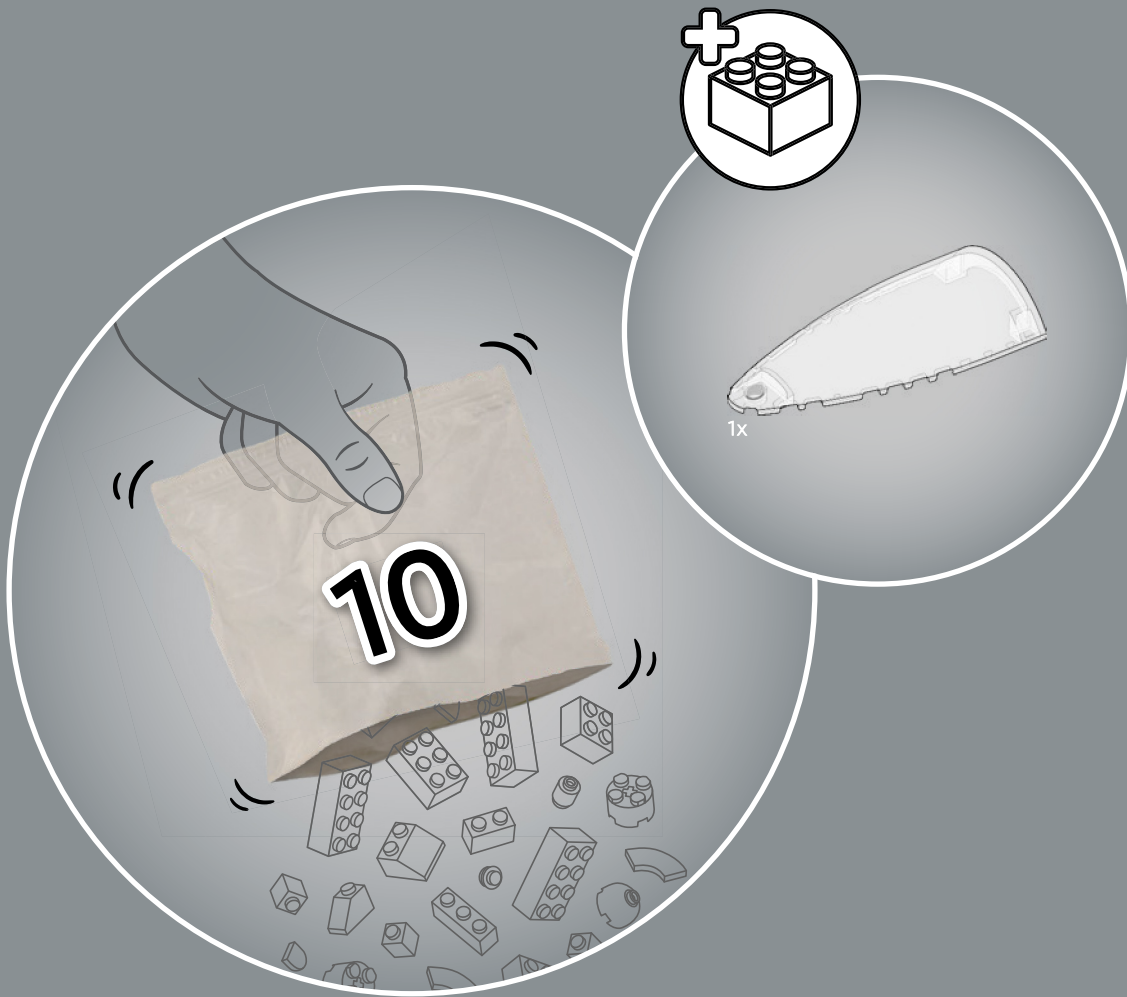

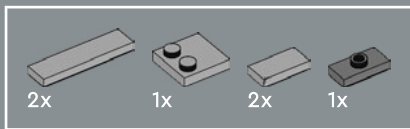

312

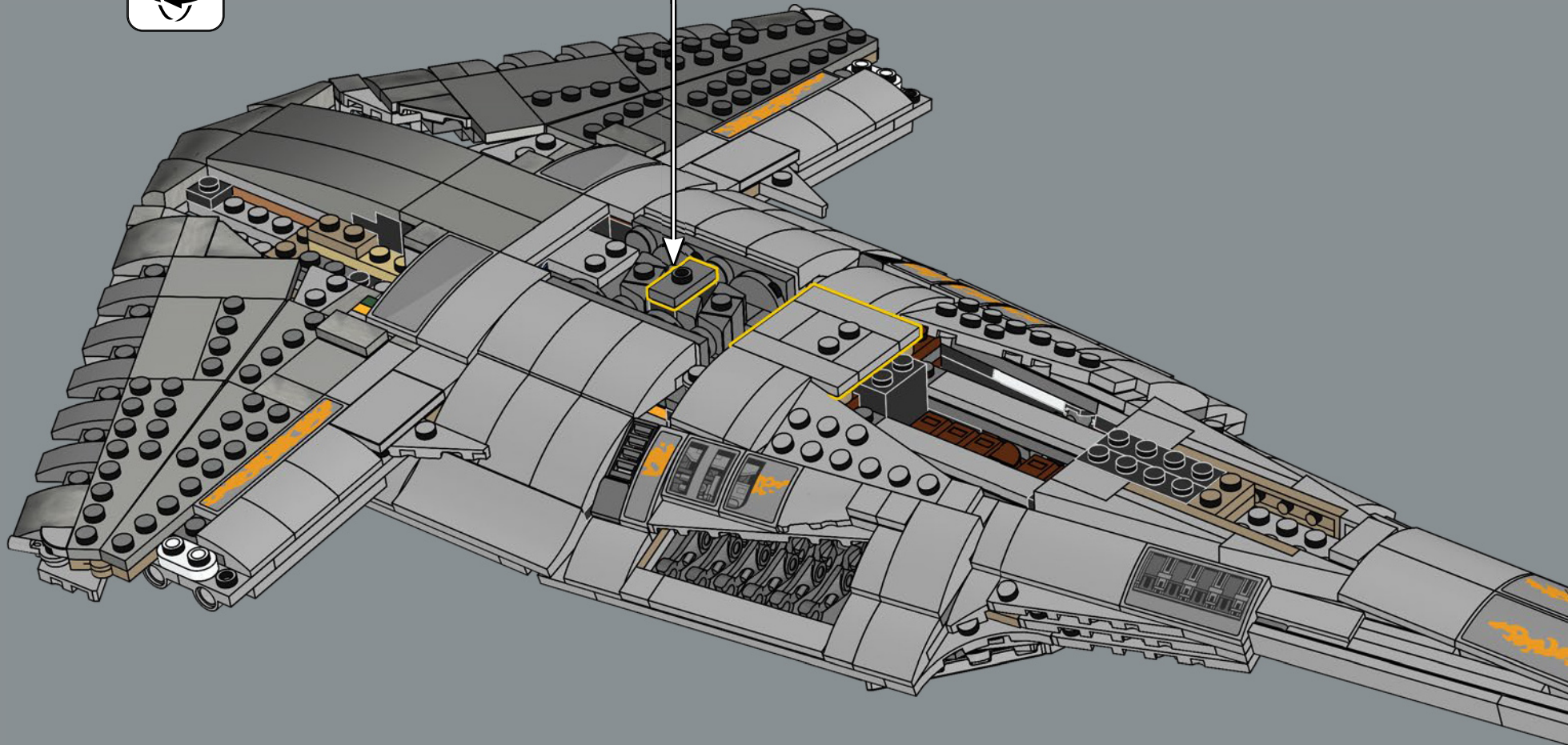
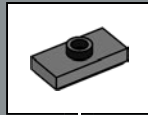

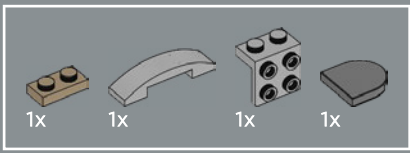

313

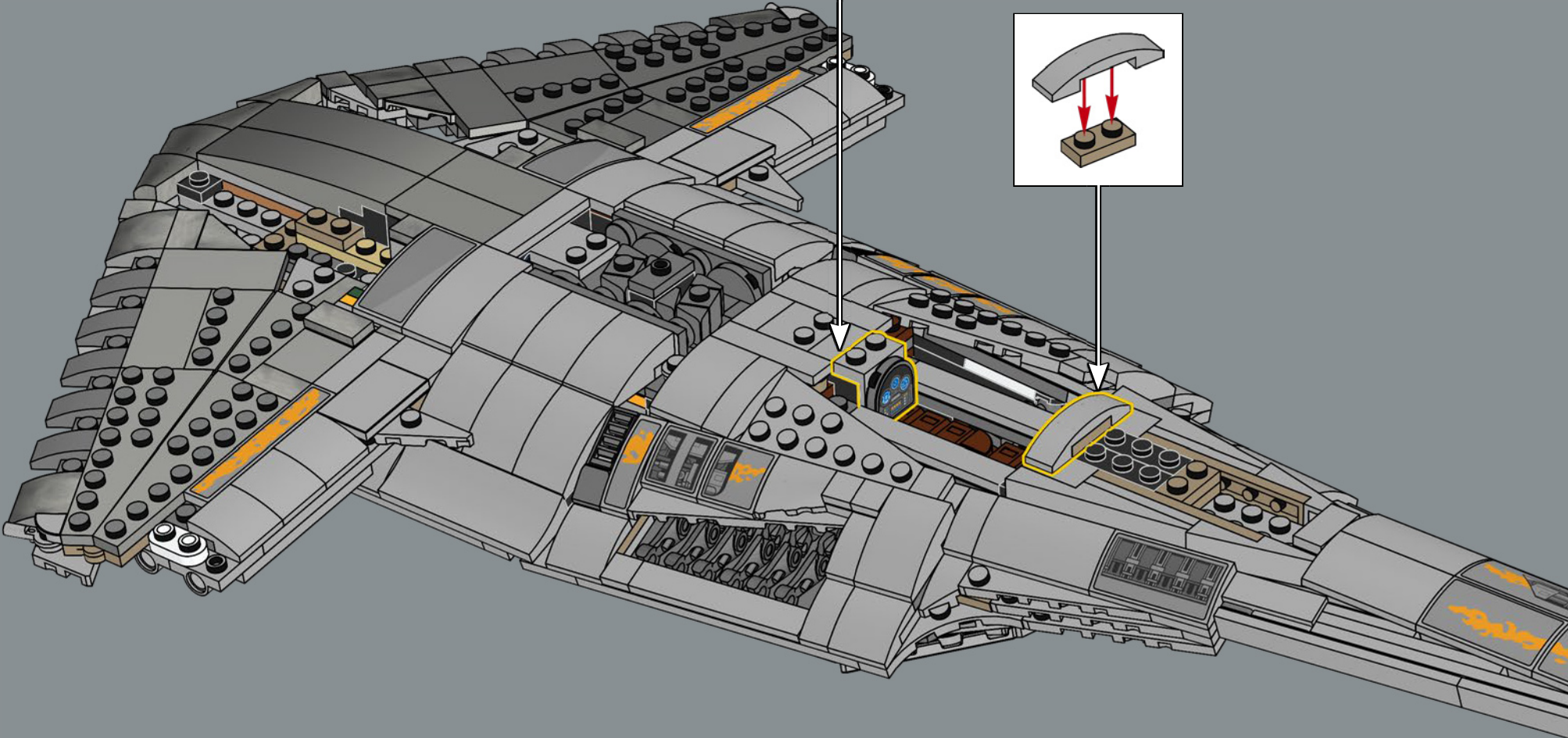
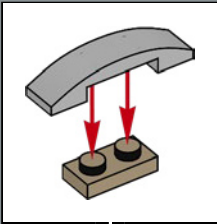
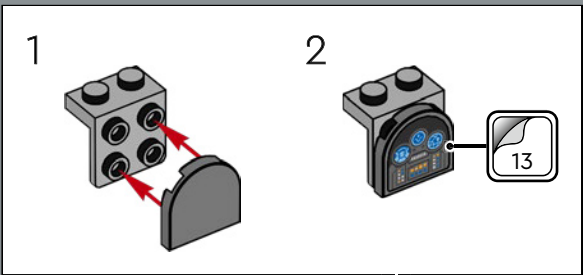



2x



6x

314

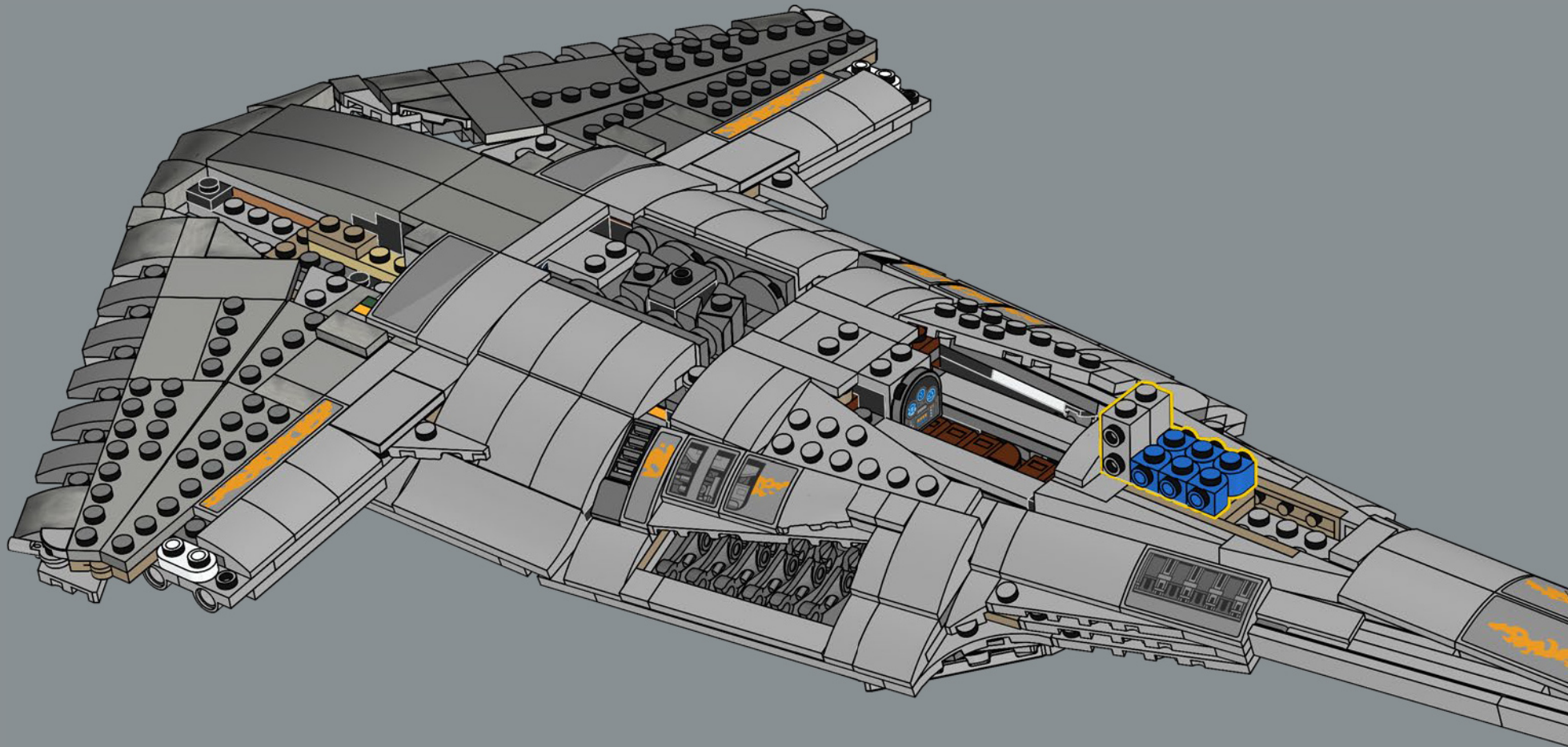

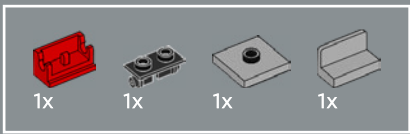

315

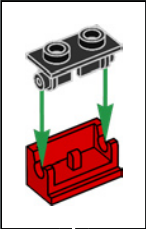
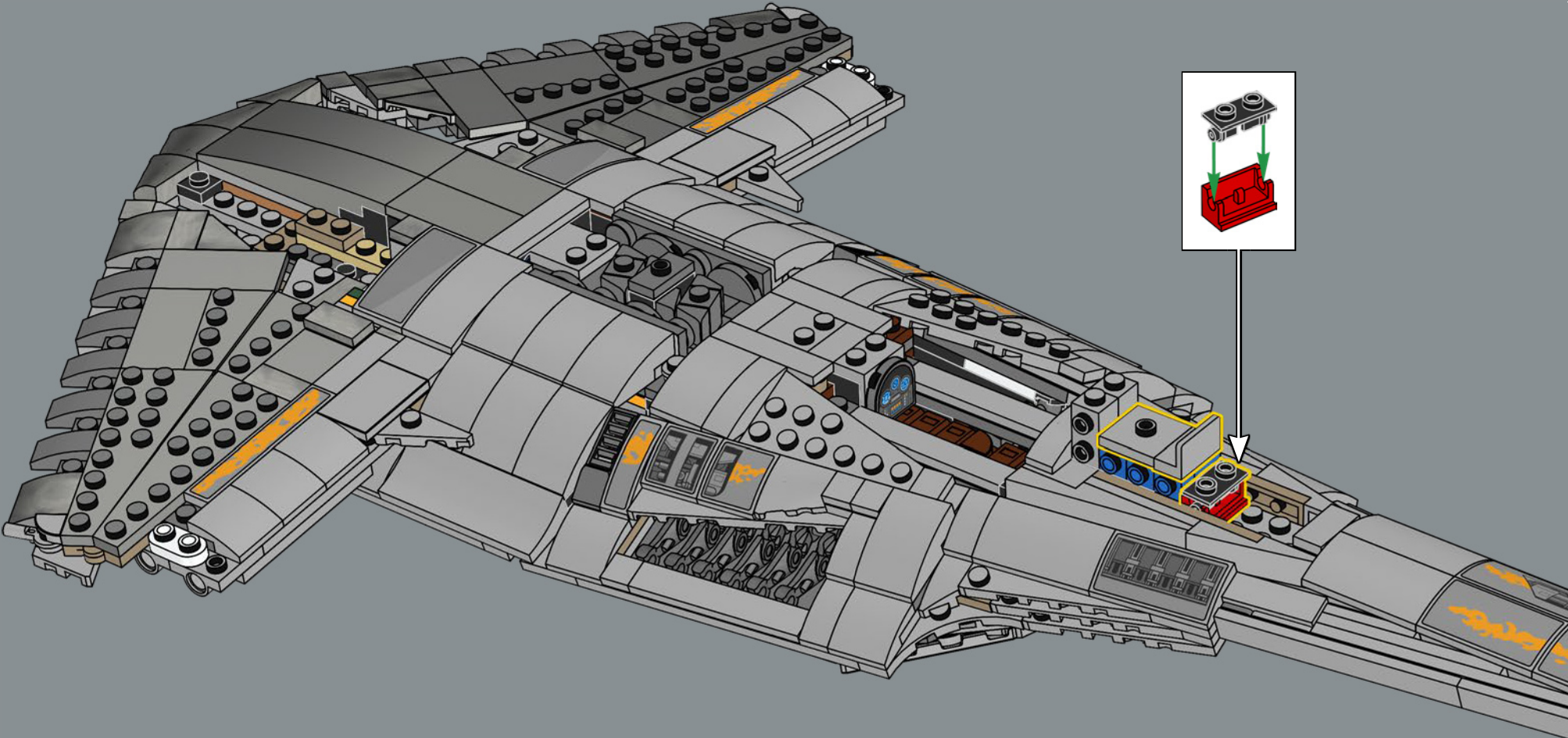

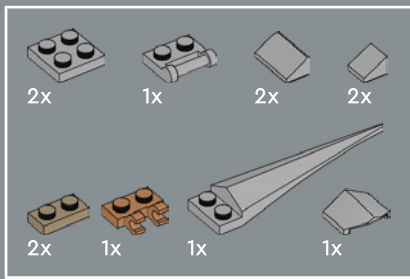

316

1

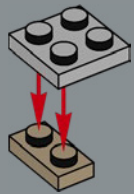

2

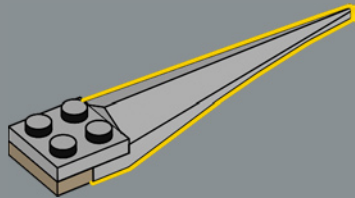

3

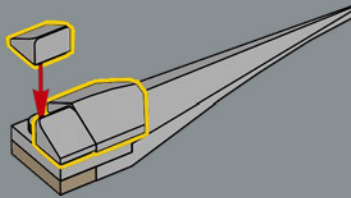

4

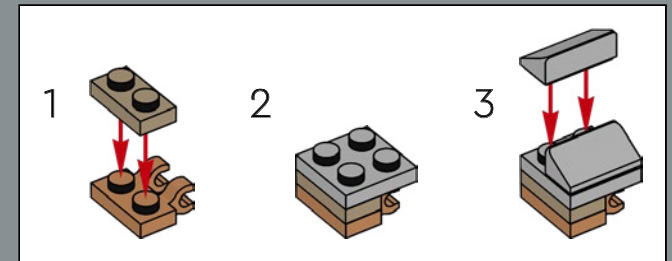
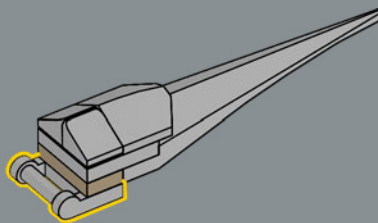

5

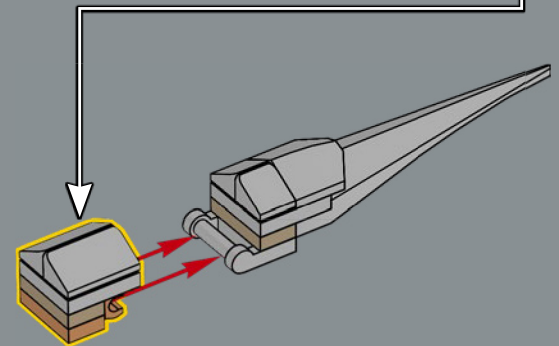

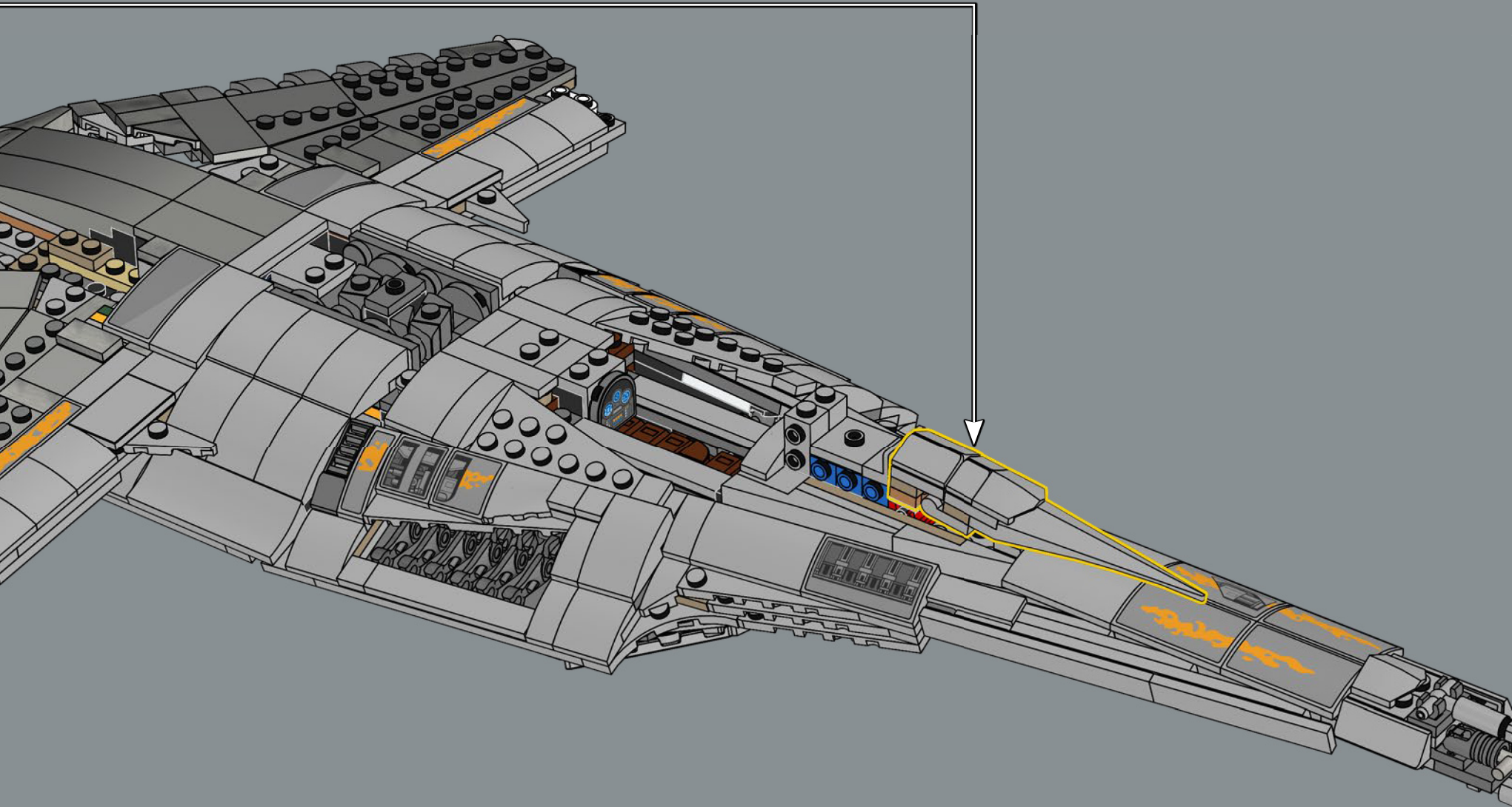

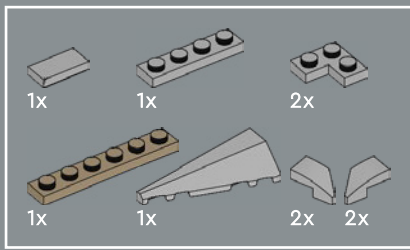

317

1

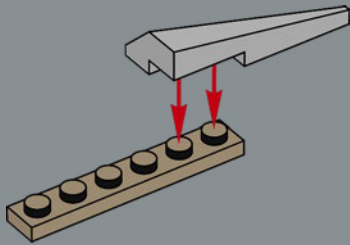

2

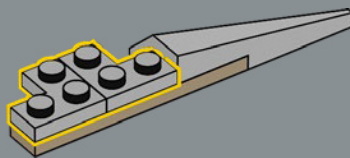

3

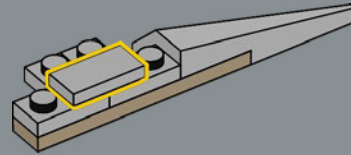

4

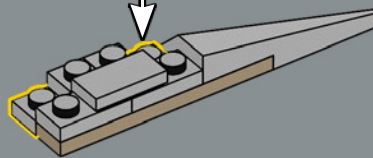
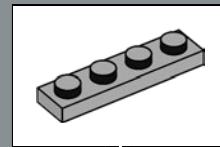

5

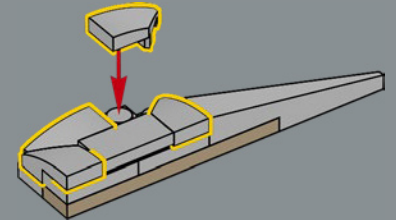

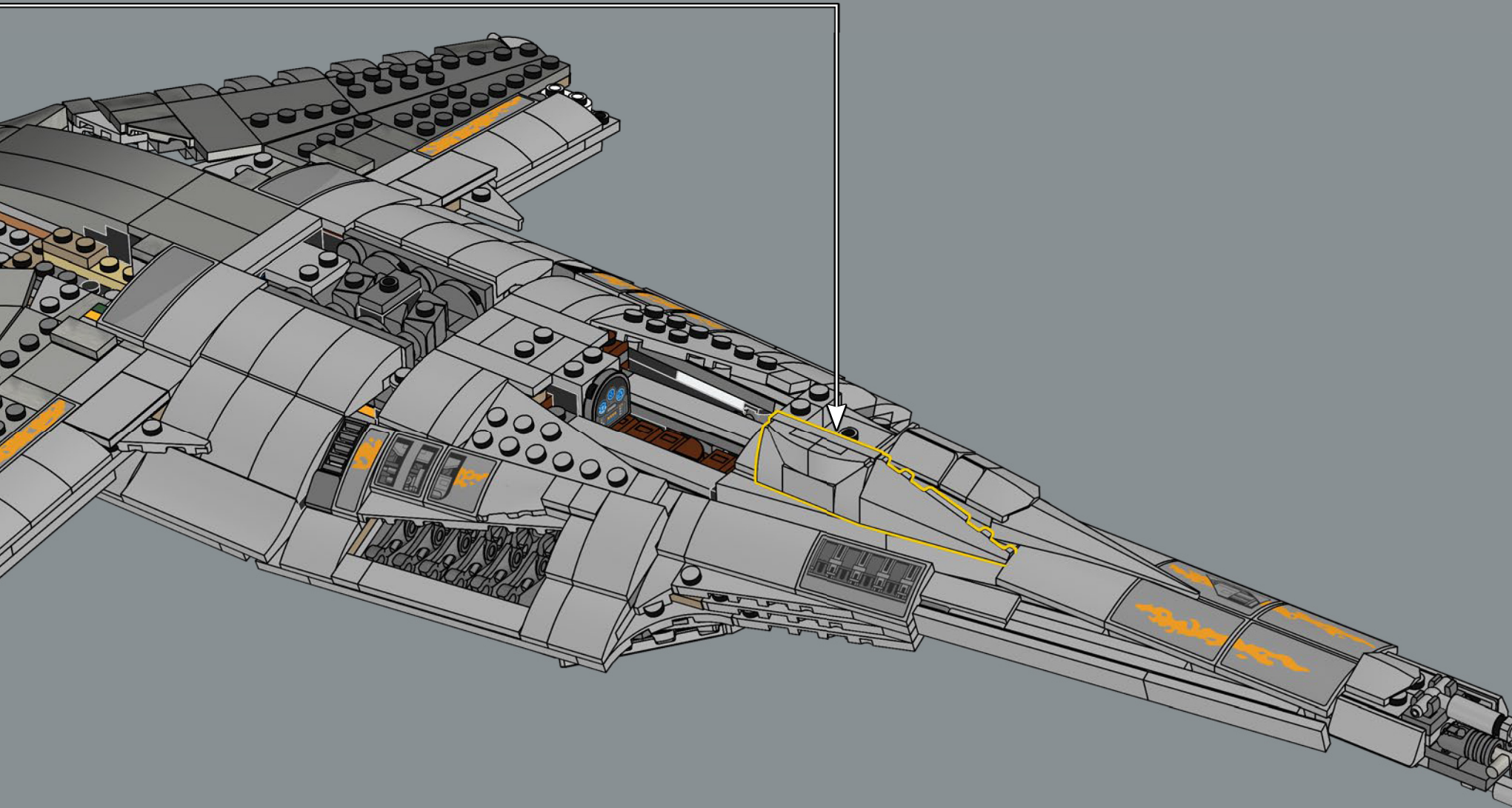

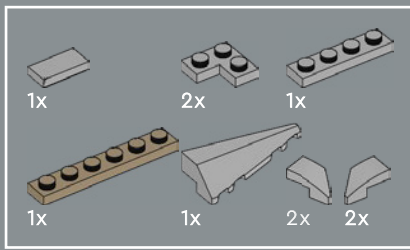

318

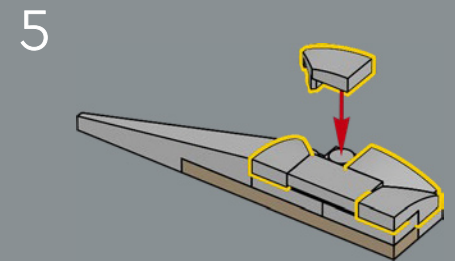
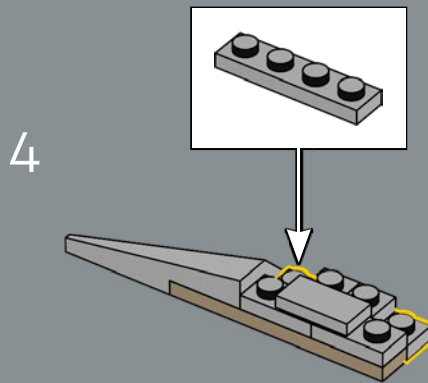
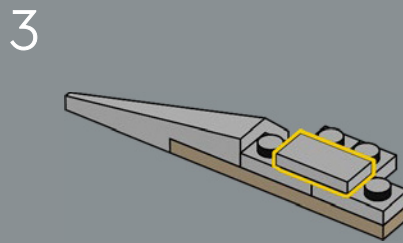
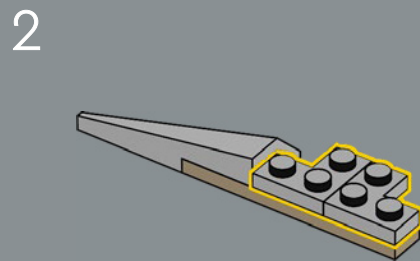
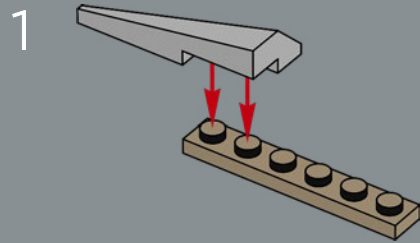

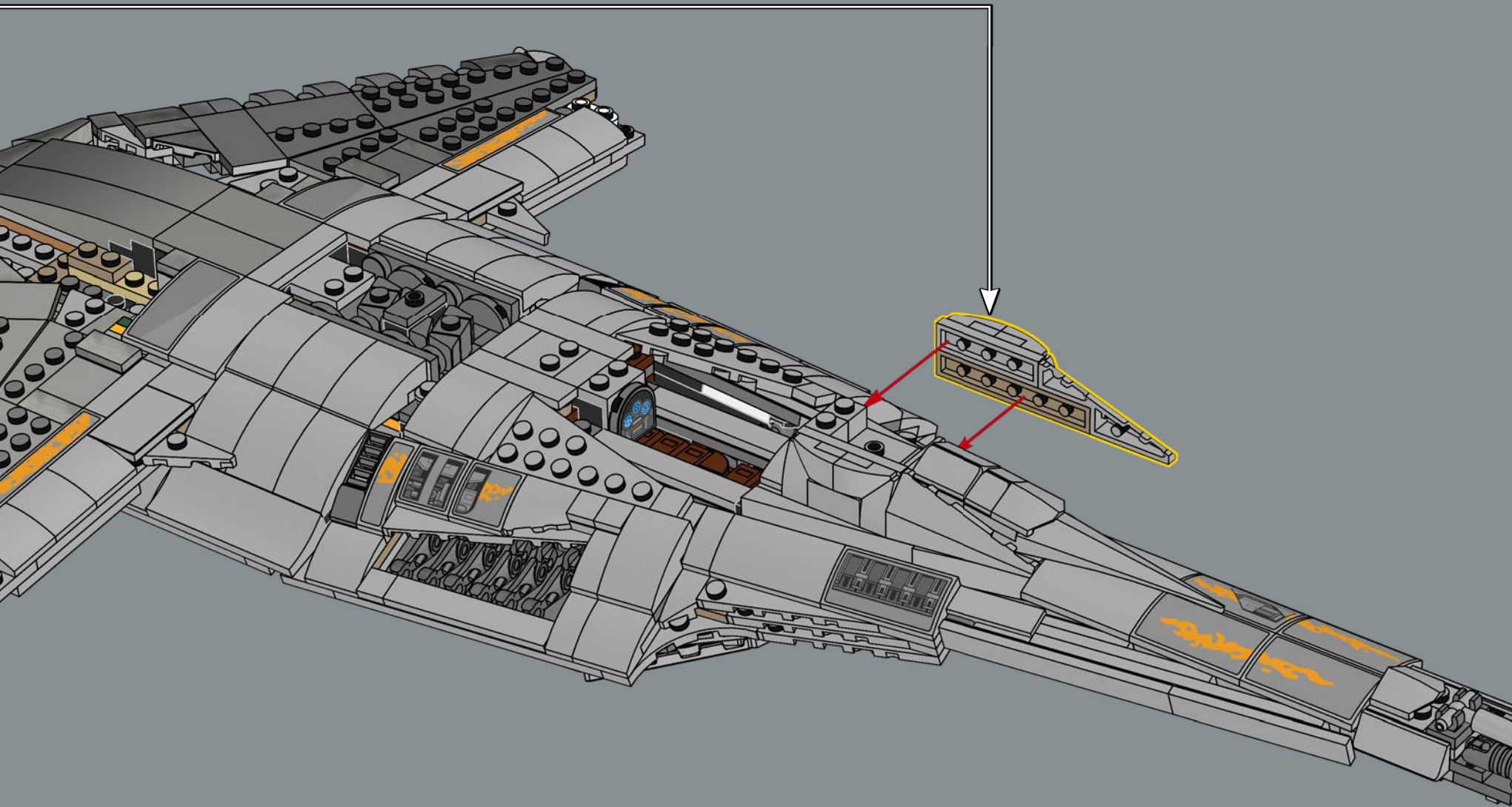

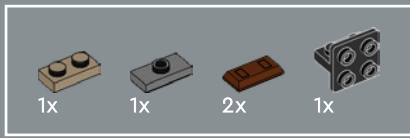

319

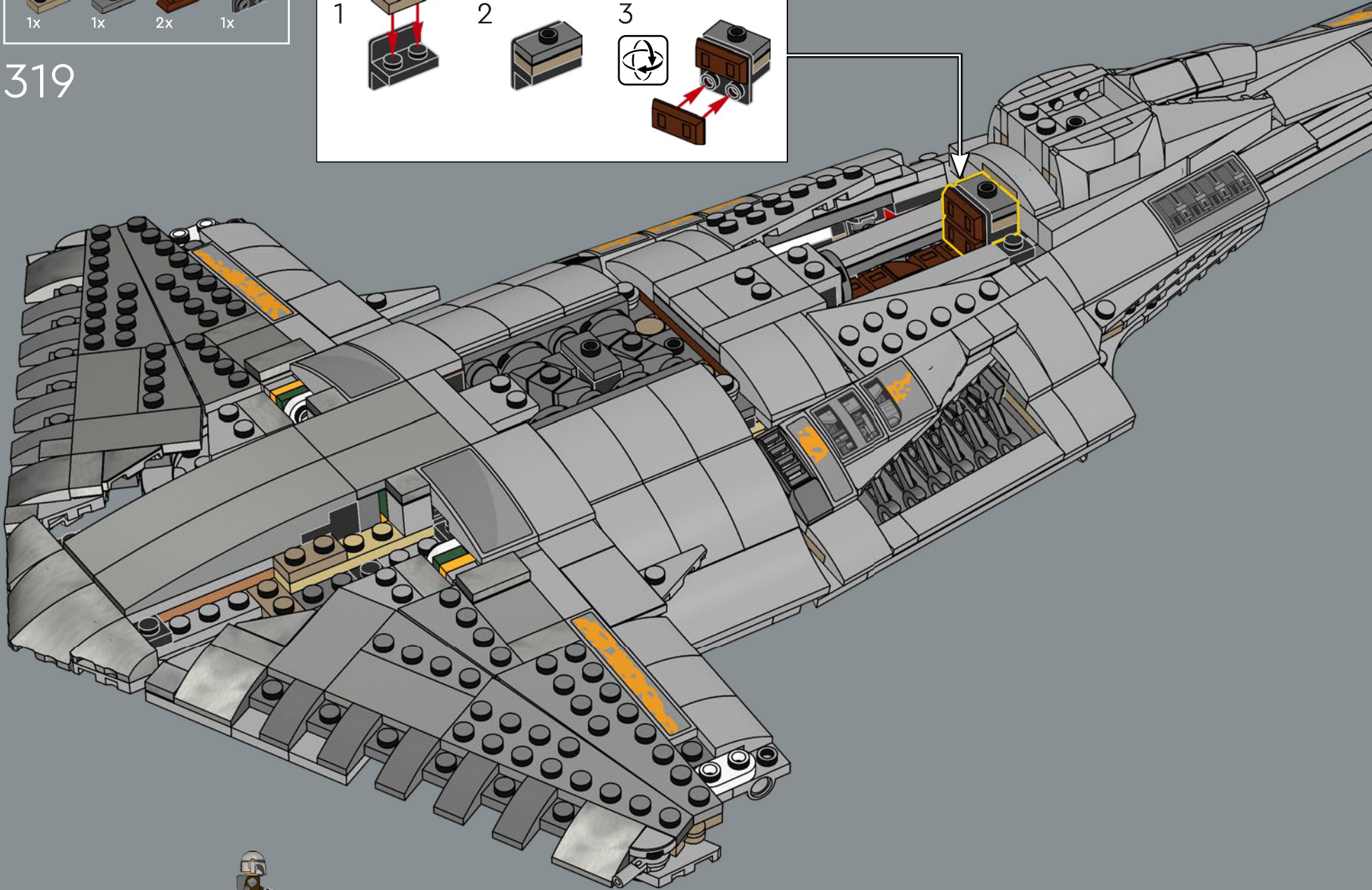
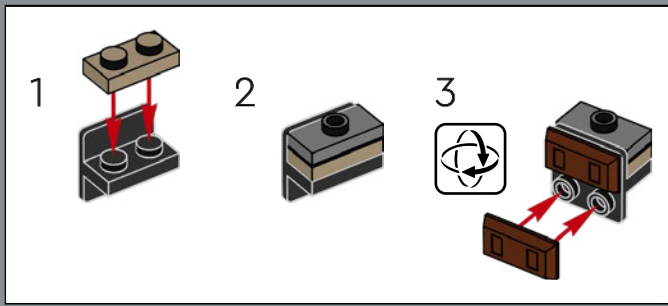

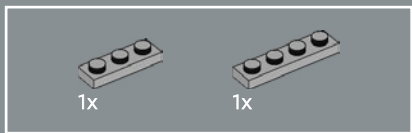

320

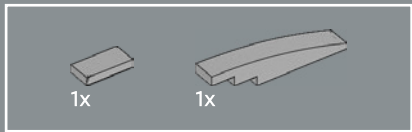
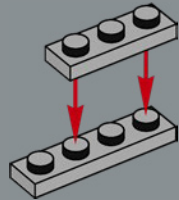

321

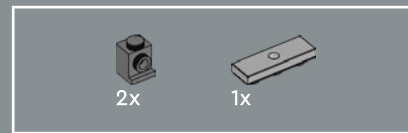
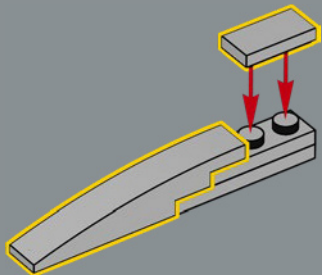

322

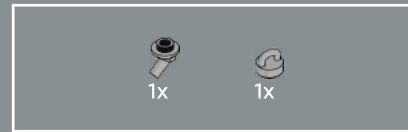
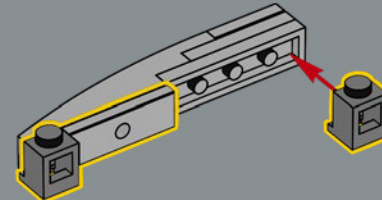

323

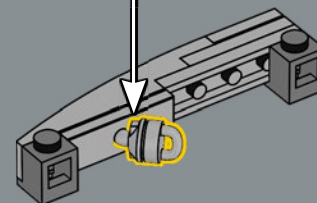
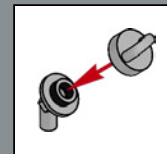

324

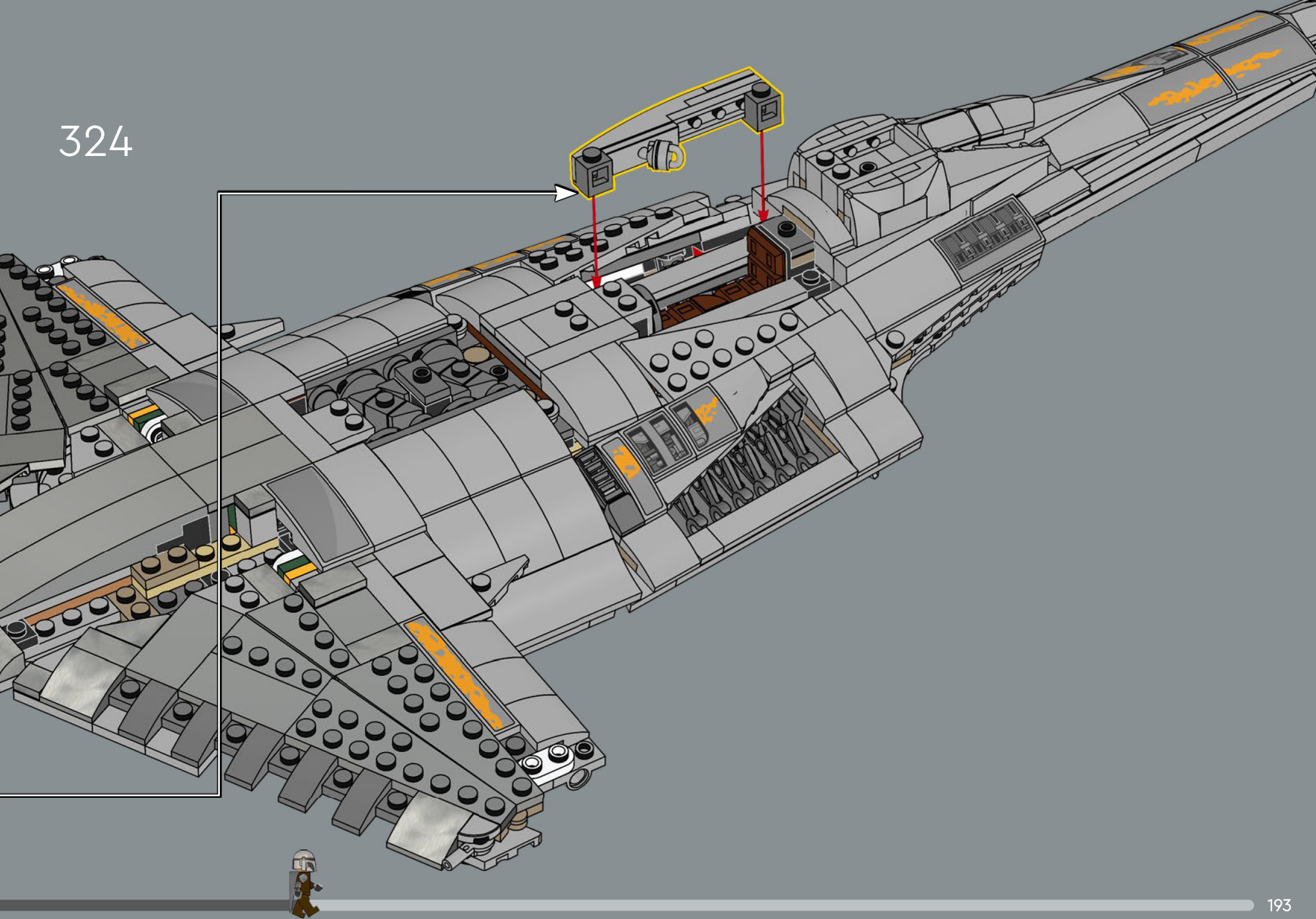

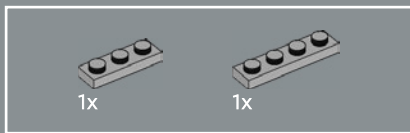

325

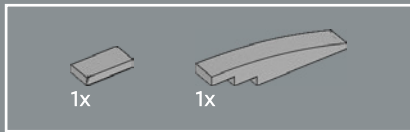
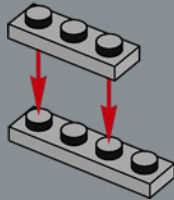

326

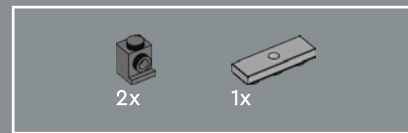
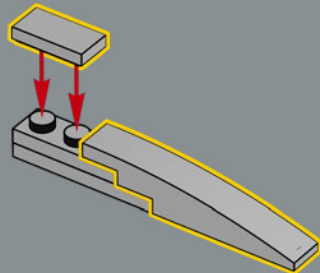

327

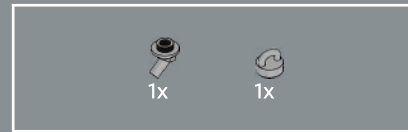
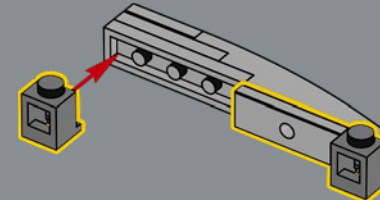

328

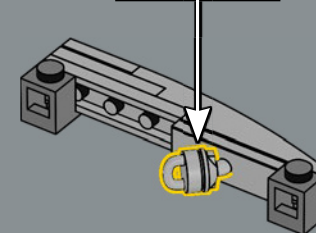
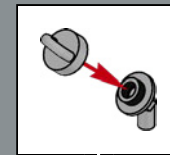

329

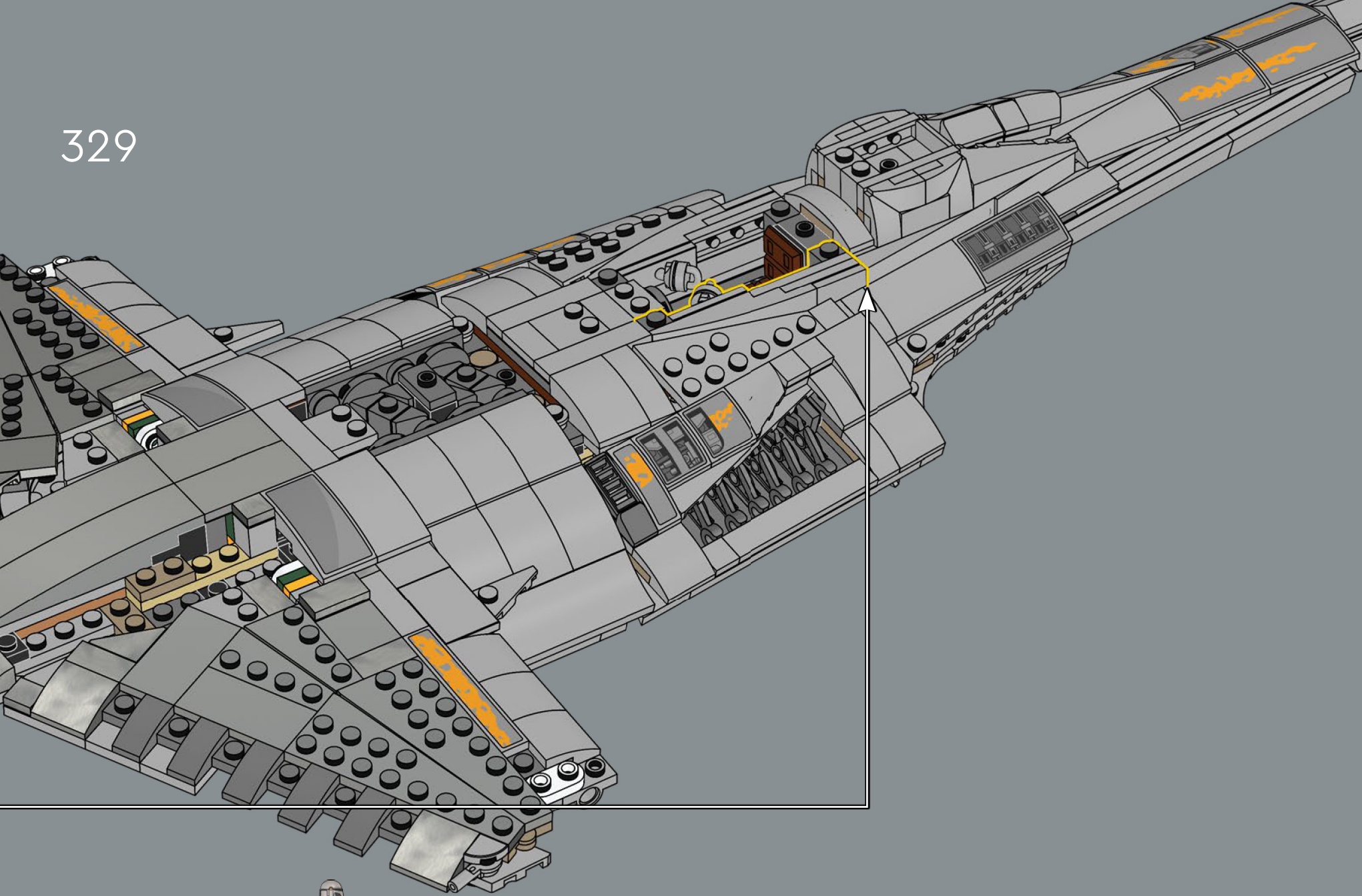

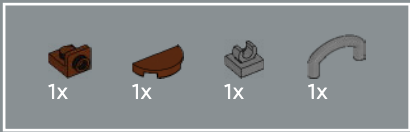

330

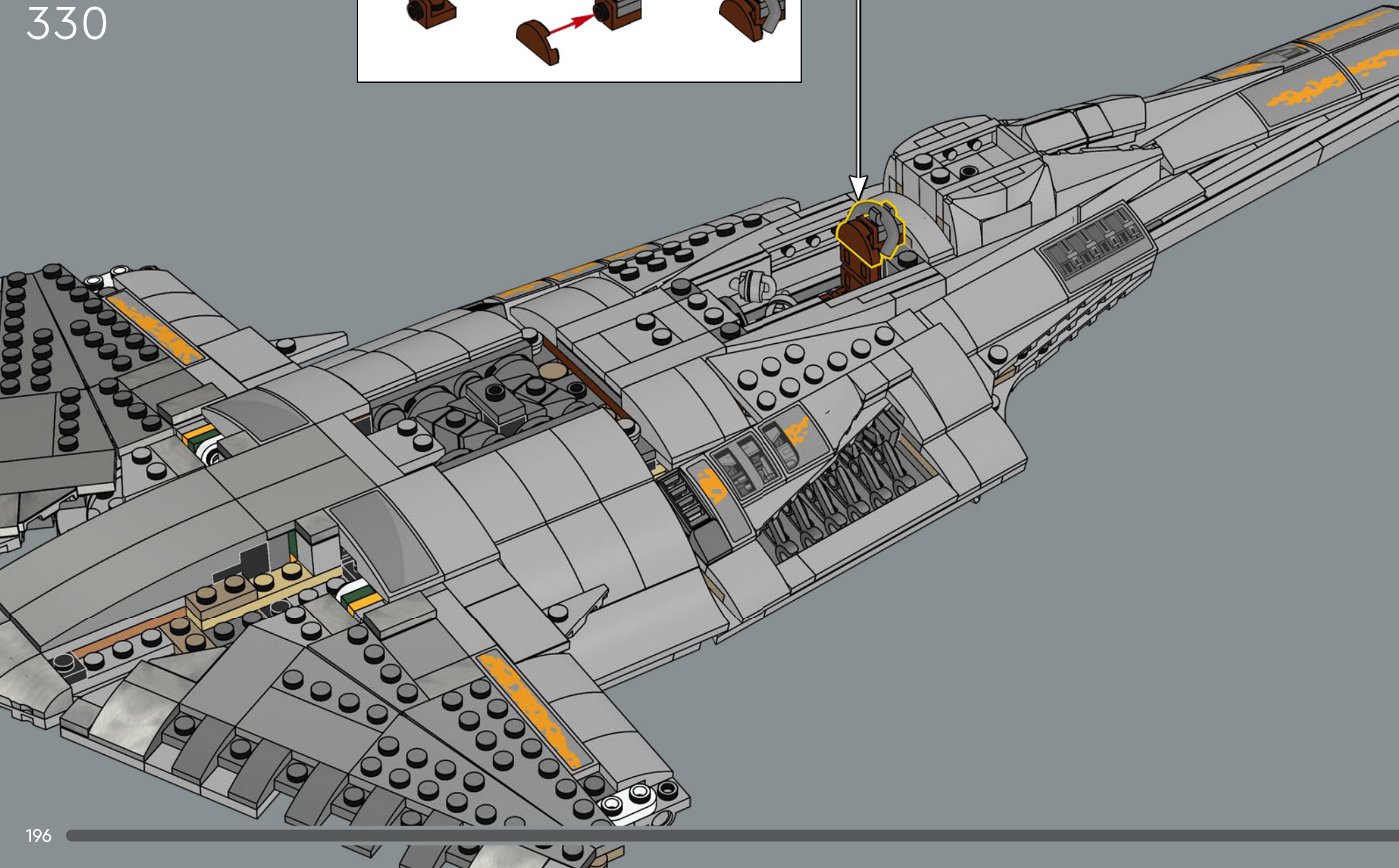
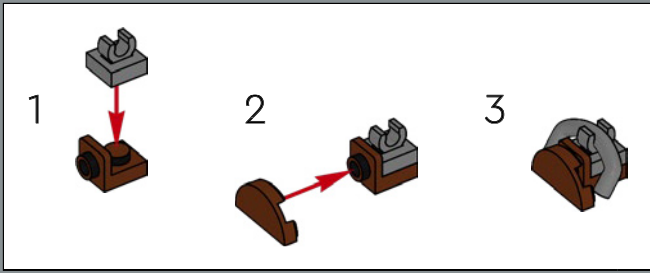

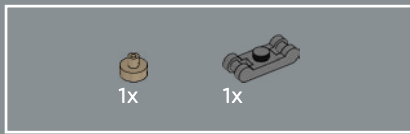

331

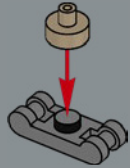

332

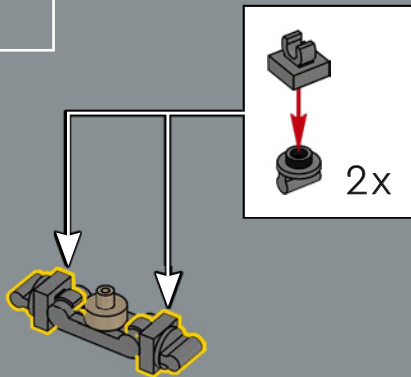

333

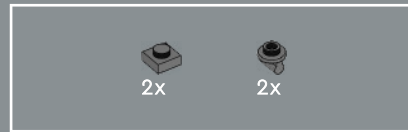
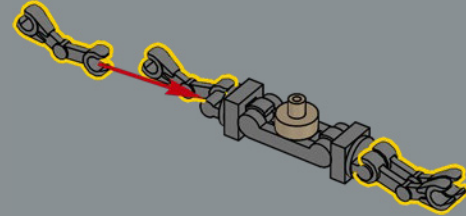

334

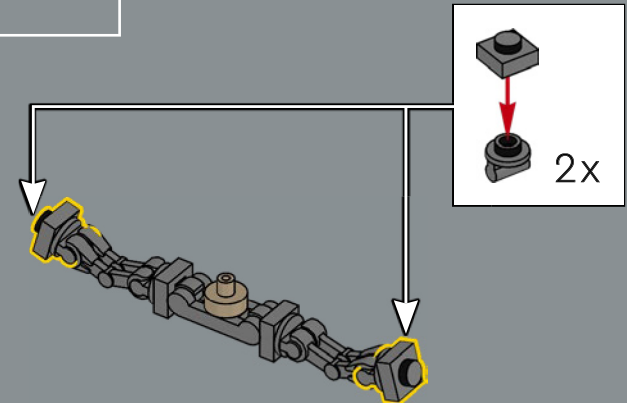

335

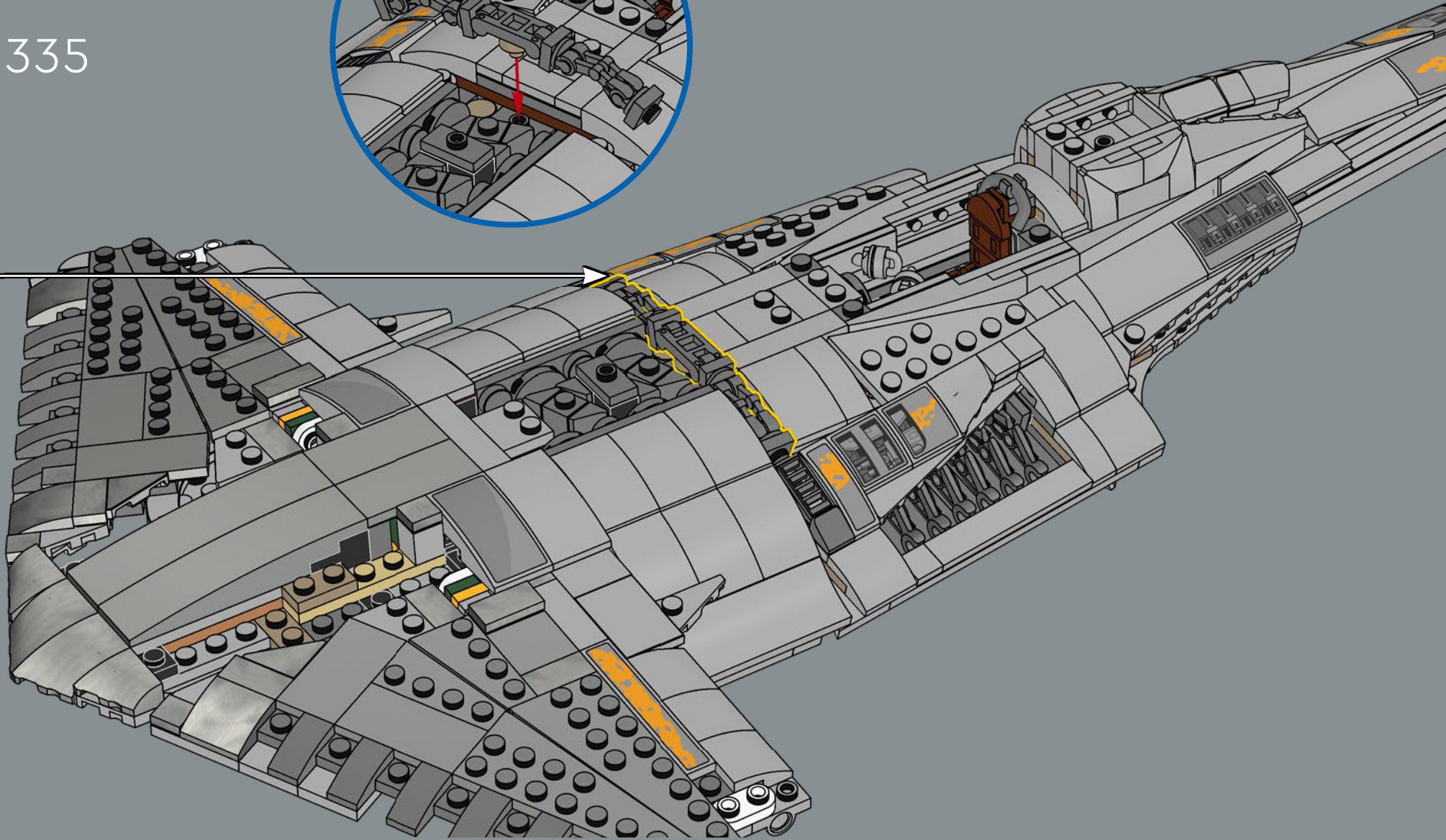
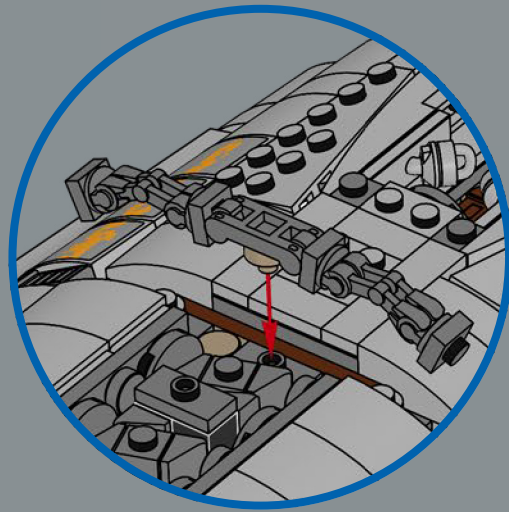

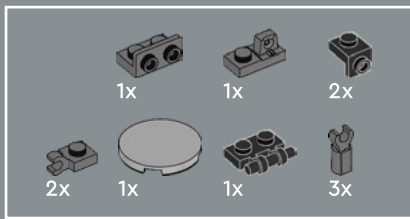

336

1

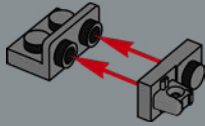

2

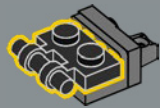

3

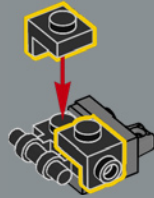

4

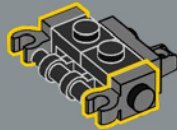

5

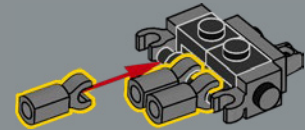

6

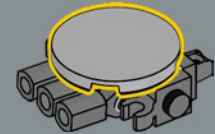

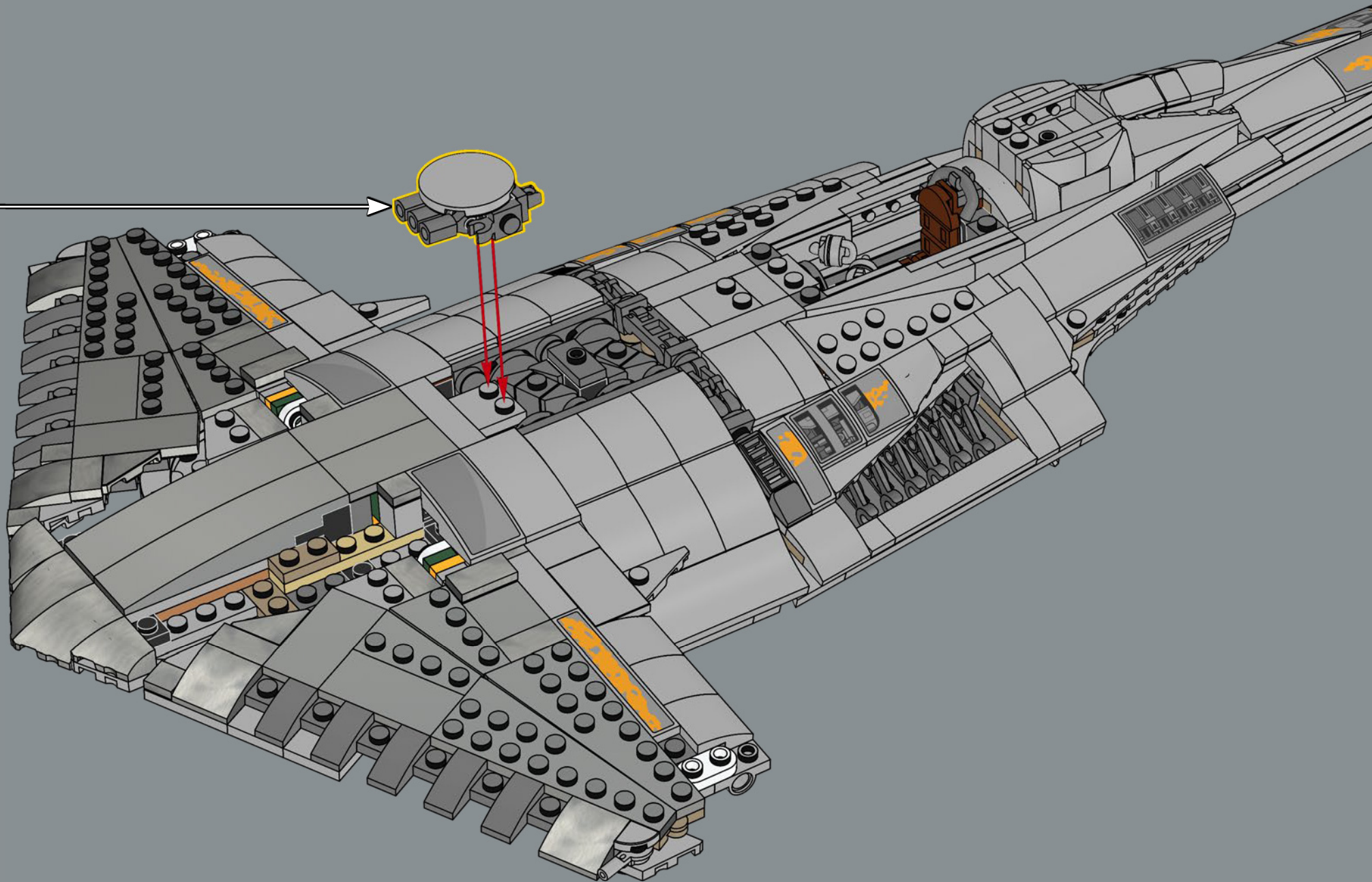

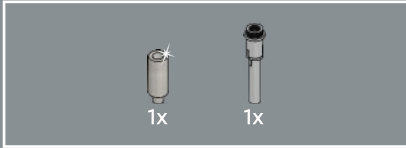
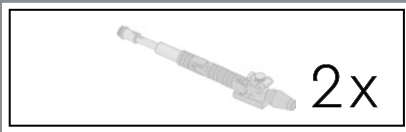

337

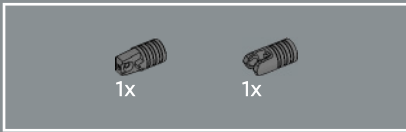
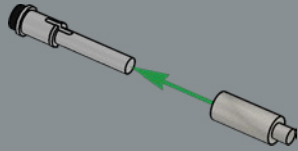

338

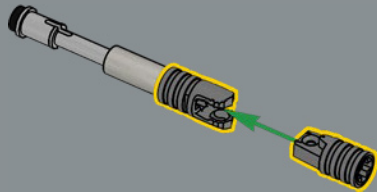

339

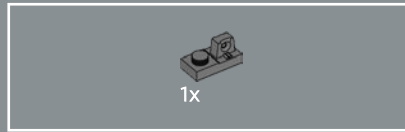
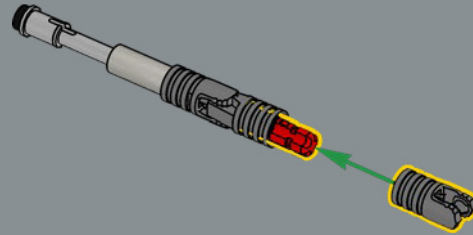

340

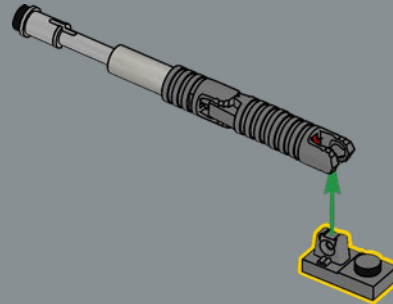

341

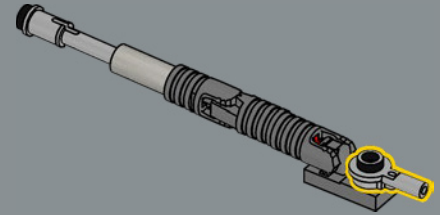

342

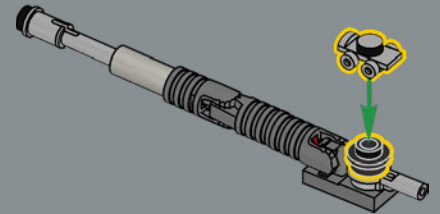



343

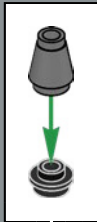

2x

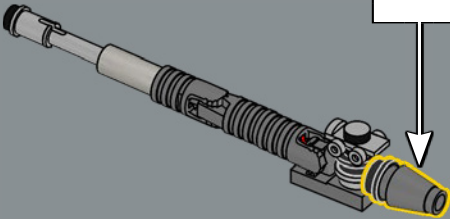

344

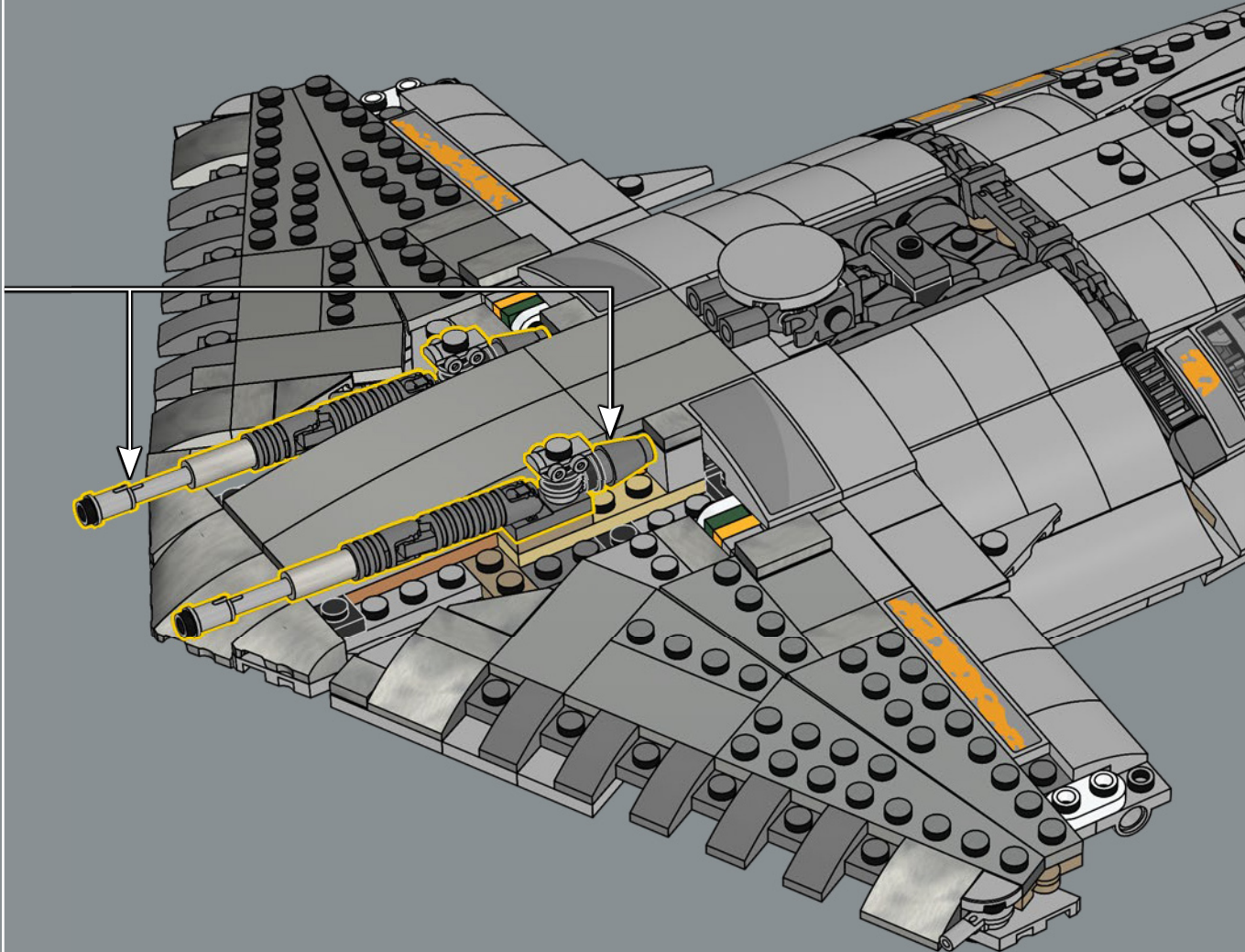

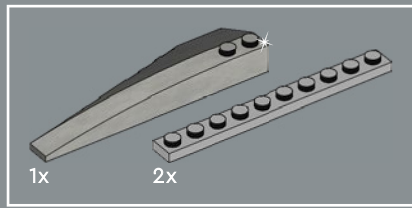

345

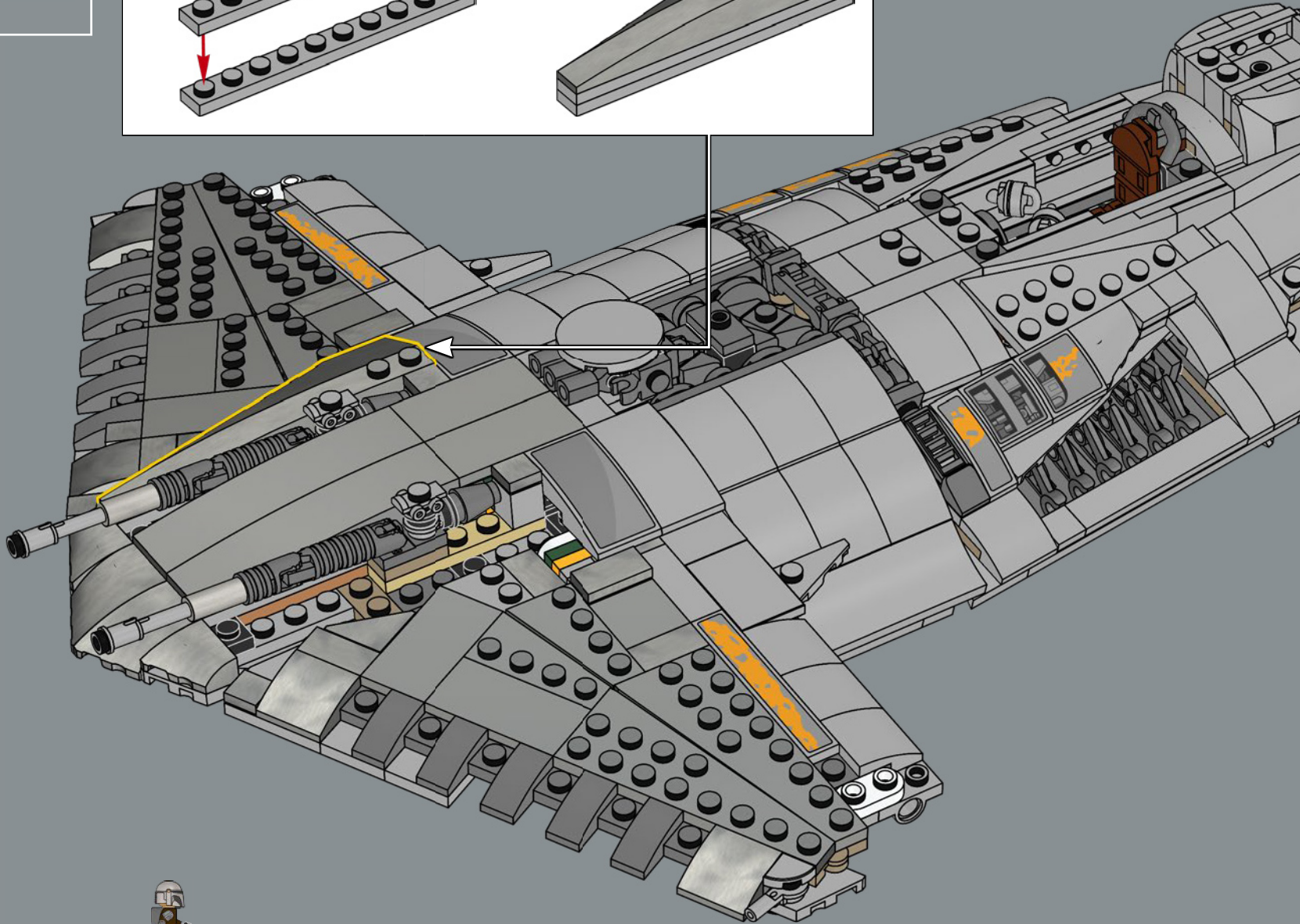
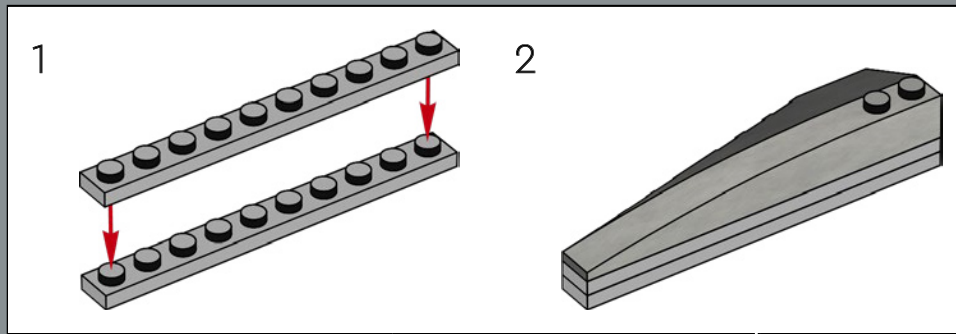

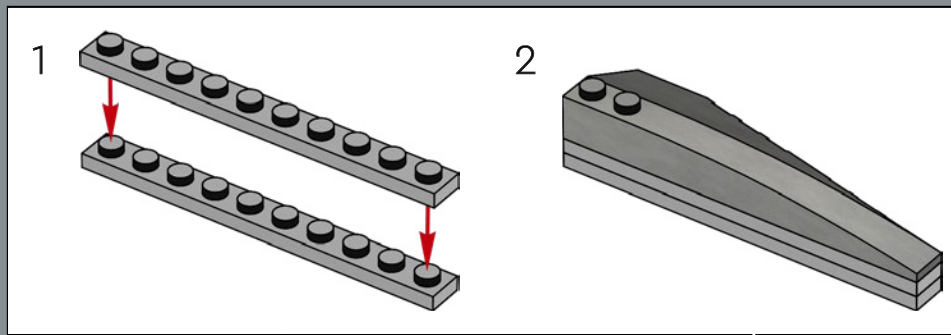
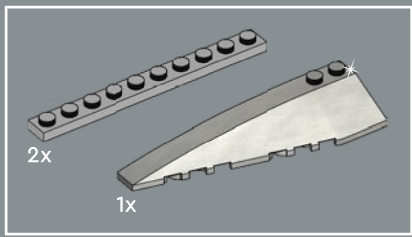

346

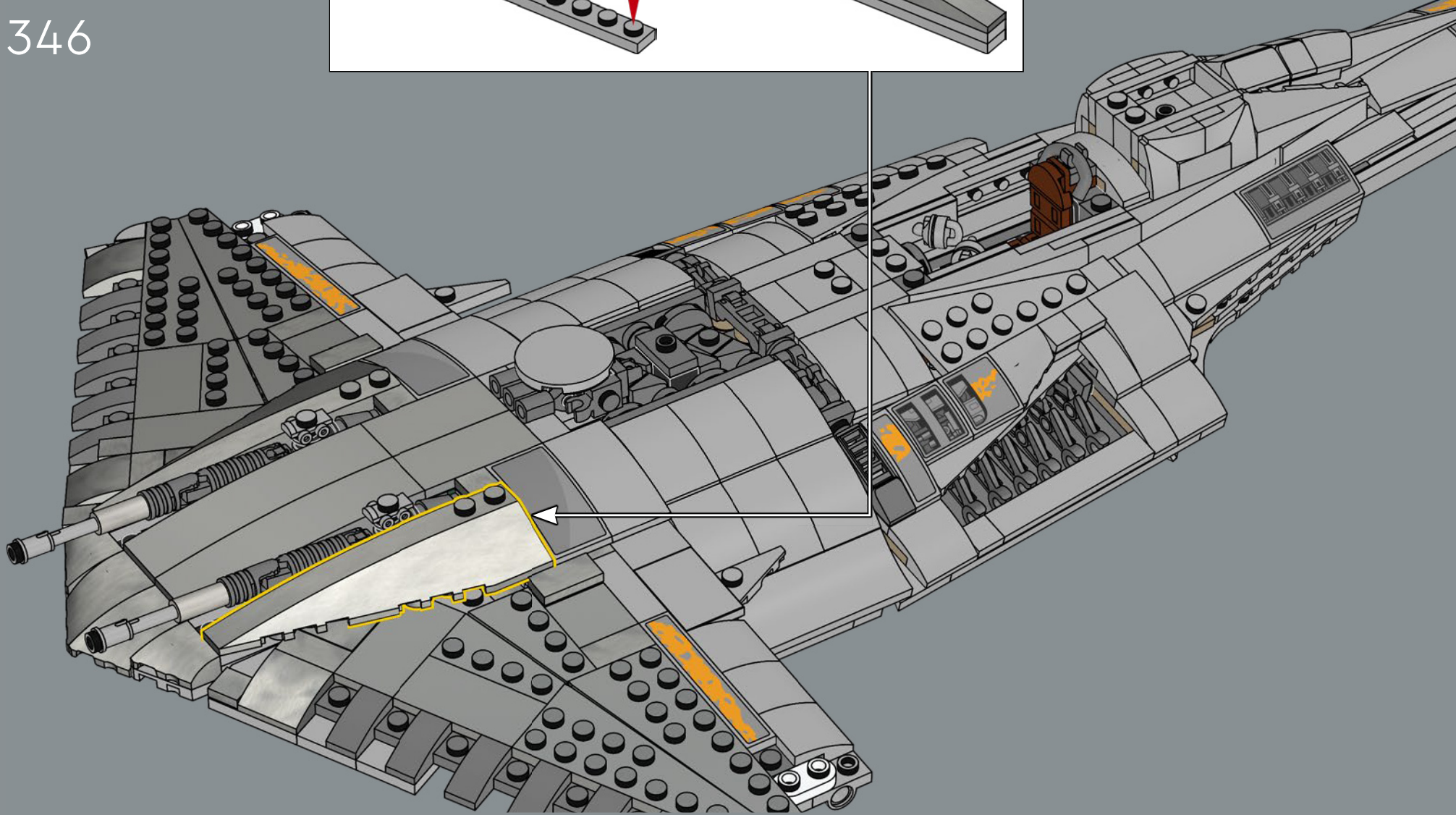

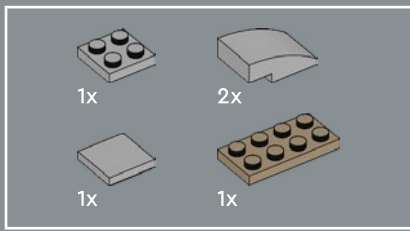

347

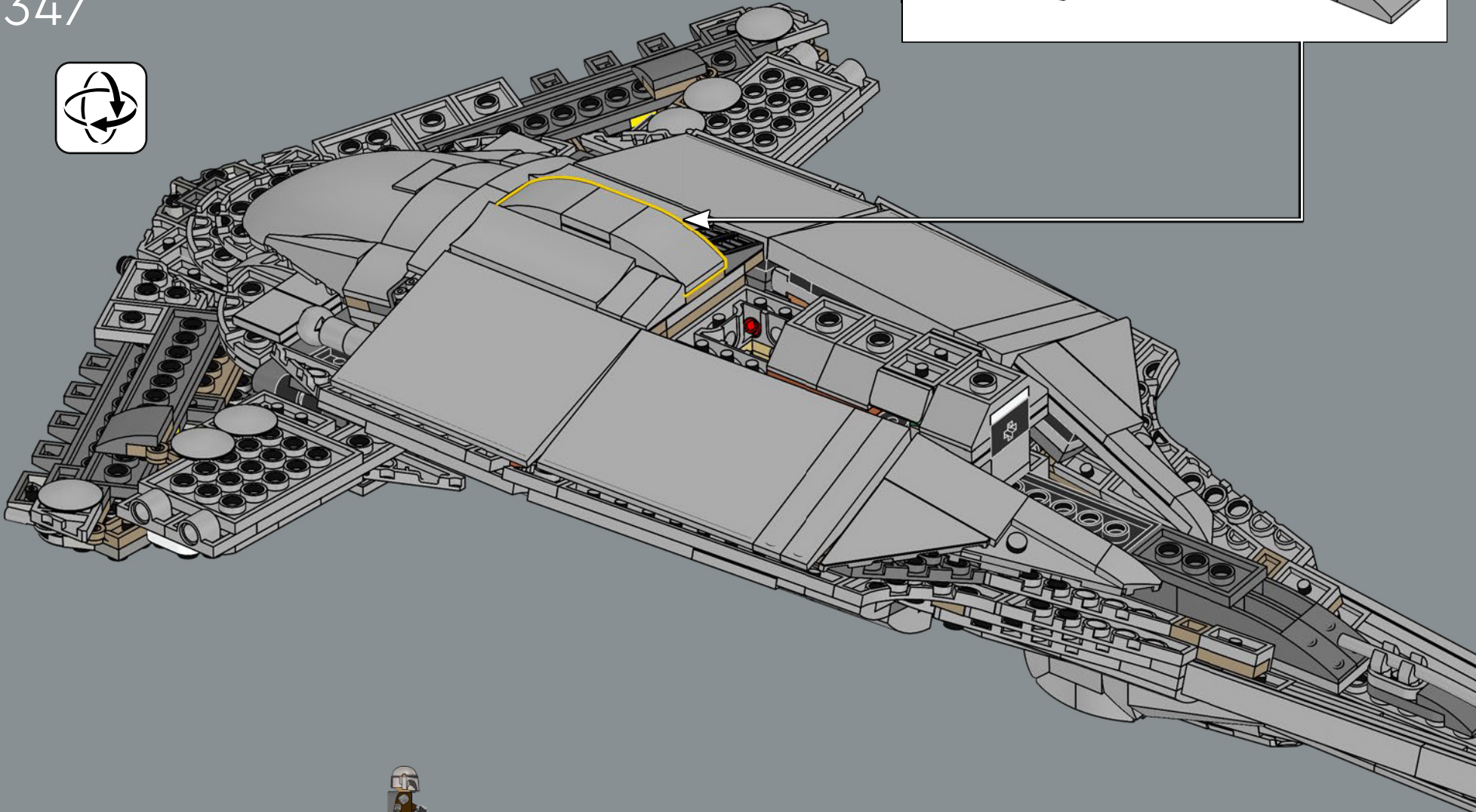
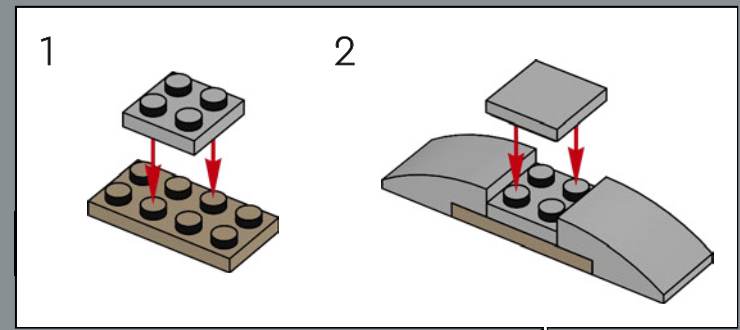

348

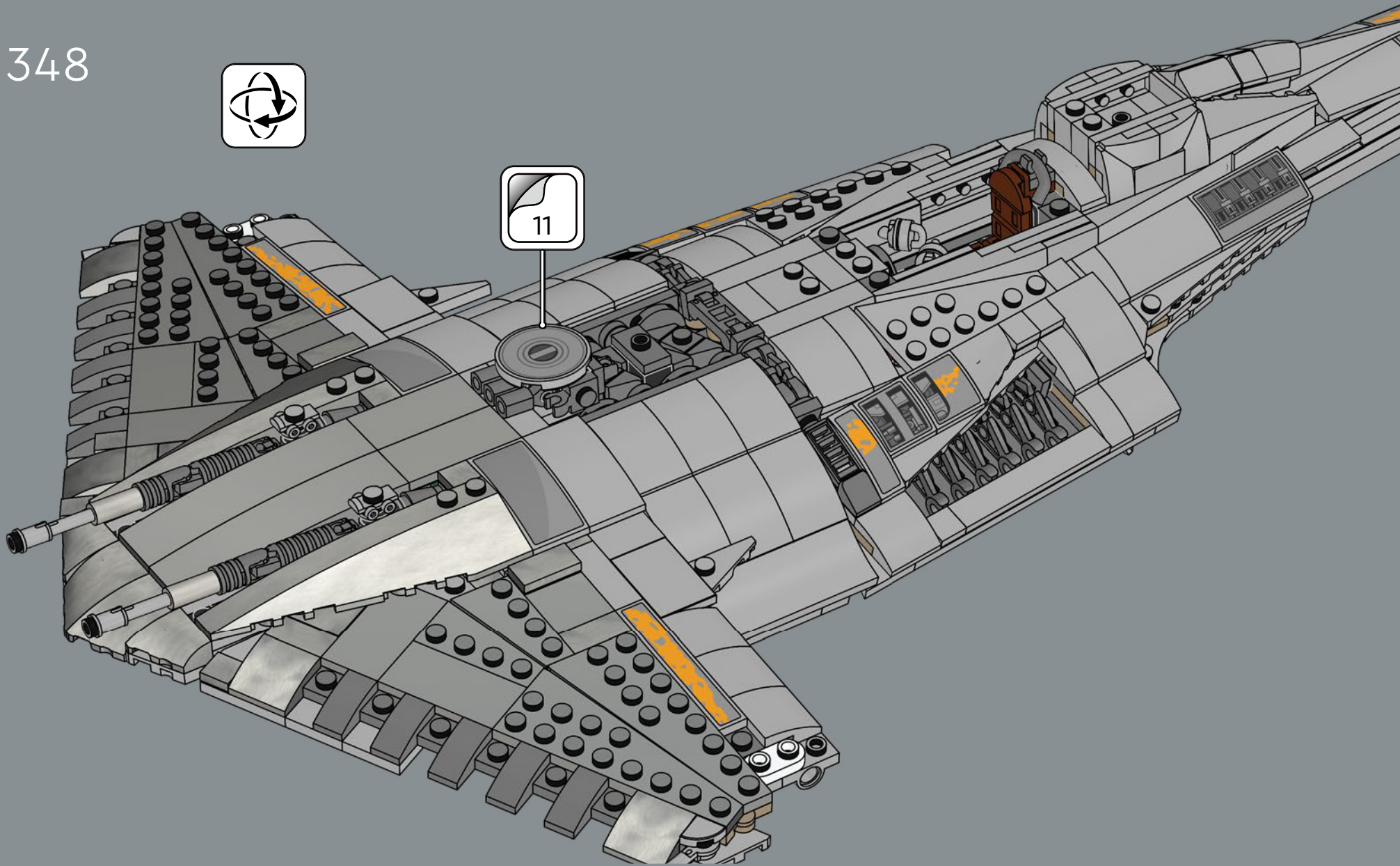

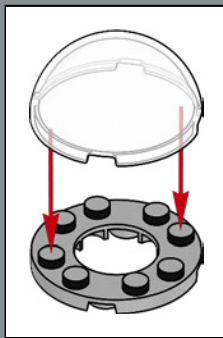
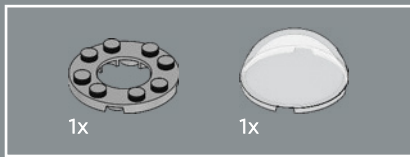

349

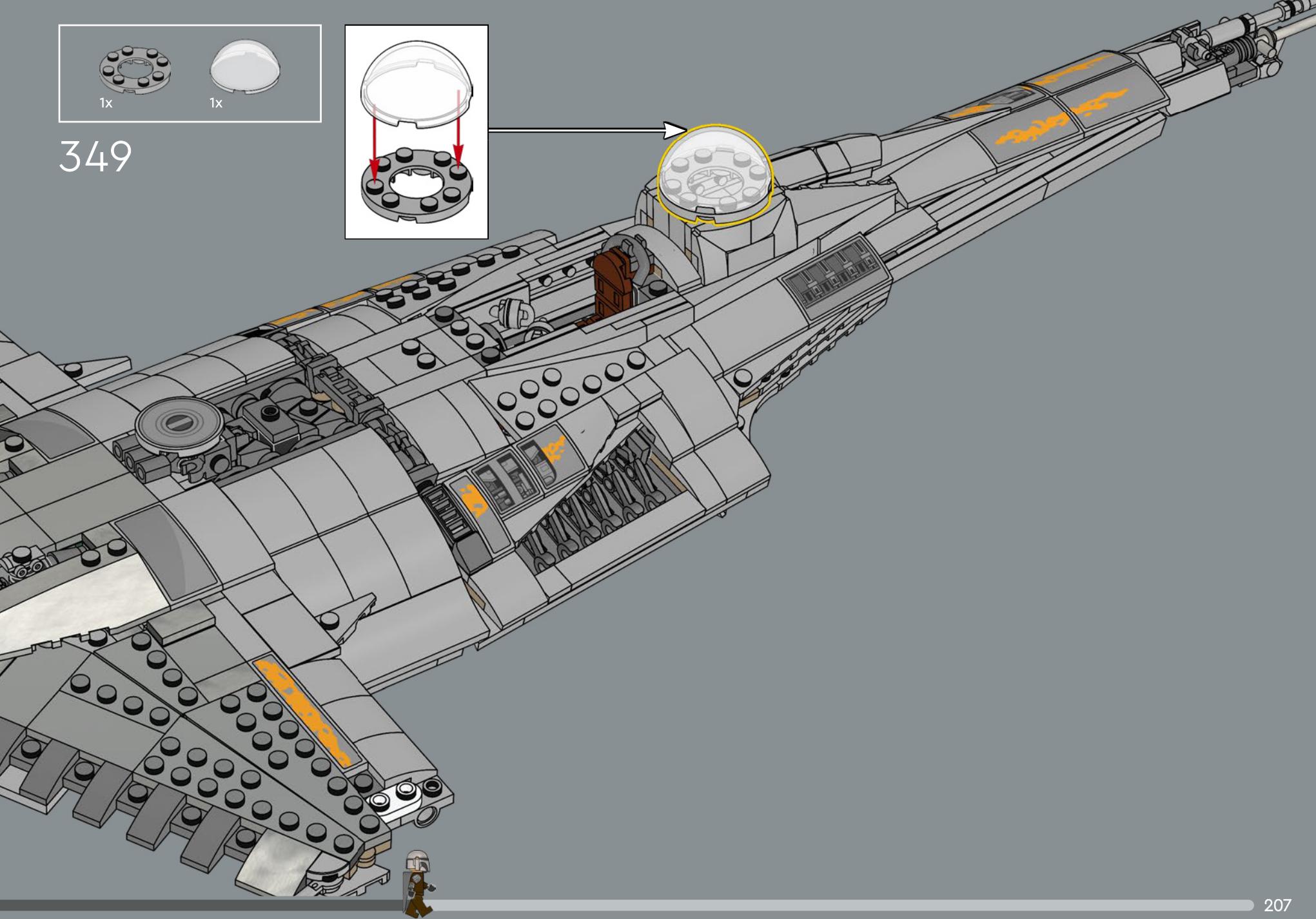

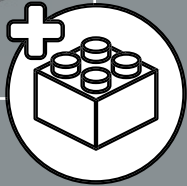
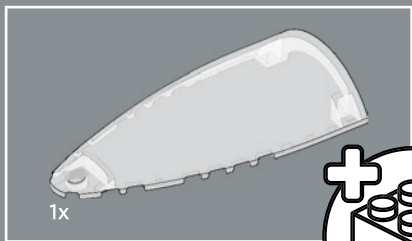

350

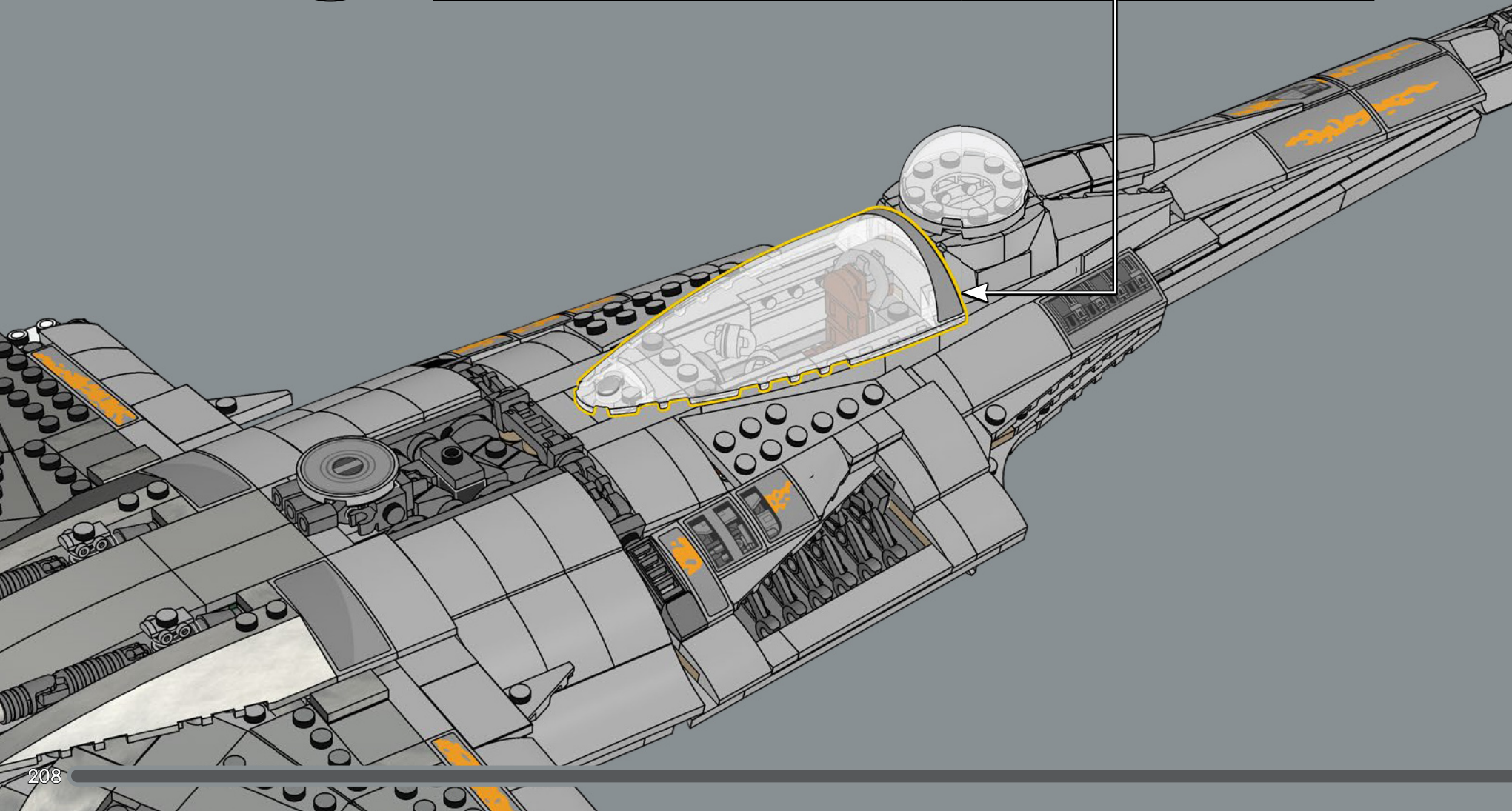
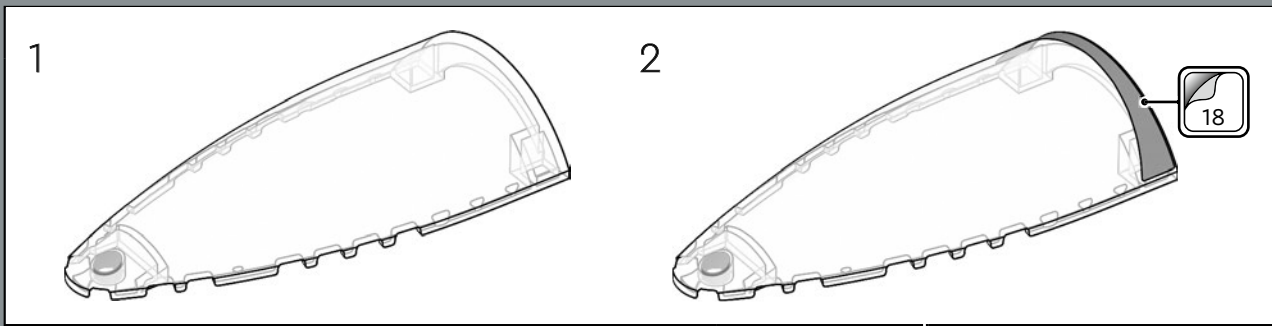

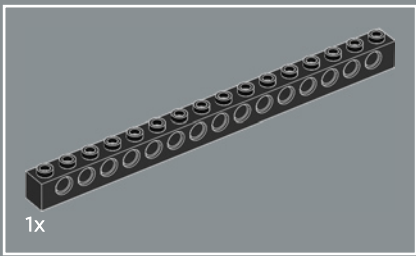

352

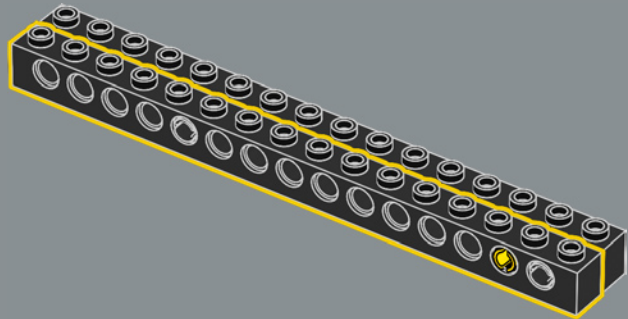

353

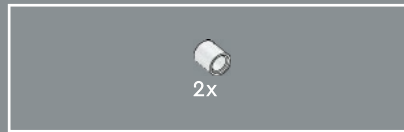
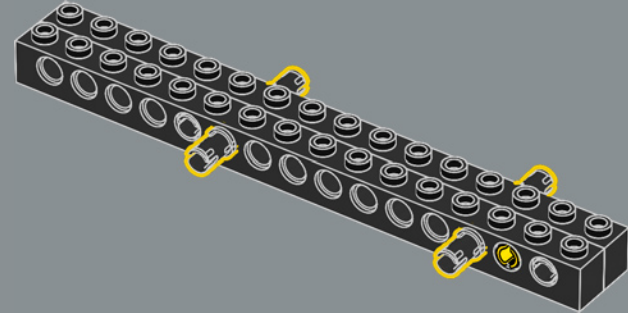

354

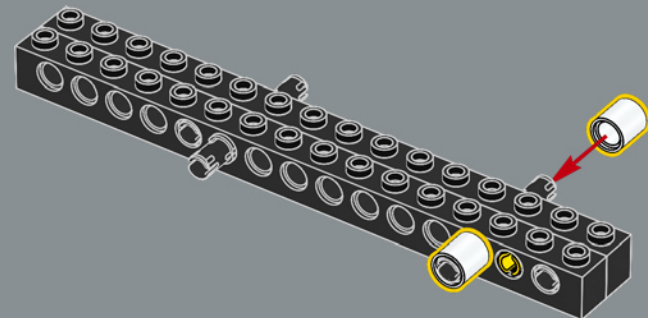

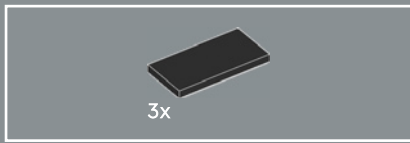

355

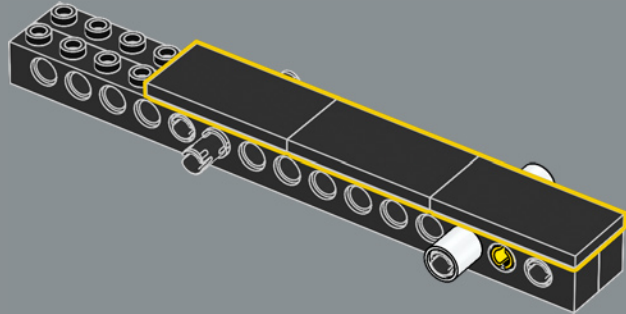

356

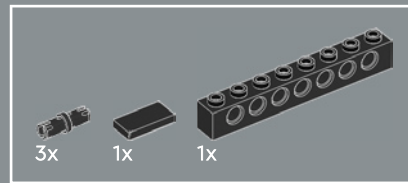
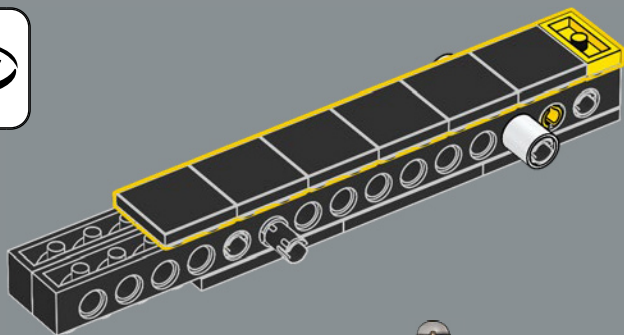

357

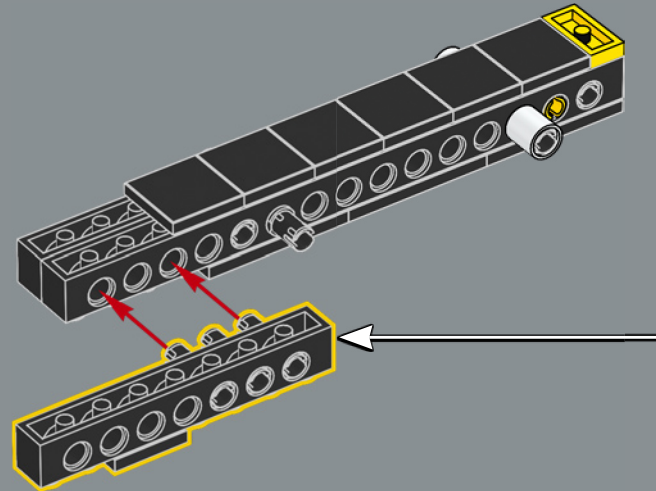
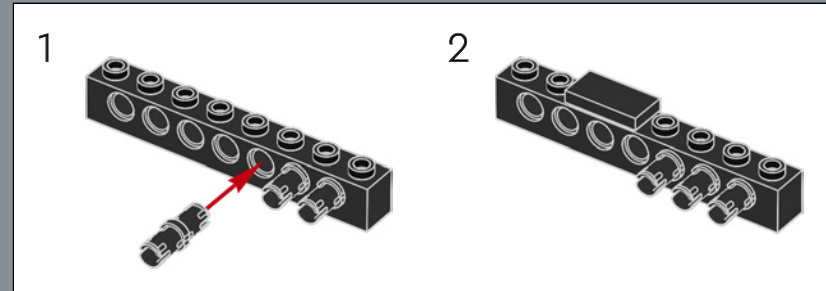

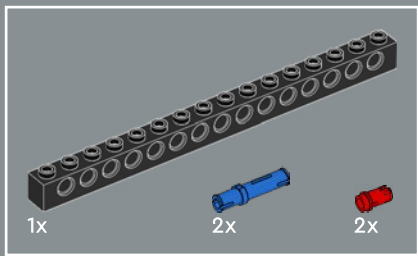

358

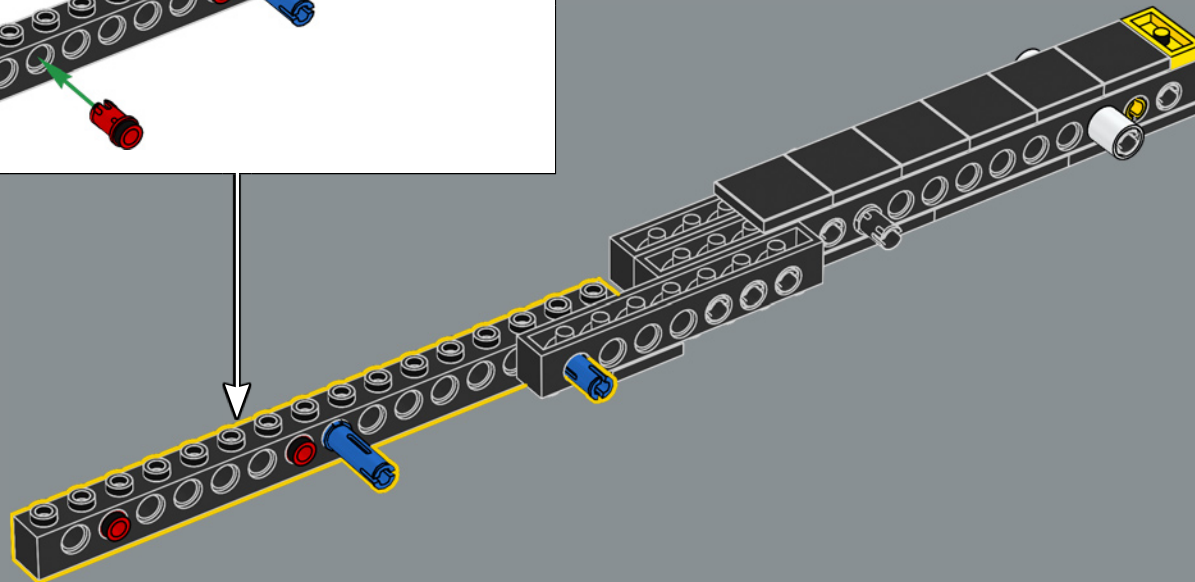
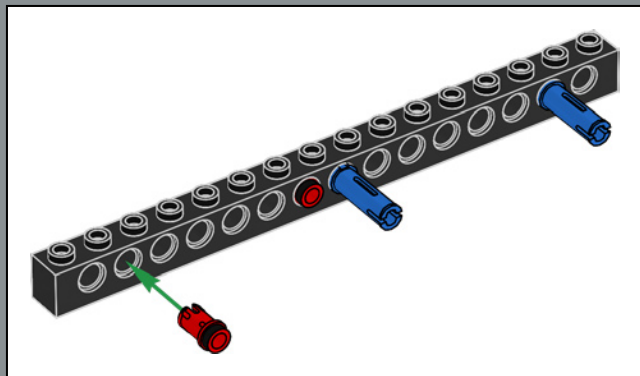

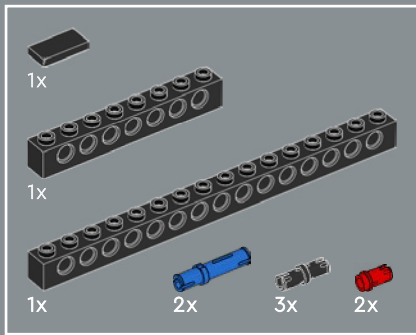

359

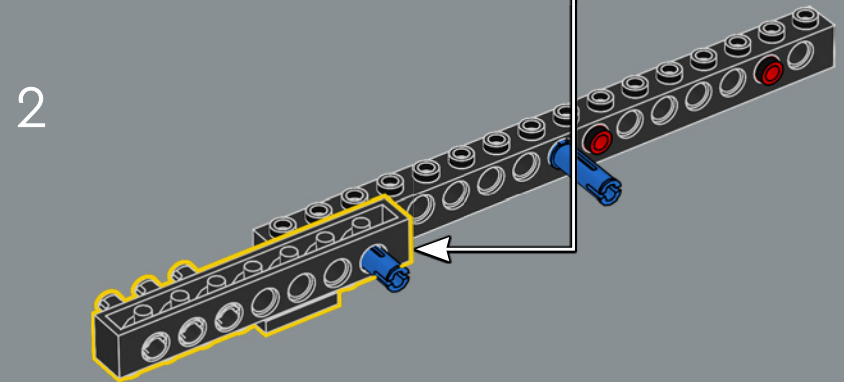
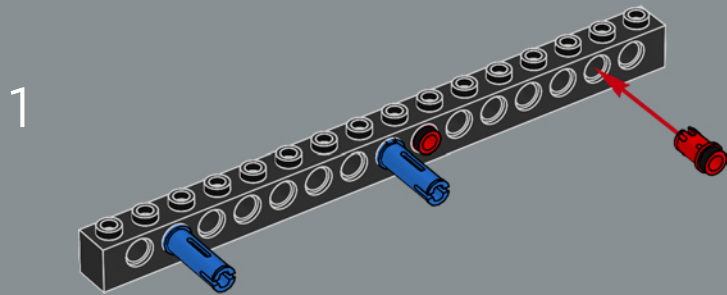
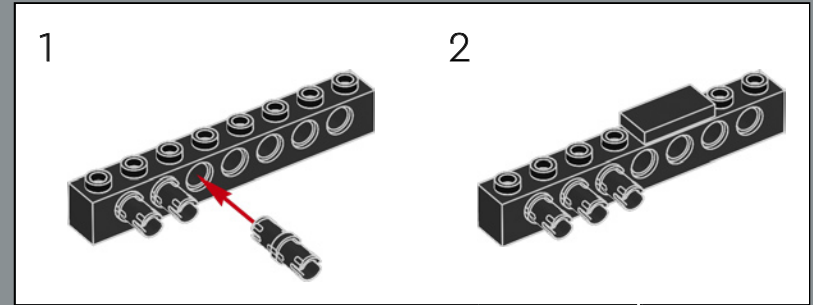

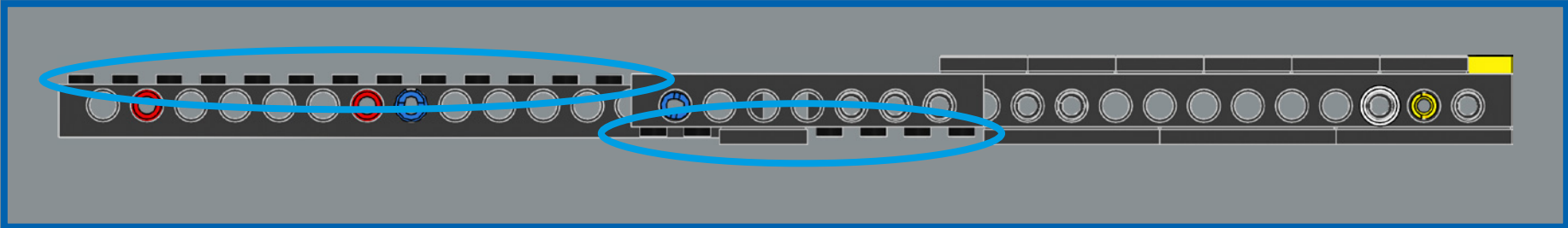
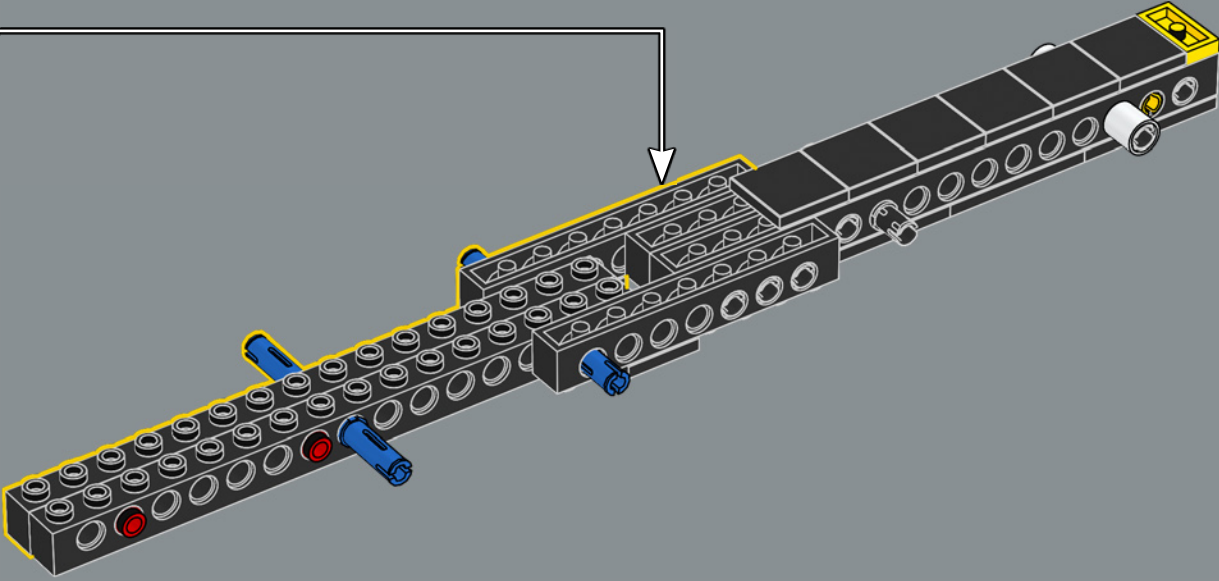

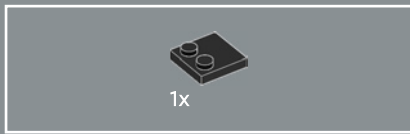

360

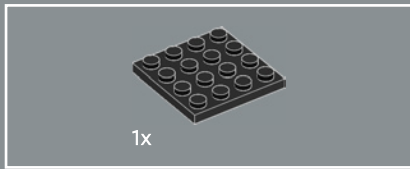
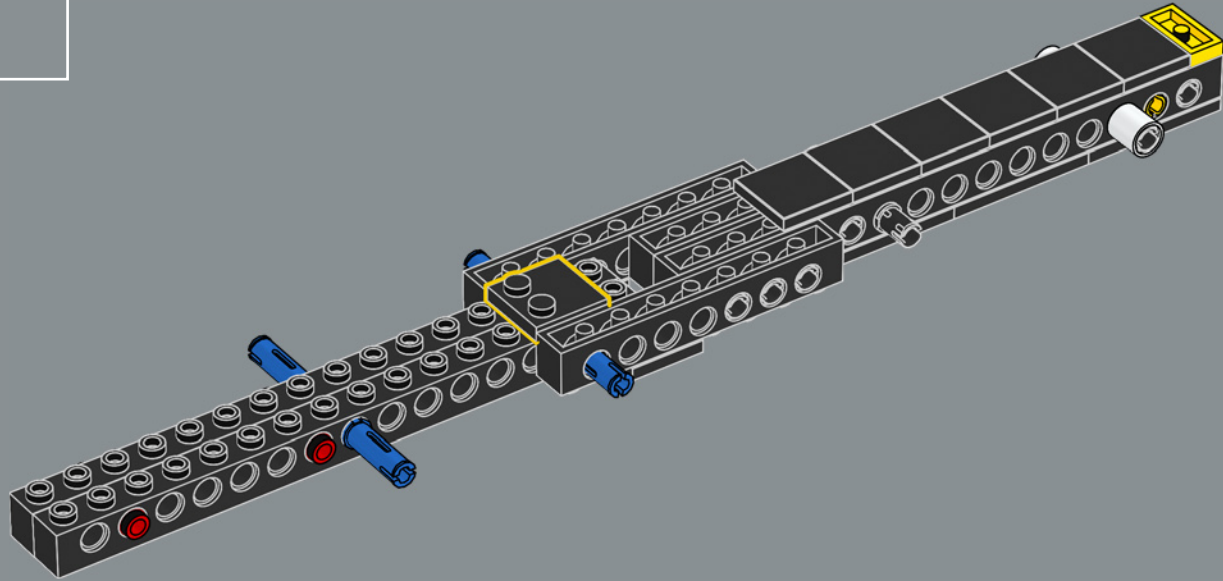

361

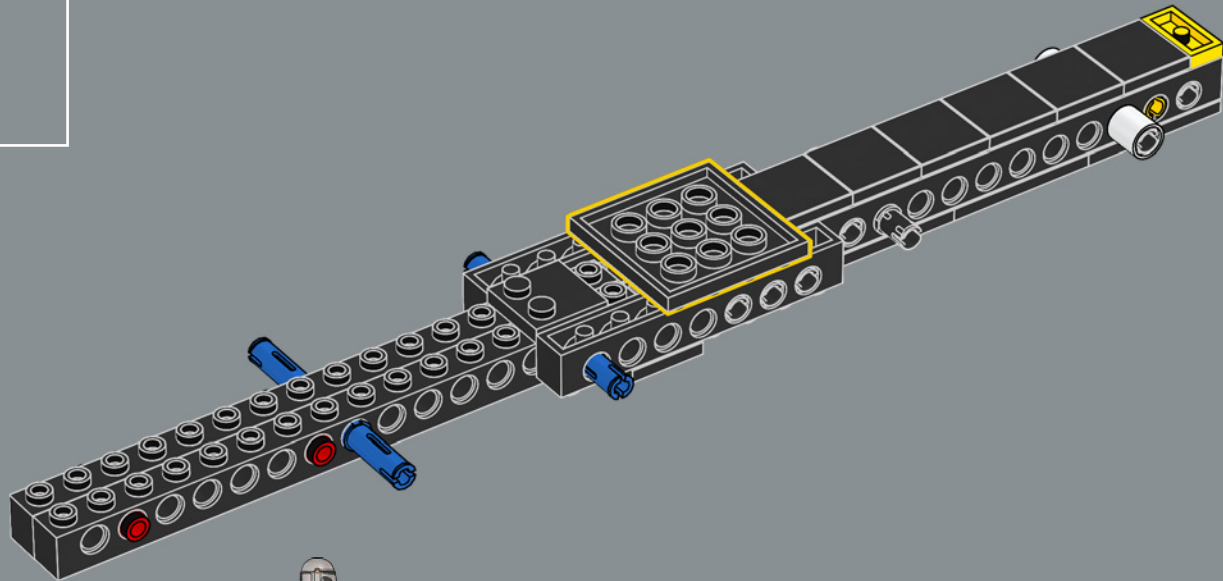

362

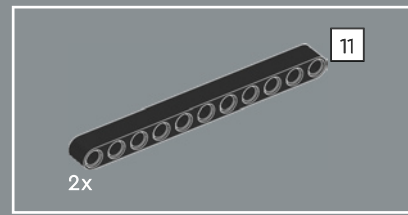
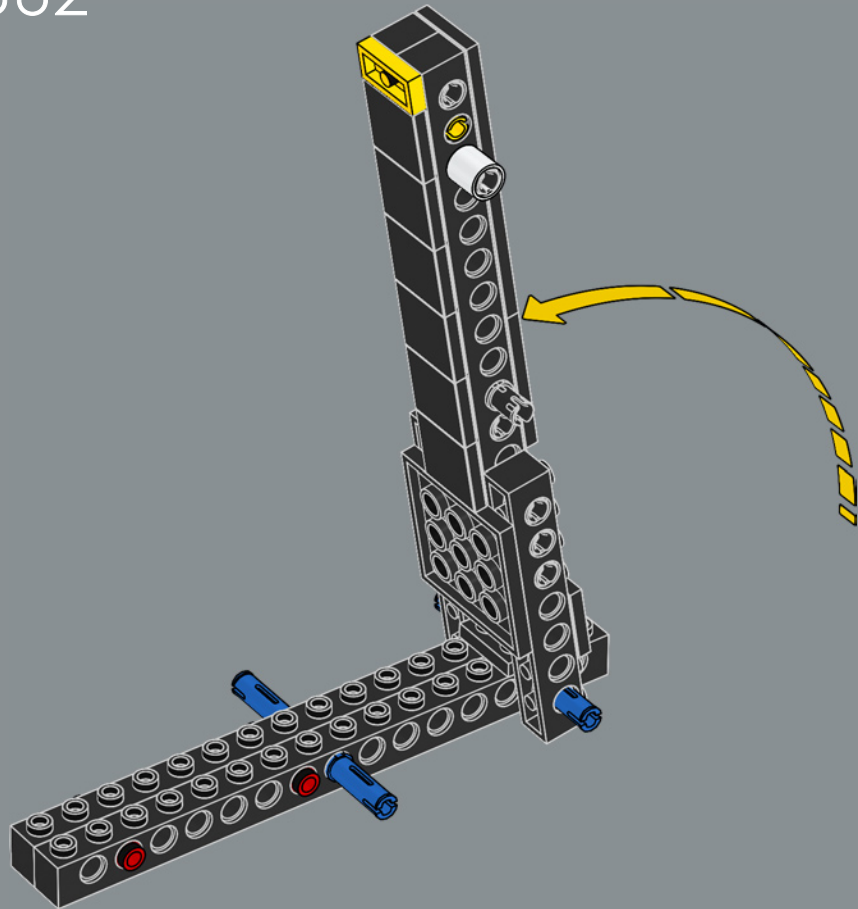

363

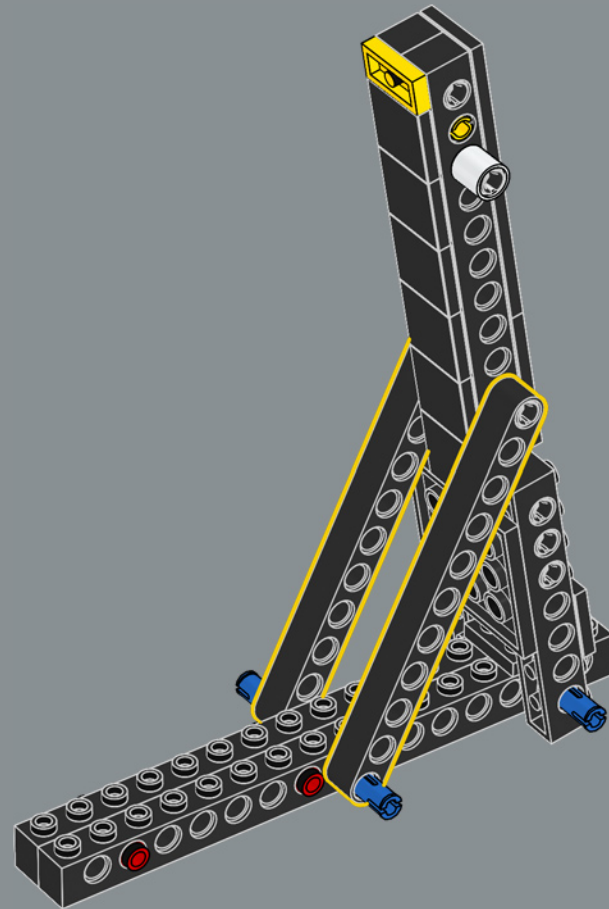

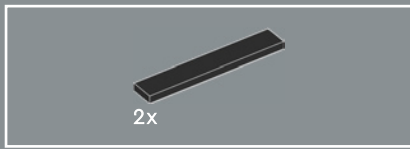

364

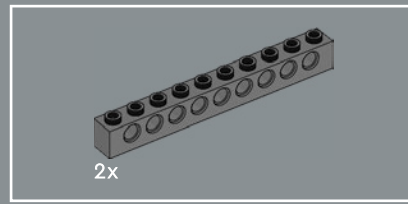
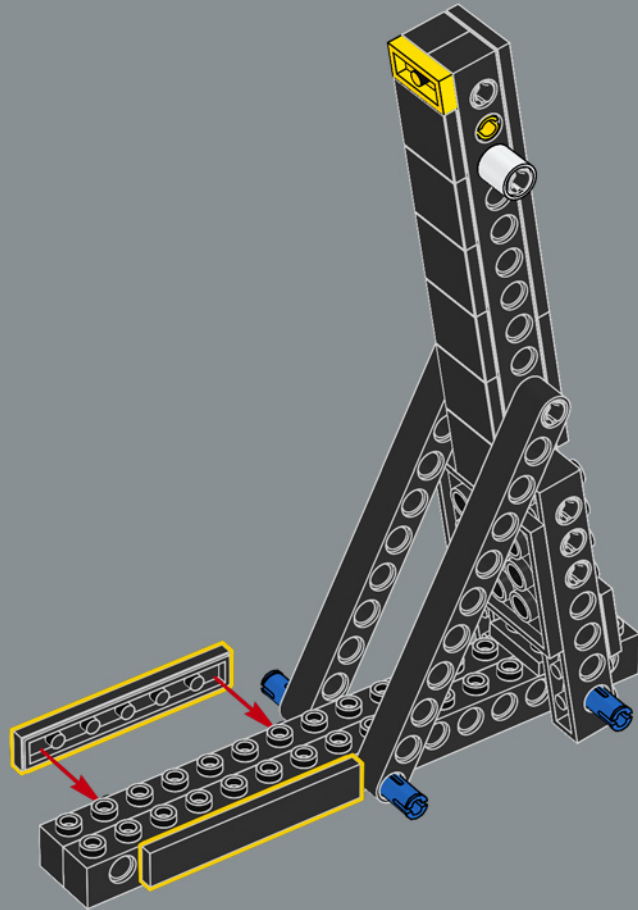

365

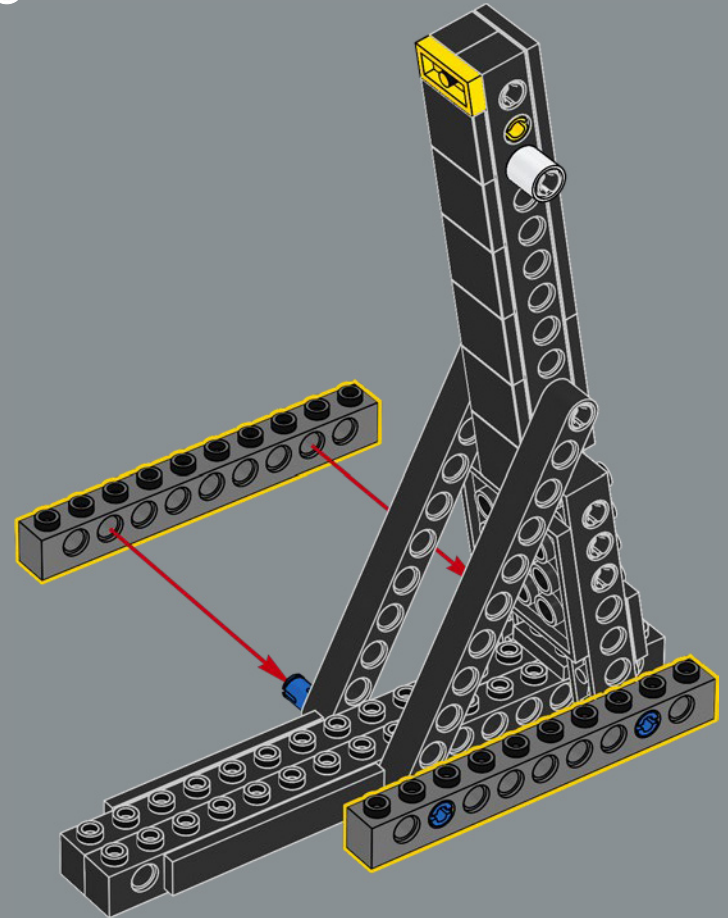

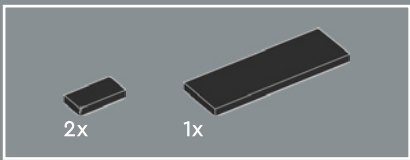

366

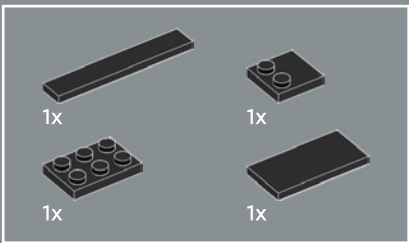
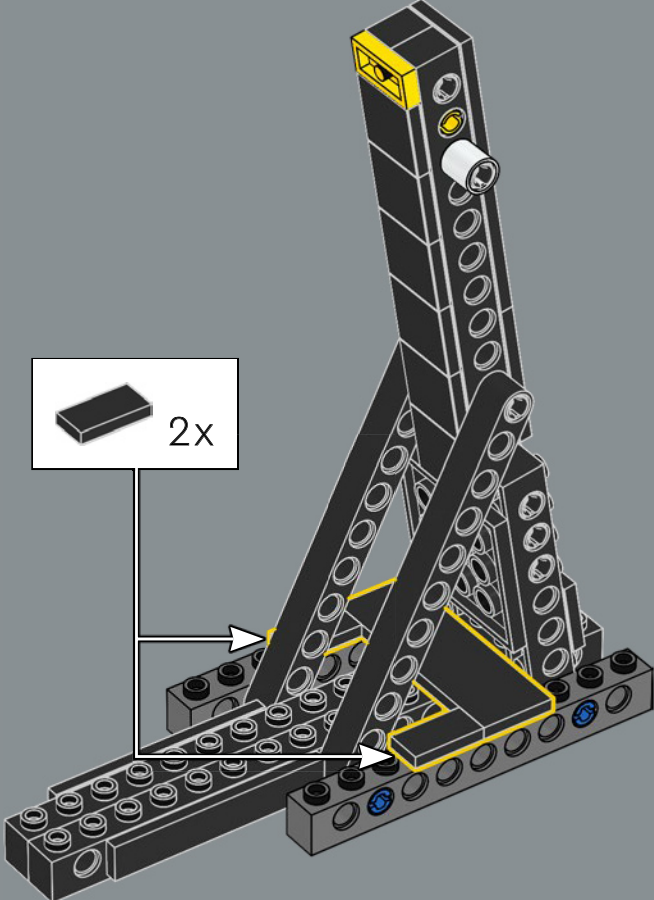

367

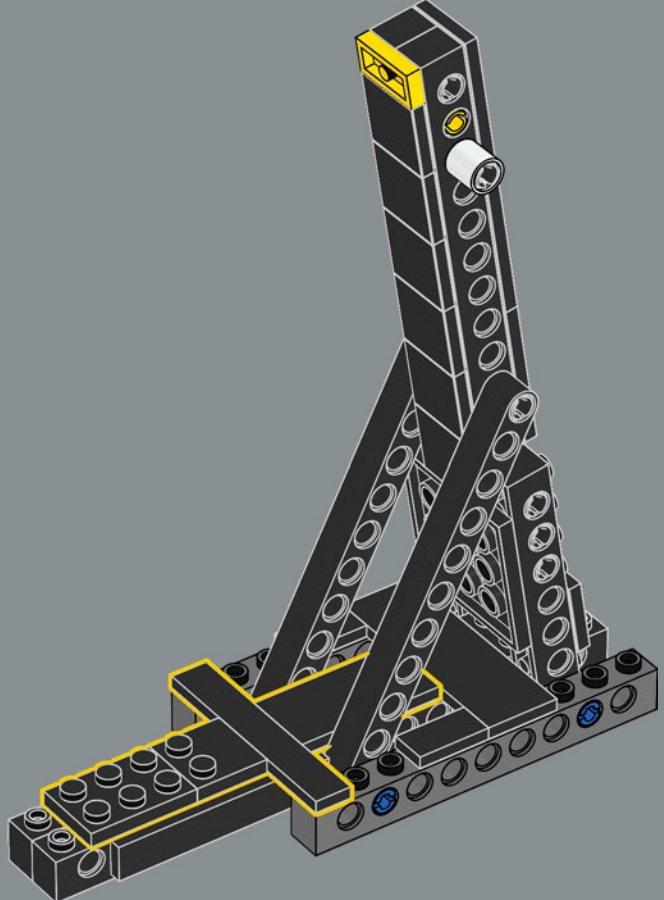

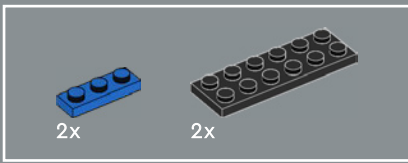

368

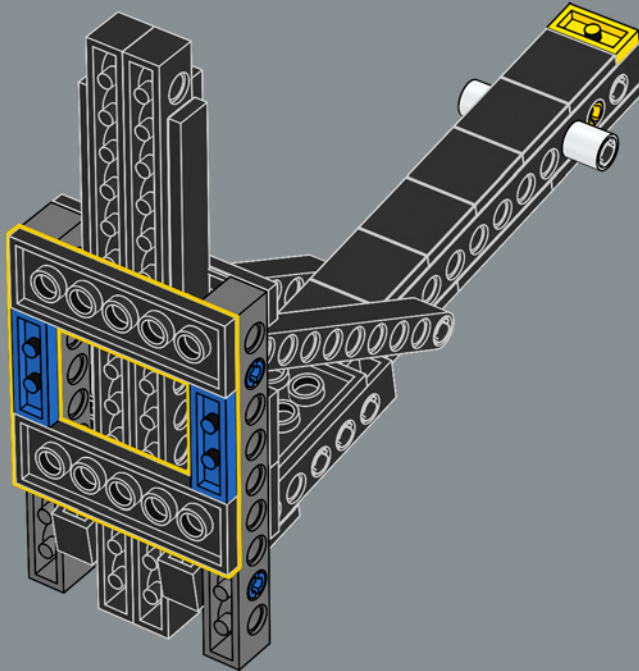

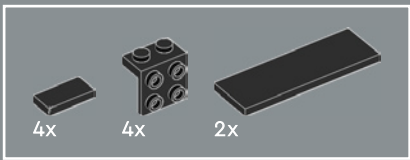

369

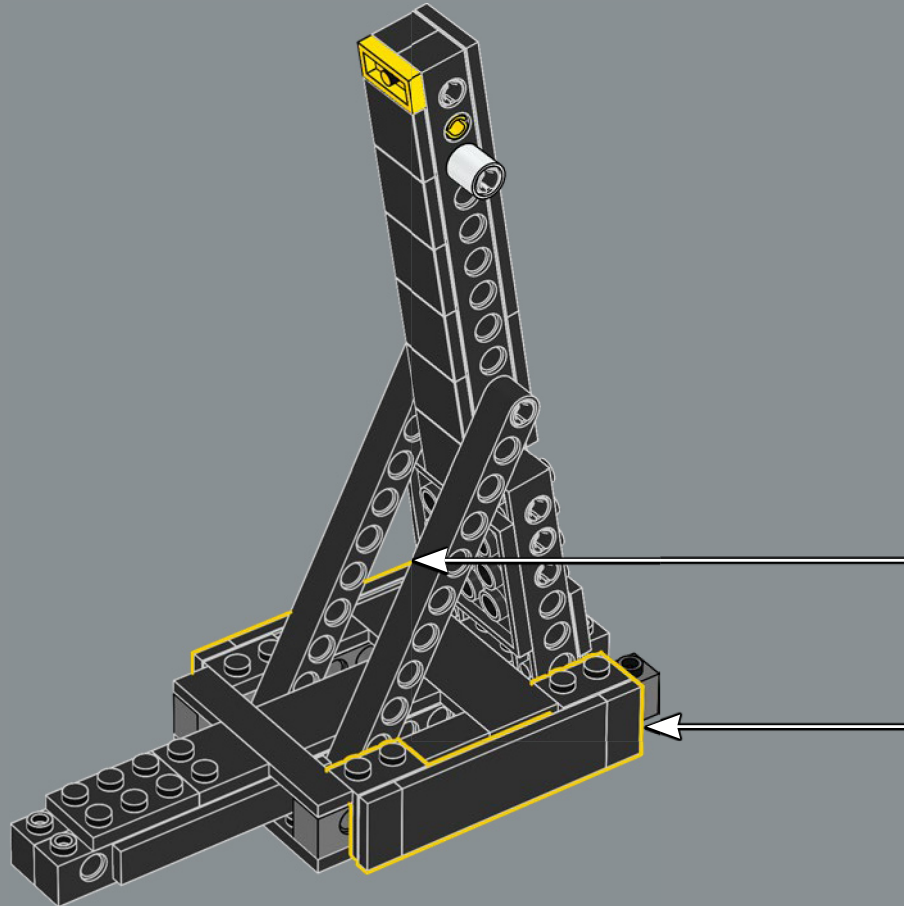
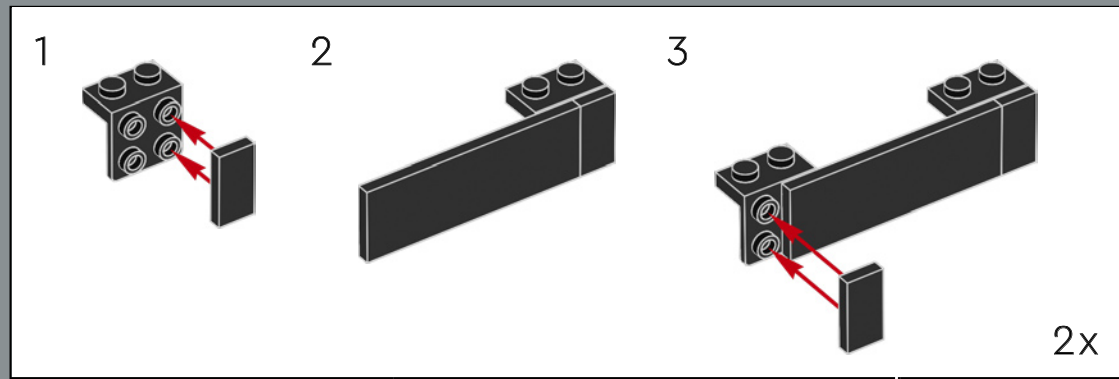

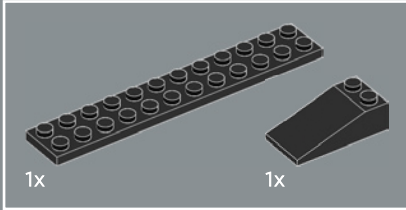
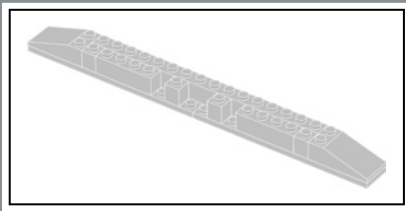

370

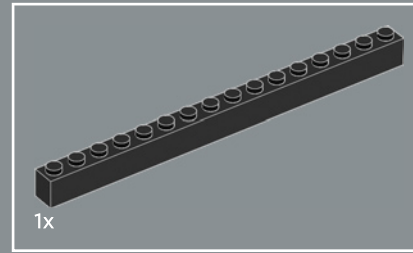
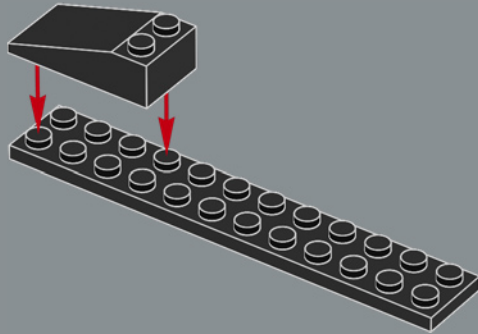

371

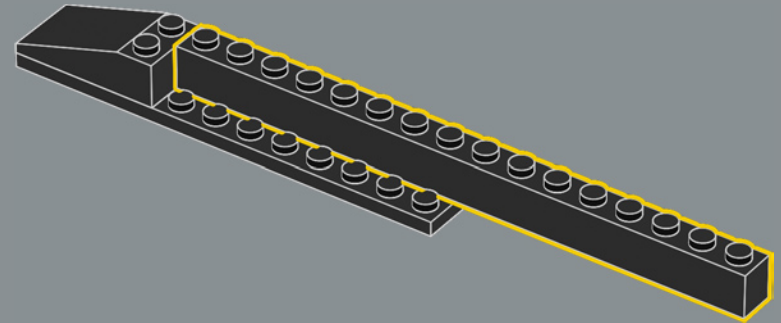

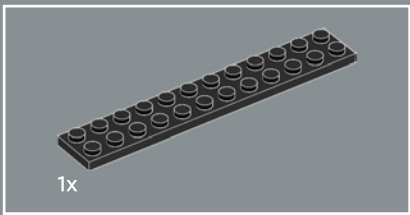

372

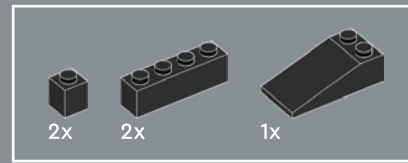
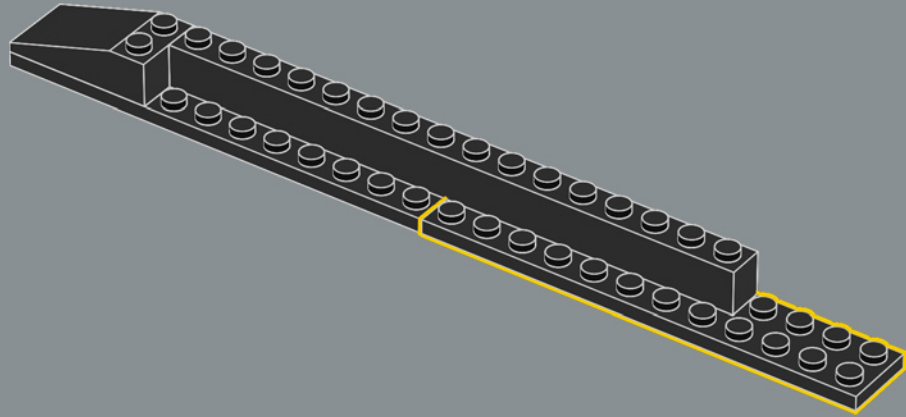

373

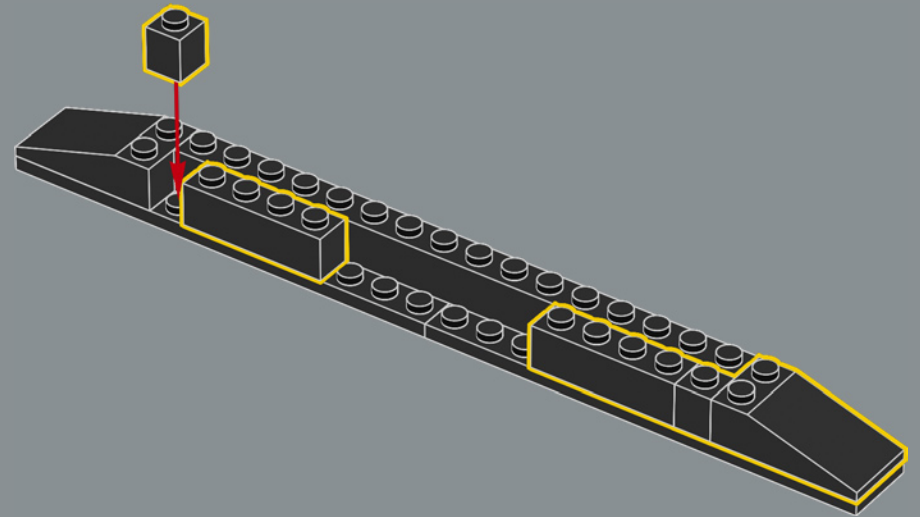



2x

374

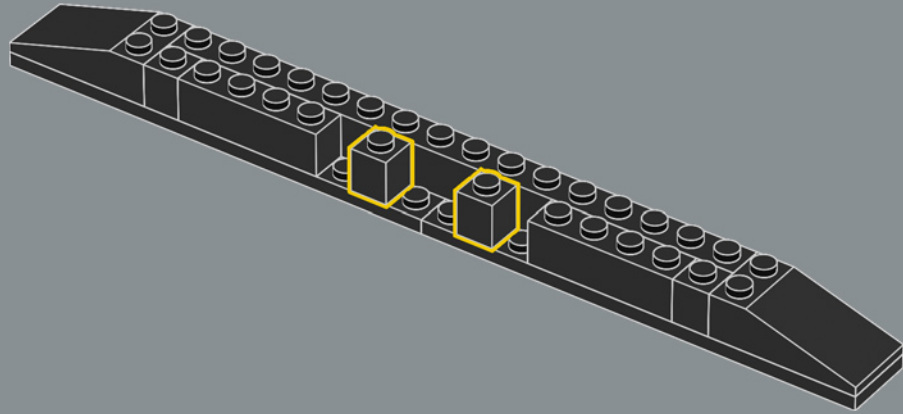

375

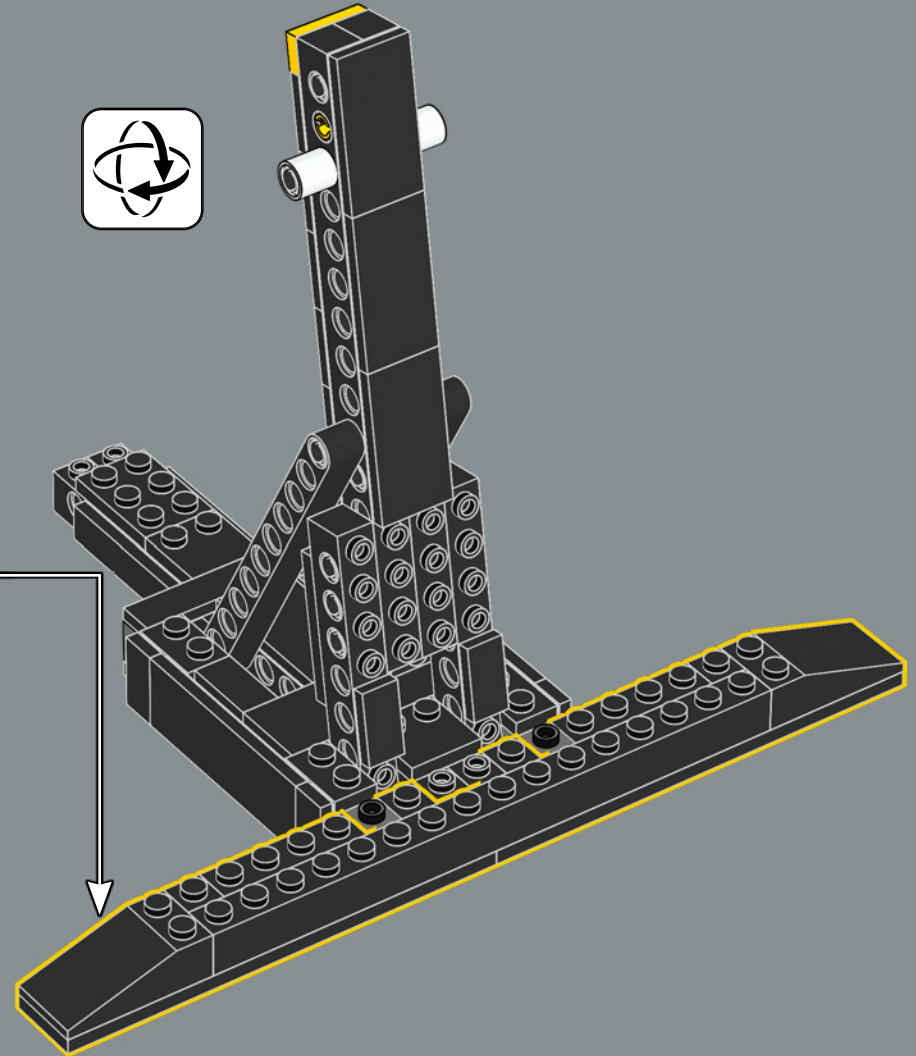

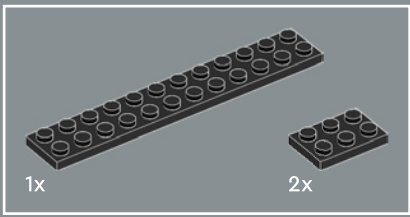

376

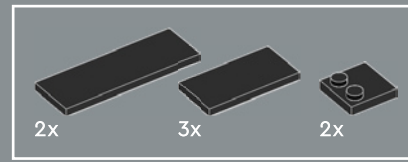
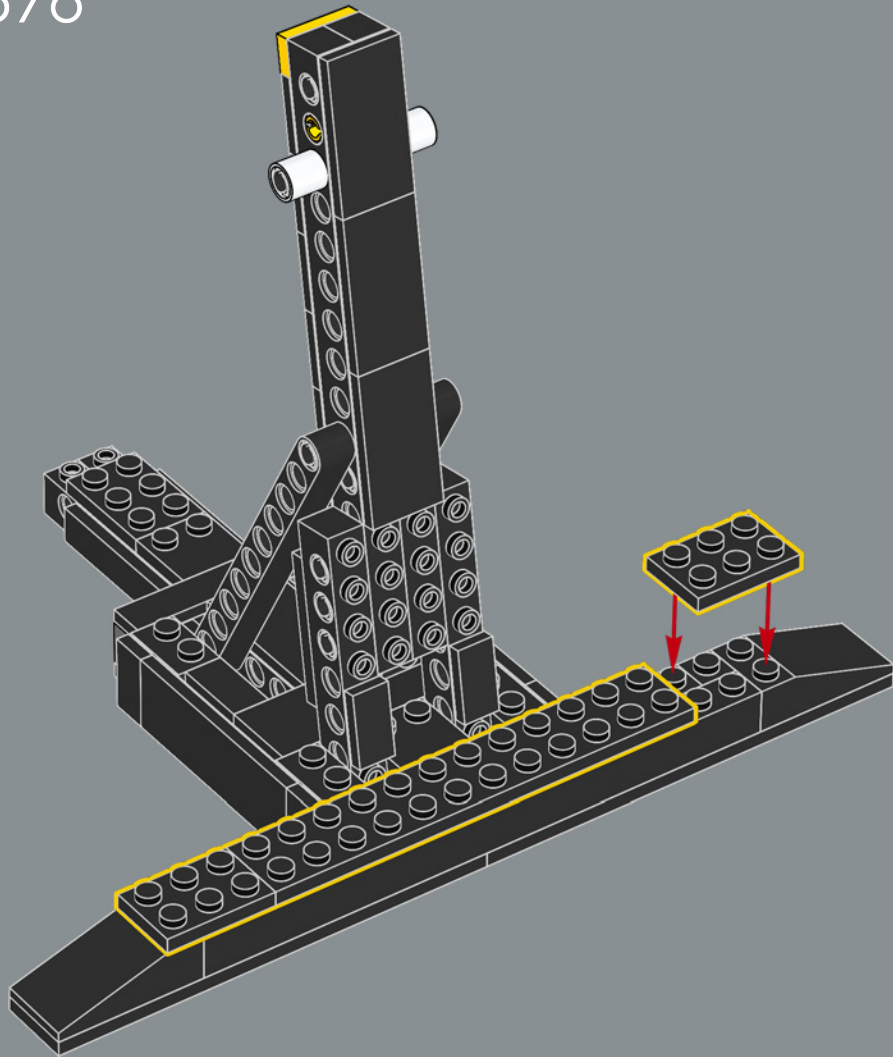

377

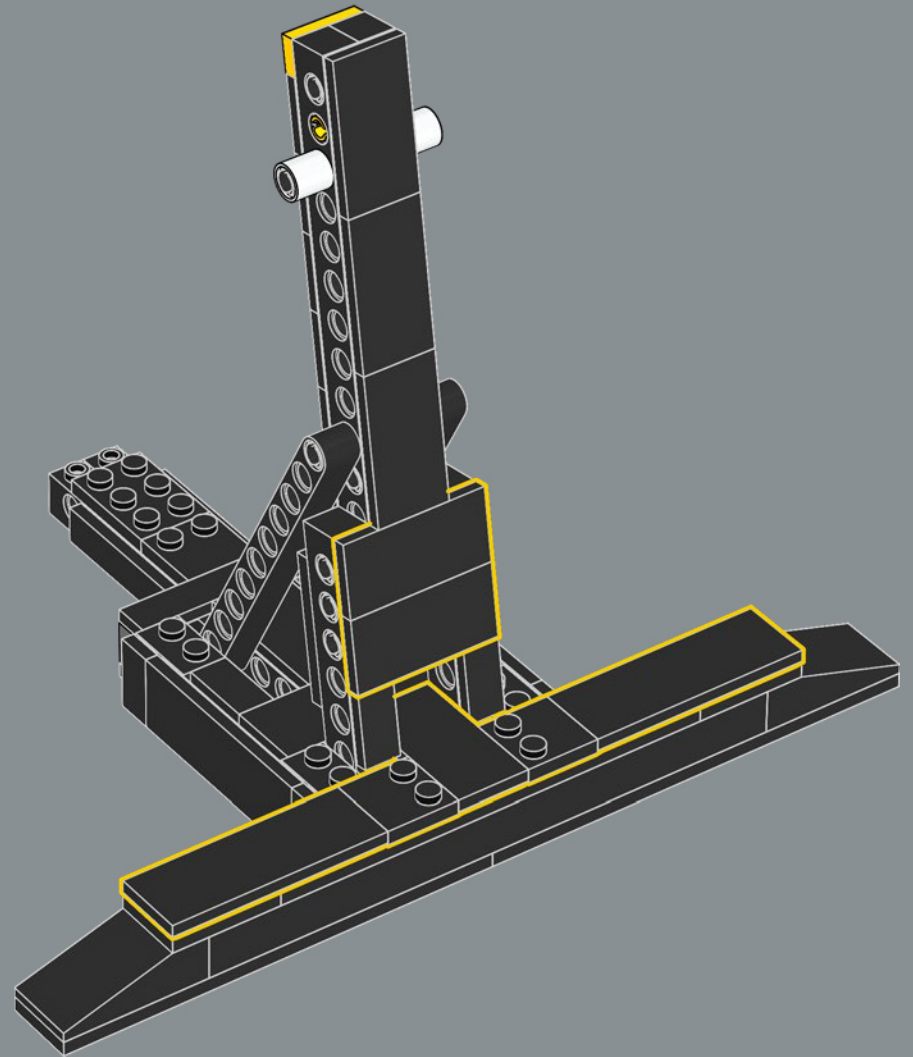

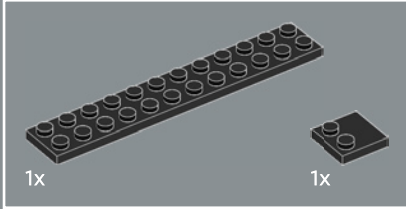
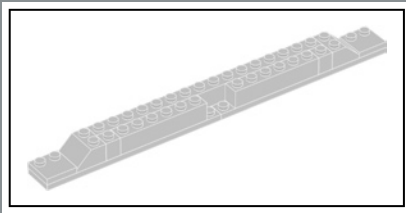

378

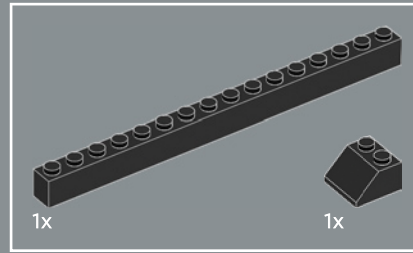
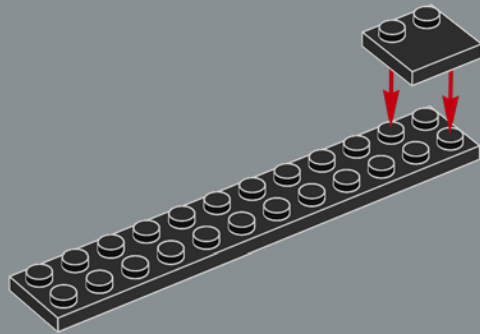

379

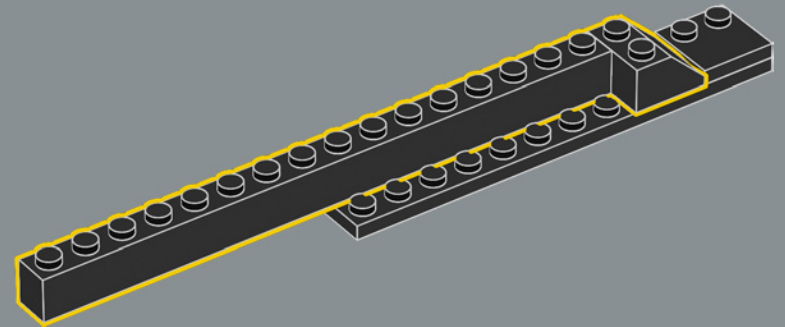

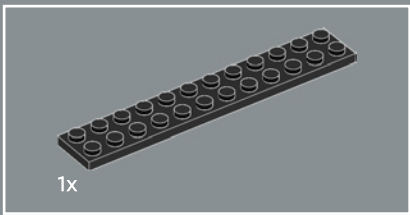

380

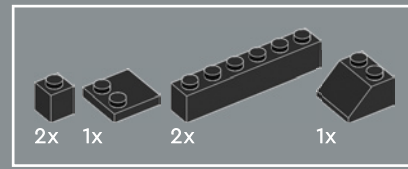
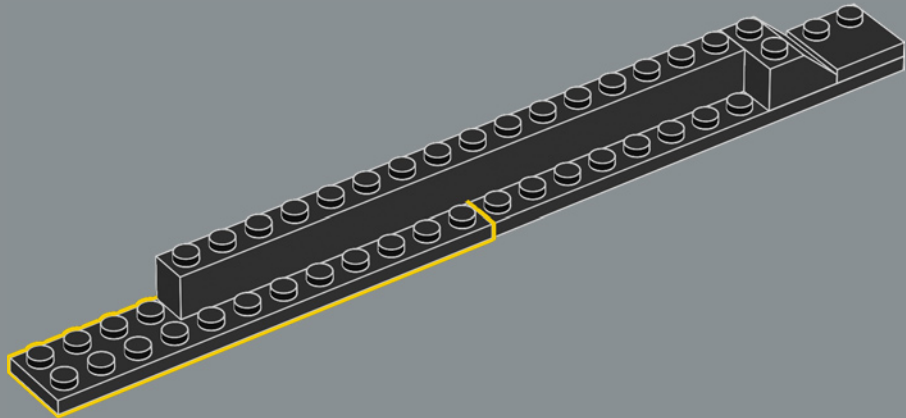

381

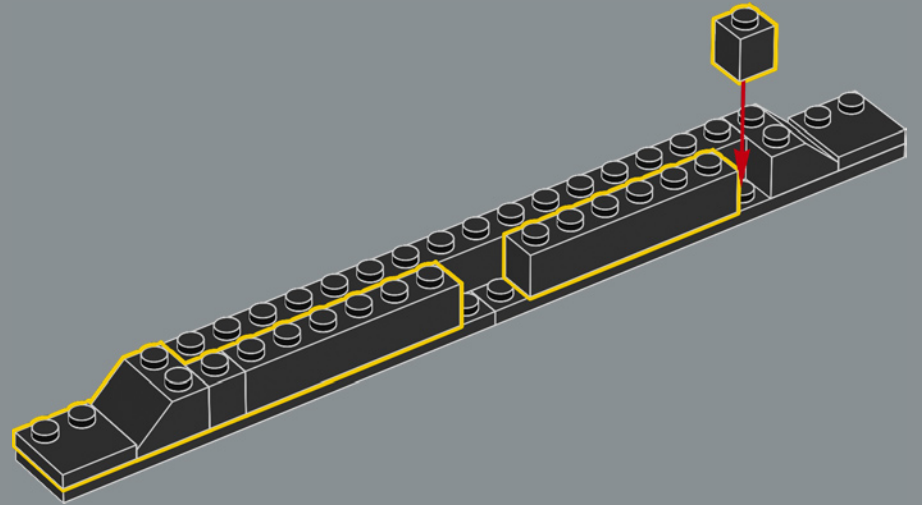

382

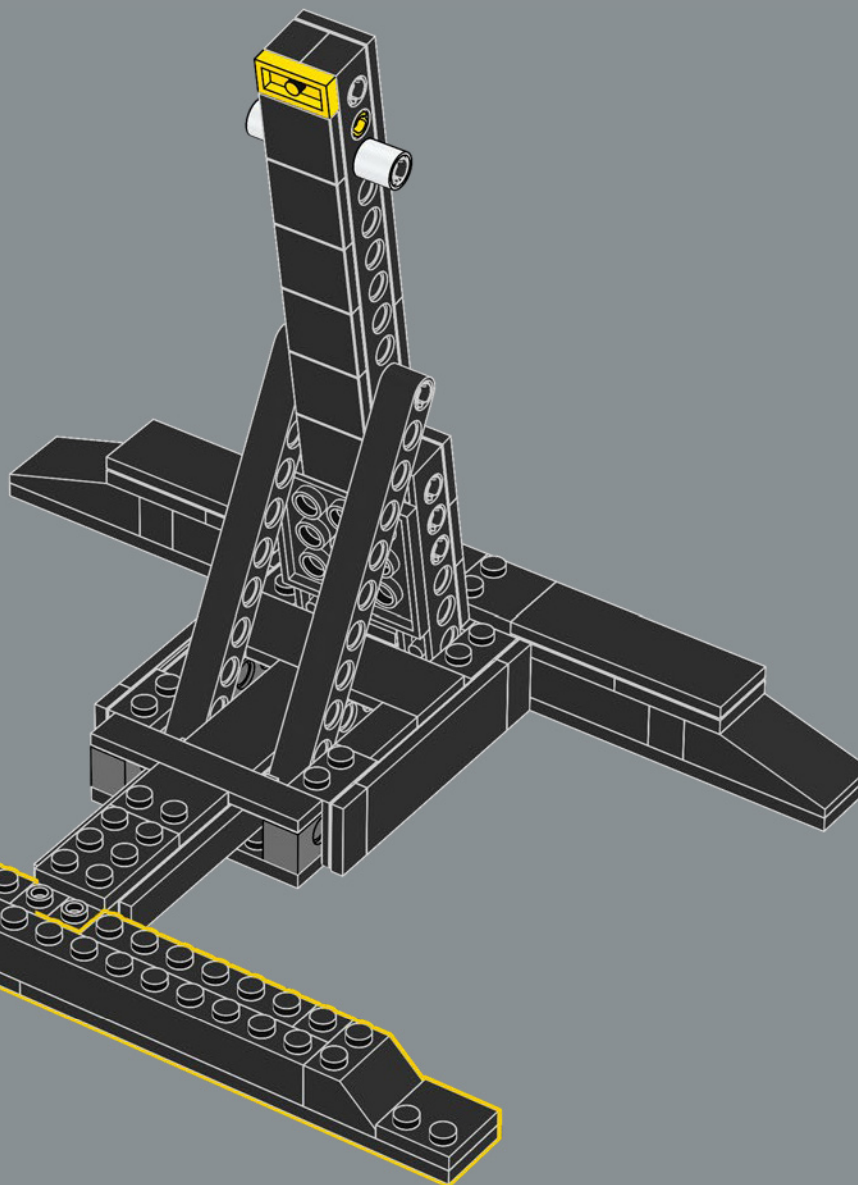

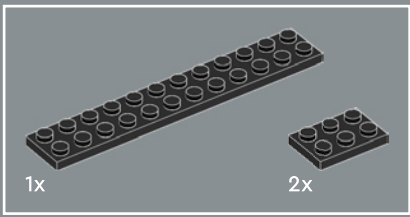

383

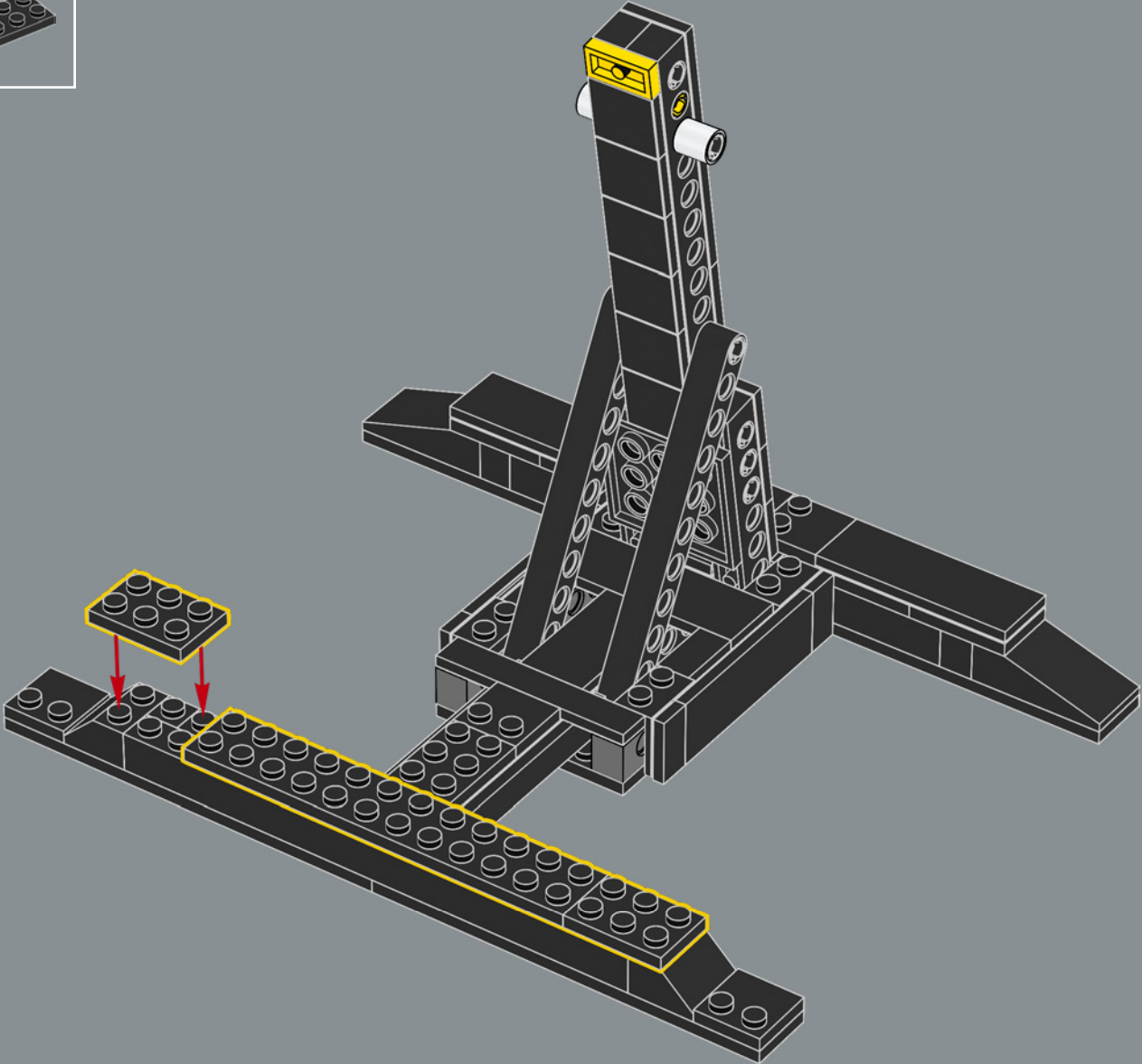

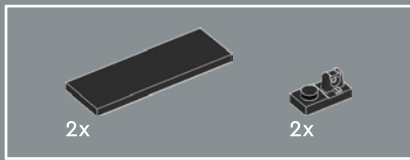

384

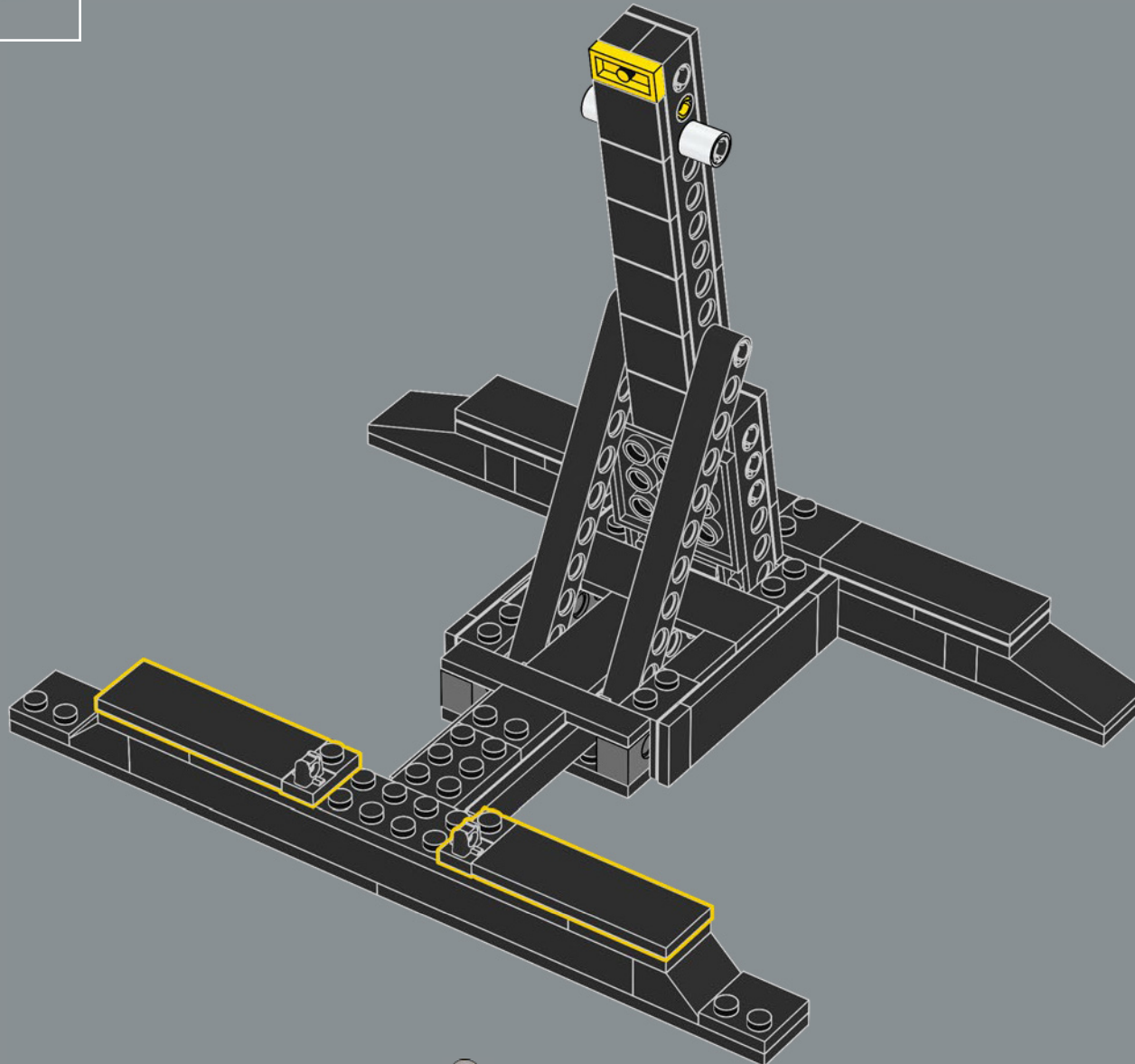

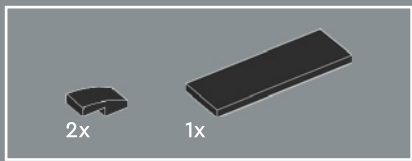

385

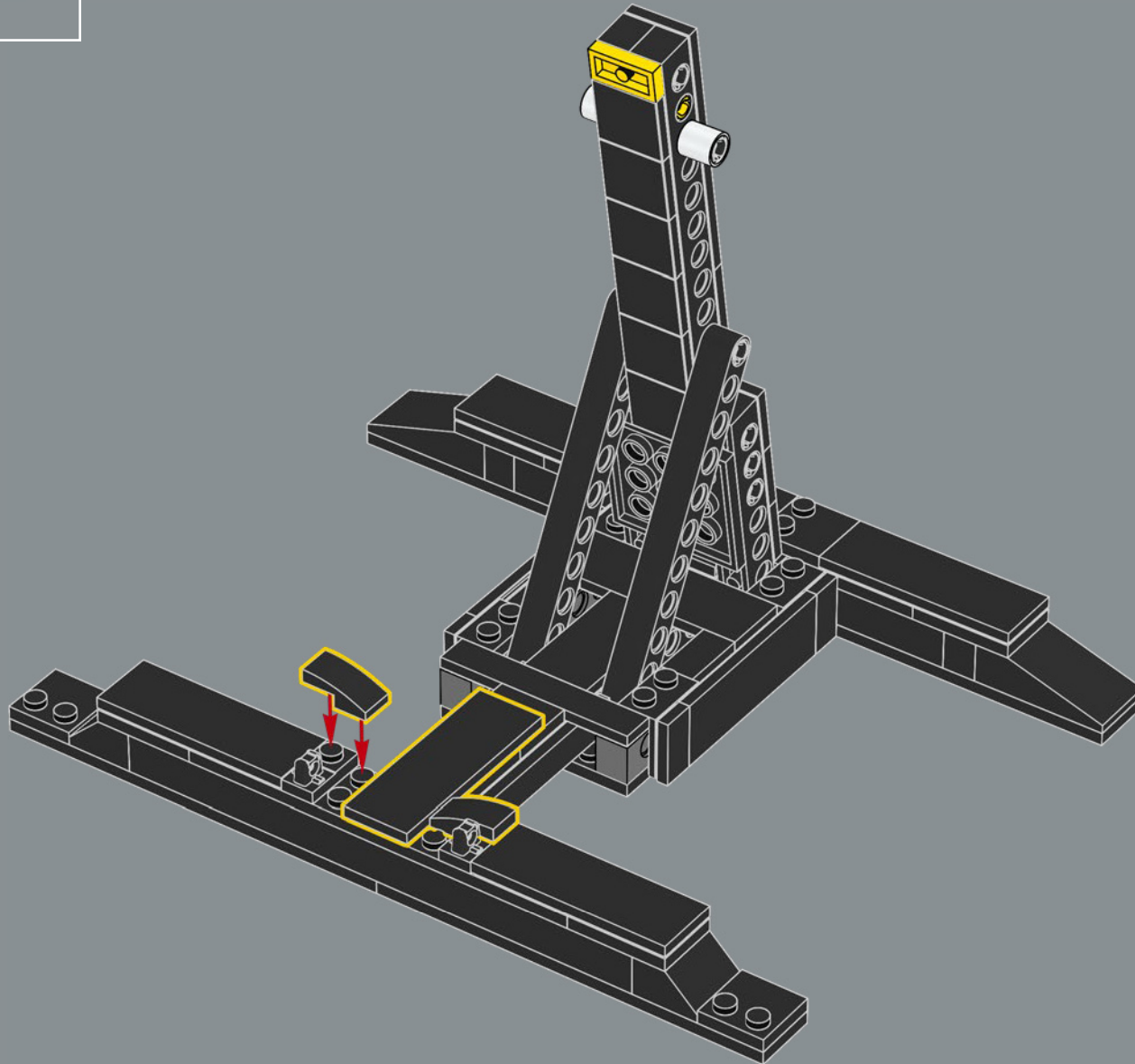

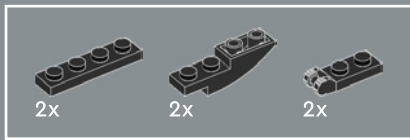

386

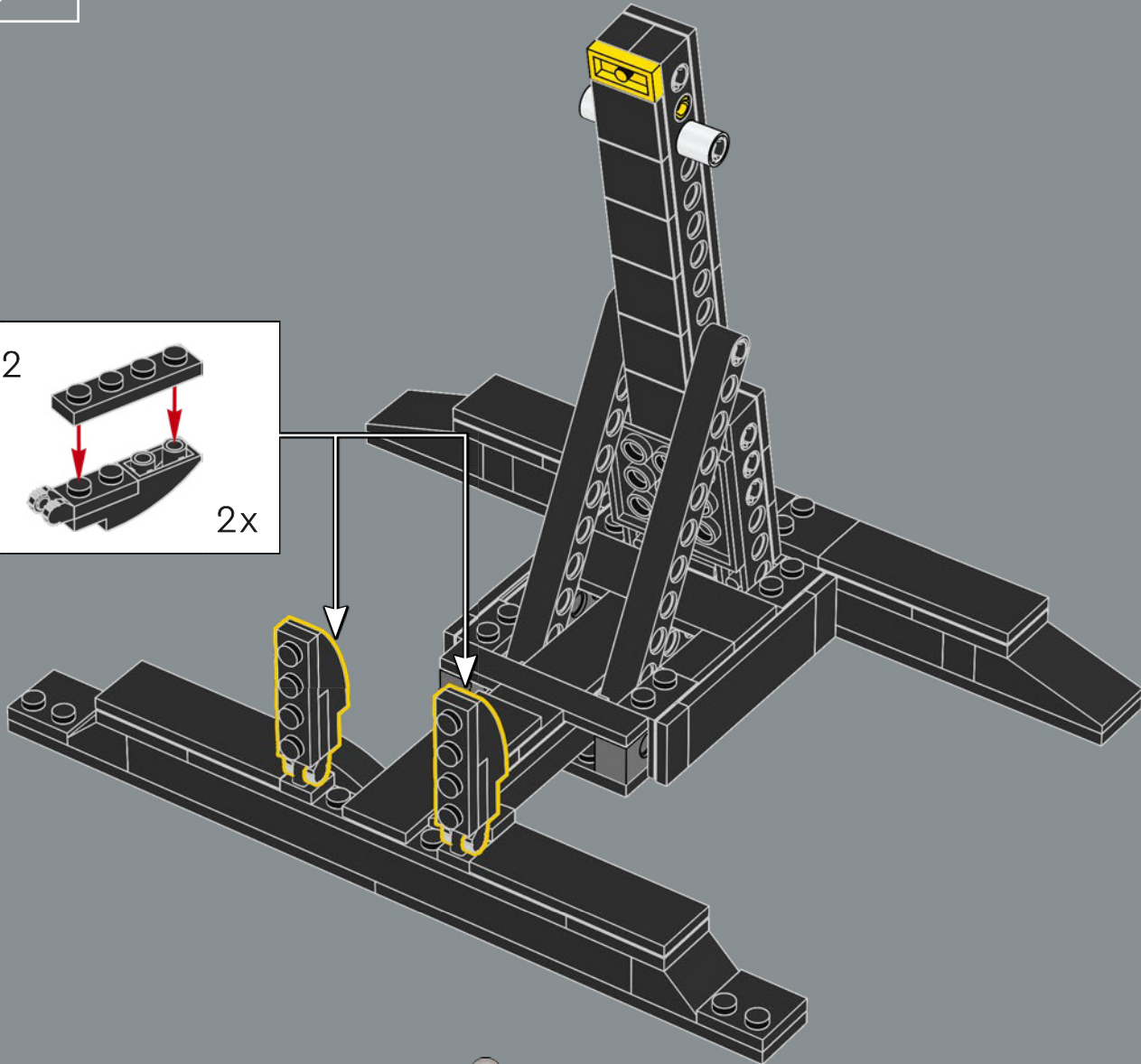
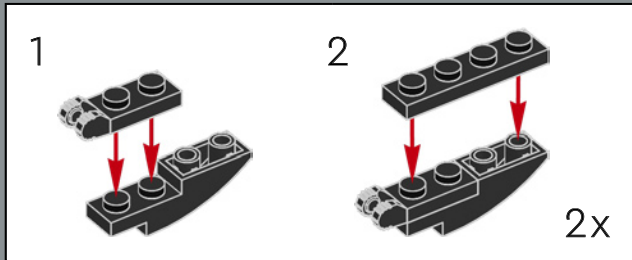

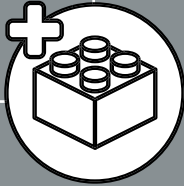
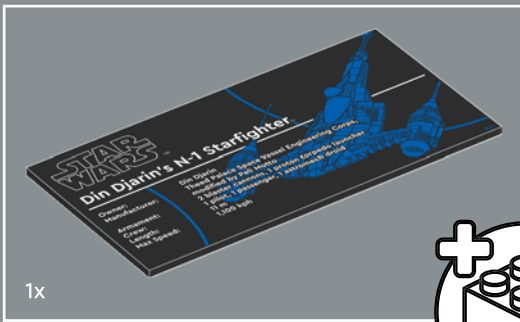

387

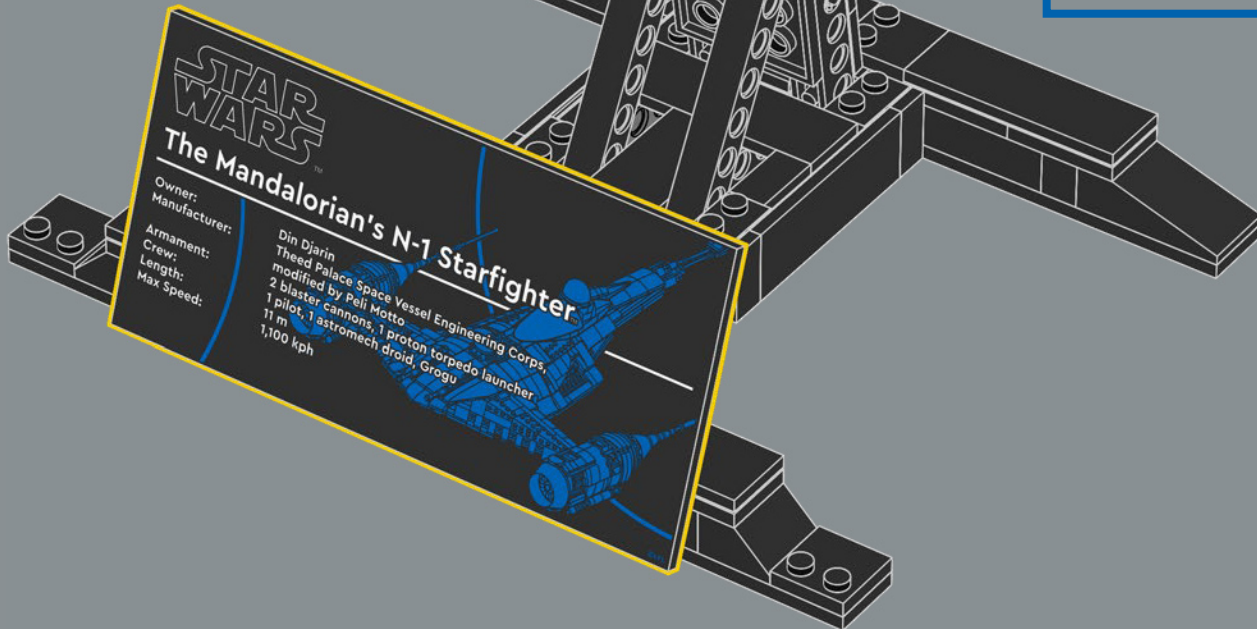
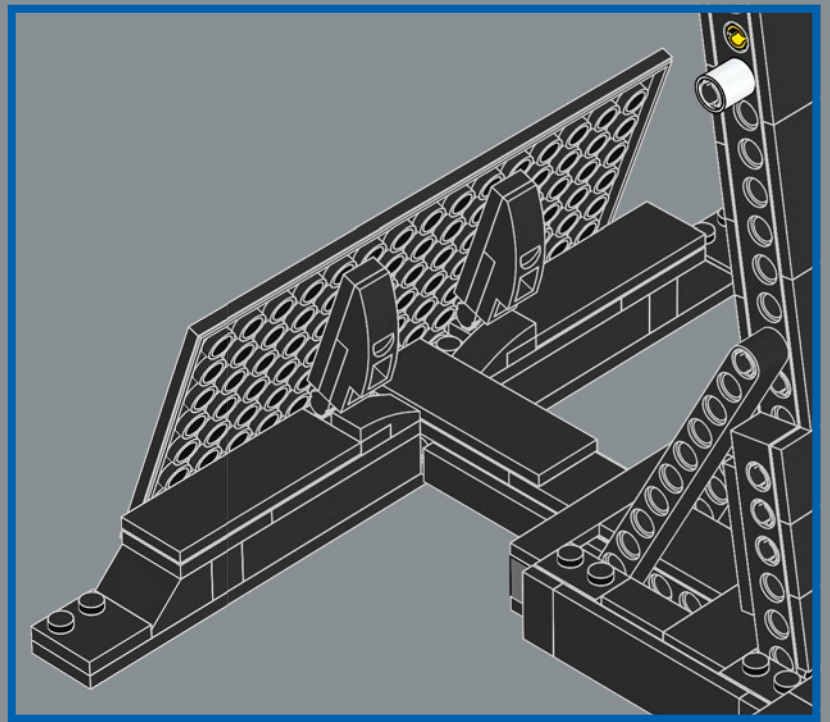

388

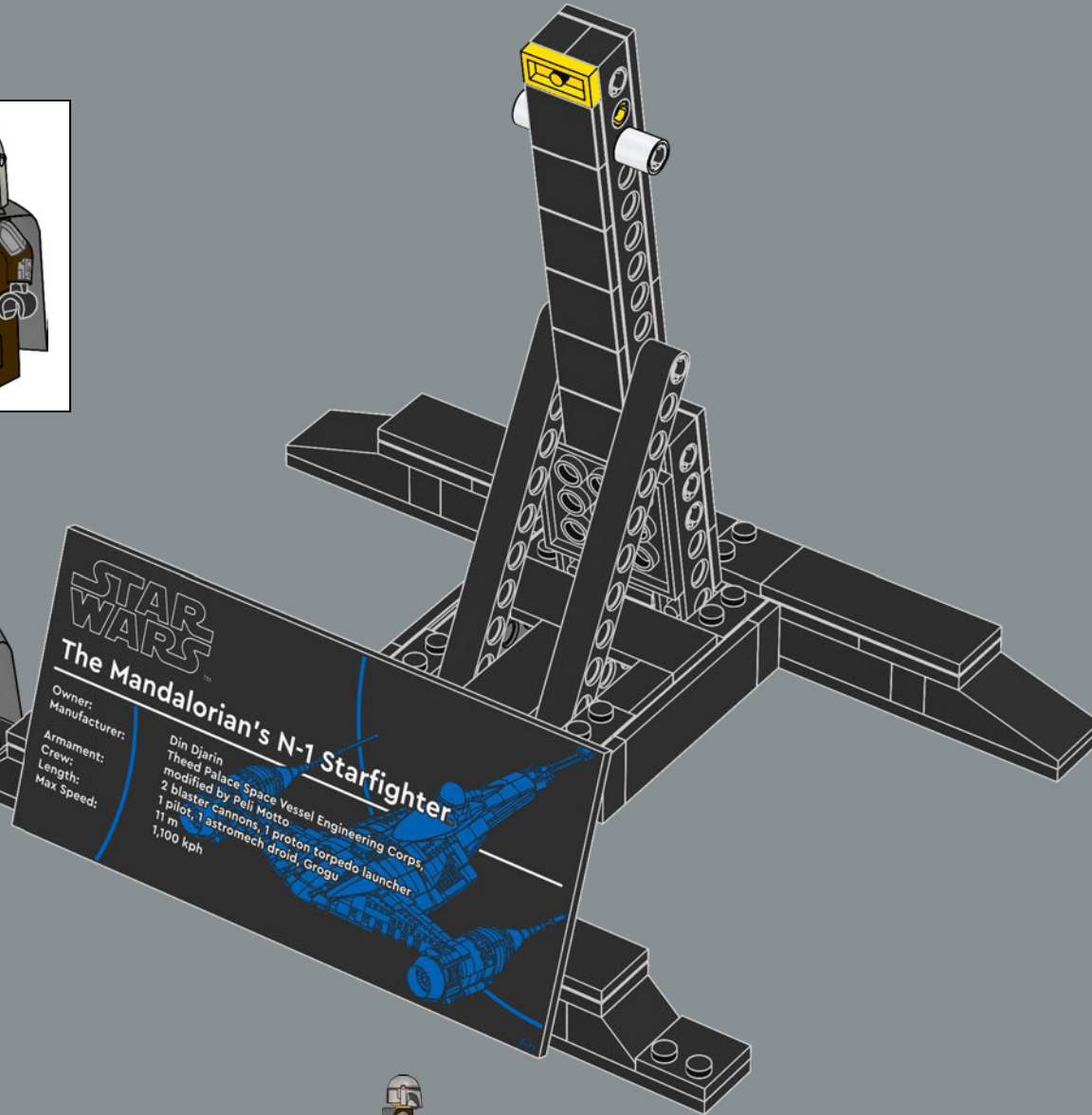

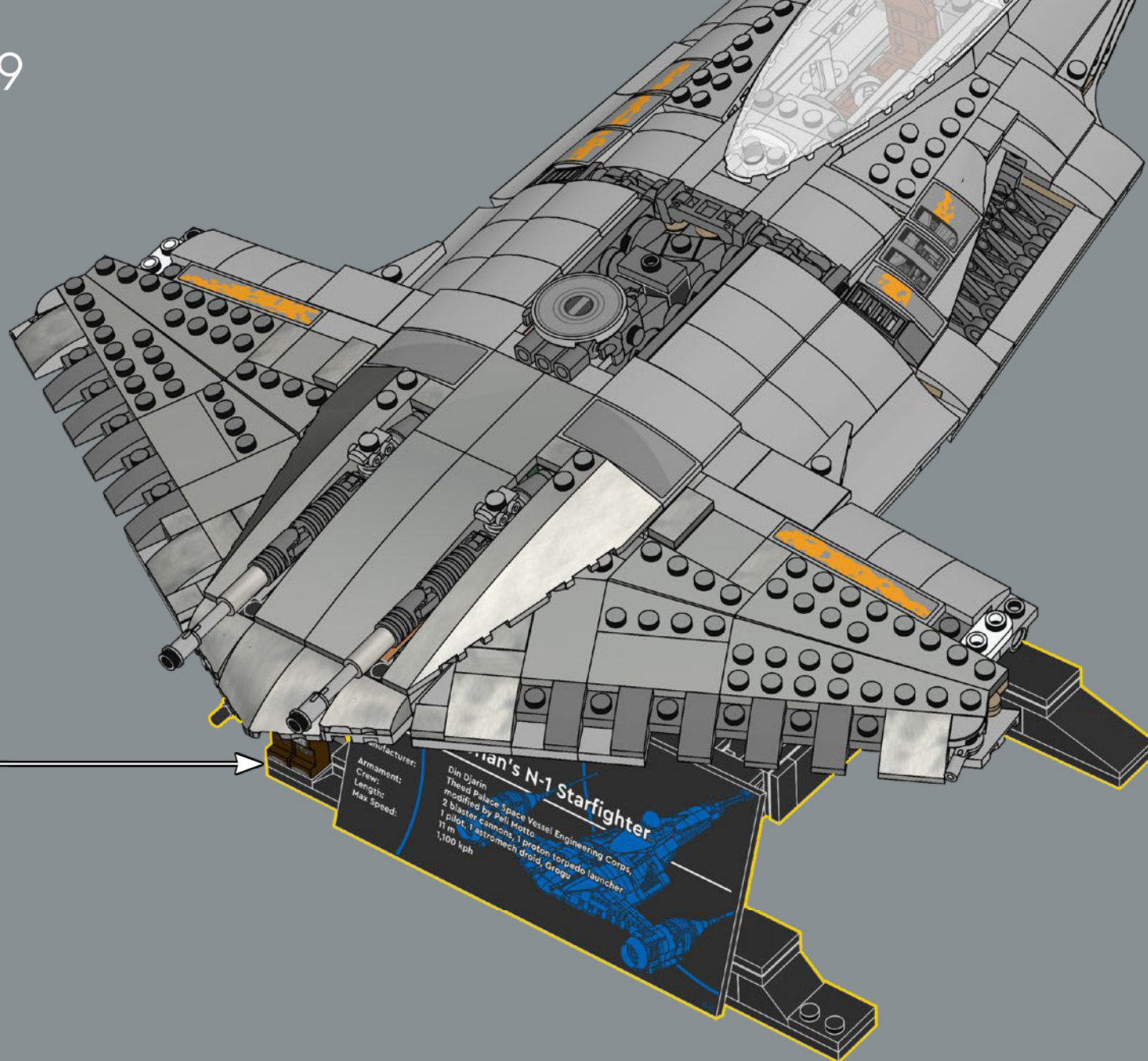

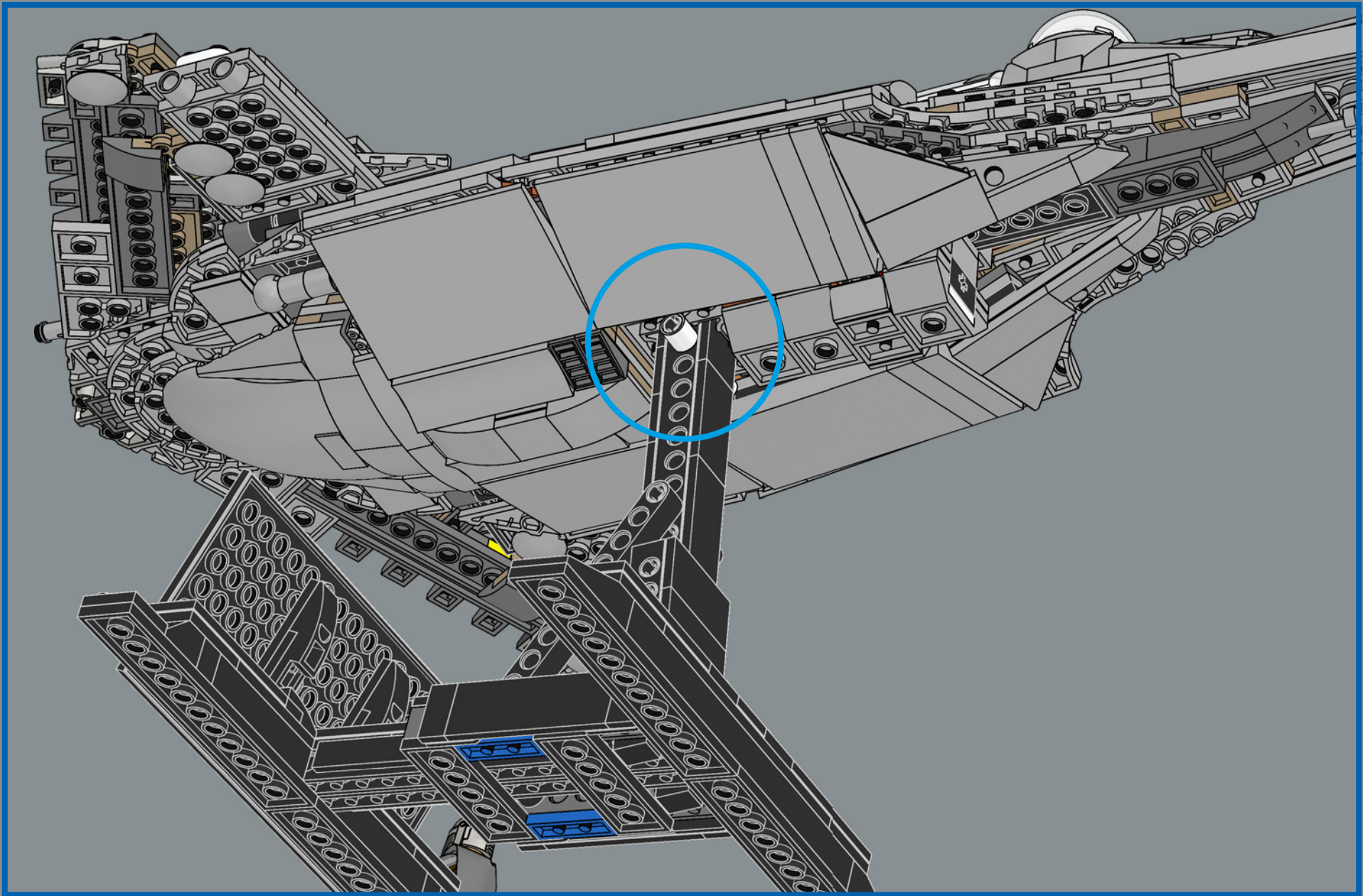



390

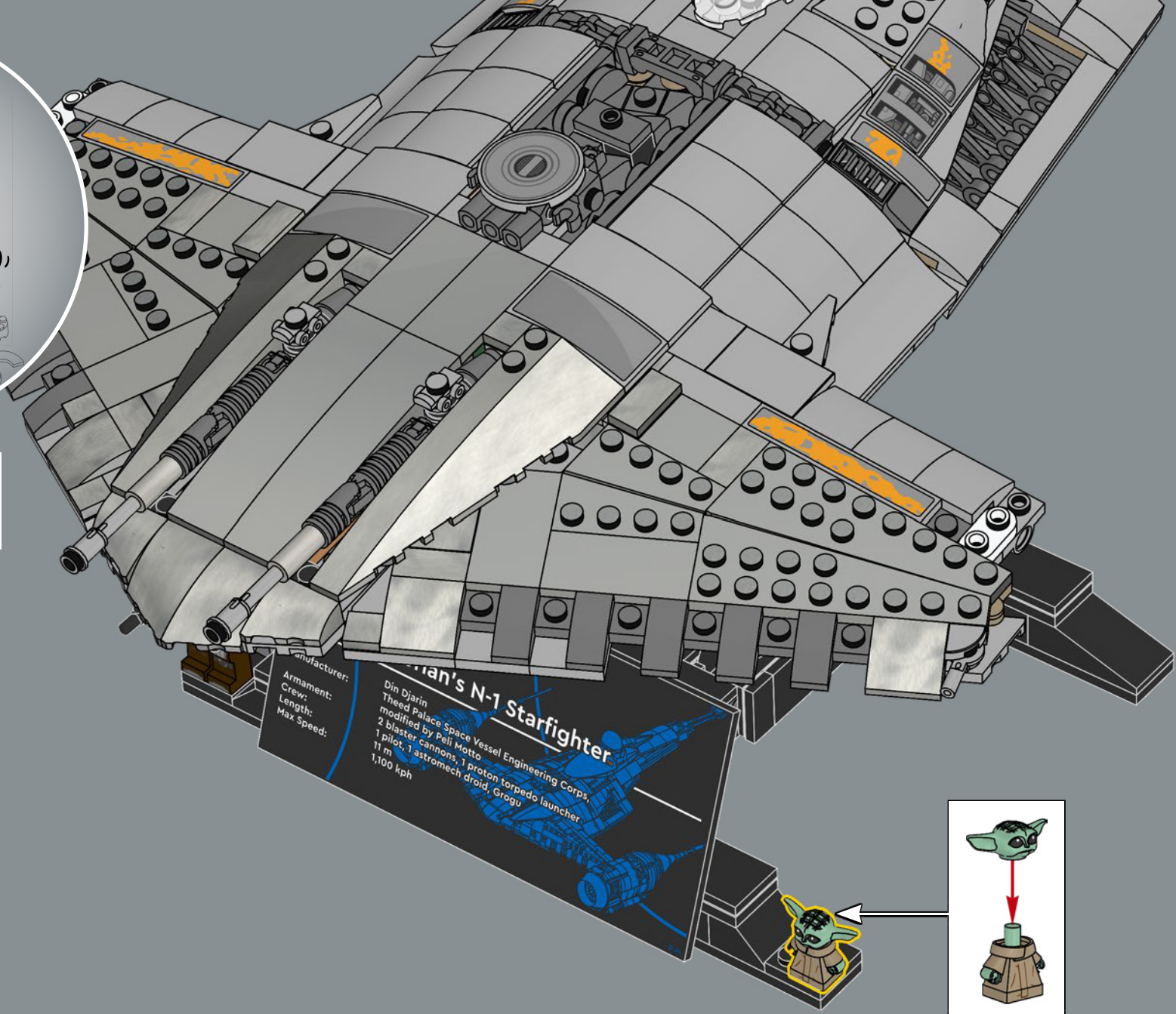

Manufacturer: **Wan's N-1 Starfighter**
Armament: Theed Palace Space Vessel Engineering Corps.
Crew: modified by Paji Motto
Length: 2 blaster cannons, 1 proton torpedo launcher
Max Speed: 11 m
1 pilot, 1 astromech droid, Grogu
1,100 kph

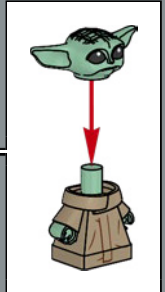

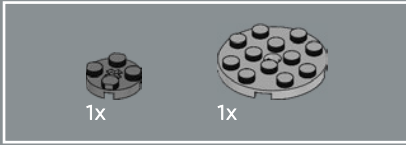
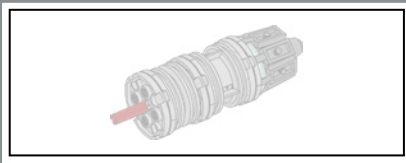

391

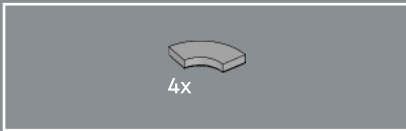

392

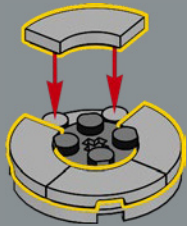

393

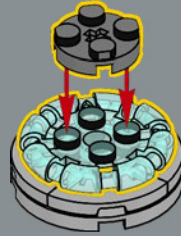

394

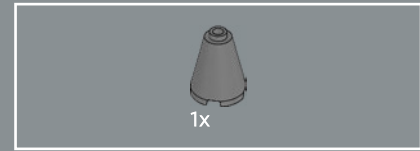
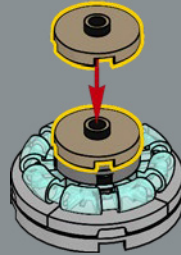

395

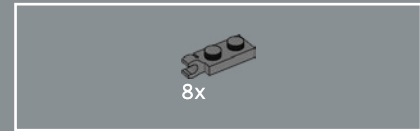

396

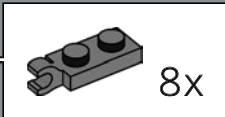
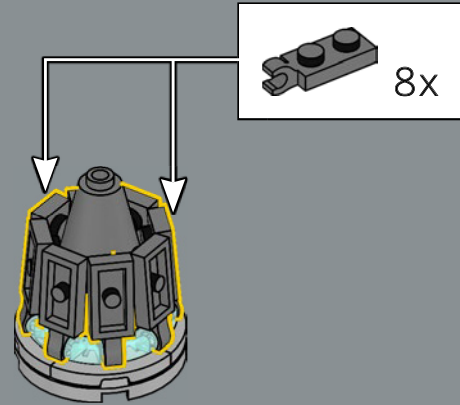

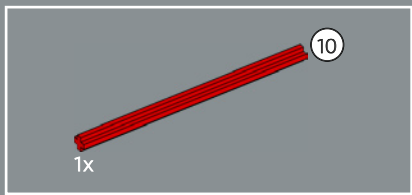

397

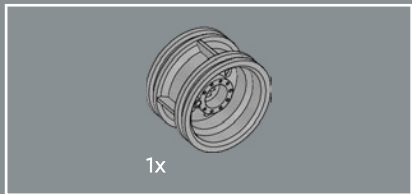
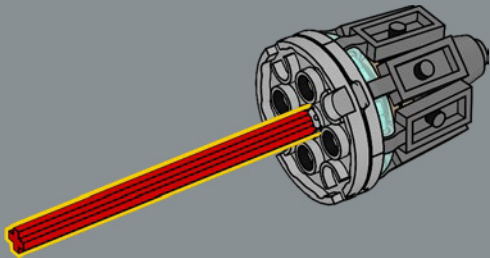

398

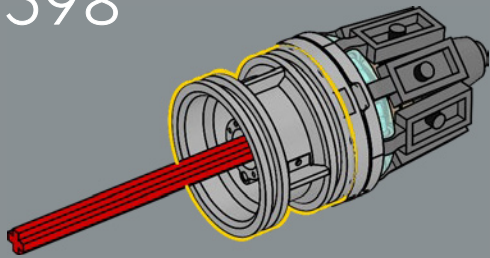

399

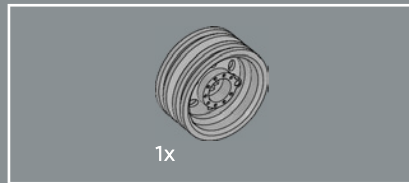
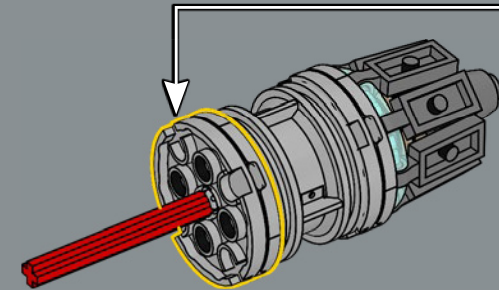

400

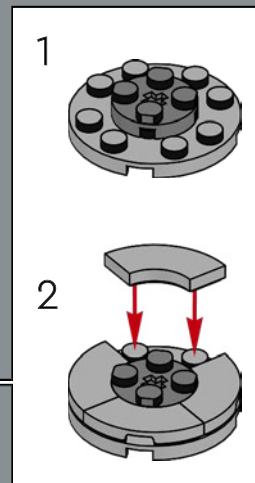
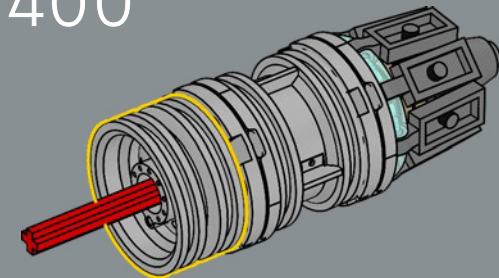

401

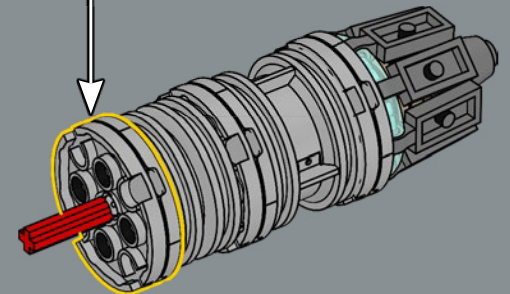
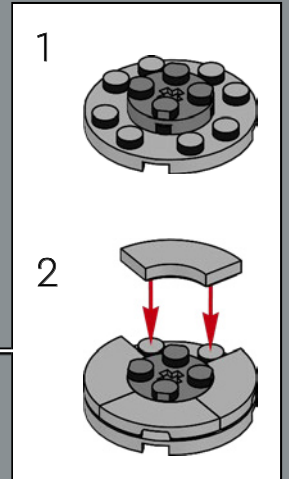

402

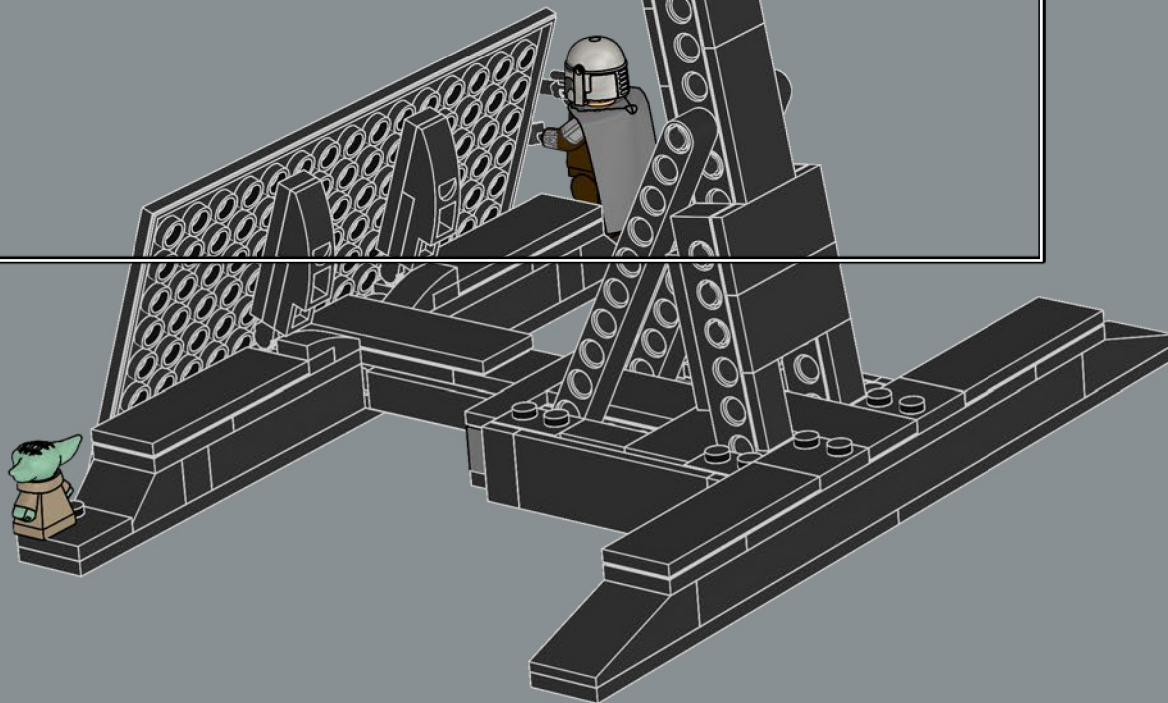
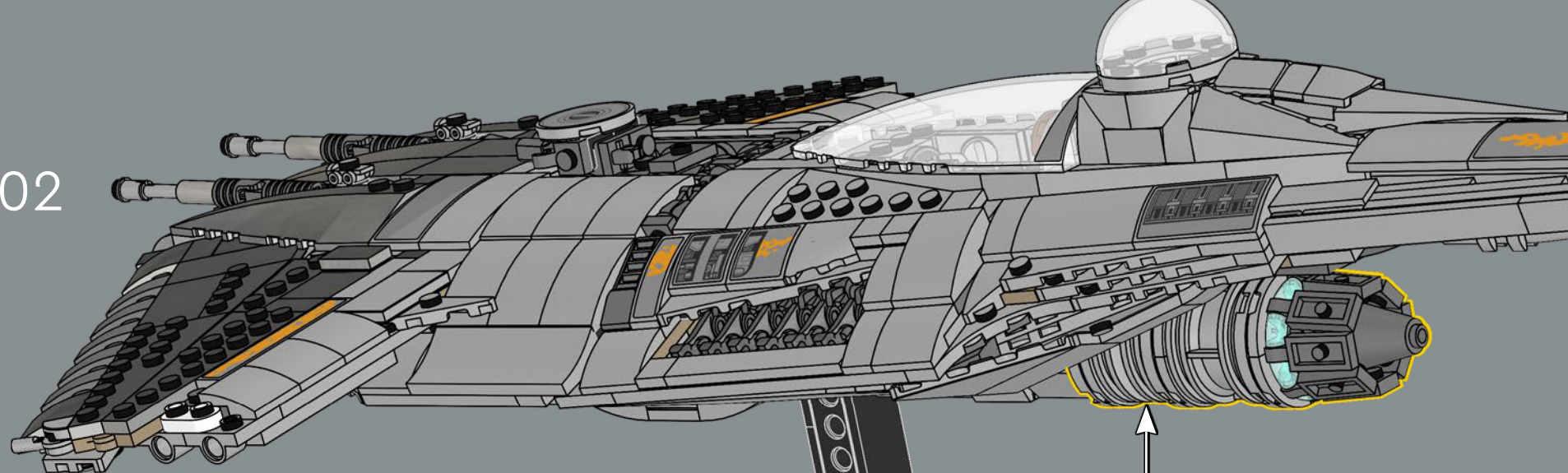

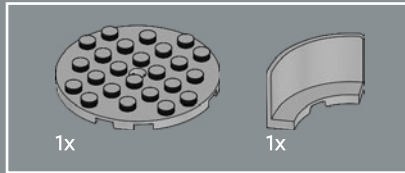
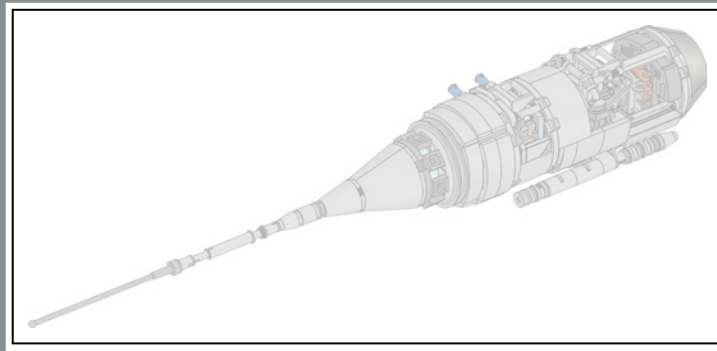

403

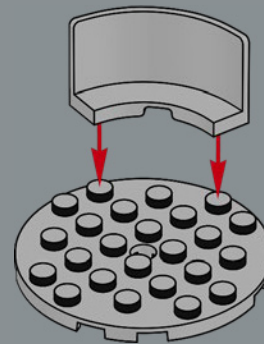

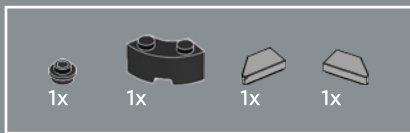

404

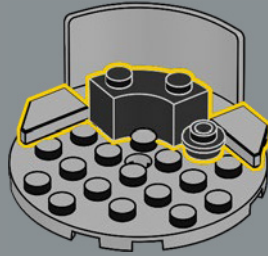

405

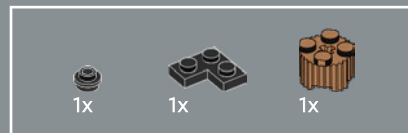
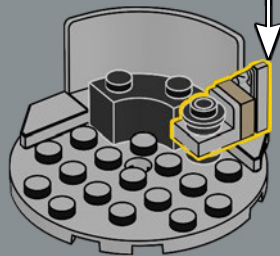
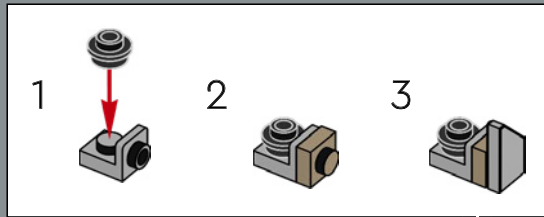

406

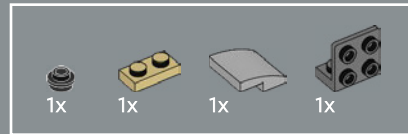
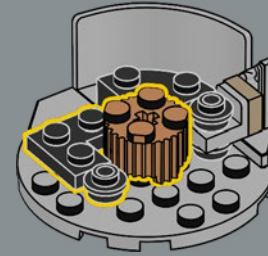

407

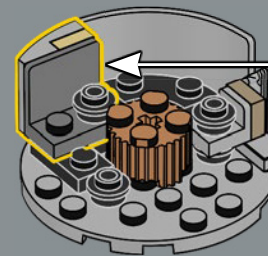
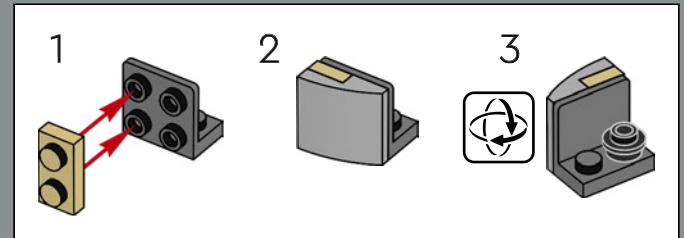

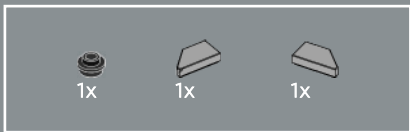

408

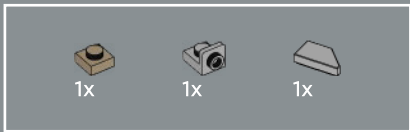
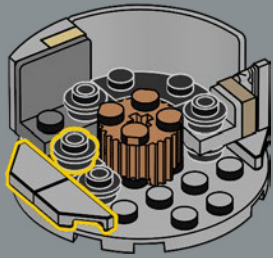

409

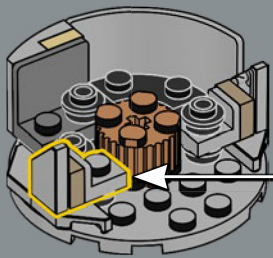
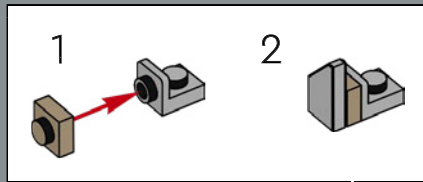

410

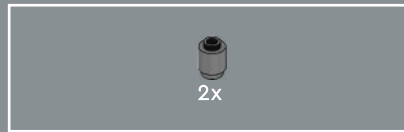
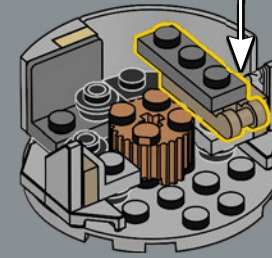
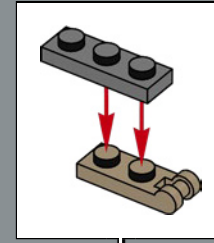

411

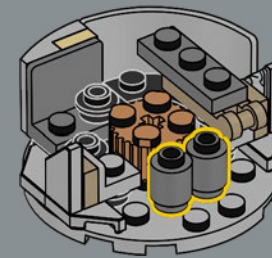

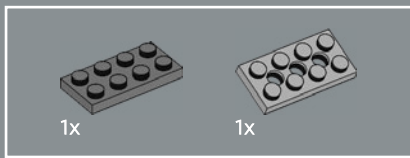

412

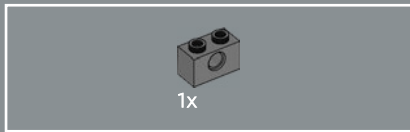
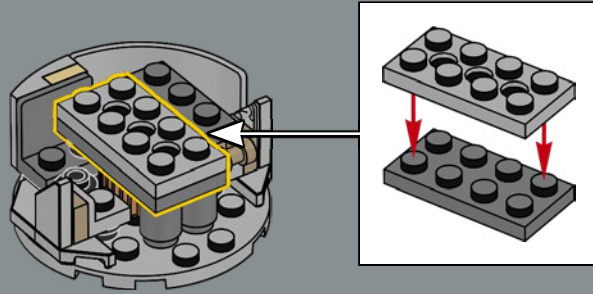

413

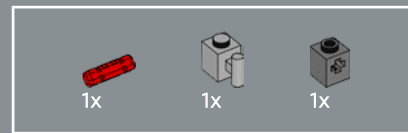
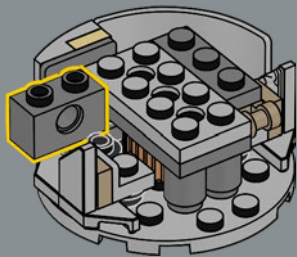

414

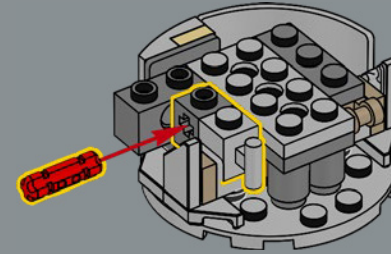

415

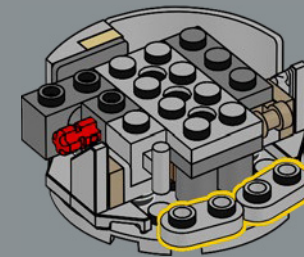

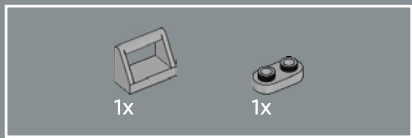

416

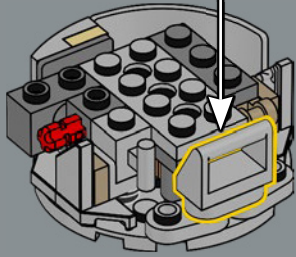
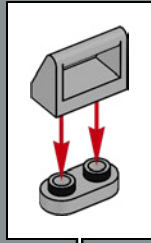

417

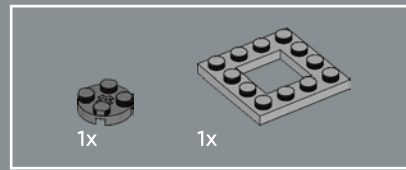
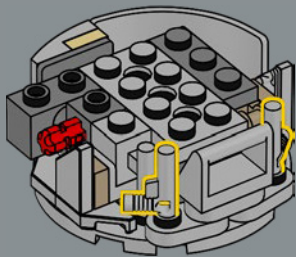

418

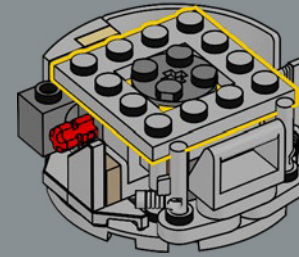

419

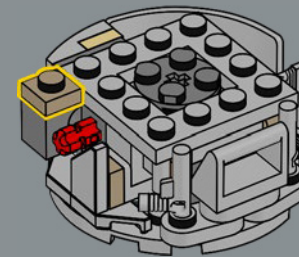

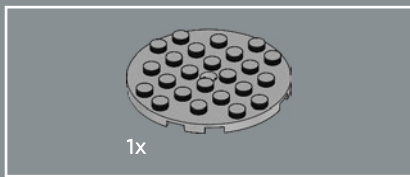

420

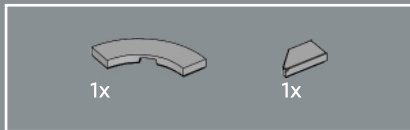
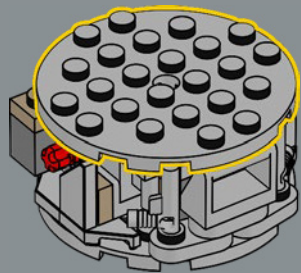

421

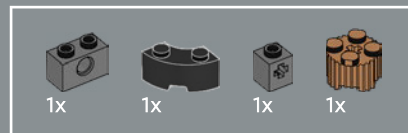
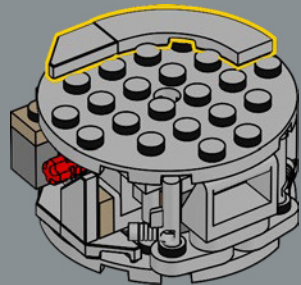

422

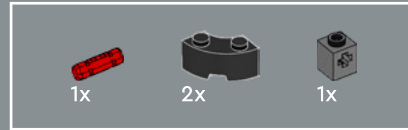
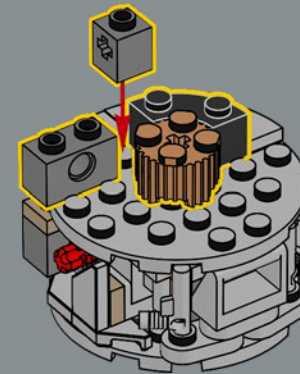

423

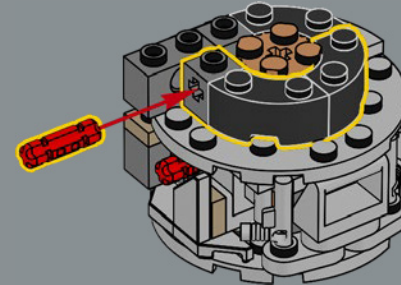

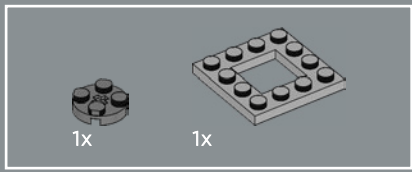

424

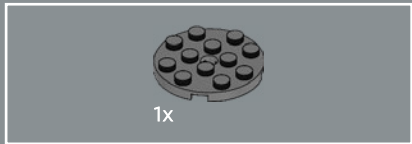
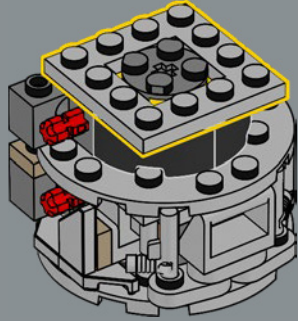

425

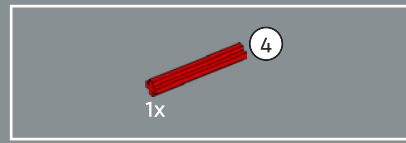
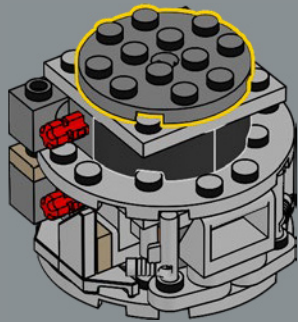

426

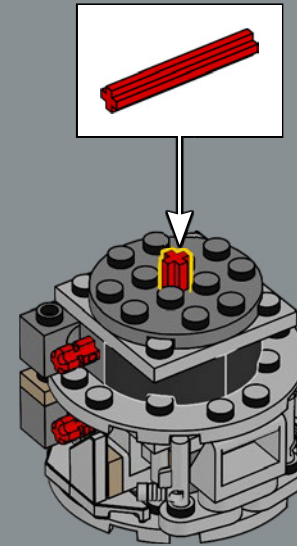

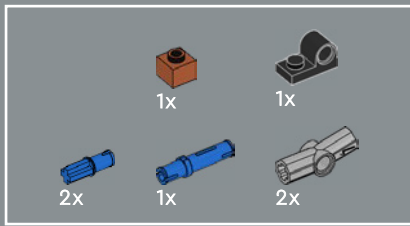

427

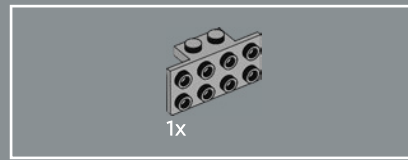
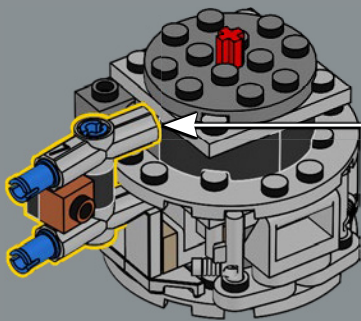
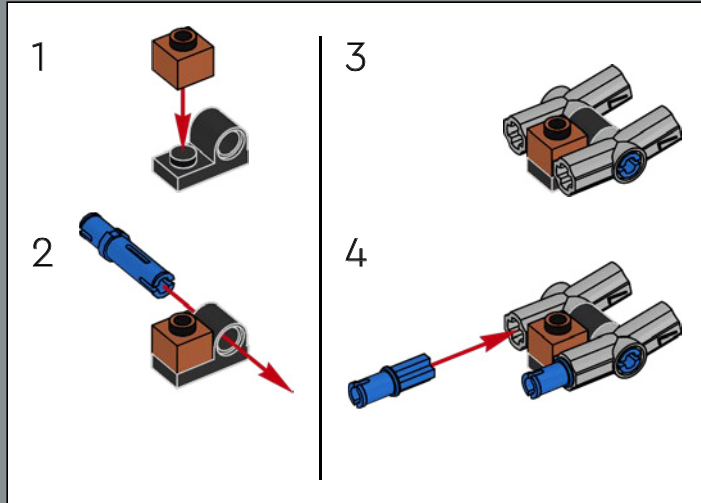

428

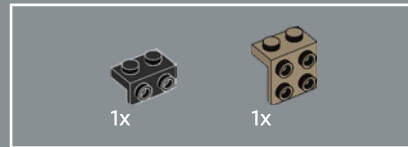
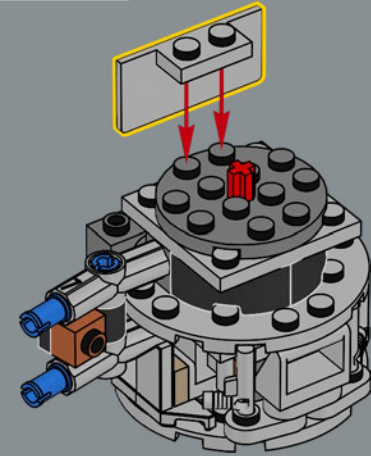

429

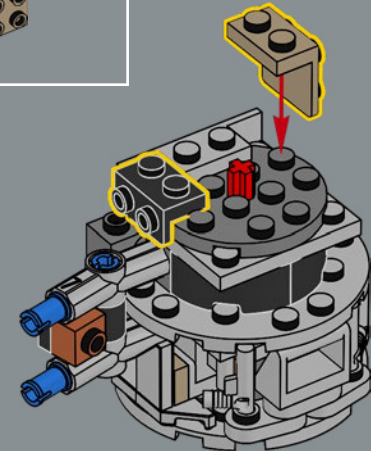

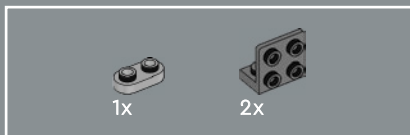

430

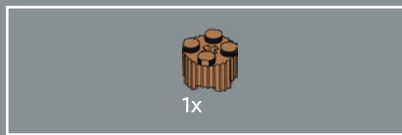
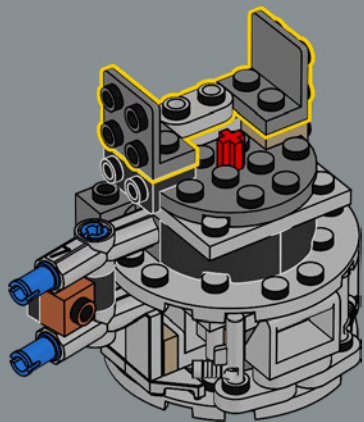

432

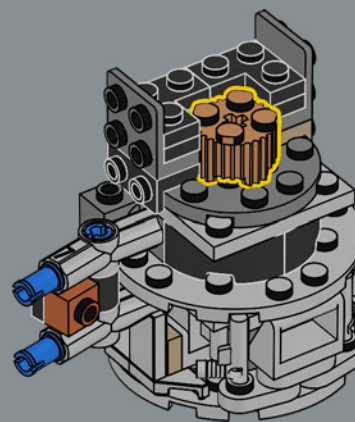

431

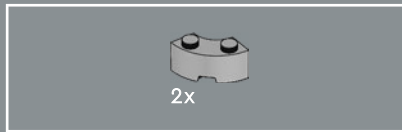
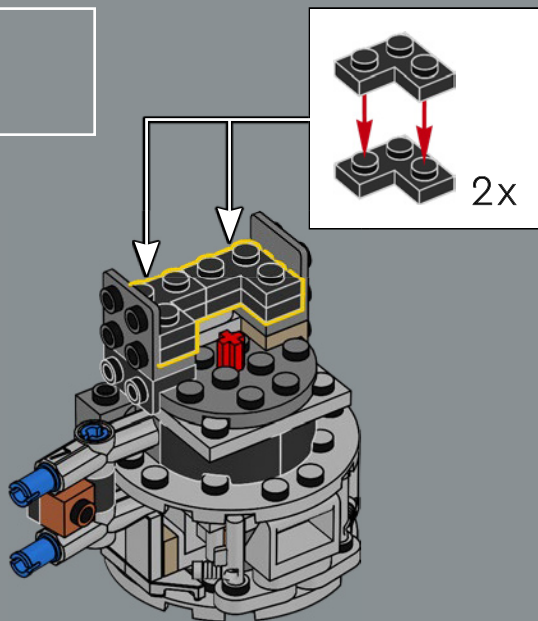

433

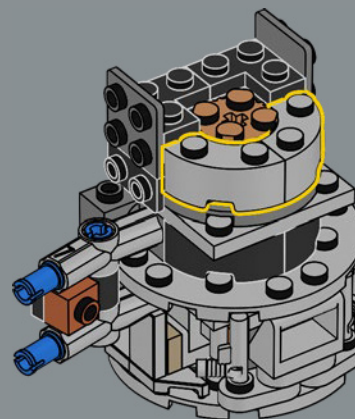

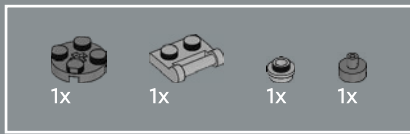

434

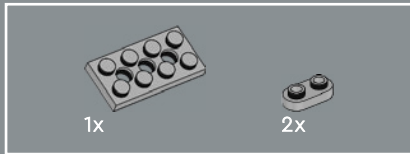
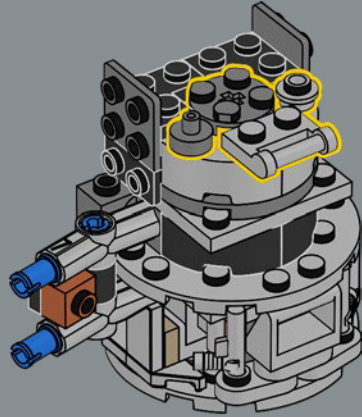

435

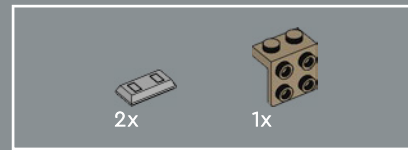
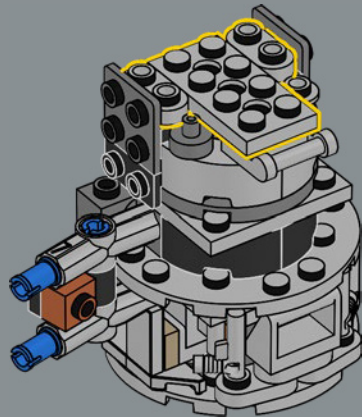

436

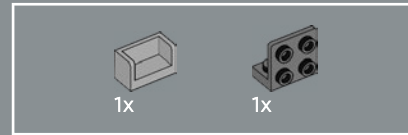
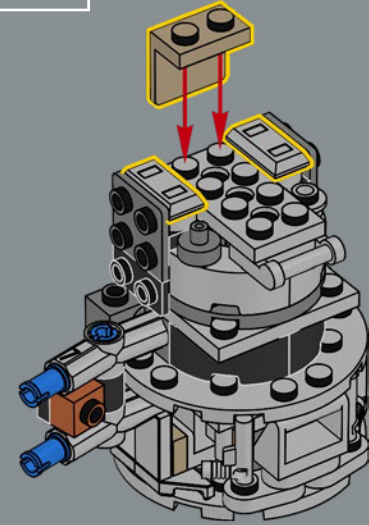

437

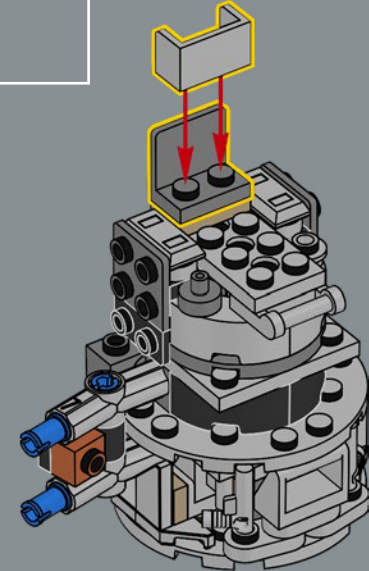

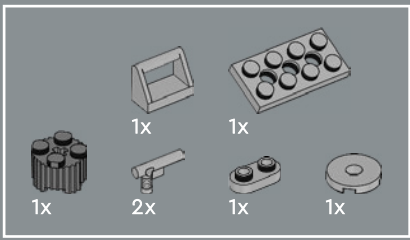

438

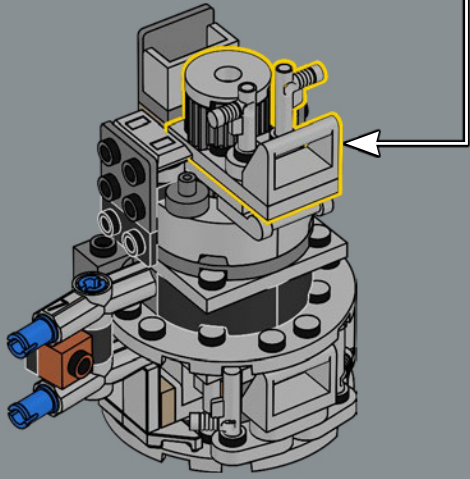
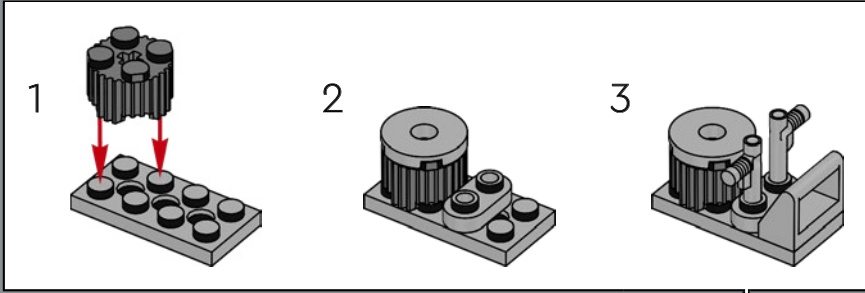

439

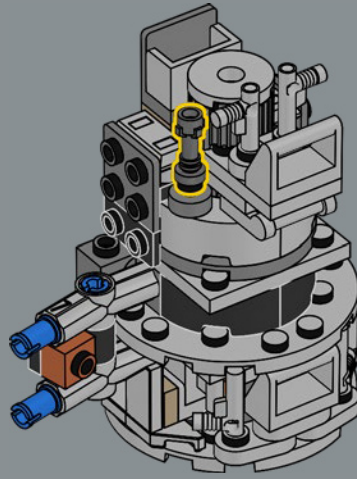

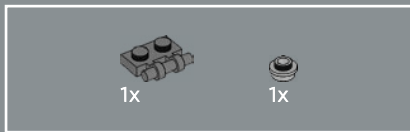

440

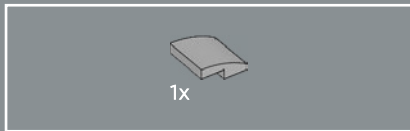
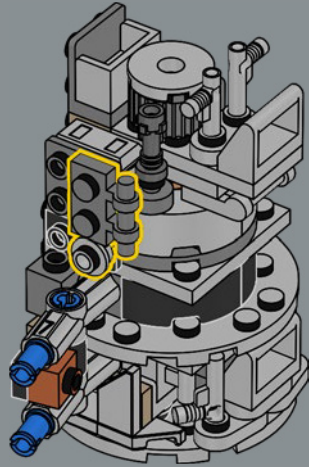

441

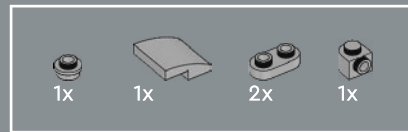
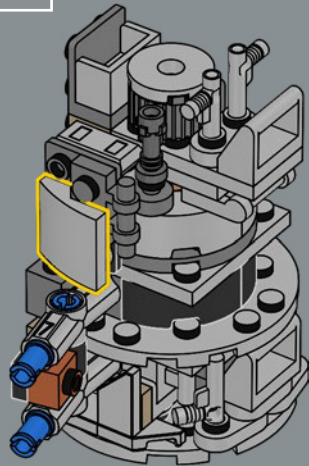

442

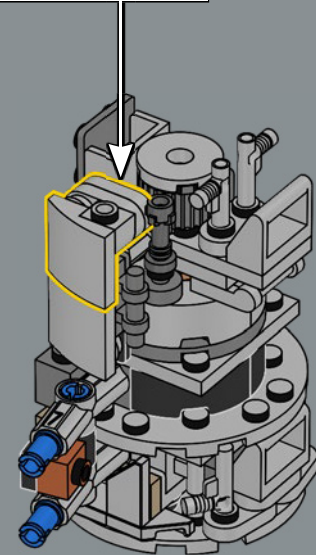
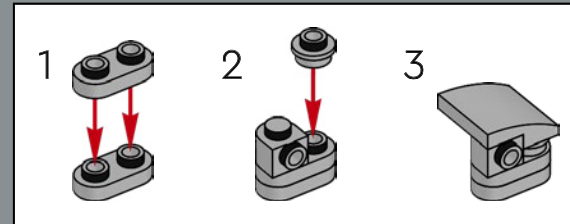

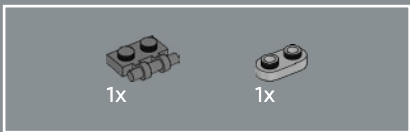

443

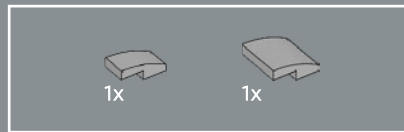
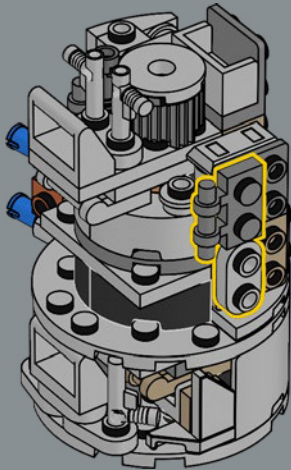

444

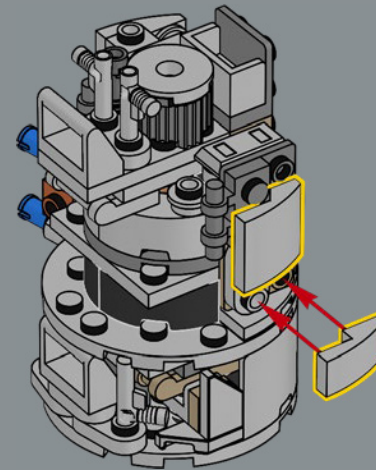

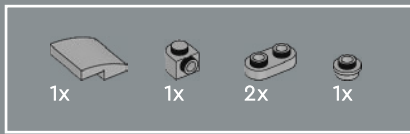

445

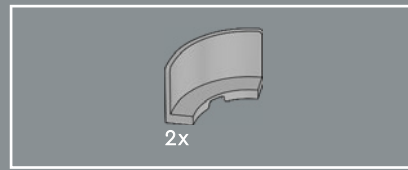
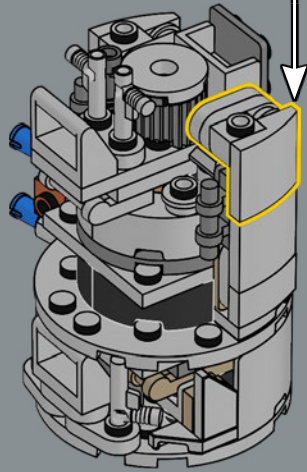
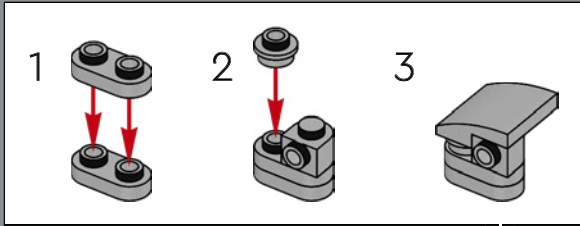

446

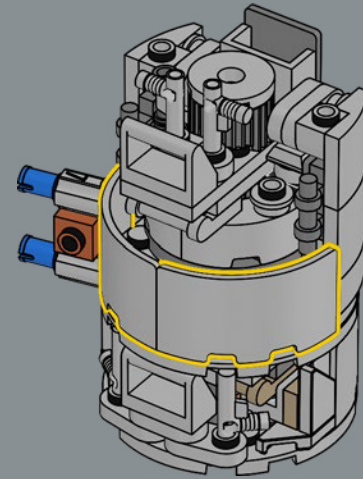

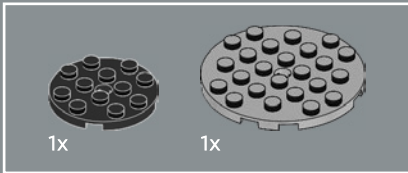
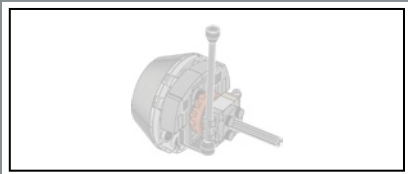

447

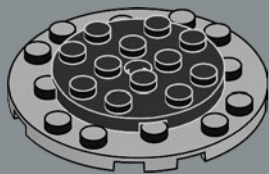

448

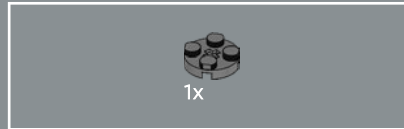
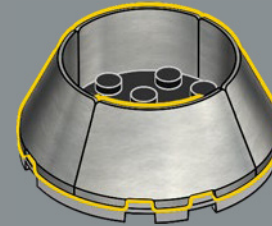

449

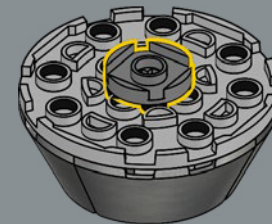

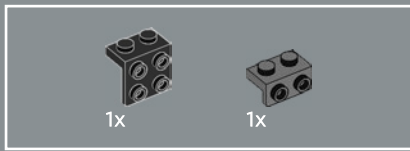

450

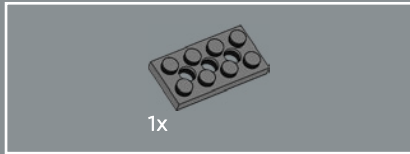
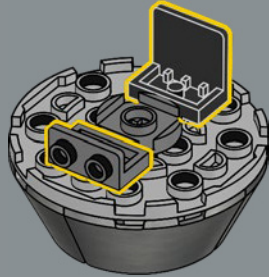

451

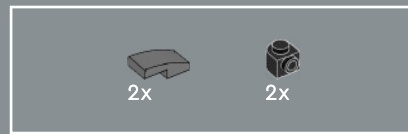
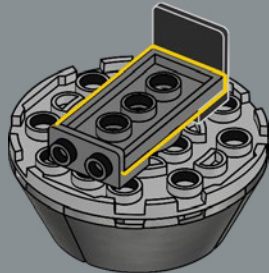

452

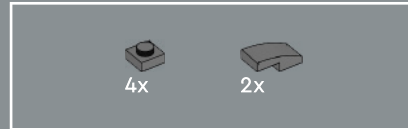
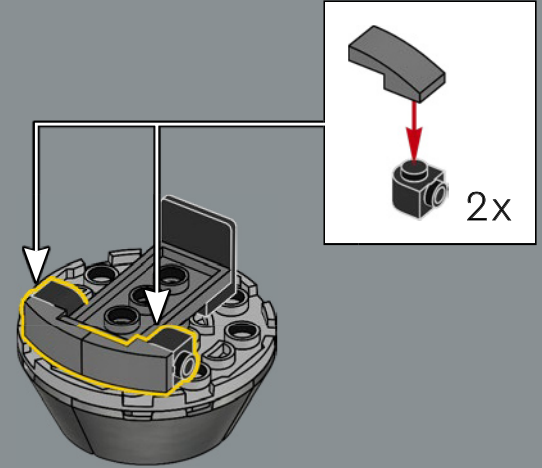

453

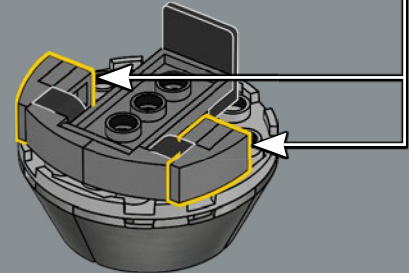
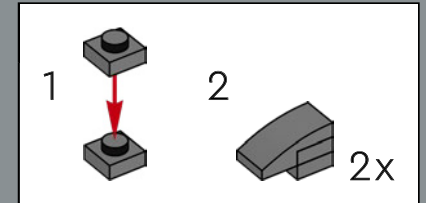

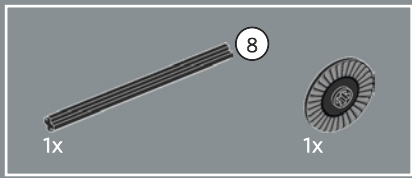

454

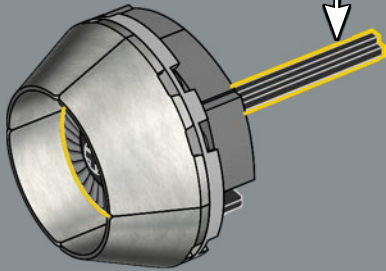
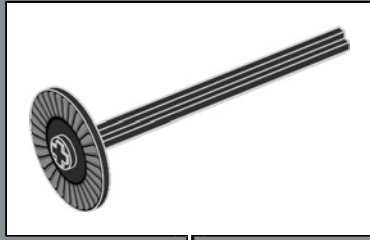

455

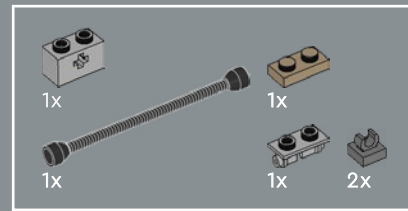
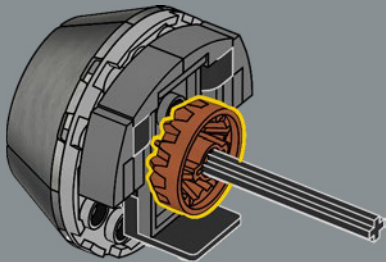

456

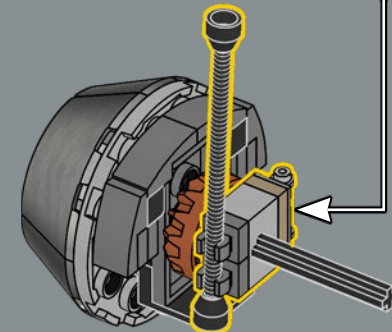
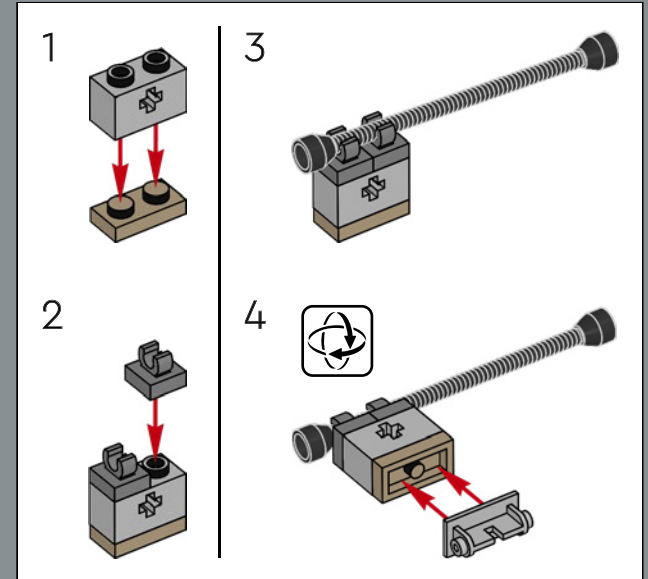



457

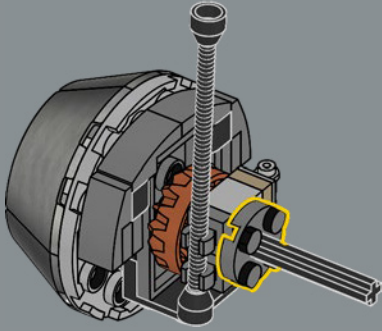

458

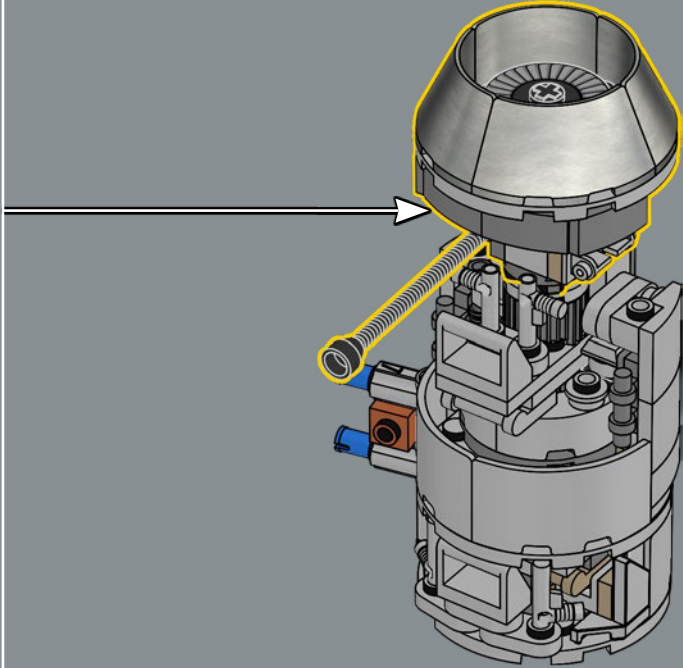

459

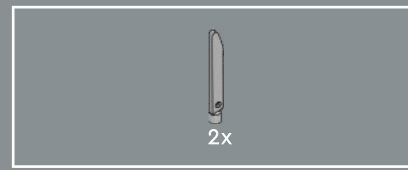
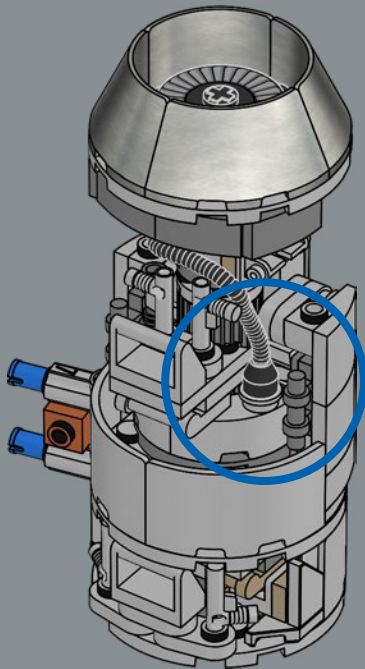

460

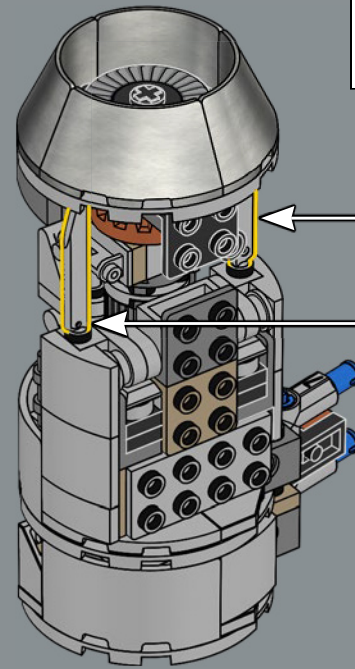
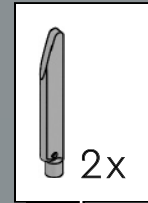

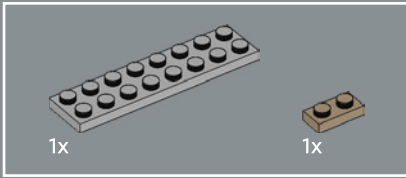
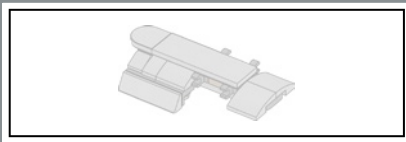

461

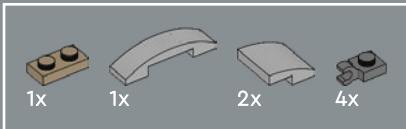
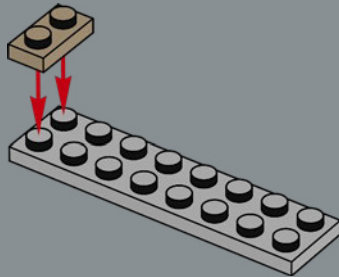

462

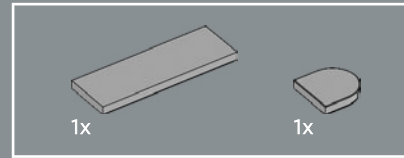
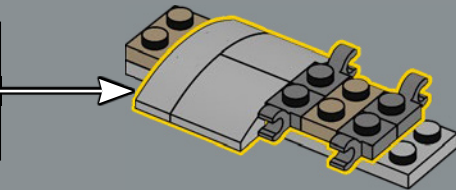
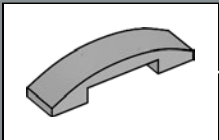

463

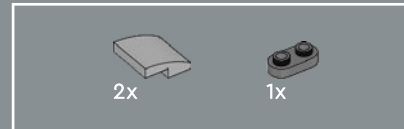
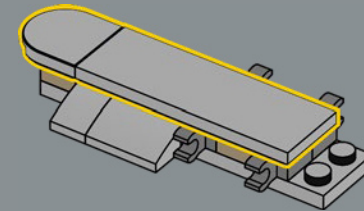

464

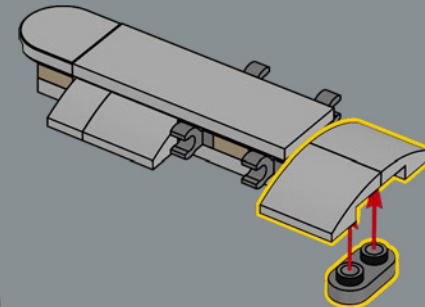

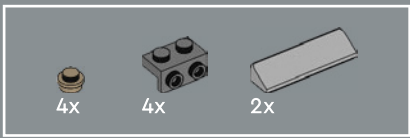

465

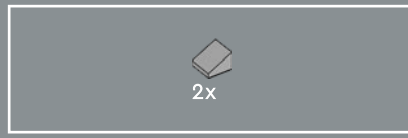
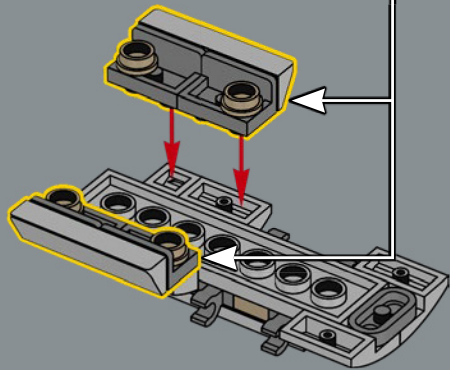
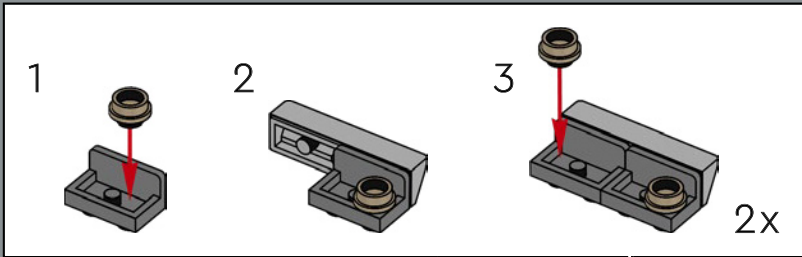

466

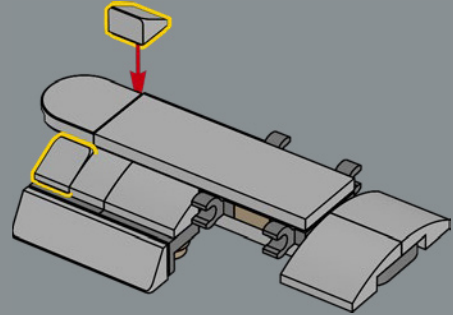

467

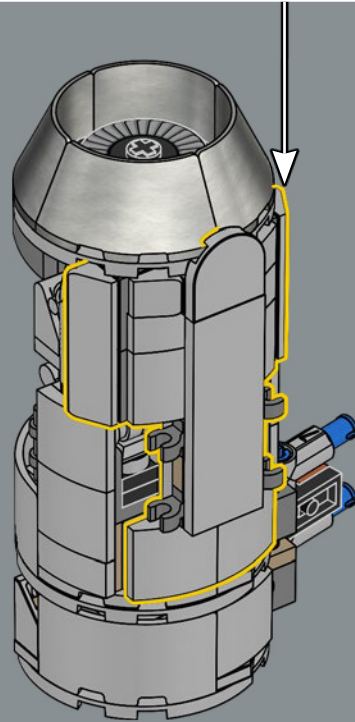

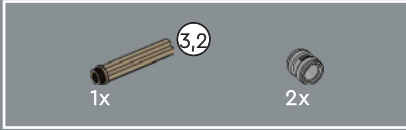
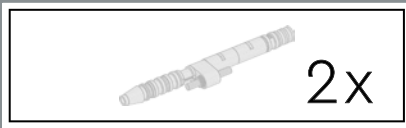

468

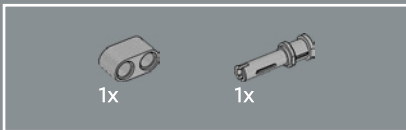
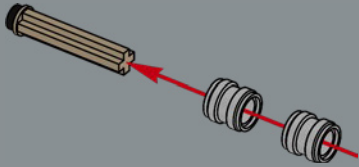

469

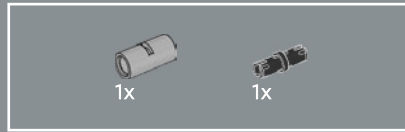
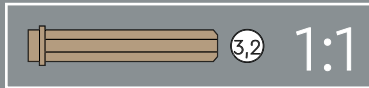
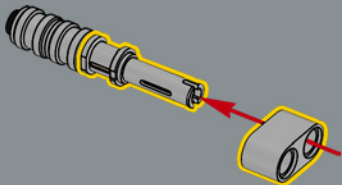

470

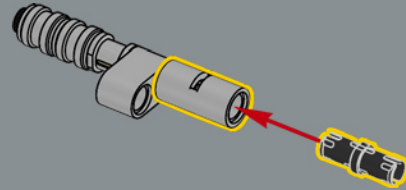

471

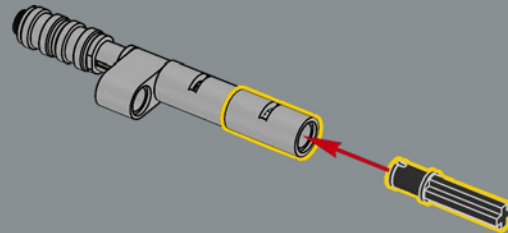

472

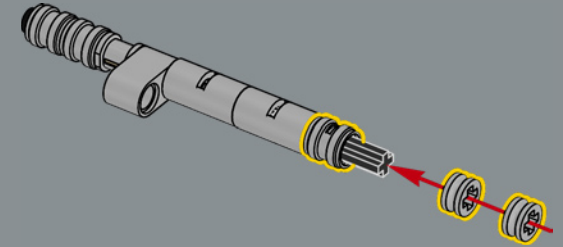

473

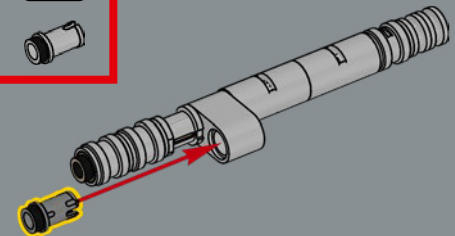
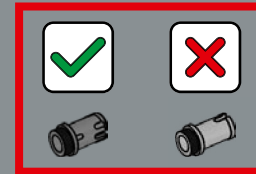

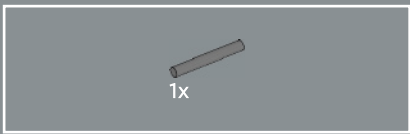

474

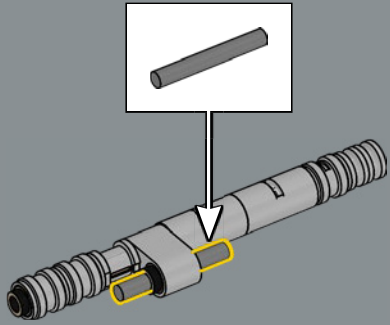

475

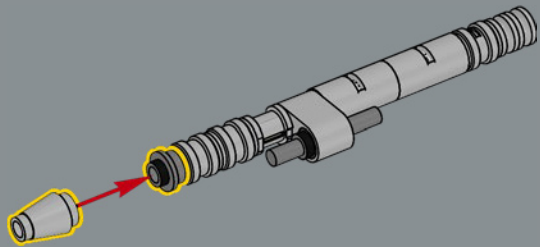

2x

476

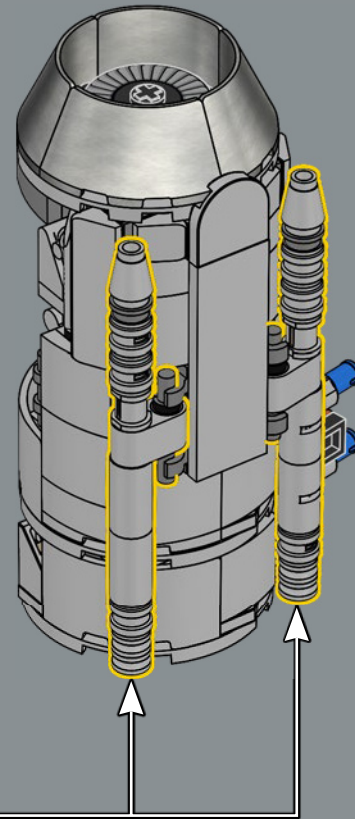

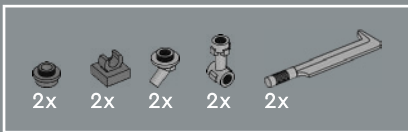

477

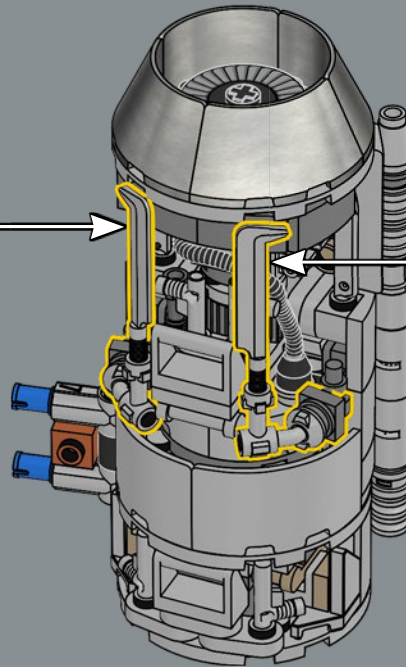
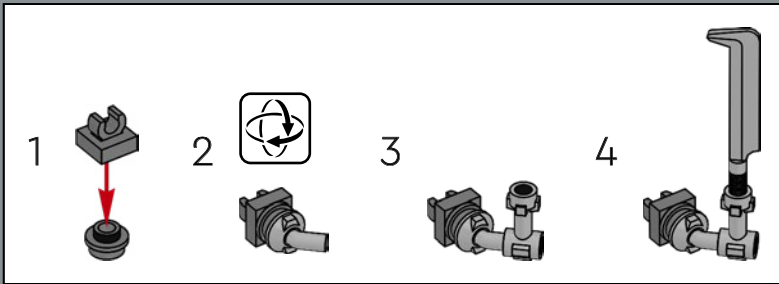
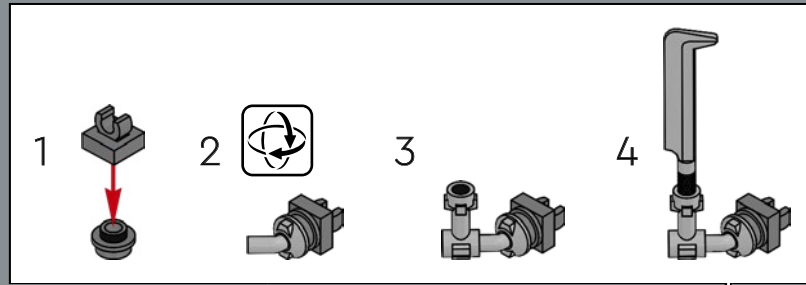

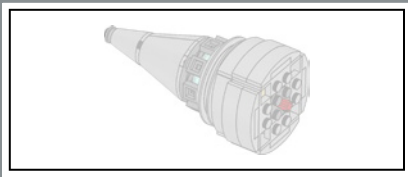

478

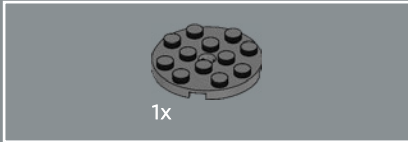

479

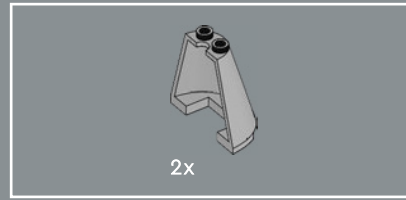

480

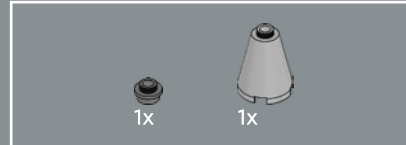
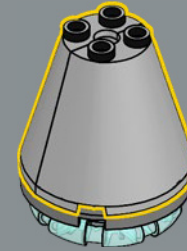

481

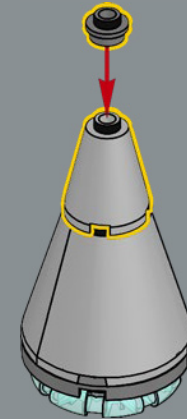

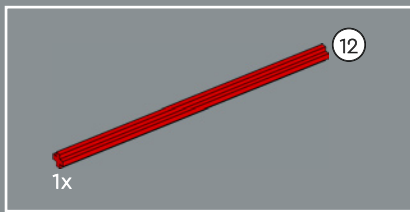

482

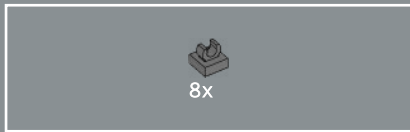
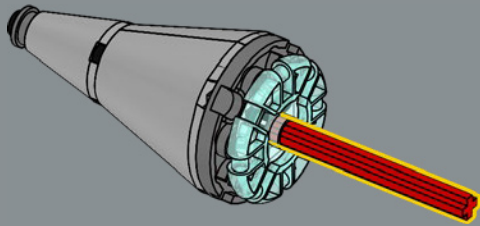

483

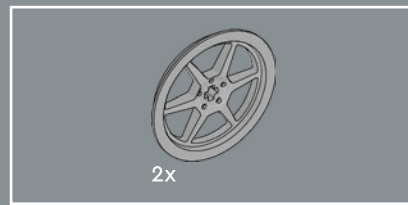
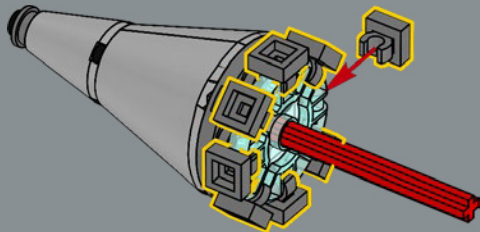

484

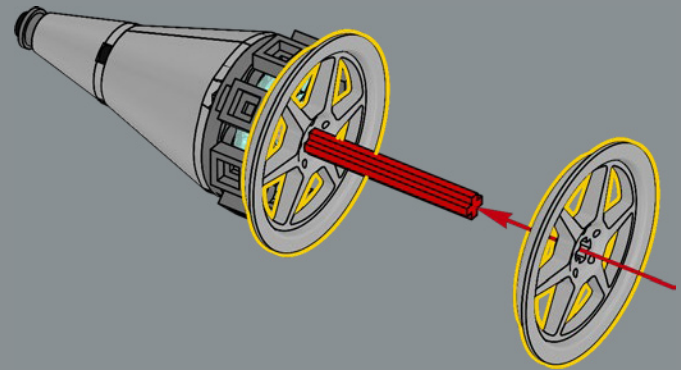

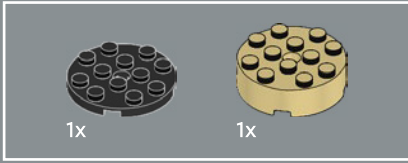
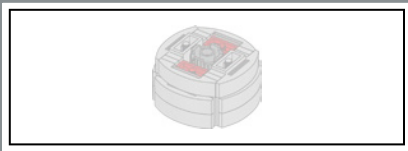

485

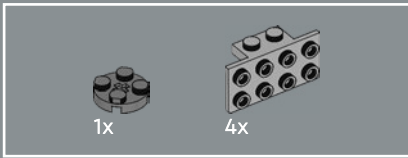
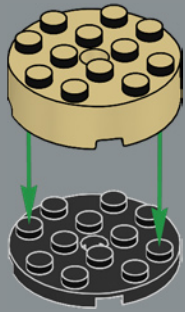

486

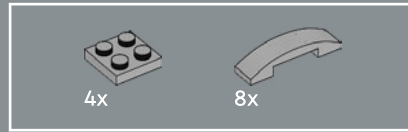
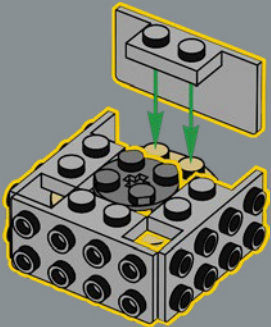

487

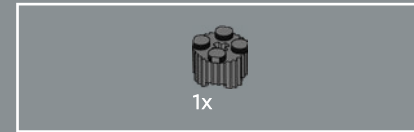
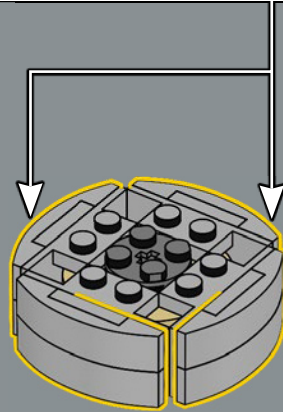
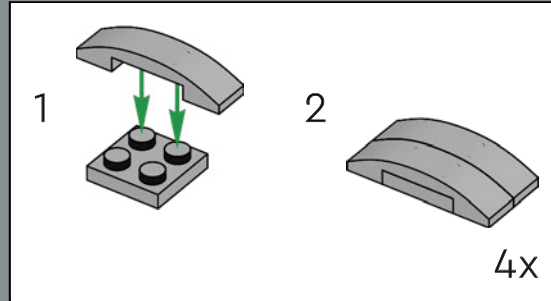

488

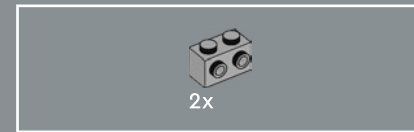
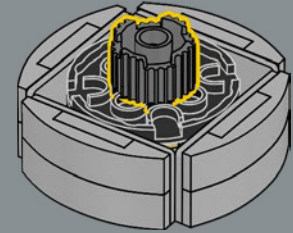

489

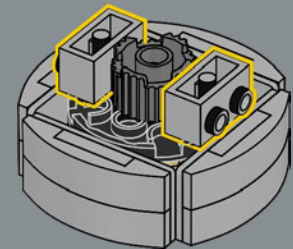

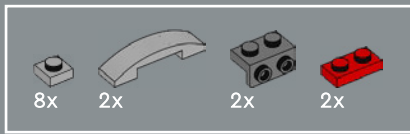

490

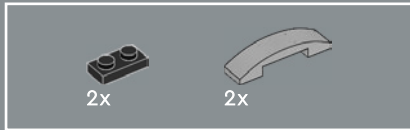
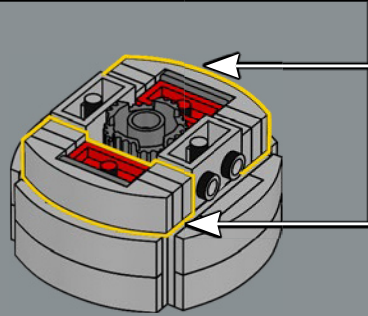
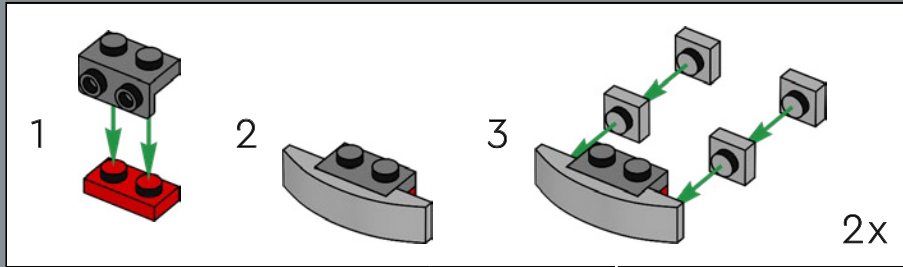

491

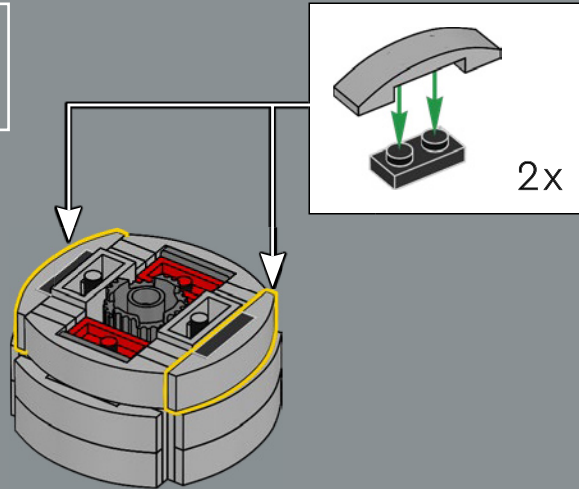

492

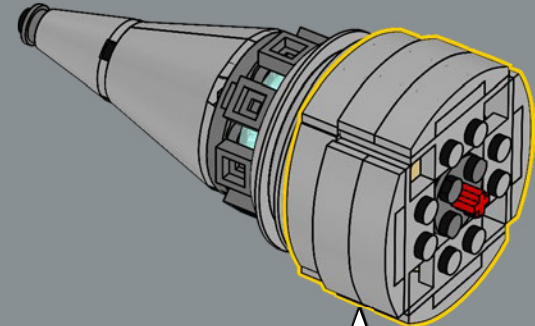

493

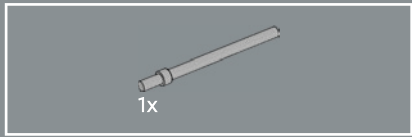
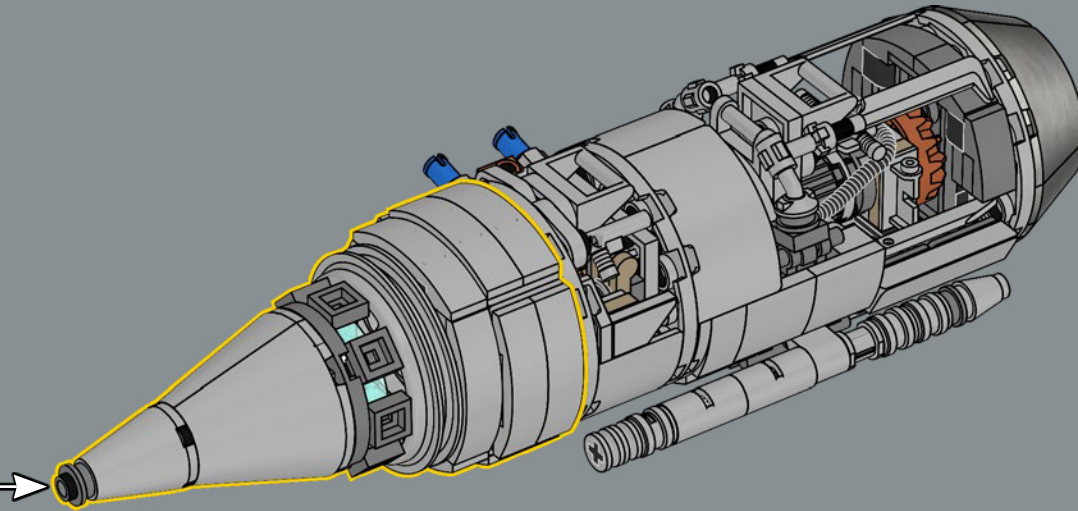

494

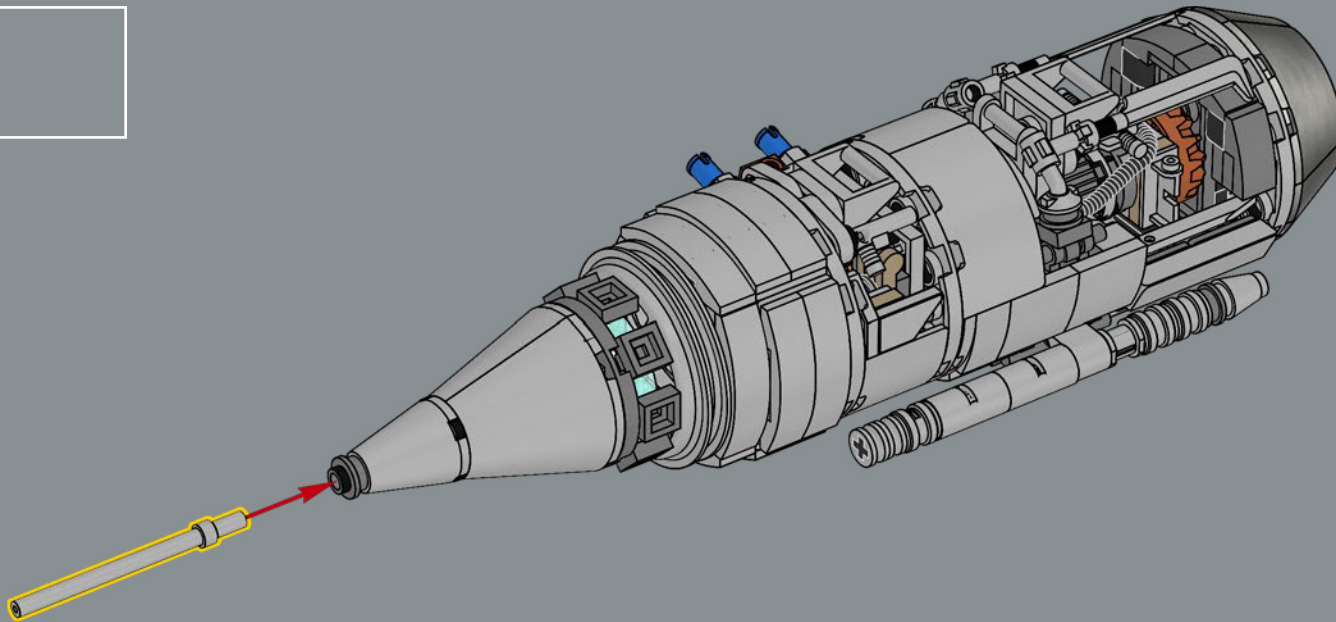

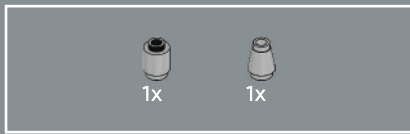

495

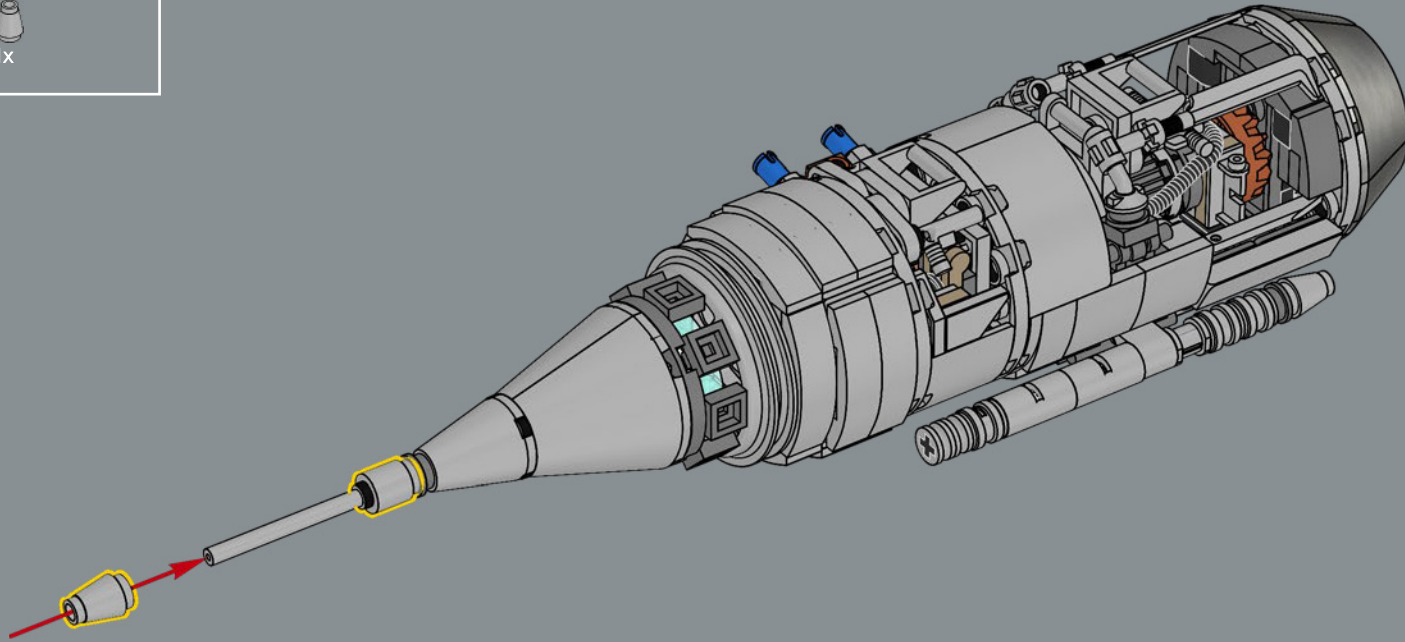

496

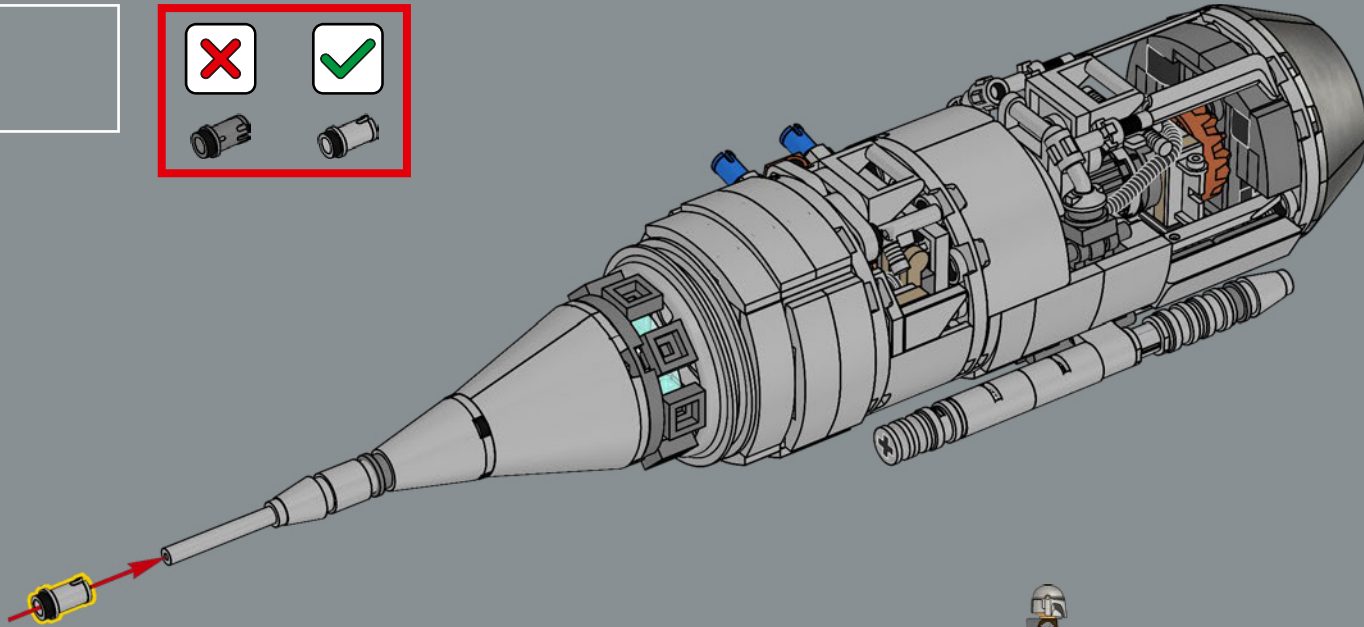
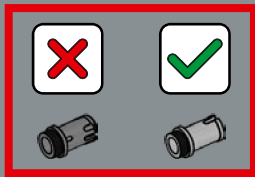

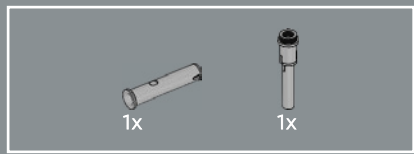

497

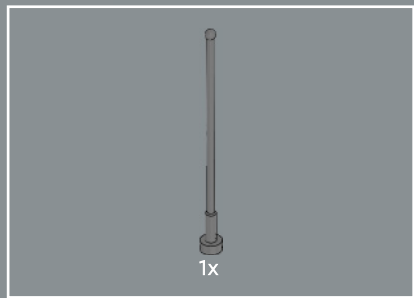
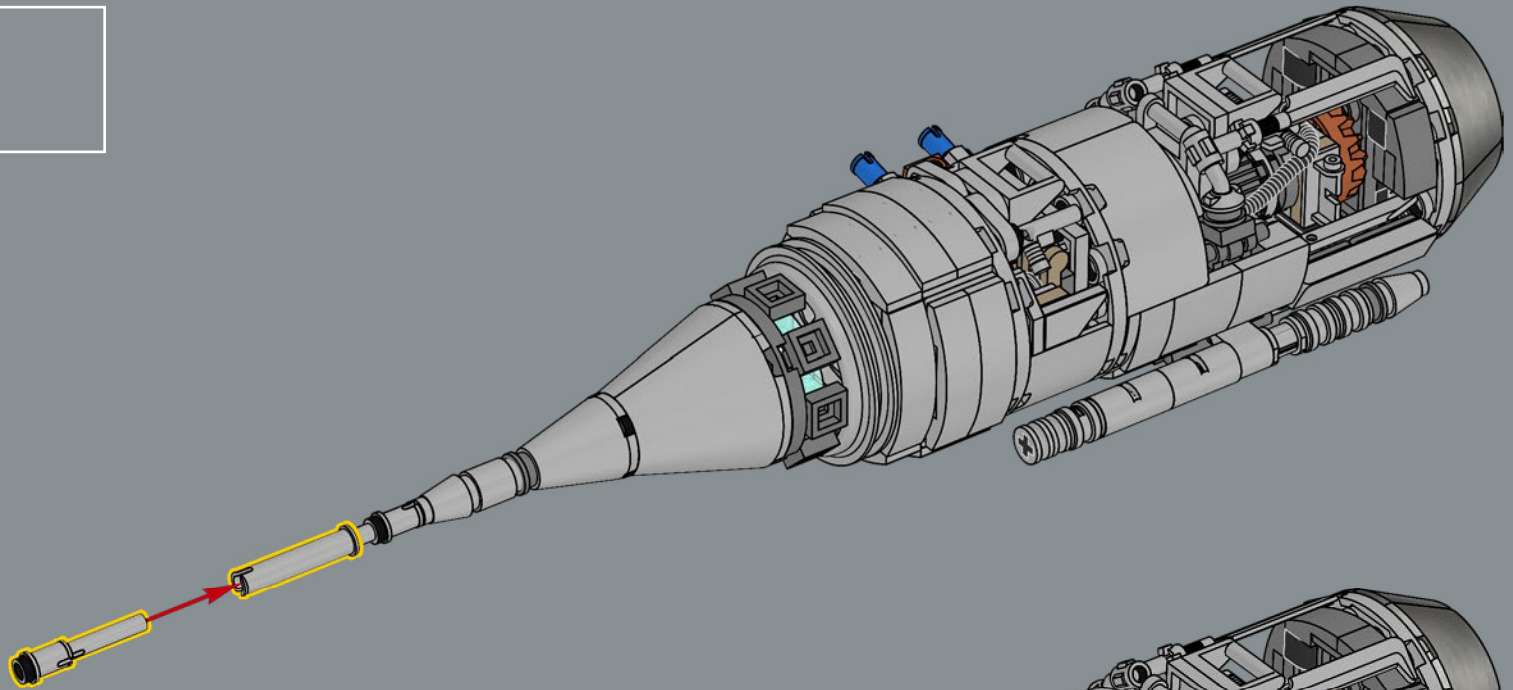

498

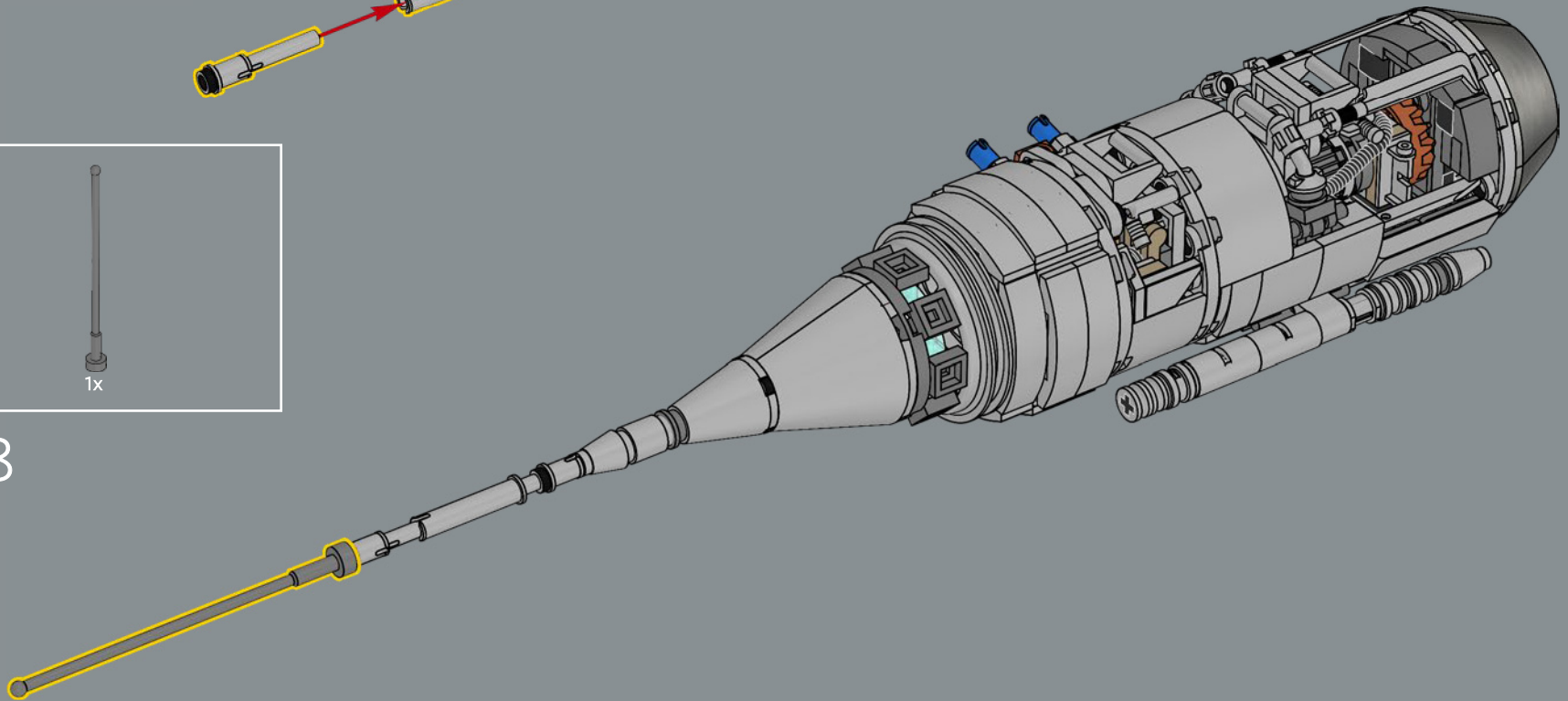

499

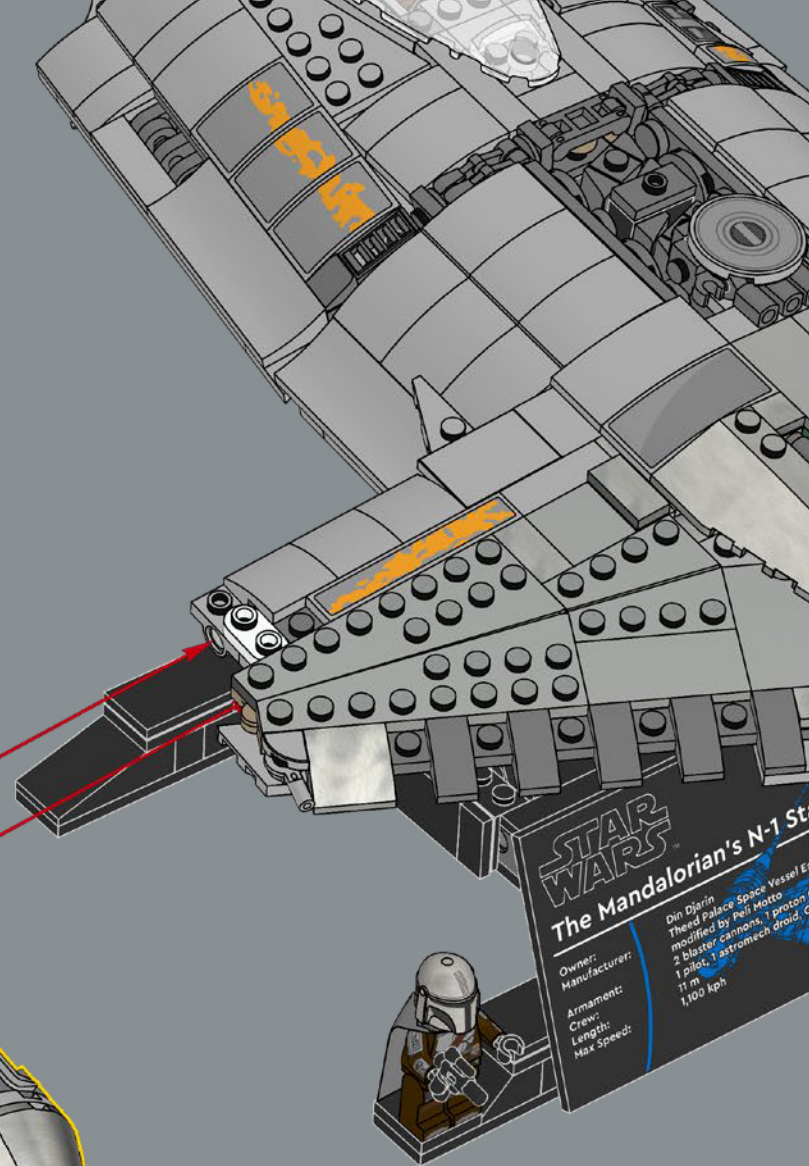
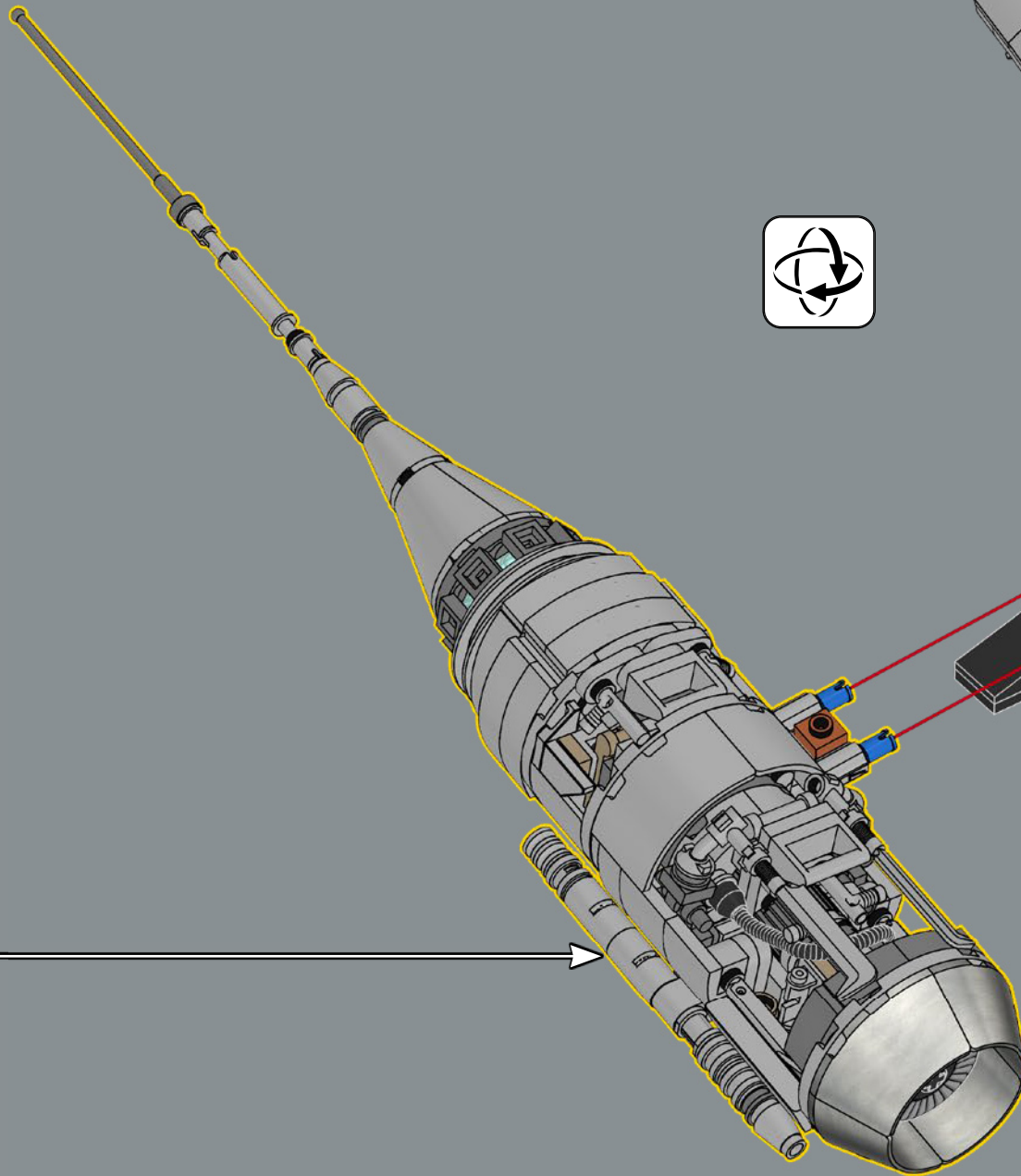

STAR WARS
The Mandalorian's N-1 Starline
Din Djarin
Theed Palace Space Vessel E
modified by Peli Motto
2 blaster cannons, 1 proton
1 pilot, 1 astromech droid,
11 m
1,100 kph

Owner:
Manufacturer:
Armament:
Crew:
Length:
Max Speed:



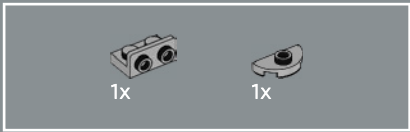

500

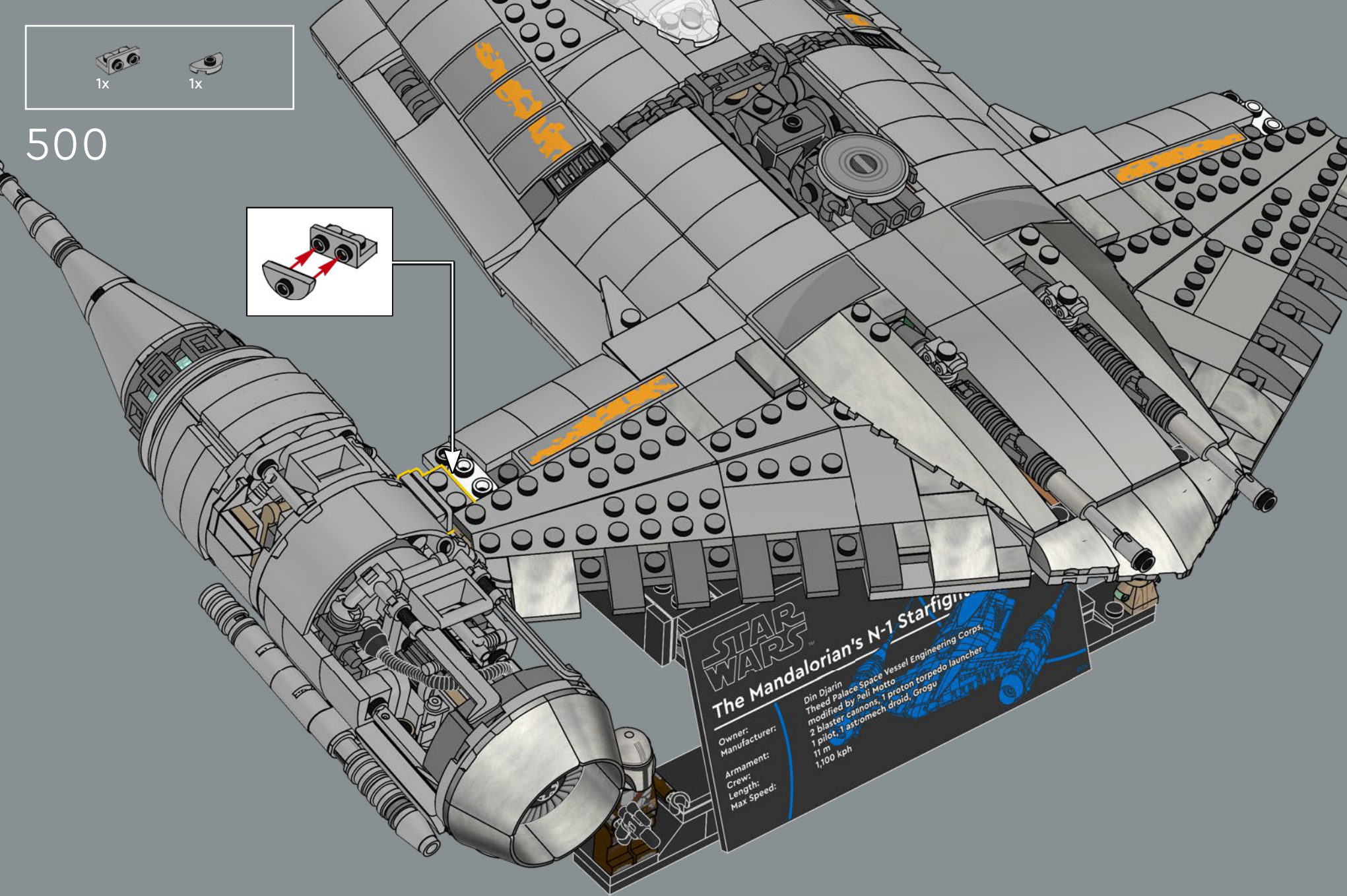
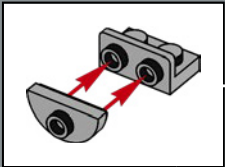

STAR WARS
The Mandalorian's N-1 Starfighter

Owner: Din Djarin
Manufacturer: Theed Palace Space Vessel Engineering Corps, modified by Peli Motto
Armament: 2 blaster cannons, 1 proton torpedo launcher
Crew: 1 pilot, 1 astromech droid, Grogu
Length: 11 m
Max Speed: 1,100 kph

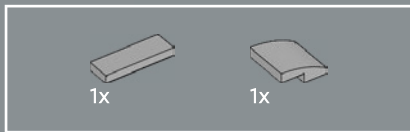

501

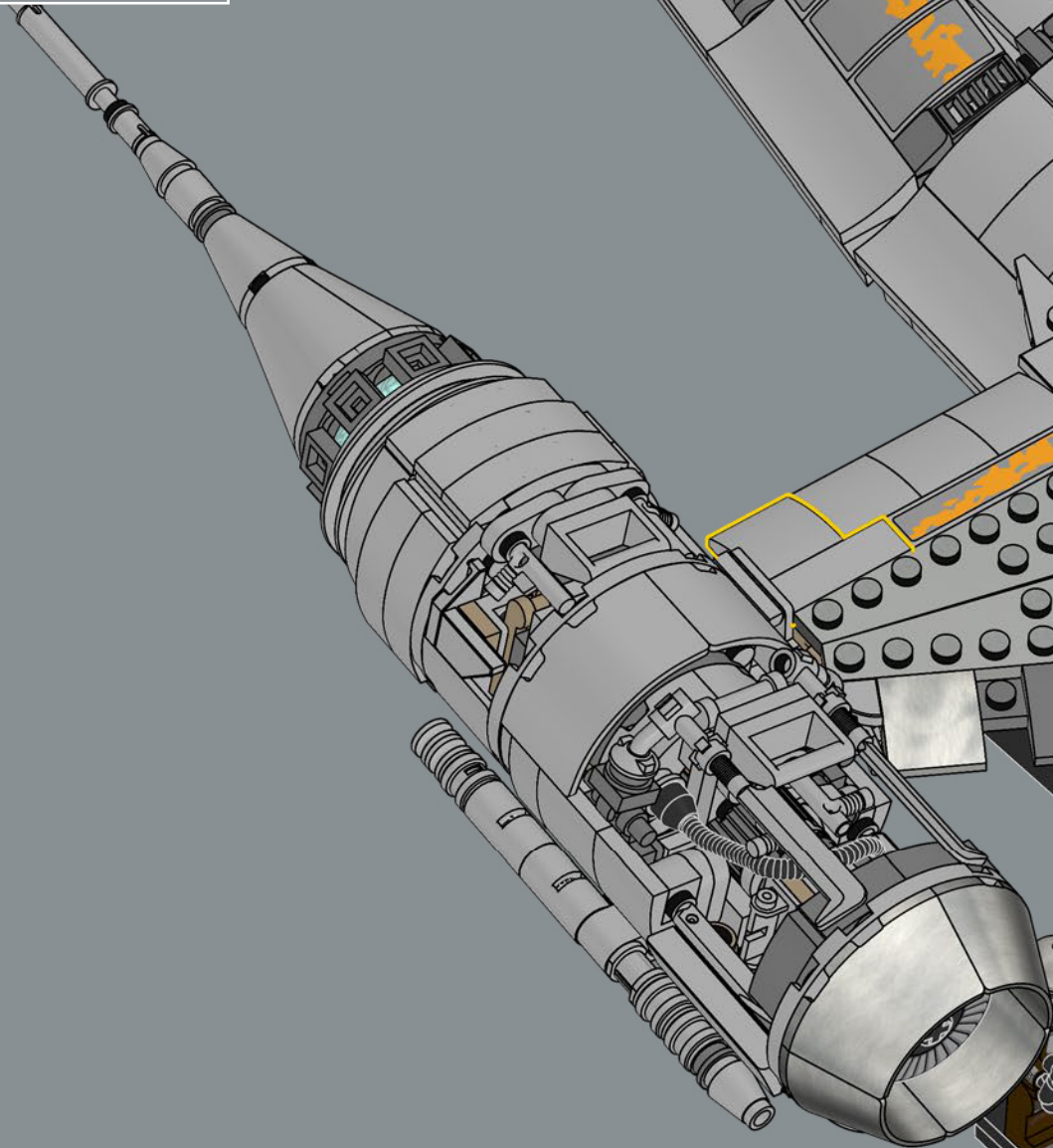

STAR WARS™
The Mandalorian's N-1 Starfighter

Din Djarin
Theed Palace Space Vessel Engineering Corps,
modified by Peli Motto

Owner:
Manufacturer:

Armament:
Crew:
Length:
Max Speed:

2 blaster cannons, 1 proton torpedo launcher
1 pilot, 1 astromech droid, Grogu
11 m
1,100 kph





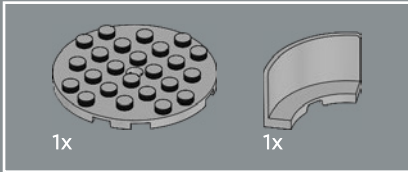
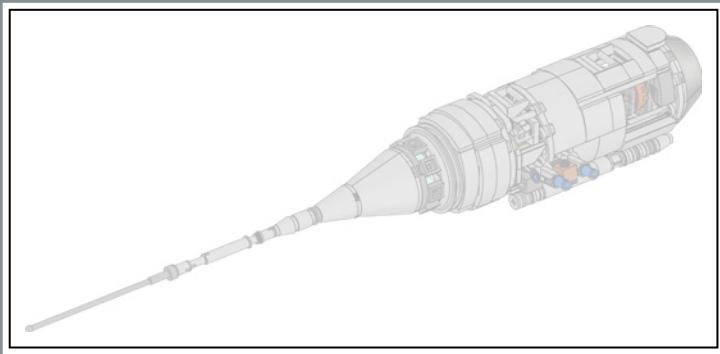

502

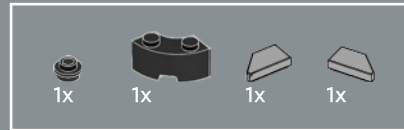
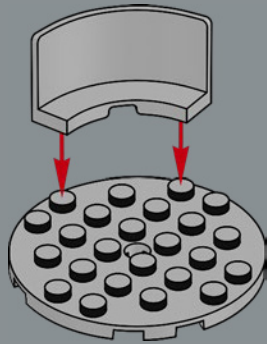

503

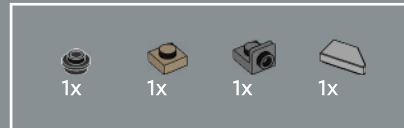
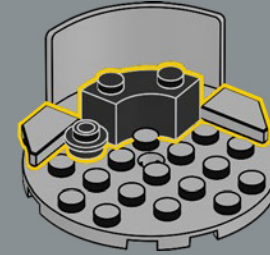

504

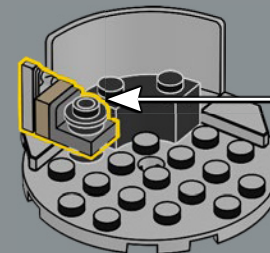
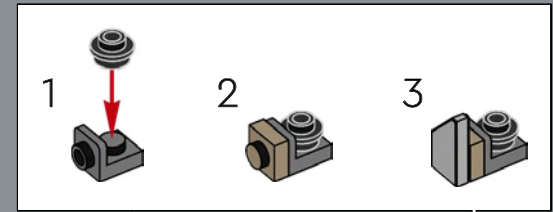



505

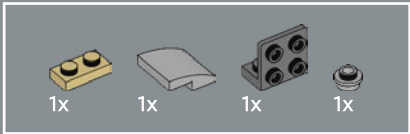
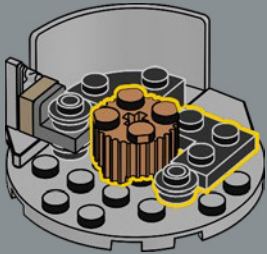

506

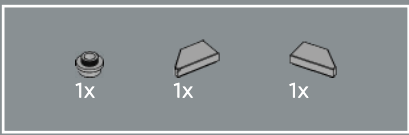
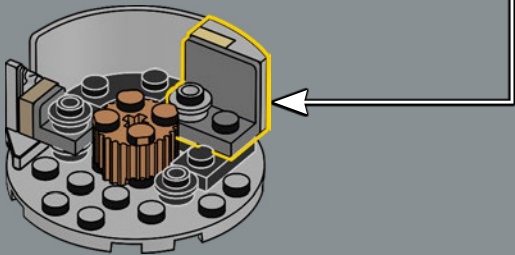
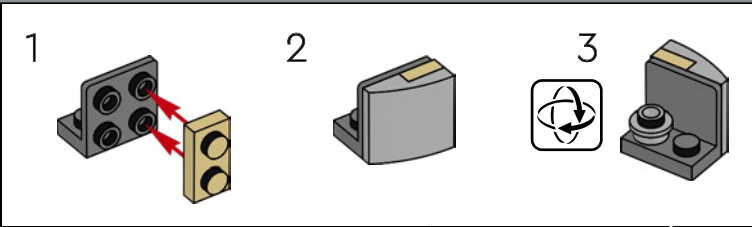

507

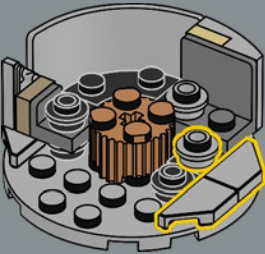

508

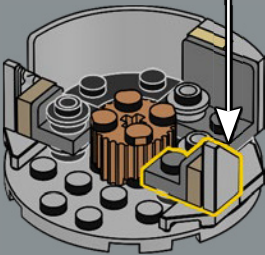
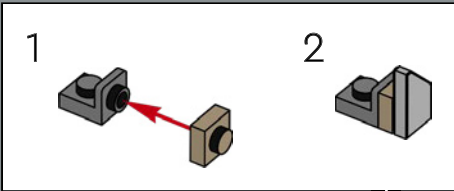

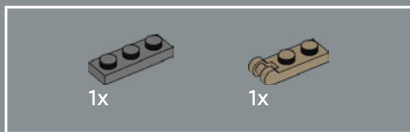

509

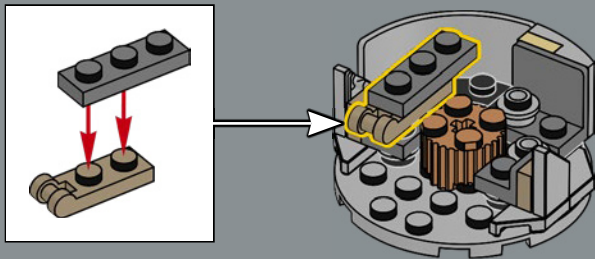

510

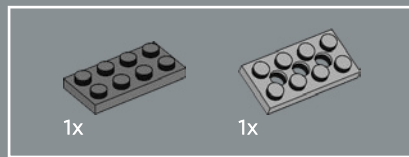
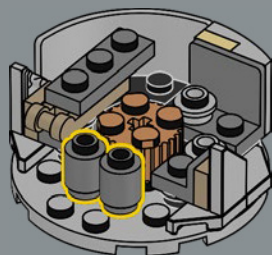

511

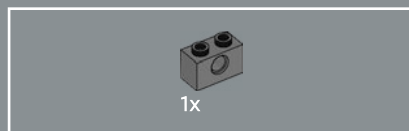
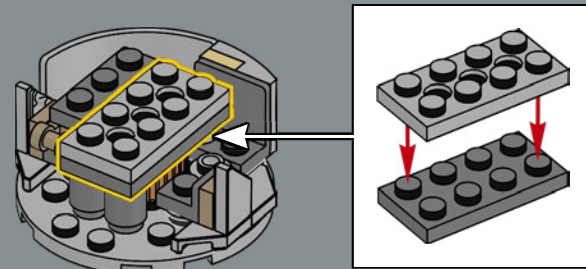

512

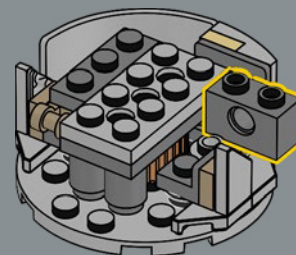



513

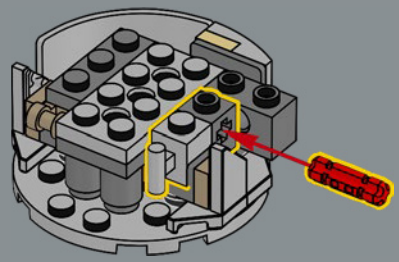

514

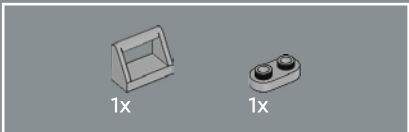
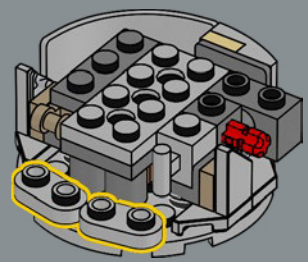

515

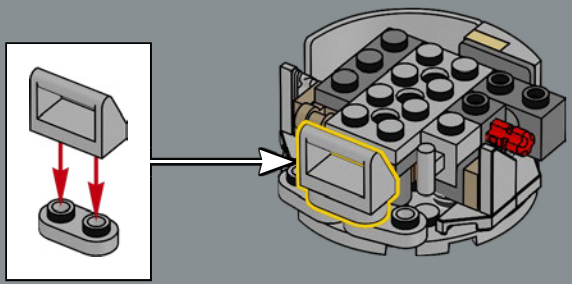

516

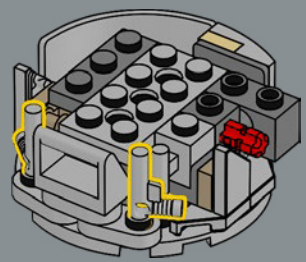

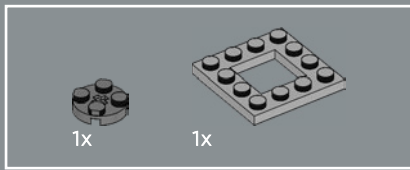

517

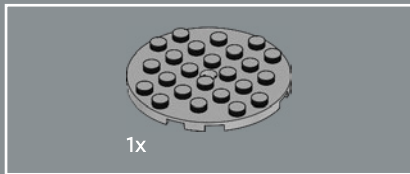
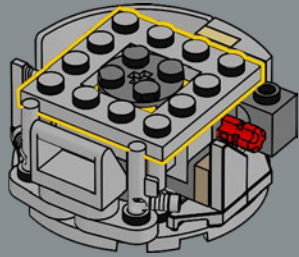

518

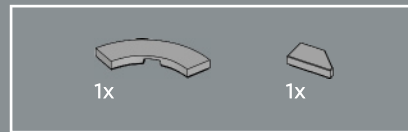
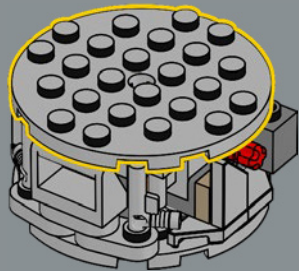

519

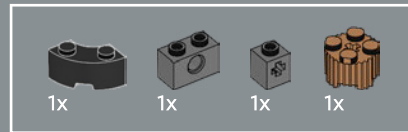
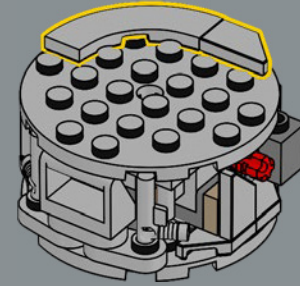

520

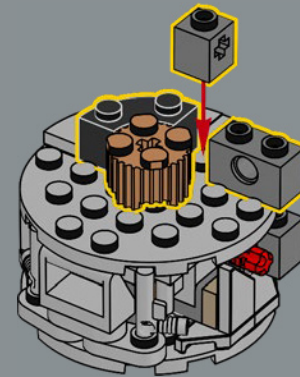

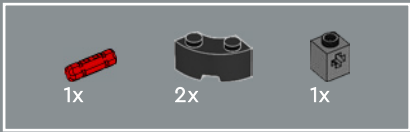

521

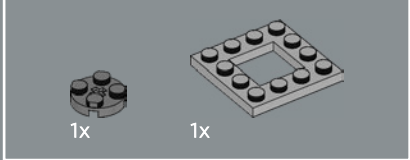
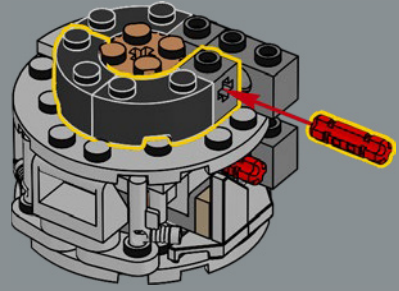

522

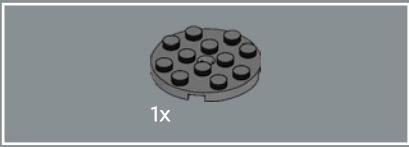
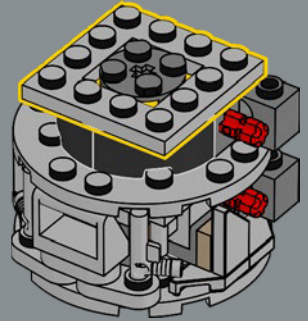

523

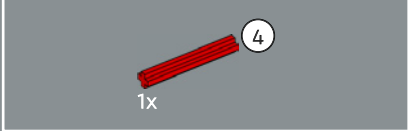
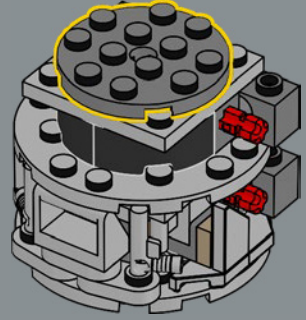

524

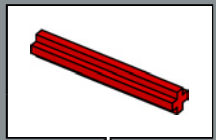
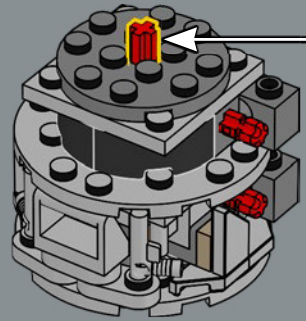

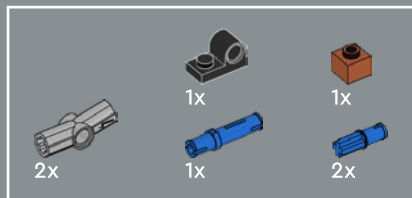

525

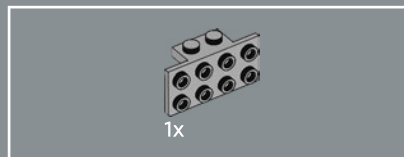
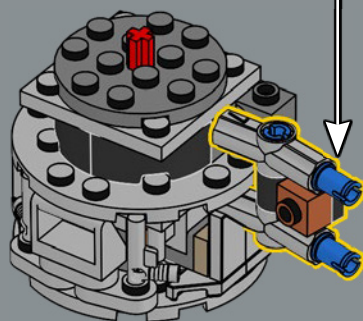
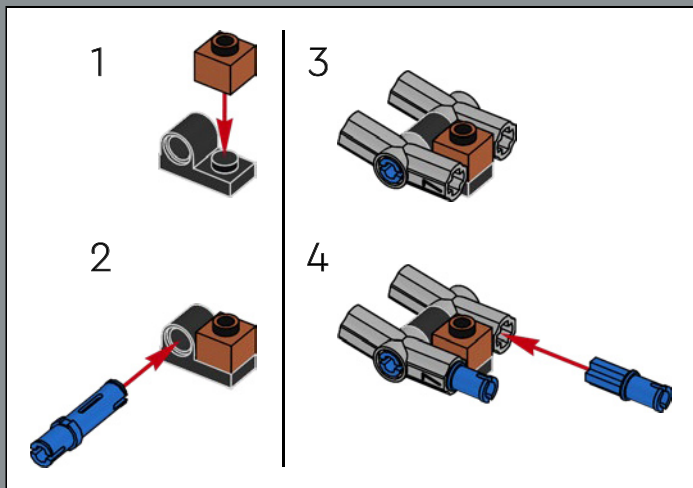

526

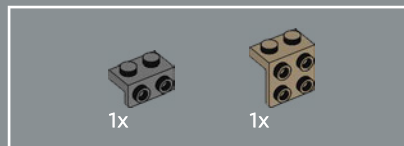
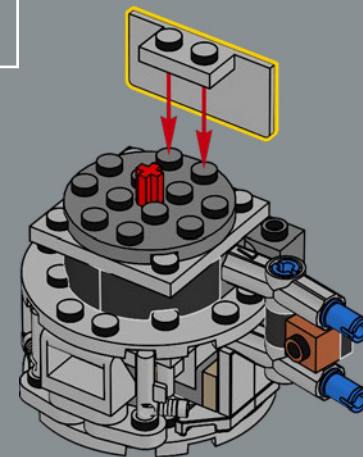

527

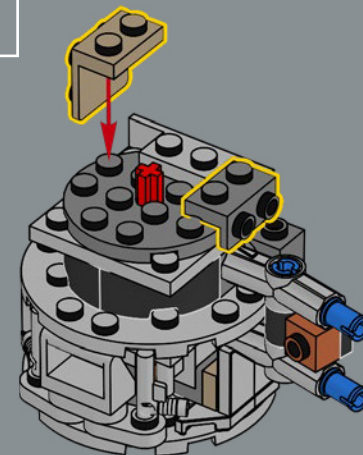

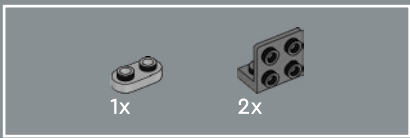

528

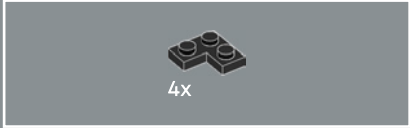
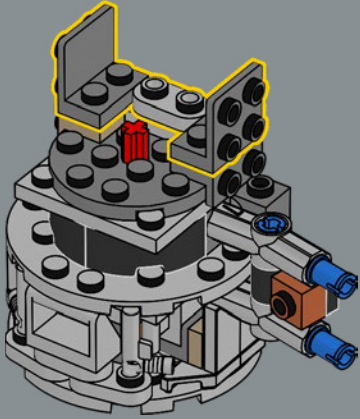

529

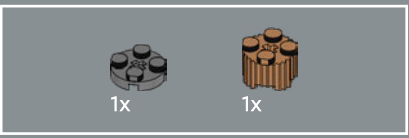
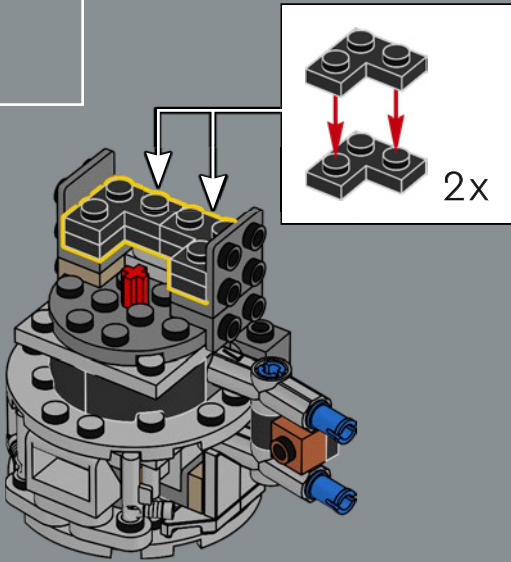

530

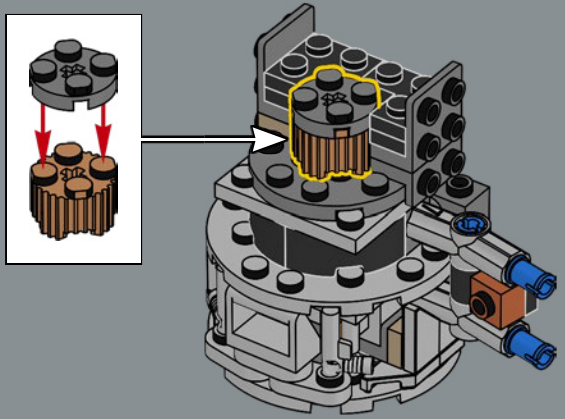

531

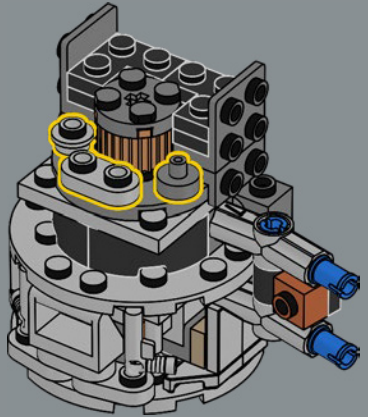

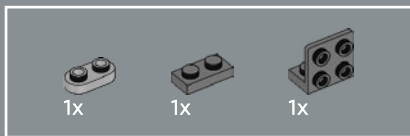

532

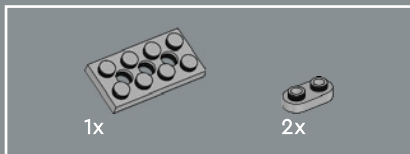
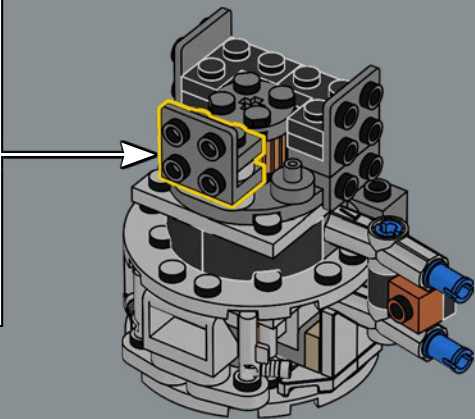
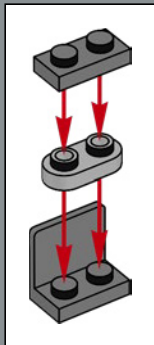

533

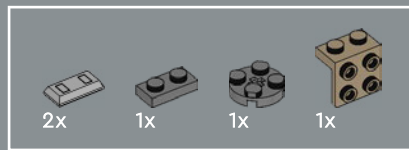
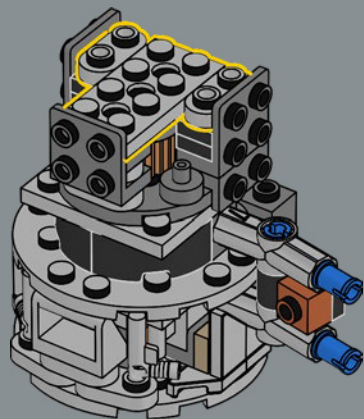

534

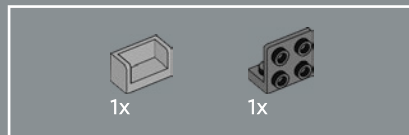
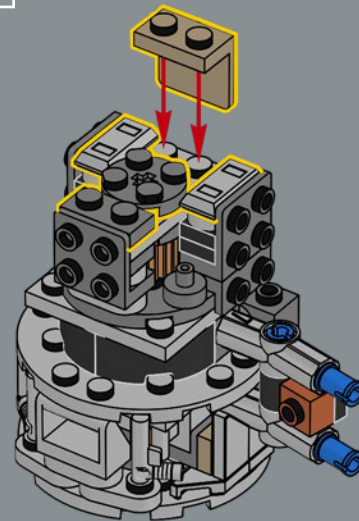

535

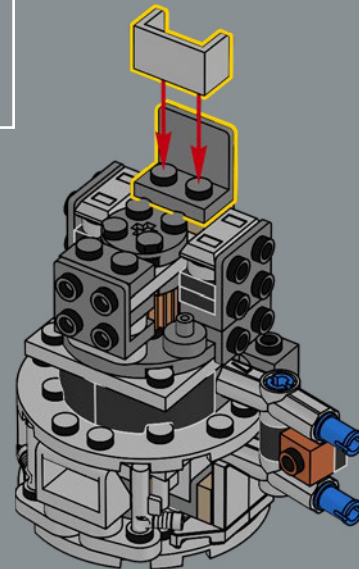

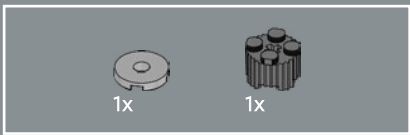

536

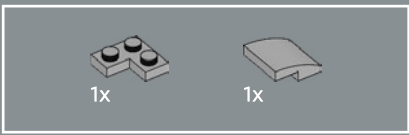
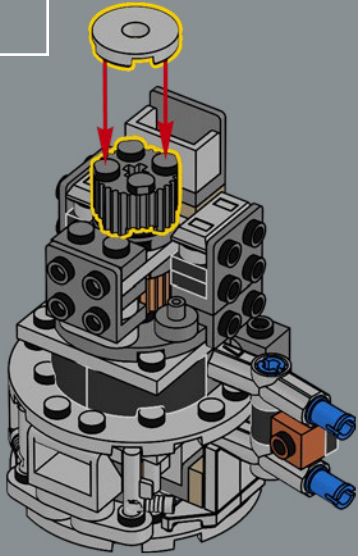

538

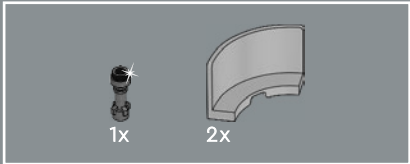
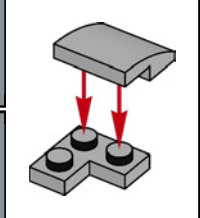
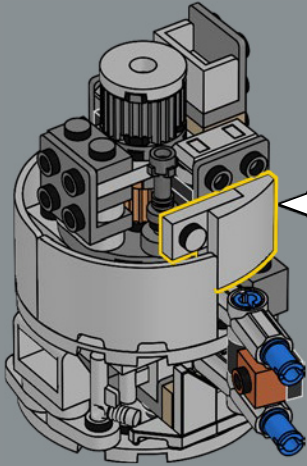

537

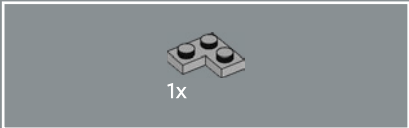
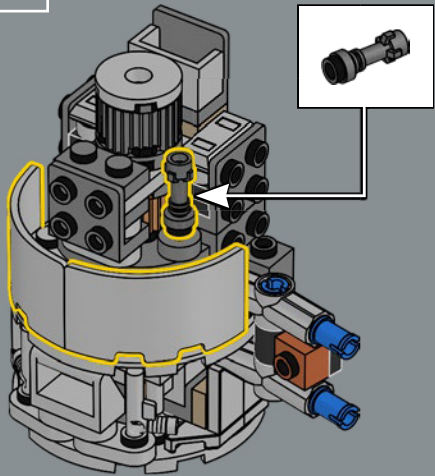

539

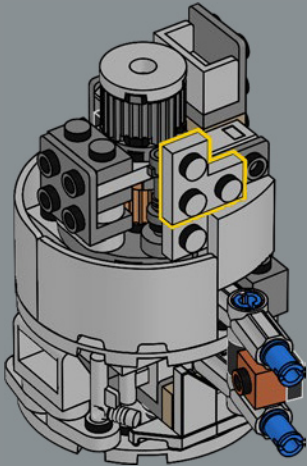

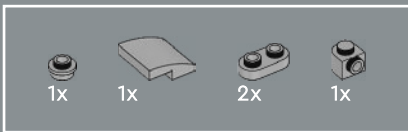

540

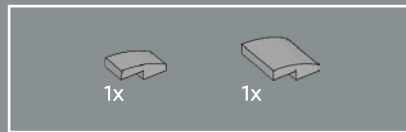
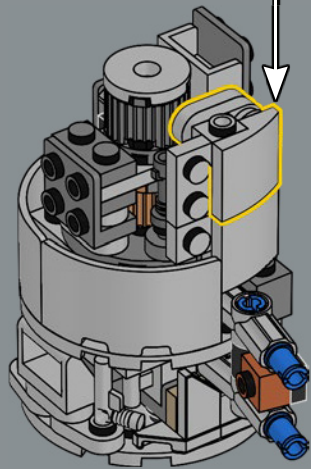
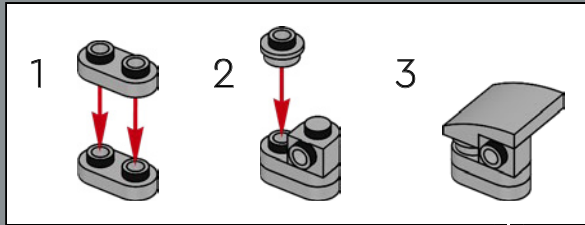

541

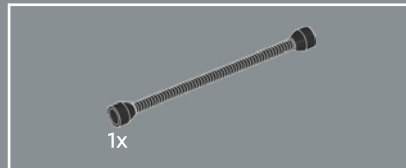
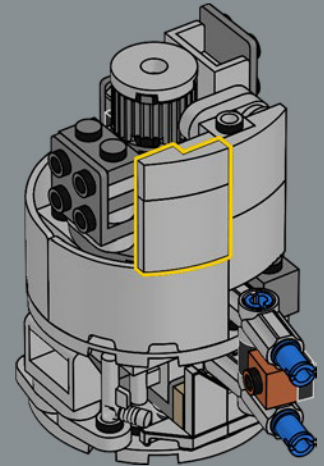

542

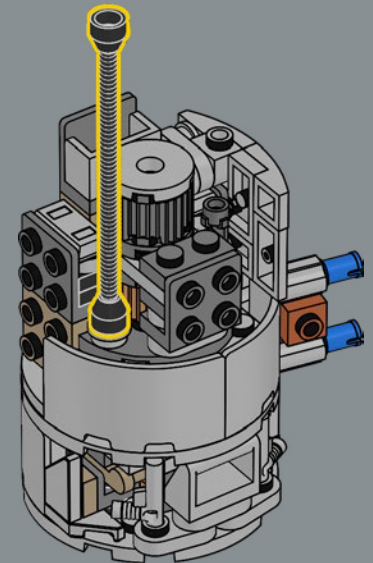

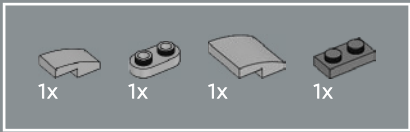

543

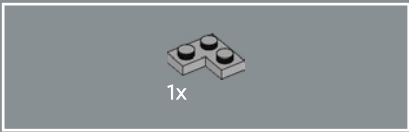
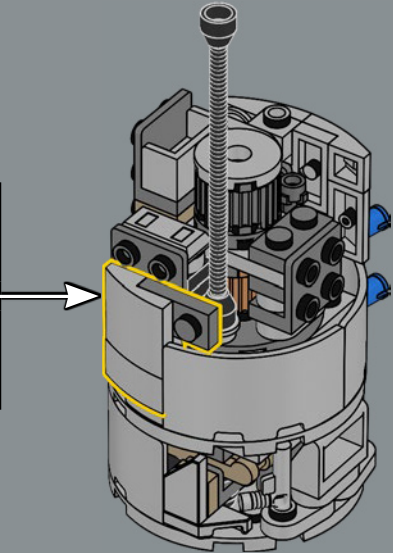
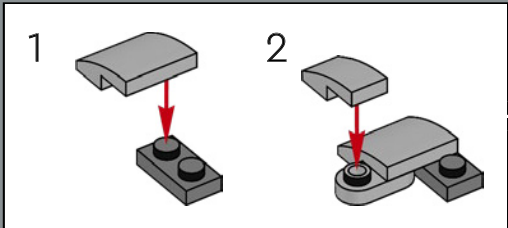

544

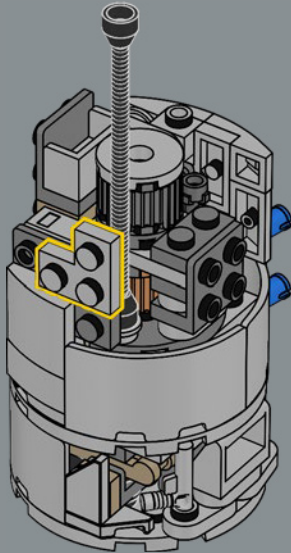

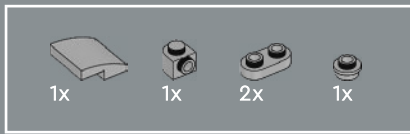

545

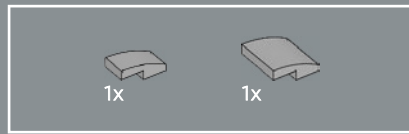
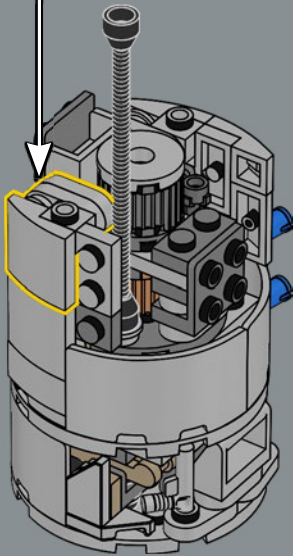
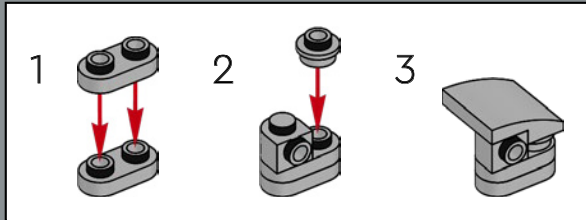

546

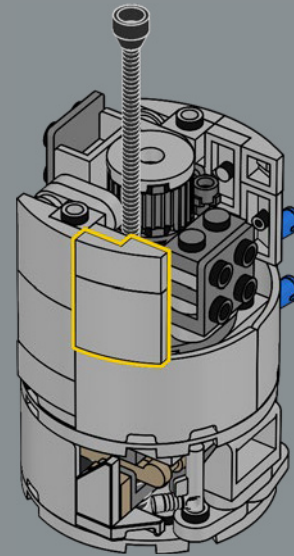

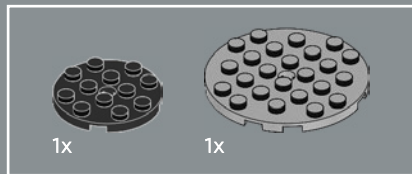
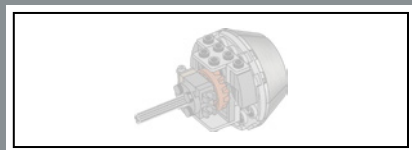

547

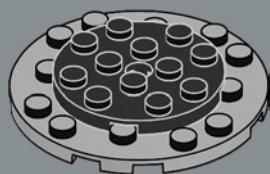

548

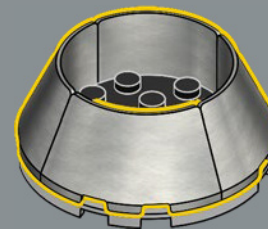

549

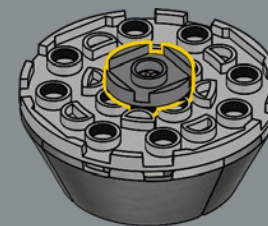

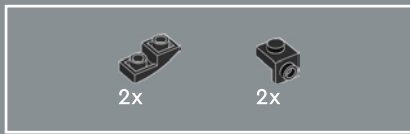

550

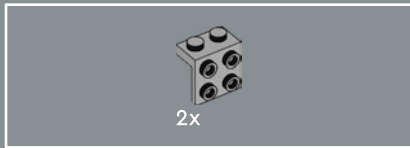
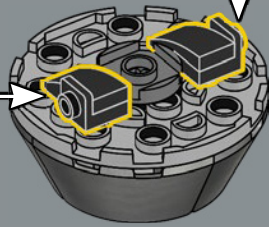
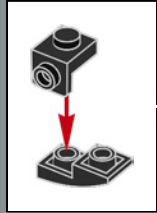
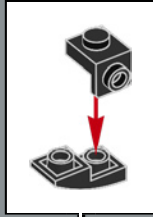

551

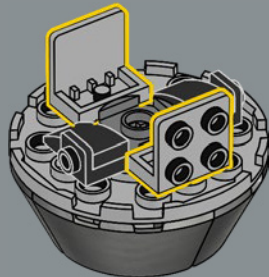

552

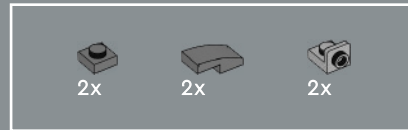
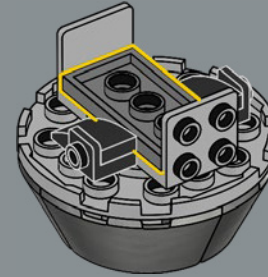

553

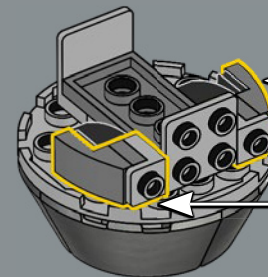
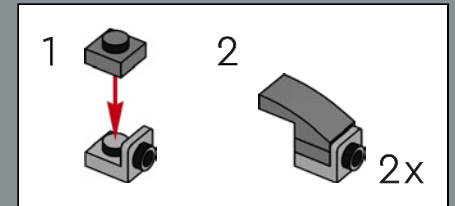

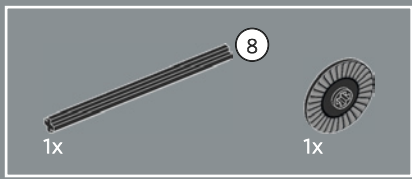

554

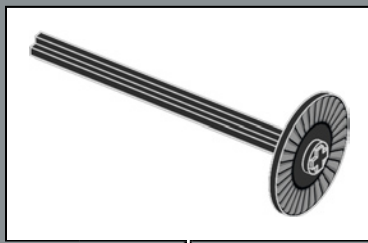
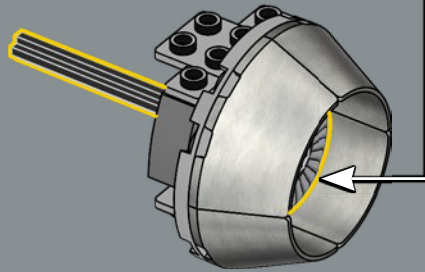

555

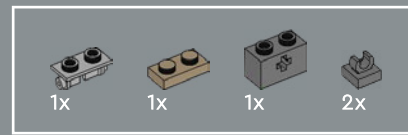
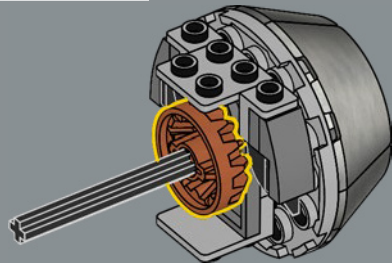

556

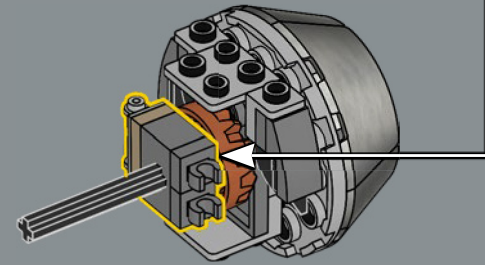
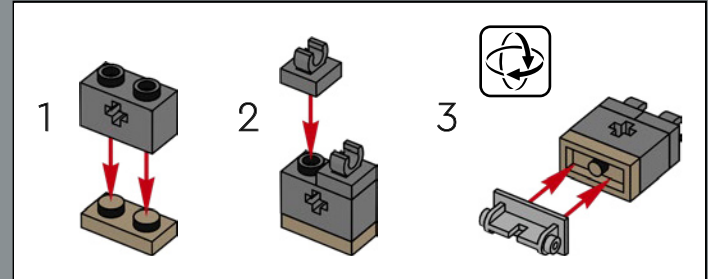

557

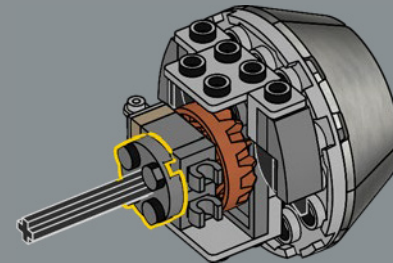

558

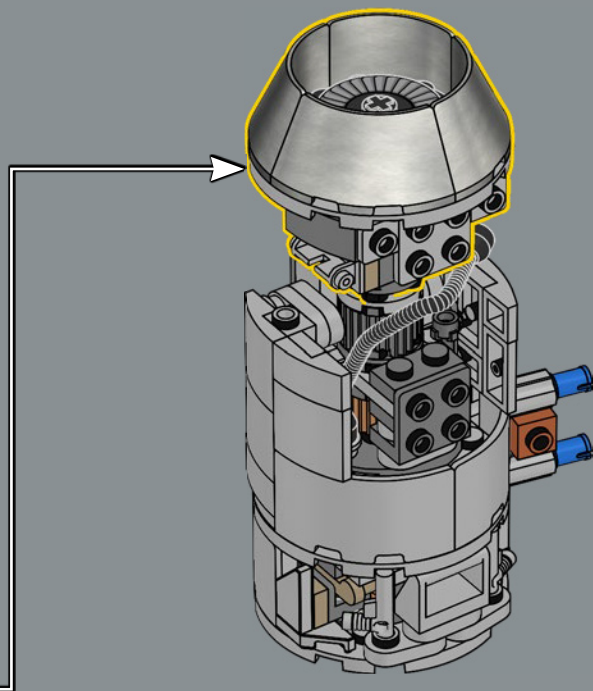

559

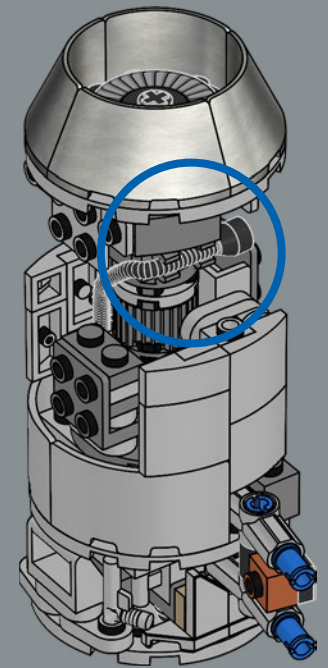

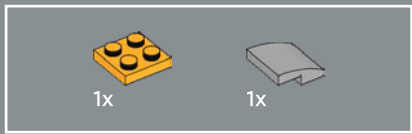

560

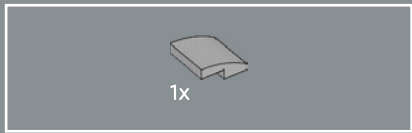
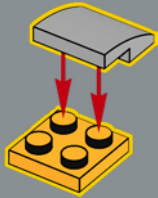

561

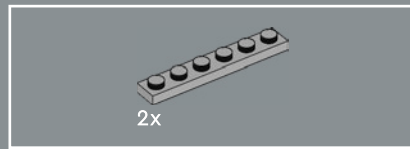
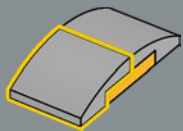

562

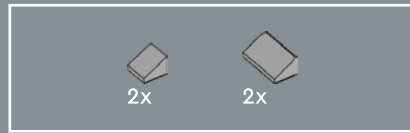
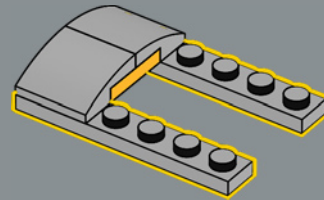

563

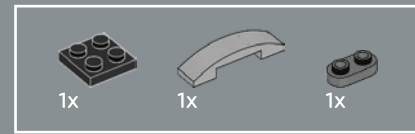
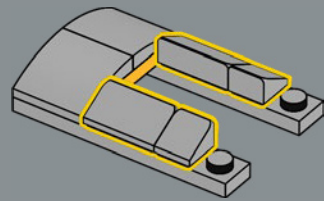

564

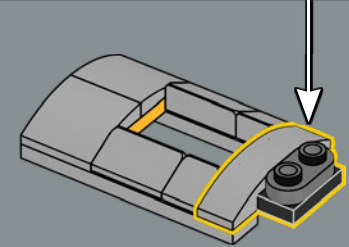
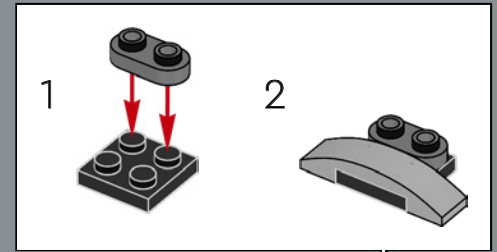

565

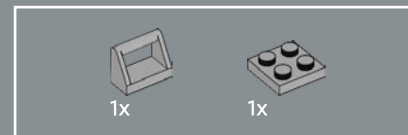
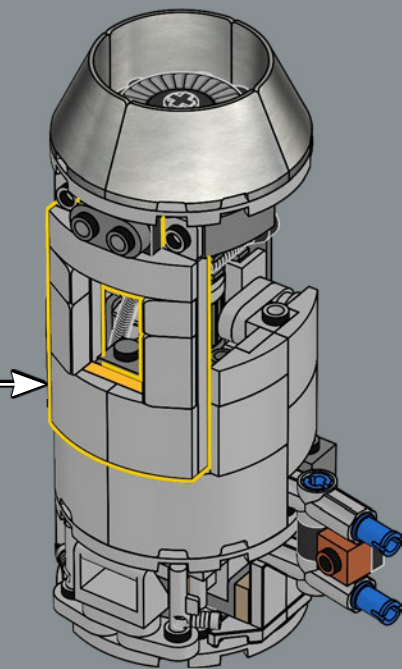

566

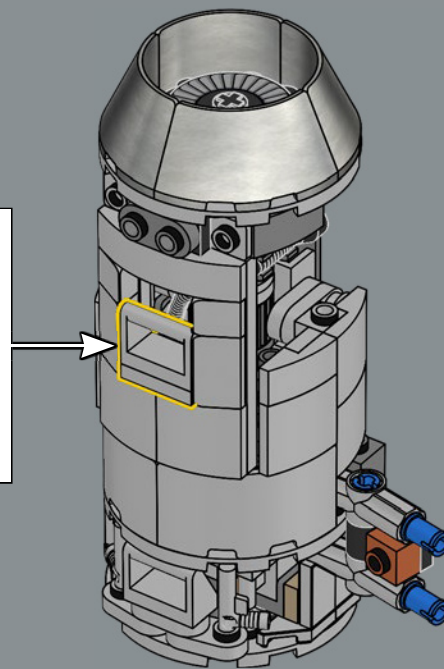
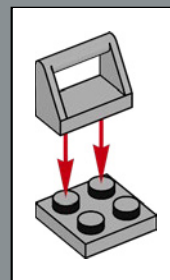

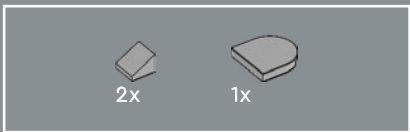

567

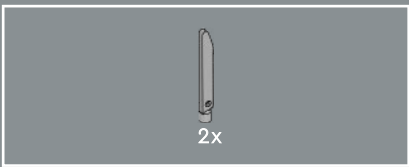
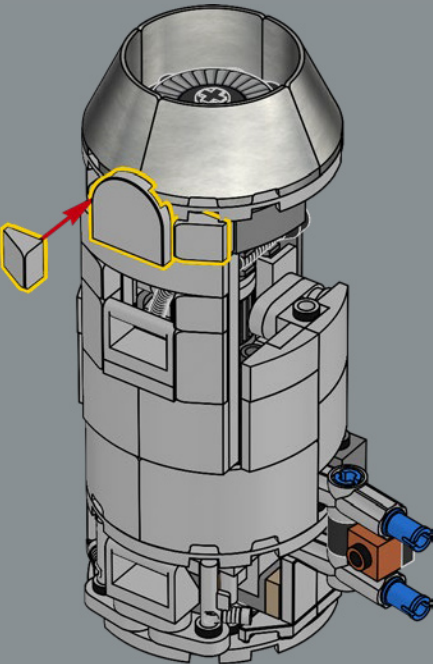

568

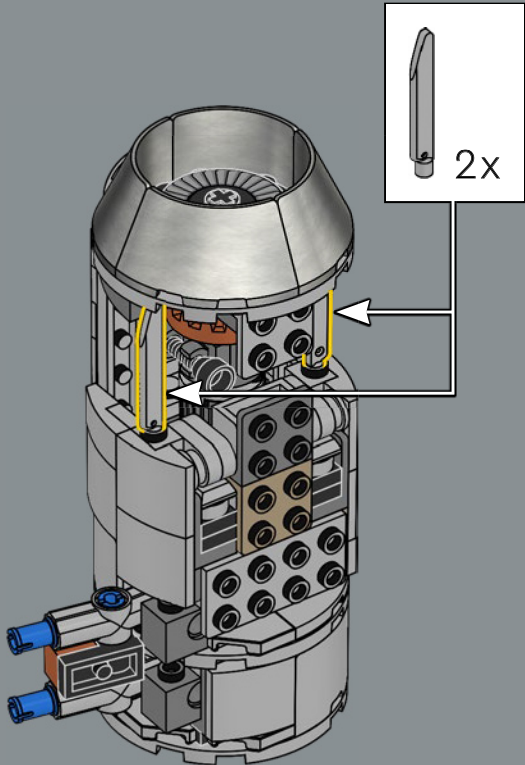

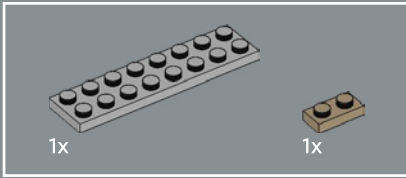
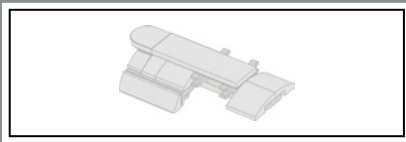

569

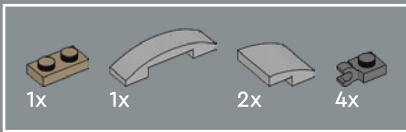
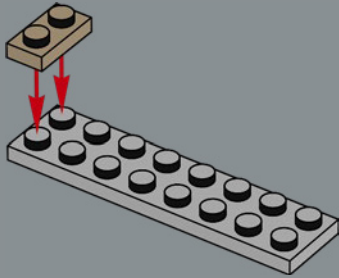

570

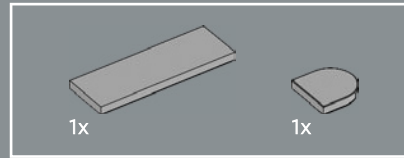
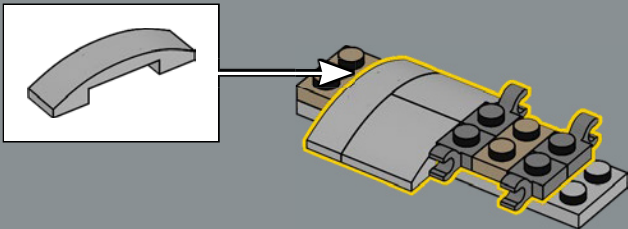

571

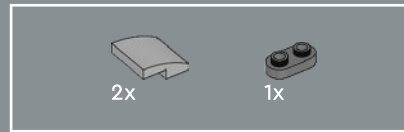
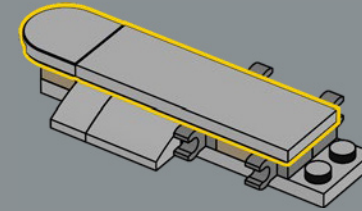

572

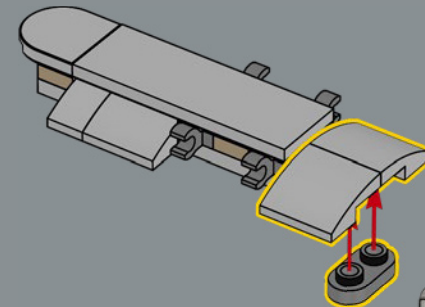

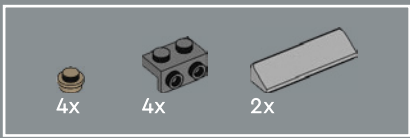

573

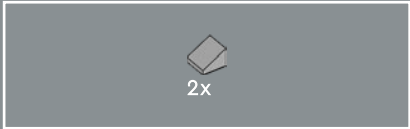
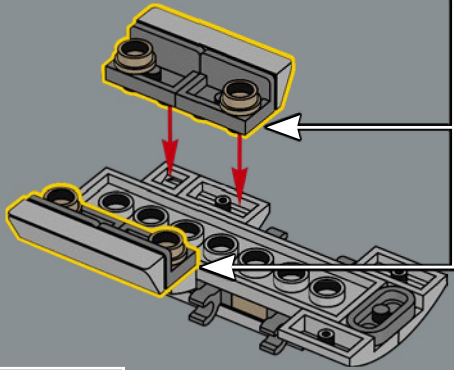
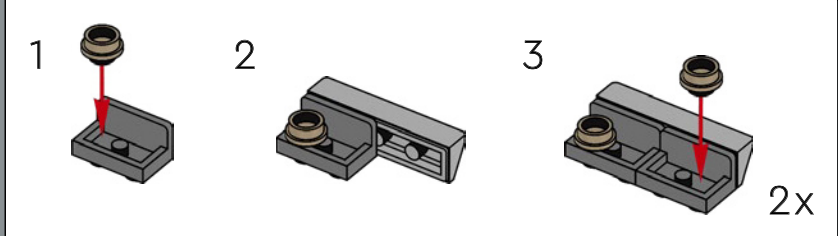

574

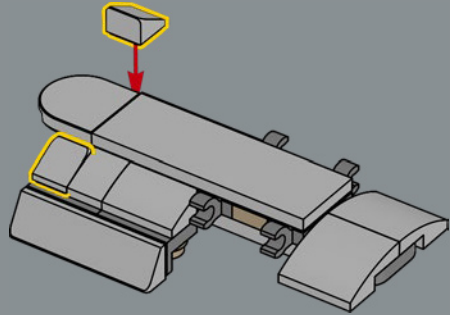

575

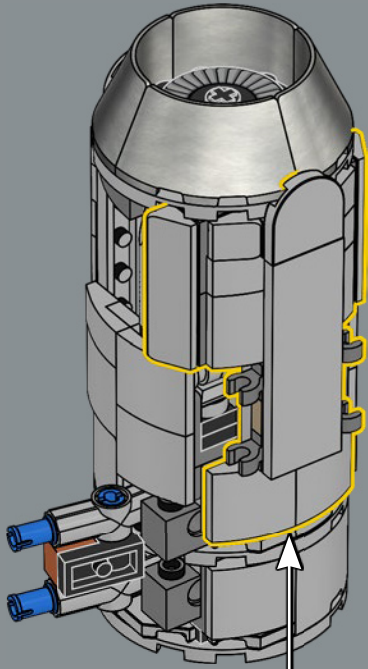

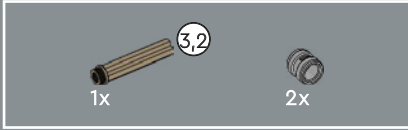
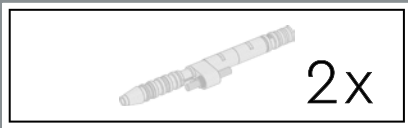

576

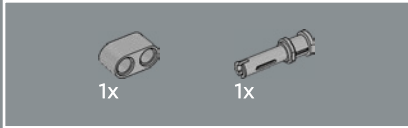
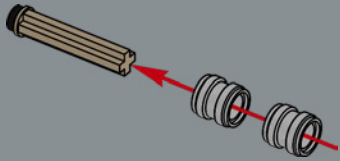

577

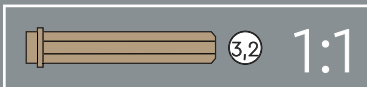
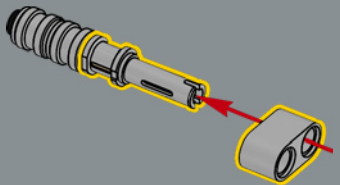

578

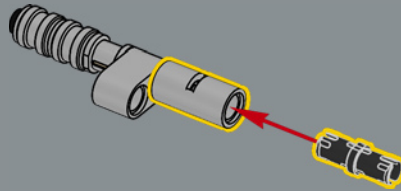

579

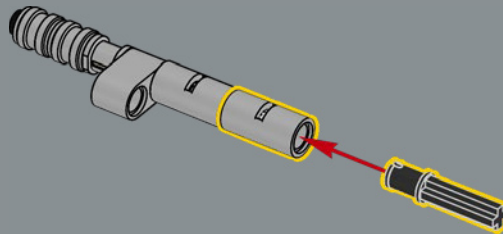

580

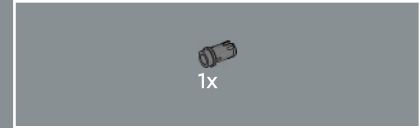
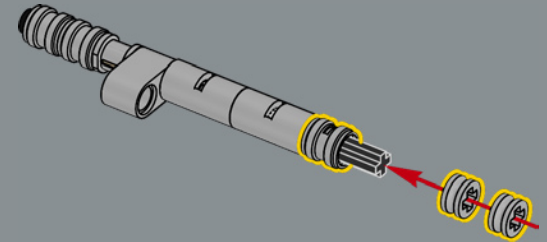

581

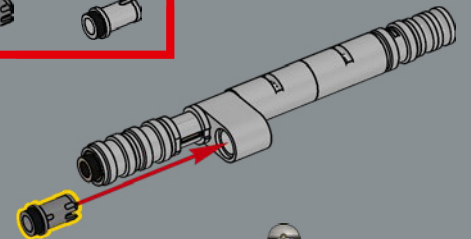
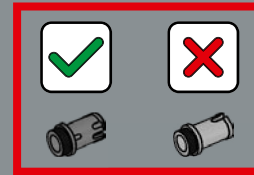

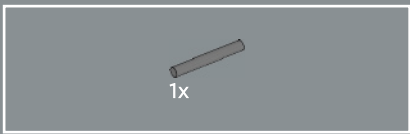

582

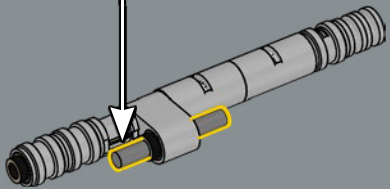
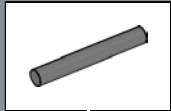

583

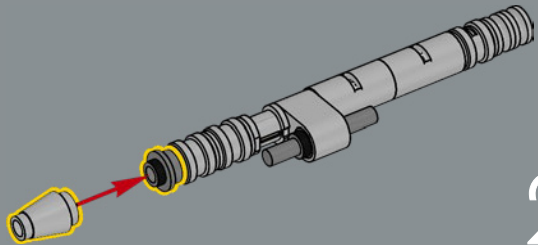

2x

584

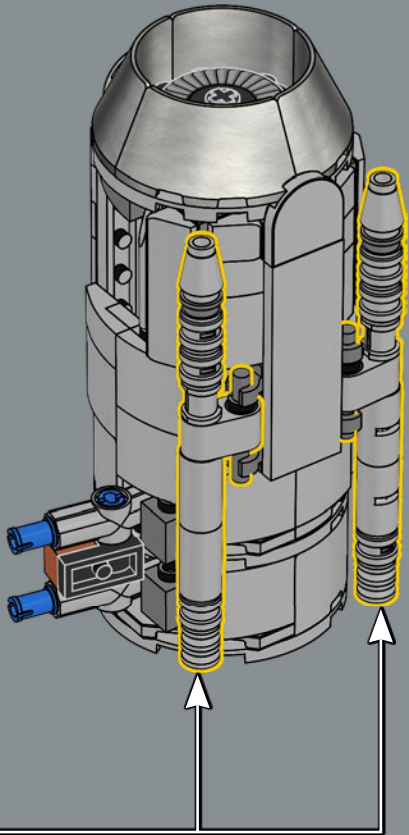

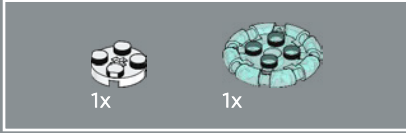
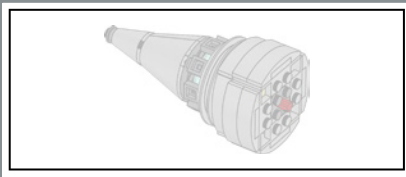

585



586

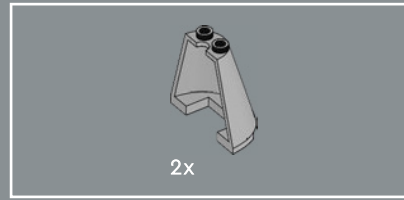

587

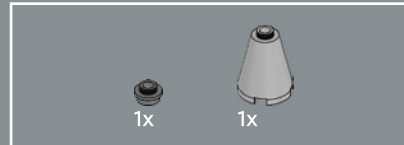
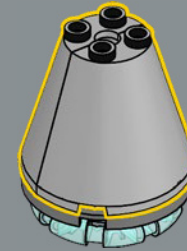

588

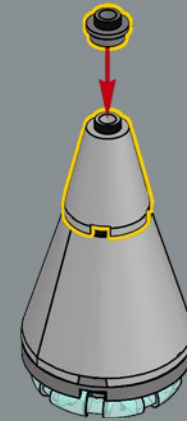

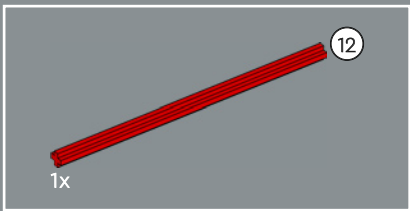

589

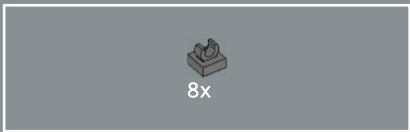
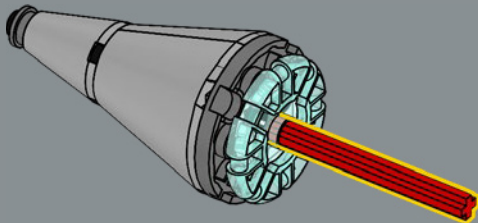

590

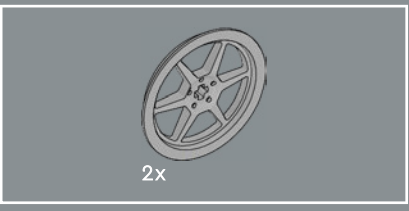
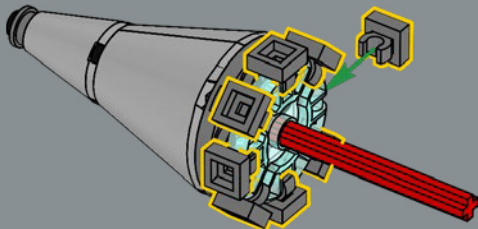

591

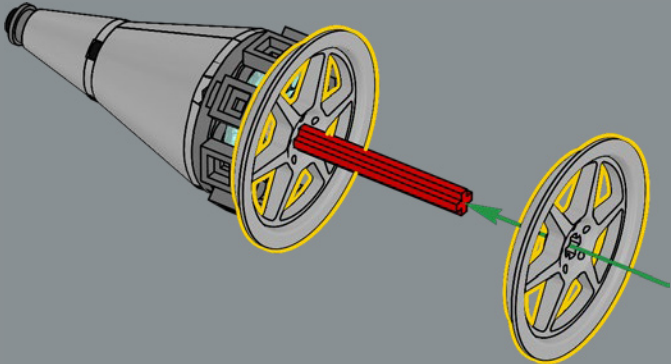

600

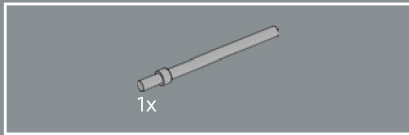
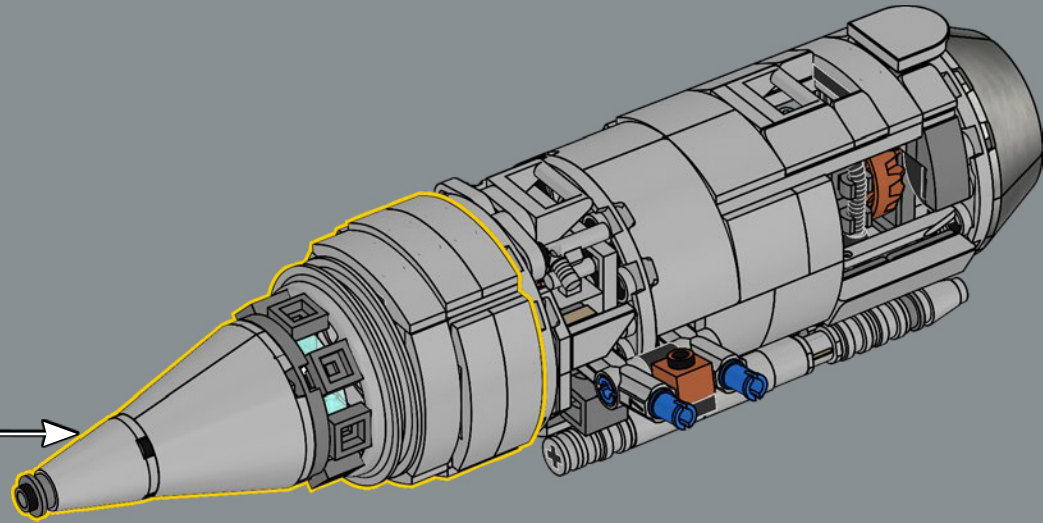

601

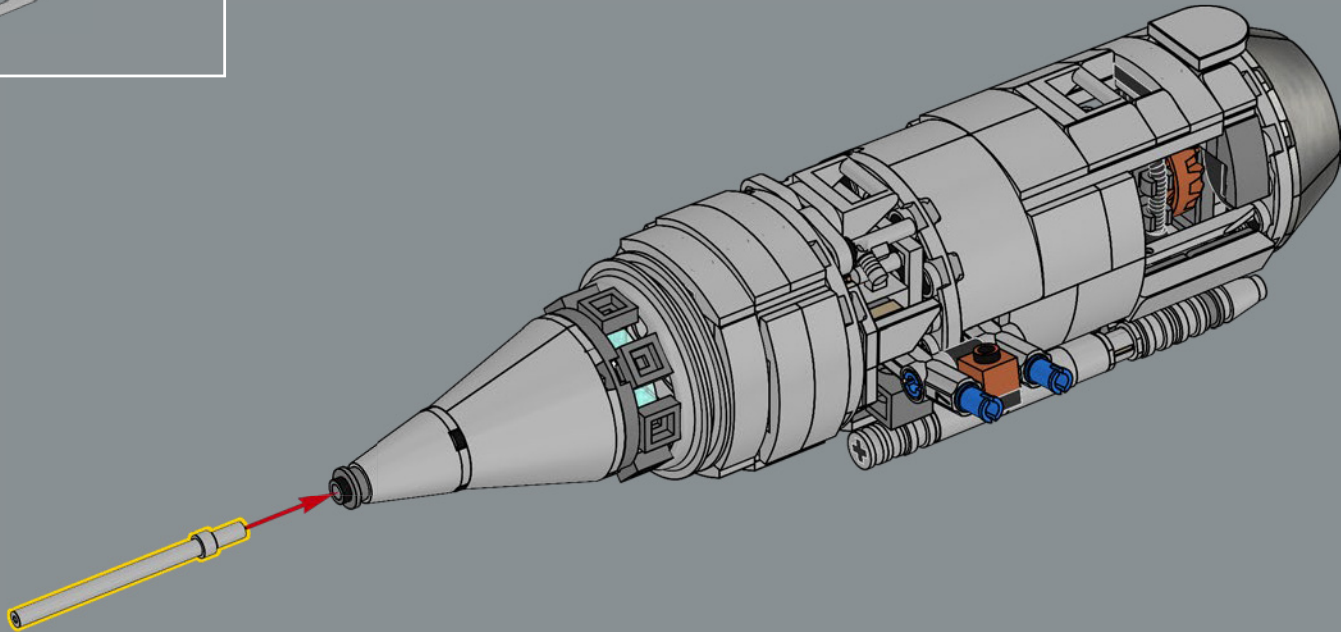

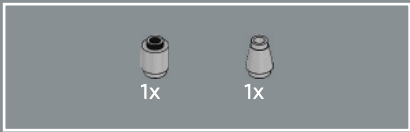

602

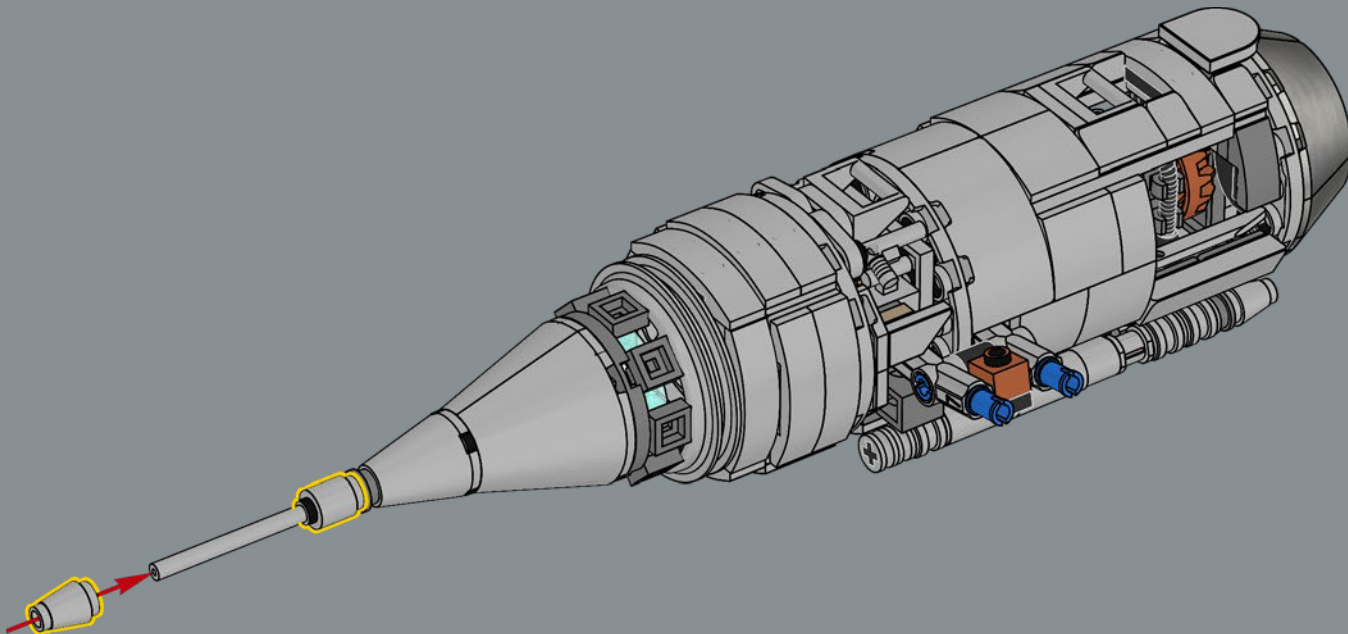

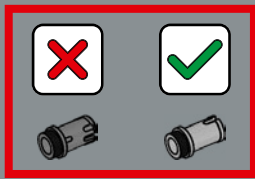

603

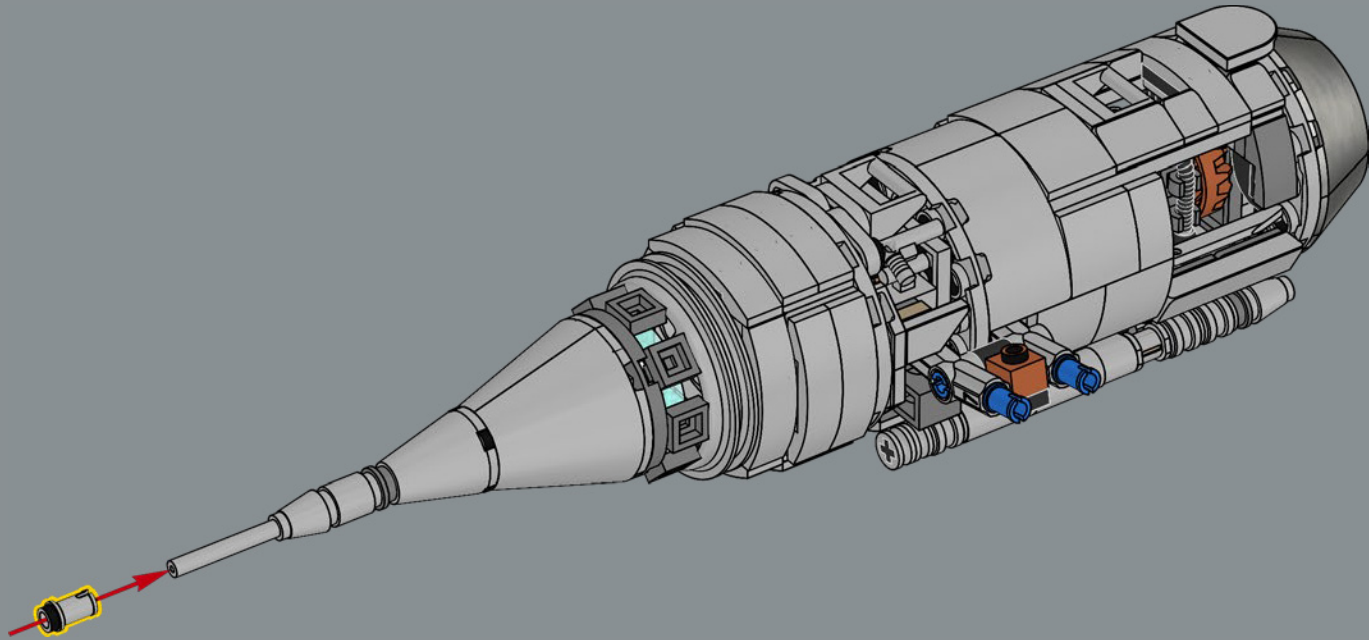

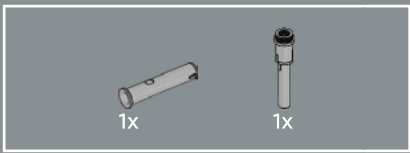

604

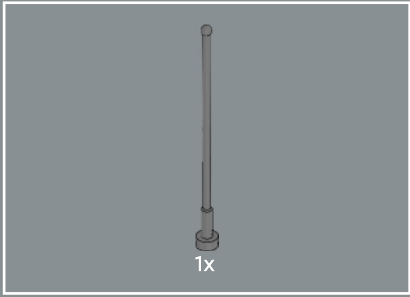
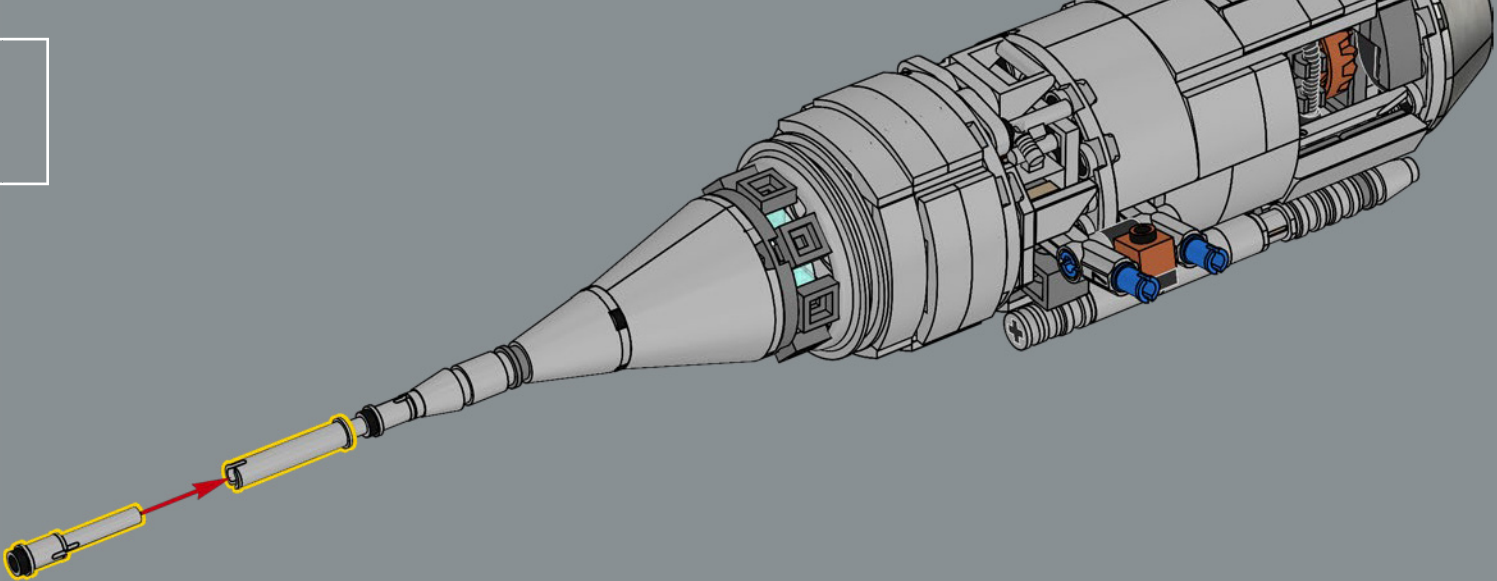

605

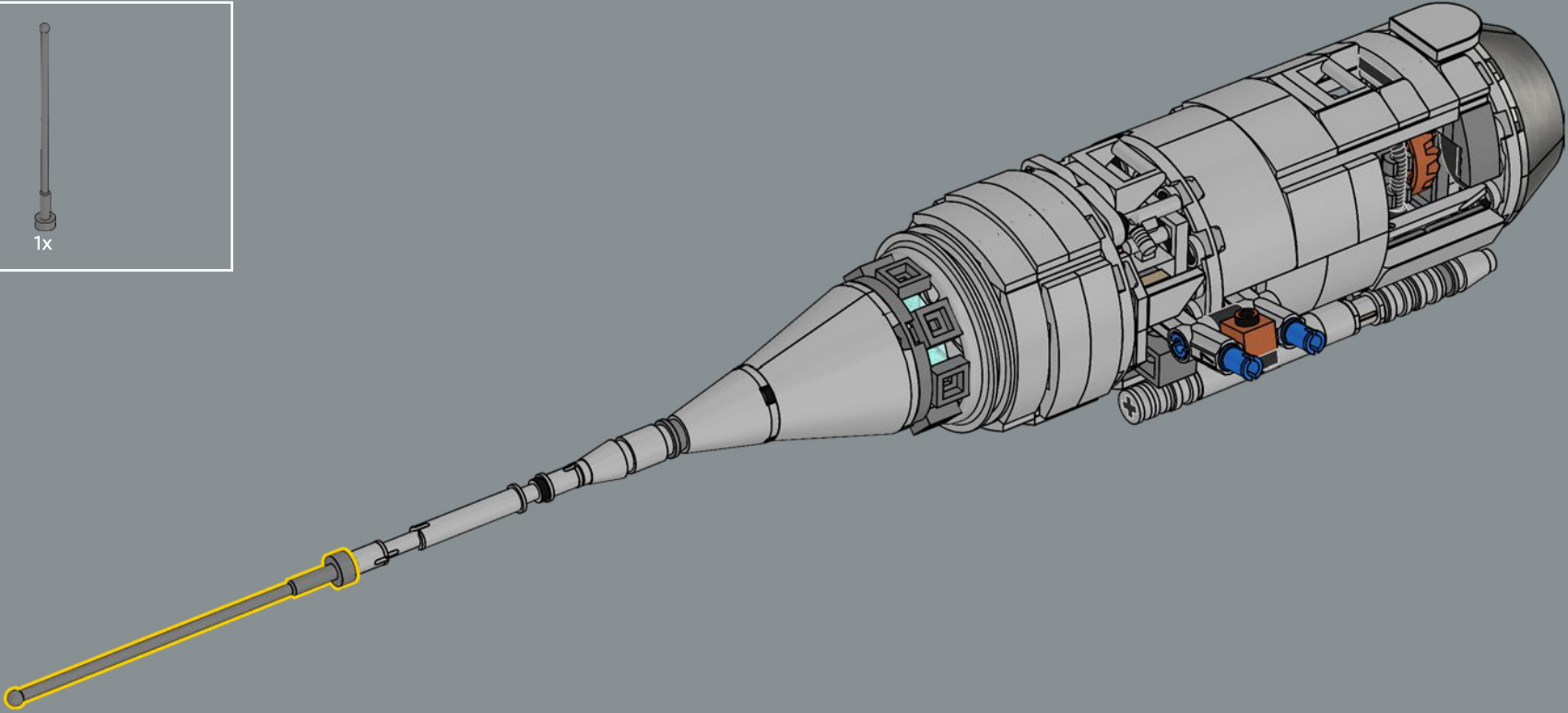

606

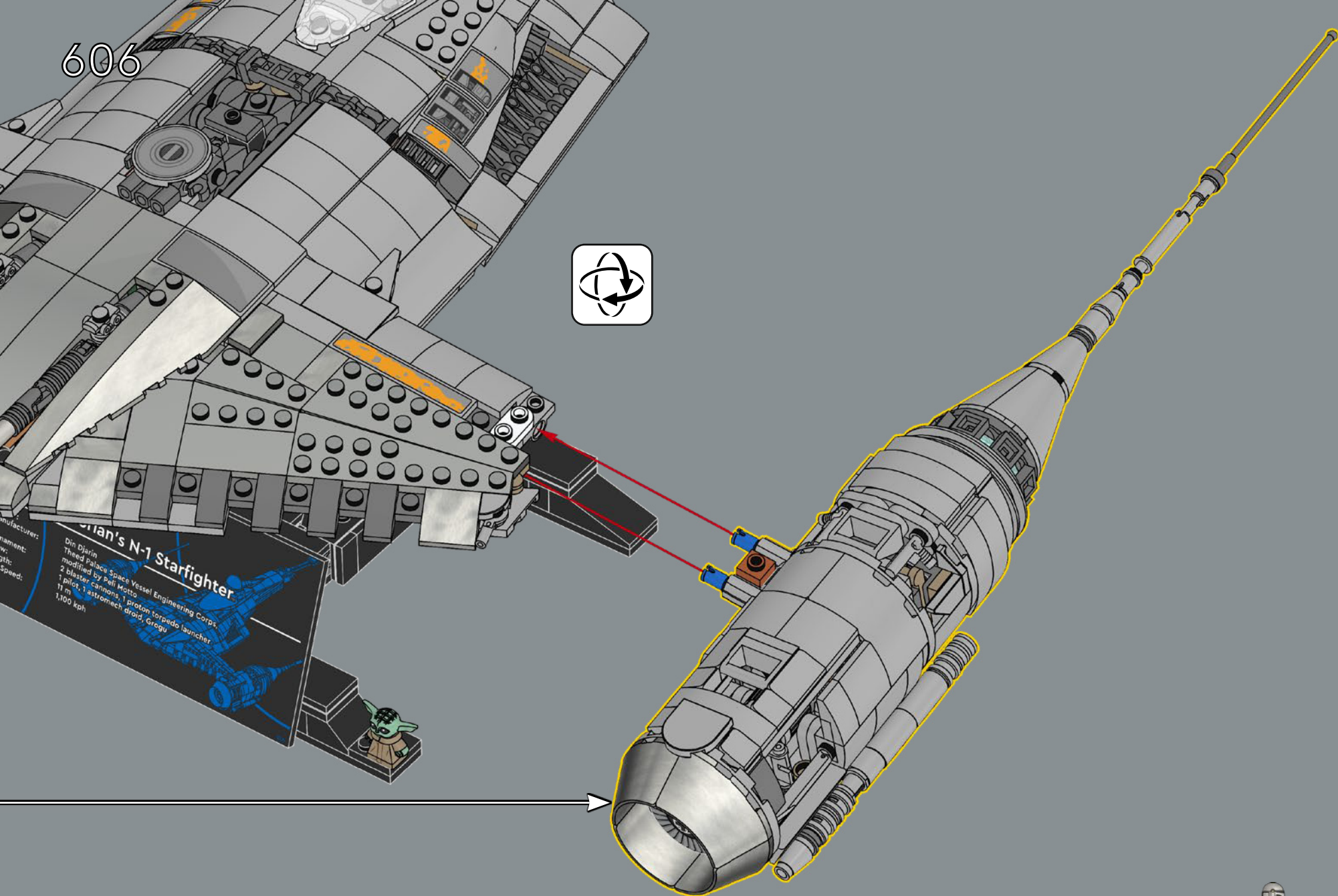

Manufacturer:
Name:
Length:
Speed:
Manufacturer:
Name:
Length:
Speed:

Djarin's N-1 Starfighter

Theed Palace Space Vessel Engineering Corp.
modified by Pelli Motto
2 blaster cannons, 1 proton torpedo launcher
1 pilot, 1 astromech droid, Grogu
1,100 kph





607

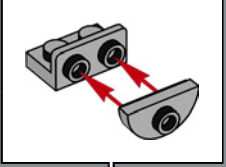

Manufacturer:
 Armament:
 Crew:
 Length:
 Max Speed:

Din Djarin's N-1 Starfighter

Theed Palace Space Vessel Engineering Corps
 modified by Peli Motto

2 blaster cannons, 1 proton torpedo launcher
 1 pilot, 1 astromech droid, Grogu

11 m
 1,100 kph



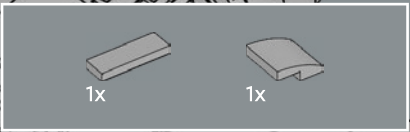

608

Manufacturer:
Arms and Armaments
Crew:
Length:
Max Speed:

Din Djarin
Theed Palace Space Vessel Engineering Corps
modified by Peli Motto
2 blaster cannons, 1 proton torpedo launcher
1 pilot, 1 astromech droid, Grogu
11 m
1,100 kph

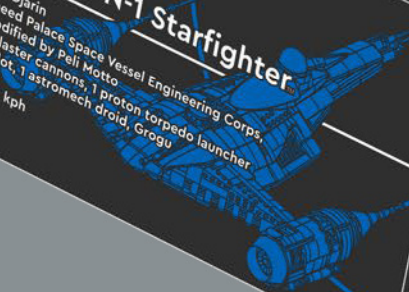

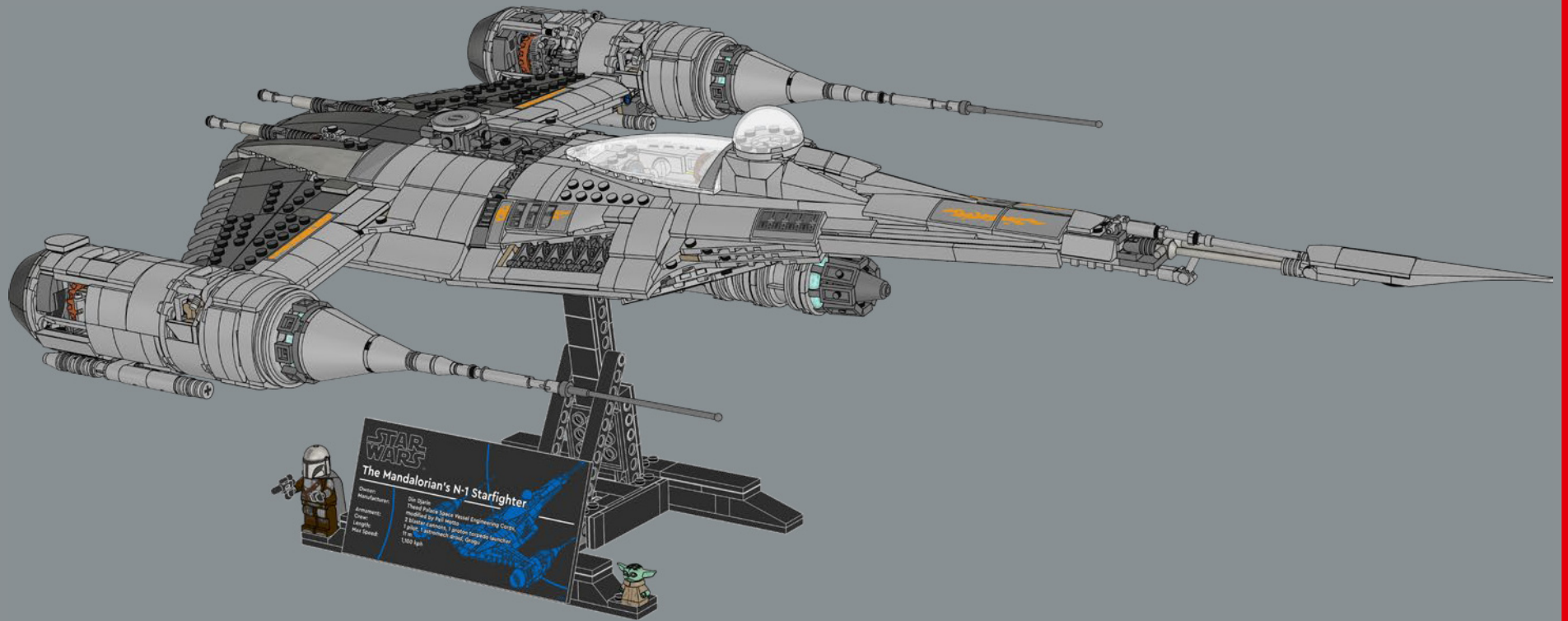

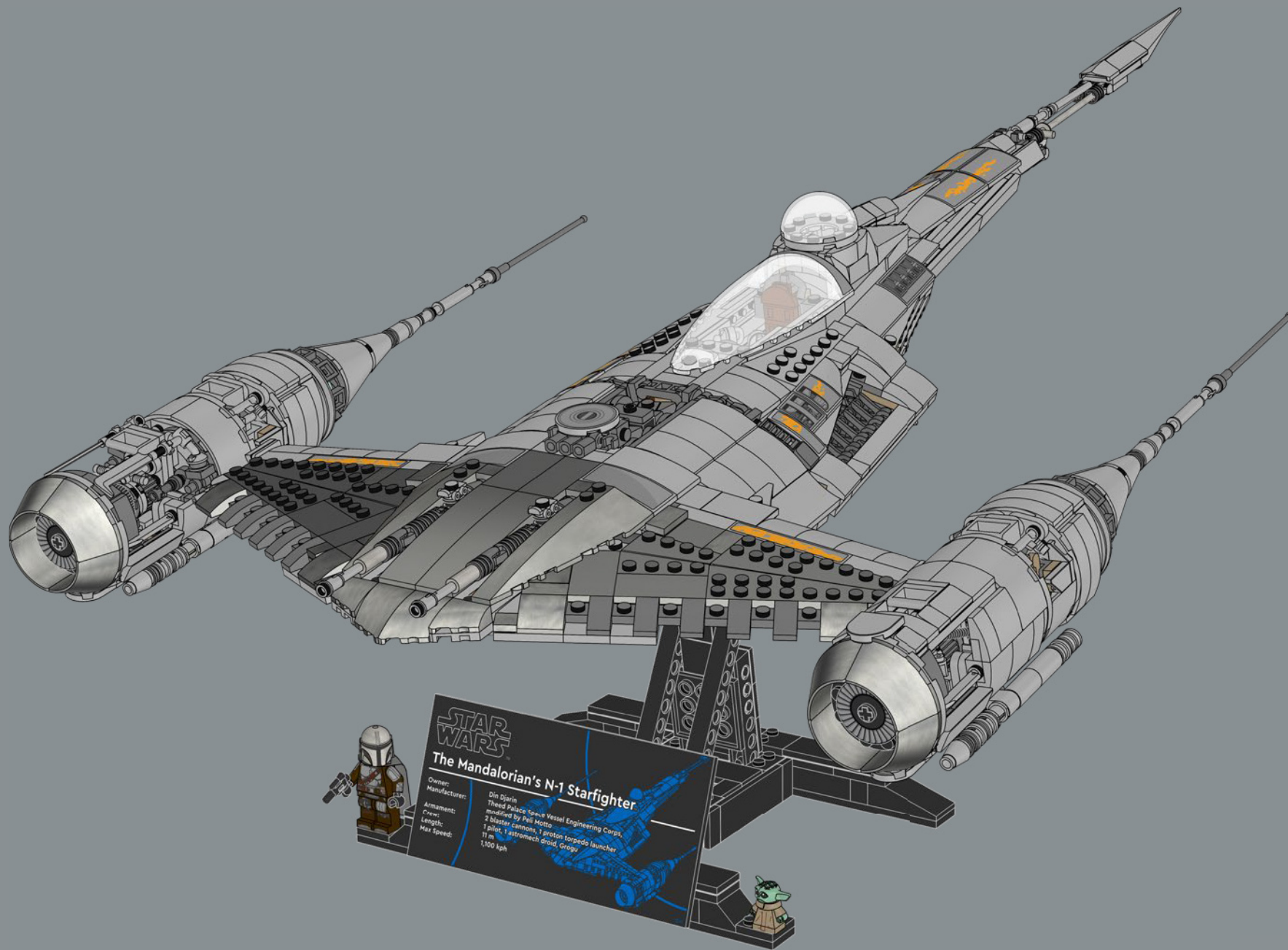

STAR WARS

The Mandalorian's N-1 Starfighter

Owner: Din Djarin
Manufacturer: Theed Palace Space Vessel Engineering Corps
Armament: 2 blaster cannons, 1 proton torpedo launcher
Crew: 1 pilot, 1 astromech droid, Grogu
Length: 11 m
Max Speed: 1,100 kph

- 2x 6177114
- 4x 6210272
- 2x 403201
- 2x 242001
- 1x 302101
- 4x 302001
- 1x 303401
- 3x 4161734
- 2x 4666579
- 2x 4218749
- 10x 4113917
- 6x 4118790
- 2x 4159739
- 2x 6294592
- 2x 6223291
- 3x 4124067
- 2x 6156462
- 2x 306221
- 12x 6378120
- 2x 6399645
- 6x 4142865
- 1x 393721
- 4x 302321
- 2x 6129995
- 4x 371021
- 2x 346021
- 1x 6130005
- 2x 6147702
- 6x 6482573
- 6x 4206482
- 20x 6299413
- 2x 362323
- 2x 302424
- 3x 6248971
- 1x 6331822
- 1x 302324
- 1x 300324
- 1x 4514844
- 12x 6168646
- 2x 6186675
- 2x 614126
- 2x 6424674
- 6x 300526
- 2x 4558954
- 2x 302426
- 4x 6299338
- 1x 6335317
- 1x 6360207
- 21x 6279875
- 2x 6338799
- 8x 306926
- 2x 6047276
- 4x 393726
- 1x 6178922
- 4x 302326
- 2x 6114987
- 1x 393826
- 2x 6147050
- 5x 6117973
- 1x 6563402
- 1x 6016172
- 2x 6306819
- 1x 4140588
- 4x 6336989
- 6x 6192346
- 2x 303926
- 6x 6013867
- 4x 6273226
- 16x 242026
- 3x 6506032
- 1x 6061032
- 1x 302226
- 8x 4567436
- 4x 6089119
- 2x 6267045
- 5x 362326
- 5x 302126
- 1x 6435928
- 2x 301026
- 2x 6039869
- 5x 370126
- 2x 4162443
- 4x 4515350
- 2x 6174917
- 4x 6416444
- 7x 4560182
- 2x 6194233
- 10x 302026
- 2x 4185583
- 1x 6171066
- 2x 6020193
- 2x 371026
- 2x 300926
- 3x 663626
- 7x 366626
- 1x 4243819
- 8x 6318582
- 5x 379526
- 2x 370726
- 9x 346026
- 3x 370226
- 1x 303426
- 2x 6327402
- 2x 6029578
- 3x 4514845
- 6x 244526
- 1x 6001494
- 4x 370326
- 2x 246526
- 1x 6614514
- 2x 6493351
- 2x 6347288
- 2x 303428
- 2x 6382577
- 2x 6228840
- 2x 6628591
- 1x 6186007
- 9x 6074892
- 3x 6585259
- 2x 4157103
- 1x 6136553
- 1x 6293710
- 1x 6240515
- 1x 6561723
- 2x 6322841
- 8x 6315781
- 1x 6300320
- 26x 4549436
- 2x 6231386

11

8

4

10

12



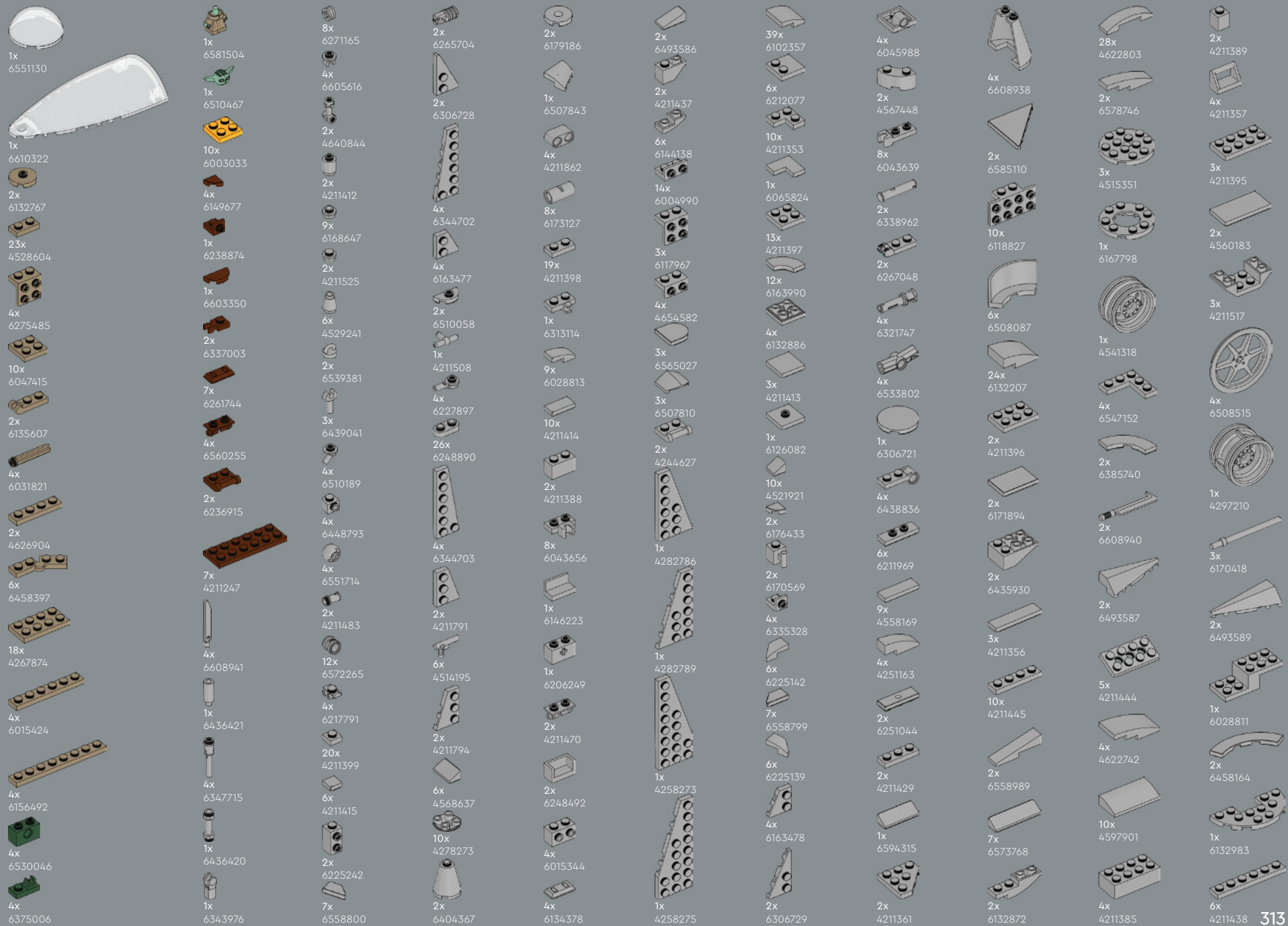

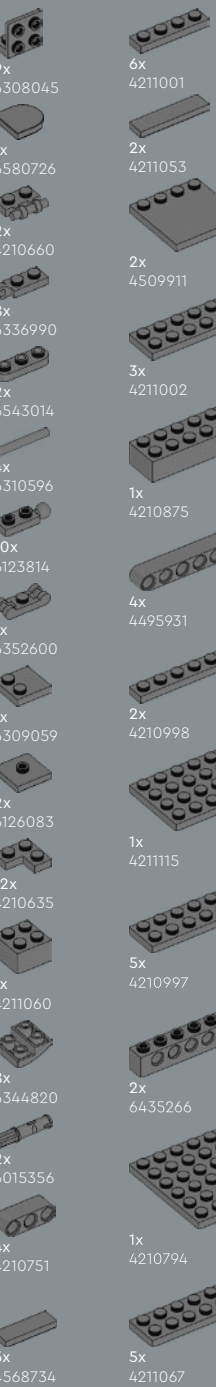
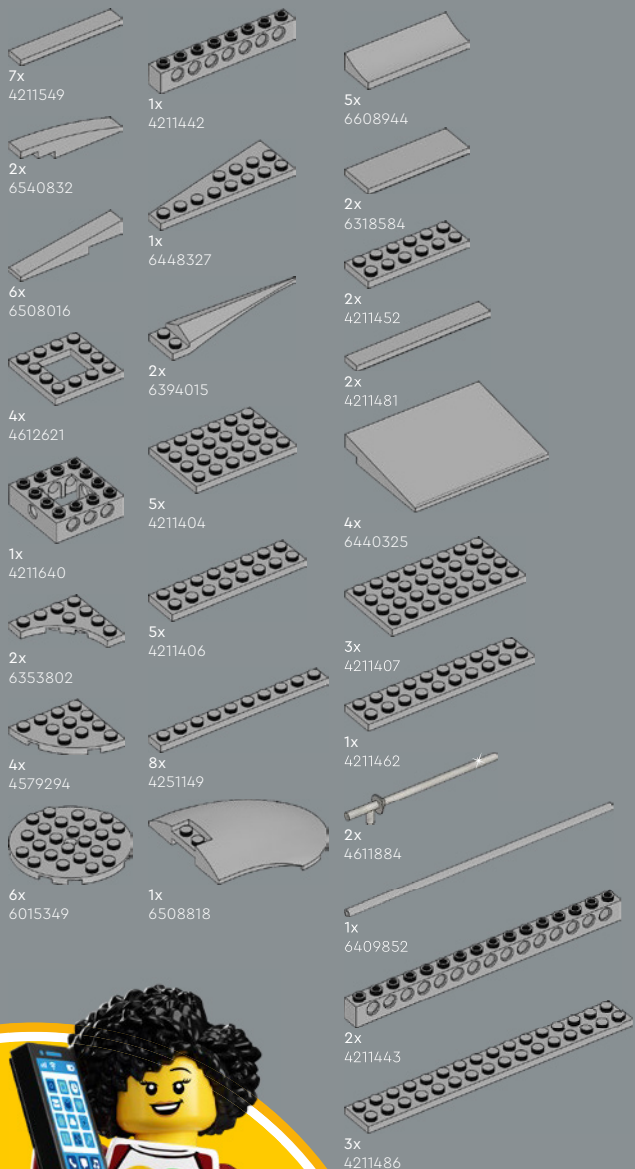

7



 [LEGO.com/service](https://www.LEGO.com/service)



YOU COULD
WIN



**YOU COULD
WIN**

Your feedback will help shape the future development of this product series.

Visit:

**DU KÖNNTEST
GEWINNEN**

Dein Feedback trägt zur Weiterentwicklung dieser Produktreihe bei.

Geh auf:

**VOUS POURRIEZ
GAGNER**

Vos commentaires nous aideront à concevoir les futurs produits de cette gamme.

Visitez :

**POTRESTI
VINCERE TU**

La tua opinione ci aiuterà a migliorare la creazione futura di questa linea di prodotti.

Visita:

**PUEDES
GANAR**

Tu opinión contribuirá al futuro de esta serie de productos.

Visita:

轻松获奖

您的反馈将有助于我们在今后改进本产品系列。

请访问:

LEGO.com/productfeedback

You also have the chance to win a LEGO® set.

Terms and conditions apply.*

Außerdem hast du die Chance, ein LEGO® Set zu gewinnen.

Es gelten die Teilnahmebedingungen.*

Vous pourriez également gagner un ensemble LEGO®.

Des conditions s'appliquent.*

Hai anche la possibilità di vincere un set LEGO®.

Termini e condizioni sono applicabili.*

También tienes la oportunidad de ganar un set LEGO®.

Aplican términos y condiciones.*

您还有机会赢取乐高®套装。

条款和条件适用。*

*LEGO.com/productfeedback-terms



LEGO and the LEGO logo are trademarks of the/sont des marques de commerce du/son marcas registradas de LEGO Group.

©2026 The LEGO Group.

© & ™ Lucasfilm Ltd.

 6643790