

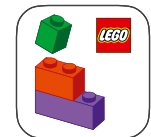

11378



Available in English
Disponible en français
Disponible en español



LEGO® Builder

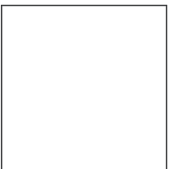



WE'RE MAKING OUR PACKAGING MORE SUSTAINABLE

We're transitioning from single-use plastic to paper-based packaging. As we progress, you may find a mix of paper and plastic in our boxes.

NOUS RENDONS NOS EMBALLAGES PLUS DURABLES

Nous passons des emballages en plastique à usage unique aux emballages à base de papier. Durant la transition, vous pourriez trouver un mélange de papier et de plastique dans nos boîtes.

QUEREMOS HACER MÁS SUSTENTABLES NUESTROS MATERIALES DE EMBALAJE

Estamos cambiando las bolsas de plástico desechables por bolsas con base de papel. Conforme avanzamos en este propósito, puedes encontrar una mezcla de papel y de plástico en nuestras cajas.

LEGO.com/sustainable-packaging



BUILDER



Apple and the Apple logo are trademarks of Apple Inc., registered in the U.S. and other countries and regions. App Store is a service mark of Apple Inc. Google Play and the Google Play logo are trademarks of Google LLC. Tencent and the Tencent logo are trademarks of Tencent Inc.

LEGO.com/devicecheck

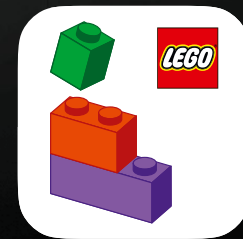

LEGO® Builder



Enjoying the ride since 1927™

Founded in 1927 and operating until 1991, Pan American World Airways – Pan Am® – entered its most glamorous era with the commission of the venerable PAA® Douglas™ DC-3™ in the mid-1930s. As the first airline to fly worldwide, Pan Am, as well as the DC-3, are still regarded as icons that transformed air travel and pioneered world travel as a lifestyle. Crossing continents meant more than transportation; it signaled prestige and sophistication. The PAA DC-3 brought unmatched reliability to both domestic and transatlantic routes. Pan Am's service, renowned for the flight crew's crisp, stylish uniforms, refined cabins and unrivaled hospitality, still epitomizes the golden age of flying, setting the global standard for refinement, luxury, and elegance in the skies.



À l'aventure depuis 1927

Fondée en 1927 et active jusqu'en 1991, Pan American World Airways – Pan Am® – a connu son âge d'or prestigieuse au milieu des années 1930, avec l'arrivée de l'emblématique PAA® Douglas™ DC-3™. Première compagnie aérienne à voler autour du globe, Pan Am – tout comme le DC-3 – est devenue un icône ayant transformé le voyage aérien et fait du tour du monde un véritable art de vivre. Traverser les continents, ce n'était pas simplement se déplacer : c'était un symbole de prestige et de raffinement. Le DC-3 de PAA a introduit une fiabilité inégalée sur les routes tant intérieures que transatlantiques. Le service de Pan Am, célèbre pour les uniformes impeccables de son équipage, ses cabines raffinées et son hospitalité incomparable, incarne encore aujourd'hui l'âge d'or de l'aviation, établissant la norme mondiale en matière de raffinement, de luxe et d'élégance dans les airs.



Disfrutando el viaje desde 1927

Fundada en 1927 y en funcionamiento hasta 1991, Pan American World Airways, Pan Am®, inició su época de mayor glamour con la adopción del venerable PAA® Douglas™ DC-3™ a mediados de la década de 1930. Al ser la primera aerolínea en volar por todo el mundo, Pan Am, igual que el DC-3, sigue siendo considerada un ícono que transformó los viajes aéreos y fue pionera en convertir los viajes internacionales en un estilo de vida. Cruzar continentes significaba más que usar un medio de transporte: era un sinónimo de prestigio y sofisticación. El PAA DC-3 aportó una confiabilidad sin igual tanto en las rutas nacionales como en las transatlánticas. El servicio de Pan Am, renombrado por los impecables y elegantes uniformes de su tripulación, sus refinadas cabinas y su incomparable hospitalidad, sigue siendo el emblema por excelencia de la época dorada de la aviación, habiendo consagrado para siempre el ideal del refinamiento, el lujo y la elegancia en las alturas.

A collage of vintage Pan Am promotional materials. It includes a travel poster for South America with a sun and a map, a poster for Europe with the text "This is the most comfortable way to go to EUROPE", and a globe. In the foreground, four Lego minifigures represent Pan Am crew members: a pilot, a flight attendant, a stewardess, and a passenger. A circular logo in the bottom right corner reads "You Can't Beat the Experience." with the Pan Am logo above it.



The world is yours

The Douglas™ DC-3™ first flew on December 17, 1935, with the first delivery in June 1936, and went on to dominate 1940s airline fleets, with 455 DC-3s built for commercial use by 1946. A low-wing, twin-engine monoplane, it can take off from short runways and comfortably land in a tight squeeze, which made it ideal for almost any destination and terrain. Pilots have favored the DC-3 for its reliability and maneuverability, while passengers enjoyed its pristine comforts and, of course, exotic travel adventures across the world! Today, if you know where to look, you might still see a few of them soaring through the skies.

Le monde est à vous

Le Douglas™ DC-3™ a effectué son premier vol le 17 décembre 1935, avec une première livraison en juin 1936, et a ensuite dominé les flottes aériennes des années 1940, avec 455 DC-3 construits pour un usage commercial d'ici 1946. Cet avion monoplan à aile basse et à deux moteurs pouvait décoller de pistes courtes et atterrir aisément dans des espaces restreints, ce qui le rendait idéal pour presque toutes les destinations et tous les terrains. Les pilotes appréciaient le DC-3 pour sa fiabilité et sa maniabilité, tandis que les passagers profitaient de son confort impeccable et, bien sûr, d'aventures et de voyage exotiques aux quatre coins du monde! Aujourd'hui encore, si vous savez où regarder, vous pourriez en apercevoir quelques-uns planer dans le ciel.

El mundo es tuyo

El Douglas™ DC-3™ voló por primera vez el 17 de diciembre de 1935 y, con las primeras unidades entregadas en junio de 1936, pasó a dominar en las flotas aéreas de los años 40, alcanzando 455 DC-3 fabricados para uso comercial en 1946. En términos aeronáuticos, es un monoplano bimotor de ala baja que puede despegar desde pistas cortas y aterrizar cómodamente en espacios reducidos, lo que lo hace ideal para casi cualquier destino y terreno. Su confiabilidad y maniobrabilidad convirtieron al DC-3 en un favorito de los pilotos. Por su parte, sus pasajeros disfrutaban de comodidades de primer nivel y, por supuesto, ¡de exóticas aventuras por todos los rincones del mundo! Hoy en día, si sabes hacia dónde mirar, aún puedes observar algunos de ellos surcando los cielos.



Although the Douglas name has been retired, its history and designs live on within Boeing's Commercial Airplanes division, which continues to proudly steward the legacy of the DC-3.

Même si le nom Douglas n'est plus utilisé, son histoire et ses conceptions perdurent dans la division des avions commerciaux de Boeing, qui continue de préserver fièrement l'héritage du DC-3.

Si bien el nombre Douglas ha pasado a la historia, su legado y diseños permanecen vivos en la división Boeing Commercial Airplanes de The Boeing Company, que preserva con orgullo la memoria del DC-3.



DOUGLAS DC-3

SPECS

LENGTH:
64 FT. 6 IN. (19.7 M)

WINGSPAN:
95 FT. (29 M)

CAPACITY:
A CREW OF THREE, 21-28 DAY
PASSENGERS (14 SLEEPER
PASSENGERS), OR 4,500 LBS.
(2,041 KG) OF CARGO

CRUISING SPEED:
207 MPH (333 KM/H) FOR UP
TO 2,125 MI. (3,420 KM)

CARACTÉRISTIQUES

LONGUEUR :
19,7 M (64 PI 6 PO)

ENVERGURE :
29 M (95 PI)

CAPACITÉ :
ÉQUIPAGE DE TROIS PERSONNES,
21 À 28 PASSAGERS DE JOUR
(14 PASSAGERS COUCHETTES)
OU 2 041 KG (4 500 LB) DE
CARGAISON

VITESSE DE CROISIÈRE :
333 KM/H JUSQU'À 3 420 KM



ESPECIFICACIONES

LONGITUD:
19,7 M

ENVERGADURA:
29 M

CAPACIDAD:
UNA TRIPULACIÓN DE TRES
PERSONAS Y 21-28 PASAJEROS
SENTADOS (O 14 EN LITERAS),
O 2041 KG DE CARGA

VELOCIDAD DE CRUCERO:
333 KM/H EN TRAYECTOS DE
HASTA 3420 KM



From your LEGO® Icons Design crew

The Douglas™ DC-3™ is a great candidate for our travel-themed LEGO® Icons vehicles collection. We wanted to create a highly detailed model, a nostalgic nod to an exciting era, that is also sturdy enough to be taken off the stand and studied in detail. The tops of the cockpit and passenger cabin can be removed so you can peek inside. With great help from our partners at Pan Am® and Boeing, who retrieved a rare color cabin illustration from their archives to share with us, we built the model almost to LEGO minifigure scale, with retractable landing gear and an impressive wingspan. Early in the design process, we decided on what is probably the most iconic Pan Am 1959 livery, seen on only a few DC-3s, as an homage to the era when this aircraft was the backbone of air travel. (Chances are you've seen it in movies that either premiered or took place around that time!) Printed decorations on the model include a new windshield and the iconic Pan Am Globe® logo on a new 6x6 LEGO tile. To complete the scene, we designed a LEGO minifigure crew clad in vintage uniforms, including a new, historically accurate hat element, and we built in the signature blue fuselage strip.



"We hope you'll enjoy your time aboard and explore a world of building fun!"

- The LEGO® Icons Design Team

« Nous espérons que vous apprécierez votre voyage à bord et que vous explorerez un univers de plaisir de construction! »

- L'équipe de conception LEGO® Icons

"¡Esperamos que disfrutes tanto de tu estancia a bordo como de explorar el divertido mundo de la construcción!"

- El equipo de diseño de LEGO® Icons

De l'équipe de conception LEGO® Icons

Le Douglas™ DC-3™ est un excellent choix pour notre collection de véhicules LEGO® Icons sur le thème du voyage. Nous voulions créer un modèle très détaillé, clin d'œil nostalgique à une époque palpitante, tout en étant assez robuste pour être retiré du socle et examiné en détail. Le dessus de l'habitacle et de la cabine passagers peut être retiré pour permettre de voir l'intérieur. Grâce à l'aide précieuse de nos partenaires chez Pan Am® et Boeing, qui ont extrait des archives une rare illustration en couleurs de la cabine pour nous la partager, nous avons construit le modèle presque à l'échelle des figurines LEGO, avec un train d'atterrissage rétractable et une envergure impressionnante. Dès le début du processus de conception, nous avons opté pour ce qui est probablement la livrée Pan Am de 1959 la plus emblématique, observée sur seulement quelques DC-3, en hommage à l'époque où cet avion constituait l'épine dorsale du transport aérien. (Il y a de fortes chances que vous l'ayez vu dans des films sortis ou se déroulant à cette époque!) Les décors imprimés du modèle incluent un nouveau pare-brise et le logo emblématique Pan Am Globe® sur une nouvelle tuile LEGO 6x6. Pour compléter la scène, nous avons conçu un équipage de figurines LEGO vêtu d'uniformes d'époque, incluant un nouvel élément de chapeau fidèle à l'histoire, et nous avons intégré la bande bleue emblématique du fuselage.



Impresiones de la tripulación de diseño de LEGO® Icons

El Douglas™ DC-3™ era un formidable candidato para nuestra colección de vehículos LEGO® Icons inspirada en los viajes. Queríamos crear un modelo altamente detallado que, además de evocar con un poco de nostalgia un emocionante episodio de la historia, fuera lo suficientemente sólido como para retirarlo de la base y estudiarlo de cerca. Puedes quitar las partes superiores de la cabina de pilotos y la cabina de pasajeros para dar un vistazo al interior. Con la invaluable ayuda de nuestros socios de Pan Am® y Boeing, que sacaron de sus archivos una rara ilustración a color de la cabina para compartirla con nosotros, logramos dar forma al modelo casi a escala de minifigura LEGO, con una impresionante envergadura y tren de aterrizaje retráctil. Al inicio del proceso de diseño, nos decidimos por la que quizá sea la combinación de colores más icónica de Pan Am, la de 1959 (vista en solo unos pocos DC-3), como un tributo a la era en la que esta aeronave fue la columna vertebral del transporte aéreo. (¡Seguramente la has visto en películas estrenadas o ambientadas alrededor de esa época!). Las decoraciones impresas en el modelo incluyen un nuevo parabrisa y el icónico logotipo del globo estilizado de Pan Am® plasmado en una nueva cubierta LEGO 6x6. Para completar la escena, diseñamos una tripulación de minifiguras LEGO vestidas con uniformes clásicos que incluyen un nuevo sombrero fiel a la historia. Y, como broche de oro, ¡integramos al fuselaje del avión la característica franja azul!

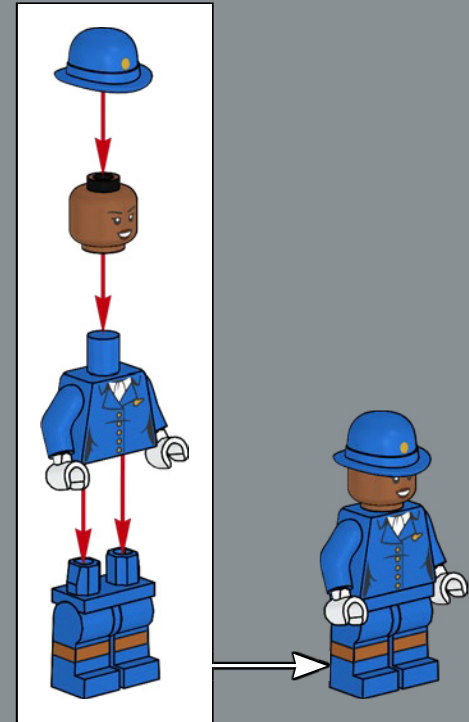
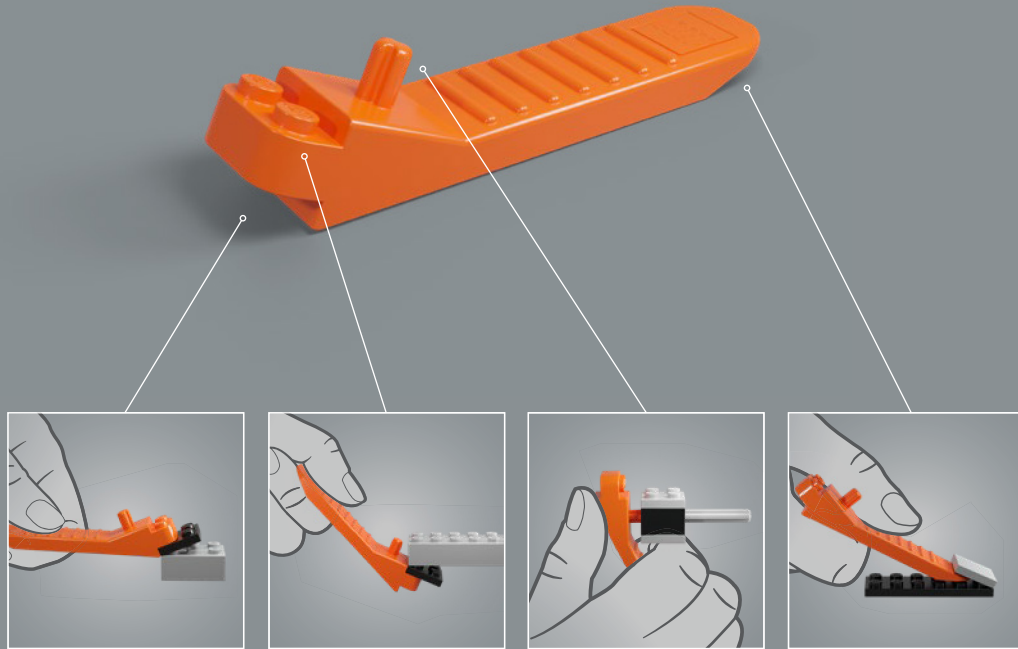

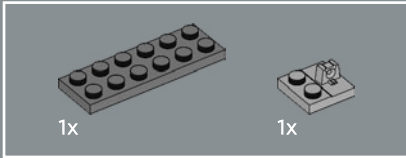
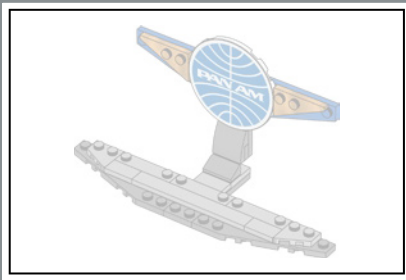

1

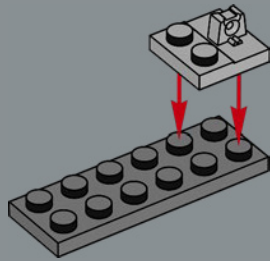

The uniform hat introduced in 1970 was sometimes called a derby hat, but within the company, it was commonly referred to as the bowler hat.

Le chapeau d'uniforme introduit en 1970 était parfois appelé chapeau melon, mais au sein de l'entreprise, on l'appelait couramment un chapeau rond.

Se incorporó al uniforme un sombrero bombín en los años 70, conocido al interior de la compañía por su nombre británico, *bowler hat*, si bien a veces se usaba el término estadounidense *derby hat*.

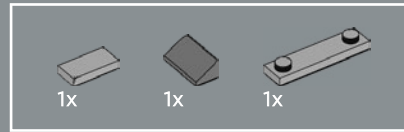

2

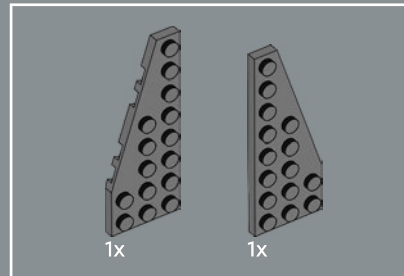
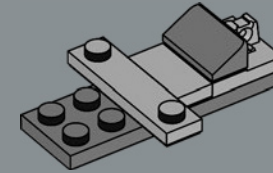

3

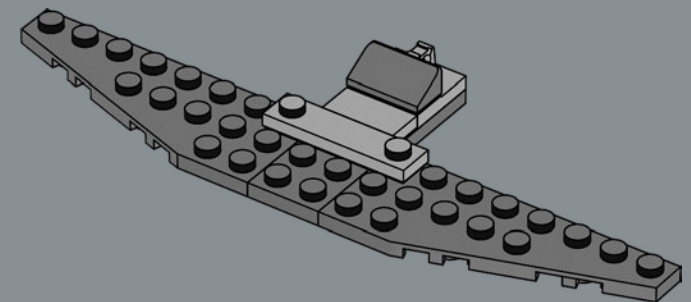

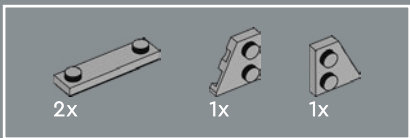

4

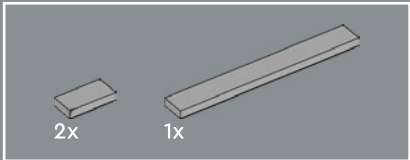
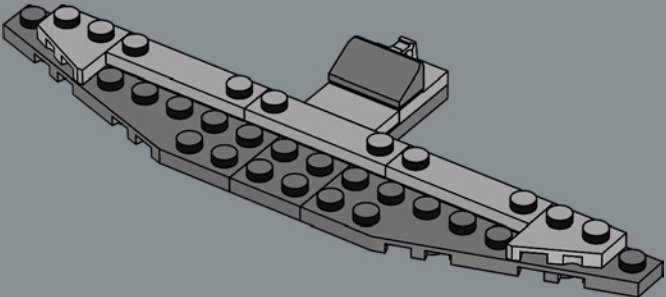

5

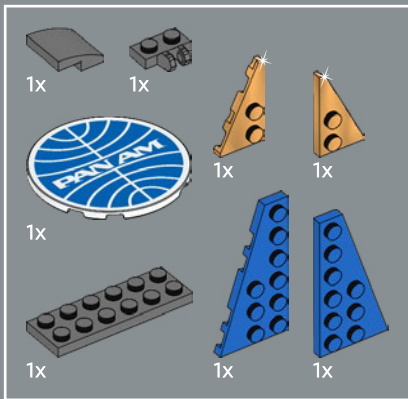
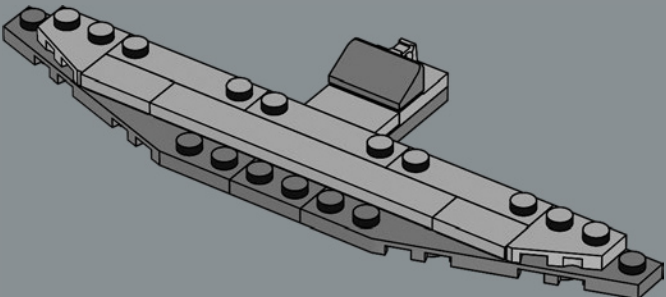

6

1

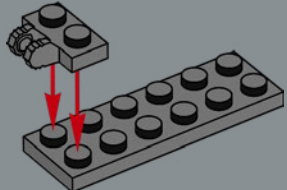

2

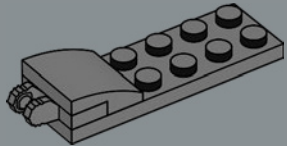

3



4



5

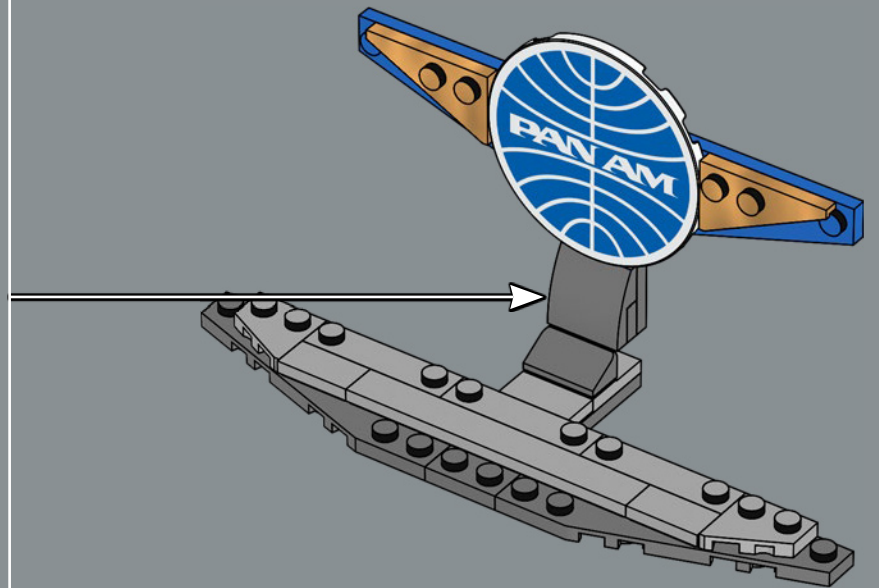

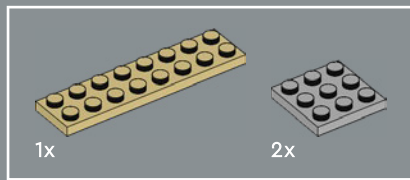

11

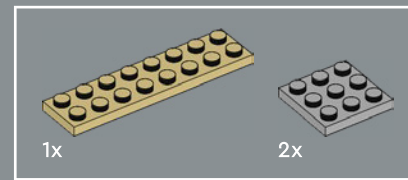
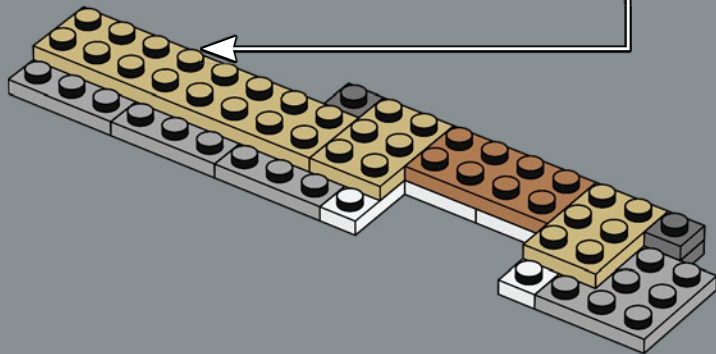
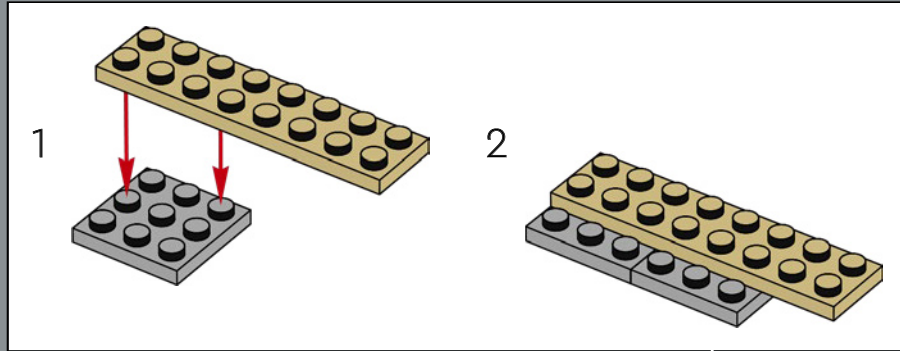

12

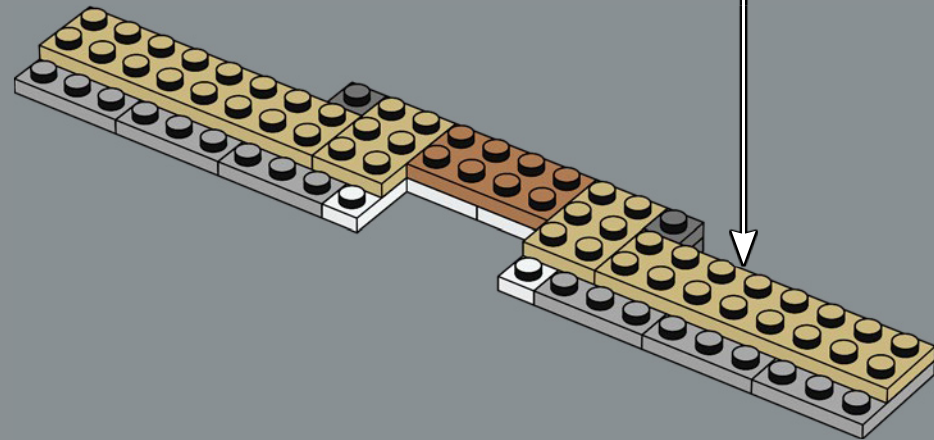
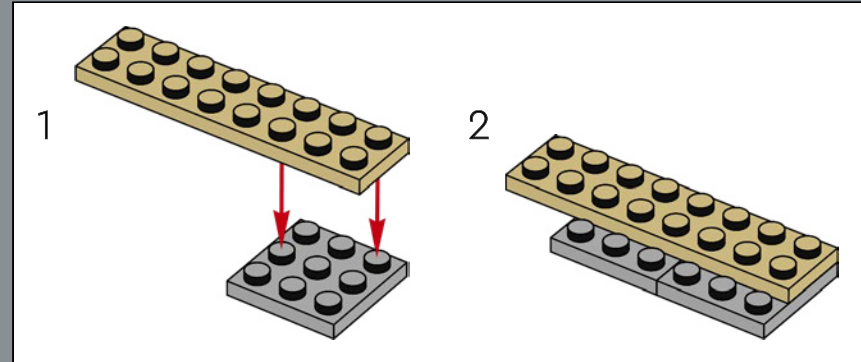

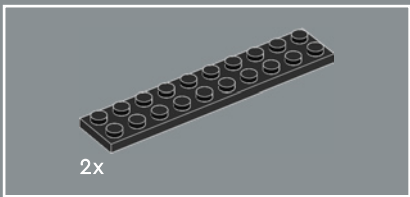

13

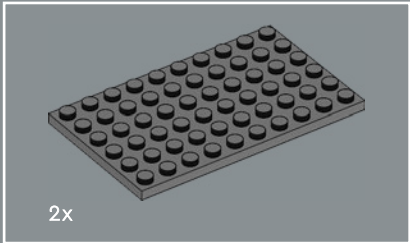
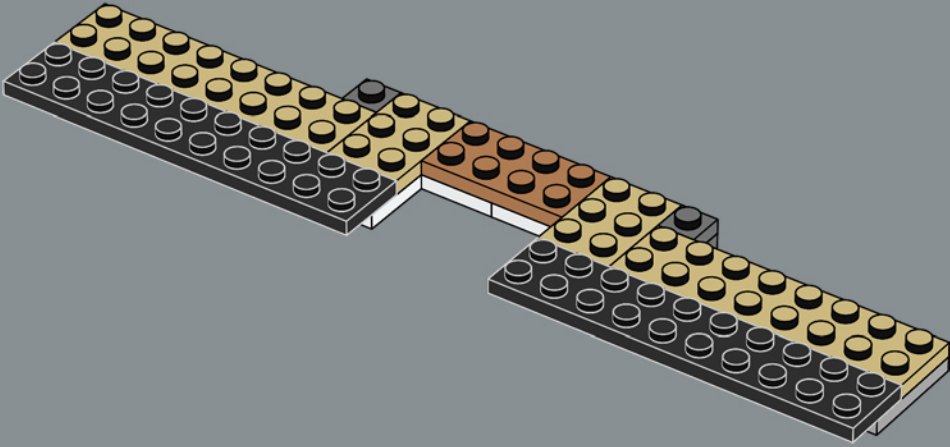

14

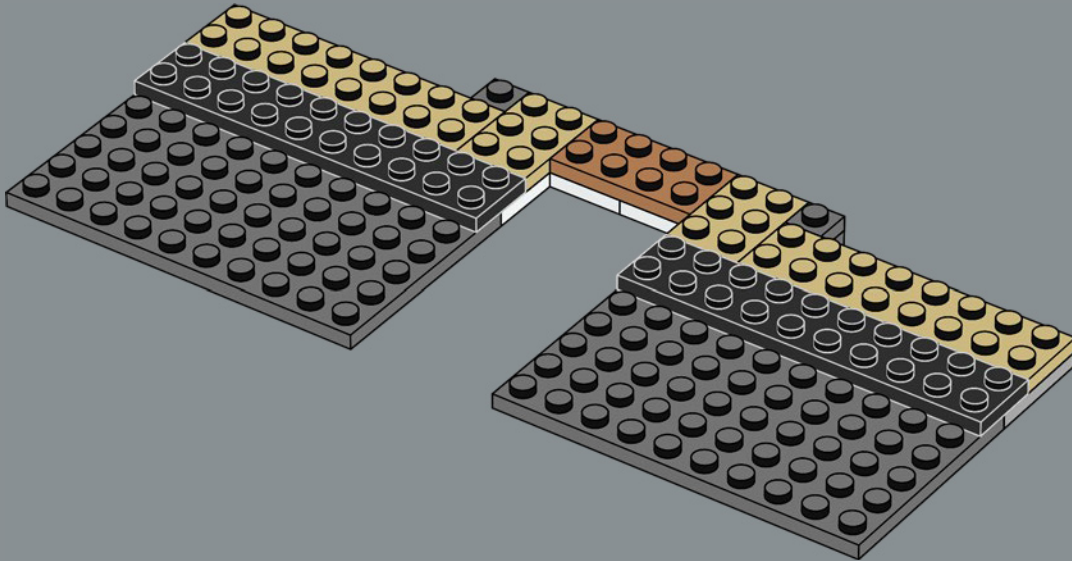

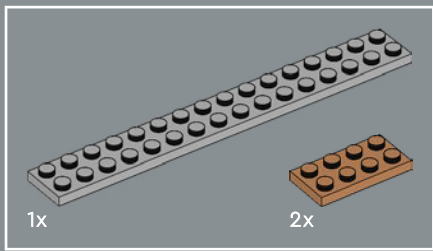

15

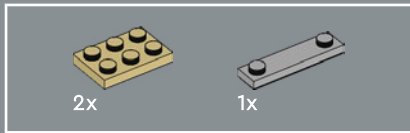
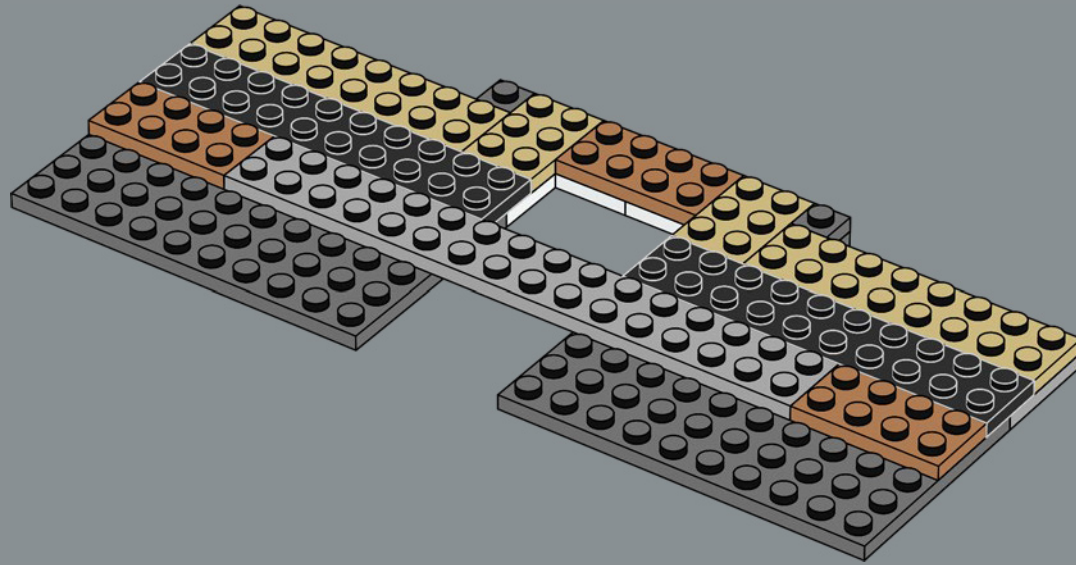

16

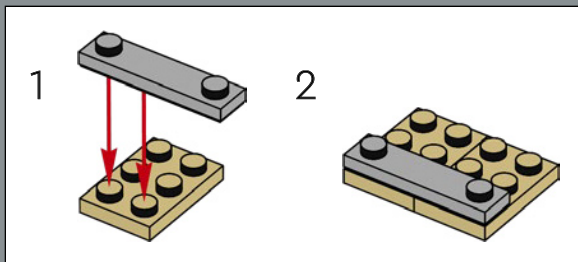
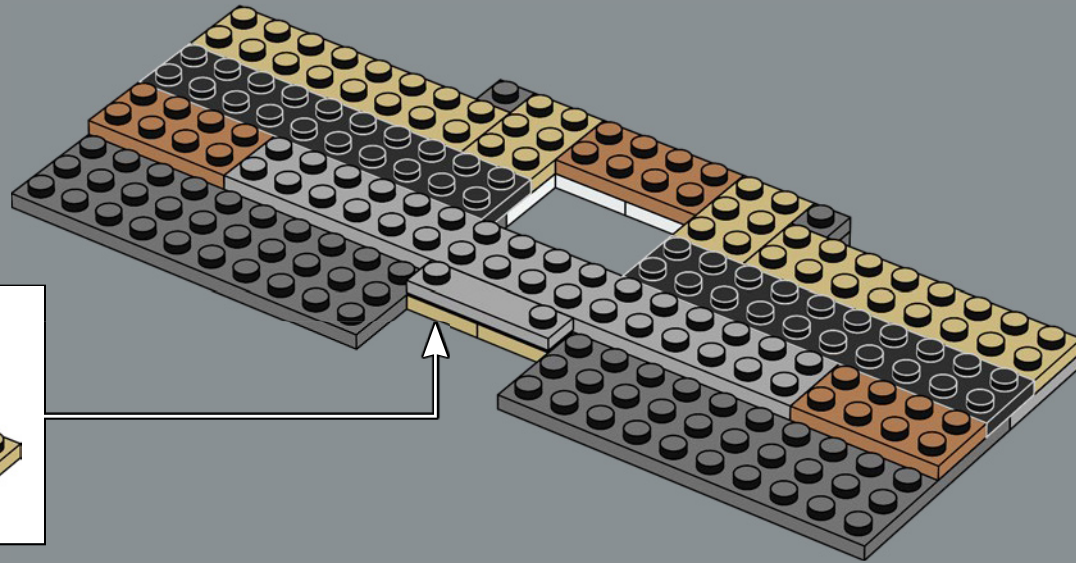

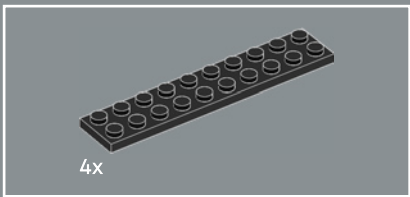

17

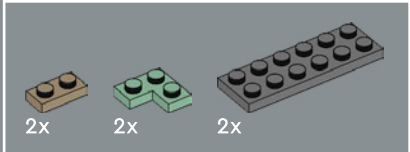
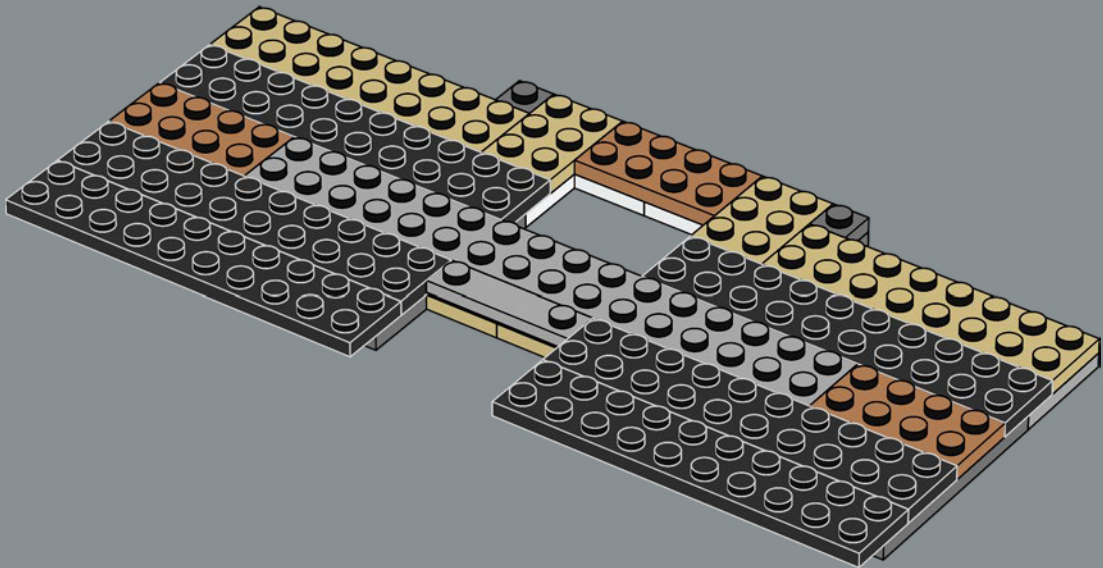

18

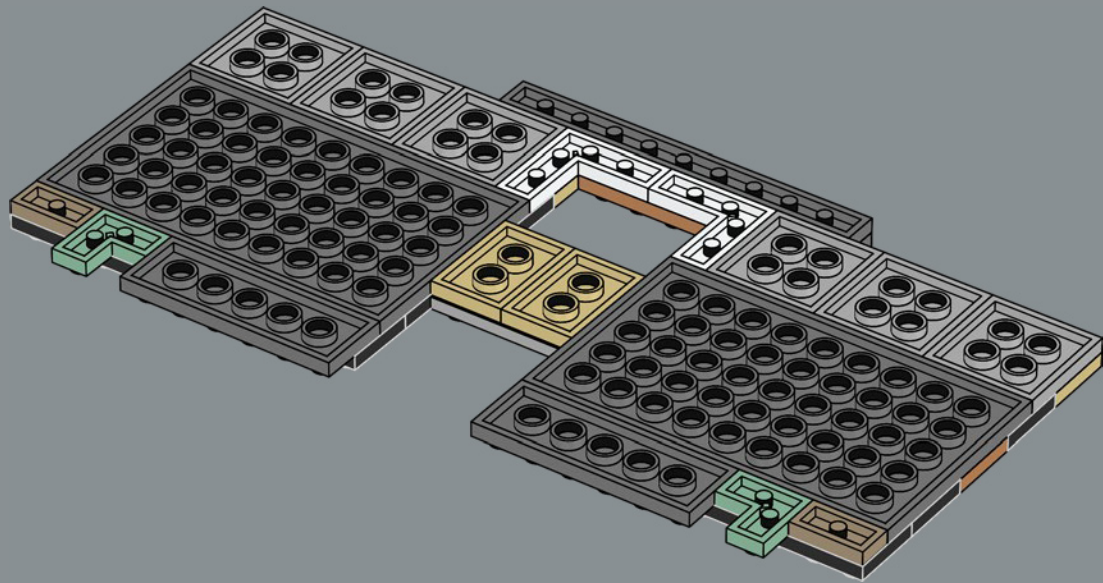

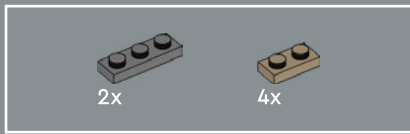

19

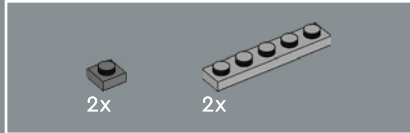
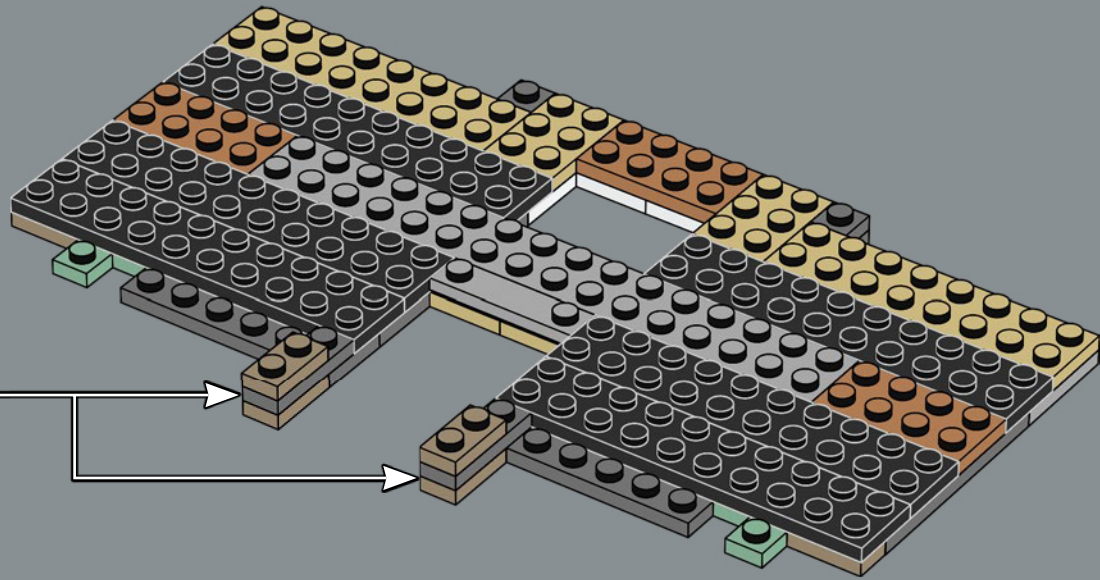
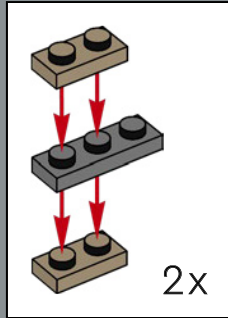

20

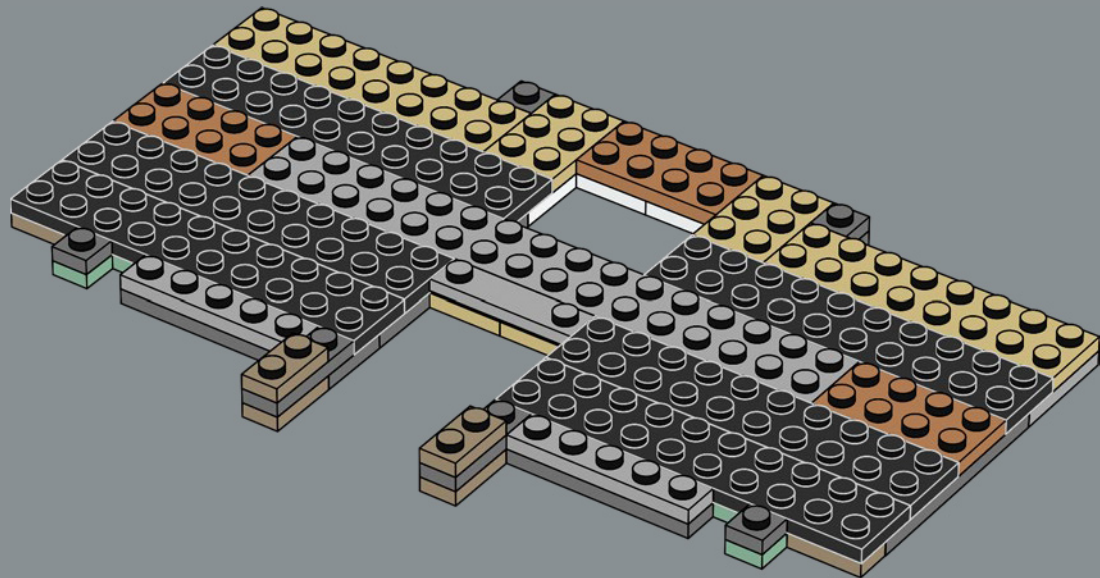

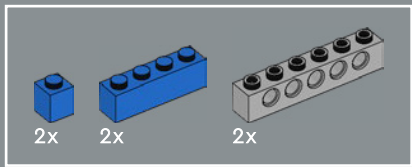

21

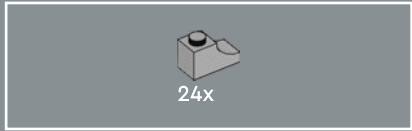
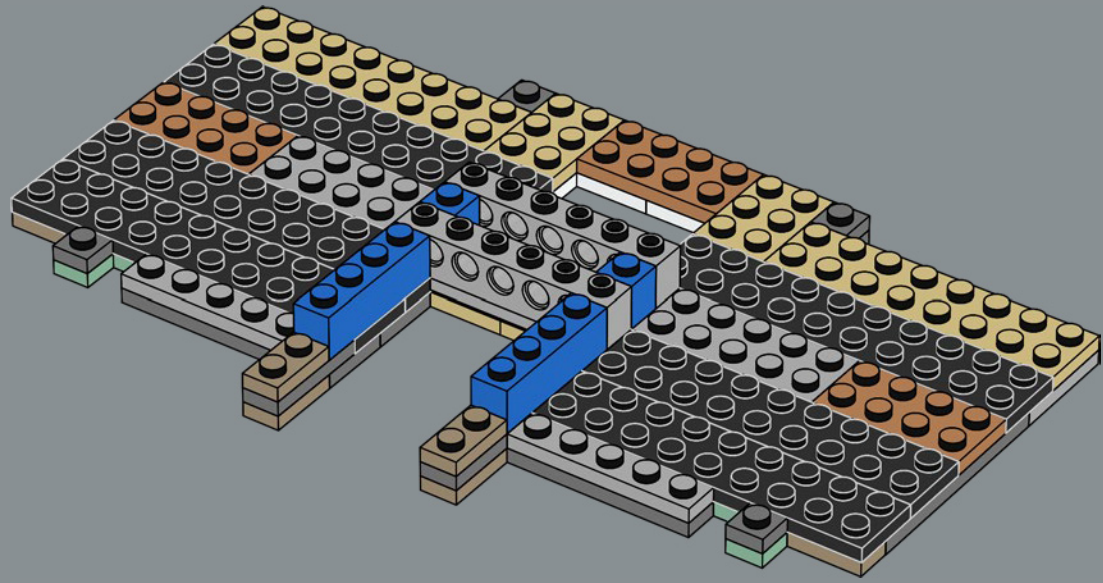

22

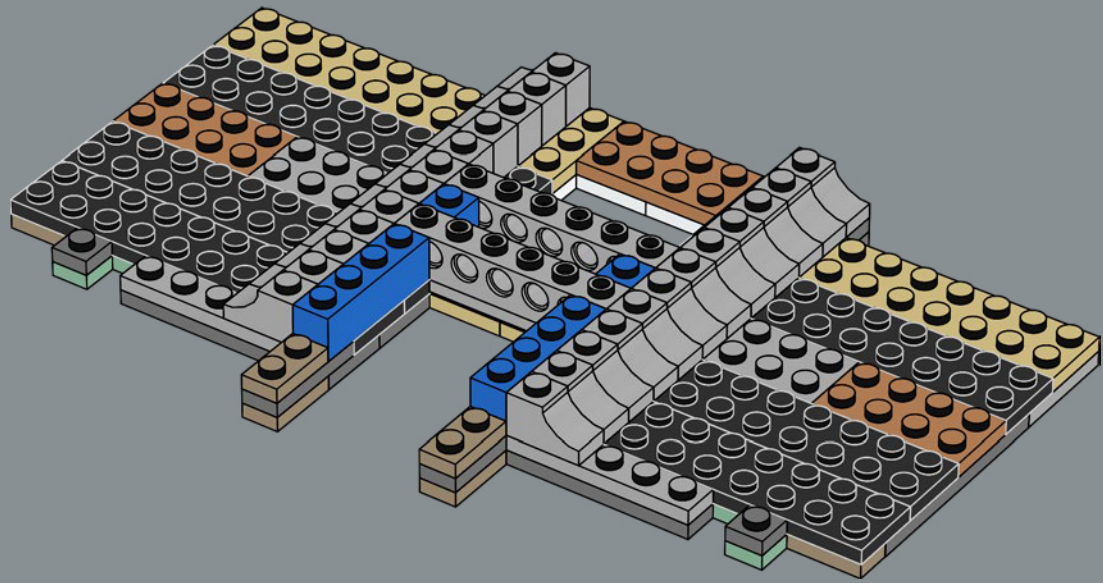

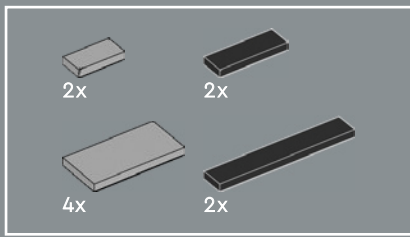

23

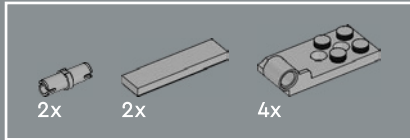
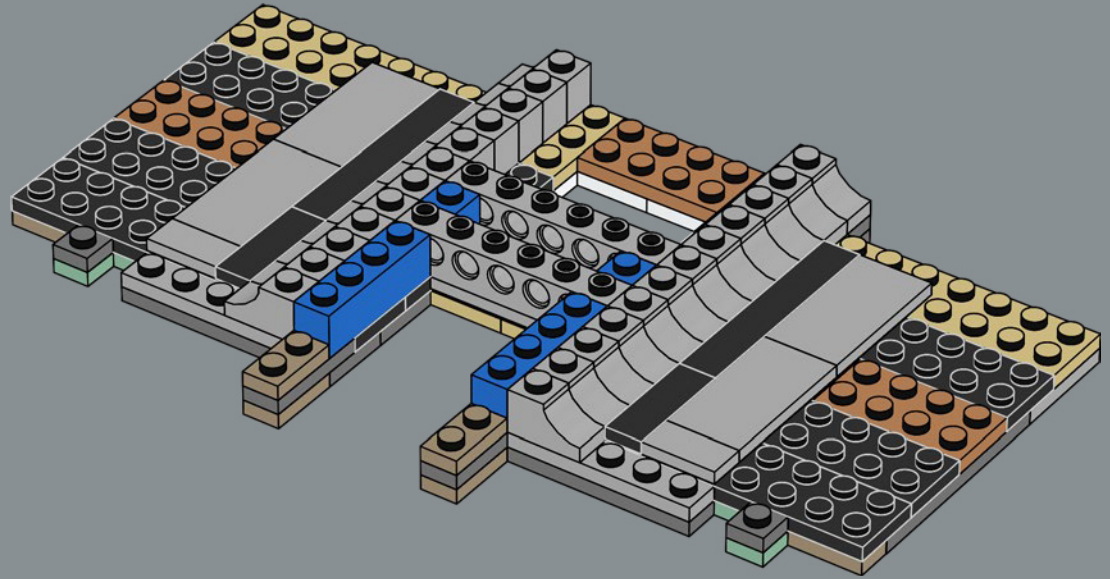

24

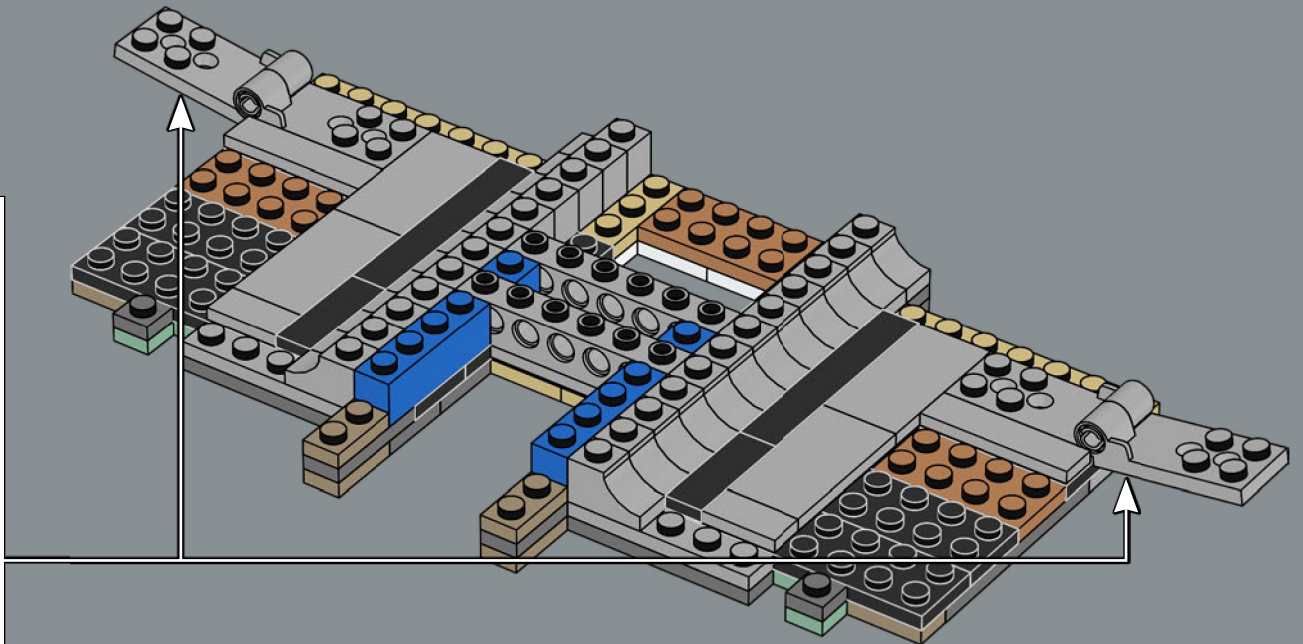
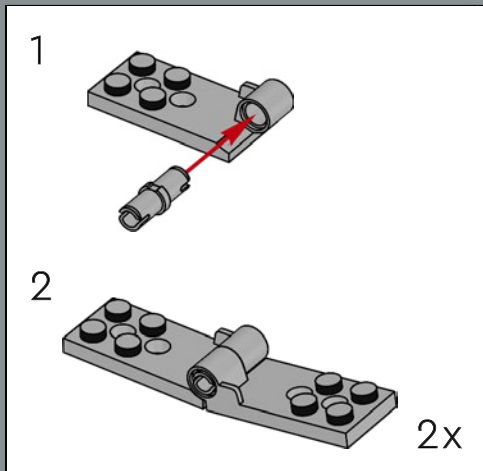

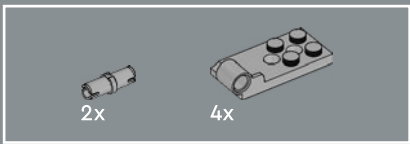

25

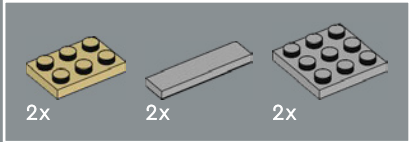
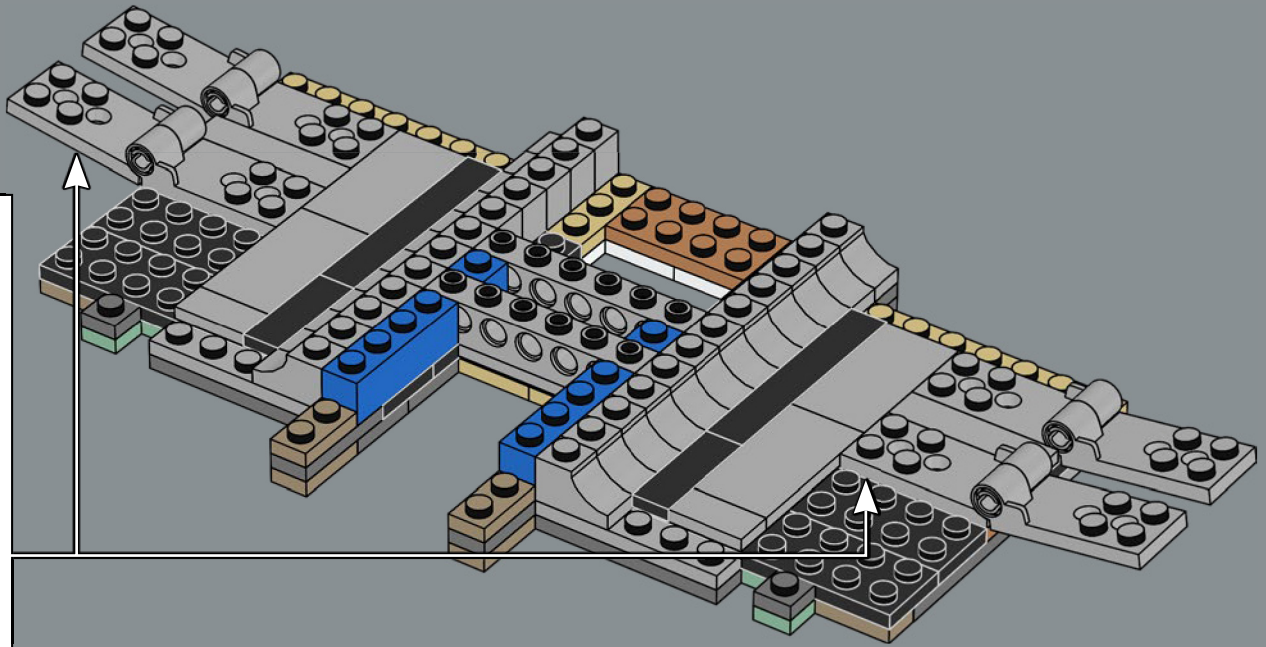
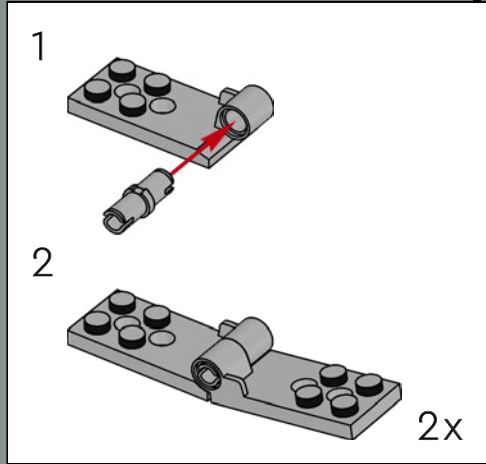

26

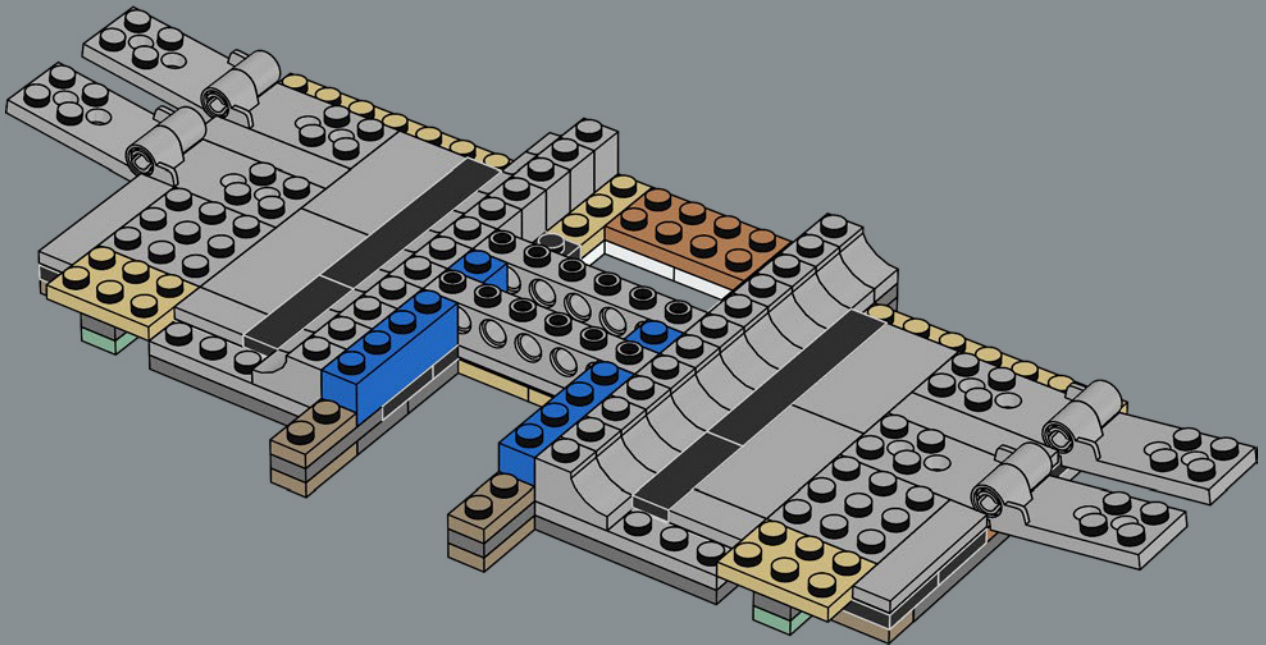

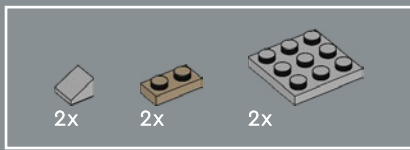

27

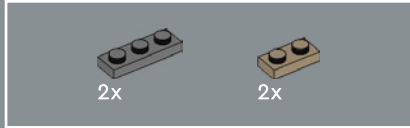
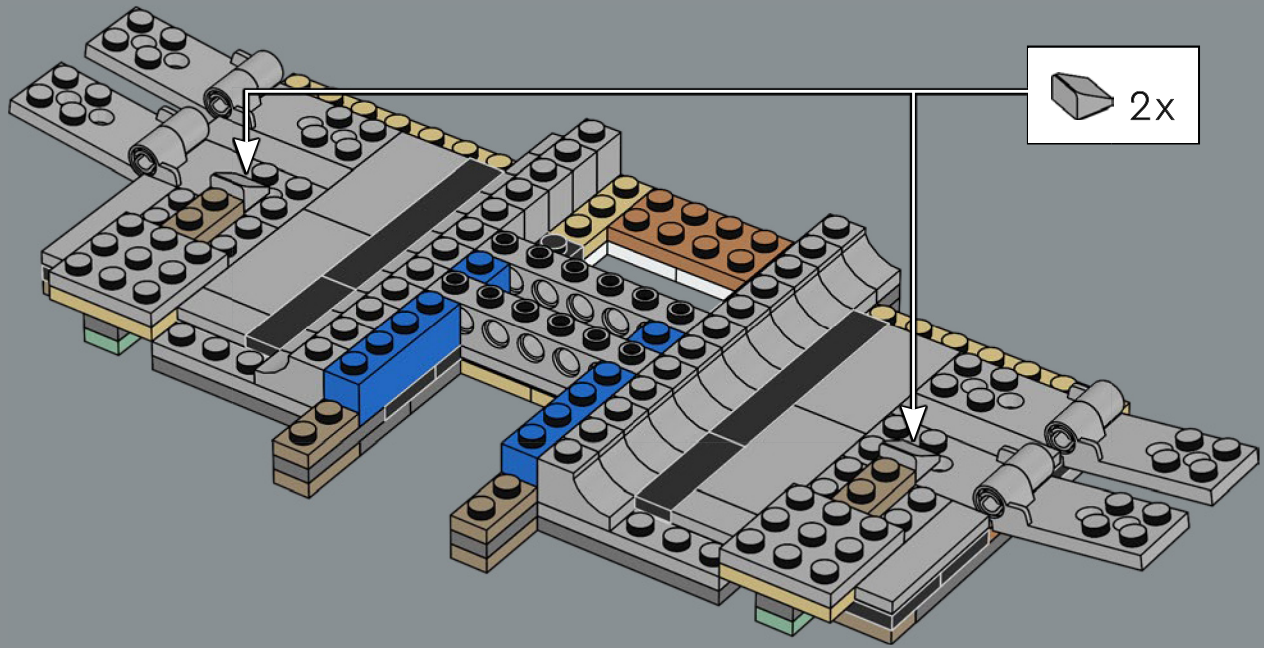

28

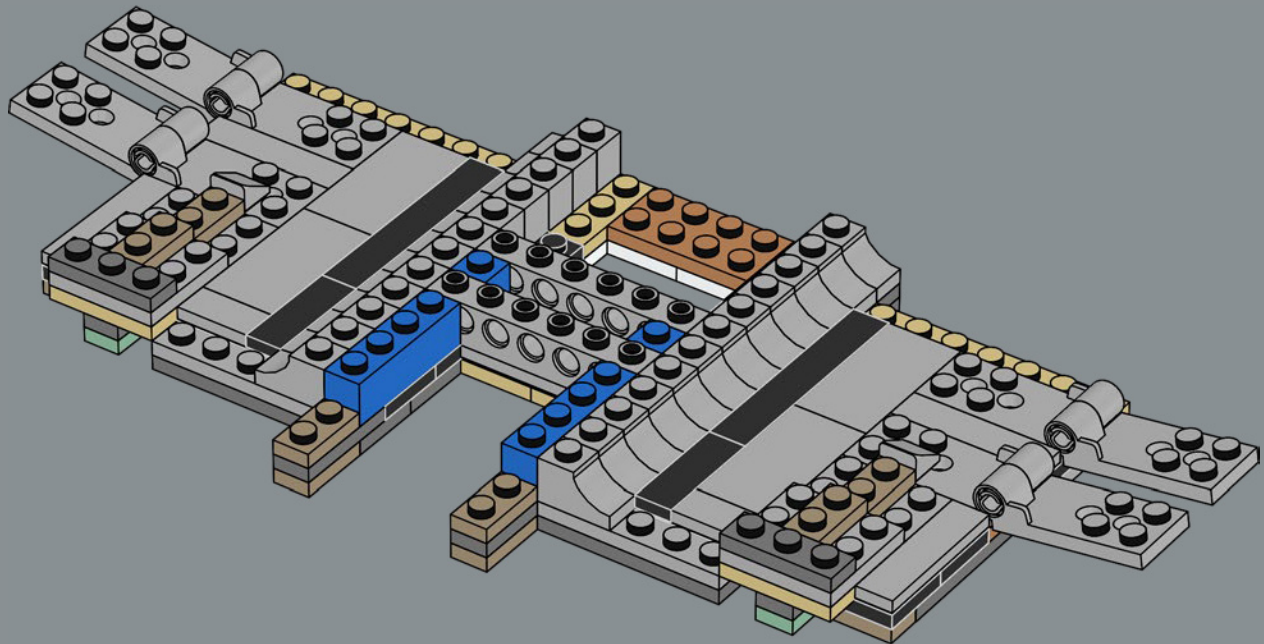

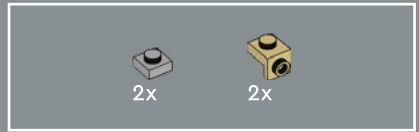

29

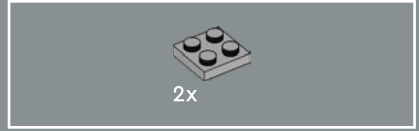
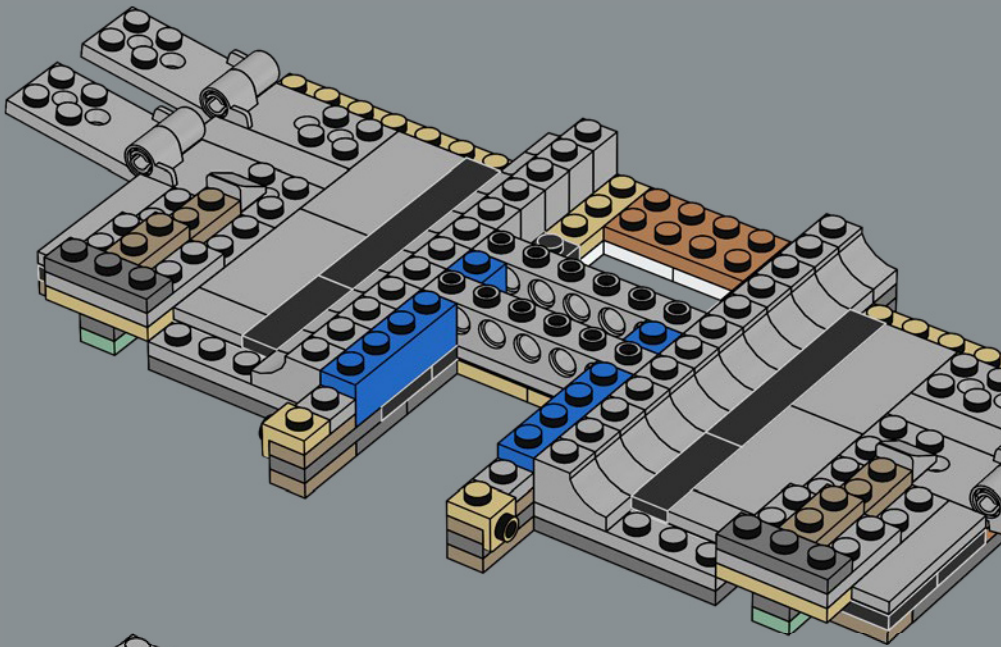

30

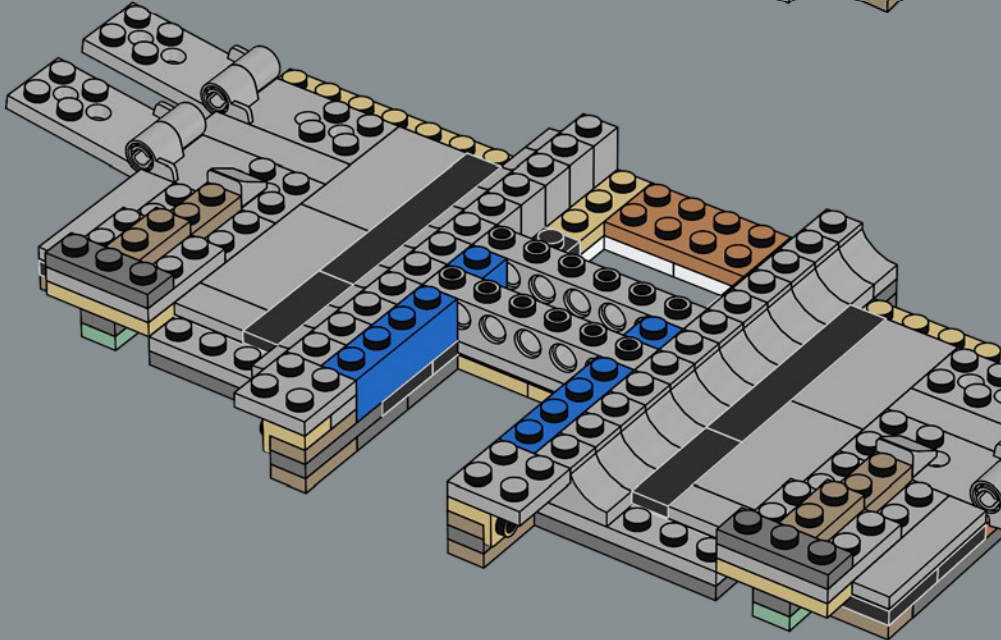

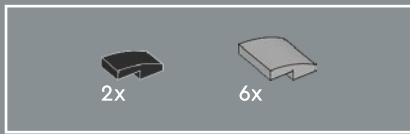

31

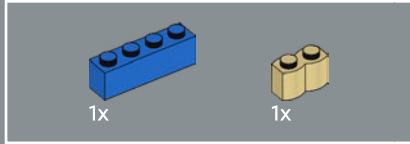
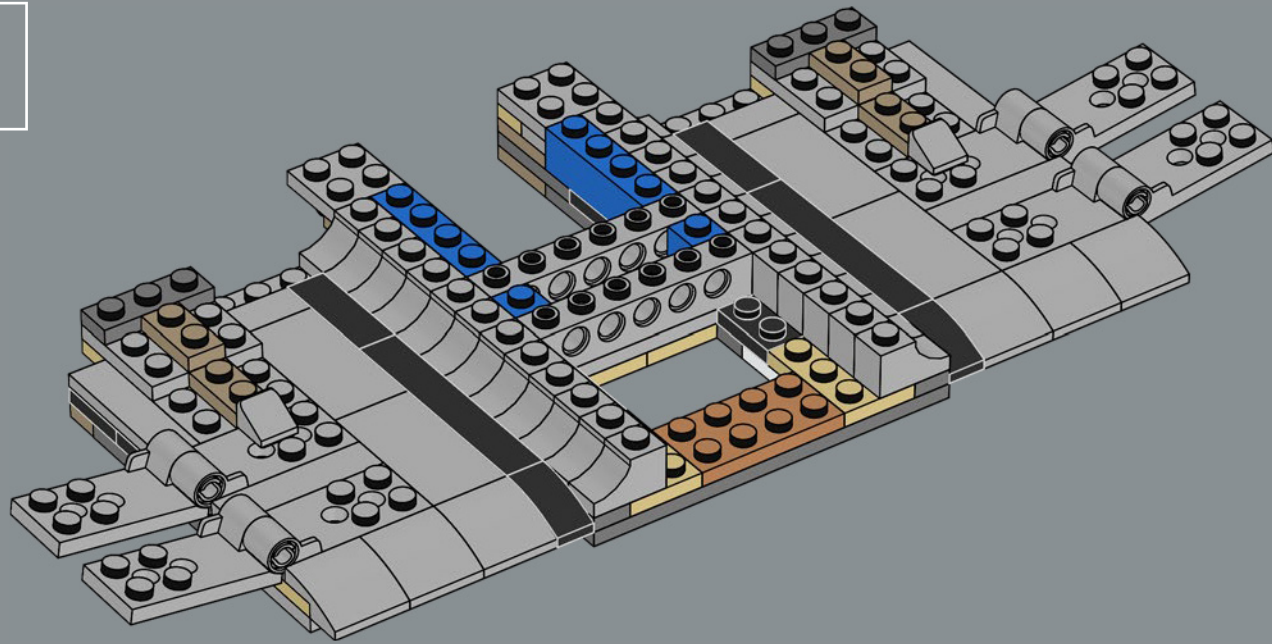

32

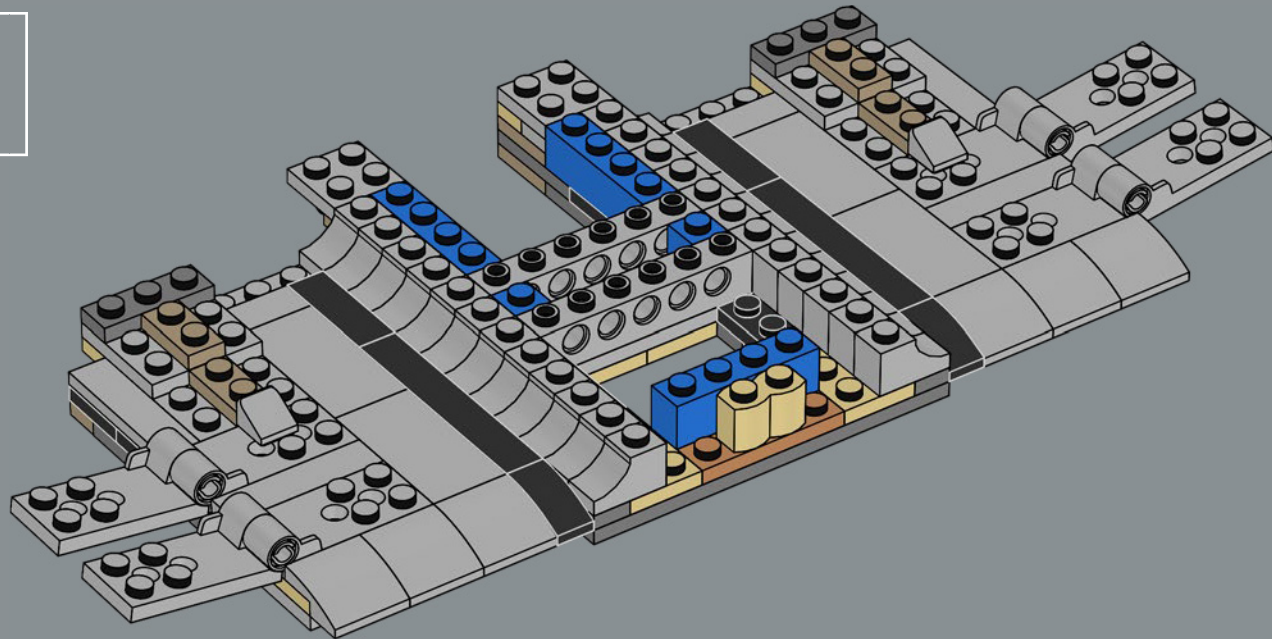

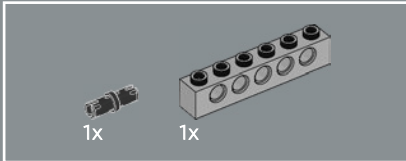
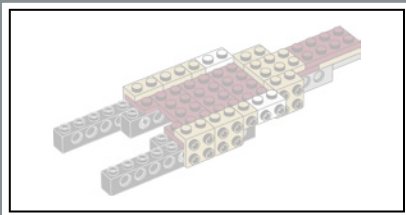

33

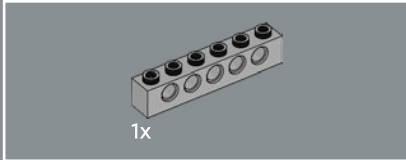
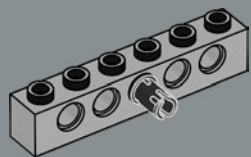

34

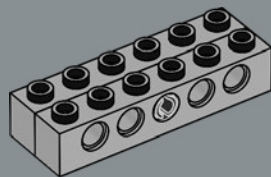

35

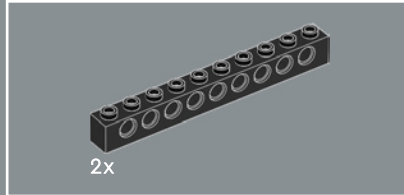
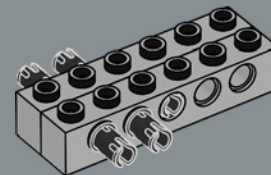

36

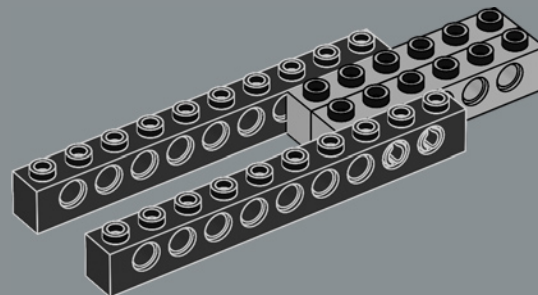

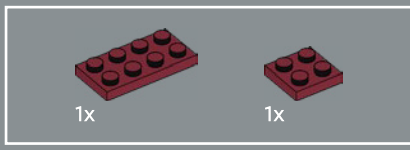

37

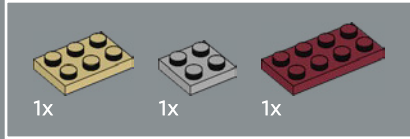
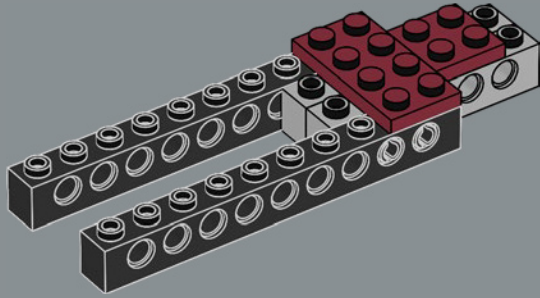

38

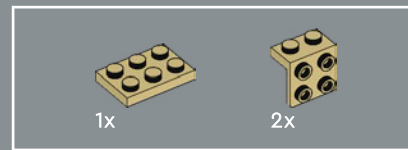
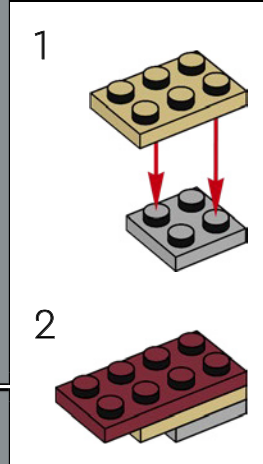
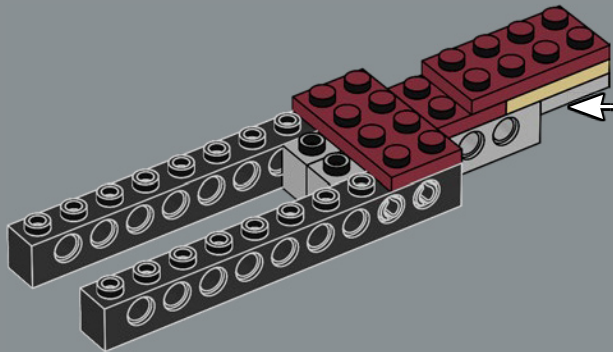

39

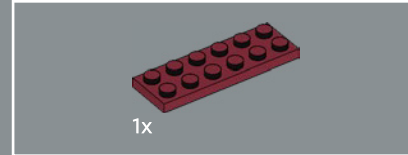
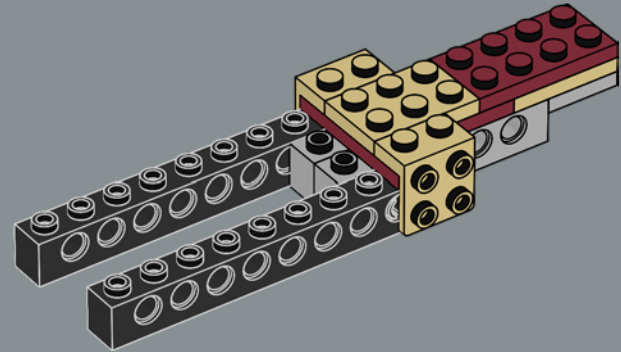

40

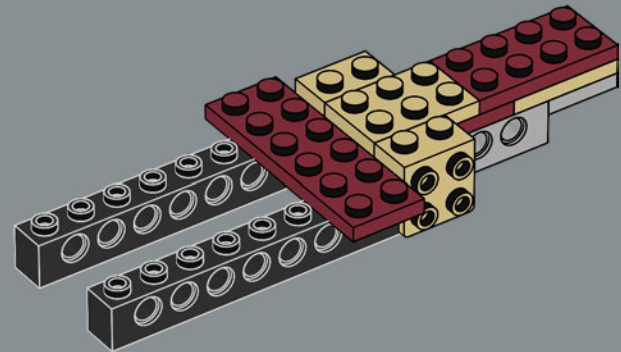

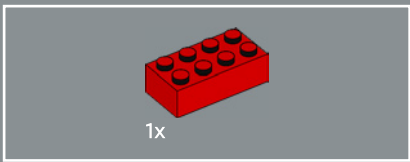

41

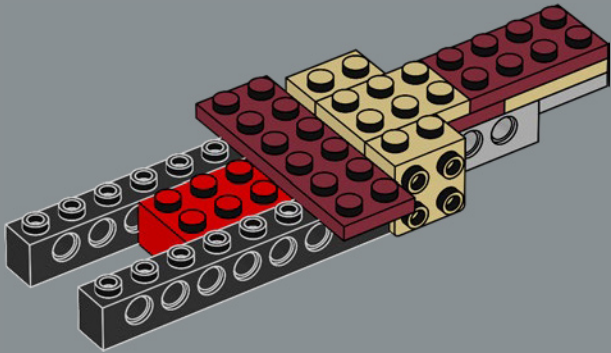

42

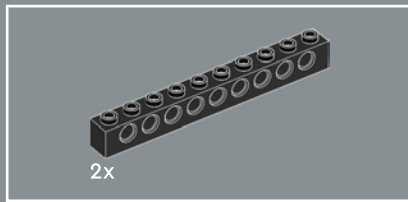
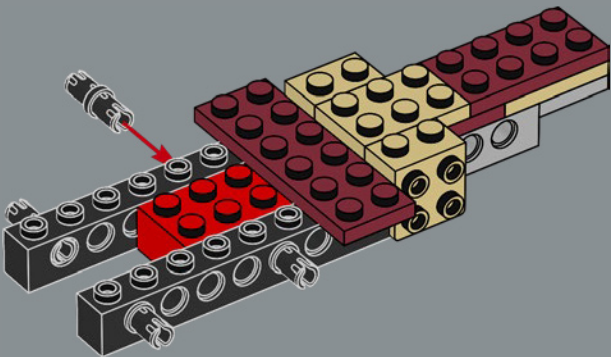

43

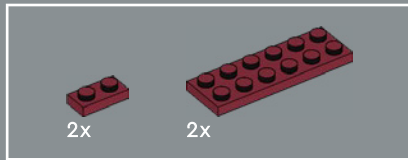
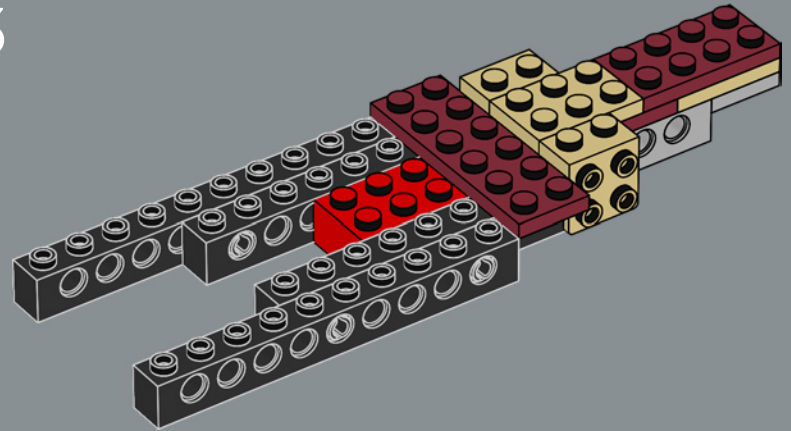

44

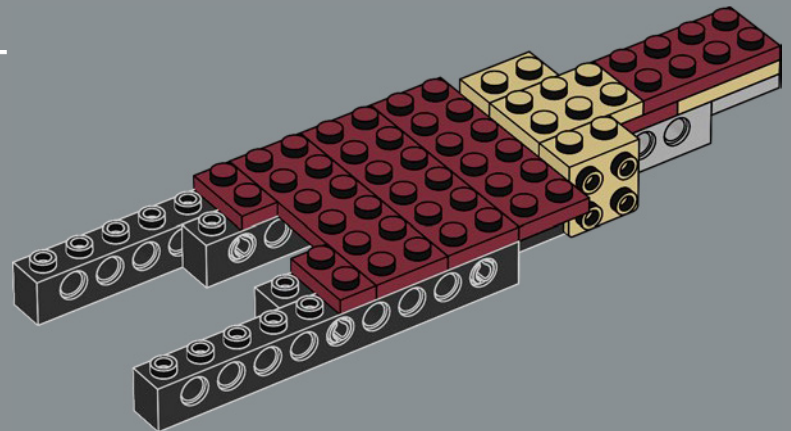



45

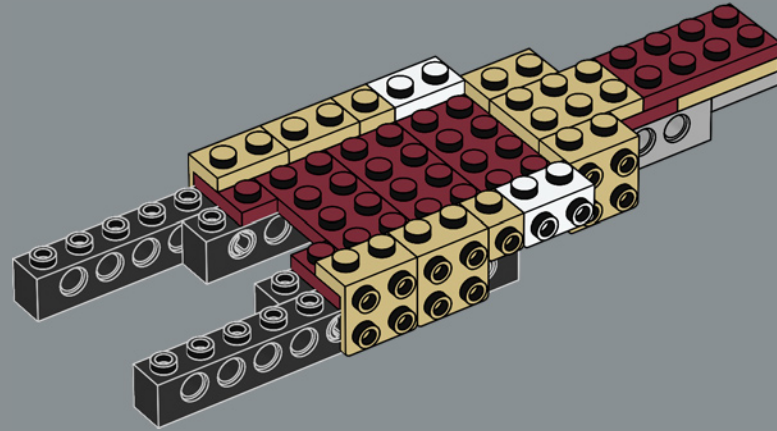

46

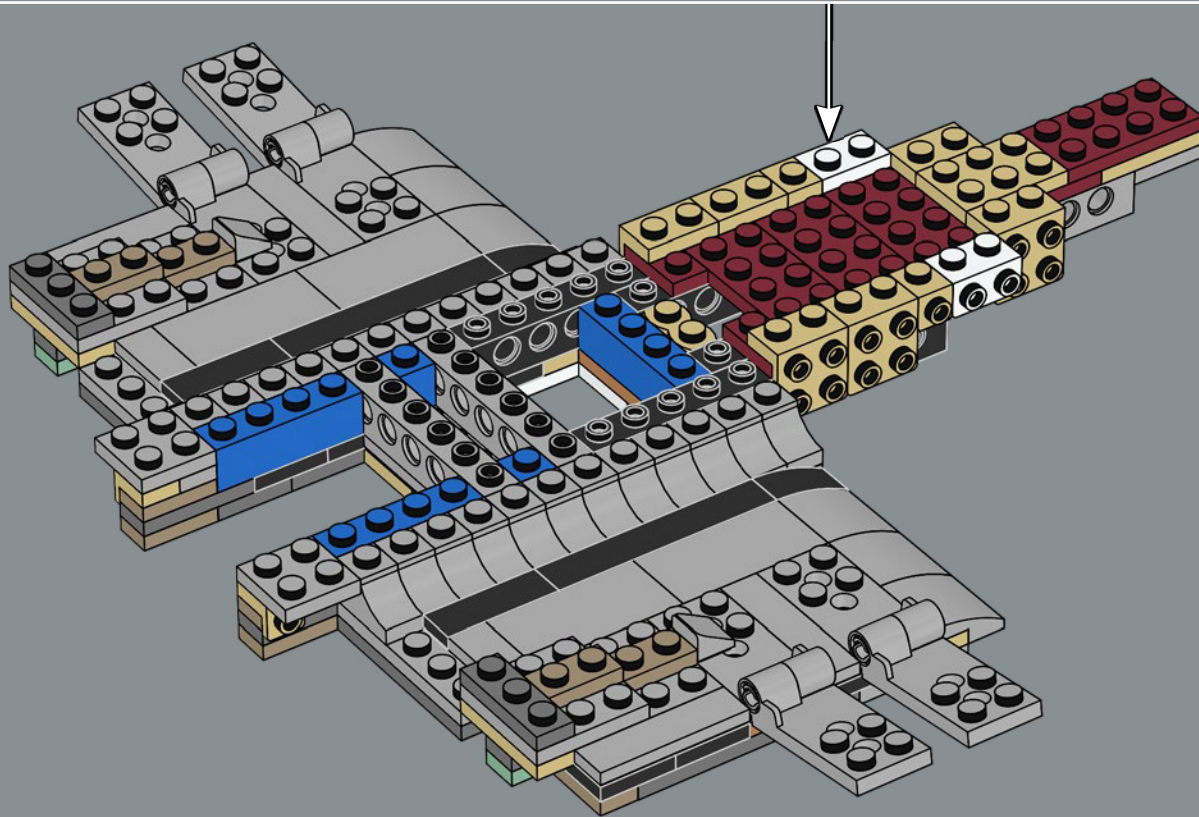

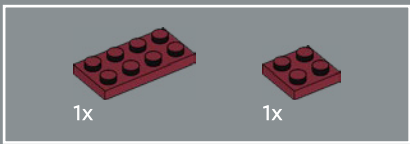

47

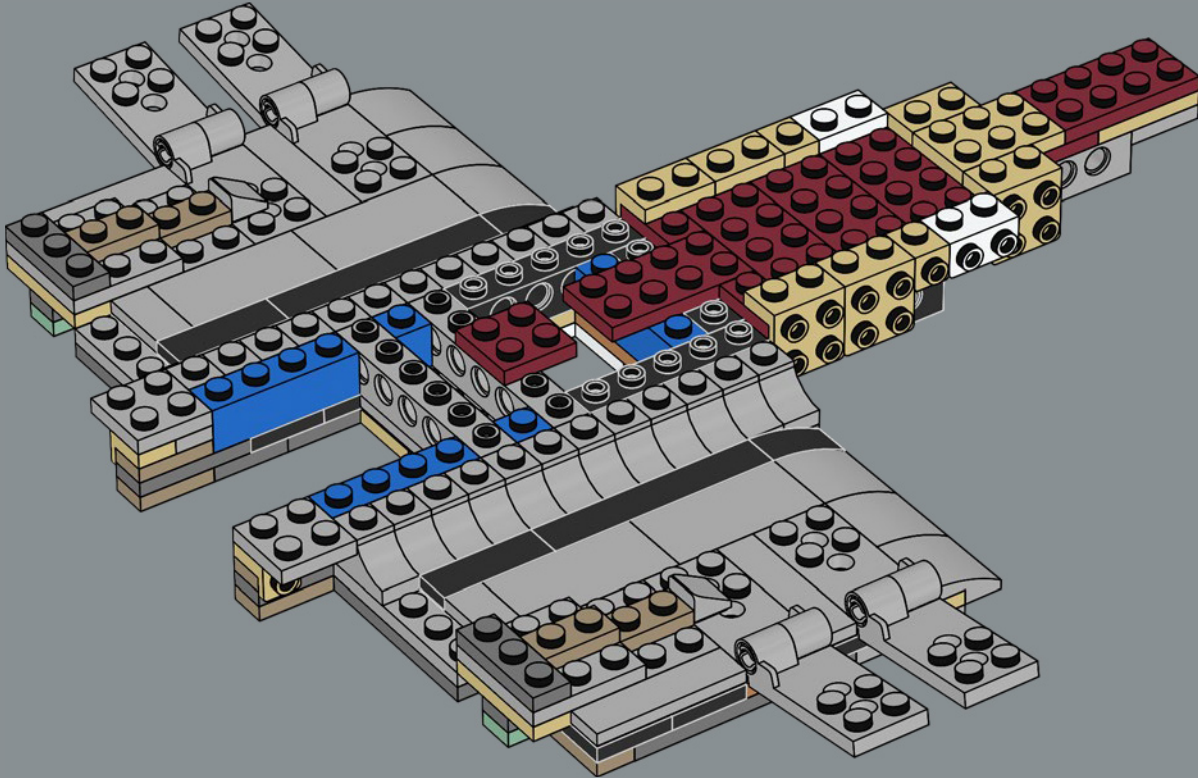

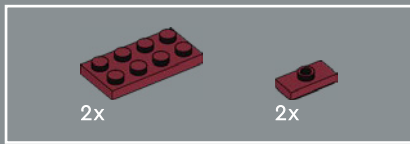

48

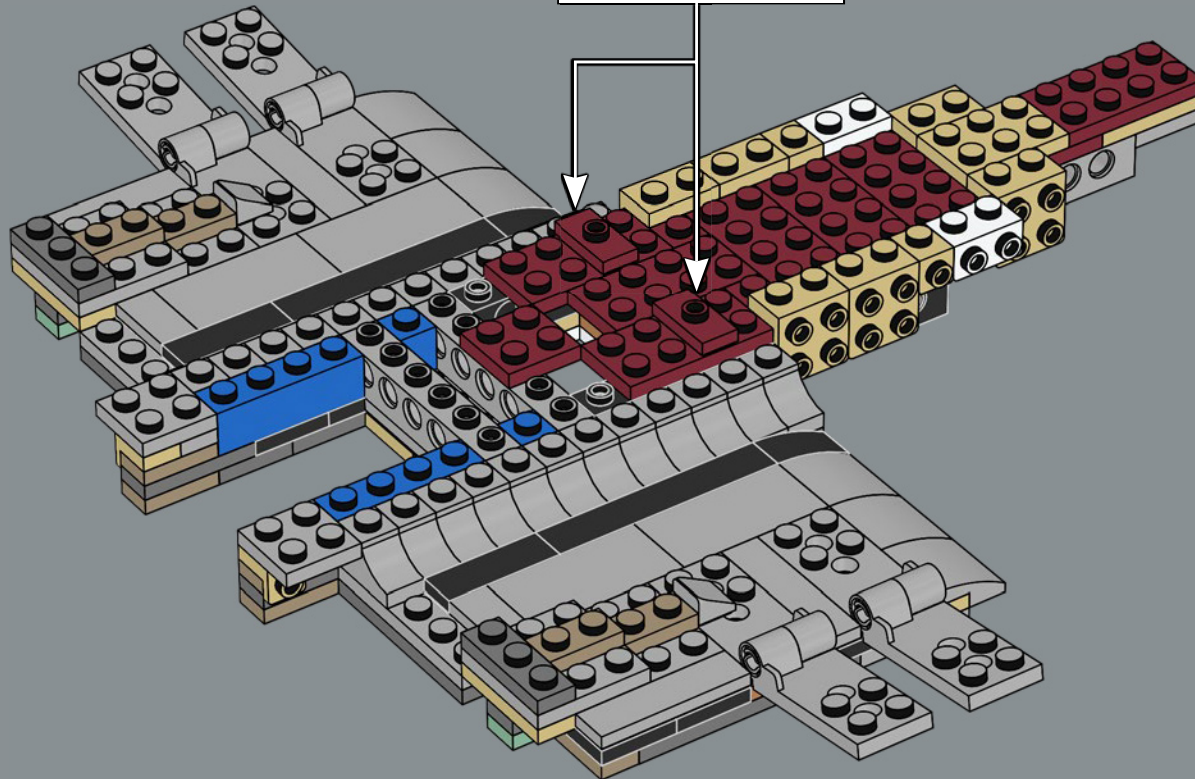
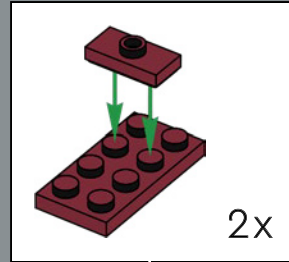

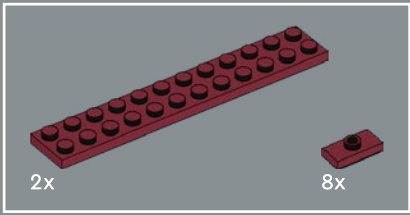

49

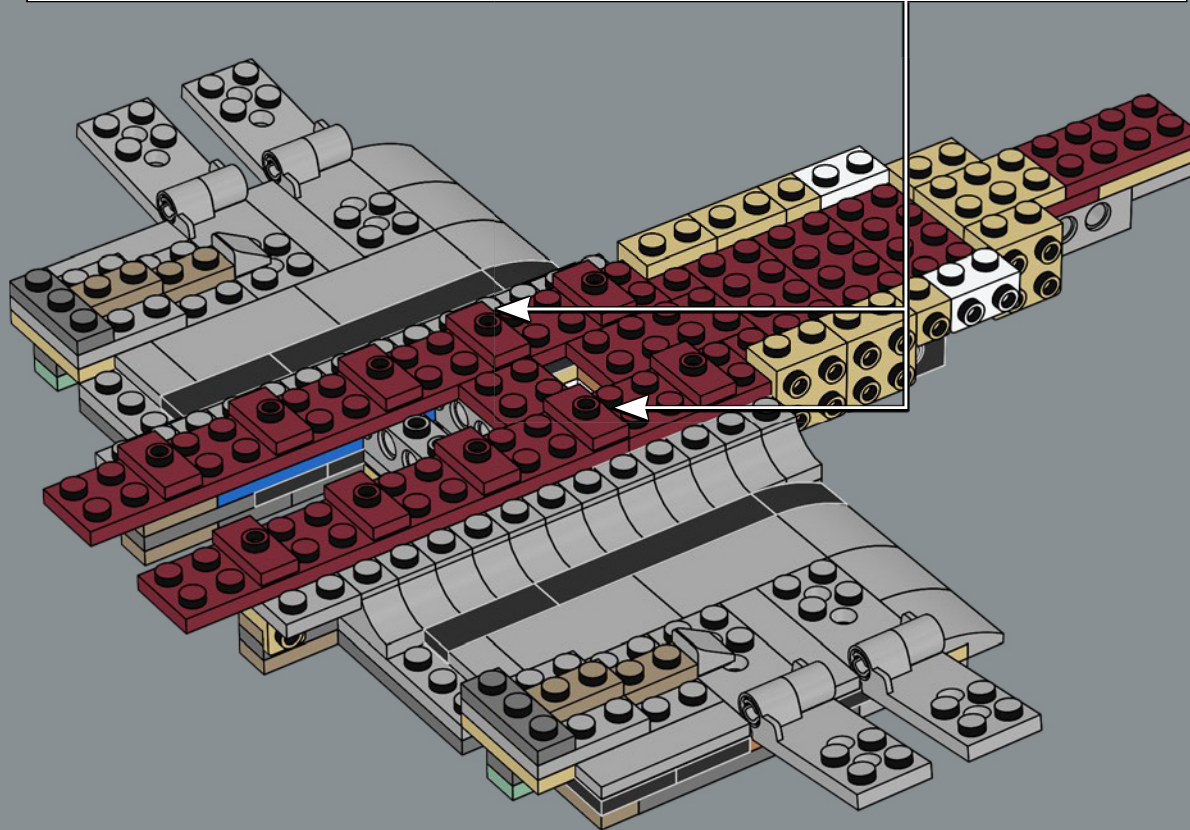
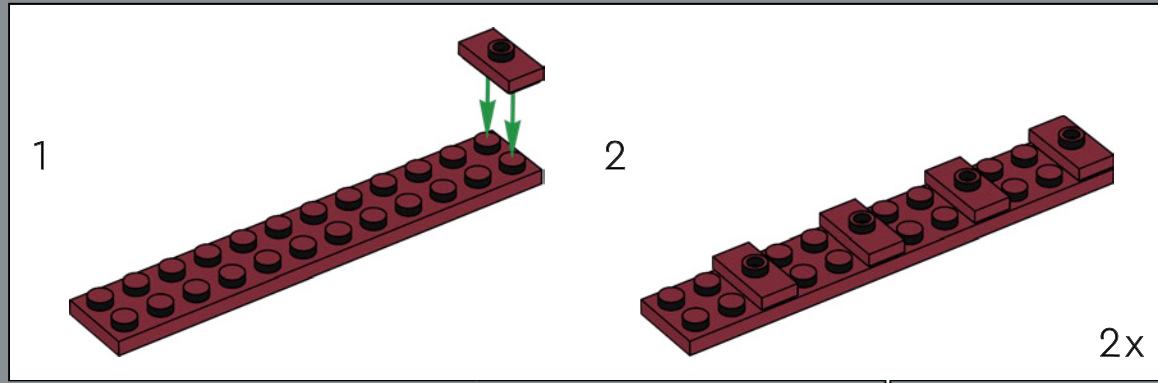

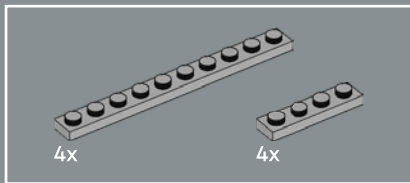

50

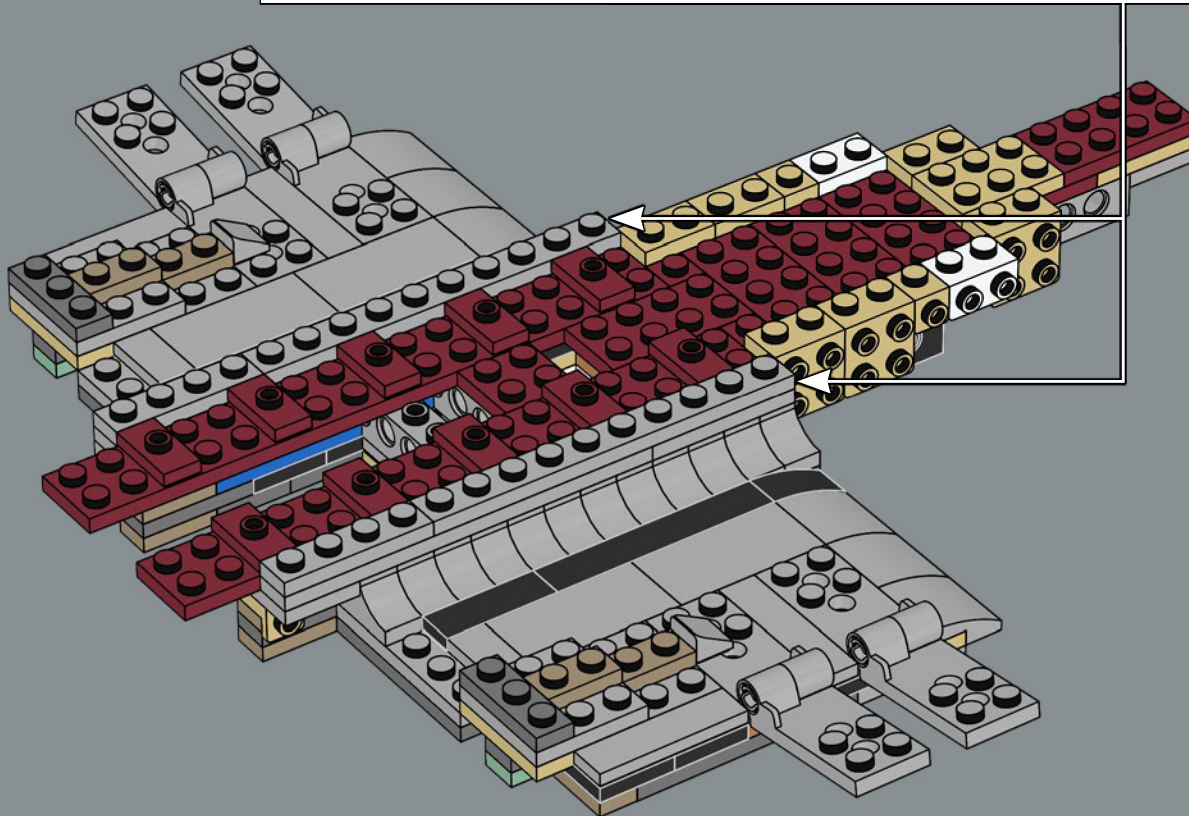
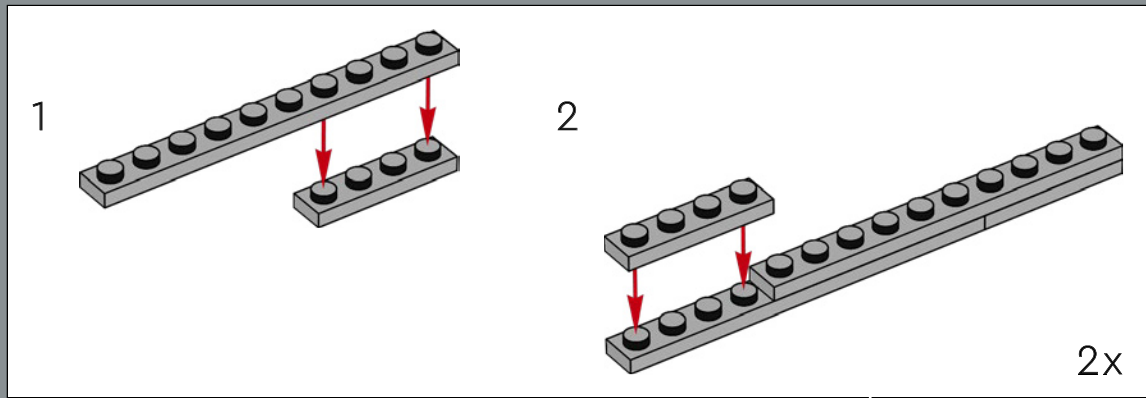



2x

51

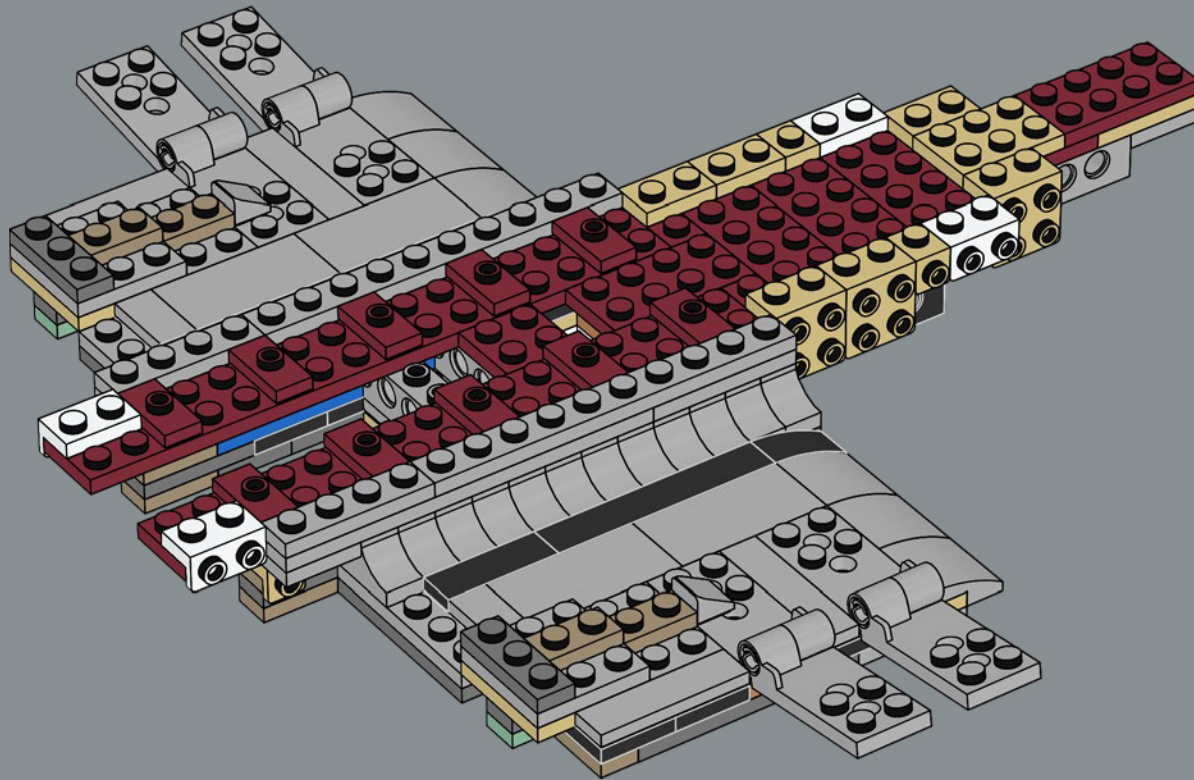

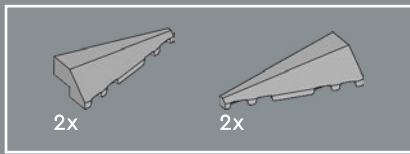

52

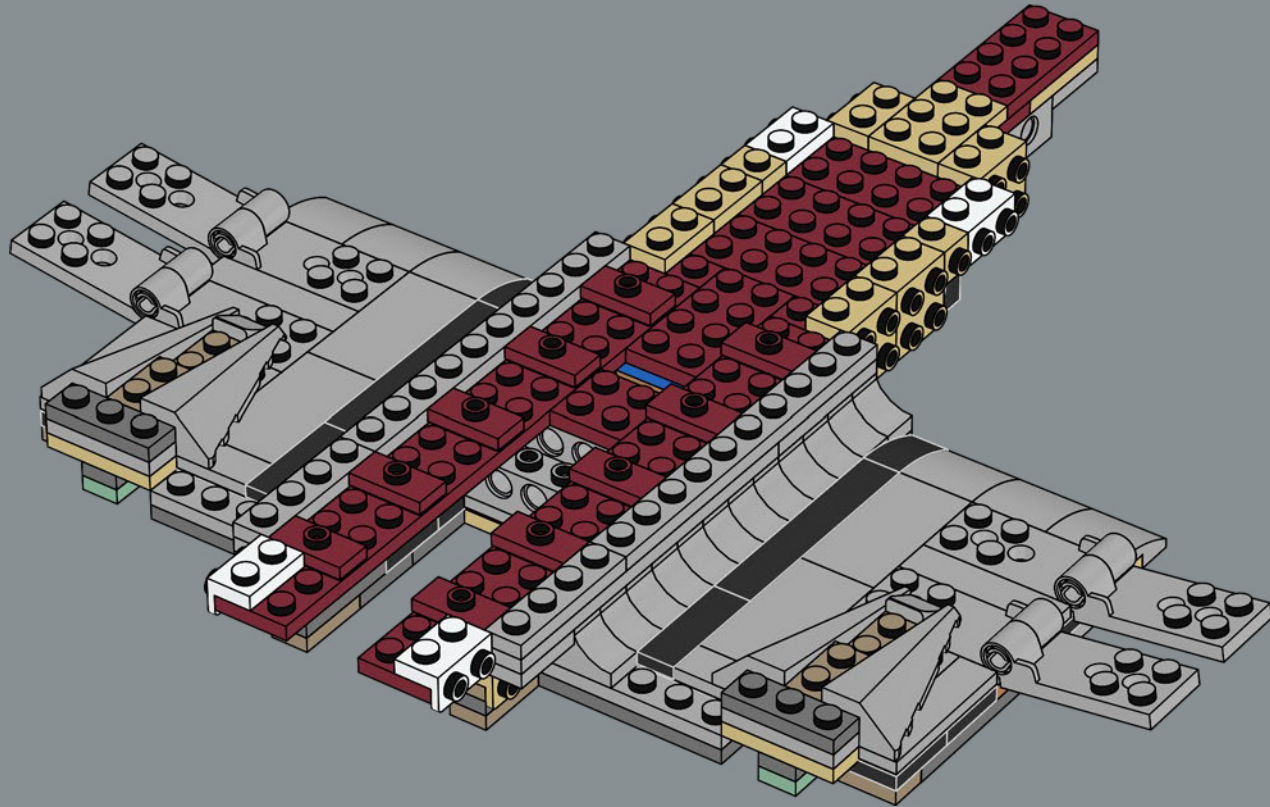

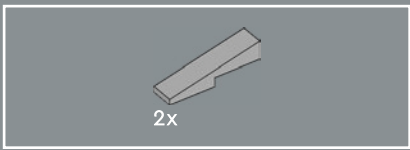

53

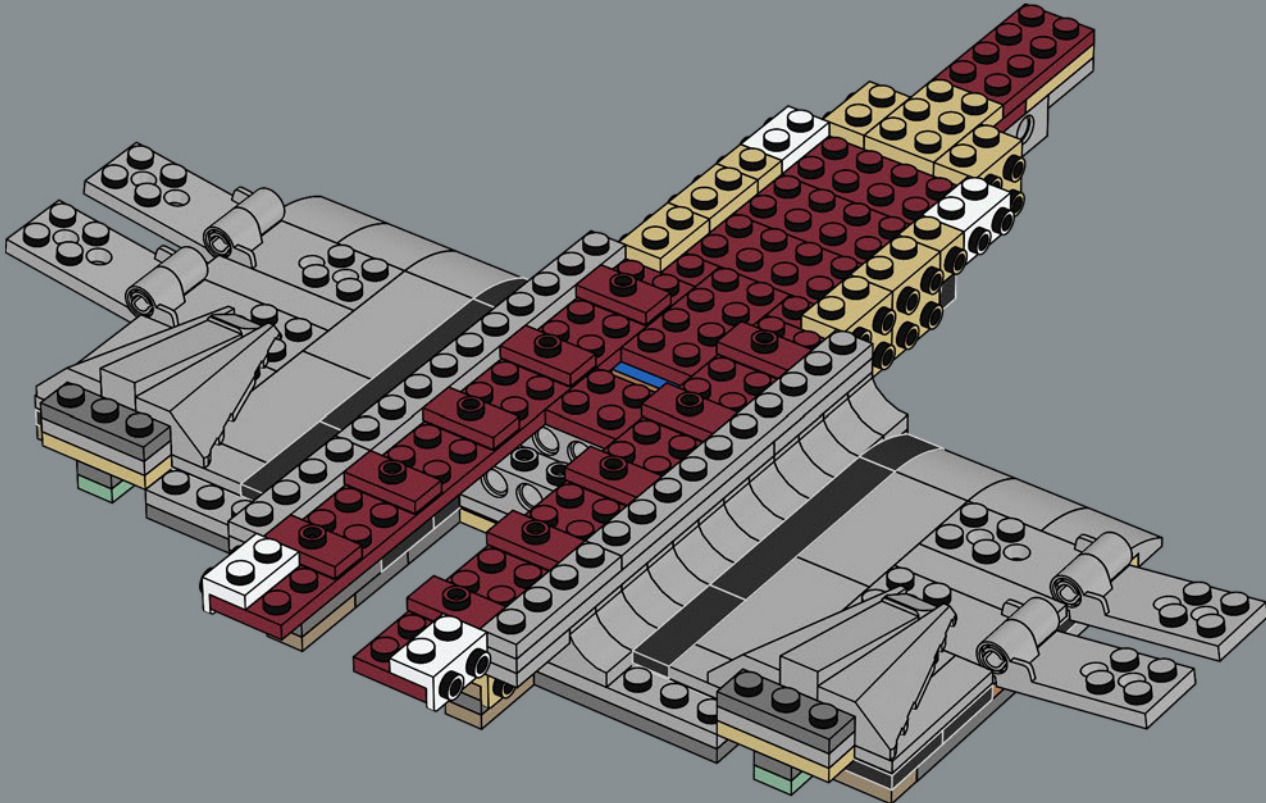



2x

54

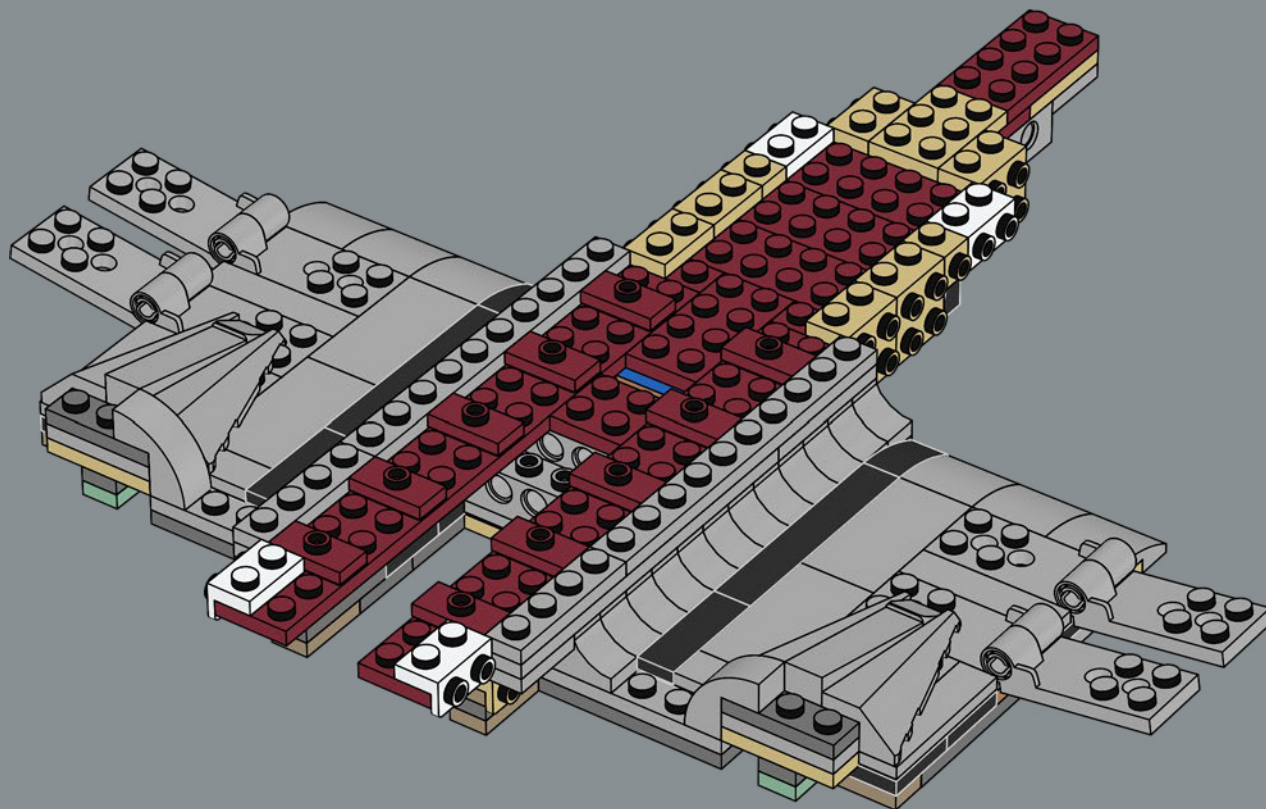



55

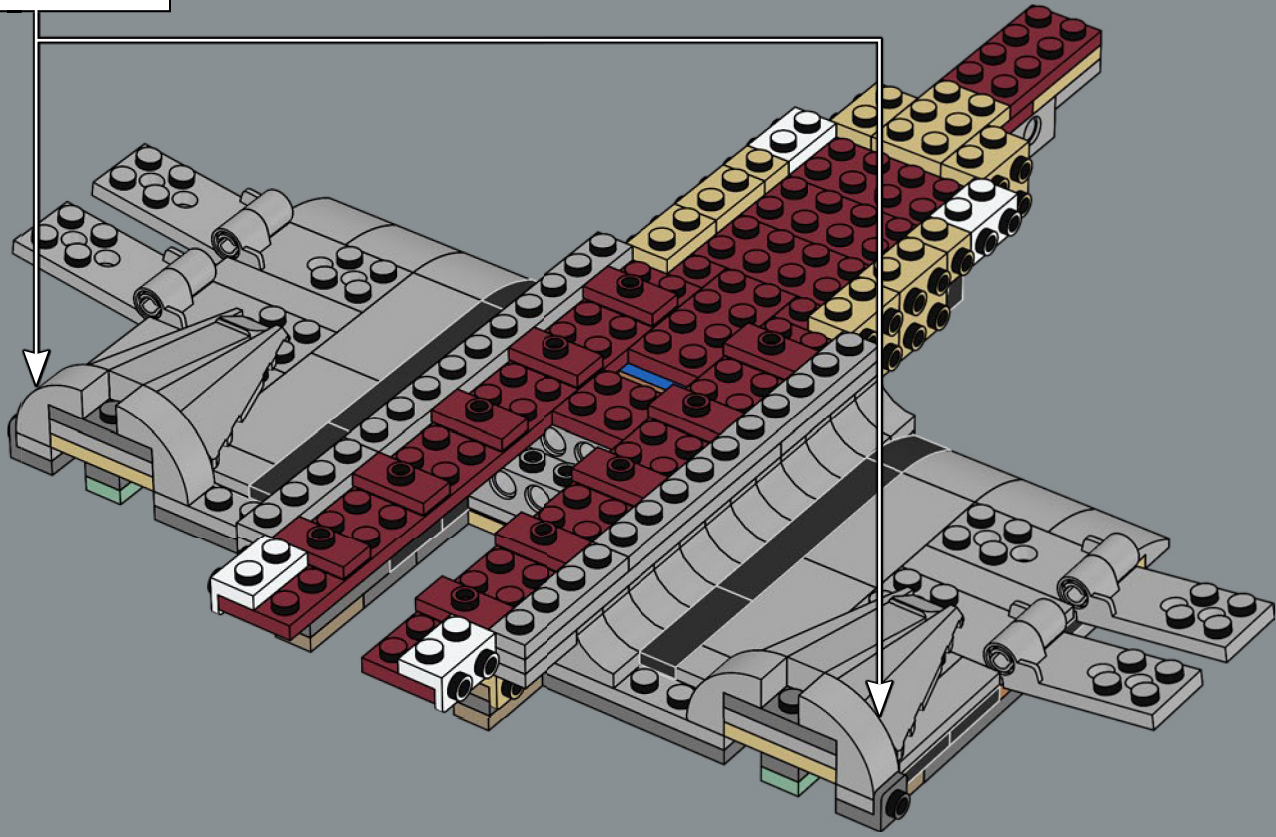
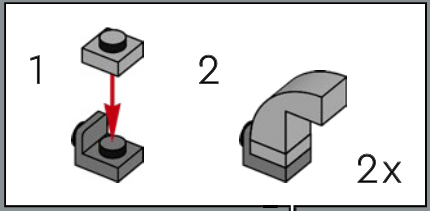

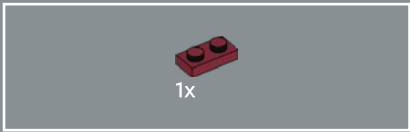

56

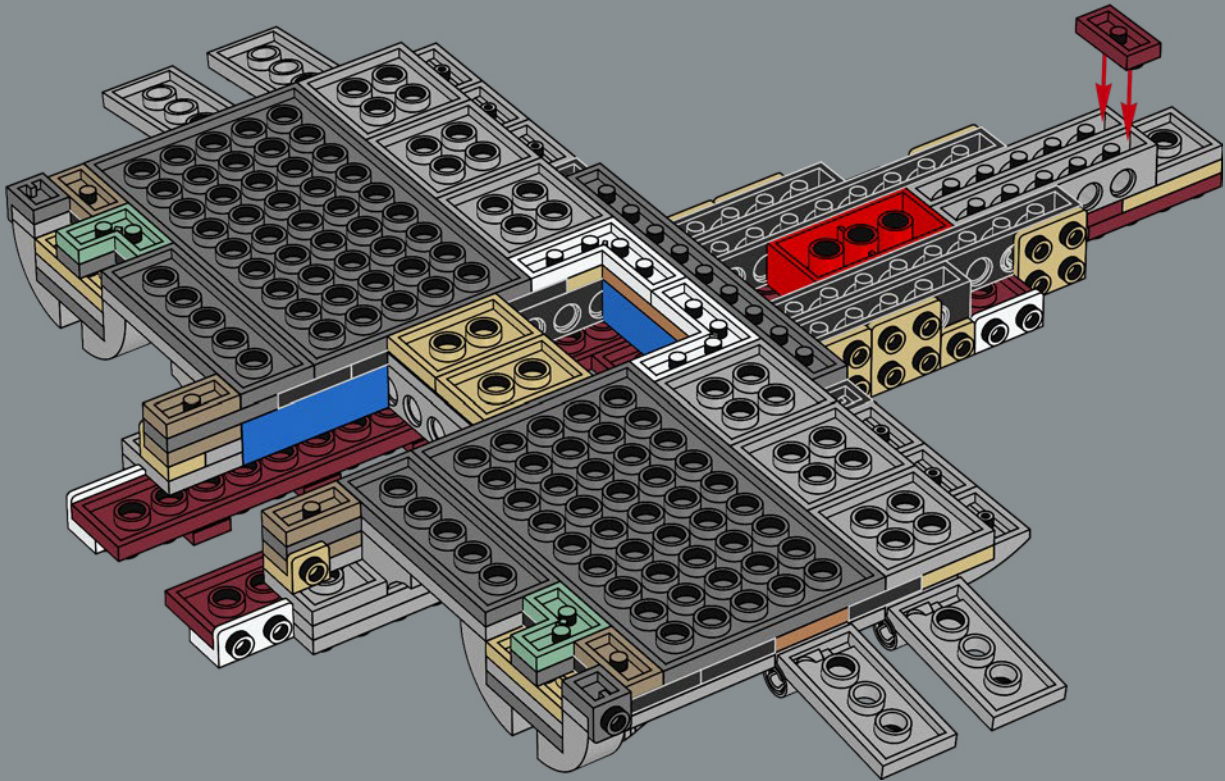

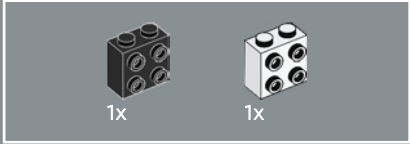
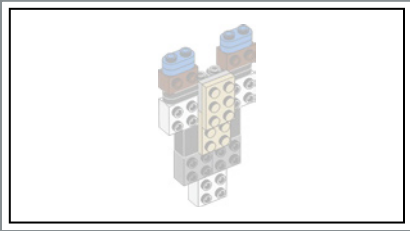

57

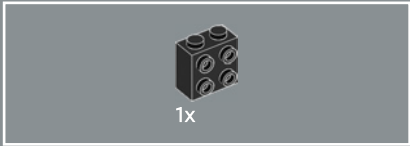
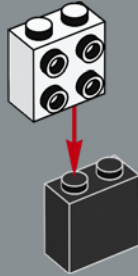

58

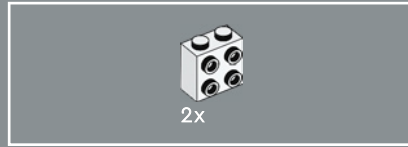
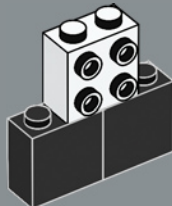

59

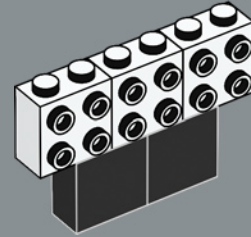

60

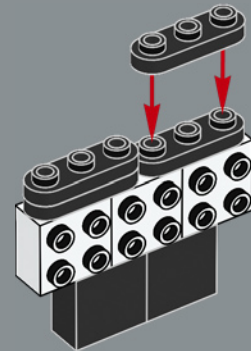

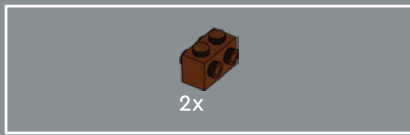

61

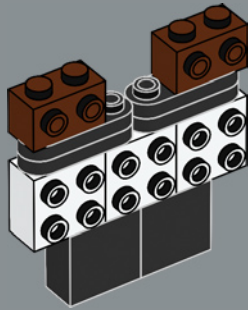

62

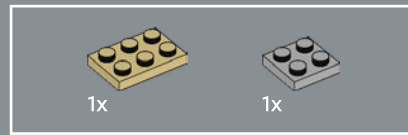
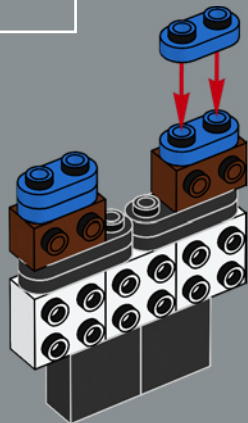

63

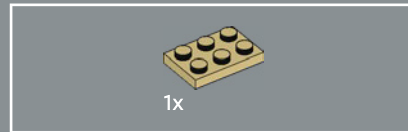
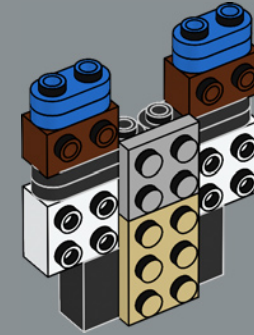

64

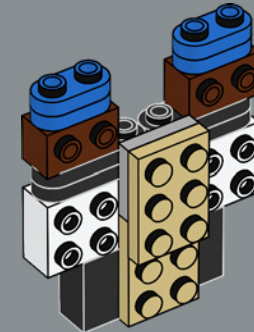



2x

65

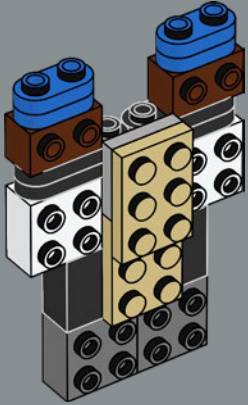

1x

66

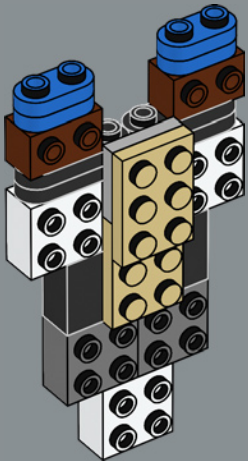

67

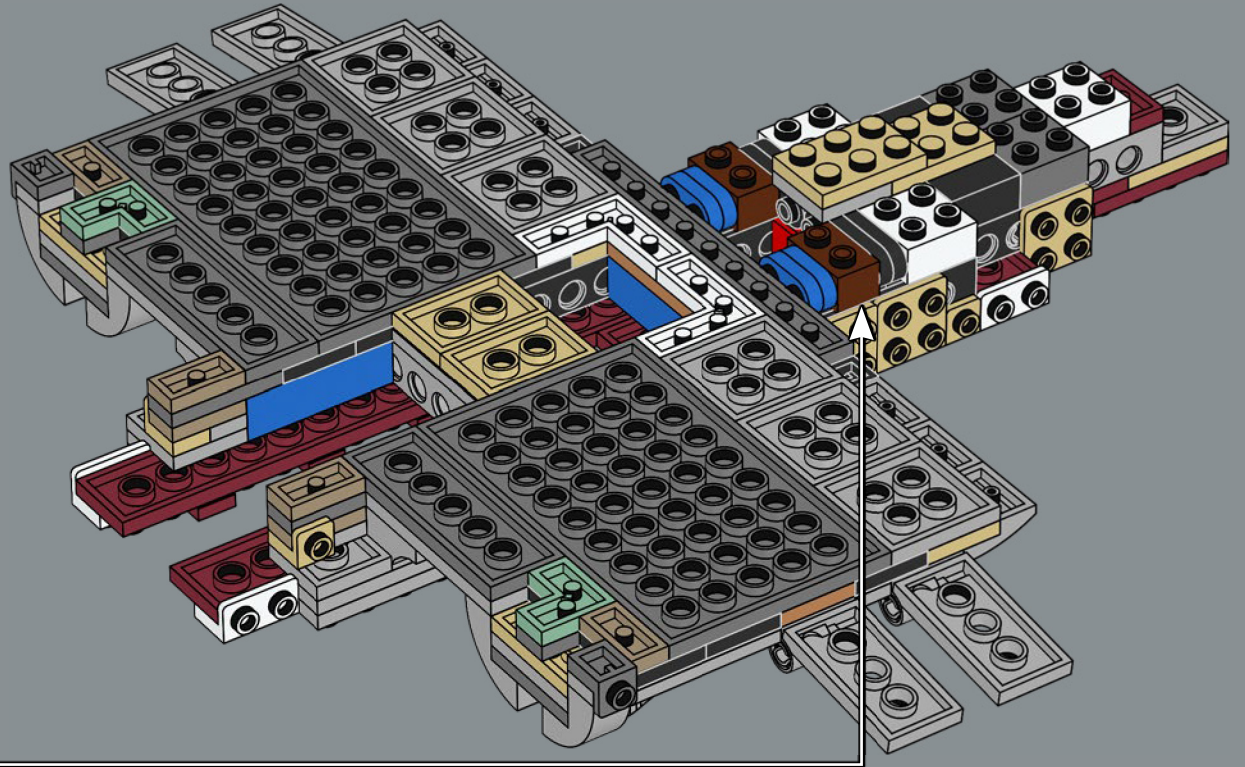

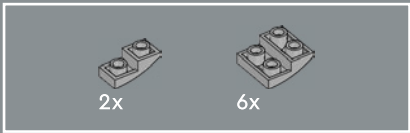

68

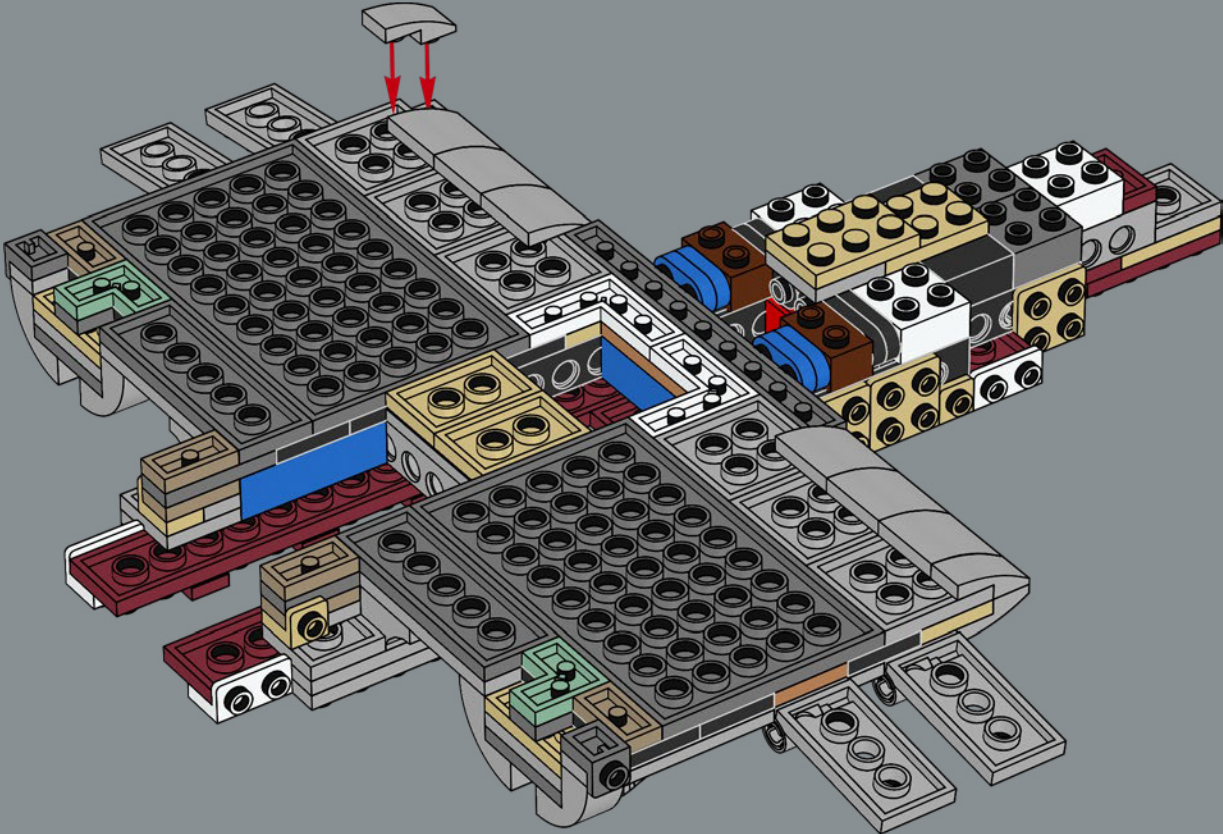

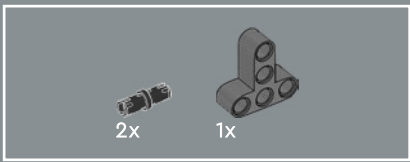

69

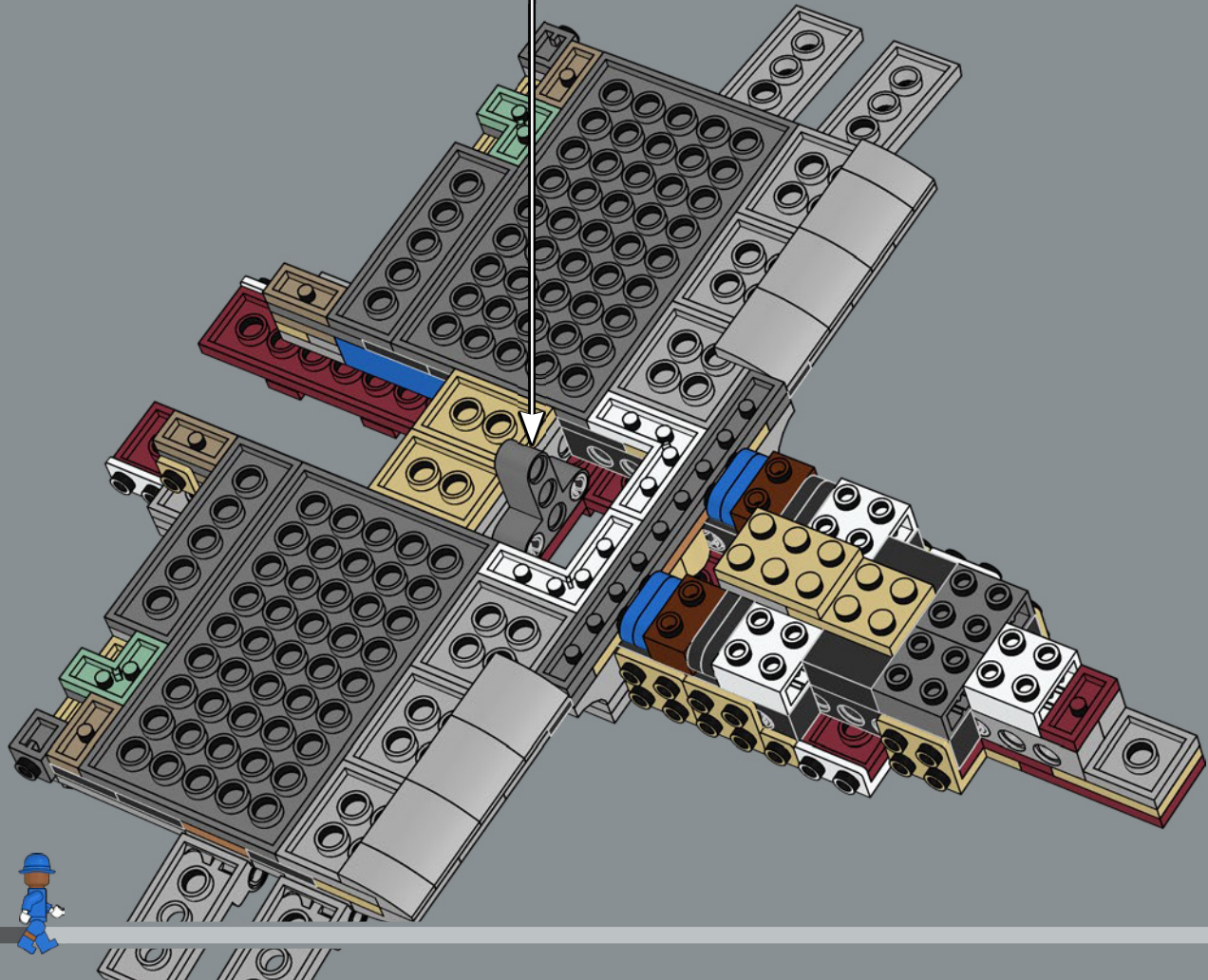
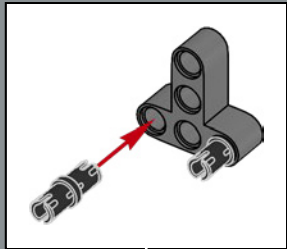

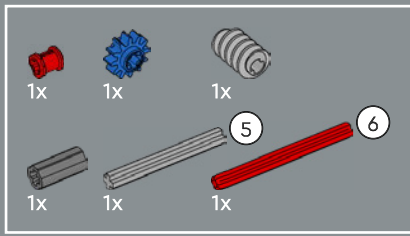

70

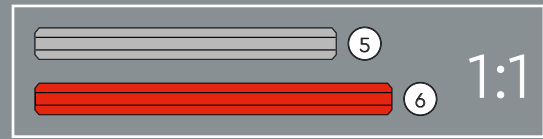
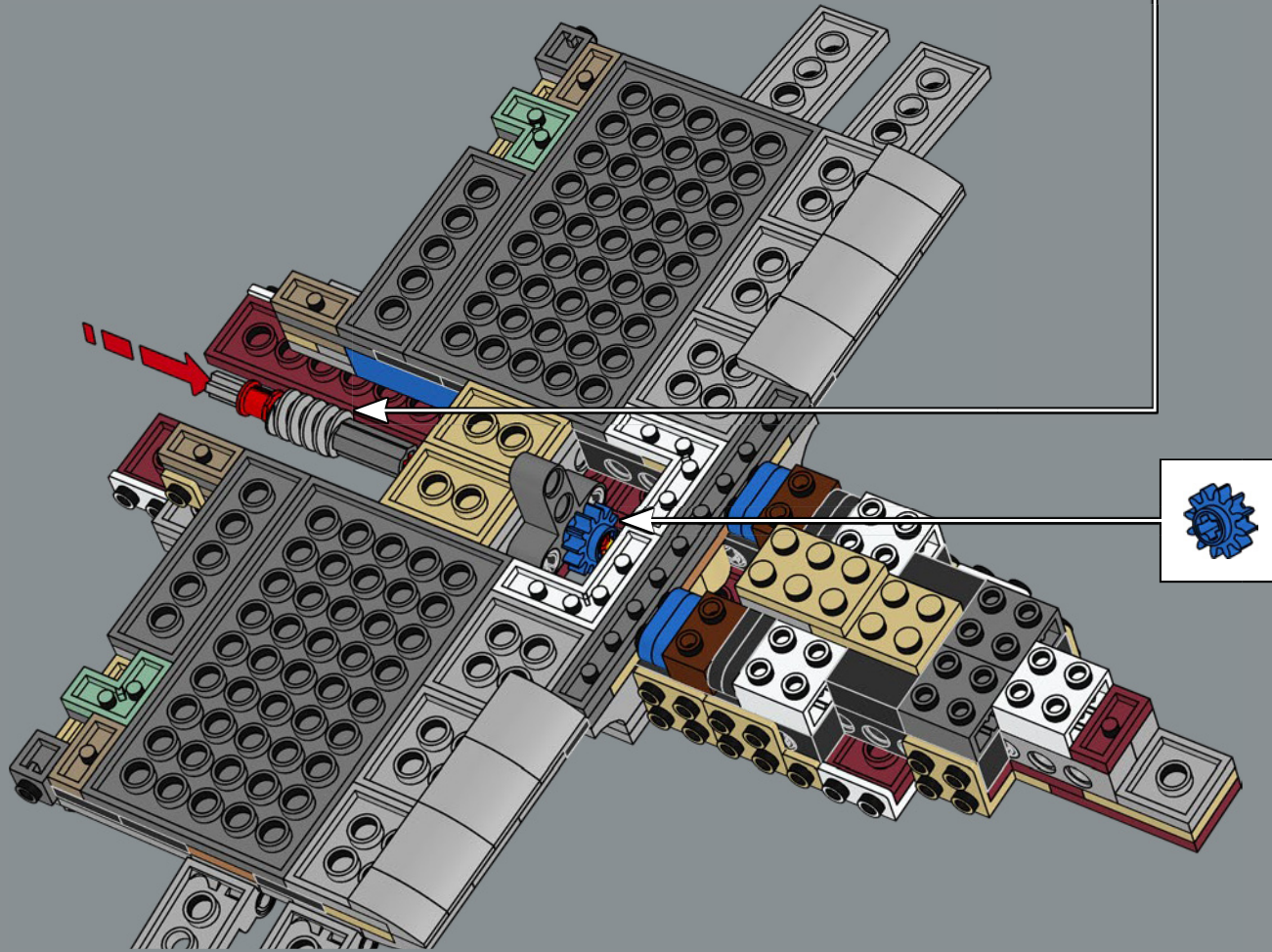
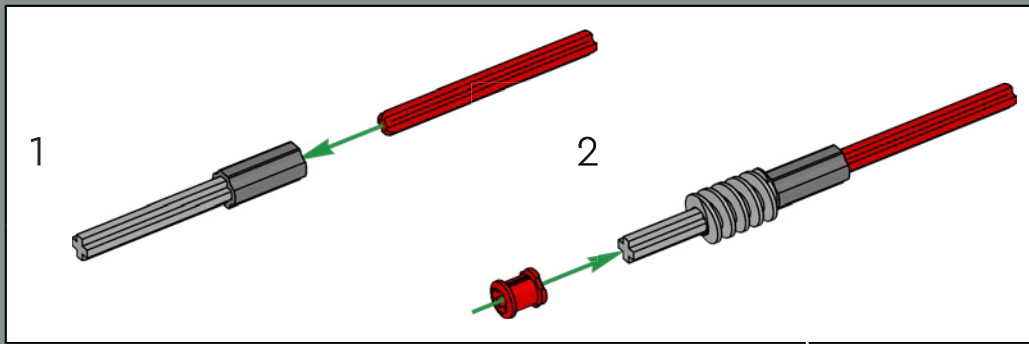

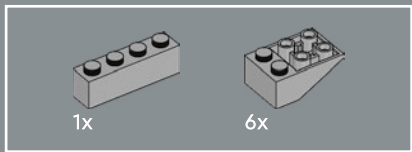

71

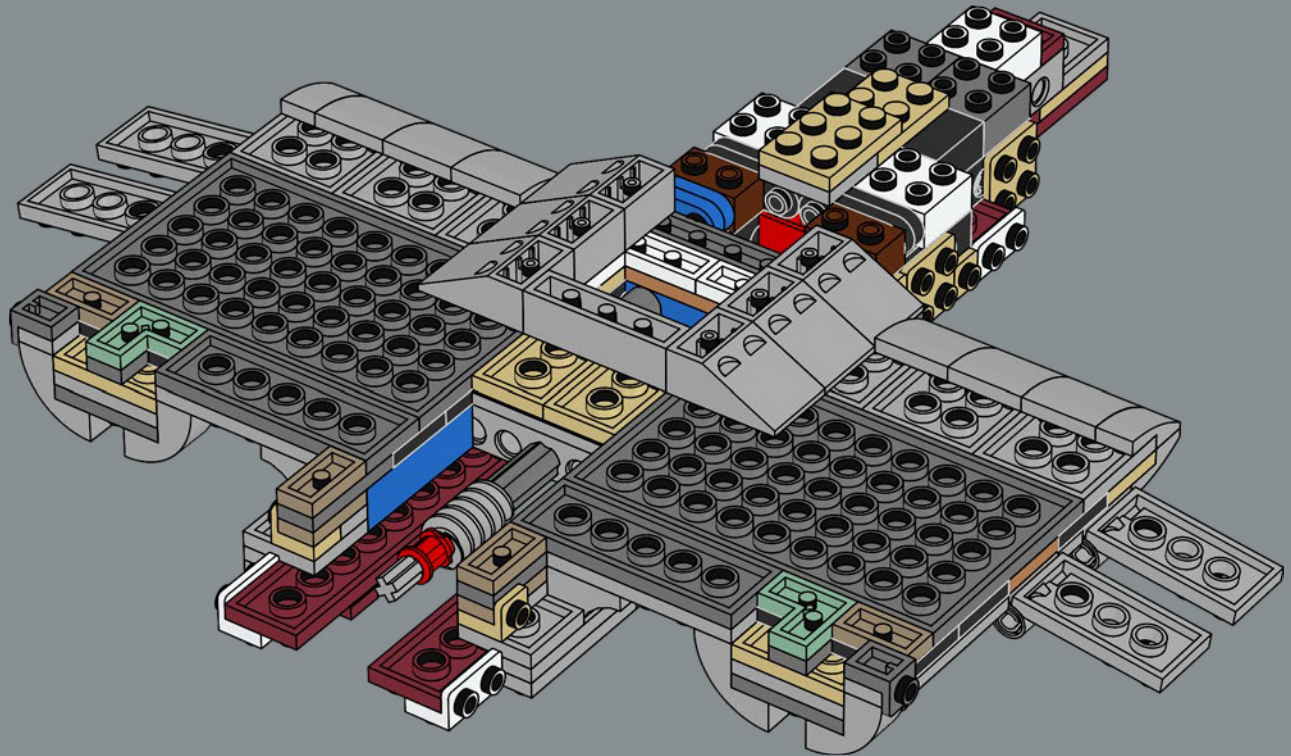

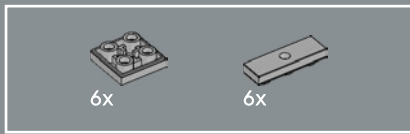

72

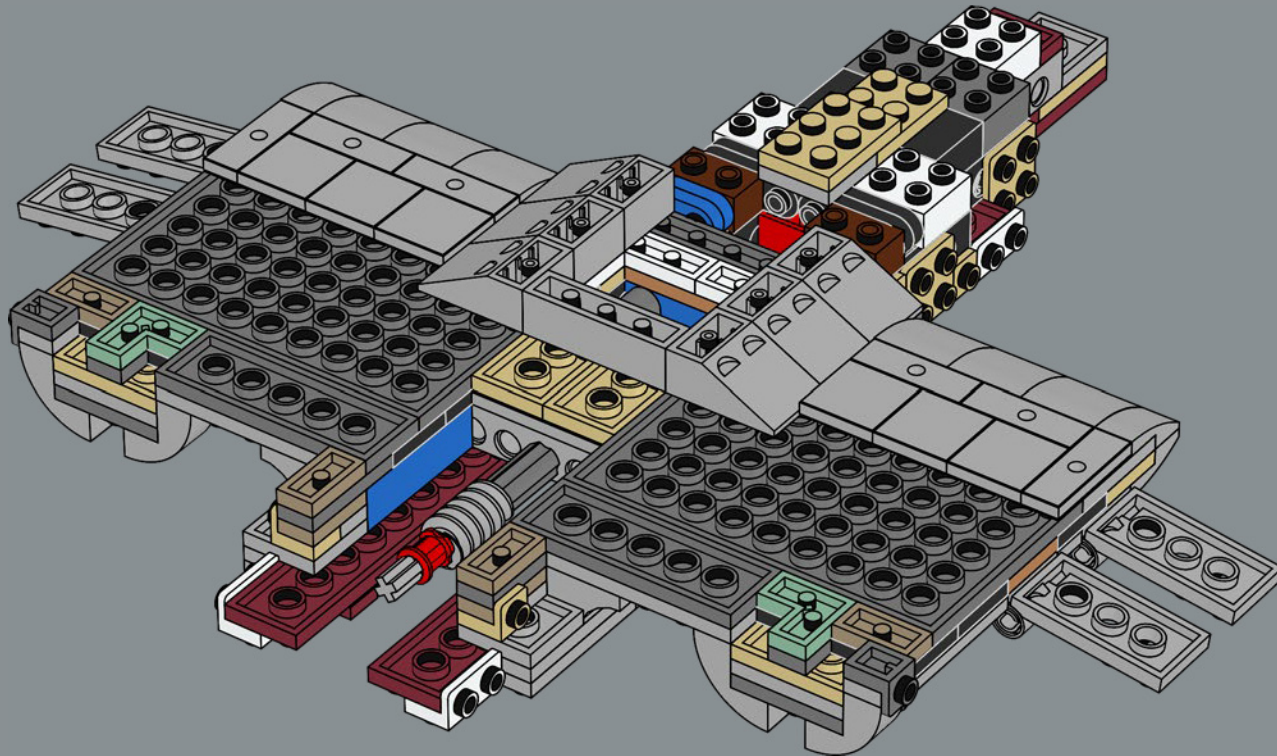

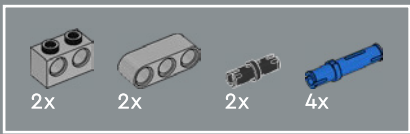

73

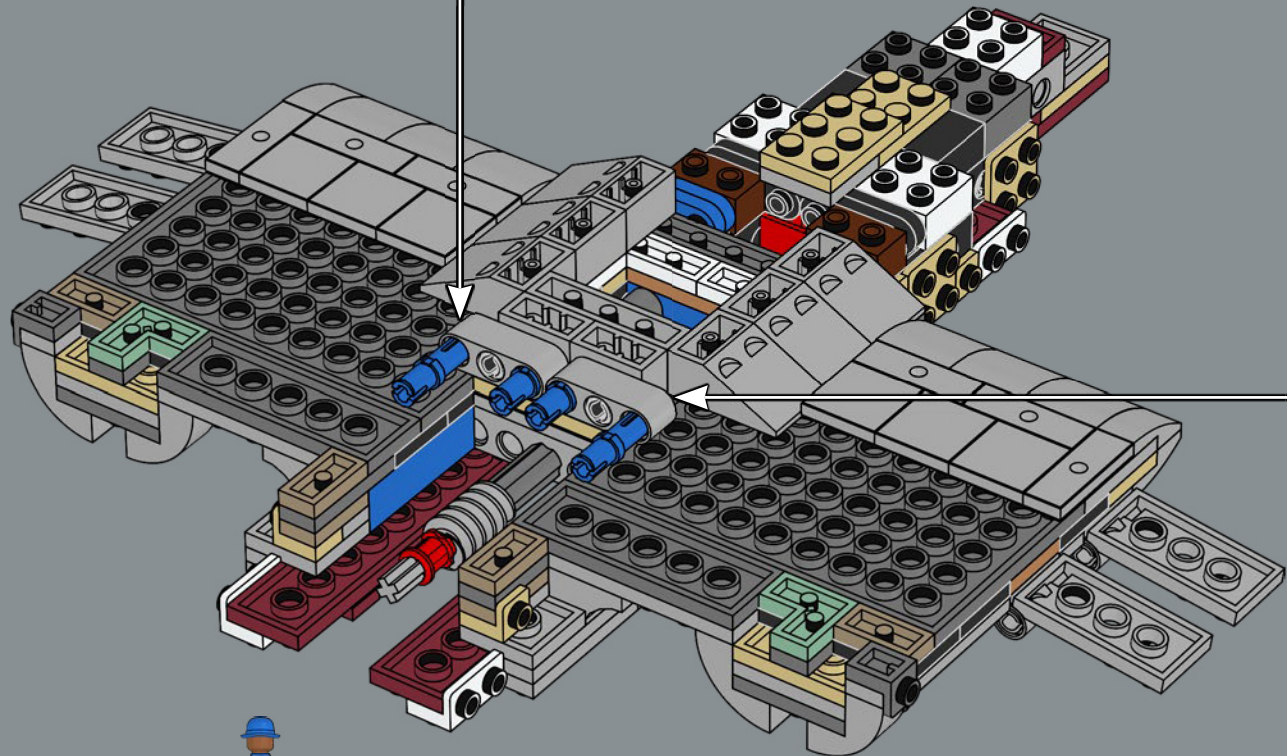
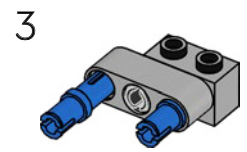
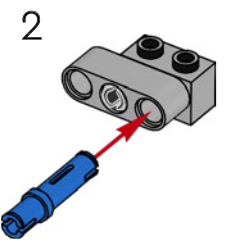
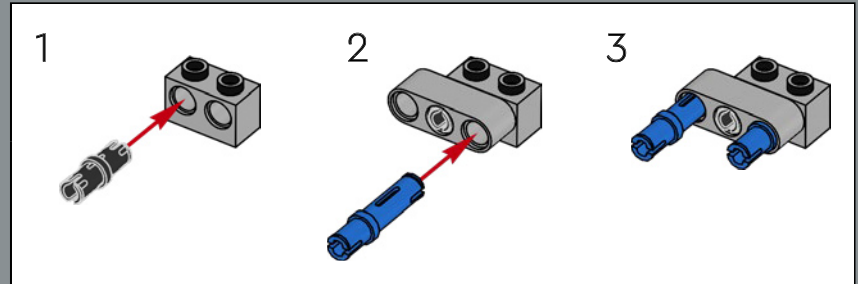
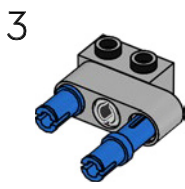
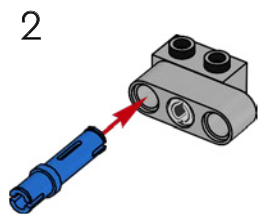
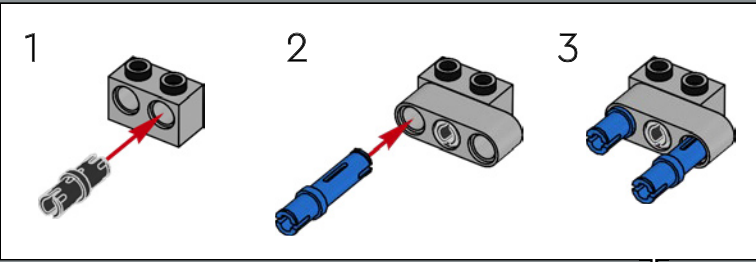

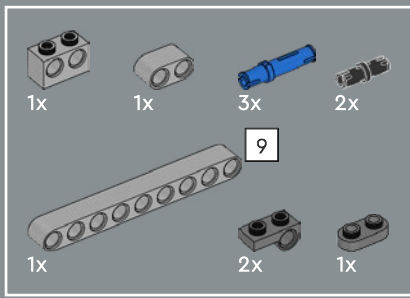

74

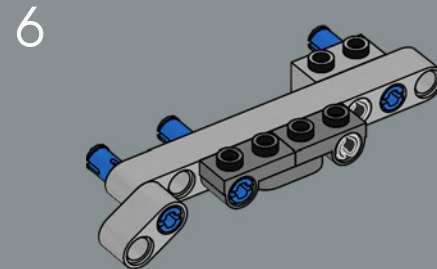
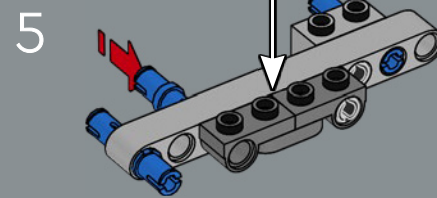
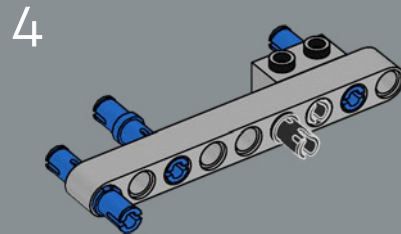
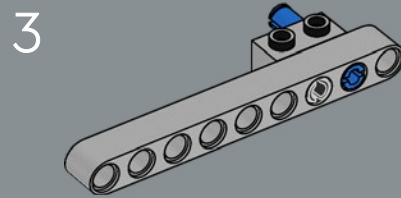
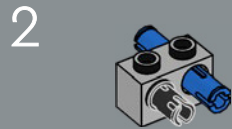
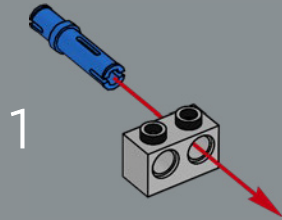
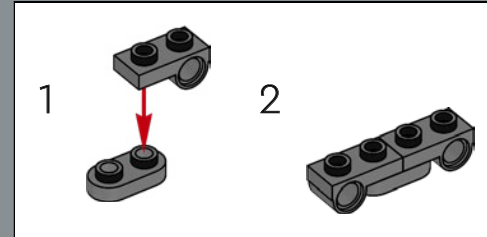

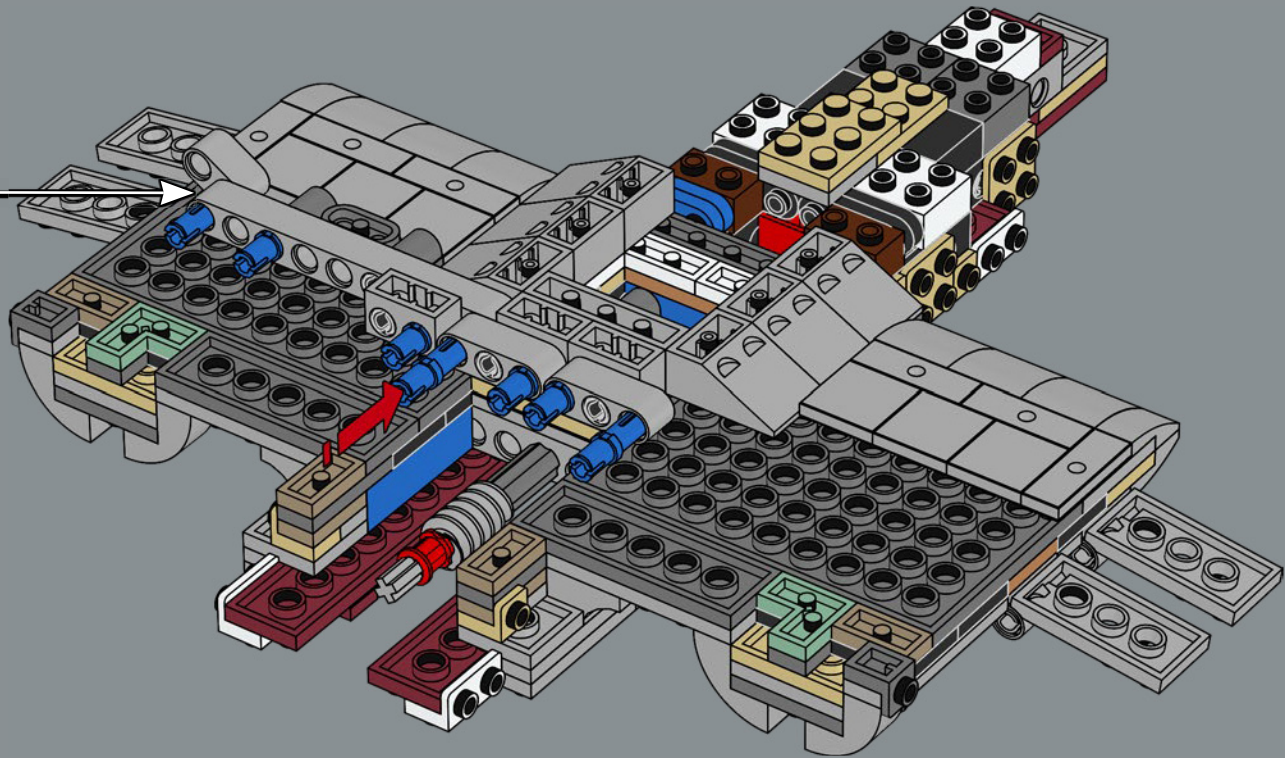

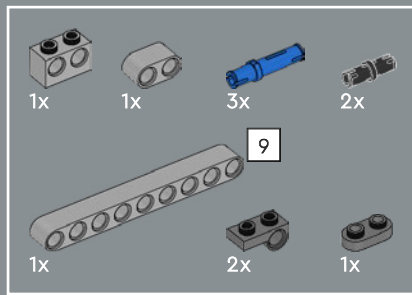

75

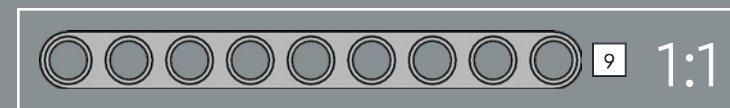
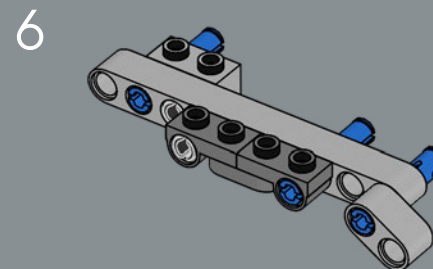
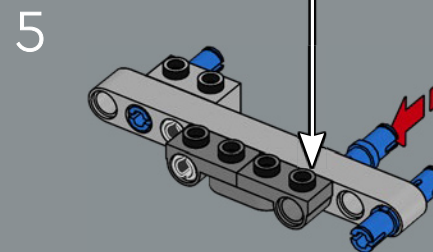
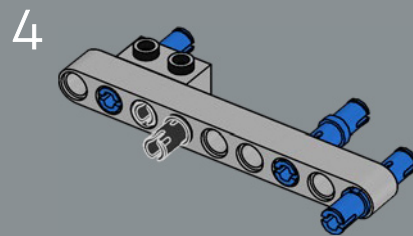
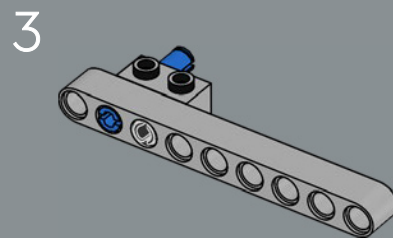
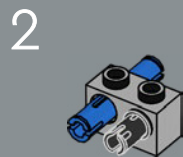
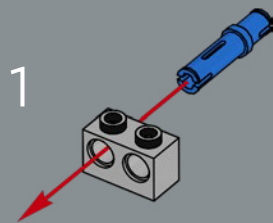
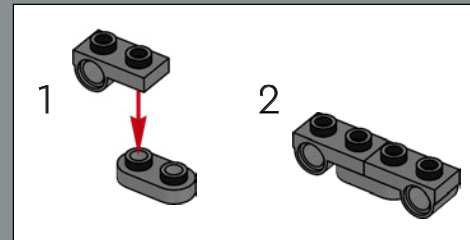

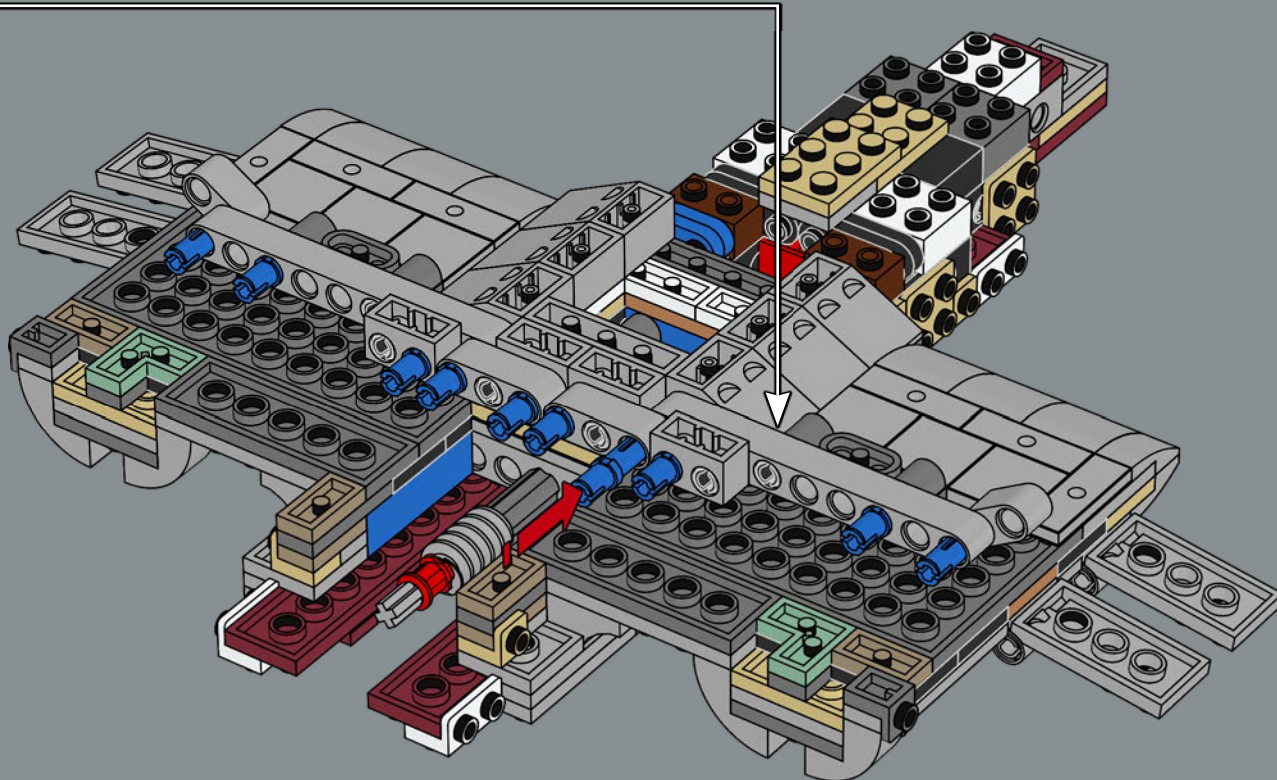

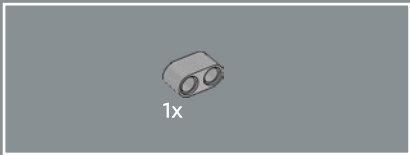

76

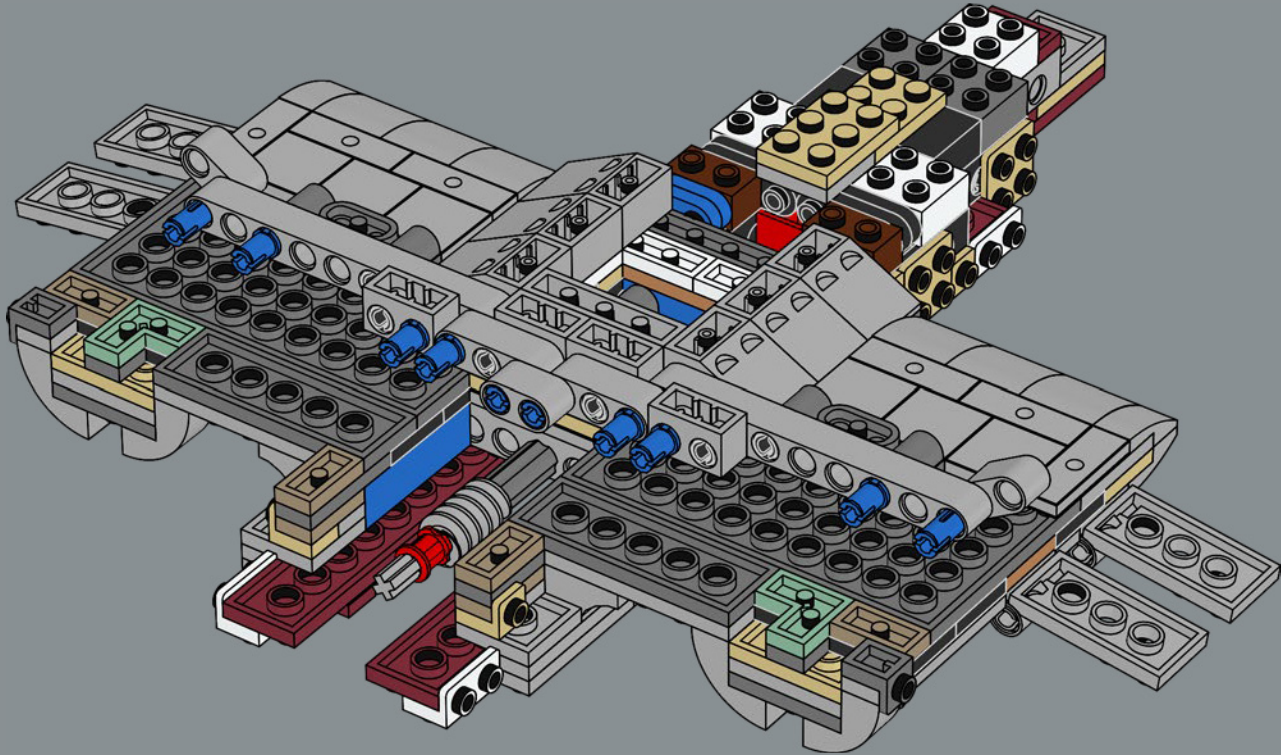

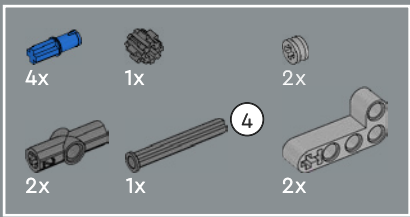

77

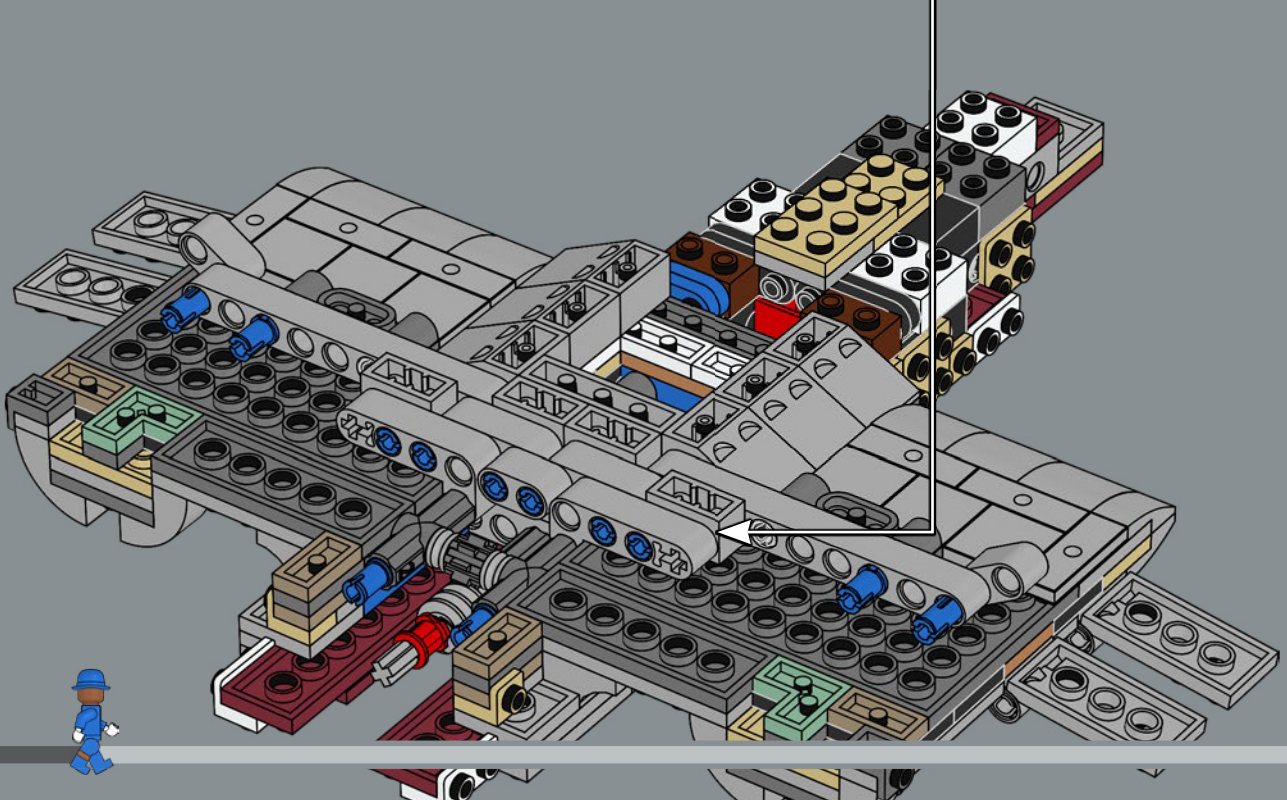
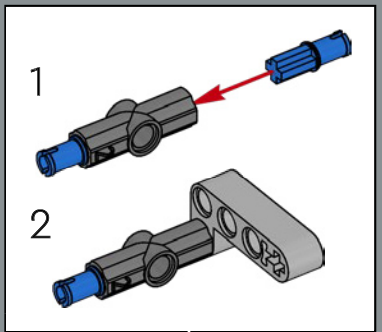
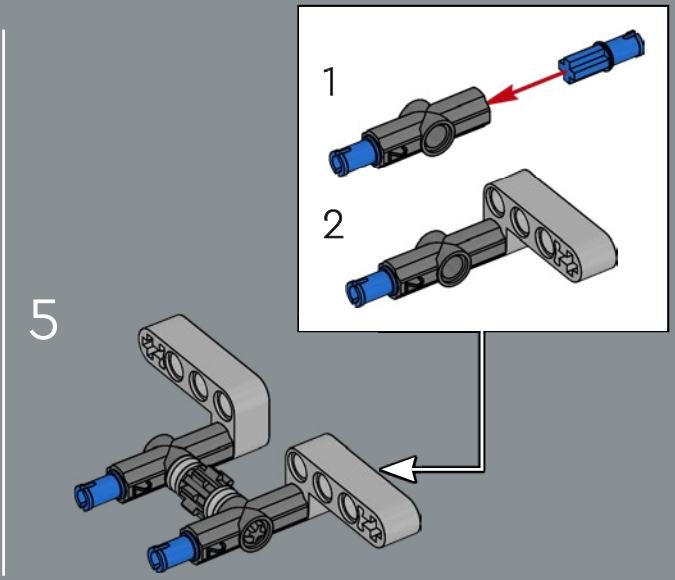
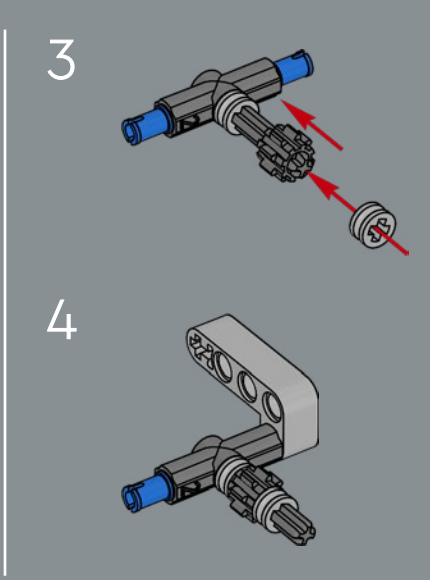
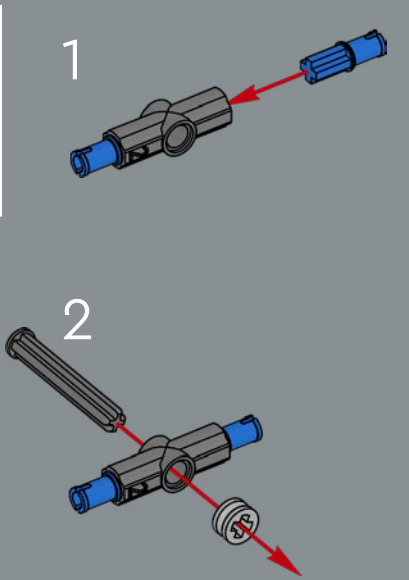

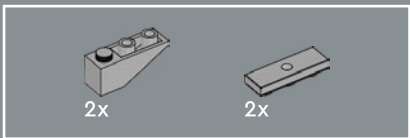

78

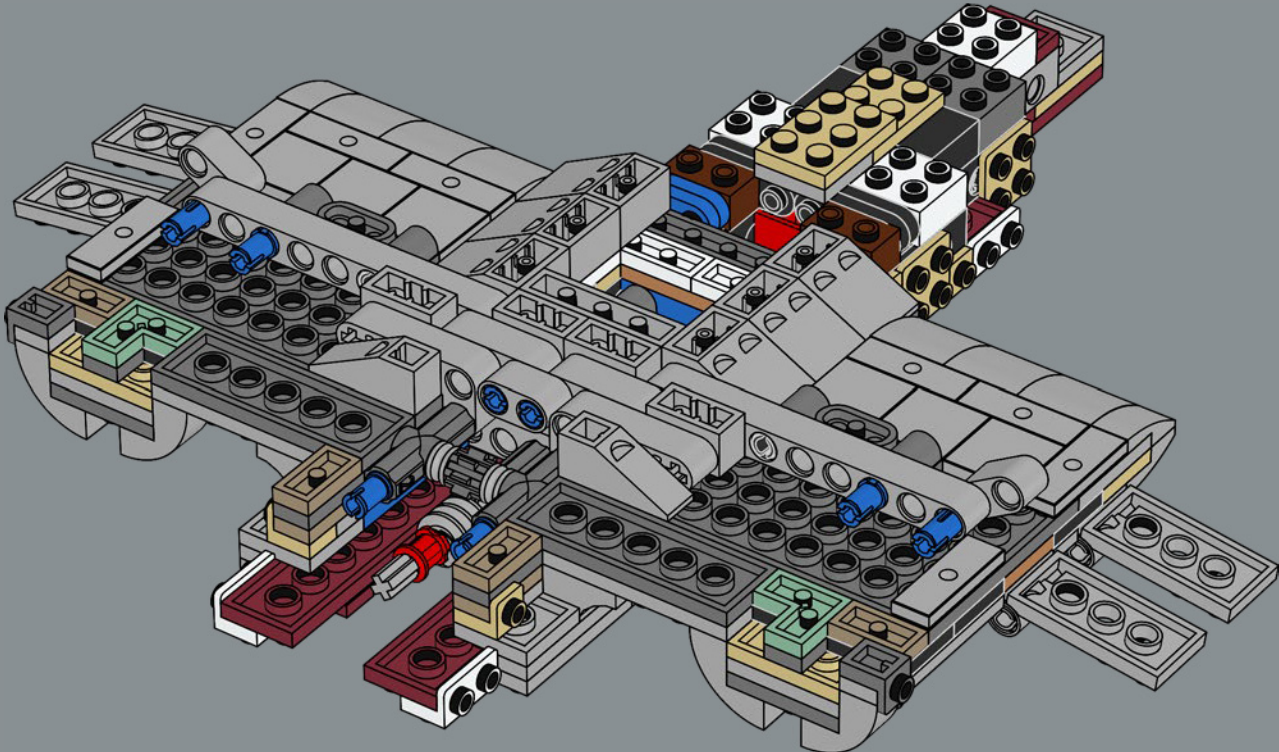

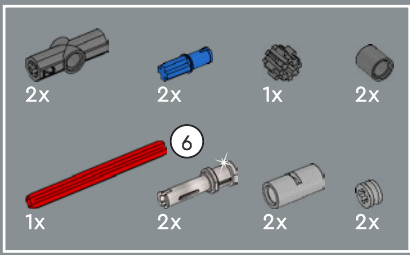

79

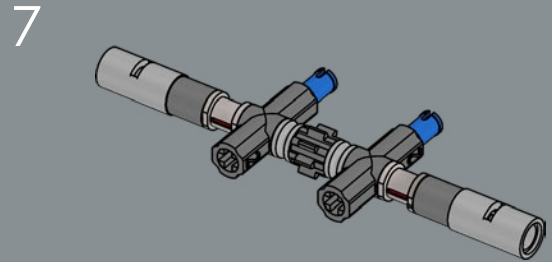
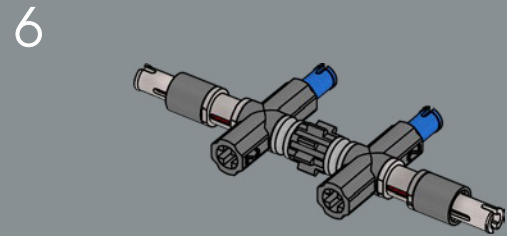
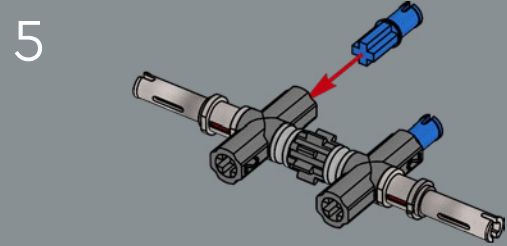
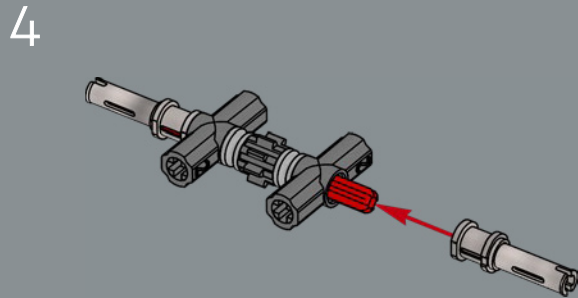
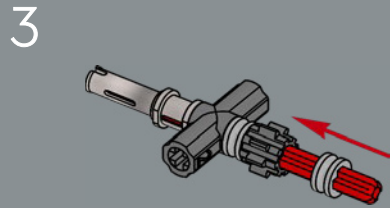
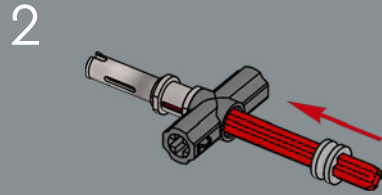
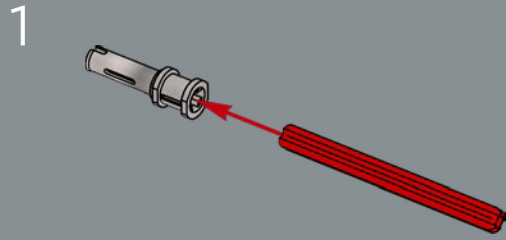

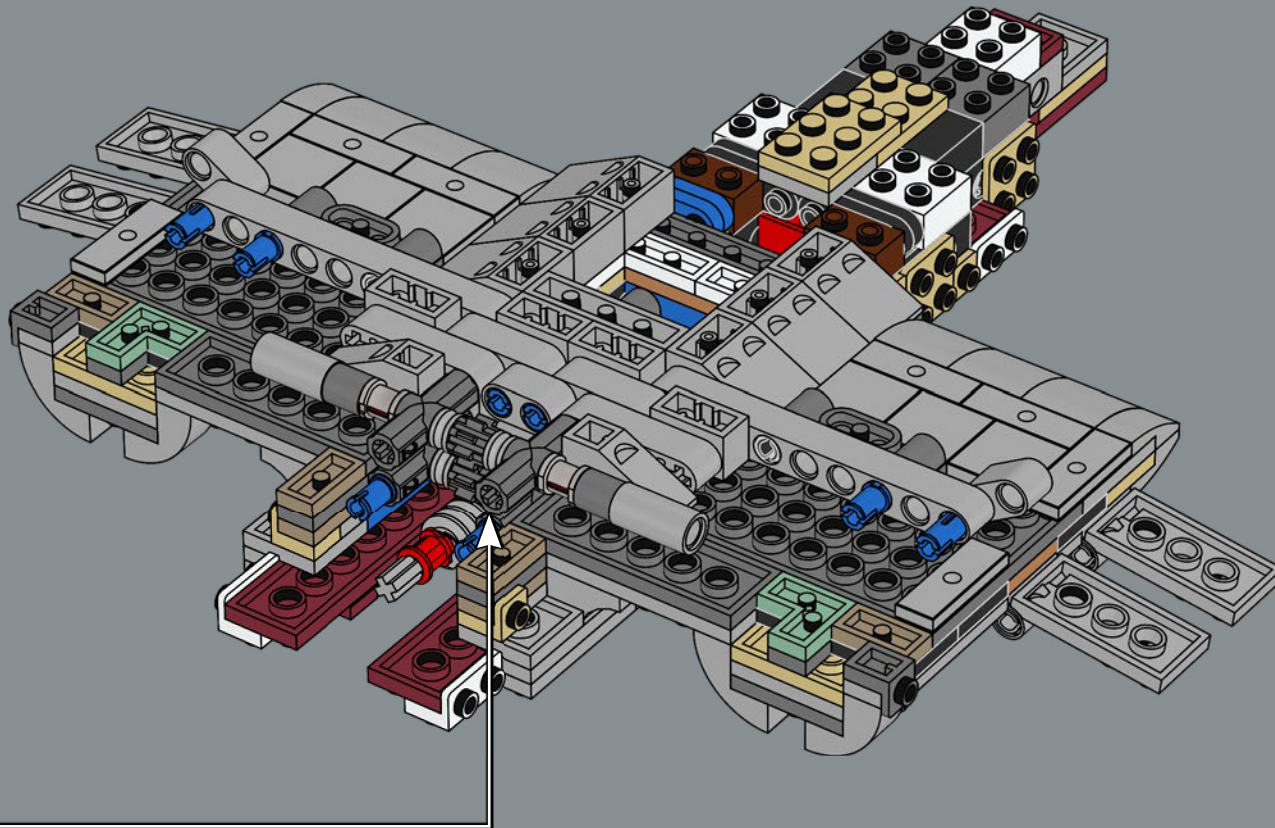



2x

80

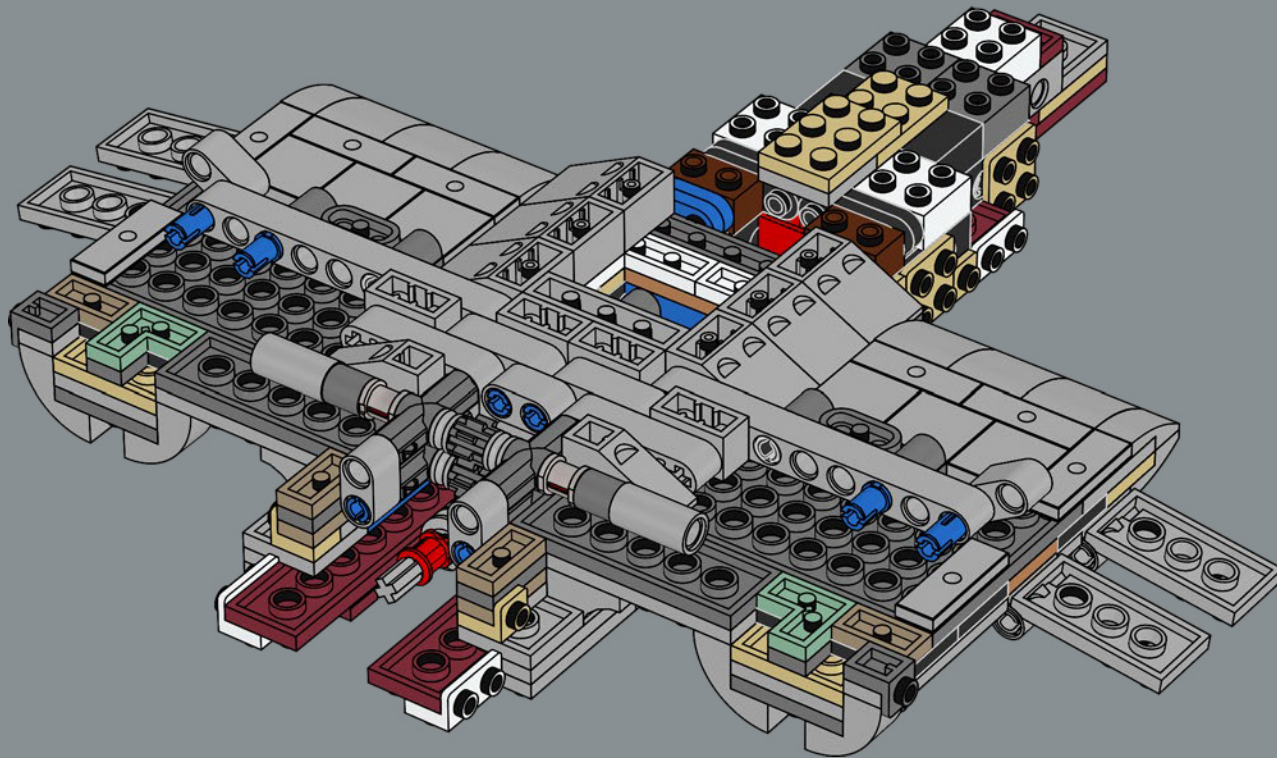

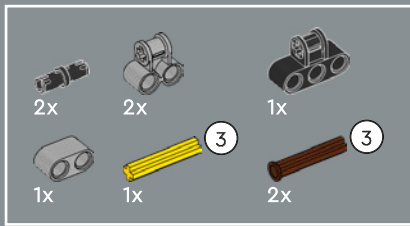

81

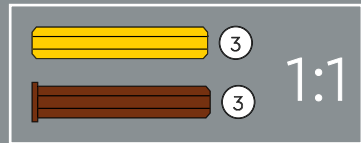
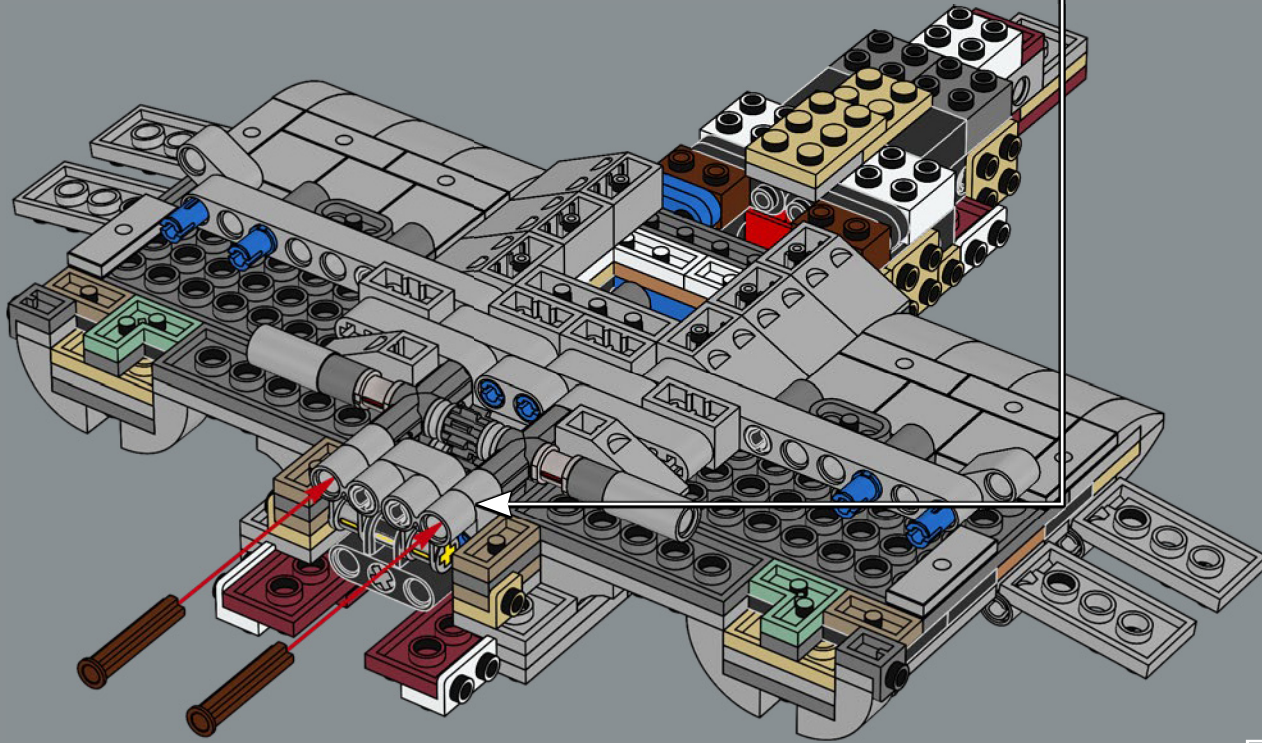
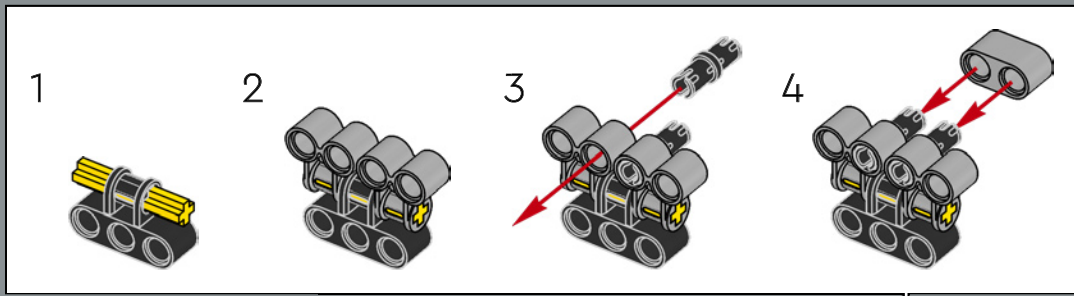

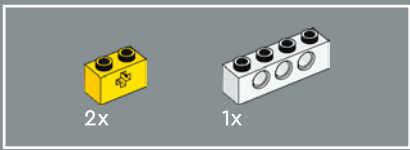

82

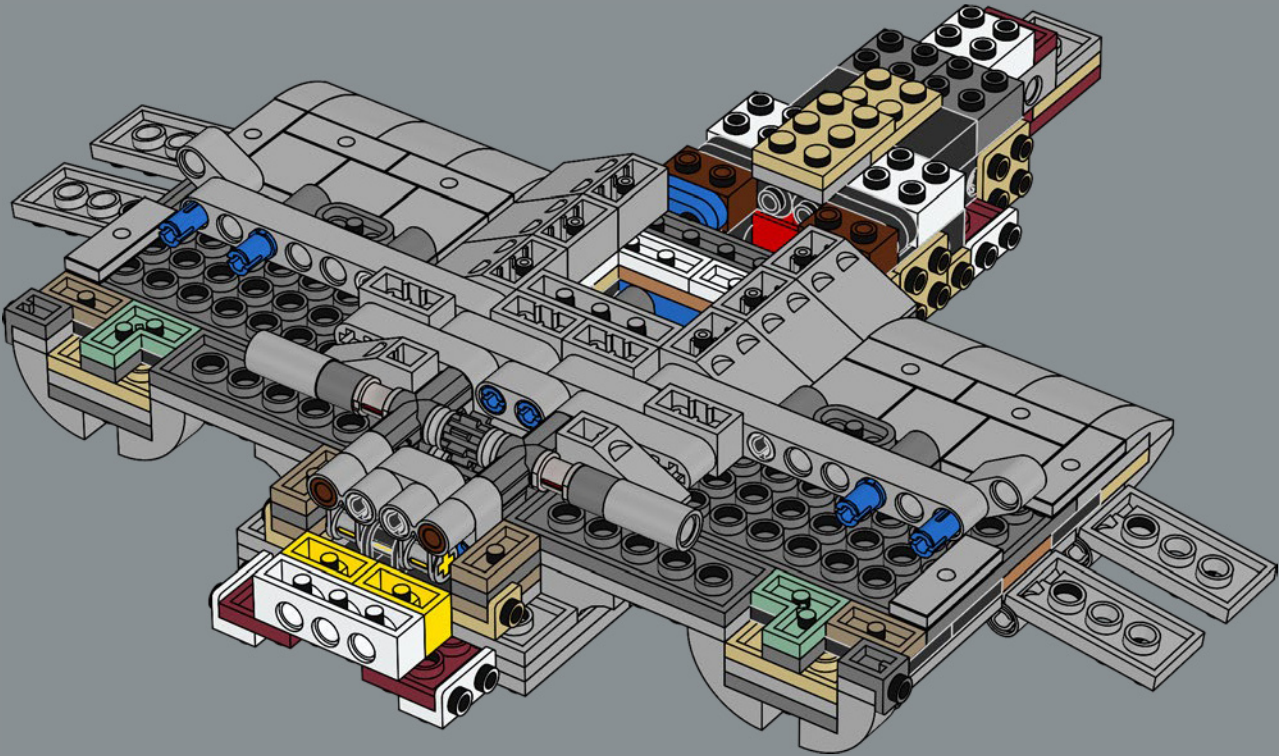

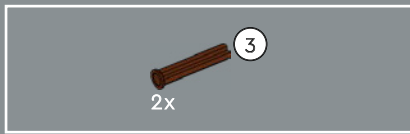

83

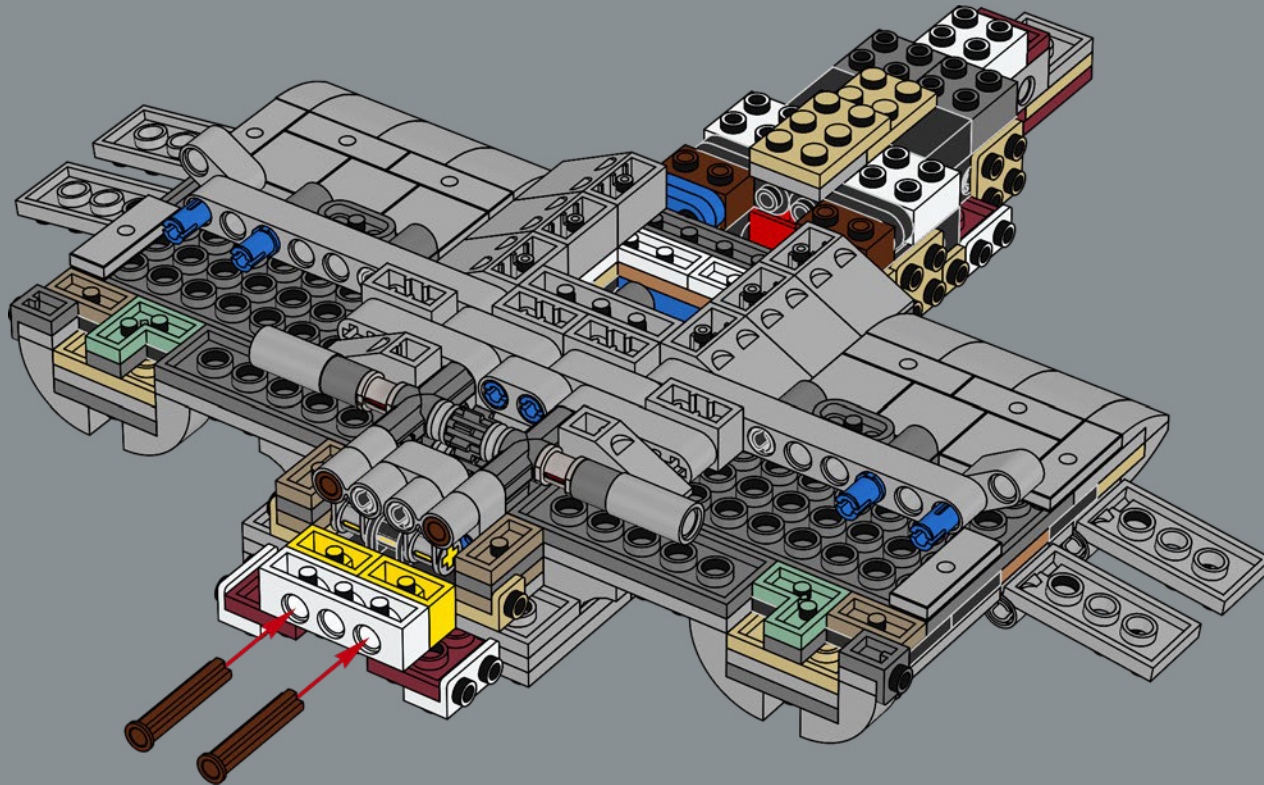

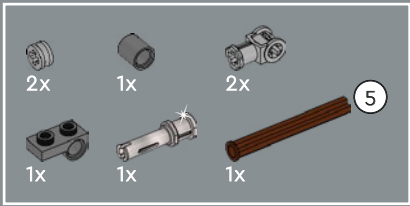

84

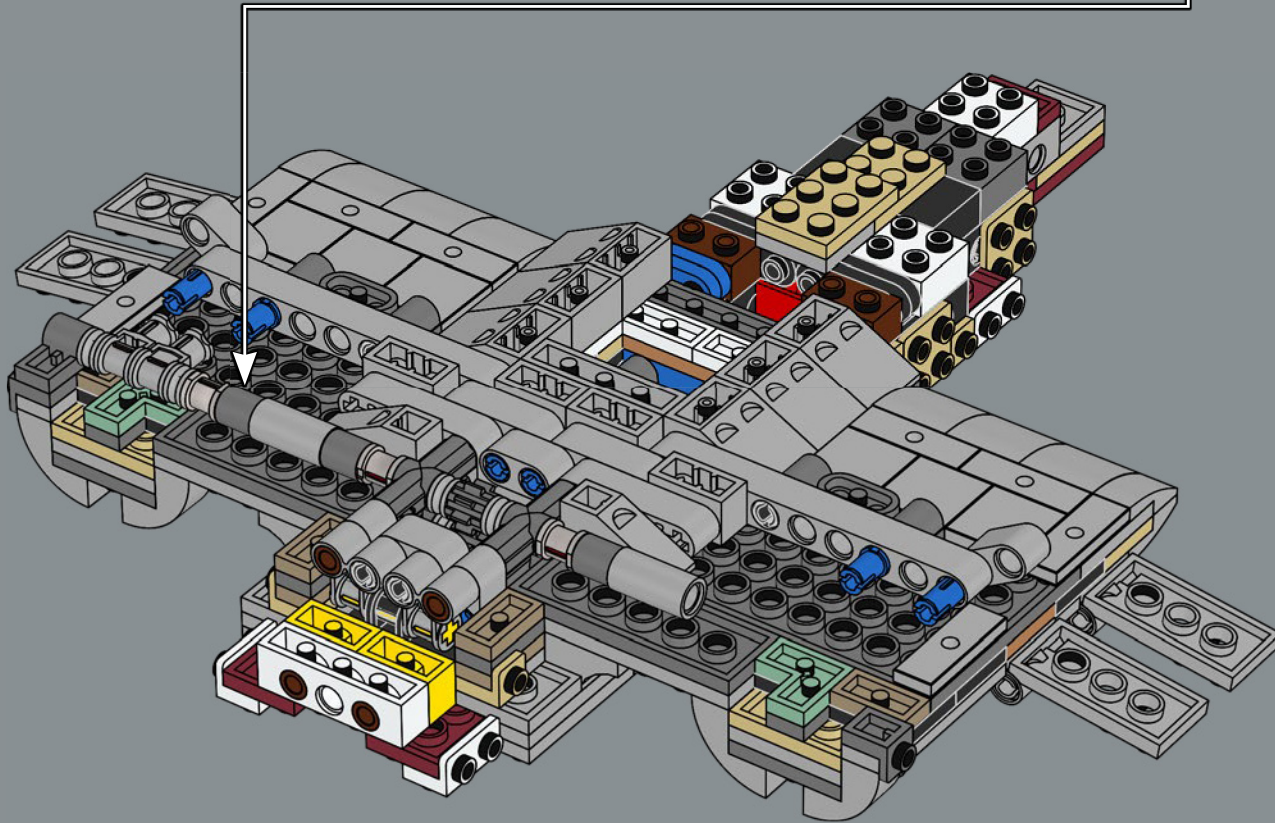
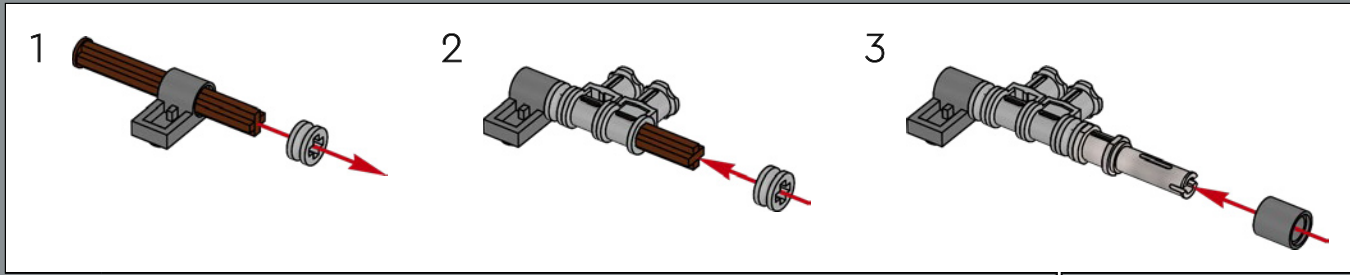

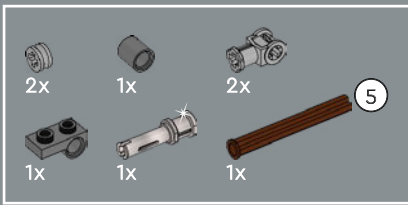

85

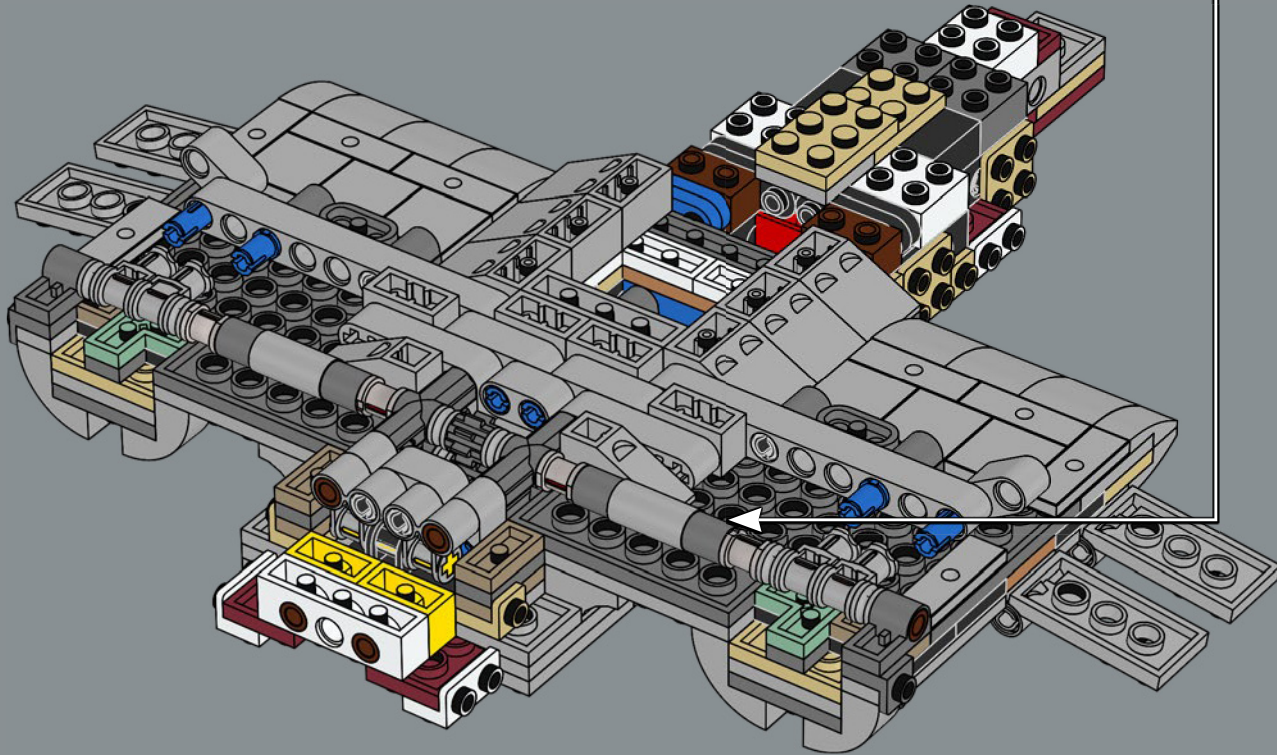
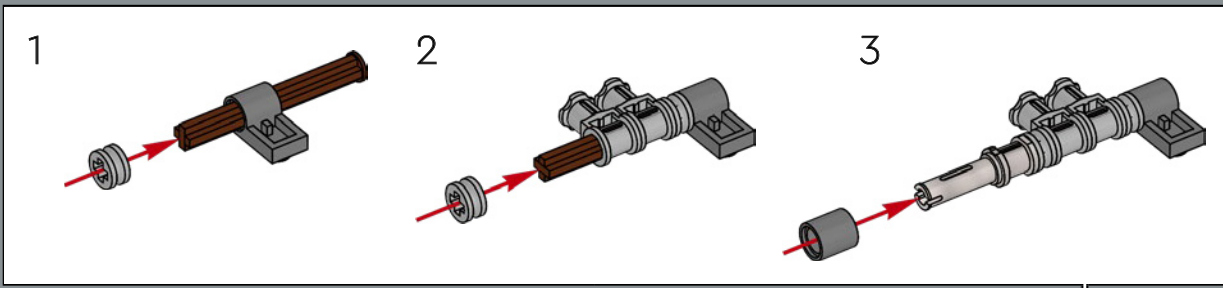

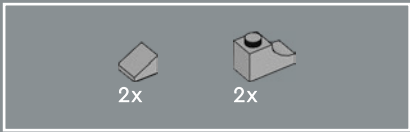

86

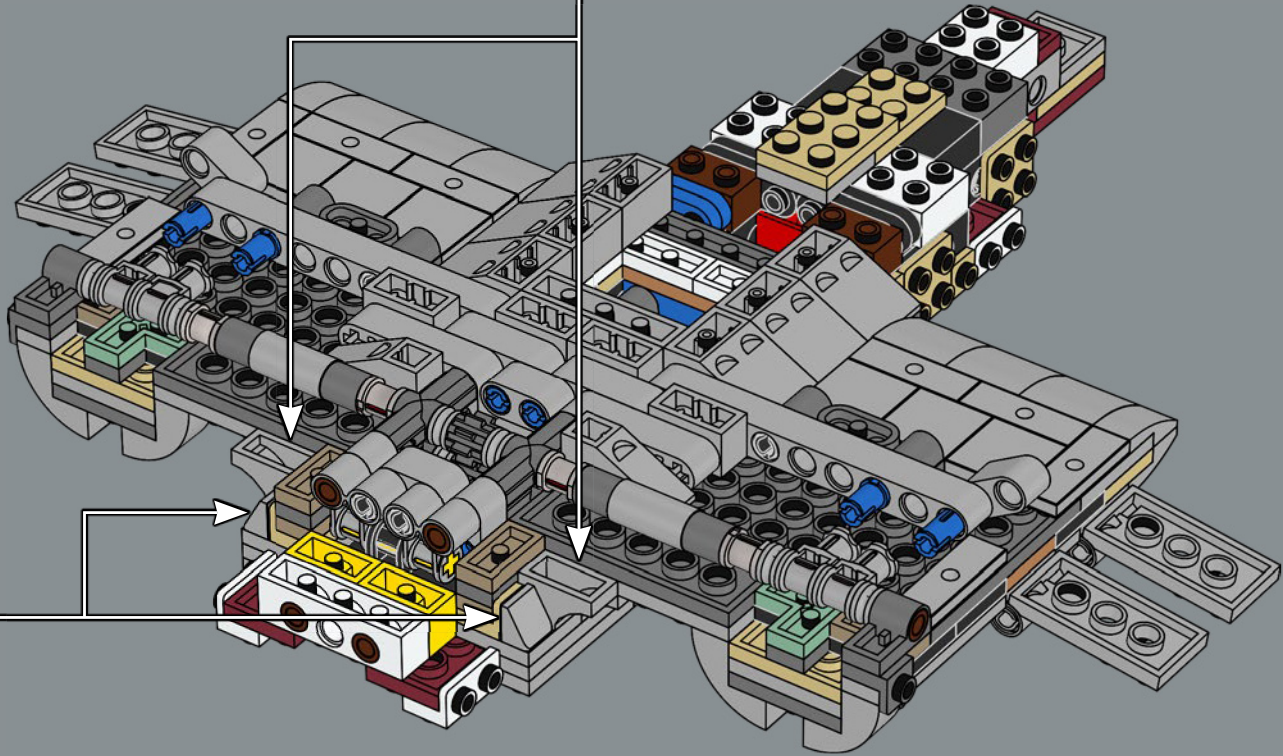
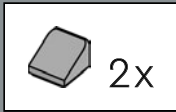
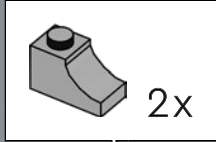



87

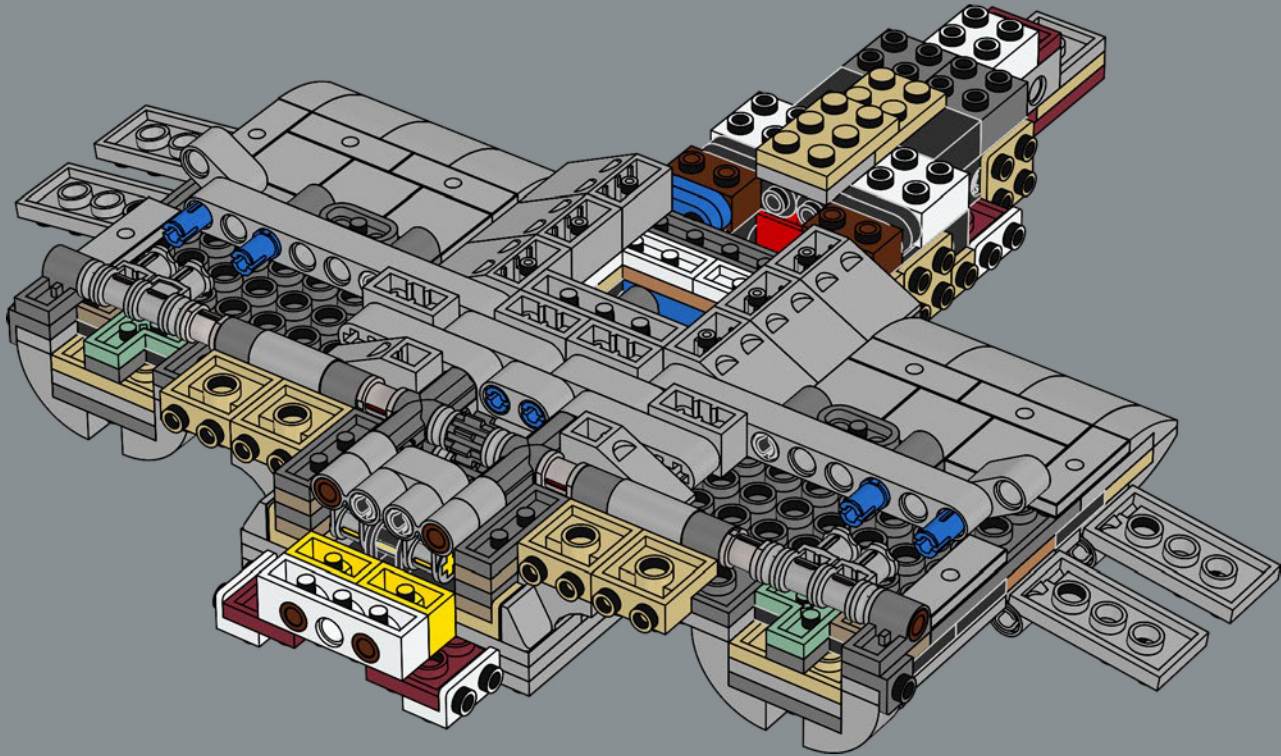

	
4x	4x

88

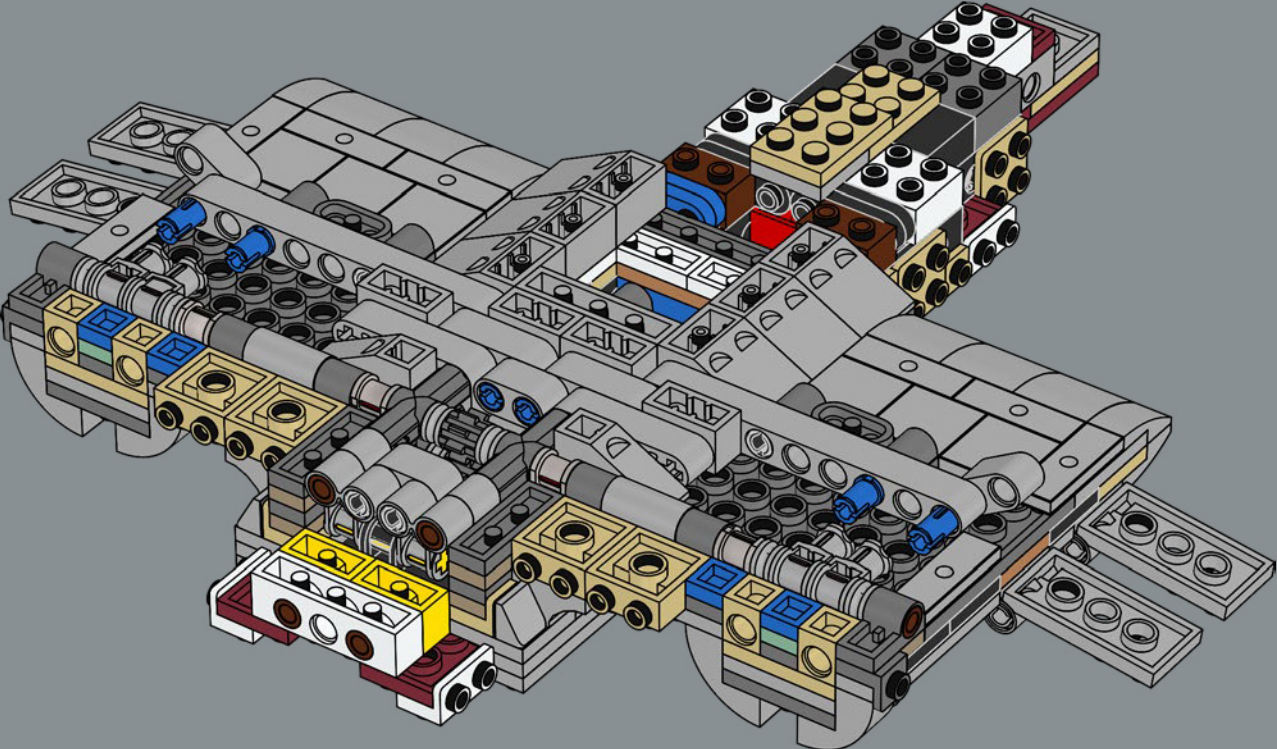

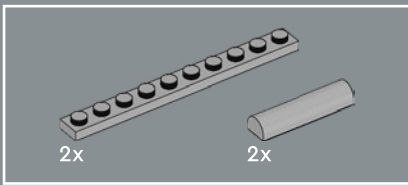

89

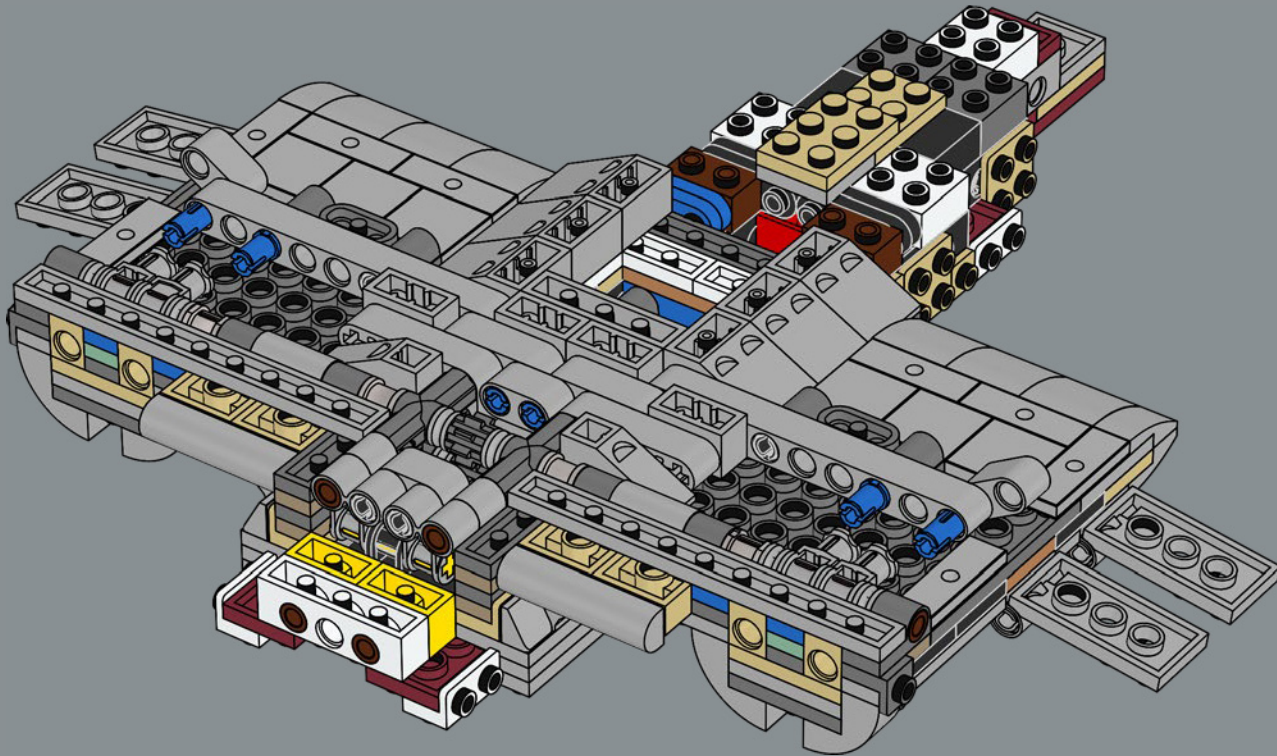

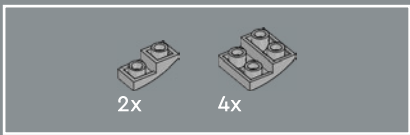

90

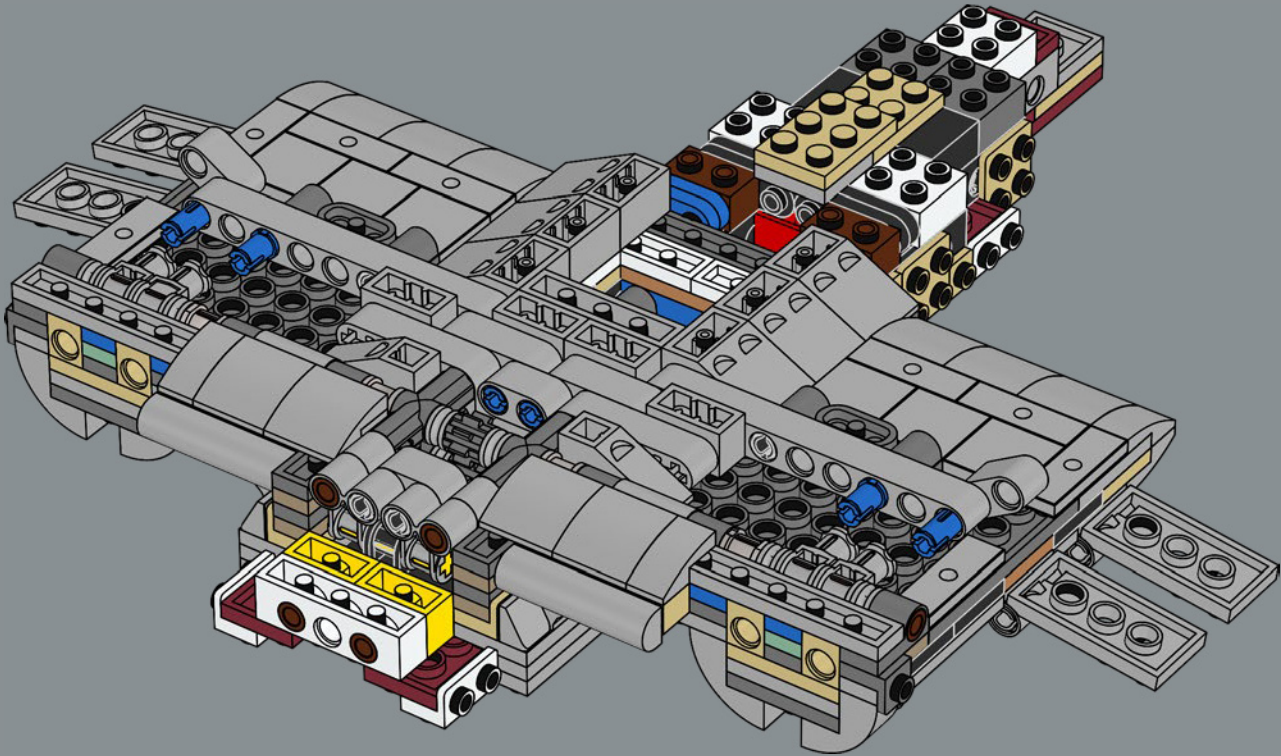

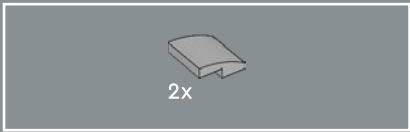

91

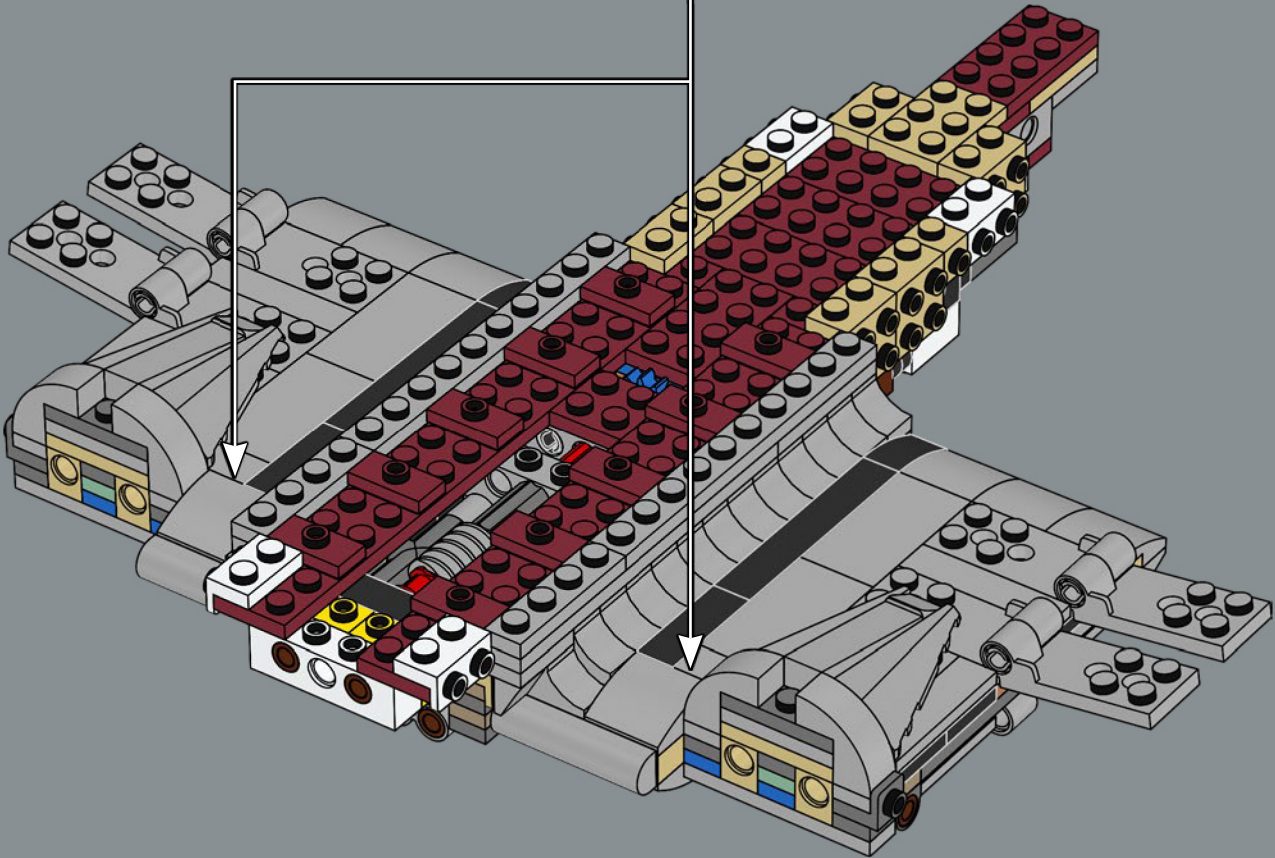
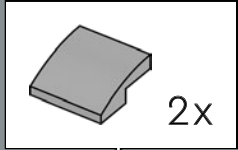



Color illustrations of the DC-3™ are hard to find, so for Boeing to share a colored cabin illustration from their archives was a real treat! It revealed that the interior featured a dark red carpet and sand-blue seats.

Les illustrations en couleur du DC-3™ sont rares, alors le fait que Boeing ait partagé une illustration en couleur de la cabine tirée de ses archives a été un véritable privilège! Celle-ci révélait un intérieur avec un tapis rouge foncé et des sièges bleu sable.

Es difícil encontrar ilustraciones a color del DC-3™, ¡por lo que fue todo un privilegio que Boeing nos compartiera una de la cabina tomada de sus archivos! Esta nos permitió determinar que el interior tenía asientos en azul apagado y estaba recubierto de alfombra roja.

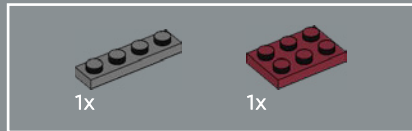

92

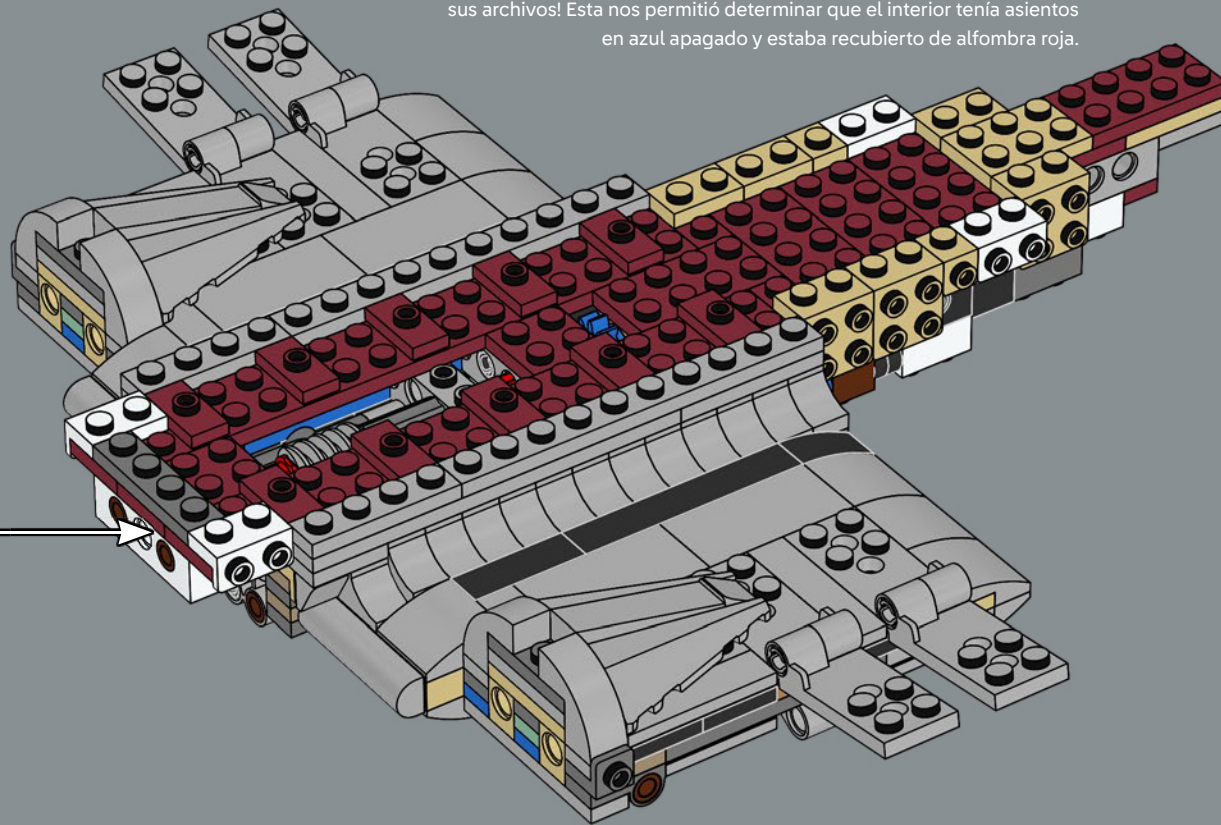
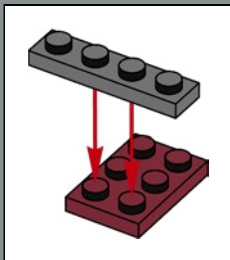

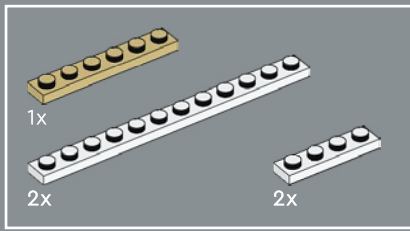

93

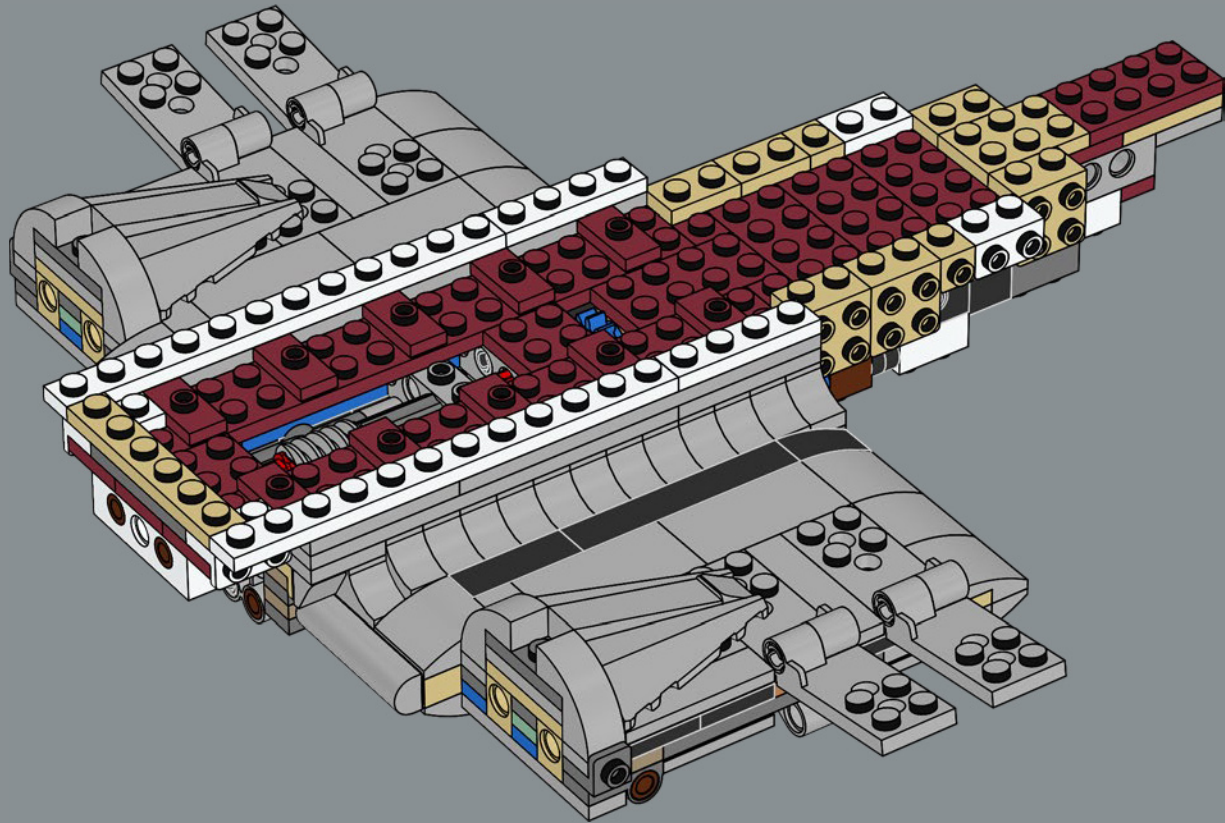

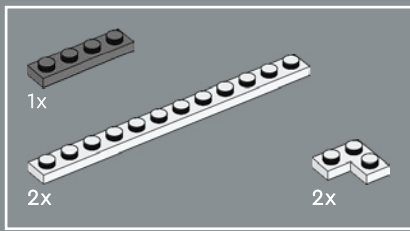

94

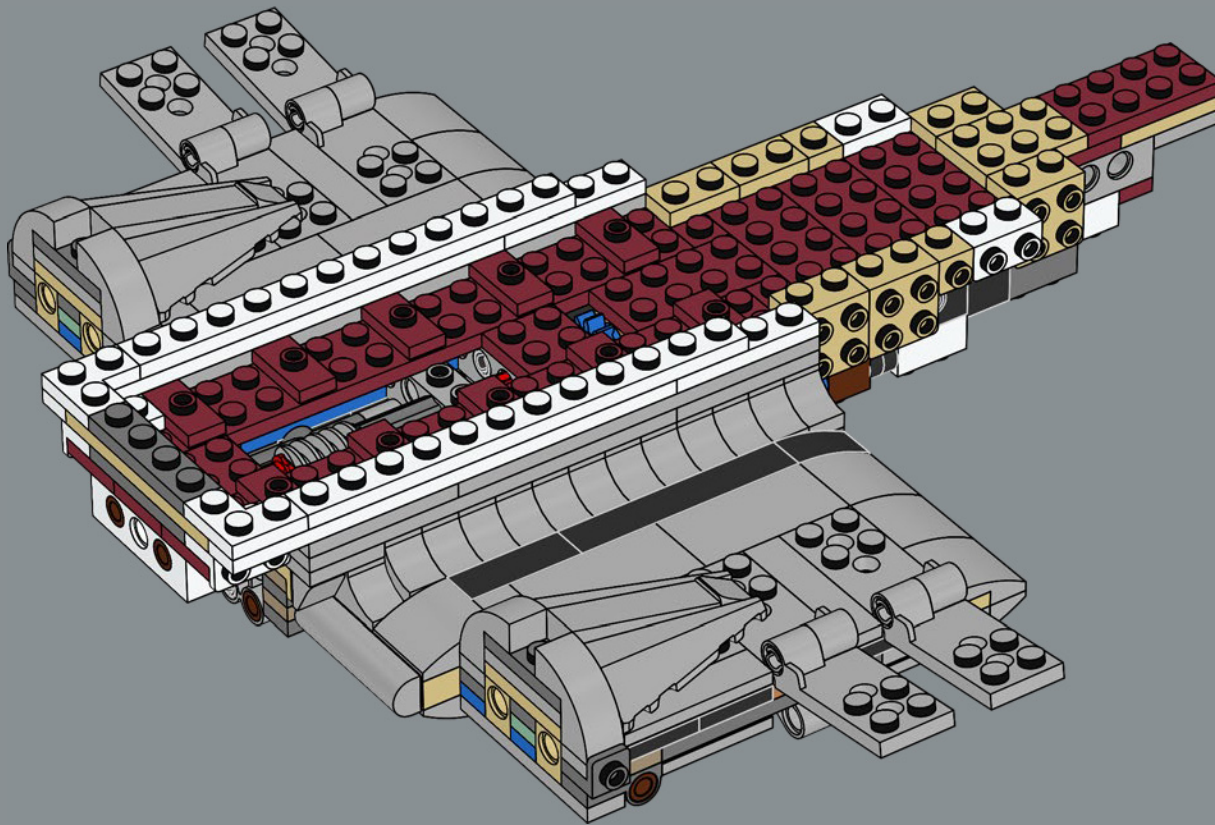

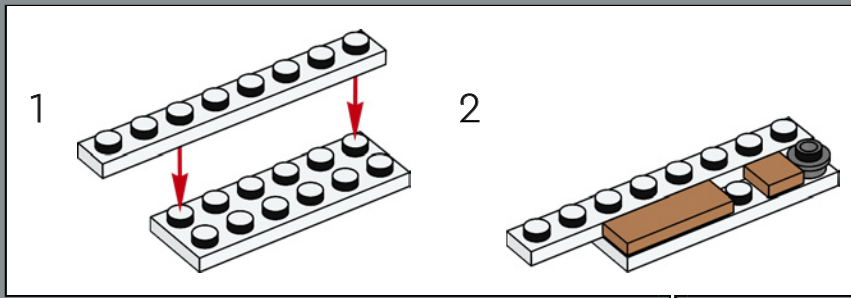
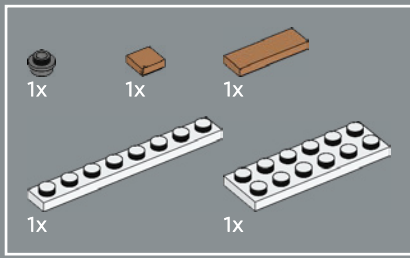

95

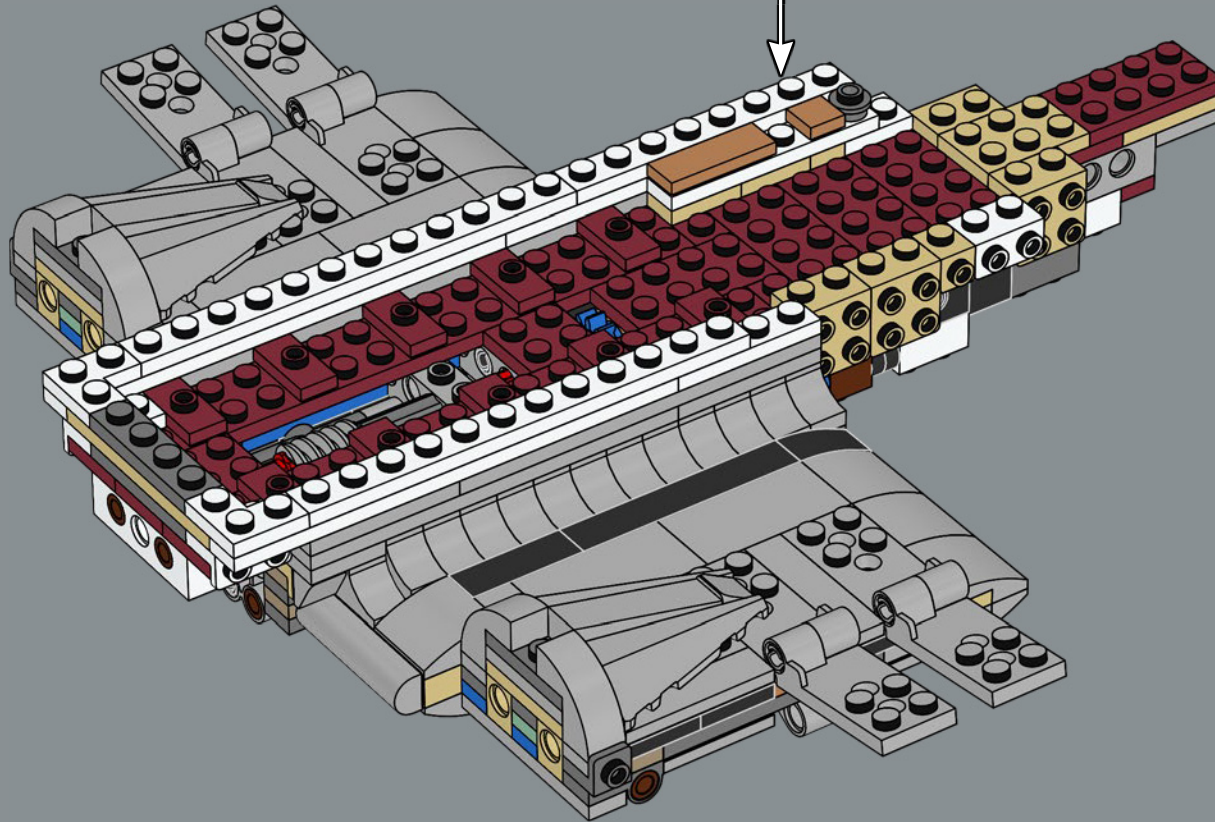

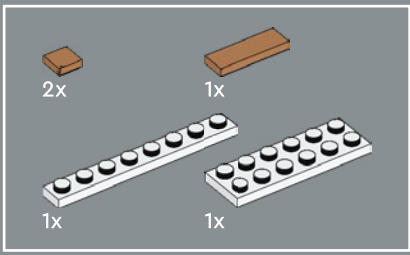

96

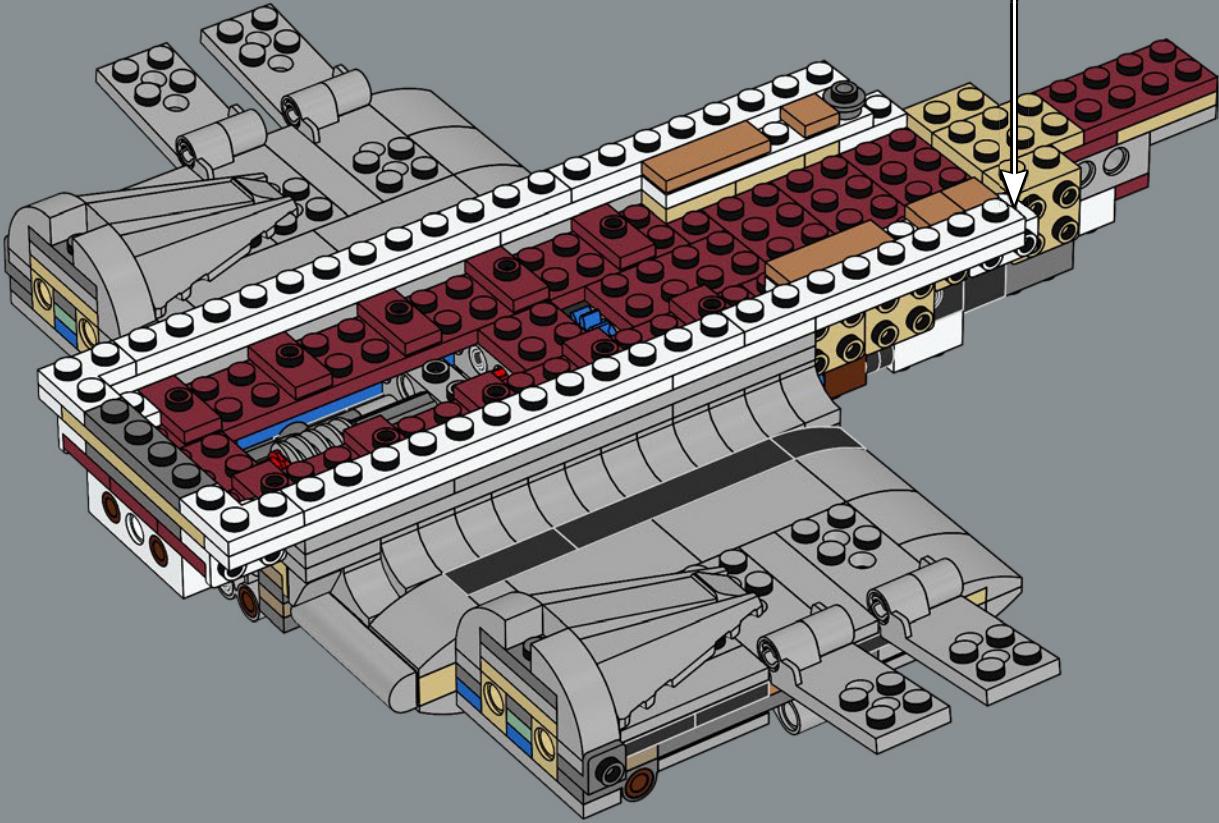
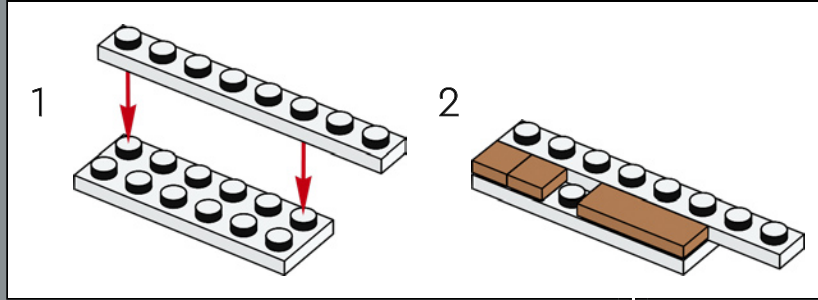

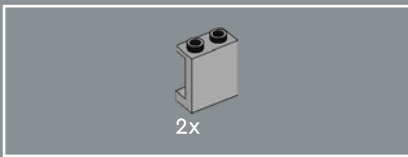

97

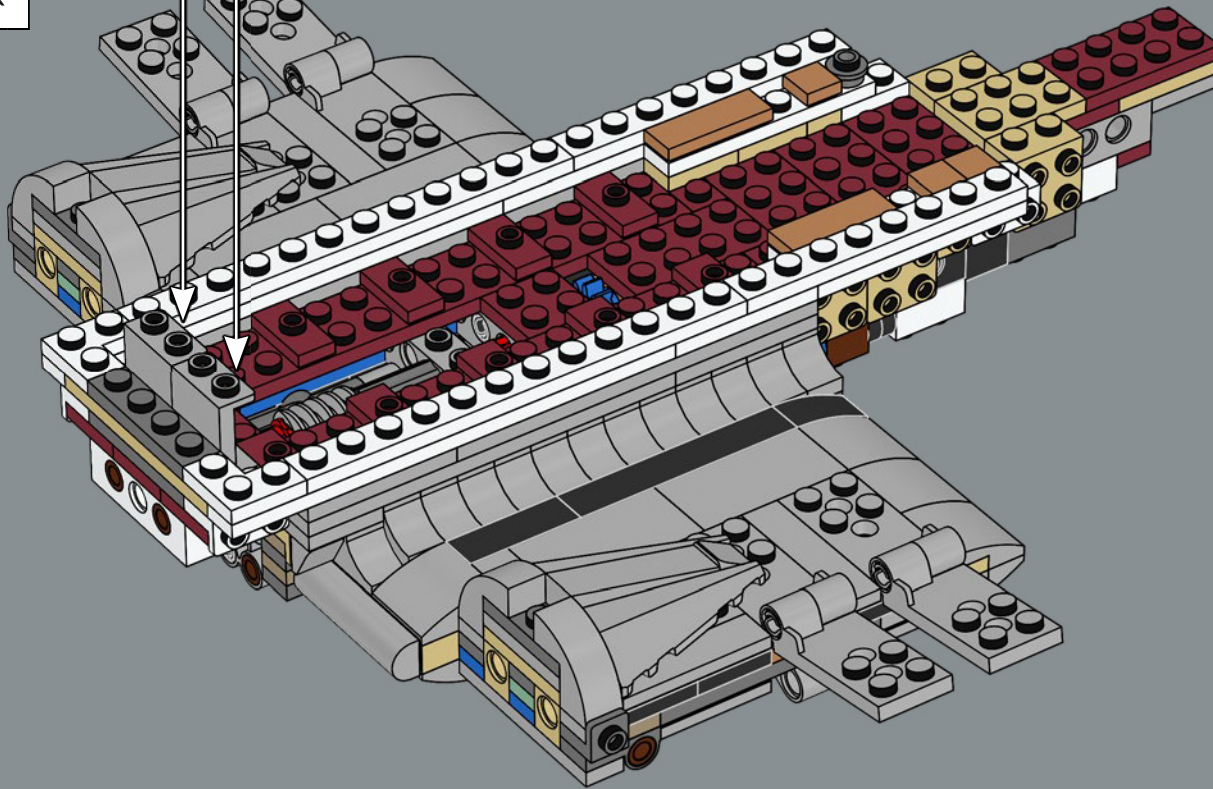
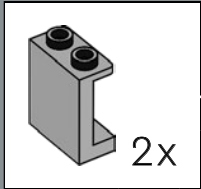

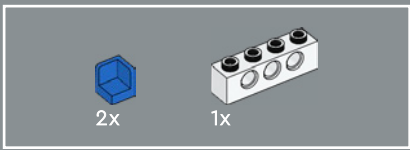



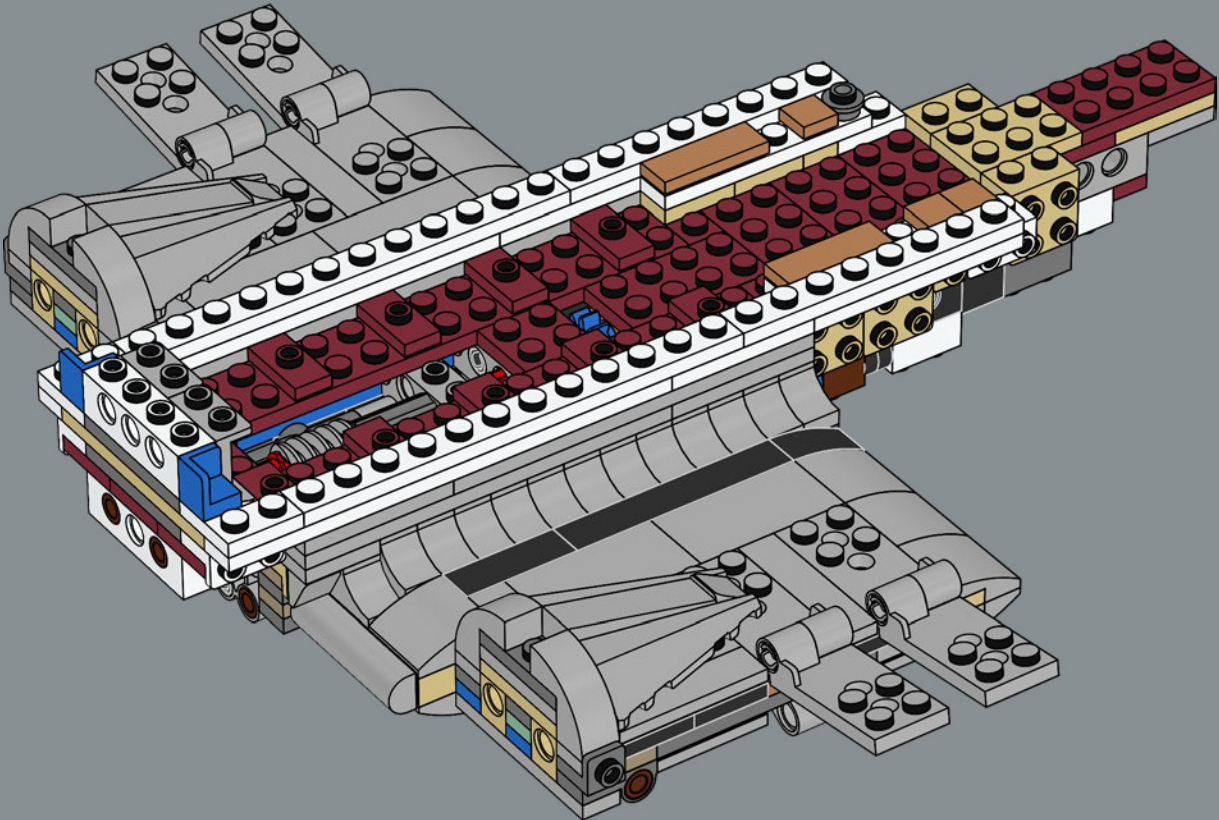

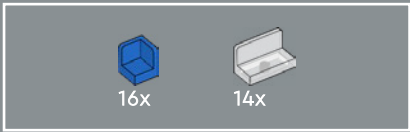
98



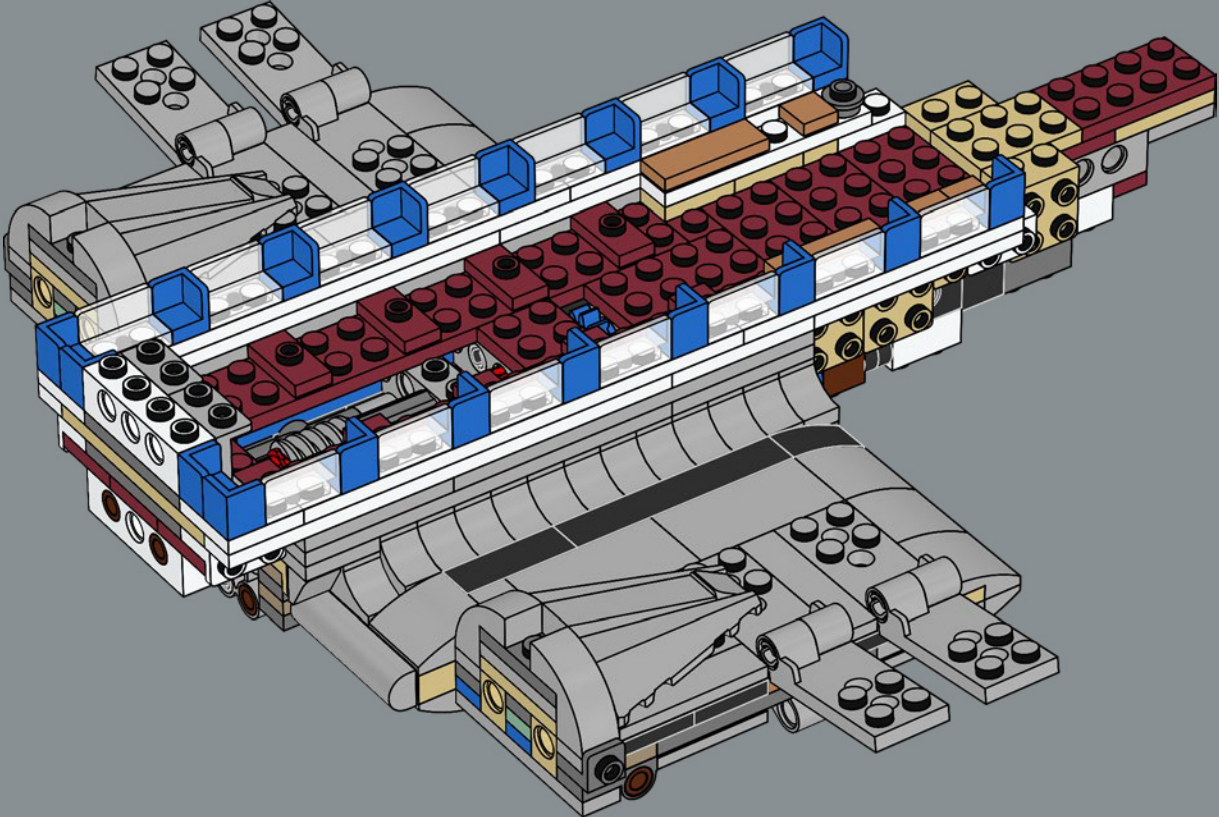

99



- 1x 
- 1x 
- 1x 
- 1x 

100

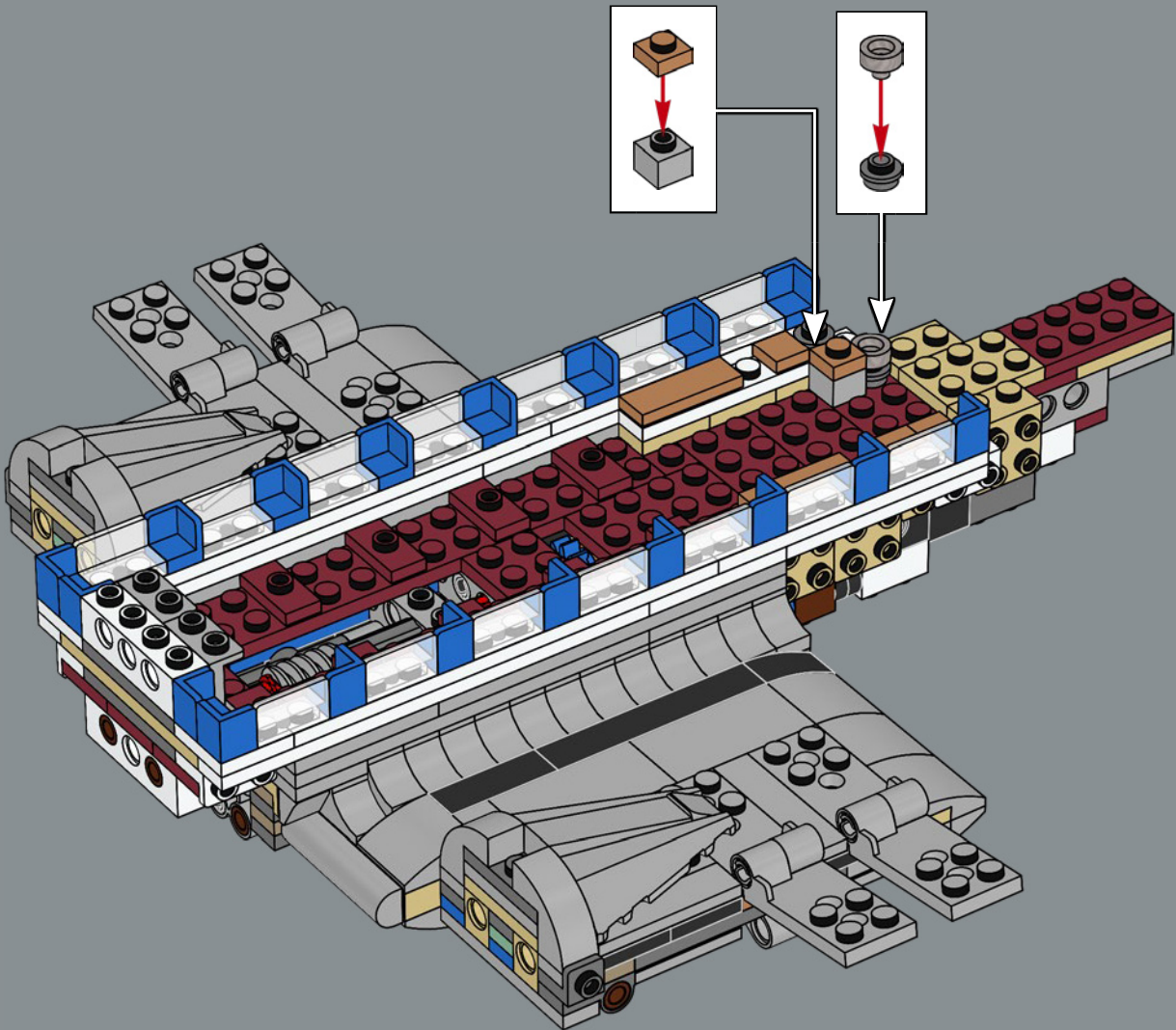

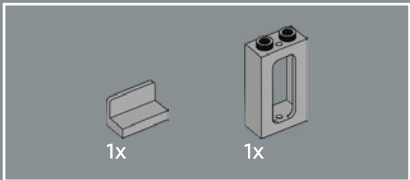

101

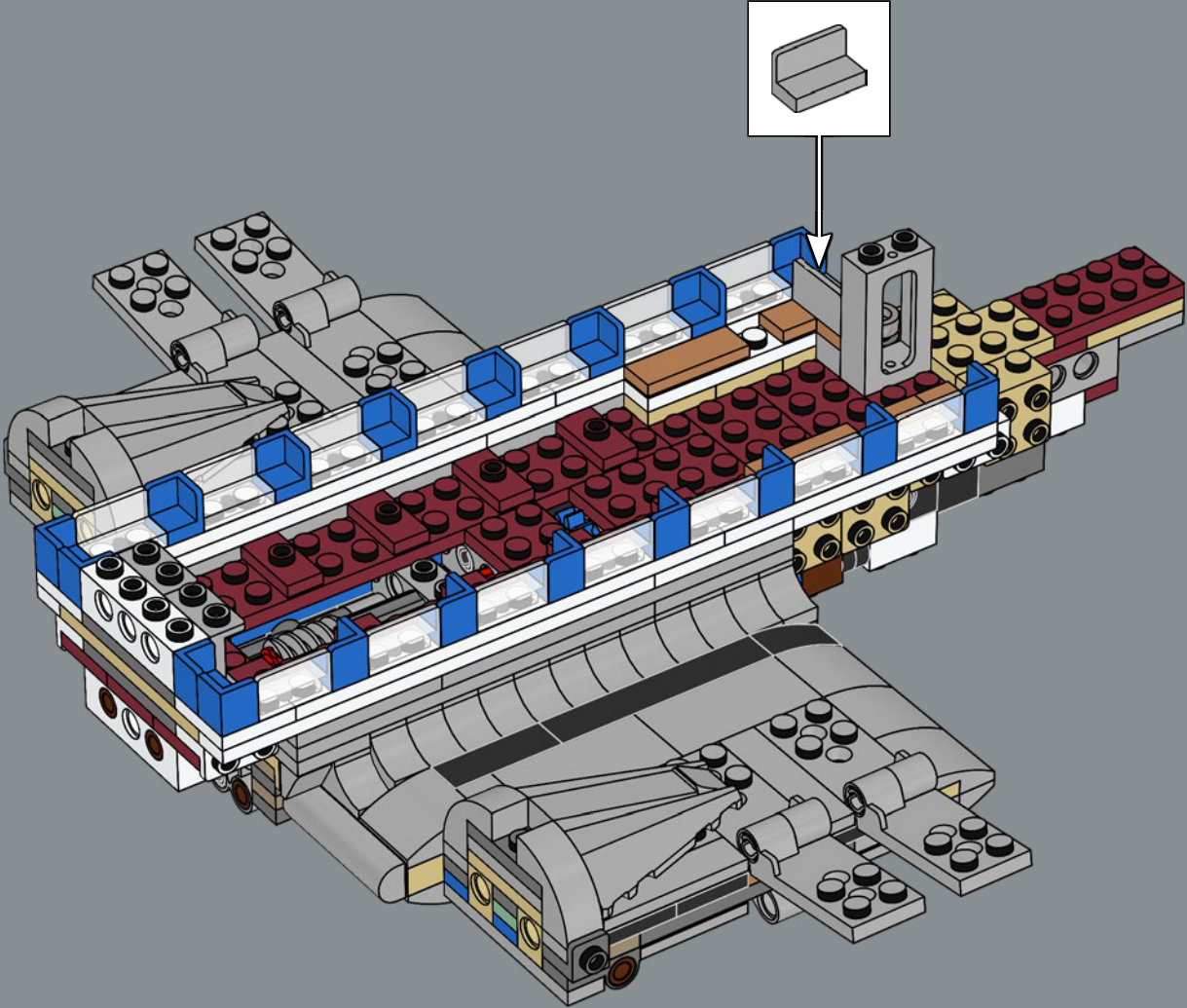

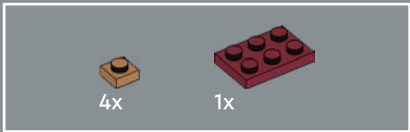

102

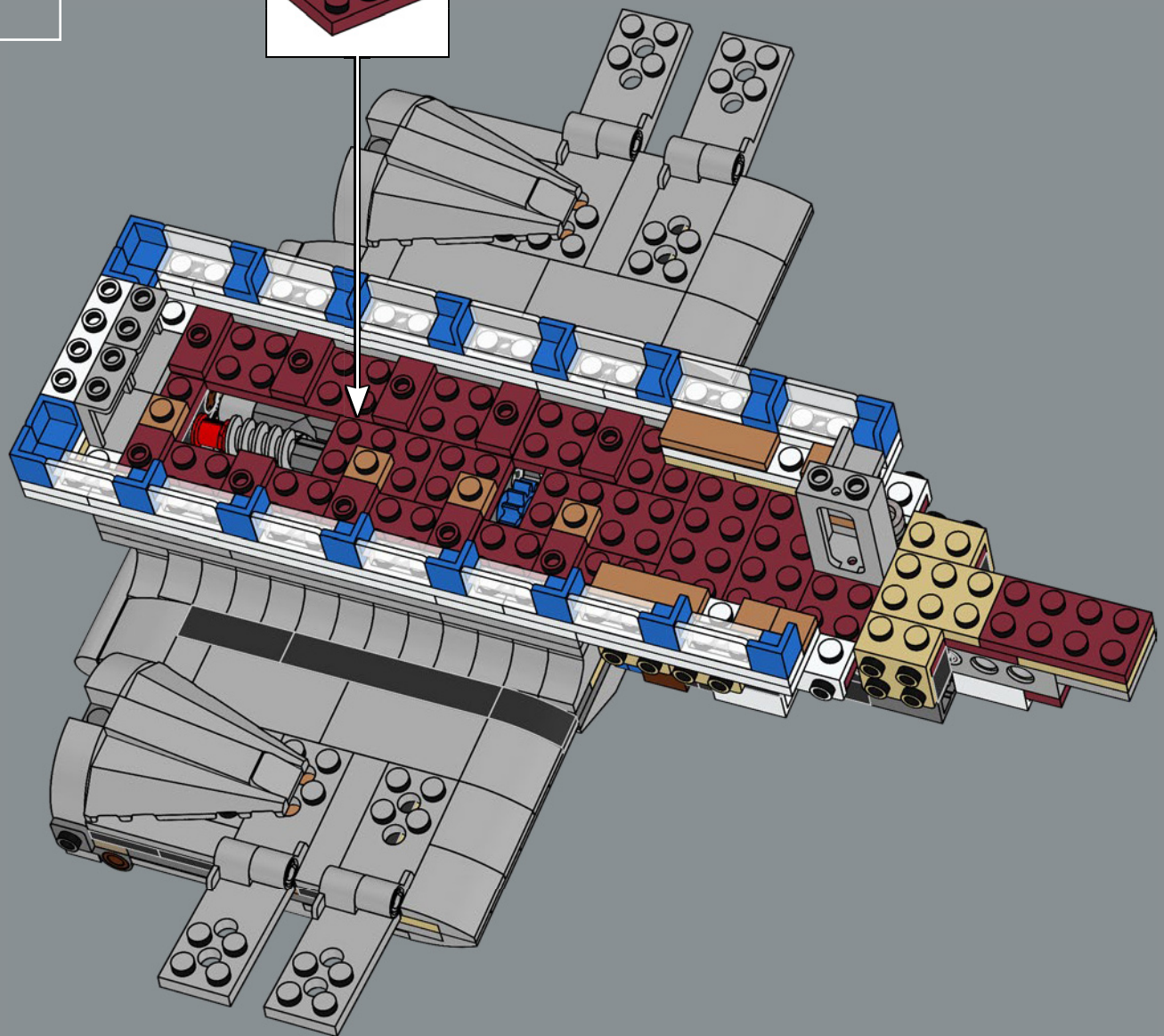
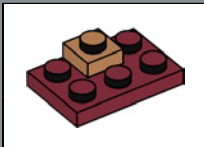

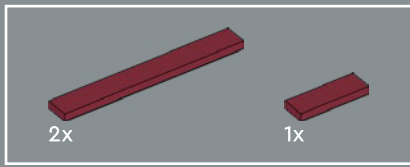

103

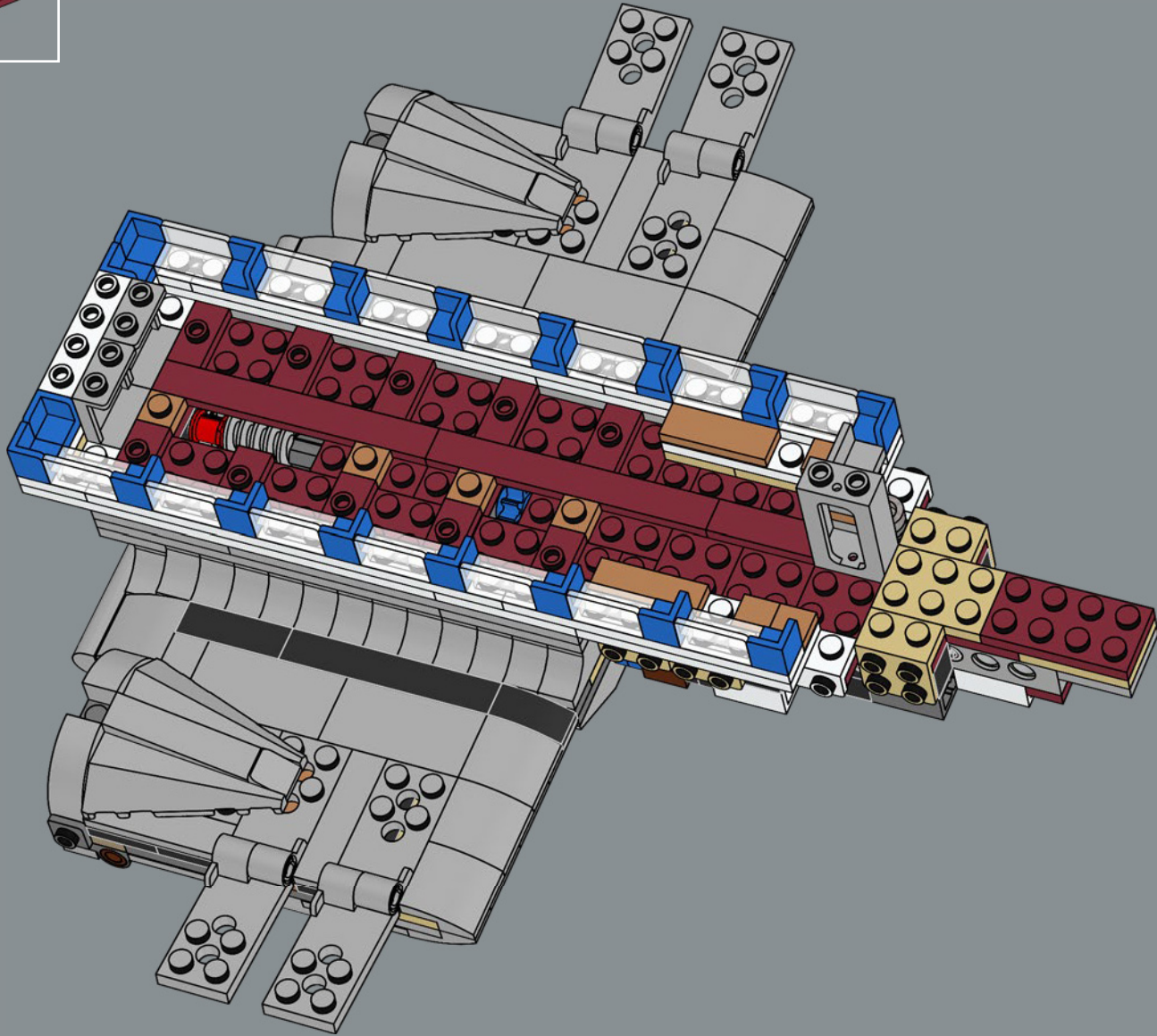



2x

104

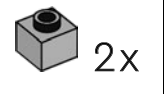
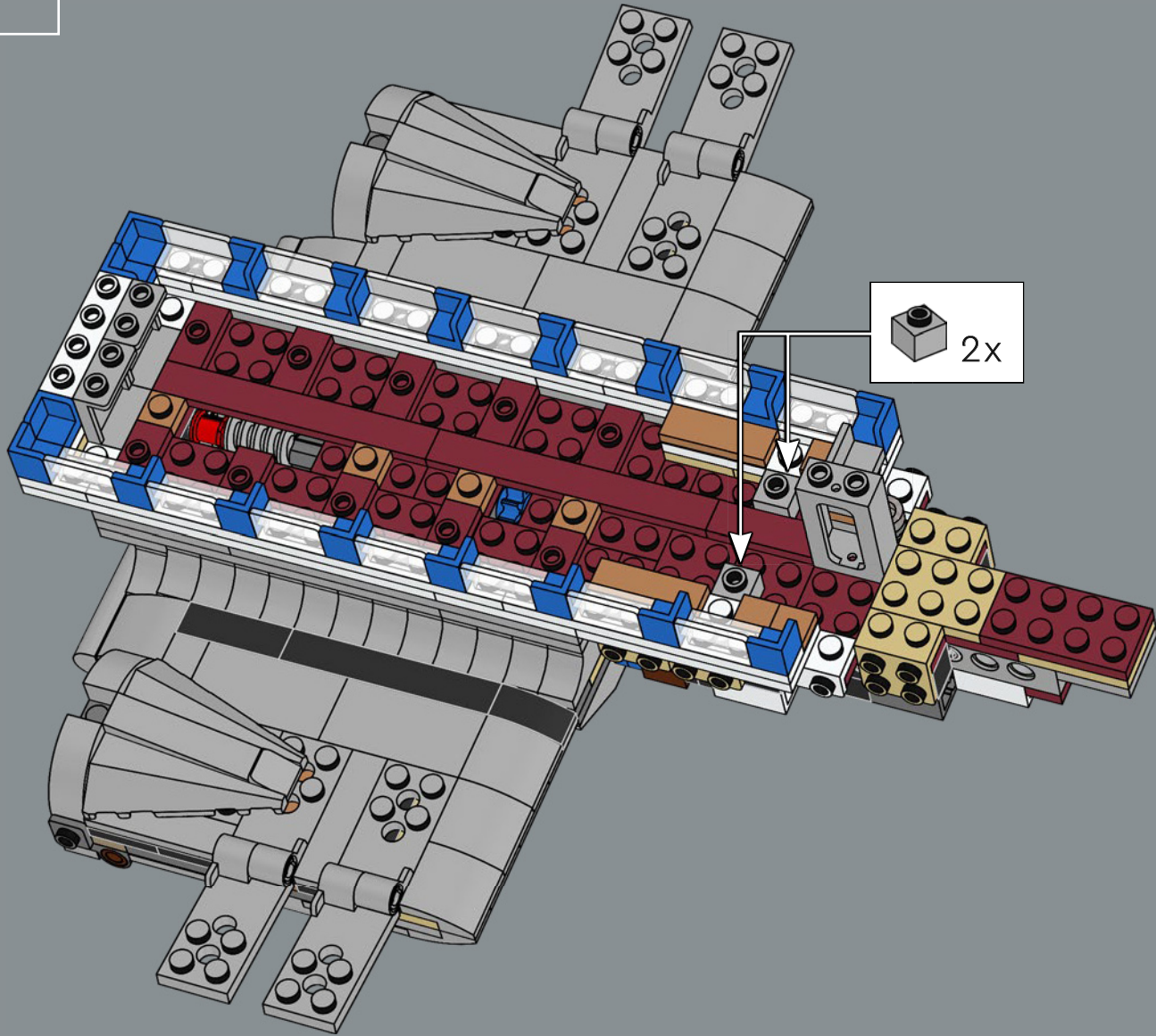

2x



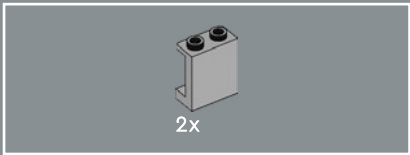

105

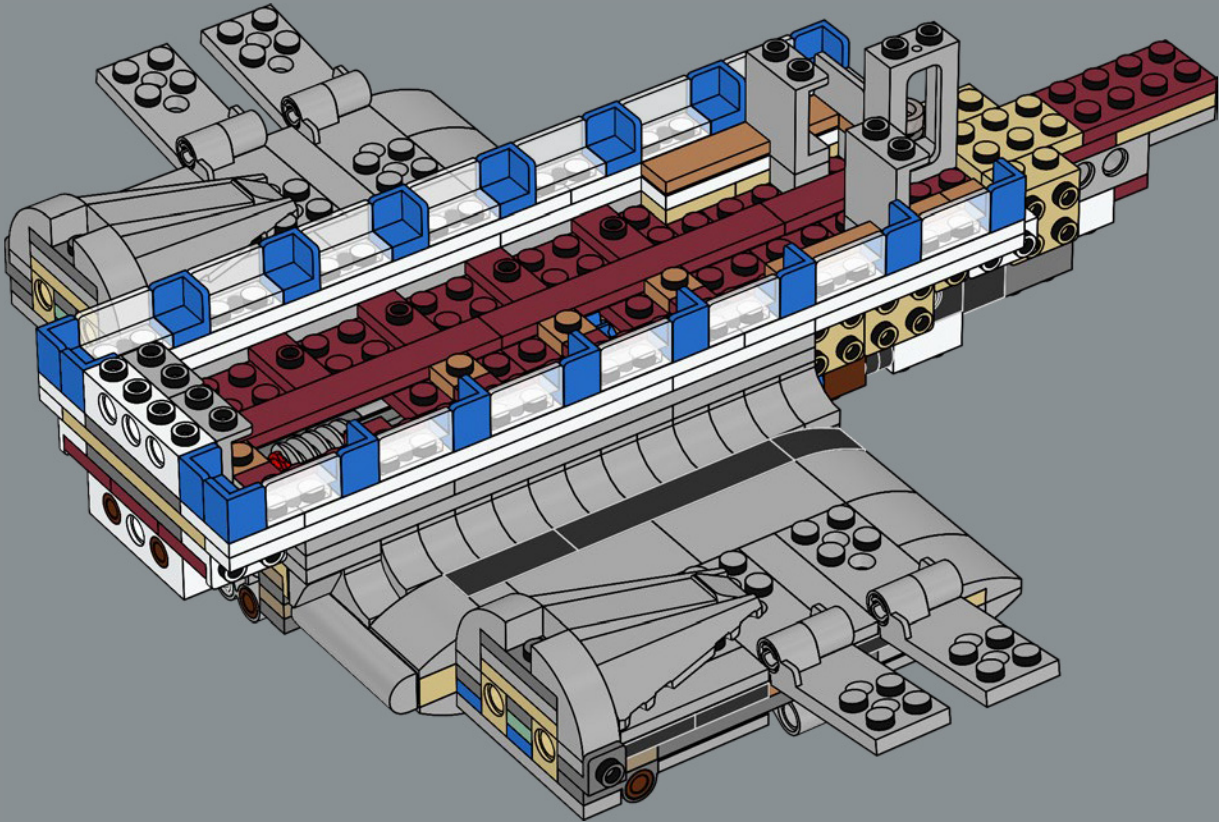

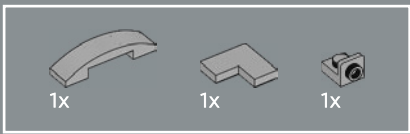

106

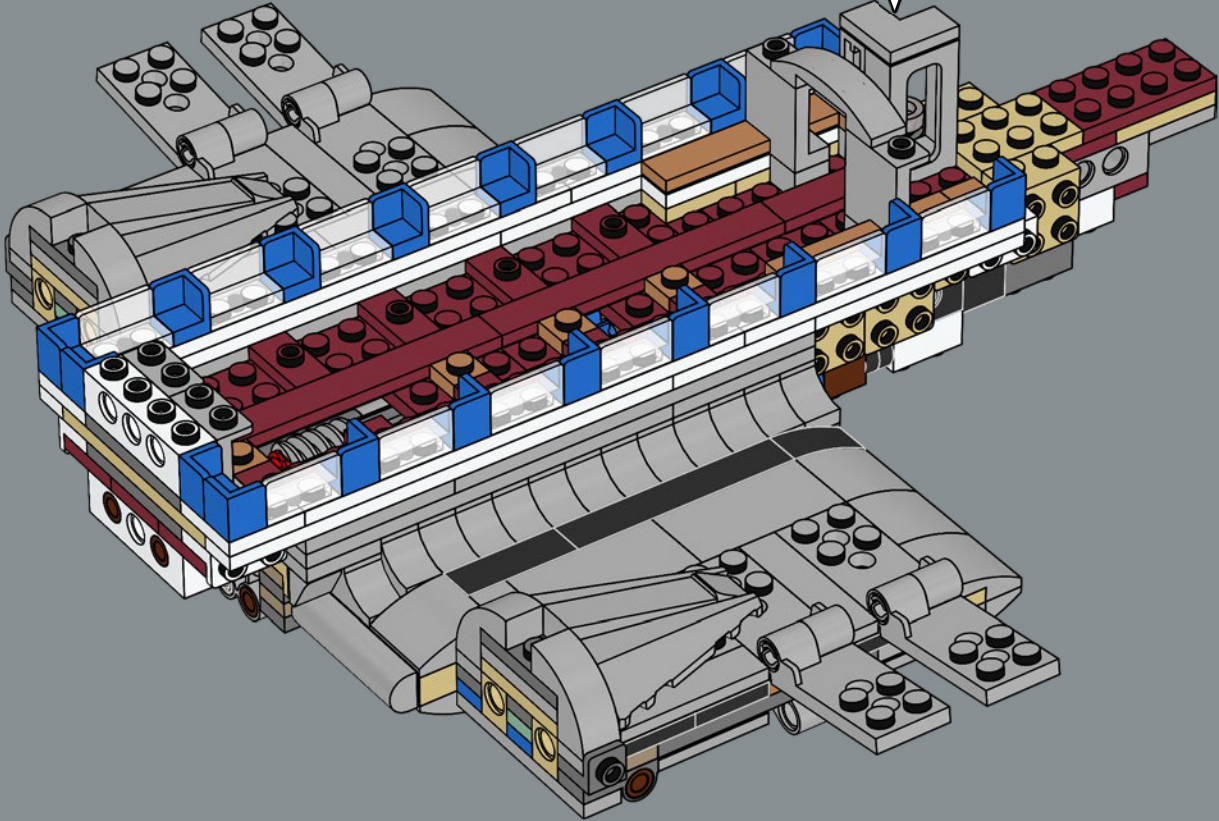
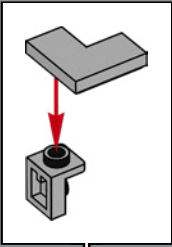

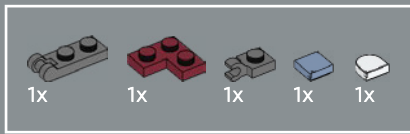

107

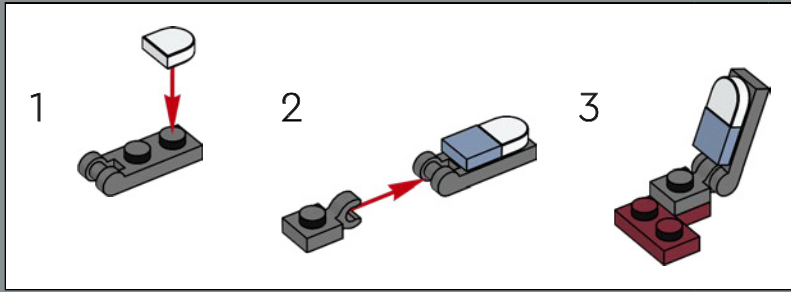
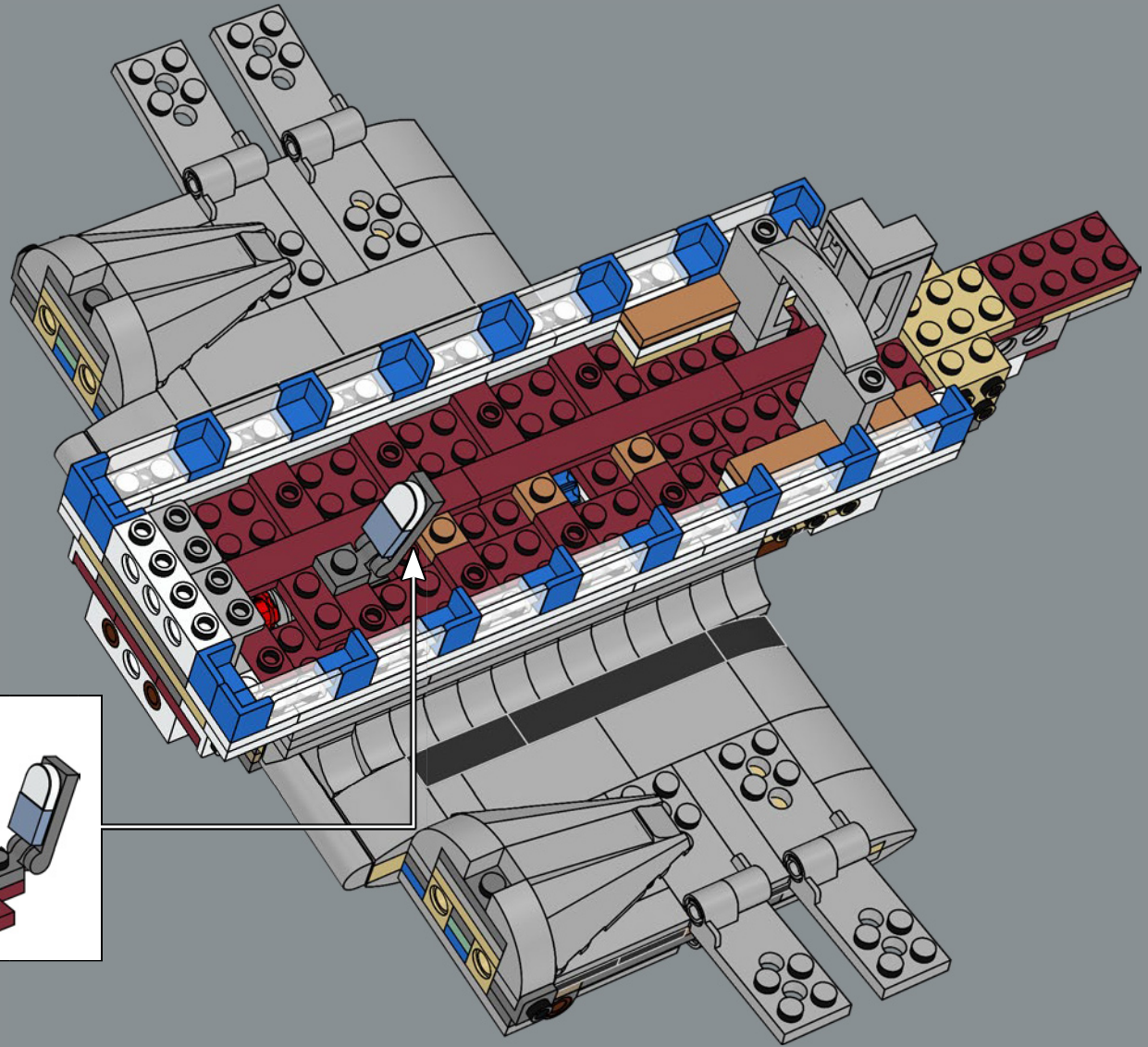

14x 14x 14x 14x

108

1 2 14x

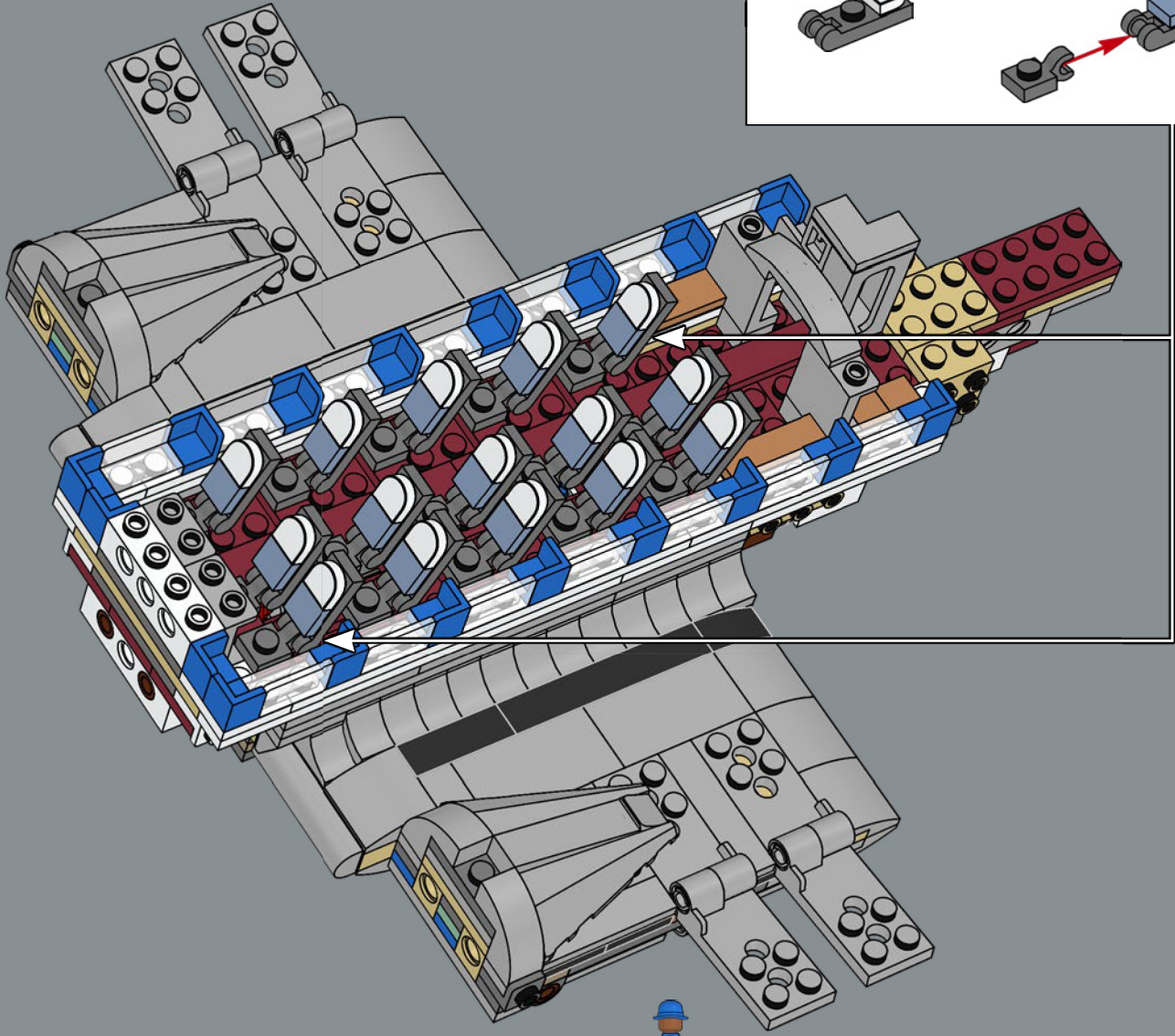

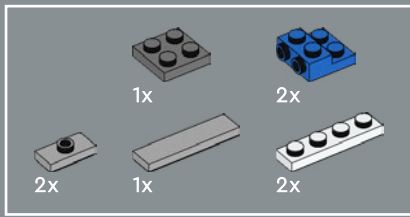

109

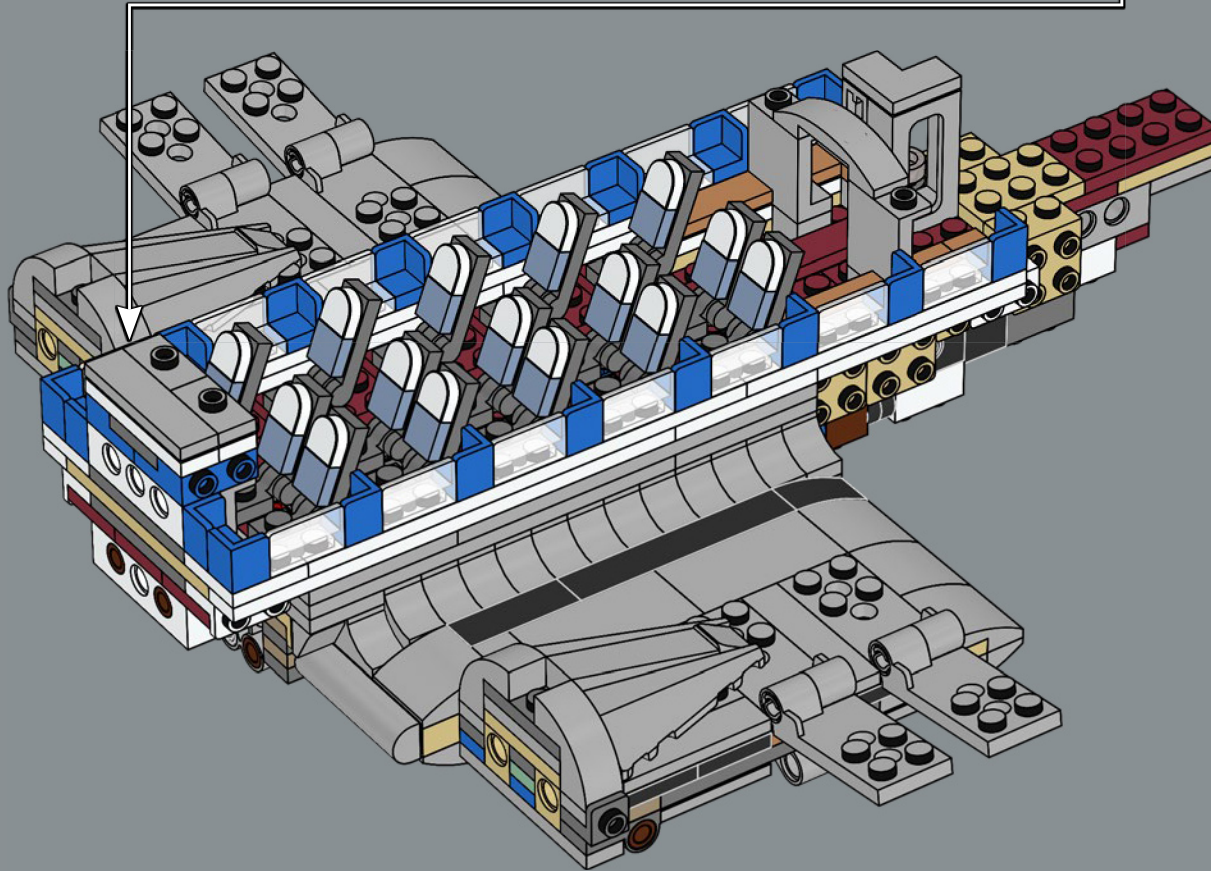
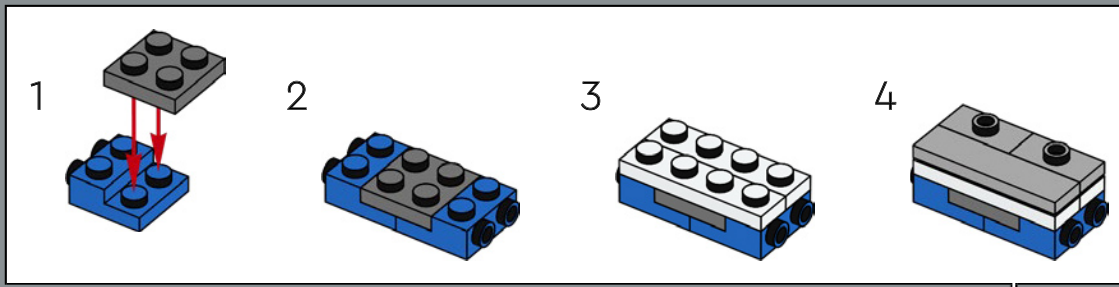

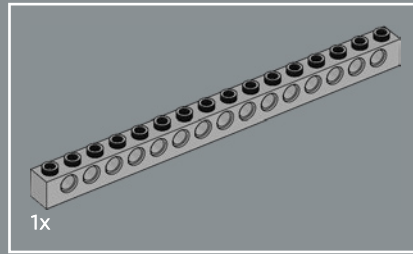
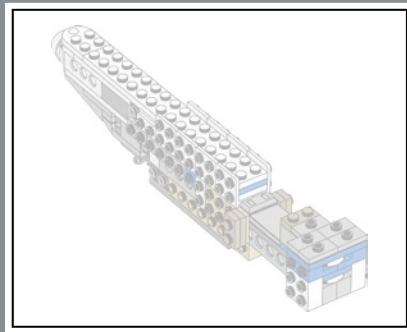

1x

111

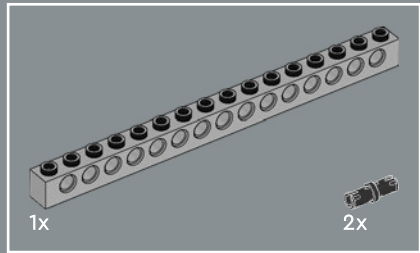
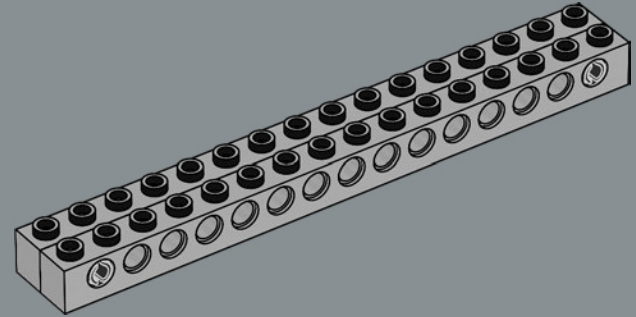

1x

2x

110

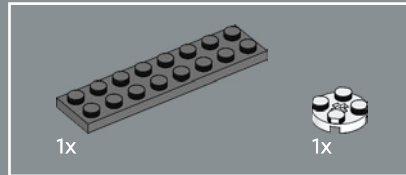
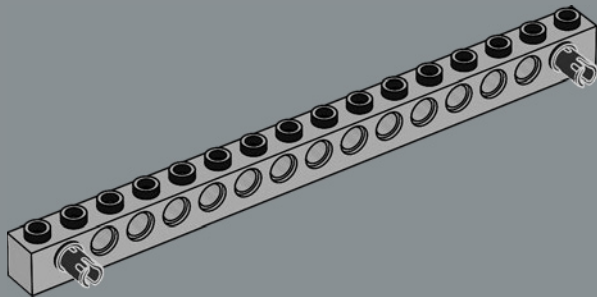

1x

1x

112

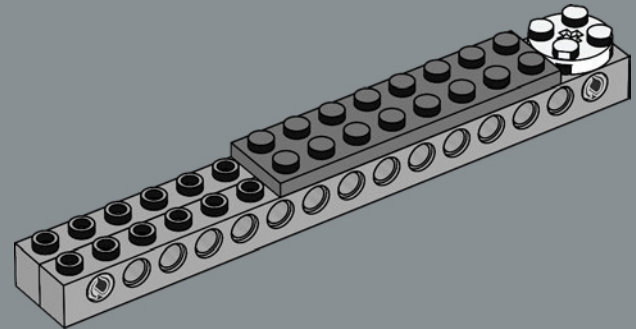

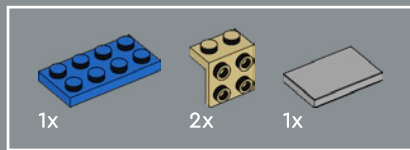

113

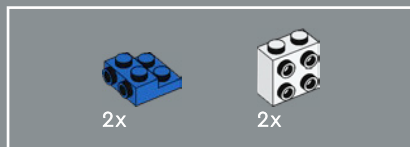
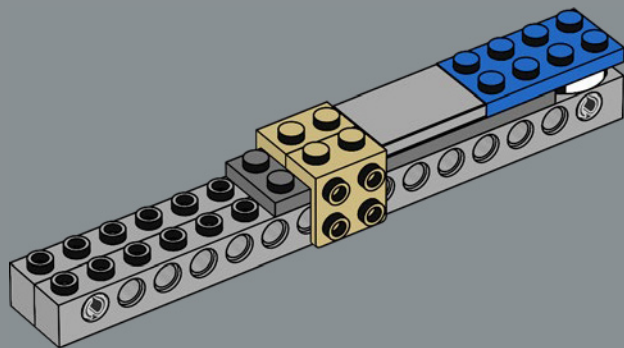

114

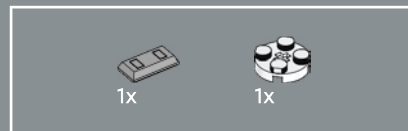
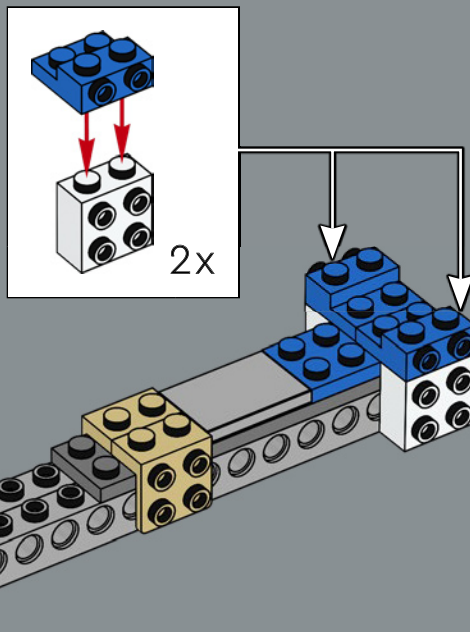

115

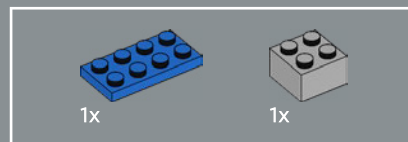
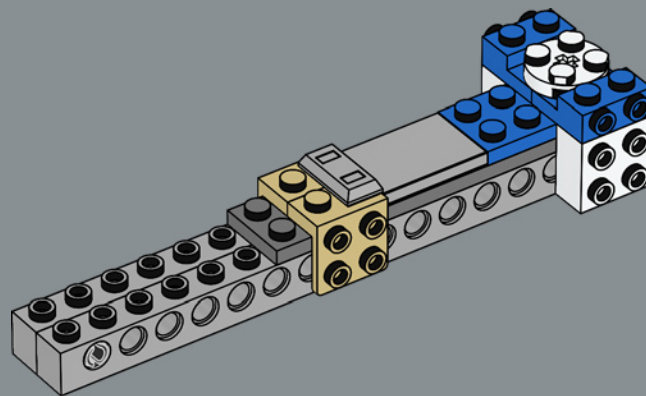

116

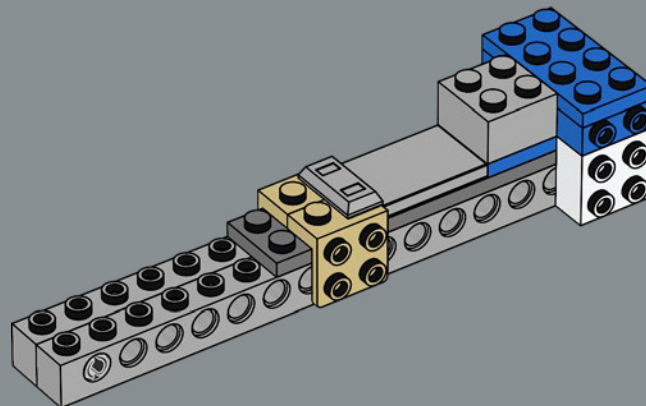

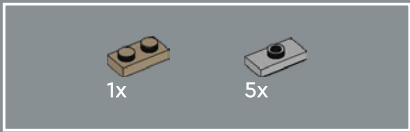

117

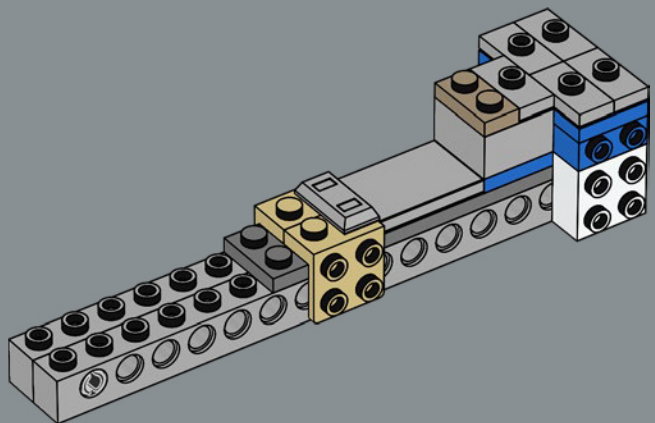

118

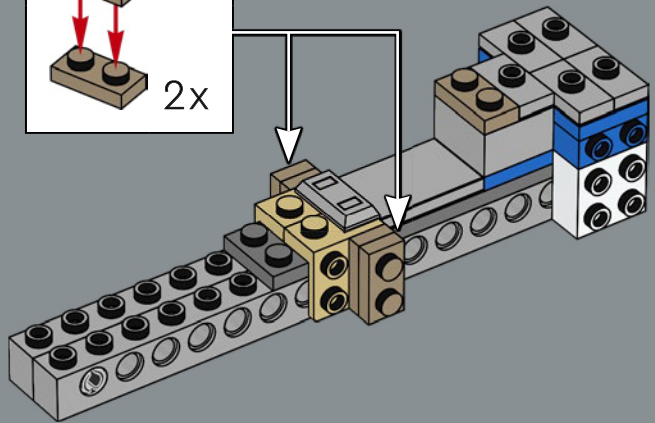
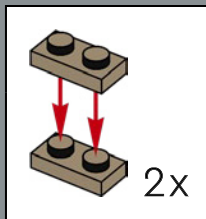

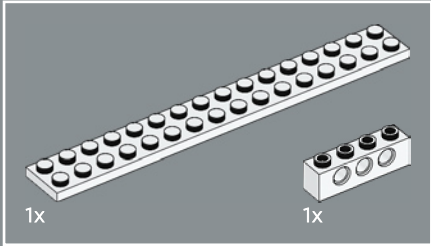
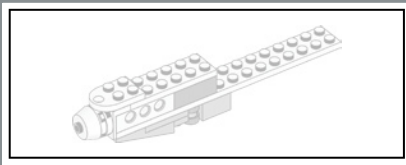

119

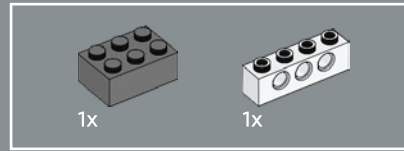
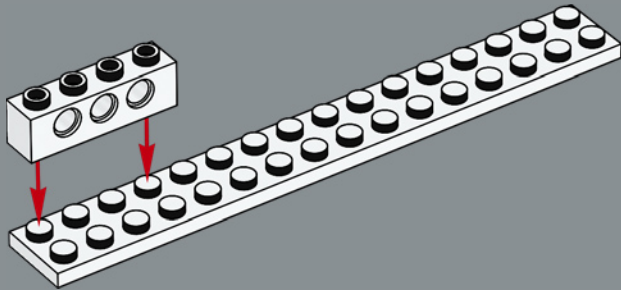

120

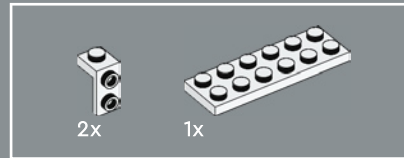
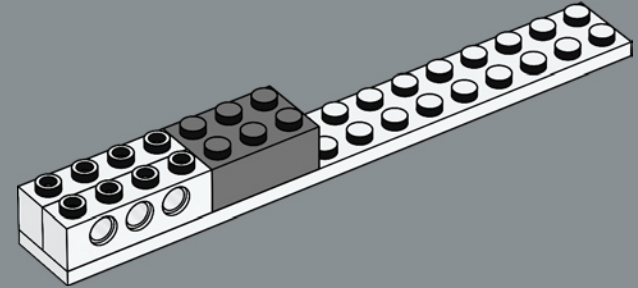

121

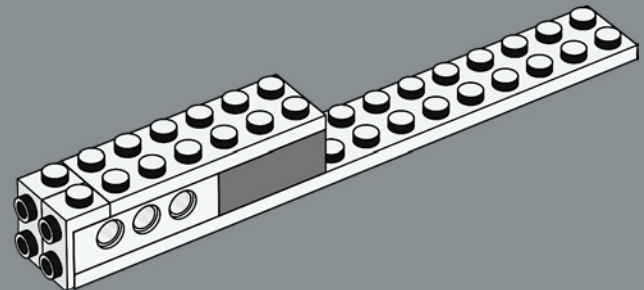

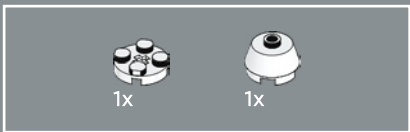

122

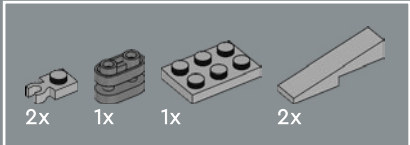
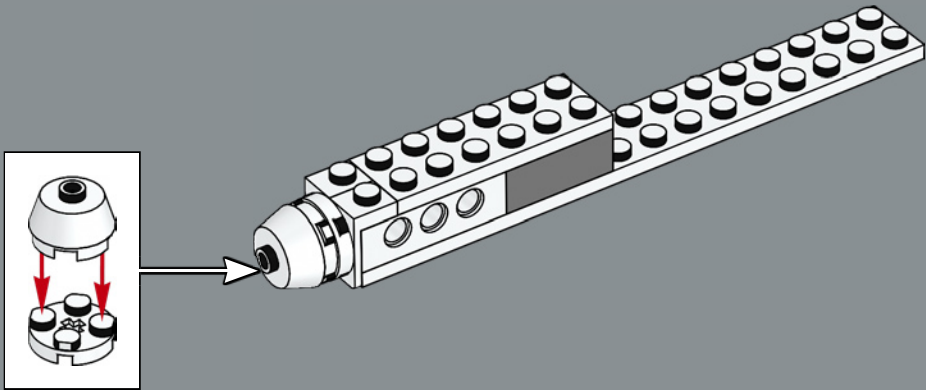

123

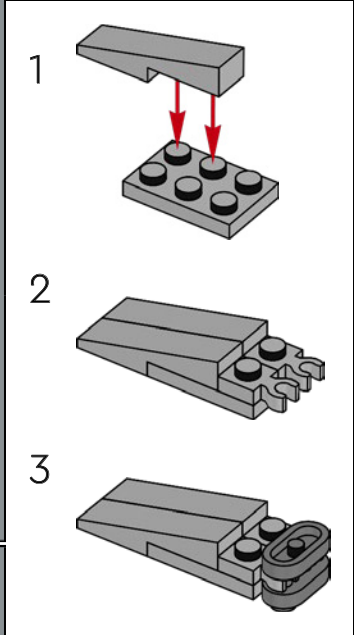
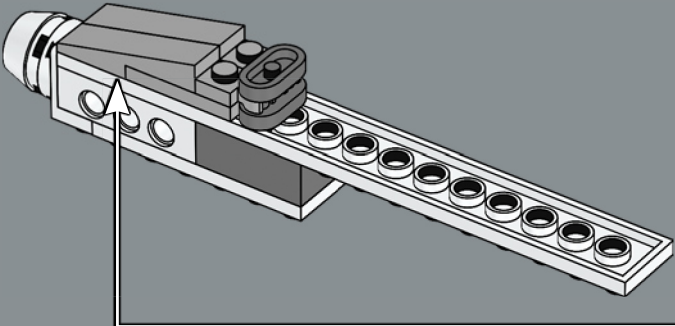
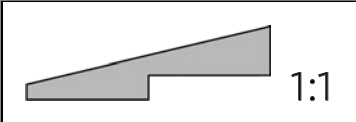

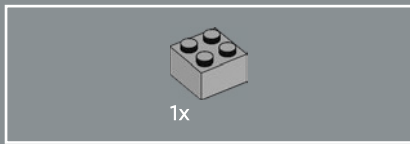

124

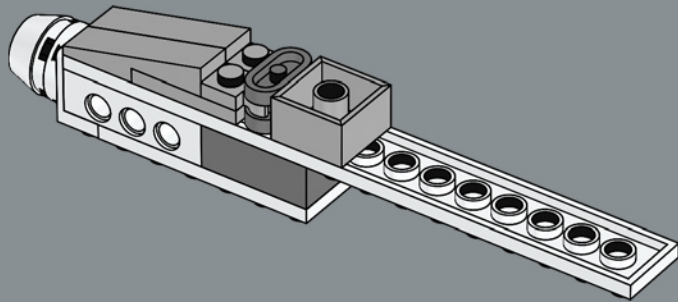

125

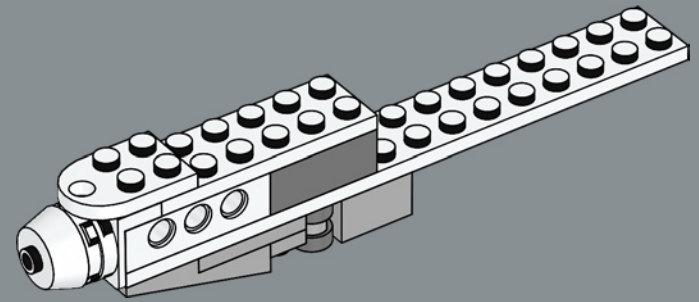

126

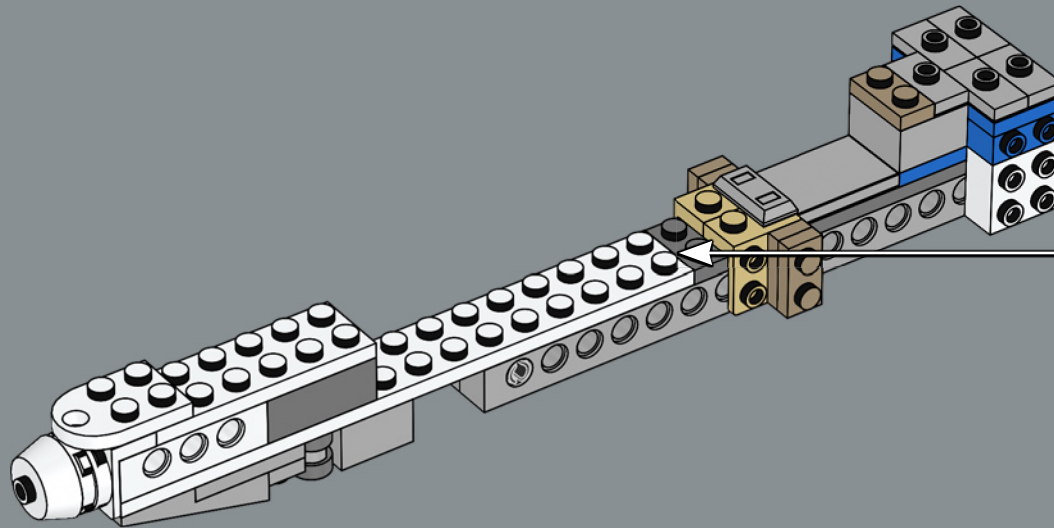

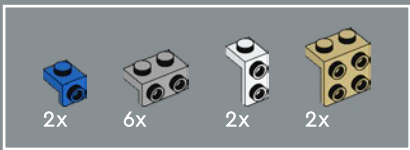

127

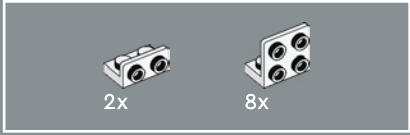
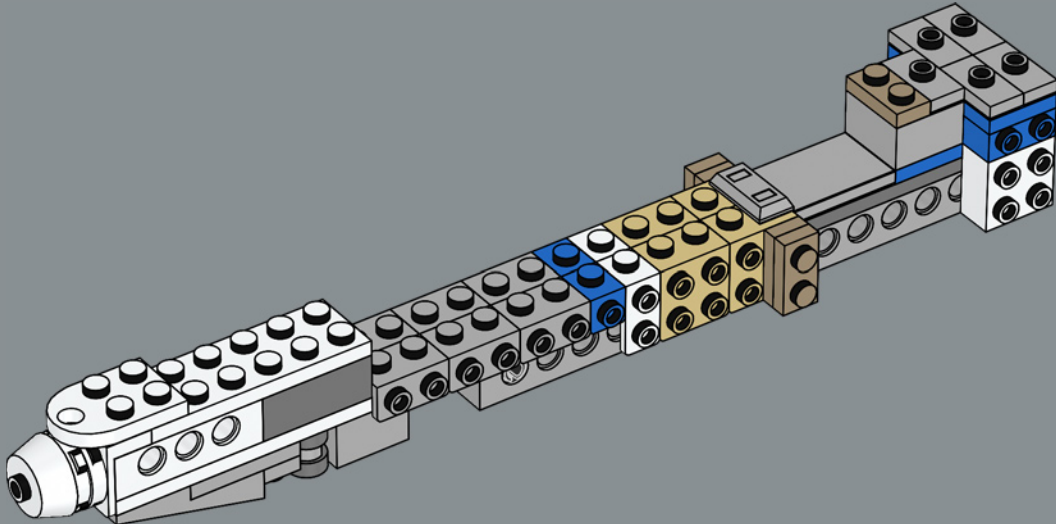

128

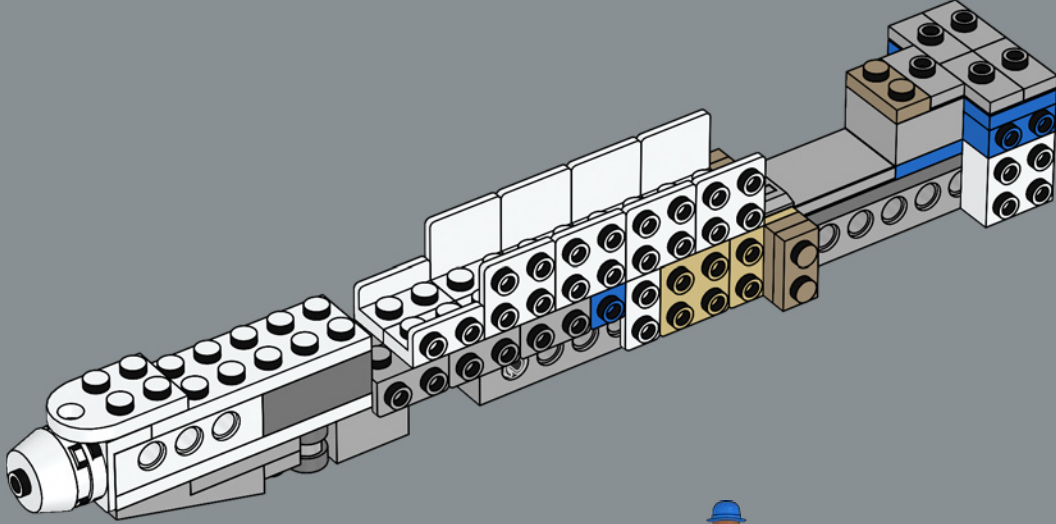

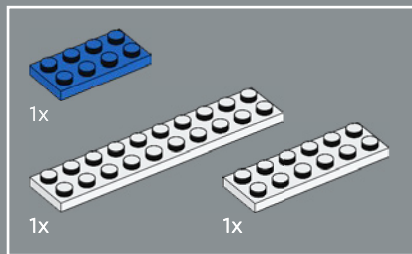

129

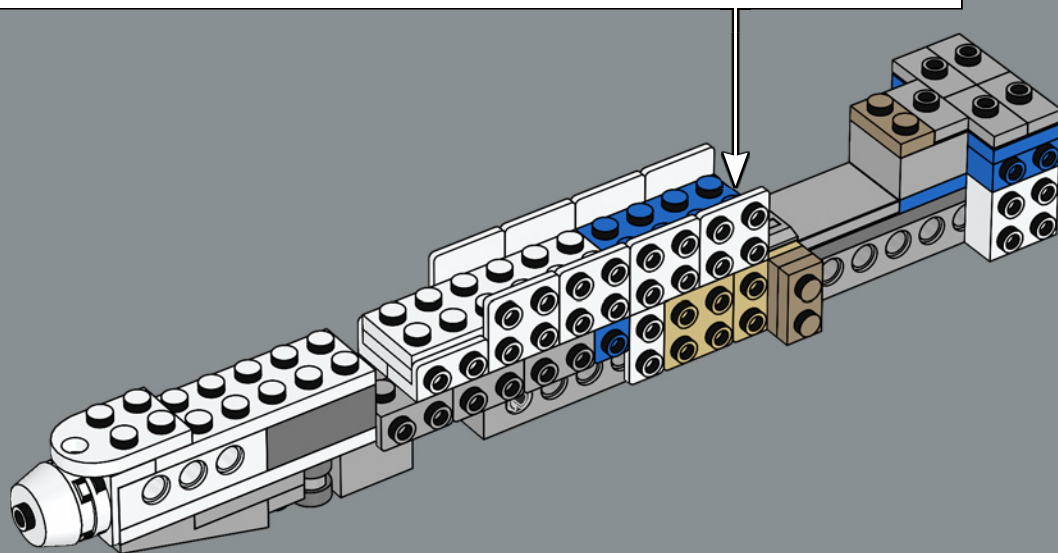
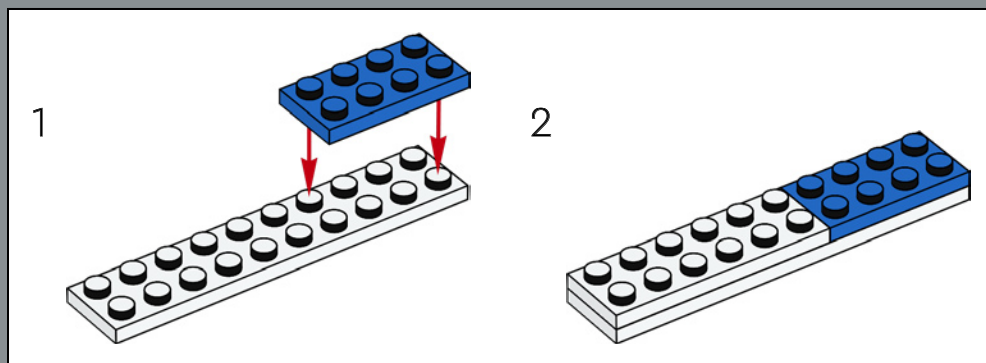



2x

130

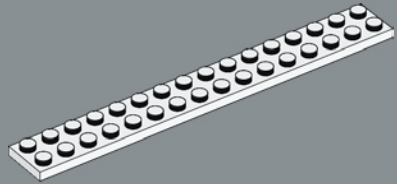
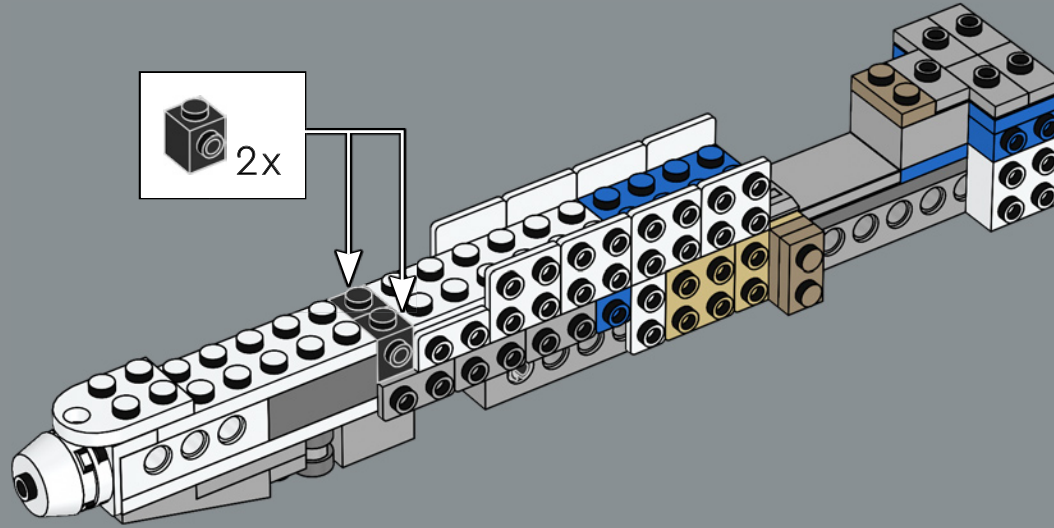

1x

131

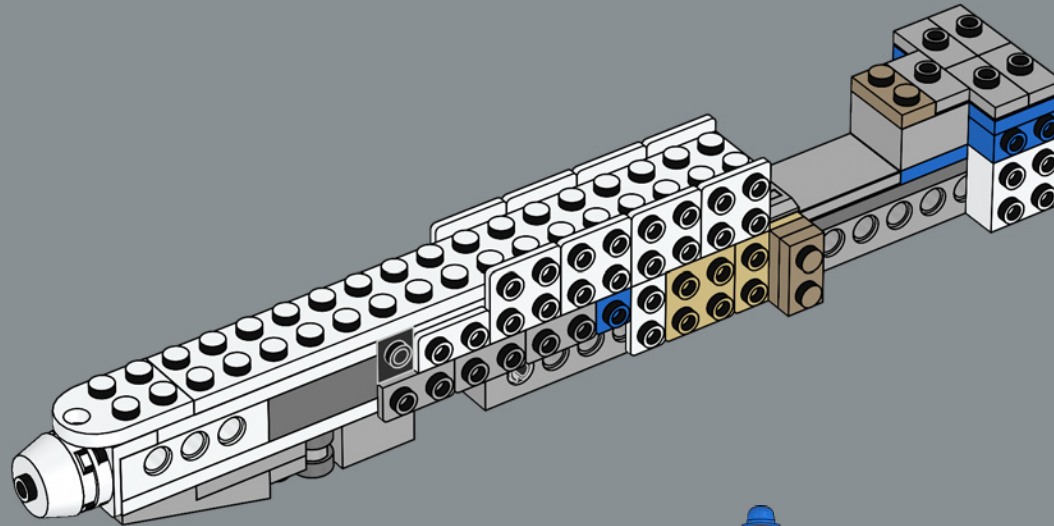

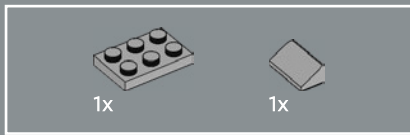

132

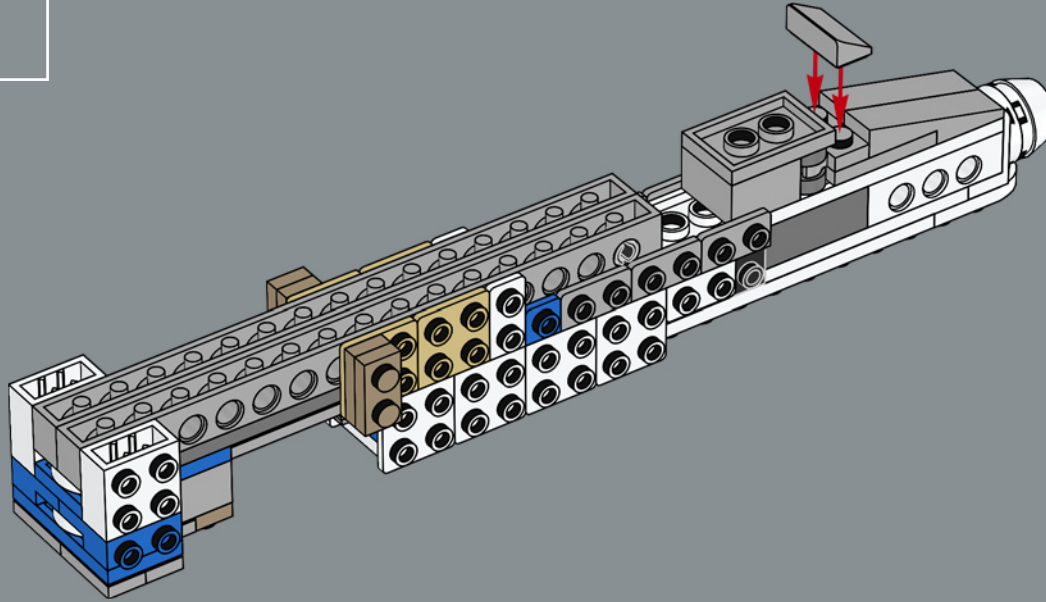

133

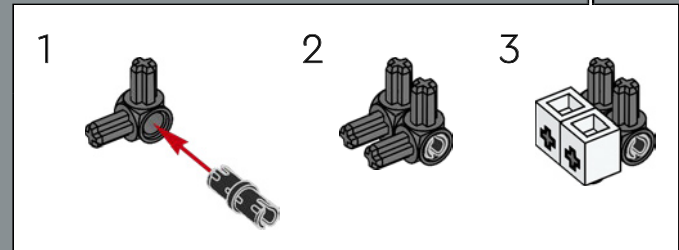
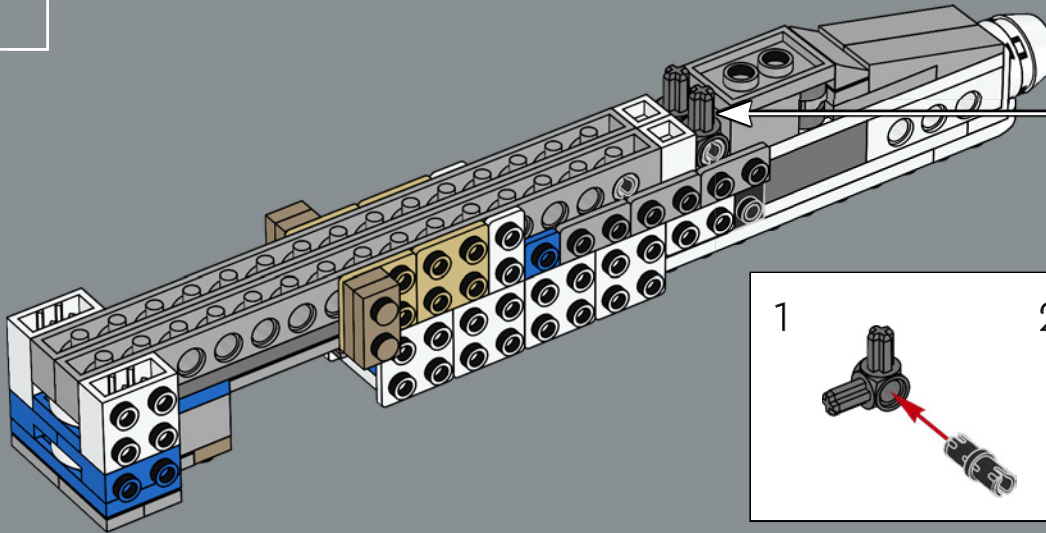

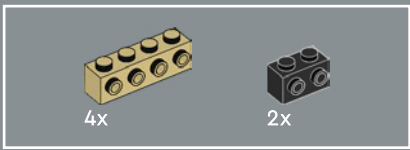

134

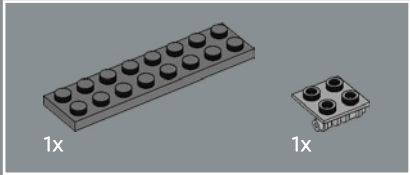
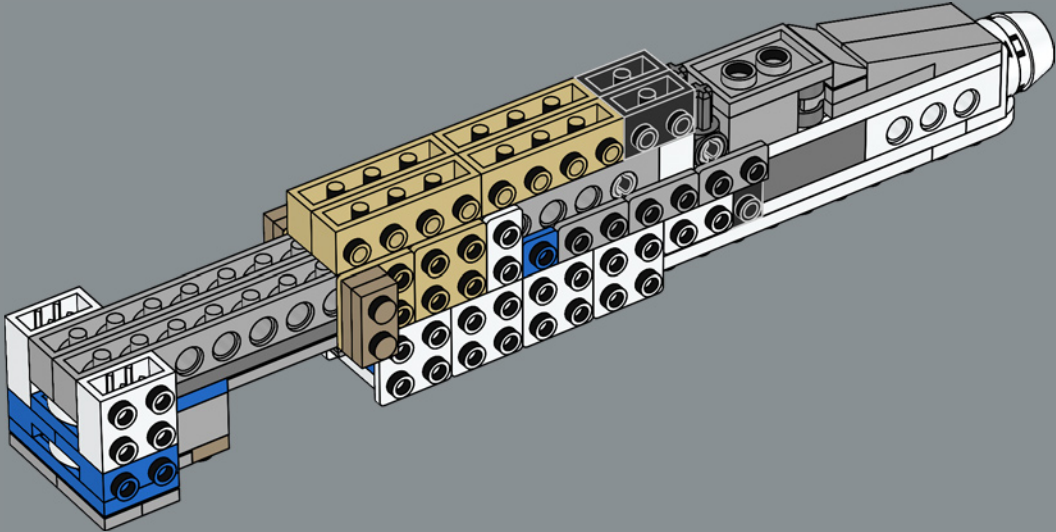

135

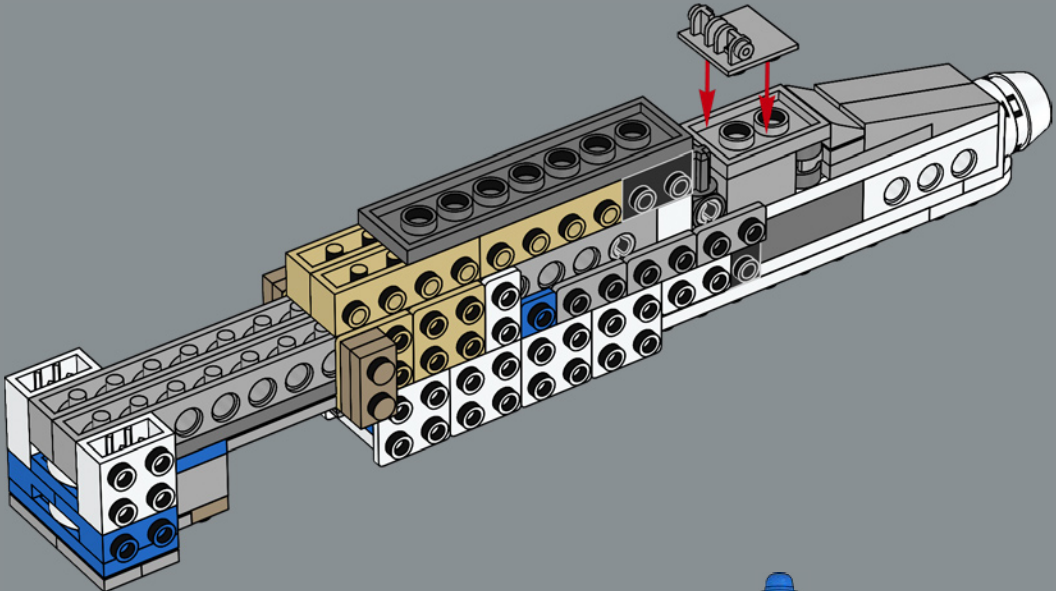

136

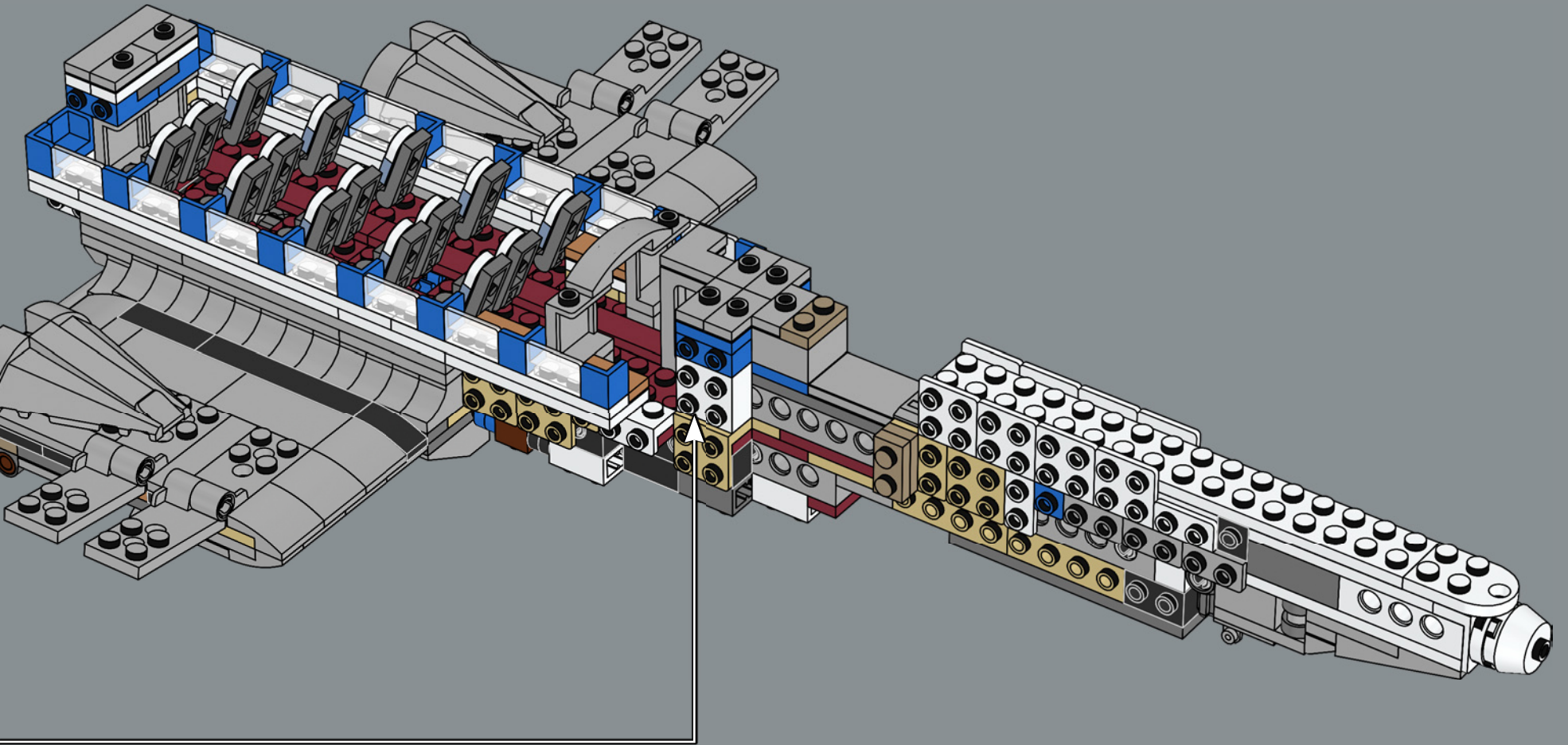



1x

137

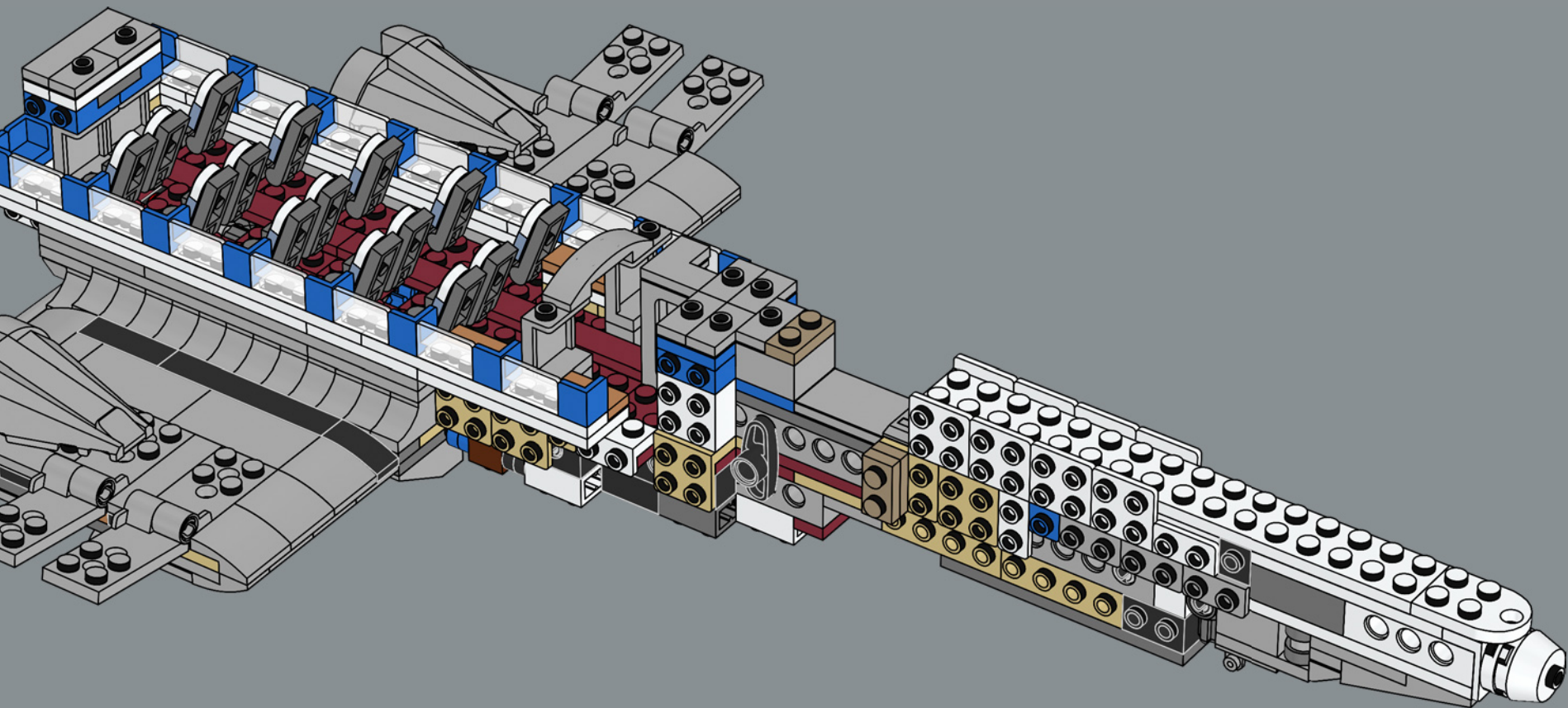

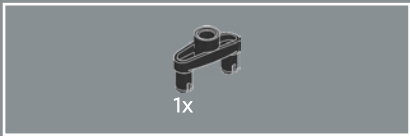

138

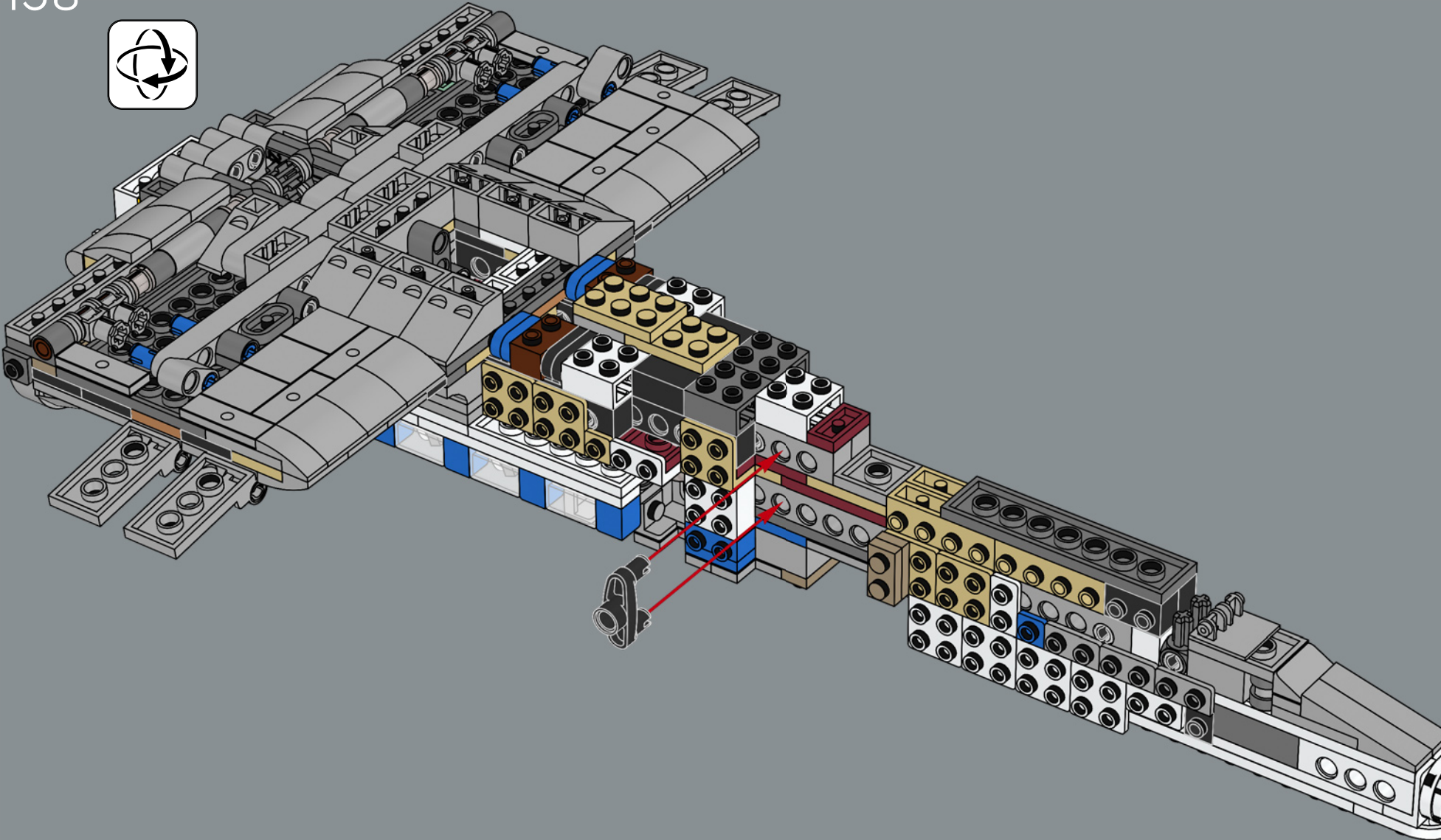

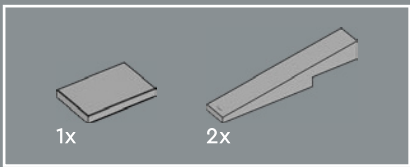

139

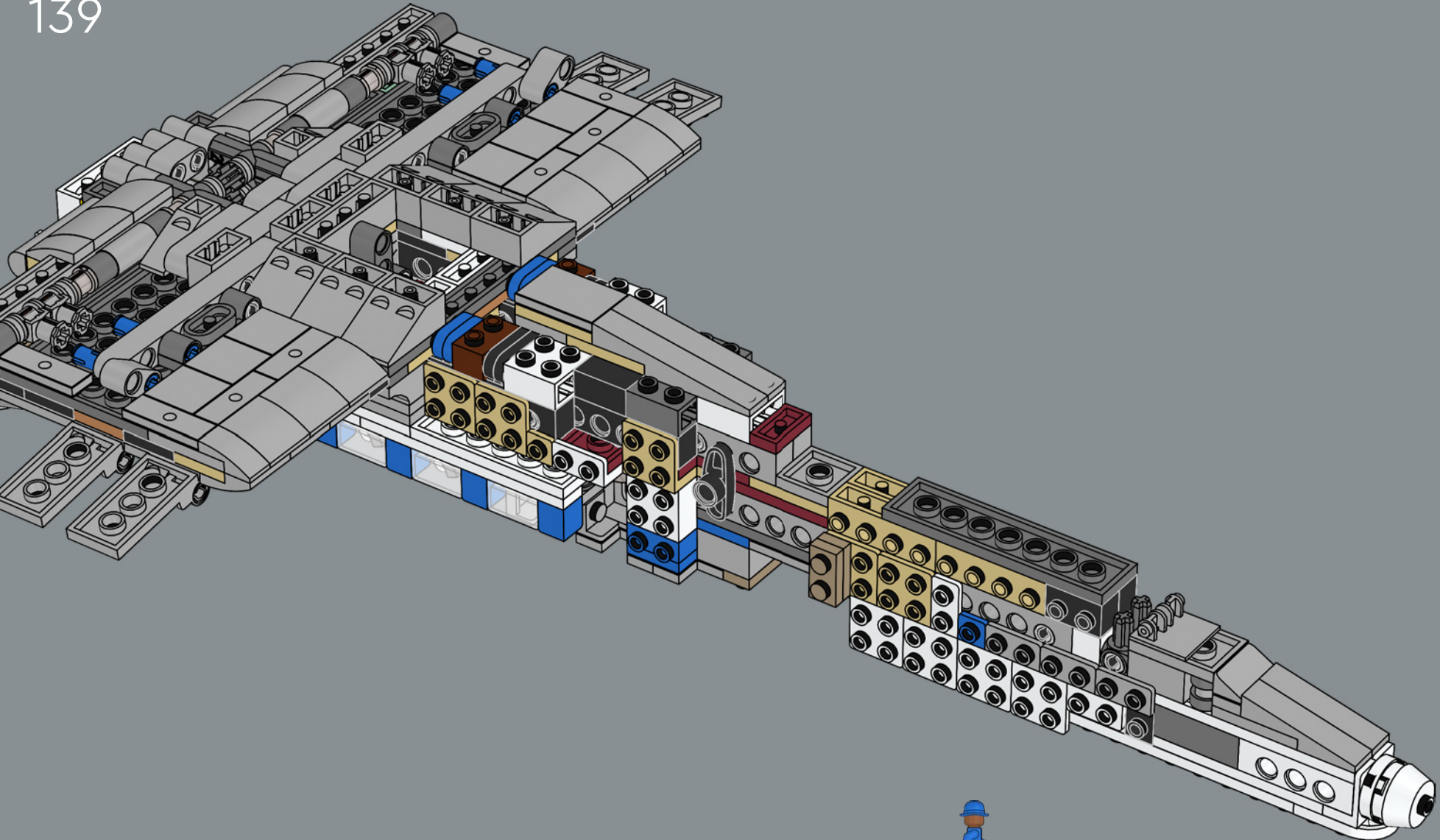

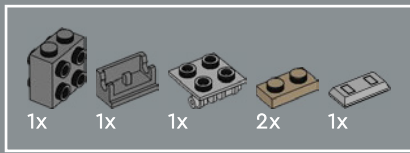

140

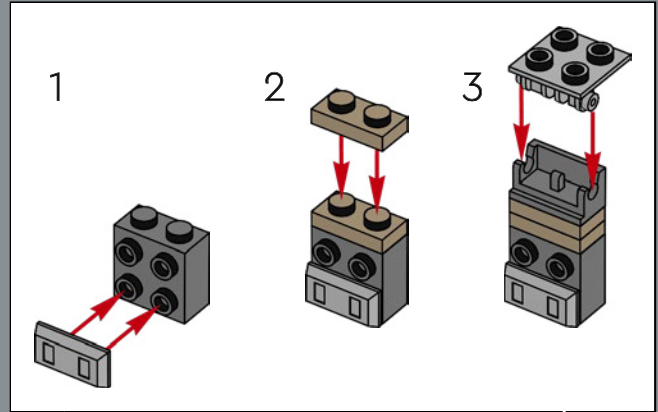
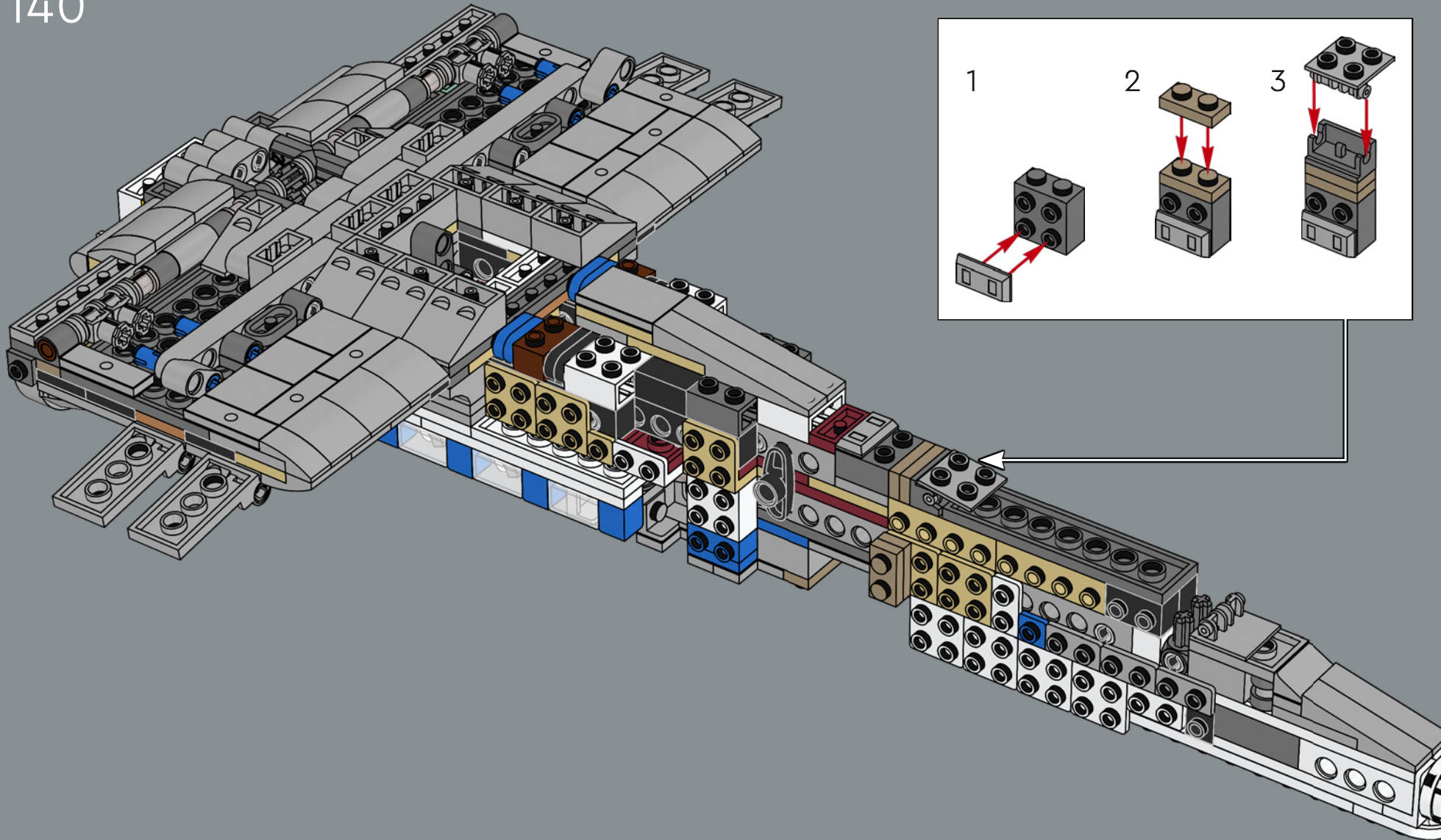

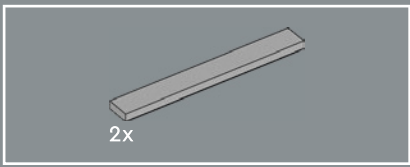

141

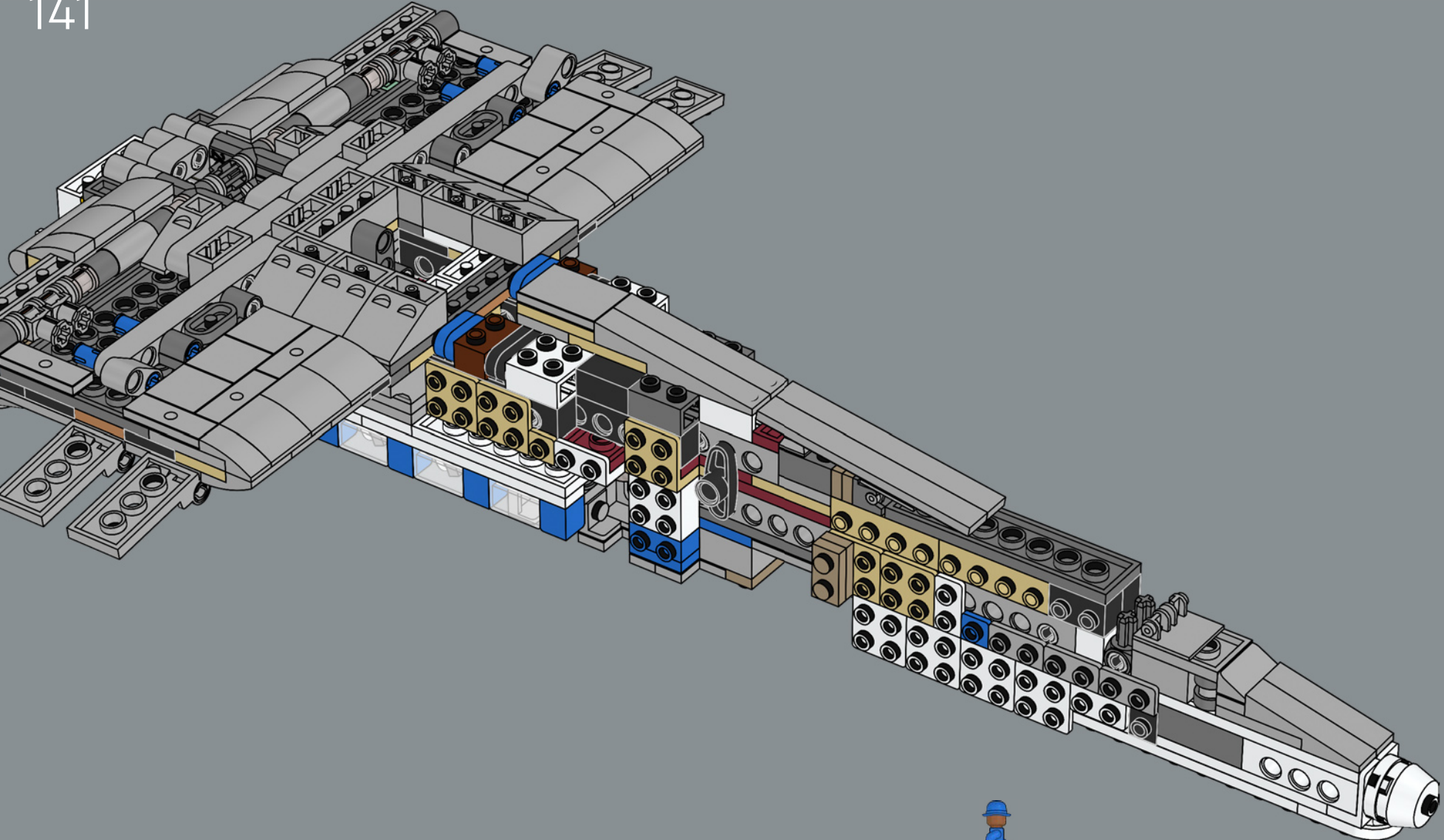

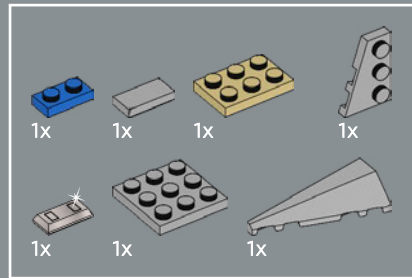
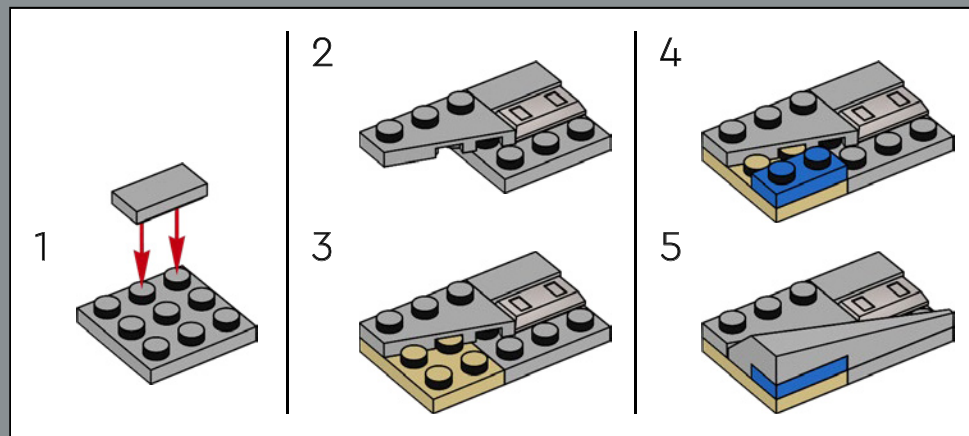

142

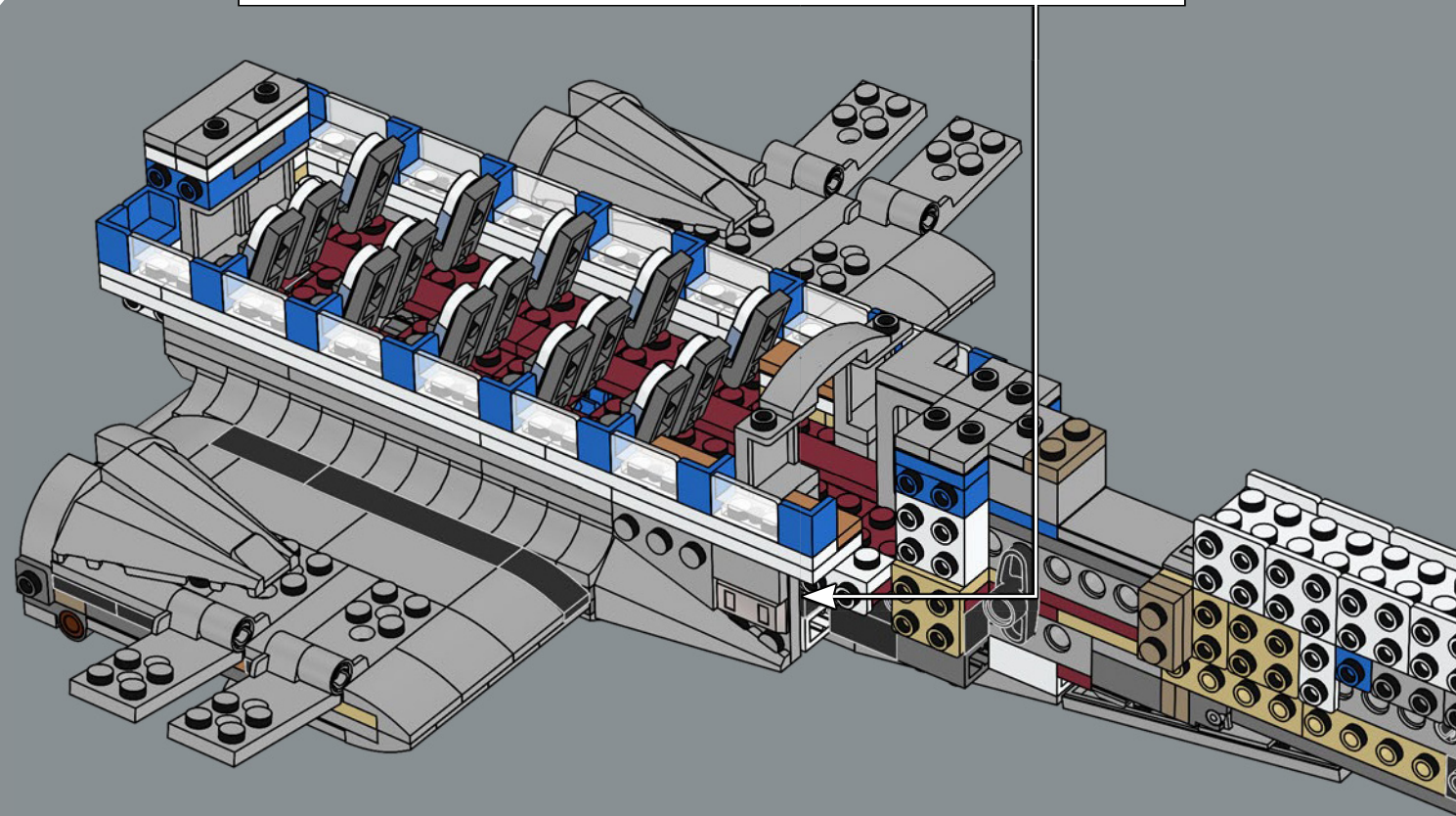

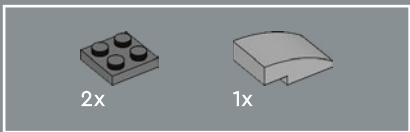

143

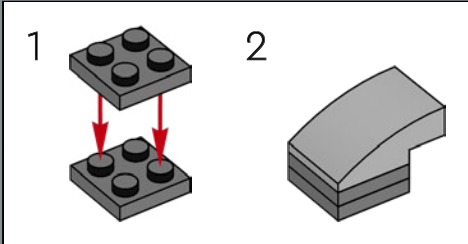
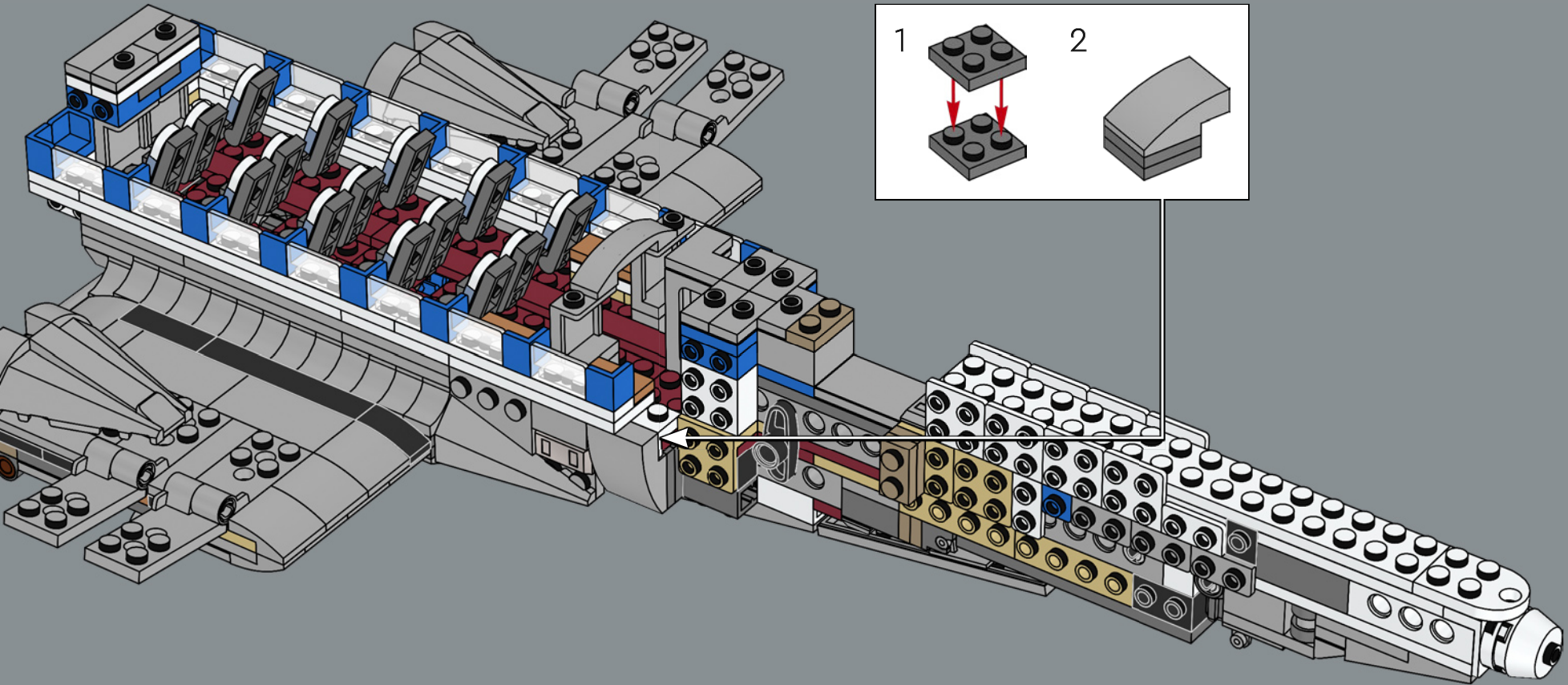

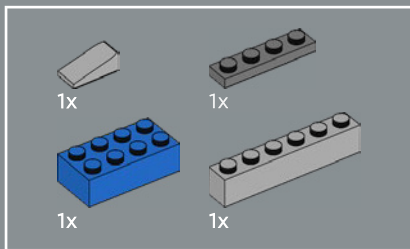

144

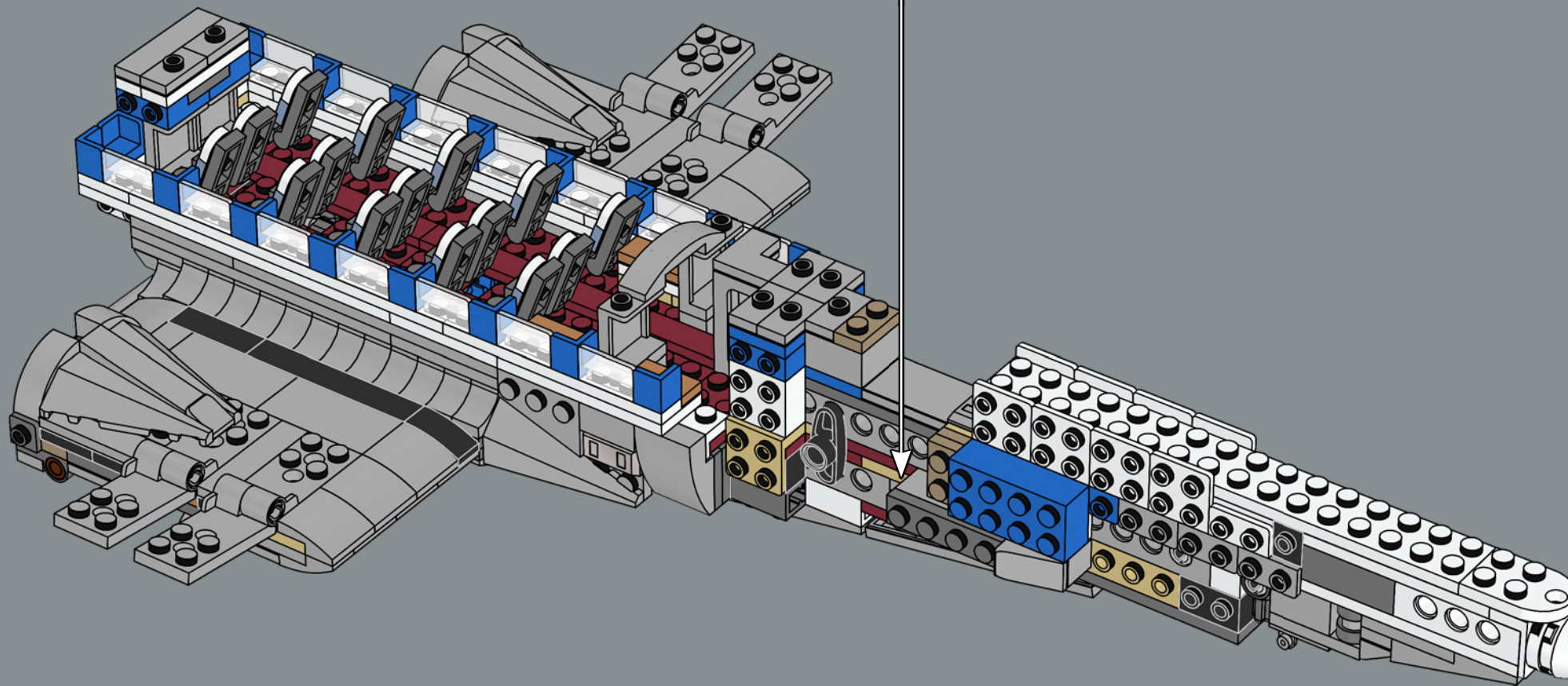
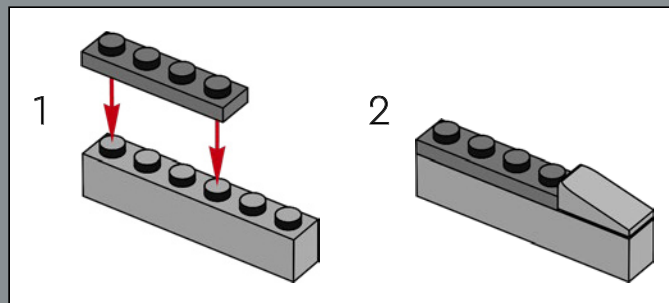

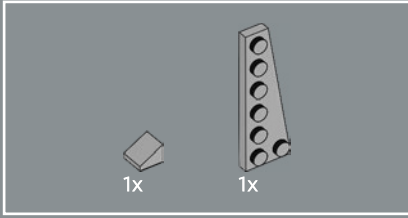
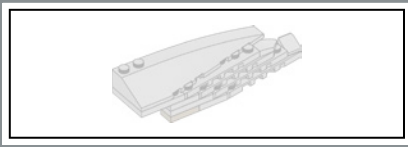

145

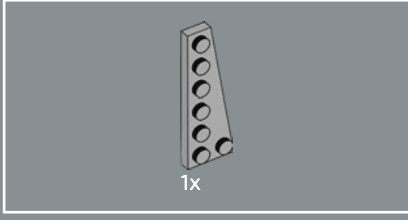
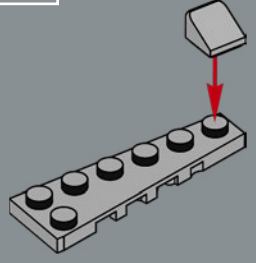

146

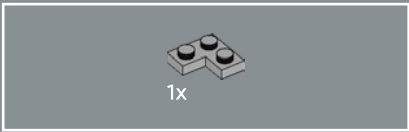
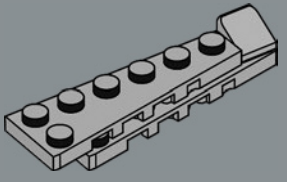

147

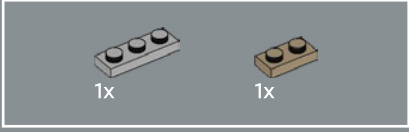
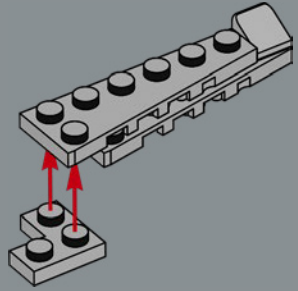

148

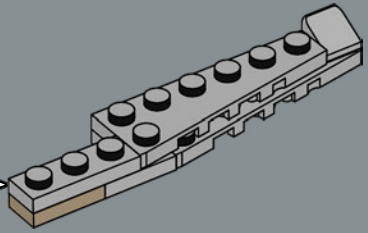
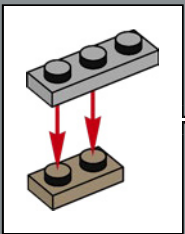

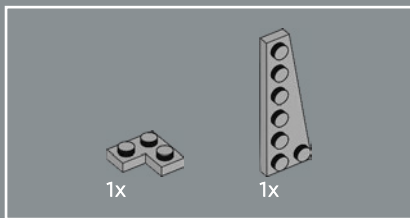

149

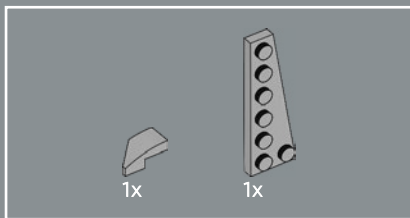
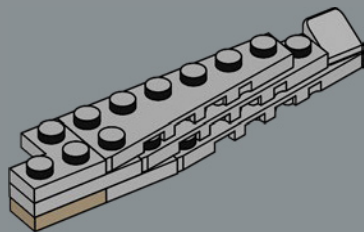

150

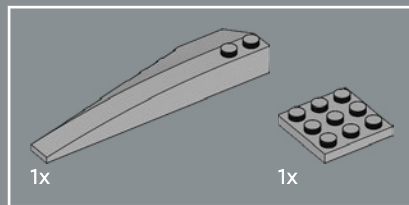
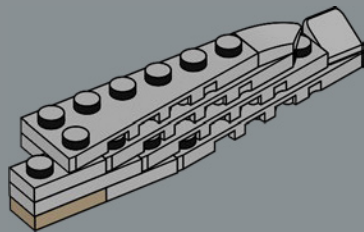

151

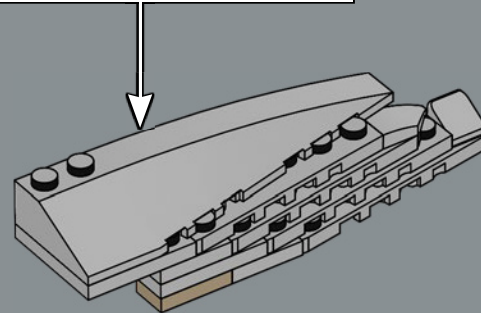
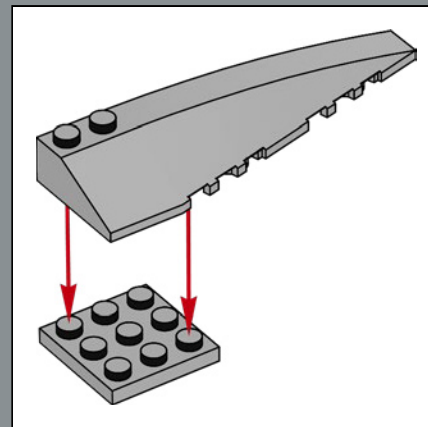

152

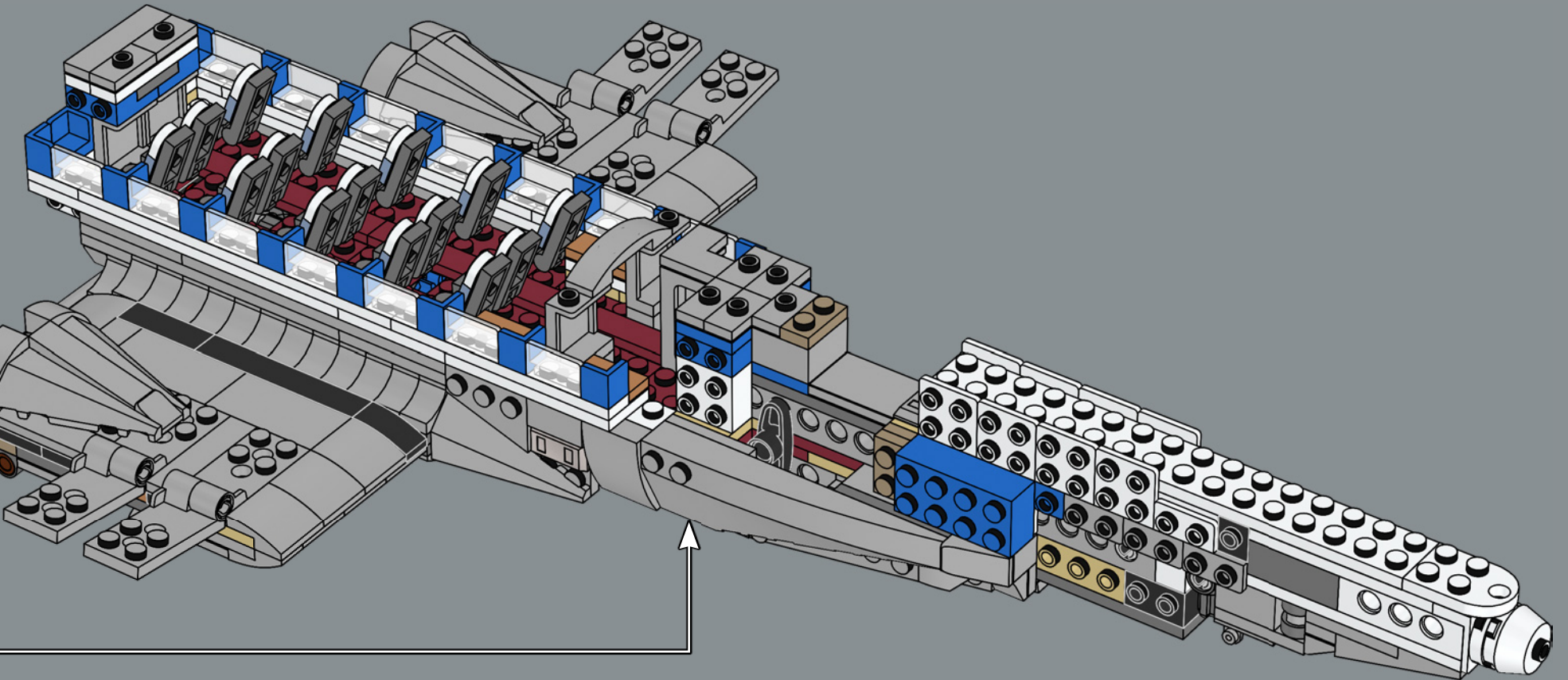

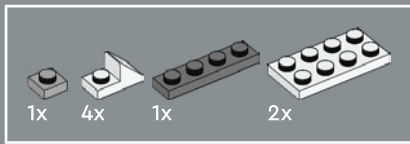

153

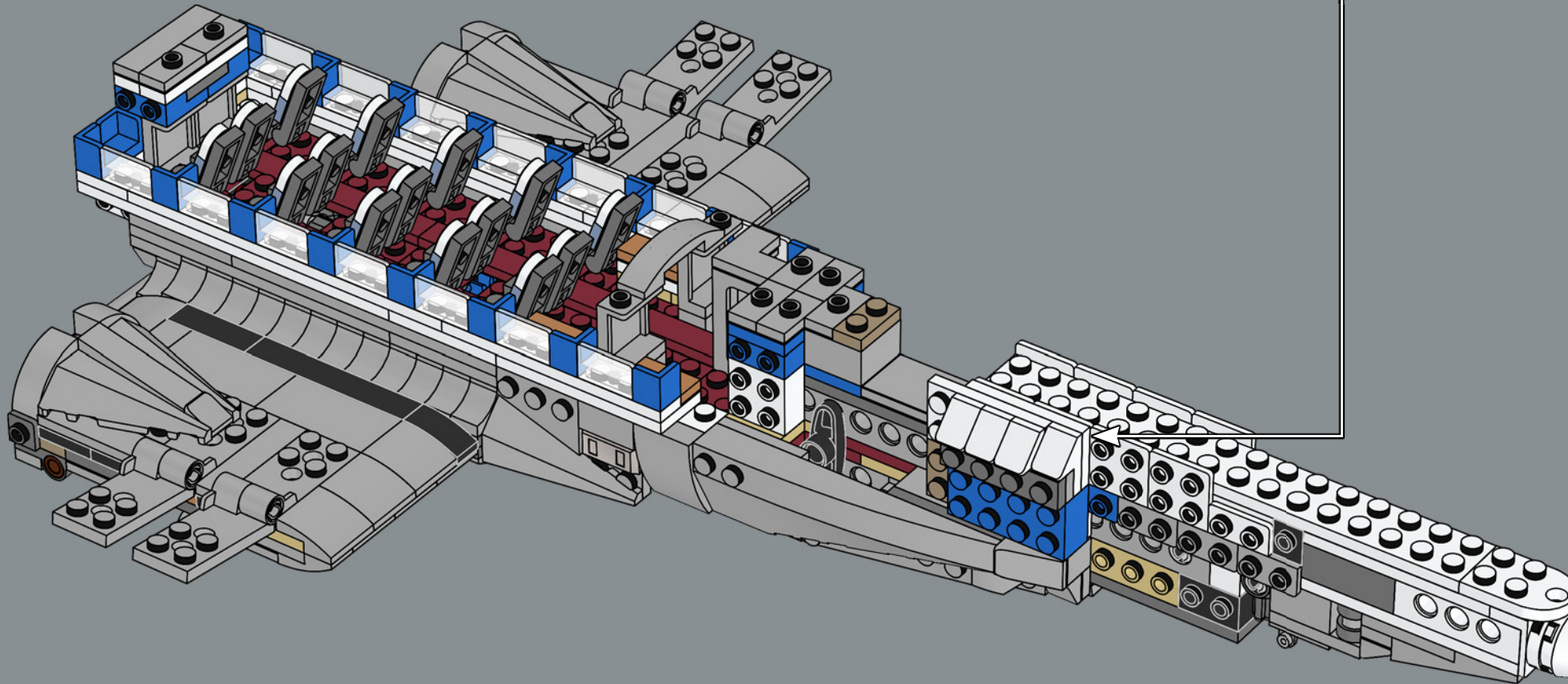
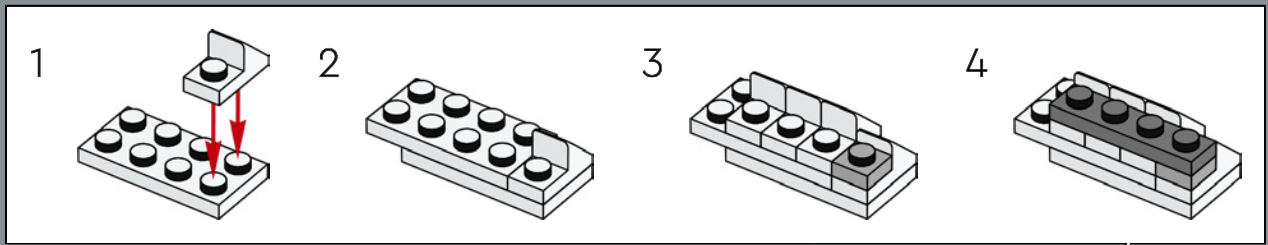

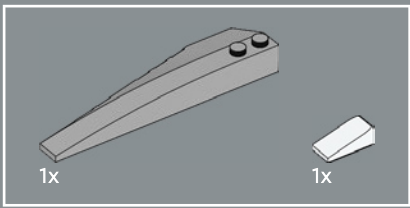

154

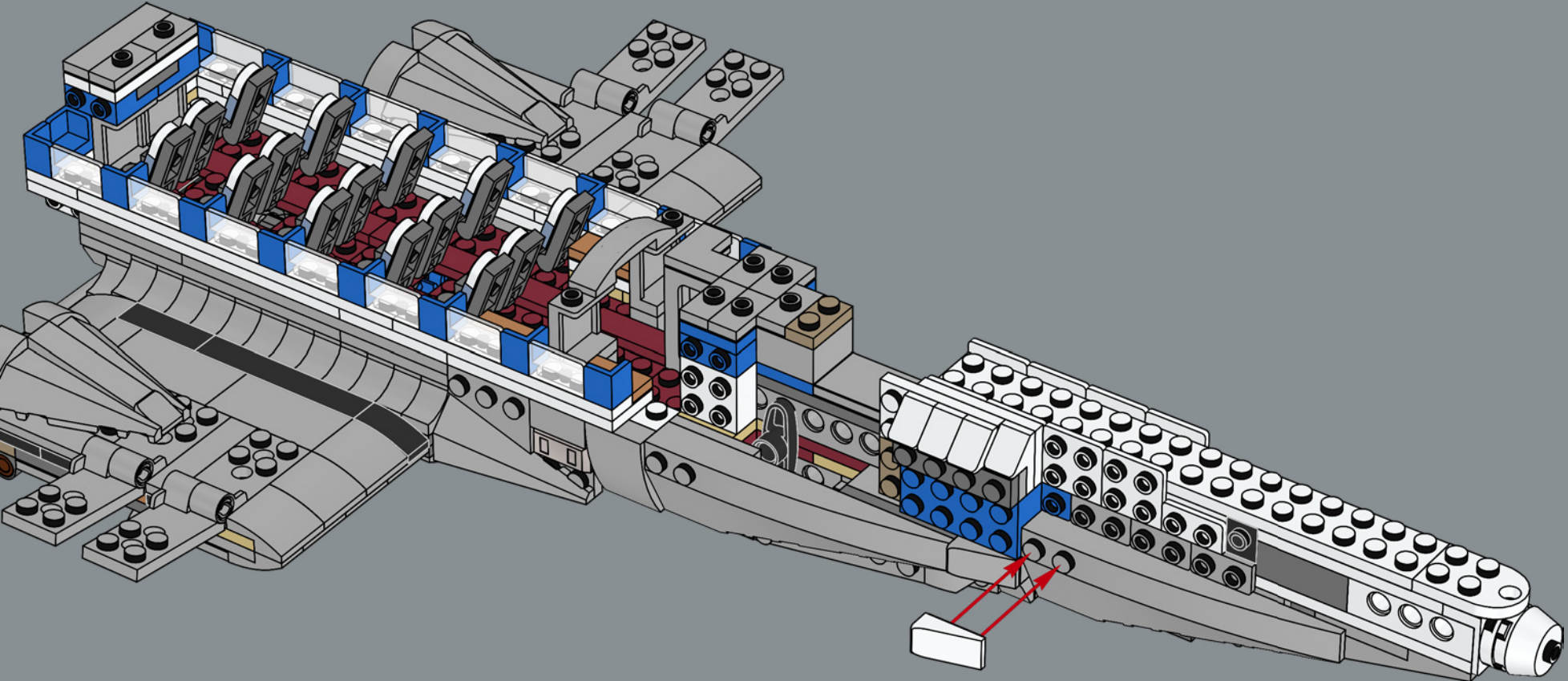

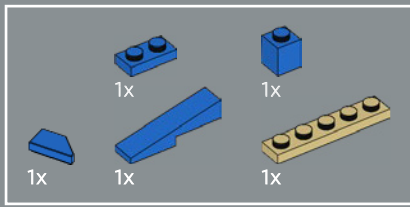

155

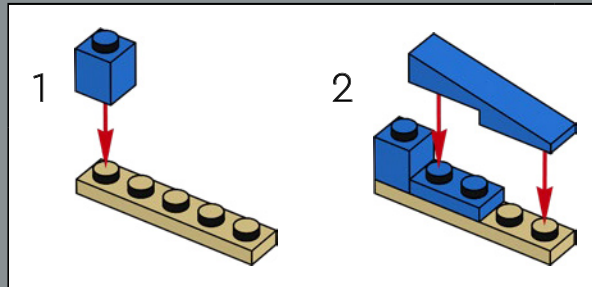
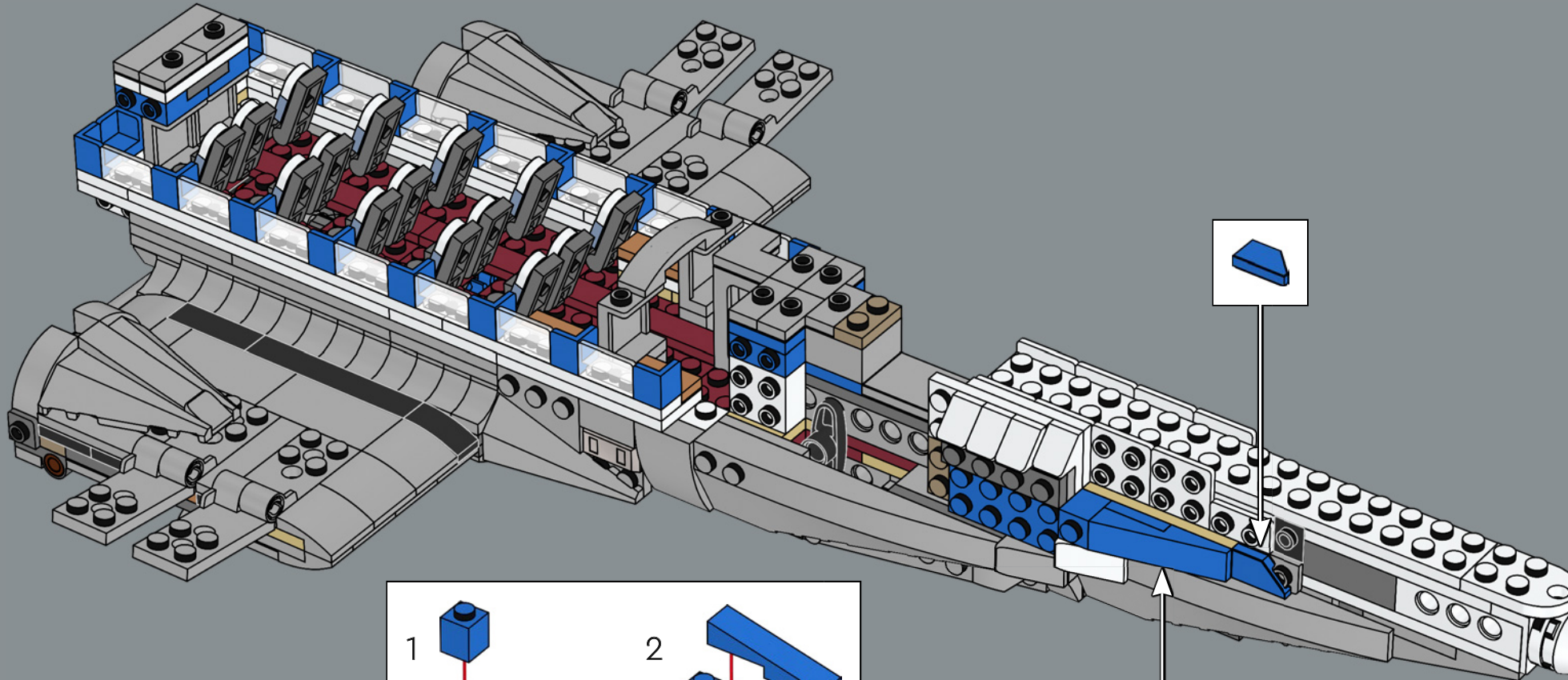

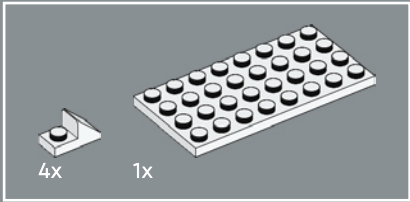
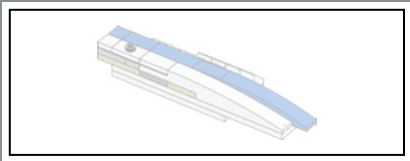

156

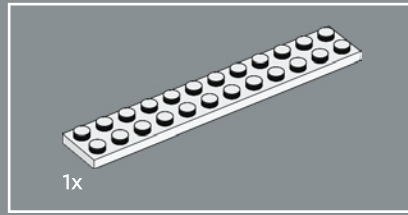
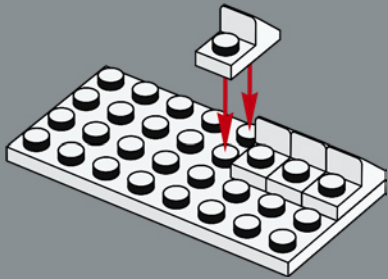

157

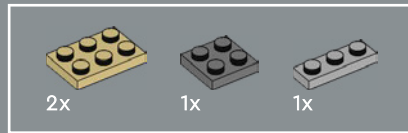
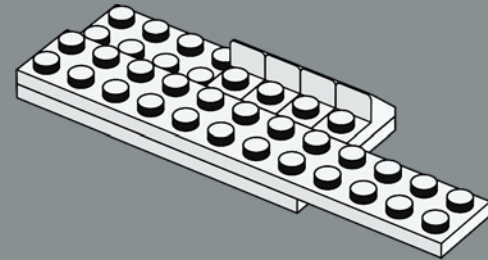

158

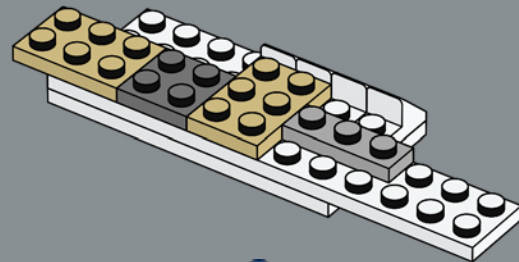

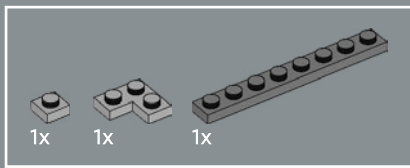

159

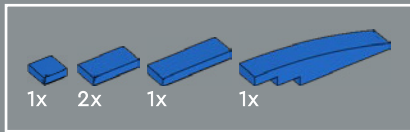
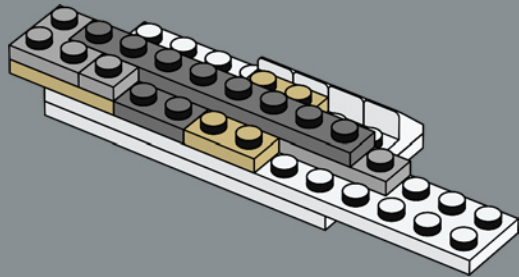

160

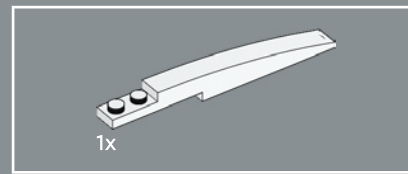
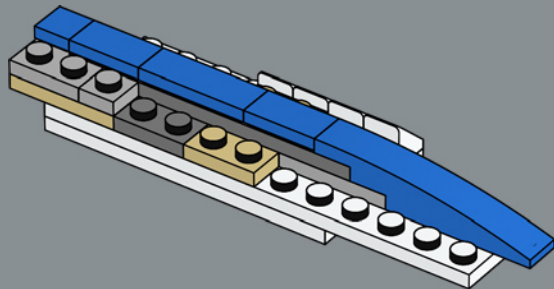

161

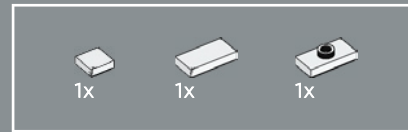
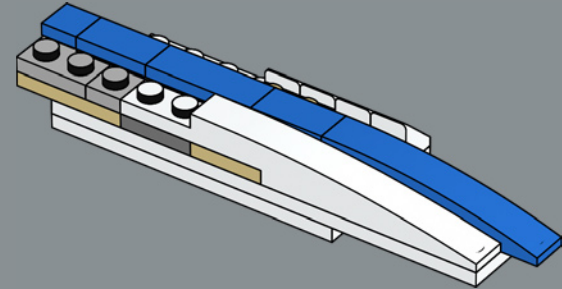

162

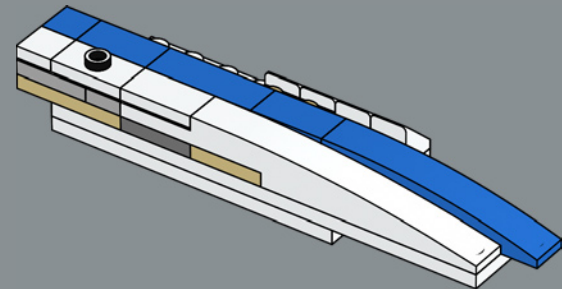

163

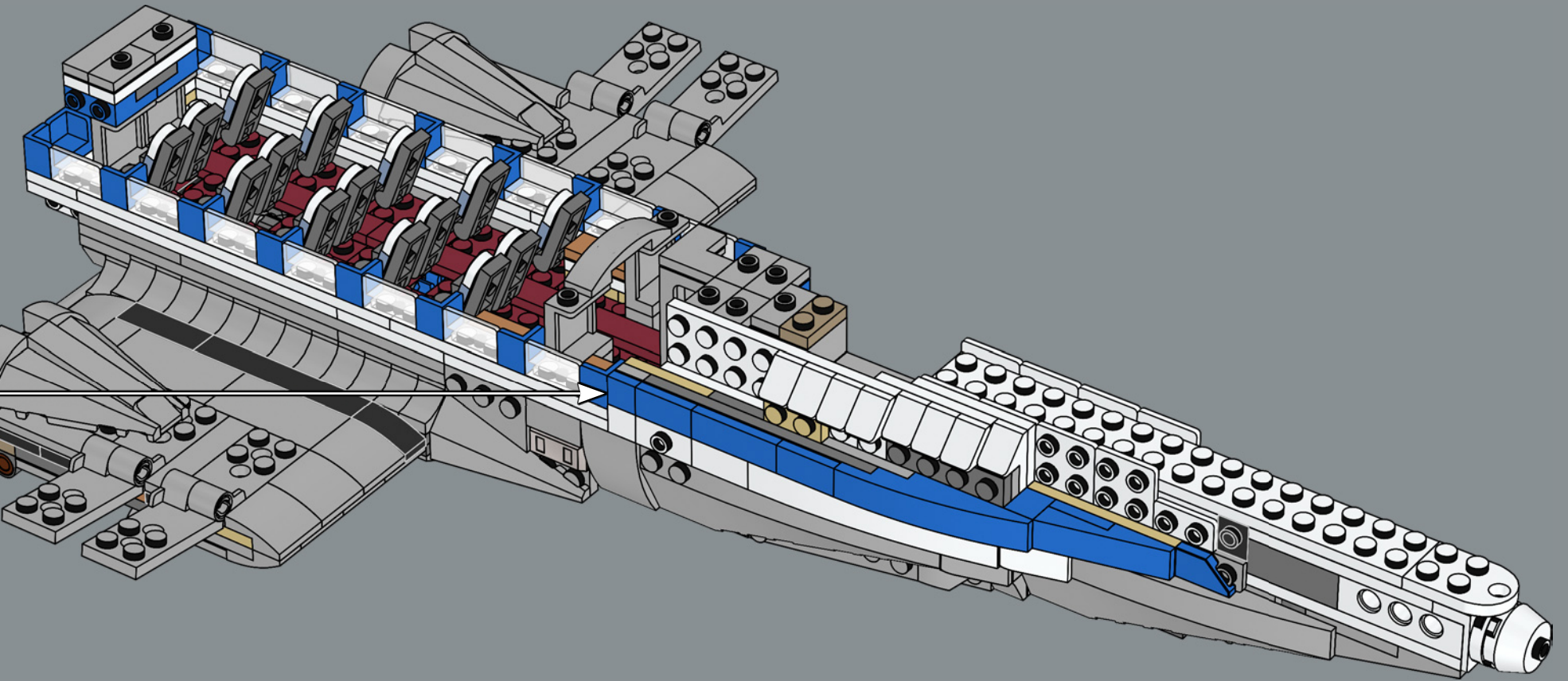

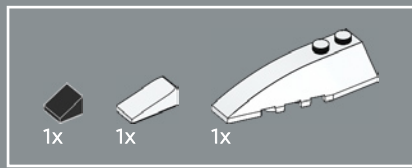

164

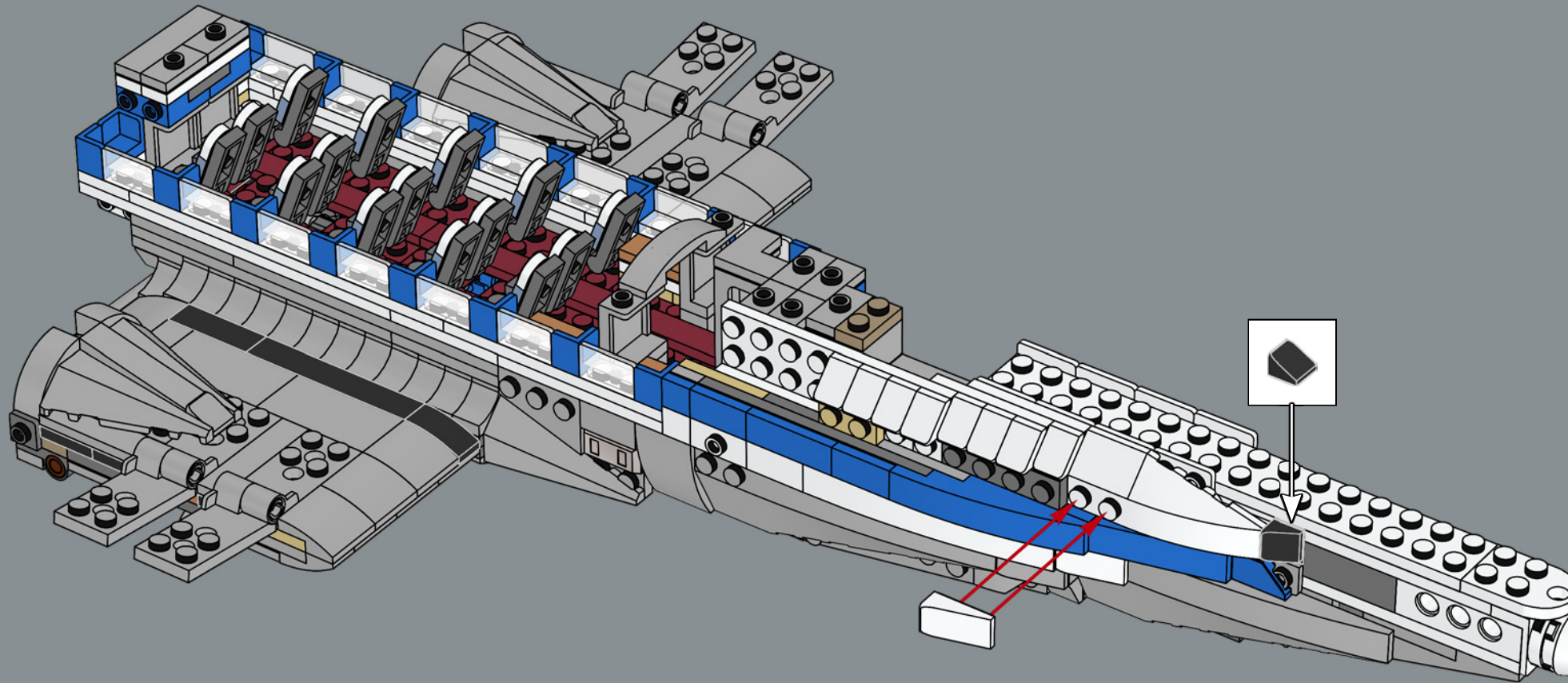

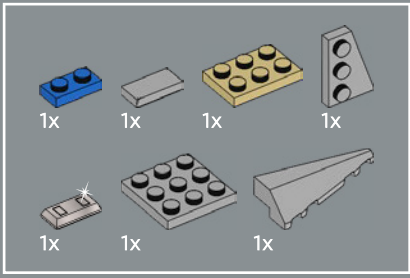

165

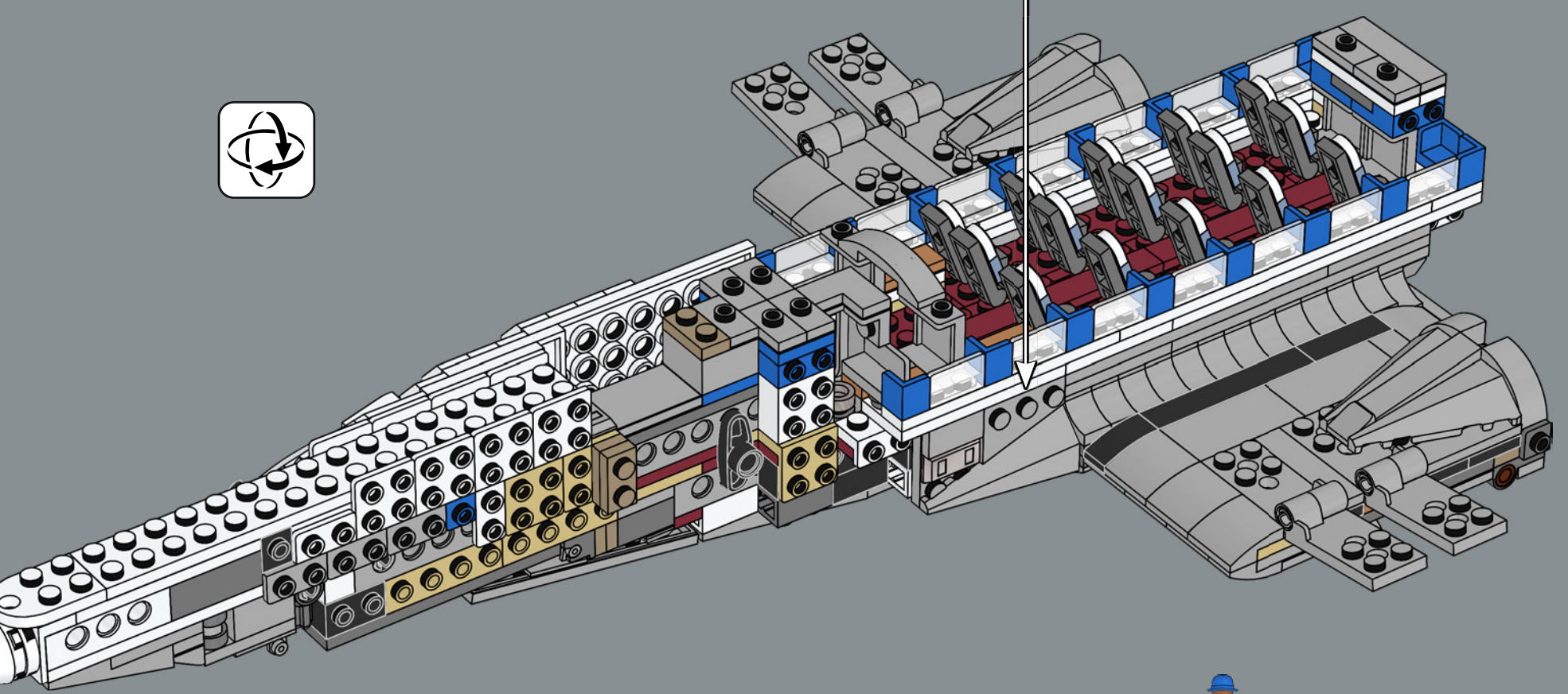
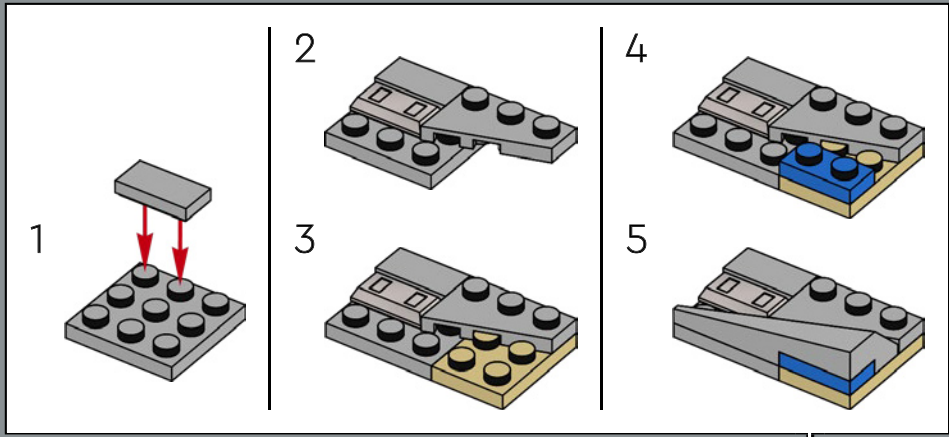

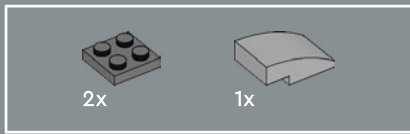

166

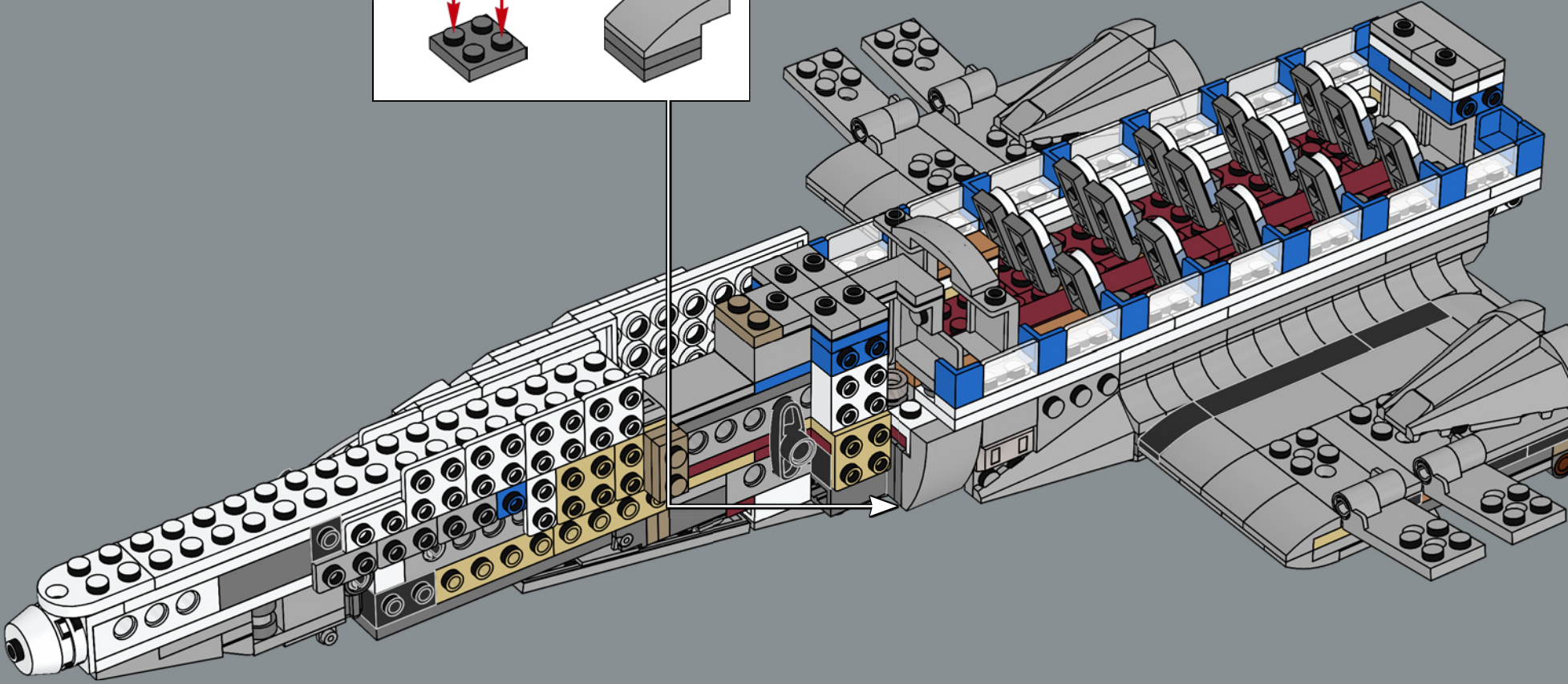
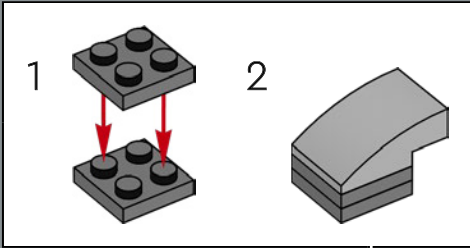

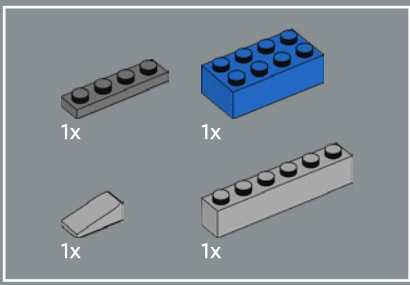

167

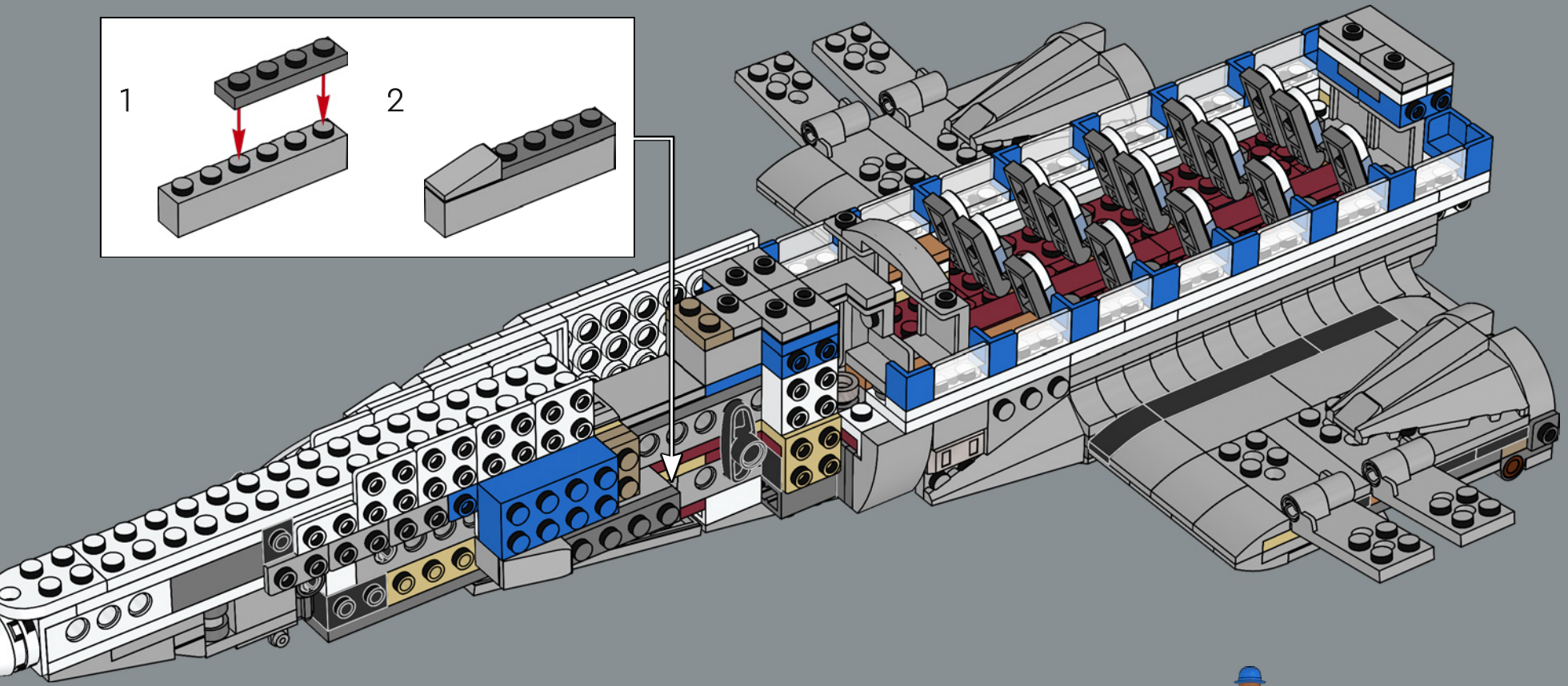
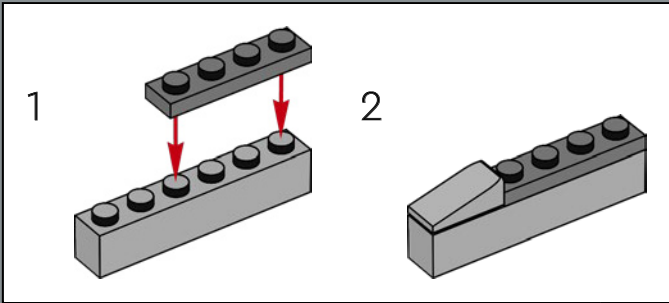

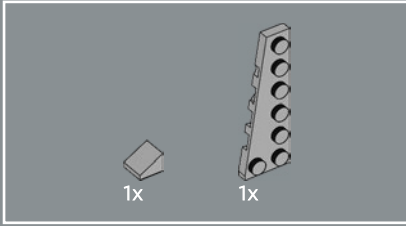
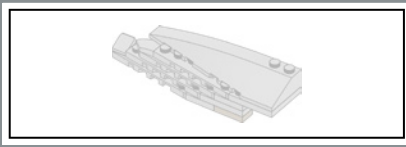

168

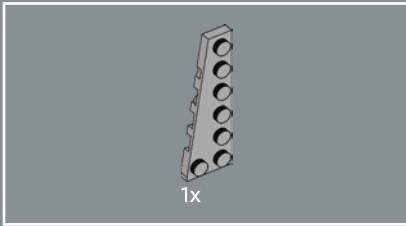
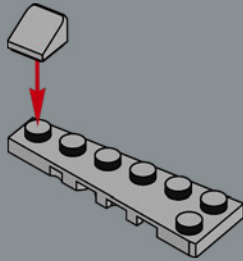

169

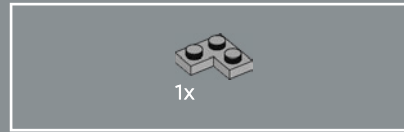
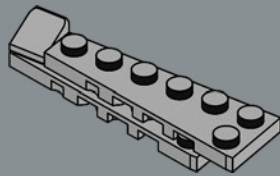

170

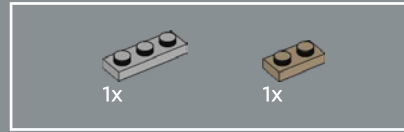
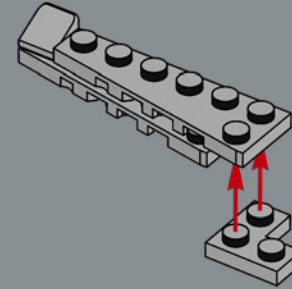

171

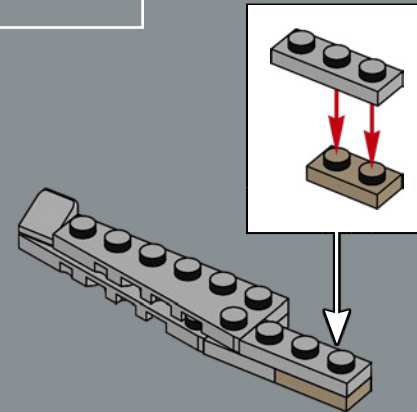

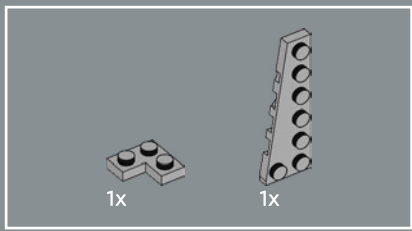

172

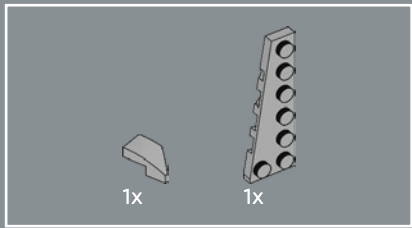
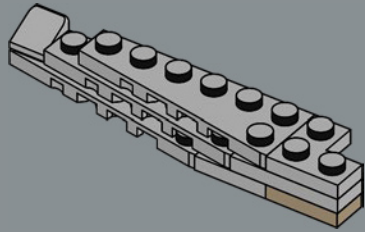

173

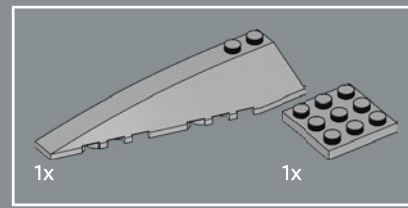
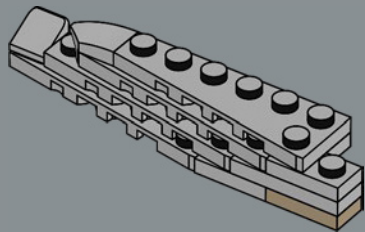

174

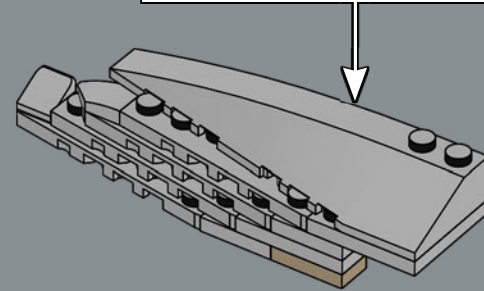
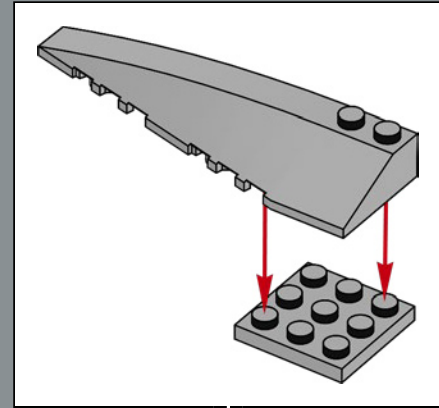

175

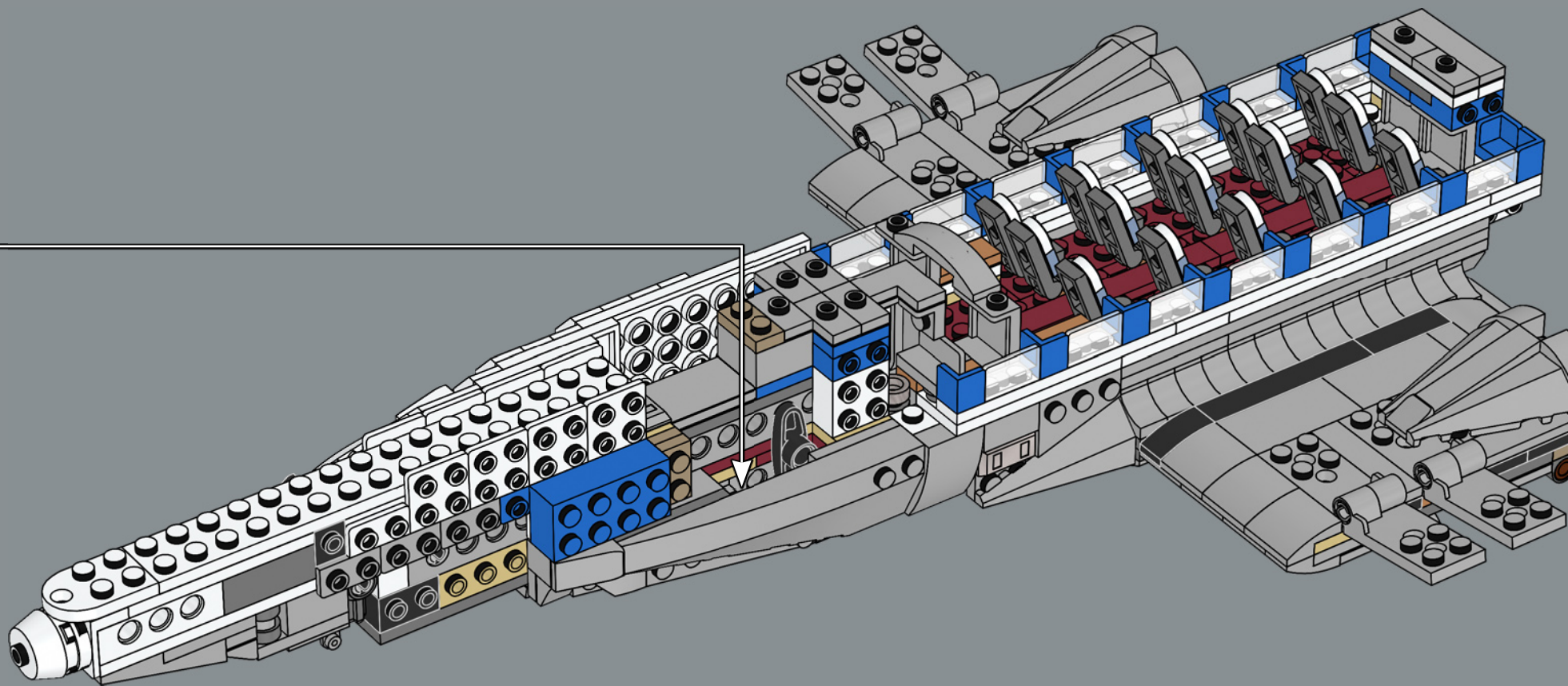

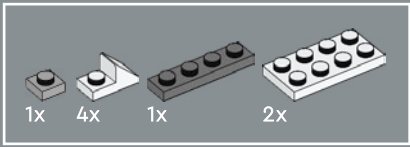

176

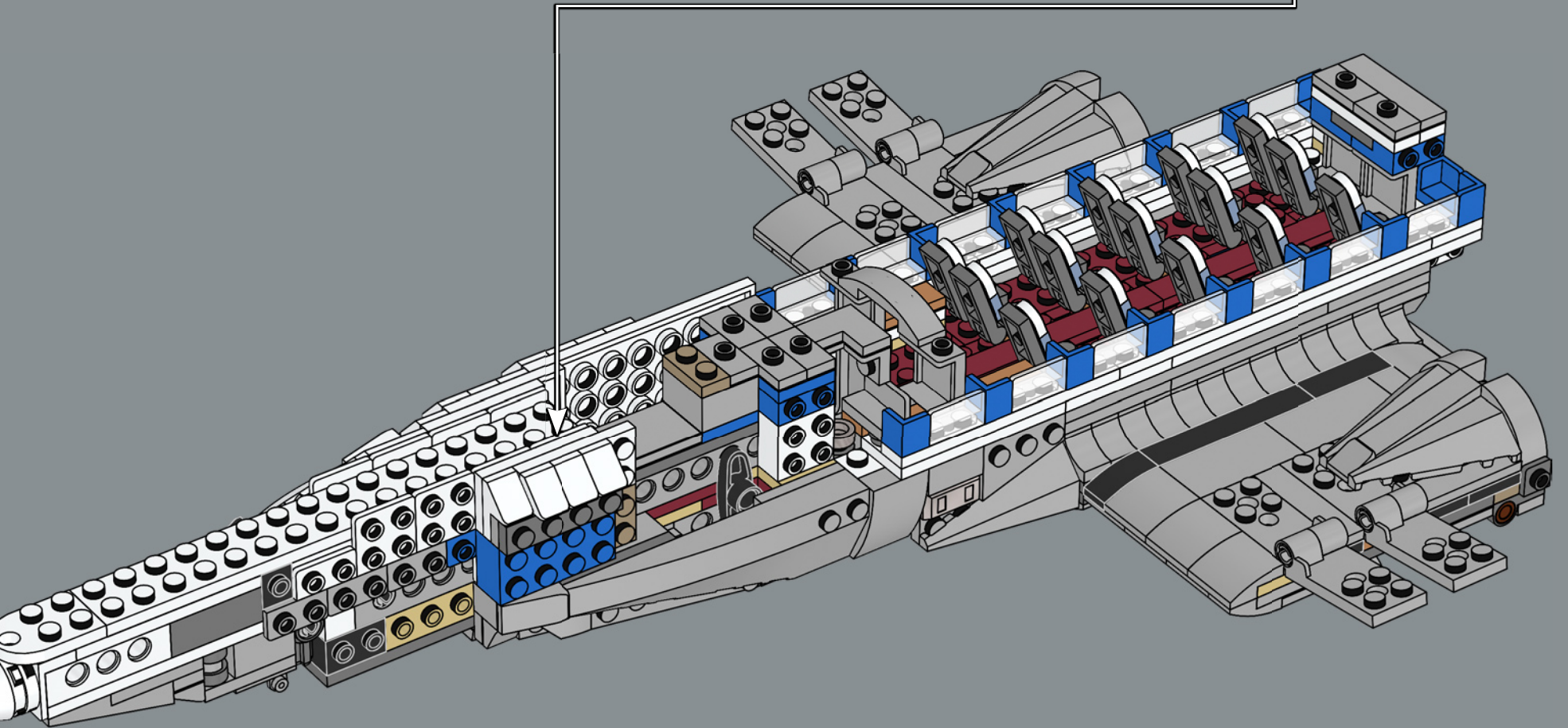
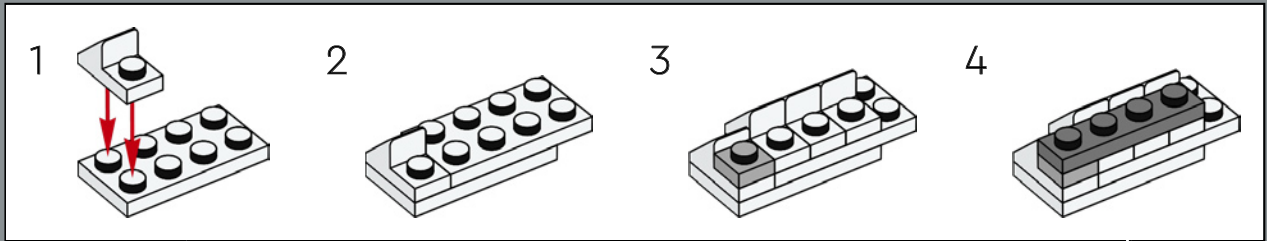

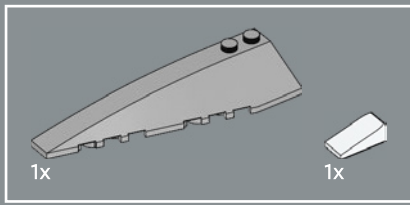

177

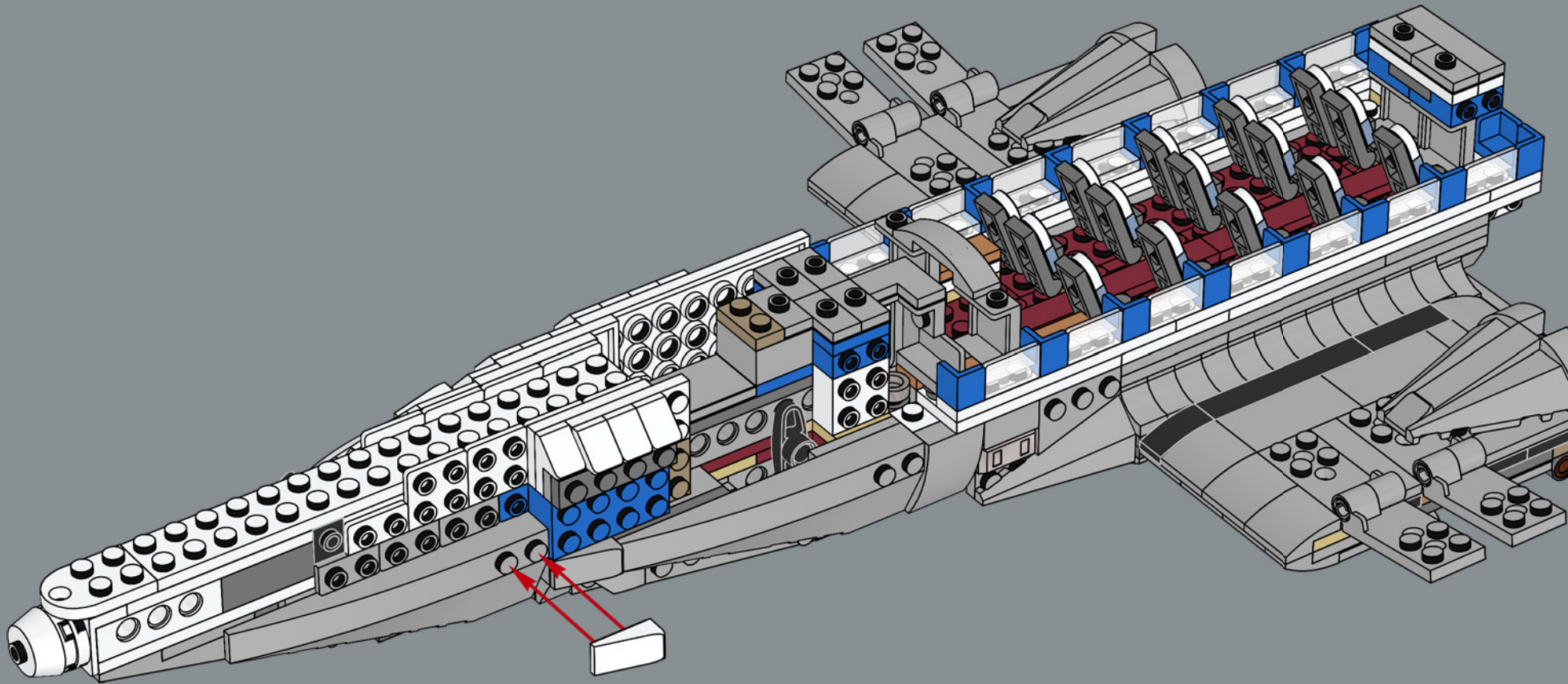

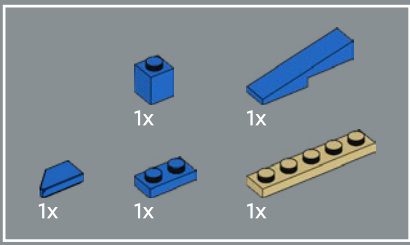

178

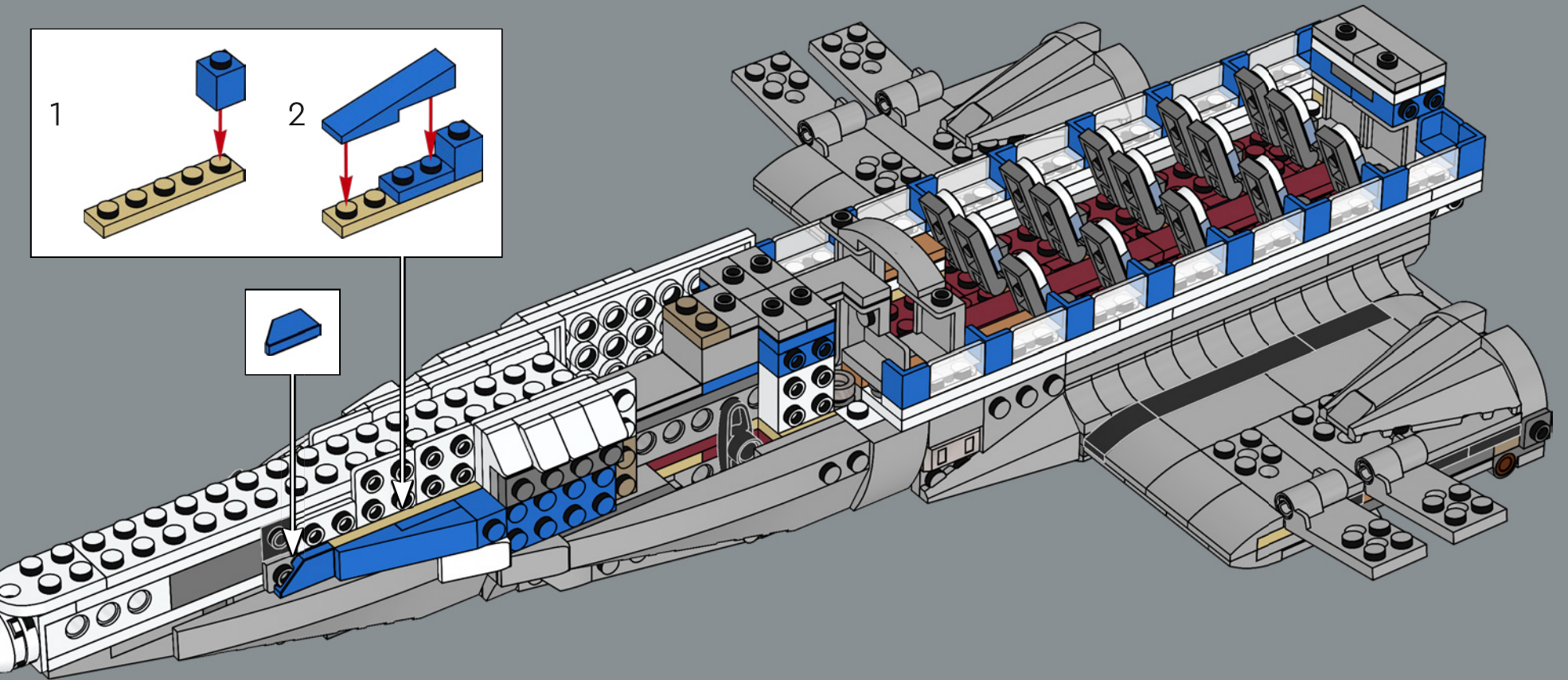
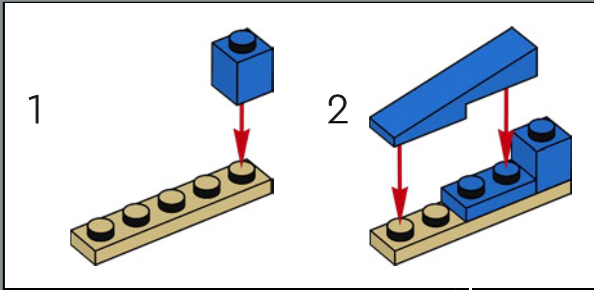

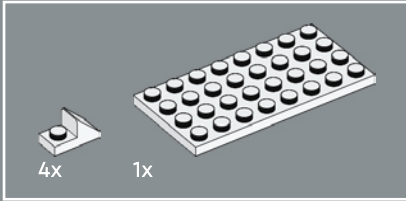
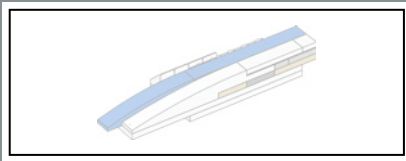

179

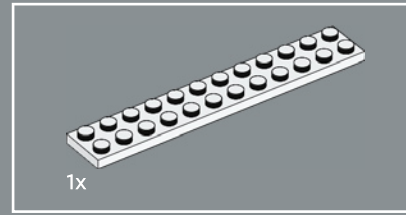
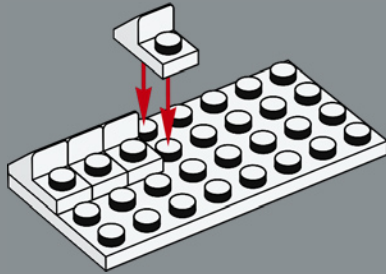

180

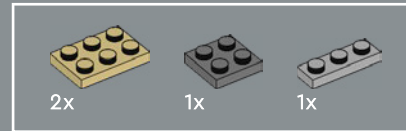
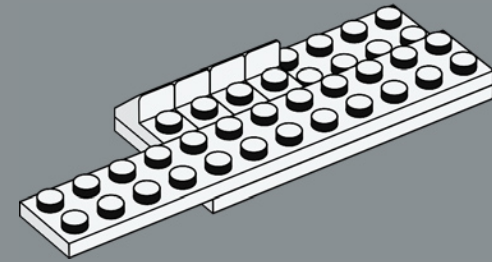

181

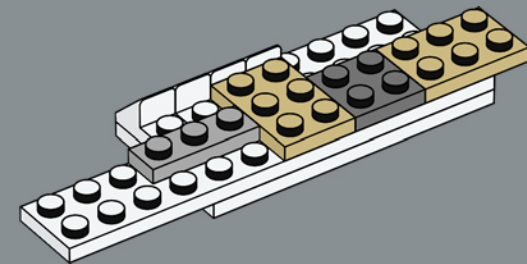

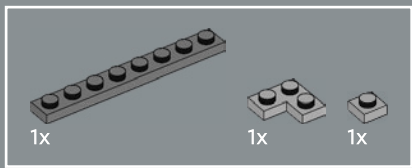

182

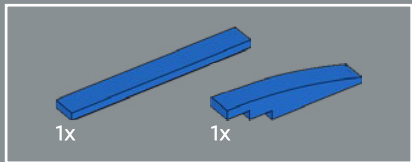
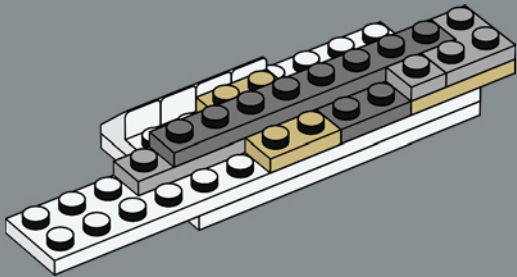

183

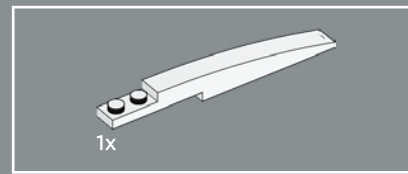
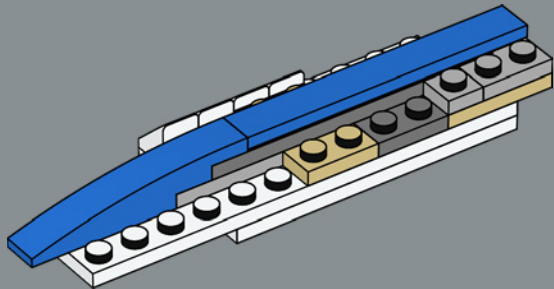

184

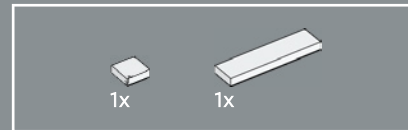
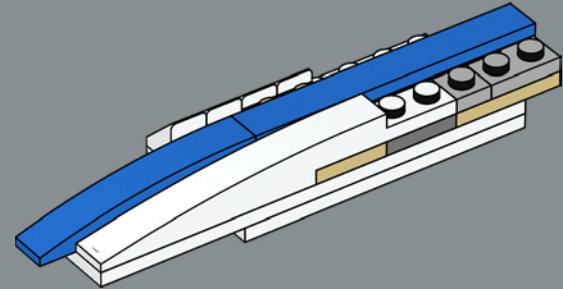

185

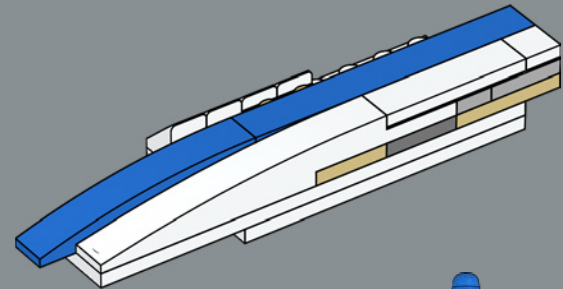

186

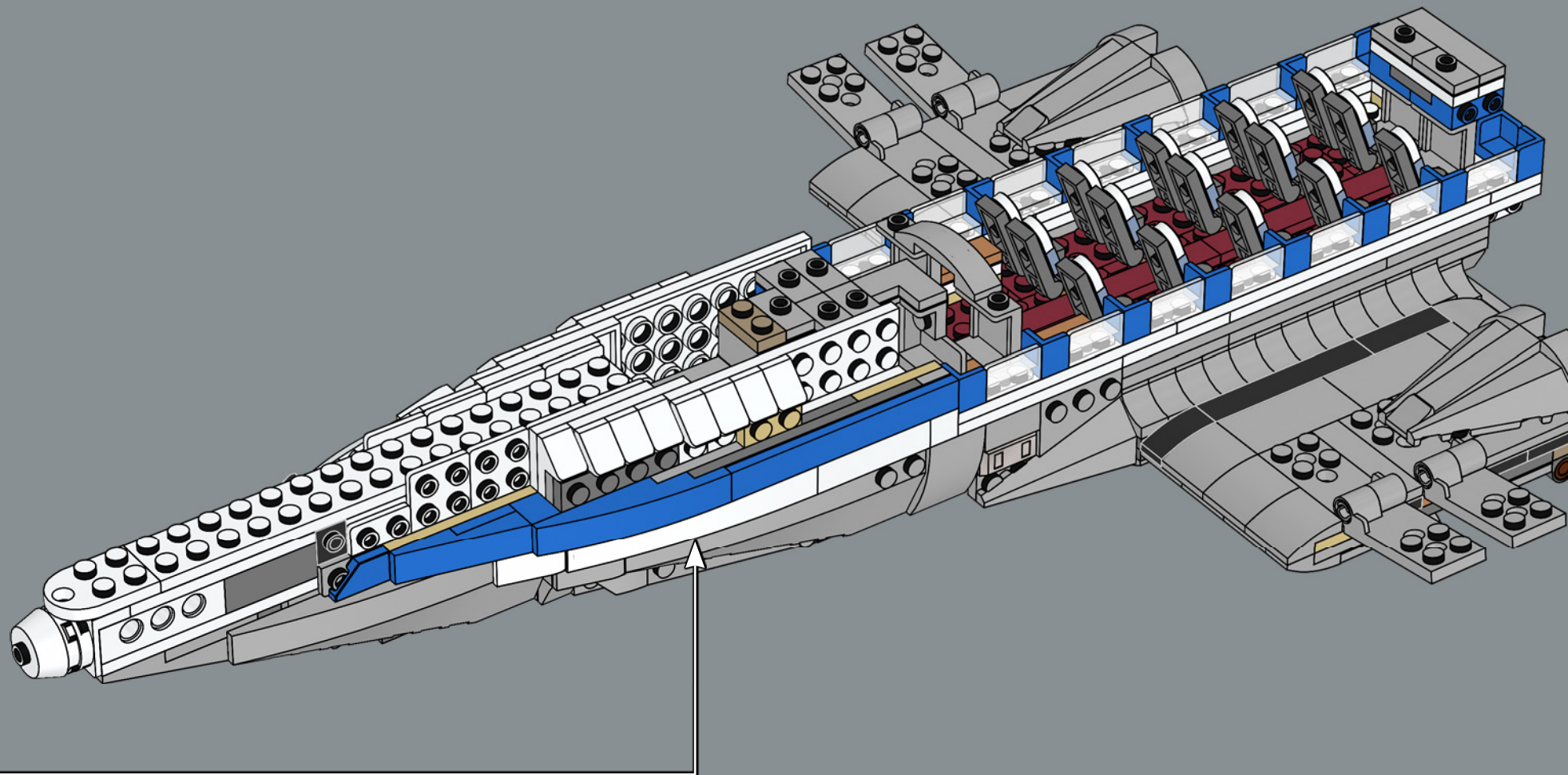

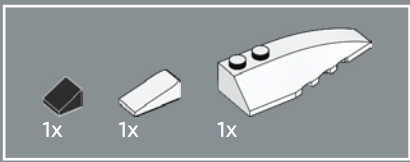

187

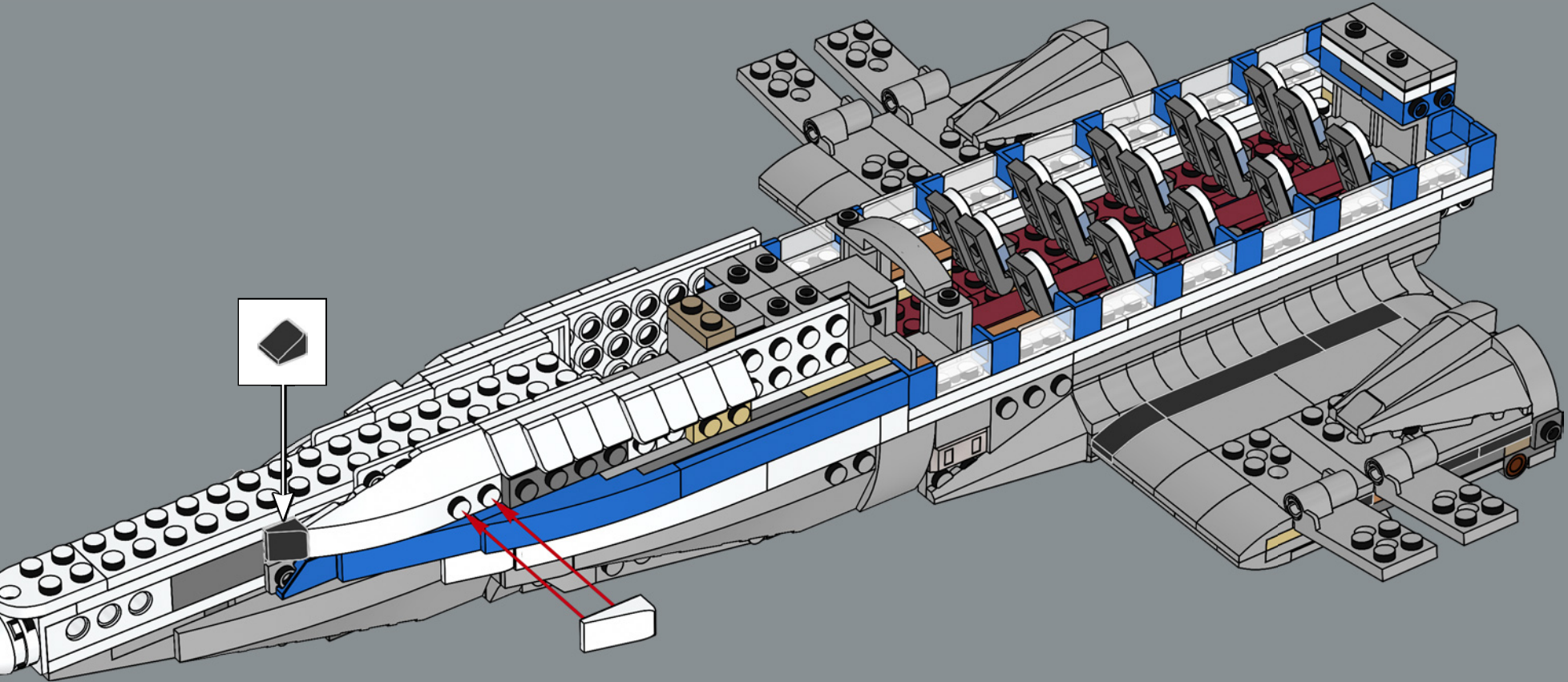



Pan Am® was the first airline to introduce standardized, naval-inspired uniforms for pilots.

Pan Am® a été la première compagnie aérienne à introduire des uniformes standardisés, inspirés de la marine, pour ses pilotes.

Pan Am® fue la primera aerolínea en introducir uniformes estandarizados de inspiración naval para los pilotos.

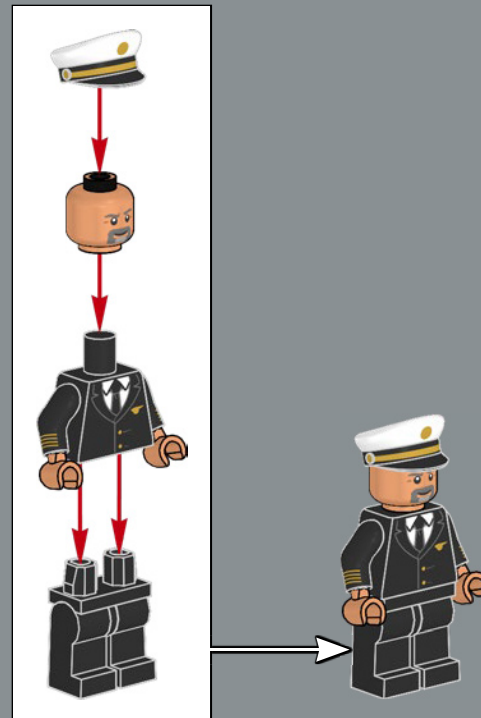

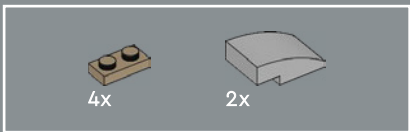

188

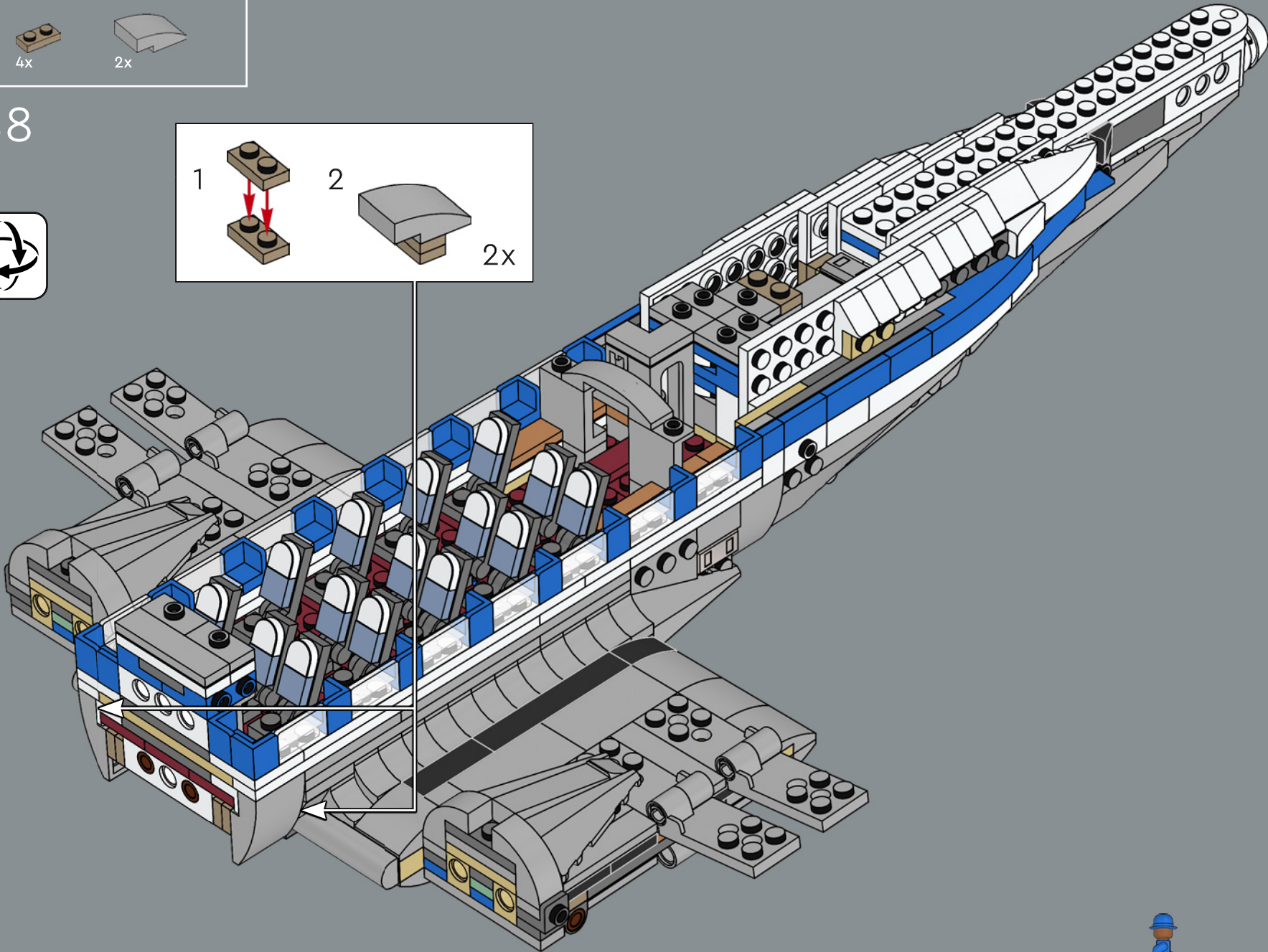
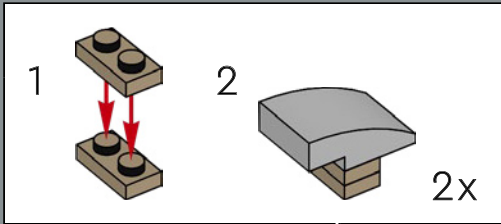

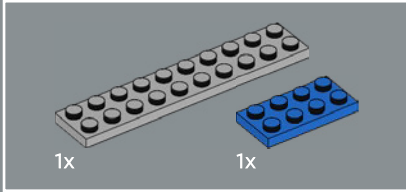
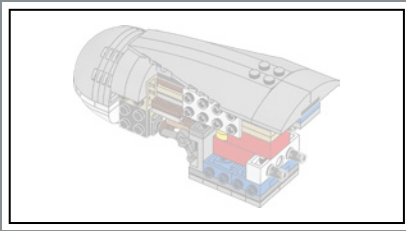

189

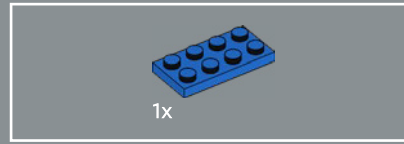
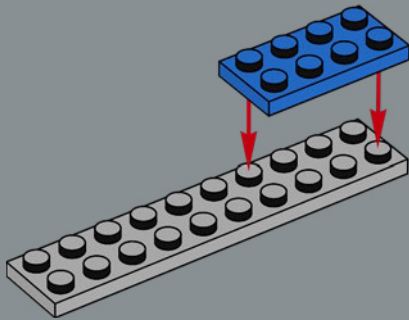

190

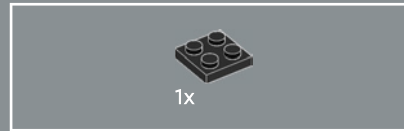
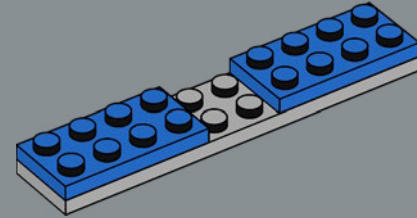

191

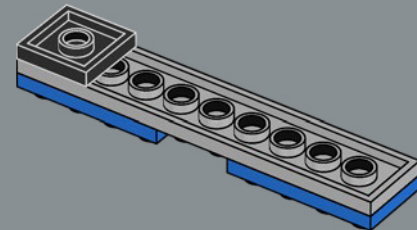



192

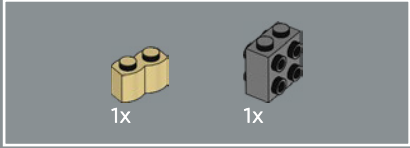
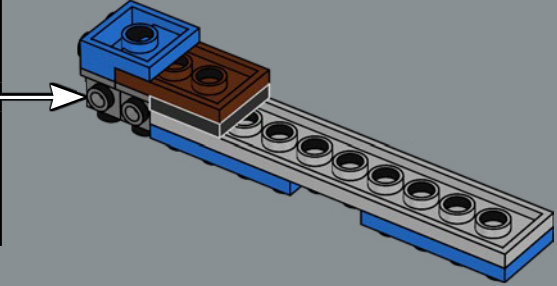
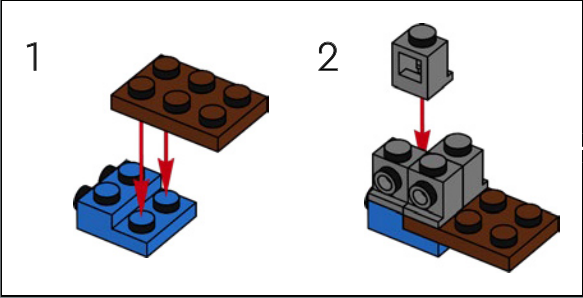

193

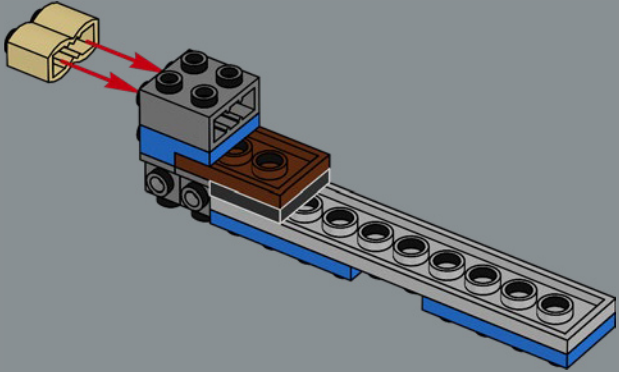

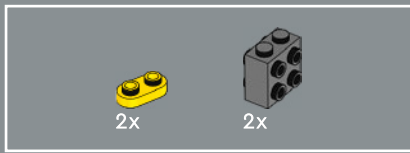

194

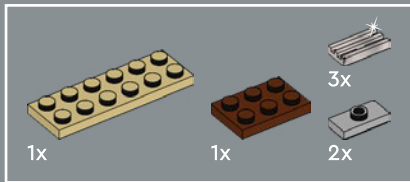
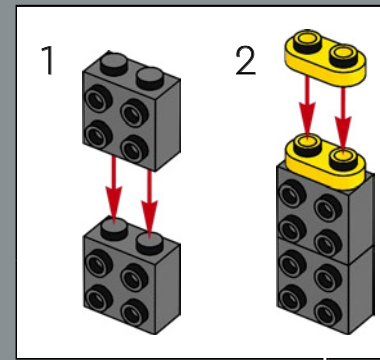
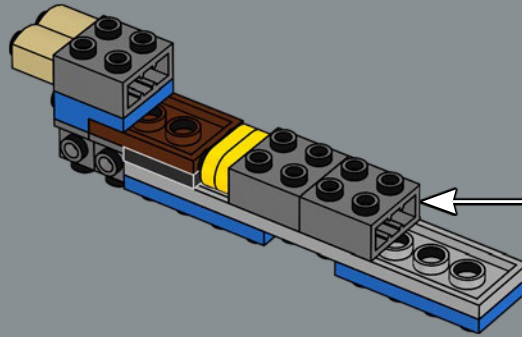

195

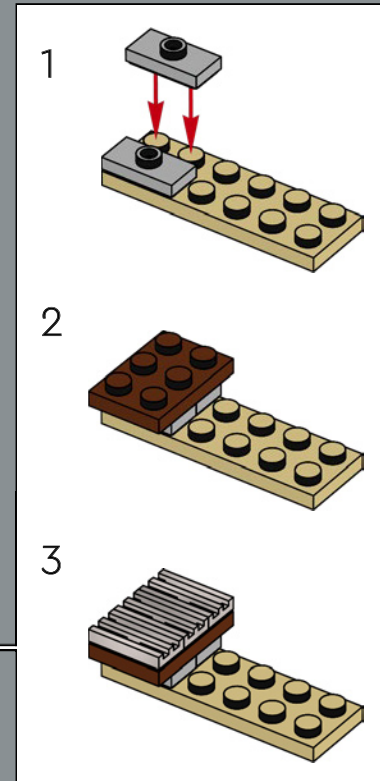
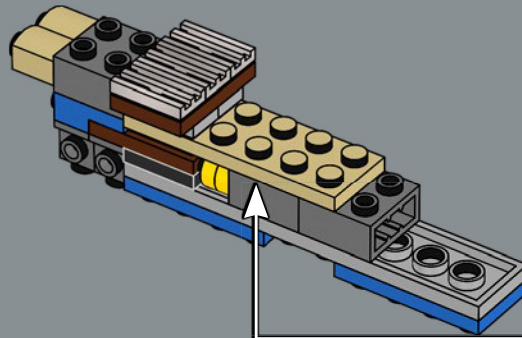



196

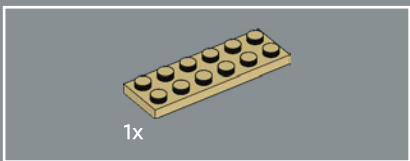
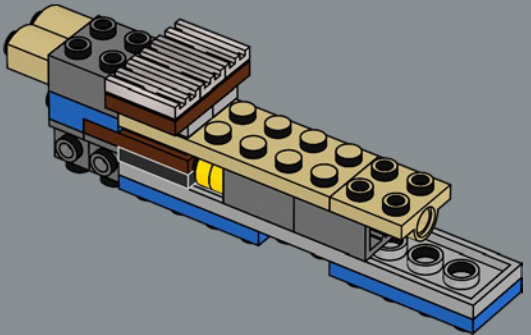

197

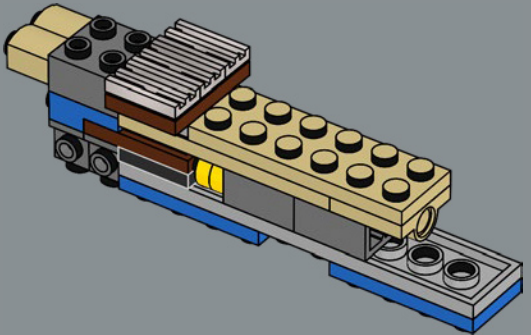

198

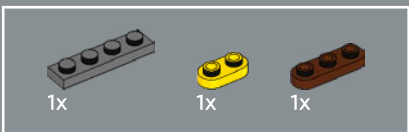
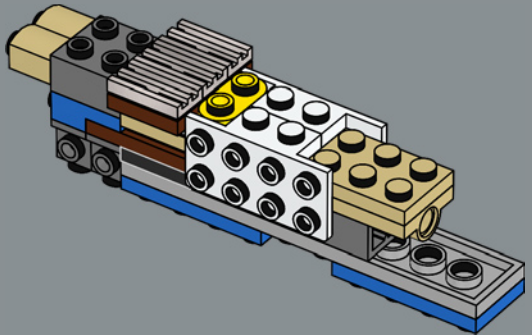

199

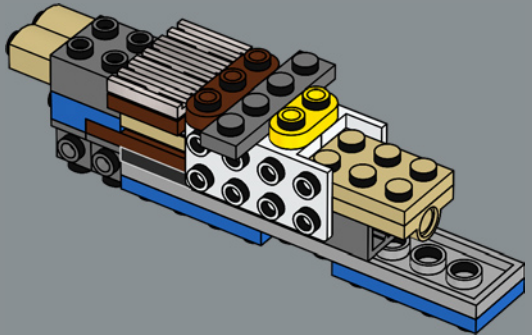

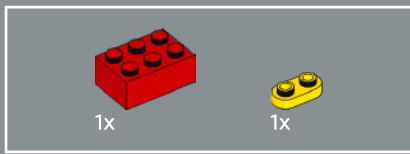

200

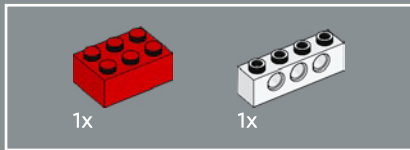
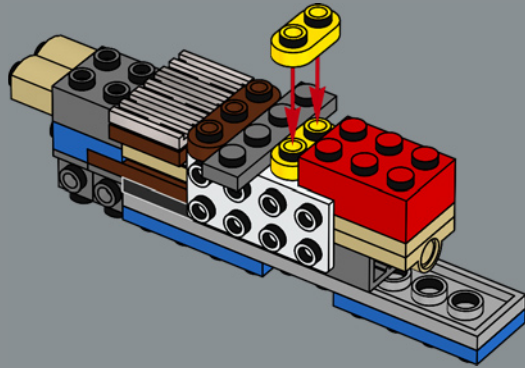

201

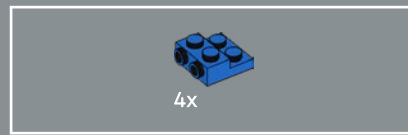
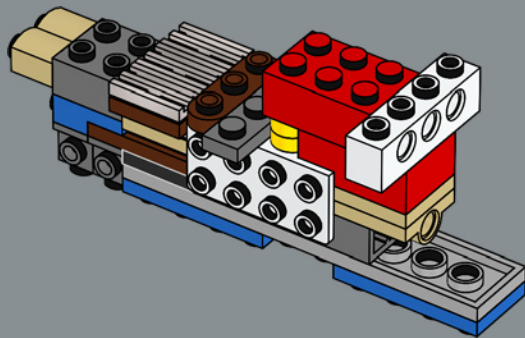

202

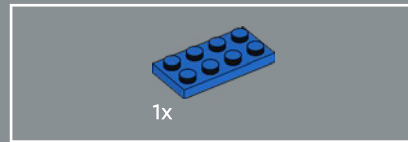
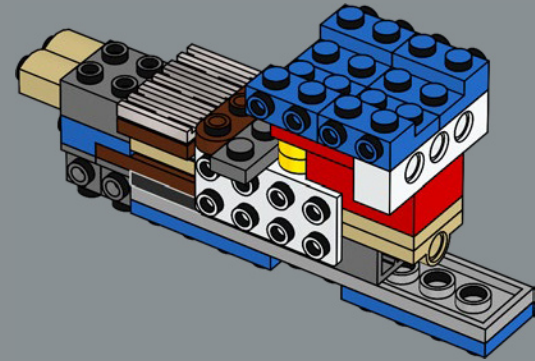

203

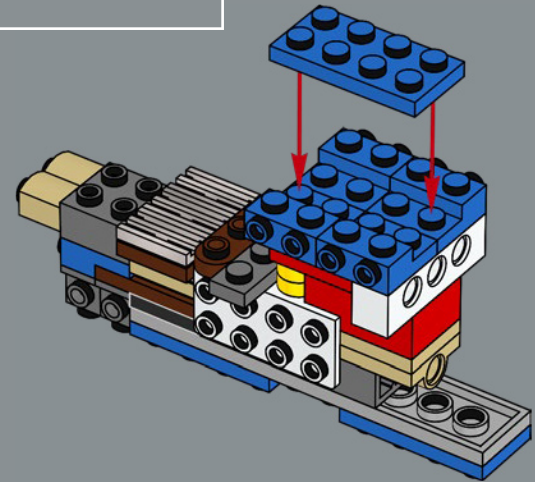

3x

204

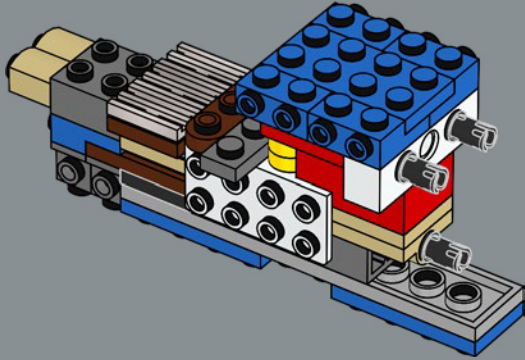

2x

205

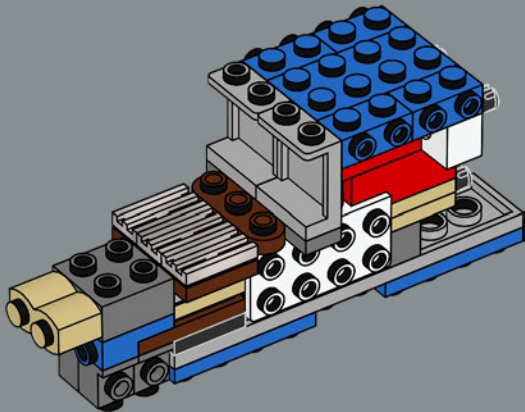

1x

1x

206

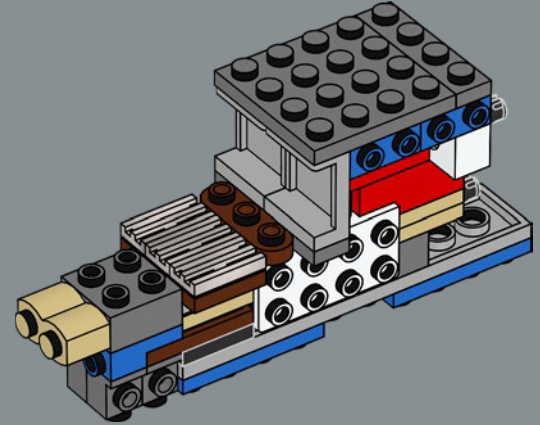

10x

207

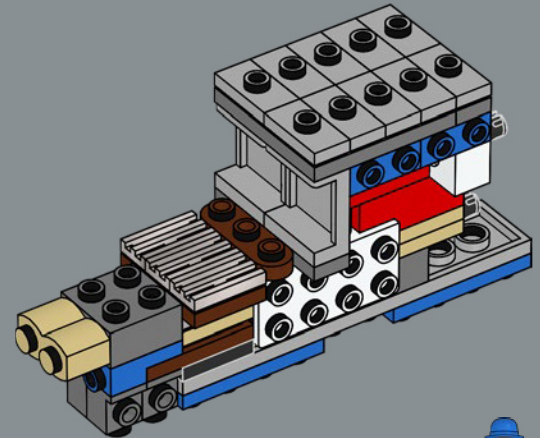

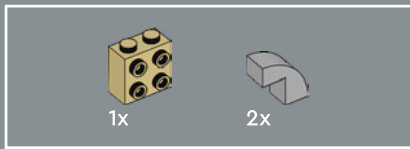

208

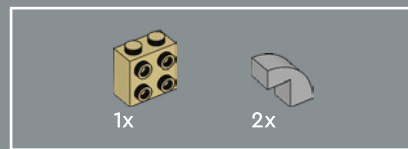
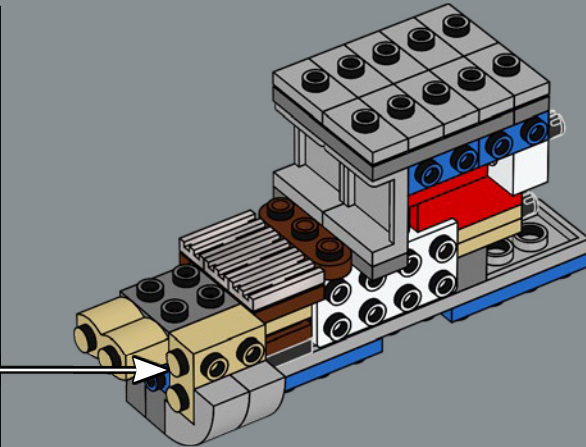
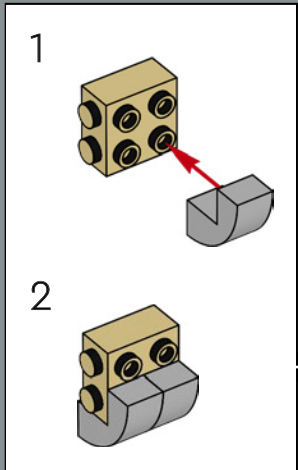

209

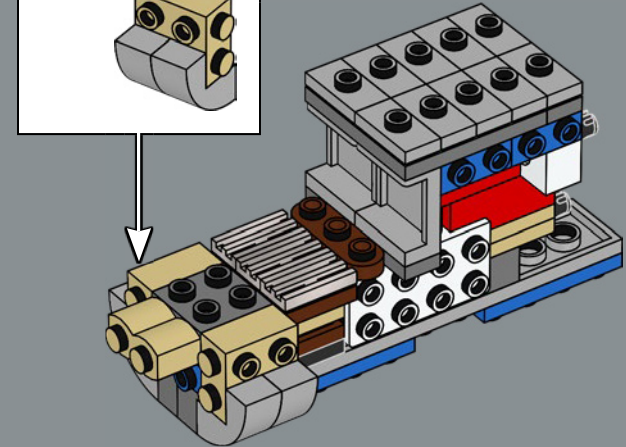
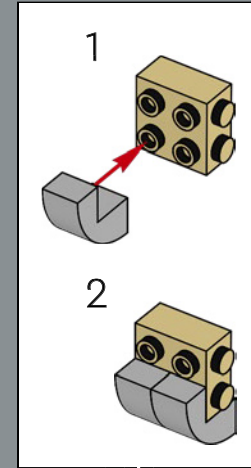



2x

210

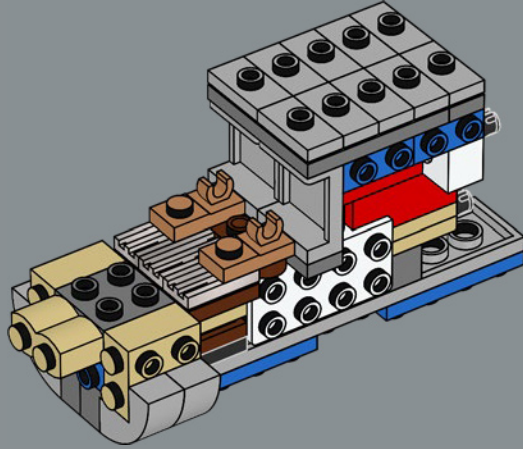

2x



4x

211

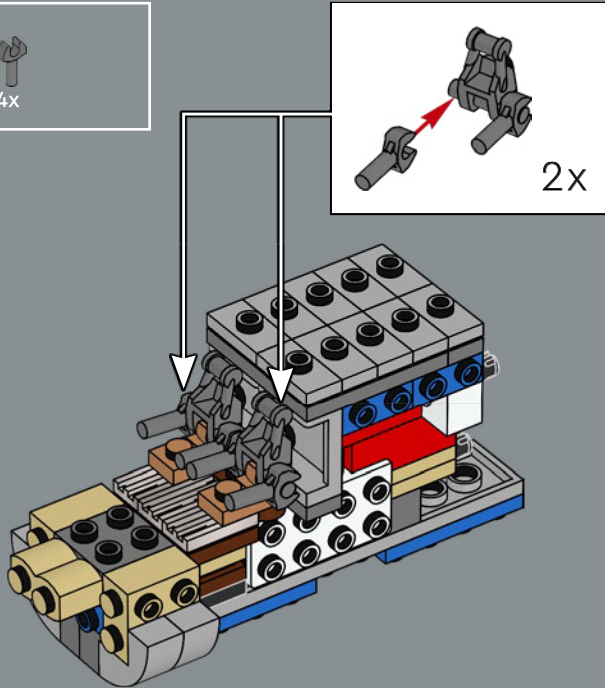

2x



1x



1x



1x



1x



1x



1x

212

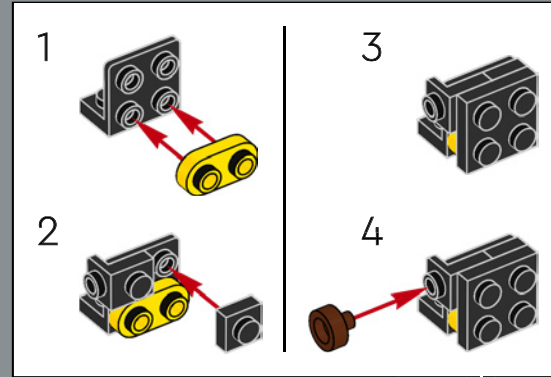

4



3

1

2



4



3

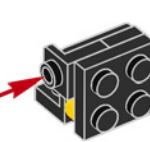

4



3

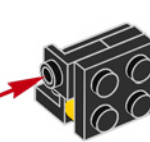

4



3

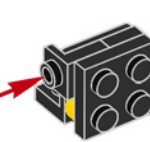

4



3

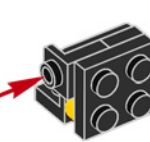

4



3

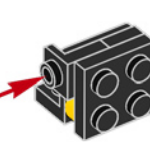

4



3

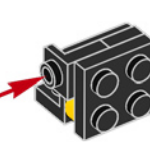

4



3

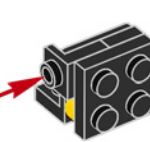

4



3

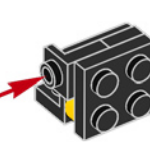

4



3

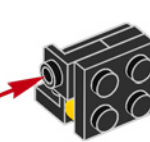

4



3

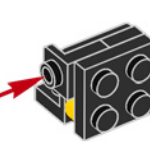

4



3

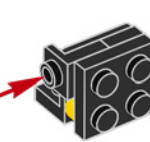

4



3

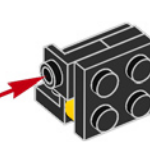

4



3

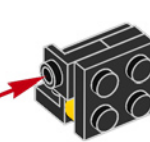

4



3

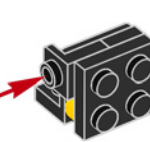

4



3

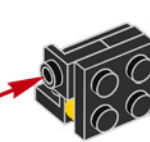

4



3

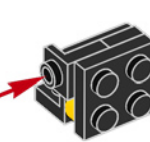

4



3

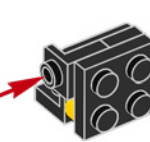

4



3

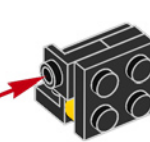

4



3

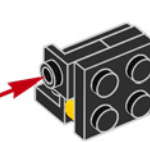

4



3

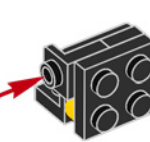

4



3

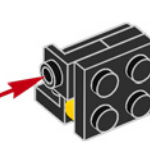

4



3

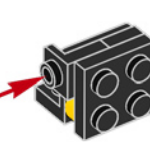

4



3

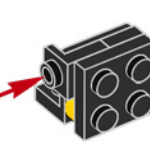

4



3

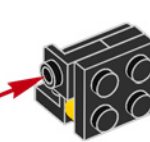

4



3

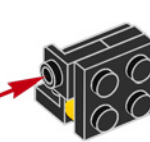

4



3

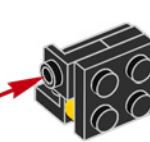

4



3

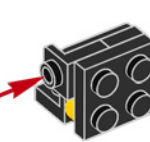

4



3

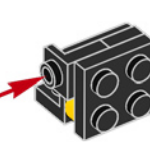

4



3

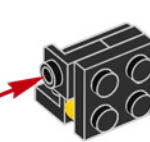

4



3

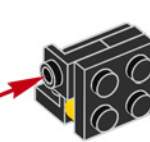

4



3

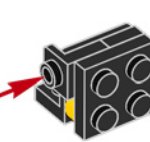

4



3

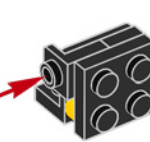

4



3

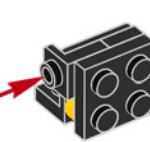

4



3

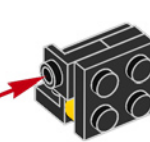

4



3

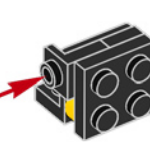

4



3

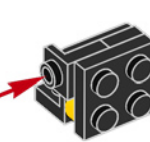

4



3

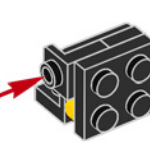

4



3

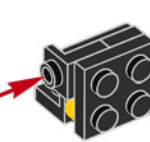

4



3

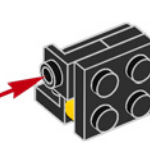

4



3

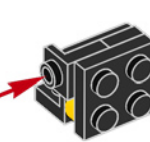

4



3

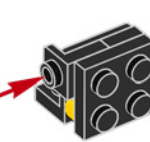

4



3

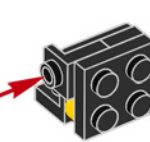

4



3

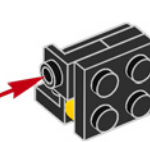

4



3

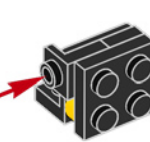

4



3

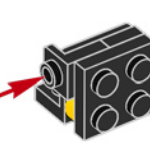

4



3

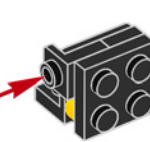

4



3

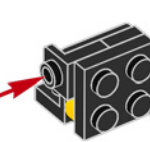

4



3

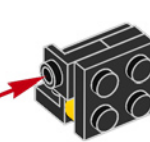

4



3

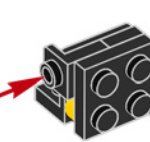

4



3

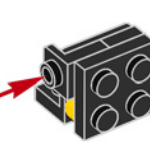

4



3

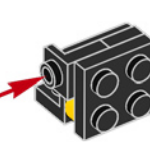

4



3

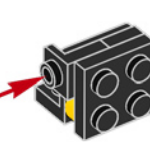

4



3

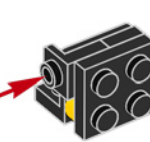

4



3

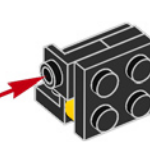

4



3

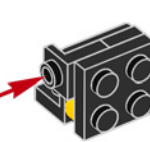

4



3

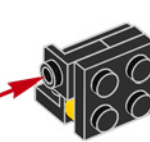

4



3

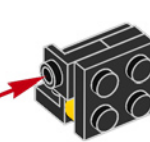

4



3

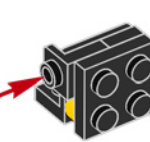

4



3

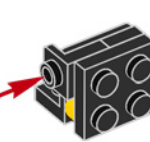

4



3

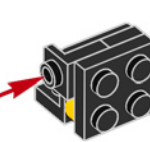

4



3

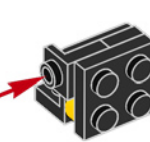

4



3

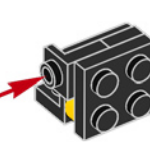

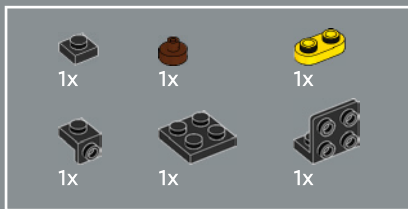

213

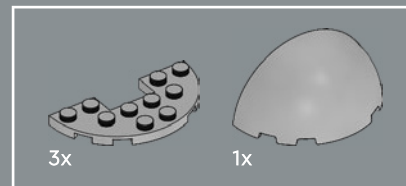
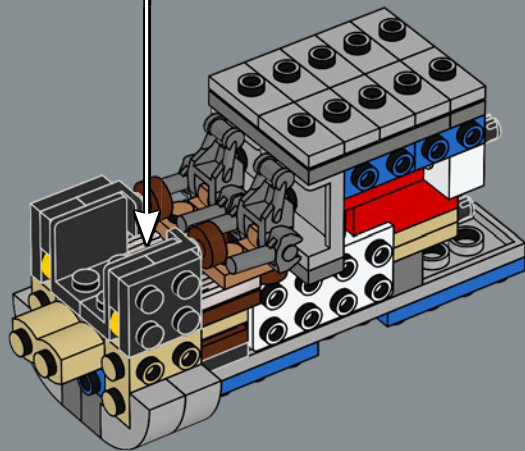
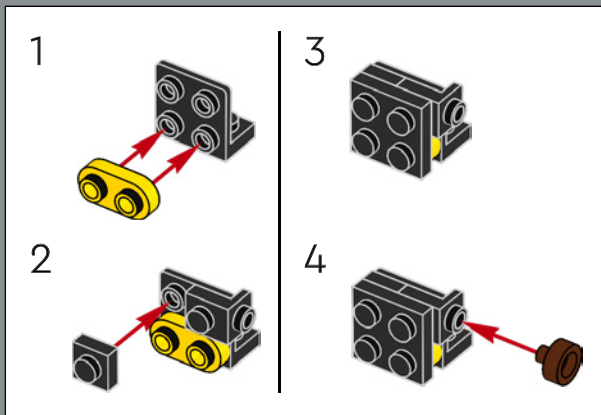

214

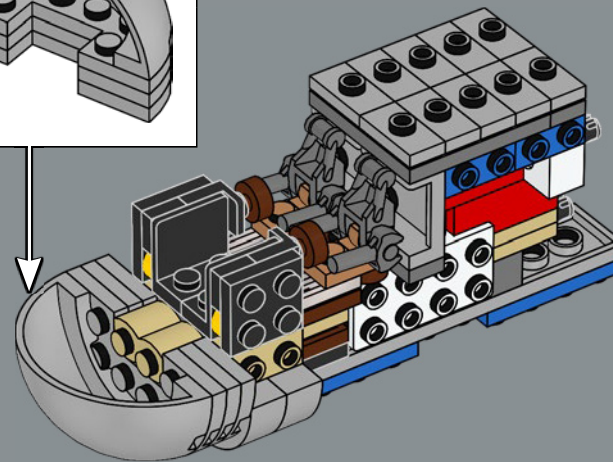
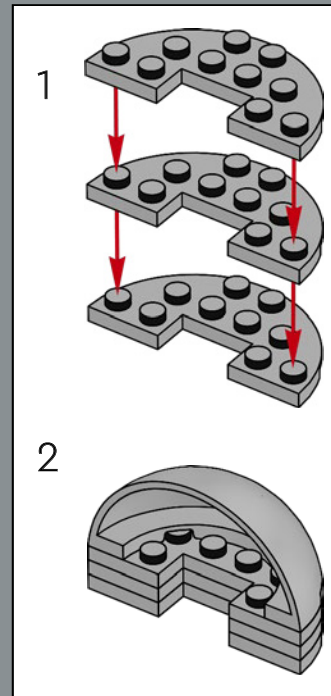



1x

215

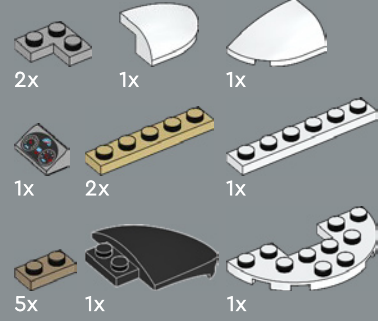
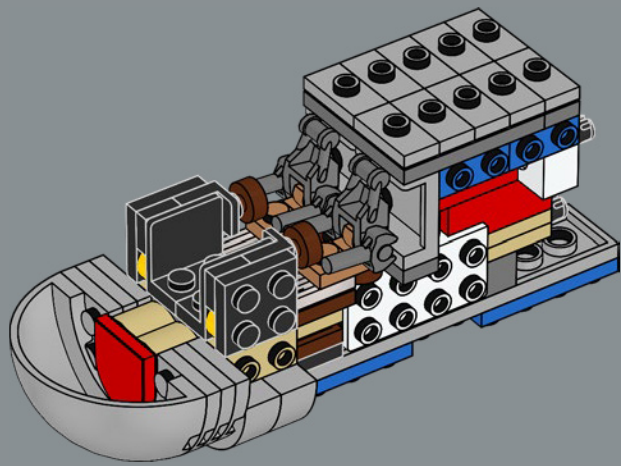

216

1

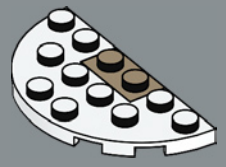

2

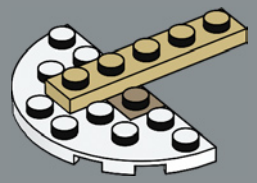

3

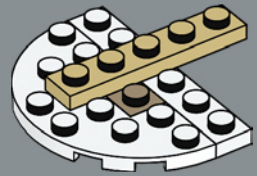

4

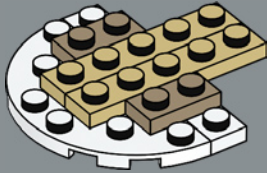

5

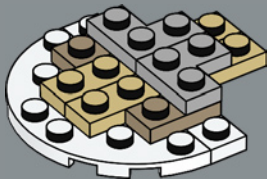

6

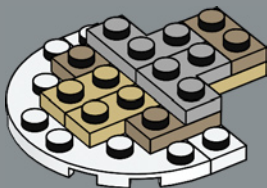

7

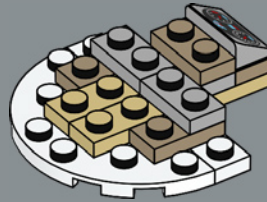

8

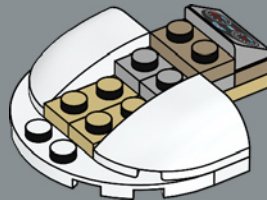

9

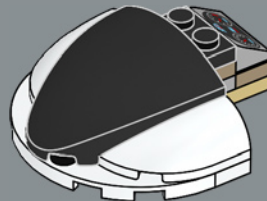

The black nose piece is a LEGO® element that was originally created as a petal piece for building tulips.

La pièce noire du nez est un élément LEGO® à l'origine conçu comme pétale pour construire des tulipes.

La pieza negra de la nariz es un elemento LEGO® que se concibió originalmente como pétalo de tulipán.

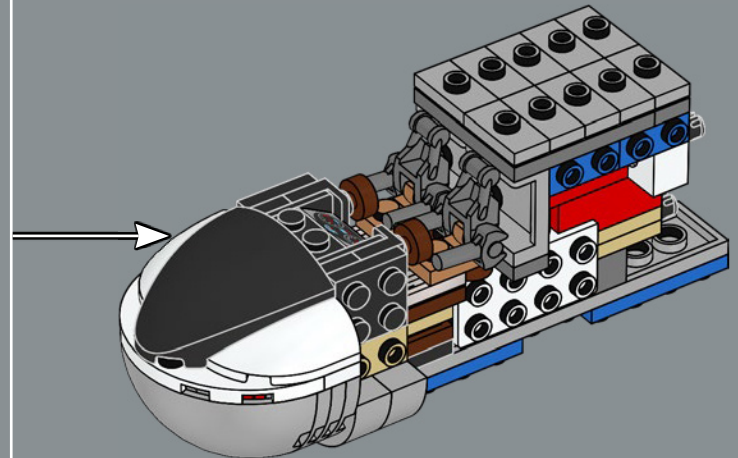

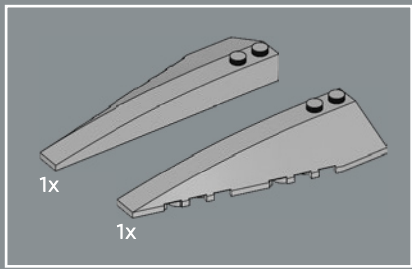

217

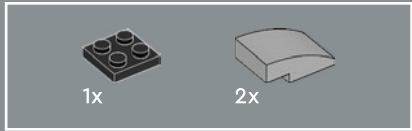
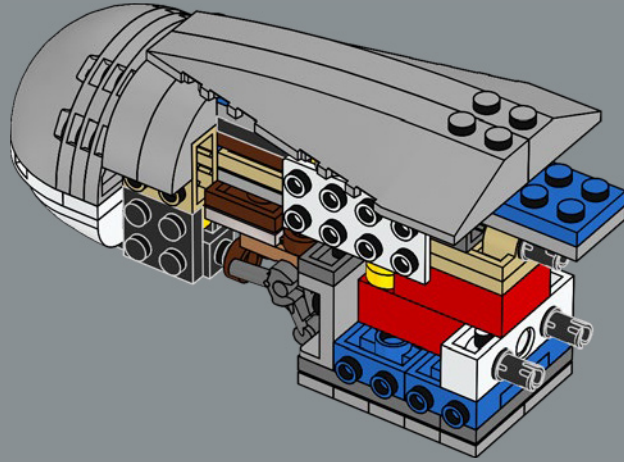

218

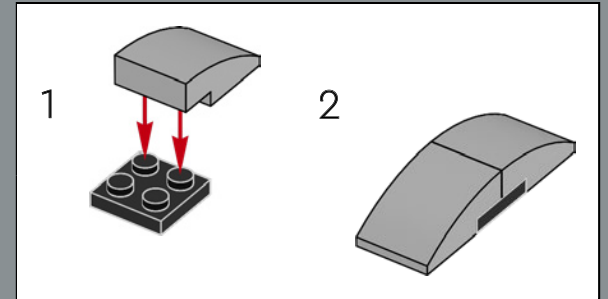
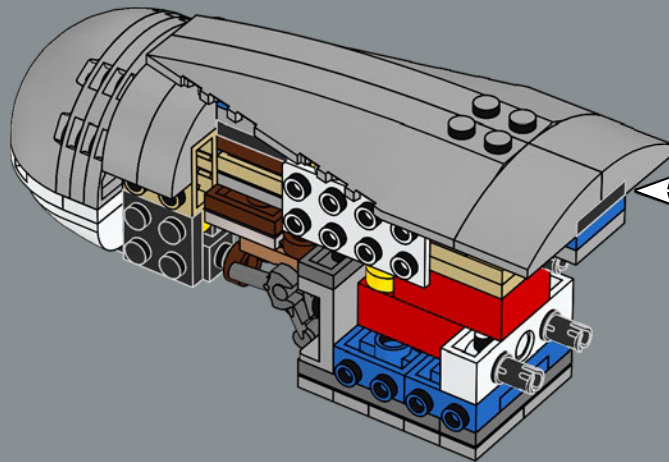

219

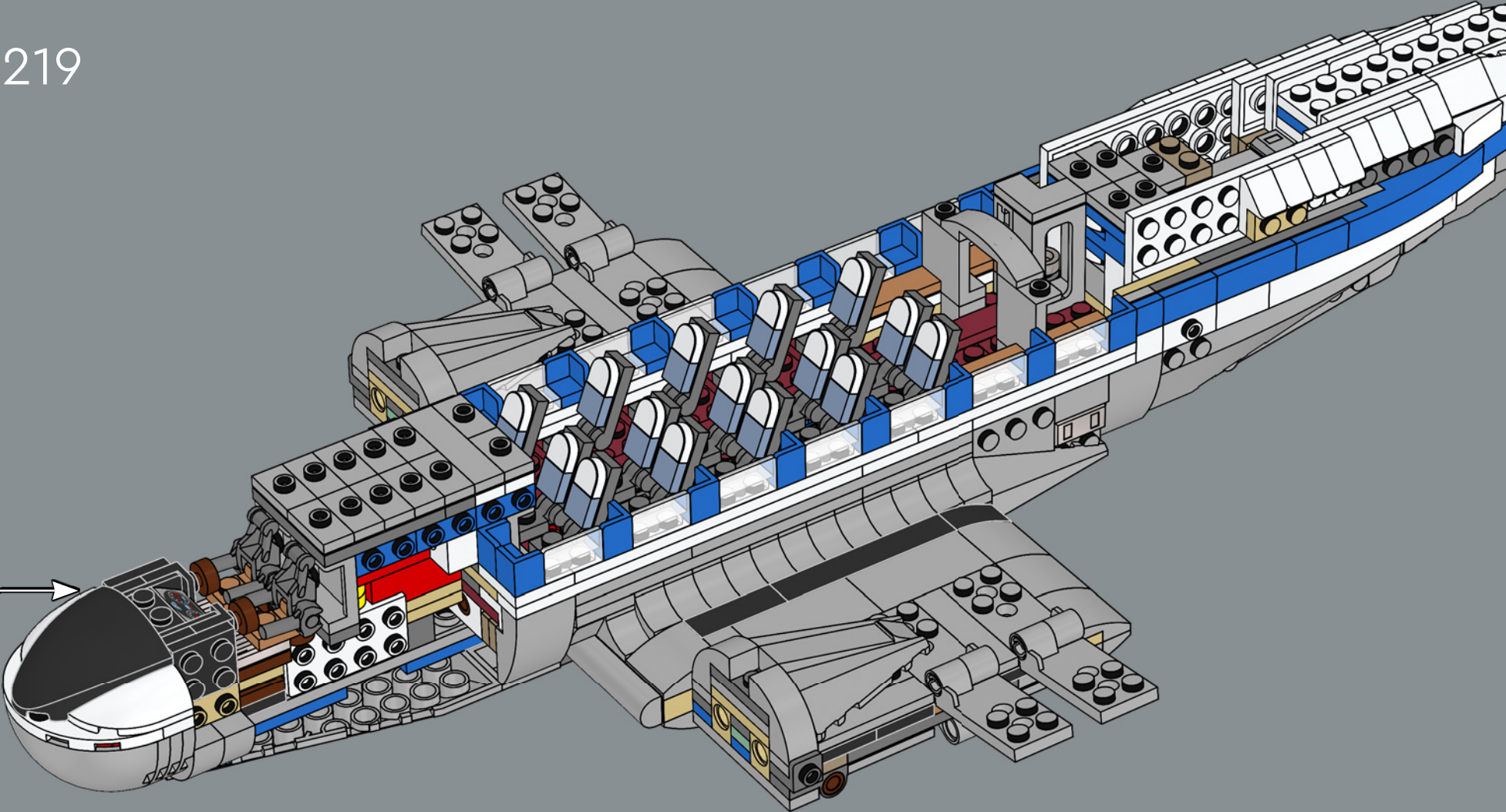

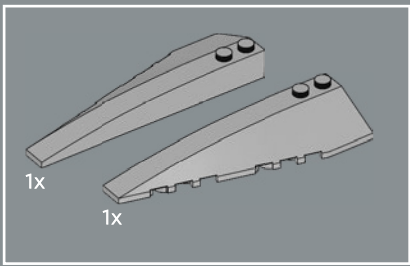

220

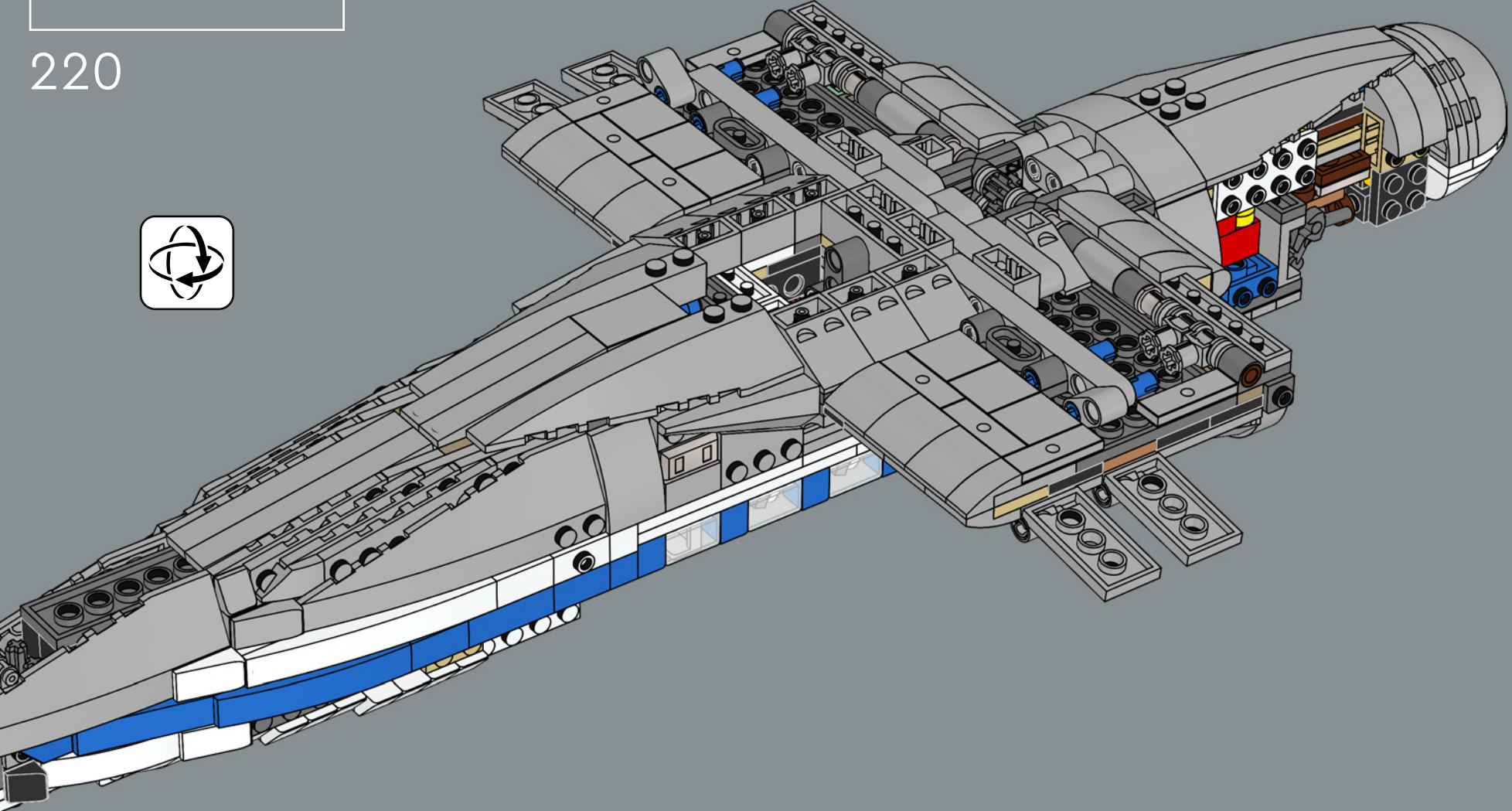

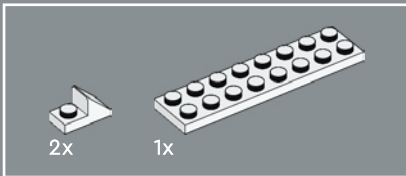
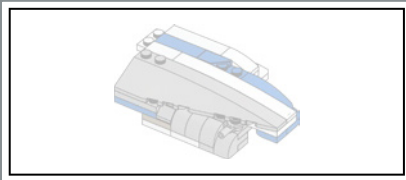

221

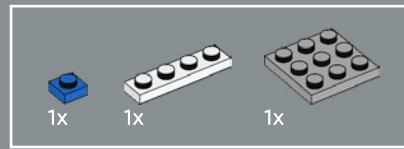
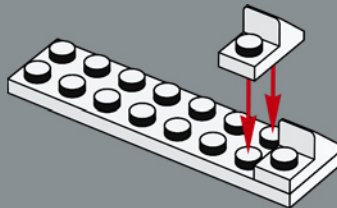

222

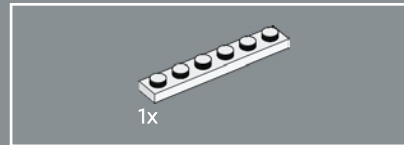
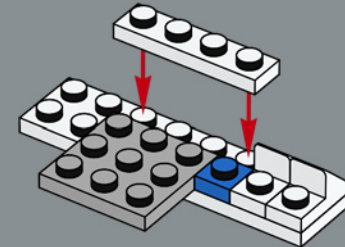

223

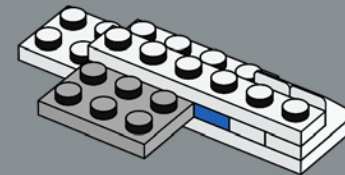

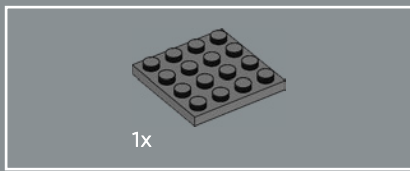

224

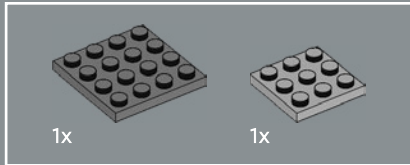
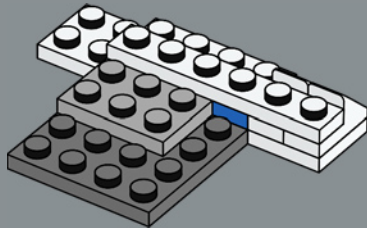

225

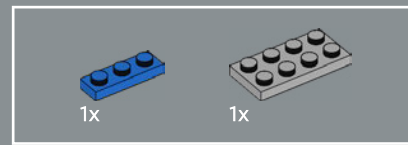
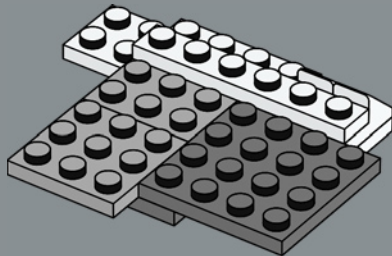

226

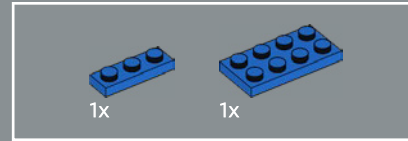
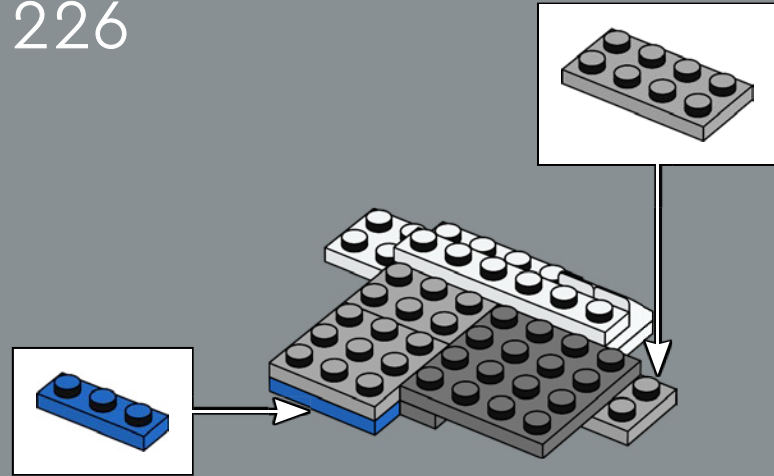

227

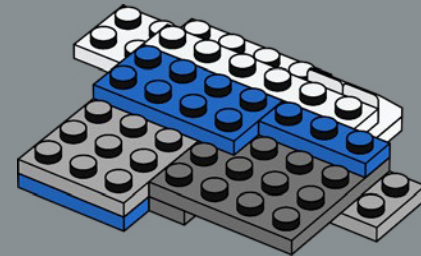

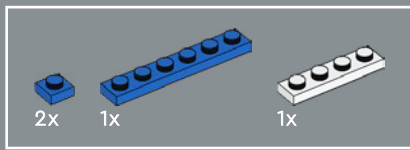

228

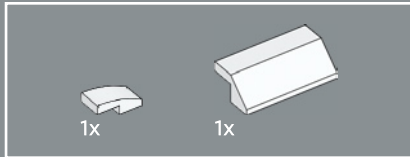
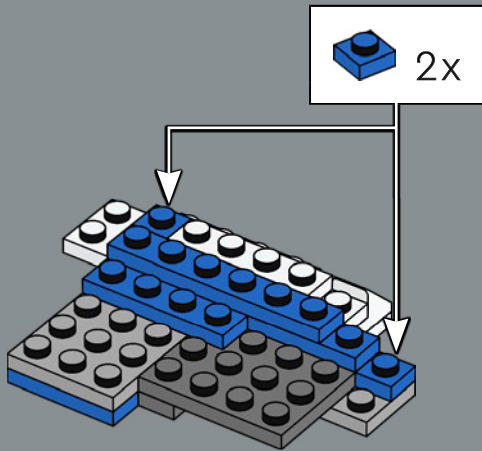

229

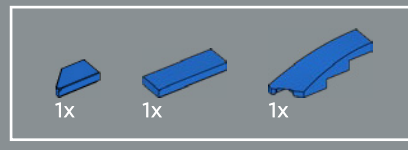
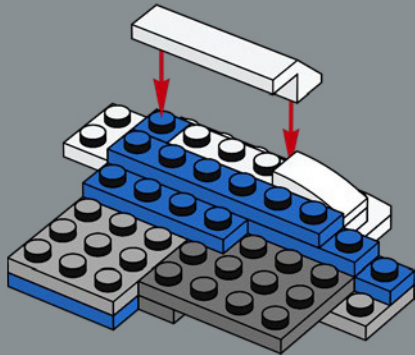

230

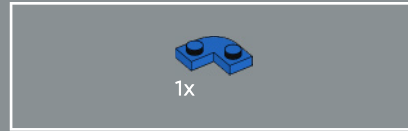
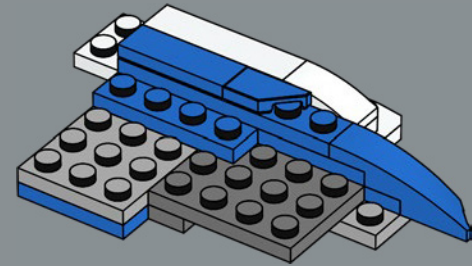

231

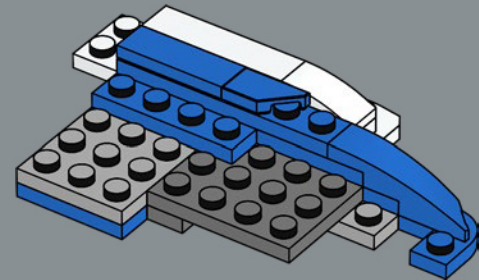

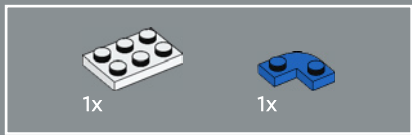

232

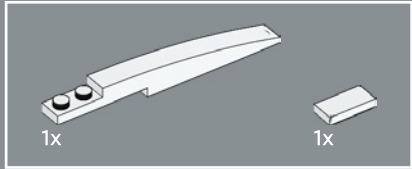
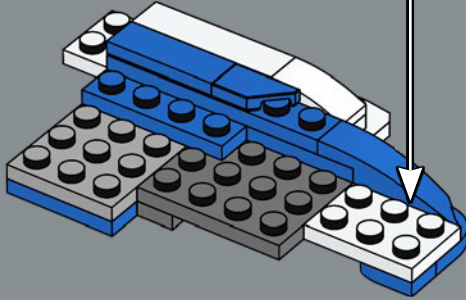
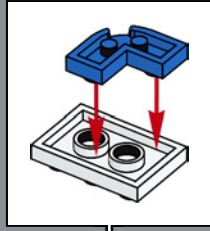

233

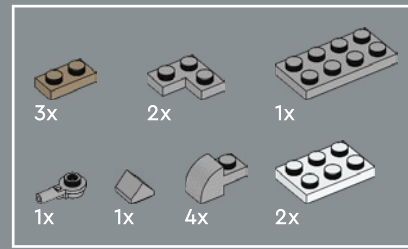
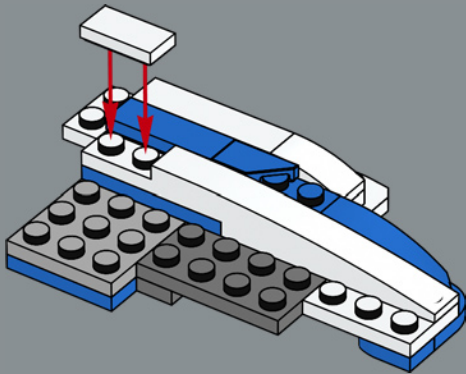

234

1

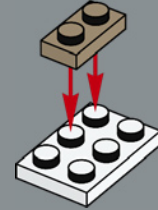

2

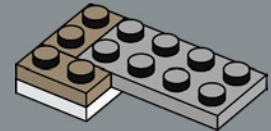

3

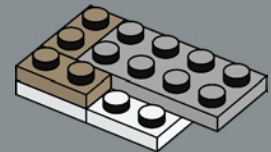

4

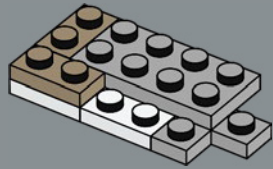

5

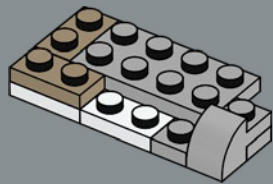

6

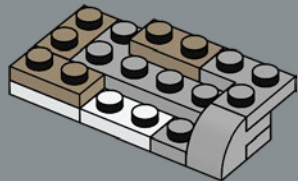

7

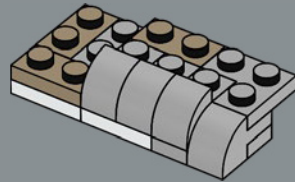

8

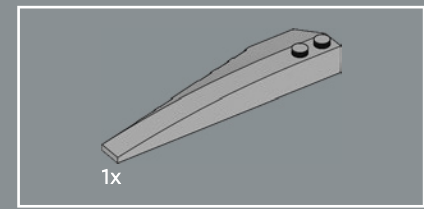
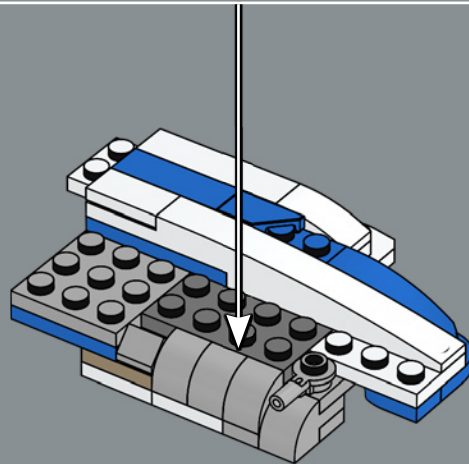
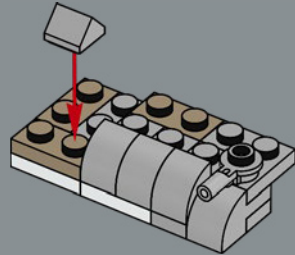

235

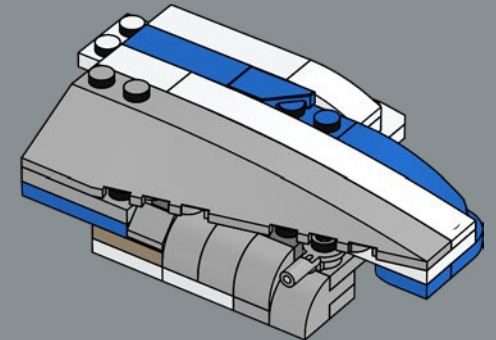

236

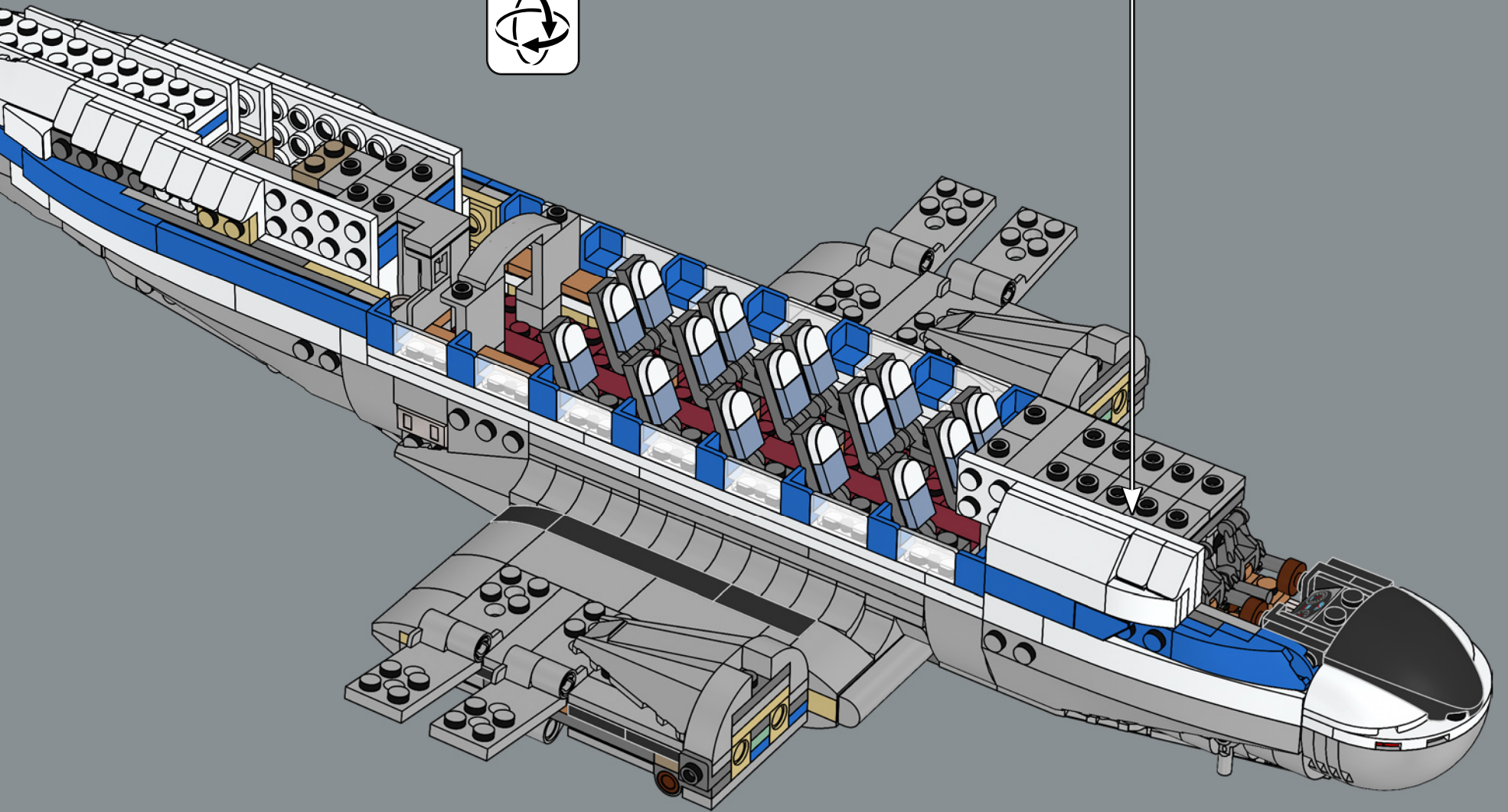

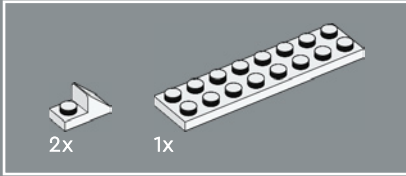
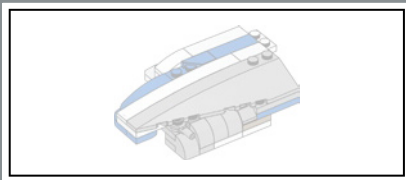

237

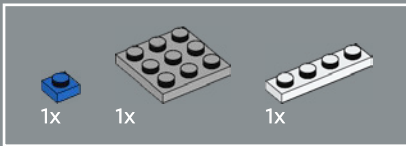
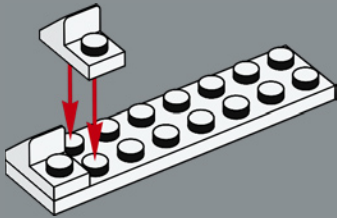

238

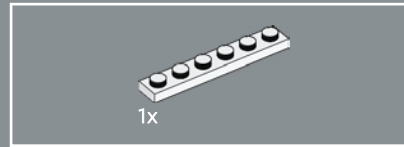
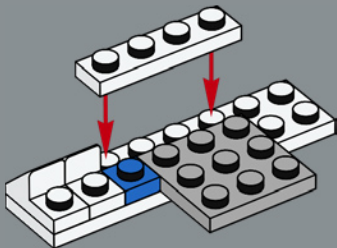

239

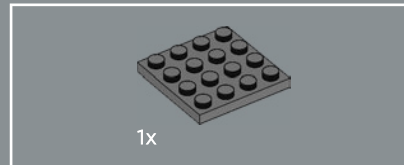
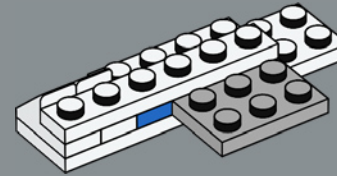

240

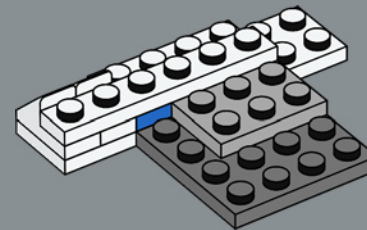

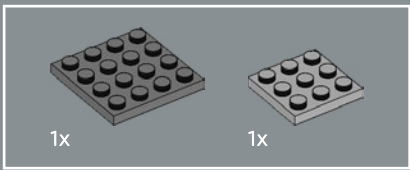

241

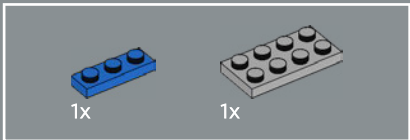
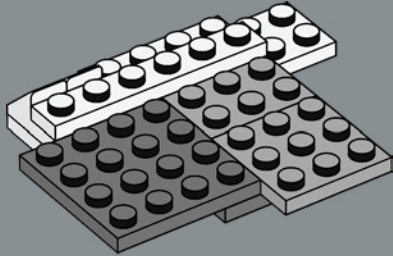

242

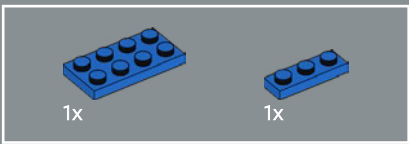
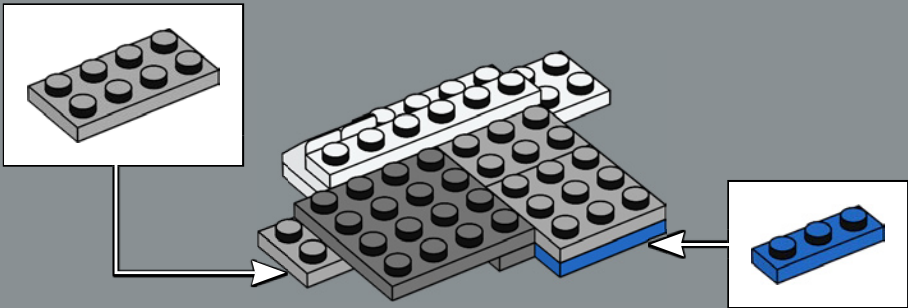

243

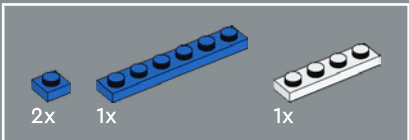
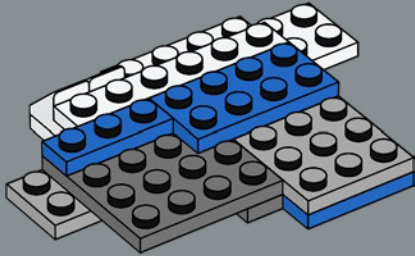

244

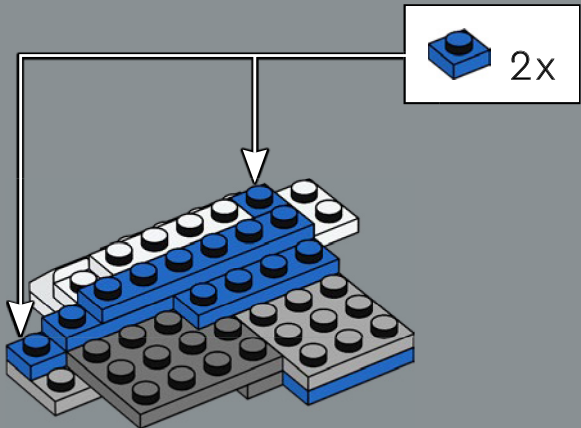

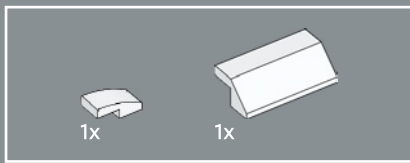

245

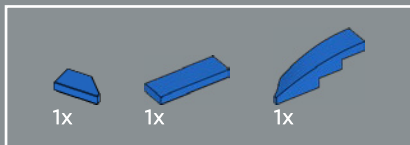
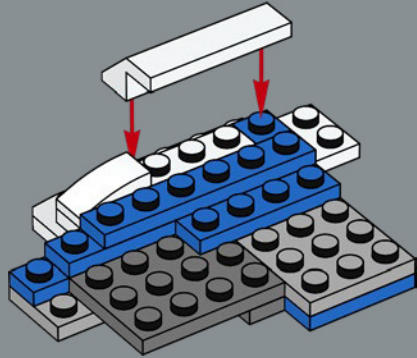

246

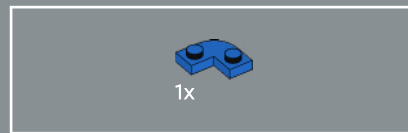
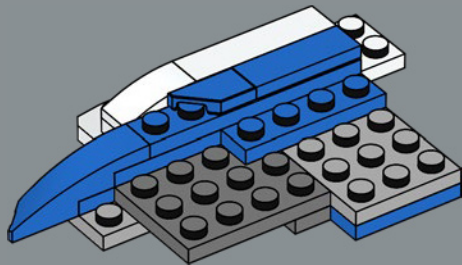

247

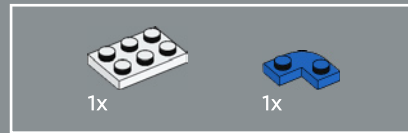
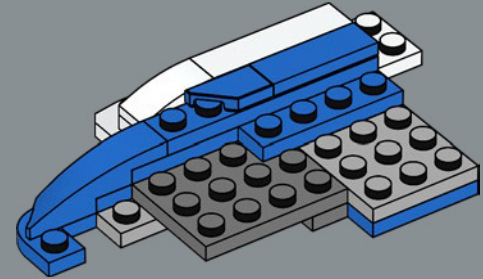

248

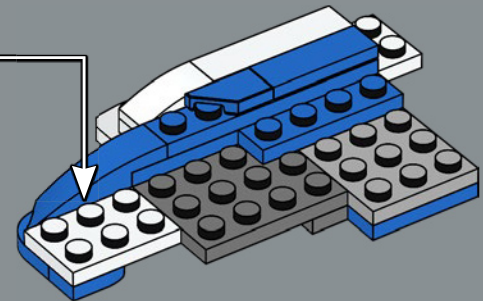
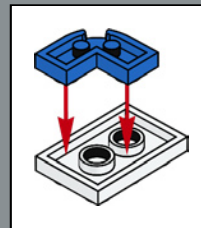

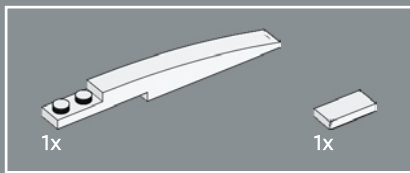

249

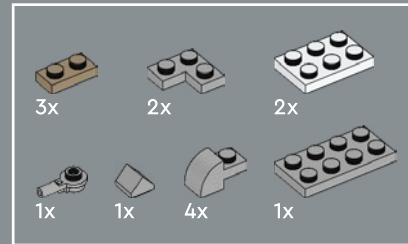
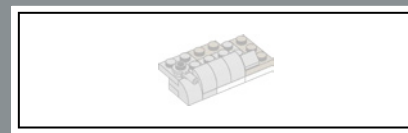
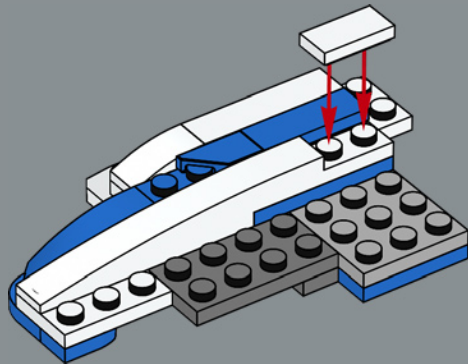

250

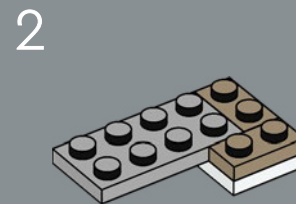
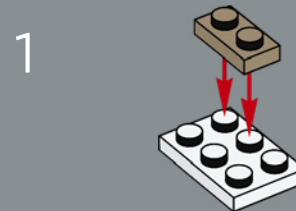

3

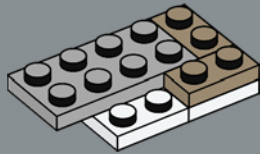

4

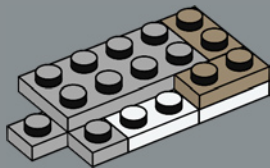

5

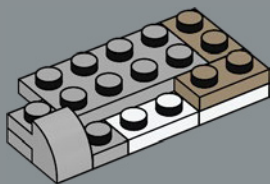

6

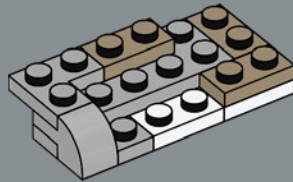

7

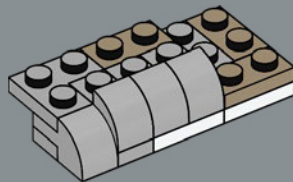

8

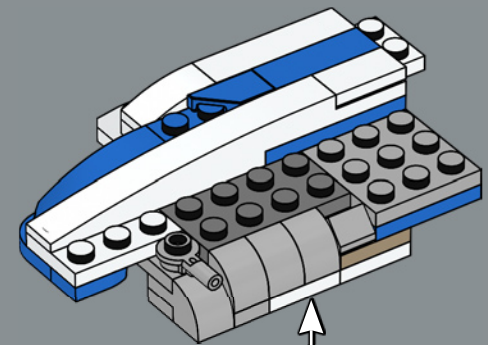
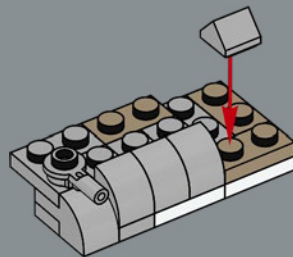

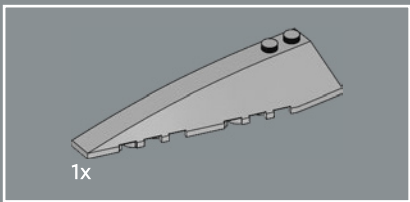

251

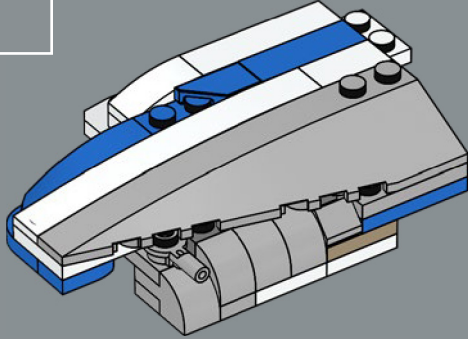

The iconic Pan Am® 'Globe' livery, with a blue line at window level and black lettering on a white background, was introduced in 1958 and used until 1984.

La livrée emblématique « Globe » de Pan Am®, avec une ligne bleue au niveau des hublots et des lettres noires sur fond blanc, a été introduite en 1958 et utilisée jusqu'en 1984.

El icónico esquema cromático Globe de Pan Am®, con el globo estilizado, una franja azul a la altura de las ventanillas e inscripciones en negro sobre un fondo blanco, se introdujo en 1958 y se usó hasta 1984.

252

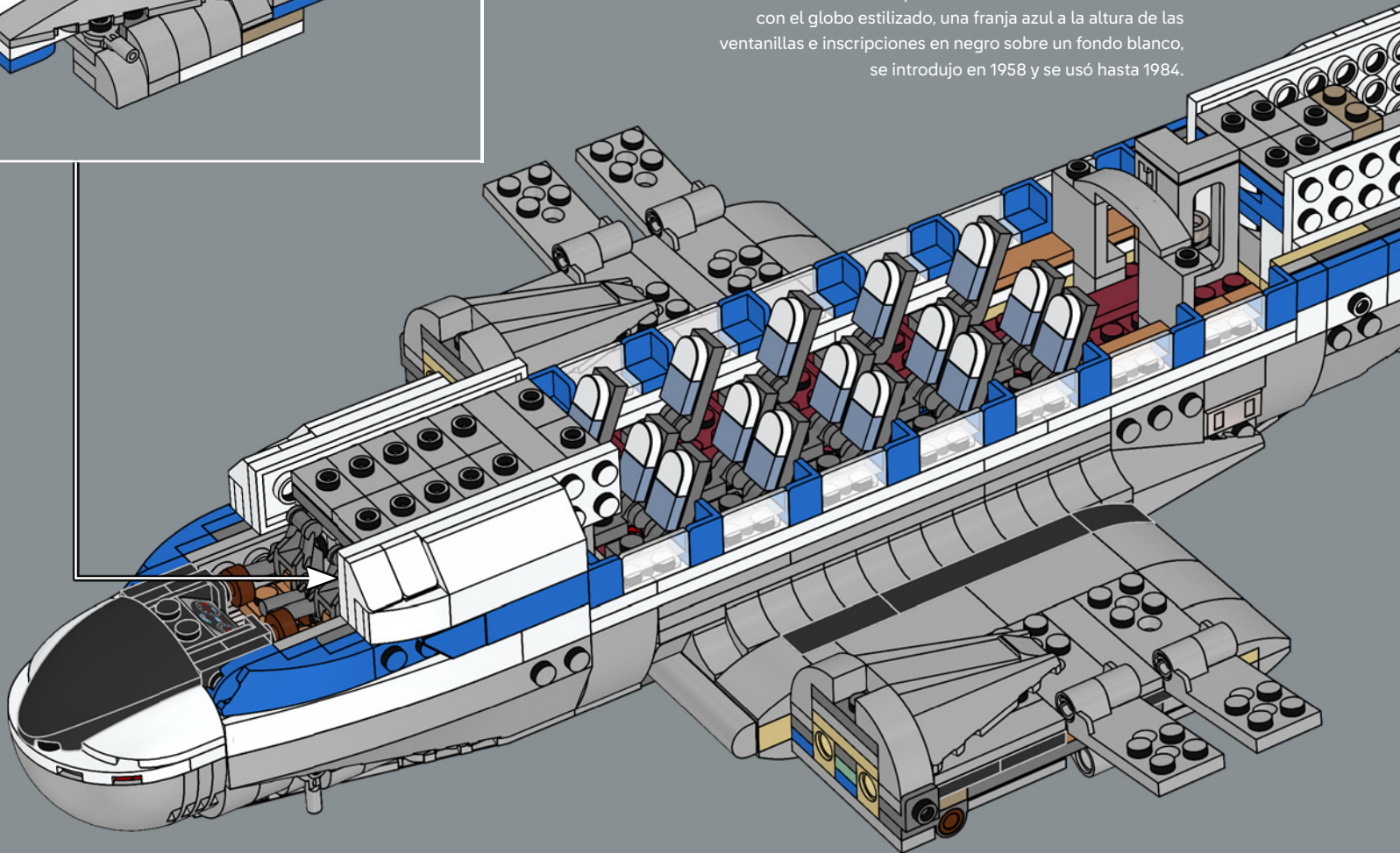

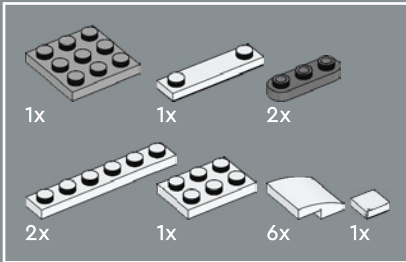
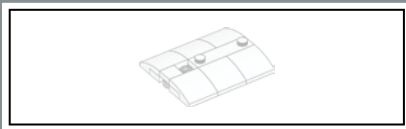

253

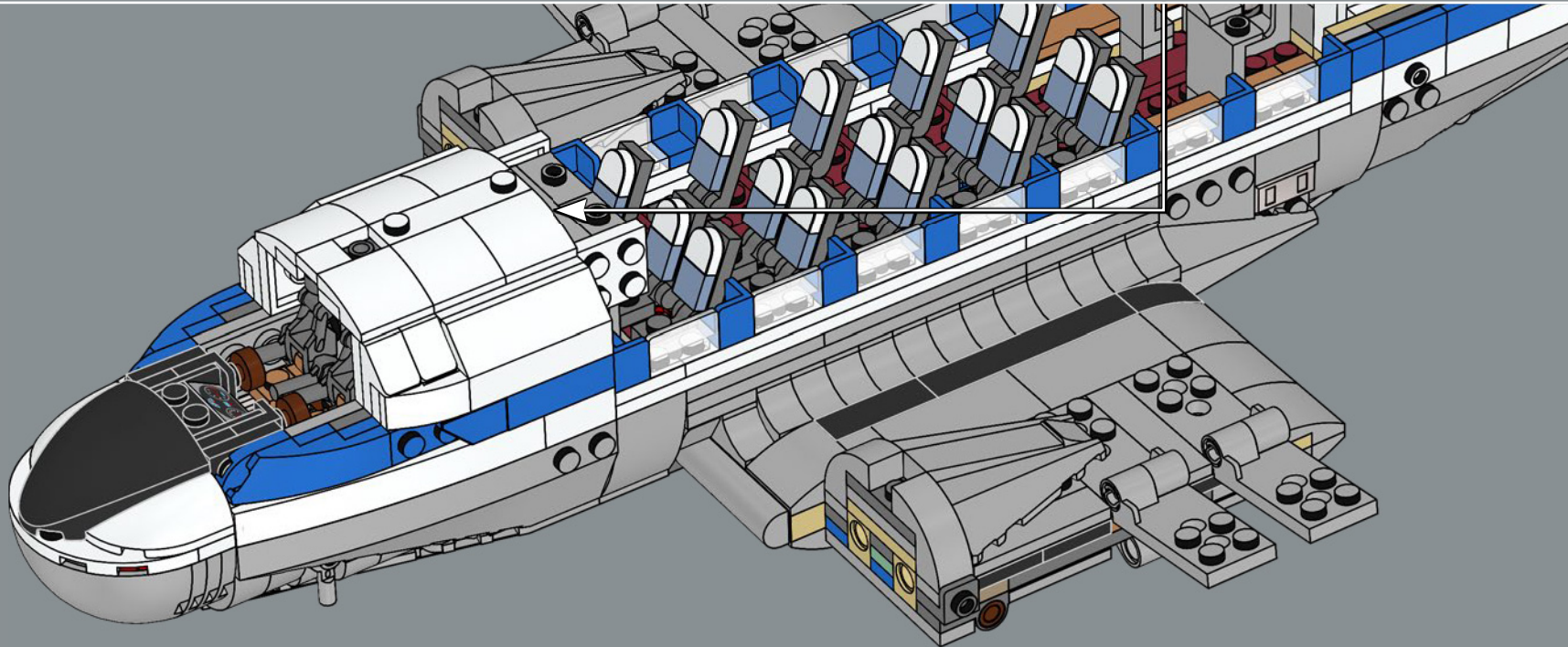
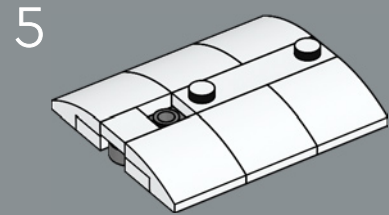
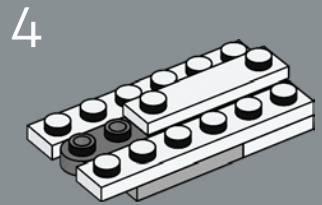
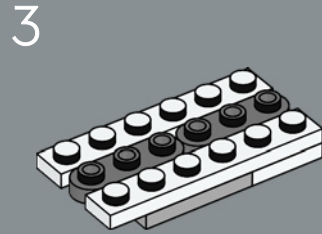
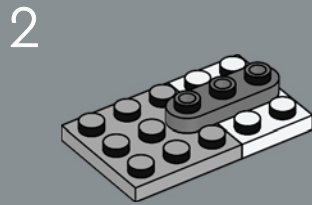
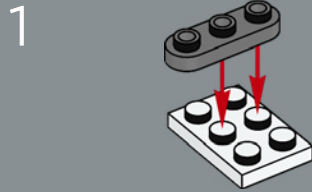

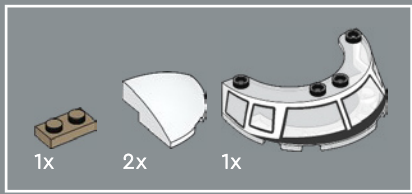

254

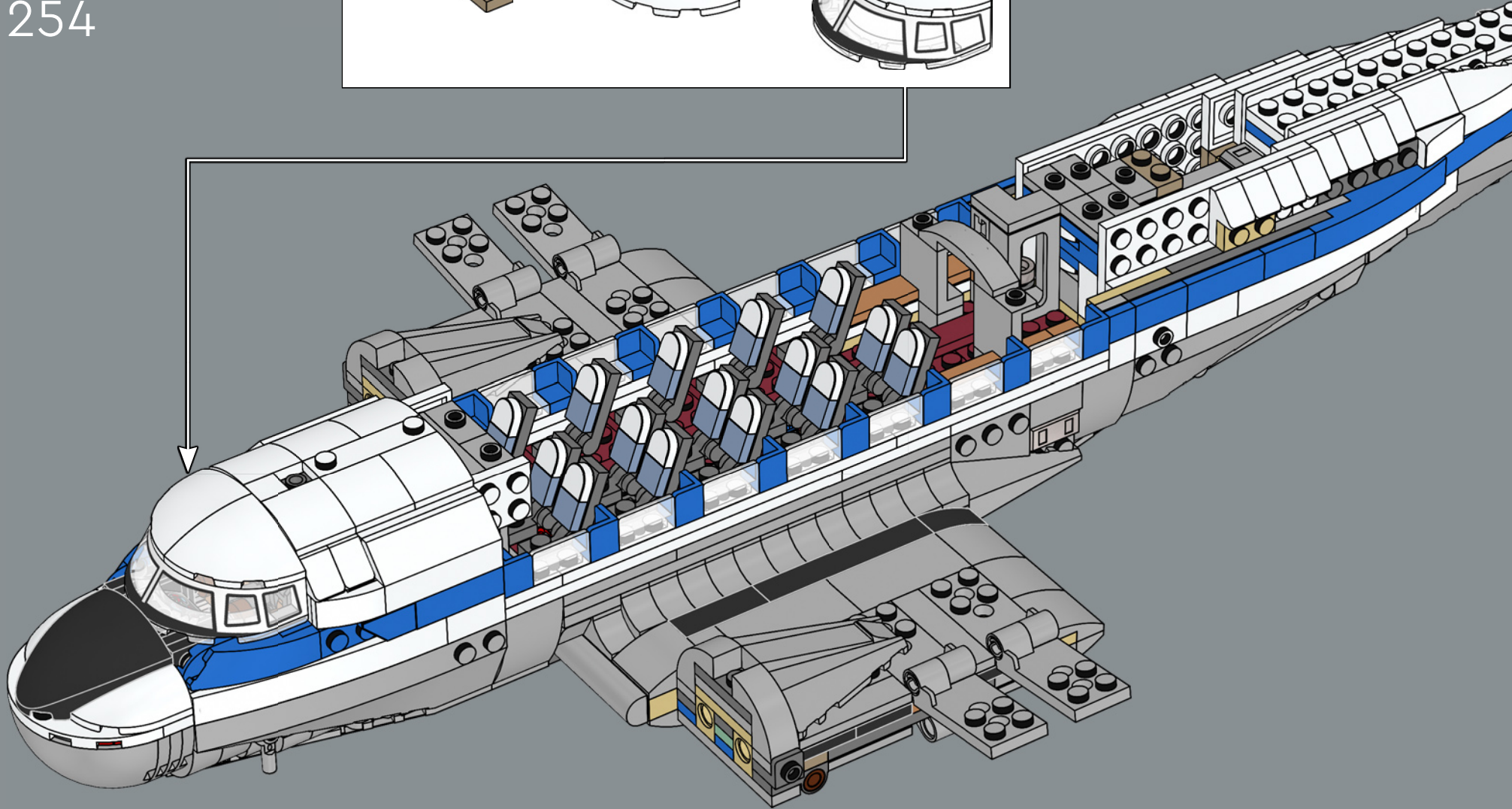
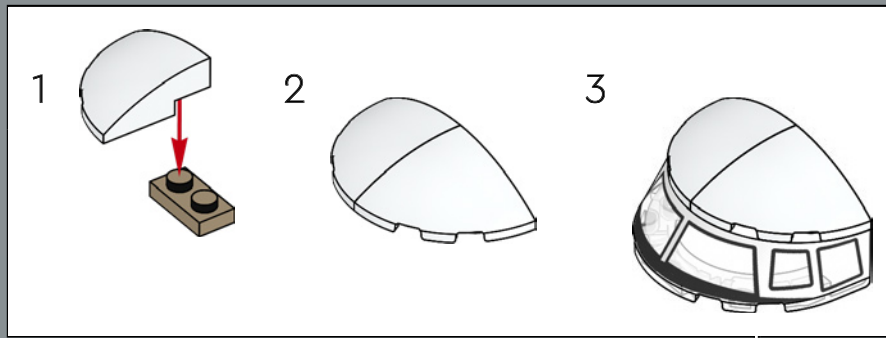

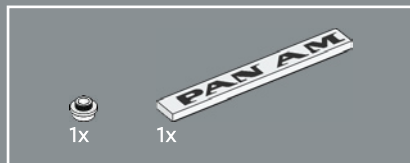
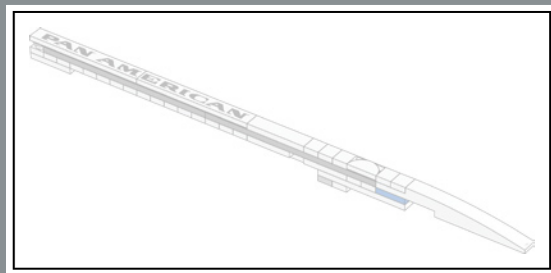

255

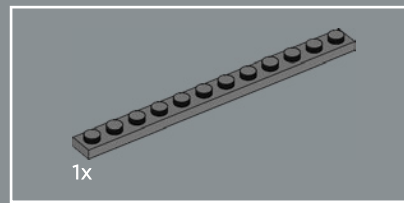

256

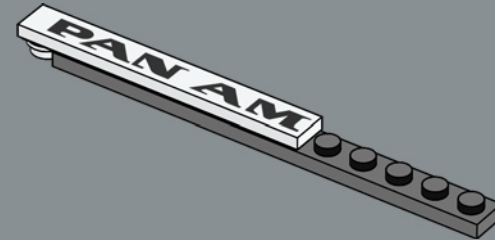

257

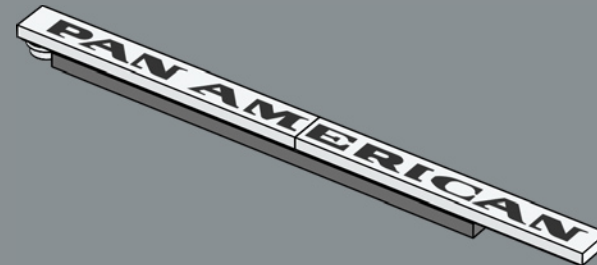

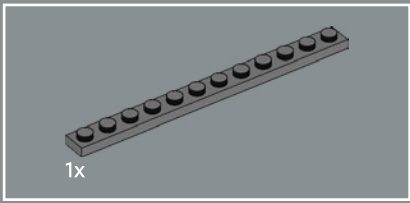

258

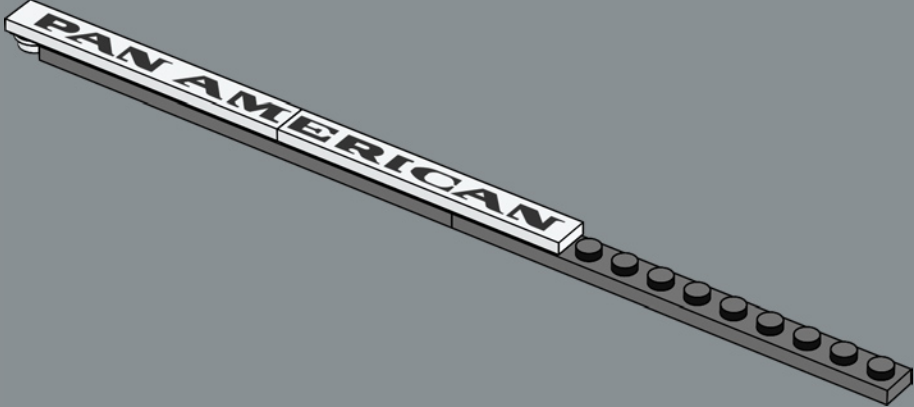

259

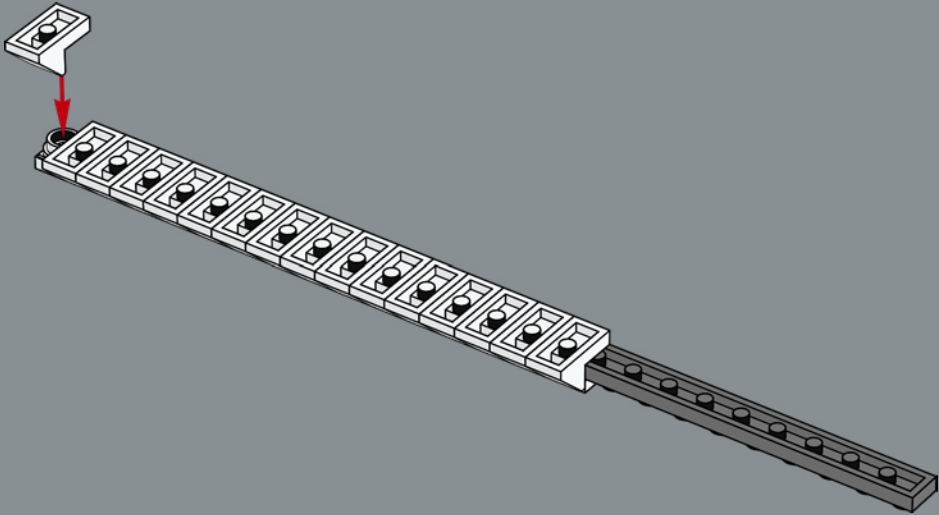

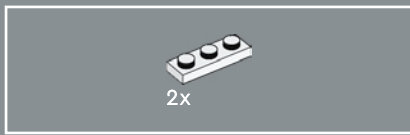

260

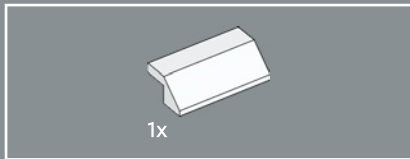
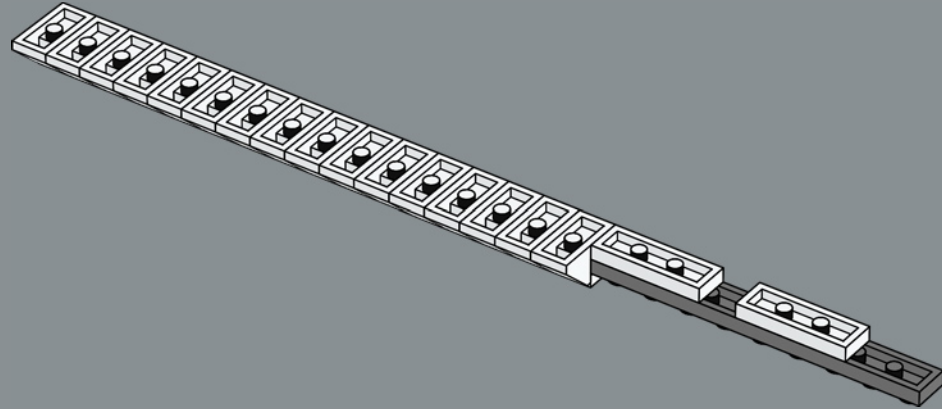

261

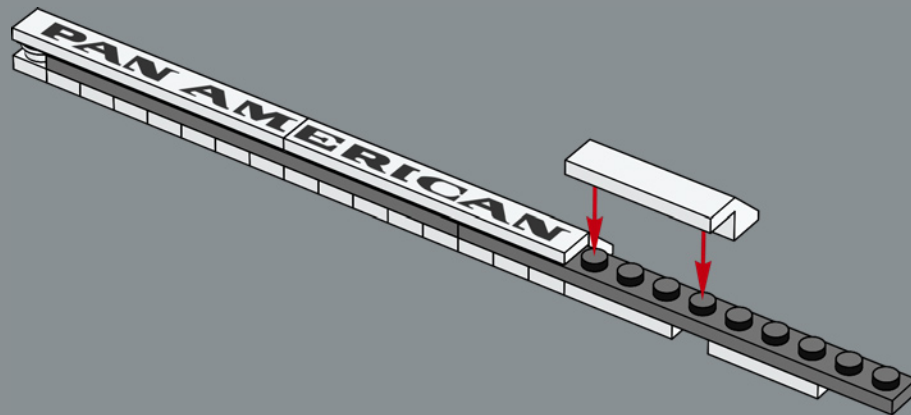

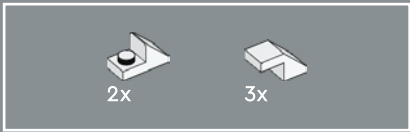

262

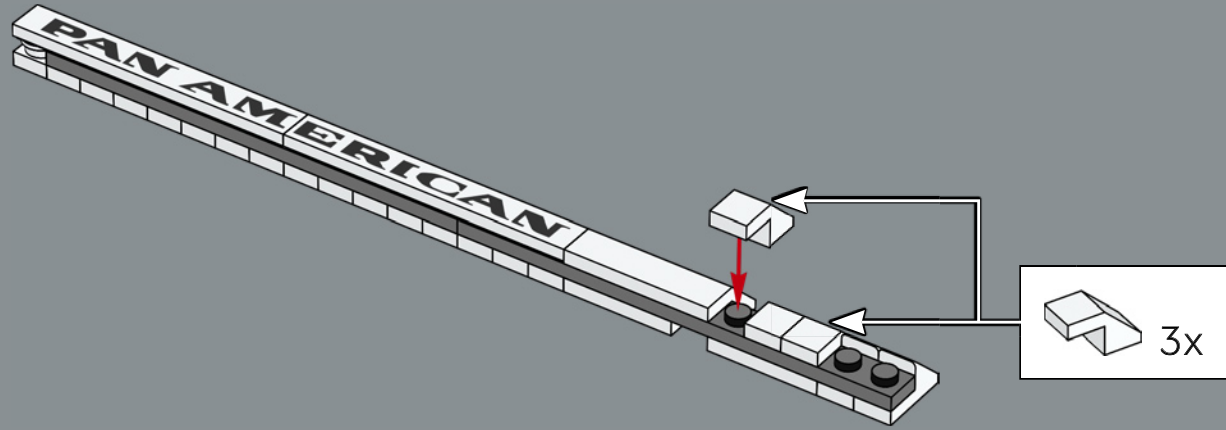

263

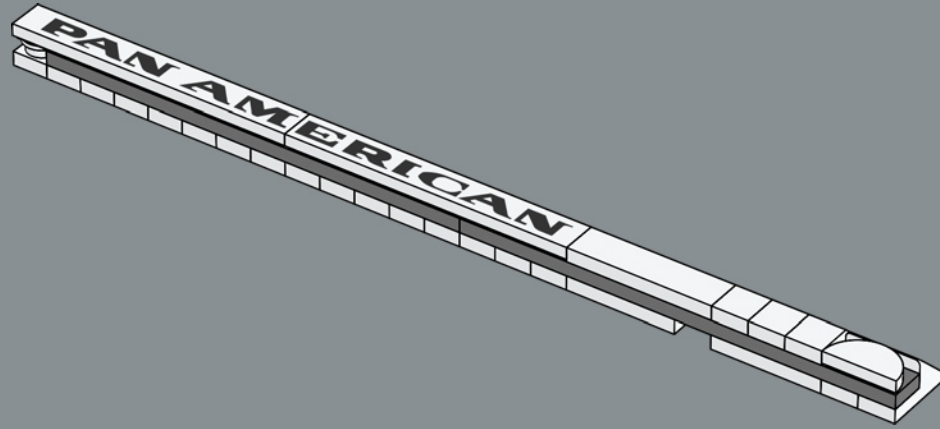

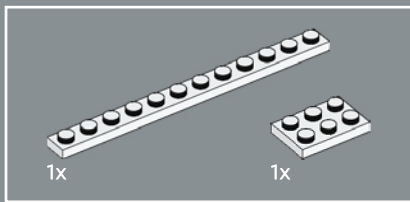

264

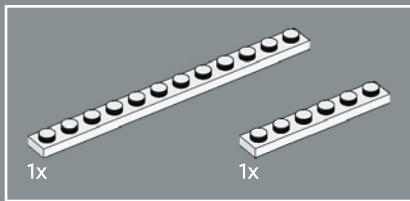
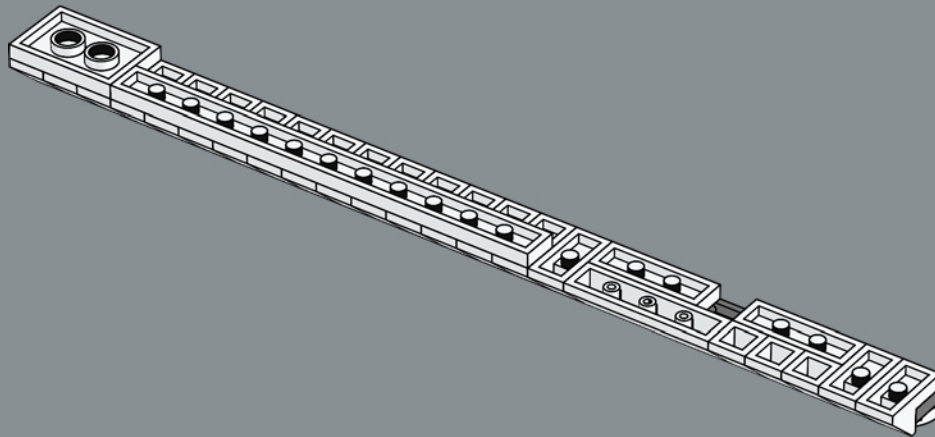

265

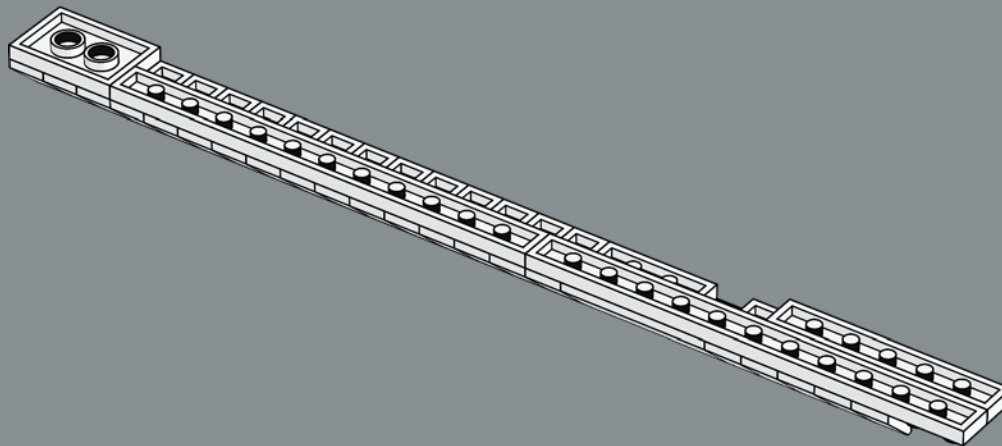

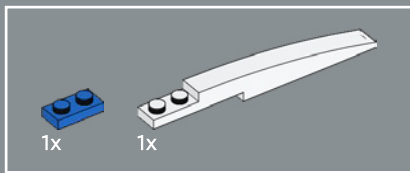

266

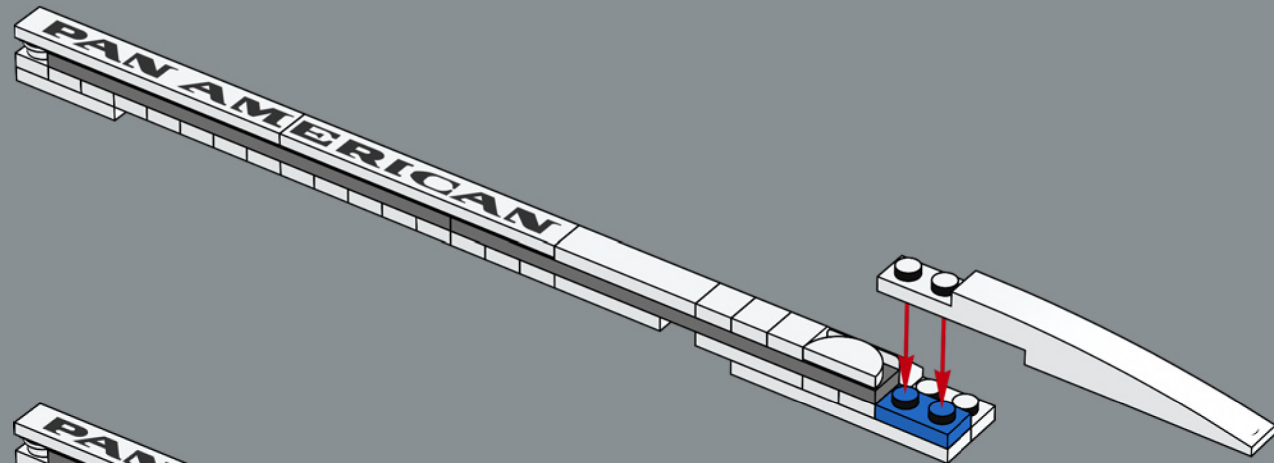

267

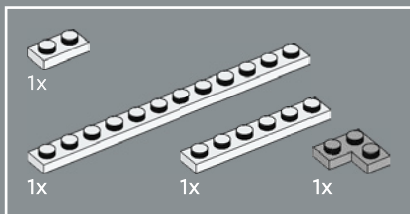
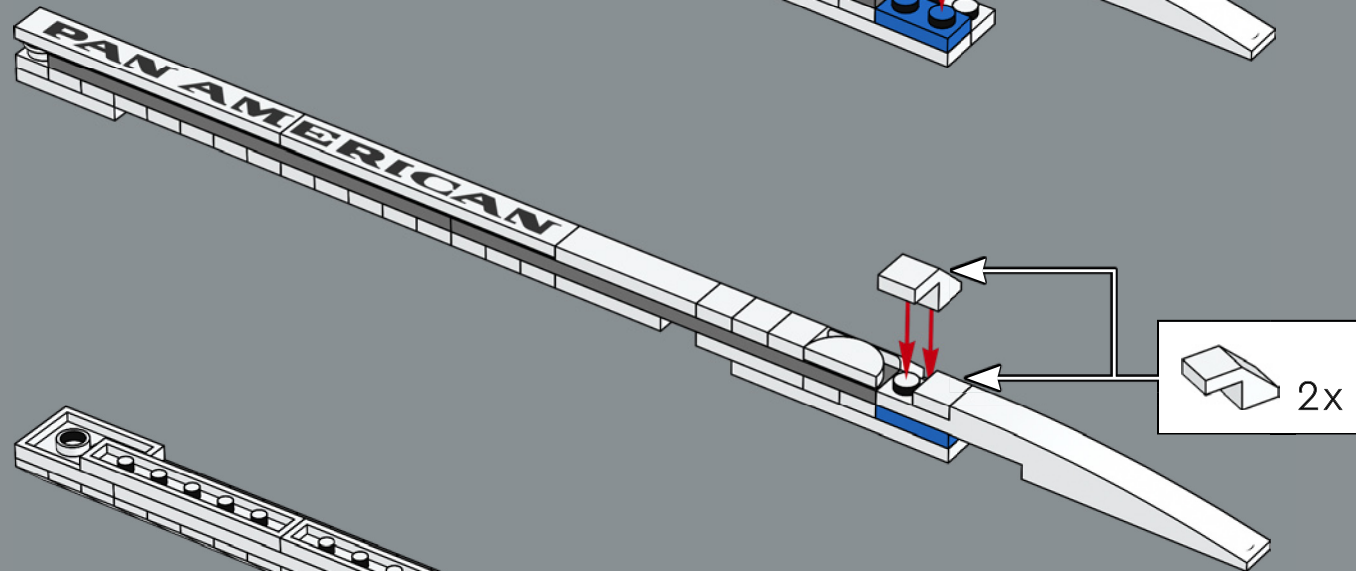

268

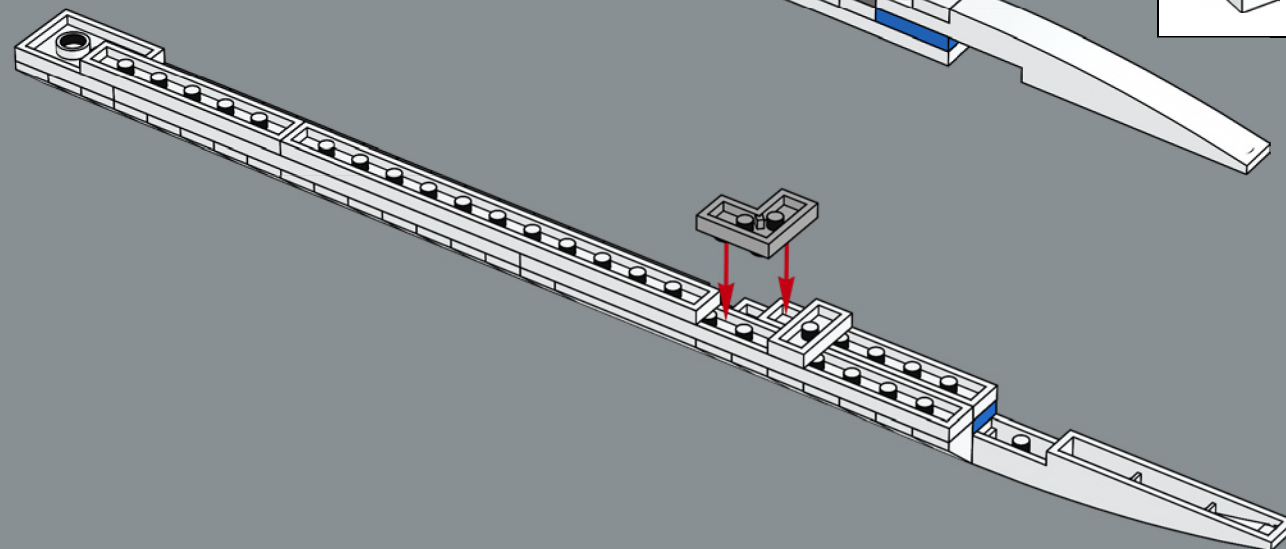

269

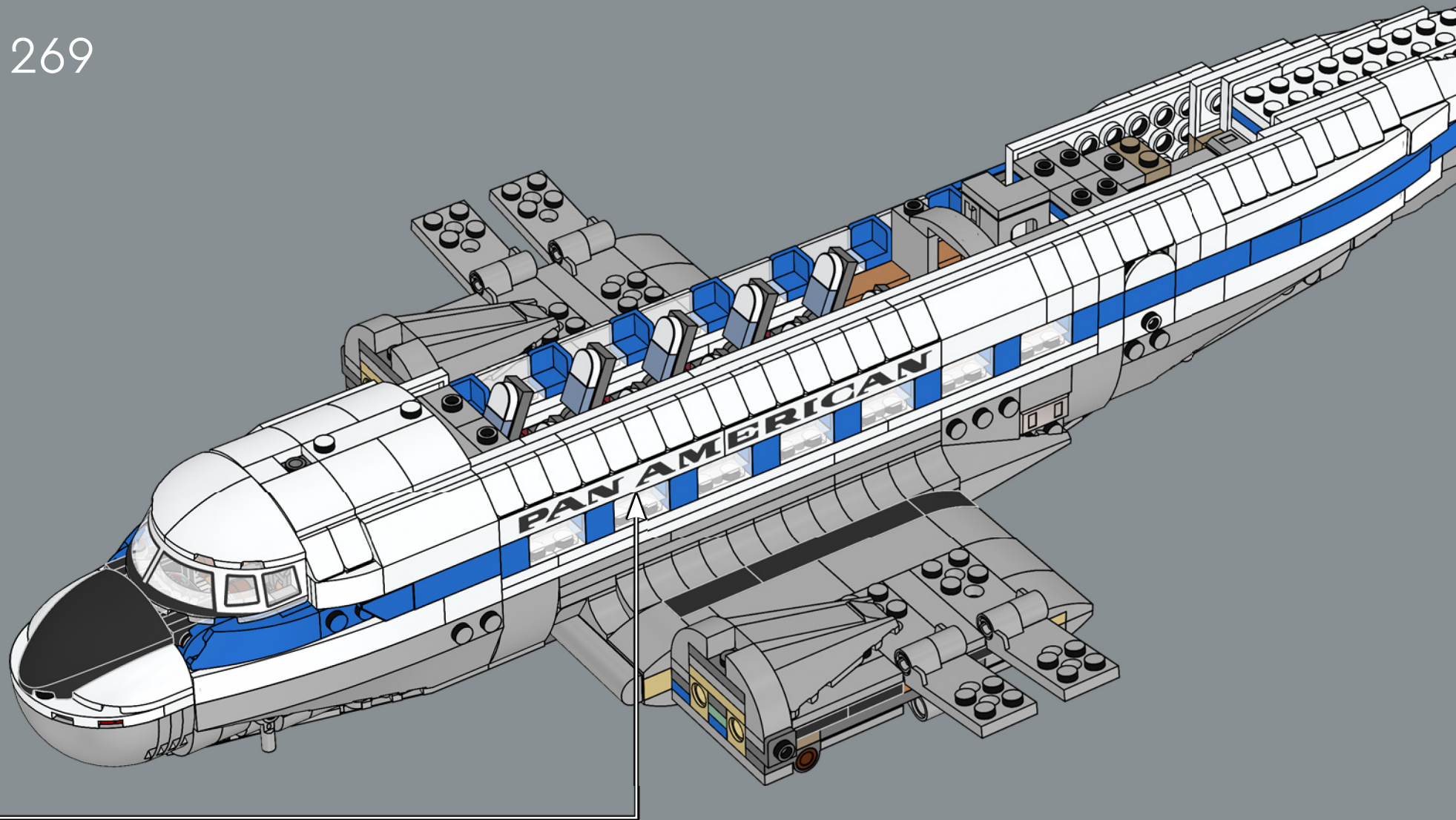

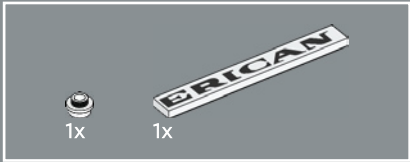
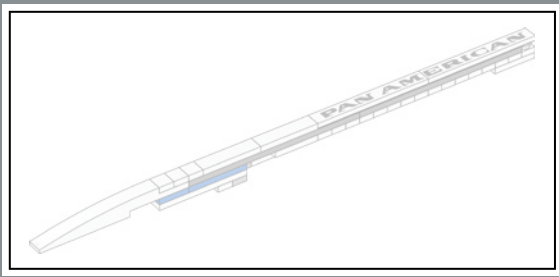

270

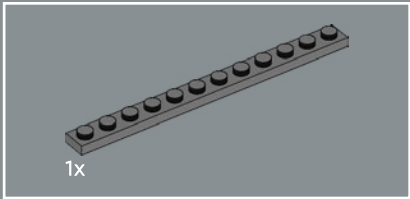

271

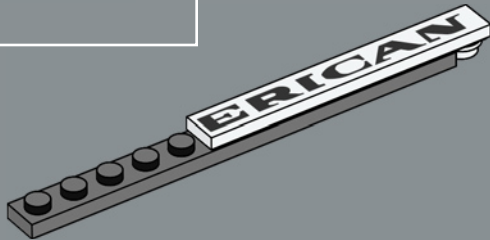

272

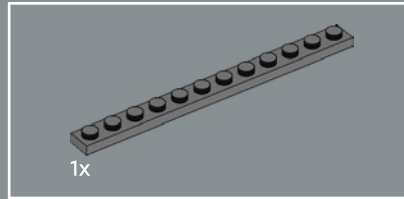
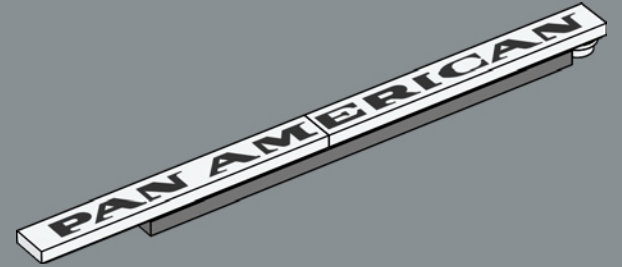

273

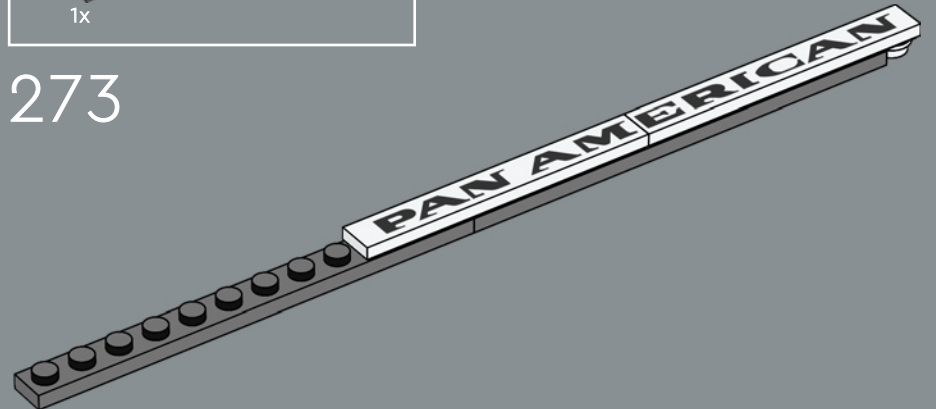



274

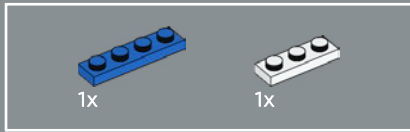
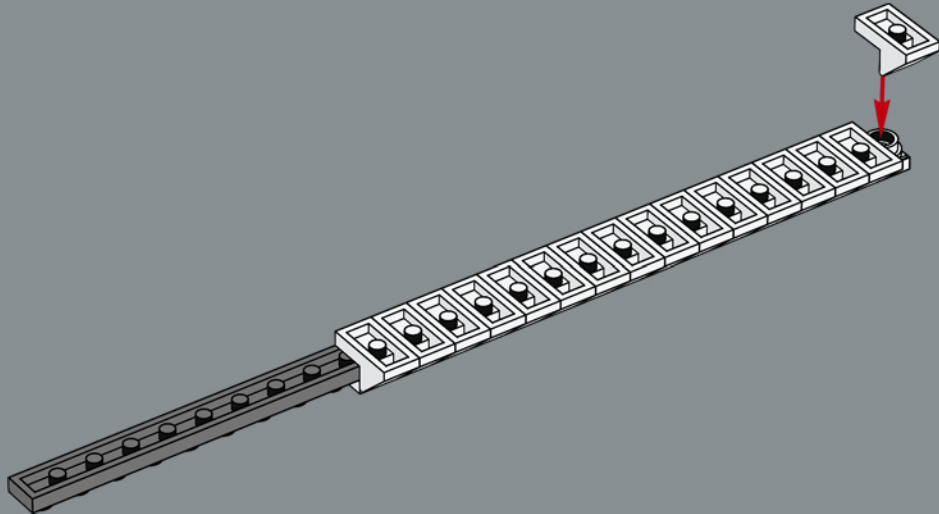

275

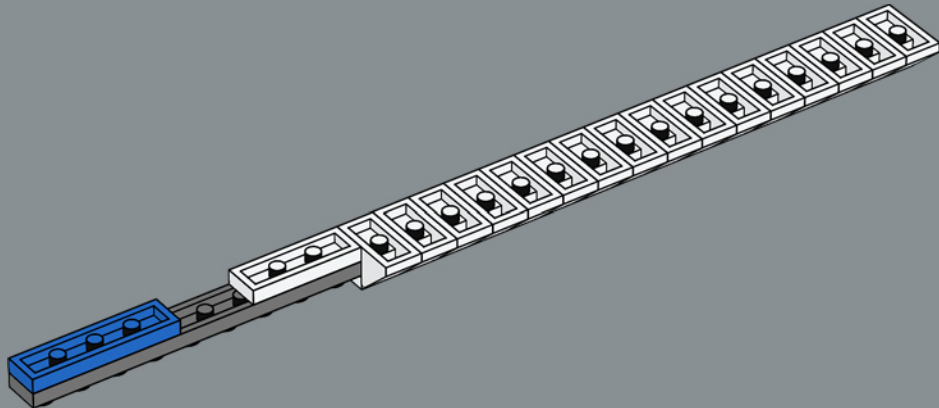

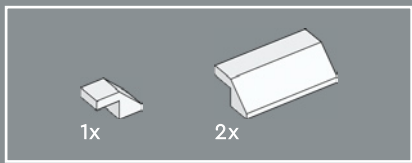

276

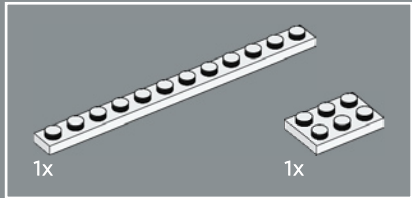
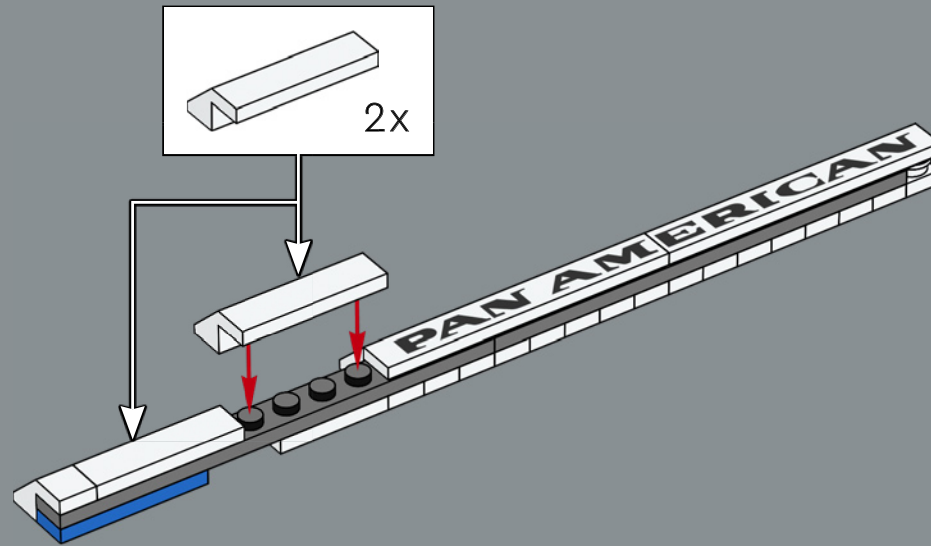

277

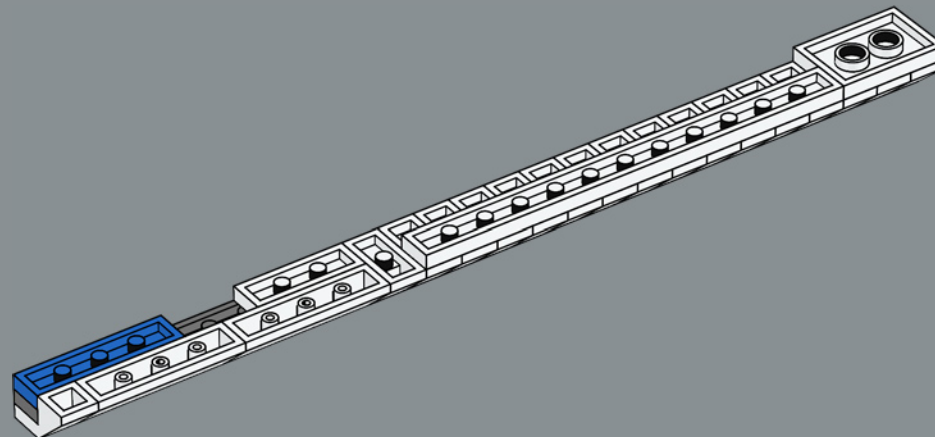

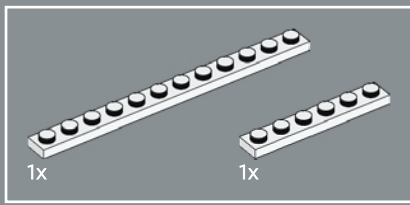

278

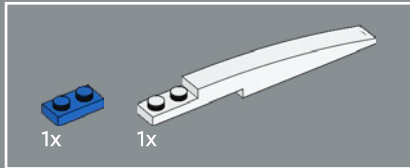
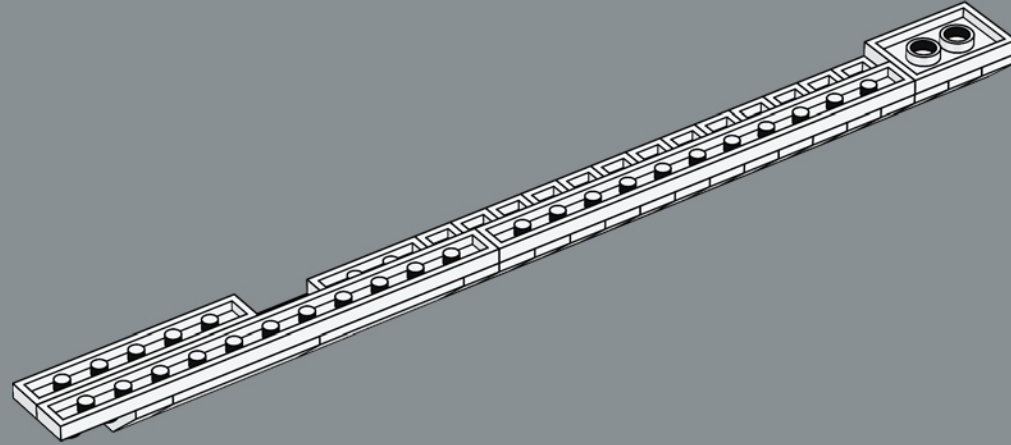

279

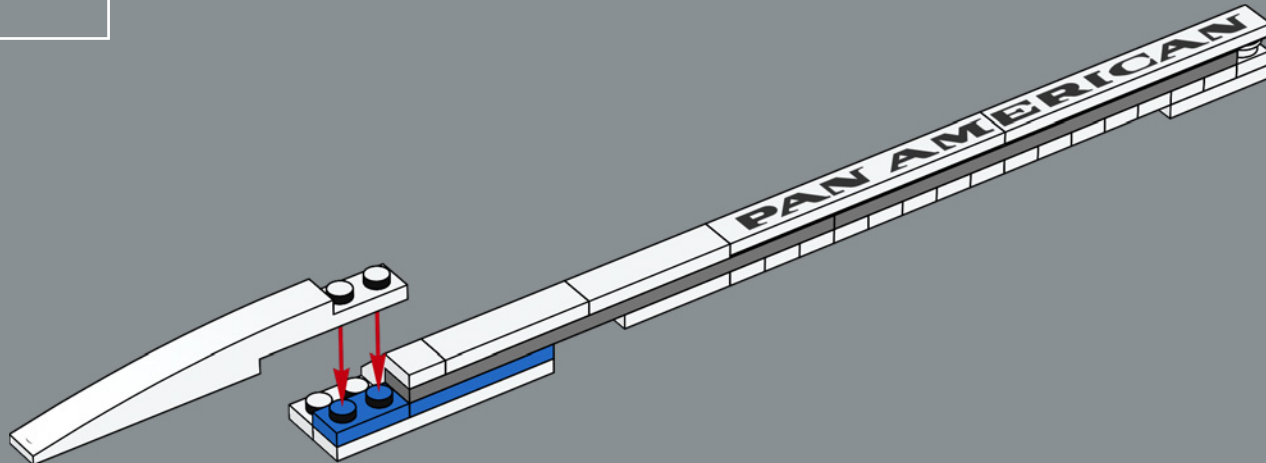



2x

280



2x

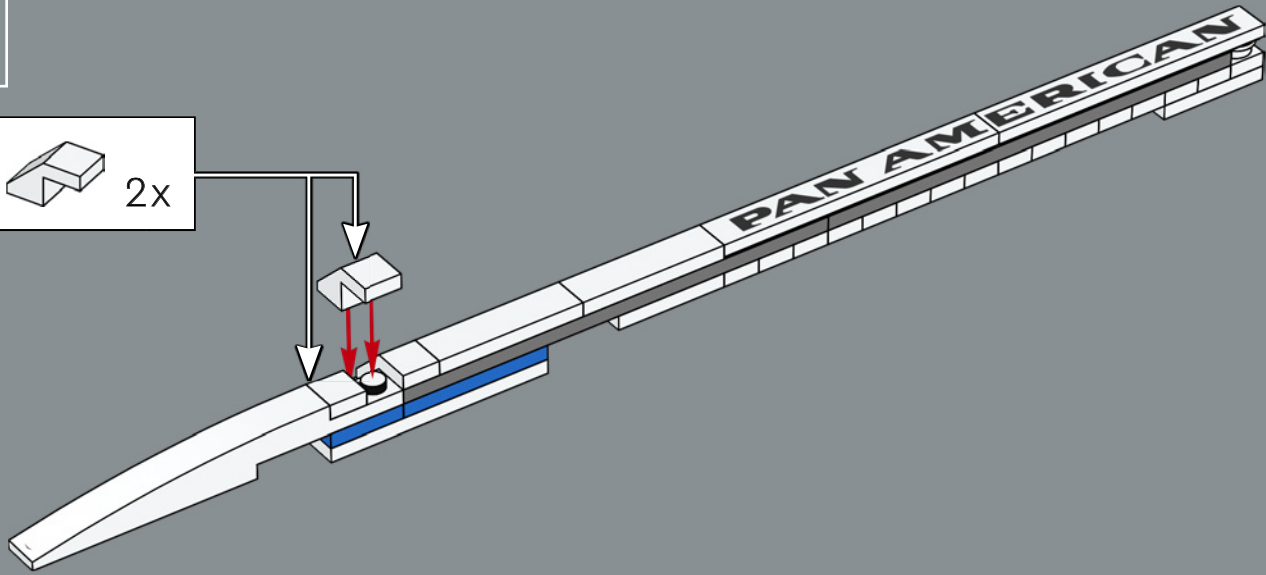

1x



1x

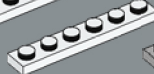

1x



1x

281

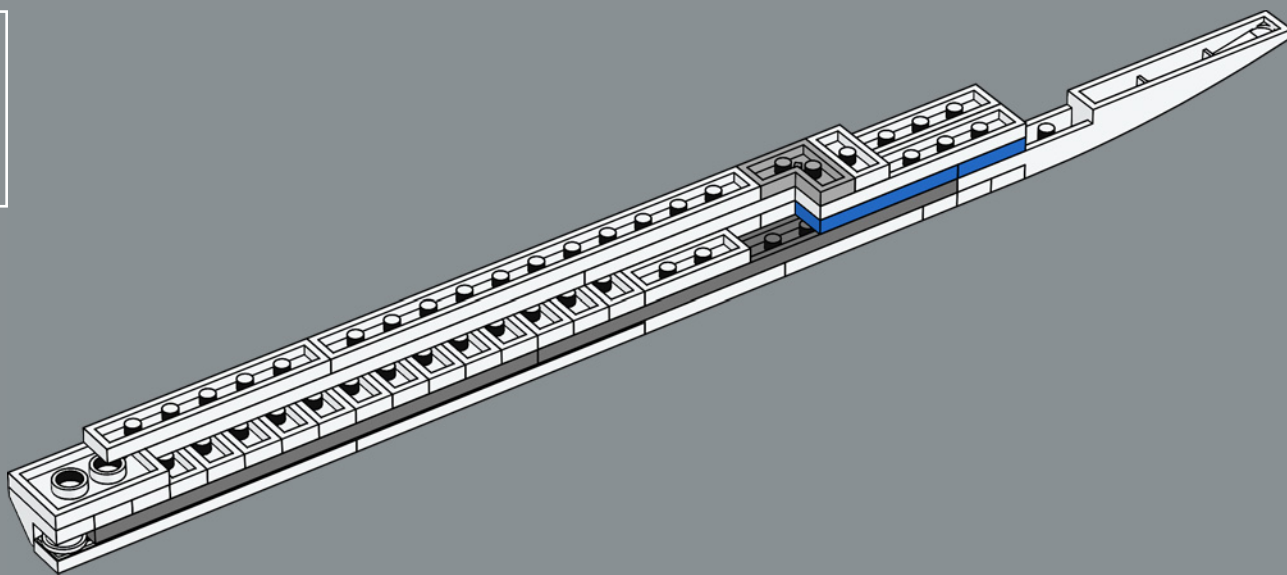

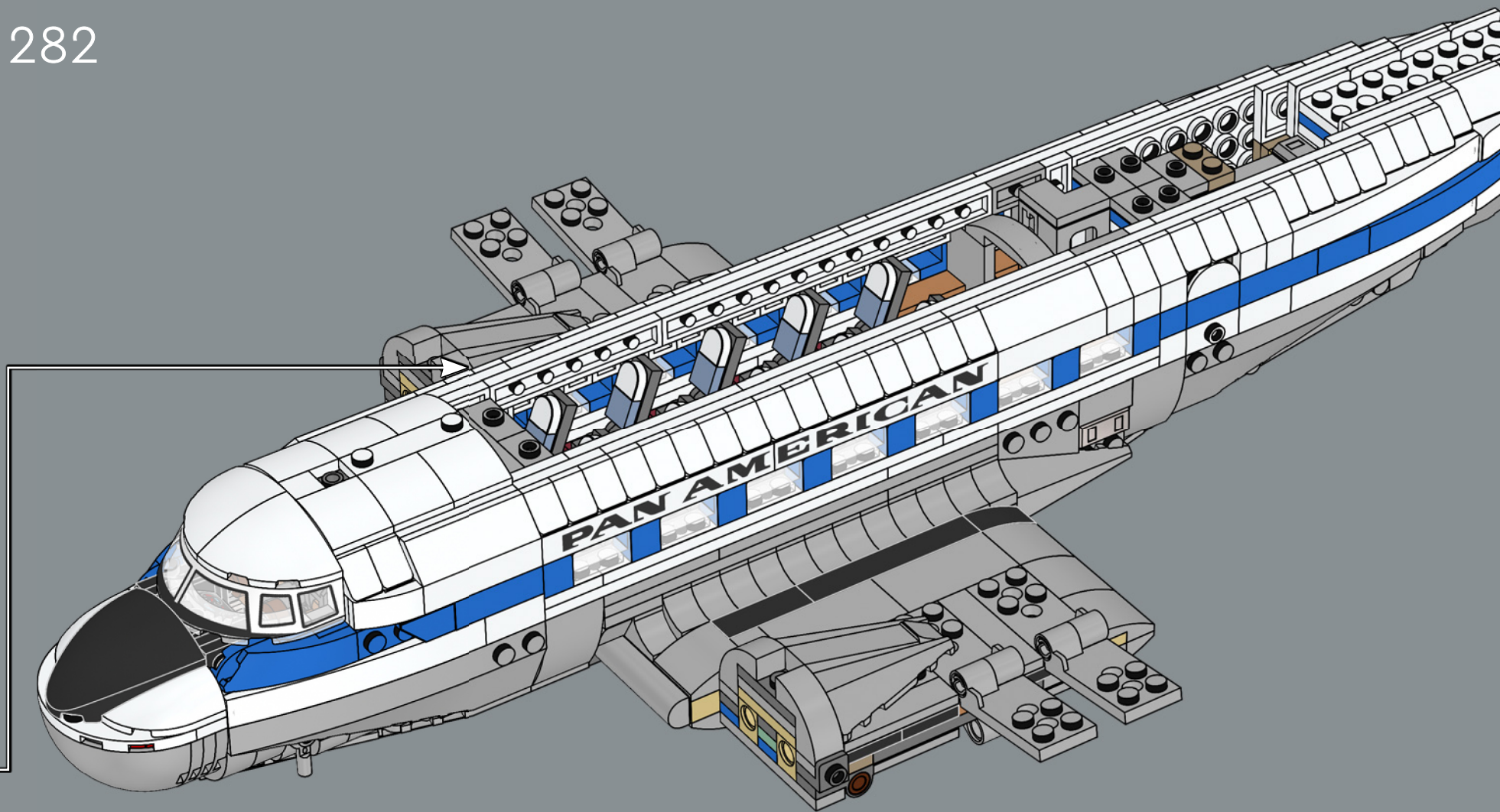

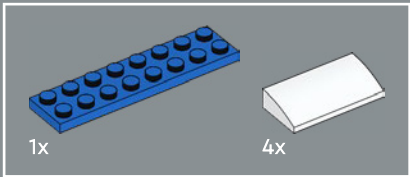

283

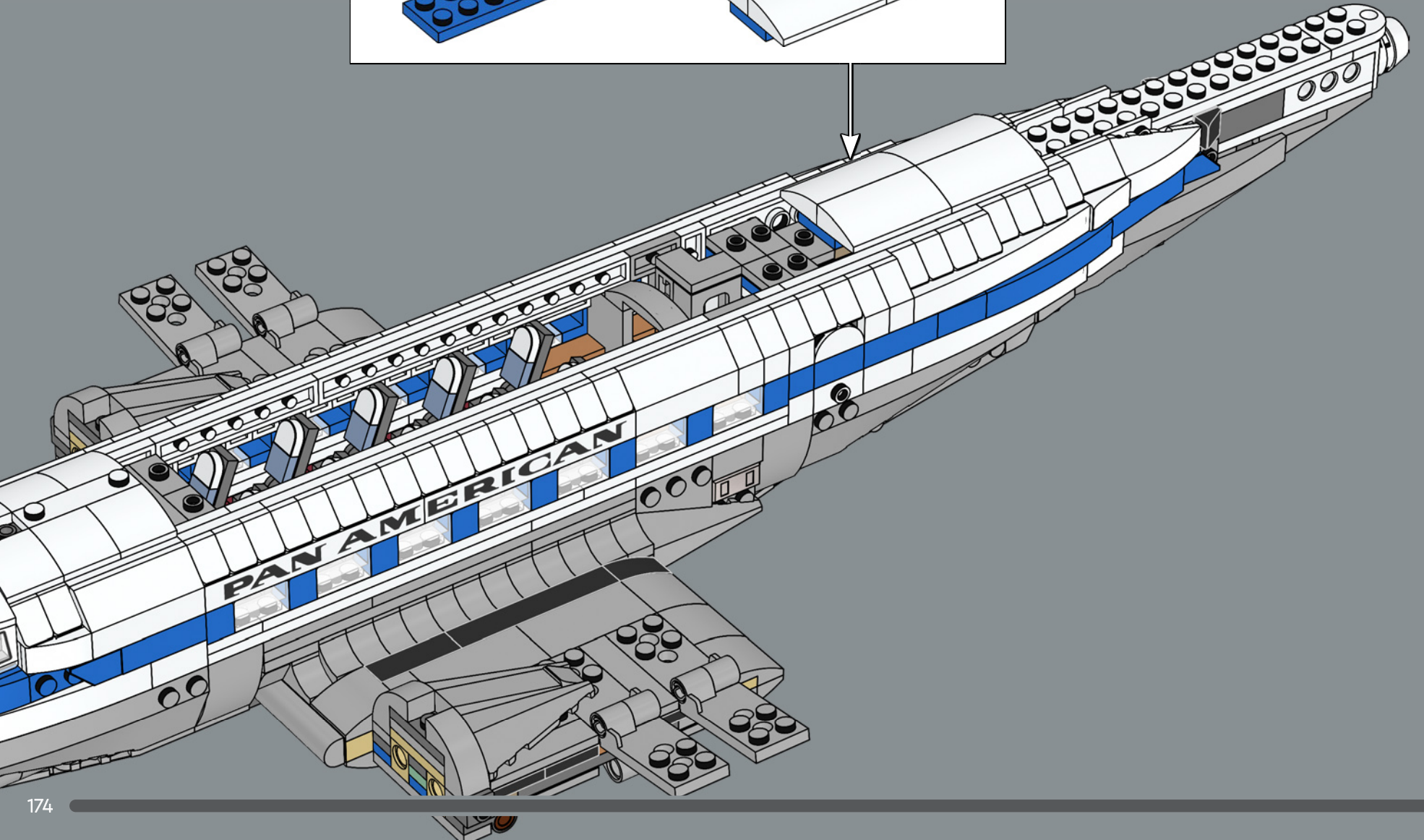
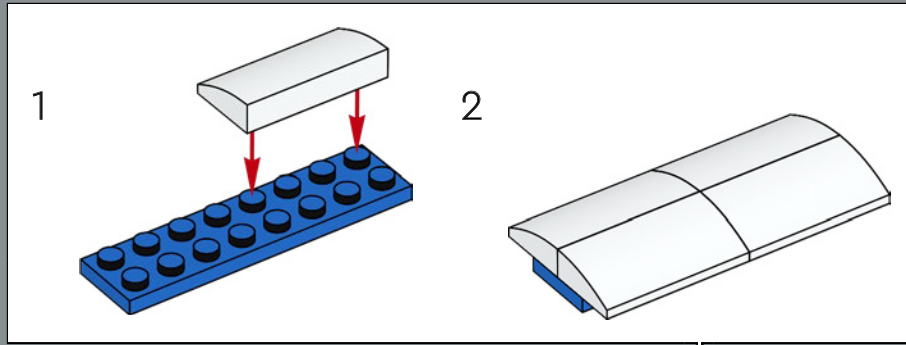

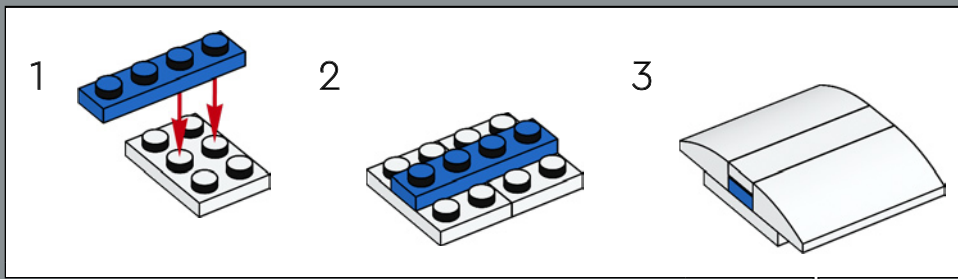
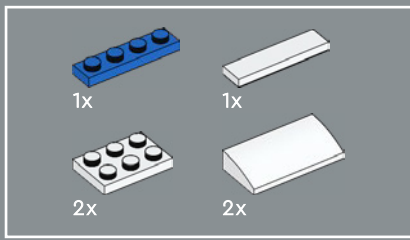

284

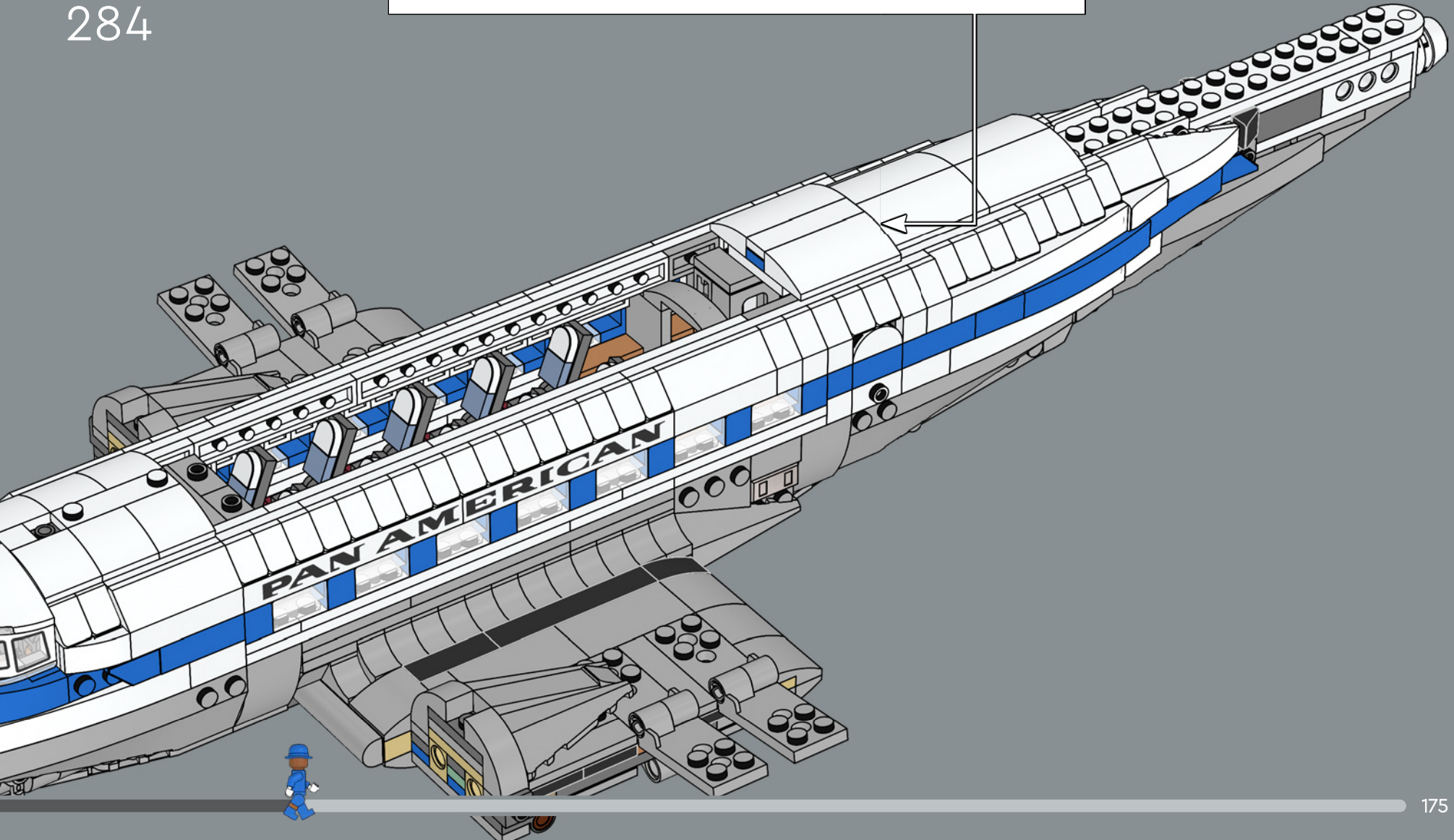

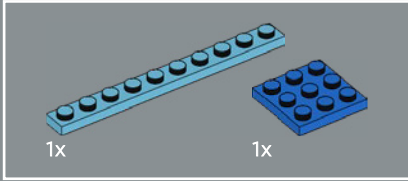
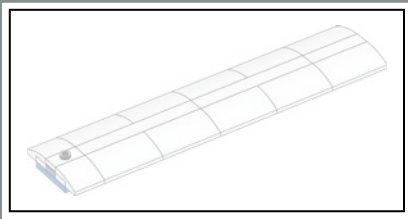

285

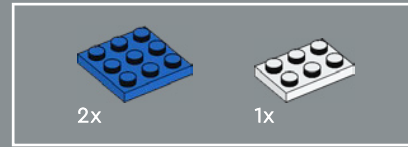
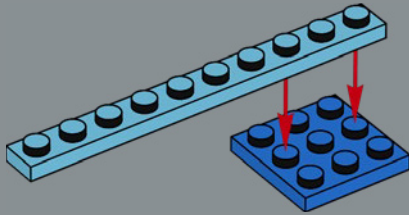

286

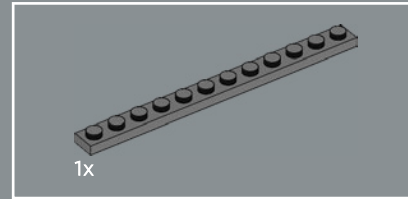
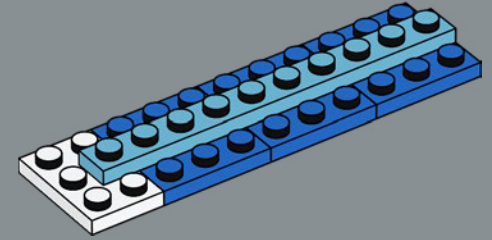

287

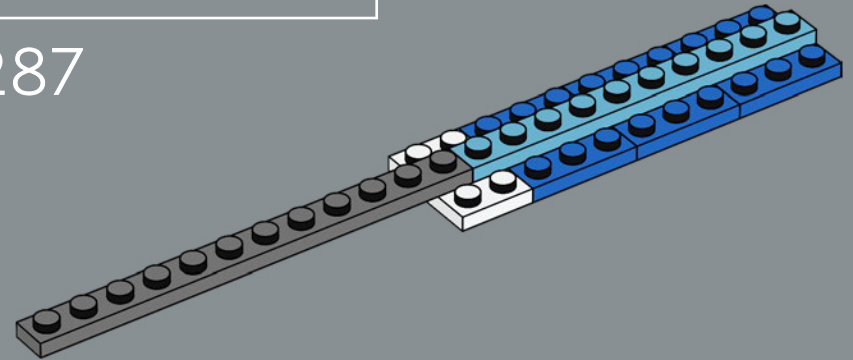

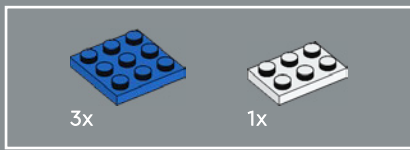

288

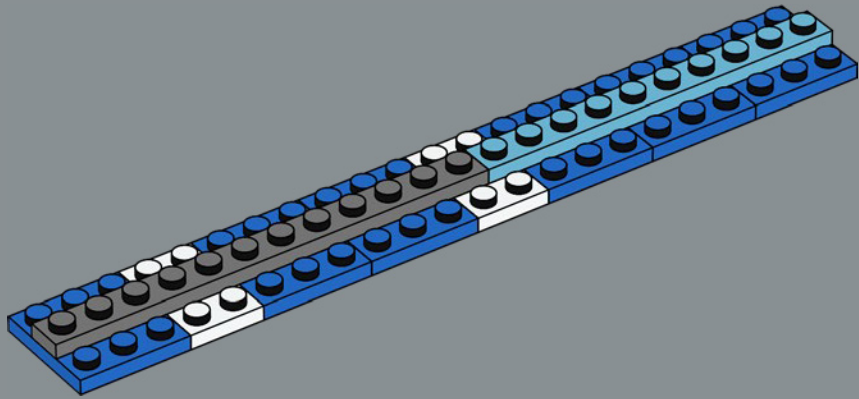

289

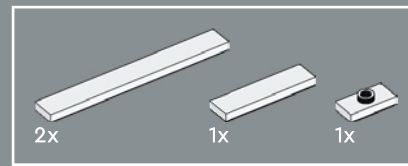
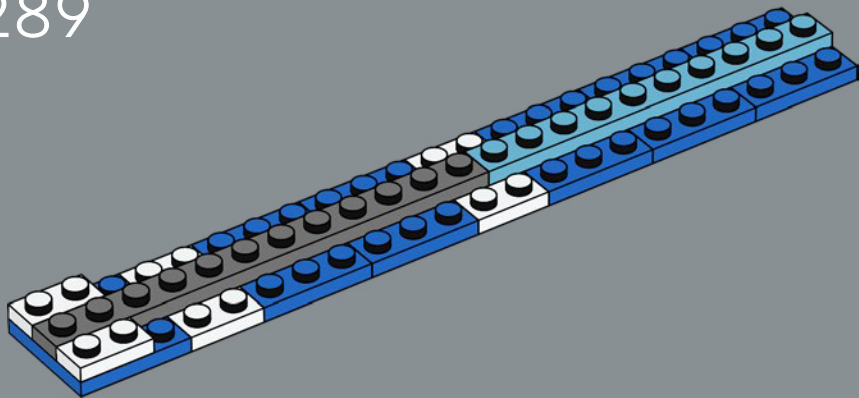

290

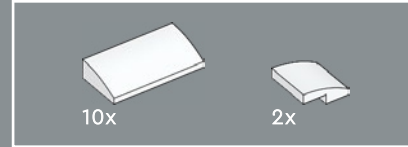
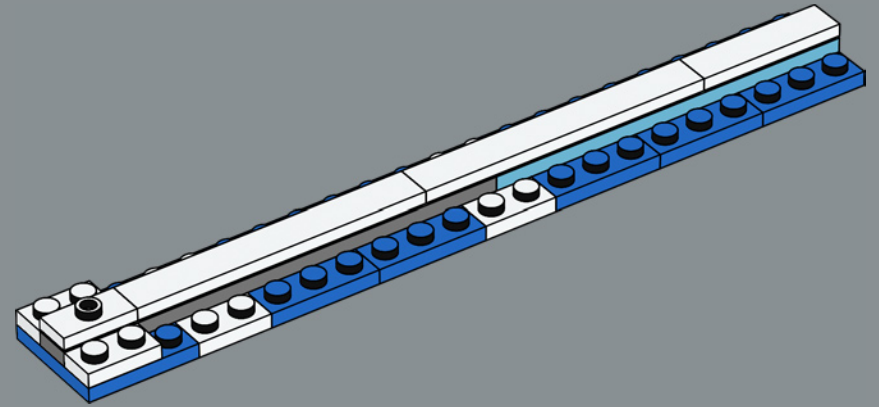

291

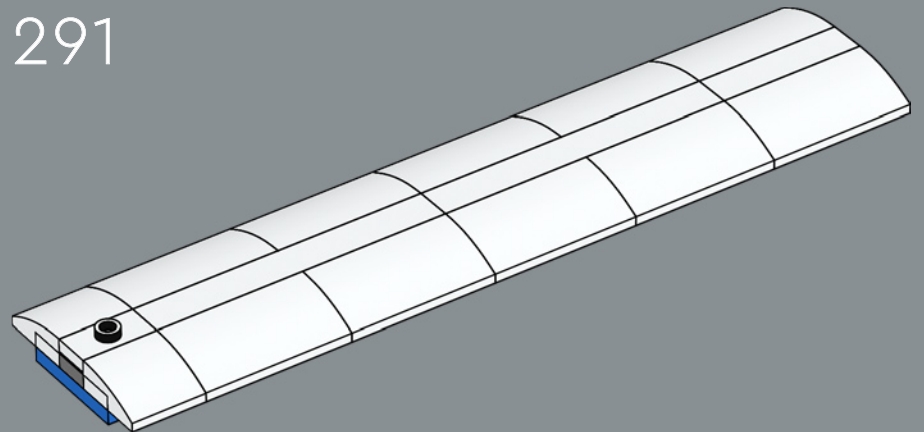

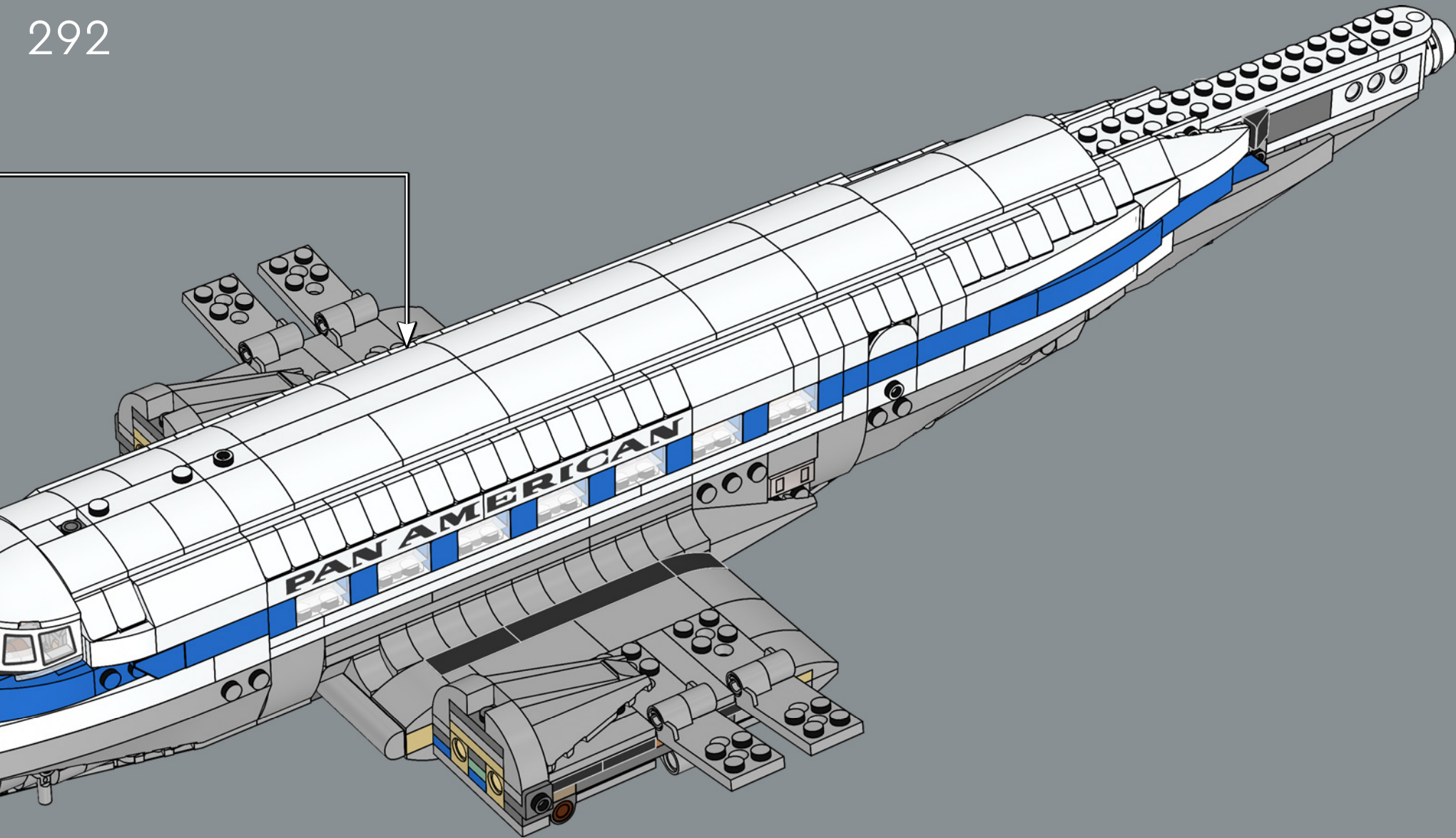

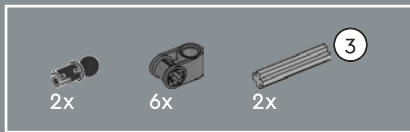

293

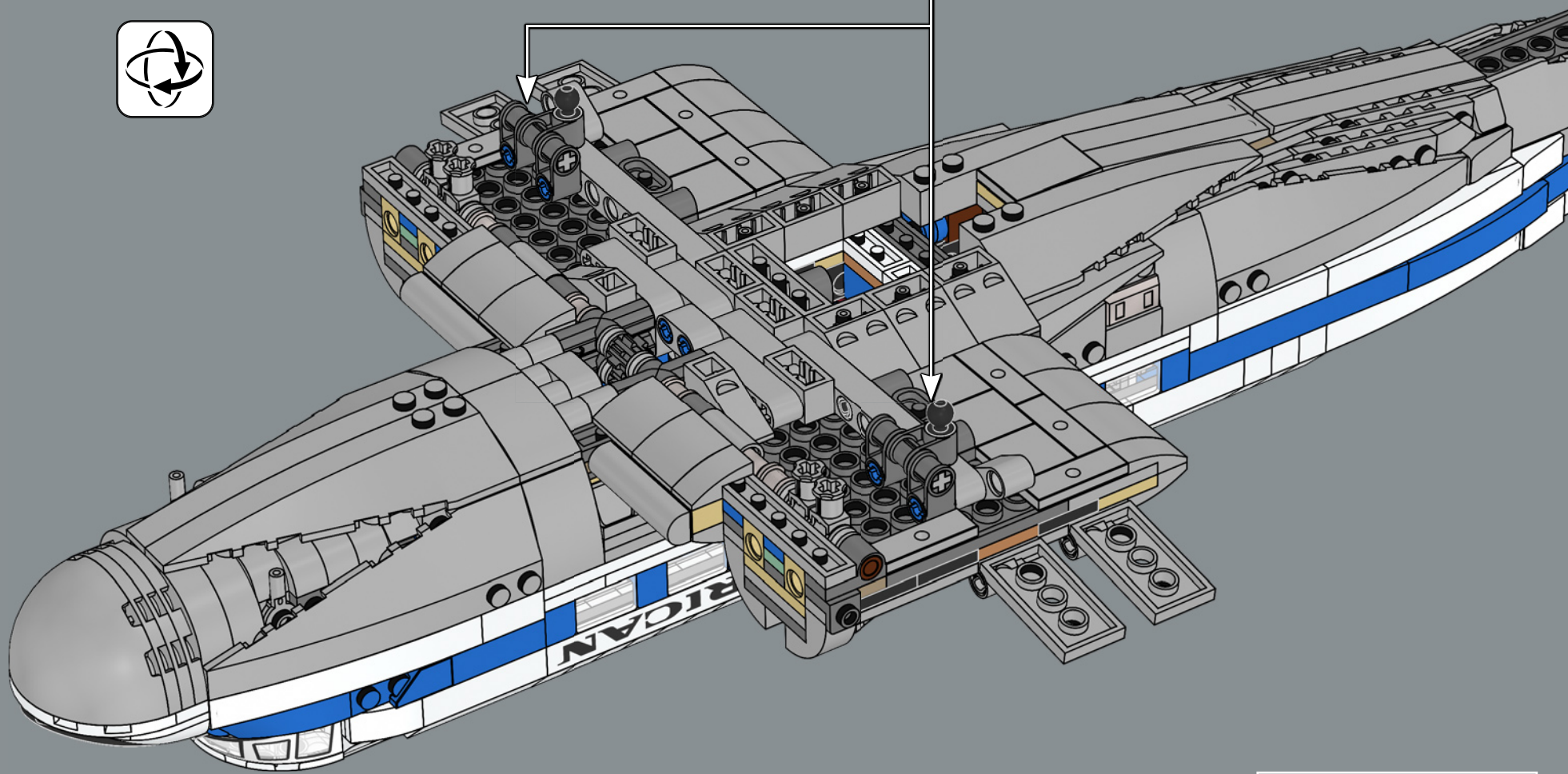
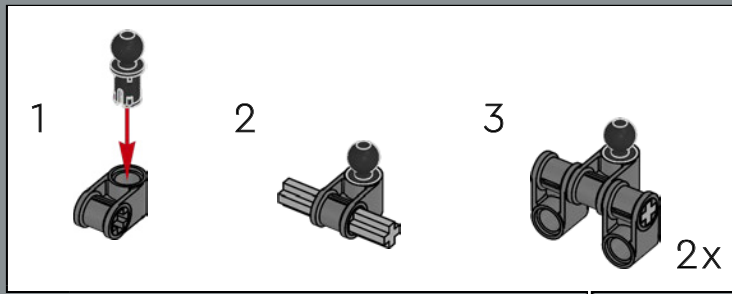

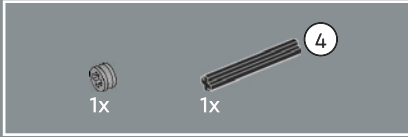
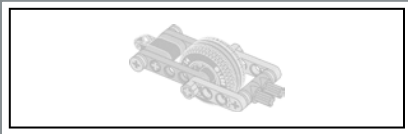

294

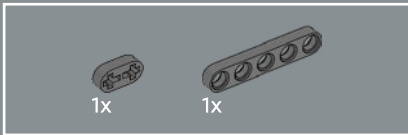

295

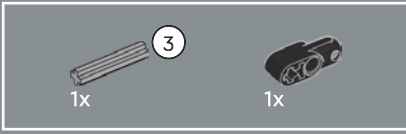
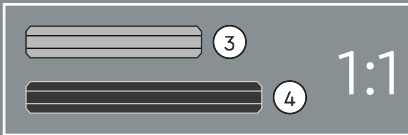
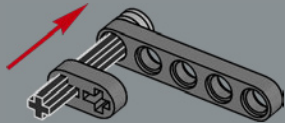

296

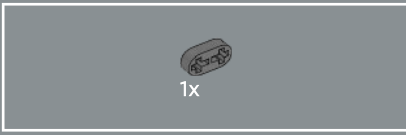
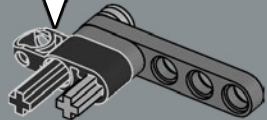
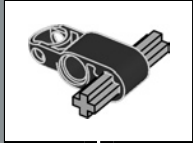

297

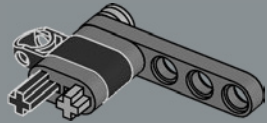

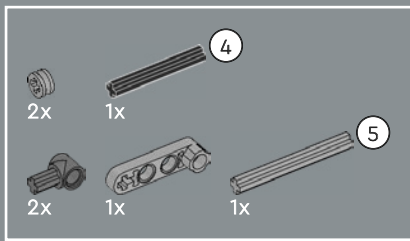

298

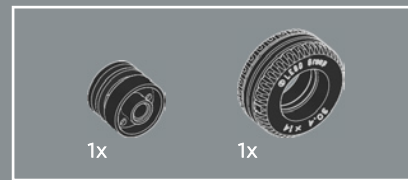
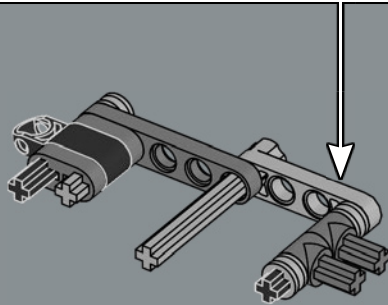
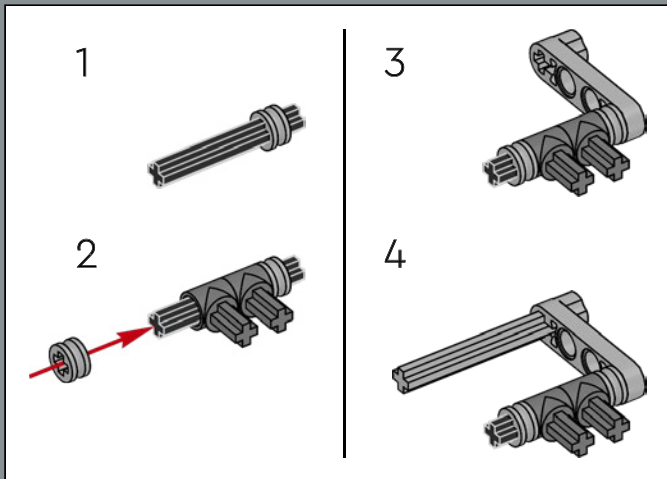

299

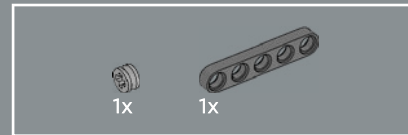
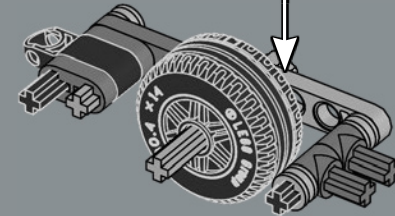
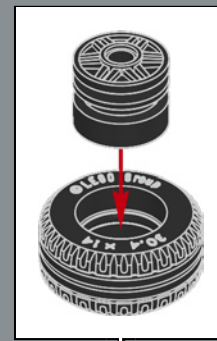

300

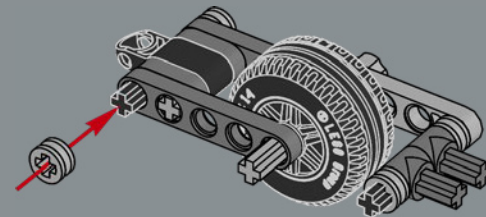



301

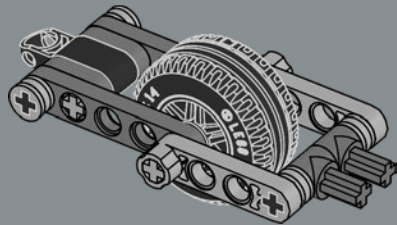

302

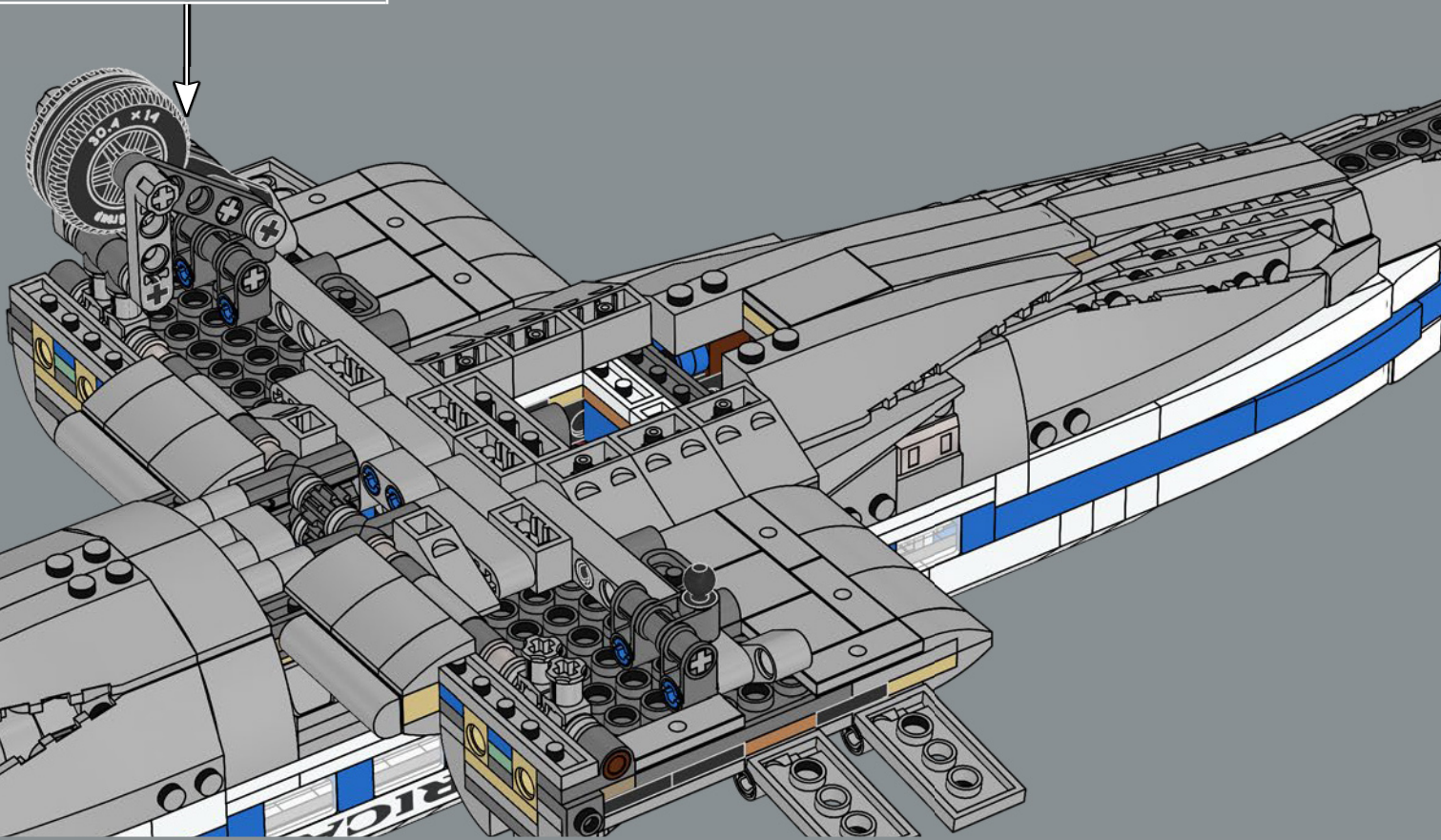

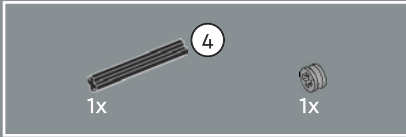
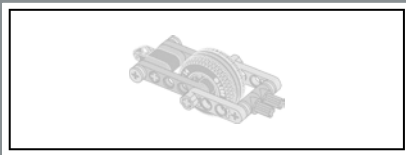

303

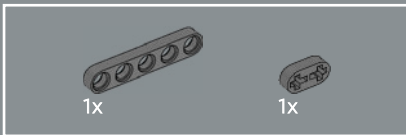

304

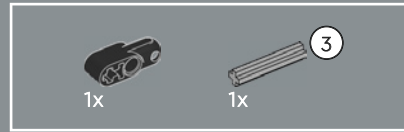
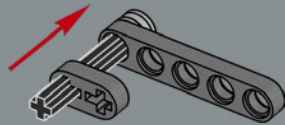

305

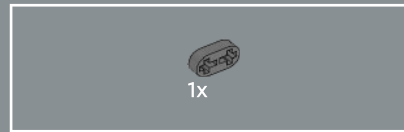
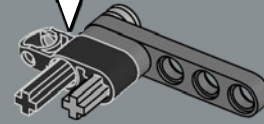
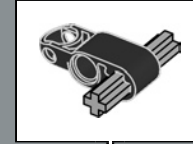

306

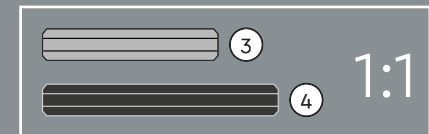
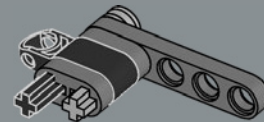

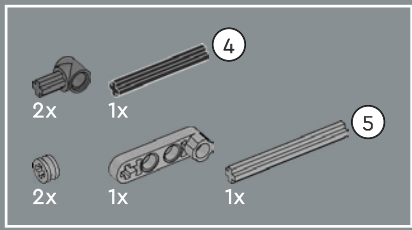

307

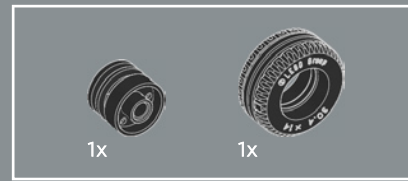
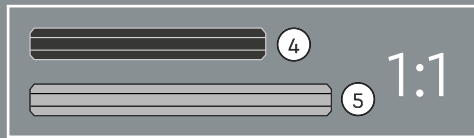
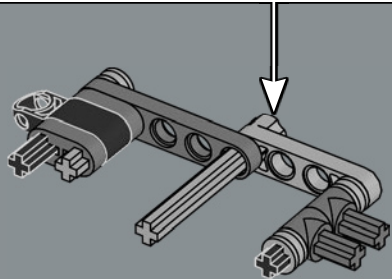
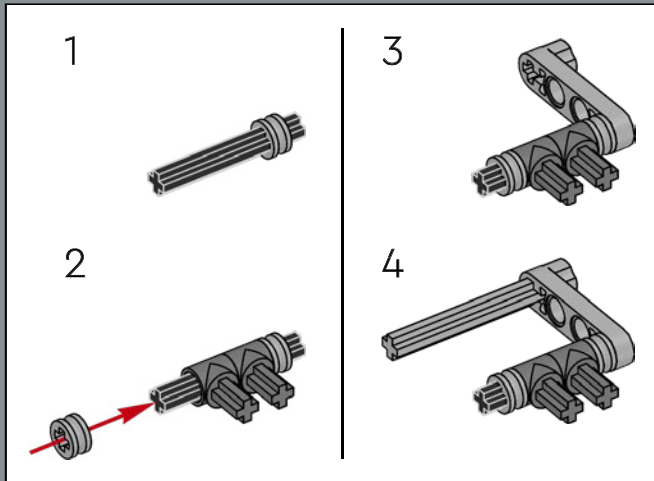

308

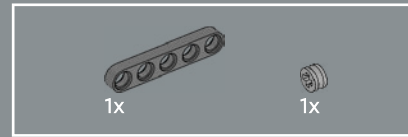
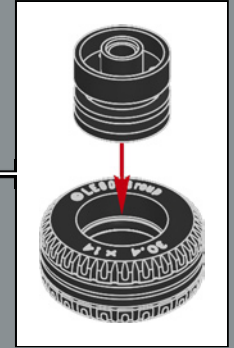
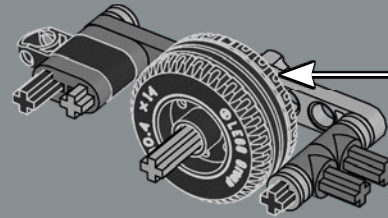

309

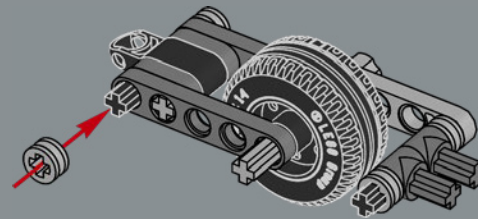



310

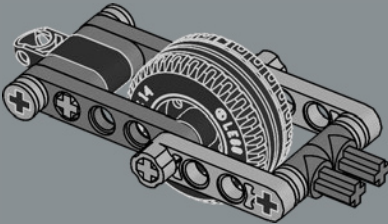

311

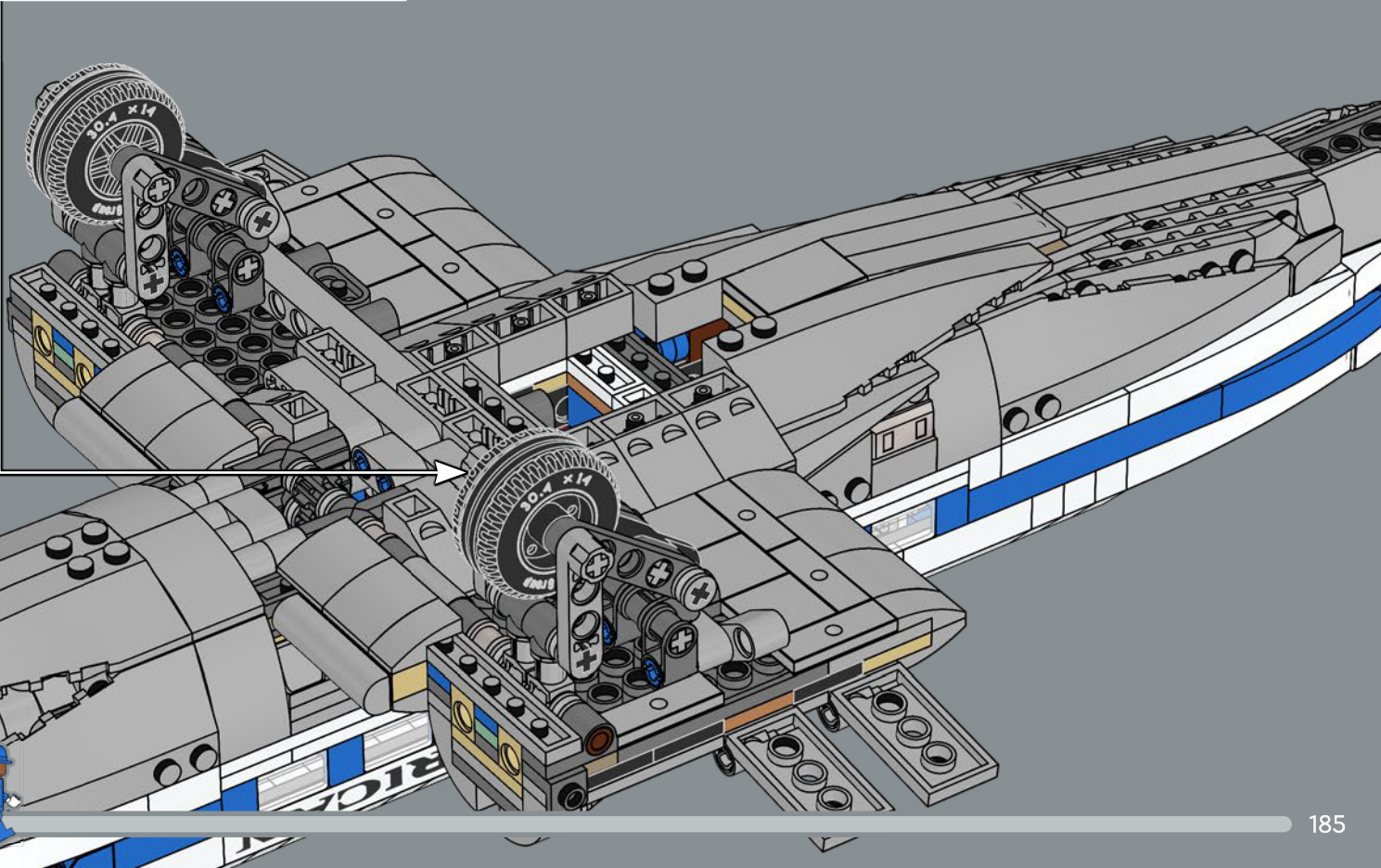

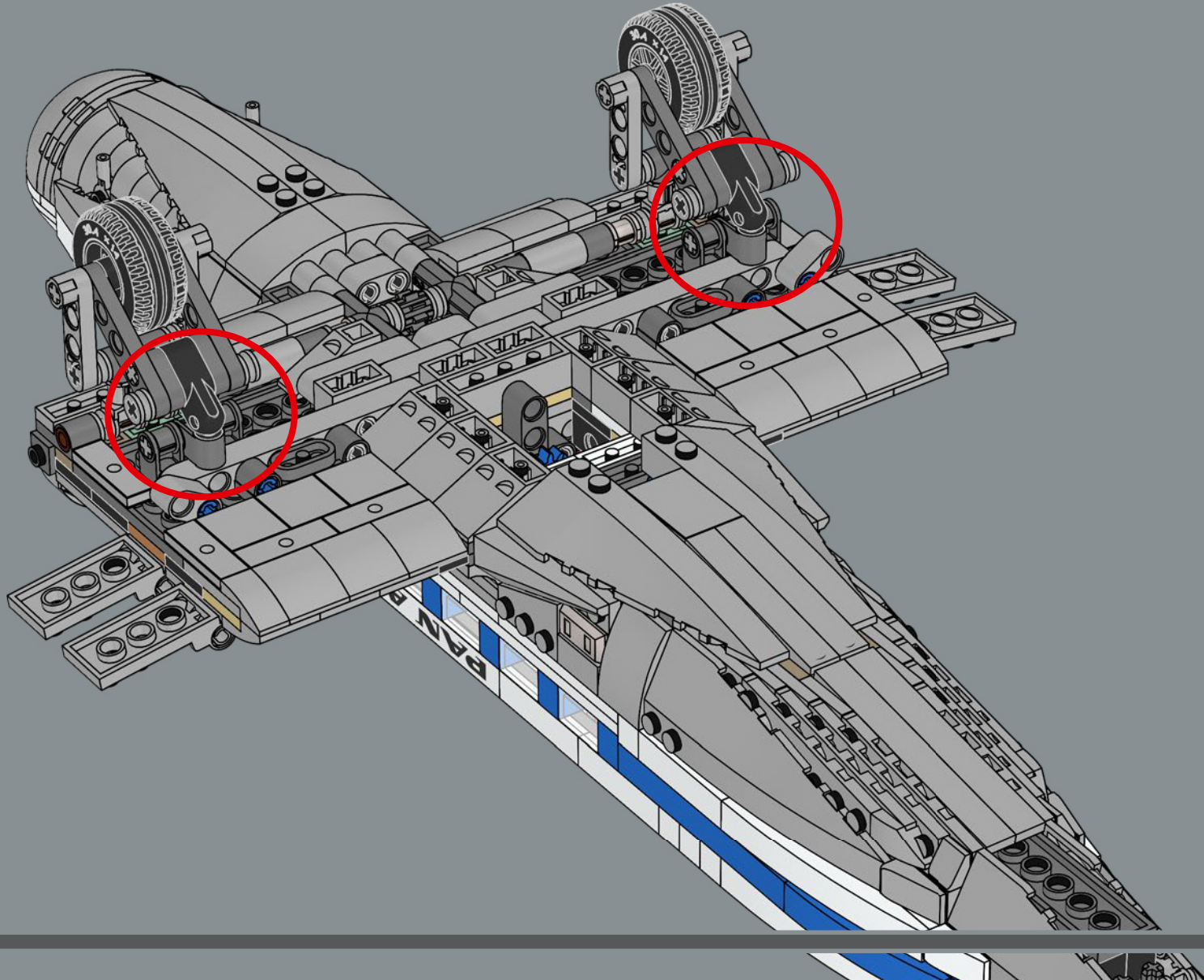

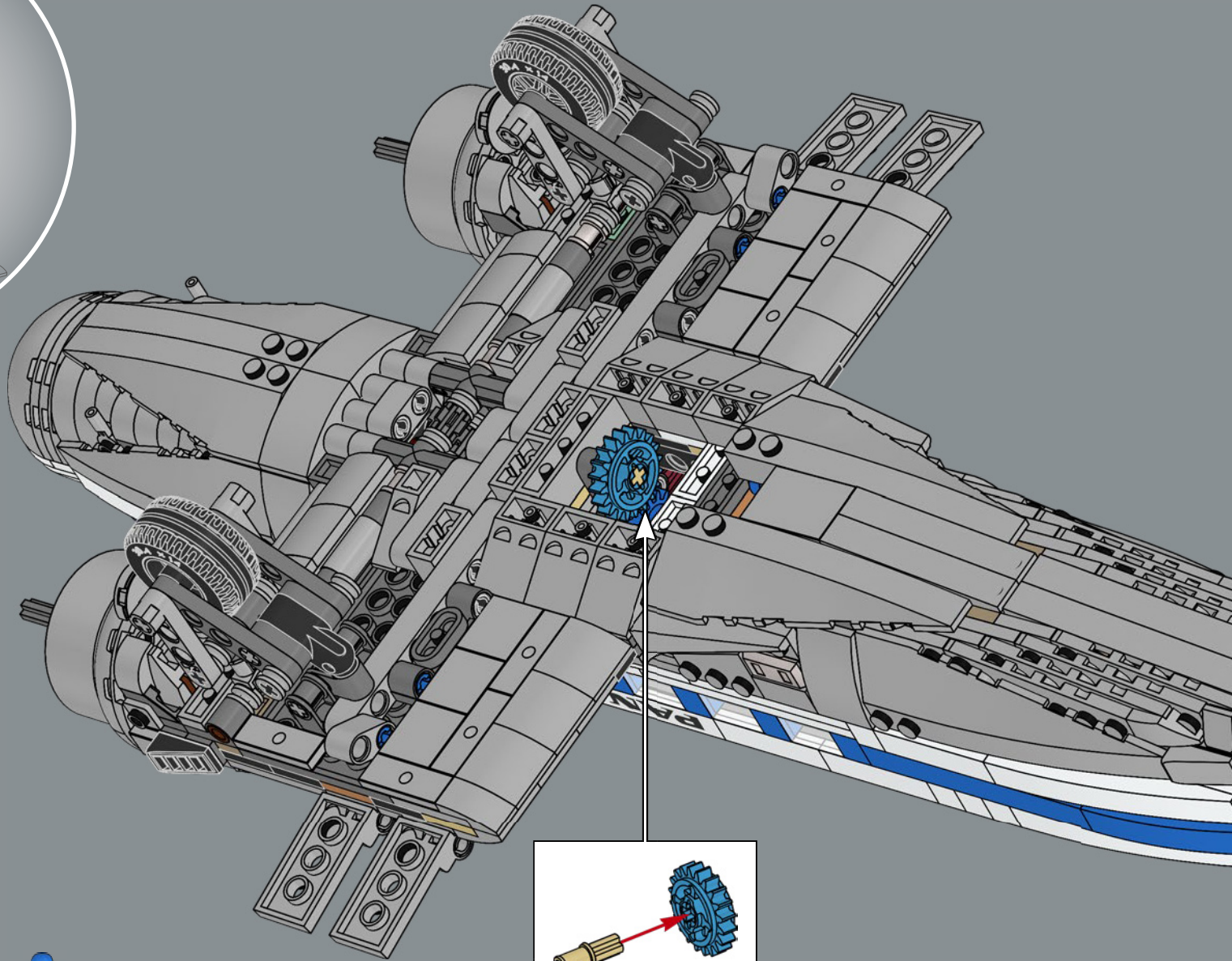

313

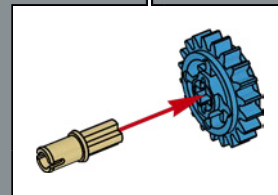

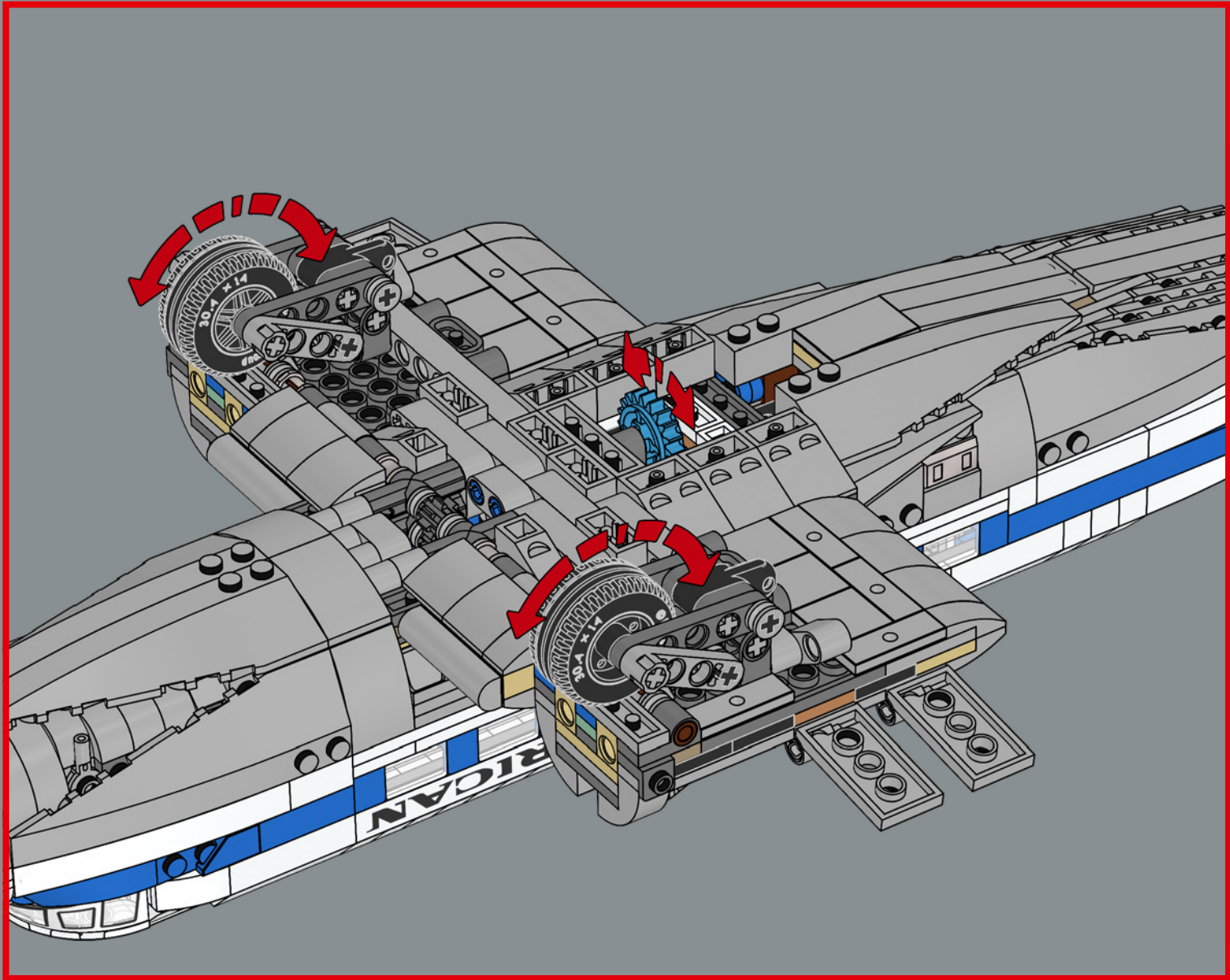

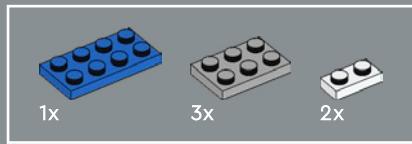

314

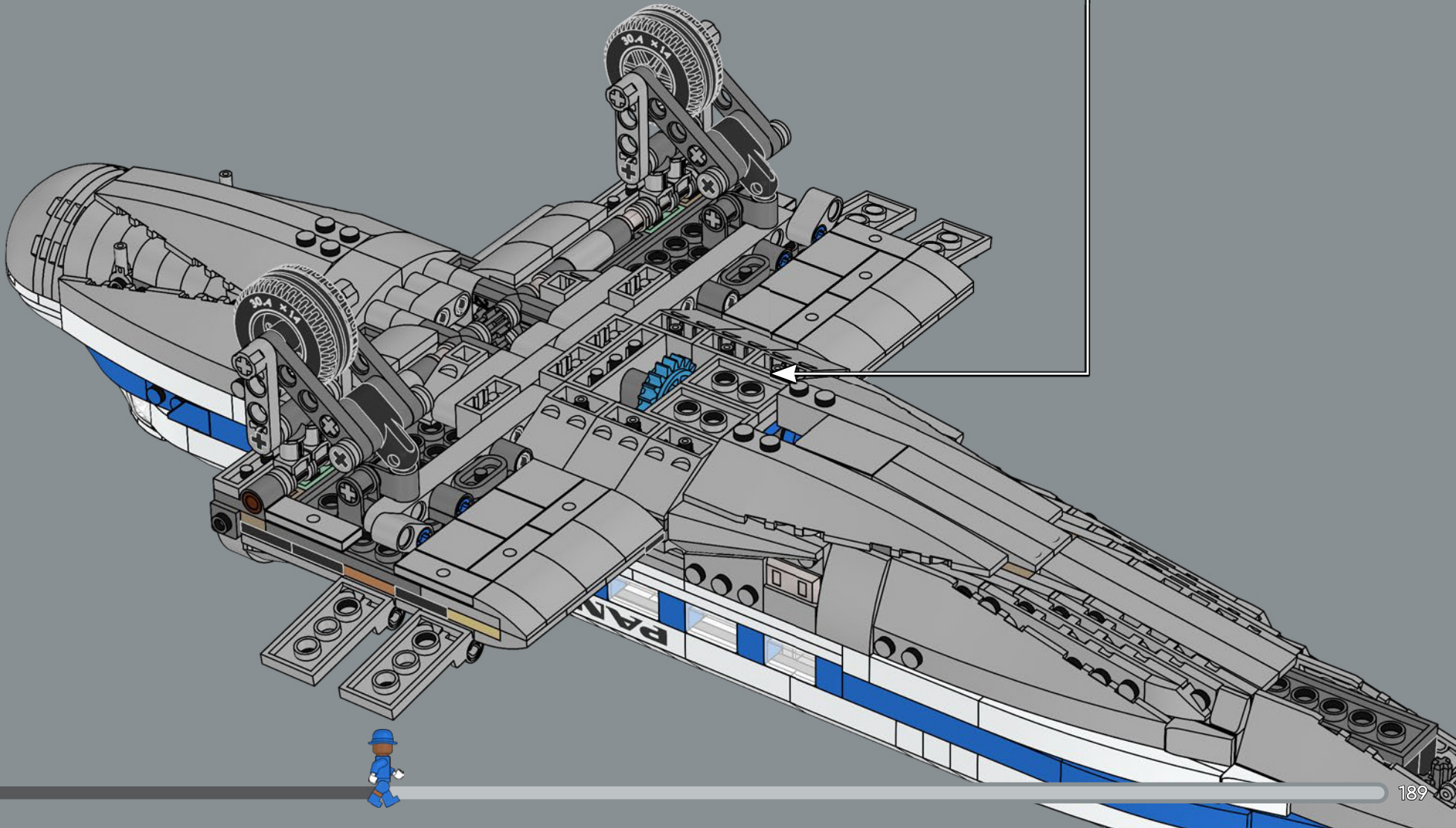
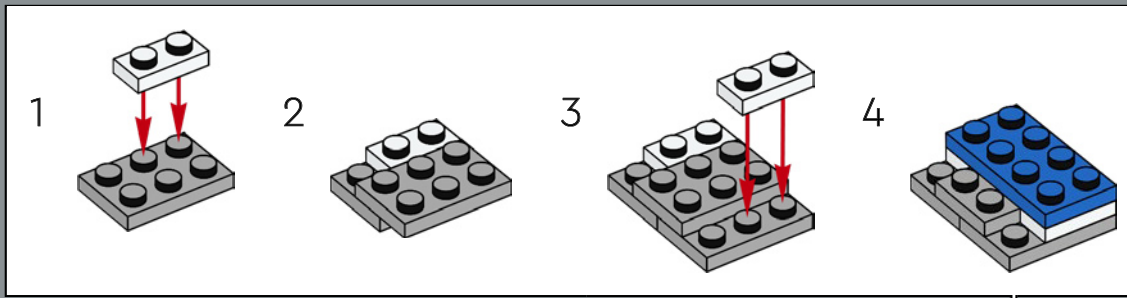



4x

315

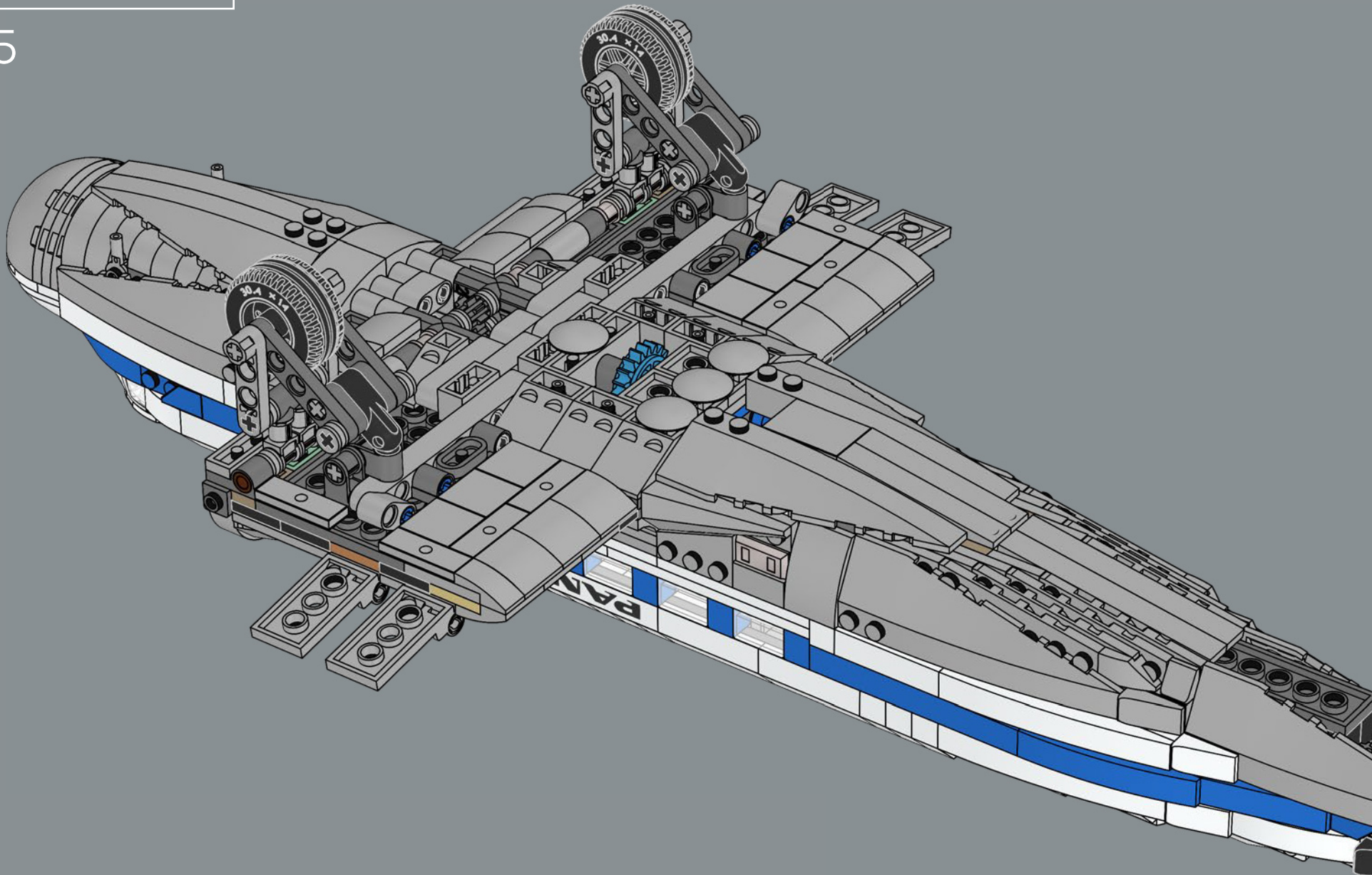

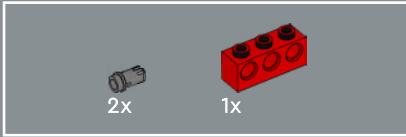
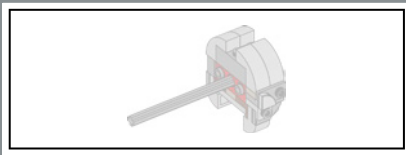

316

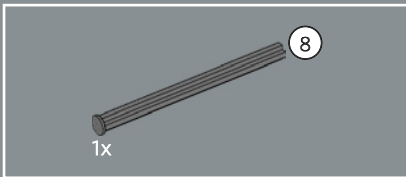
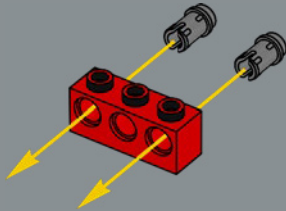

317

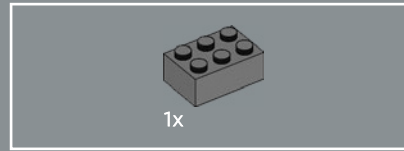
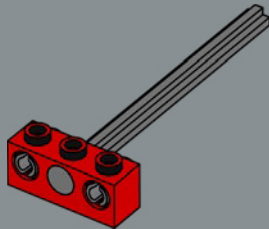

318

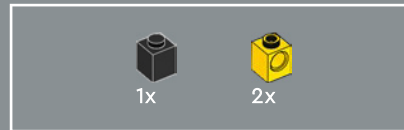
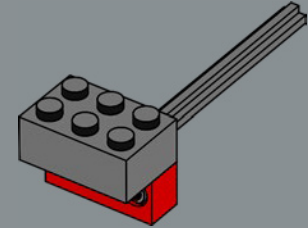

319

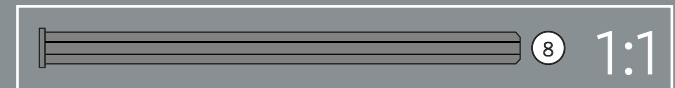
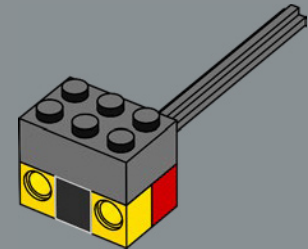

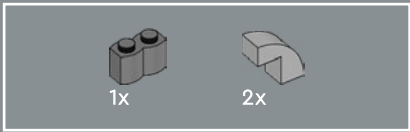

320

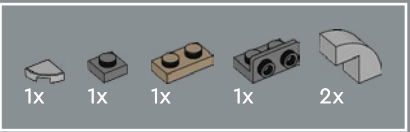
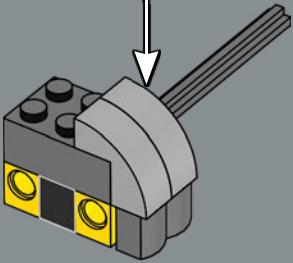
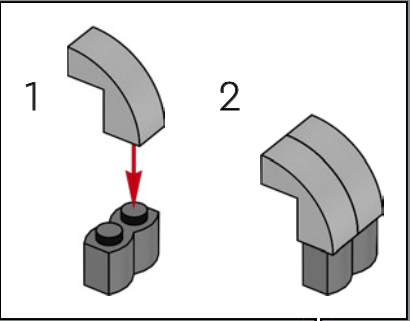

321

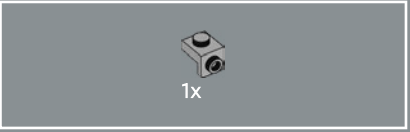
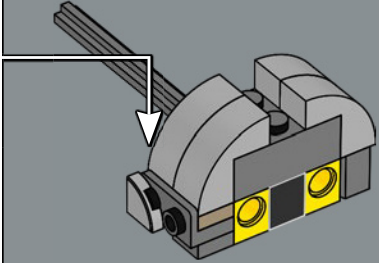
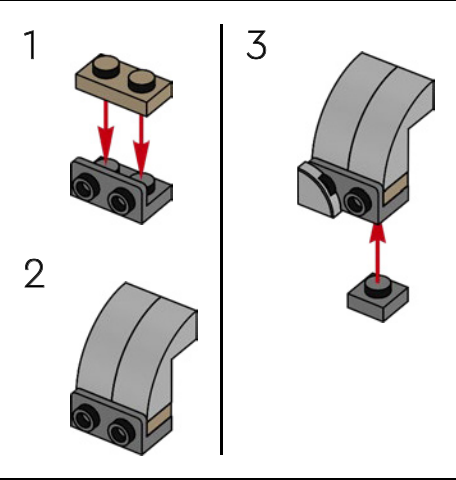

322

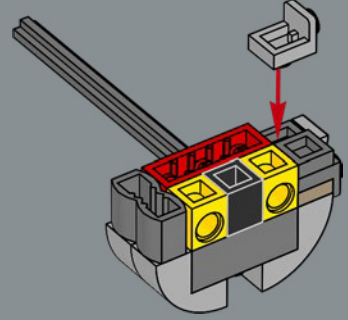



323

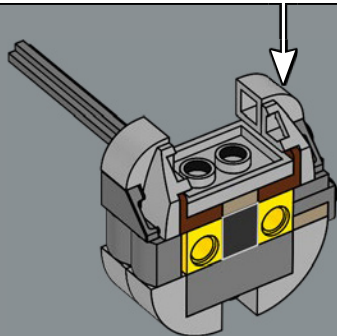
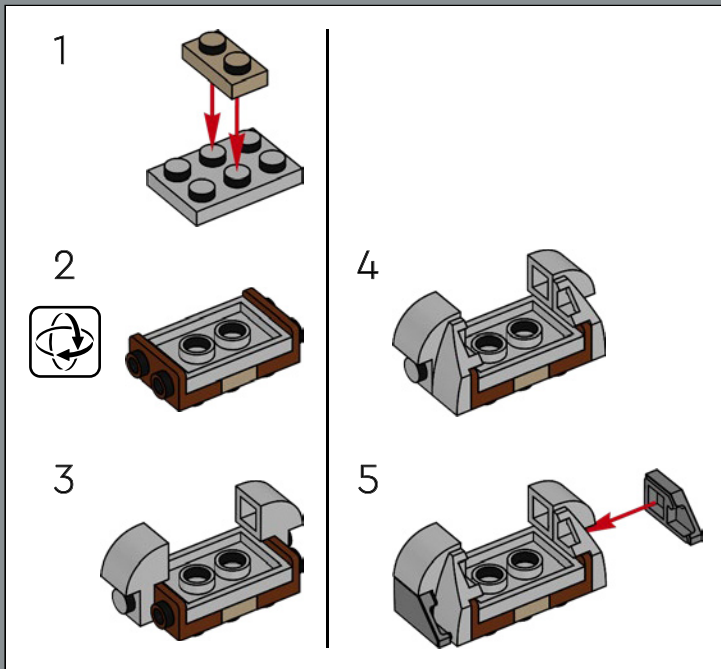

324

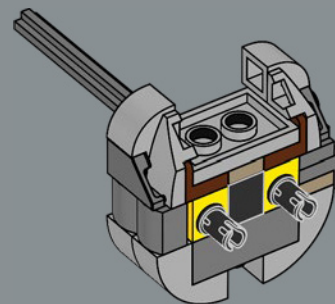



1x

325

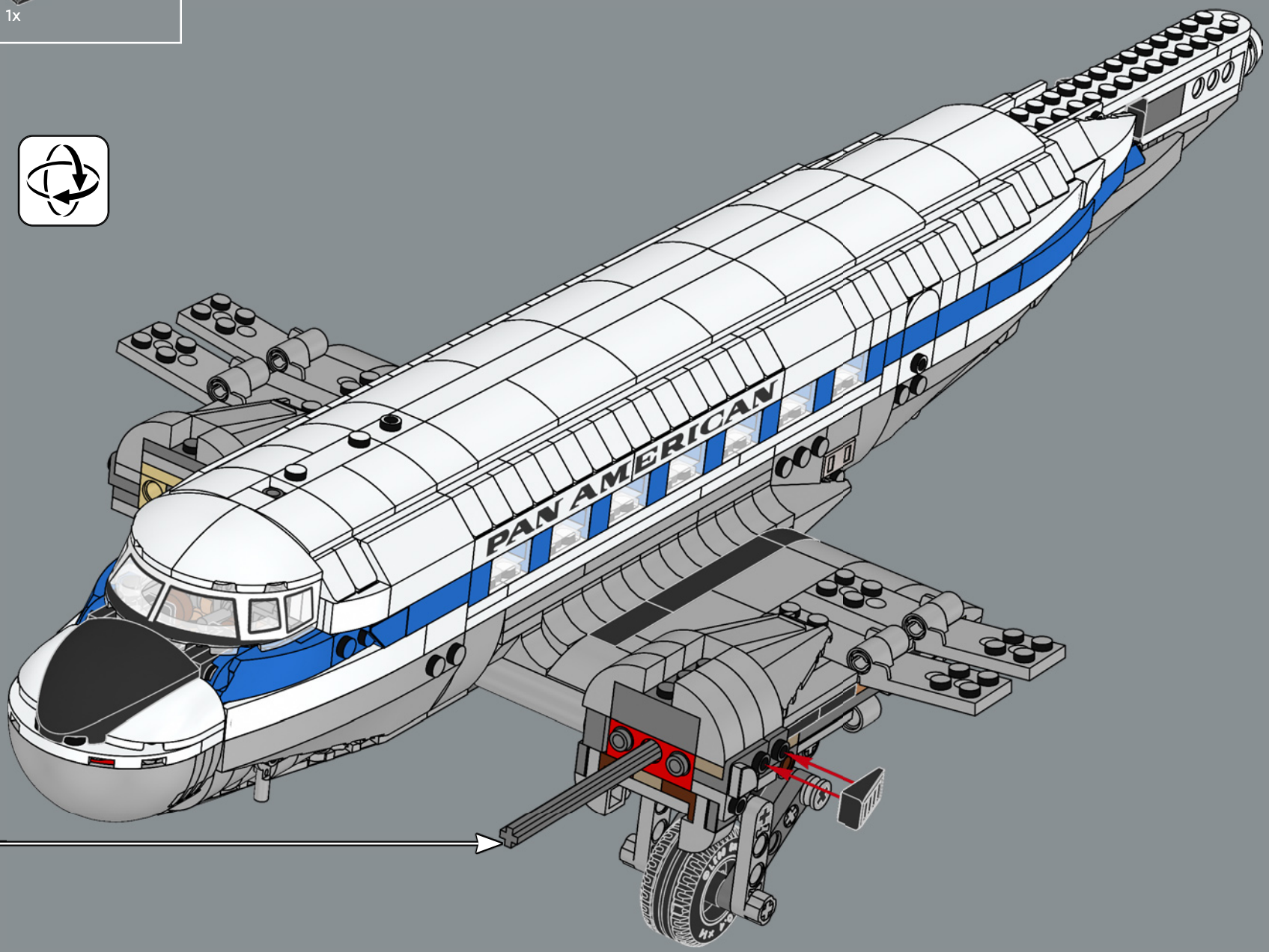

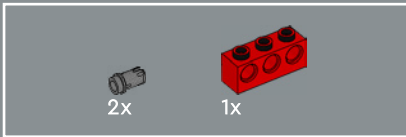
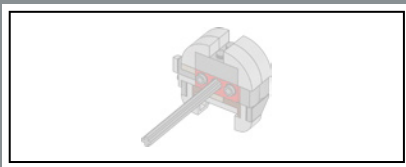

326

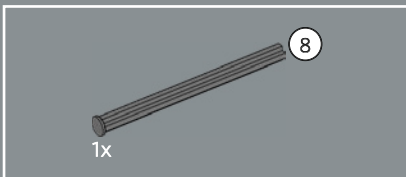
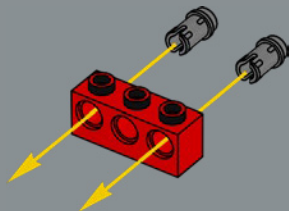

327

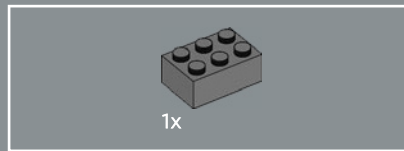
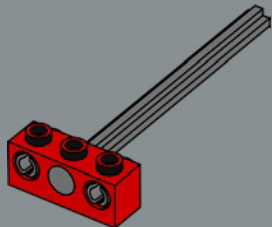

328

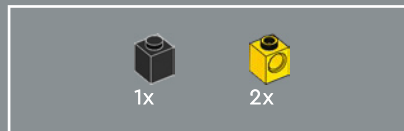
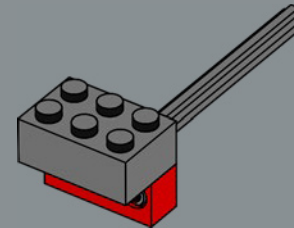

329

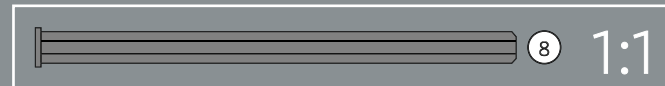
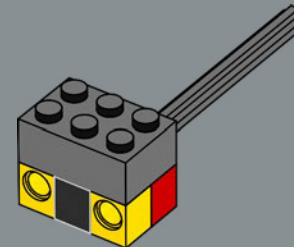

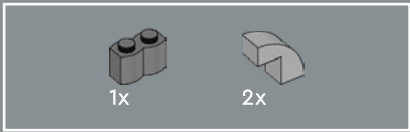

330

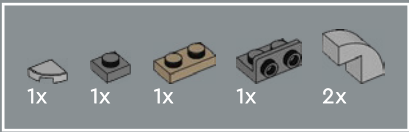
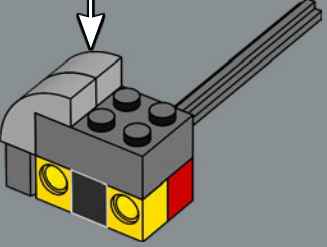
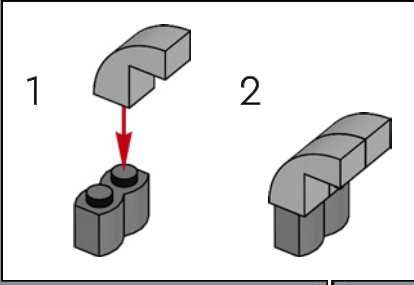

331

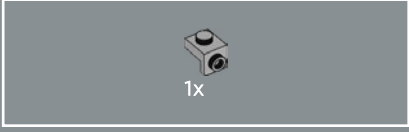
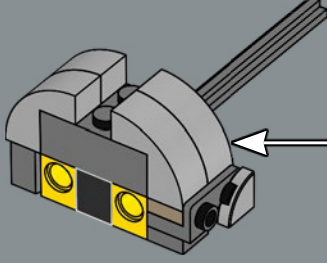
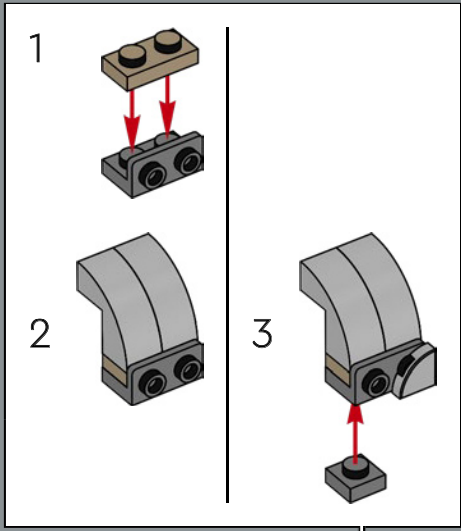

332

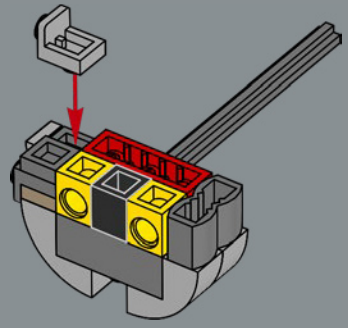

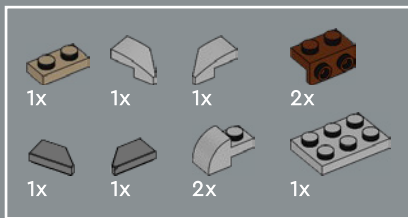

333

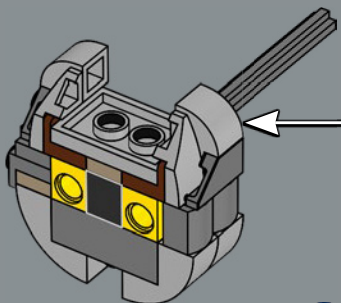
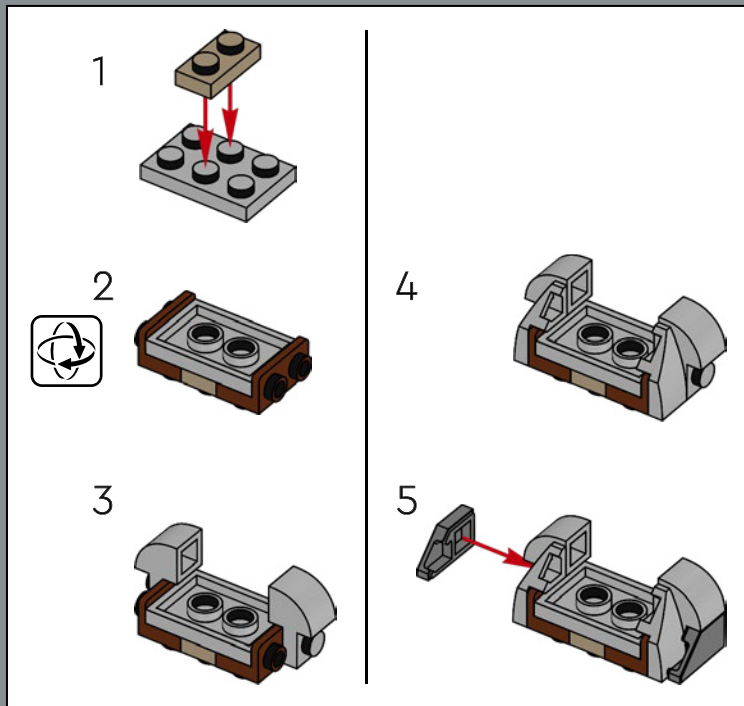

334

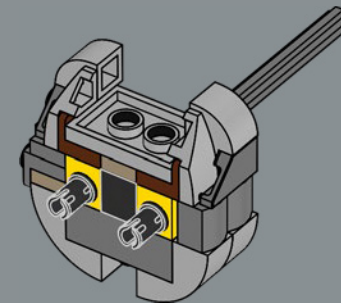



1x

335

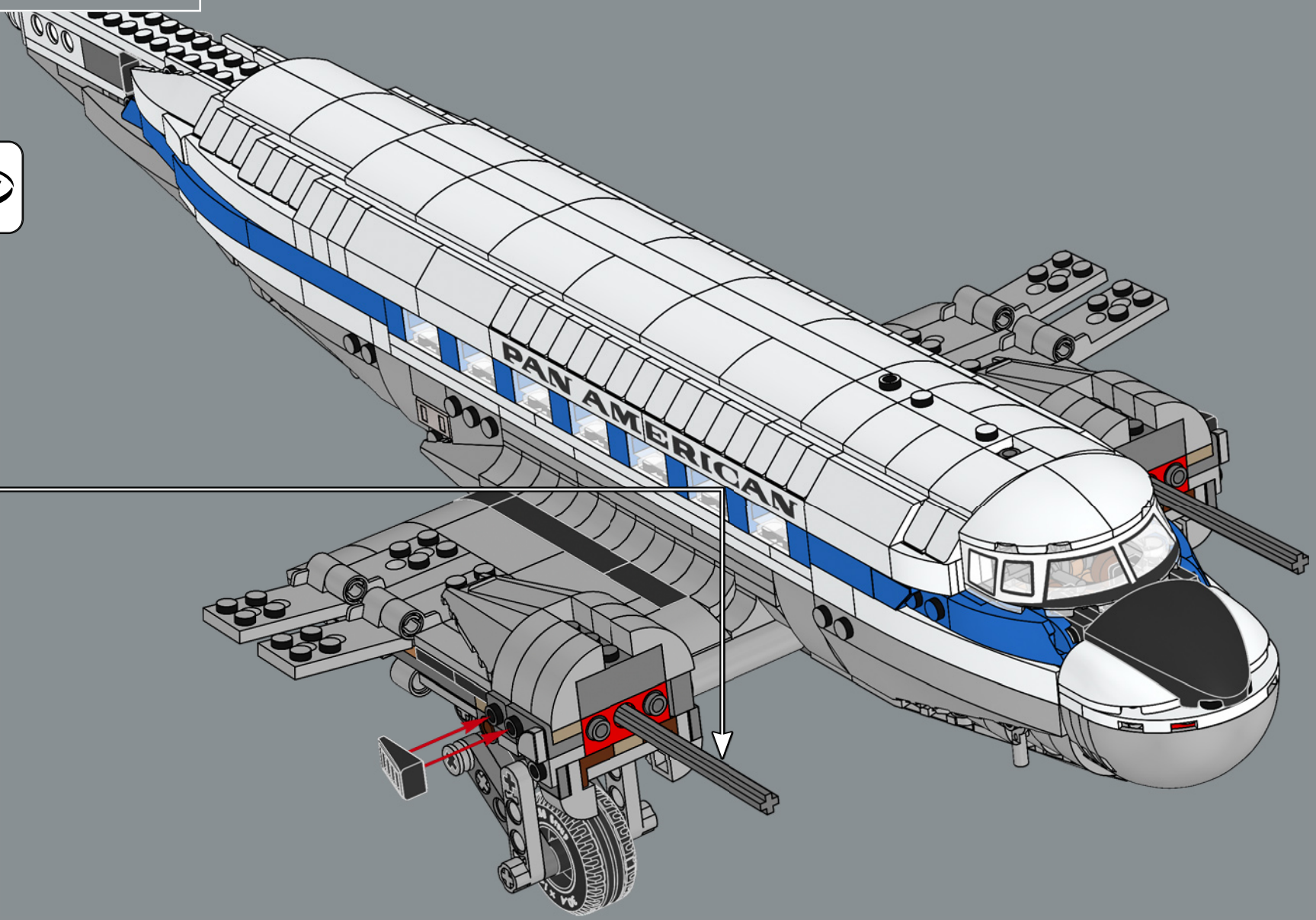

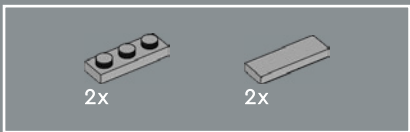

336

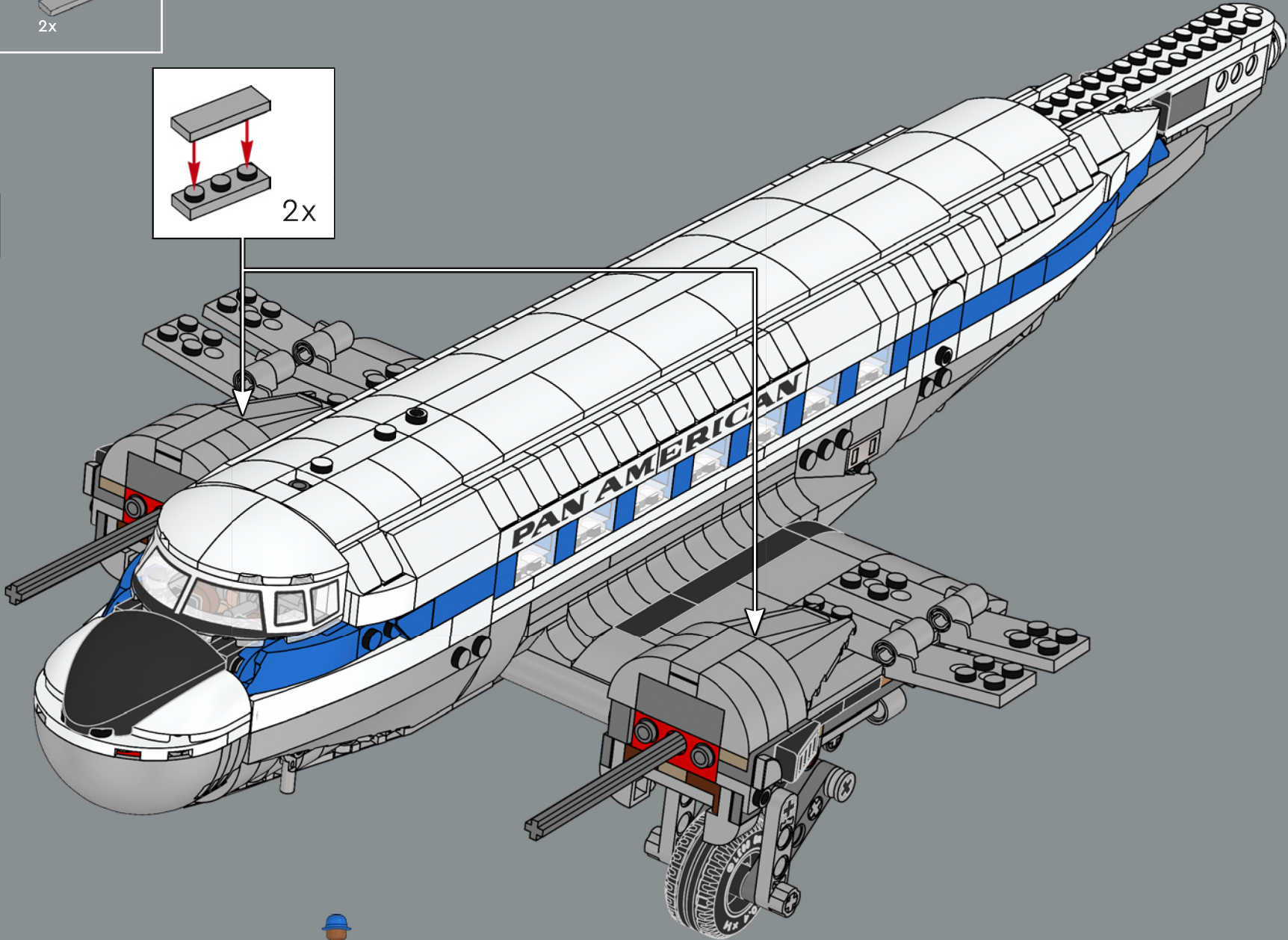
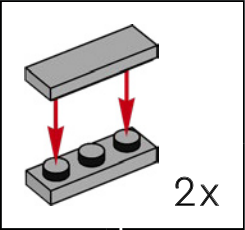

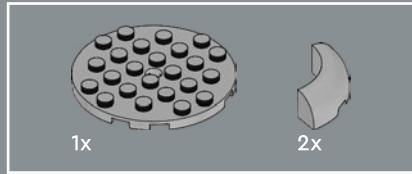

337

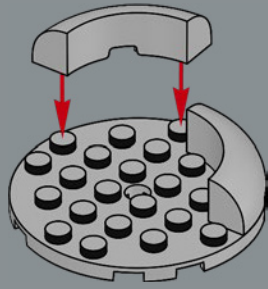

338

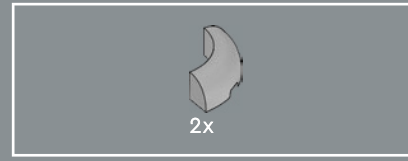
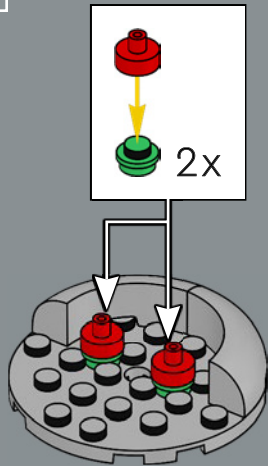

339

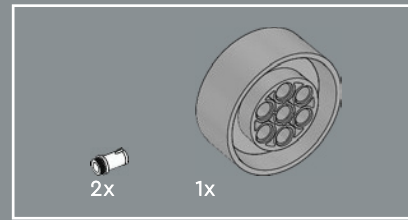
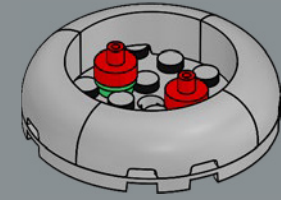

340

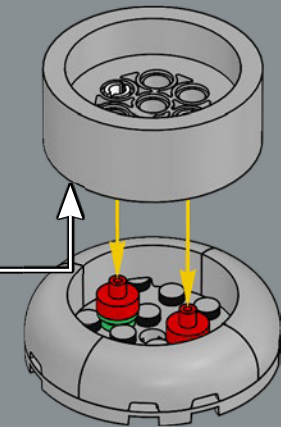
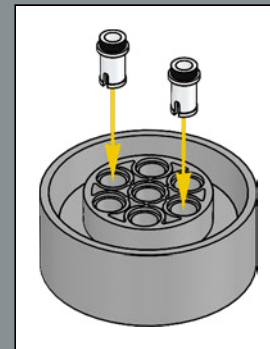

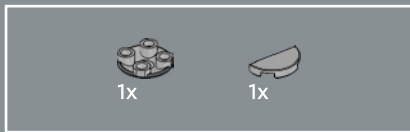

341

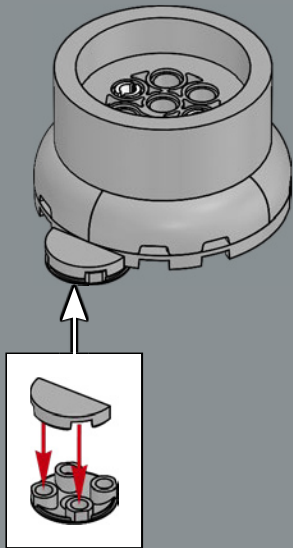

342

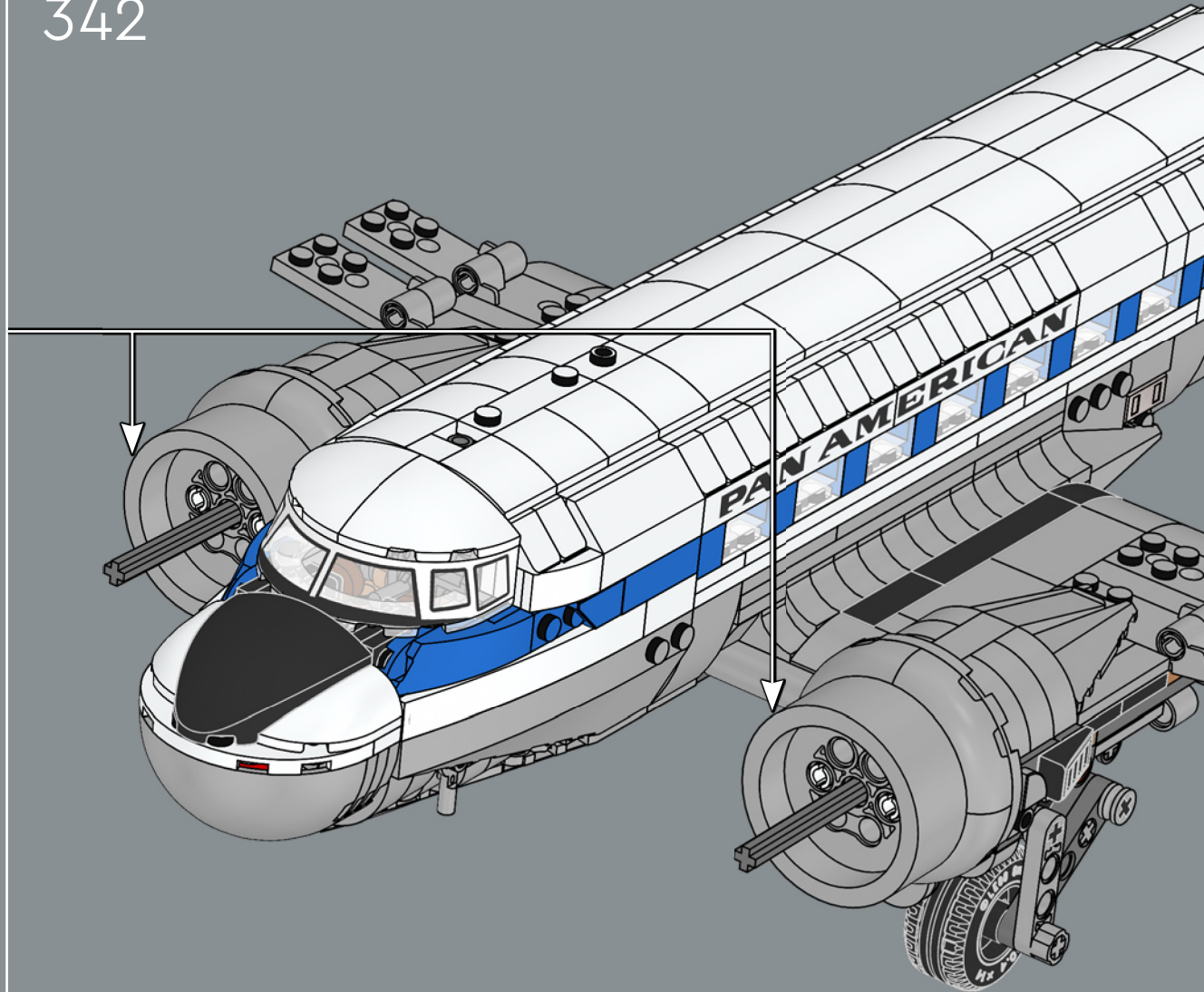

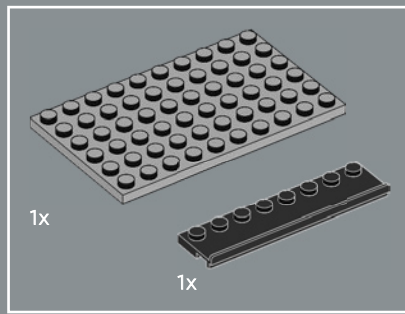
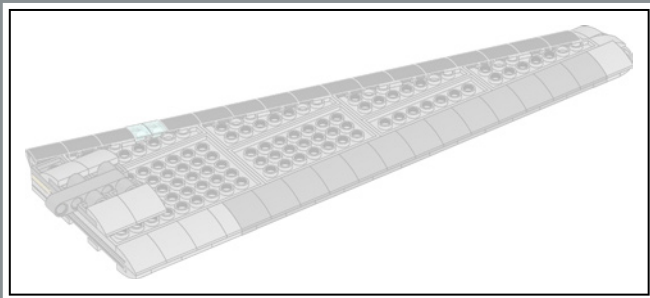

343

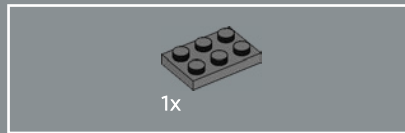
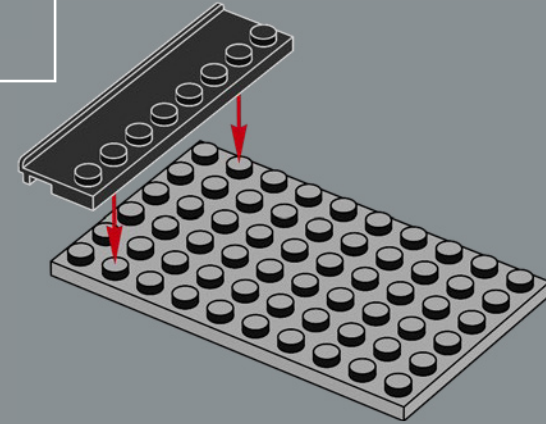

344

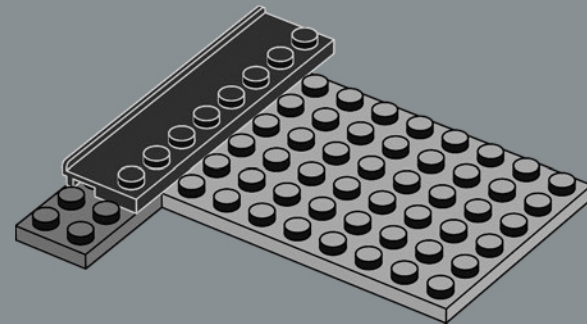

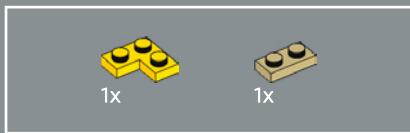

345

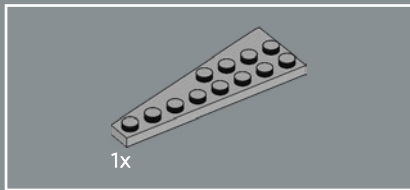
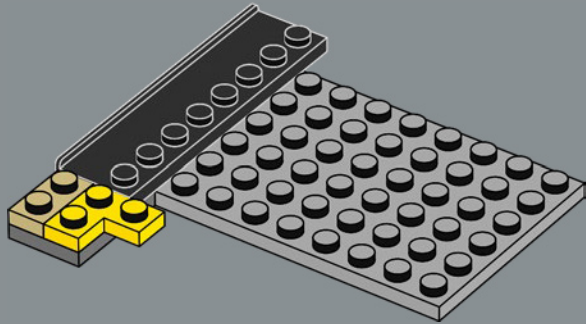

346

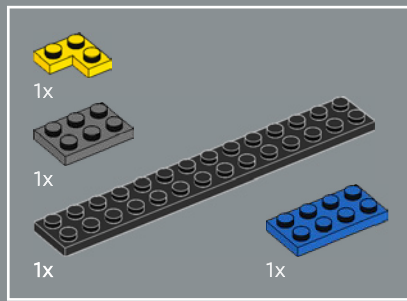
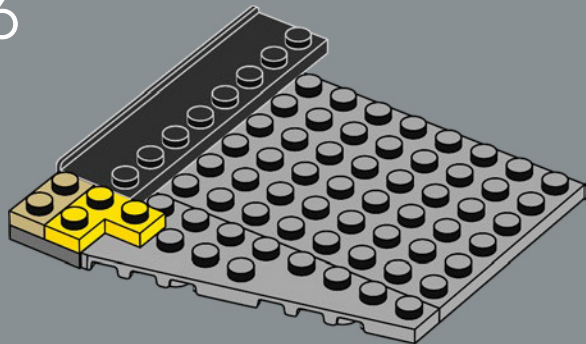

347

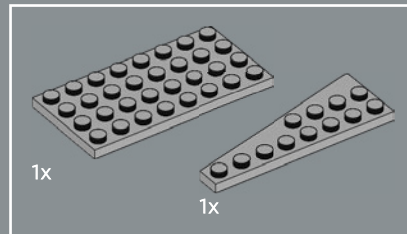
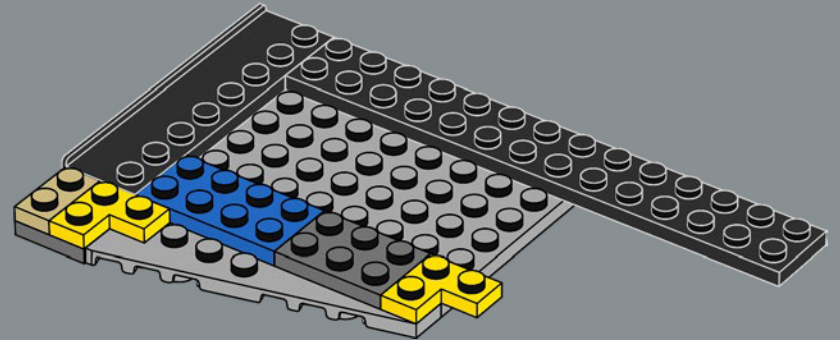

348

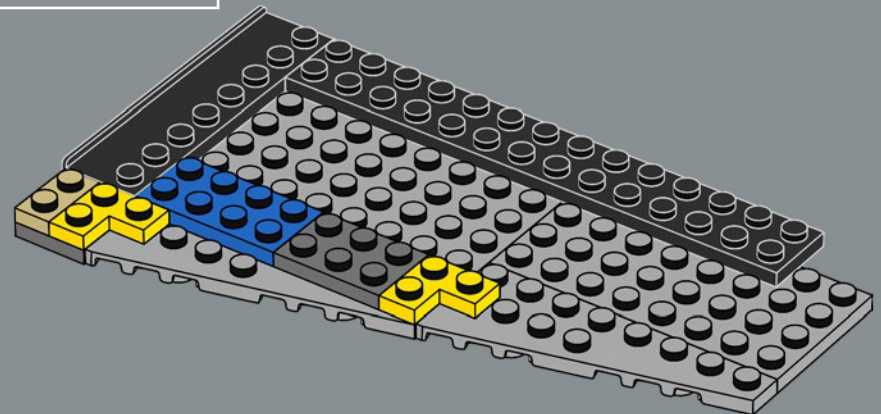

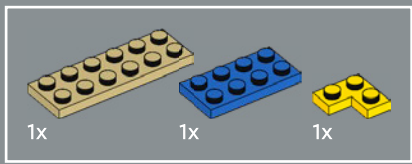

349

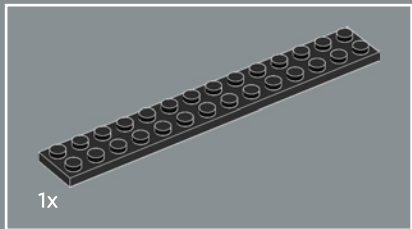
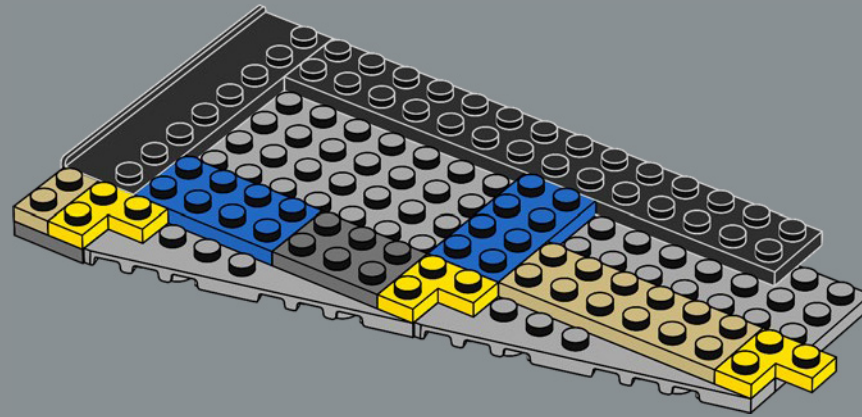

350

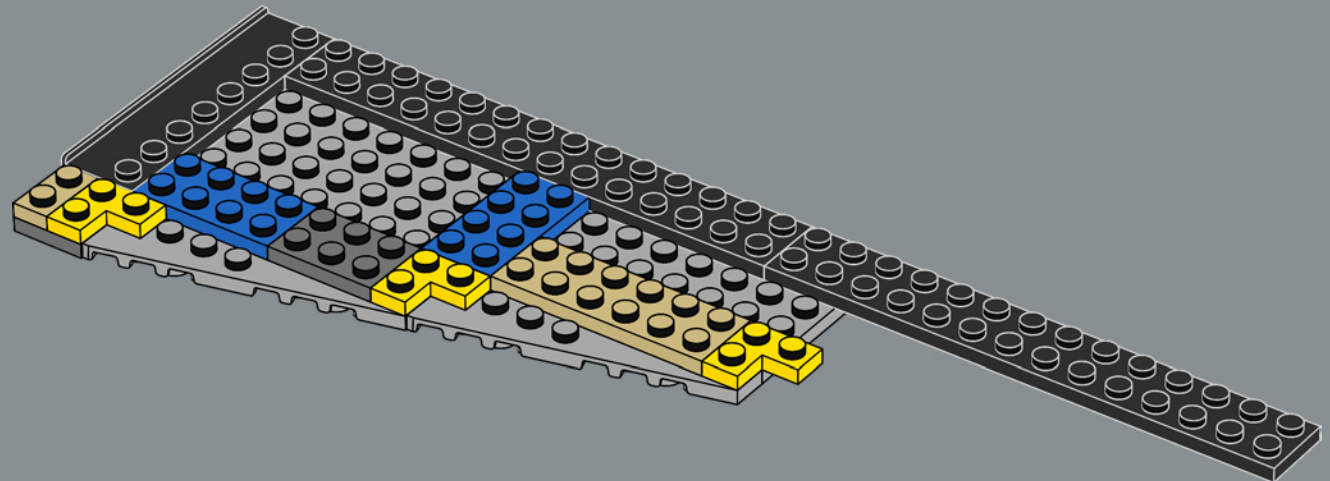

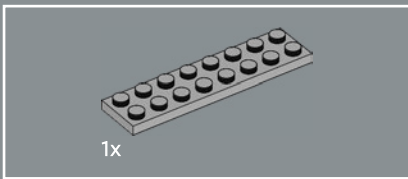

351

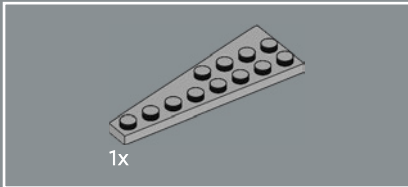
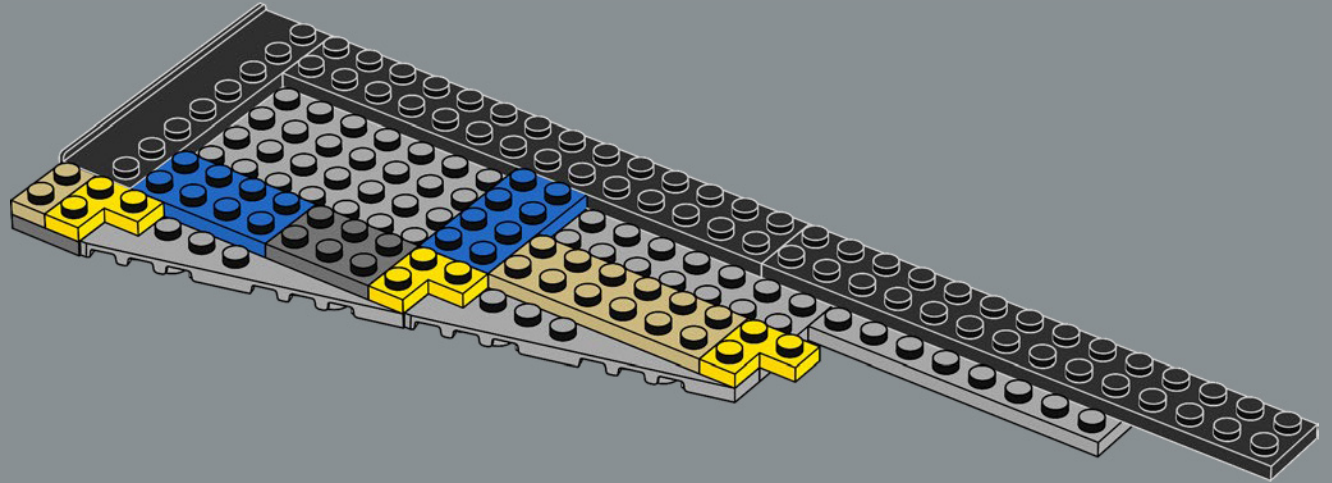

352

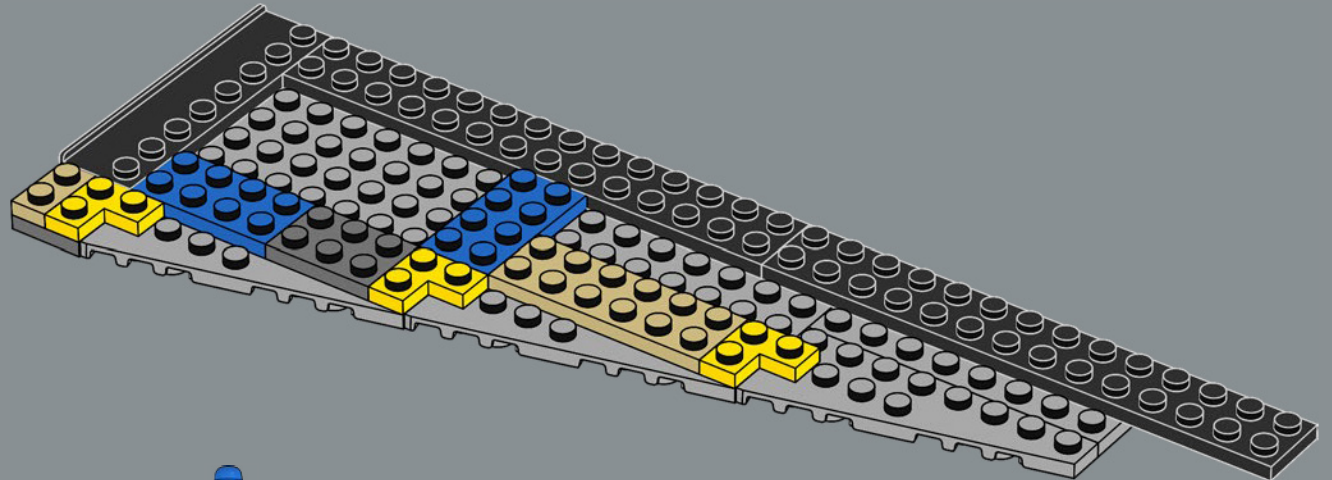

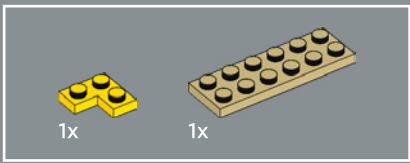

353

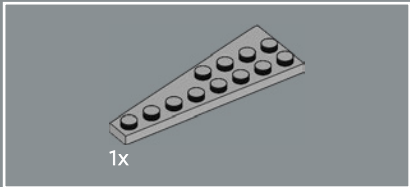
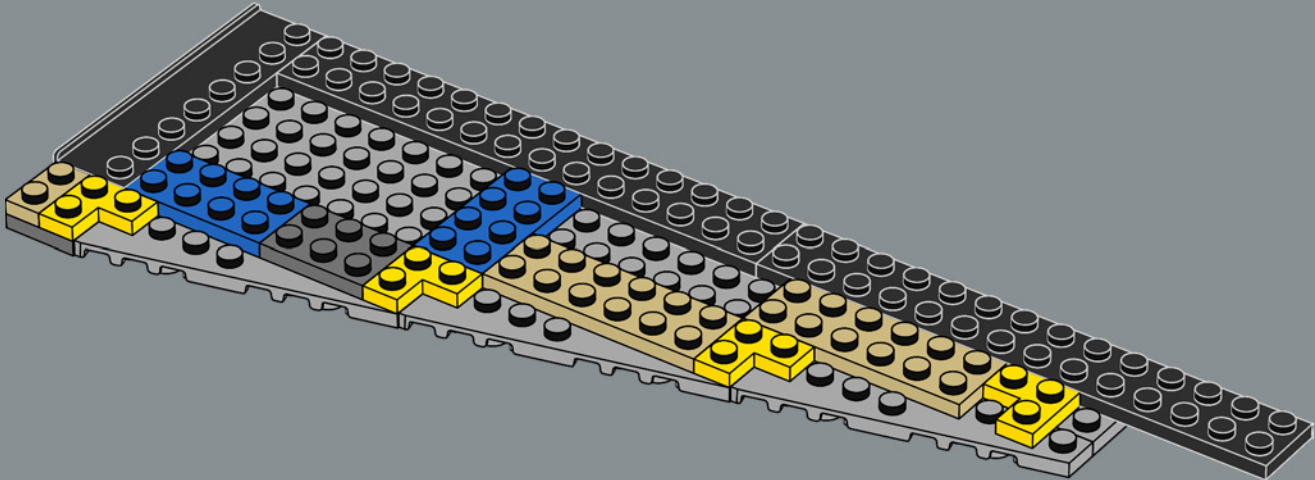

354

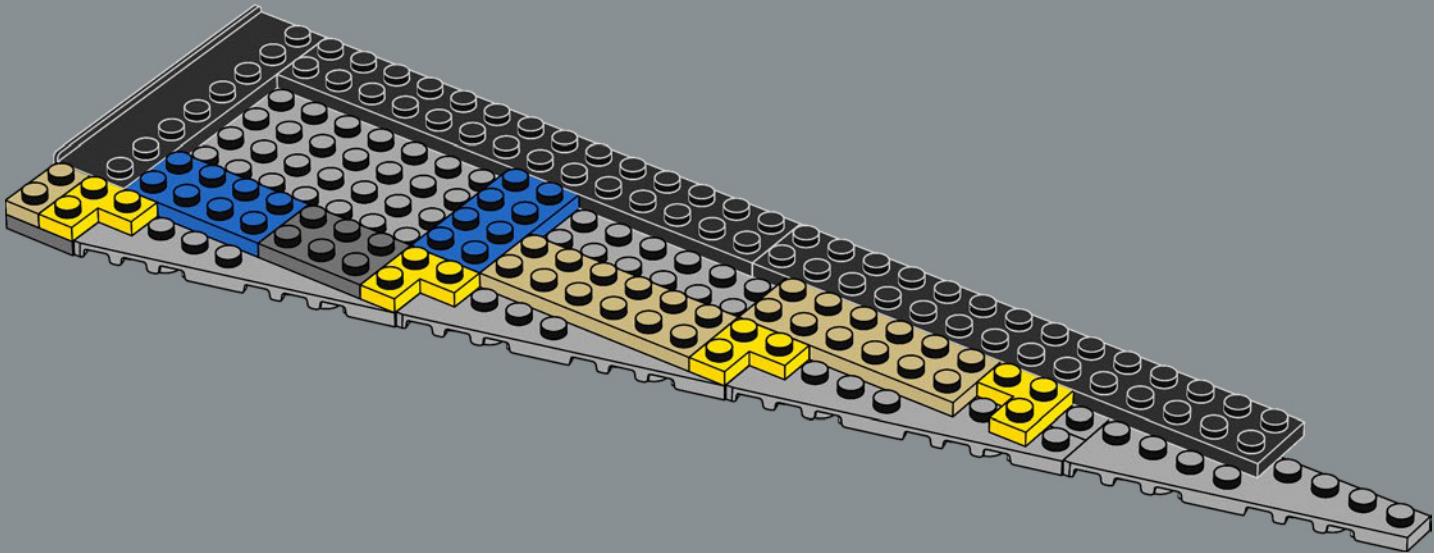

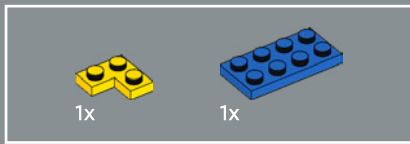

355

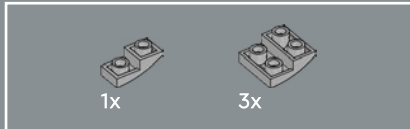
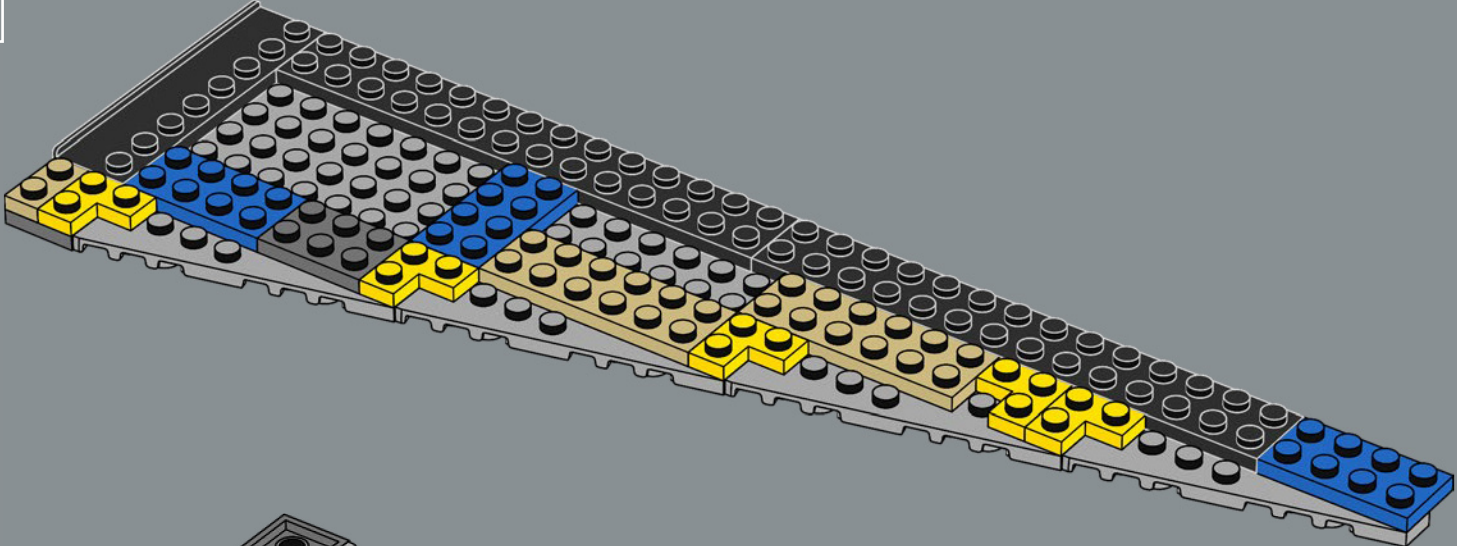

356

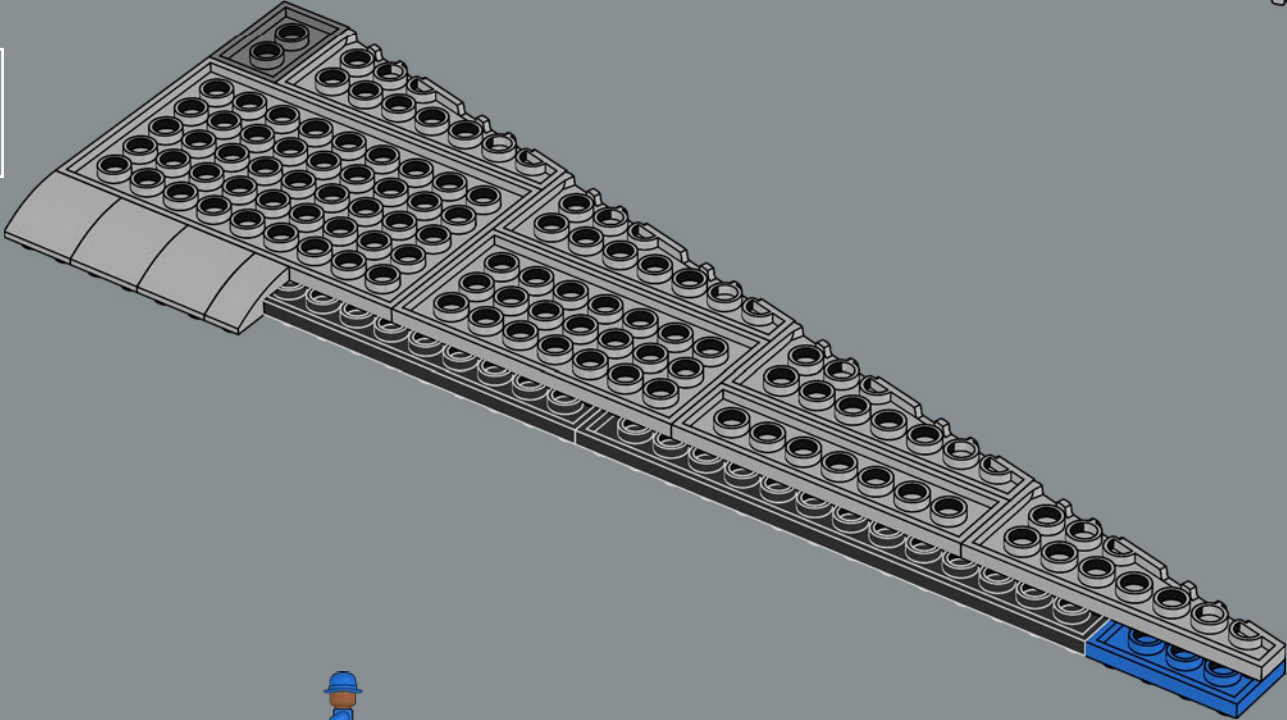

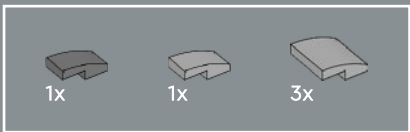

359

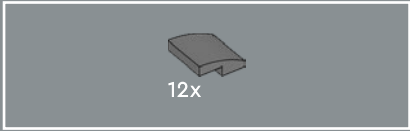
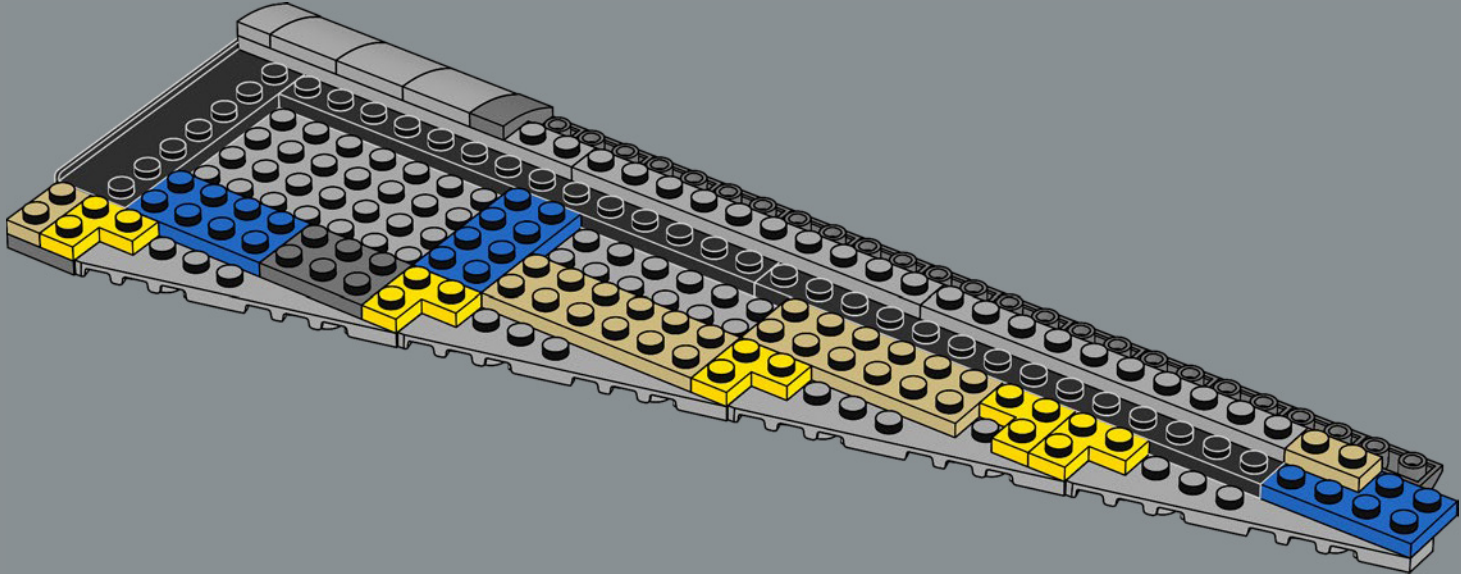

360

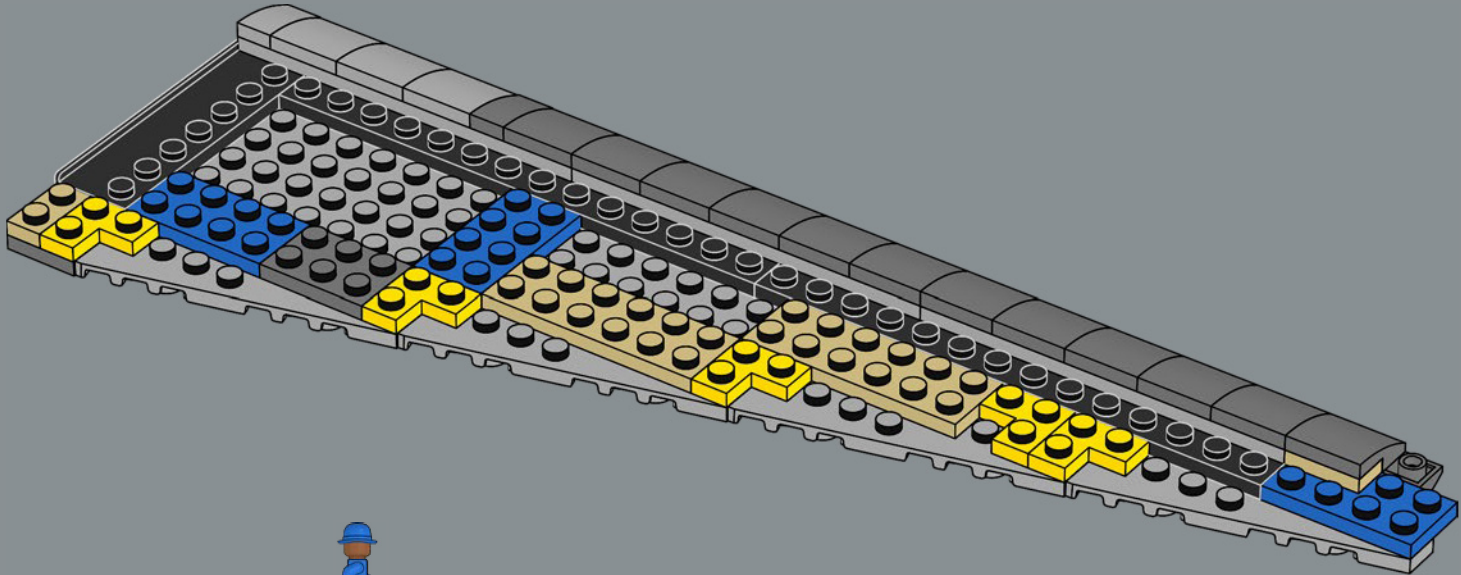

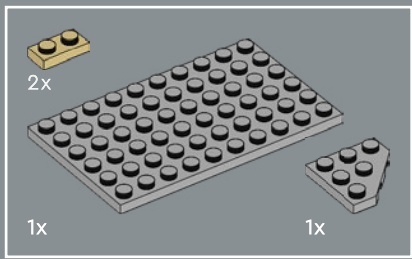

361

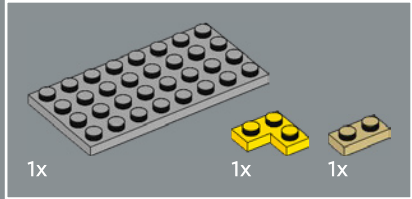
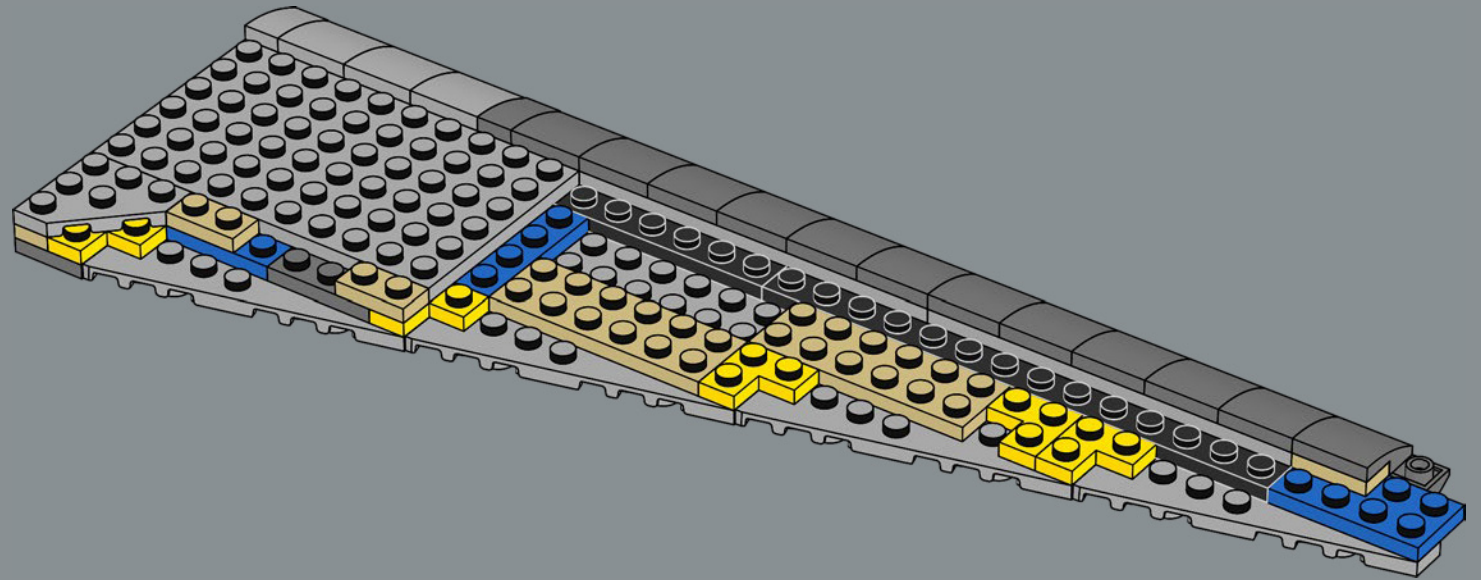

362

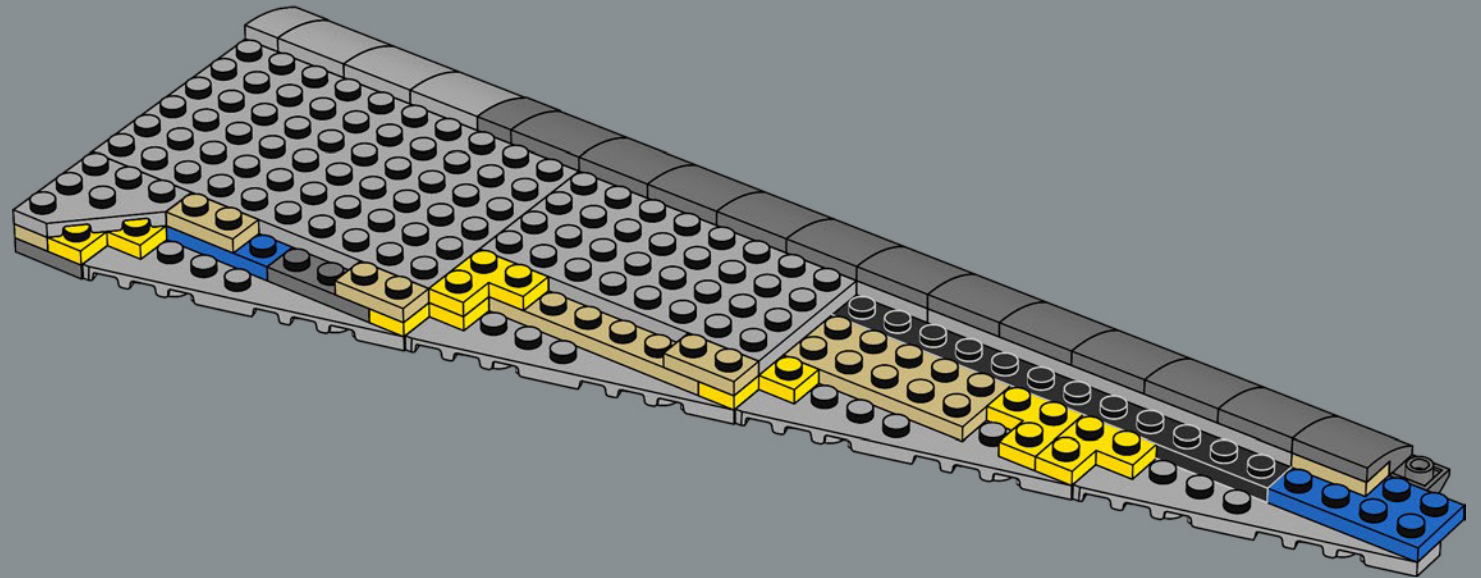

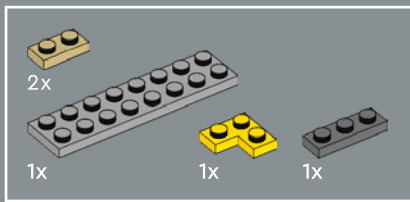

363

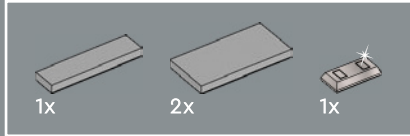
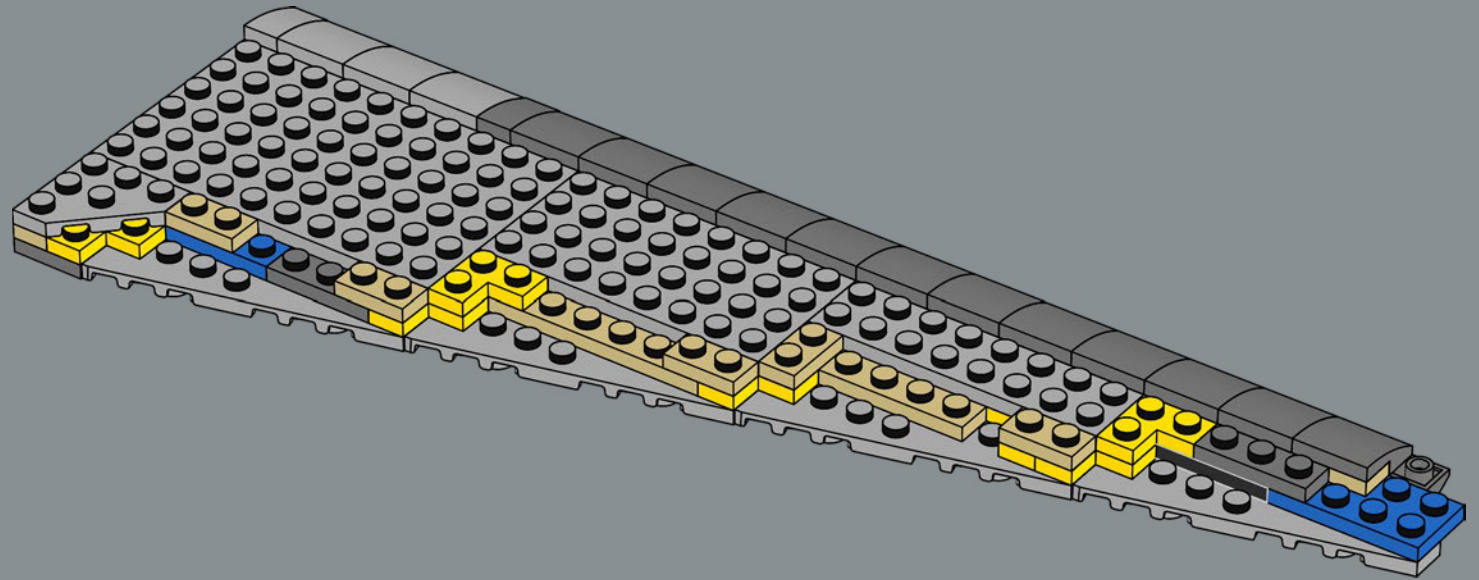

364

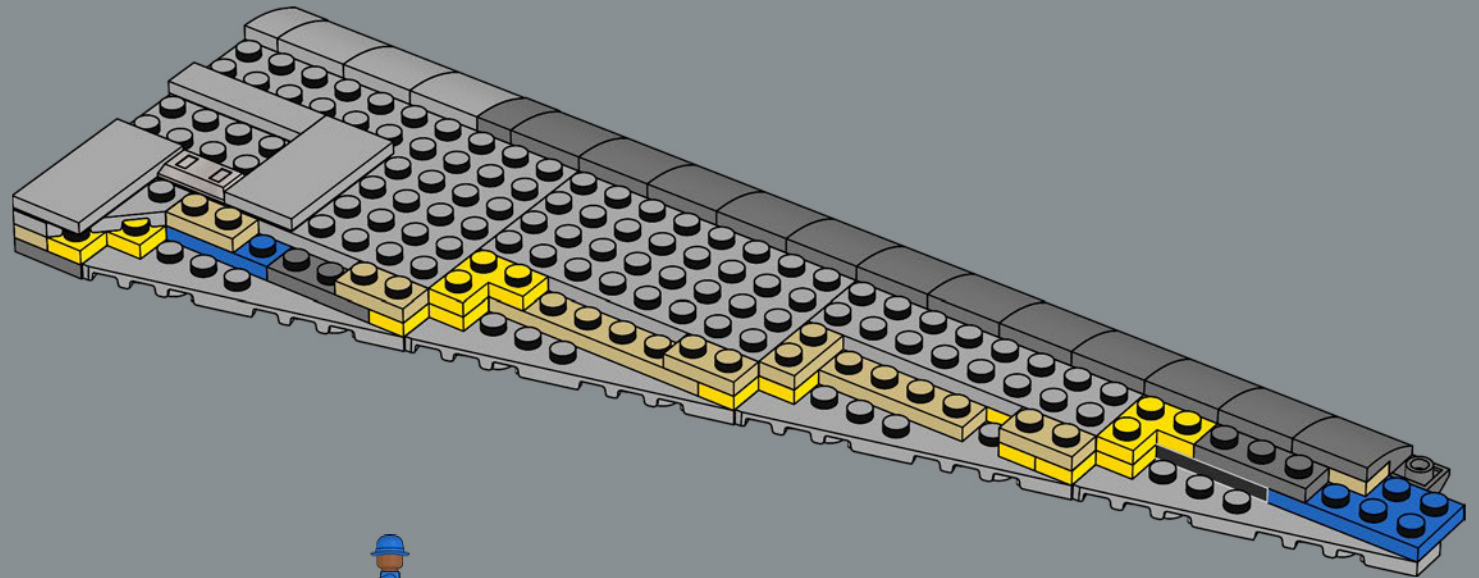

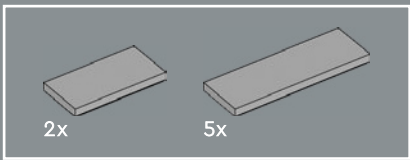

365

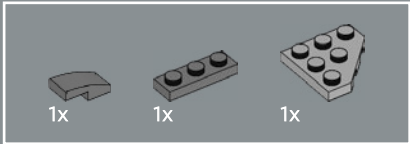
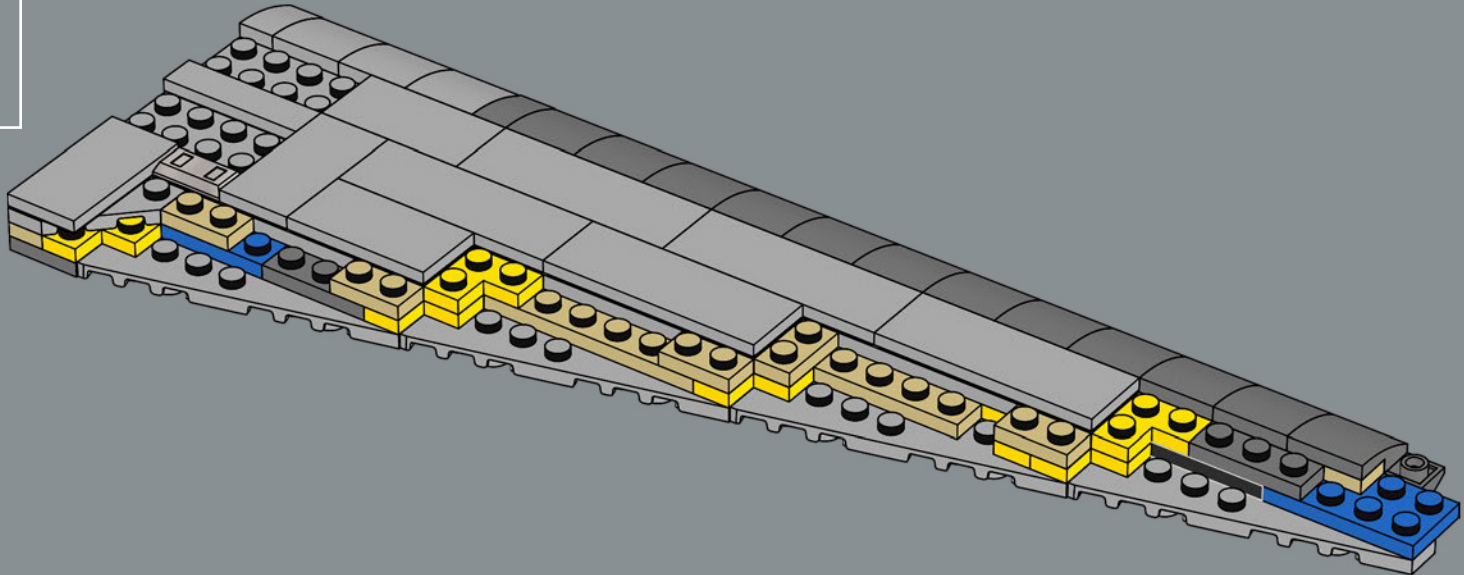

366

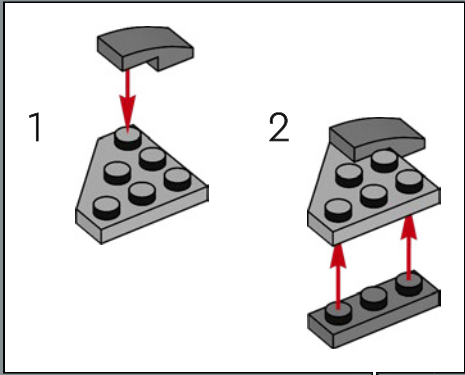
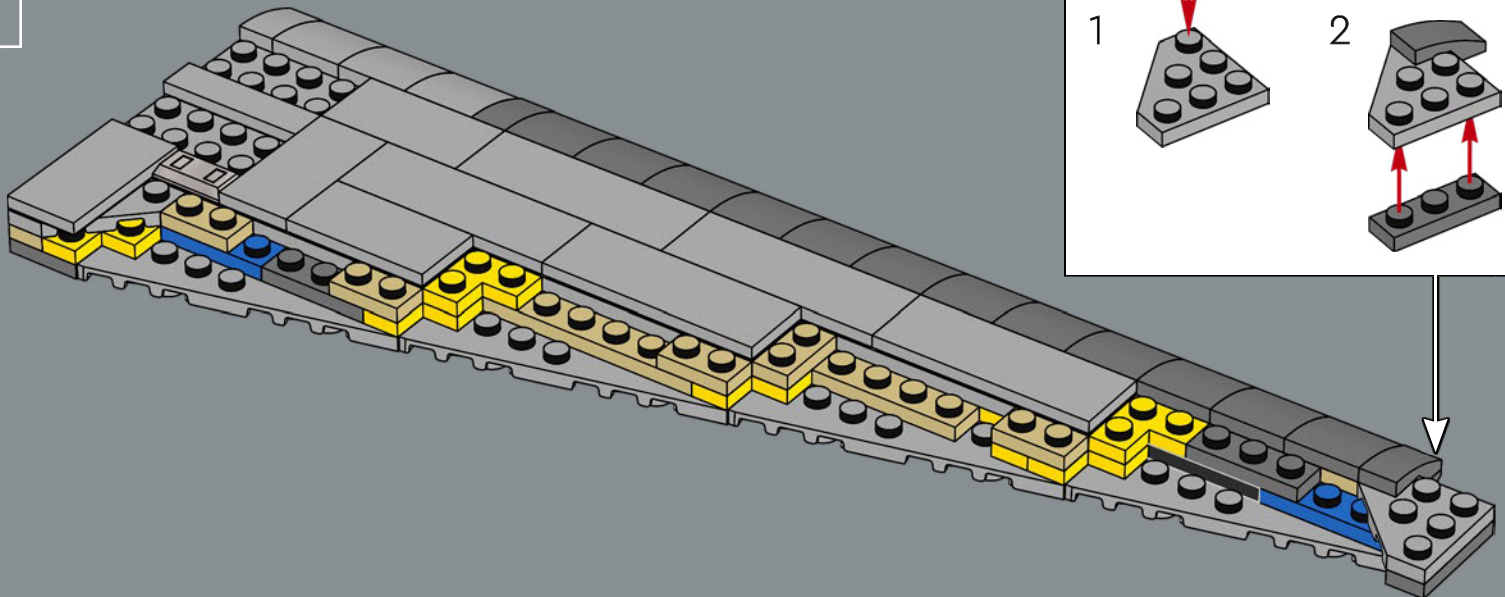

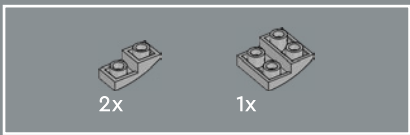

367

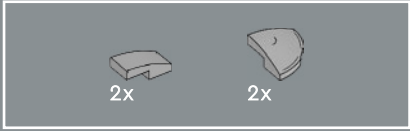
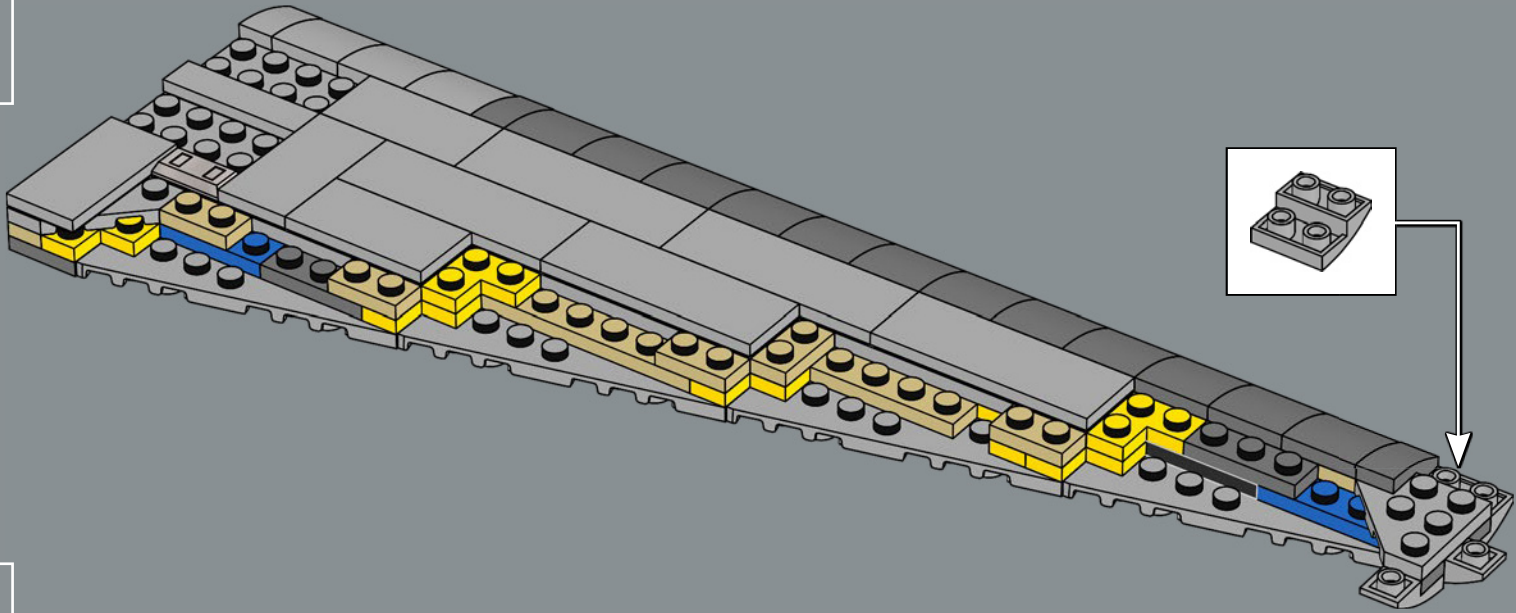

368

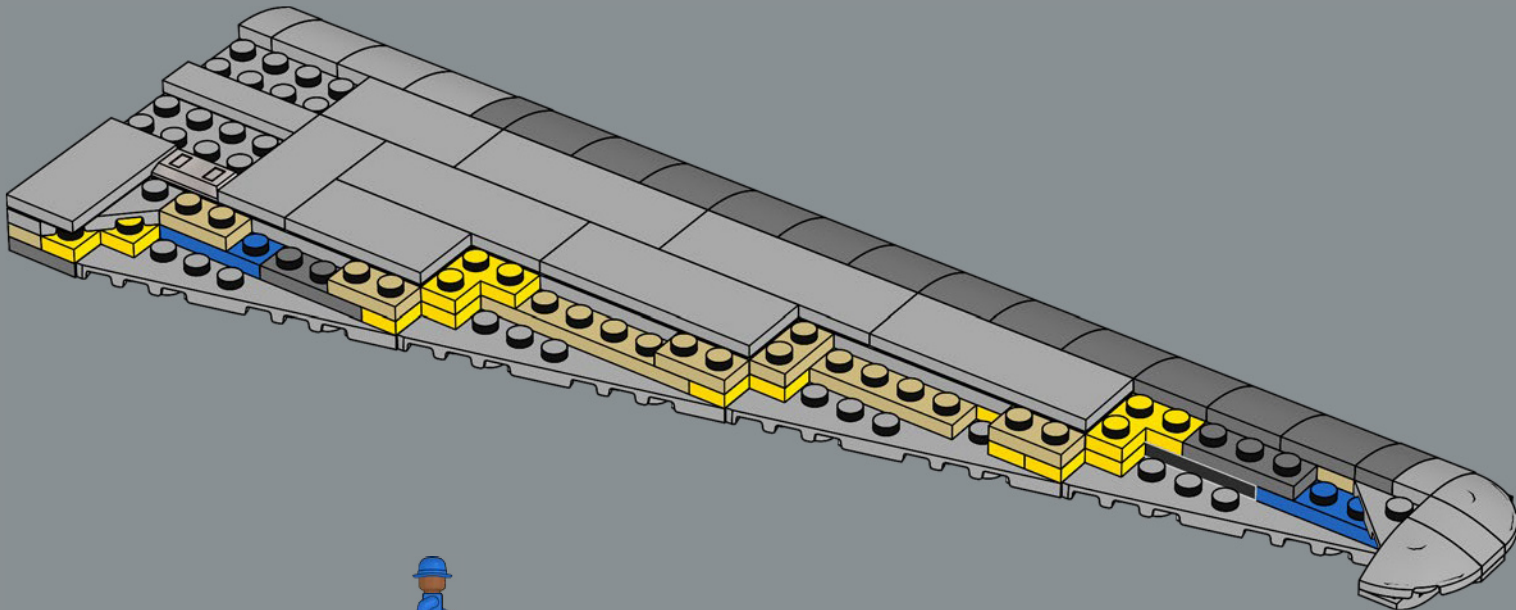

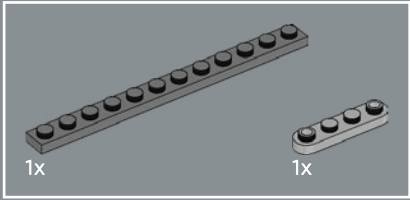
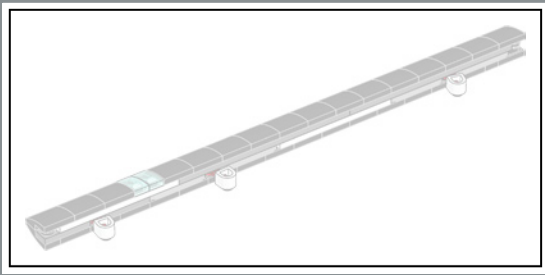

369

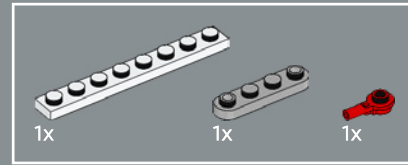
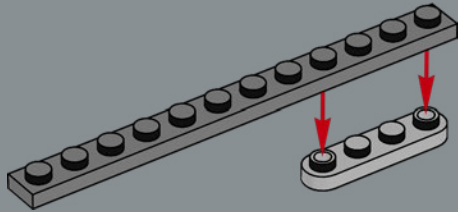

370

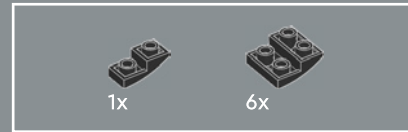
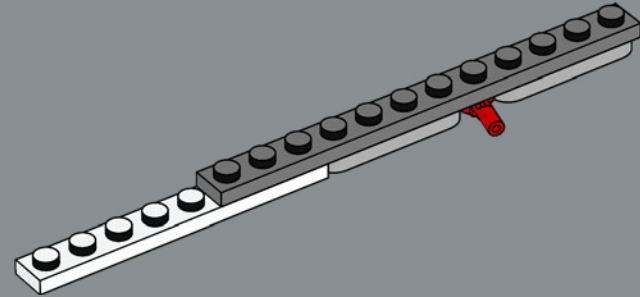

371

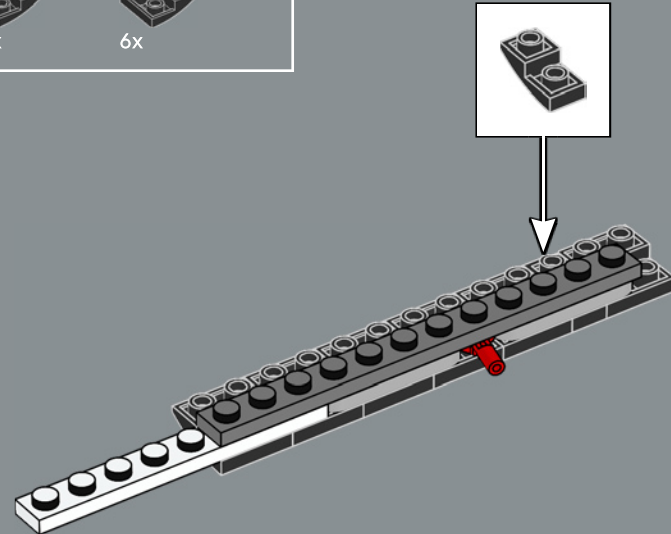



372

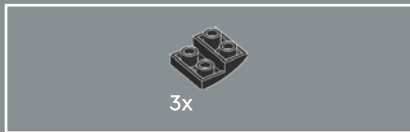
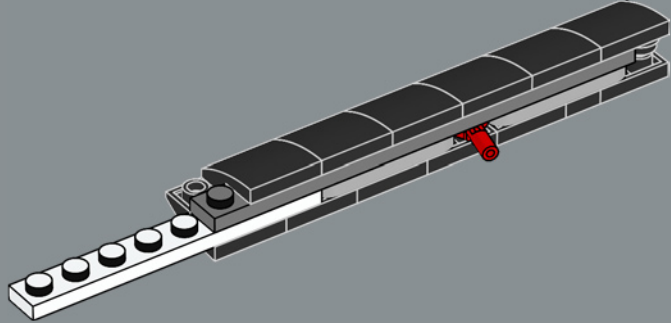
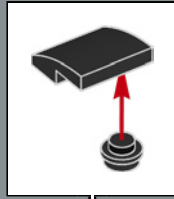

373

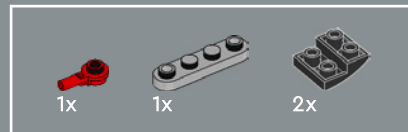
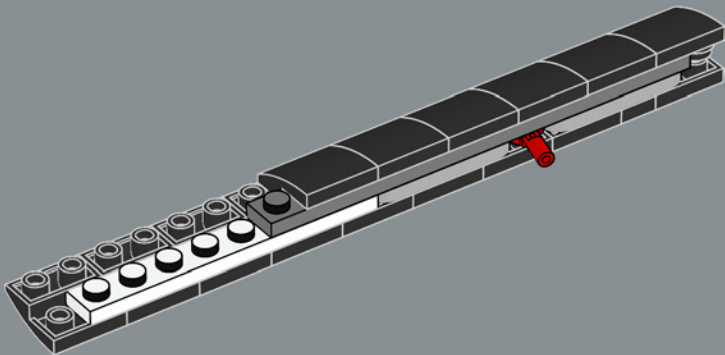

374

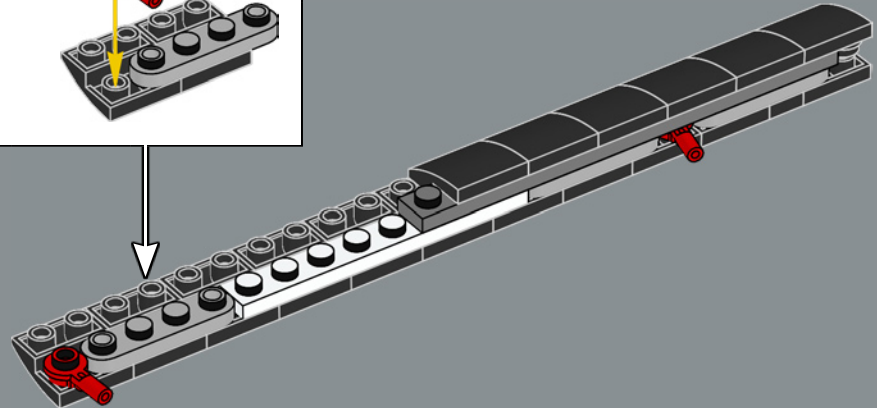
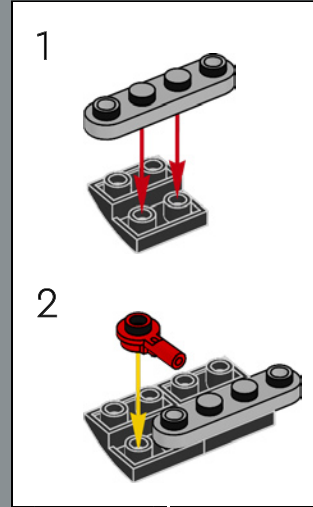

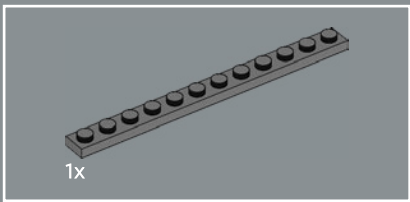

375

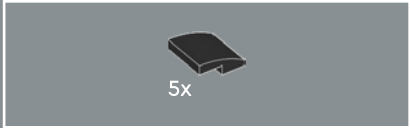
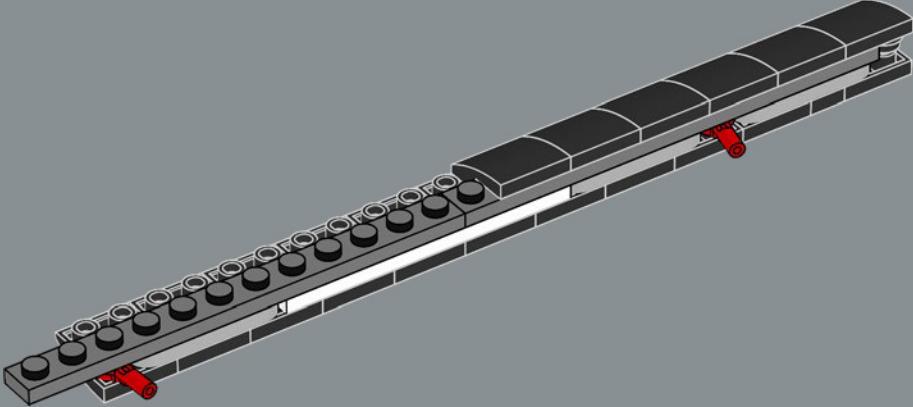

376

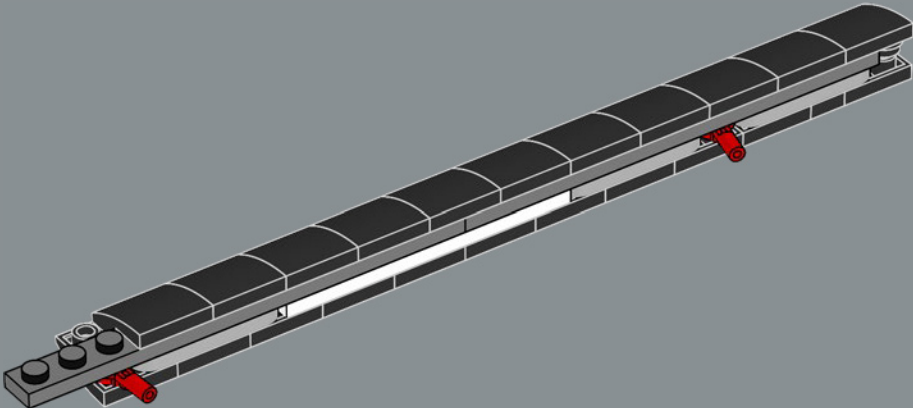

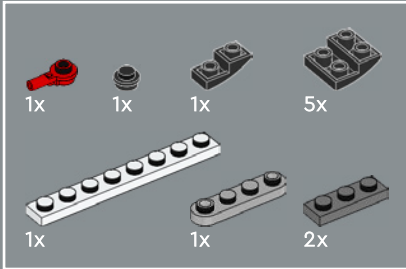
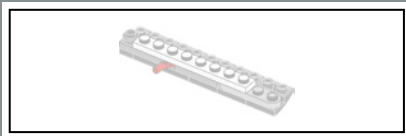

377

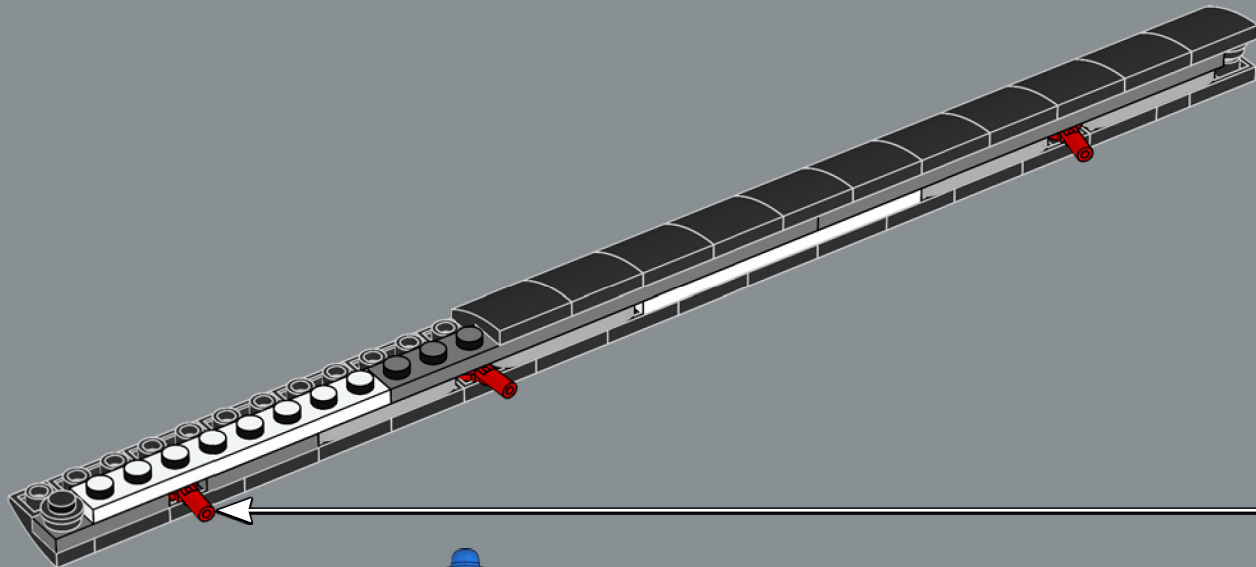
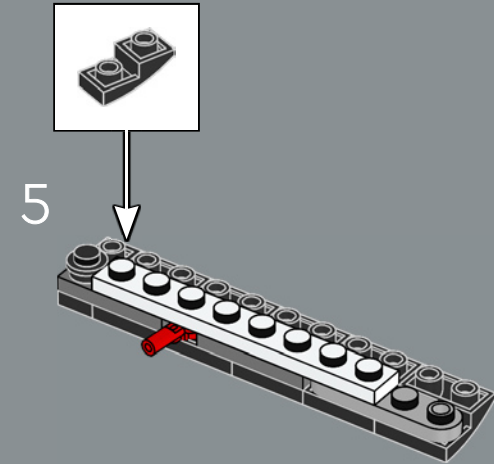
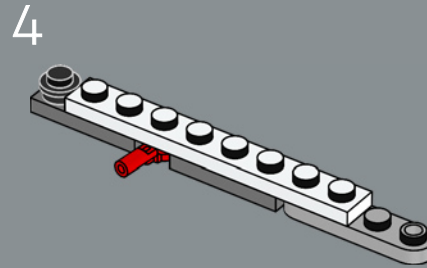
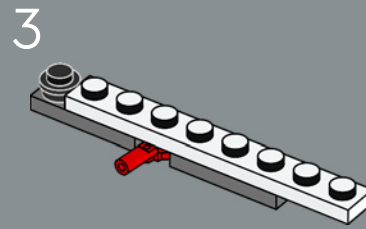
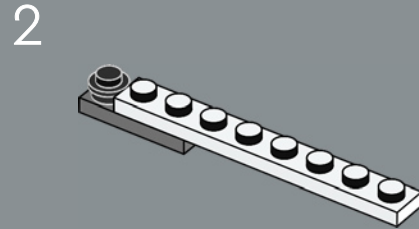
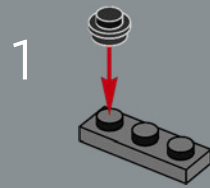



378

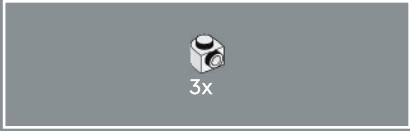
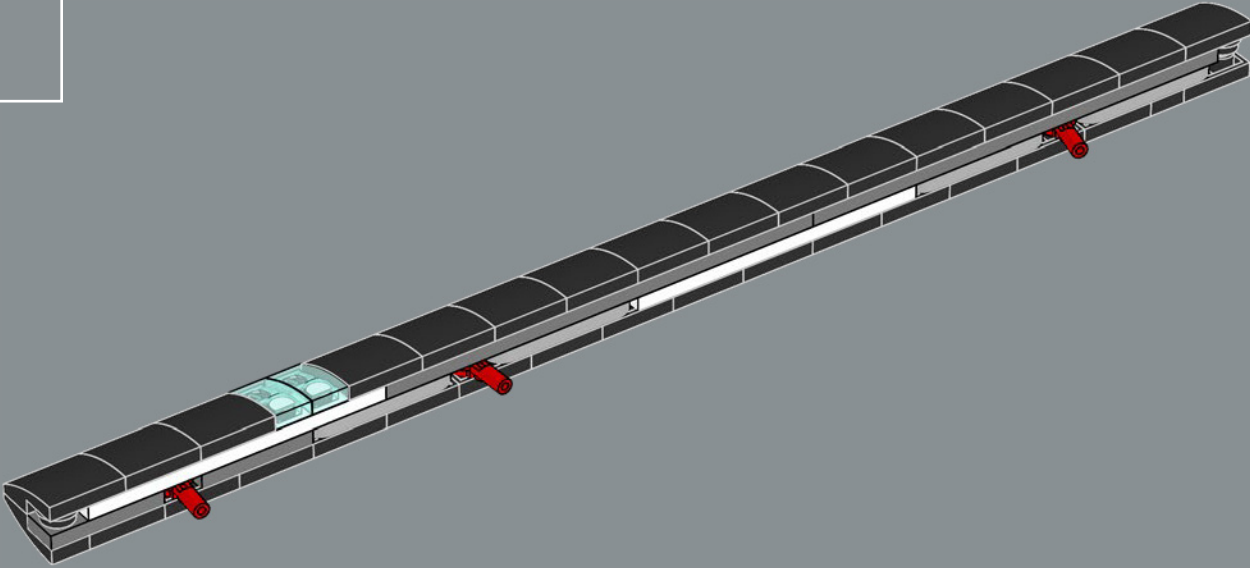

379

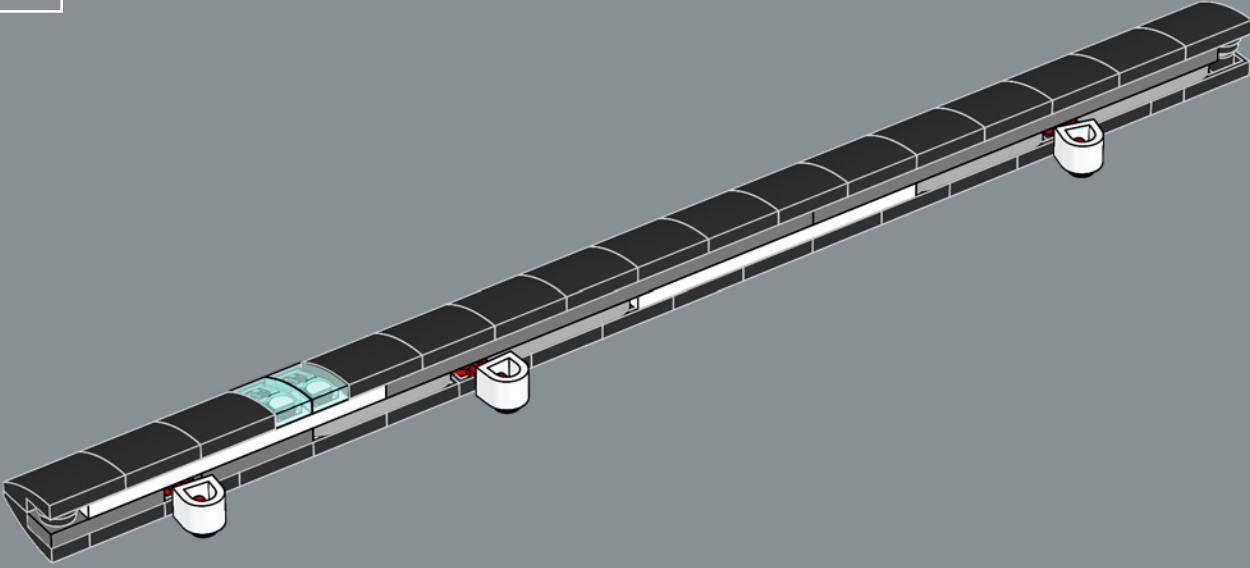

380

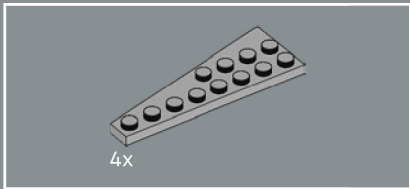
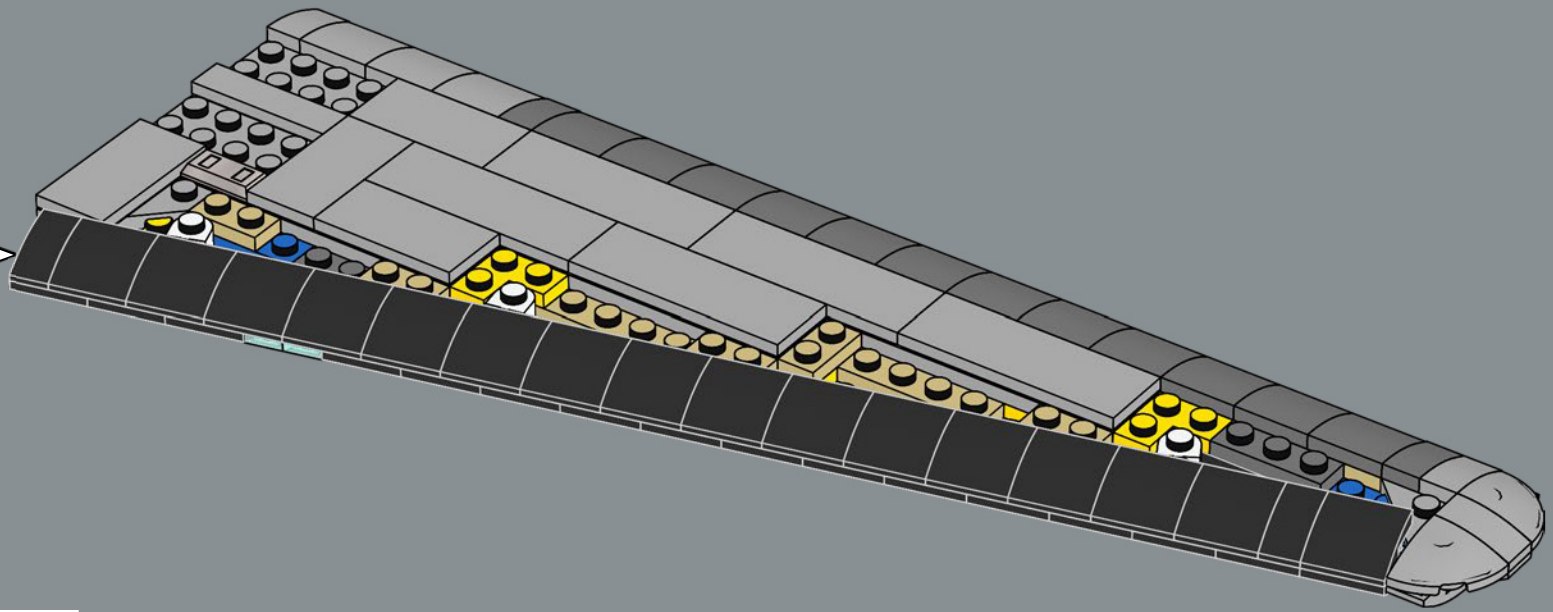

4x

381

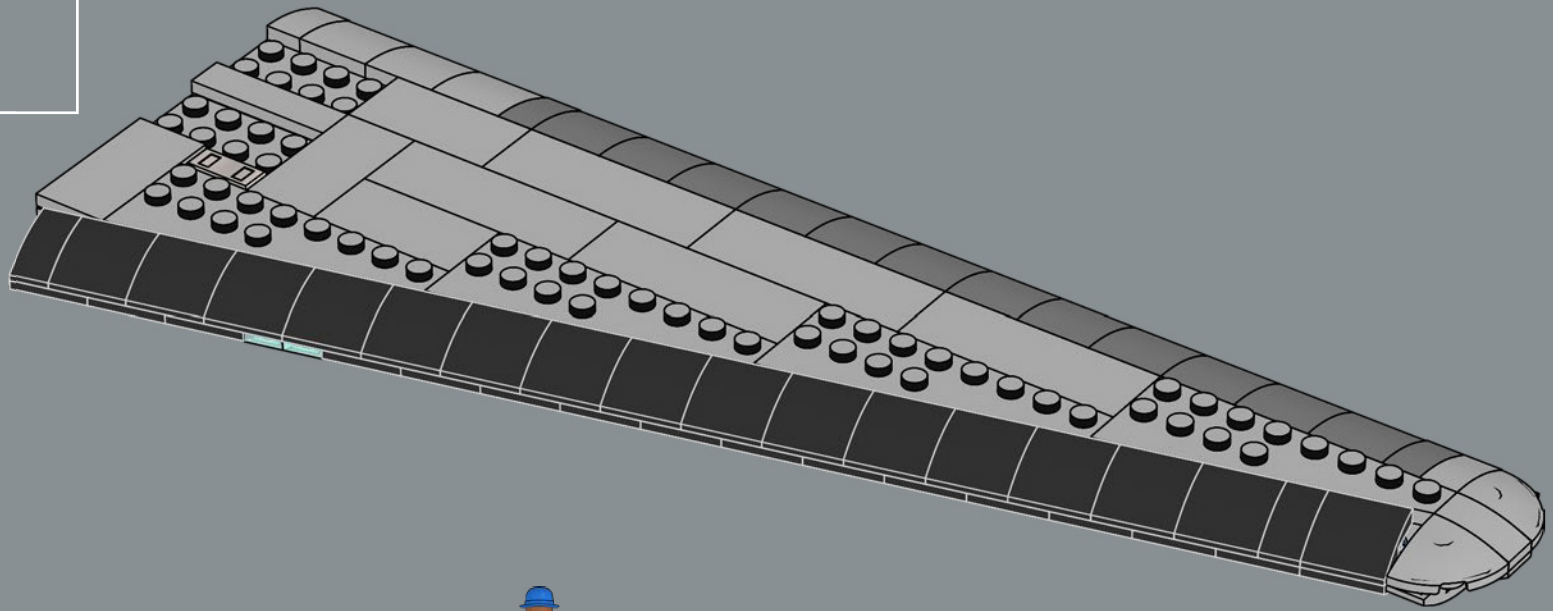

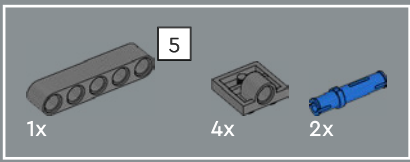

382

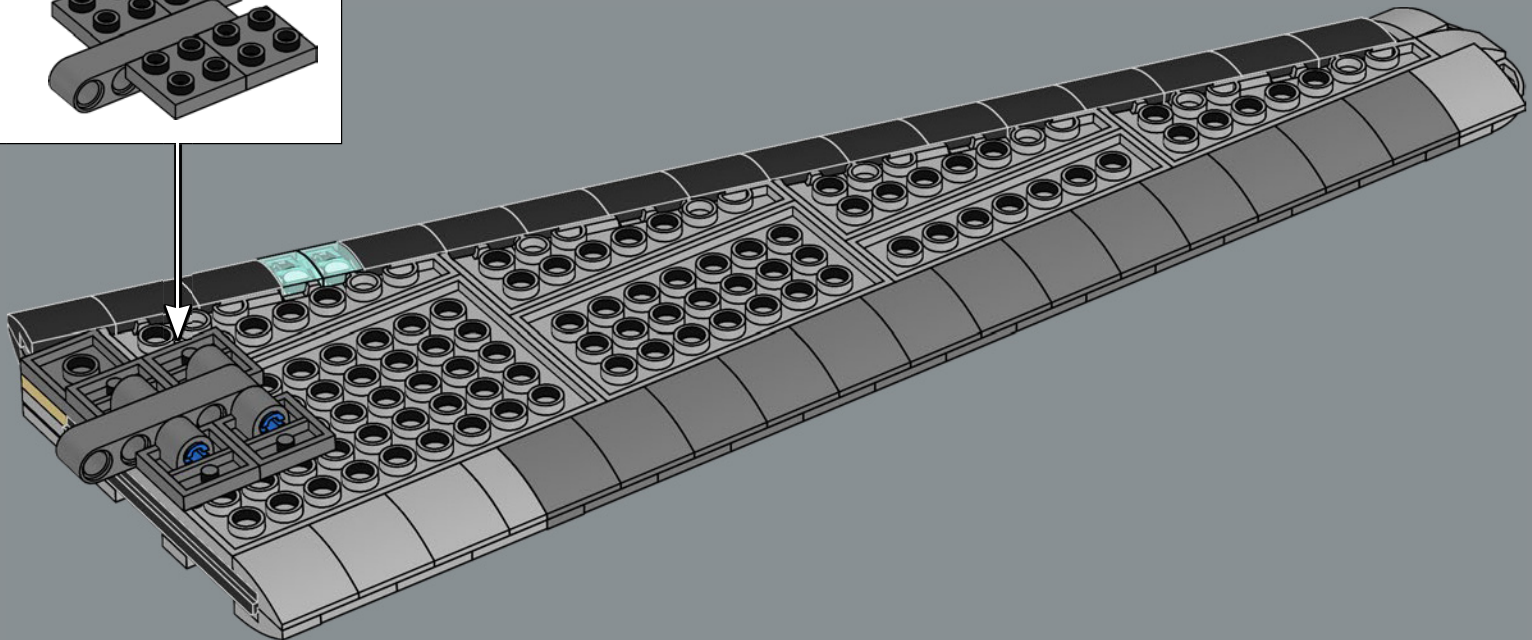
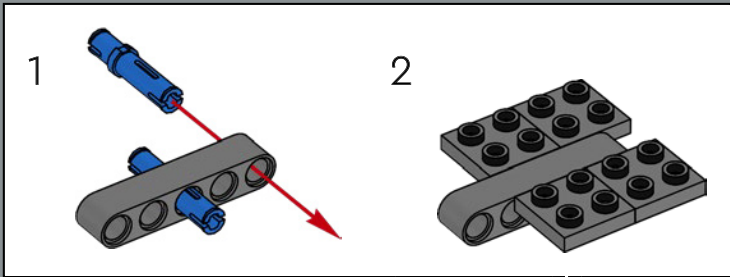



4x

383

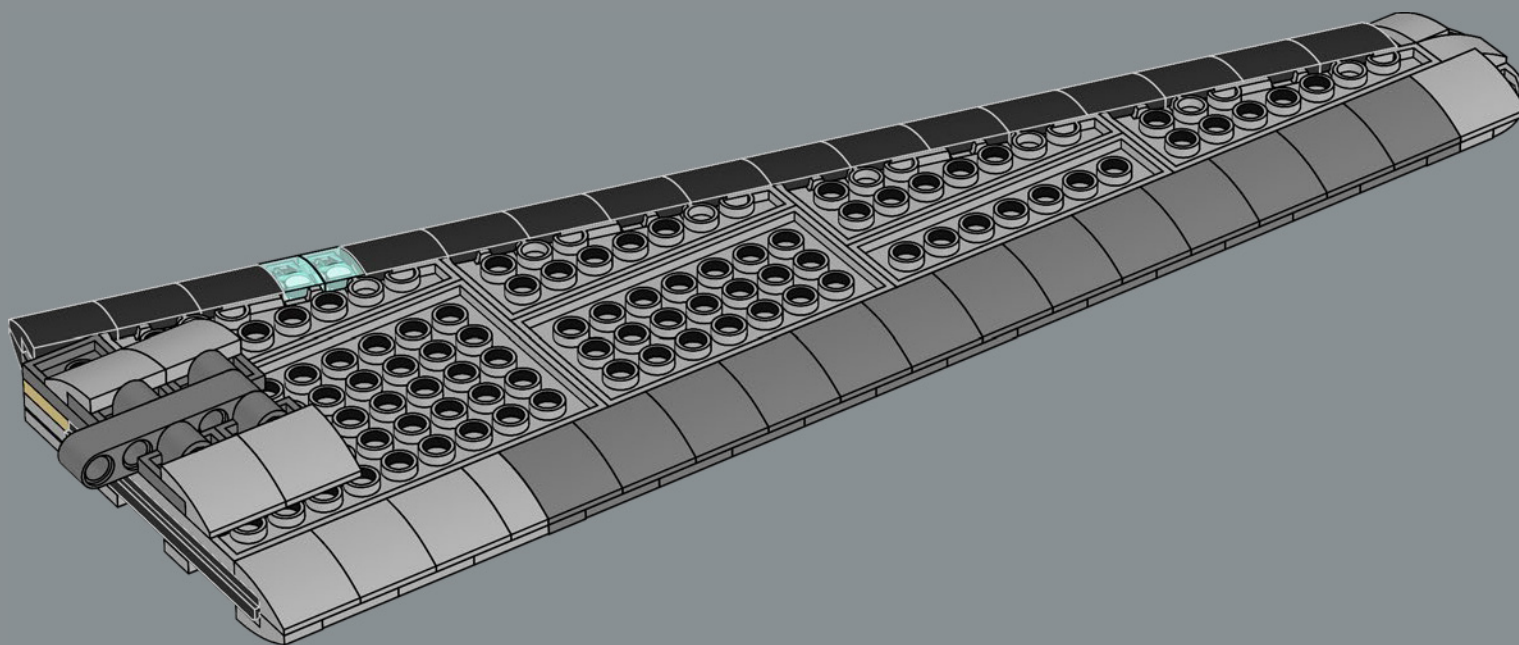

384

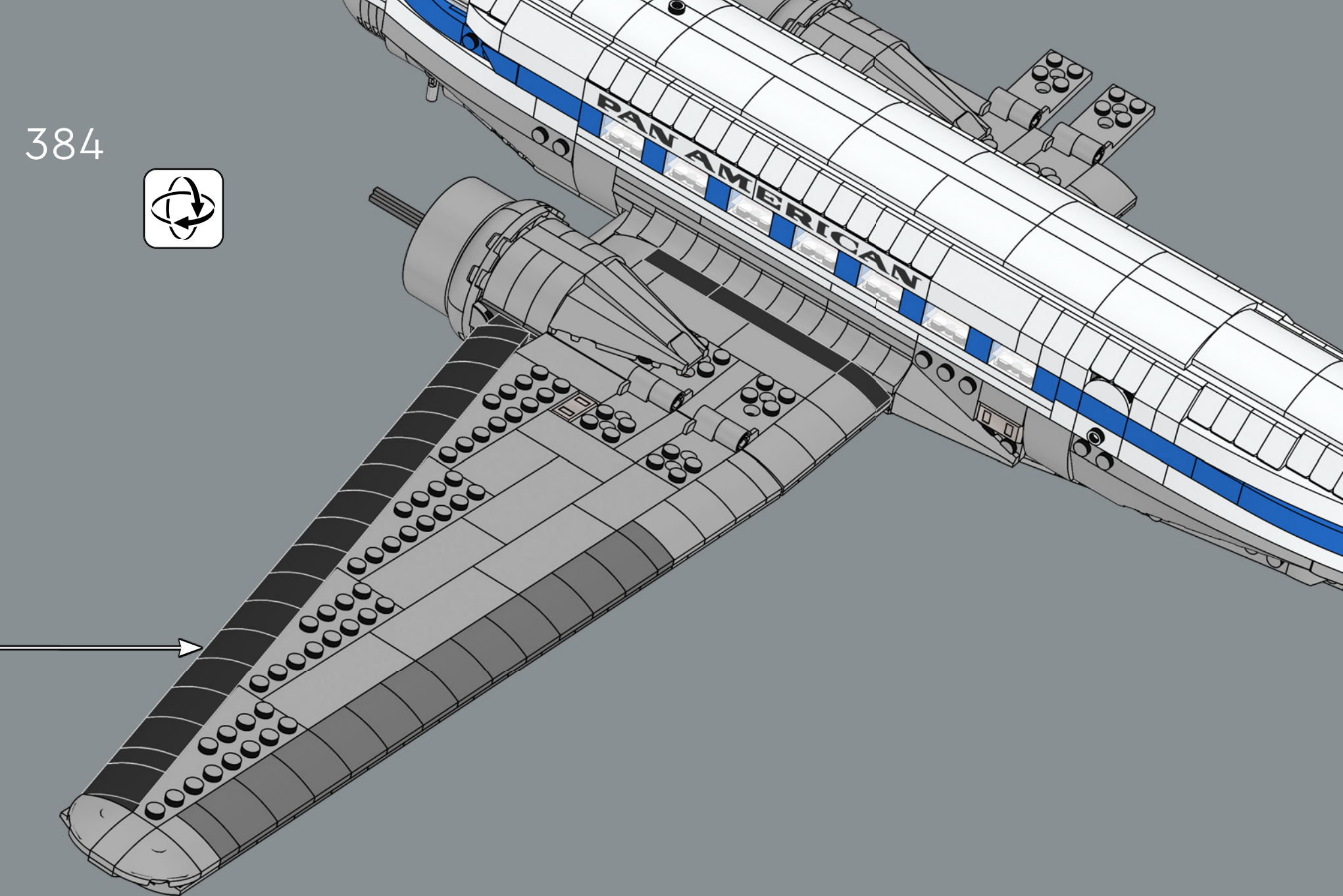



A LEGO® Technic™ pin on the underside fixates the wing. LEGO designers call this piece a 'bike valve'.

Une goupille LEGO® Technic™ située sous l'aile permet de la fixer en place. Les concepteurs LEGO appellent cette pièce une « valve de vélo ».

Un conector LEGO® Technic™ fija el ala por la parte inferior. Los diseñadores de LEGO suelen llamar a esta pieza "válvula de bicicleta".

385

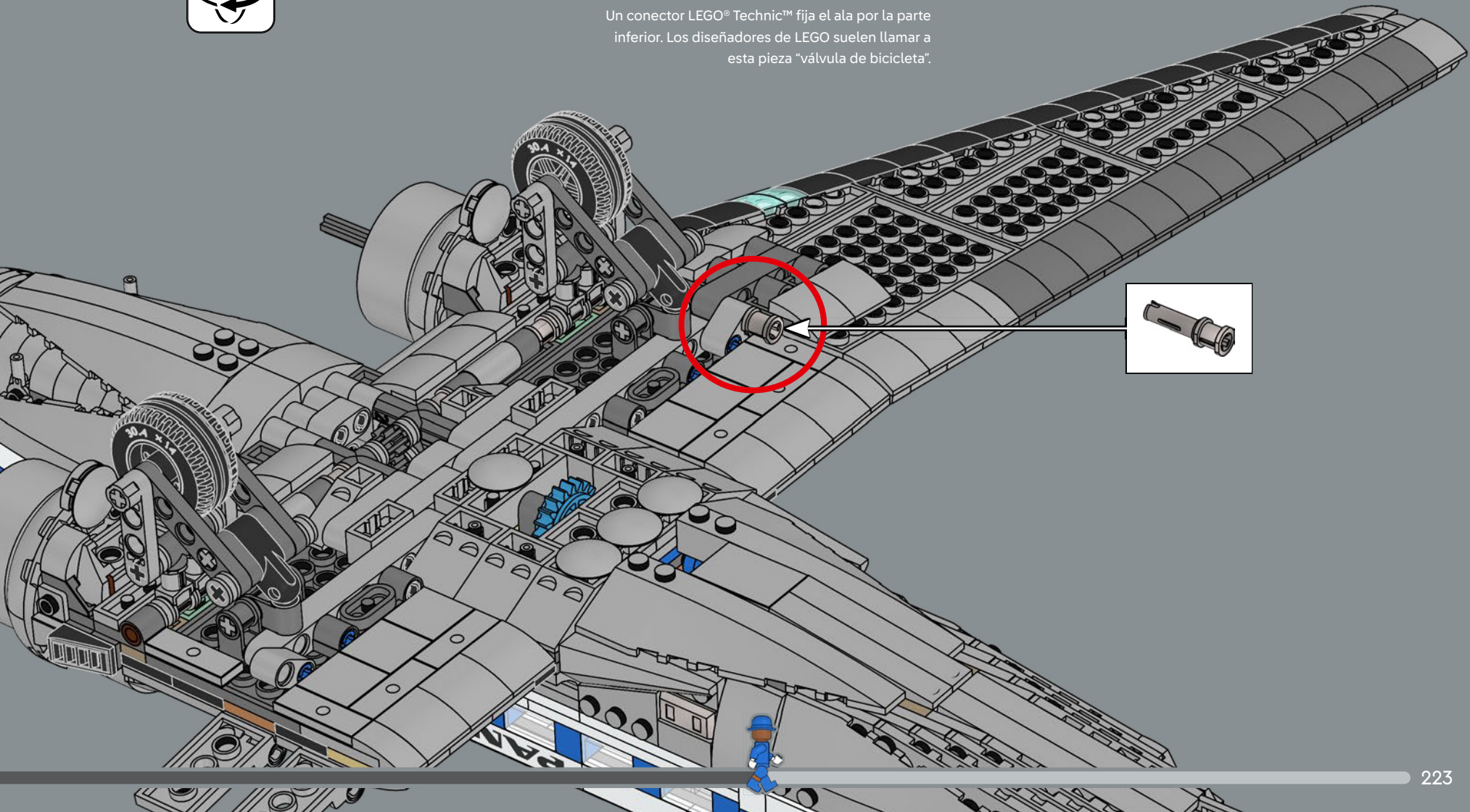

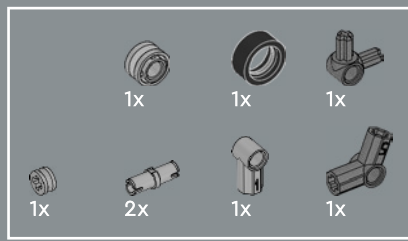

386



The actual celebrity designer uniforms began in 1958 with the launch of the B-707. Hollywood fashion designer Don Loper designed the uniforms for Pan Am® stewardesses at the launch of the Jet Age.

Les véritables uniformes conçus par un créateur renommé sont apparus en 1958 avec le lancement du B-707. Le designer de mode hollywoodien Don Loper a créé les uniformes des hôtesse de l'air de Pan Am® pour marquer l'arrivée de l'ère du Jet.

La era de los uniformes de diseñador empezó en 1958 con el lanzamiento del B-707. El diseñador de modas de Hollywood Don Loper diseñó los uniformes de los sobrecargos de Pan Am® para el inicio de la era del jet.

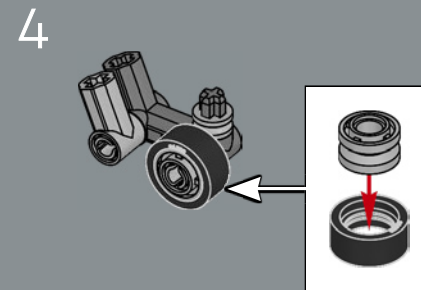
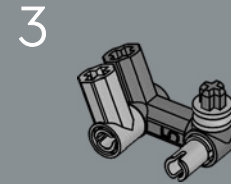
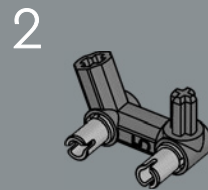
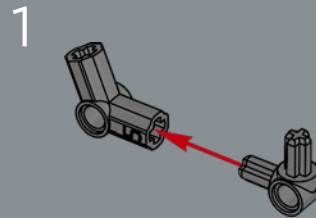
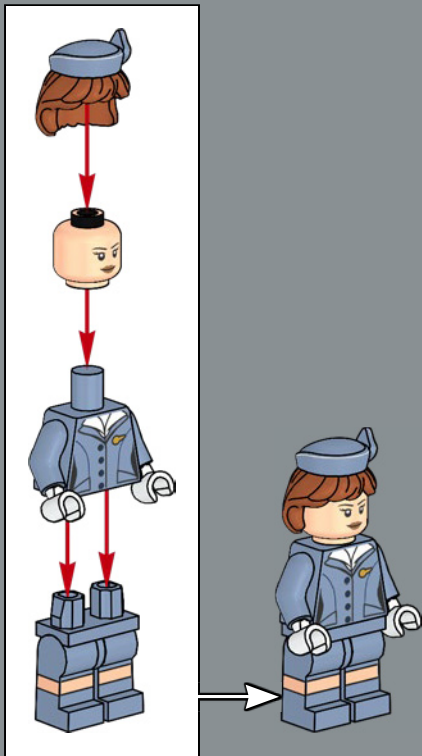



Both male and female flight attendants could be promoted to fly the Purser (lead) position on the aircraft. From the 1960s onward, women increasingly filled this role.

Les agents de bord, hommes comme femmes, pouvaient être promus au poste de chef de cabine (Purser). À partir des années 1960, ce rôle a été occupé de plus en plus souvent par des femmes.

Los sobrecargos, tanto masculinos como femeninos, podían ascender al puesto de sobrecargo jefe de la aeronave. A partir de la década de 1960, cada vez más mujeres desempeñaron esta función.

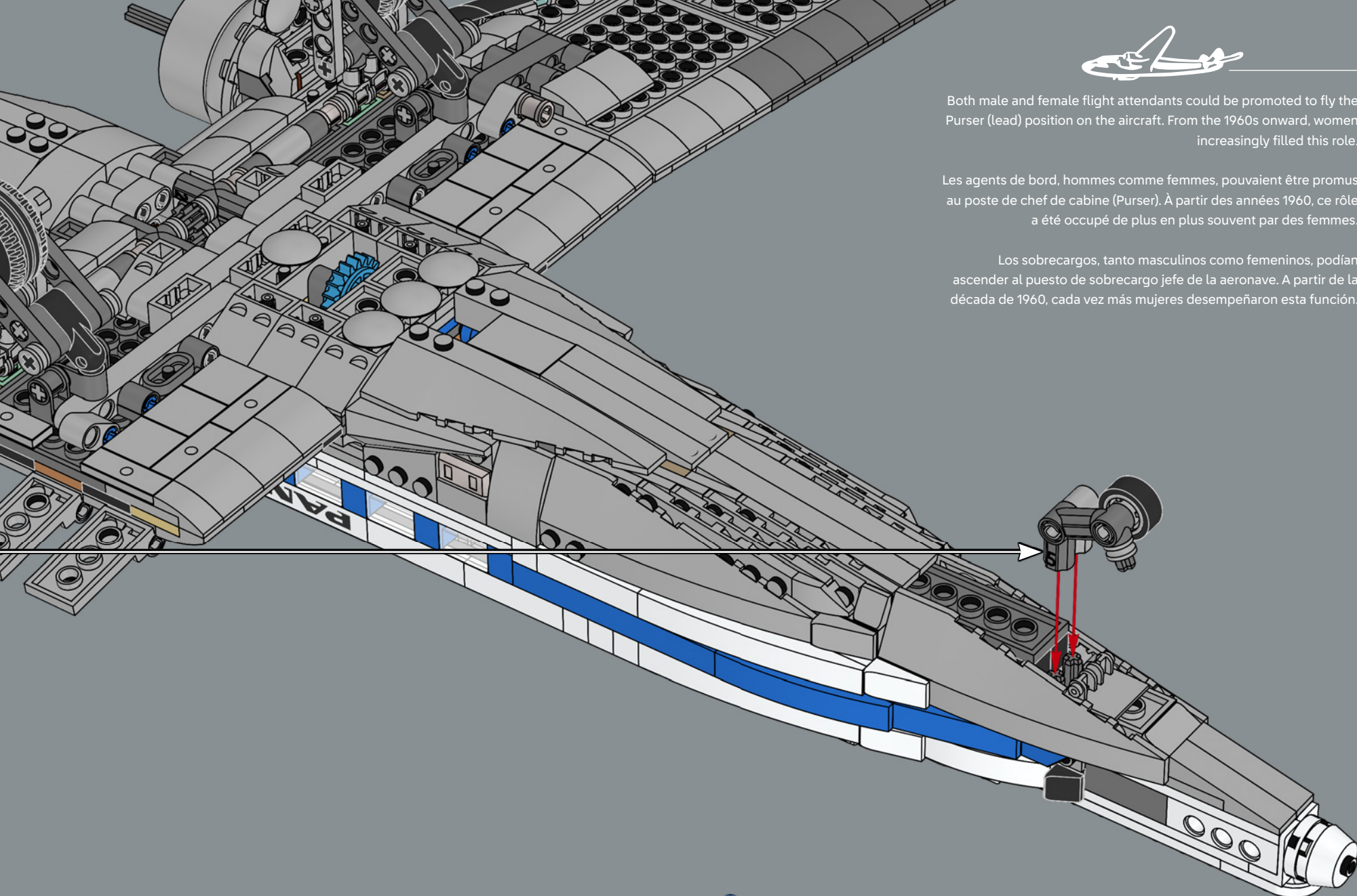

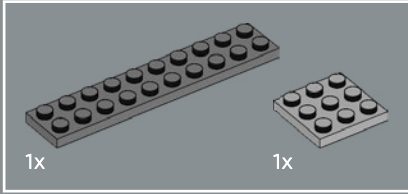
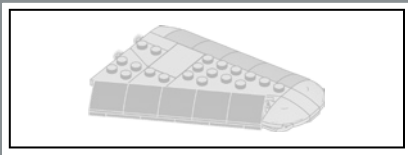

387

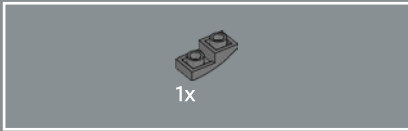
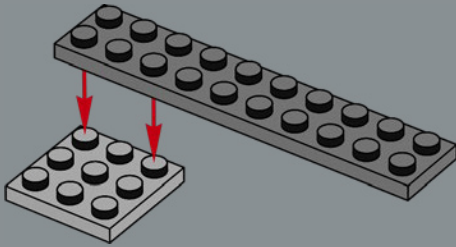

388

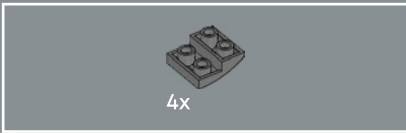
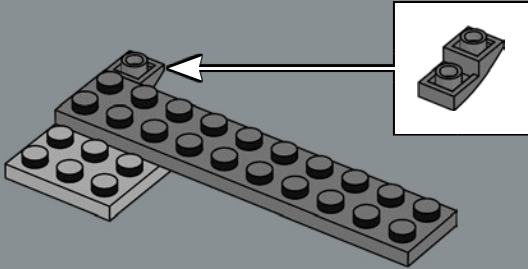

389

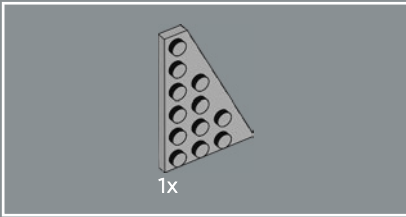
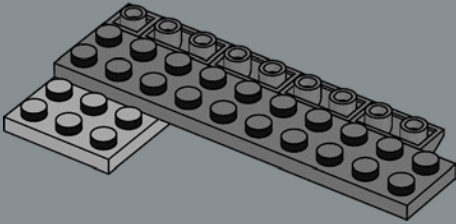

390

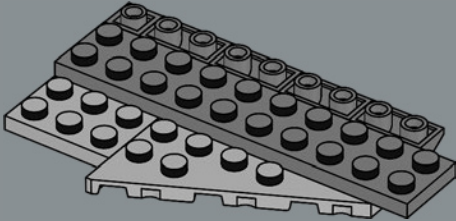

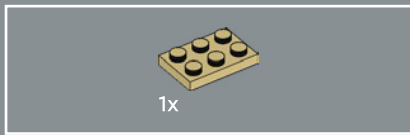

391

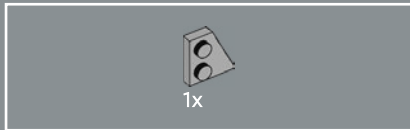
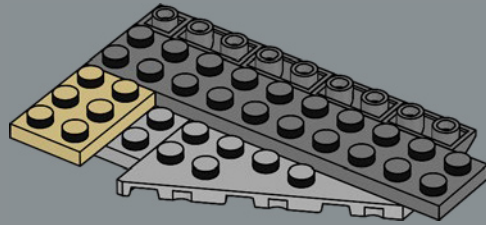

392

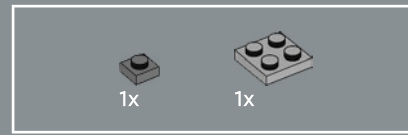
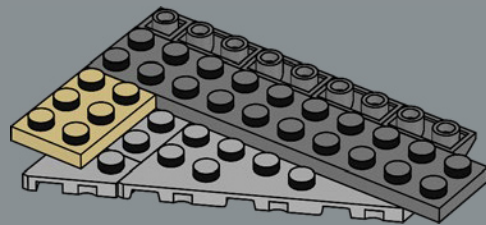

393

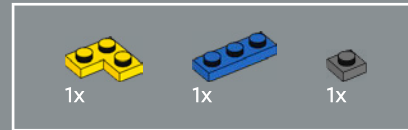
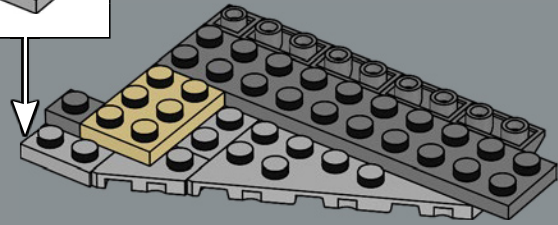
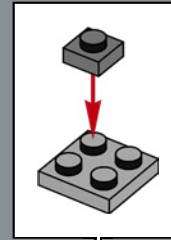

394

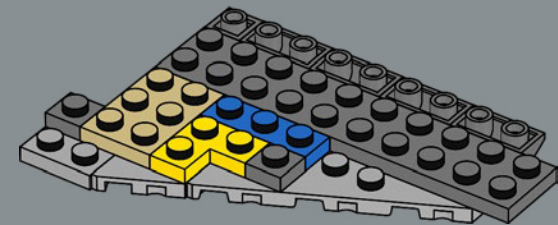

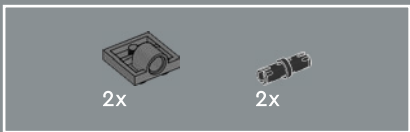

395

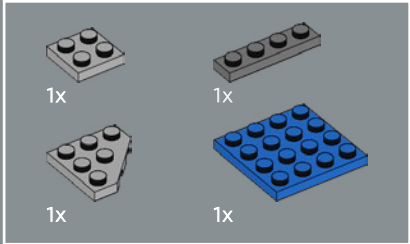
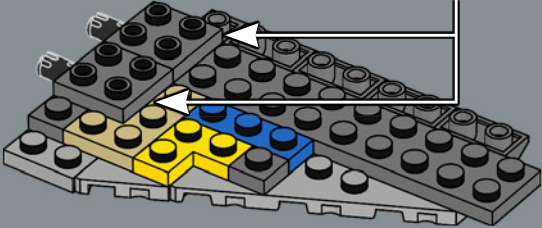
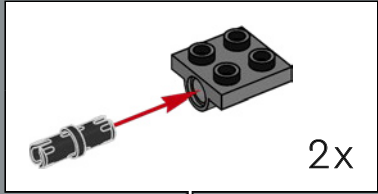

396

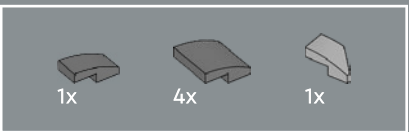
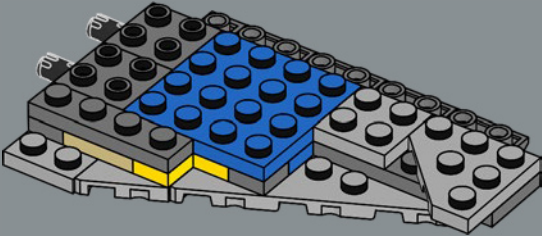

397

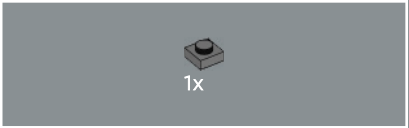
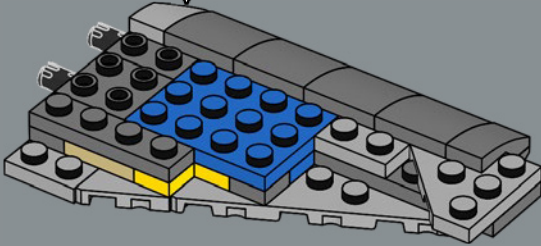
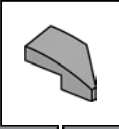

398

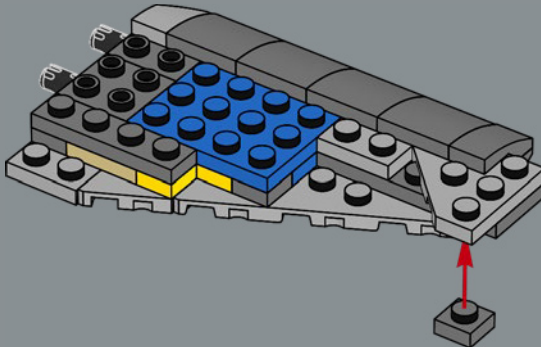



399

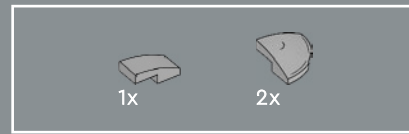
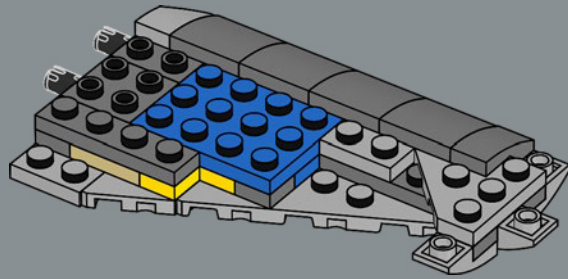

400

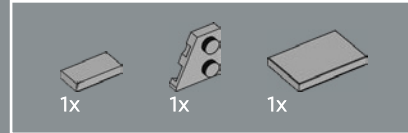
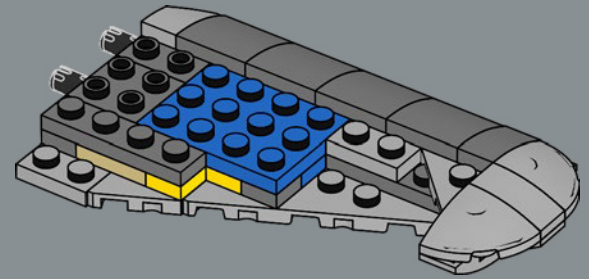

401

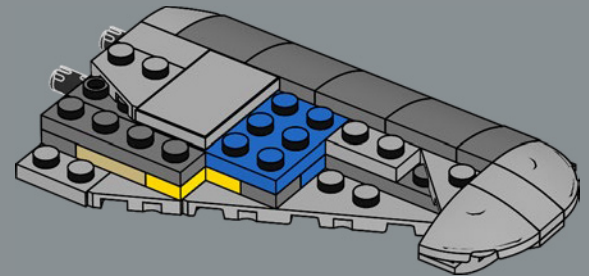

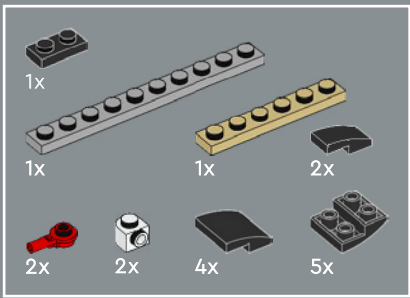

402

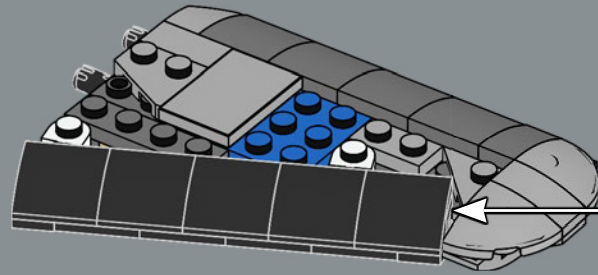
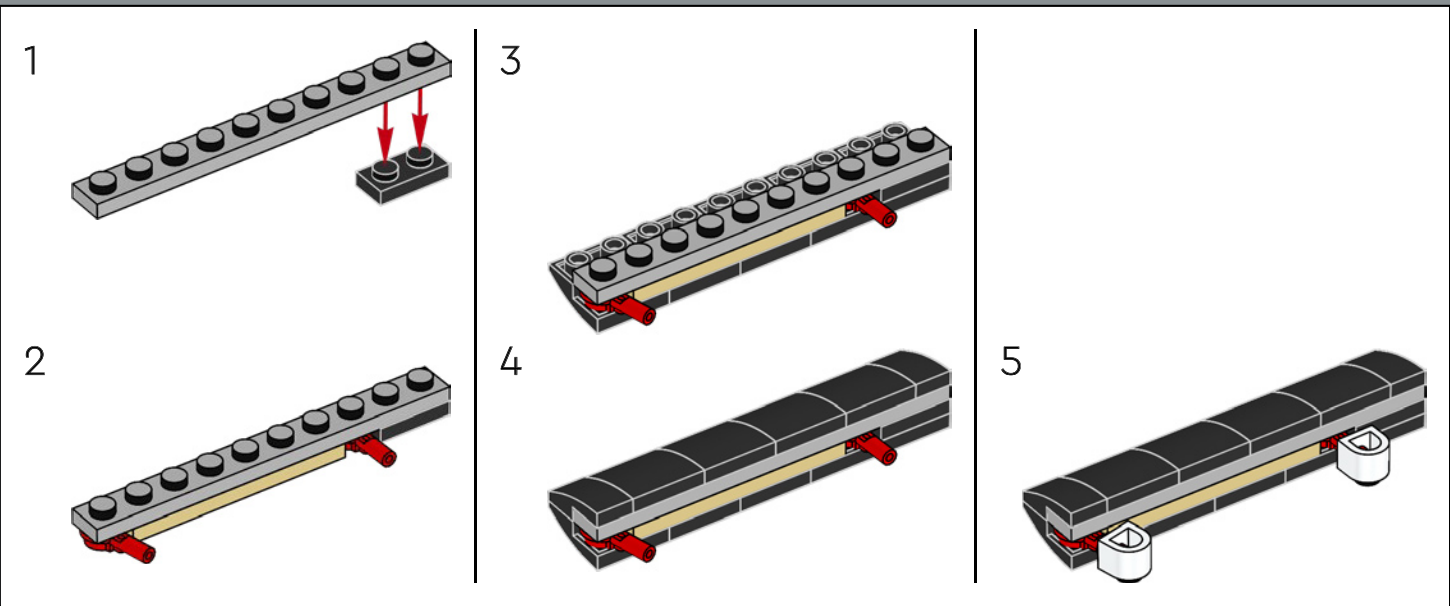

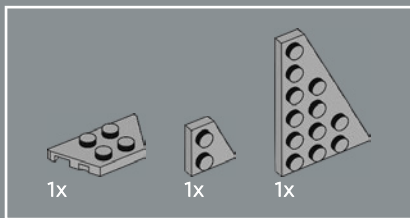

403

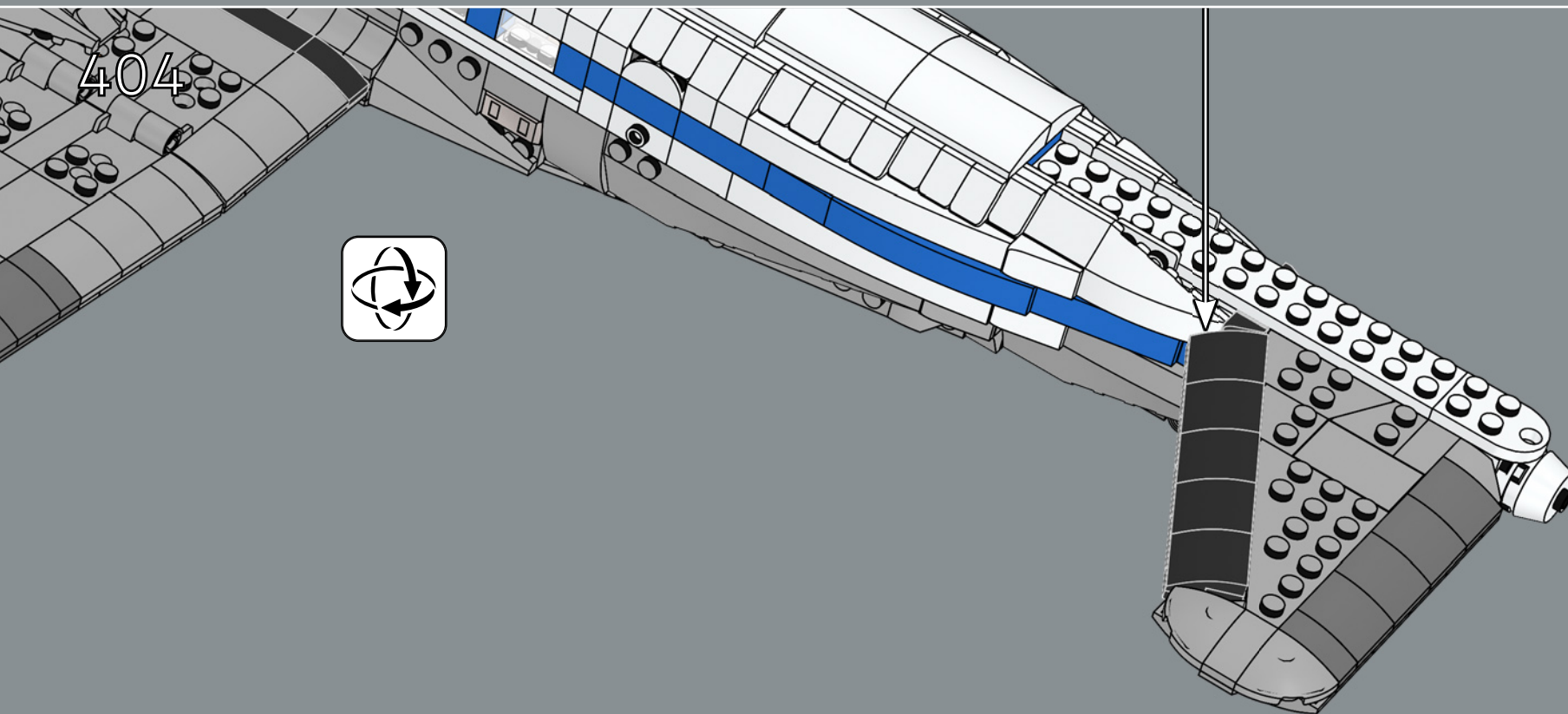
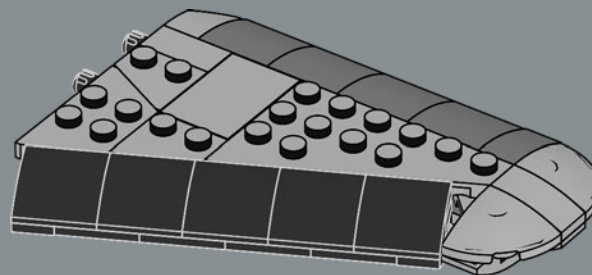

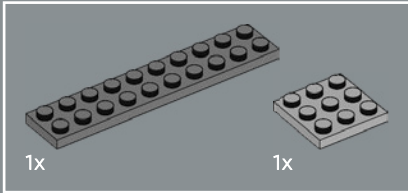
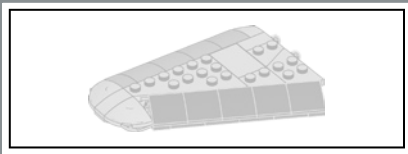

405

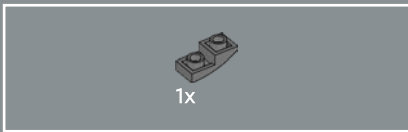
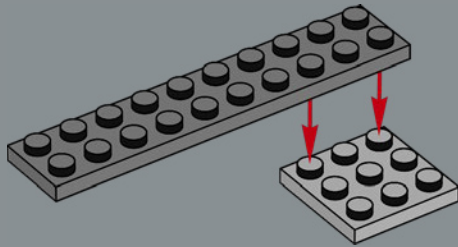

406

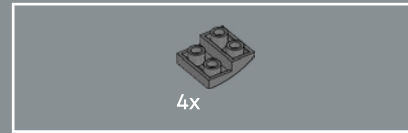
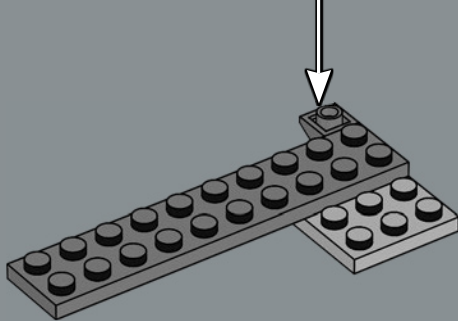
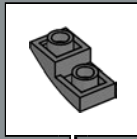

407

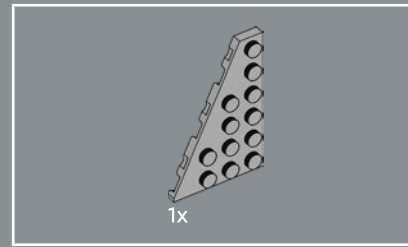
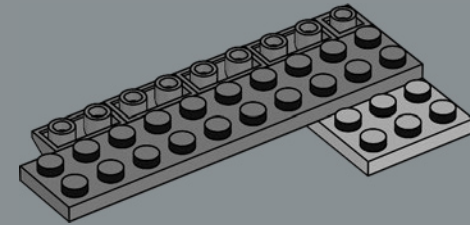

408

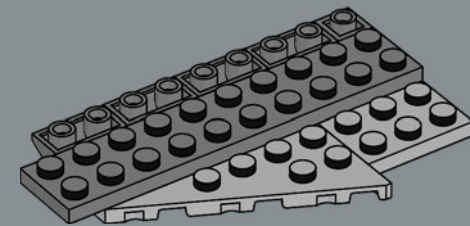

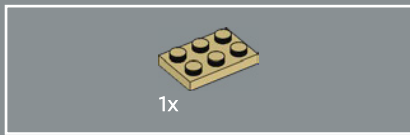

409

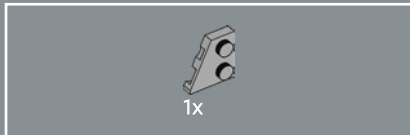
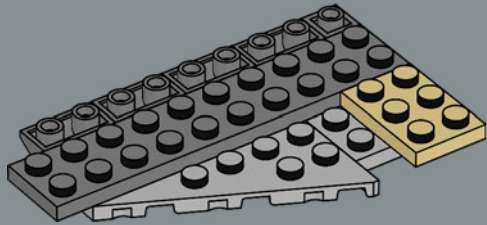

410

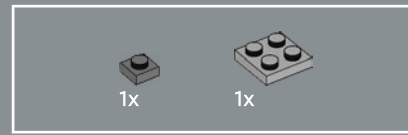
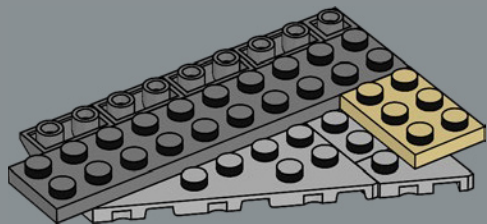

411

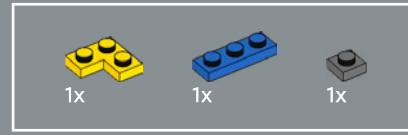
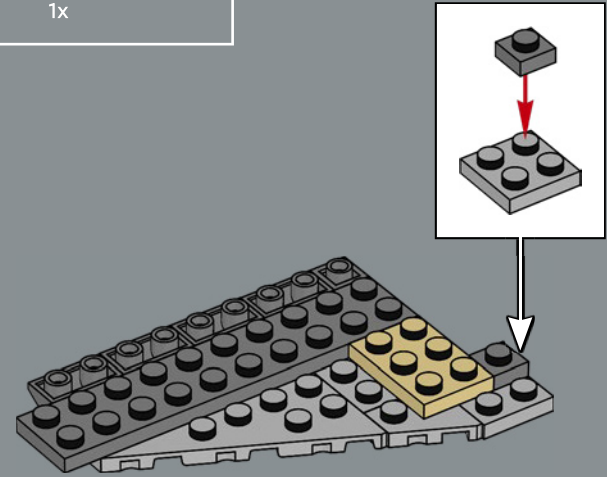

412

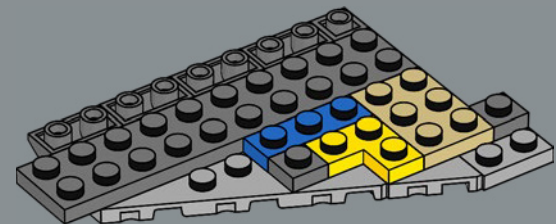



413

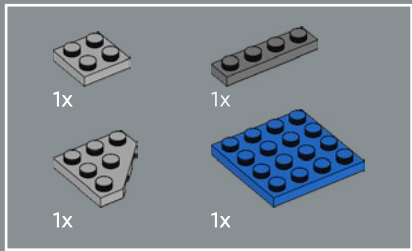
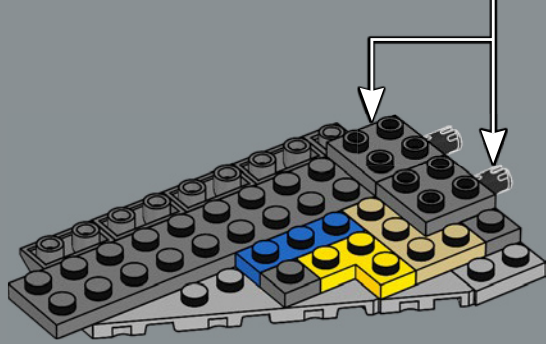
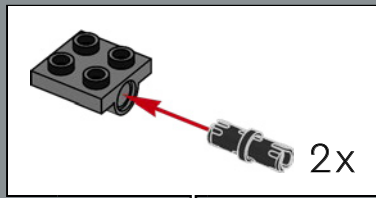

414

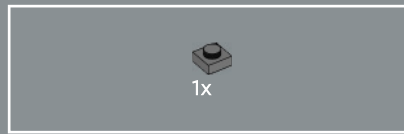
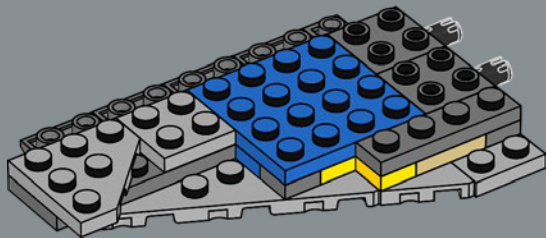

415

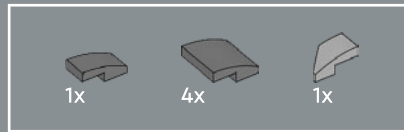
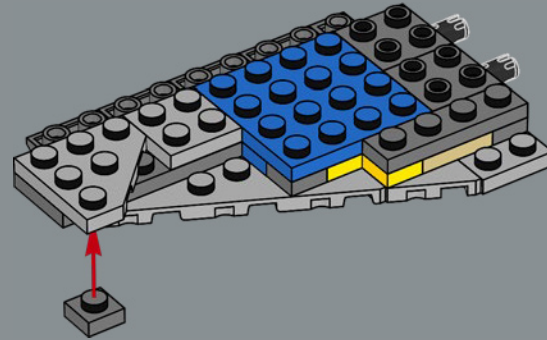

416

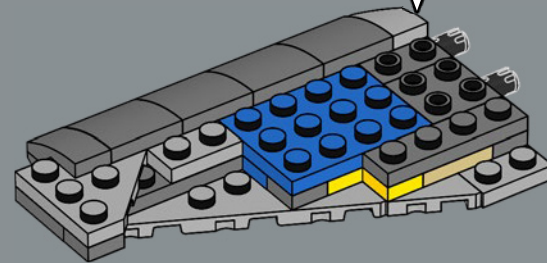
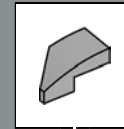

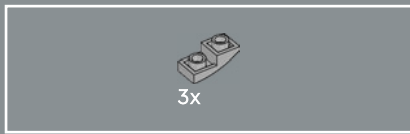

417

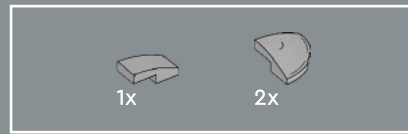
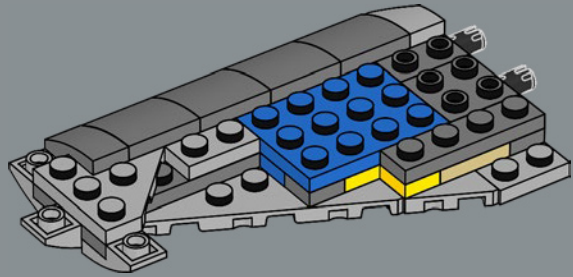

418

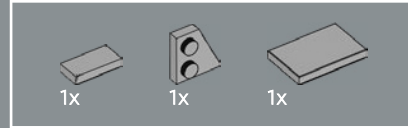
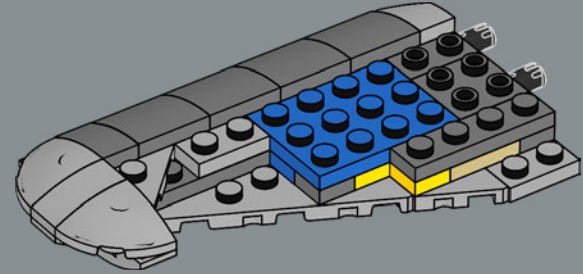

419

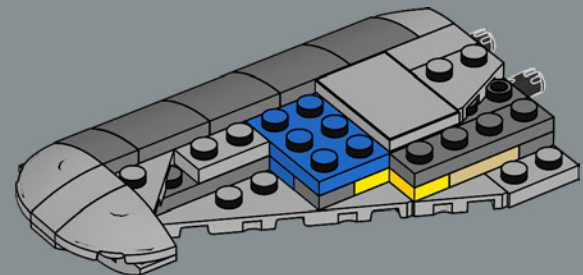

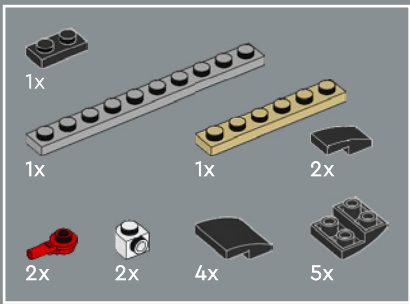

420

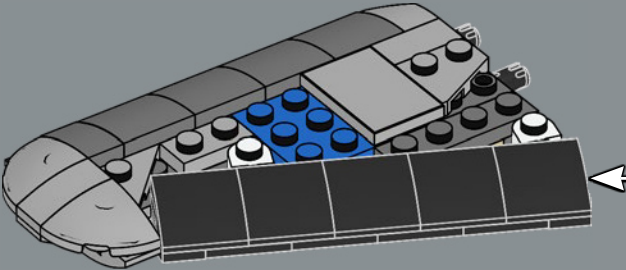
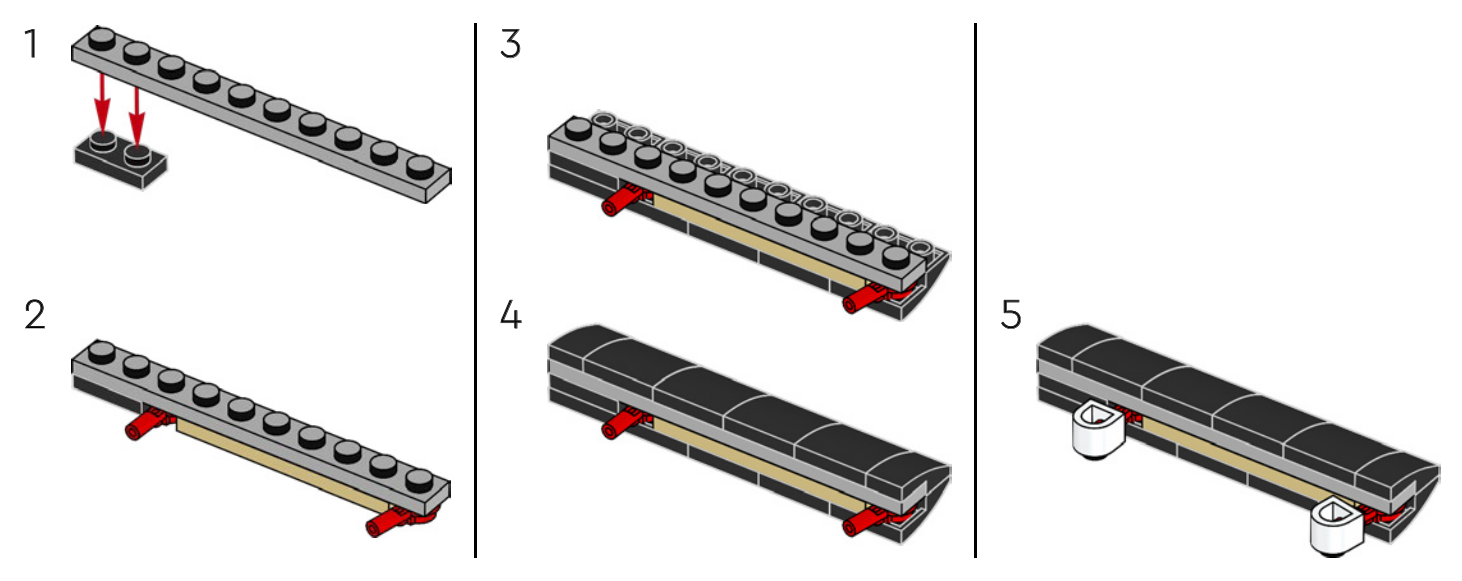

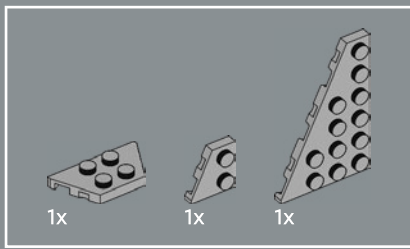

421

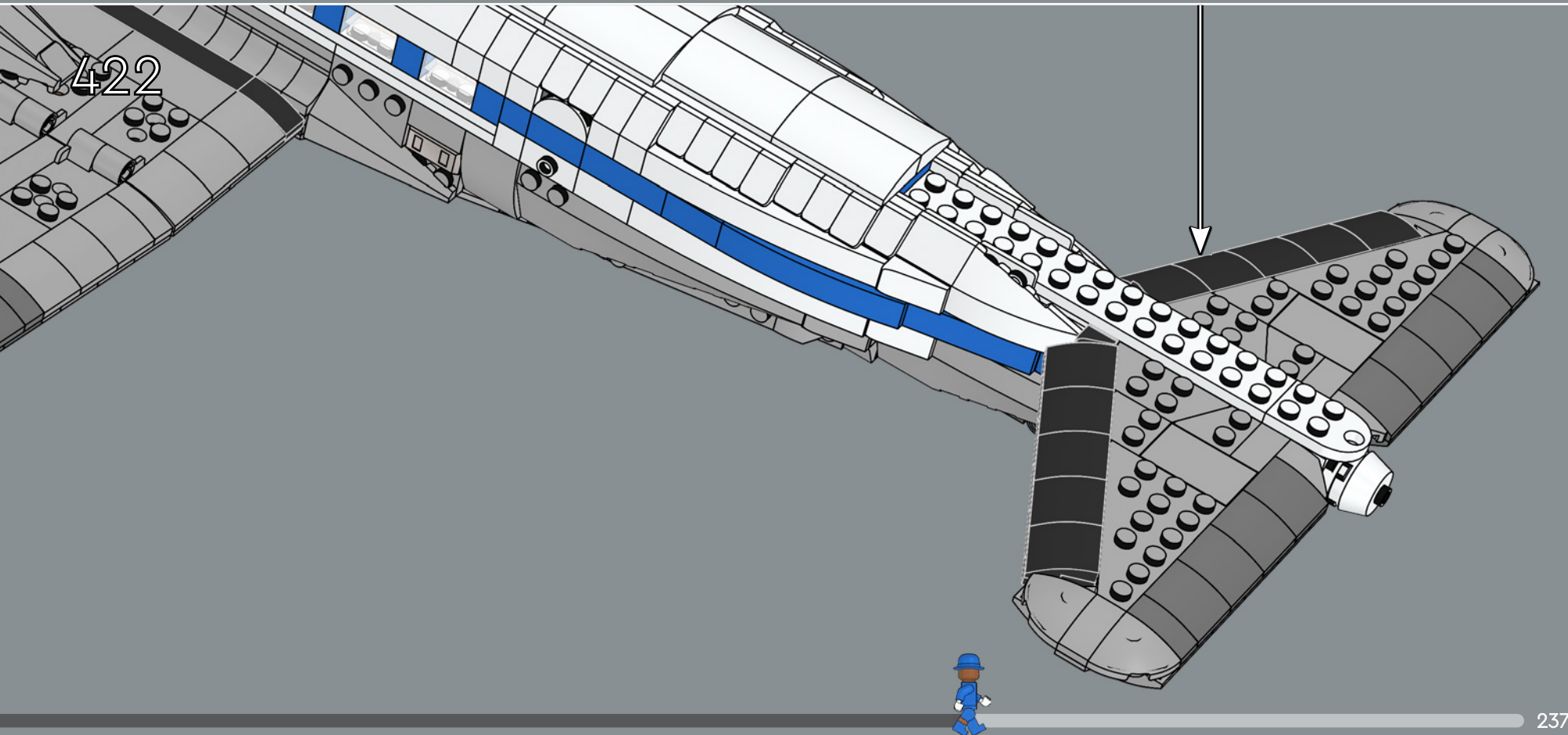
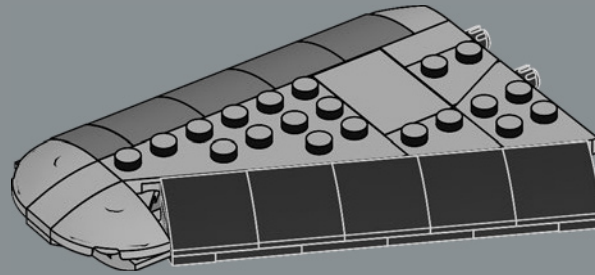

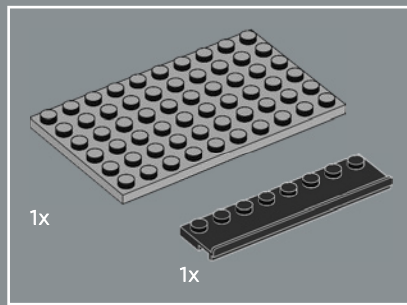
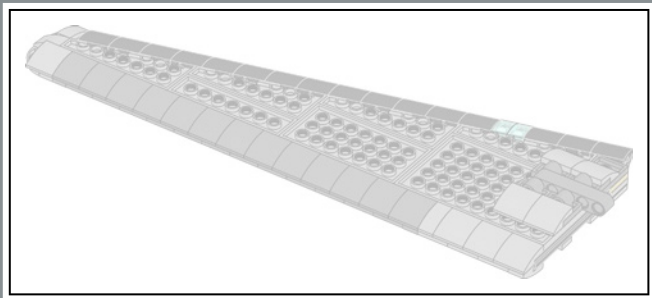

423

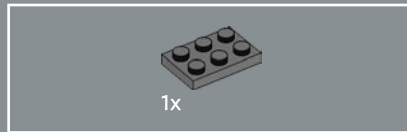
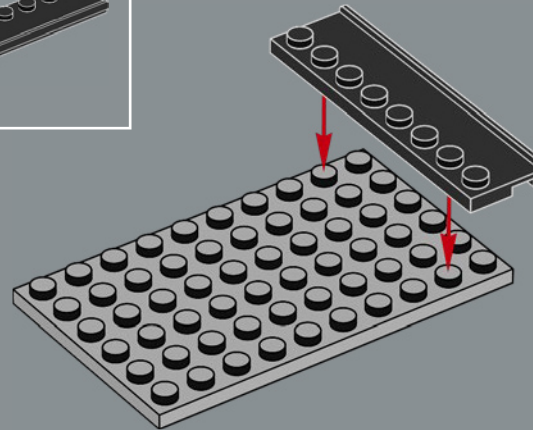

424

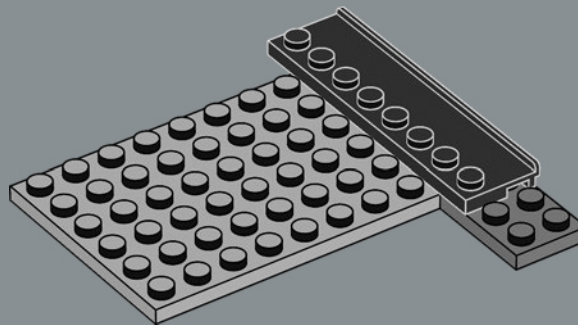



425

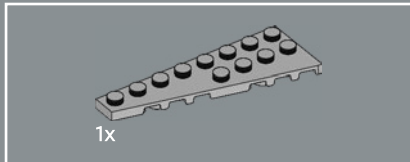
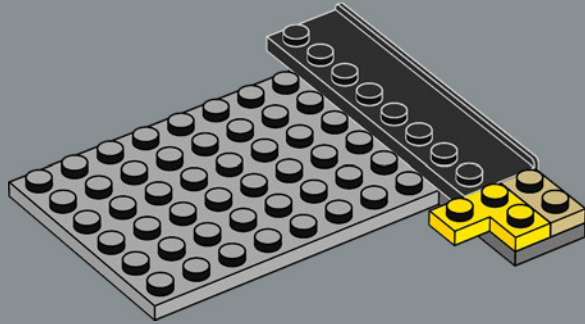

426

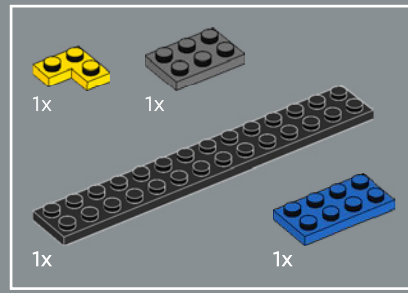
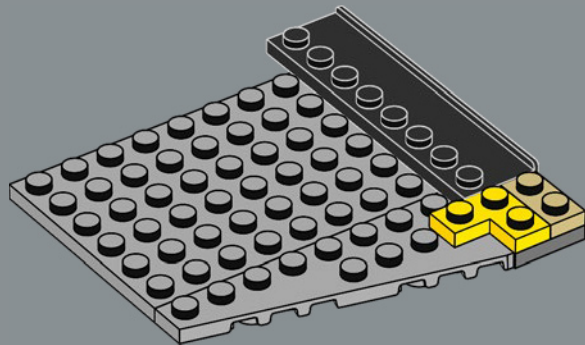

427

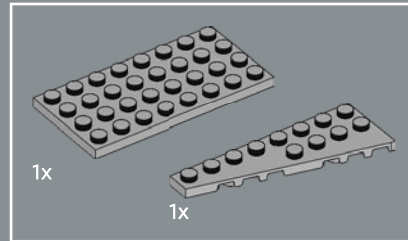
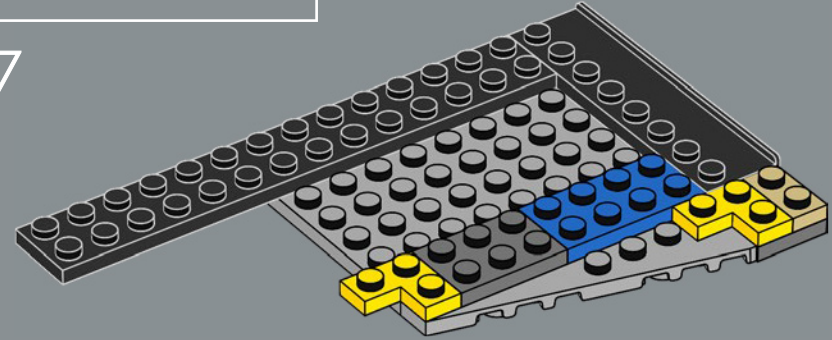

428

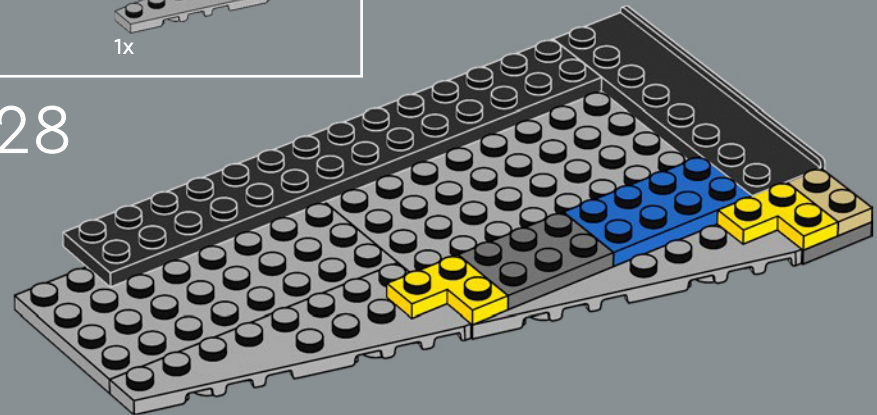

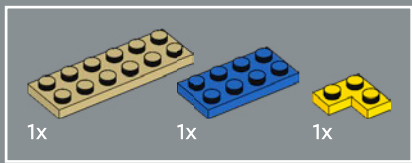

429

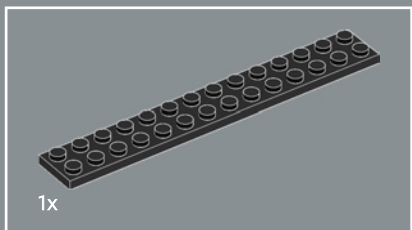
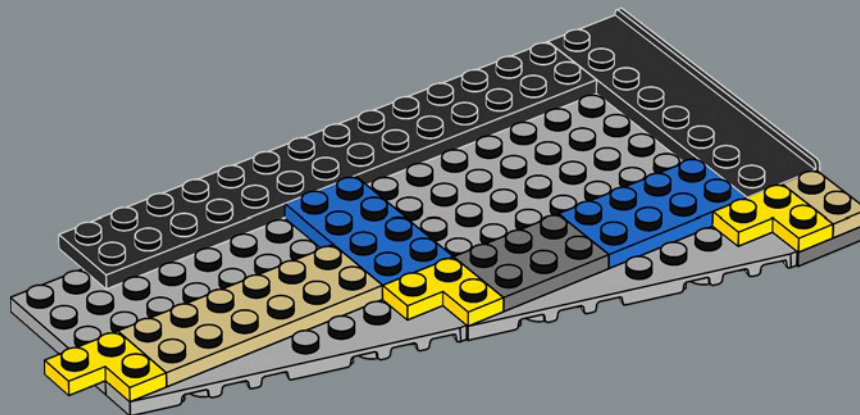

430

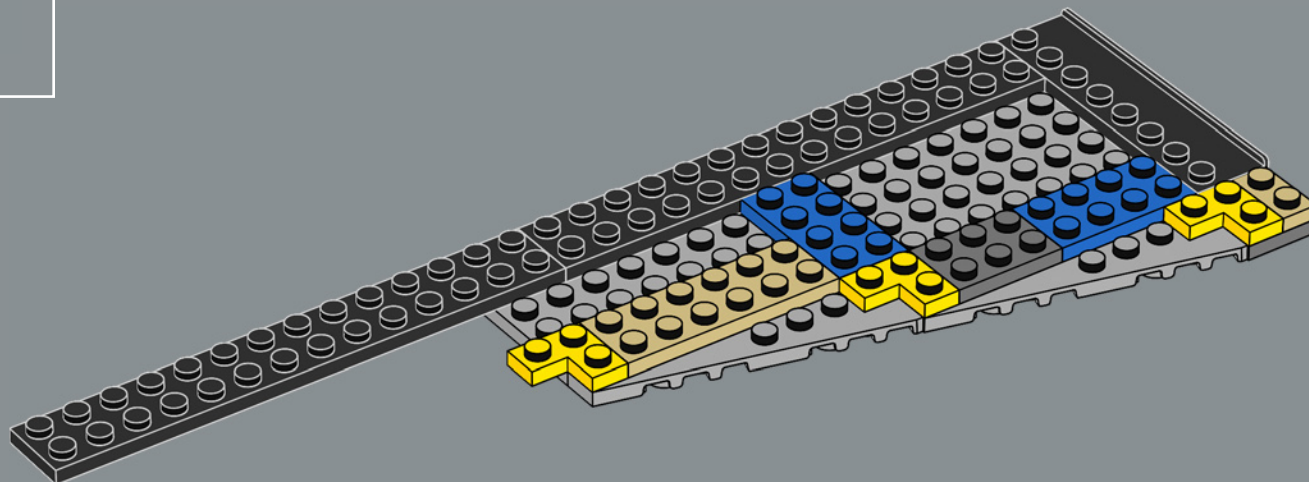

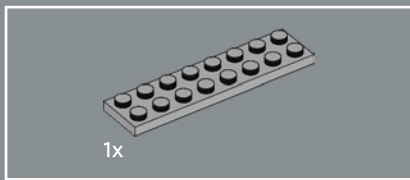

431

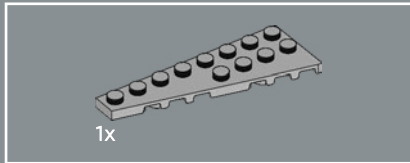
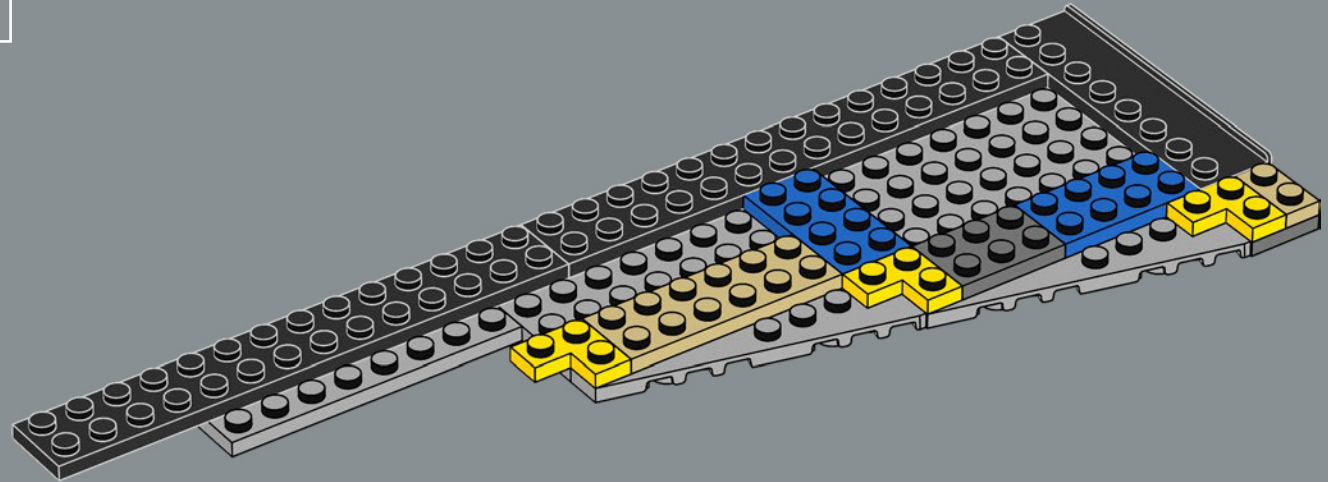

432

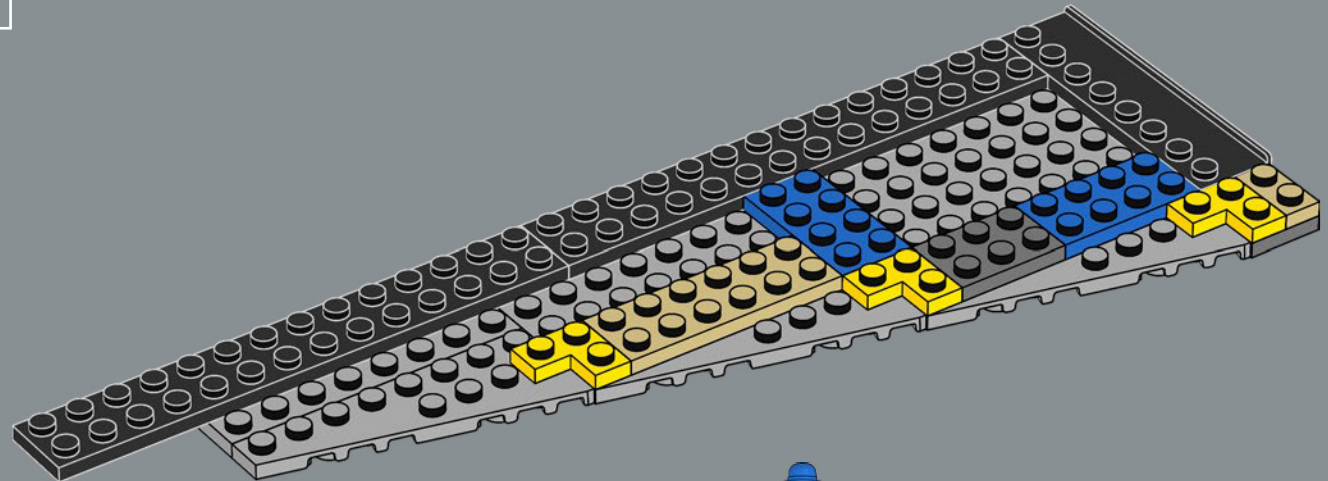

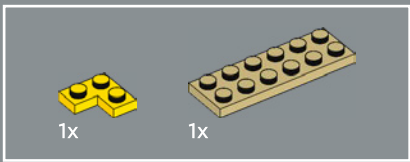

433

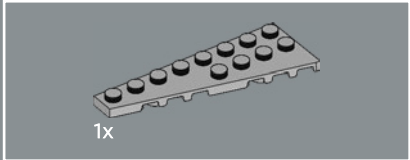
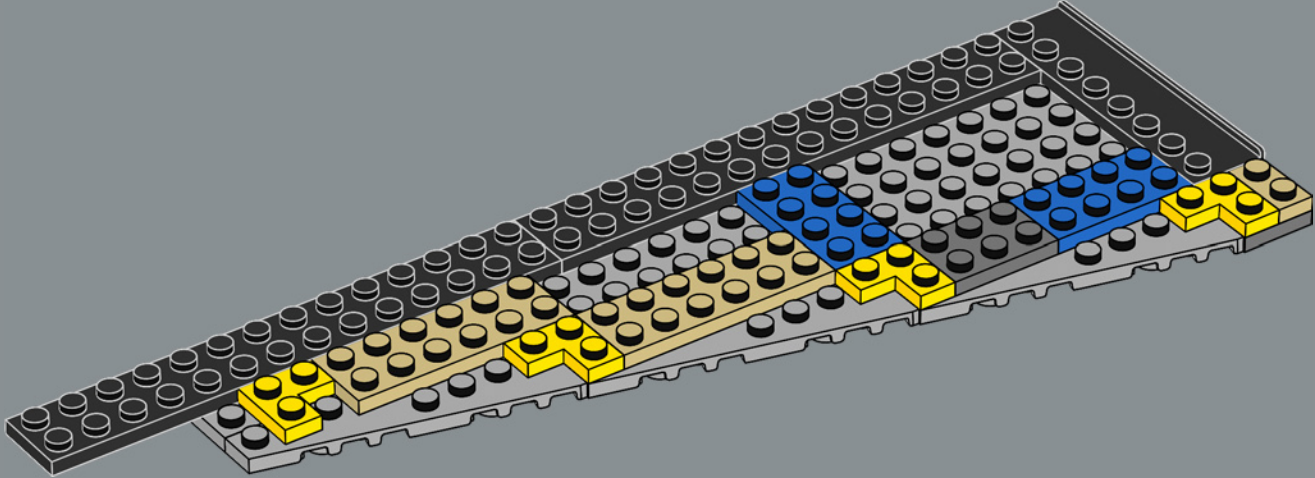

434

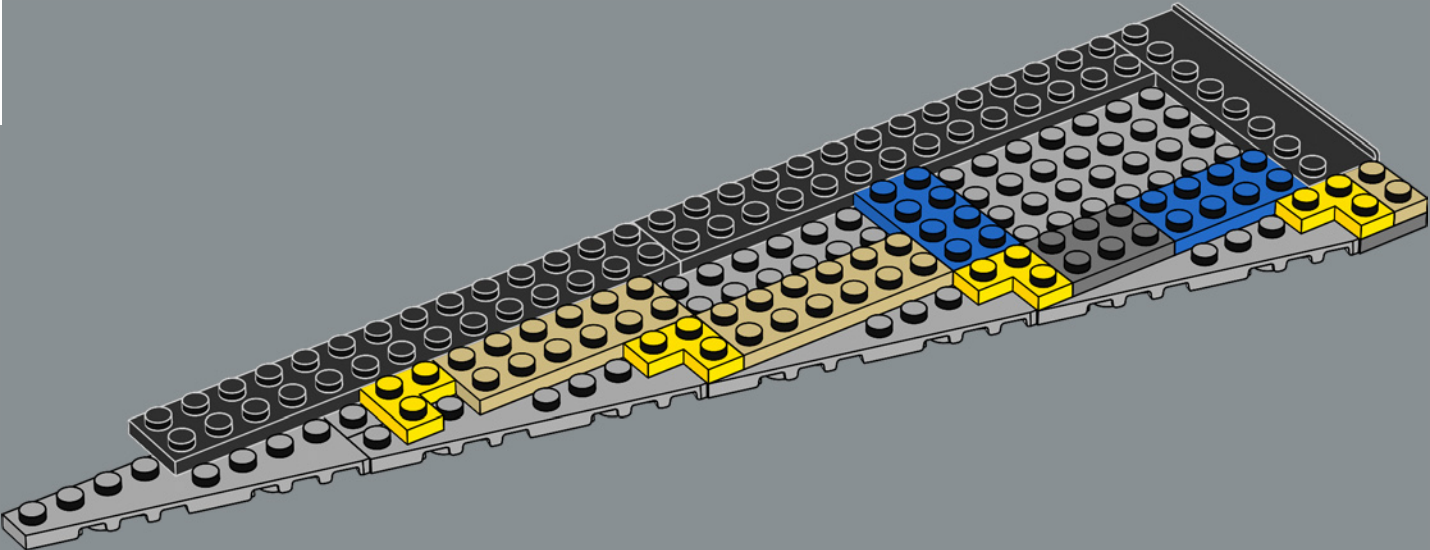

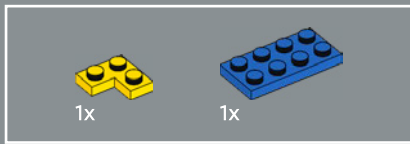

435

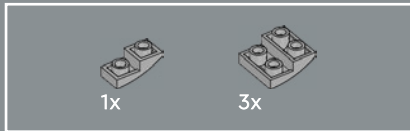
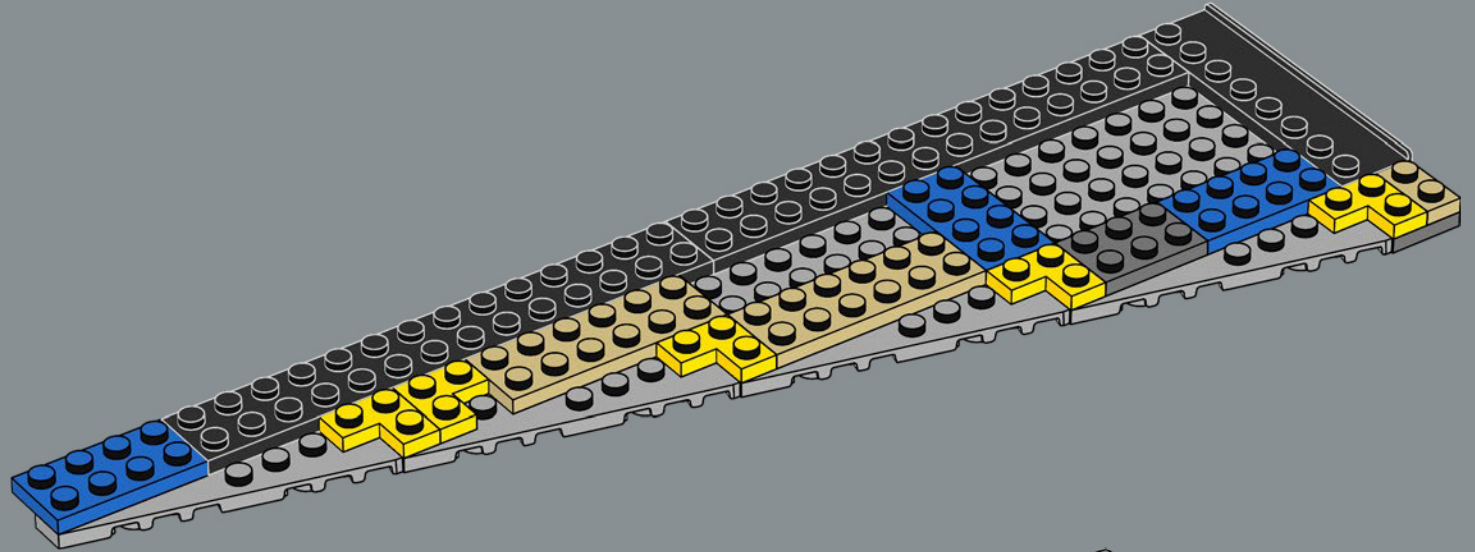

436

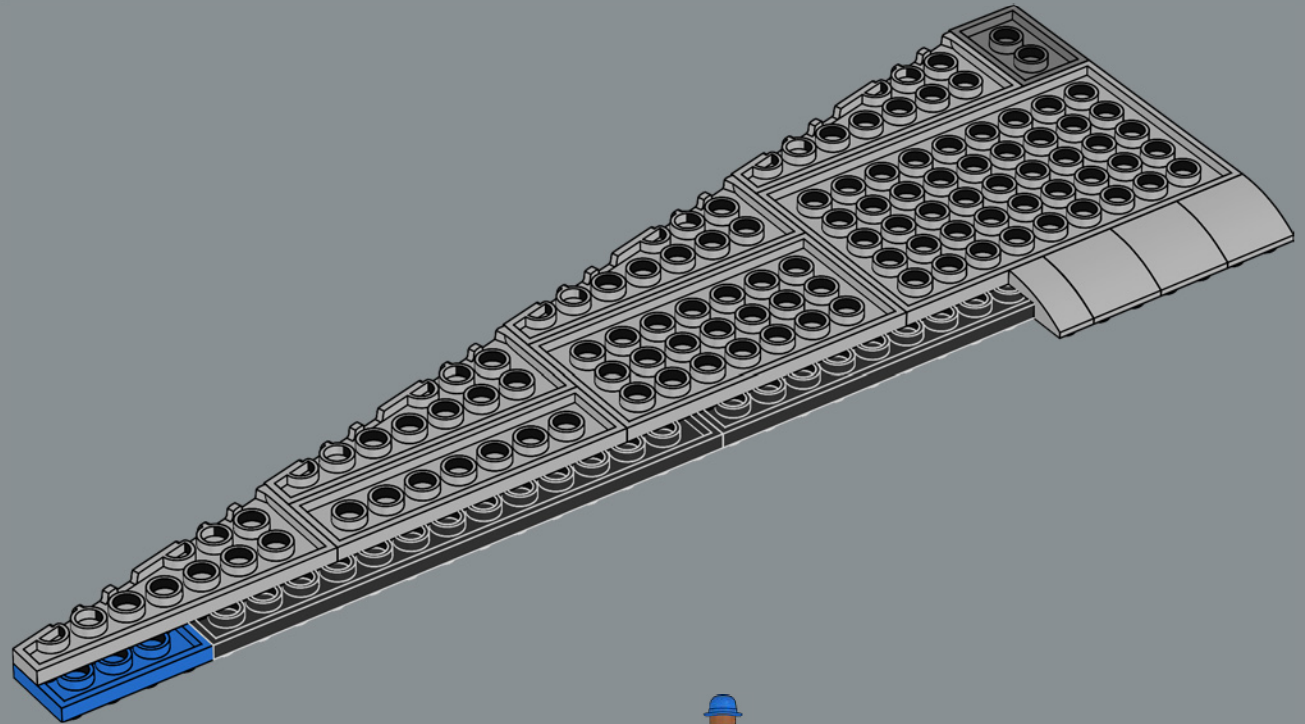

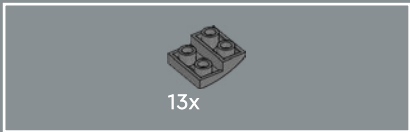

437

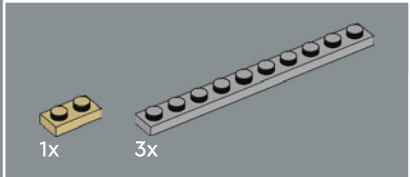
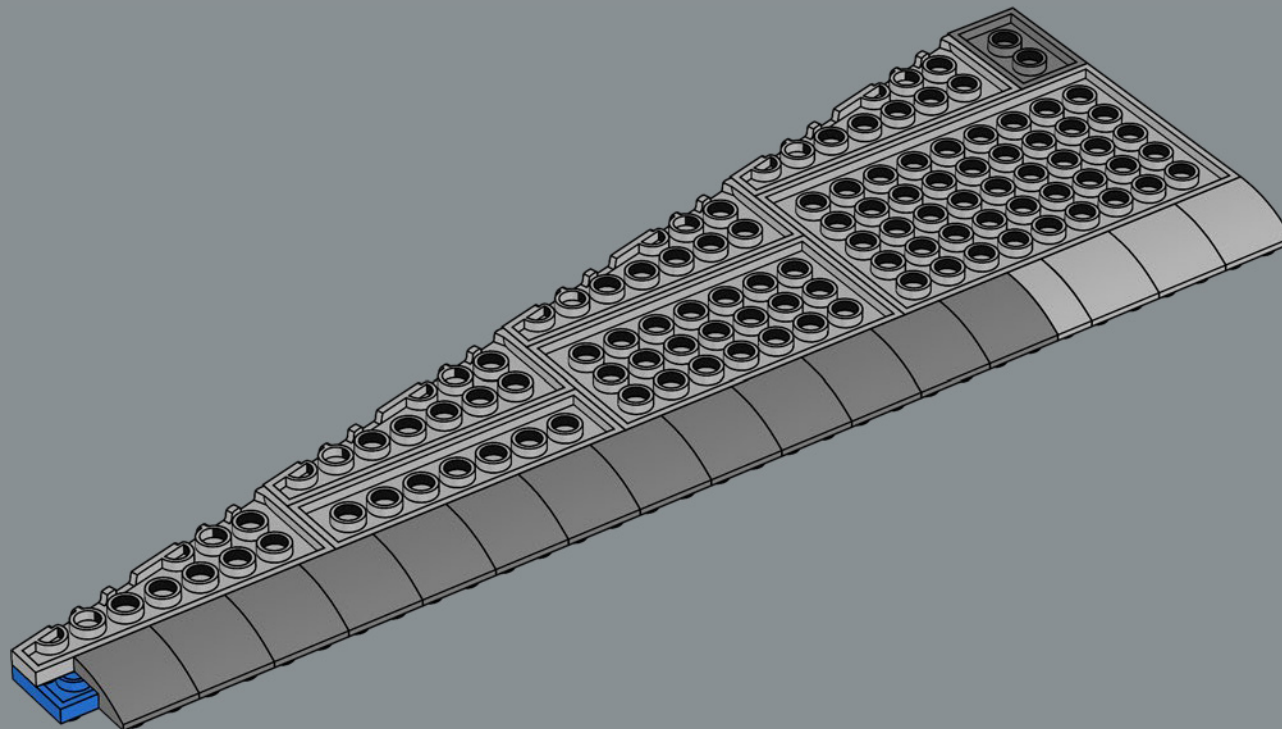

438

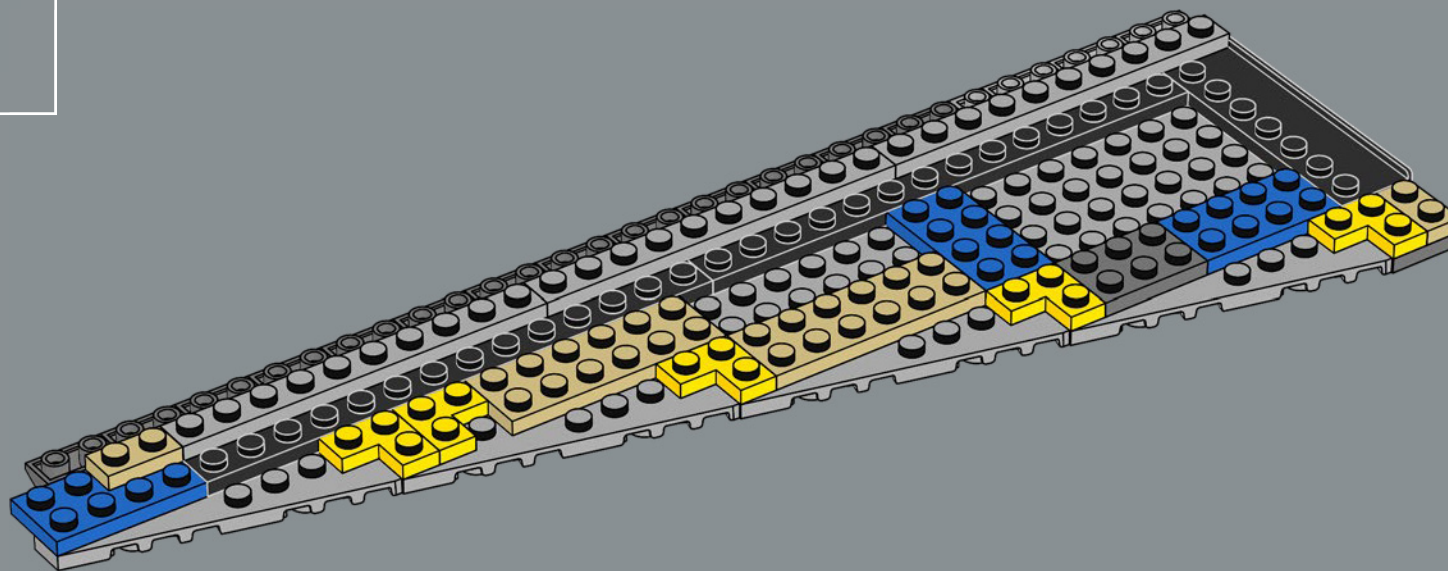

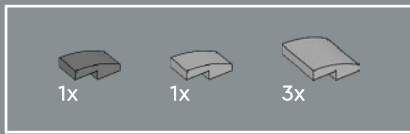

439

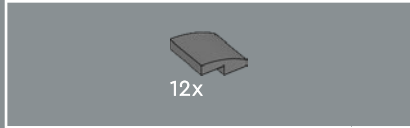
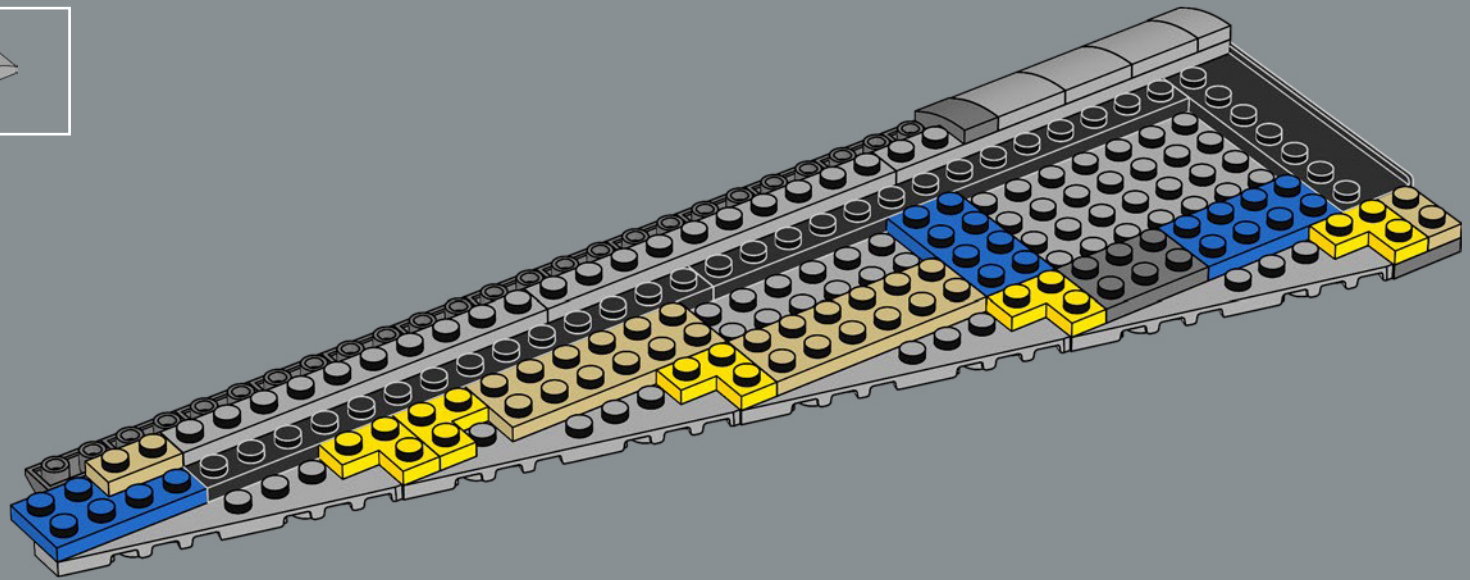

440

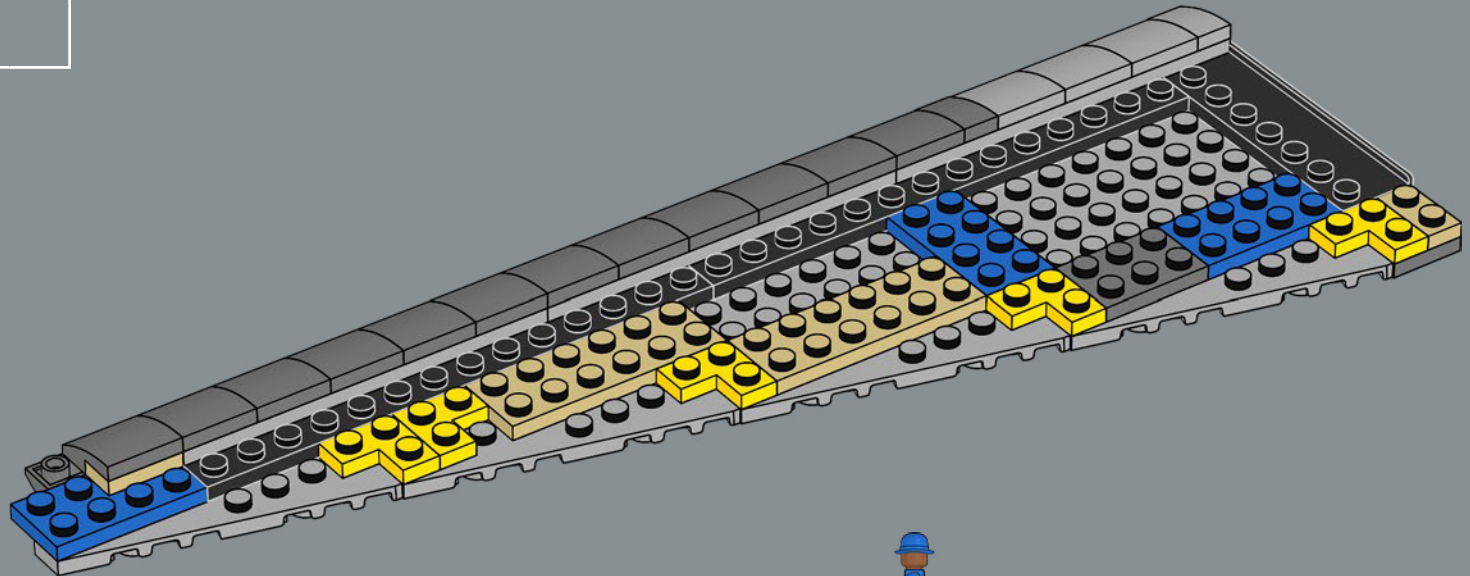

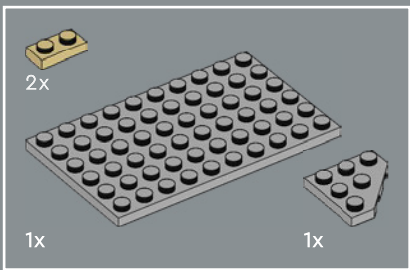

441

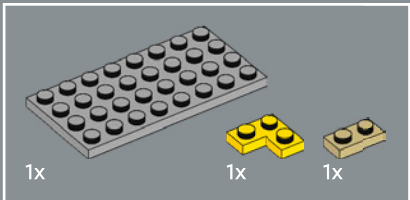
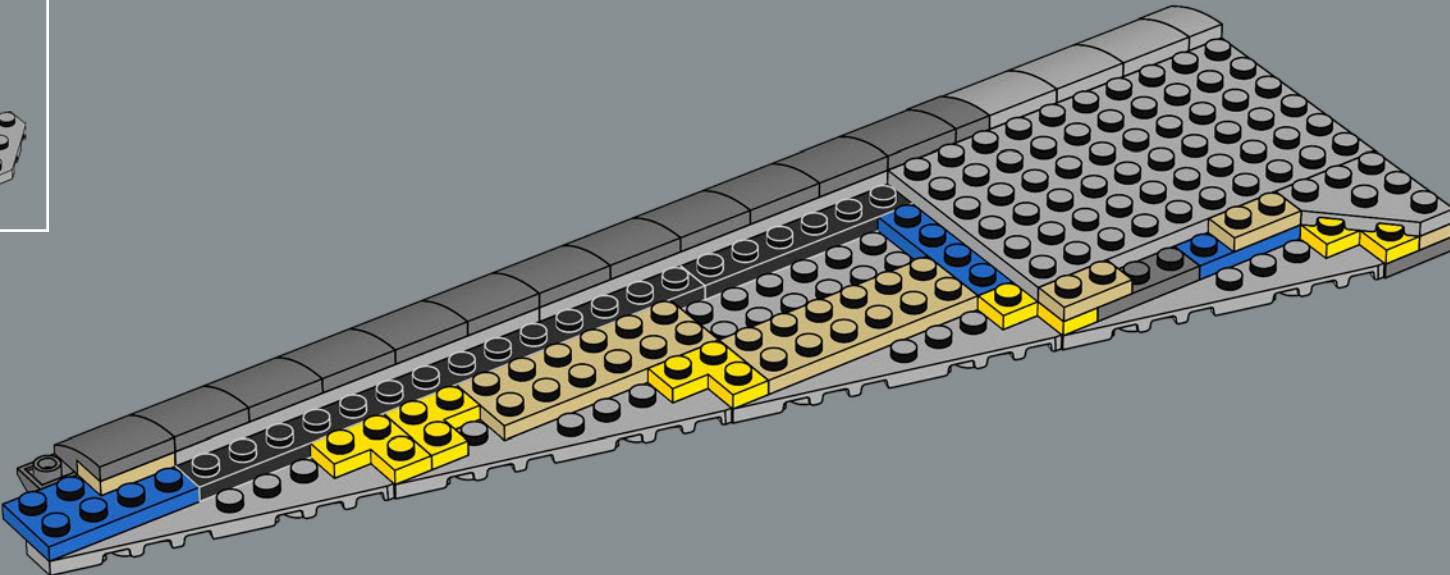

442

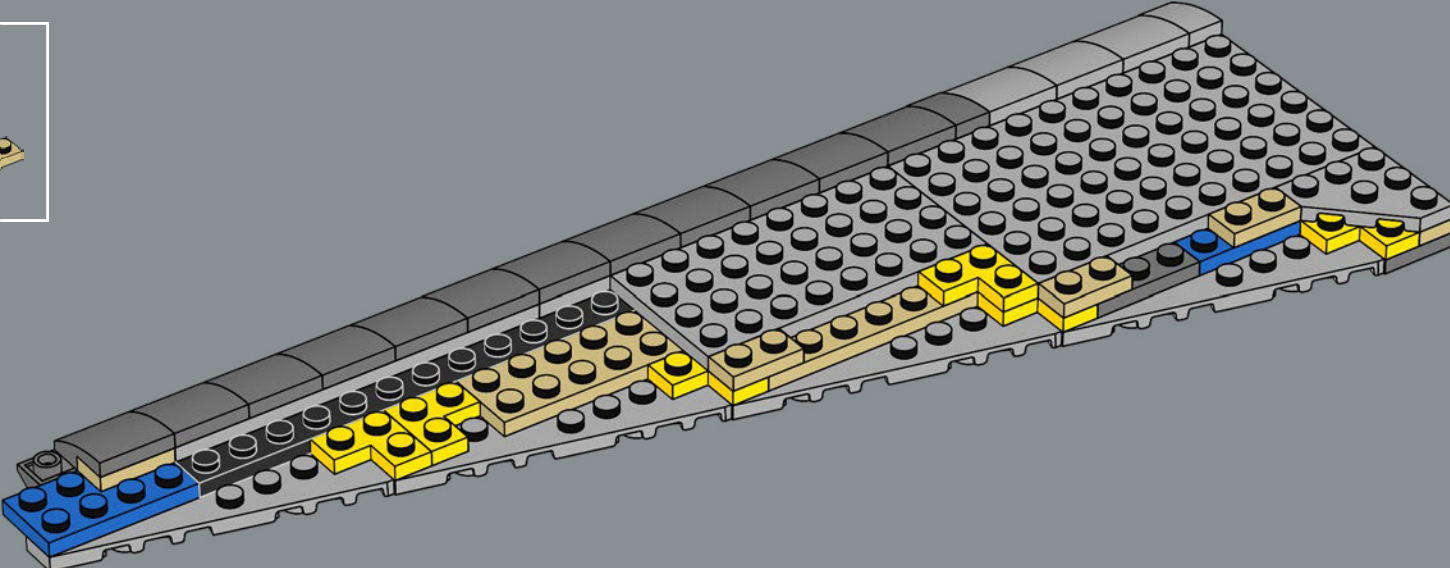

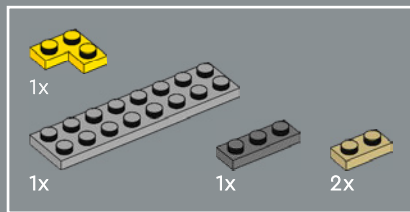

443

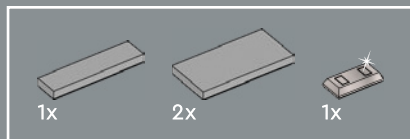
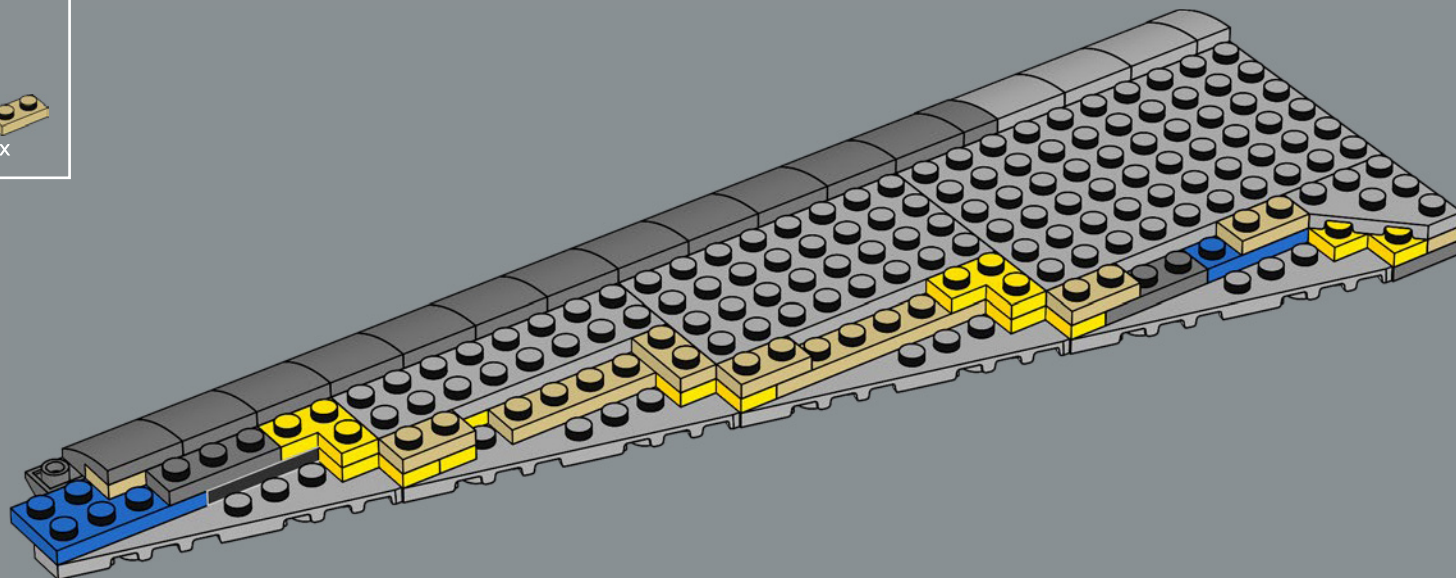

444

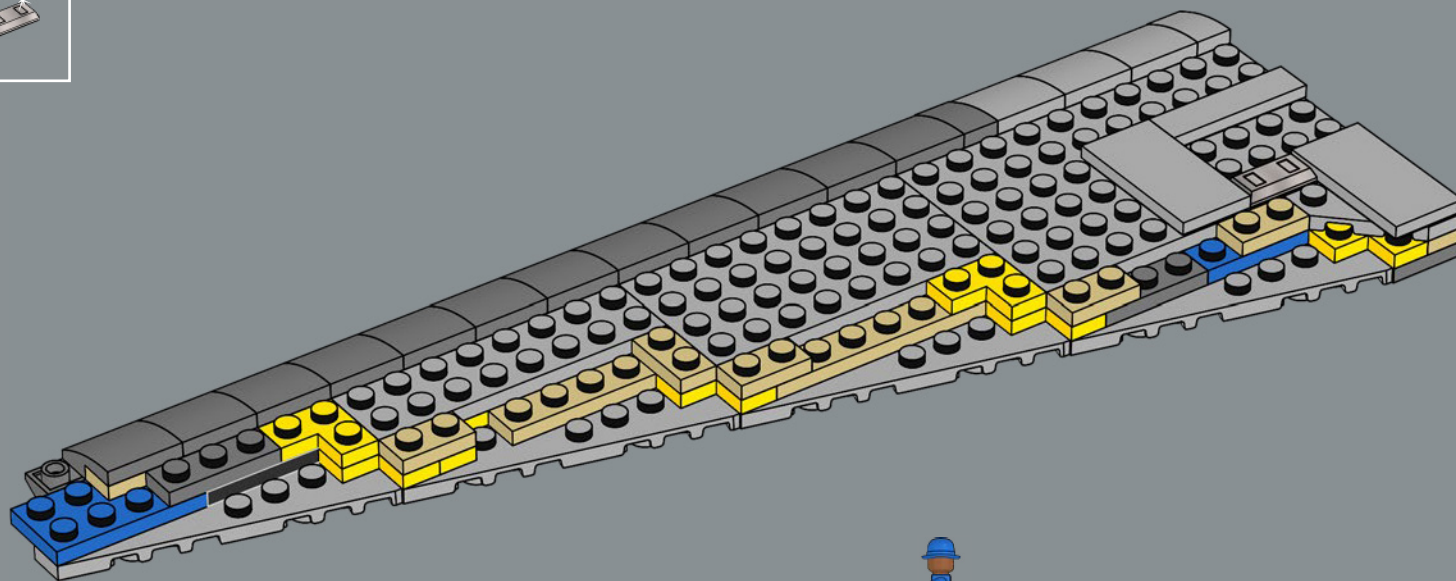

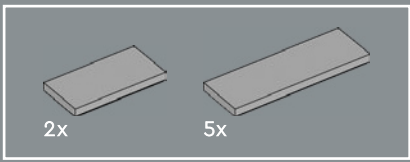

445

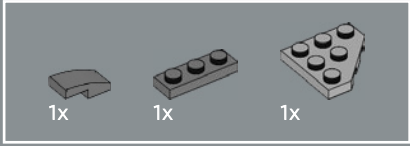
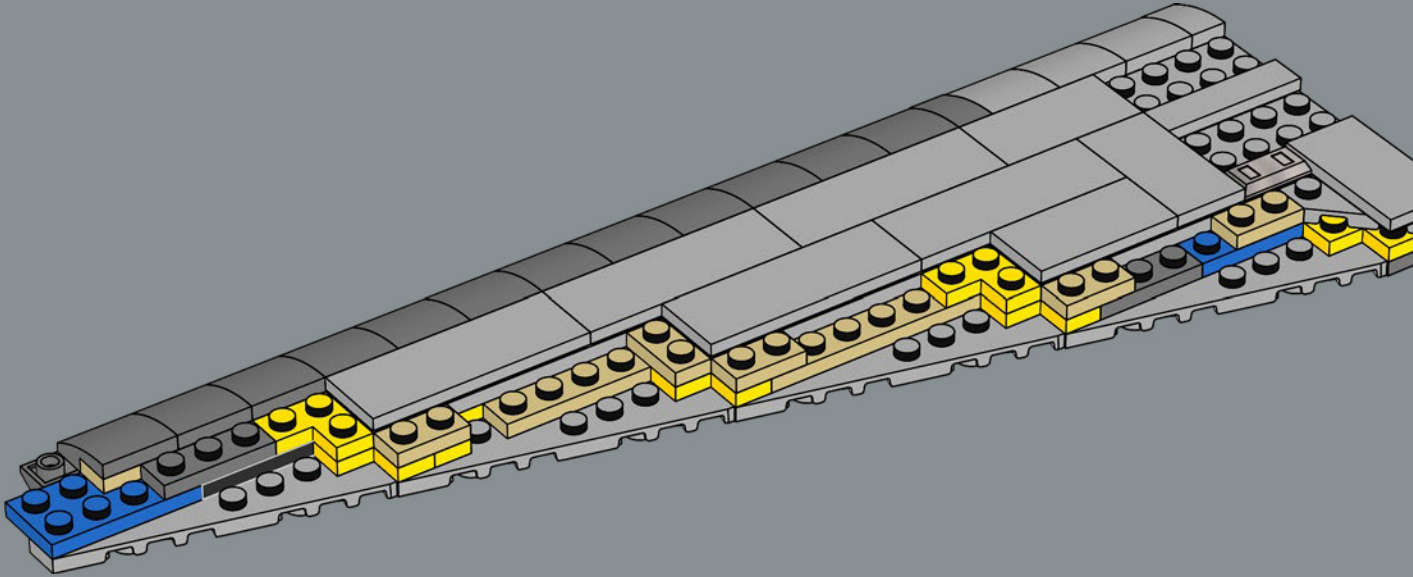

446

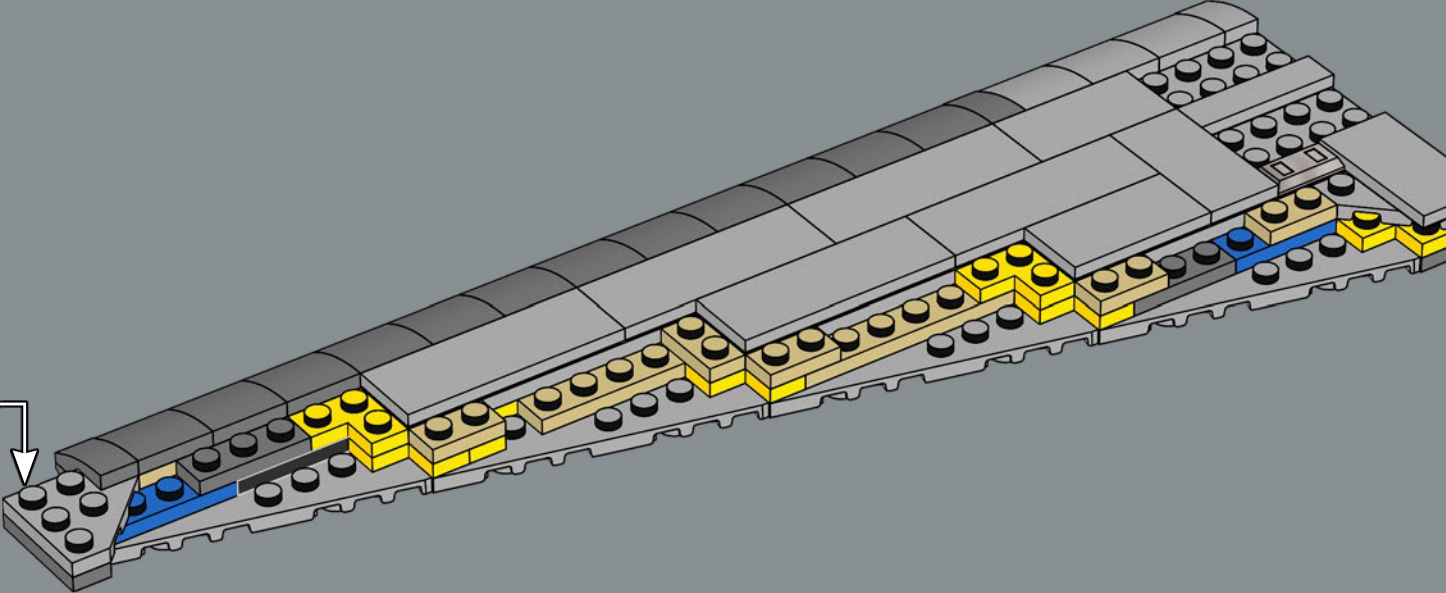
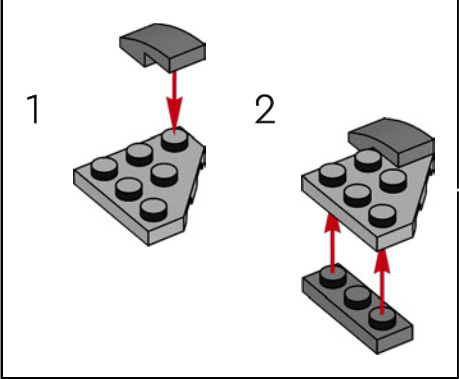

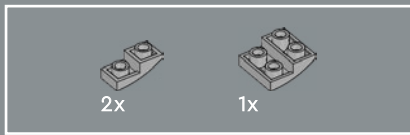

447

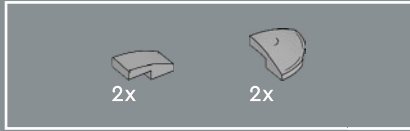
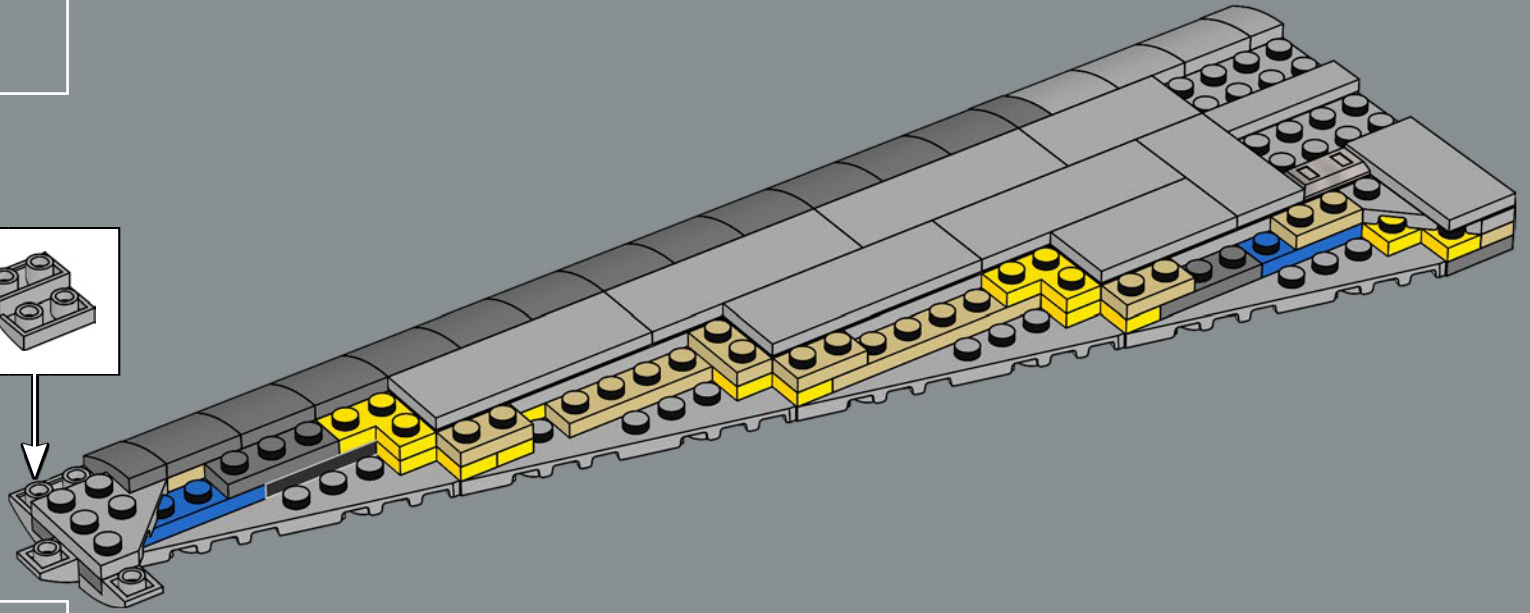
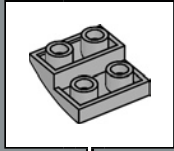

448

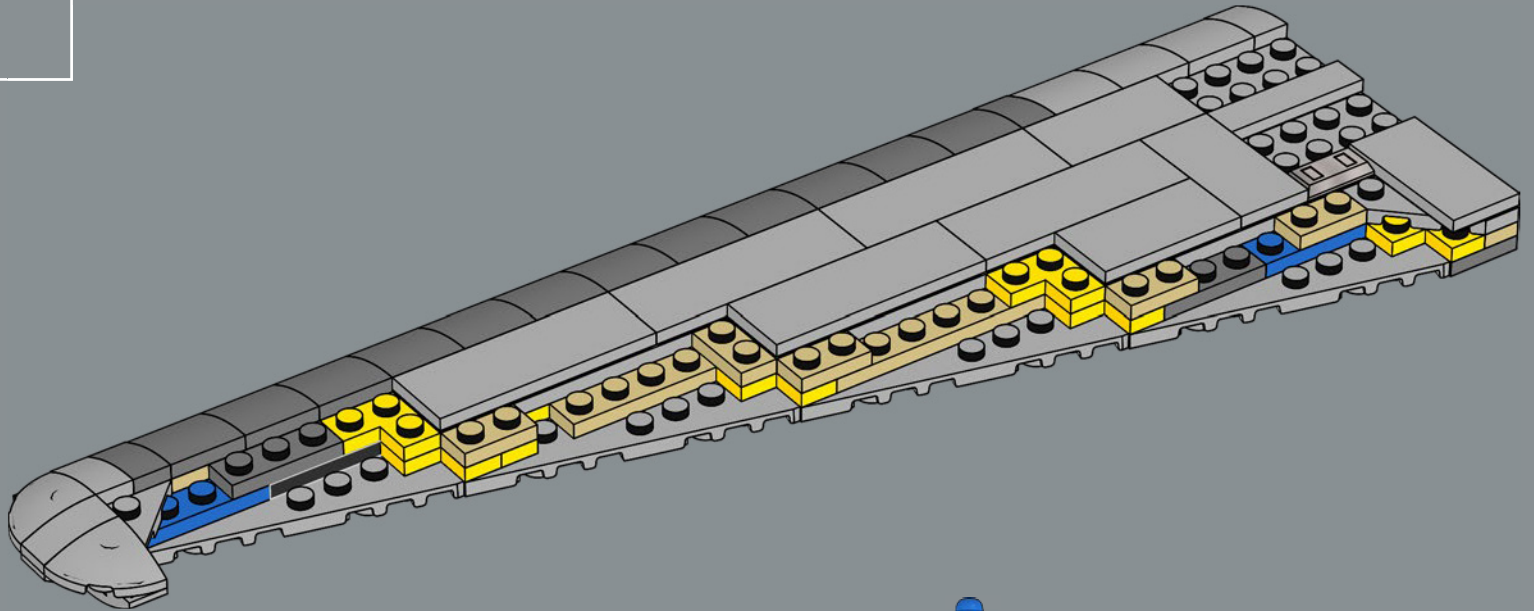

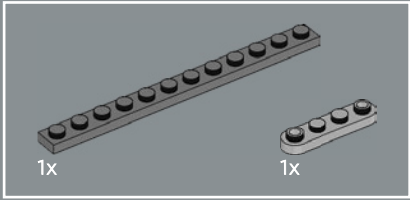
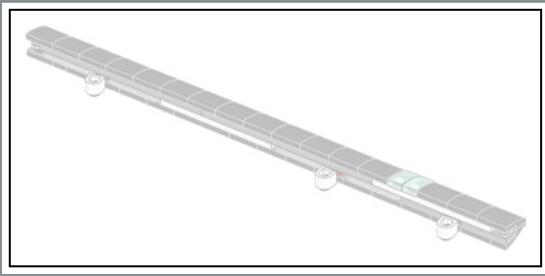

449

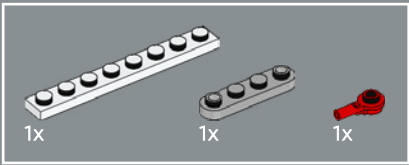
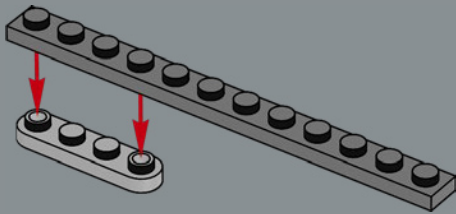

450

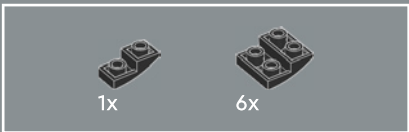
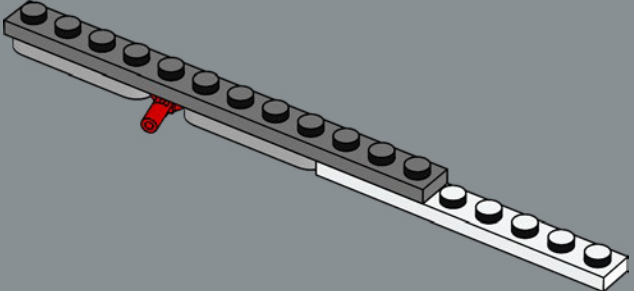

451

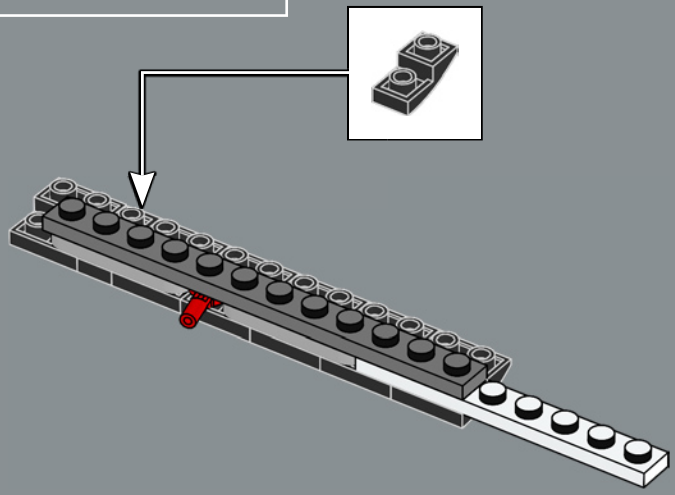



452

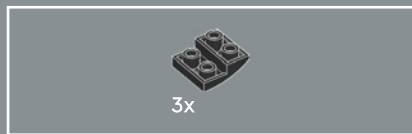
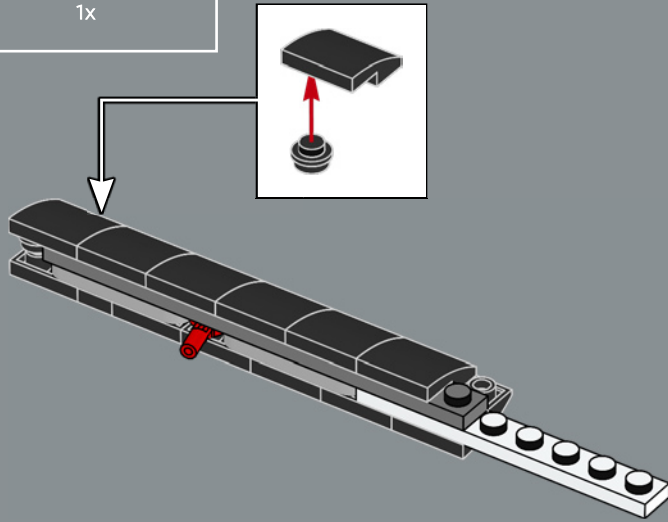

453

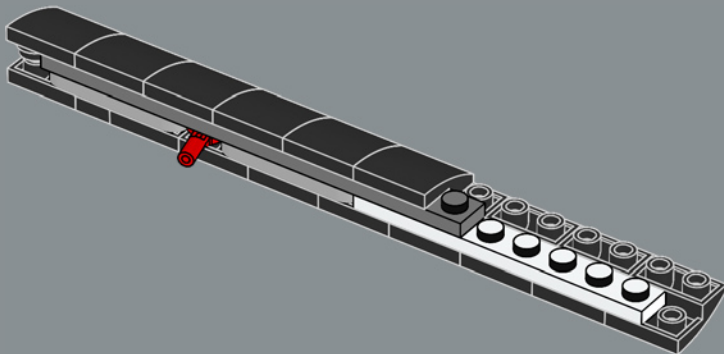

454

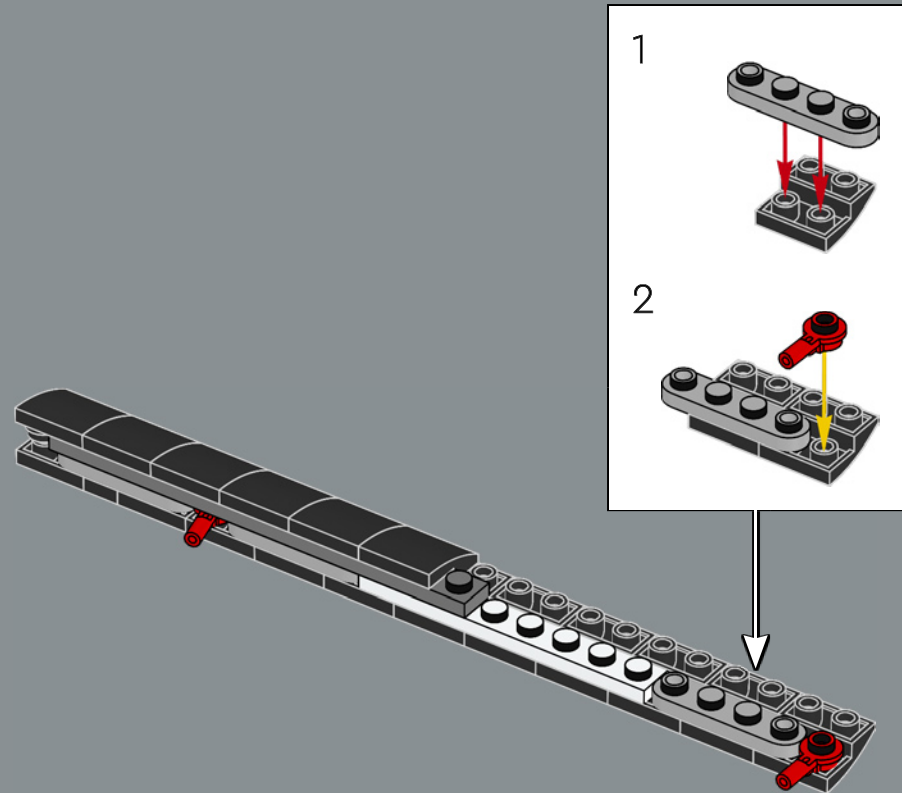

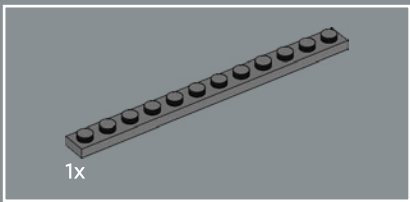

1x

455

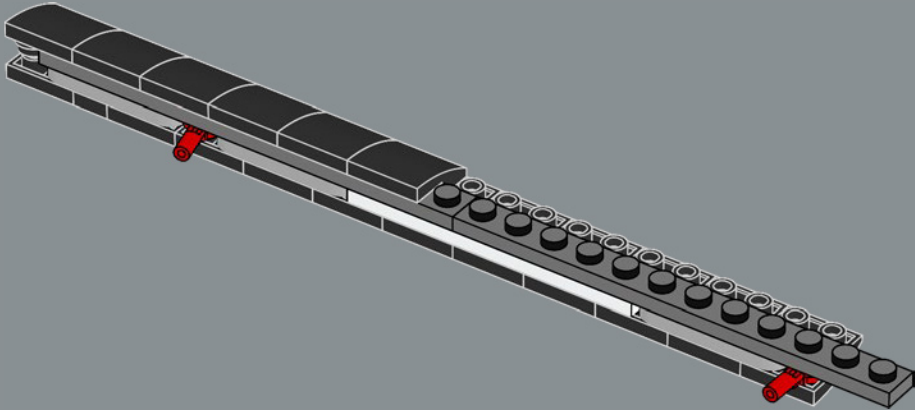

5x

456

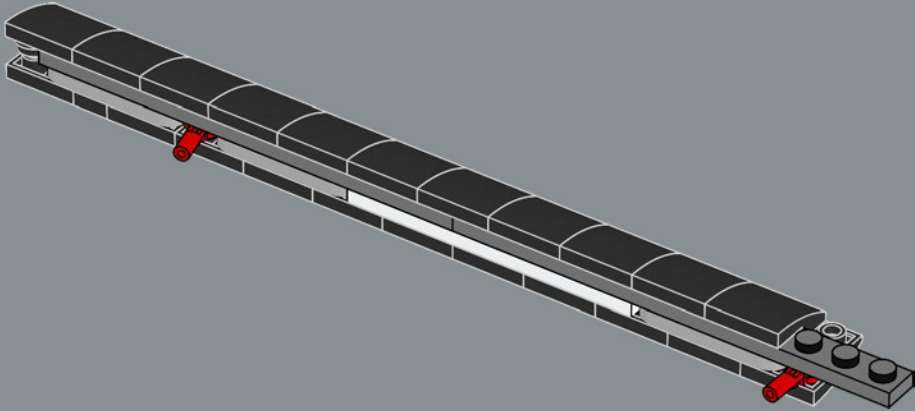

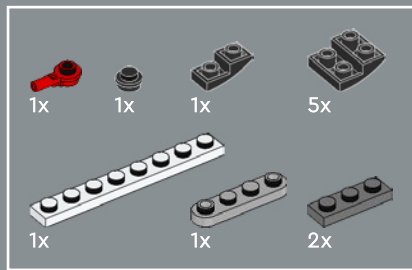

457

1

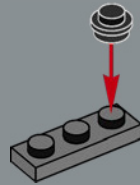

2

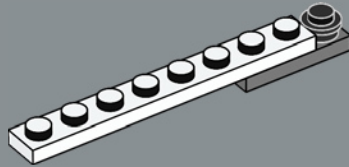

3

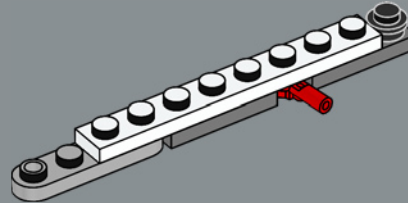

4

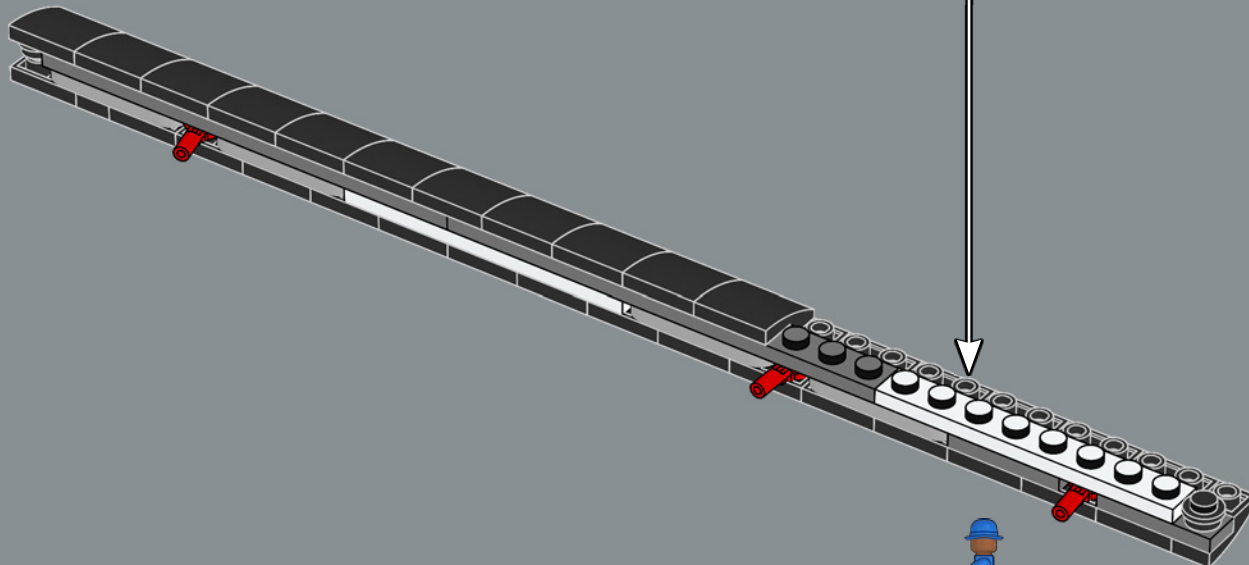
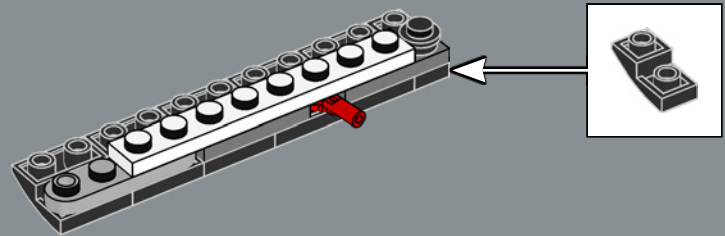



458

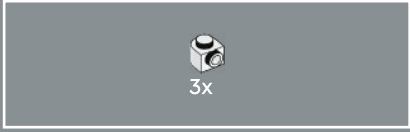
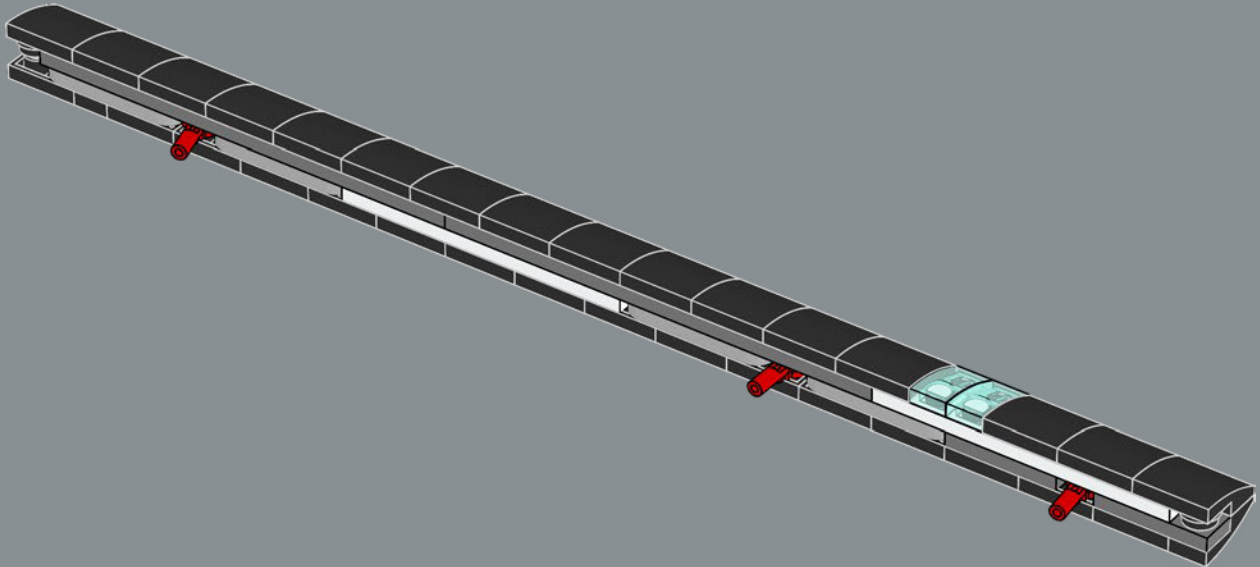

459

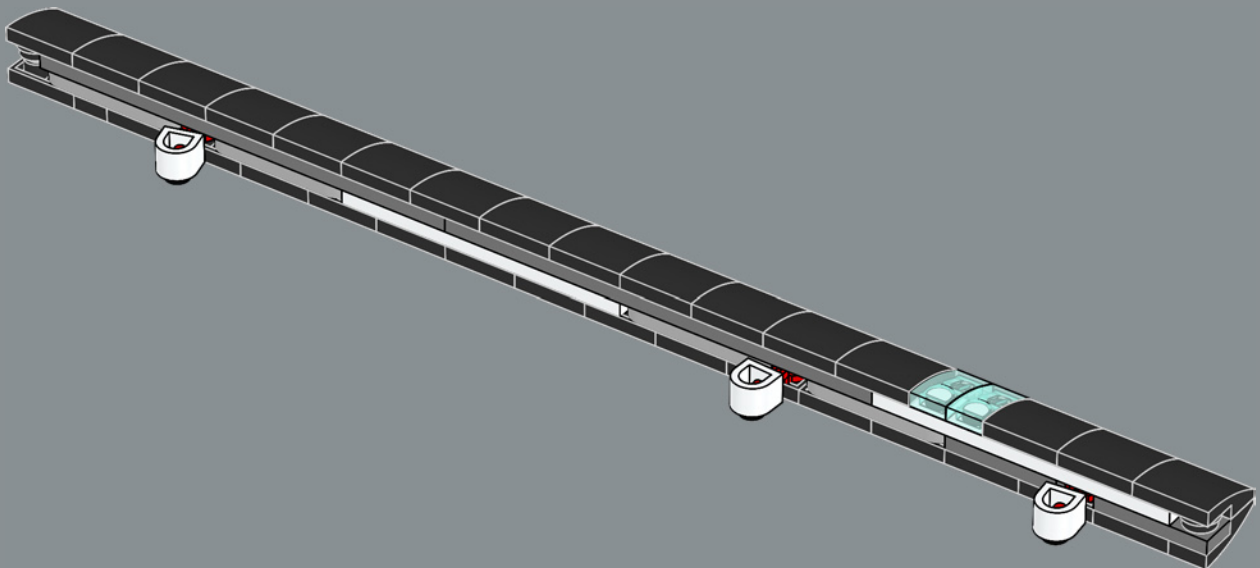

460

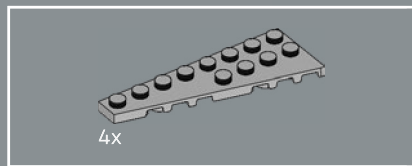
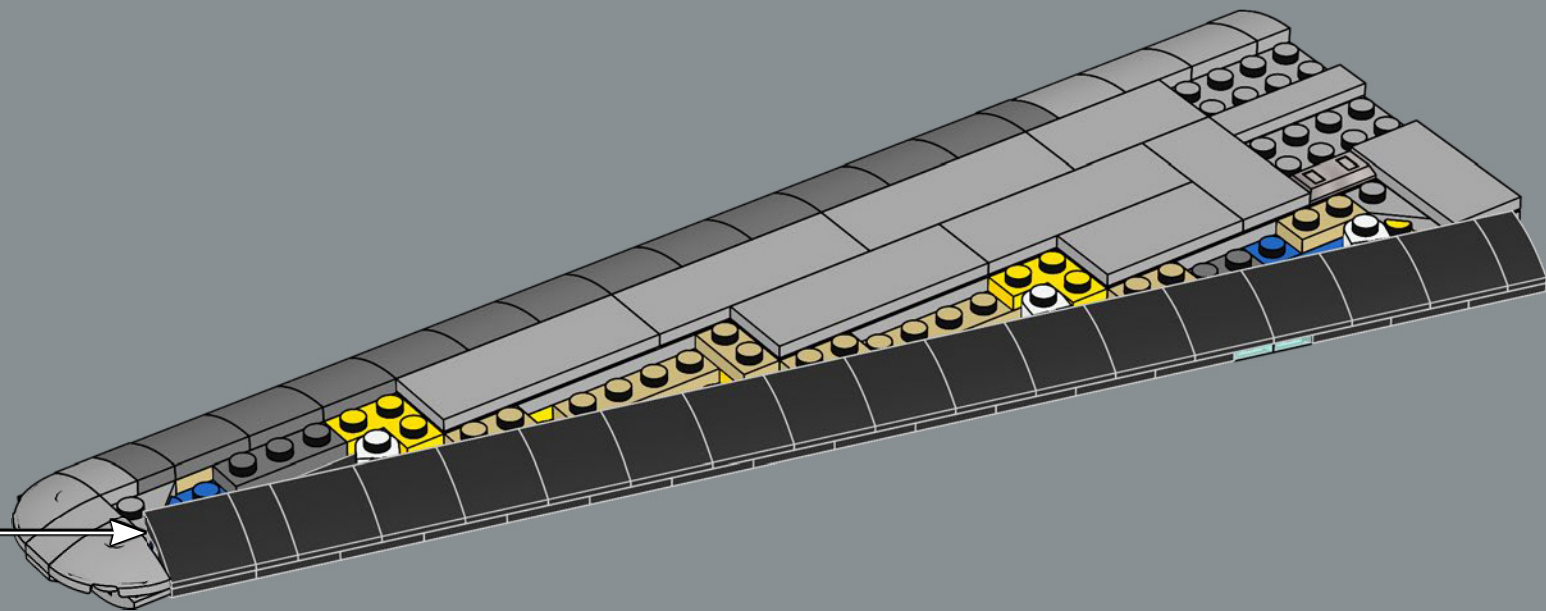

461

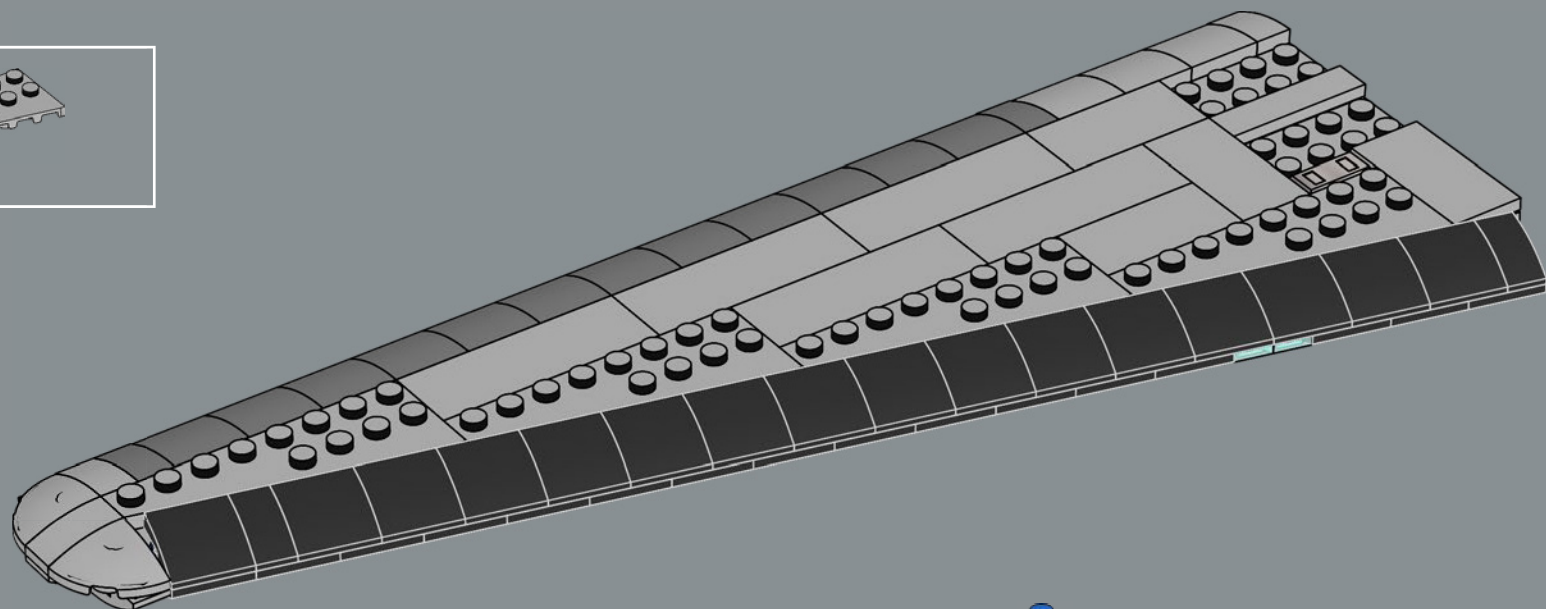

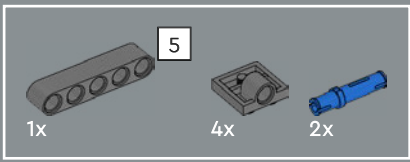

462

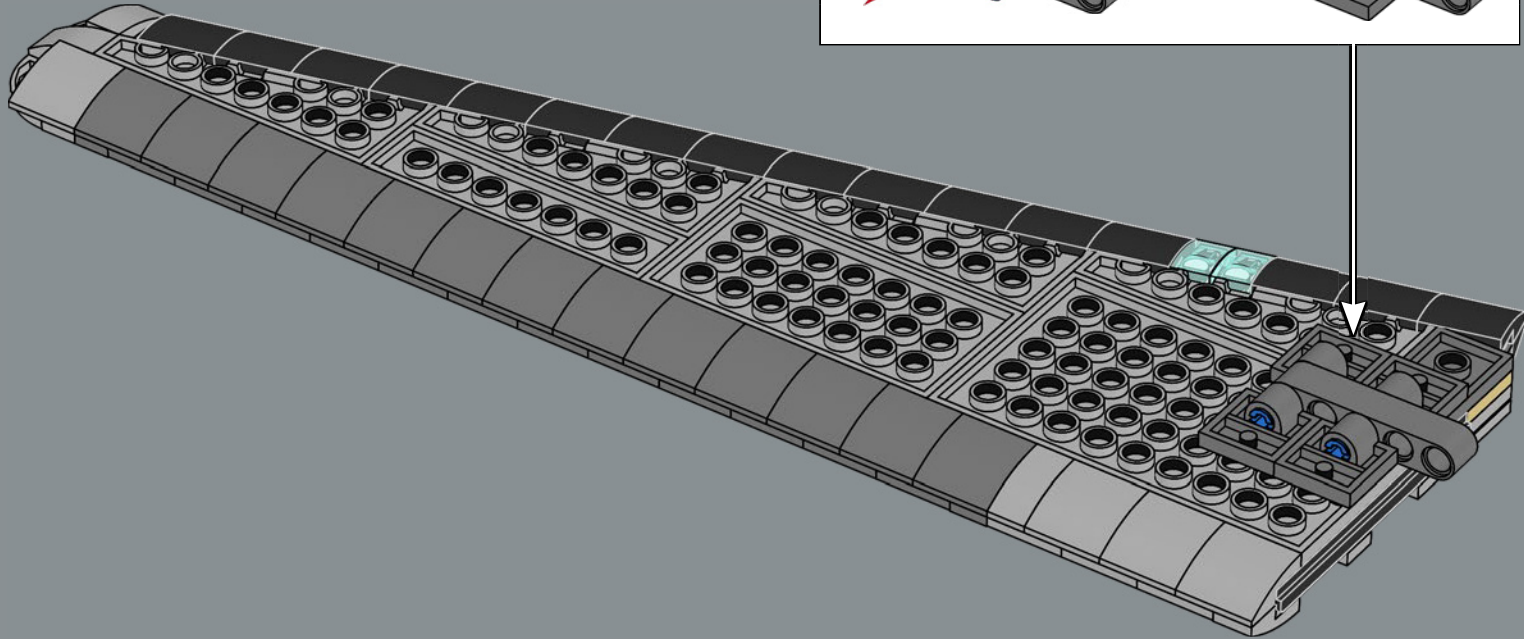
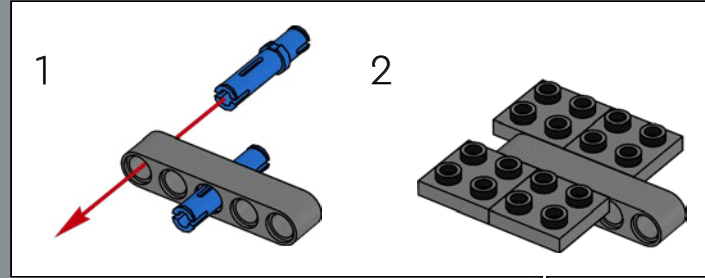

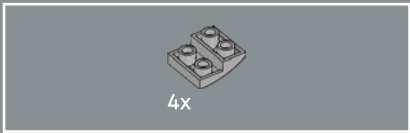

463

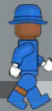
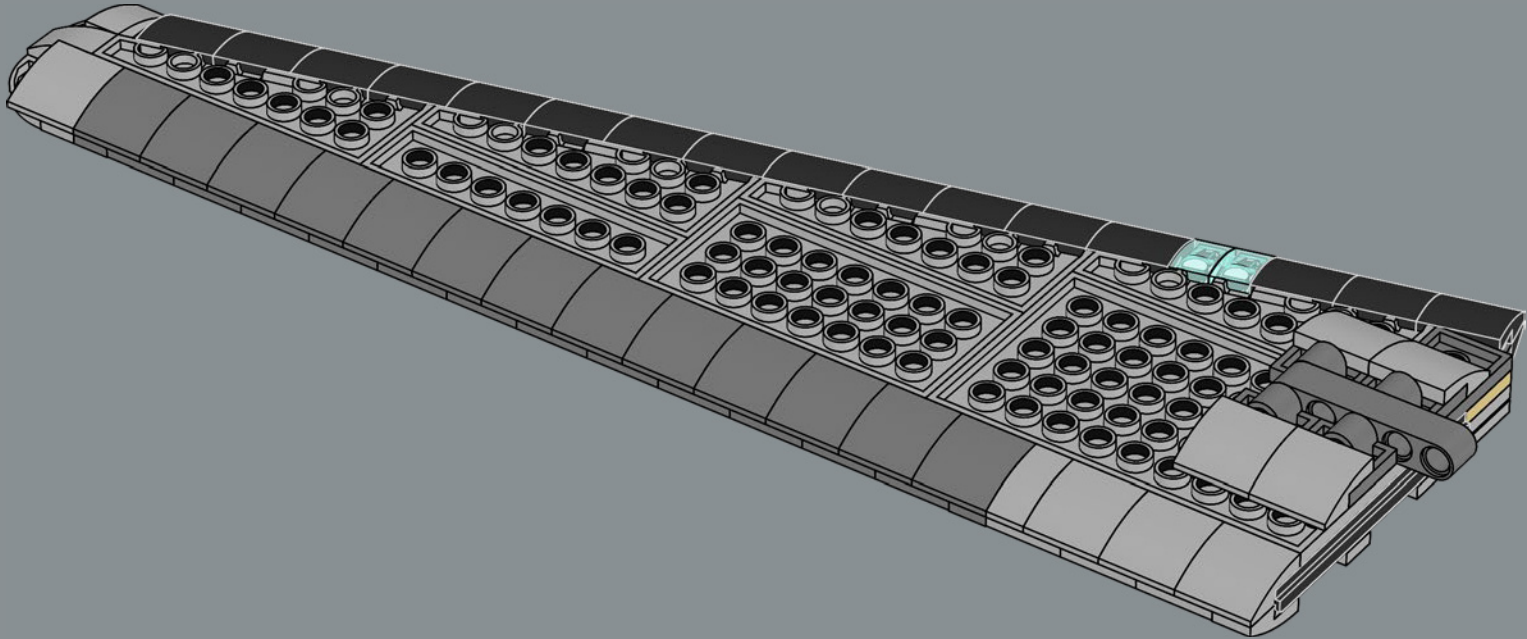

464

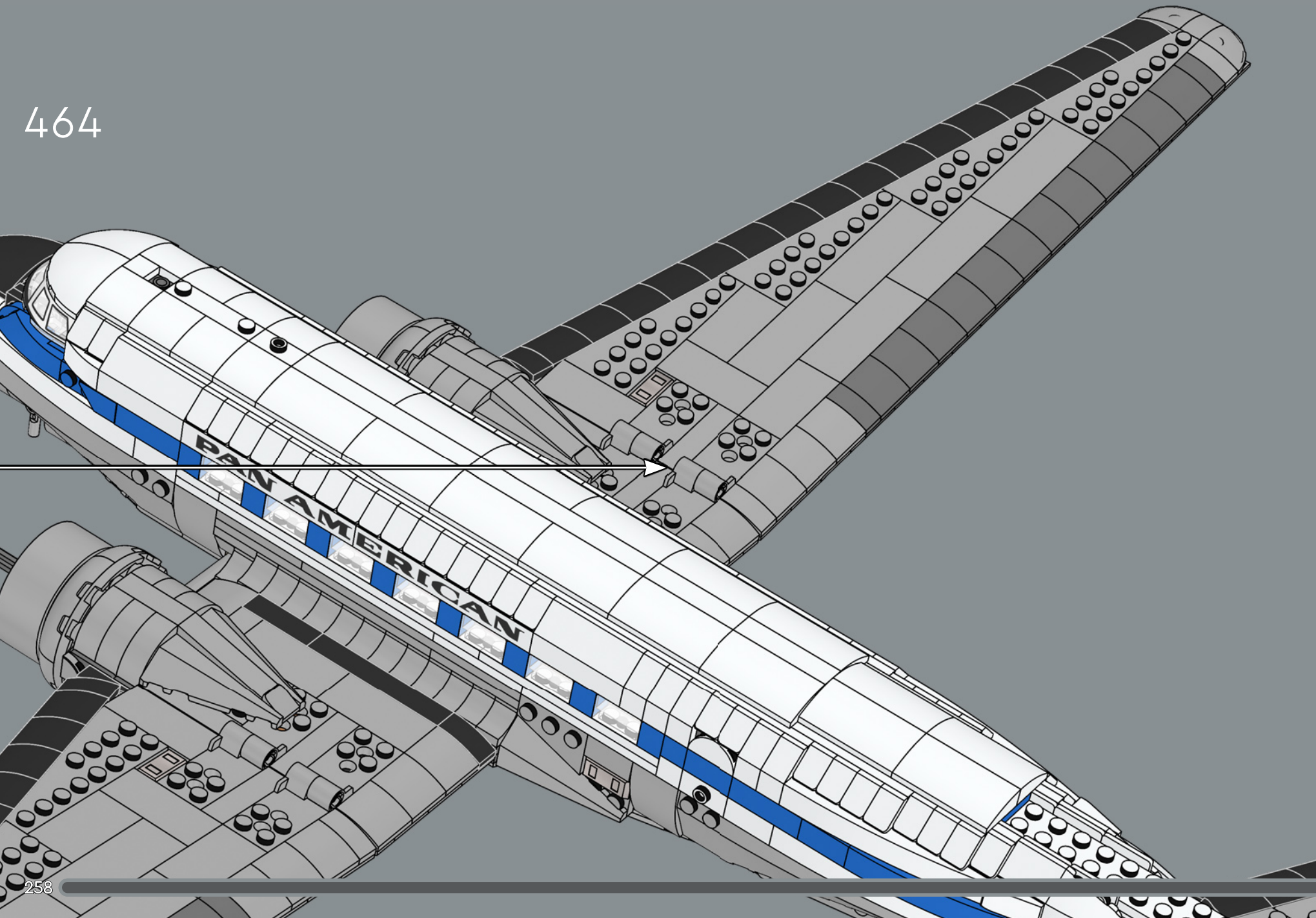



465

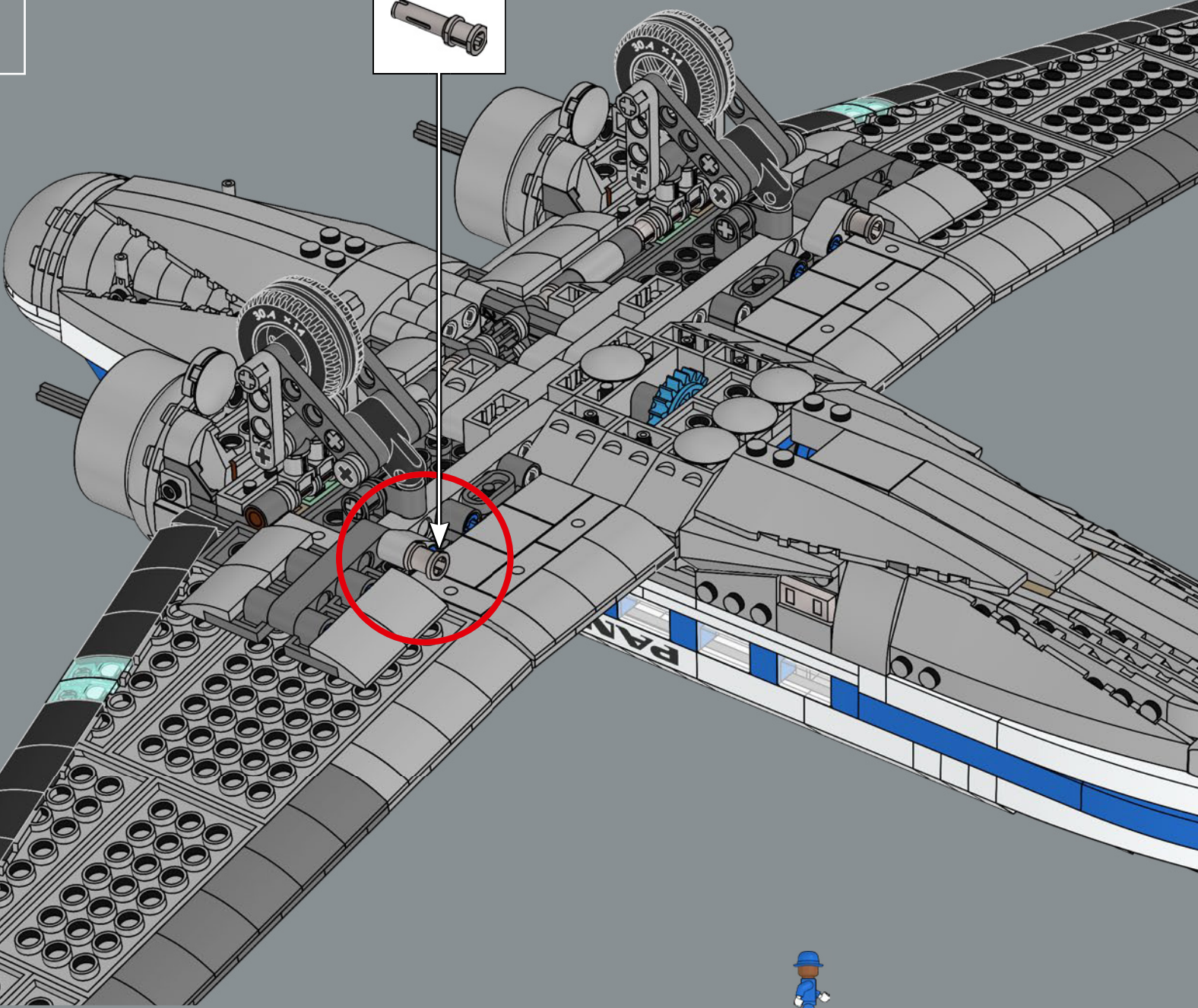



New uniforms, designed by an American fashion house, were introduced in 1980. Male flight attendants were called Pursers.

De nouveaux uniformes, conçus par une maison de couture américaine, ont été introduits en 1980. Les agents de bord masculins étaient appelés chefs de cabine (Pursers).

En 1980 se introdujeron nuevos uniformes diseñados por una casa de modas estadounidense. *Pursers* era como llamaban a los sobrecargos masculinos.

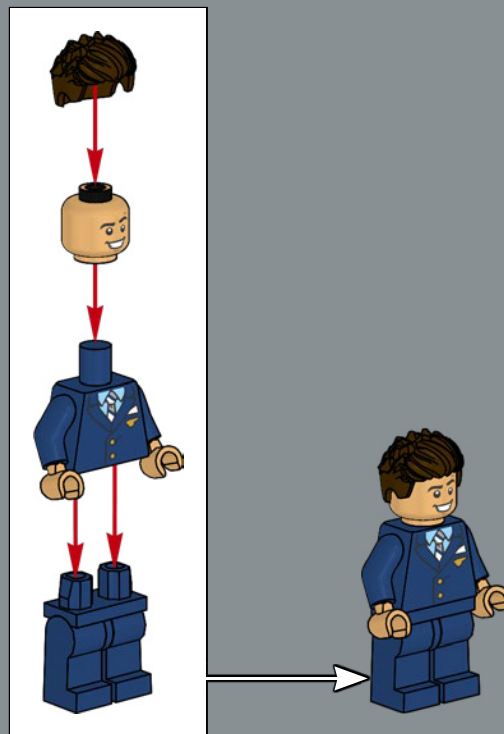

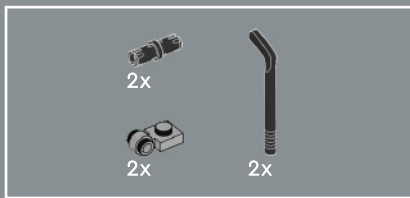

466

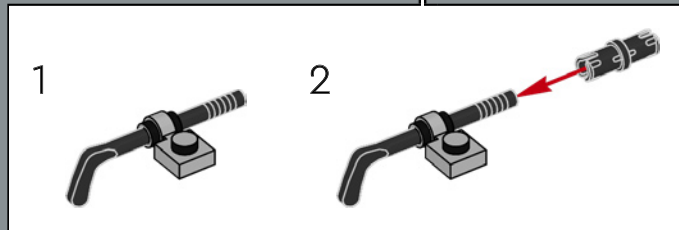
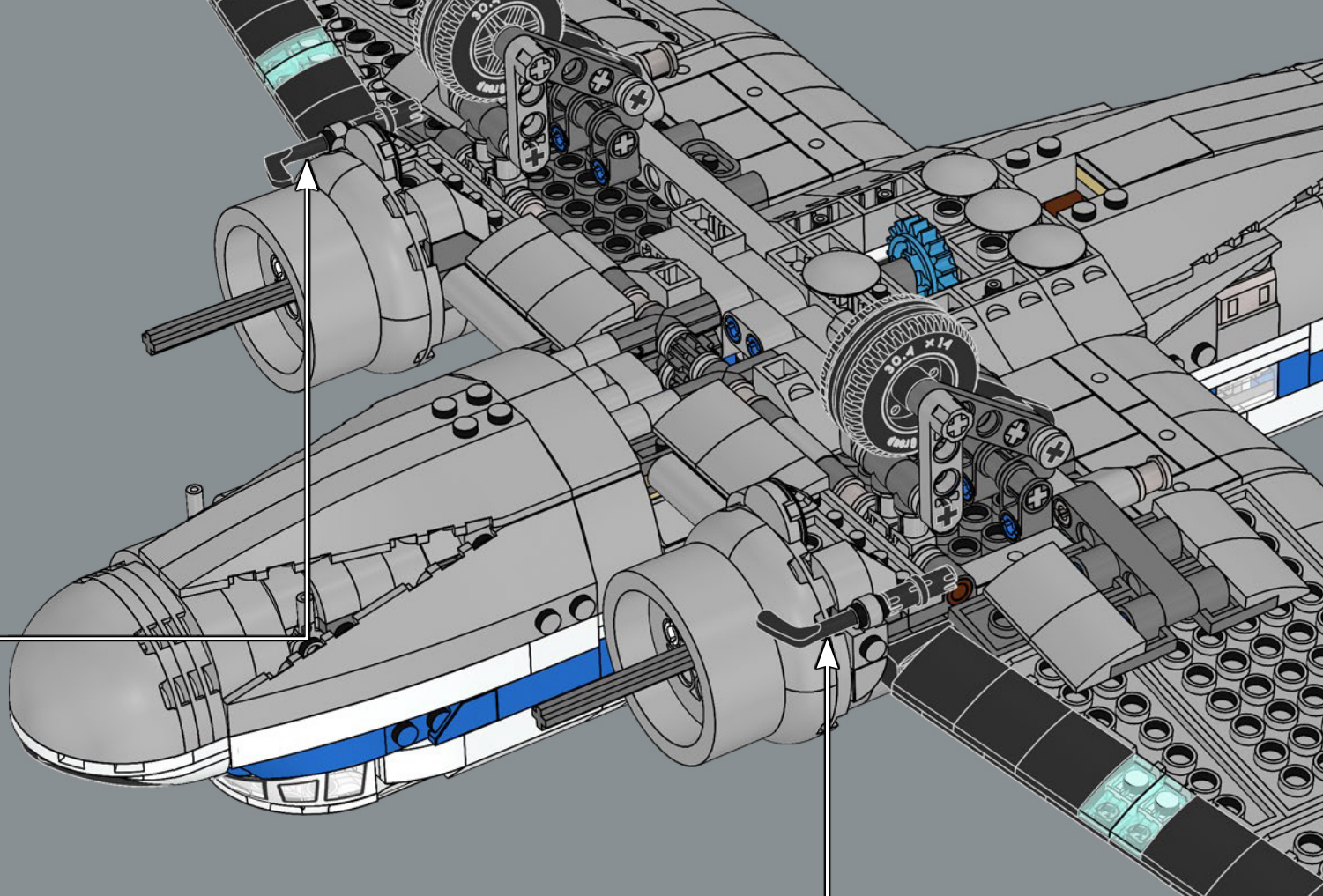
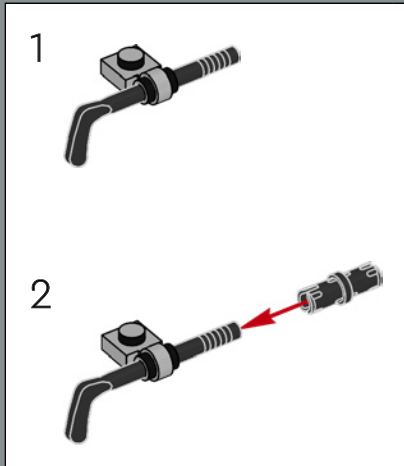



467

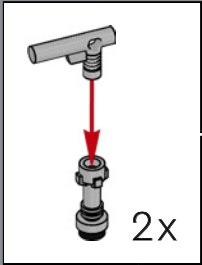

The protrusions below the cockpit area represent air speed sensors.

Les parties en relief sous l'habitacle représentent des capteurs de vitesse de l'air.

Las protuberancias de debajo de la cabina representan sensores de velocidad aerodinámica.

2x

468

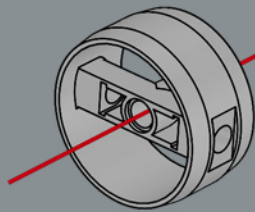

2x 2x



469

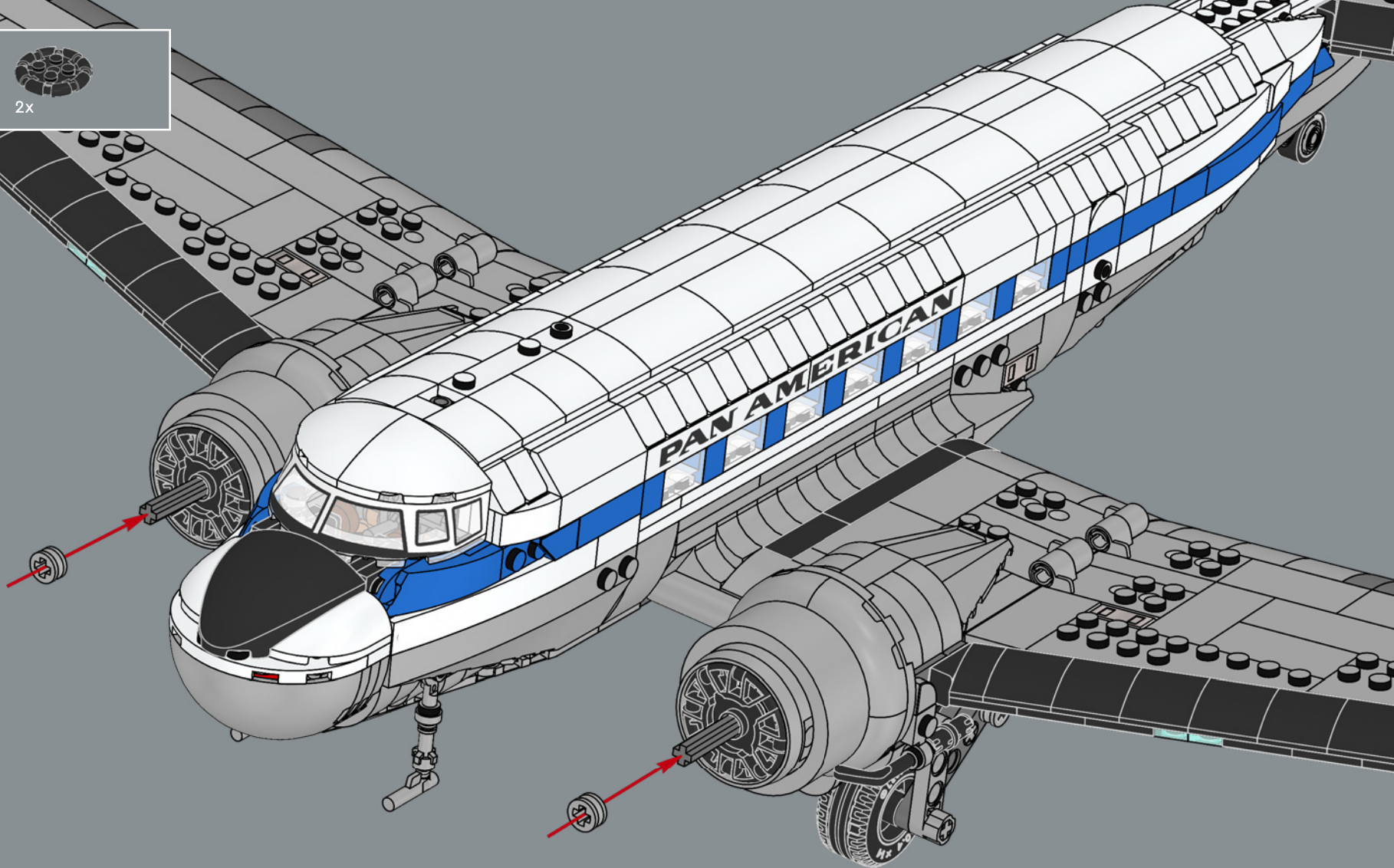

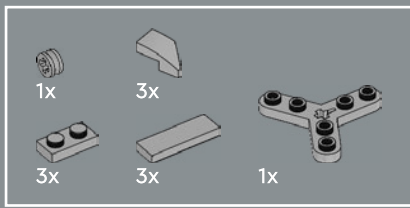

470

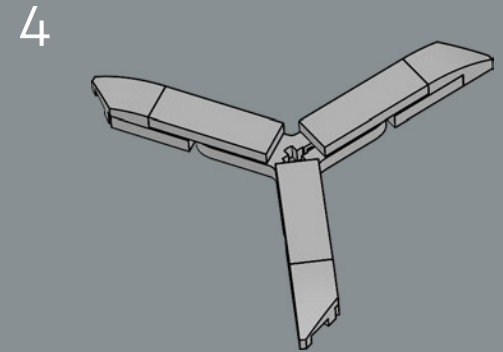
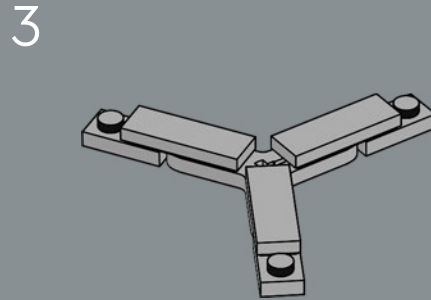
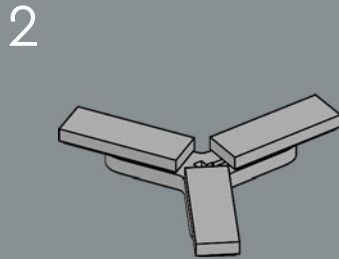
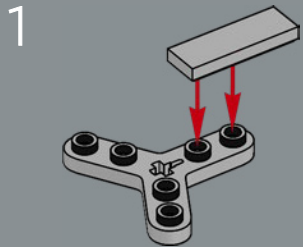

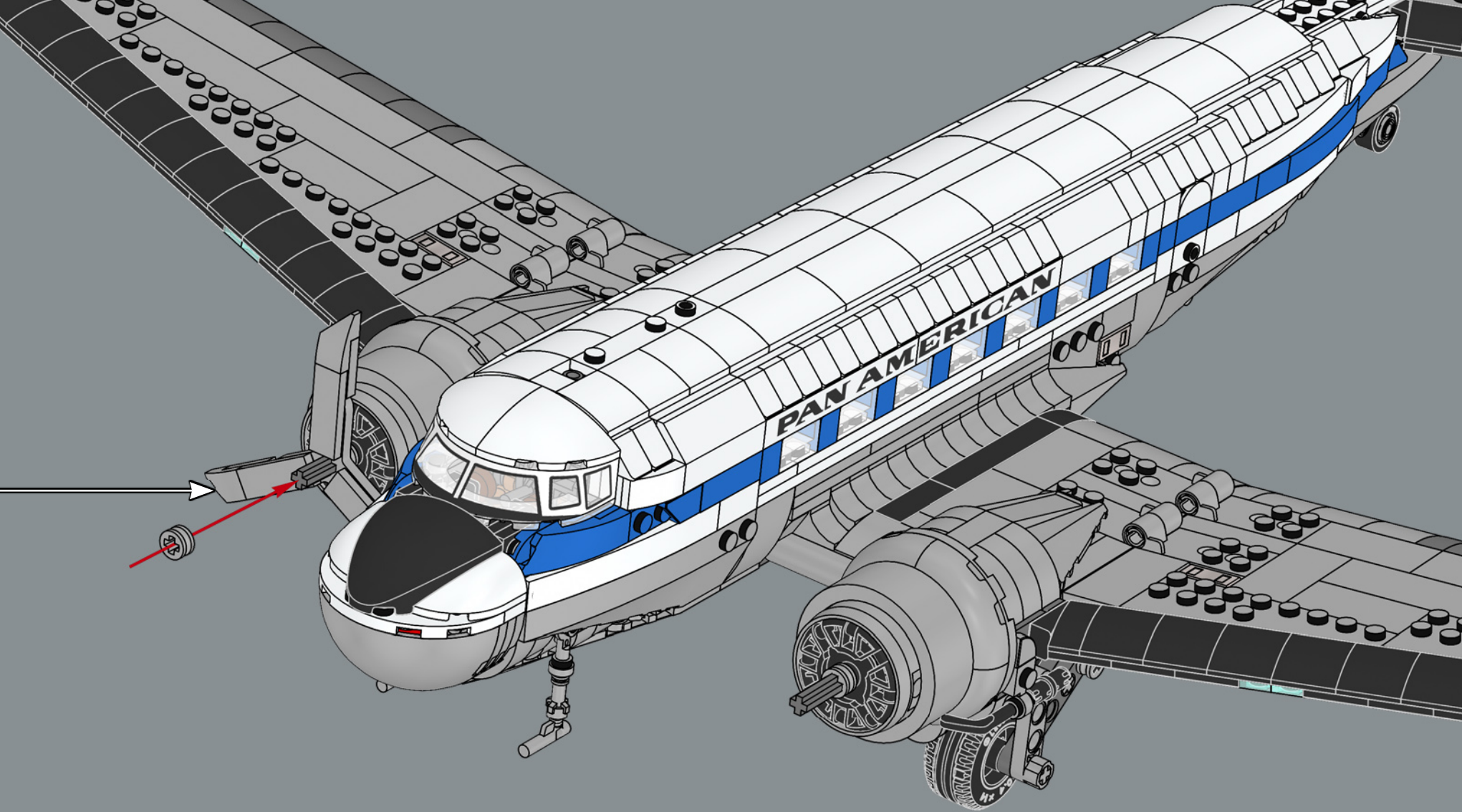

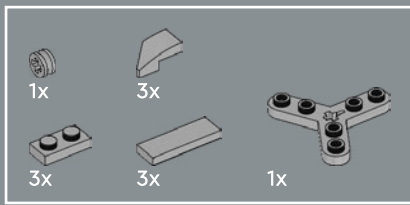

471

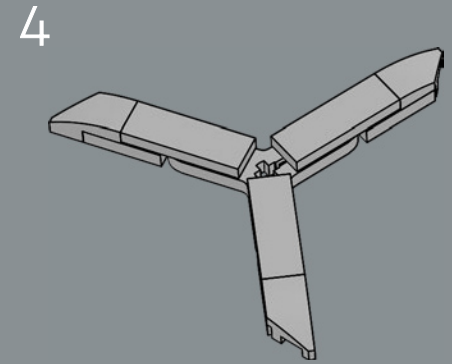
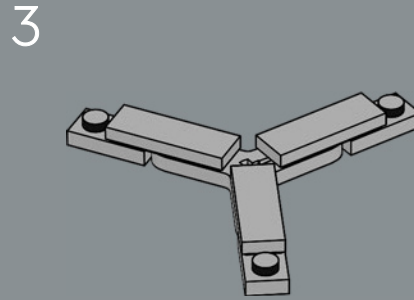
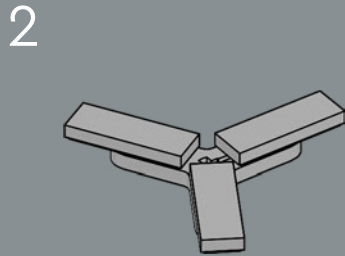
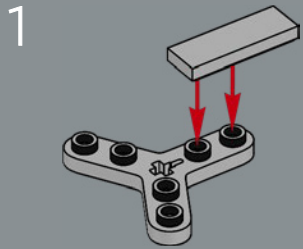

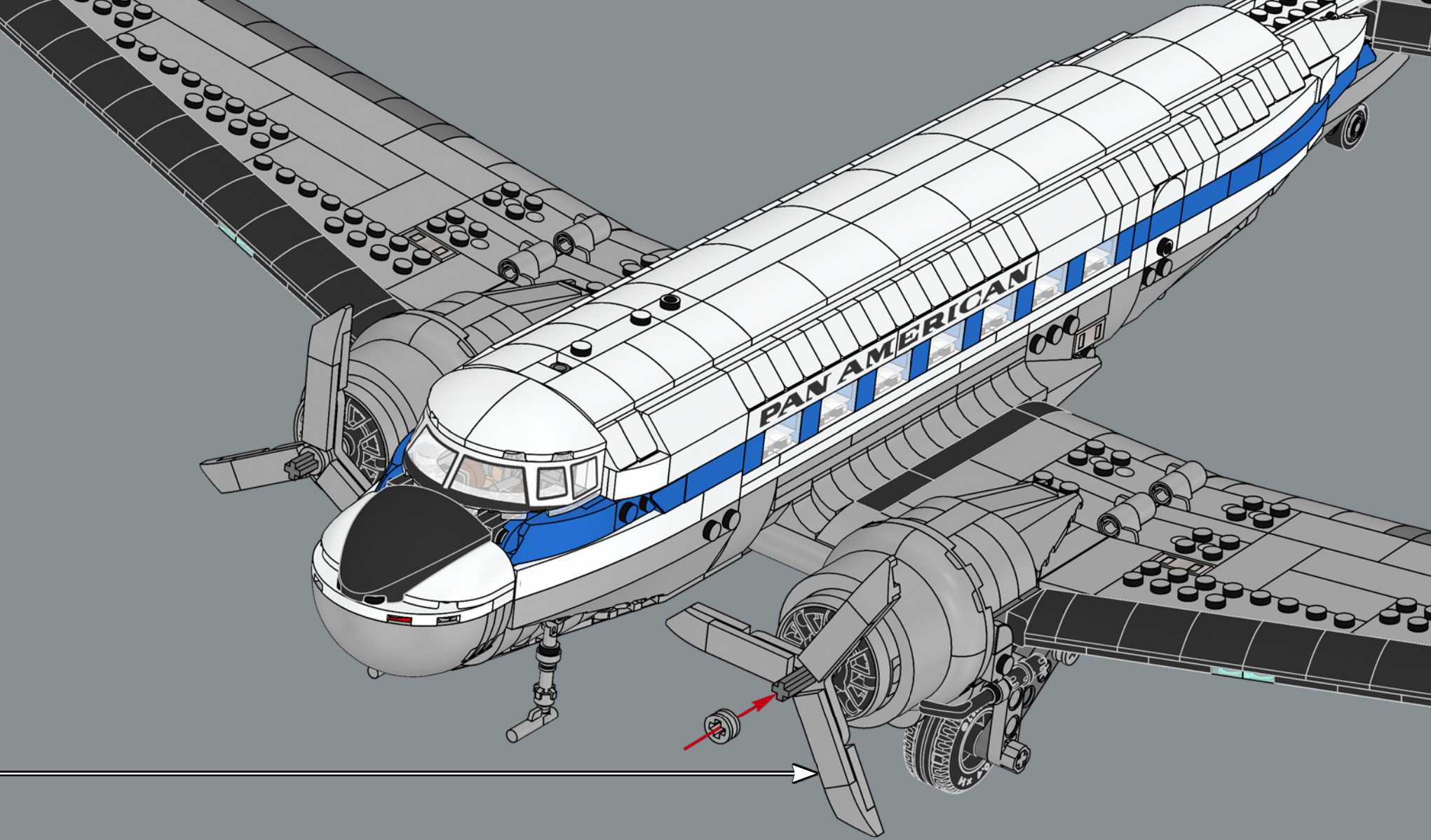



2x

472

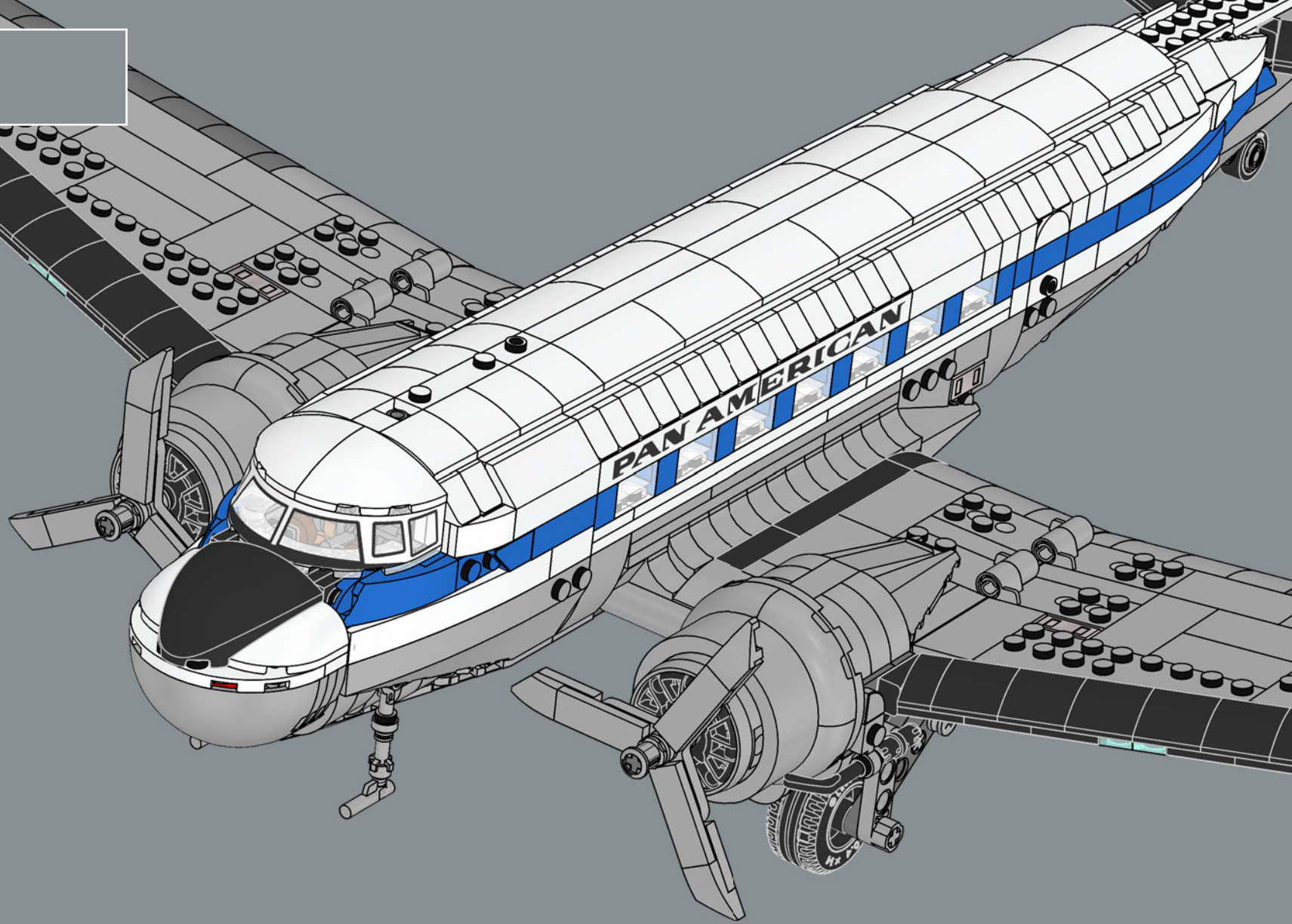

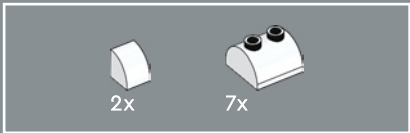

473

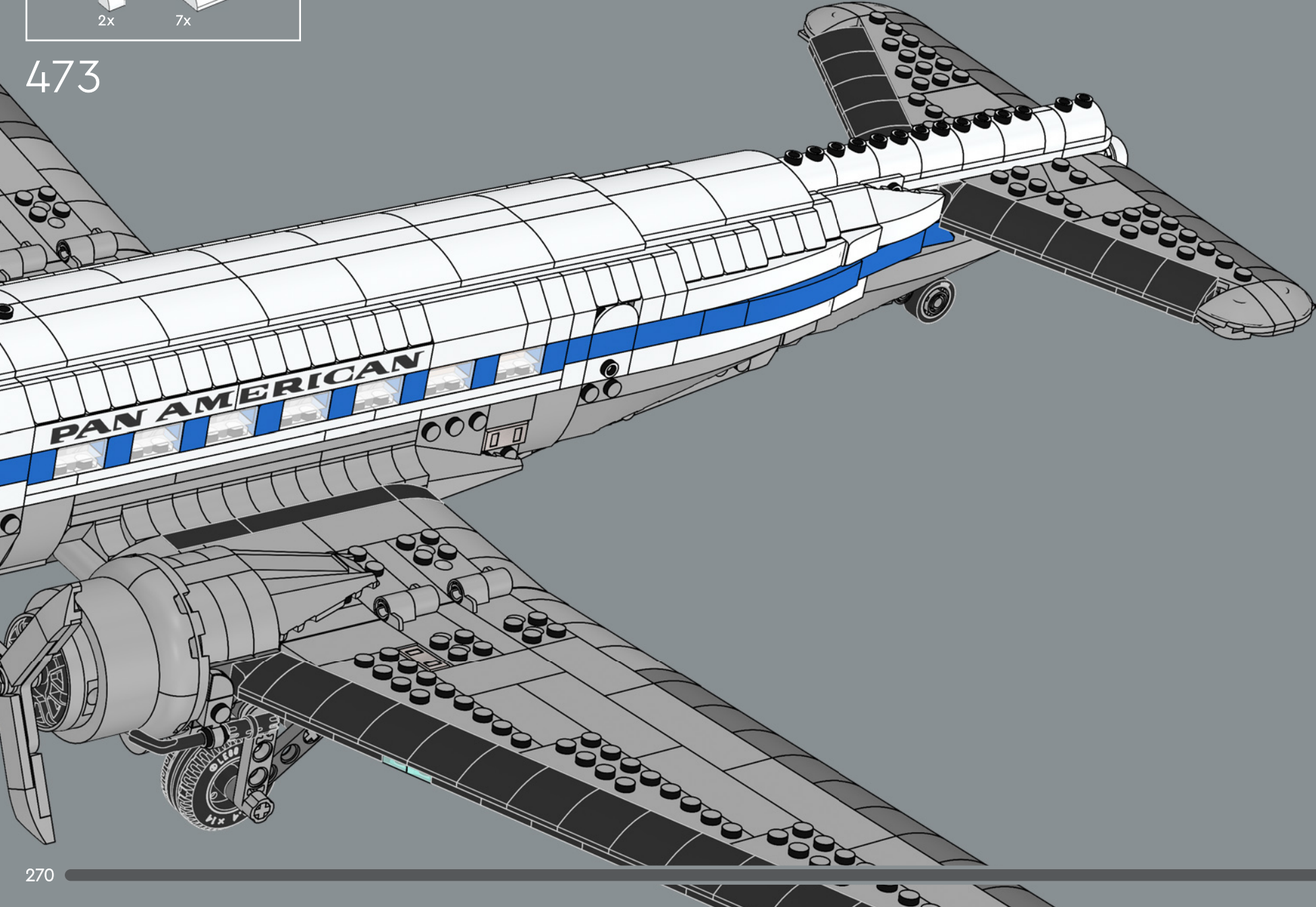

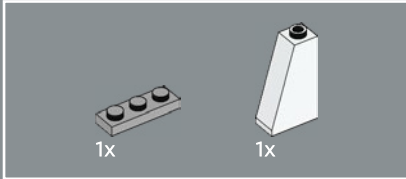
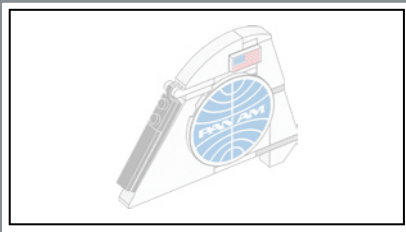

474

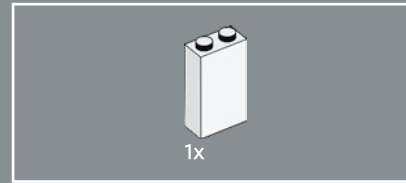
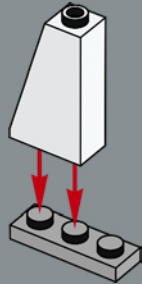

475

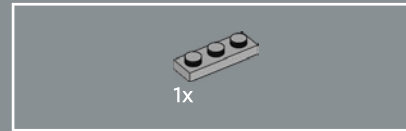
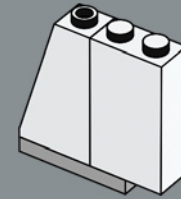

476

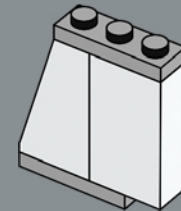

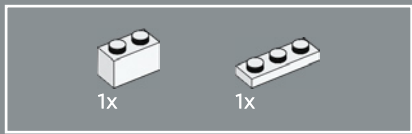

477

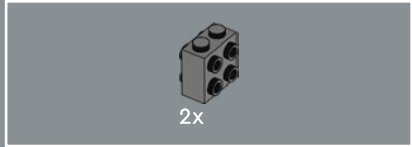
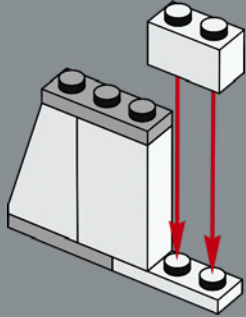

478

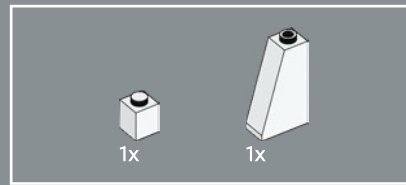
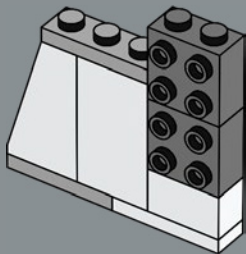

479

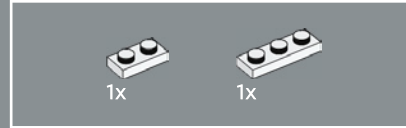
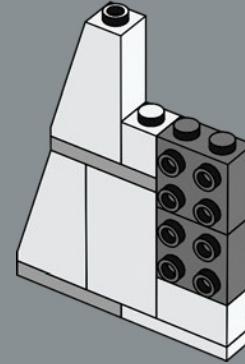

480

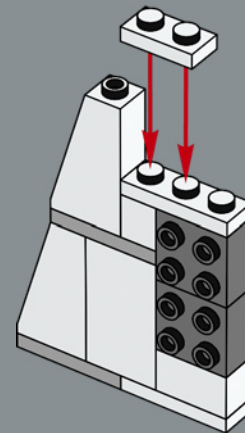

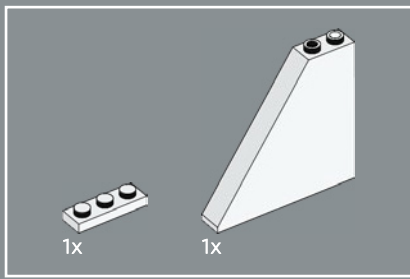

481

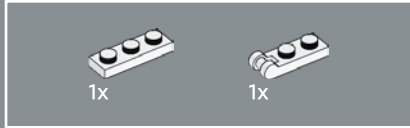
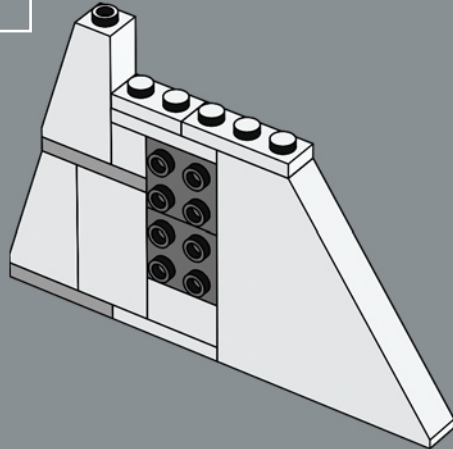

482

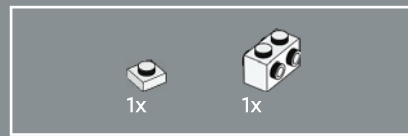
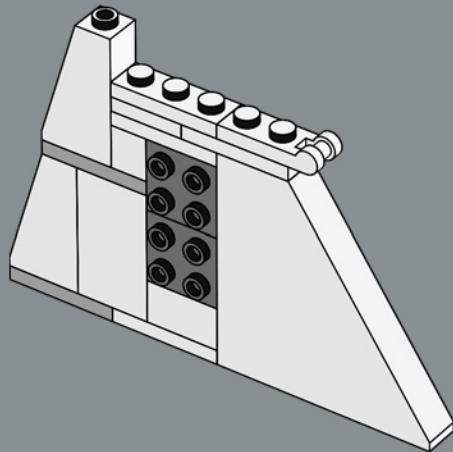

483

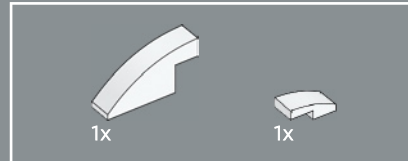
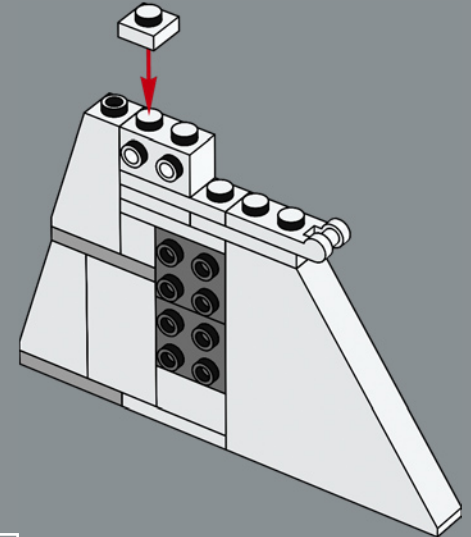

484

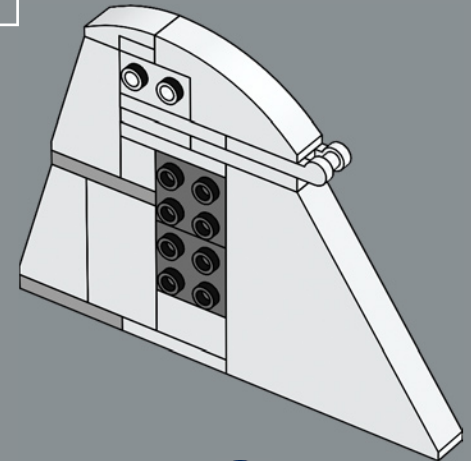

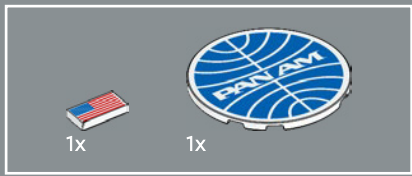

485

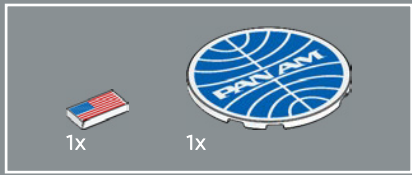
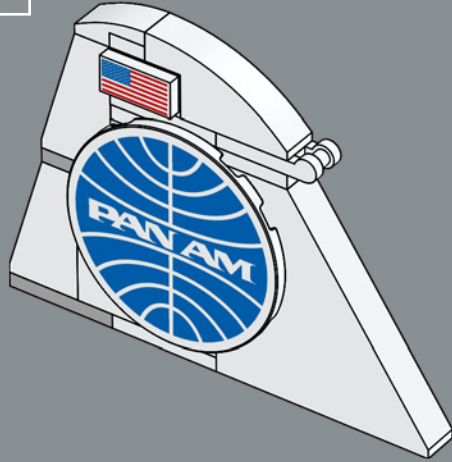

486

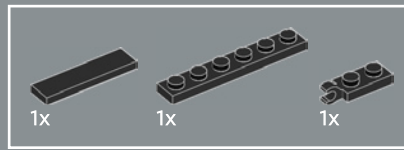
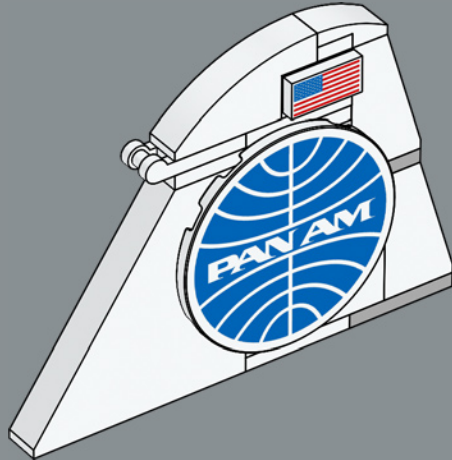

487

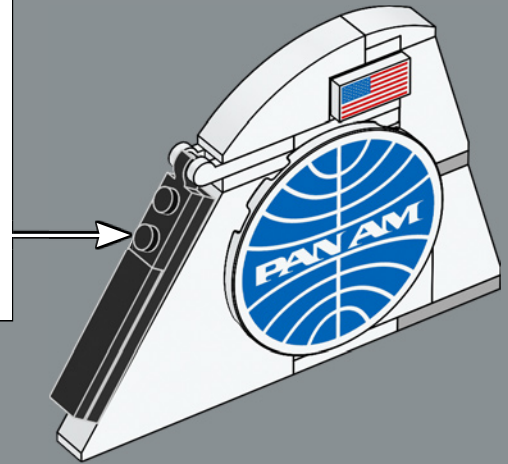
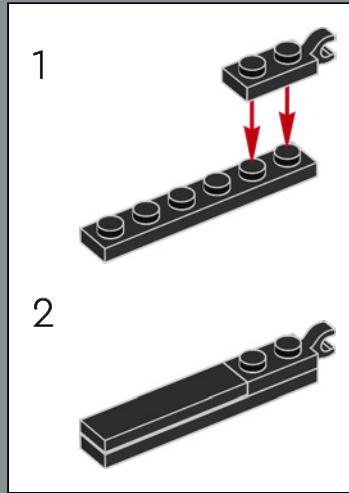



1x

488

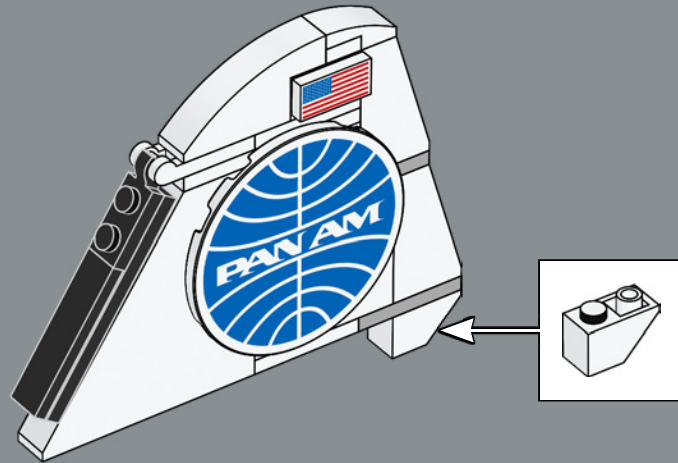

489

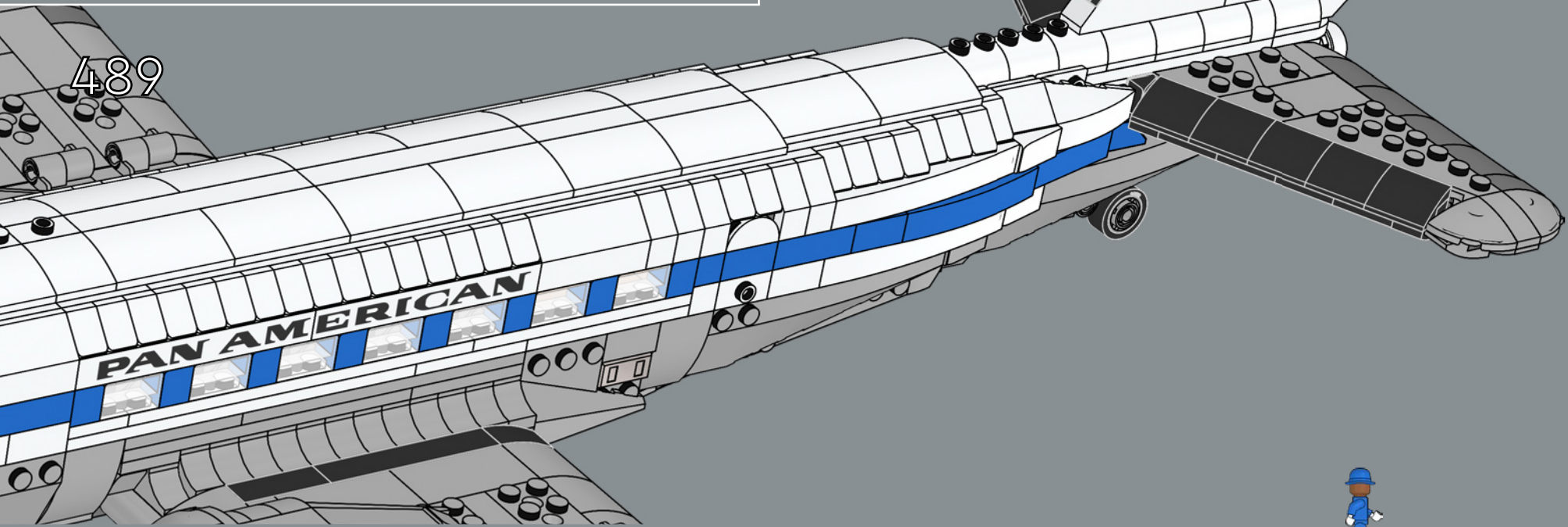

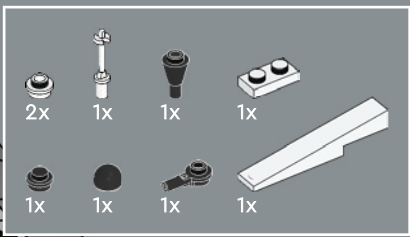

The black pod is part of the Automatic Direction Finder (ADF), a radio-navigation instrument displaying the relative bearing from the aircraft to a suitable radio station.

Le dôme noir fait partie du système ADF (Automatic Direction Finder), un instrument de radionavigation qui indique l'angle de relèvement de l'appareil par rapport à une station radio.

490

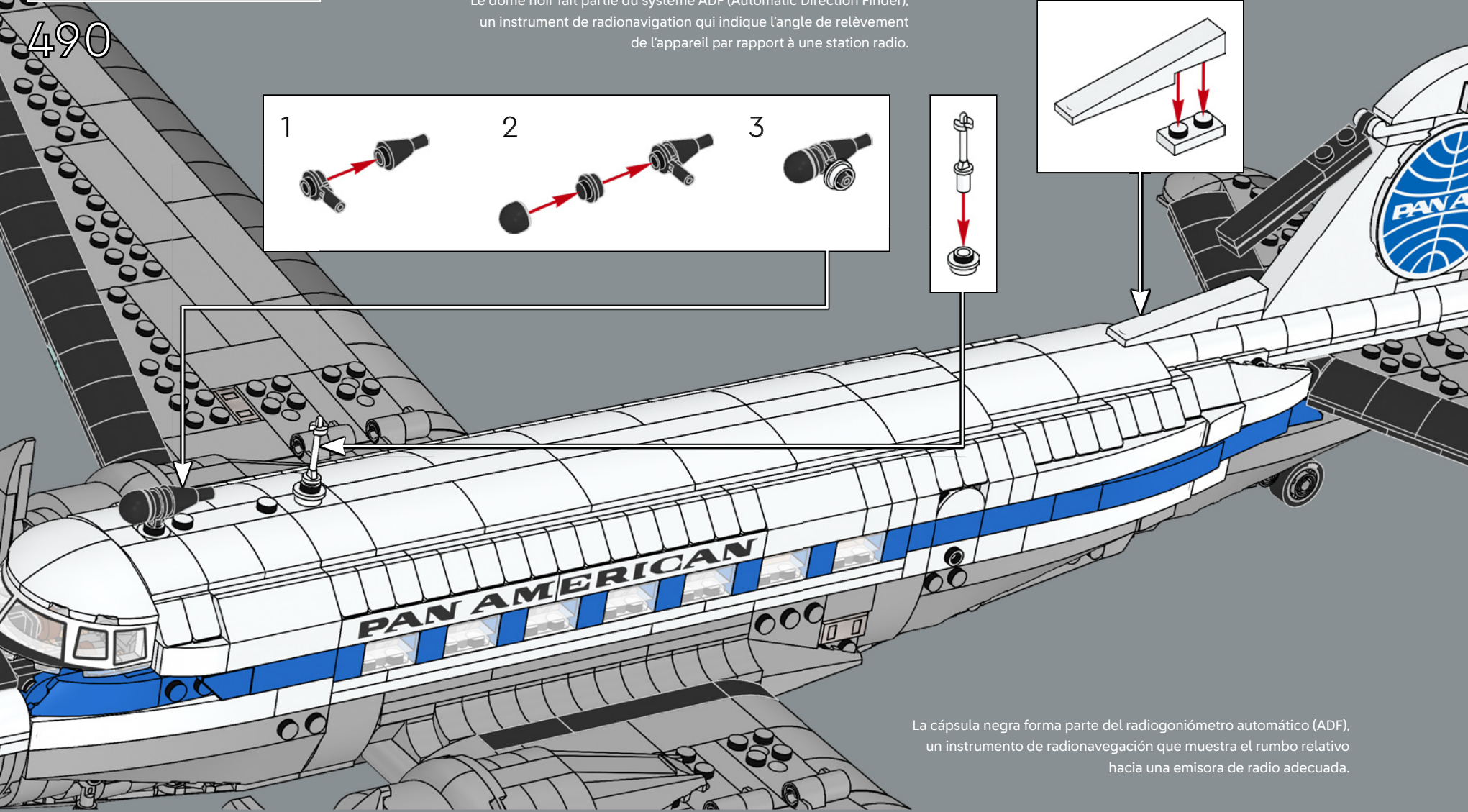
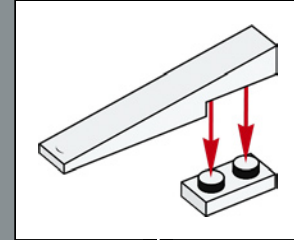
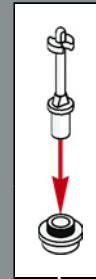
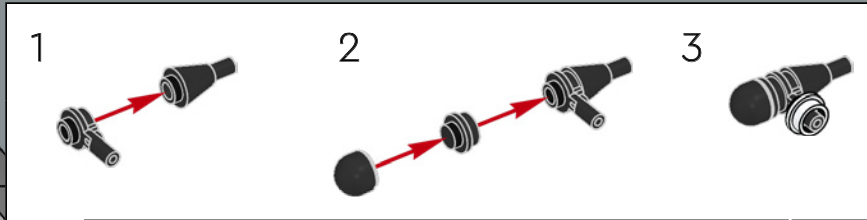

La cápsula negra forma parte del radiogoniómetro automático (ADF), un instrumento de radionavegación que muestra el rumbo relativo hacia una emisora de radio adecuada.

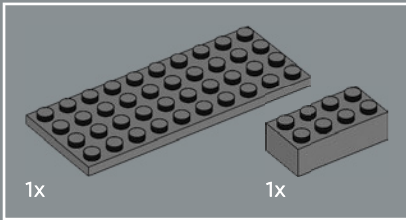
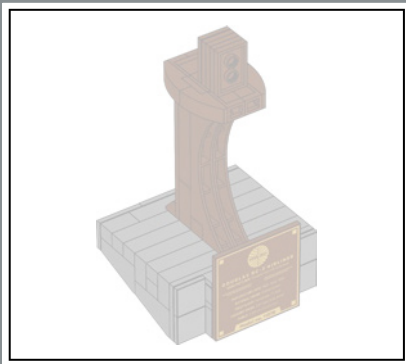

491

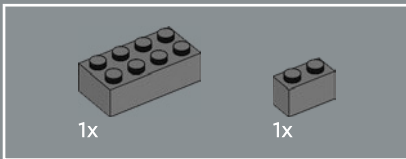
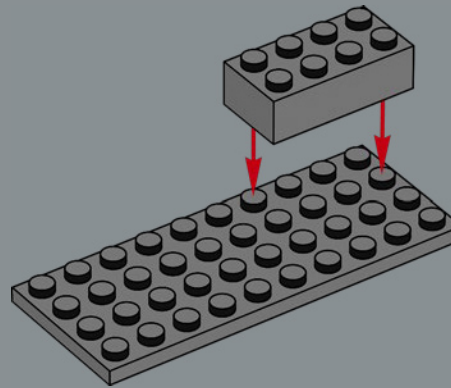

492

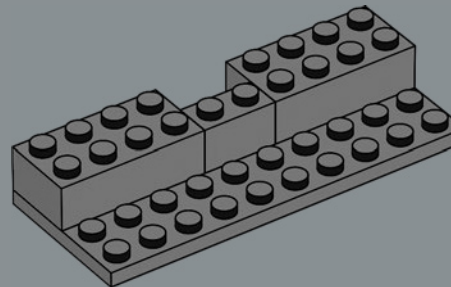

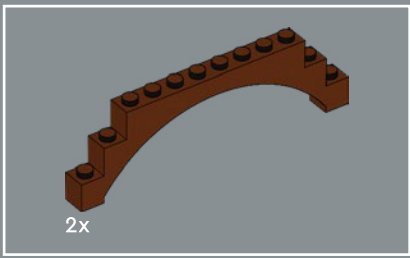

493

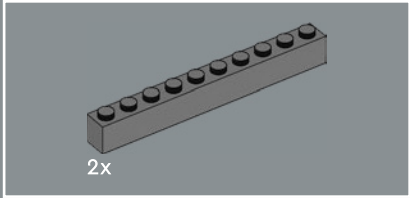
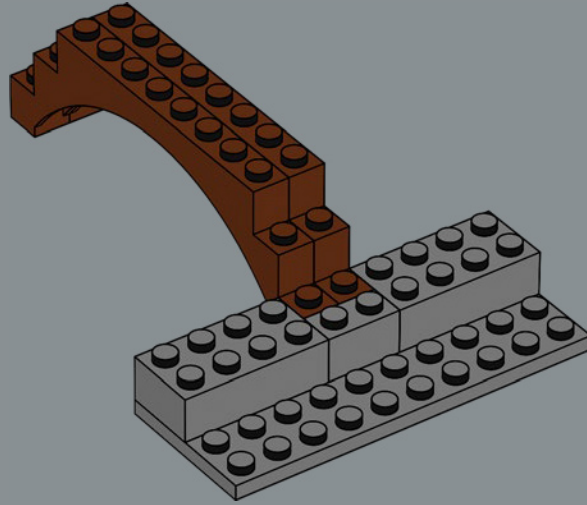

494

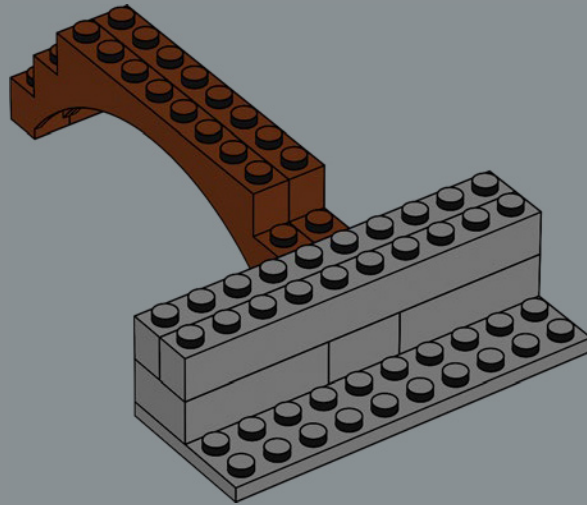

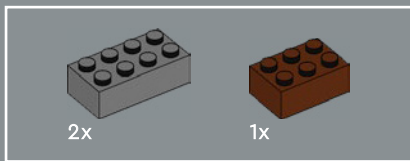

495

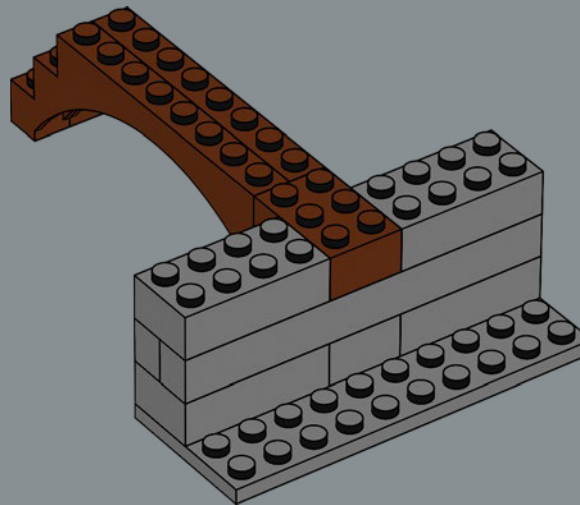

496

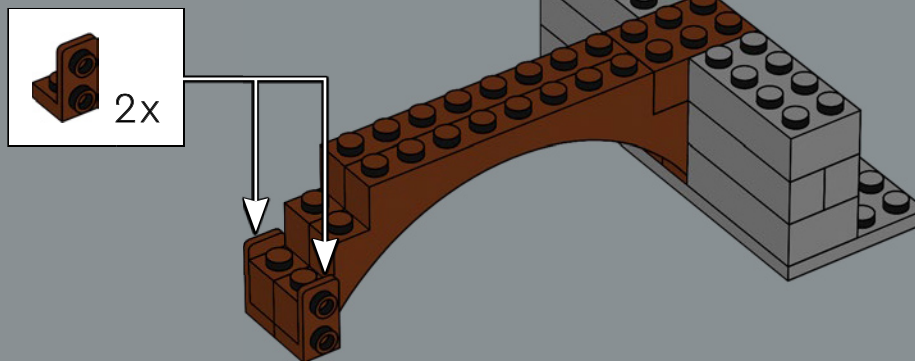

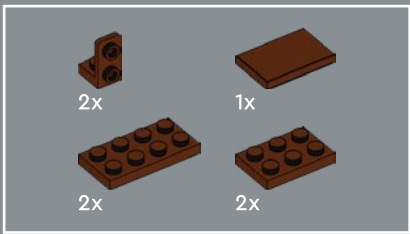

497

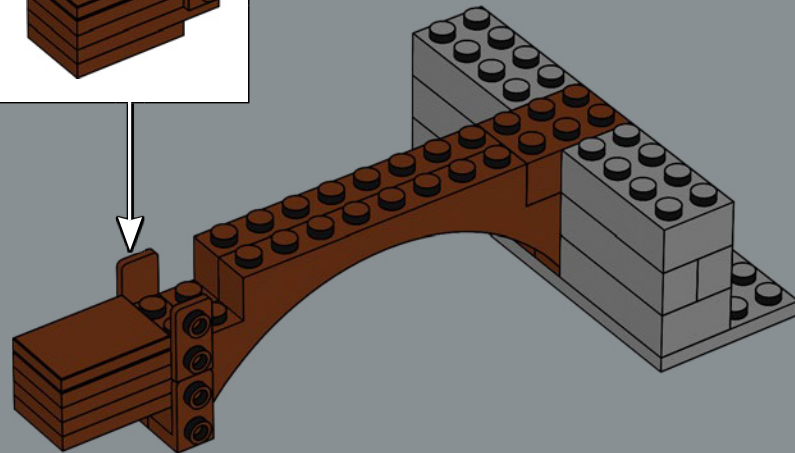
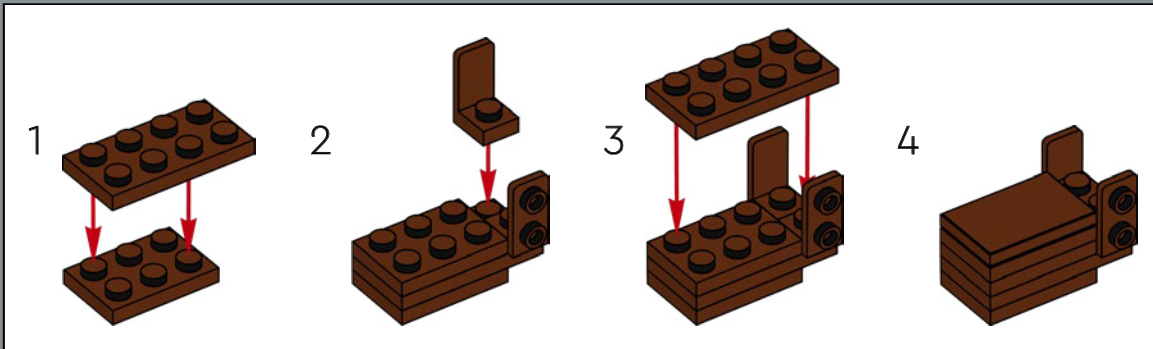

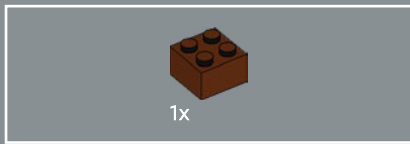

498

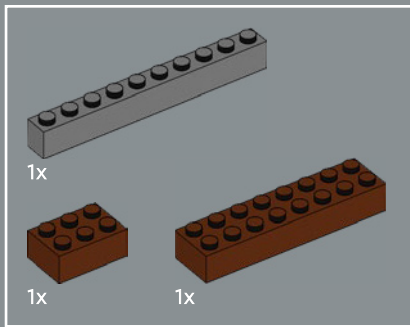
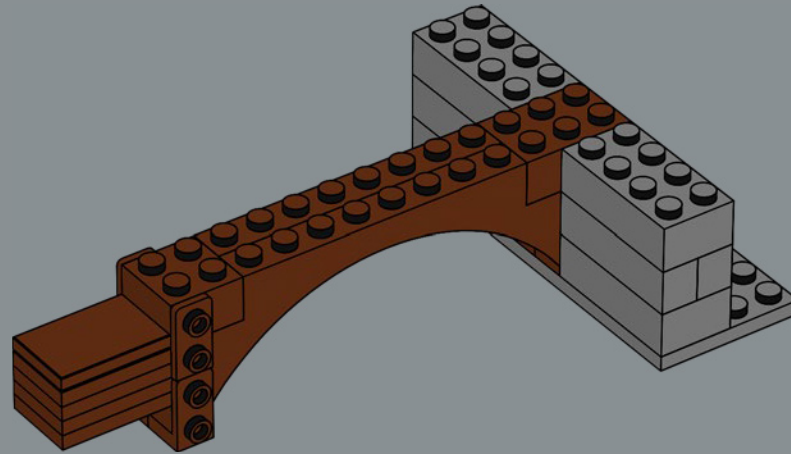

499

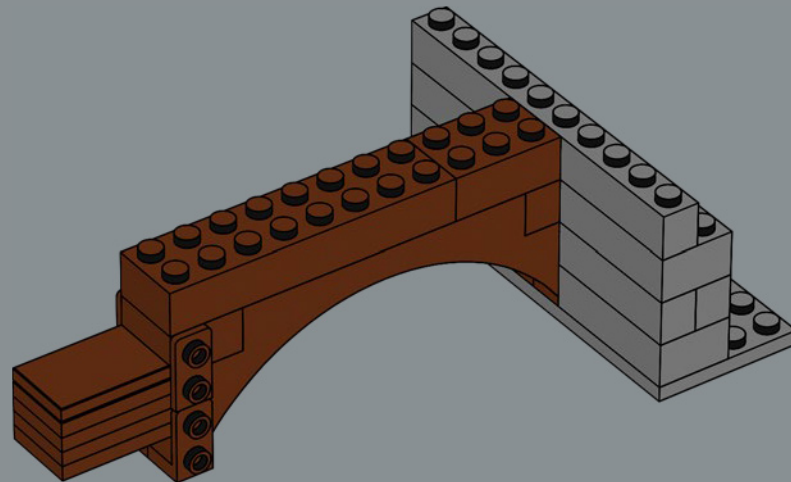

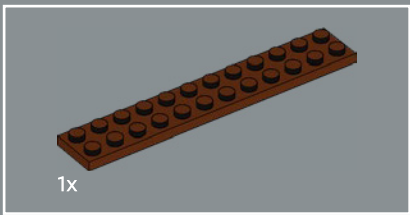

500

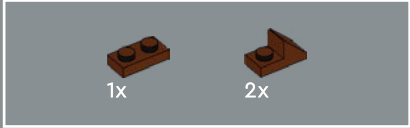
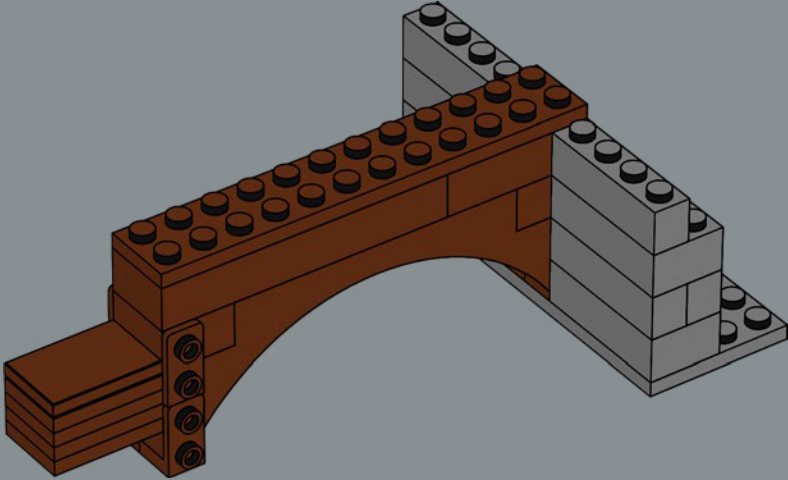

501

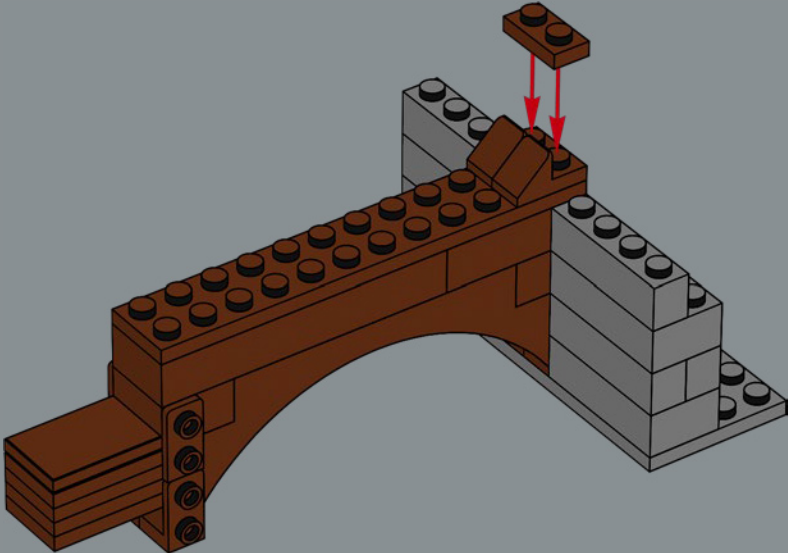



502

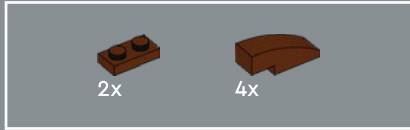
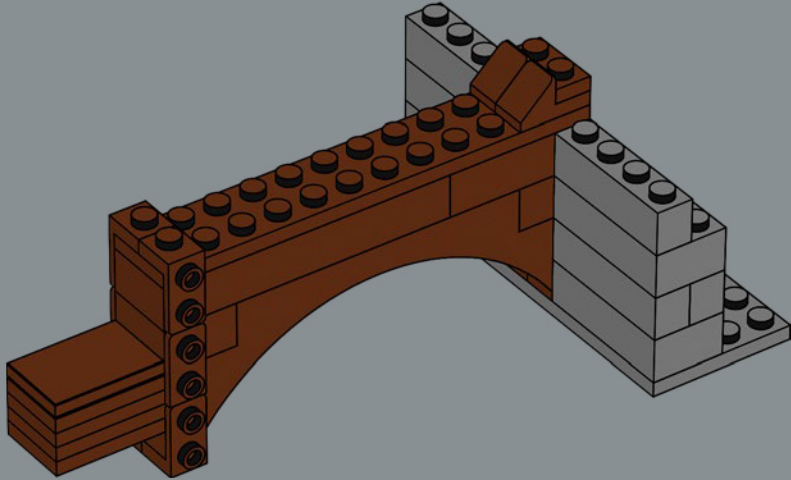

503

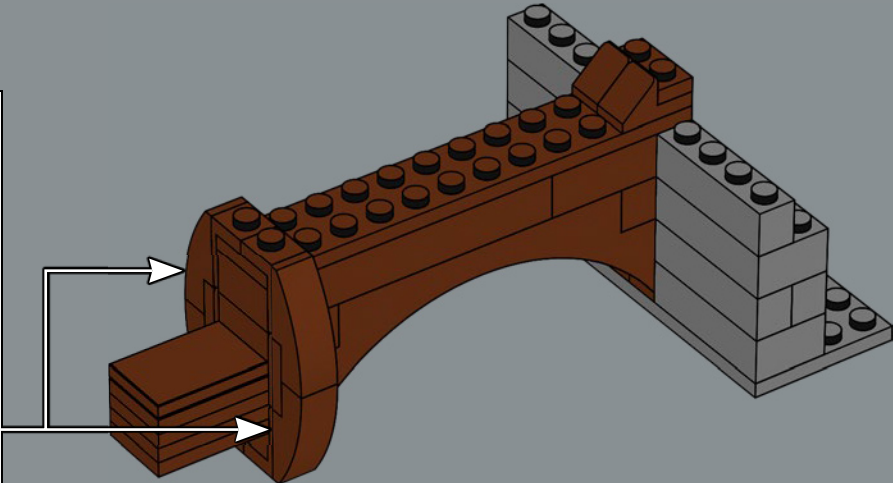
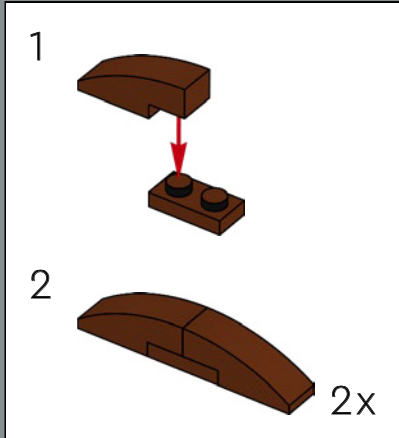



2x

504

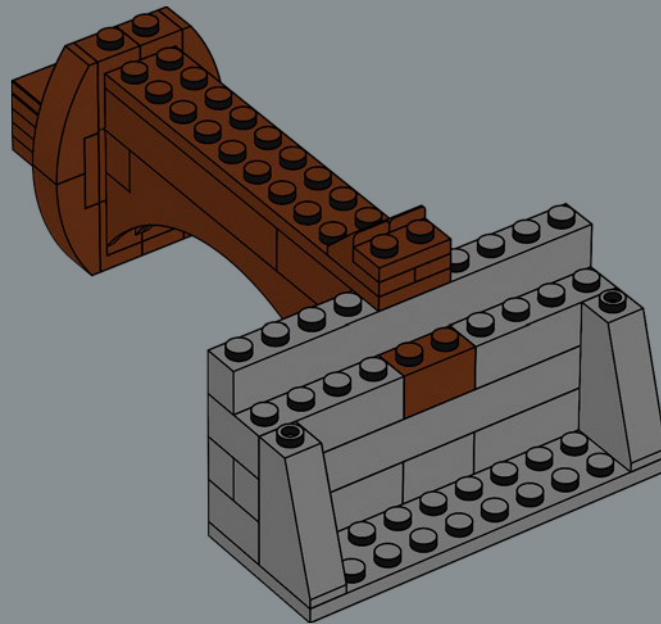

2x

505

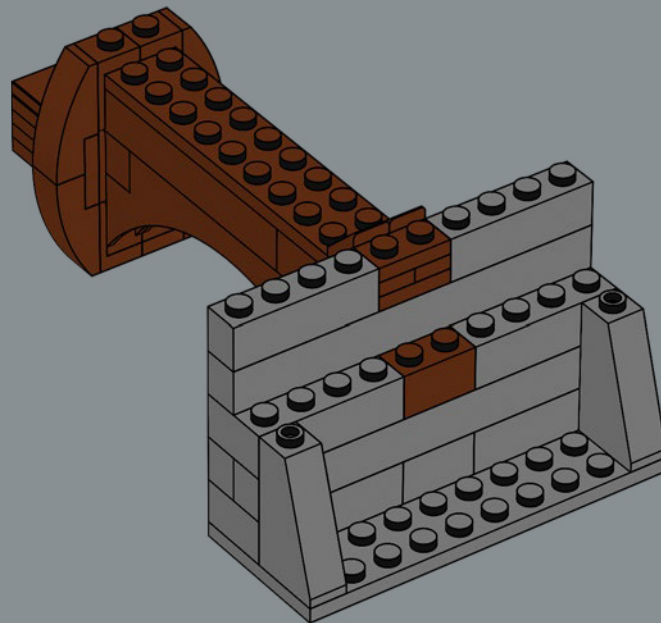

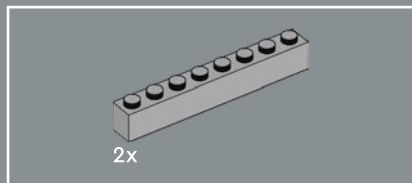

506

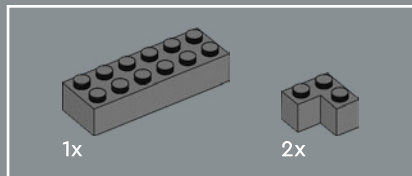
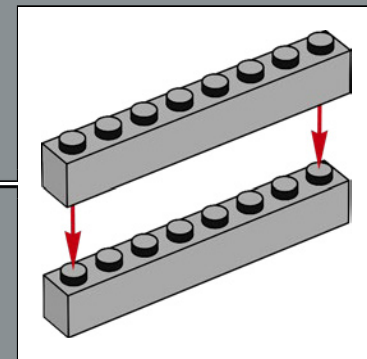
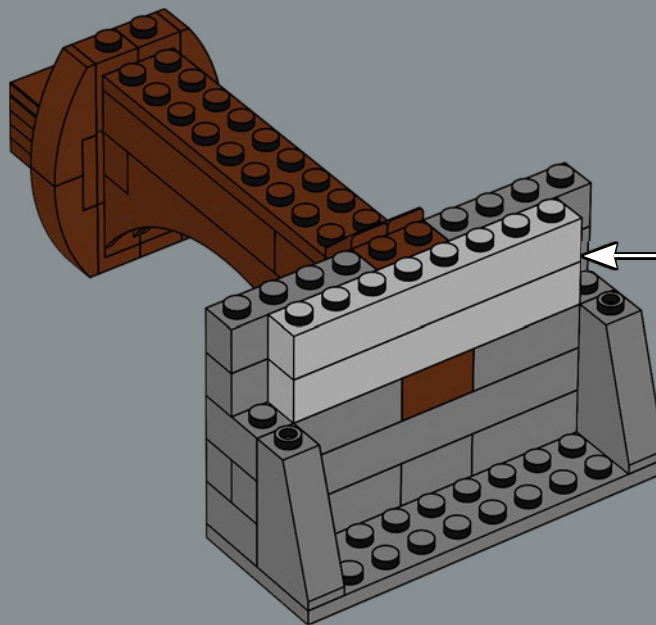

507

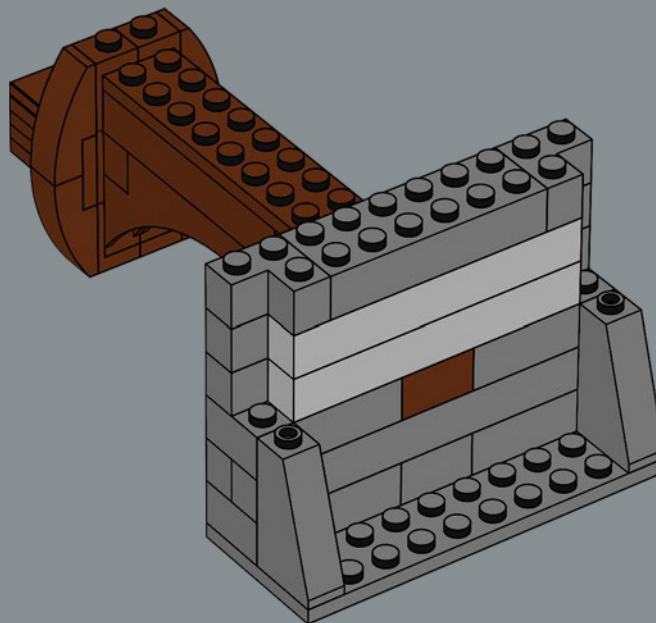



2x

508

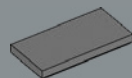
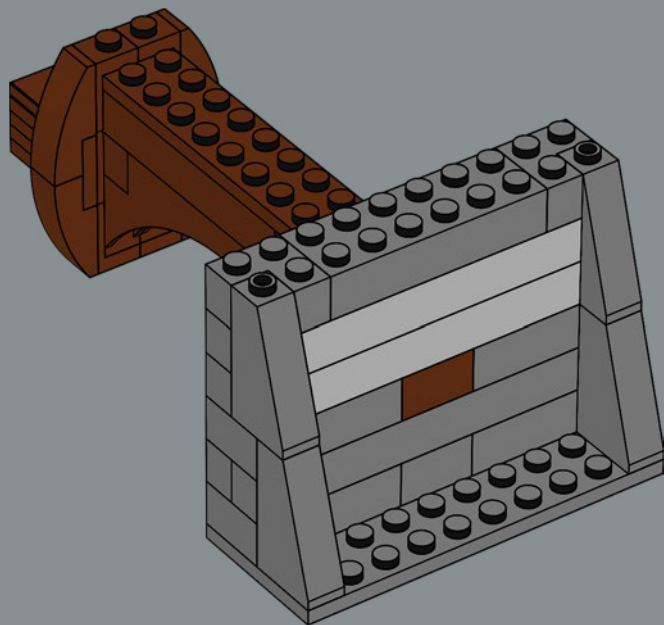

1x

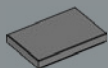

2x

509

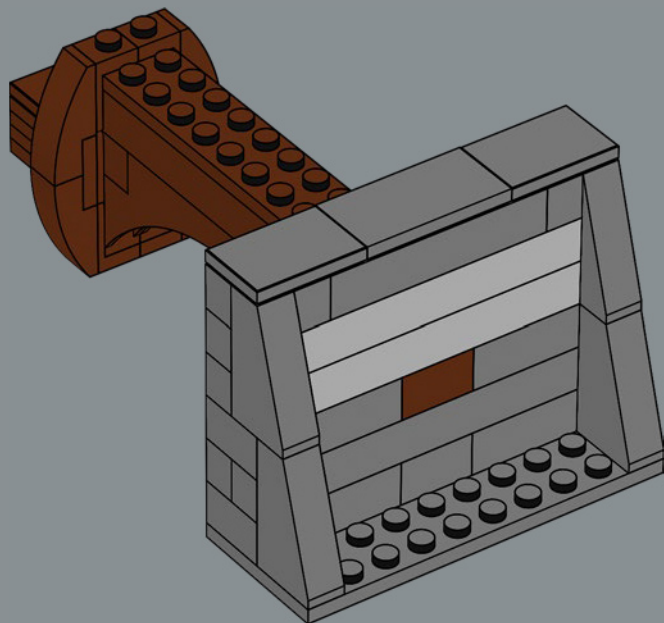



510

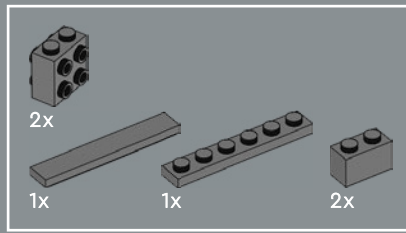
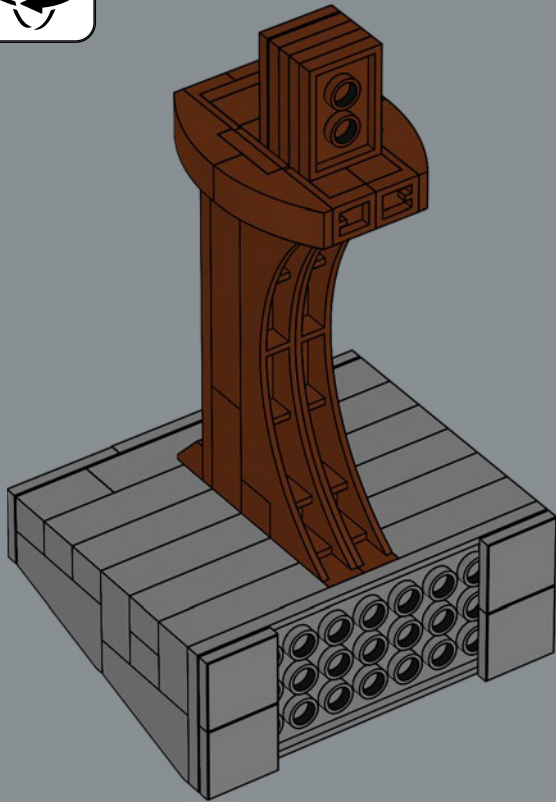

511

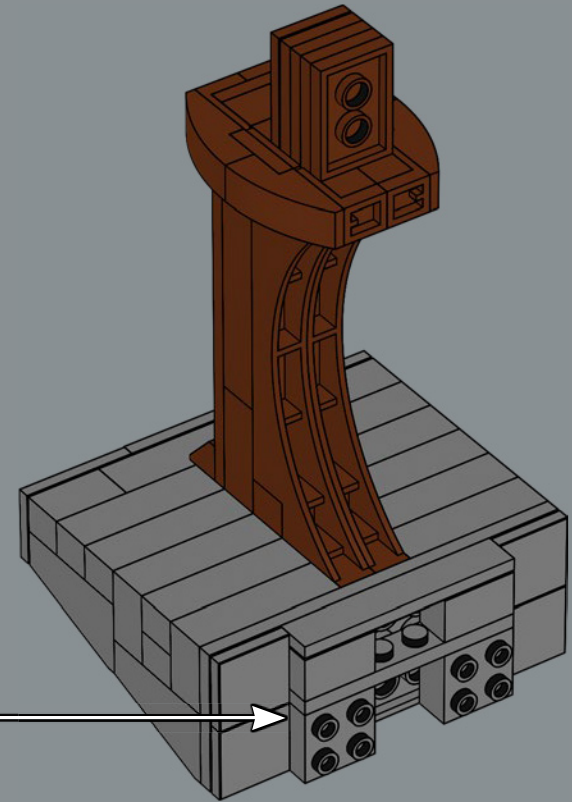
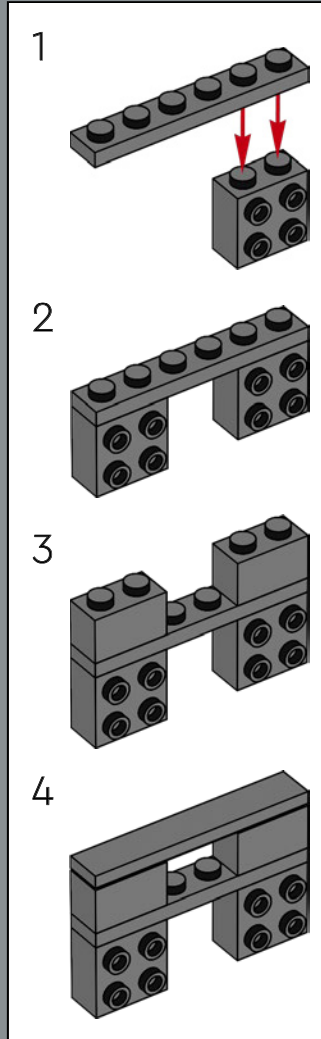



1x

512



513

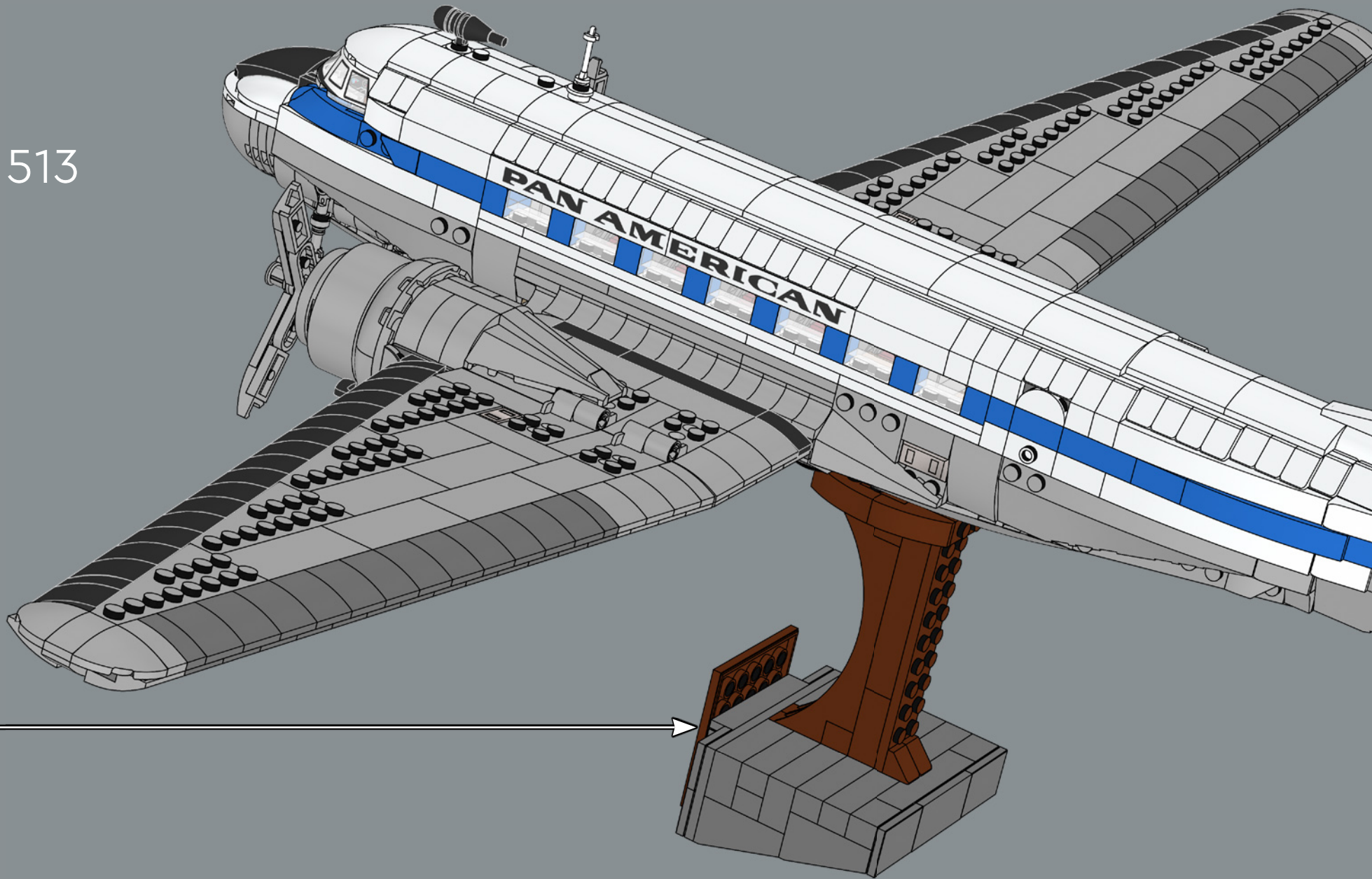



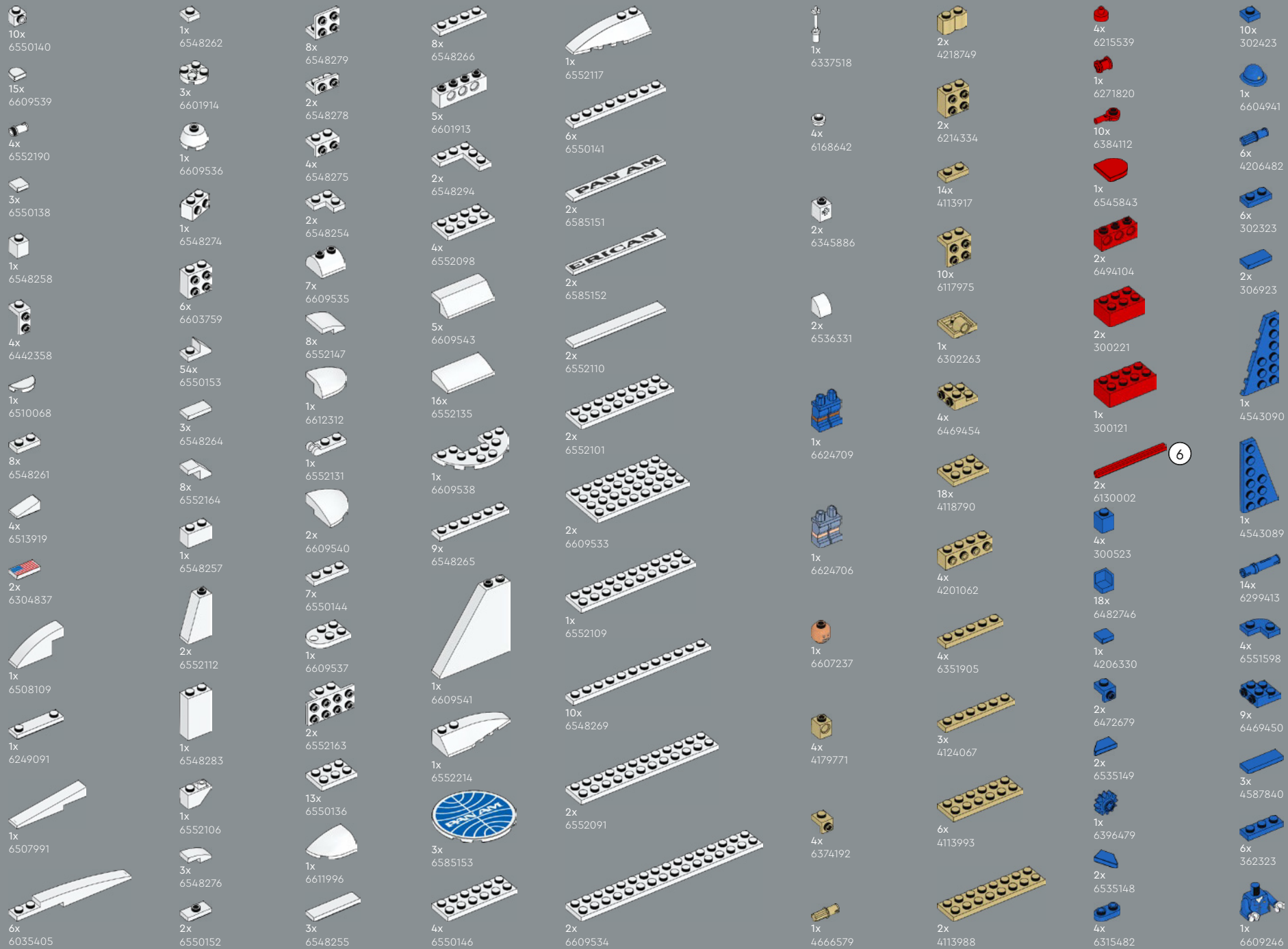

6

- 1x 6558857
- 1x 6558916
- 2x 371023
- 3x 301023
- 2x 6555137
- 6x 6307275
- 15x 302023
- 2x 300123
- 2x 6535145
- 2x 366623
- 2x 4243815
- 1x 416223
- 1x 303423
- 4x 654124
- 7x 6248971
- 2x 6206240
- 16x 242024
- 1x 6130007
- 5x 614126
- 1x 6538443
- 2x 6473449
- 2x 4558954
- 2x 4504382
- 2x 300526
- 2x 302426
- 2x 6299338
- 2x 6344752
- 1x 6585195
- 1x 6196548
- 1x 4246901
- 35x 6279875
- 1x 9339
- 4x 6147050
- 2x 6275806
- 2x 6138173
- 6x 6047276
- 2x 4541191
- 2x 302326
- 2x 6000650
- 2x 6325521
- 4x 6428168
- 1x 6336989
- 2x 6506201
- 40x 6053077
- 4x 302226
- 42x 6211476
- 2x 6109682
- 1x 6362991
- 2x 4558170
- 1x 6609279
- 2x 6537354
- 4x 370526
- 2x 6601610
- 1x 243126
- 1x 6597398
- 1x 366626
- 1x 6560654
- 2x 663626
- 2x 6161298
- 4x 273026
- 6x 383226
- 4x 6001494
- 4x 4569058
- 1x 6604940
- 14x 6514121
- 1x 6585145
- 4x 6508249
- 1x 6240515
- 1x 6486027
- 1x 6609230
- 39x 4528604
- 1x 4162916
- 1x 6609257
- 2x 6282619
- 10x 6092597
- 3x 4539097
- 2x 4585479
- 1x 4585751
- 1x 4583299
- 2x 6264030
- 5x 4539071
- 3x 4618986
- 1x 6604944
- 2x 6347304
- 2x 6365746
- 3x 6093494
- 4x 6208446
- 3x 4619636
- 6x 6287673
- 1x 6396480
- 1x 6423273
- 1x 6410056
- 1x 6404026
- 1x 6527824
- 1x 6508103
- 1x 6537328
- 3x 6177146
- 5x 6215606
- 2x 4539083
- 2x 6544174
- 15x 6138232
- 2x 6186673
- 4x 6341553
- 2x 6472546
- 2x 6223599
- 3x 4211150
- 2x 6075287
- 4x 6443654
- 1x 6551600
- 1x 4211210
- 4x 6135494
- 4x 6325975
- 4x 4211189

3

4

3



2x
4216668



1x
6311441



2x
4211186



2x
6159763

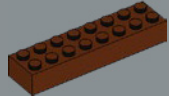

1x
6096701



1x
6609285

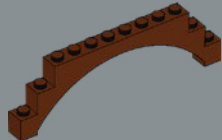

2x
6246843



1x
4225700



2x
4539481



21x
6271165



2x
6275844



1x
6296859



6x
4521921



2x
6253436



8x
4211399



2x
6176433



3x
6401023



1x
6335328



2x
6248078



7x
6225142



7x
6225139



1x
4211758



4x
6163478



4x
6163477



4x
6344702



2x
6510070



4x
6344703



2x
6227897



1x
4211791



1x
4211794



8x
6294038



2x
6296894



2x
4514195



6x
6134378



16x
6144138



16x
6548933



6x
4593679



12x
6539831



6x
6529502



1x
6185471



6x
4211862



4x
6380605



2x
6280396



2x
6173127



9x
4211414



19x
6066097



2x
6493586



4x
4211541



26x
6396791



2x
6134378



16x
6144138



16x
6548933



6x
4593679



12x
6539831



6x
4211398



1x
6146223



8x
6028813



1x
6435915



6x
4654582



1x
6265742



14x
4211353



1x
6065824



8x
4211397



6x
6132886



14x
6102357



2x
4211387



26x
6185676



2x
4211881



4x
4211815



2x
4211655



8x
4211429



8x
6251044



2x
4211489



6x
4211361



8x
4558169



2x
6262083



2x
6262082



8x
6456718



2x
4507056



6x
6132207



7x
4211396



6x
6435930



4x
6171894



6x
6435930



4x
6171894



2x
6271831



4x
6331574



4x
6257593



4x
4211445



1x
4211394



7x
4211356



2x
6402876



4x
6558989



1x
4622803



21x
6015347



2x
4507052



3x
6493587



12x
4560183



8x
6258903



4x
4211395



2x
6307999



3x
4211639



2x
6372029



3x
6493589



2x
6303442



3x
6132983



1x
6597400



1x
6597400



1x
4211462



4x
4211407

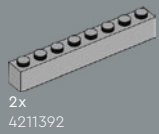

2x
4211392



3x
4211481



8x
6448327



4x
4211406

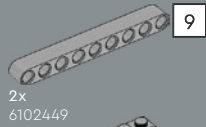

2x
6102449



8x
6448326

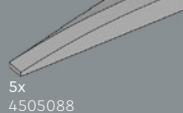

5x
4505088

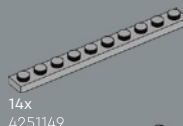

14x
4251149

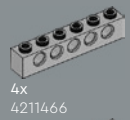

4x
4211466



2x
6508016



2x
6015349

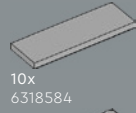

10x
6318584

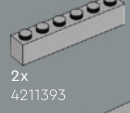

2x
4211393



5x
4505087

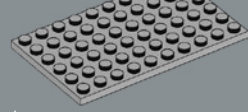

4x
4211405



2x
4211443

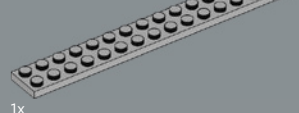

1x
4211486



2x
6510131



1x
6510213



15x
6360111



2x
6221607



4x
6338422



2x
4521512



6x
6261374



1x
4567887



3x
6005331



2x
4211095



4x
6135014



10x
6514456



1x
4516546



3x
4211088



4x
4221745



1x
6342558



6x
6396058



1x
4211066



2x
6215212



6x
6029948



2x
6000606



1x
6271356



2x
6543014



1x
4529728



1x
4529727



4x
6013082



2x
4211109



33x
6071261



7x
4211094



12x
6047417



34x
6344820



15x
4521187



1x
4552349



4x
6271876



14x
4211133



2x
6187008



3x
4211105



4x
4211043



1x
6083620



2x
4211103



10x
4211001



4x
6215176



4x
6395635



2x
6631413



2x
6231765



4x
6439040



4x
6100030



4x
4211085



1x
4560184



2x
4210686



1x
4211056



1x
4210651



5x
4243831



1x
4210875



4x
4211002



2x
4499858



12x
4210719



2x
6225494



2x
6510145



4x
4211044



2x
4210998



2x
4210997



1x
4257526



3x
4211107



2x
4210678



9x
6133611



1x
4211122



2x
4211114

9

5

4

8



YOU COULD
WIN



**YOU COULD
WIN**

Your feedback will help shape the future development of this product series.

Visit:

**DU KÖNNTEST
GEWINNEN**

Dein Feedback trägt zur Weiterentwicklung dieser Produktreihe bei.

Geh auf:

**VOUS POURRIEZ
GAGNER**

Vos commentaires nous aideront à concevoir les futurs produits de cette gamme.

Visitez :

**POTRESTI
VINCERE TU**

La tua opinione ci aiuterà a migliorare la creazione futura di questa linea di prodotti.

Visita:

**PUEDES
GANAR**

Tu opinión contribuirá al futuro de esta serie de productos.

Visita:

轻松获奖

您的反馈将有助于我们在今后改进本产品系列。

请访问:

LEGO.com/productfeedback

You also have the chance to win a LEGO® set.

Terms and conditions apply.*

Außerdem hast du die Chance, ein LEGO® Set zu gewinnen.

Es gelten die Teilnahmebedingungen.*

Vous pourriez également gagner un ensemble LEGO®.

Des conditions s'appliquent.*

Hai anche la possibilità di vincere un set LEGO®.

Termini e condizioni sono applicabili.*

También tienes la oportunidad de ganar un set LEGO®.

Aplican términos y condiciones.*

您还有机会赢取乐高®套装。

条款和条件适用。*

*LEGO.com/productfeedback-terms

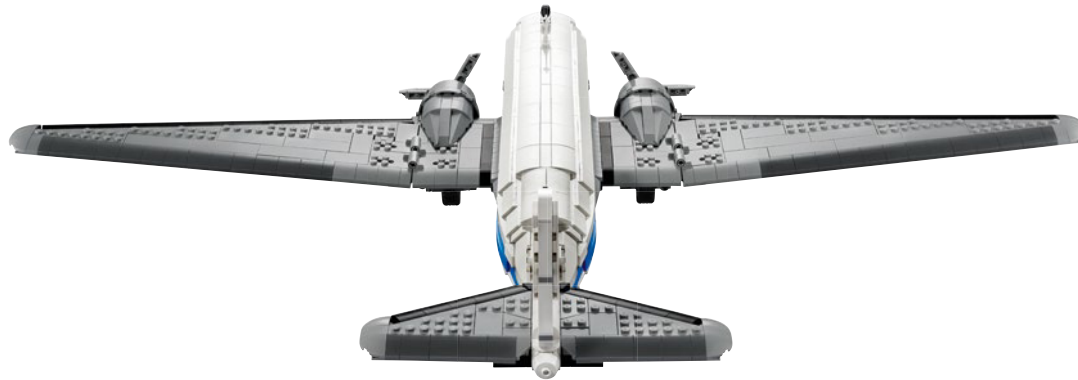

LEGO and the LEGO logo are trademarks of the/son des marques de commerce du/son marcas registradas de LEGO Group. ©2026 The LEGO Group.
Produced under license from The Boeing Company. BOEING, DOUGLAS and DC-3 and the distinctive Boeing logos, product markings and trade dress are trademarks of The Boeing Company.
™ All related logos, characters, names, and distinctive likenesses thereof are the exclusive property of Pan American World Airways, LLC. Used under authorization.