

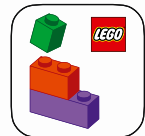

21367



Available in English
Disponible en français
Disponible en español



LEGO® Builder





WE'RE MAKING OUR PACKAGING MORE SUSTAINABLE

We're transitioning from single-use plastic to paper-based packaging. As we progress, you may find a mix of paper and plastic in our boxes.

NOUS RENDONS NOS EMBALLAGES PLUS DURABLES

Nous passons des emballages en plastique à usage unique aux emballages à base de papier. Durant la transition, vous pourriez trouver un mélange de papier et de plastique dans nos boîtes.

QUEREMOS HACER MÁS SUSTENTABLES NUESTROS MATERIALES DE EMBALAJE

Estamos cambiando las bolsas de plástico desechables por bolsas con base de papel. Conforme avanzamos en este propósito, puedes encontrar una mezcla de papel y de plástico en nuestras cajas.

LEGO.com/sustainable-packaging



BUILDER



LEGO® Builder



Apple and the Apple logo are trademarks of Apple Inc., registered in the U.S. and other countries and regions. App Store is a service mark of Apple Inc. Google Play and the Google Play logo are trademarks of Google LLC. Tencent and the Tencent logo are trademarks of Tencent Inc.

LEGO.com/devicecheck

MEET THE FAN DESIGNER

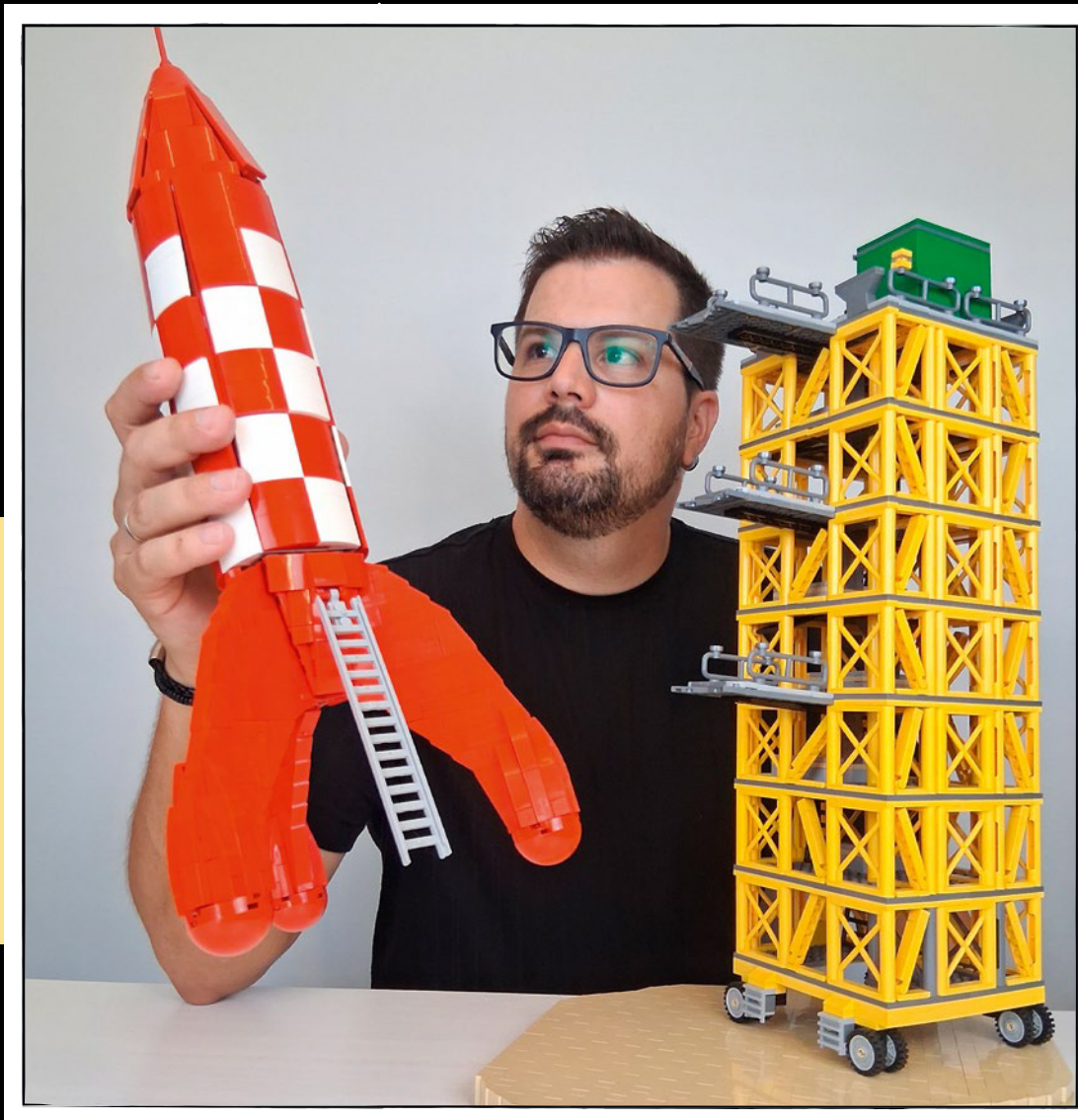

How Alexis Dos Santos (LEGO® Ideas name Tkel86) from Portugal finds enough hours in the day for his job as a programmer and web designer is a mystery to us. With an extensive portfolio of intricate MOCs (My Own Creations), this Fan Designer keeps busy!

"In my free time, I love doing anything that mixes creativity with ingenuity – LEGO building, electronic projects, woodworking, drawing, graphic design, 3D models and sculpting. I love reusing materials for new purposes, like disassembling a LEGO set to create another. I always remember playing with LEGO bricks – when I was a child, I inherited a box full of pieces from a cousin, and from then on, I grew my collection until I was a teenager. I had what you call a 'dark age' away from the bricks from when I was 16 to 26. Then I rediscovered my passion when, by chance, I visited a LEGO fan exhibition created by a community. I ended up joining them, and this hobby grew exponentially. This project took about six months. I've always admired Tintin, and a co-worker inspired me to recreate this model in LEGO bricks. I used some

Technic™ parts to obtain the fittings for the legs and the top cone. I like that the model uses round and conical elements made from multiple pieces, as it is always a challenge to be able to reduce visible gaps with relatively complex fittings. Some of these elements in red were difficult to find! After I shared it on the LEGO Ideas website, my plan was to keep refining it, but little by little, while I was busy working on other projects, it reached 10,000 supporters. I love it when models combine mechanized movements and beautiful aesthetics. I hope fans will love the final model's wow factor."

LEGO® Ideas Fan Designer Alexis Dos Santos with his original model / Alexis Dos Santos, concepteur amateur LEGO® Ideas, avec son modèle original / El fan diseñador de LEGO® Ideas Alexis Dos Santos con su modelo original

RENCONTRE AVEC LE CONCEPTEUR AMATEUR

Comment Alexis Dos Santos (nom LEGO® Ideas : Tkel86), originaire du Portugal, trouve suffisamment de temps dans la journée pour exercer son métier de programmeur et de concepteur Web reste un mystère pour nous. Avec un large éventail de MOC (My Own Creations, mes propres créations) complexes, ce concepteur amateur ne chôme pas!

« Pendant mon temps libre, j'aime faire tout ce qui mêle créativité et ingéniosité – construction LEGO, projets électroniques, menuiserie, conception graphique, modèles 3D et sculpture. J'aime redonner une nouvelle vie aux matériaux, par exemple, en démontant un ensemble LEGO pour en construire un autre. J'ai toujours aimé jouer avec des briques LEGO. Quand j'étais enfant, j'ai hérité d'une boîte pleine de pièces d'un cousin, et dès de ce moment, ma collection n'a cessé de grandir jusqu'à mon adolescence. J'ai ensuite traversé ce qu'on appelle une « période

sombre », loin des briques, entre mes 16 et 26 ans. Puis, j'ai redécouvert ma passion par hasard, en visitant une exposition d'amateurs de LEGO organisée par une communauté. J'ai fini par me joindre à eux, et ce passe-temps a rapidement pris de l'ampleur. Ce projet m'a pris environ six mois. J'ai toujours admiré Tintin, et c'est un collègue qui m'a encouragé à recréer ce modèle en briques LEGO. J'ai utilisé certaines pièces Technic™ pour obtenir les ajustements nécessaires aux jambes et au cône supérieur. Ce que j'aime dans ce modèle, c'est l'utilisation d'éléments ronds et coniques formés de plusieurs pièces. C'est toujours un beau défi de réduire les espaces visibles avec des ajustements aussi complexes. Certains de ces éléments en rouge ont été particulièrement difficiles à trouver! Après avoir partagé mon modèle sur le site LEGO Ideas, mon intention était de le peaufiner petit à petit mais, alors que j'étais occupé par d'autres projets, celui-ci a tranquillement atteint les 10 000 appuis. J'adore les modèles qui allient mouvements mécaniques et esthétique soignée. J'espère que les amateurs seront épatés par le facteur "wow" du modèle final. »

Alexis' model, and the image from the book that sparked his idea

Le modèle d'Alexis et l'illustration tirée du livre qui a inspiré son idée

El modelo de Alexis y la imagen del libro que inspiró su idea

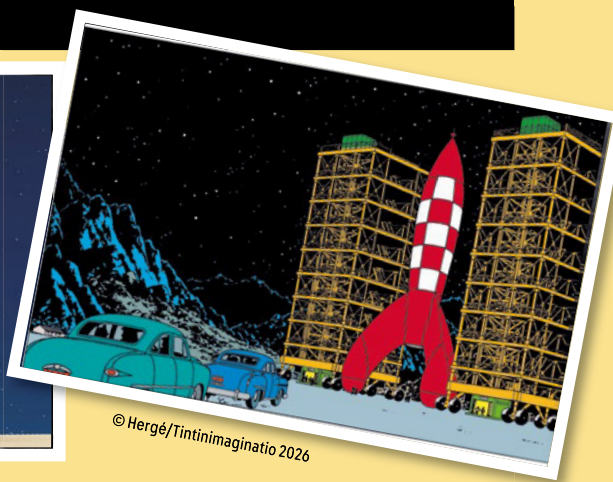

© Hergé/Tintinimaginatio 2026

CONOCE AL FAN DISEÑADOR

No sabemos cómo es que a Alexis Dos Santos (conocido en LEGO® Ideas como Tkel86), de Portugal, le alcanza el tiempo para hacer todo su trabajo como programador y diseñador web. Con una amplia cartera de complejos modelos MOC (siglas en inglés de "My Own Creation", es decir, "mi propia creación"), ¡este fan diseñador se mantiene muy ocupado!

"En mi tiempo libre, me encanta hacer cualquier cosa que combine creatividad e ingenio, como construir con LEGO y proyectos de electrónica, carpintería, dibujo, diseño gráfico, modelos 3D y escultura. Me encanta reutilizar materiales para nuevos fines, como cuando desarmo un set LEGO para crear otro modelo. Tengo muchos recuerdos de jugar con bricks LEGO cuando era un niño. Heredé una caja llena de piezas de un primo y, desde entonces, fui ampliando mi colección hasta la adolescencia. Me alejé de los bricks de los 16 a los 26 años, en lo que se podría

llamar 'una época oscura'. Pero redescubrí mi pasión cuando, por casualidad, visité una exhibición para fans de LEGO organizada por una comunidad. Terminé por unirme a ellos, y mi interés por este pasatiempo creció exponencialmente. Este proyecto duró aproximadamente seis meses. Siempre he admirado a Tintin, y un compañero del trabajo me inspiró para recrear este modelo usando bricks LEGO. Para hacer los acoples de las patas y el cono superior, usé algunas partes Technic™. Me gusta que el modelo presente elementos redondos y cónicos creados a partir de varias piezas, ya que, cuando las construcciones alcanzan cierta complejidad, minimizar las separaciones visibles es siempre un desafío. ¡Y también fue bastante difícil encontrar en rojo algunos de esos elementos! Mi plan era seguir perfeccionándolo después de compartirlo en el sitio web de LEGO Ideas. Pero poco a poco, mientras estaba ocupado trabajando en otros proyectos, alcanzó los 10.000 seguidores. Me encanta cuando los modelos combinan mecanismos con movimiento y una estética hermosa. Espero que a los fans les guste el asombro que inspira la versión definitiva".

AN EXPLORER ON THE MOON!

The red-and-white checkered rocket from *Destination Moon* (1953) and *Explorers on the Moon* (1954) remains one of the most recognizable symbols from *The Adventures of Tintin*. In the story, Tintin, Captain Haddock, Snowy and Professor Calculus embark on a daring journey to explore the dark side of the Moon, launching a groundbreaking rocket from the fictional country of Syldavia. When first published, the adventure transported readers into a future where human space travel felt within reach, at a time when an actual lunar landing was still only a dream. The rocket quickly became a signature image of technological progress and innovation, as Tintin and his friends captured the imagination of millions with a blend of adventure, suspense and modern science.

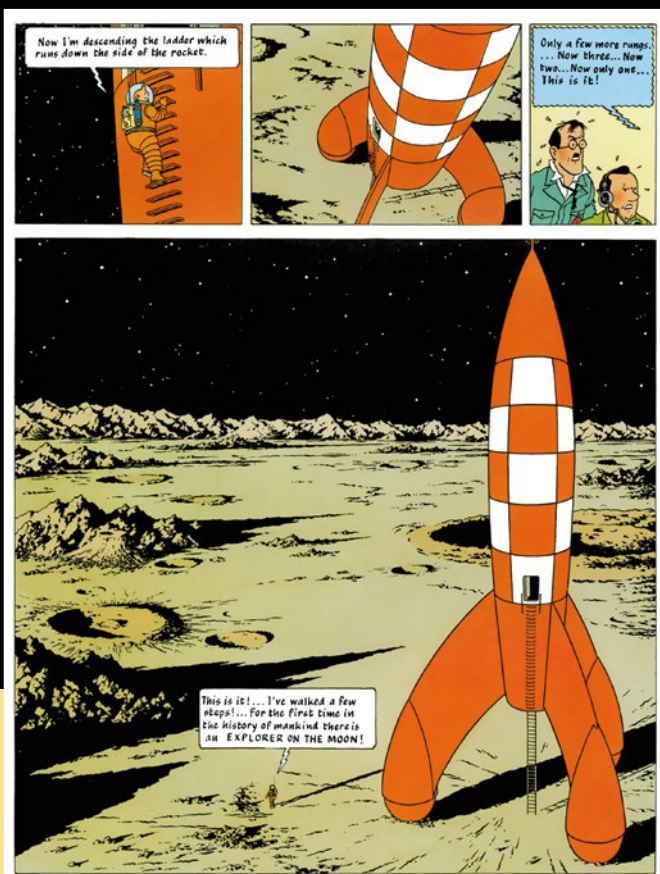

© Hergé/Tintinimaginatio 2026

ON A MARCHÉ SUR LA LUNE!

La fusée à damier rouge et blanc de *Objectif Lune* (1953) et *On a marché sur la Lune* (1954) demeure l'un des symboles les plus reconnaissables des *Aventures de Tintin*. Dans cette histoire, Tintin, le capitaine Haddock, Milou et le professeur Tournesol se lancent dans une mission audacieuse pour explorer la face cachée de la Lune, en décollant à bord d'une fusée révolutionnaire depuis le pays fictif de la Syldavie. Lors de sa parution, cette aventure transportait les lecteurs dans un futur où les voyages spatiaux humains semblaient à portée de main, à une époque où un véritable alunissage n'était encore qu'un rêve. La fusée est rapidement devenue une image emblématique du progrès technologique et de l'innovation, alors que Tintin et ses amis captivaient l'imaginaire de millions de lecteurs grâce à un savant mélange d'aventure, de suspense et de science moderne.

¡UN EXPLORADOR EN LA LUNA!

El cohete a cuadros rojos y blancos de *Destination Moon* (1953) y *Explorers on the Moon* (1954) sigue siendo uno de los iconos más reconocibles de *The Adventures of Tintin*. En la historia, Tintin, Captain Haddock, Snowy y Professor Calculus se embarcan en un temerario viaje para explorar la cara oculta de la Luna lanzando un innovador cohete desde el país ficticio de Syldavia. Cuando se publicó por primera vez, la aventura transportó a los lectores a un futuro en el que los viajes espaciales tripulados parecían estar al alcance de la mano, en una época en la que el alunizaje real todavía era solo un sueño. Con una mezcla de aventura, suspense y ciencia moderna, Tintin y sus amigos cautivaron la imaginación de millones de lectores, y el cohete no tardó en convertirse en un símbolo del avance tecnológico y la innovación.



ART MEETS SCIENCE

The story seamlessly wove the characters' familiar banter, wit and humor into a suspenseful tale of espionage and scientific discovery. Because the rocket design, the Sprodj Atomic Research Center and the journey's technical details were all based on real research available at the time, the story

felt both novel and convincing, and the richly detailed scenes brought advanced science to a wider audience. Tintin's legacy is now preserved in places like the Musée Hergé, and the pioneering spirit of his rocket continues to inspire dreamers and explorers alike.

Hergé compiled extensive research materials and documents. Some are of unclear origin, like these black/white photos, that are classified under a separate 'Hergé Documentation' category.

© Hergé/Tintinimaginatio 2026

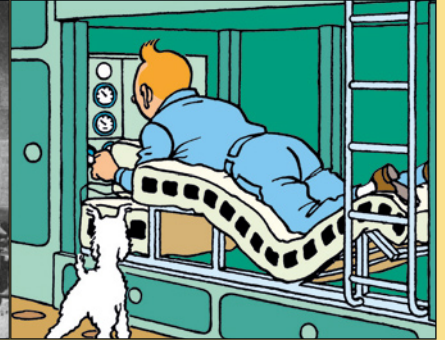
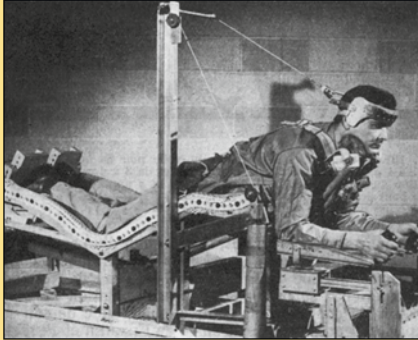
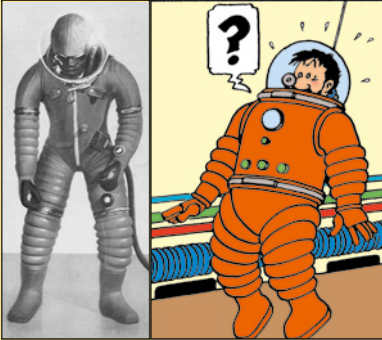

Many details were based on real science.

Plusieurs éléments de l'histoire sont directement inspirés de la science réelle.

Numerosas detalles se basaban en datos científicos reales.

QUAND L'ART RENCONTRE LA SCIENCE

L'histoire intégrait avec brio les échanges pleins d'esprit et l'humour bien connus des personnages à une intrigue haletante mêlant espionnage et découvertes scientifiques. Parce que la conception de la fusée, le Centre de recherches atomiques de Sprodj et les aspects techniques du voyage reposaient sur des recherches scientifiques réelles de l'époque,

le récit paraissait à la fois original et crédible. Les scènes richement détaillées permettaient aussi de vulgariser des notions scientifiques complexes auprès du grand public. L'héritage de Tintin est aujourd'hui préservé dans des lieux comme le Musée Hergé, et l'esprit visionnaire de sa fusée continue d'inspirer rêveurs et explorateurs d'hier à aujourd'hui.

Hergé avait rassemblé une vaste collection de documents et de matériel de recherche. Certains d'entre eux sont d'origine incertaine, comme ces photos en noir et blanc, qui sont classées dans une catégorie distincte intitulée « Documentation Hergé ».



© Danny Gys - Atelier Christian de Portzamparc Hergé-Tintinimaginatio 2026

EL ARTE Y LA CIENCIA SE UNEN

La historia entretejió con naturalidad los ingeniosos diálogos y el característico humor de los personajes con una narrativa llena de suspenso que giraba en torno al espionaje y los descubrimientos científicos. Dado que tanto el diseño del cohete como el Sprodj Atomic Research Center y los detalles técnicos del viaje se basaban en investigaciones reales disponibles en la época, la trama resultaba tan novedosa como convincente y los nutridos detalles de las escenas acercaban los avances científicos a un público más amplio. El legado de Tintin se conserva ahora en lugares como el Musée Hergé, y el espíritu pionero de su cohete sigue inspirando a soñadores y exploradores por igual.

Hergé recopiló una gran cantidad de materiales de investigación y documentos. Algunos cuyo origen es poco claro, como estas fotos en blanco y negro, están clasificados en una categoría aparte llamada « Documentación de Hergé ».

THE LEGO® IDEAS CREW

The fan model was really well done – it was also enormous! So, we agreed to remove the tower and focus on the rocket itself, take Alexis' model from Earth to space, and feature the characters in their iconic space suits, including, of course, a LEGO® Snowy figure! Hergé famously paid vigilant attention to detail and accuracy, and we wanted to do his work justice. The rocket is a 6-sided shape with a subtle curve from top to bottom. We explored countless different building techniques and angles to achieve this shape. The squares of the checkered pattern on the rocket surface are trapezoidal, and to stay true to the design, the smooth surface and authentic pattern were an exciting challenge. The fins were another technical part of the model. The solution for this was to use a reflected triangle for each of the fins to create the correct angle and lock them in to add

strength to the model. For the rocket's top cone, we created a new cone element that's similar to the rocket's feet for consistency.

We included a control room at the top of the rocket to show an iconic scene after take-off, when the characters see Earth from space for the first time. We made it as accurate as possible, with decorations, details and stickers, and we even managed to add the hatch for the door into the next level in the rocket.

'Translating' the characters into minifigure form was such a fun process. They have so much personality and comic history, so we narrowed it down to expressions that reflect this storyline. The spacesuits are inspired by *Explorers on the Moon*, and Thomson and Thompson have their green hair as a nod to a hilarious scene in the comic book!

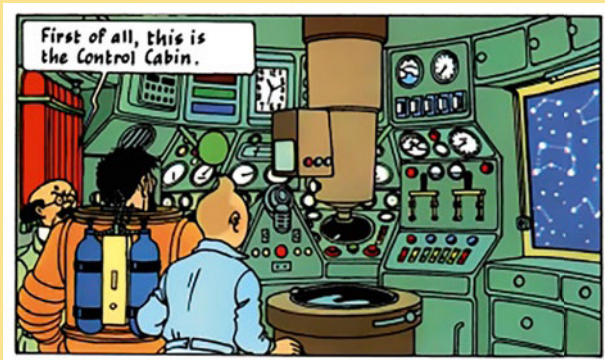

© Hergé/Tintinmaginatio 2026

L'ÉQUIPE LEGO® IDEAS

Le modèle créé par un amateur était remarquablement bien réalisé – et gigantesque! Nous avons donc convenu de retirer la tour pour nous concentrer sur la fusée elle-même, en faisant passer le modèle d'Alexis de la Terre à l'espace, et en mettant en vedette les personnages dans leurs combinaisons spatiales emblématiques, y compris, bien sûr, Milou en version LEGO®! Hergé était reconnu pour son extraordinaire souci du détail et de la précision, et nous voulions honorer son œuvre avec le même niveau d'exigence. La fusée présente une forme à six faces marquée par une courbe subtile du haut vers le bas. Nous avons exploré d'innombrables techniques de construction et angles différents pour obtenir cette forme. Les carrés du motif à damier sur la surface de la fusée sont en réalité des trapèzes, et pour rester fidèles à la conception originale, reproduire la surface lisse et le motif authentique a représenté un défi passionnant. Les ailerons constituaient un autre élément technique du modèle. Nous avons trouvé la solution en utilisant un triangle réfléchi pour chacun des ailerons, ce qui permettait d'obtenir l'angle exact tout en solidifiant la structure du modèle. Pour le cône

supérieur de la fusée, nous avons créé un nouvel élément conique, semblable aux pieds de la fusée pour la cohérence.

Nous avons également intégré une salle de commande au sommet de la fusée, pour représenter la scène emblématique après le décollage, lorsque les personnages aperçoivent la Terre depuis l'espace pour la première fois. Nous avons poussé le réalisme le plus loin possible, avec des décorations, des détails et des autocollants; nous avons même ajouté la trappe menant au niveau inférieur de la fusée.

La transposition des personnages en figurines a été un pur plaisir. Ils ont tellement de personnalité et d'histoire comique que nous avons sélectionné des expressions qui reflètent fidèlement cette aventure. Leurs combinaisons spatiales s'inspirent directement de *On a marché sur la Lune*, et Dupont et Dupond arborent leurs cheveux verts, clin d'œil à une scène hilarante de l'album original!



LIFESTYLE



LA TRIPULACIÓN DE LEGO® IDEAS

El modelo del fan estaba muy bien hecho, ¡y también era enorme! Por este motivo, decidimos eliminar la torre y centrarnos en el cohete, llevar el modelo de Alexis de la Tierra al espacio y mostrar a los personajes con sus icónicos trajes espaciales, ¡incluida la figura LEGO® de Snowy! Hergé era famoso por prestar muchísima atención a los detalles y la precisión, y queríamos hacer justicia a su trabajo. La forma del cuerpo del cohete es, básicamente, la de un prisma hexagonal con caras redondeadas, levemente ensanchado por el centro. Exploramos innumerables técnicas de construcción y ángulos diferentes para lograr esta silueta. El diseño a cuadros del cohete se compone de formas trapezoidales, y recrearlo fielmente con una superficie prácticamente lisa y un patrón auténtico fue un apasionante desafío. Otra parte técnicamente compleja fueron las aletas. La solución fue utilizar un triángulo reflejado en cada una de ellas, algo que, además de crear el ángulo correcto, las asegura con firmeza al modelo. Para la punta del cohete, creamos un nuevo elemento cónico similar a los de las patas para mantener la coherencia.

Incluimos una sala de control en la parte superior para recrear una escena icónica de los momentos posteriores al despegue, cuando los personajes ven la Tierra desde el espacio por primera vez. Maximizamos su precisión con decoraciones, detalles y calcomanías, e incluso logramos incluir la escotilla que conduce al nivel inferior del cohete.

"Traducir" los personajes al formato de minifigura fue un proceso muy divertido. Tienen una gran personalidad y una vasta trayectoria en la trama, y eso se refleja en sus expresiones. Los trajes espaciales están inspirados en *Explorers on the Moon*, ¡y el pelo verde de Thomson and Thompson es una referencia a una divertidísima escena del cómic!

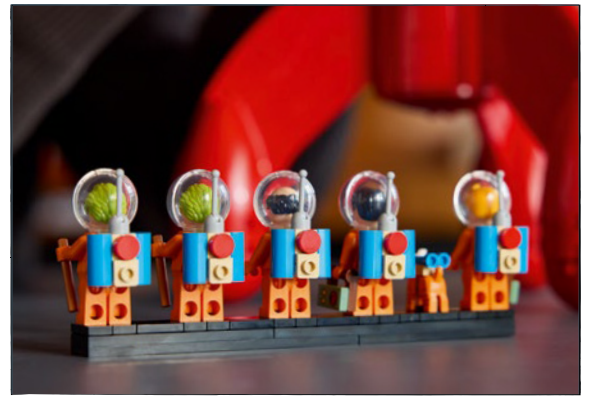

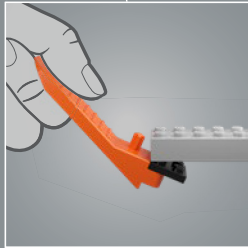
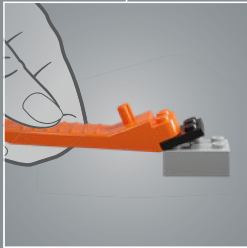
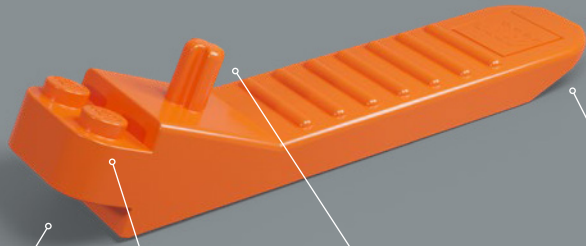

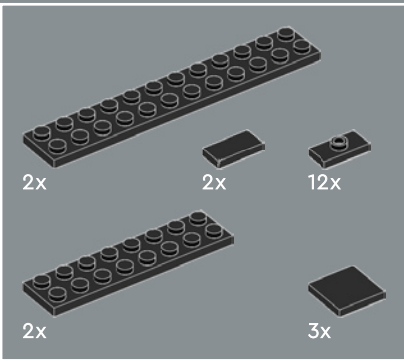
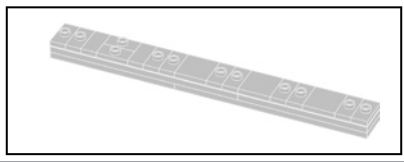

1

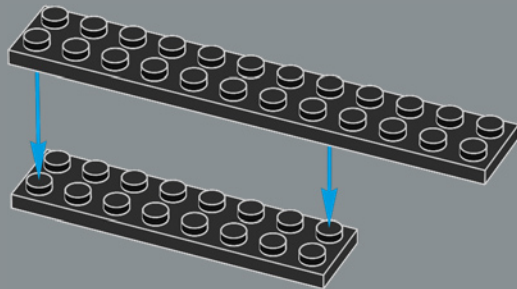

2

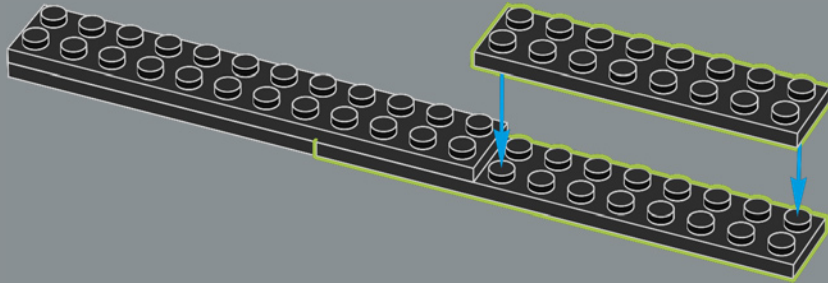

3

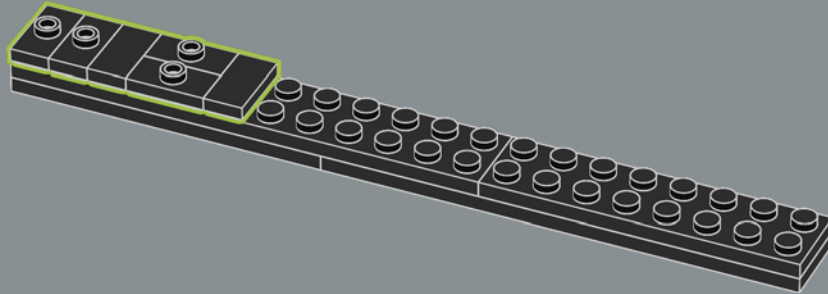

4

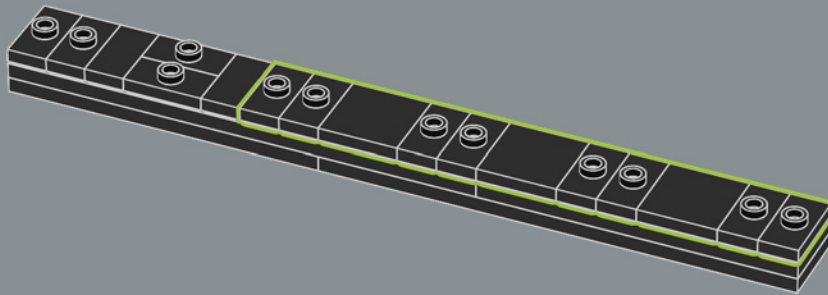

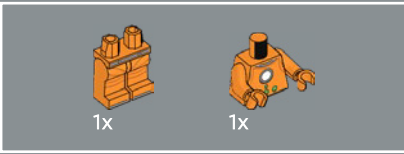
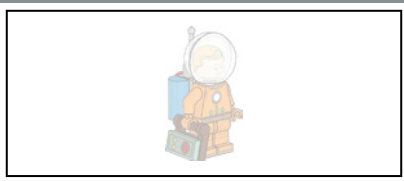

1

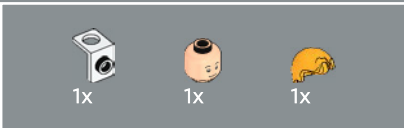
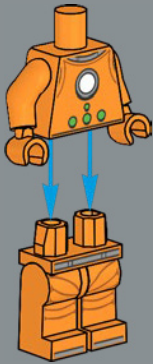

2

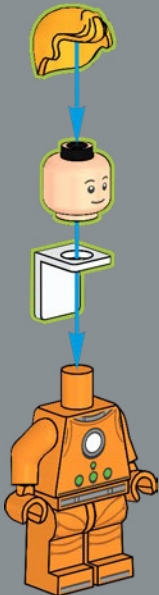

3

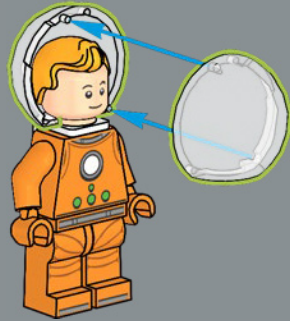

4

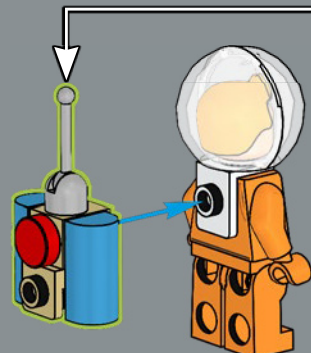
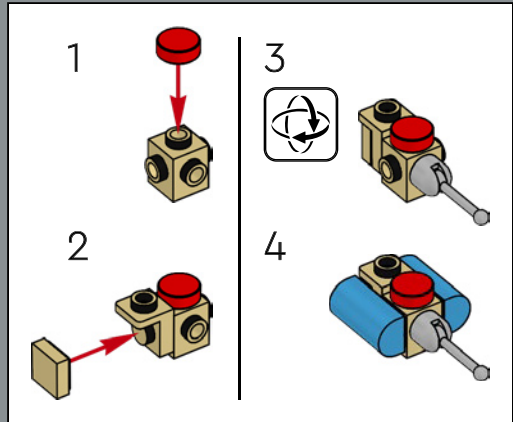

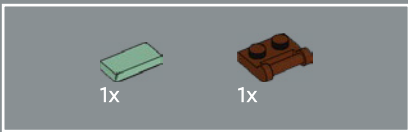

5

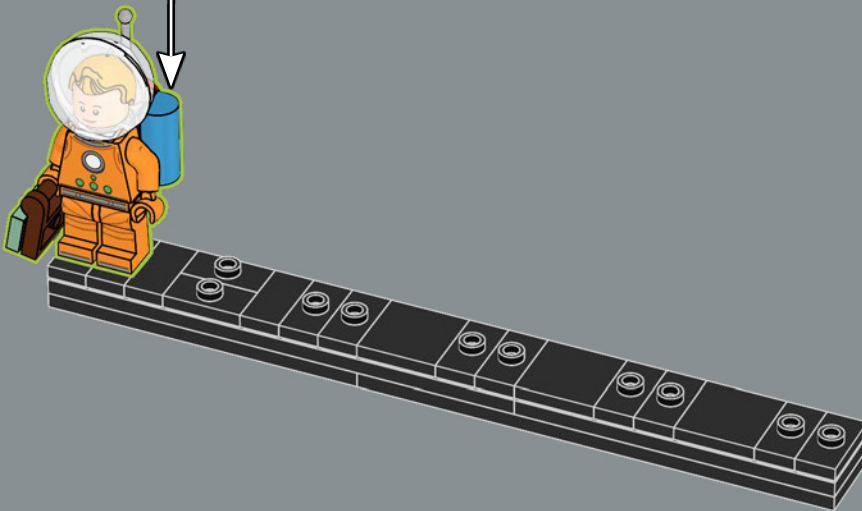
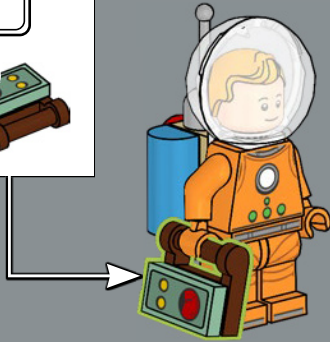
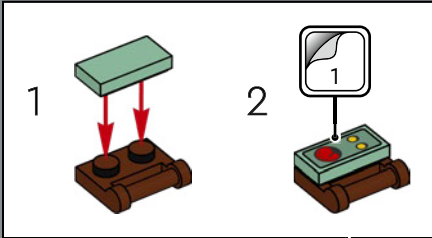

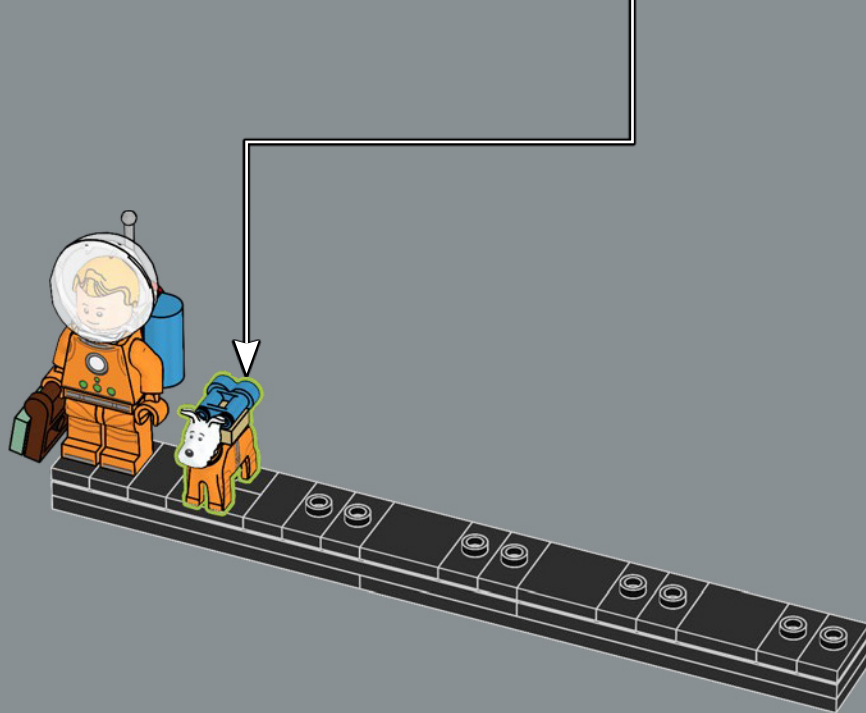

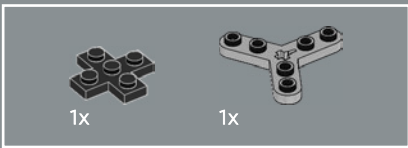
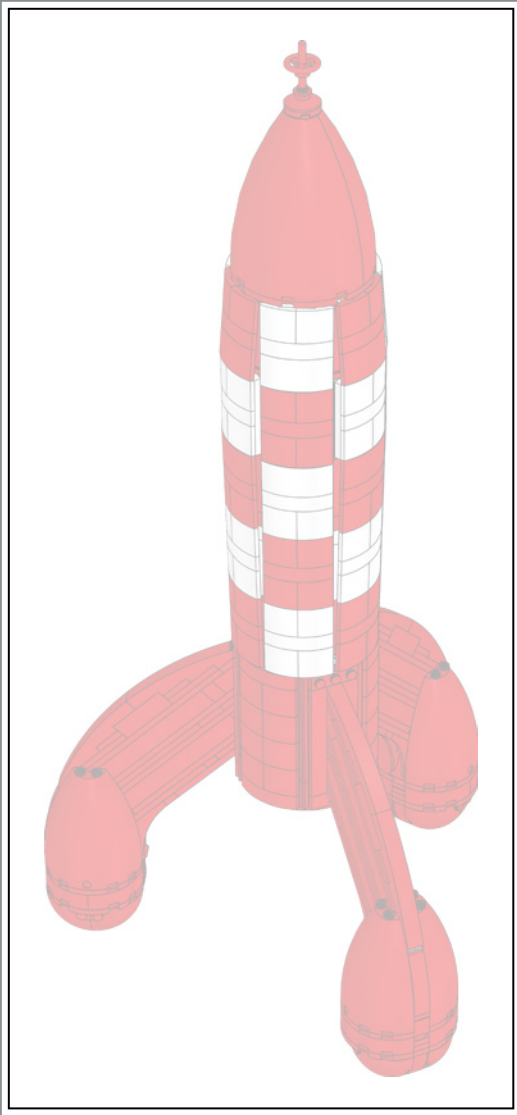

1

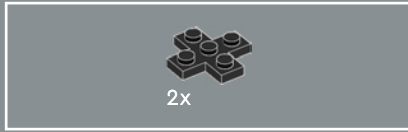
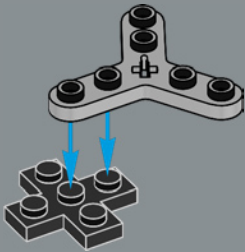

2

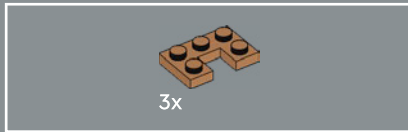
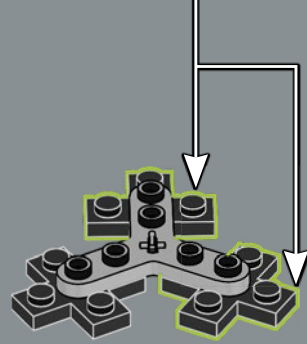
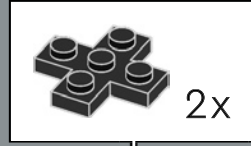

3

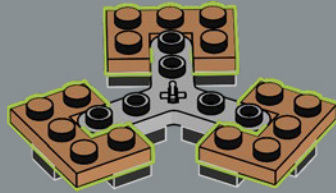

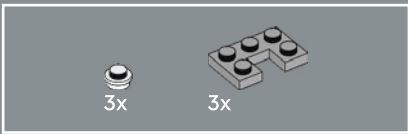

8

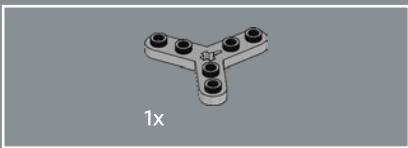

9

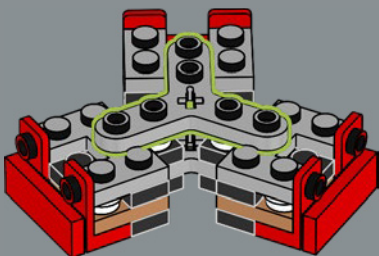

10

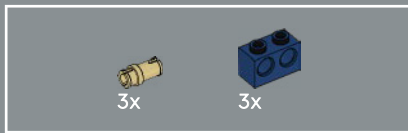
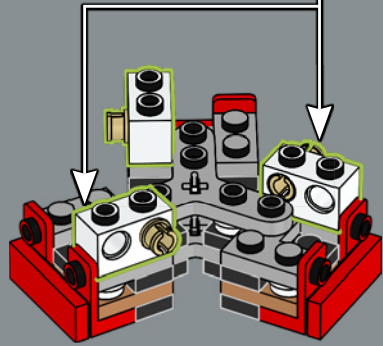
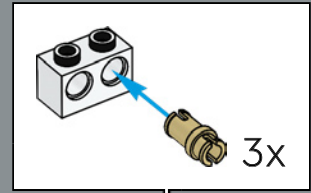

11

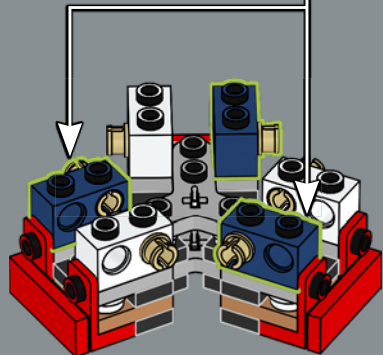
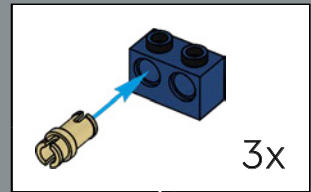



12

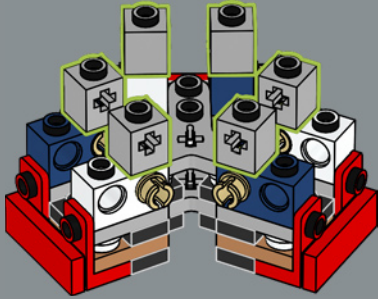

14

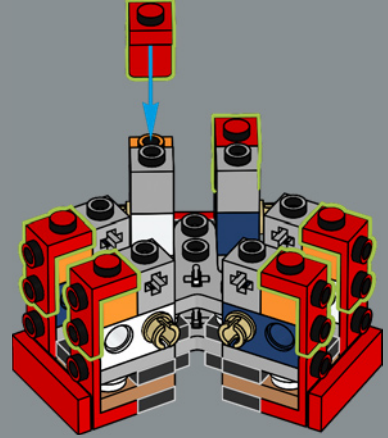

13

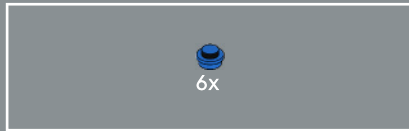
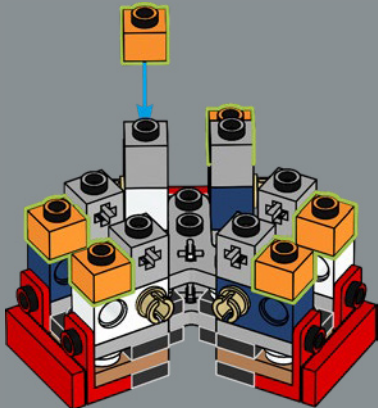

15

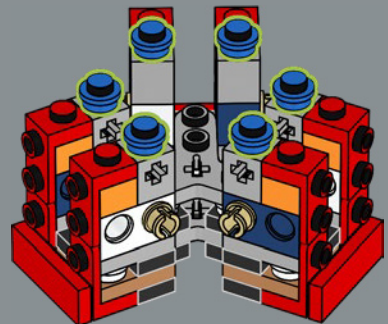

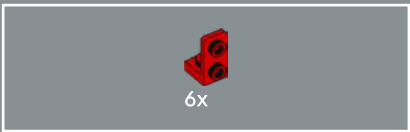

16

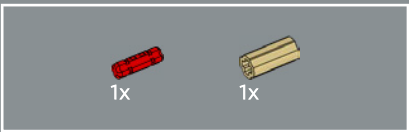
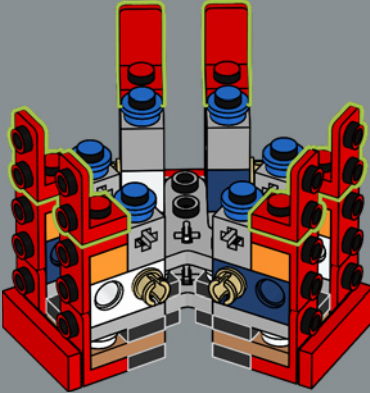

18

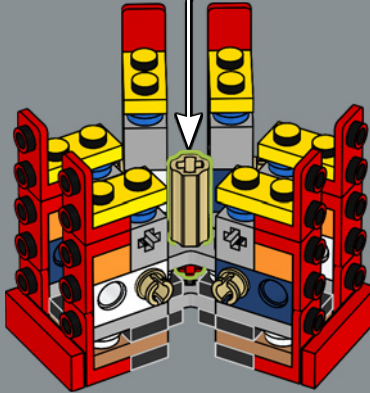
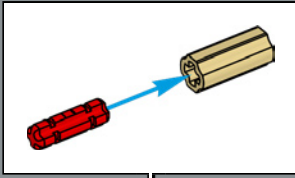

17

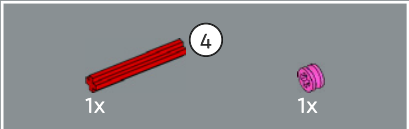
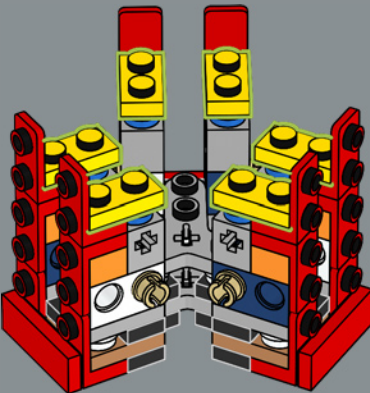

19

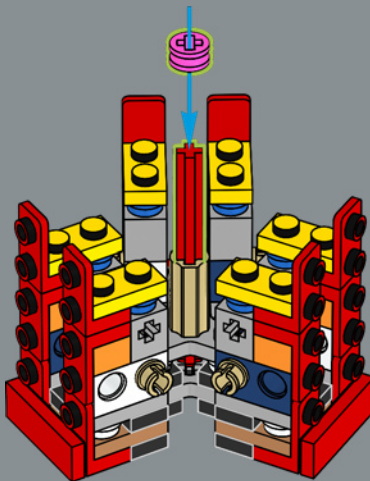

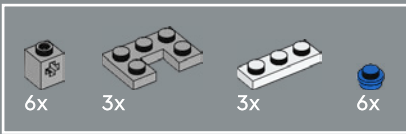

20

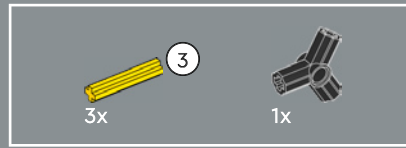
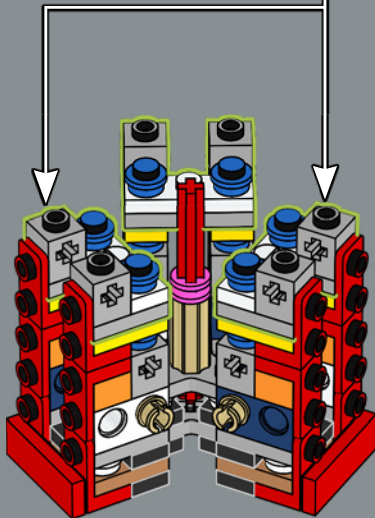
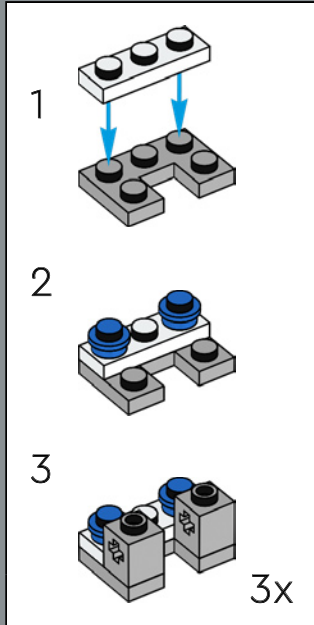

21

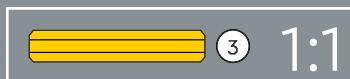
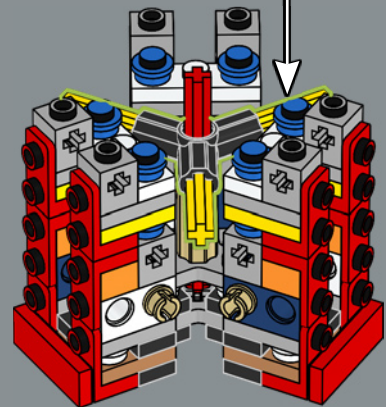
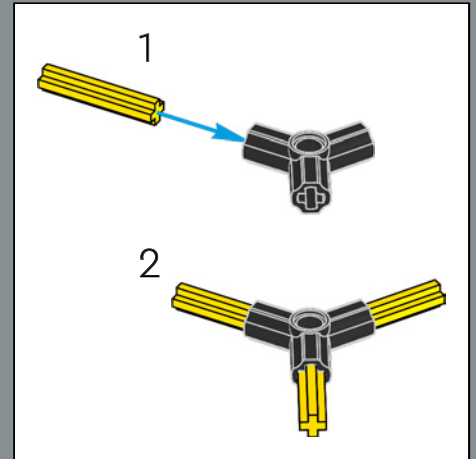

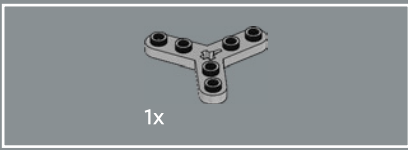

22

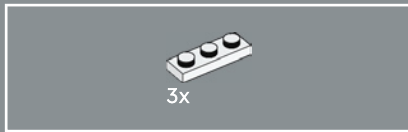
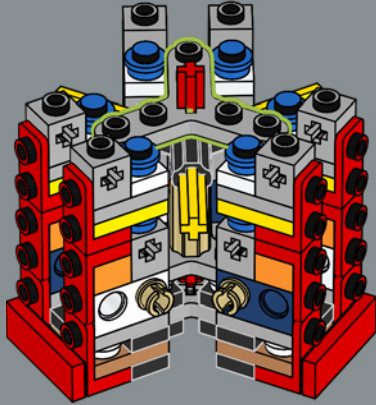

23

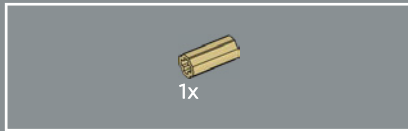
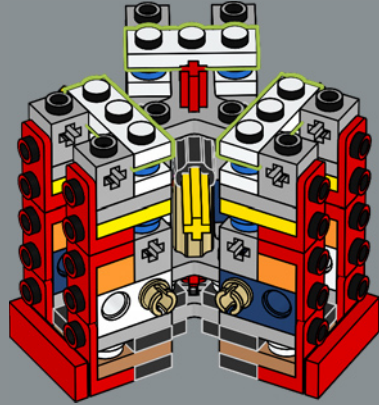

24

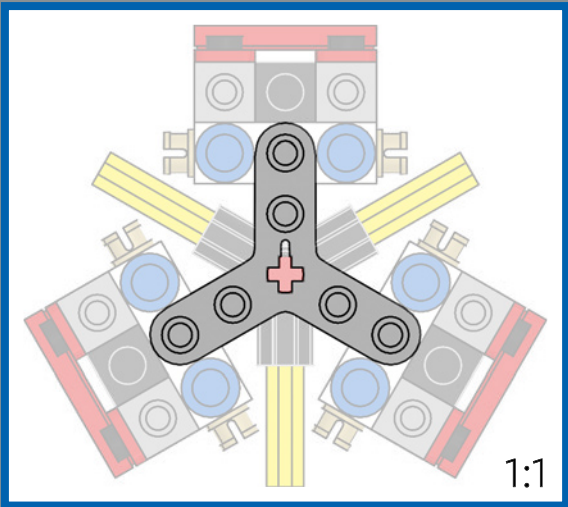
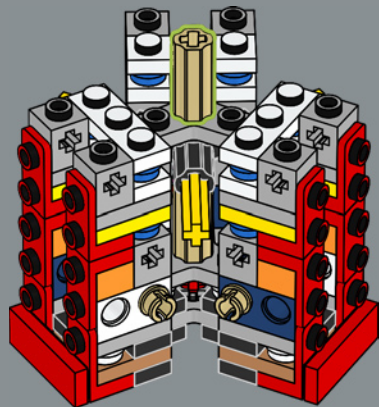

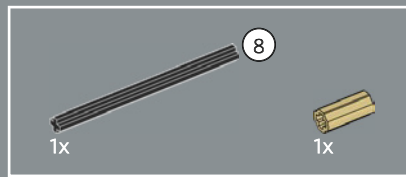

25

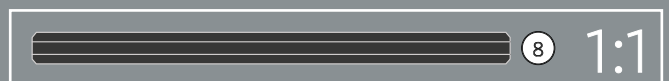
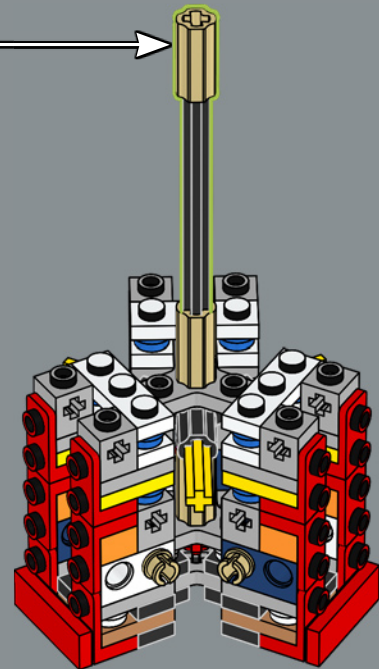
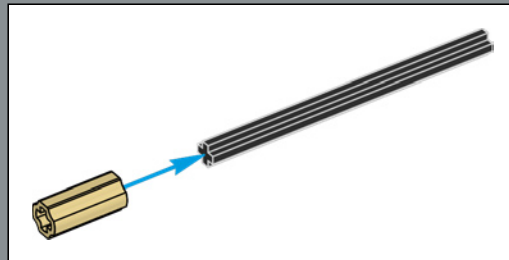

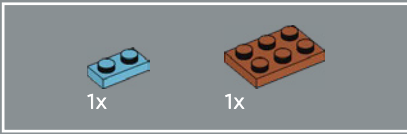
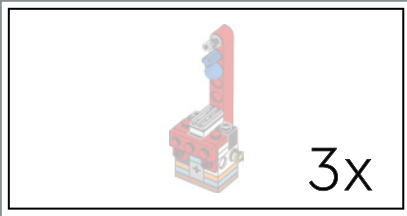

26

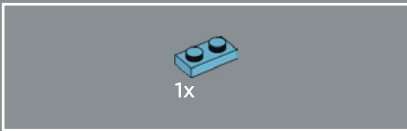
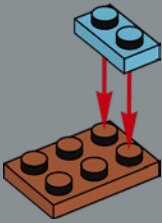

27

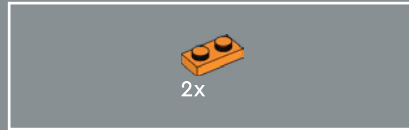
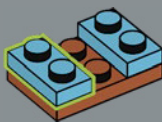

28

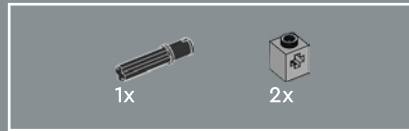
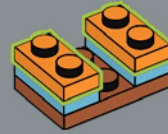

29

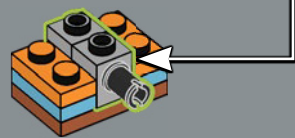
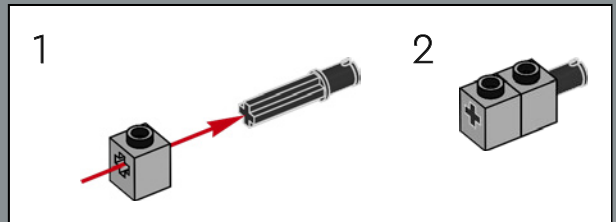

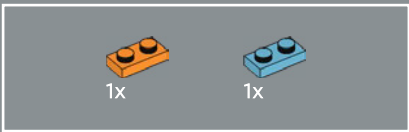

30

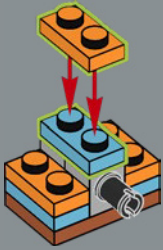

32

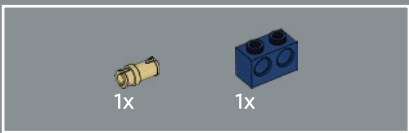
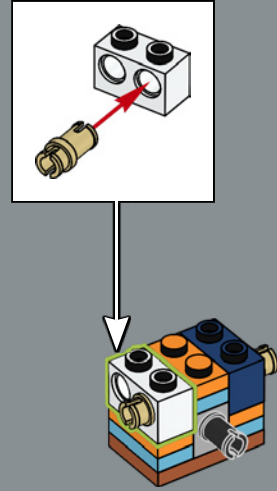

31

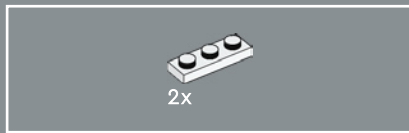
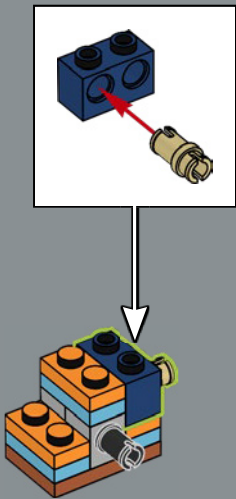

33

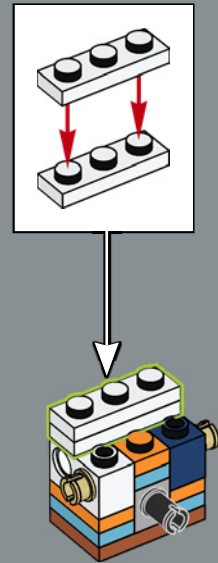

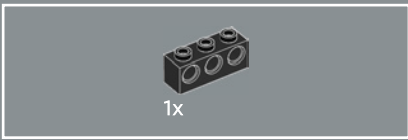

34

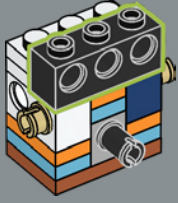

35

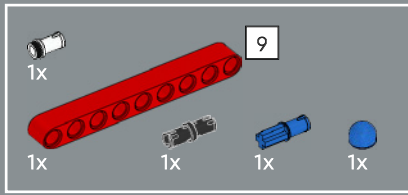
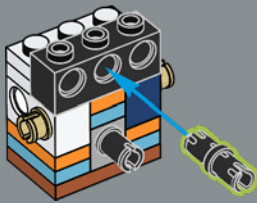

36

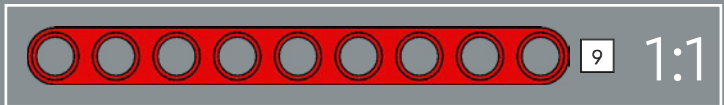
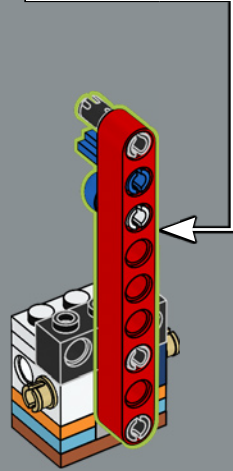
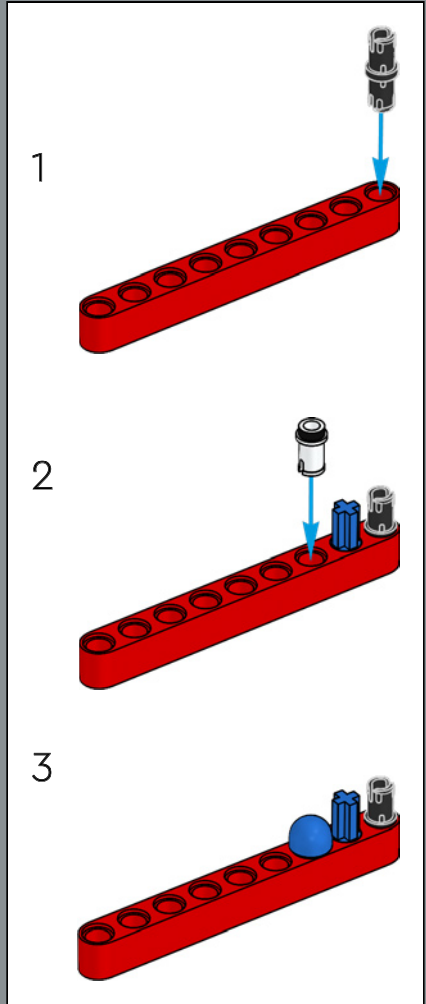

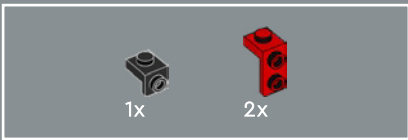

37

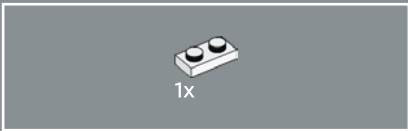
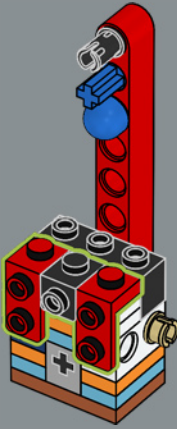

38

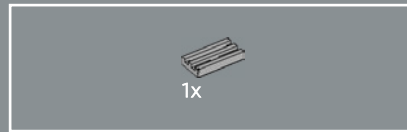
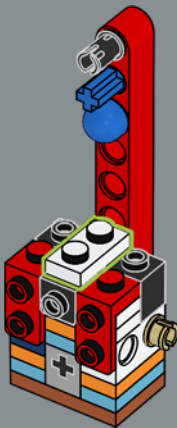

39

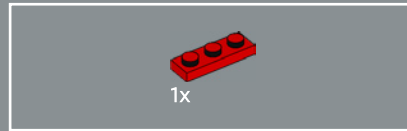
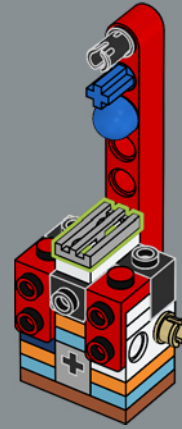

40

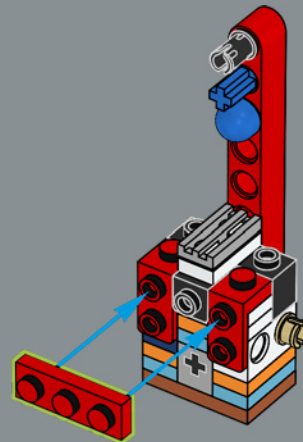

3x

41

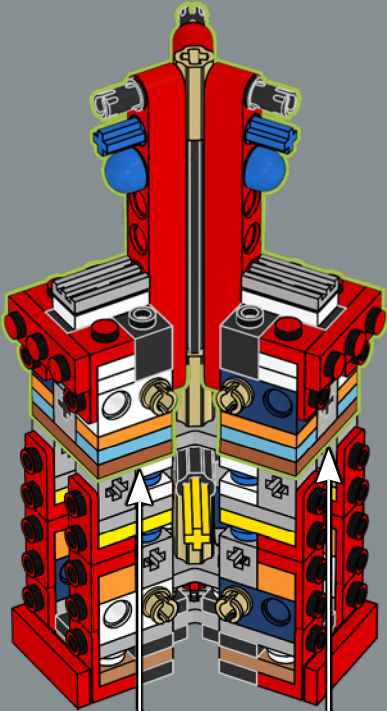

42

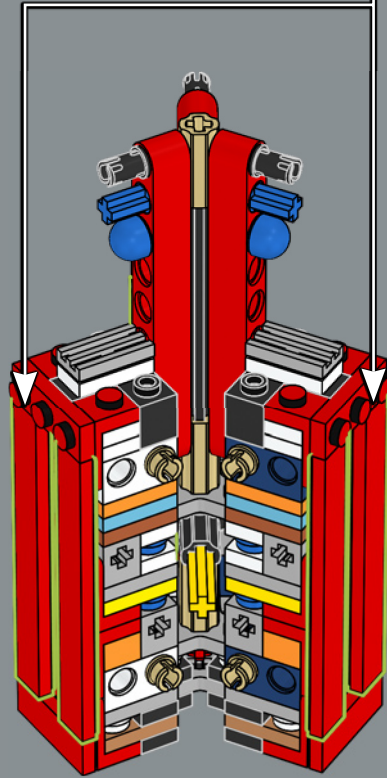
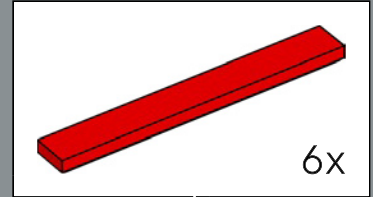
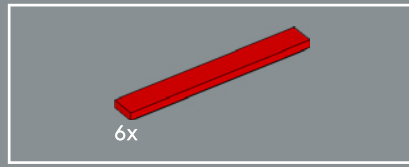



2

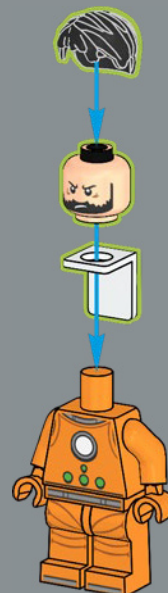

3

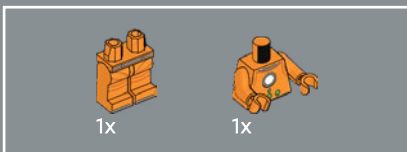
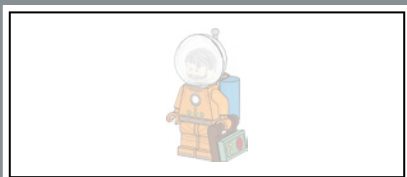
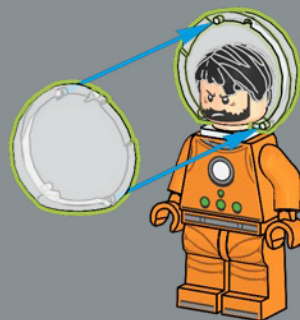

1

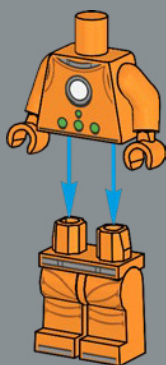



4

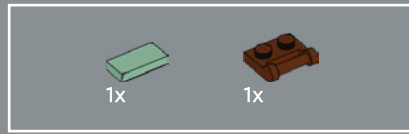
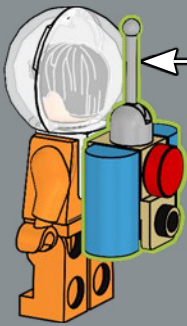
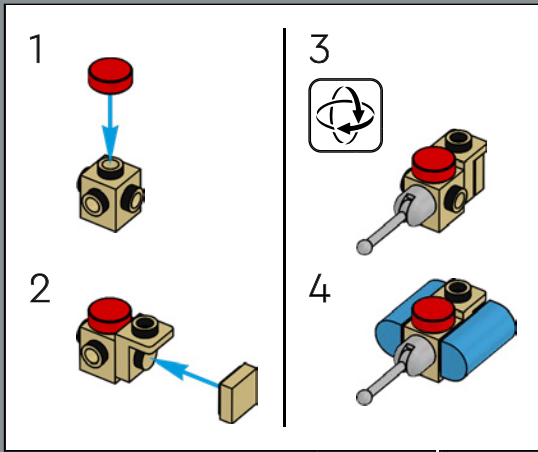

5

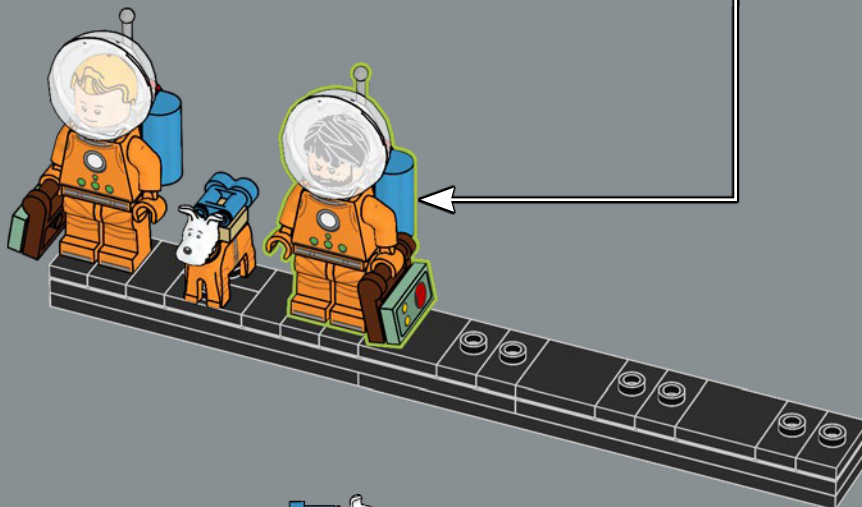
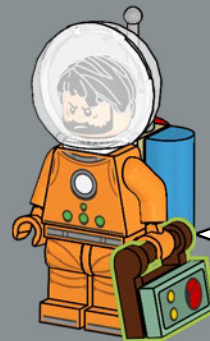
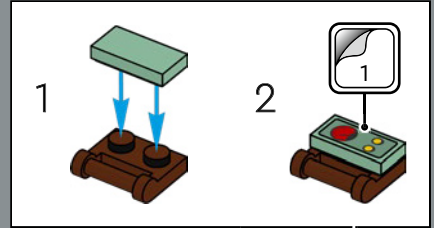

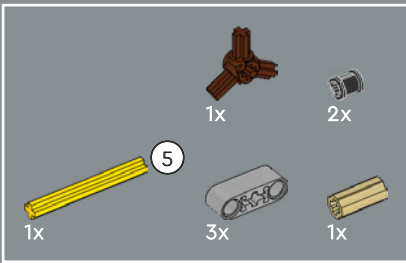

43

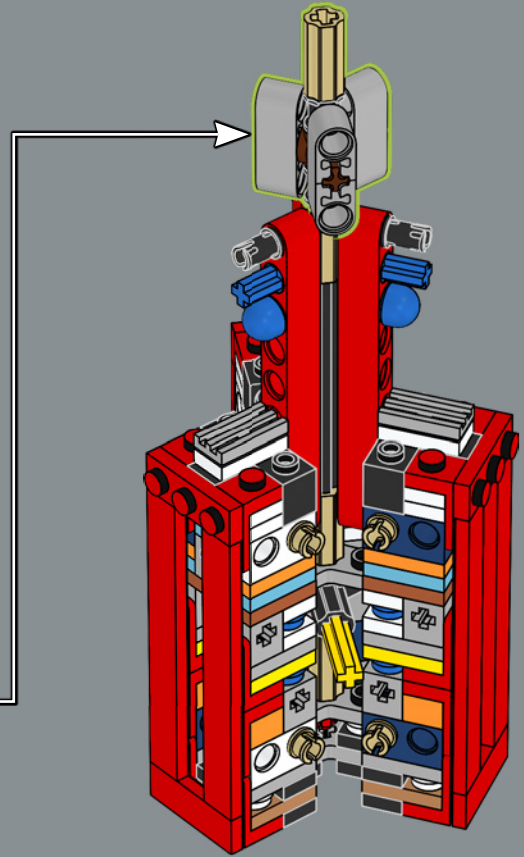
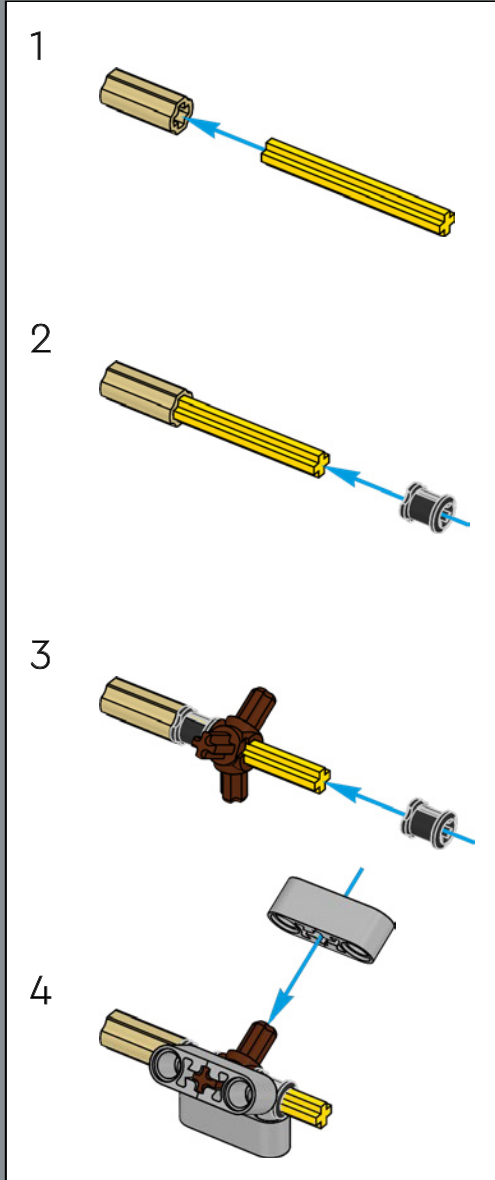
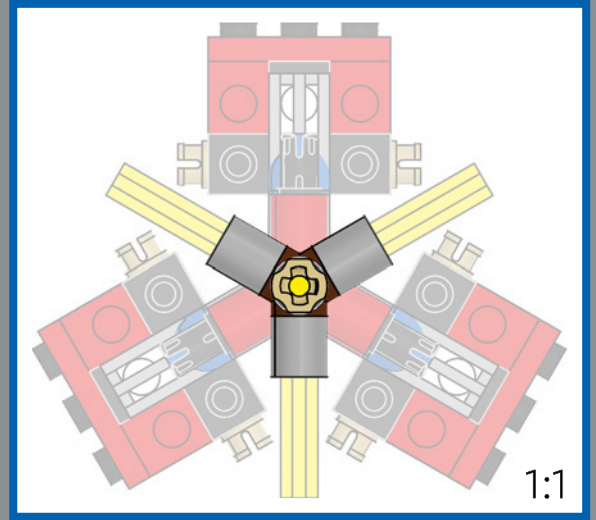

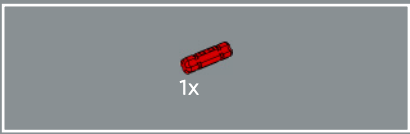

44

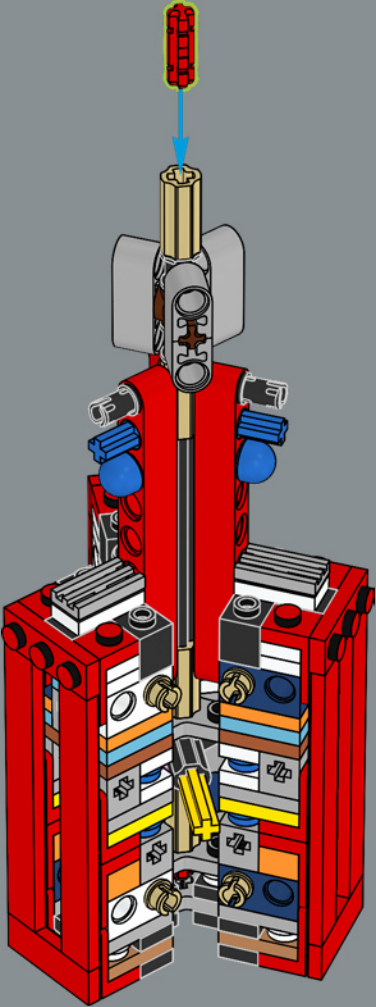

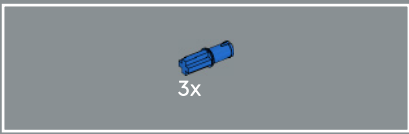

45

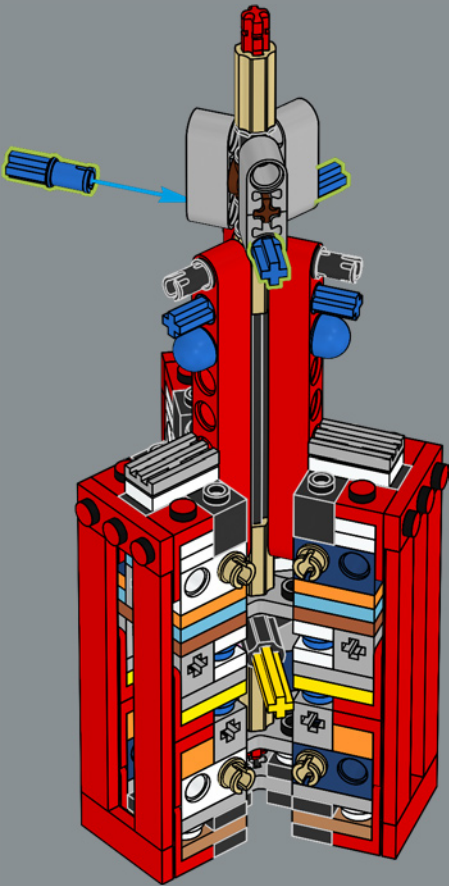

46

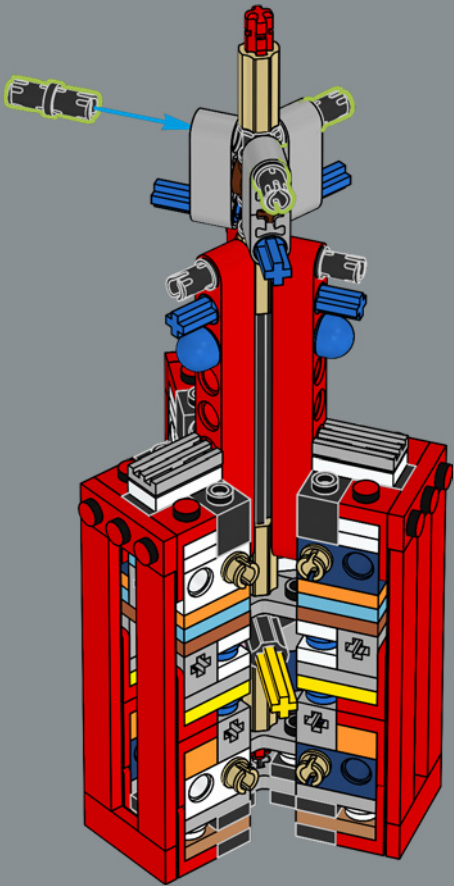

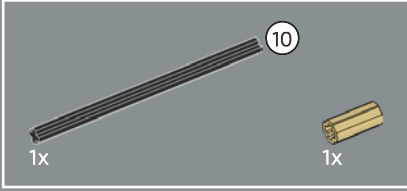
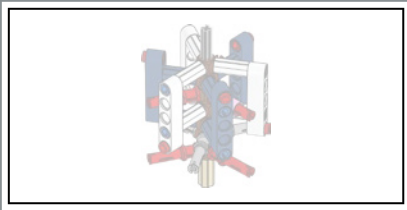

47

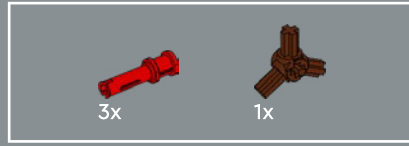
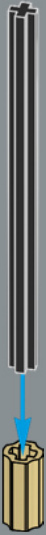

48

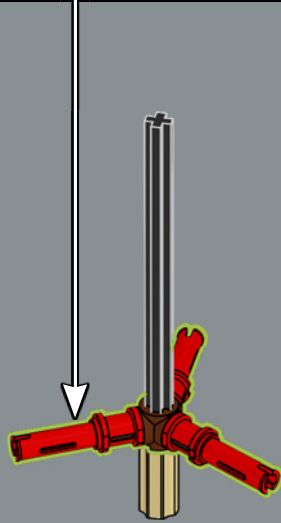
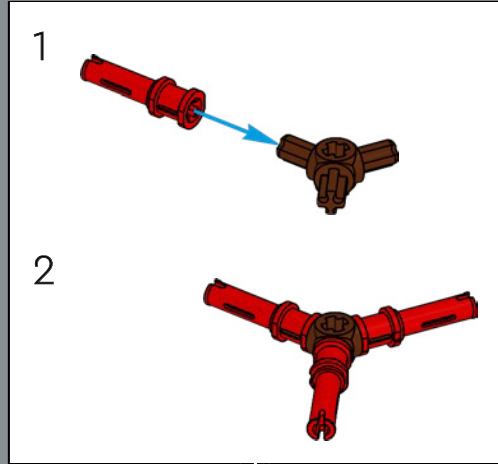

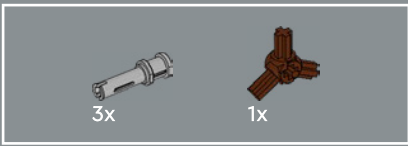

49

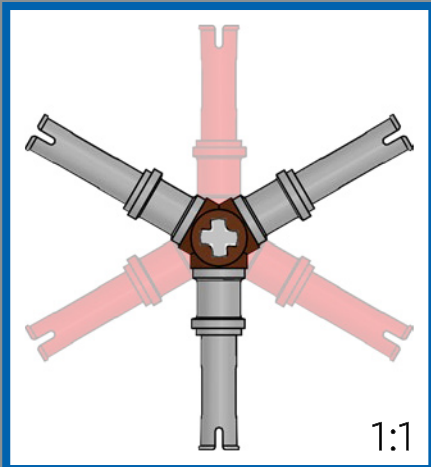
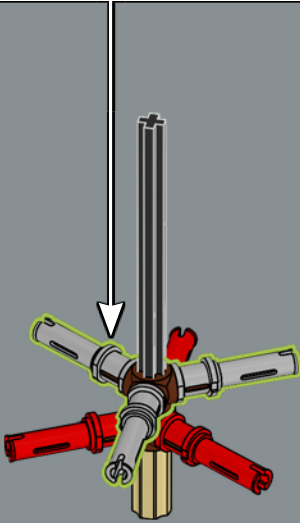
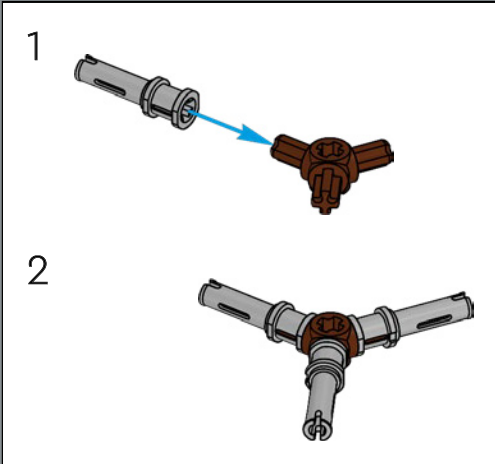

50

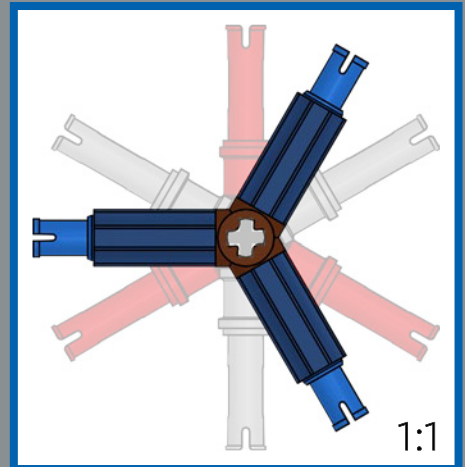
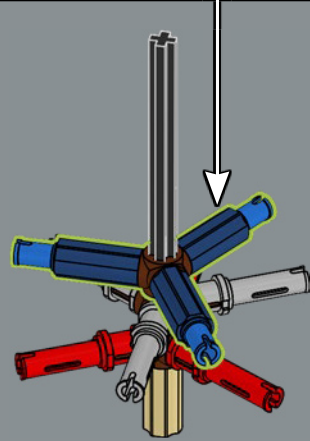
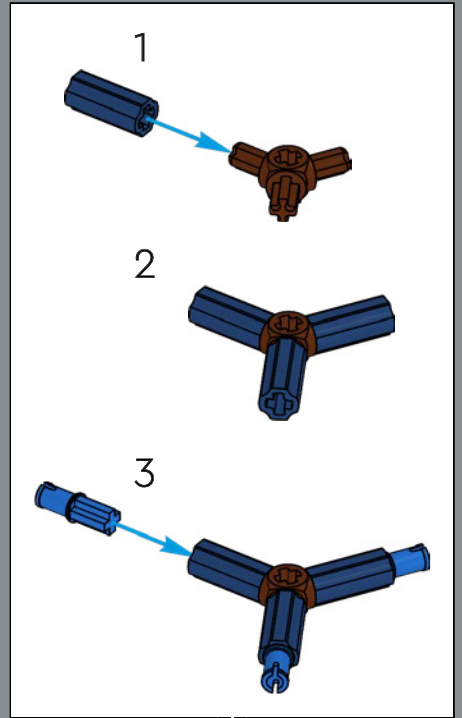

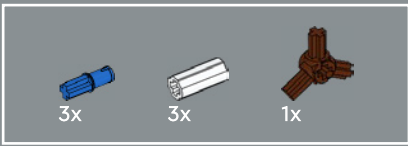

51

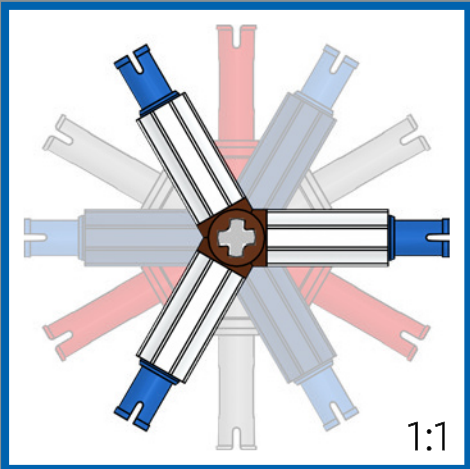
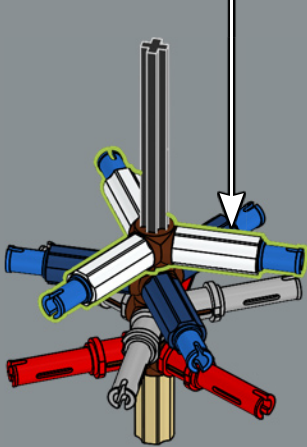
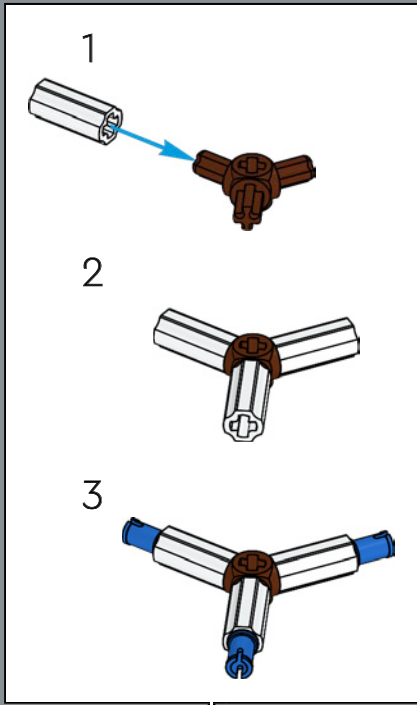

1:1

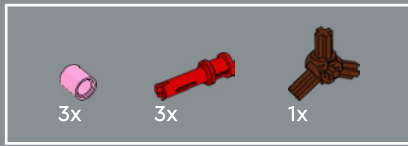

52

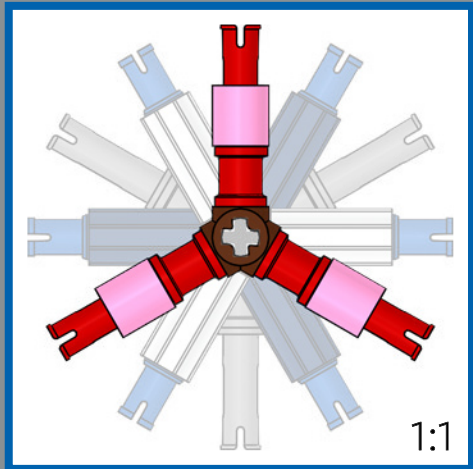
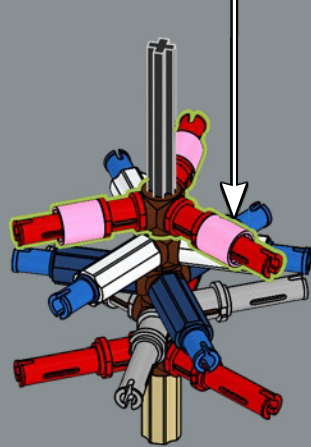
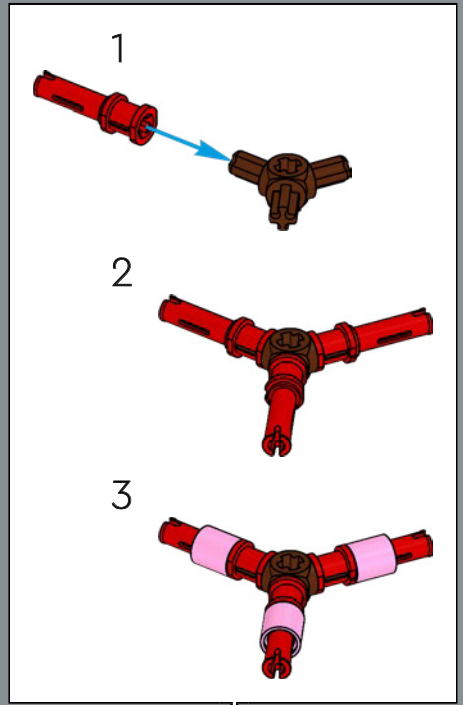

1:1



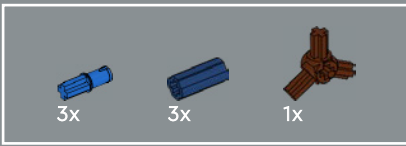

53

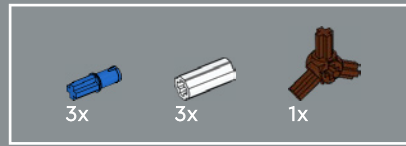
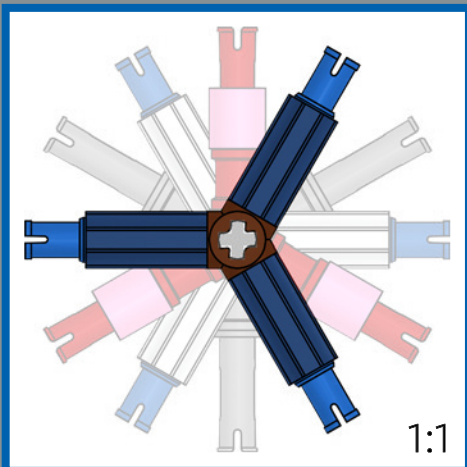
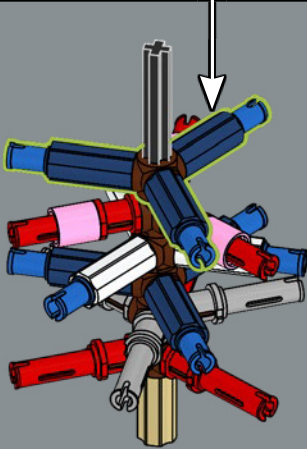
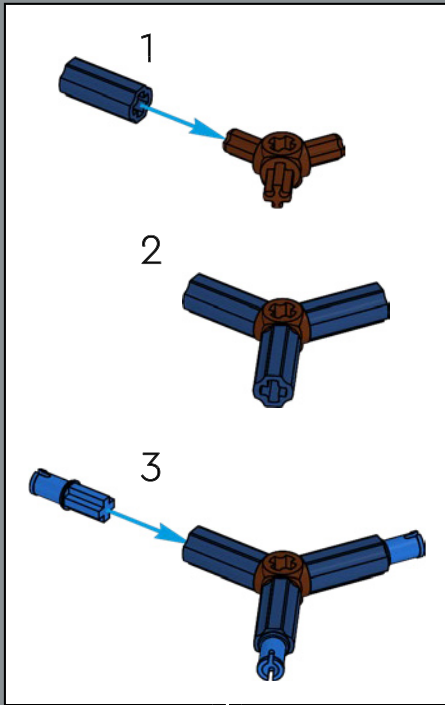

54

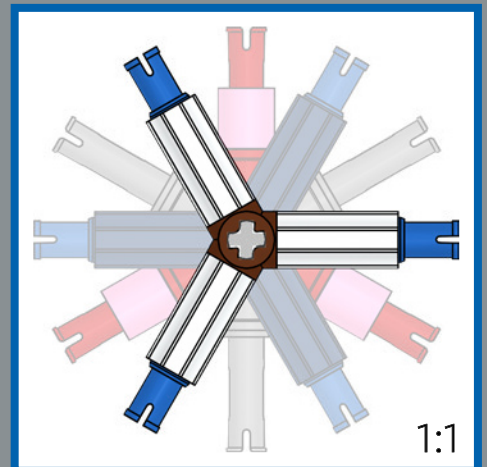
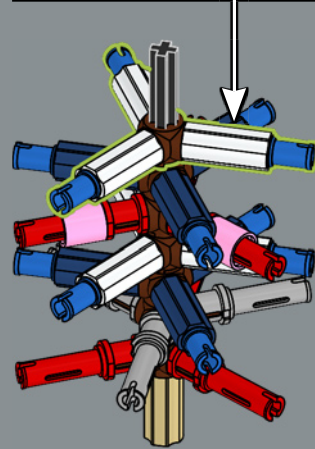
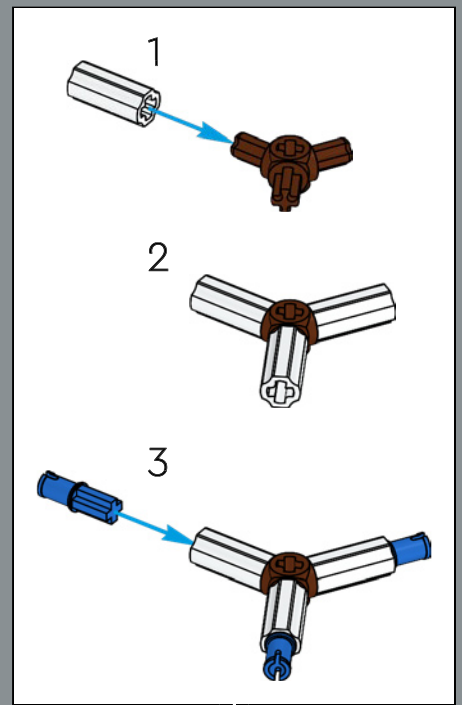

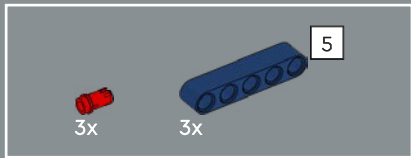

55

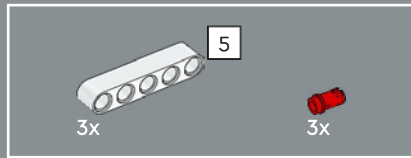
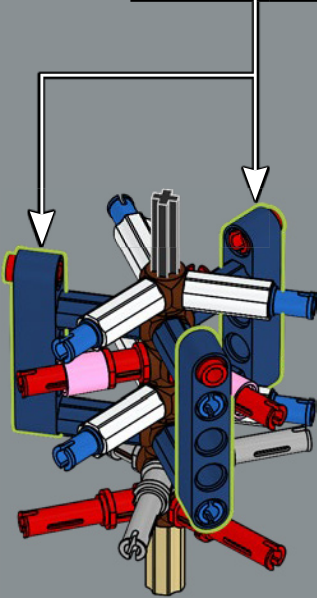
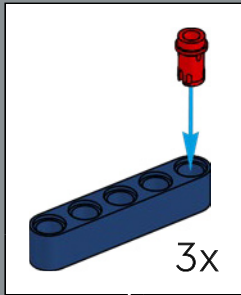

56

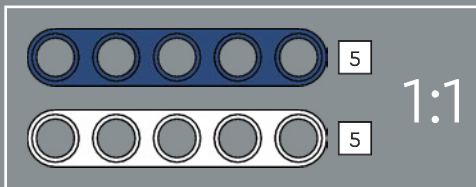
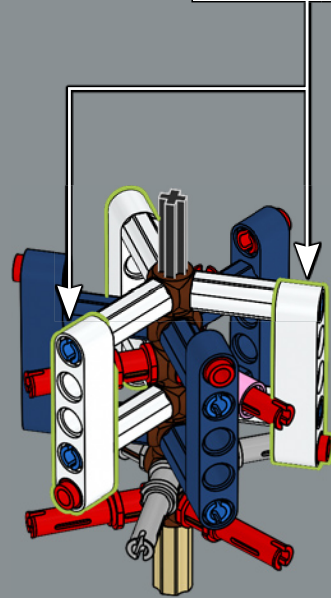
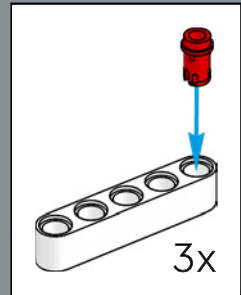

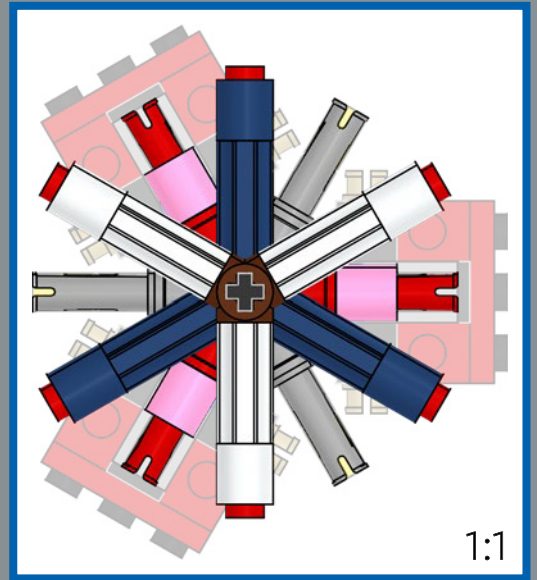
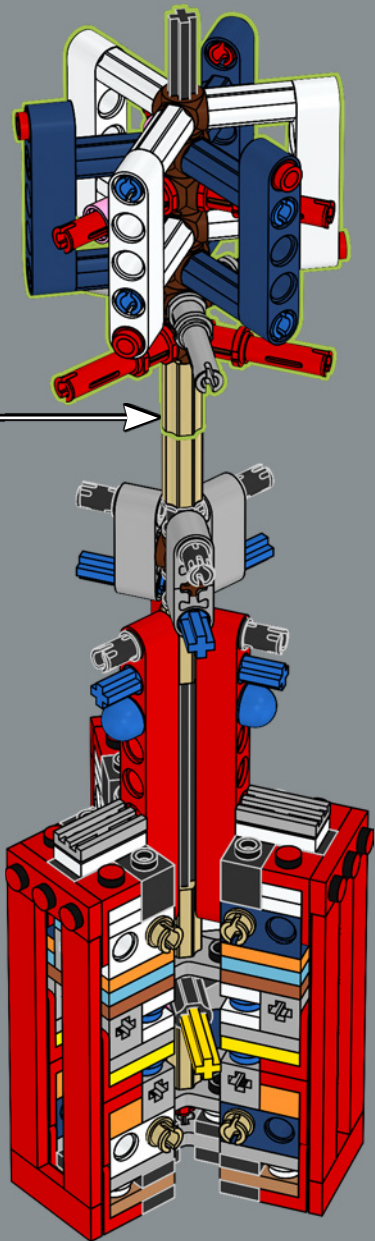

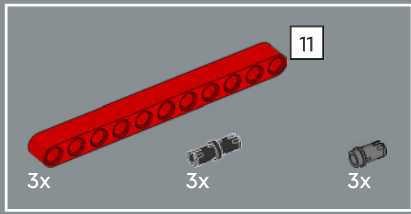

58

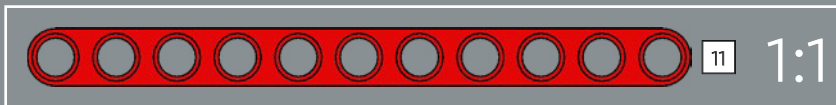
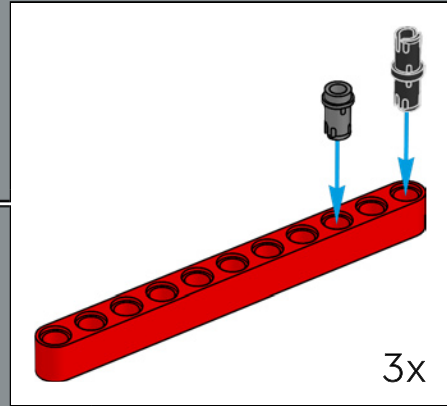
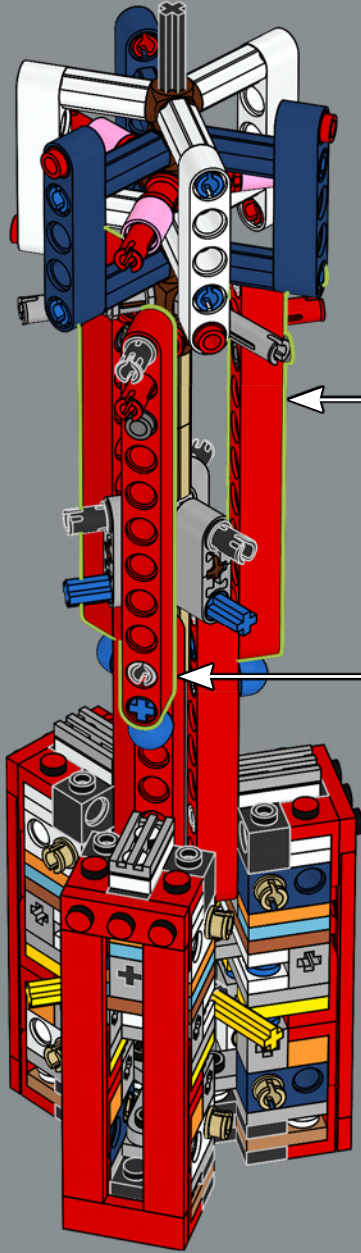

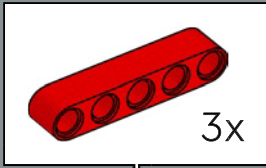
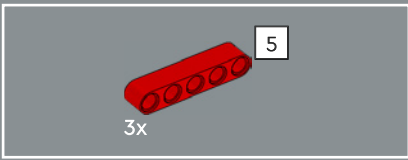

59

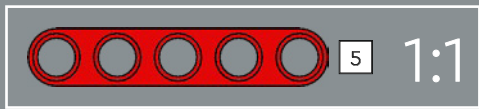
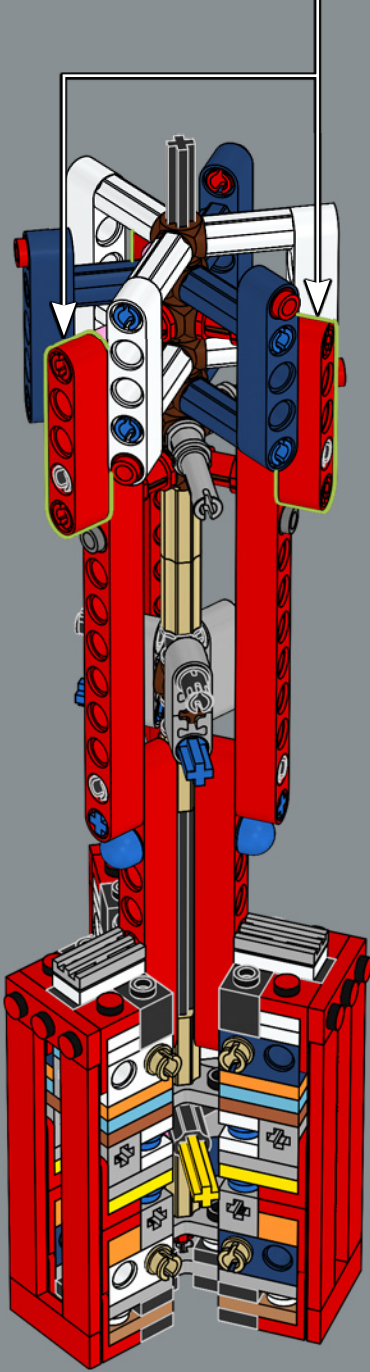

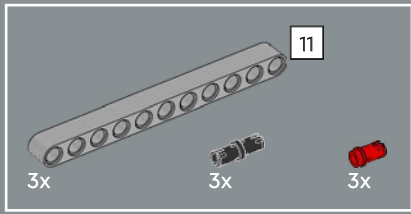

60

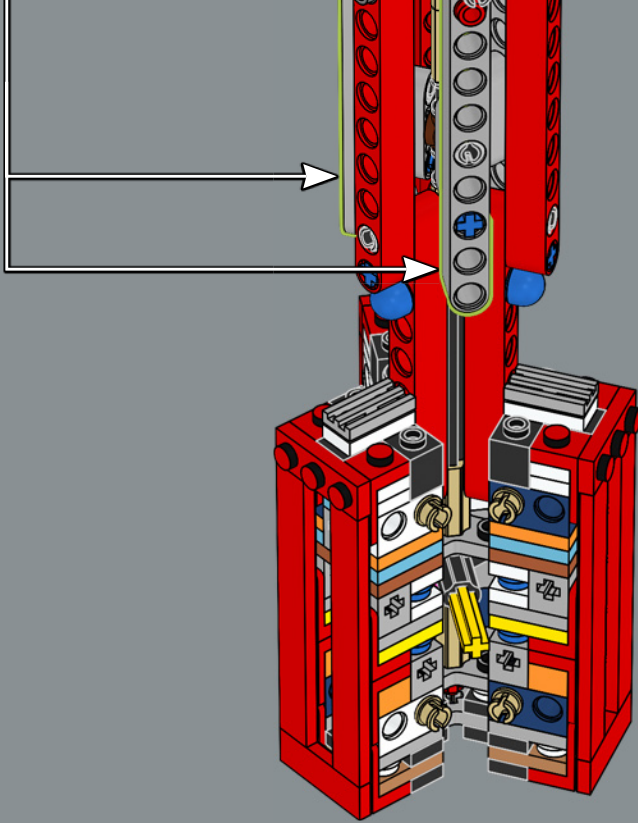
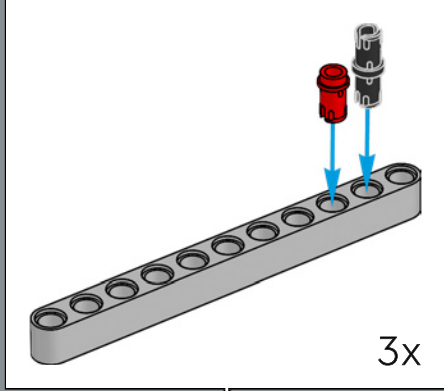



61

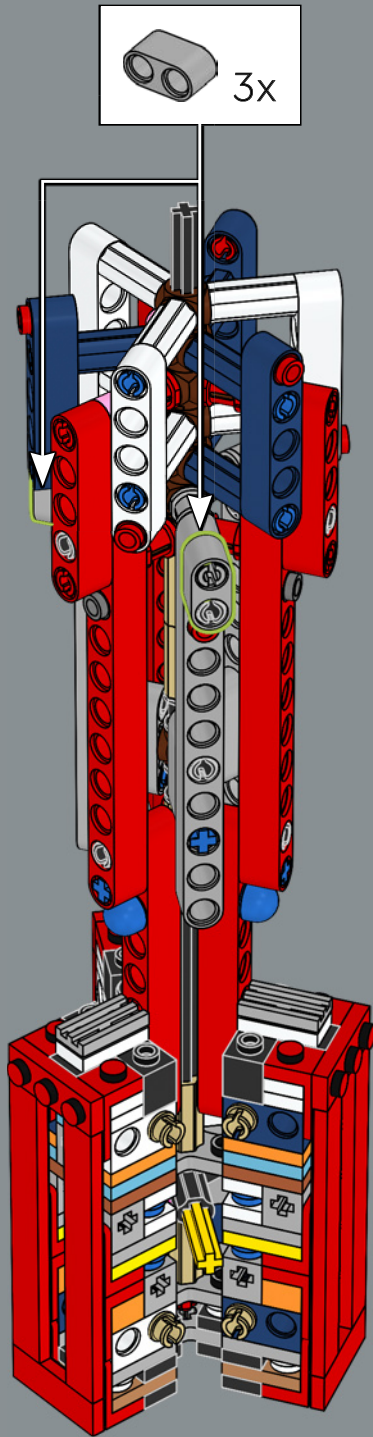

62

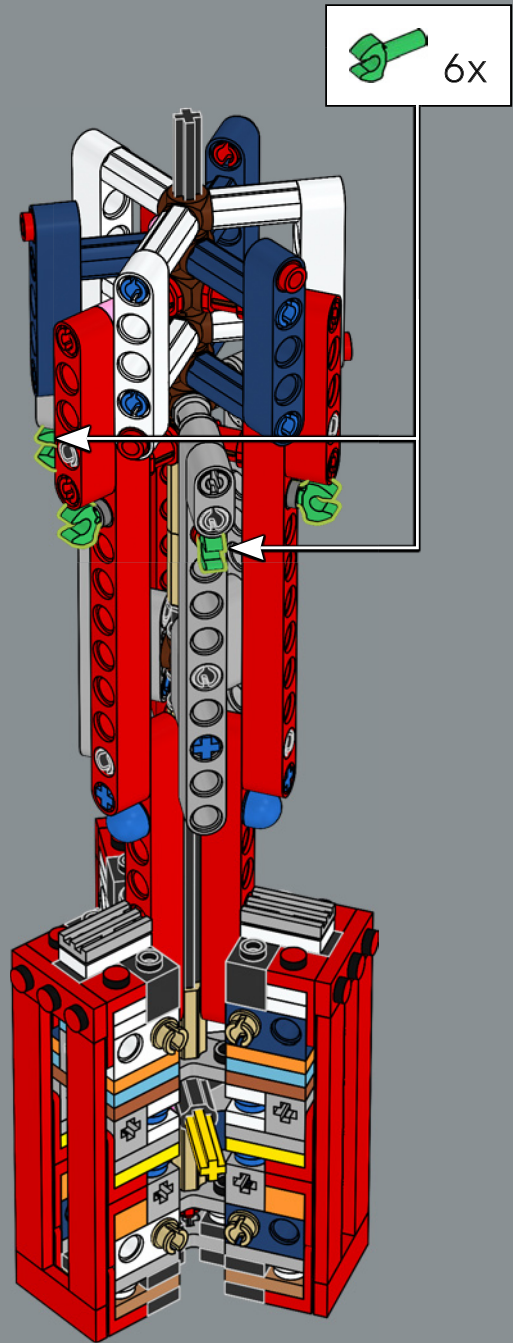



63

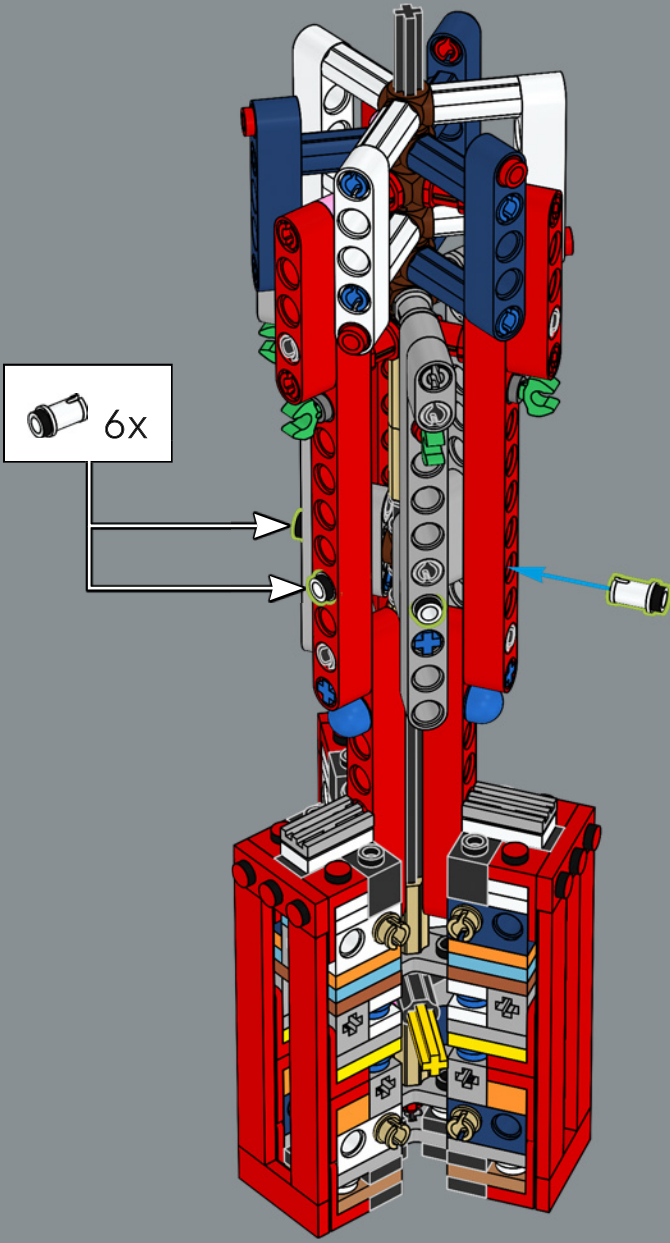



65

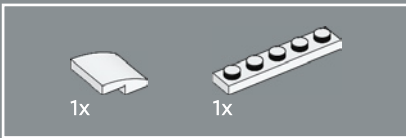
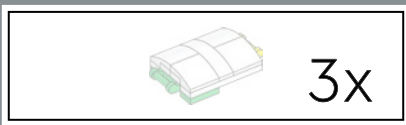
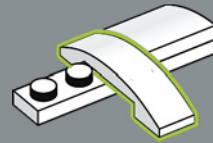

64

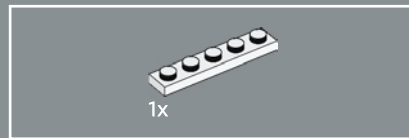
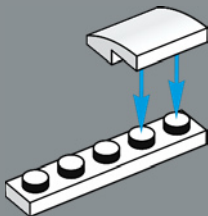

66

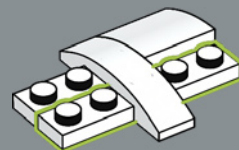



67

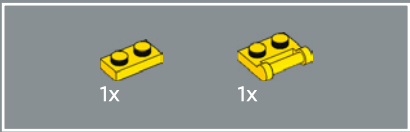
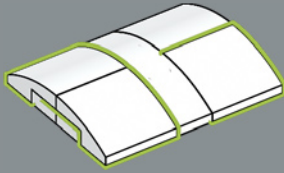

68

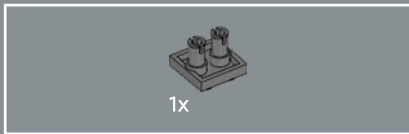
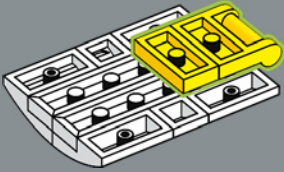

69

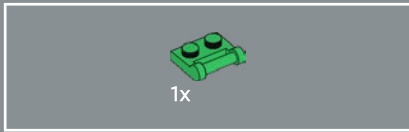
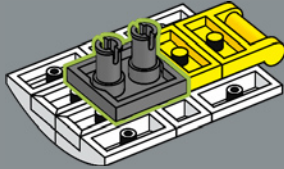

70

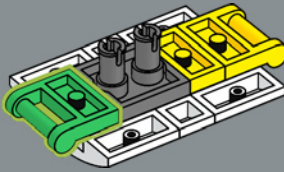

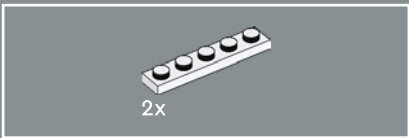

2x

71

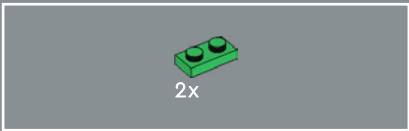
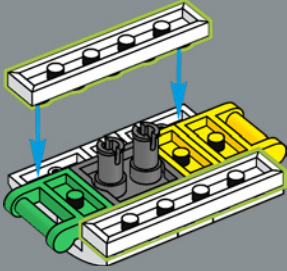

2x

72

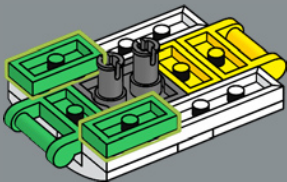

3x

73

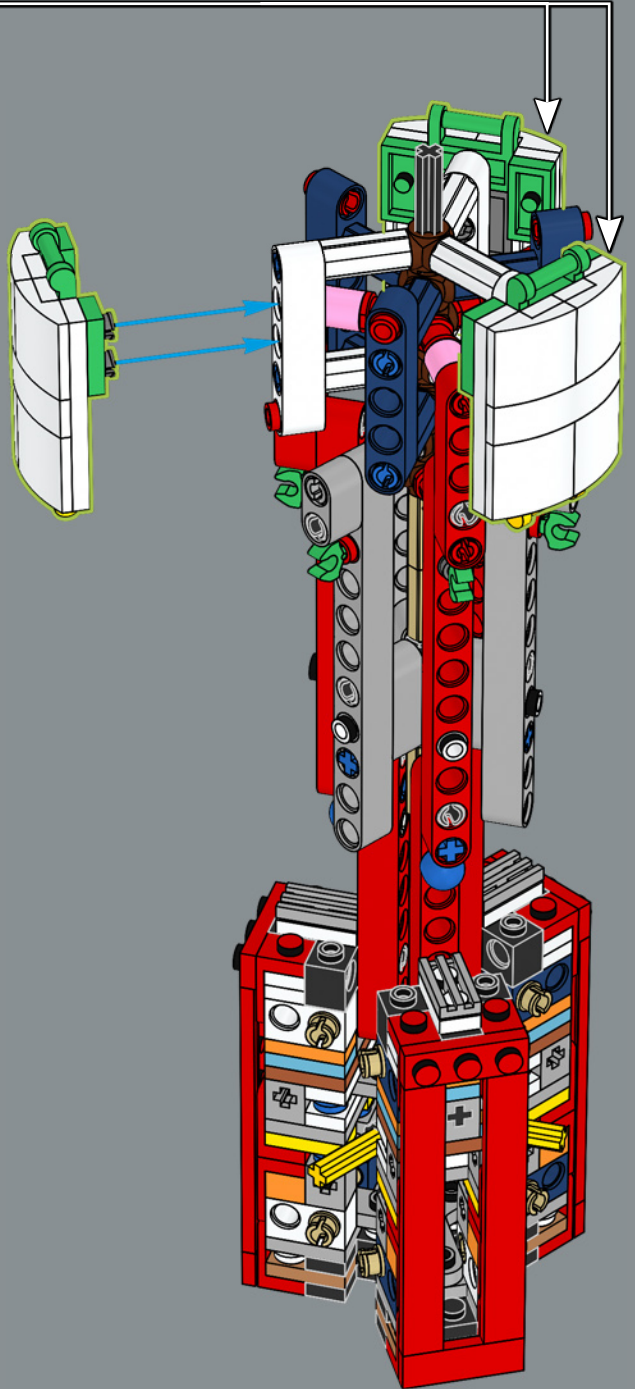

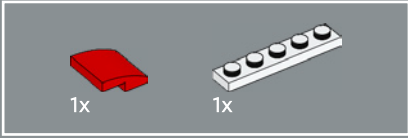
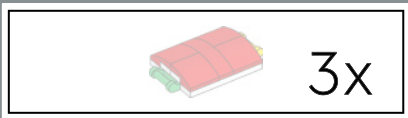

74

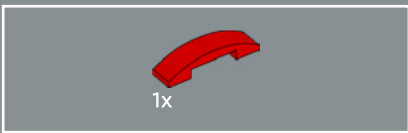
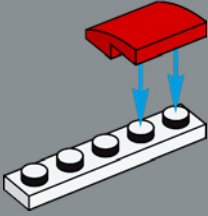

75

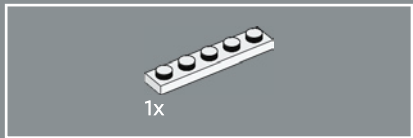
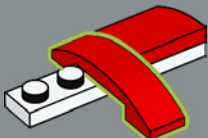

76

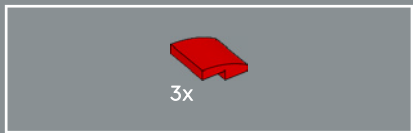
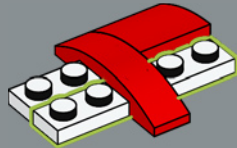

77

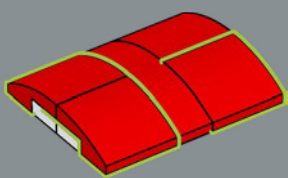

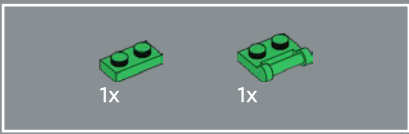

78

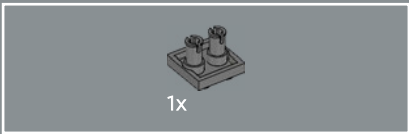
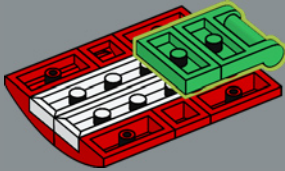

79

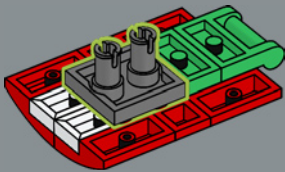

80

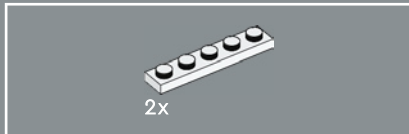
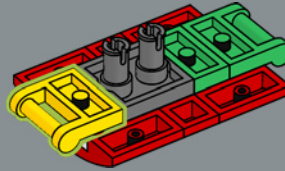

81

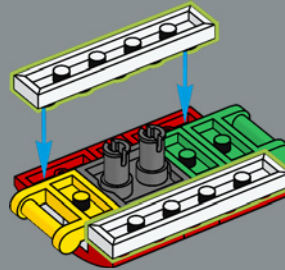

3x

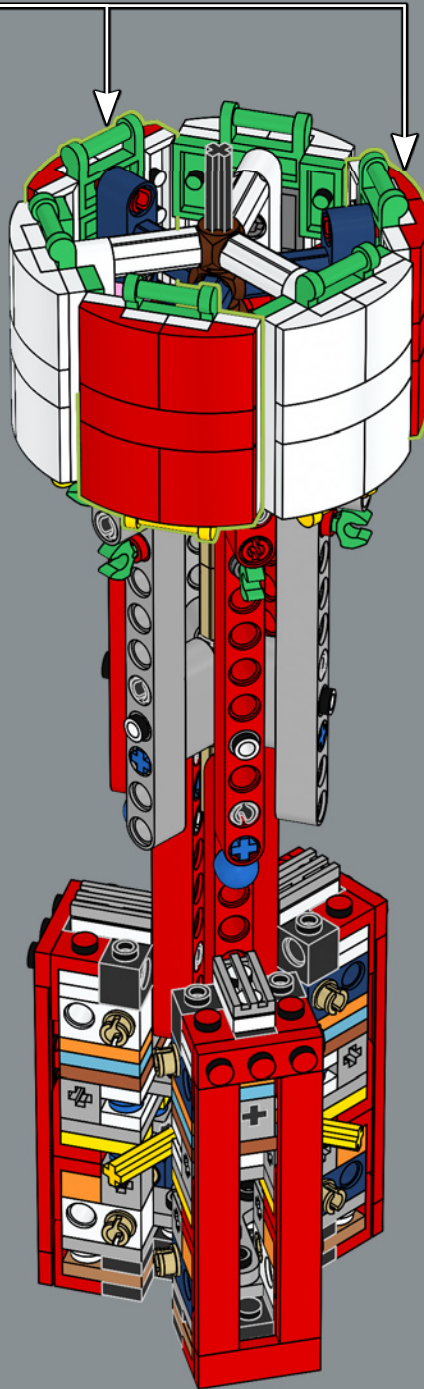

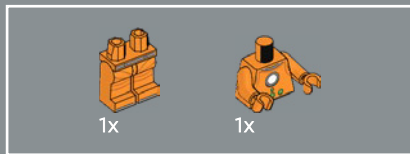

1

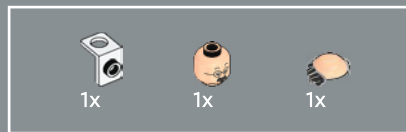
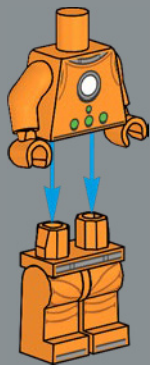

2

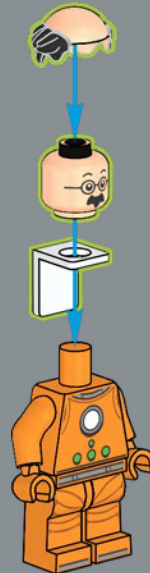

3

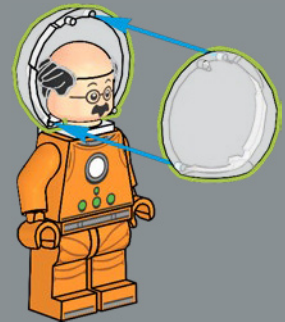



4

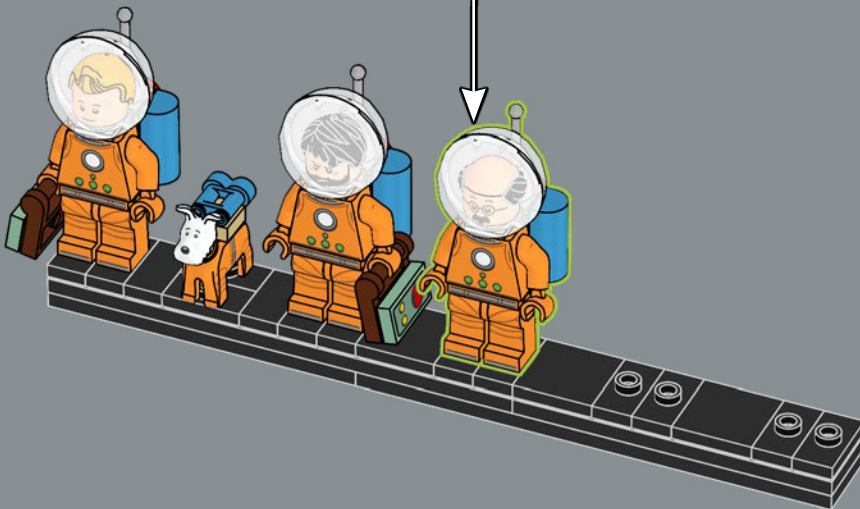
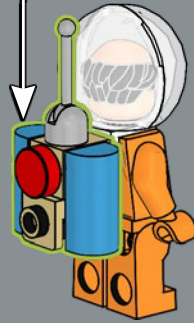
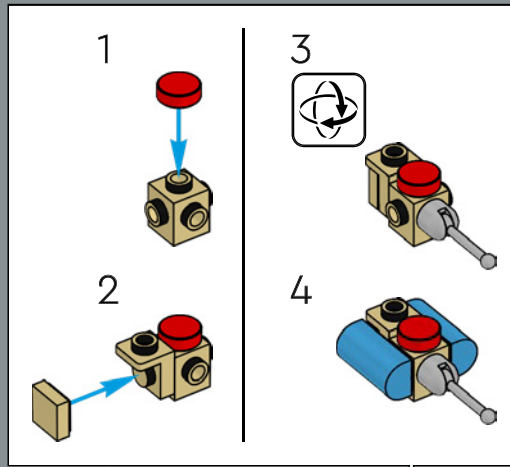

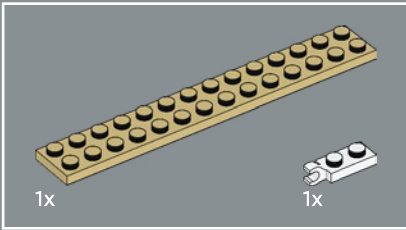
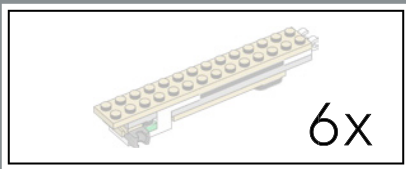

83

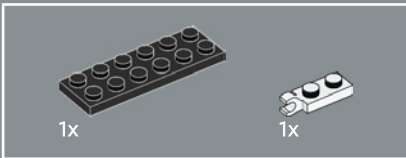
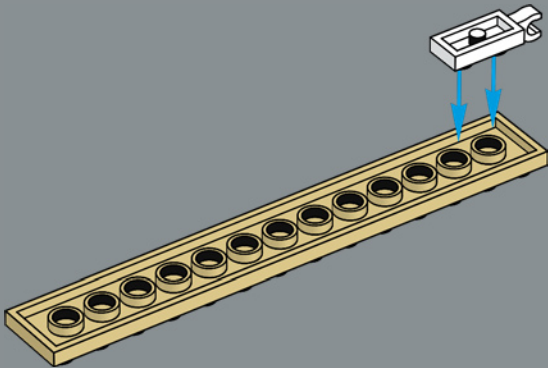

84

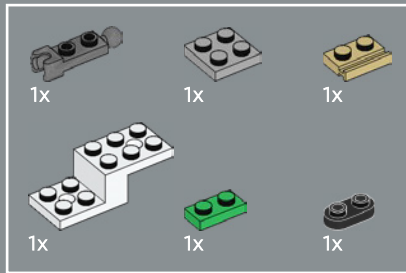
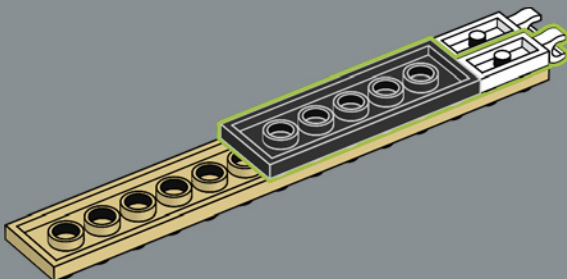

85

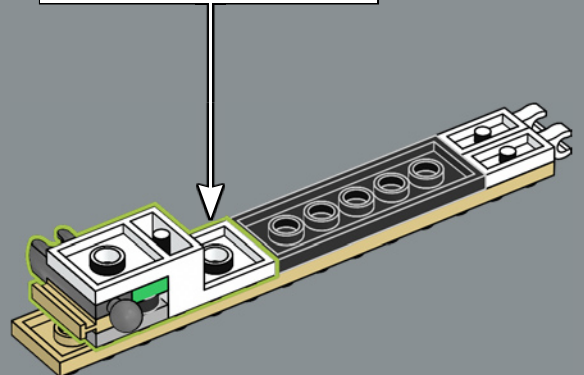
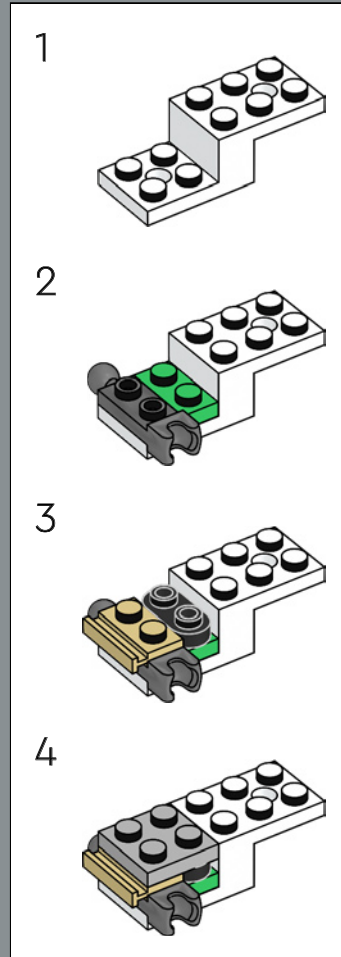

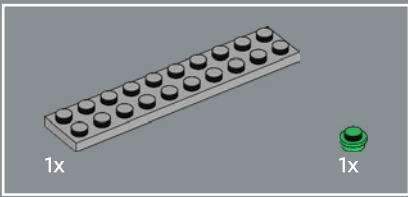

86

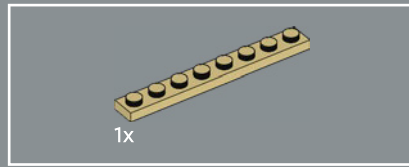
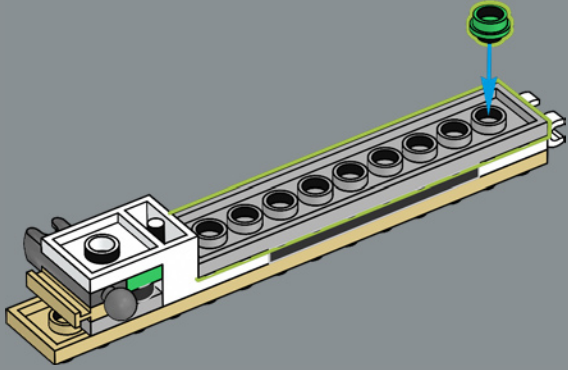

88

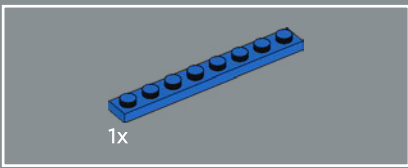
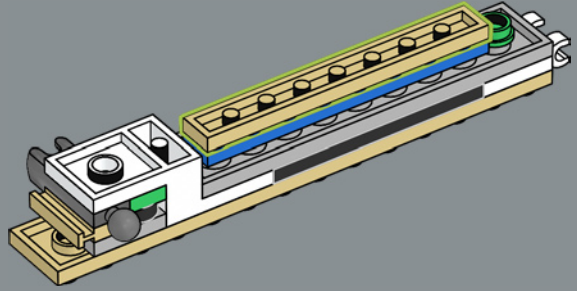

87

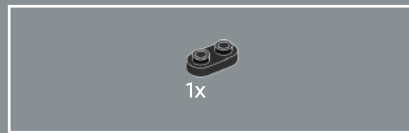
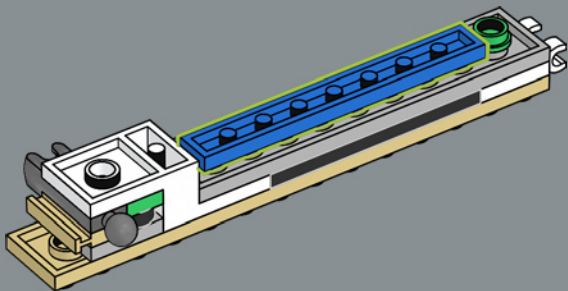

89

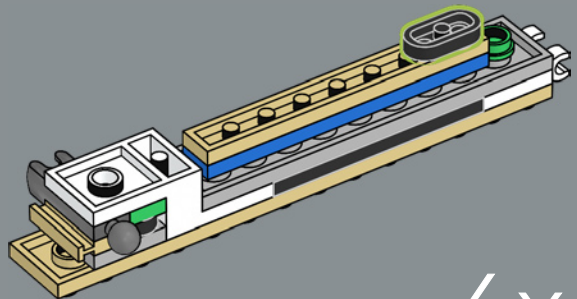

6x



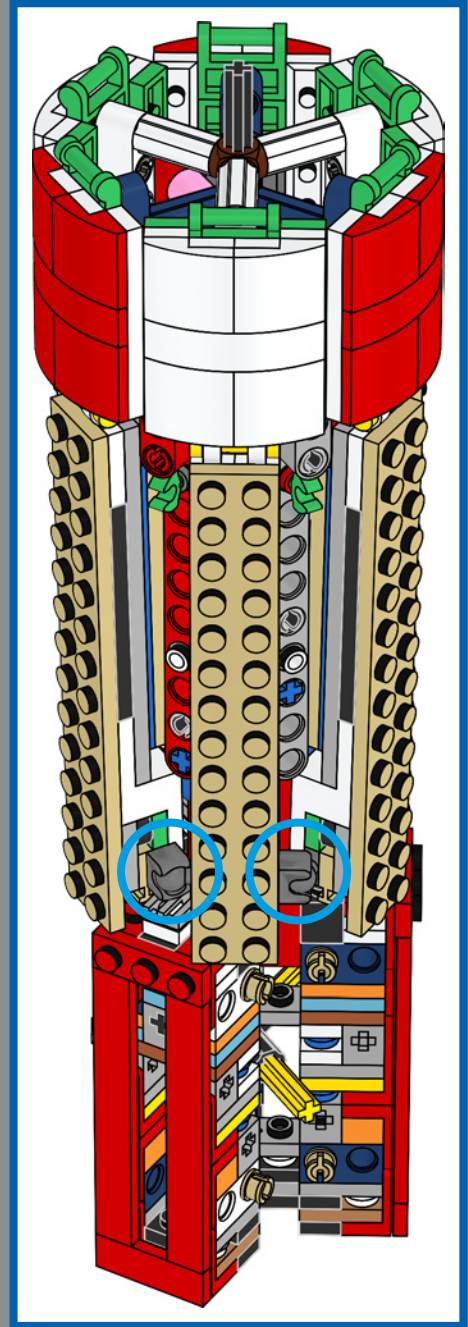
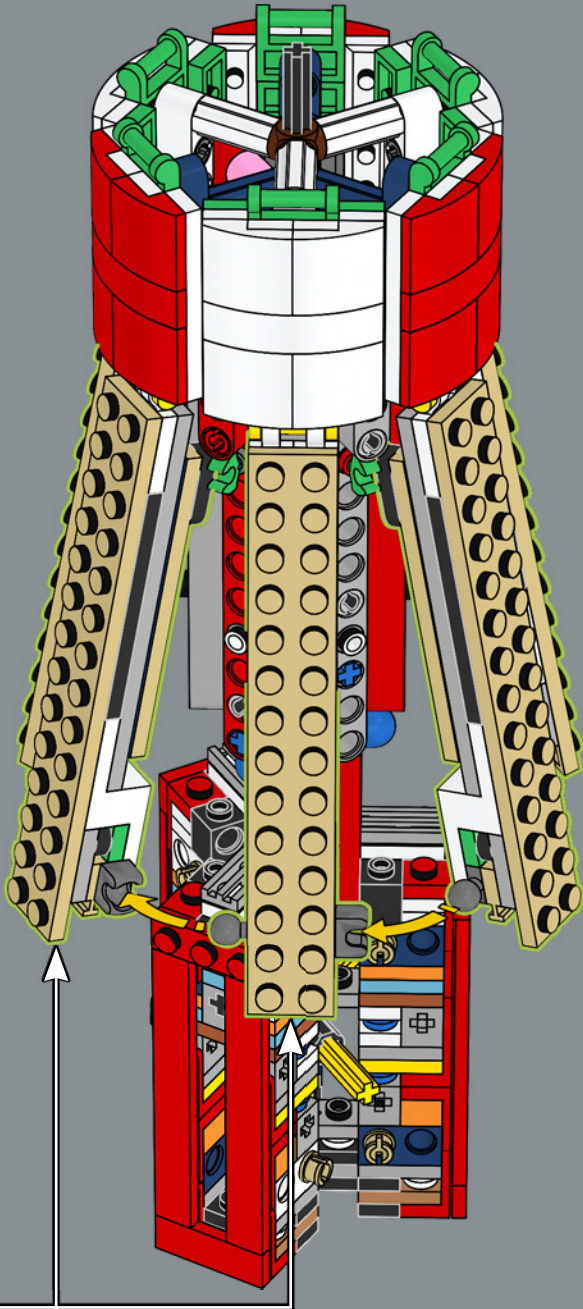

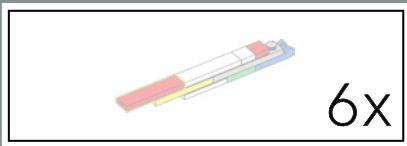

6x

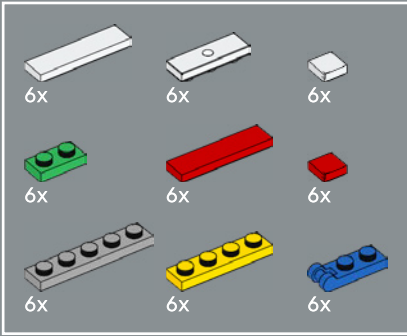

91

1

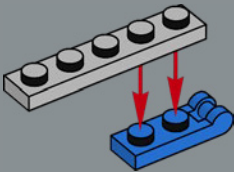

2

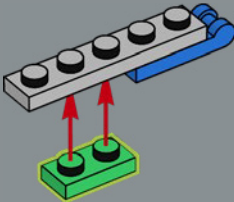

3

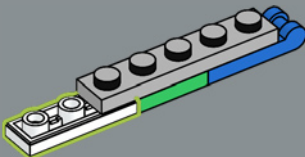

4

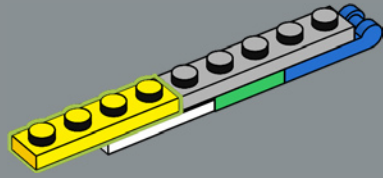

5

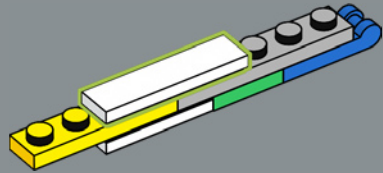

6

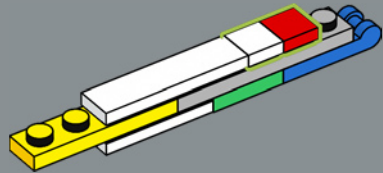

7

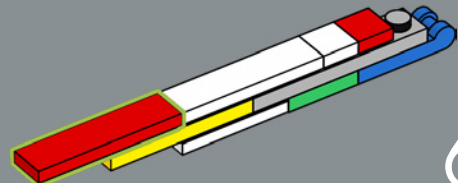

6x



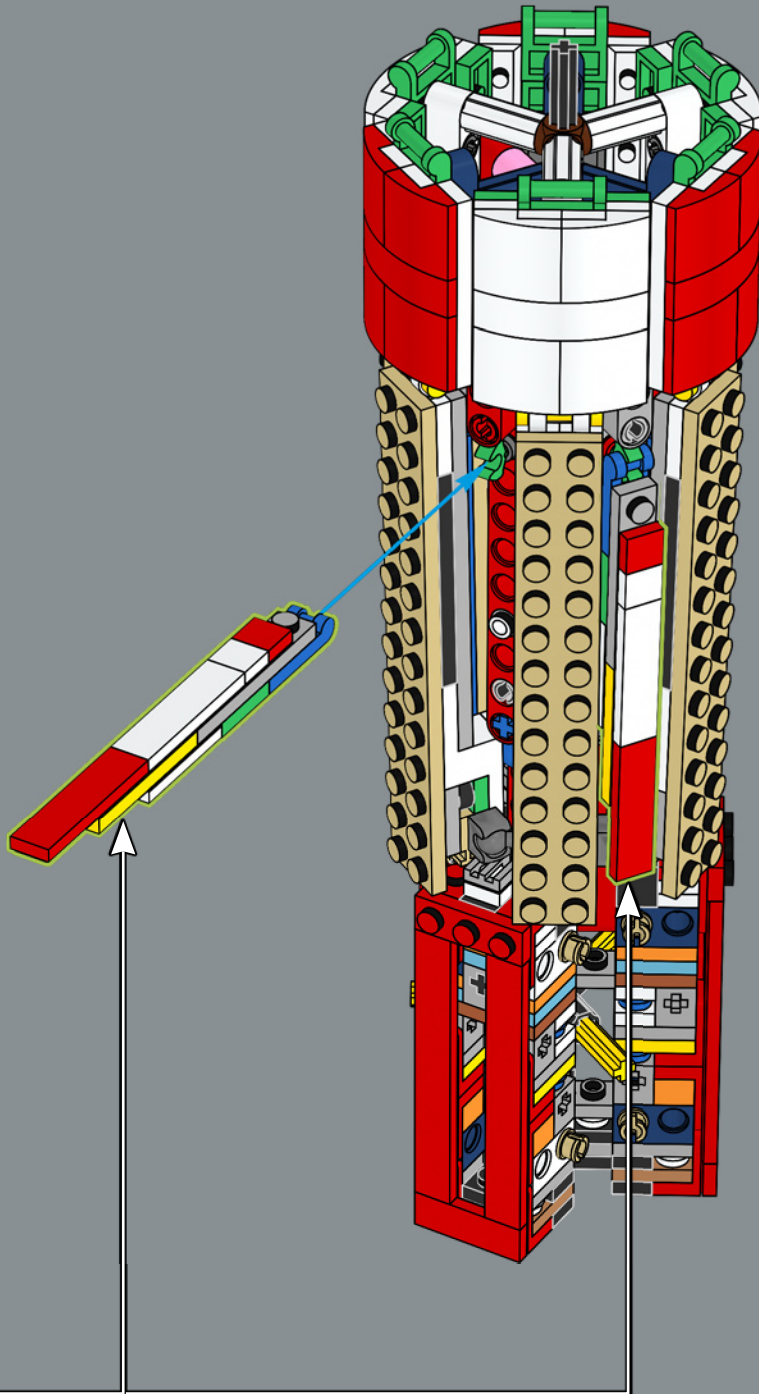

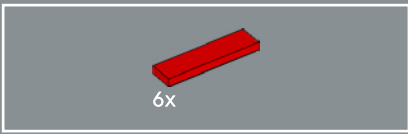

92

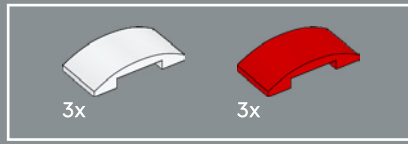
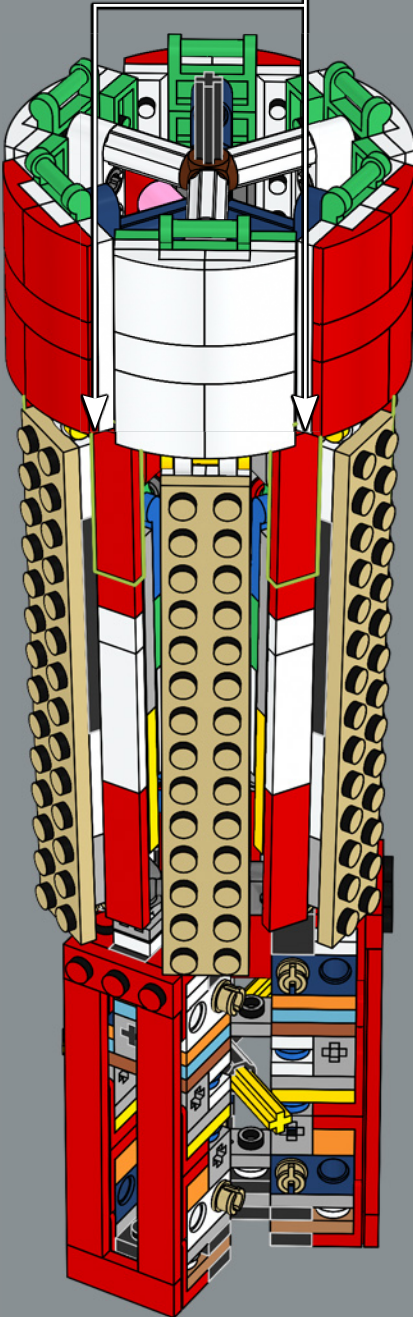
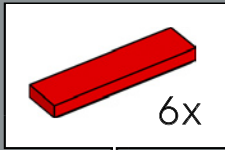

93

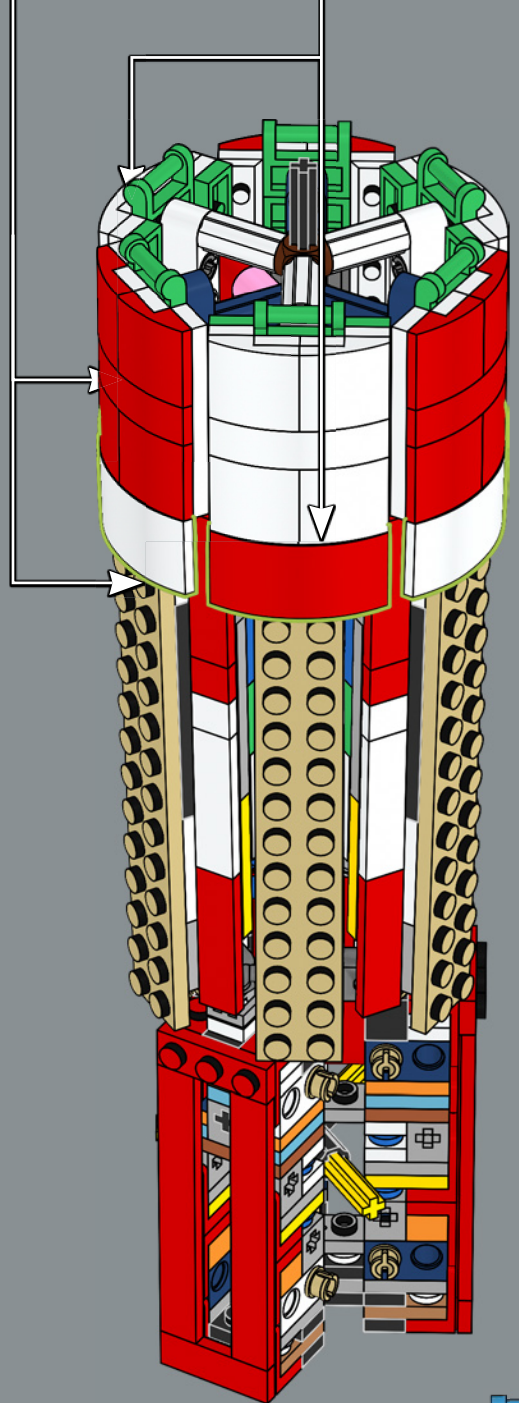
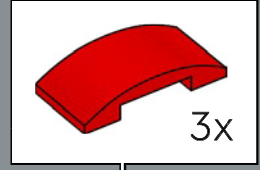
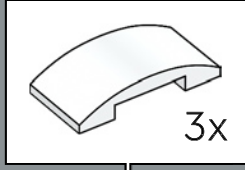

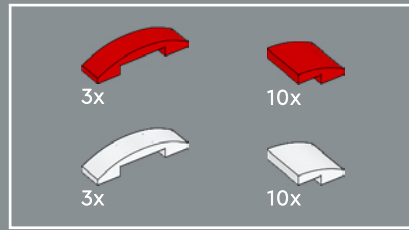

94

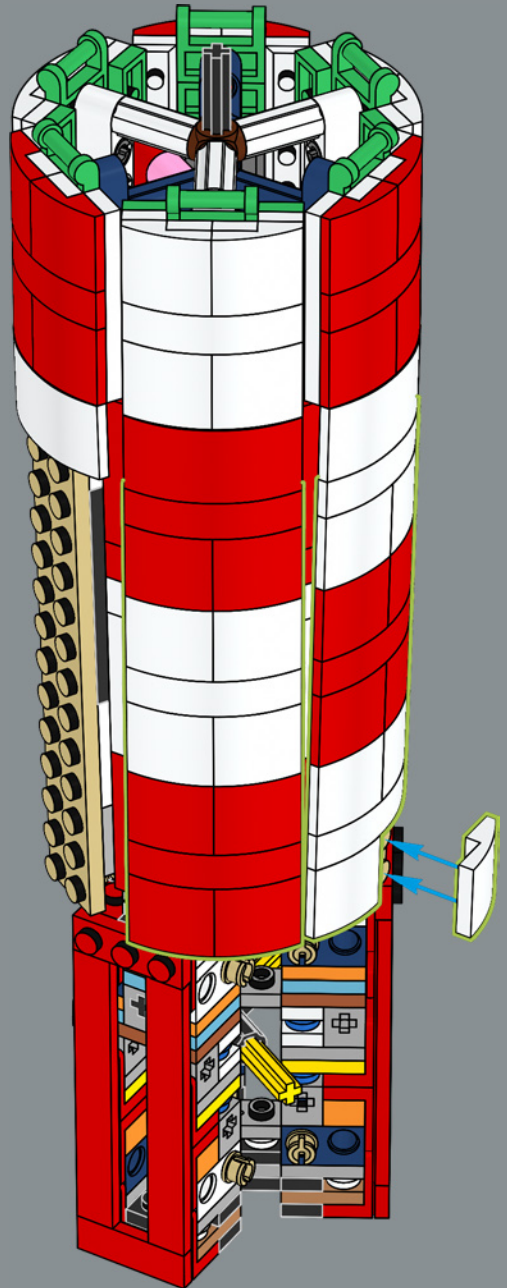

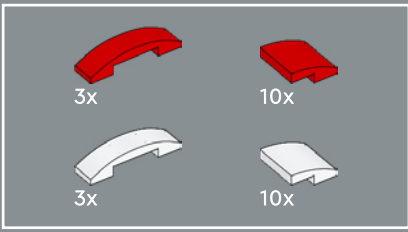

95

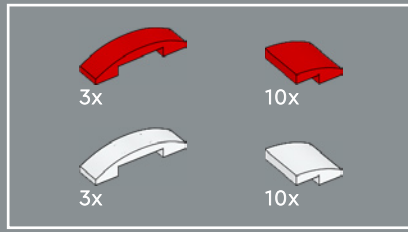
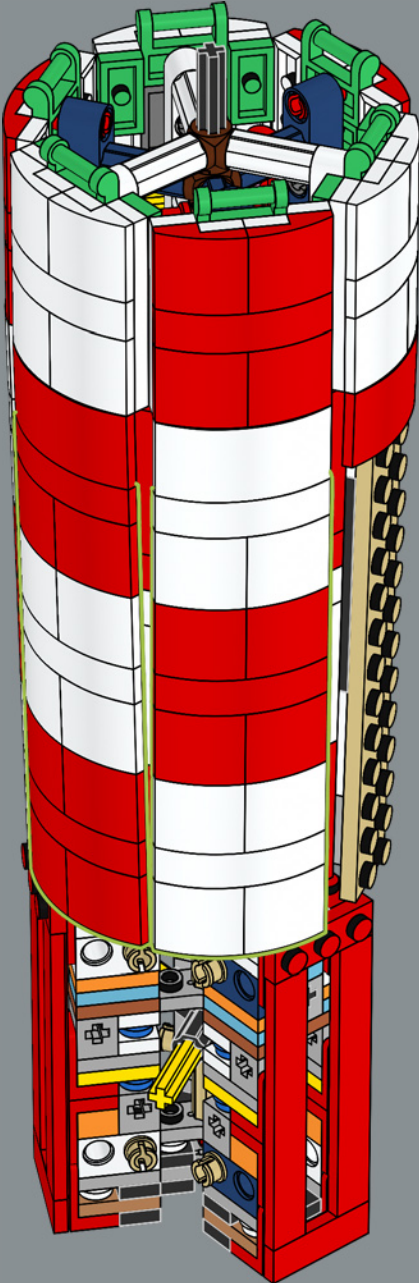

96

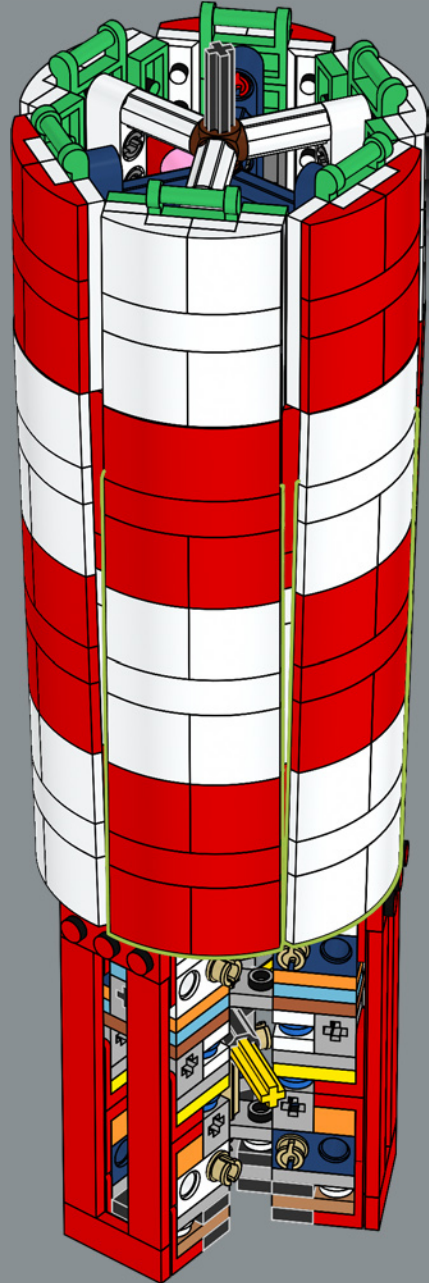





97

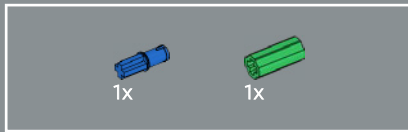
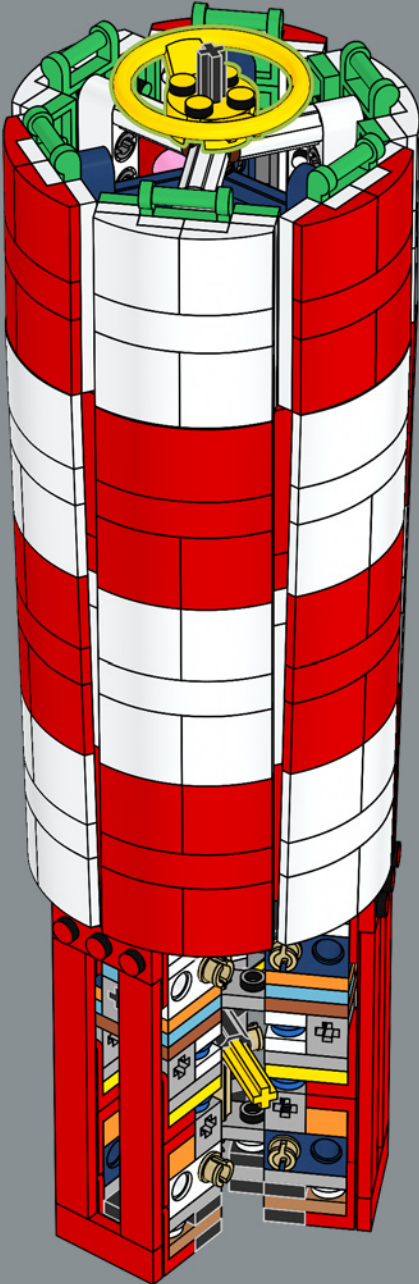

98

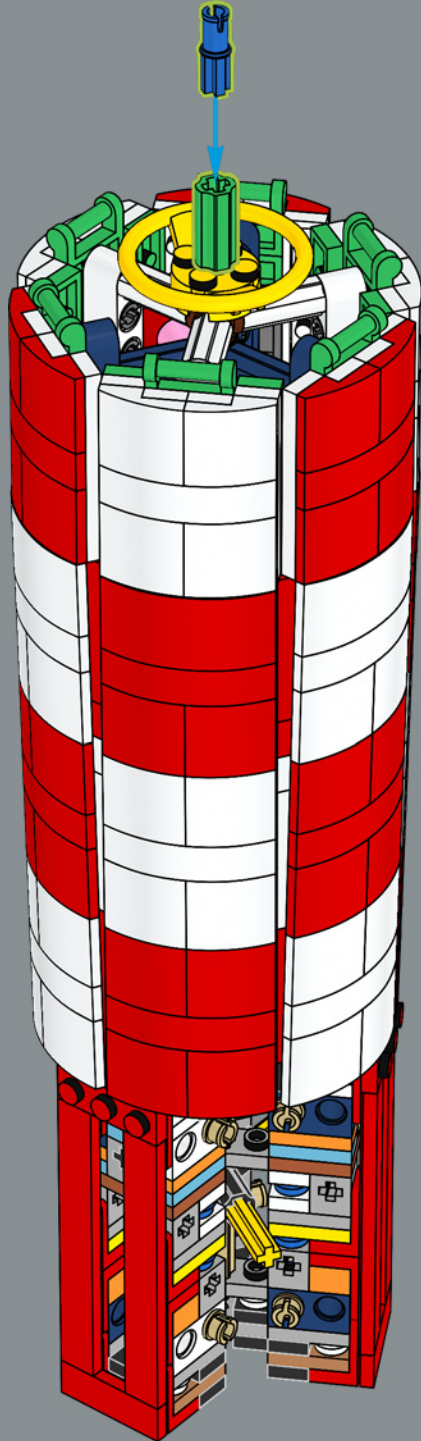

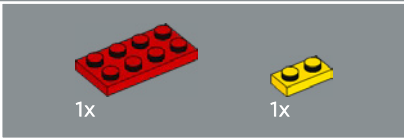
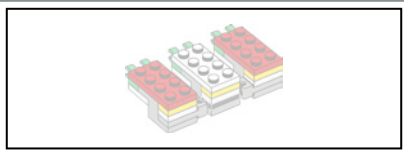

99

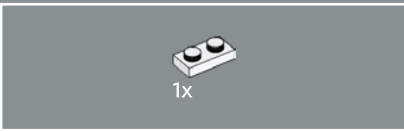
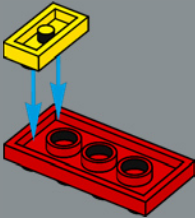

100

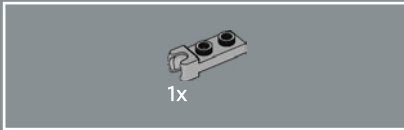
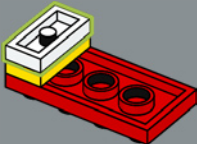

101

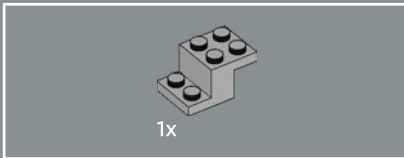
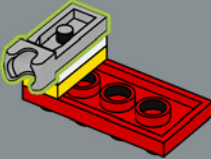

102

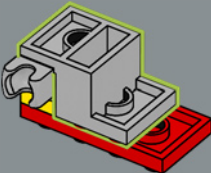

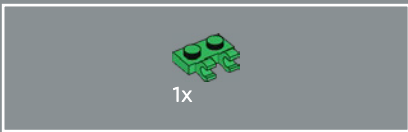

103

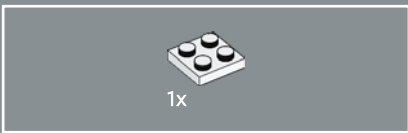
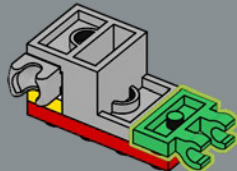

104

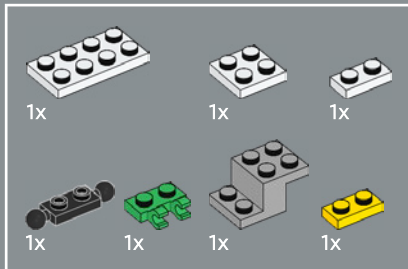
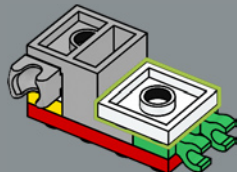

105

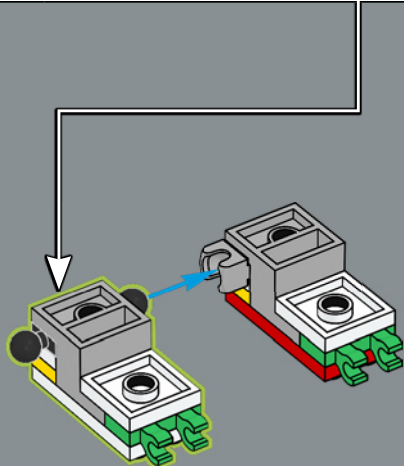
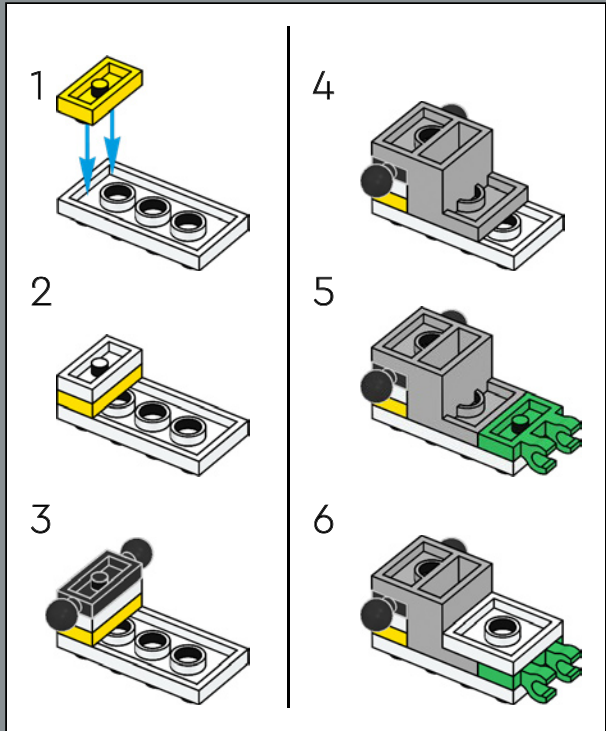

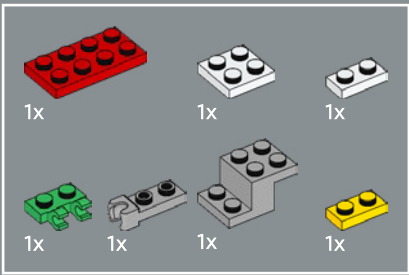

106

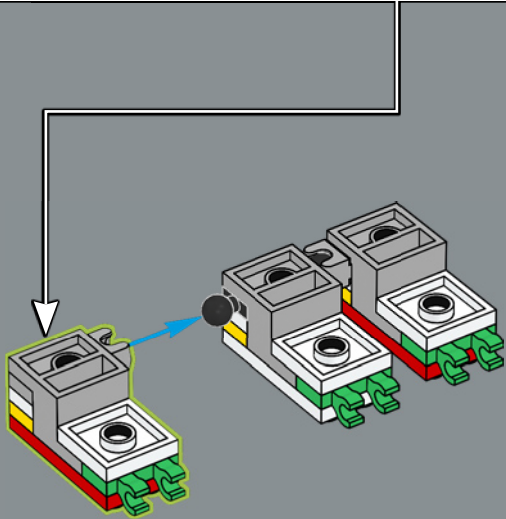
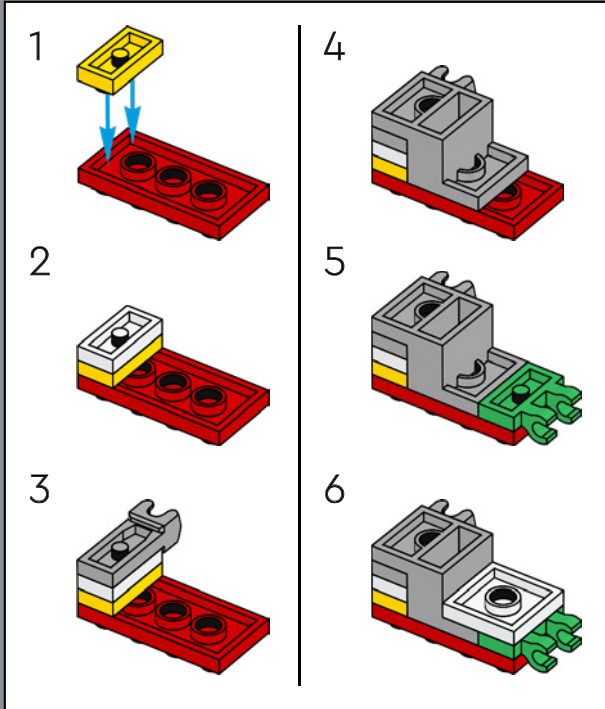

107

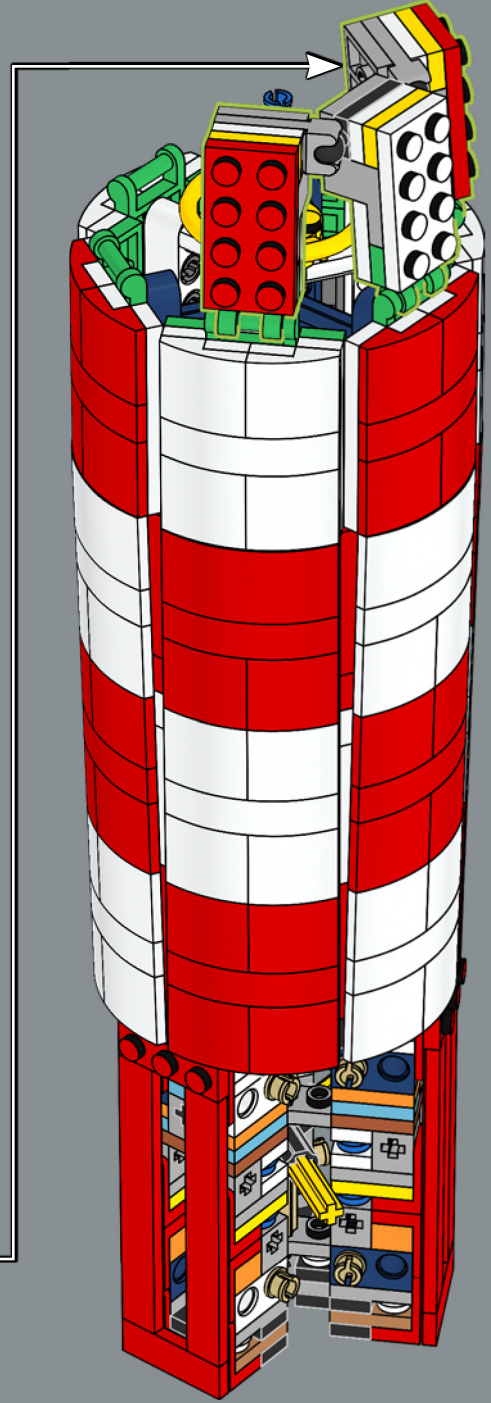

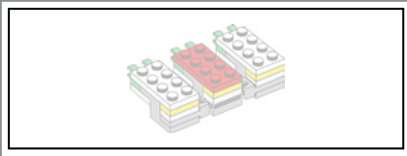

108

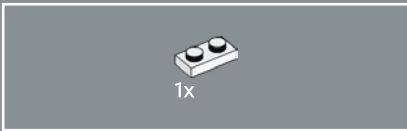
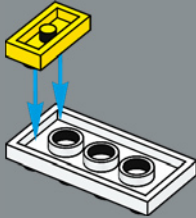

109

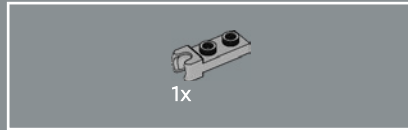

110

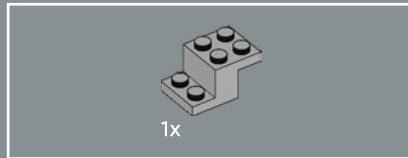
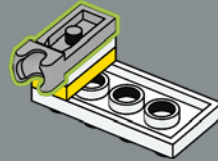

111

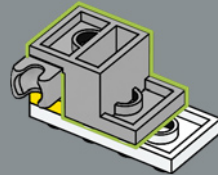

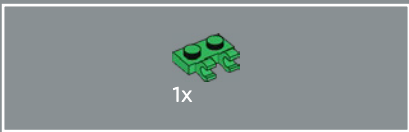

112

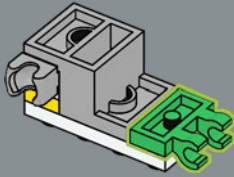

113

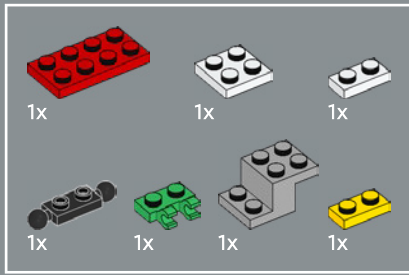
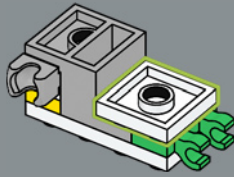

114

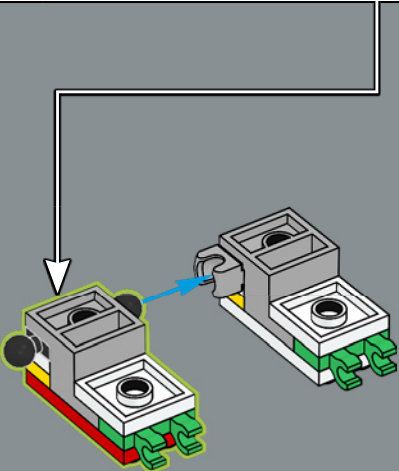
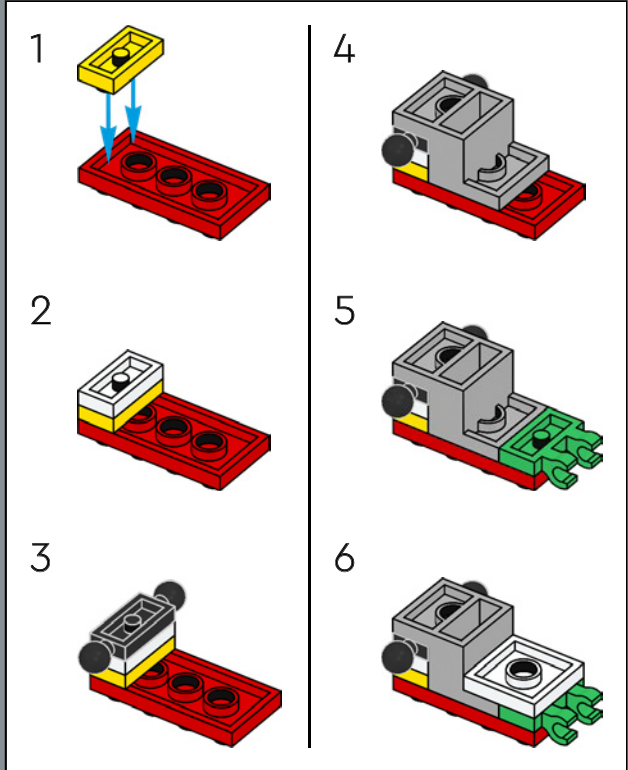

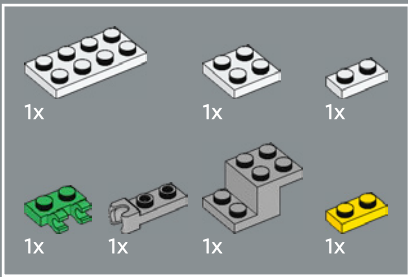

115

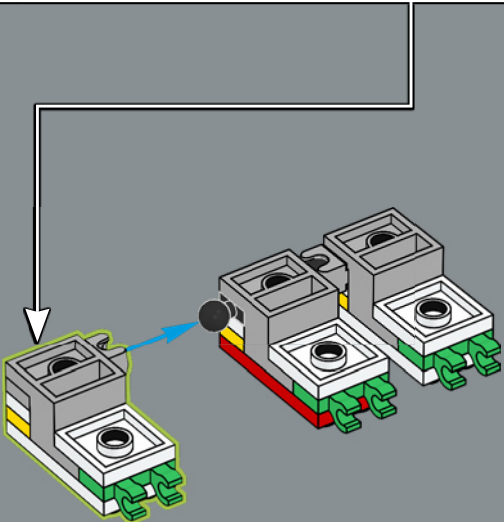
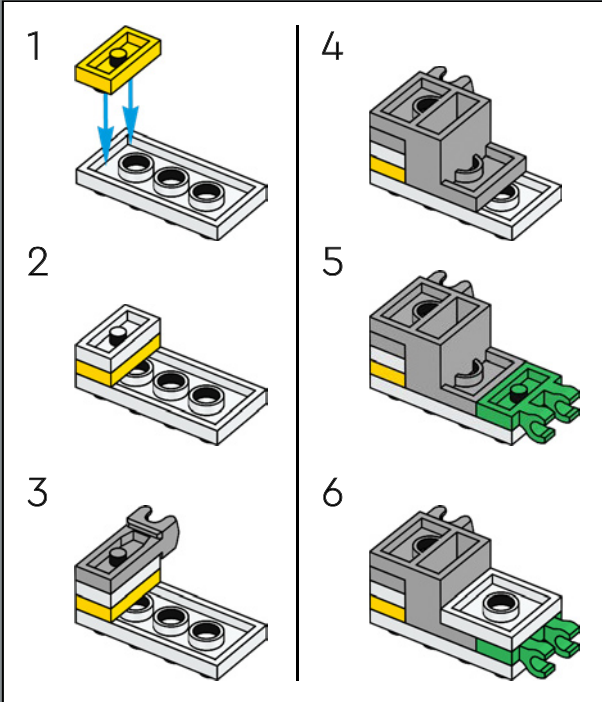

116

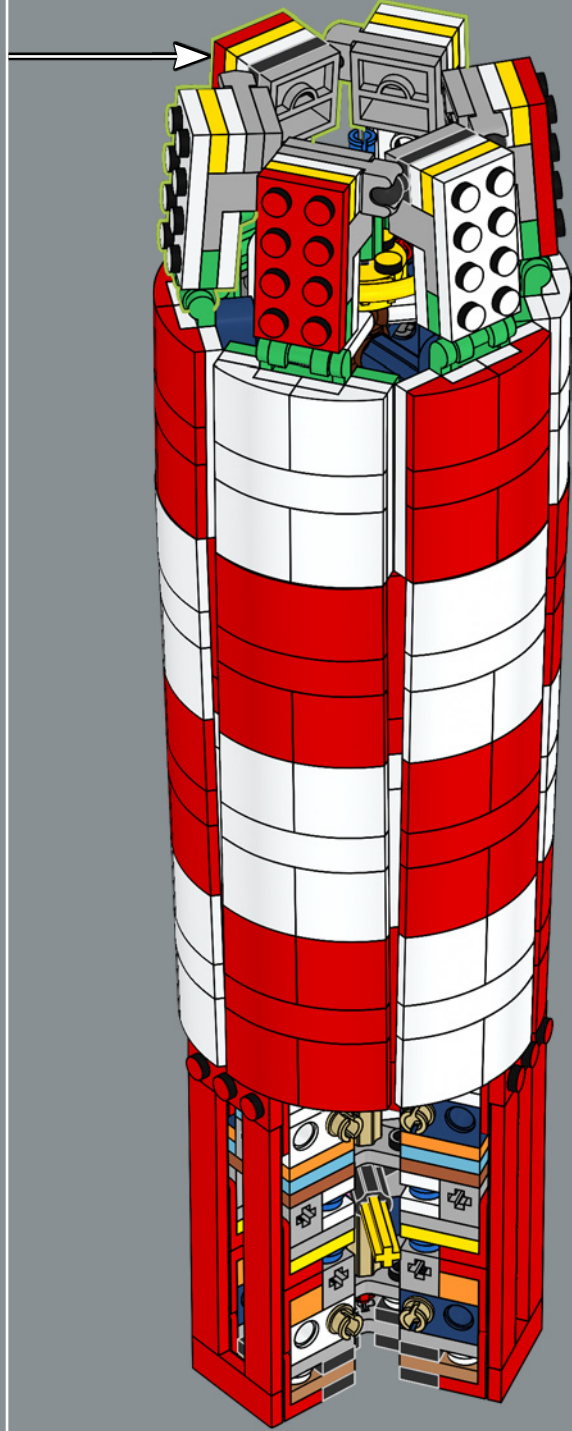

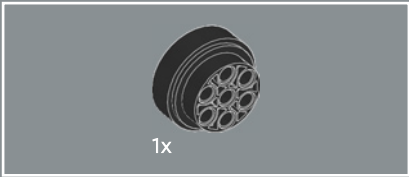

117

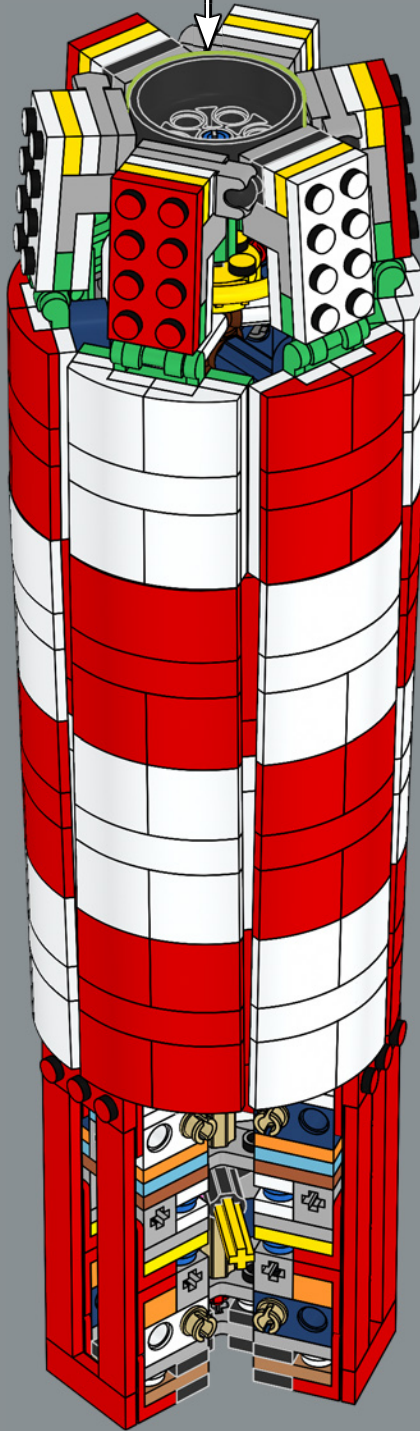

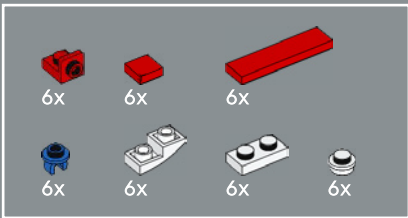

118

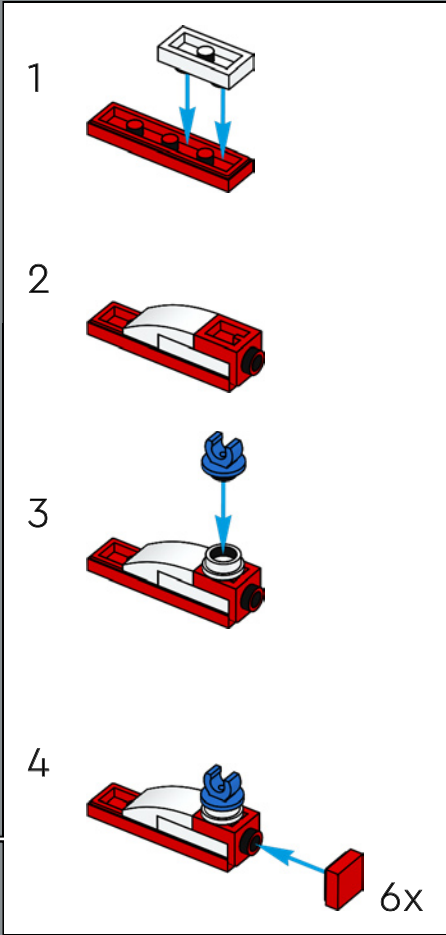
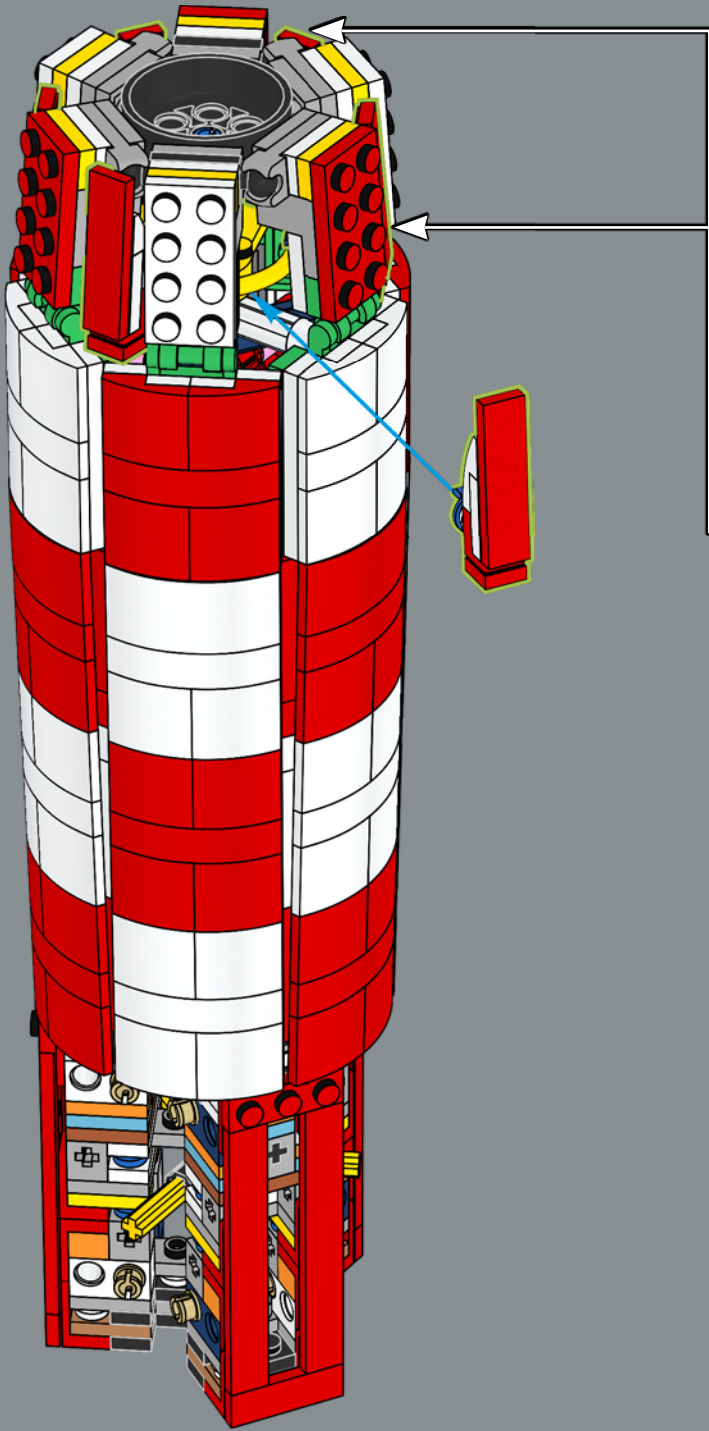

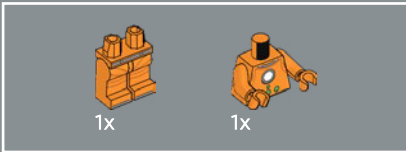
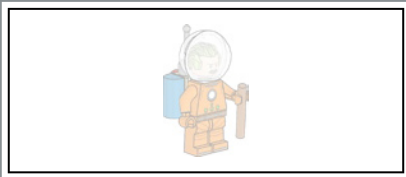

1

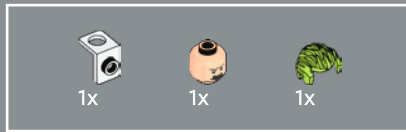
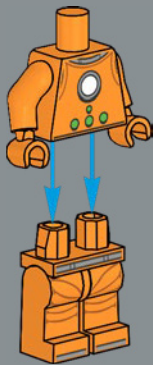

2

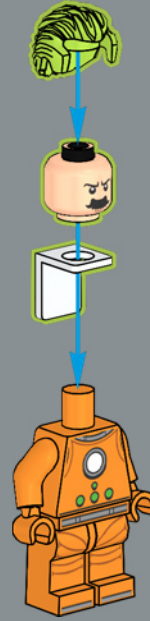

3

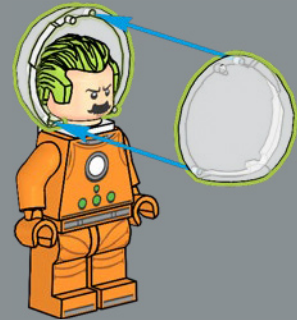



4

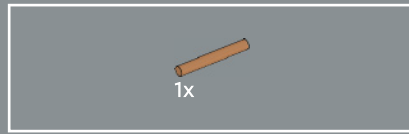
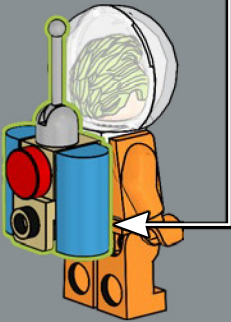
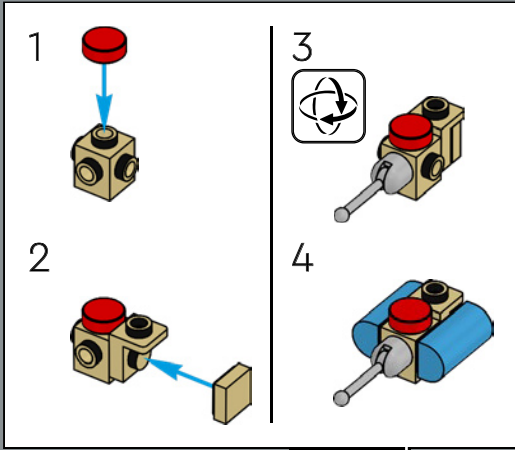

5

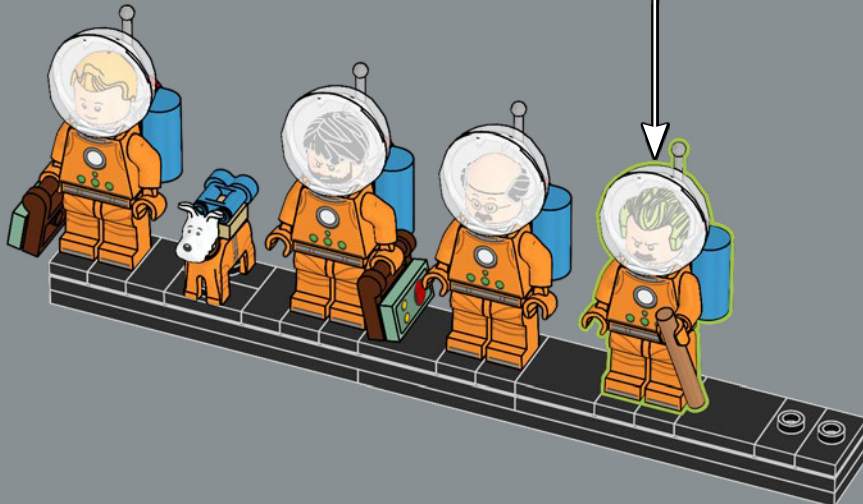

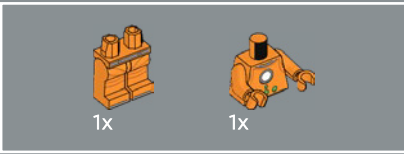
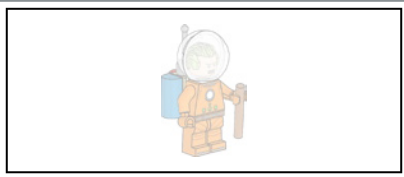

1

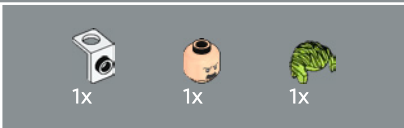
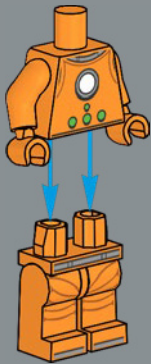

2

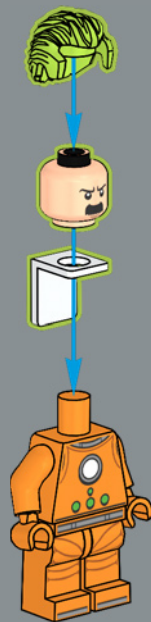

3

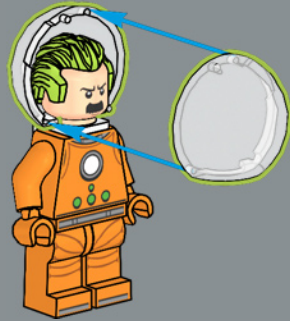

4

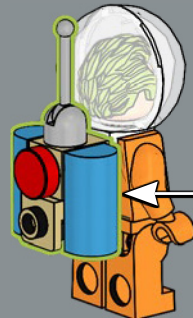
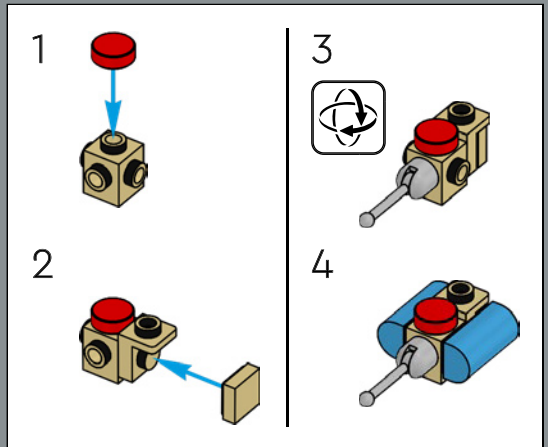

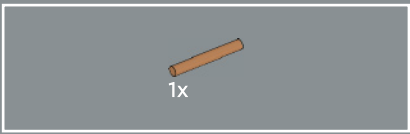

5

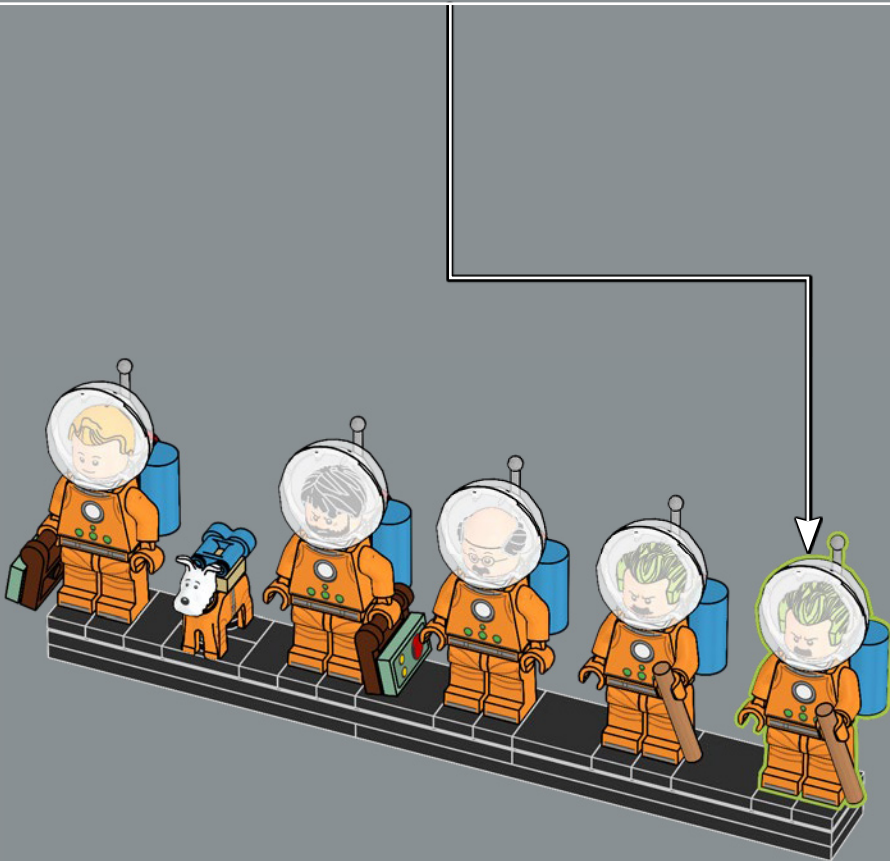
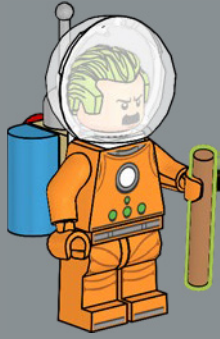

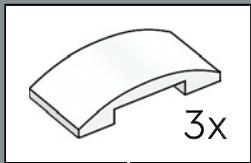
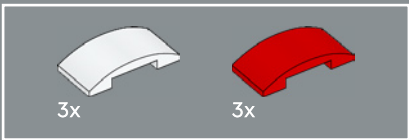

119

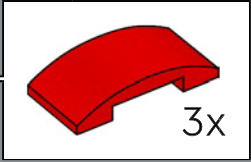
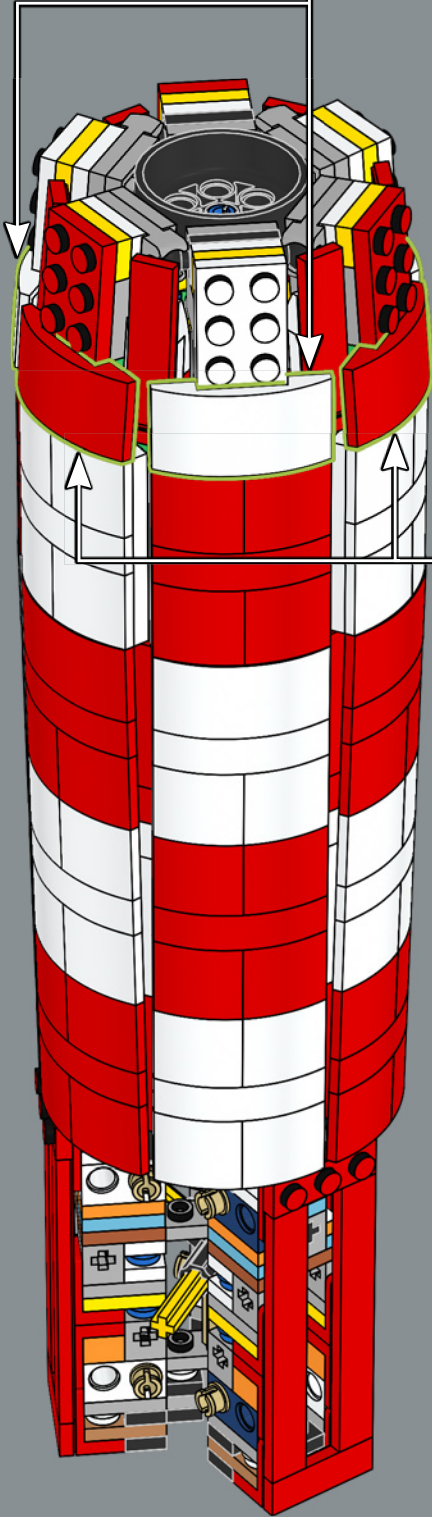

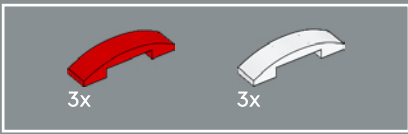

120

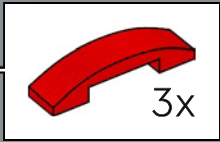
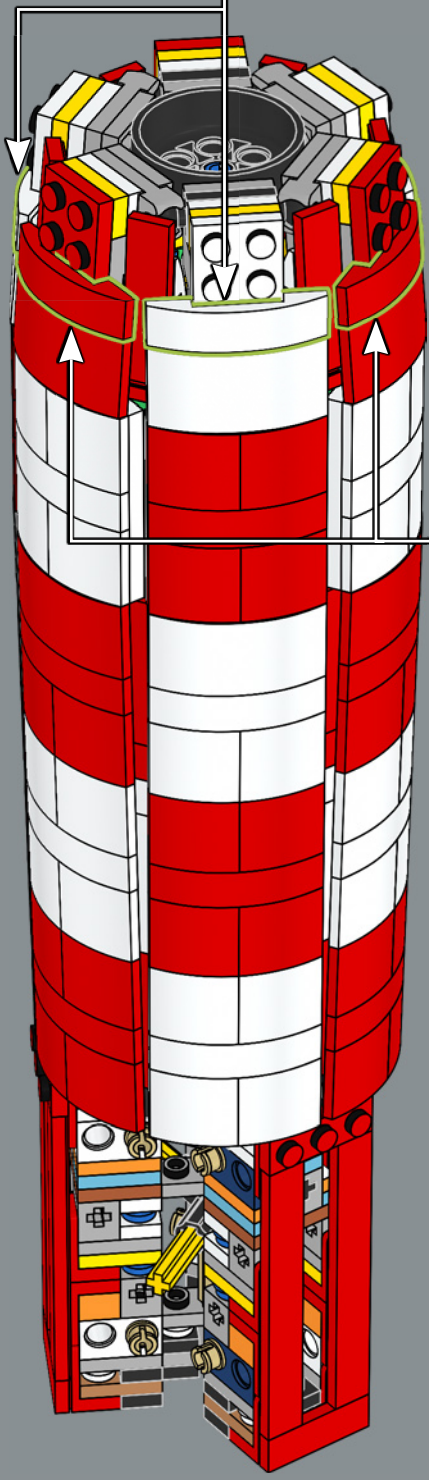
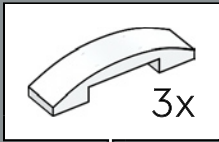

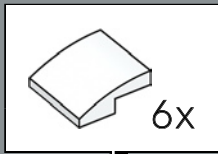
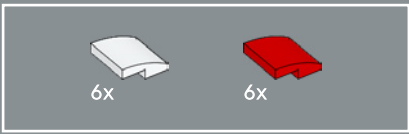

121

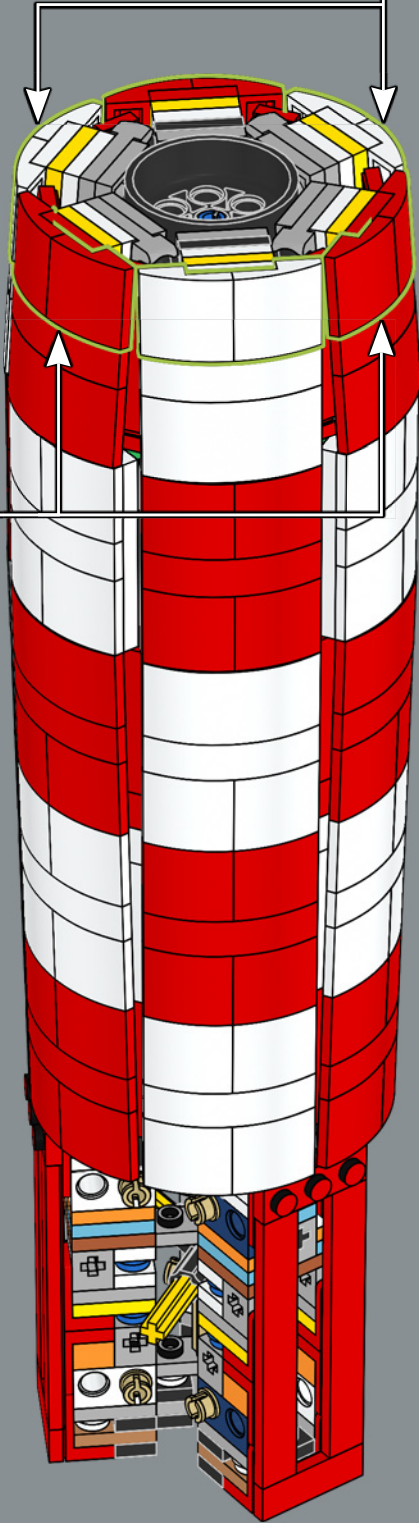
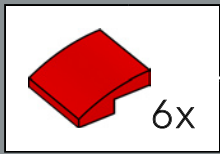

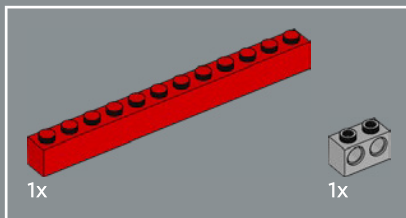
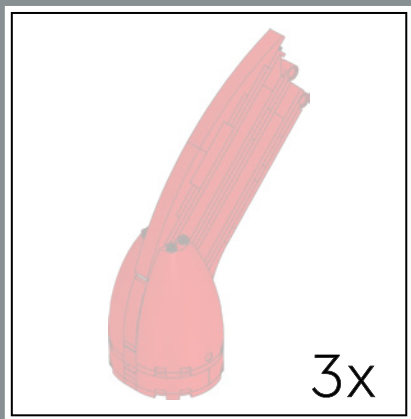

122

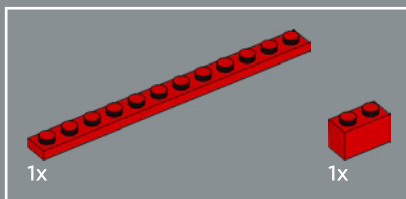
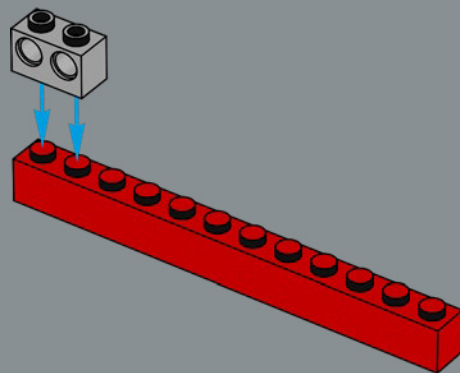

123

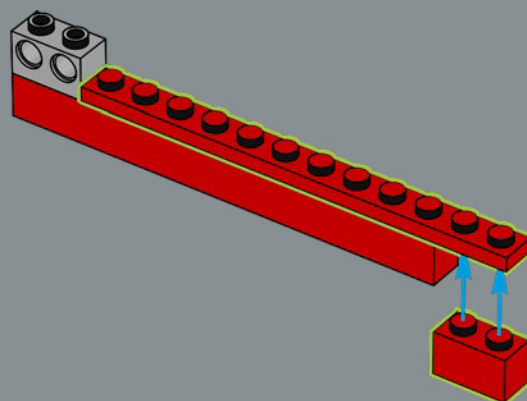

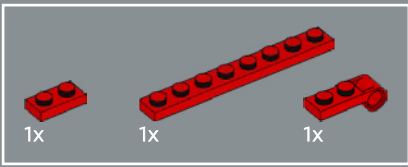

124

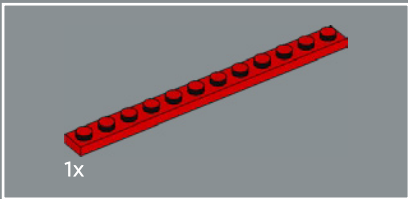
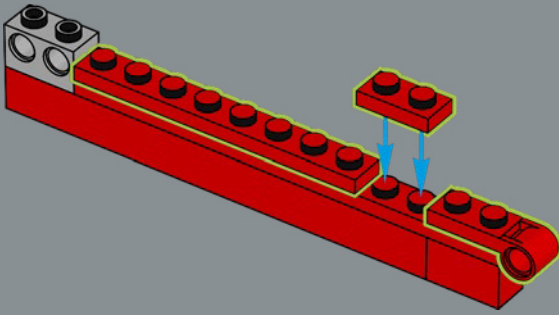

125

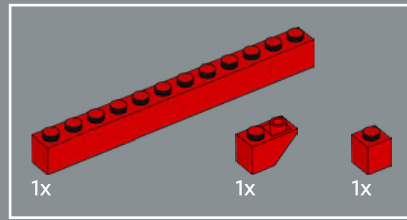
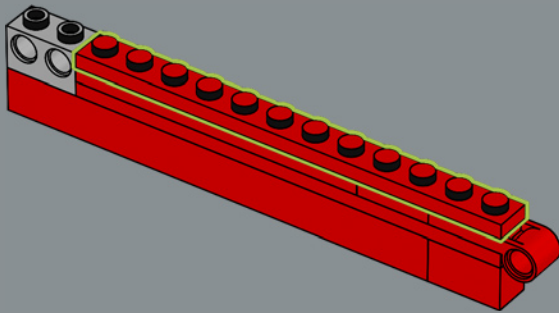

126

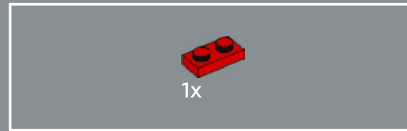
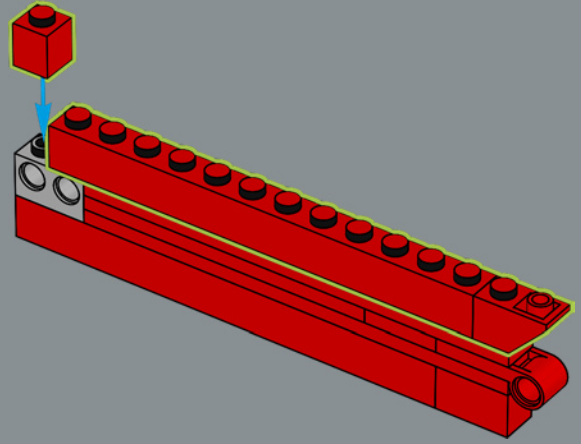

127

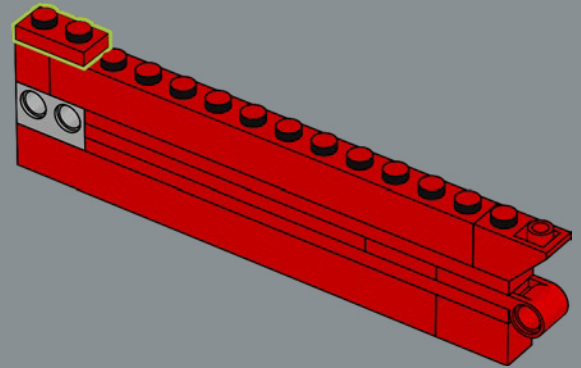

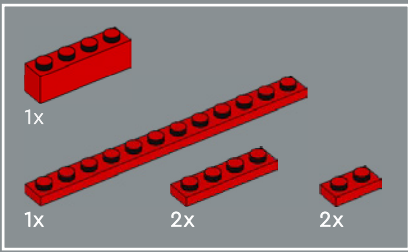

128

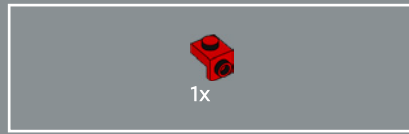
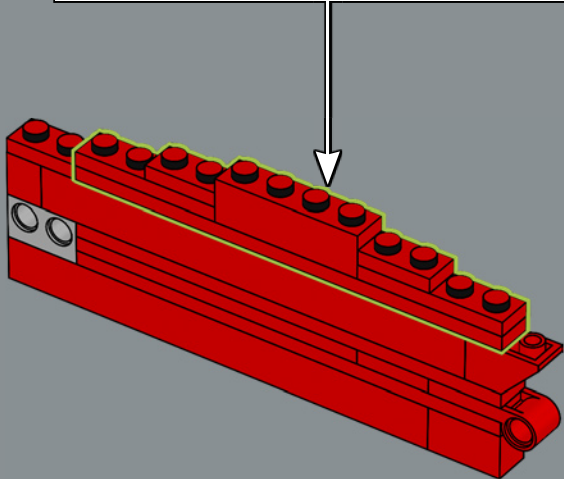
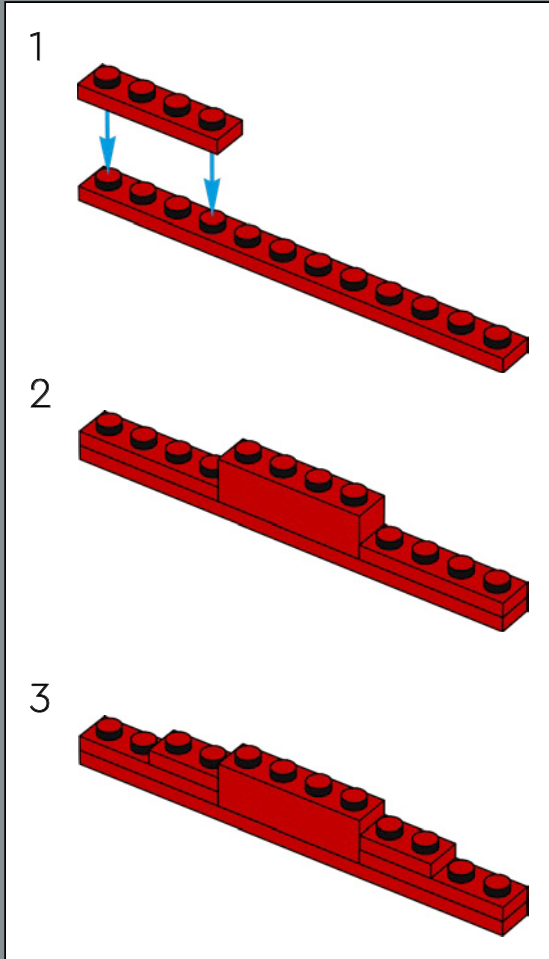

129

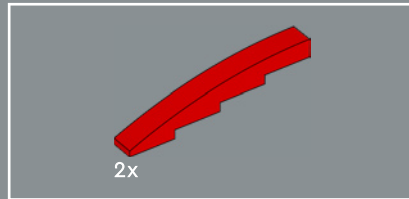
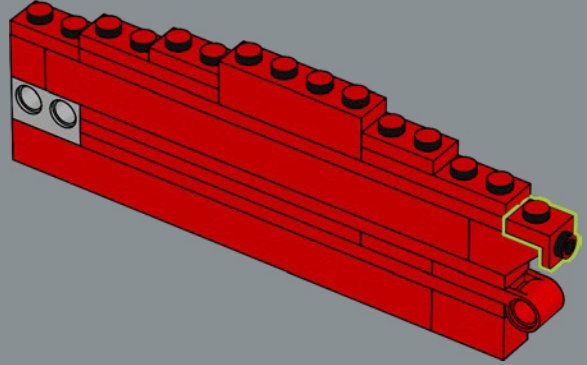

130

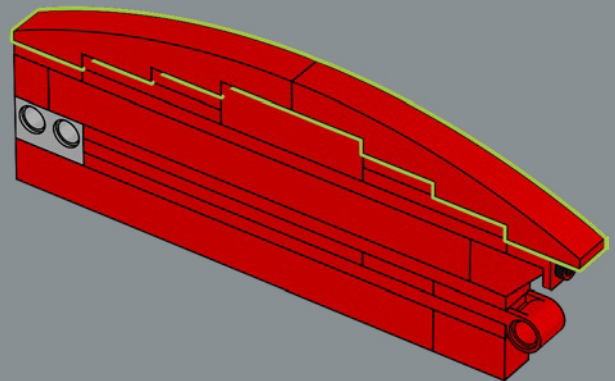

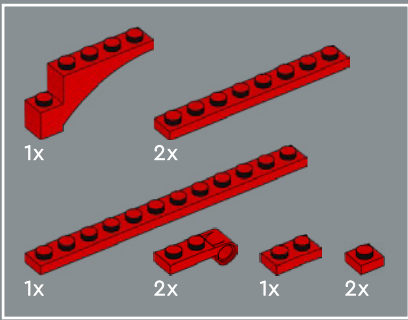

131

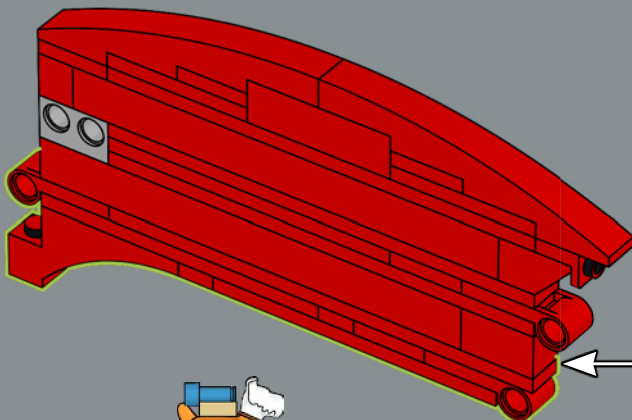
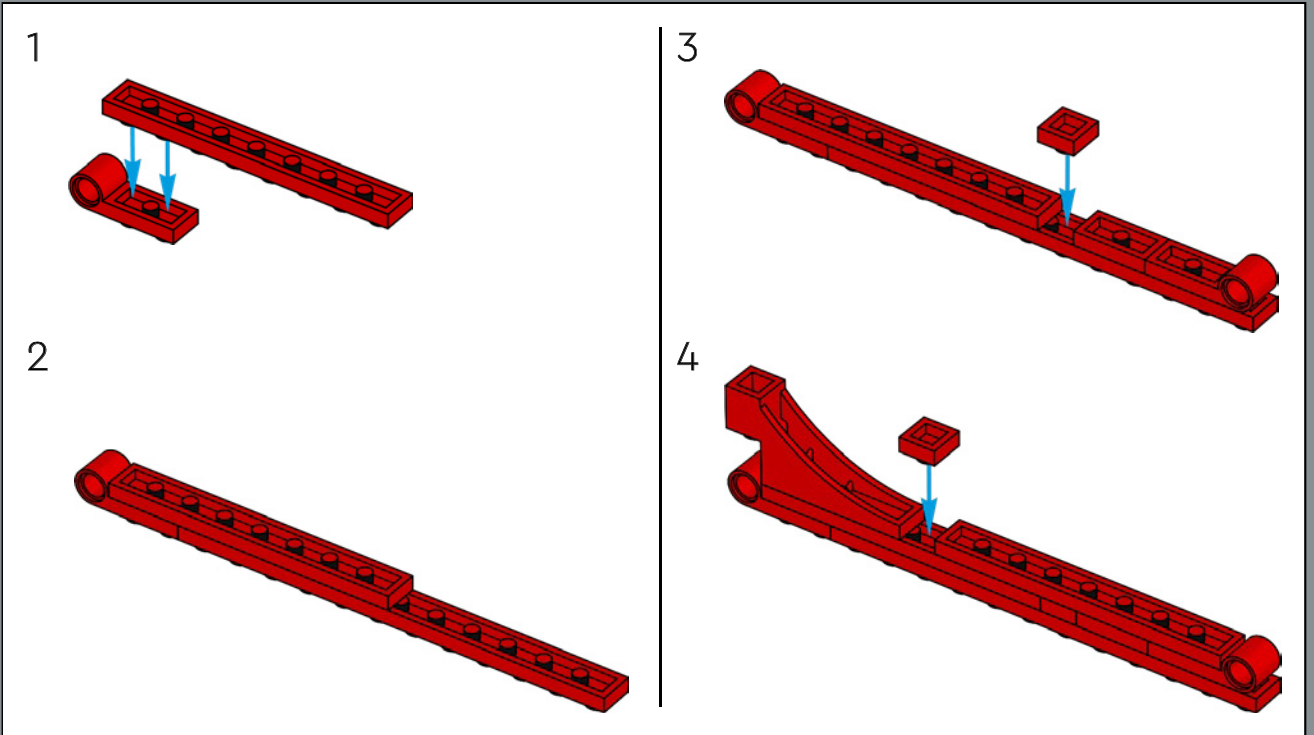

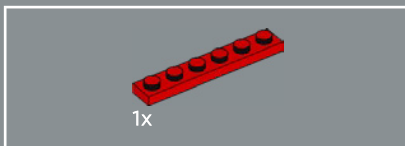

133

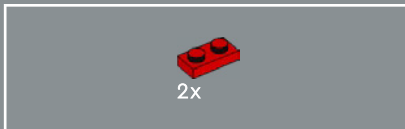
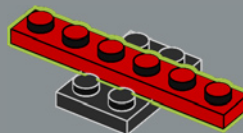

134

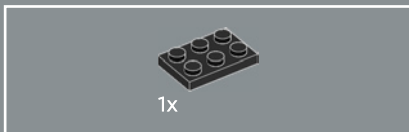
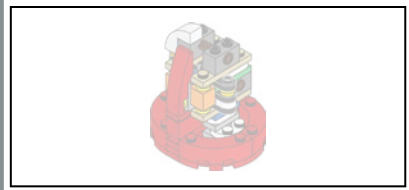

132

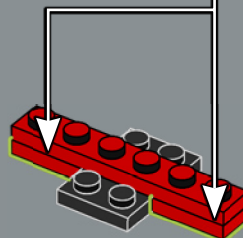
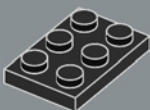



135

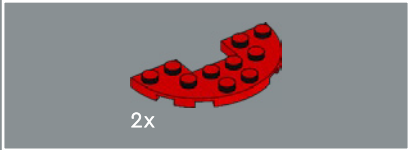
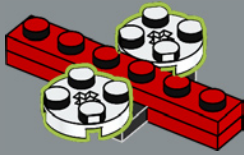

136

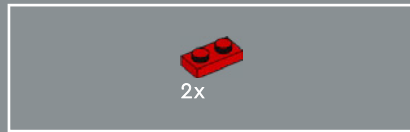
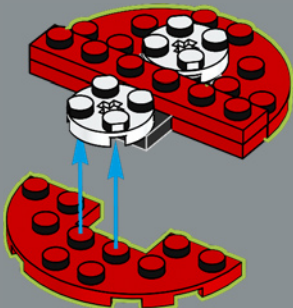

137

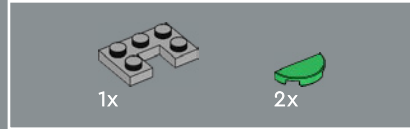
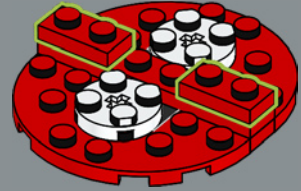

138

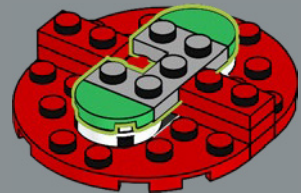

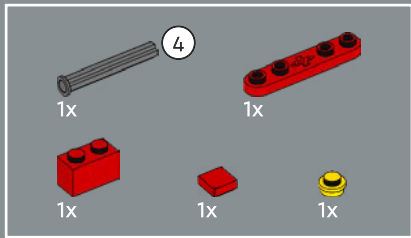

139

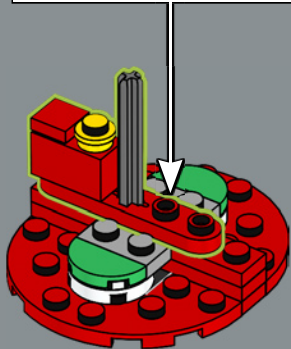
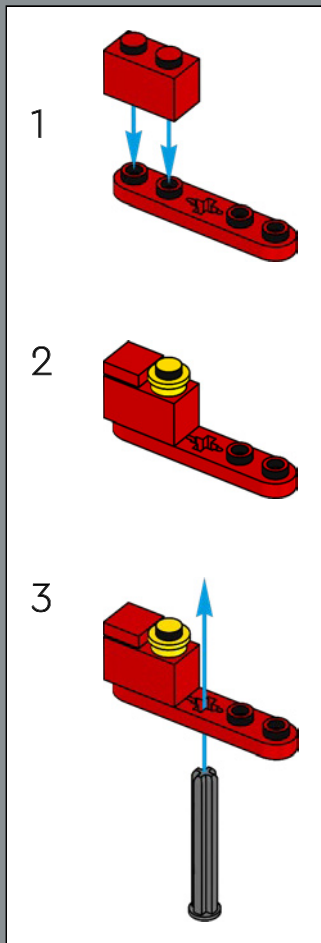

140

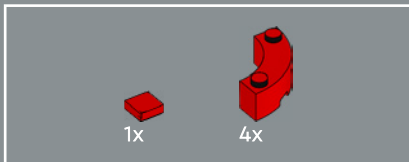
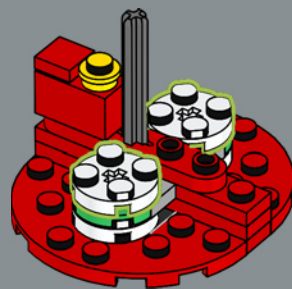

141

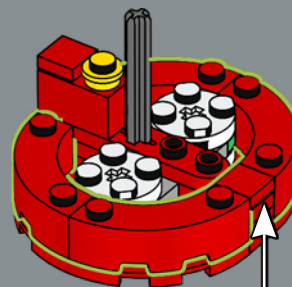

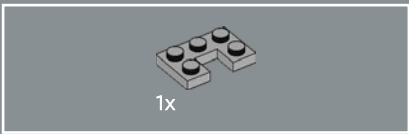

142

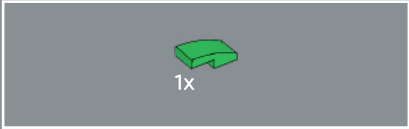
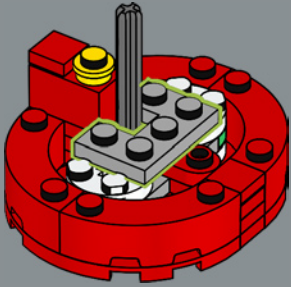

143

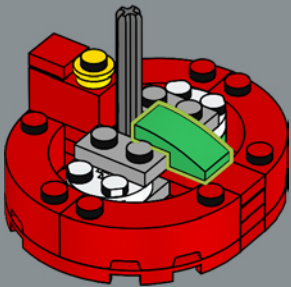

144

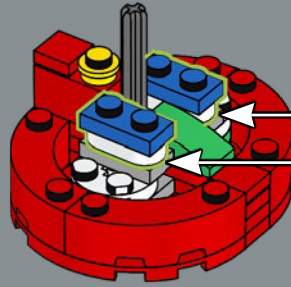
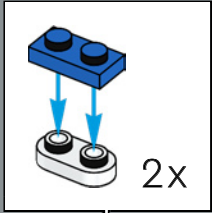

145

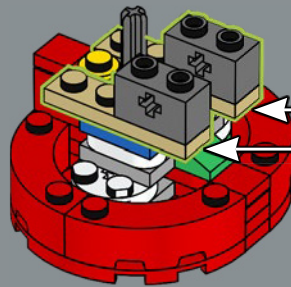
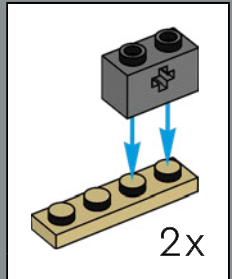

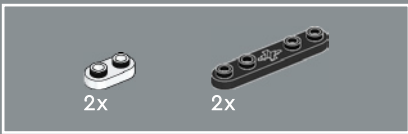

146

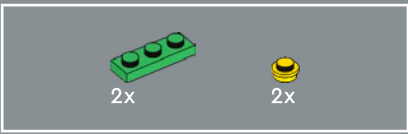
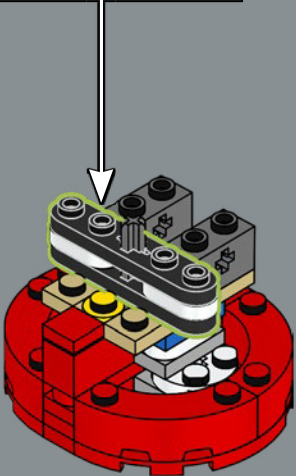
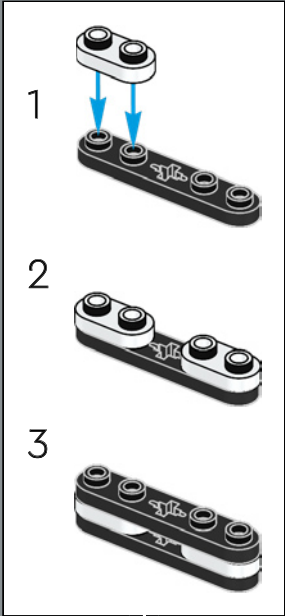

147

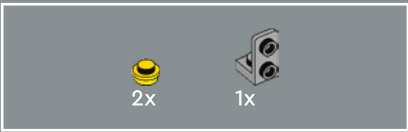
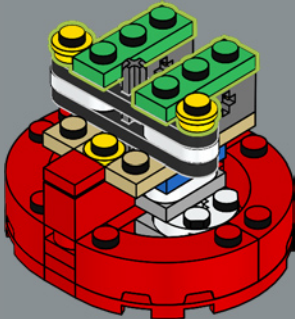

148

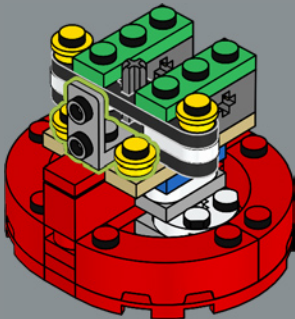

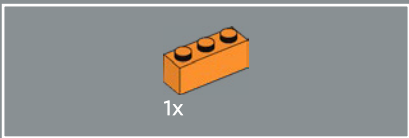

149

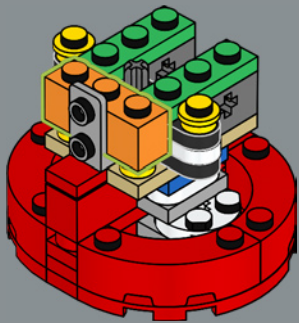

151

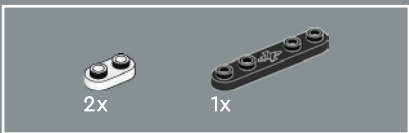
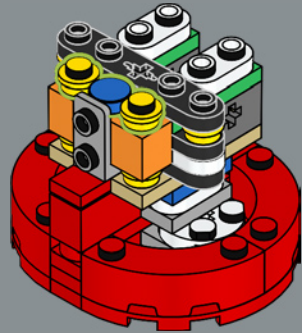

150

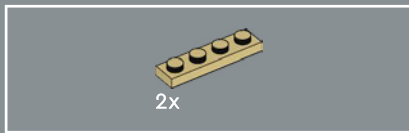
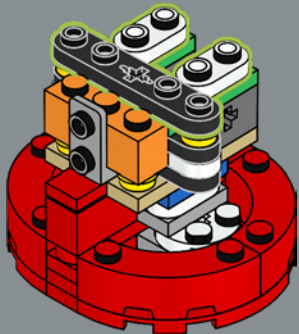

152

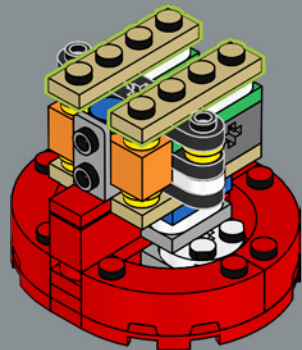

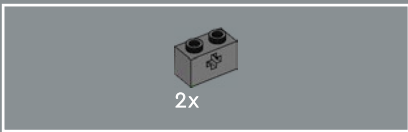

153

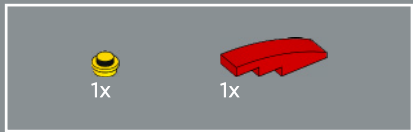
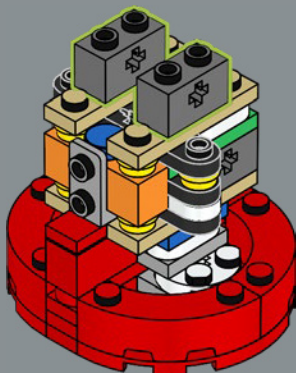

155

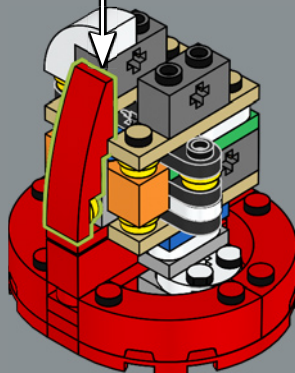
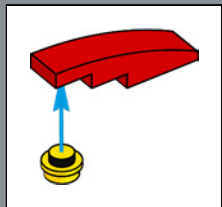

154

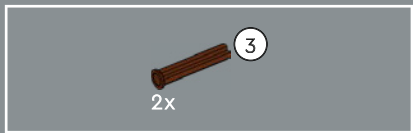
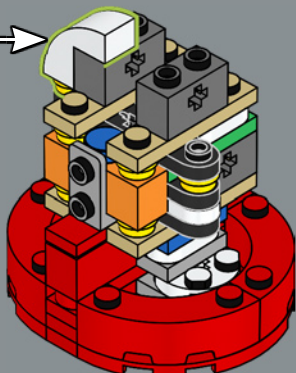
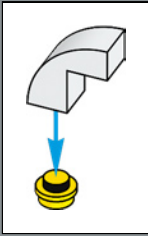

156

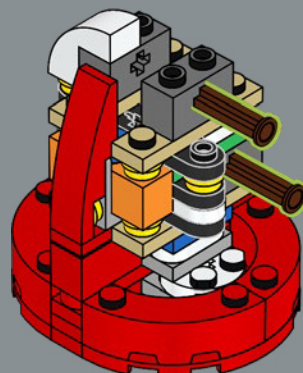

157

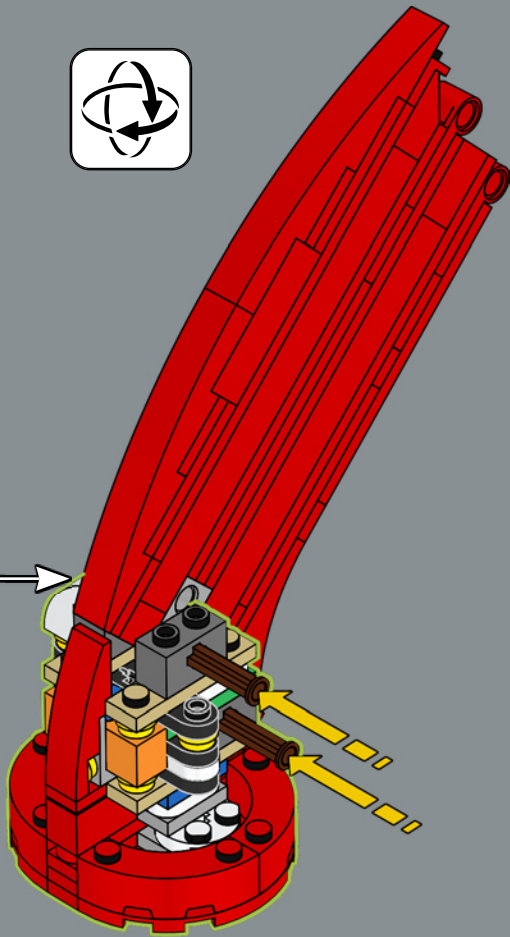

158

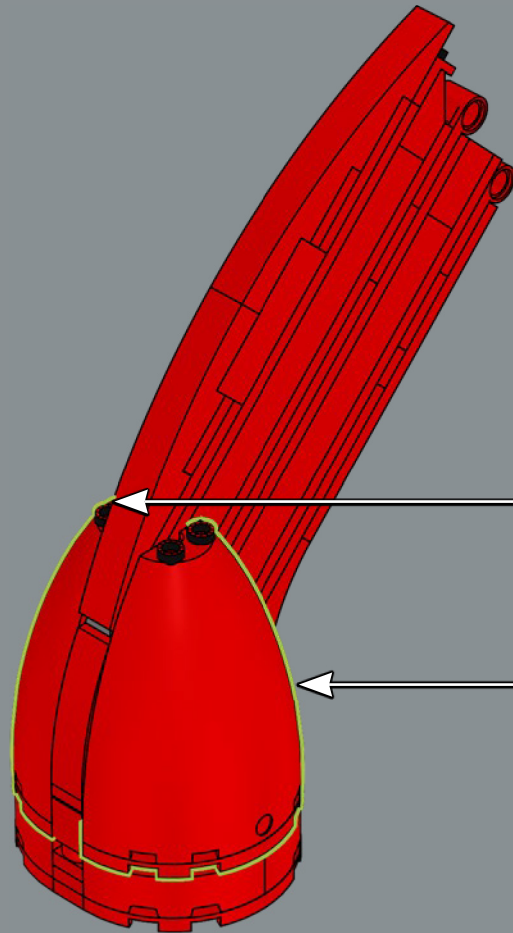
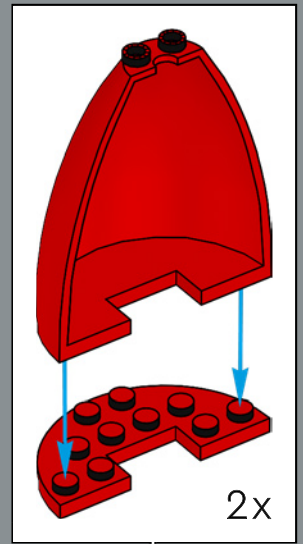
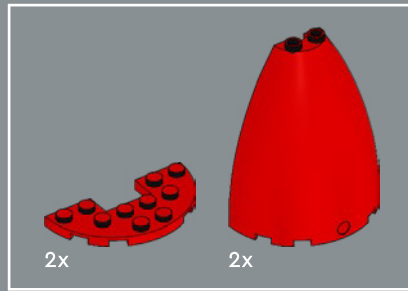

3x



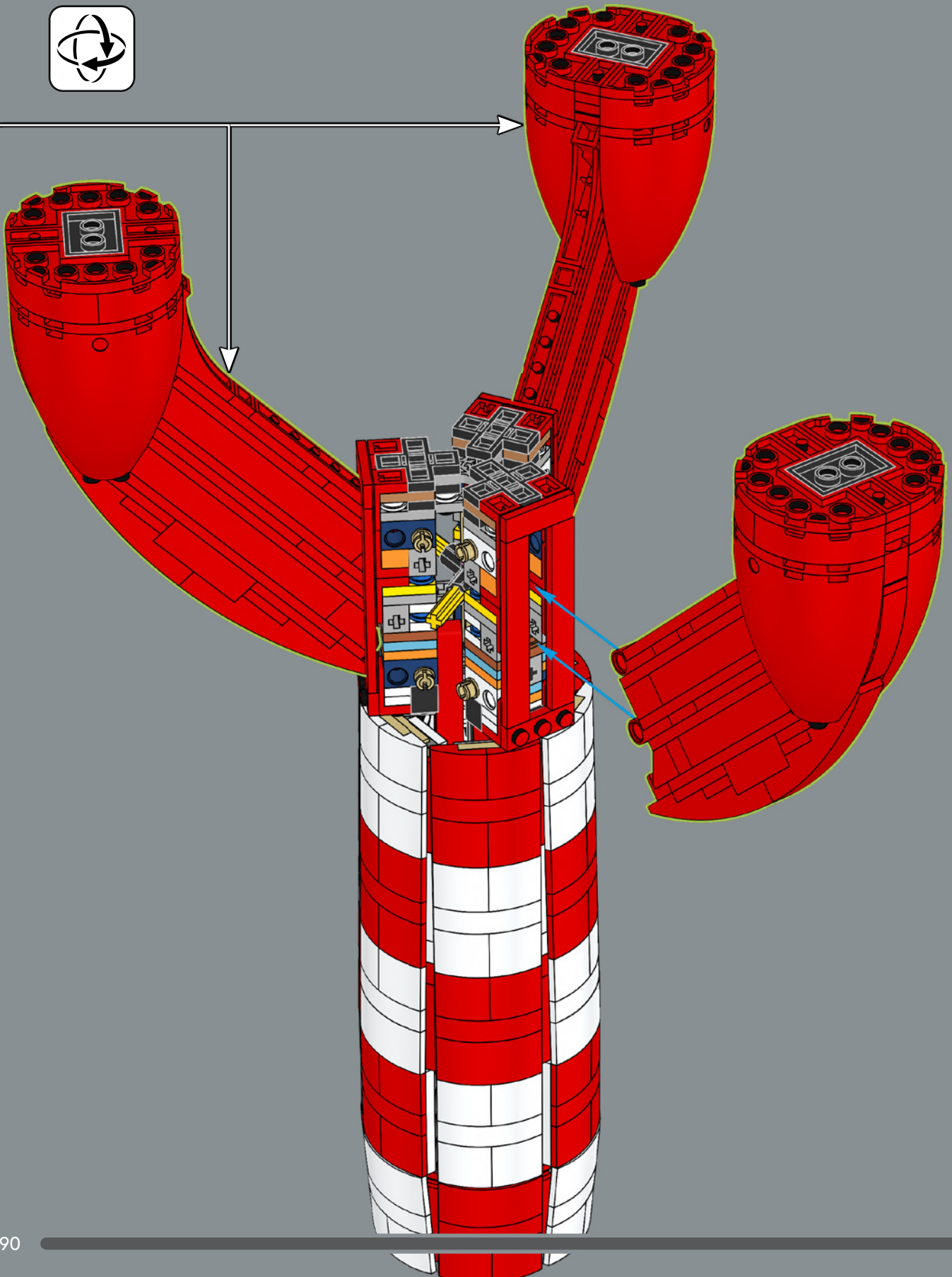

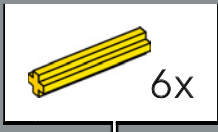
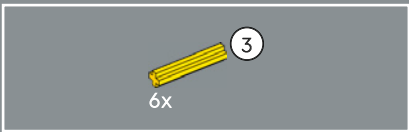

160

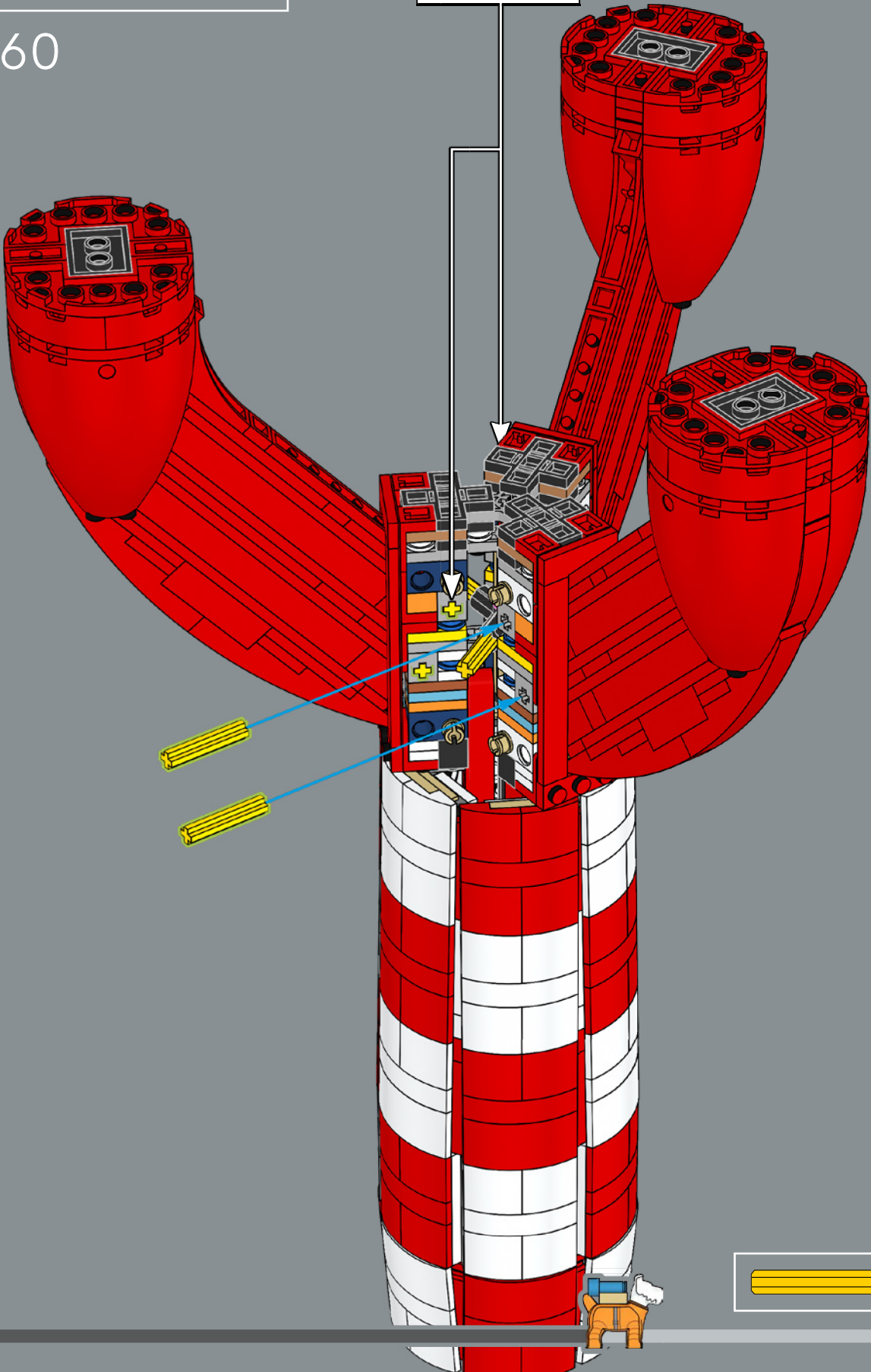

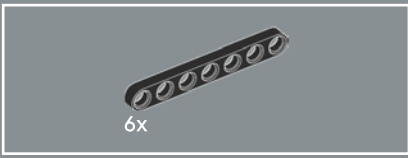

161

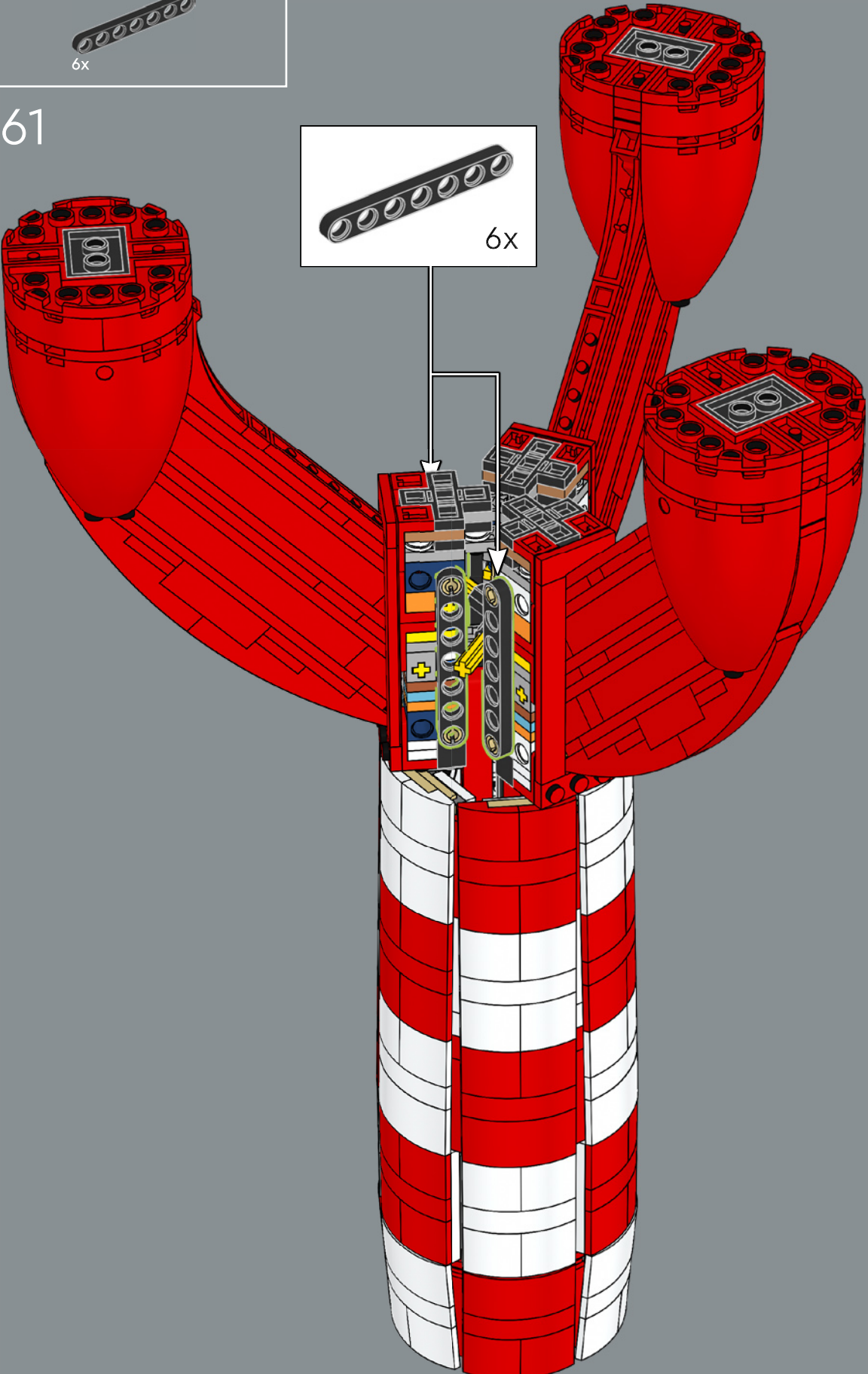
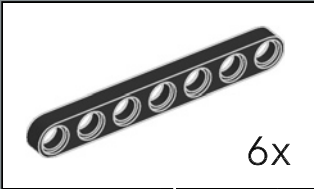

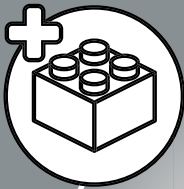

2x



3x

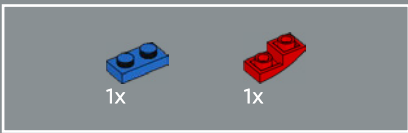

1x

1x

162

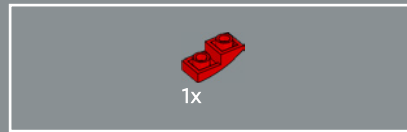
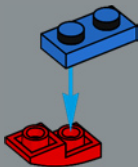

1x

163

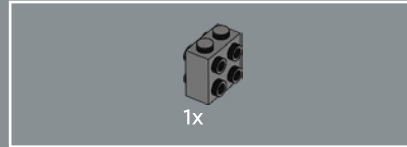
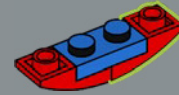

1x

164

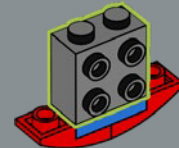



165

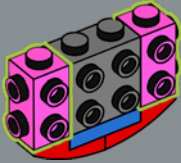

166

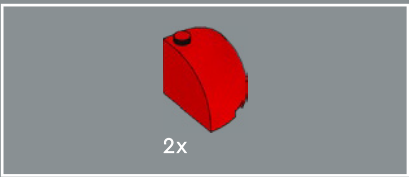
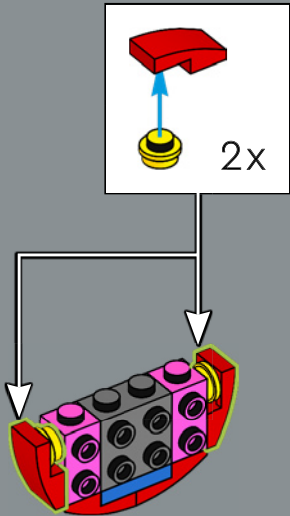

167

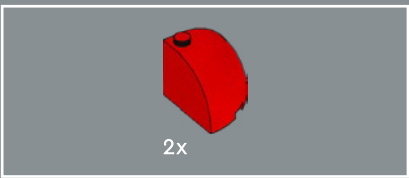
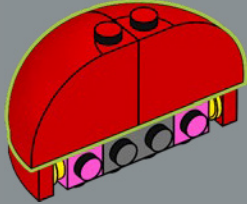

168

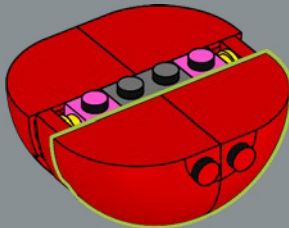

3x

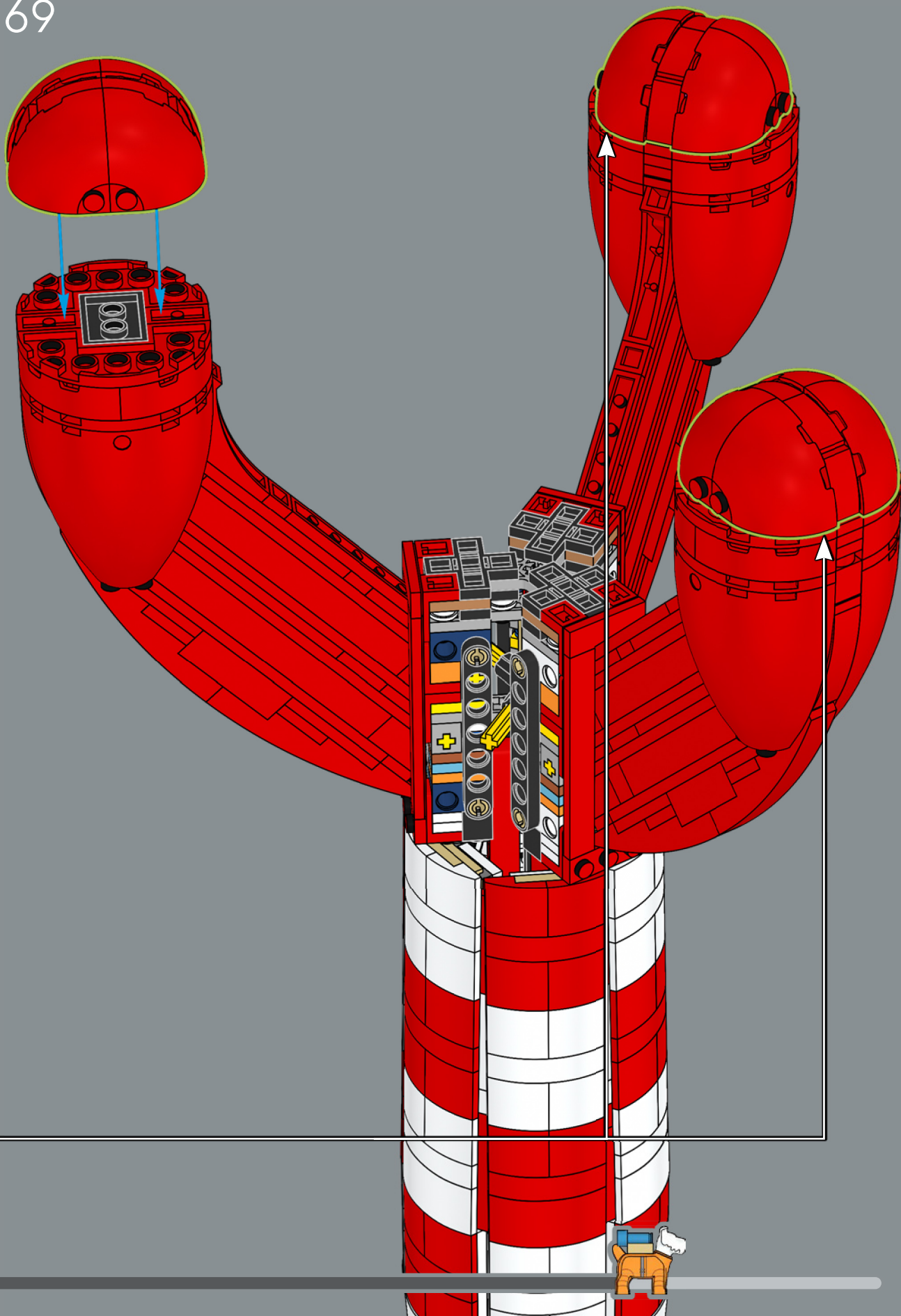

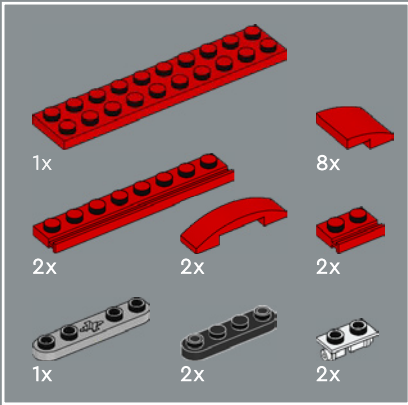
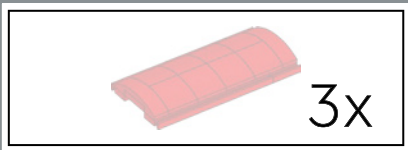

170

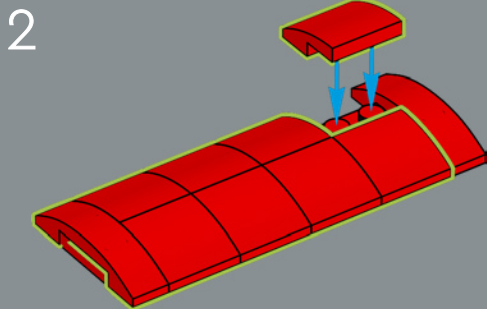
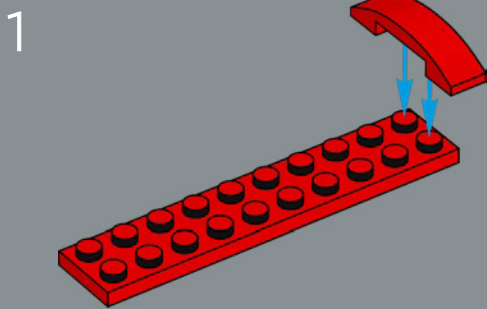

3

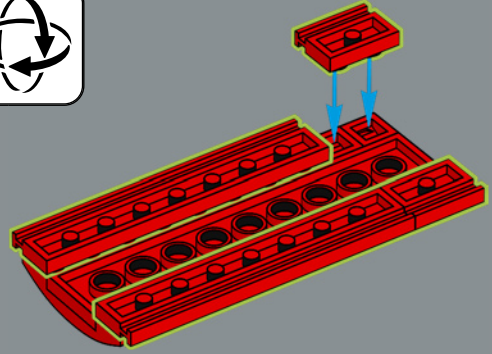

4

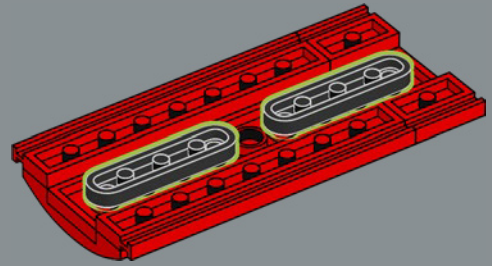

5

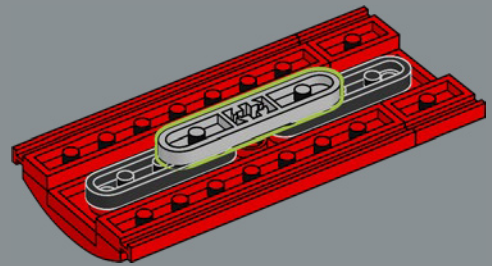

6

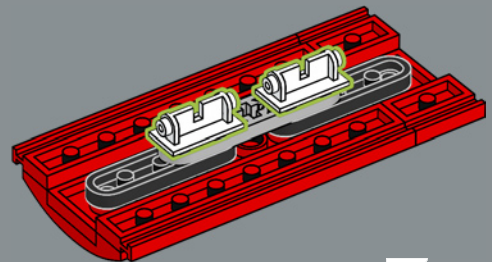

3x

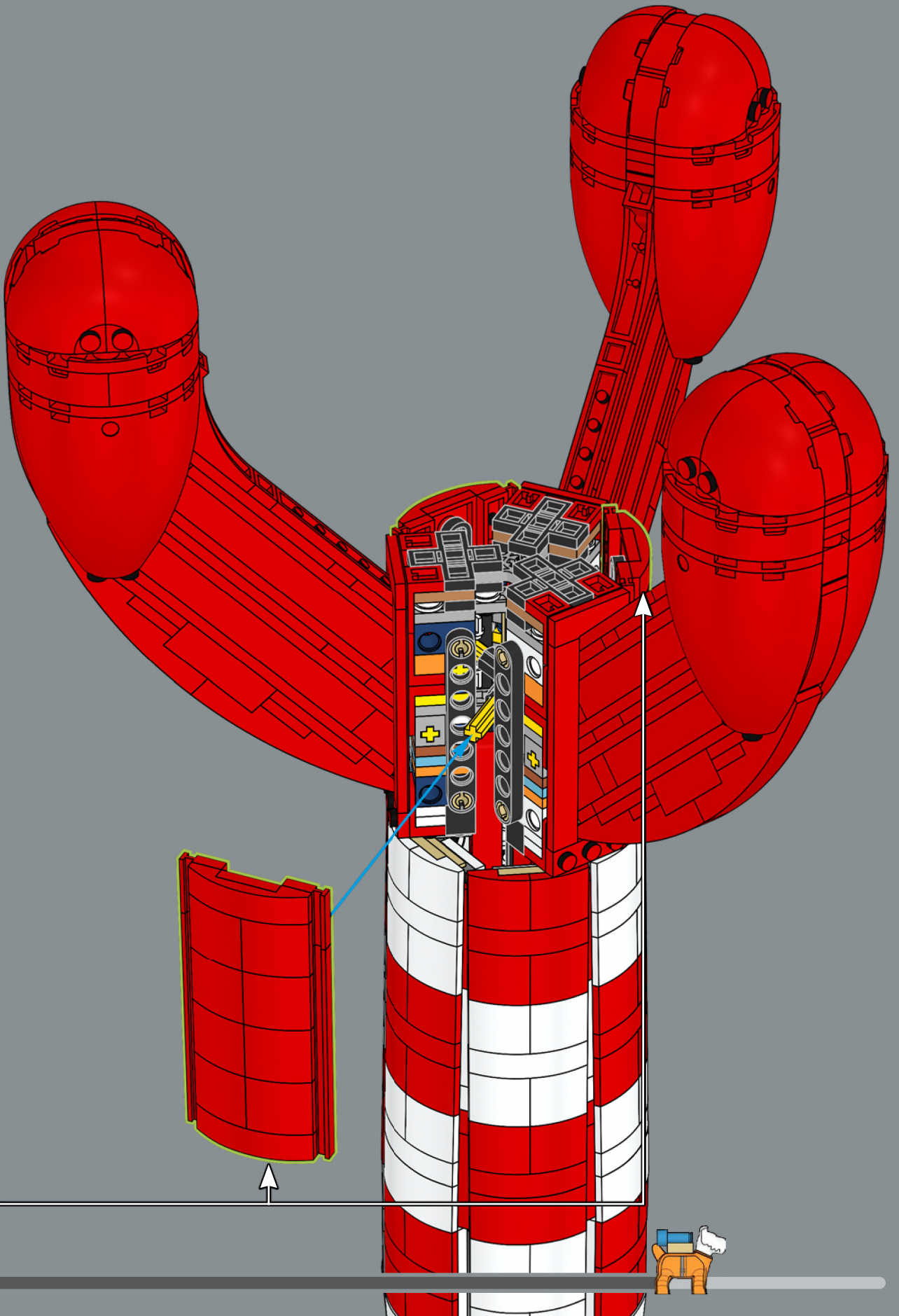

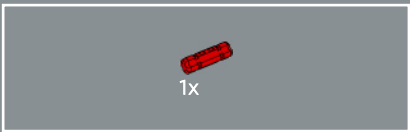

171

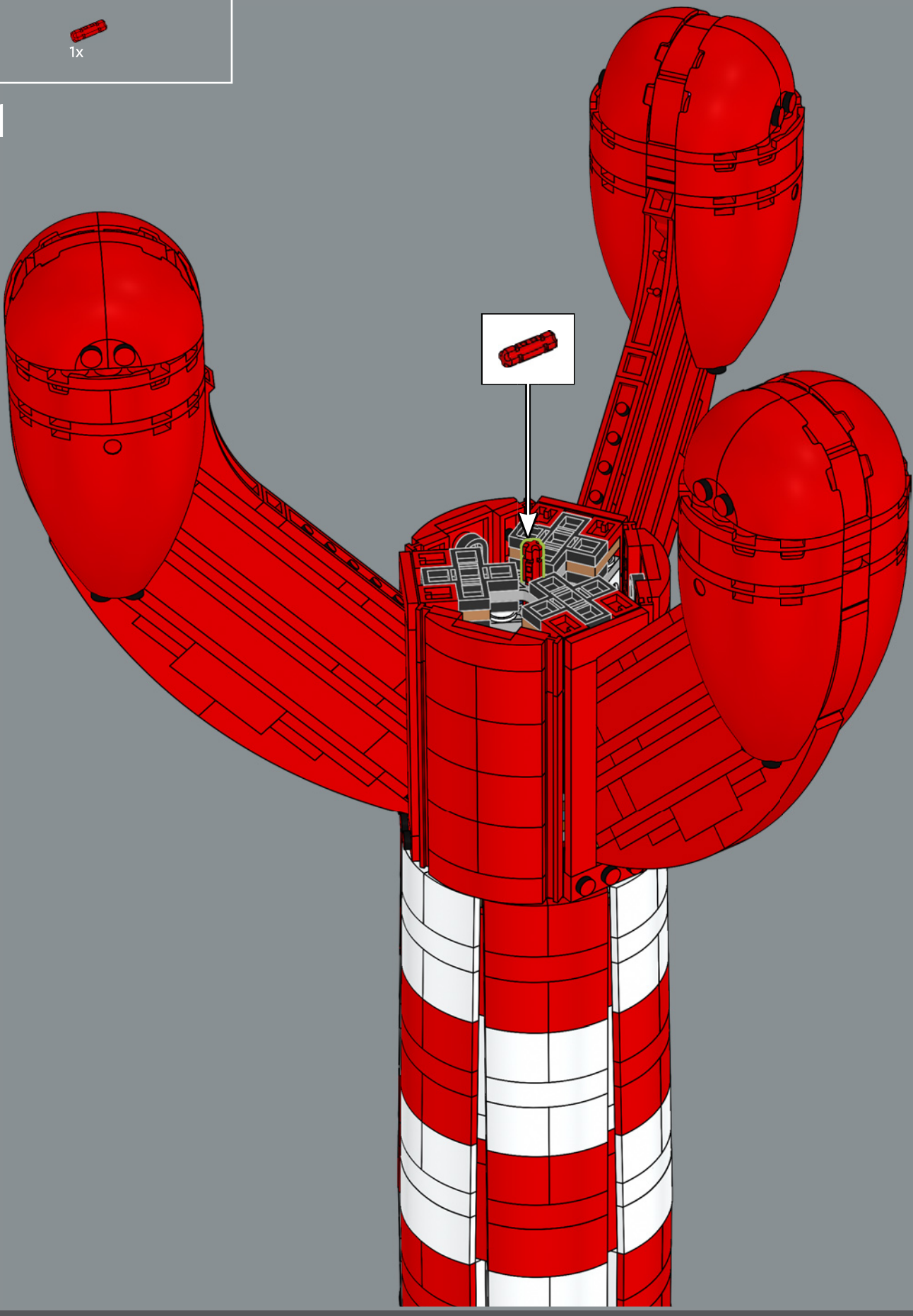

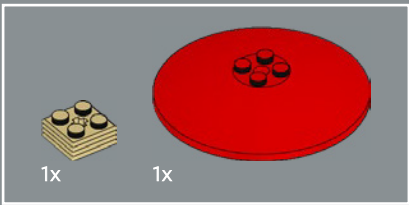

172

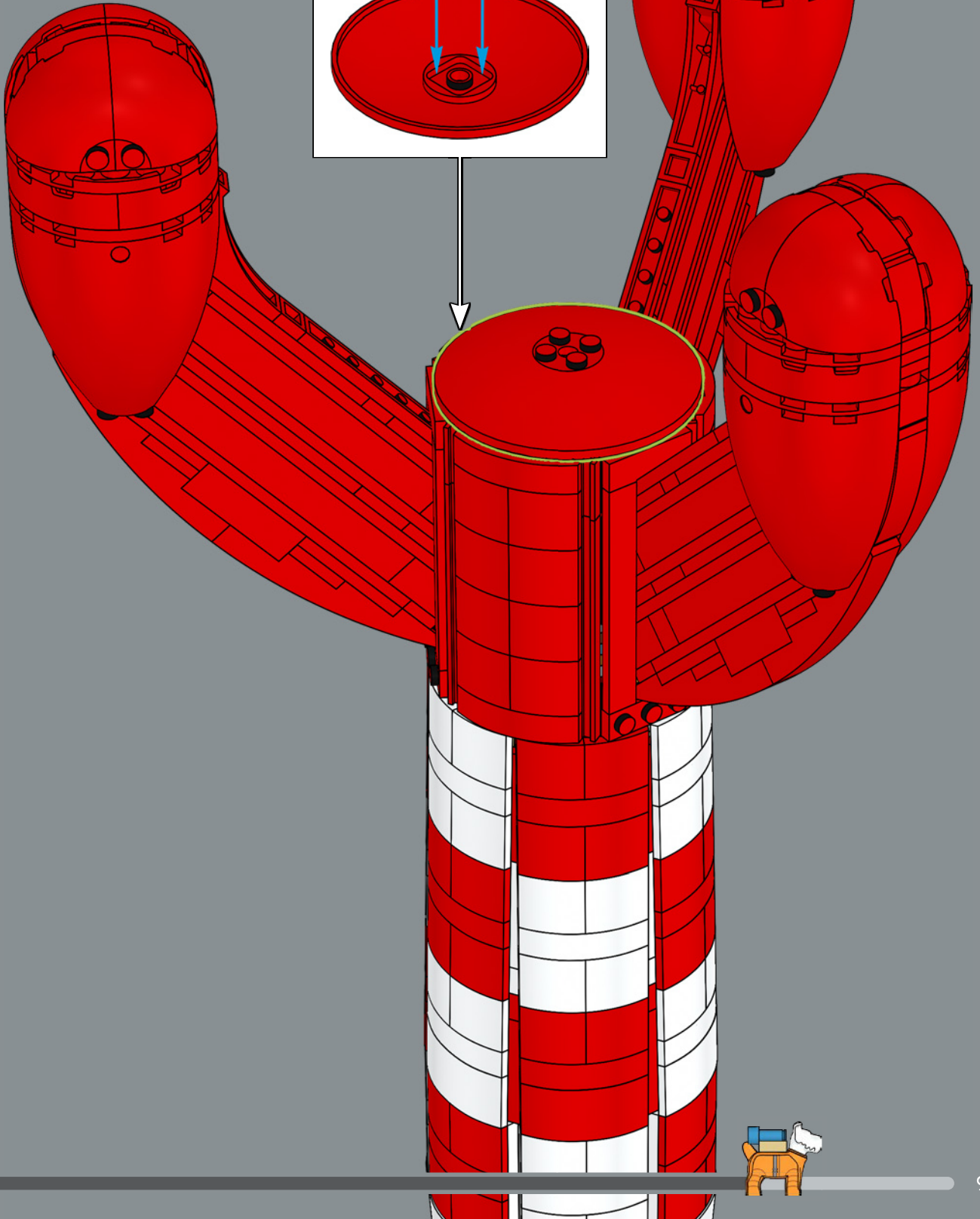
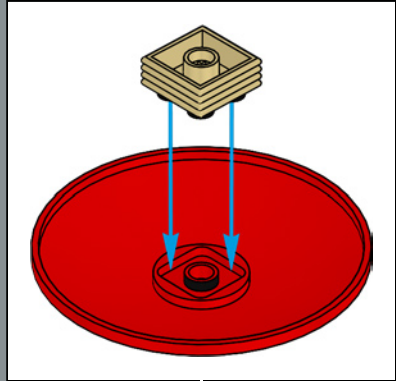

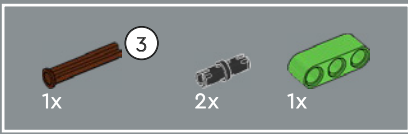

173

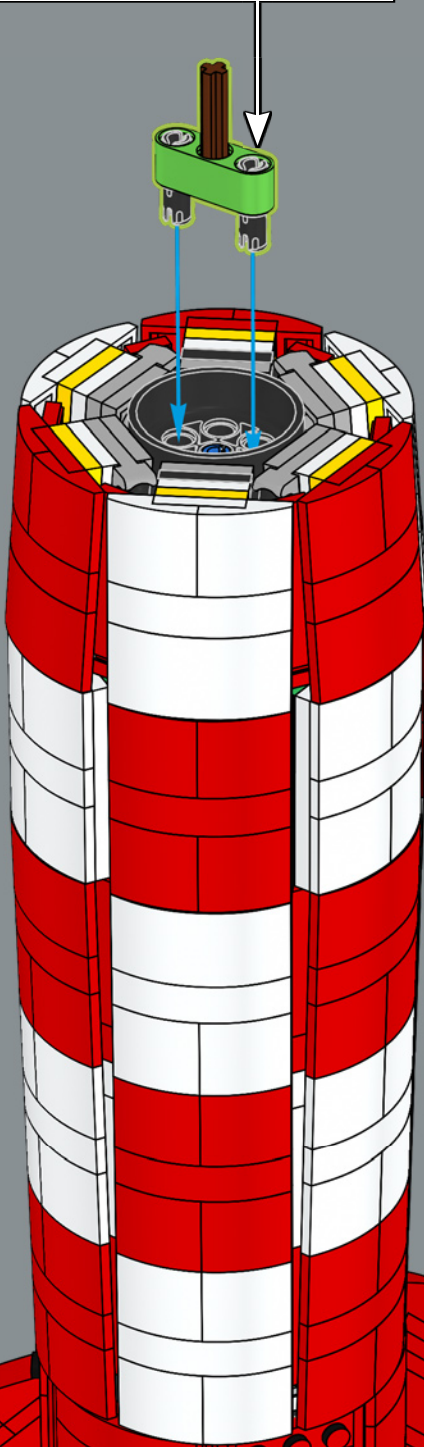
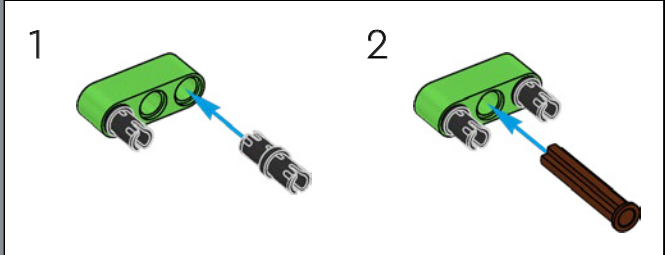

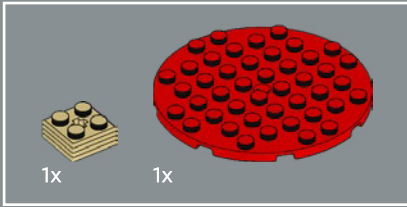

174

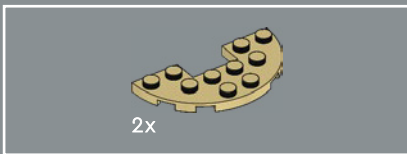
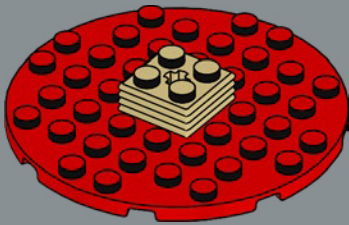

175

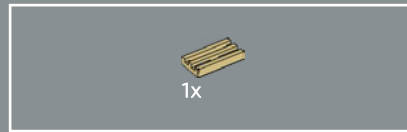
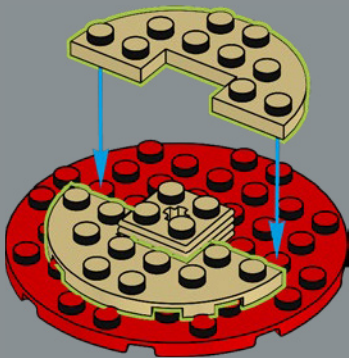

176

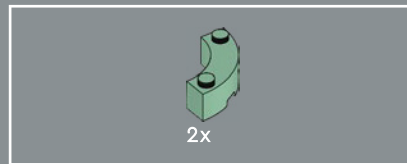
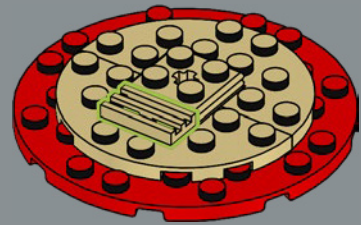

177

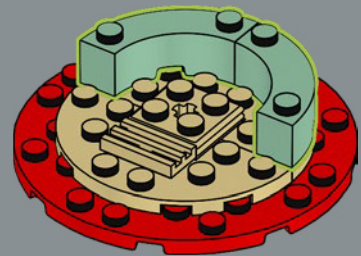



178

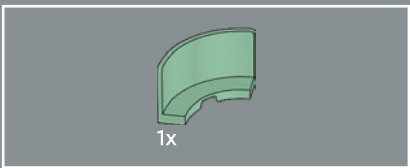
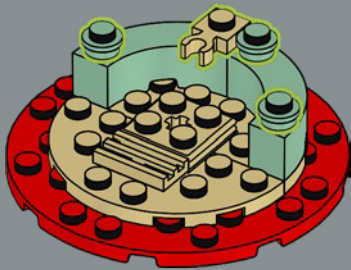

179

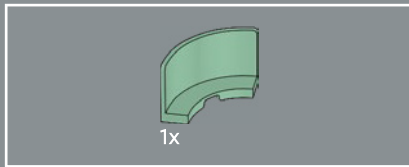
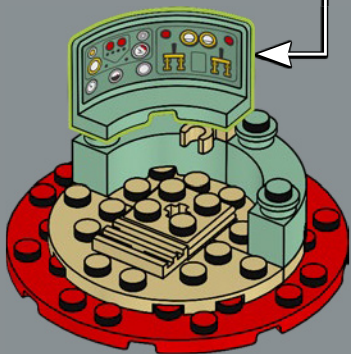
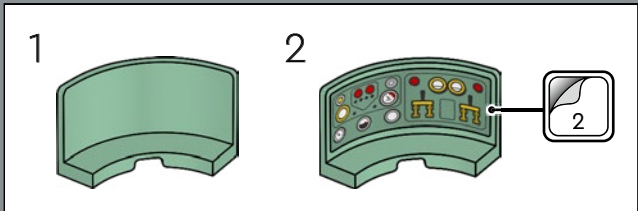

180

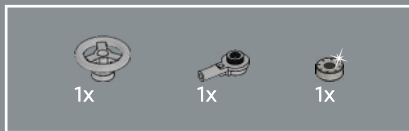
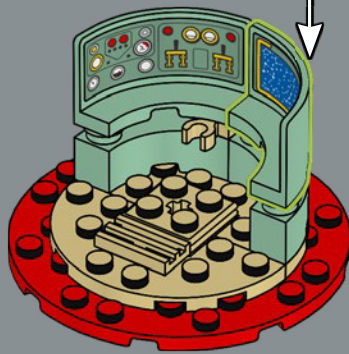
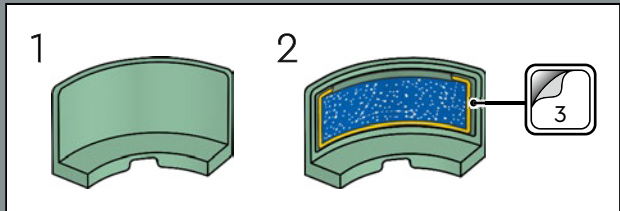

181

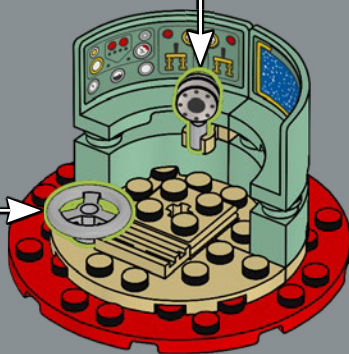
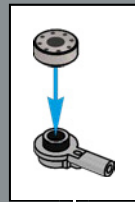

182

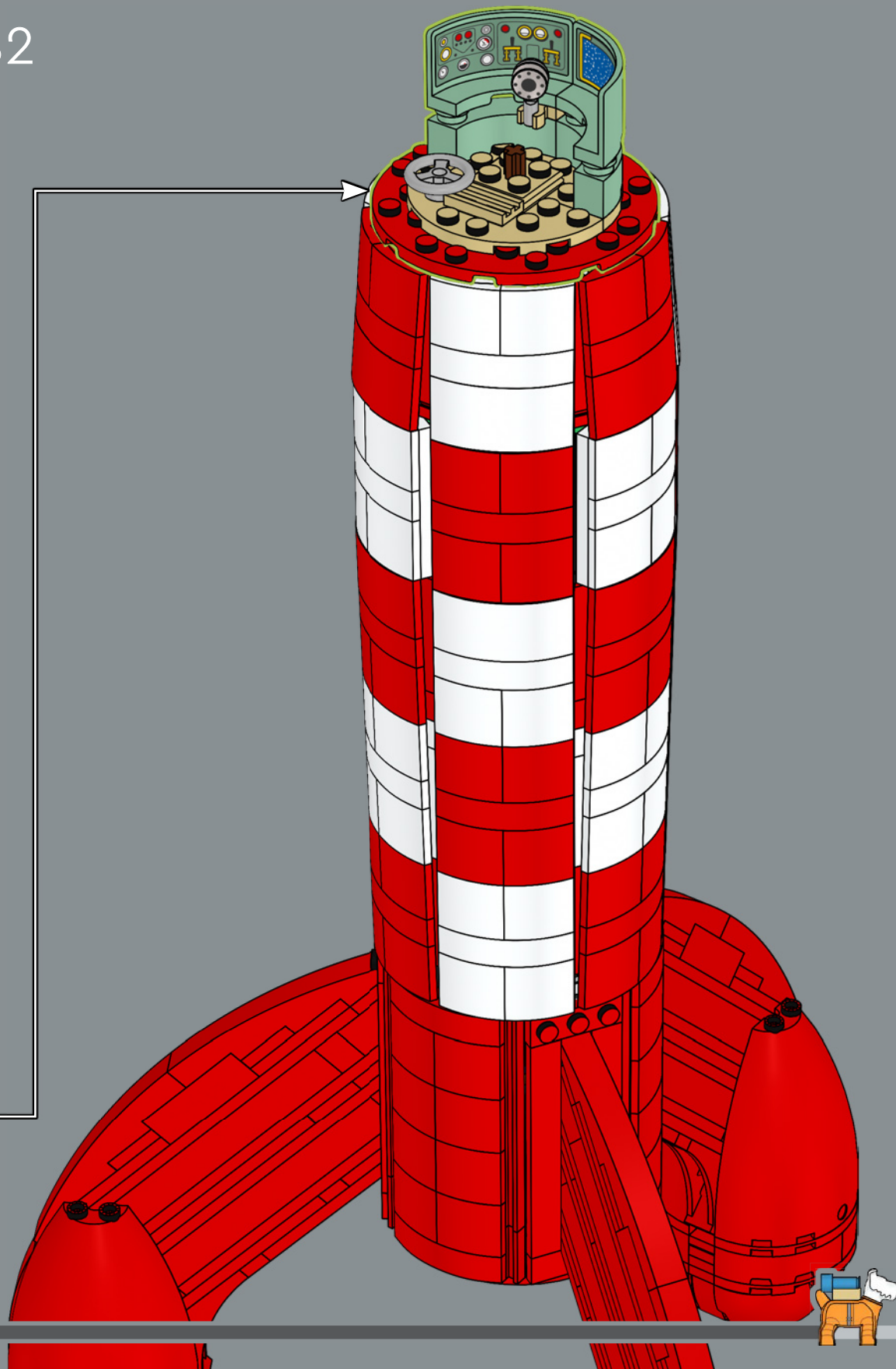

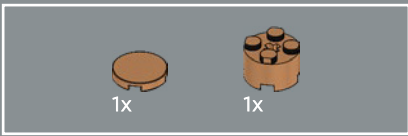

183

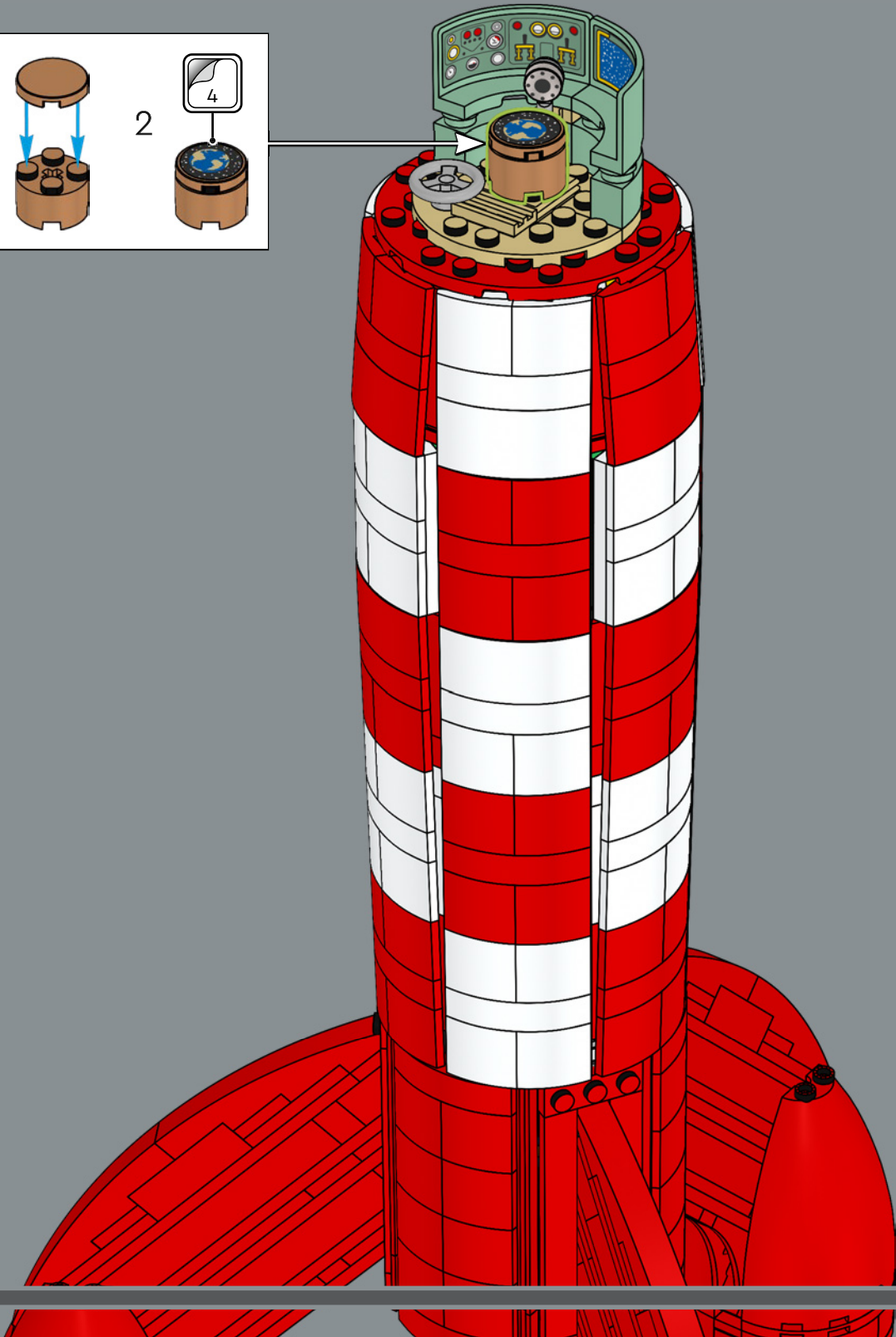
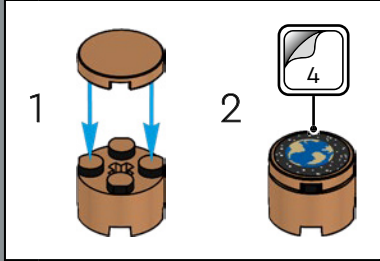



1x

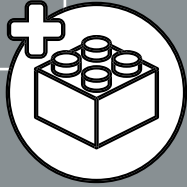

184

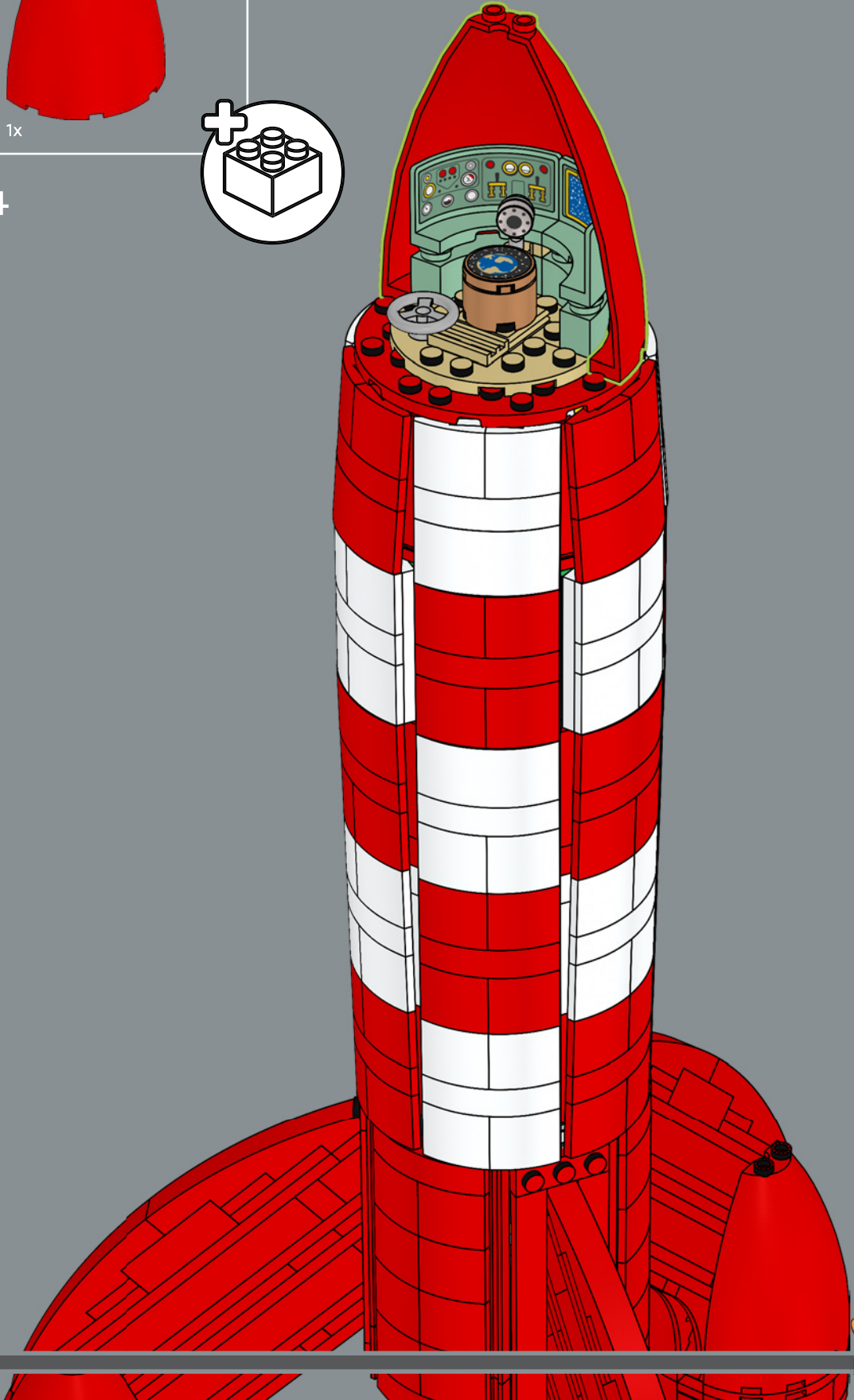

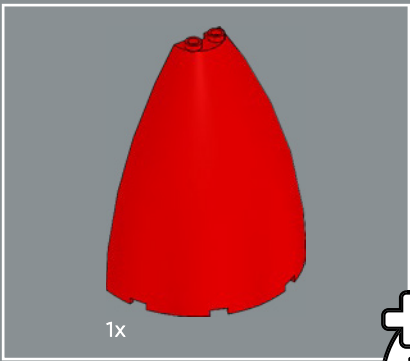

1x

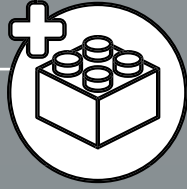

185

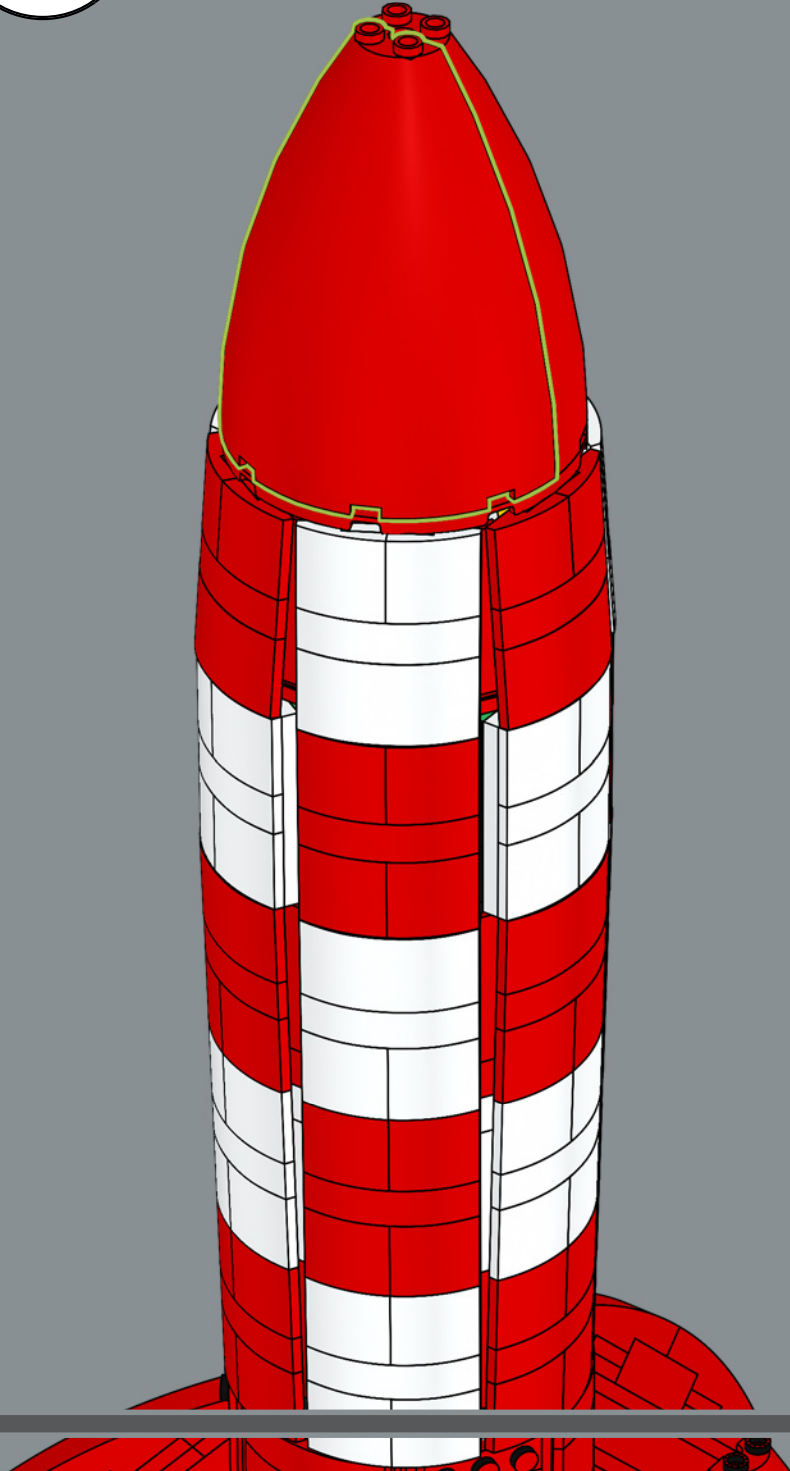

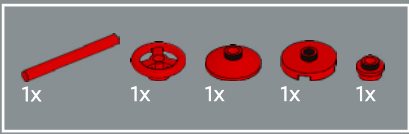

186

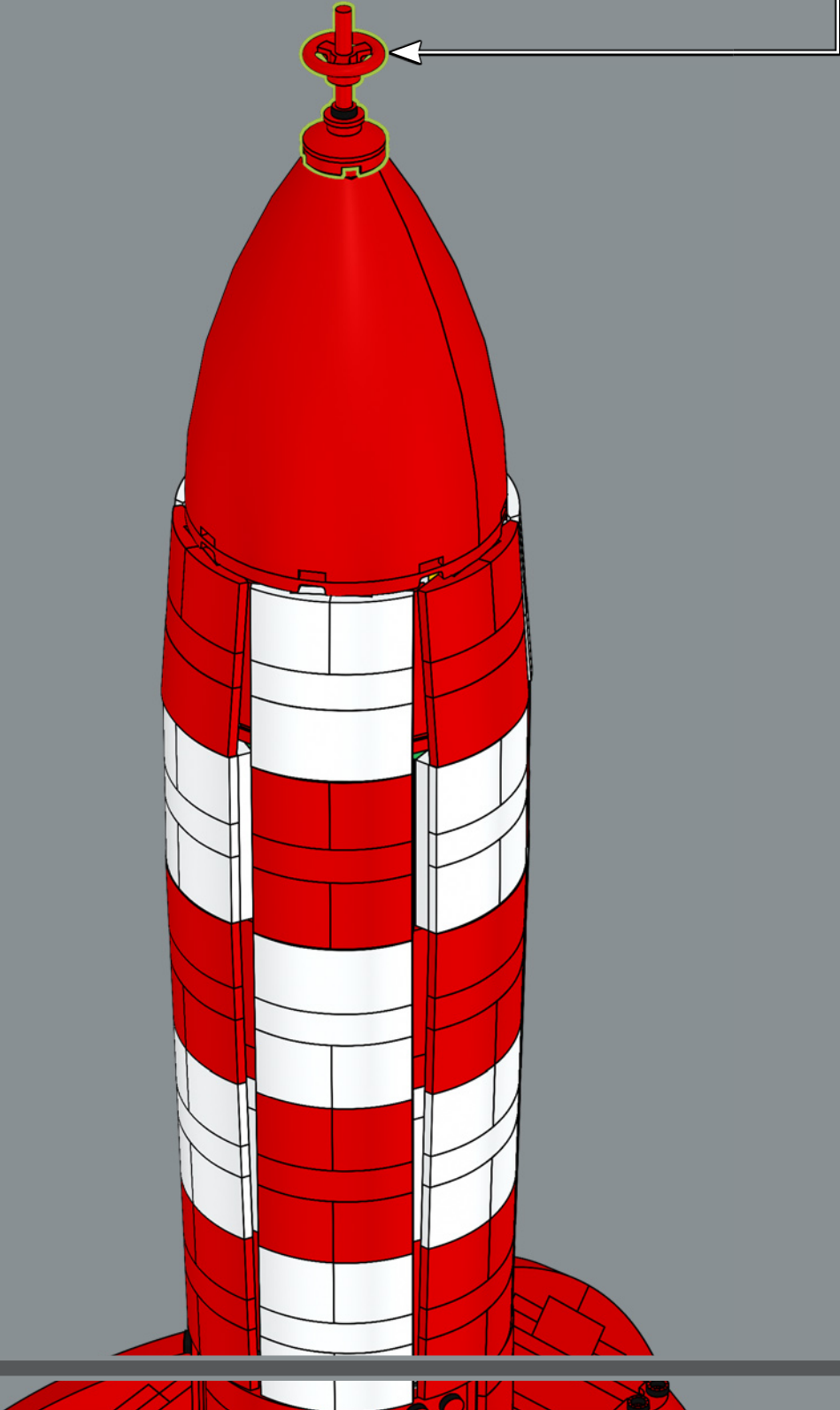
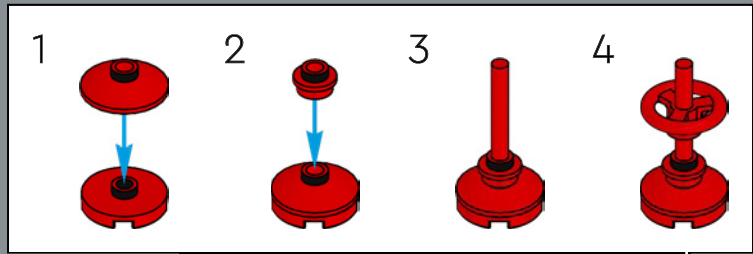

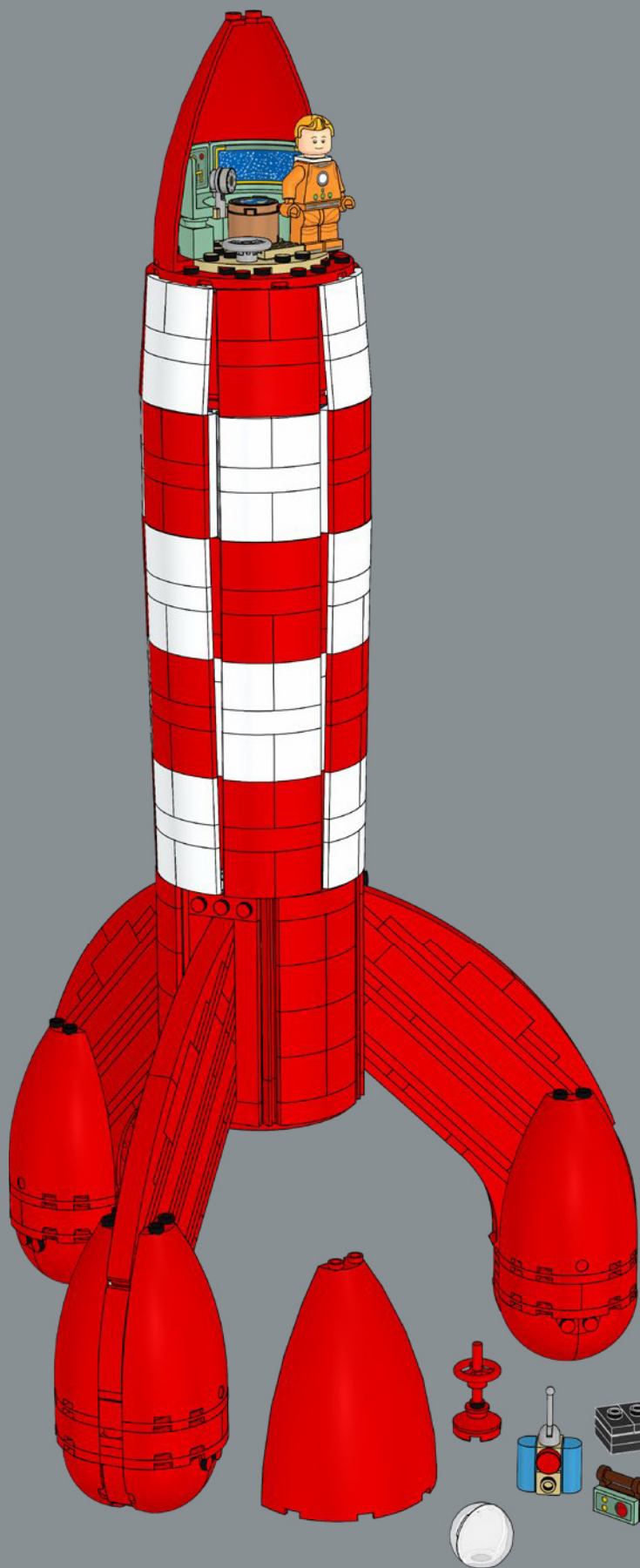

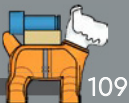
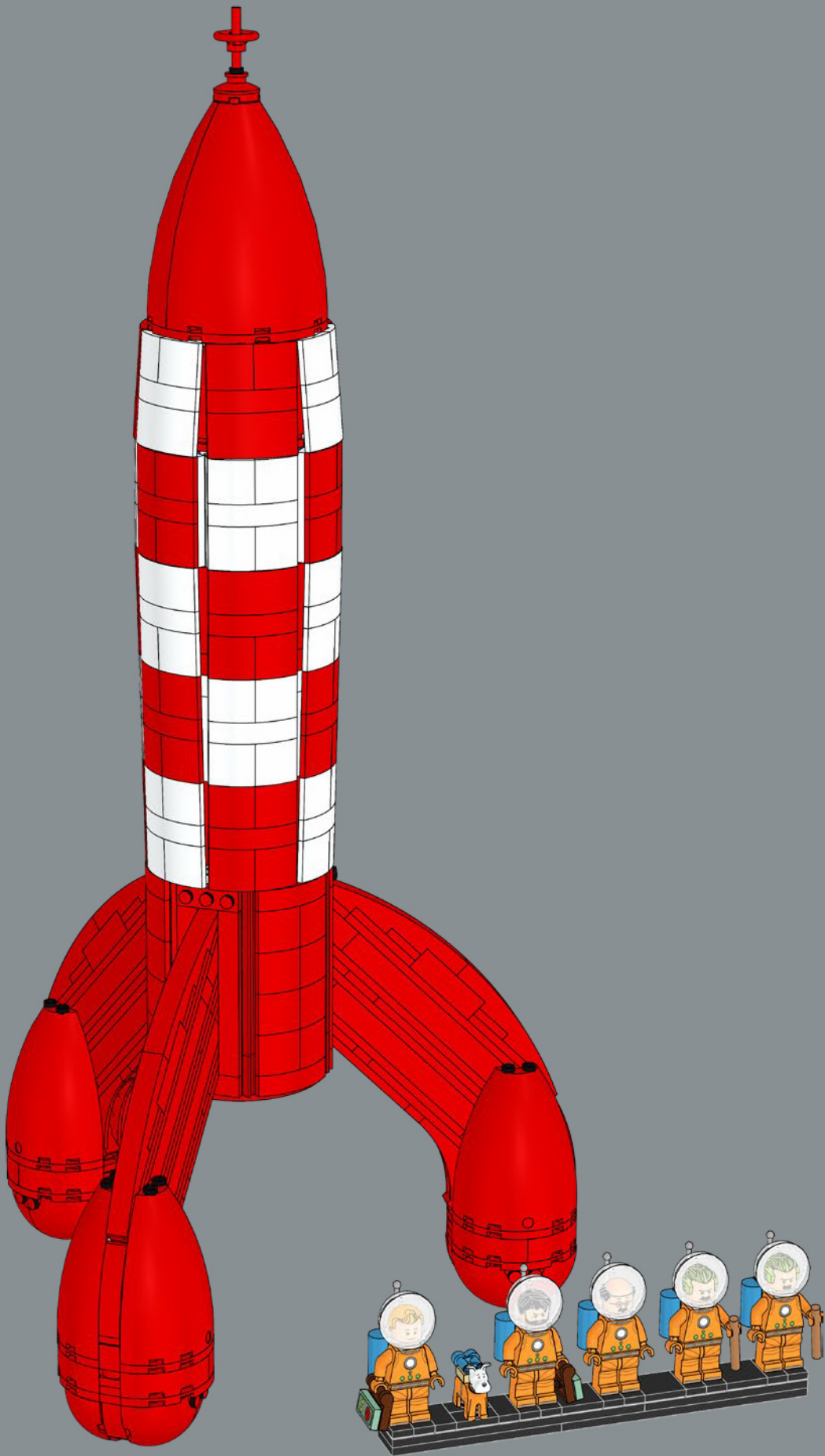

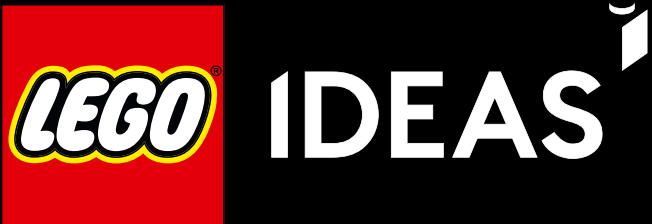

GATHER SUPPORT
OBTENEZ DE L'APPUI
OBTÉN APOYOS

SHARE YOUR IDEA
PARTAGEZ VOTRE IDÉE
COMPARTE TU IDEA

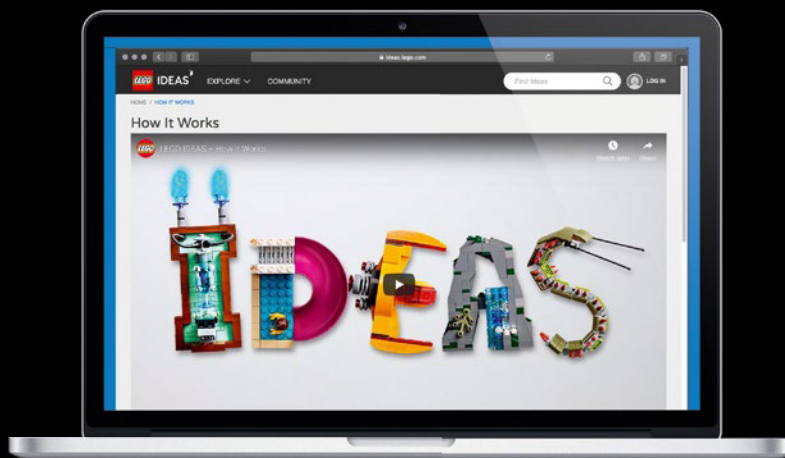
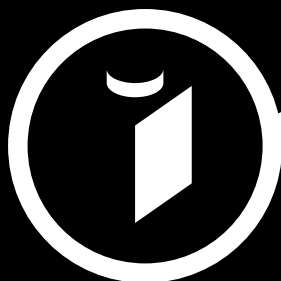
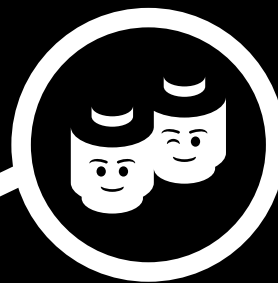

NEW LEGO® PRODUCT
NOUVEAU PRODUIT LEGO®
NUEVO PRODUCTO LEGO®

LEGO® REVIEW
EXAMEN LEGO®
REVISIÓN DE LEGO®

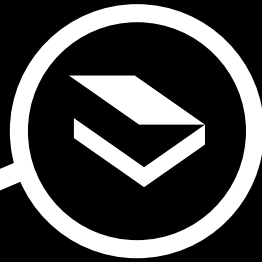

ideas.LEGO.com

- 9x 6388018
- 15x 614101
- 6x 307001
- 5x 6277181
- 6x 6212049
- 18x 6210272
- 6x 393801
- 15x 302301
- 3x 6548968
- 6x 6172927
- 12x 403201
- 6x 3200001
- 12x 6361170
- 48x 6047220
- 6x 6223491
- 12x 362301
- 6x 302201
- 15x 6023806
- 6x 243101
- 6x 6554416
- 3x 302001
- 24x 6350399
- 3x 4249021
- 6x 6053026
- 5x 6365720
- 1x 4159553
- 5x 4125253
- 5x 6609636
- 1x 6352222
- 5x 6262188
- 12x 6013938
- 1x 4124456
- 2x 6330903
- 6x 4160483
- 12x 4113233
- 2x 6099893
- 6x 4114324
- 6x 6036487

5

- 5x 6284574
- 9x 6378120
- 6x 6249907
- 1x 6223427
- 18x 307021
- 6x 302421
- 3x 6372478
- 12x 6345637
- 3x 300521
- 12x 6435047
- 1x 6527648
- 1x 6132541
- 6x 6029946
- 1x 4585146
- 3x 4142865
- 27x 302321
- 6x 6186398
- 3x 366521
- 6x 300421
- 6x 6540808
- 72x 6105976
- 9x 6433069
- 6x 6347789
- 6x 4612575
- 3x 4533742
- 3x 362321
- 12x 6334053
- 1x 6296954
- 1x 6129995
- 3x 6583512
- 3x 6547141
- 21x 4633914
- 6x 371021
- 18x 243121
- 6x 6592314
- 3x 302021
- 3x 301021
- 3x 4142132

4

5

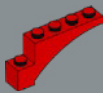

3x
6594986



12x
6295298



3x
366621



6x
6594751

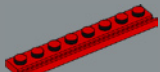

6x
6078594



6x
416221



9x
346021



6x
6594753



2x
6595787

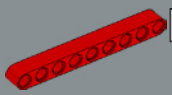

3x
4645733



1x
6603363



1x
6594752

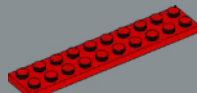

3x
383221

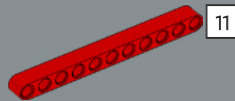

3x
4562805

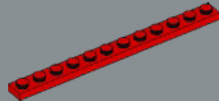

12x
4514843

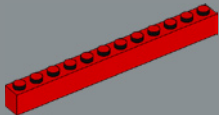

6x
611221



3x
6284575



3x
6584954



6x
6537695



12x
614123



19x
4206482



9x
302323



6x
6073890

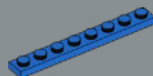

6x
346023



33x
614124



15x
302324



9x
6130007



6x
4501232



1x
6130008



6x
371024



1x
6389951



2x
6332148



1x
4526110



3x
6299338



17x
6279875



12x
6210270



12x
6092585



2x
306926



3x
6089119



6x
6097283



3x
306826



3x
6572774



1x
6460708



6x
6428167



2x
6416838



3x
302126



9x
6280168



1x
6438426



6x
6271573

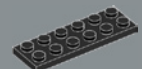

6x
379526



1x
370726

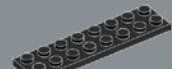

2x
303426



1x
373726

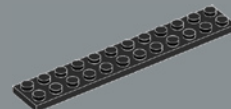

2x
244526



6x
4569058



6x
6541878



6x
6510079



1x
6374076



3x
6047426



21x
302328



6x
6347288



6x
4521931



6x
4107758



1x
6573947



3x
6359717



10x
6414564



6x
6442359

9

3

5

8

10



9x
4177932



5x
6593094



1x
6593089



3x
4118787



5x
6607486

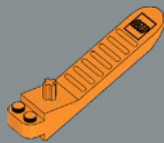

1x
6240515



6x
6539419



6x
6574771



3x
6420960



3x
6403175



2x
4616578



2x
6599347



2x
6599346



2x
6607967



1x
6595785



2x
6236915



7x
6135494



8x
6441316



5x
6267587



3x
6345639



18x
6336539



1x
6227897



3x
4211350



1x
6092956



3x
4211862



3x
4211541



3x
6540763



3x
6321747



4x
6043639



6x
4211397



12x
6421522



6x
6347992



3x
6549304



3x
6307999



6x
6372029

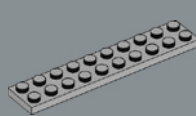

6x
4211462

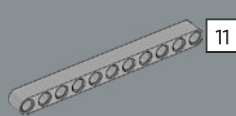

3x
4611705



3x
6395635



12x
6178919



3x
6514456



6x
6284702

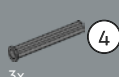

3x
6083620



6x
6039482



1x
6443852



6x
6574782



3x
6573660



1x
6593099



1x
6593098



1x
6593097



1x
6593096



1x
6593095



1x
6593090



1x
6368592



1x
6454167



2x
6600809



3x
6336665



1x
6551965



1x
6603200



10x
6601287



9x
6097419



YOU COULD WIN



YOU COULD WIN

Your feedback will help shape the future development of this product series.

Visit:

DU KÖNNTEST GEWINNEN

Dein Feedback trägt zur Weiterentwicklung dieser Produktreihe bei.

Geh auf:

VOUS POURRIEZ GAGNER

Vos commentaires nous aideront à concevoir les futurs produits de cette gamme.

Visitez :

POTRESTI VINCERE TU

La tua opinione ci aiuterà a migliorare la creazione futura di questa linea di prodotti.

Visita:

PUEDES GANAR

Tu opinión contribuirá al futuro de esta serie de productos.

Visita:

轻松获奖

您的反馈将有助于我们在今后改进本产品系列。

请访问:

LEGO.com/productfeedback

You also have the chance to win a LEGO® set.

Terms and conditions apply.*

Außerdem hast du die Chance, ein LEGO® Set zu gewinnen.

Es gelten die Teilnahmebedingungen.*

Vous pourriez également gagner un ensemble LEGO®.

Des conditions s'appliquent.*

Hai anche la possibilità di vincere un set LEGO®.

Termini e condizioni sono applicabili.*

También tienes la oportunidad de ganar un set LEGO®.

Aplican términos y condiciones.*

您还有机会赢取乐高®套装。

条款和条件适用。*

*LEGO.com/productfeedback-terms



In partnership with the Hergé Museum
En partenariat avec le Musée Hergé
En colaboración con el Museo Hergé

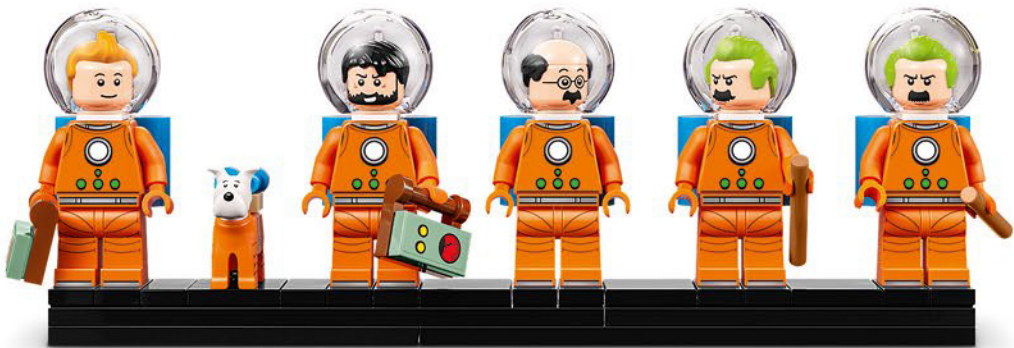

LEGO and the LEGO logo are trademarks of the/son des marques de commerce du/
son marcas registradas de LEGO Group. ©2026 The LEGO Group.

©Hergé-Tintinimaginatio - 2026

 6640662