



We're making our packaging more sustainable

We're transitioning from single-use plastic to paper-based packaging. As we progress, you may find a mix of paper and plastic in our boxes.

Nous rendons nos emballages plus durables

Nous passons des emballages en plastique à usage unique aux emballages à base de papier. Durant la transition, vous pourriez trouver un mélange de papier et de plastique dans nos boîtes.

Queremos hacer más sustentables nuestros materiales de embalaje

Estamos cambiando las bolsas de plástico desechables por bolsas con base de papel. Conforme avanzamos en este propósito, puedes encontrar una mezcla de papel y de plástico en nuestras cajas.

LEGO.com/sustainable-packaging



42143 FERRARI DAYTONA SP3

Copy writer: Scott Selkirk Neillands

Graphic design: Henriette Solgaard, Dennis Rønneby

Packaging concept: Natacha Héléne Marie Lesty, Tomas Due-Pedersen

BOOK 1 / LIVRE 1

Booklet available in English on
Folleto disponible en español en

[LEGO.com/service/buildinginstructions](https://www.LEGO.com/service/buildinginstructions)

BILLUND - DENMARK/DANEMARK

LEGO®

FOUNDED/ FONDÉE : 1934



(c) Adam Mørk

The LEGO Group and Ferrari are two distinct companies but with the same goal: the never-ending pursuit of perfection in everything they do. The result? The incredible Ferrari Daytona SP3, and now the LEGO® Technic™ interpretation of it. Enjoy.

MARANELLO - ITALY/ ITALIE

FERRARI

FOUNDED/ FONDÉE : 1947



Le Groupe LEGO et Ferrari sont deux entreprises distinctes, mais qui partagent la même ambition : la recherche permanente de la perfection dans tout ce qu'elles font. Le résultat ? L'incroyable Ferrari Daytona SP3, et maintenant, sa version LEGO® Technic™. Amusez-vous !









“

FERRARI'S HERITAGE IS GENUINELY BOUNDLESS AND A MASSIVE SOURCE OF INSPIRATION. THAT IS THE LINK BETWEEN OUR PAST AND FUTURE.
L'HÉRITAGE DE FERRARI EST EXCEPTIONNEL ET UNE GRANDE SOURCE D'INSPIRATION. C'EST LE LIEN ENTRE NOTRE PASSÉ ET NOTRE AVENIR.

Flavio Manzoni, Chief Design Officer, Ferrari.

With a background in architecture and industrial design, Flavio Manzoni brings an original approach to car design. As head of Ferrari's in-house design set-up, he ensures a continuity and coherency in the company's iconic design language: "In the Centro Stile, when we use particular styling elements, we are using linguistic codes, a formal vocabulary so unique that it has made form, Ferrari's identity, famous. It is by drawing on very fertile terrain, on this meta-language and these aesthetic codes in their various forms, that masterpieces of the future are born: cars that are all different from each other but recognizable because of their shared Ferrari identity. Our starting point with the Daytona SP3 was to imagine a possible successor to the iconic Monza SP1 project and for this model we looked primarily to the sports racers of the 1960s, such as the legendary 1967 Ferrari 330 P4. This then became an extremely modern, sophisticated sports prototype clothed in very sculptural forms that remains faithful to the formal principles that produced the Monza, even though it has a completely different identity."

Avec son expertise en architecture et en conception industrielle, Flavio Manzoni apporte une approche originale à la conception des voitures. En tant que responsable de l'équipe de conception interne de Ferrari, il assure la continuité et la cohérence du langage de conception emblématique de l'entreprise : « Au Centro Stile, lorsque nous utilisons des éléments stylistiques particuliers, nous utilisons des codes linguistiques, un vocabulaire formel si unique qu'il a rendu célèbre la forme, l'identité de Ferrari. C'est en puisant dans ce terrain très fertile, dans ce métalangage et ces codes esthétiques sous leurs différentes formes, que naissent les chefs-d'œuvre de l'avenir : des voitures toutes différentes les unes des autres, mais reconnaissables grâce à leur identité Ferrari commune. Notre point de départ avec la voiture Daytona SP3 était d'imaginer la succession possible de l'emblématique projet Monza SP1, et pour ce modèle, nous nous sommes principalement inspirés des voitures de course des années 1960, comme la légendaire Ferrari 330 P4 de 1967. Il est ensuite devenu un prototype sportif extrêmement moderne et sophistiqué, doté de formes très sculpturales, qui reste fidèle aux principes formels qui ont donné naissance à la Monza, même s'il a une identité complètement différente. »



1967, Maranello - the two 330 P4s back at the factory after having finished first and second at the 24H of Daytona race.
1967, Maranello - les deux 330 P4 reviennent à l'usine après avoir terminé première et deuxième aux 24 Heures de Daytona.



The Ferrari Icona series was launched in 2018 to celebrate Ferrari's history using design inspired by the timeless styling of the marque's most iconic cars. With the Ferrari Daytona SP3, the focus shifted to the 1960s, and what is rightly considered the golden age of sports prototype racing. As well as the Ferrari 330 P4, an icon of an entire era, the 1967 Ferrari 350 Can Am and 1970 512 S were also important inspirations. The main aim with the Ferrari Daytona SP3, was to deliver the same visual impact as the sports prototypes of the 1960s without resorting to simple nostalgia. The car has a sculptural monolithic grace that emphasizes its dynamic stance. As is the case with all Ferraris, form is never an end in itself, but always functional to performance. The Daytona SP3's engine is a 6496 cc 65° V12 that punches out 840 cv, making it the most powerful ICE ever built by Ferrari.

La série Ferrari Icona a été lancée en 2018 pour célébrer l'histoire de Ferrari par la conception inspirée du style intemporel des voitures les plus emblématiques de la marque. Avec la voiture Ferrari Daytona SP3, l'attention s'est tournée vers les années 1960, et ce qui est considéré à juste titre comme l'âge d'or des prototypes sportifs. Outre la Ferrari 330 P4, icône de toute une époque, la Ferrari 350 Can Am de 1967 et la 512 S de 1970 ont également été d'importantes sources d'inspiration. L'objectif principal de la voiture Ferrari Daytona SP3 était de reproduire l'impact visuel des prototypes sportifs des années 1960 sans se limiter à la simple nostalgie. La voiture a une grâce monolithique sculpturale qui souligne sa prestance dynamique. Comme c'est le cas pour toutes les Ferrari, la forme sert la performance sans être une fin en soi. Le moteur de la Ferrari Daytona SP3 est un V12 de 6 496 cm³ à 65° qui peut atteindre 840 ch, ce qui en fait moteur à combustion interne le plus puissant jamais construit par Ferrari.



THE MAIN TASK FOR THE MODEL WASN'T TO PRODUCE A FAITHFUL REPLICA OF OUR ORIGINAL CAR – IT WAS BEING ABLE TO DISTILL ITS FUNDAMENTAL SPIRIT.
LA DIFFICULTÉ PRINCIPALE DE LA CRÉATION DU MODÈLE N'ÉTAIT PAS DE PRODUIRE UNE RÉPLIQUE FIDÈLE DE LA VOITURE ORIGINALE, MAIS DE POUVOIR EN DISTILLER L'ESPRIT FONDAMENTAL.

Carlo Palazzani, Head of Sports Cars Exterior Design, Ferrari.



As Head of Sports Cars Exterior Design, Carlo Palazzani played a leading role in the development of the Ferrari Daytona SP3 and worked closely with the LEGO® Technic™ designers evolving the Technic model: “Working with the LEGO team was a fascinating experience. It was interesting to see how two different design cultures converged towards a shared goal. It was definitely different getting inside the head of a LEGO Technic designer and imagining their approach to a job as tricky as interpreting such a striking car while still sticking to their own construction guidelines. The care that went into the smallest of details was very impressive. The Technic version of our model has more exaggerated angles and forms, which emphasizes the car's very powerful racing spirit and lends the Technic model an identity of its own, which is slightly different from the original's but just as appealing. The collaboration with the LEGO team was definitely one of those experiences that will enrich a designer's creative potential because it is so stimulating and develops your ability to use abstract ideas.”

En tant que responsable de la conception extérieure des voitures de sport, Carlo Palazzani a joué un rôle important dans le développement de la voiture Ferrari Daytona SP3 et a travaillé en étroite collaboration avec les concepteurs LEGO® Technic™ pour élaborer le modèle Technic : « Travailler avec l'équipe de LEGO a été une expérience fascinante. Il était intéressant de voir comment deux cultures de conception différentes pouvaient converger vers un objectif commun. C'était vraiment différent de se mettre dans la tête d'un concepteur LEGO Technic et d'imaginer son approche pour une tâche aussi délicate que la reproduction d'une voiture aussi spectaculaire tout en respectant ses propres directives de construction. Le soin accordé aux moindres détails était très impressionnant. La version Technic de notre modèle présente des angles et des formes plus exagérés, ce qui souligne l'esprit de course et la puissance de la voiture et confère au modèle Technic une identité propre, légèrement différente de celle de la voiture originale, mais tout aussi attrayante. La collaboration avec l'équipe de LEGO est l'une de ces expériences qui enrichissent le potentiel créatif d'un concepteur, car elle est très stimulante et développe la capacité à utiliser des idées abstraites. »



From left to right/ De gauche à droite :
Stefano De Simone, Lead Exterior Designer of the Ferrari Daytona SP3,
Uwe Wabra, Senior Designer, LEGO® Technic™,
Simone Sabbatucci, Lead Exterior Virtual Modeler of the Ferrari Daytona SP3,
Carlo Palazzani, Head of Sports Cars Exterior Design



A photograph showing two men in a dark studio setting, crouching and discussing the interior design of a car. The man on the left, Fabio Massari, is wearing a black leather jacket and has a beard. The man on the right, Uwe Wabra, is wearing a black jacket over a white shirt. They are surrounded by red leather car seats and parts of a car's interior. The background is a plain, light-colored wall.

From left to right/ De gauche à droite :
Fabio Massari, Head of GT Cars Interior Design, Ferrari,
Uwe Wabra, Senior Designer, LEGO® Technic™



33

**EVEN AFTER 25 YEARS AS A DESIGNER I'M STILL AMAZED WHAT
CAN BE BUILT WITH LEGO® TECHNIC™ ELEMENTS.**

**MÊME APRÈS 25 ANS COMME CONCEPTEUR, JE SUIS TOUJOURS
IMPRESSIIONNÉ PAR CE QUI PEUT ÊTRE CONSTRUIT
AVEC DES ÉLÉMENTS LEGO® TECHNIC™.**

Uwe Wabra, Senior Designer, LEGO® Technic™





“ I ALWAYS WORK ON THE OUTSIDE FIRST
...CREATING THE FORM.

JE TRAVAILLE TOUJOURS SUR L'EXTÉRIEUR EN
PREMIER... EN CONCEVANT LA FORME.

Uwe Wabra, Senior Designer, LEGO® Technic™

Senior LEGO® Technic™ Designer, Uwe Wabra, had to draw on all his years of experience while creating the Technic version of the Ferrari Daytona SP3: "The real Daytona SP3 was still in development when we started on our model, meaning both models were evolving concurrently." As both car and model progressed, it became clear that the greatest challenge would be interpreting the smooth lines of the Ferrari Daytona SP3: "Trying to capture the rounder, organic styling in Technic elements gave me more than a few sleepless nights!" When Uwe was satisfied with the exterior form, he then had to make space on the inside for the V12 engine and a working eight-speed gearbox. Throughout the entire process, Uwe also had to ensure the model would always be a straightforward and fun build: "It's easy to complicate things in a model of this size, but if the building process becomes too complex and hard, I've failed at my job."

Le concepteur LEGO® Technic™ principal, Uwe Wabra, a dû faire appel à toutes ses années d'expérience lors de la création de la version Technic de la Ferrari Daytona SP3 : « La vraie Daytona SP3 était encore en développement lorsque nous avons commencé à travailler sur notre modèle, ce qui signifie que les deux modèles évoluaient simultanément. » Au fur et à mesure de l'évolution de la voiture et du modèle, il est devenu évident que le plus grand défi serait d'interpréter les lignes harmonieuses de la vraie Ferrari Daytona SP3 : « Essayer de reproduire en éléments Technic le style plus rond et organique m'a fait passer plus d'une nuit blanche ! » Une fois satisfait de la forme extérieure, Uwe a dû faire de la place à l'intérieur pour le moteur V12 et une boîte de vitesses à huit rapports. Tout au long du processus, Uwe a également dû veiller à ce que le modèle reste simple et amusant à construire : « Il est facile de compliquer les choses dans un modèle de cette taille, mais si le processus de construction devient trop complexe et difficile, j'ai failli à mon travail. »



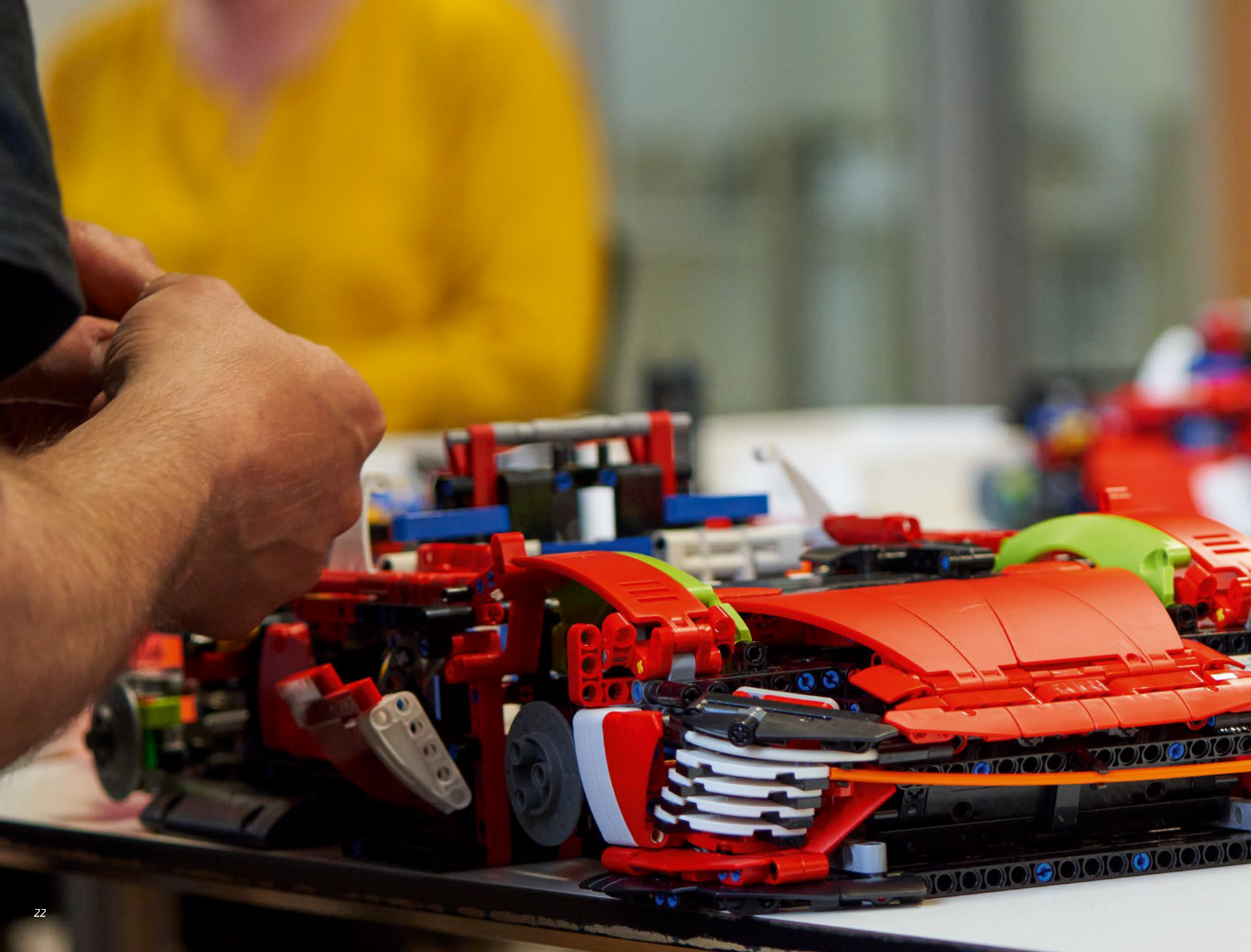









WE ALWAYS TRY TO STEP UP AND TAKE IT TO THE NEXT LEVEL

**NOUS ESSAYONS TOUJOURS D'ALLER PLUS LOIN ET
DE PASSER AU NIVEAU SUPÉRIEUR.**

Daniel Sri Sudarsono, Design Manager - Element Lead, LEGO® Technic™



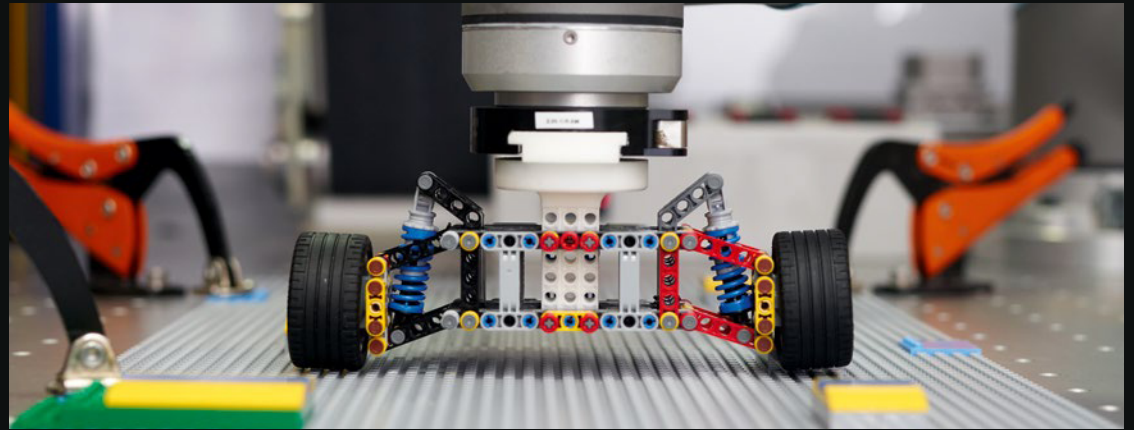
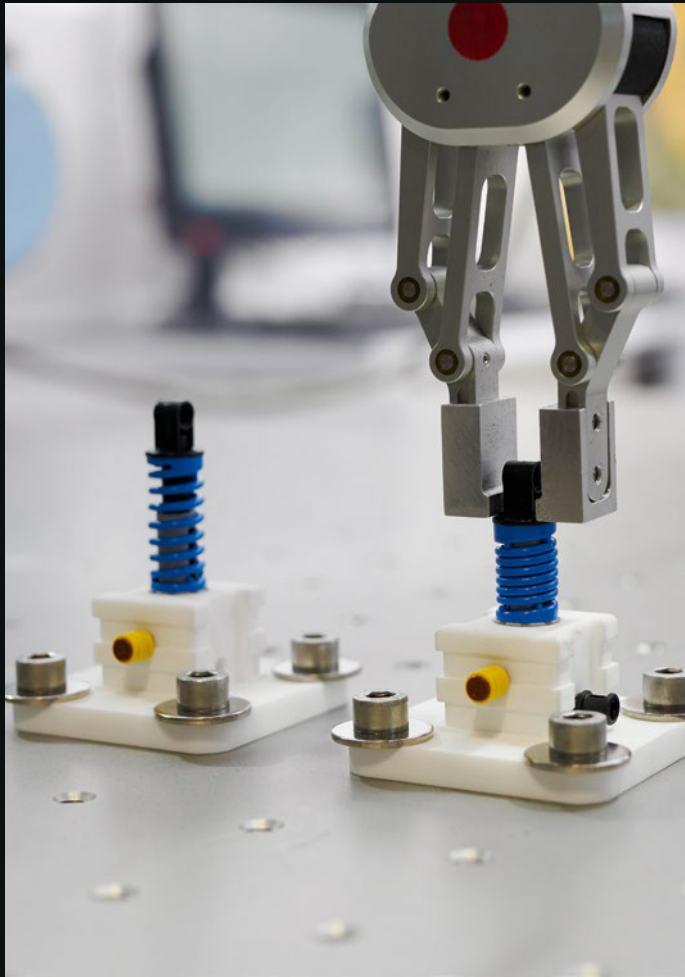

The Technic™ design team knew the LEGO® model wouldn't be complete without those iconic Ferrari rims, and it fell to Element Designer Daniel Sri Sudarsono and his team to make it happen: "When we saw the first sketches of the Daytona SP3, we discovered the right and left rims were asymmetric – a solution that serves to align the spoke design with the direction of rotation. It optimizes the management of the turbulent air flow from the wheels, directing it along the flanks of the car. This meant we were suddenly talking two versions of the rims instead of one. We worked on downscaling the design and 3D printed various iterations to test the look and construction. It was a tough development process, but now I can't imagine our Ferrari Daytona SP3 model without them."

L'équipe de conception Technic™ savait que le modèle LEGO® ne serait pas complet sans les jantes emblématiques de Ferrari, et c'est au concepteur d'éléments Daniel Sri Sudarsono et à son équipe qu'il a incombé de les réaliser: « Lorsque nous avons vu les premières esquisses de la voiture Daytona SP3, nous avons découvert que les jantes droites et gauches étaient asymétriques, une solution qui permet d'aligner le rayonnage avec le sens de rotation. Ce système optimise la gestion du flux d'air turbulent provenant des roues, en le dirigeant le long des flancs de la voiture. Cela signifie que nous nous retrouvons soudainement avec deux versions des jantes au lieu d'une. Nous avons travaillé sur la réduction de l'échelle du modèle et imprimé en 3D diverses variantes pour tester l'aspect et la construction. Le processus de développement des jantes a été ardu, mais je ne peux pas imaginer notre modèle de la voiture Ferrari Daytona SP3 sans elles. »



Once the team was satisfied with the overall design of the rims, the next challenge was getting that perfect metallic-look finish. As Daniel Sri Sudarsono explains: "We decided to use a specialist drum-rolled lacquer technology which applies an ultra-thin layer to the rims. It's a time-consuming process but it gives exactly the finish we wanted."

Une fois que l'équipe a été satisfaite de la conception générale des jantes, le défi suivant a été d'obtenir la finition métallique parfaite. Daniel Sri Sudarsono explique : « Nous avons décidé d'utiliser une technologie spécialisée de laque au tambour qui applique une couche ultramince sur les jantes. C'est un processus qui prend du temps, mais qui donne la finition que nous recherchions. »











GEARBOX & ENGINE

BOÎTE DE VITESSES ET MOTEUR

The first step in the construction of your Ferrari Daytona SP3 is to build the powerful V12 engine and the eight-speed, dual-clutch gearbox.

La première étape de la construction de votre Ferrari Daytona SP3 consiste à construire le puissant moteur V12 et la boîte de vitesses à double embrayage à huit rapports.



BOX 1 / BOÎTE 1

BAG 1 / SACHET 1



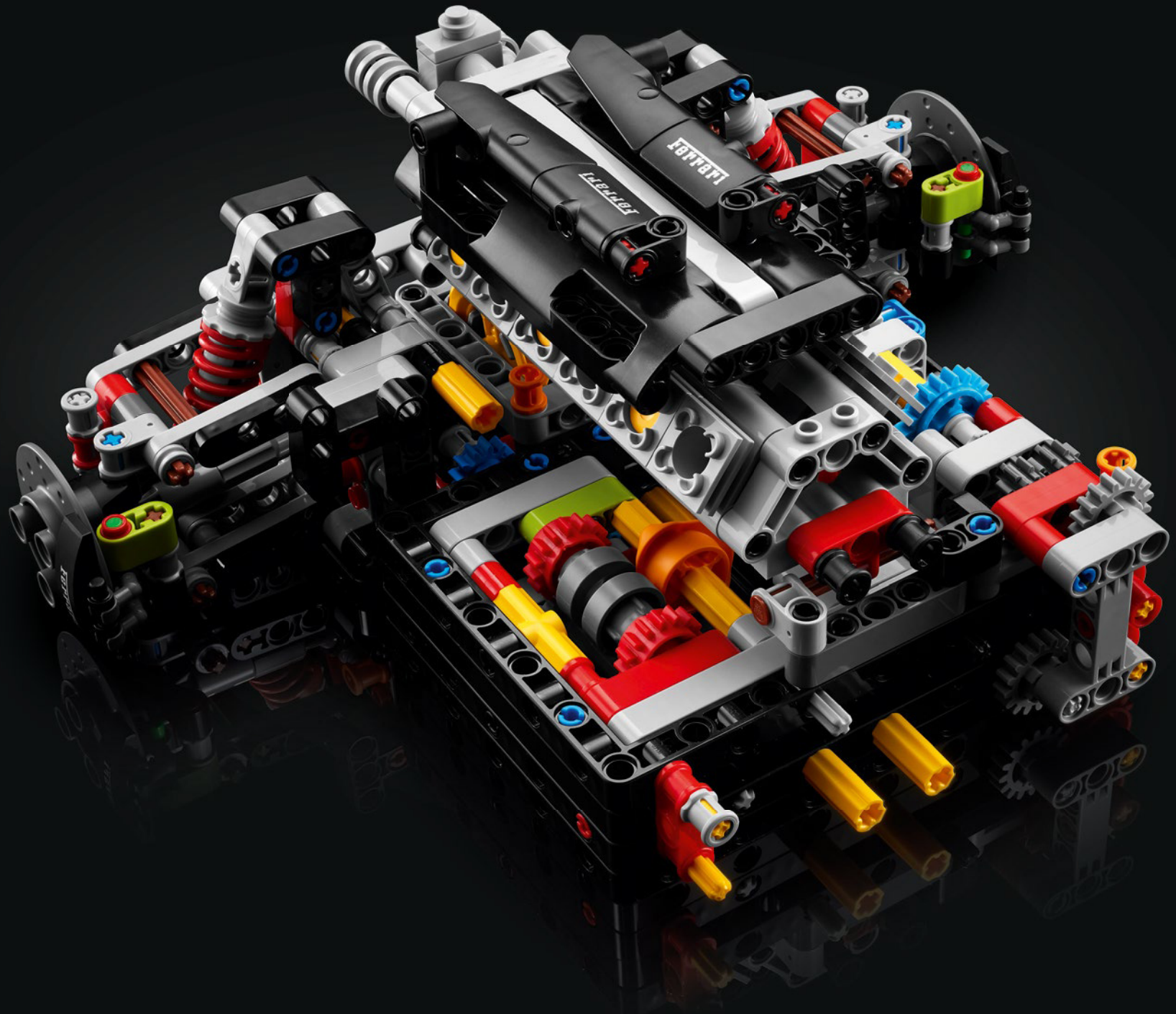

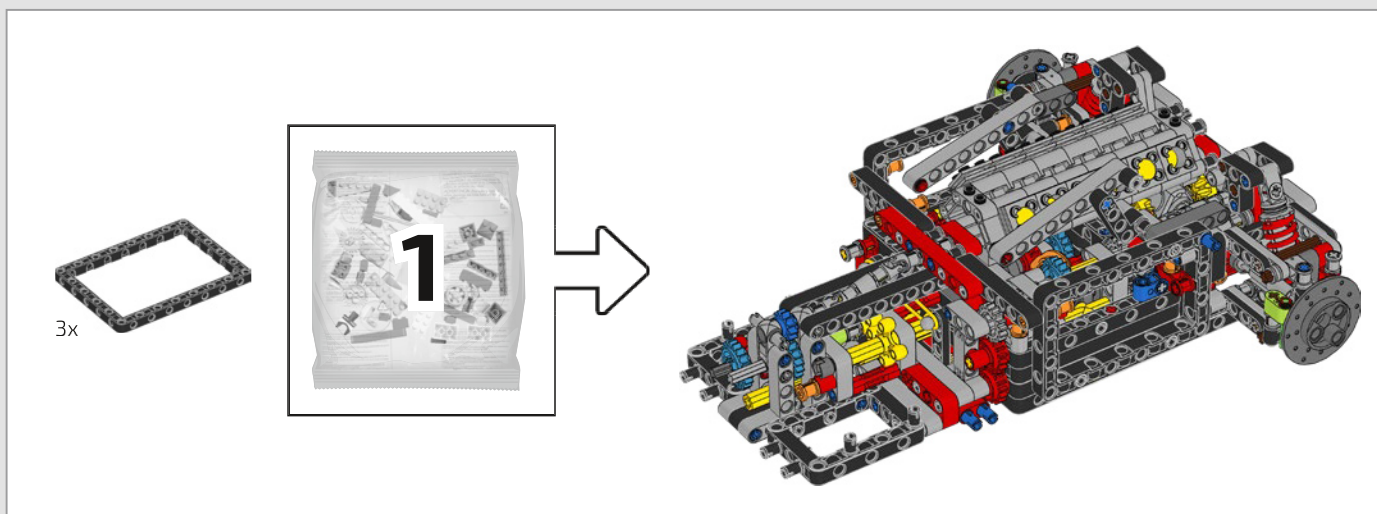

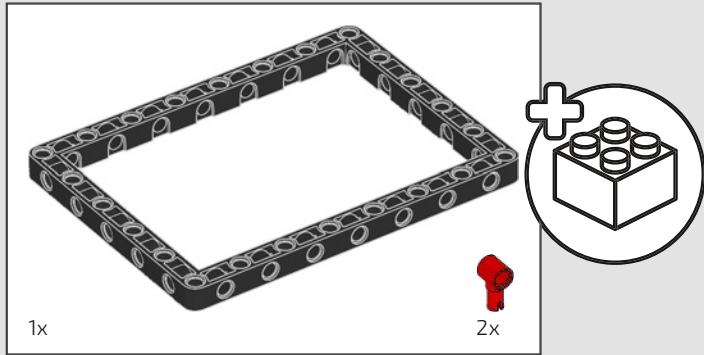

1

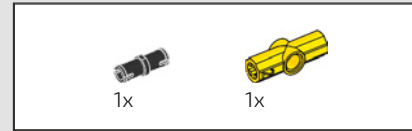
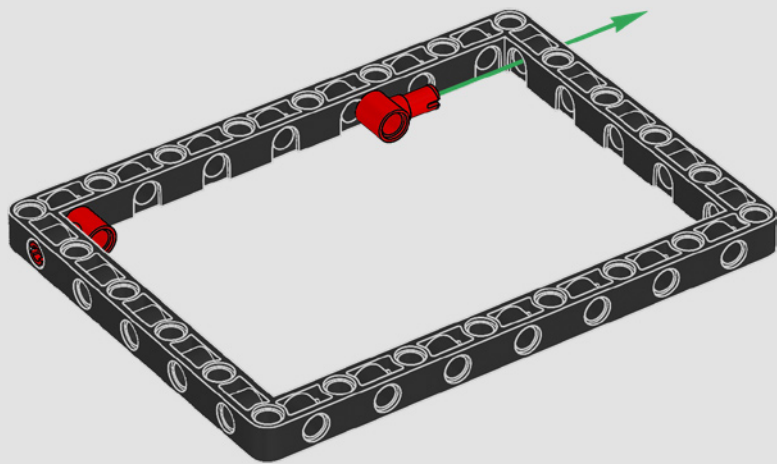

2

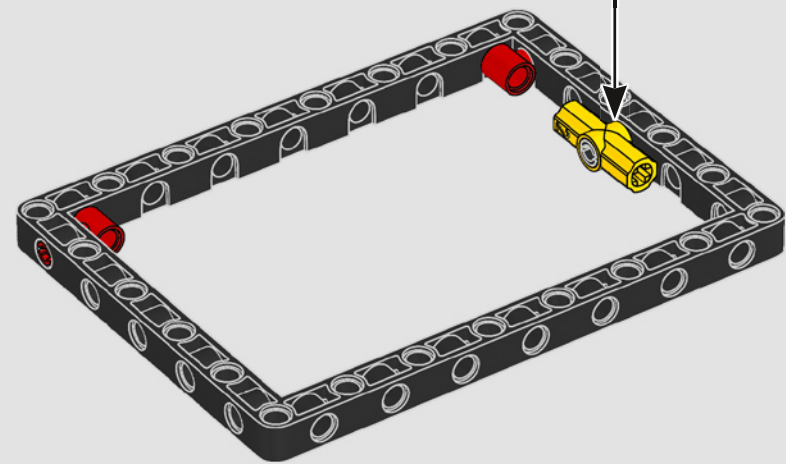
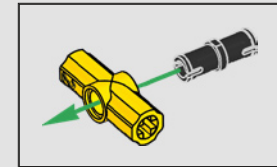



3

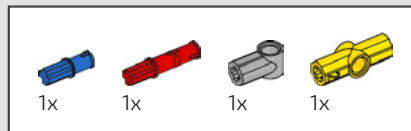
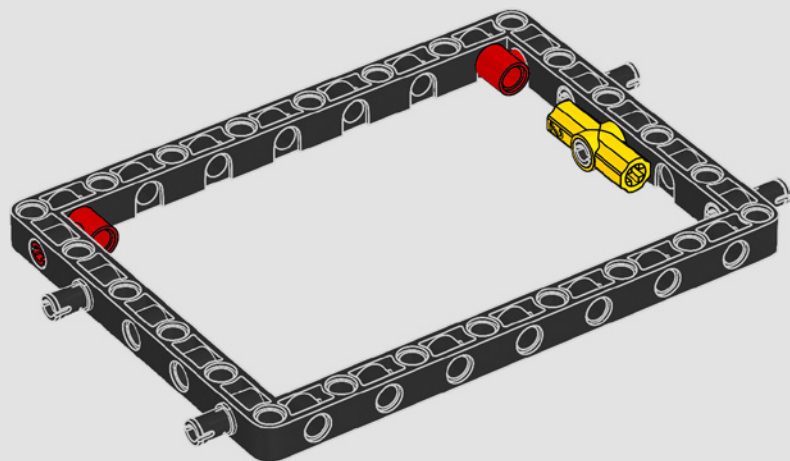

4

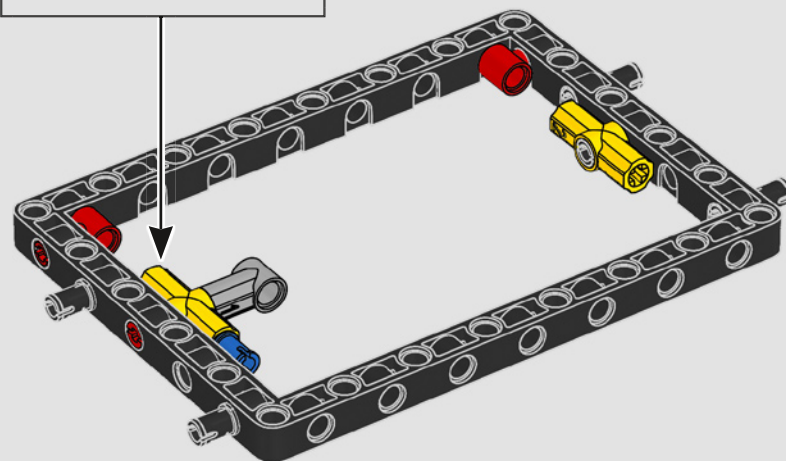
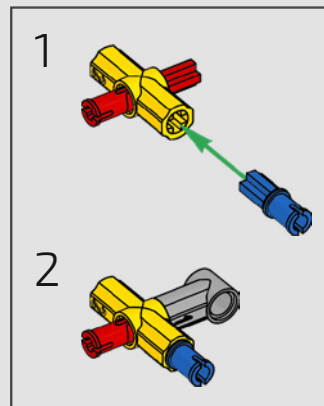

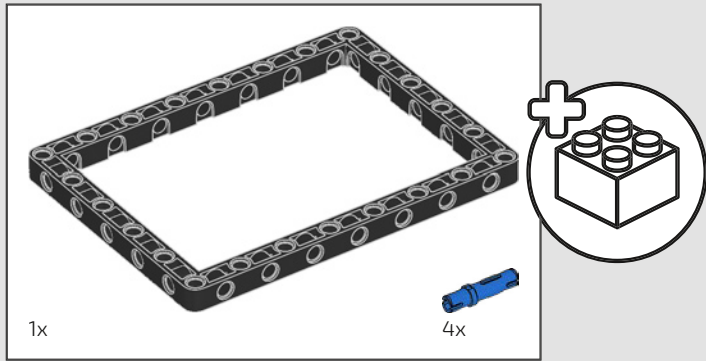

5

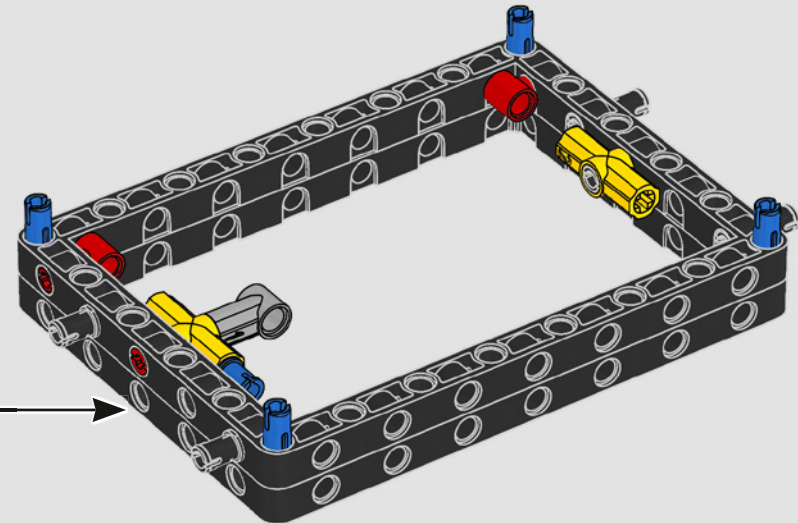
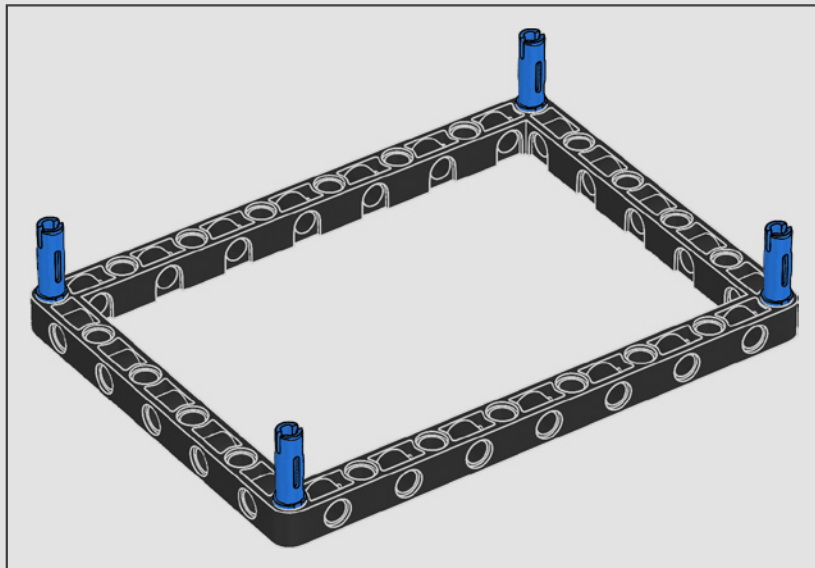

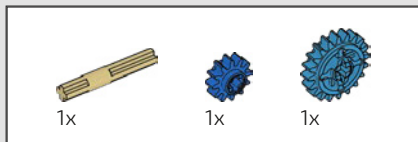

6

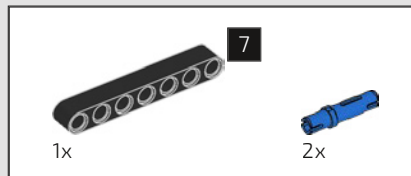
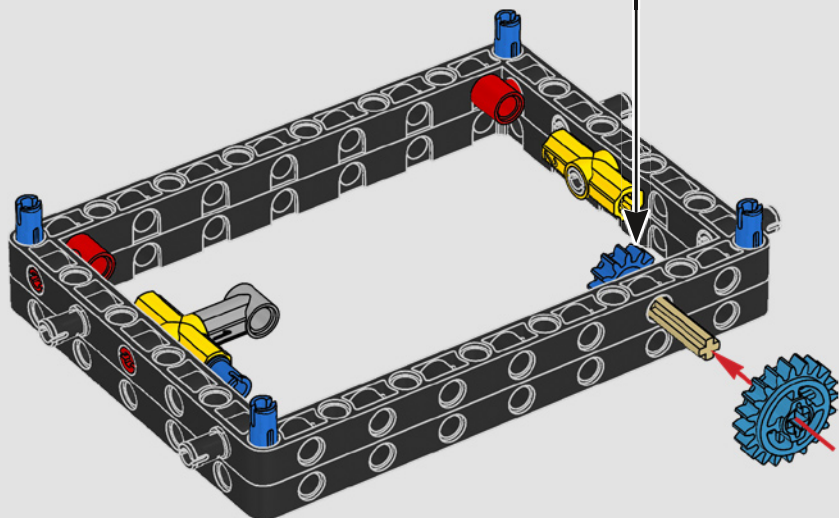
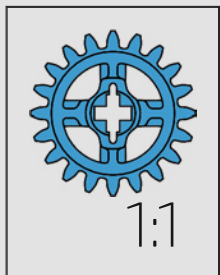

7

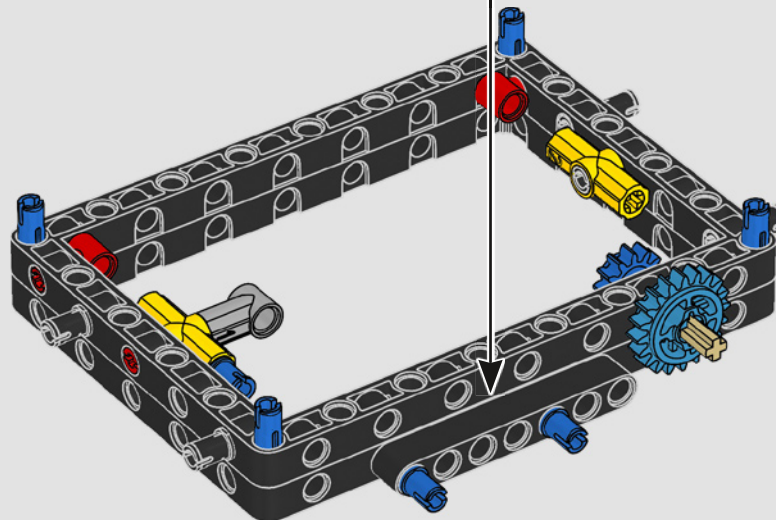
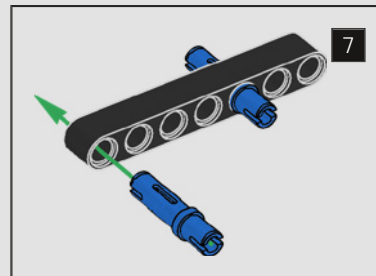

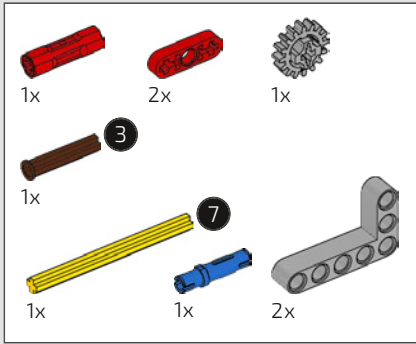

8

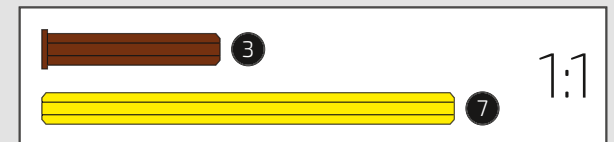
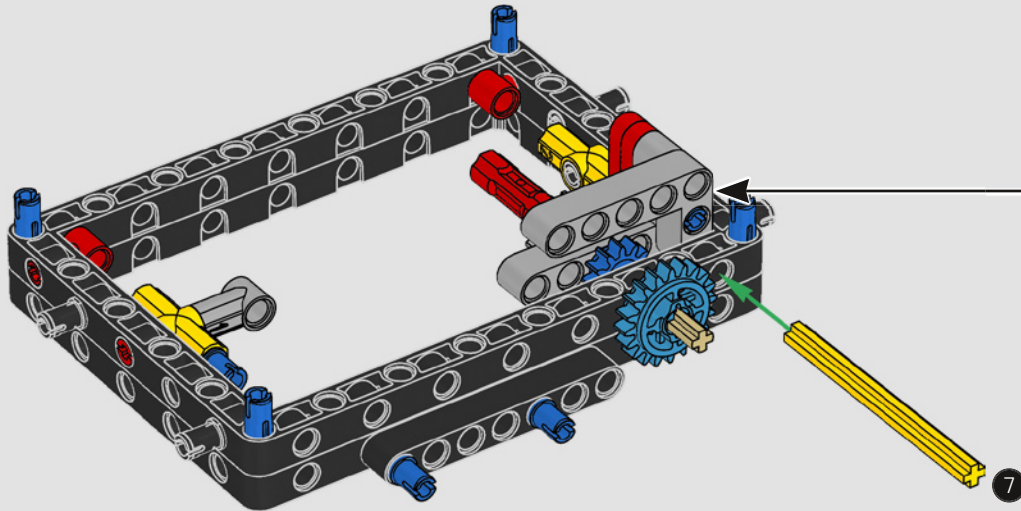
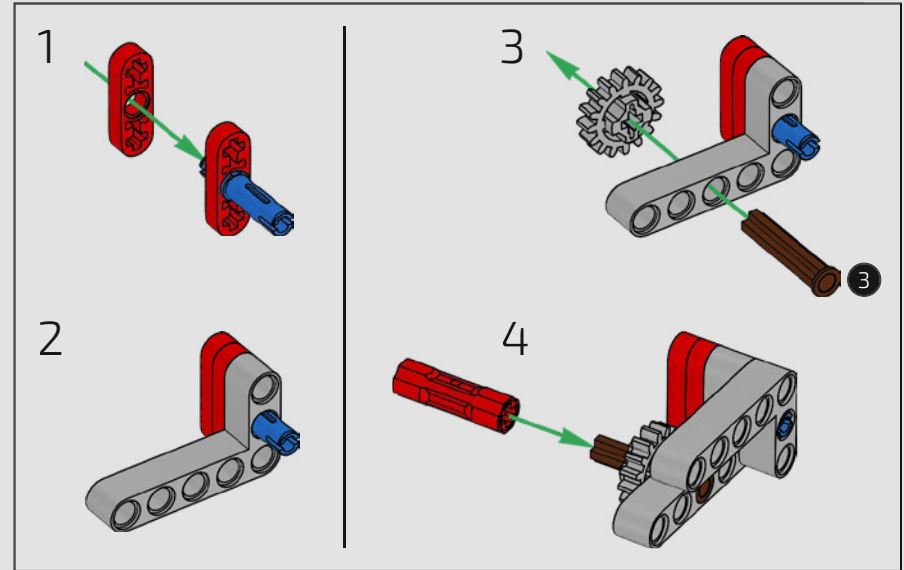

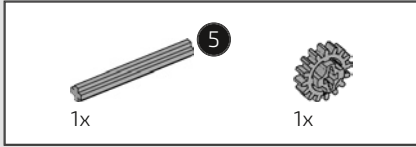

9

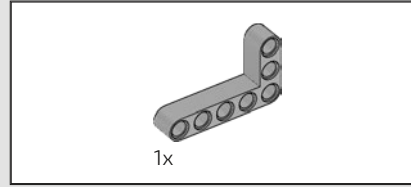
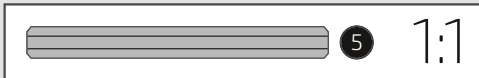
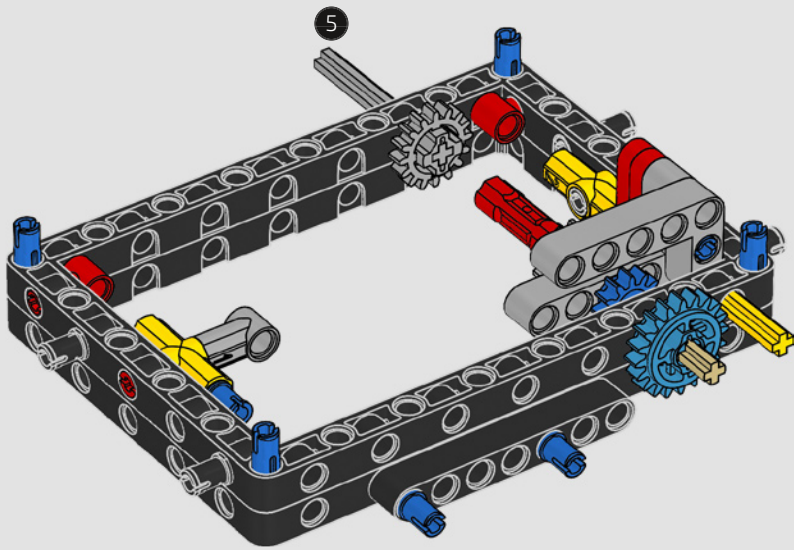

10

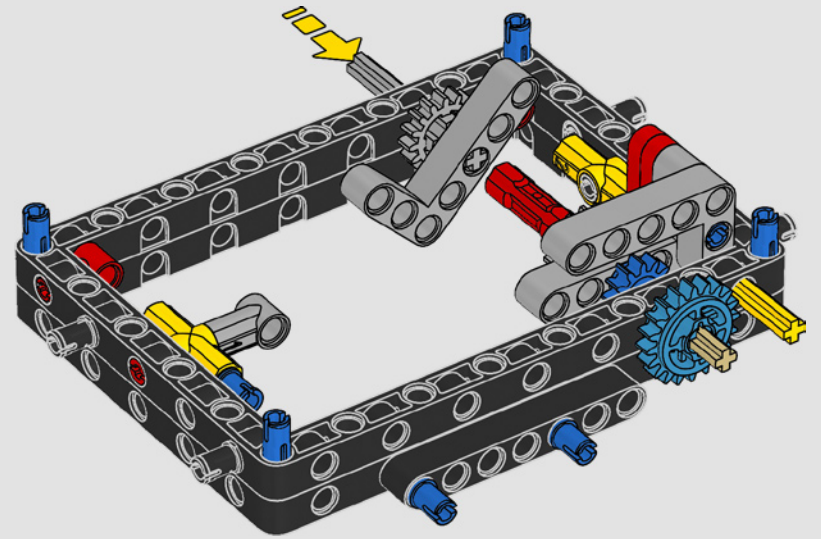

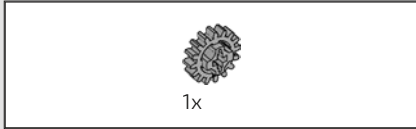

11

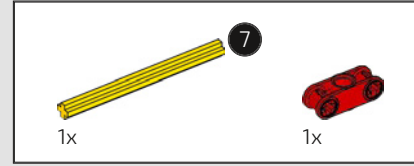
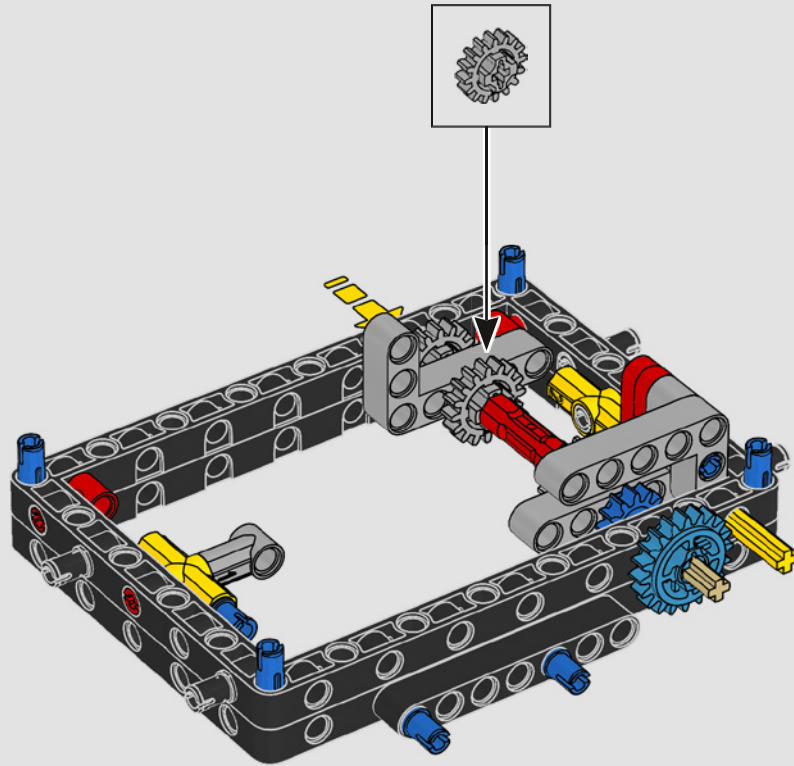

12

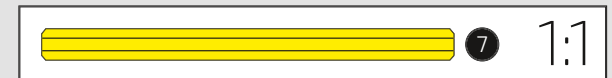
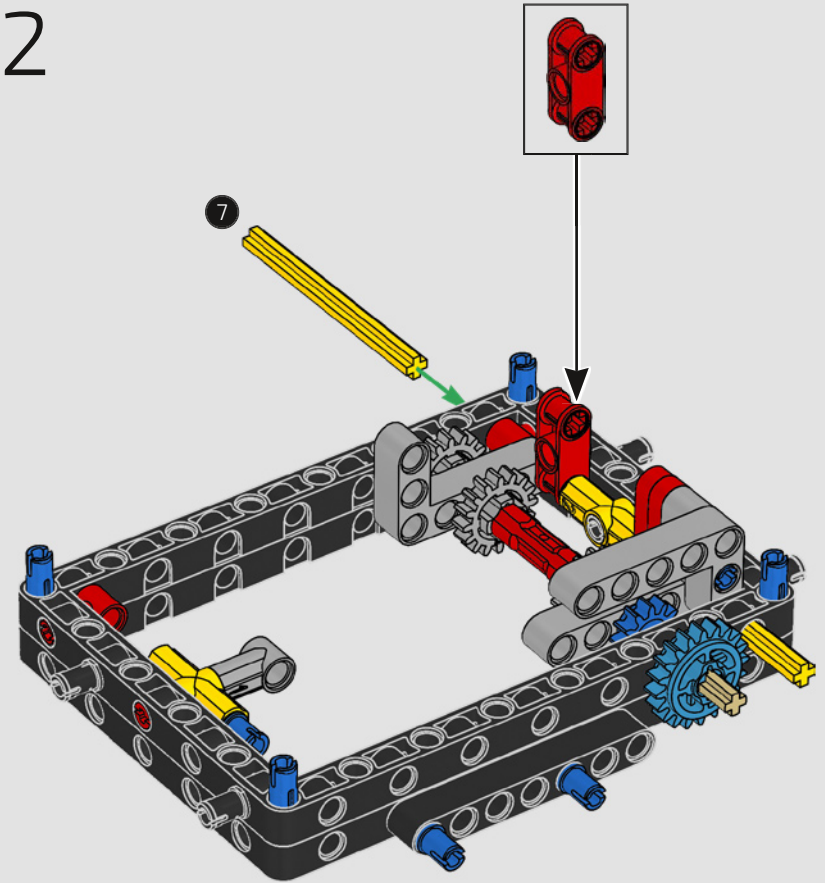

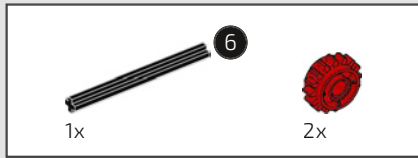

13

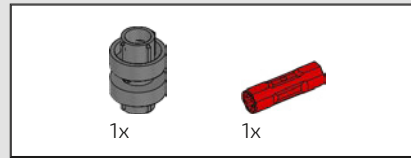
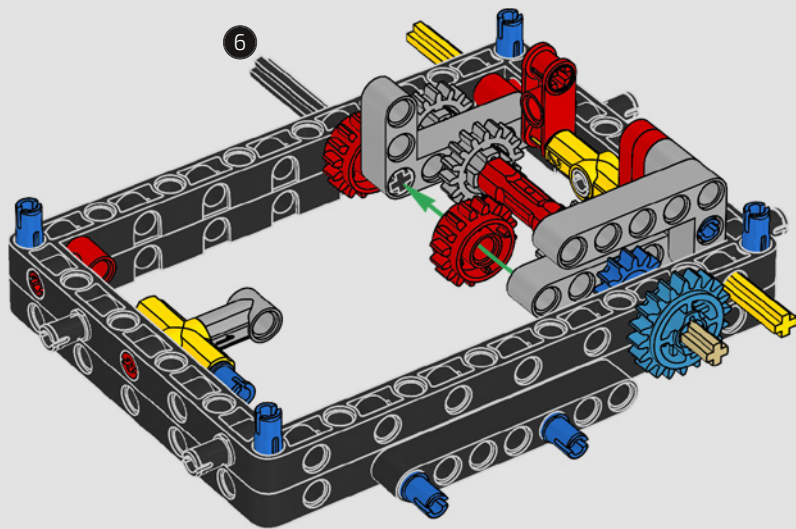

14

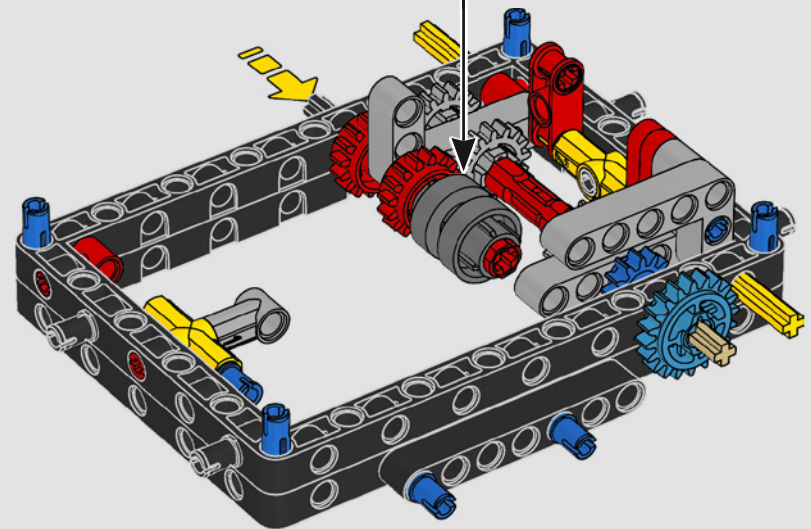
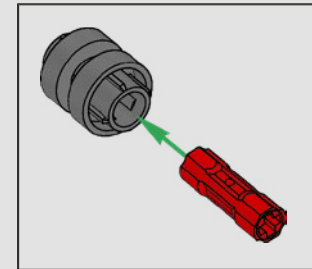

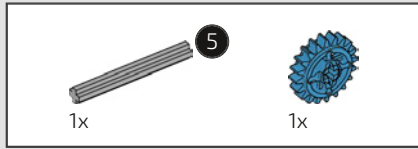

15

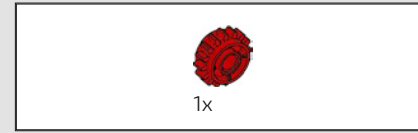
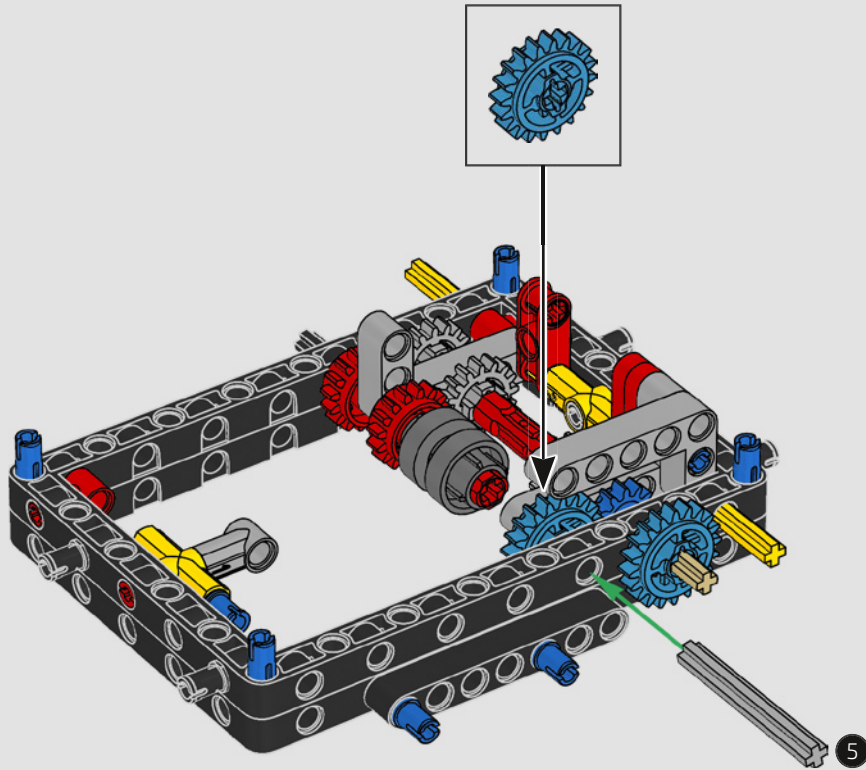
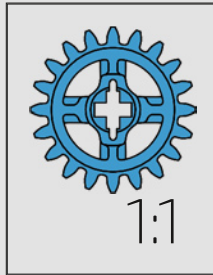

16

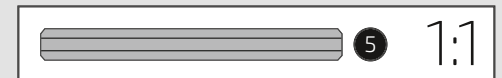
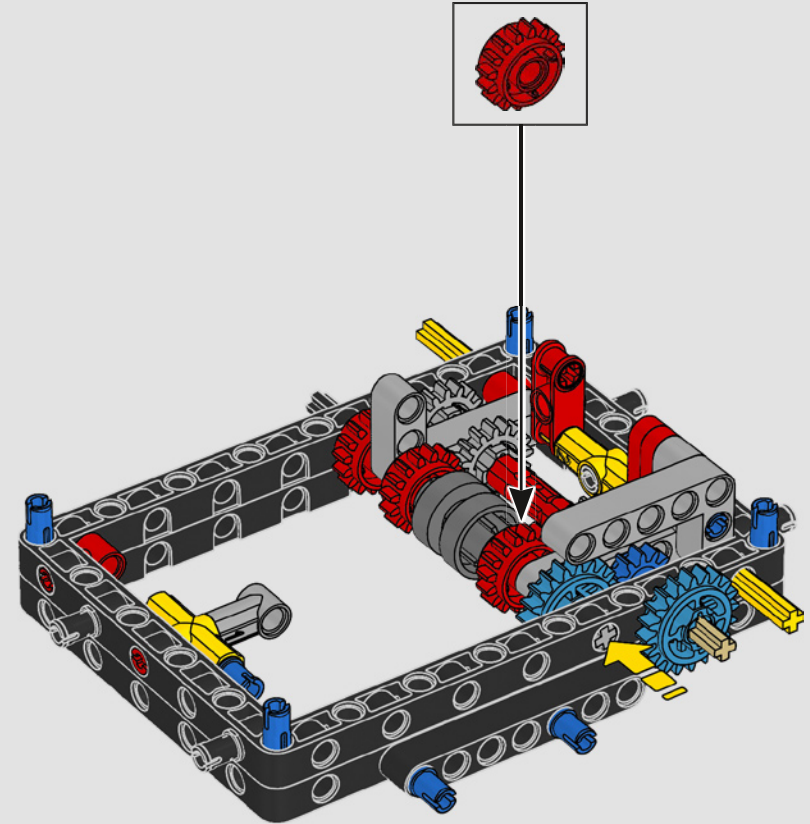

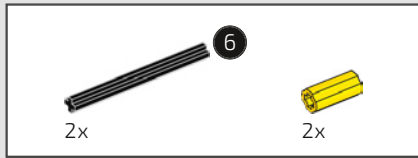

17

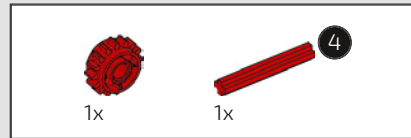
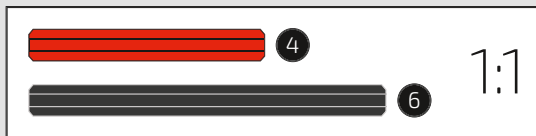
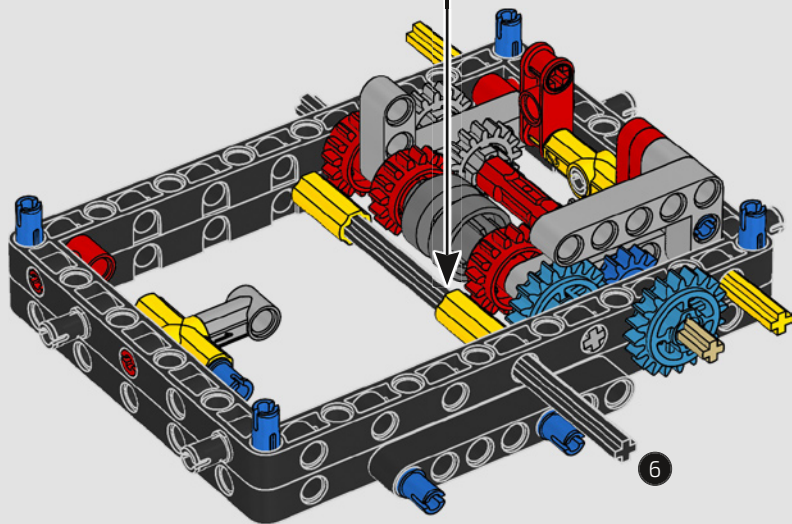
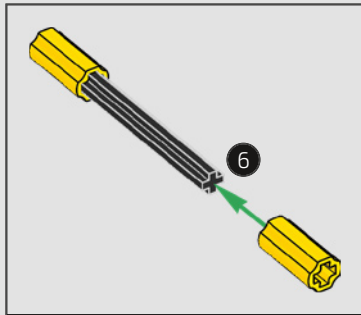

18

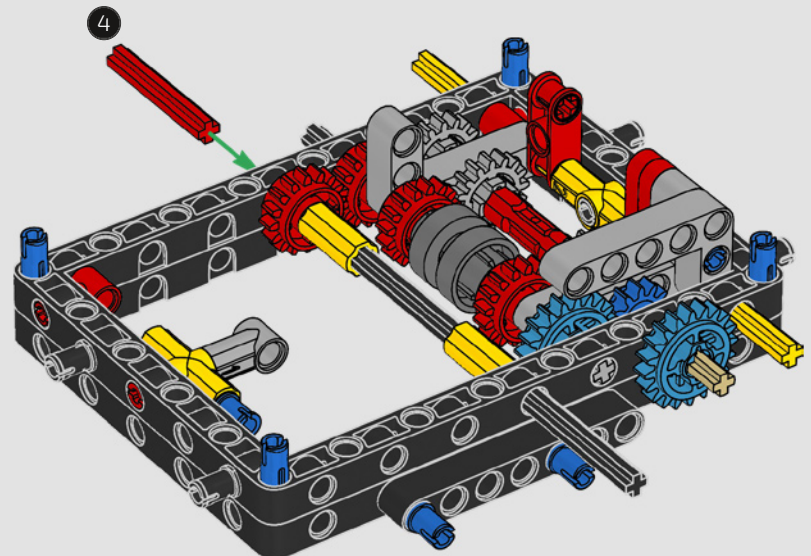

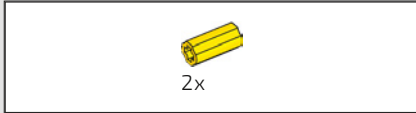

19

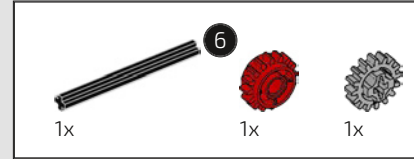
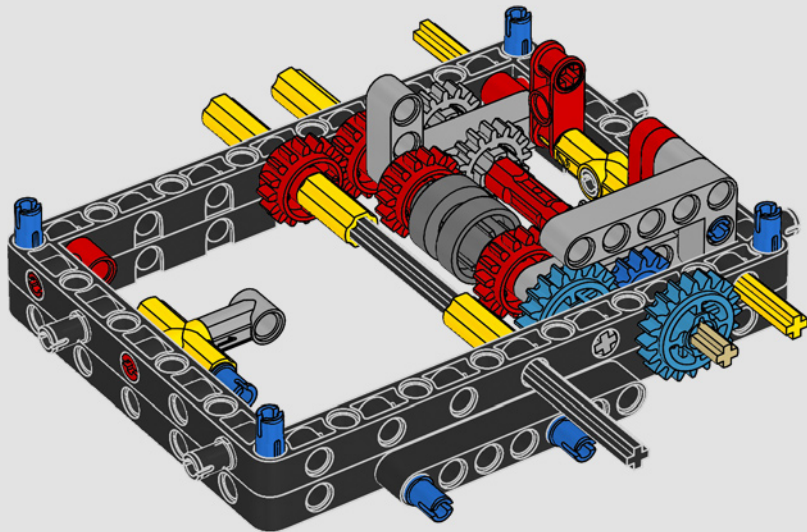

20

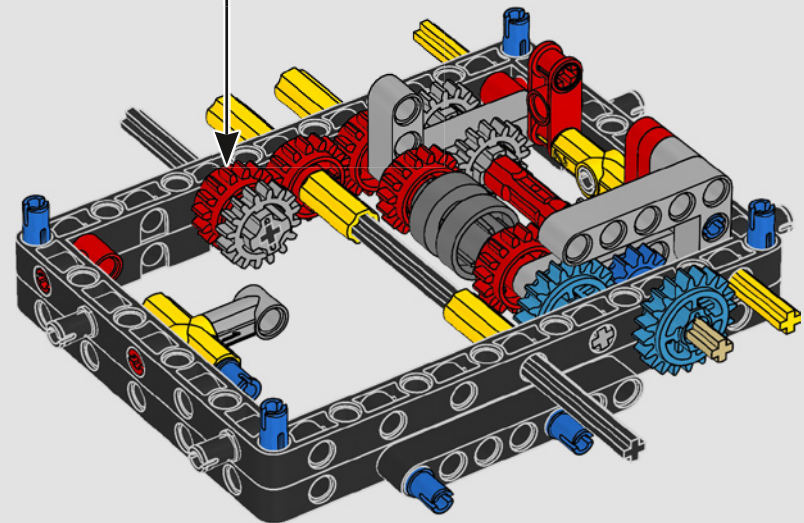
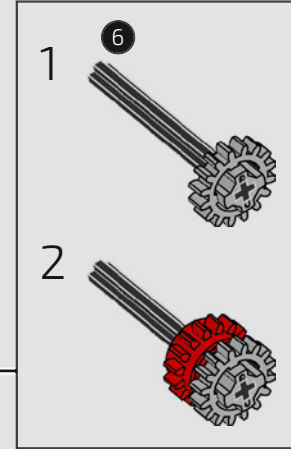

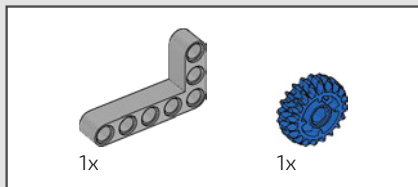

21

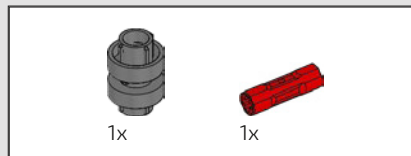
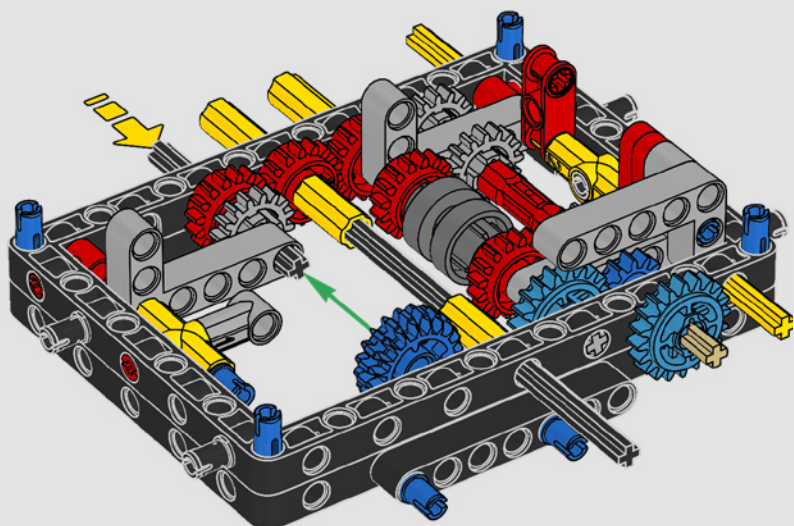

22

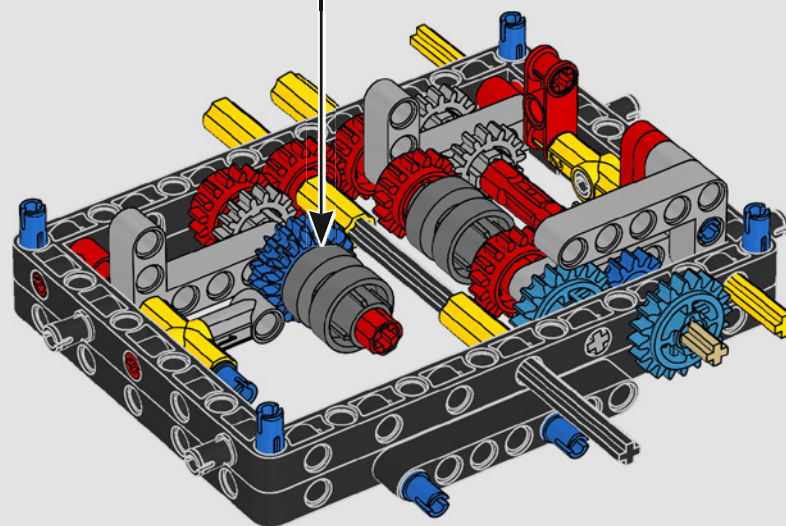
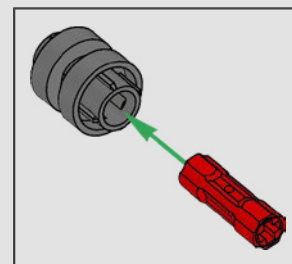

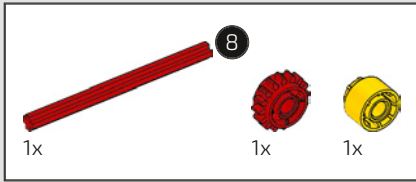

23

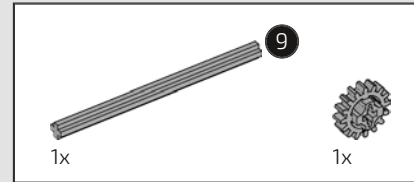
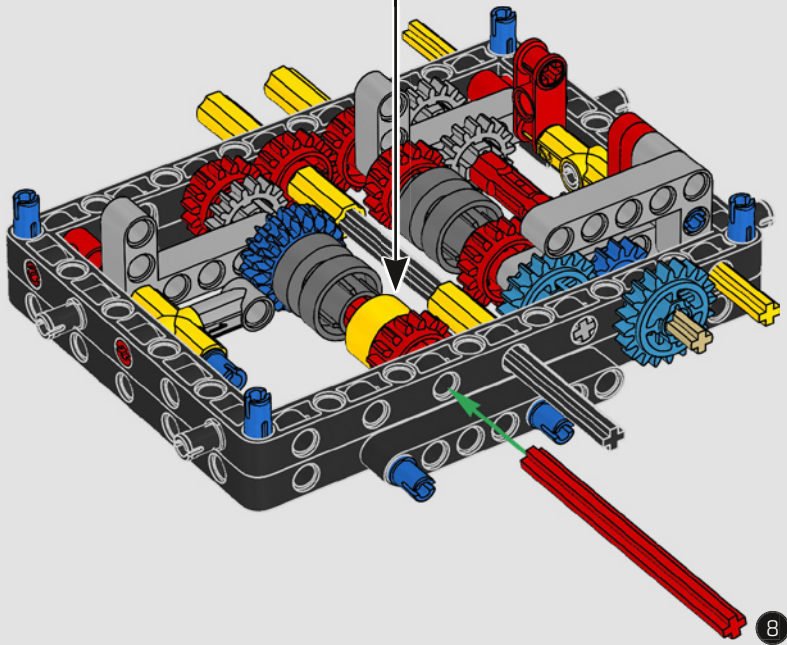
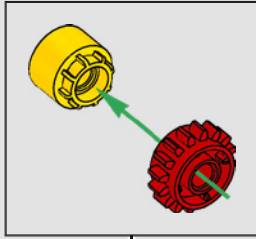

24

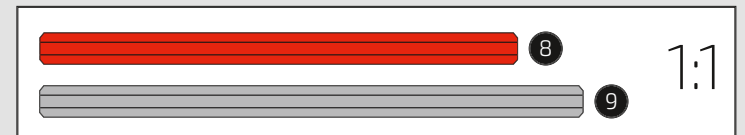
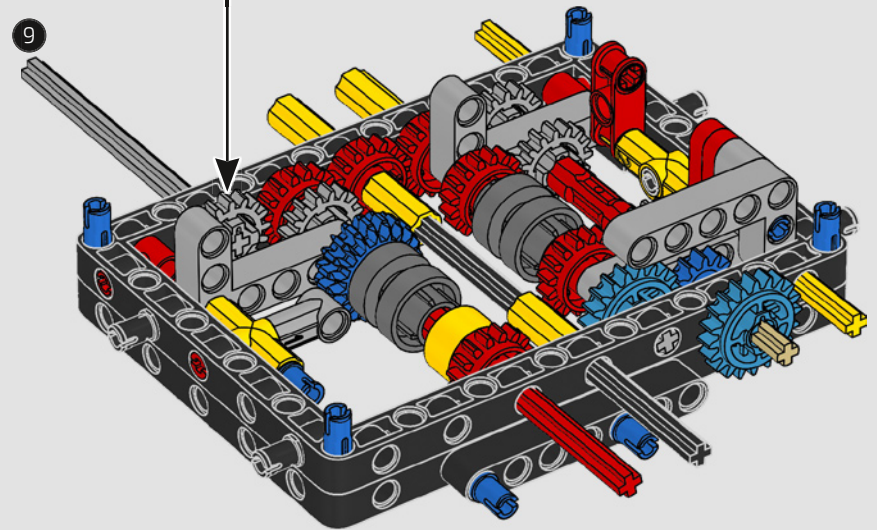
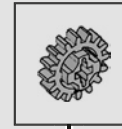

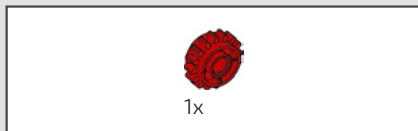

25

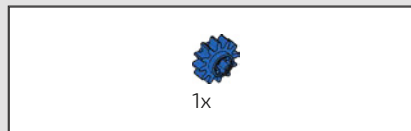
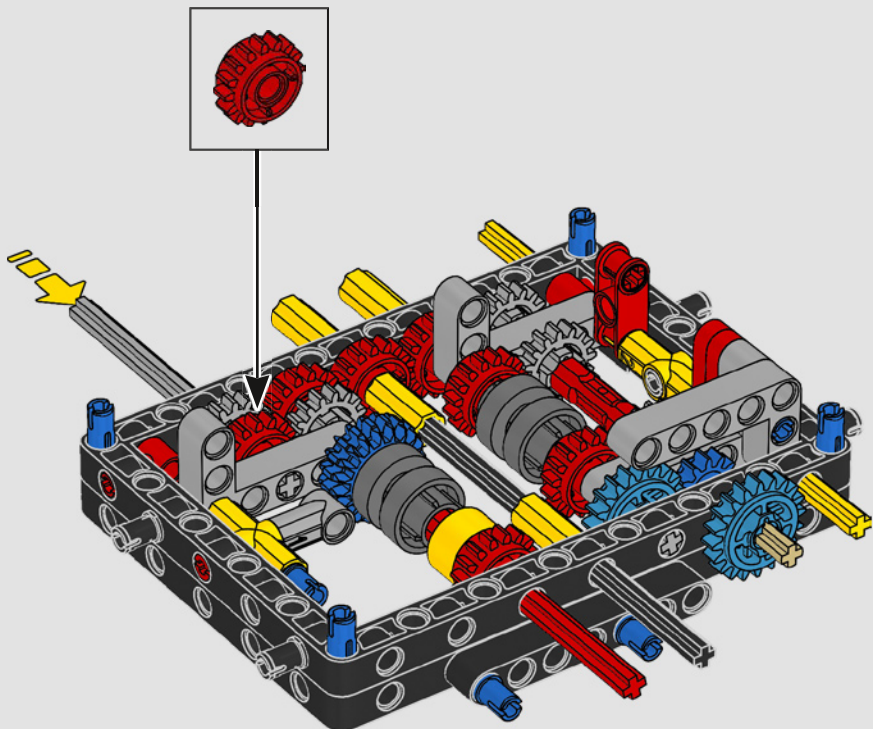

26

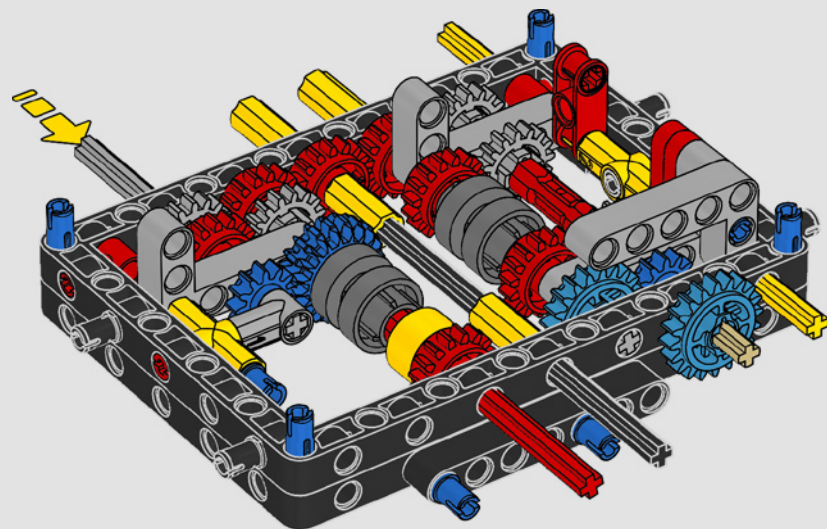

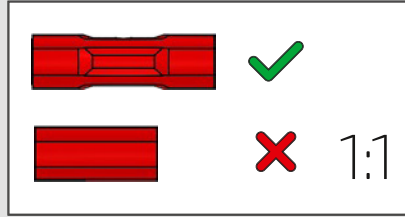
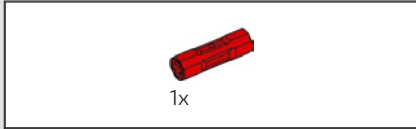

27

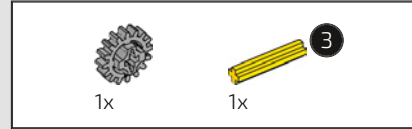
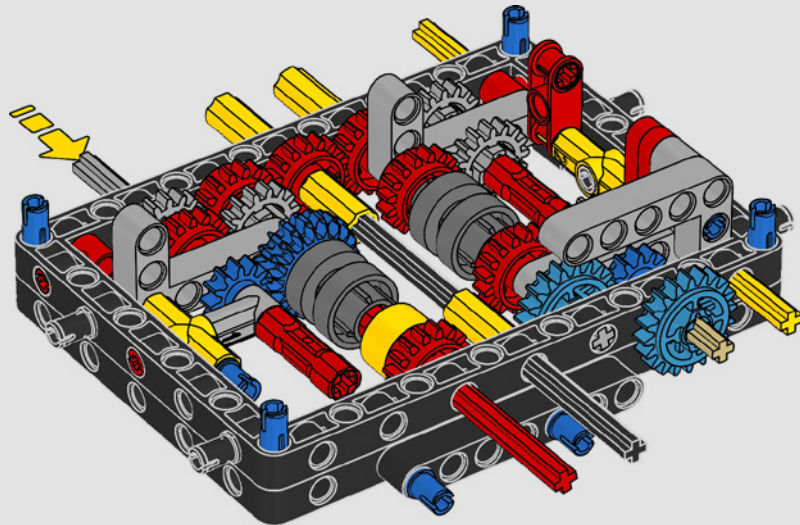

28

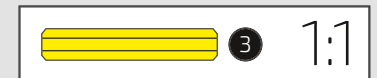
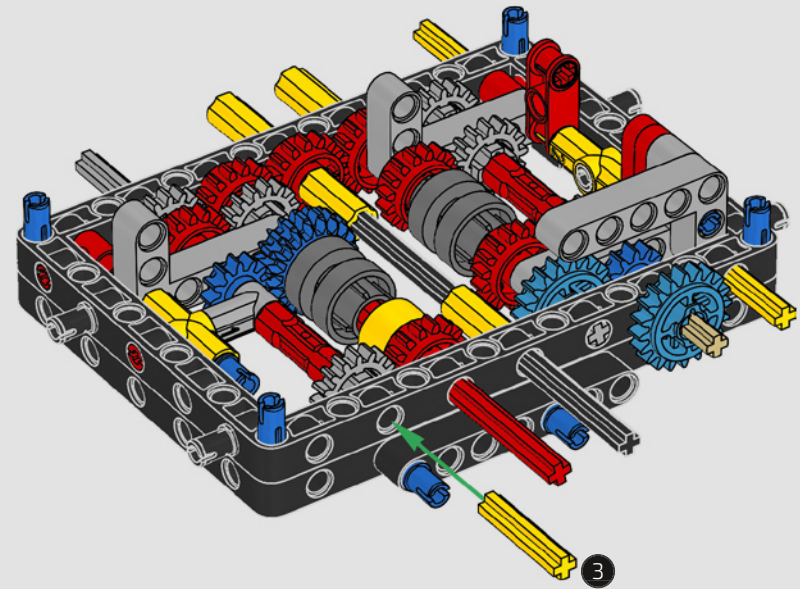



29

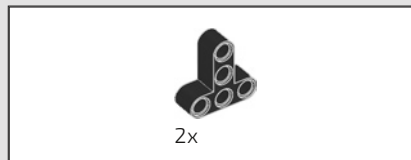
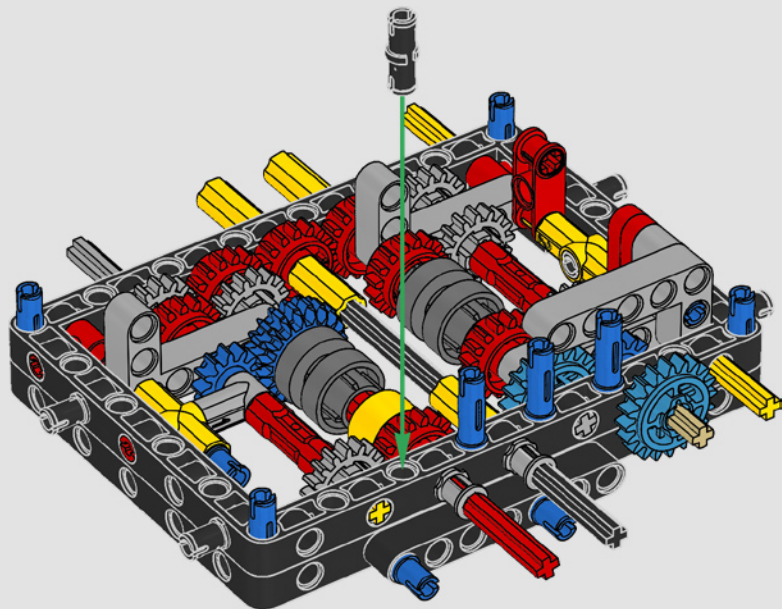

30

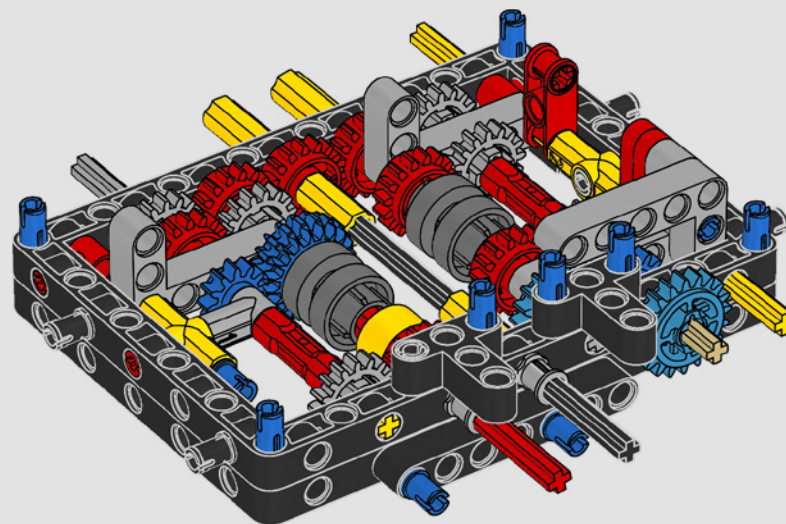

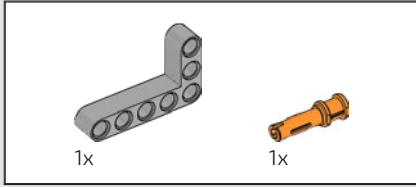

31

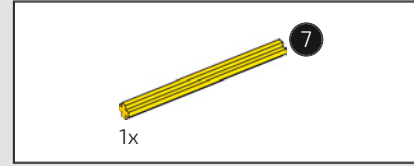
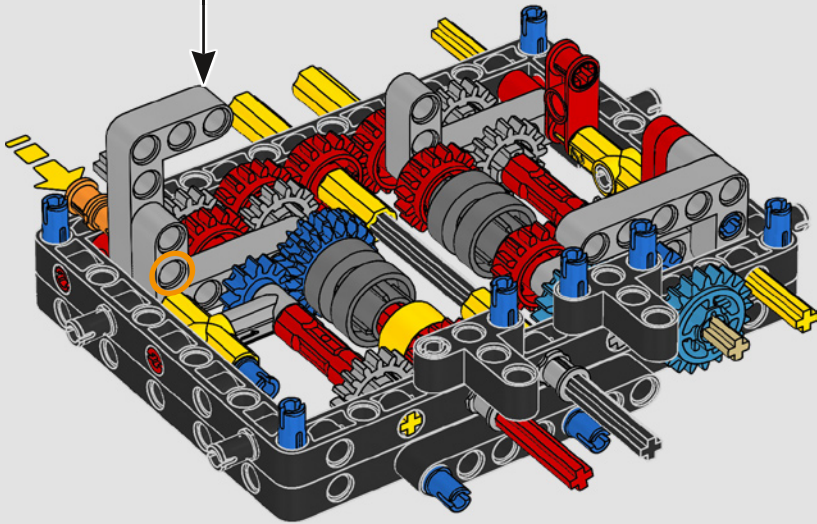
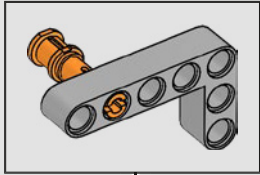

32

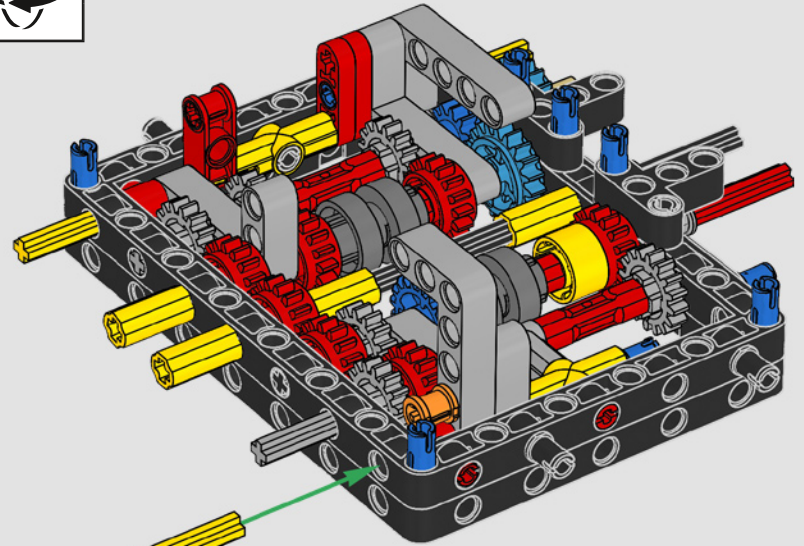

7

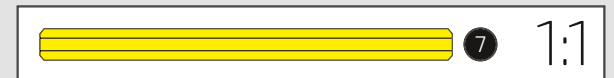

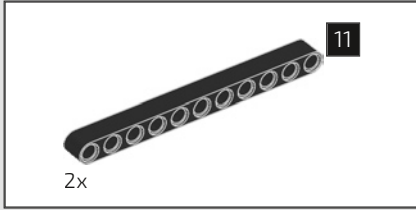

33

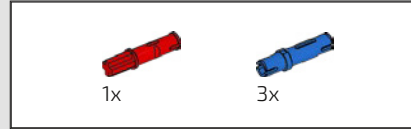
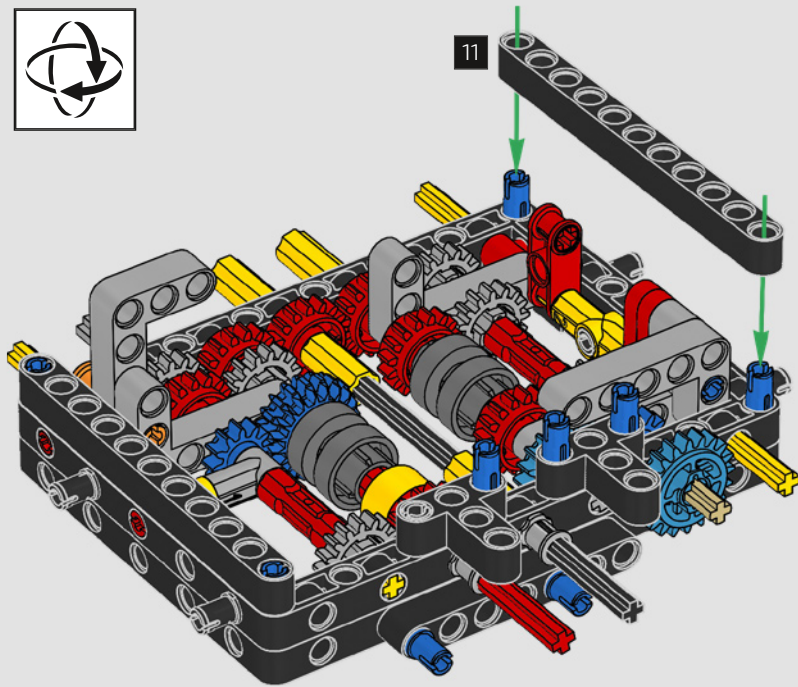

34

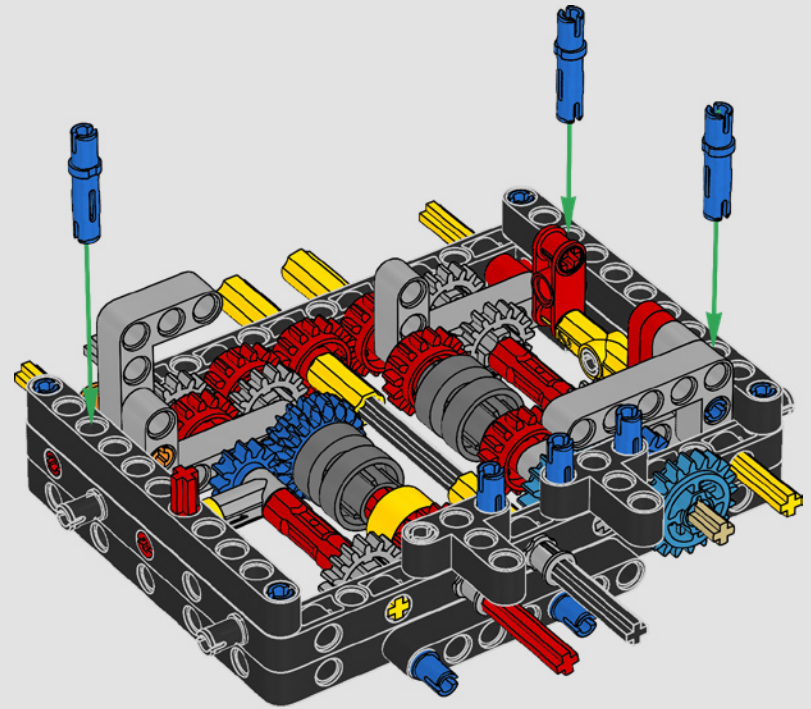

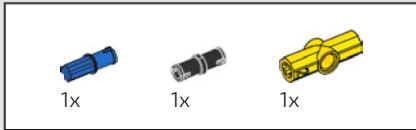
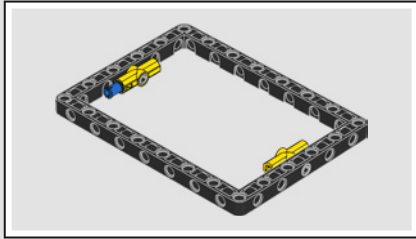

35

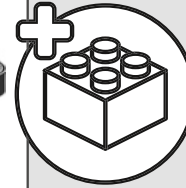
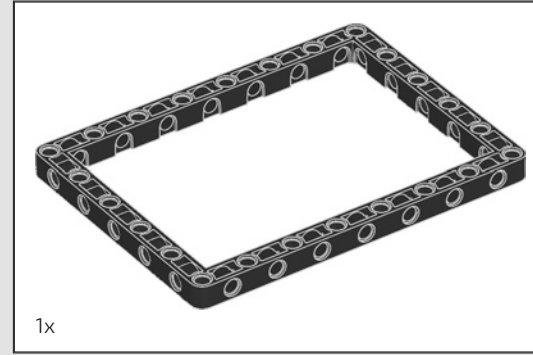
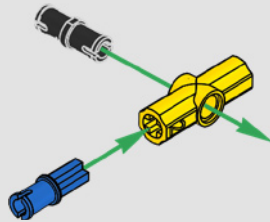

36

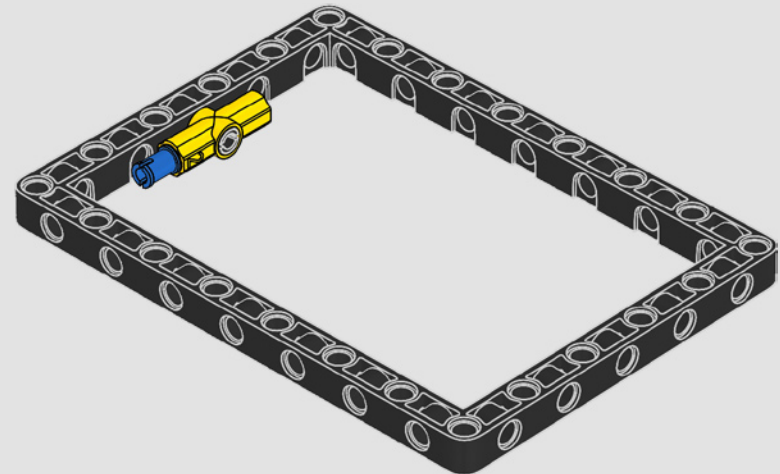

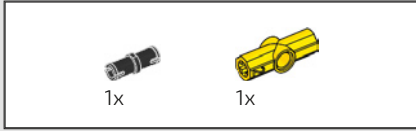

37

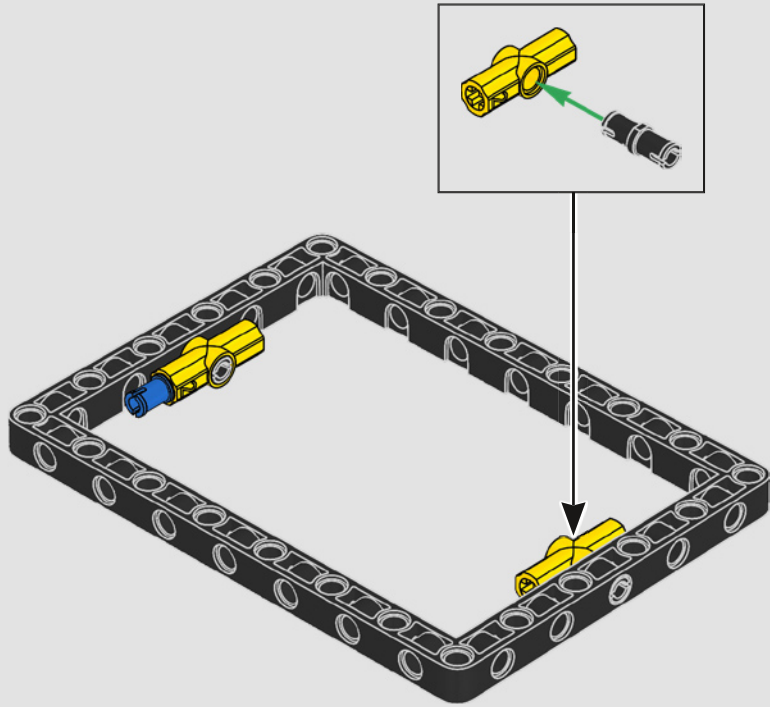

38

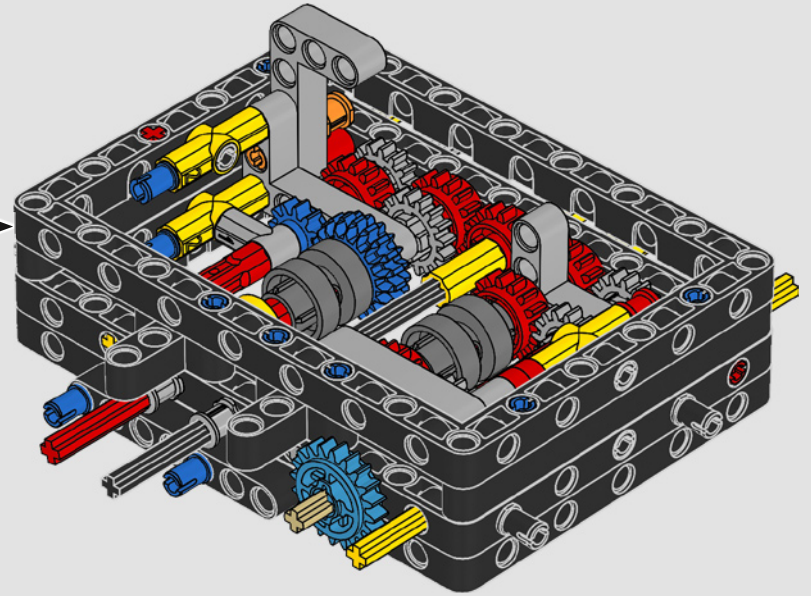



39

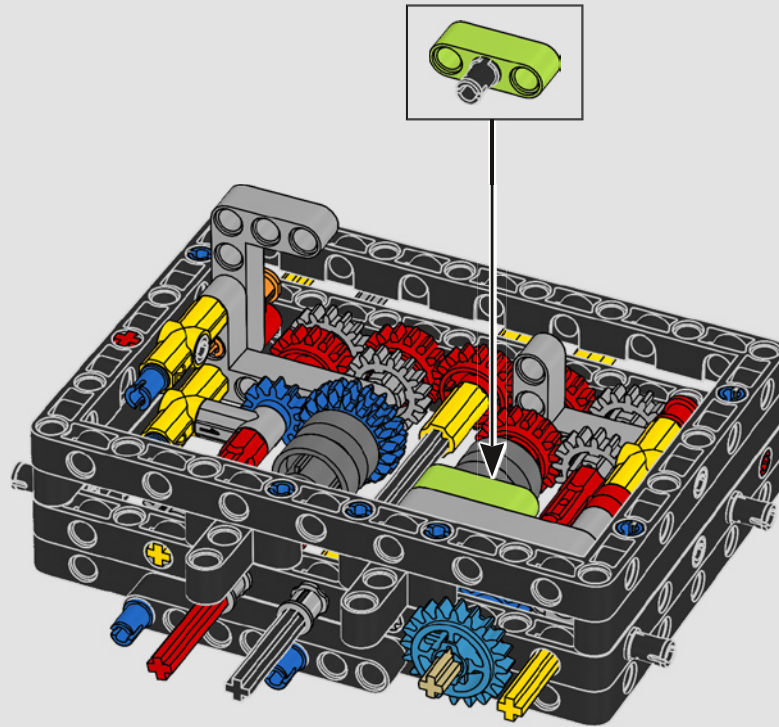

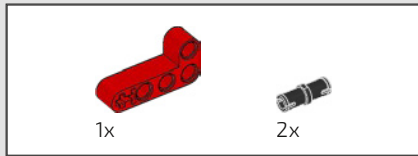

40



41

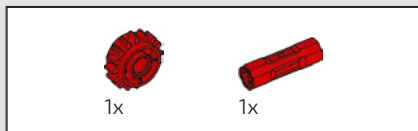
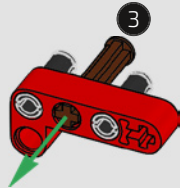

42

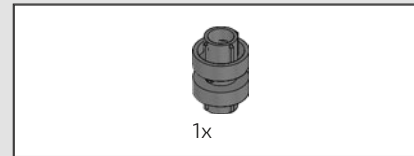
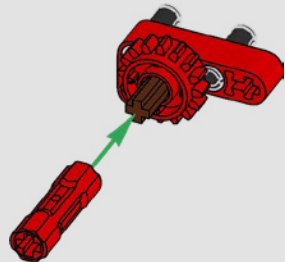

43

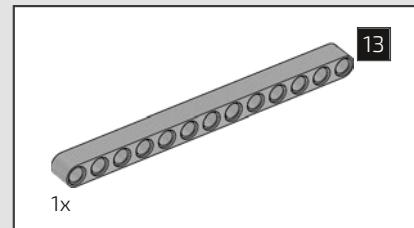
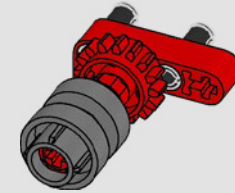

44

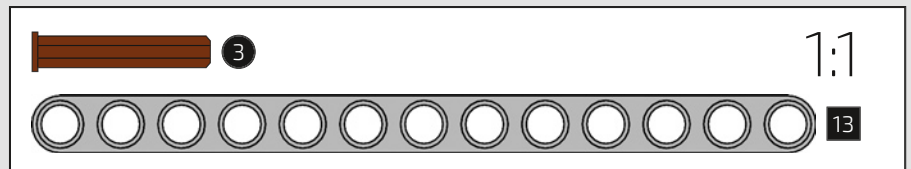
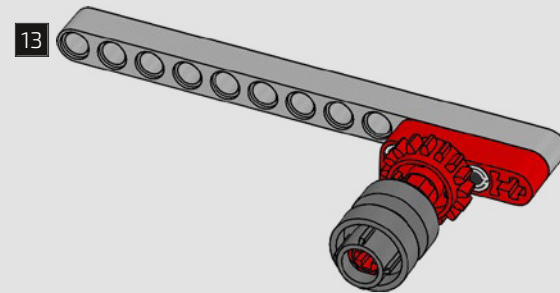

45

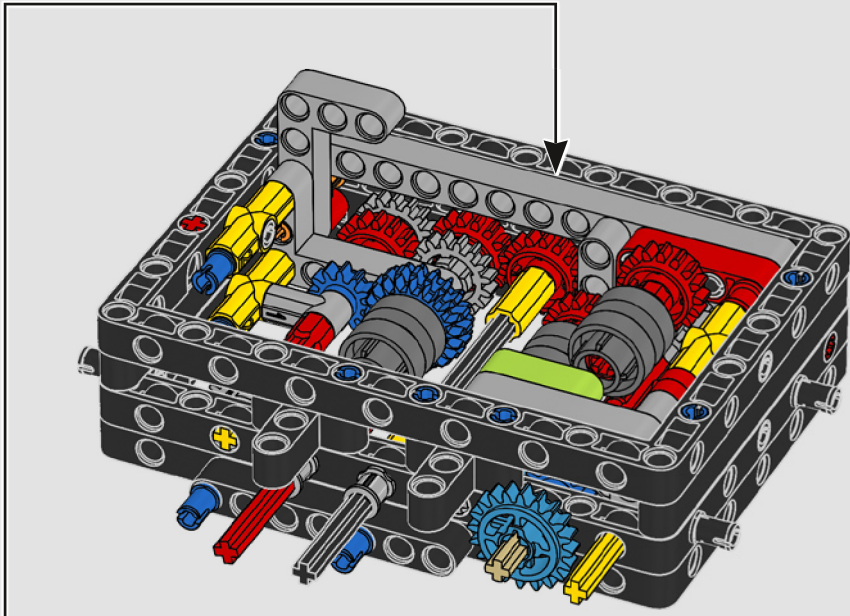

46

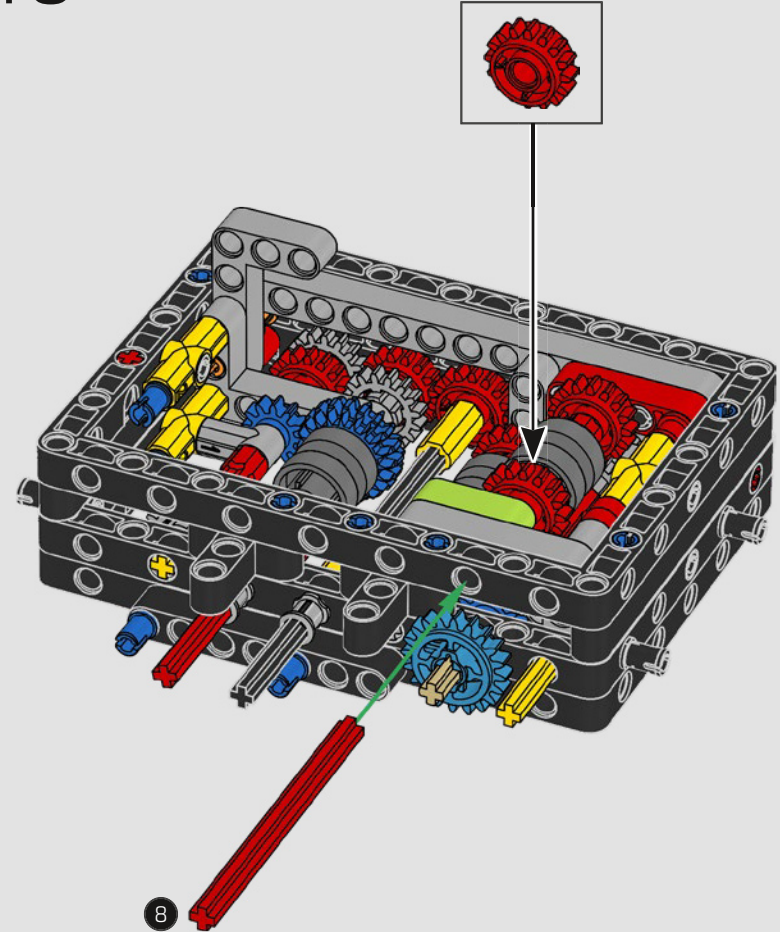
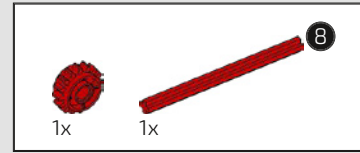

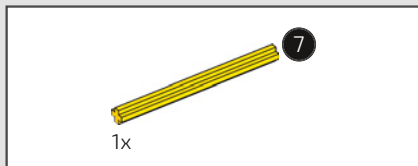

47

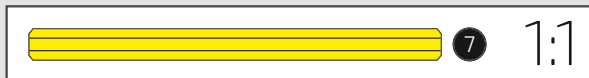
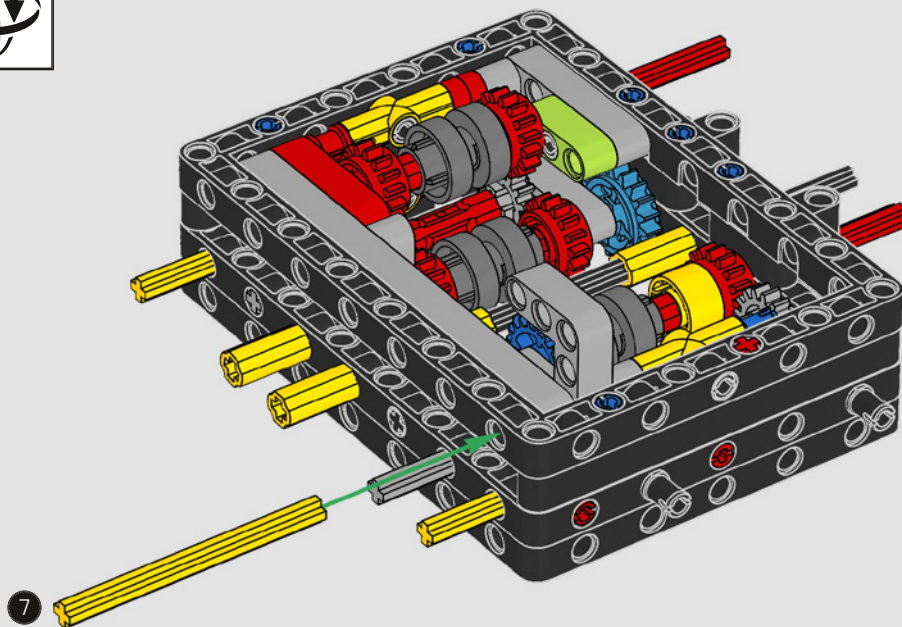

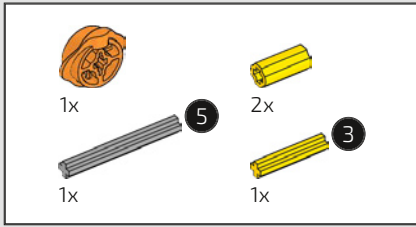

48

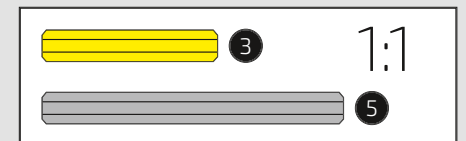
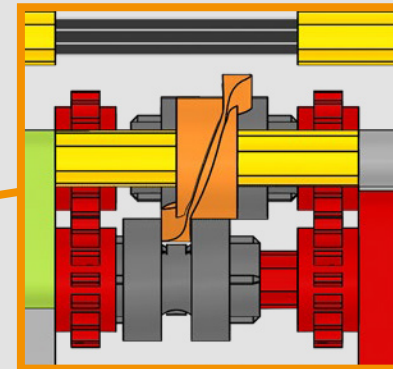
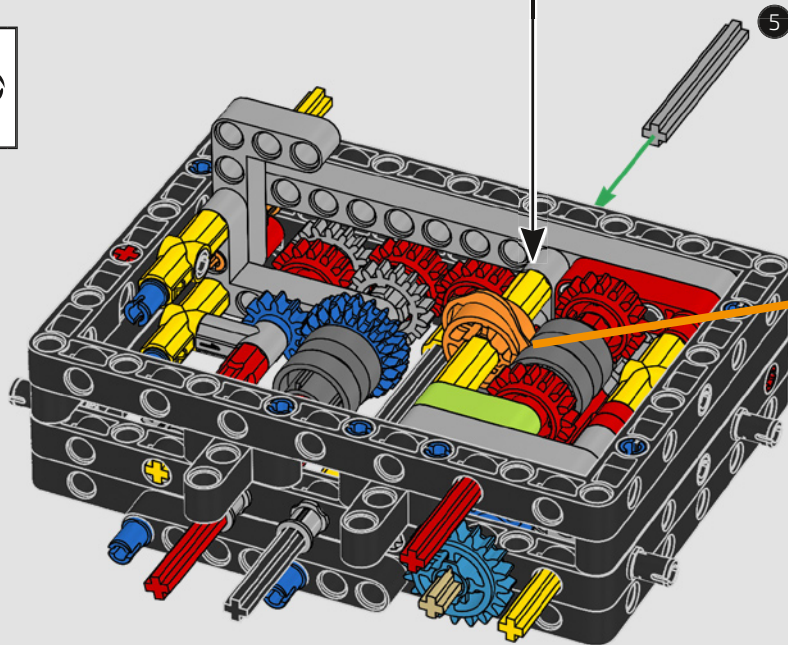
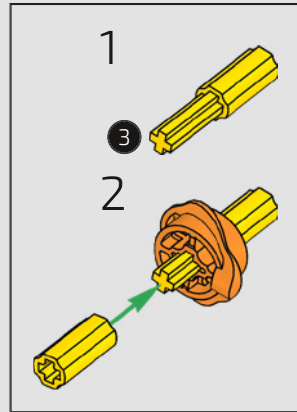

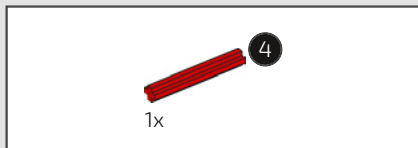

49

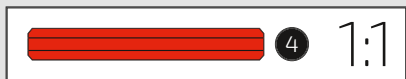
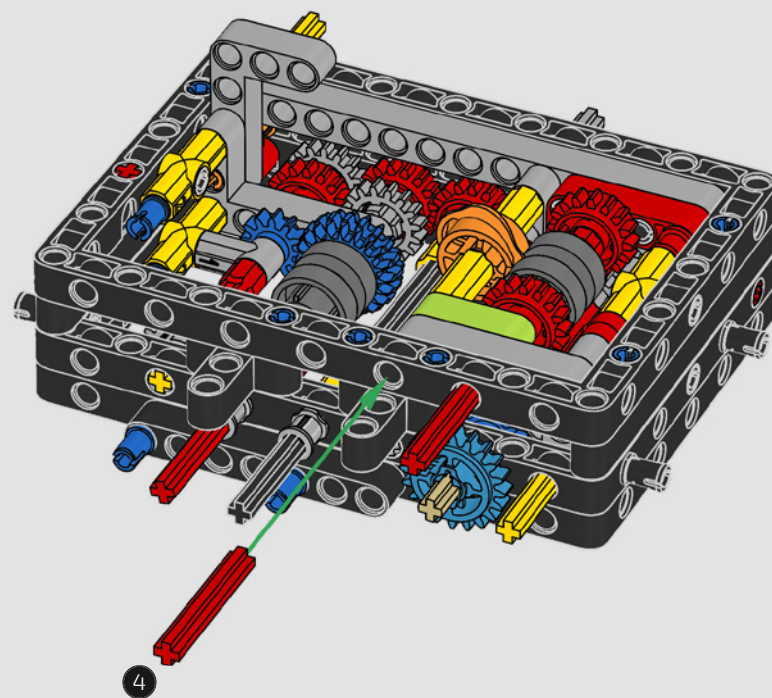

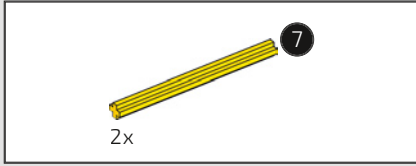

50

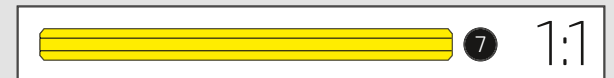
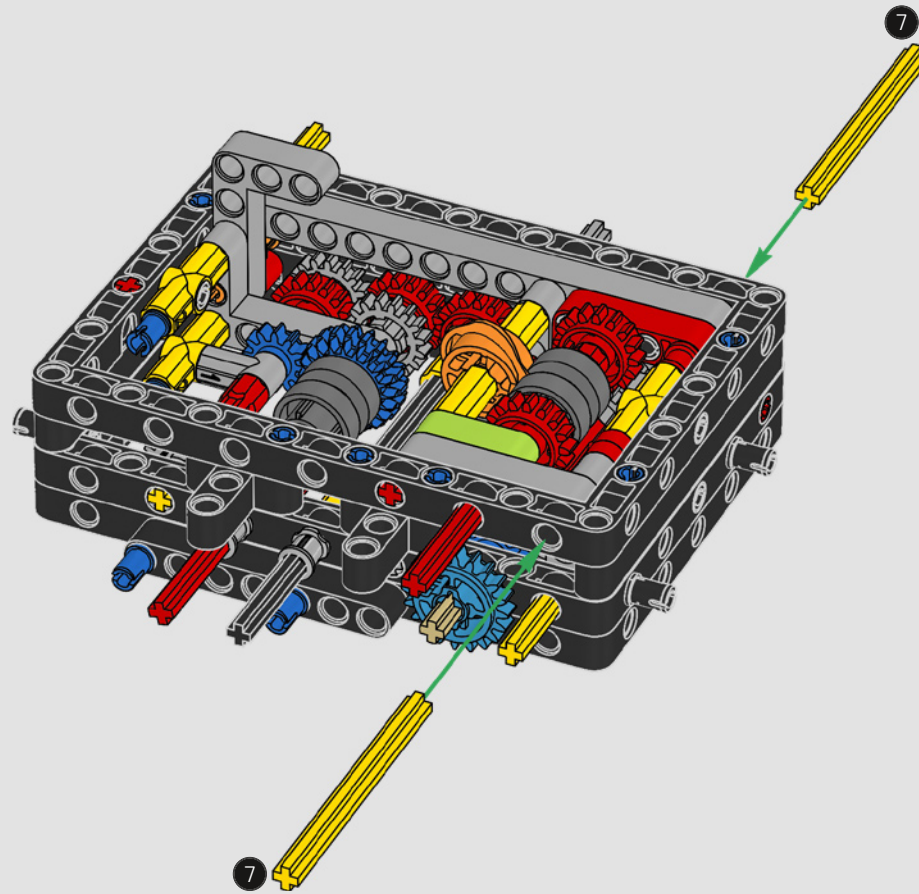



51

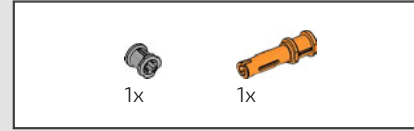
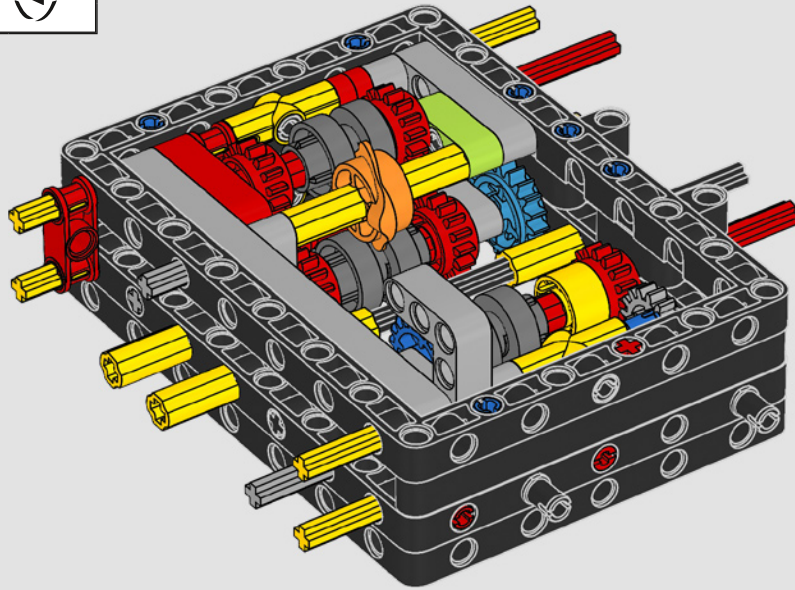

52

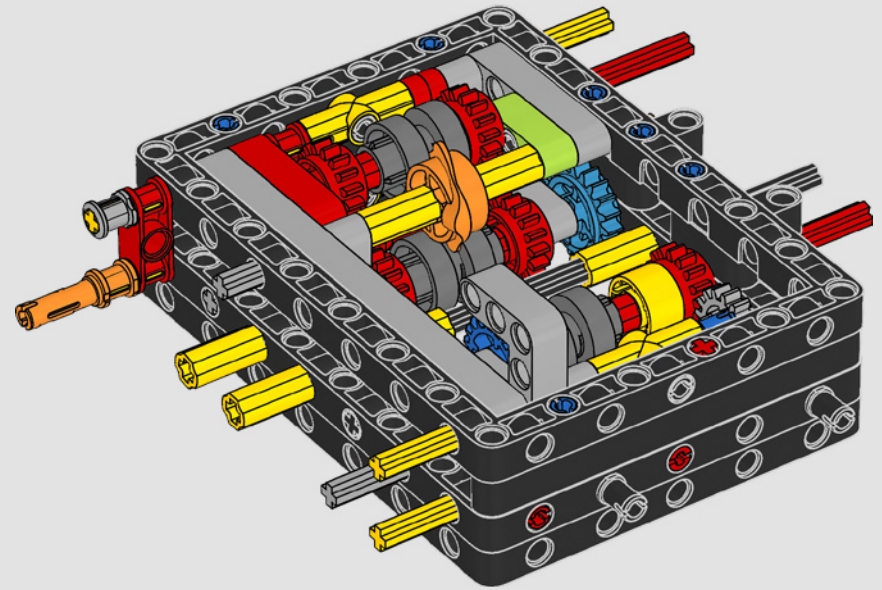

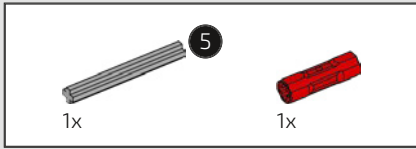

53

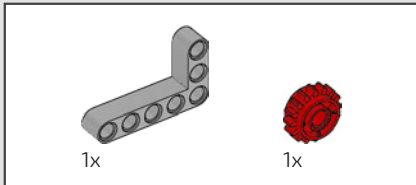
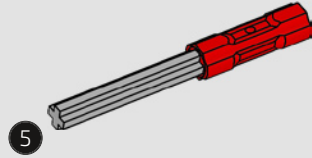

54

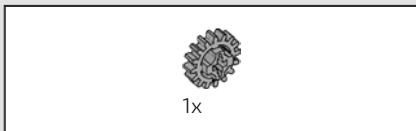
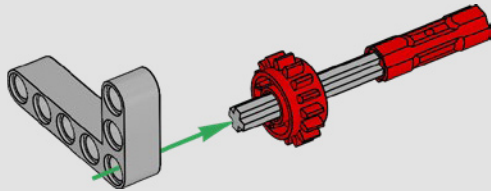

55

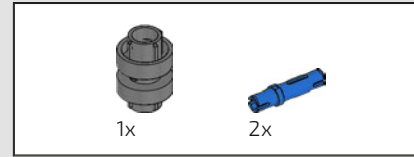
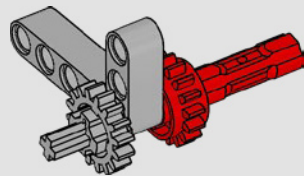

56

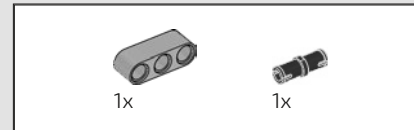
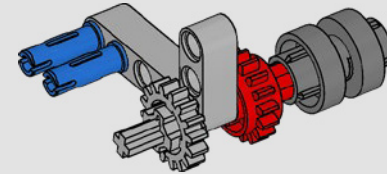

57

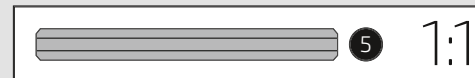
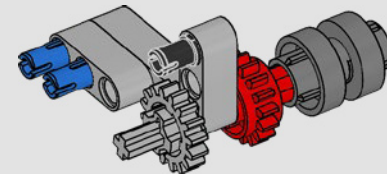

58

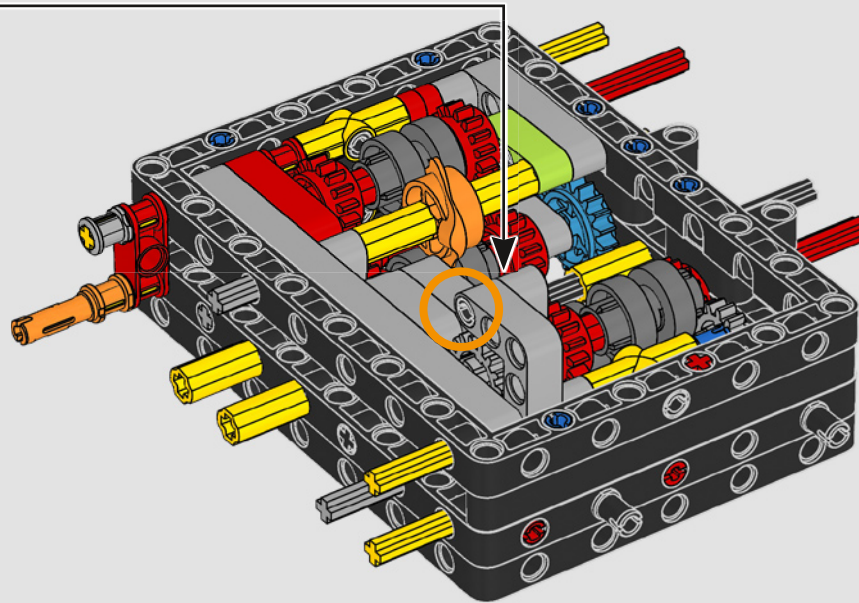

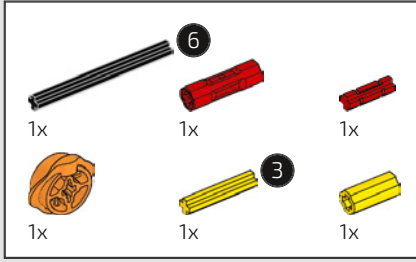

59

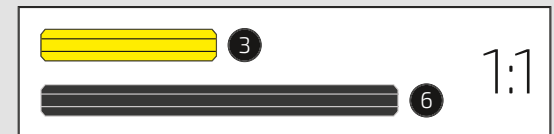
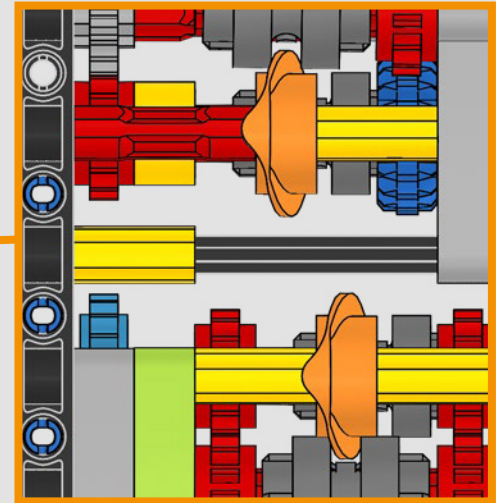
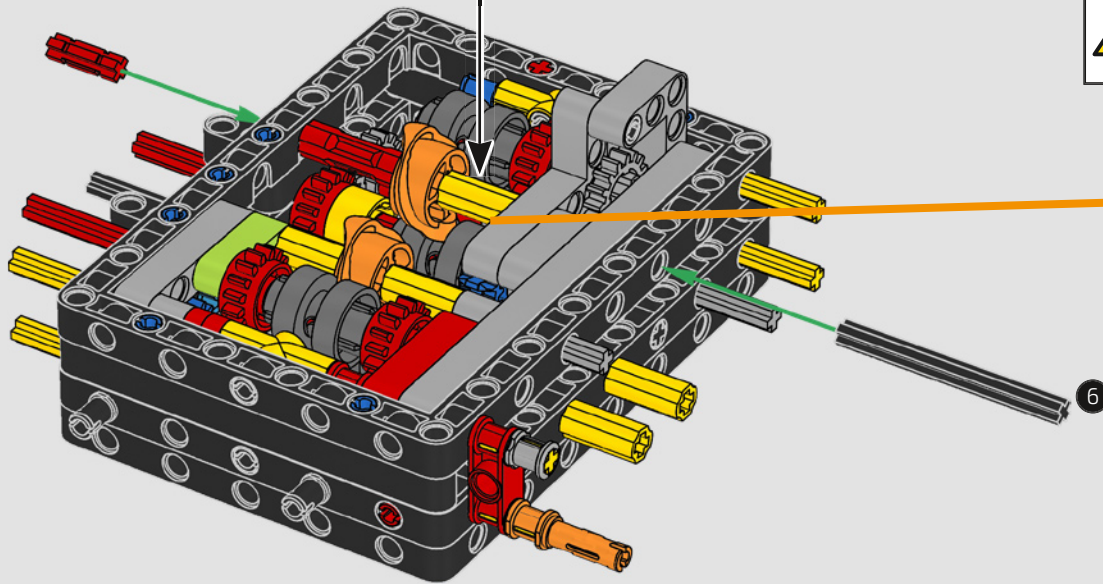
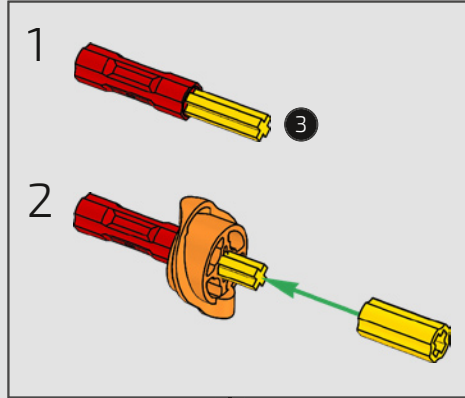

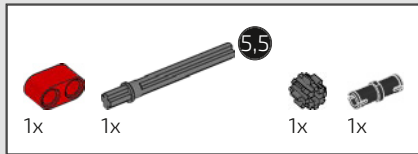

60

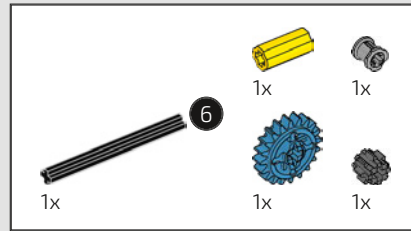
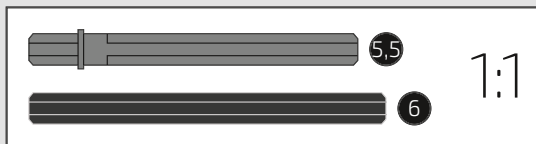
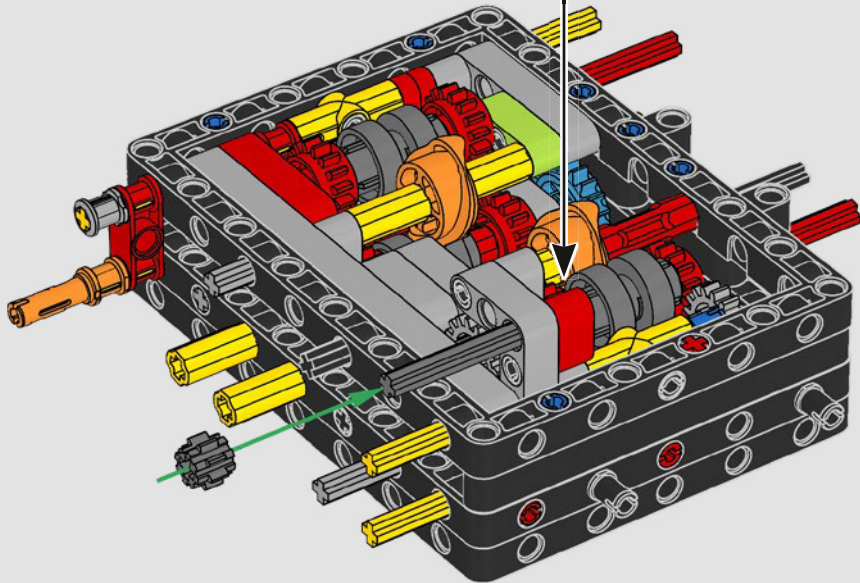
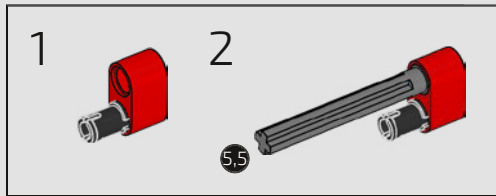

61

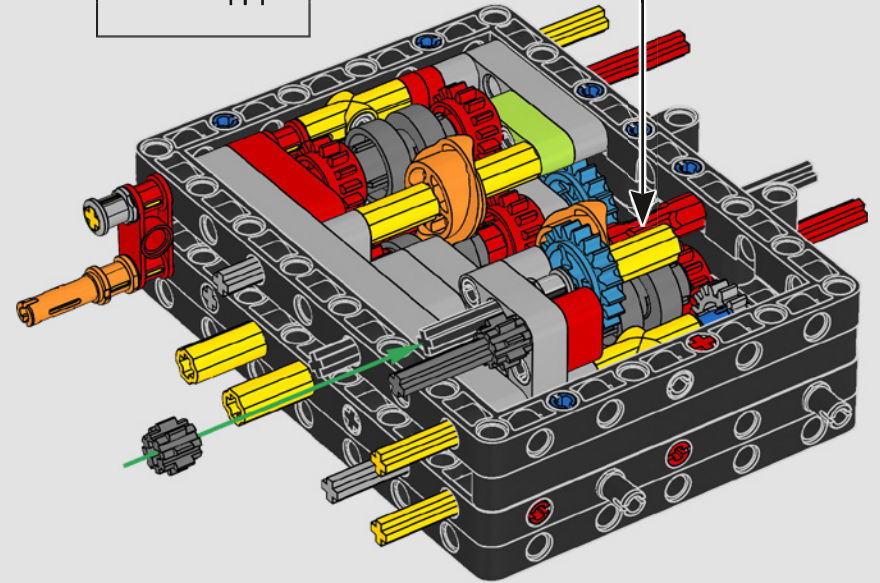
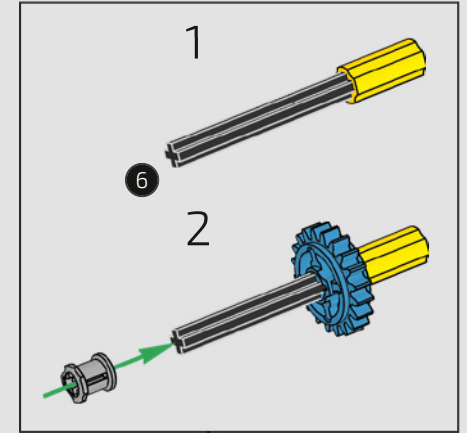
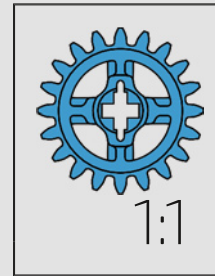

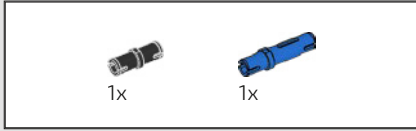

62

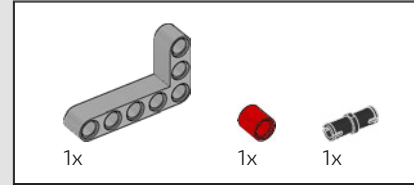
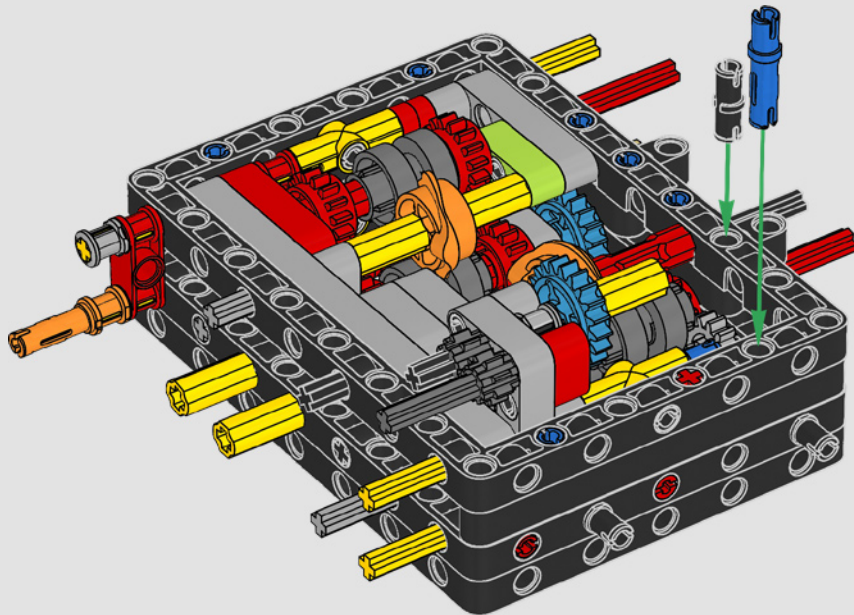

63

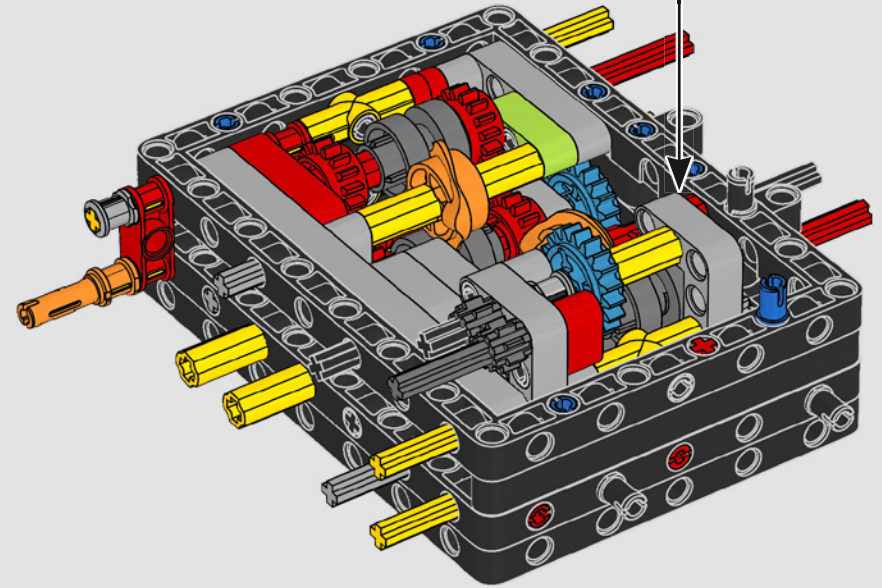
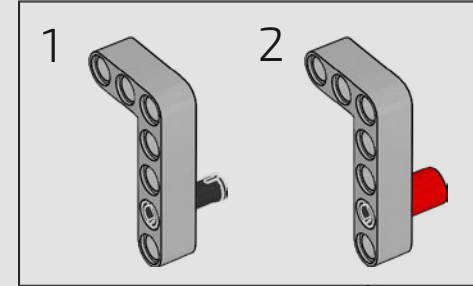

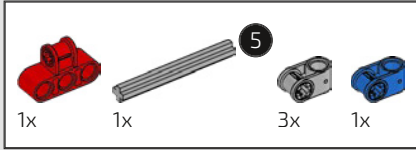

64

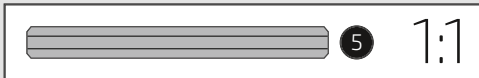
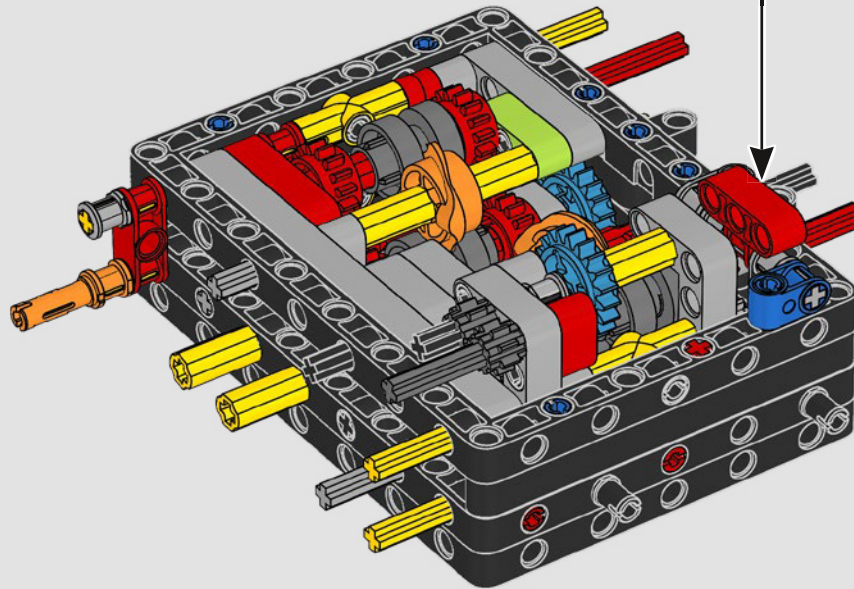
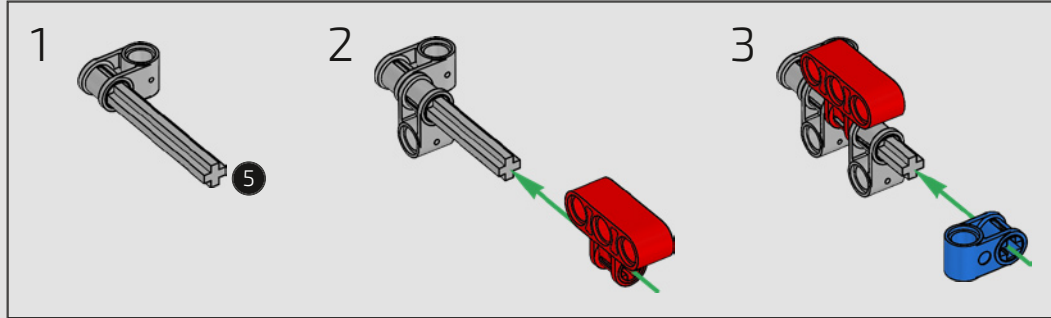

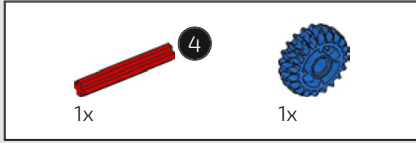

65

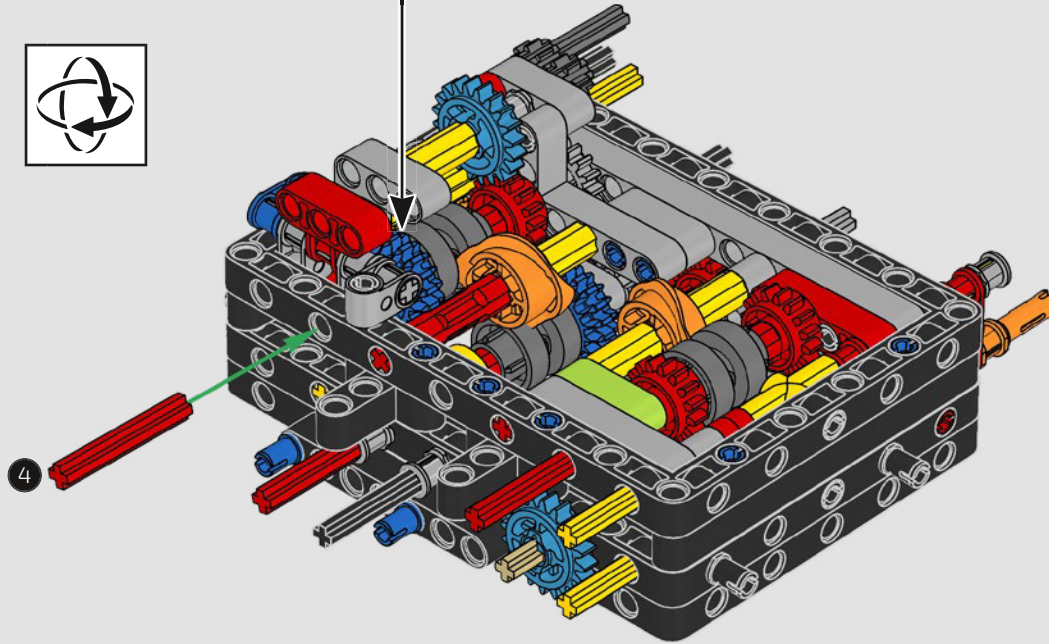
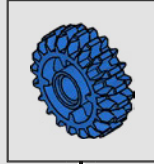
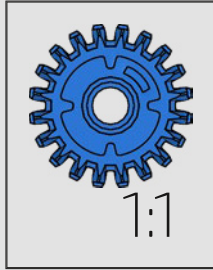

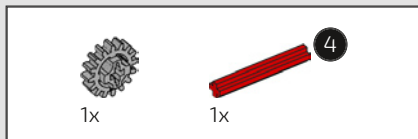

66

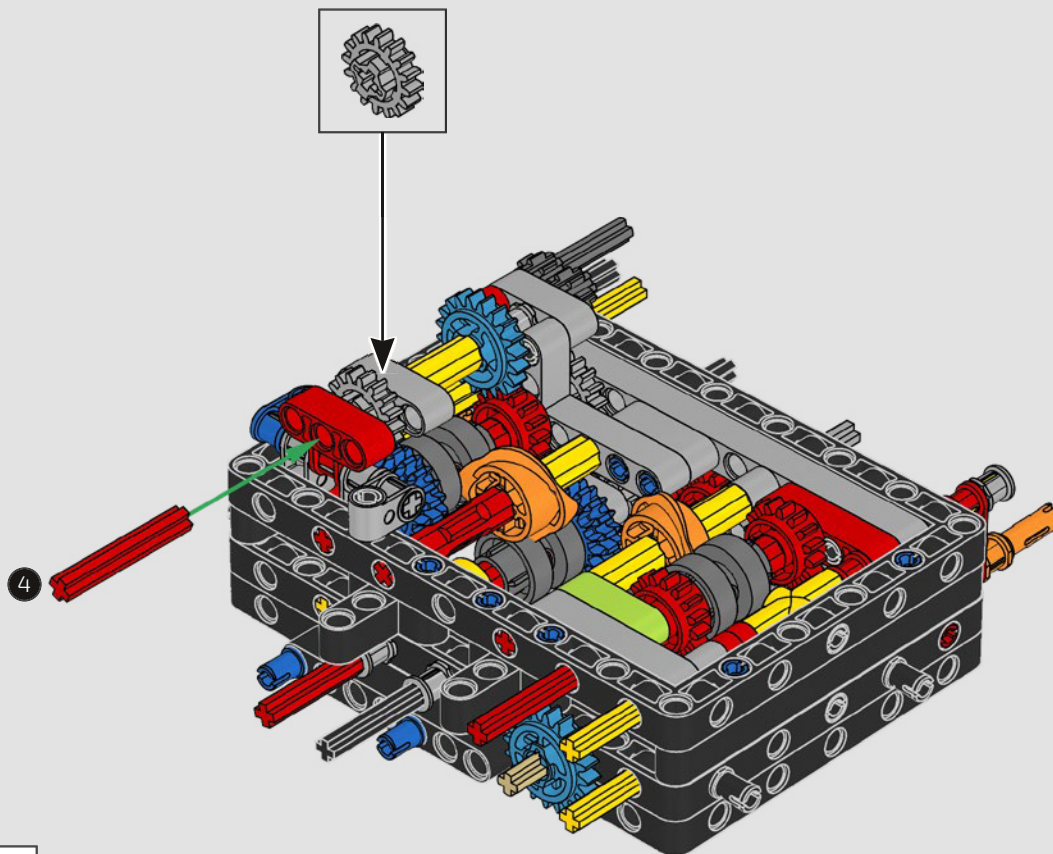

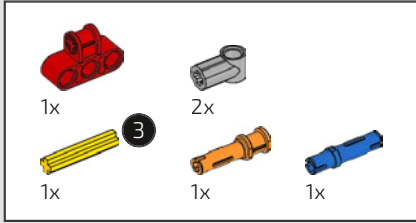

67

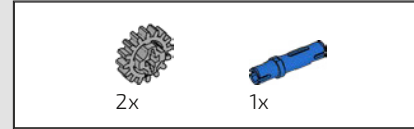
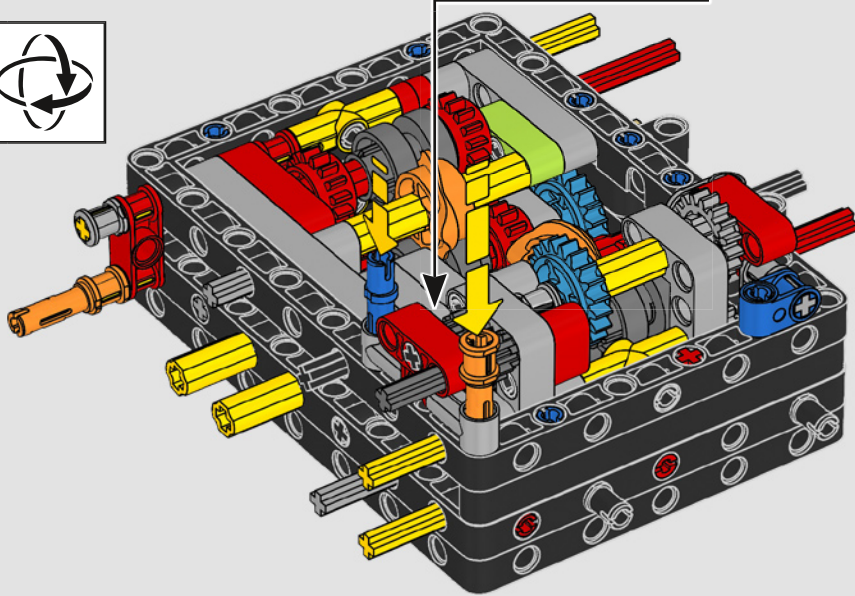
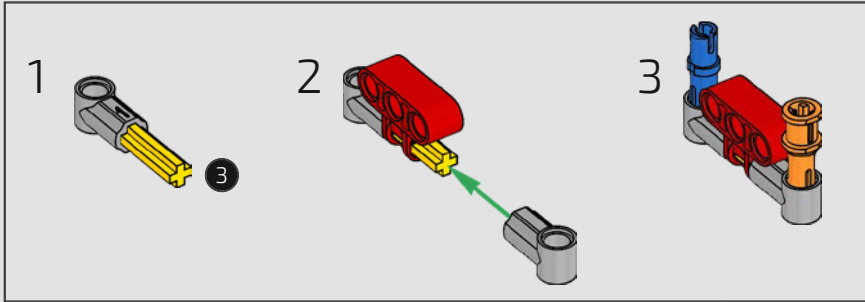

68

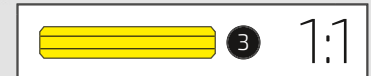
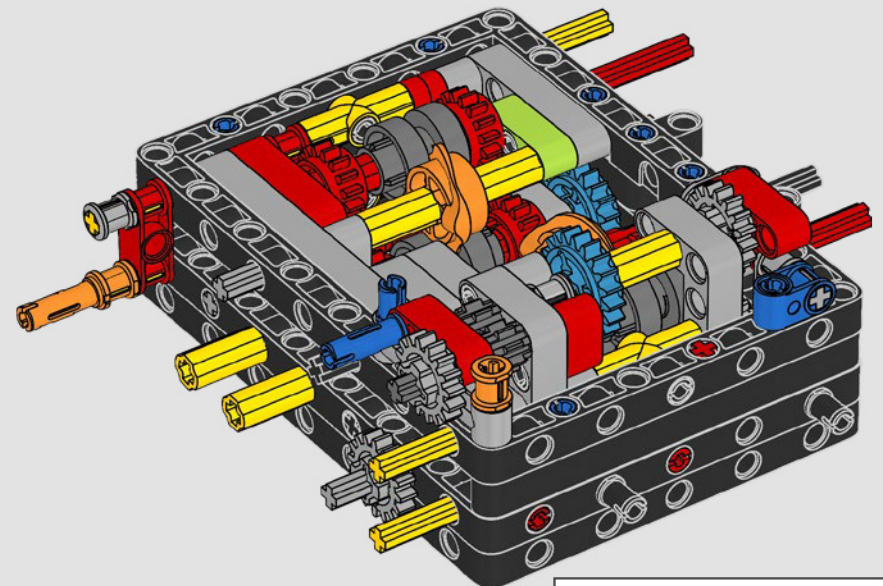

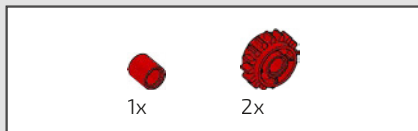

69

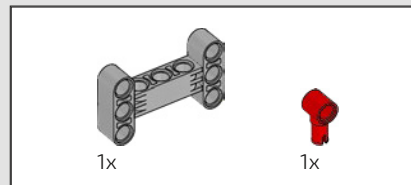
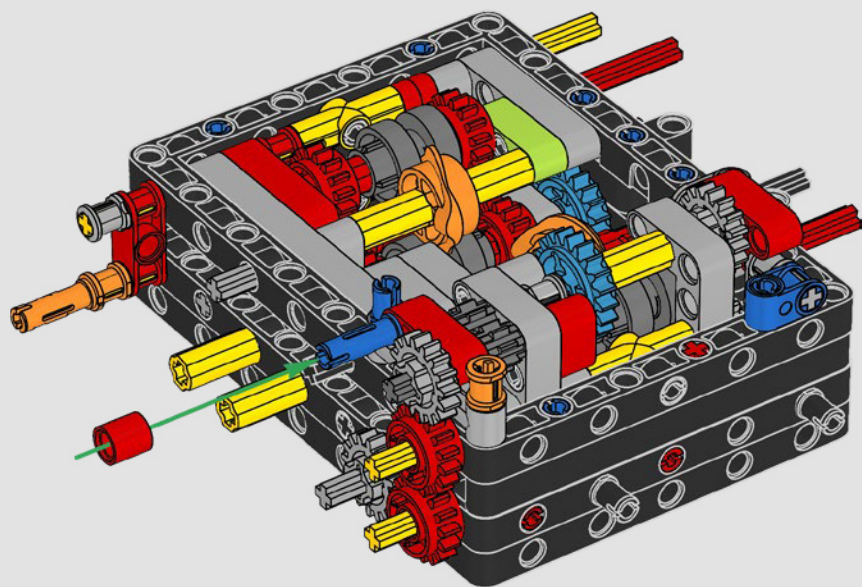

70

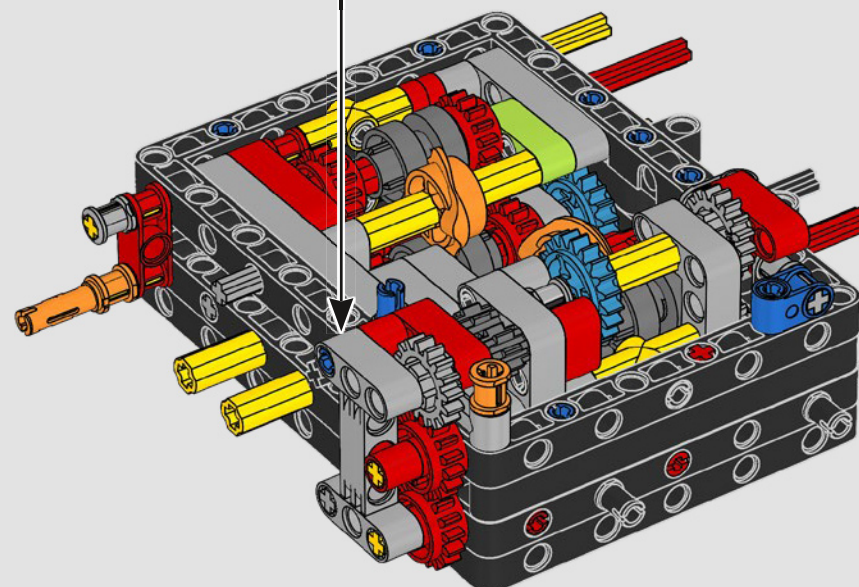
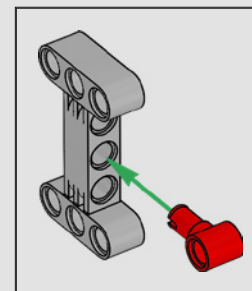

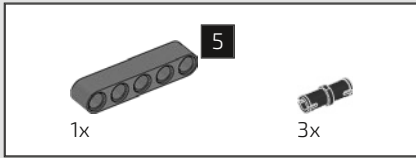

71

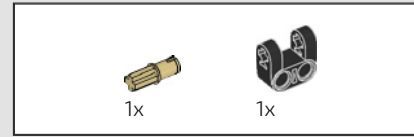
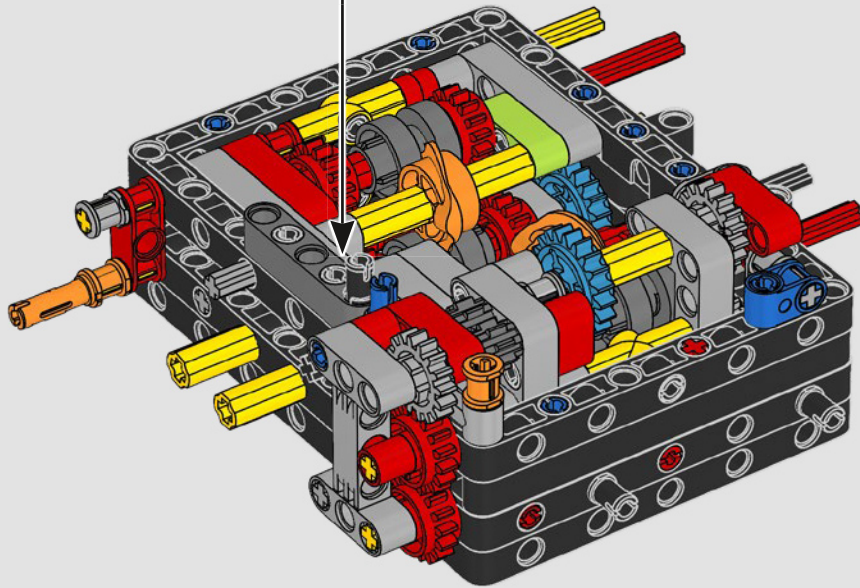
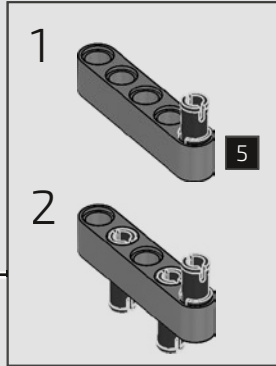

72

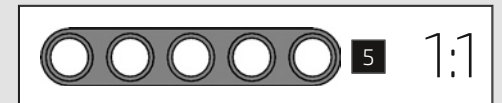
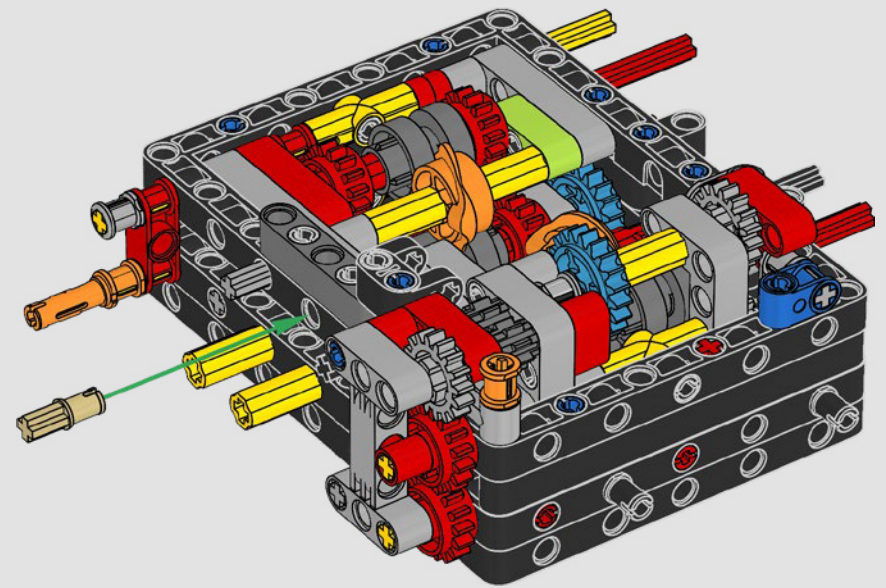

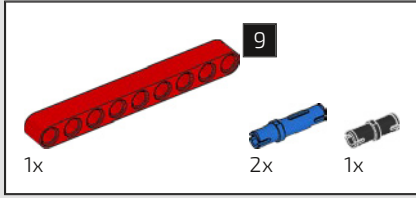

73

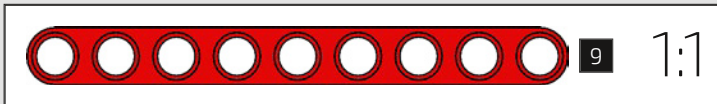
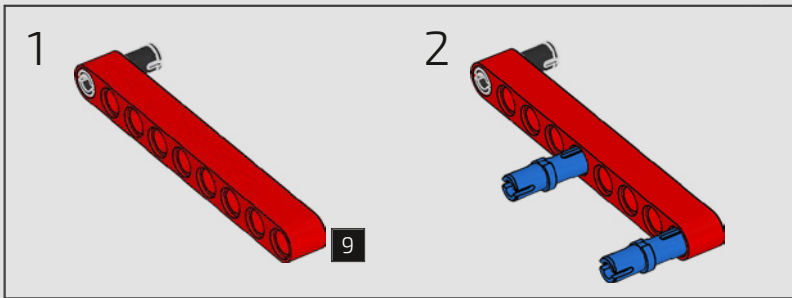
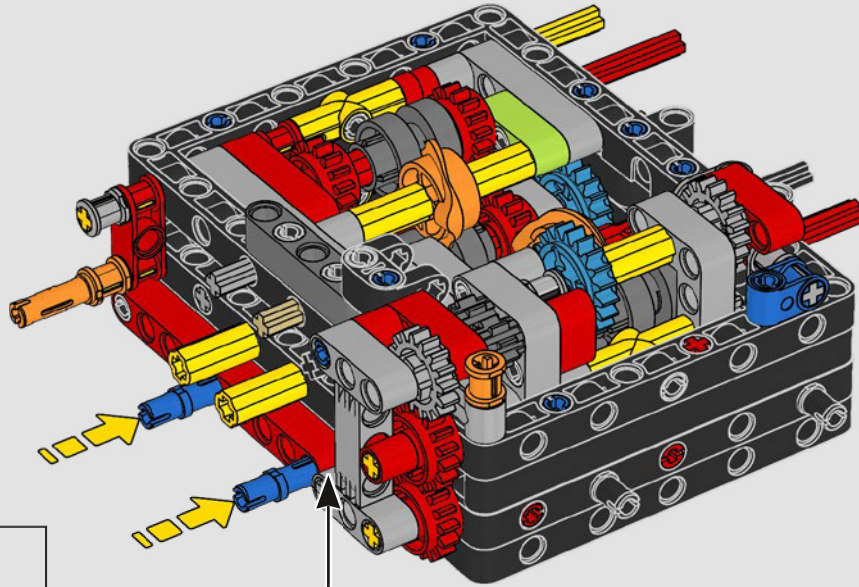

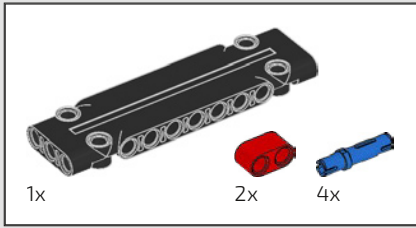

74

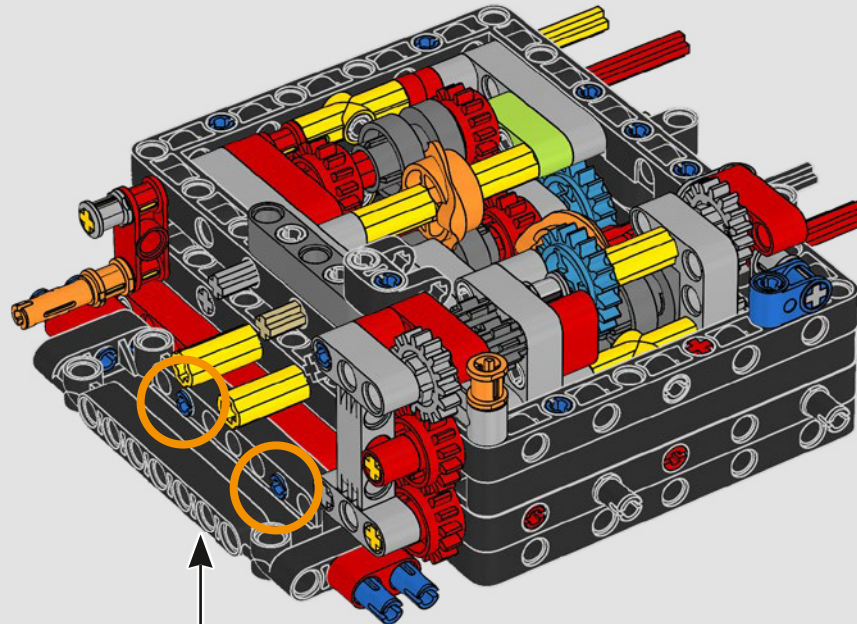
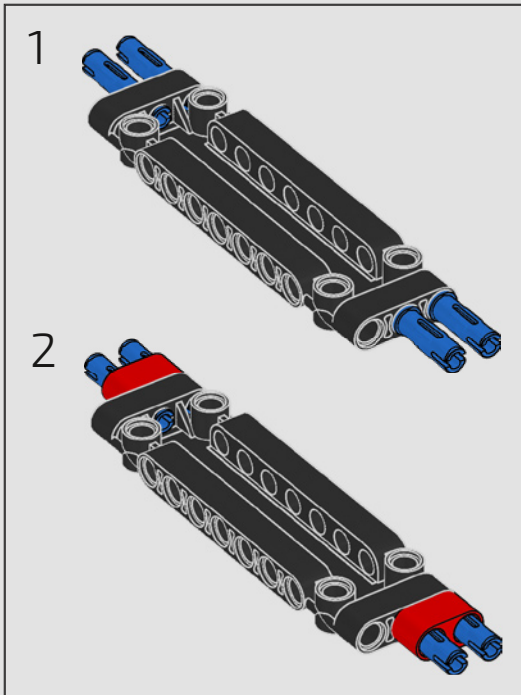

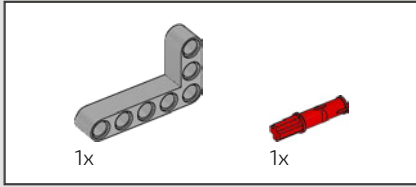
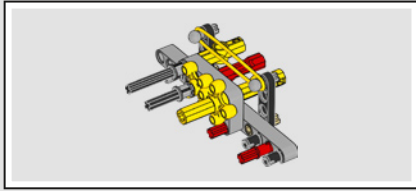

75

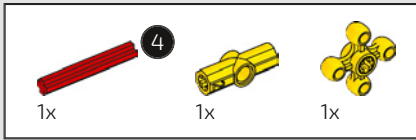
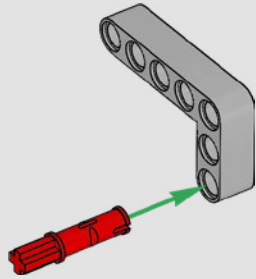

76

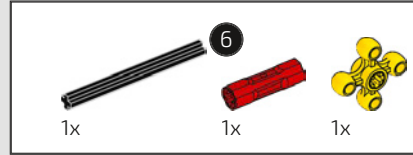
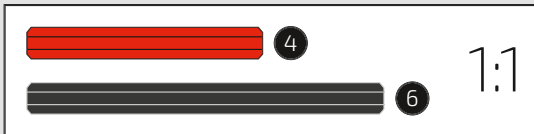
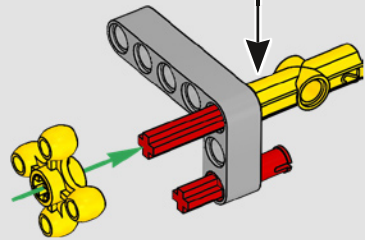
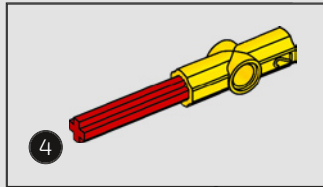

77

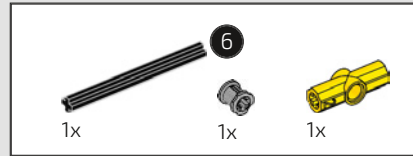
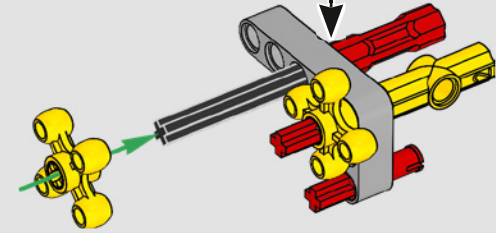
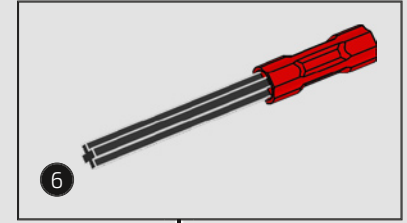

78

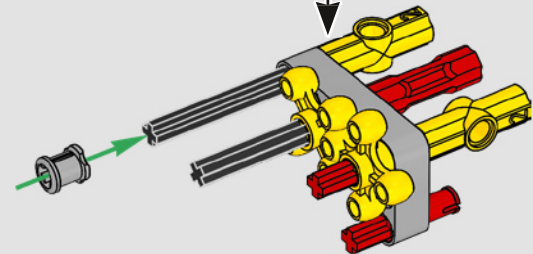
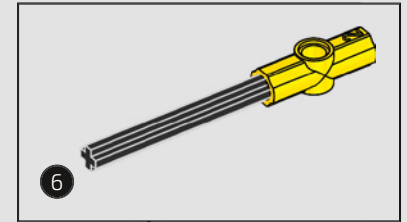

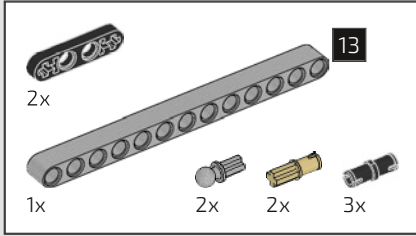

79

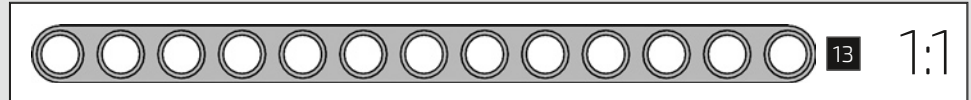
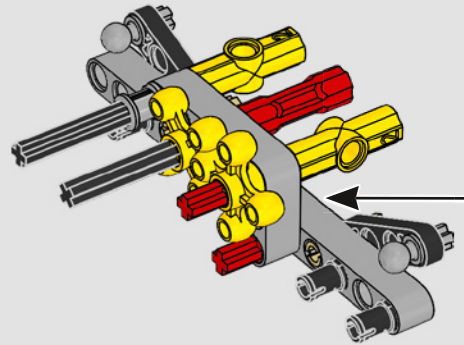
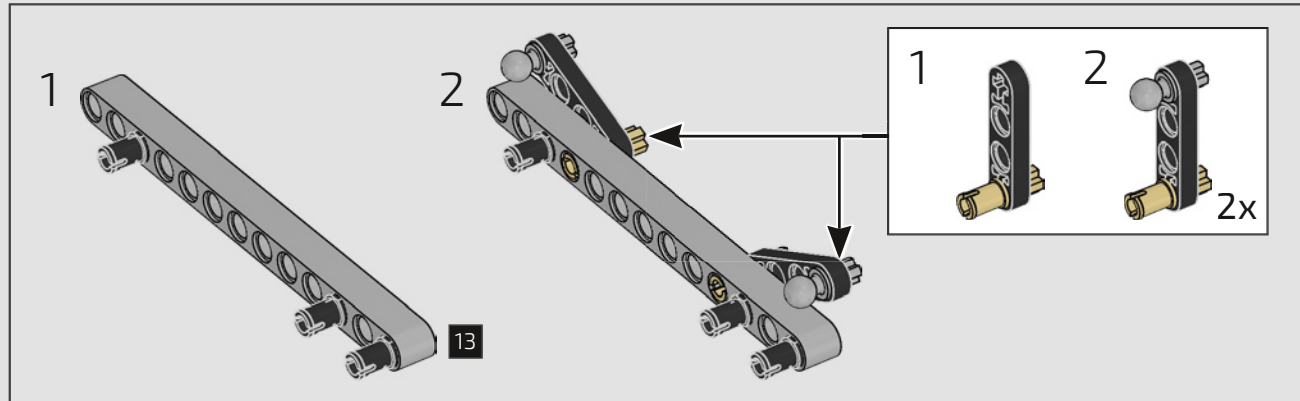

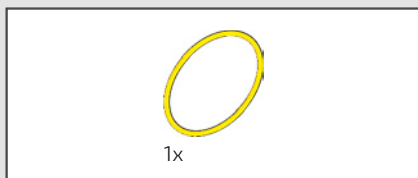

80

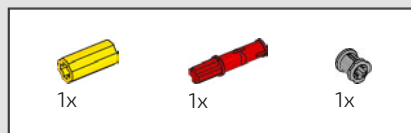
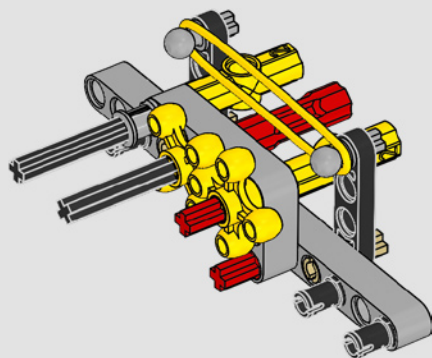

81

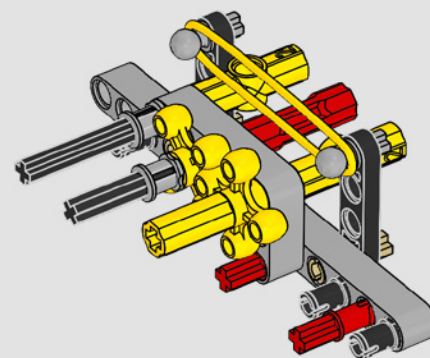

82

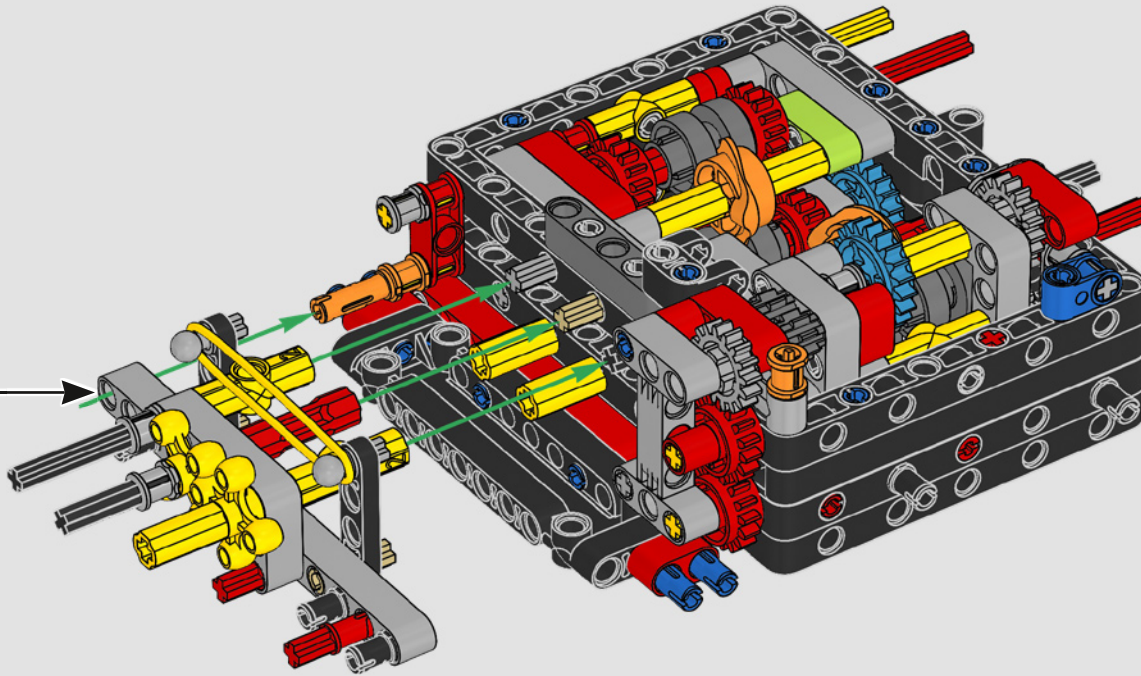

83

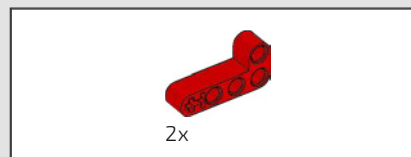
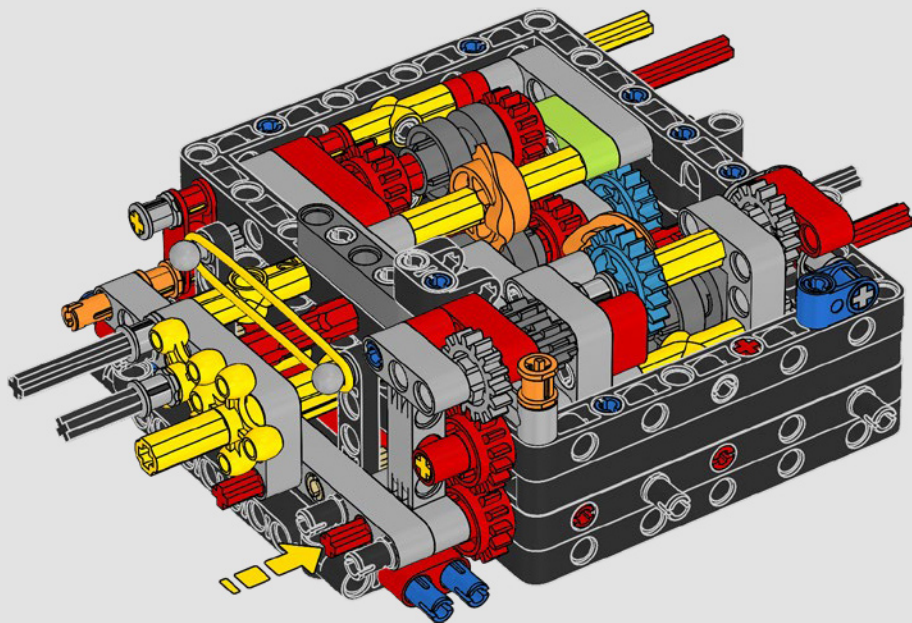

84

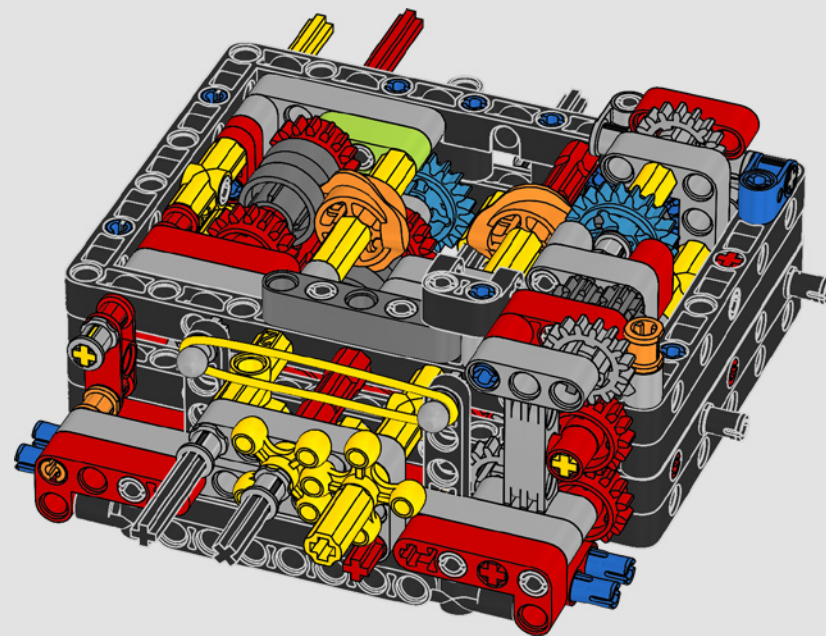

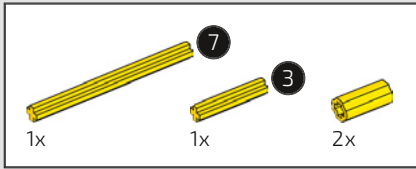

85

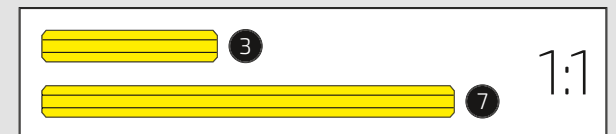
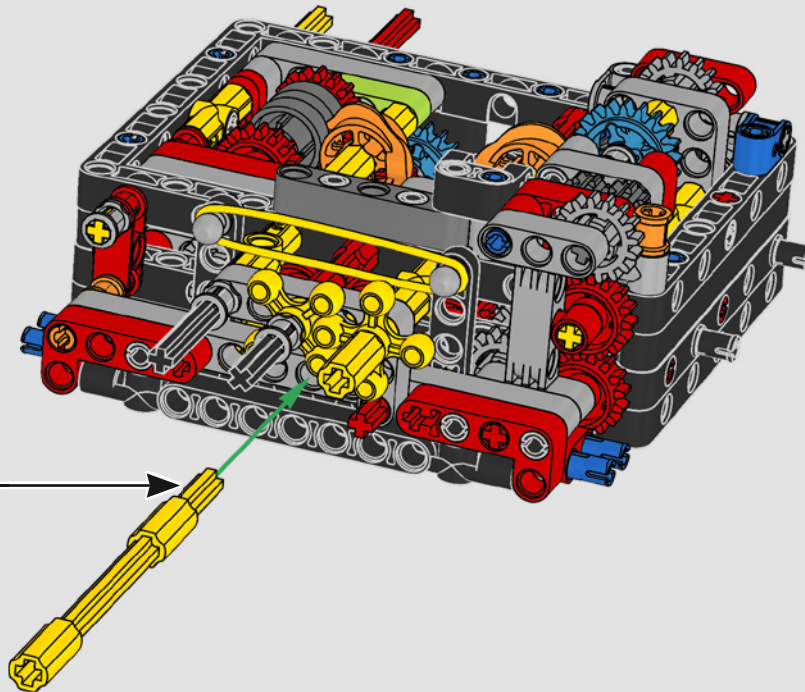
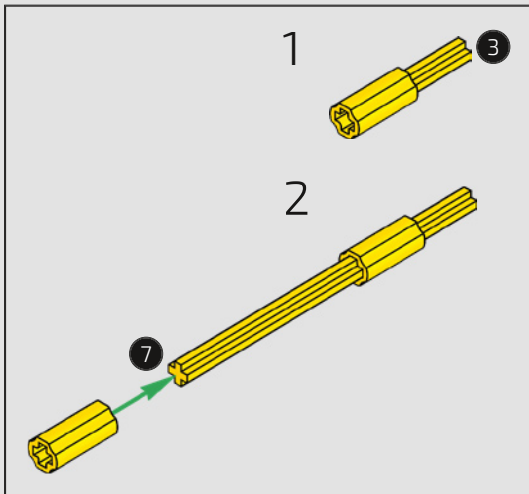

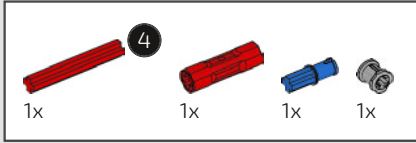

86

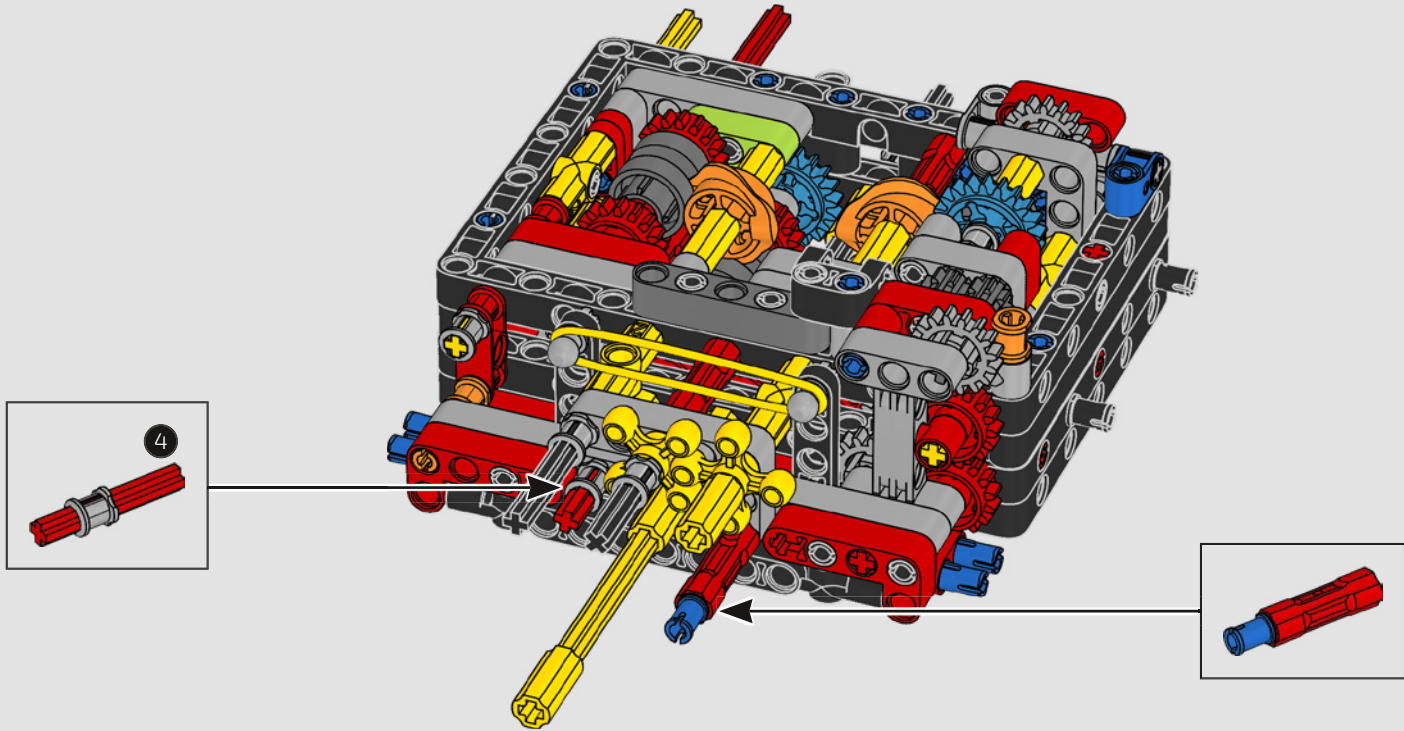

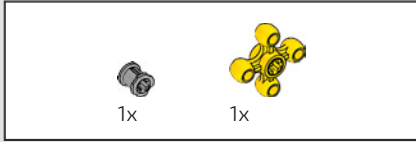

87

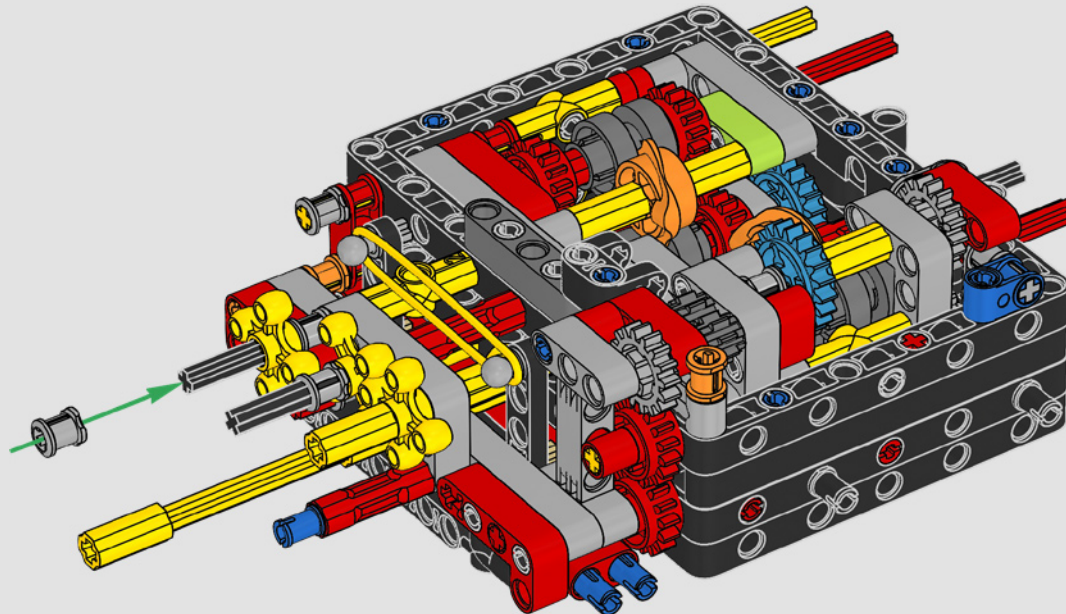



88

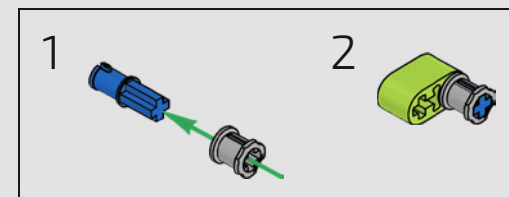
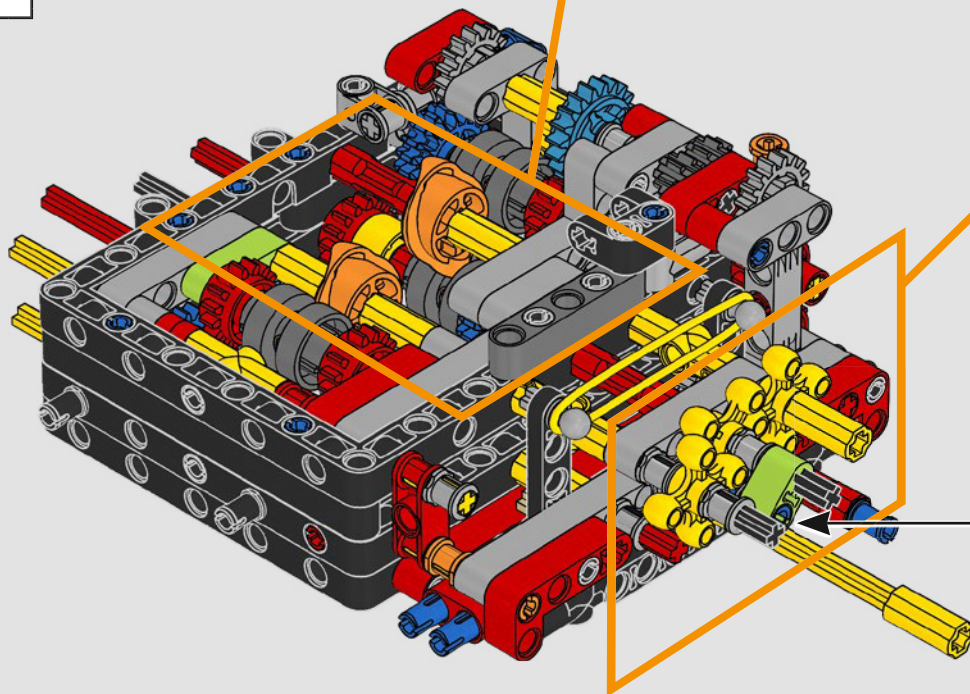
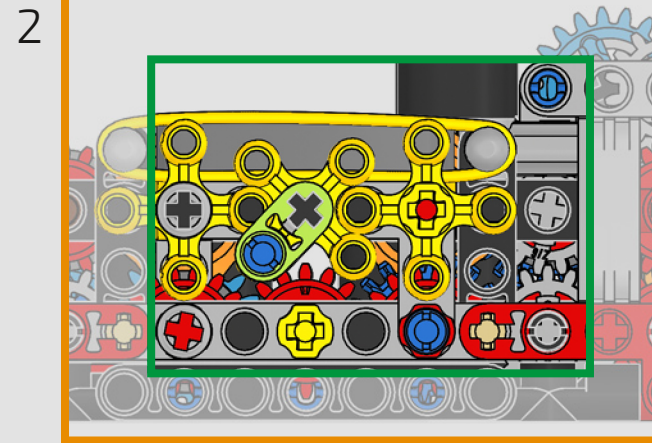
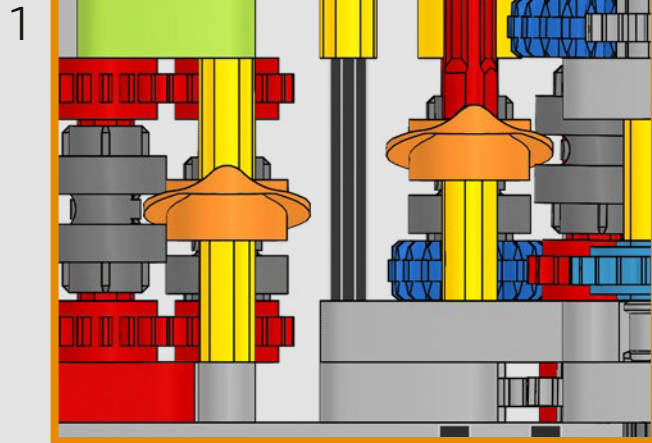

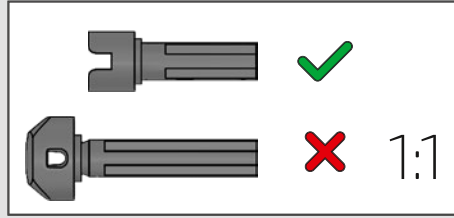
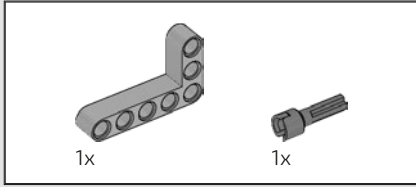

89

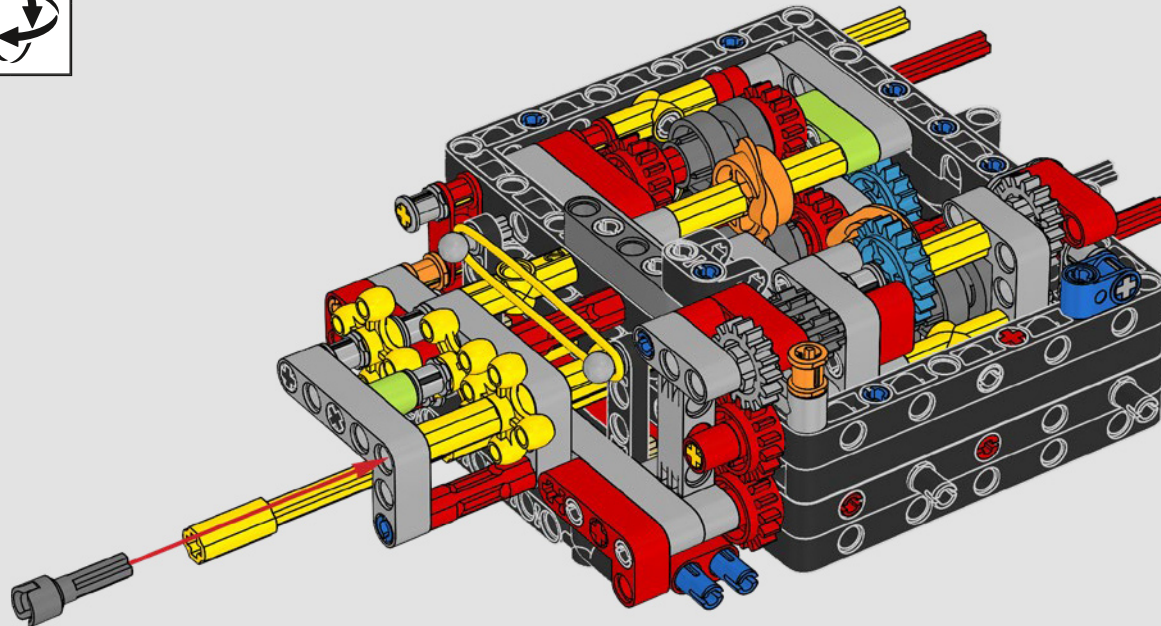

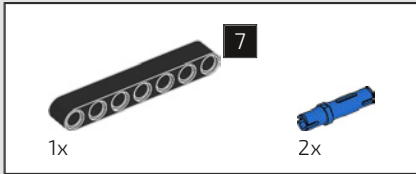
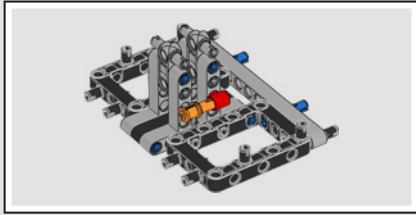

90

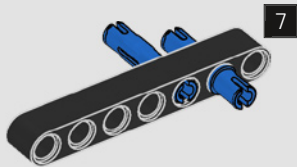

91

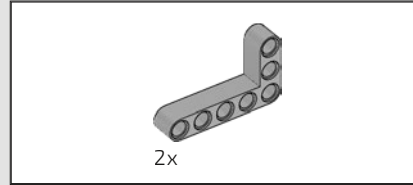
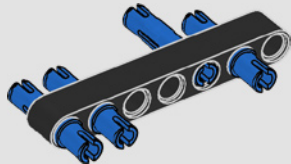

92

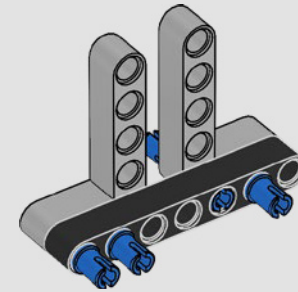

93

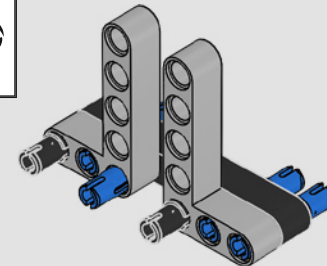

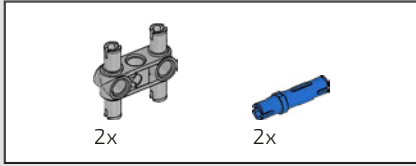

94

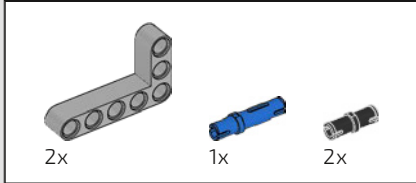
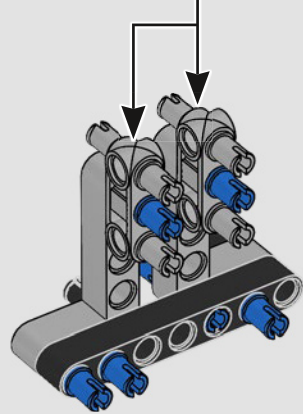
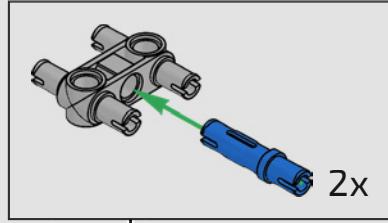

95

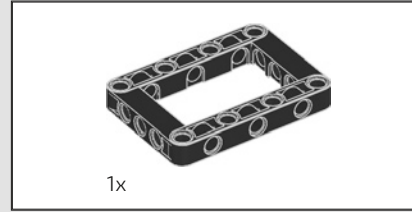
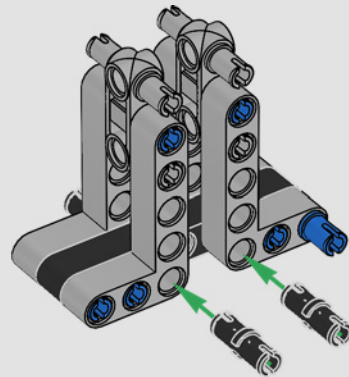

96

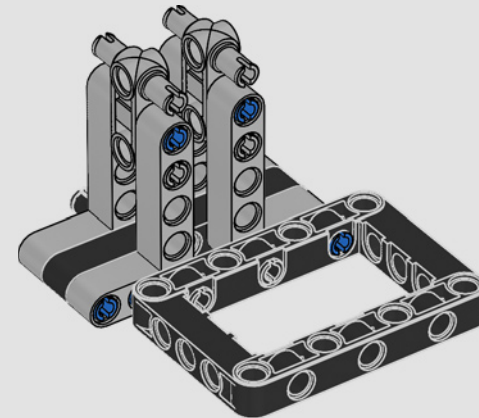

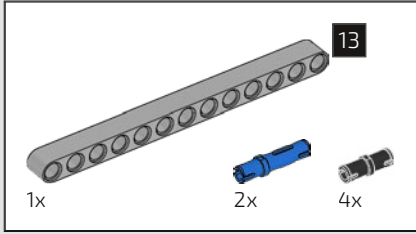

99

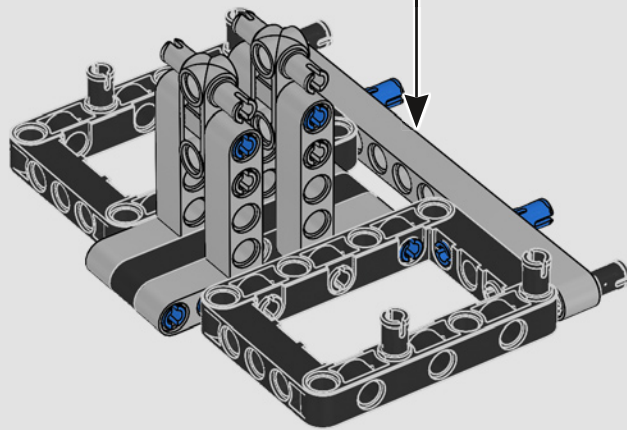
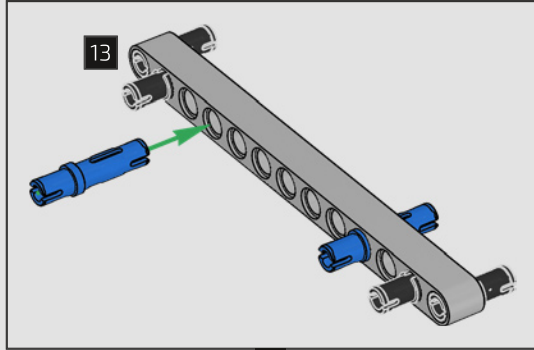

100

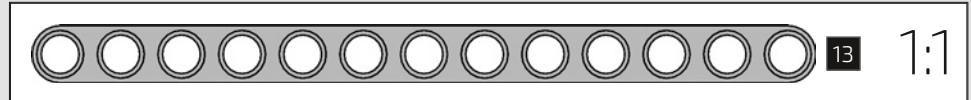
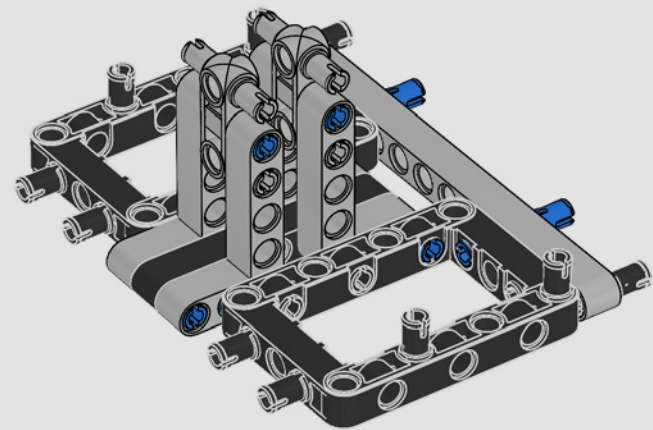

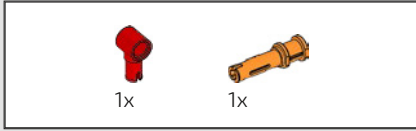

101

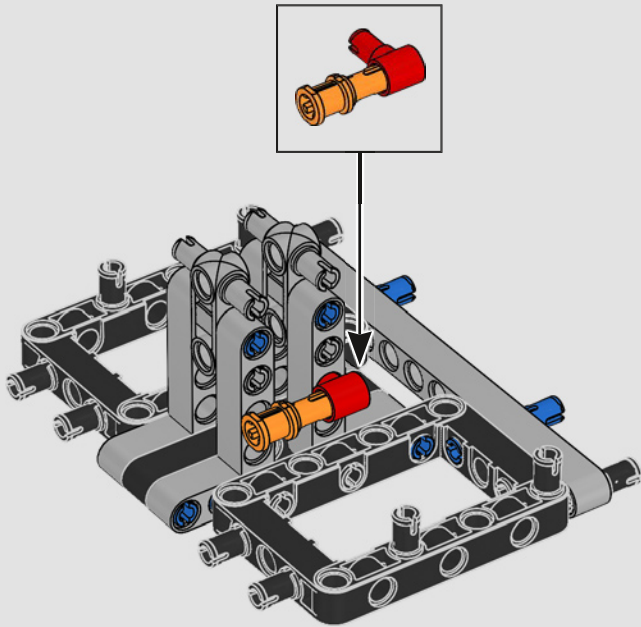

102

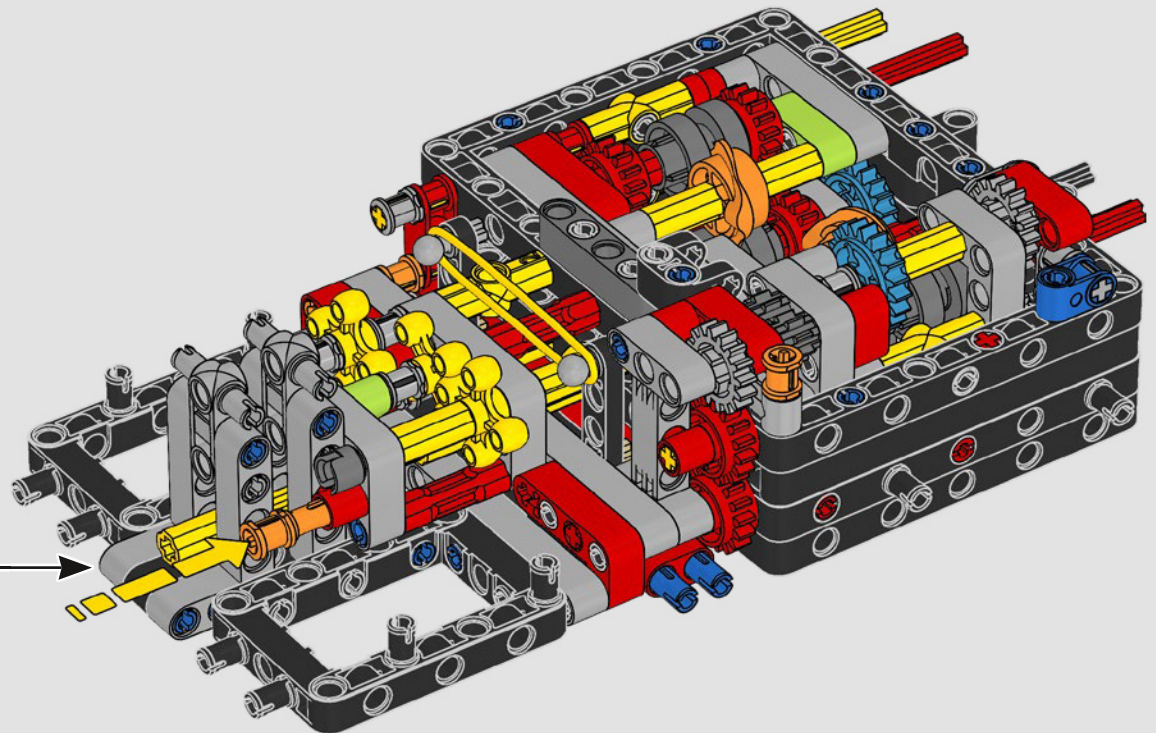

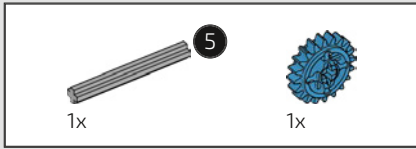

103

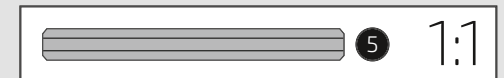
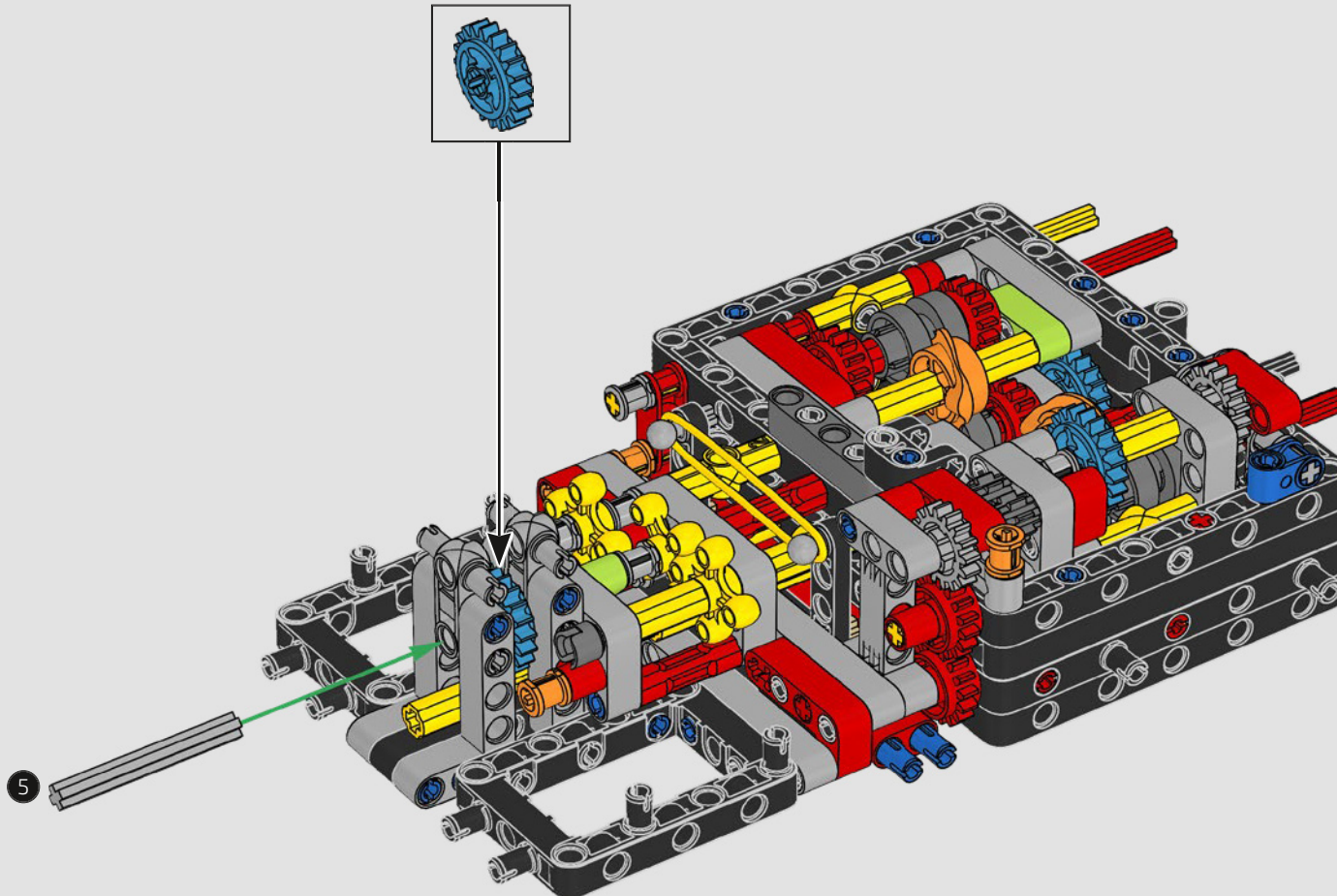
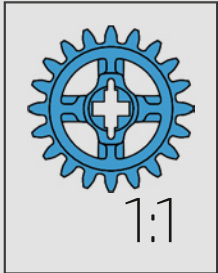

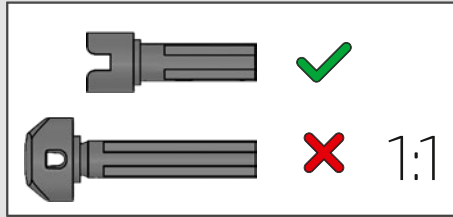
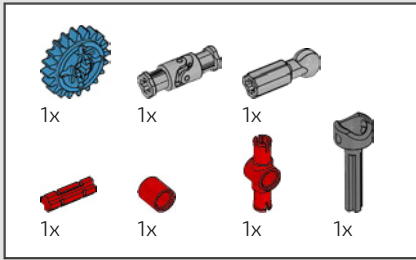

104

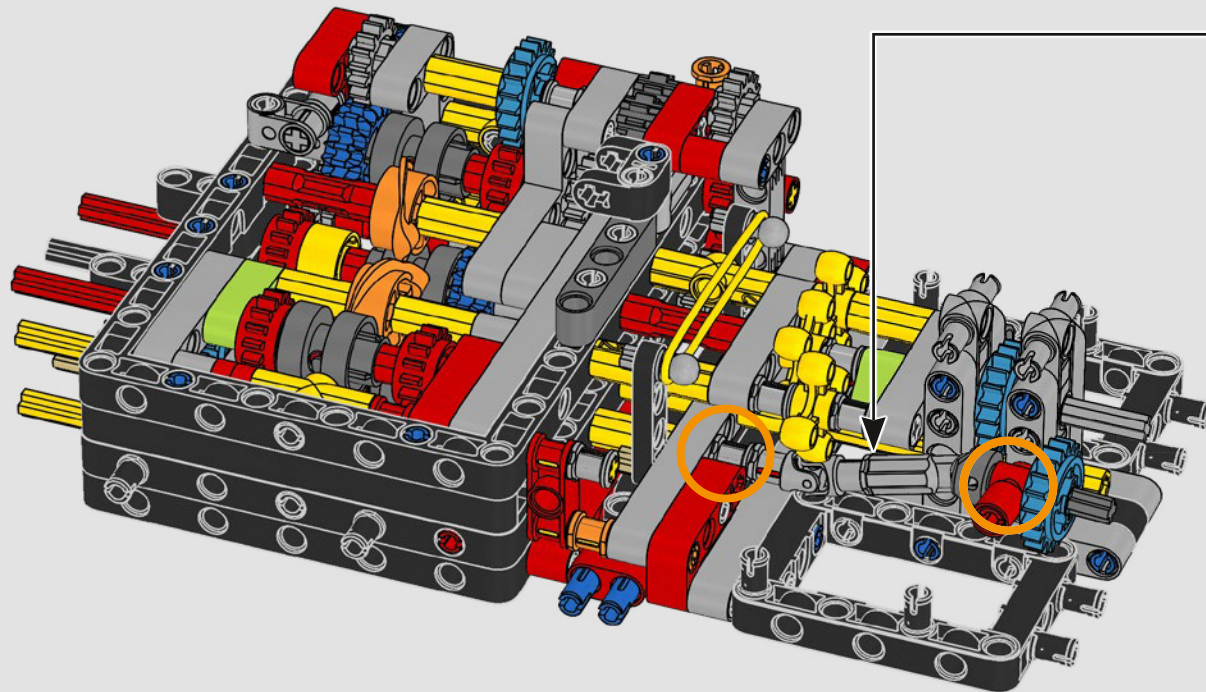
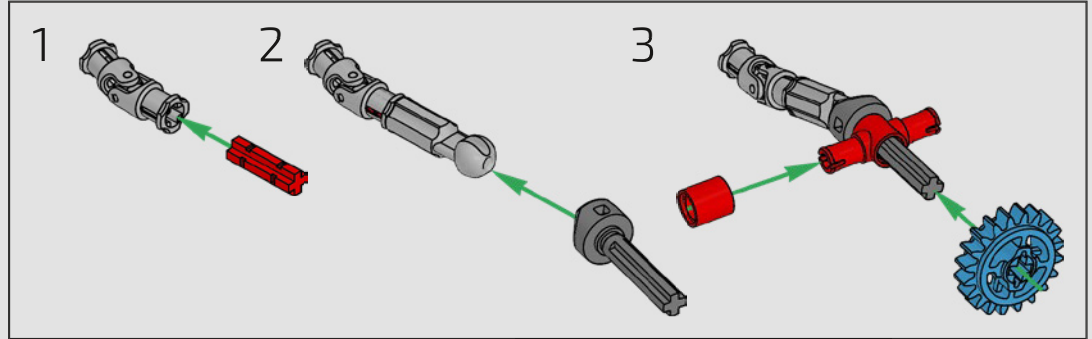

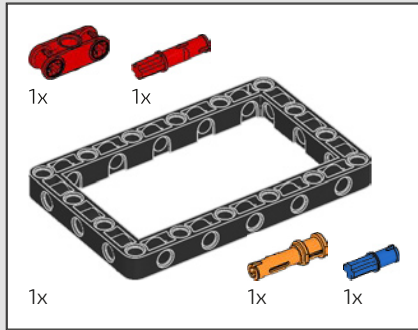

105

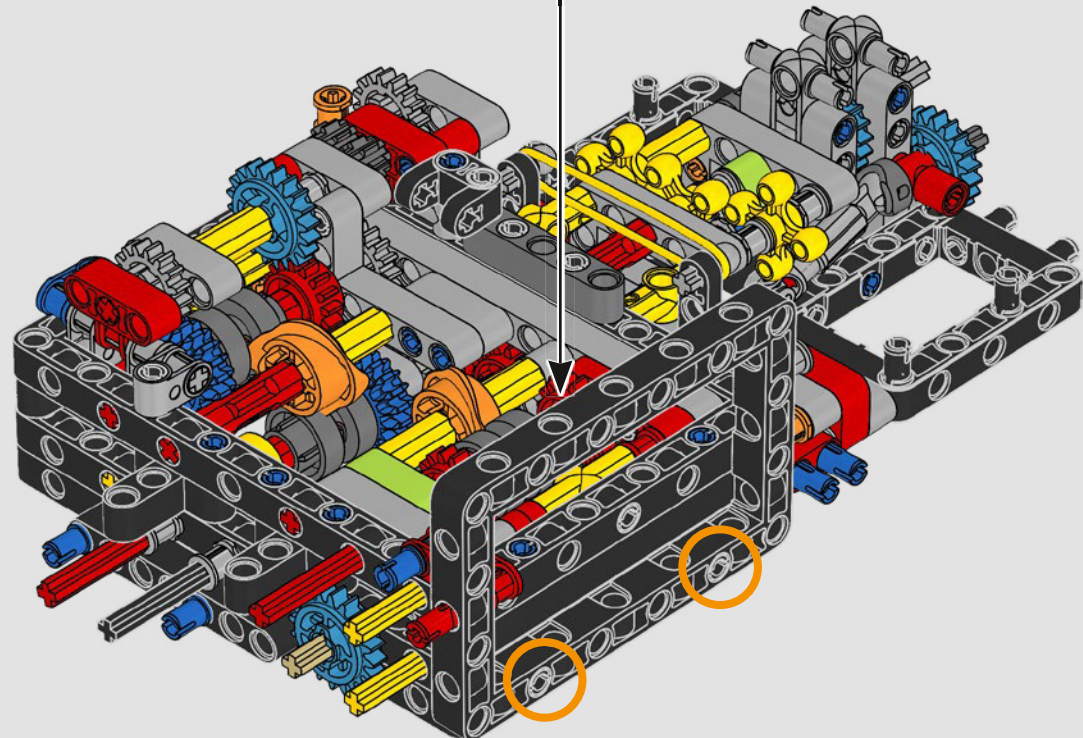
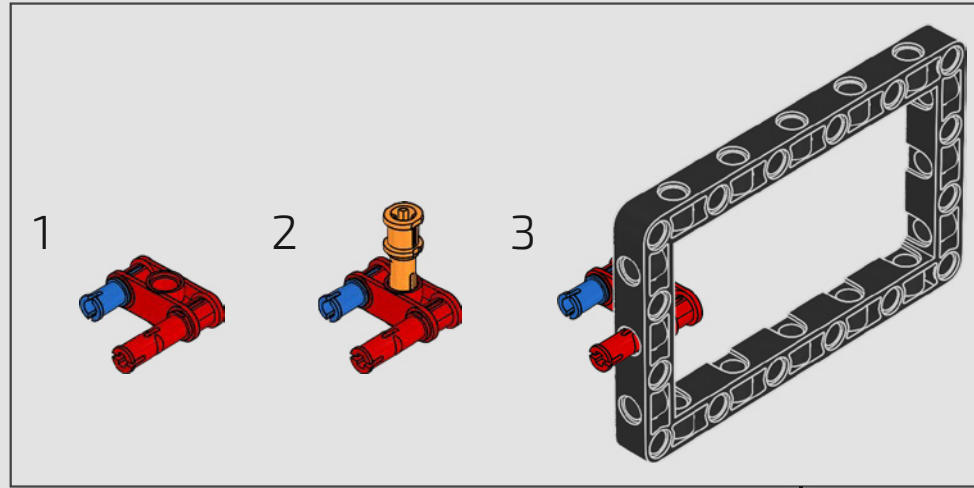

106

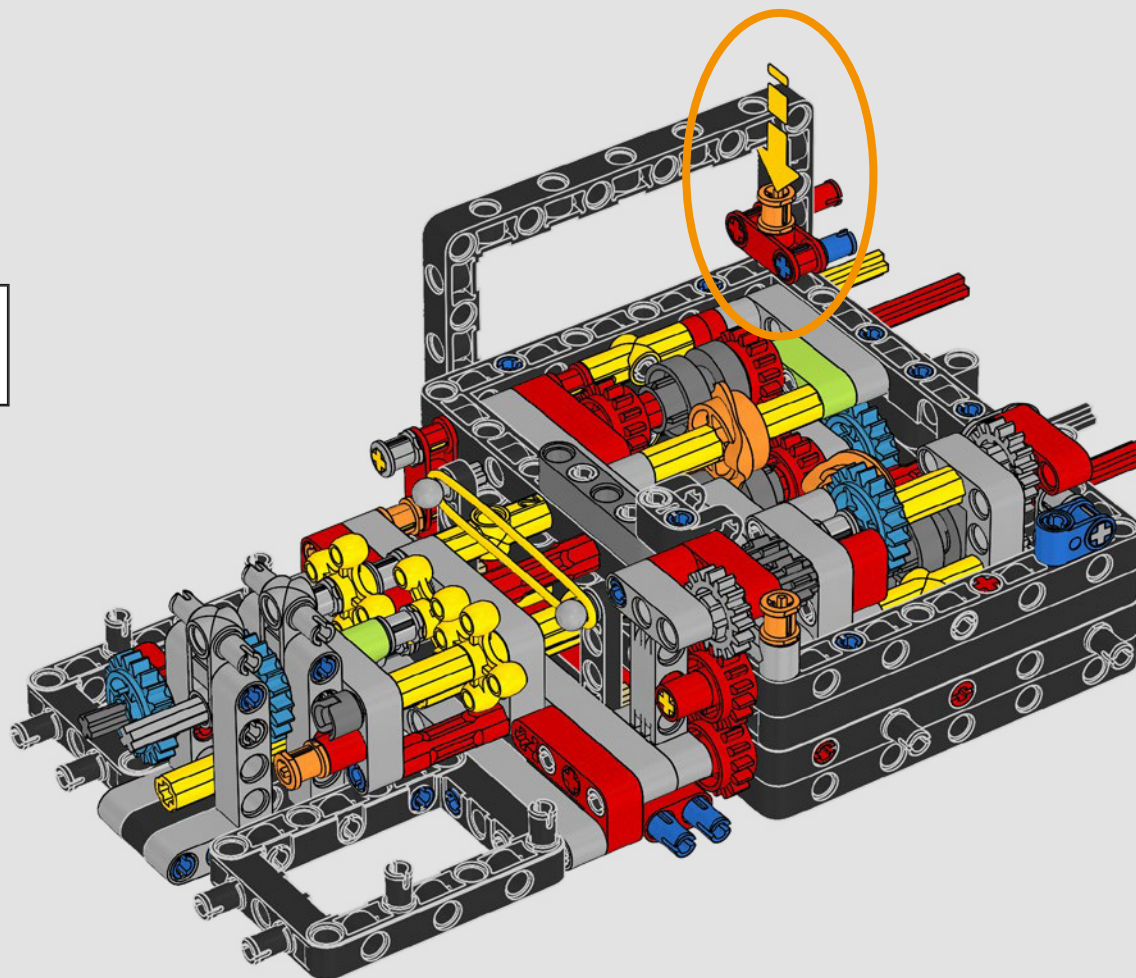

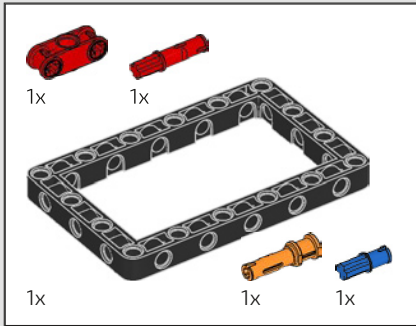

107

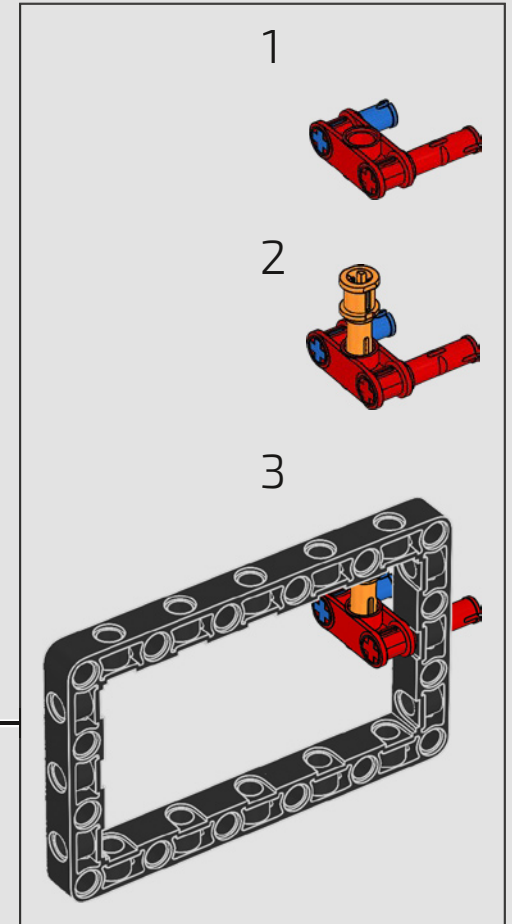
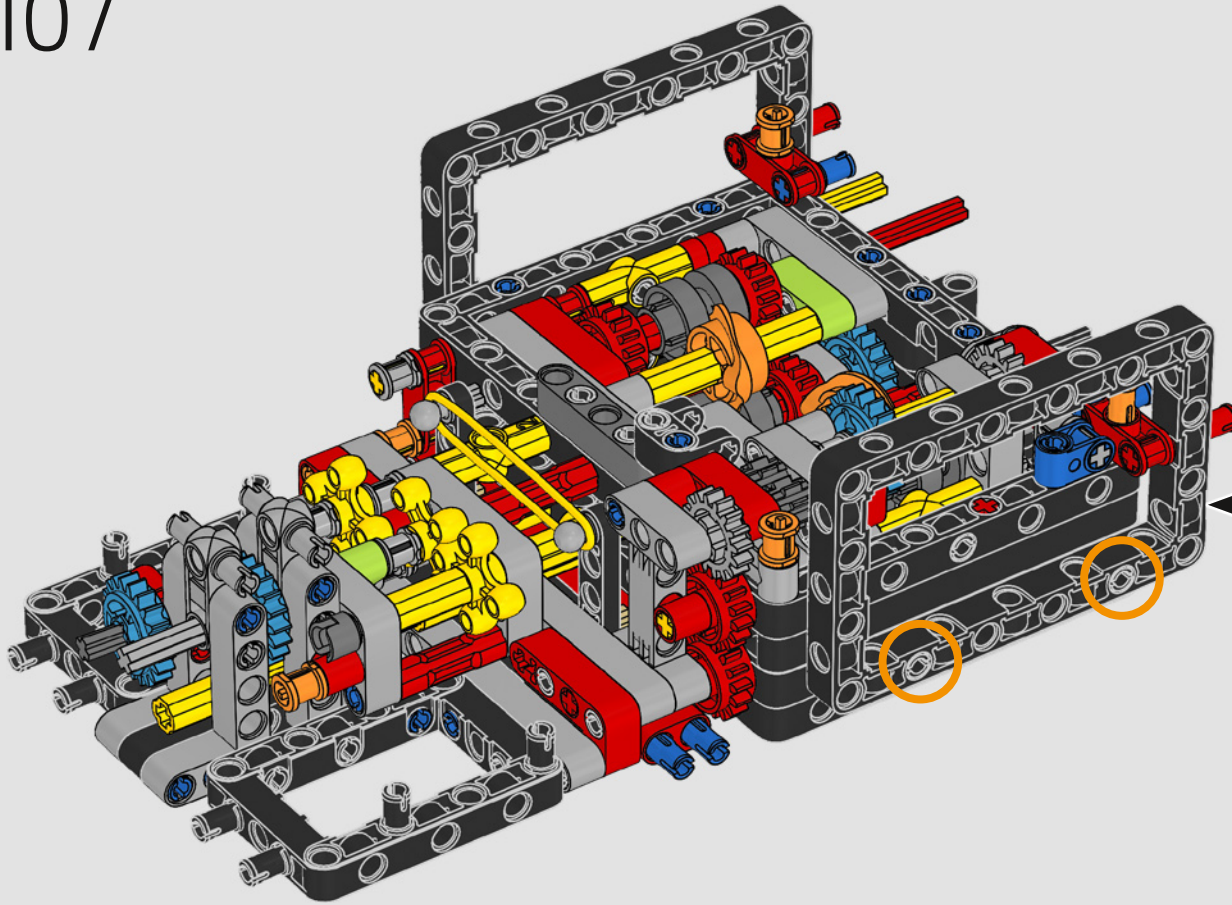

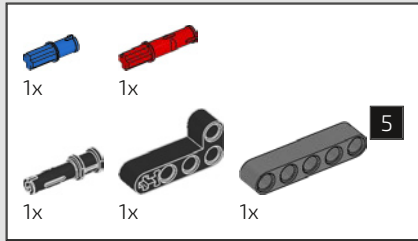

108

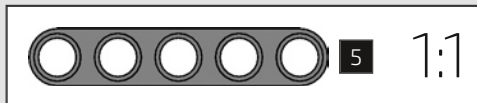
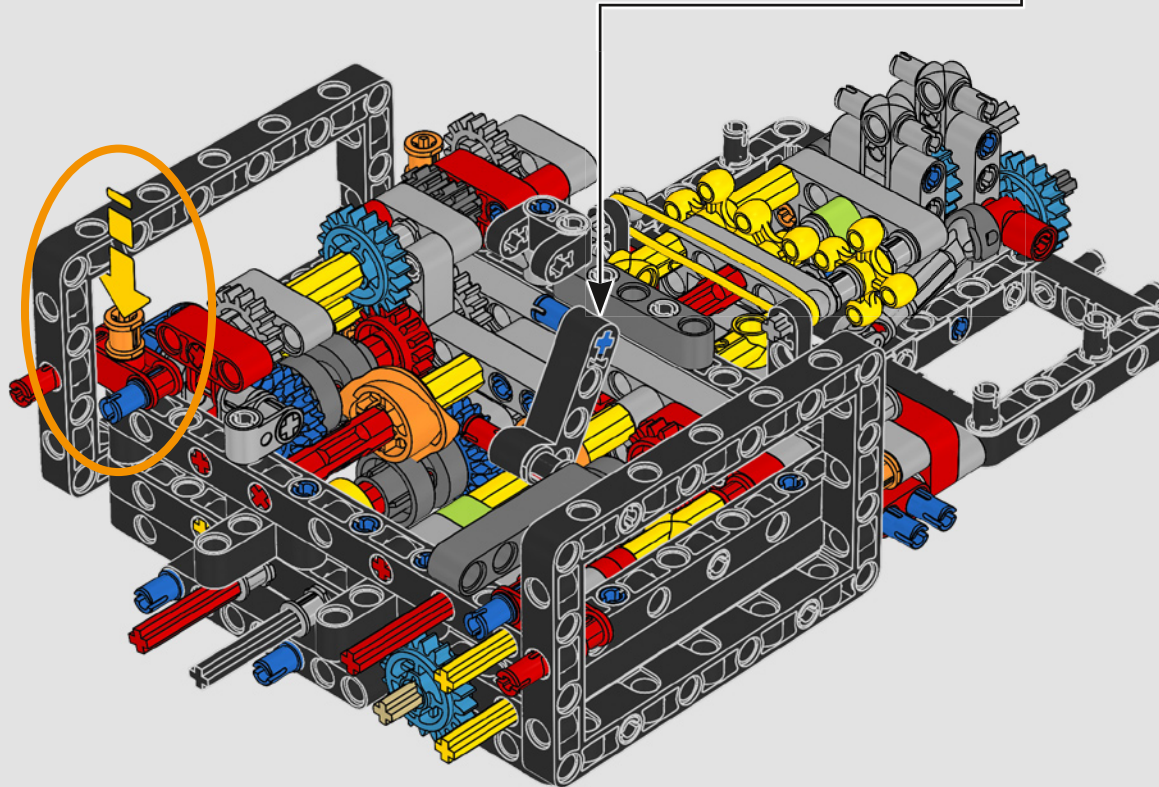
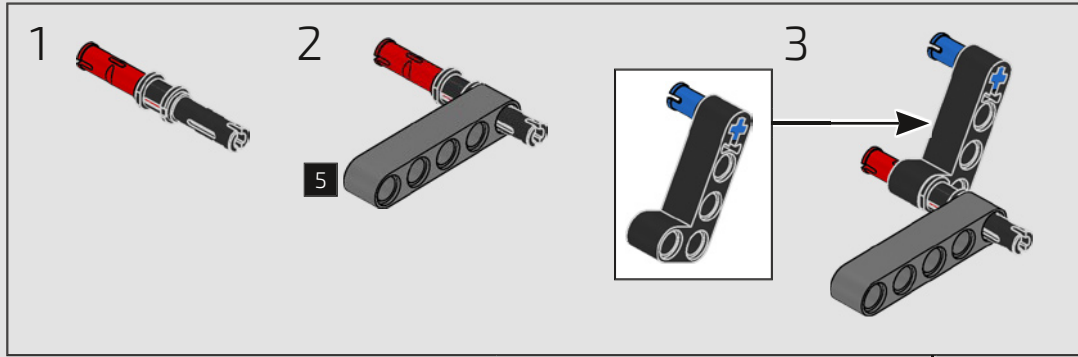

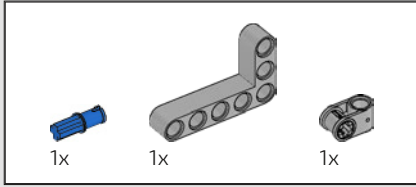

109

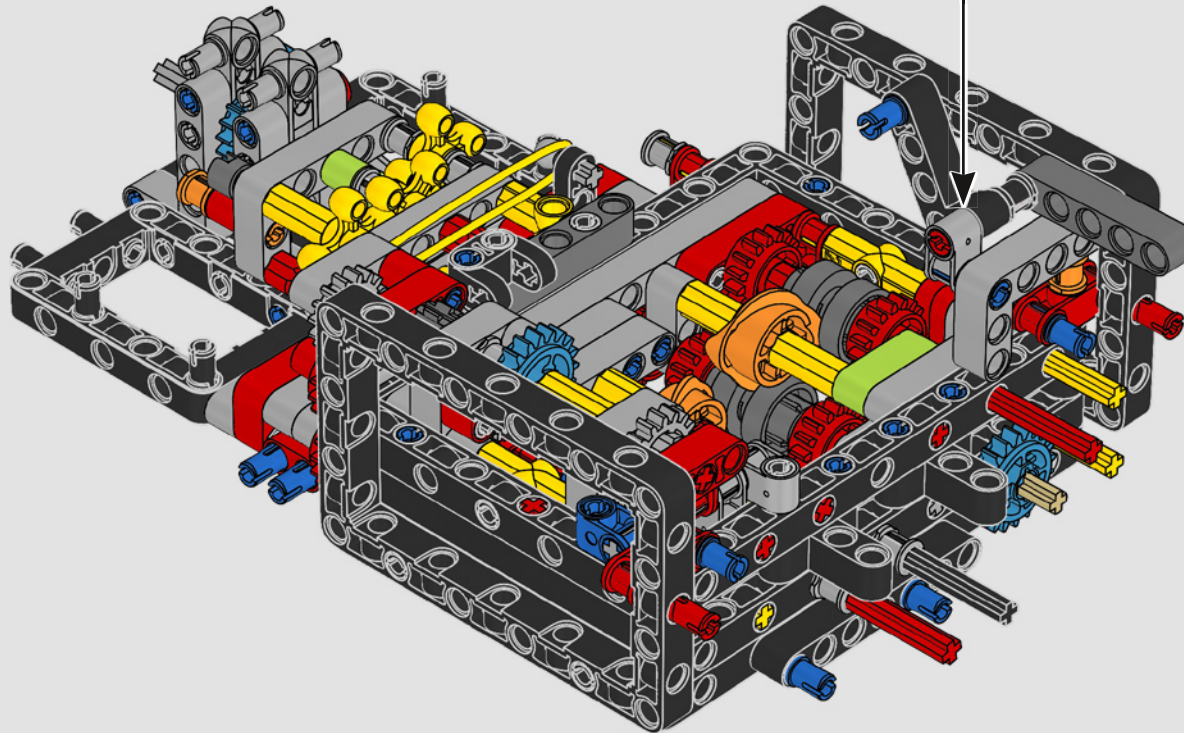
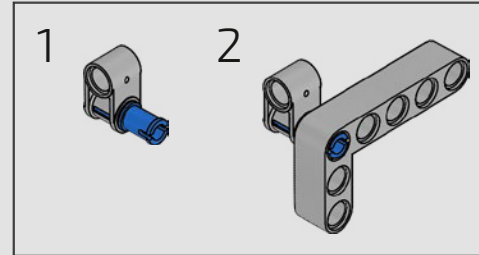



110

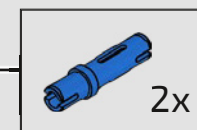
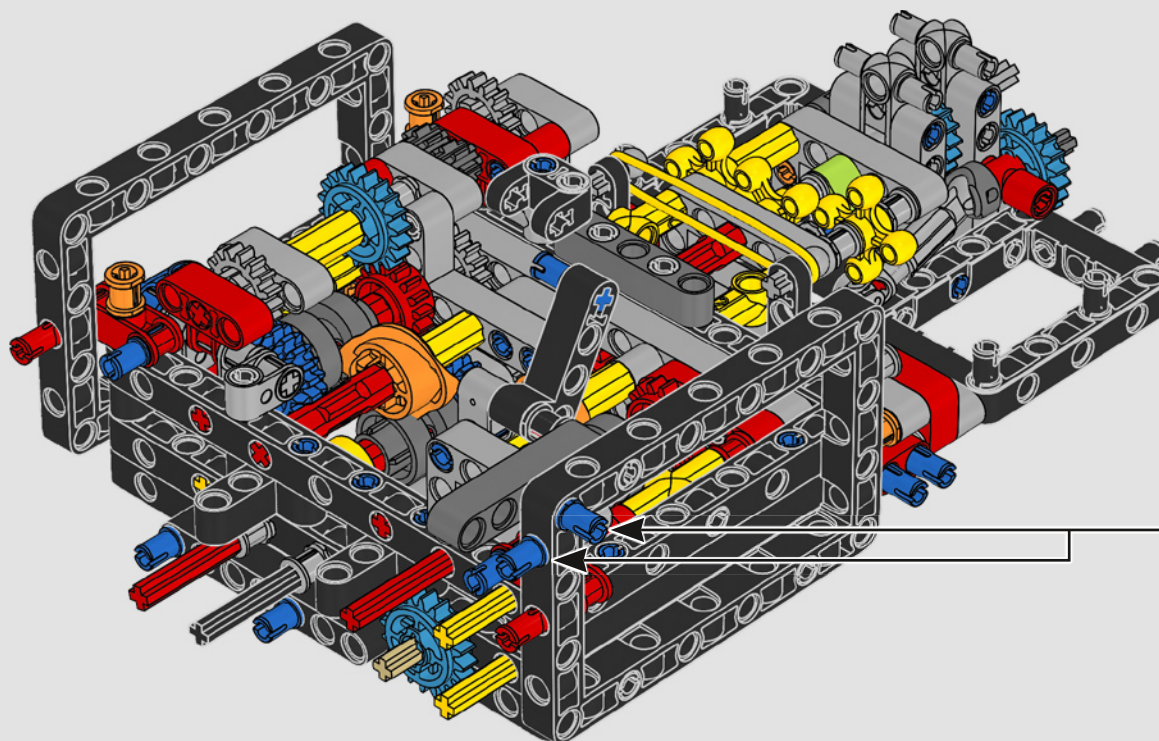

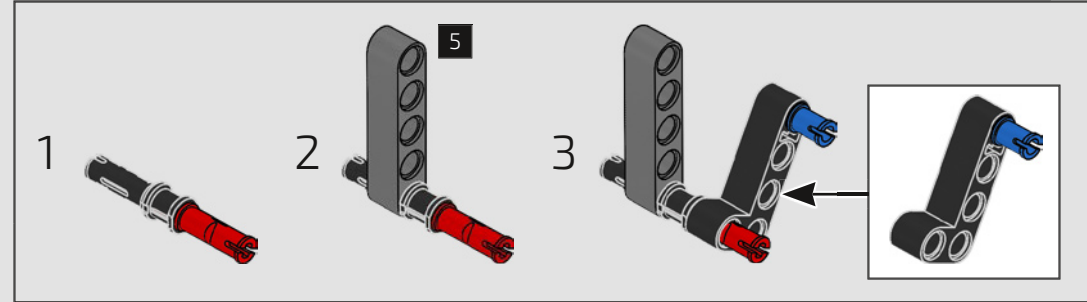
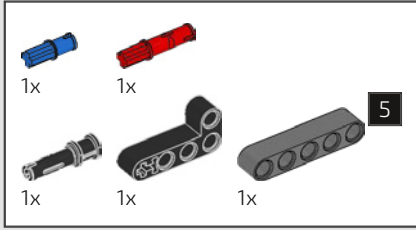

111

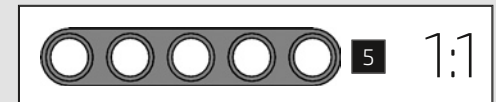
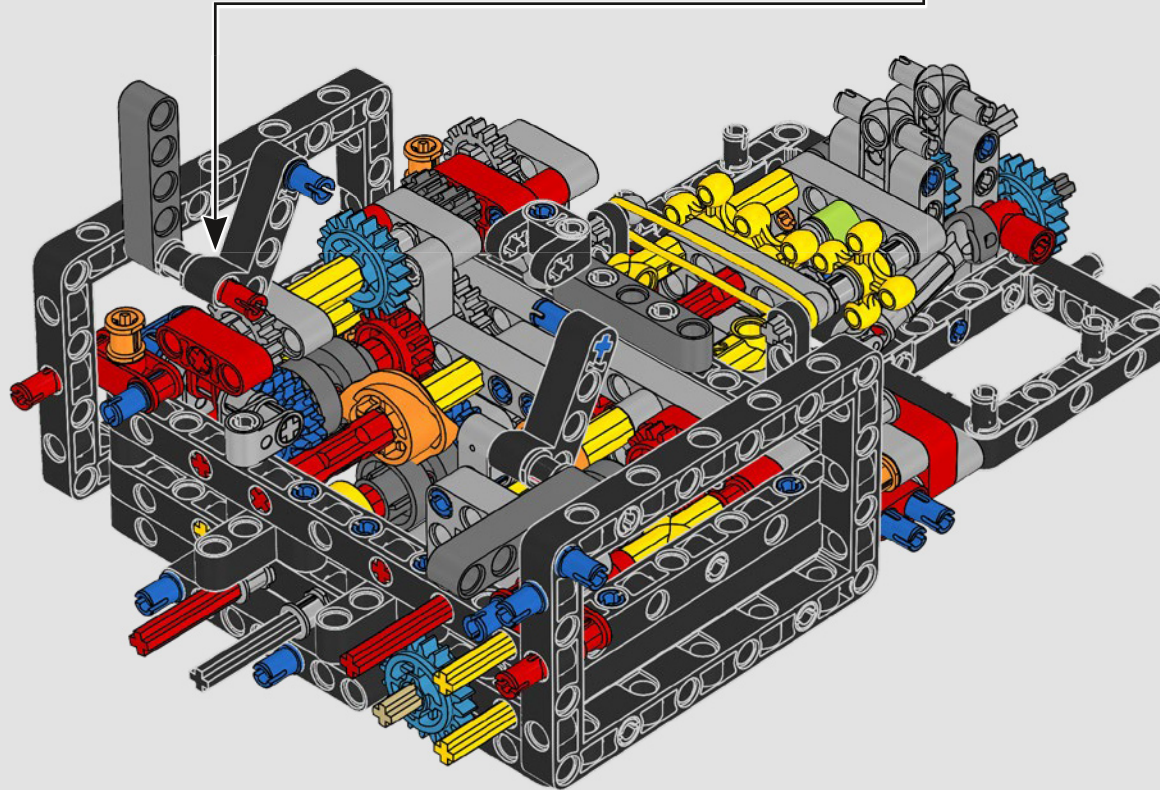

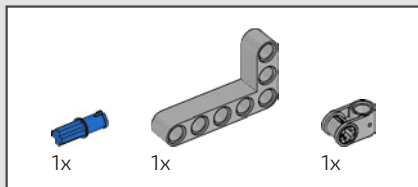

112

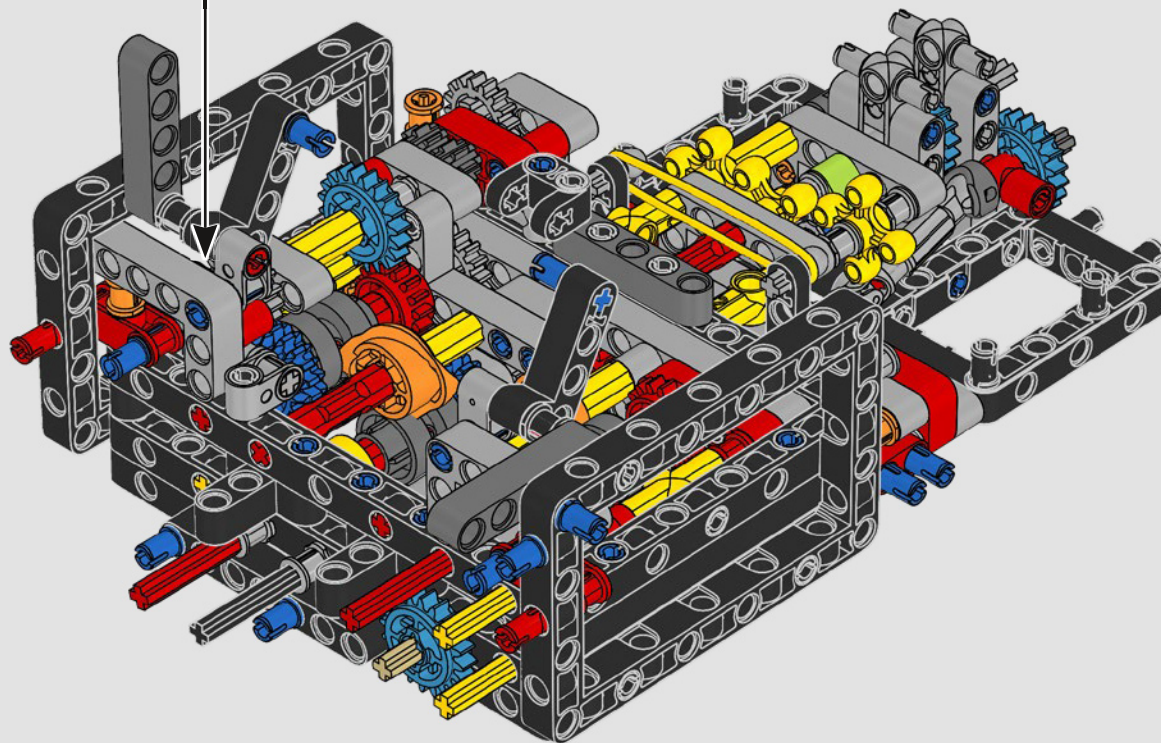
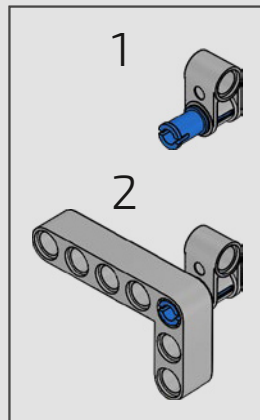



113

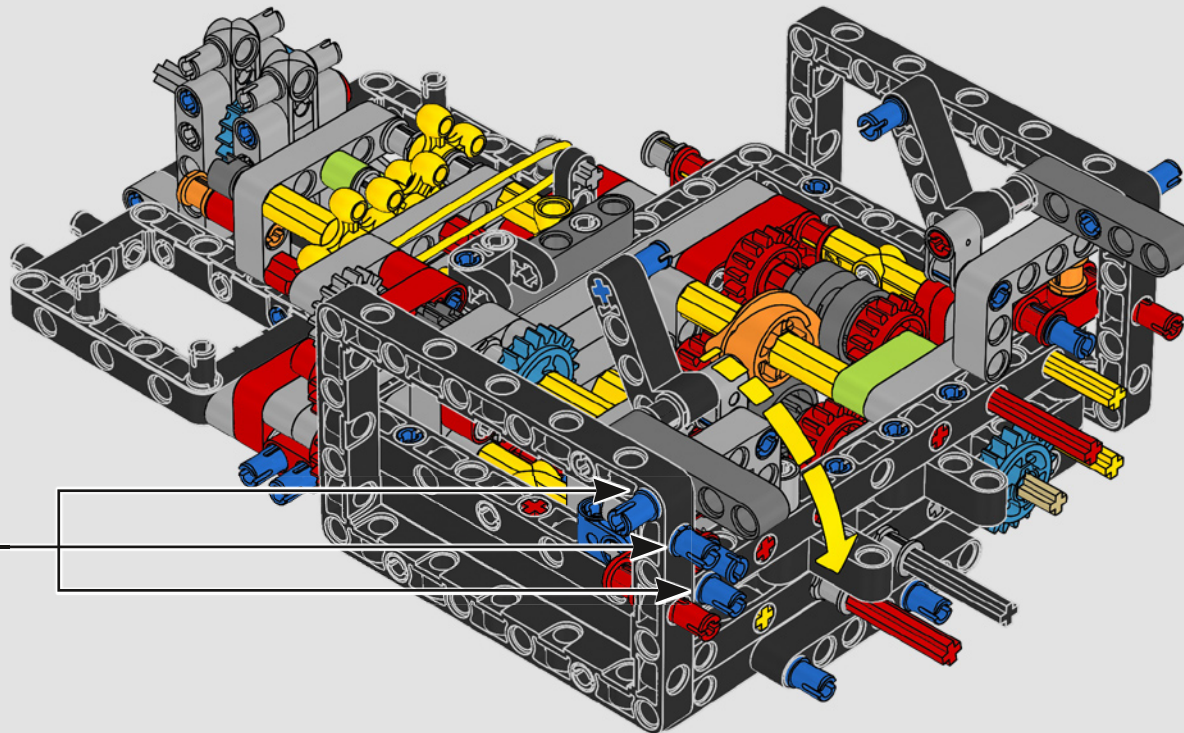



114

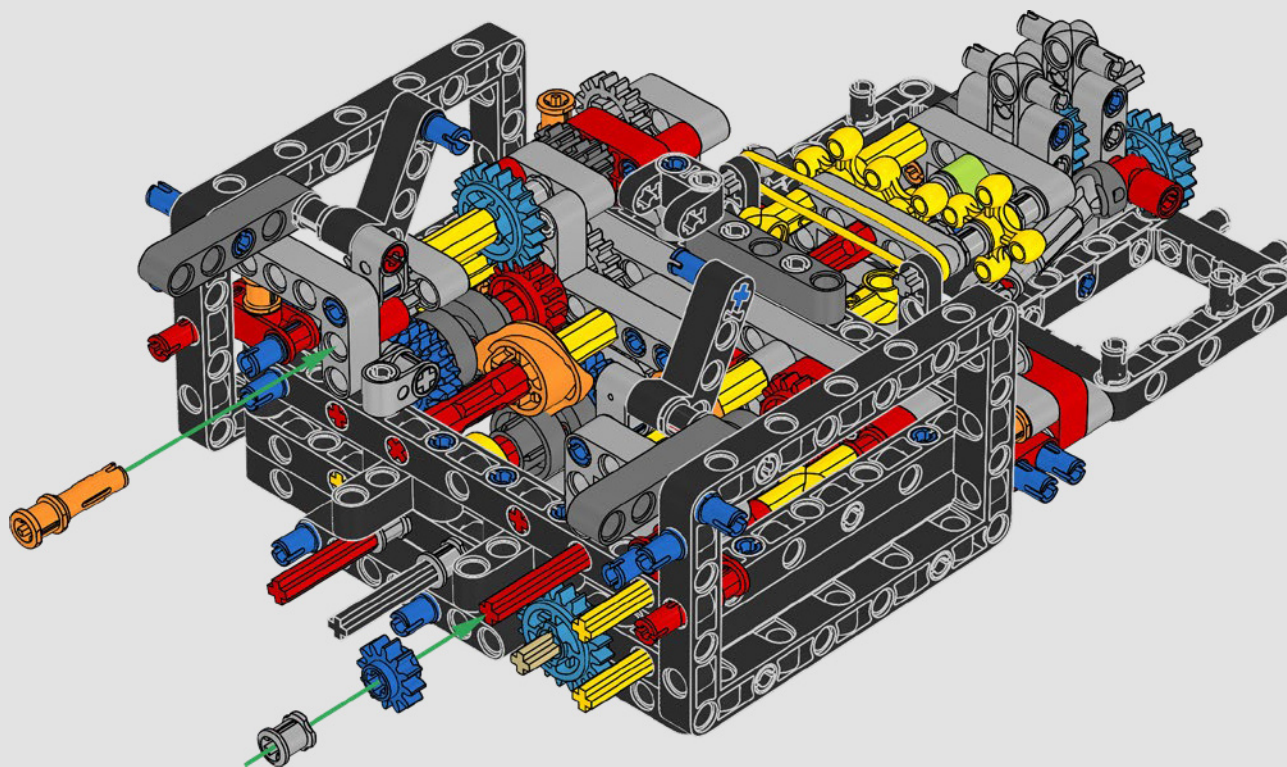

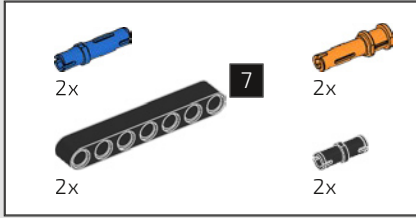

115

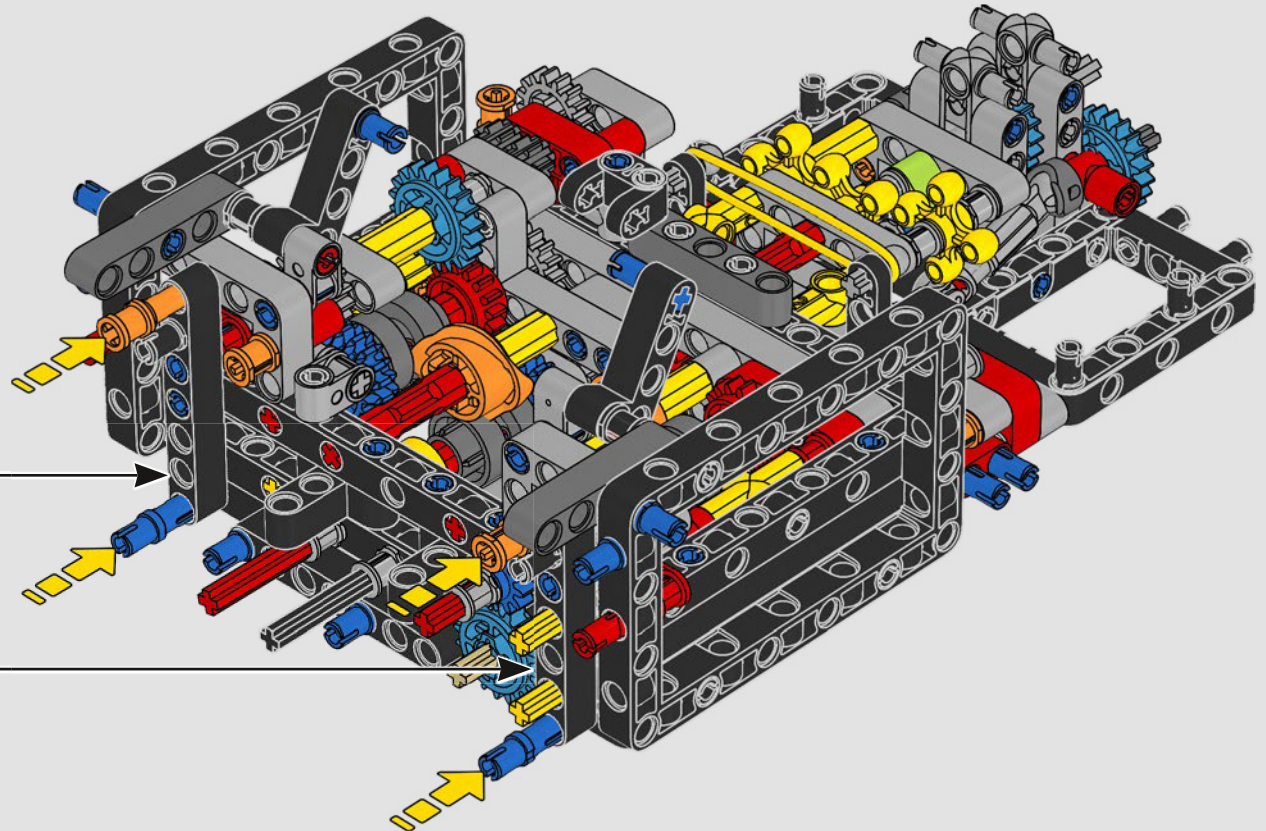
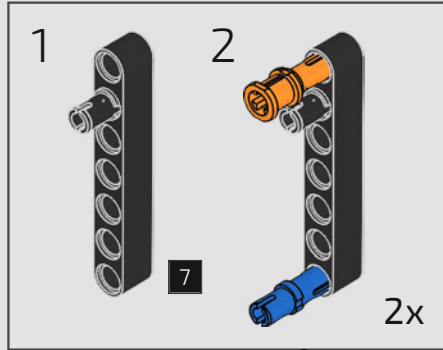

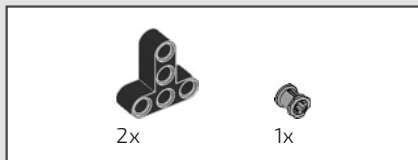

116

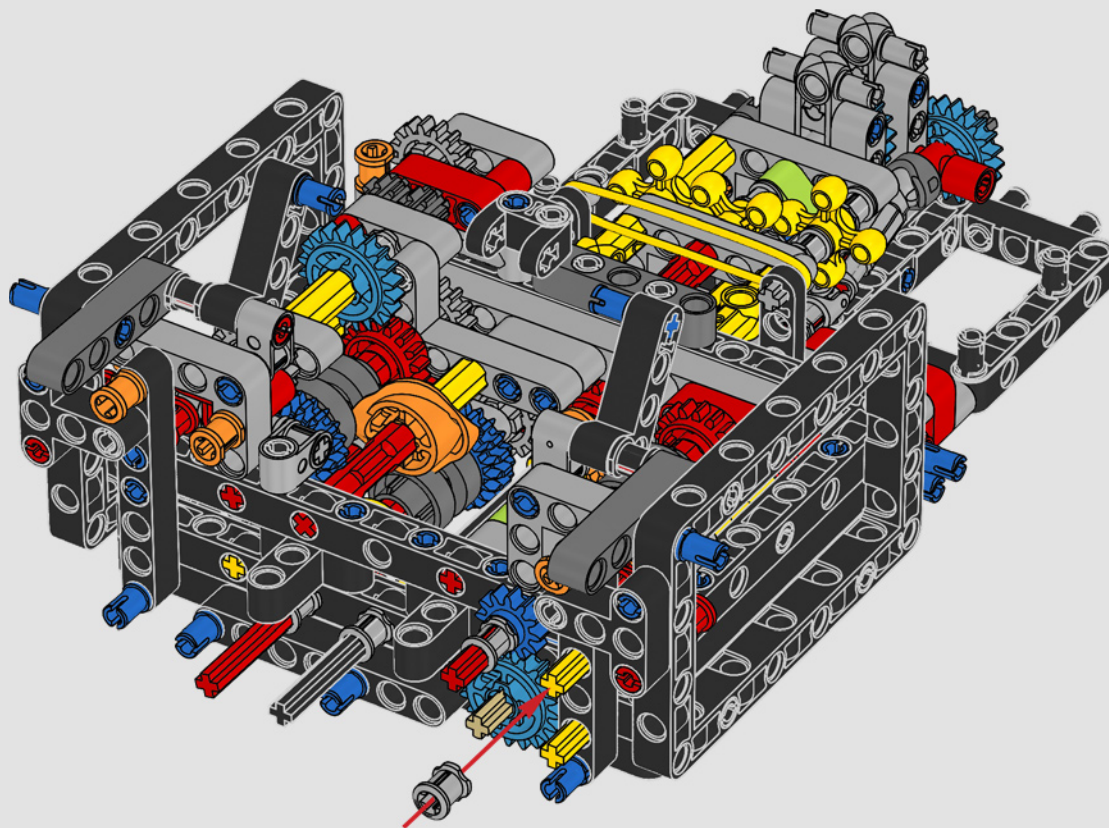

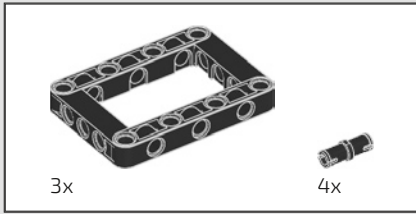

117

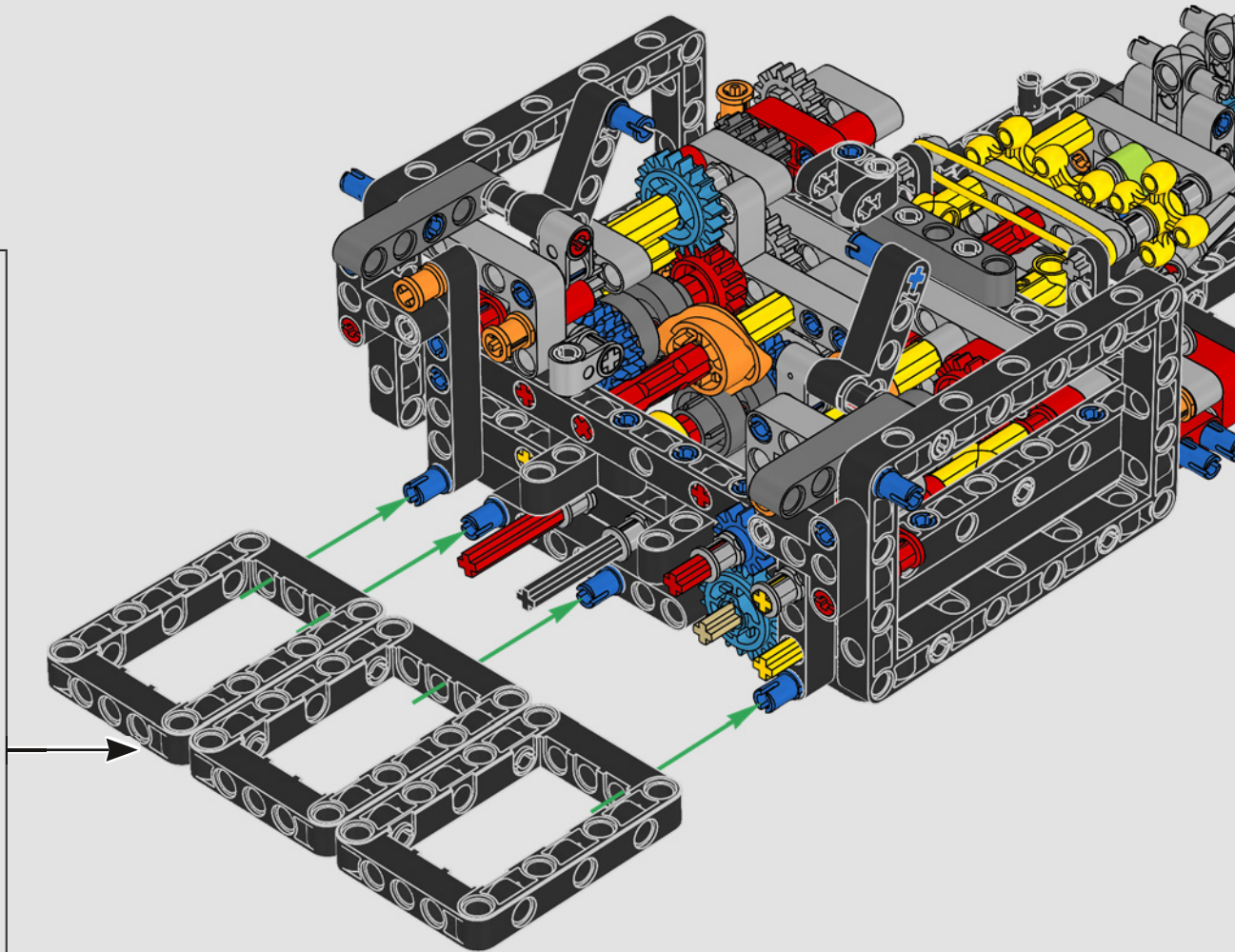
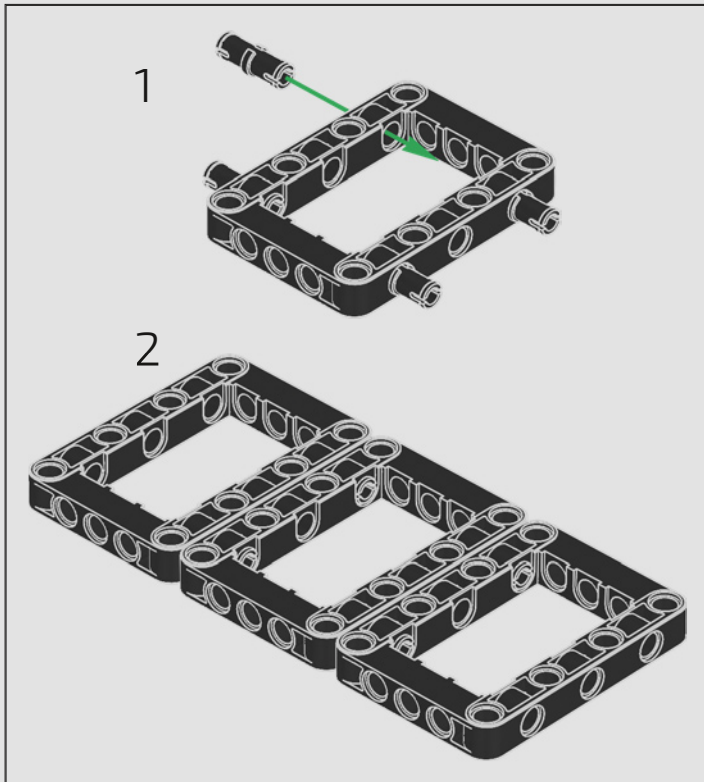

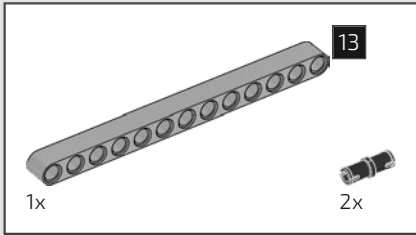
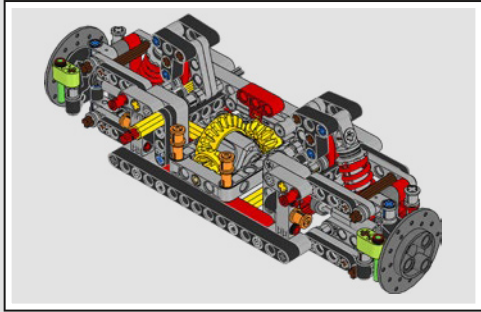

118

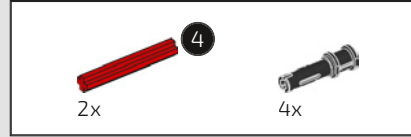
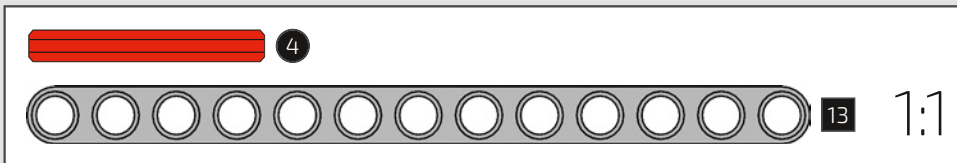
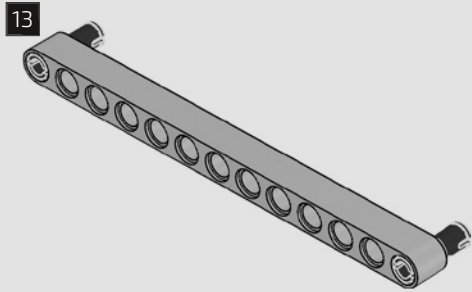

119

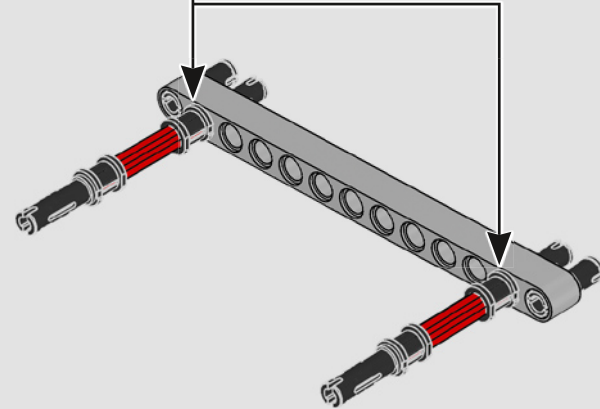
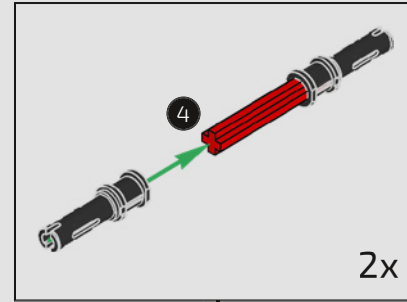

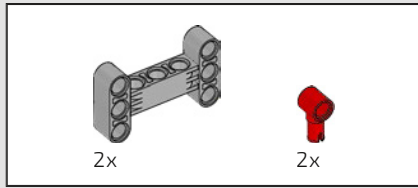

120

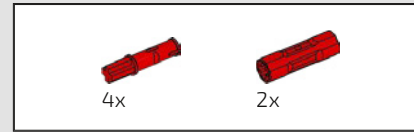
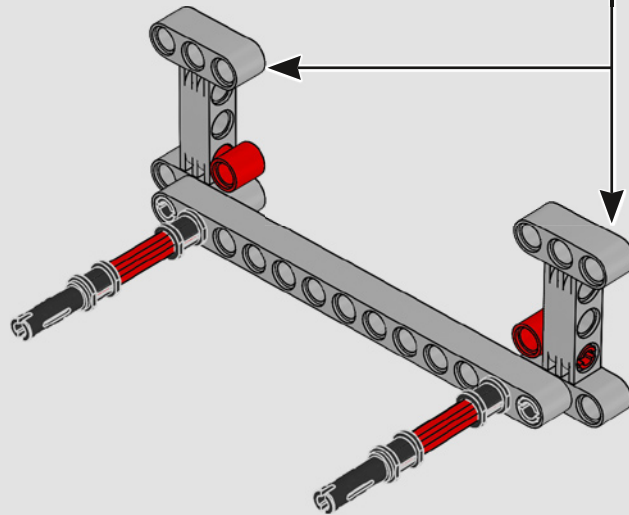
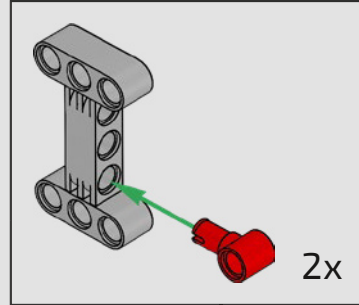

121

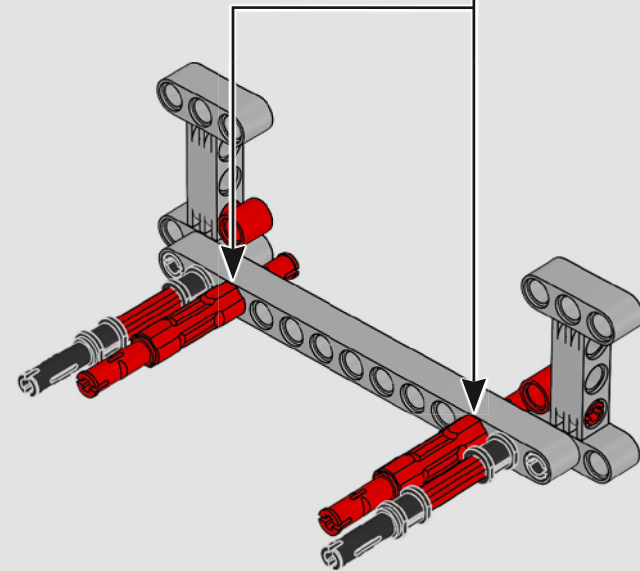
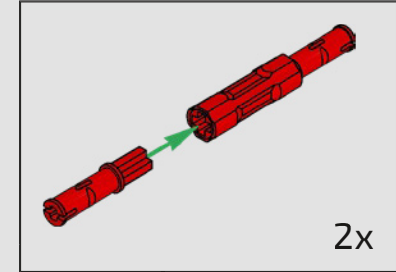

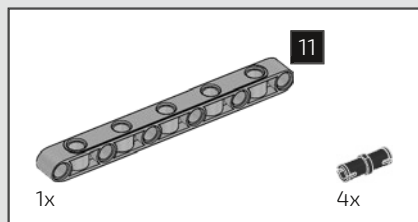

122

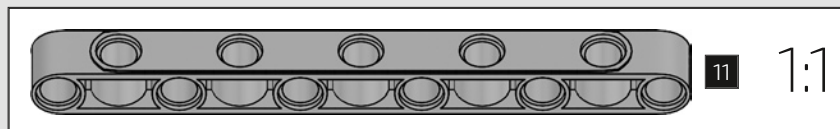
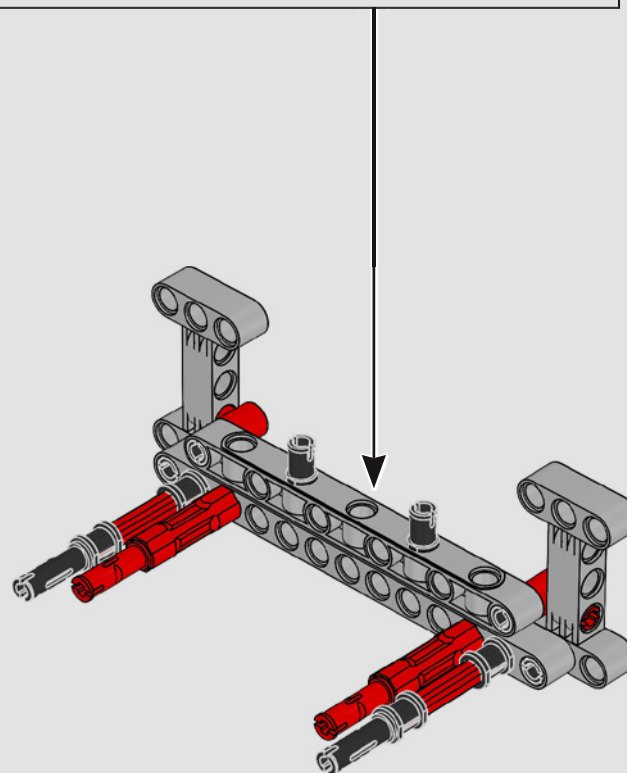
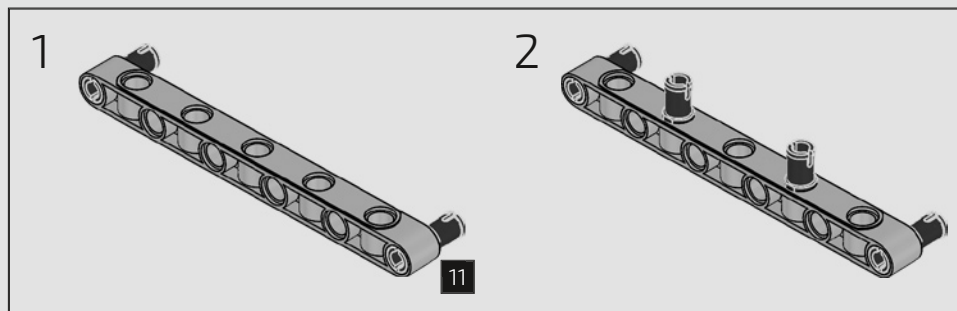

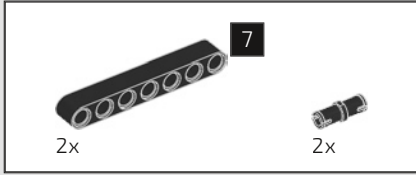

123

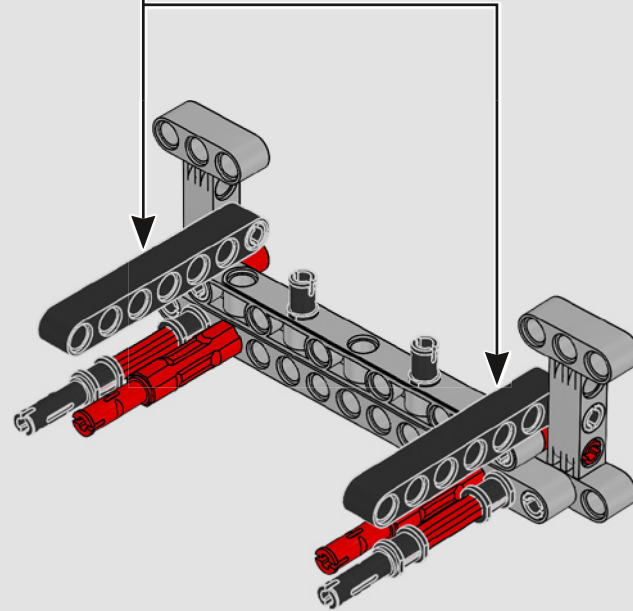
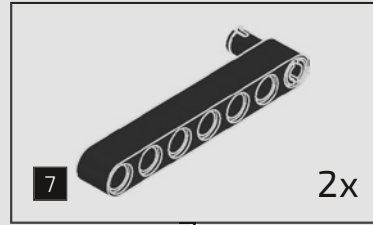

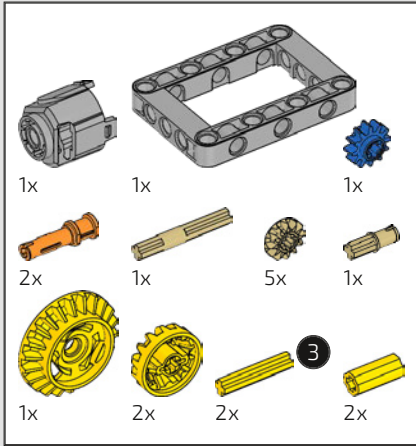
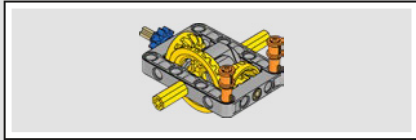

124

1

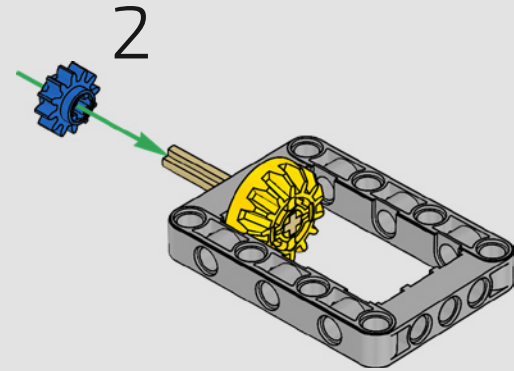
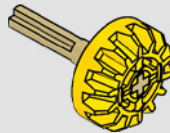

3

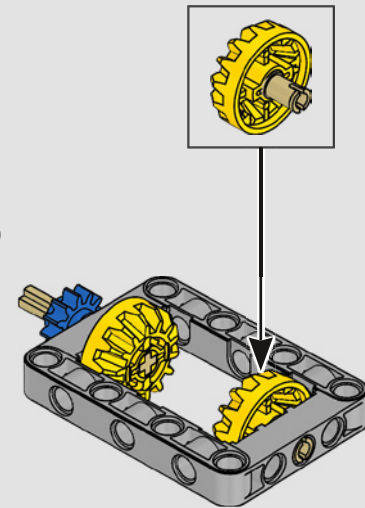

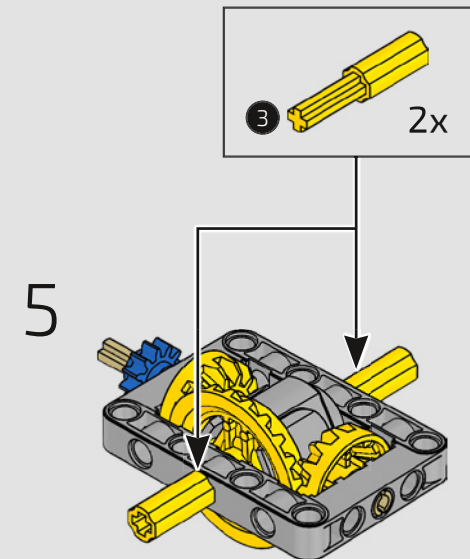
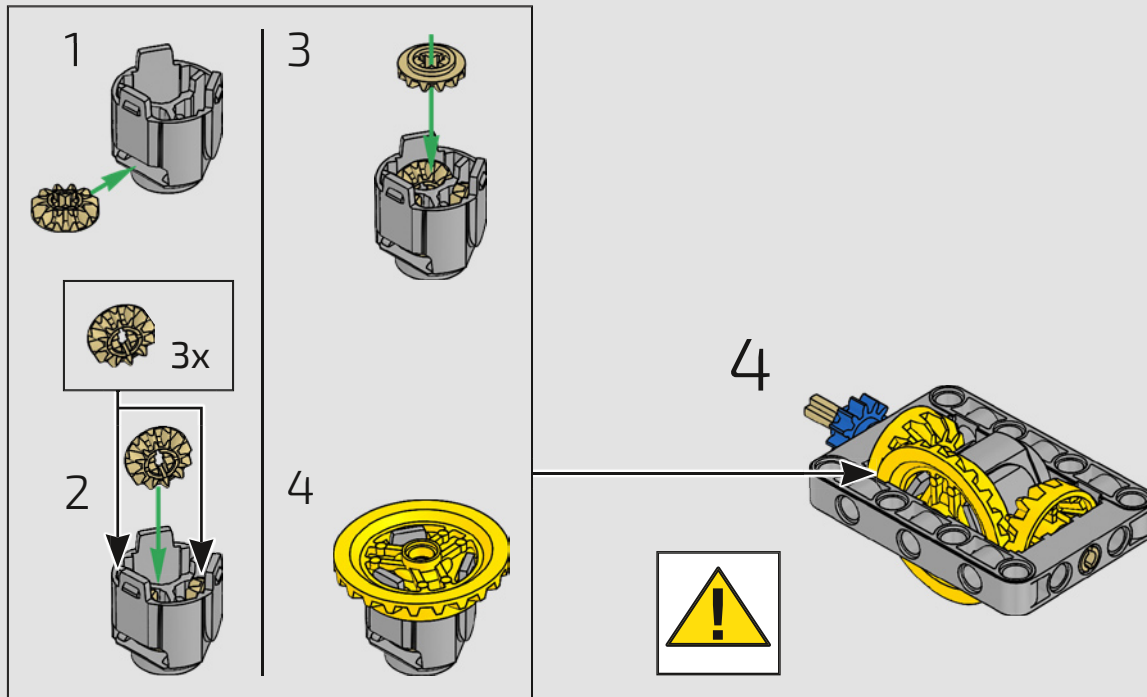

6

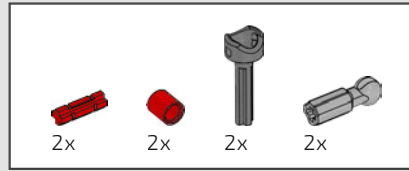
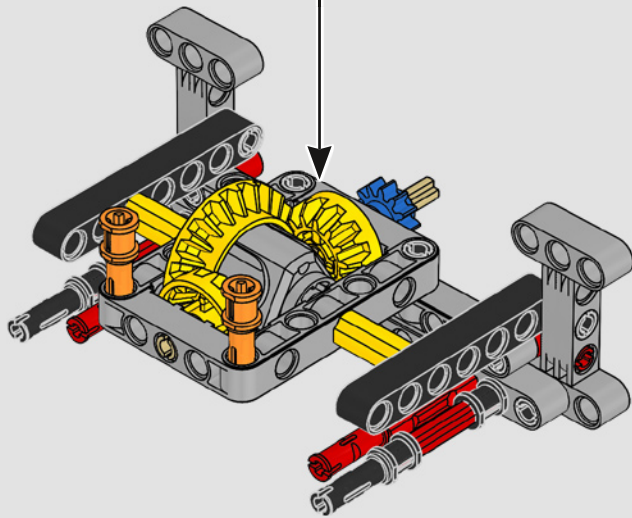
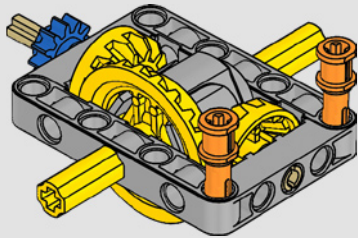

125

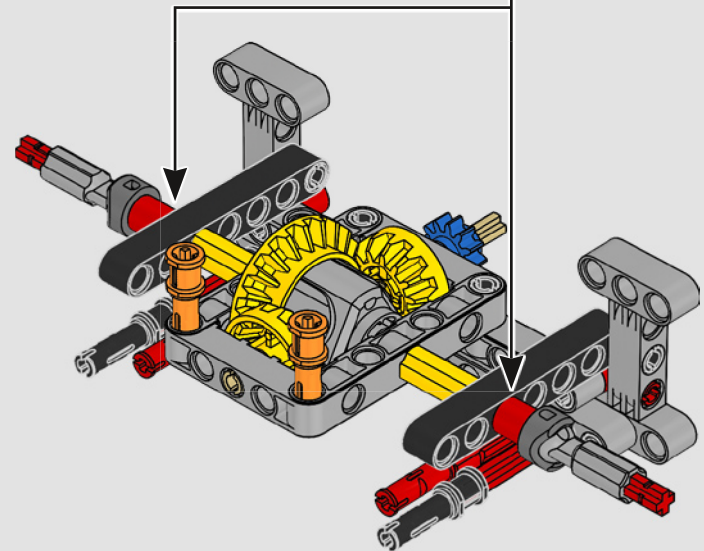
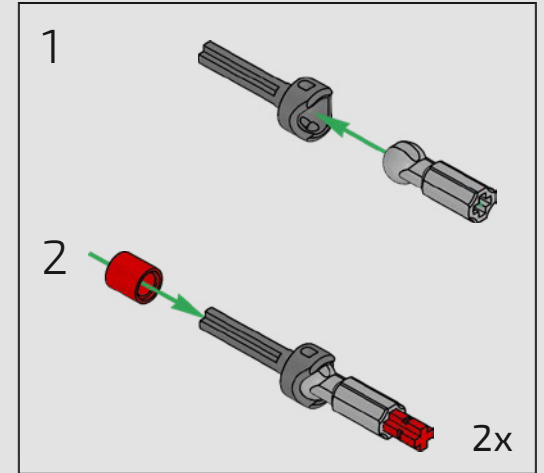

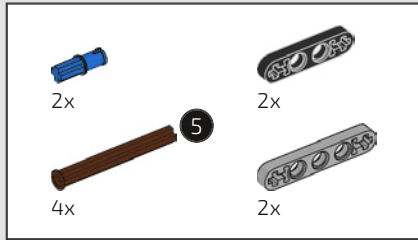

126

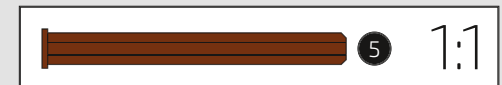
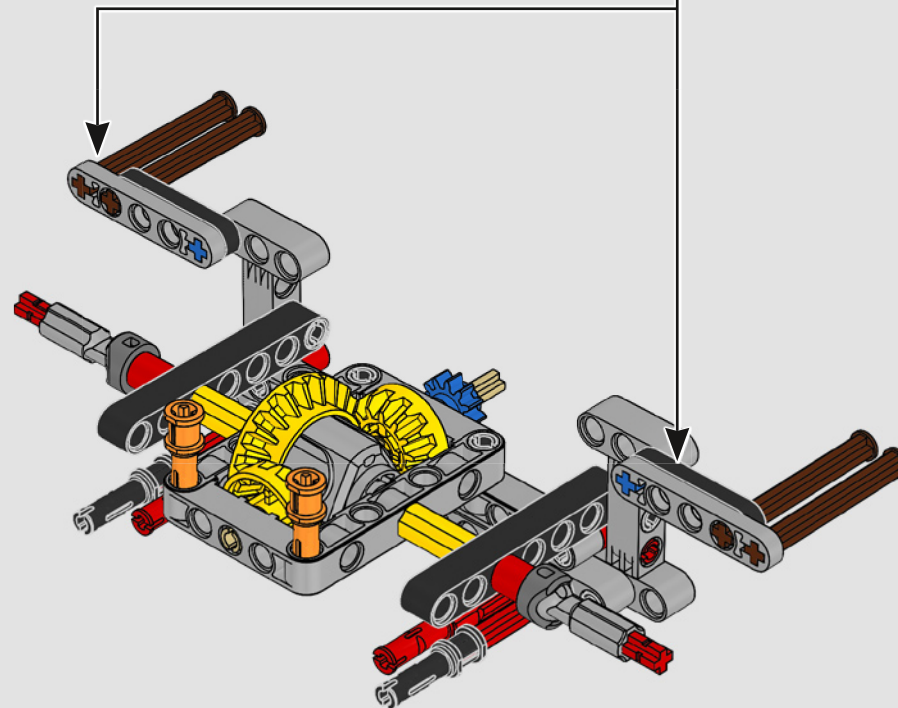
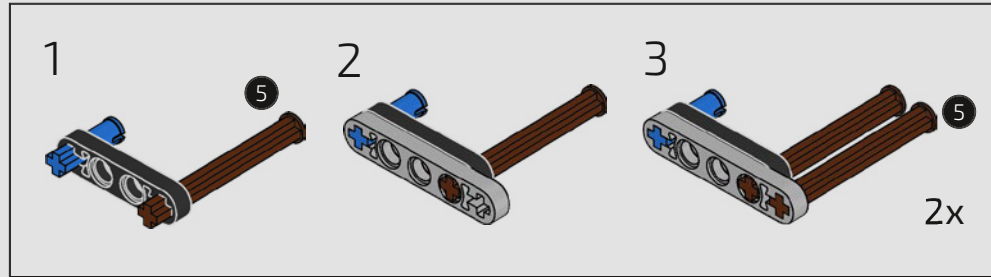

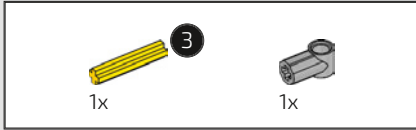
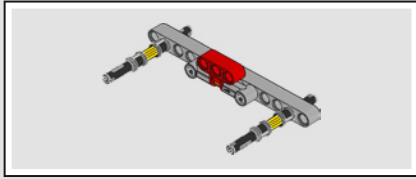

127

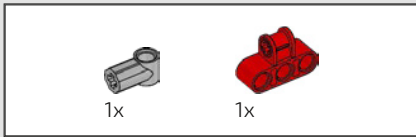
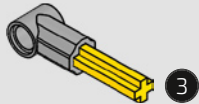

128

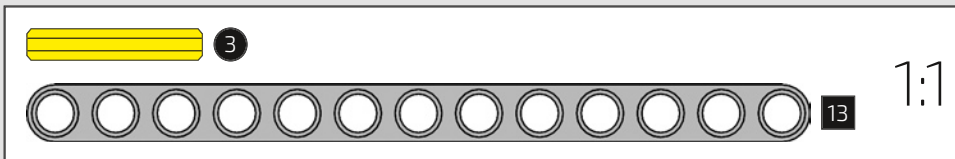
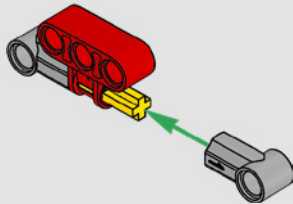

129

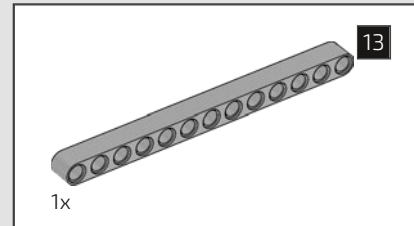
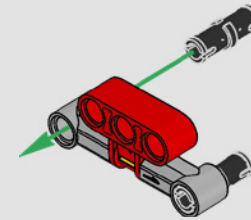

130

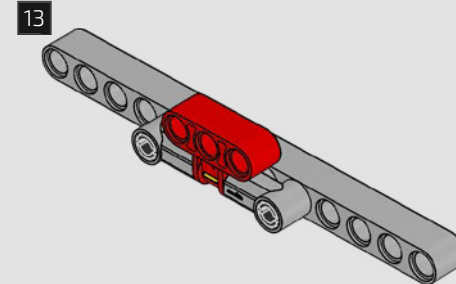

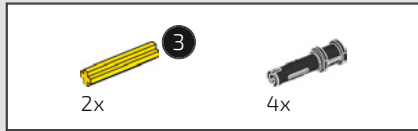

131

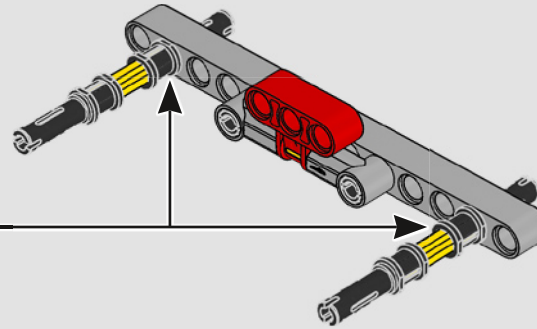
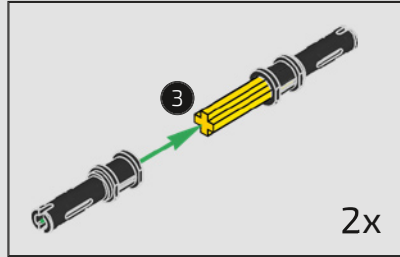

132

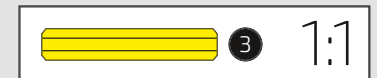
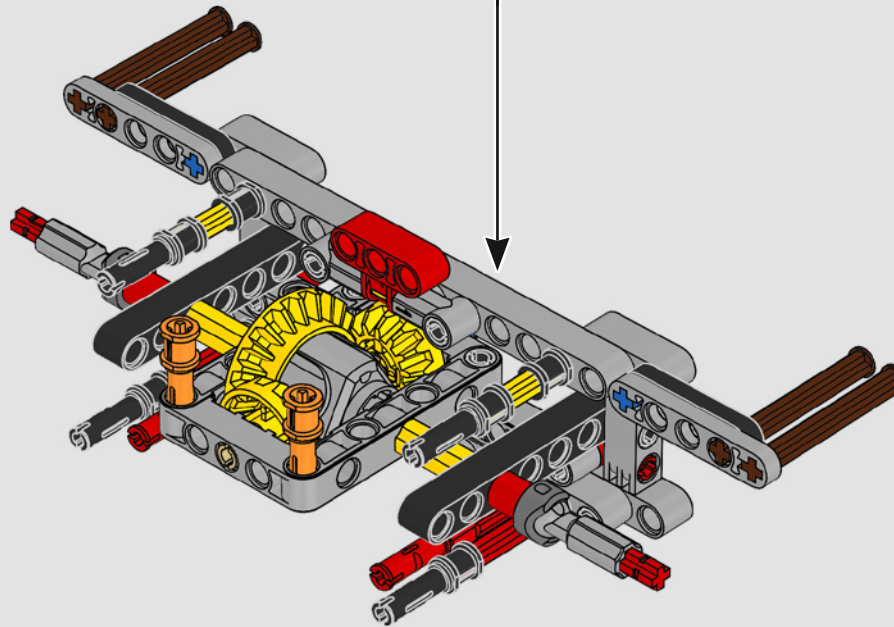

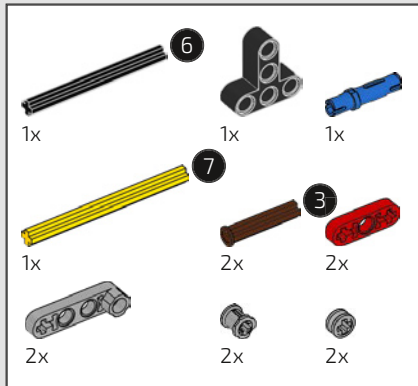

133

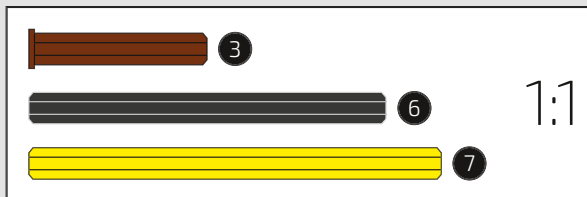
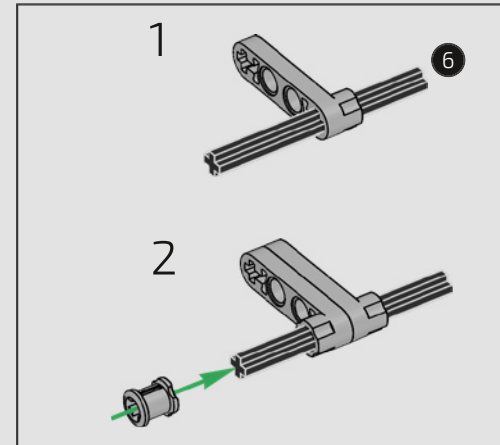
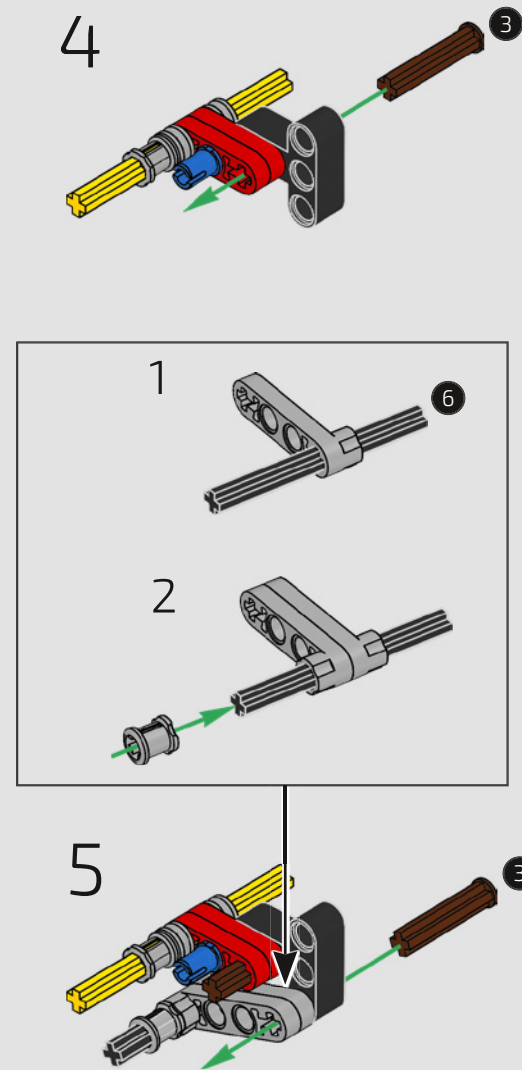
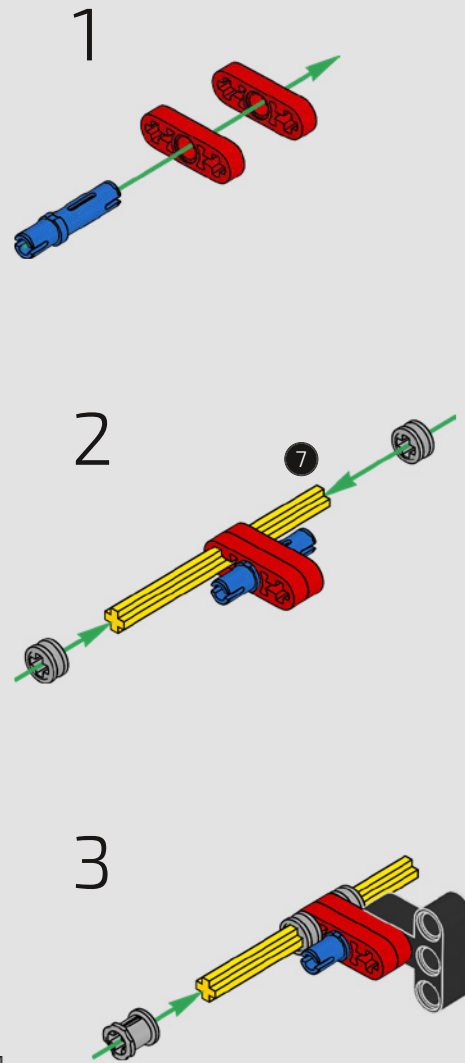

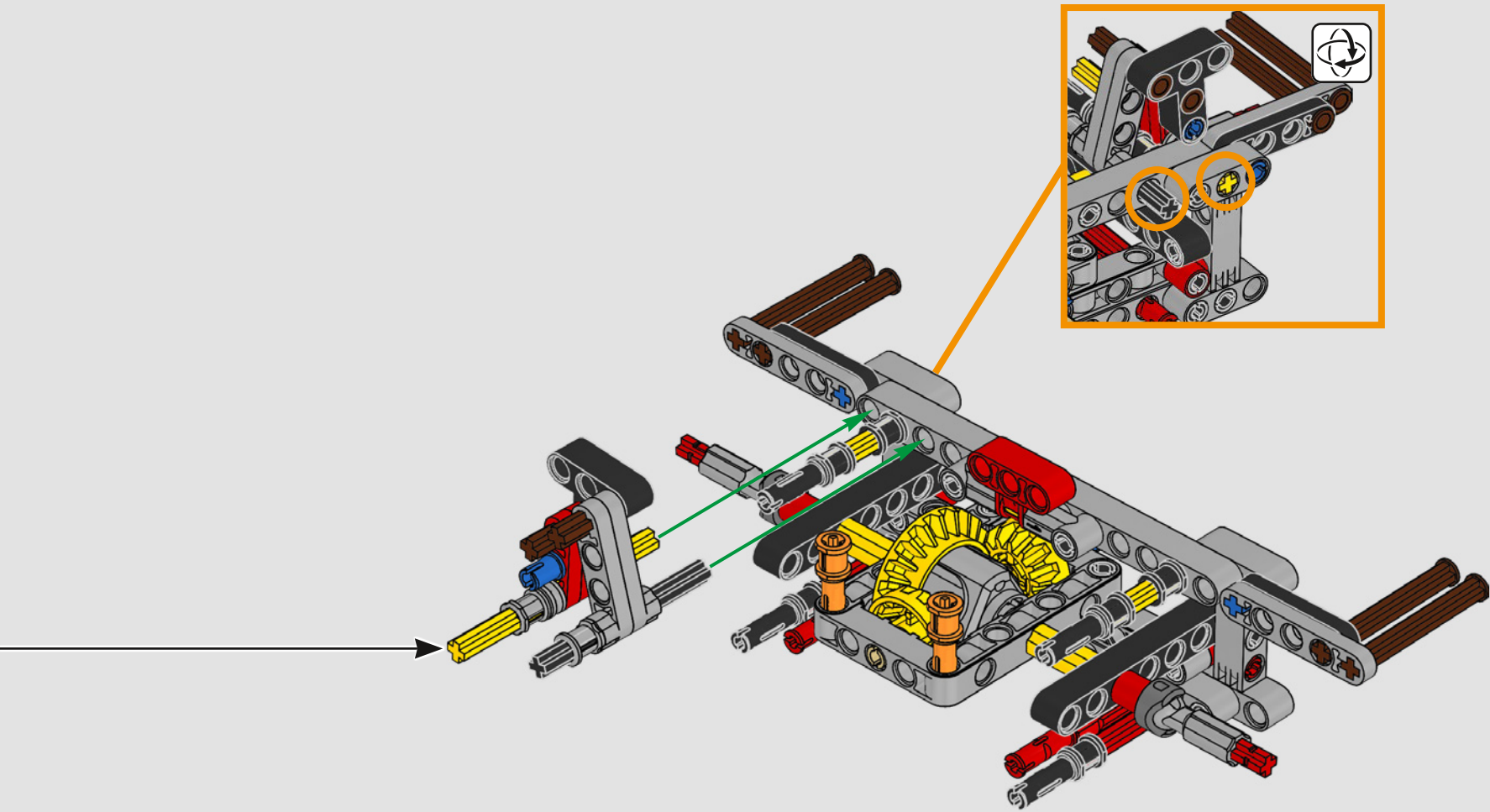

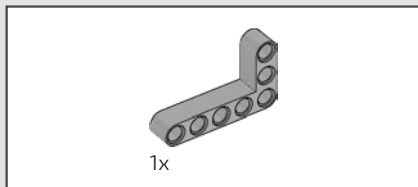

134

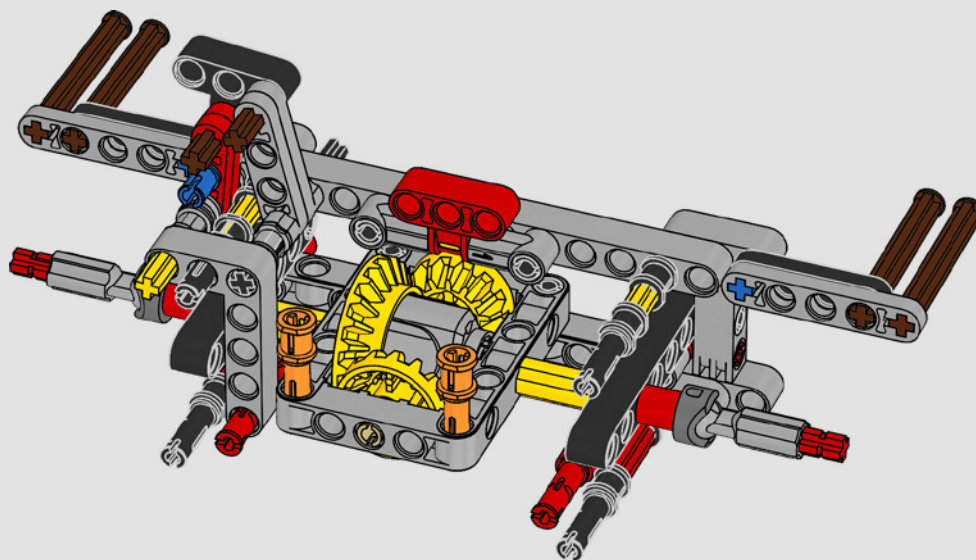

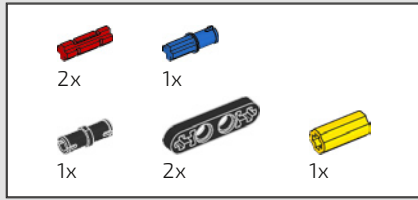

135

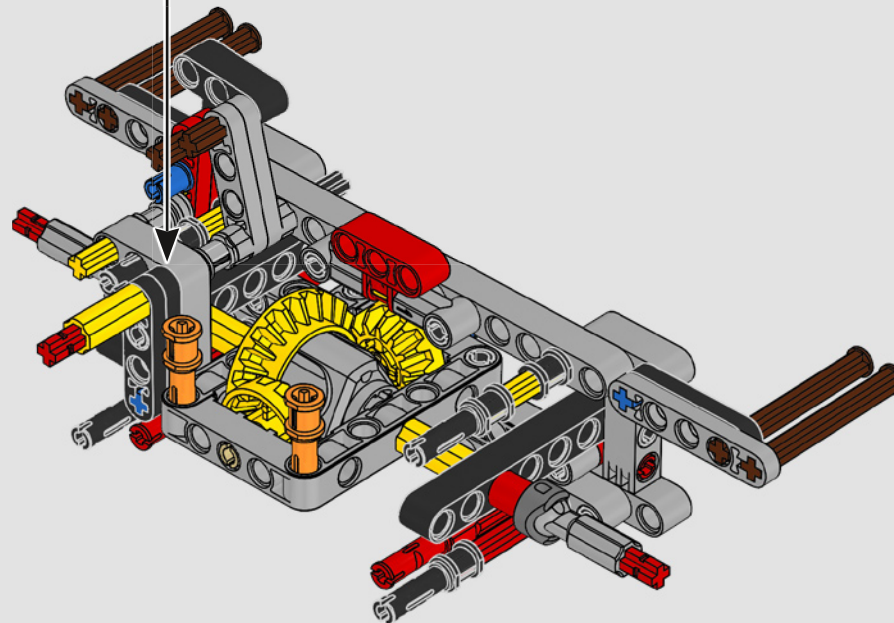
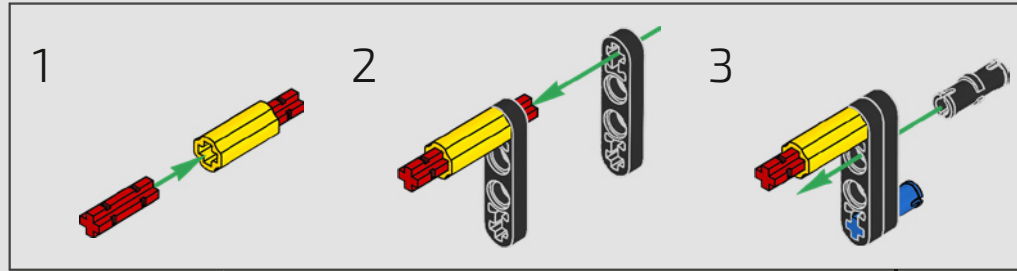

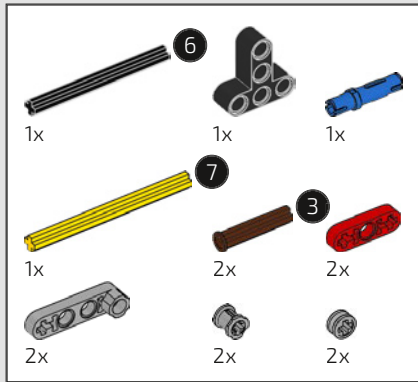

136

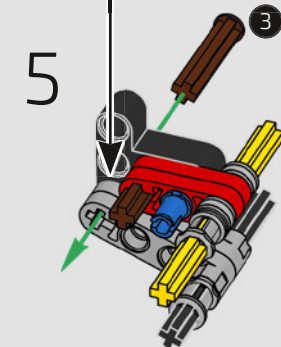
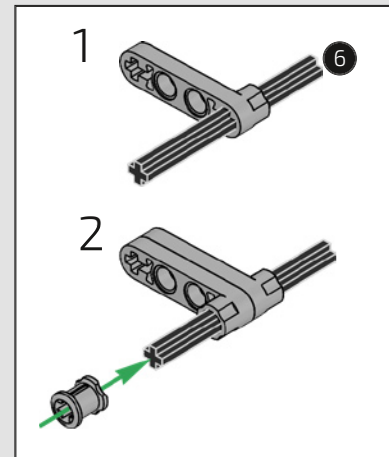
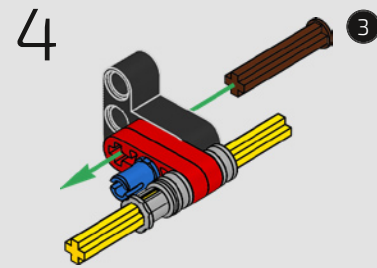
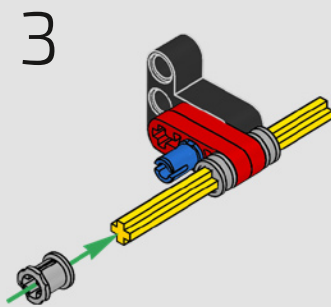
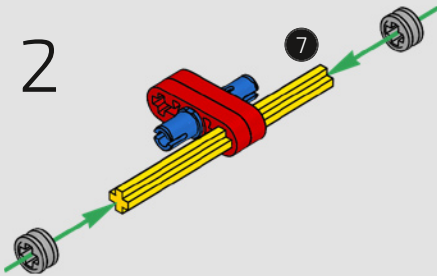
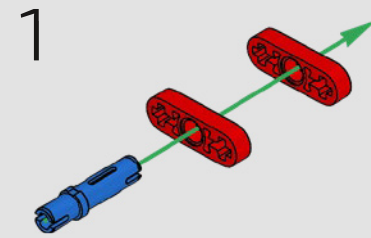
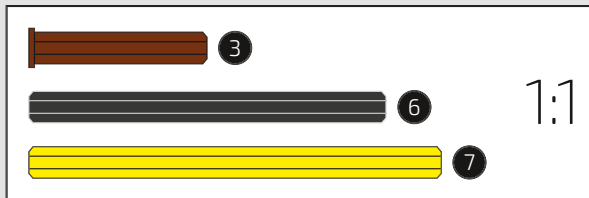

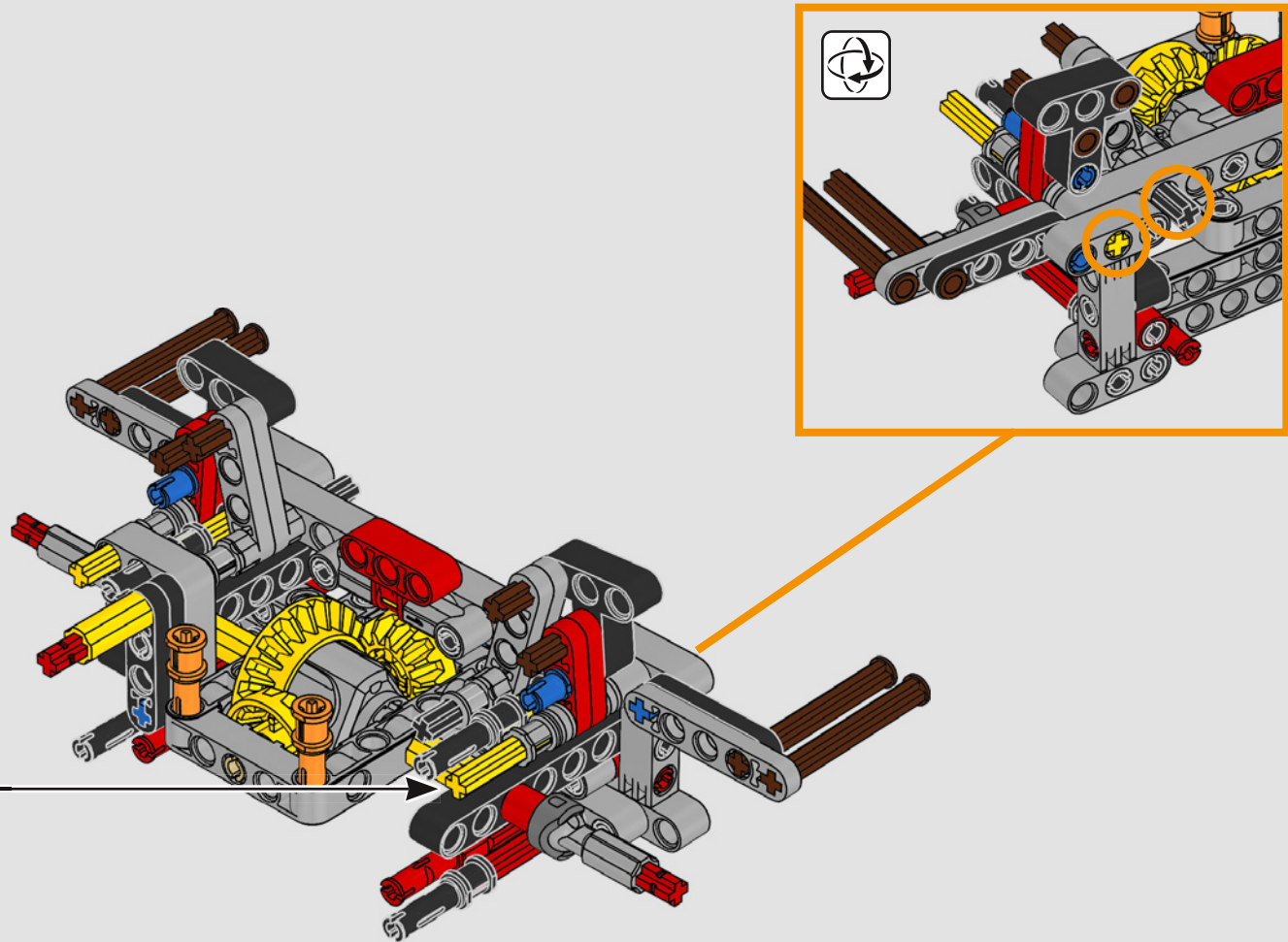

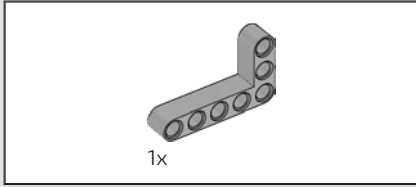

137

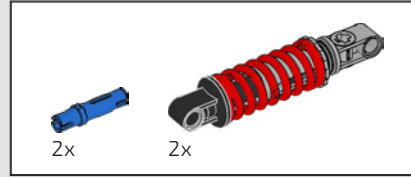
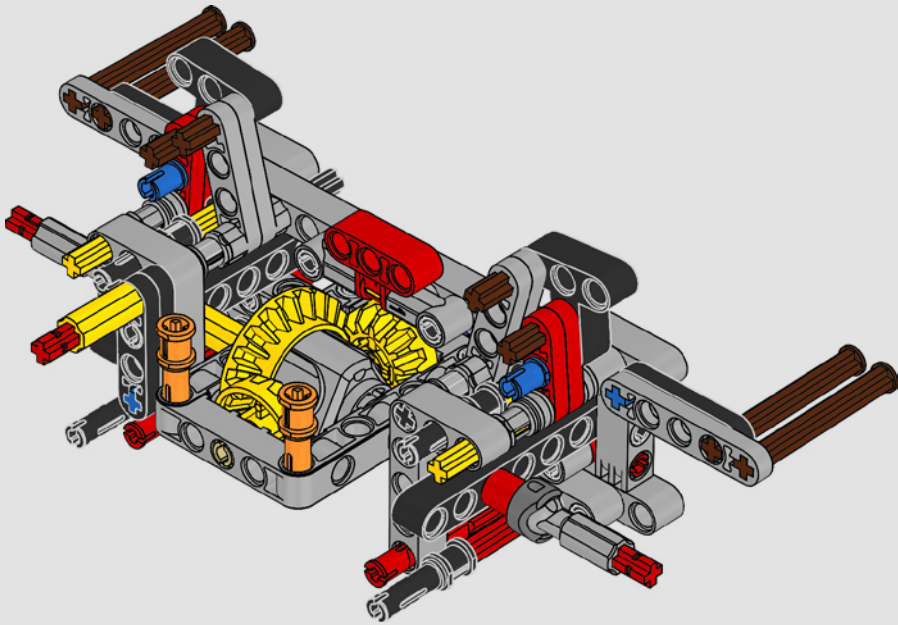

138

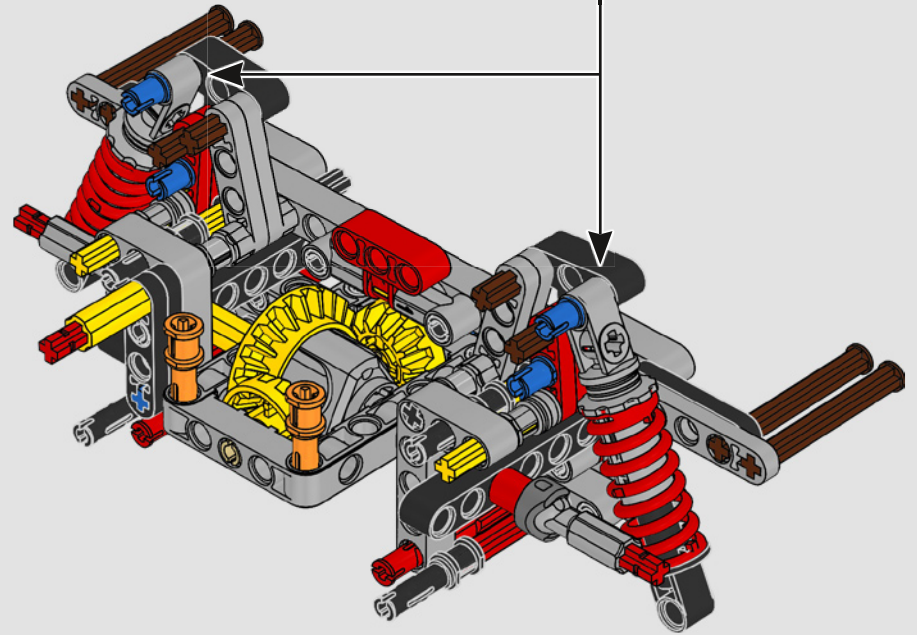
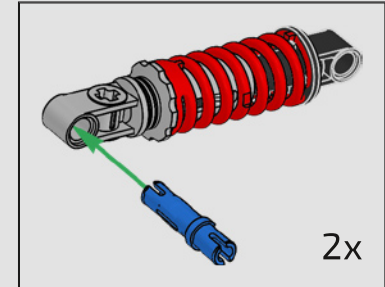

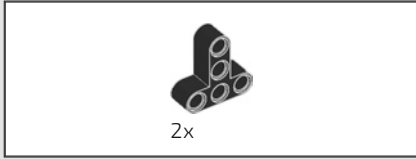

139

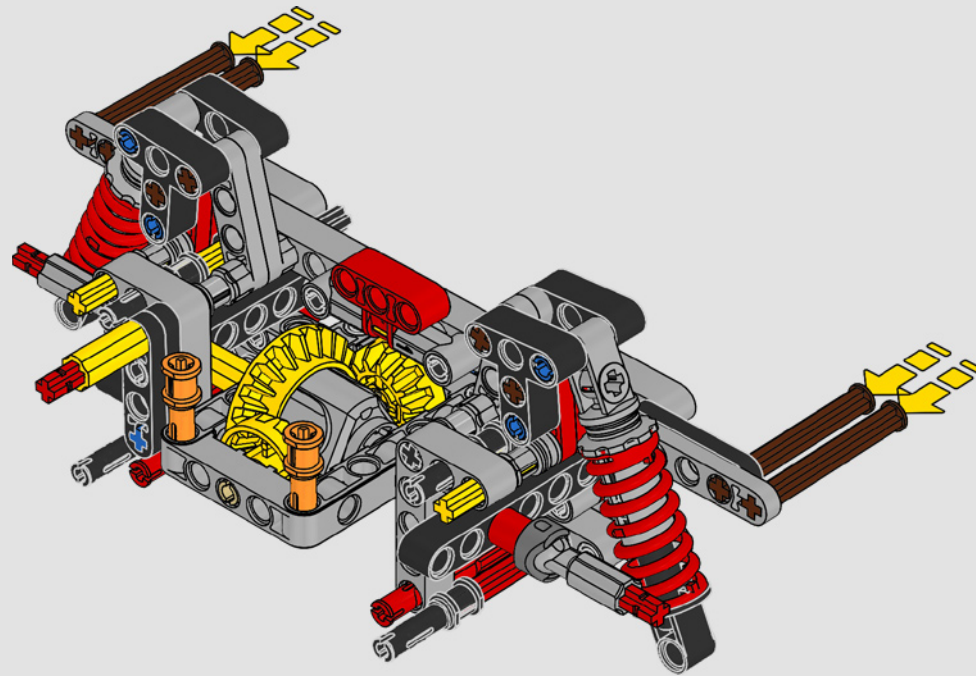

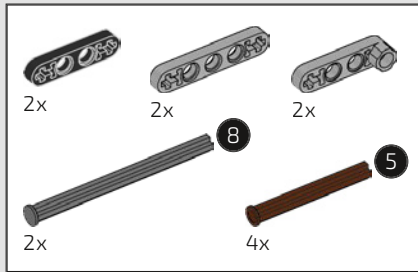

140

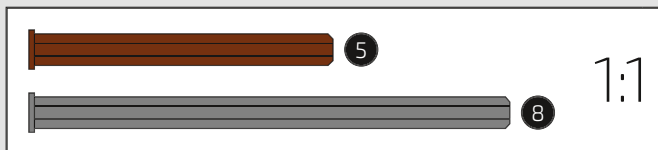
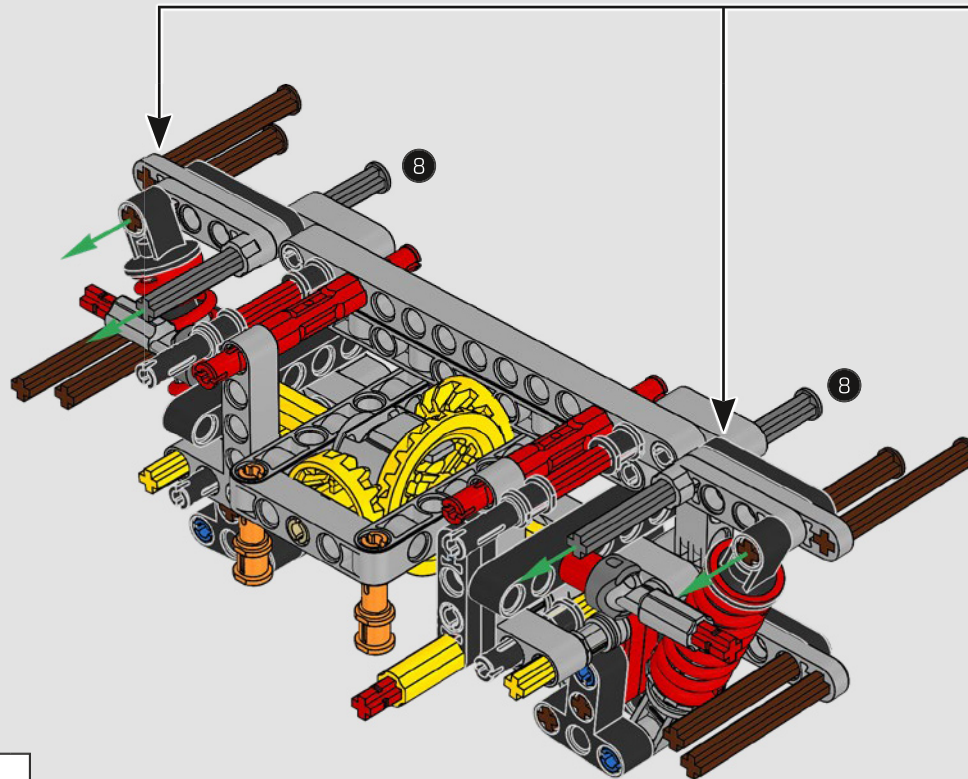
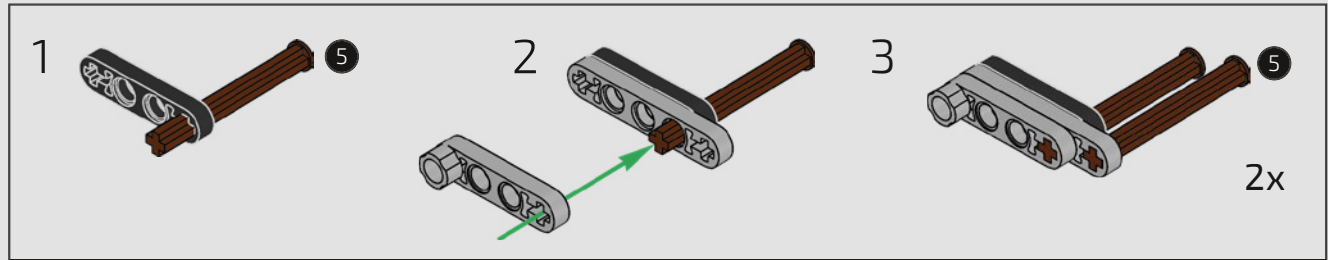

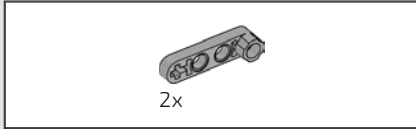

141

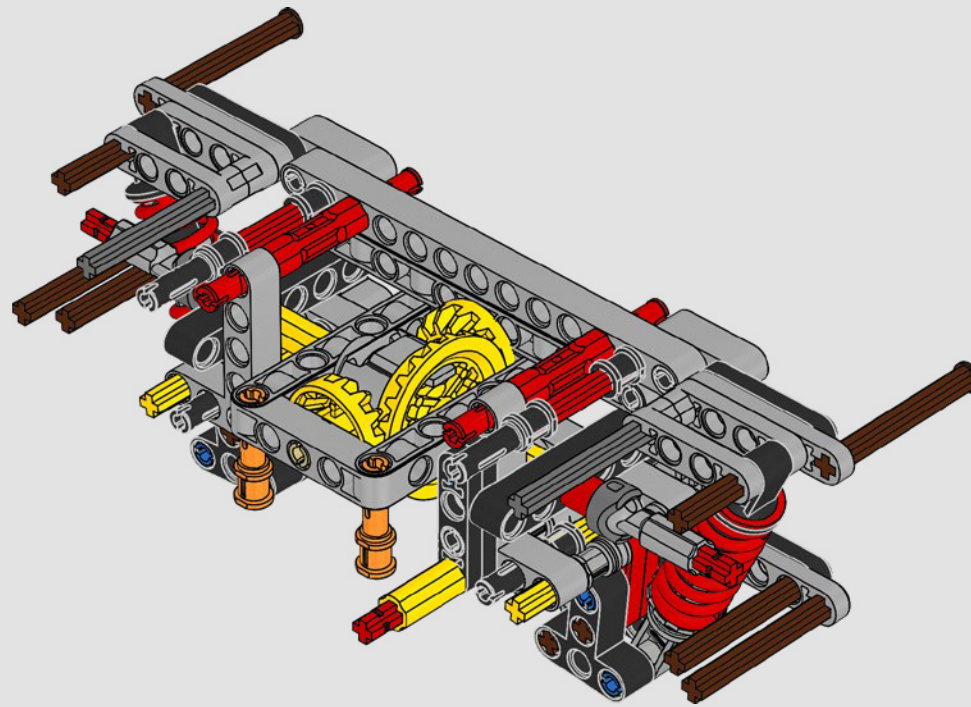



142

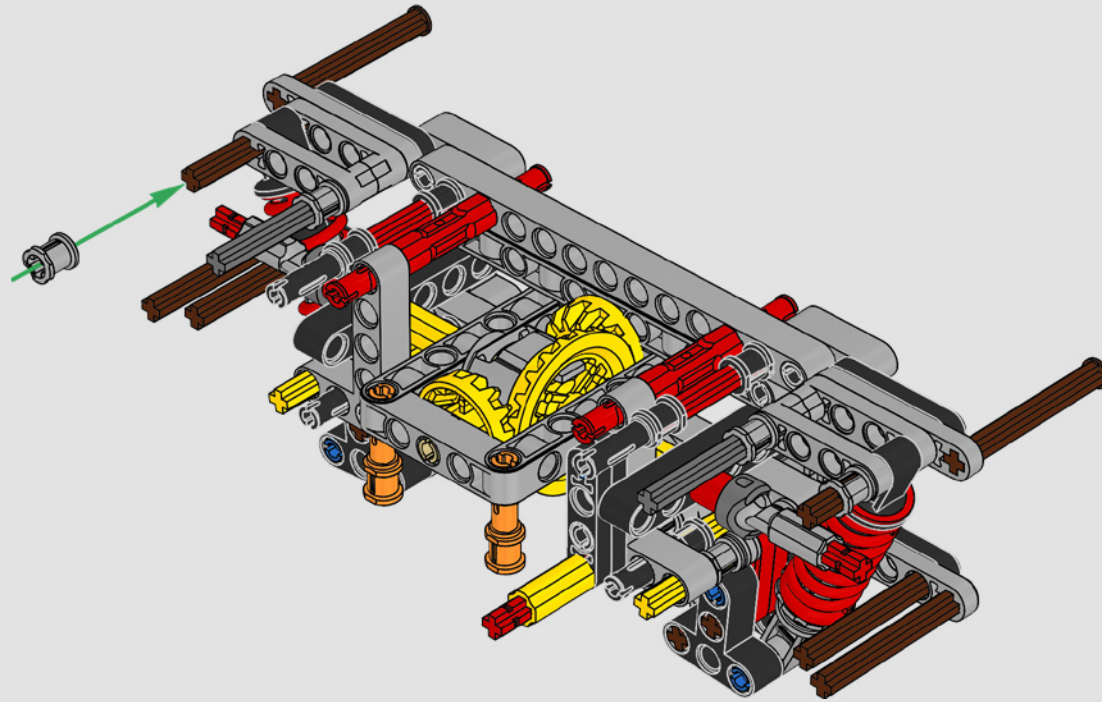

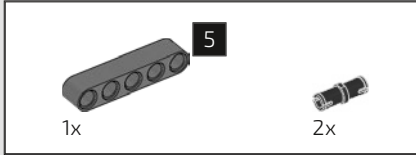
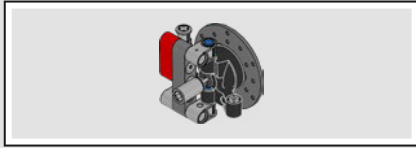

143

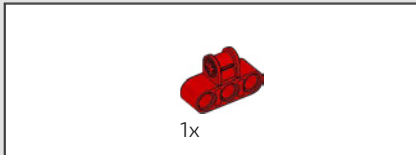
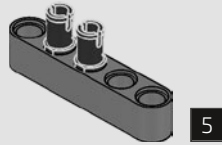

144

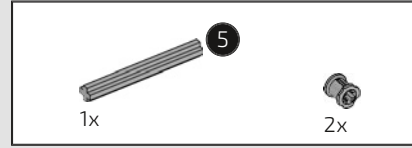
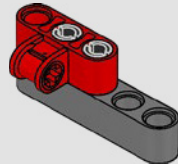

145

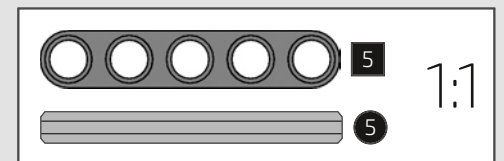
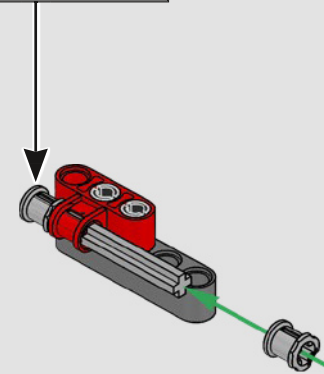
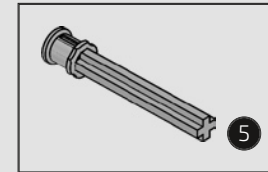

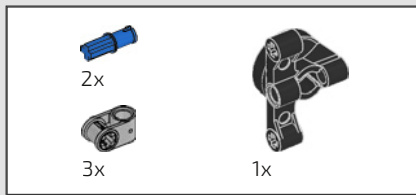

146

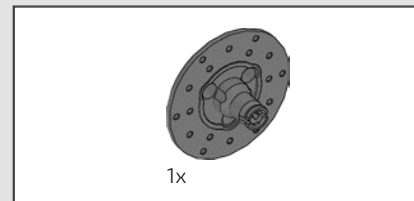
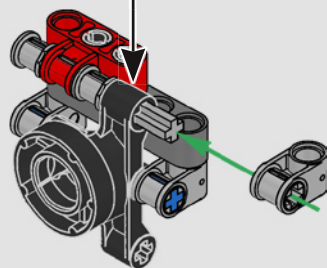
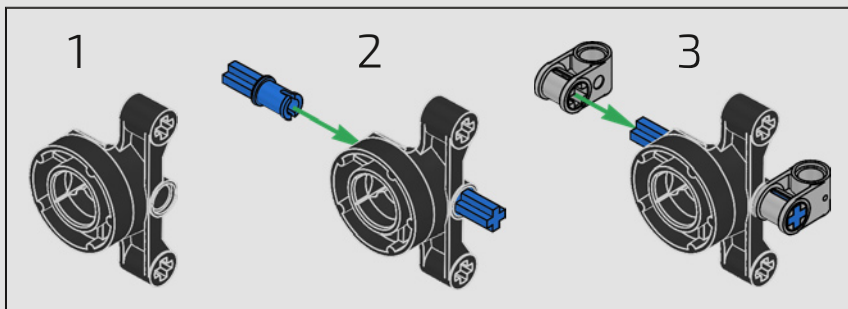

147

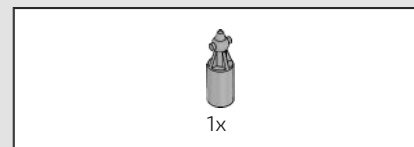
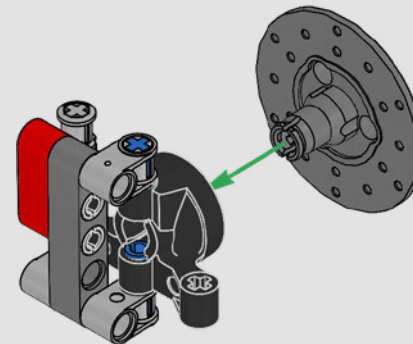

148

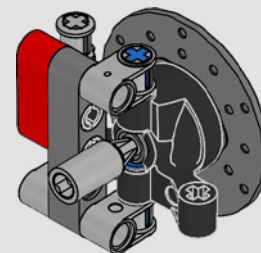

149

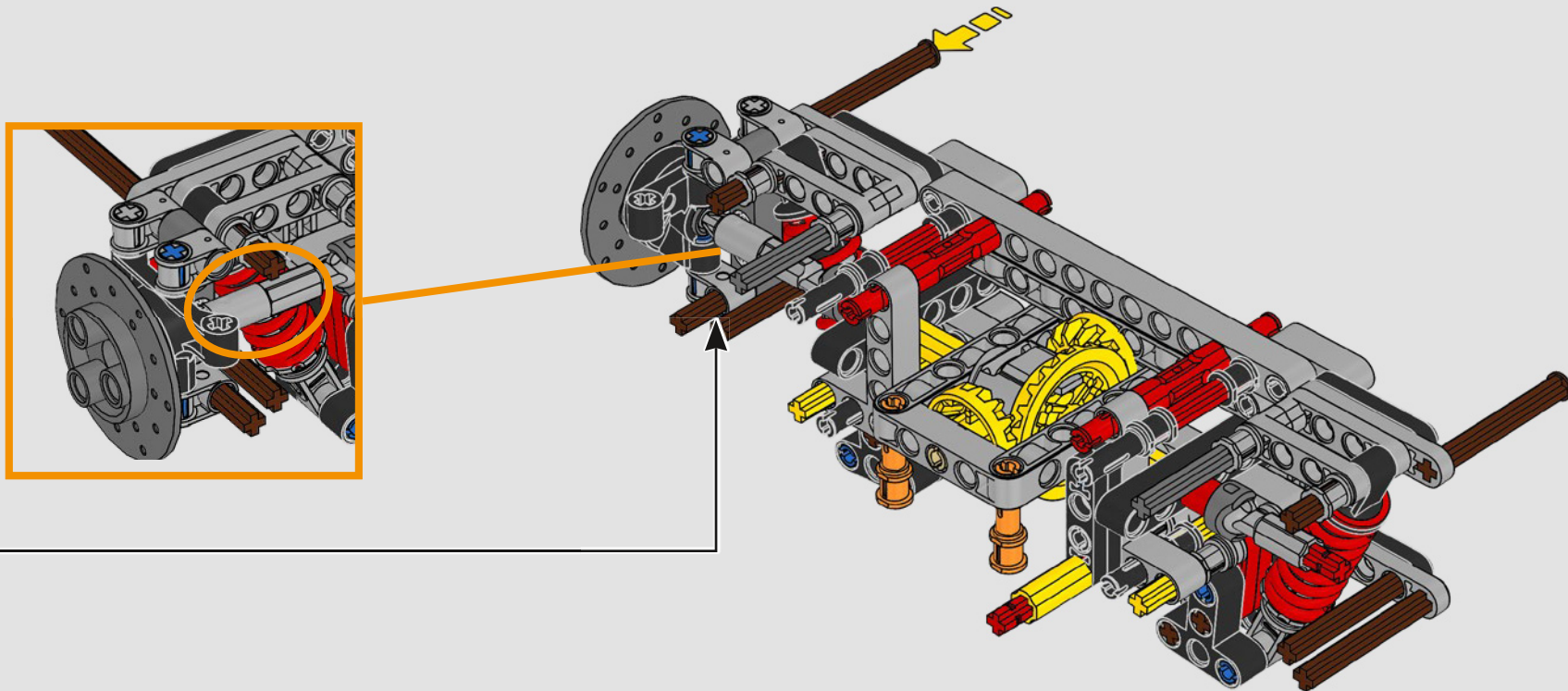

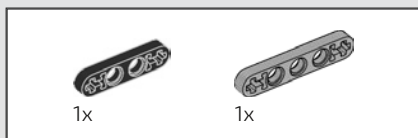

150

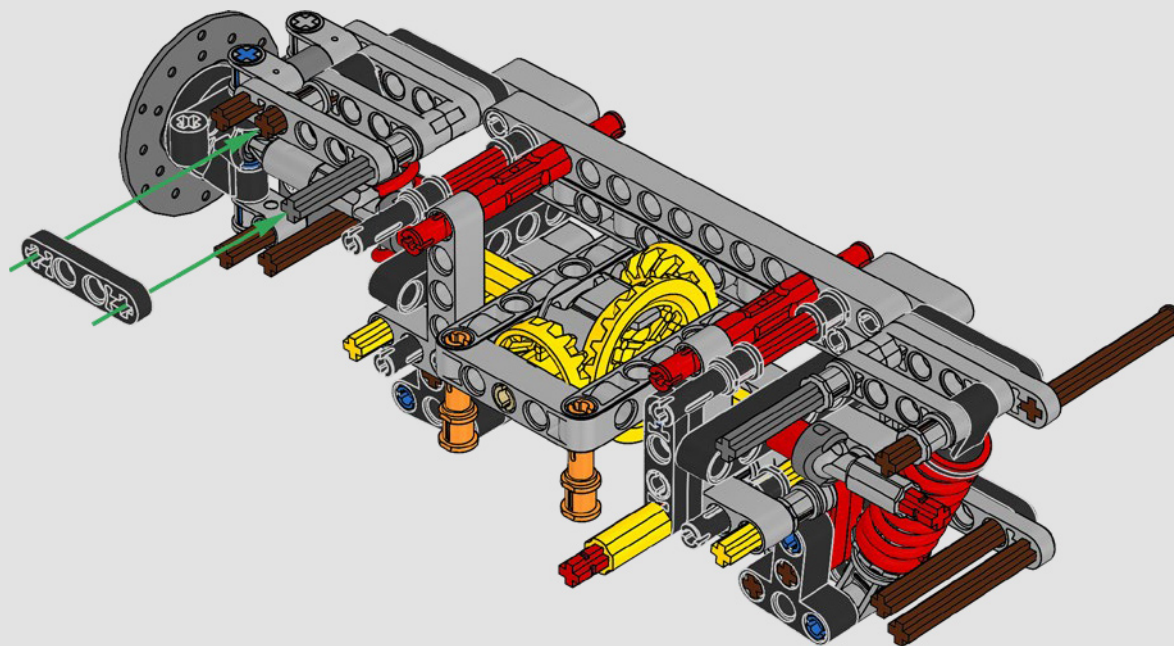



151

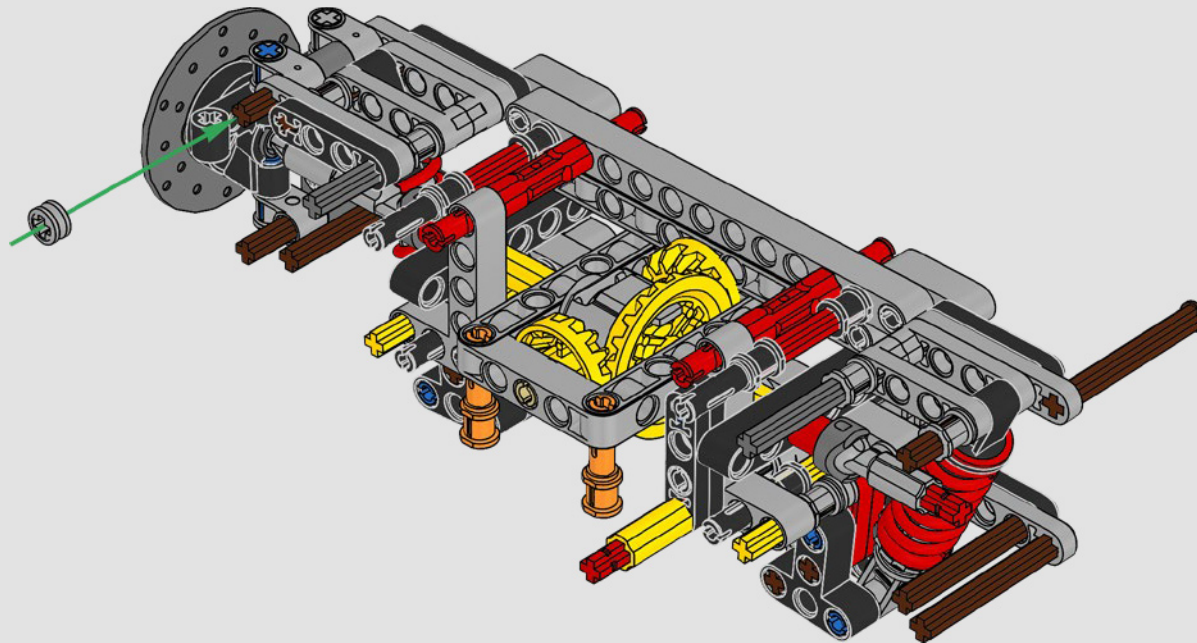



152

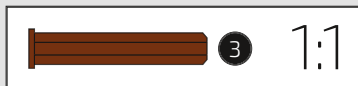
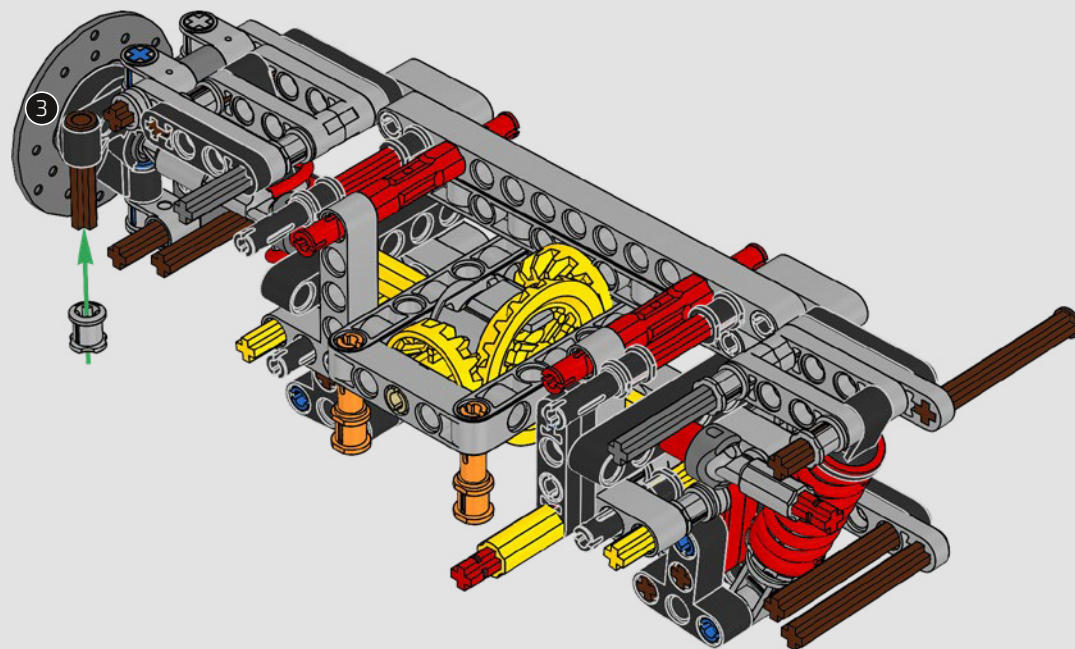

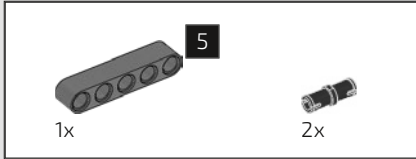
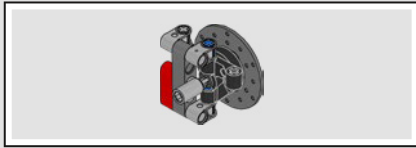

153

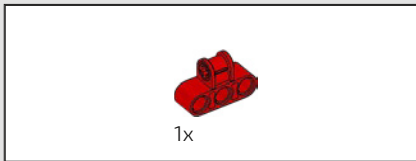
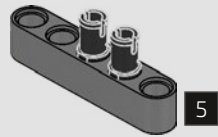

154

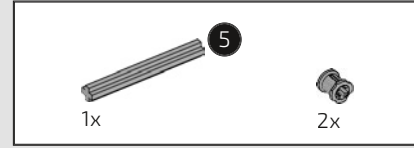
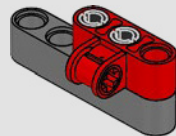

155

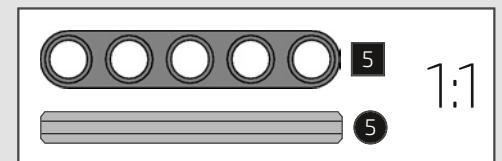
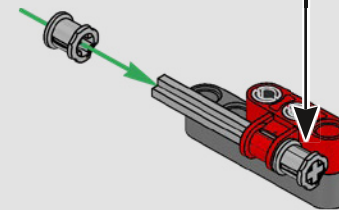
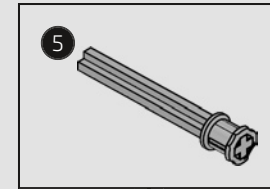

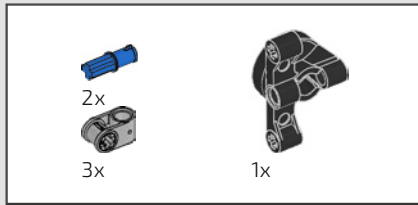

156

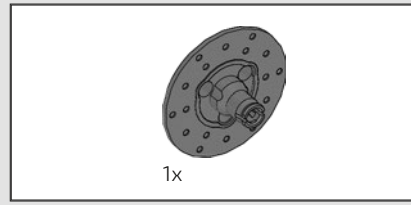
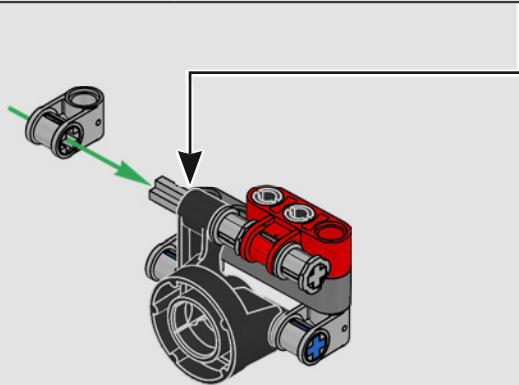
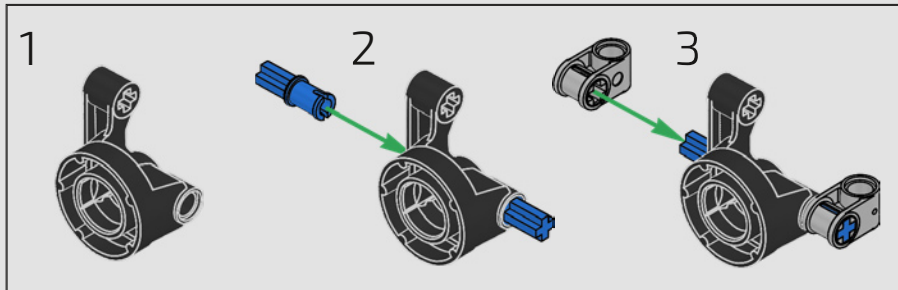

157

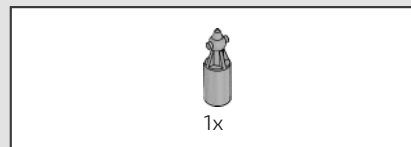
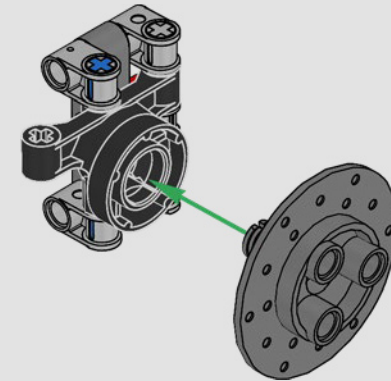

158

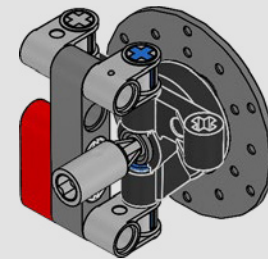

159

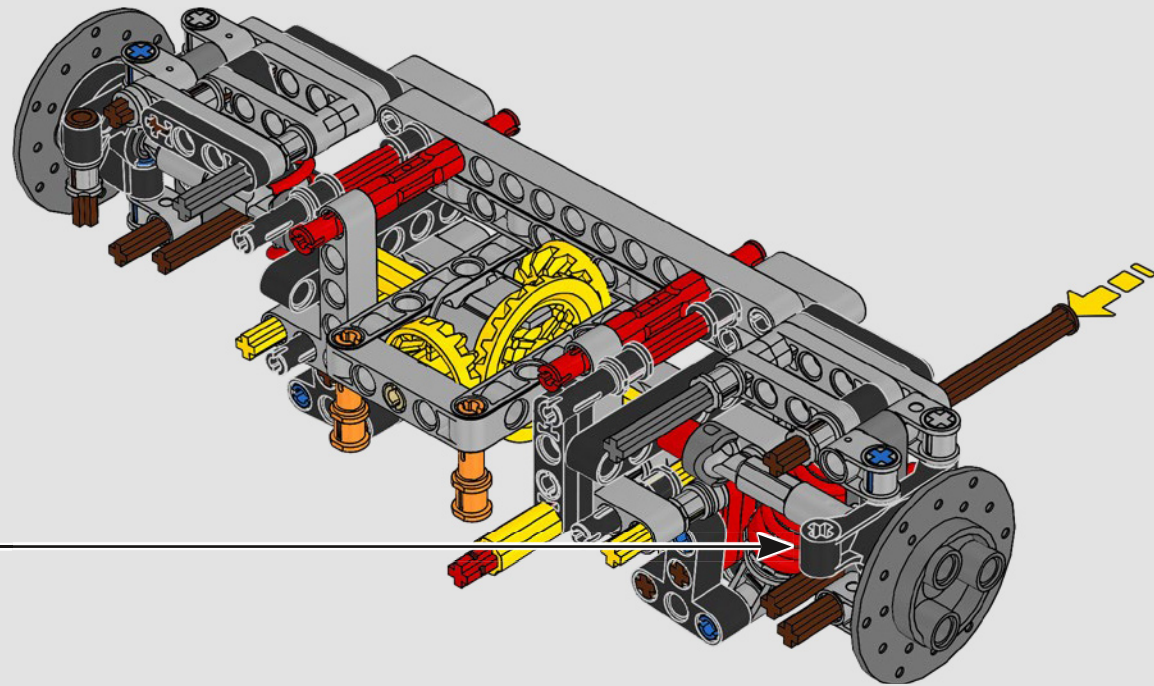

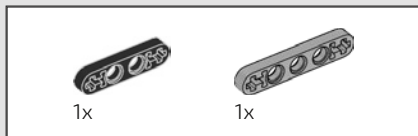

160

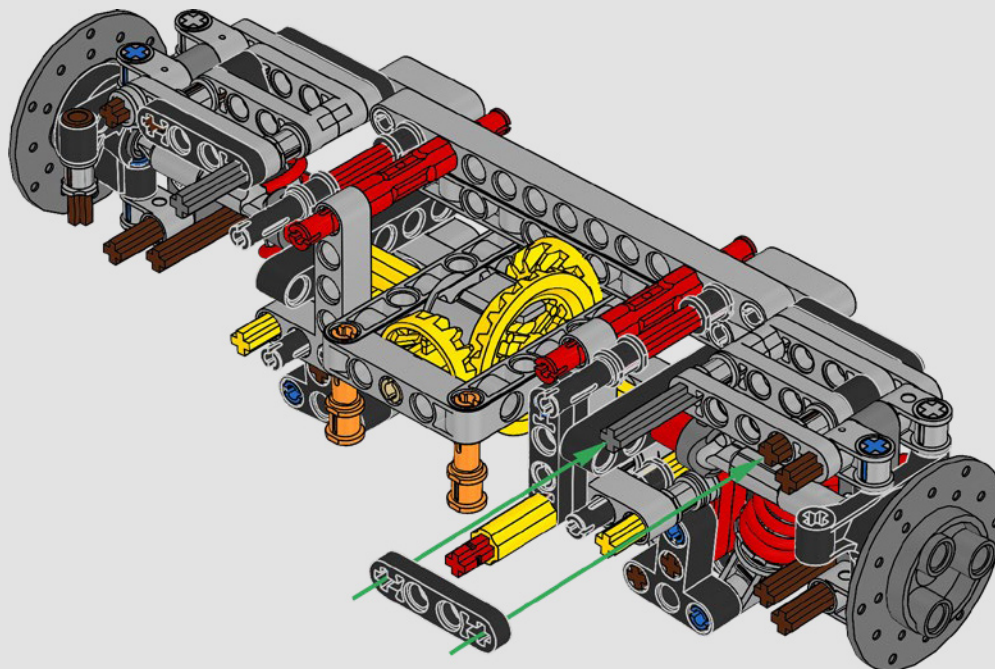



161

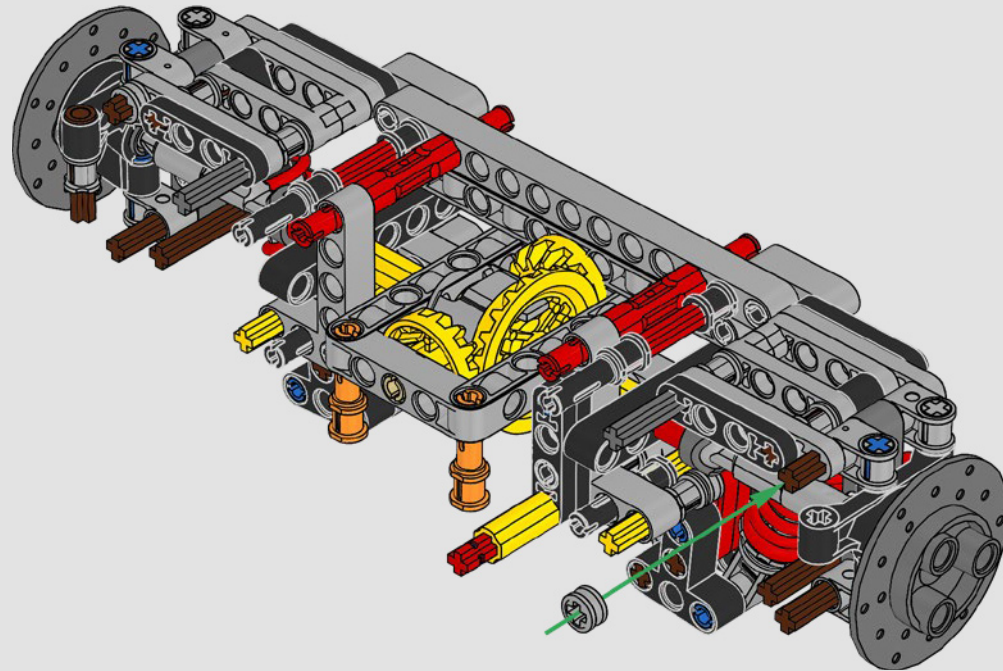



162

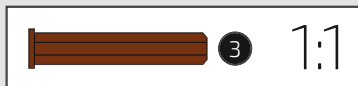
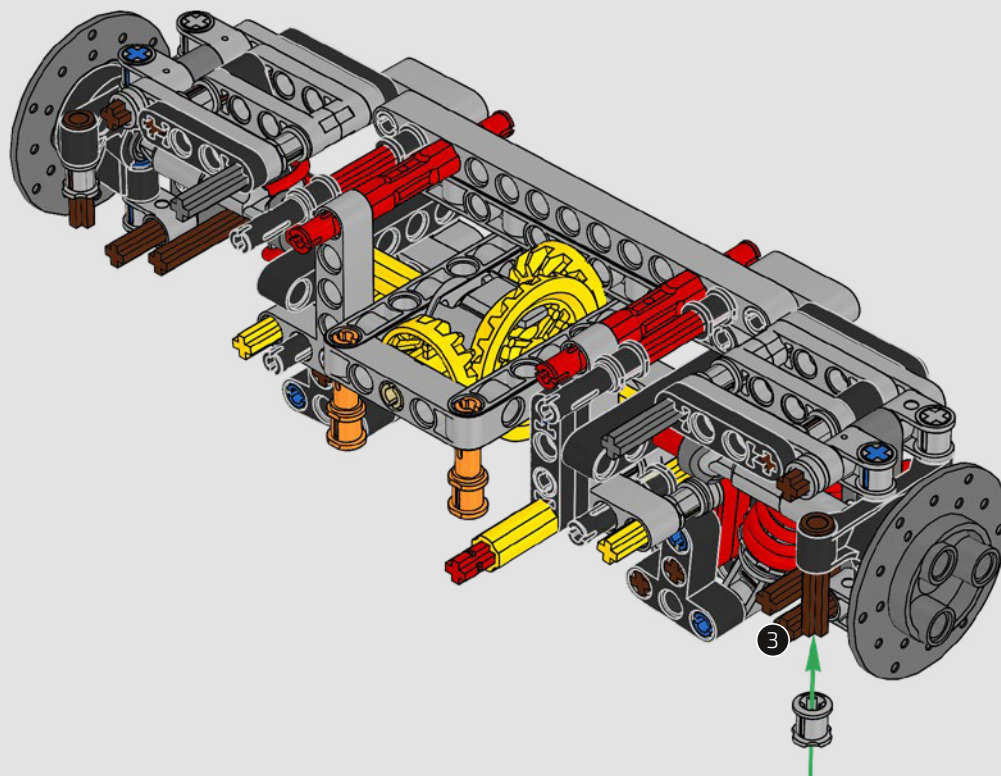

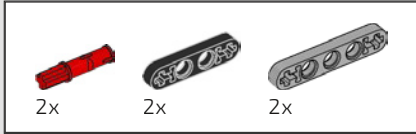

163

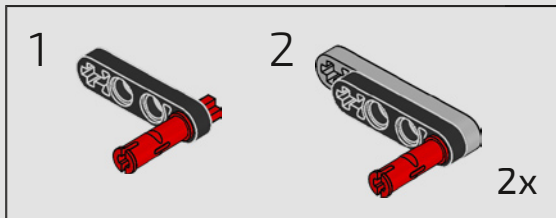
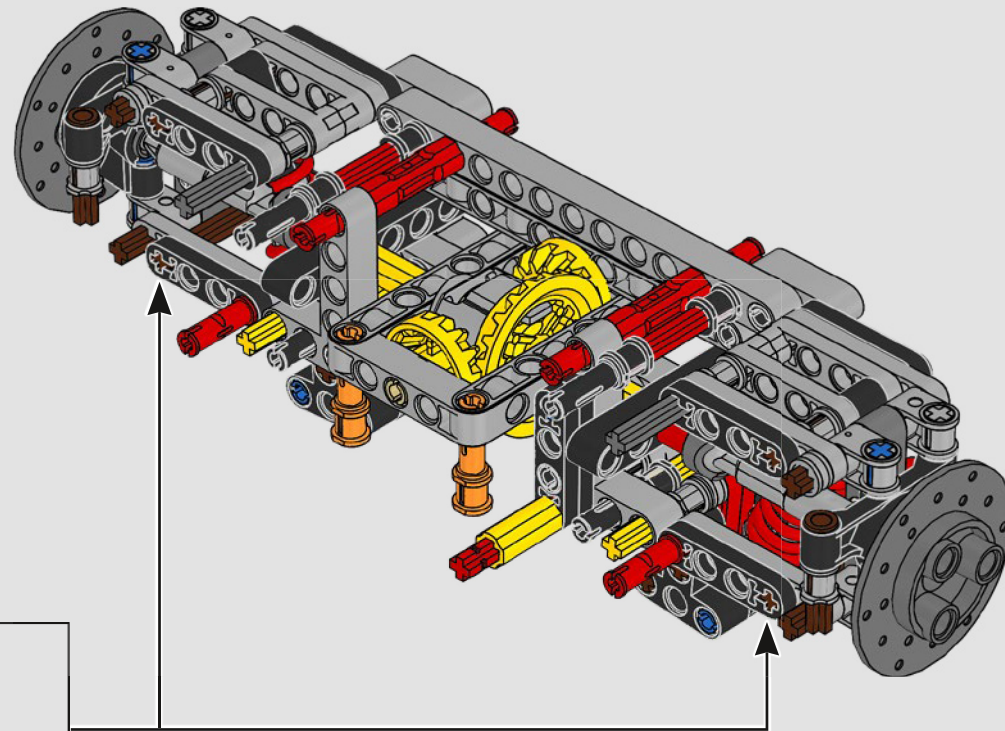

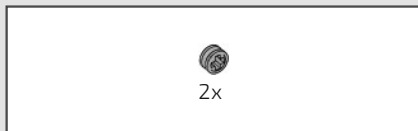

164

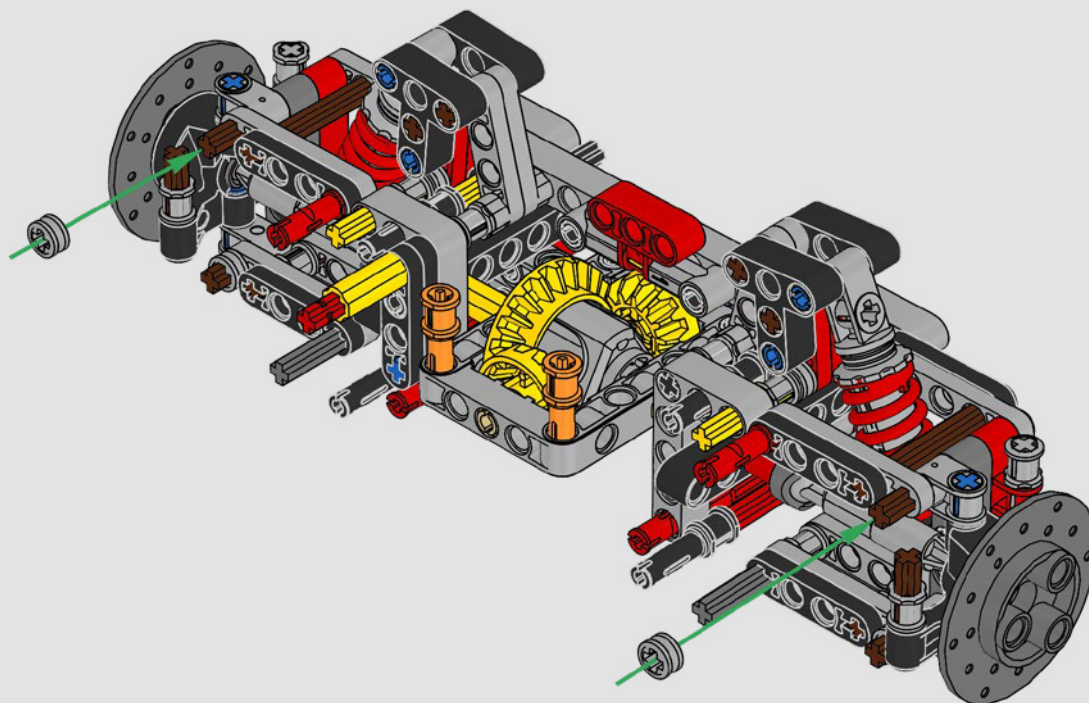



165

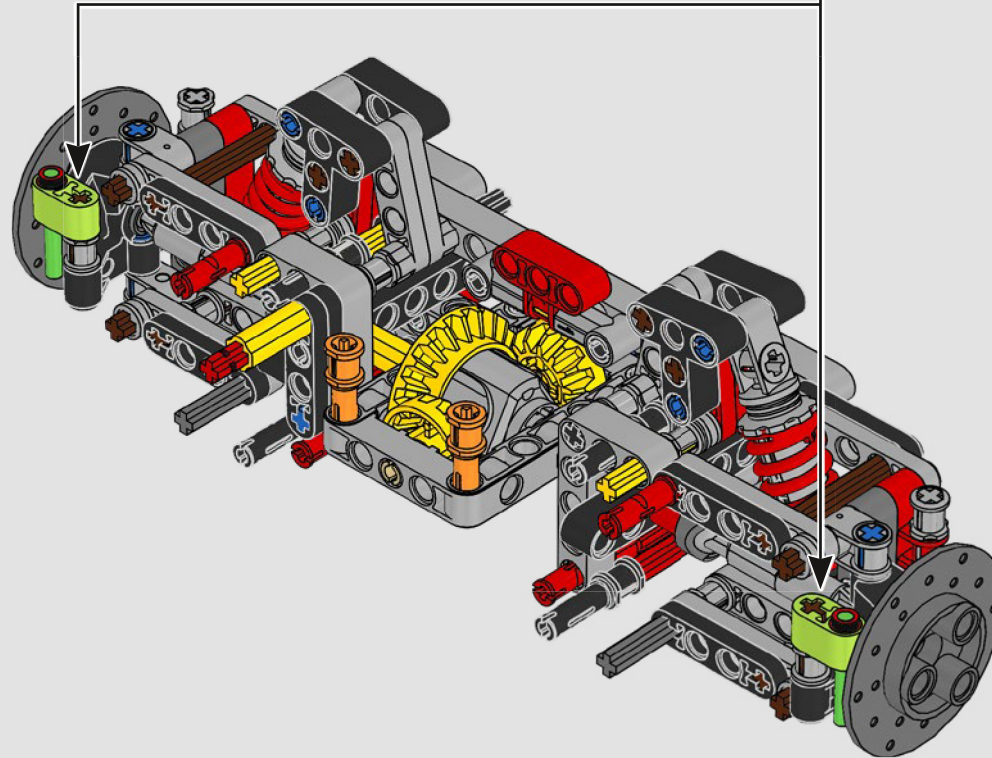
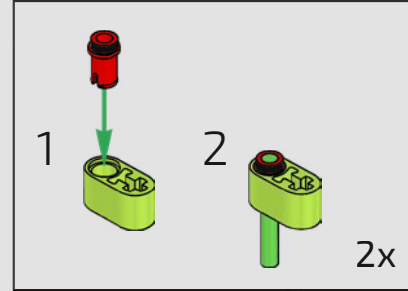

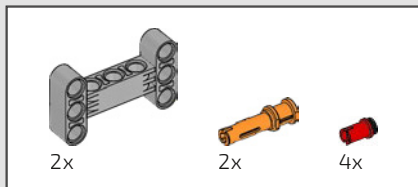

166

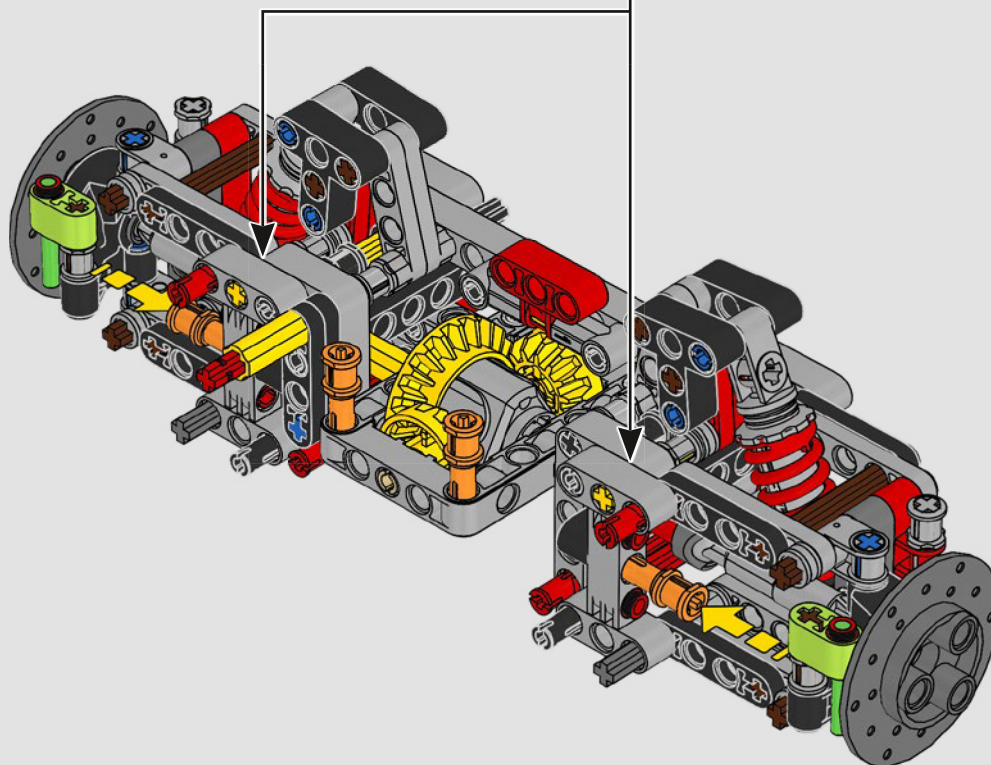
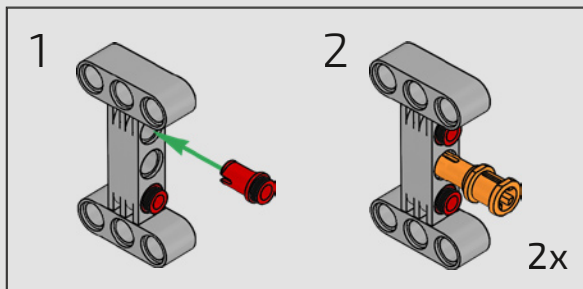

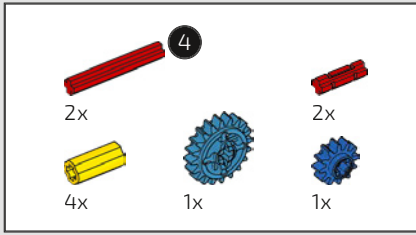

167

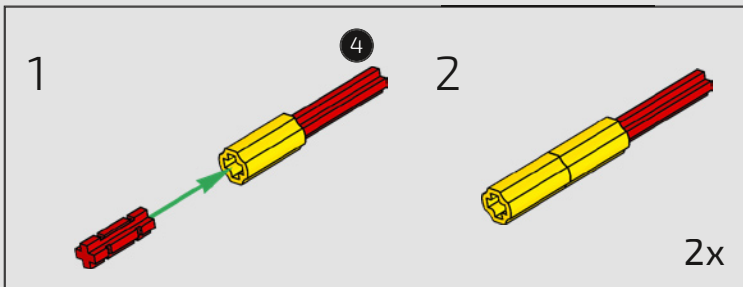
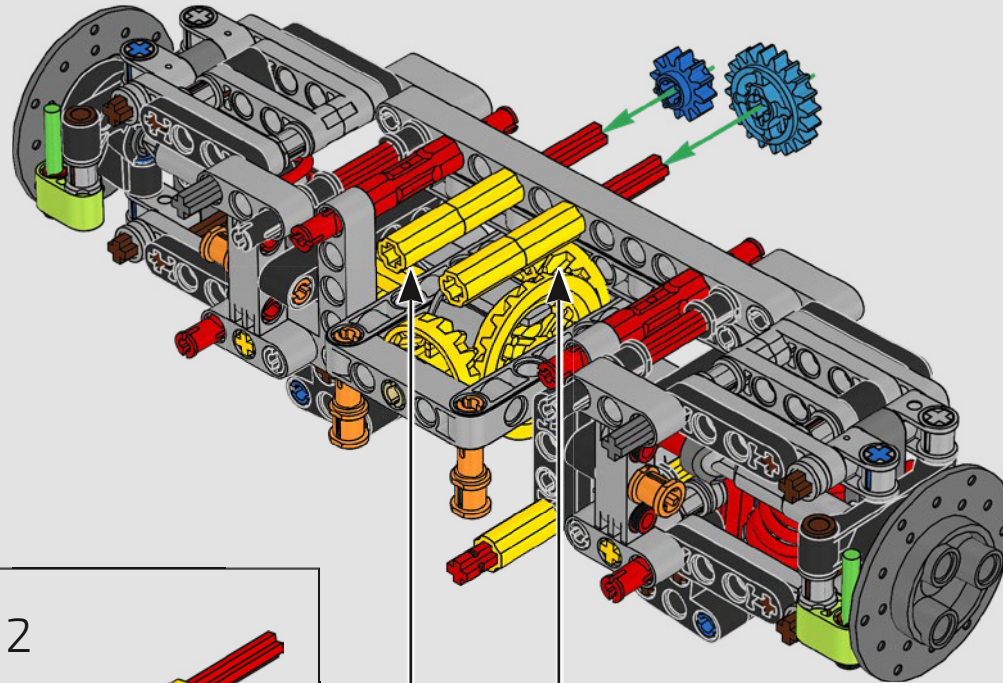

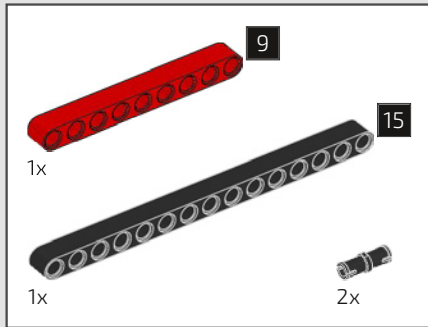

168

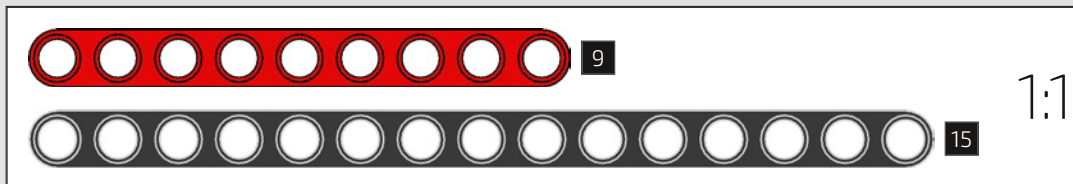
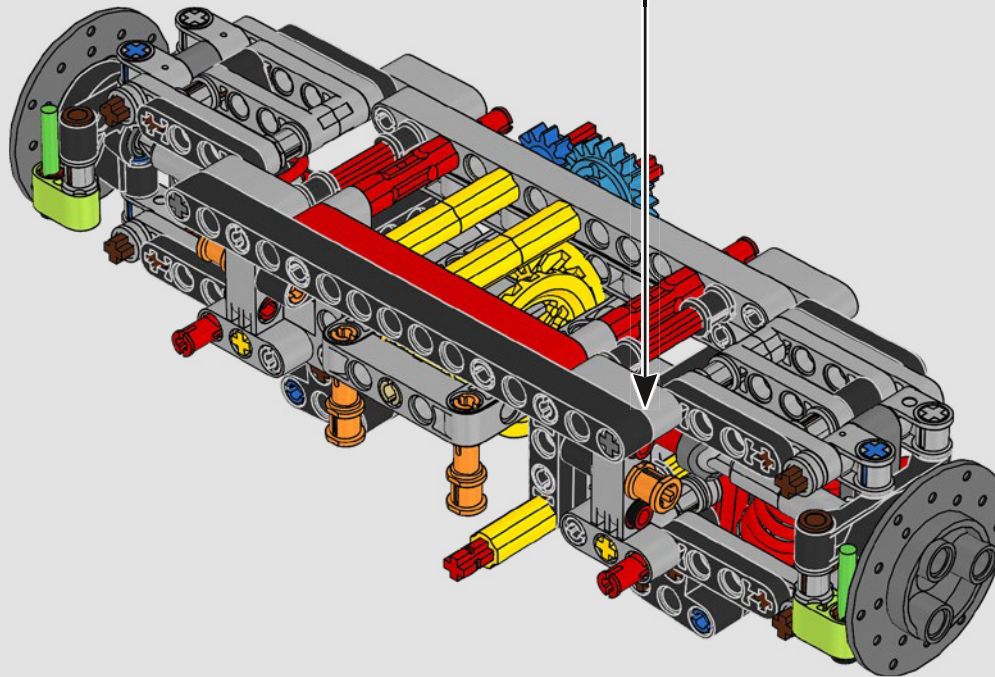
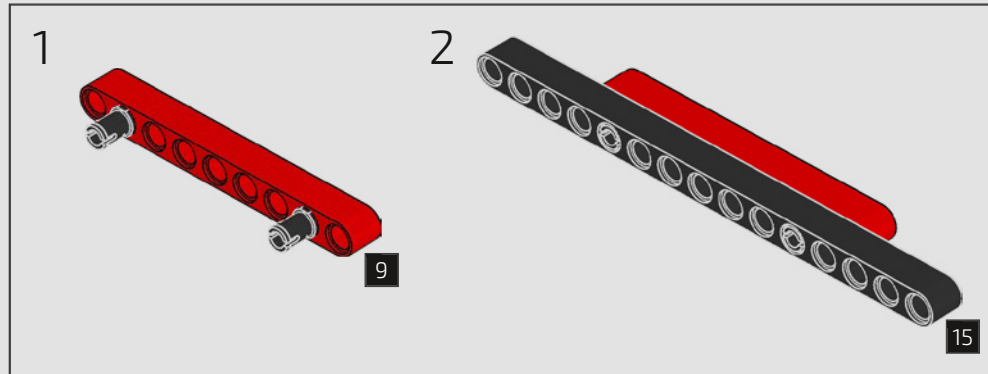

169

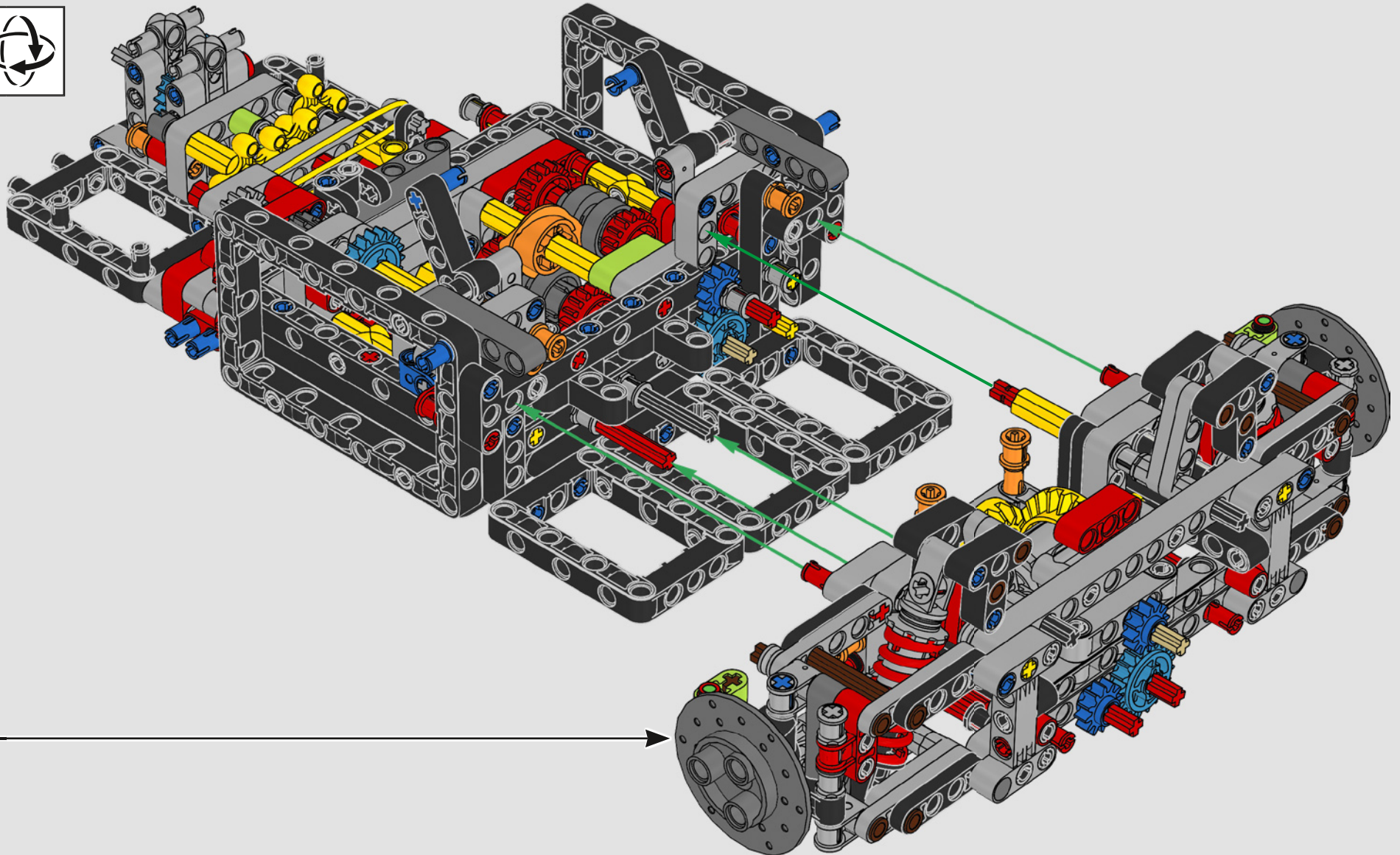

170

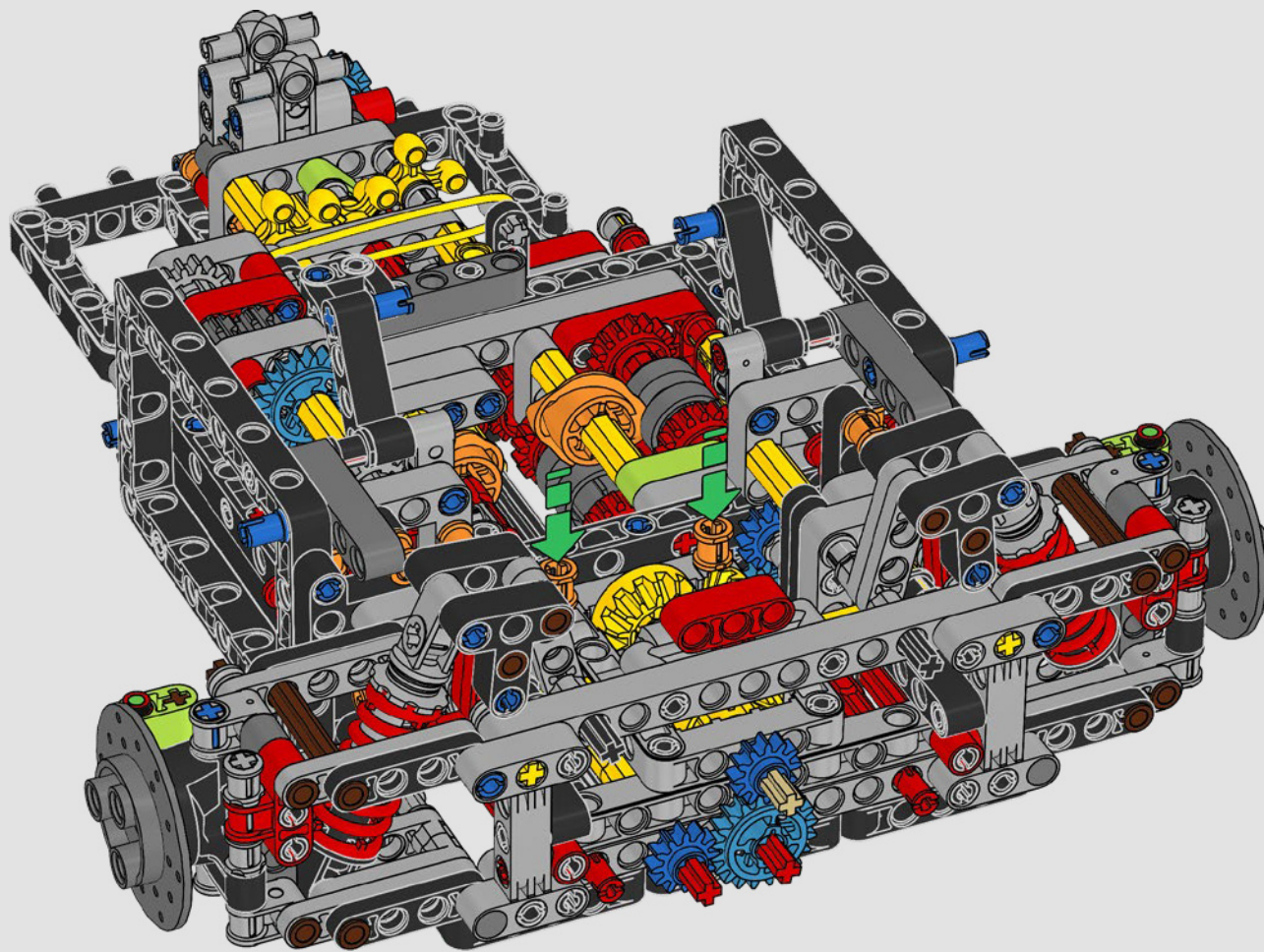



171

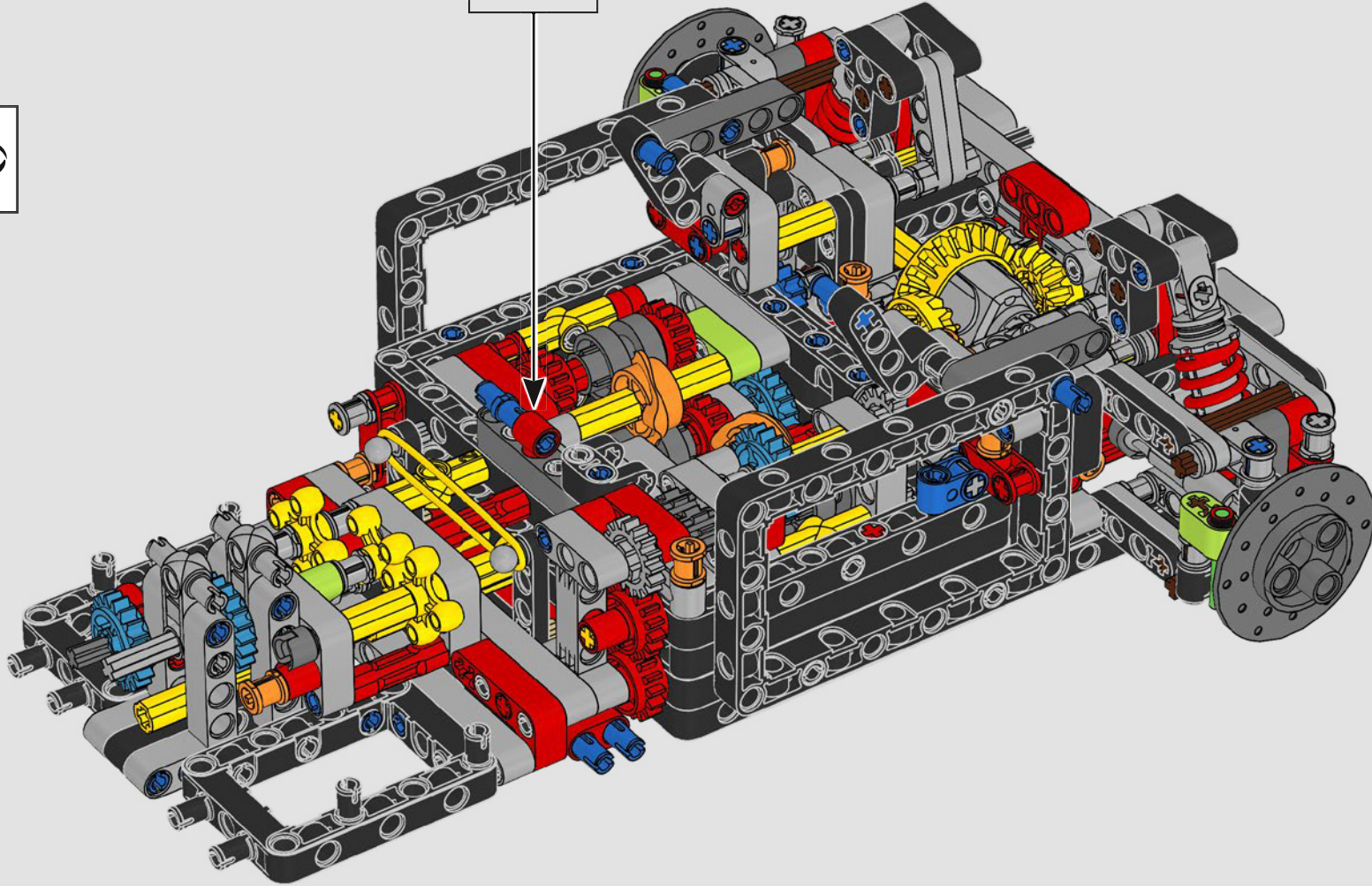
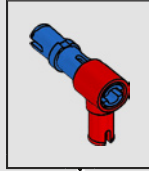

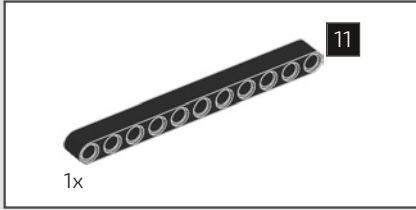

172

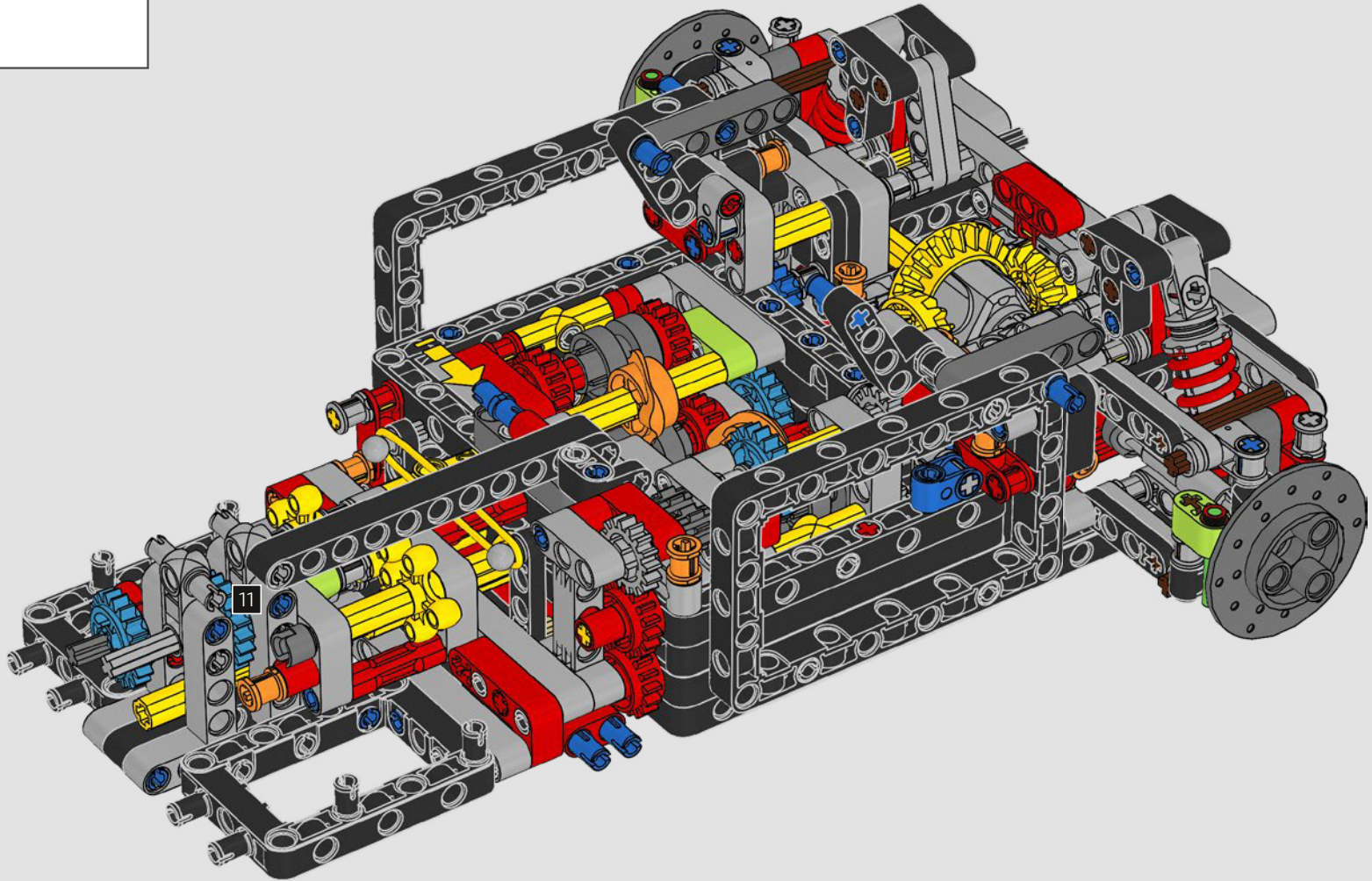

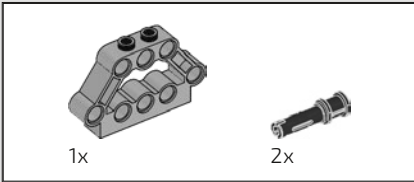
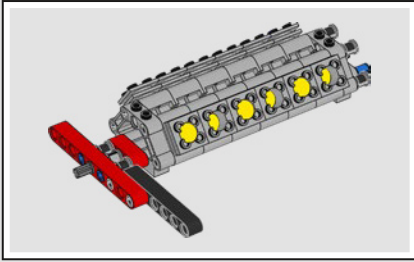

173

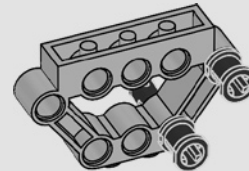

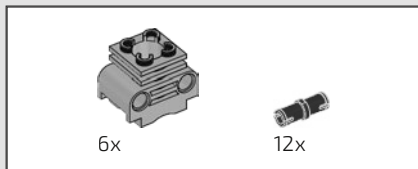

174

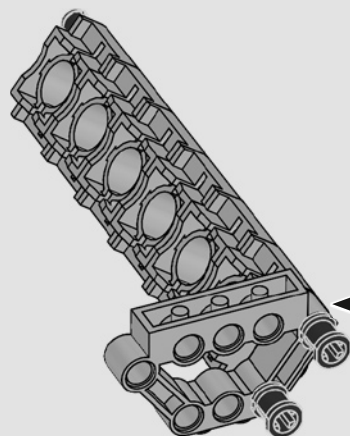
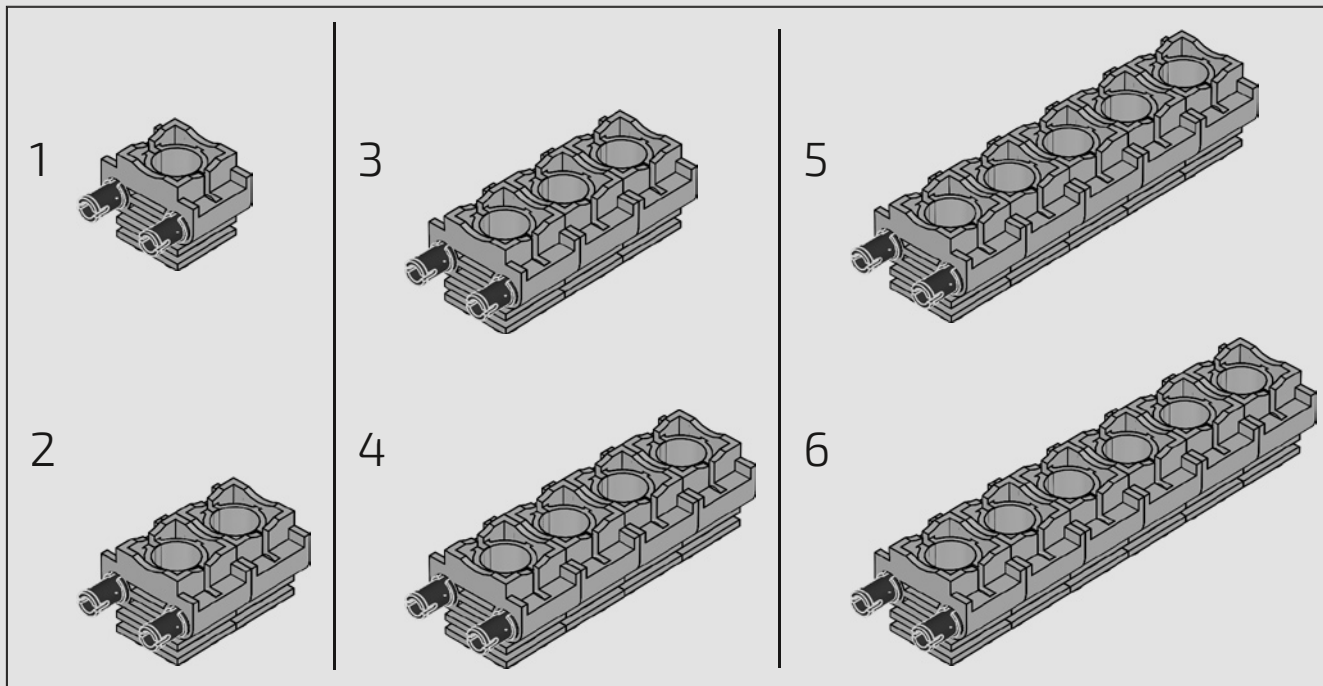

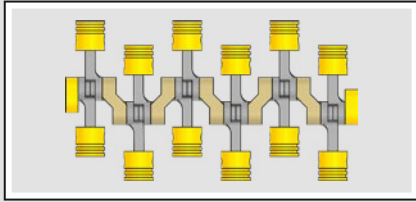

175

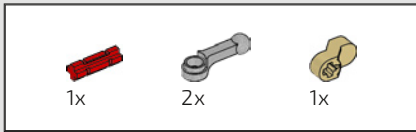
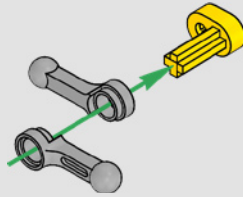

176

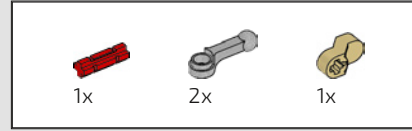
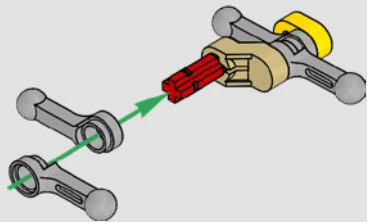

177

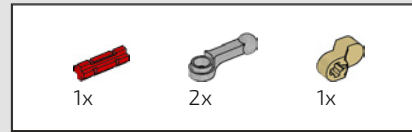
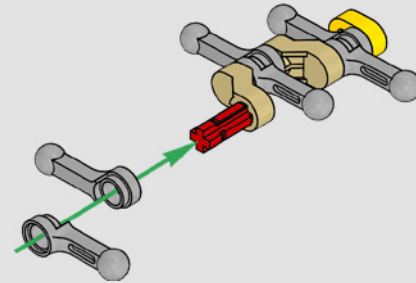

178

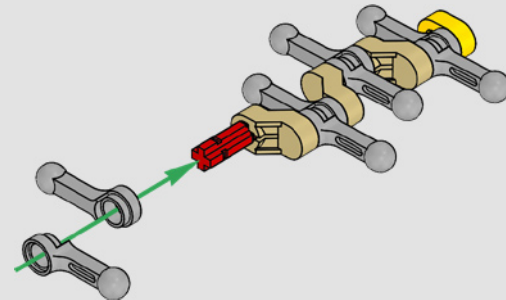

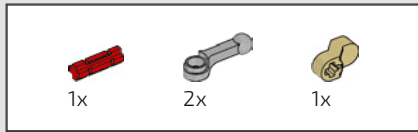

179

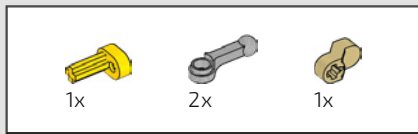
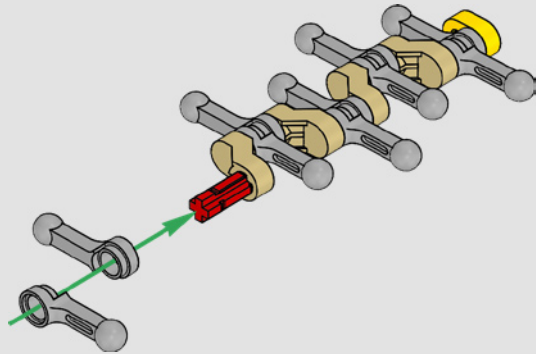

180

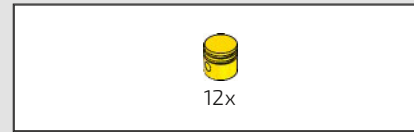
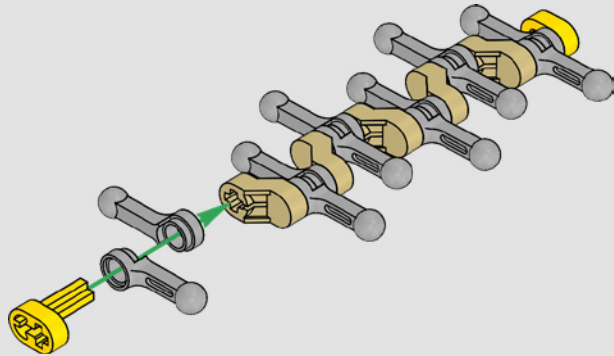

181

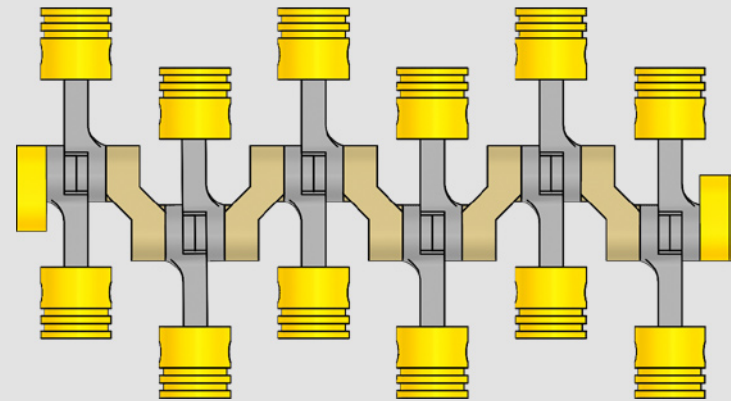

1:1

182

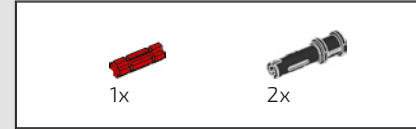
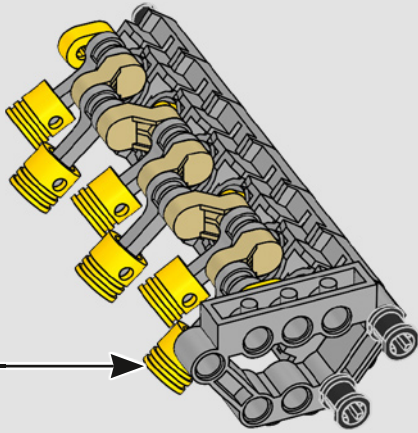

183

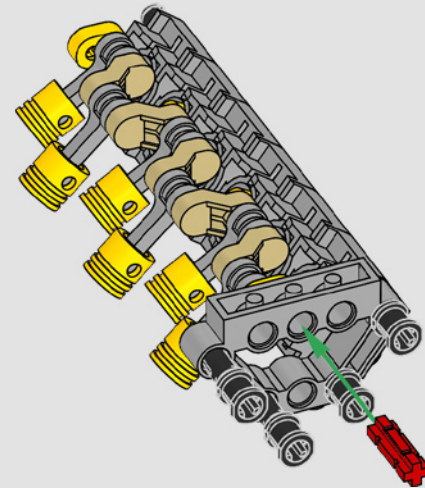

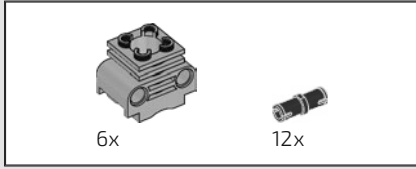

184

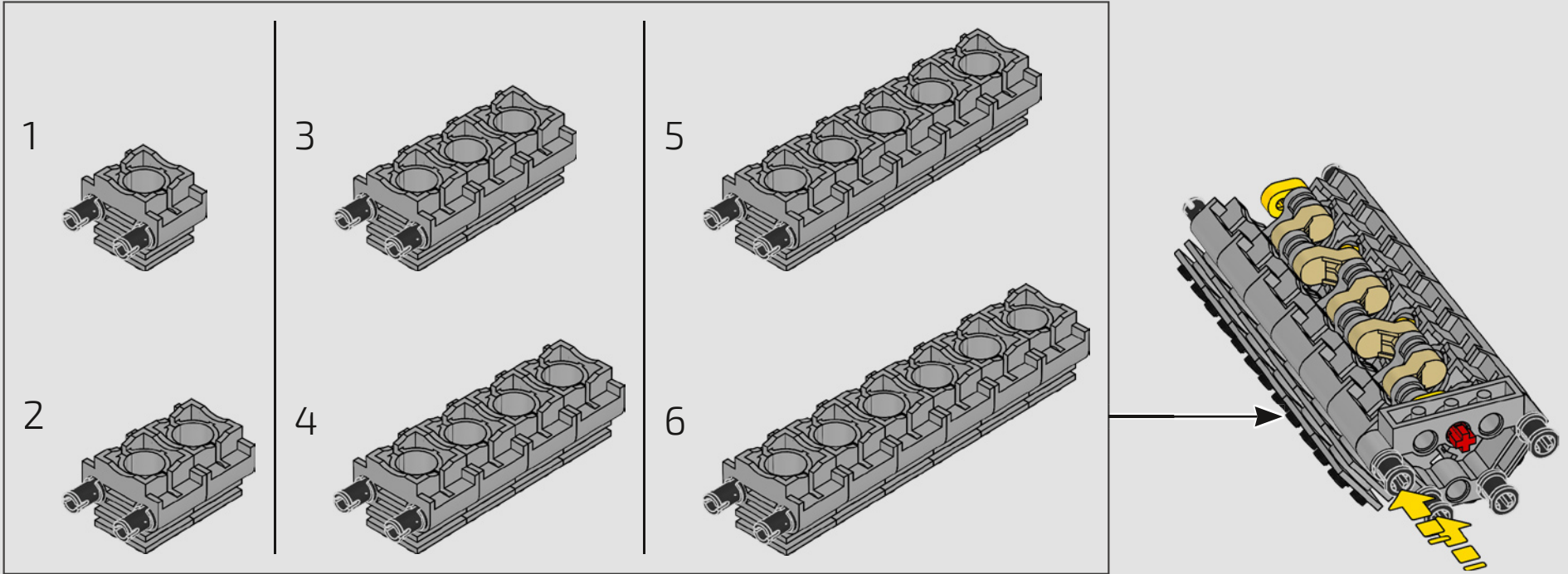

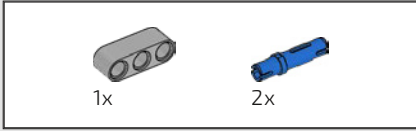

185

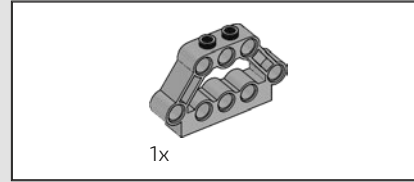
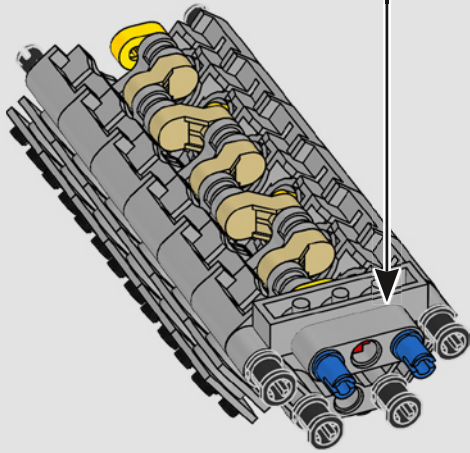
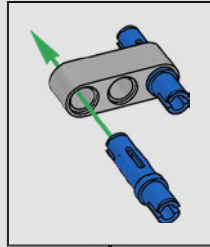

186

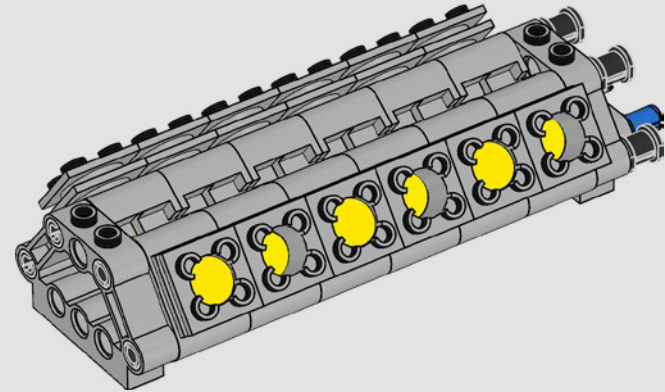

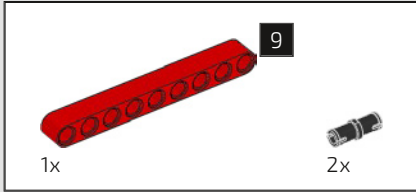
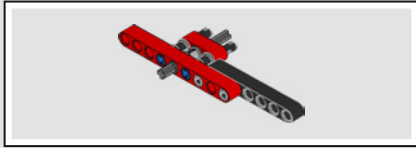

187

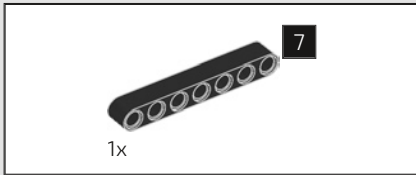
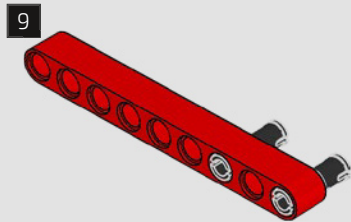

188

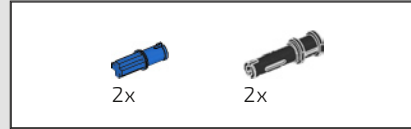
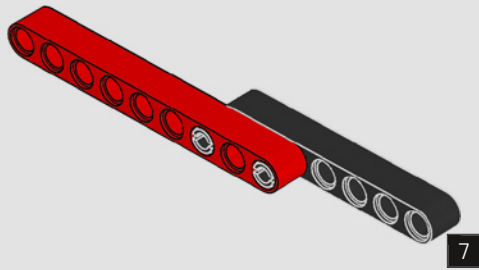

189

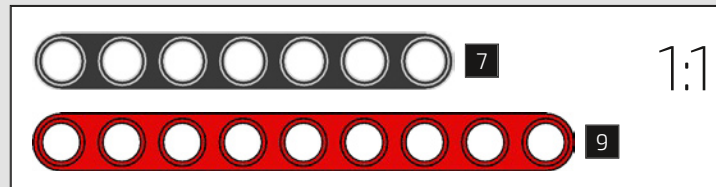
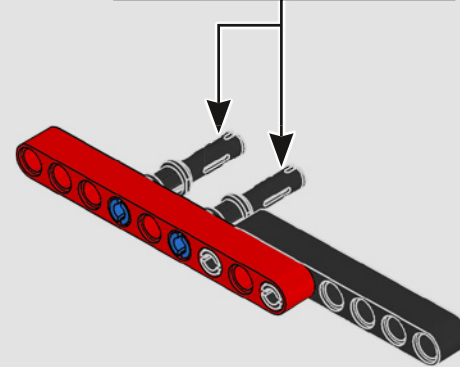
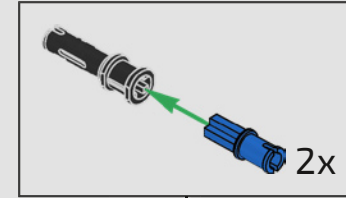

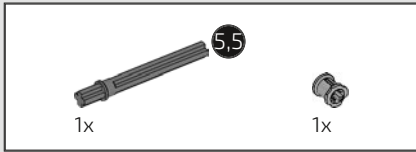

190

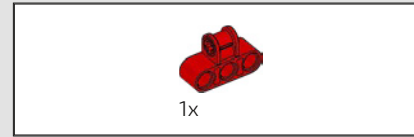
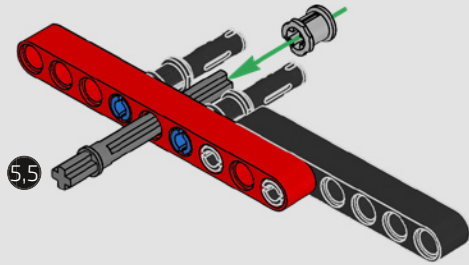

191

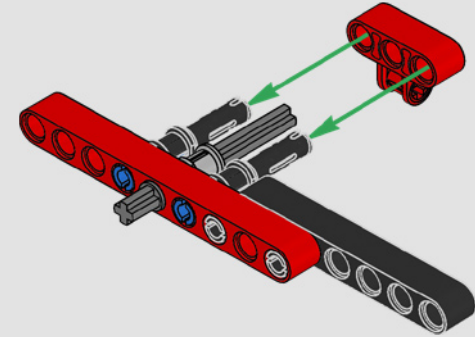

192

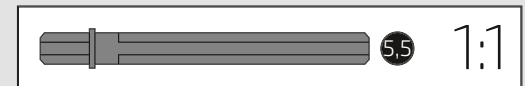
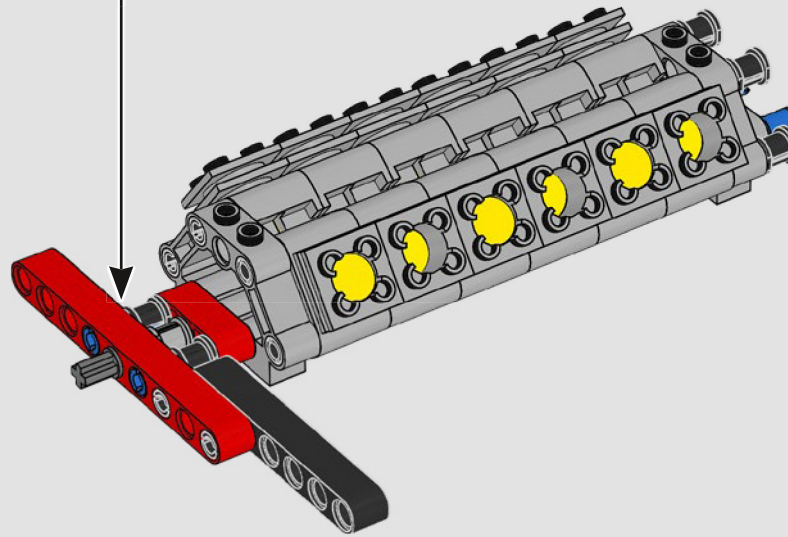

193

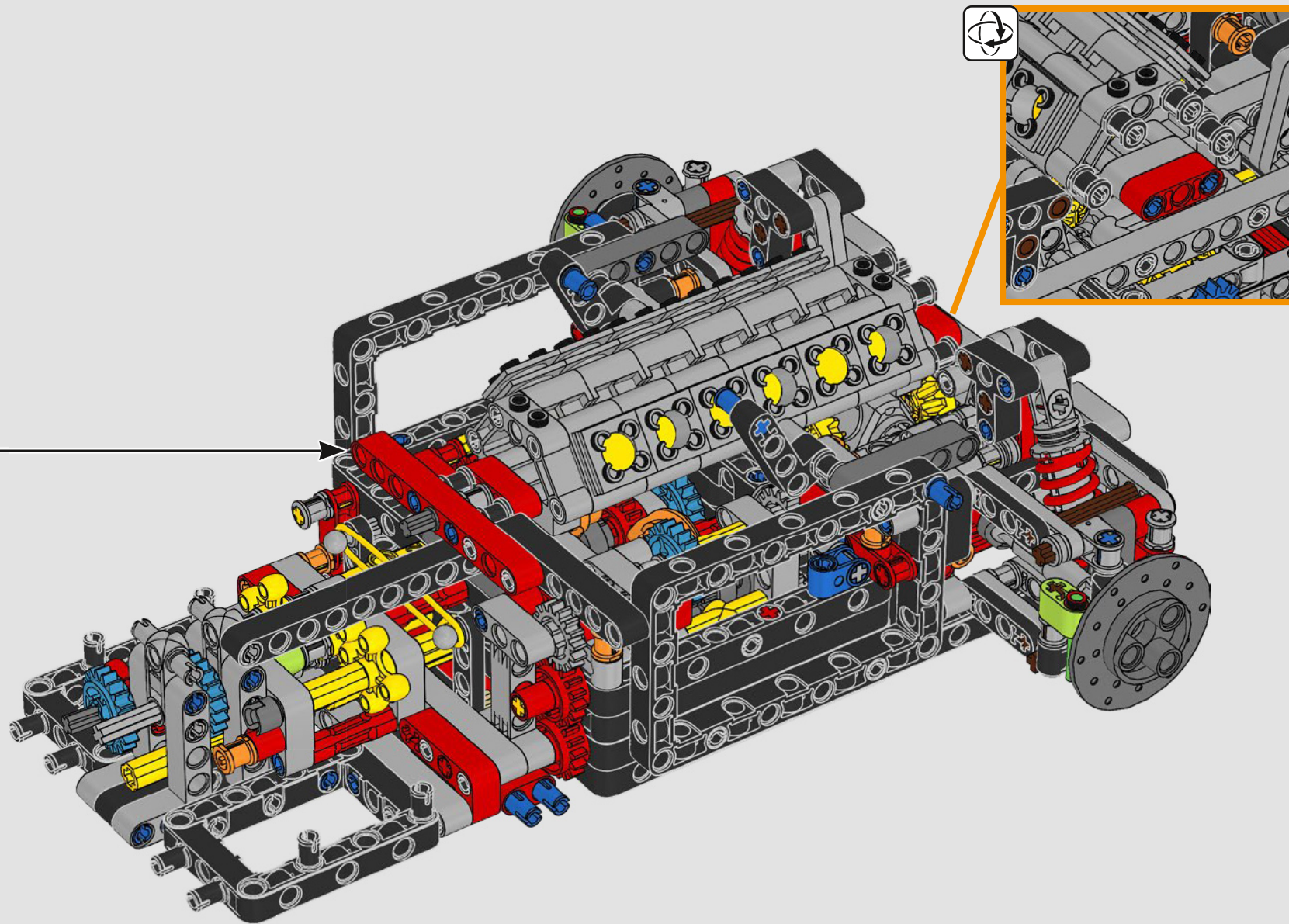

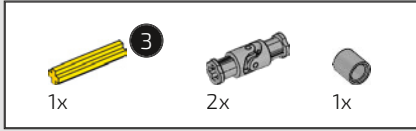

194

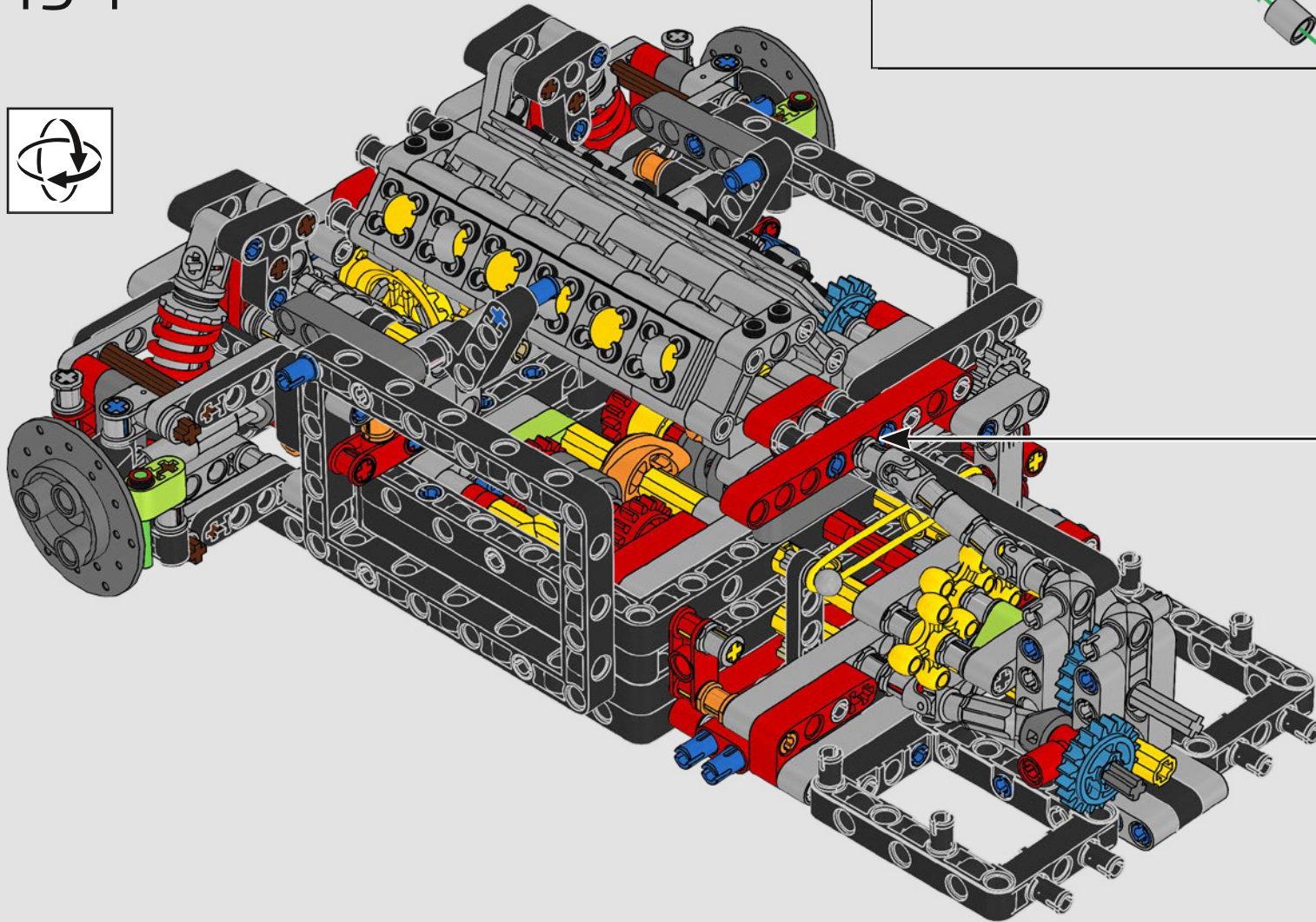
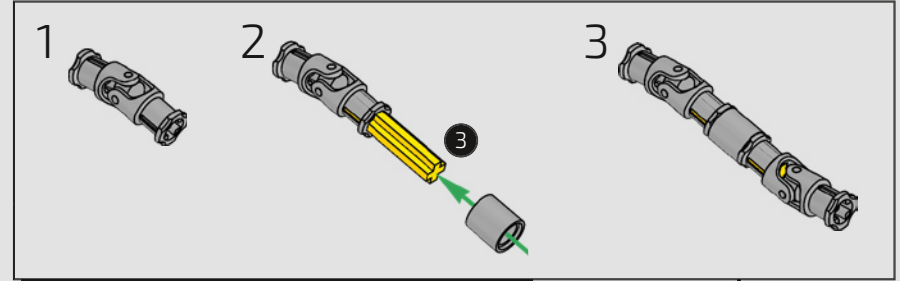

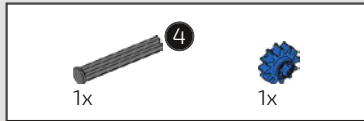

195

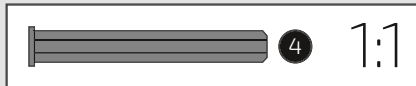
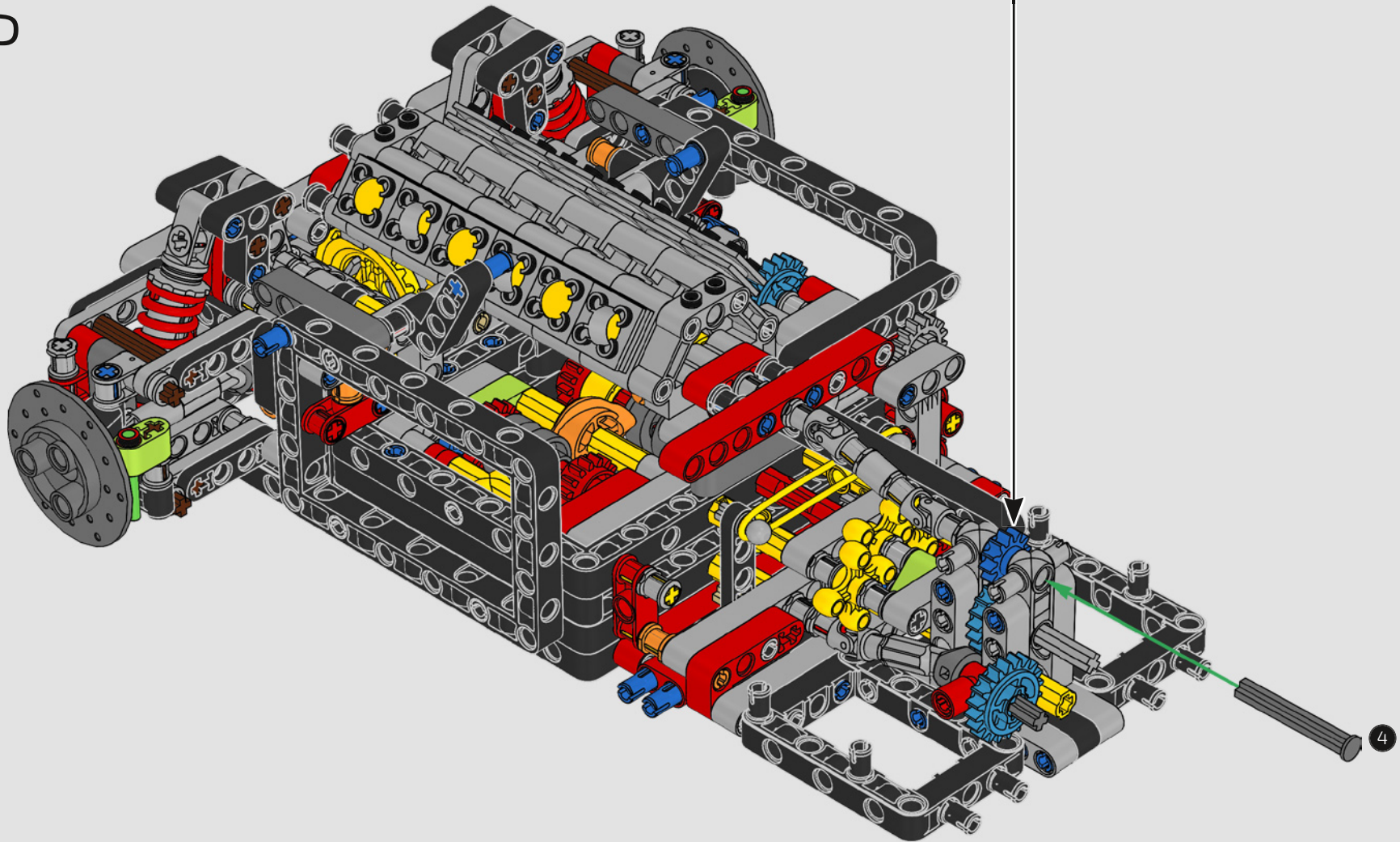
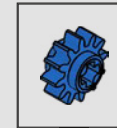

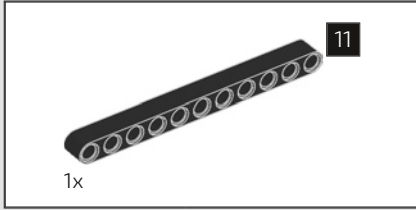

196

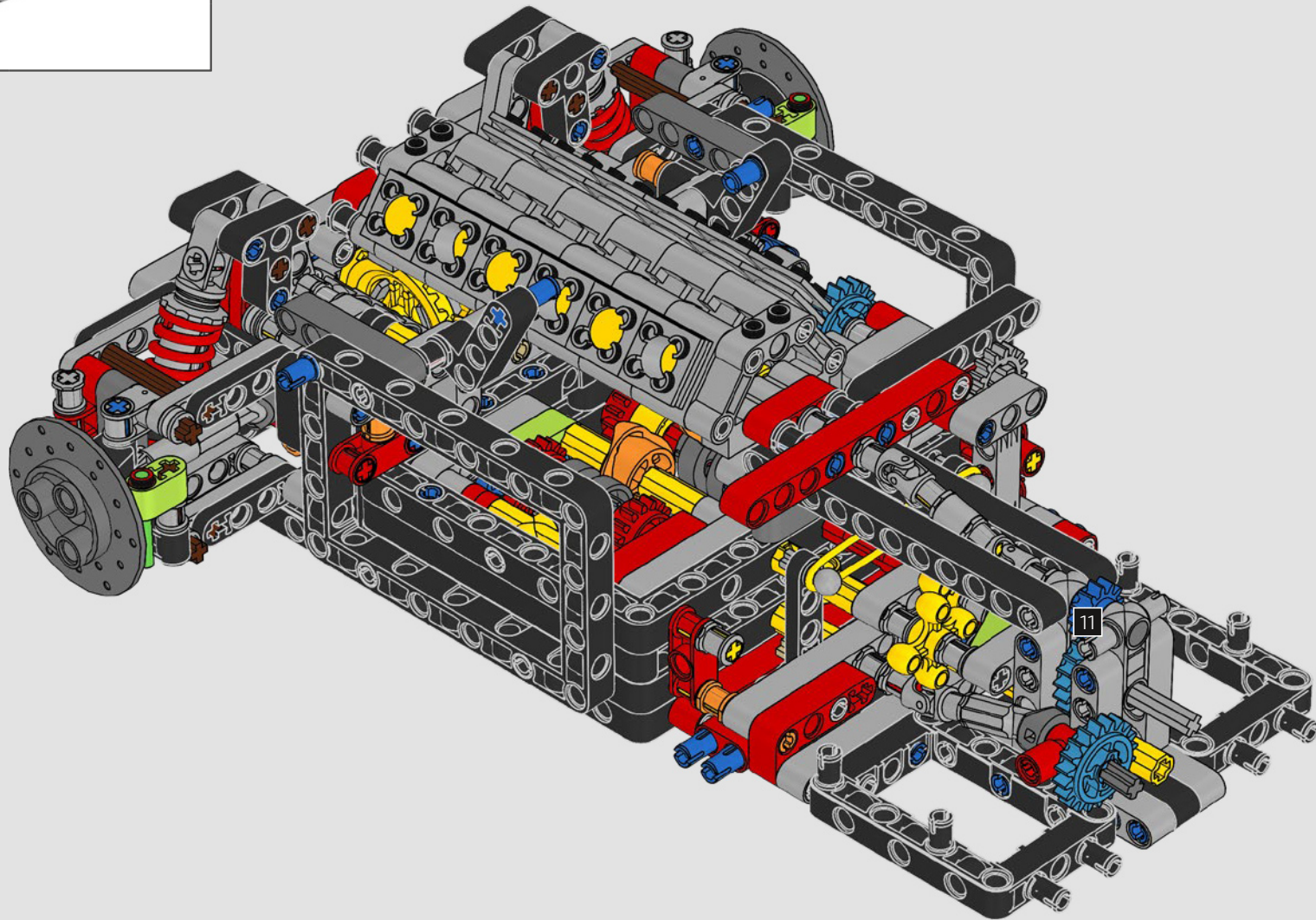

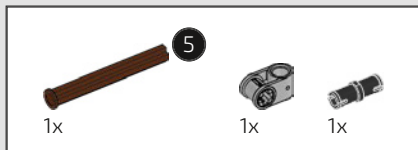

197

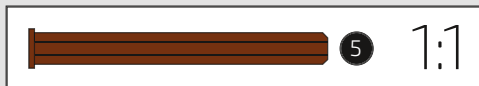
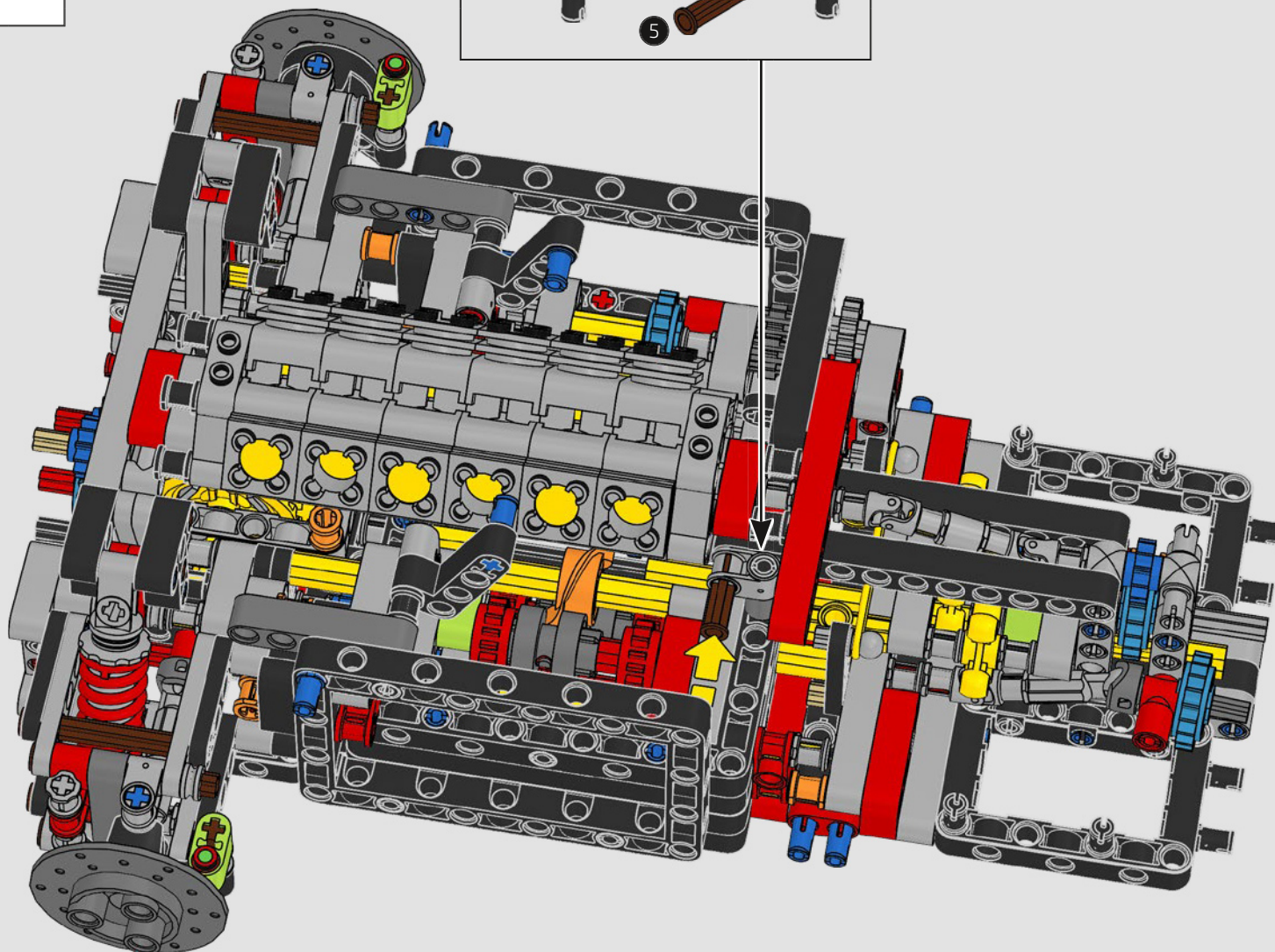
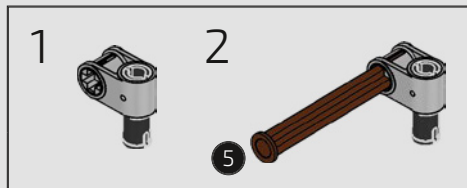

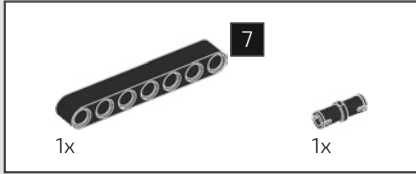

198

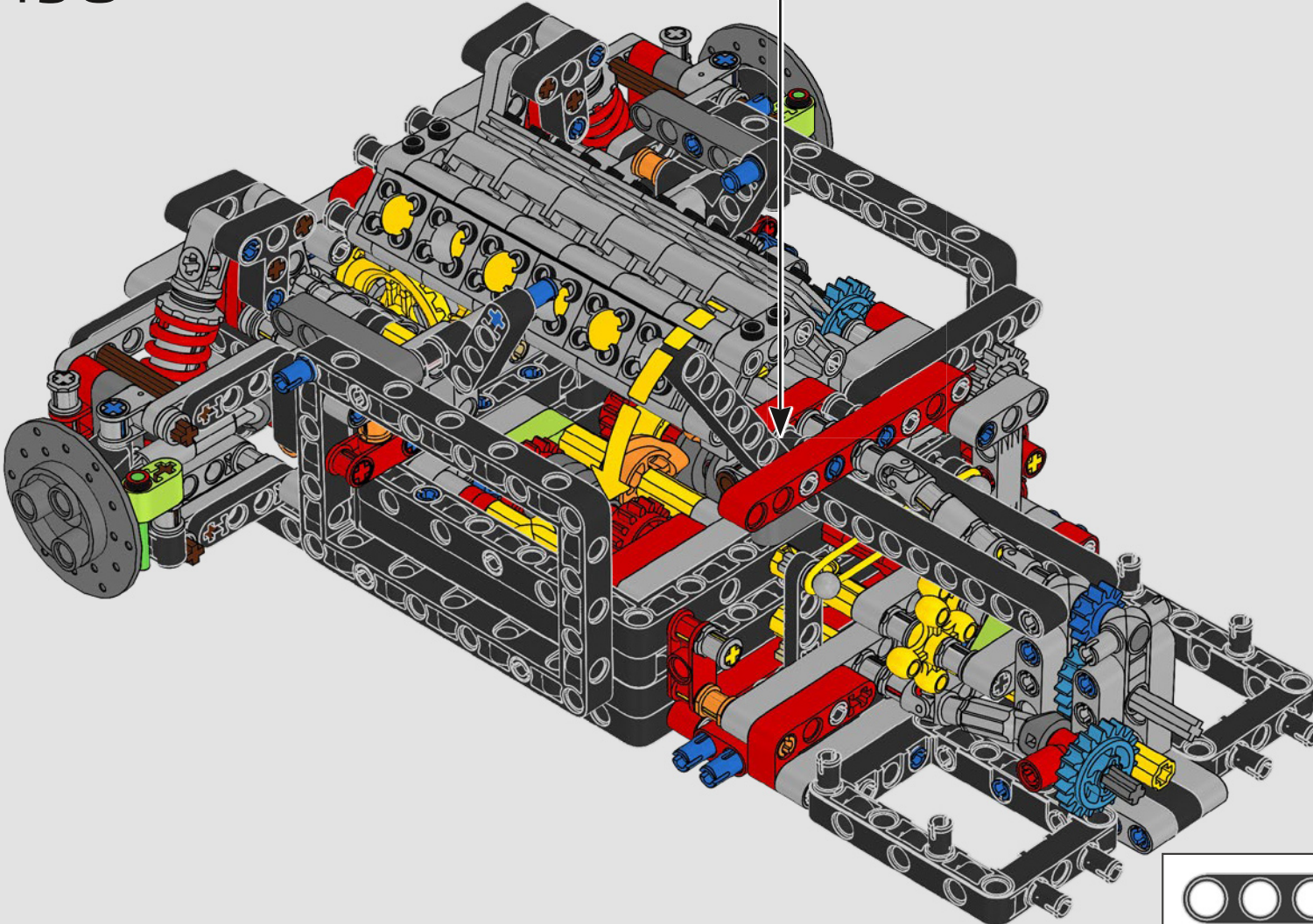
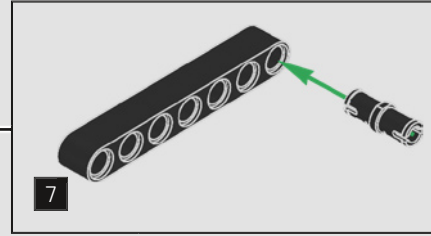

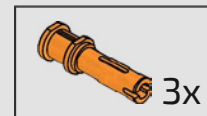
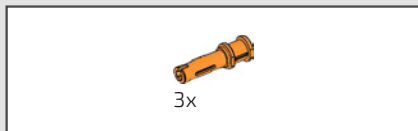

199

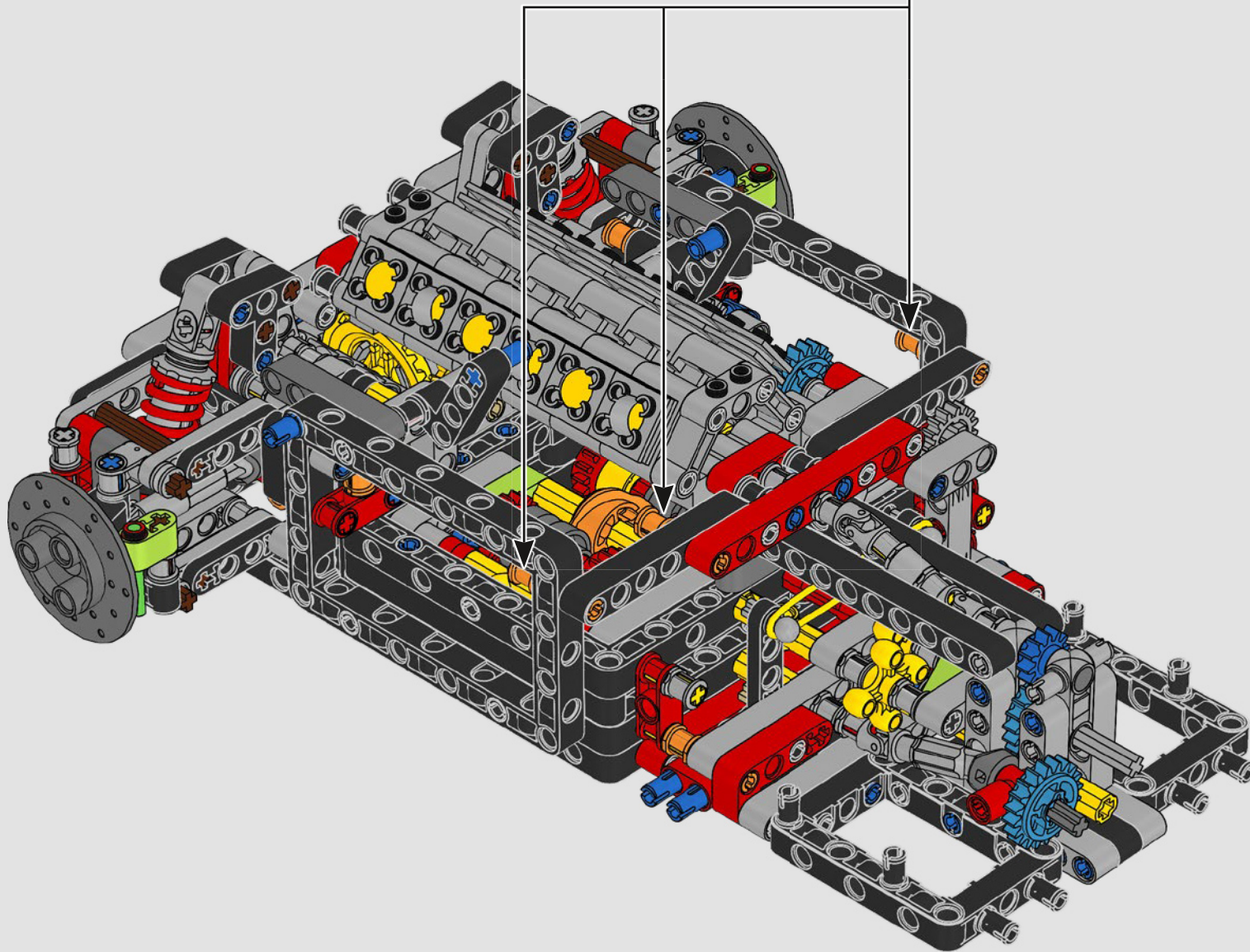

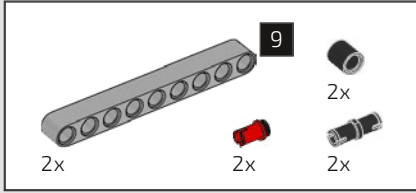

200

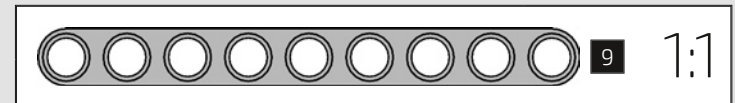
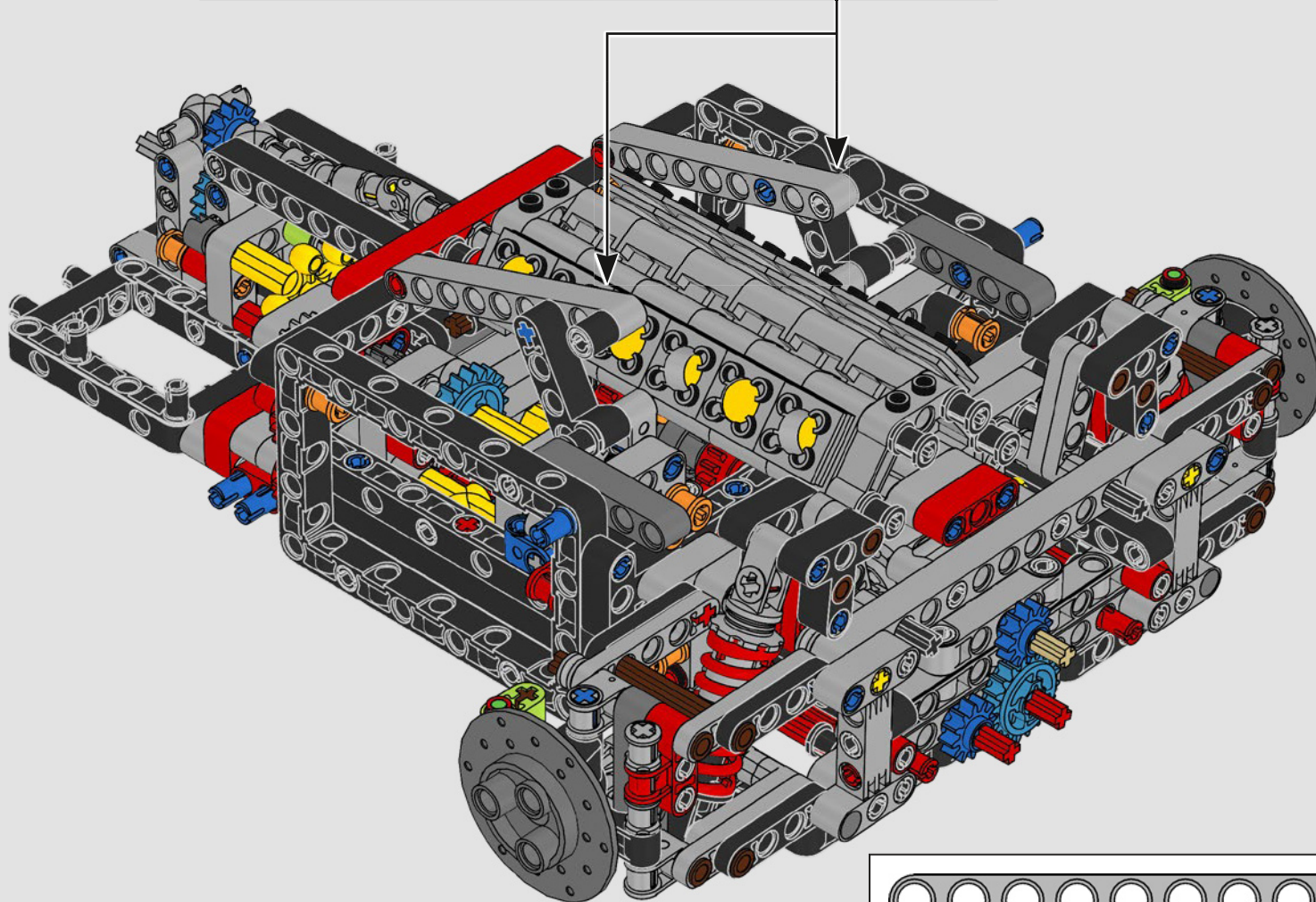
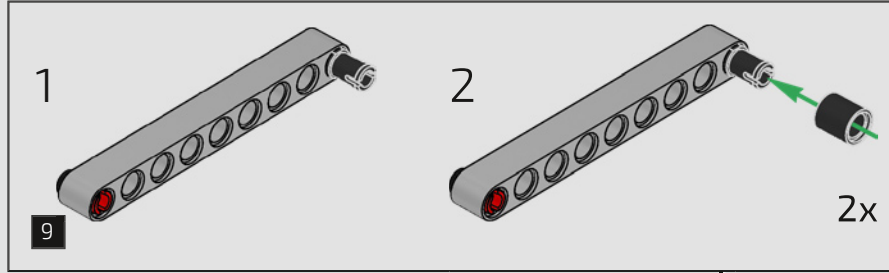

SUSPENSION

SUSPENSION

Now it's time to give your model the best handling and steering ability by constructing the suspension system.

Il est maintenant temps de donner à votre modèle une maniabilité et une direction hors pair en construisant le système de suspension.



BOX 1 / BOÎTE 1

BAG 2 / SACHET 2





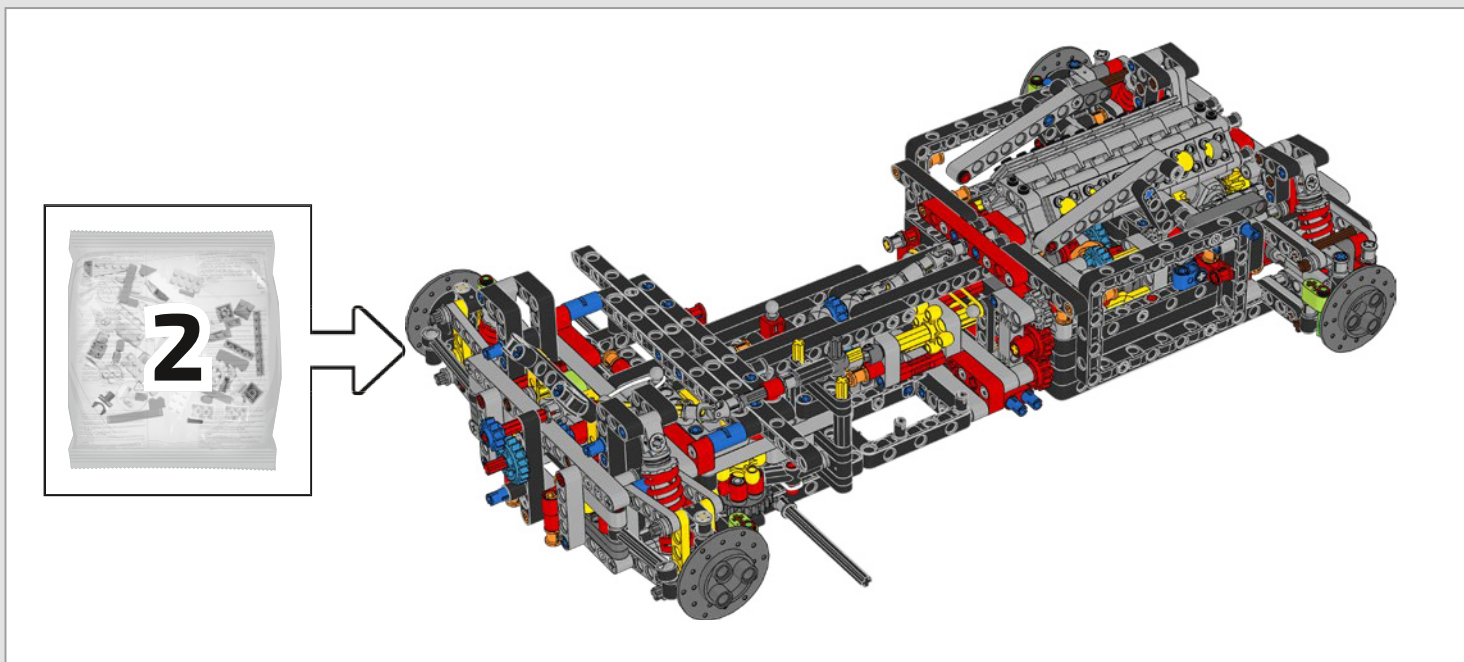

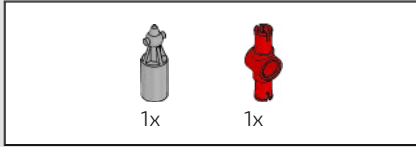

201

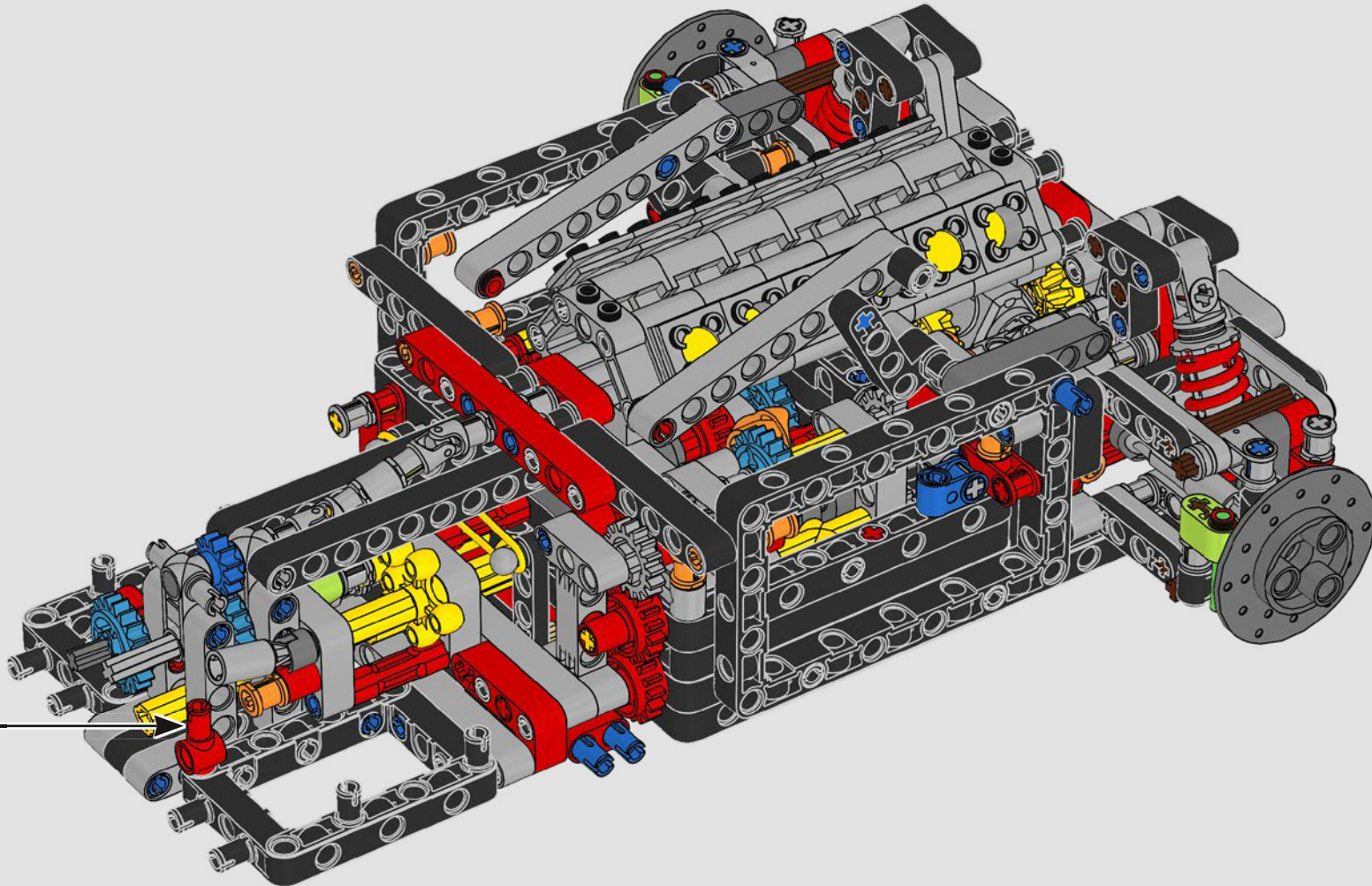
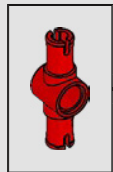

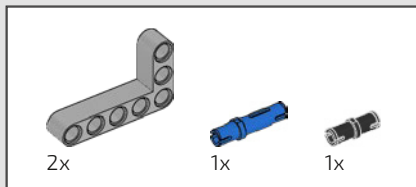

202

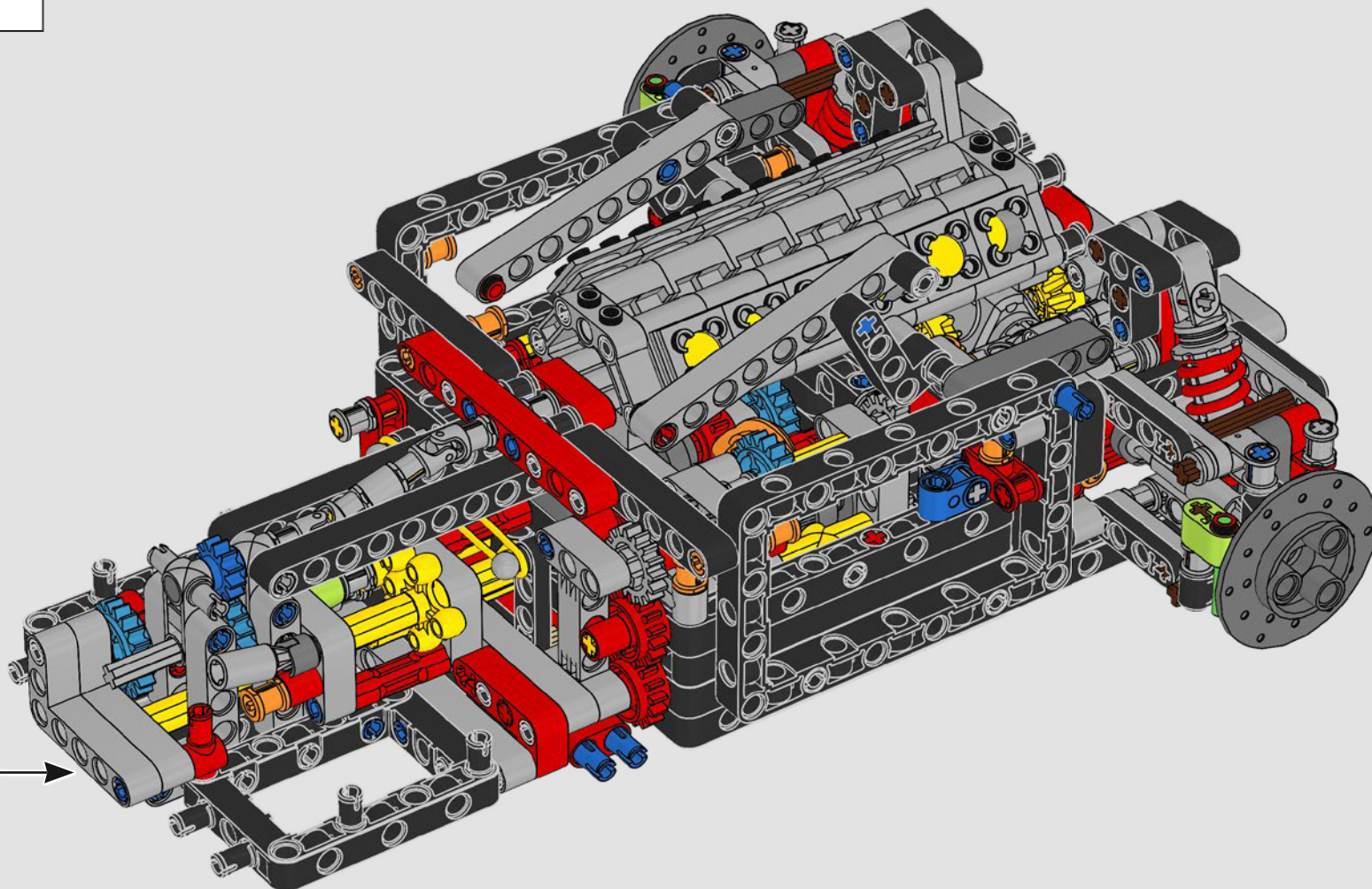
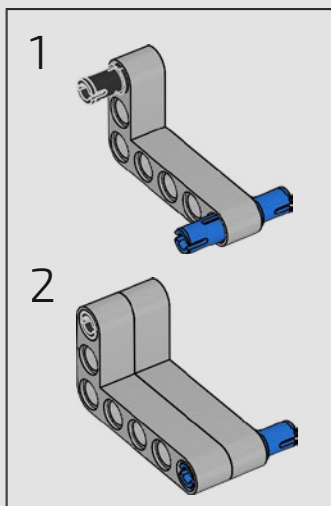

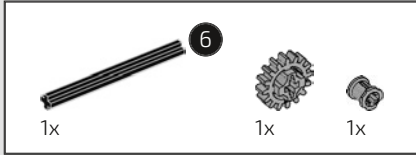

203

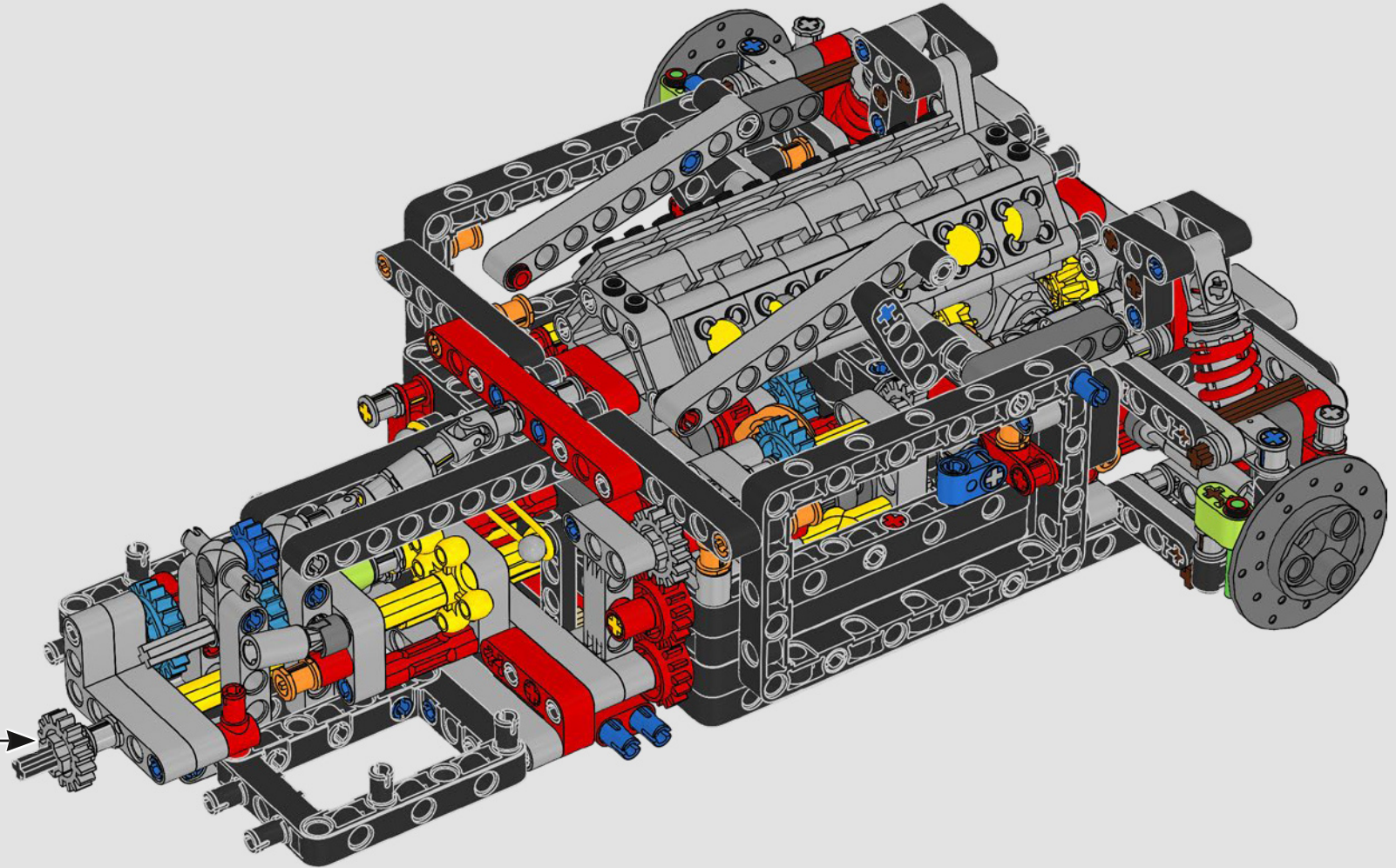
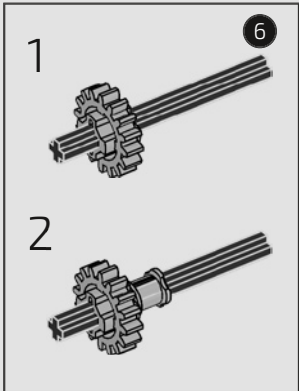

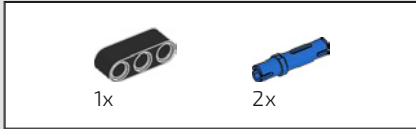
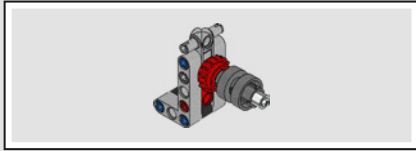

204

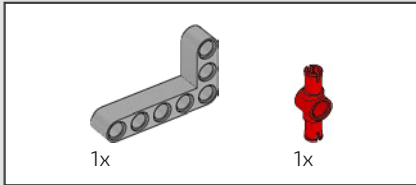
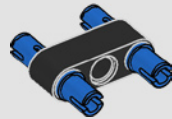

205

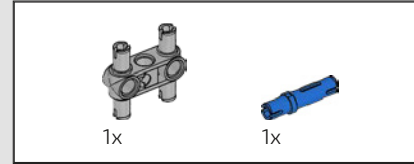
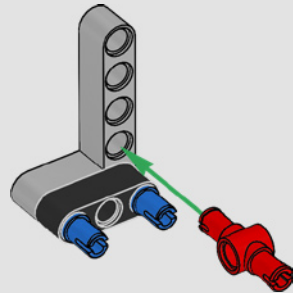

206

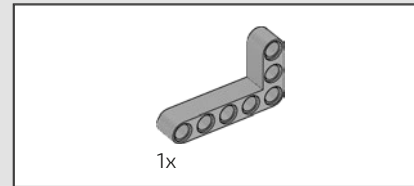
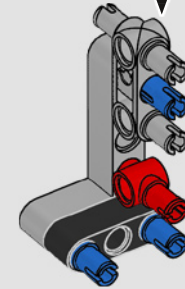
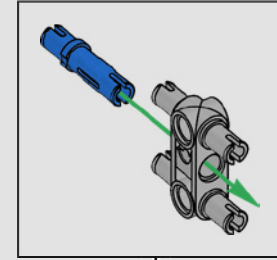

207

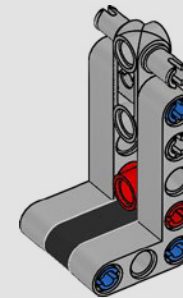

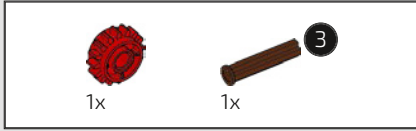

208

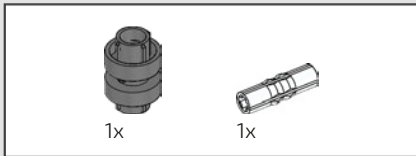
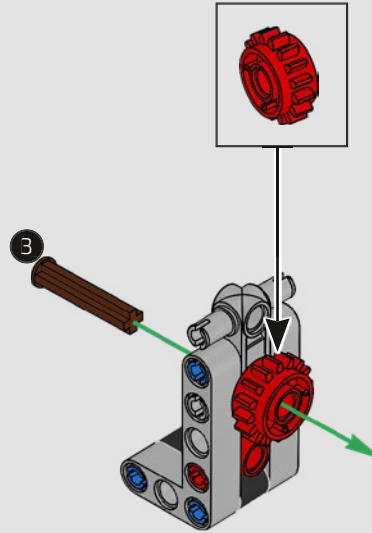

209

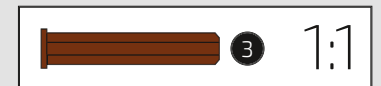
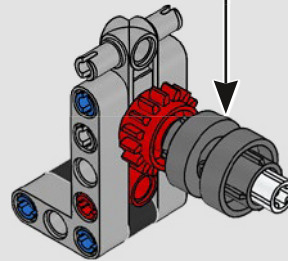
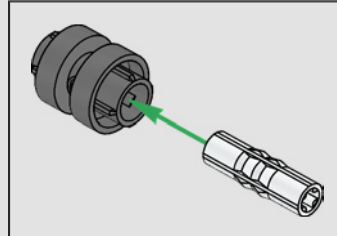

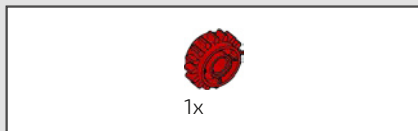

210

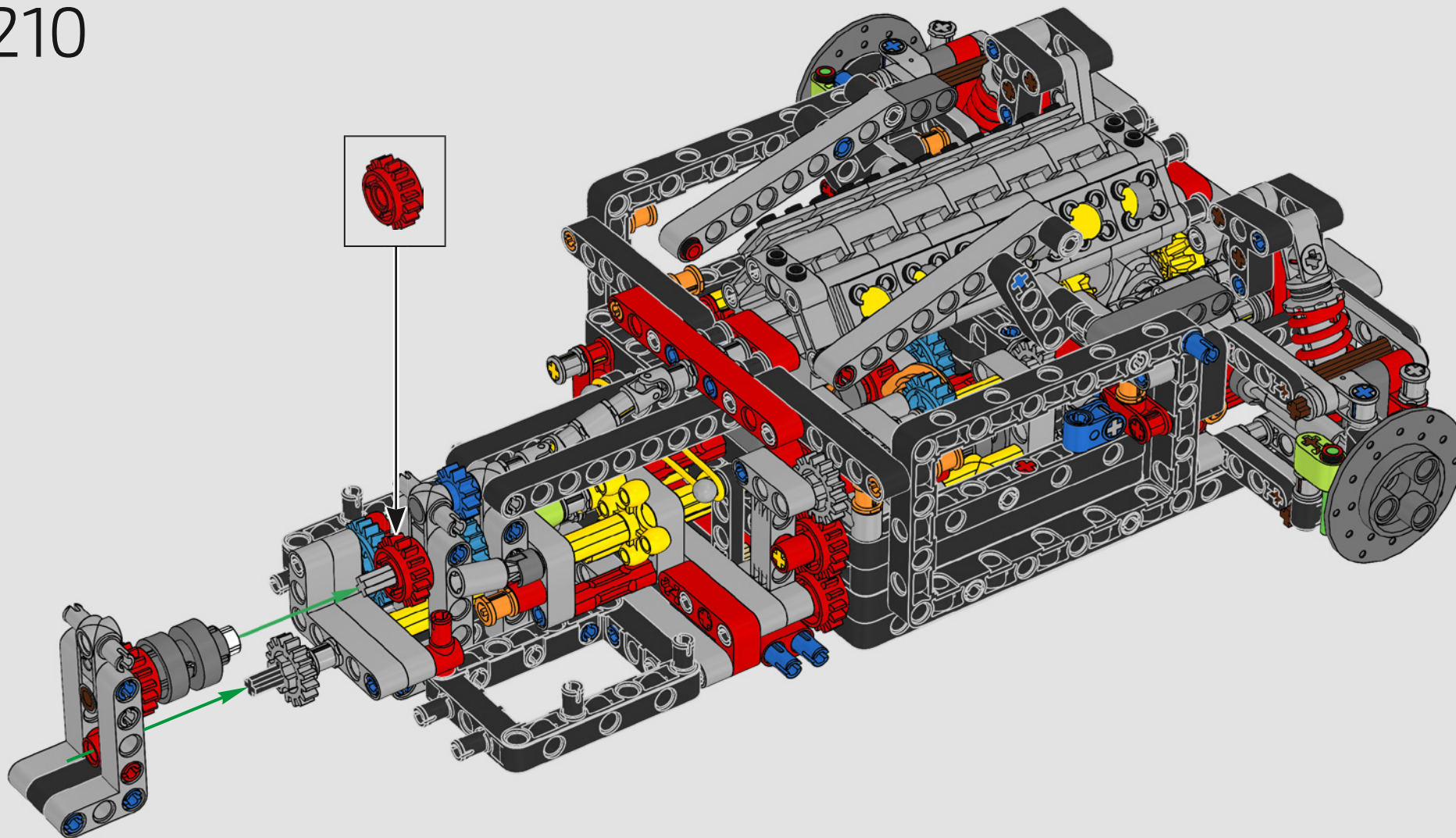

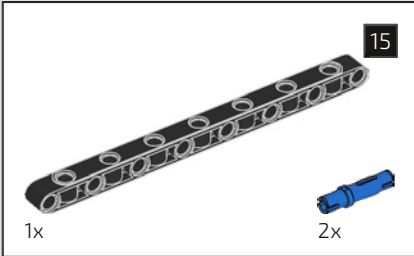
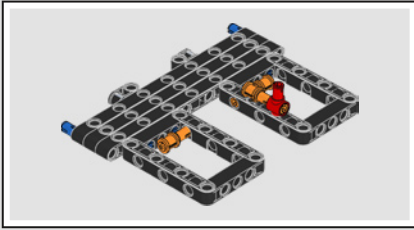

211

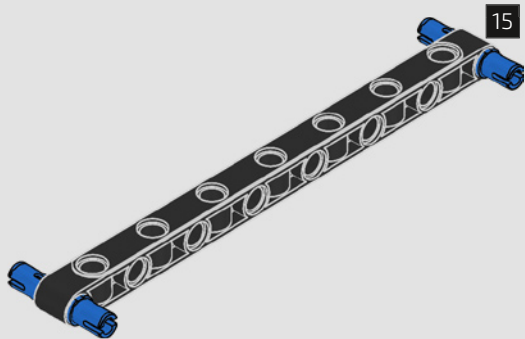

212

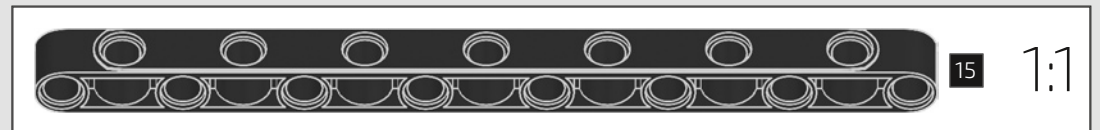
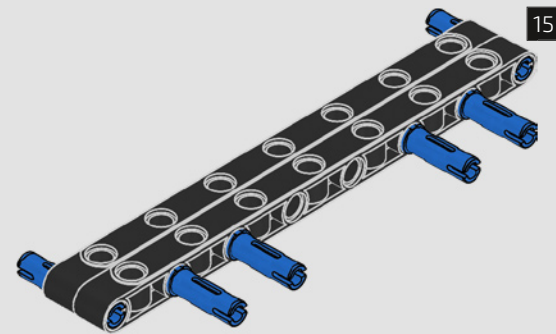

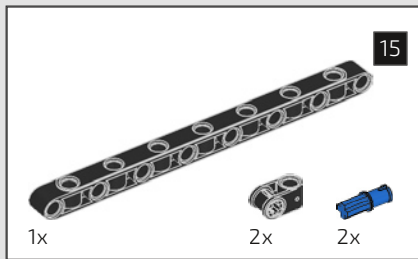

213

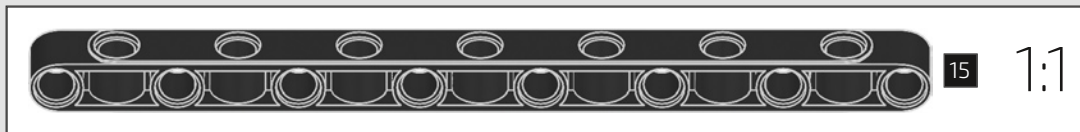
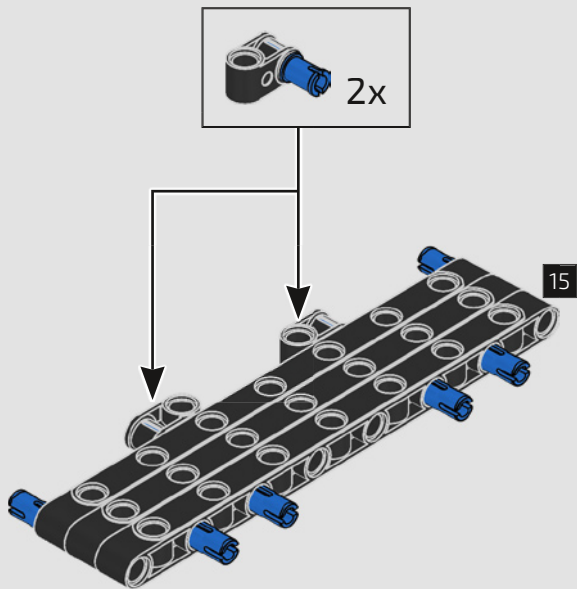

214

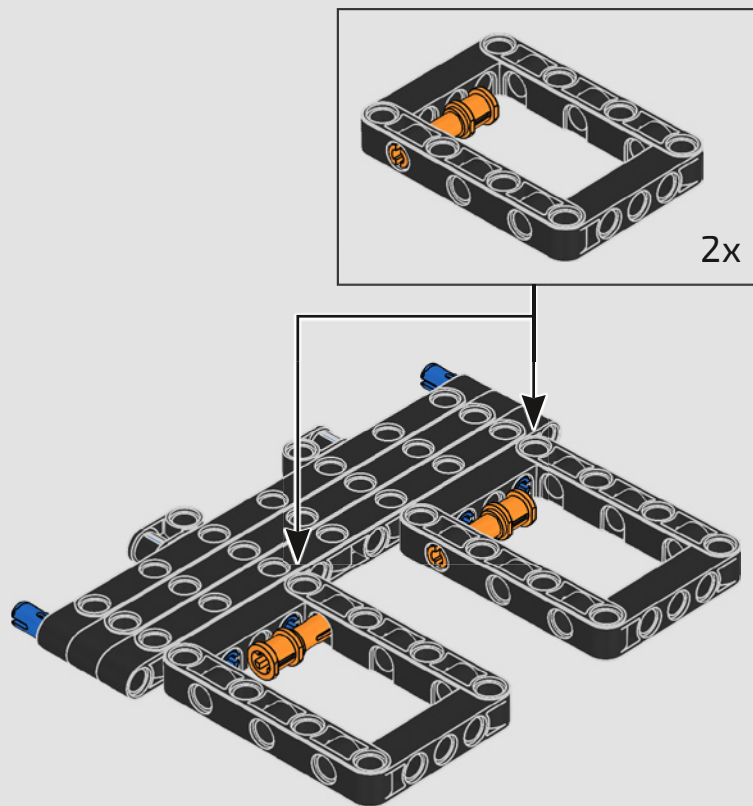

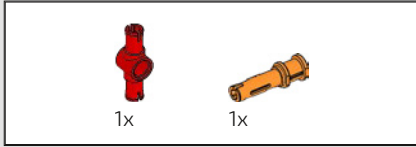

215

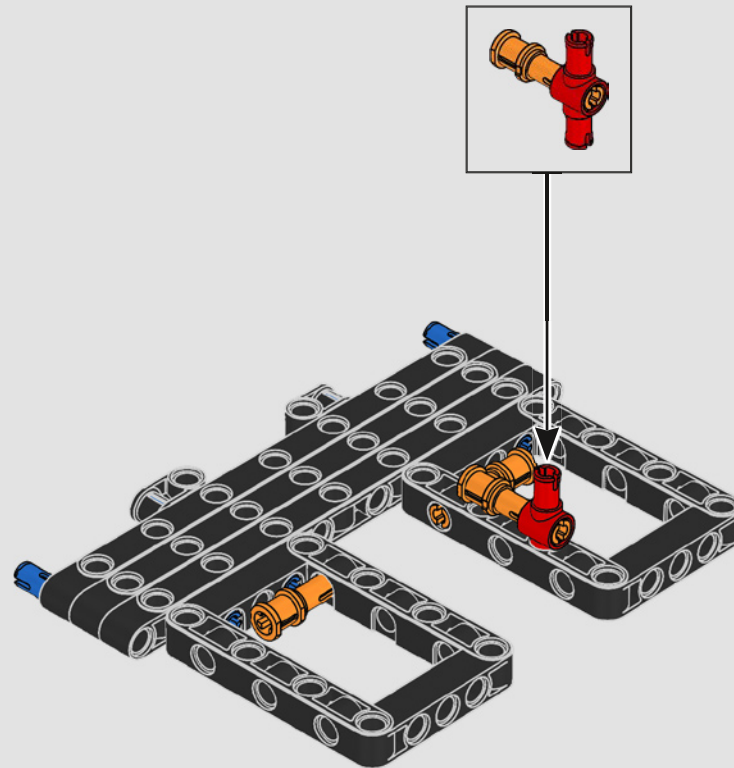

216

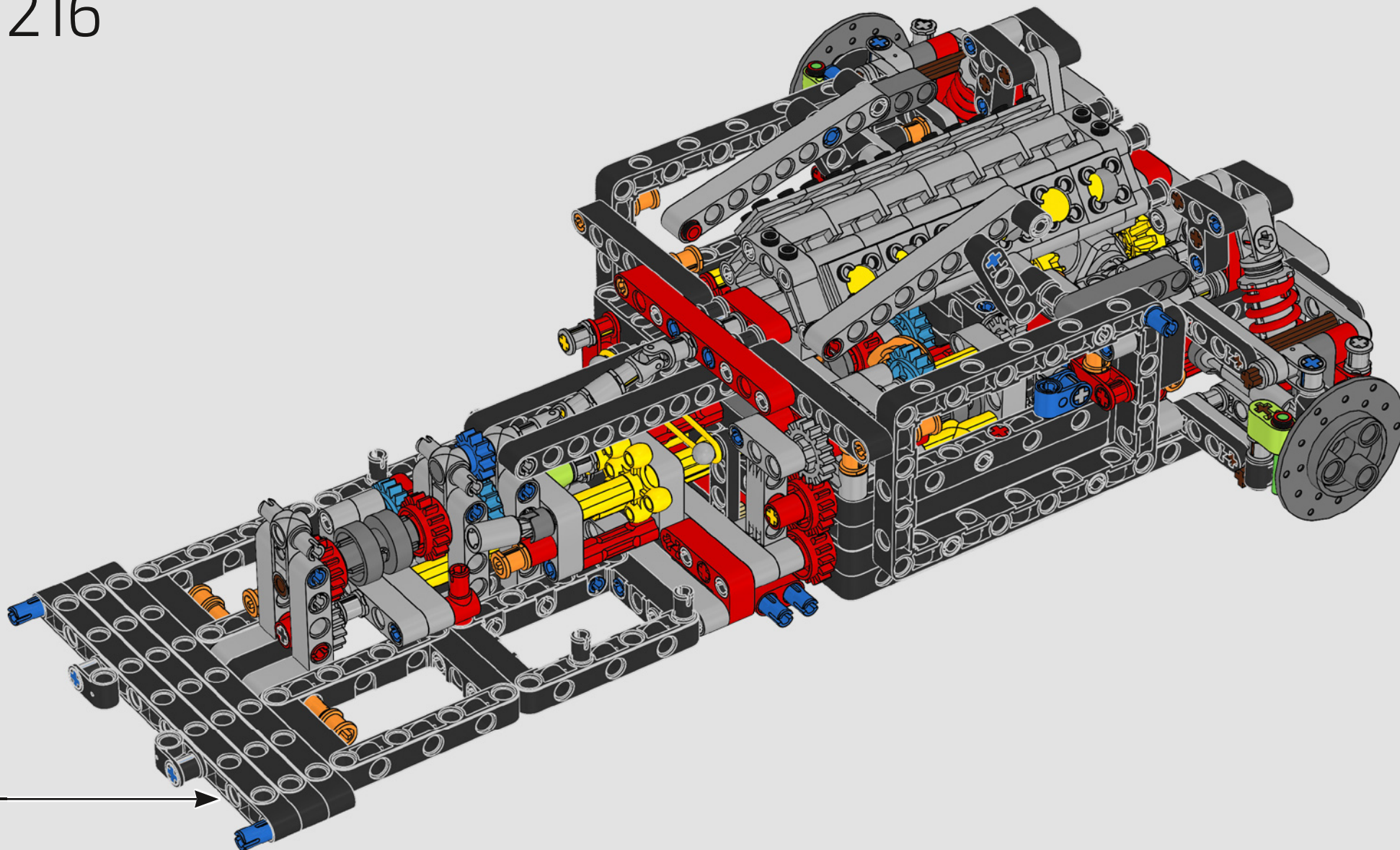

217

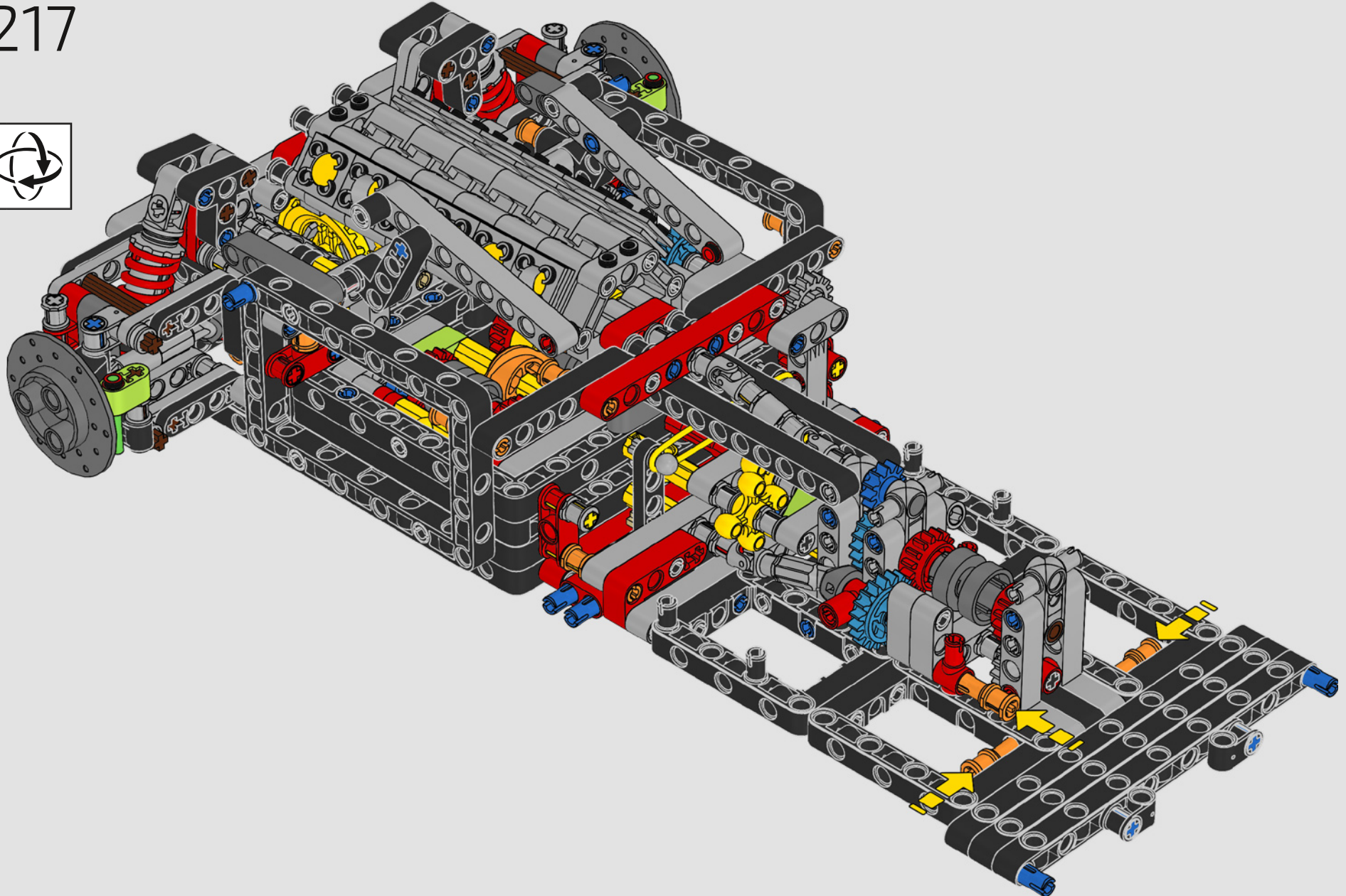



218

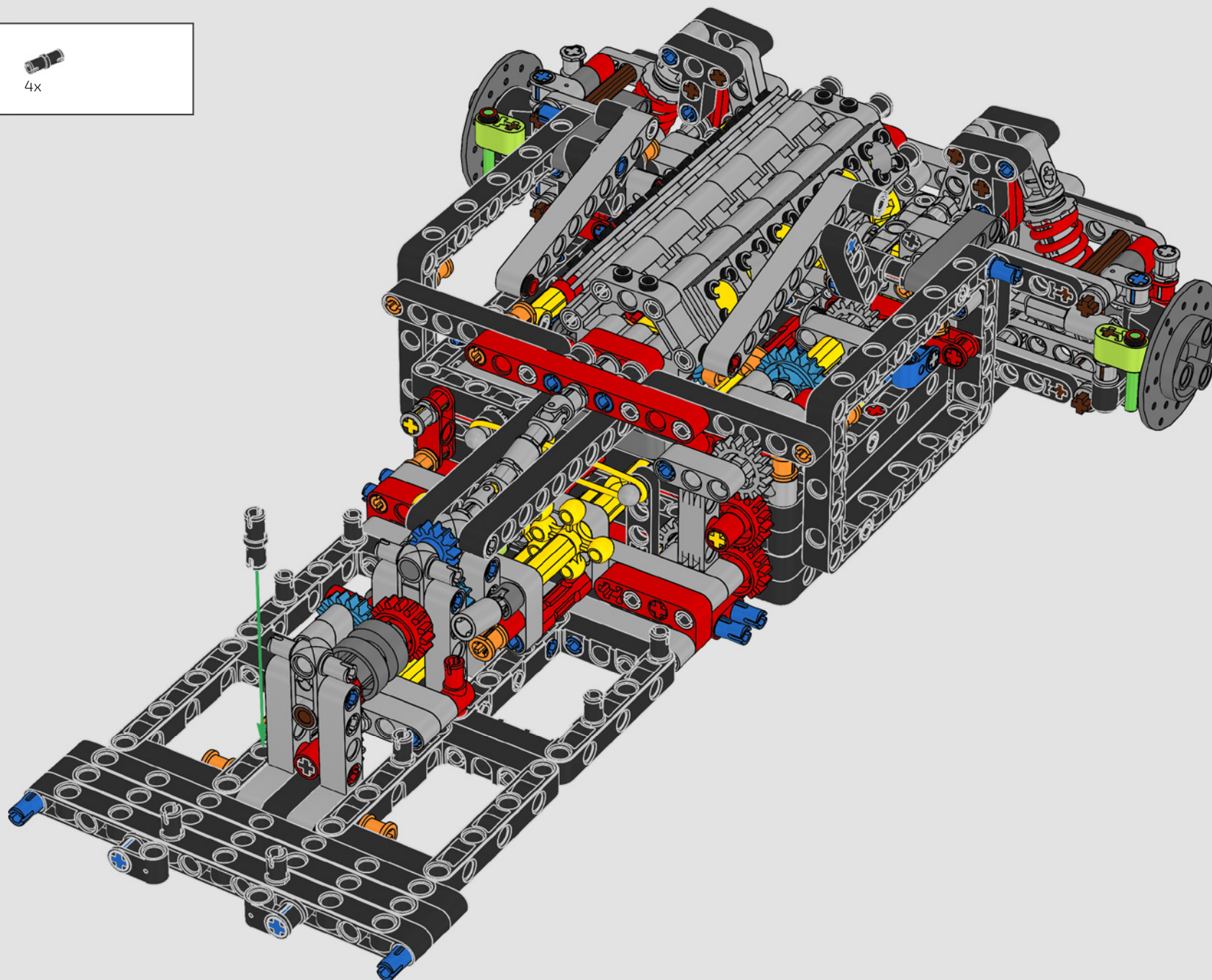

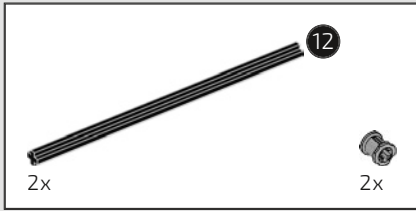

219

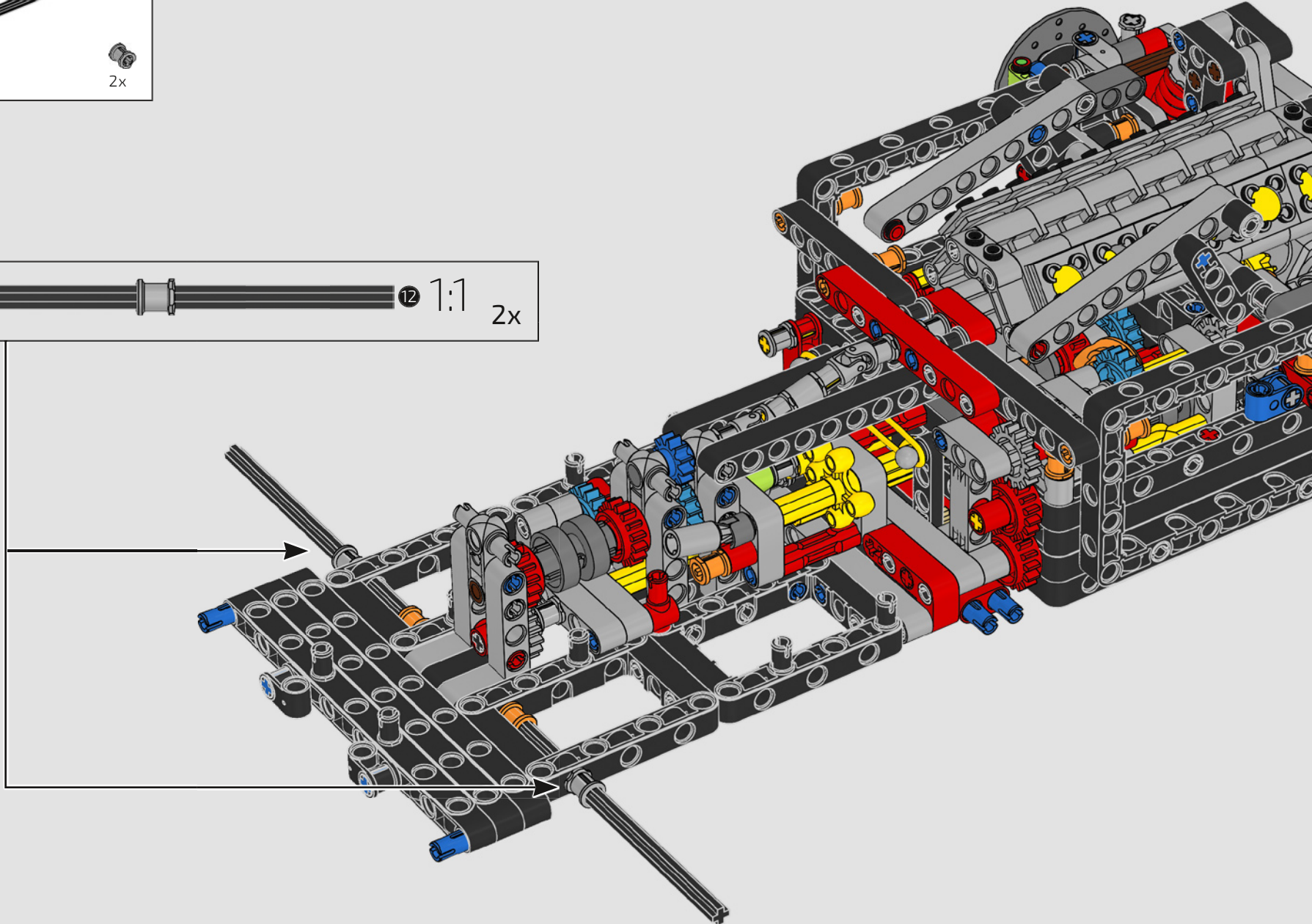
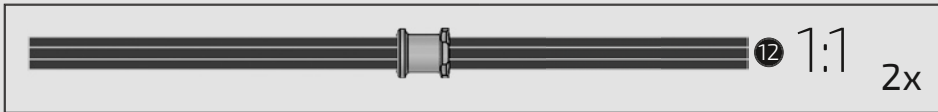

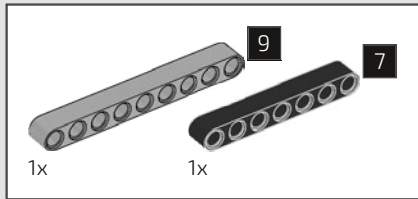

220

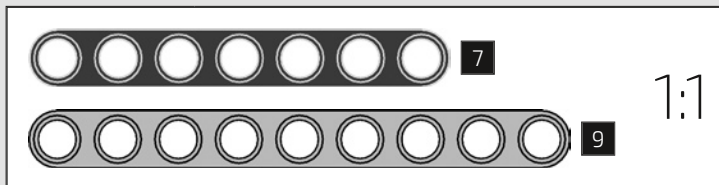
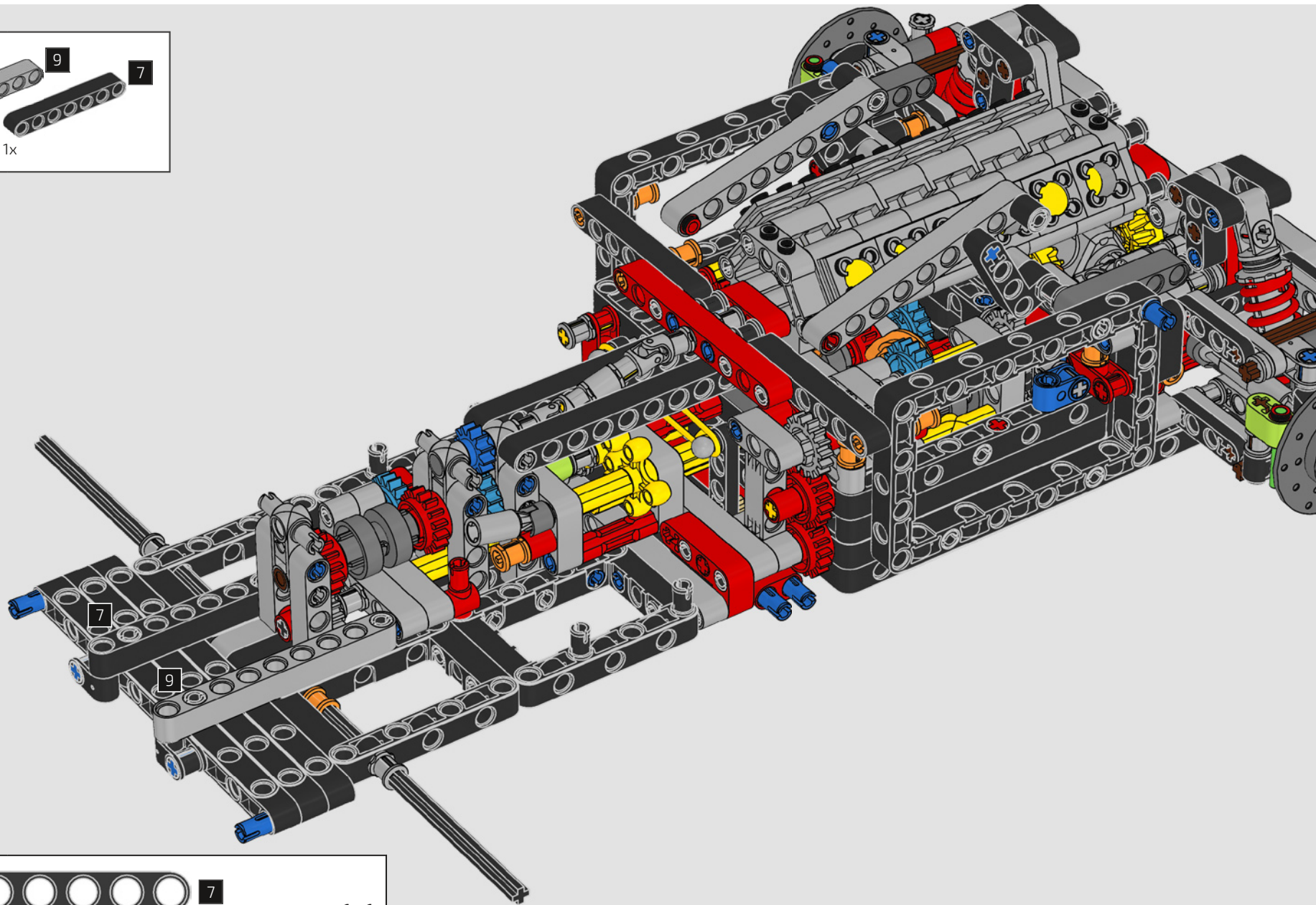



221

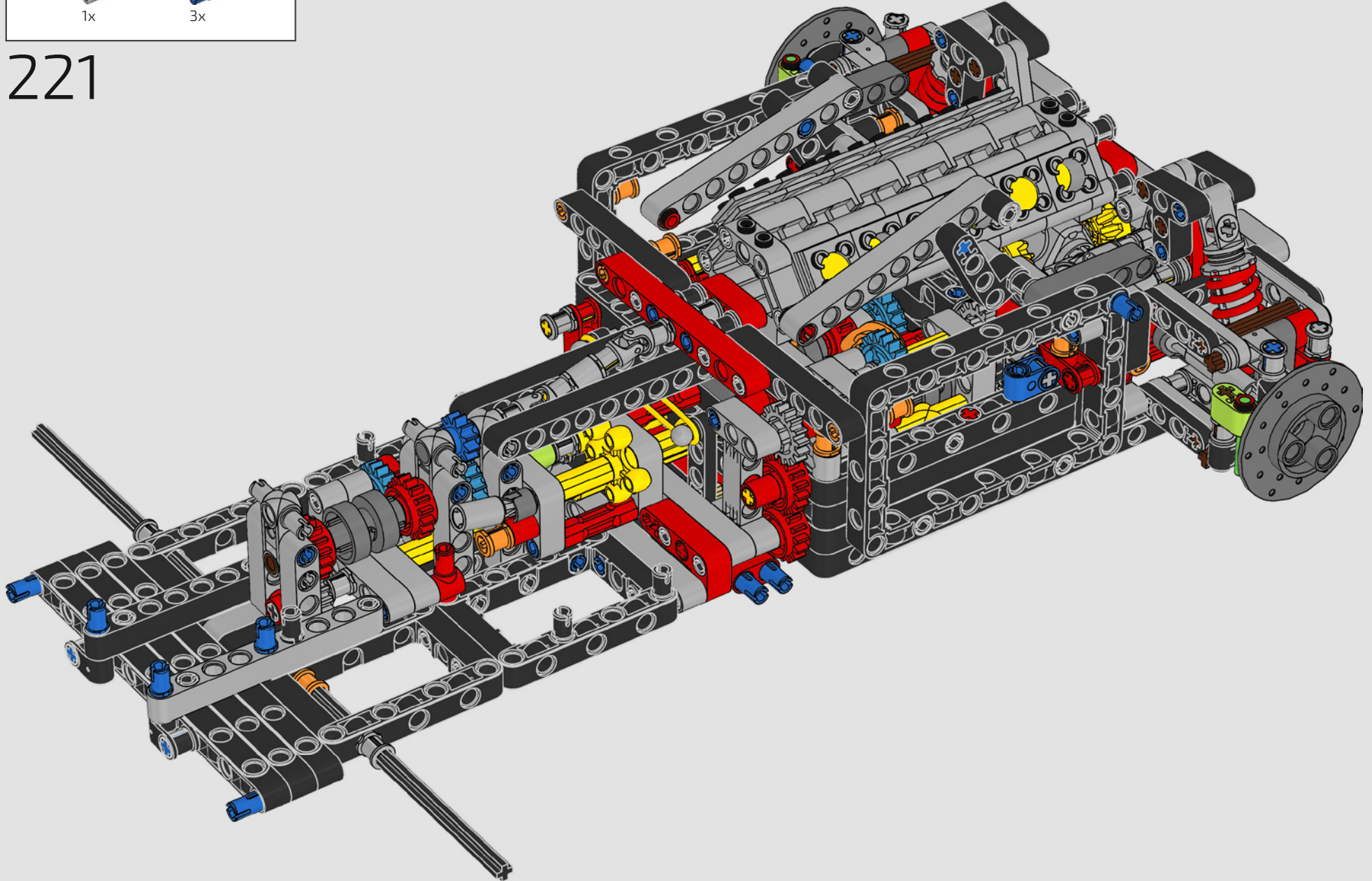

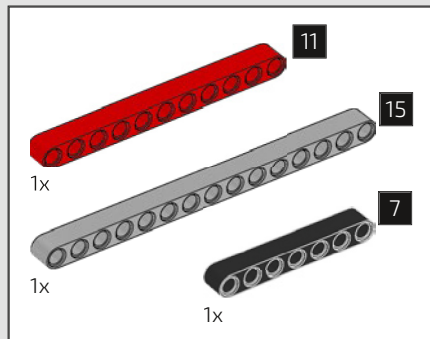

222

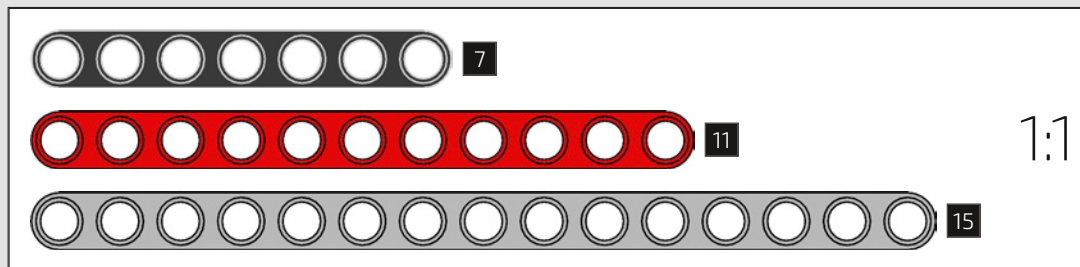
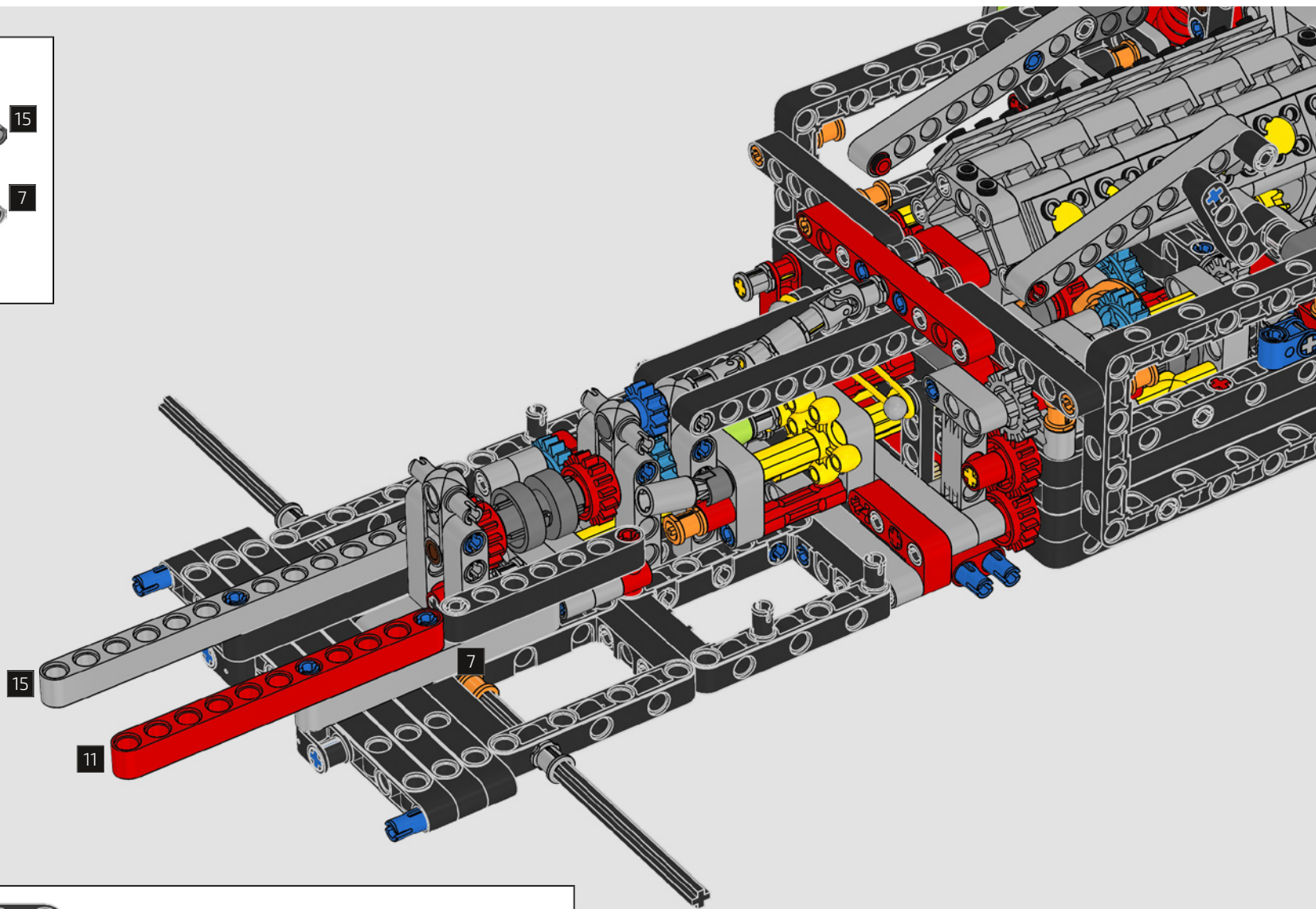



223

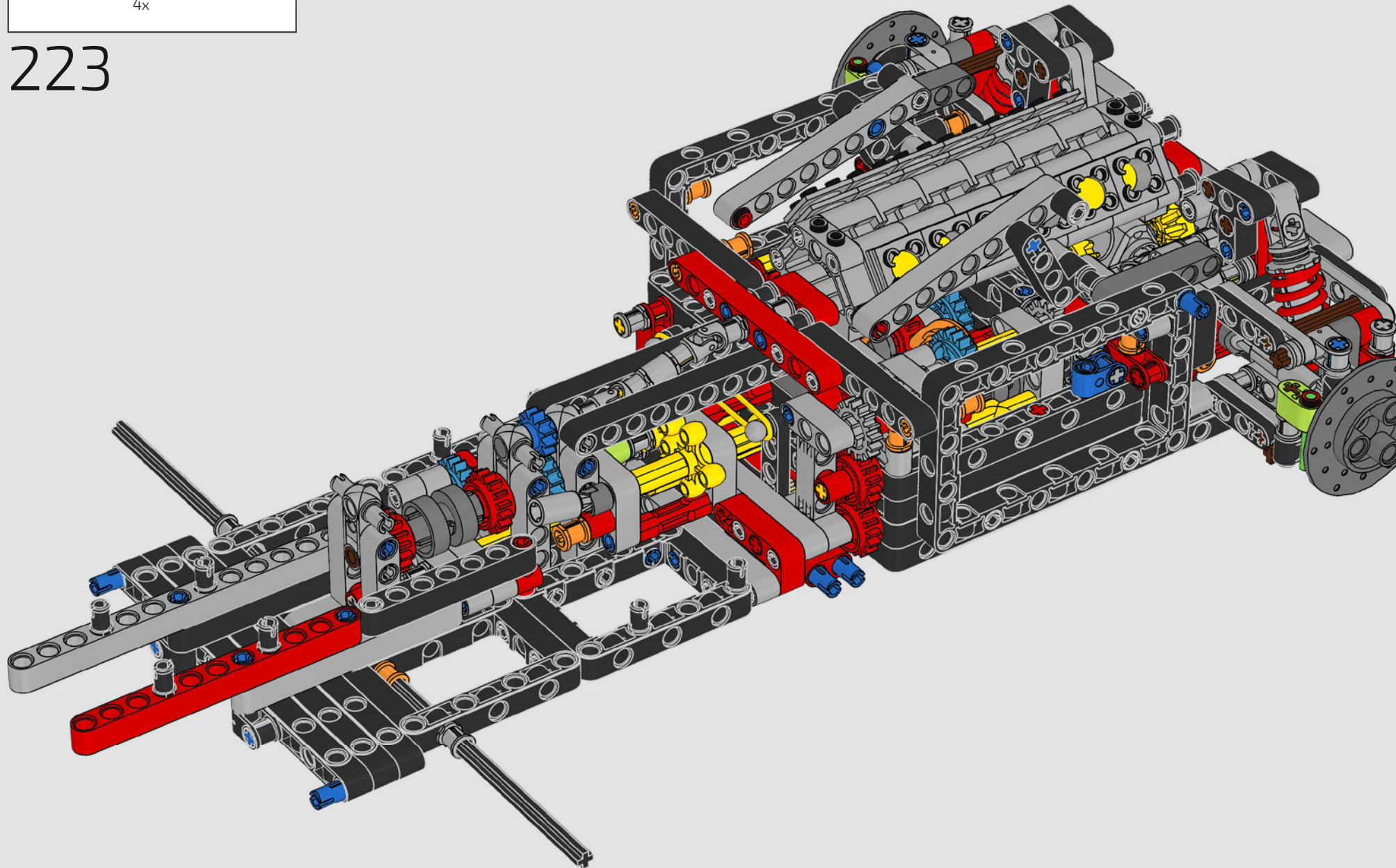



224

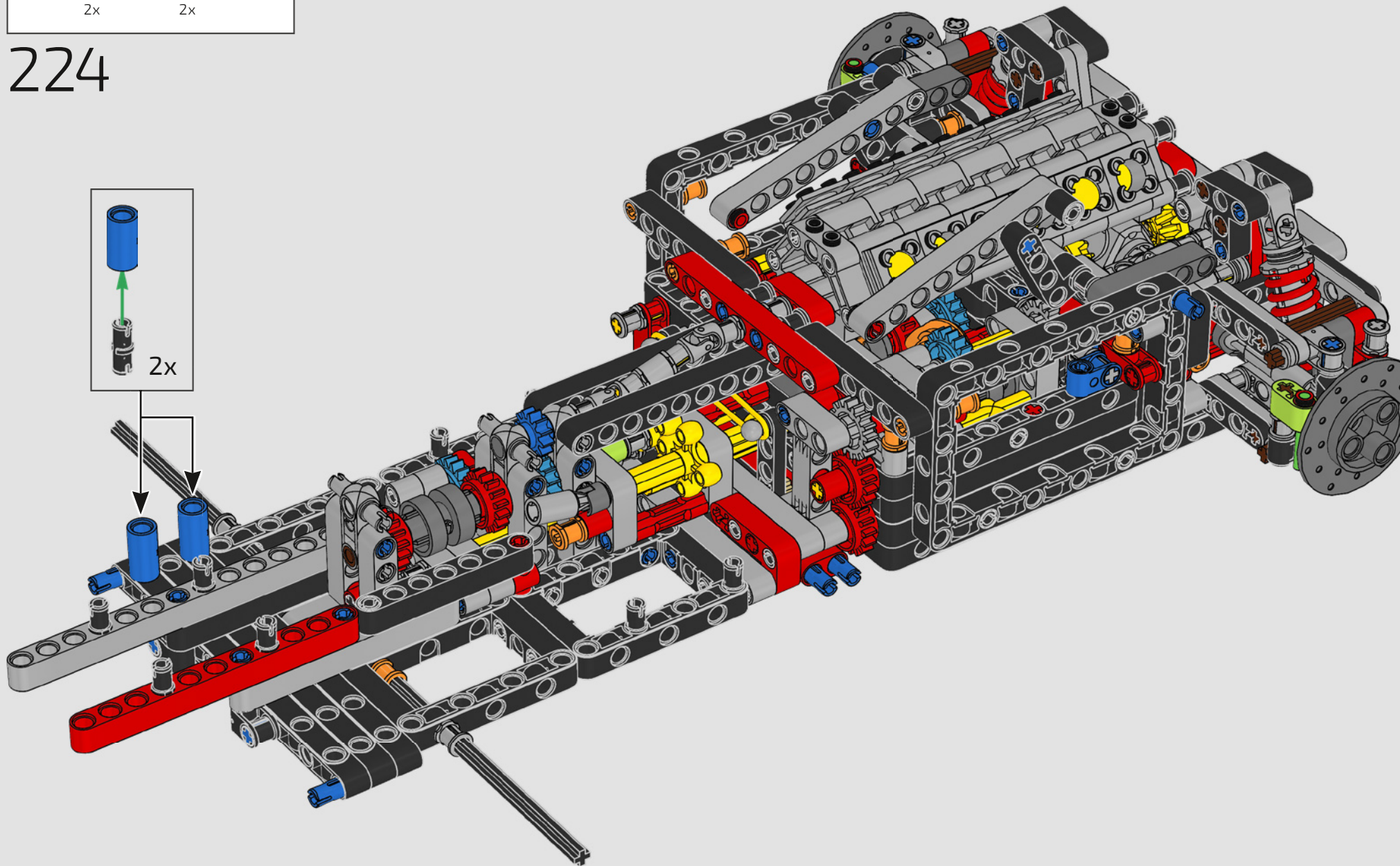
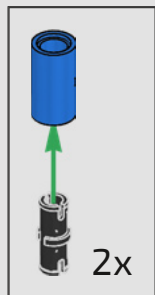

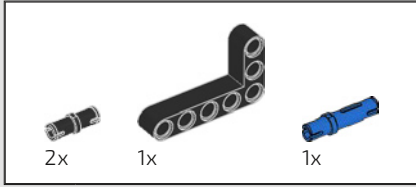

225

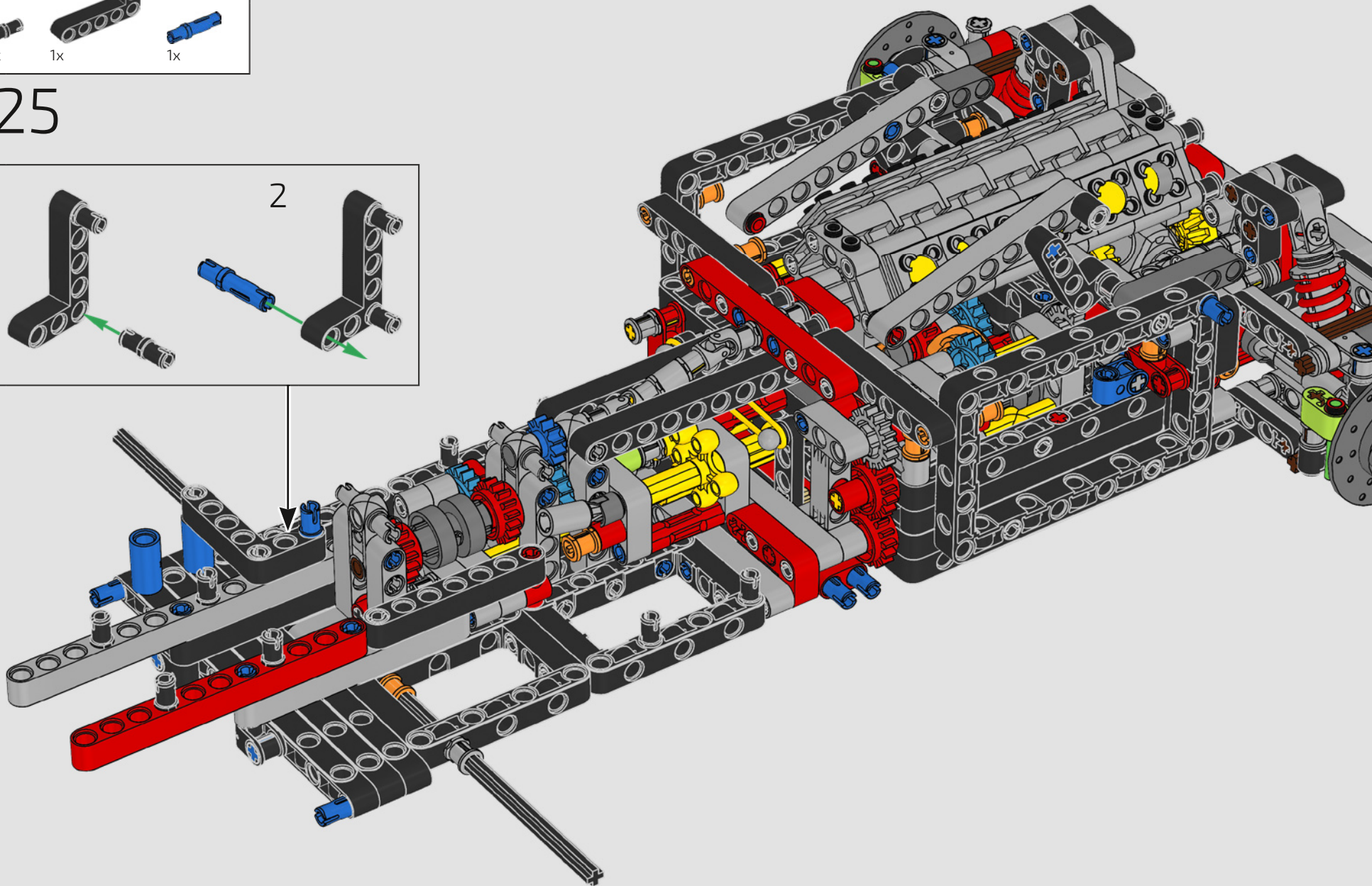
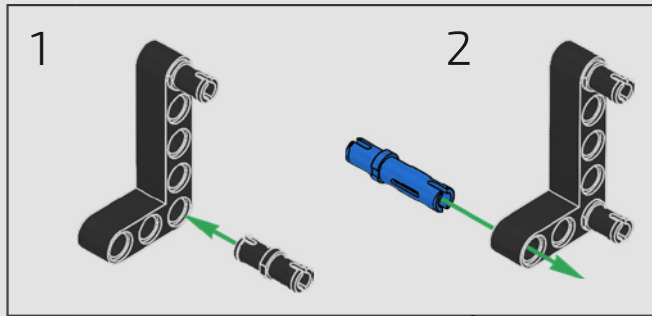

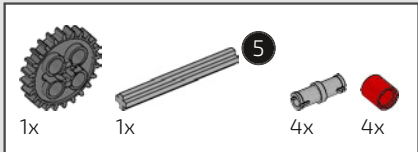

226

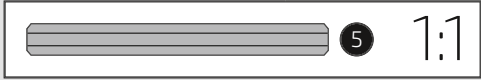
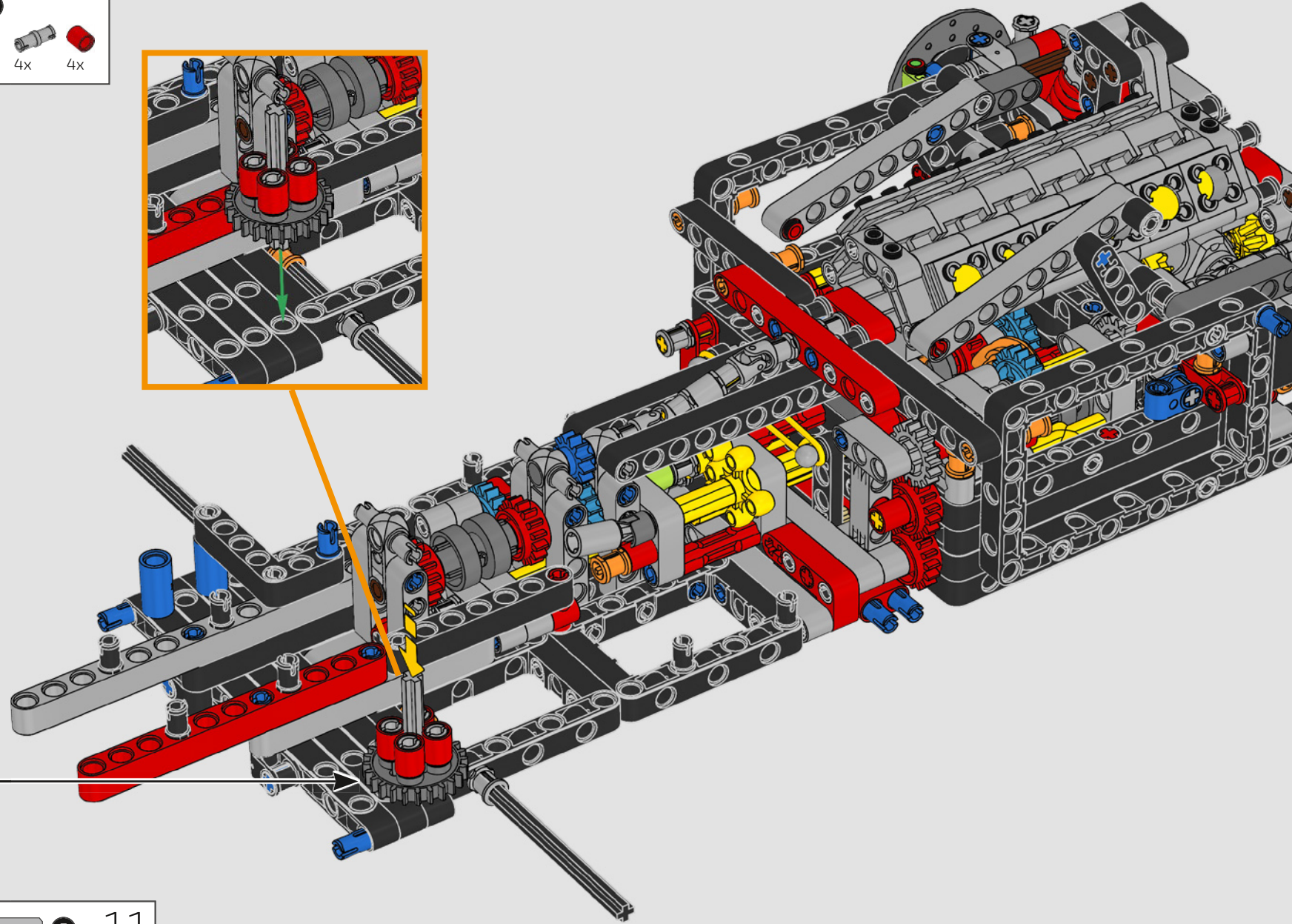
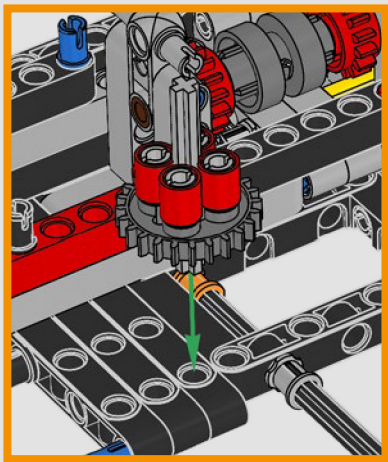
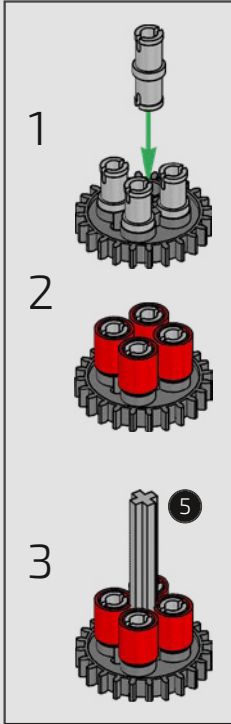

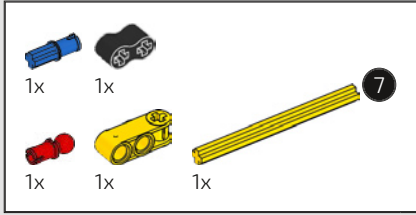

227

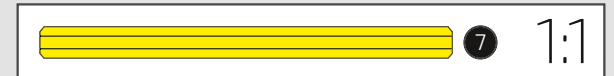
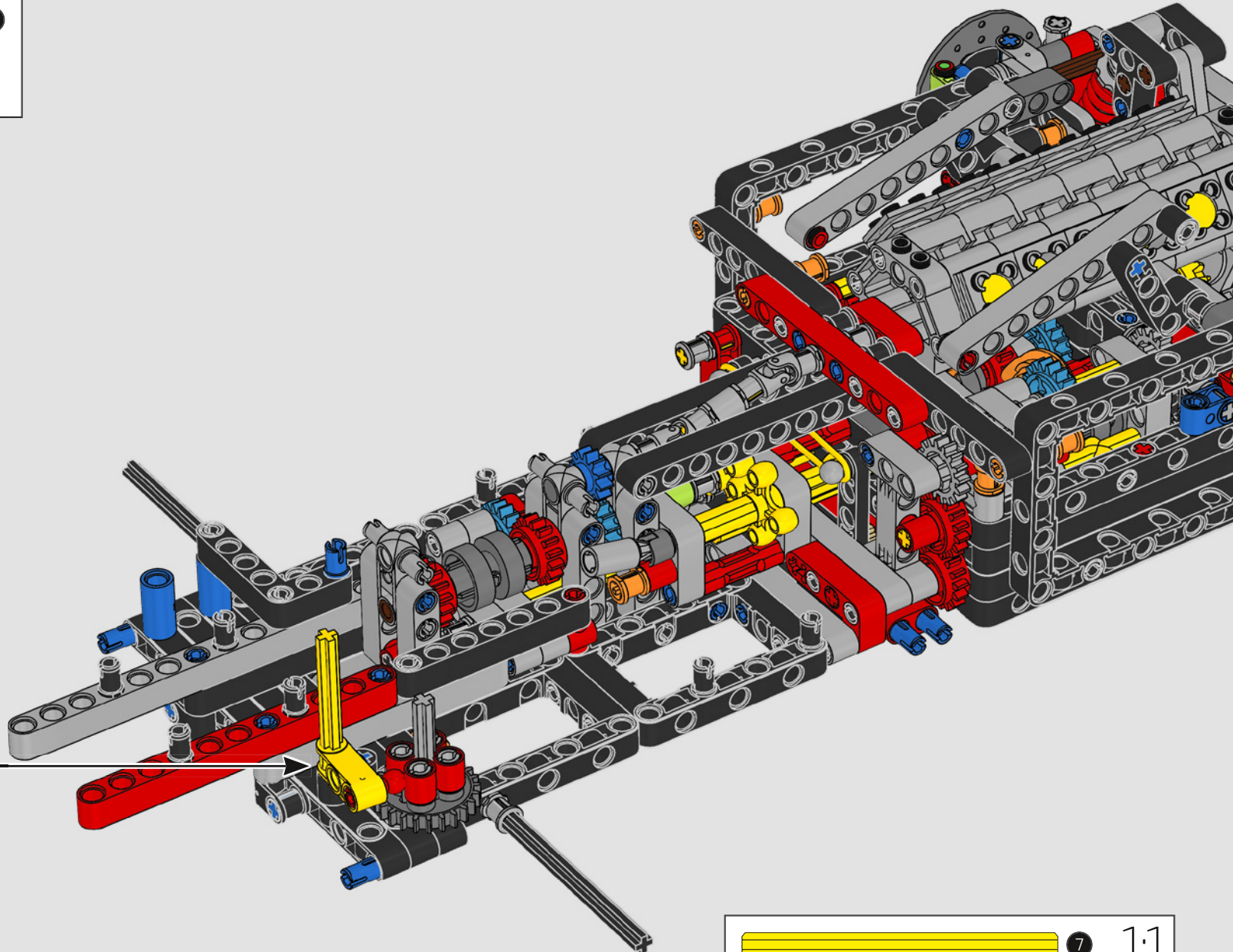
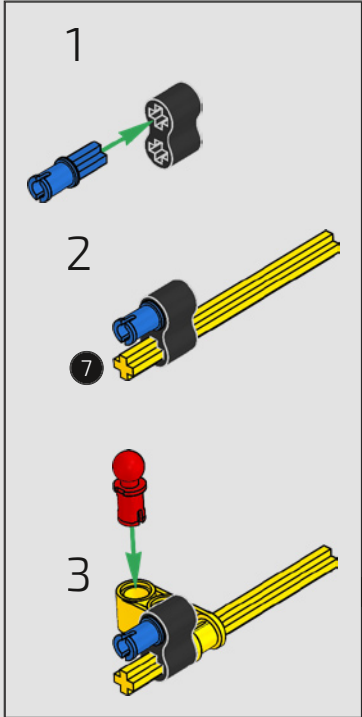

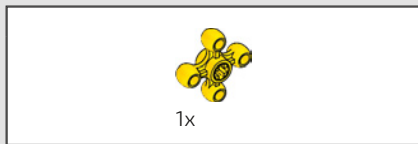

228

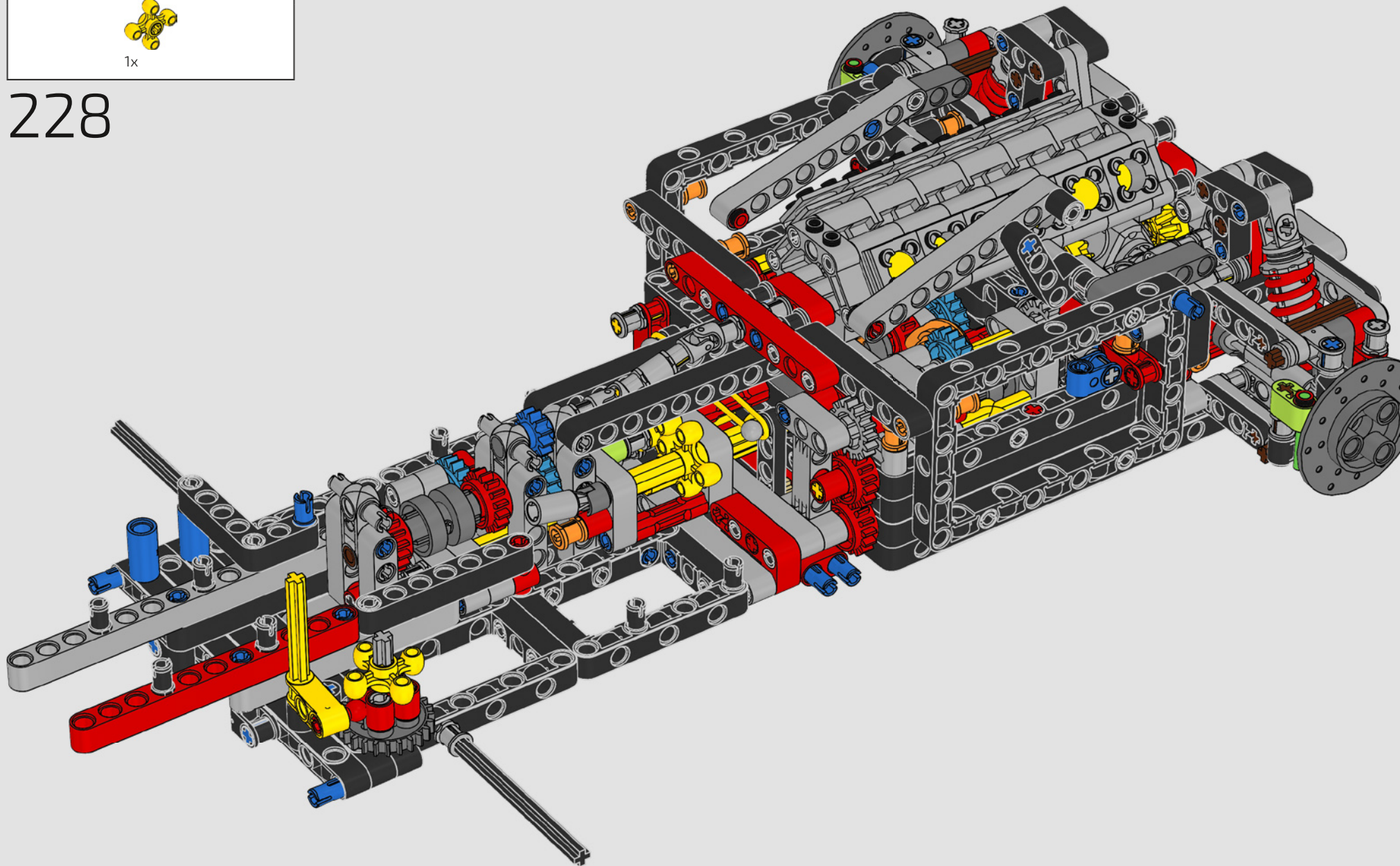

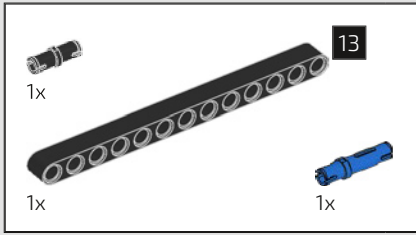

229

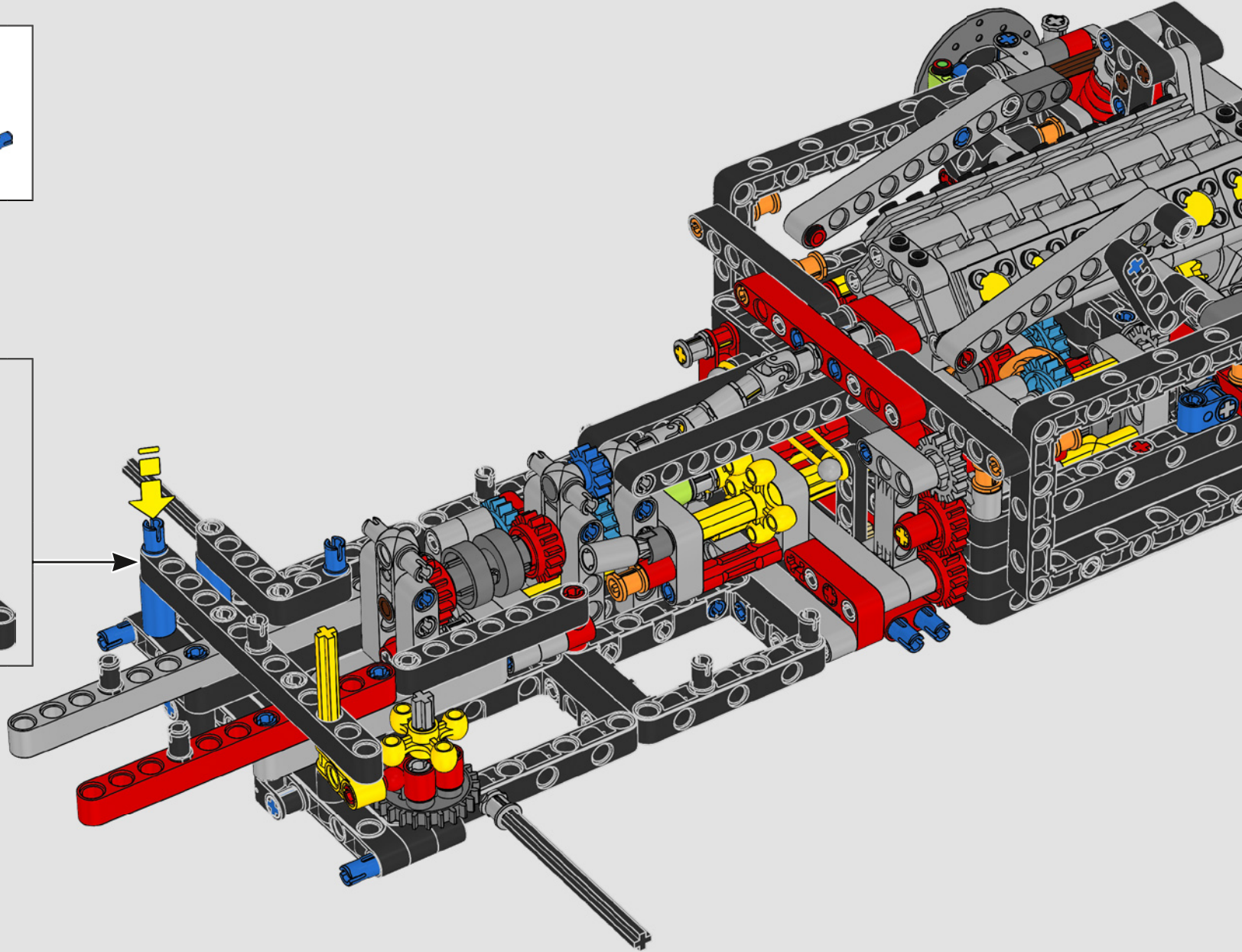
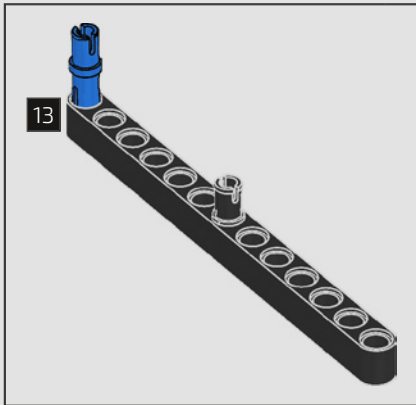

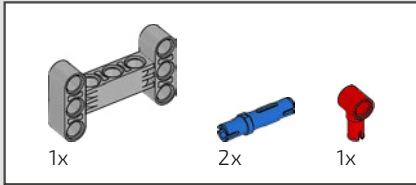
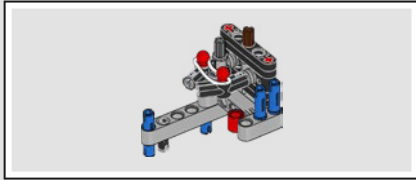

230

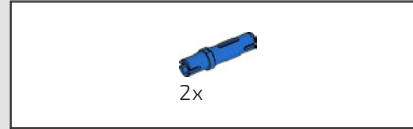
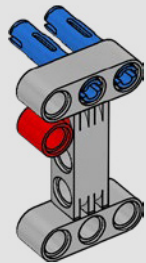

231

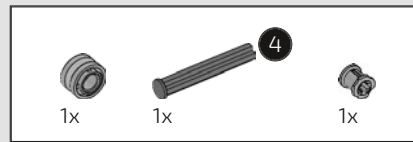
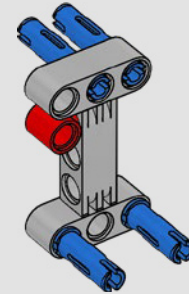

232

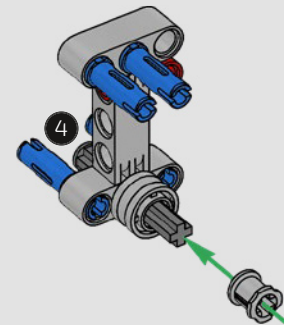

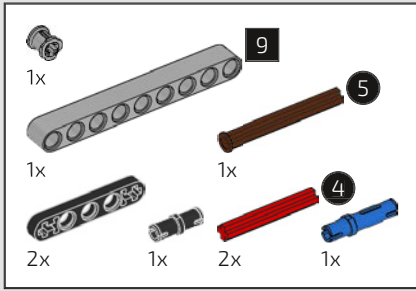

233

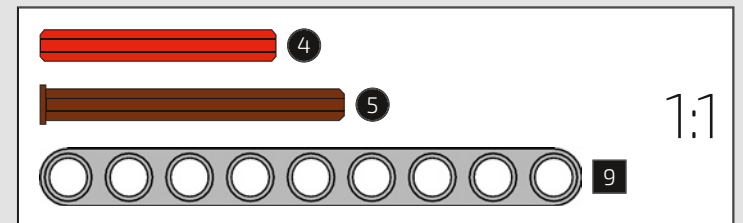
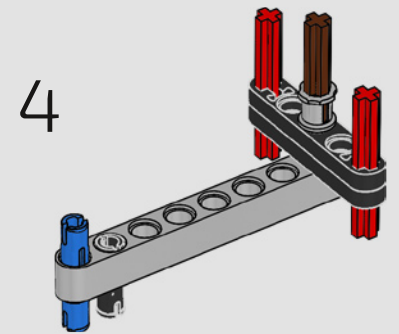
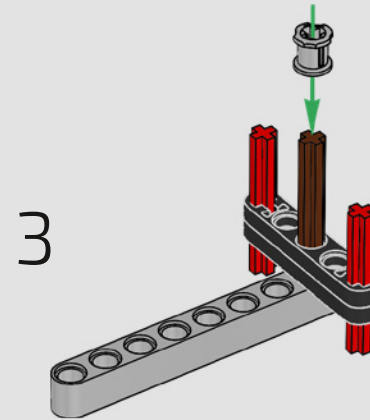
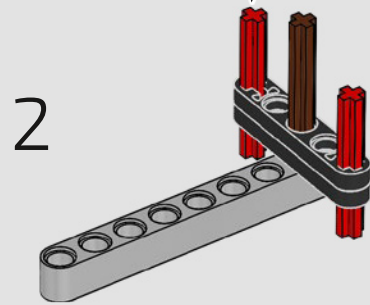
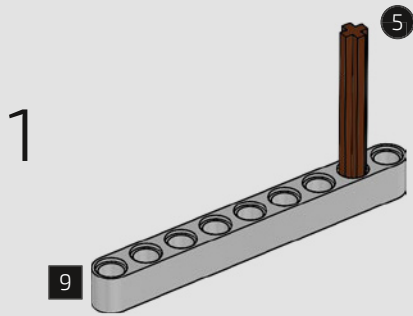
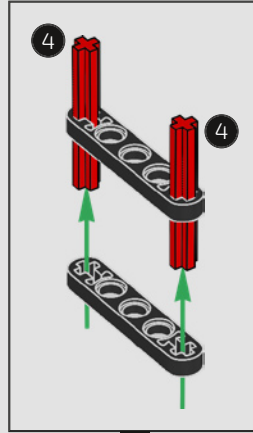

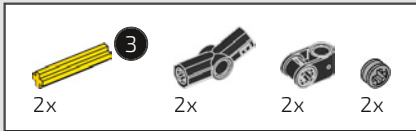
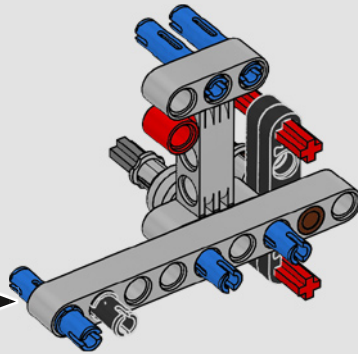

234

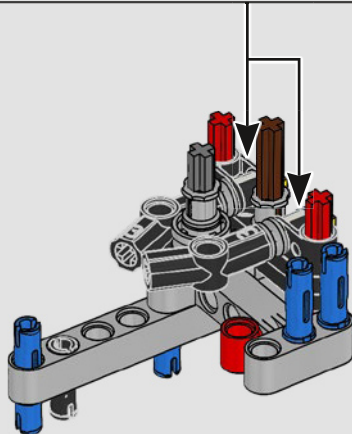
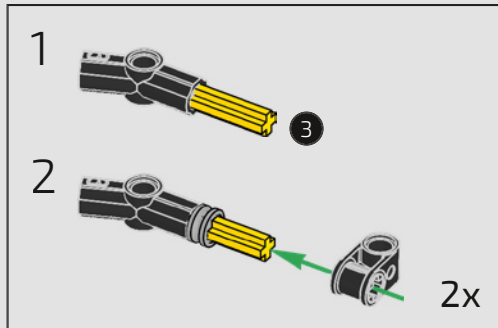

235

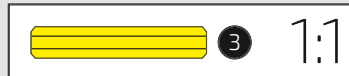
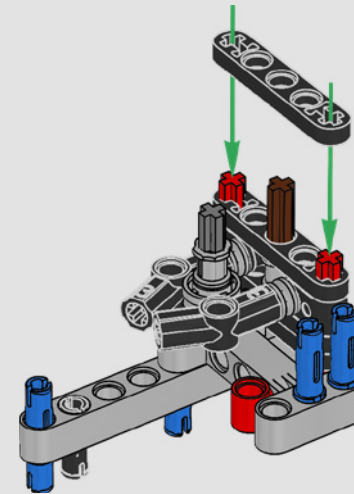

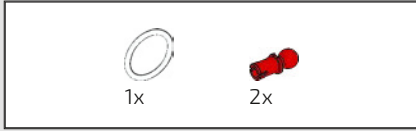

236

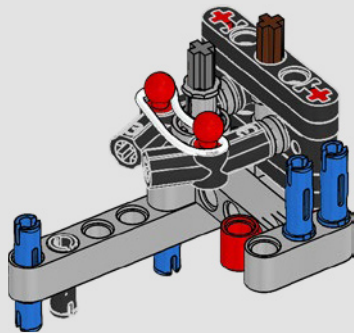

237

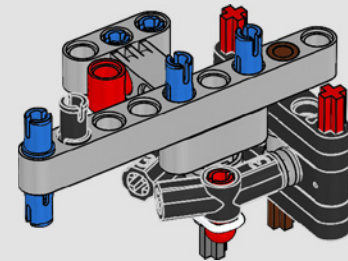

238

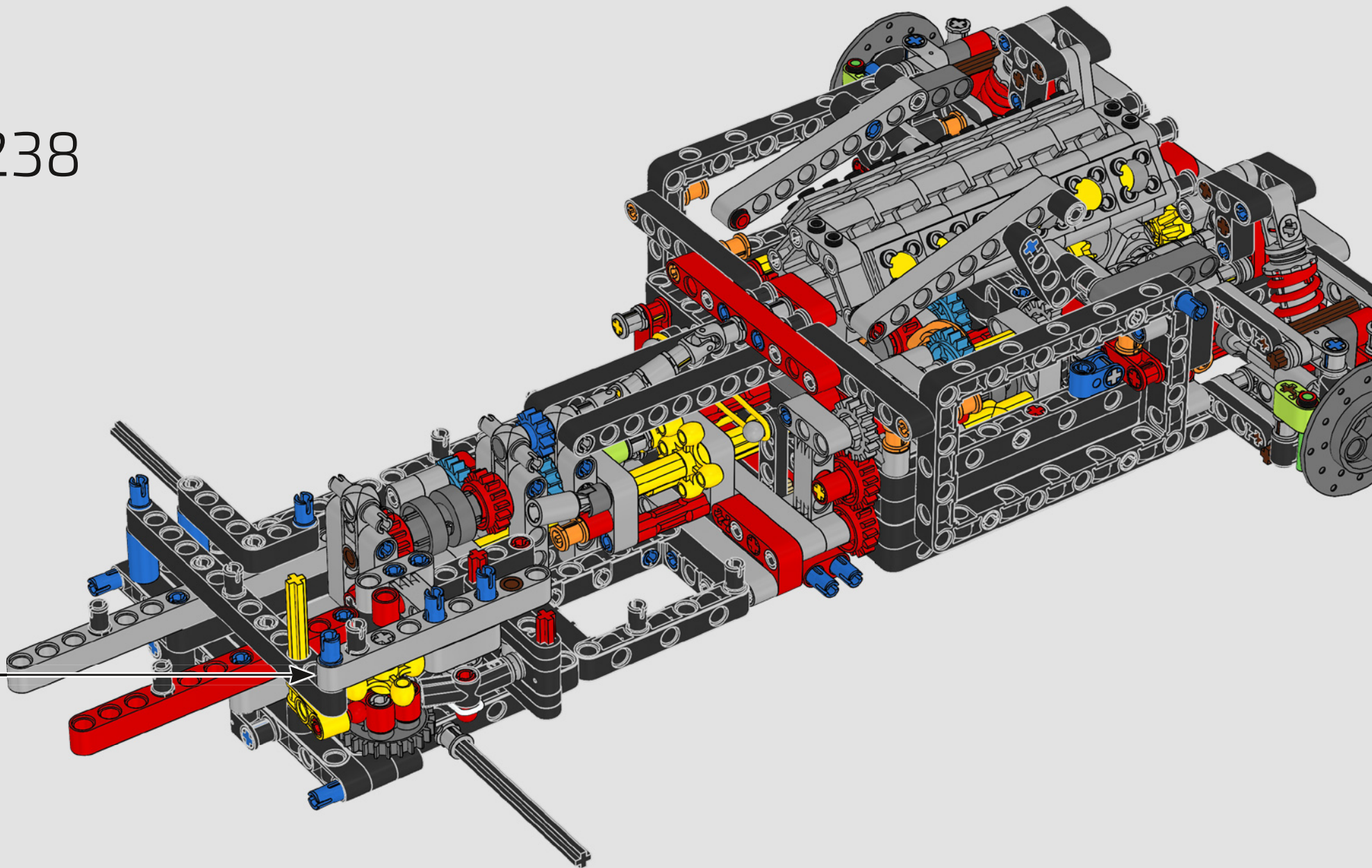

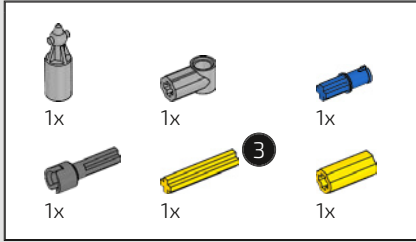

239

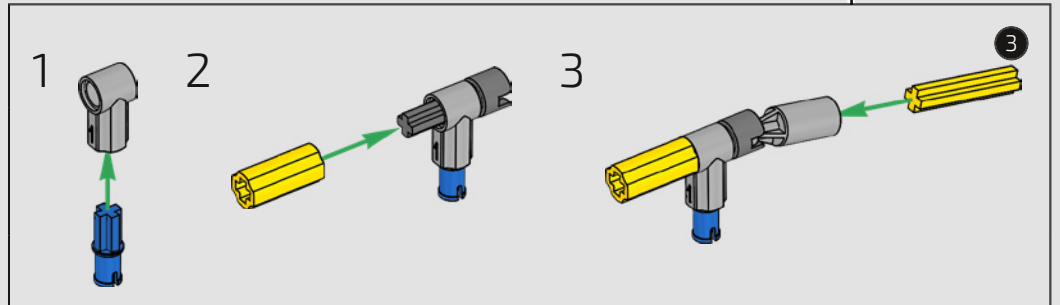
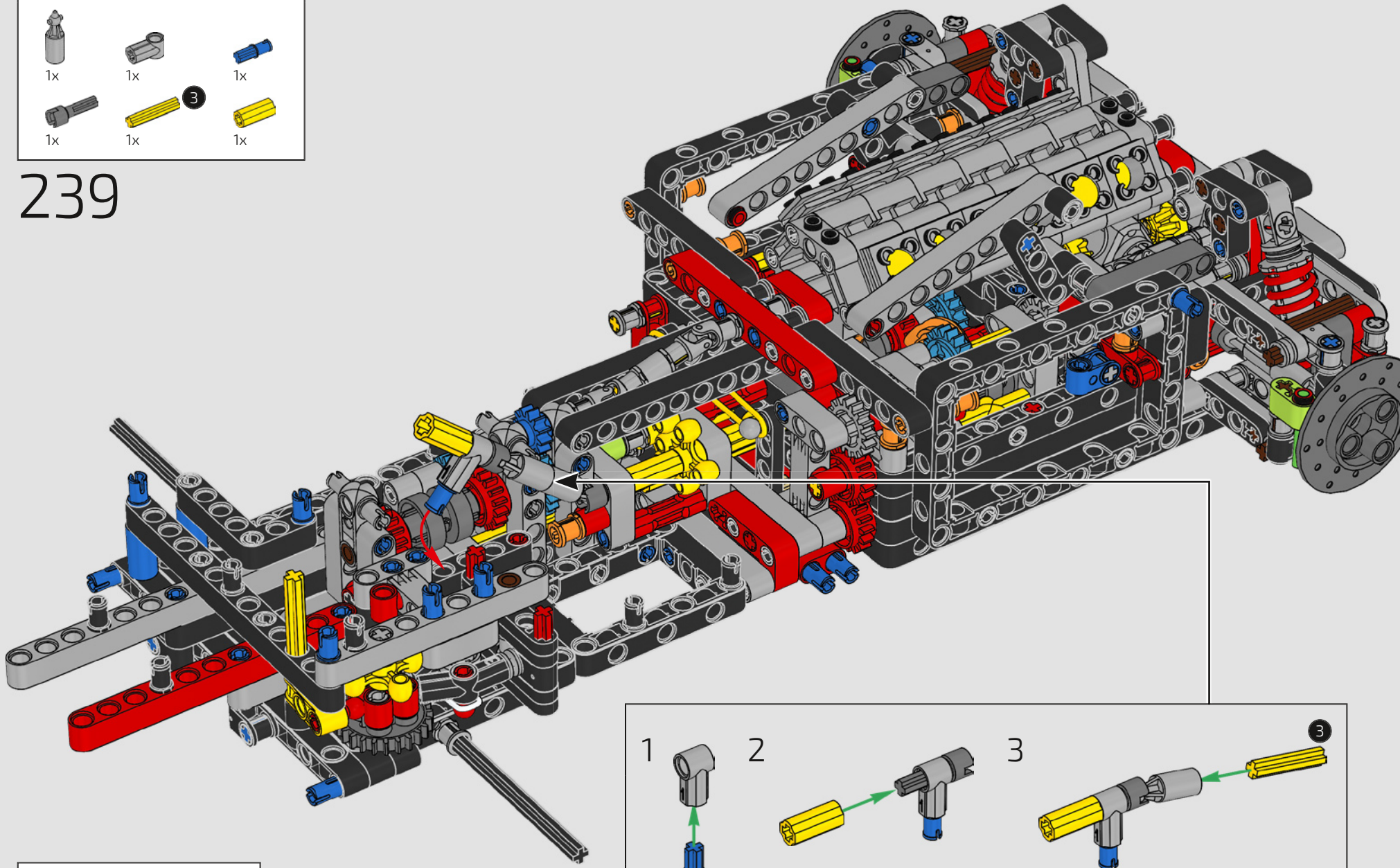

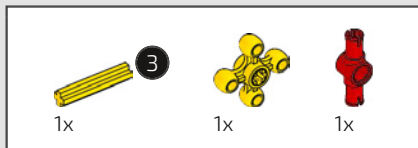

240

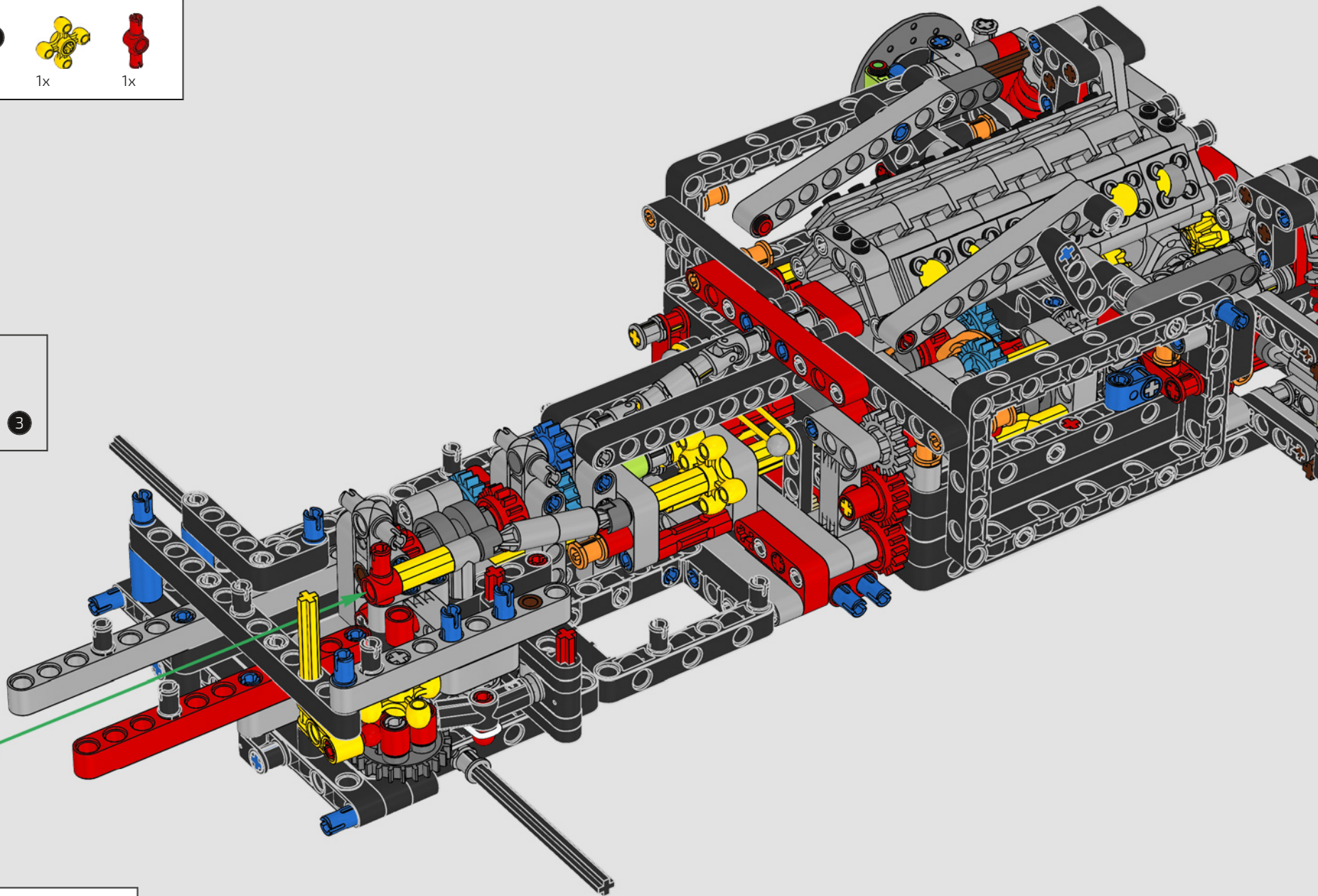
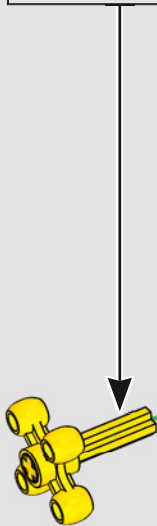
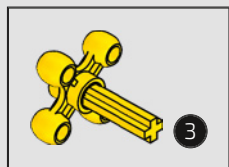

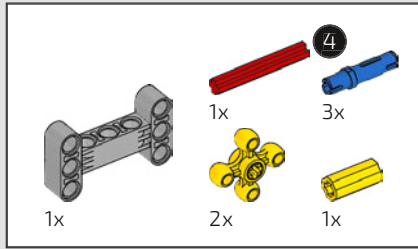

241

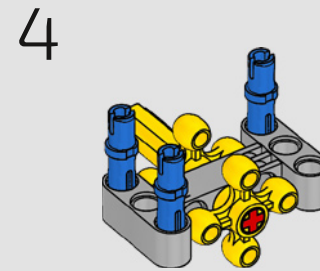
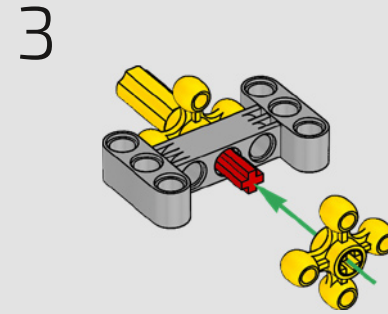
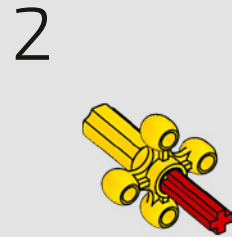
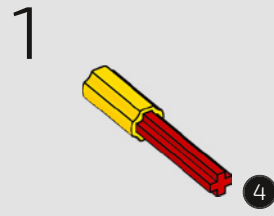

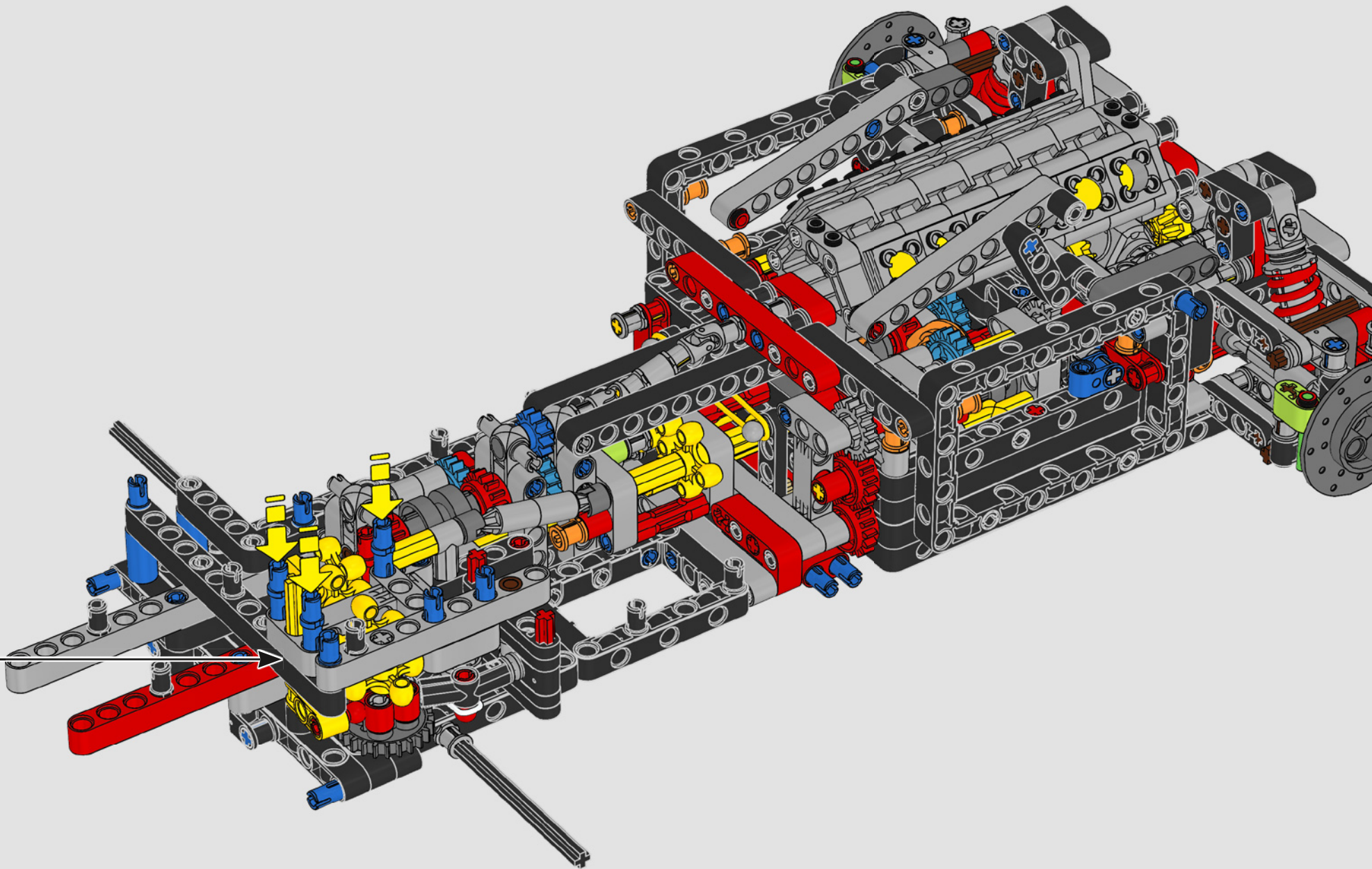

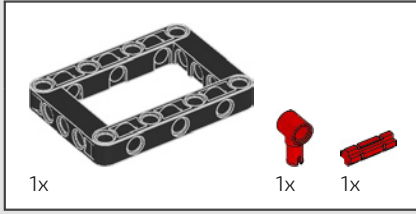

242

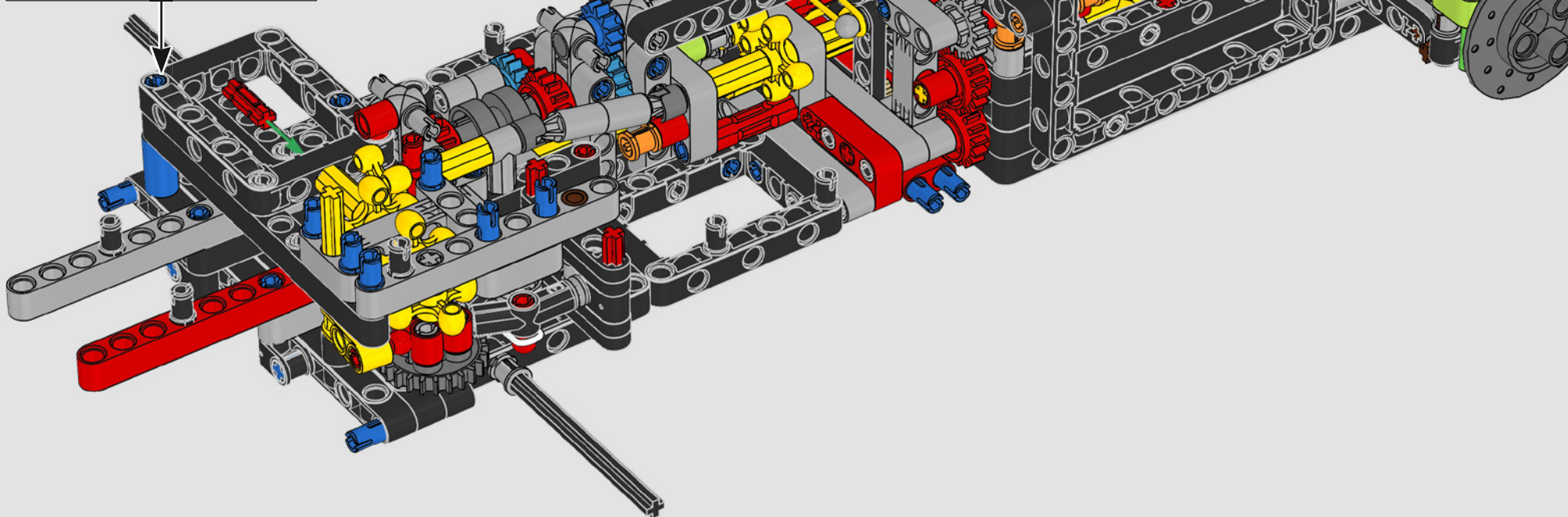
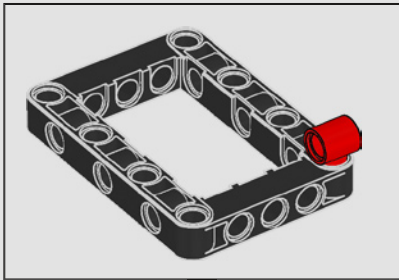

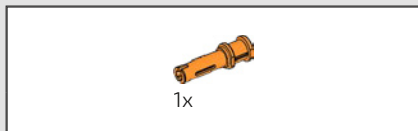

243

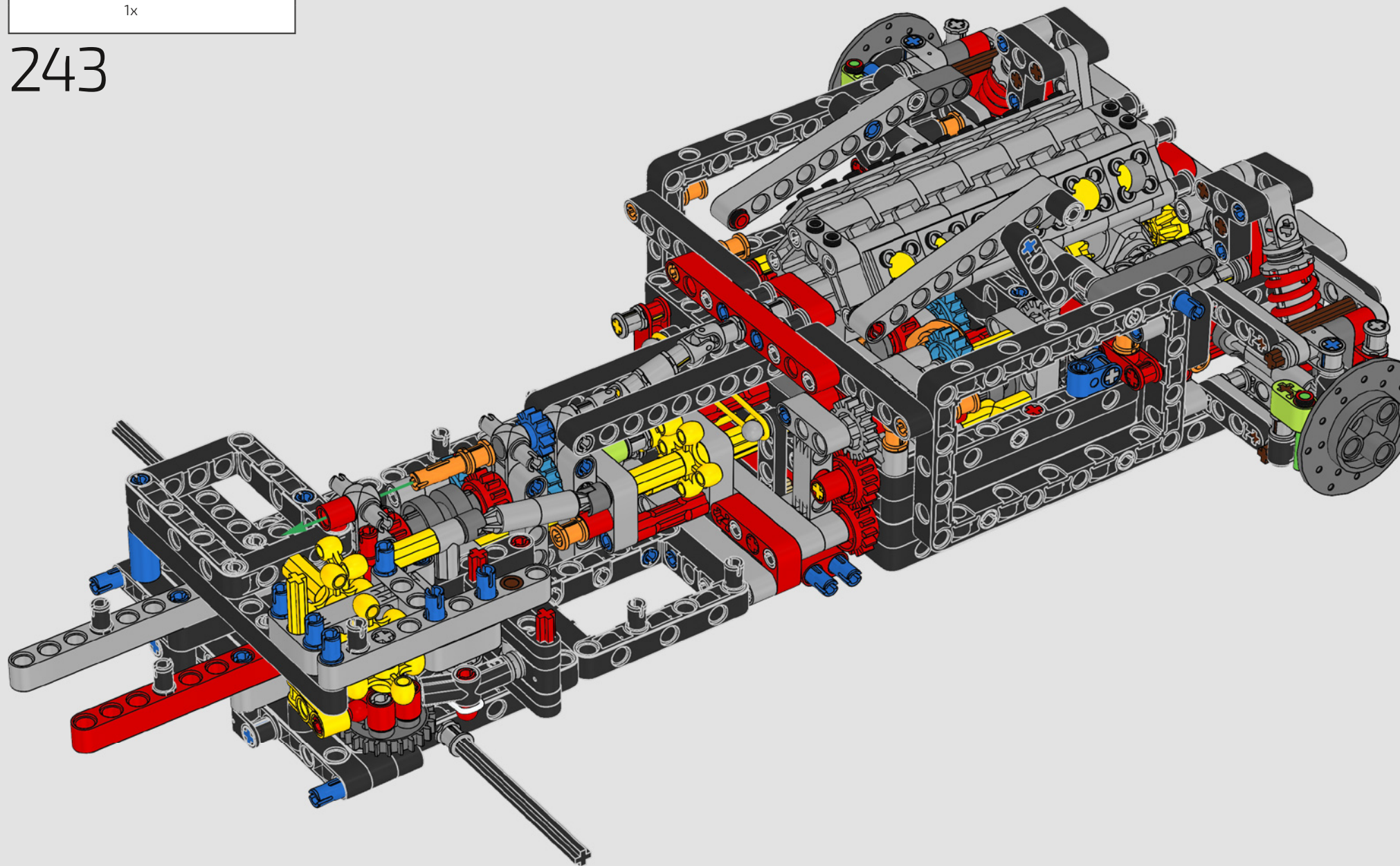

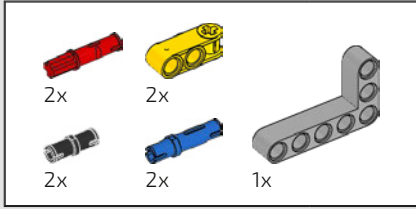

244

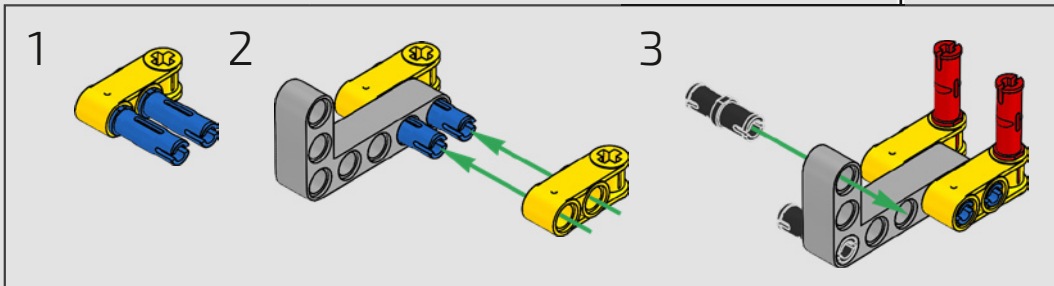
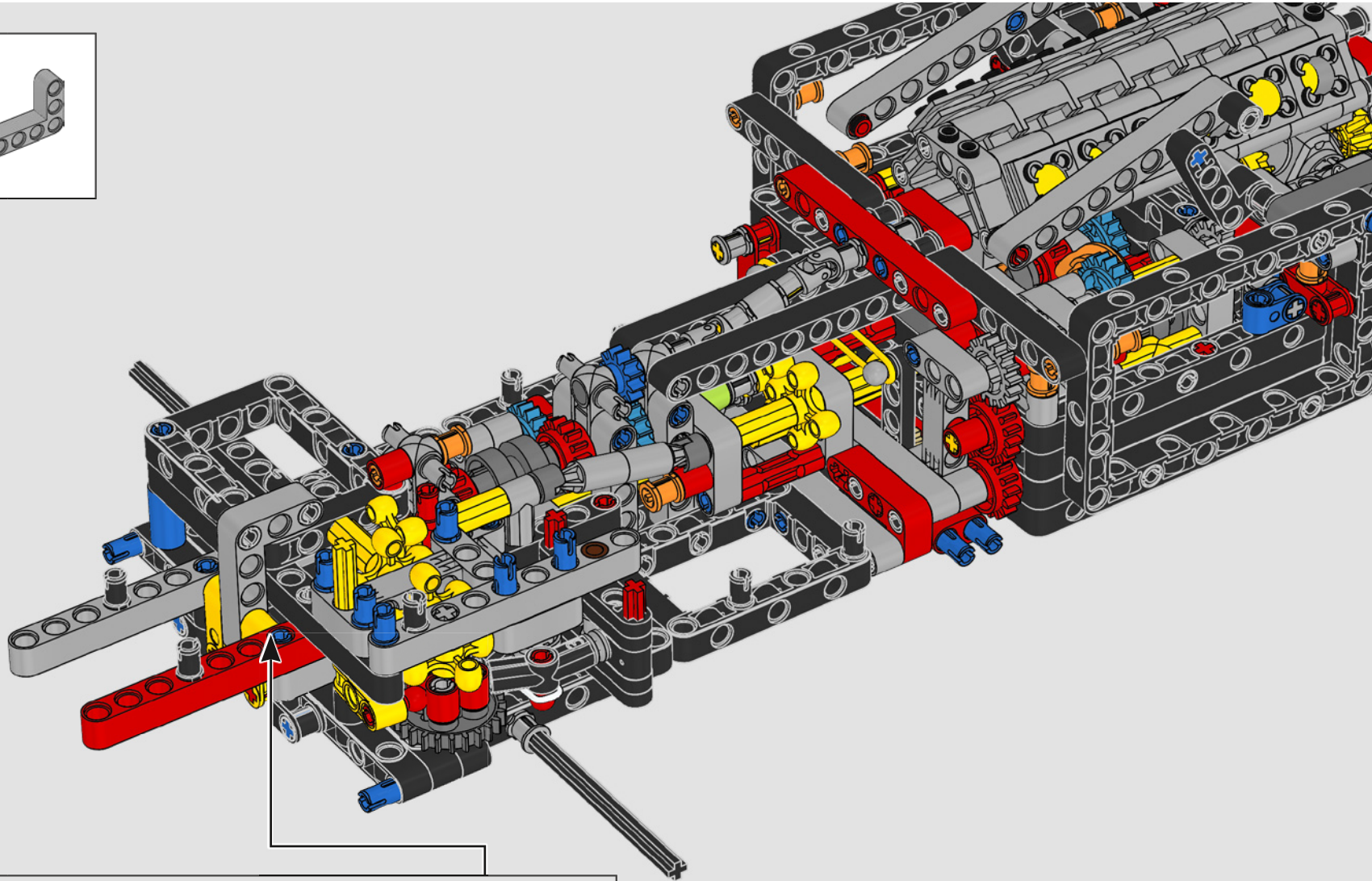

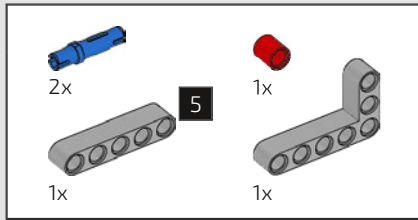

245

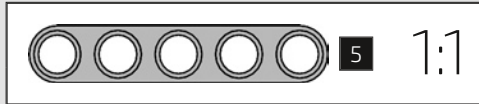
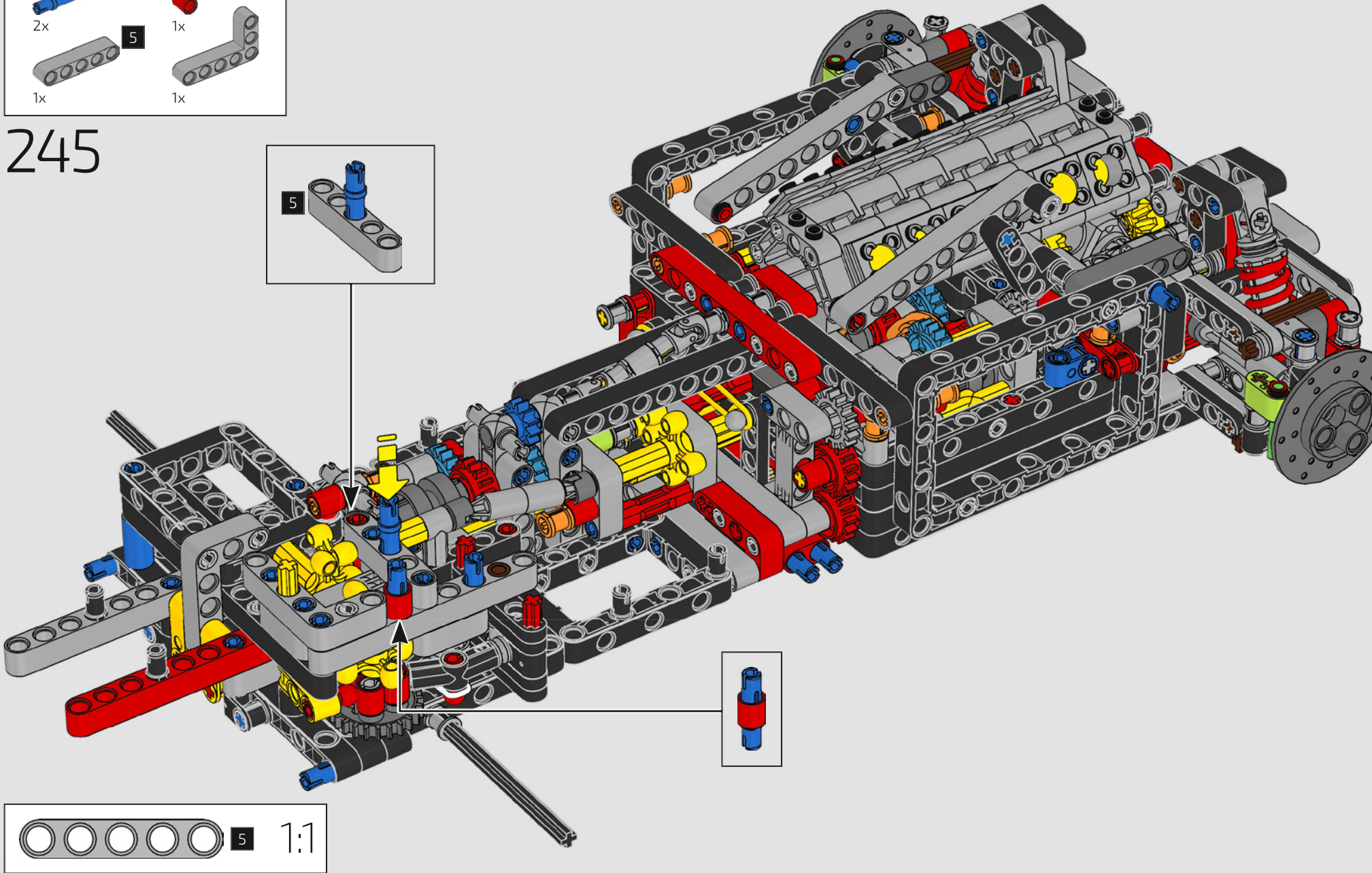
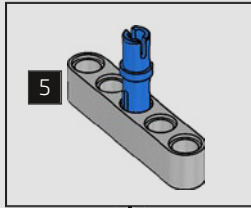

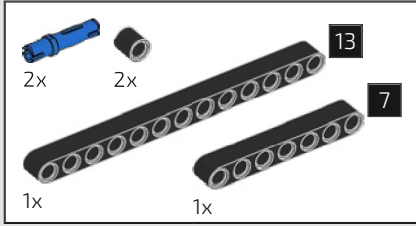

246

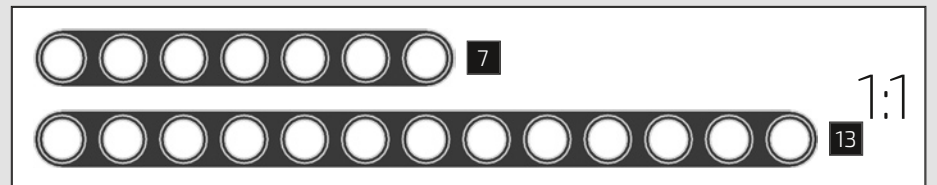
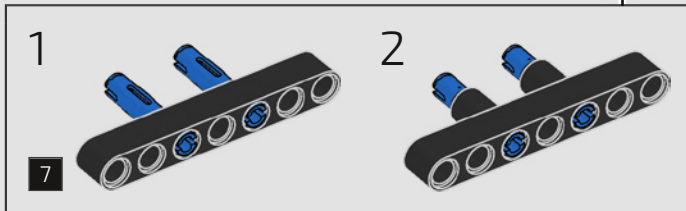
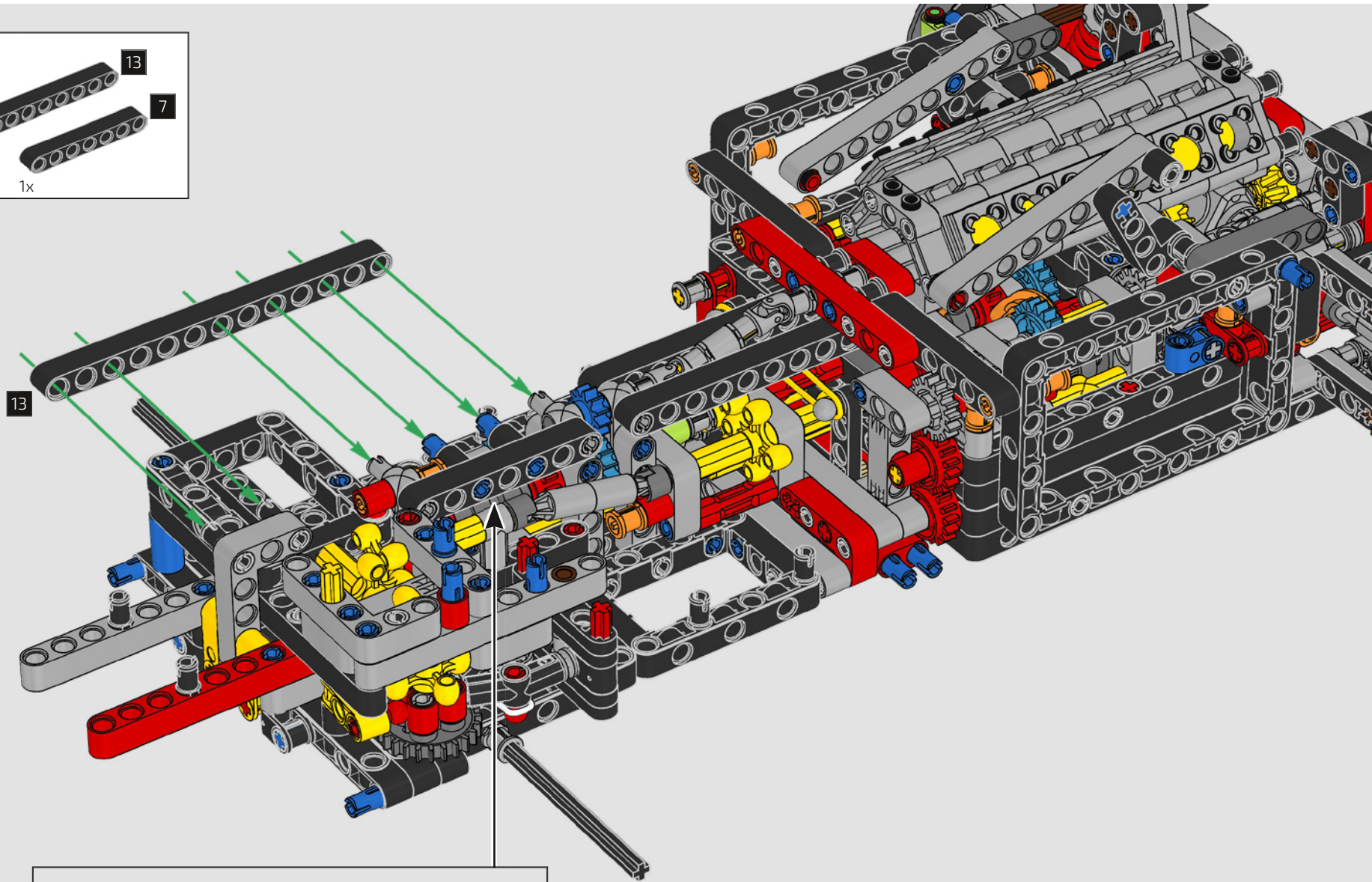

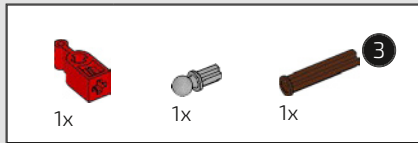

247

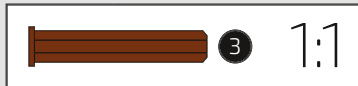
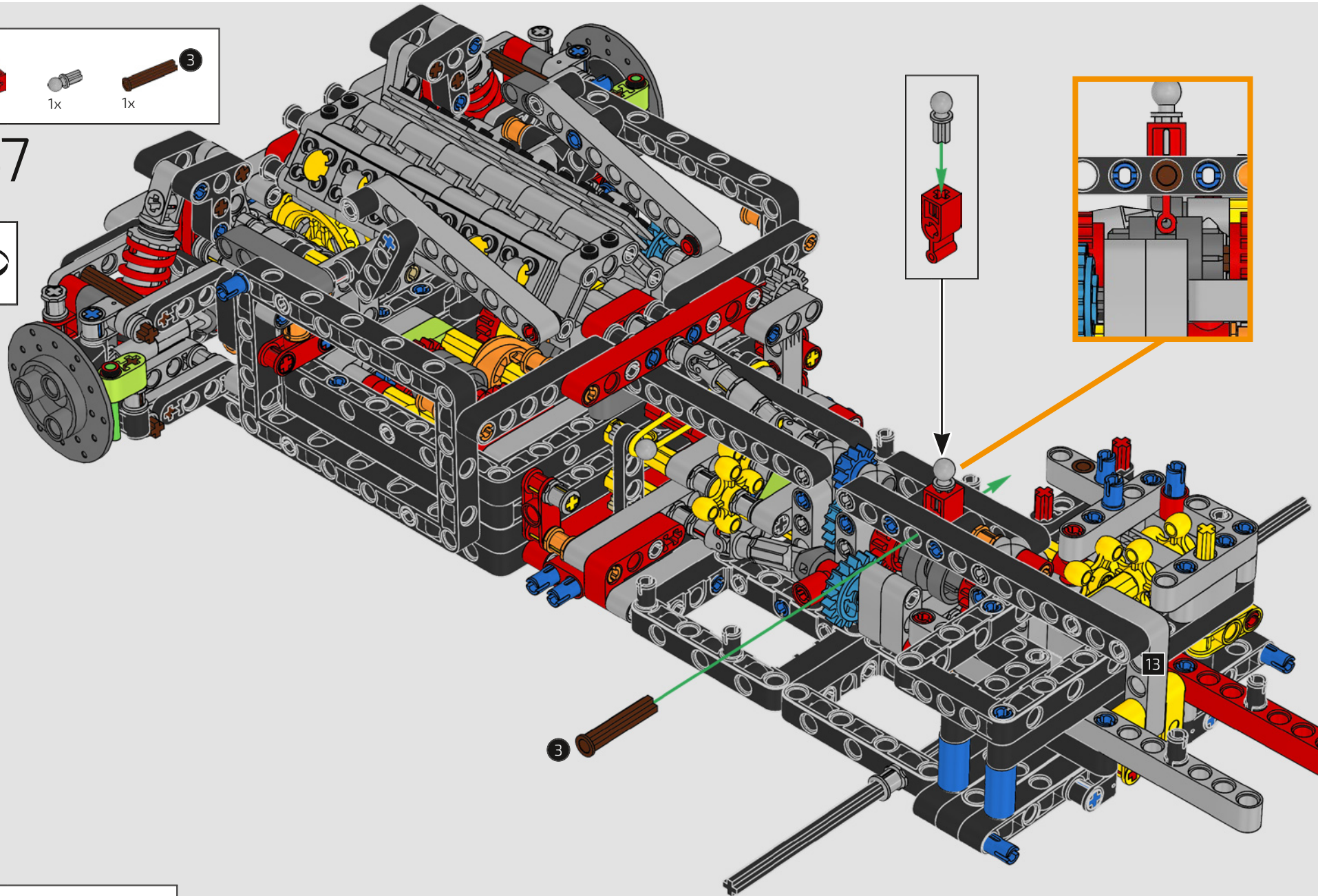

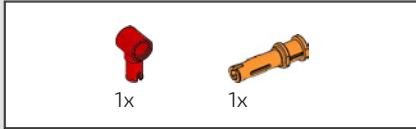

248

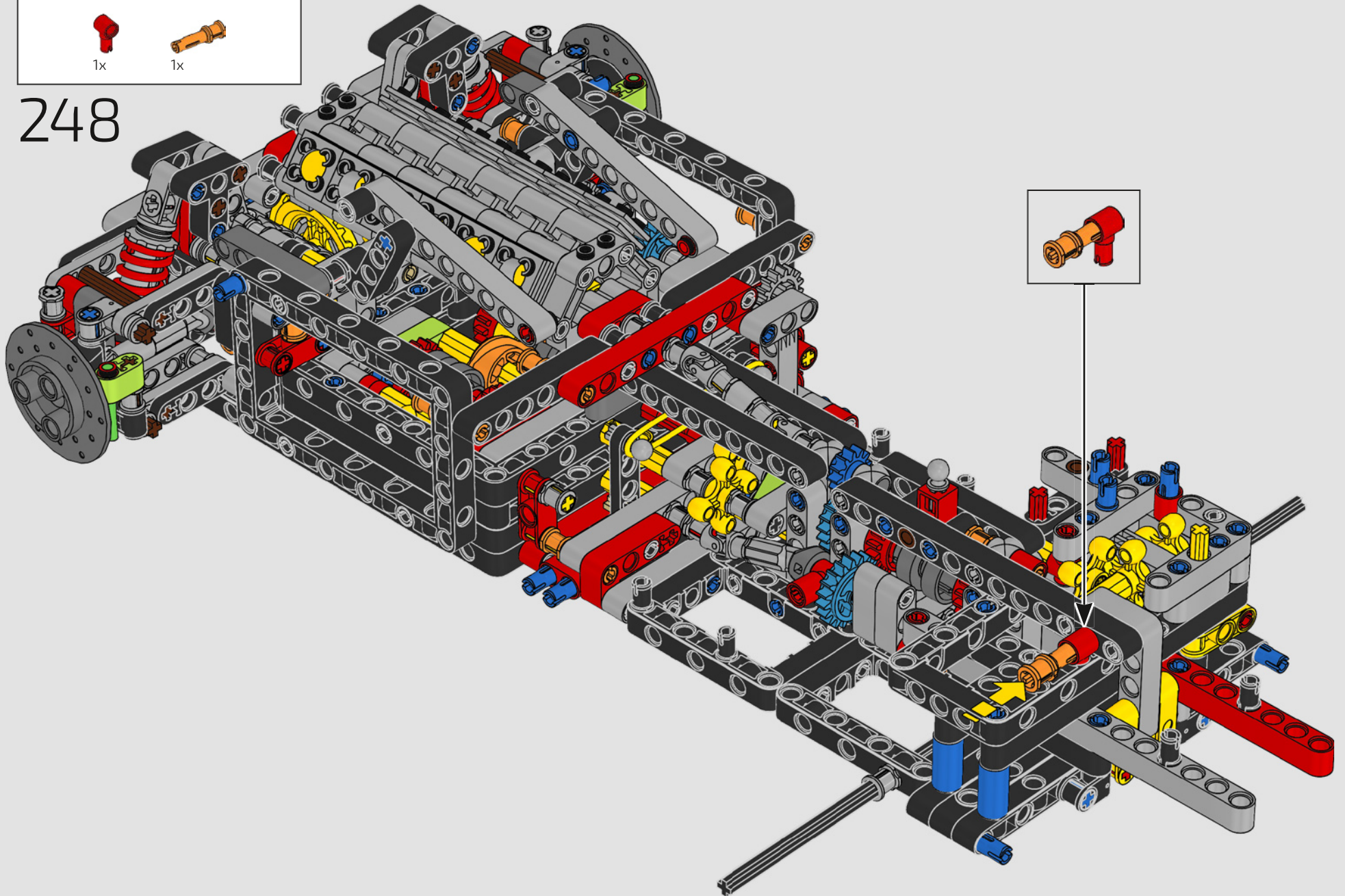



249

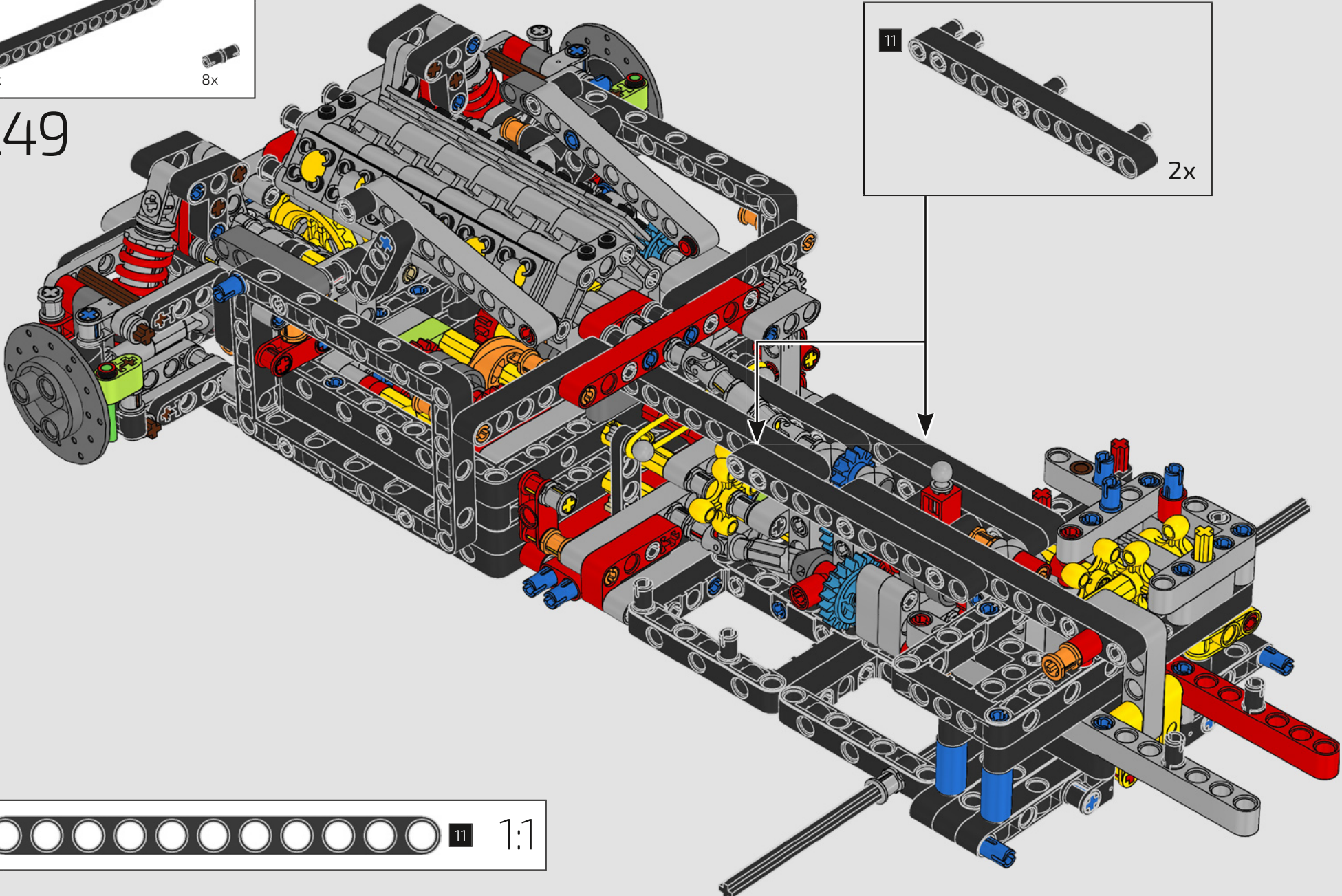
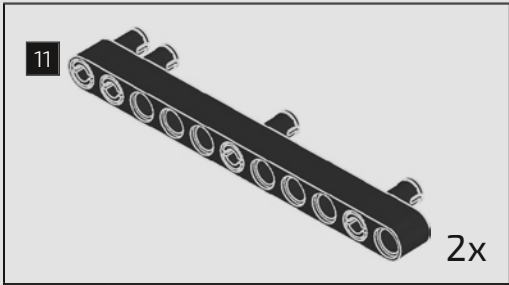

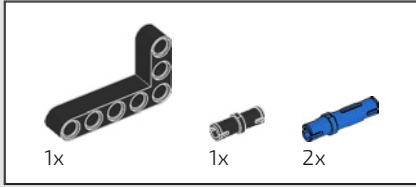

250

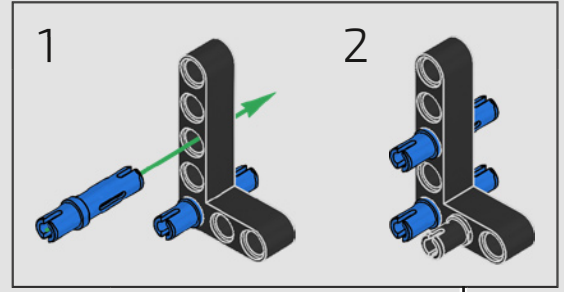
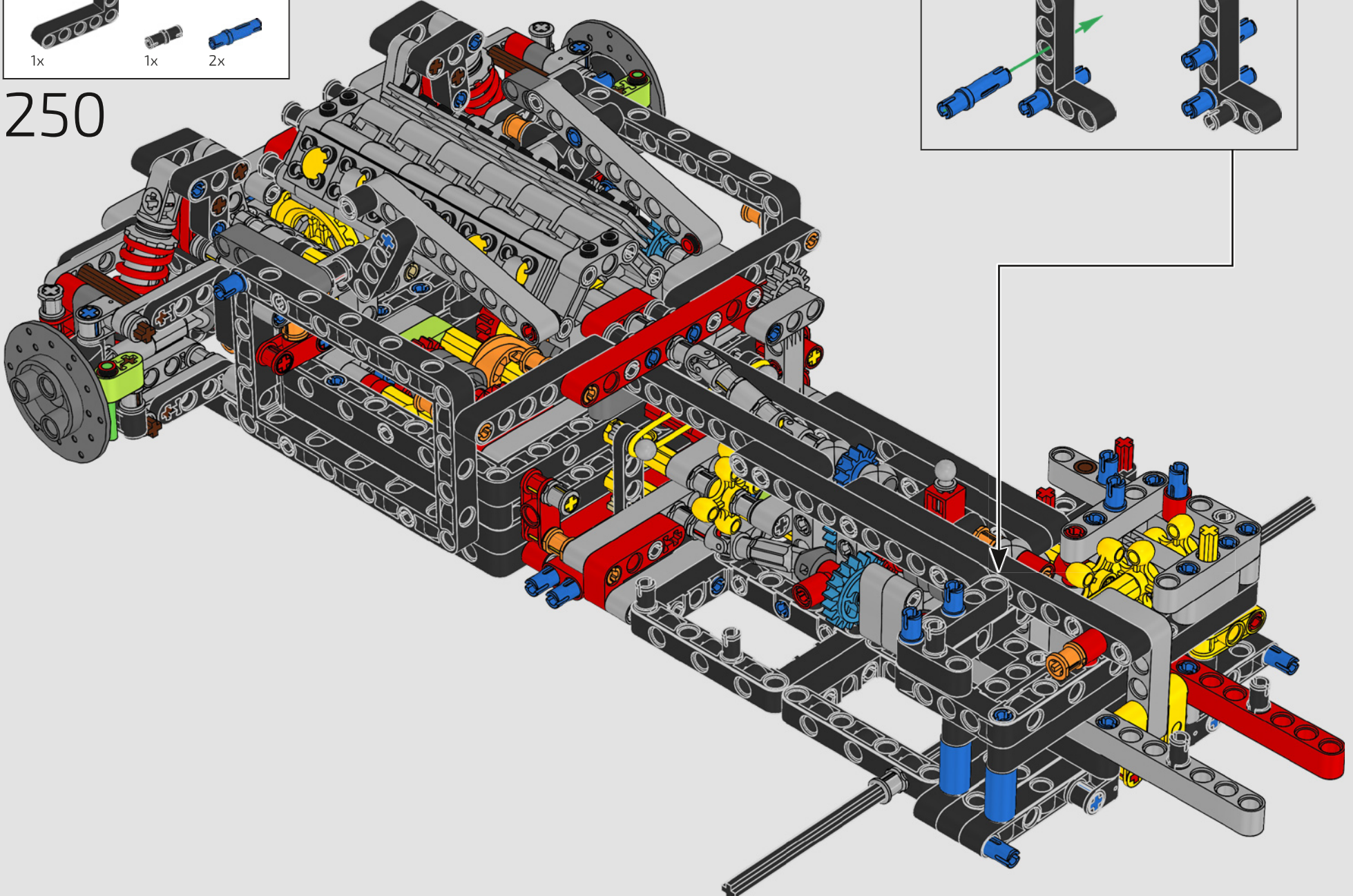

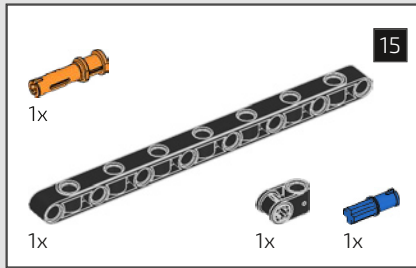

251

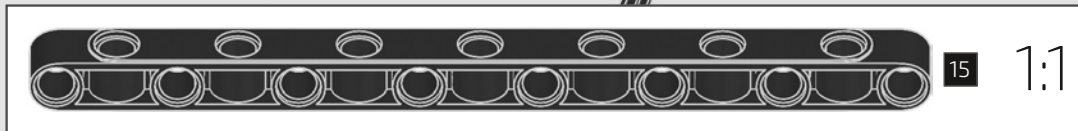
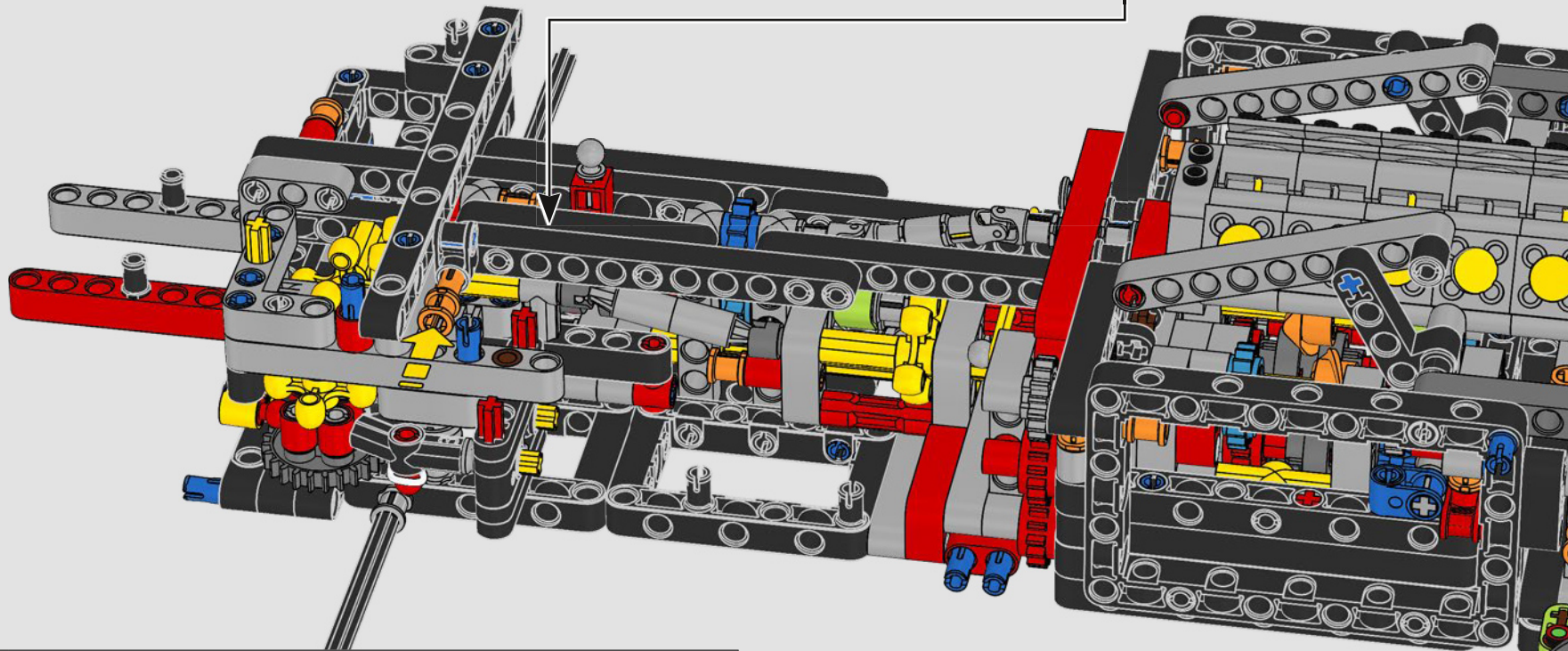
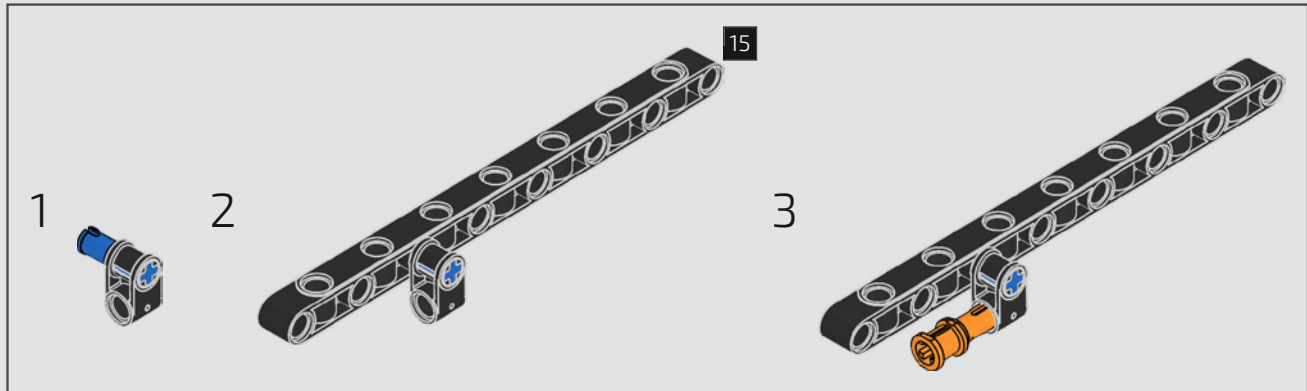

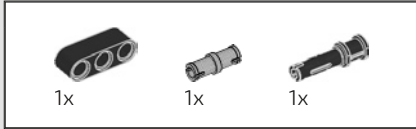

252

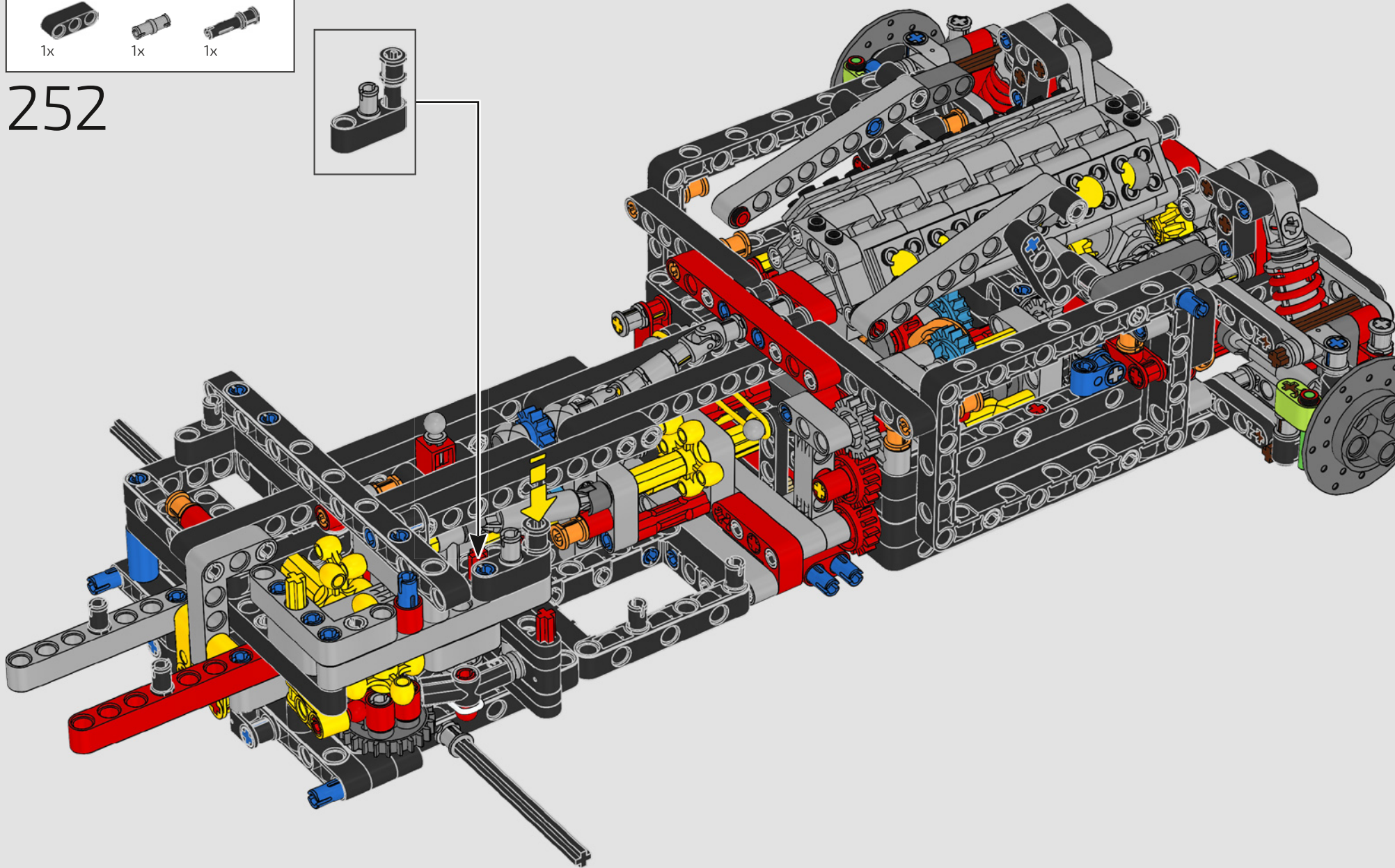
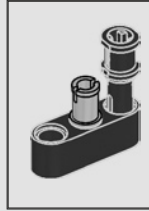

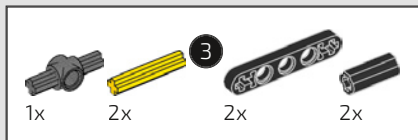

253

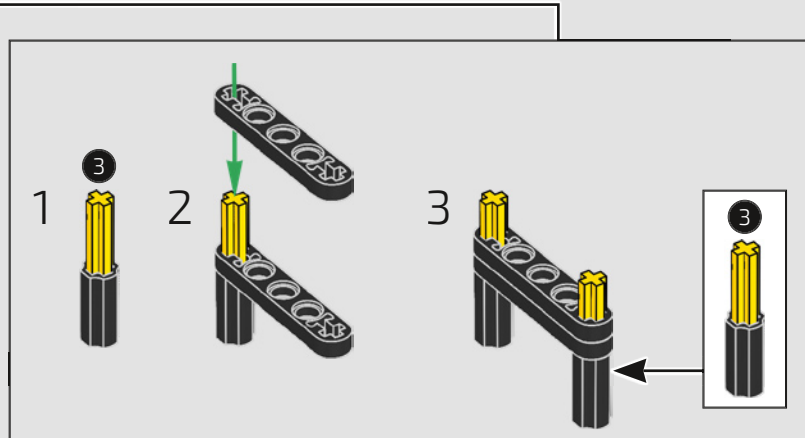
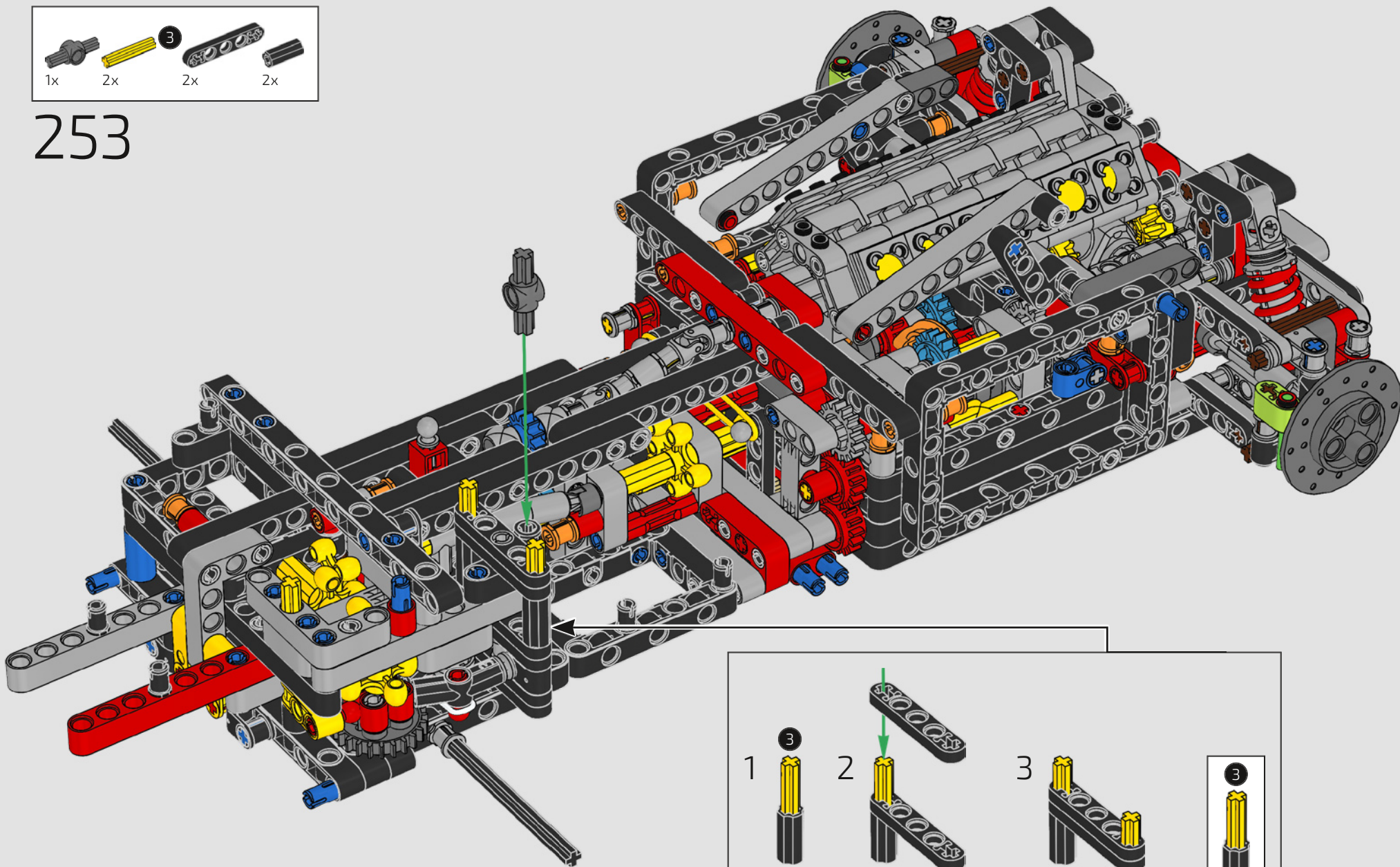

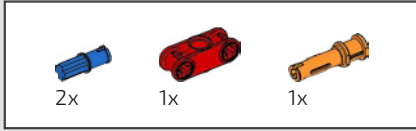

254

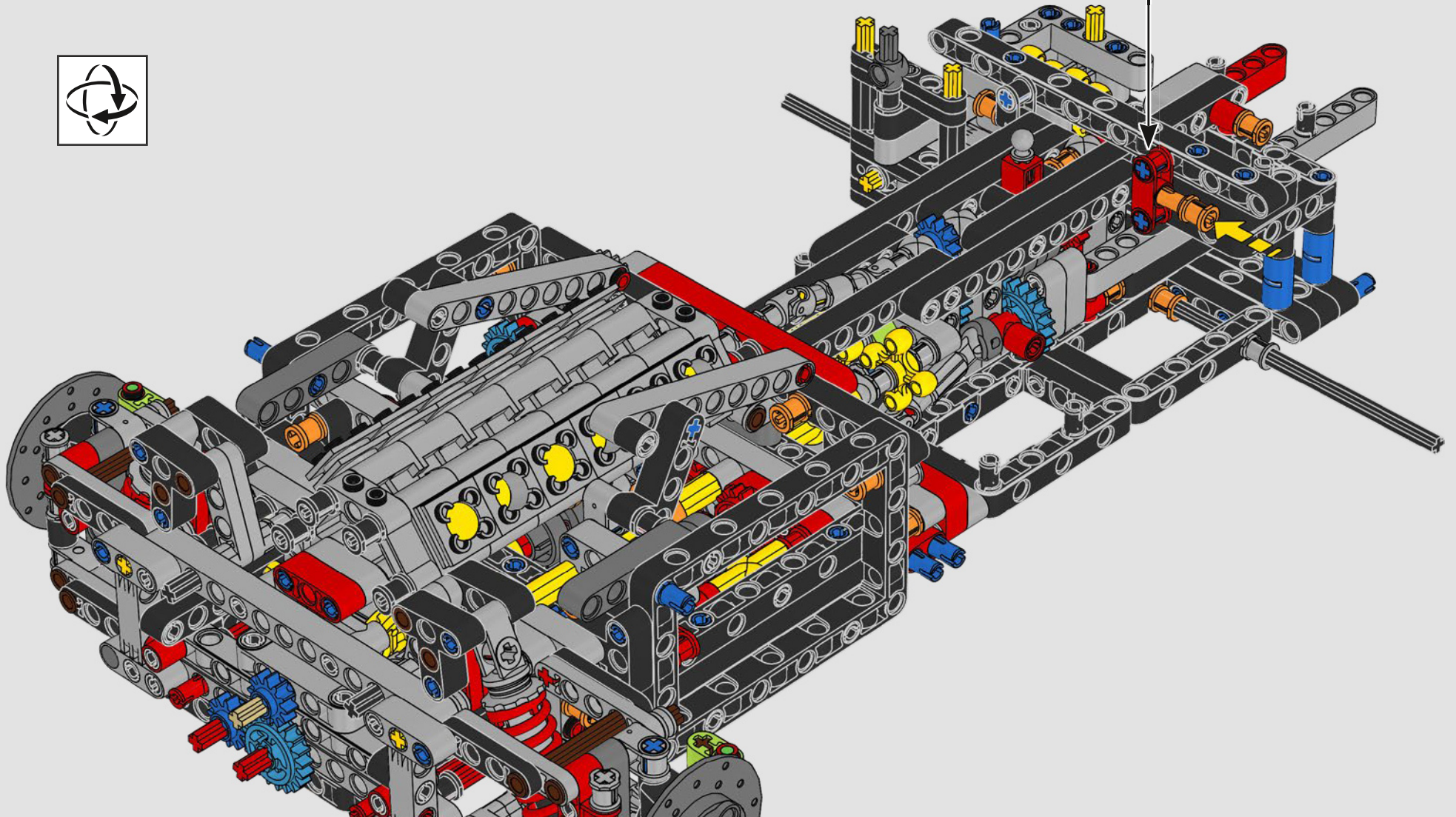
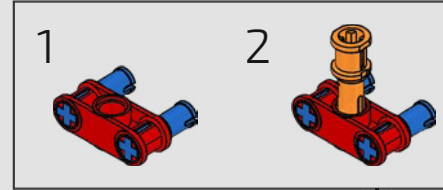

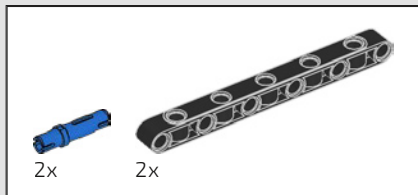

255

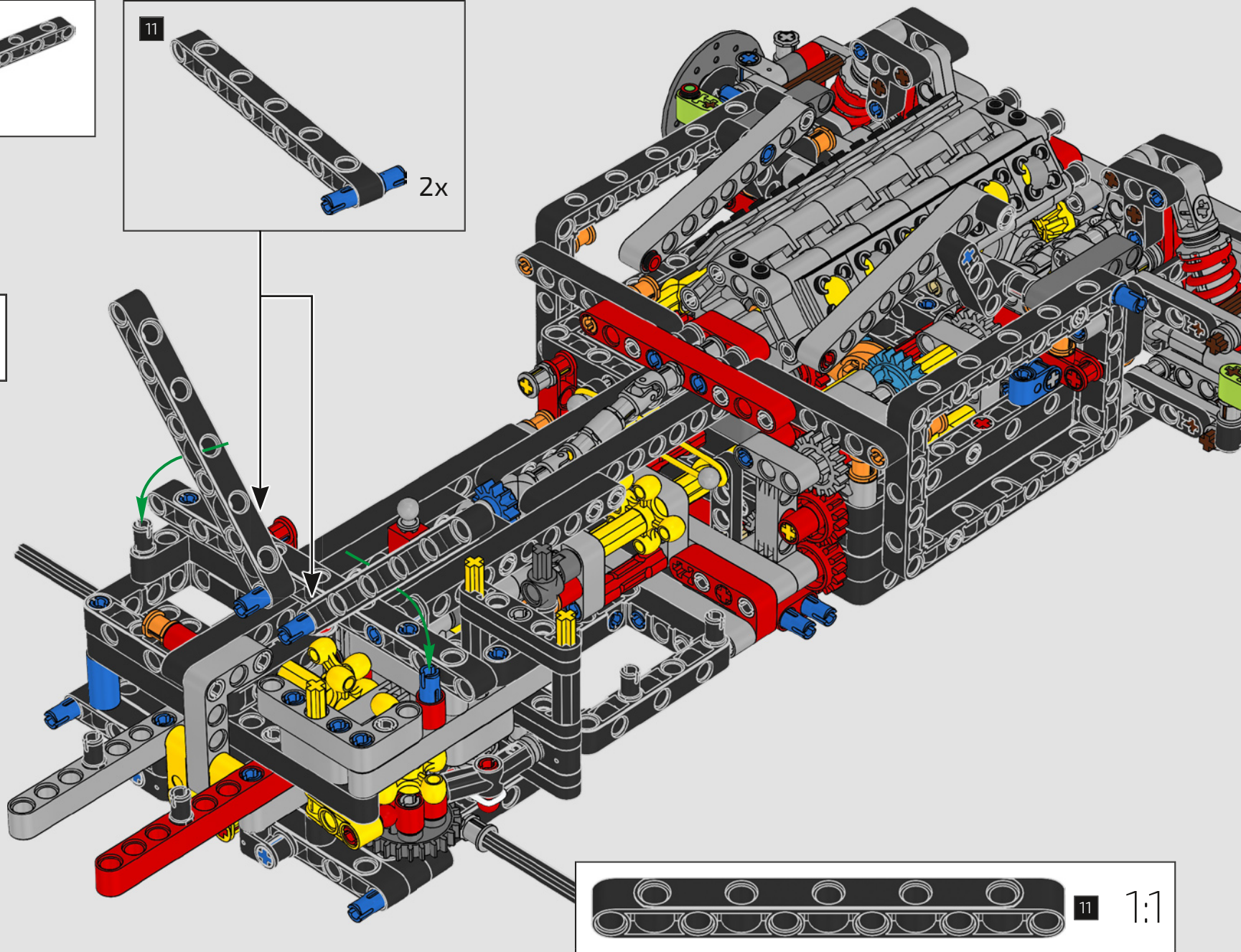
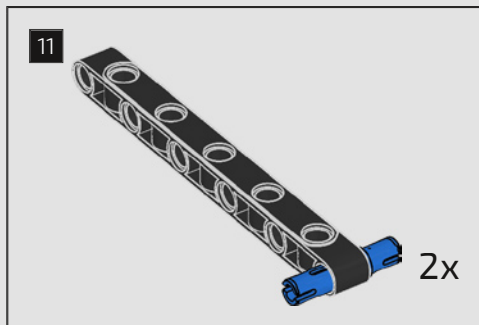

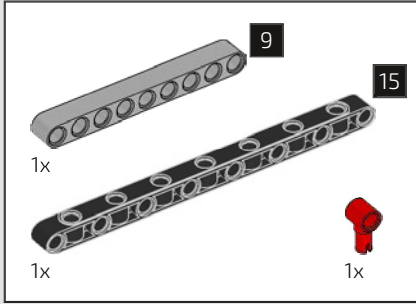

256

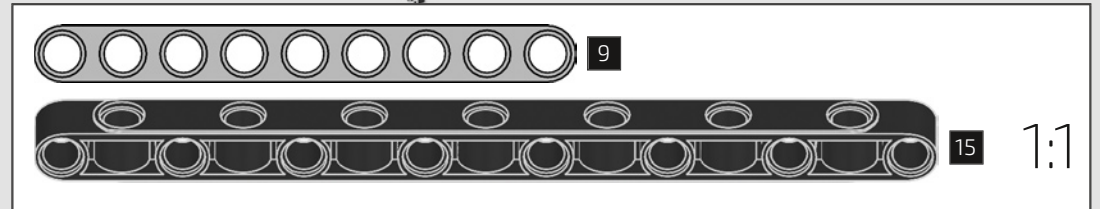
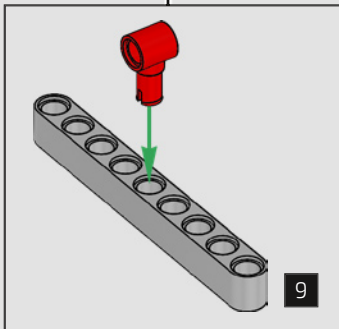
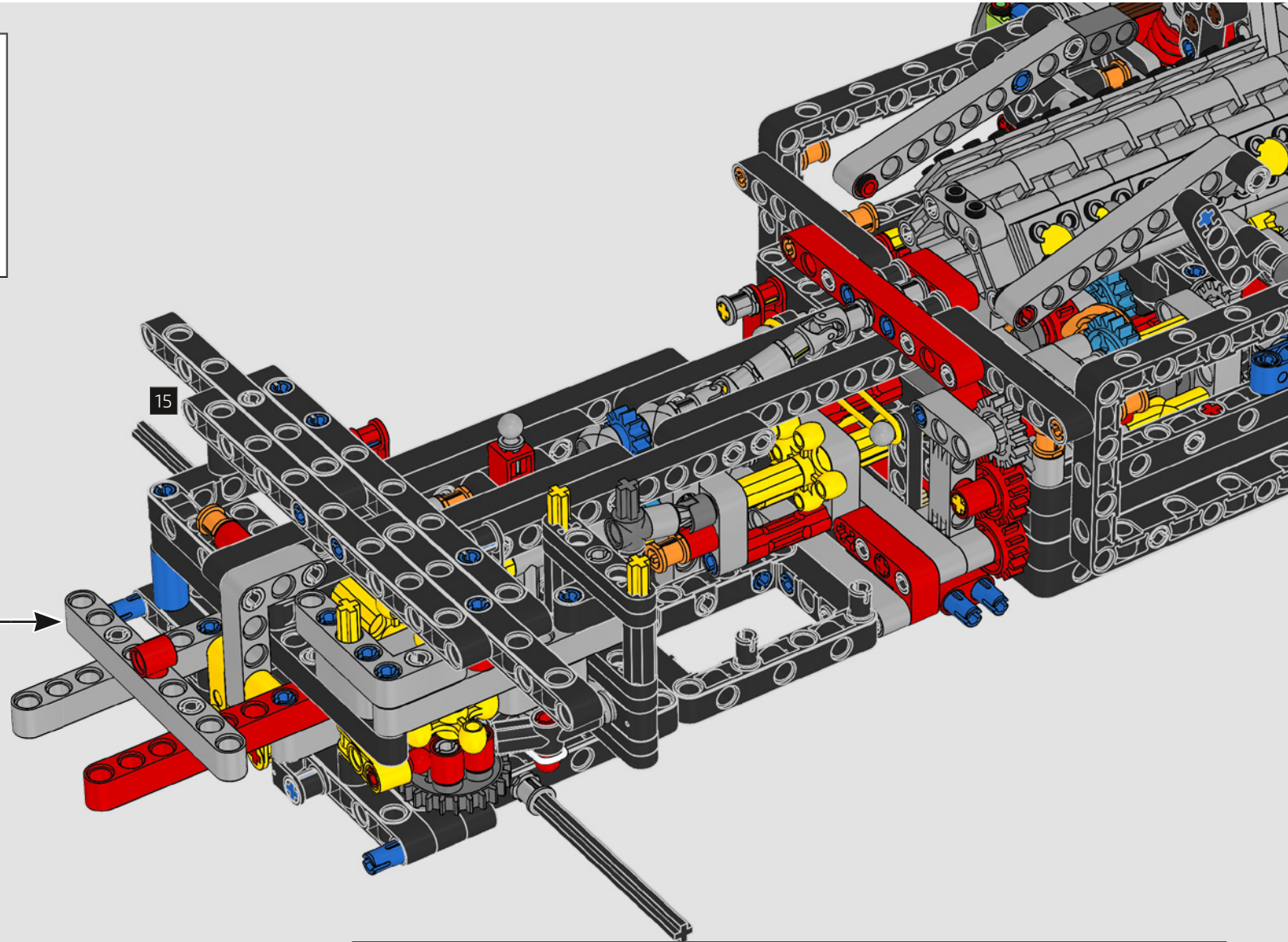



257

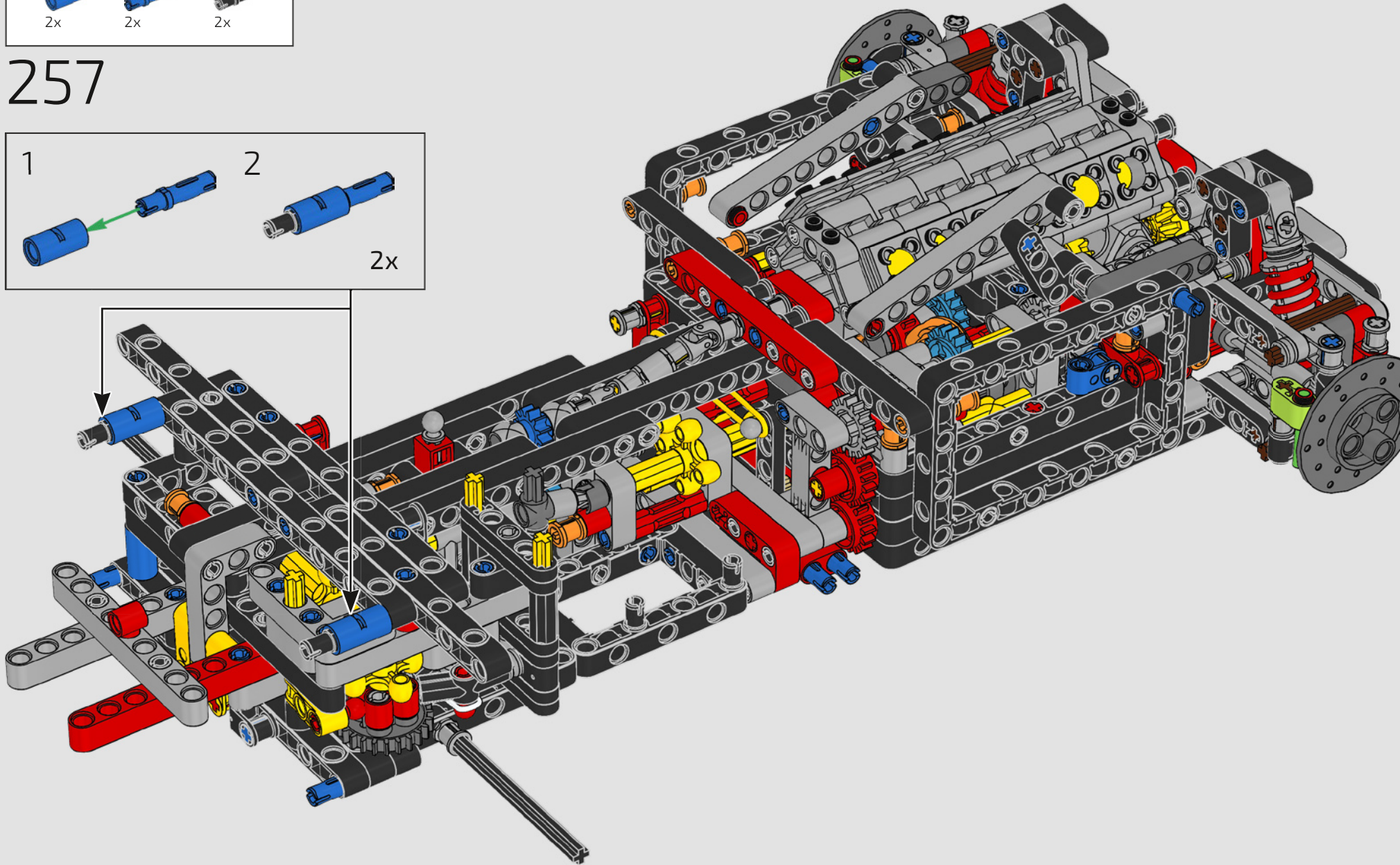
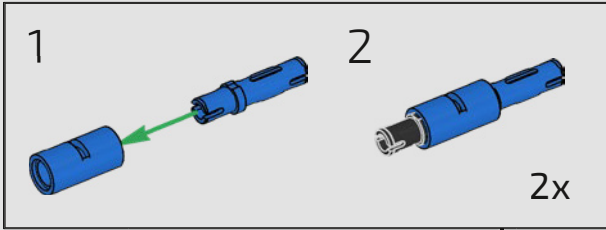

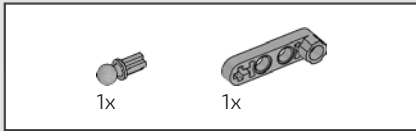

258

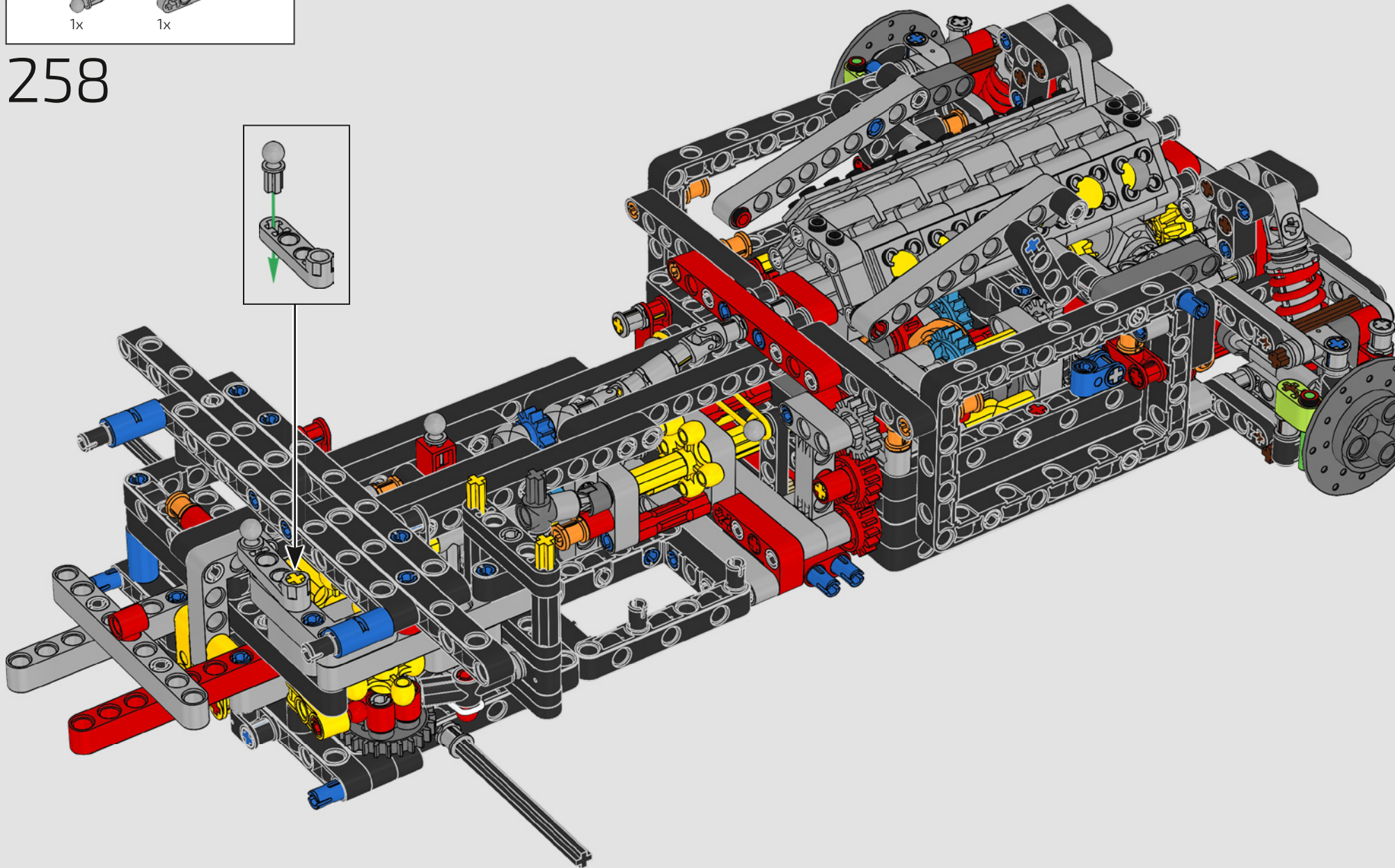
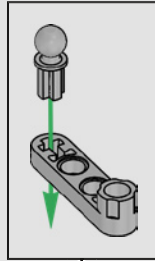

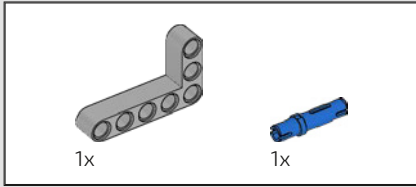
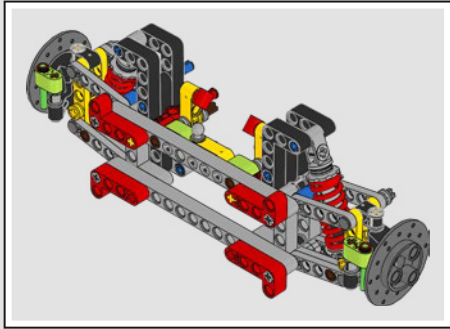

259

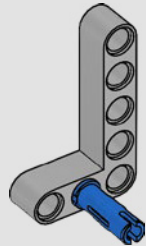

260

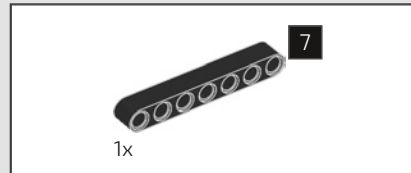
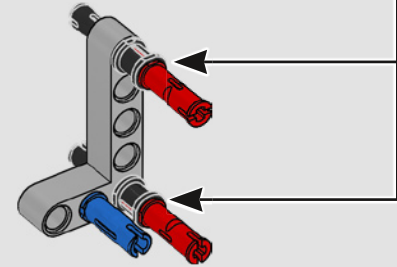
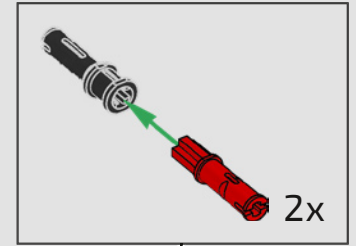

261

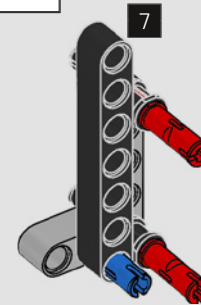

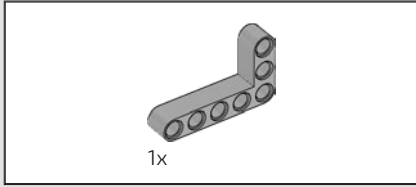

262

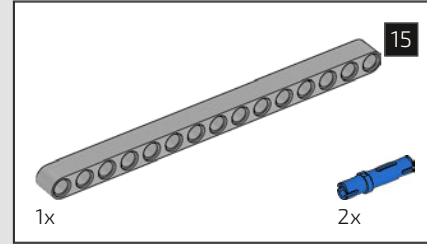
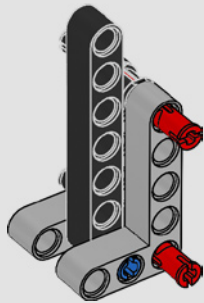

263

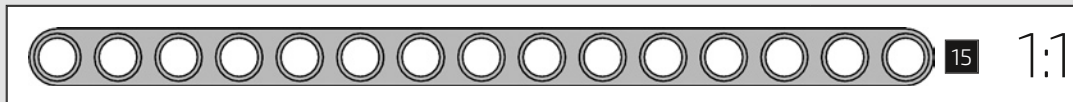
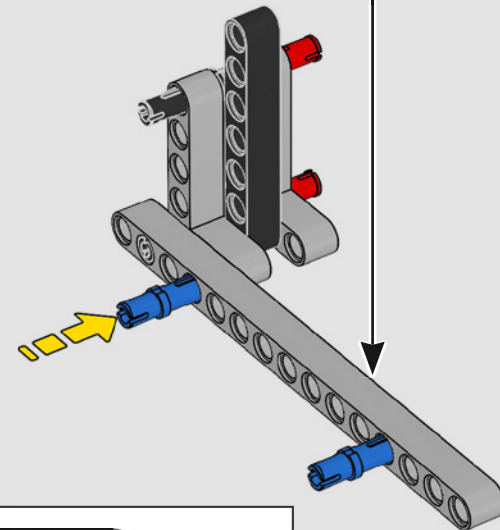
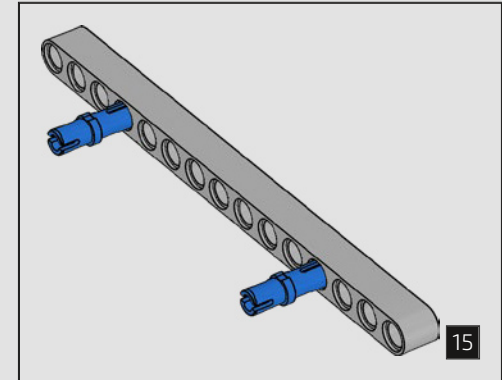

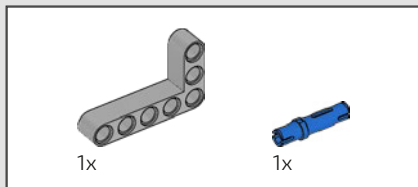

264

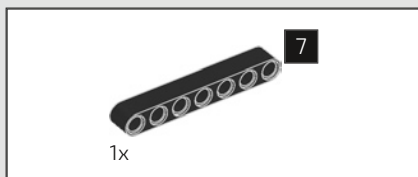
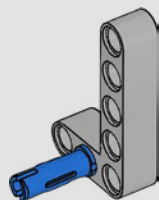

265

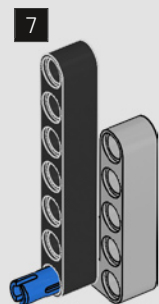

266

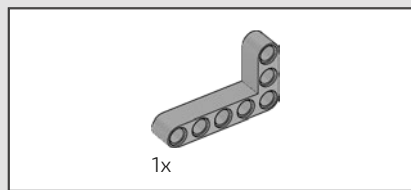
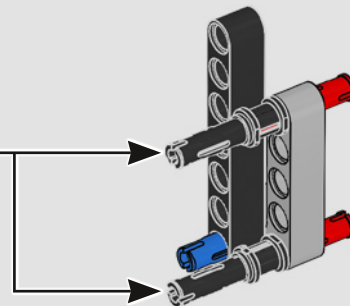
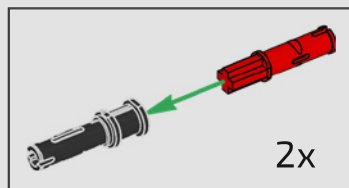

267

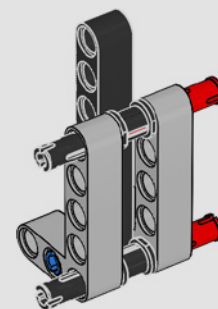

268

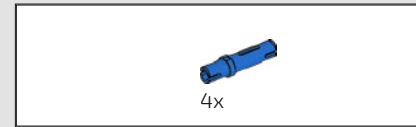
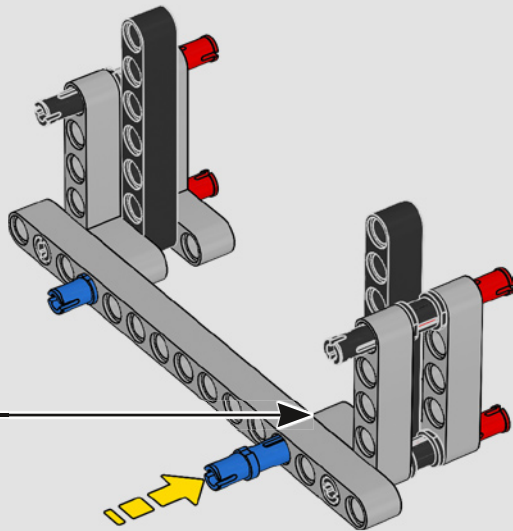

269

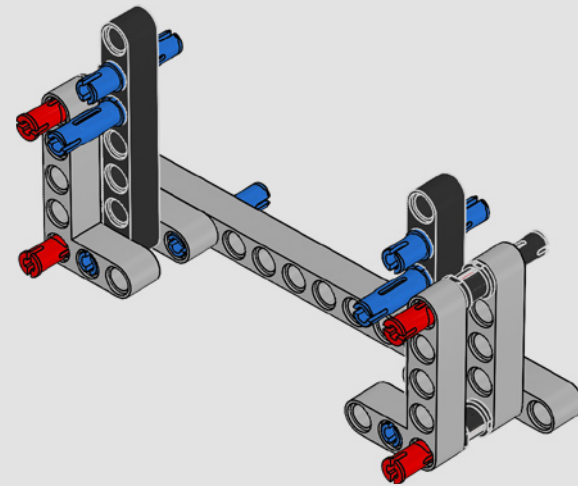

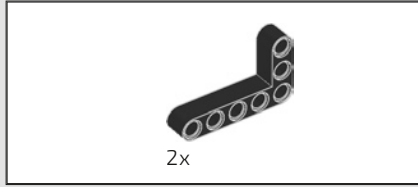

270

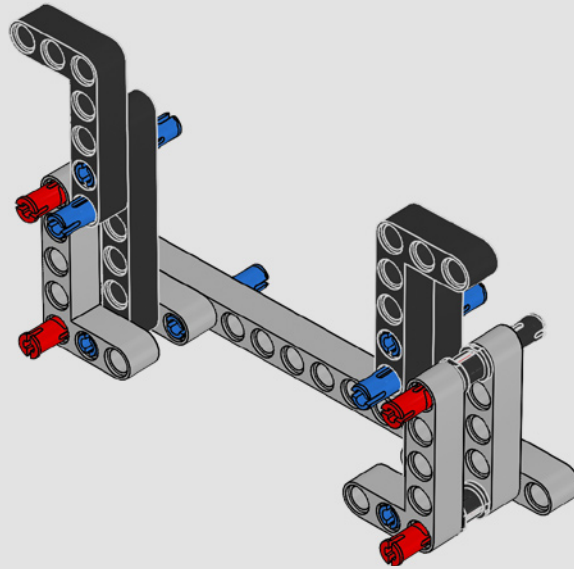

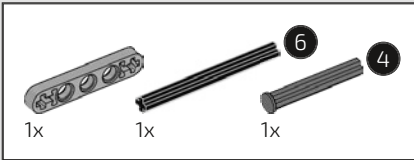
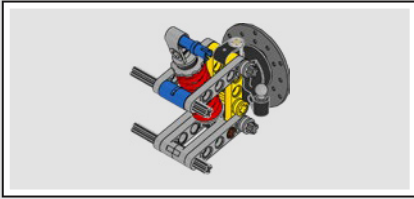

271

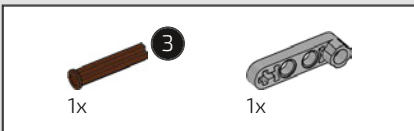
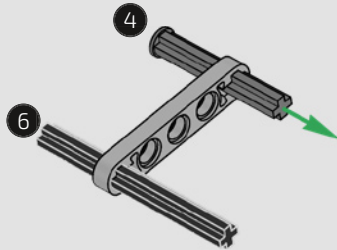

272

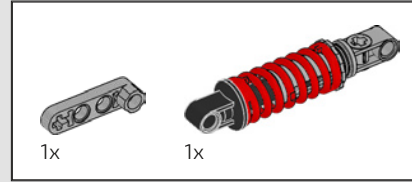
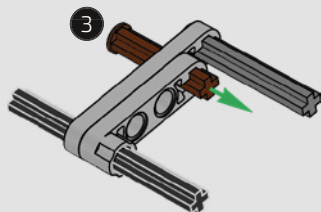

273

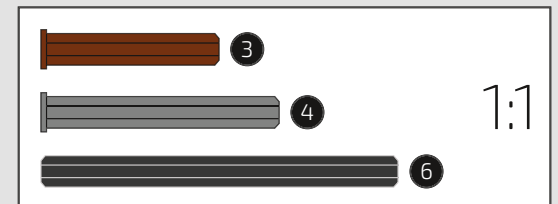
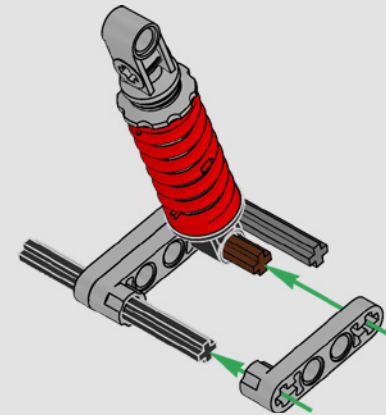

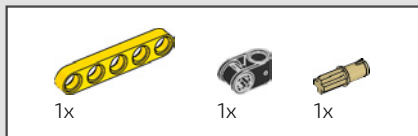

274

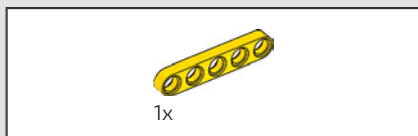
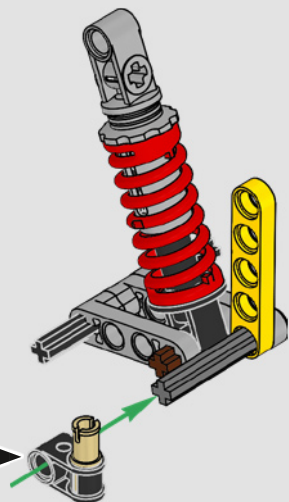
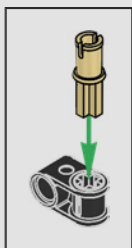

275

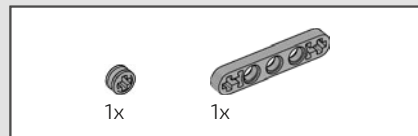
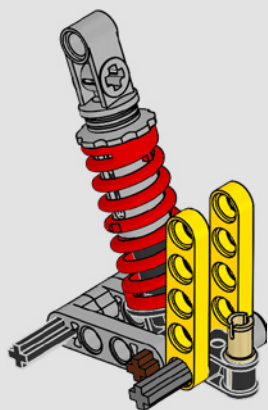

276

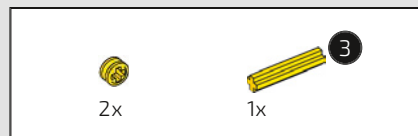
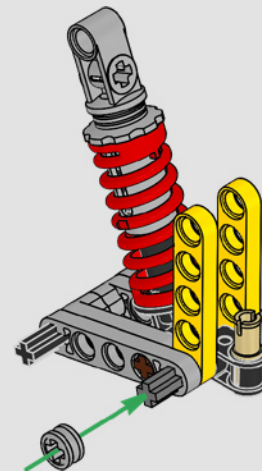

277

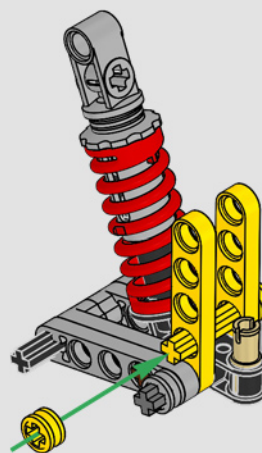
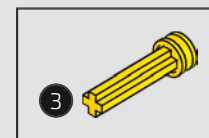

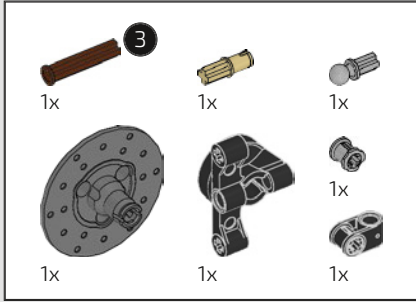

278

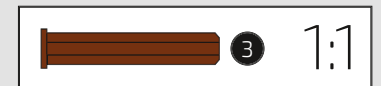
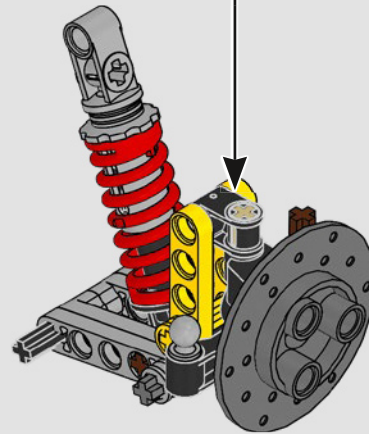
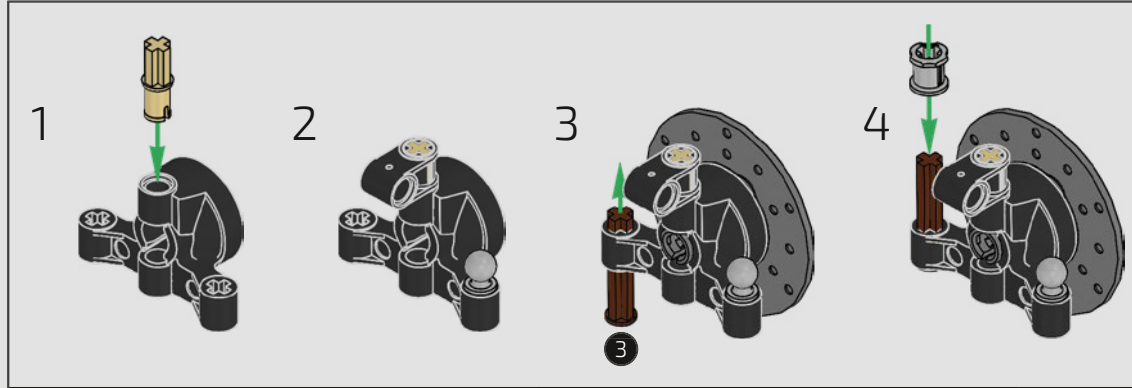

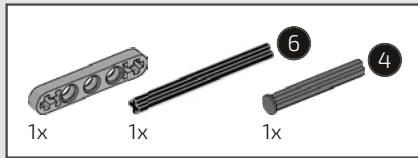

279

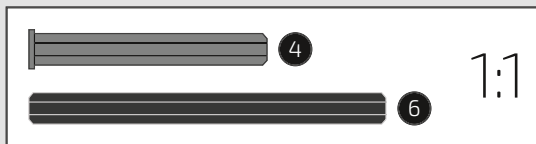
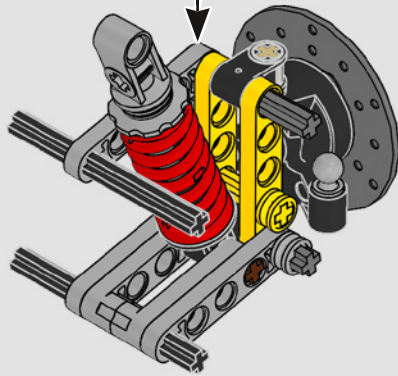
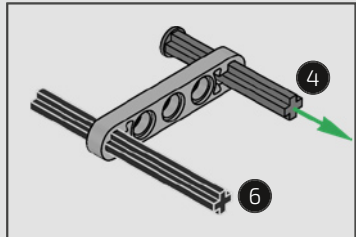

280

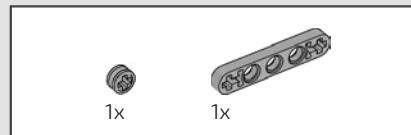
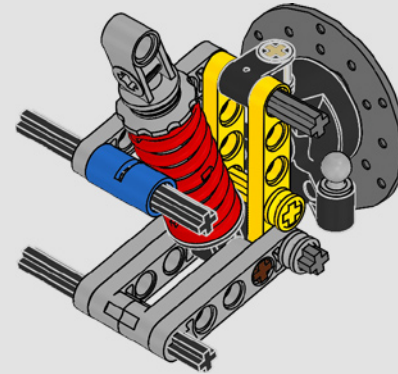

281

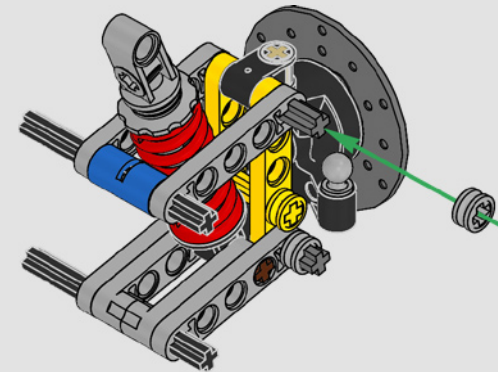

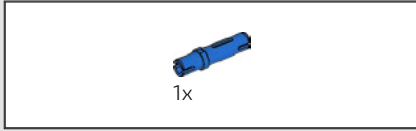

282

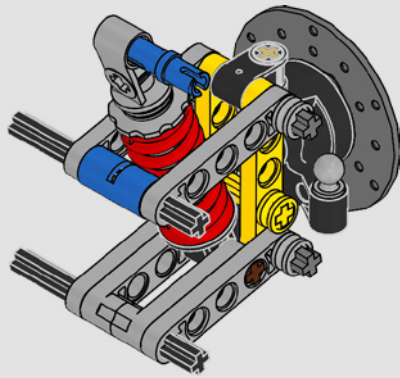

283

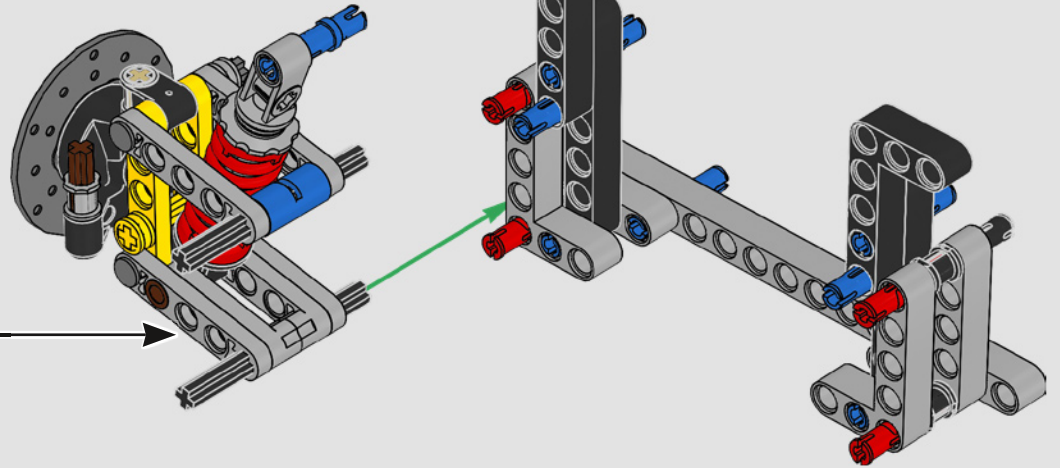

284

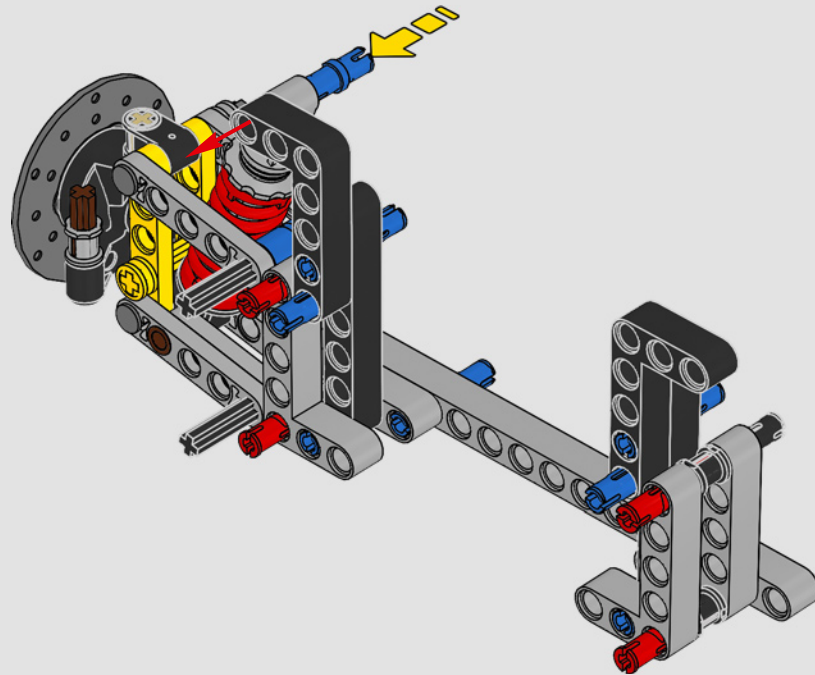

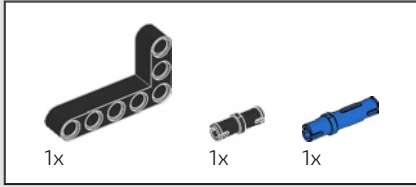

285

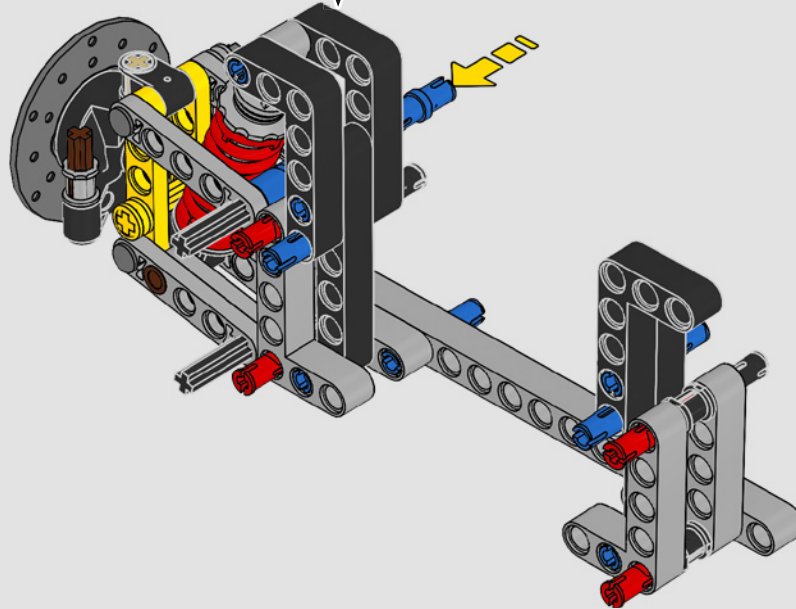
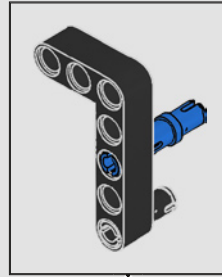

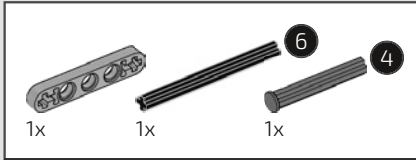
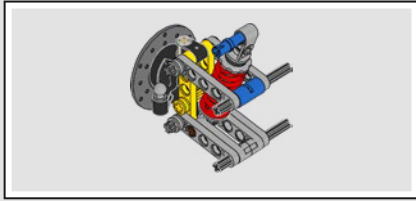

286

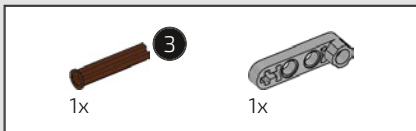
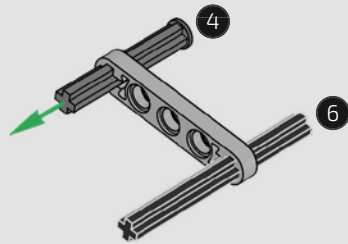

287

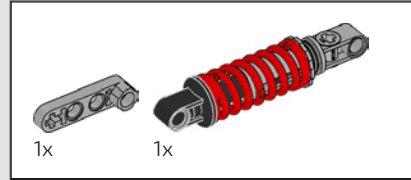
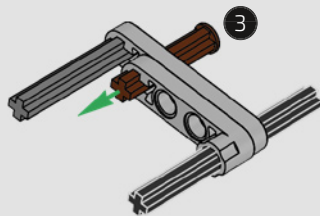

288

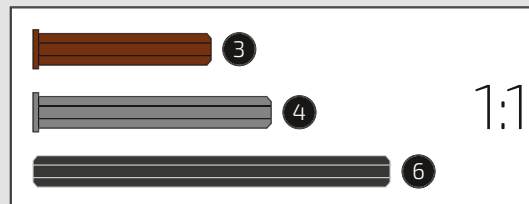
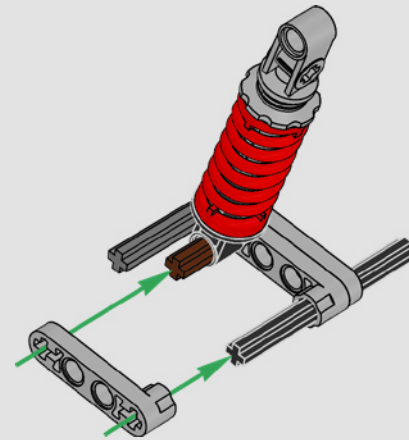

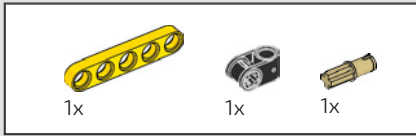

289

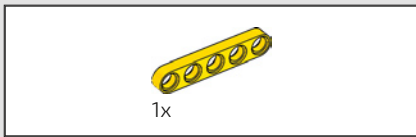
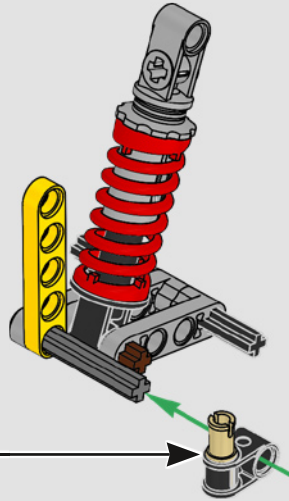

290

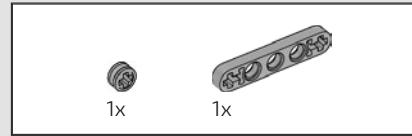
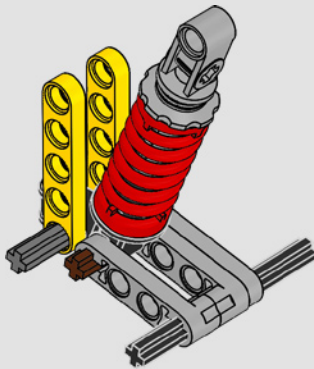

291

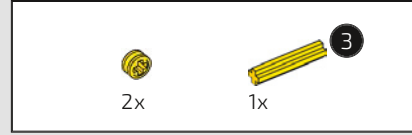
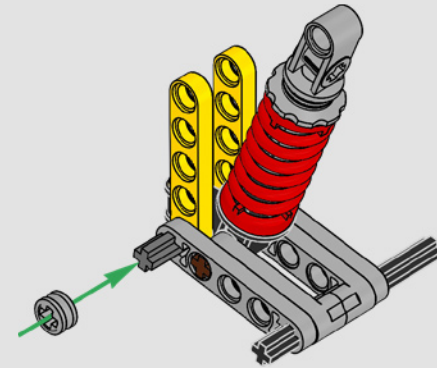

292

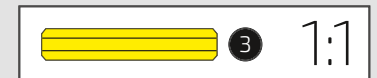
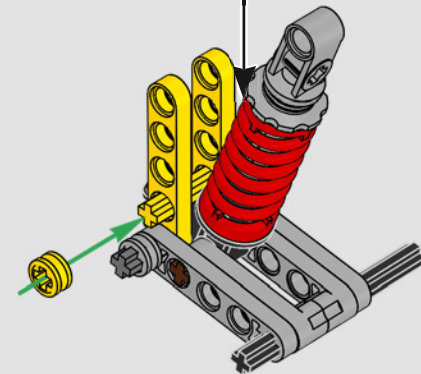
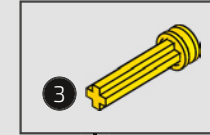

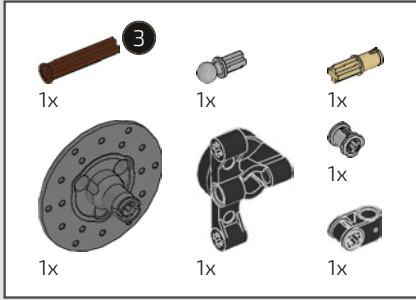

293

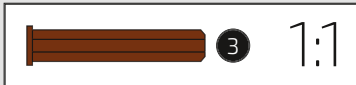
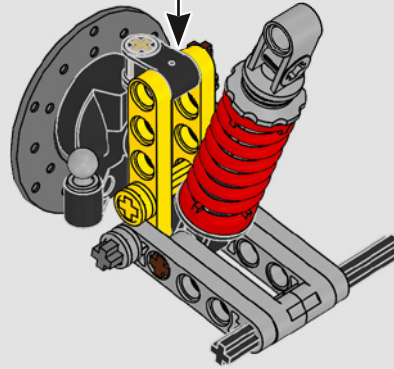
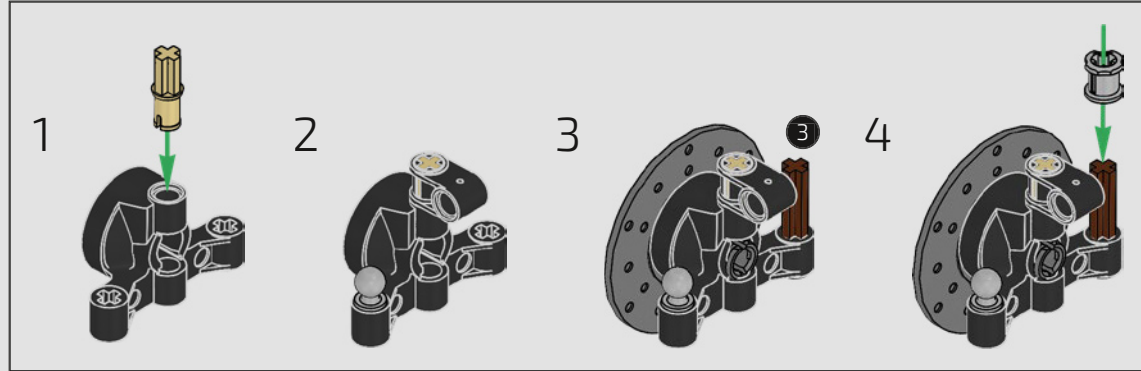

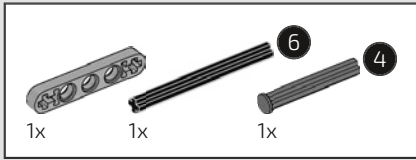

294

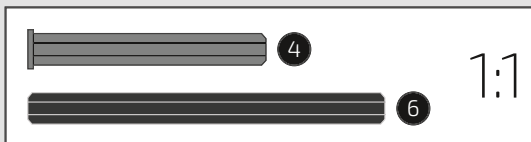
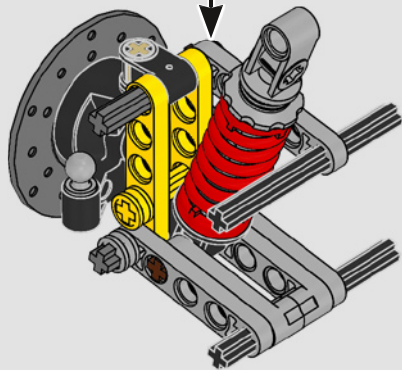
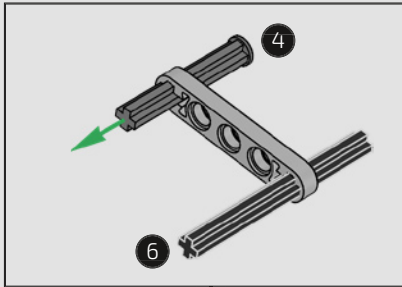

295

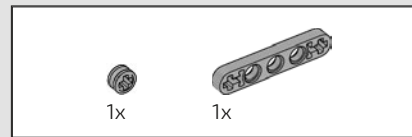
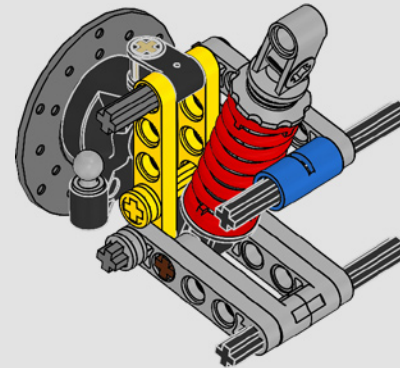

296

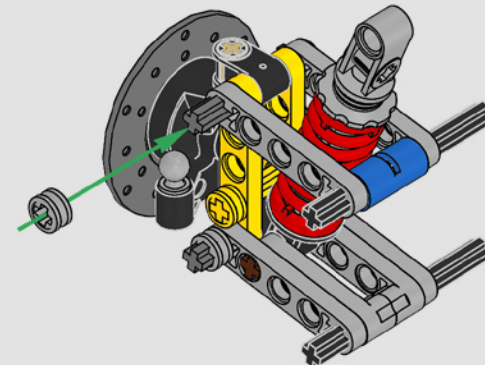

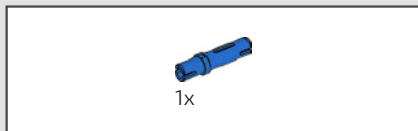

297

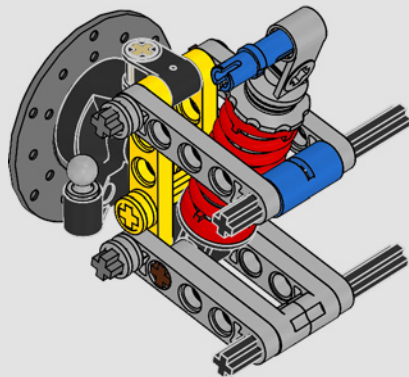

298

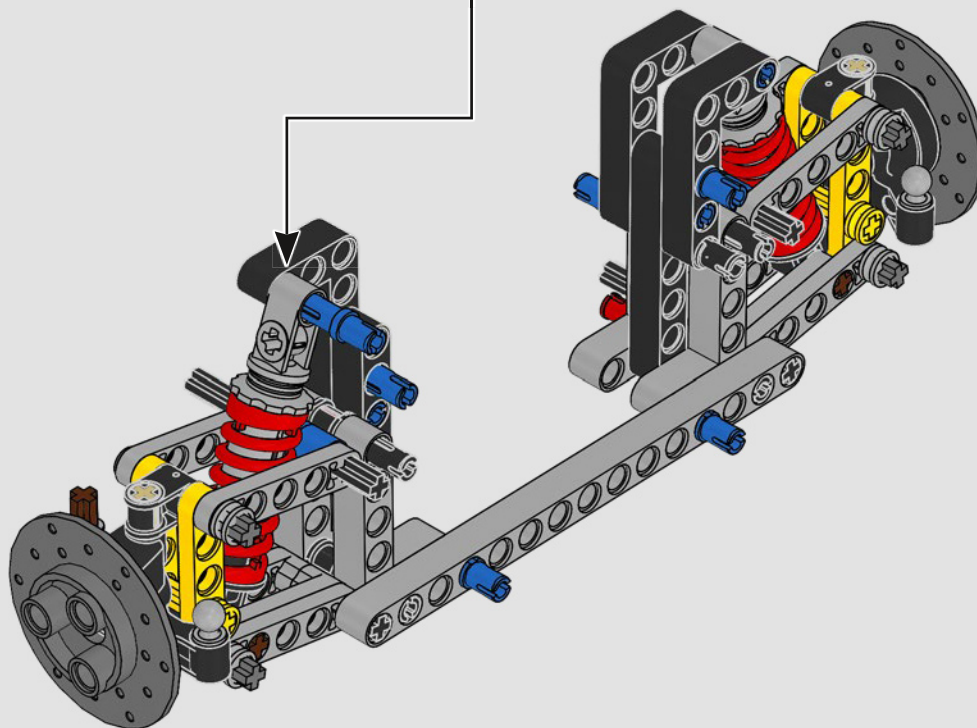

299

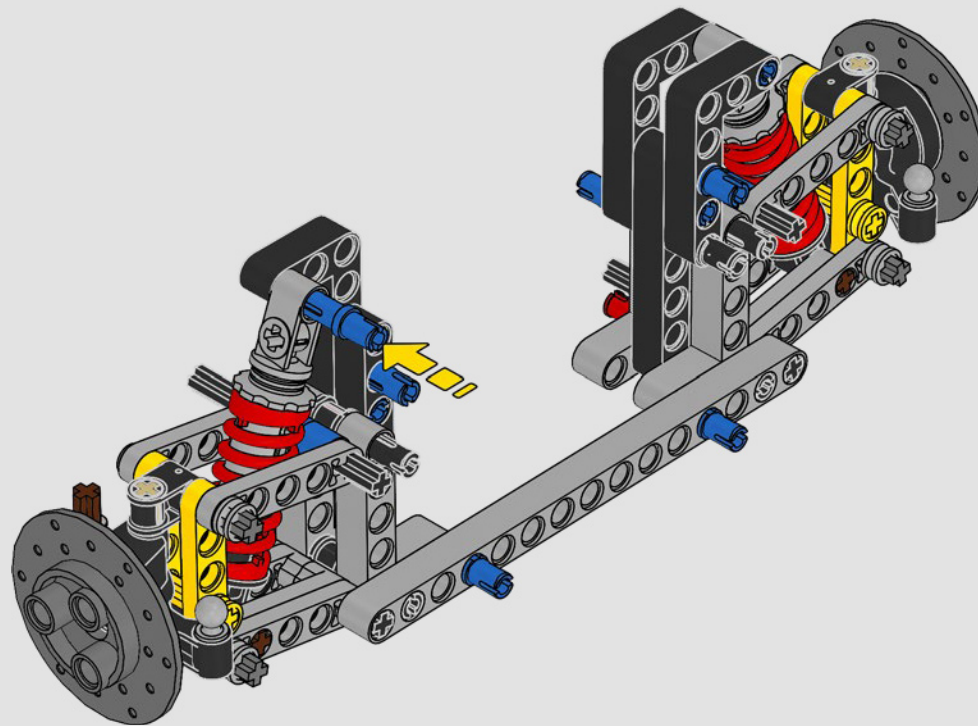

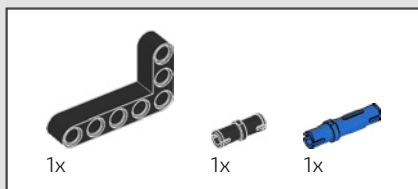

300

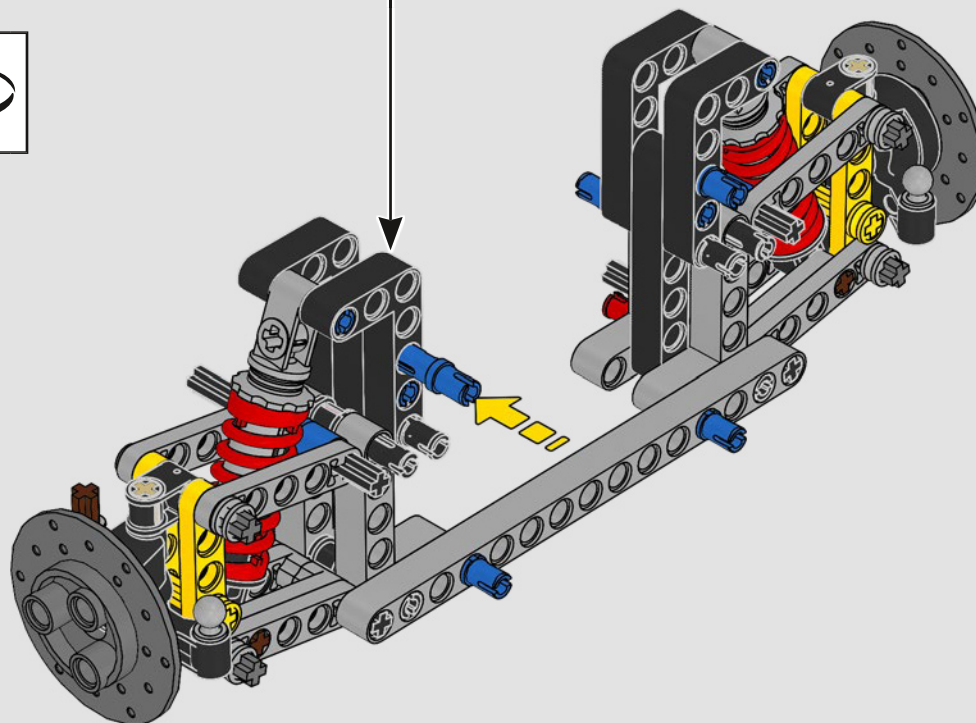
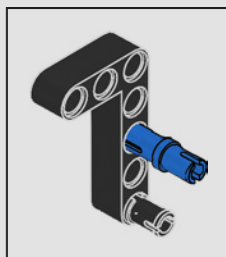

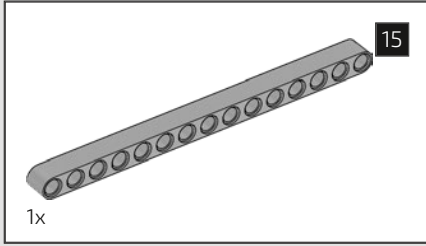

301

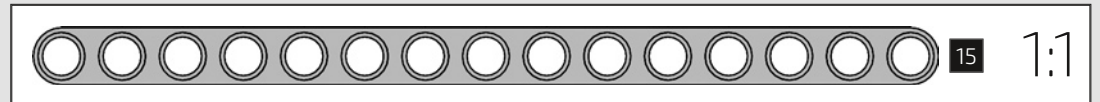
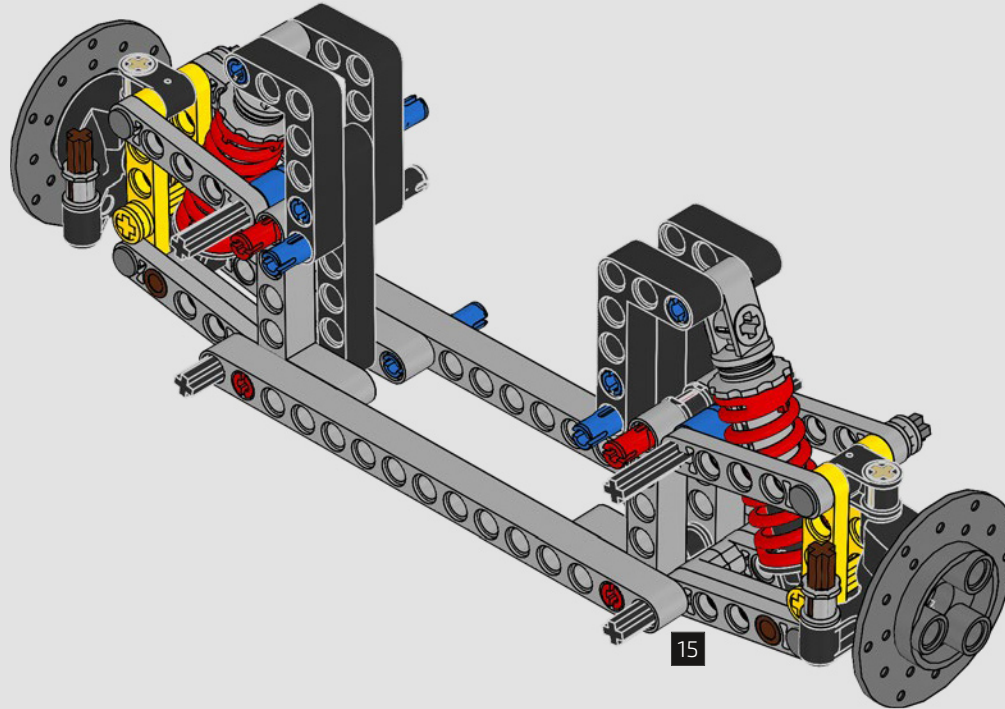

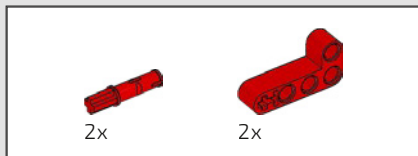

302

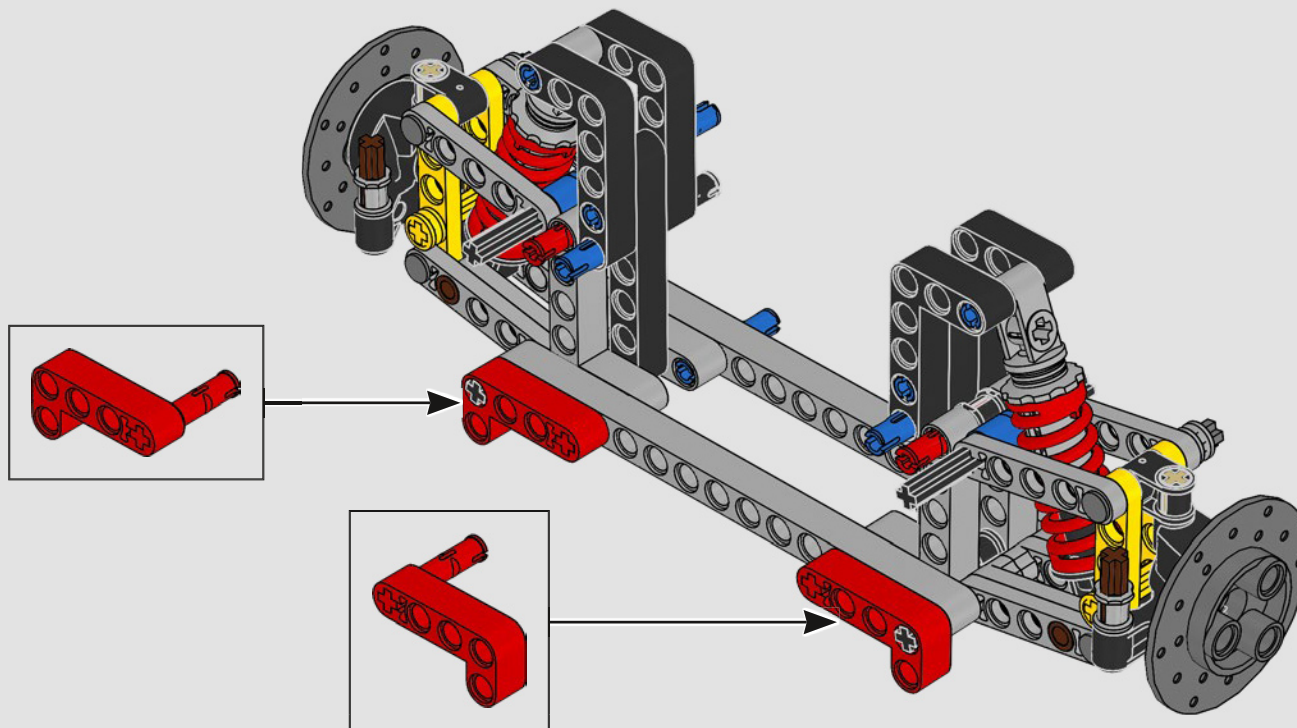

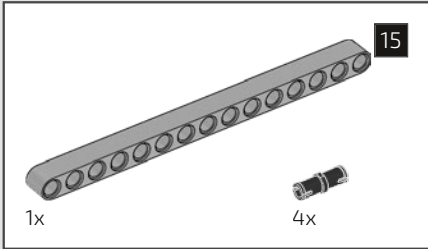
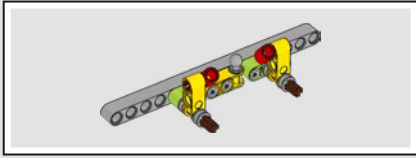

303

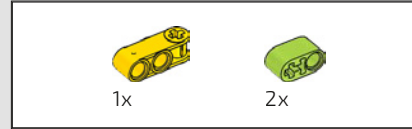
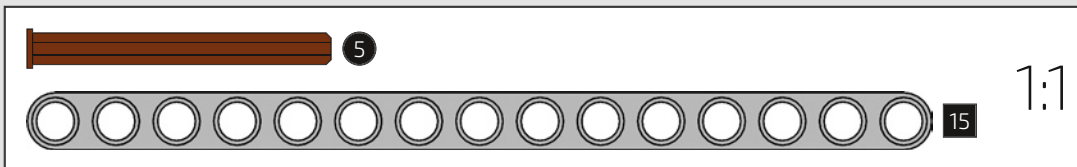
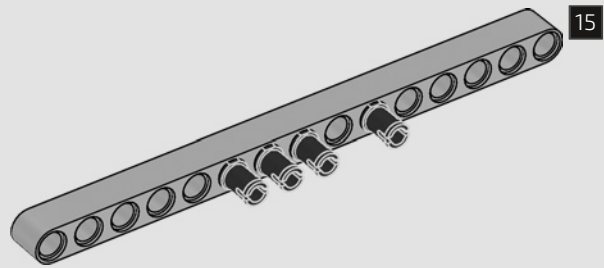

304

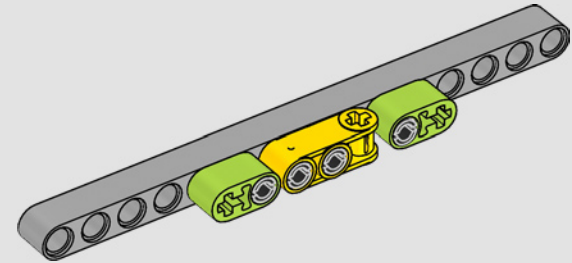

305

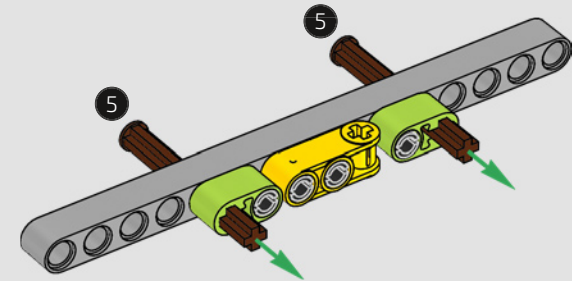

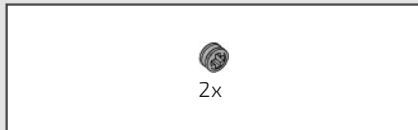

306

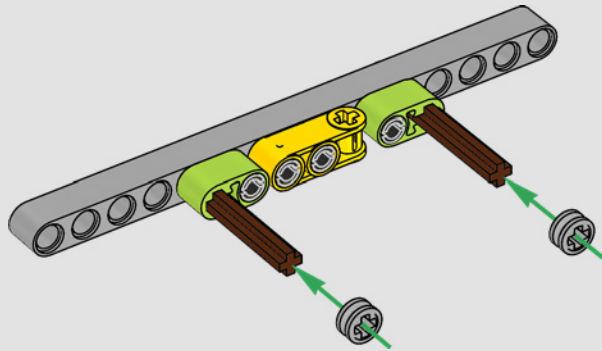

307

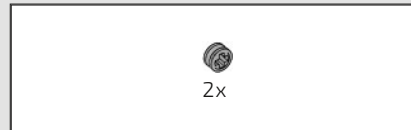
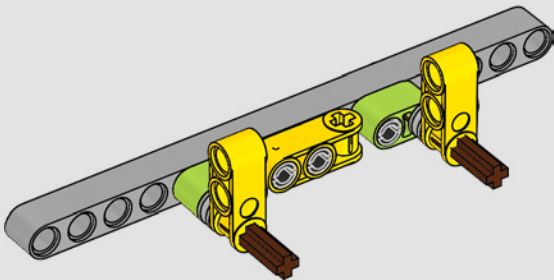

308

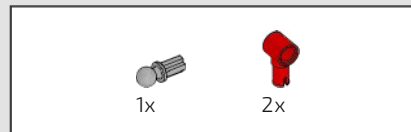
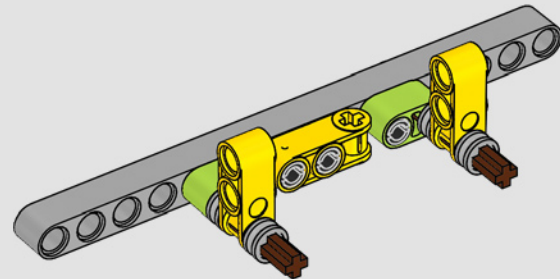

309

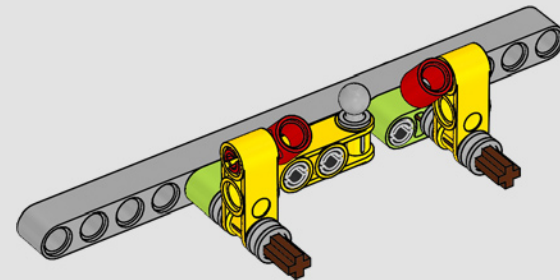

310

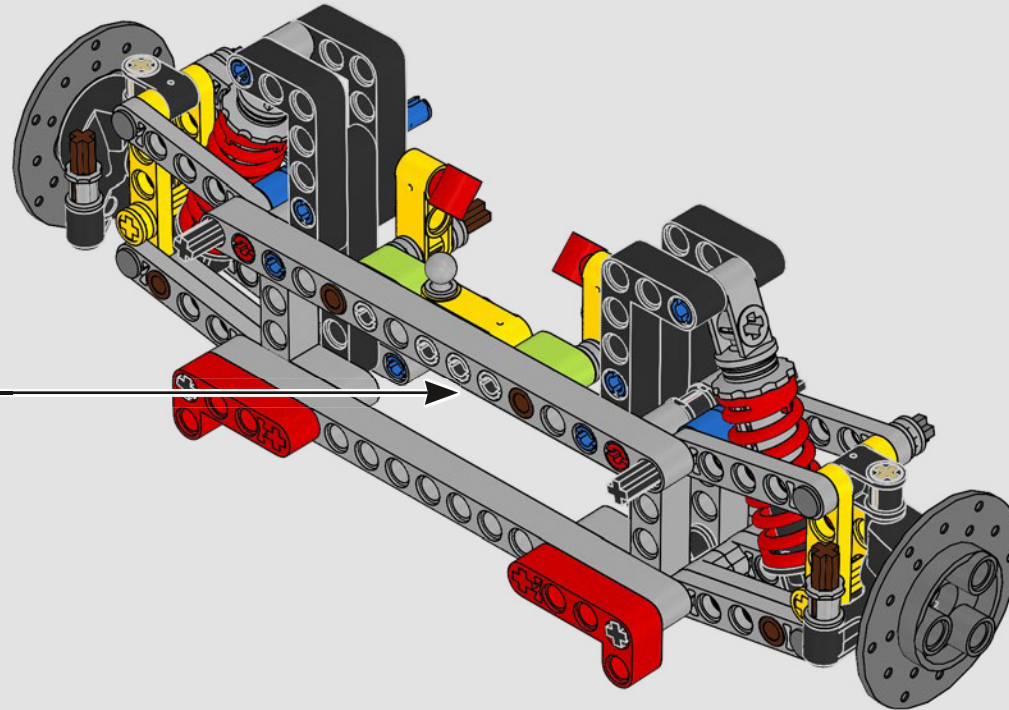

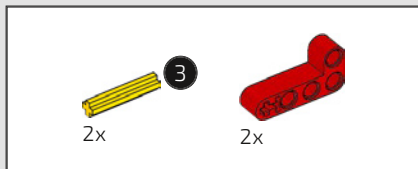

311

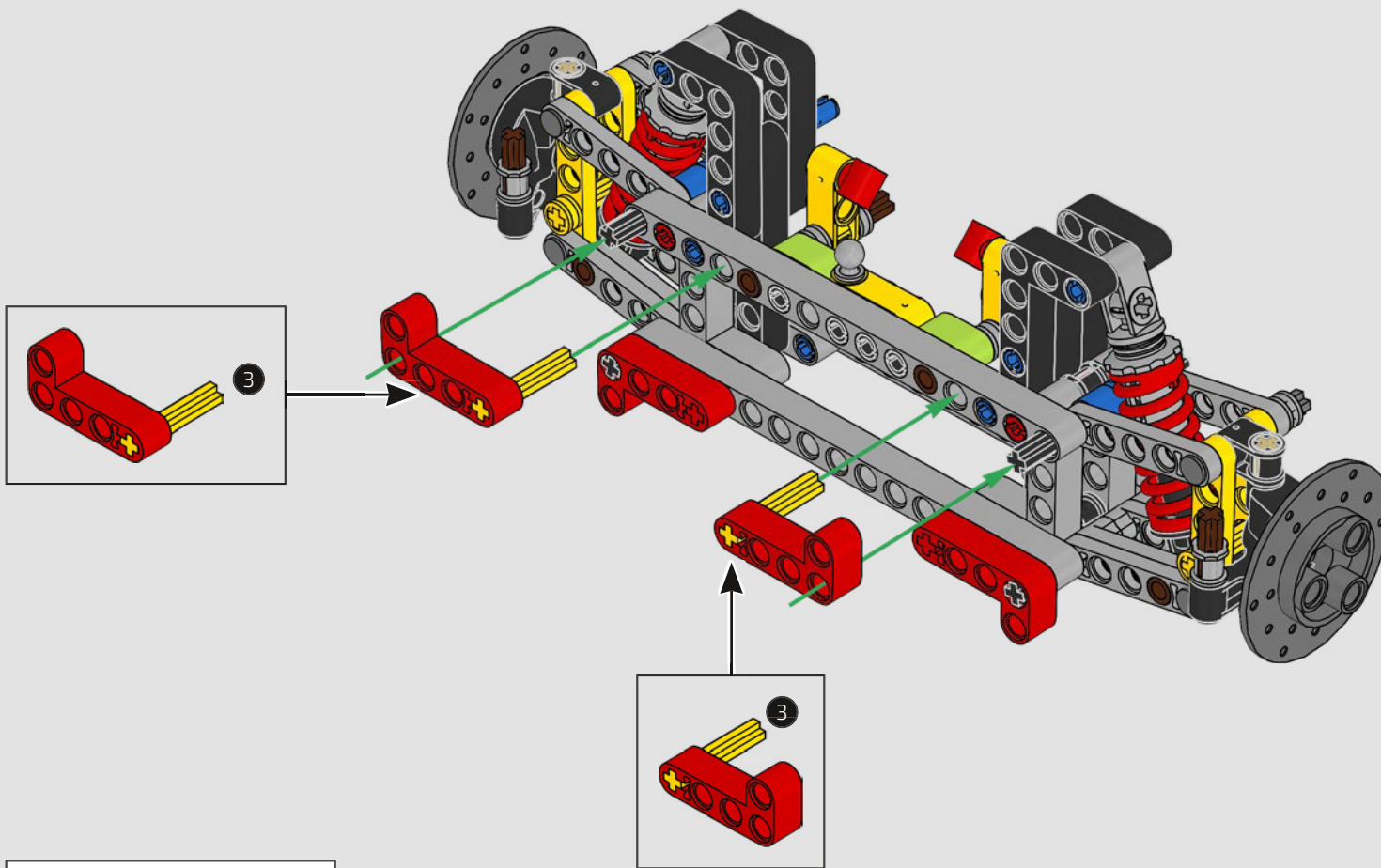

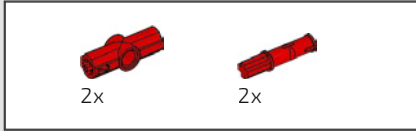

312

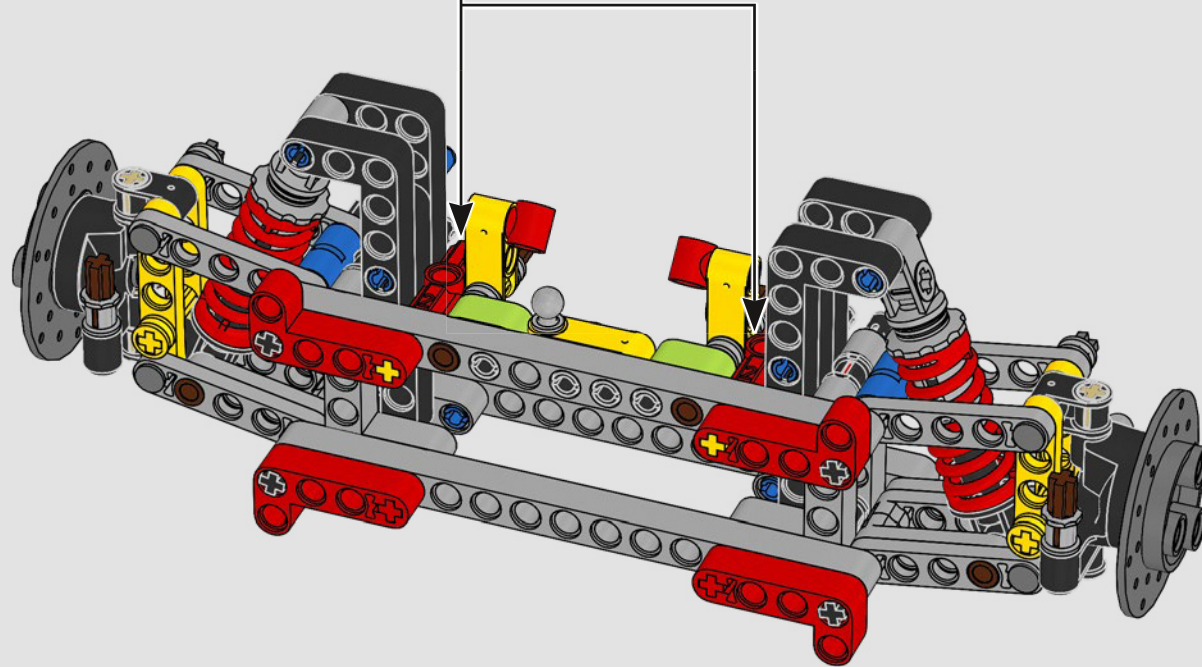
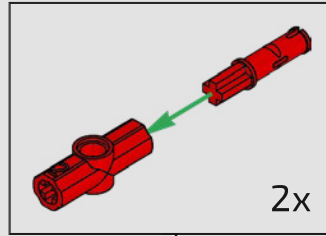

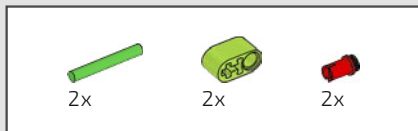

313

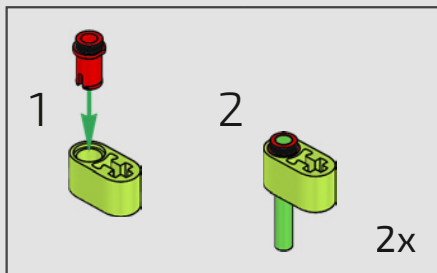

314

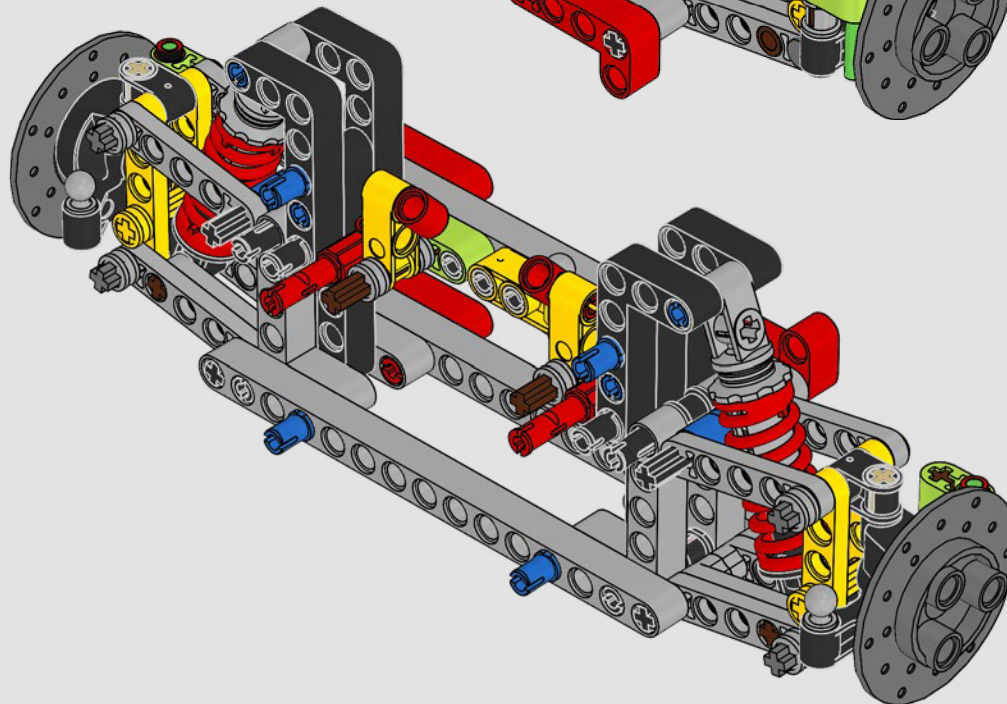
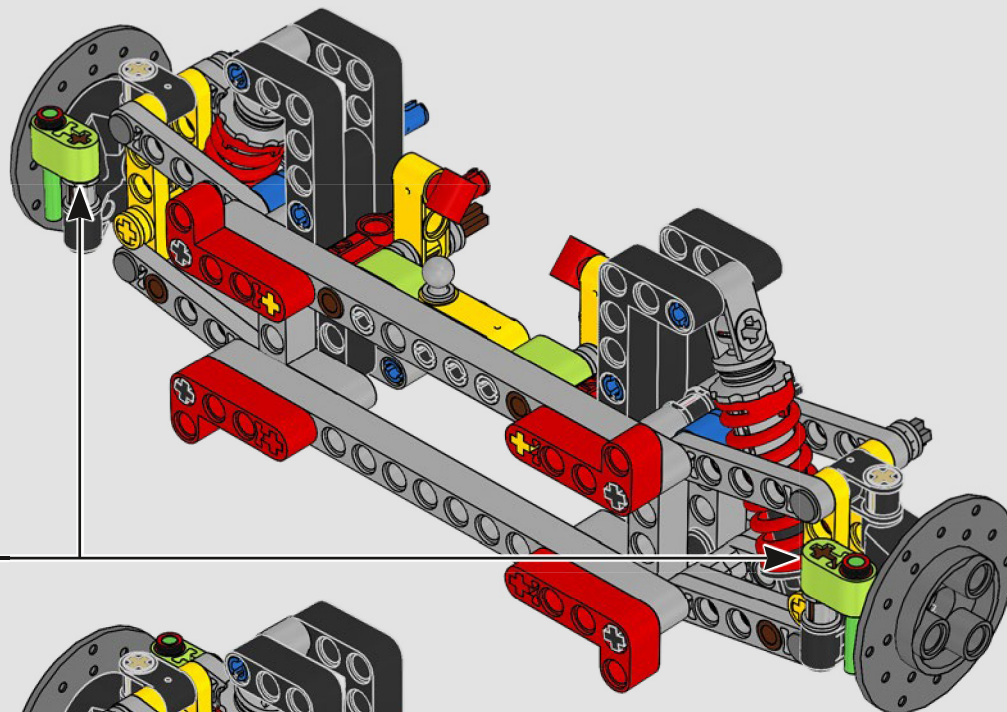

315

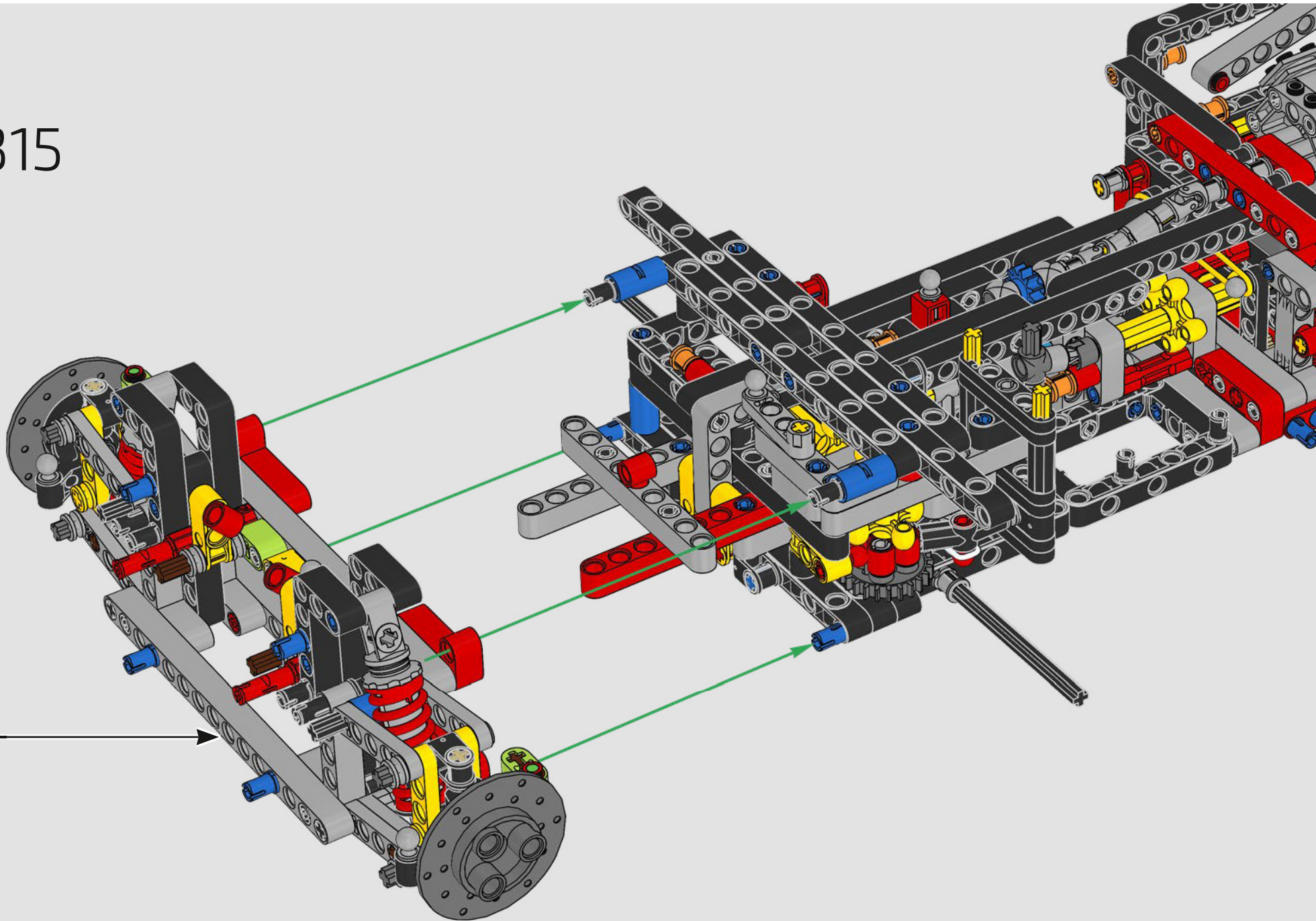

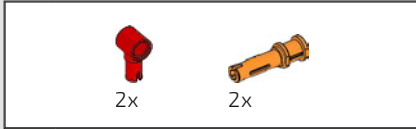

316

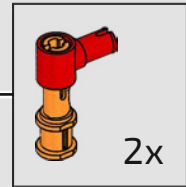
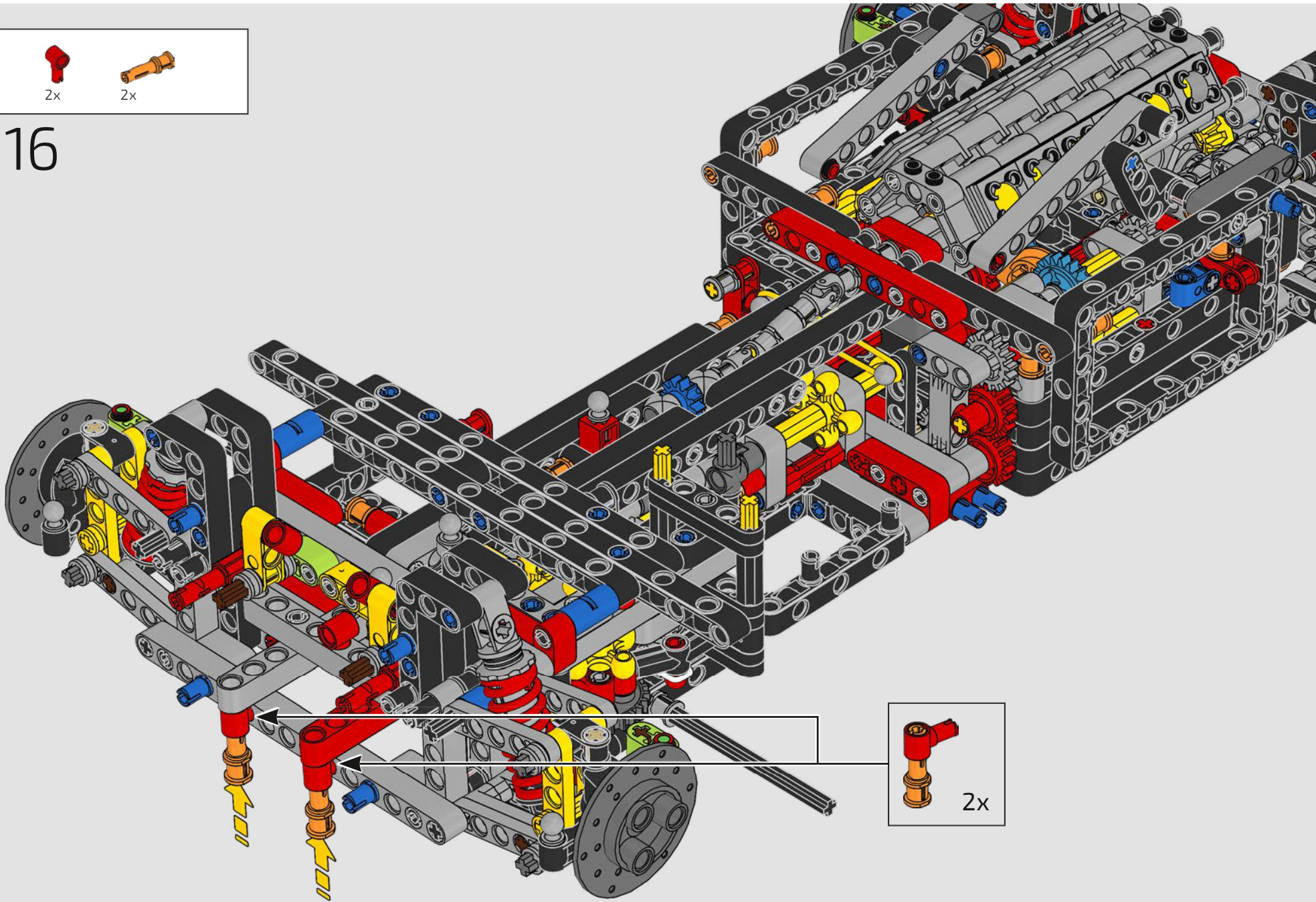

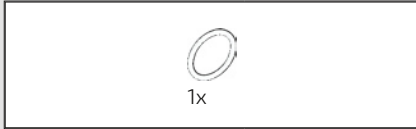

317

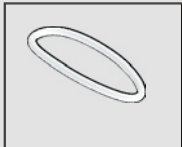
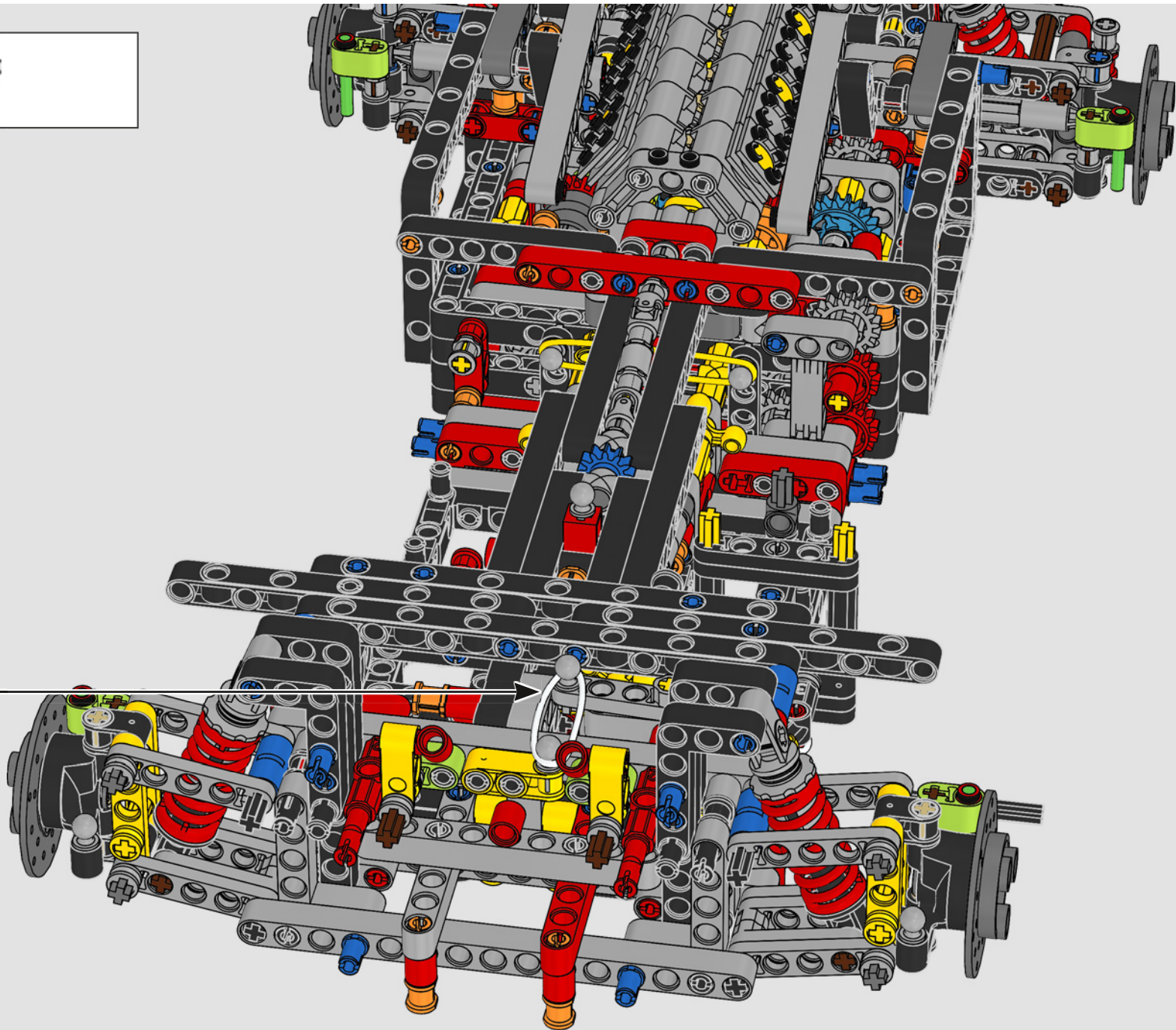

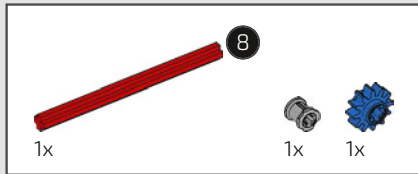

318

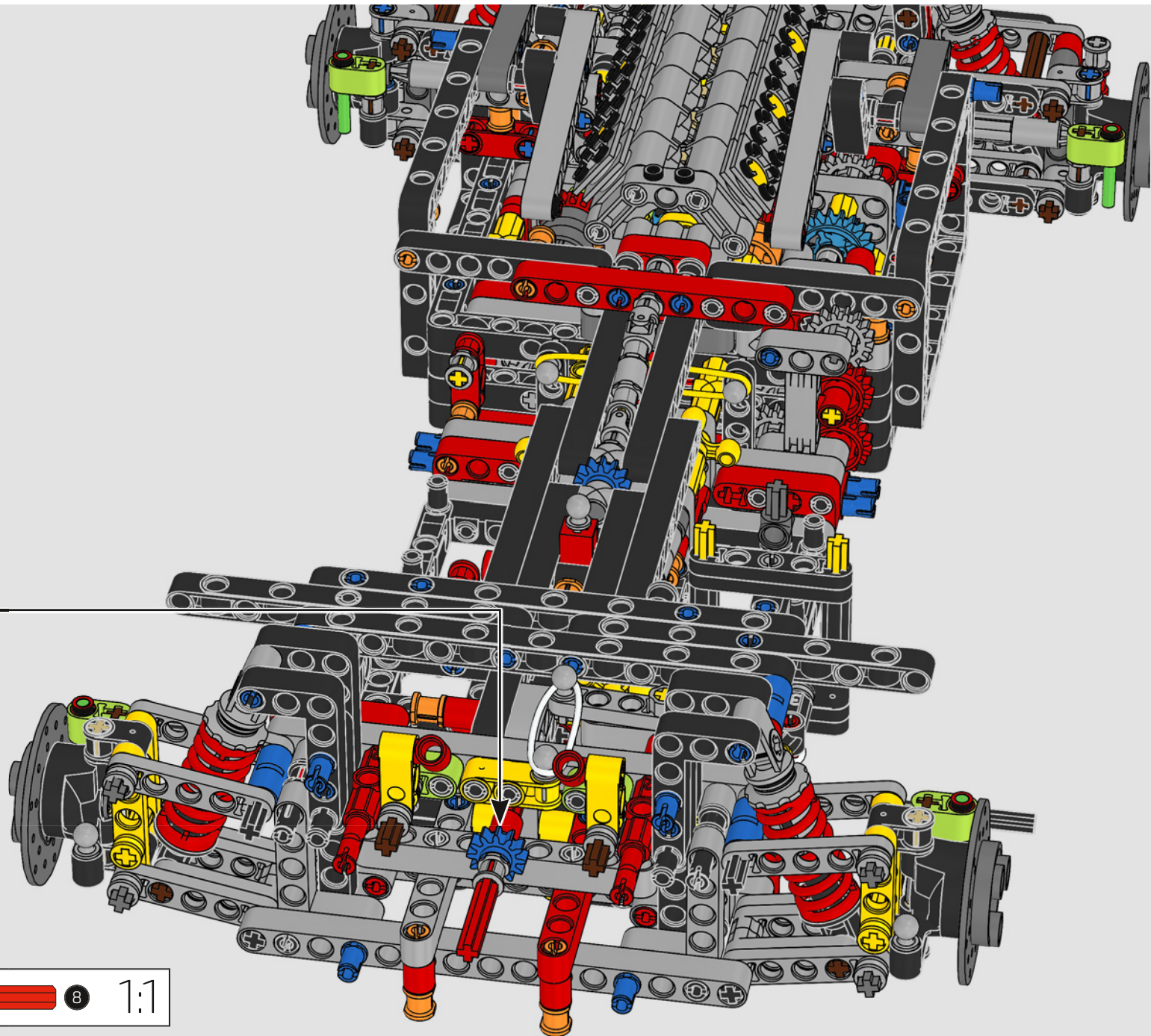
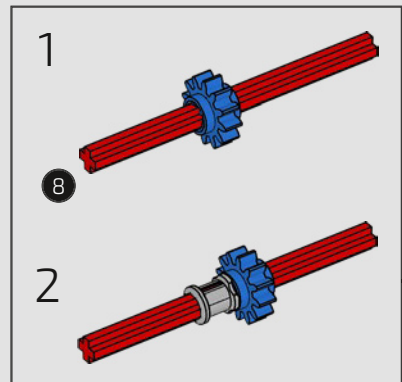

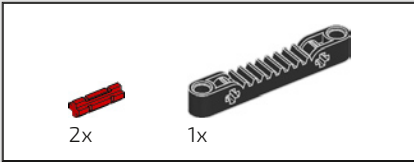
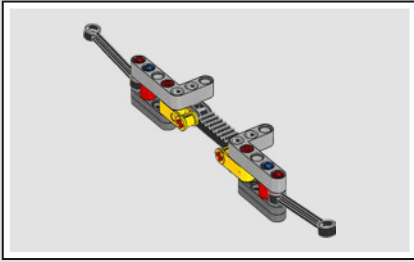

319

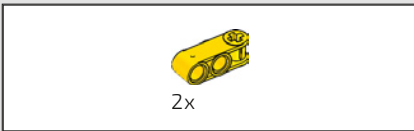
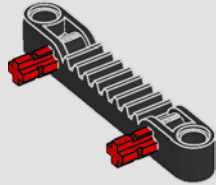

320

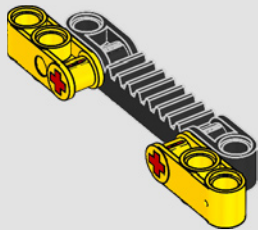

321

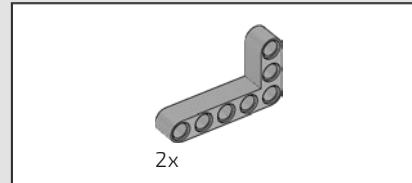
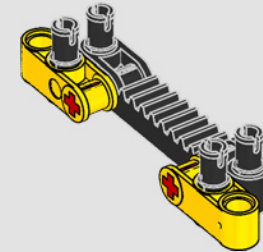

322

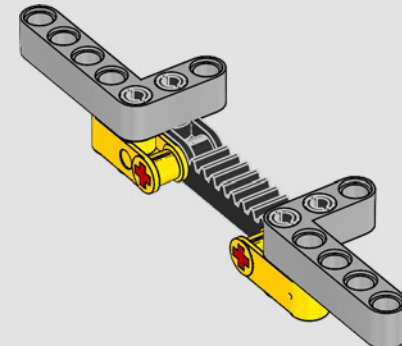

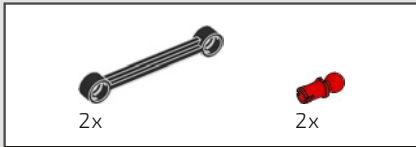

323

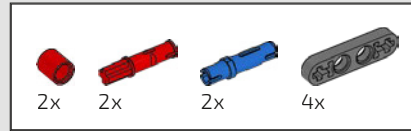
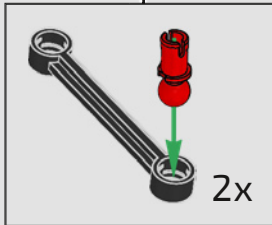
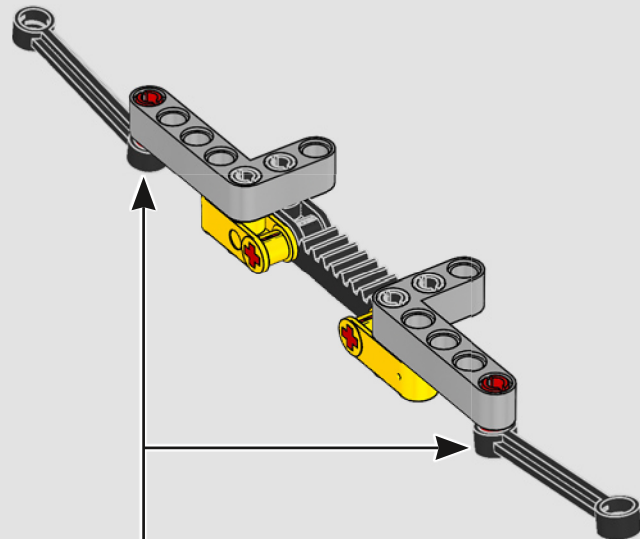

324

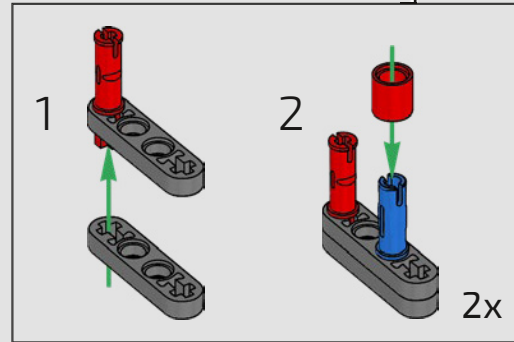
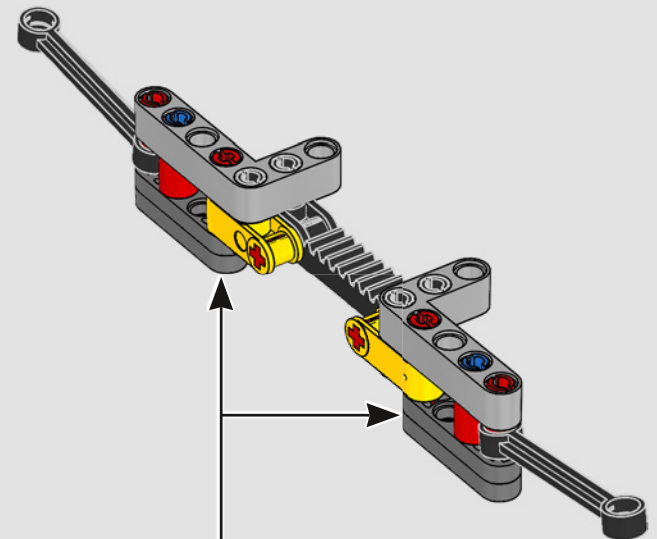

325

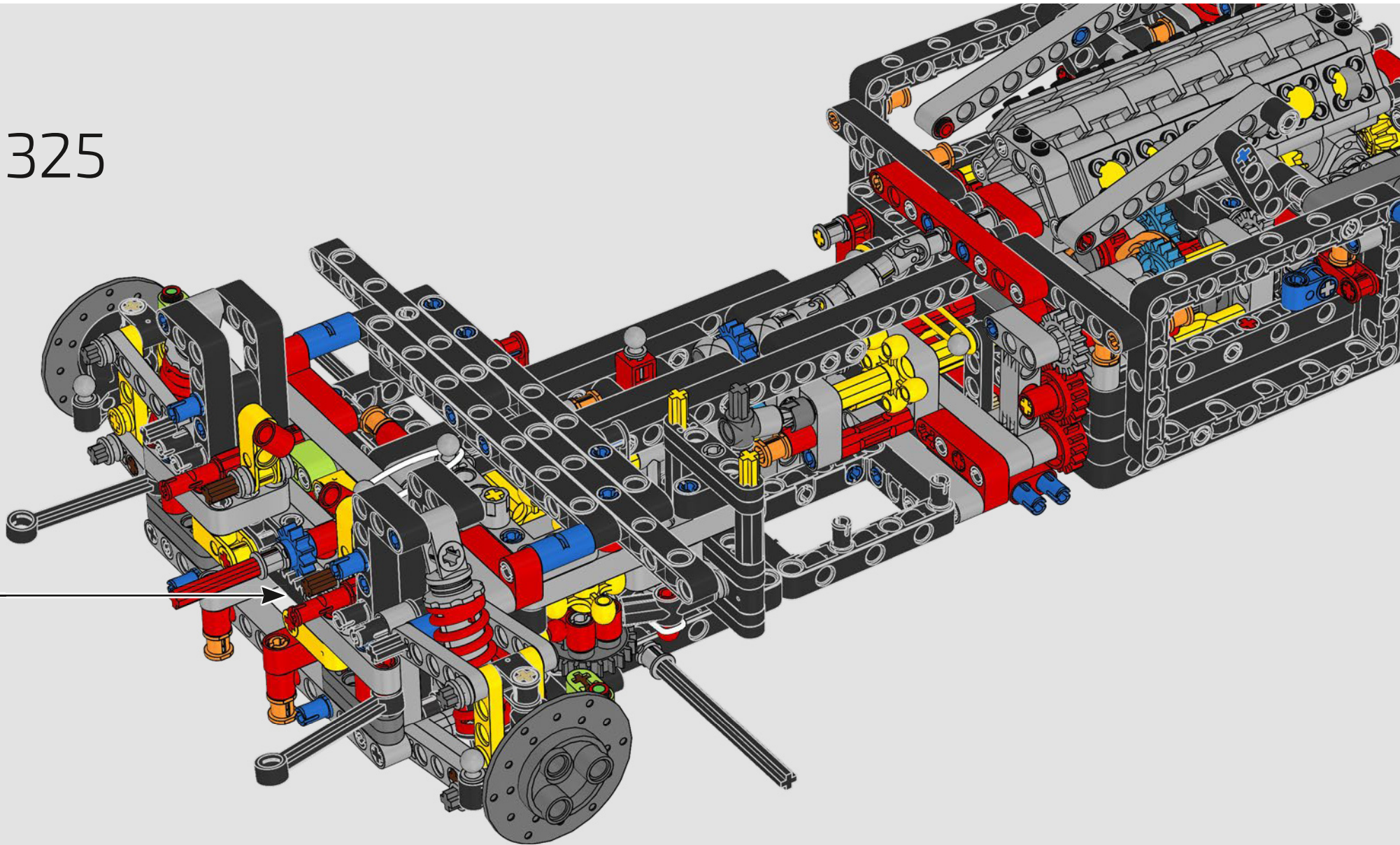

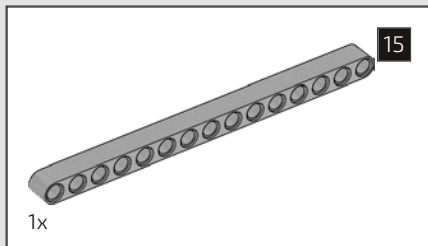

326

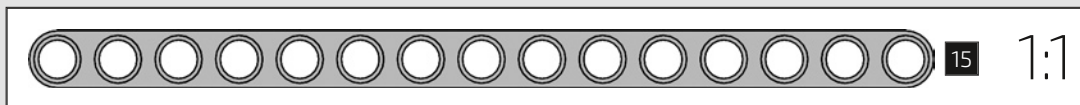
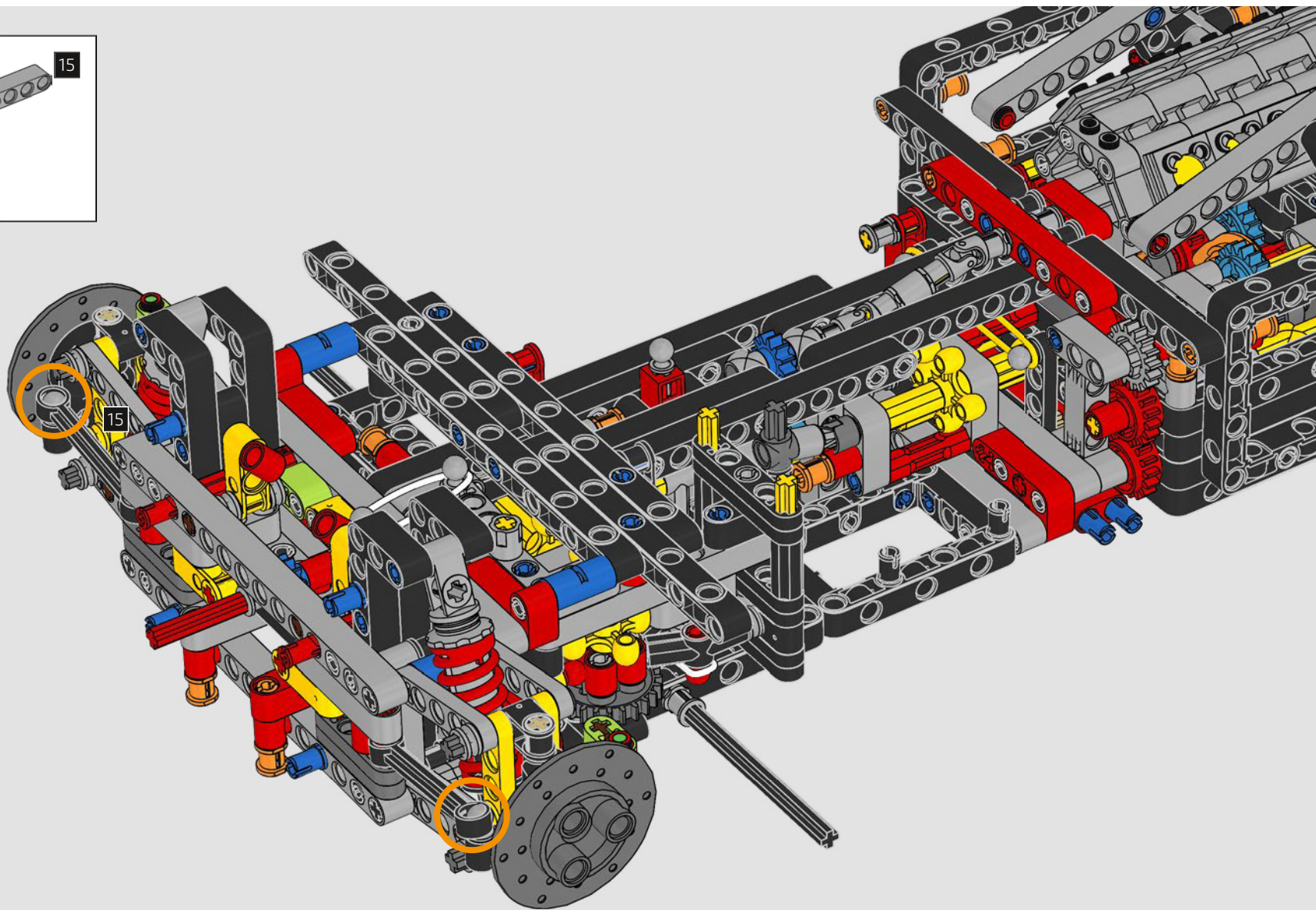

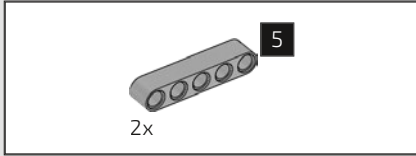

327

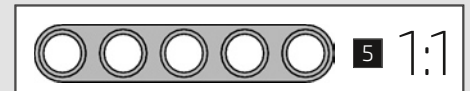
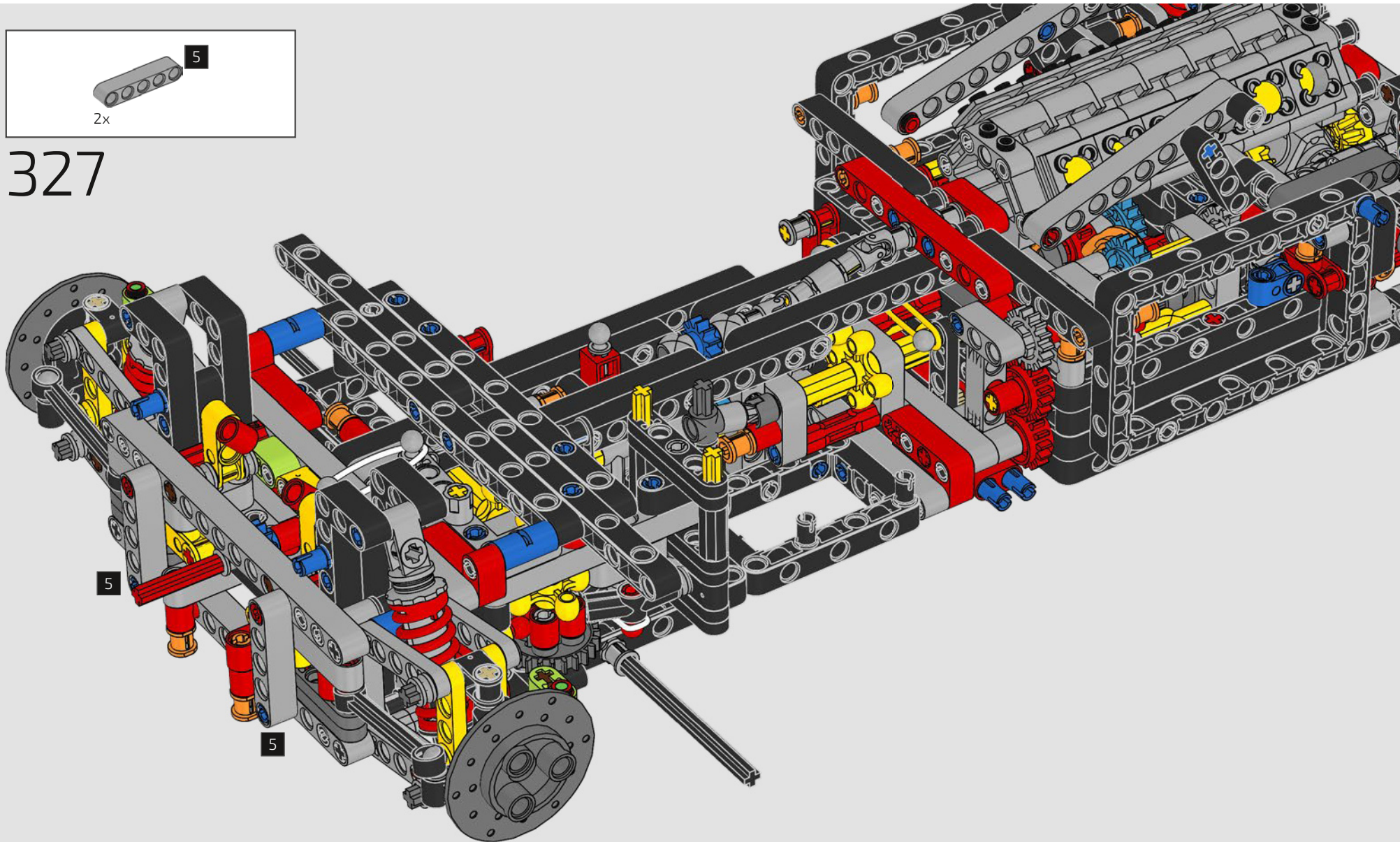

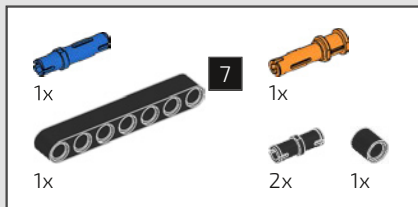

328

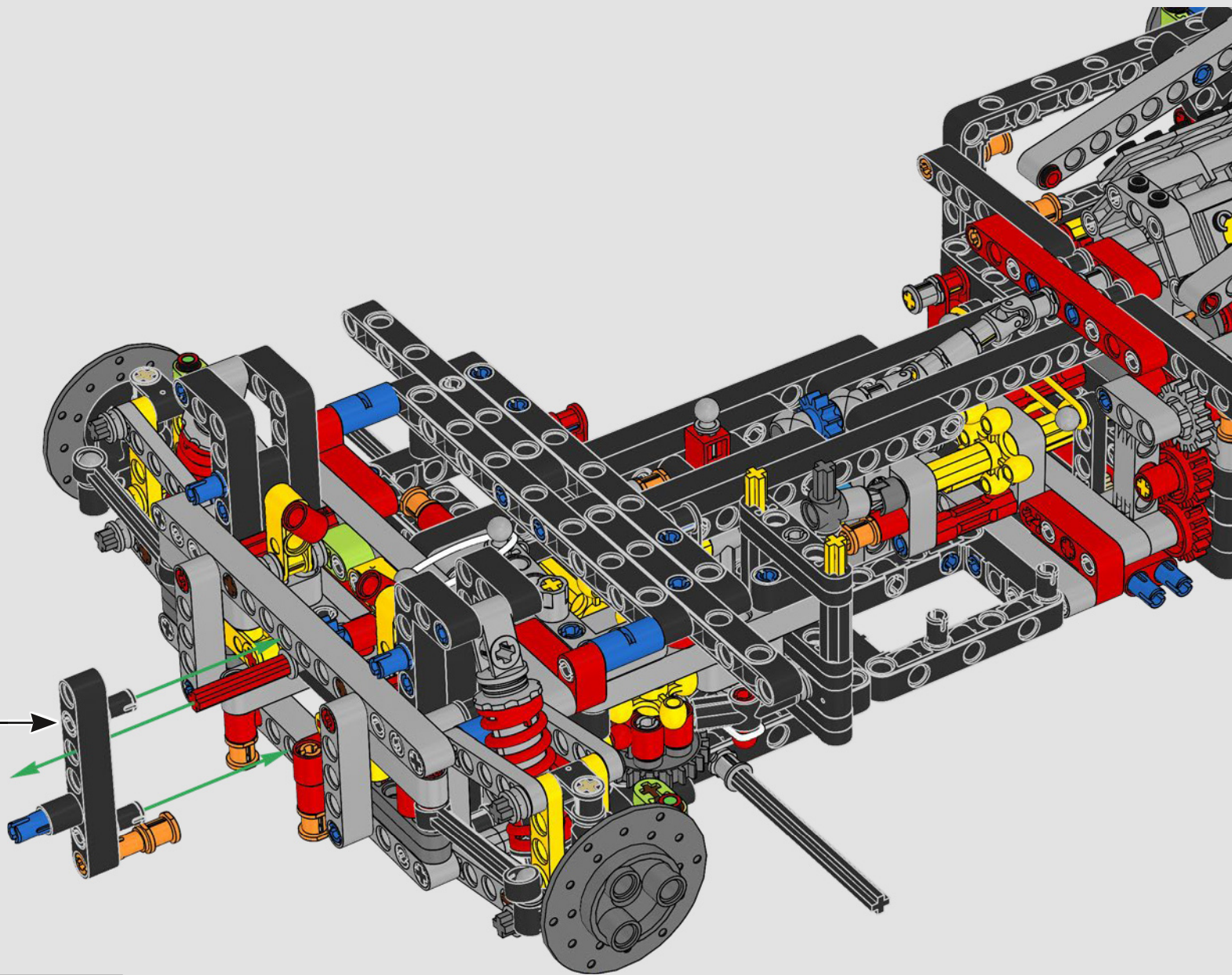
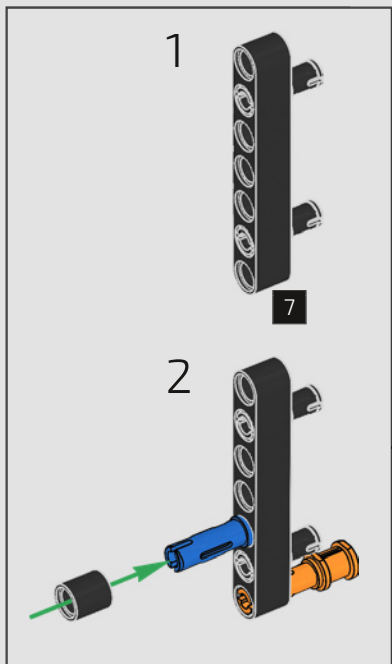

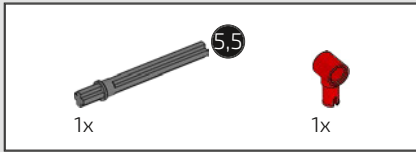

329

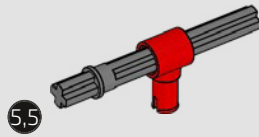

330

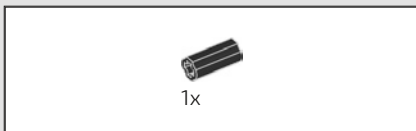
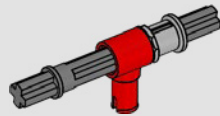

331

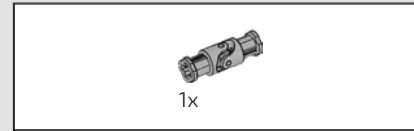
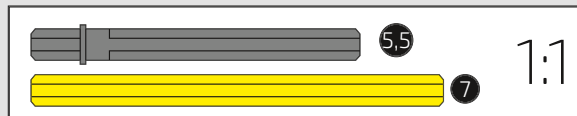
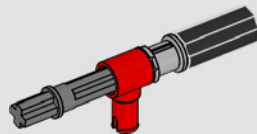

332

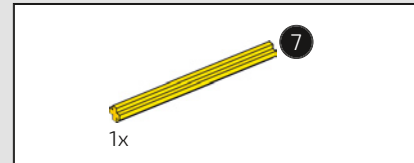
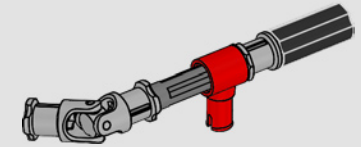

333

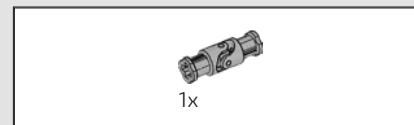
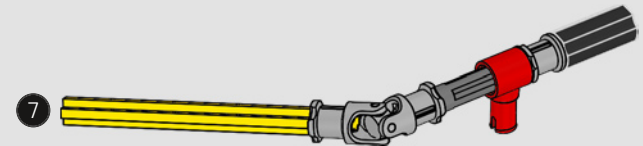

334

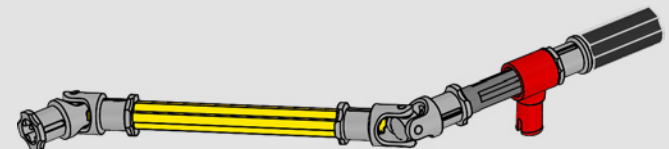

335

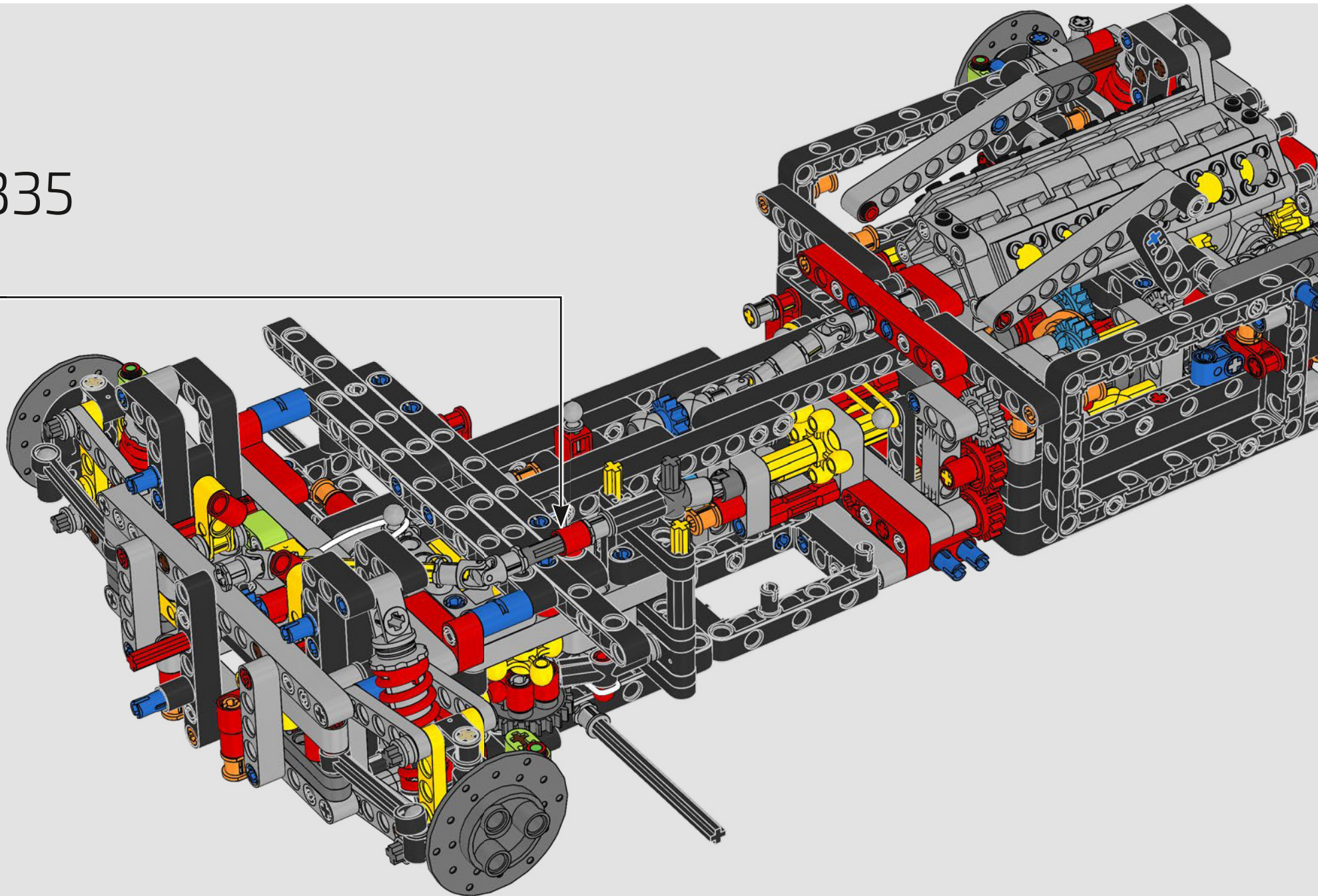

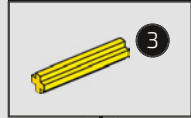
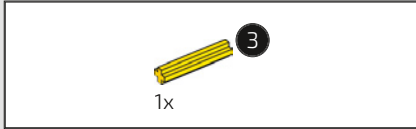

336

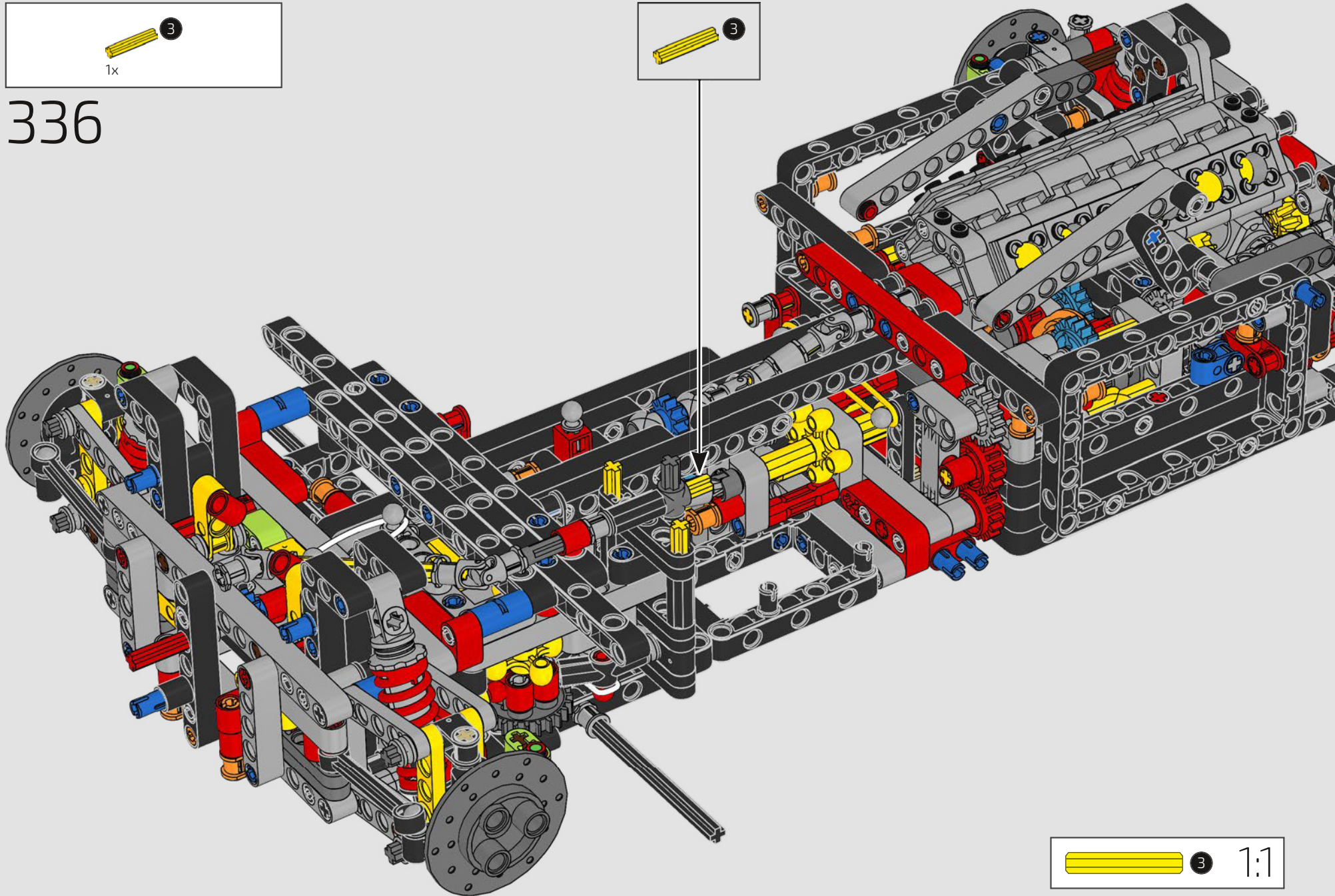

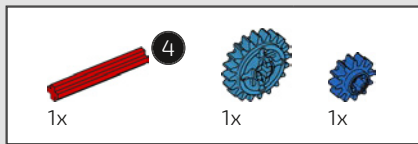

337

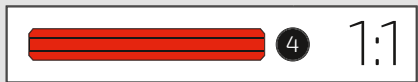
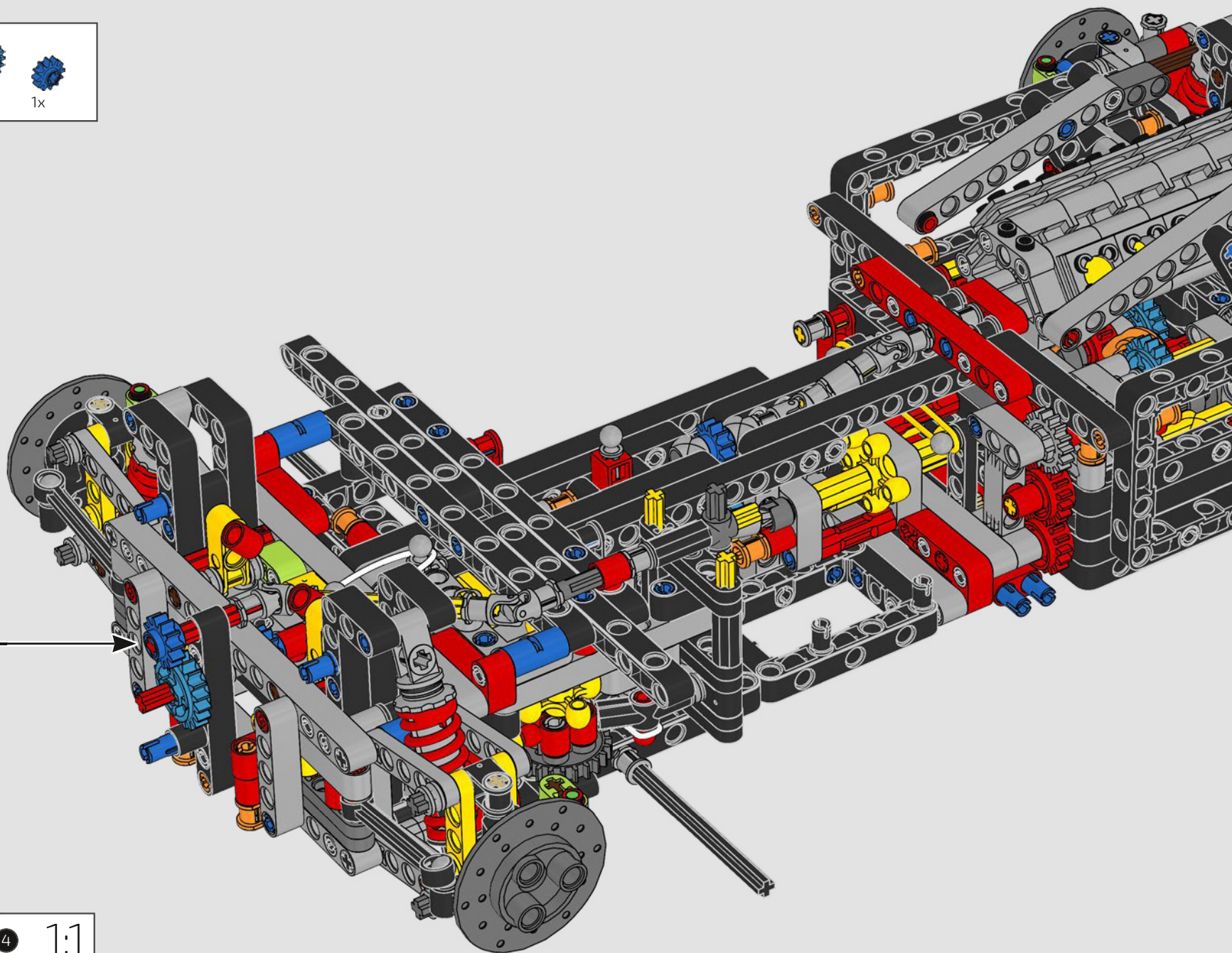
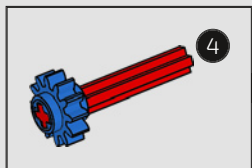

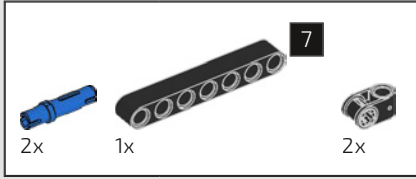

338

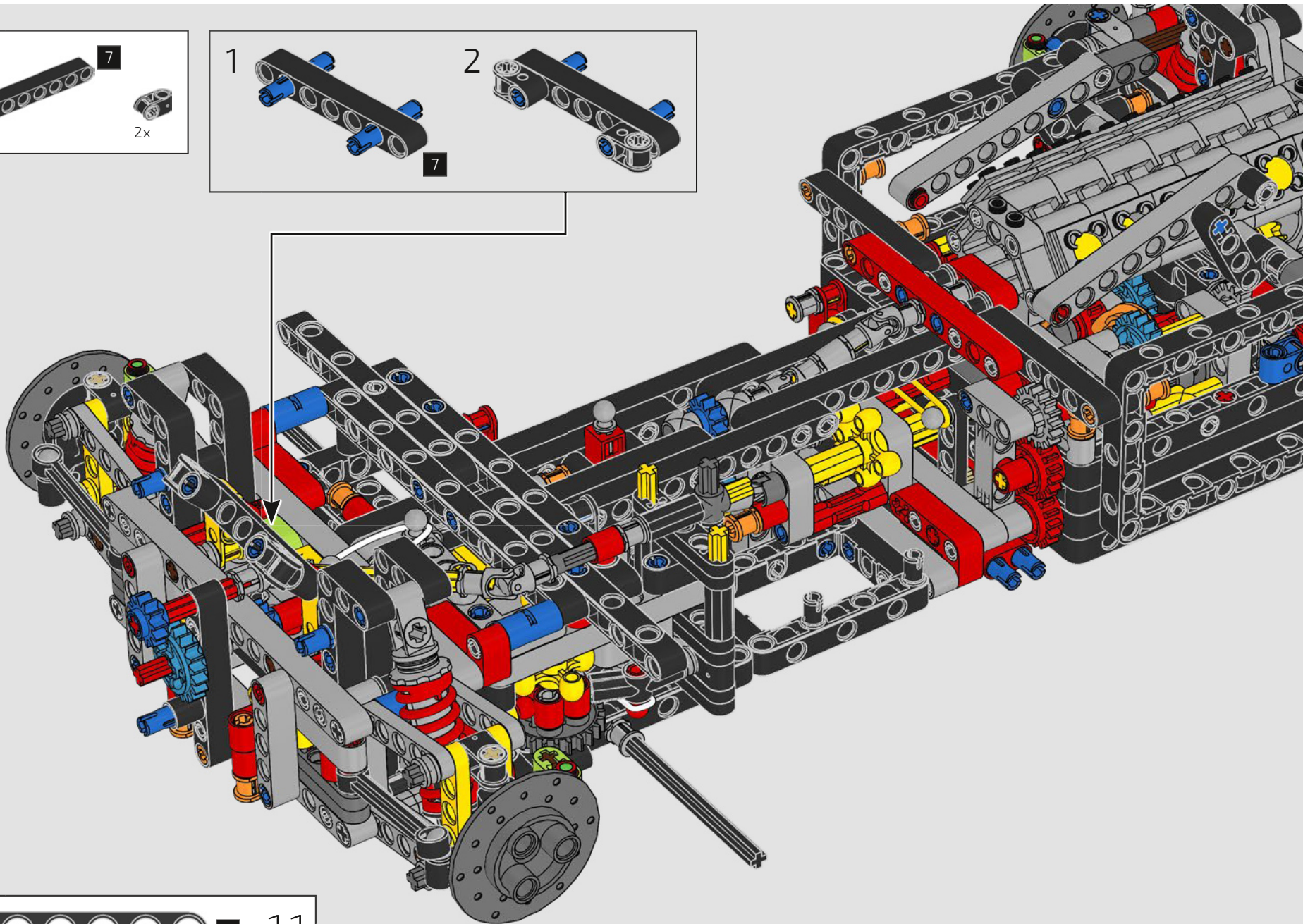
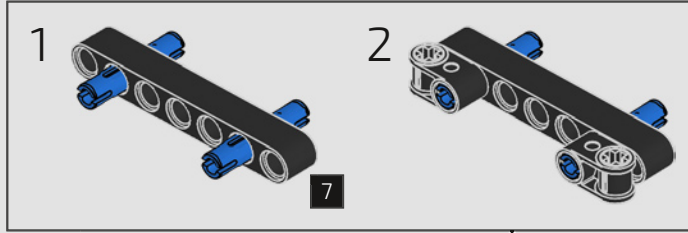

CAR FRAME CHÂSSIS

This frame construction brings the front and rear sections together and gives the needed strength and rigidity to the model.

Cette structure de châssis réunit les sections avant et arrière et donne la force et la robustesse nécessaires au modèle.



BOX 2 / BOÎTE 2

BAG 3 / SACHET 3



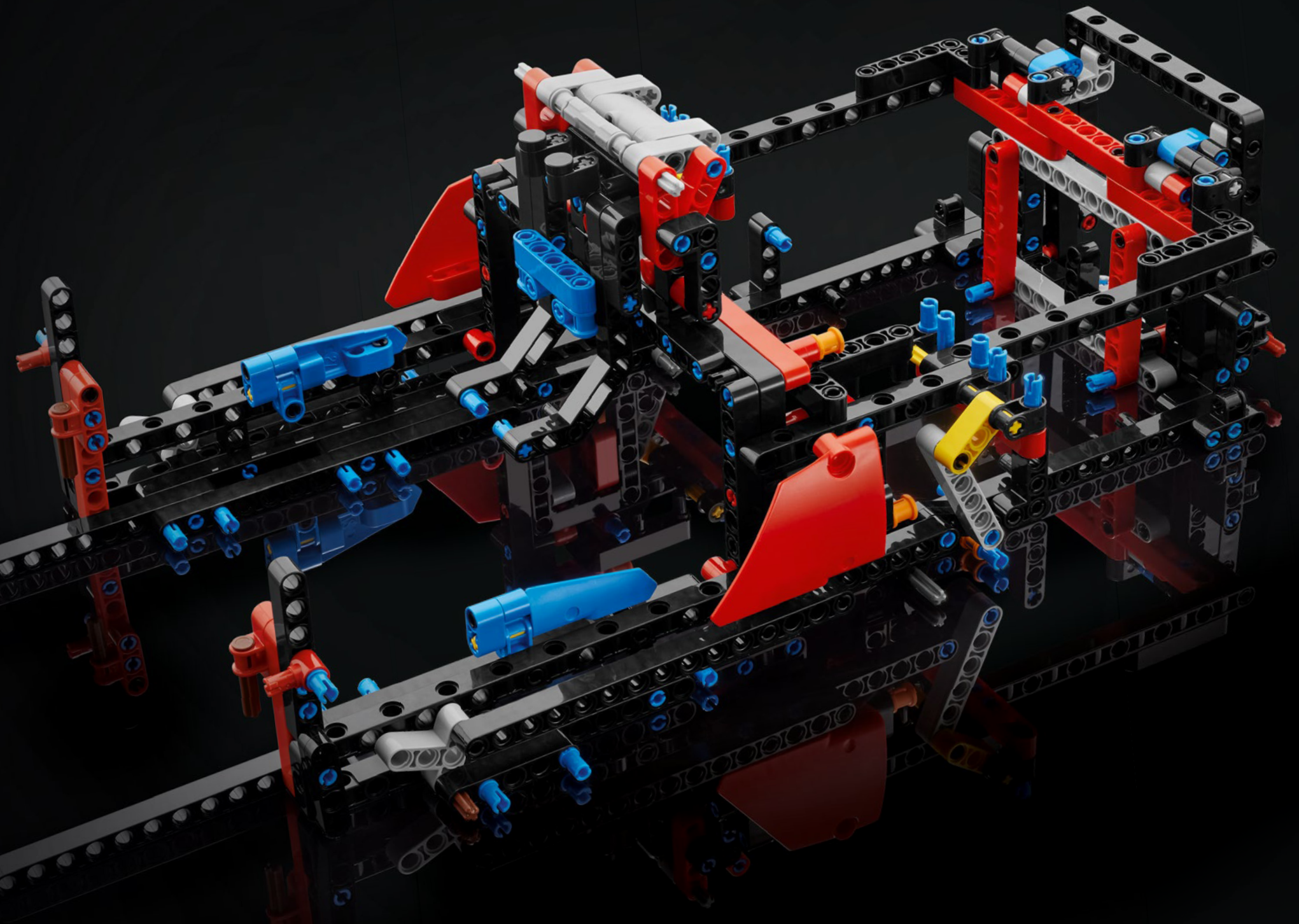

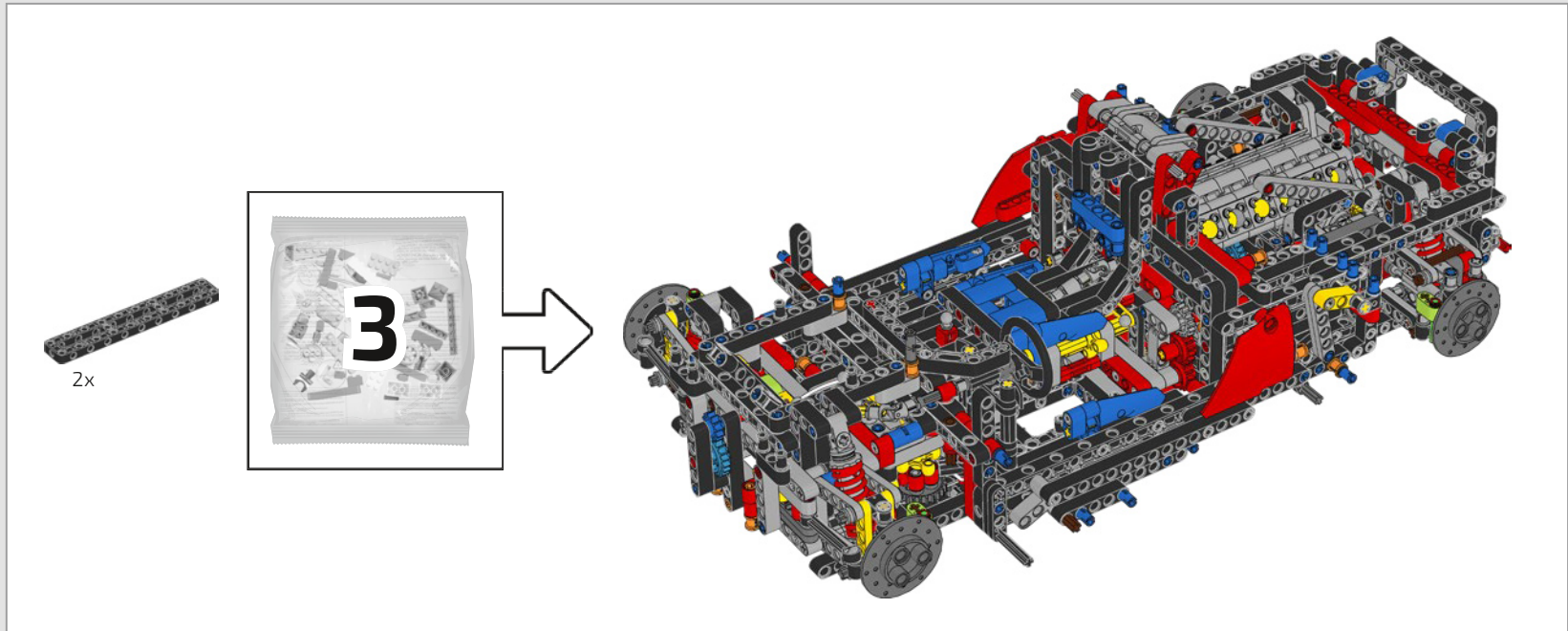

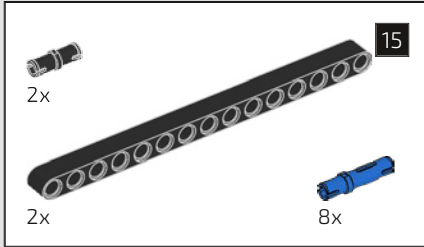
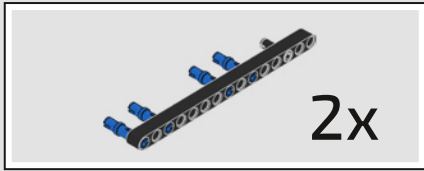

339

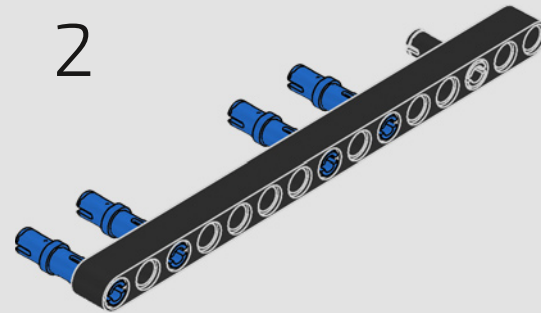
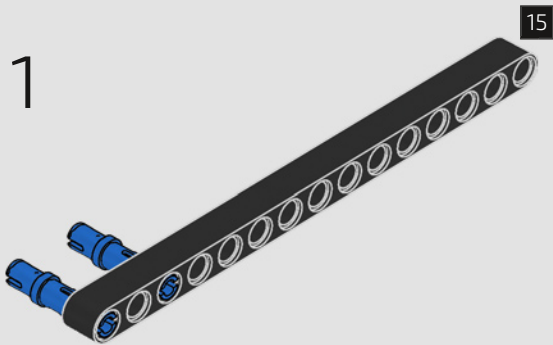

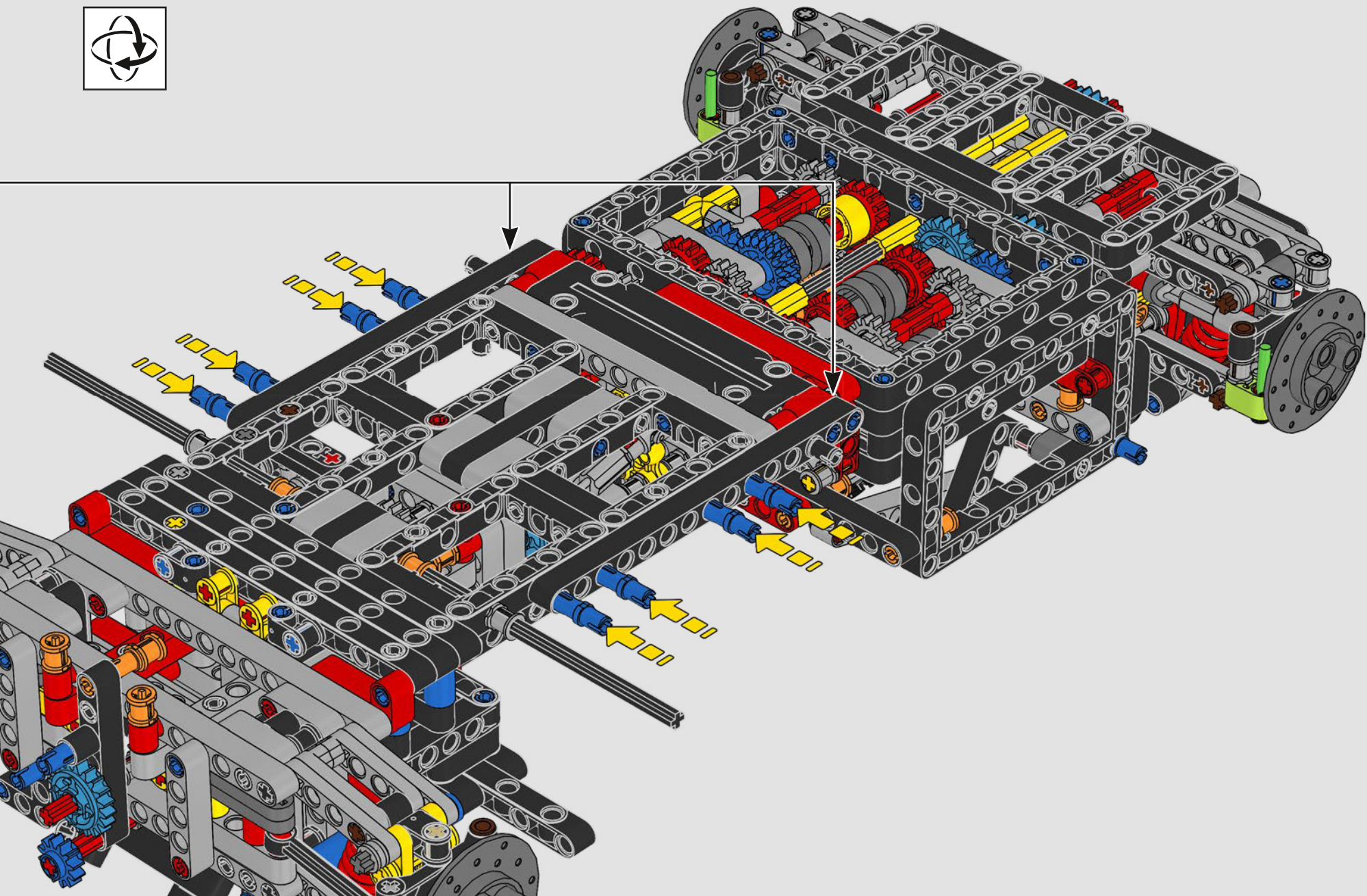

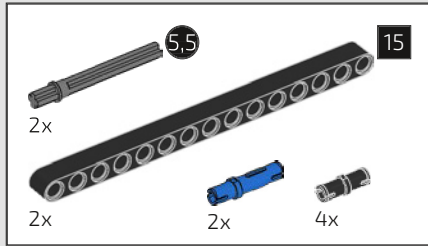

340

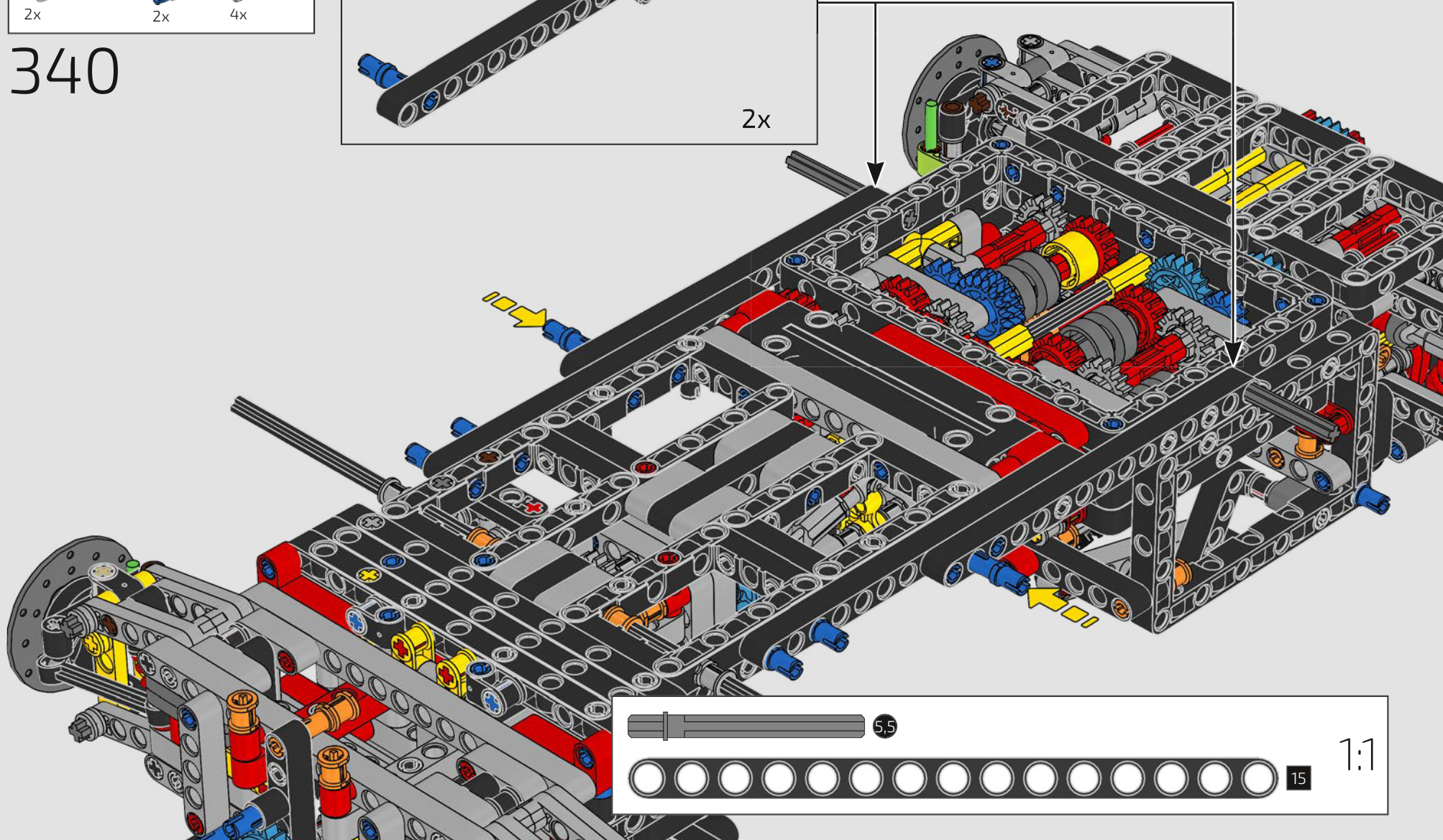
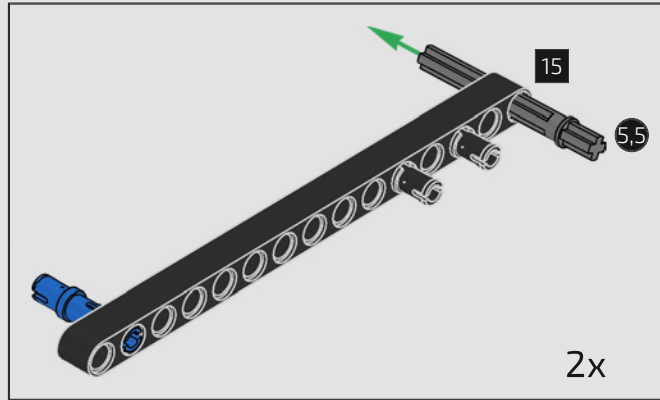

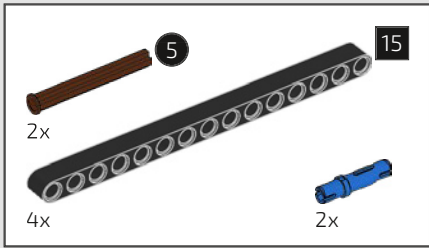
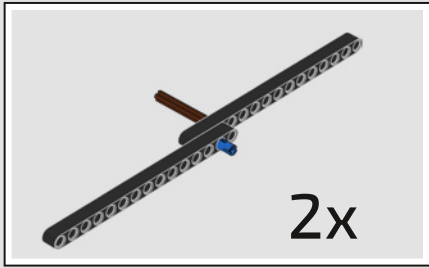

341

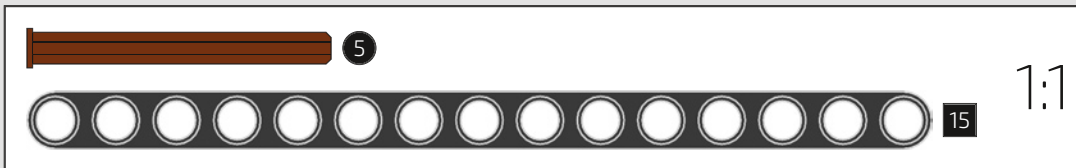
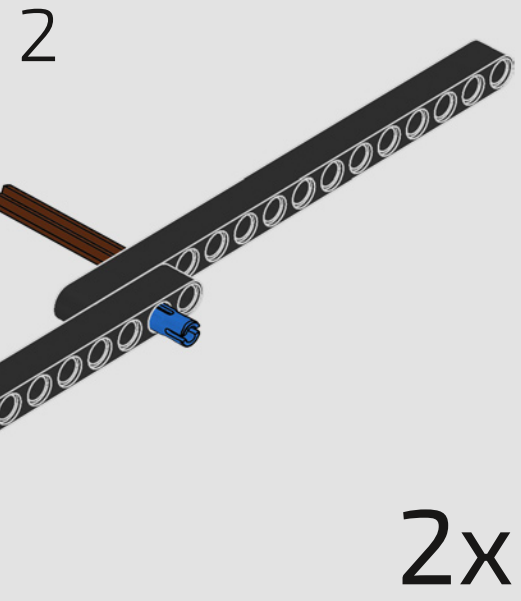
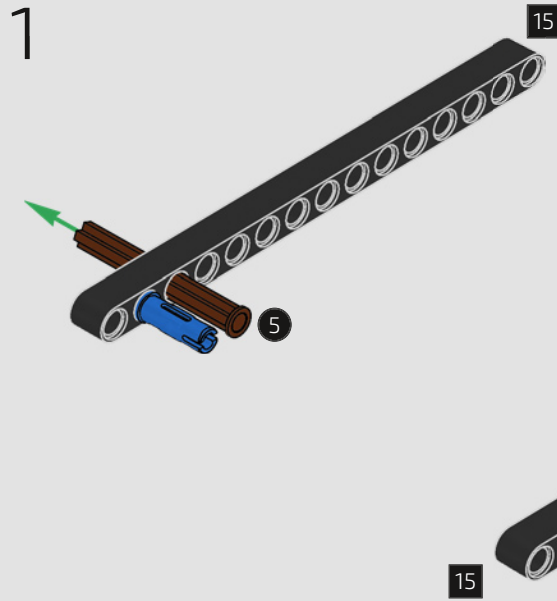

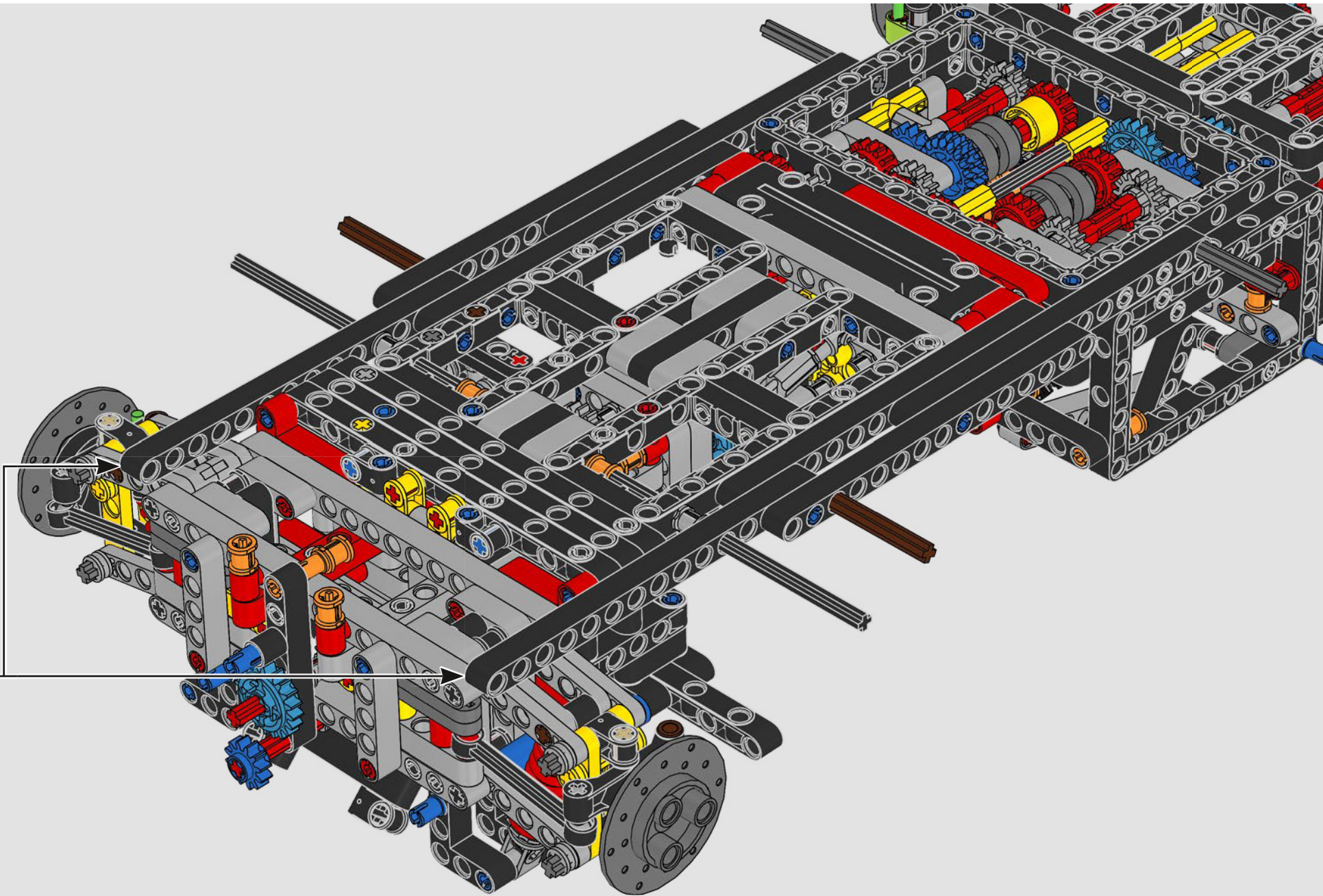

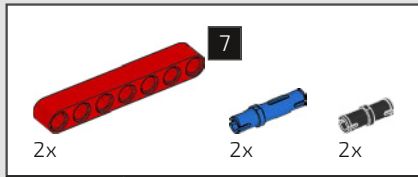

342

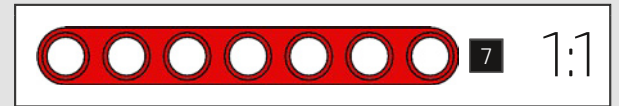
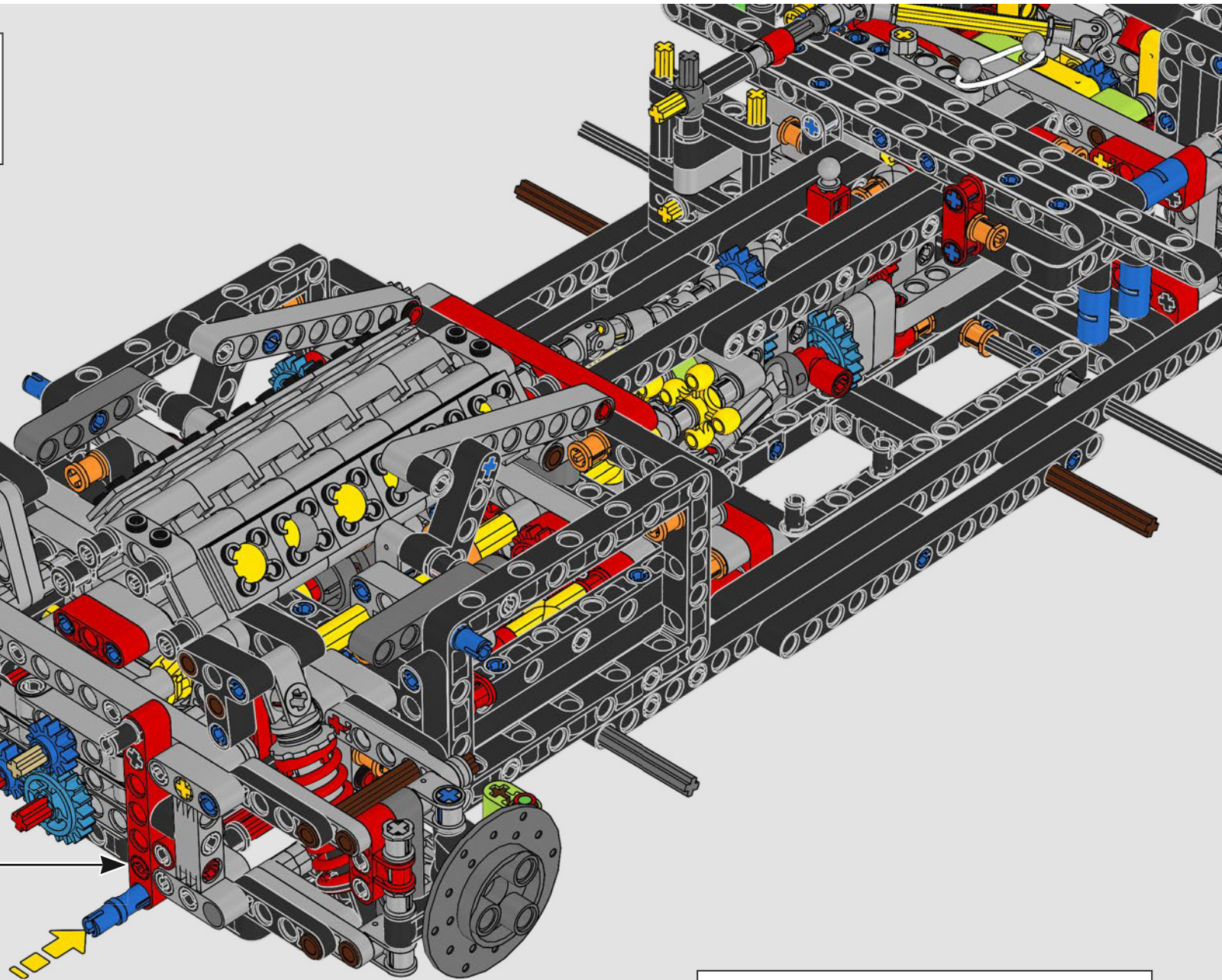
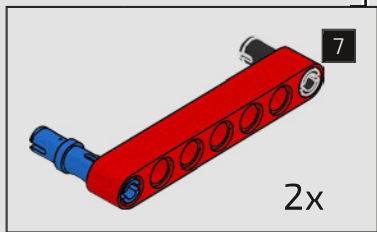

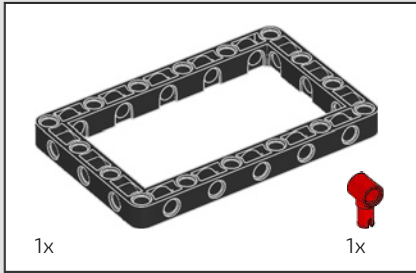
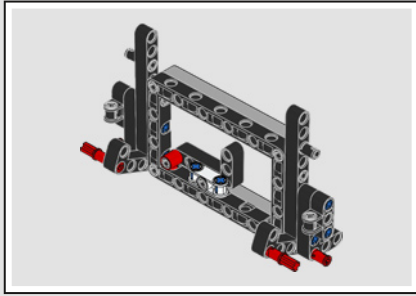

343

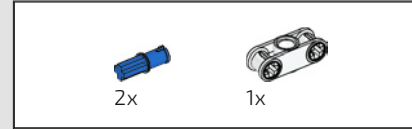
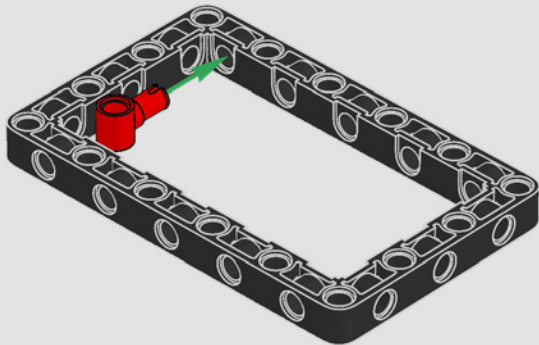

344

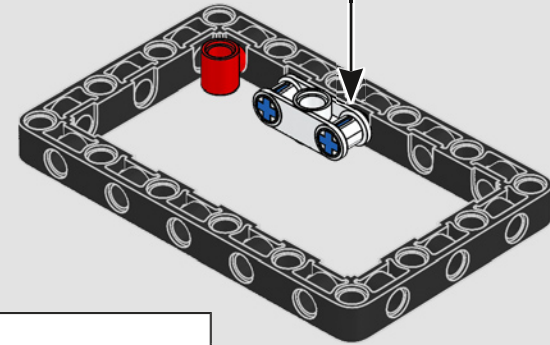
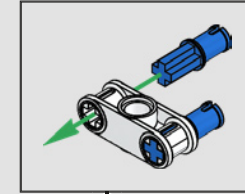

345

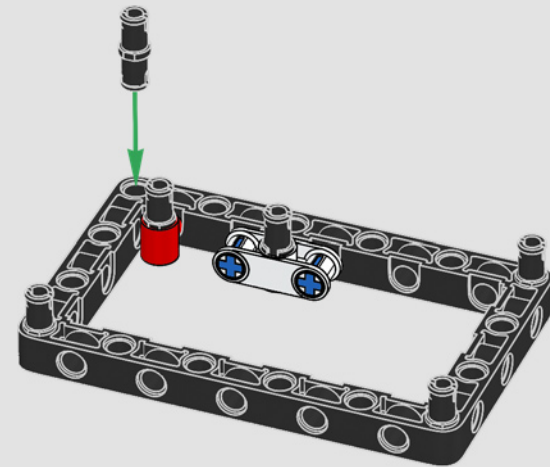

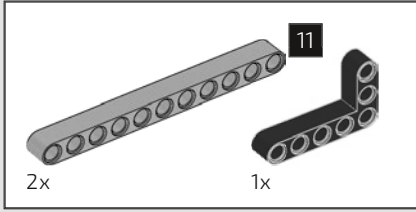

346

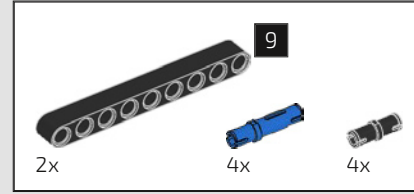
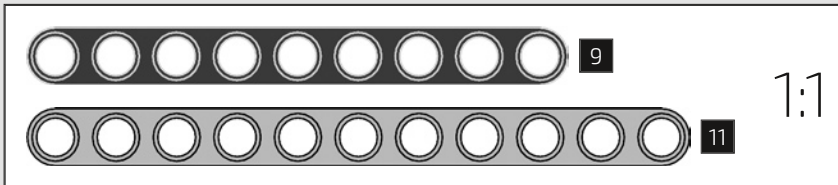
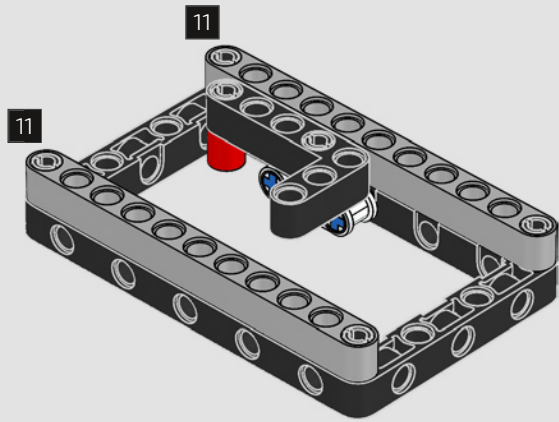

347

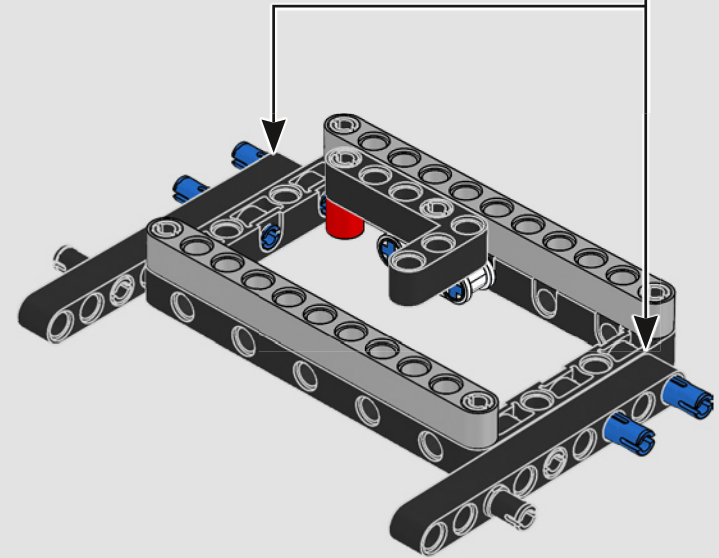
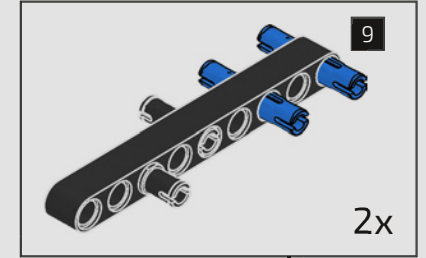

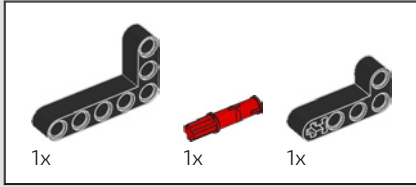

348

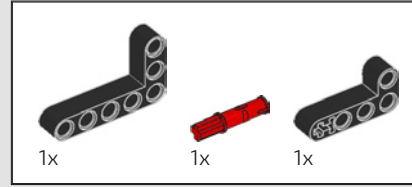
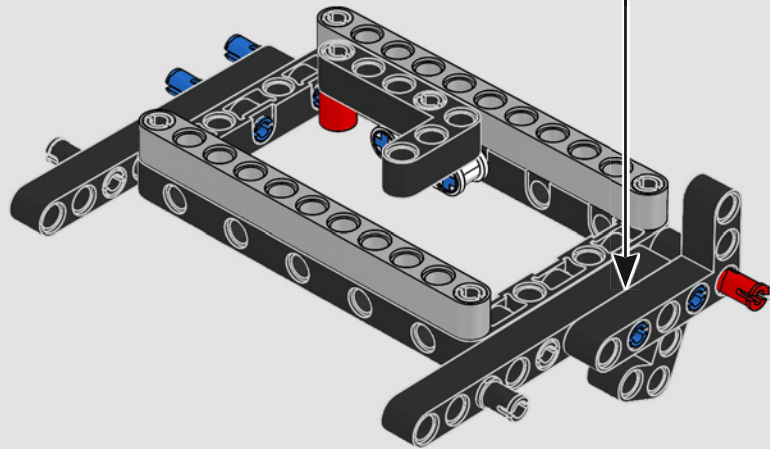
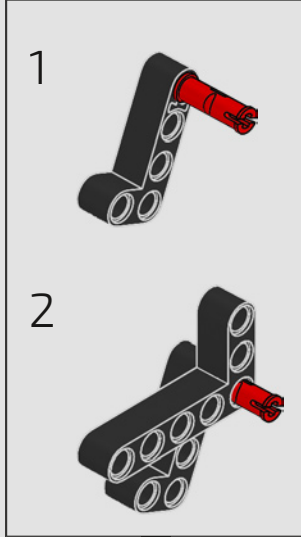

349

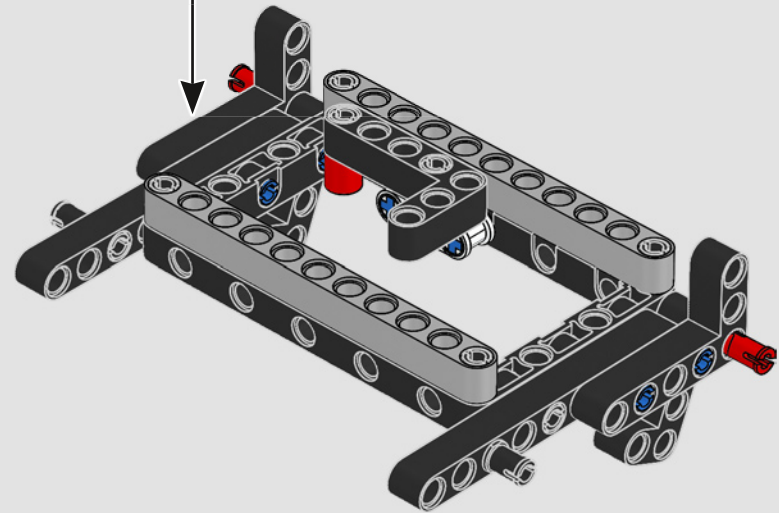
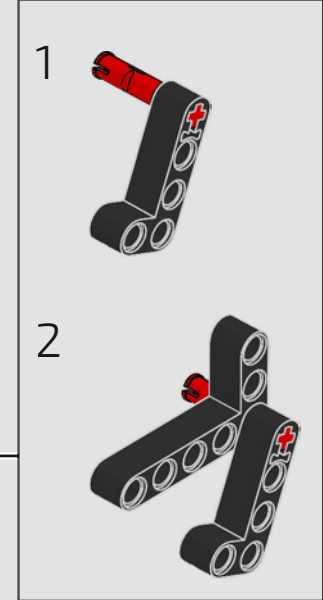



350

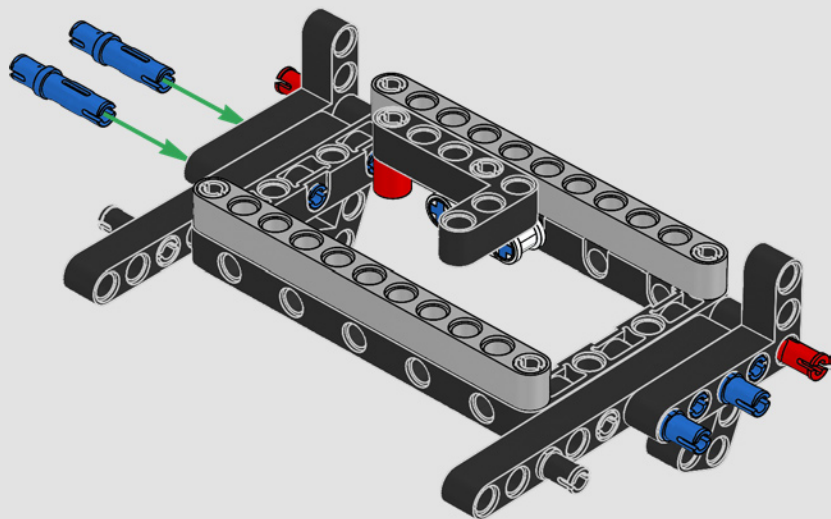

351

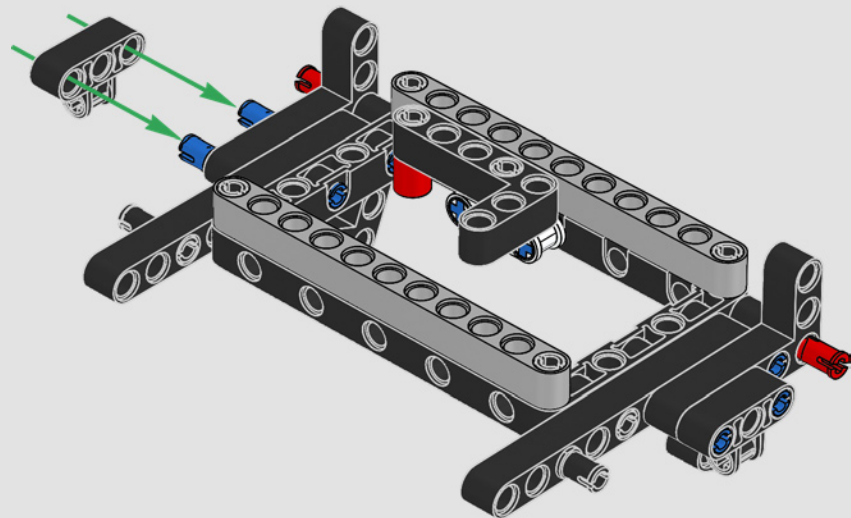

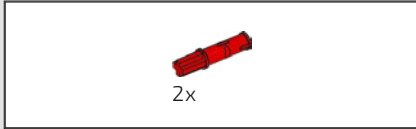

352

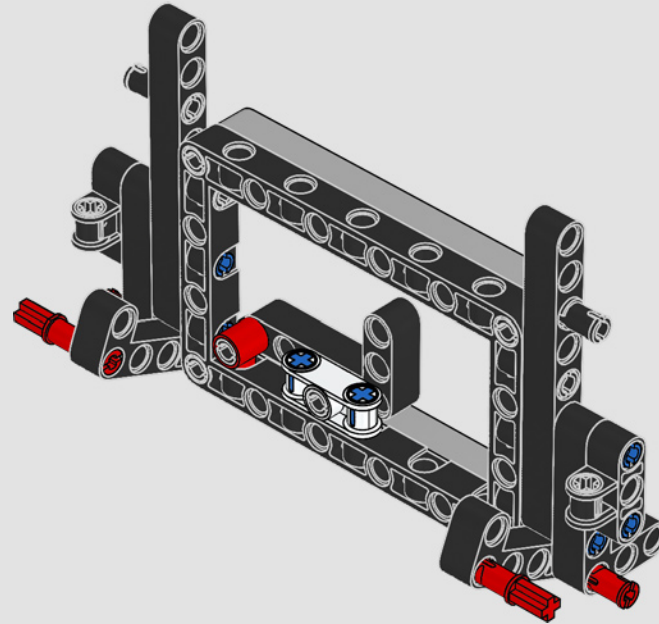

353

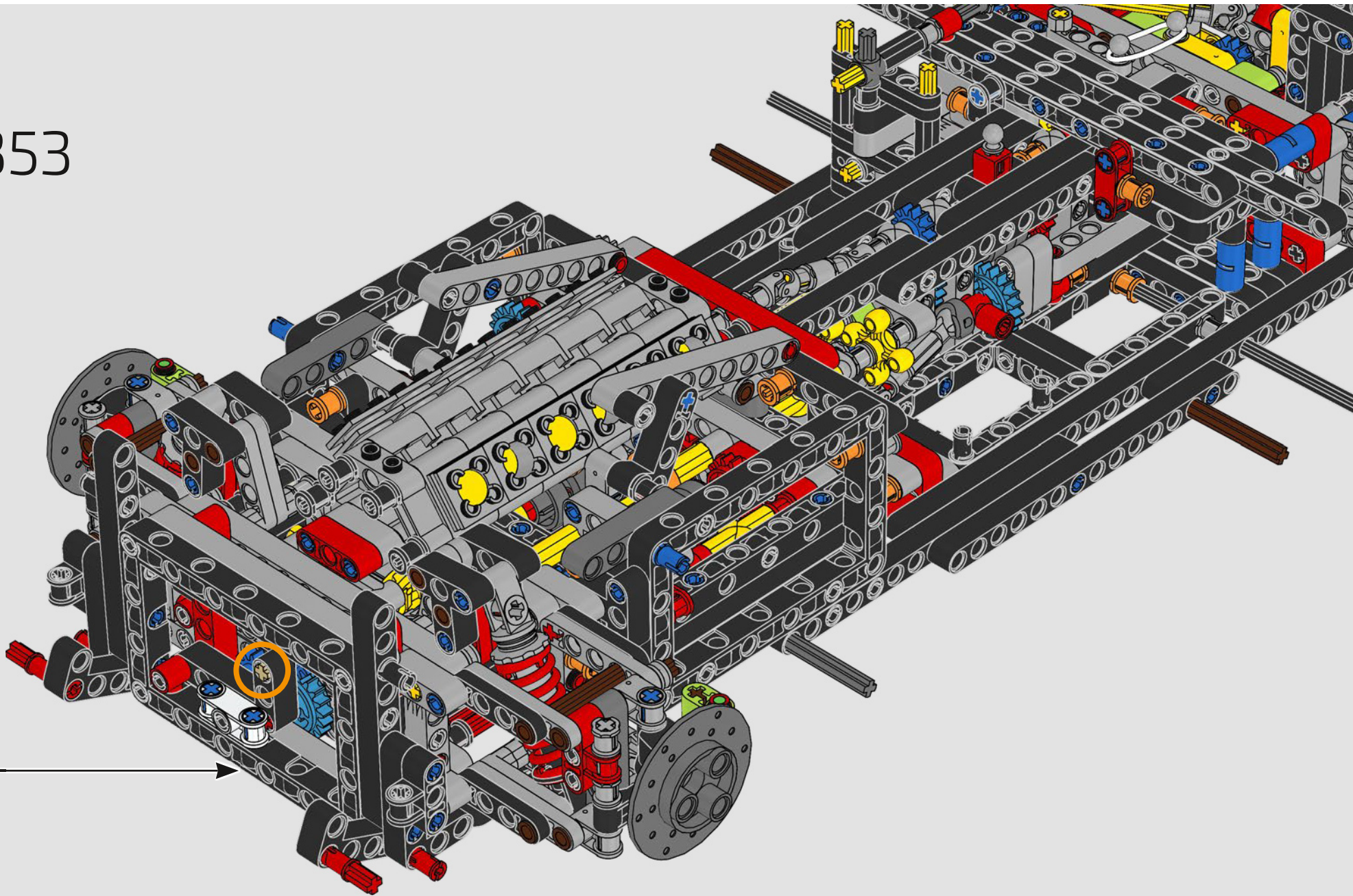



354

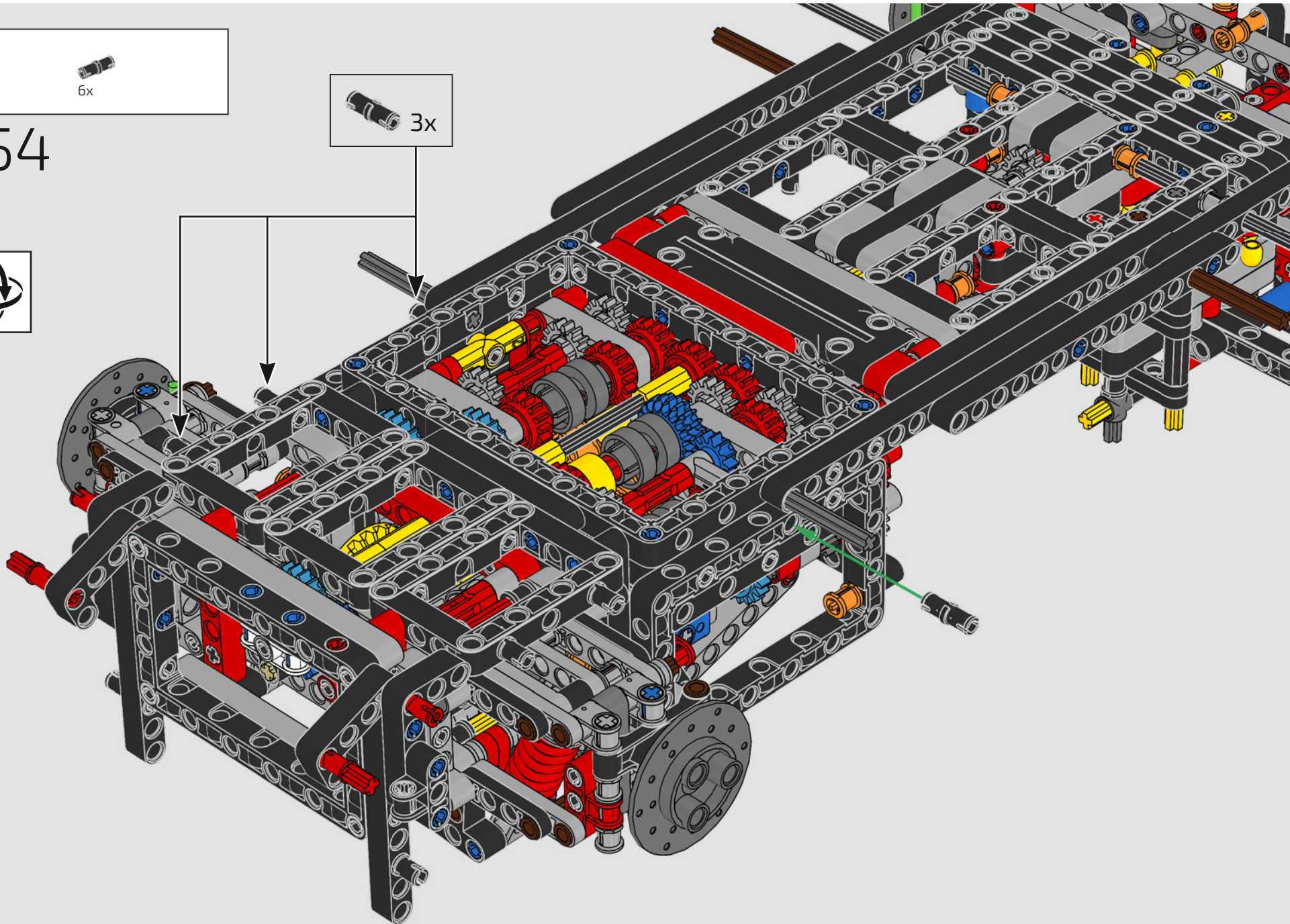

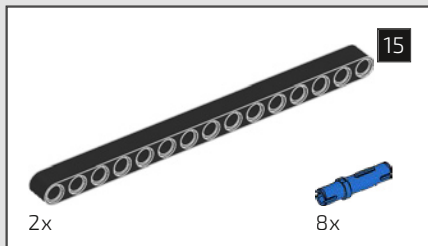

355

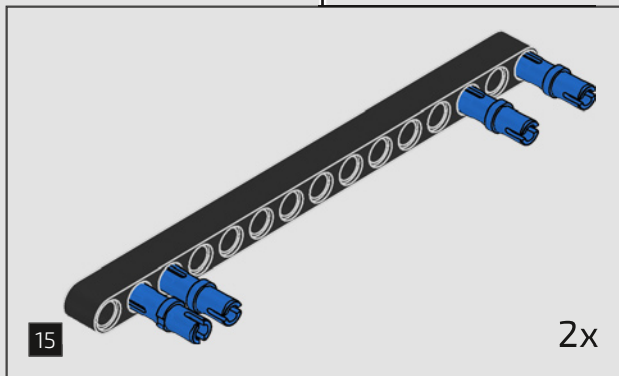
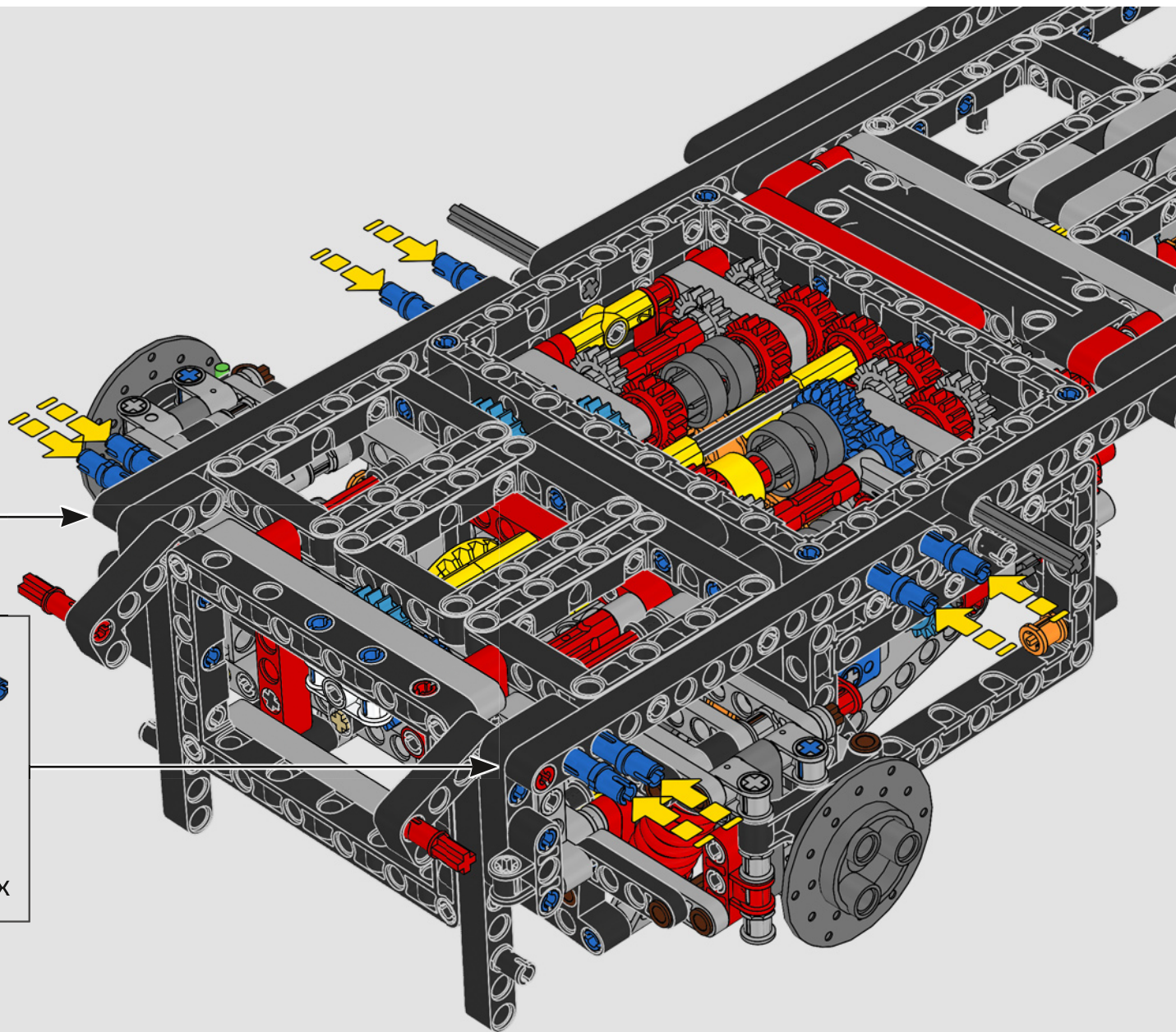

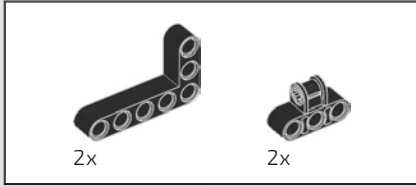

356

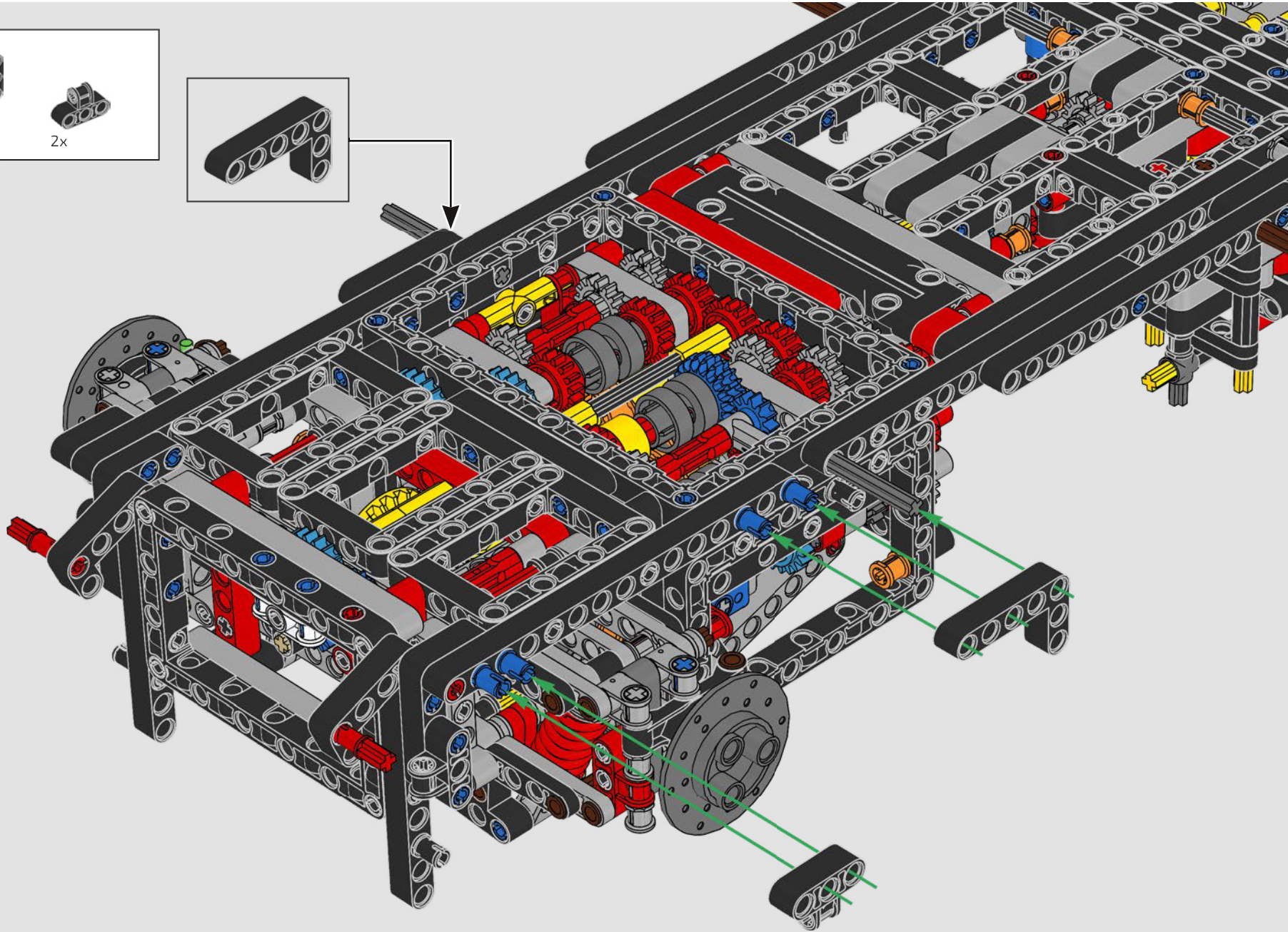
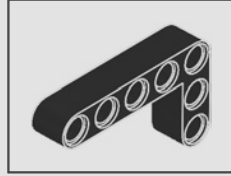

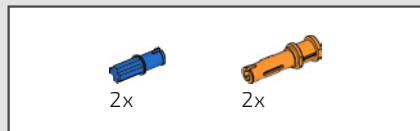

357

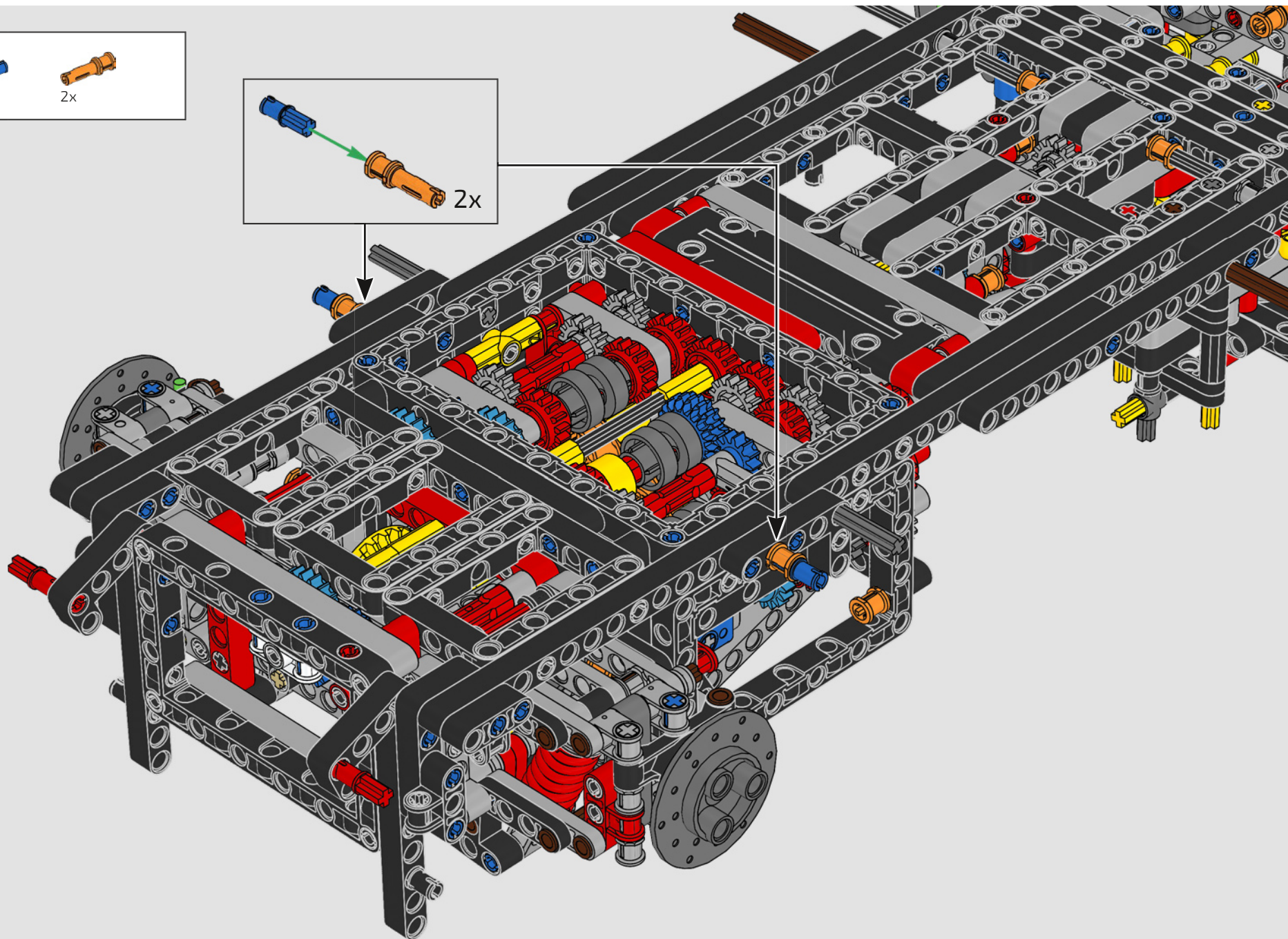
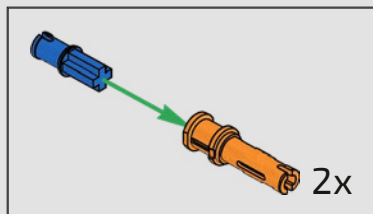

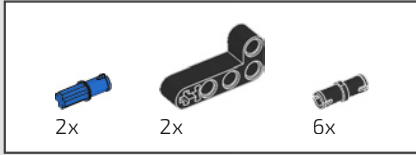

358

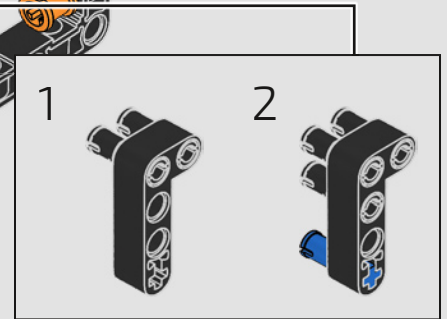
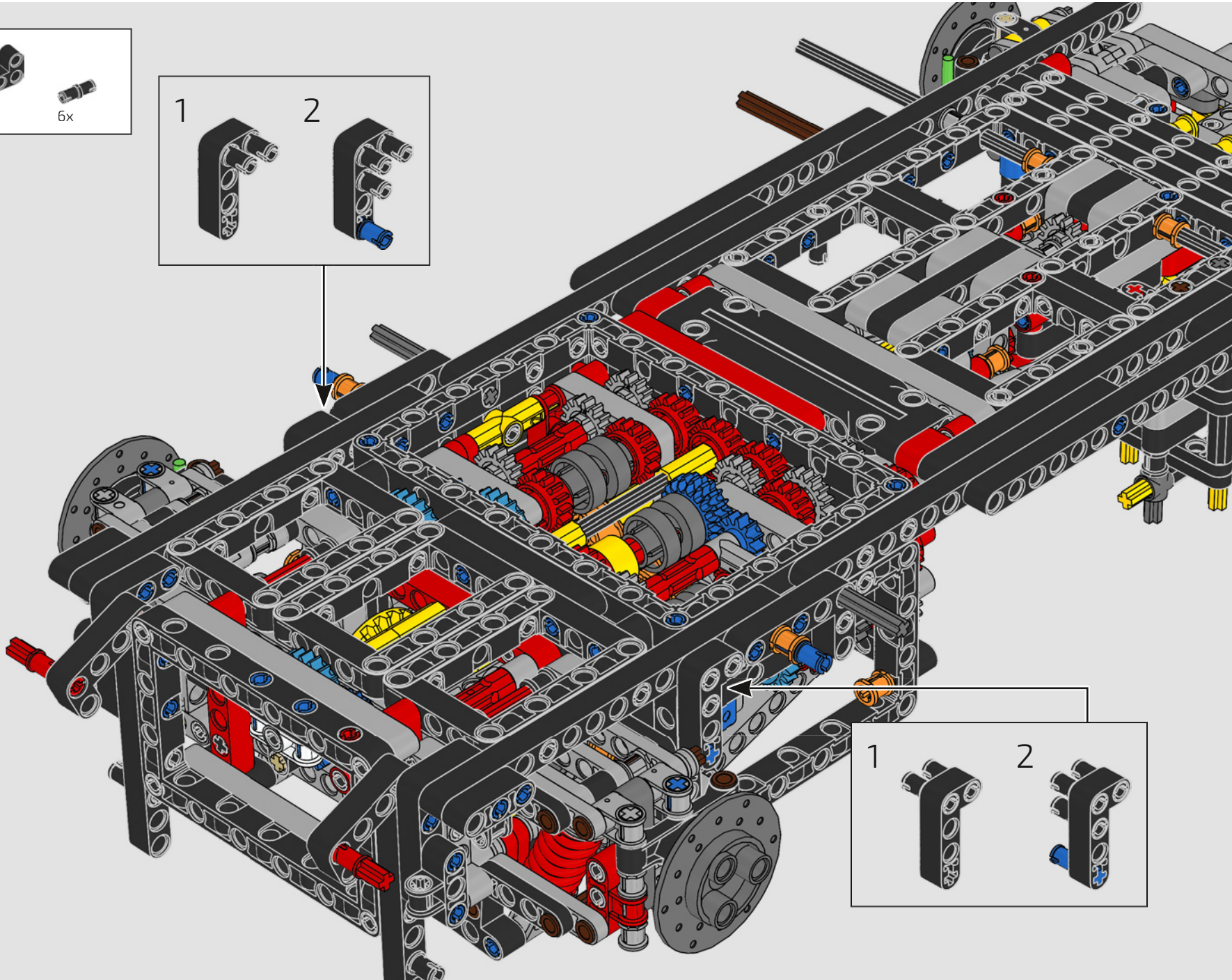
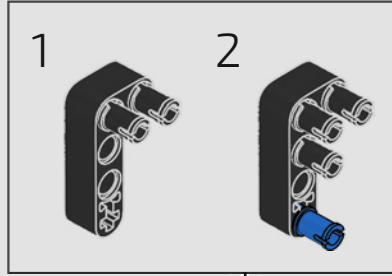



359

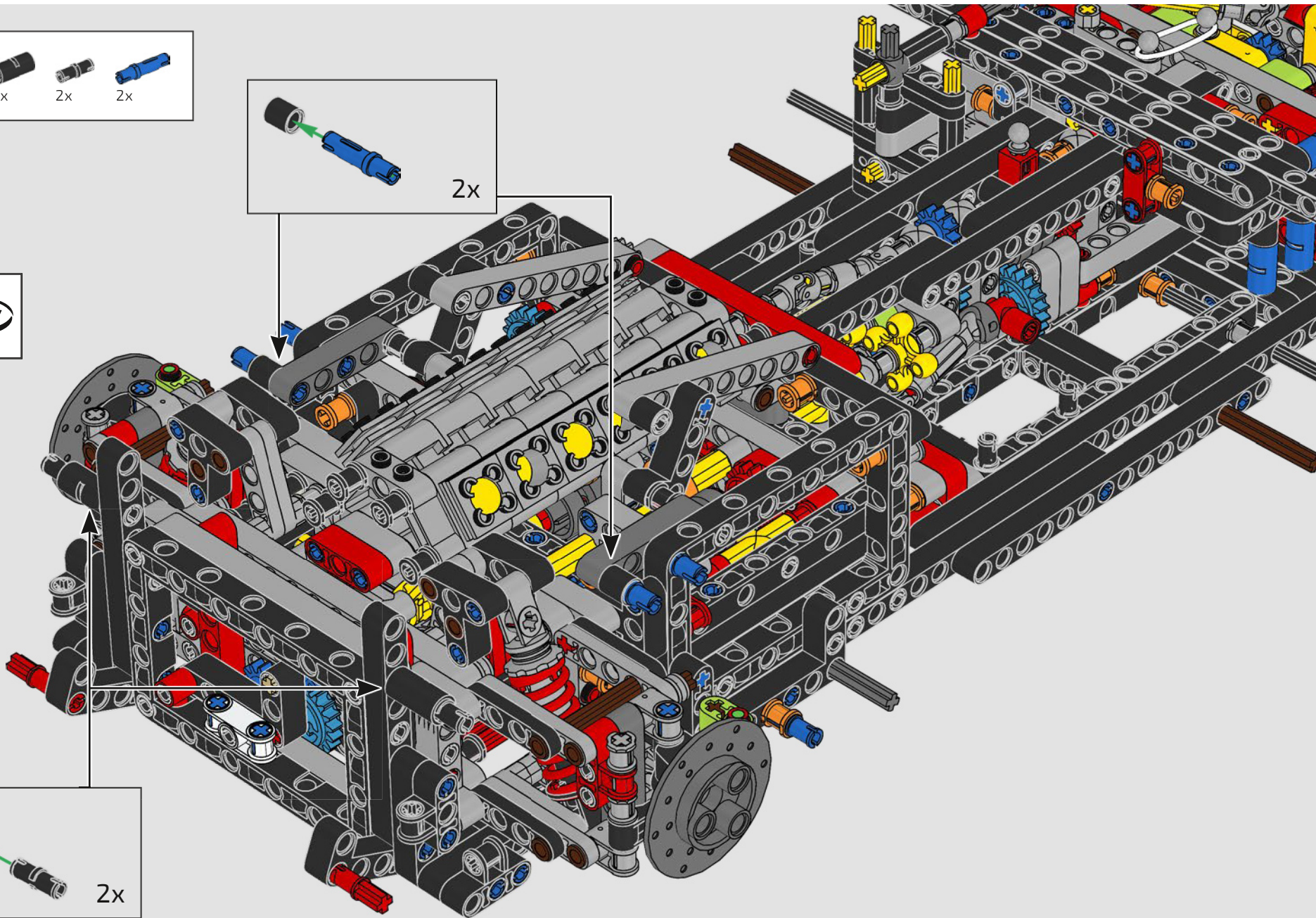
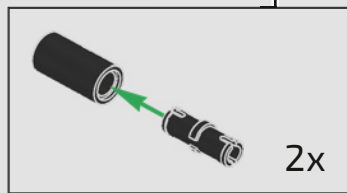
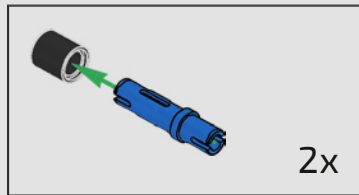



360

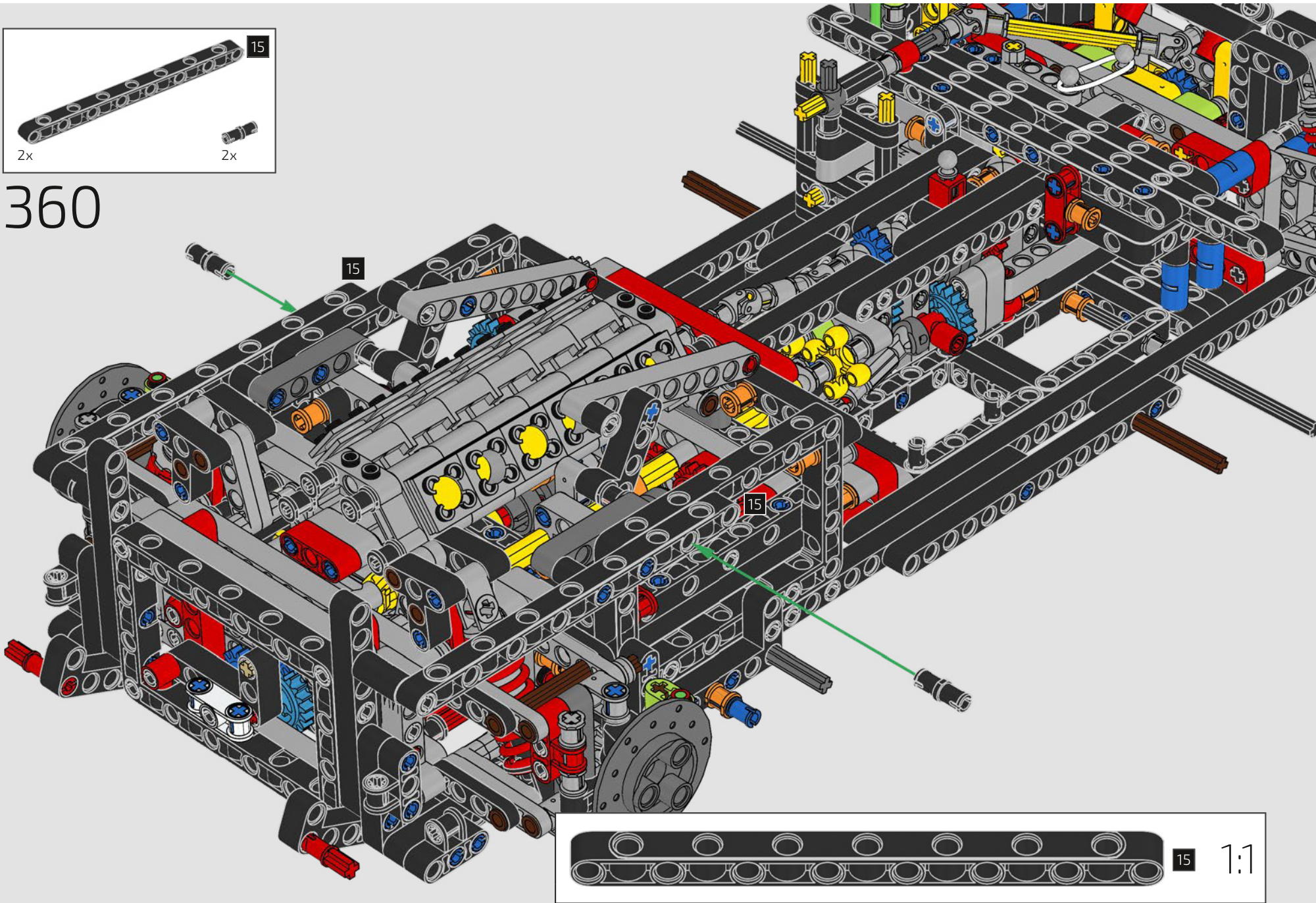



361

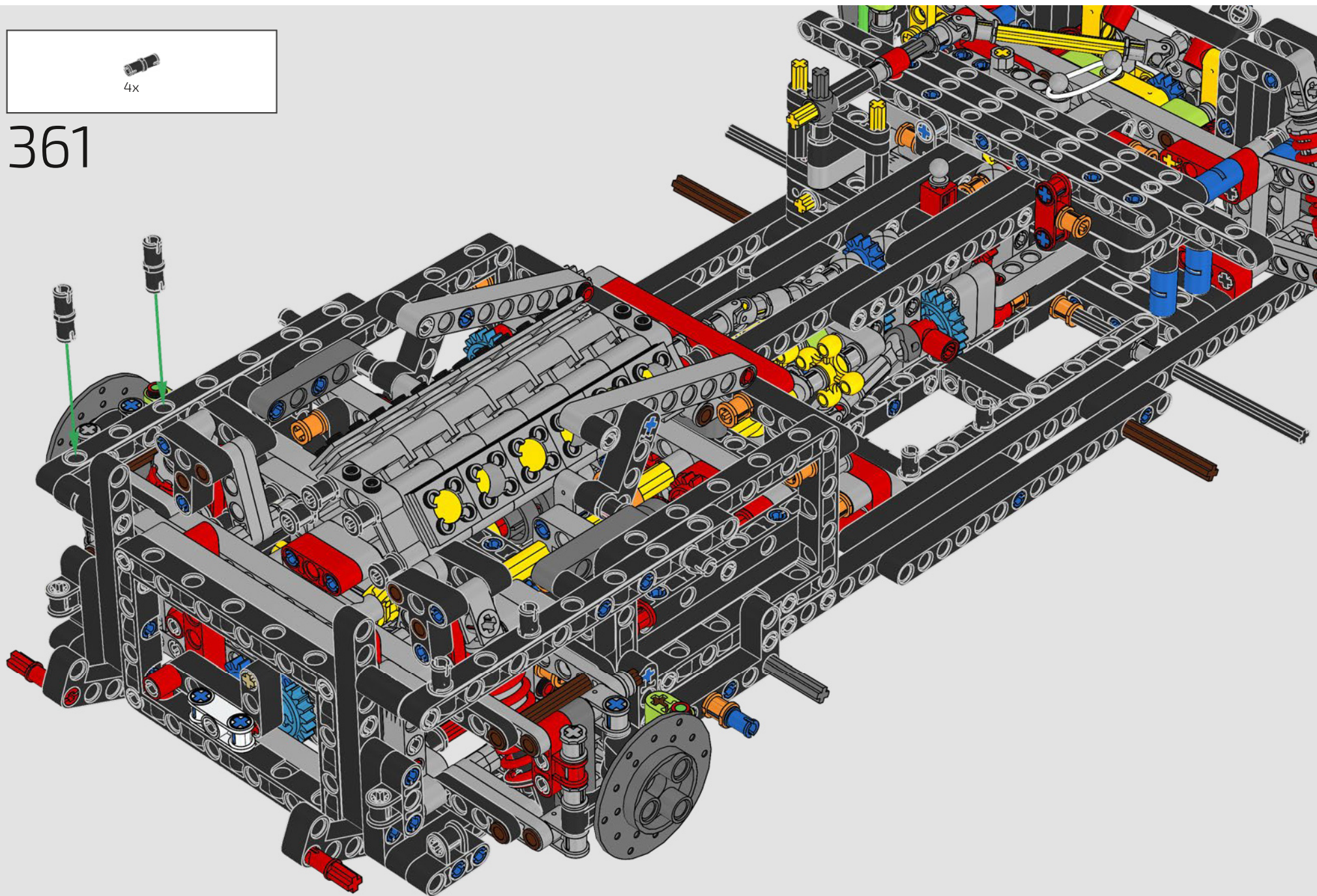

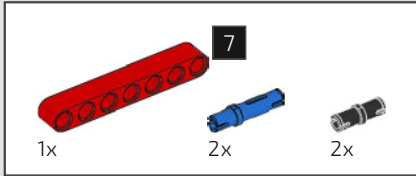
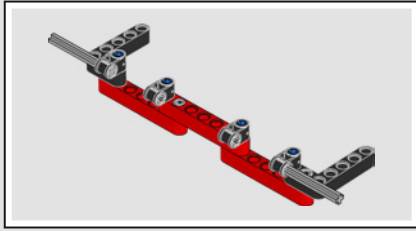

362

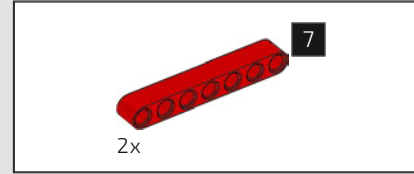
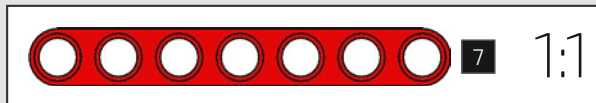
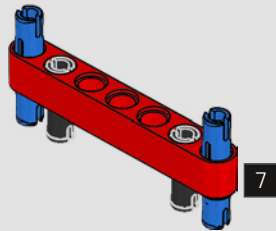

363

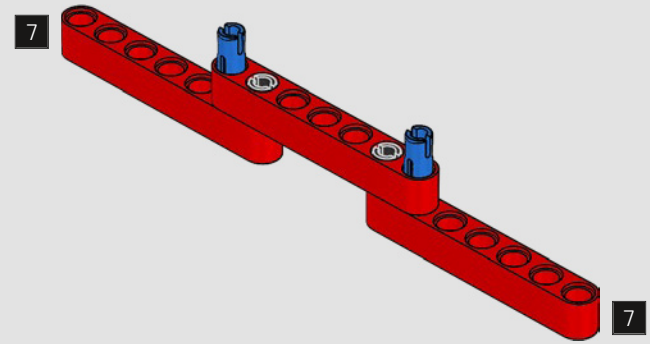

364

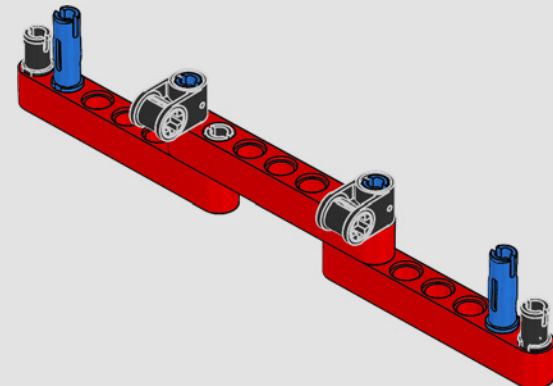

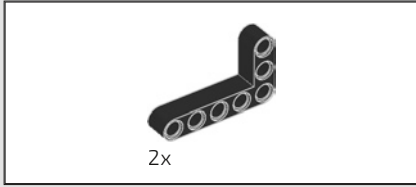

365

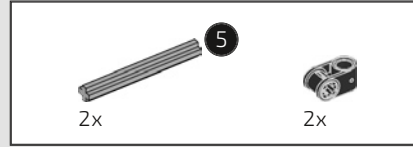
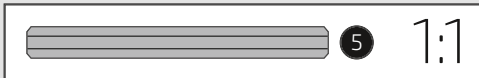
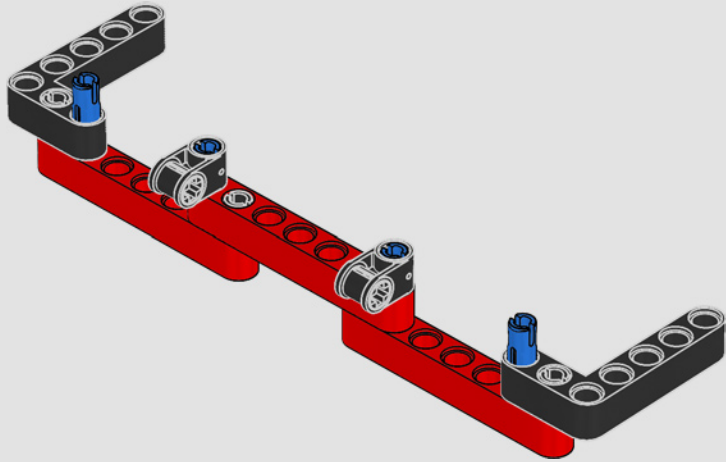

366

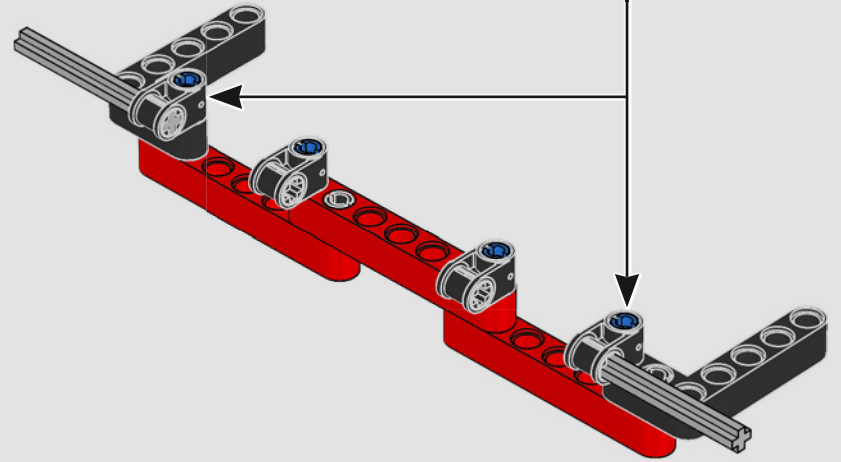
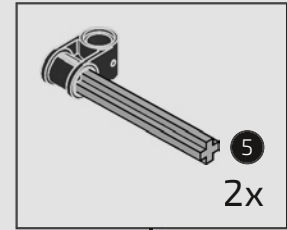

367

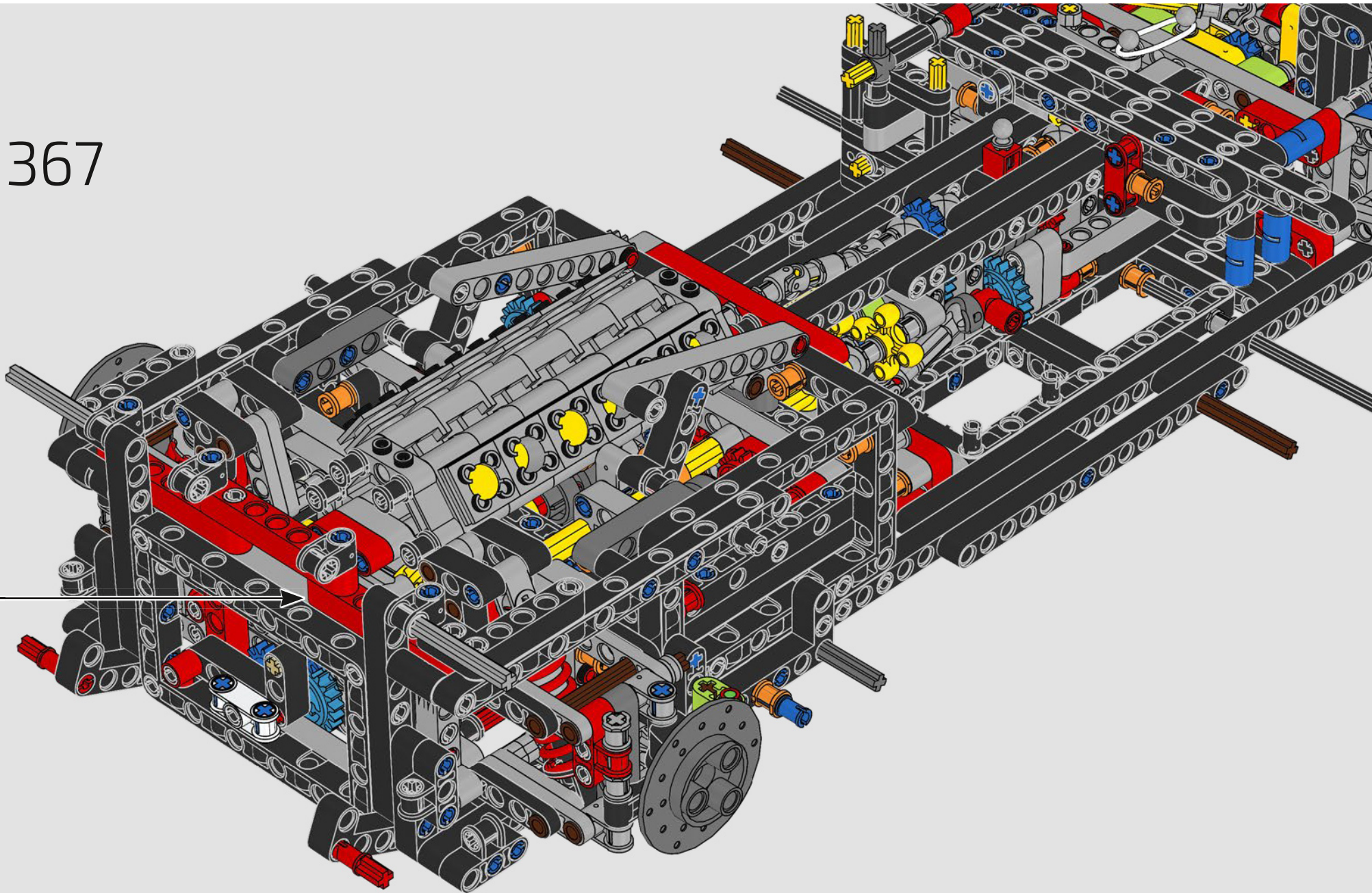

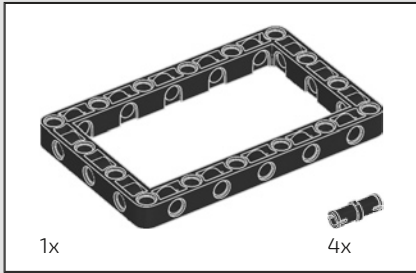
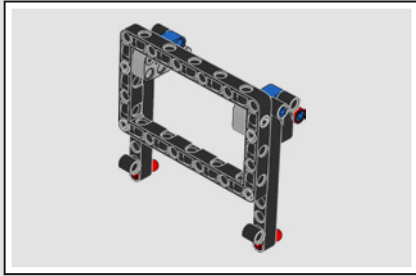

368

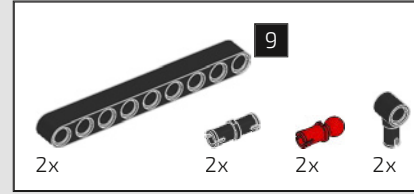
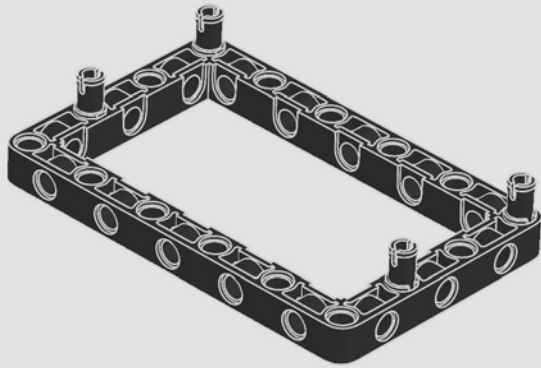

369

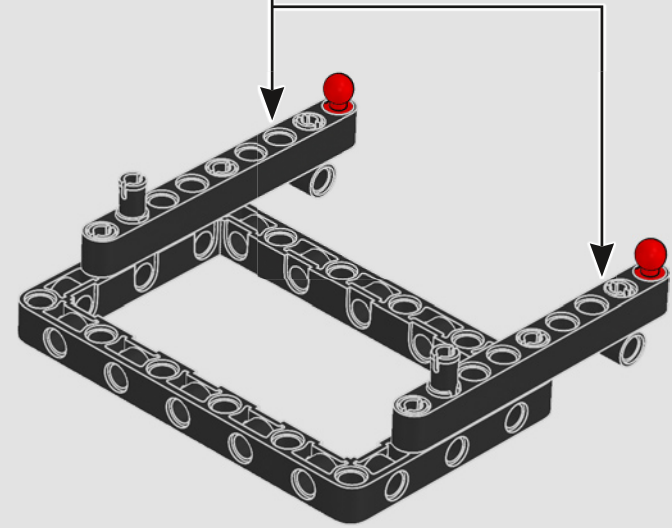
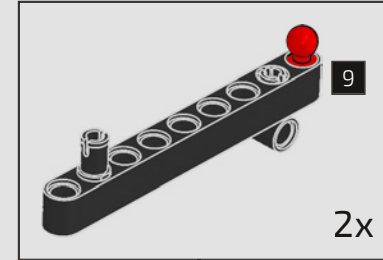

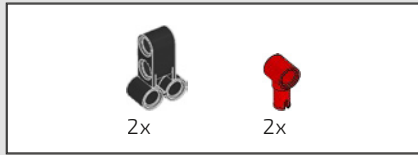

370

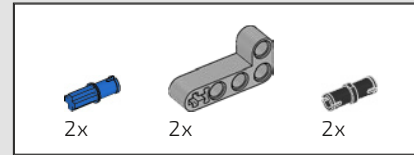
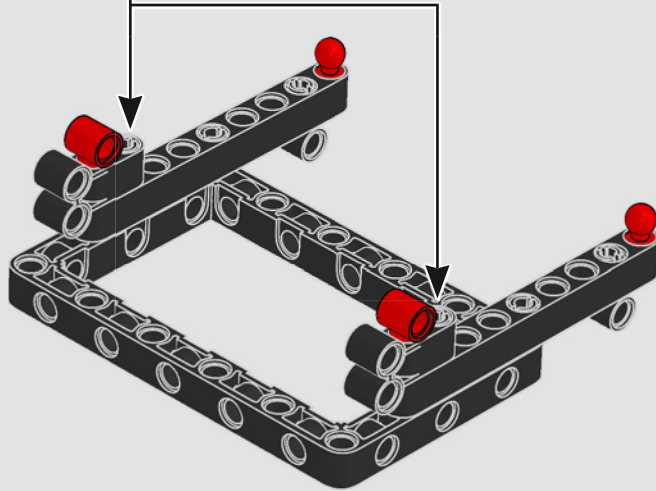
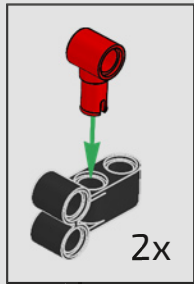

371

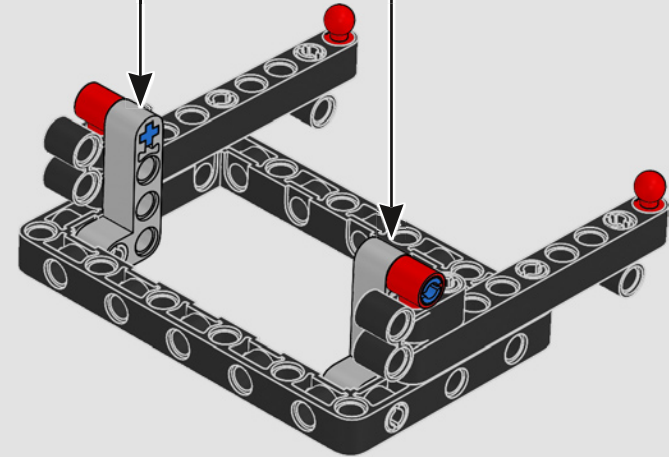
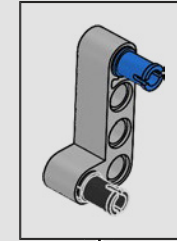
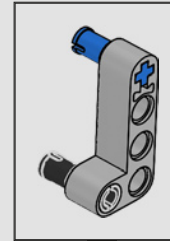

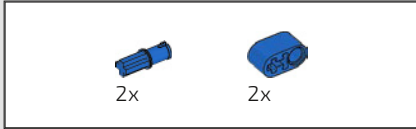

372

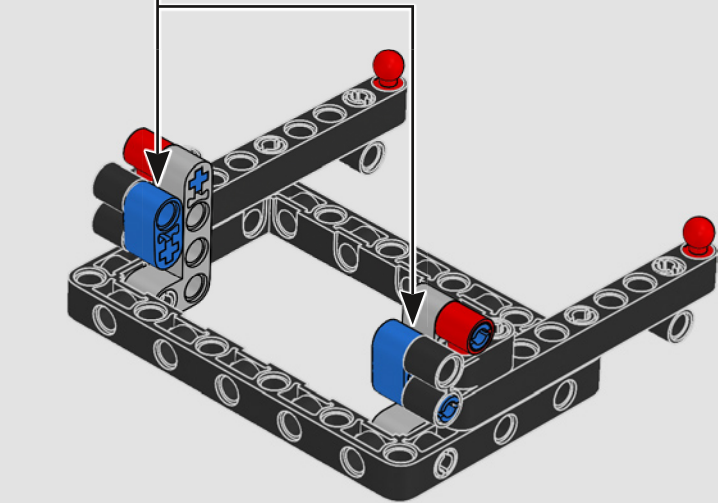
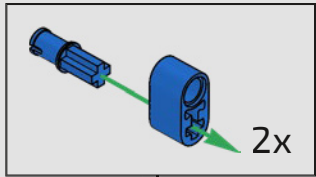

373

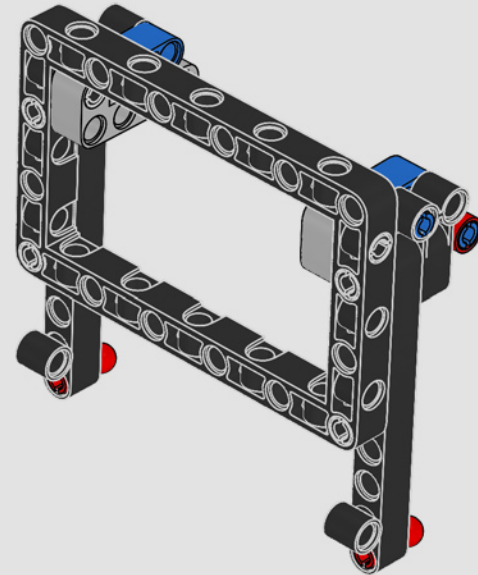

374

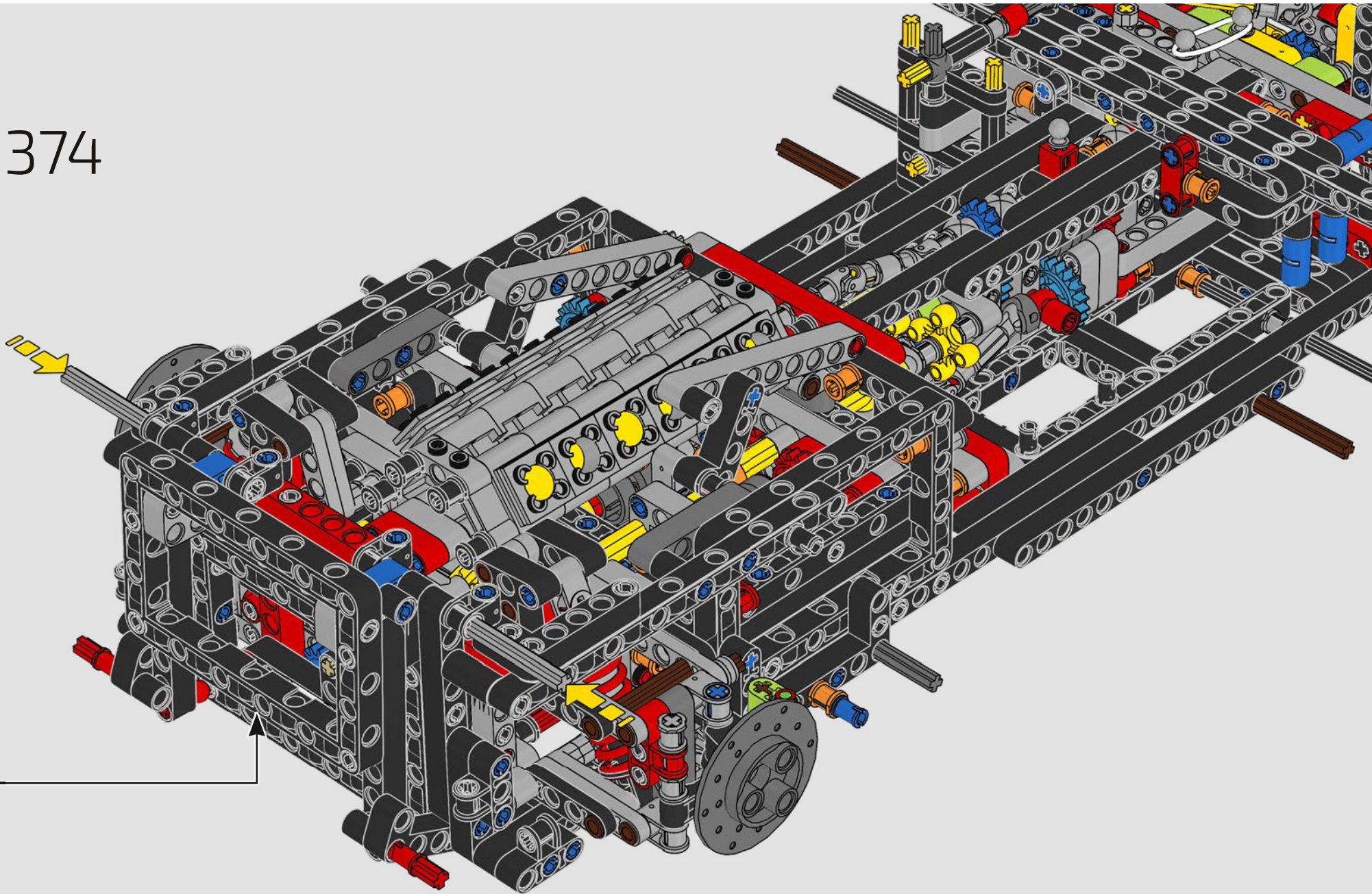

375

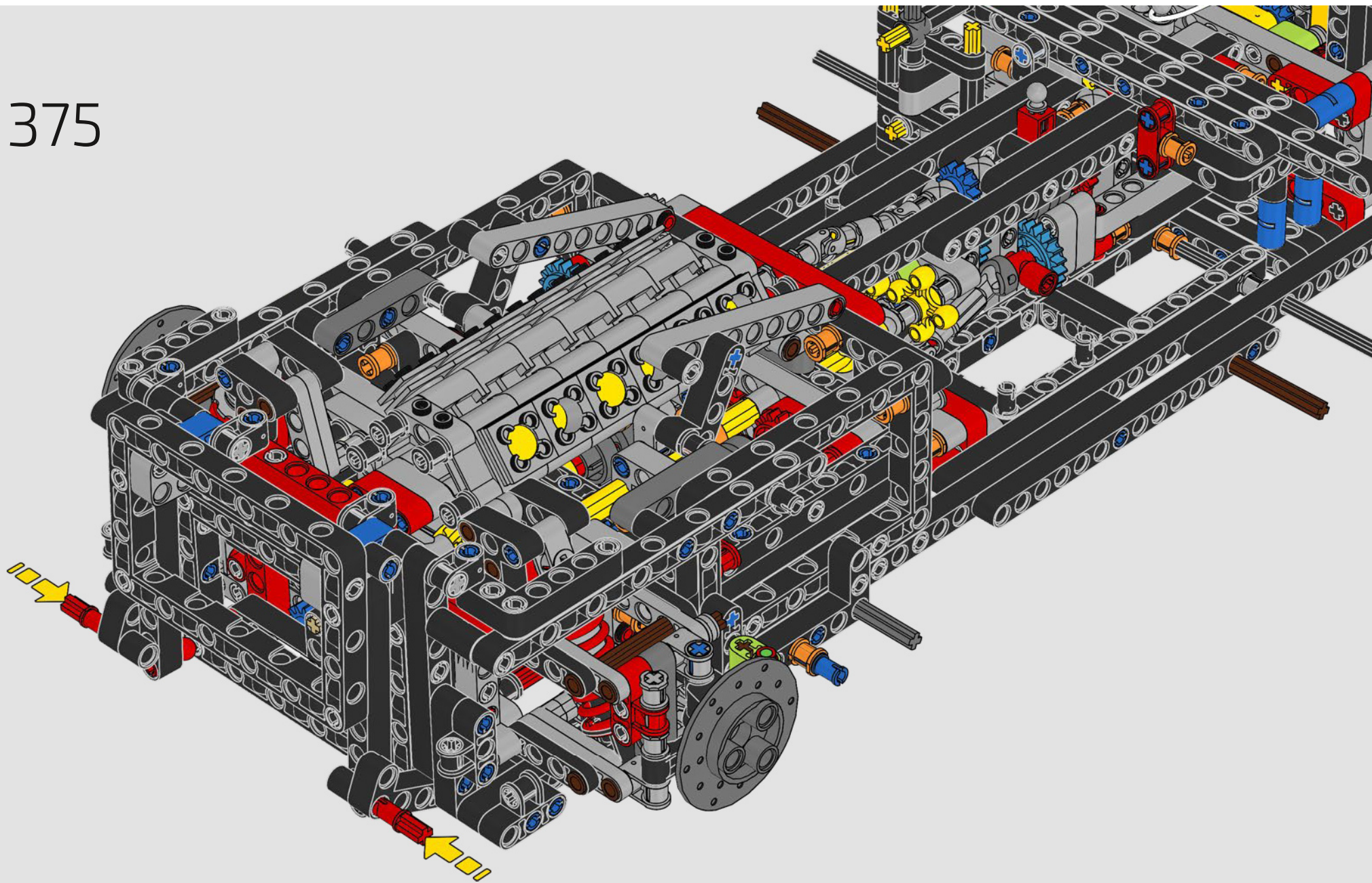

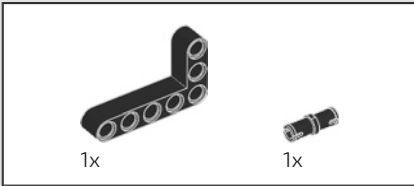
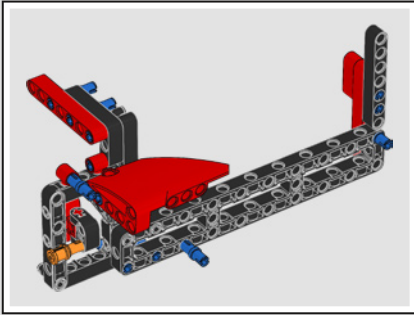

376

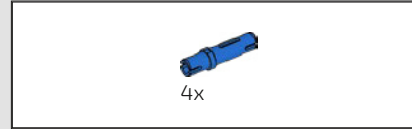
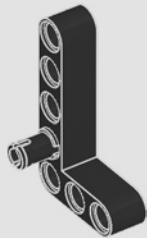

377

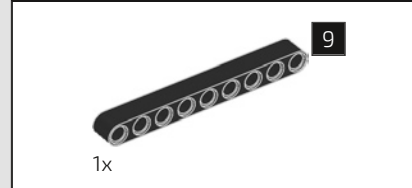
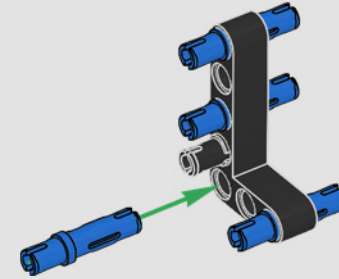

378

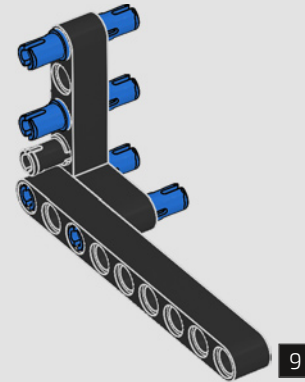



379

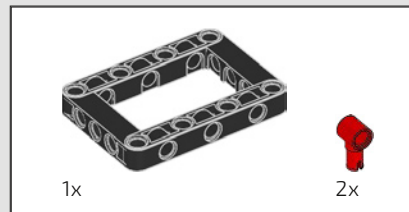
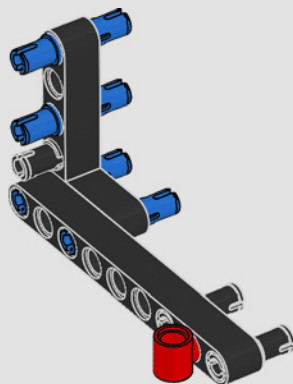

380

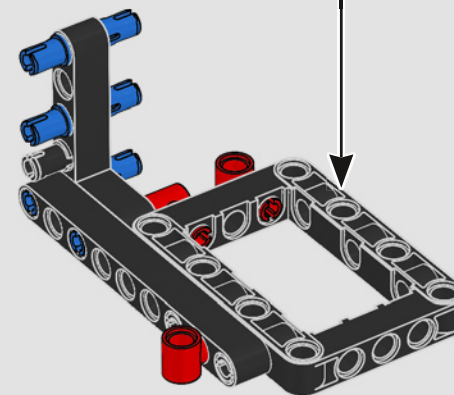
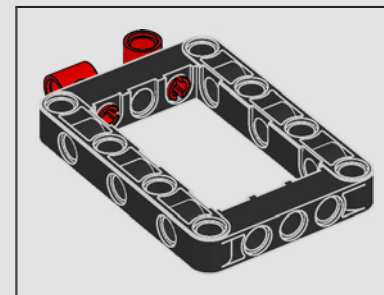

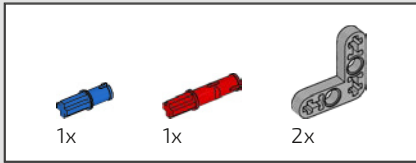

381

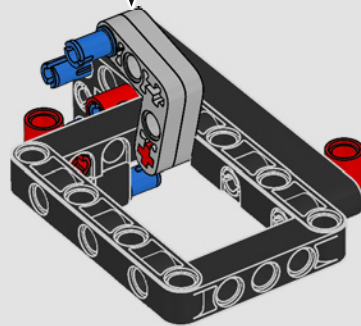
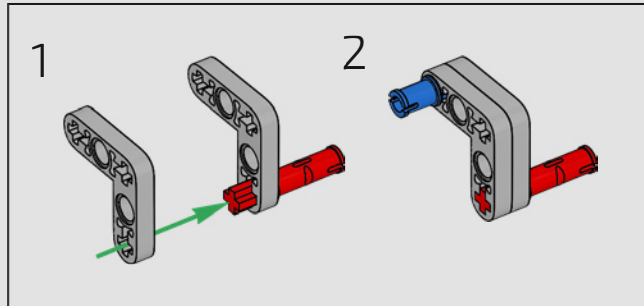

382

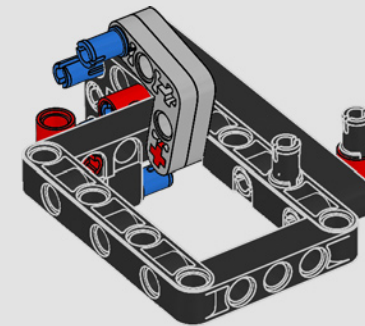

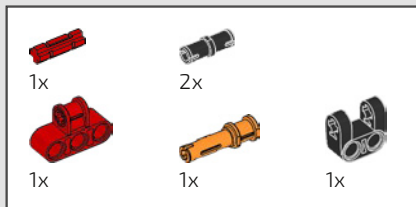

383

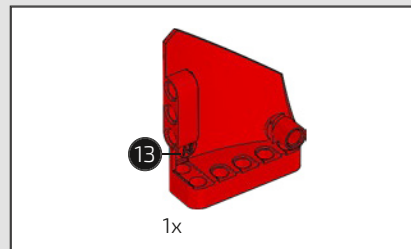
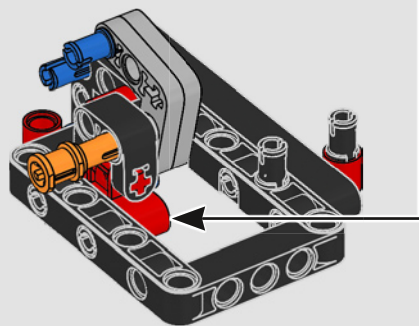
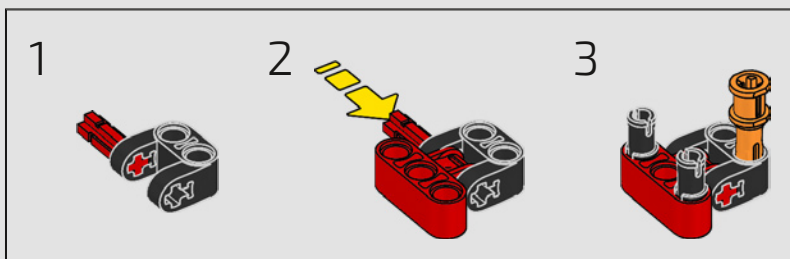

384

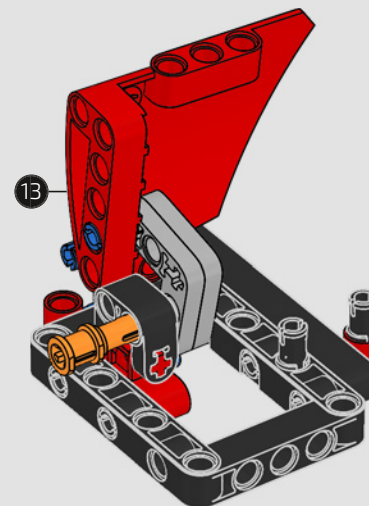

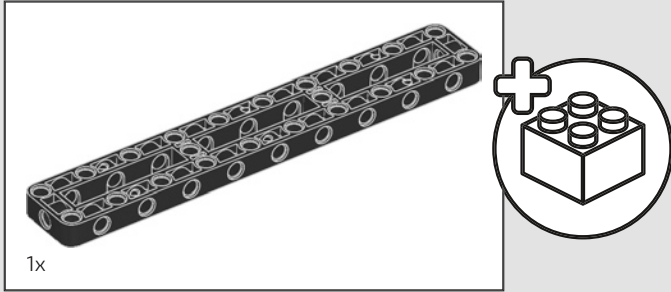

1x
385



386

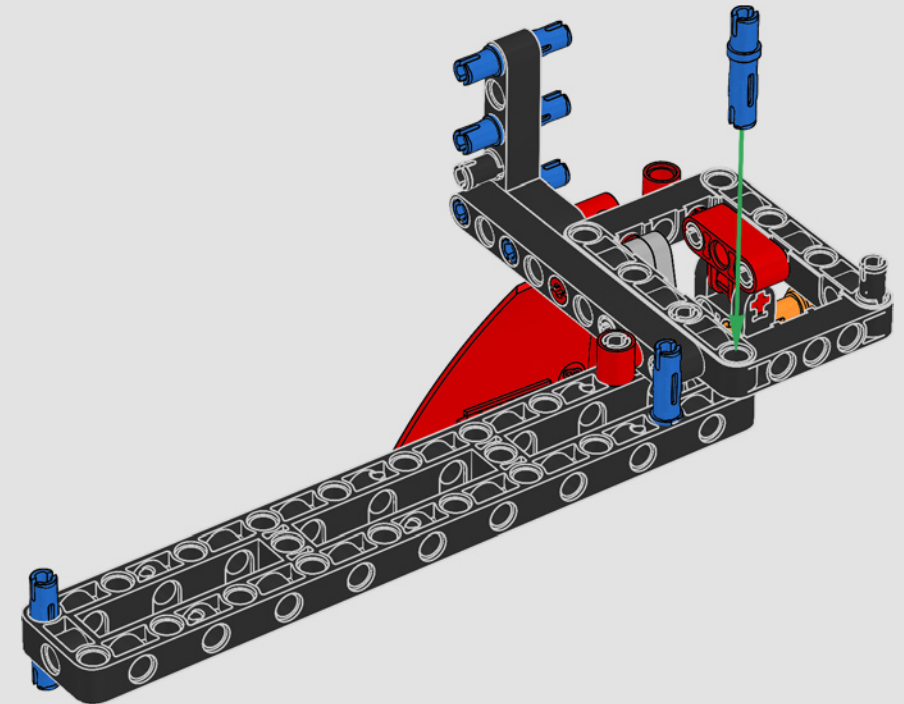

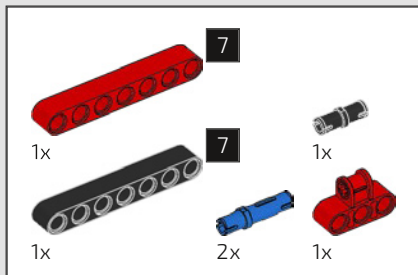

387

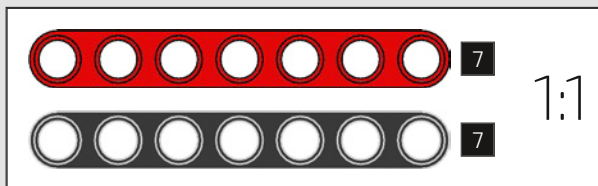
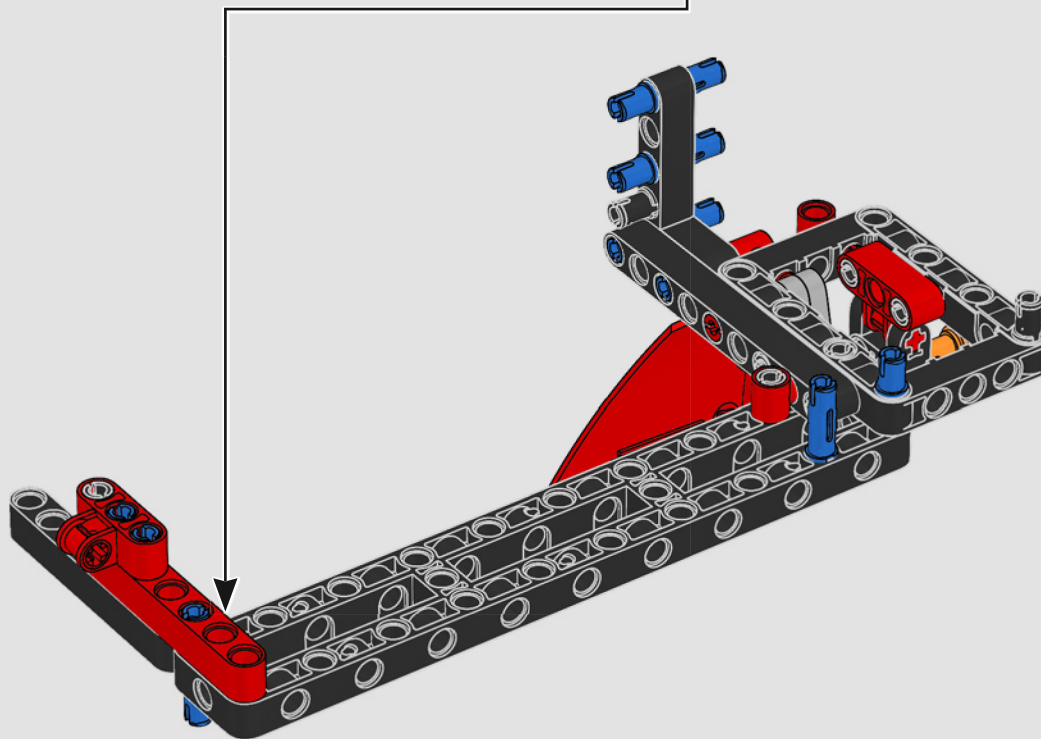
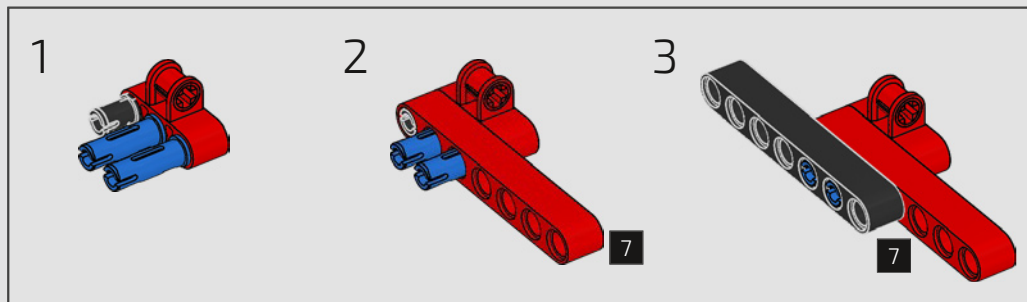

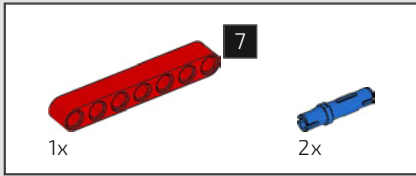

388

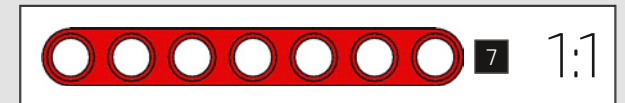
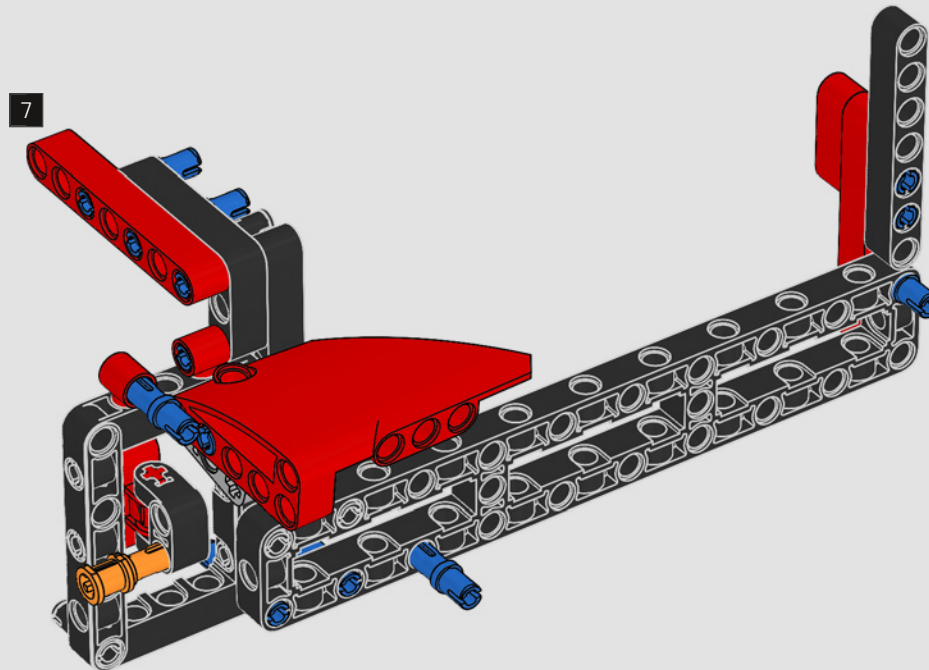

389

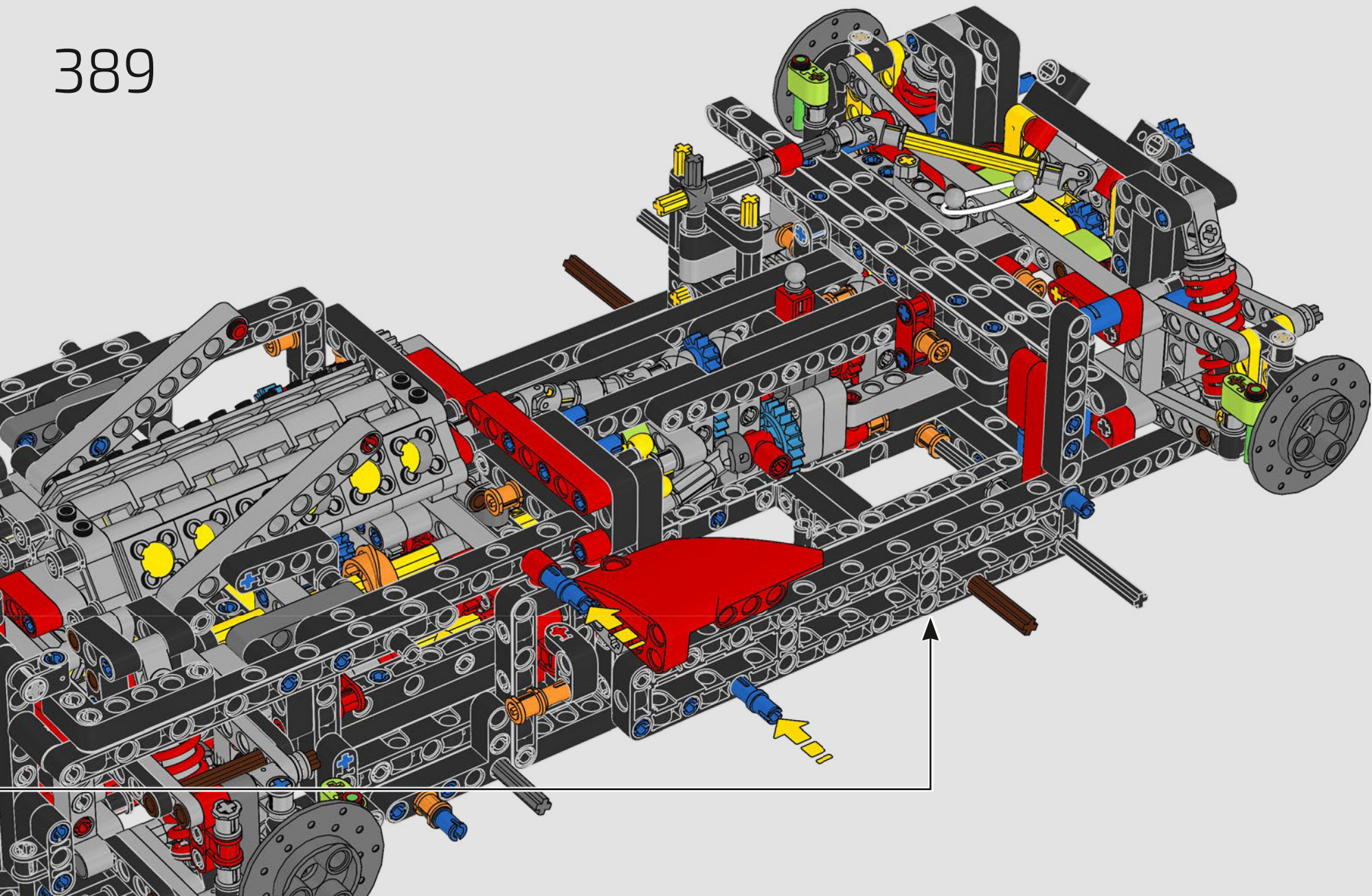

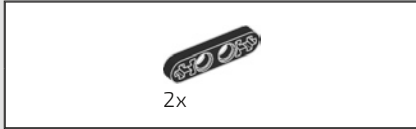

390

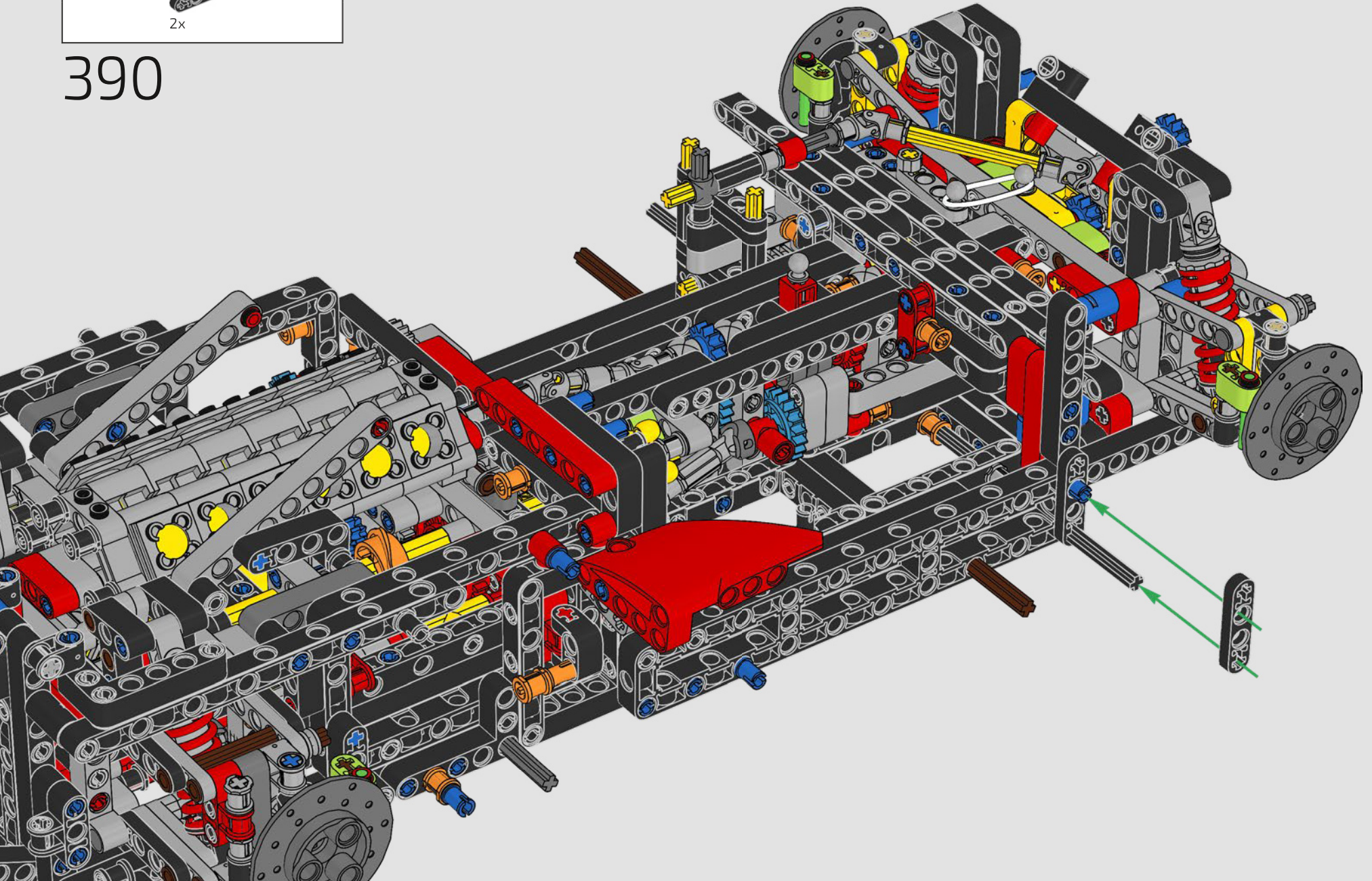

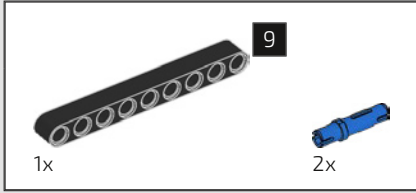

391

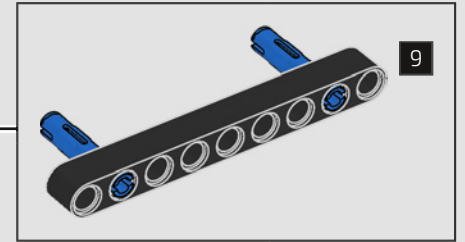
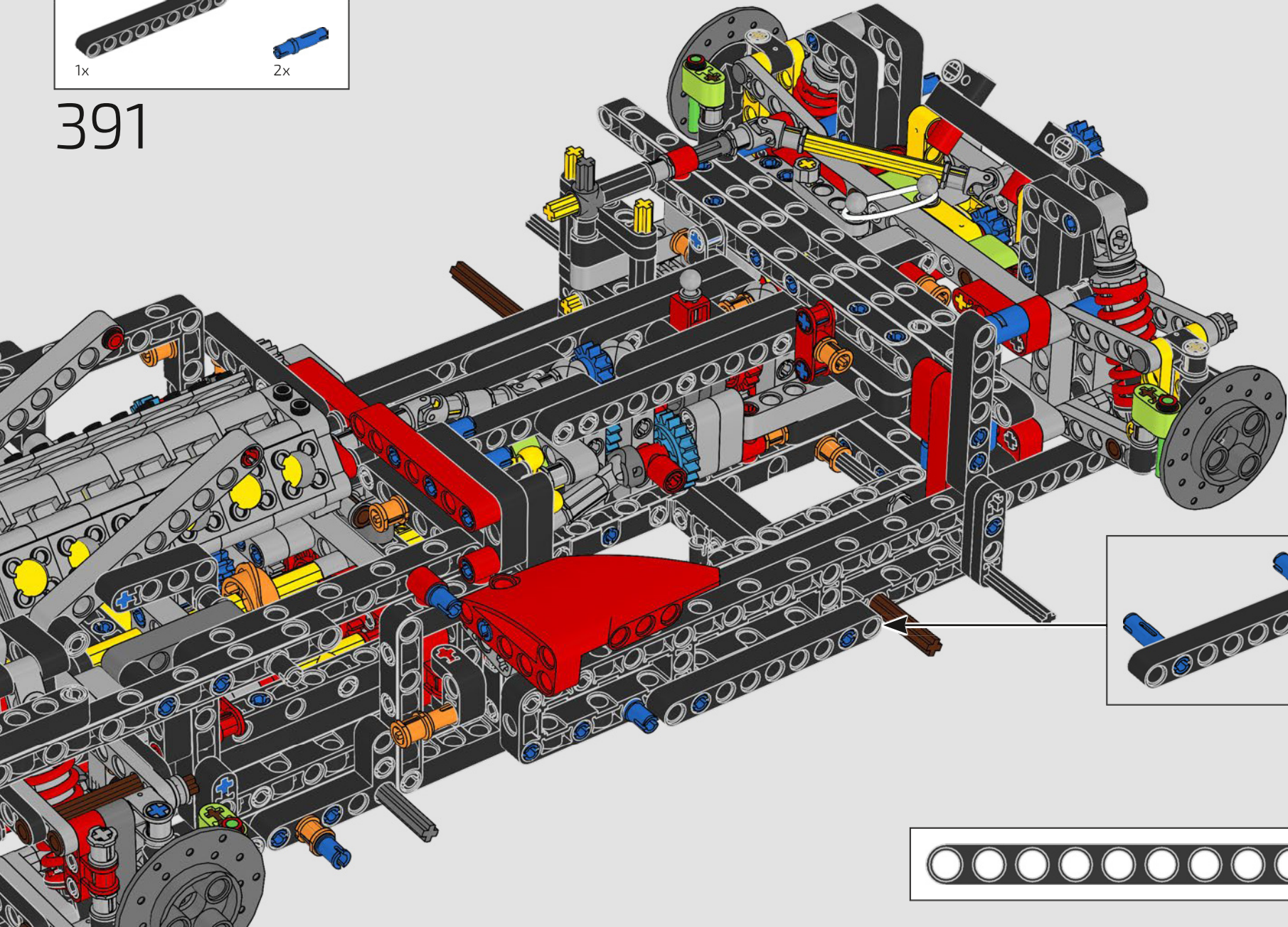

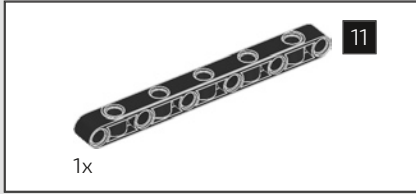

392

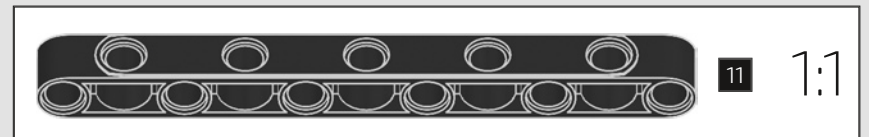
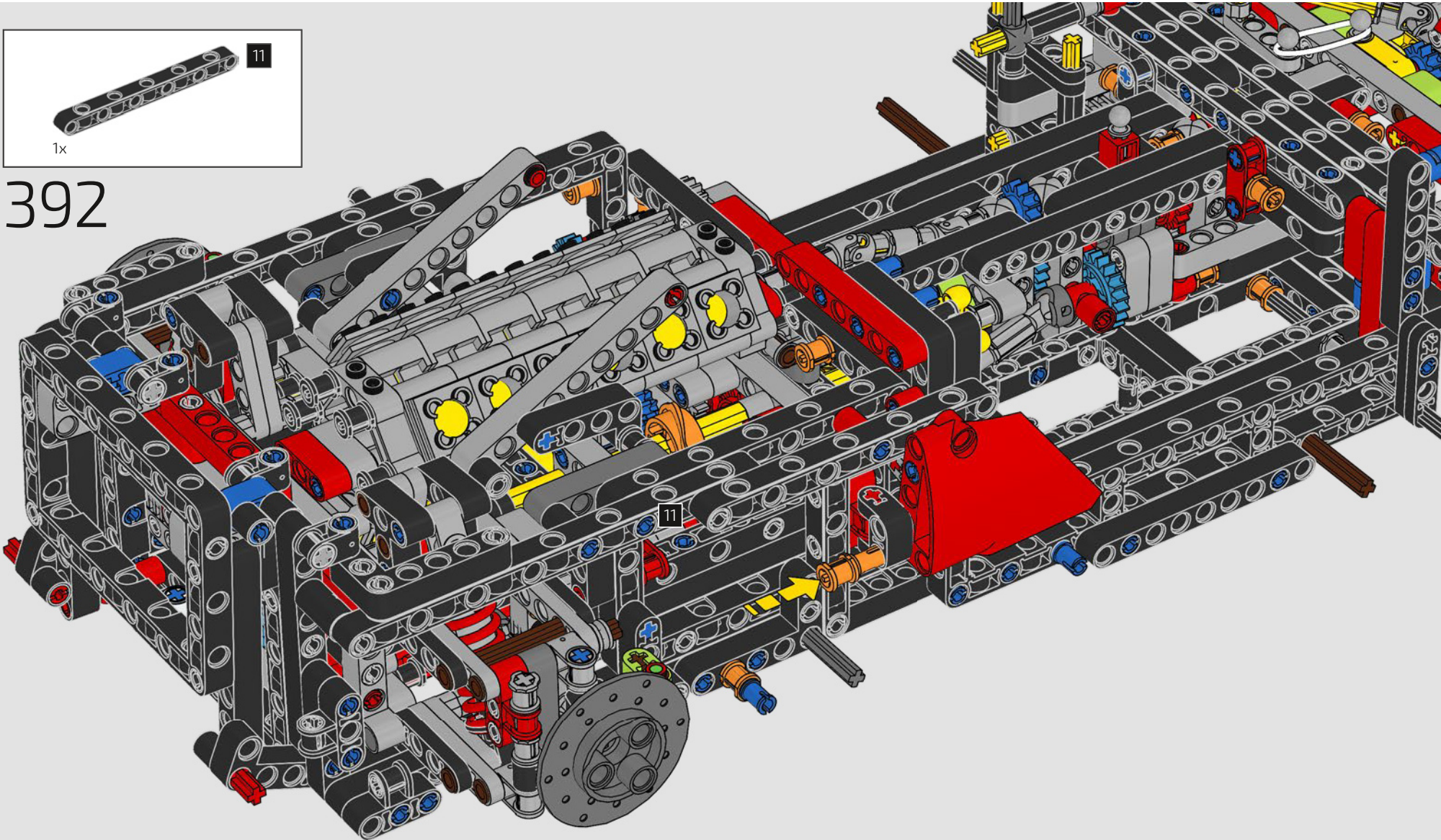

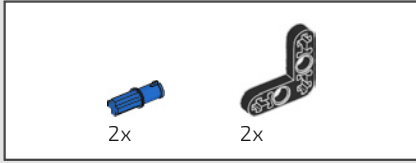

393

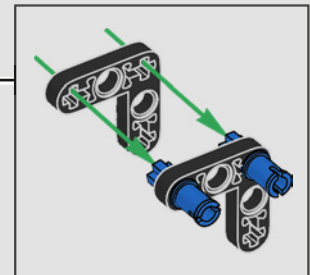
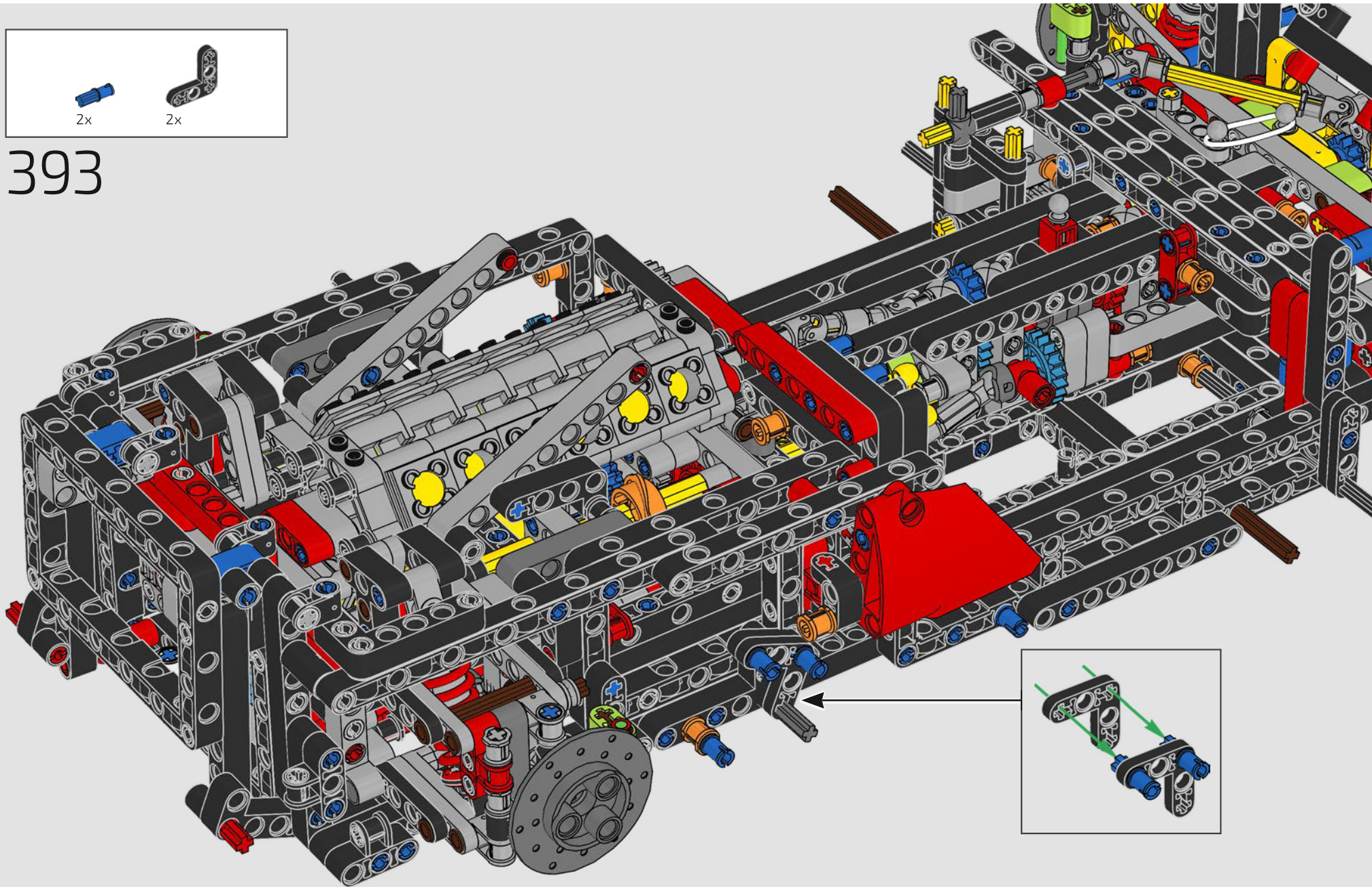

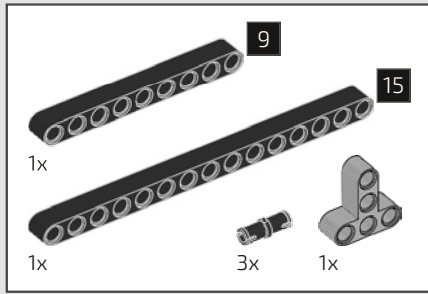

394

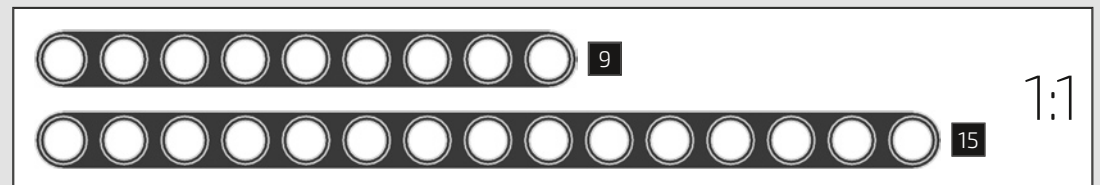
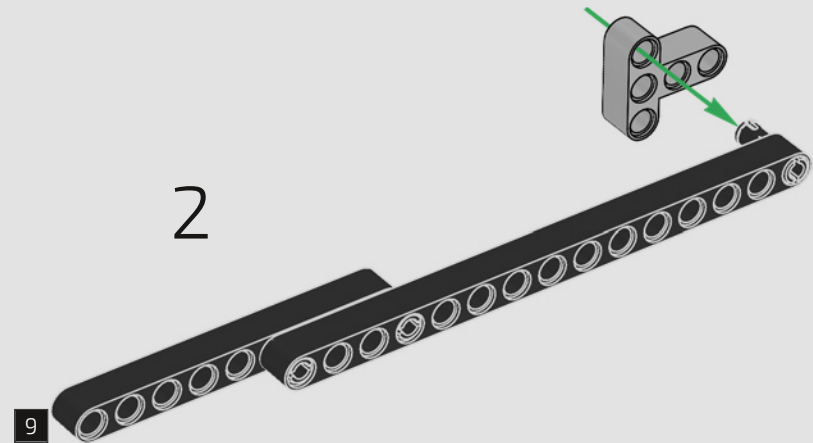
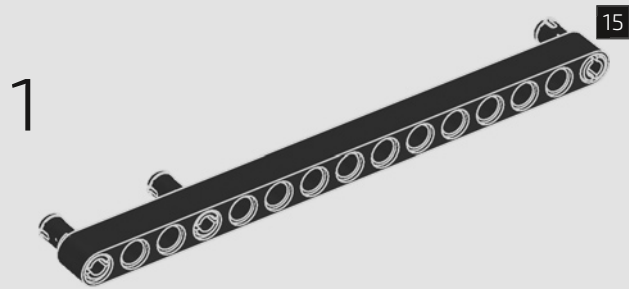

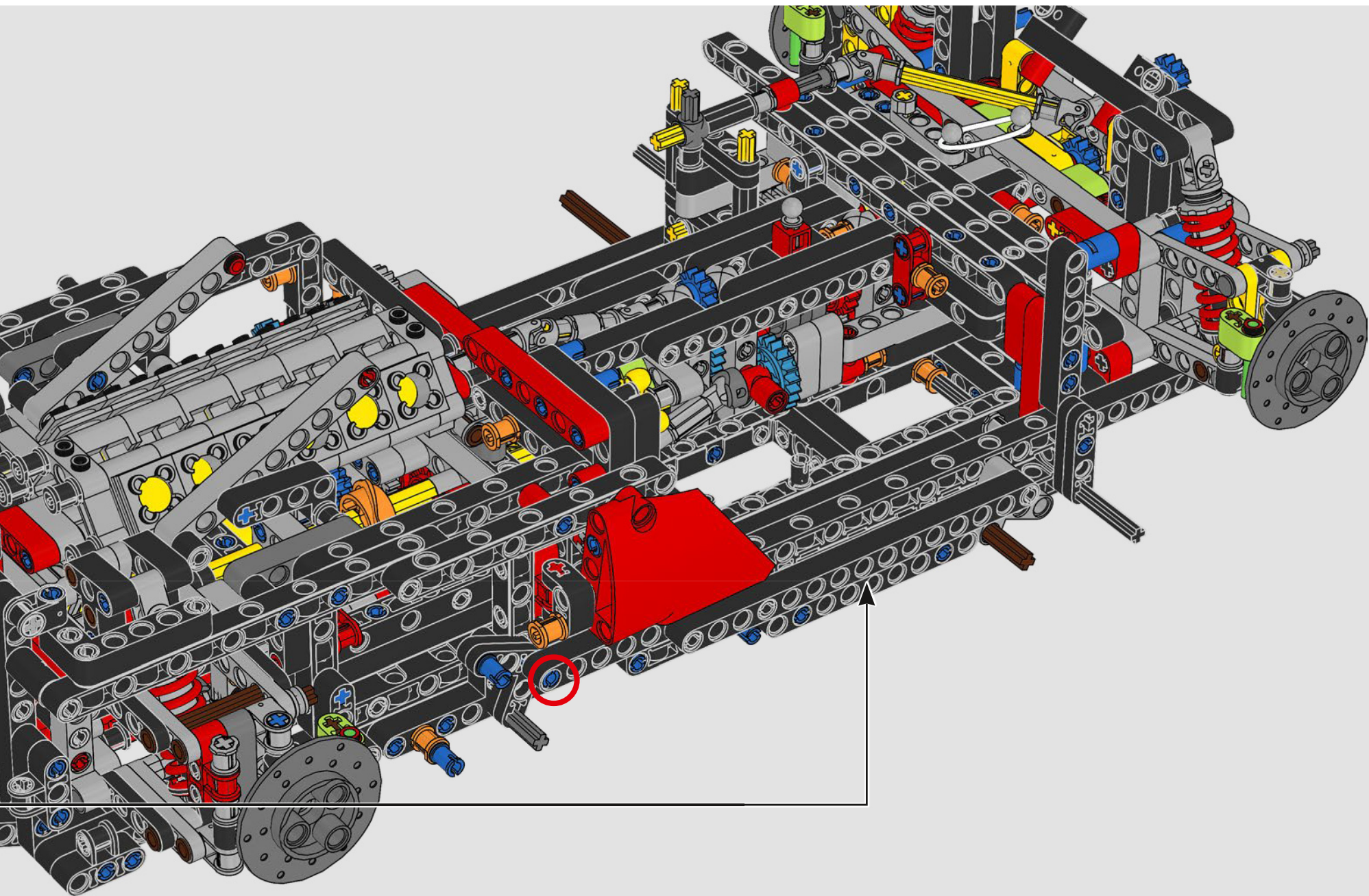

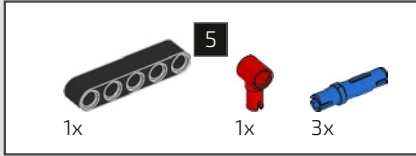

395

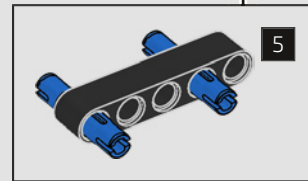
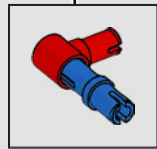
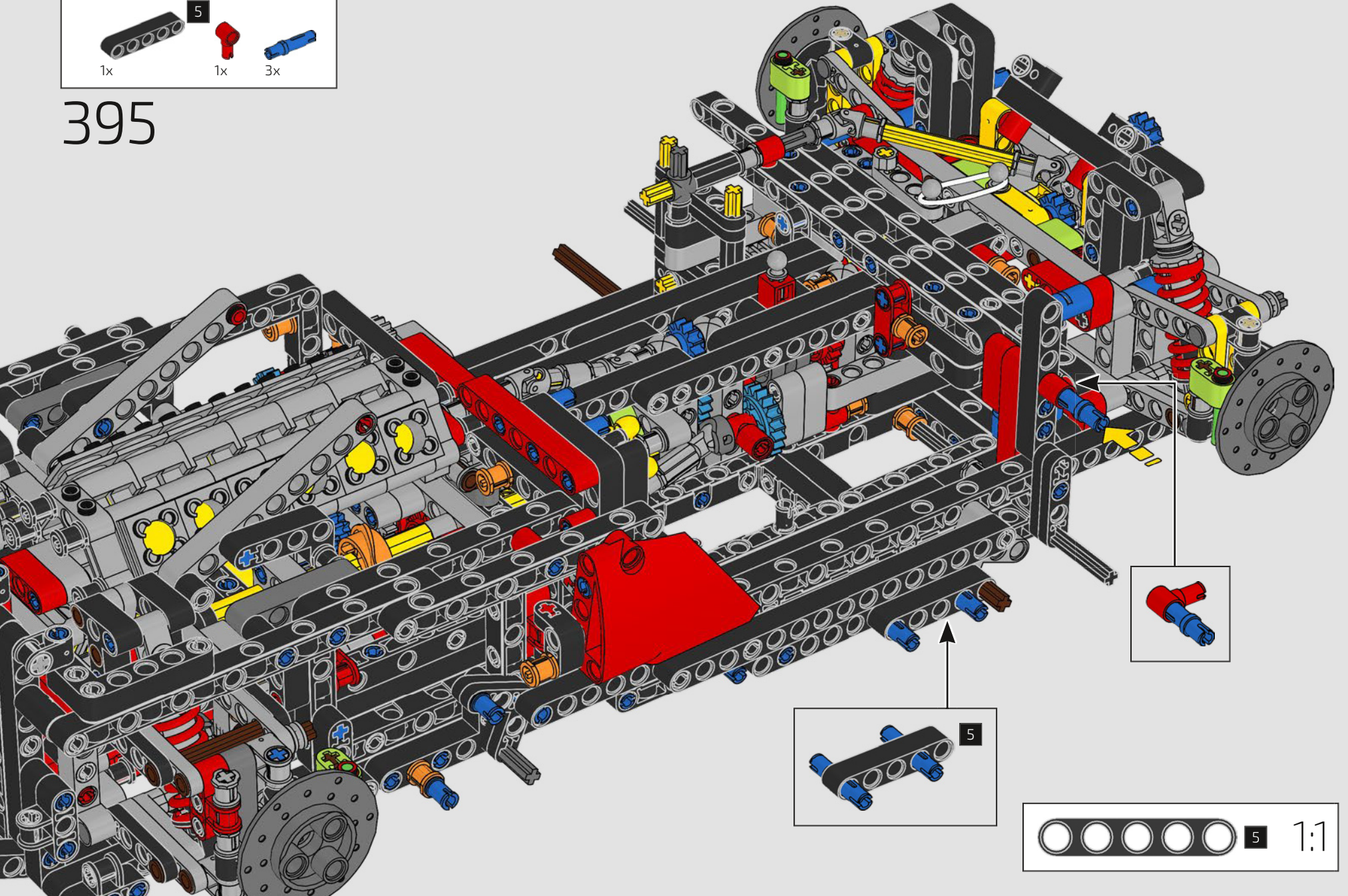

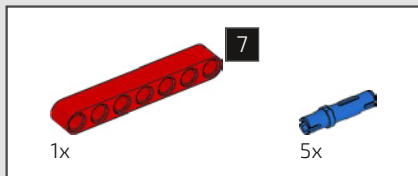

396

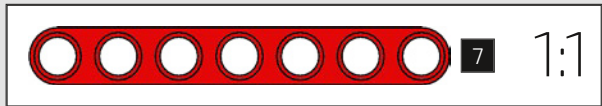
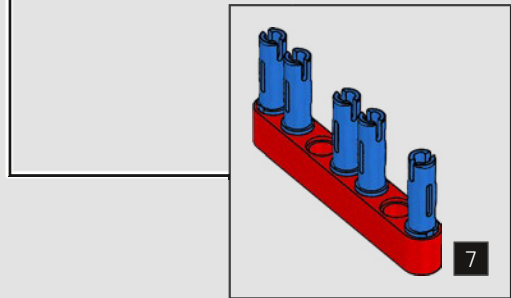
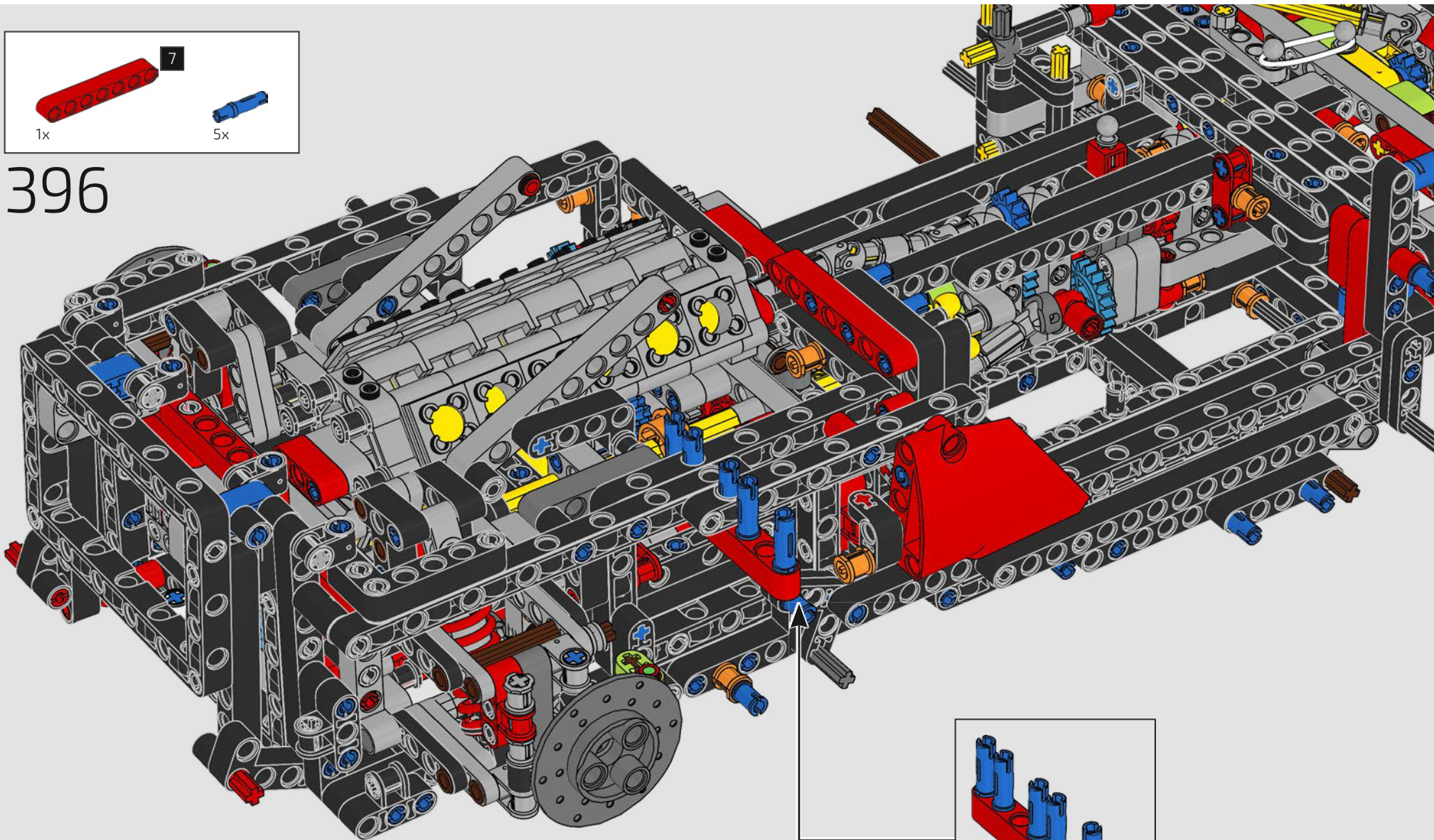



397

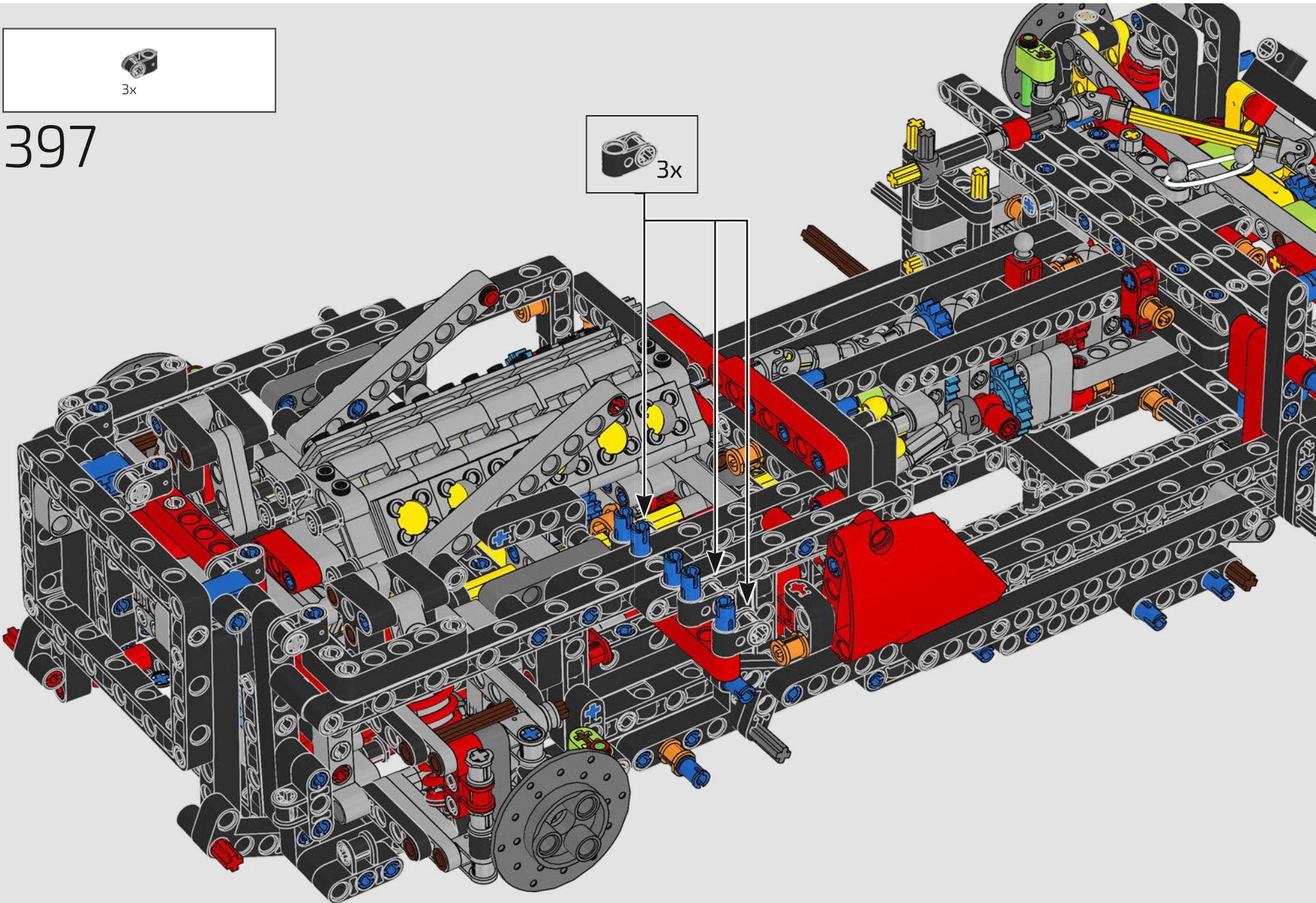

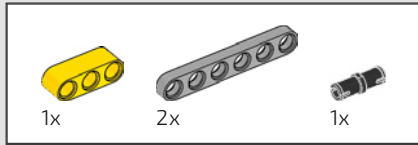

398

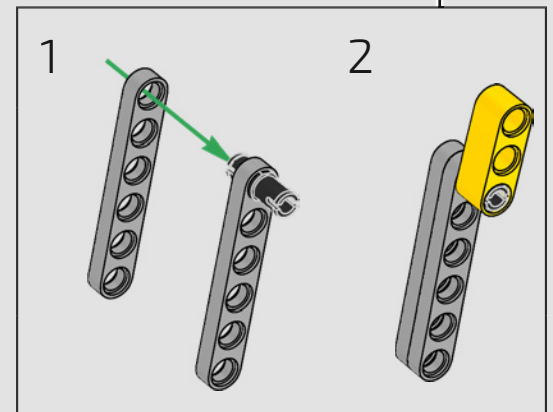
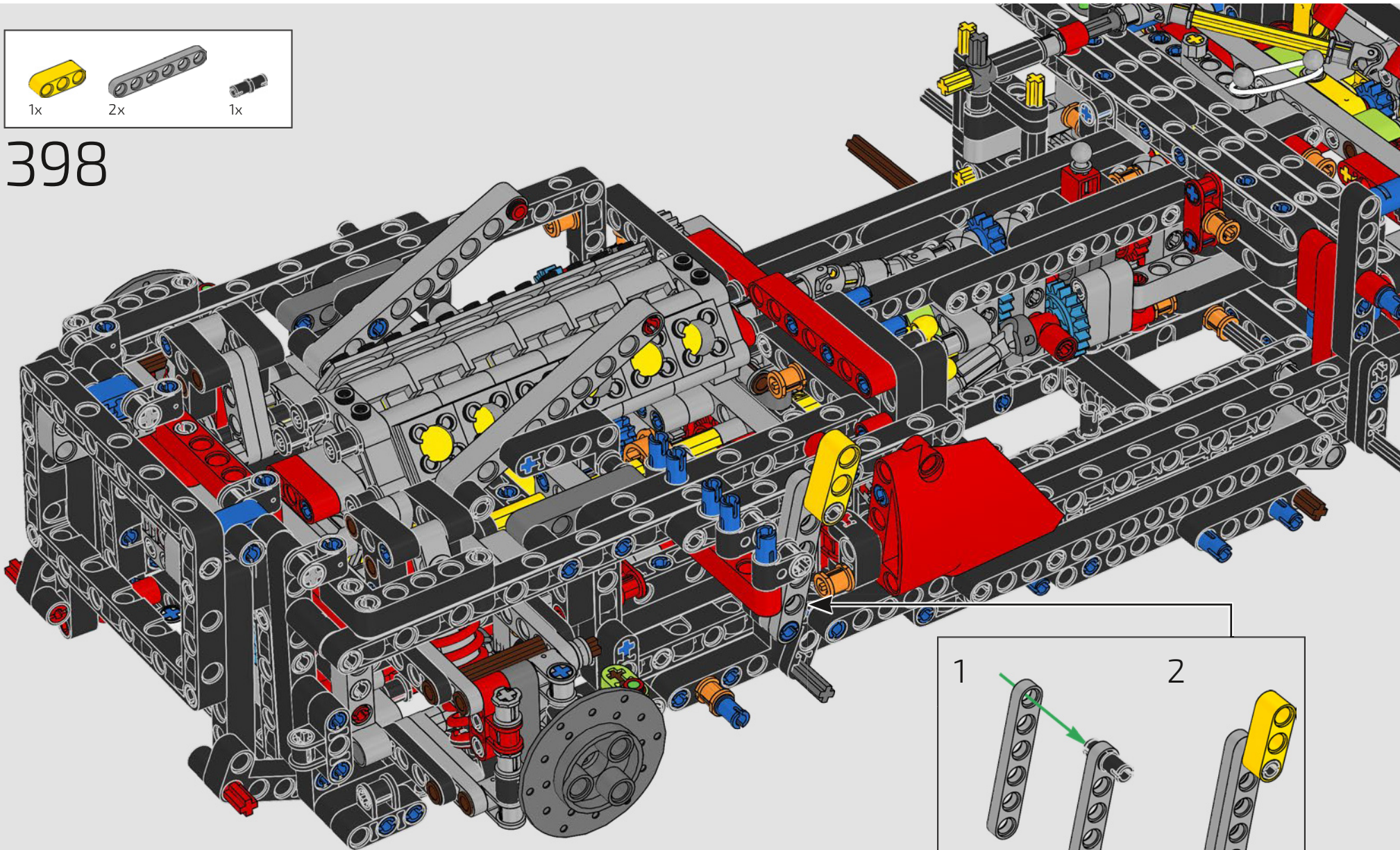

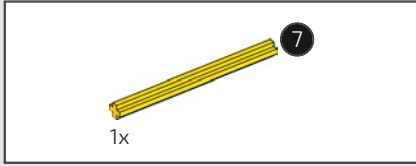

399

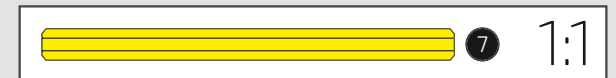
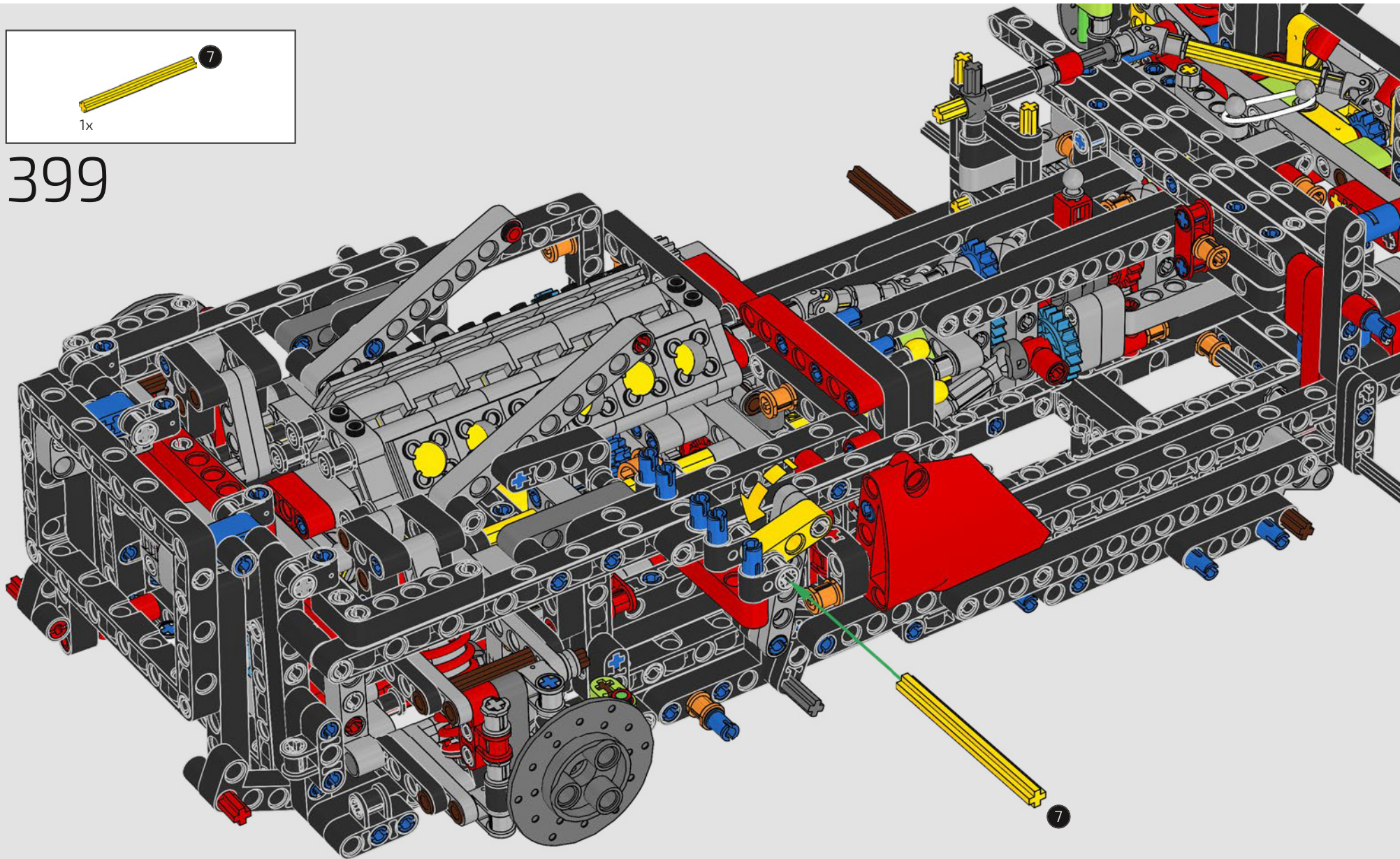

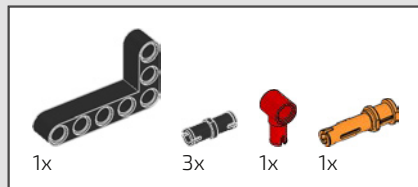

400

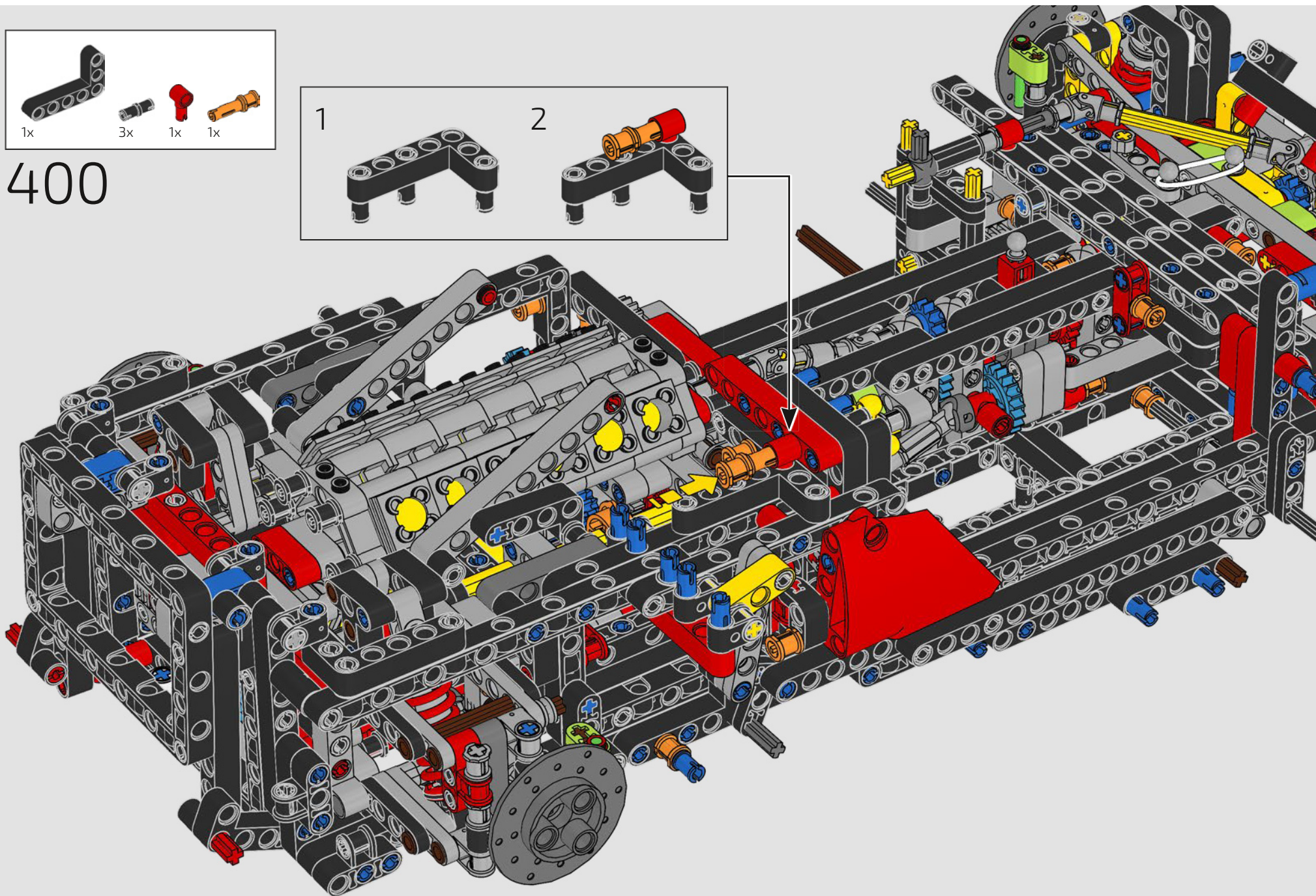
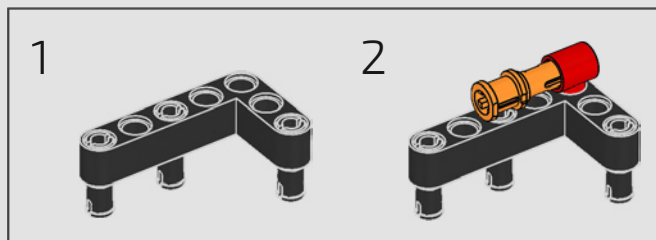

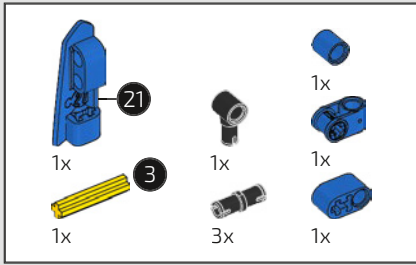

401

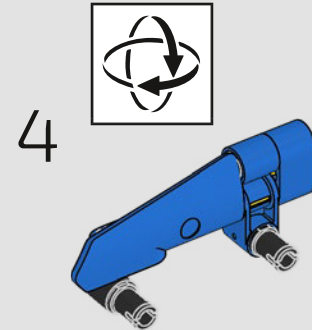
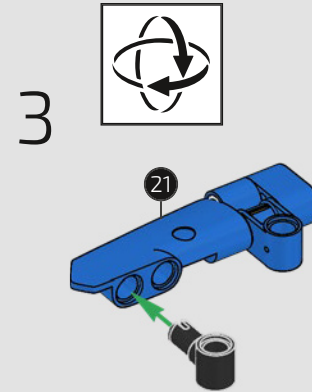
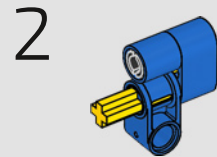
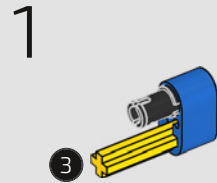

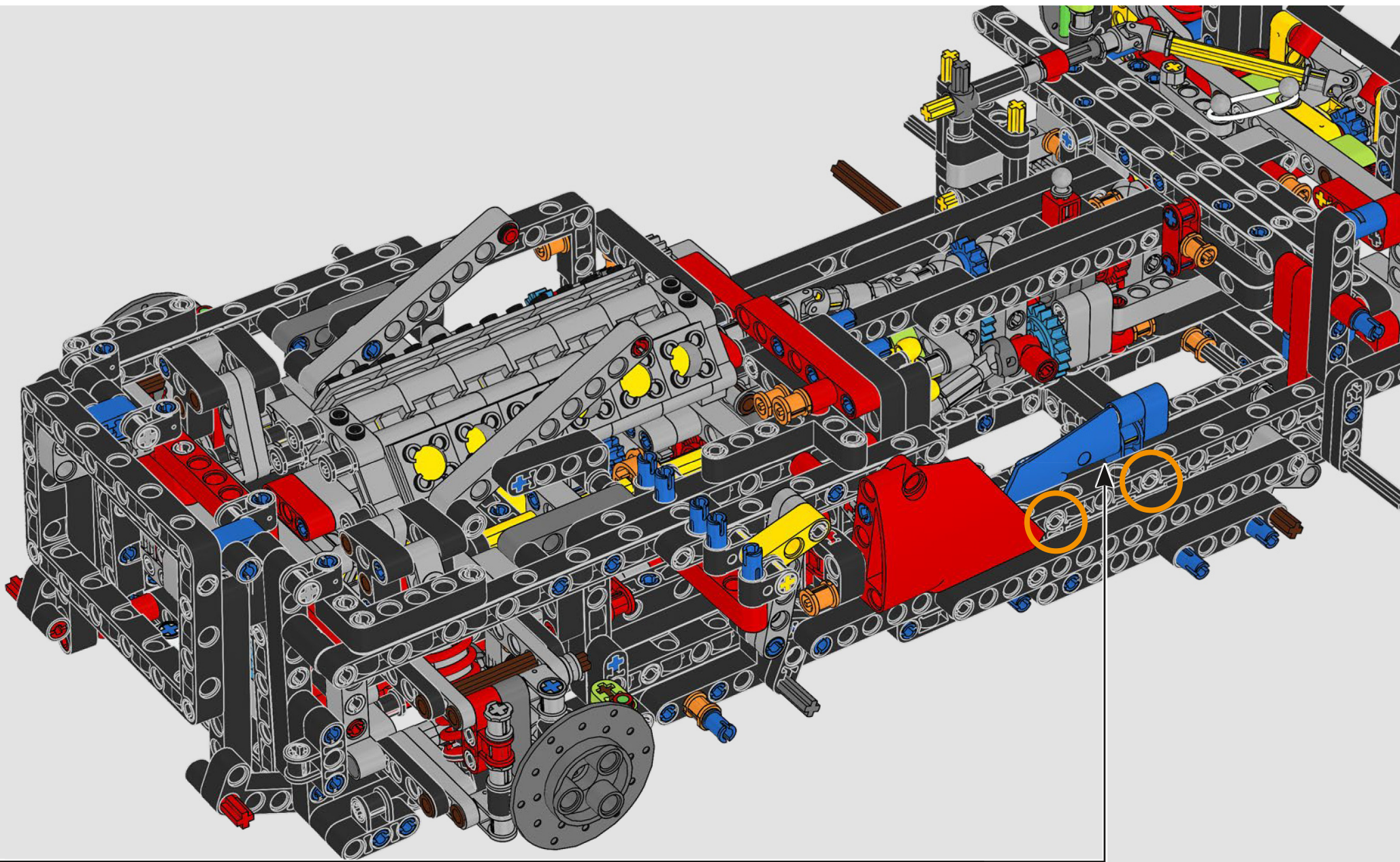

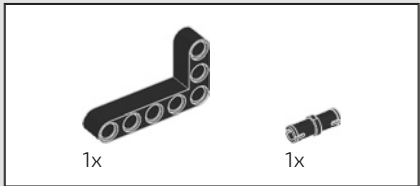
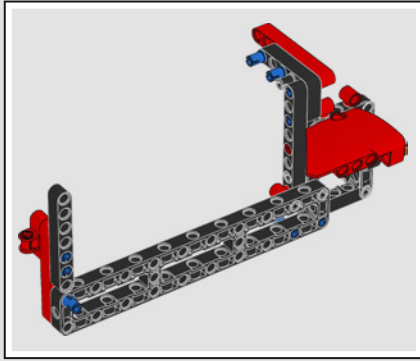

402

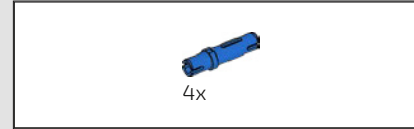
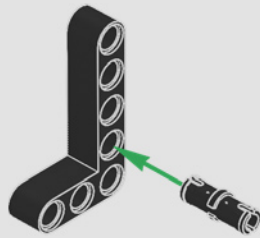

403

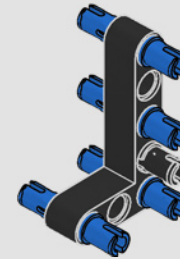

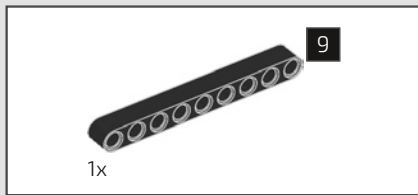

404

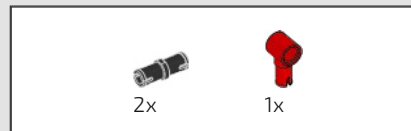
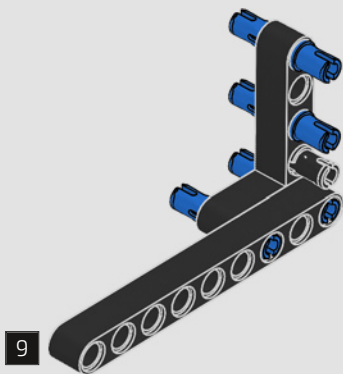

405

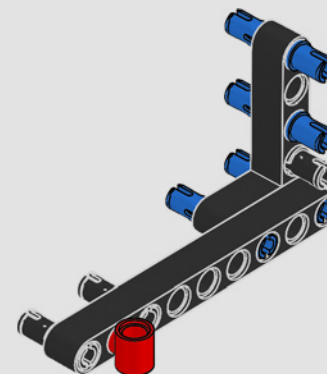

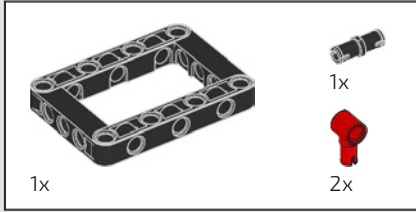

406

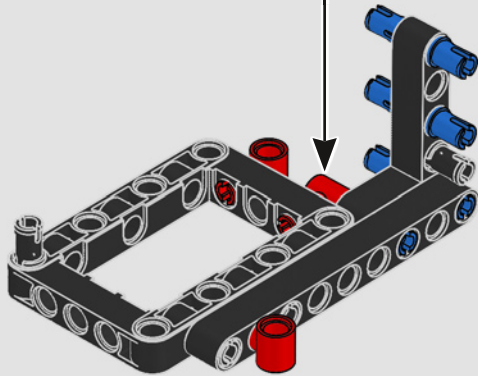
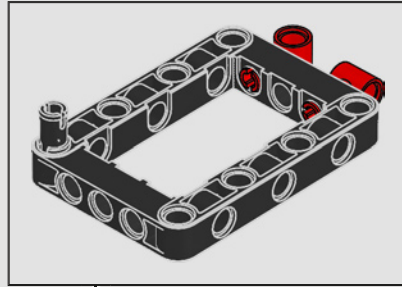

407

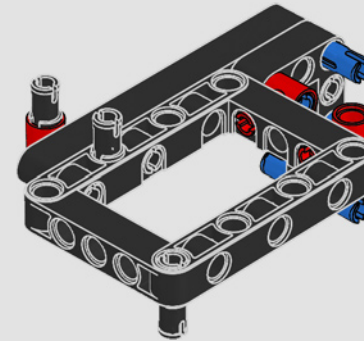

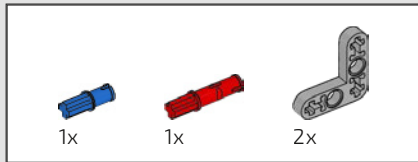

408

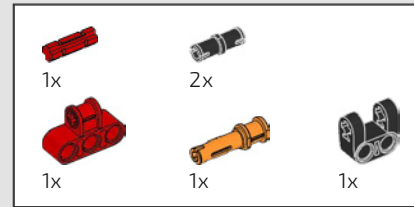
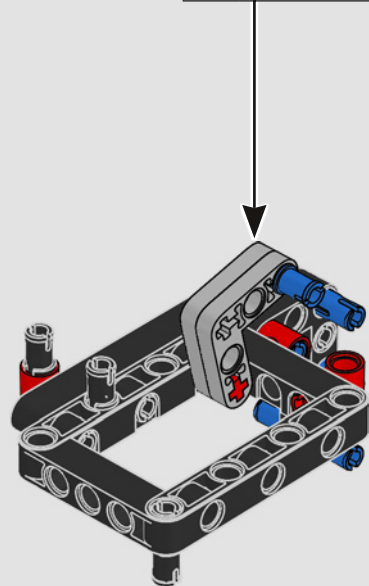
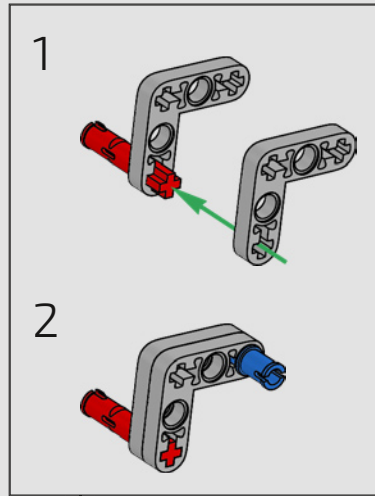

409

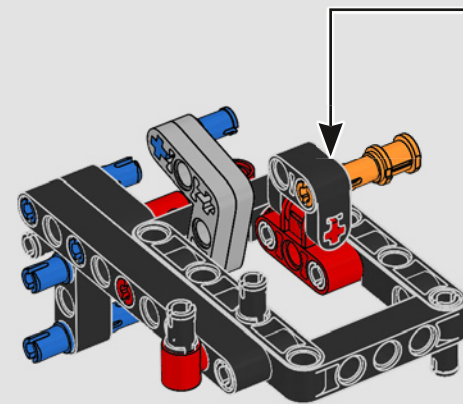
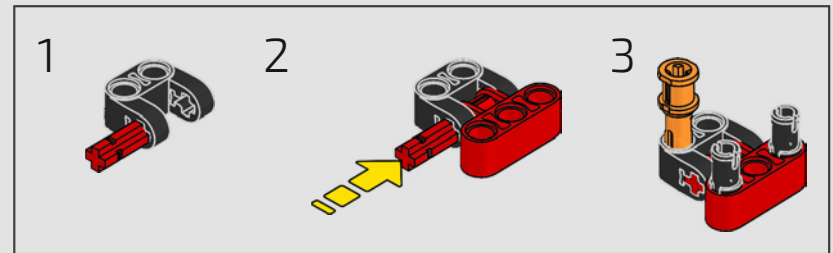

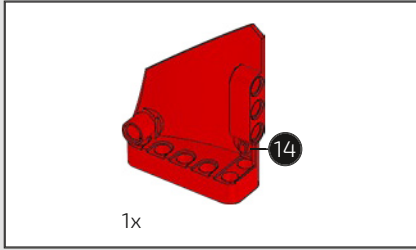

410

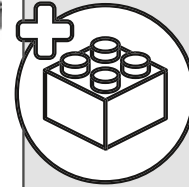
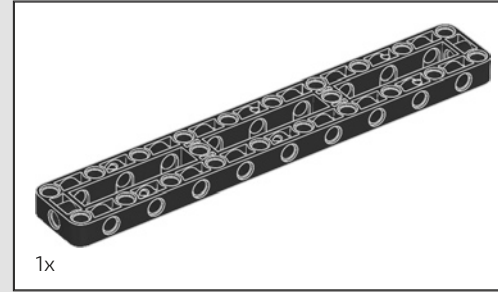
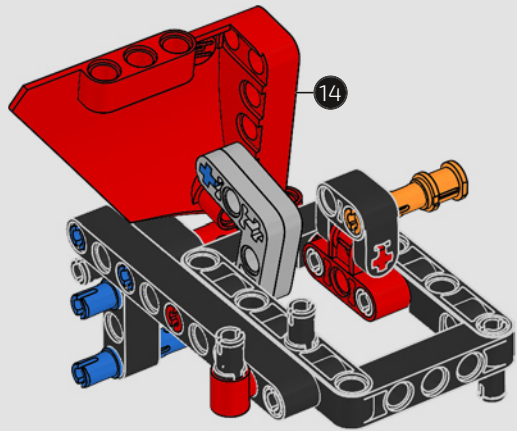

411

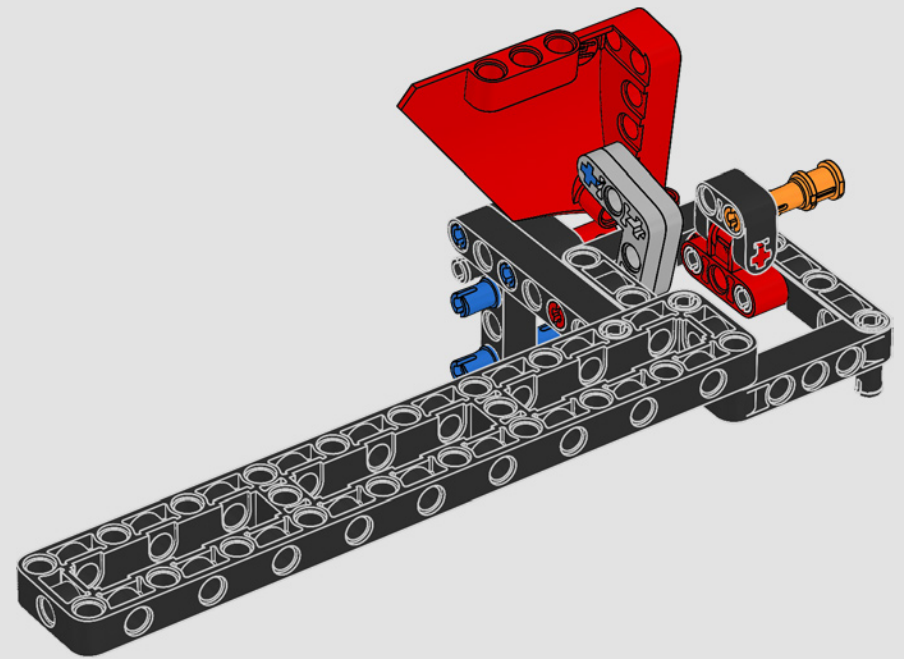

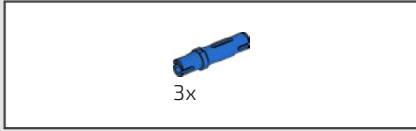

412

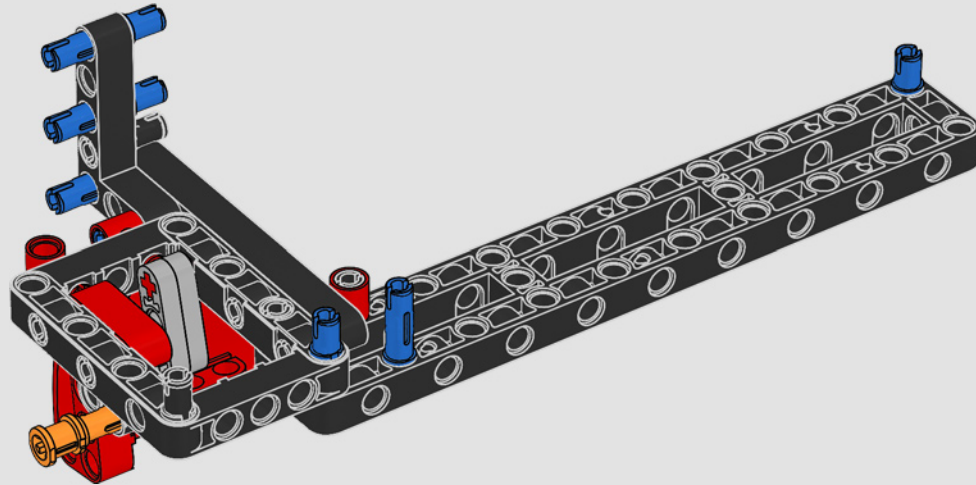

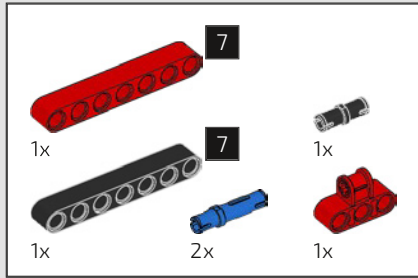

413

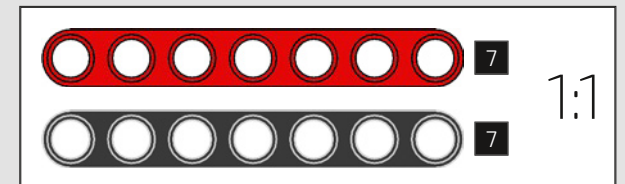
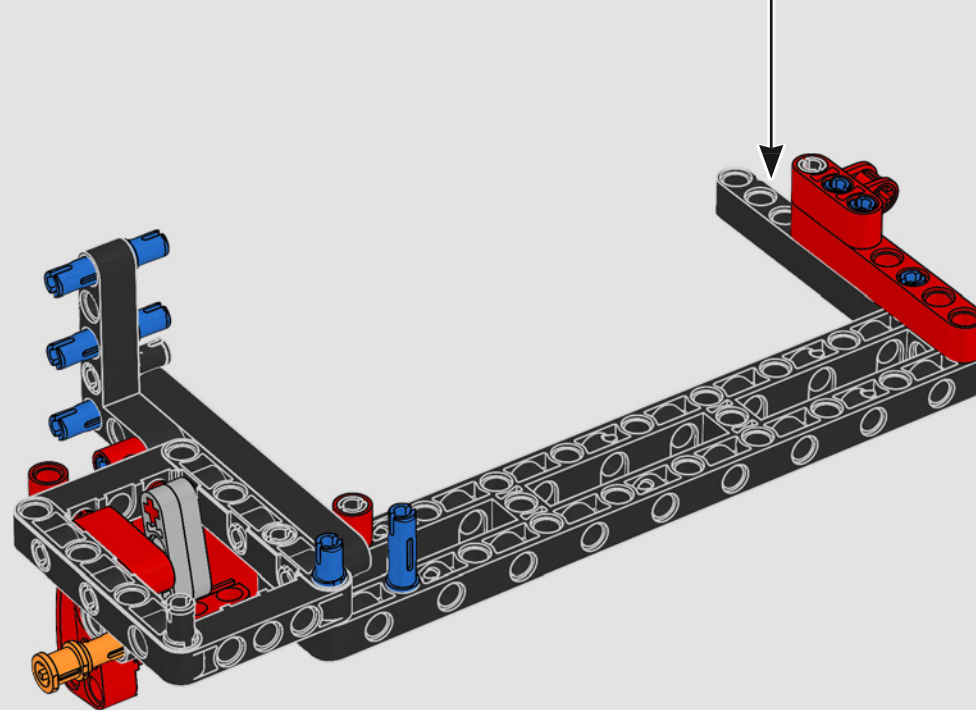
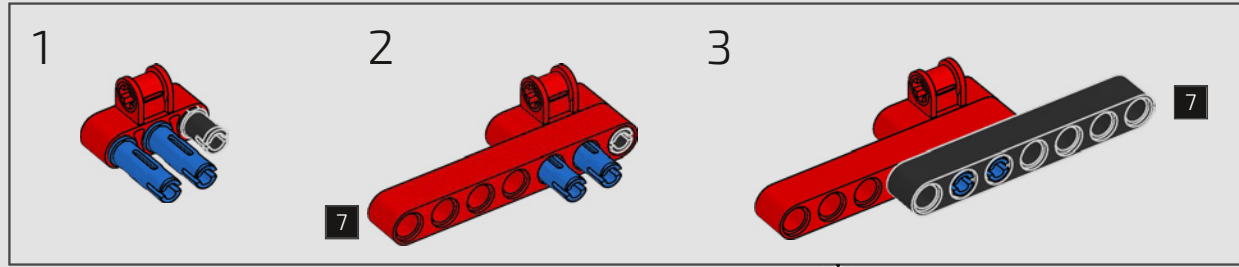

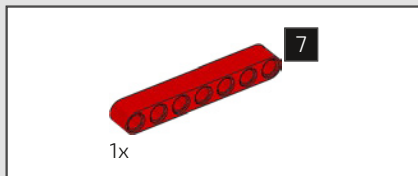

414

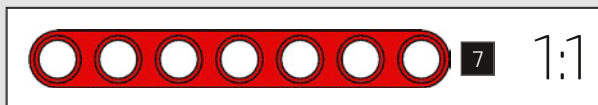
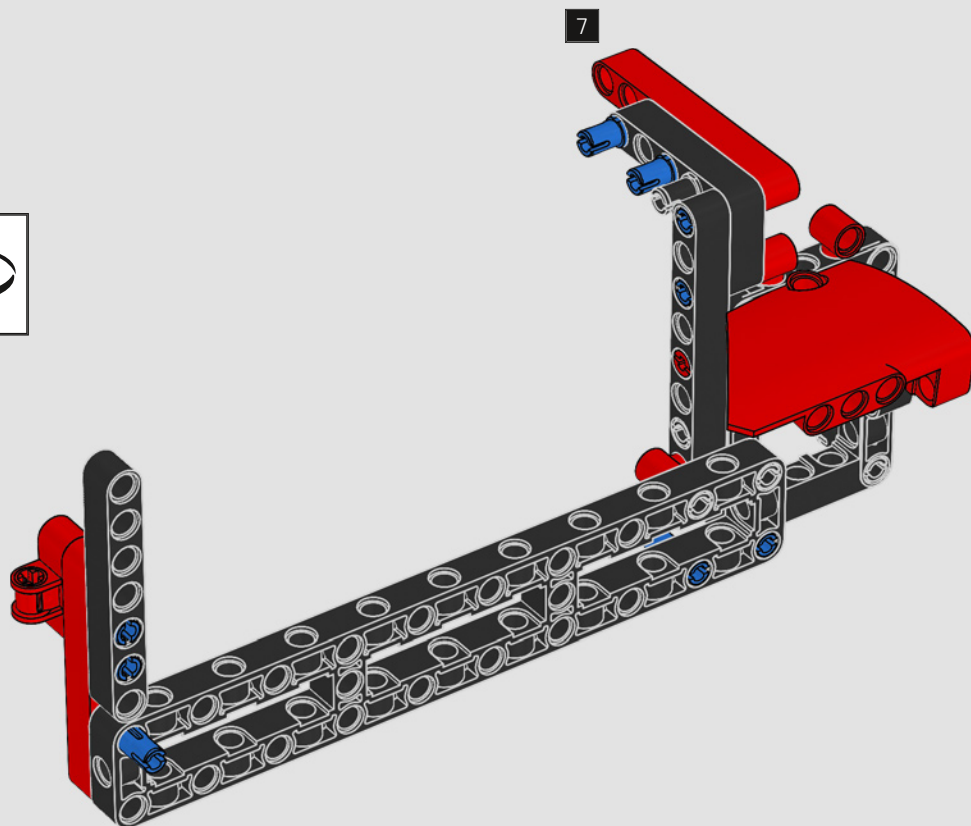



415

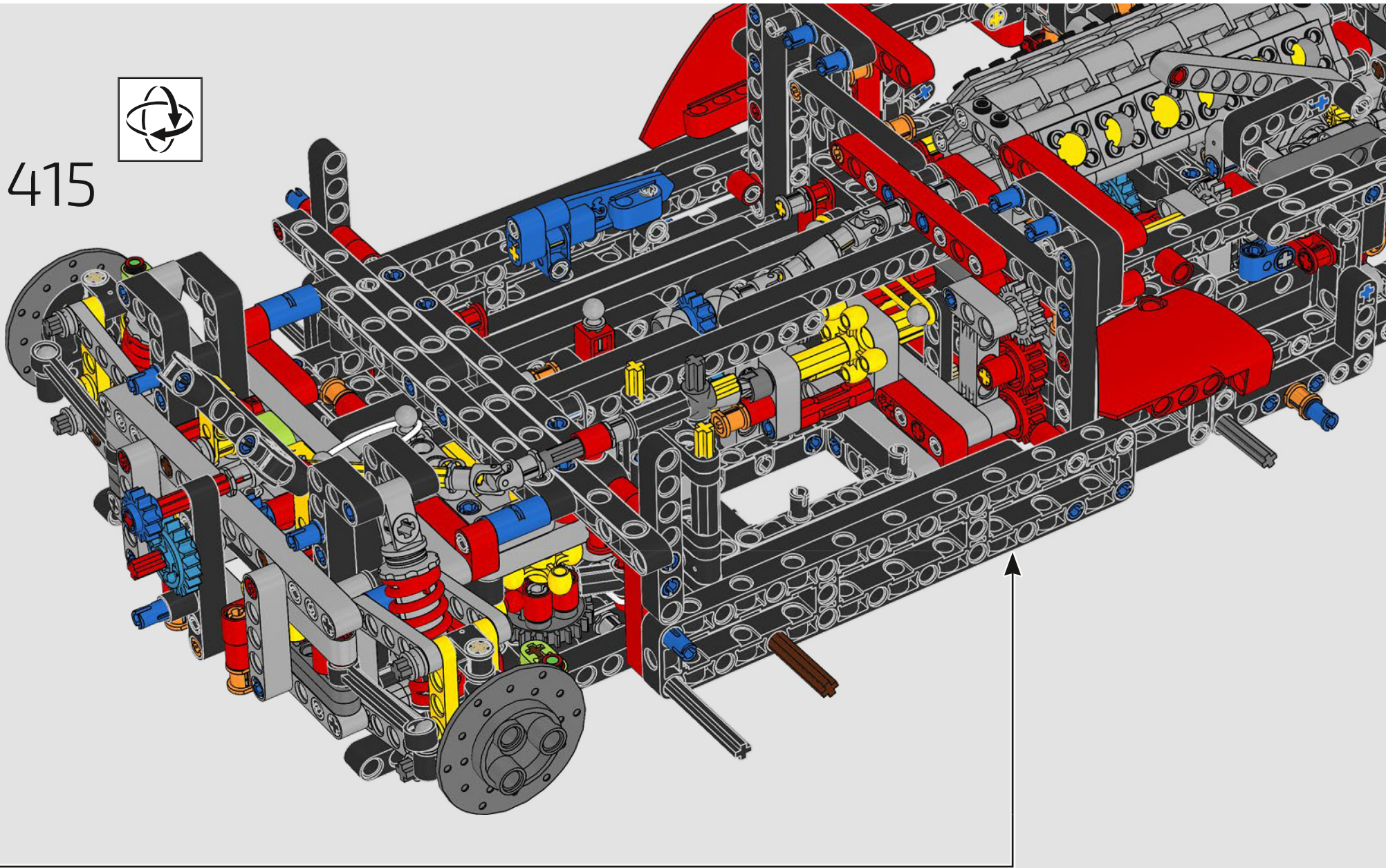

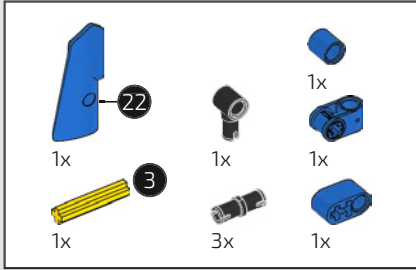

416

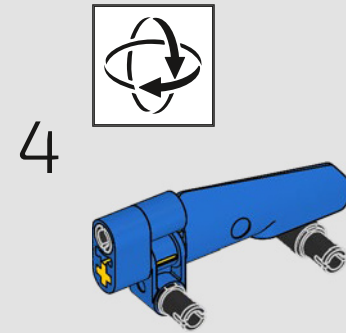
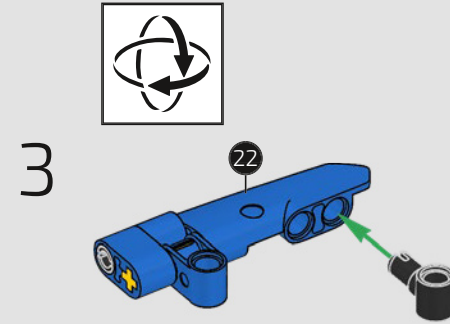
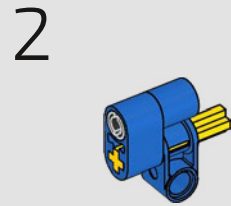
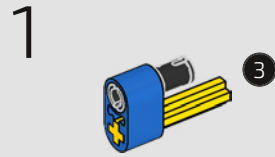

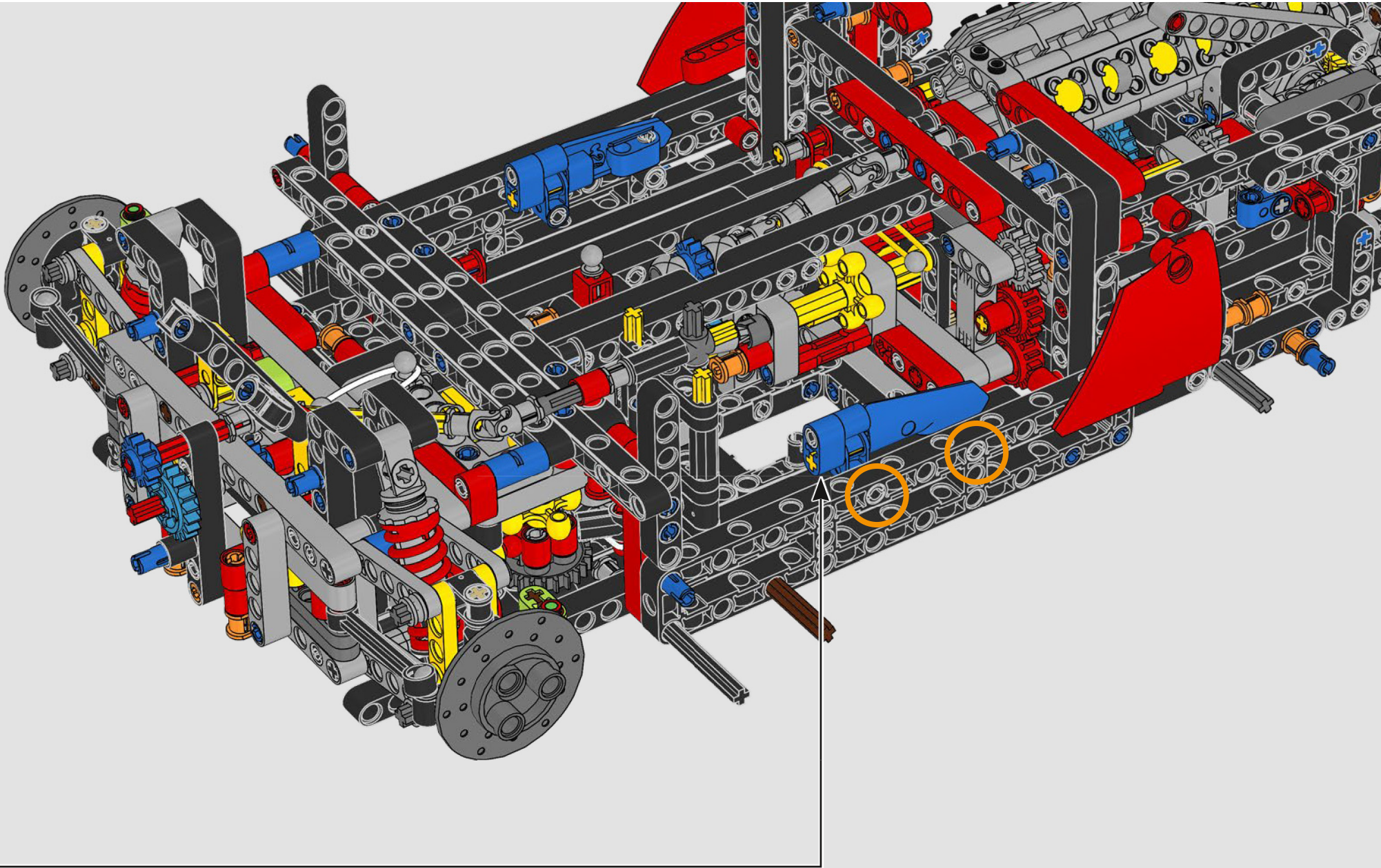

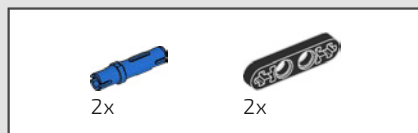

417

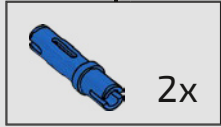
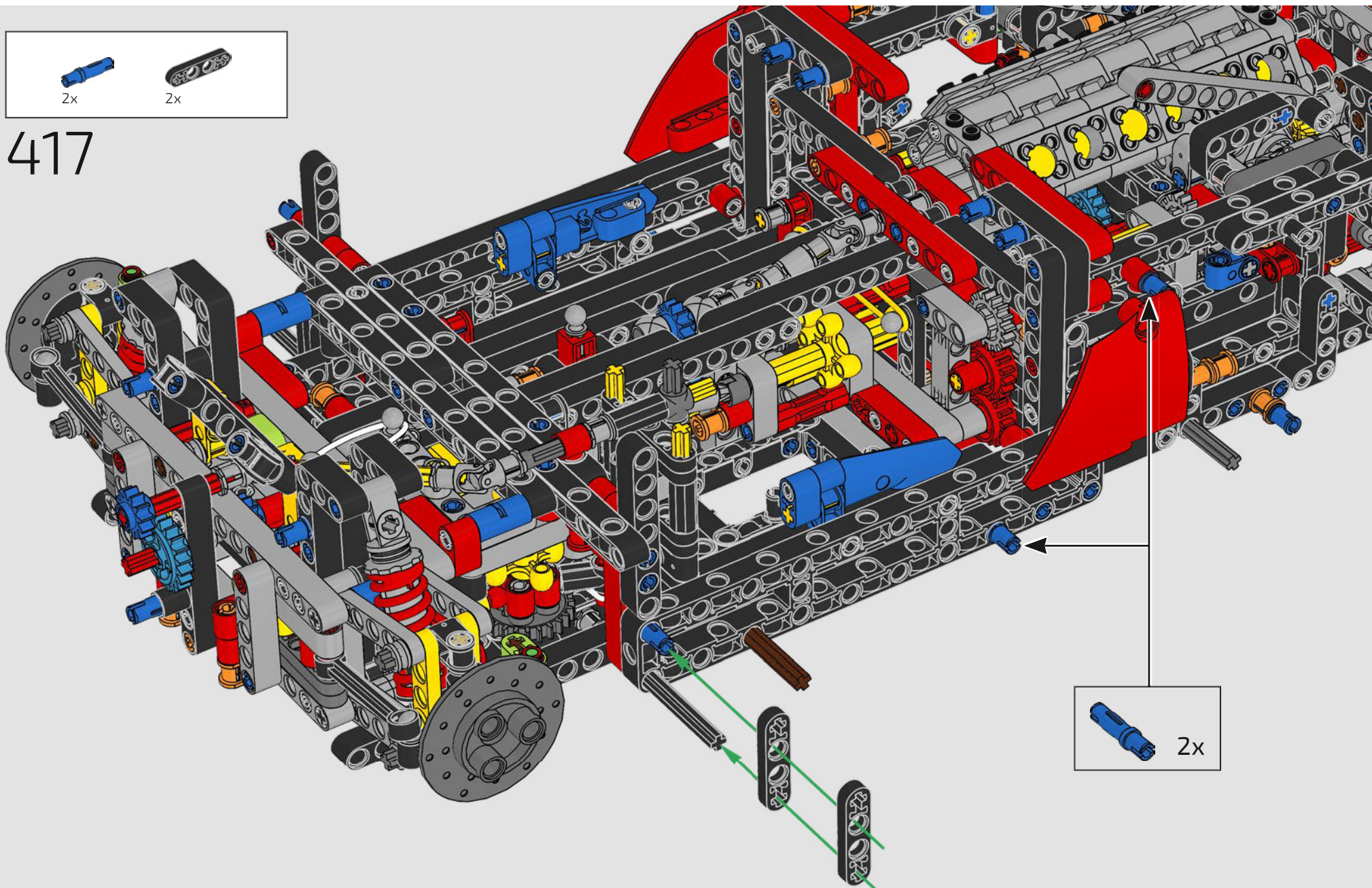

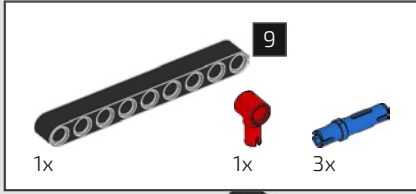

418

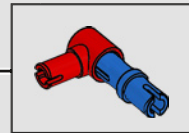
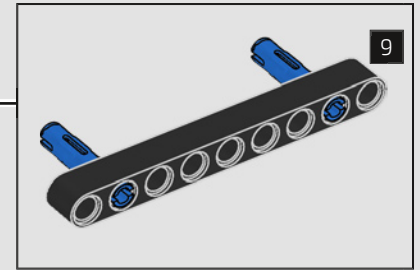
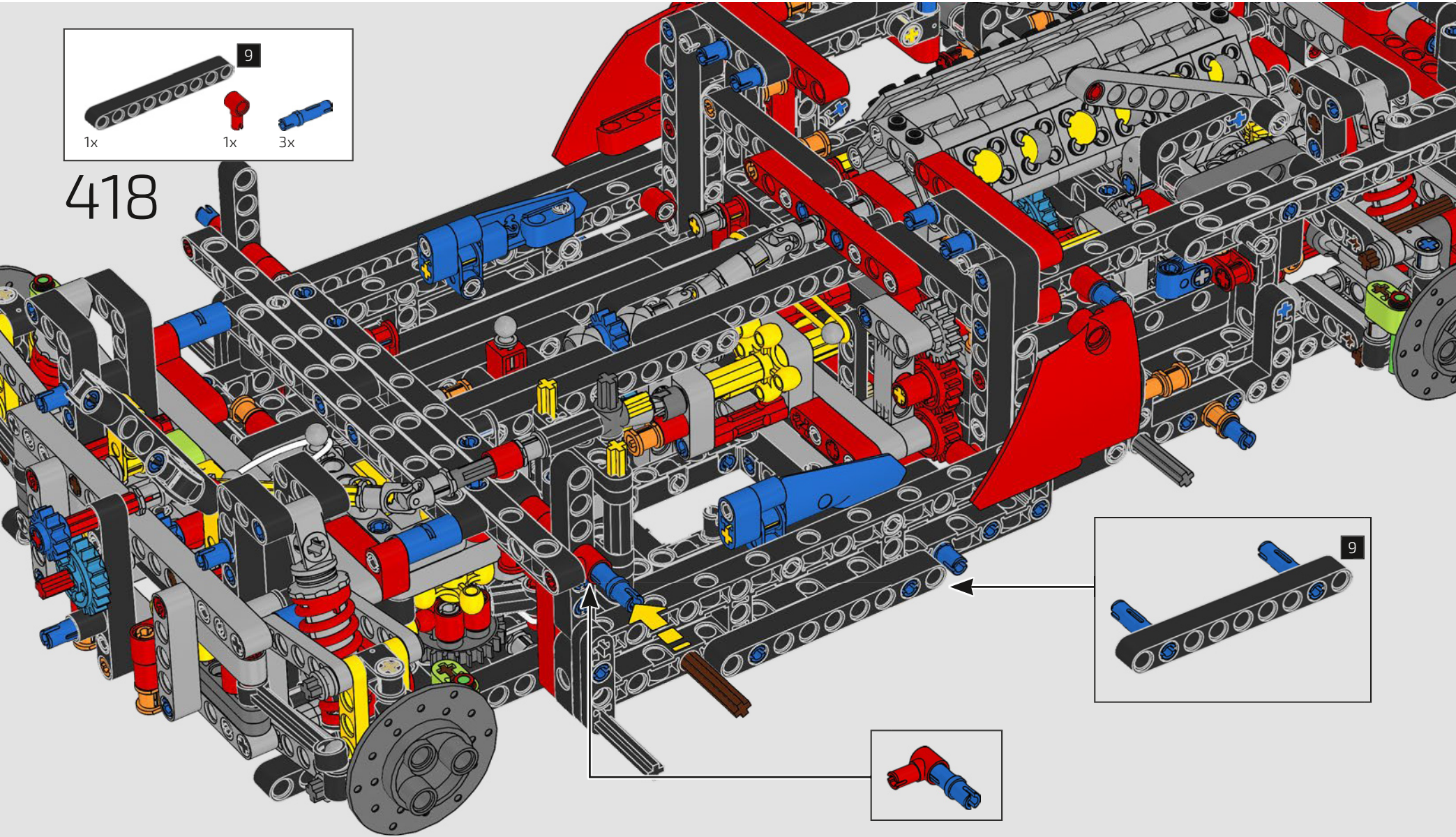

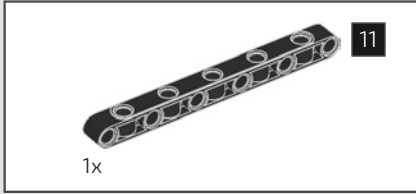

419

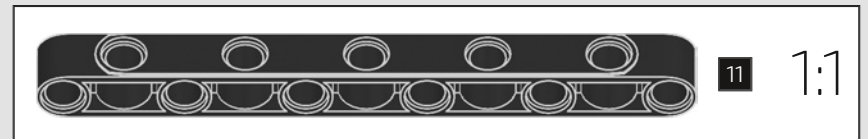
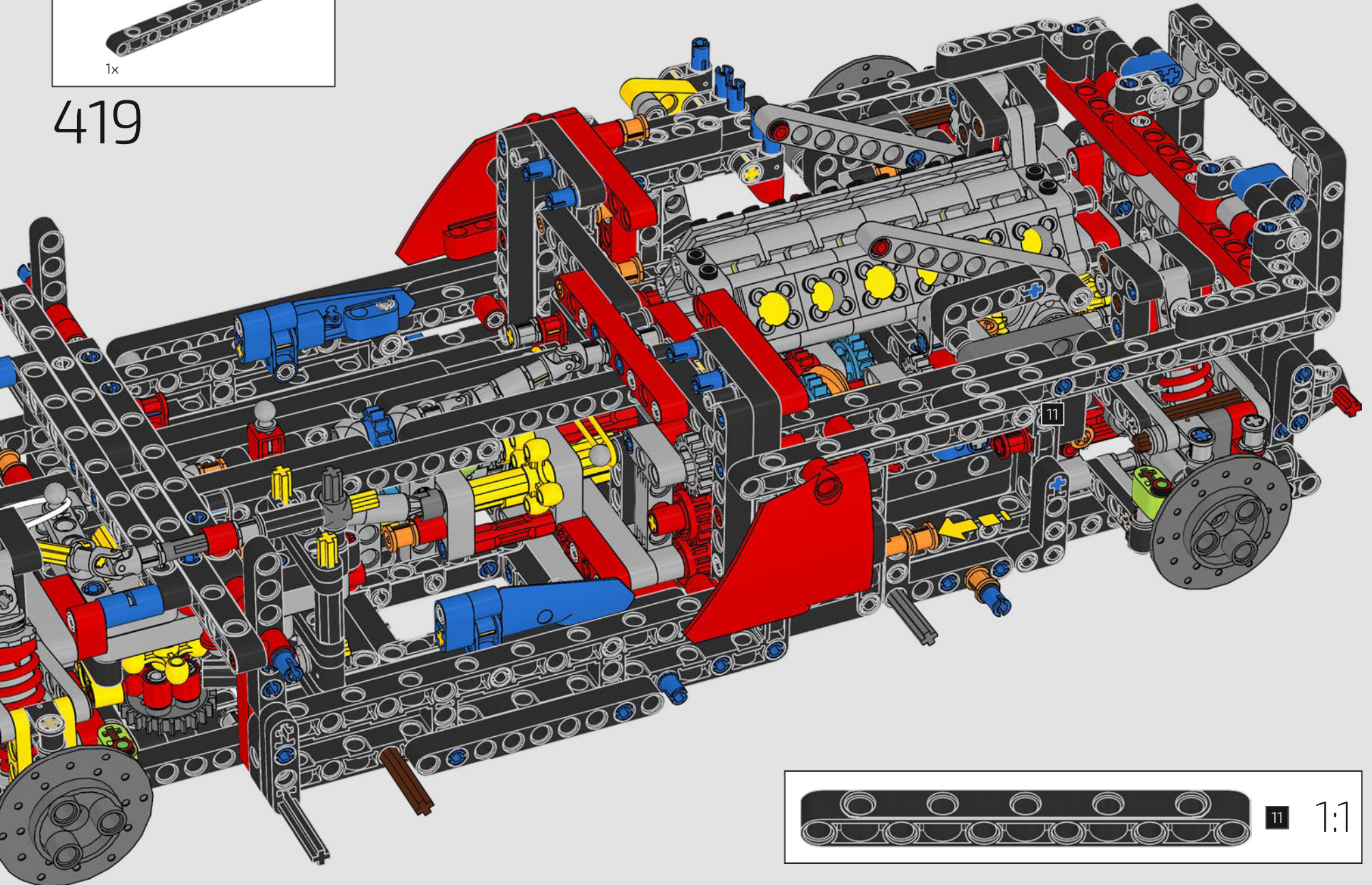

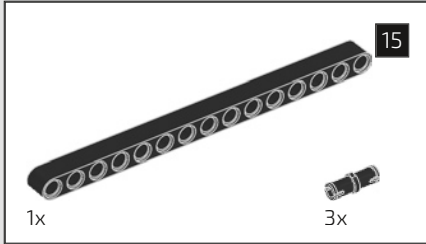
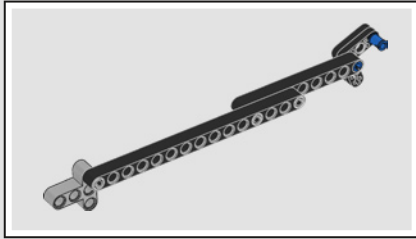

420

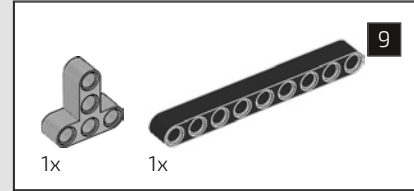
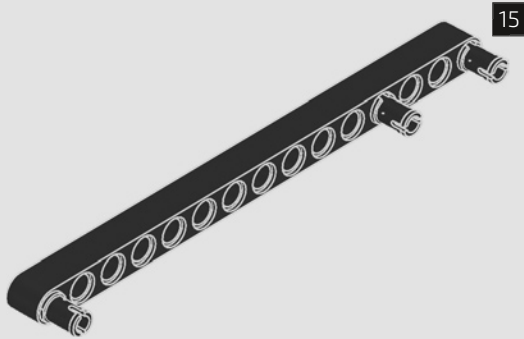

421

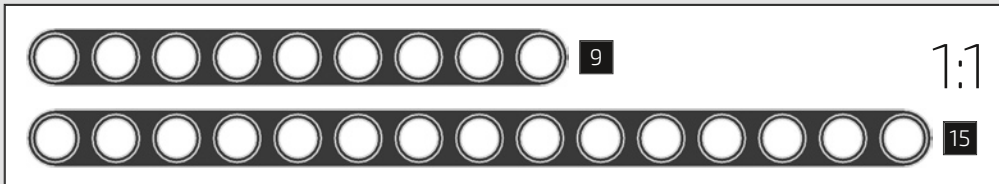
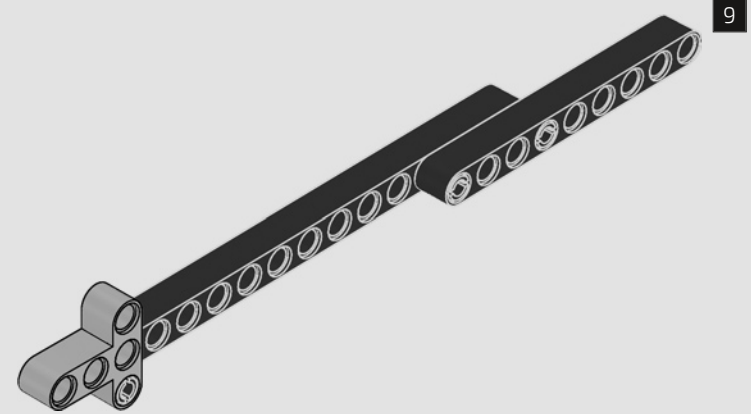

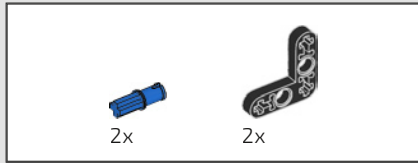

422

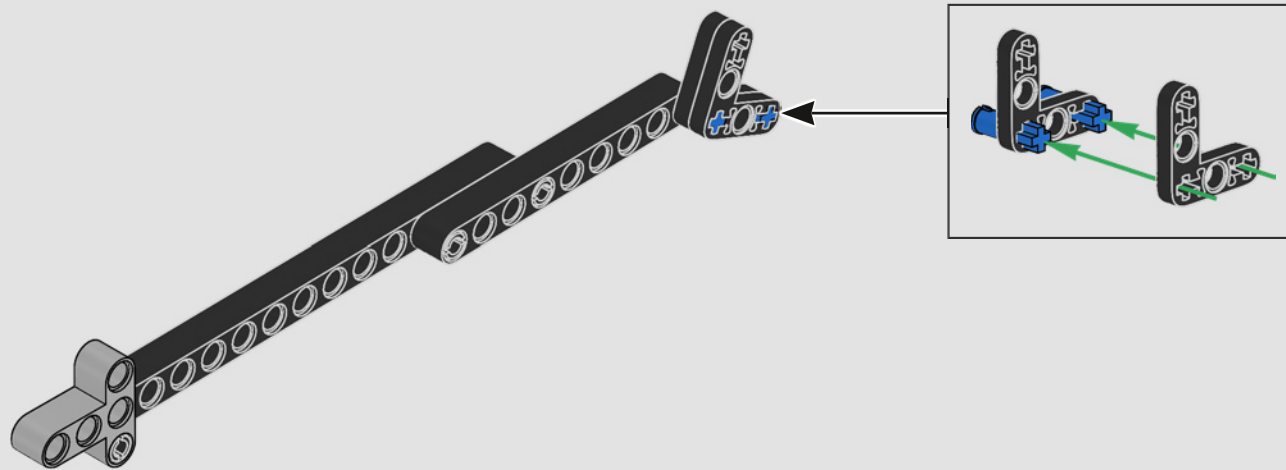

423

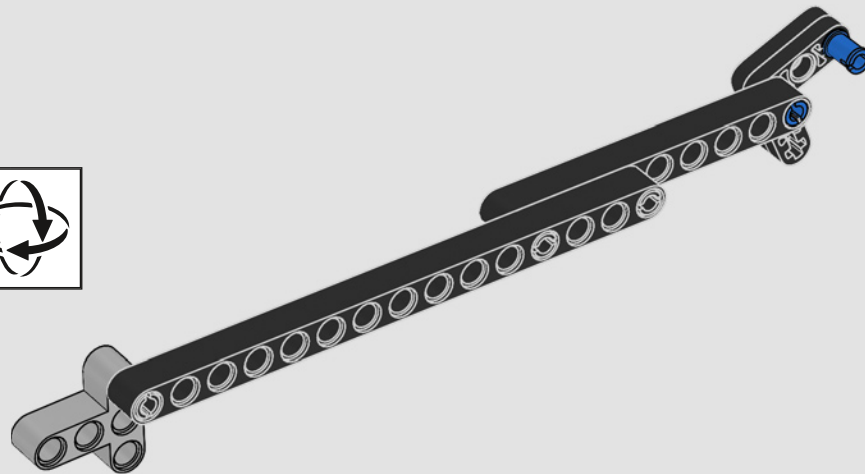

424

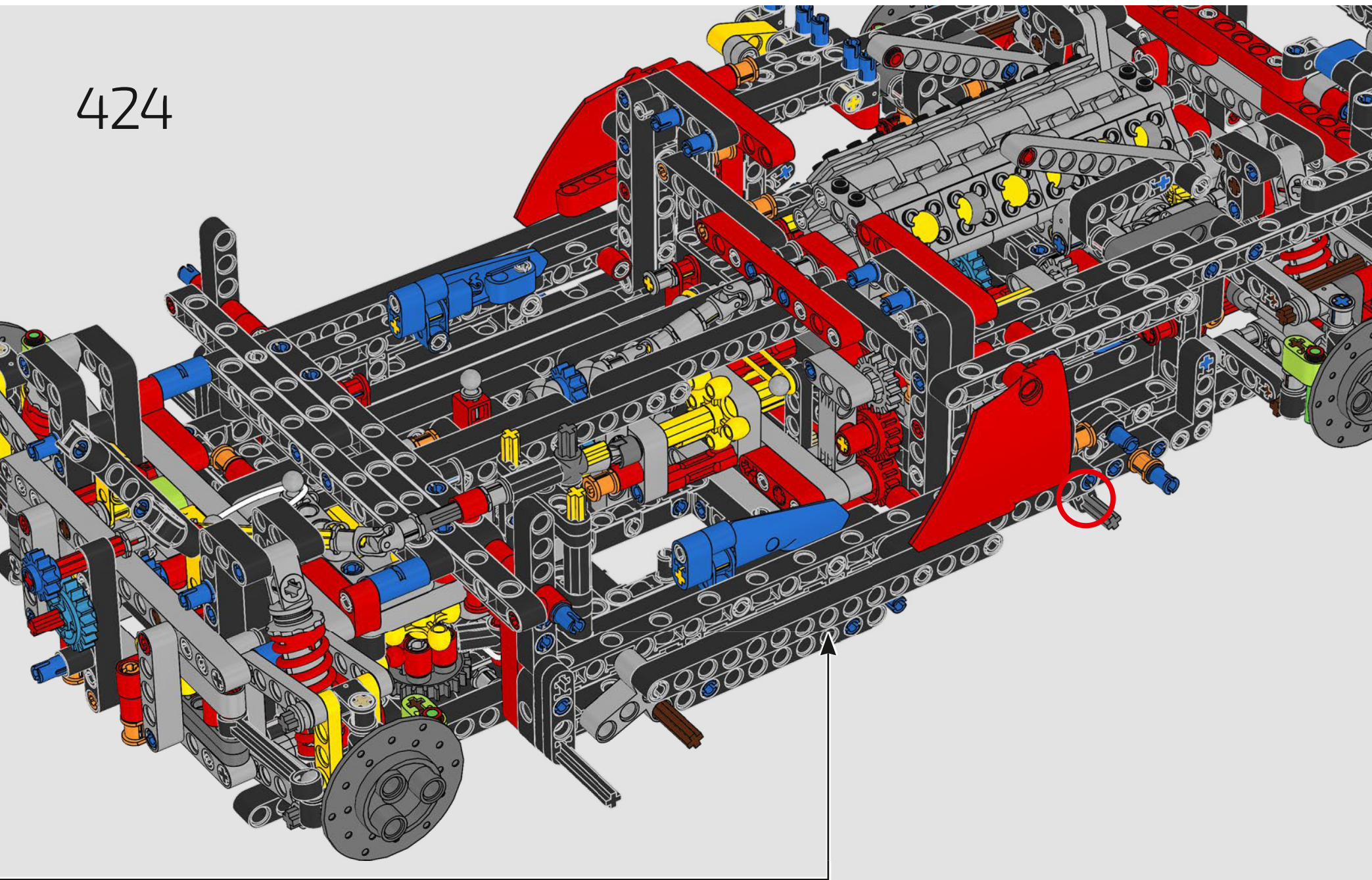

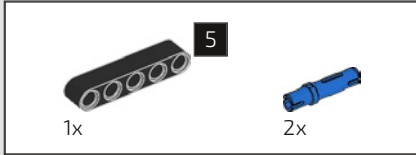

425

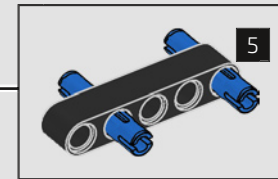
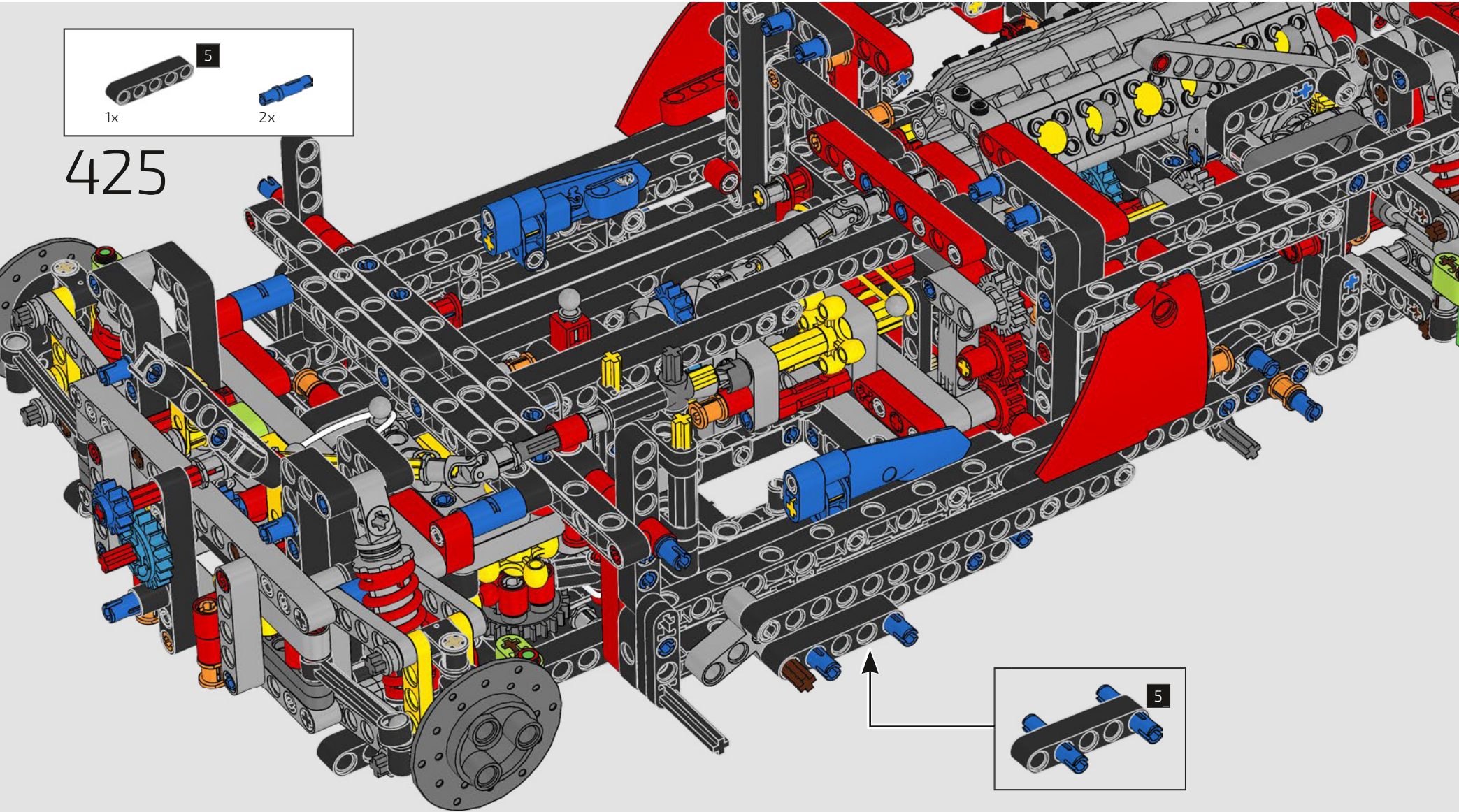

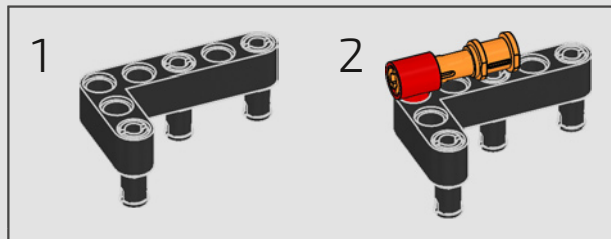
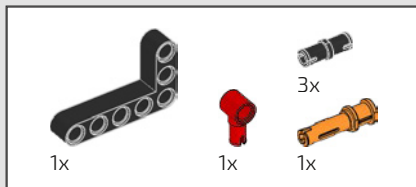

426

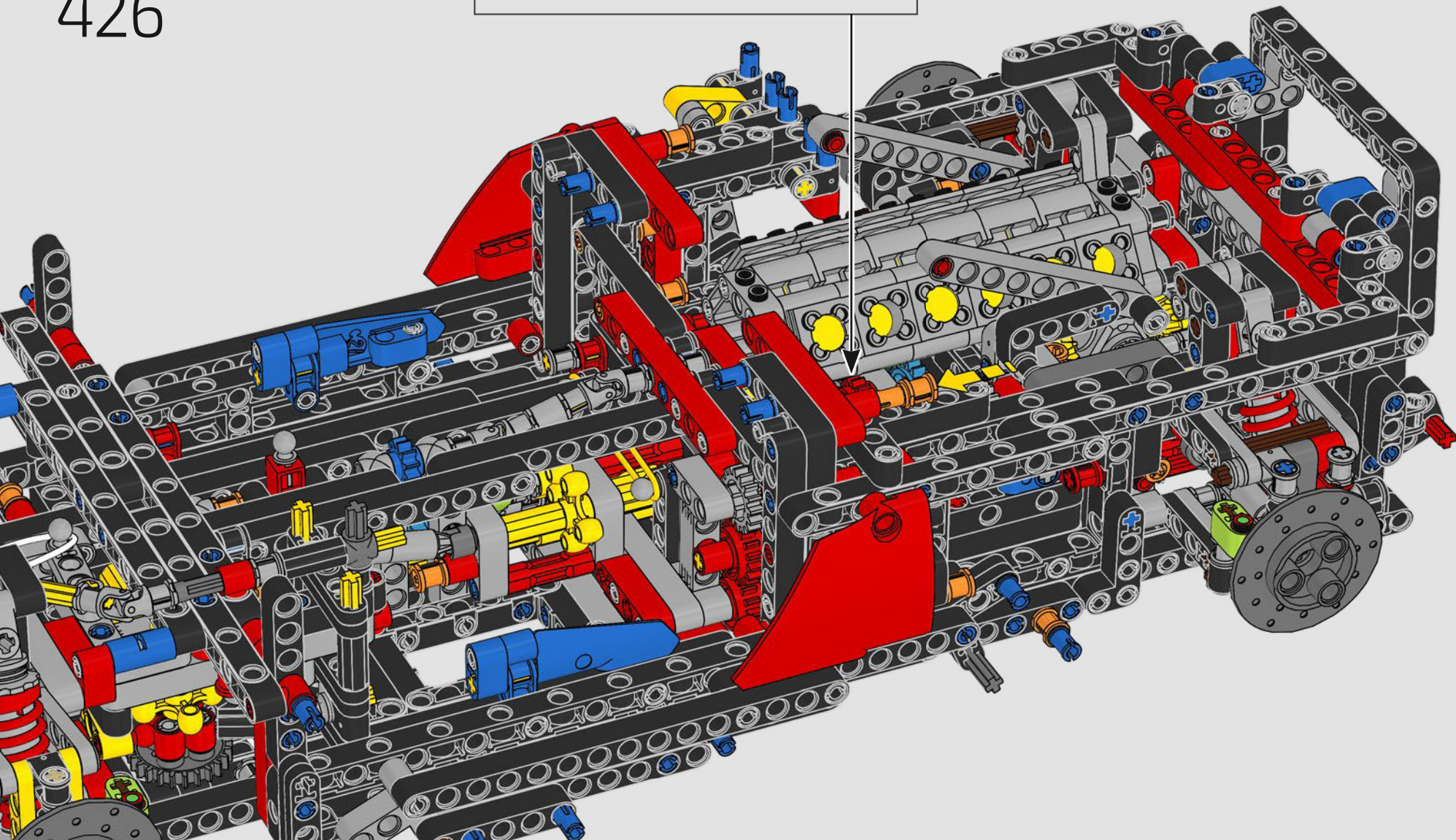



427

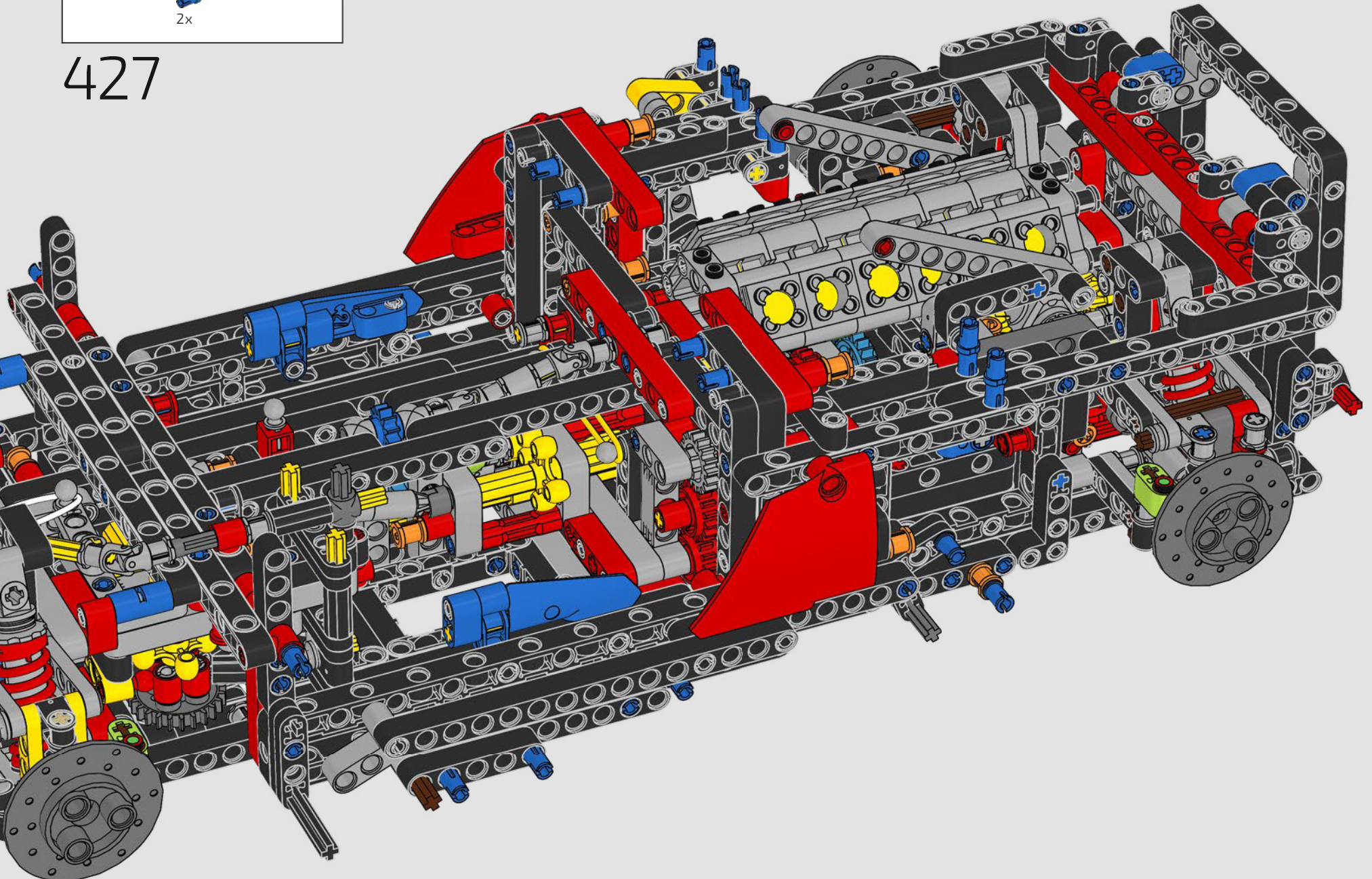

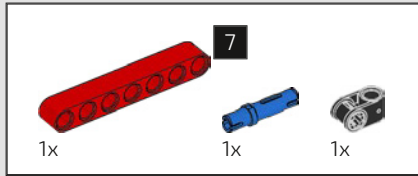

428

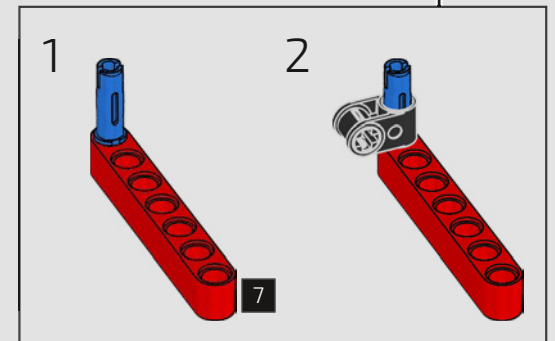
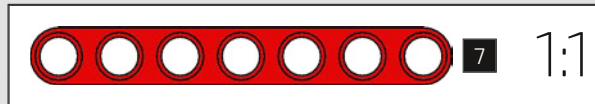
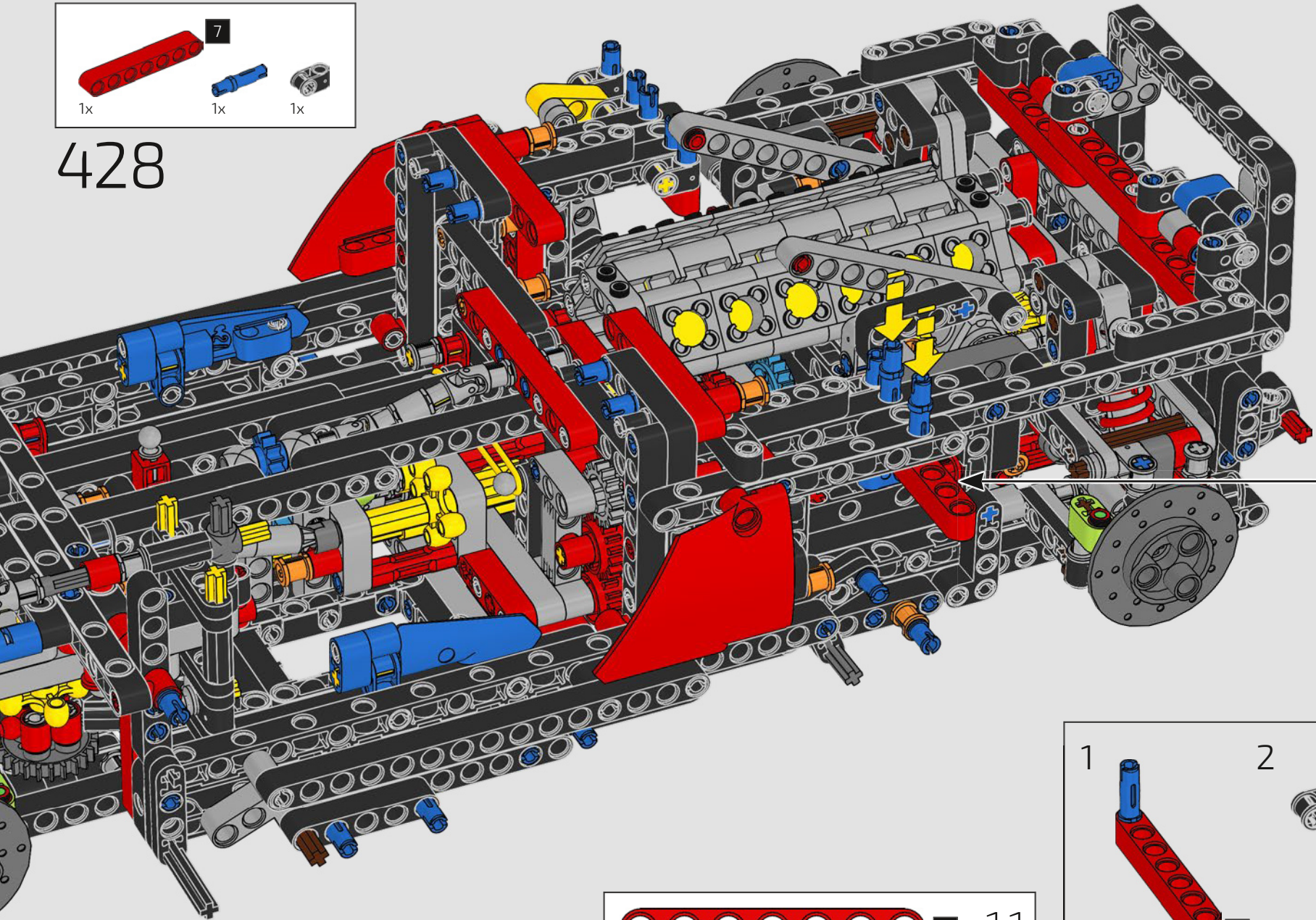

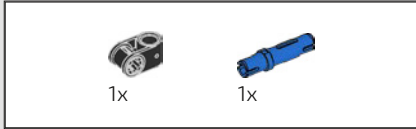

429

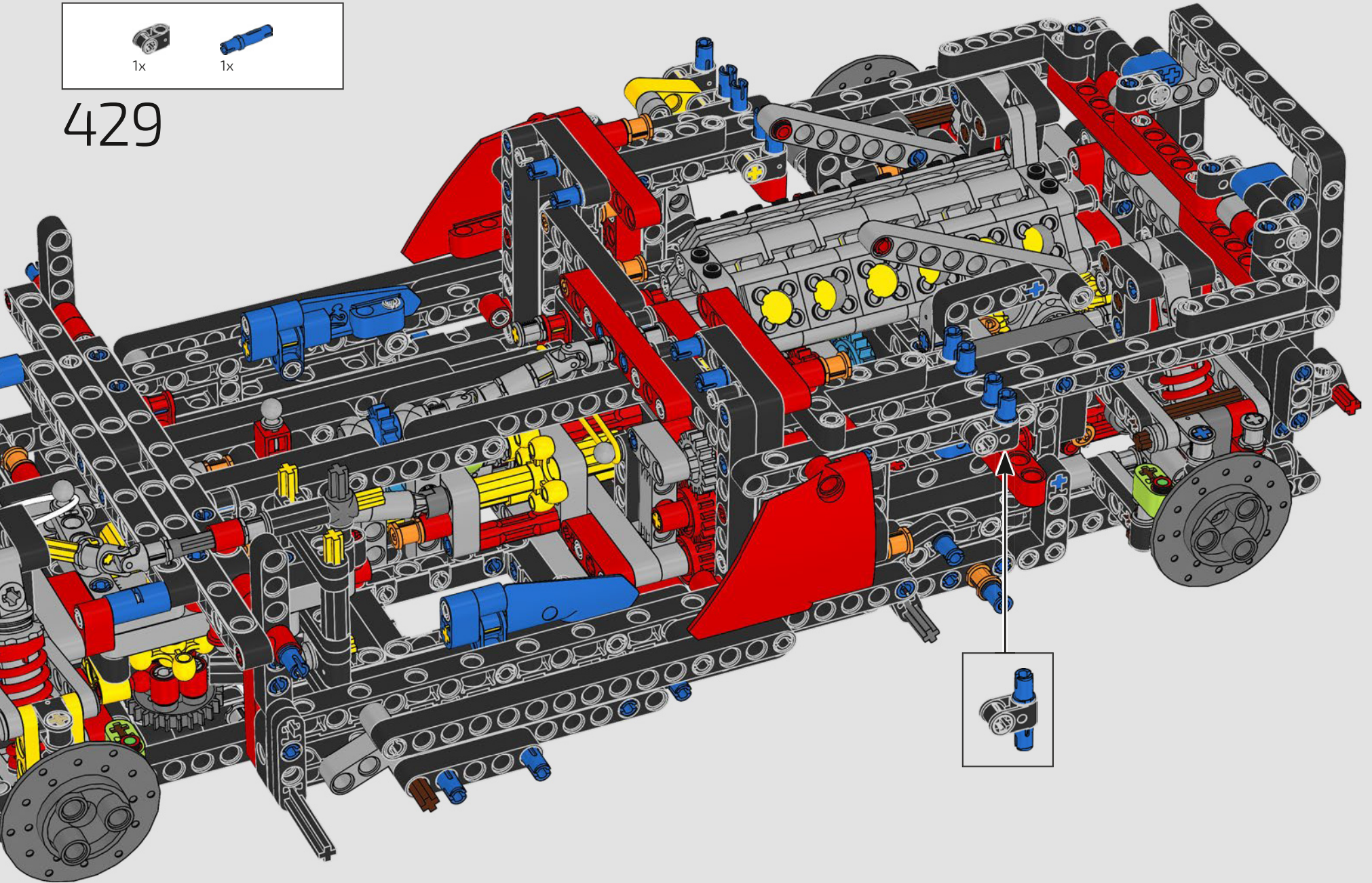

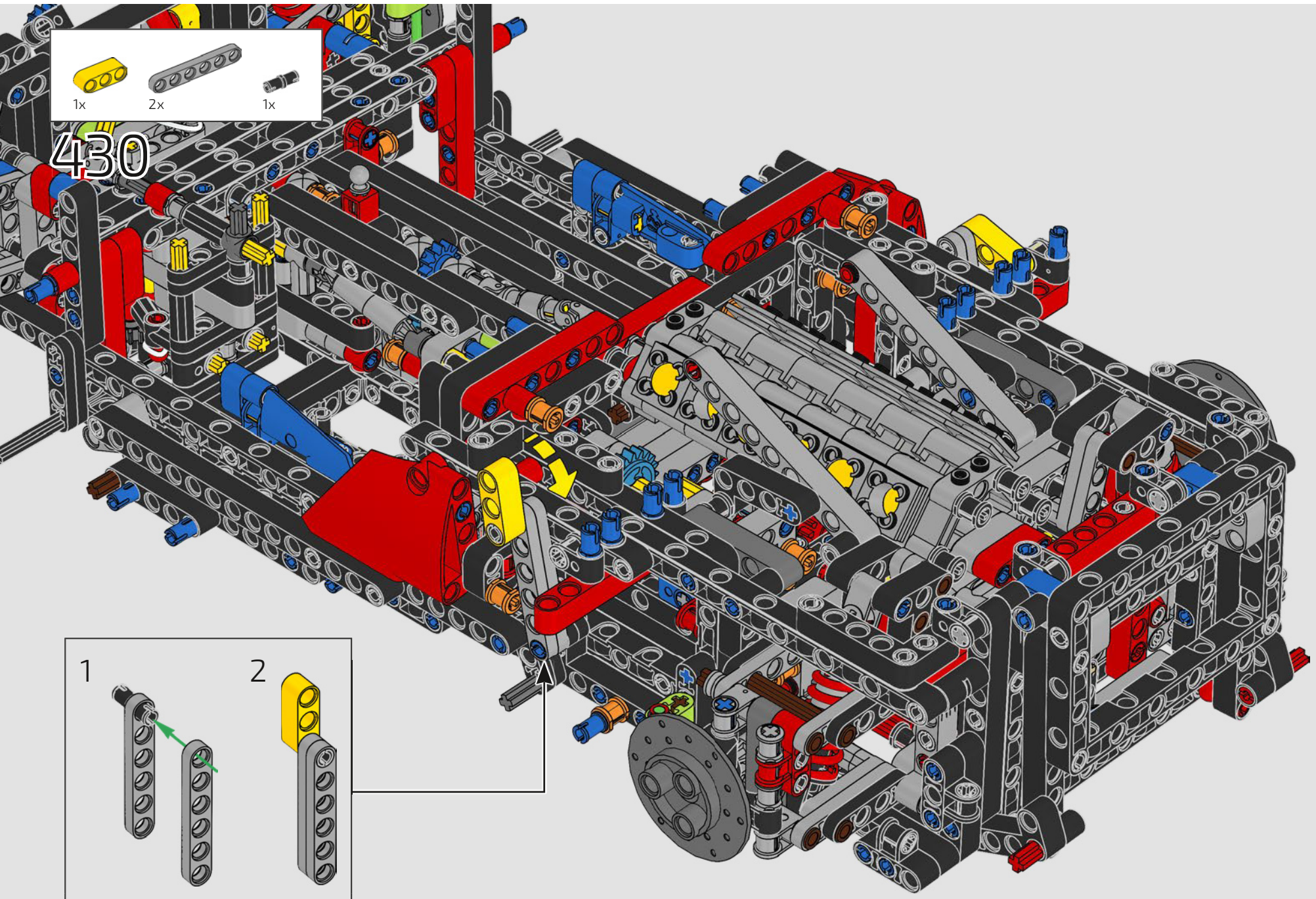

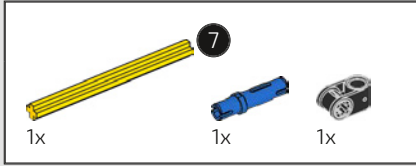

431

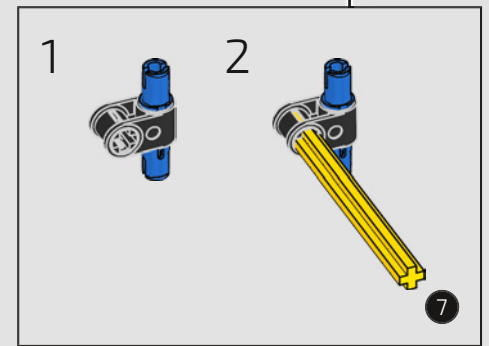
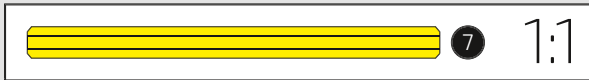
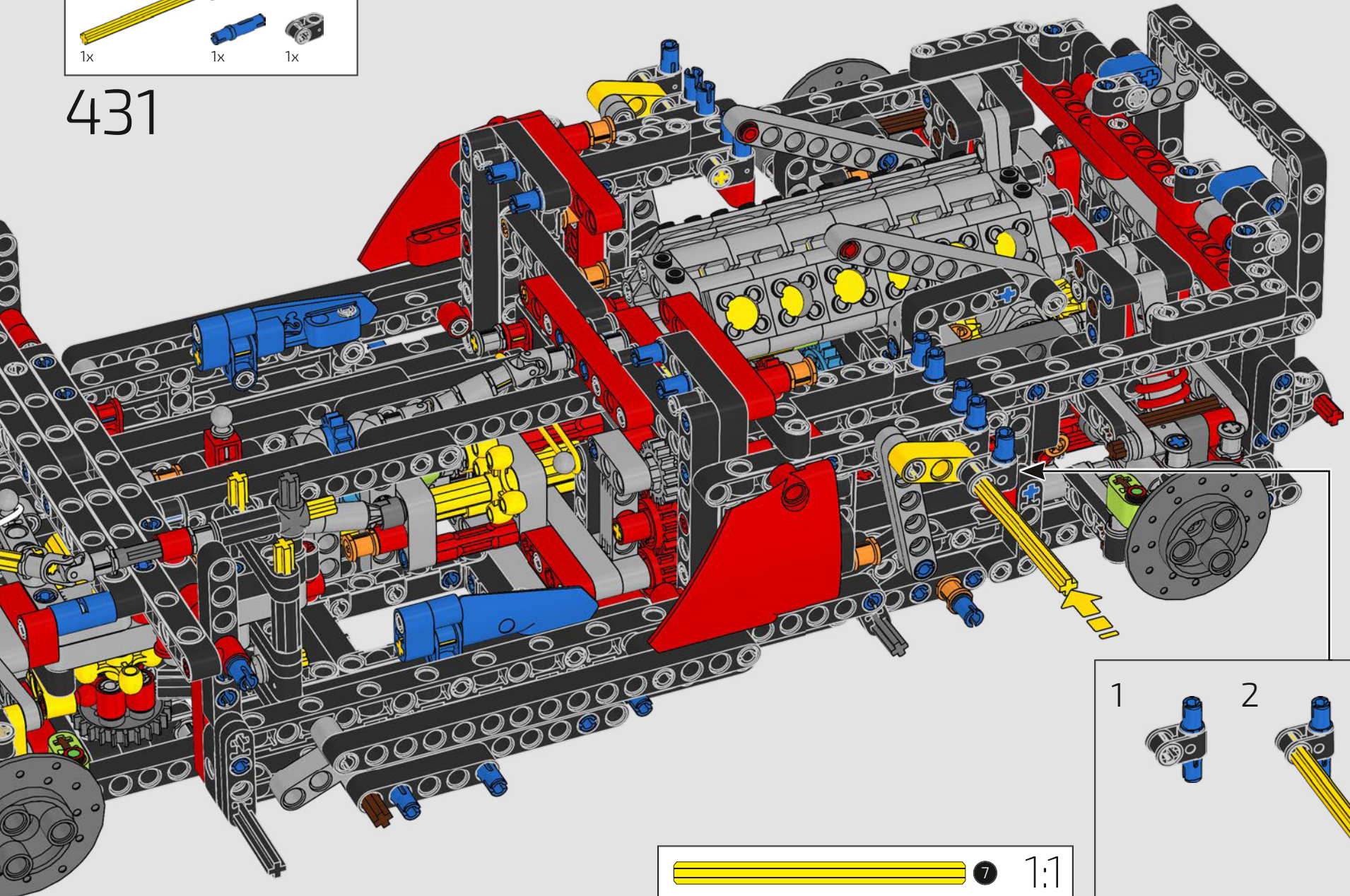

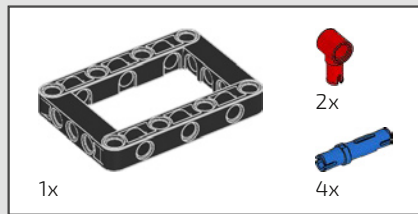

432

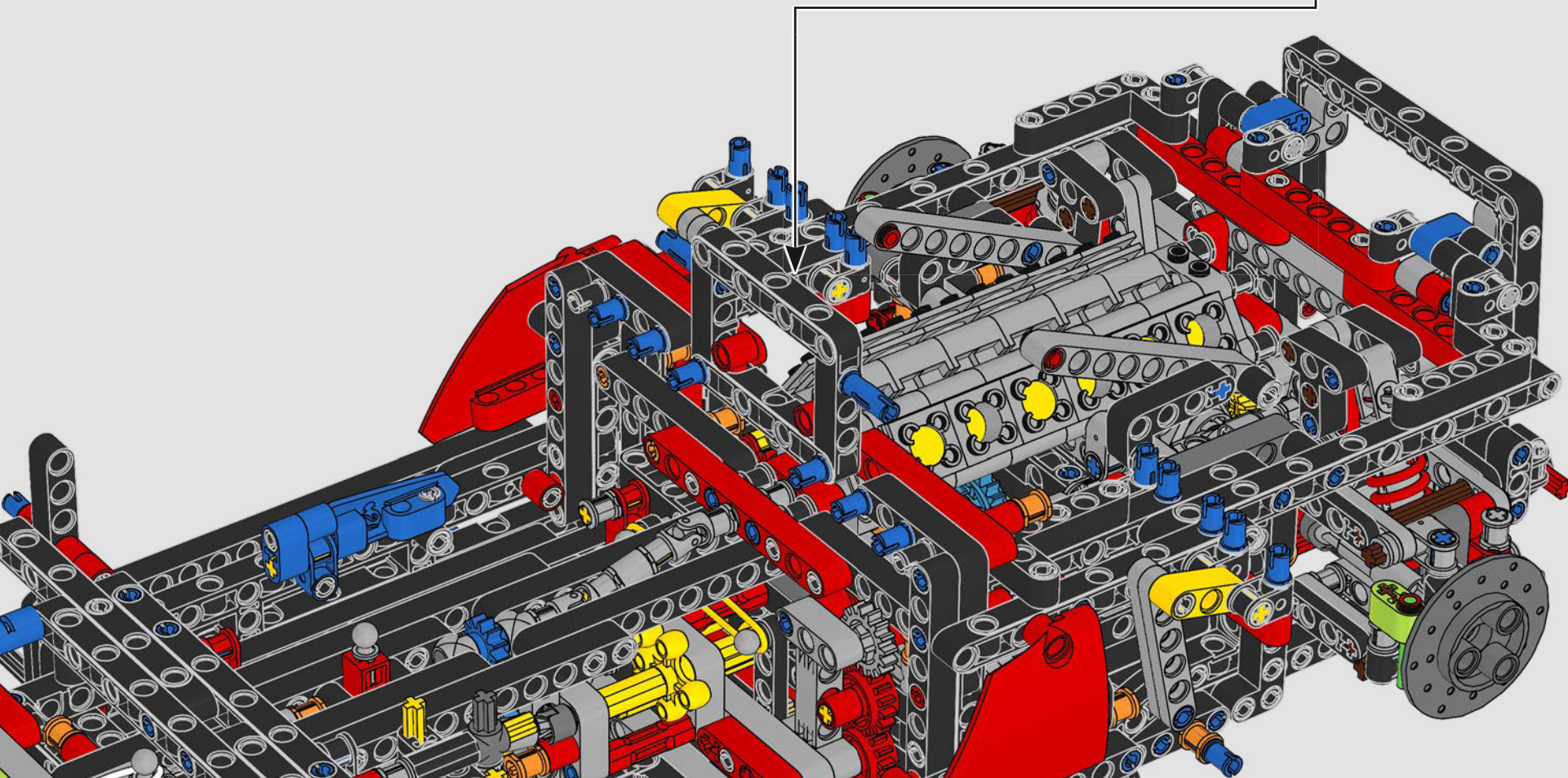
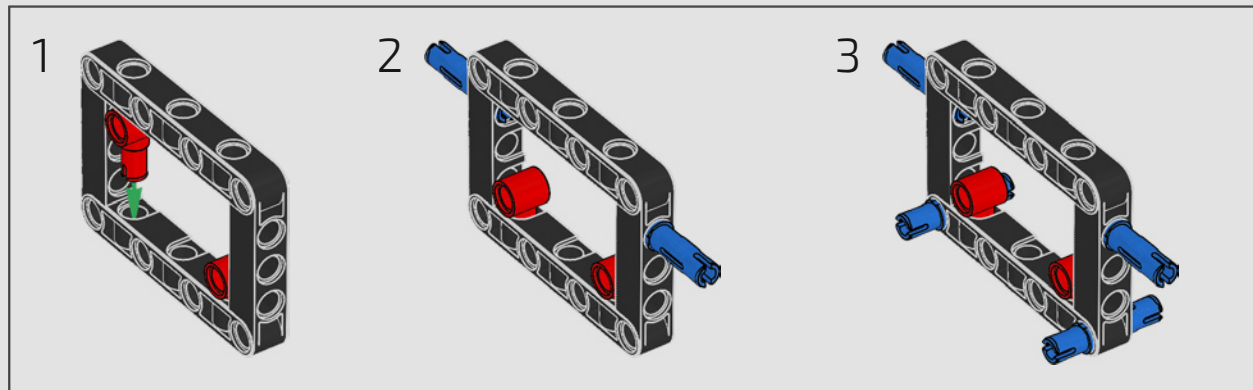

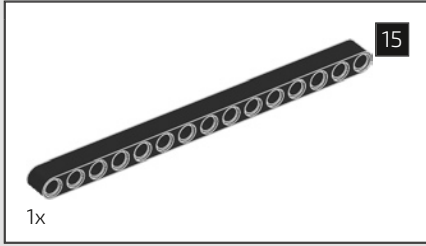

433

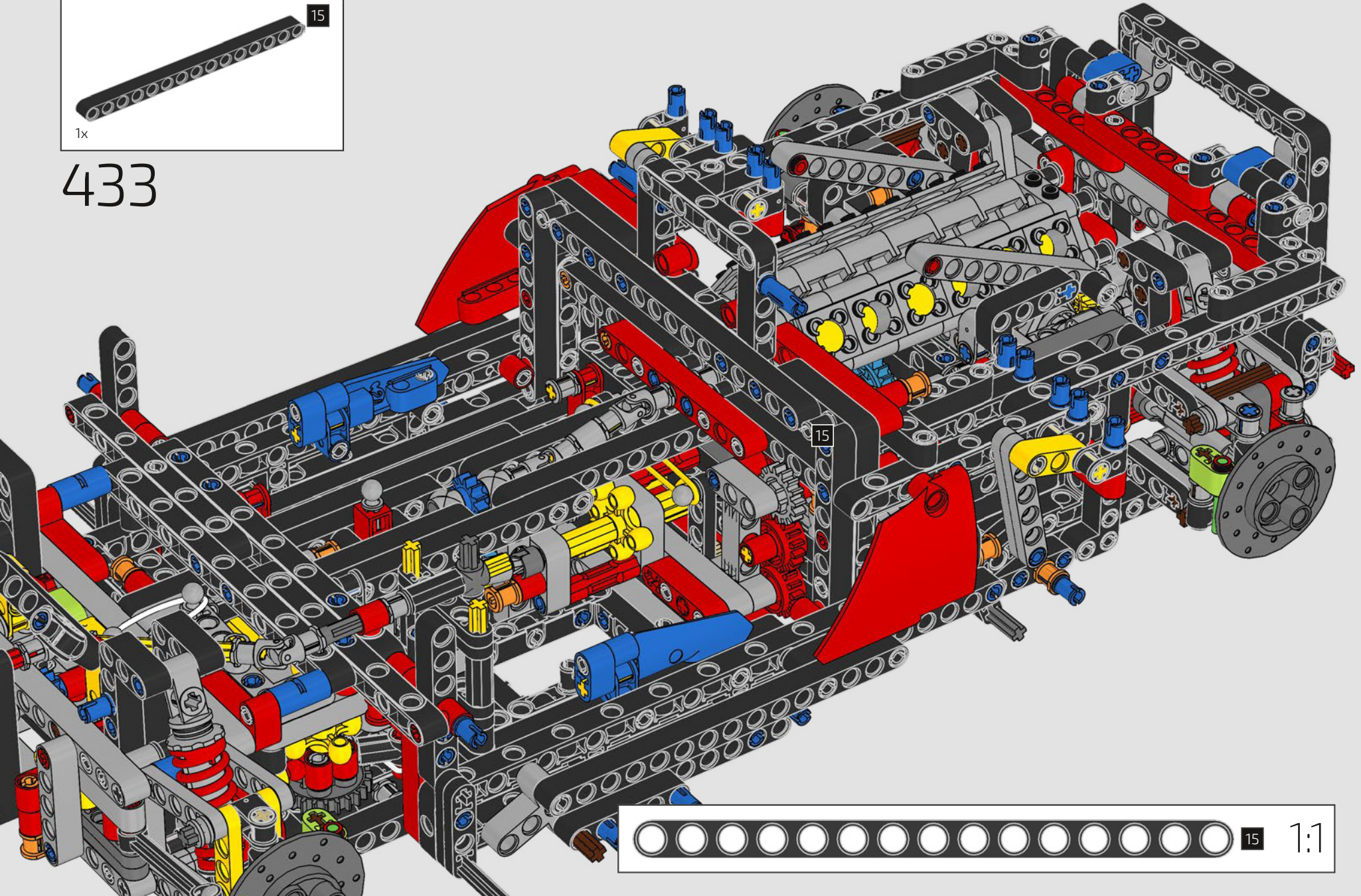

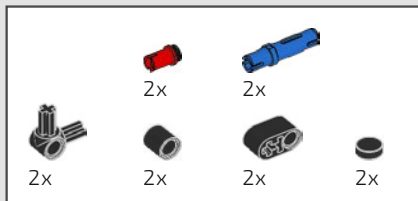

434

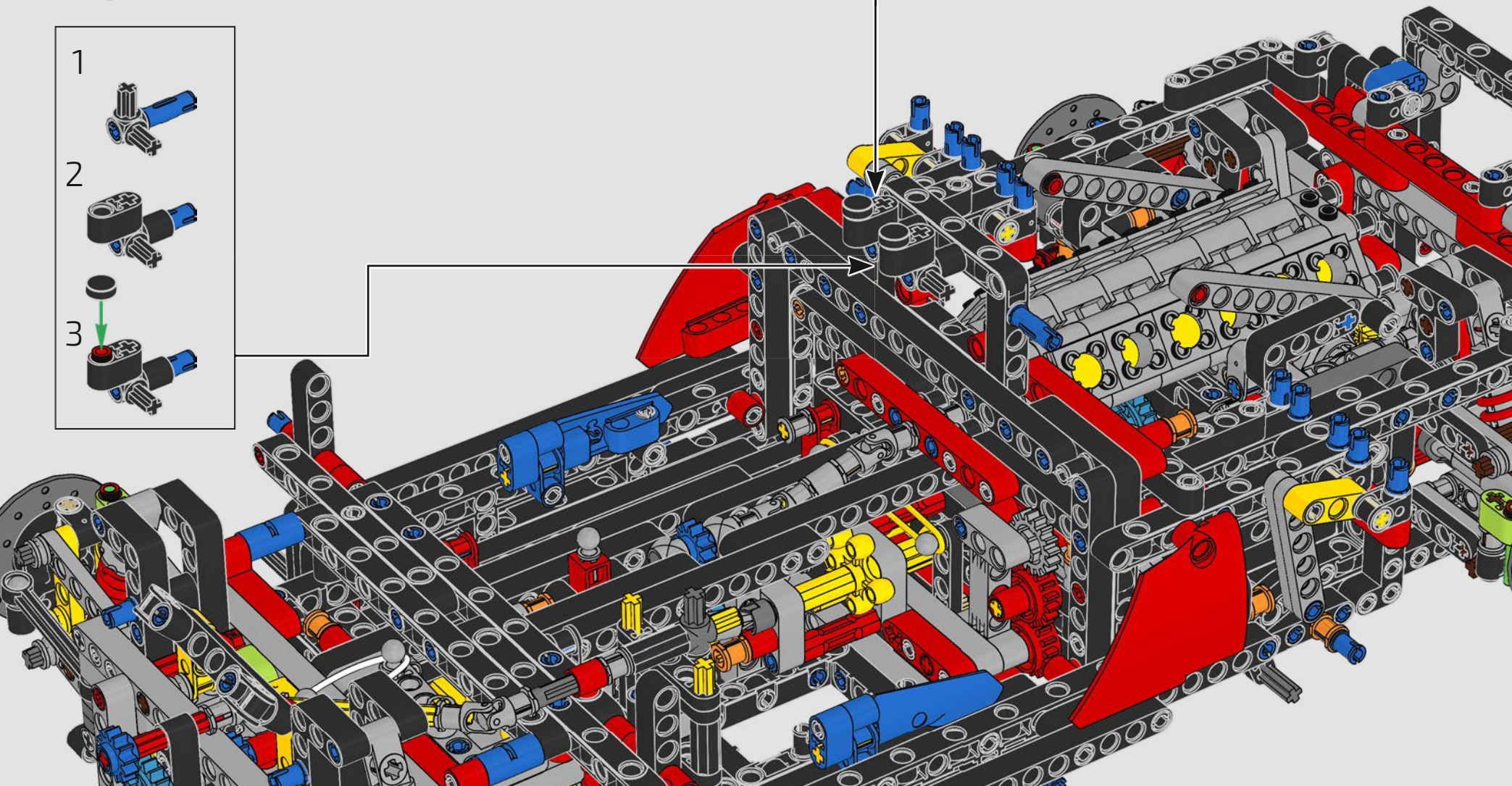
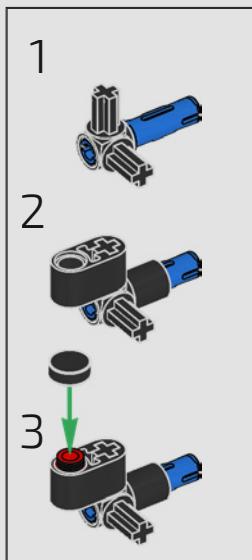
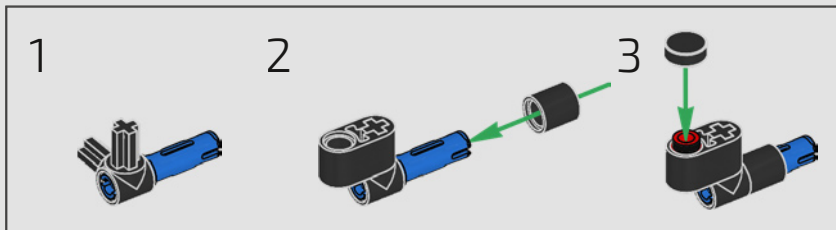

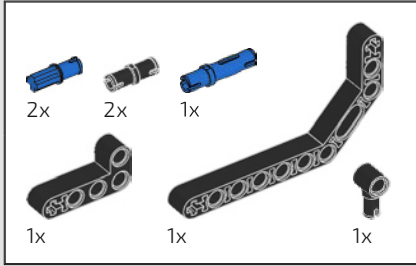

435

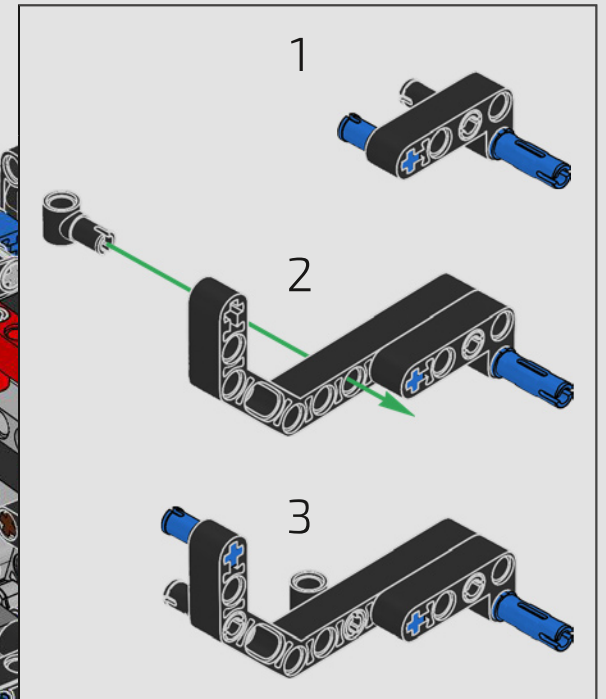
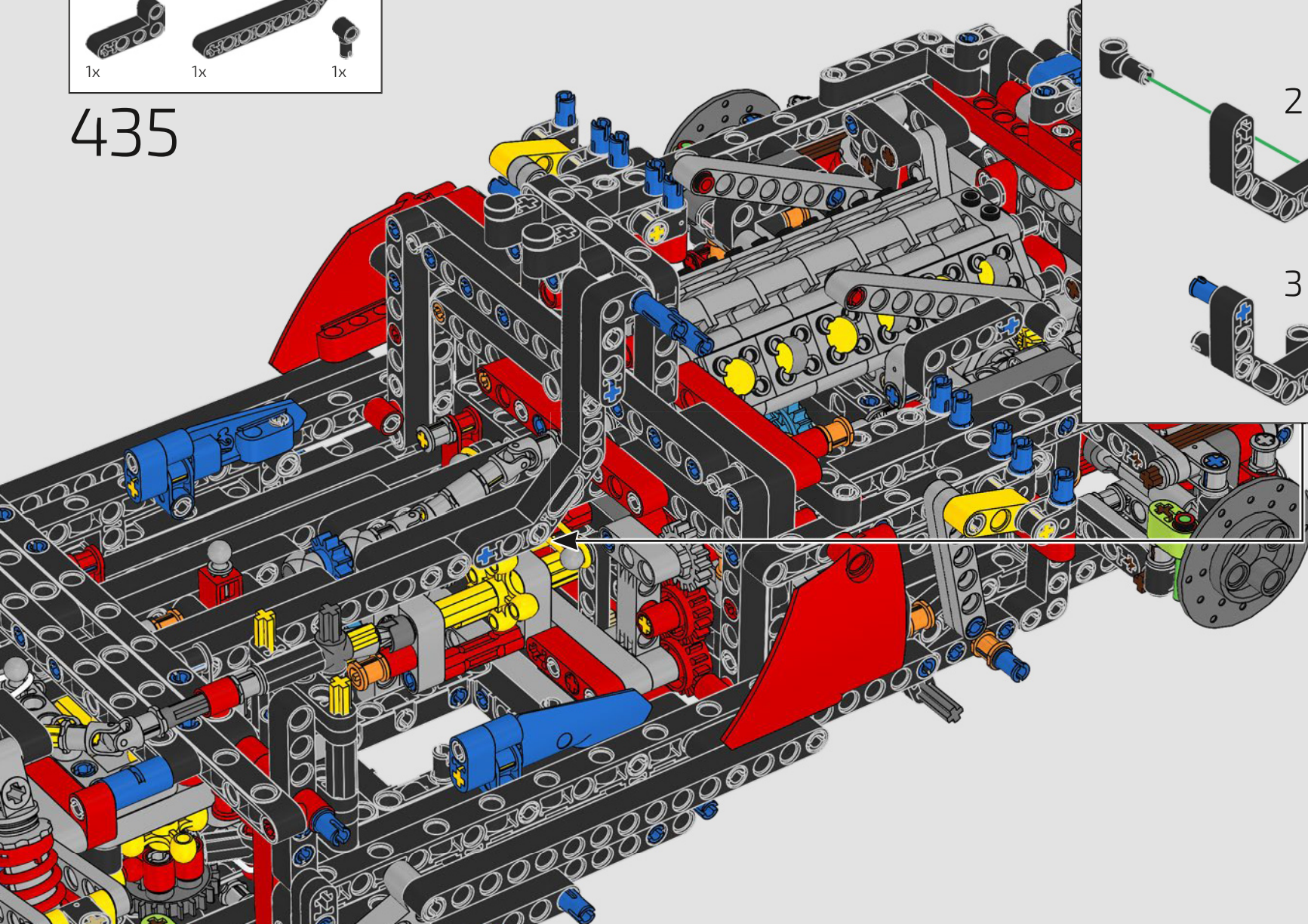

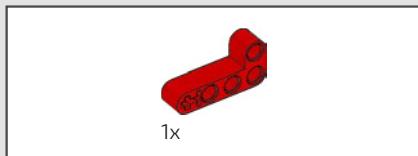

436

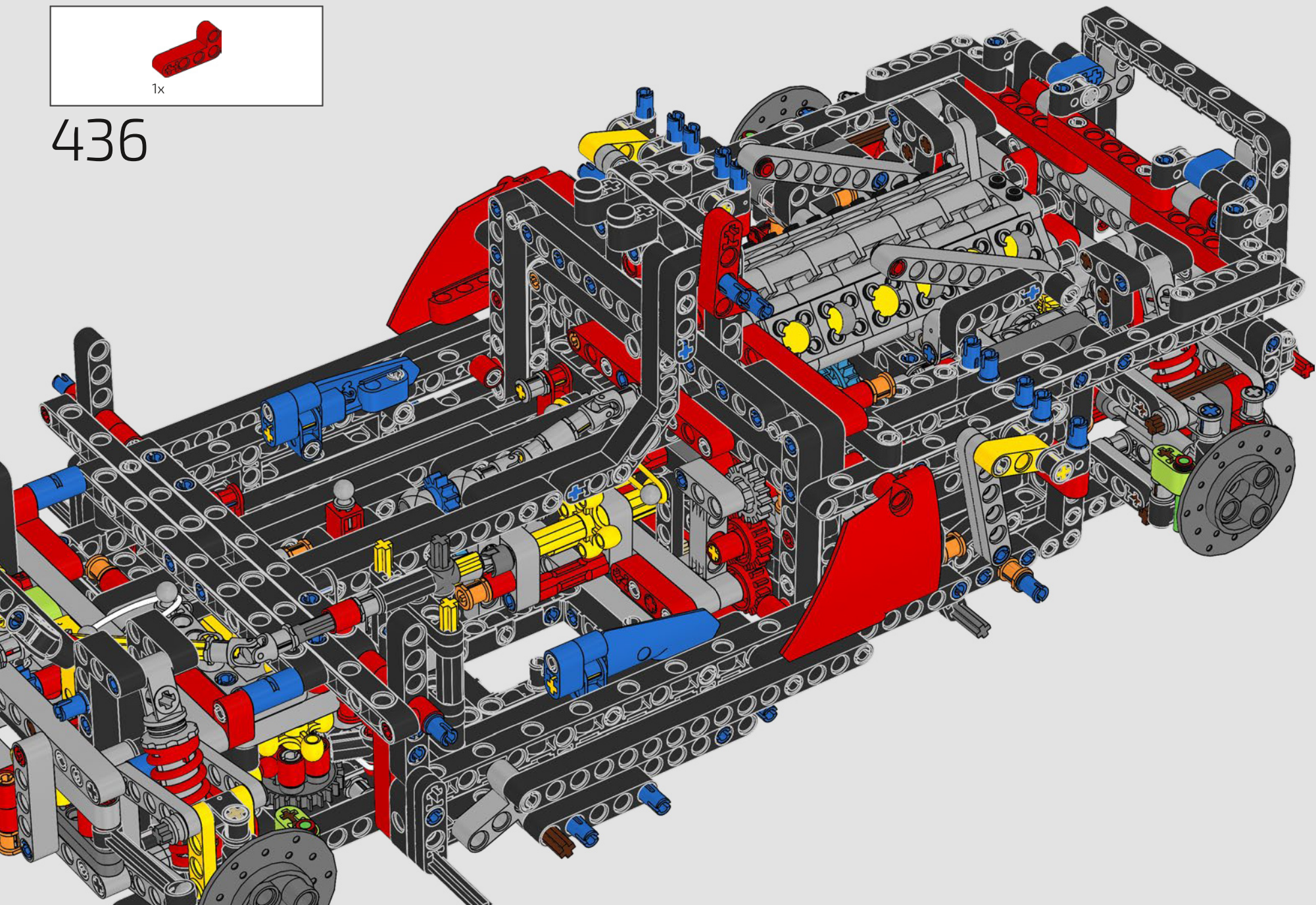

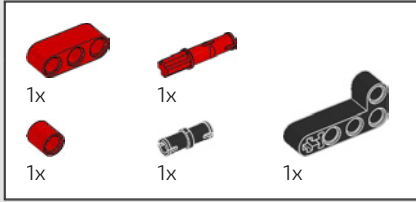

437

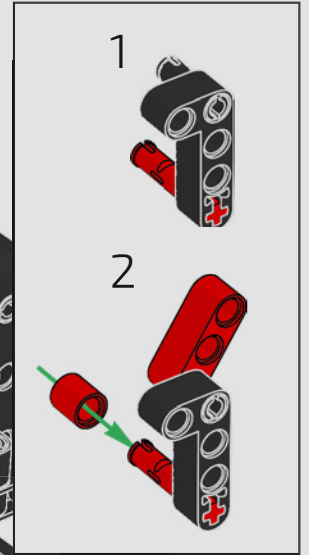
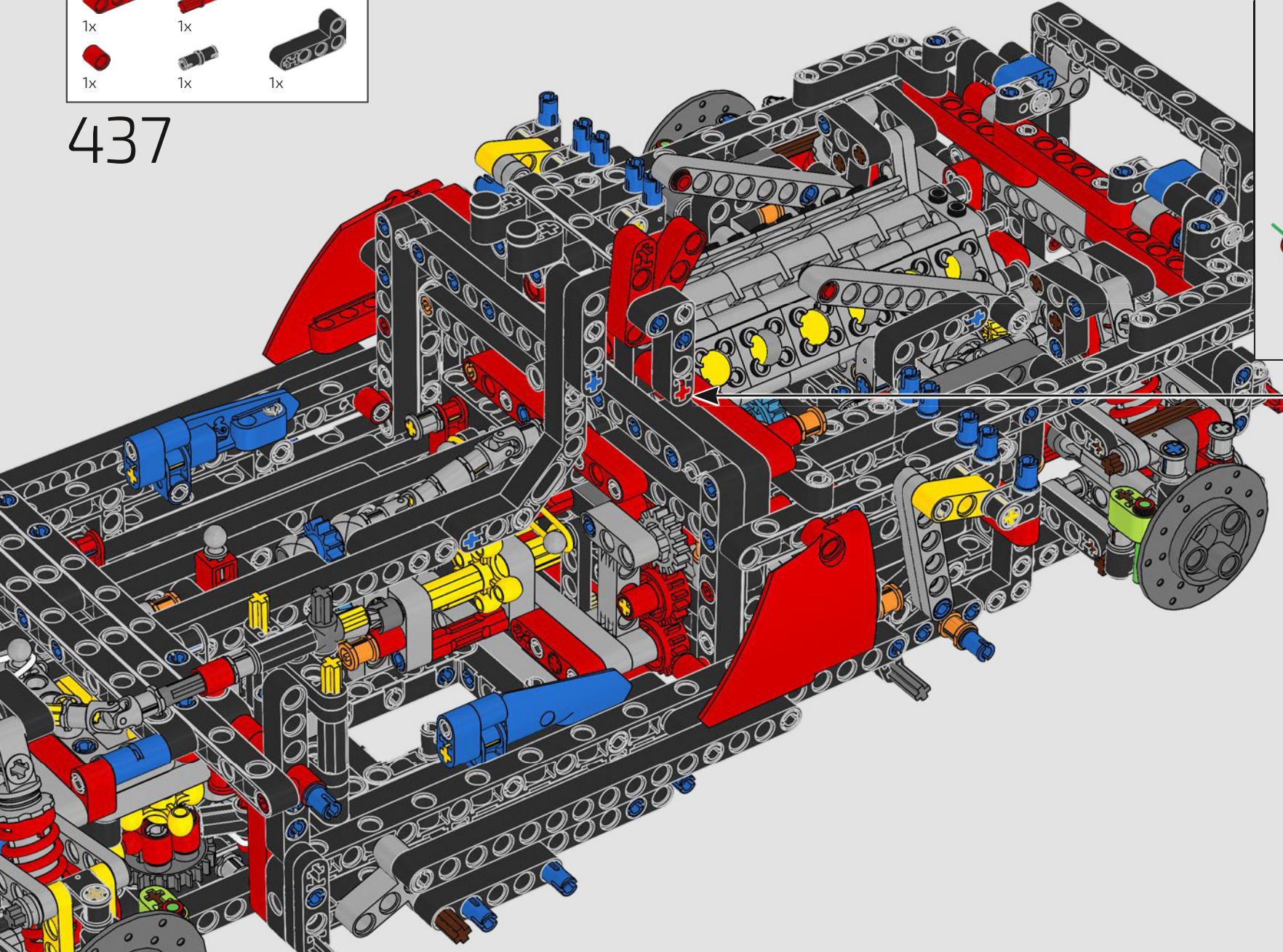

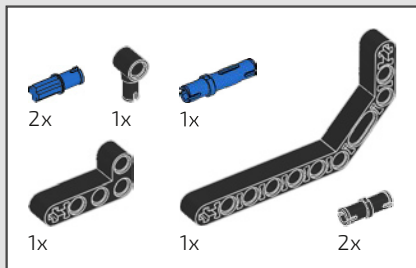

438

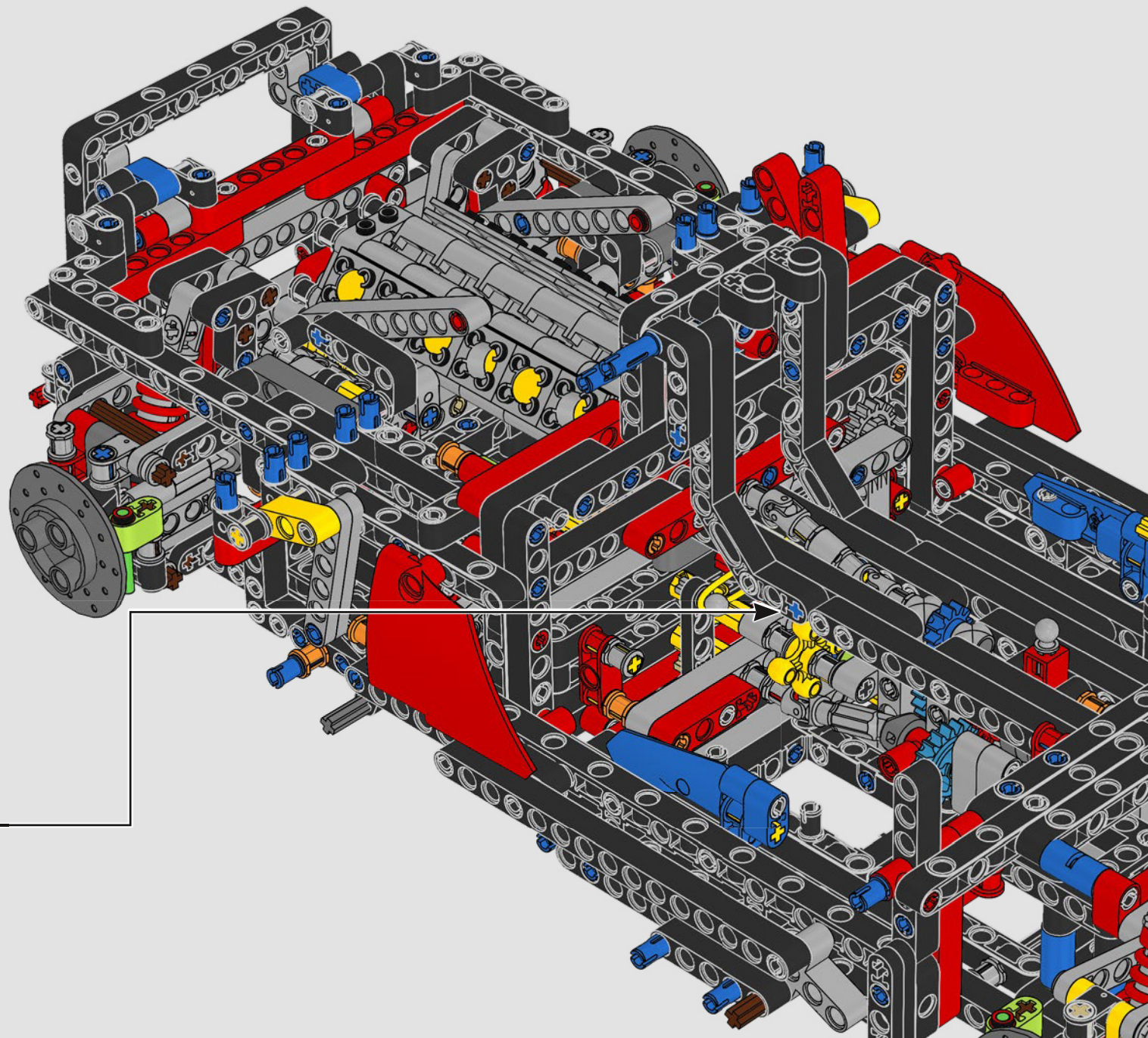
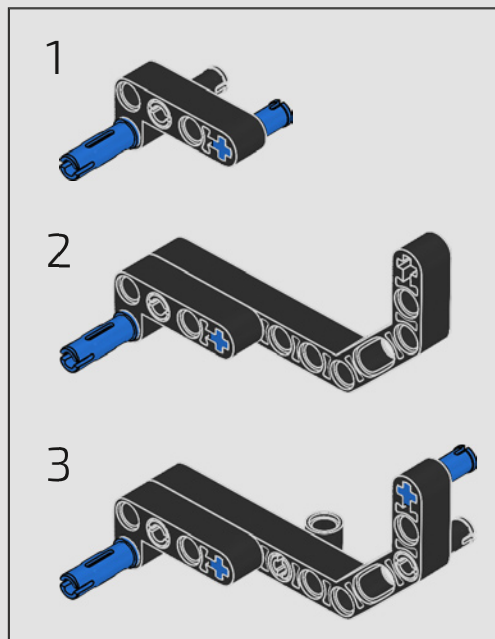

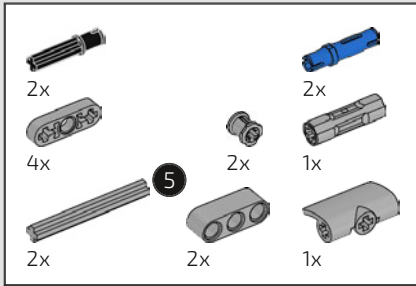

439

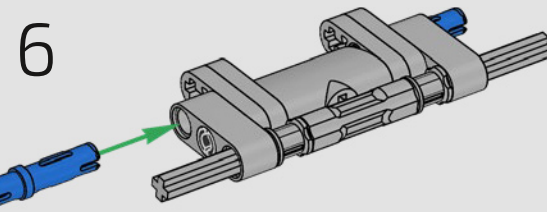
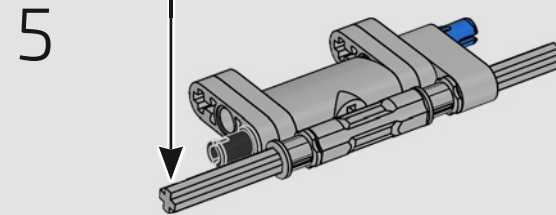
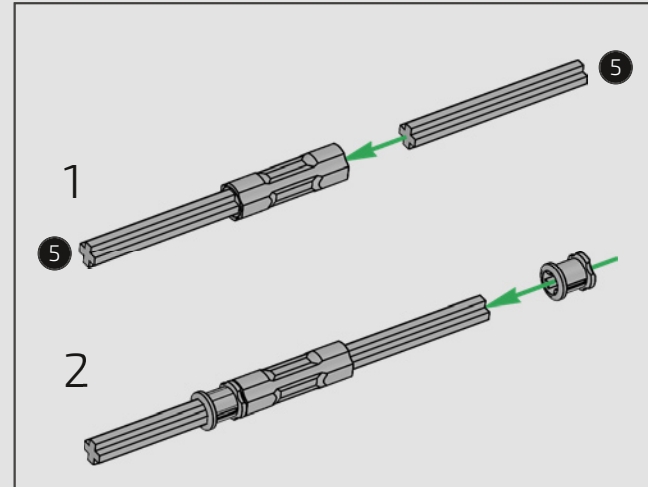
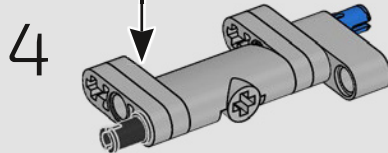
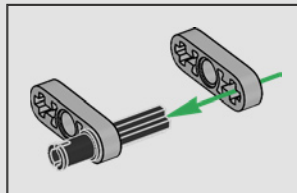
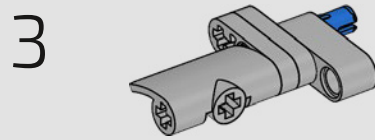
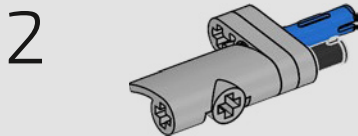
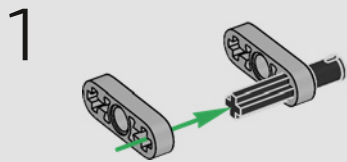

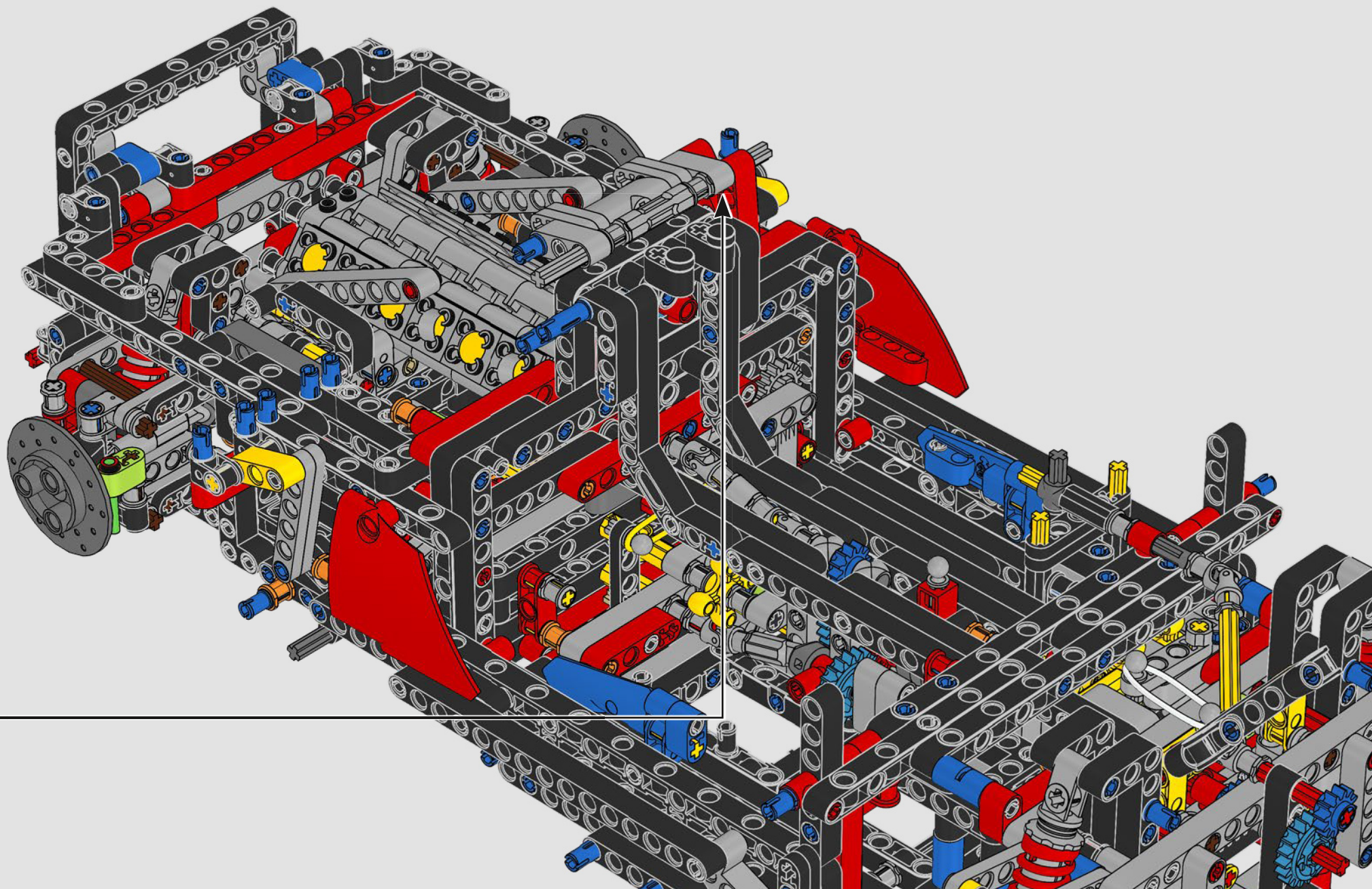

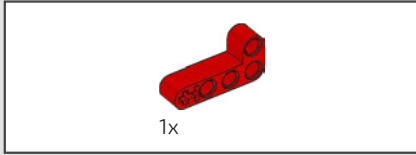

440

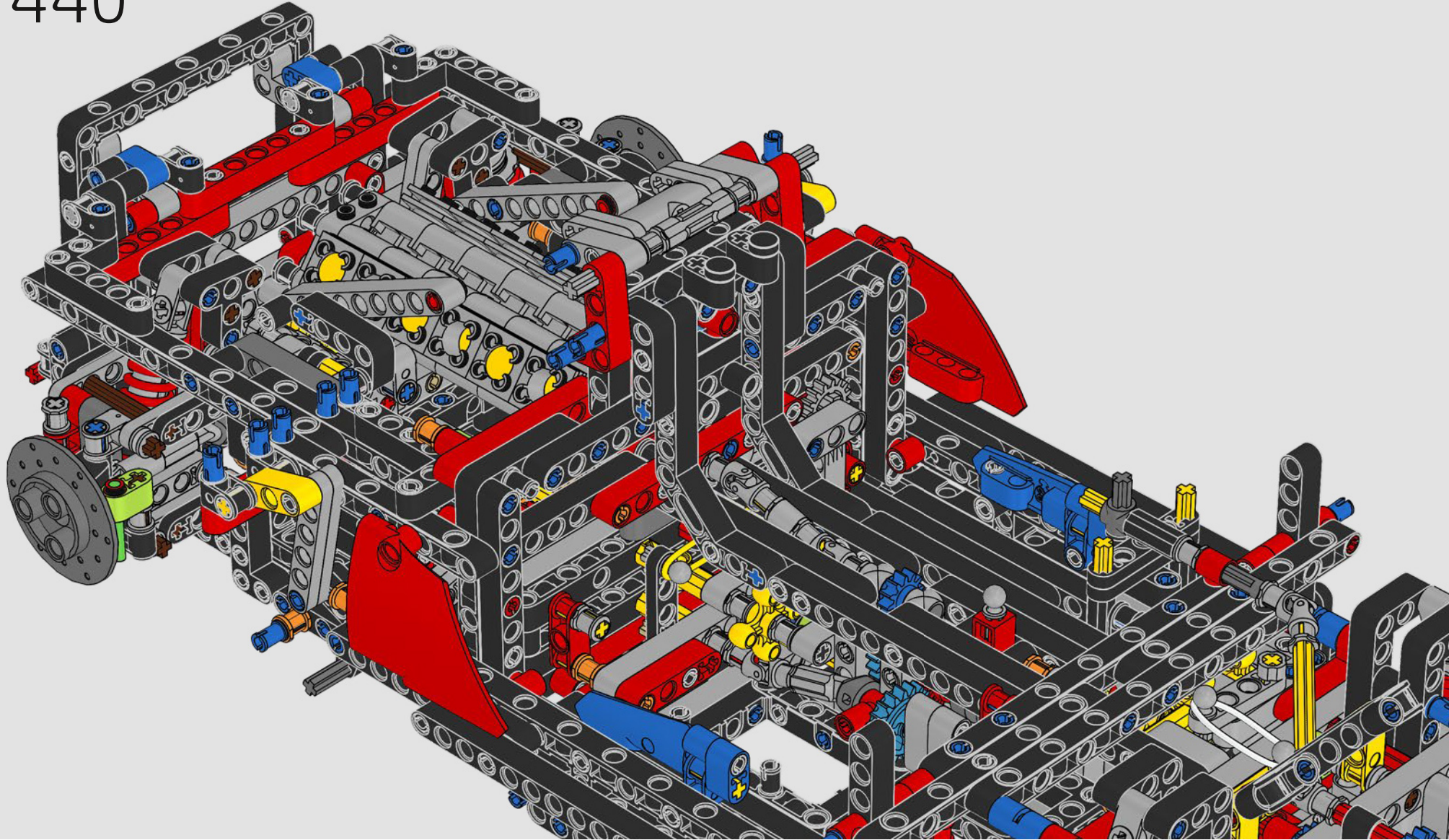

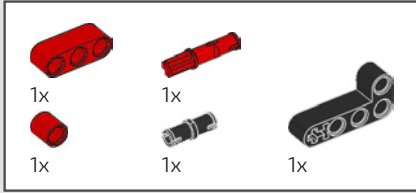

441

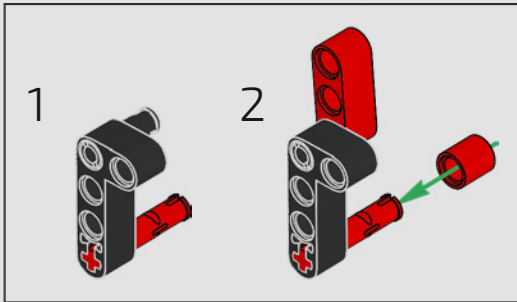
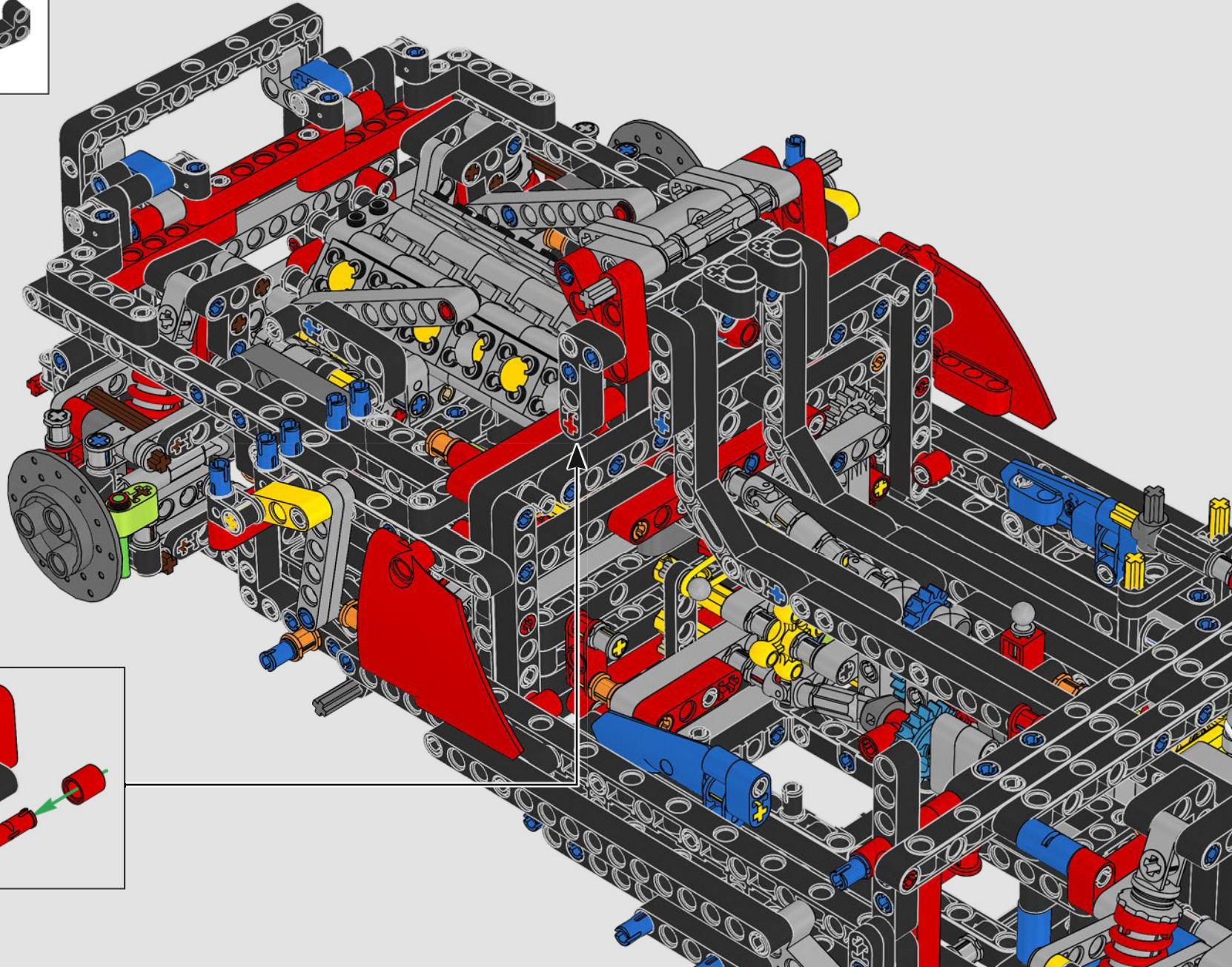

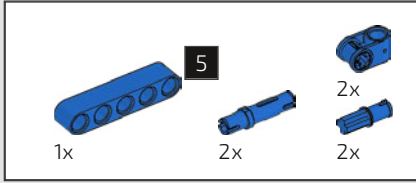

442

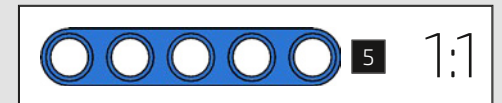
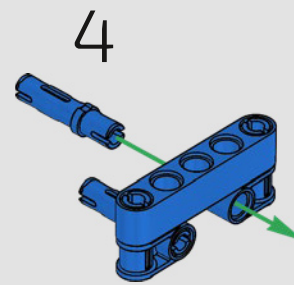
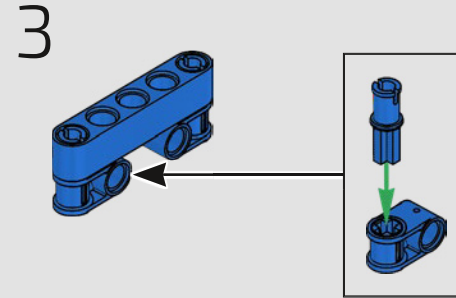
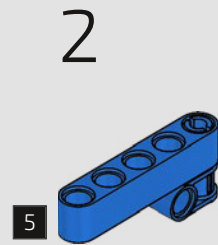
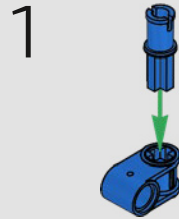

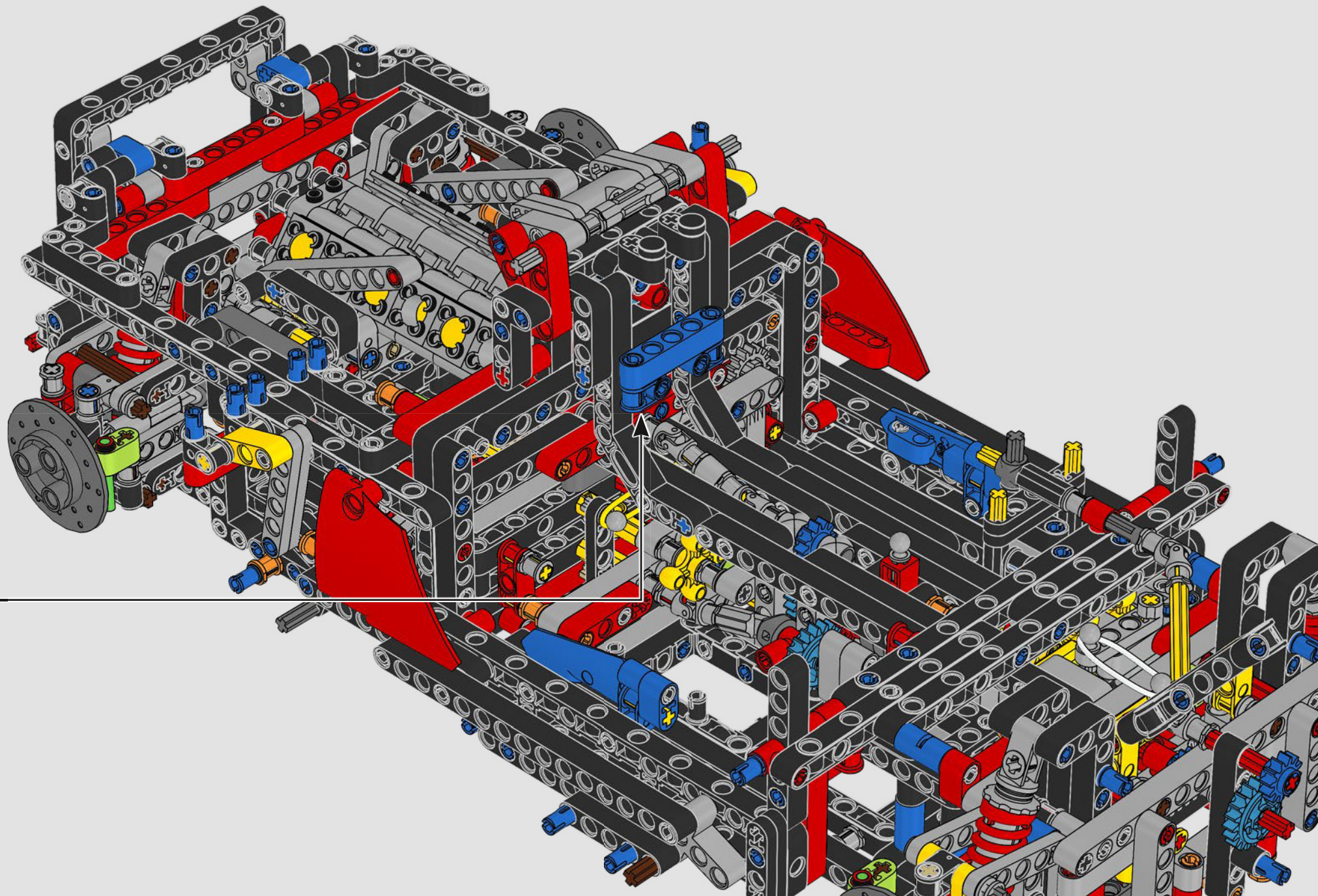

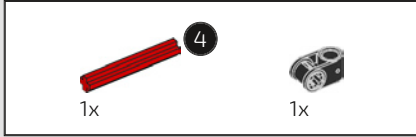
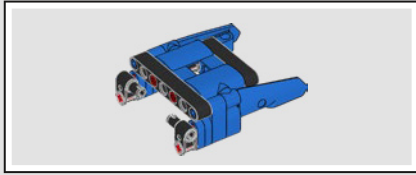

443

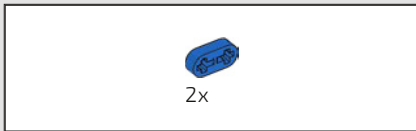
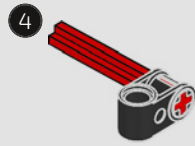

444

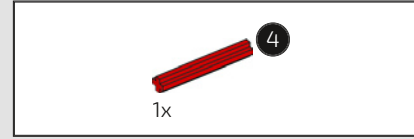
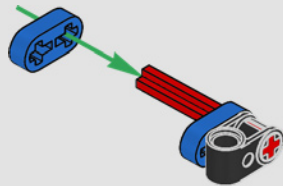

445

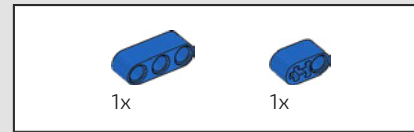
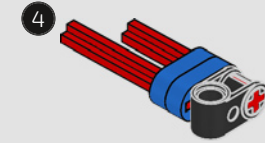

446

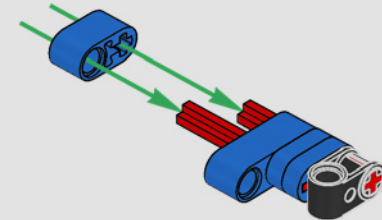

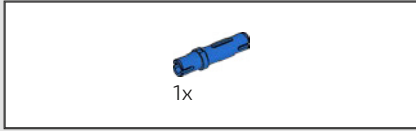

447

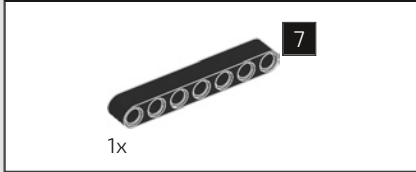
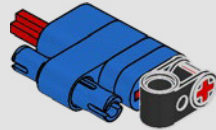

448

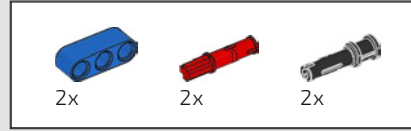
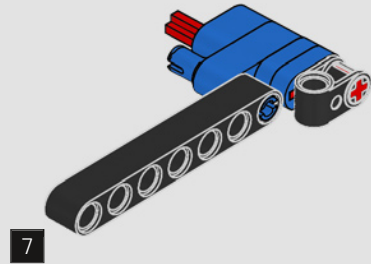

449

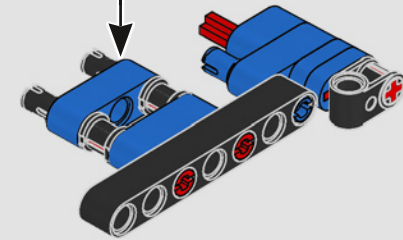
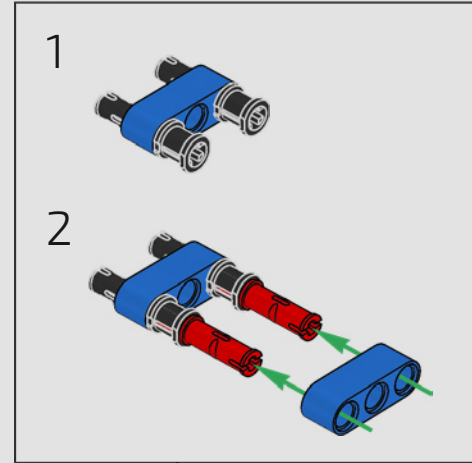

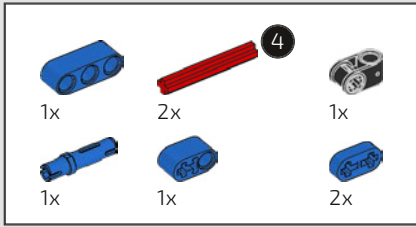

450

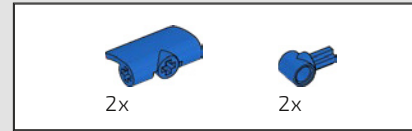
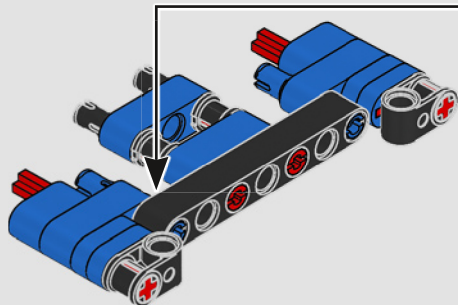
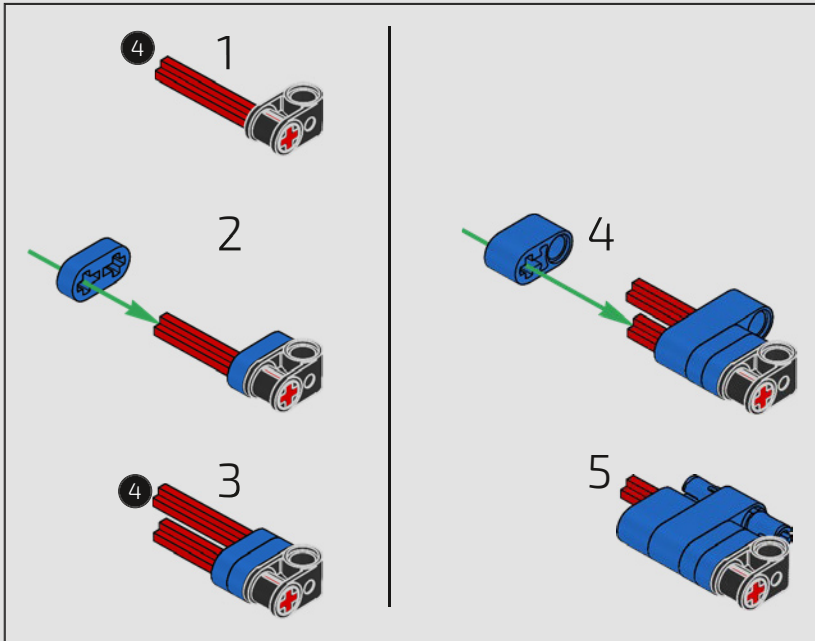

451

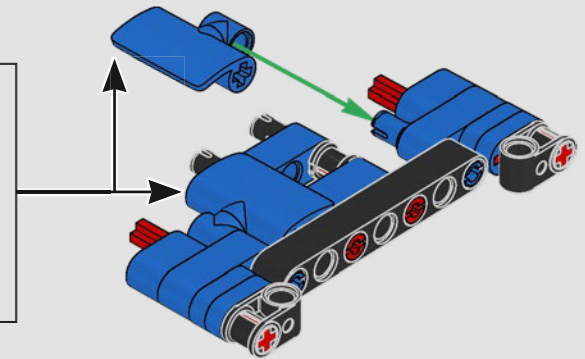
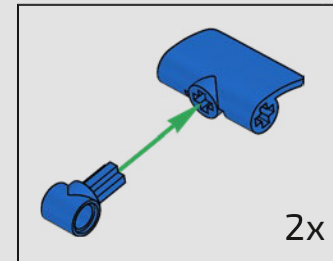

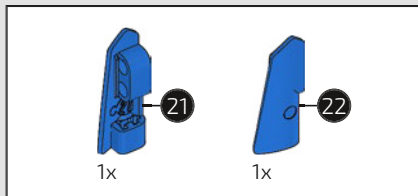

452

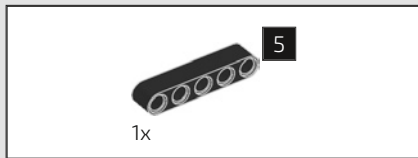
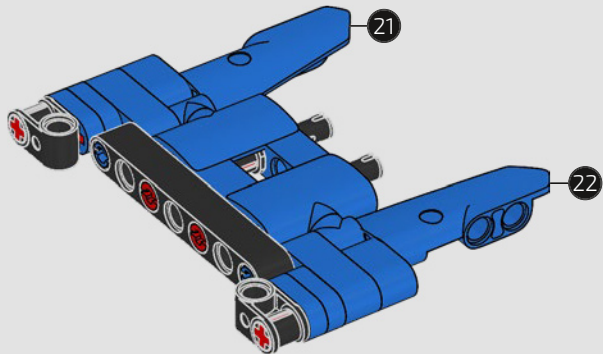

453

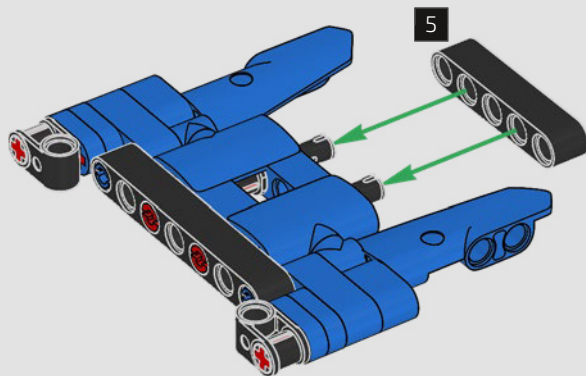

454

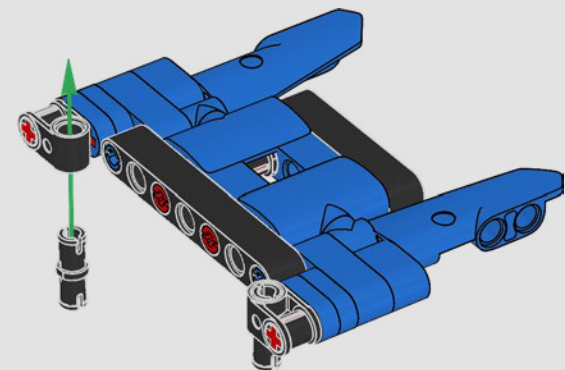

455

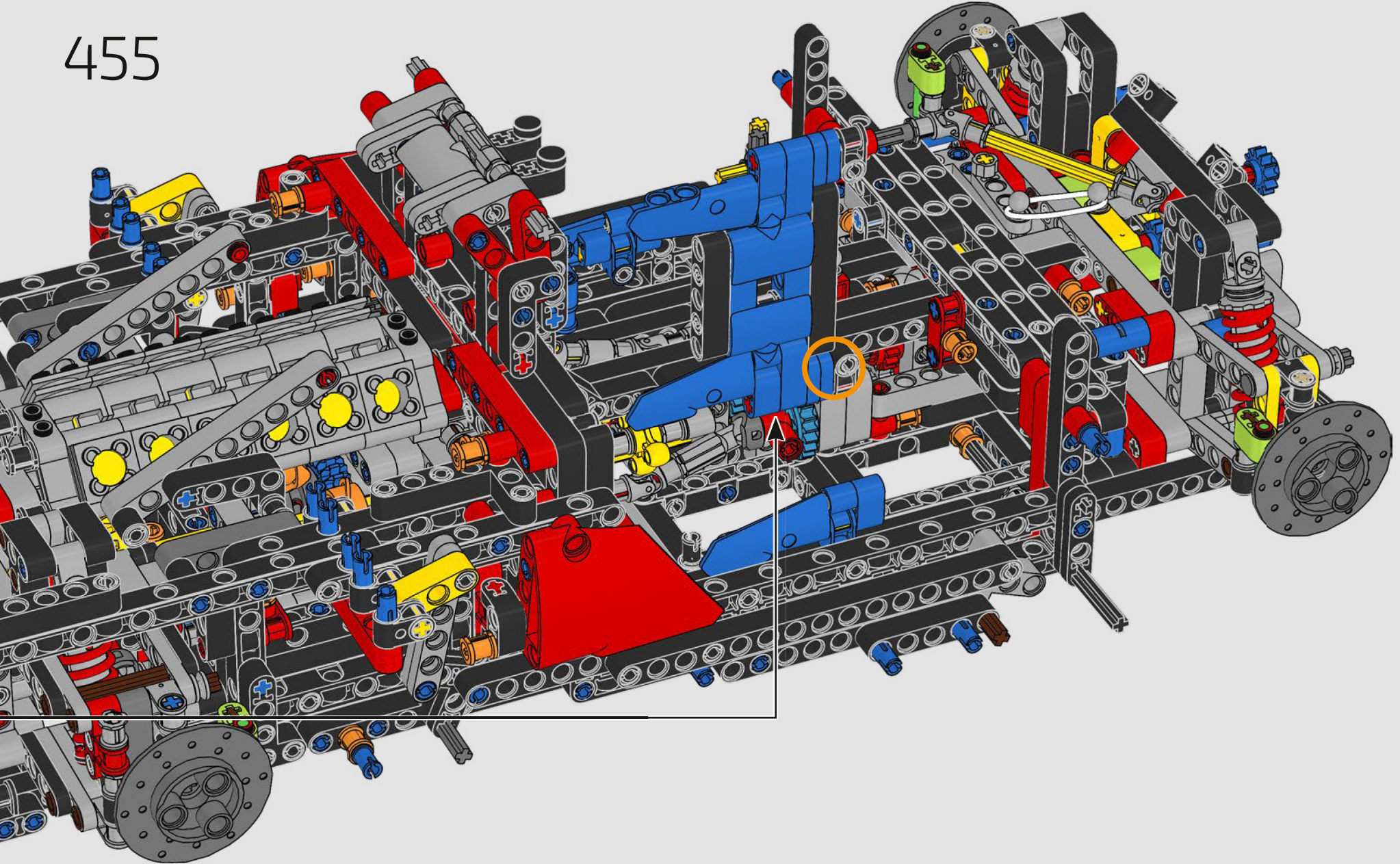

456

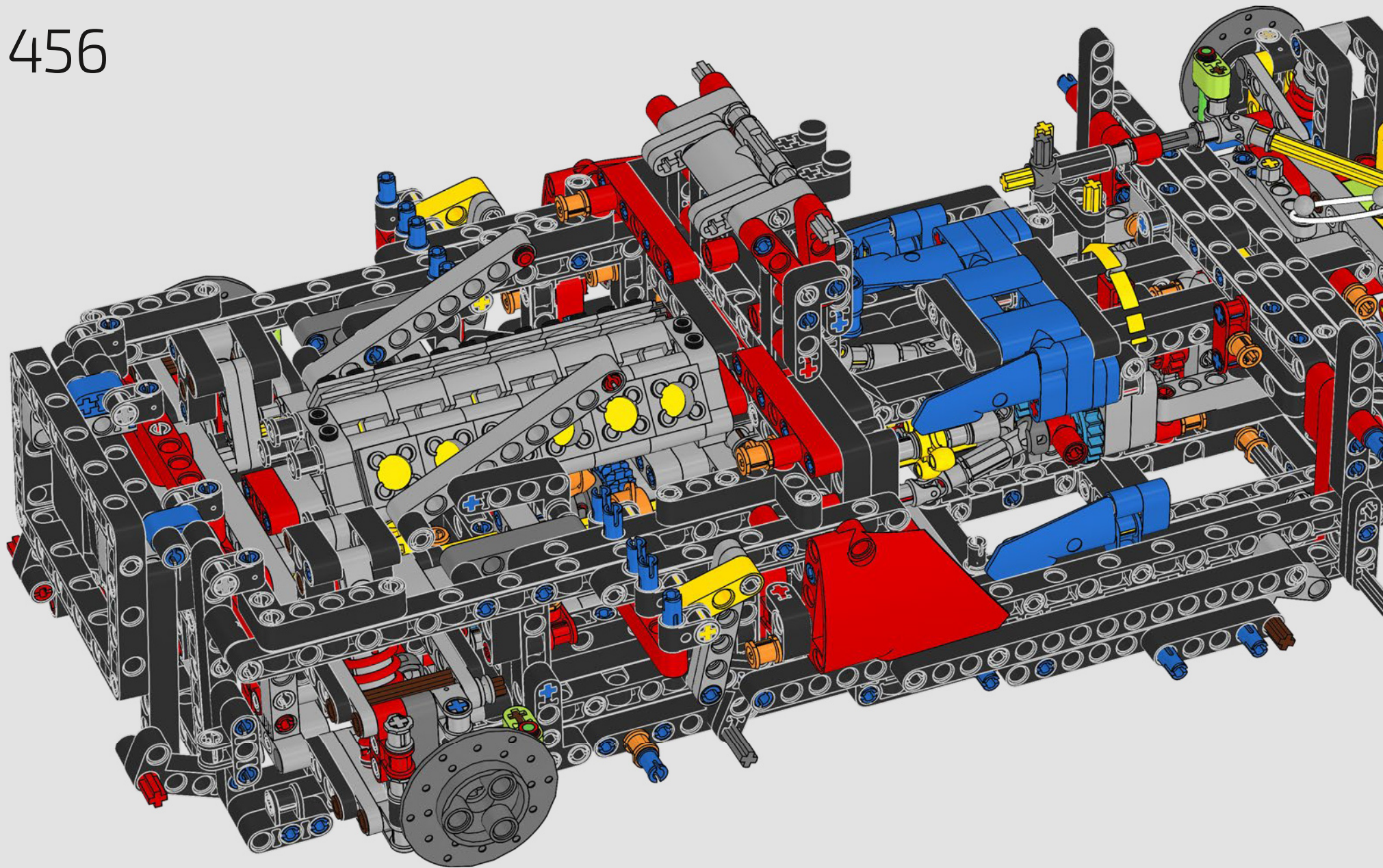

457

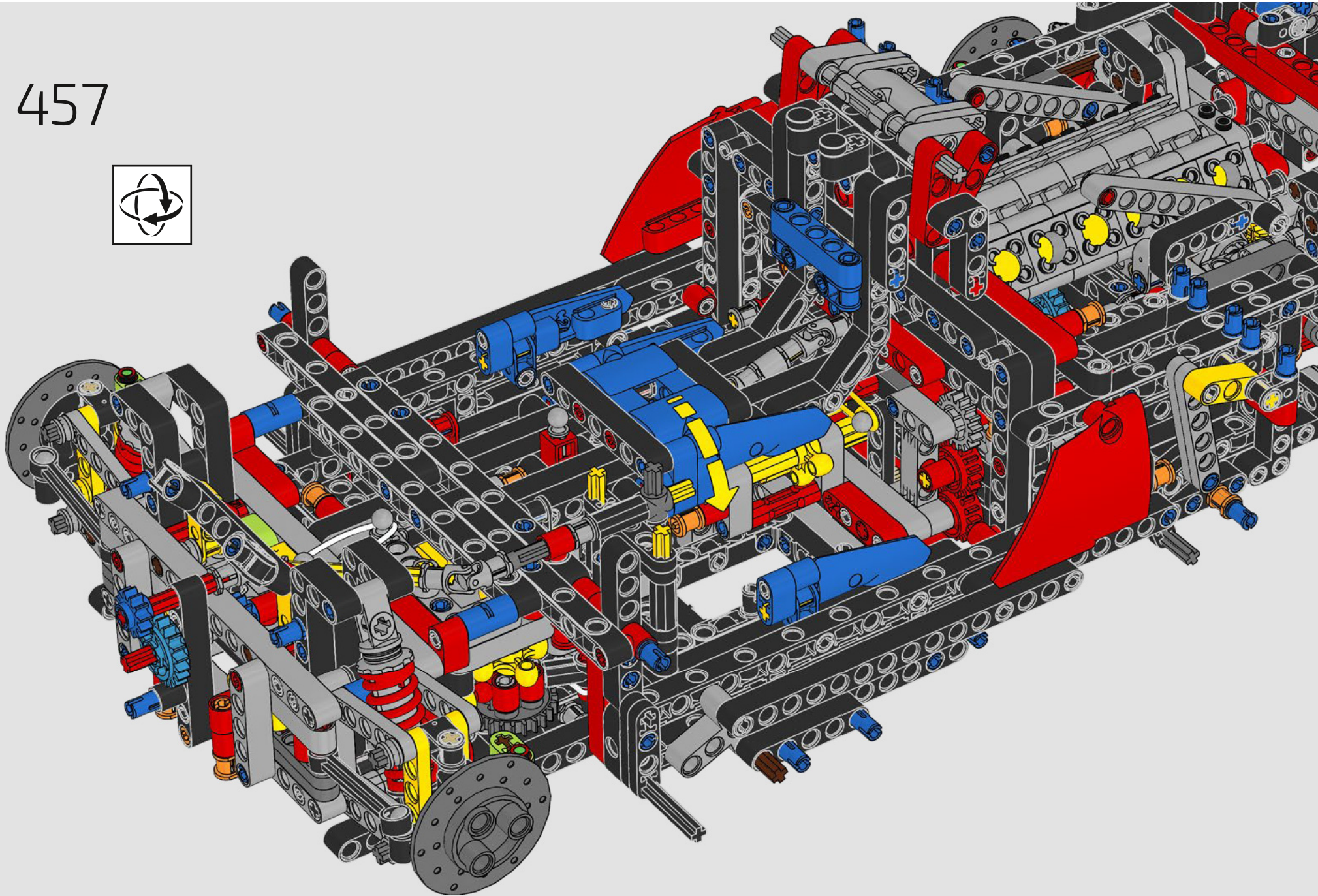



458

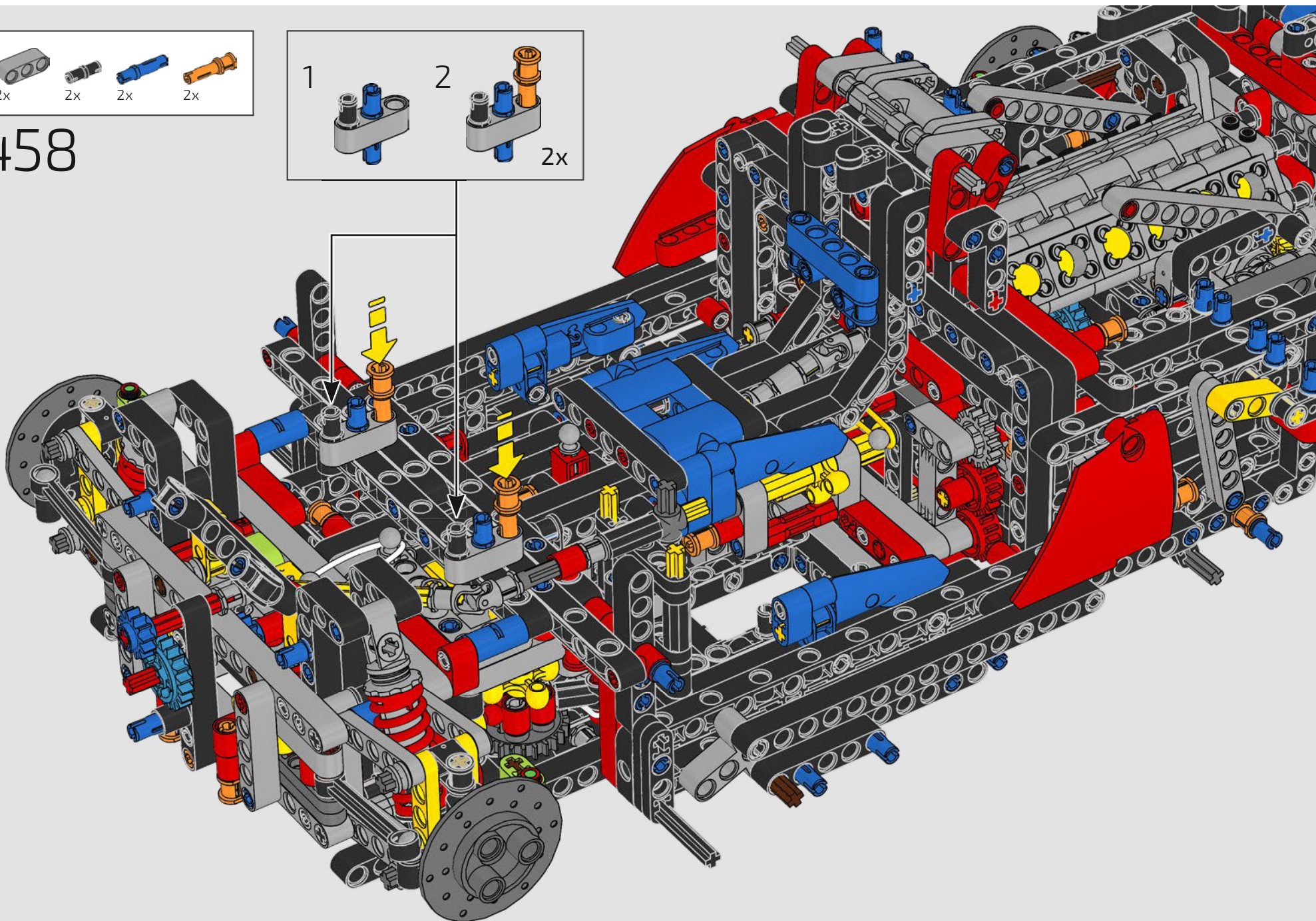
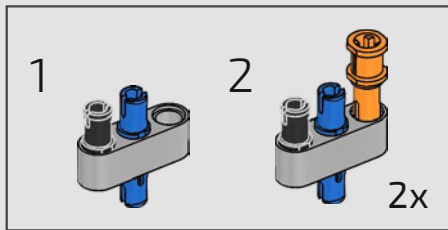

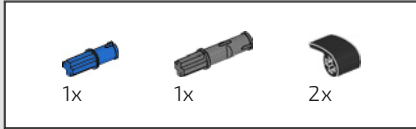

459

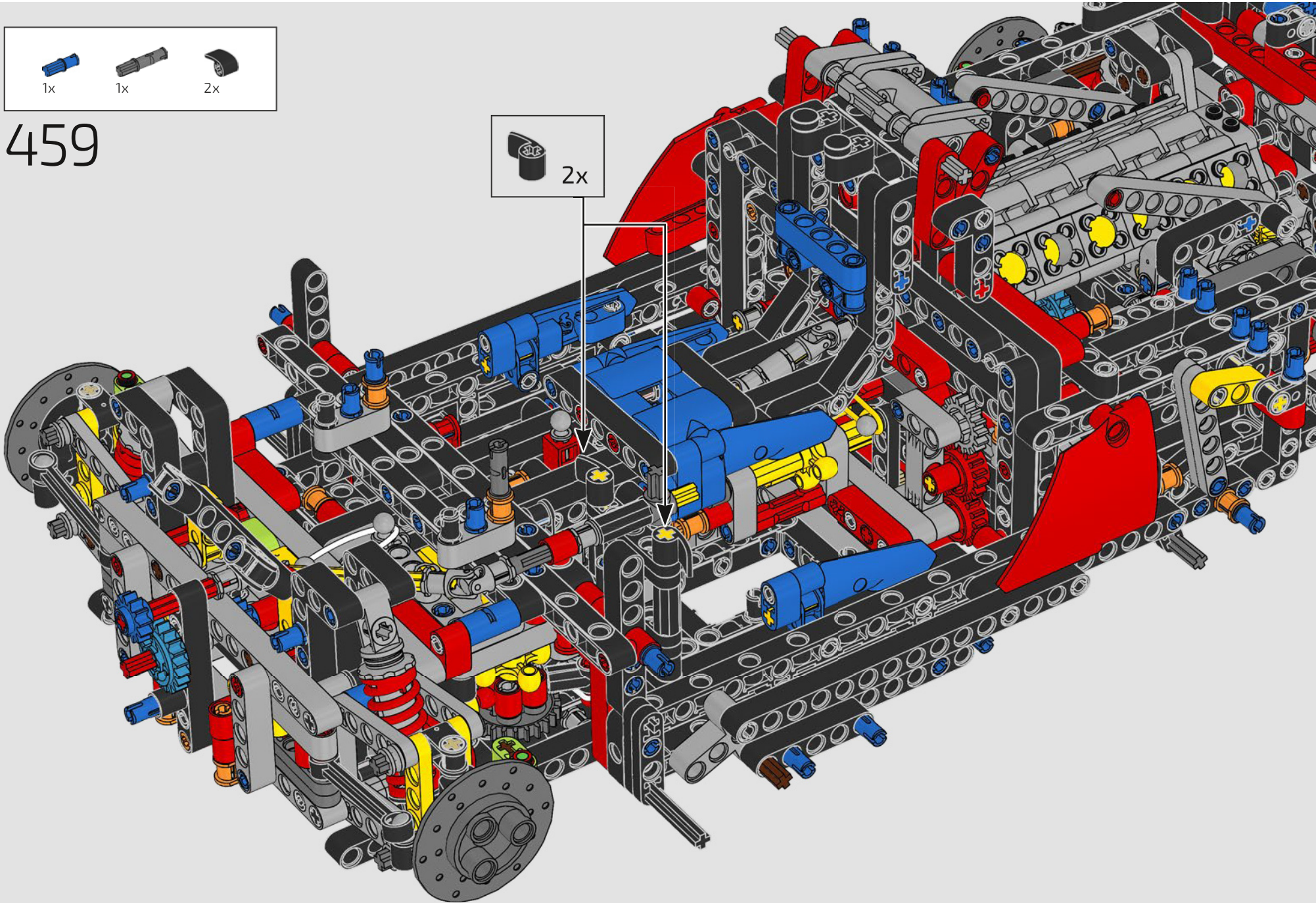

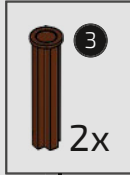
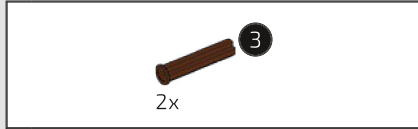

460

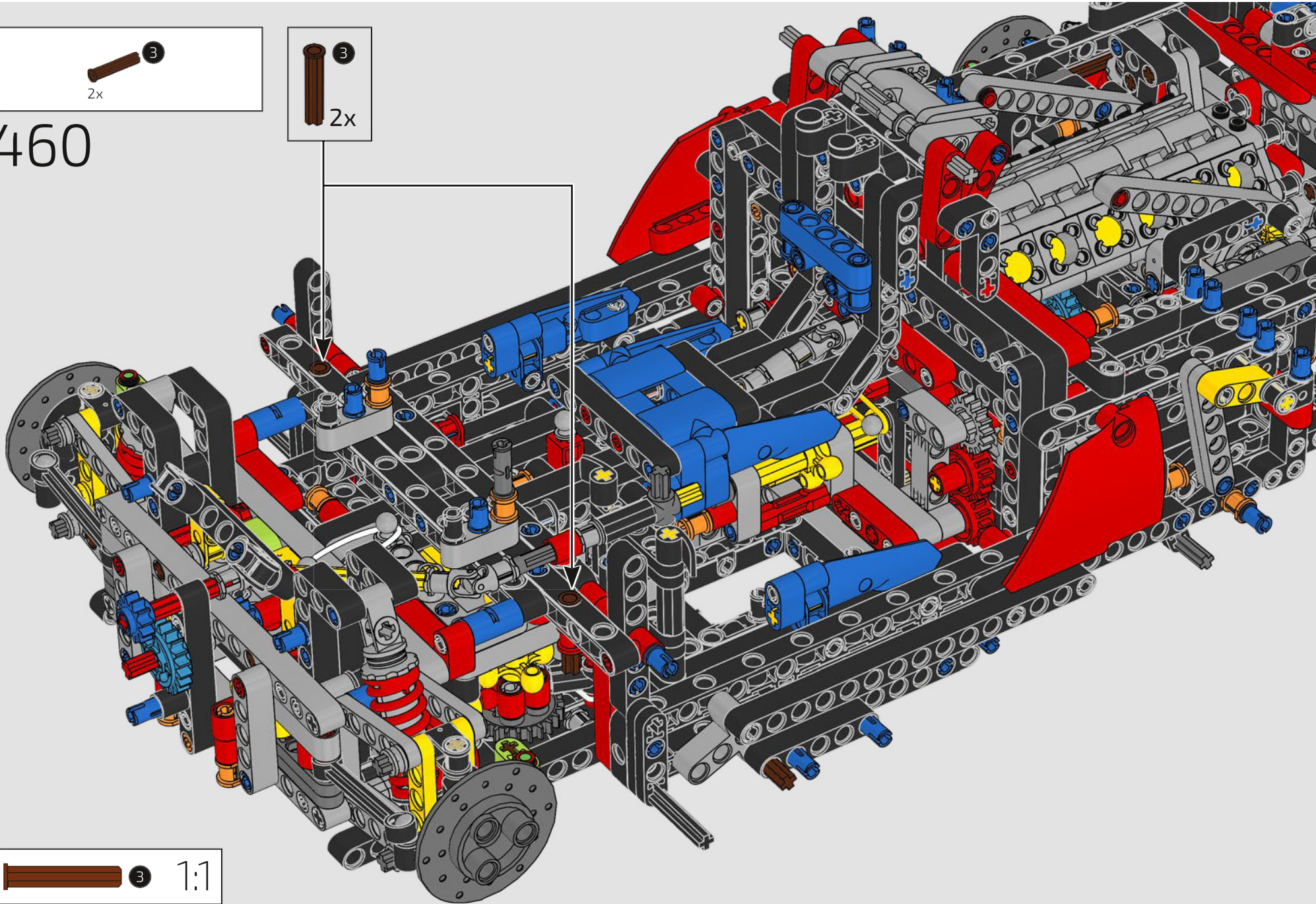

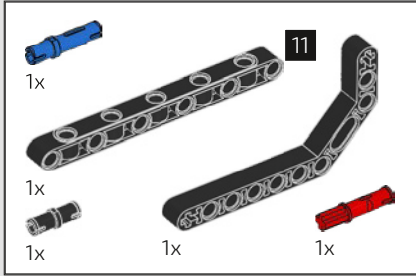

461

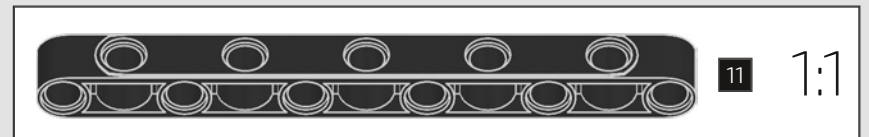
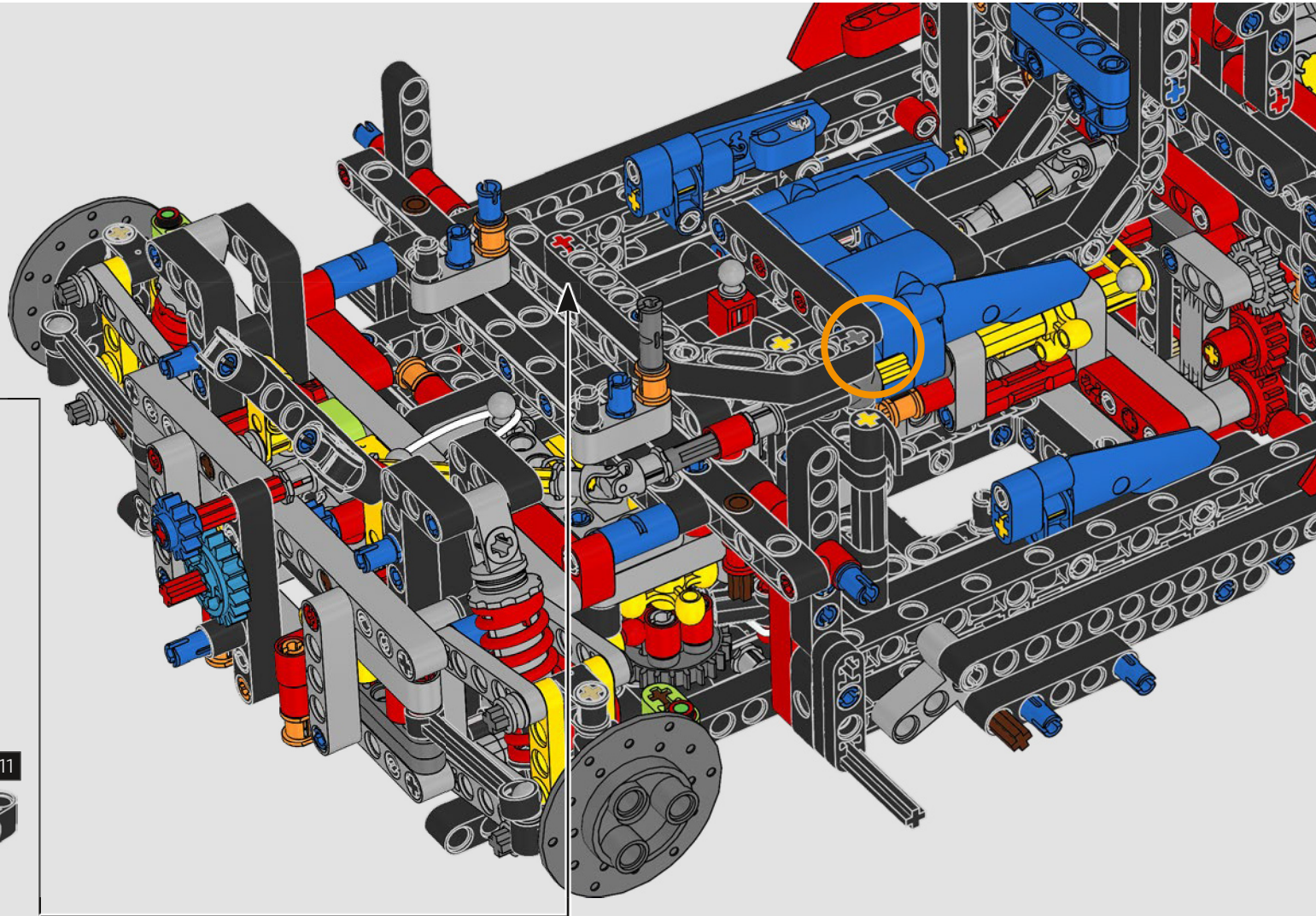
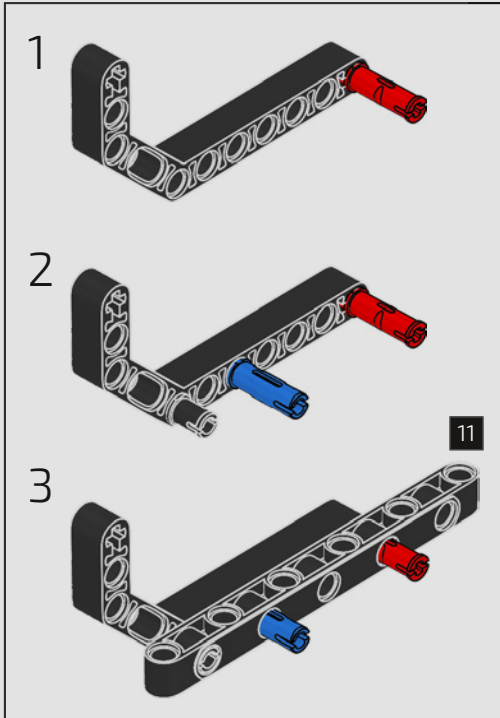

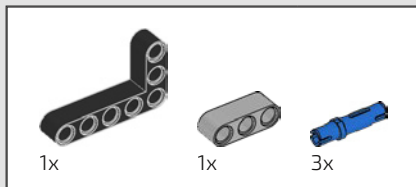

462

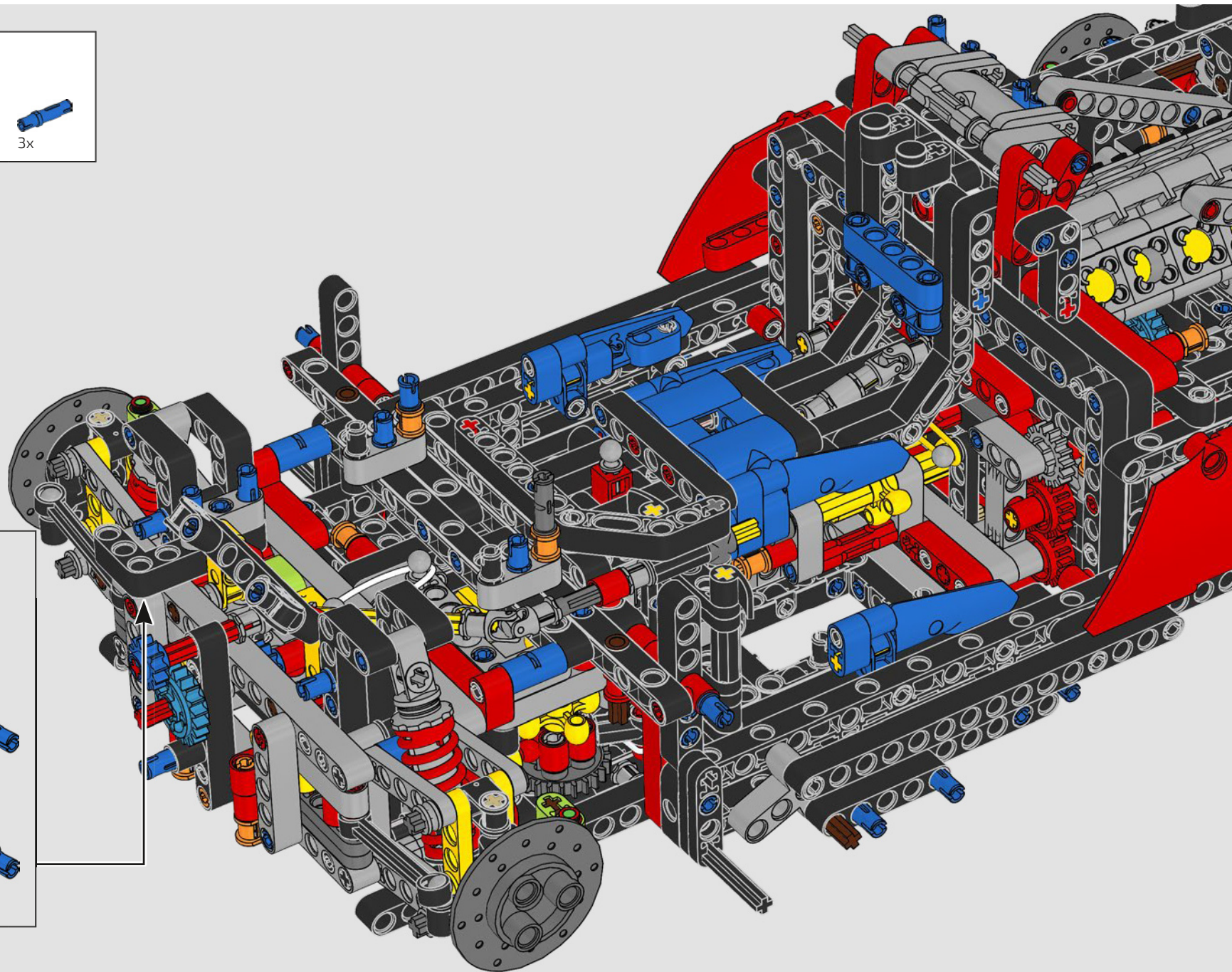
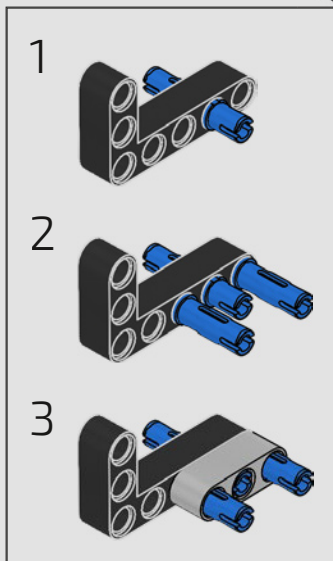

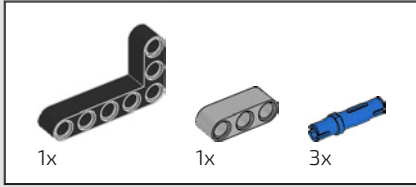

463

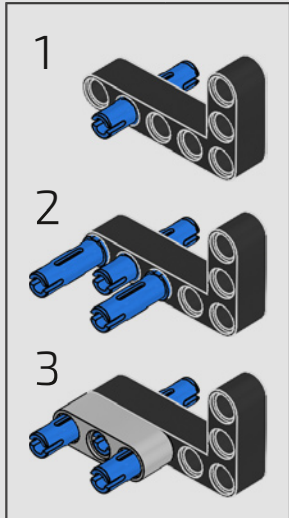
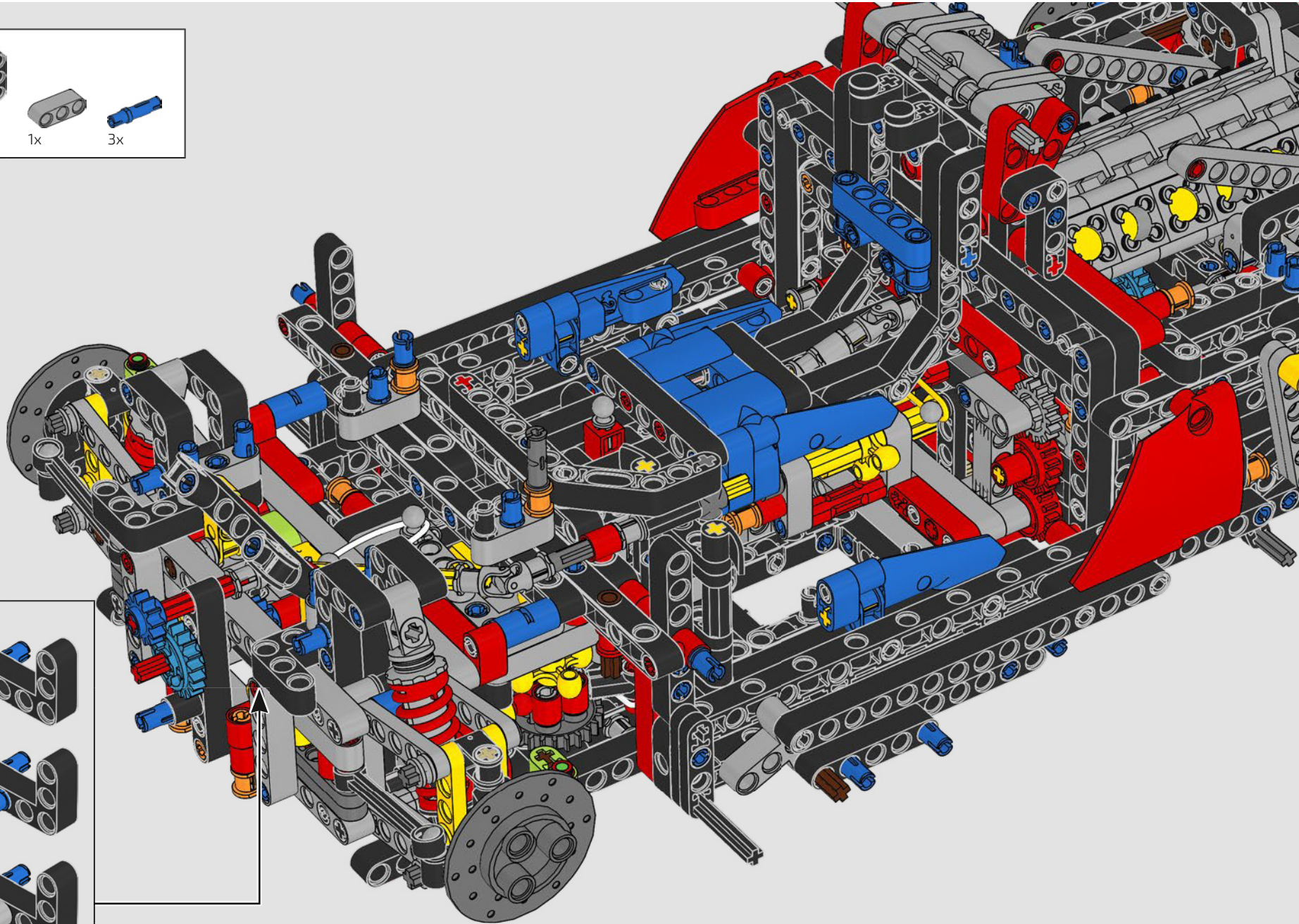

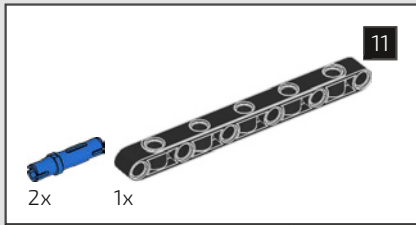

464

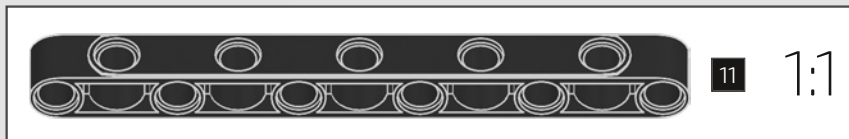
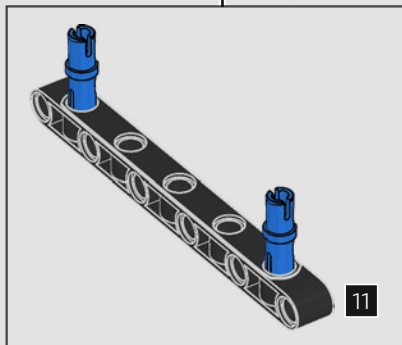
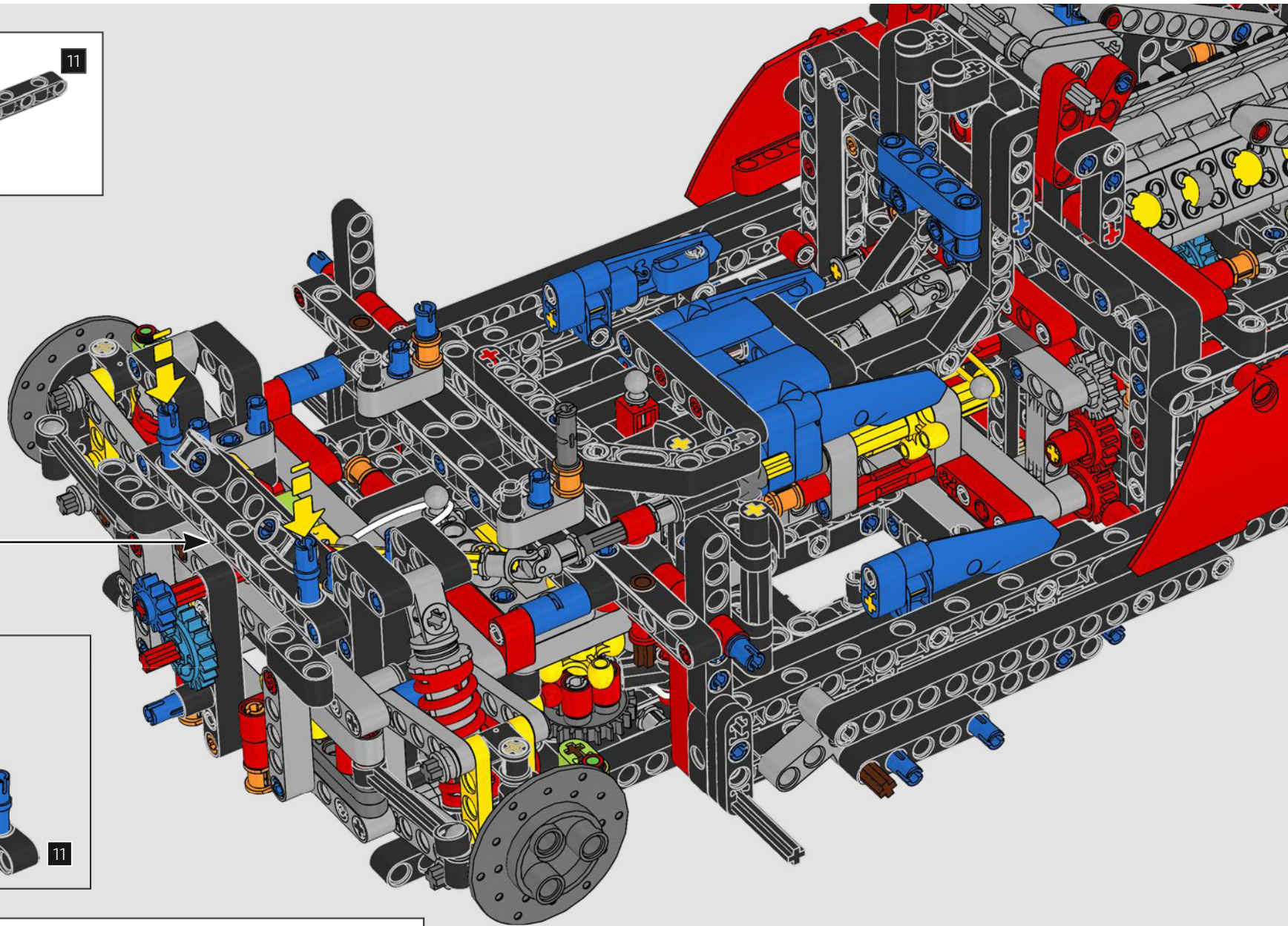



465

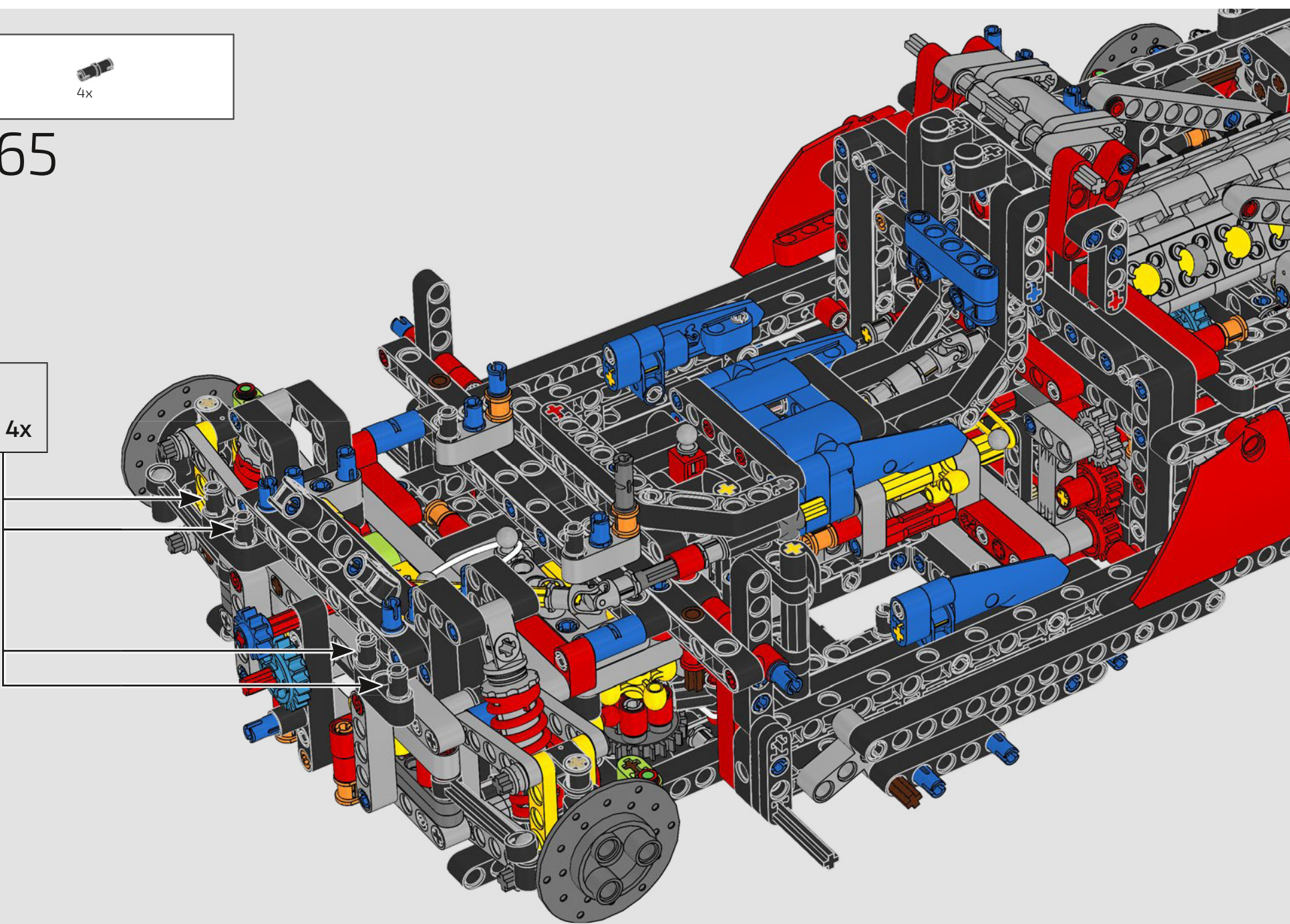

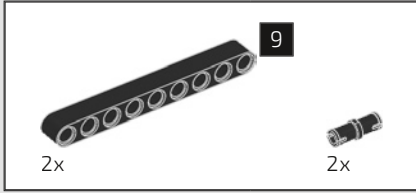

466

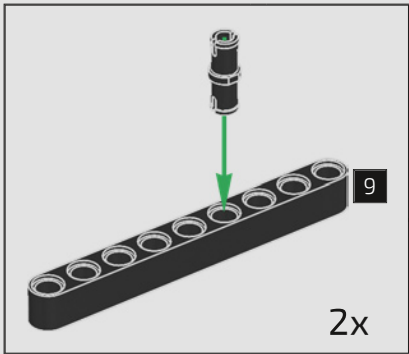
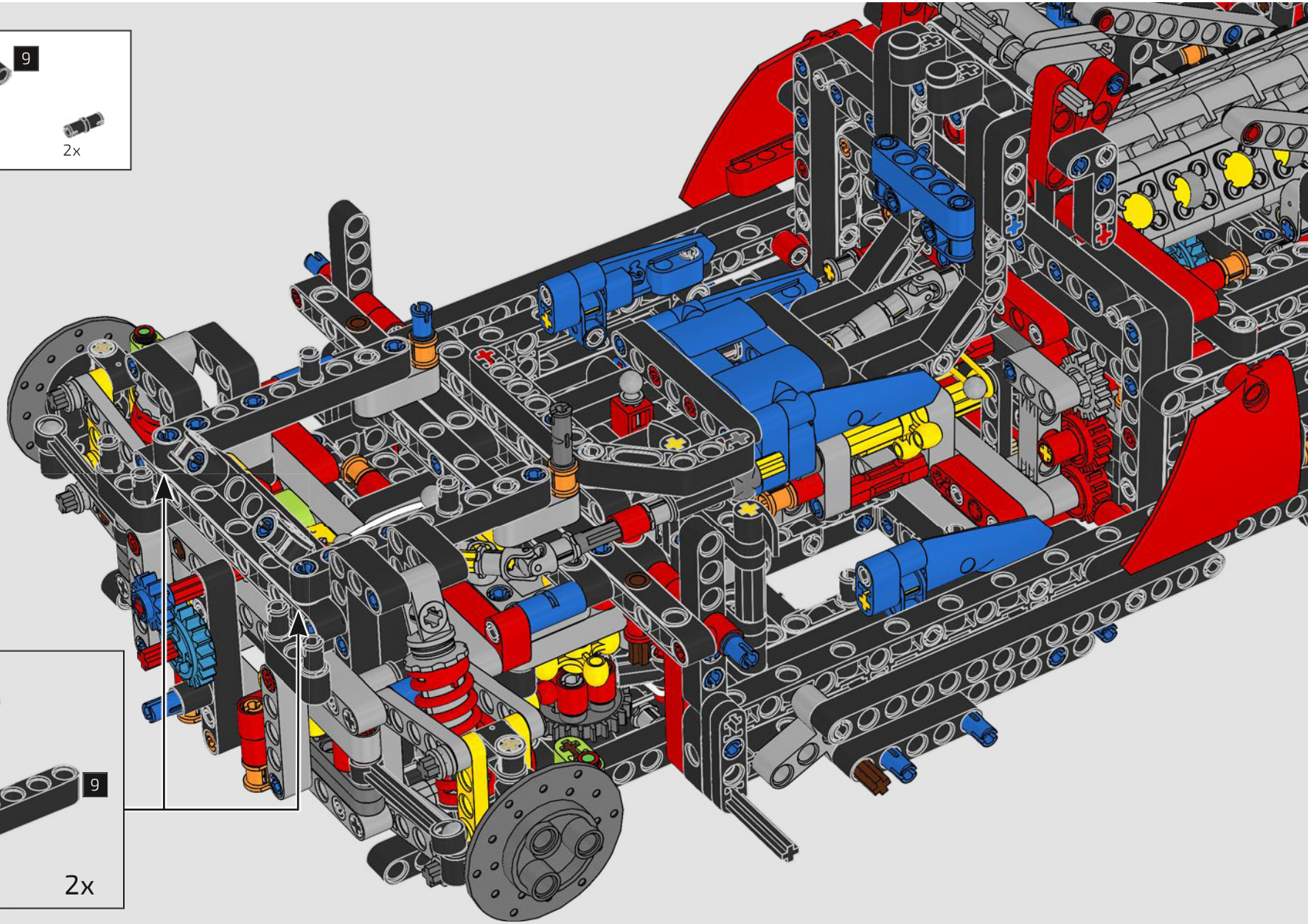

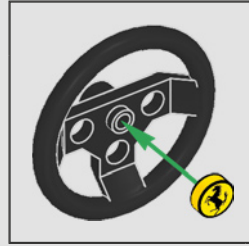

467

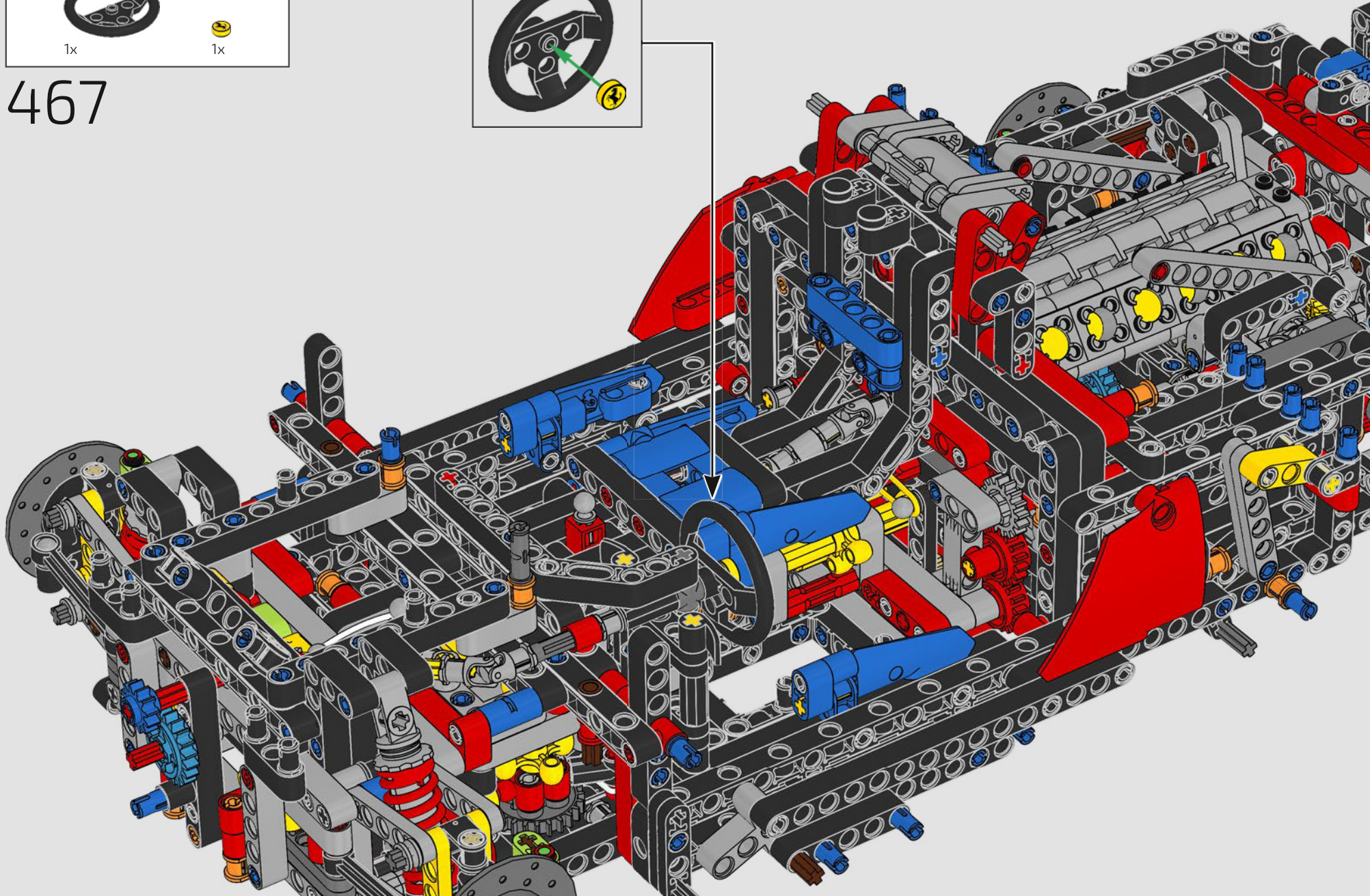

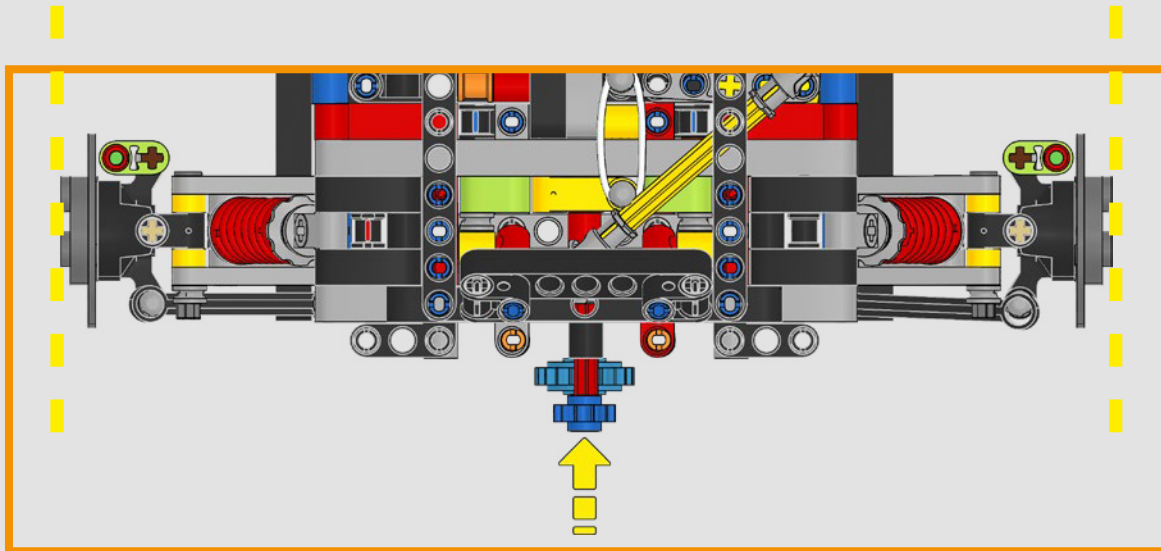
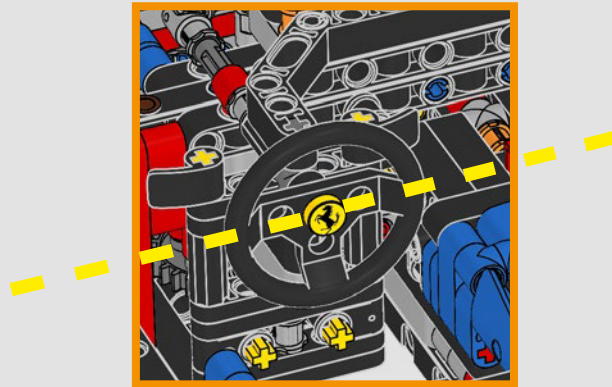

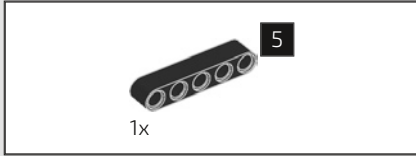

468

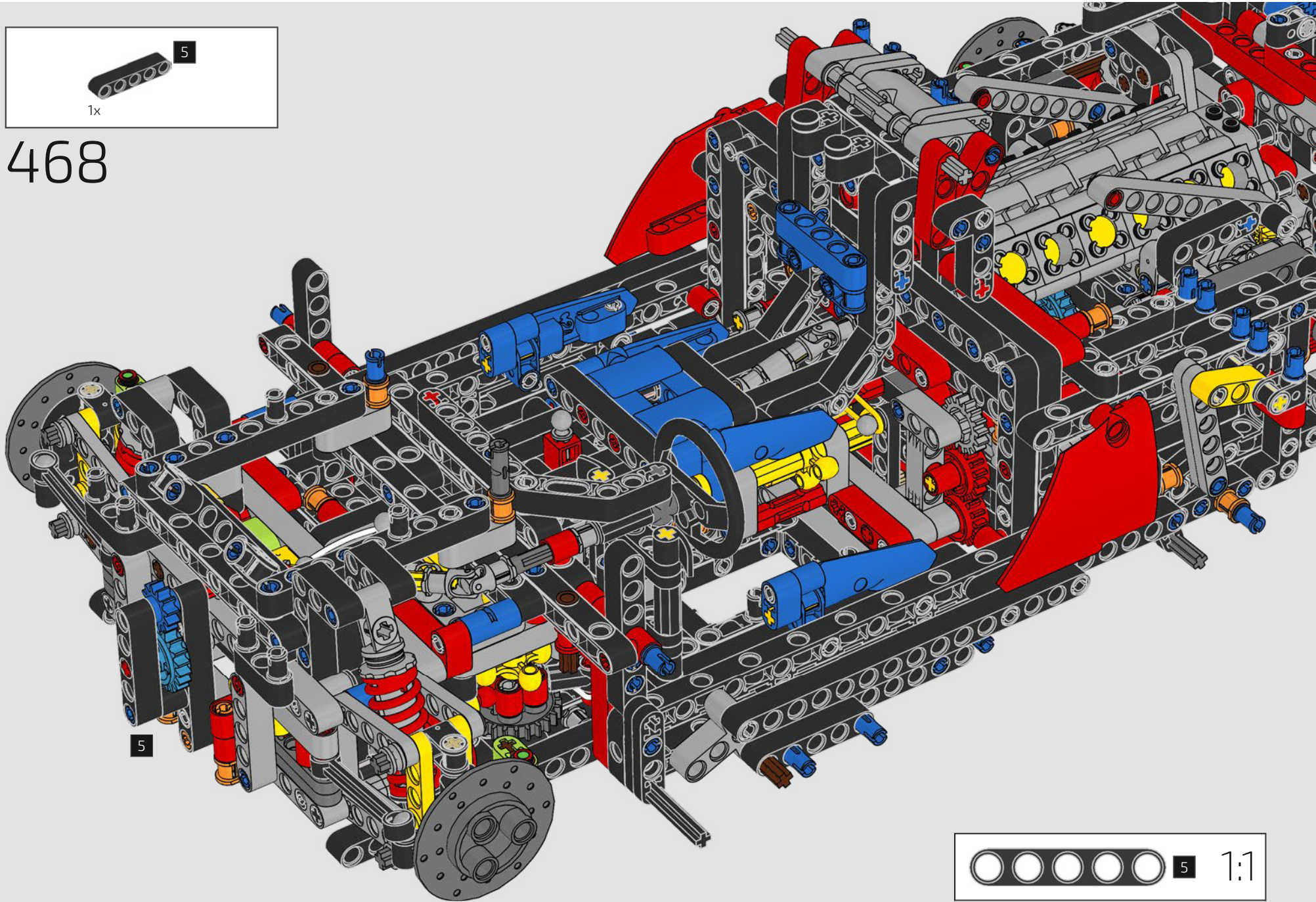

CAR FRONT

AVANT DE LA VOITURE

Now it's about styling and ensuring the front end of your LEGO® Technic™ Ferrari Daytona SP3 has the design lines of the real Ferrari.

Cette étape consiste à donner à la partie avant de votre Ferrari Daytona SP3 LEGO® Technic™ les formes de la vraie Ferrari.



BOX 2 / BOÎTE 2

BAG 4 / SACHET 4



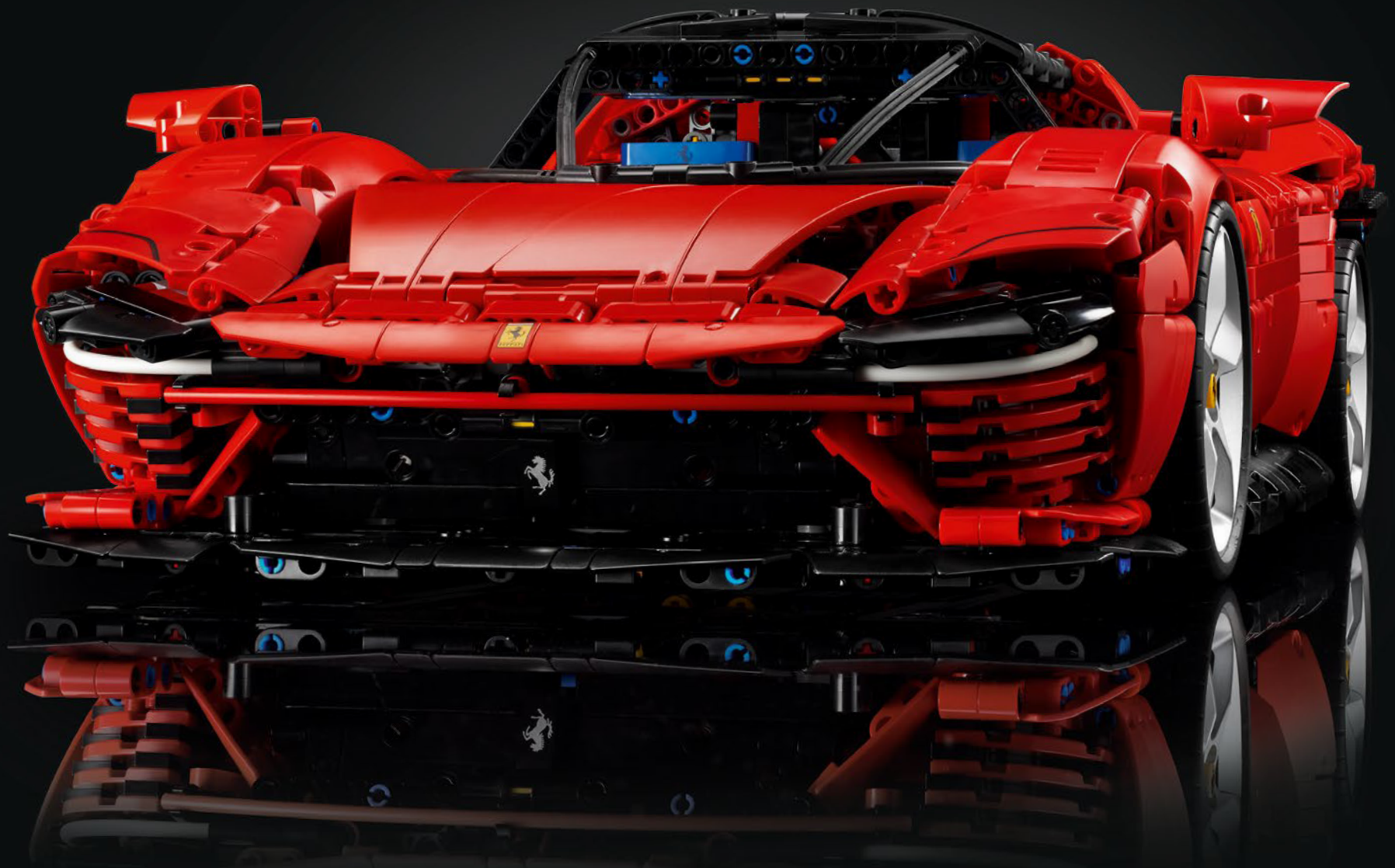

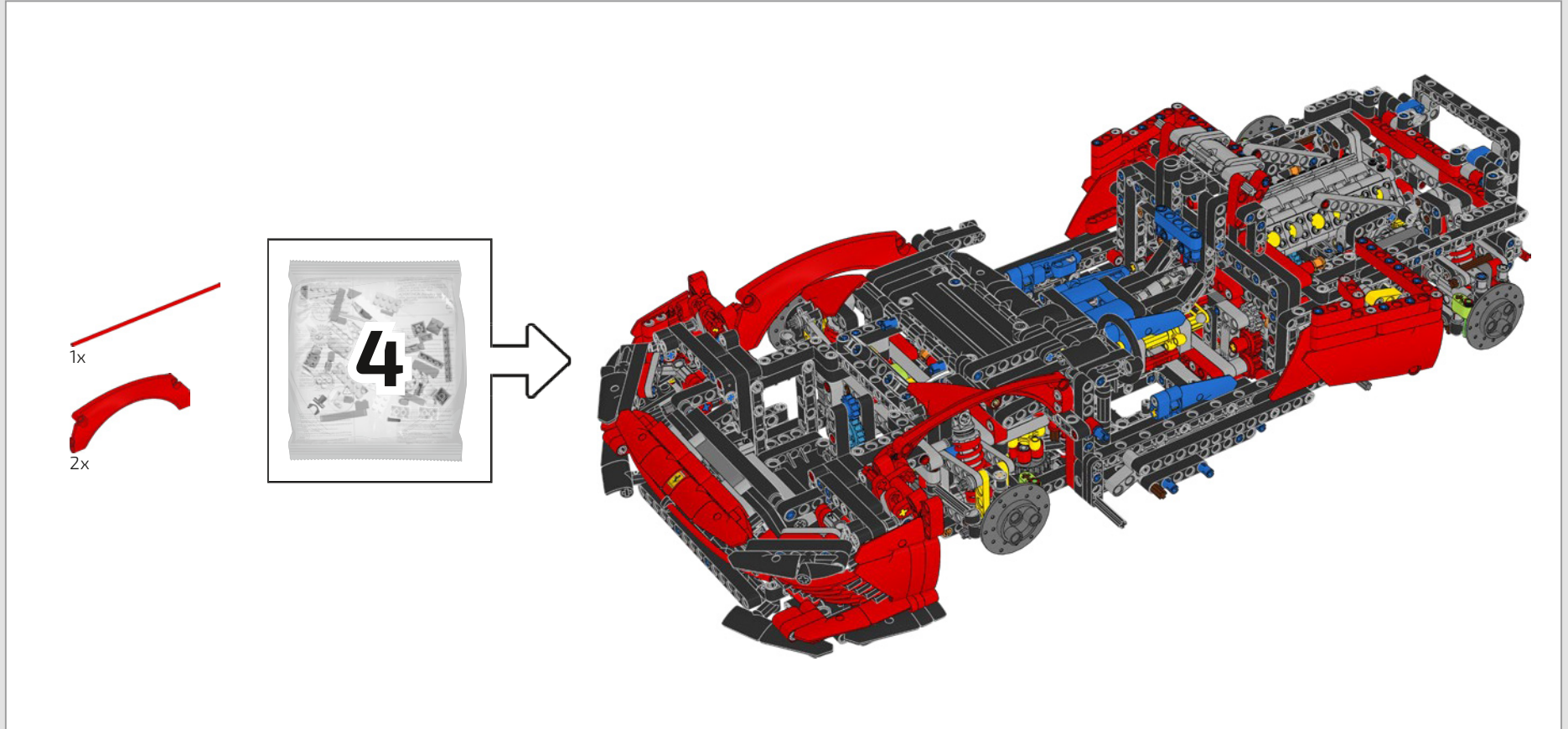

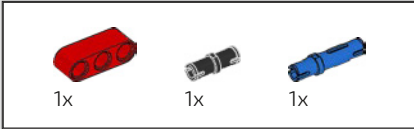
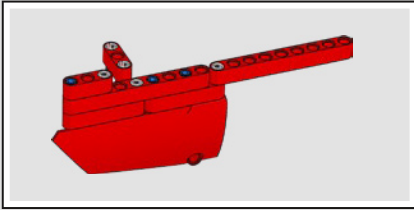

469

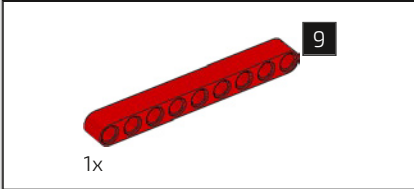
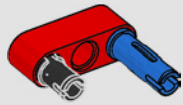

470

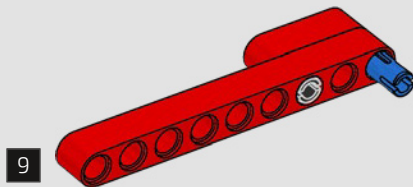

471

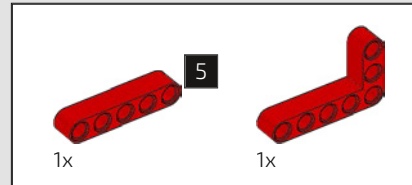
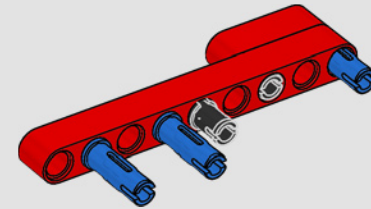

472

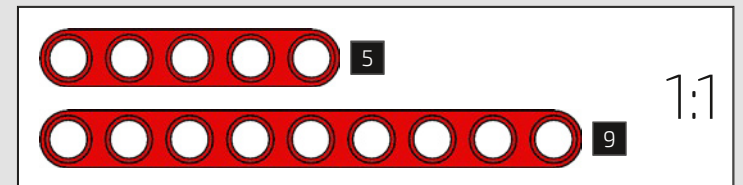
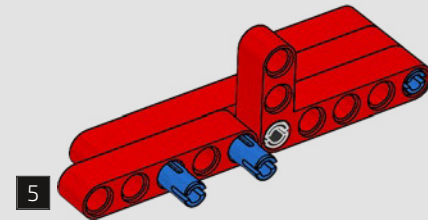

1:1

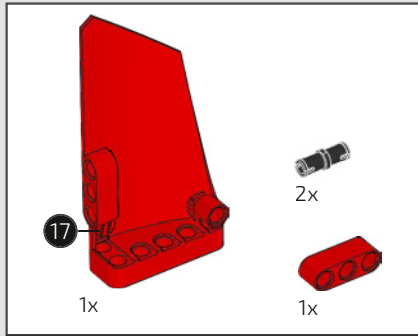

473

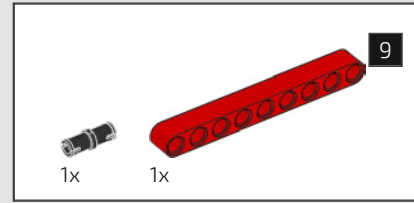
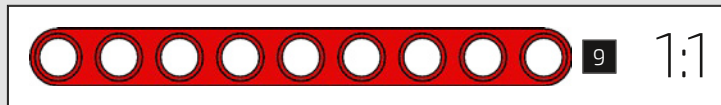
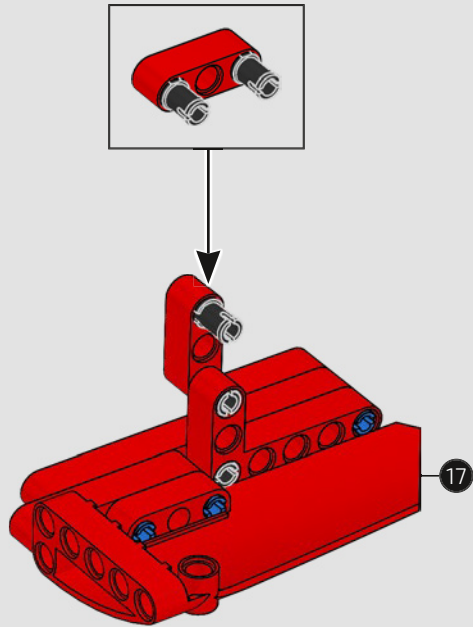

474

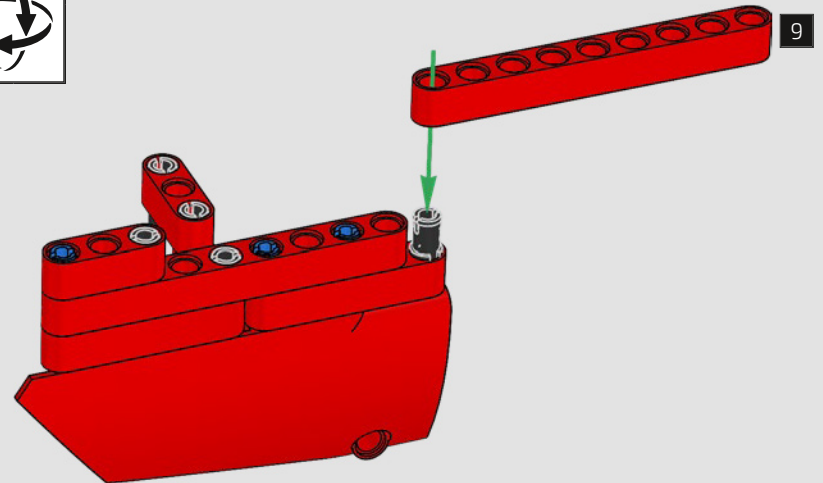

475

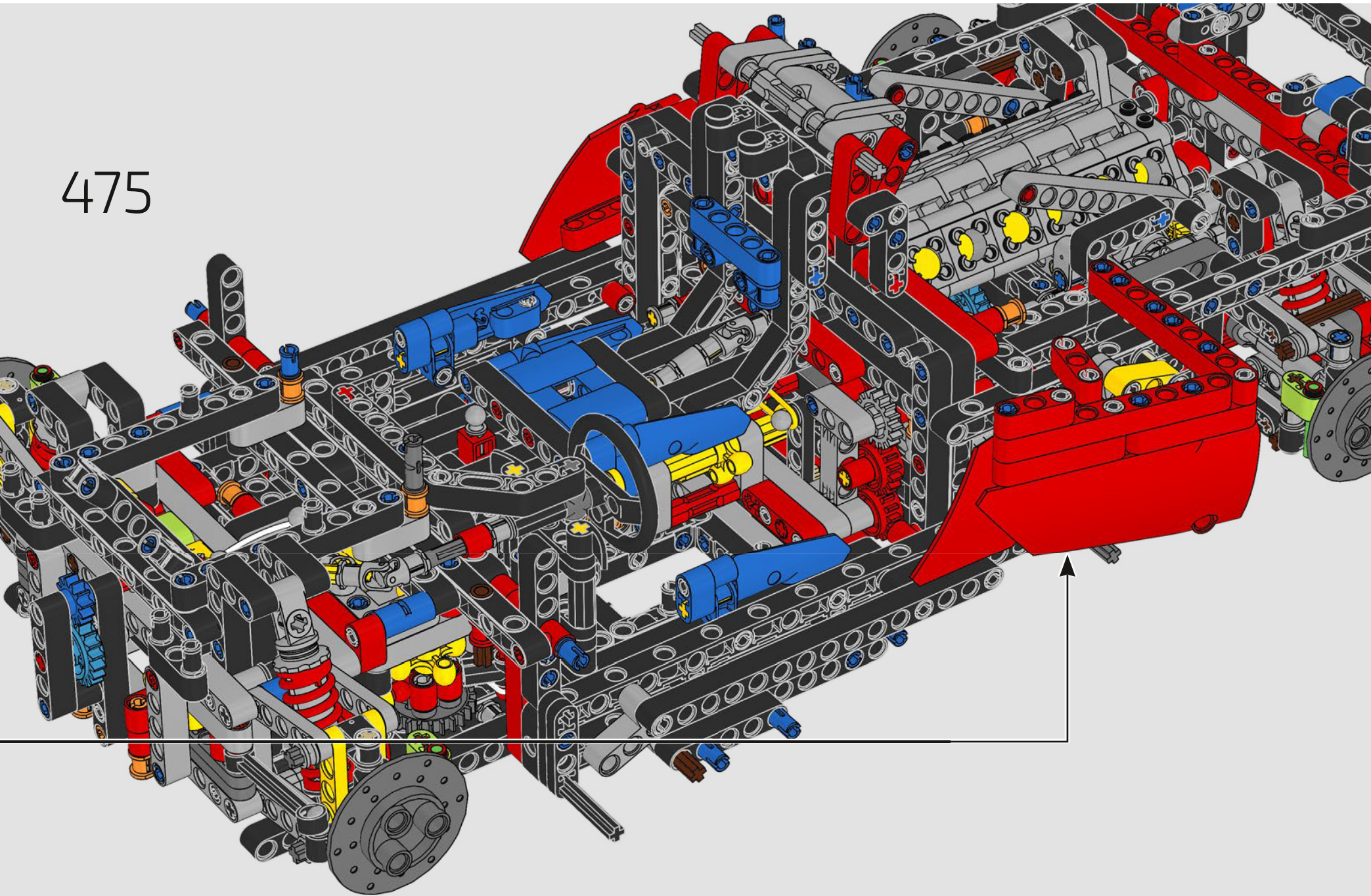

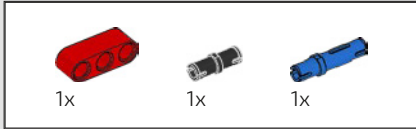
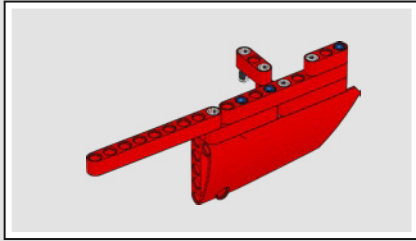

476

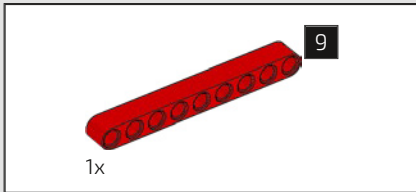
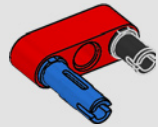

477

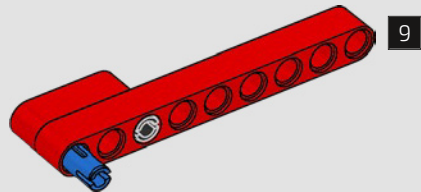

478

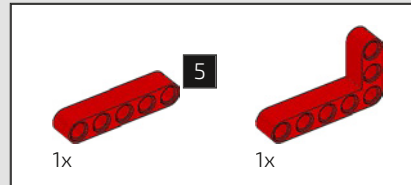
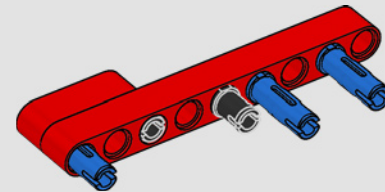

479

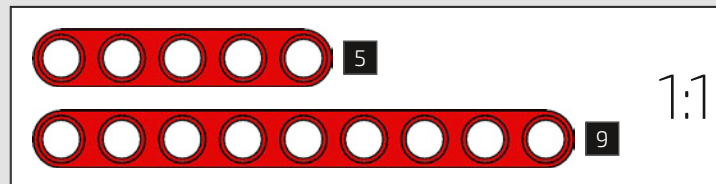
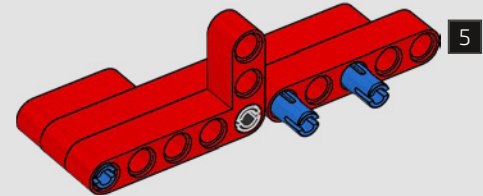

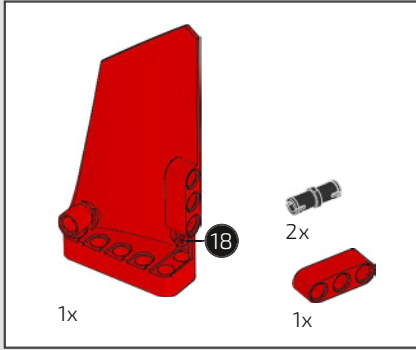

480

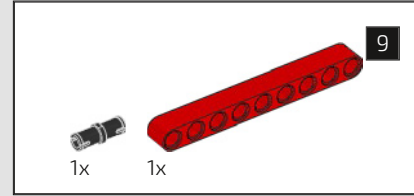
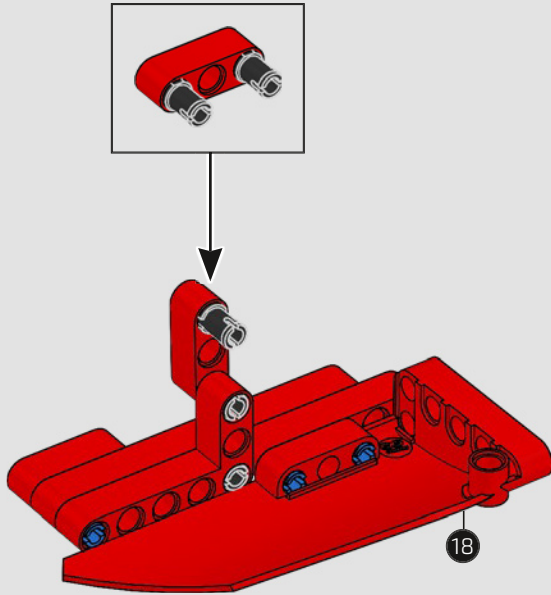

481

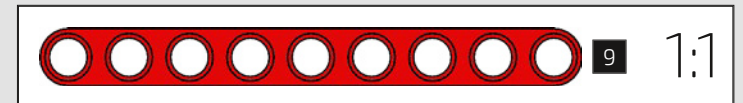
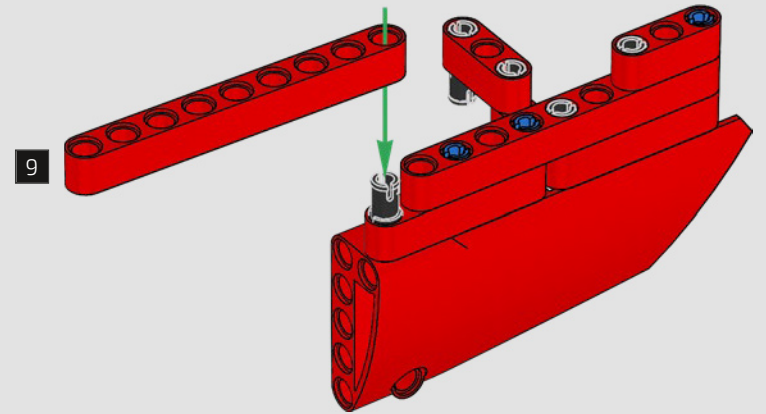

482

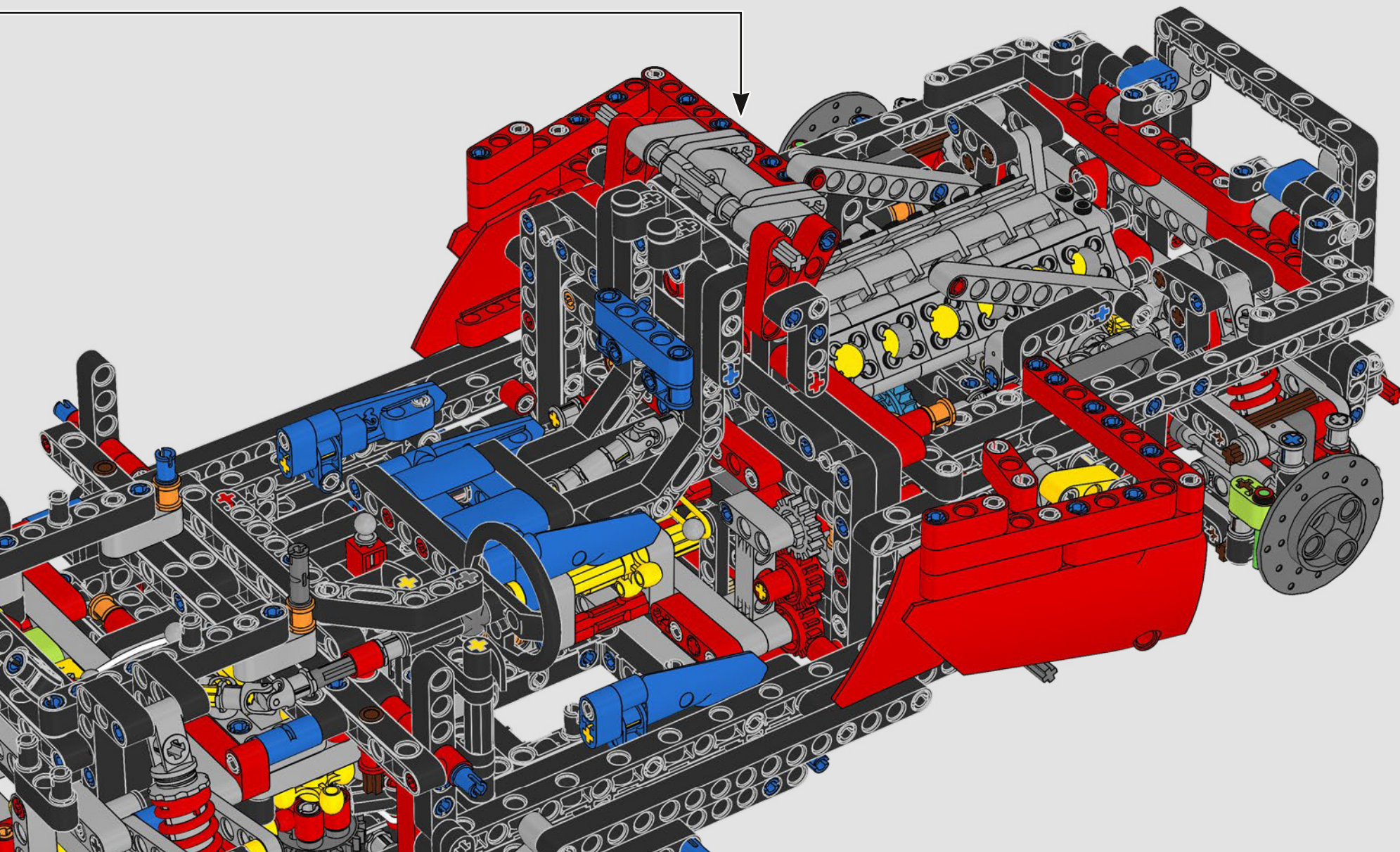

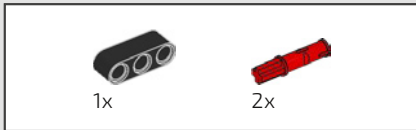
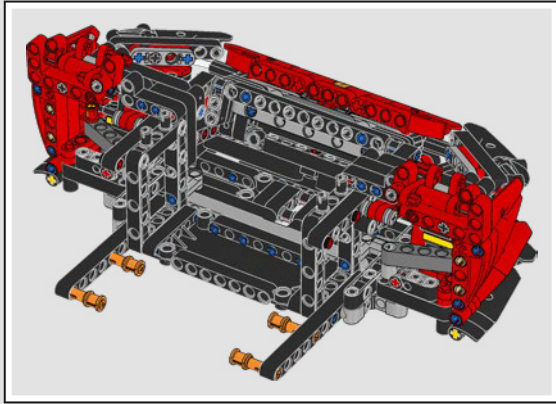

483

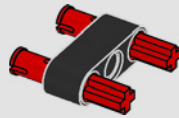

484

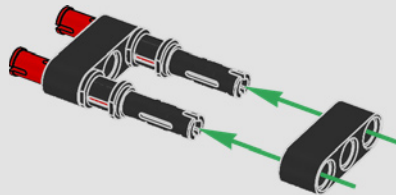

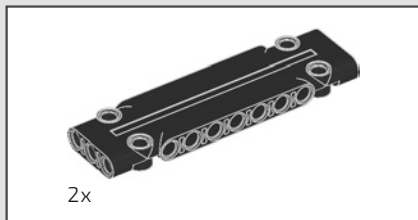

485

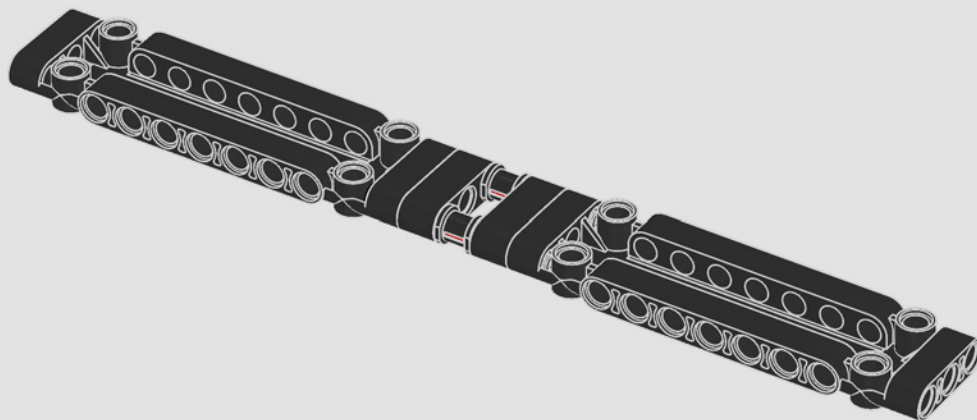

486

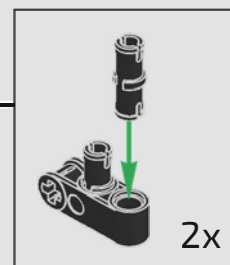
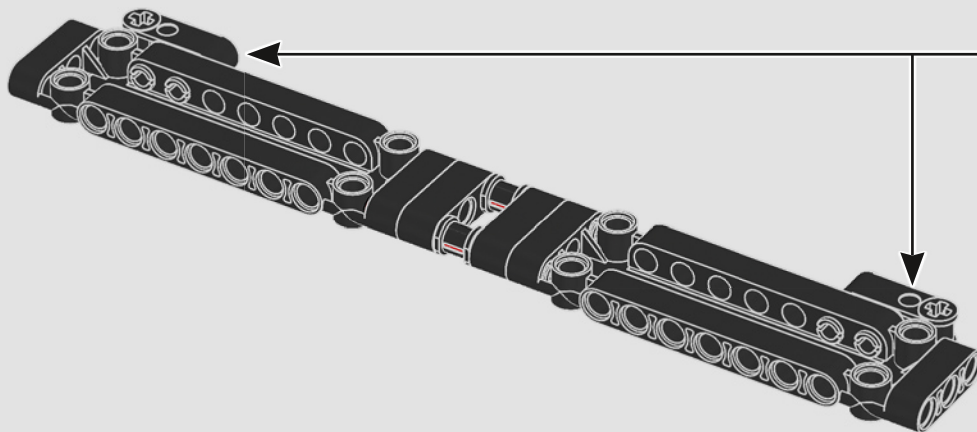



487

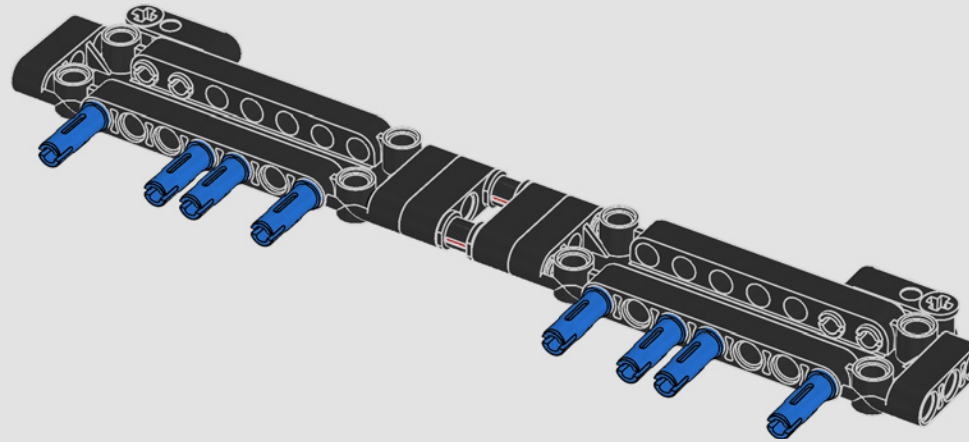

488

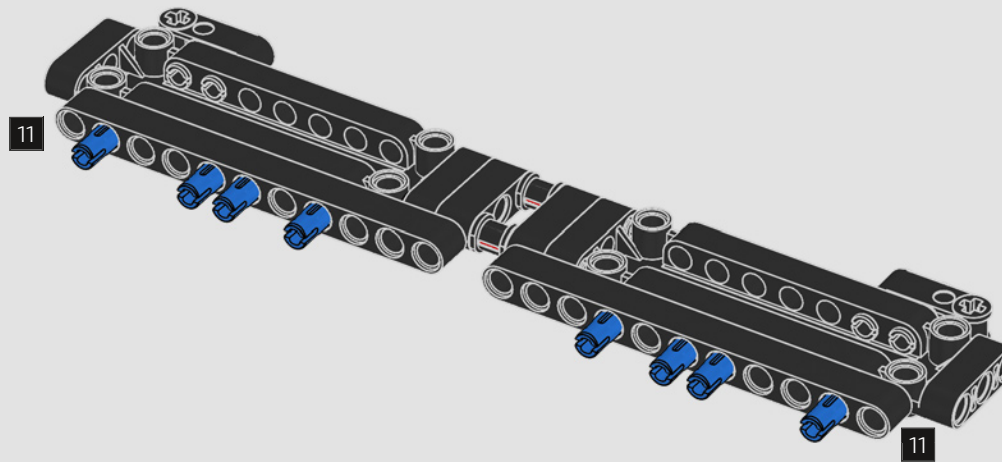

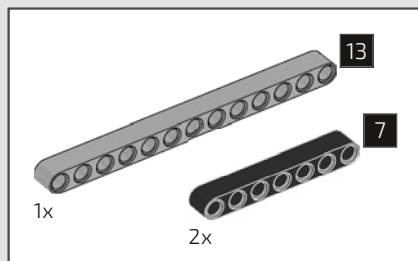

489

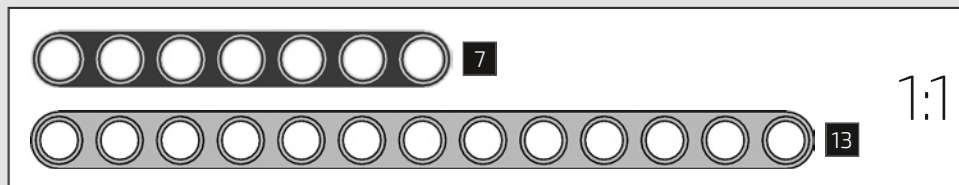
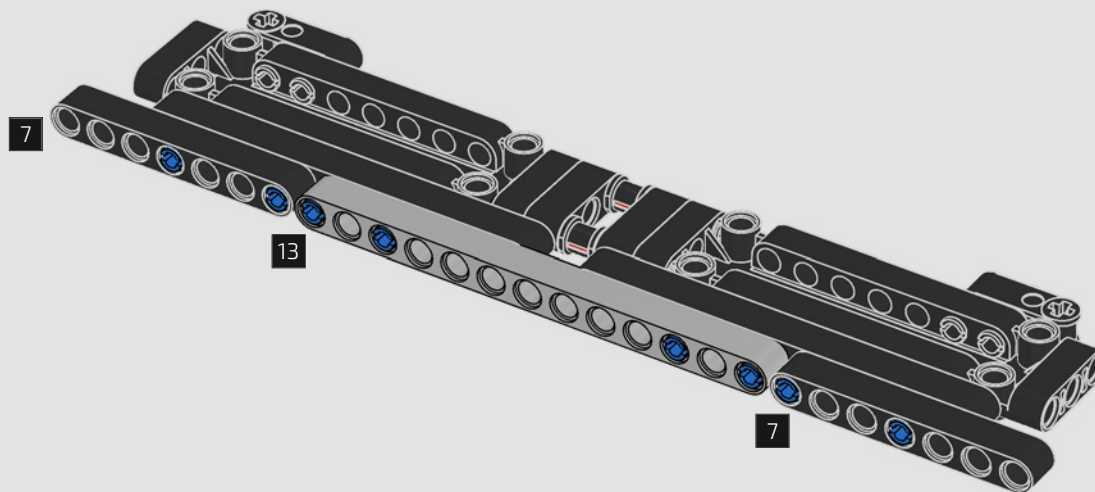



490

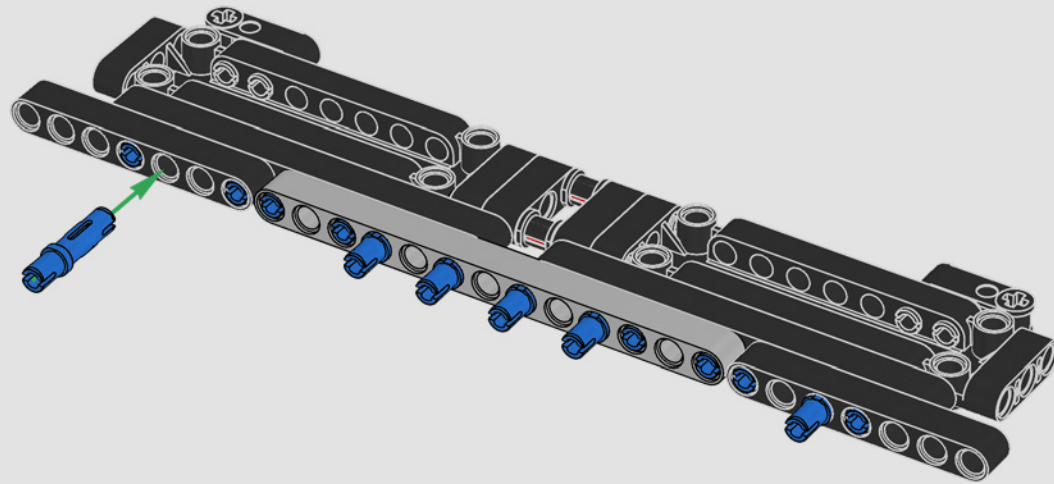

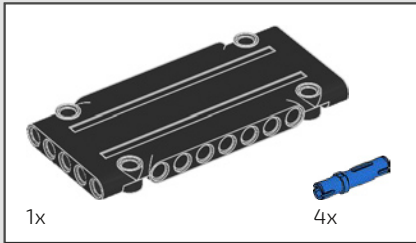
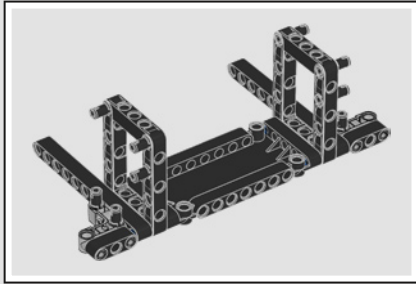

491

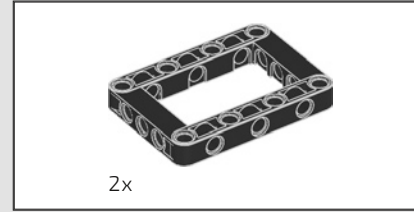
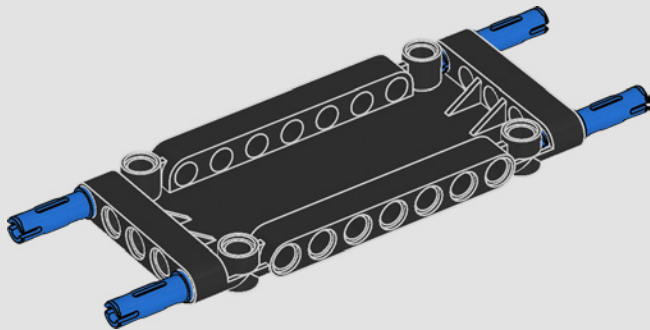

492

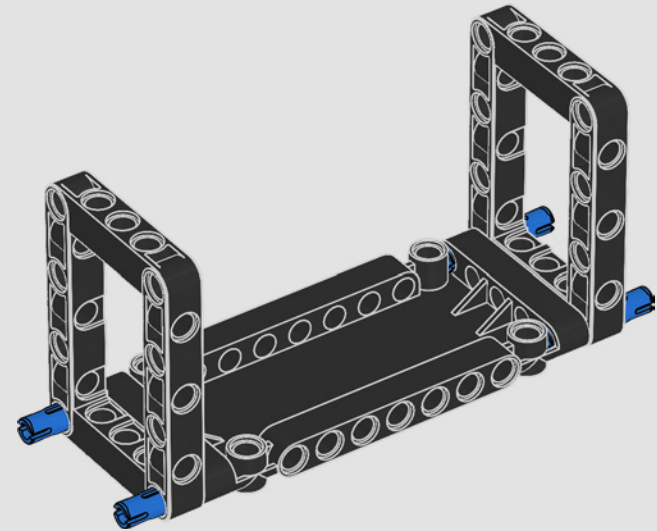

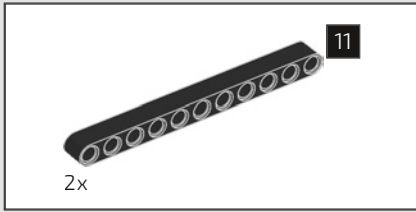

493

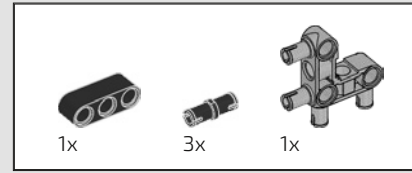
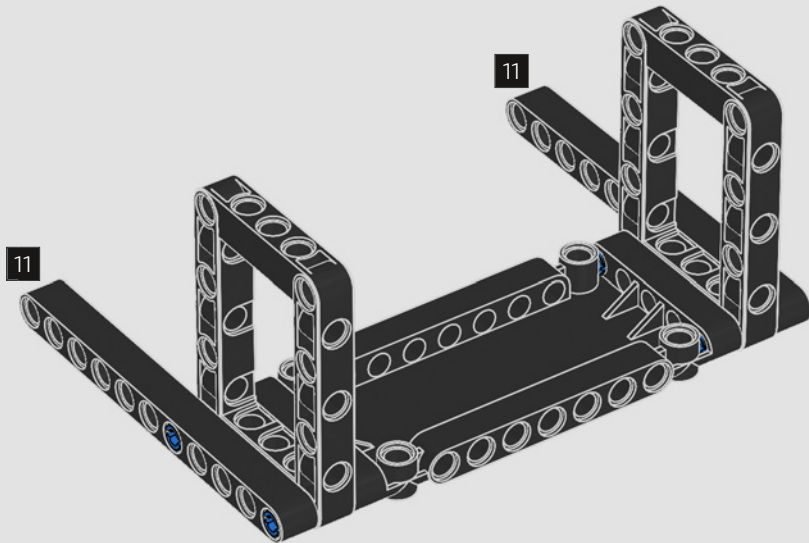

494

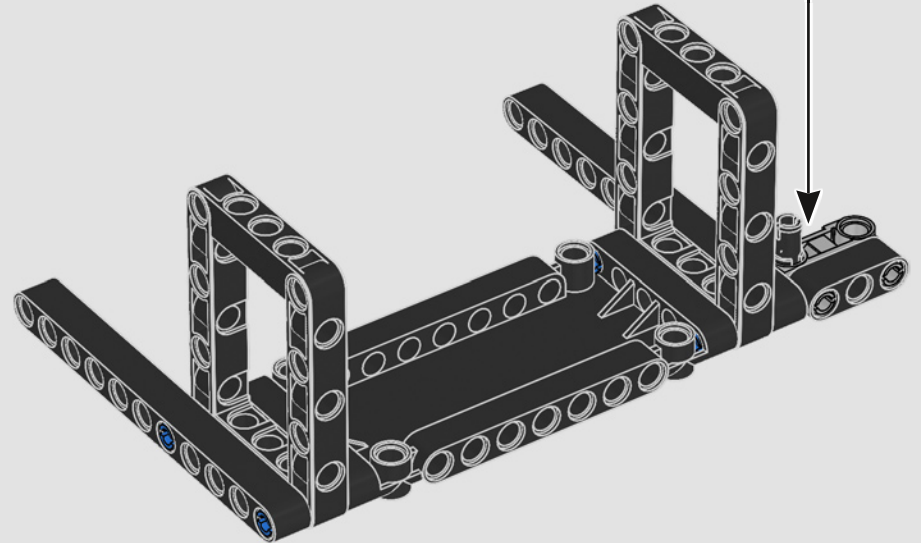
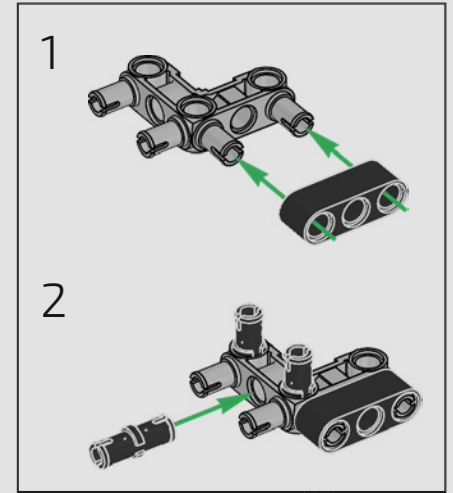

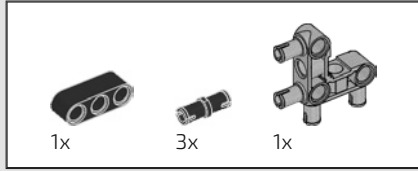

495

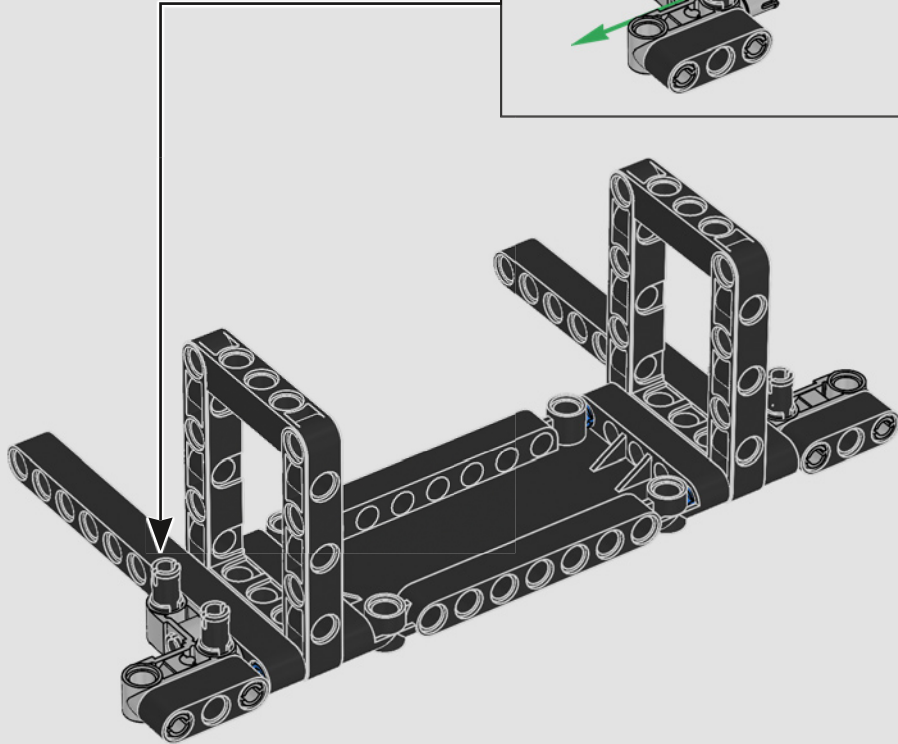
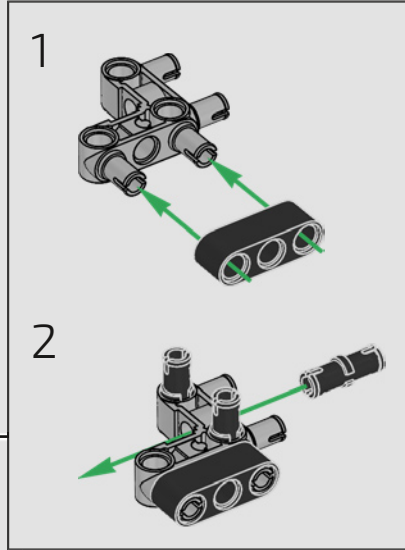

496

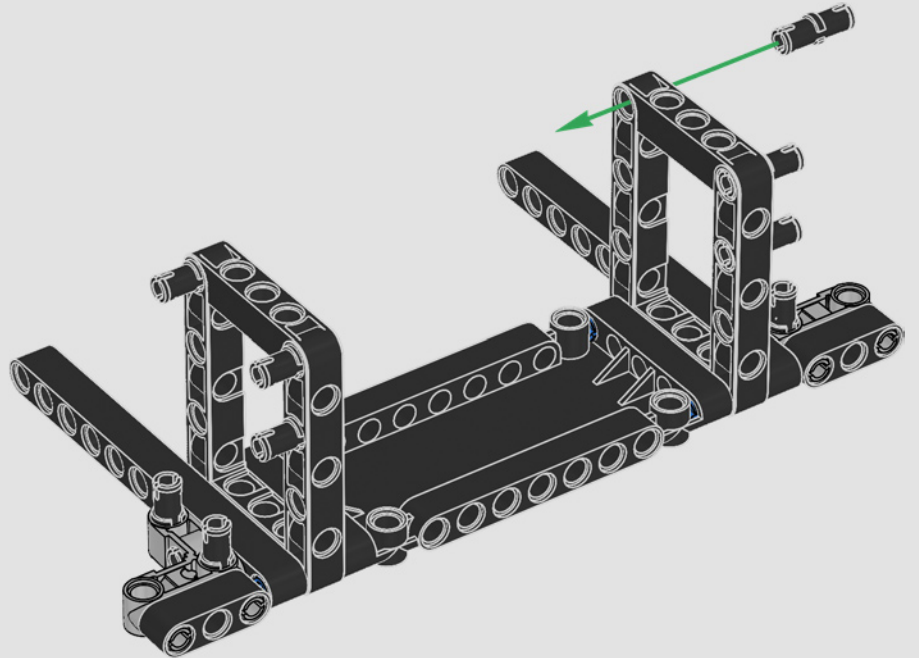

497

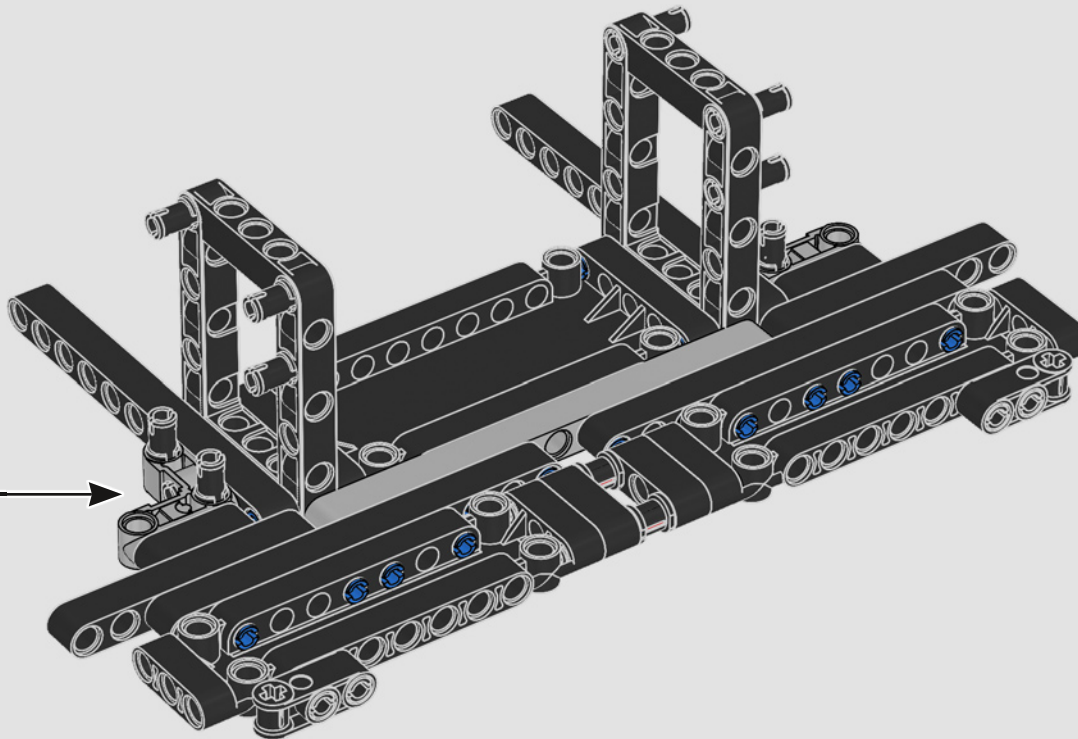

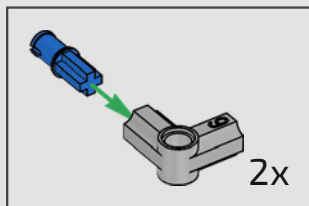
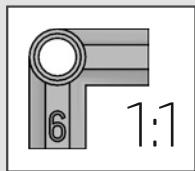
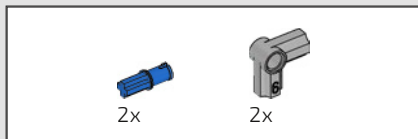

498

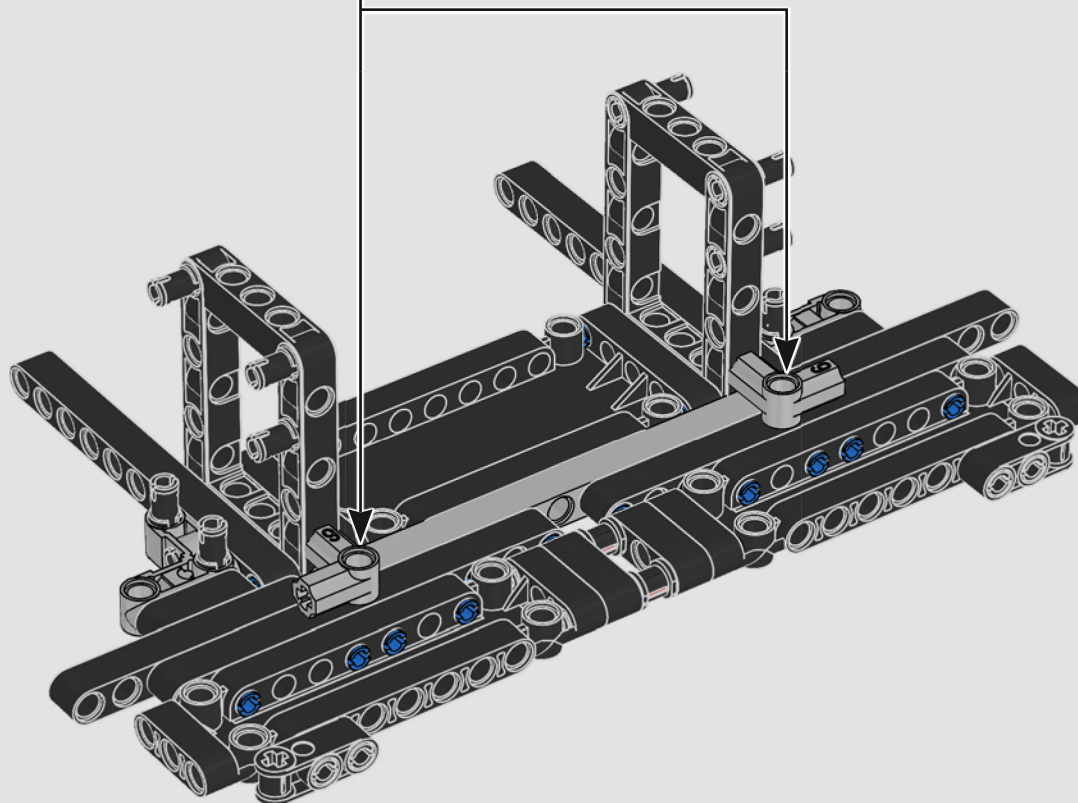

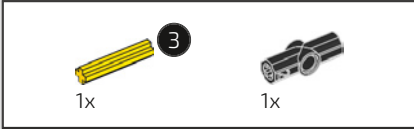
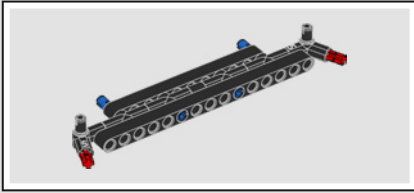

499

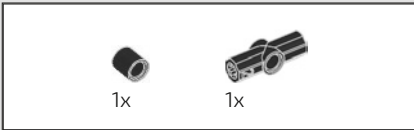
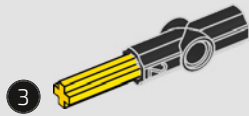

500

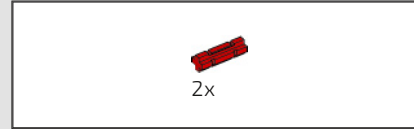
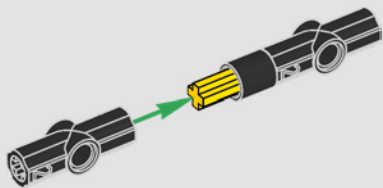

501

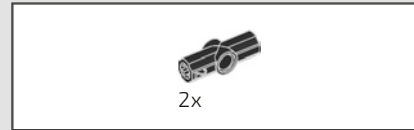
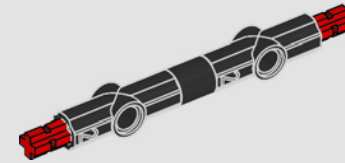

502

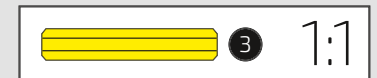
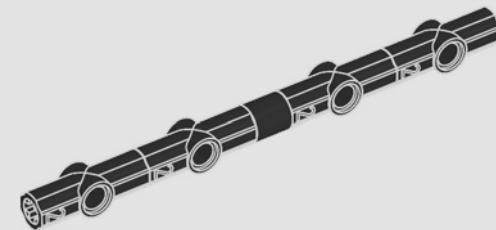

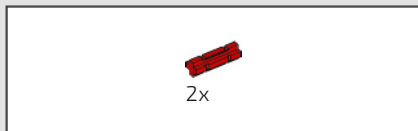

503

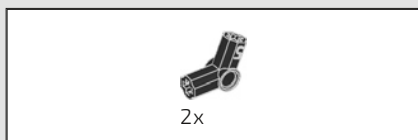
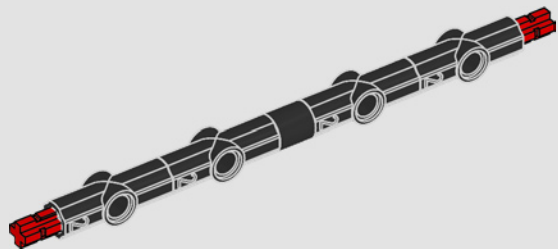

504

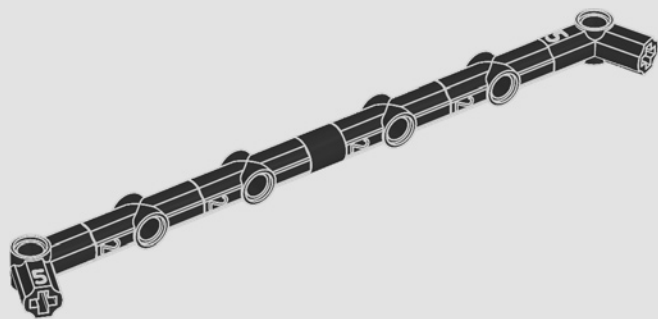

505

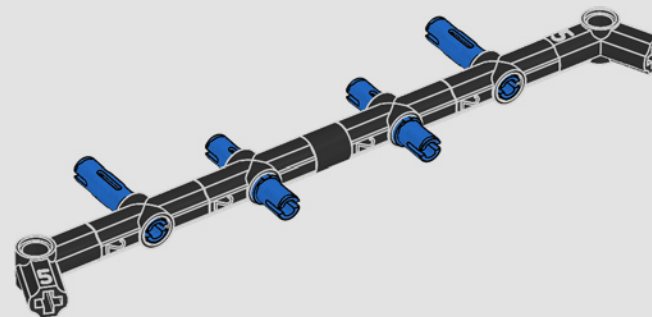

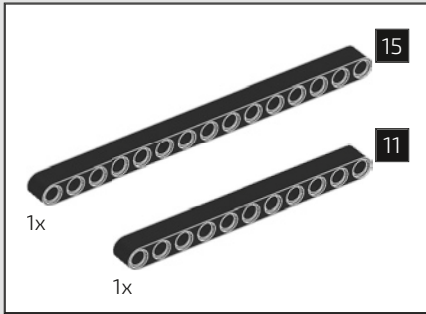

506

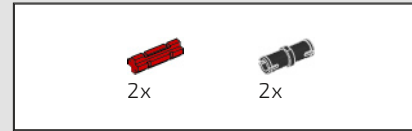
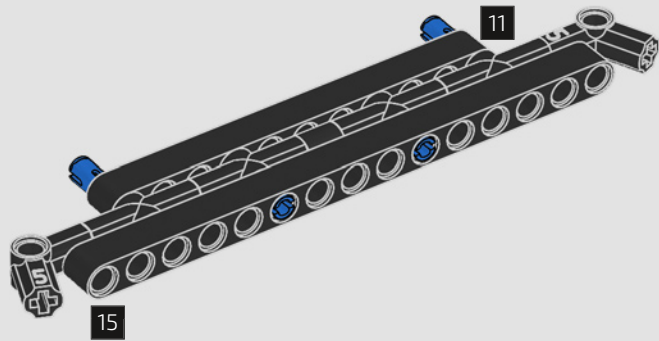

507

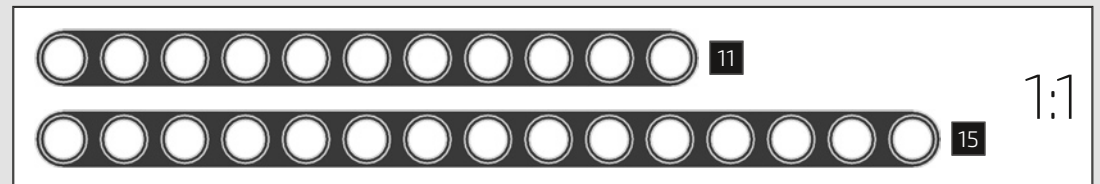
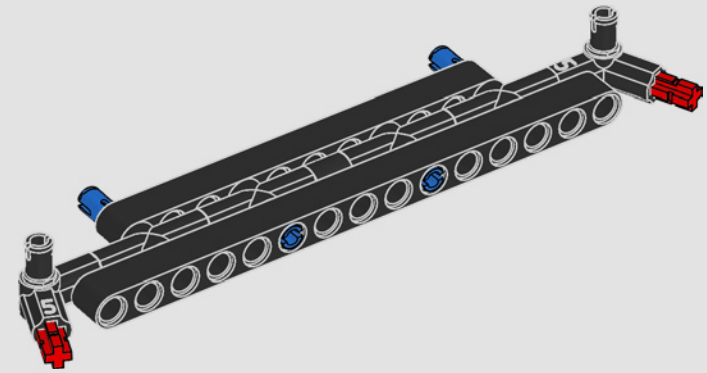

508

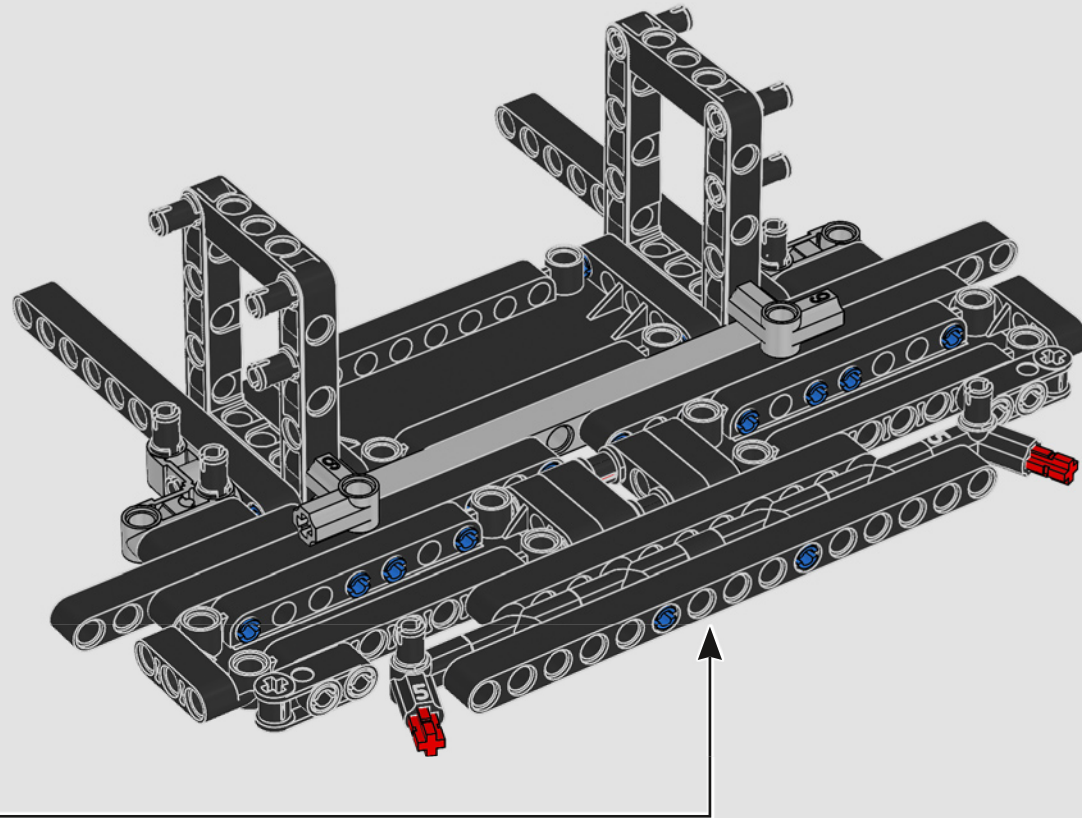

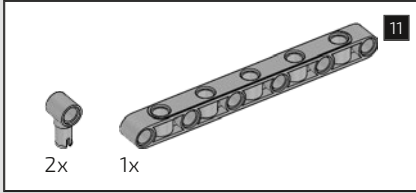
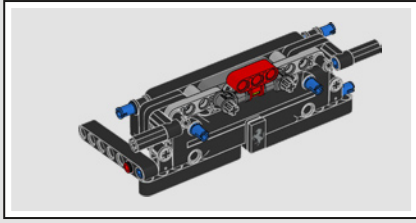

509

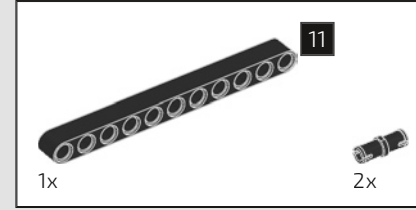
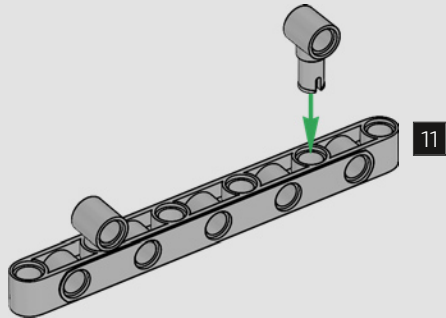

510

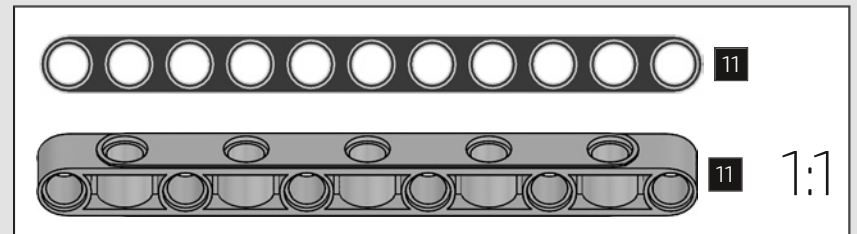
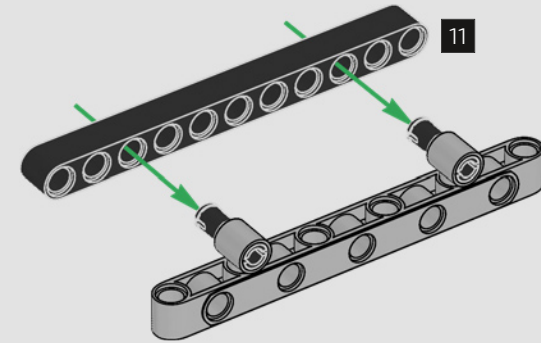

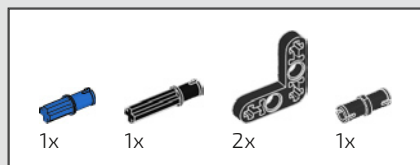

511

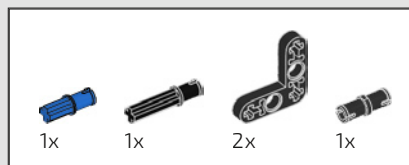
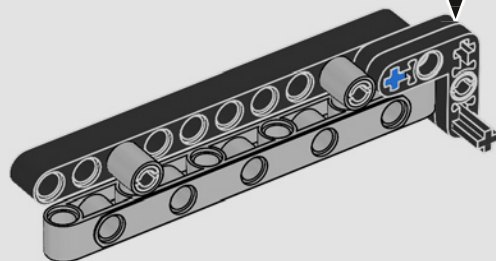
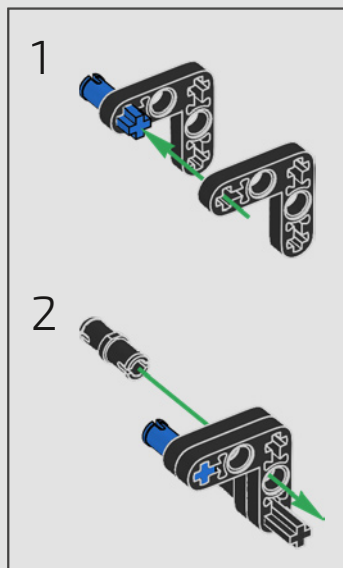

512

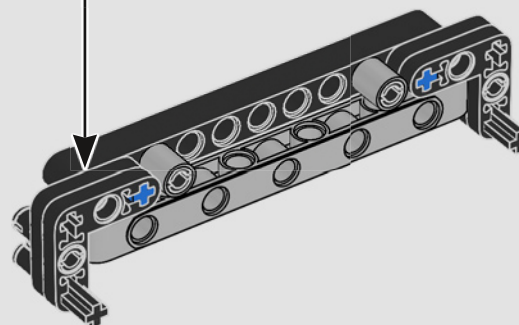
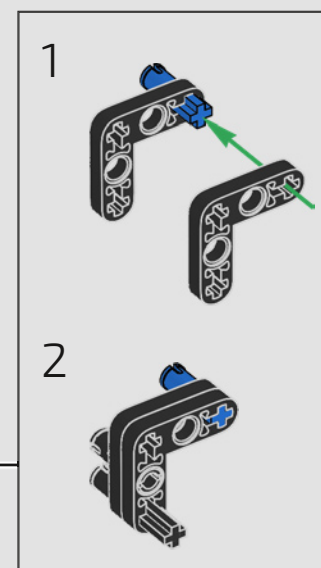

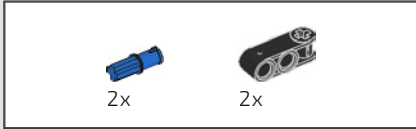

513

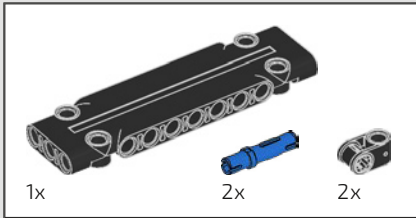
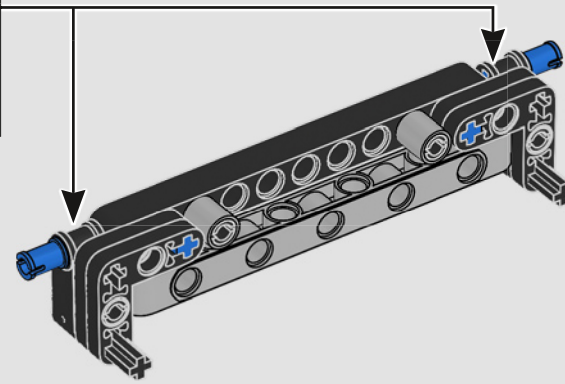
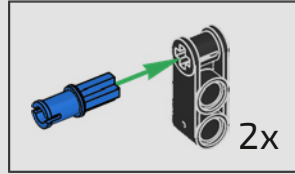

514

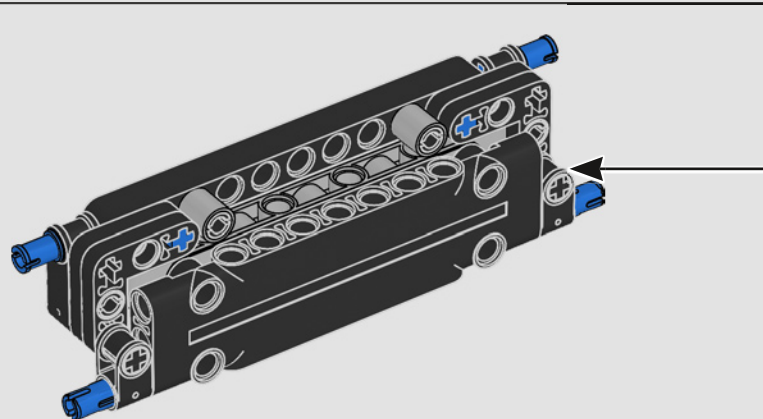
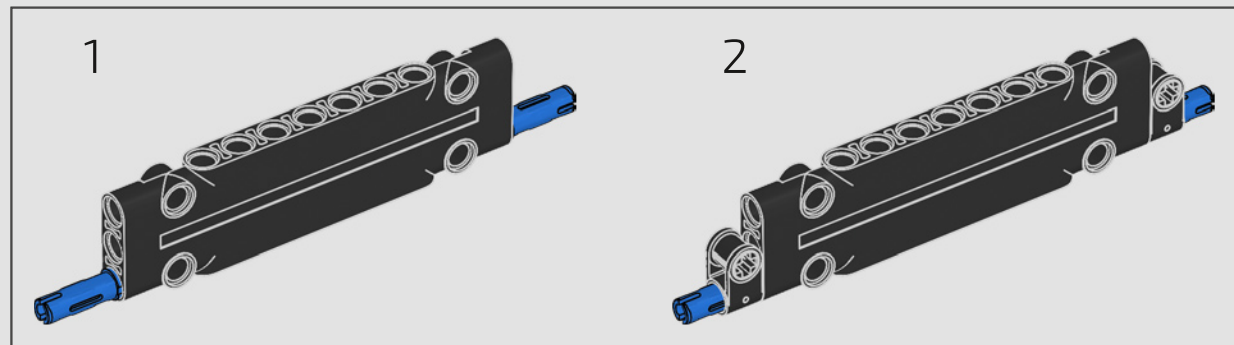

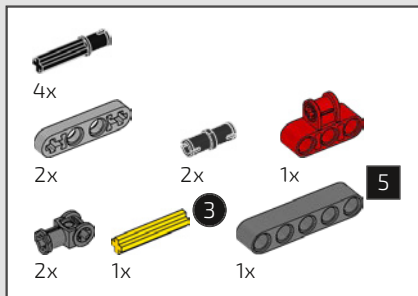

515

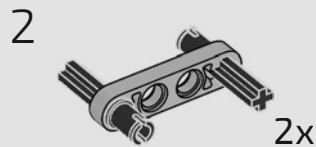
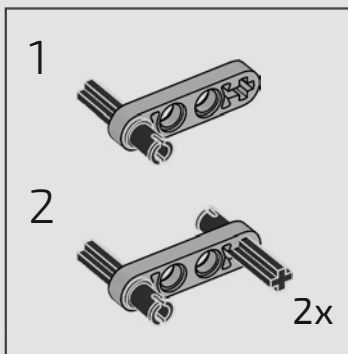
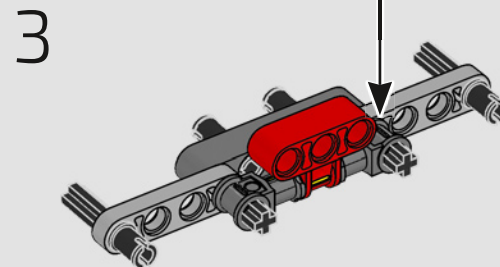
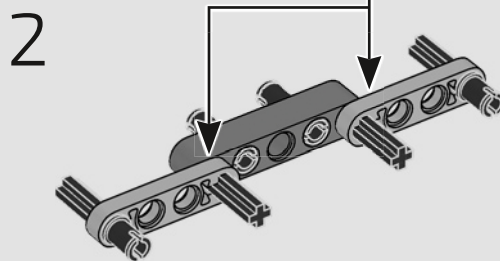
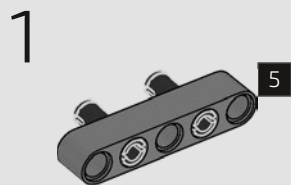

2x

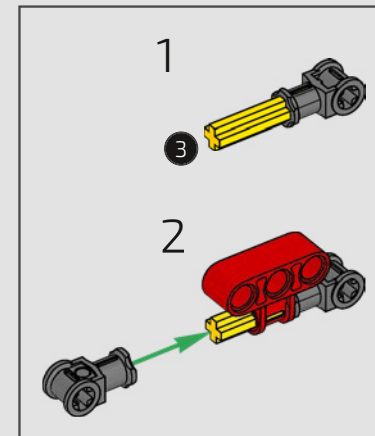

3

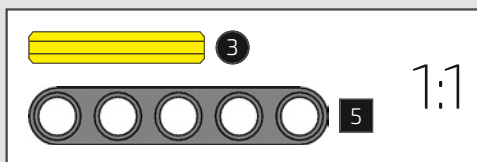
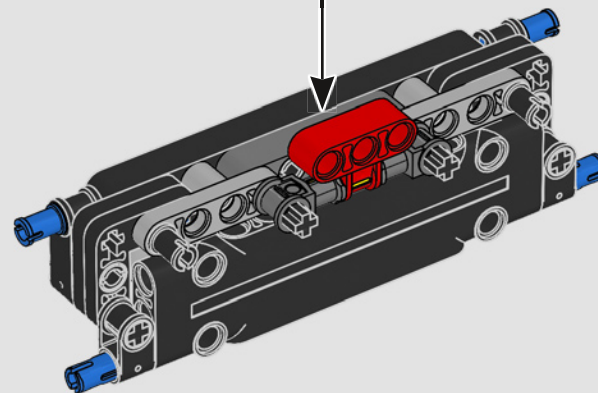
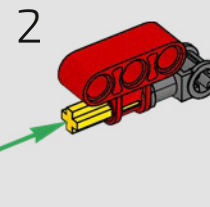

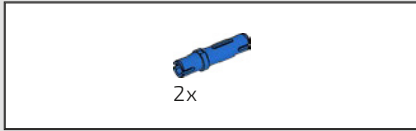

516

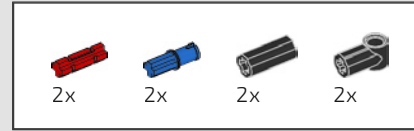
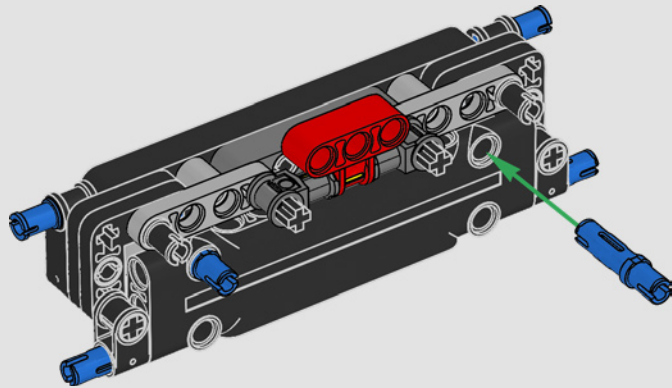

517

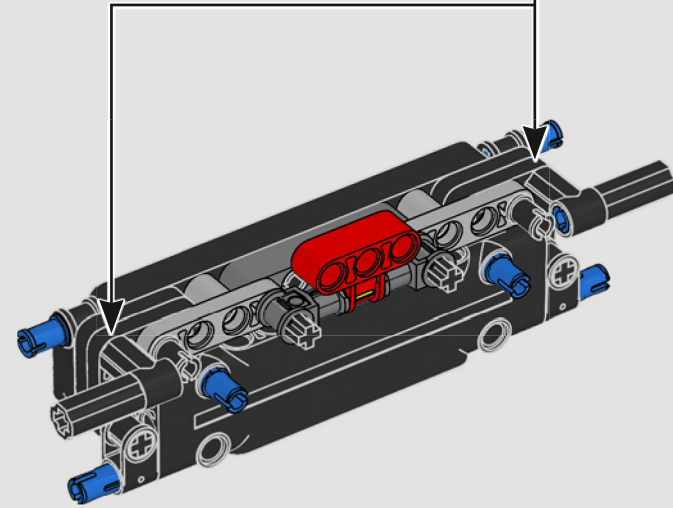
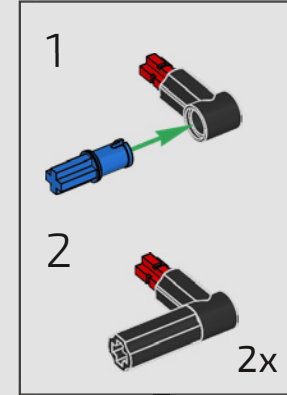

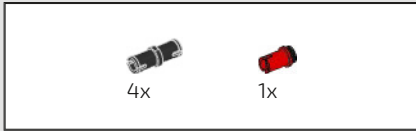

518

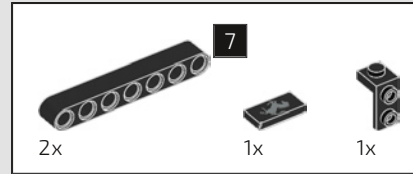
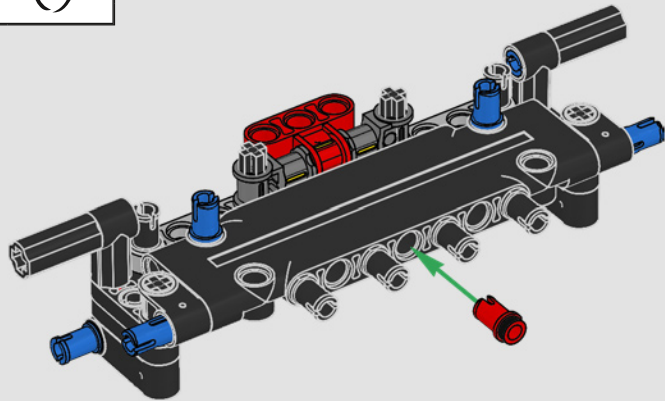

519

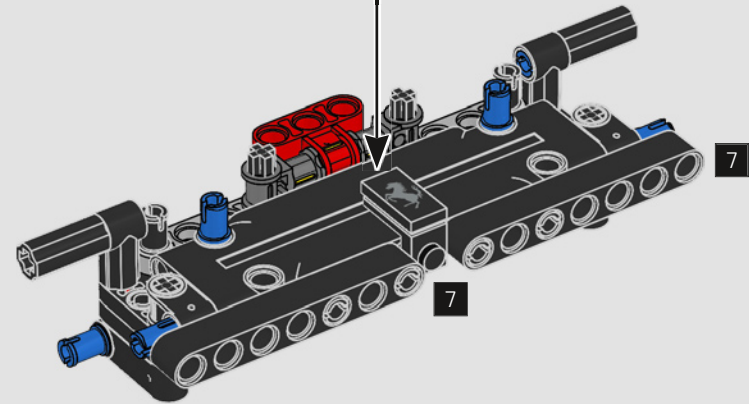
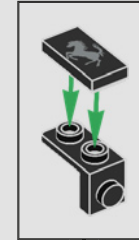

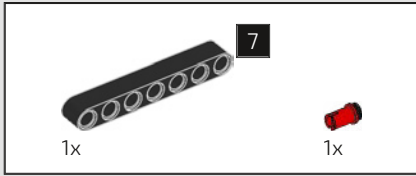

520

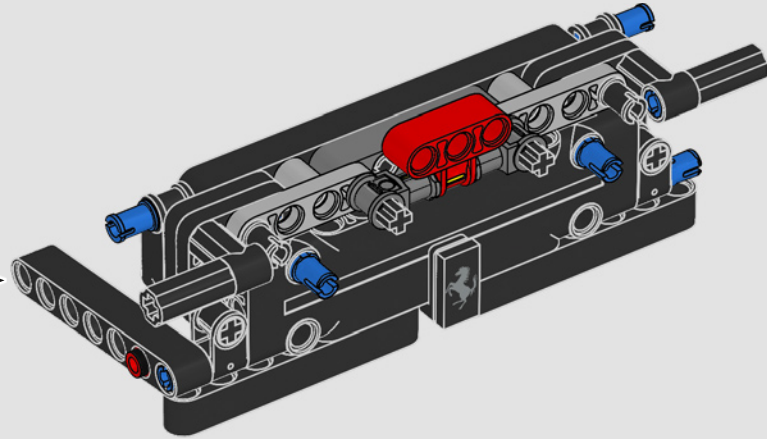
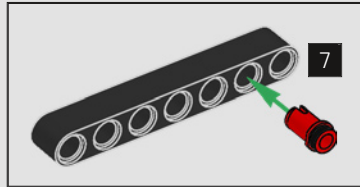

521

