



RACERS

7971



1

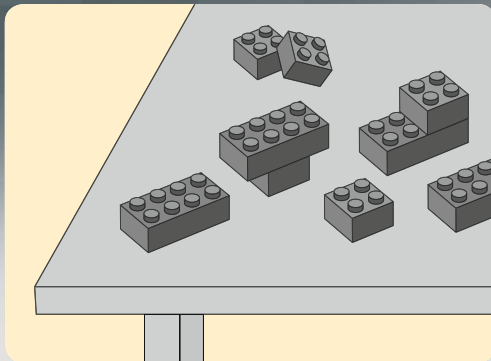
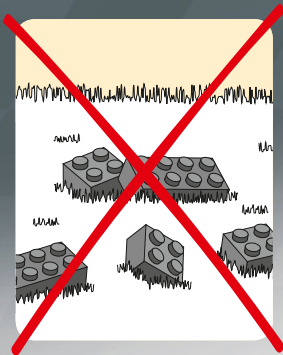

2

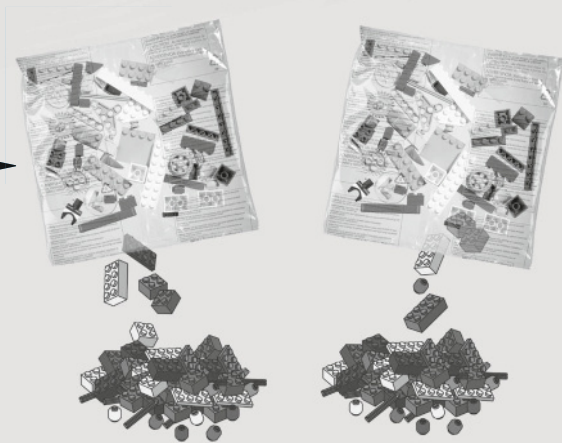



1

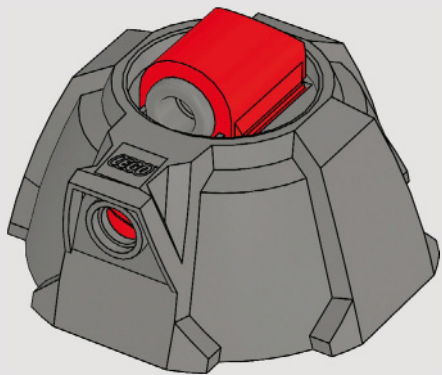

2

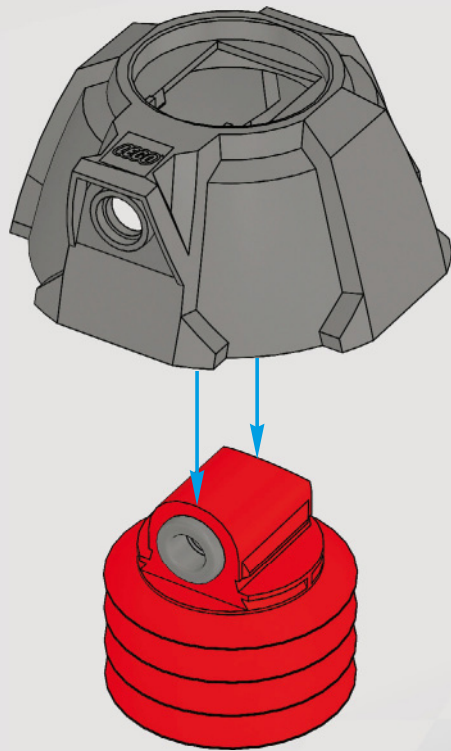

3

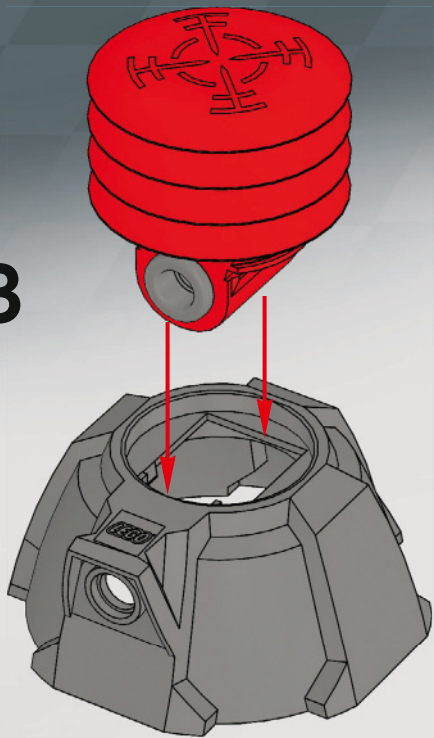

4

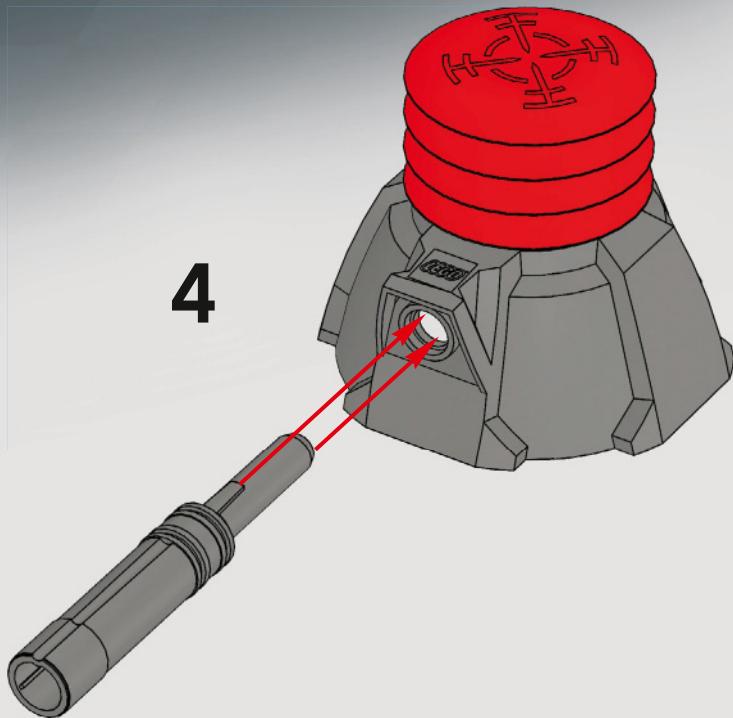

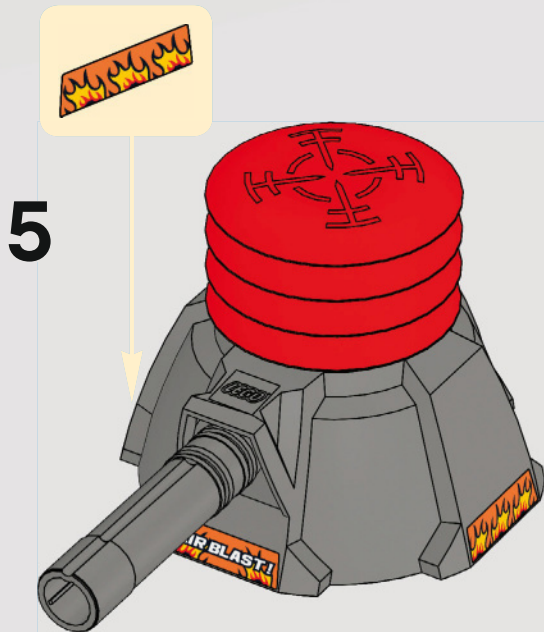



1

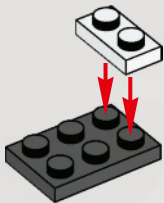

2

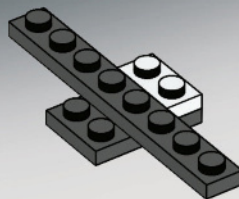

3

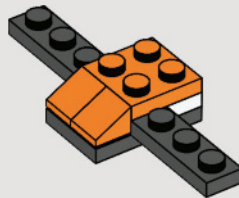

4

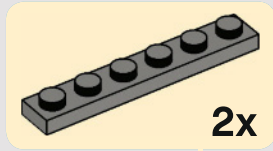
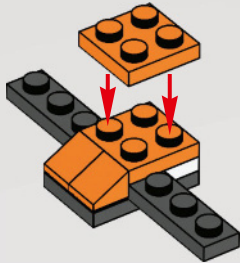

5

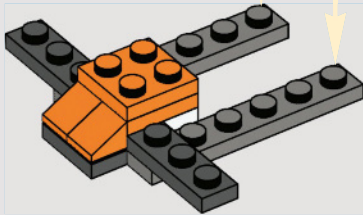

6

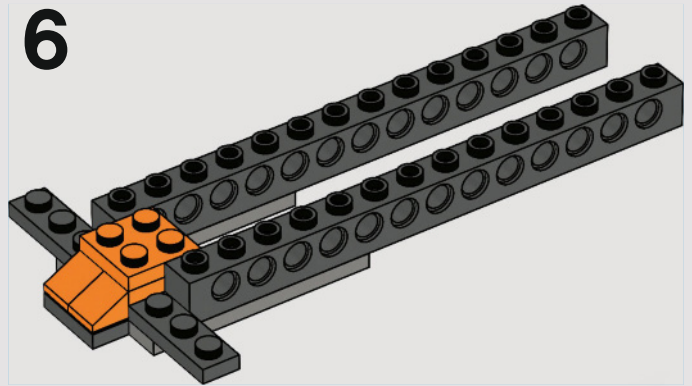

7

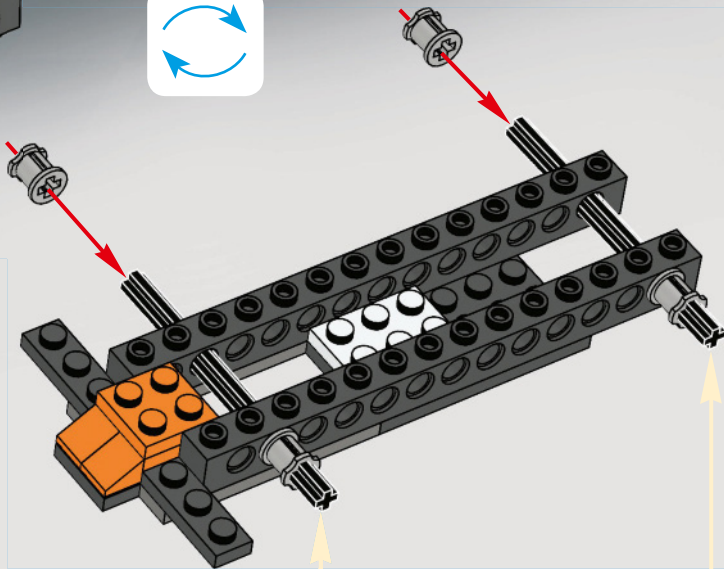
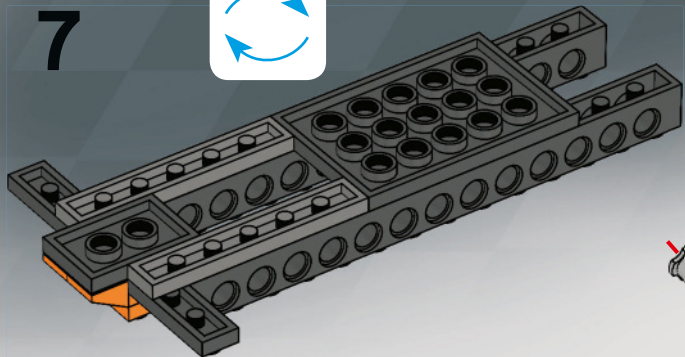

8

1:1
2x

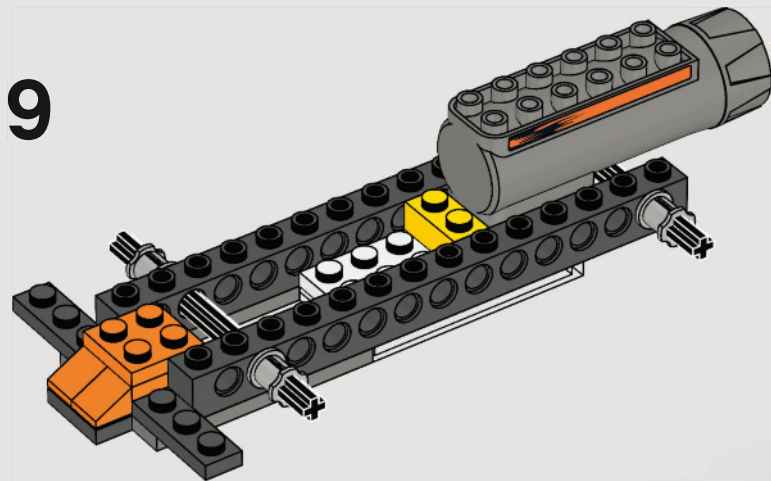
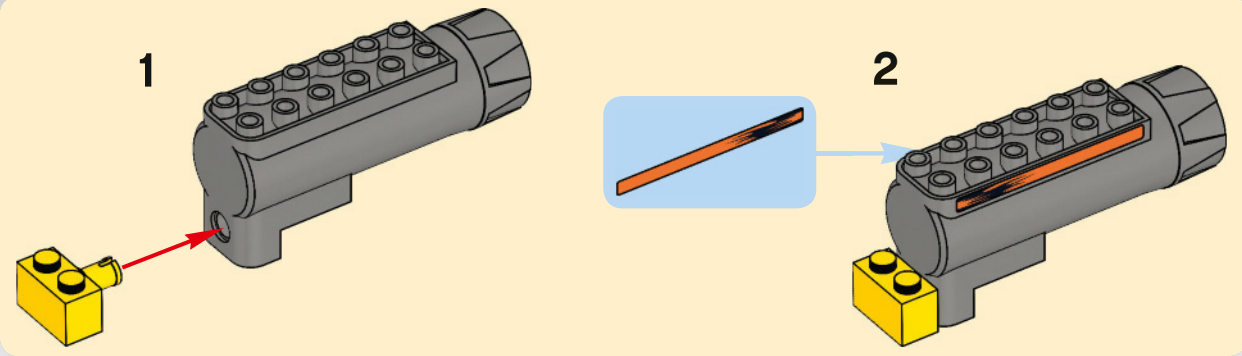

10

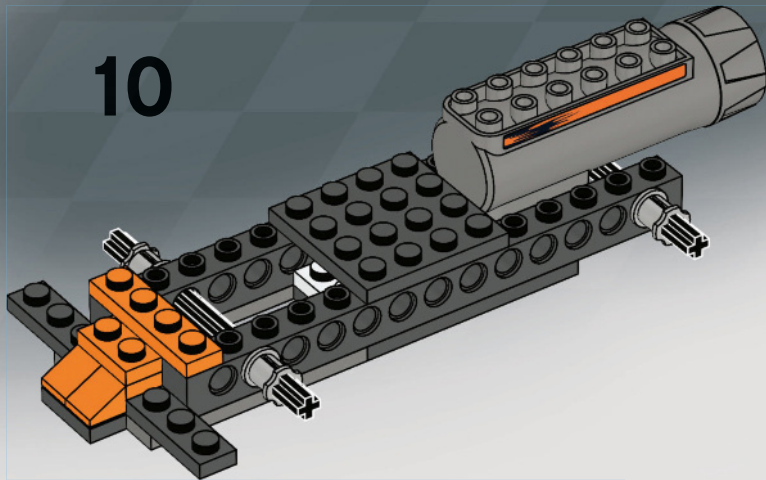

11

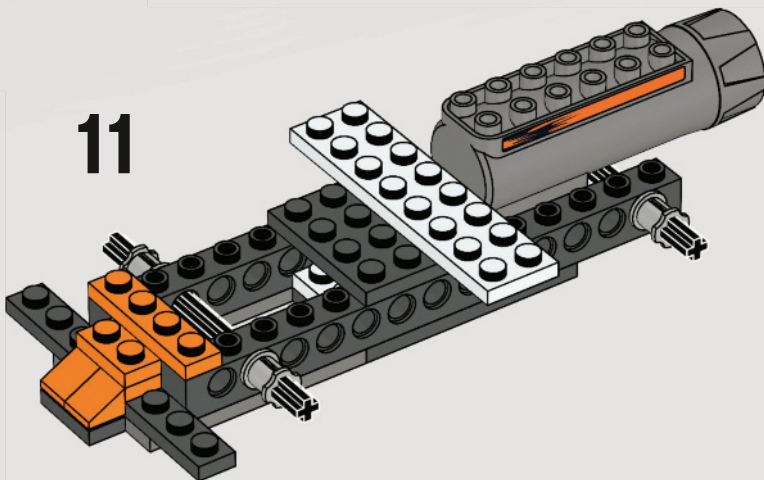

12

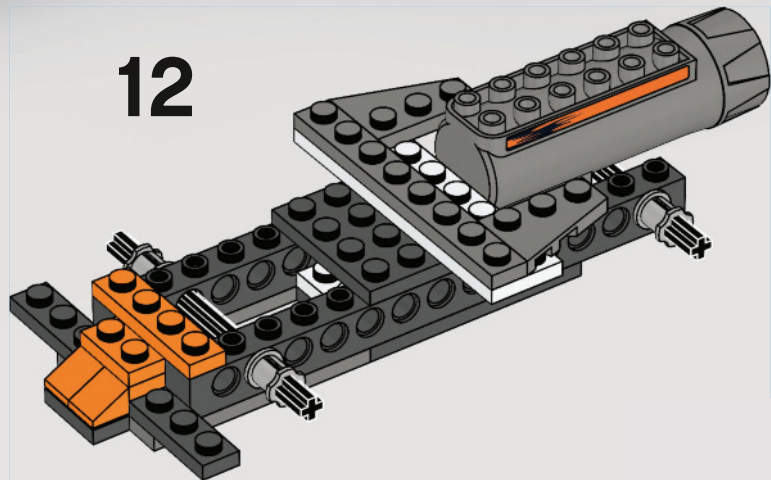

13

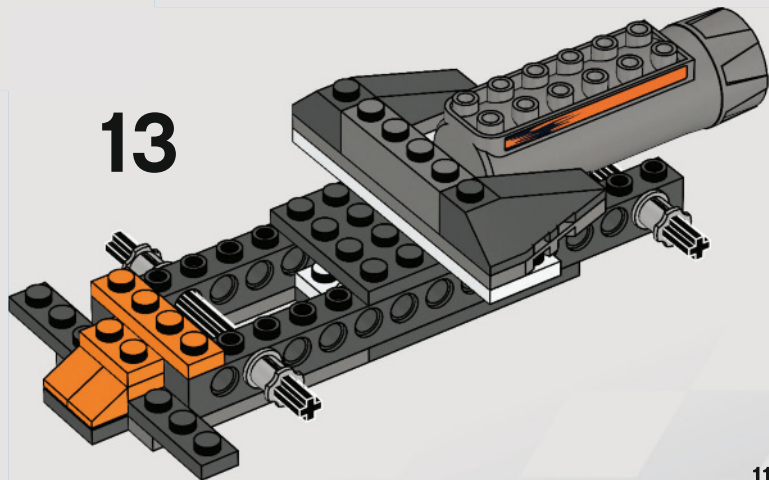

14

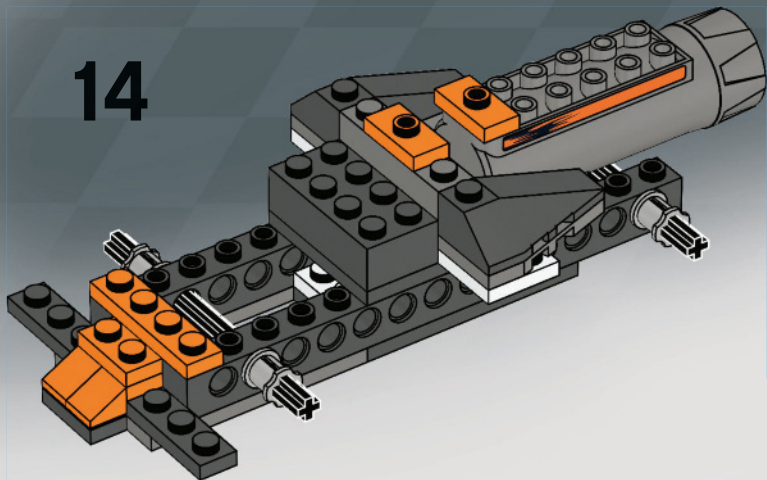

15

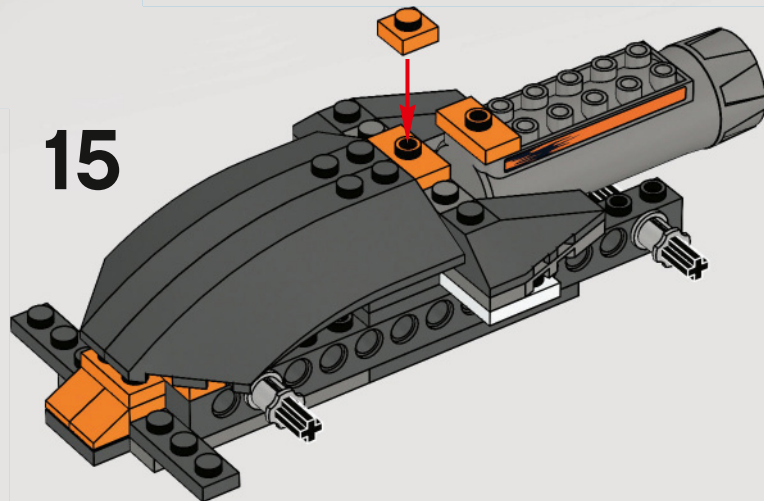

16

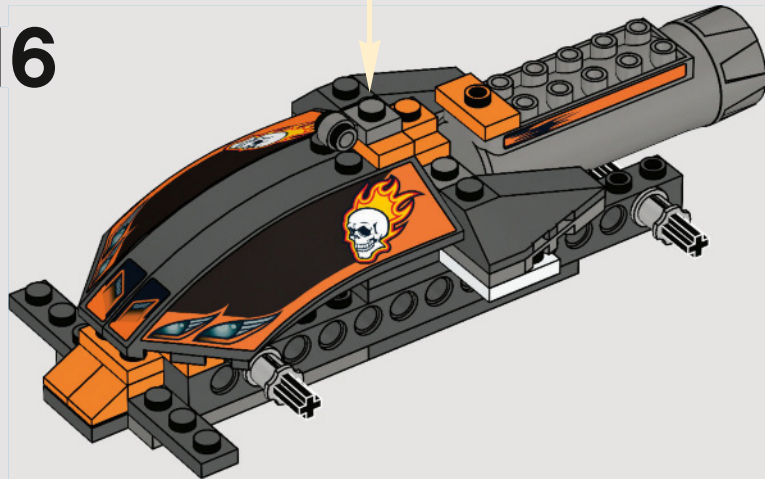
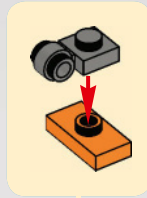

1

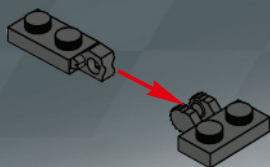

2

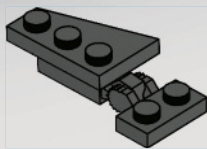

3

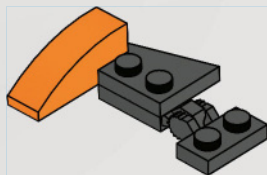

4

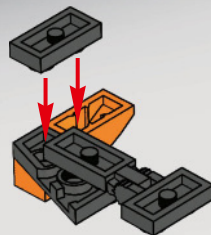

5

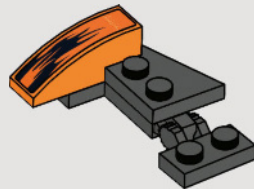

17

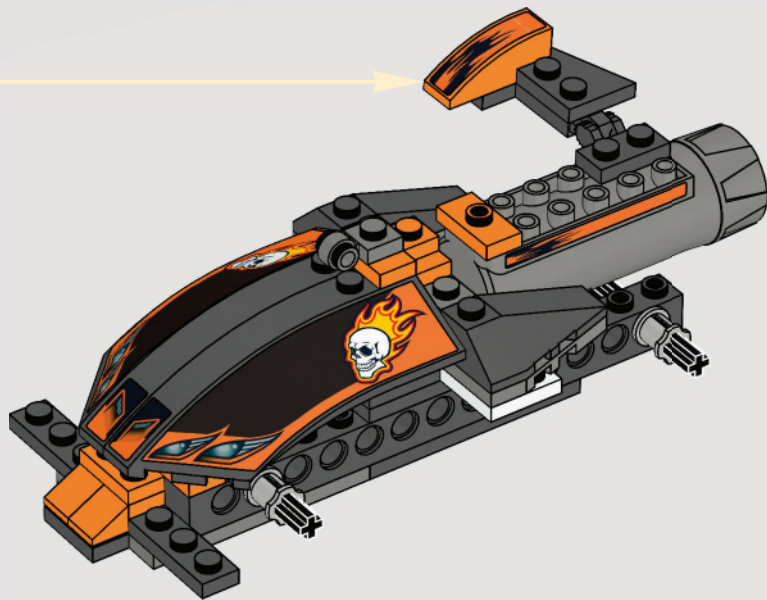

1

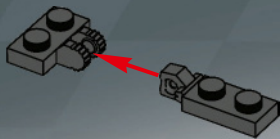

2

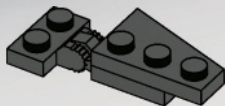

3

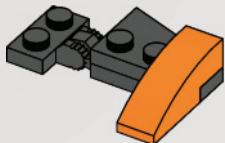

4

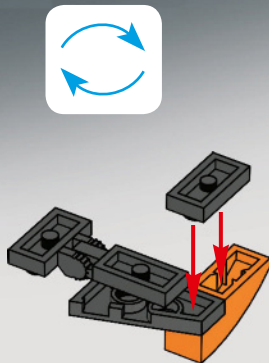

5

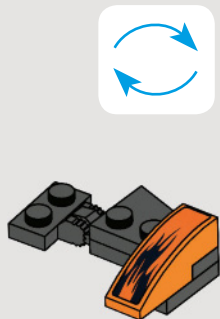

18

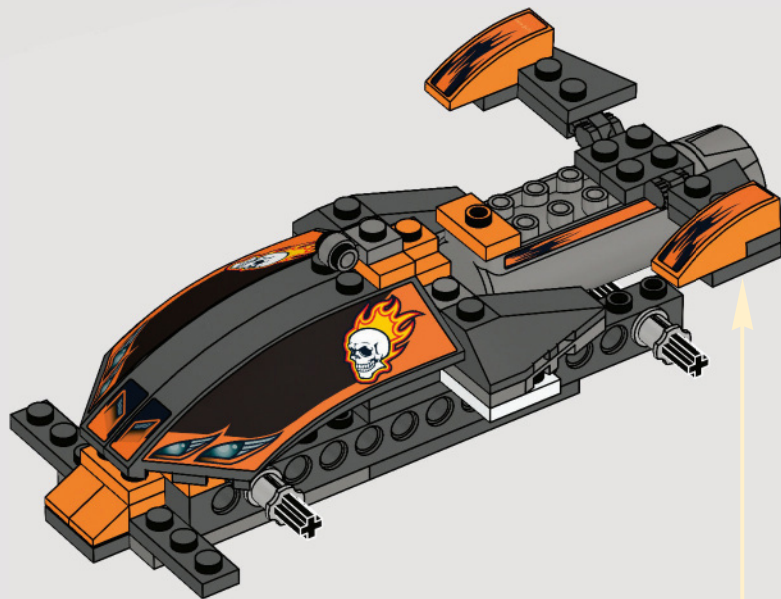

19

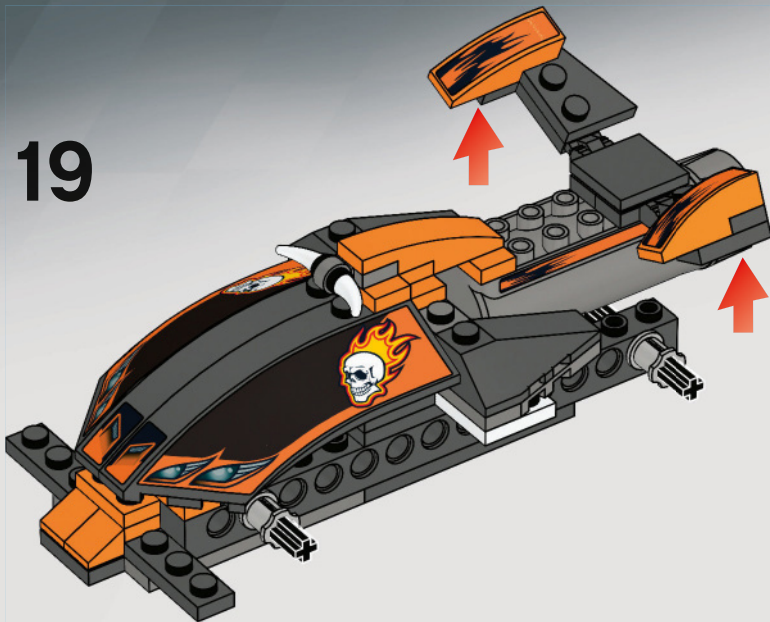

1

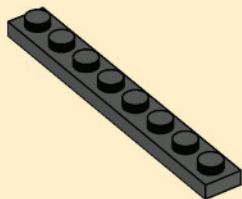

2

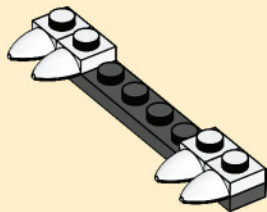

20

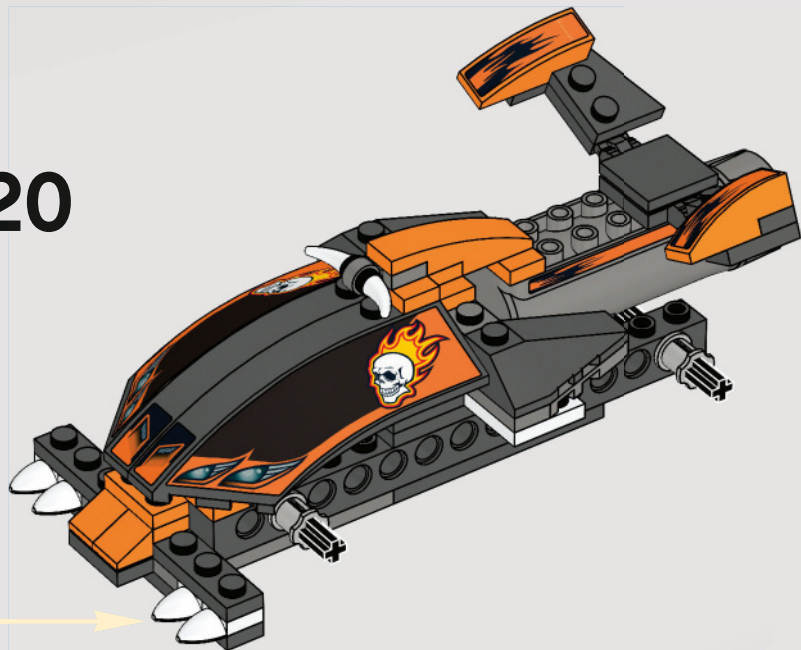

1

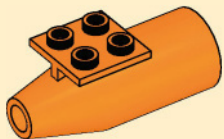

2

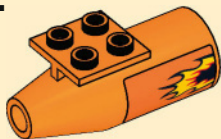

21

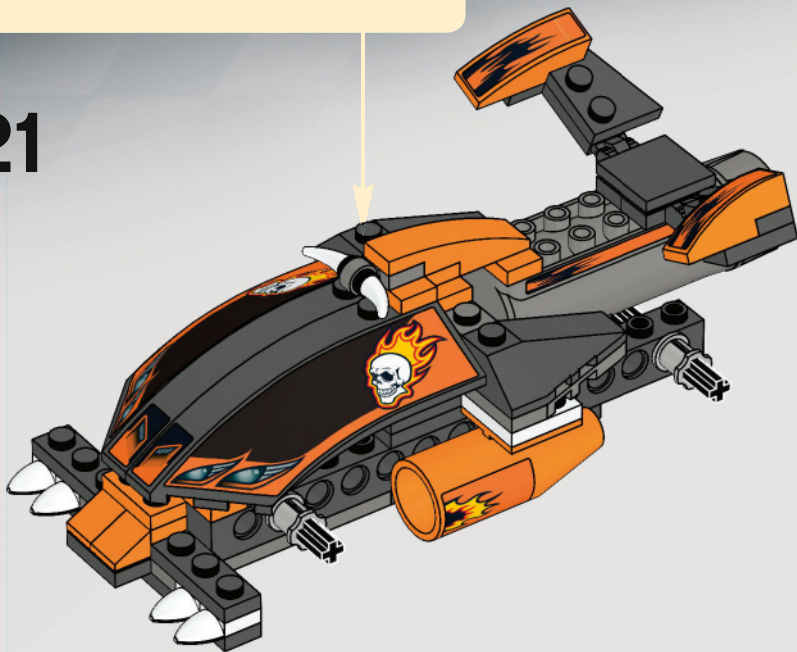

22

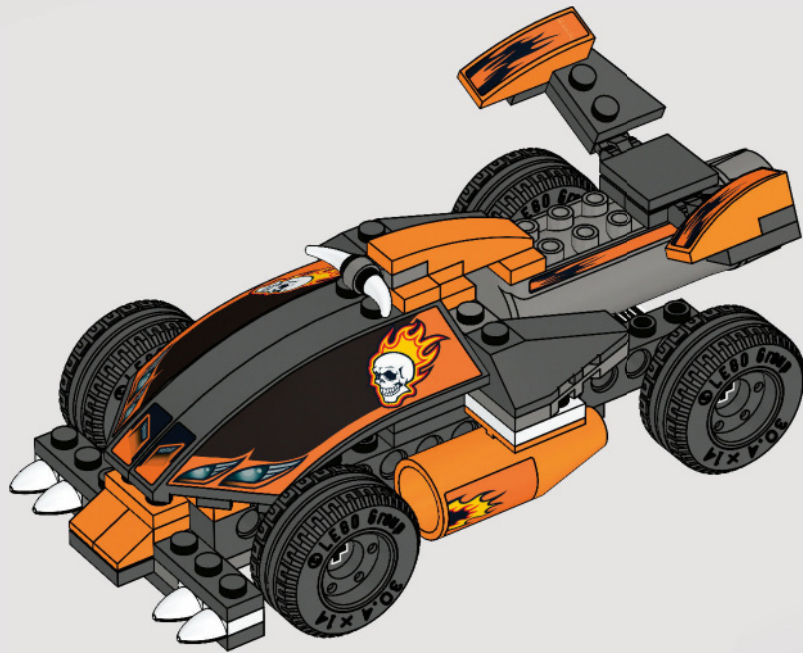

23

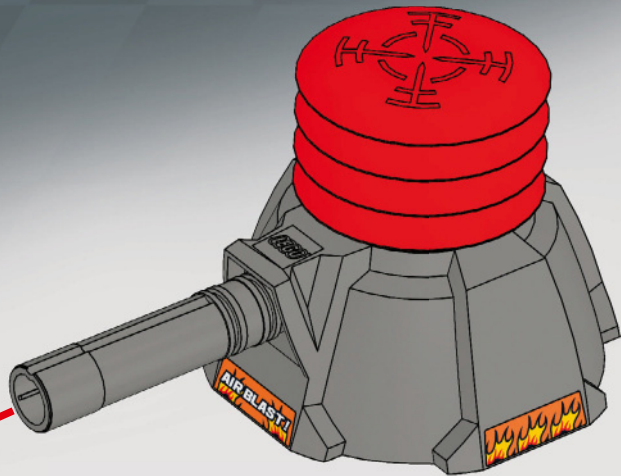
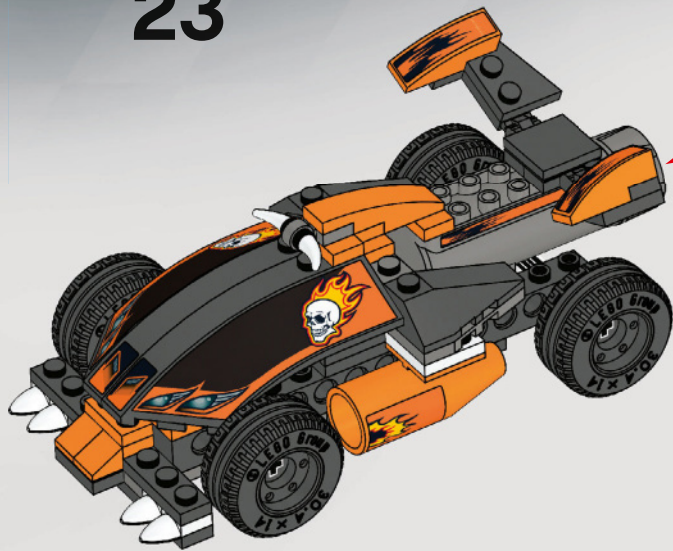

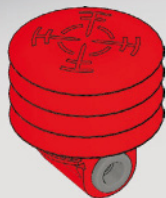

1x
4568690



1x
302101



1x
302301

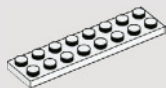

1x
303401



4x
4224792



2x
4568387



1x
300126



1x
302126



2x
302326



1x
4243819



1x
303226



1x
306826



2x
4515340



2x
370726



1x
4180423



1x
4180413



1x
4180508



1x
4180536



2x
4183043



2x
346026

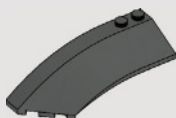

1x
4286971



1x
4286970

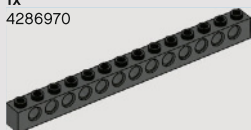

2x
4107558



4x
4517737



4x
4550937



2x
4504371



1x
4524929



2x
4251969



1x
4523603



2x
4159007



1x
4118782



3x
4547035



2x
4525190



4x
4211622



1x
245824



1x
4210872



1x
4210869



1x
4211103



1x
4210998

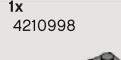

2x
4211056



1x
4210828

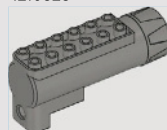

1x
4563226

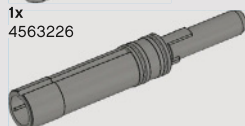

1x
4568692

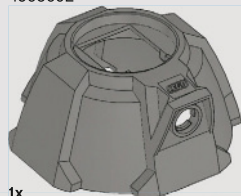

1x
4563215



Customer Service

Kundenservice

Service Consommateurs

Servicio Al Consumidor

www.lego.com/service or dial



: 00800 5346 5555

: 1-800-422-5346



WIN!

Go to www.nielsen.com/LEGO
to fill out a survey for a chance
to win a cool LEGO® Product.

No purchase necessary.

Open to all residents where not prohibited.



www.LEGO.com

www.nielsen.com/LEGO

GEWINNE!

Nimm an der Umfrage auf
www.nielsen.com/LEGO
teil und hab die Chance ein cooles
LEGO® Produkt zu gewinnen!

Die Teilnahme am Gewinnspiel führt zu keinerlei
Kaufverpflichtungen. Teilnahme in allen nicht
ausgeschlossenen Ländern möglich.

WIN!

Ga naar www.nielsen.com/LEGO,
vul een enquêteformulier in en
maak kans op een
cool LEGO® product.

Geen aankoopverplichting.
Iedereen mag deelnemen, uitgezonderd
ingezetenden
van landen waar een enquêteverbod geldt.

GAGNE!

Visite www.nielsen.com/LEGO
pour répondre à un questionnaire
et avoir une chance de gagner
un produit LEGO® très cool!

Aucune obligation d'achat.
Ouvert à tous les résidents des pays
autorisés.

当てよう!

www.nielsen.com/LEGO
にアクセスして、
アンケートにご記入ください。
当選者にはレゴ®製品を
差し上げます。

お買い上げの必要はありません。
禁止されていない限り、すべての皆様にご利用いただけます。