



75442

**STAR  
WARS**



Disney



[LEGO.com/sustainable-packaging](https://LEGO.com/sustainable-packaging)



FR  
**DONNEZ  
OU  
RECYCLEZ**



ASSOCIATION

OU



MAGASIN

OU



DÉCHÈTERIE

Adresses sur [quefairedemesdechets.fr](https://quefairedemesdechets.fr)



# BUILDER



Apple and the Apple logo are trademarks of Apple Inc., registered in the U.S. and other countries and regions. App Store is a service mark of Apple Inc. Google Play and the Google Play logo are trademarks of Google LLC. Tencent and the Tencent logo are trademarks of Tencent Inc.

[LEGO.com/devicecheck](https://LEGO.com/devicecheck)

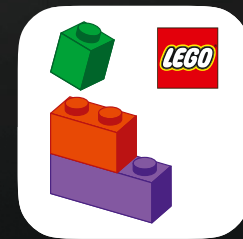

LEGO® Builder



# RIEN QU'UN TAS DE FERRAILLE !

Nous ne sommes sûrement pas les seuls fans de *Star Wars* à avoir poussé un cri de joie lorsque Peli Motto a révélé le chasseur Naboo N-1 au Mandalorien dans *Le Livre de Boba Fett*. Après tout, notre passion, c'est de construire (et reconstruire) des vaisseaux spatiaux. Nous étions impatients de découvrir les astuces que la célèbre génie mécanique/ferrailleuse de Mos Eisley avait préparées pour remplacer le tristement célèbre *Razor Crest*. Bien sûr, nous avons dû créer notre version LEGO® *Star Wars*™ – et elle est maintenant prête à quitter le garage la boîte. Ce modèle à grande échelle destiné à l'exposition rejoint notre vaste Ultimate Collector Series – garanti sans poussière et capable de passer presque inaperçu.

Bonne construction !  
L'équipe LEGO® *Star Wars*™





## UN CLASSIQUE PRÉ-EMPIRE

Un vaisseau qui tient la route n'a pas besoin de sacrifier son look. Le chasseur Naboo N-1 est l'un des designs les plus remarquables du Corps d'ingénierie spatiale du Palais de Theed. Son nez chromé poli, ses lignes sculptées, ses moteurs jumelés réglés sur mesure : un parfait exemple de la tradition nabooïenne qui marie élégance et performance. À l'origine commandé par les forces de sécurité royales de Naboo, le N-1 est un monoplace élégant mais redoutable : ses doubles canons laser et torpilles à protons sont soutenus par une vitesse et une précision redoutables. Ses fameuses « queues de rat » servent de dissipateurs de chaleur pour un refroidissement optimal des moteurs, réduisant ainsi la pollution.

## LE VAISSEAU LE PLUS RAPIDE DE LA BORDURE EXTÉRIÈRE

Des décennies après ses exploits avec Anakin Skywalker, ce vaisseau emblématique trouve un nouveau pilote. Après avoir perdu le *Razor Crest*, Le Mandalorien, Din Djarin, est à la recherche de son digne successeur. Il repère d'abord le N-1 cabossé dans le garage de Peli Motto, mais ses premières impressions sont mitigées. Les ingénieurs Jawas de Motto récupèrent ensuite les meilleurs morceaux de ferraille du monde désertique (sans poser de questions), et la vision de Motto commence à prendre forme. Équipé d'un assimilateur turbonique venturi, d'un booster de combustion à densité cryogénique et d'une prise d'air sur mesure, le vaisseau offre une poussée foudroyante, l'hyperespace sans anneau d'amarrage, et une maniabilité parfaite pour les combats aériens.

**« Dank Farrik, il est rapide. »**

– Le Mandalorien





A detailed close-up of the LEGO Star Wars N-1 starfighter, showing the intricate mechanical details of the engine and wing assembly. The model is constructed from grey and black Technic bricks, with yellow accents on the wings. The background is a solid, vibrant yellow.

## L'ÉQUIPE DE DESIGN LEGO® STAR WARS™

Nos partenaires de Lucasfilm Ltd. nous ont fourni de nombreuses images de référence du N-1 et nous avons eu des centaines de photos d'une version grandeur nature. Sa forme organique a un fort attrait visuel, mais recréer le bas bulbeux du N-1 a été un vrai défi, tout comme l'angle subtil des ailes. Aucun élément existant ne permettait de reproduire l'angle exact, il a donc fallu expérimenter pour réussir. Les moteurs regorgent de petites pièces, tubes et éléments – c'est de loin la partie la plus complexe du modèle – et nous avons dû capturer tous les détails tout en gardant la stabilité et le confort de construction. Nous sommes particulièrement fiers du nombre d'éléments laqués que nous avons pu ajouter à l'extérieur. Le chrome brillant ajoute un réalisme supplémentaire, comme dans la série, et les marquages jaunes rappellent l'histoire du vaisseau, mariant look brut et design élégant. Au final, c'est un véhicule fascinant et nous espérons que vous serez fier de l'exposer.

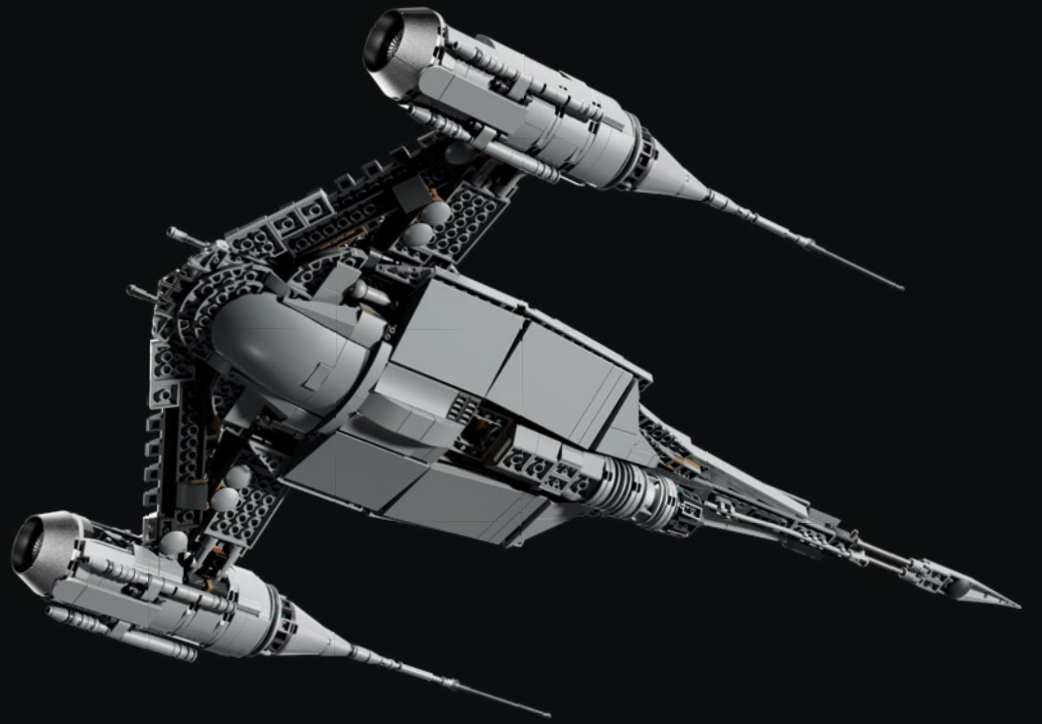









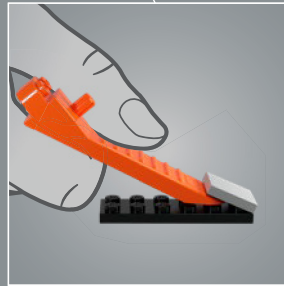
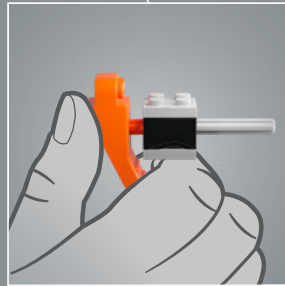
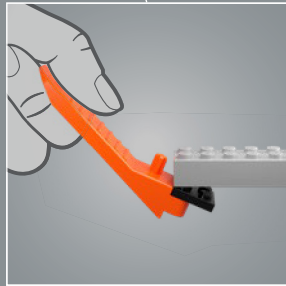
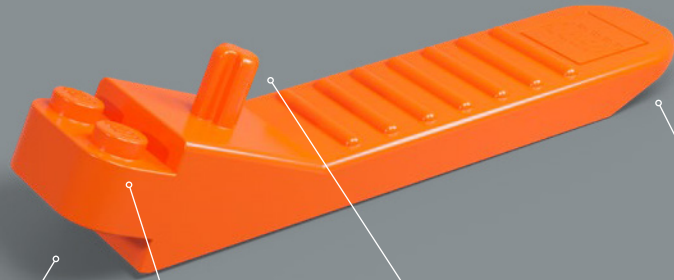

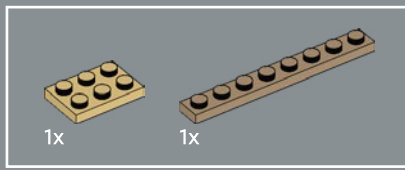

1

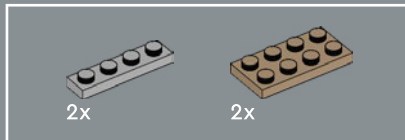
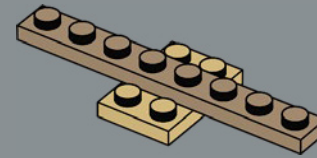

2

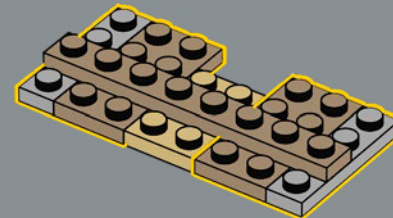

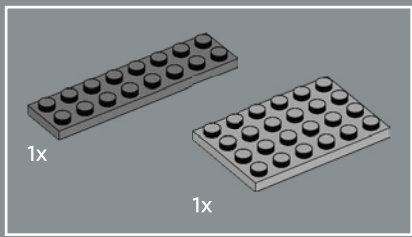

3

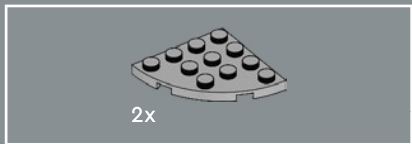
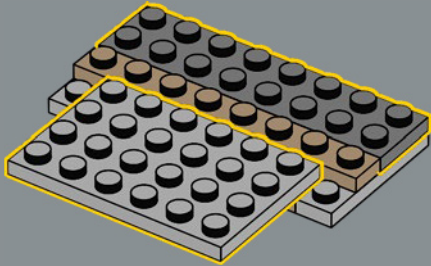

4

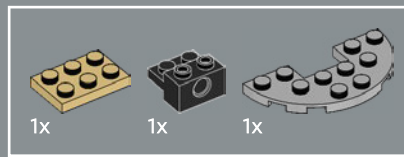
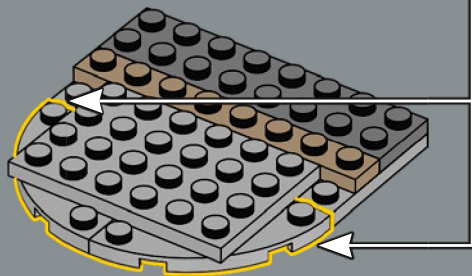
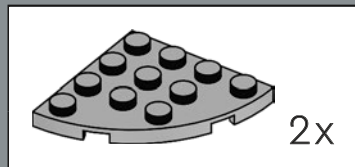

5

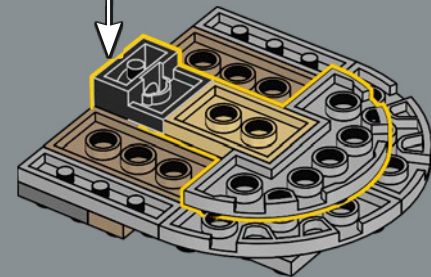
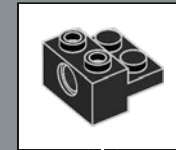

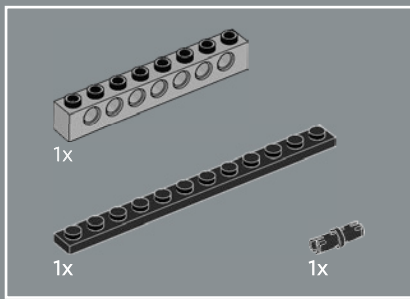

6

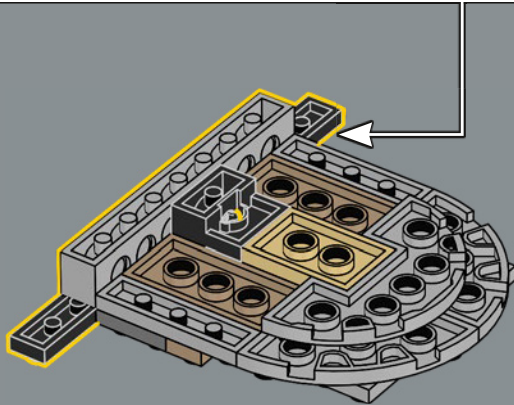
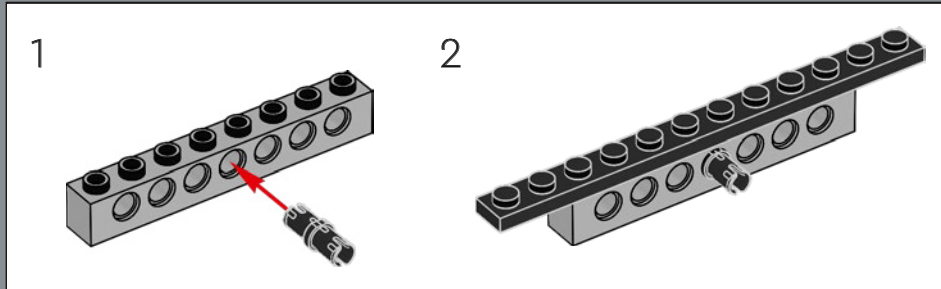

7

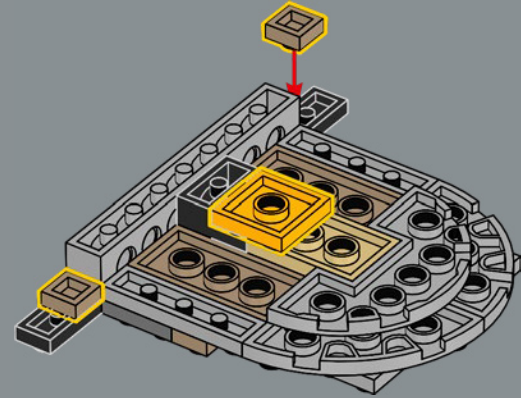

8

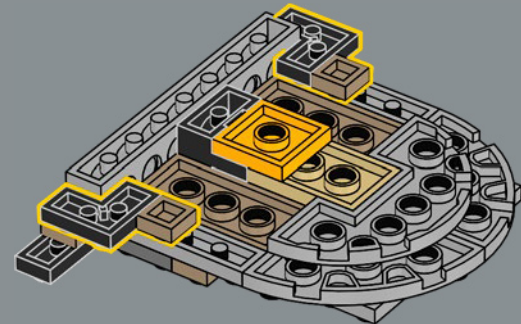

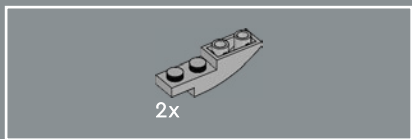

9

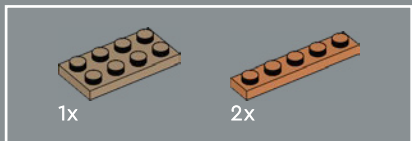
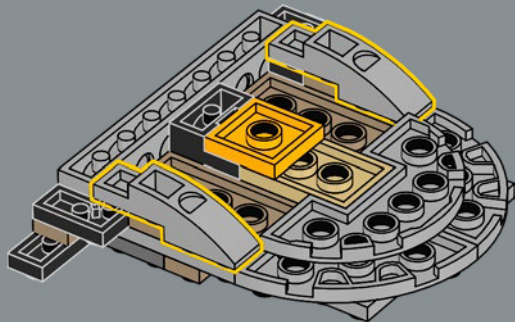

10

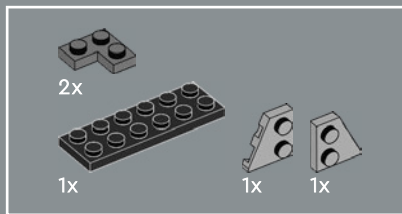
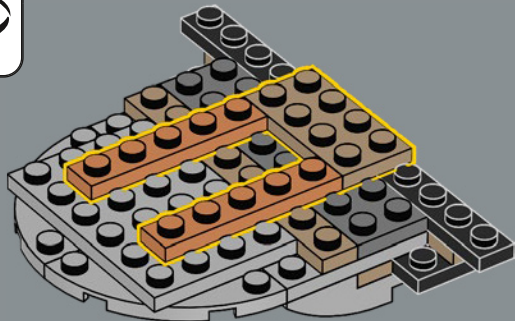

11

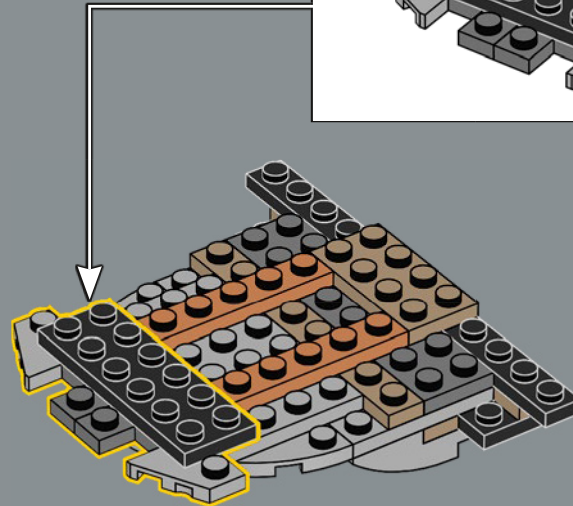
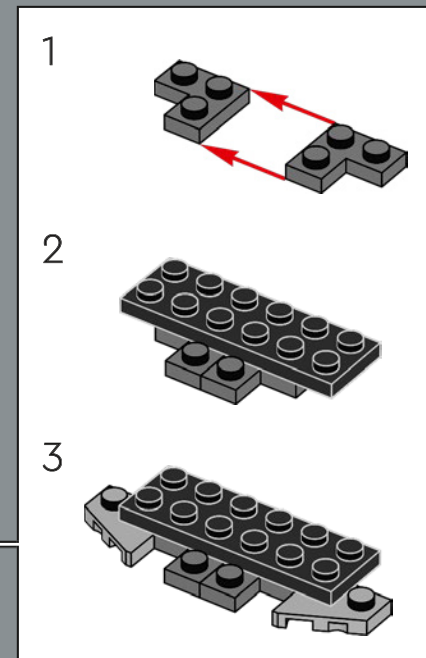

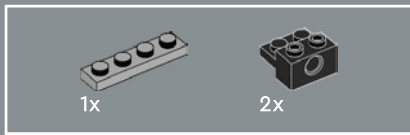

12

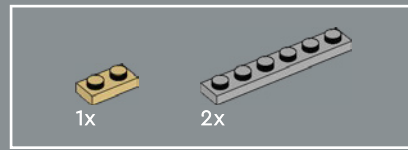
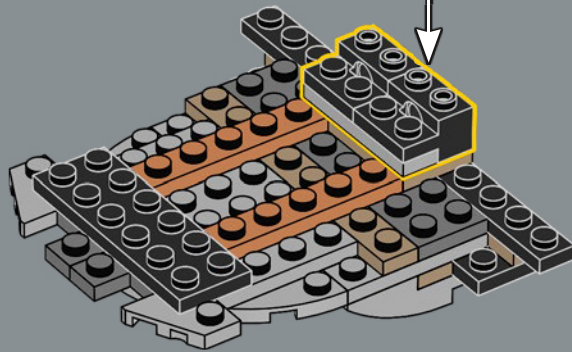
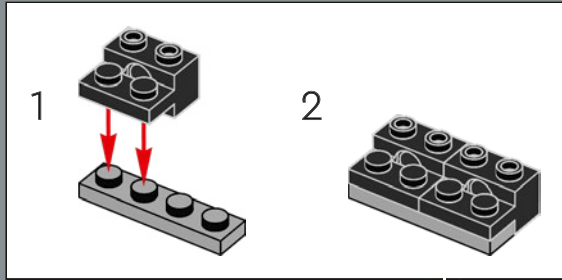

13

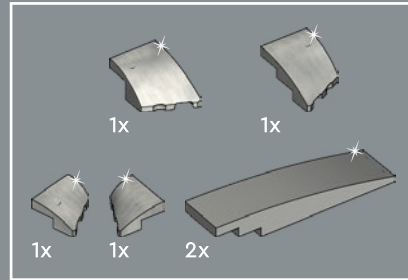
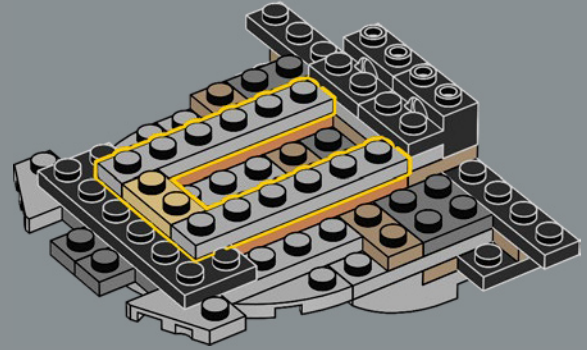

14

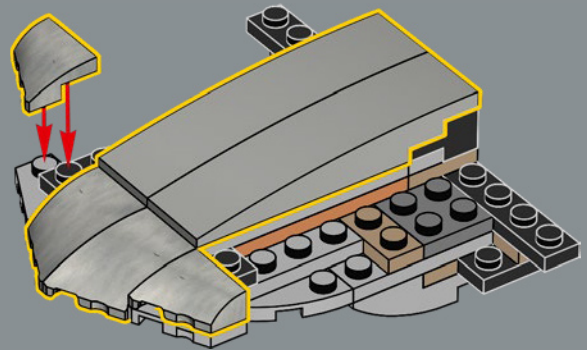

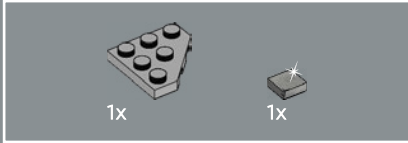
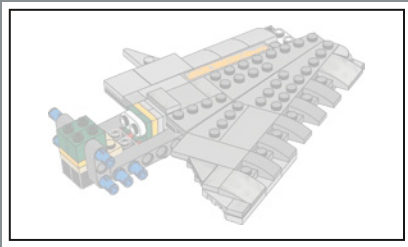

15

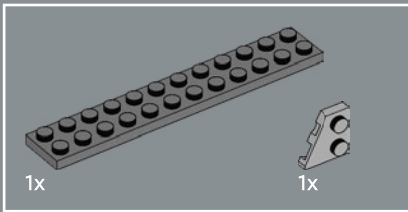
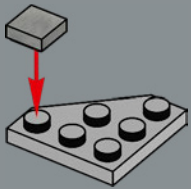

16

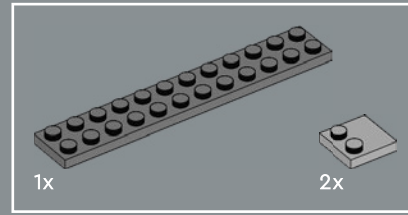
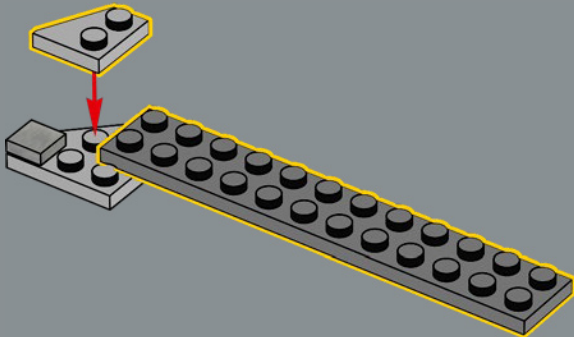

17

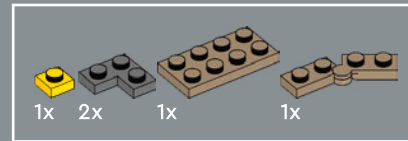
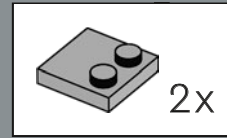
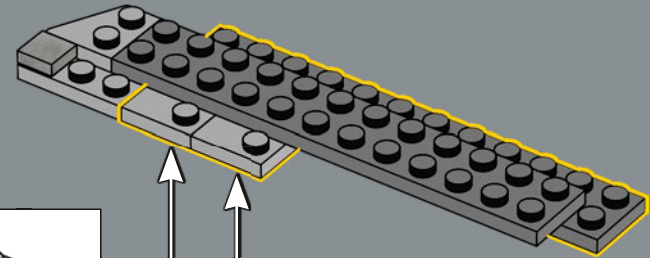

18

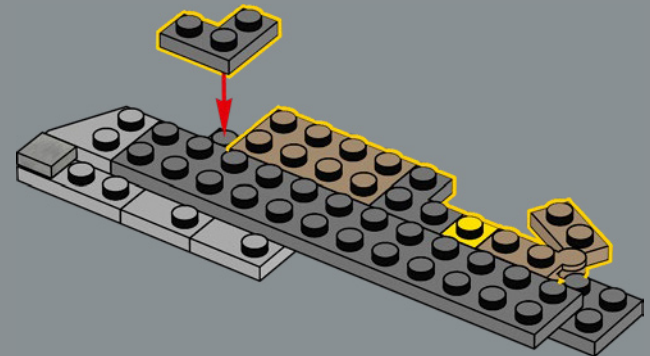

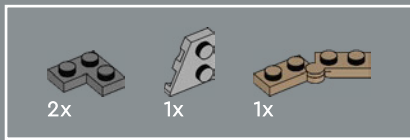

19

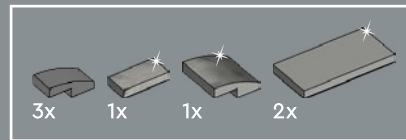
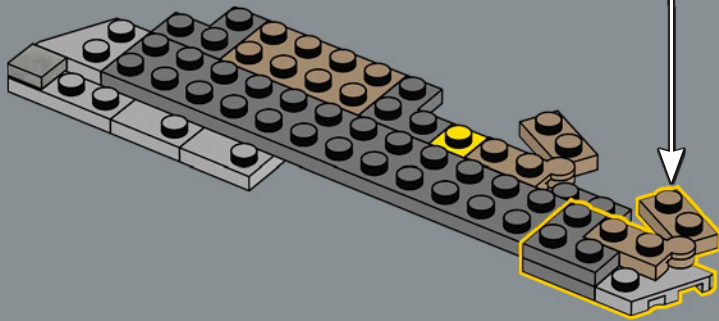
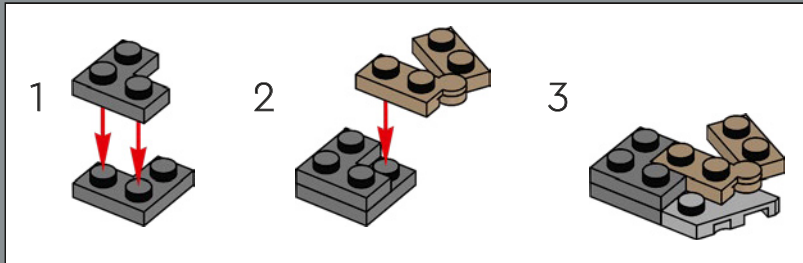

20

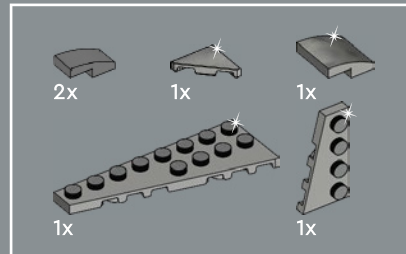
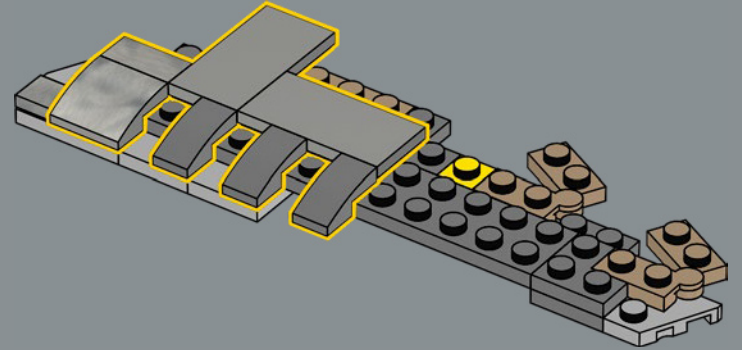

21

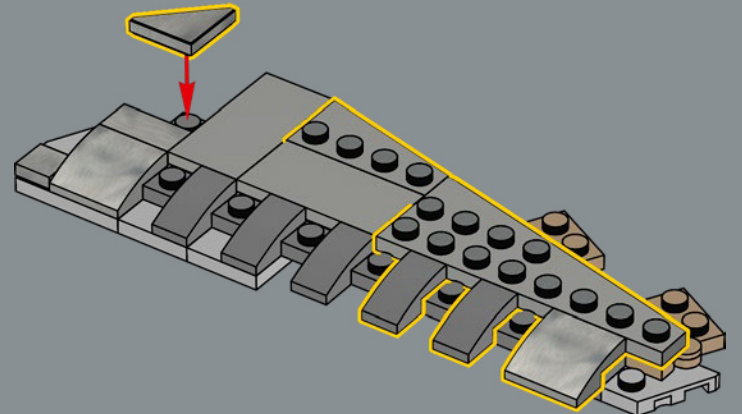

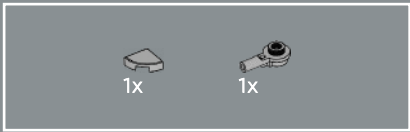

22

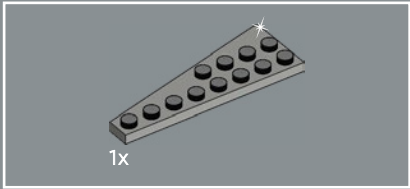
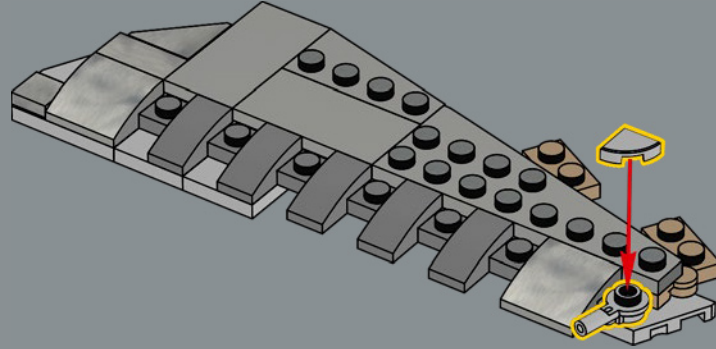

23

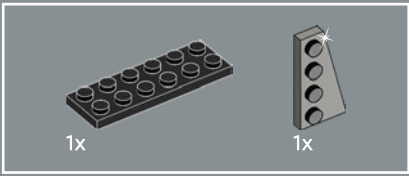
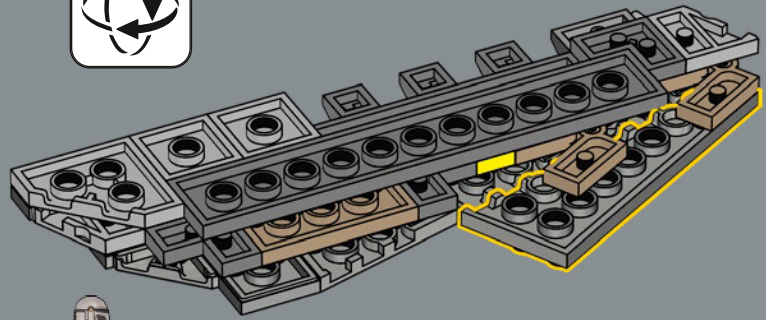

24

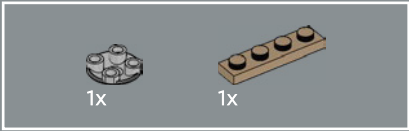
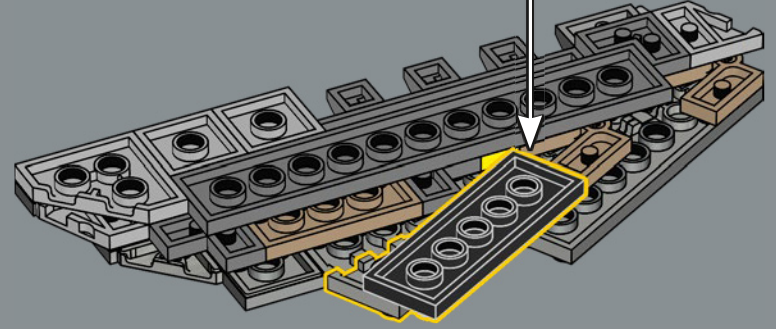
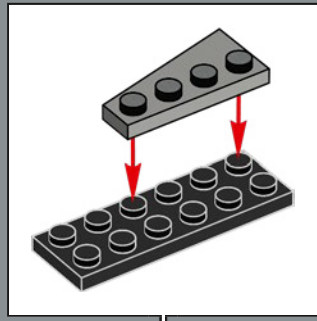

25

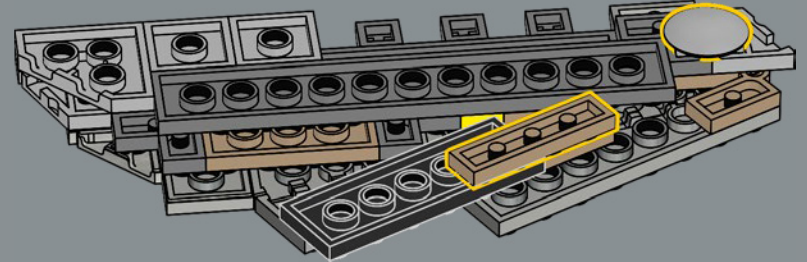

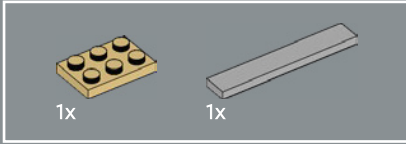
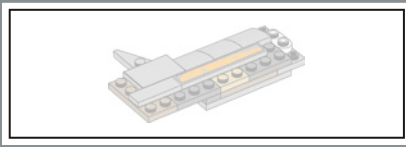

26

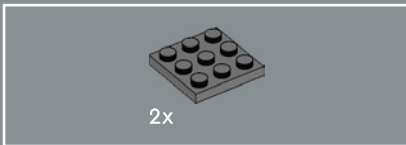
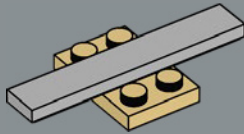

27

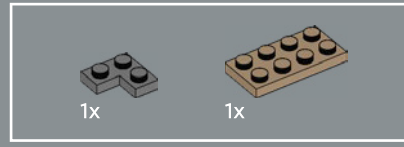
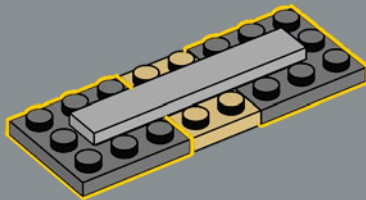

28

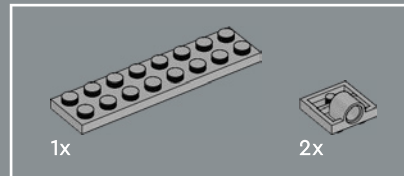
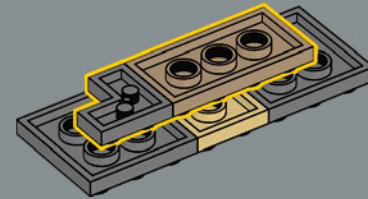

29

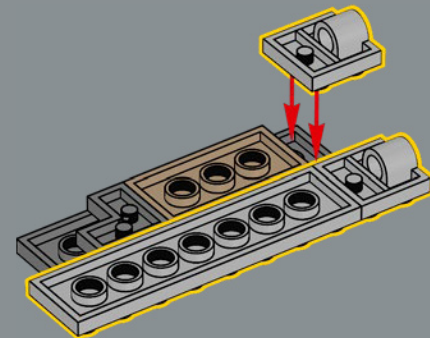

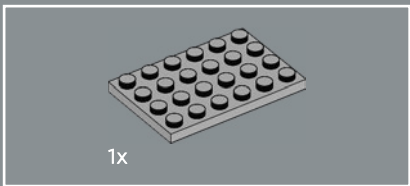

1x

30

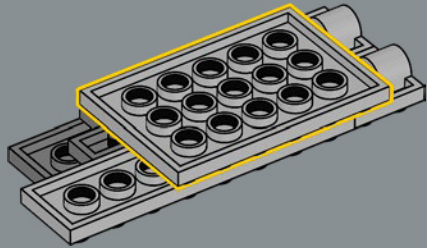

3x

1x

32

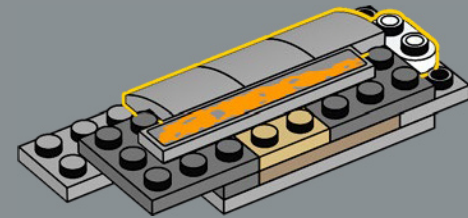

31

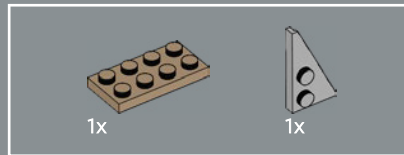
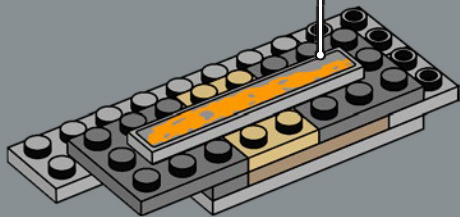

1x

1x

33

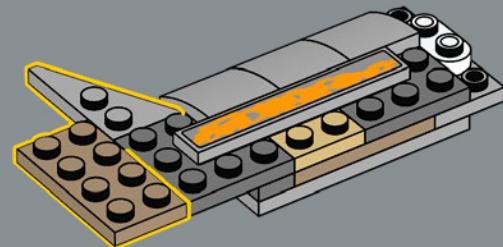

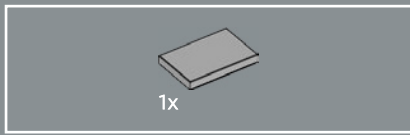

34

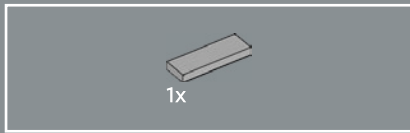
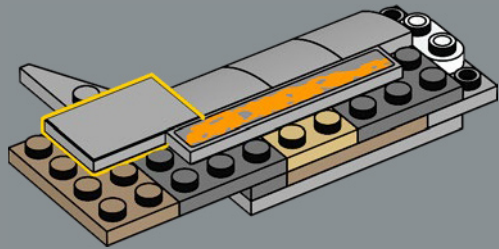

35

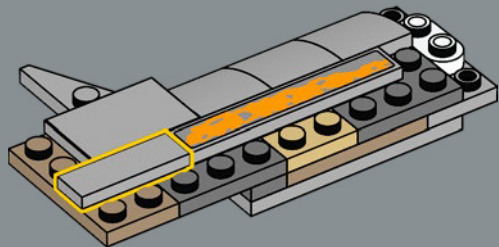

36

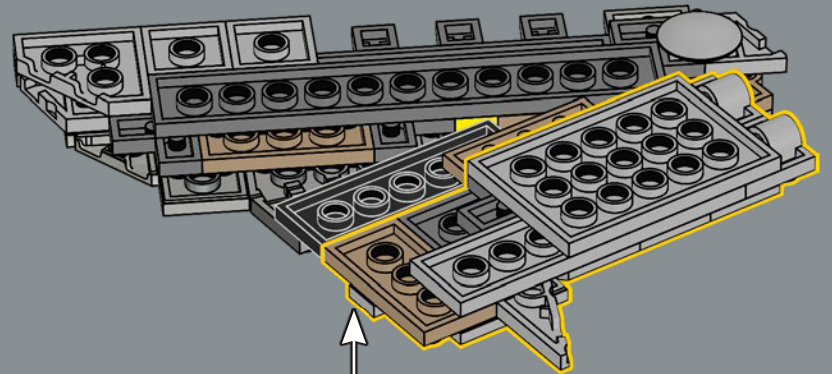

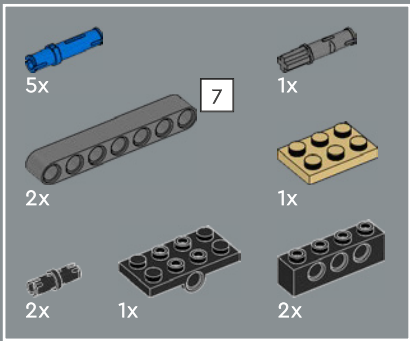
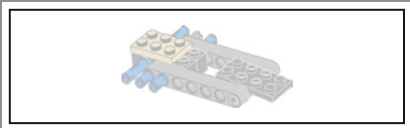

37

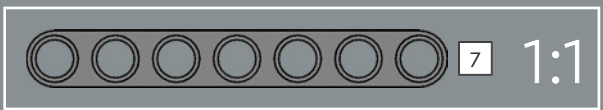
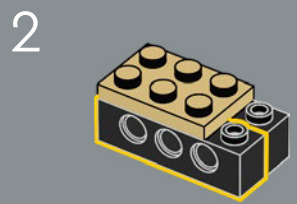
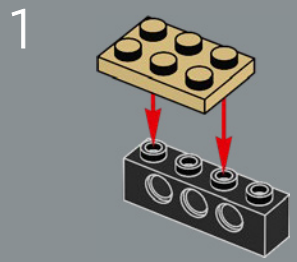

3

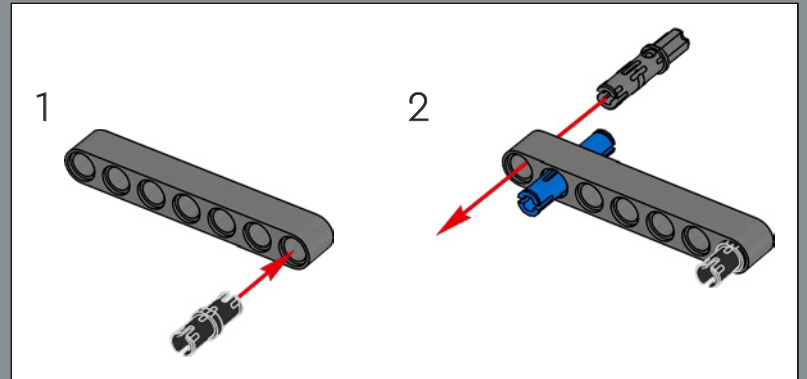
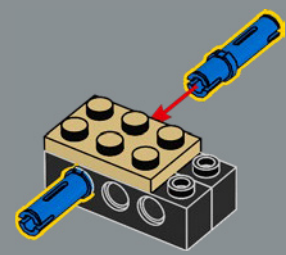

4

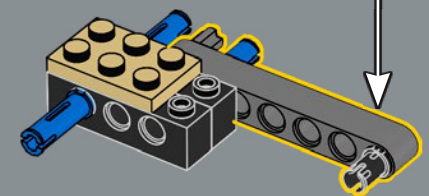

5

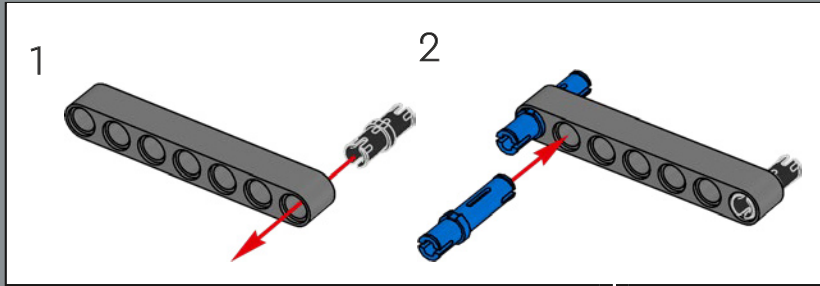
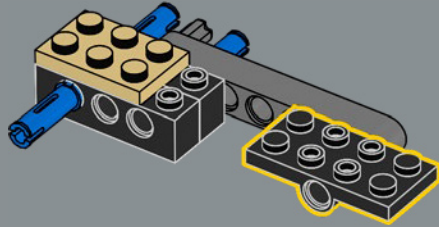

6

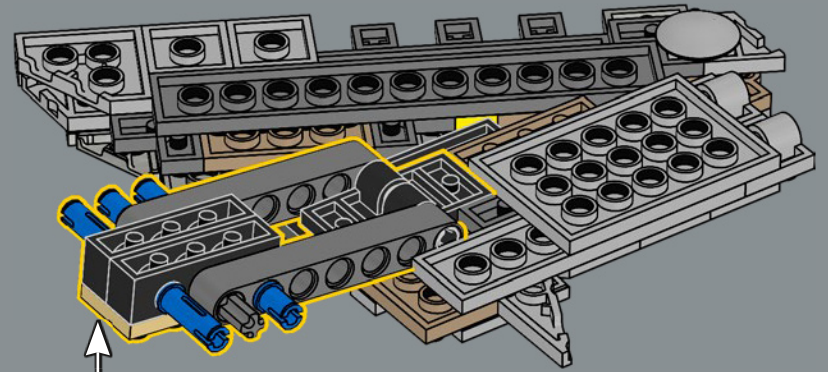
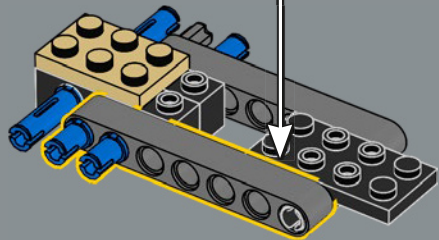

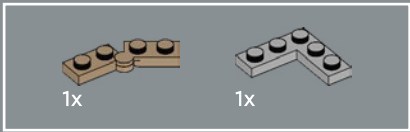

38

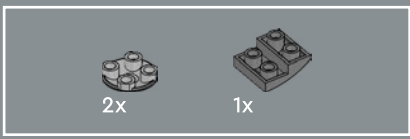
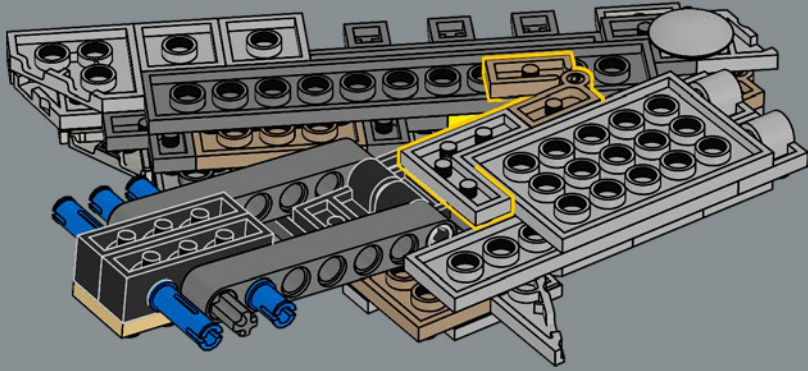

39

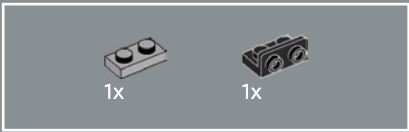
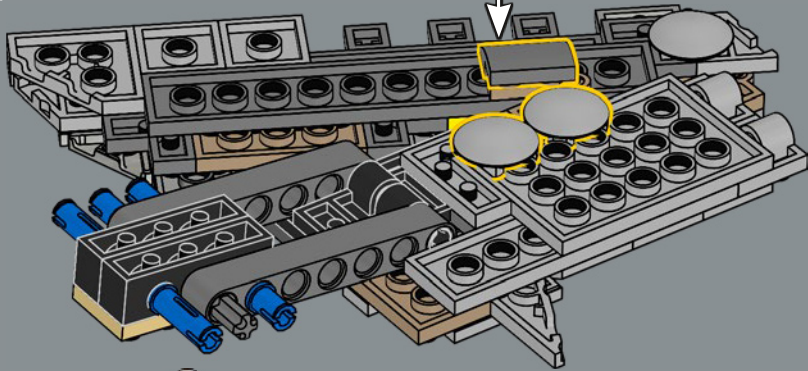
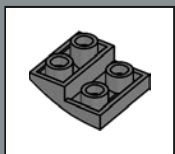

40

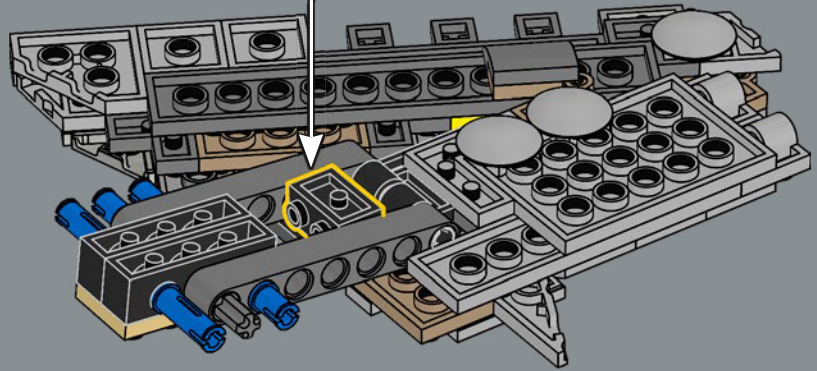
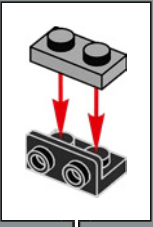



41

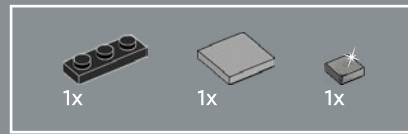
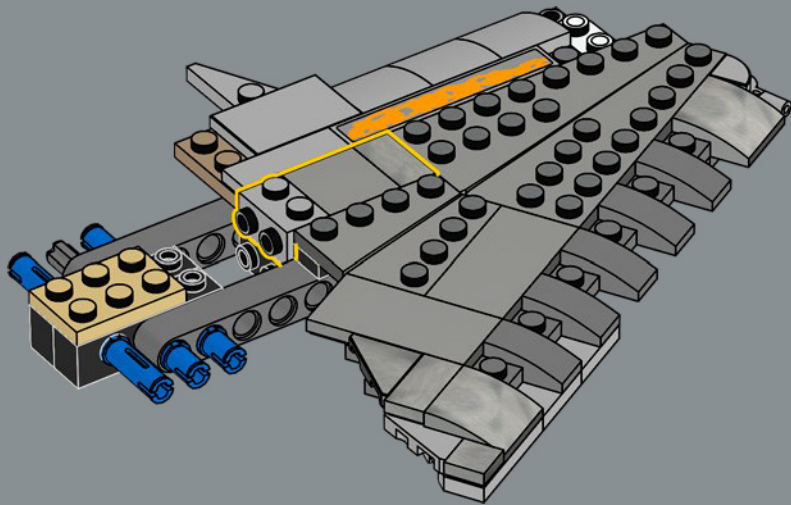

42

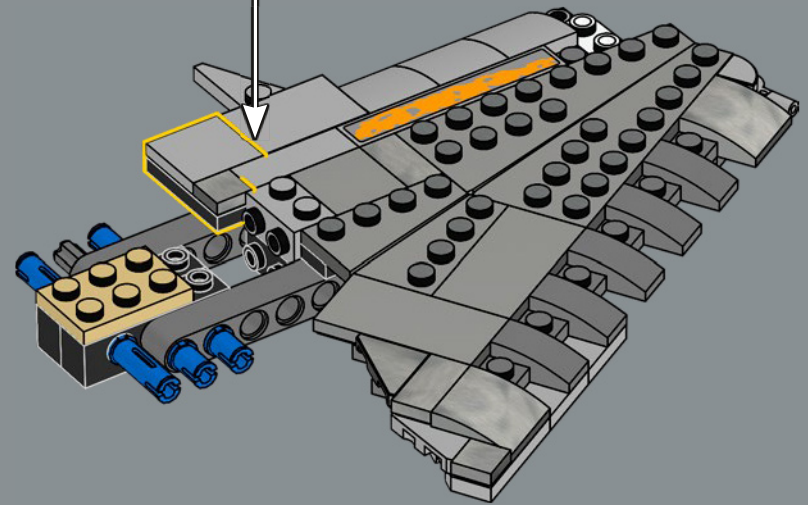
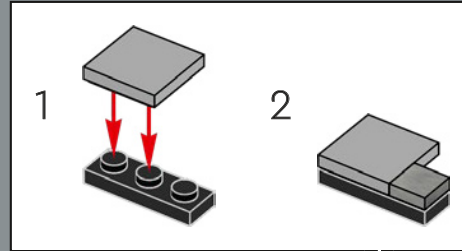

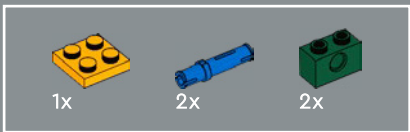

43

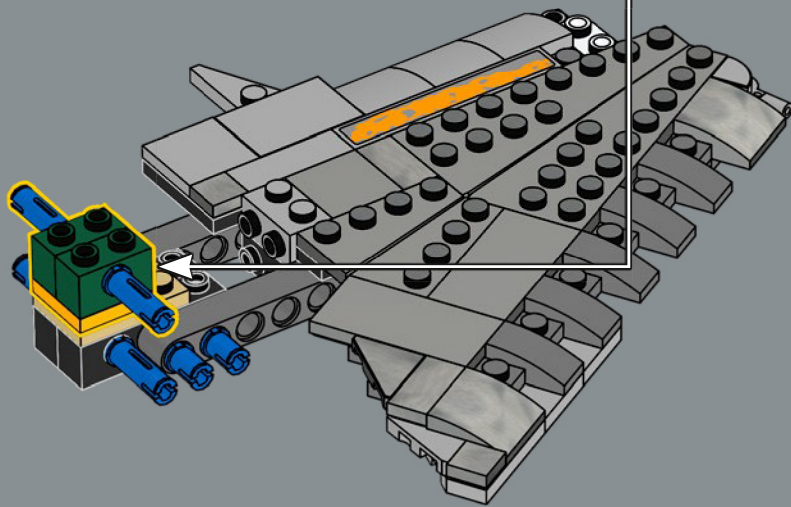
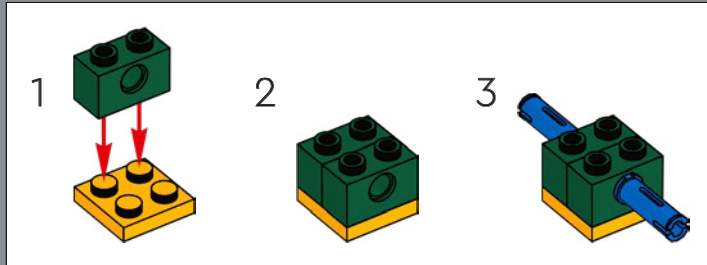

44

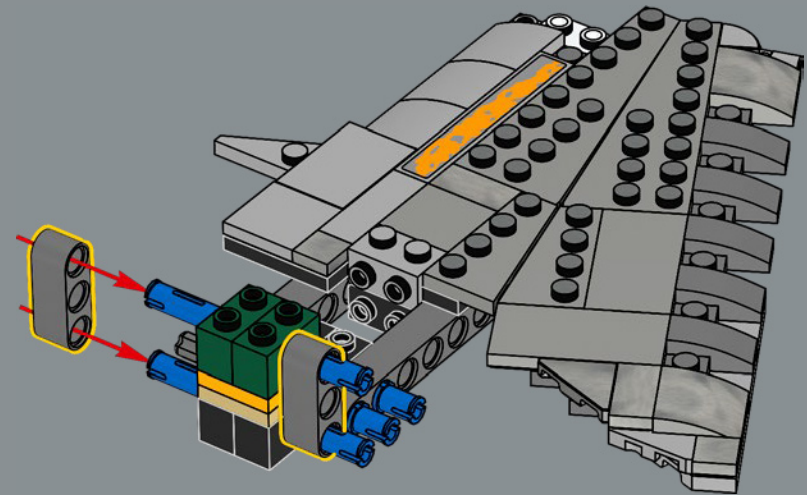

45

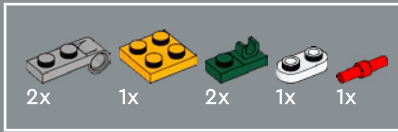
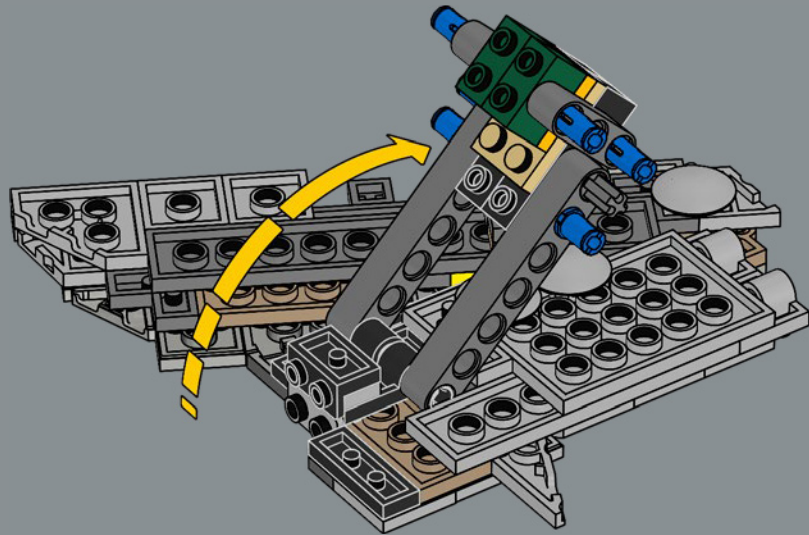

46

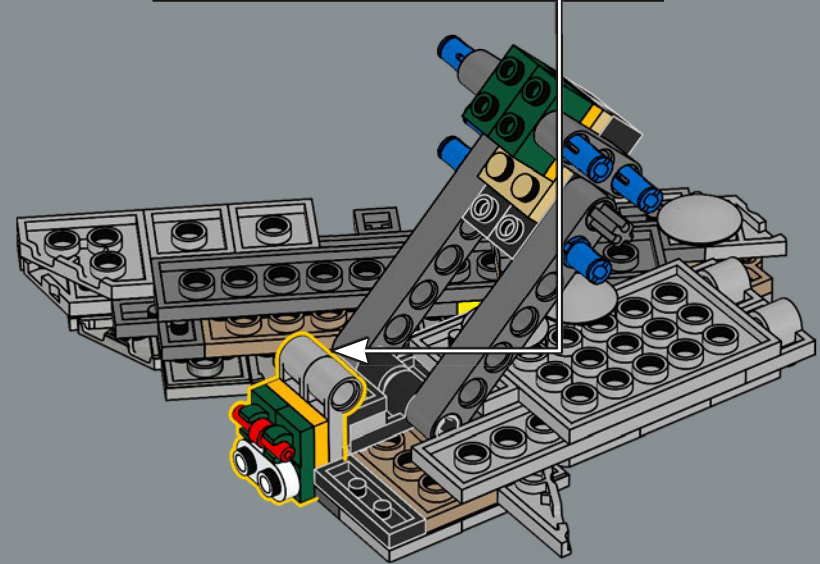
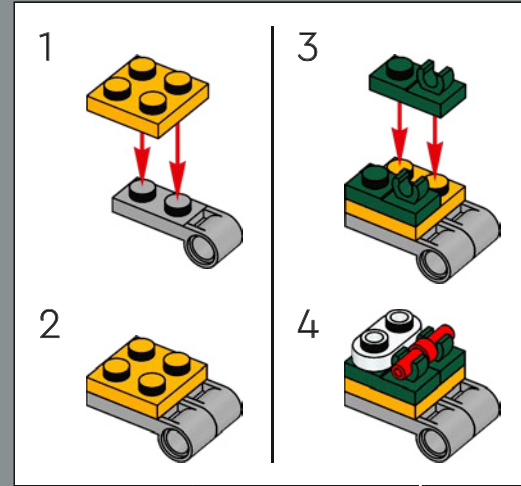

47

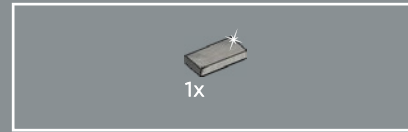
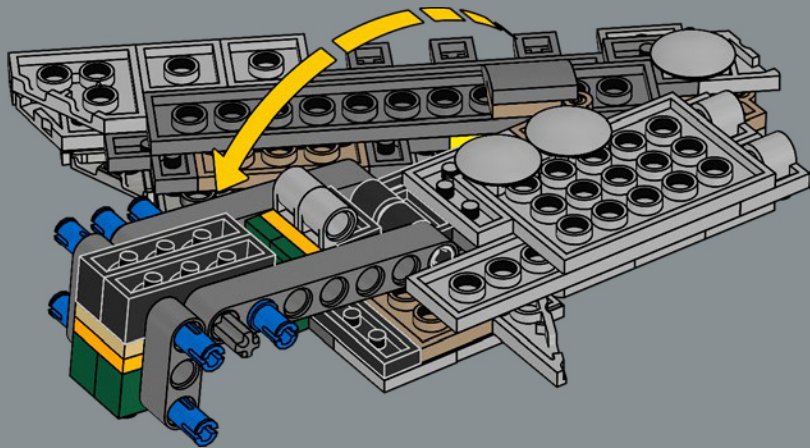

48

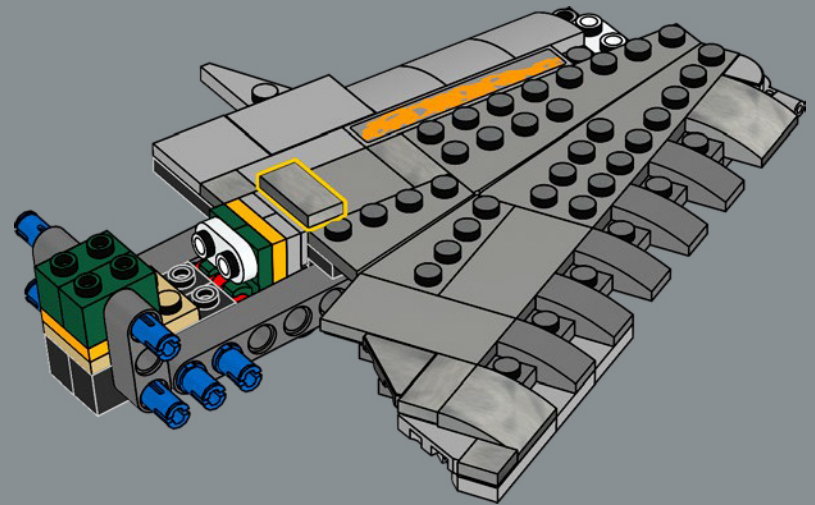

49

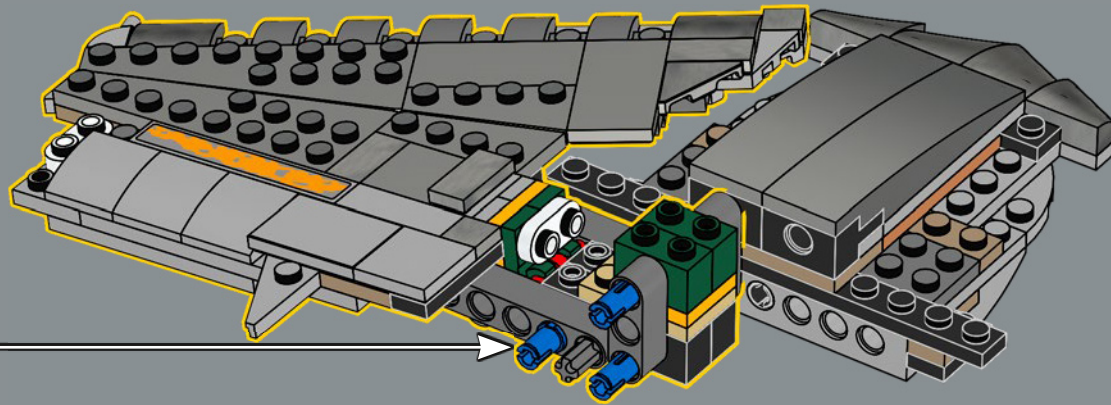

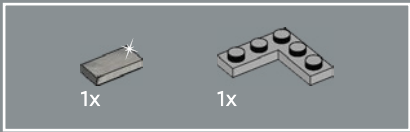

50

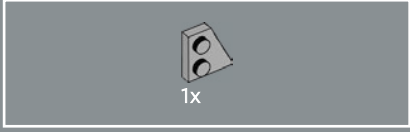
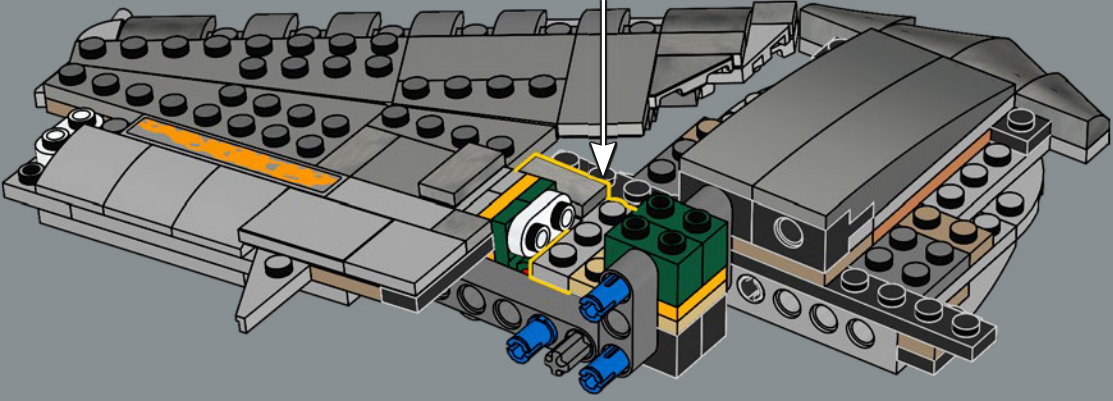
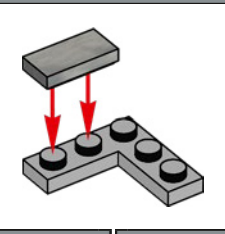

51

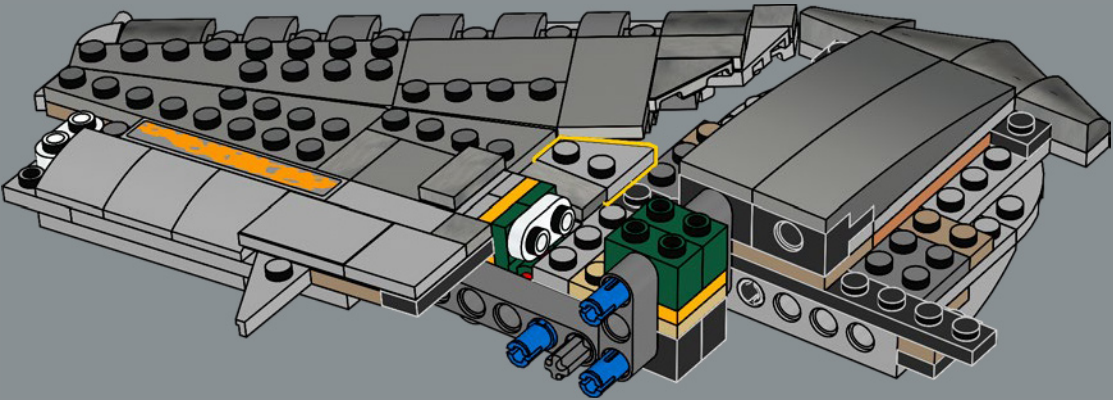



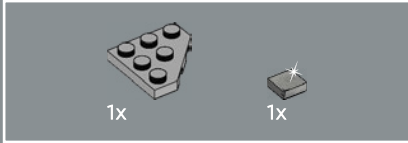
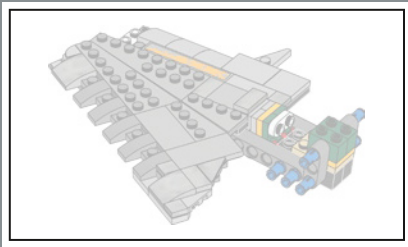

52

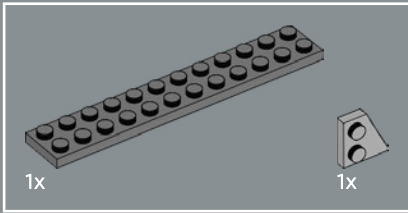
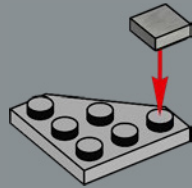

53

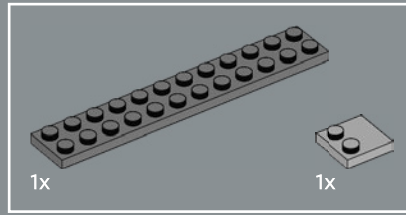
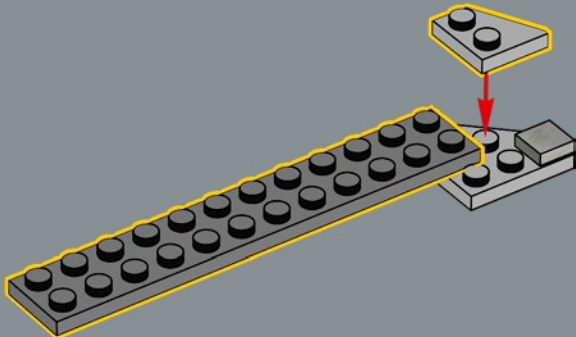

54

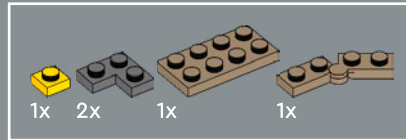
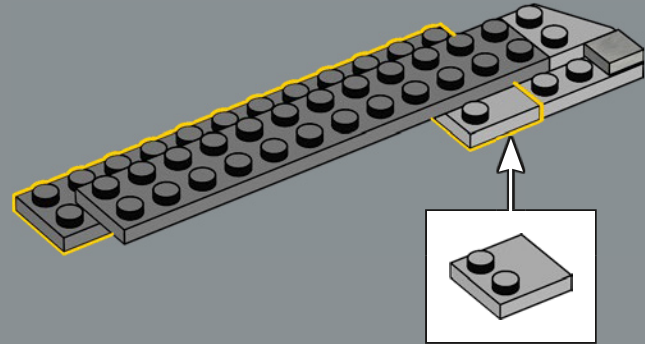

55

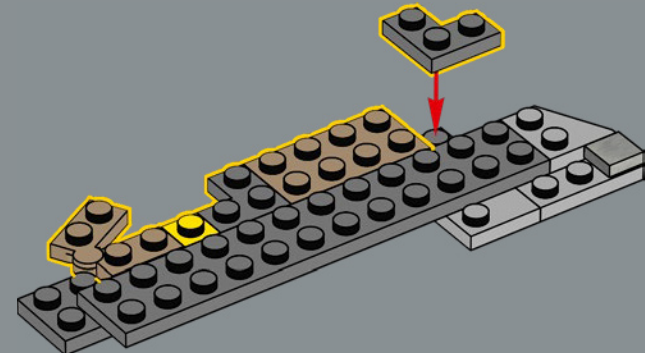

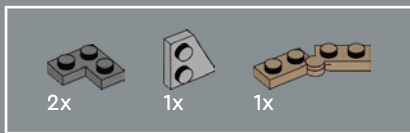

56

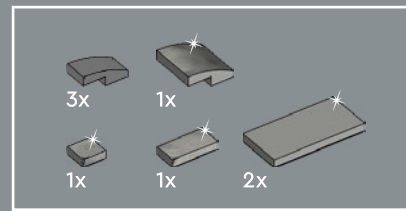
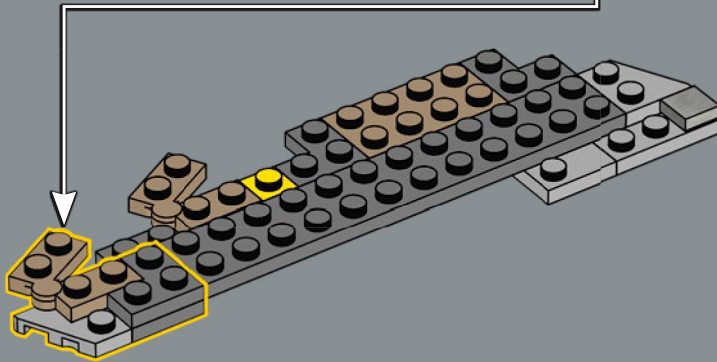
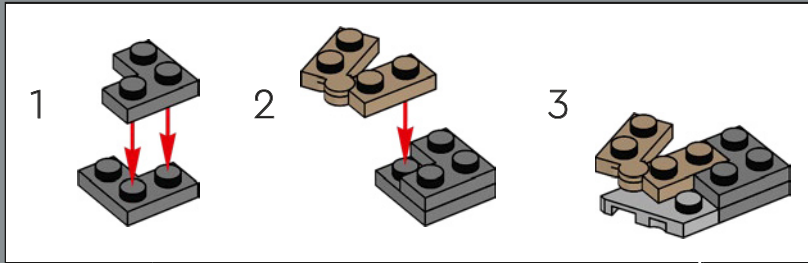

57

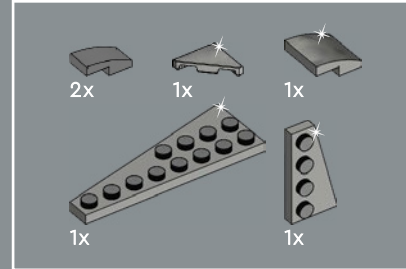
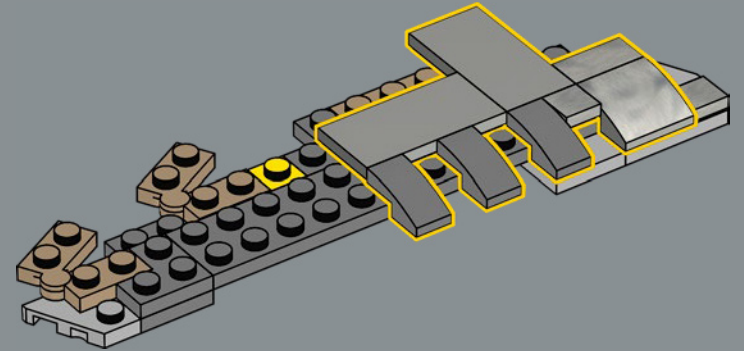

58

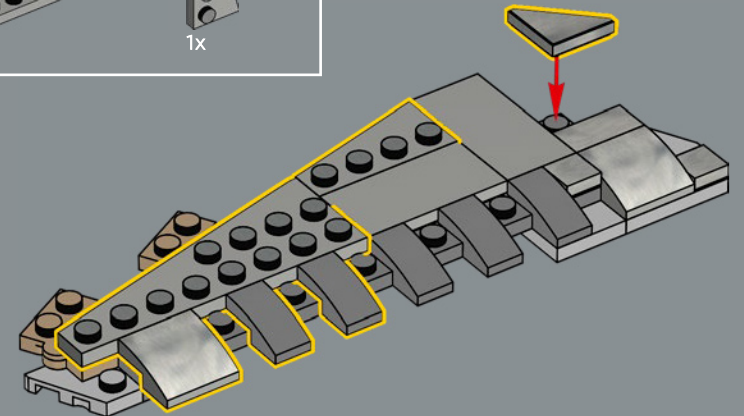

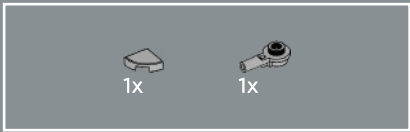

59

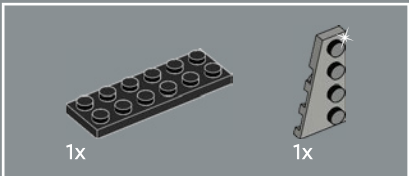
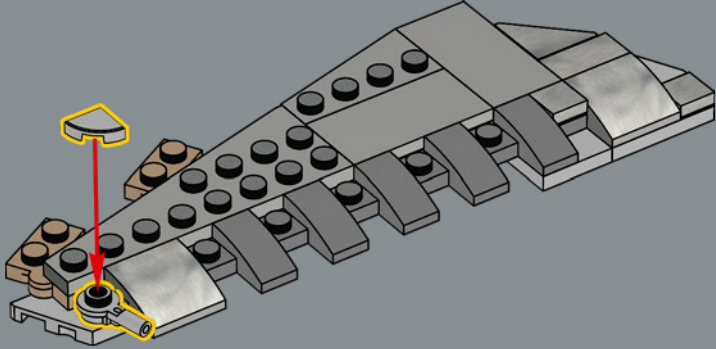

61

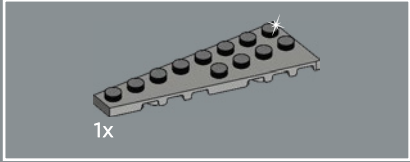
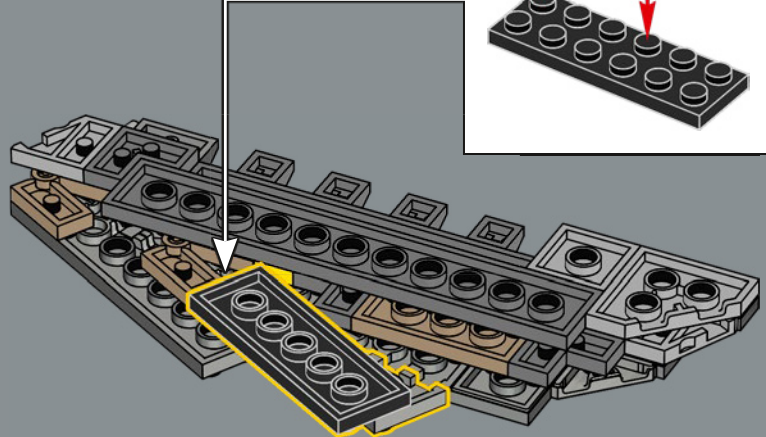

60

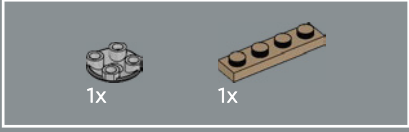
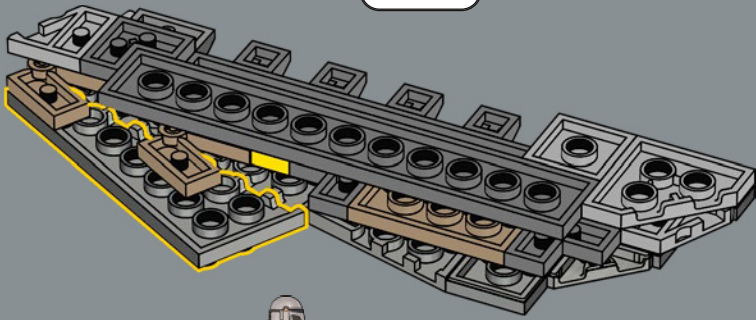

62

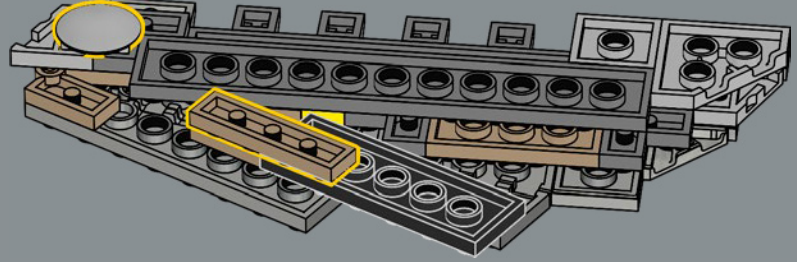

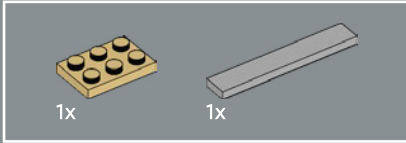
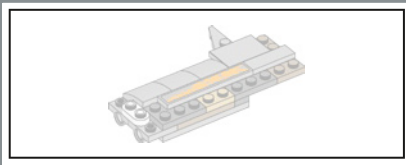

63

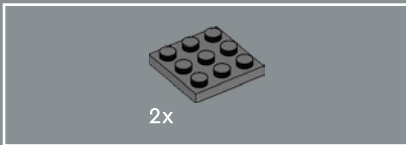
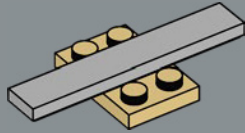

64

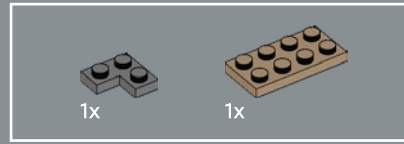
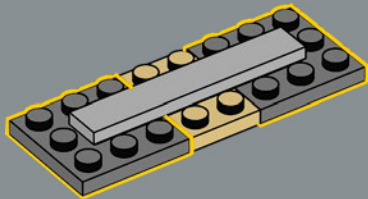

65

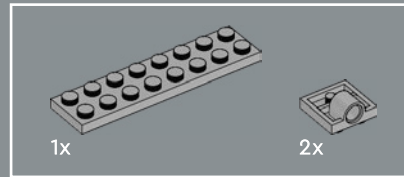
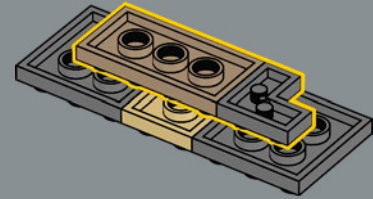

66

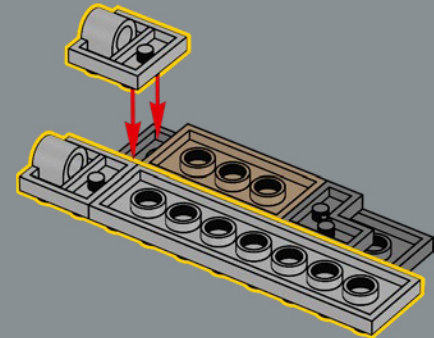

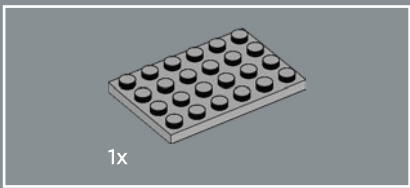

67

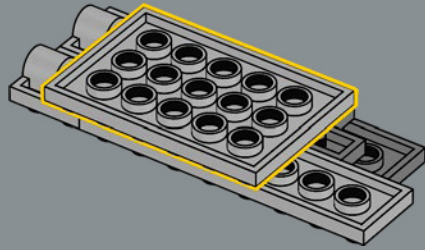

69

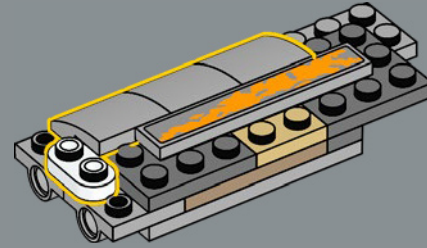

68

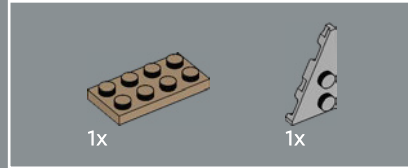
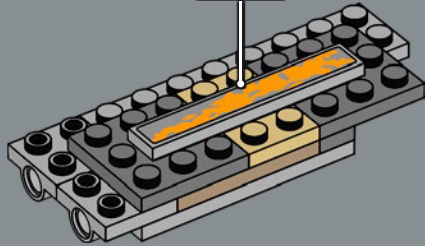

70

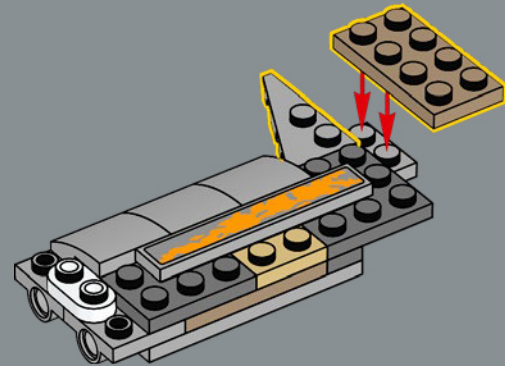

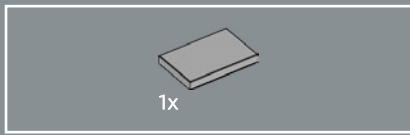

71

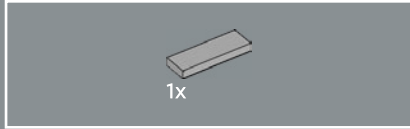
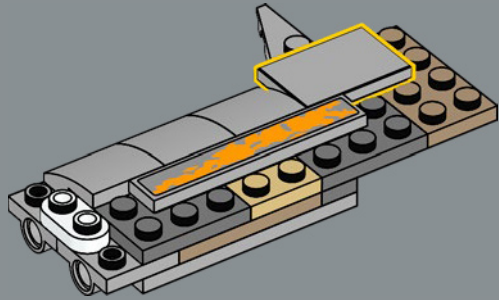

72

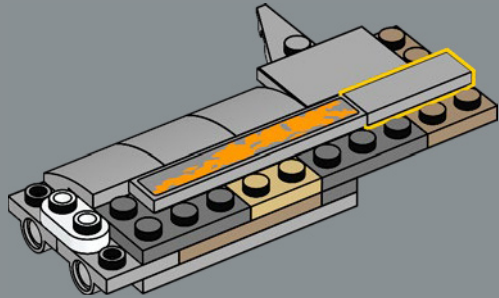

73

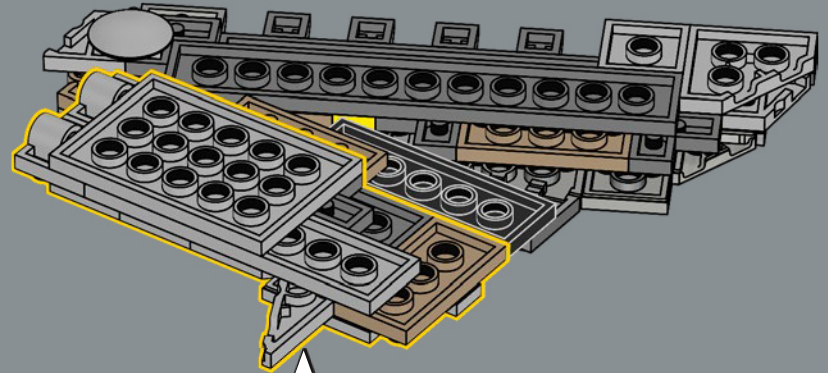

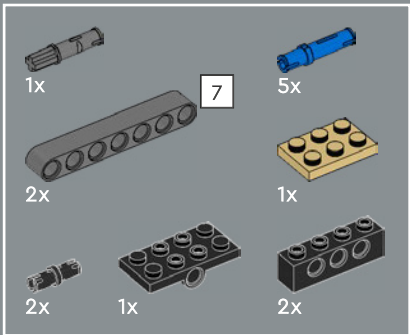
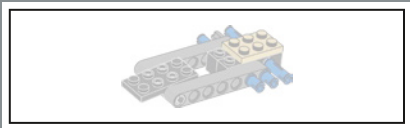

74

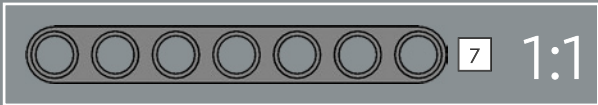
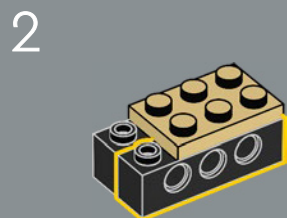
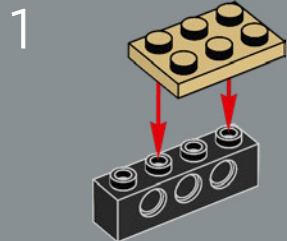

3

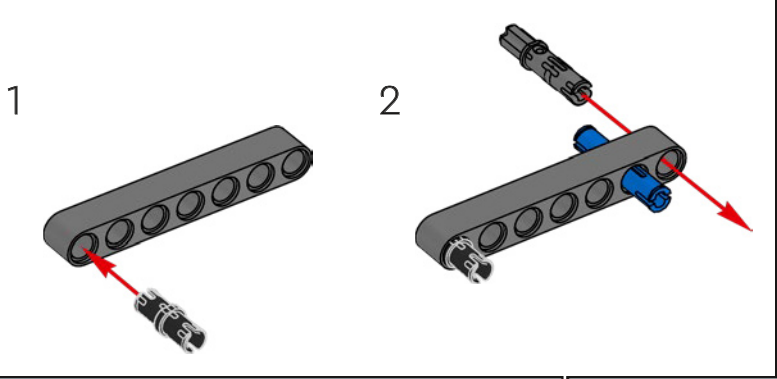
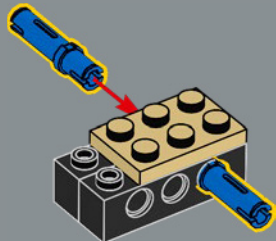

4

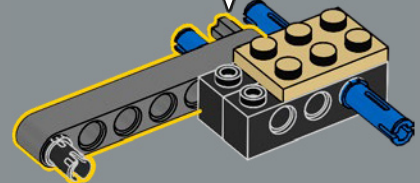

5

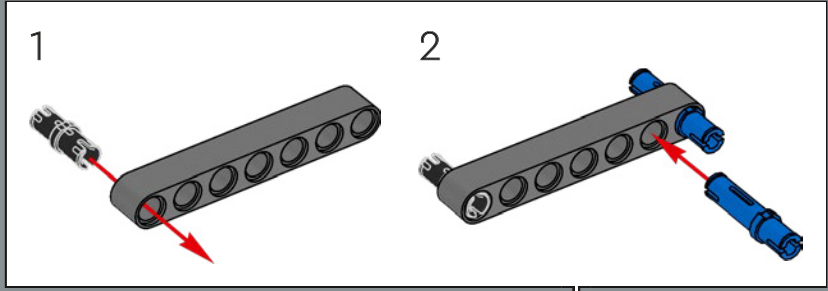
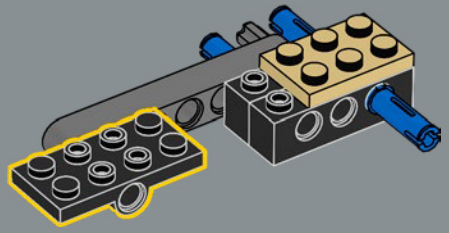

6

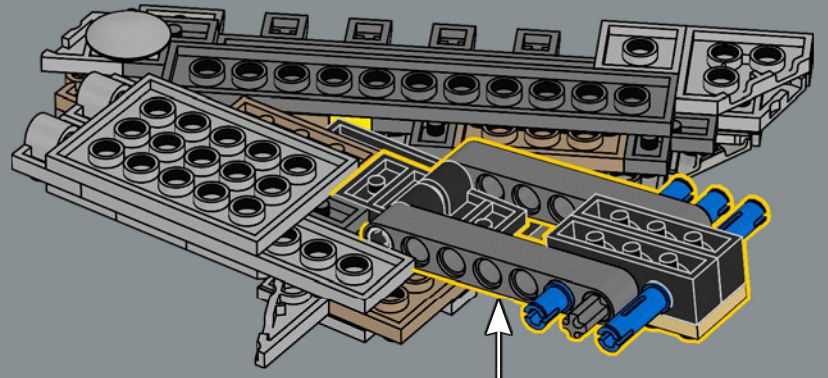
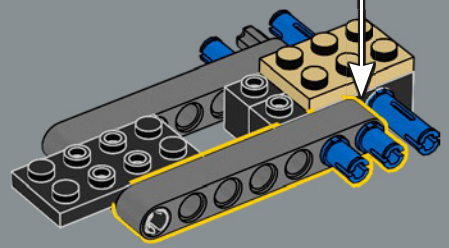

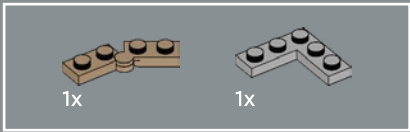

75

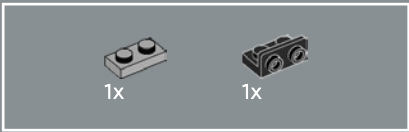
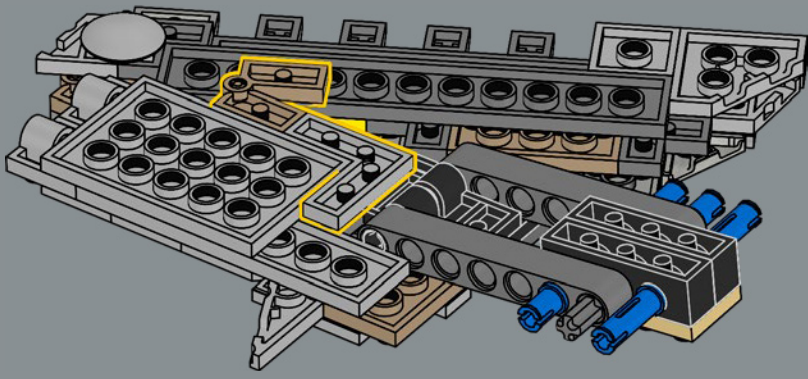

77

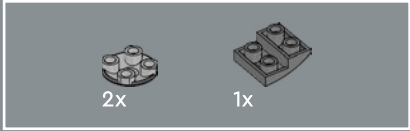
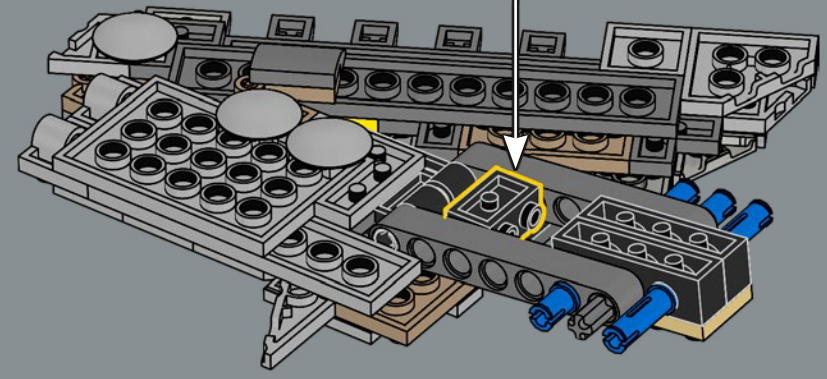
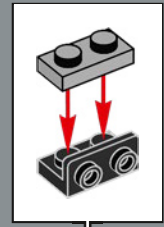

76

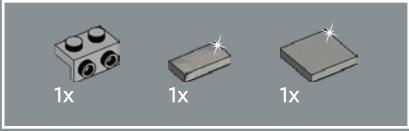
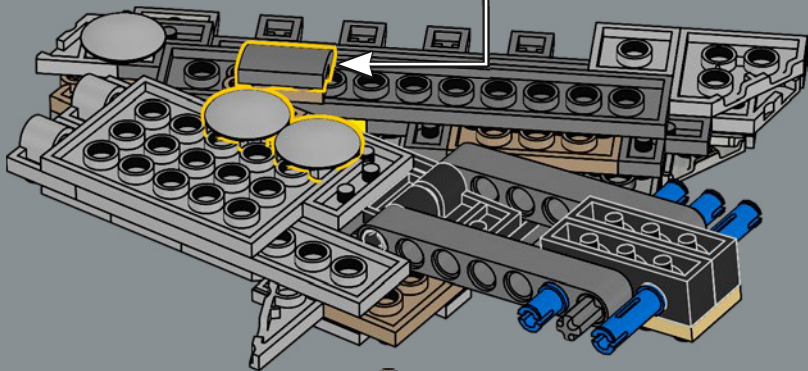
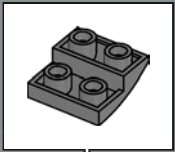

78

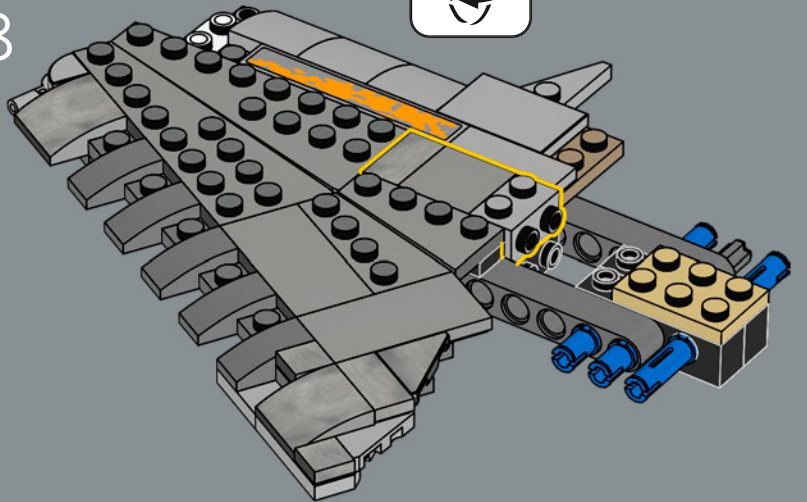

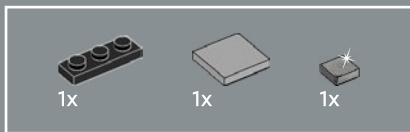

79

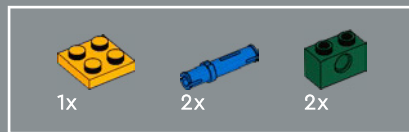
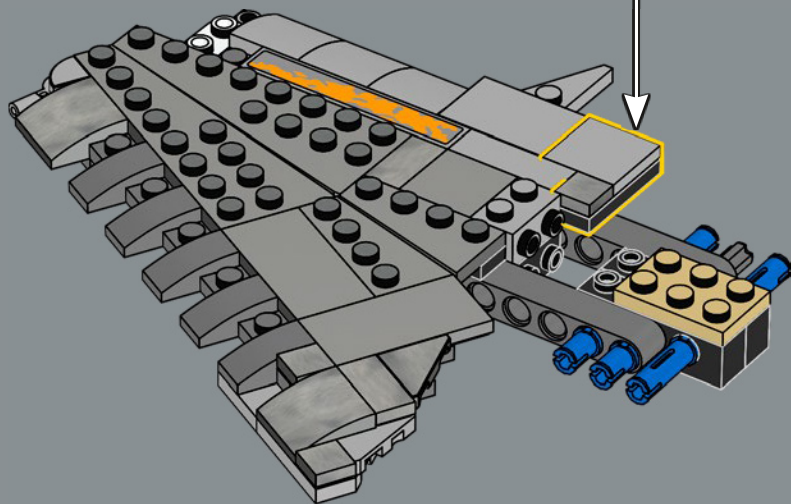
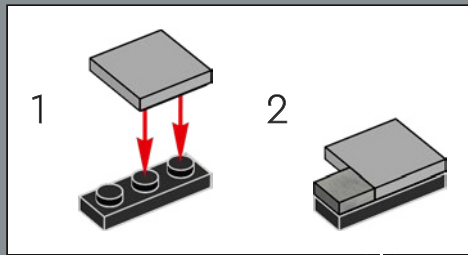

80

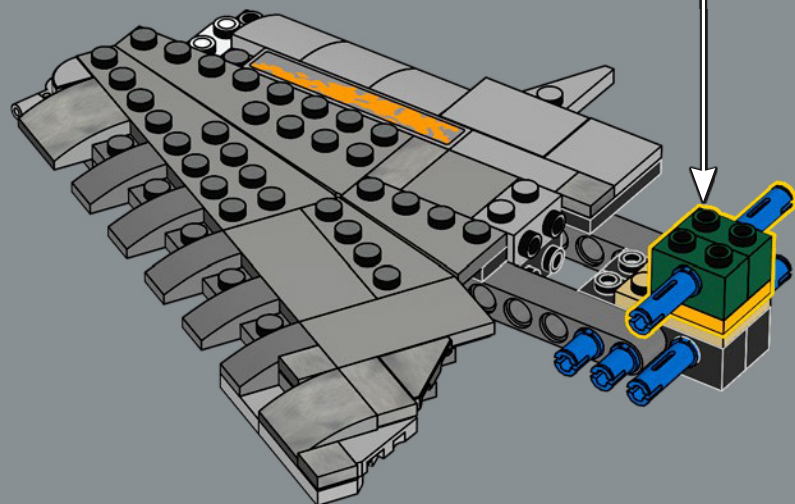
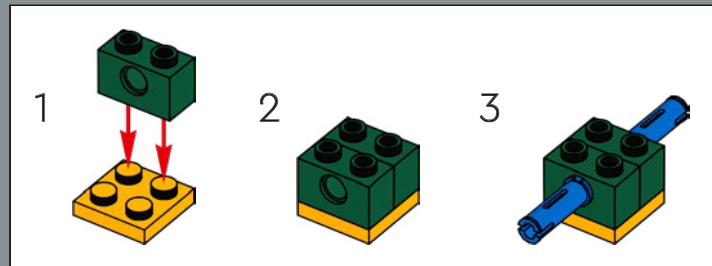

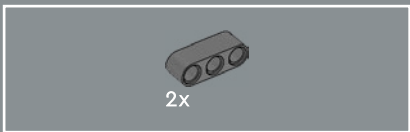

81

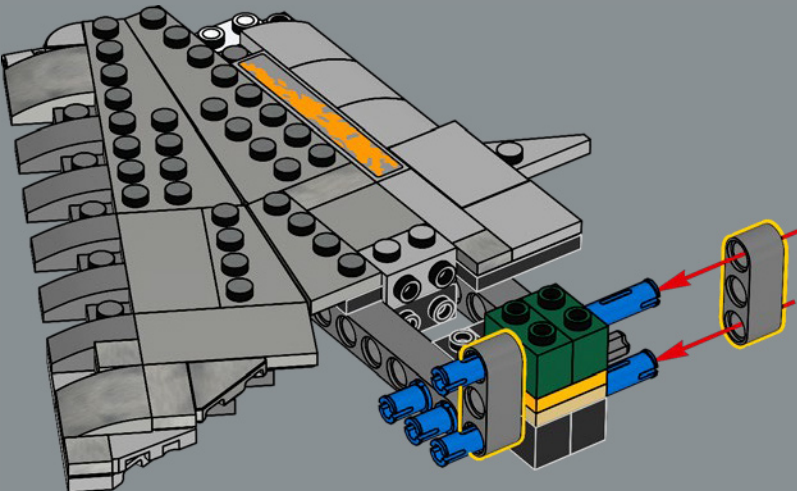

82

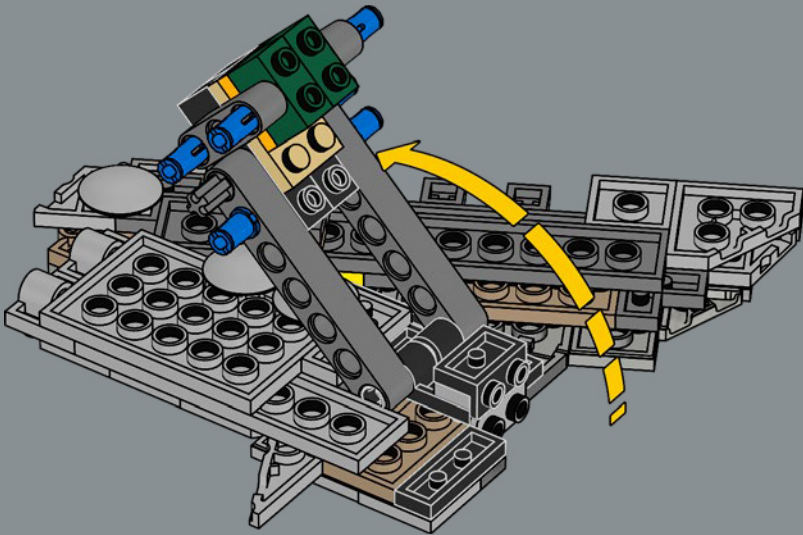

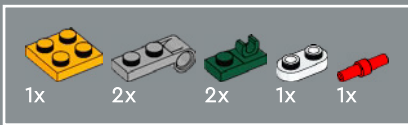

83

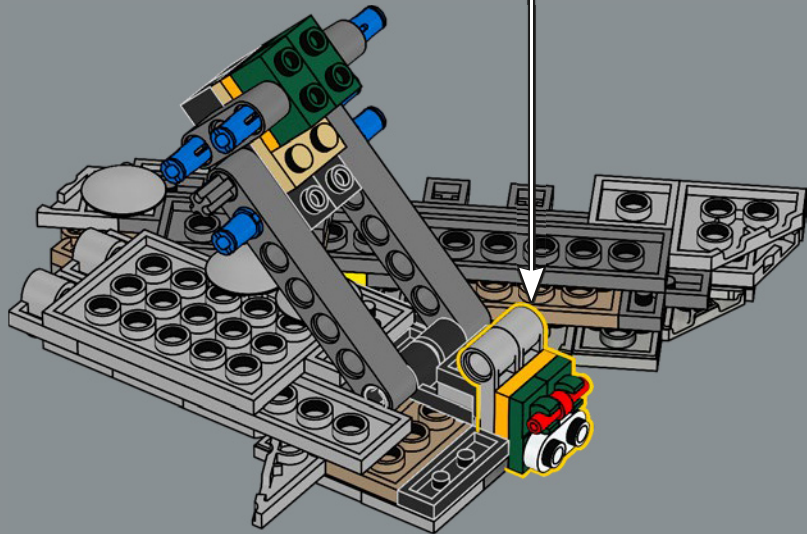
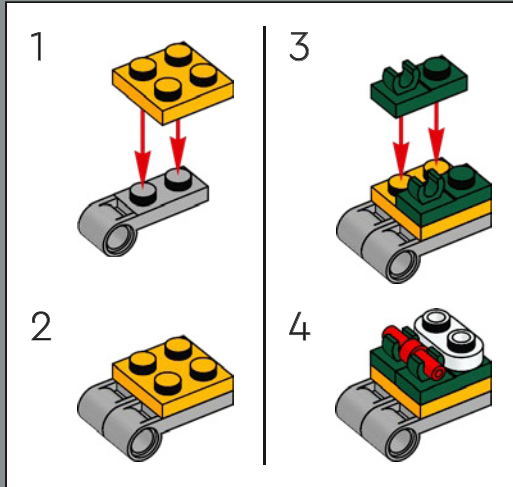

84

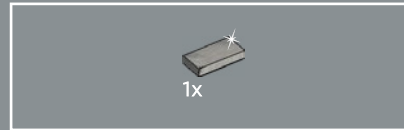
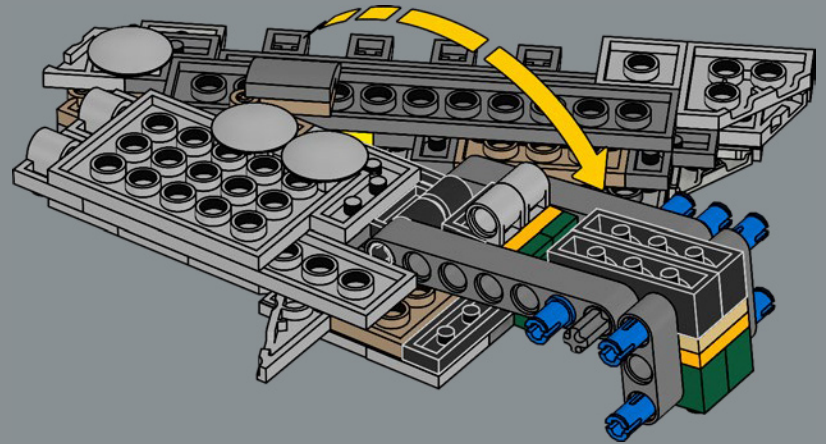

85

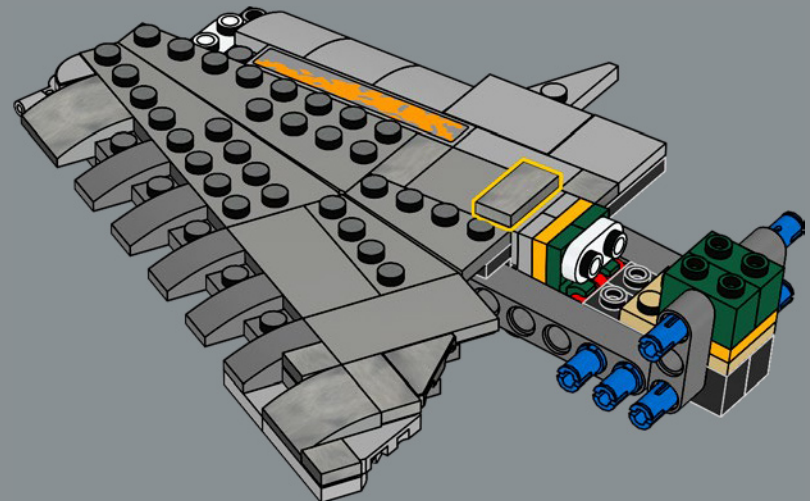

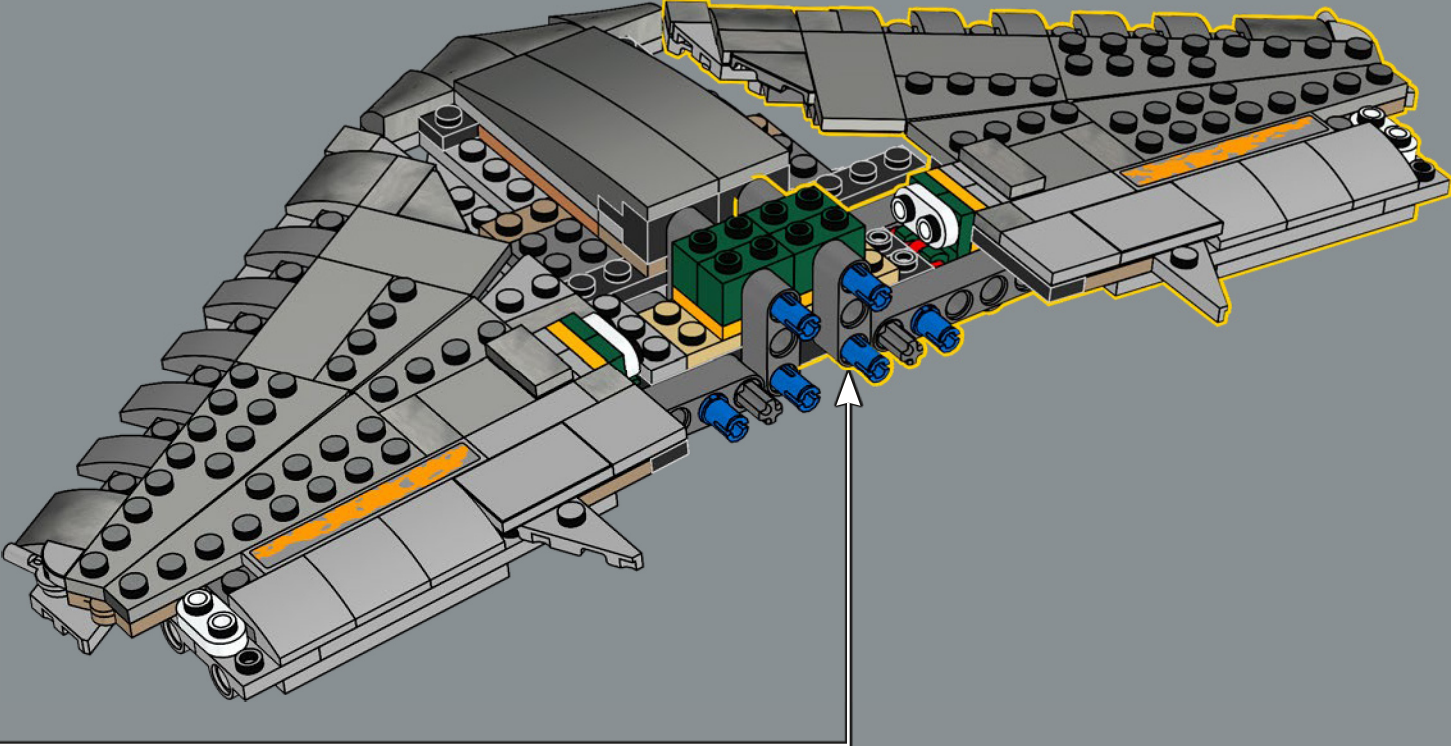

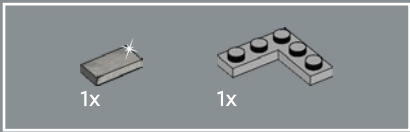

87

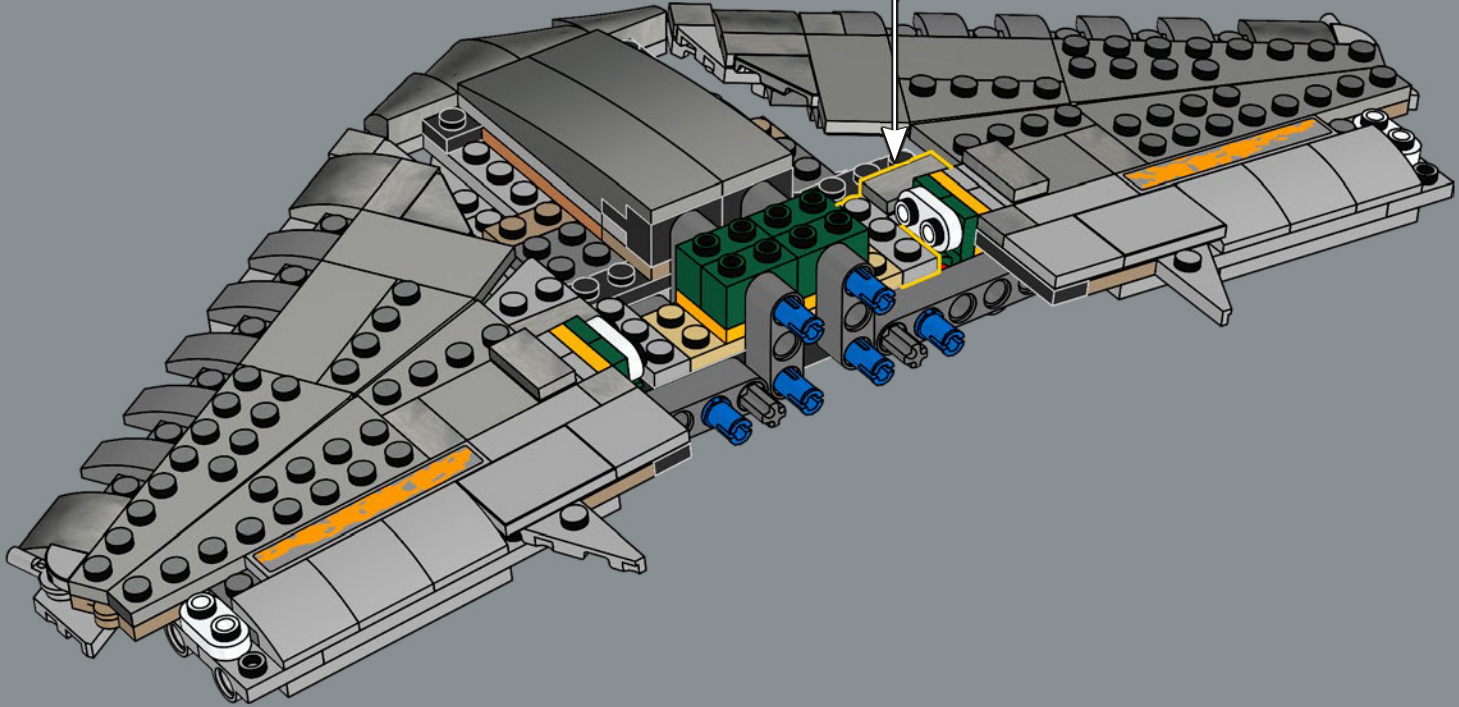
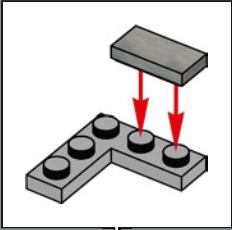



1x

88

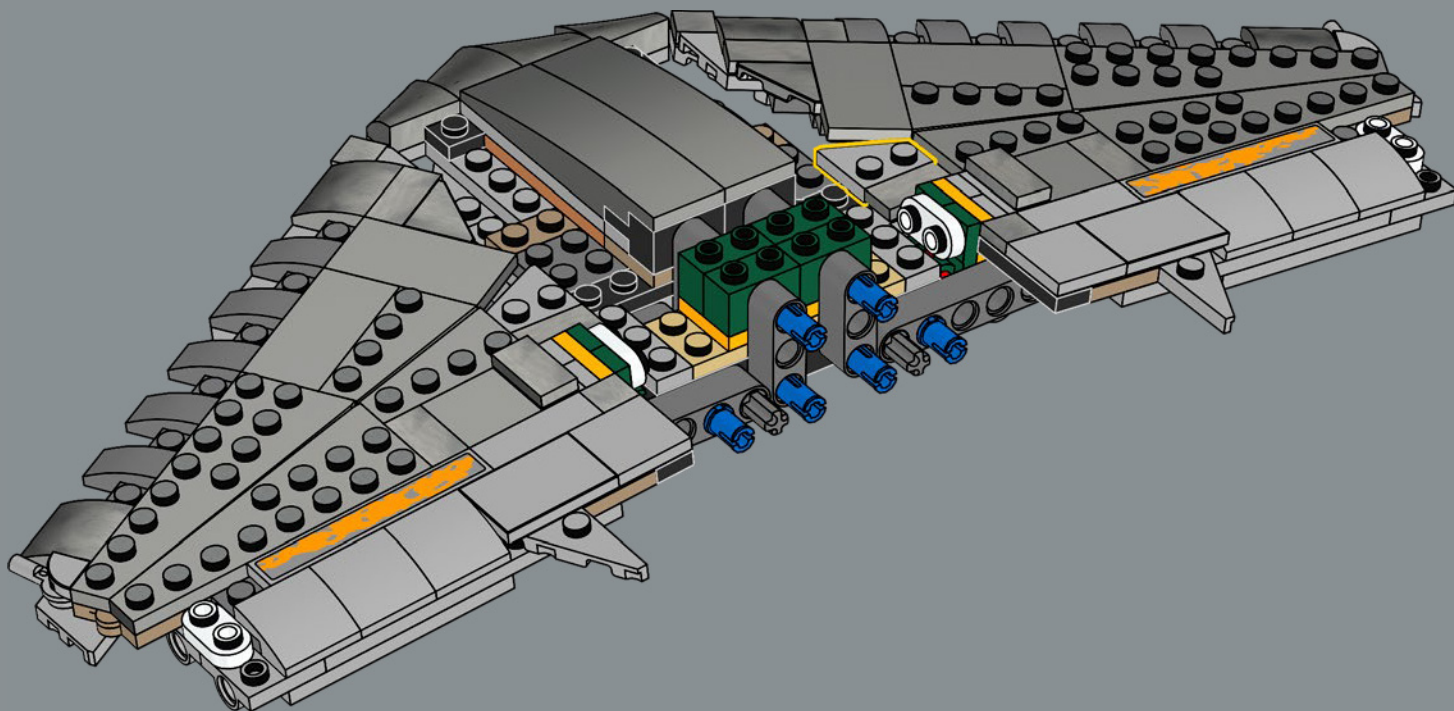

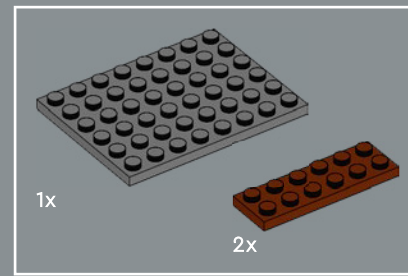
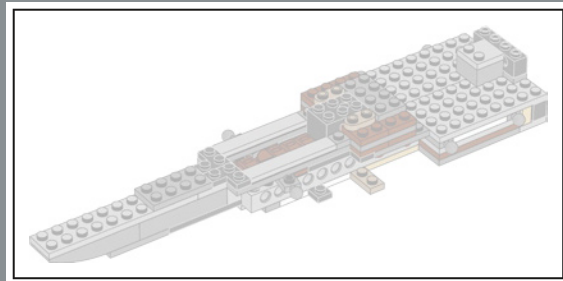

89

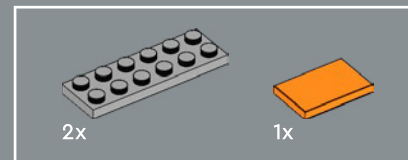
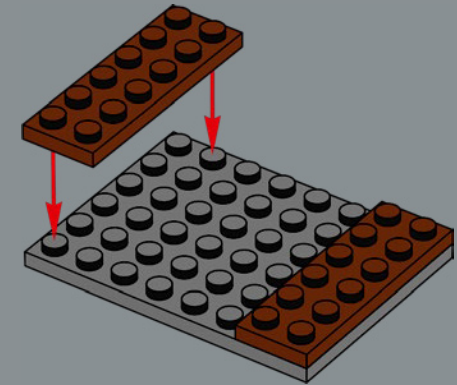

90

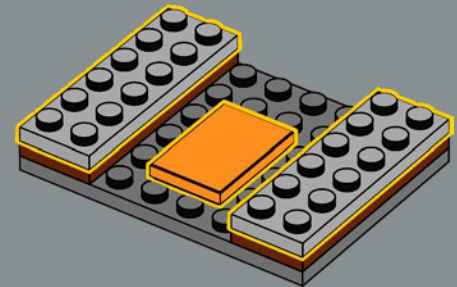

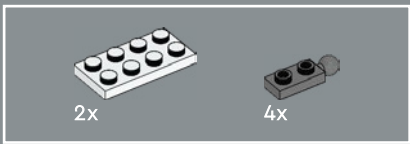

91

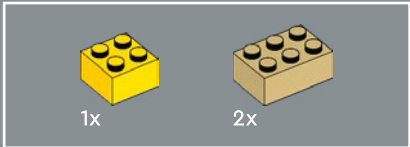
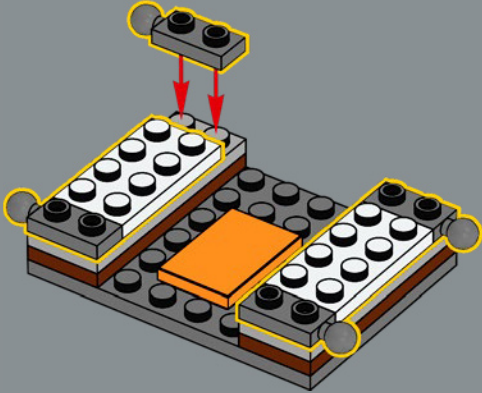

92

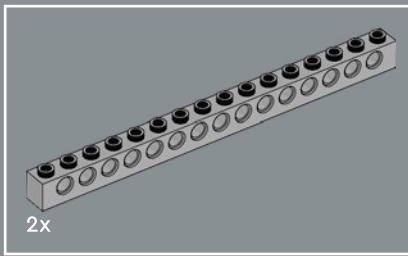
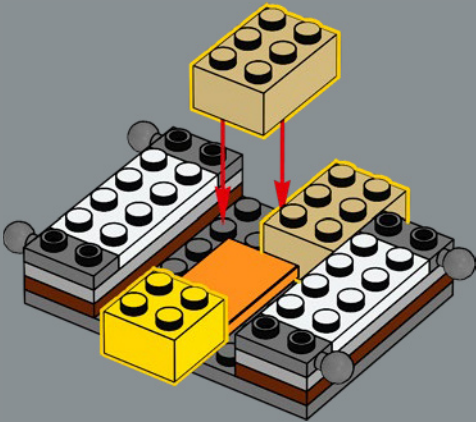

93

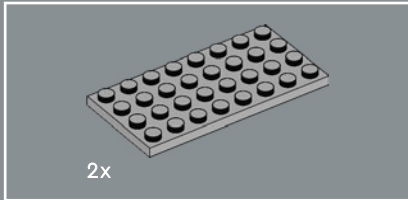
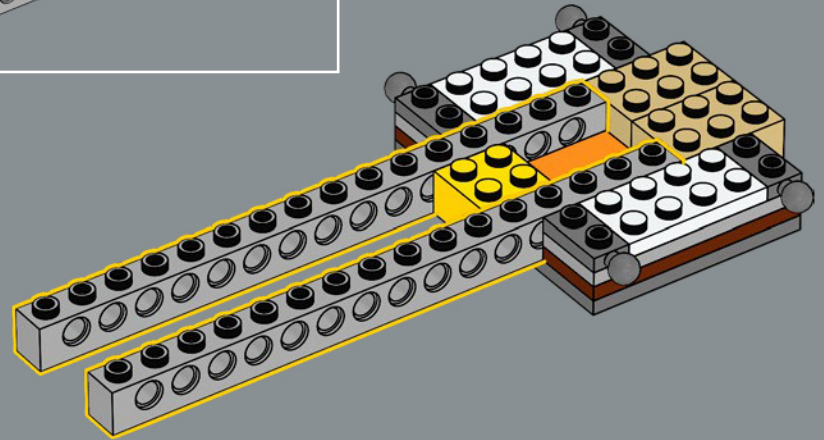

94

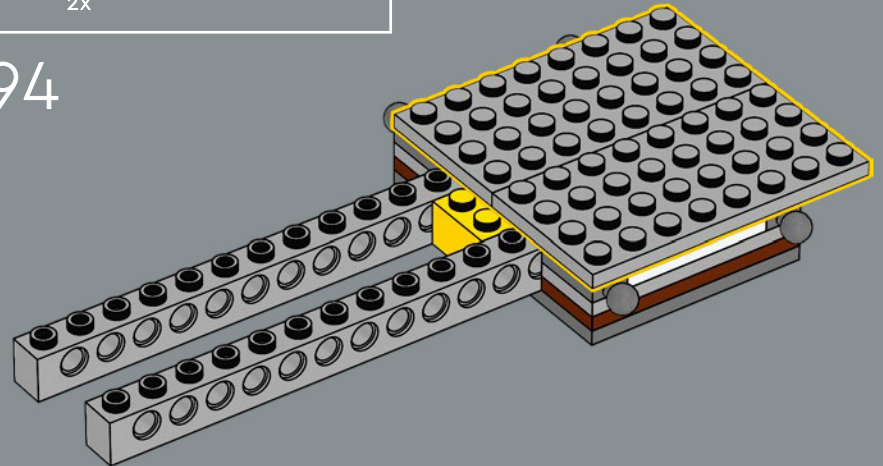



95

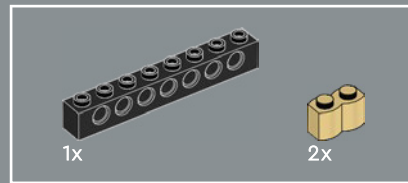
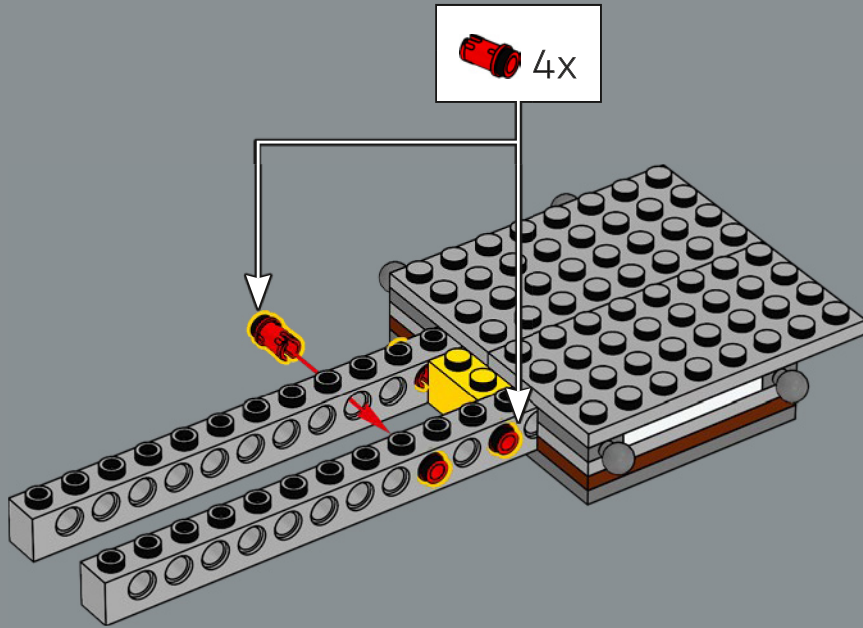

96

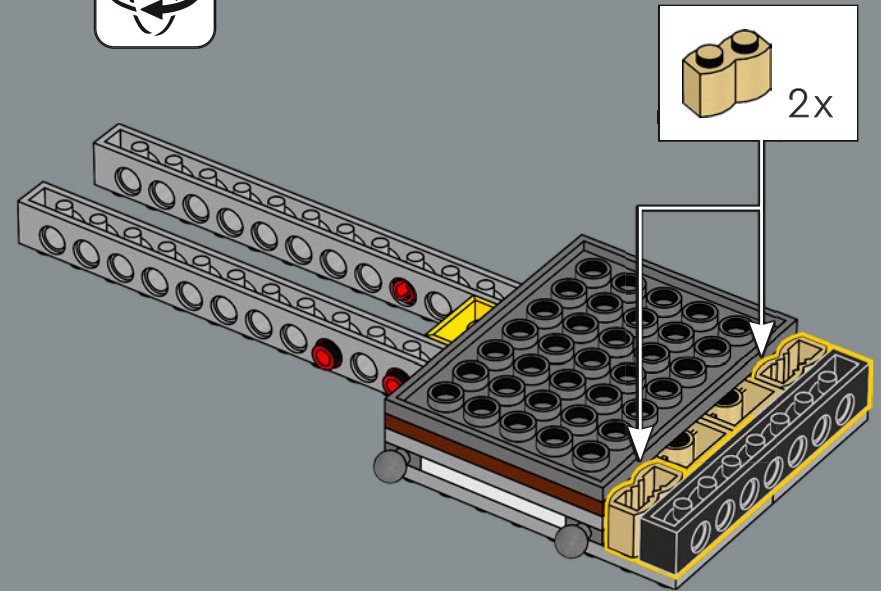

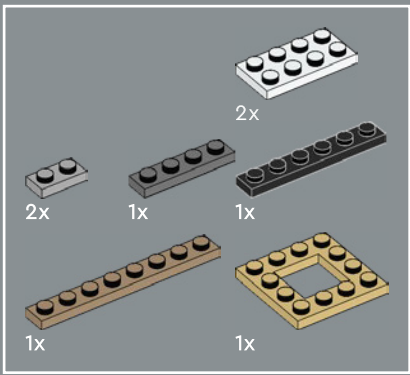

97

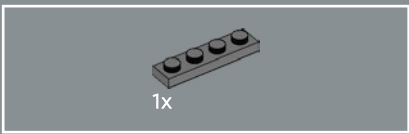
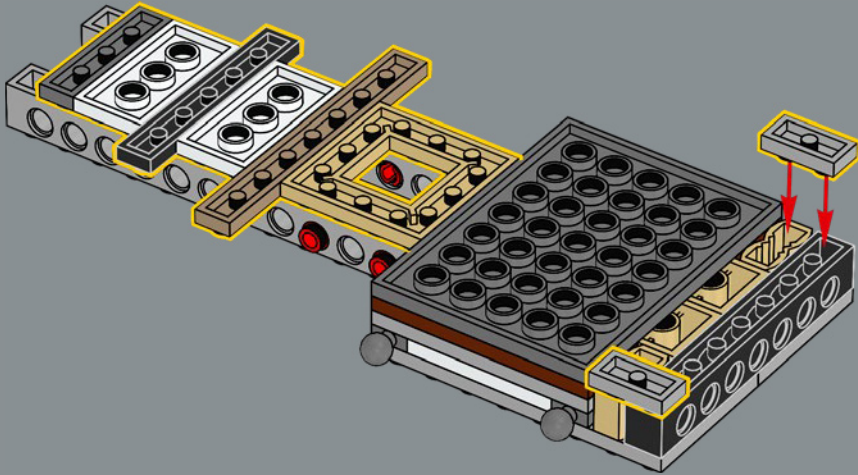

98

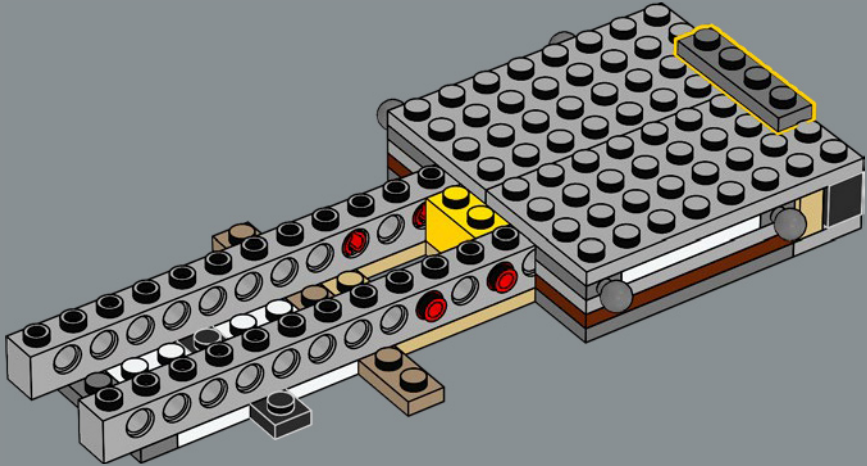

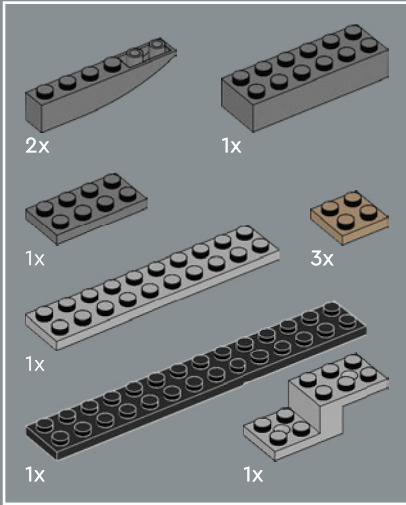
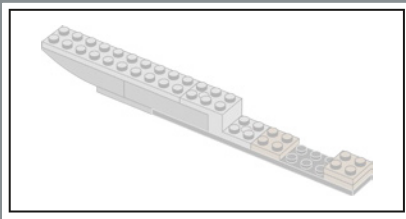

99

1

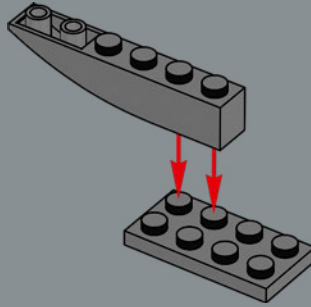

2

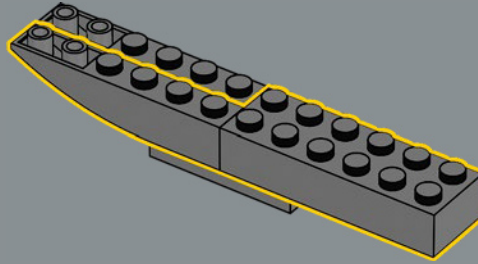

3

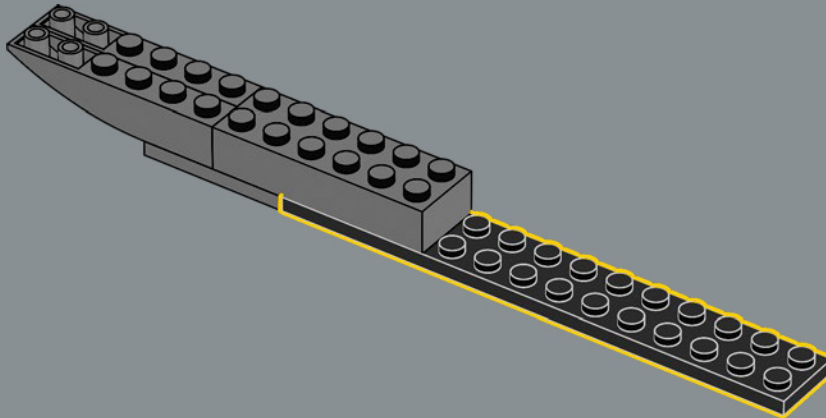

4

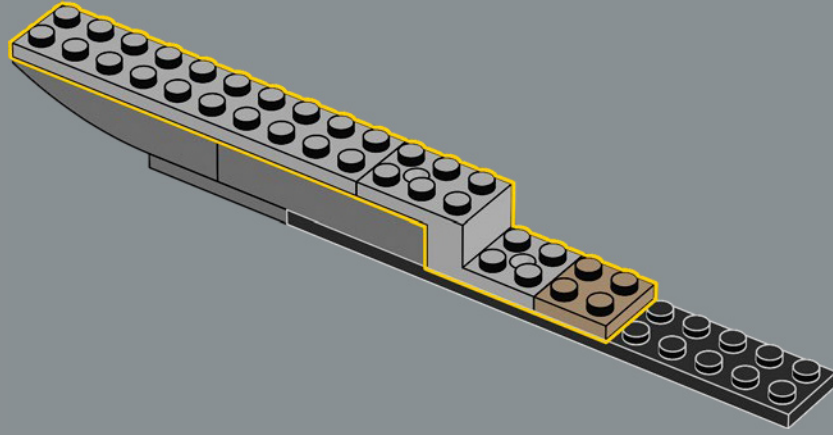

5

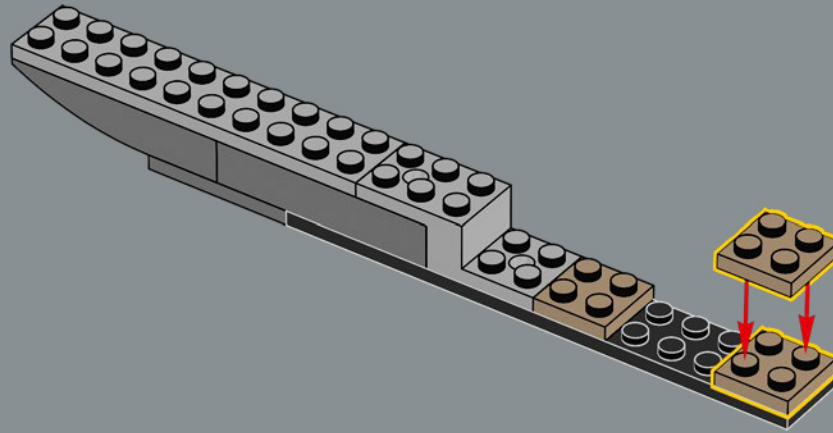

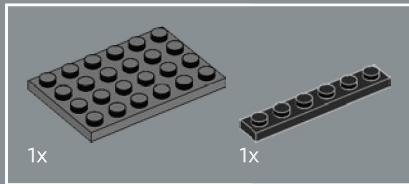
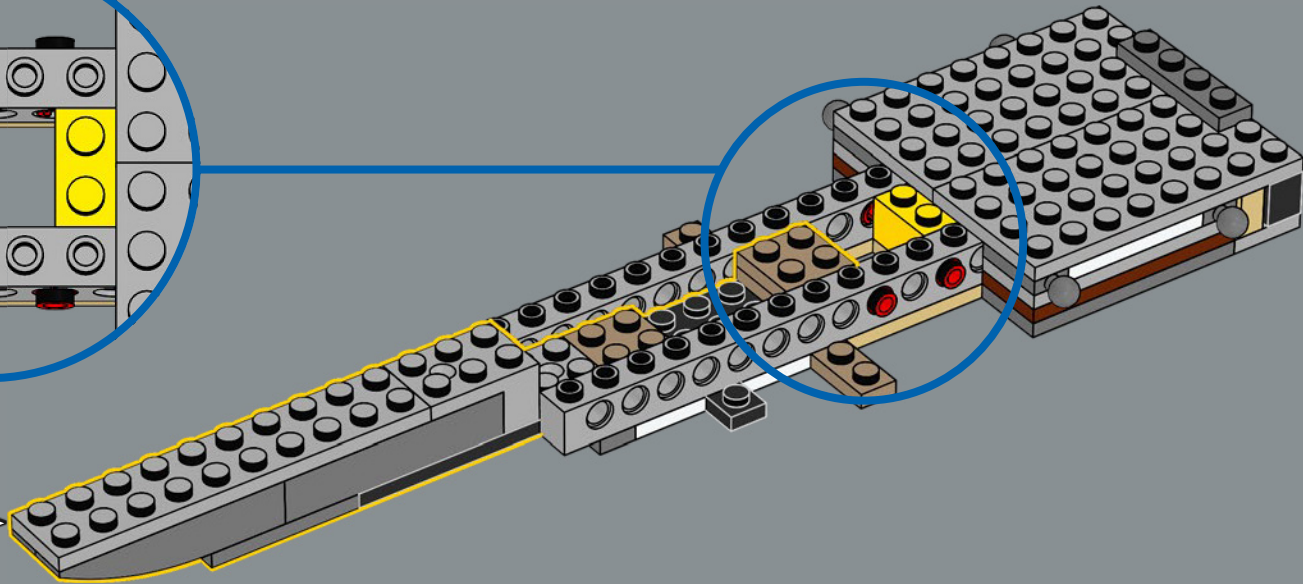
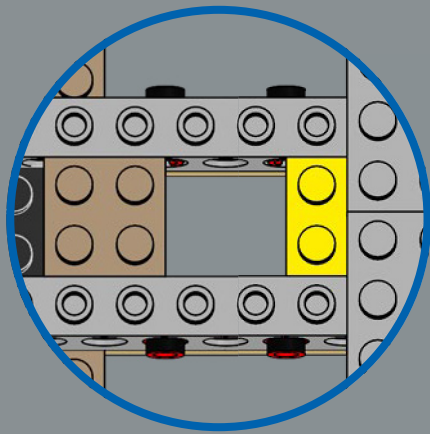

100

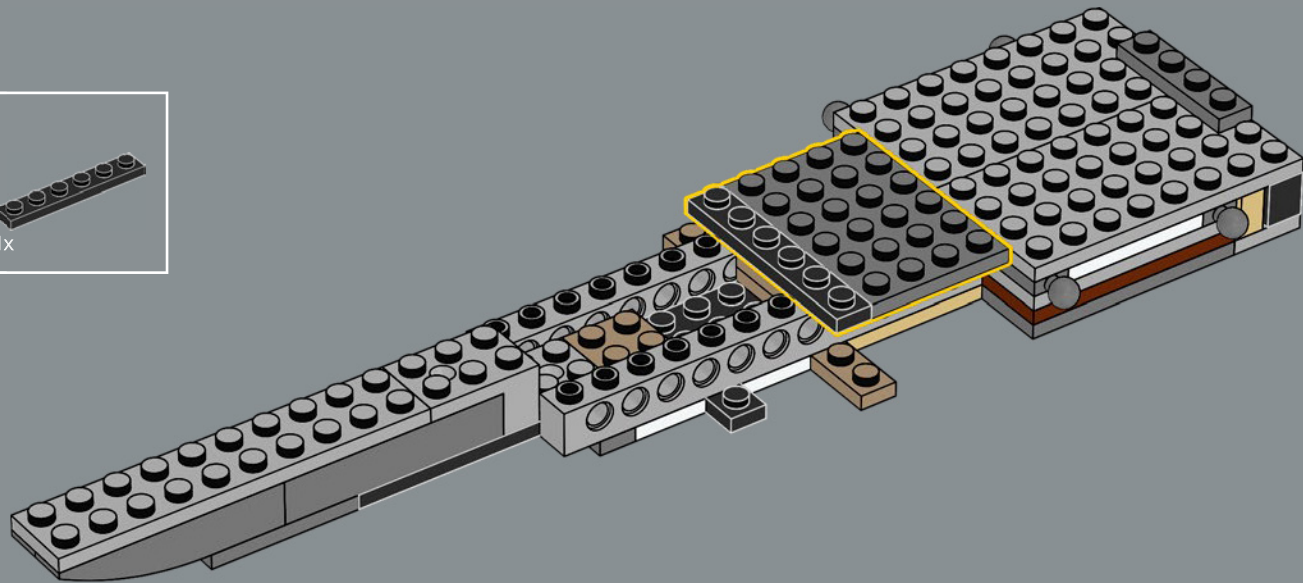

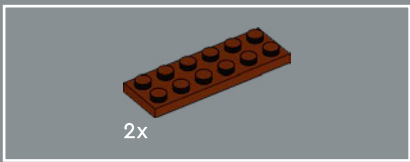

101

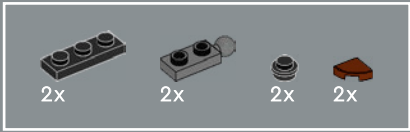
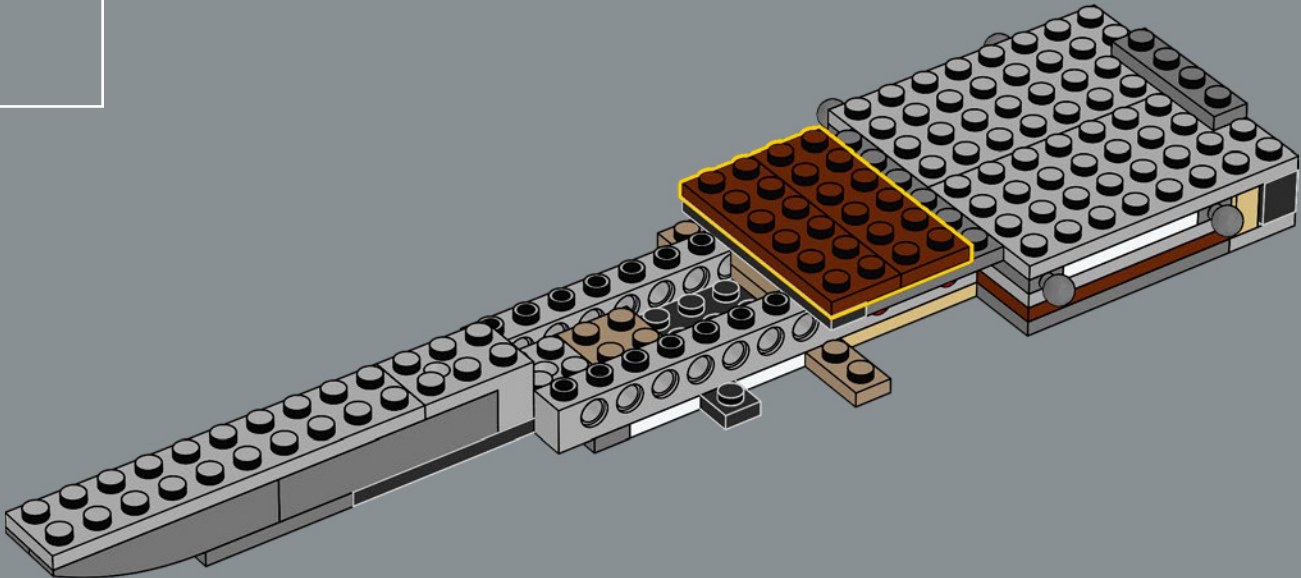

102

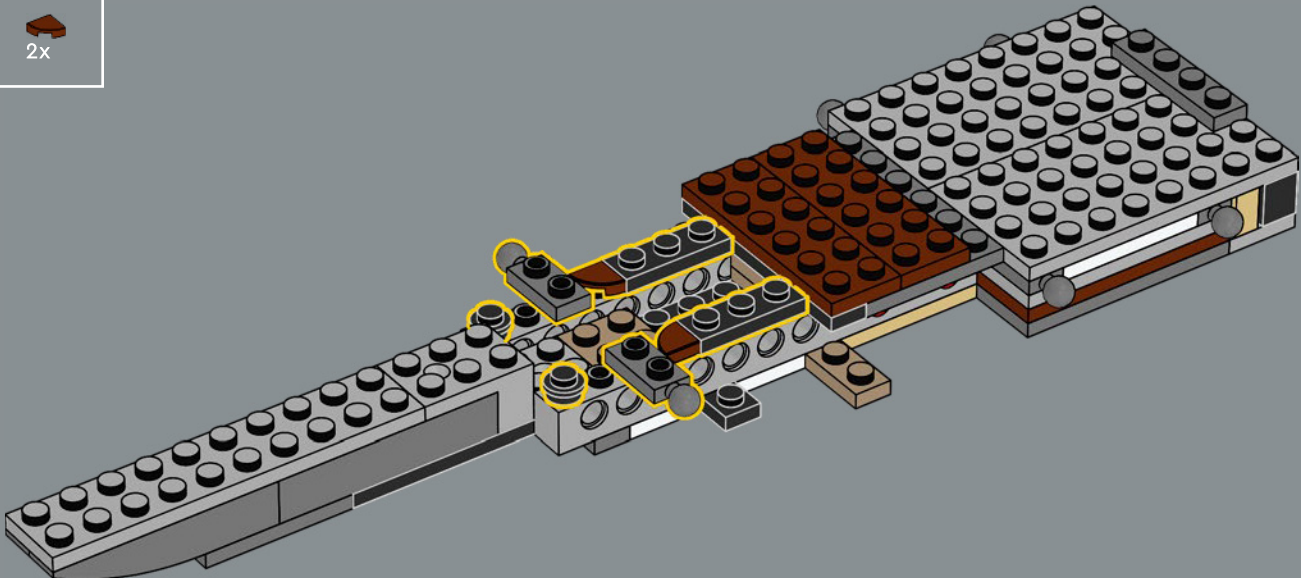

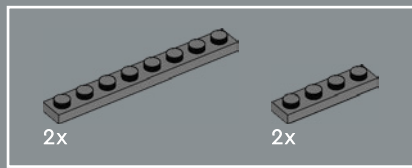

103

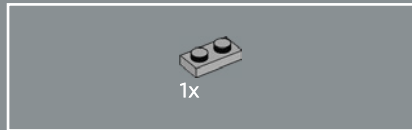
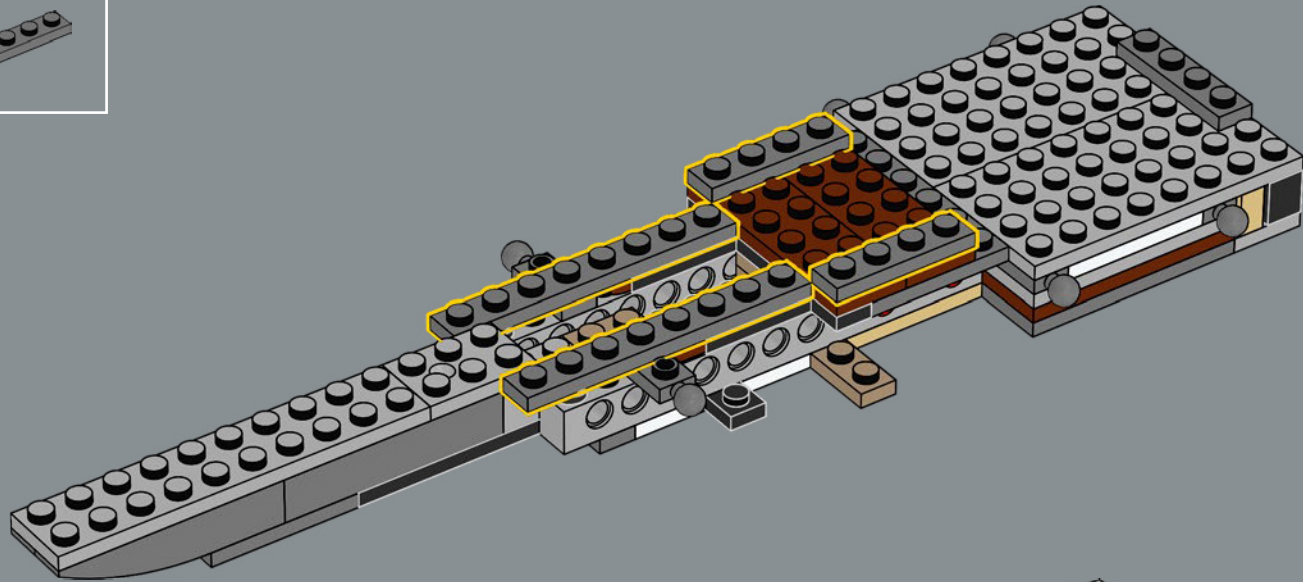

104

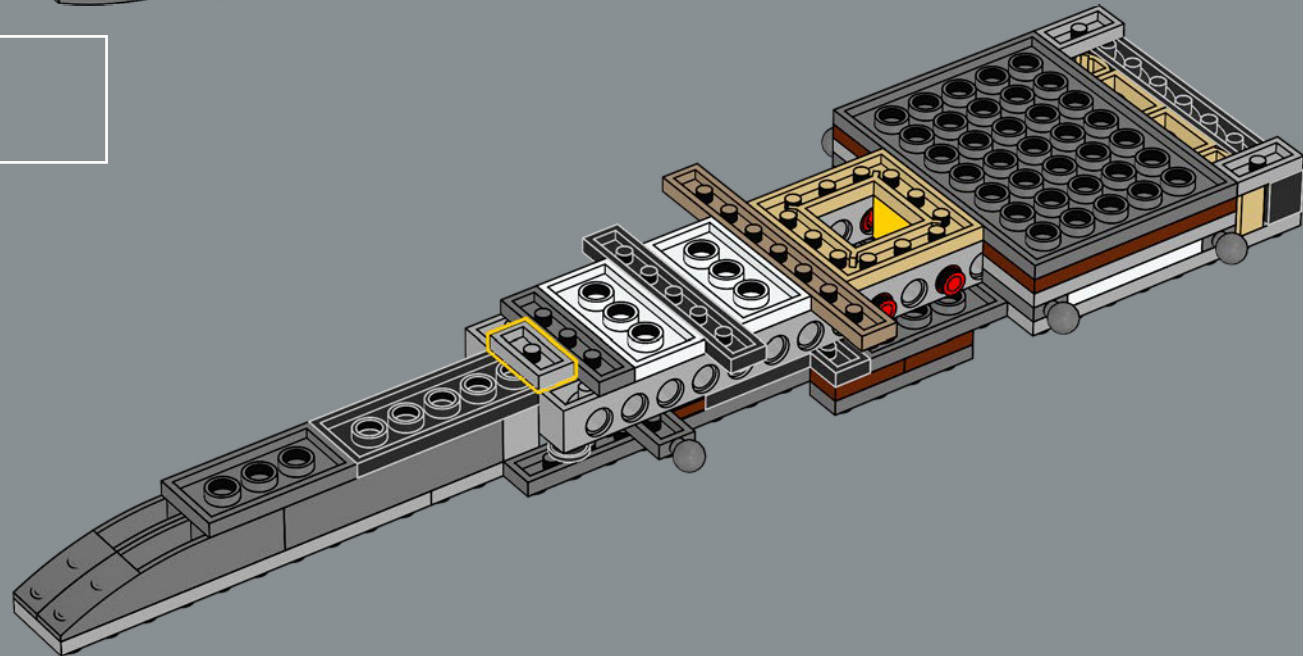

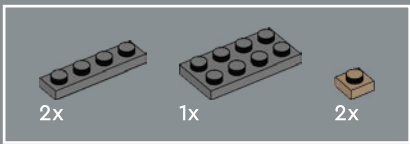

105

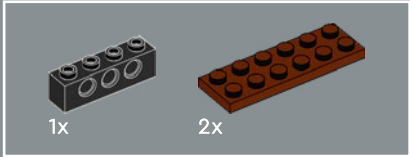
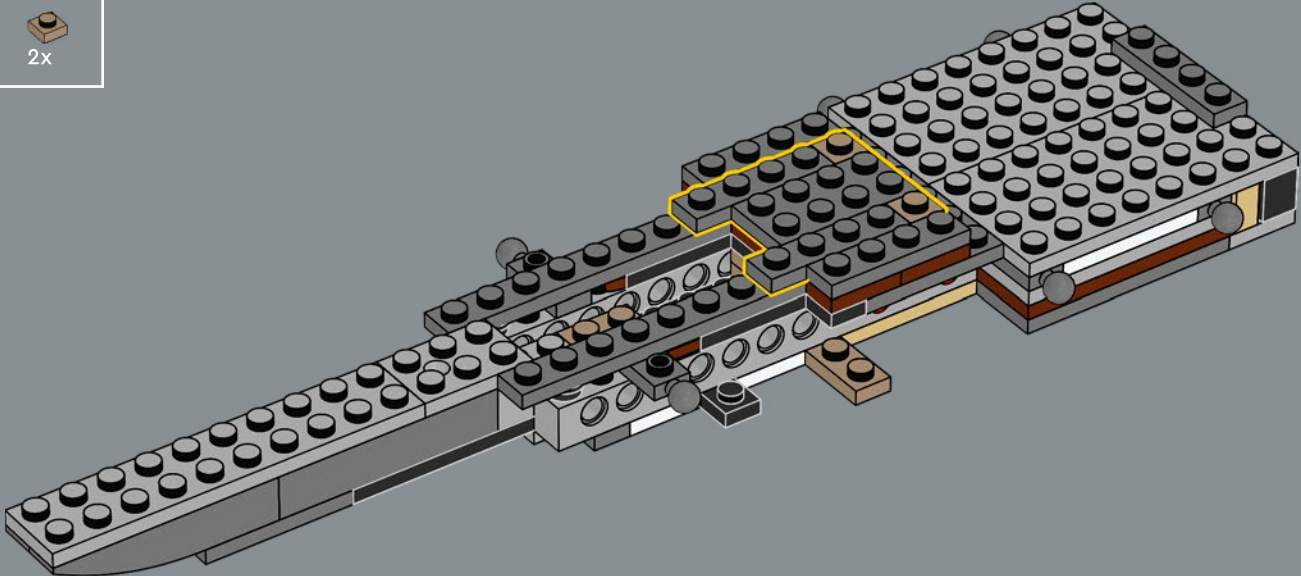

106

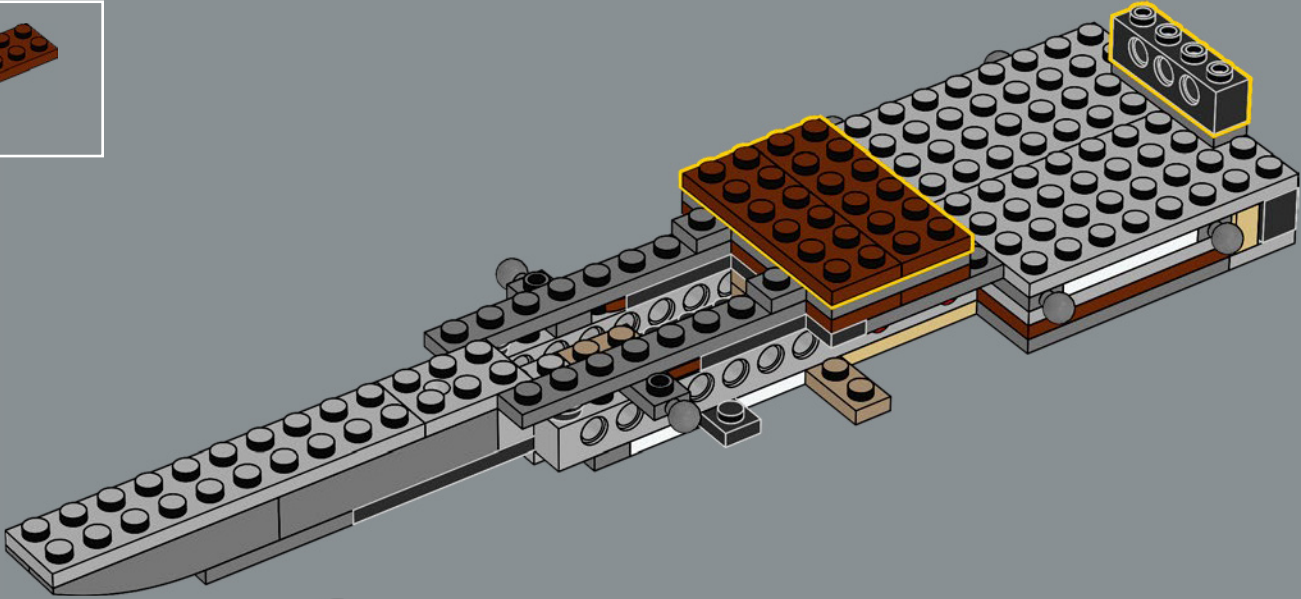

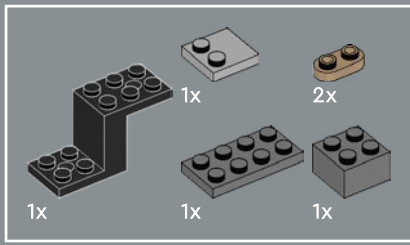

107

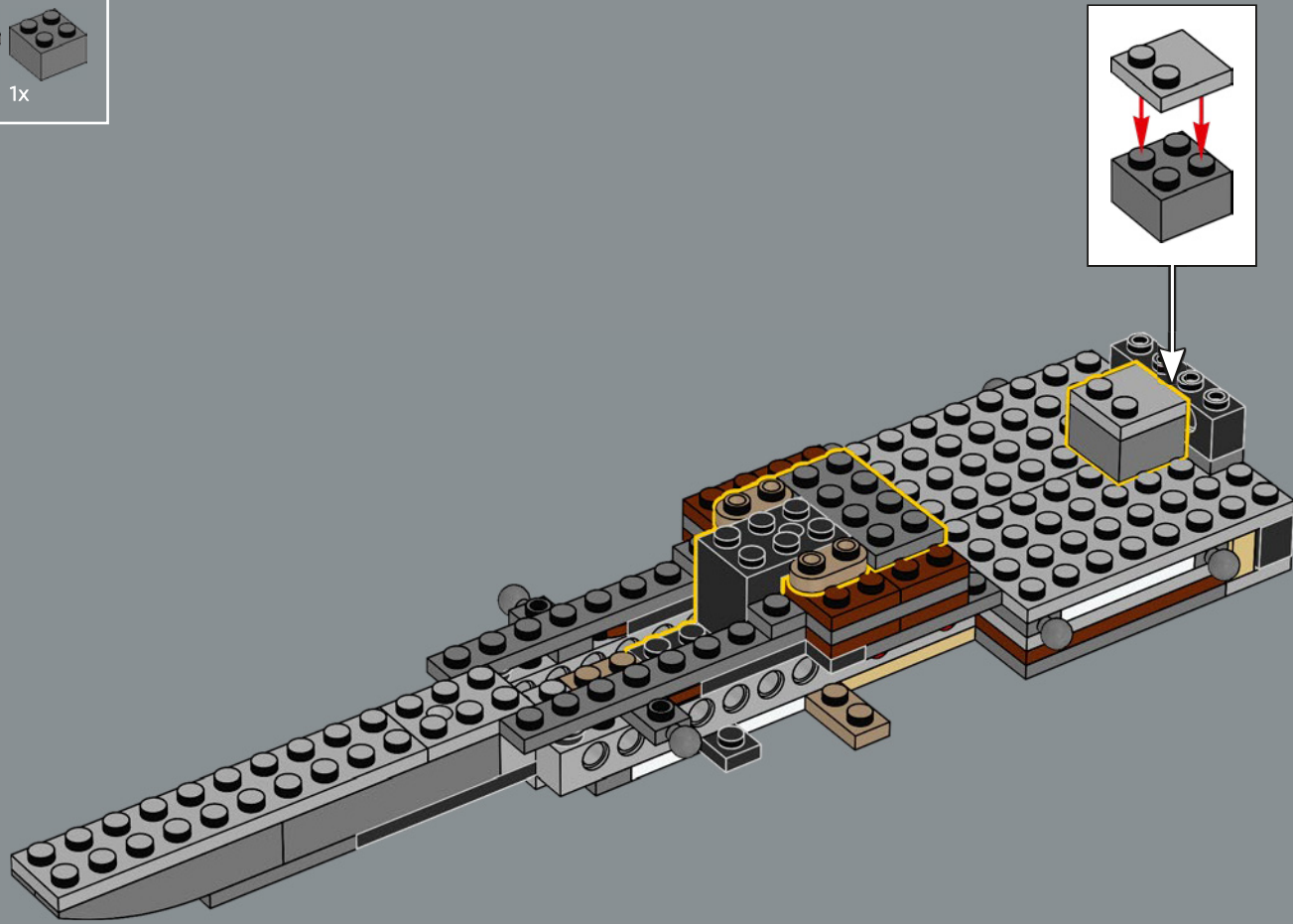

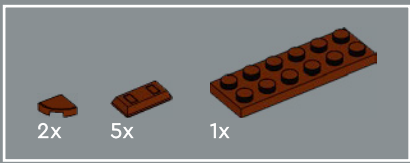

108

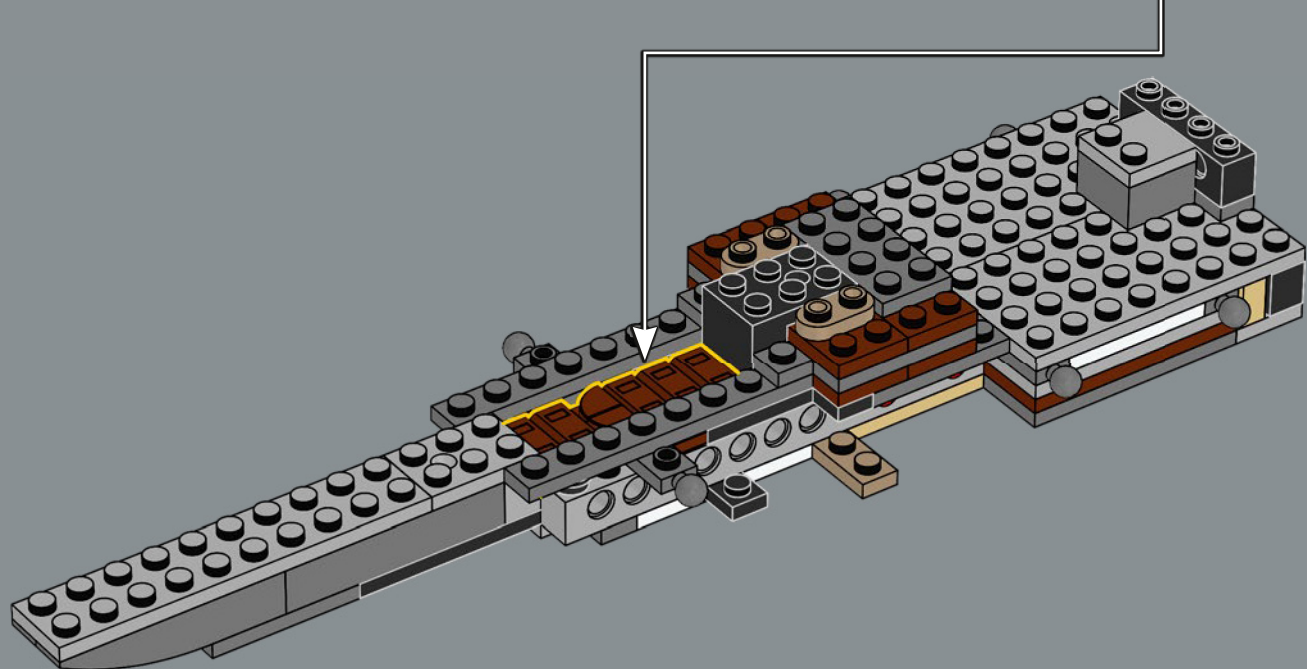
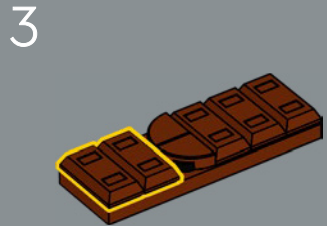
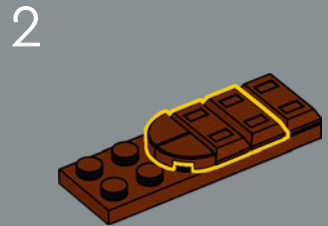
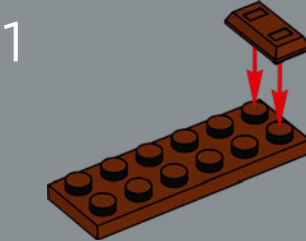

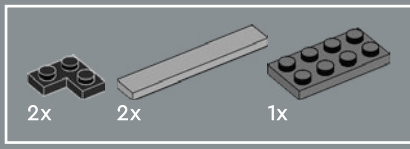

109

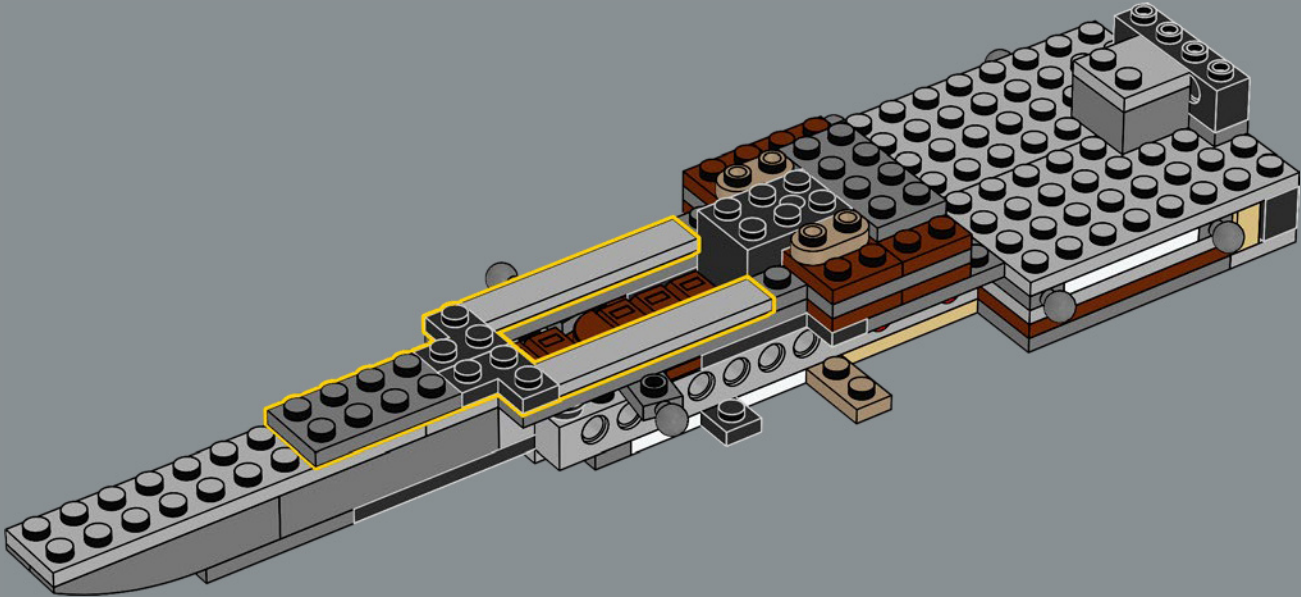

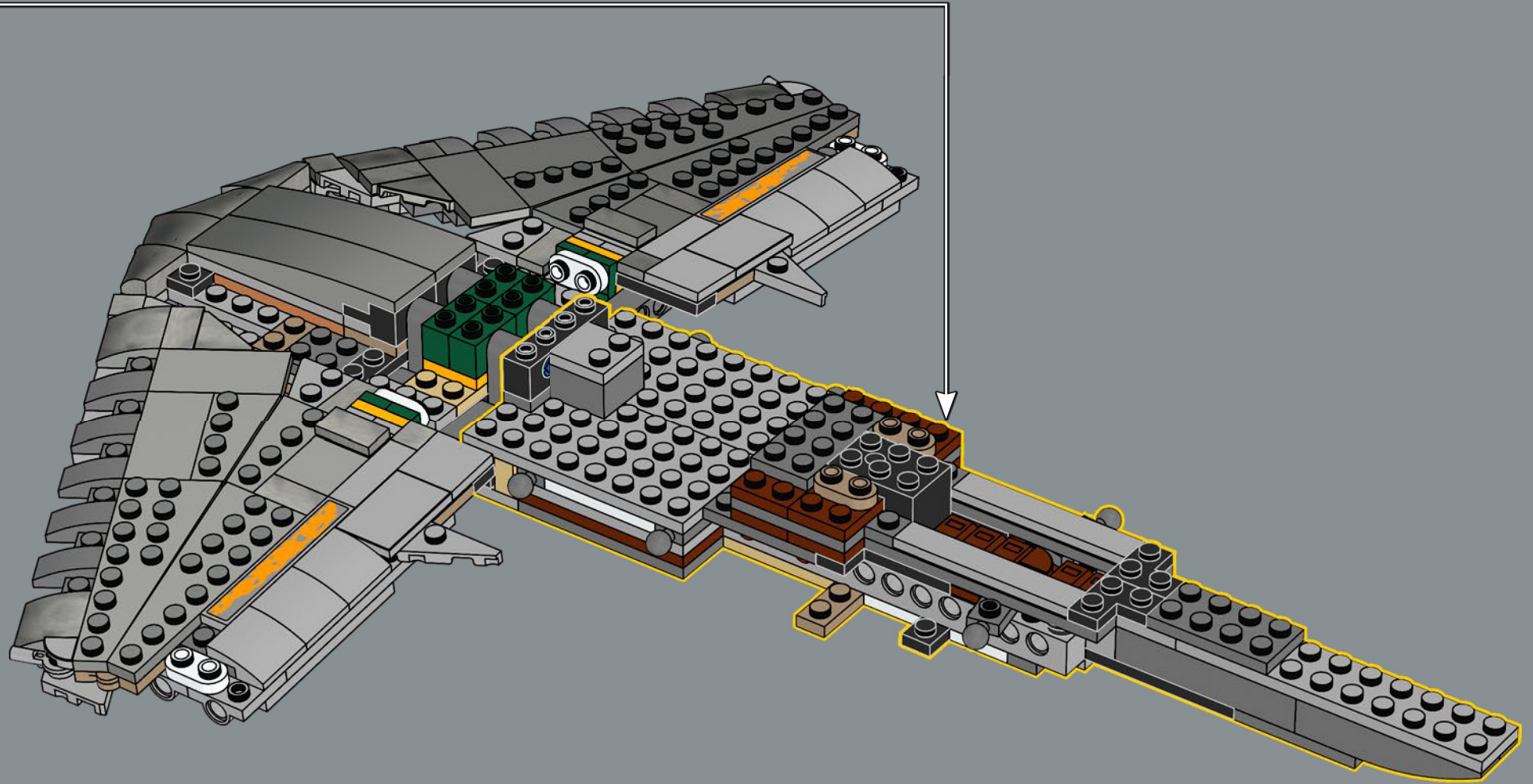



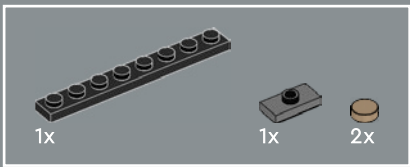

111

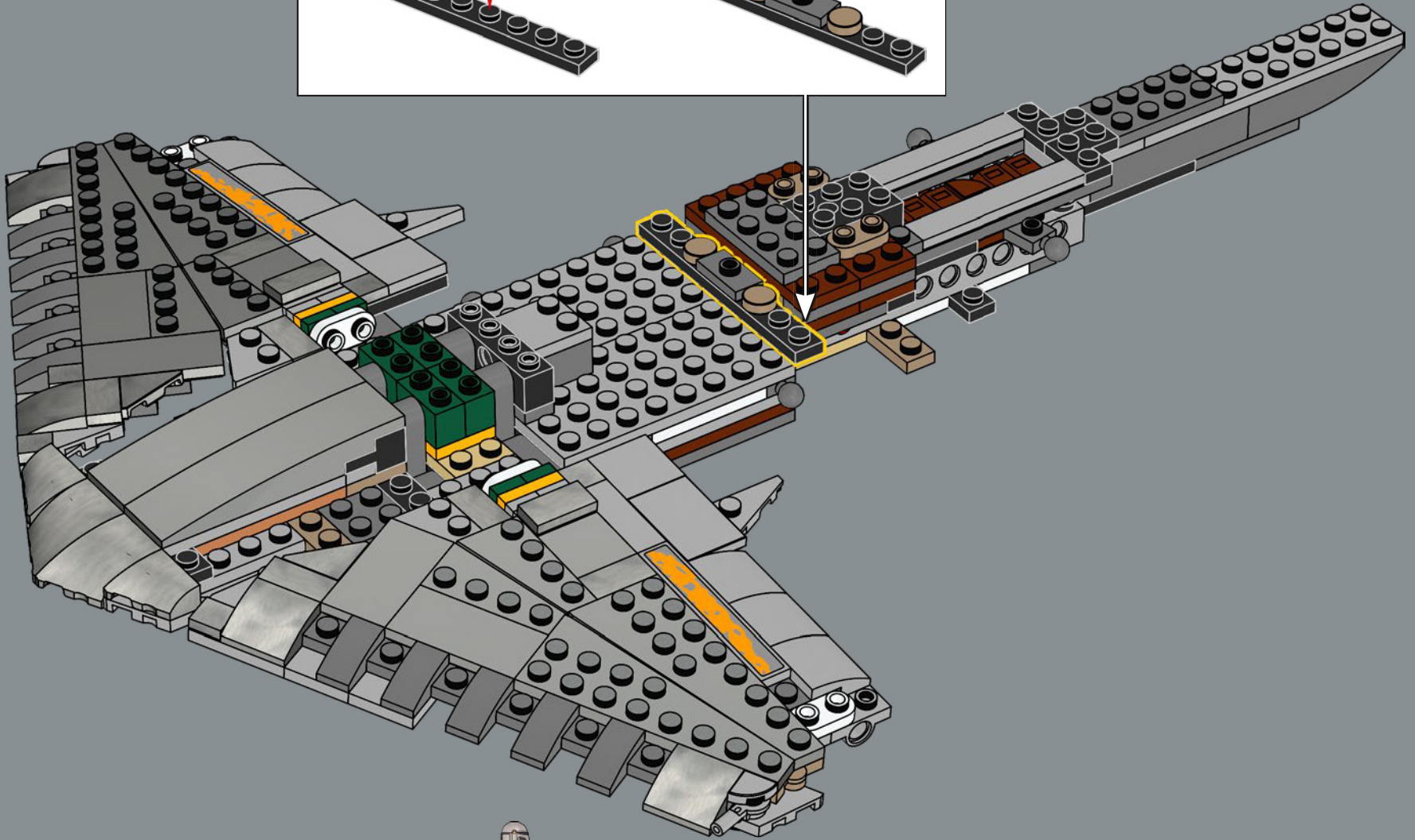
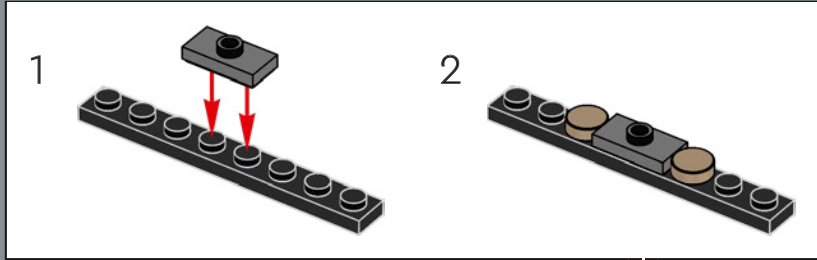

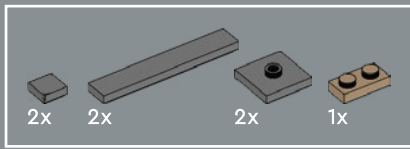

112

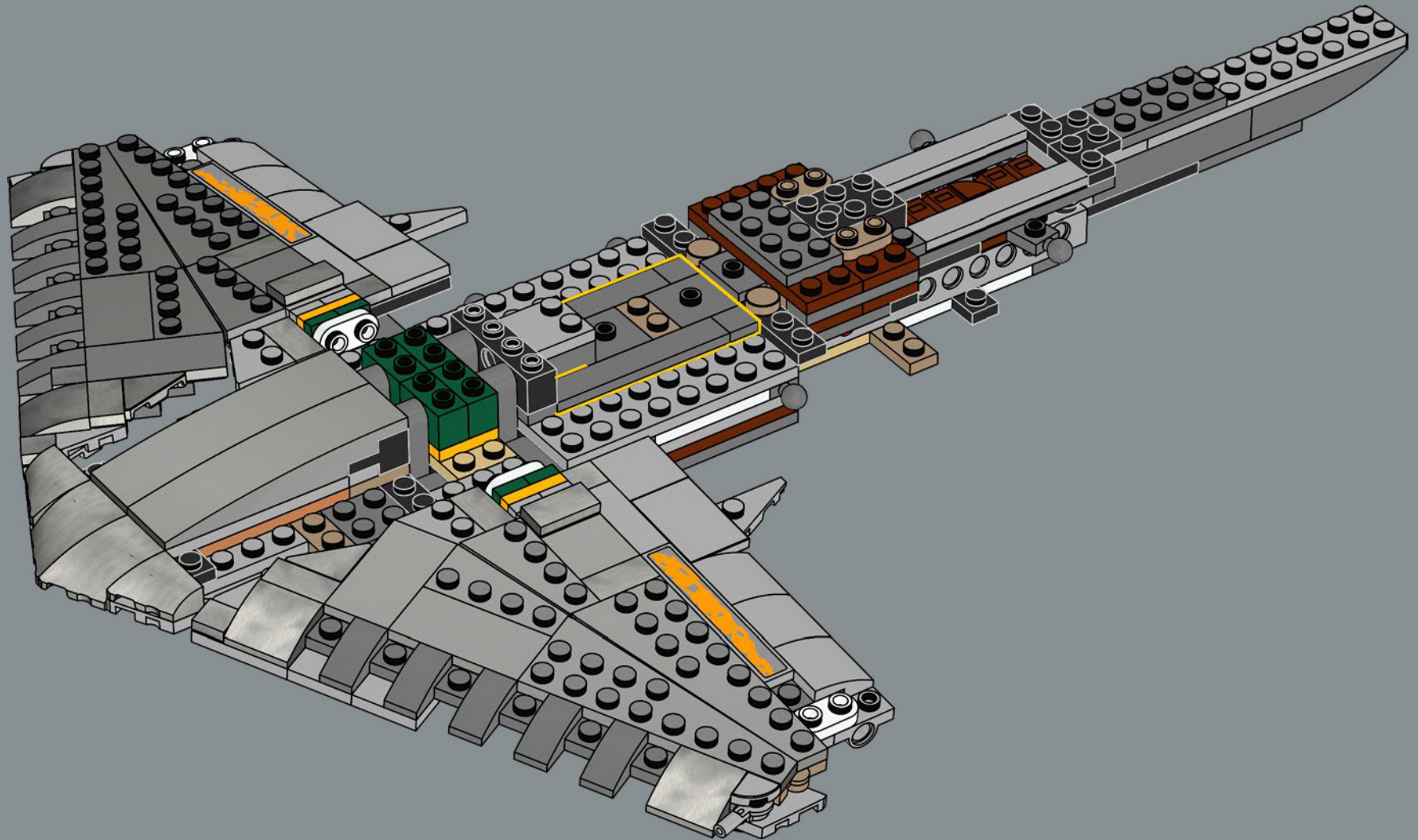

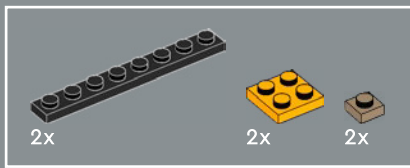

113

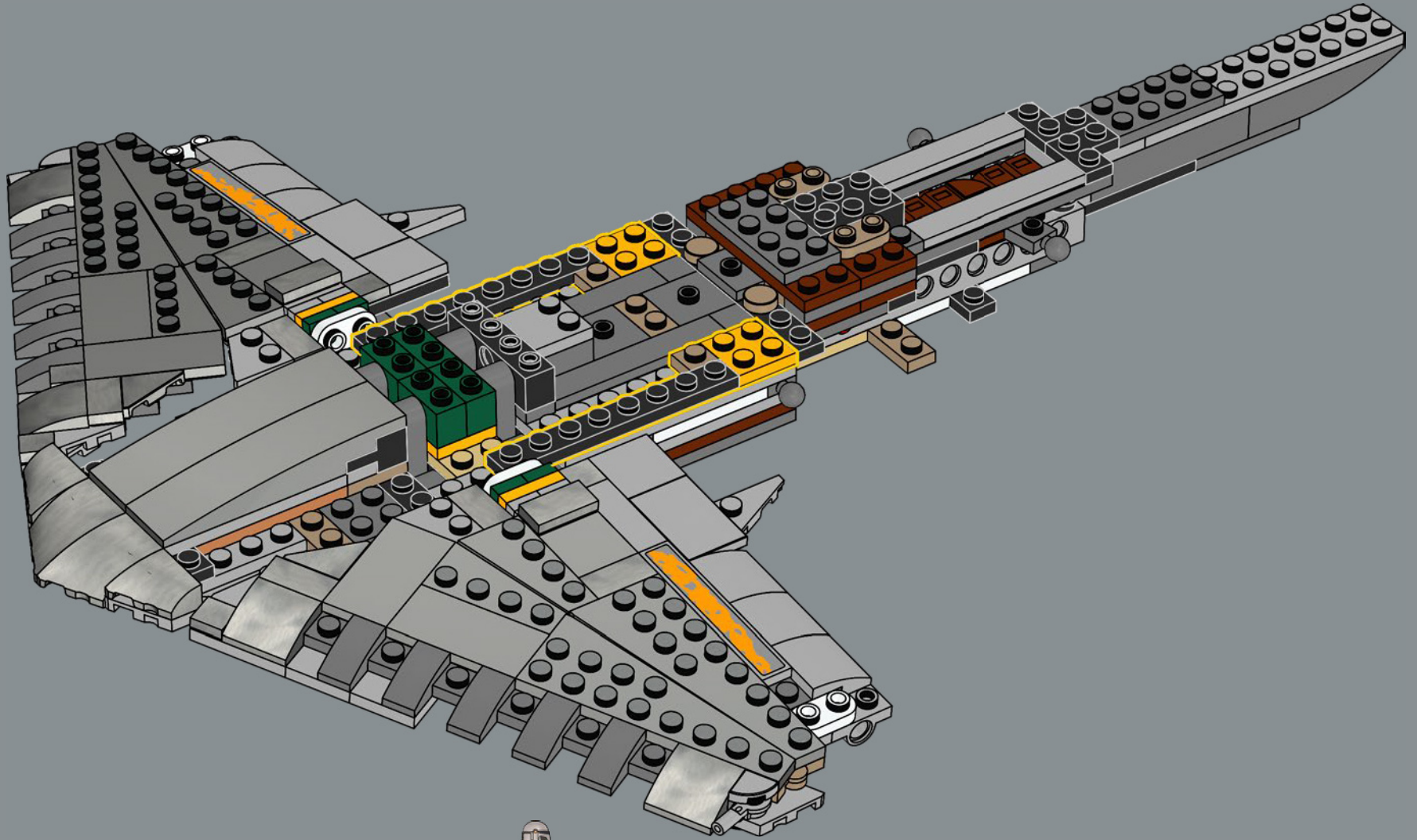

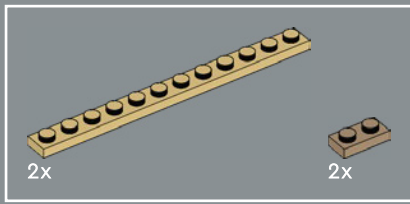

114

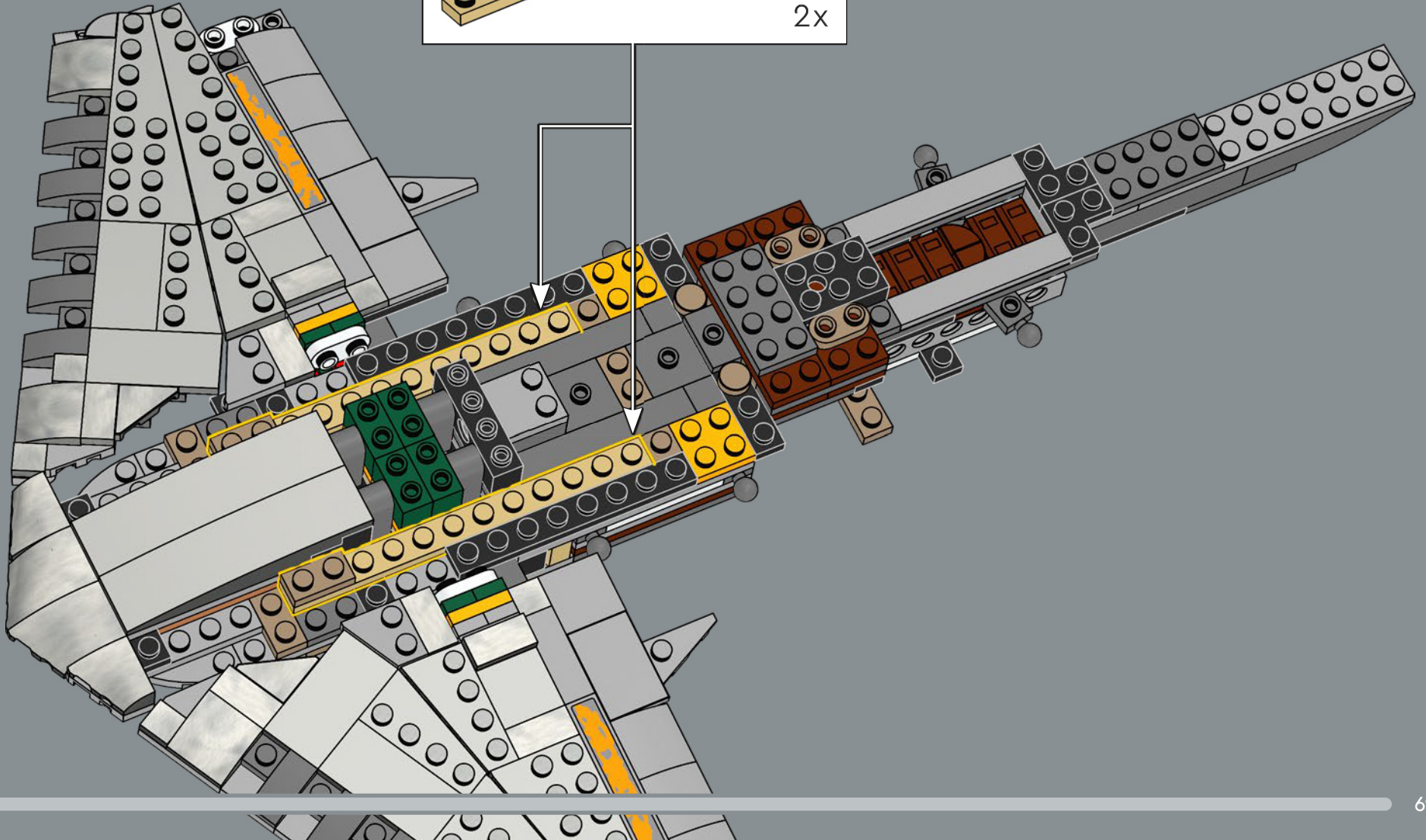
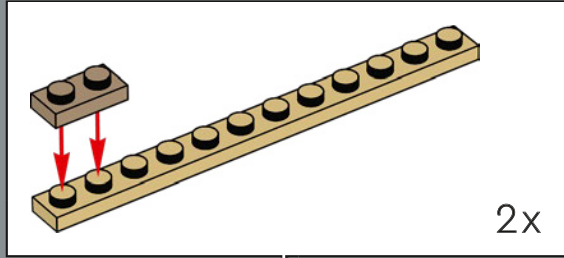



115

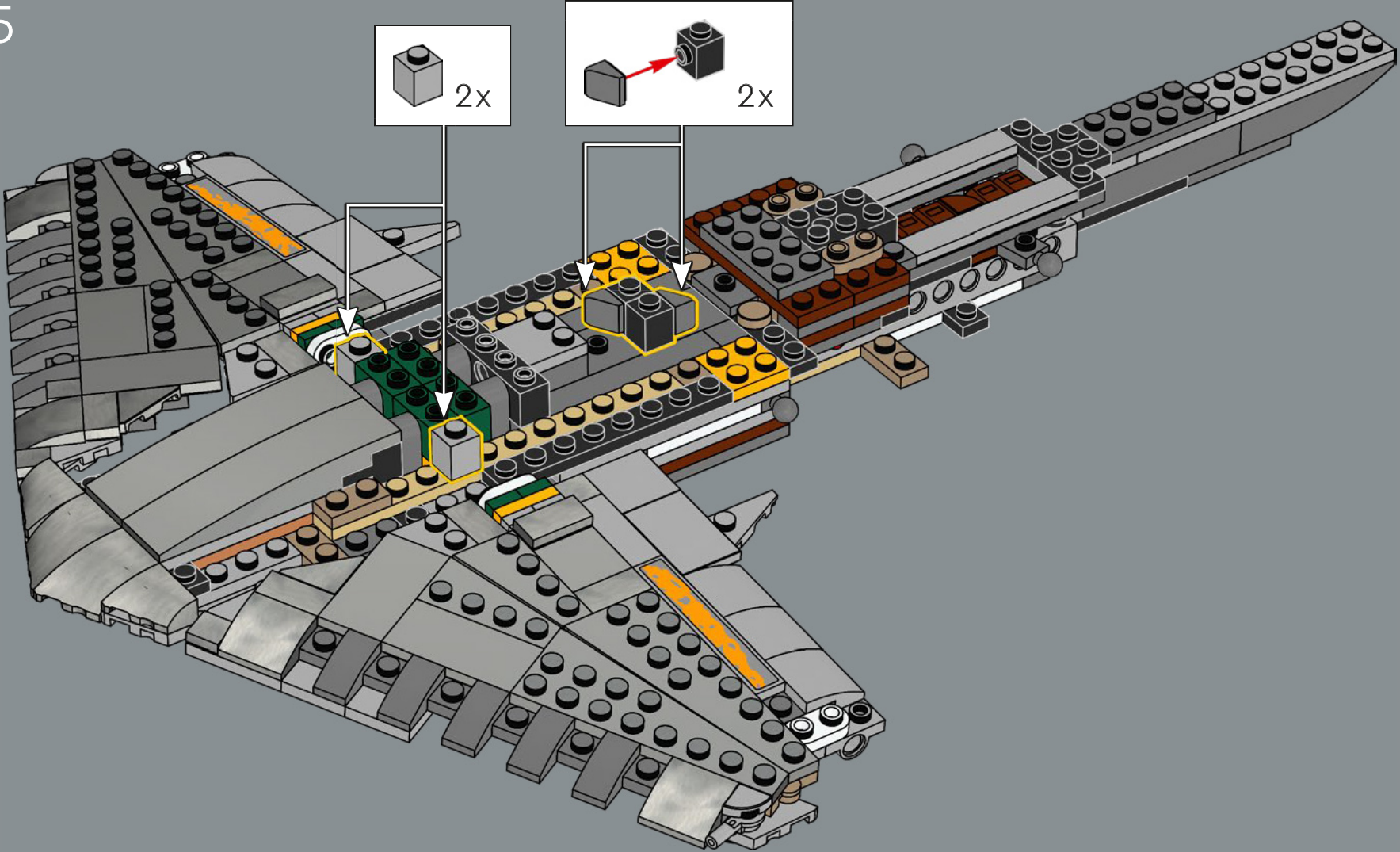

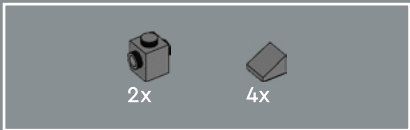

116

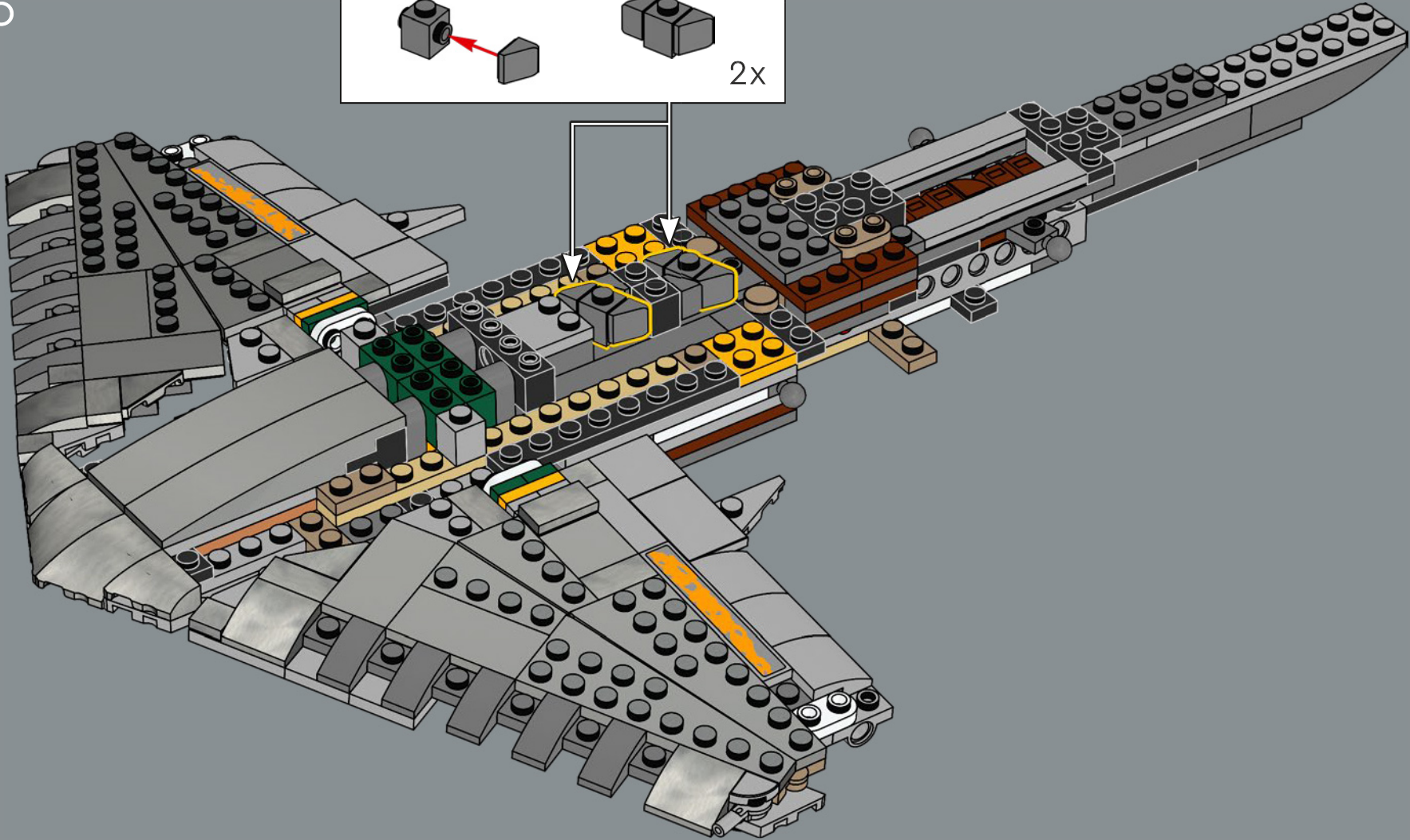
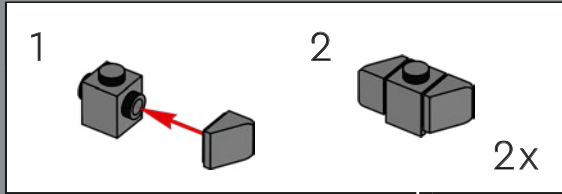

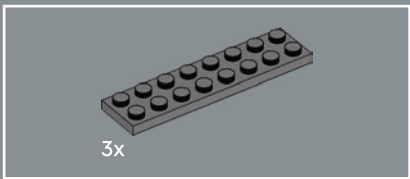

117

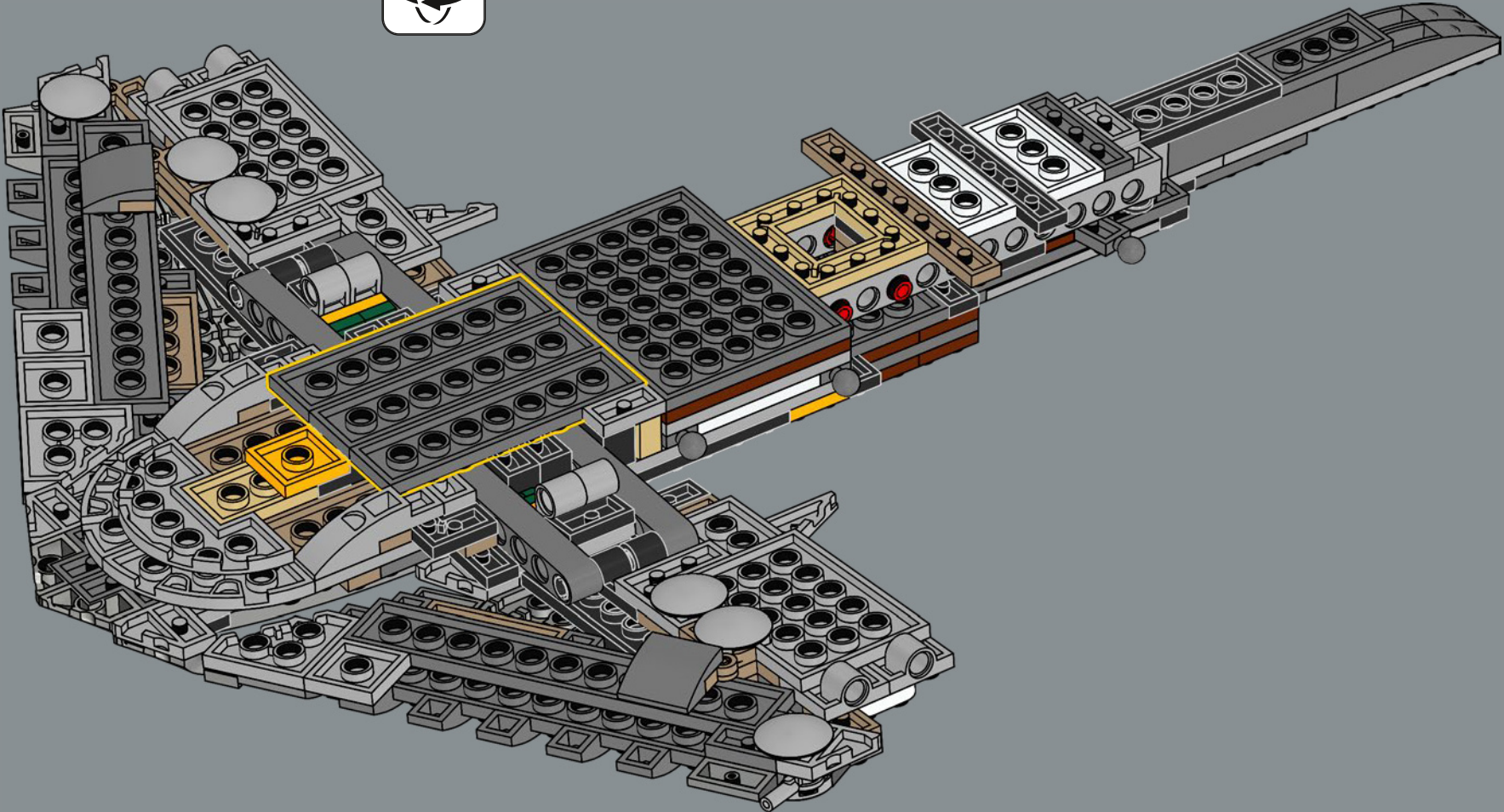

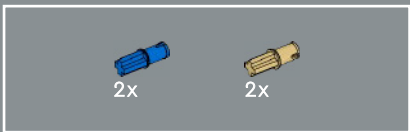

118

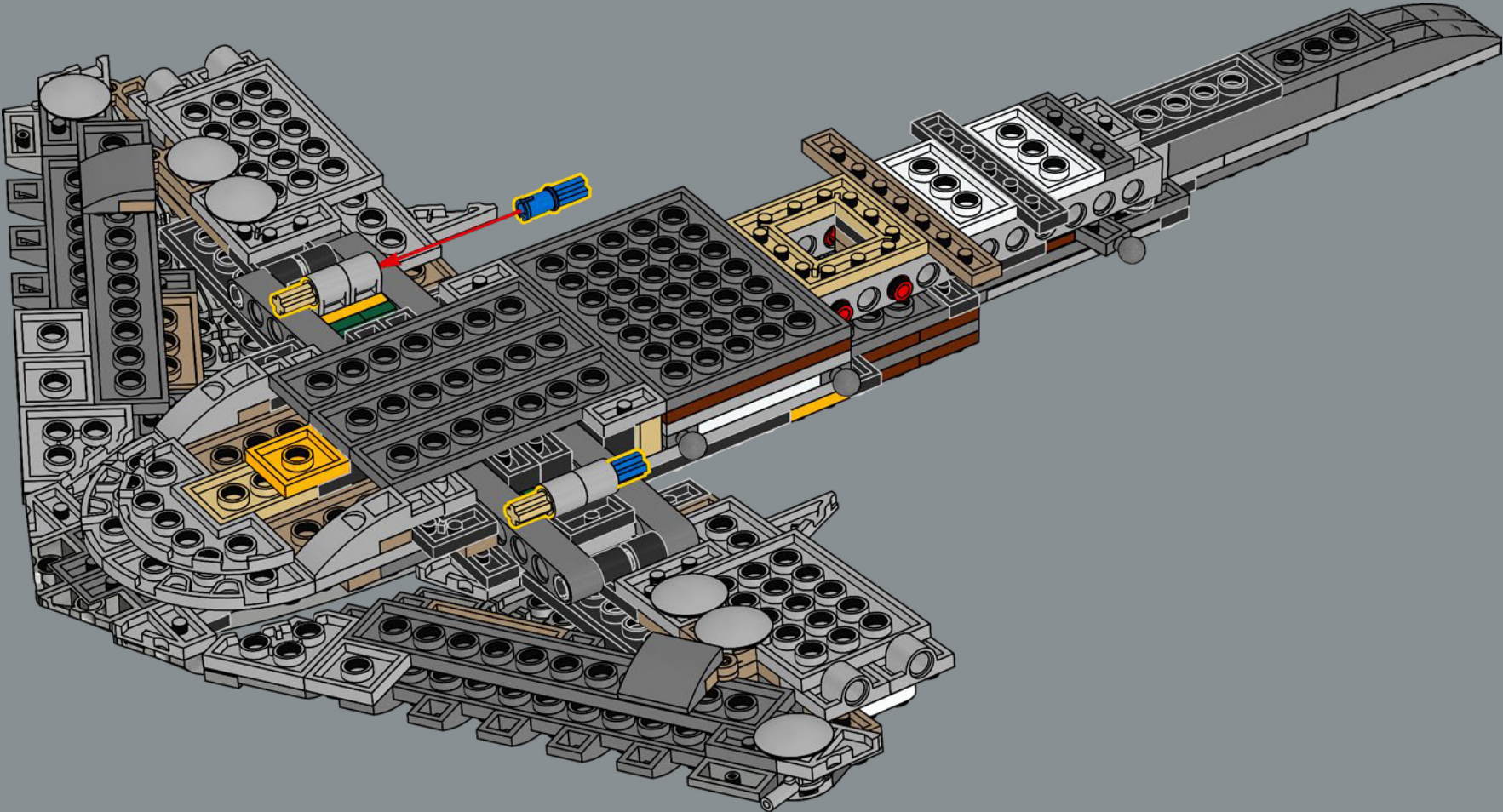



4x

119

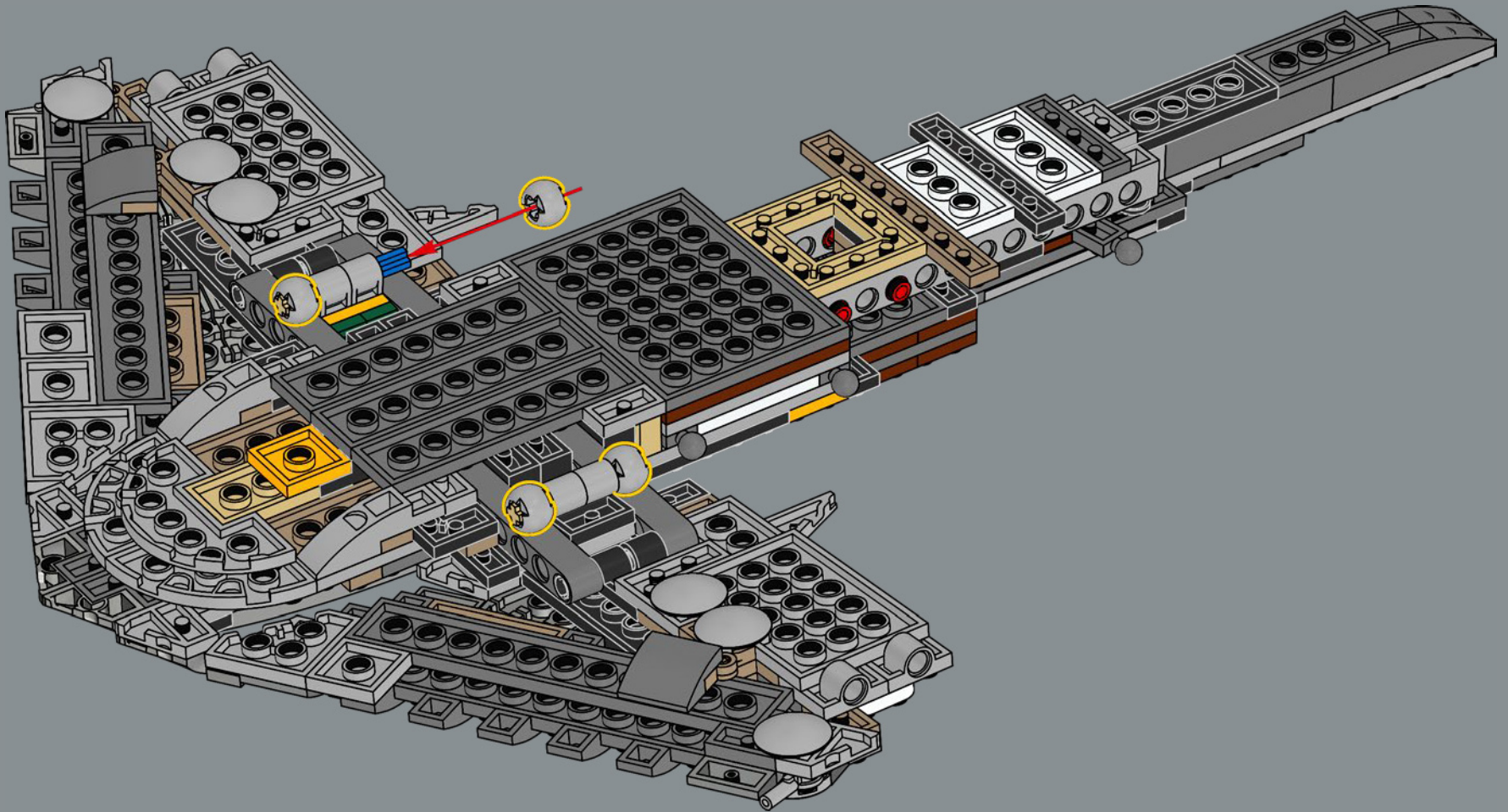

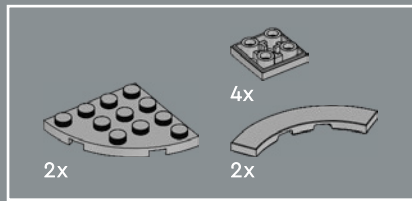

120

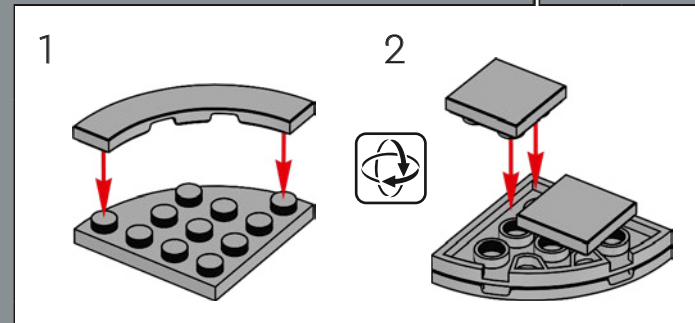
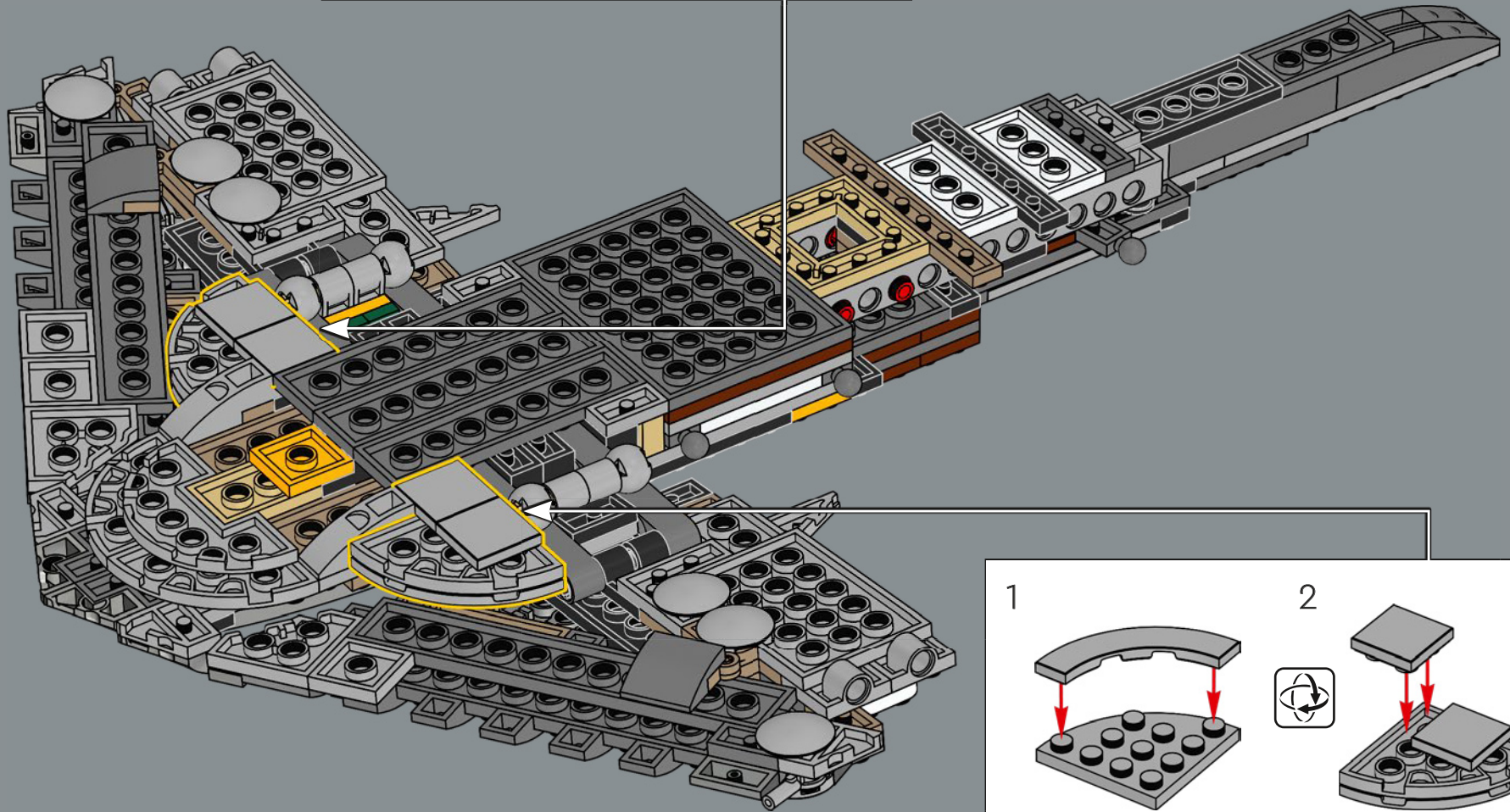
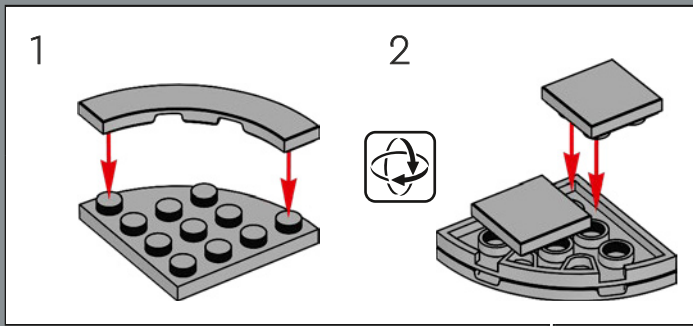

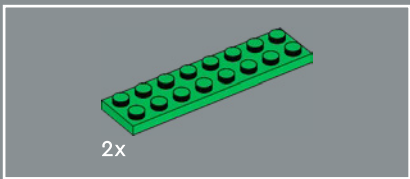

121

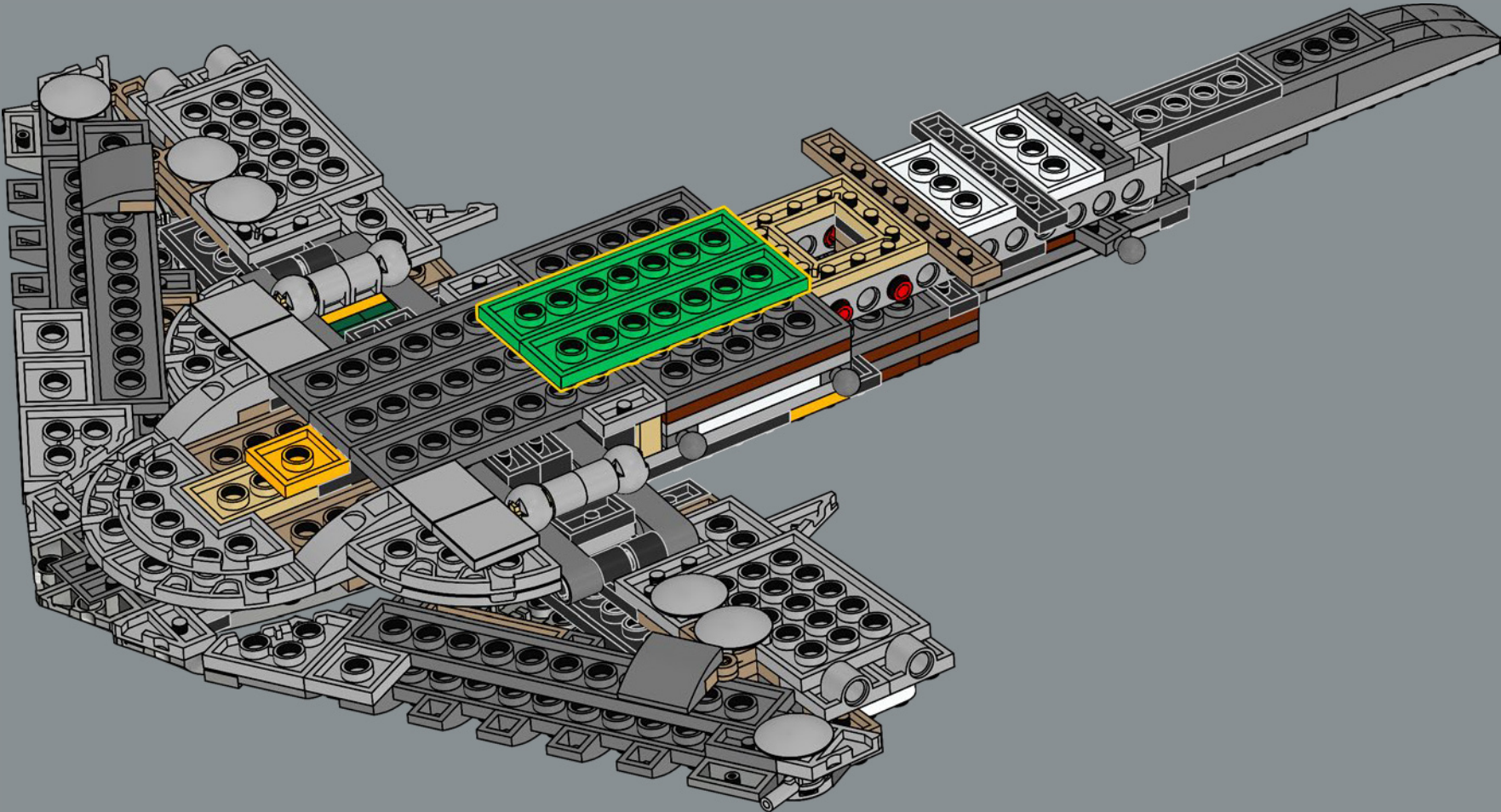

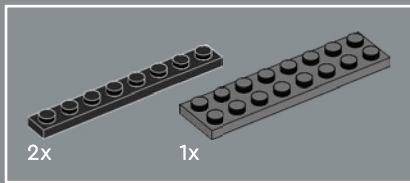

122

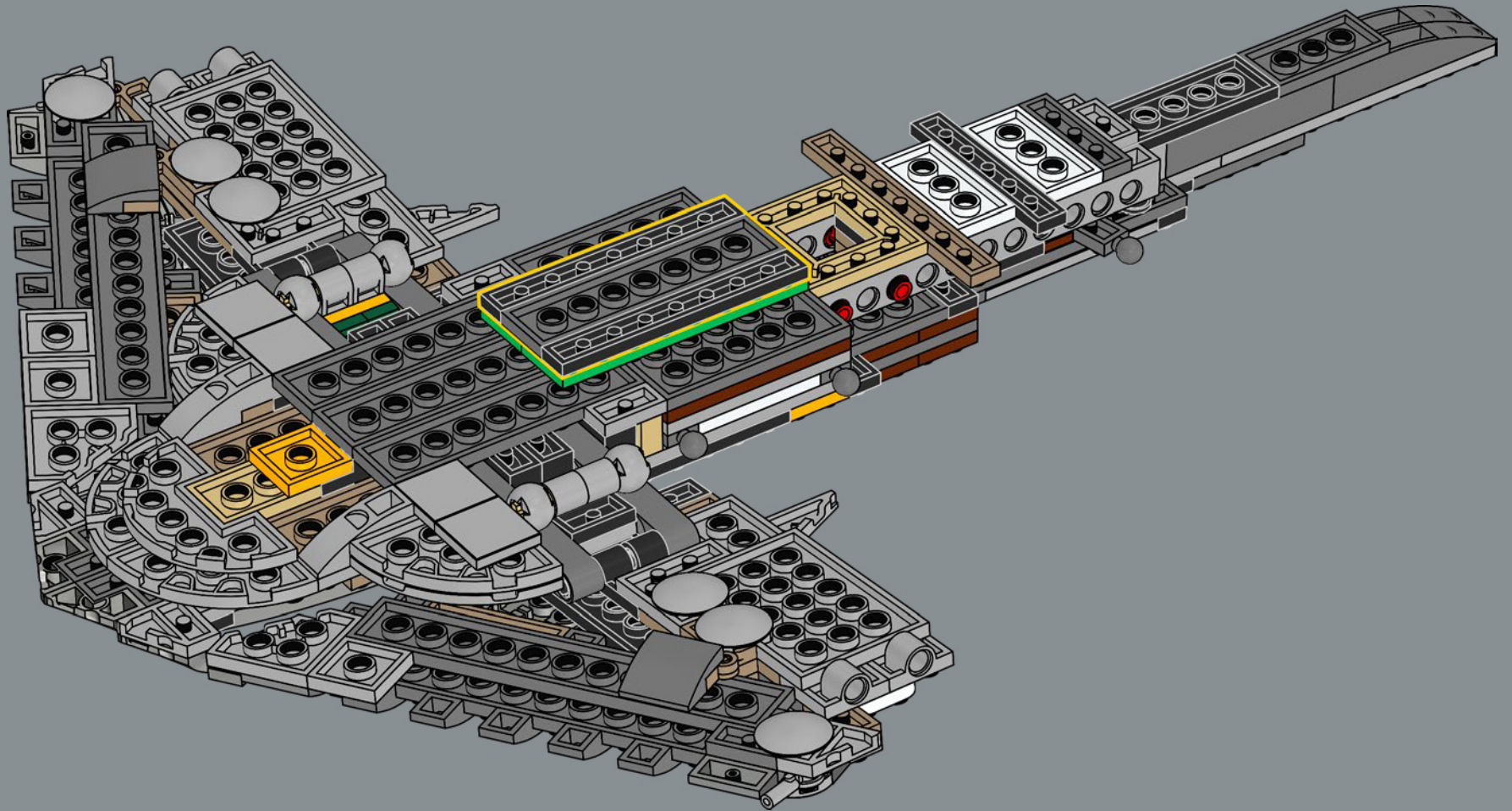

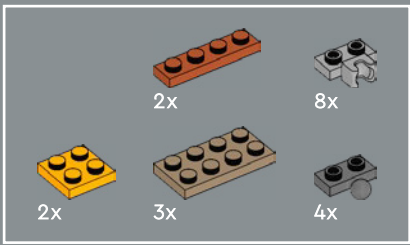

123

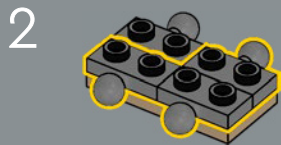
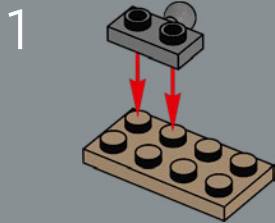

3

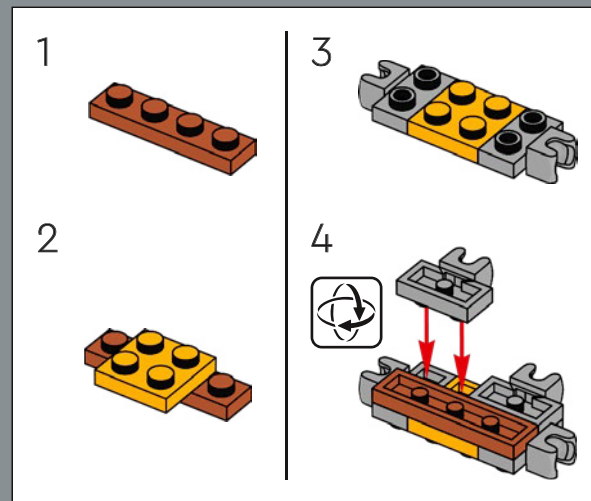
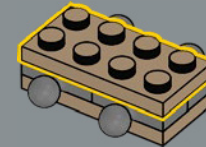

4

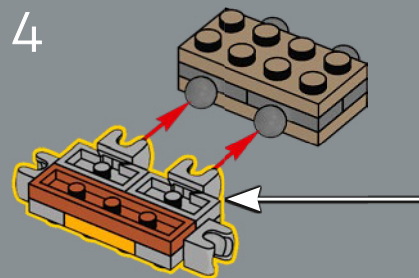

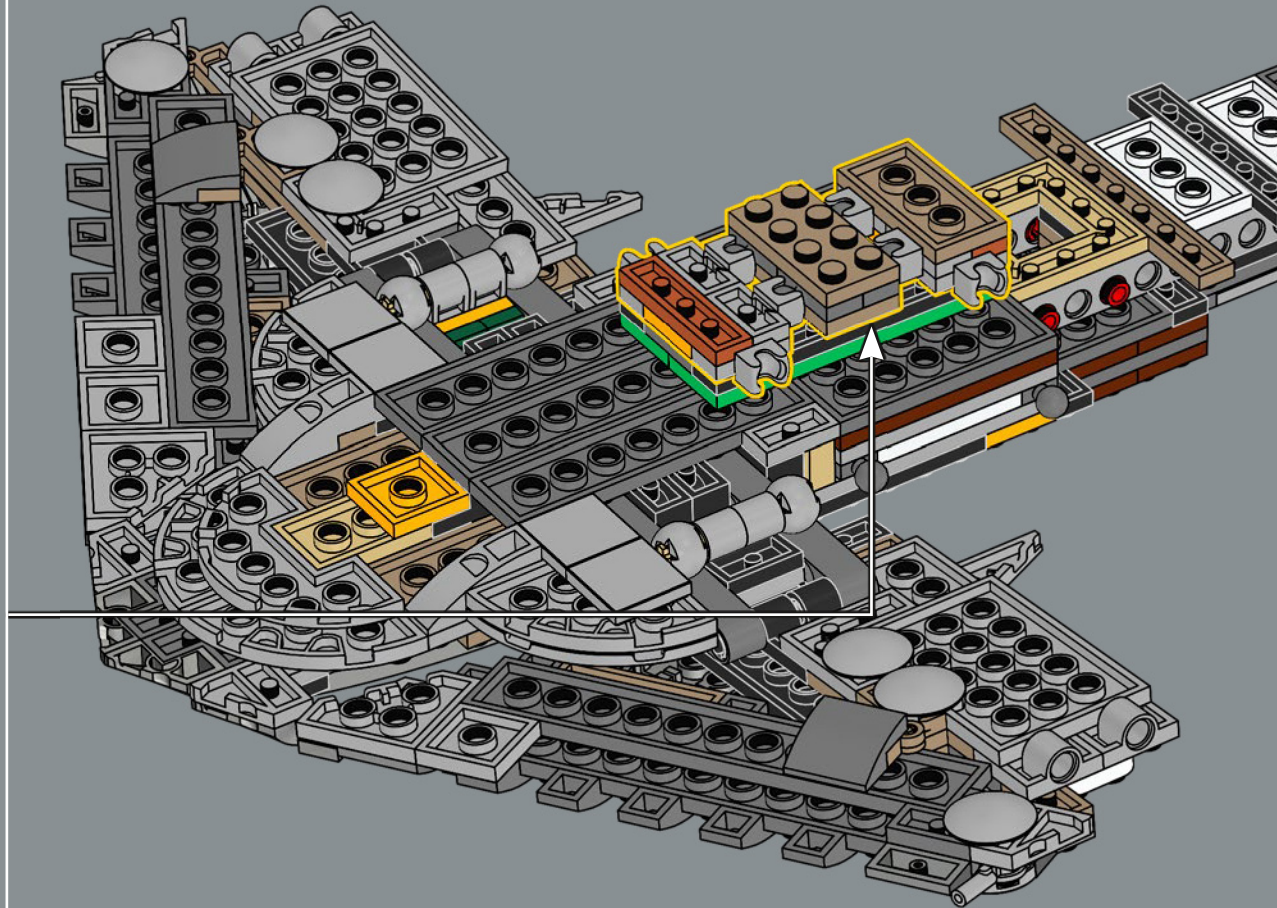
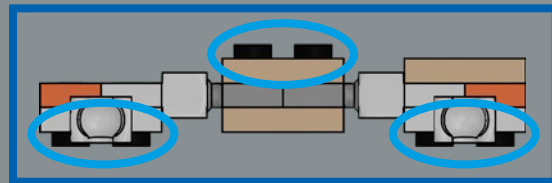
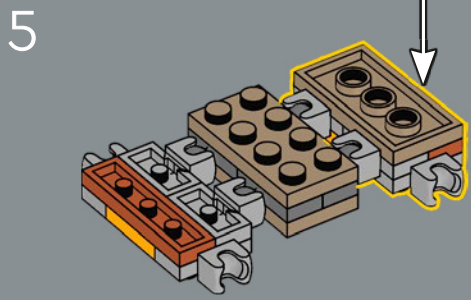
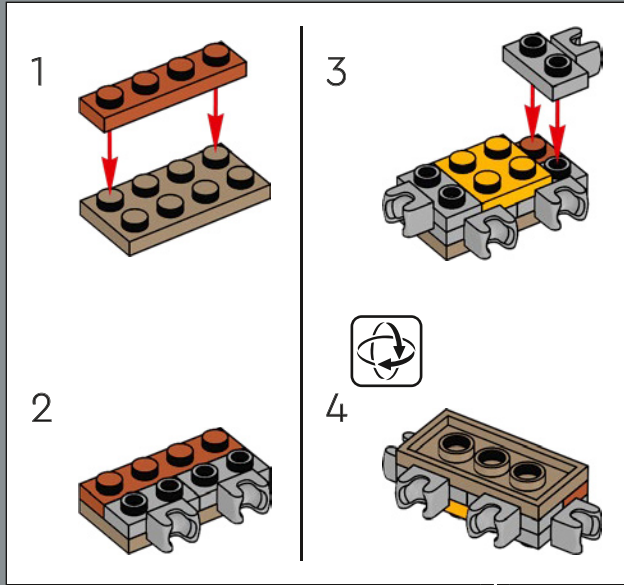

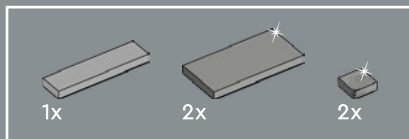

124

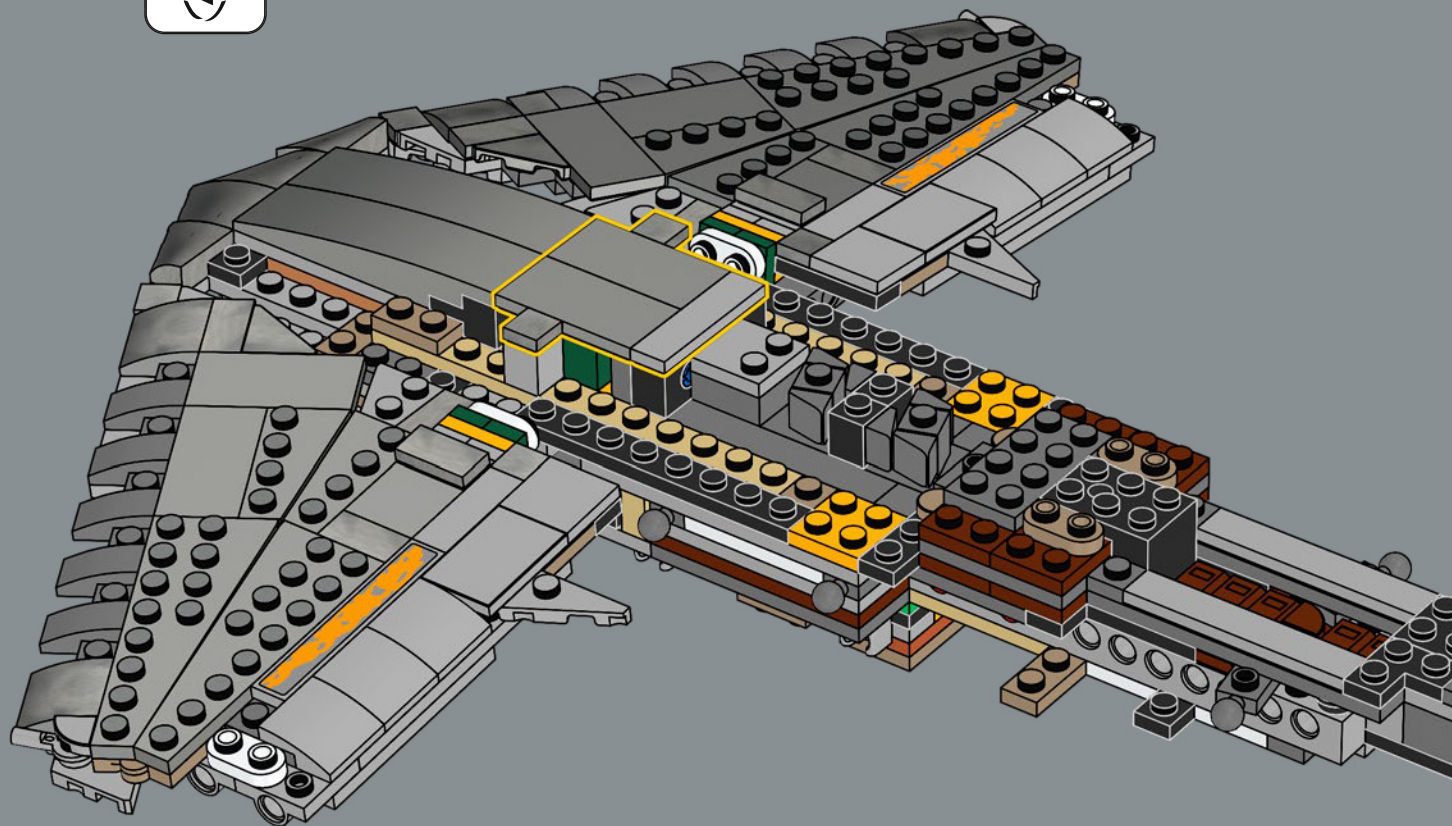



125

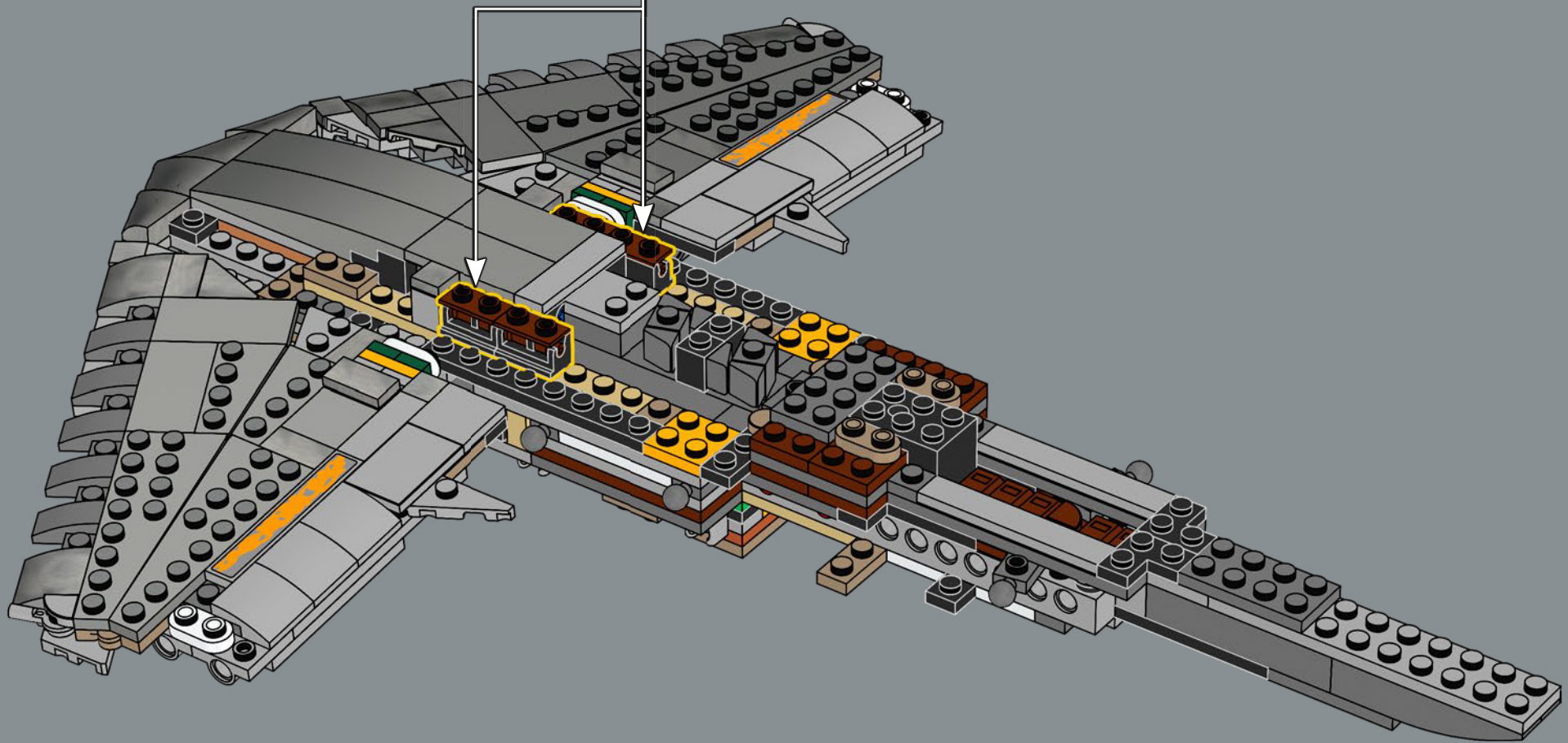
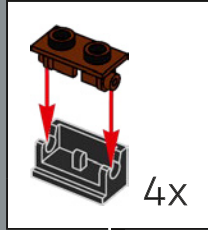

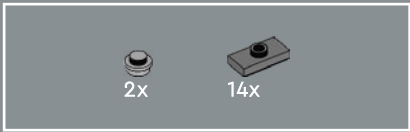

126

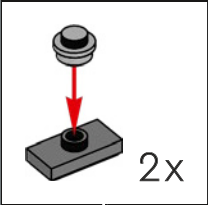
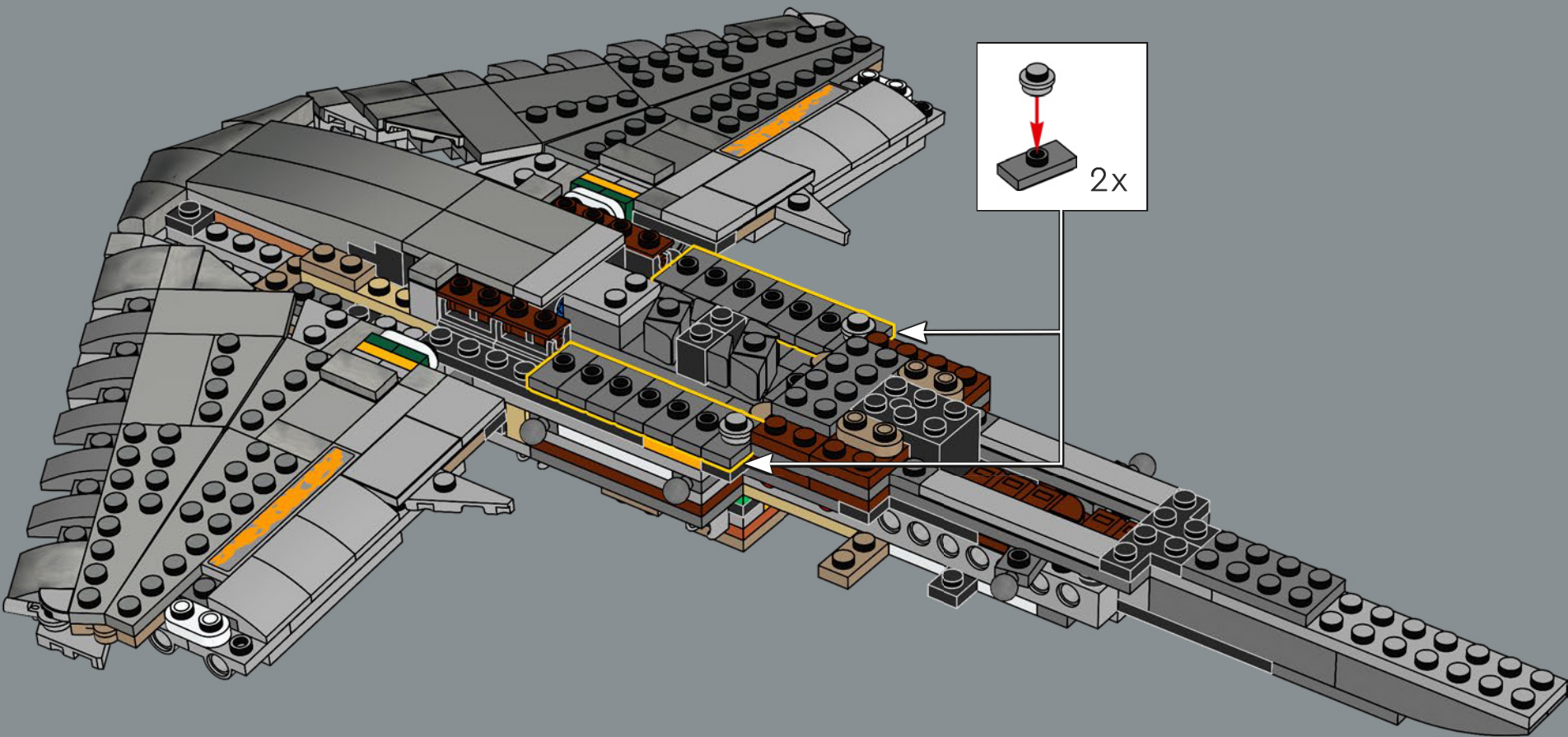

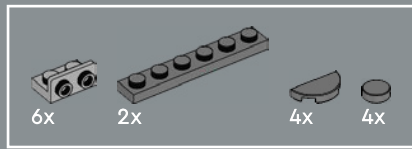

127

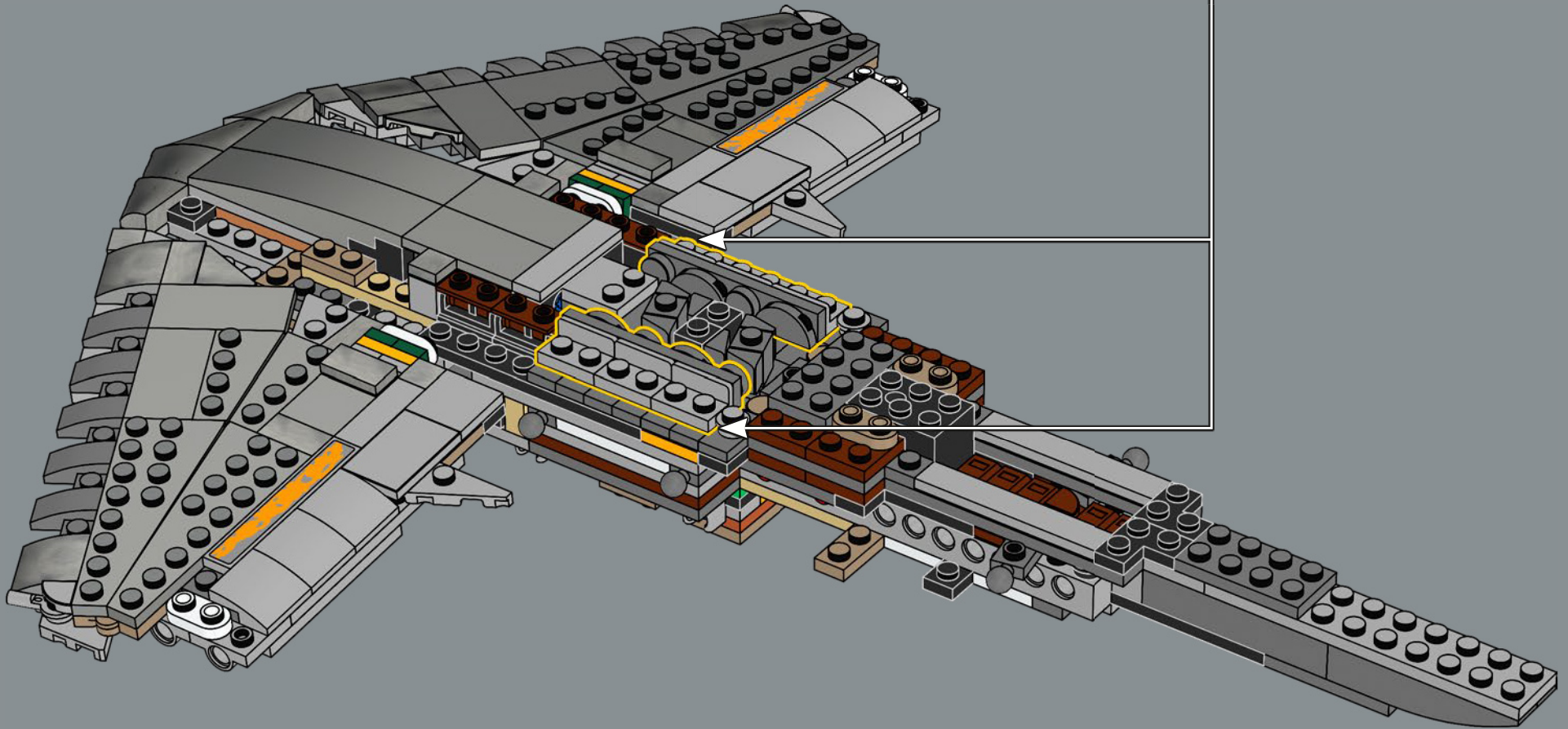
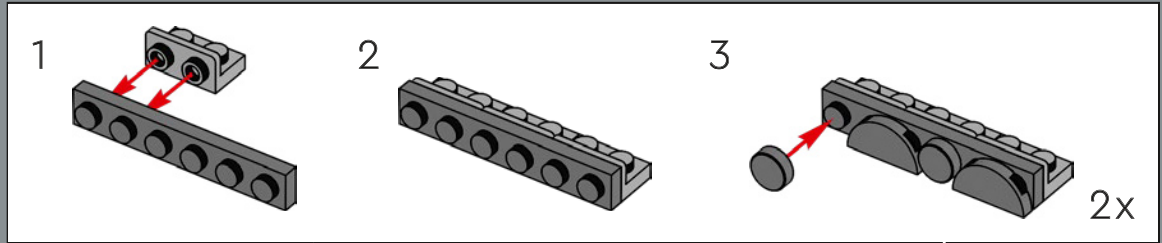

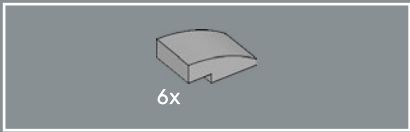

128

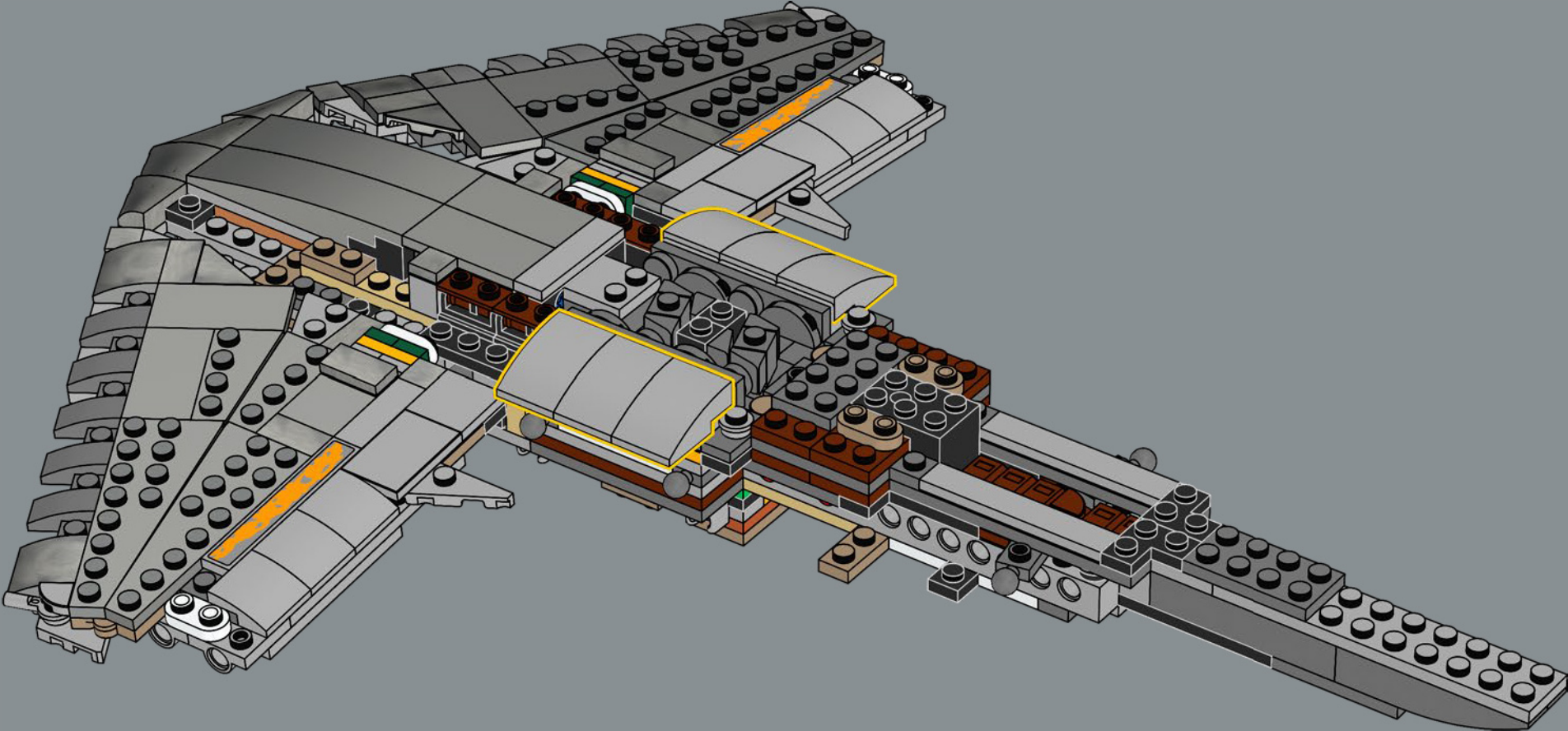

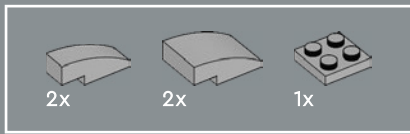

129

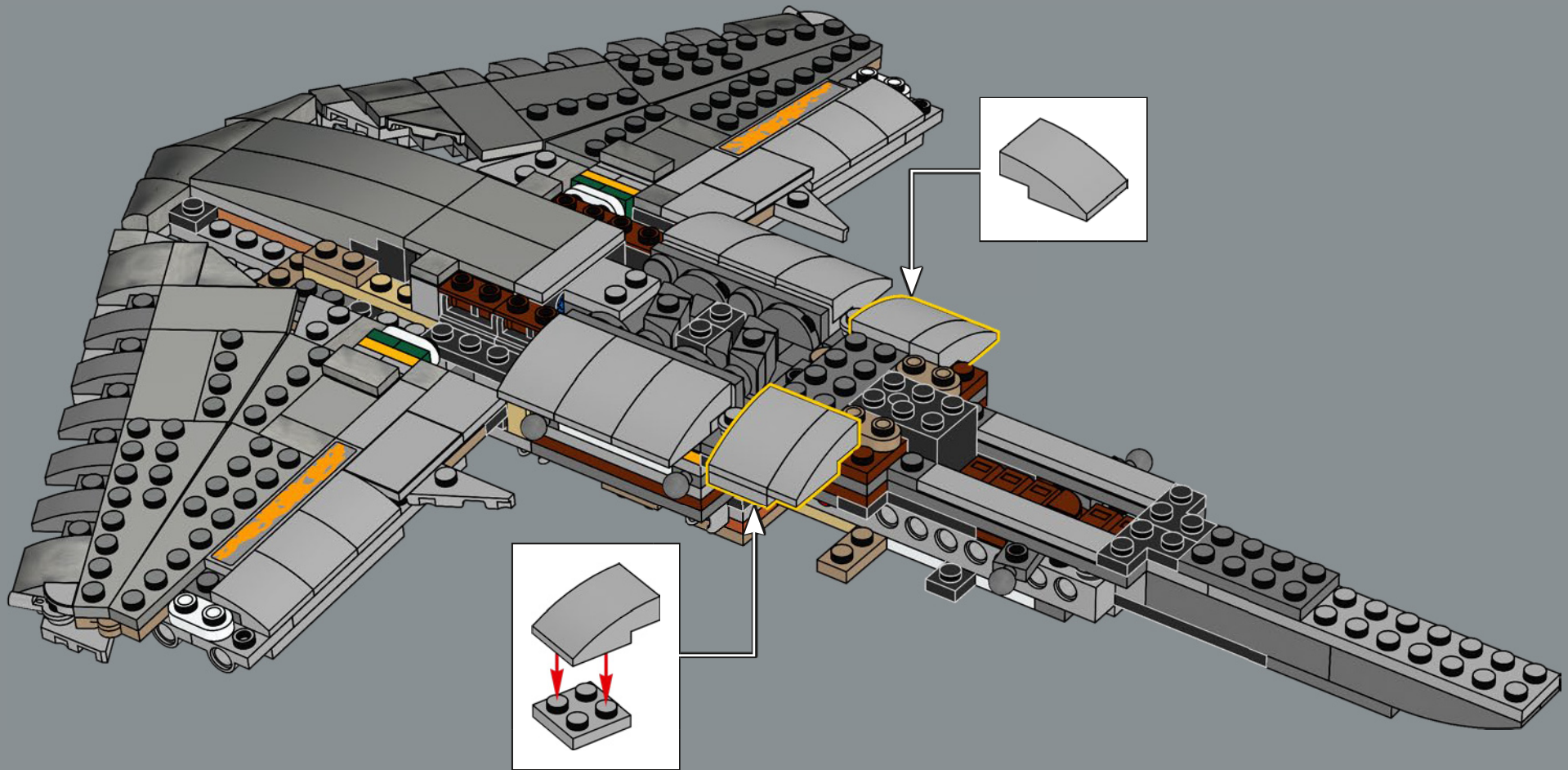

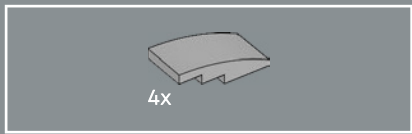

130

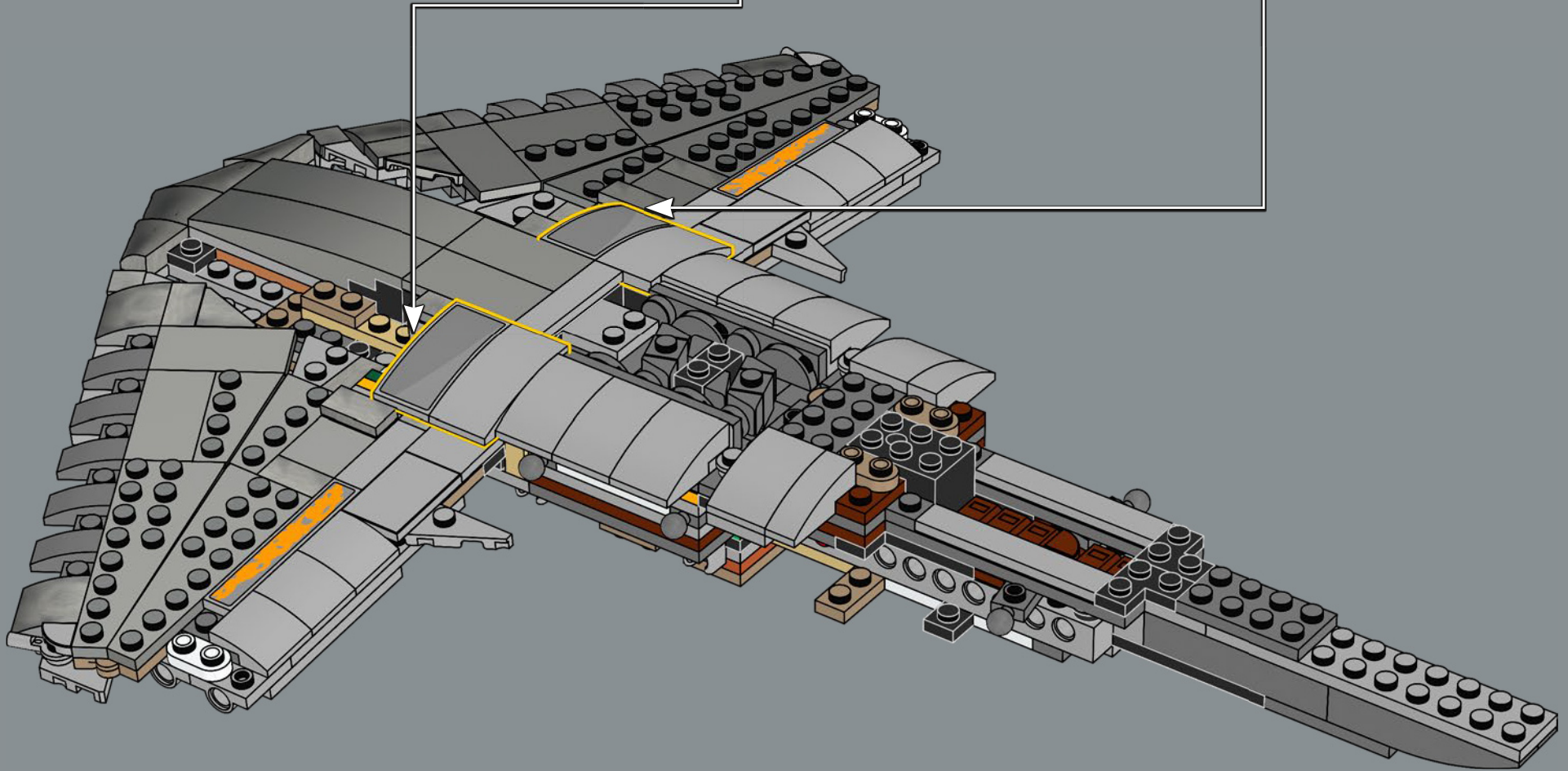
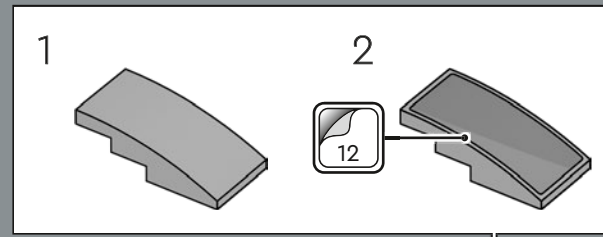
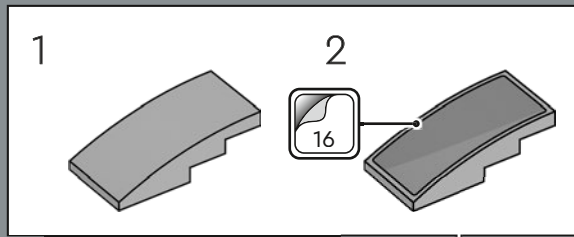

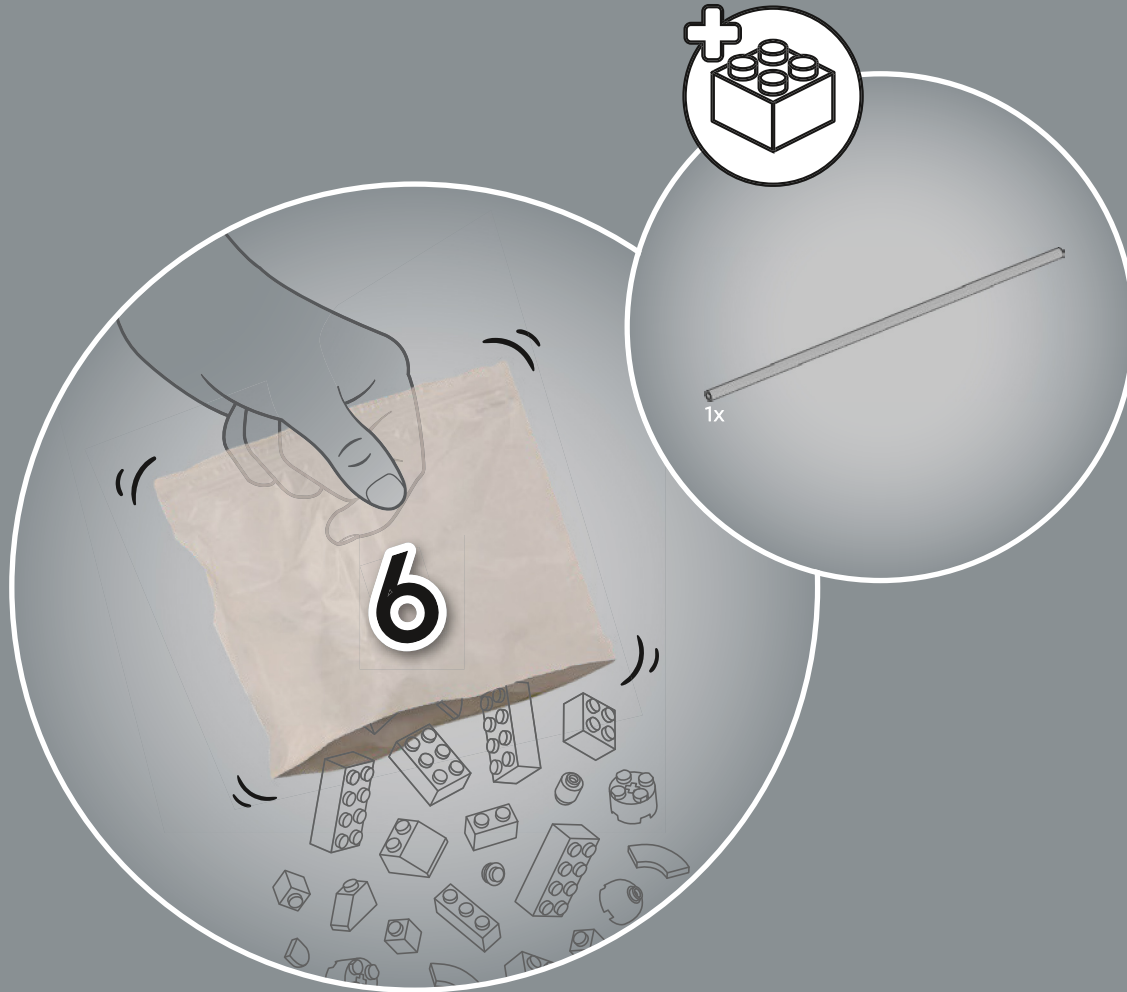

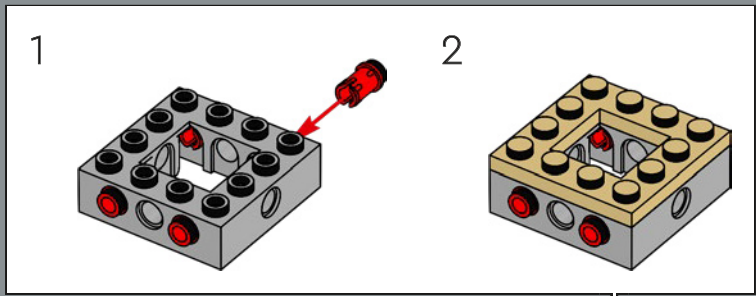
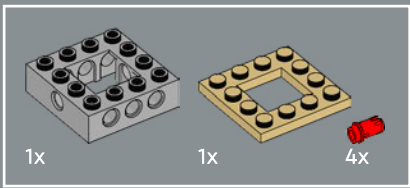

131

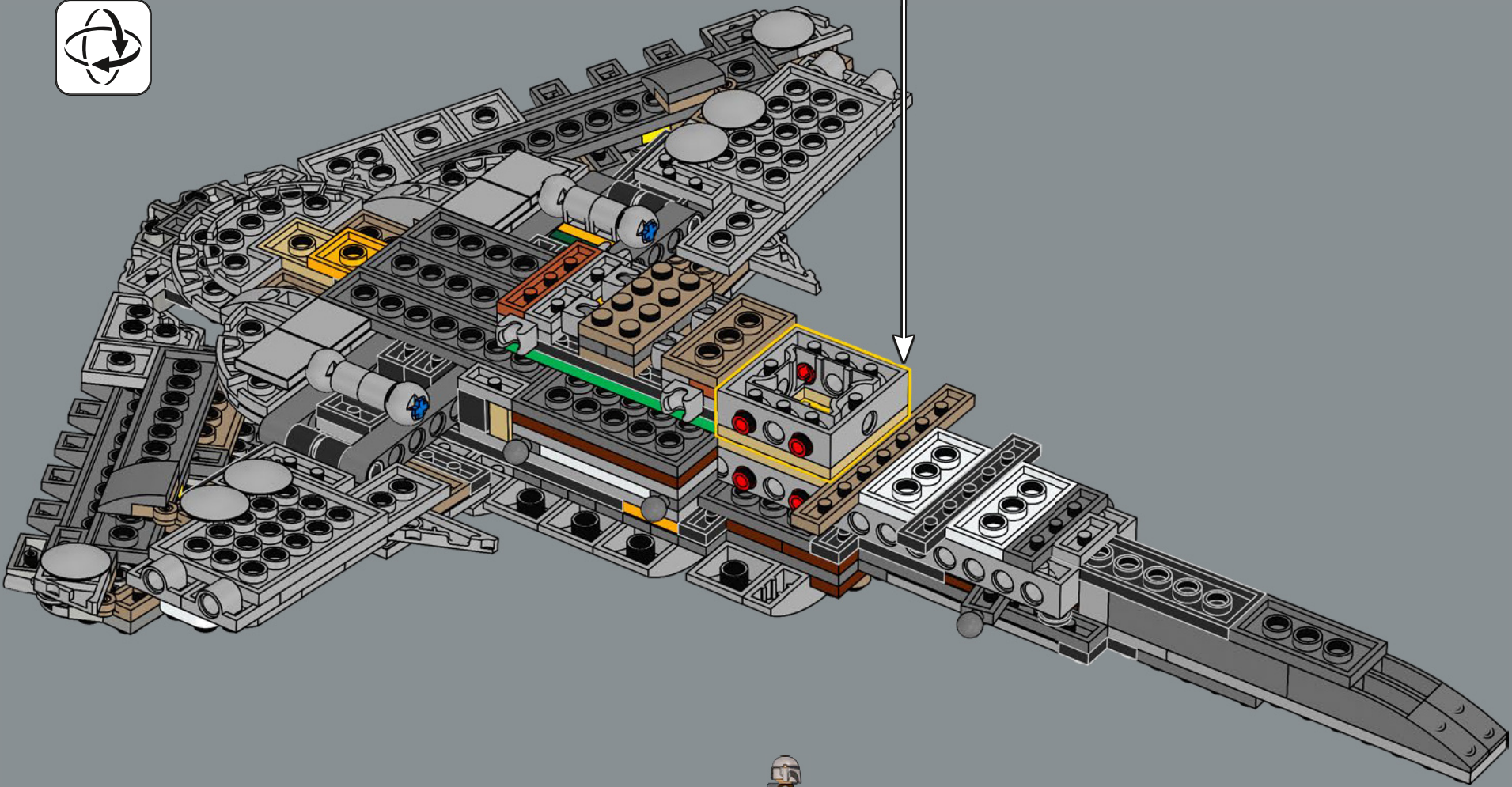

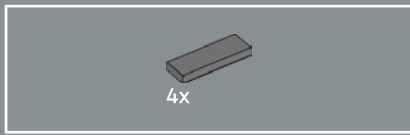

132

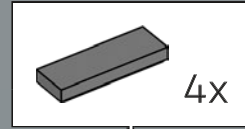
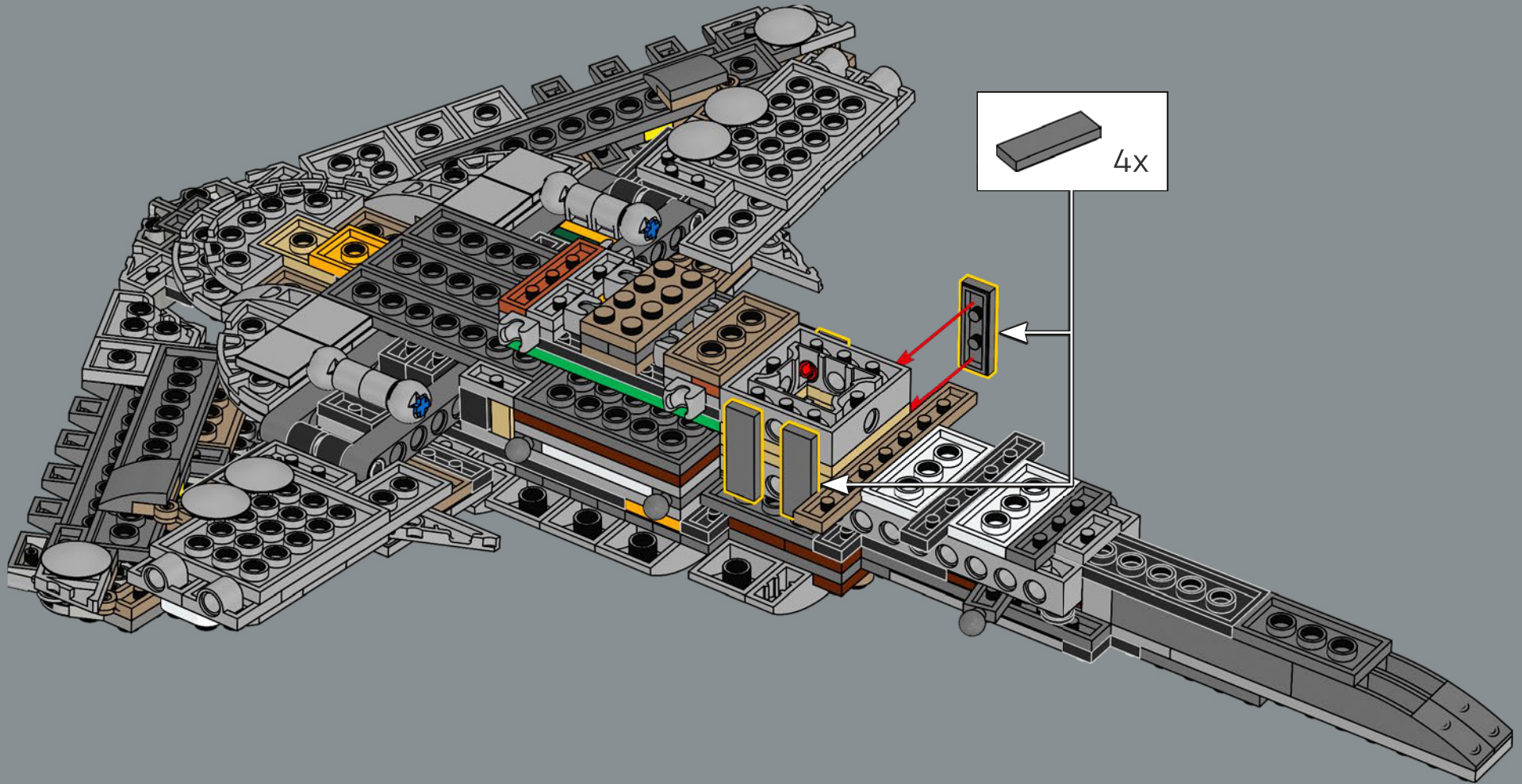

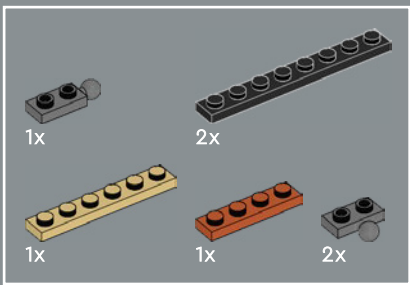

133

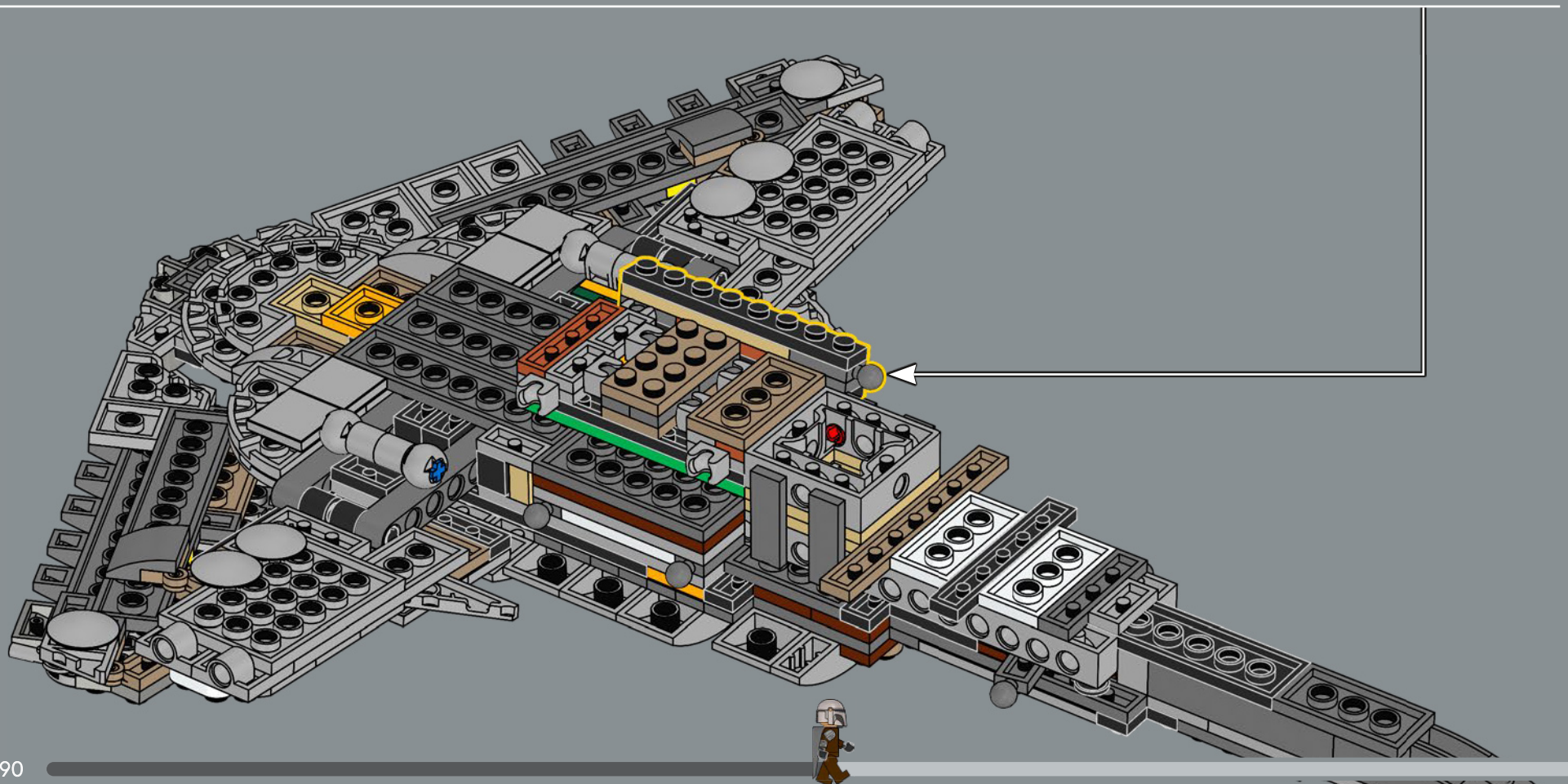
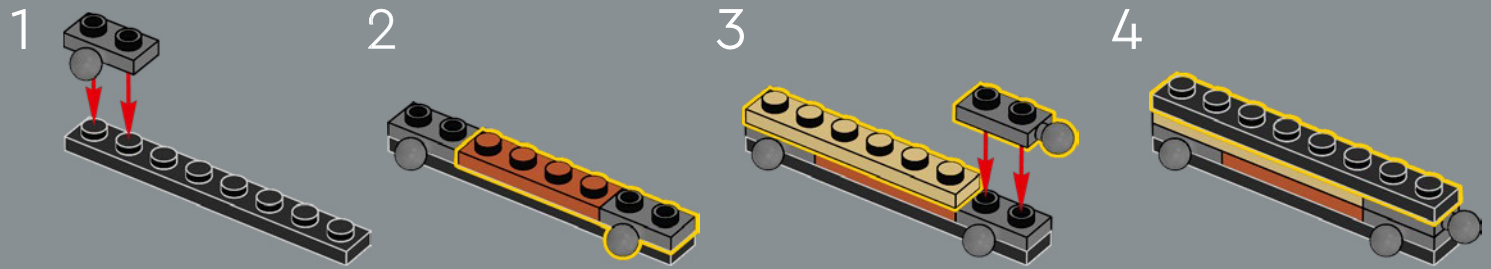

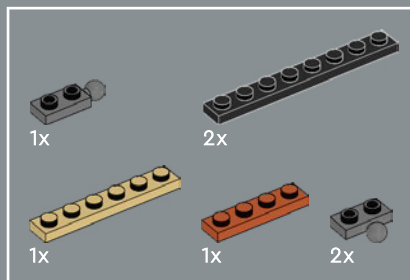

134

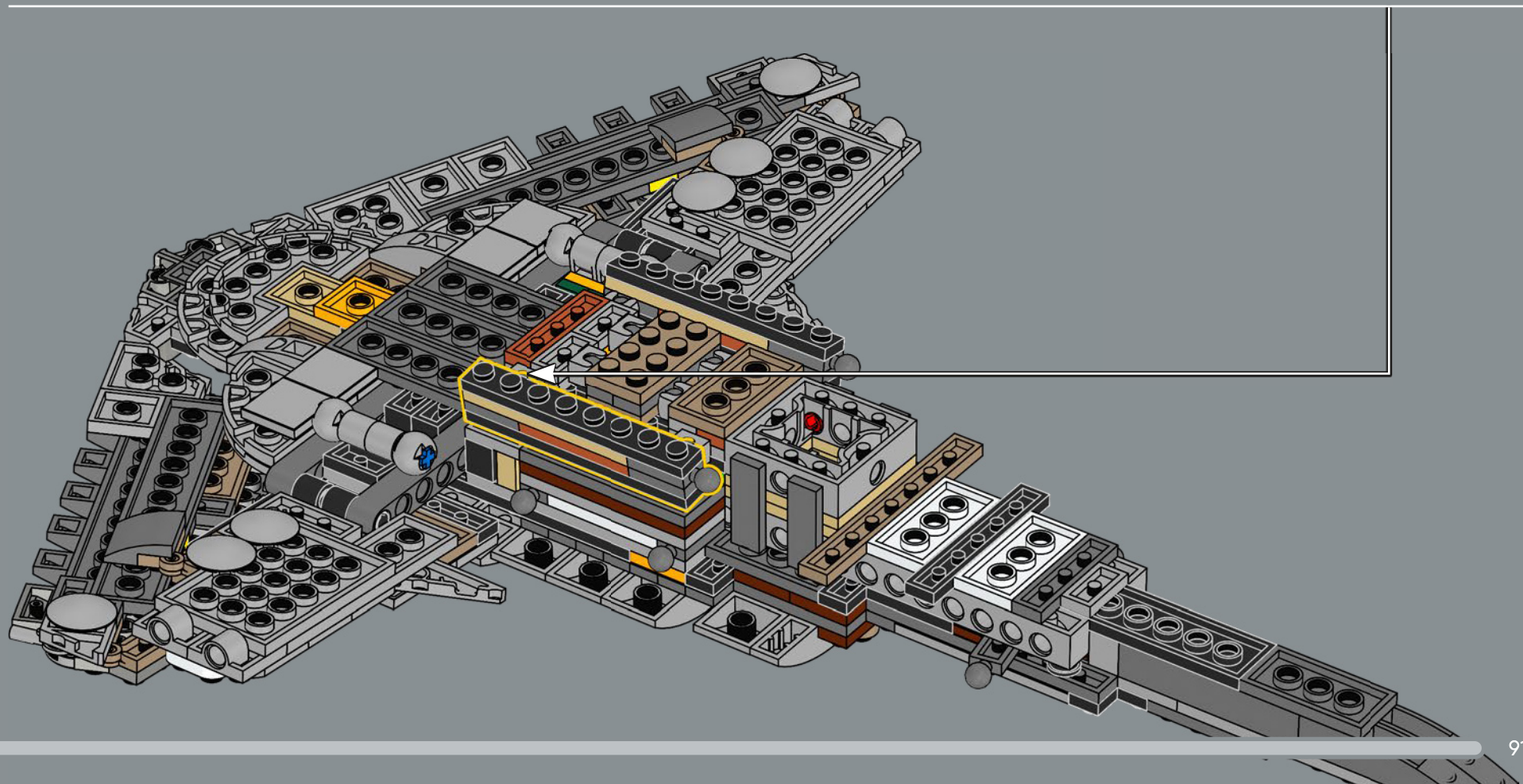
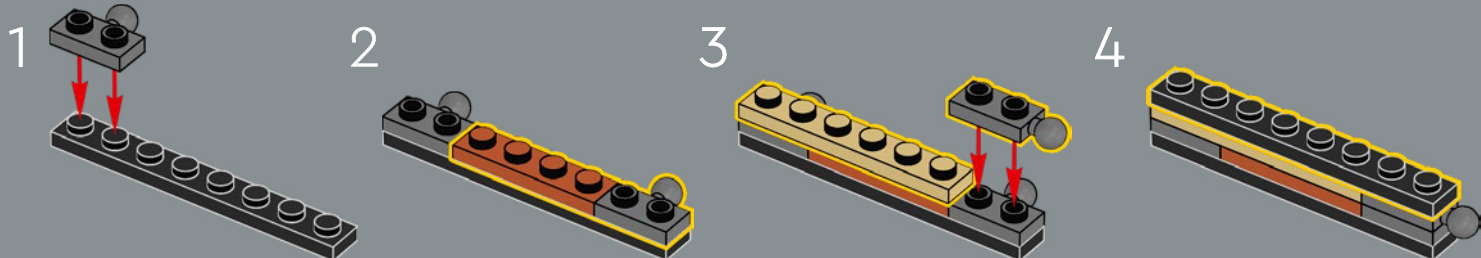

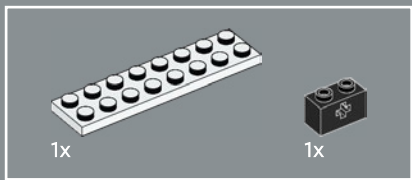

135

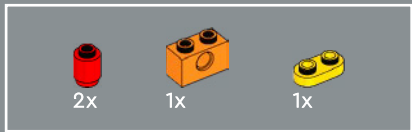
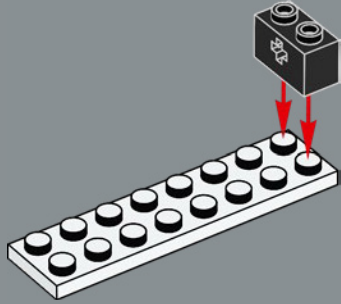

136

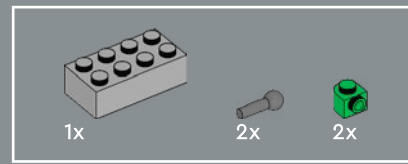
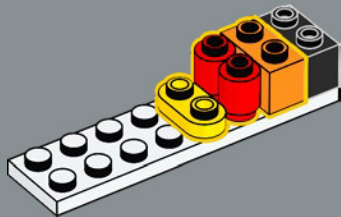

137

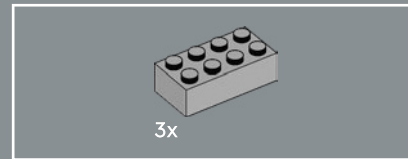
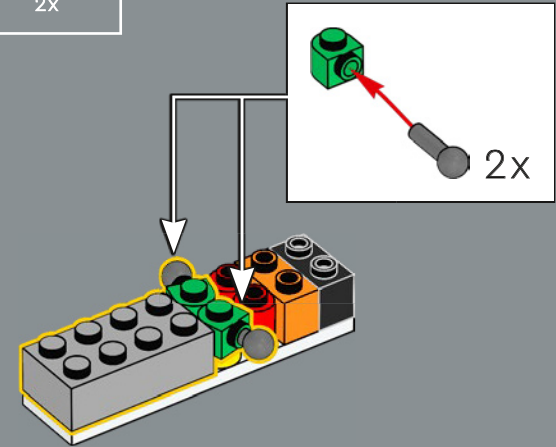

138

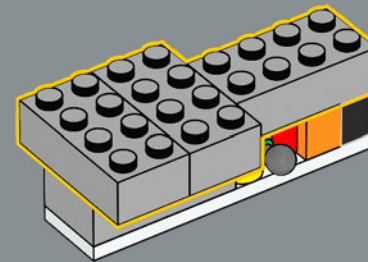

139

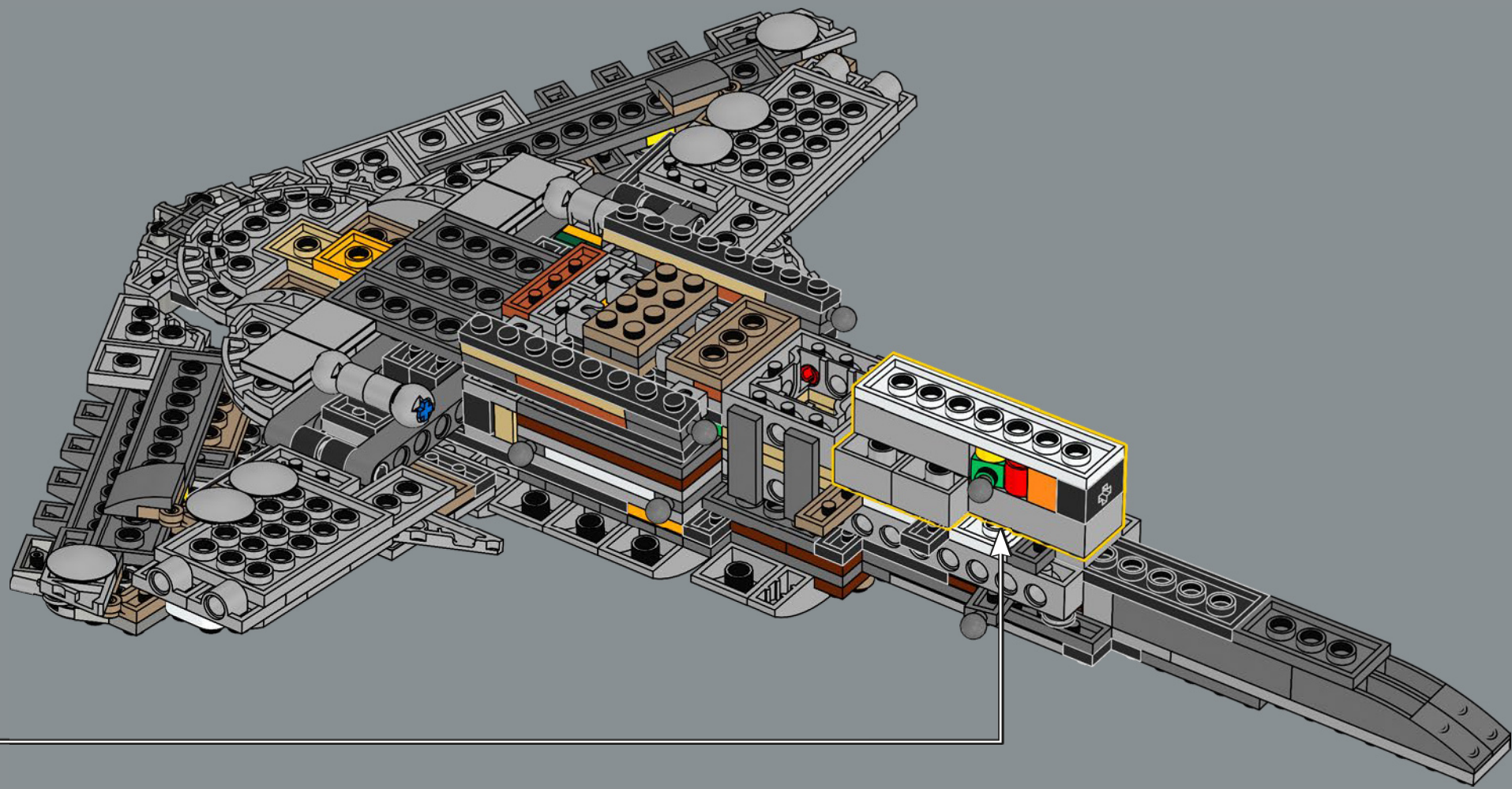

2x  2x 

140

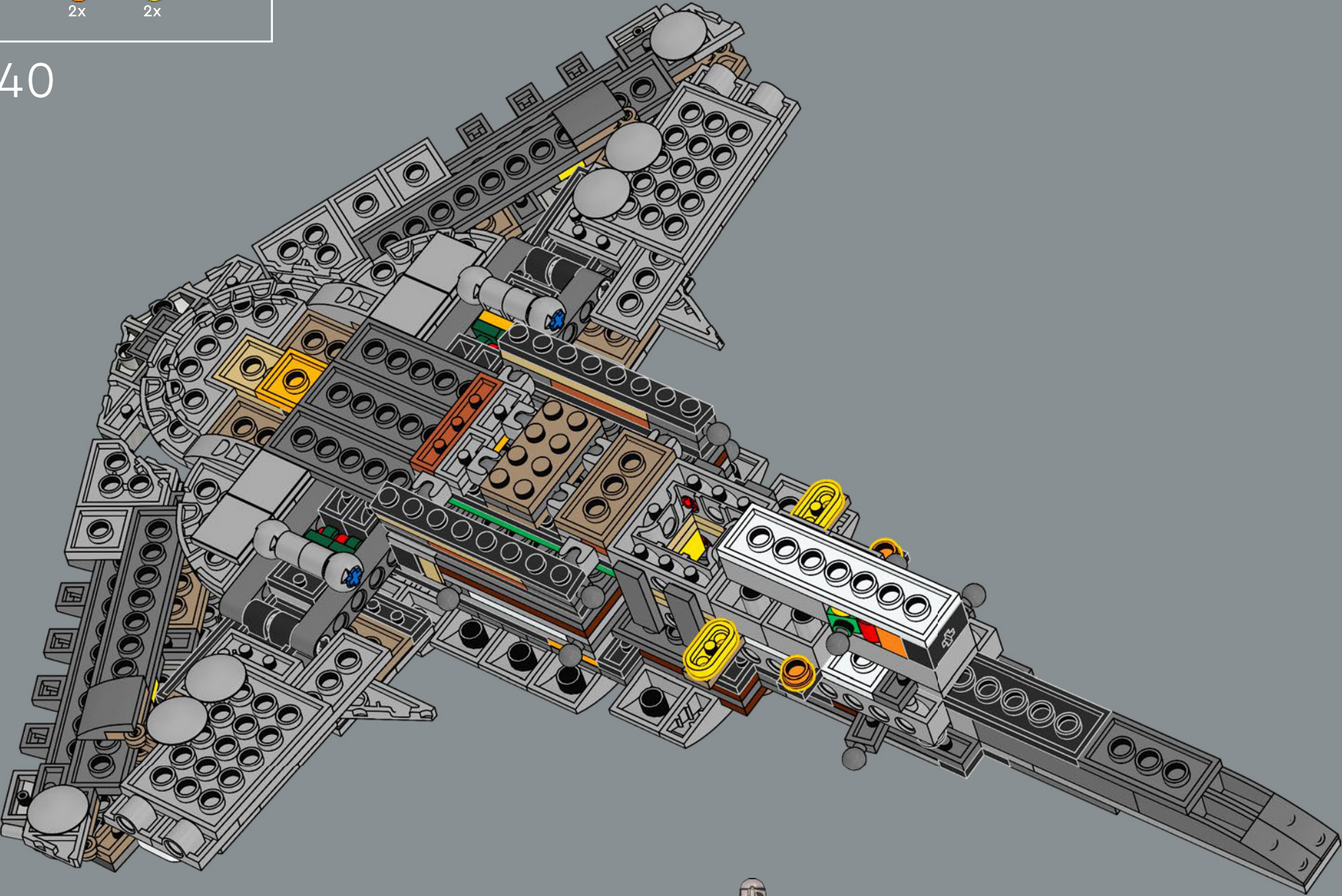

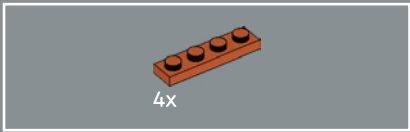

141

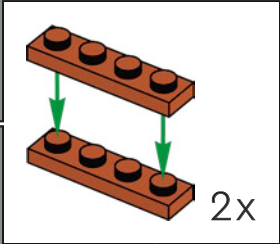
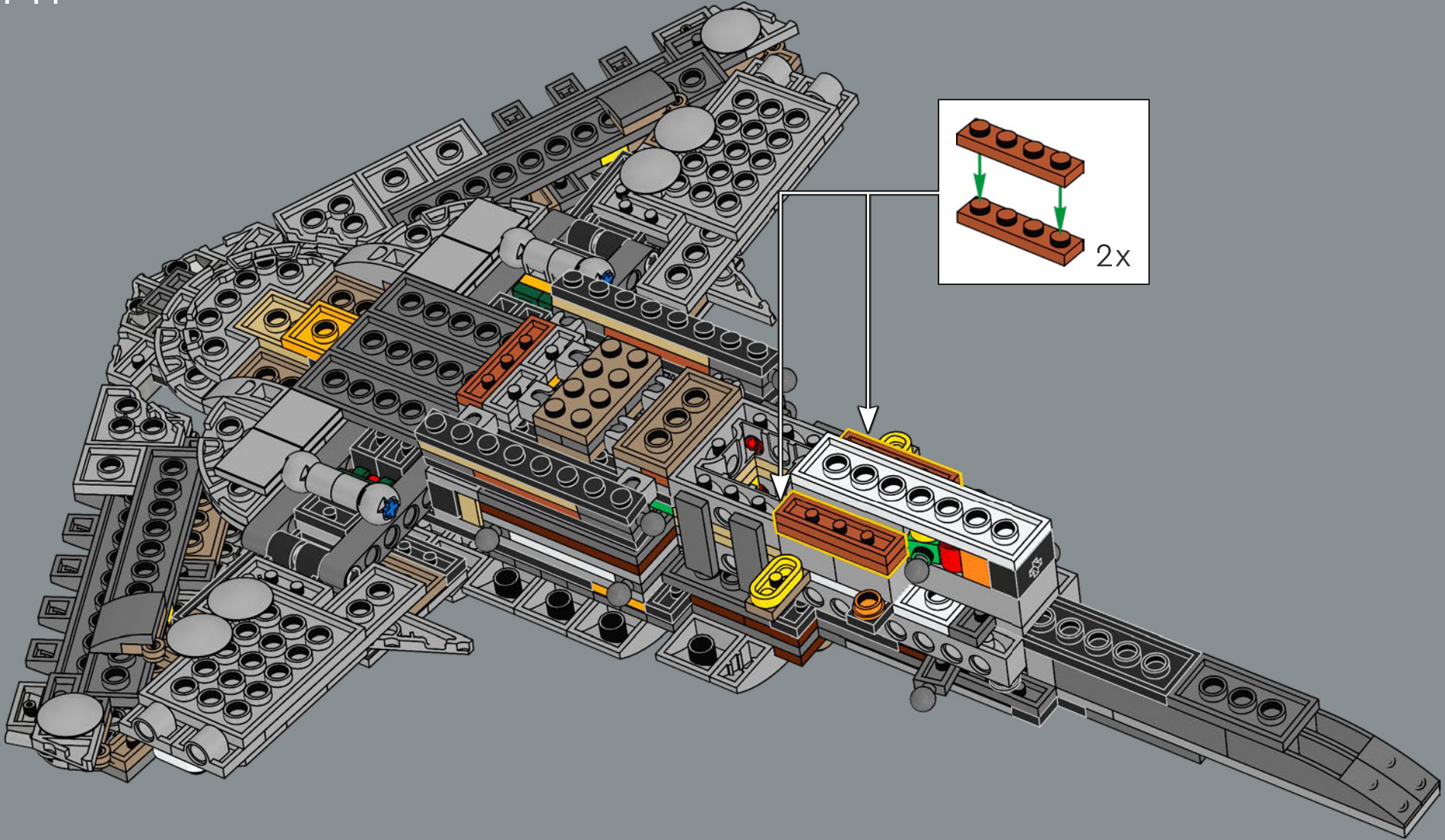

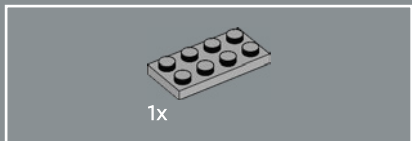
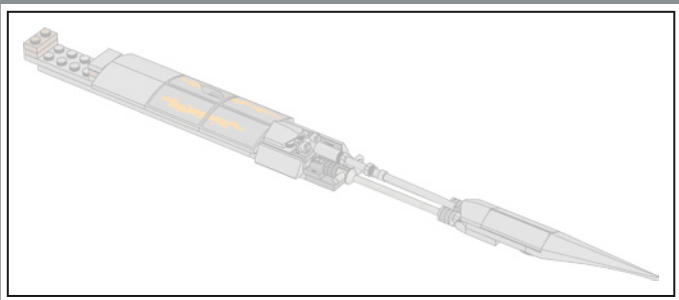

1x

142

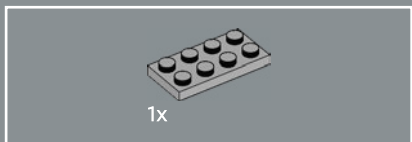
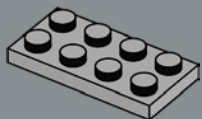

1x

143

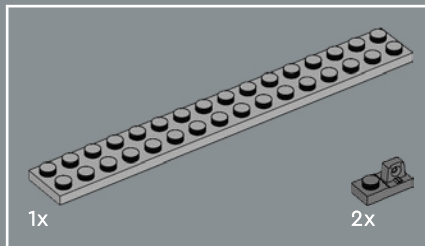
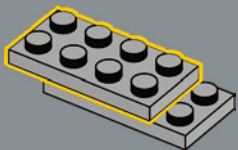

1x

2x

144

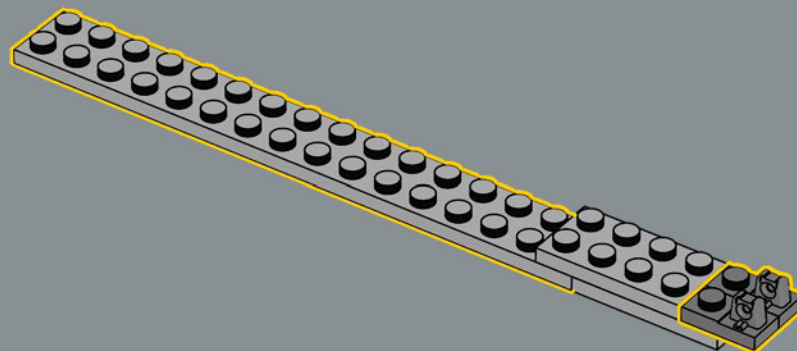

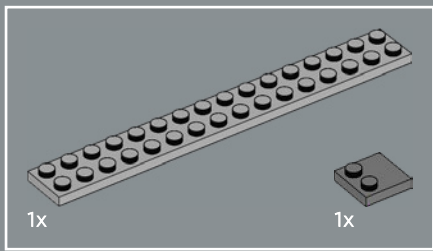

145

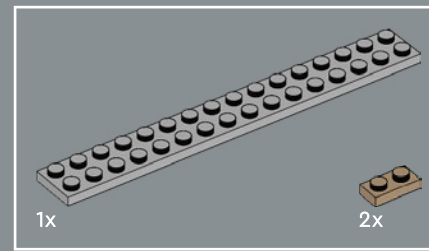
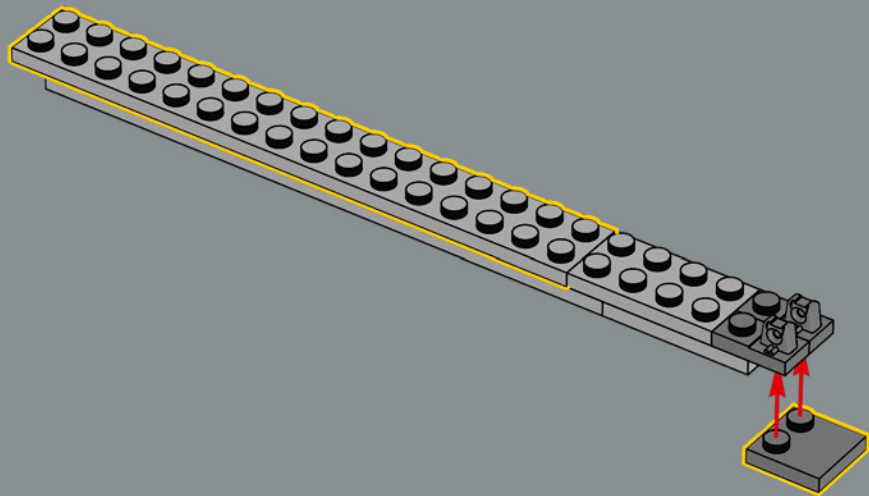

146

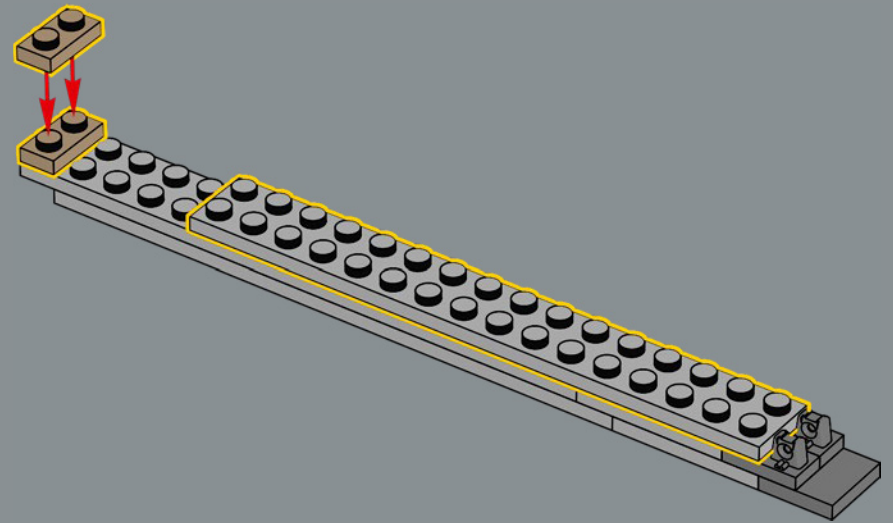

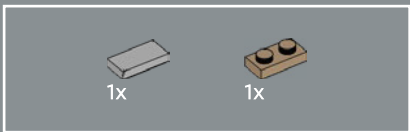

147

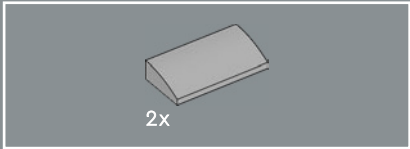
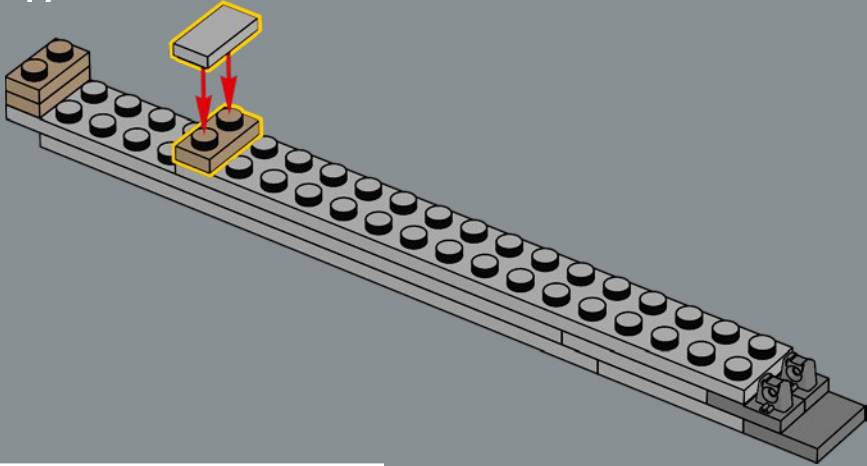

148

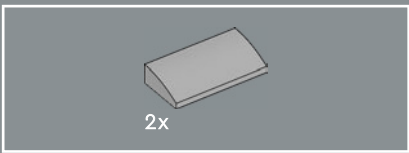
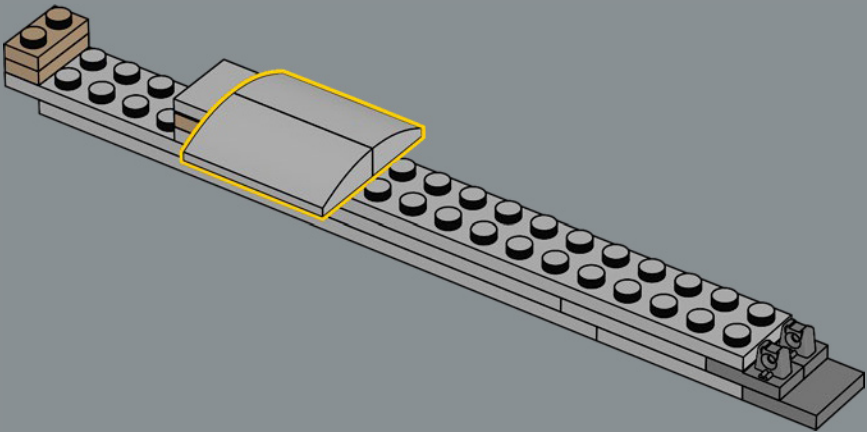

149

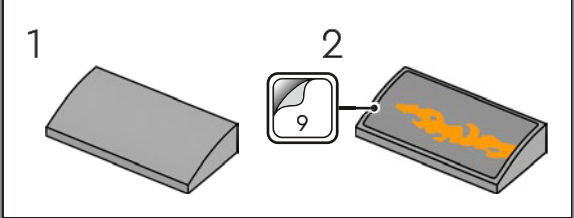
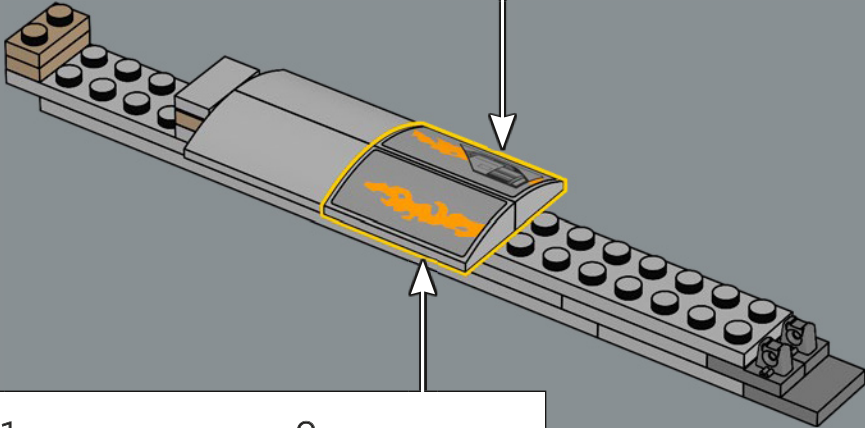
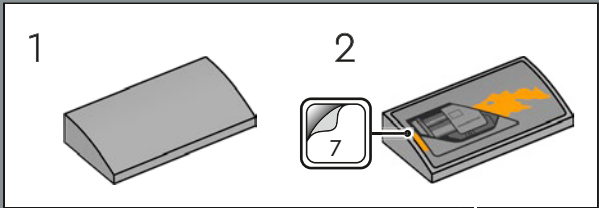

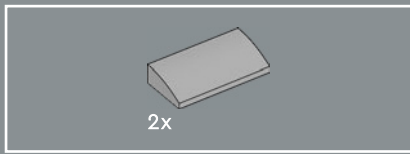

150

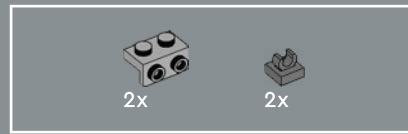
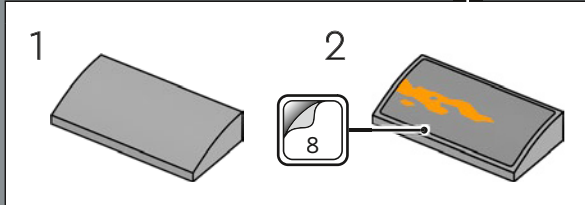
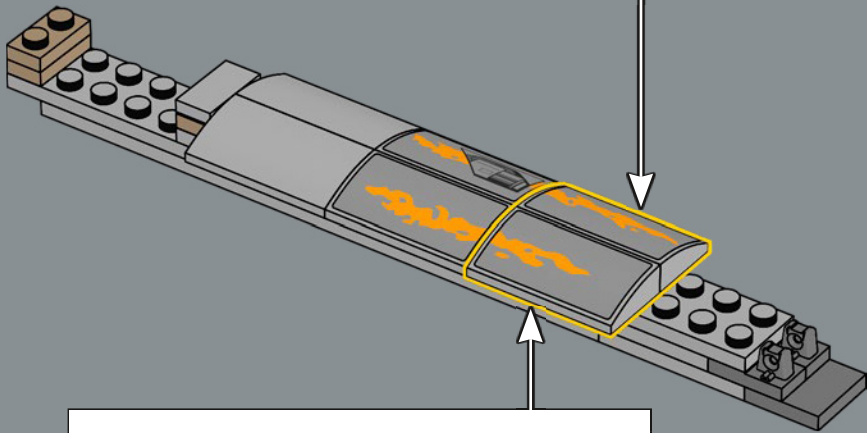
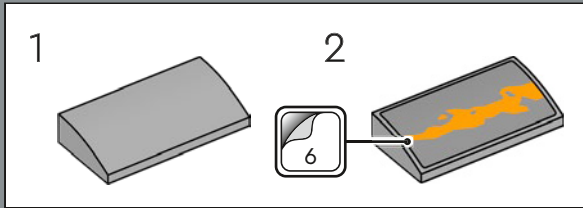

151

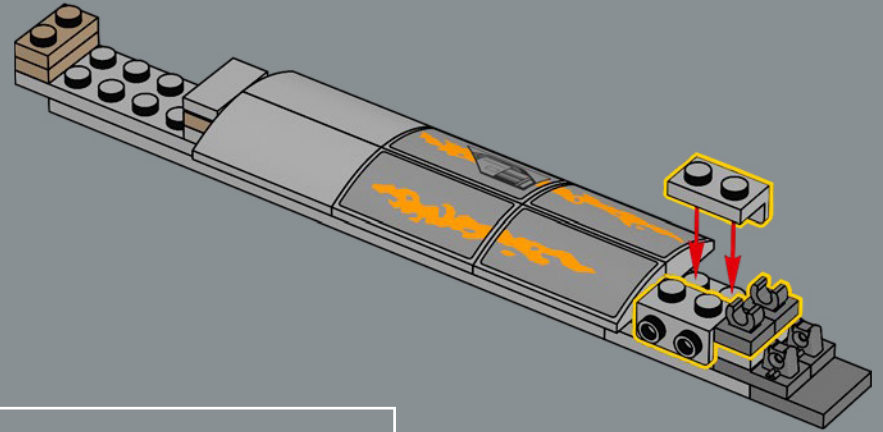

152

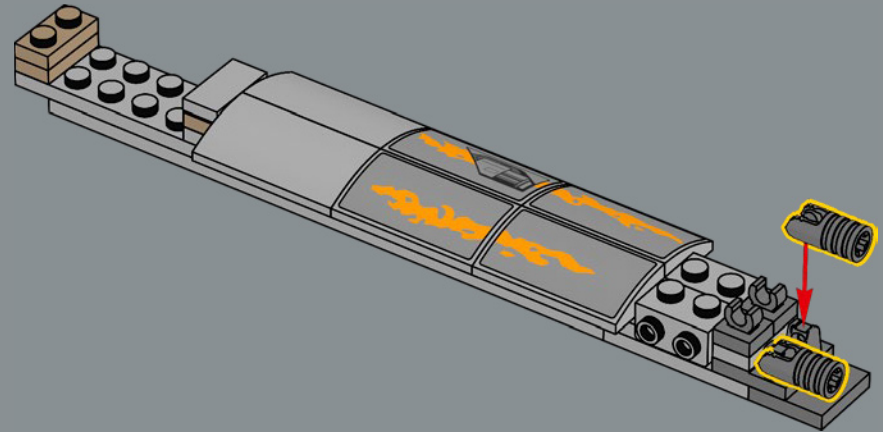

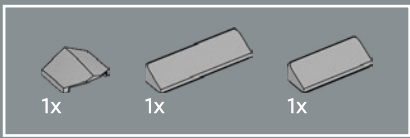

153

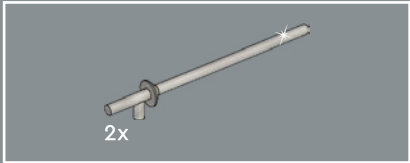
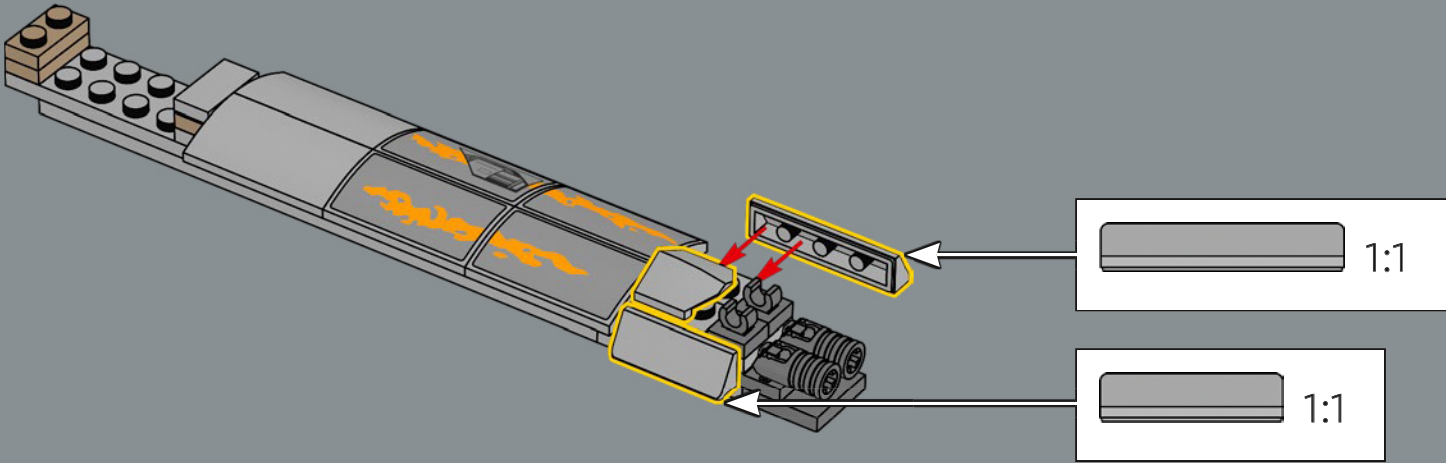

154

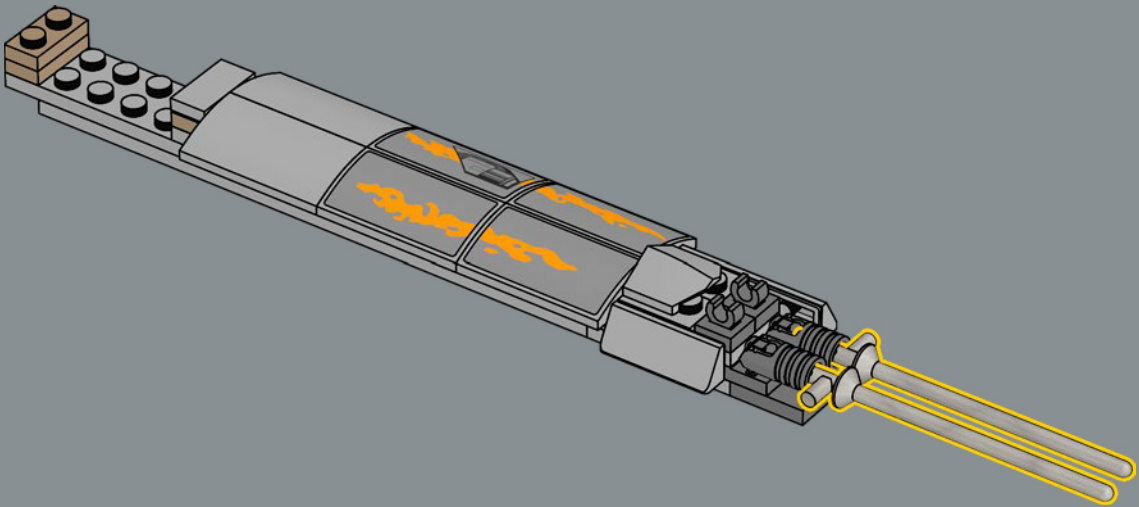

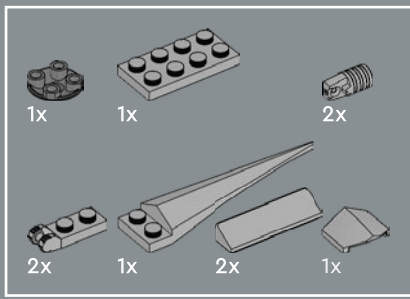

155

1

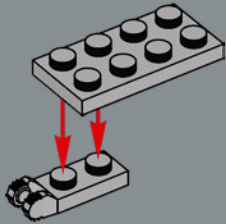

2

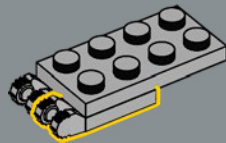

3

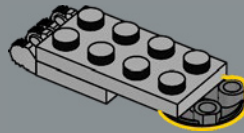

4

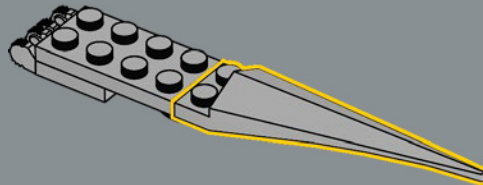

5

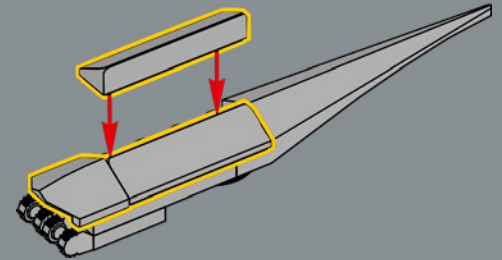

6

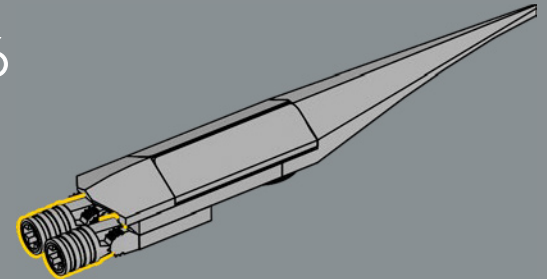

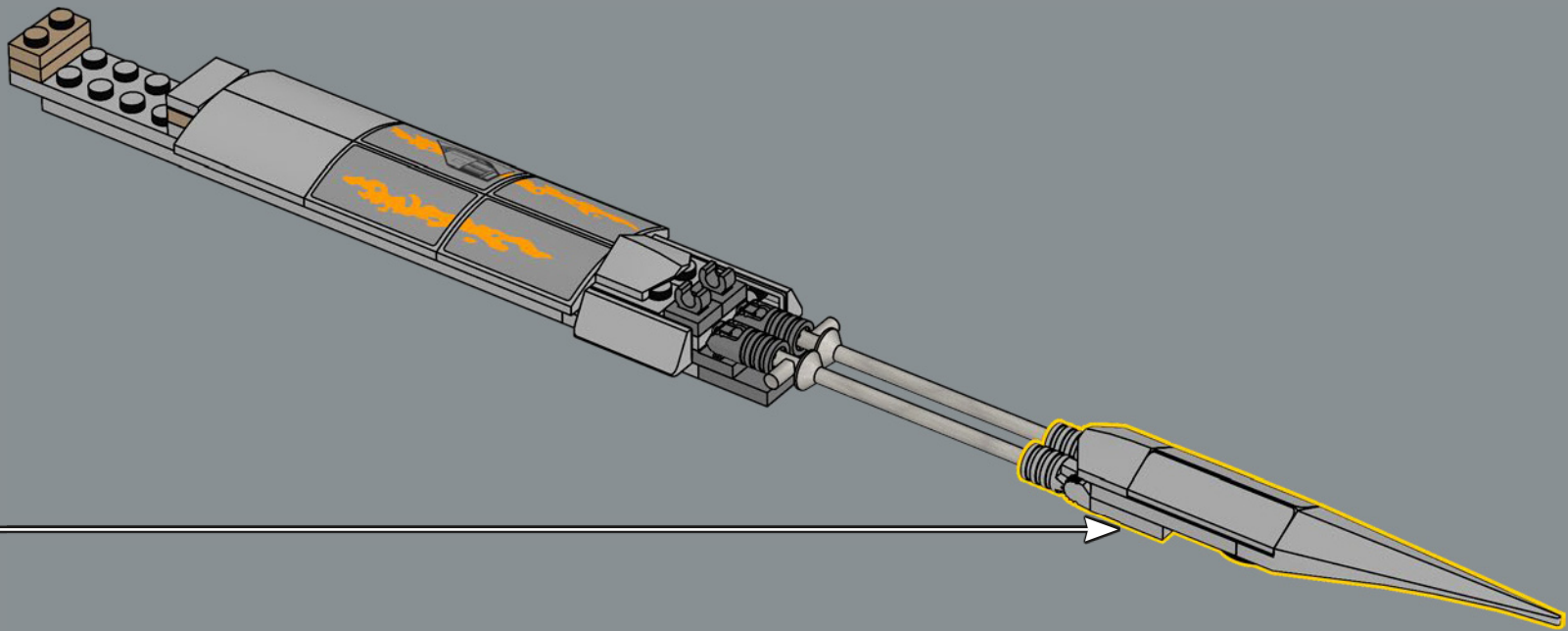



156

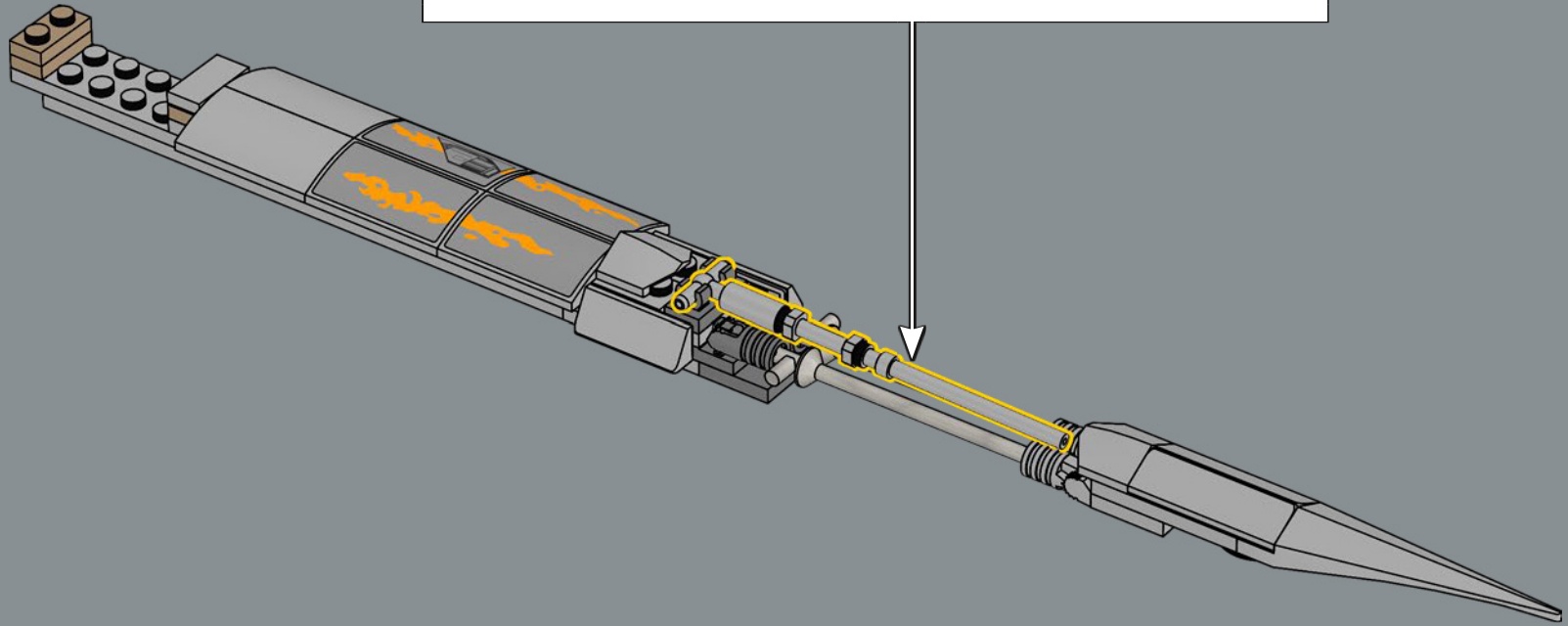
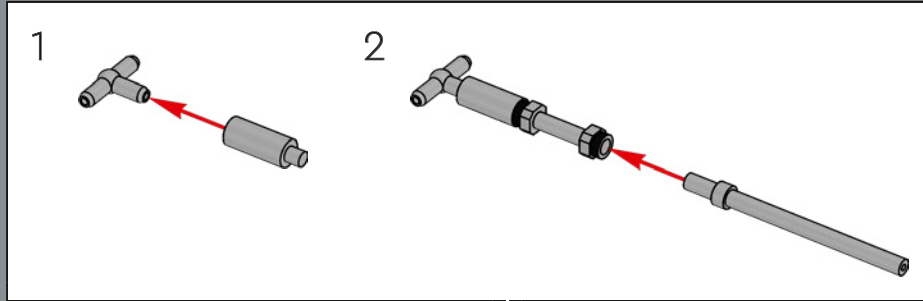

157

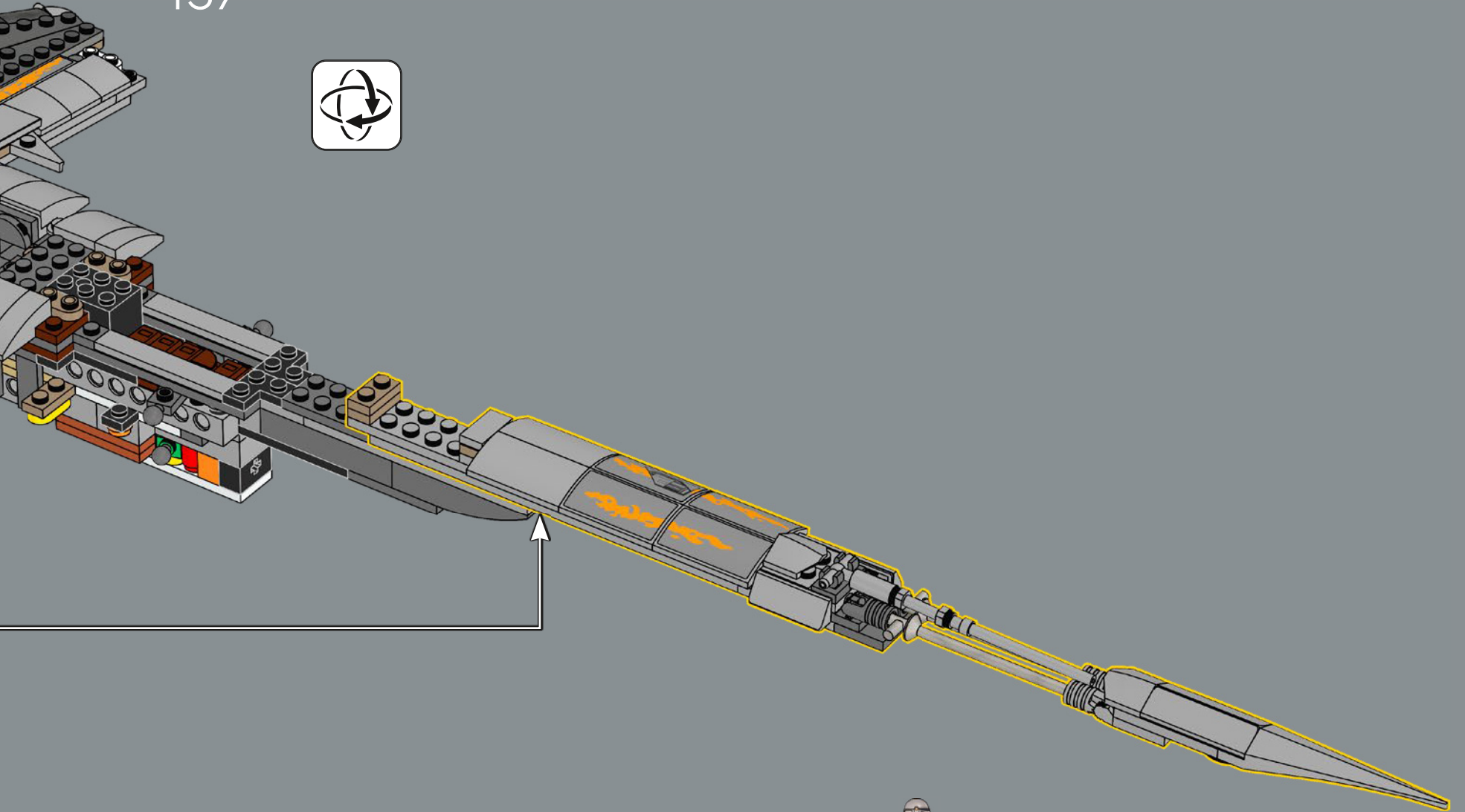

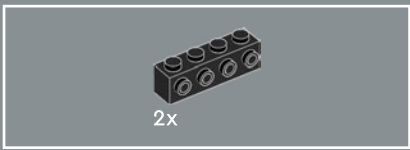

158

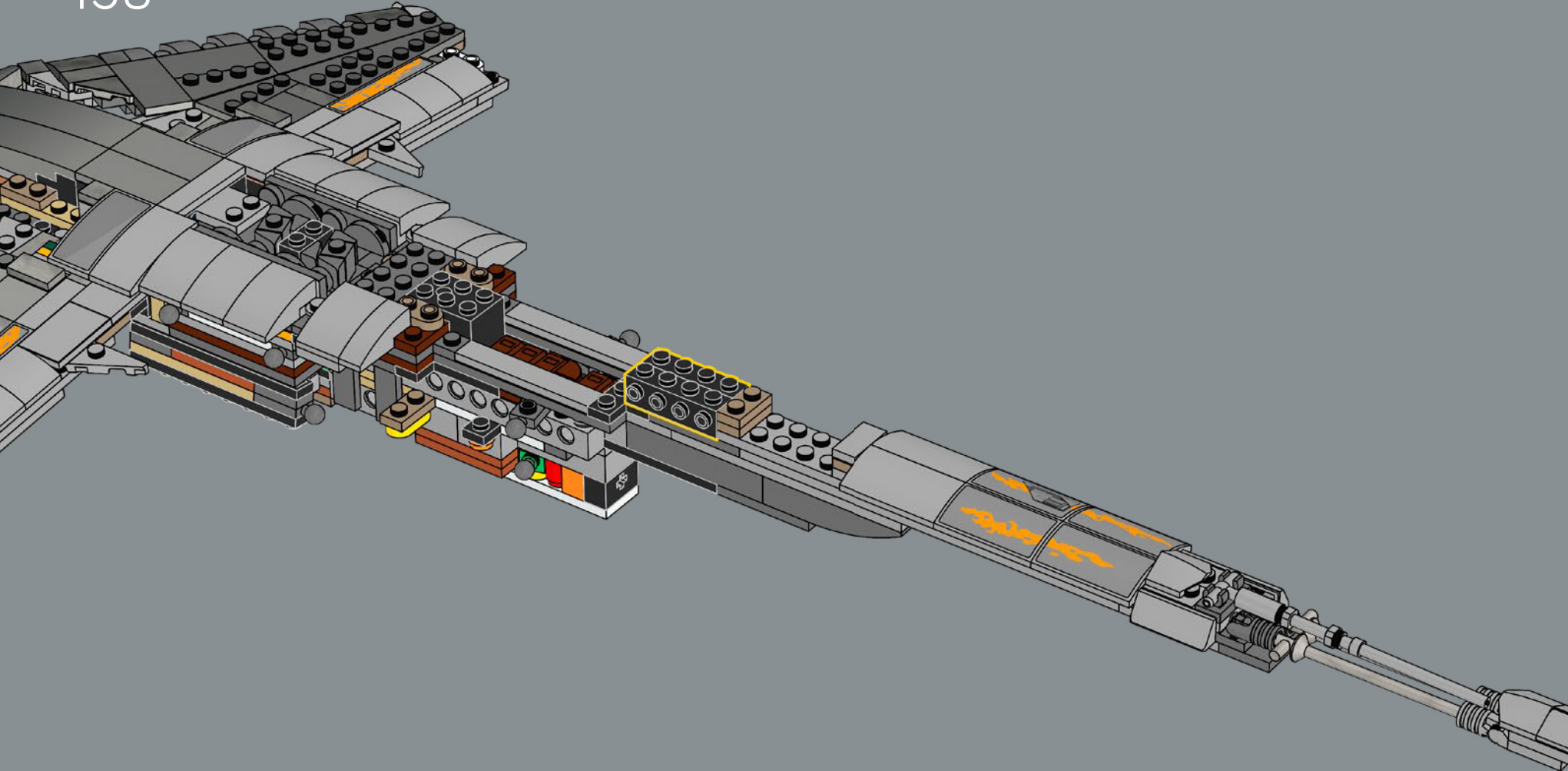

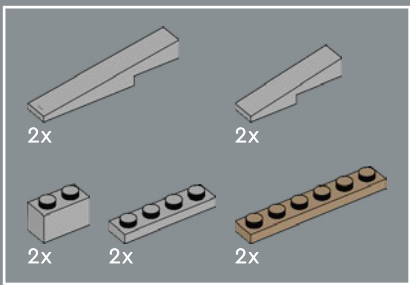

159

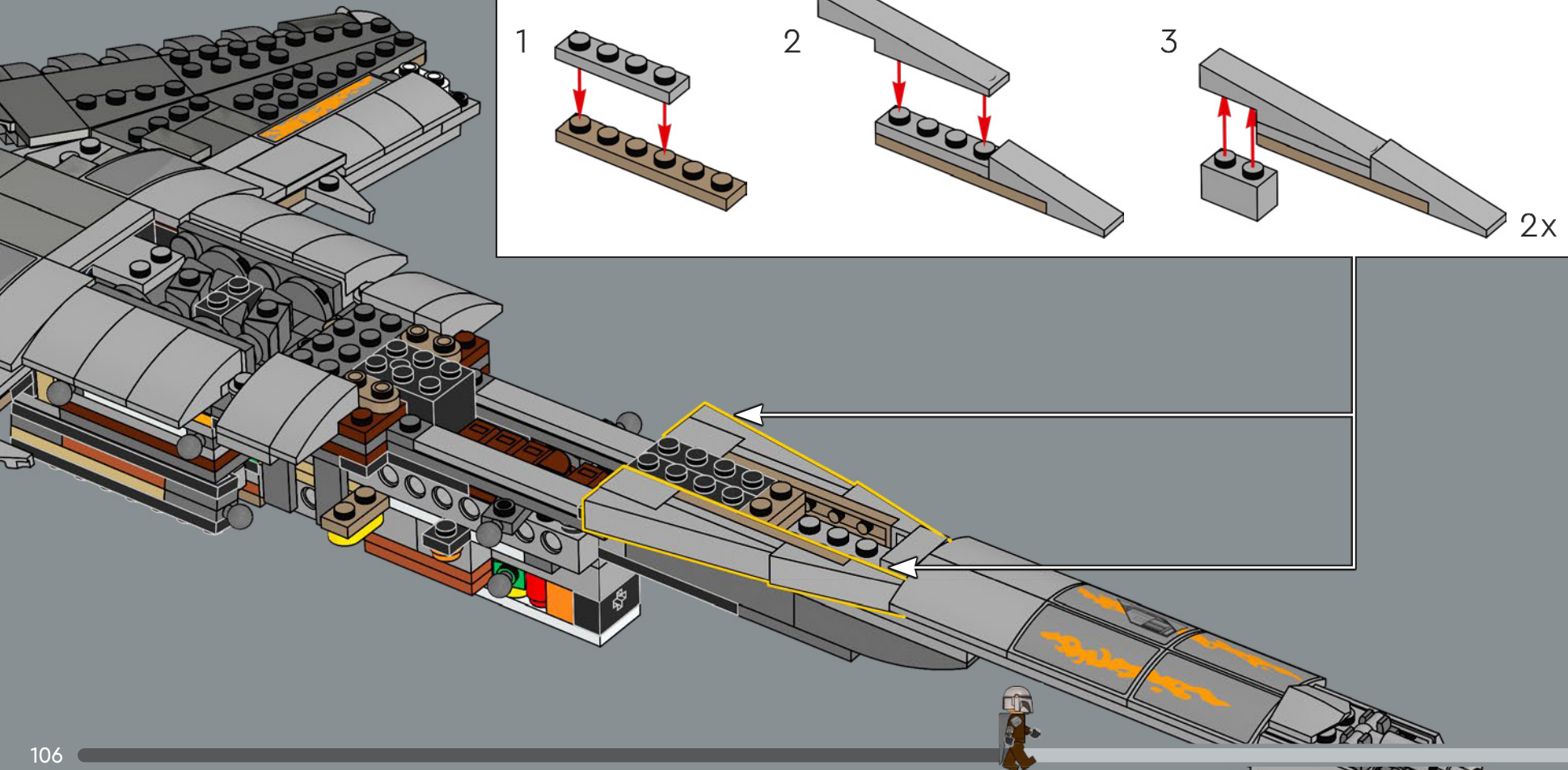

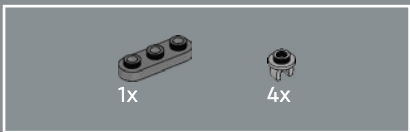

160

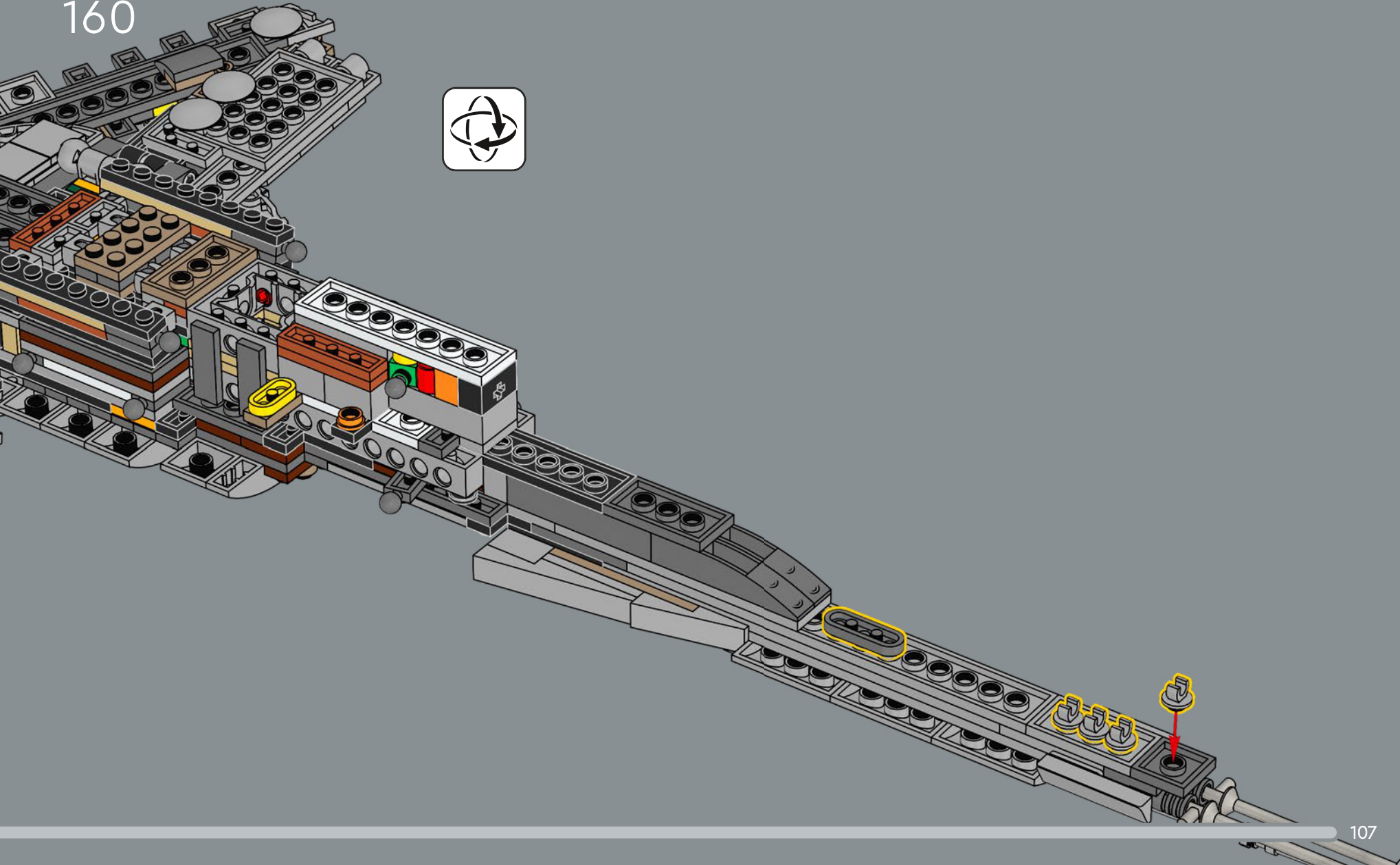



161

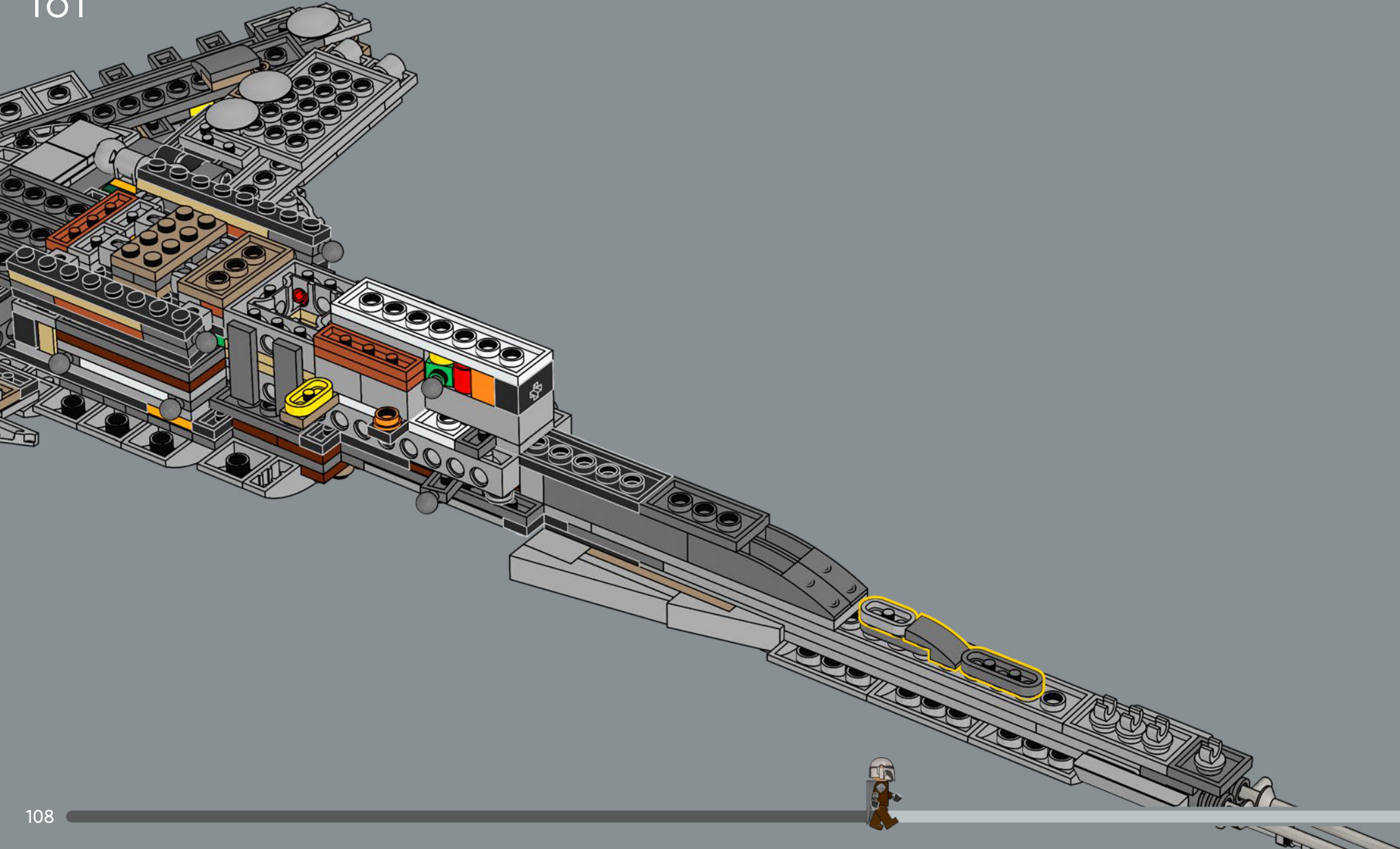



2x

162

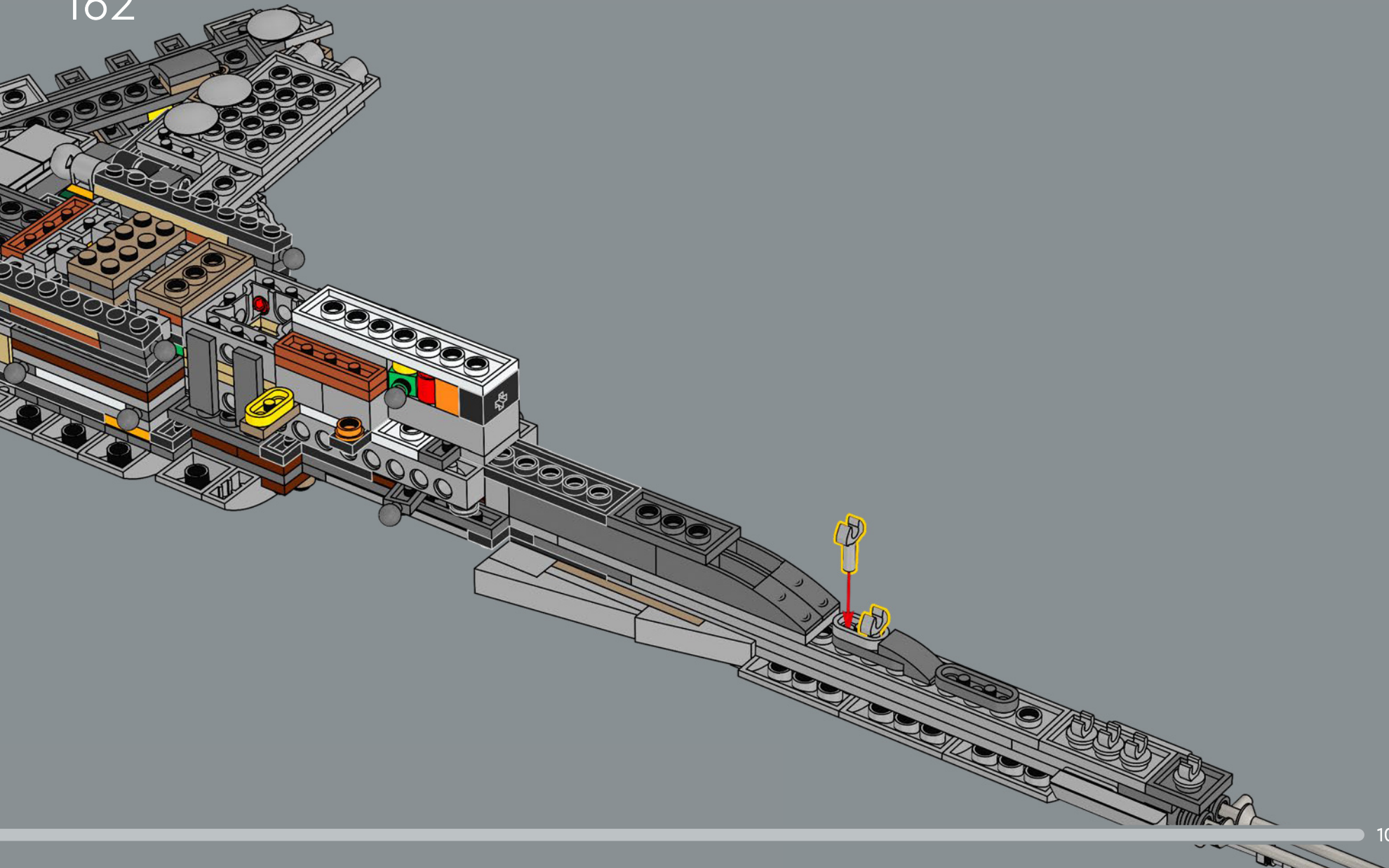

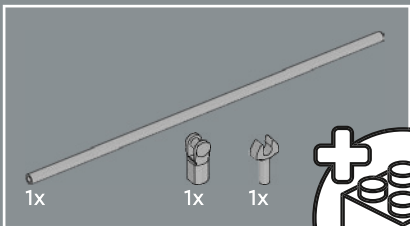

163

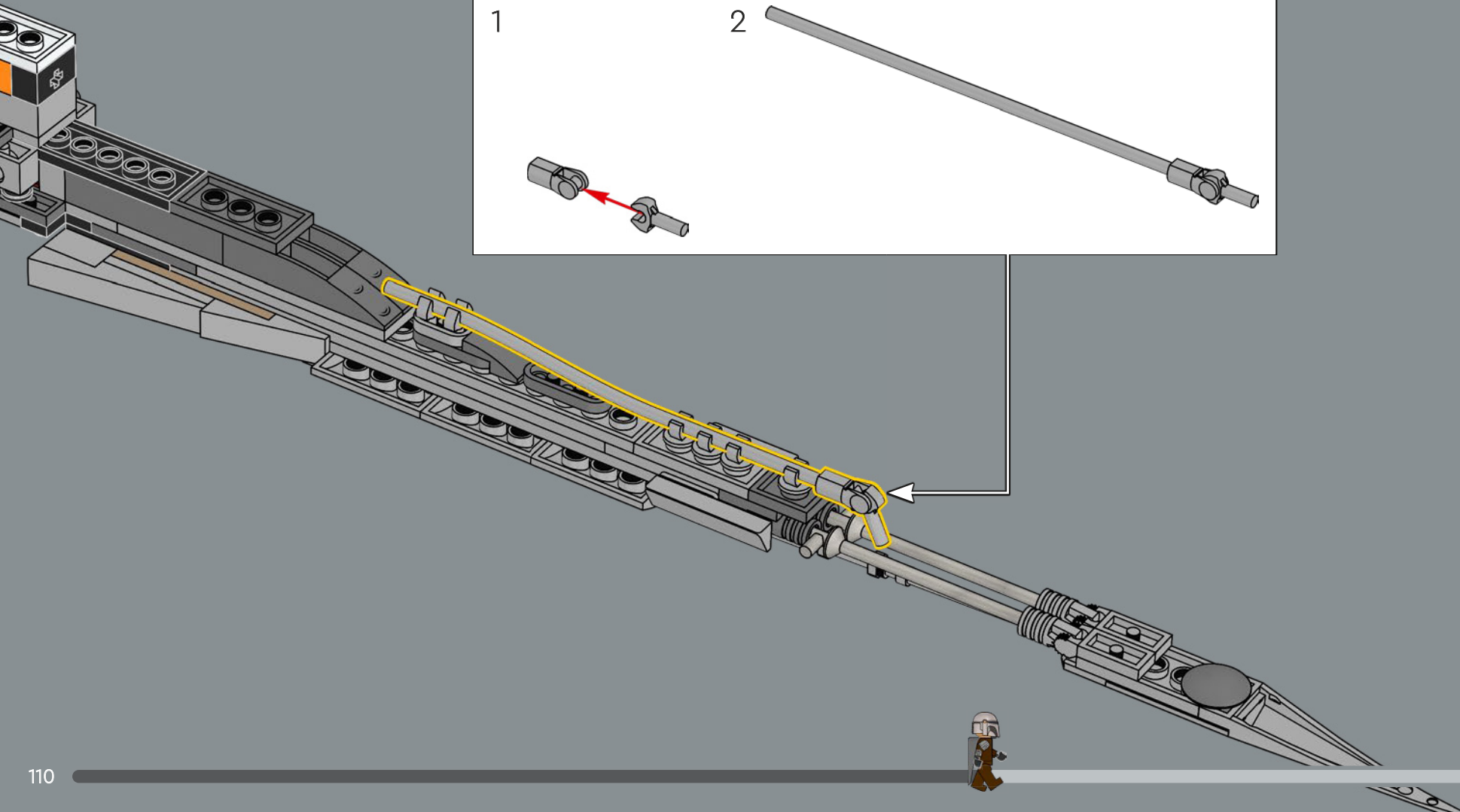
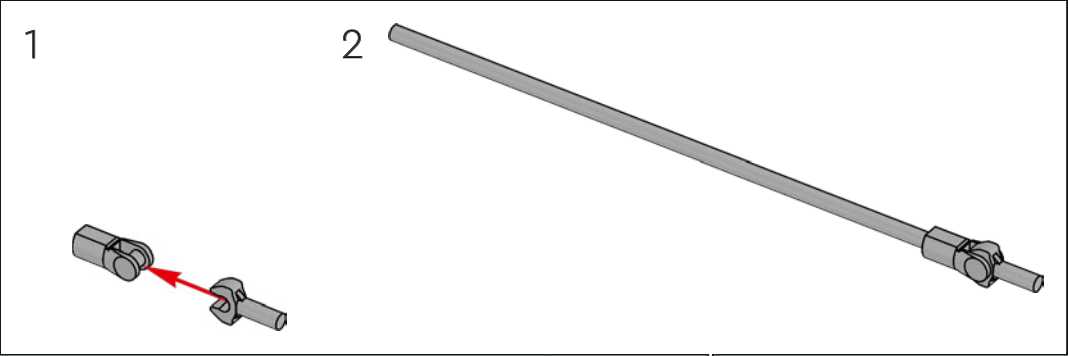

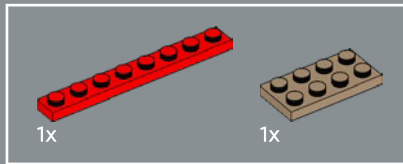
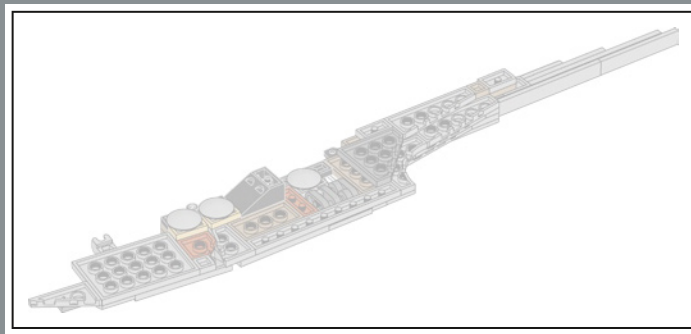

164

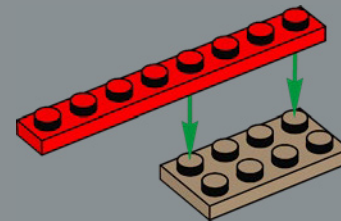

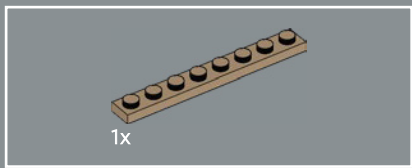

165

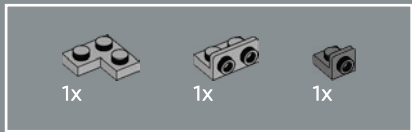
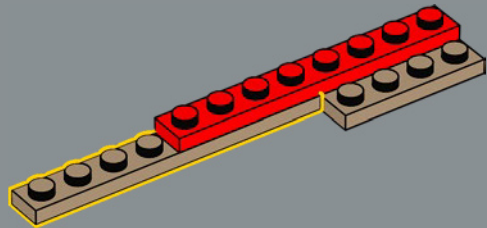

166

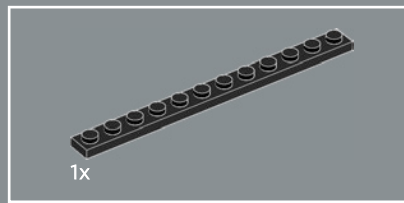
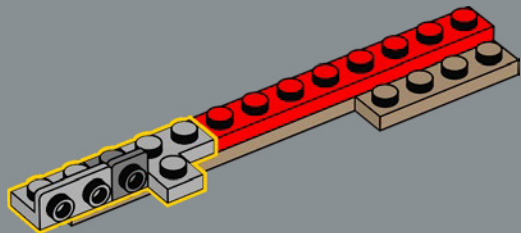

167

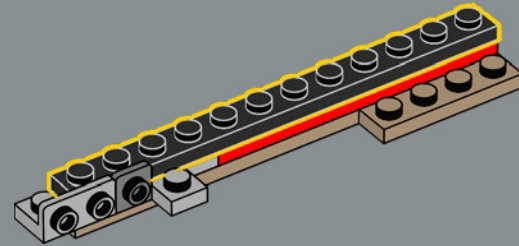

168

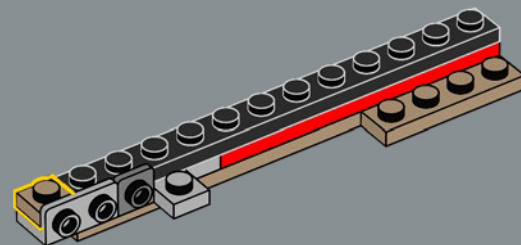

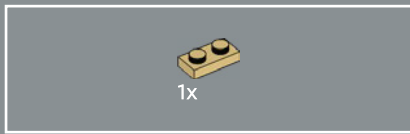

169

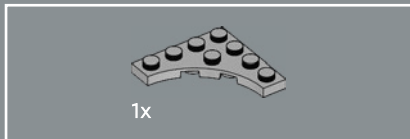
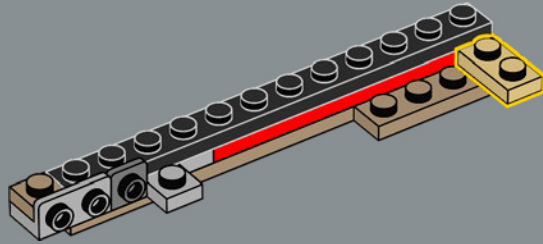

170

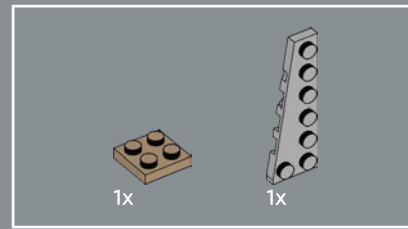
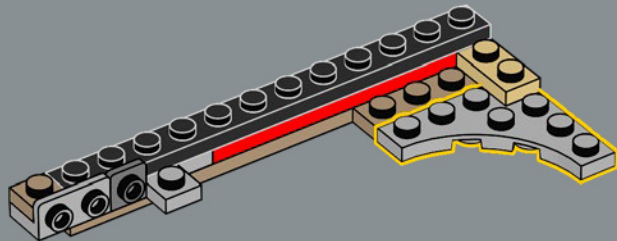

171

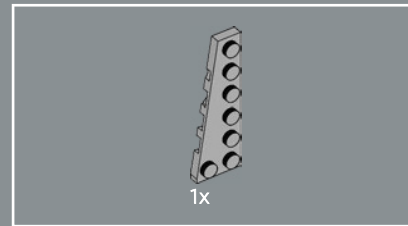
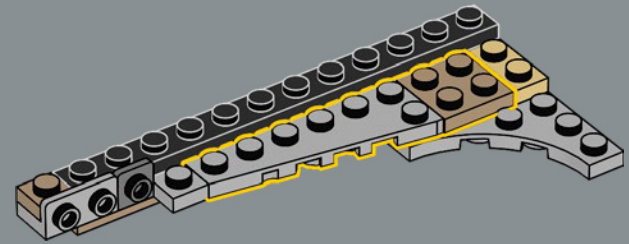

172

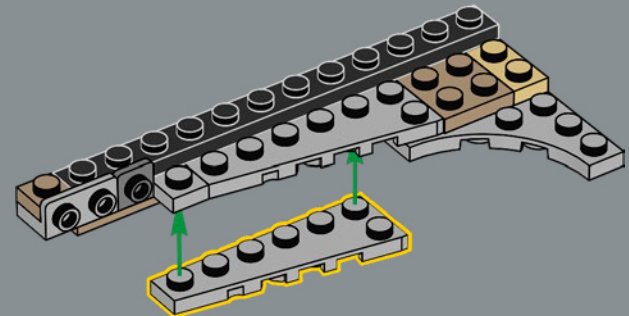

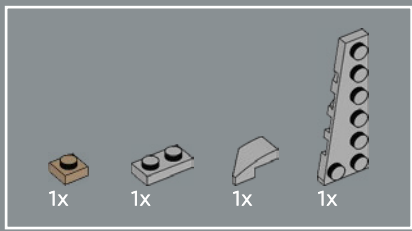

173

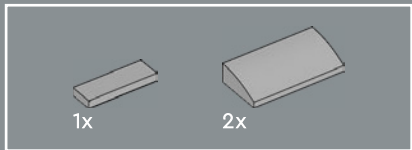
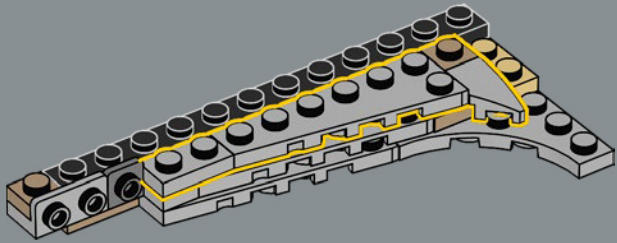

174

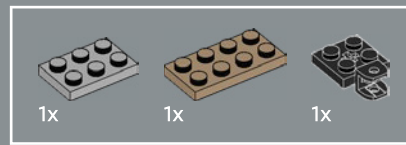
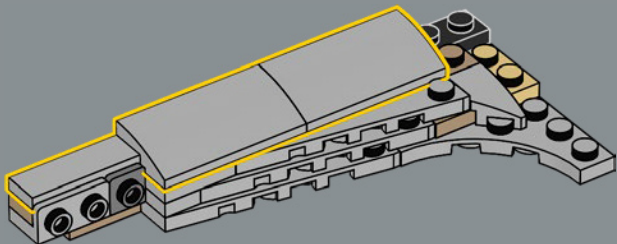

175

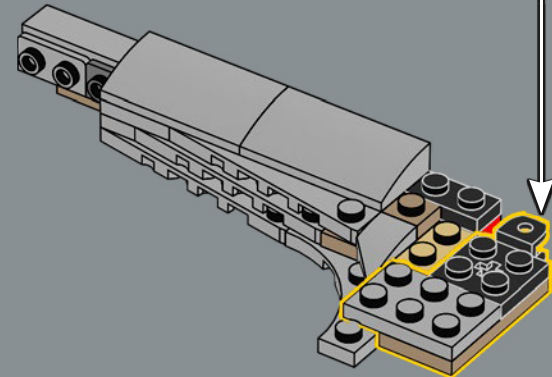
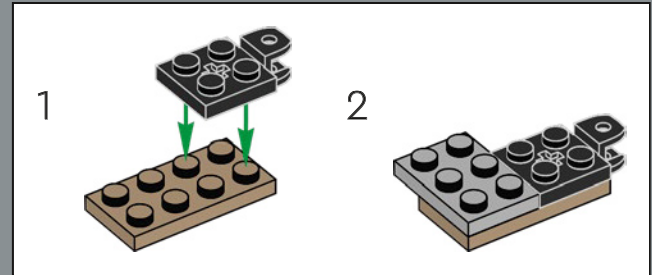

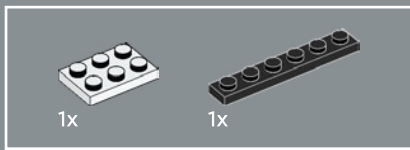

176

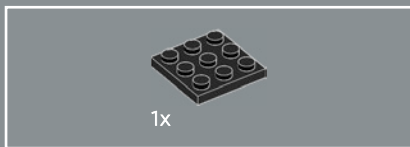
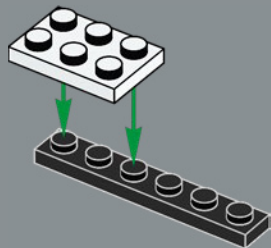

177

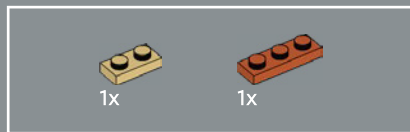
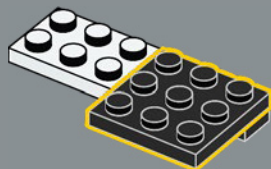

178

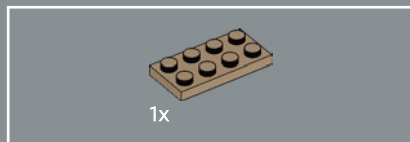
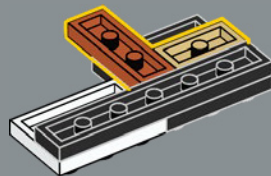

179

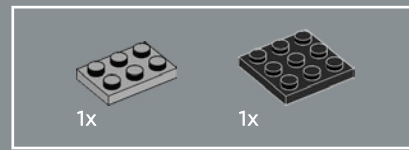
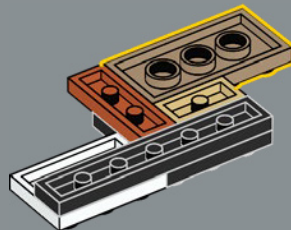

180

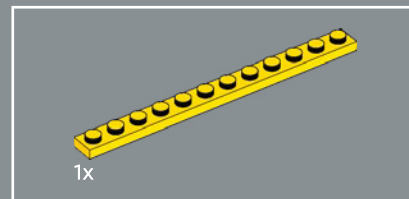
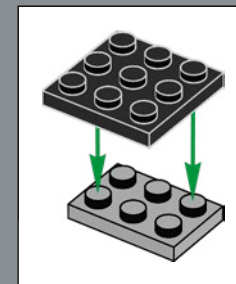
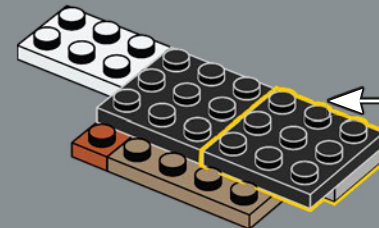

181

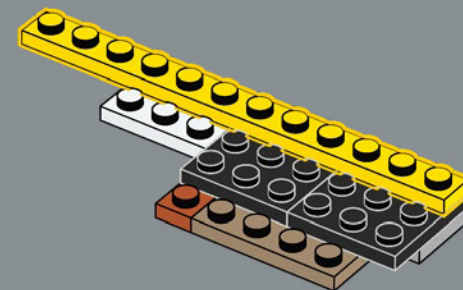



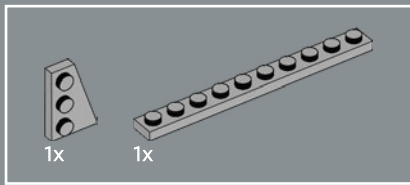

184

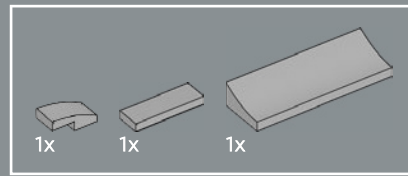
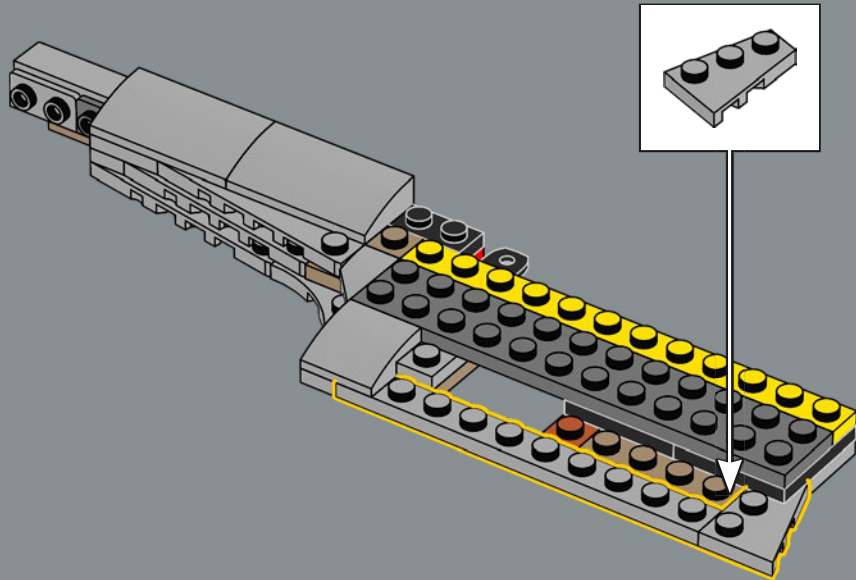

185

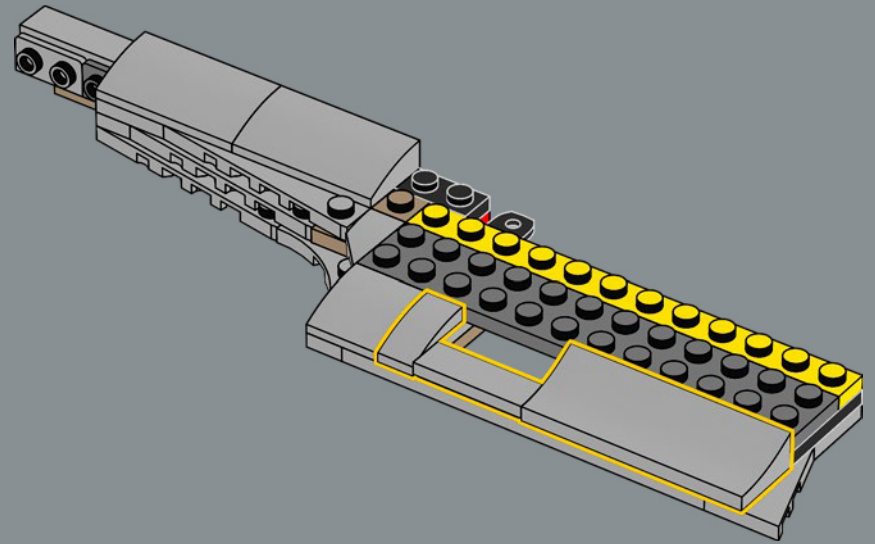

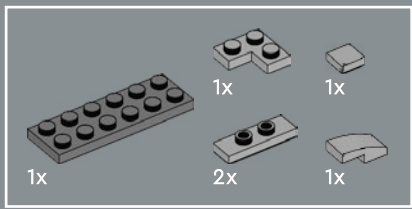

186

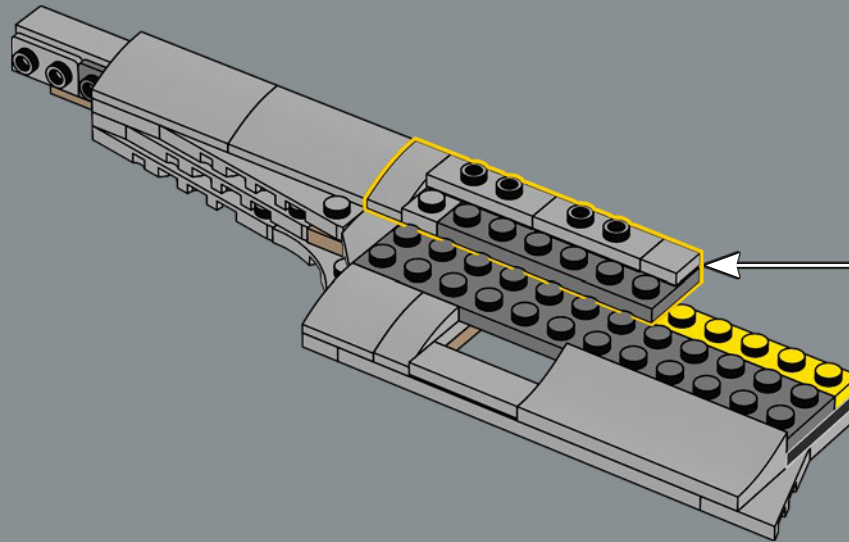
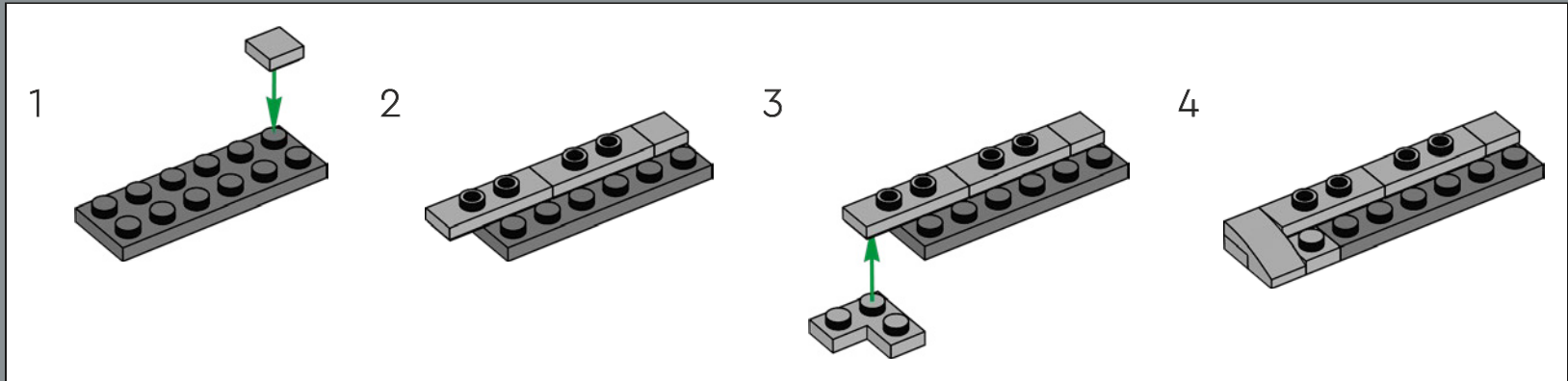

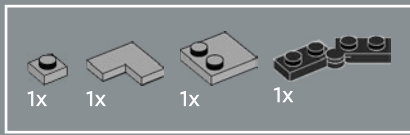

187

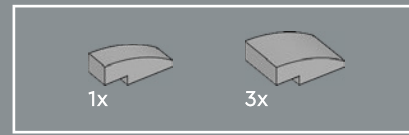
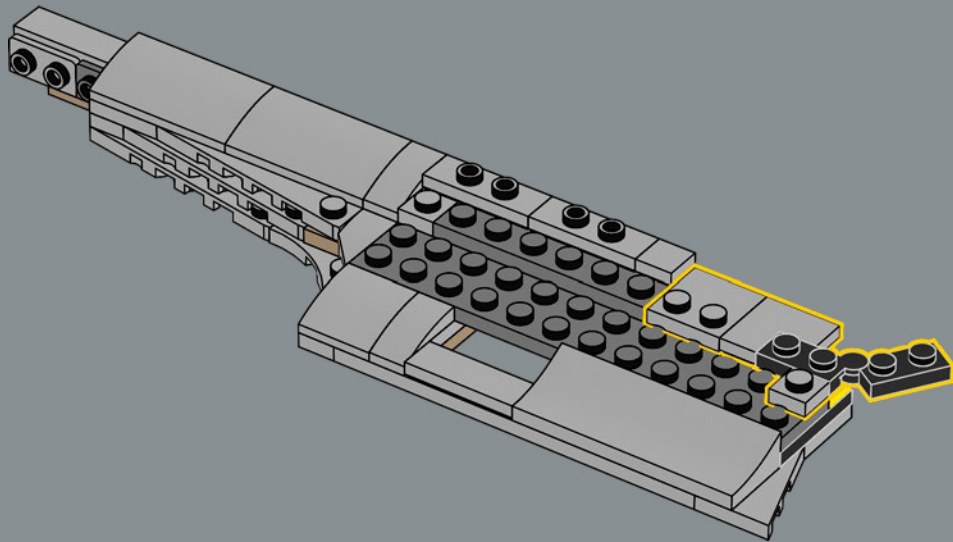

188

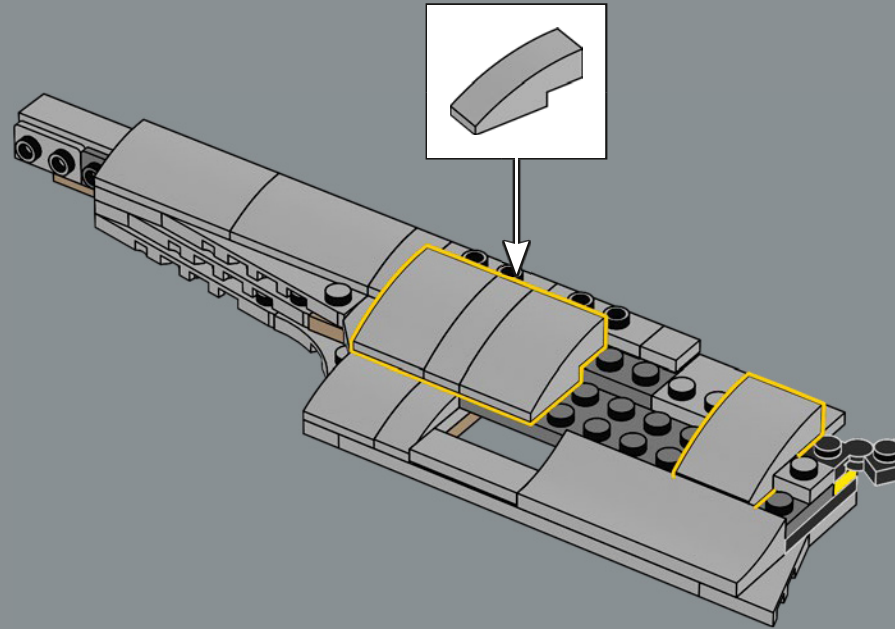

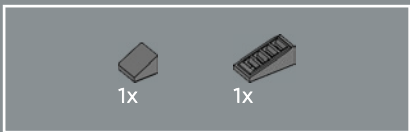

189

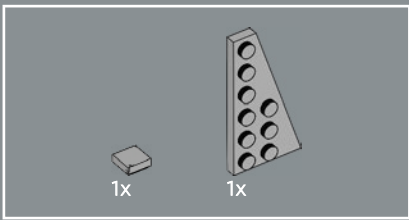
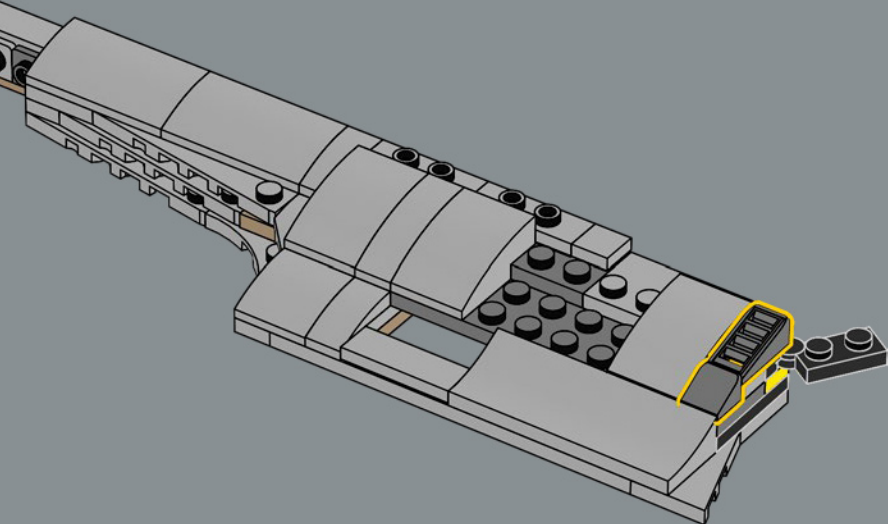

190

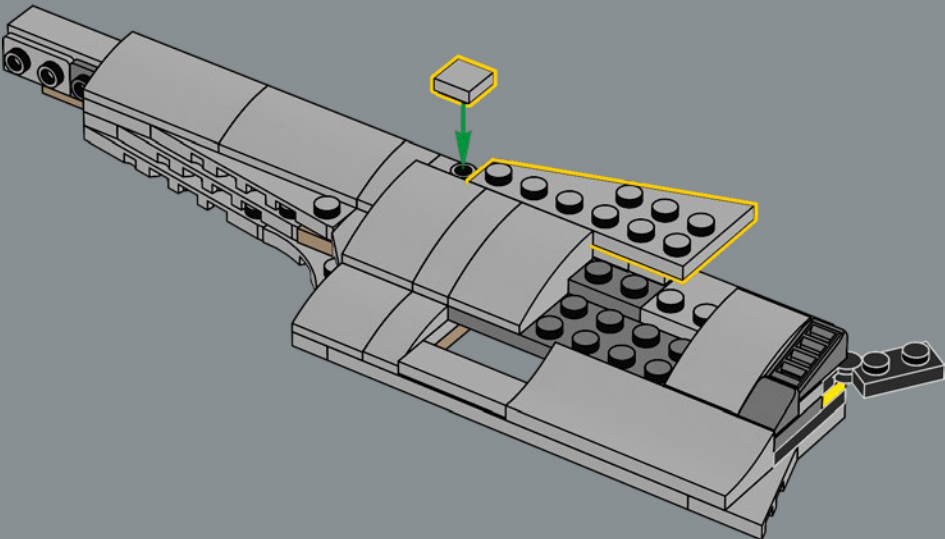

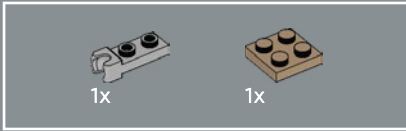
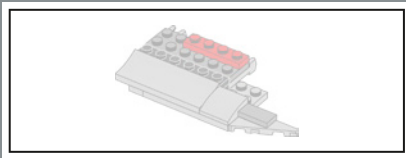

191

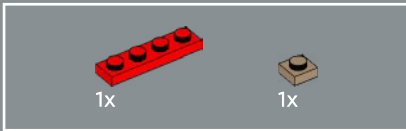
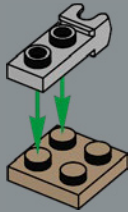

192

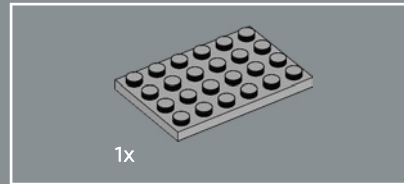
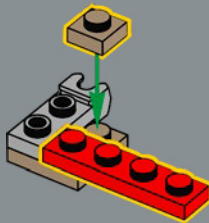

193

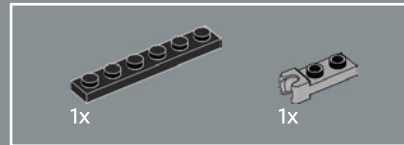
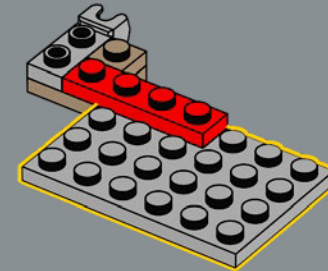

194

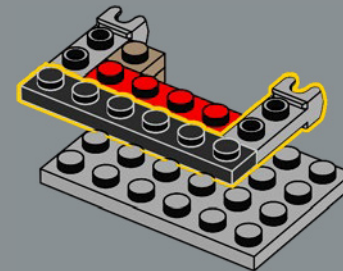



1x

195

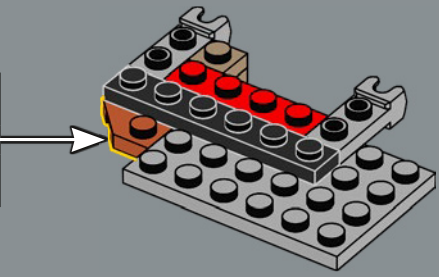
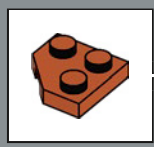

1x

197

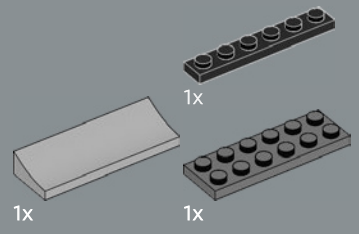
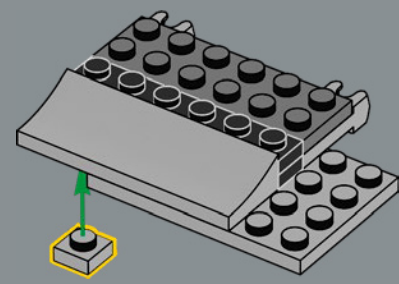

196

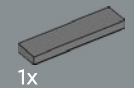
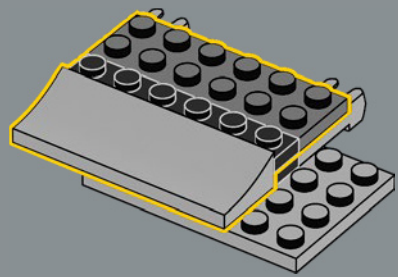

1x

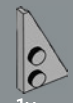

1x

198

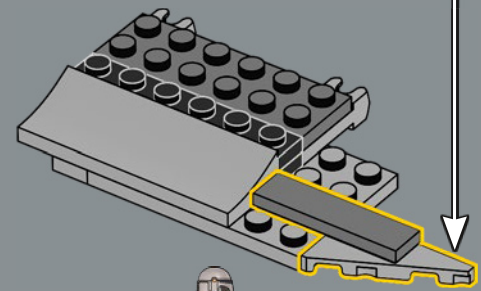
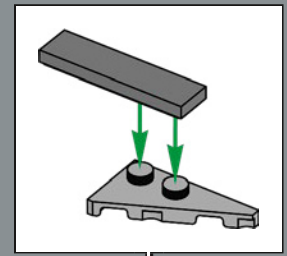

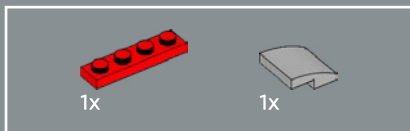

199

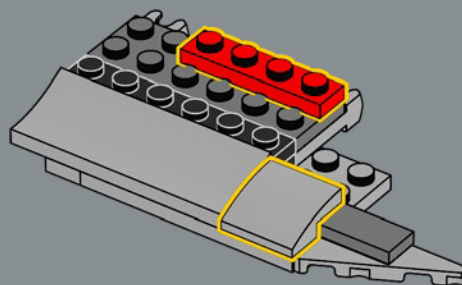

200

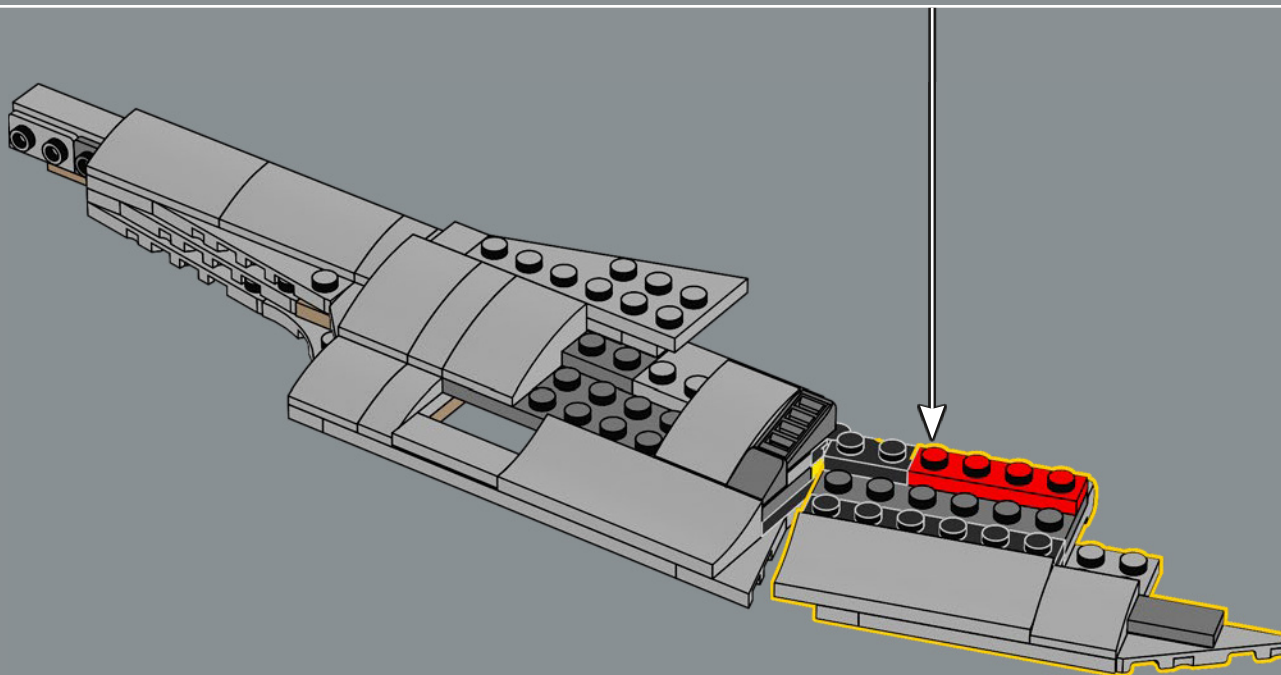

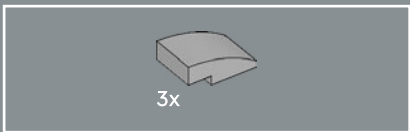

201

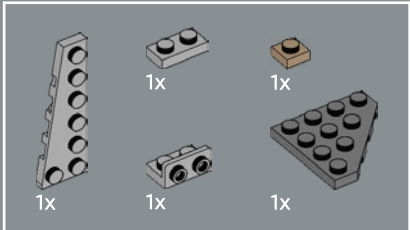
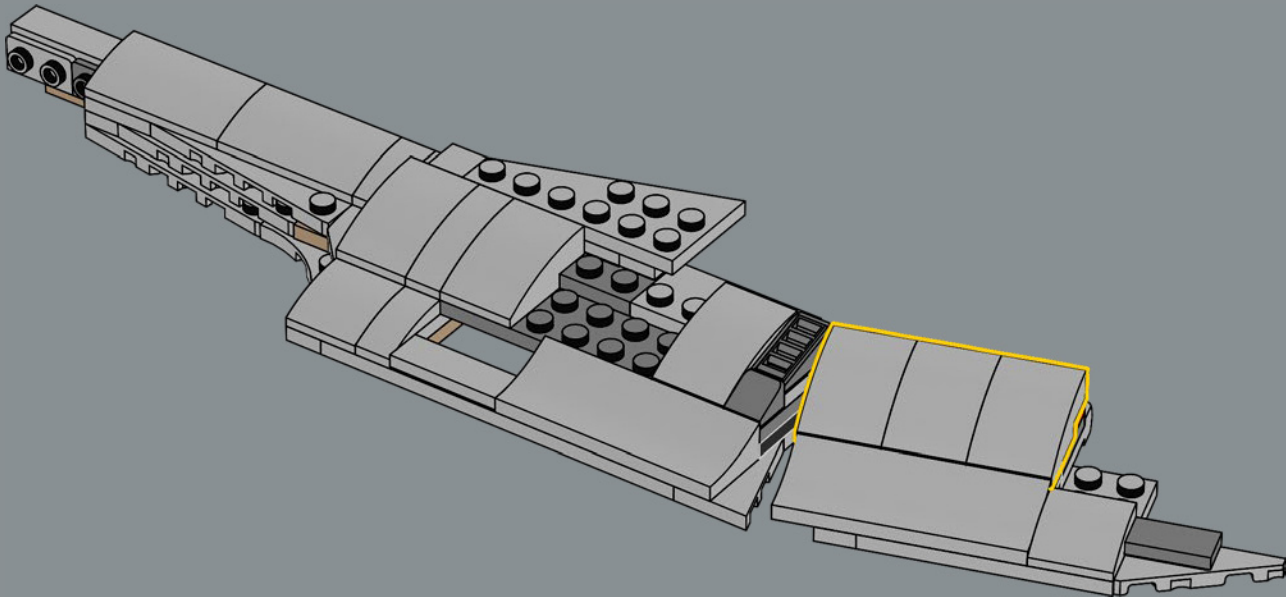

202

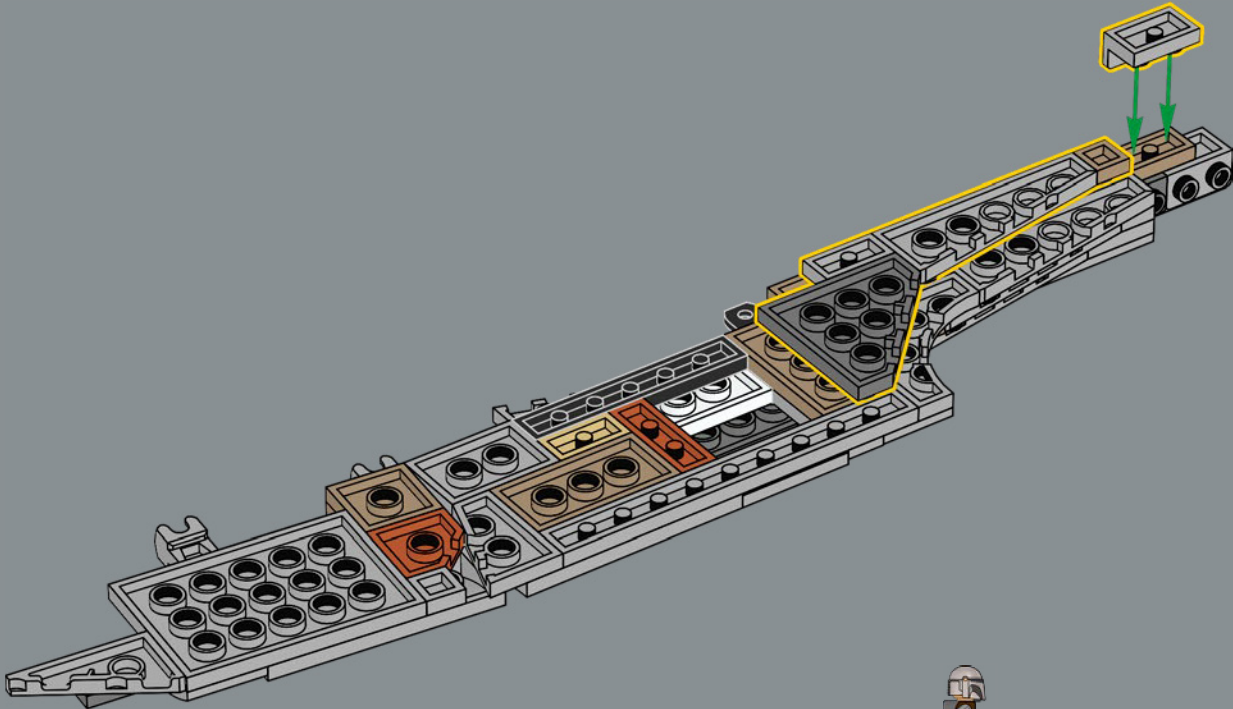

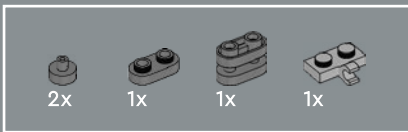

203

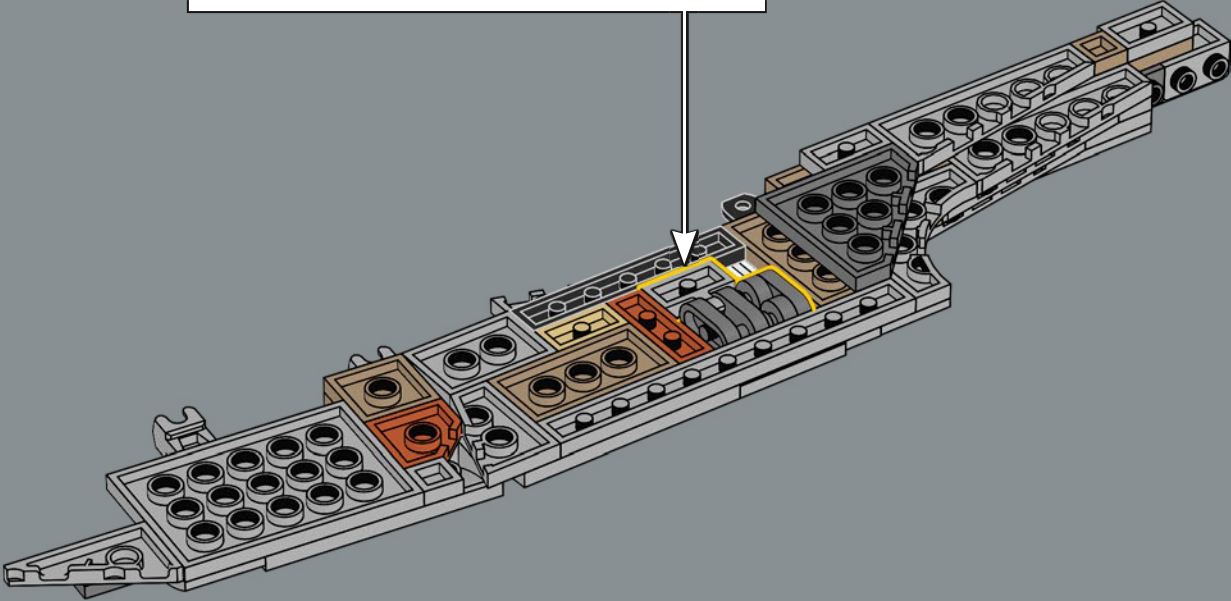
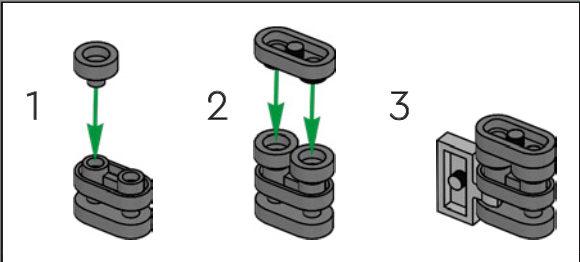

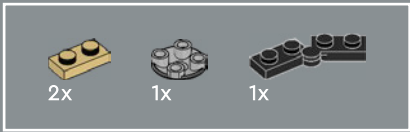

204

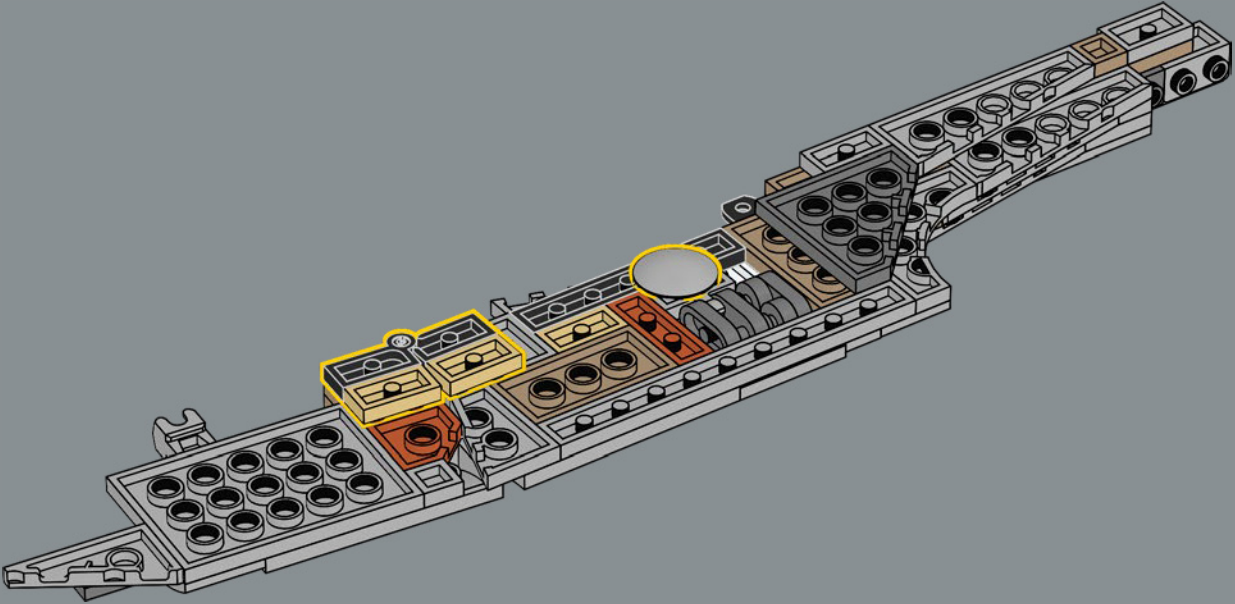

205

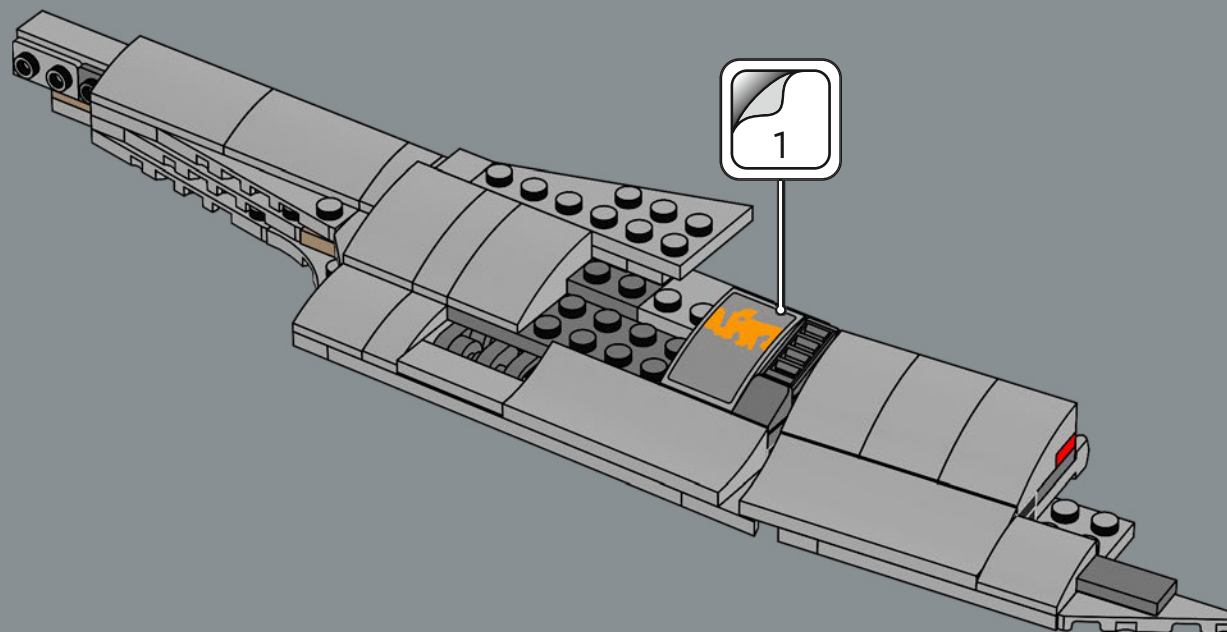

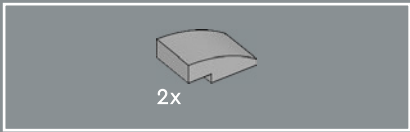

206

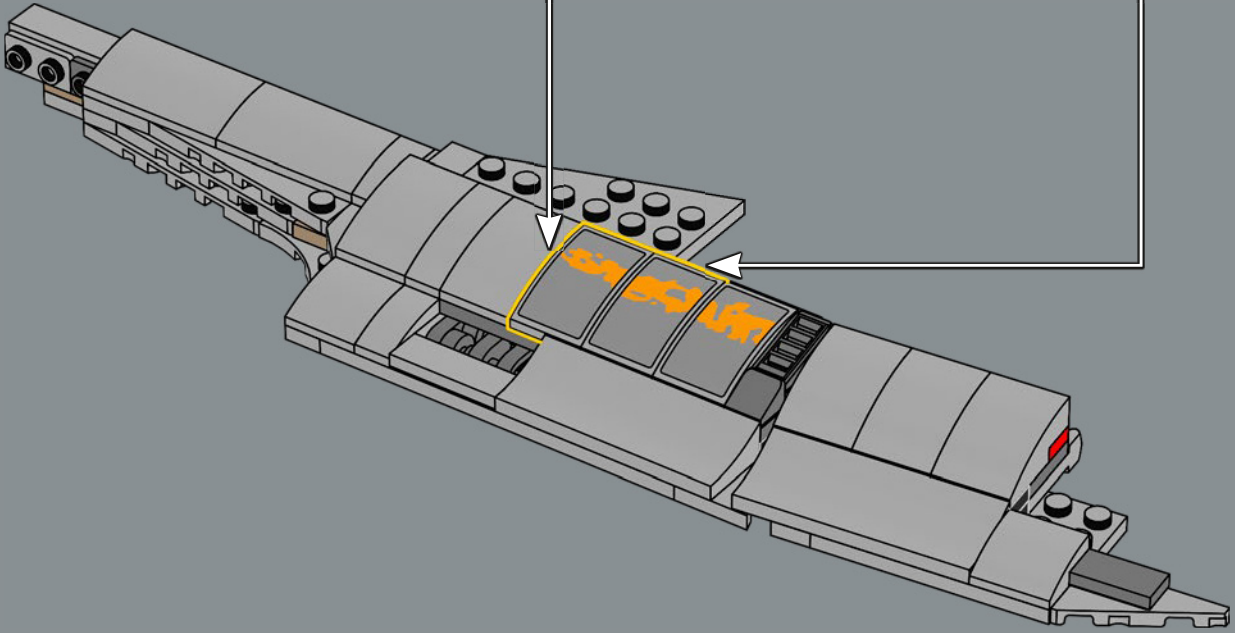
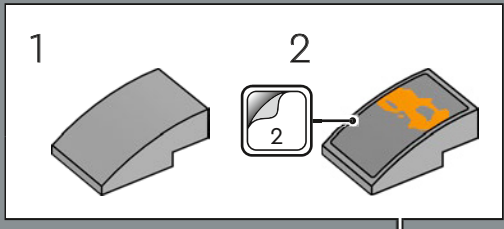
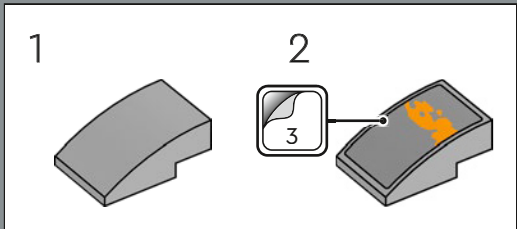

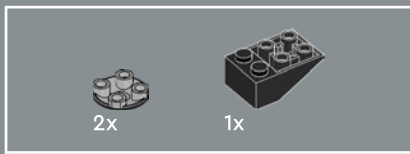

207

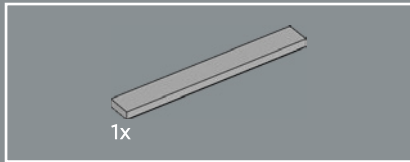
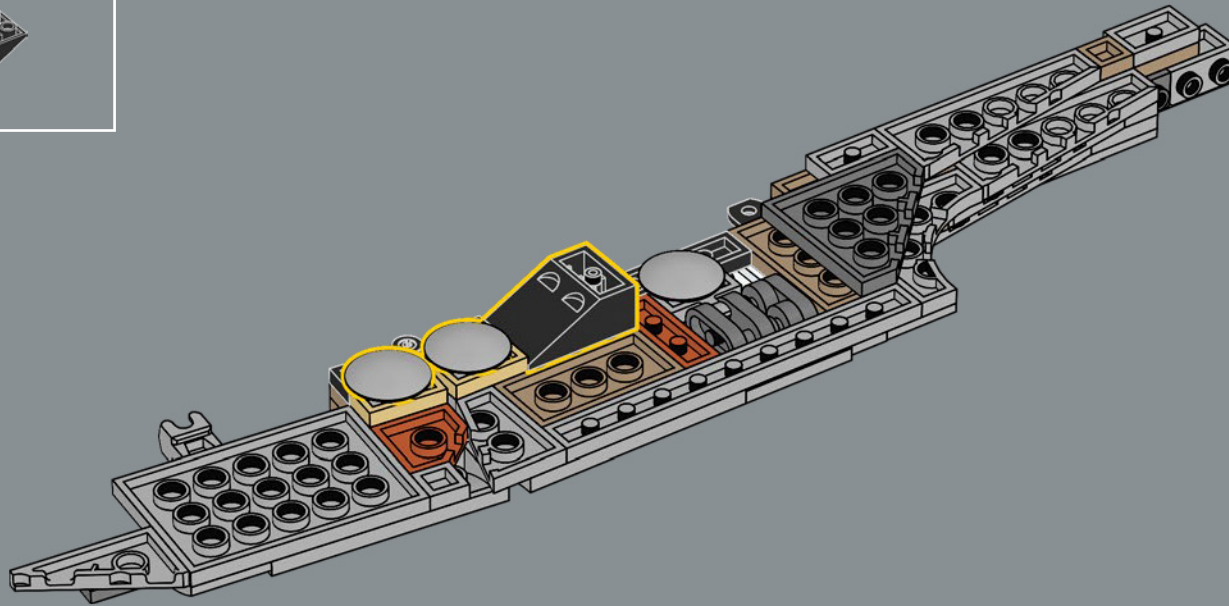

208

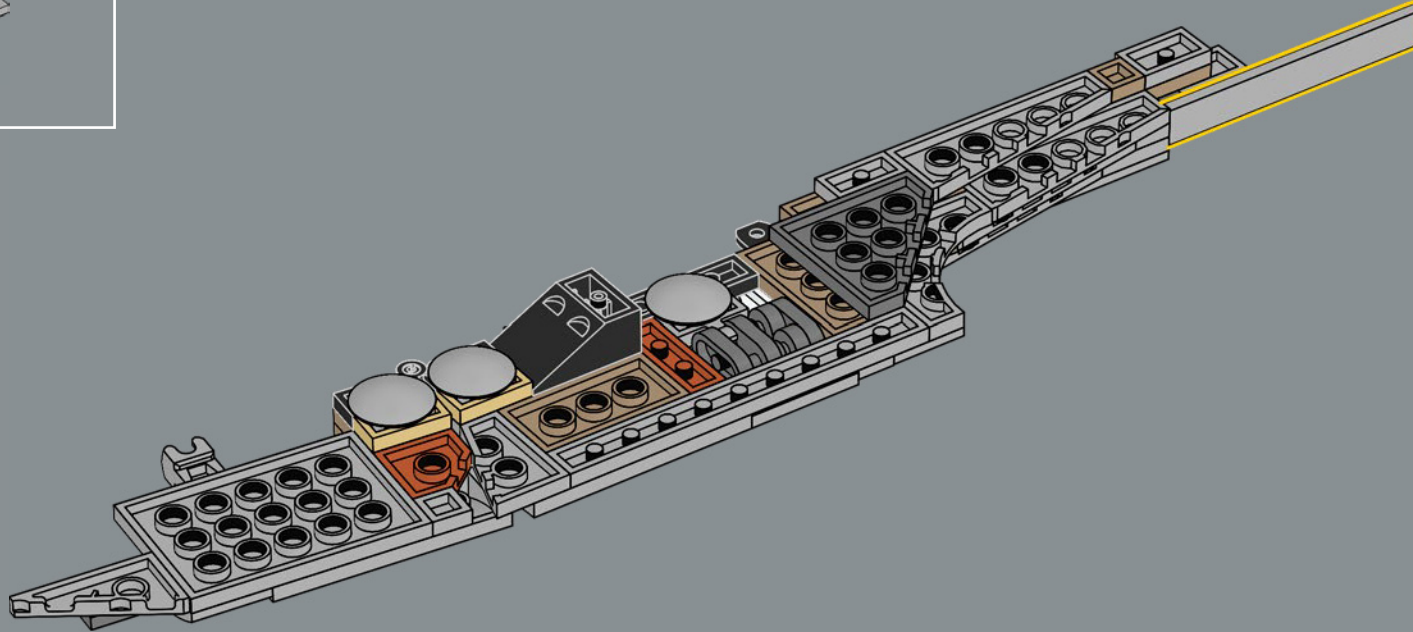

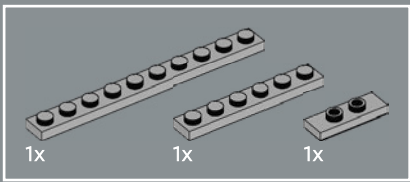

209

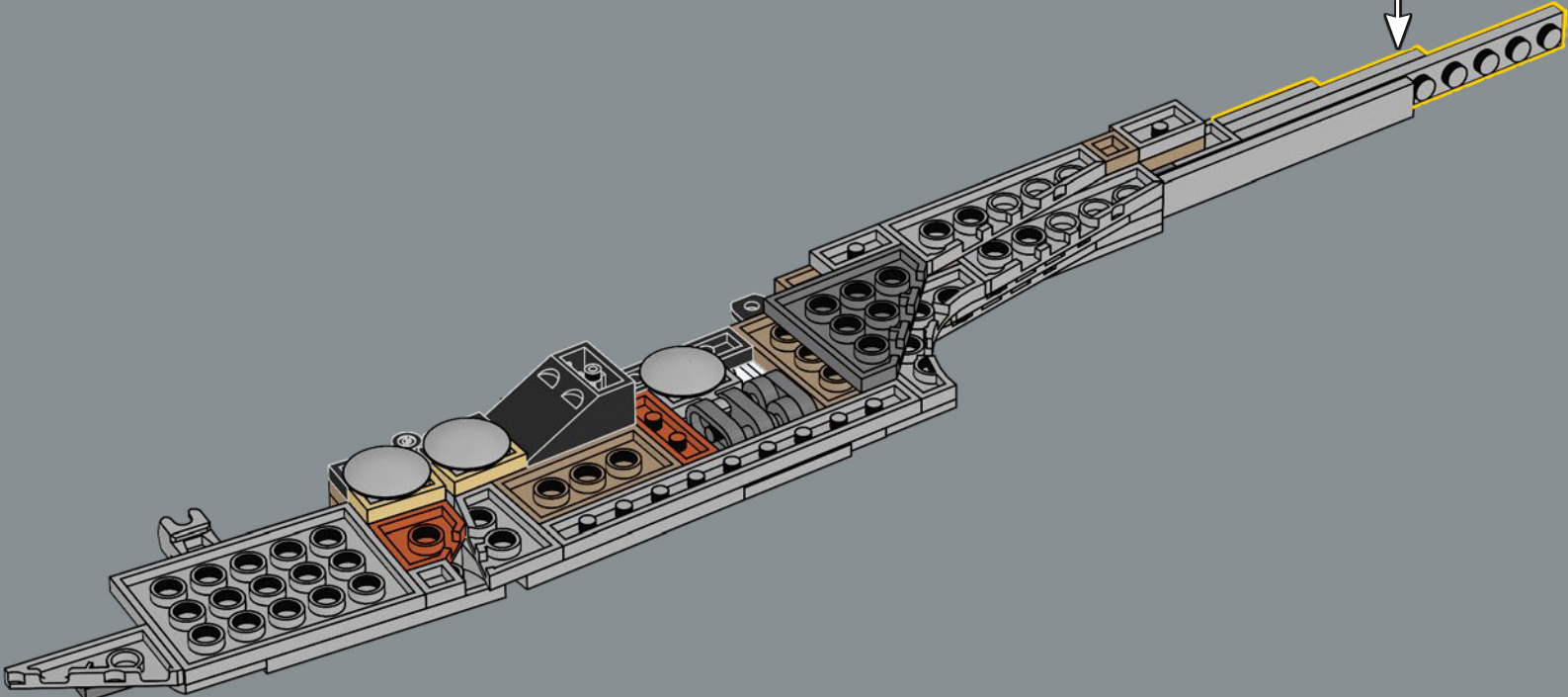
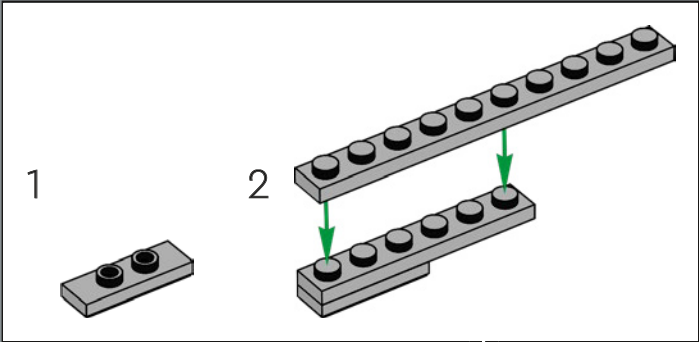

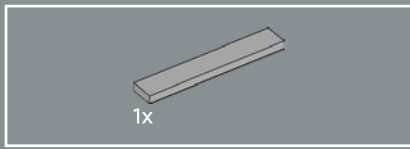

210

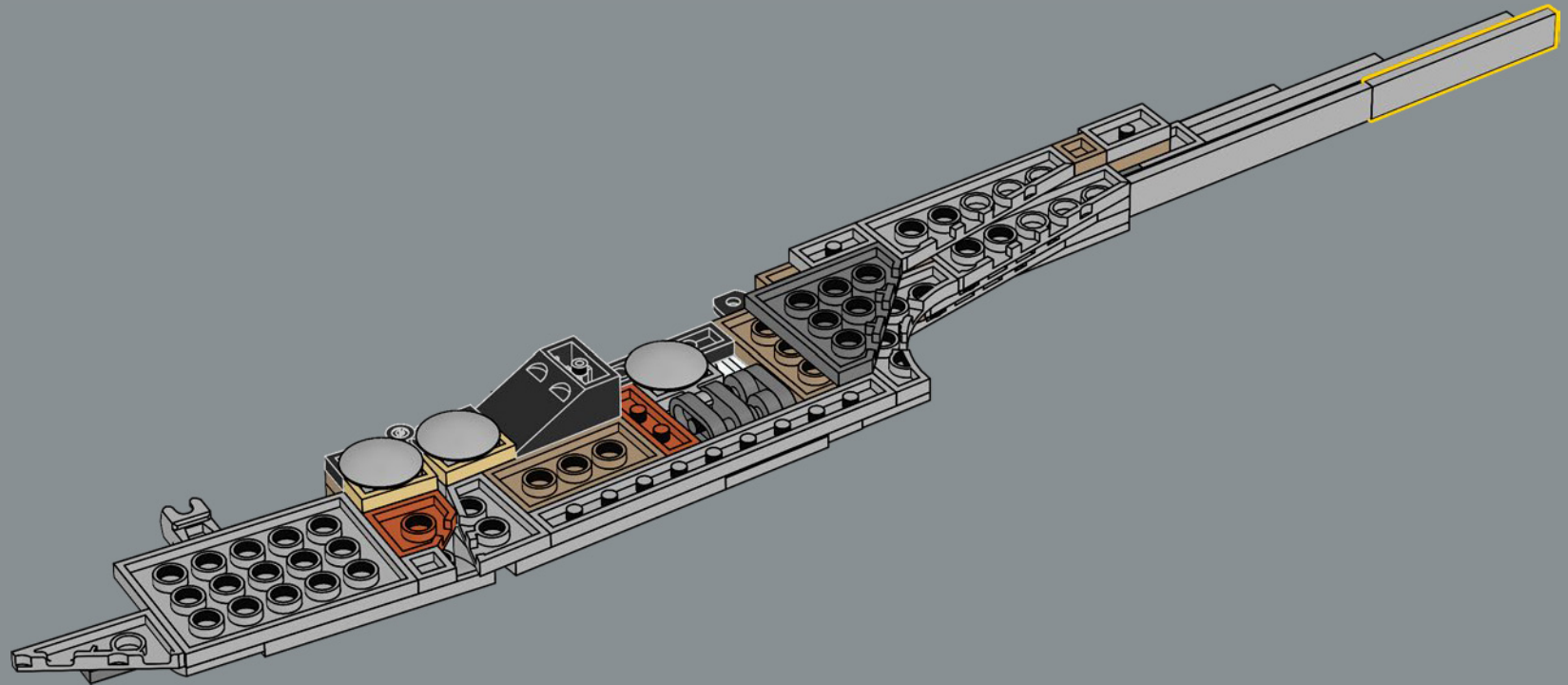

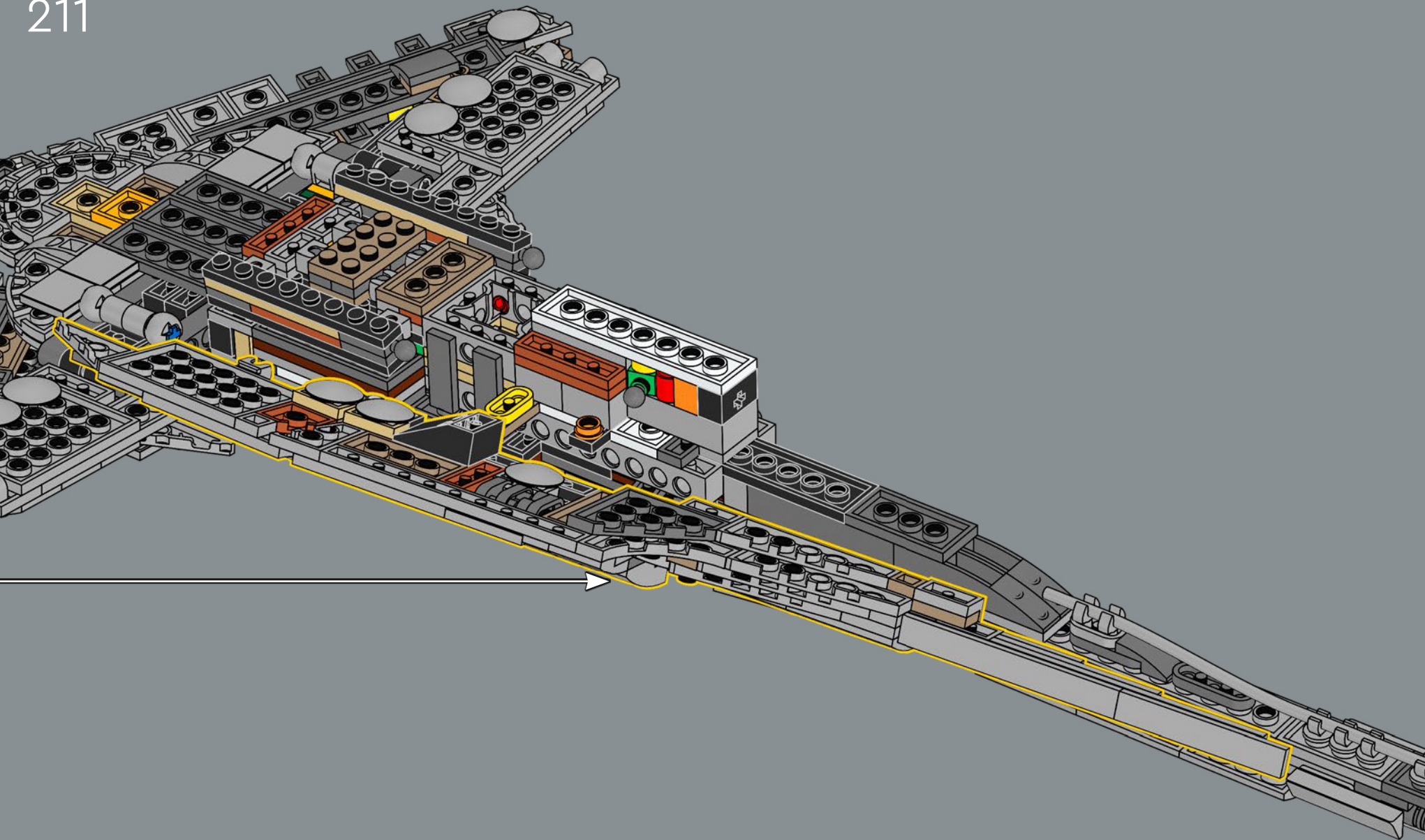

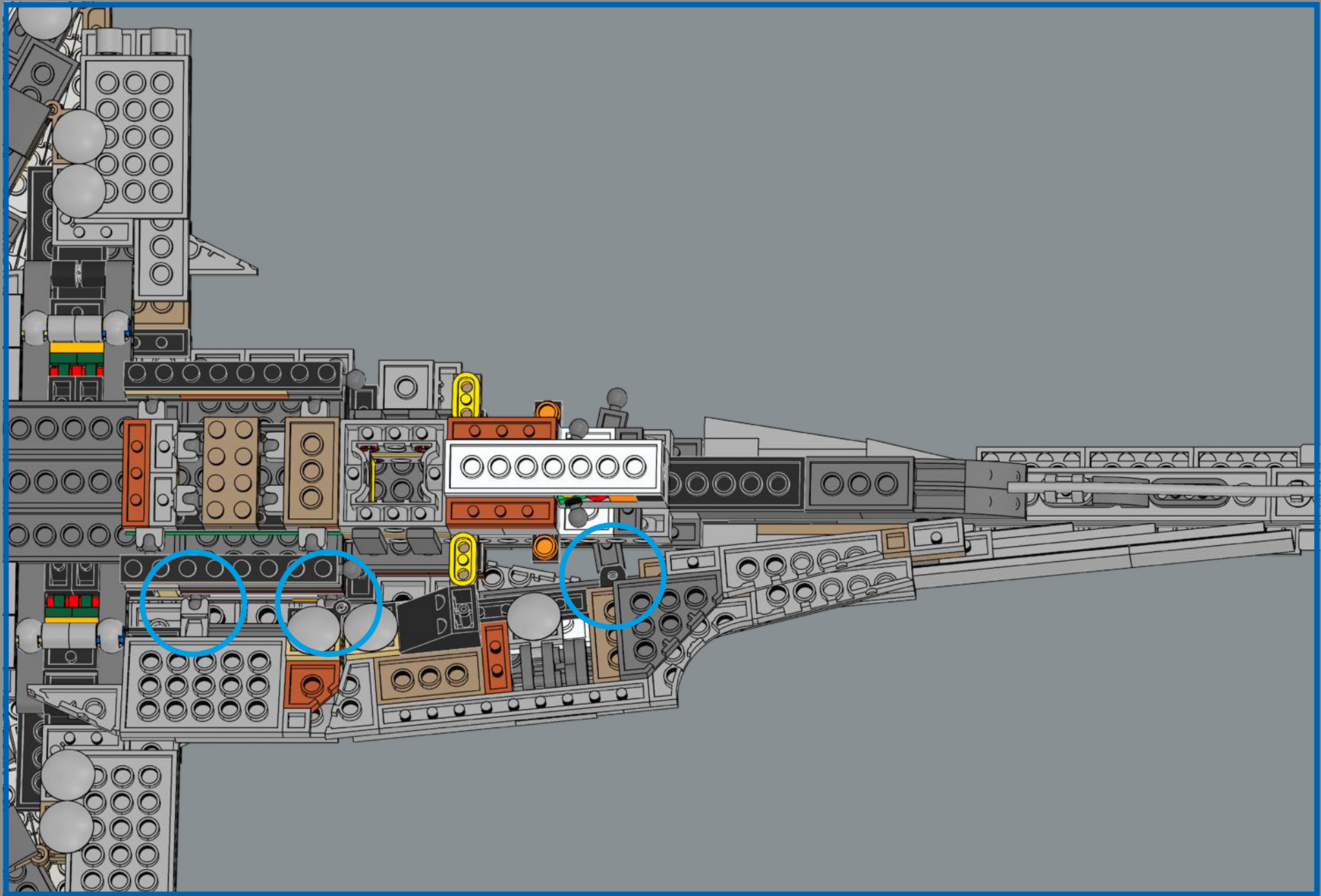

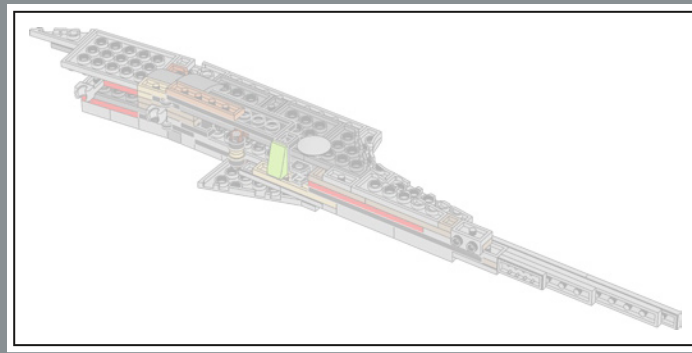

212

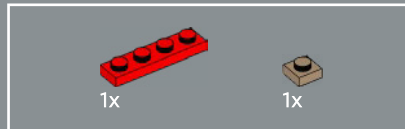
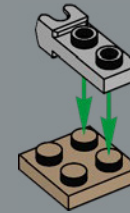

213

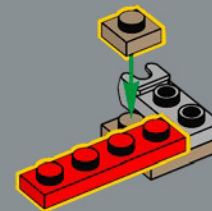

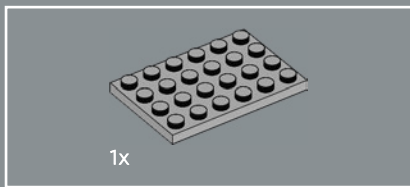

214

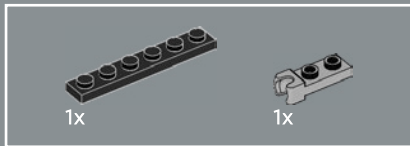
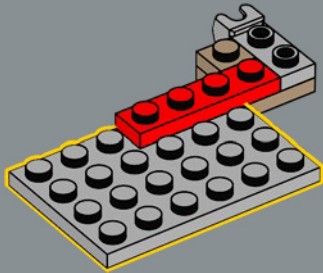

215

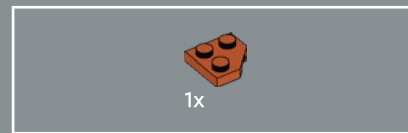
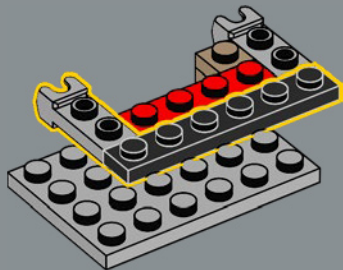

216

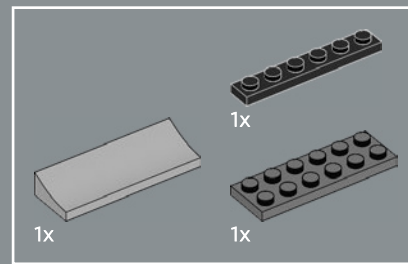
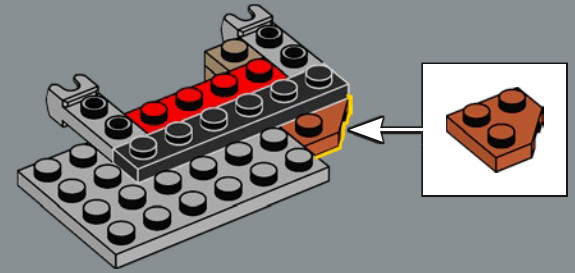

217

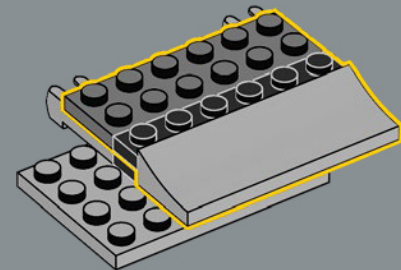



1x

218

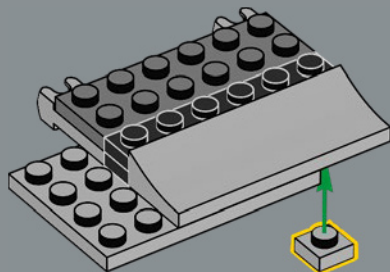

1x

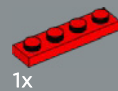

1x



1x

220

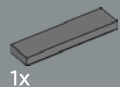
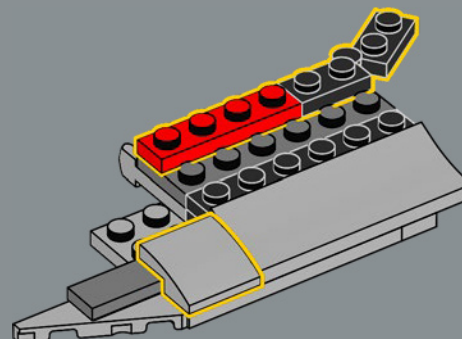

1x



1x

219

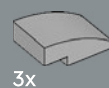
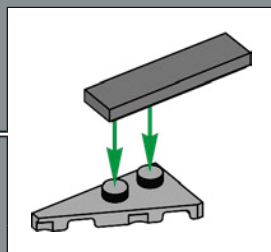
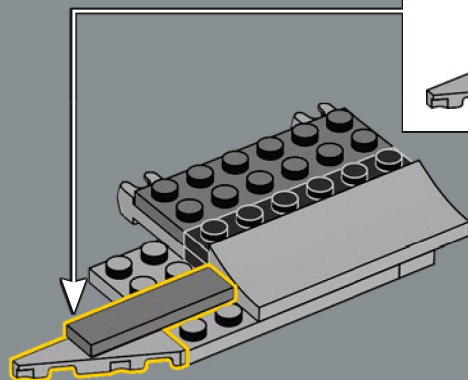

3x

221

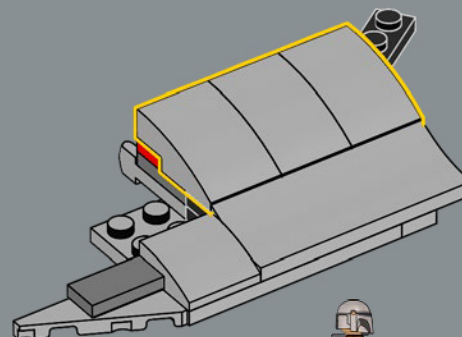



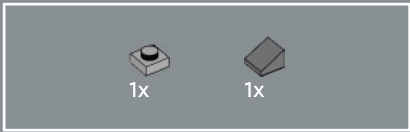

223

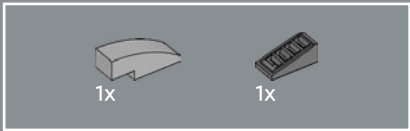
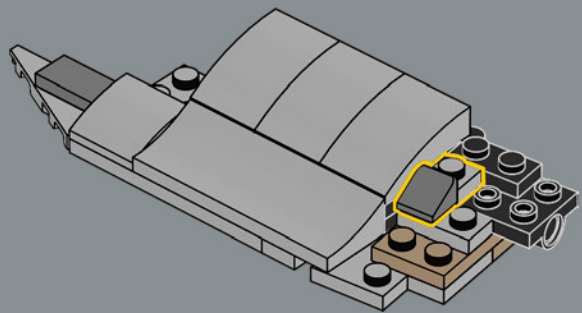

224

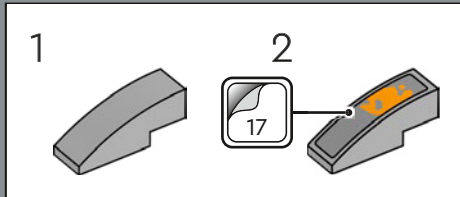
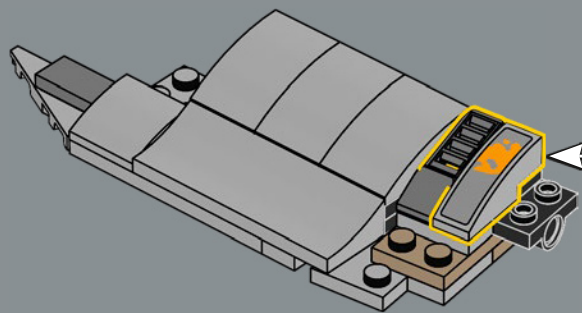

225

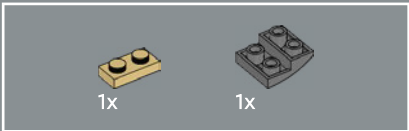
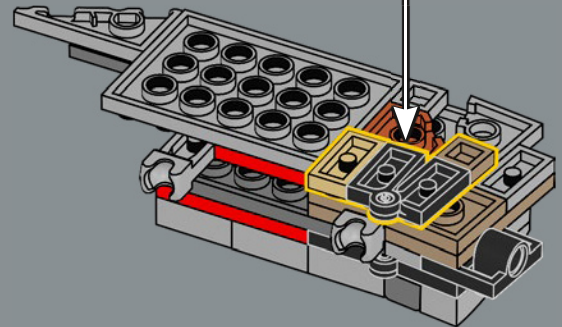

226

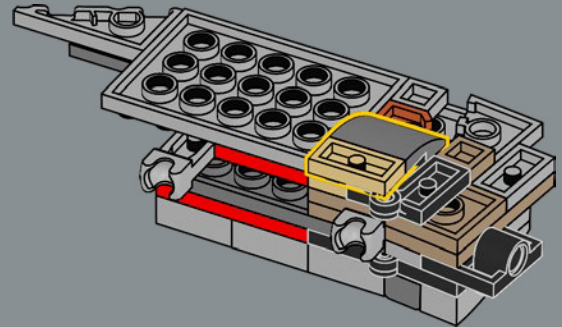

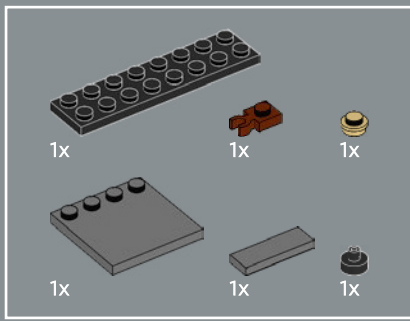

227

1

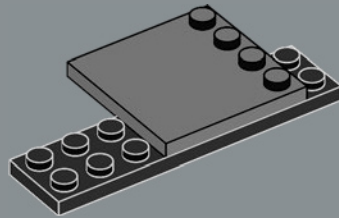

2

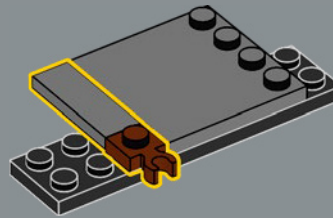

3

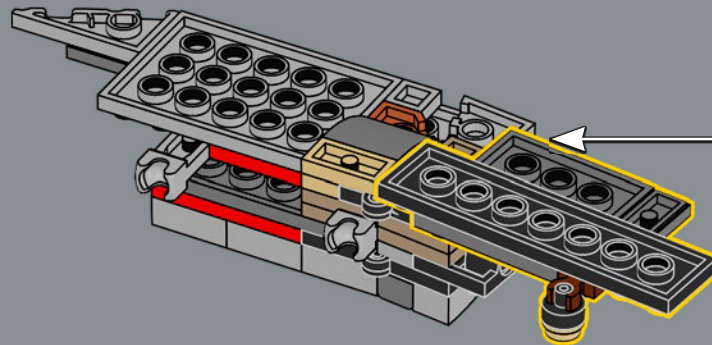
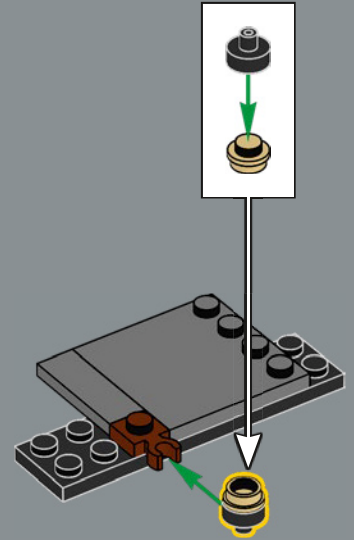

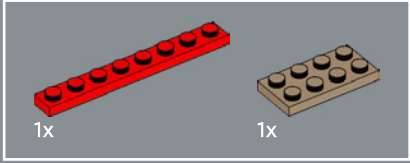
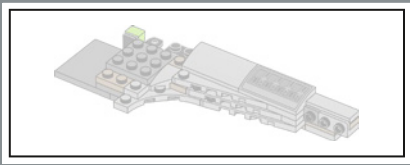

228

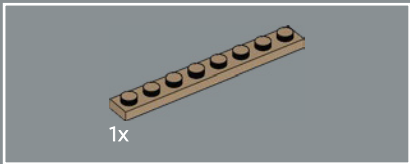
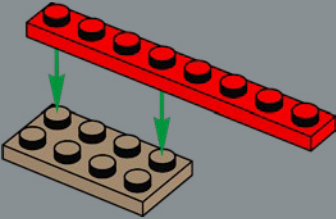

229

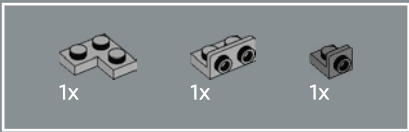
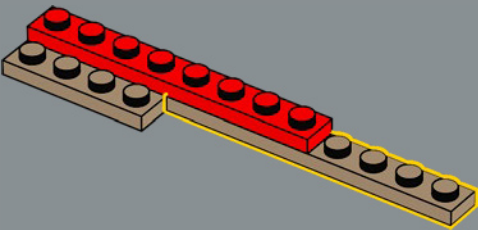

230

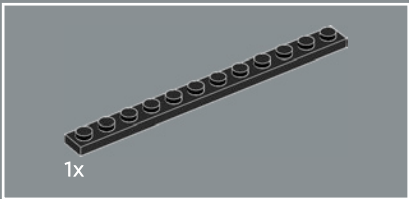
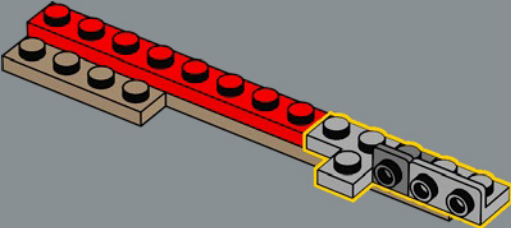

231

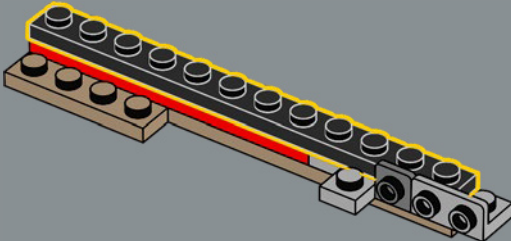



232

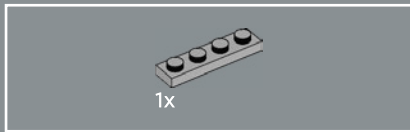
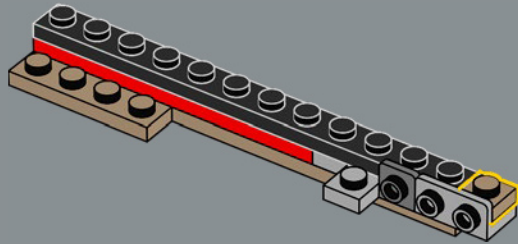

233

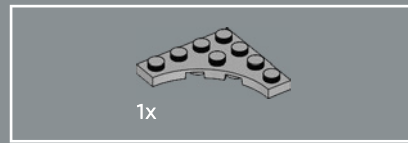
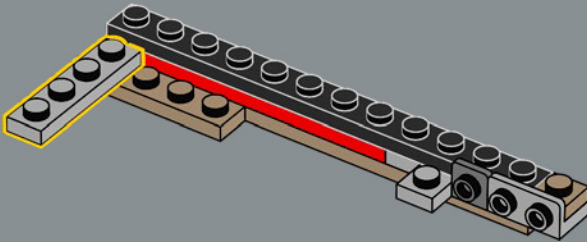

234

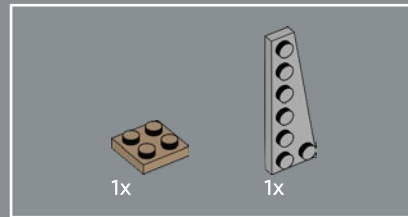
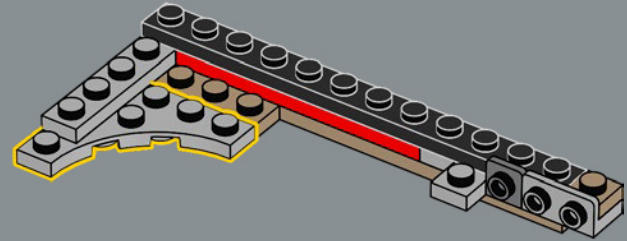

235

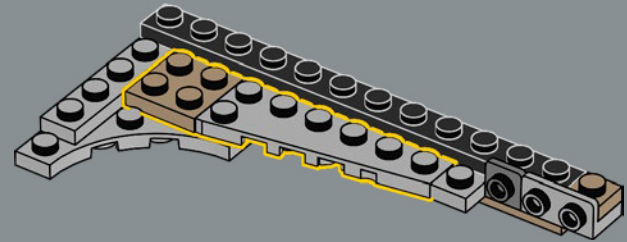



1x

236

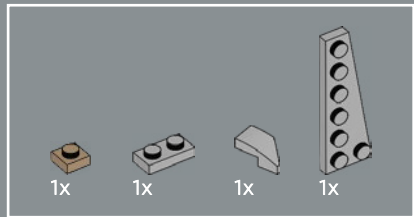
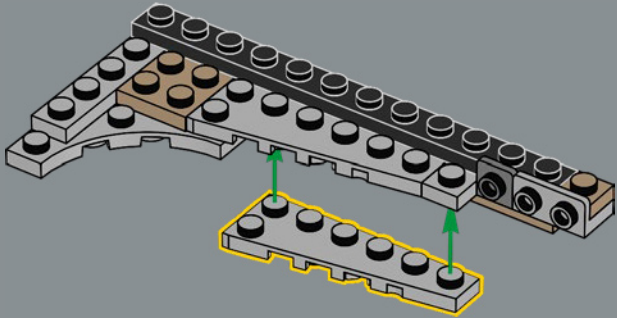

1x

1x

1x

1x

237

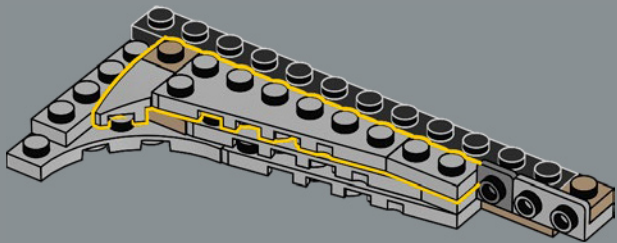

1x

238

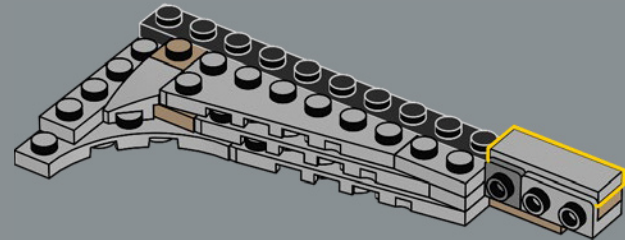

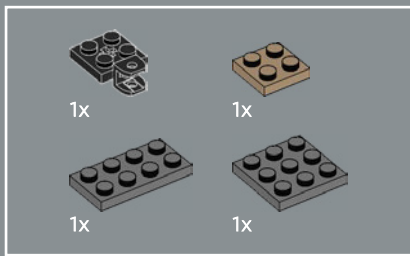

239

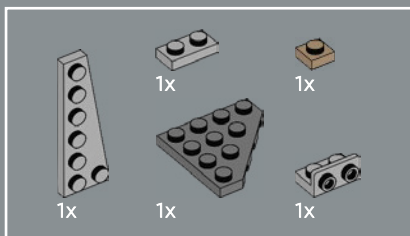
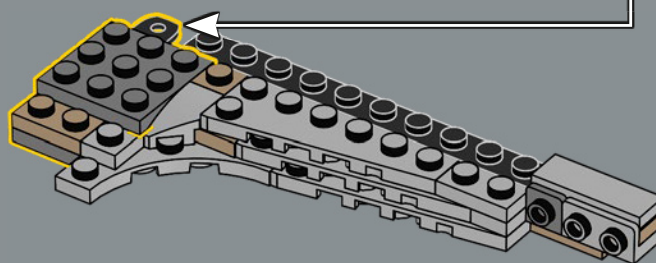
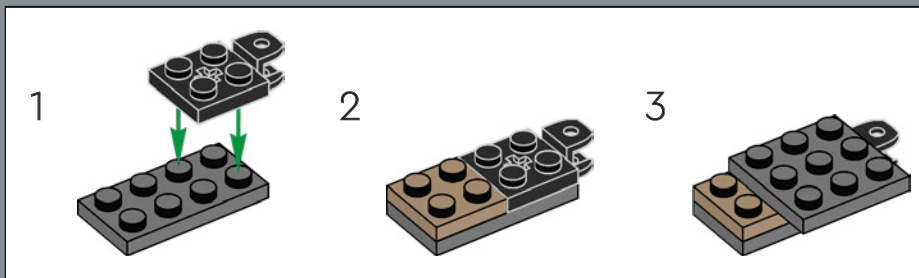

240

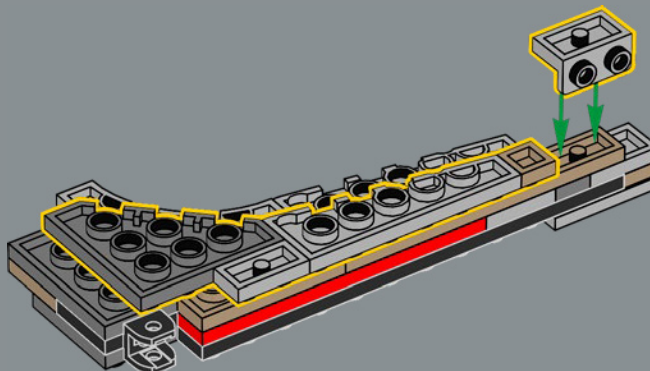

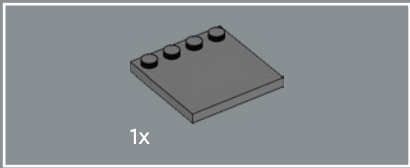

241

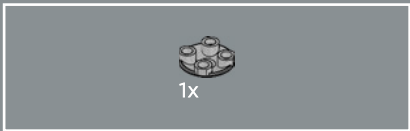
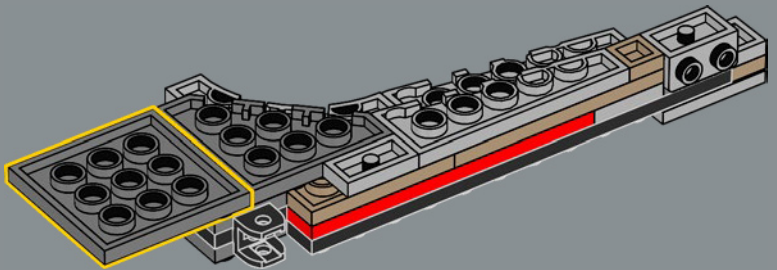

242

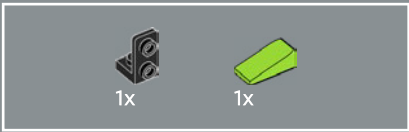
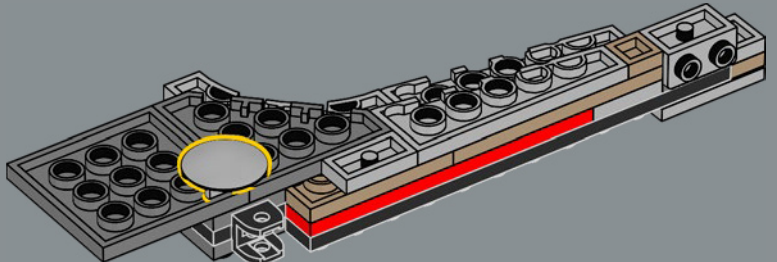

243

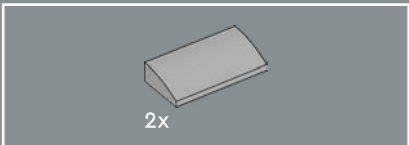
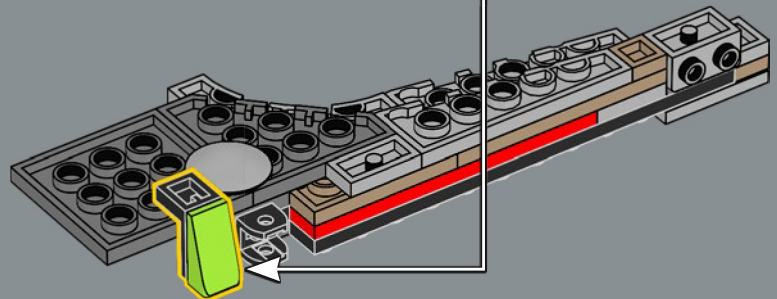
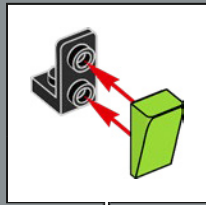

244

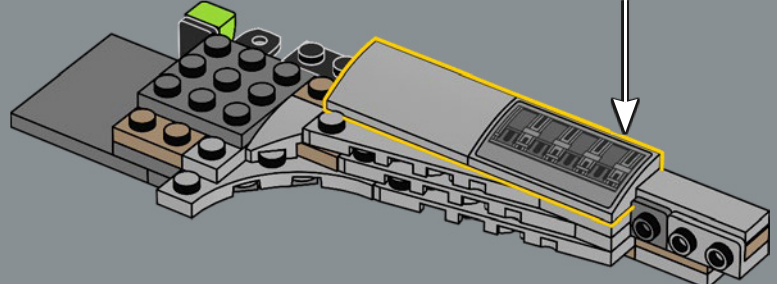
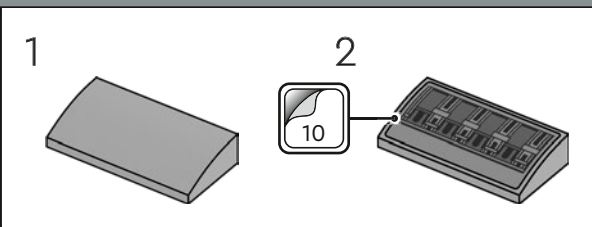

245

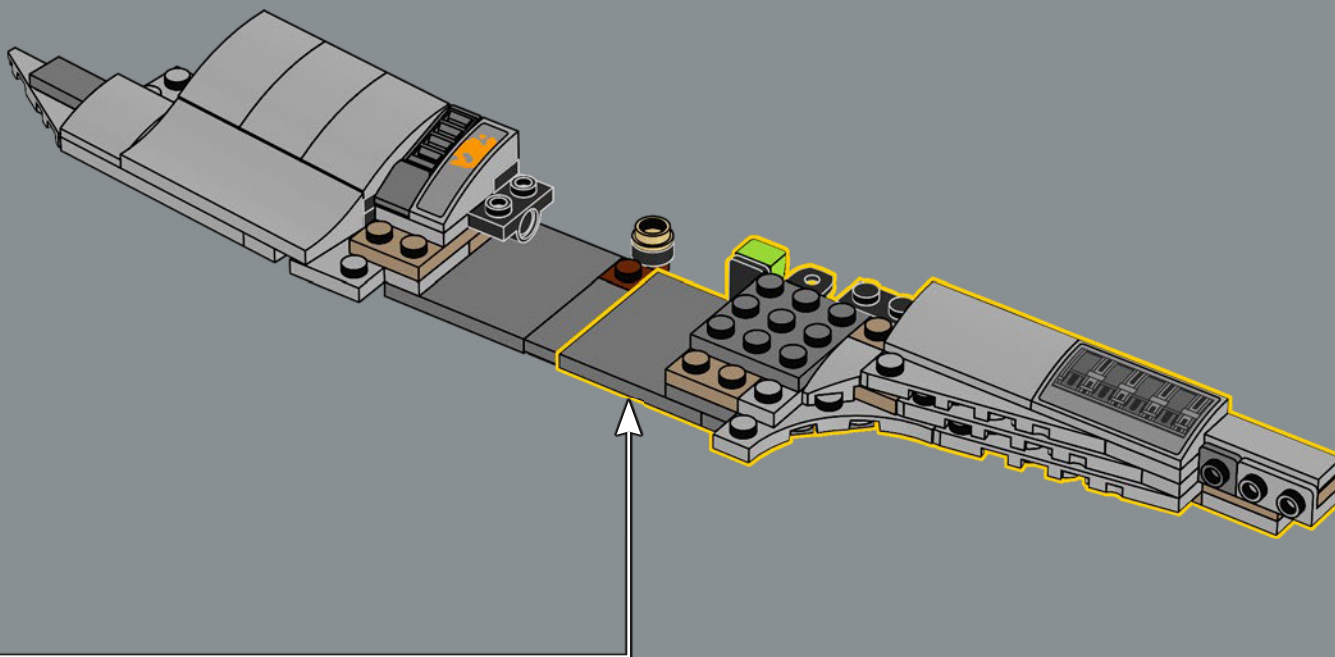

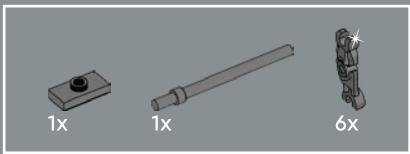

246

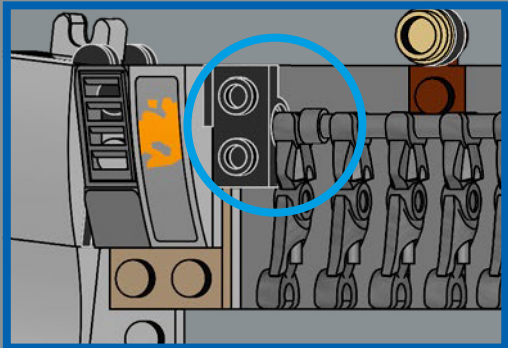
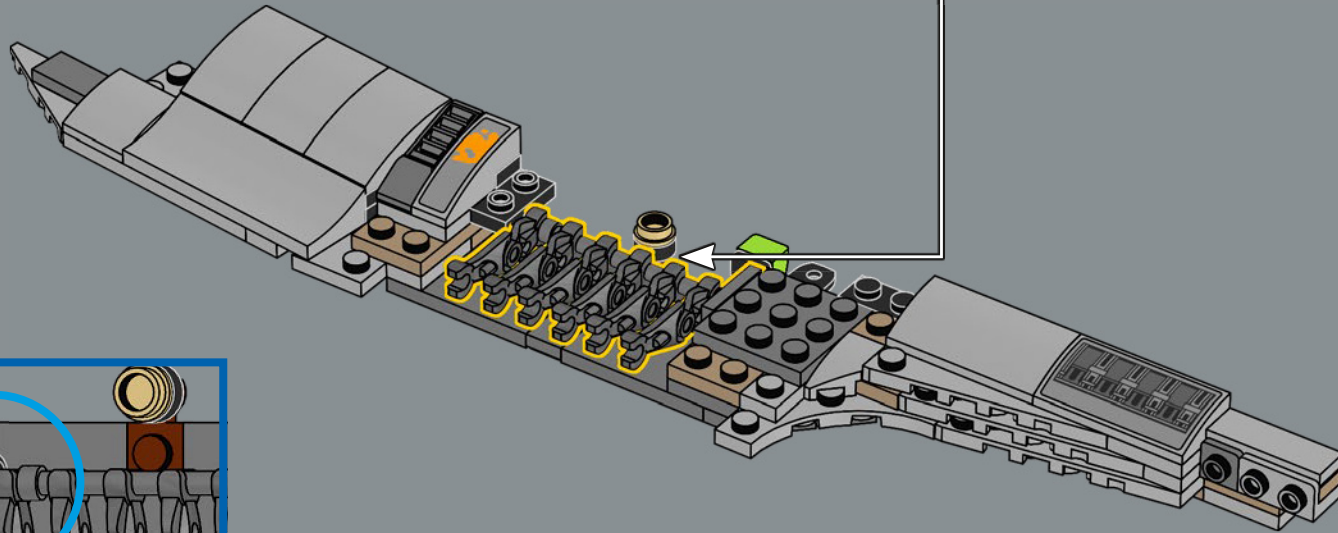
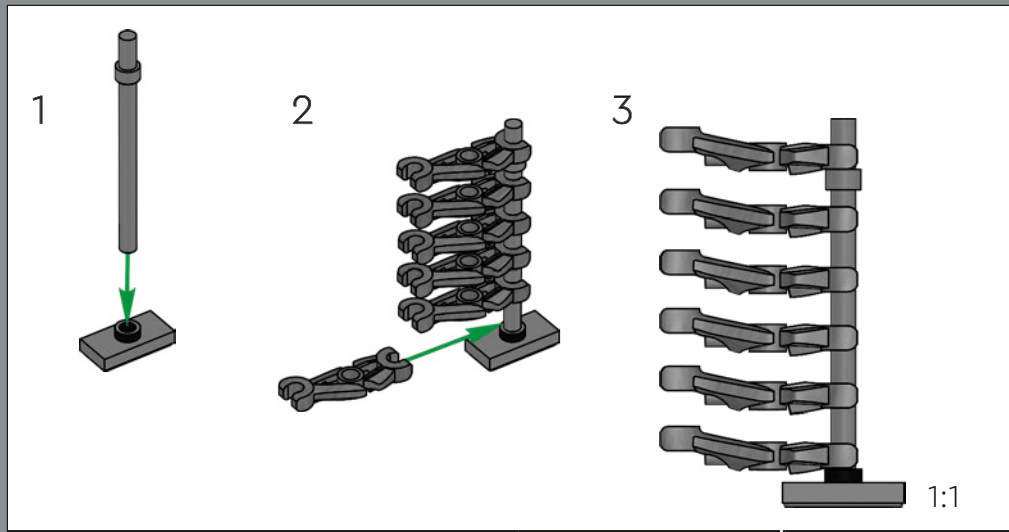

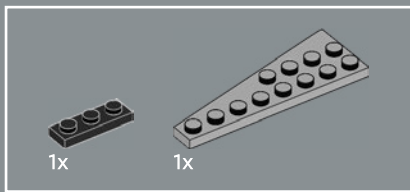

247

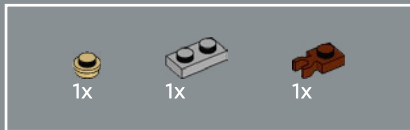
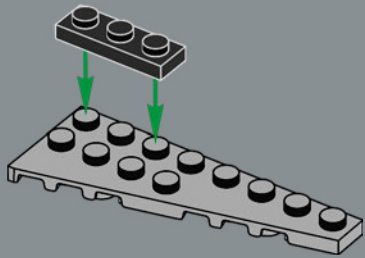

248

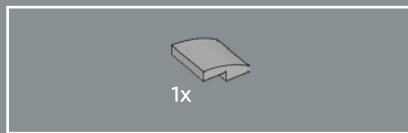
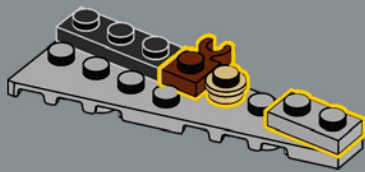

249

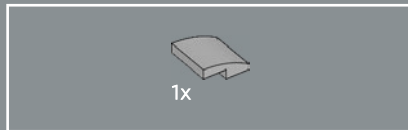
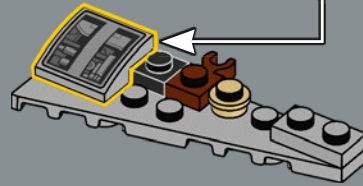
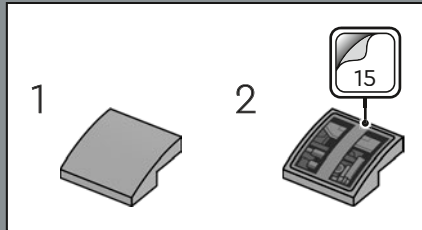

250

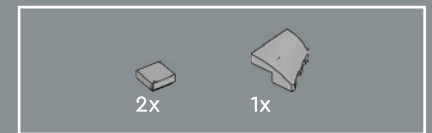
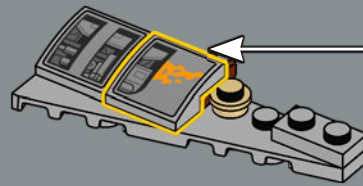
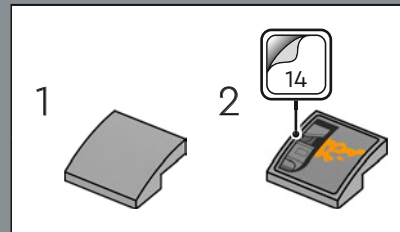

251

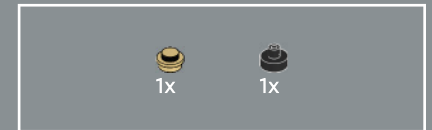
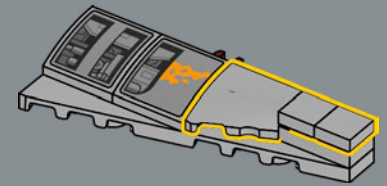

252

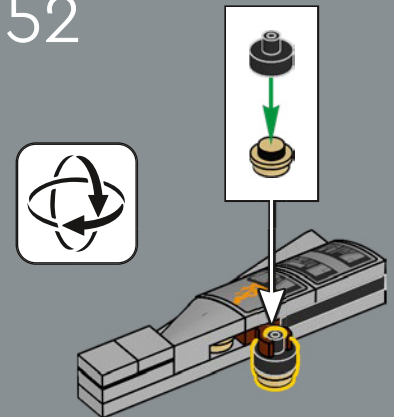

253

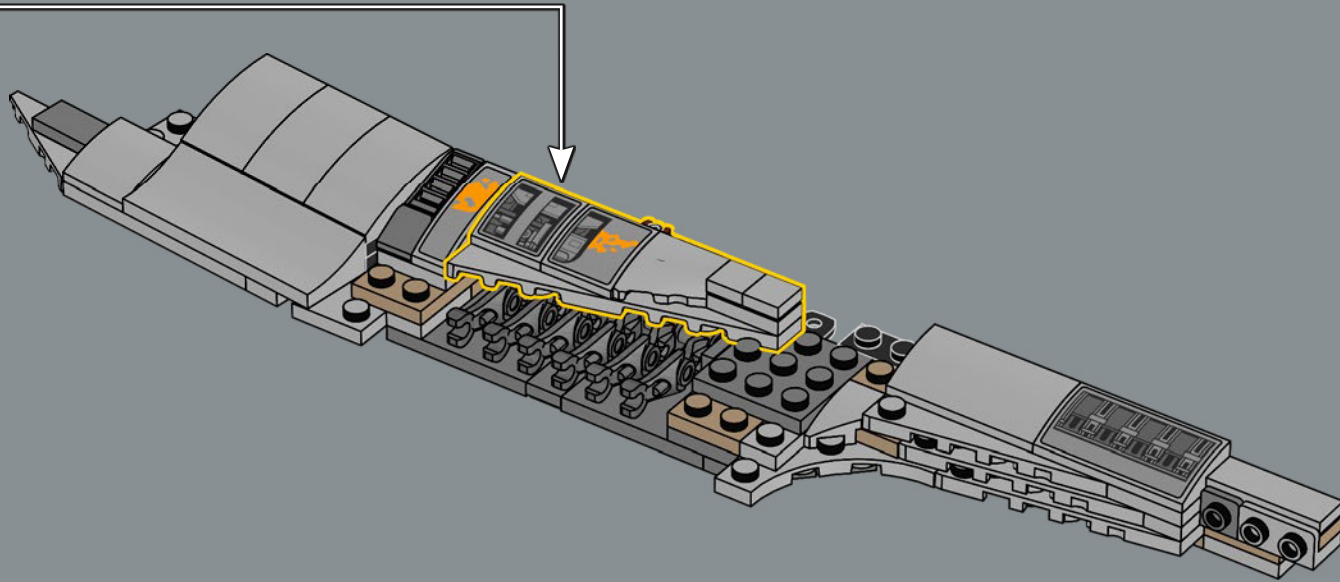

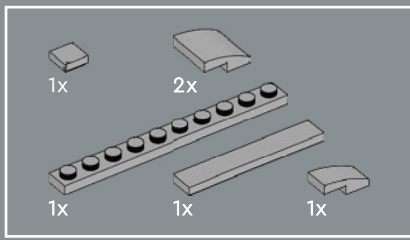

254

1

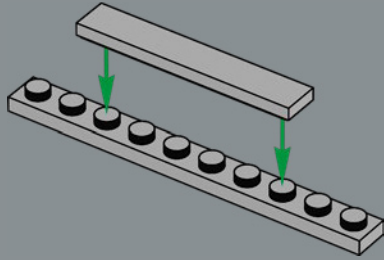

2

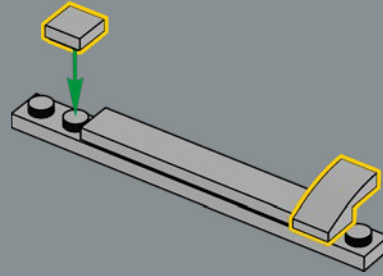

3

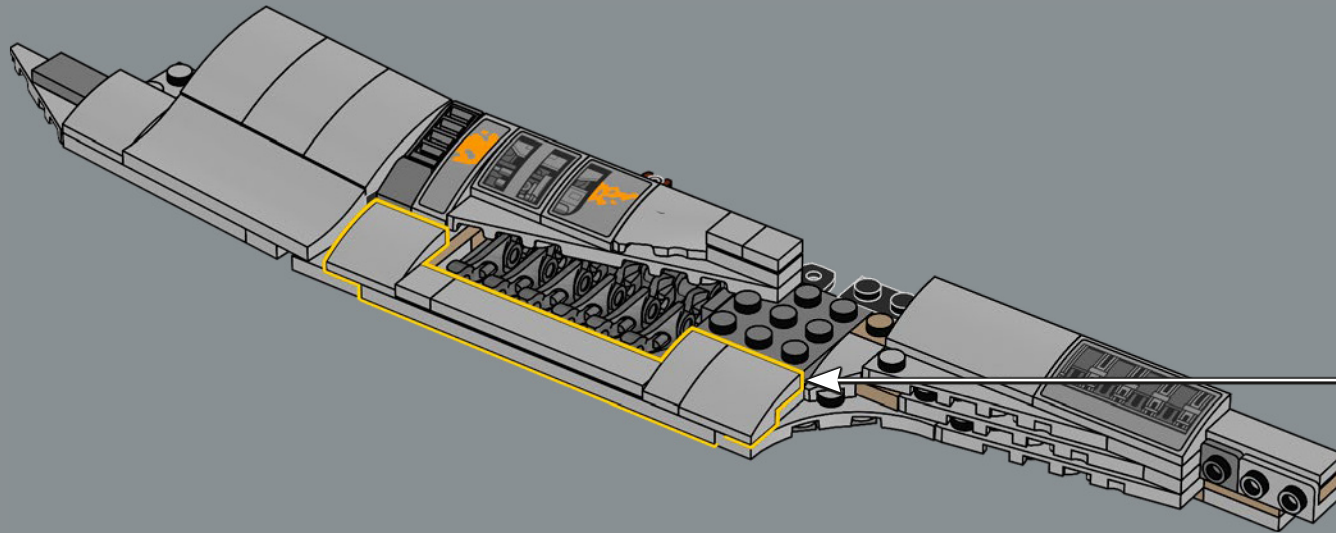
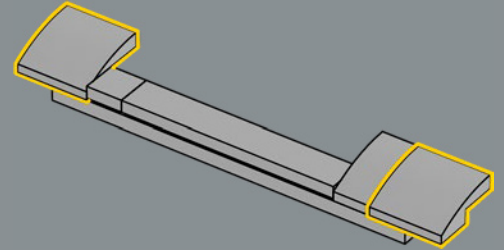

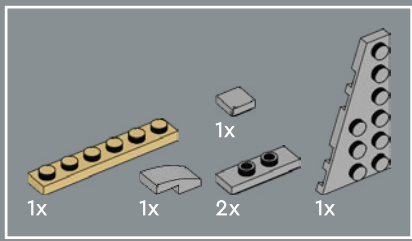

255

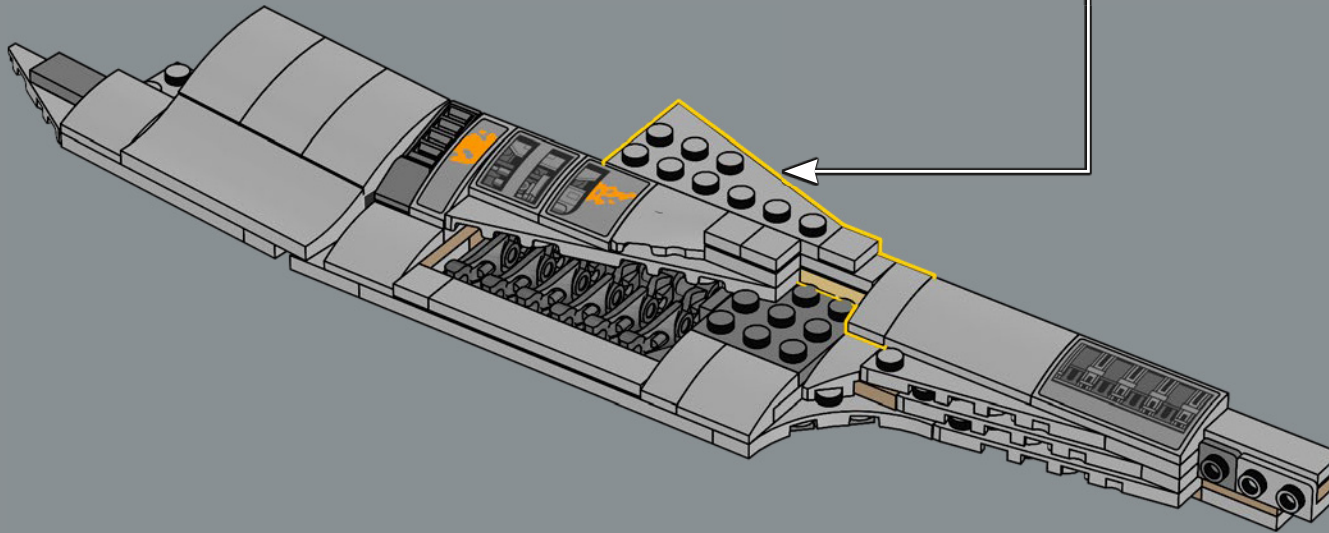
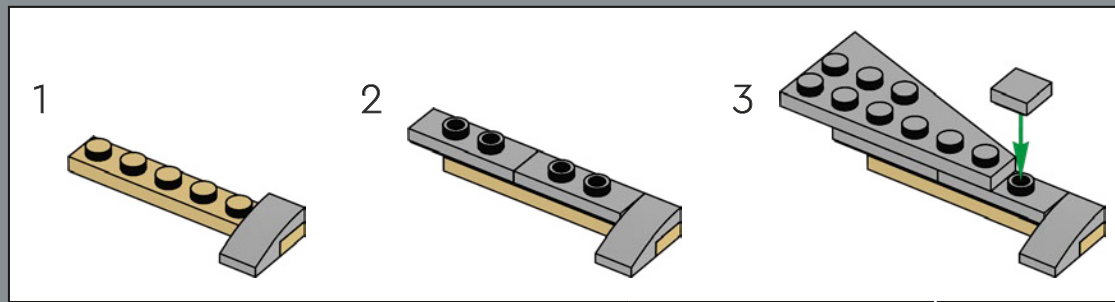

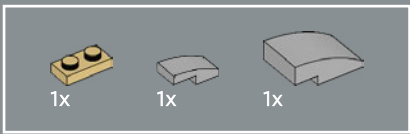

256

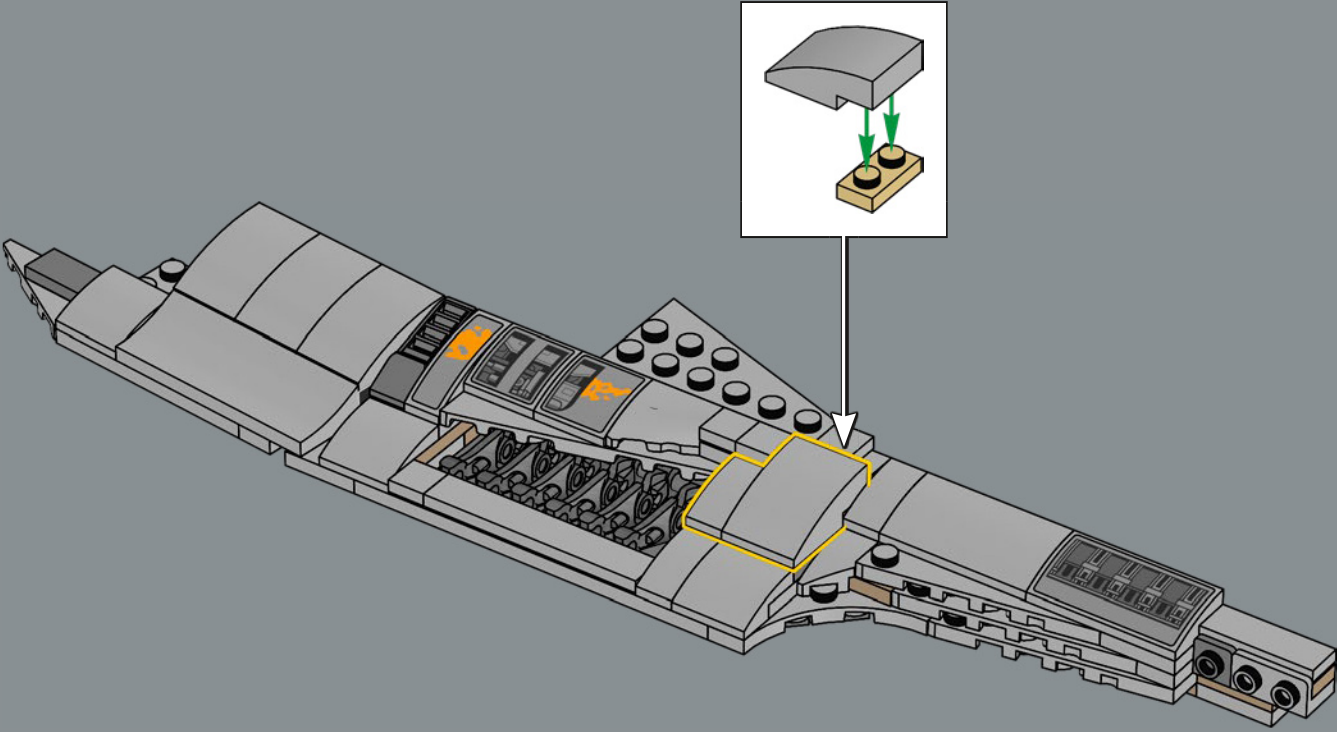

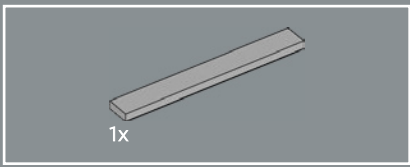

257

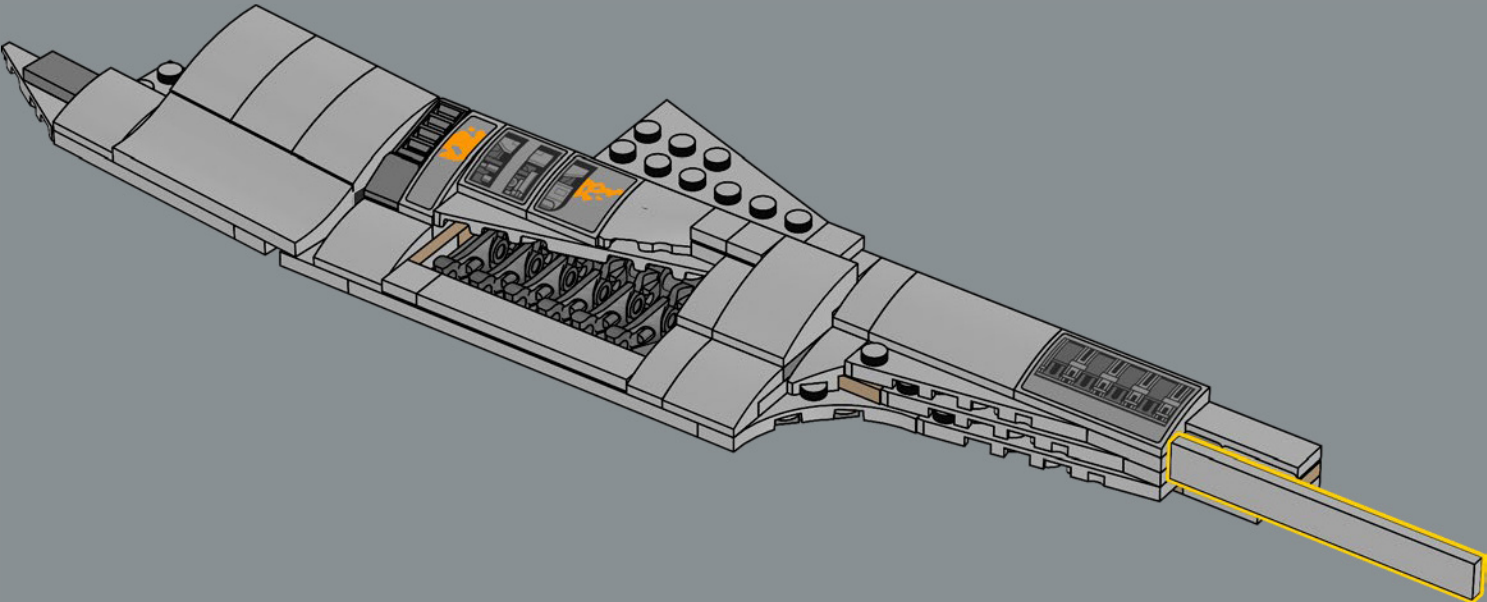

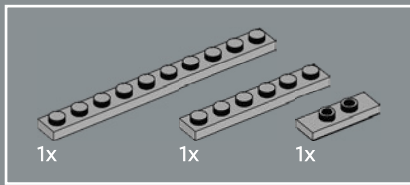

258

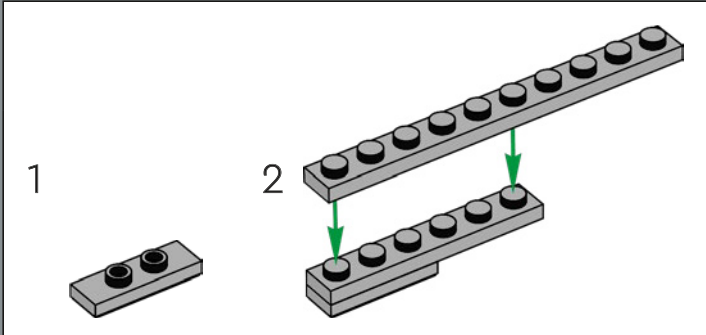
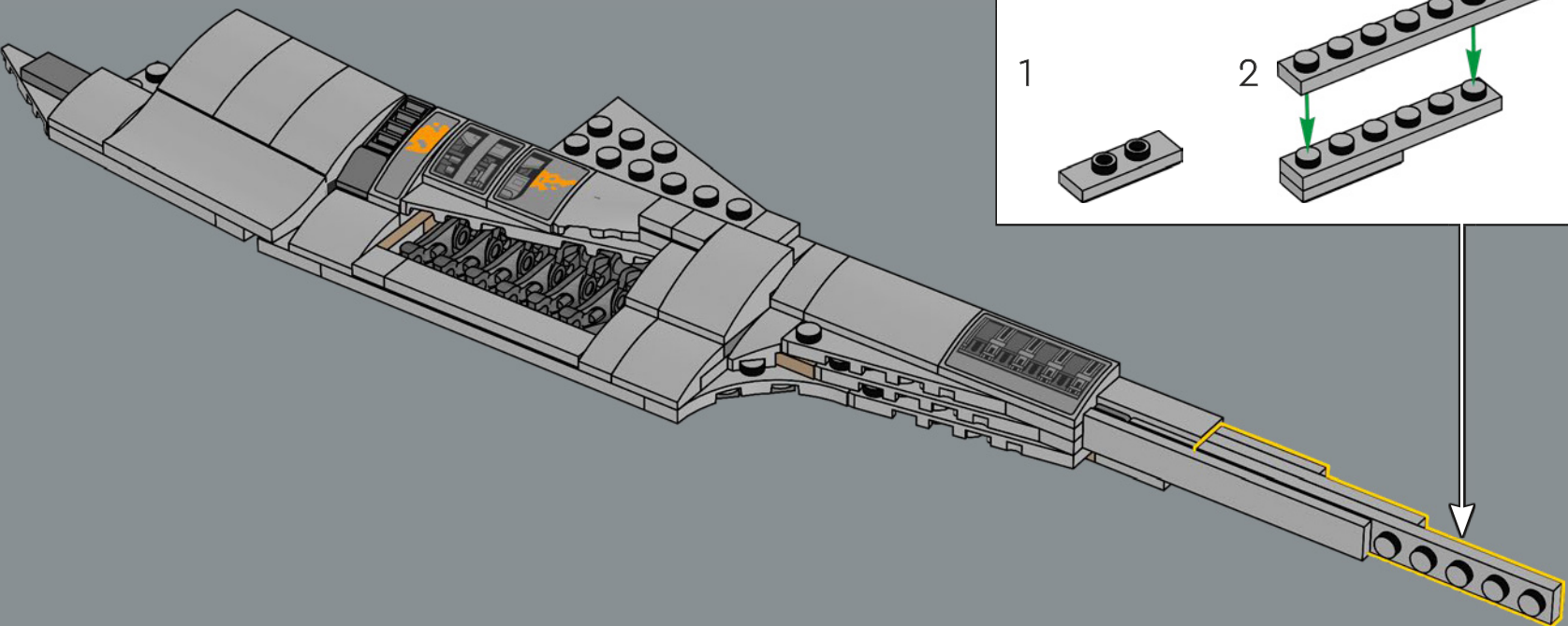

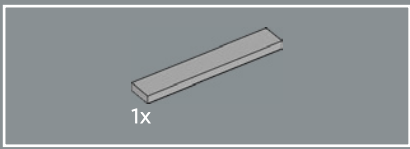

259

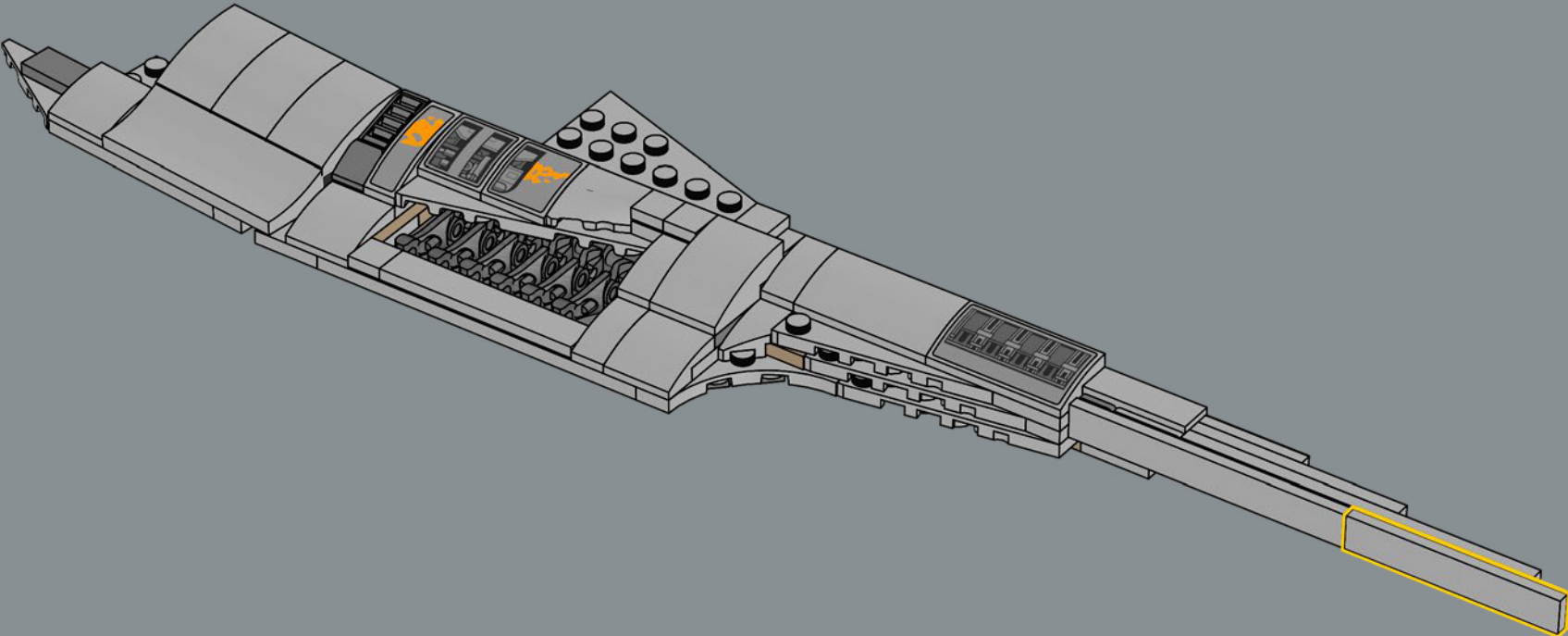

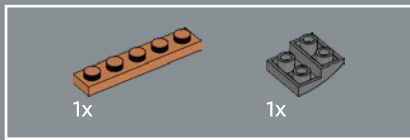

260

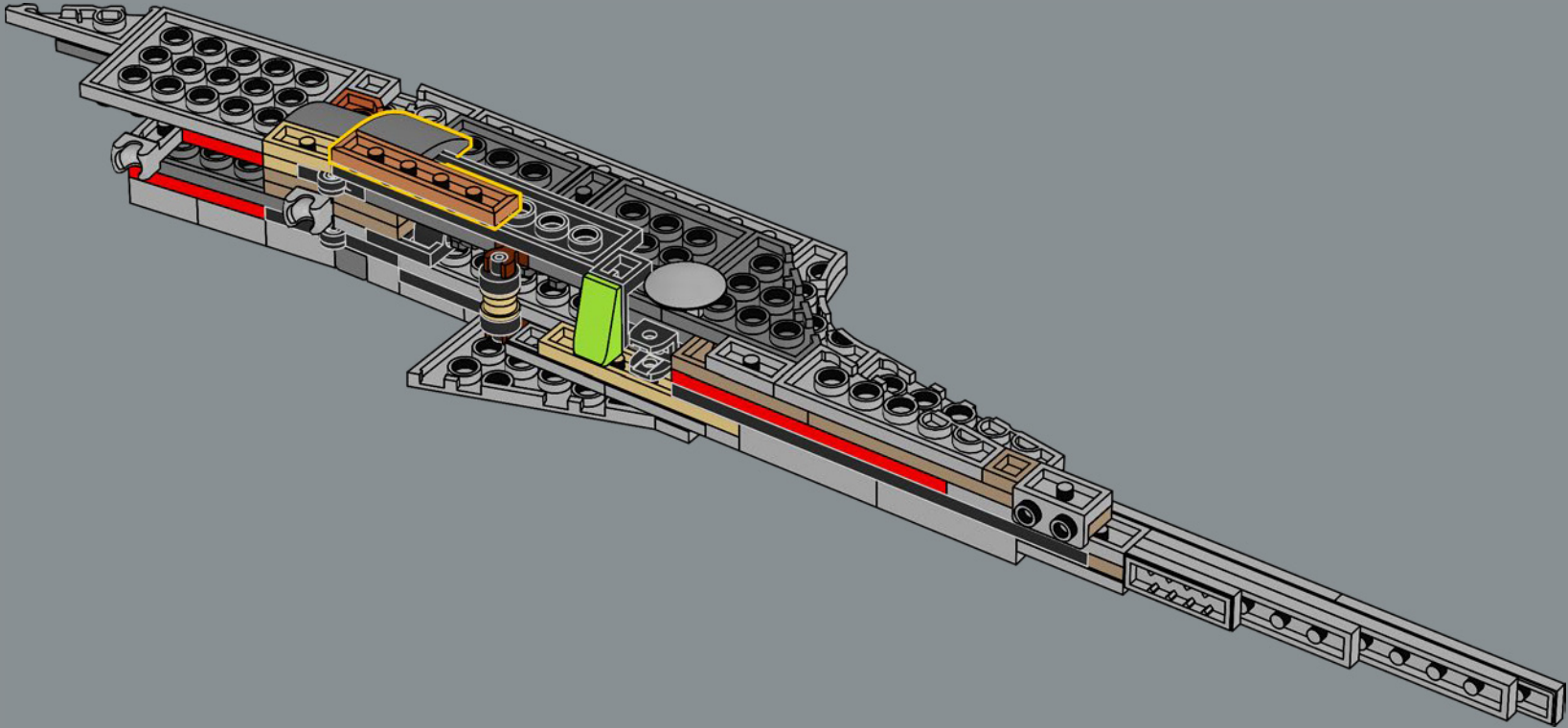

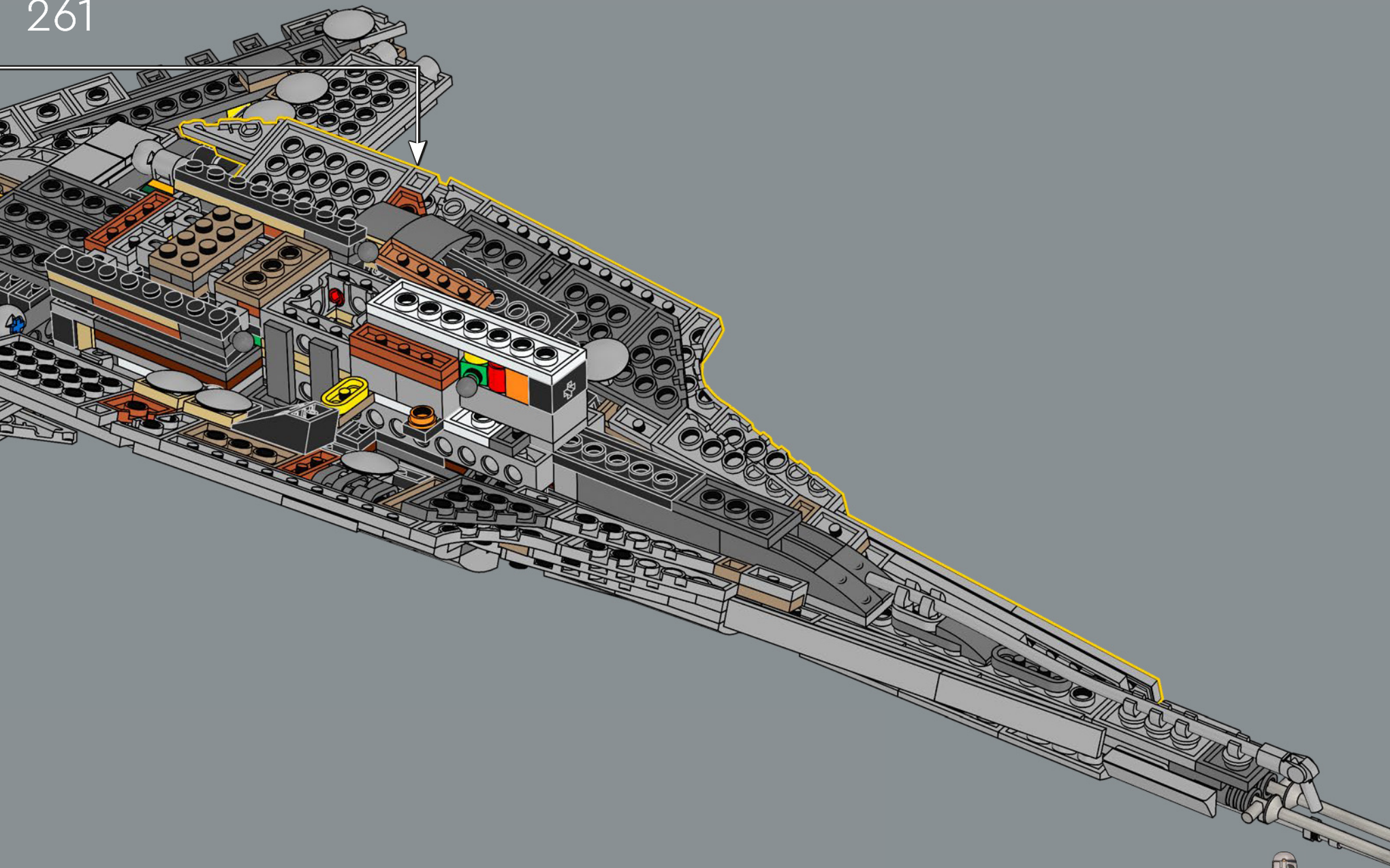

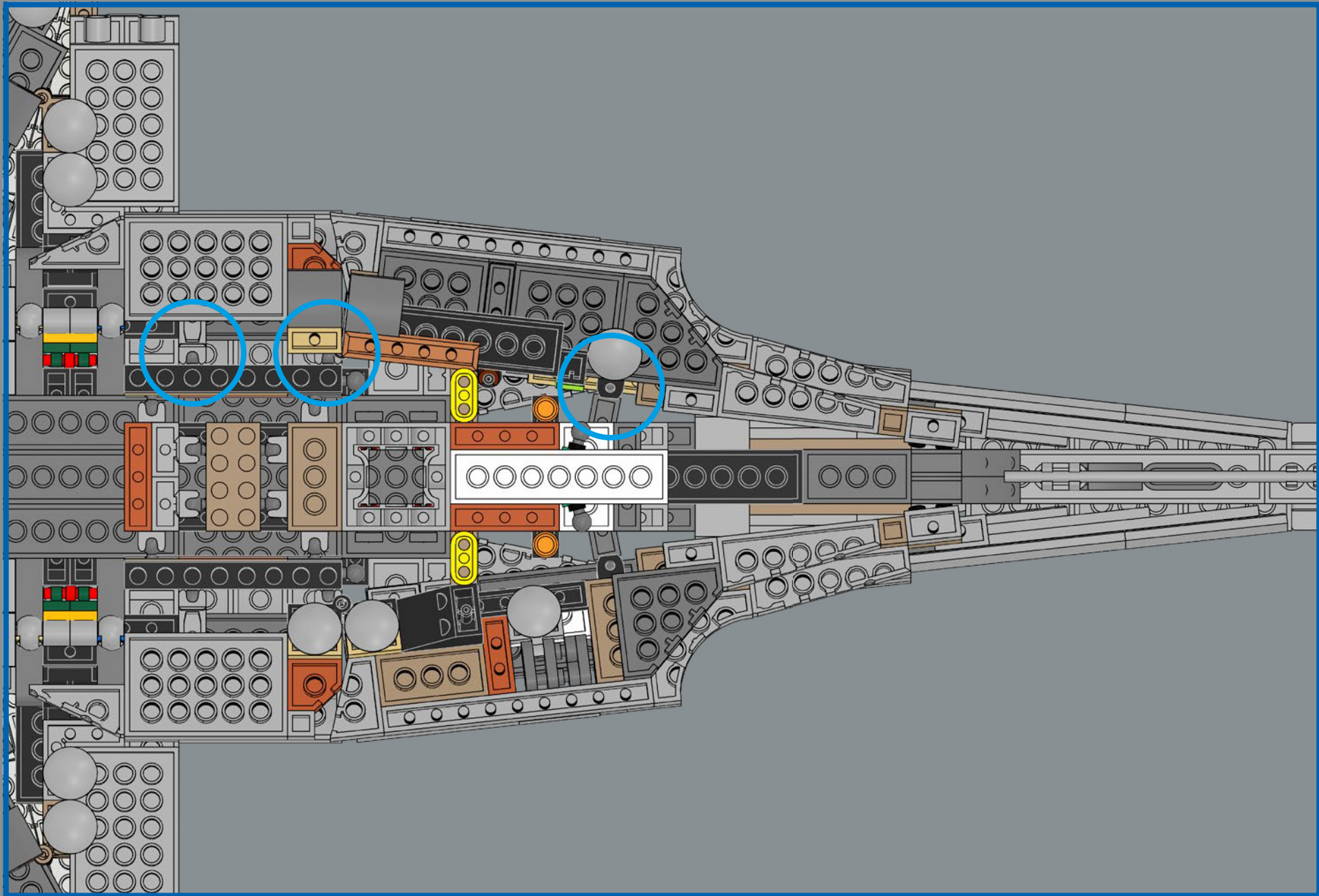



262

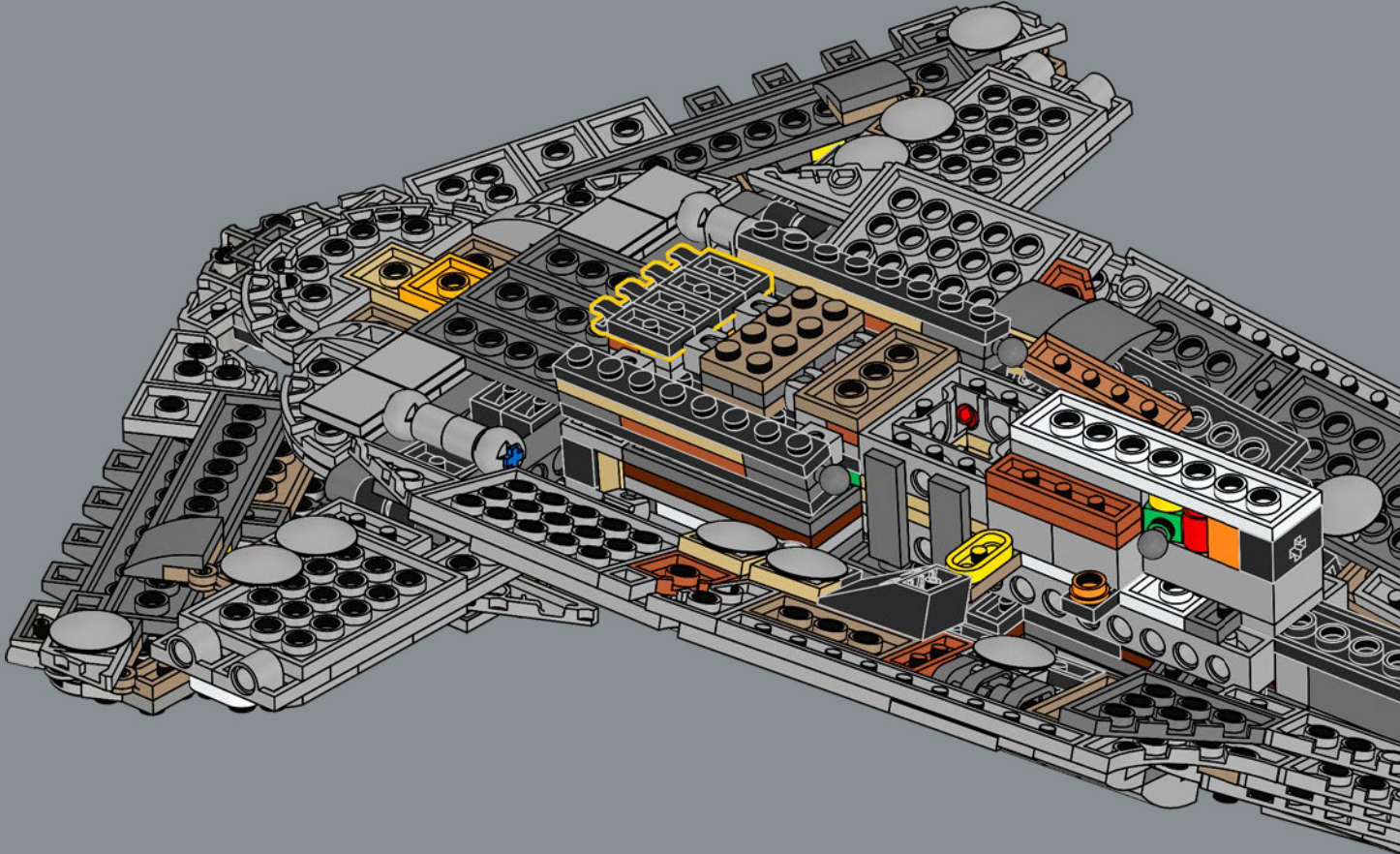

263

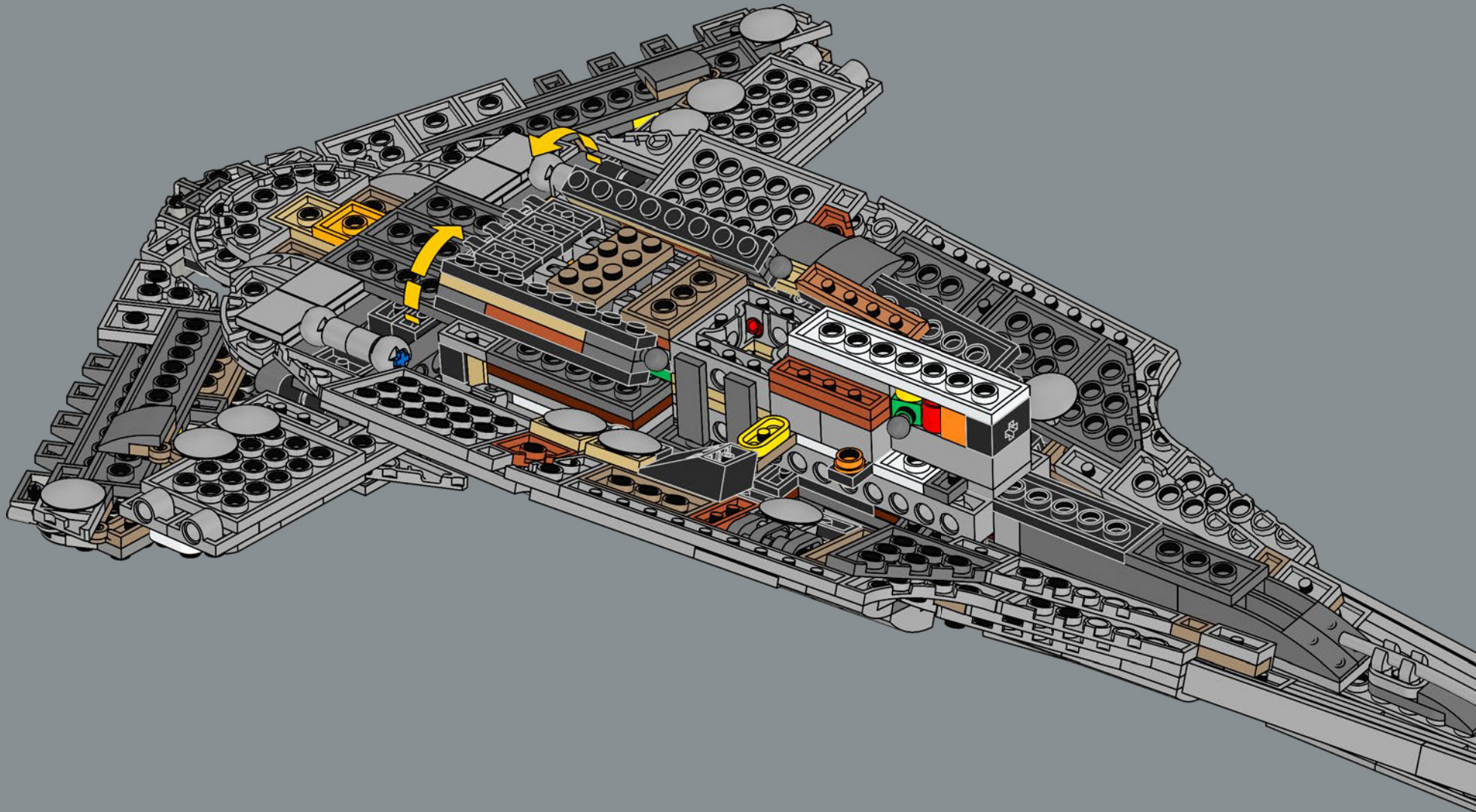

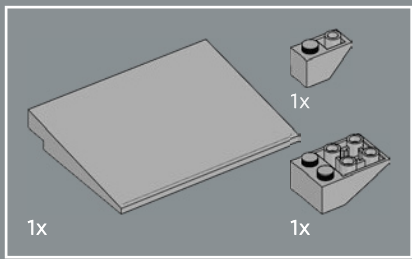

264

1

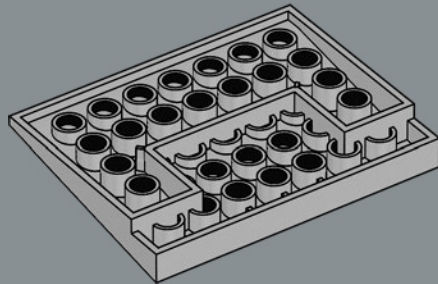

2

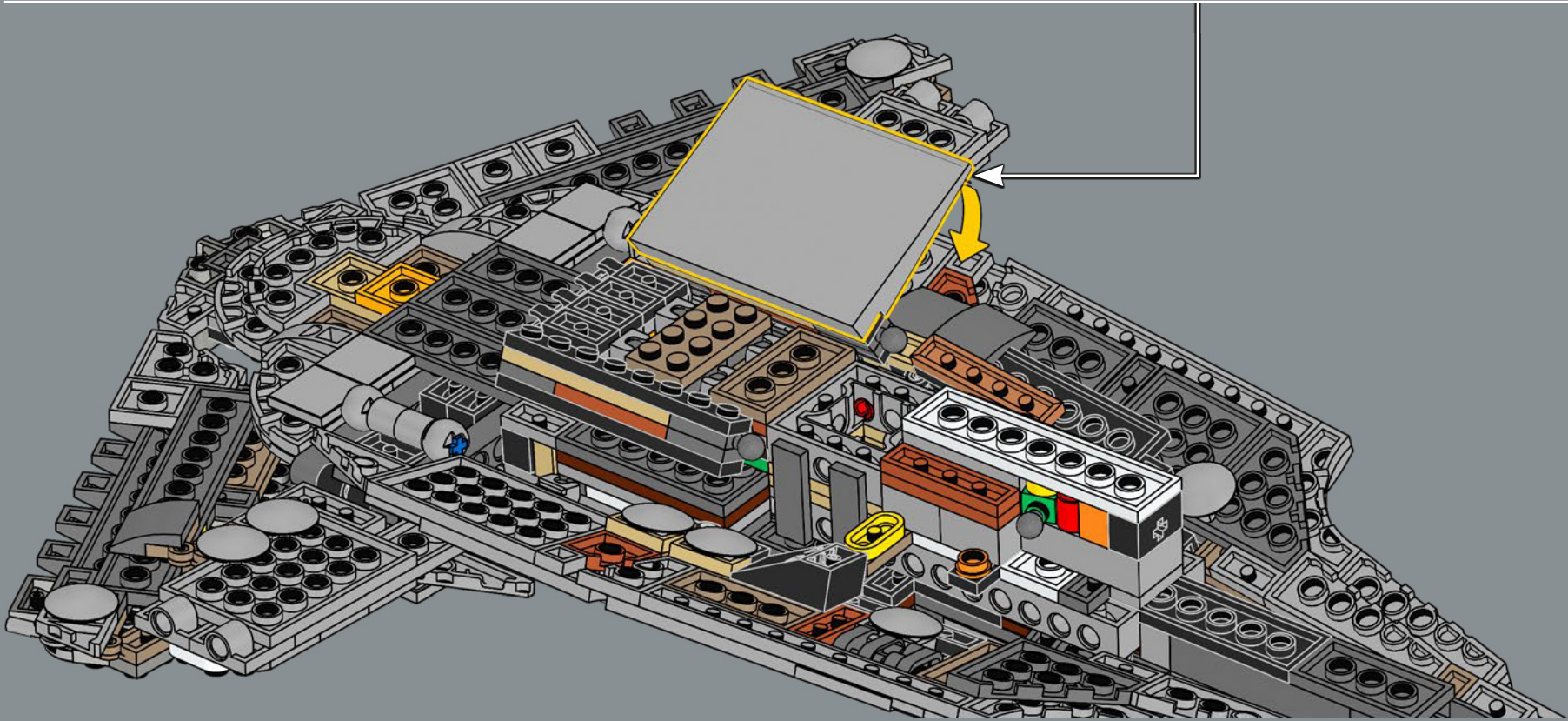
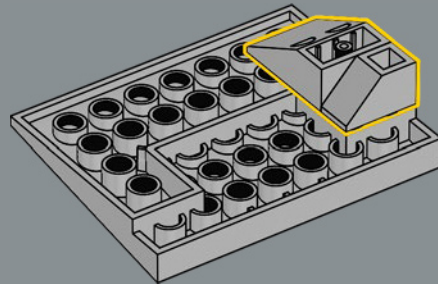

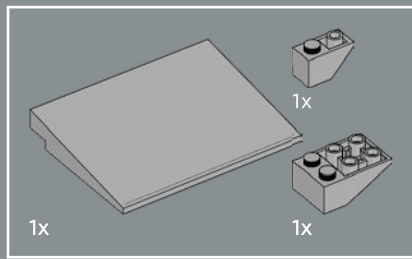

265

1

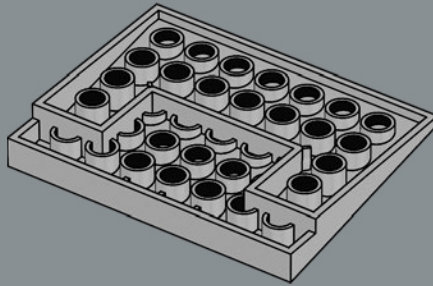

2

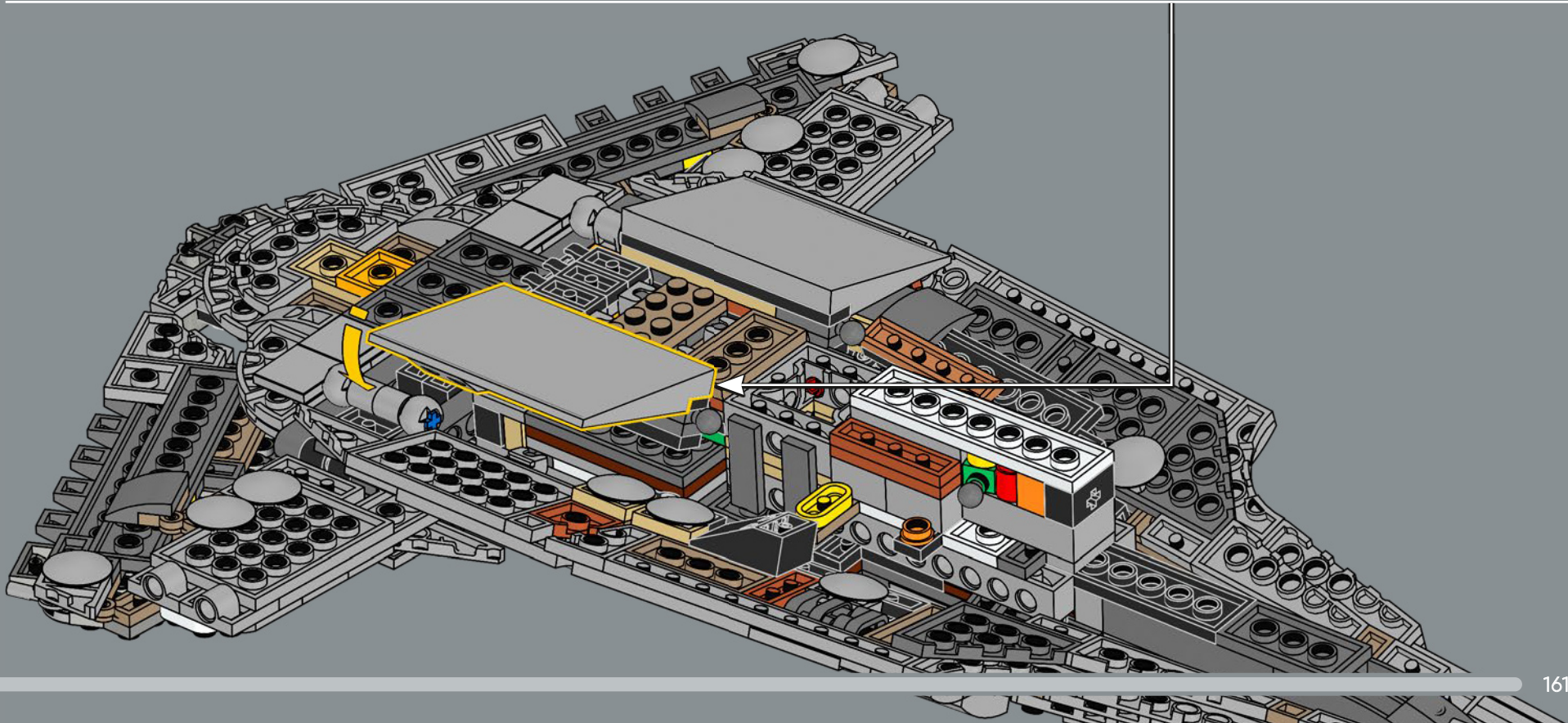
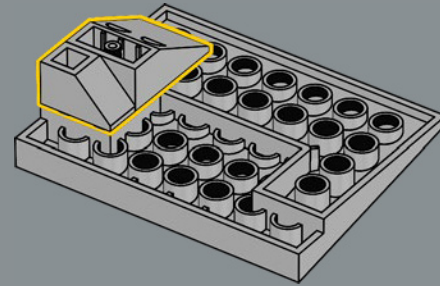

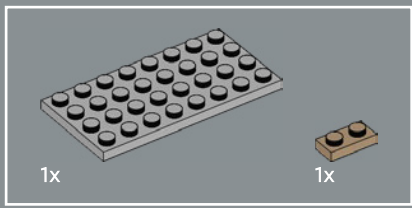

266

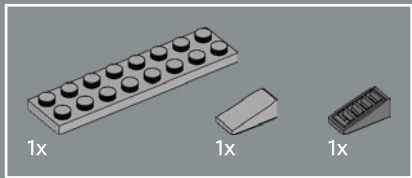
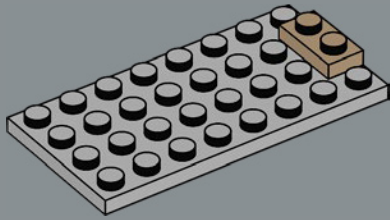

267

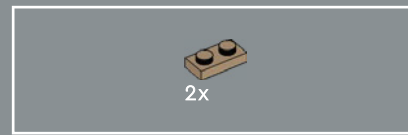
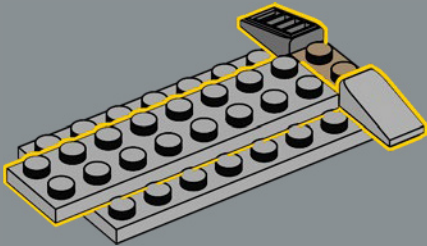

268

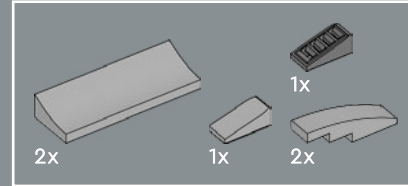
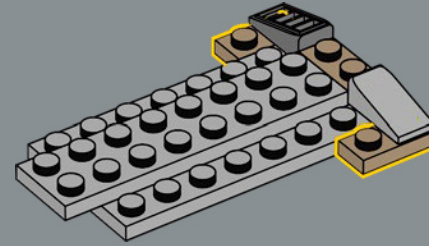

269

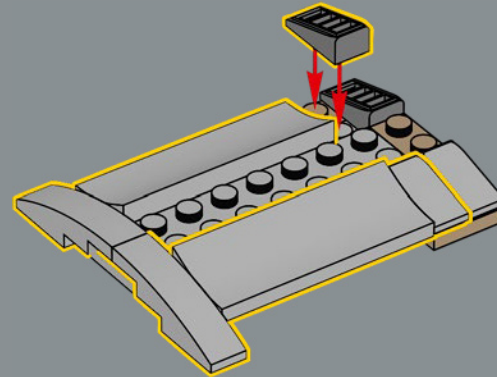

270

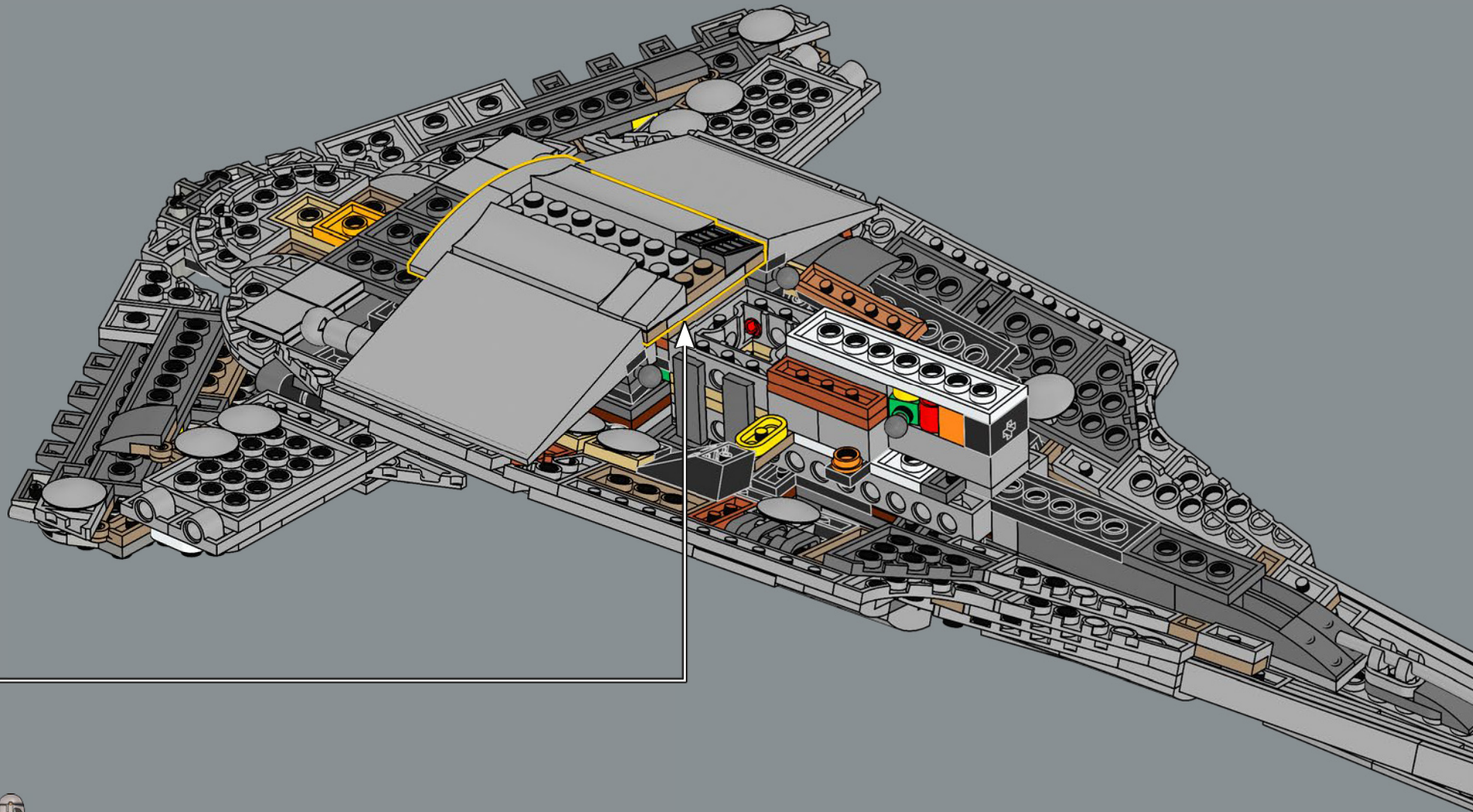

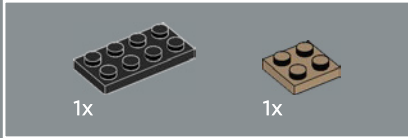
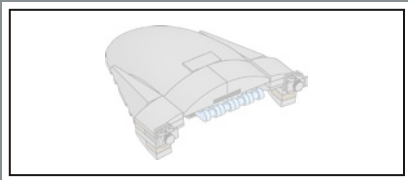

271

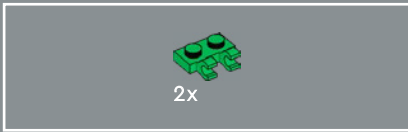
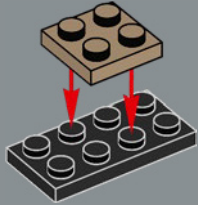

272

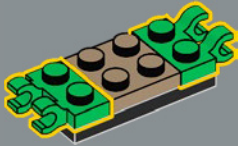

273

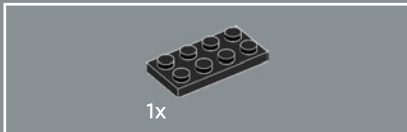
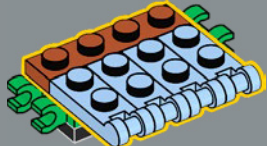

274

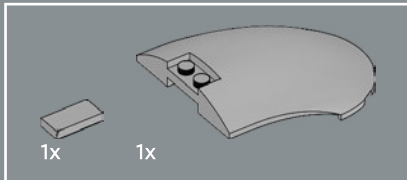
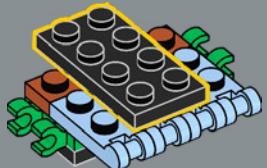

275

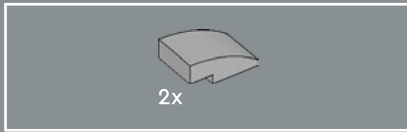
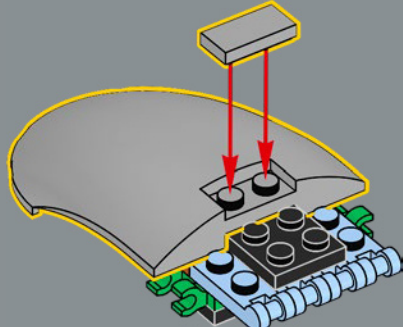

276

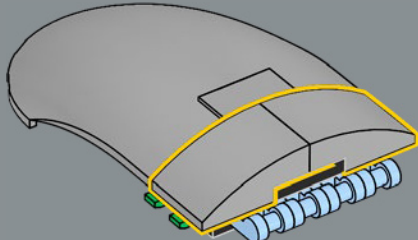



277

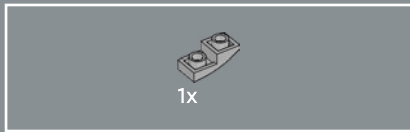
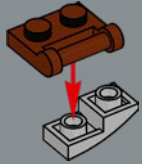

278

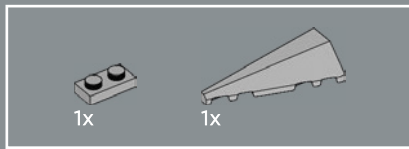
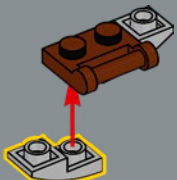

279

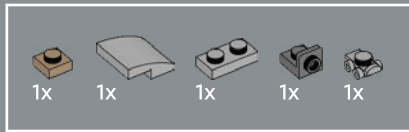
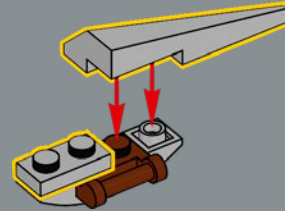

280

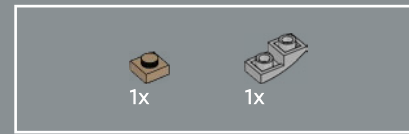
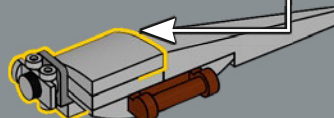
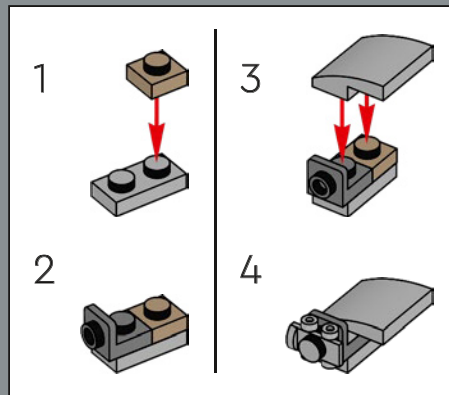

281

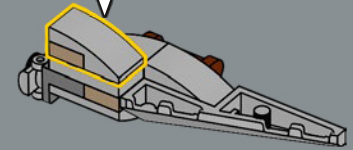
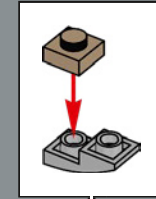

282

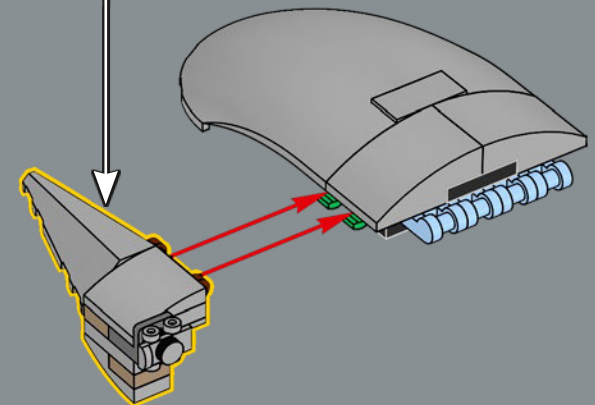



283

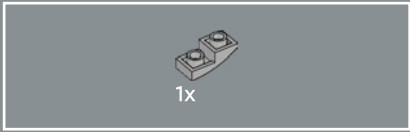
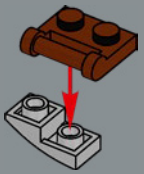

284

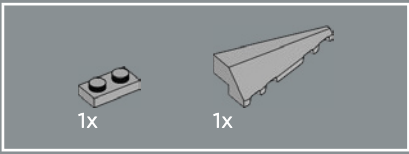
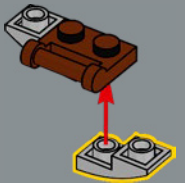

285

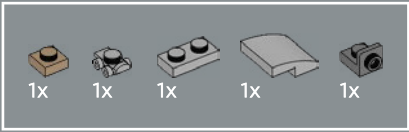
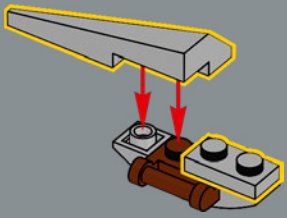

286

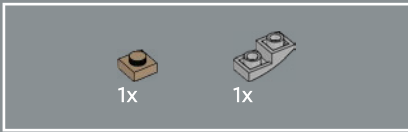
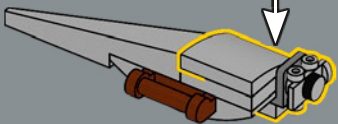
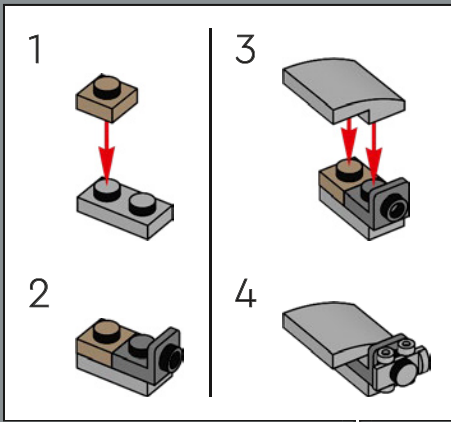

287

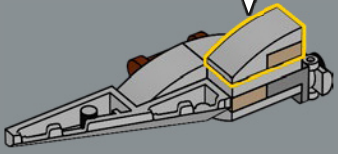
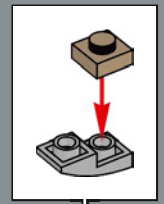

288

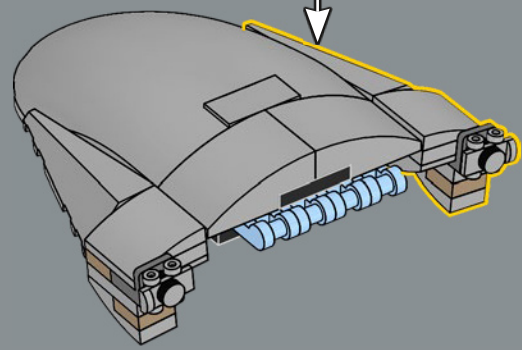

289

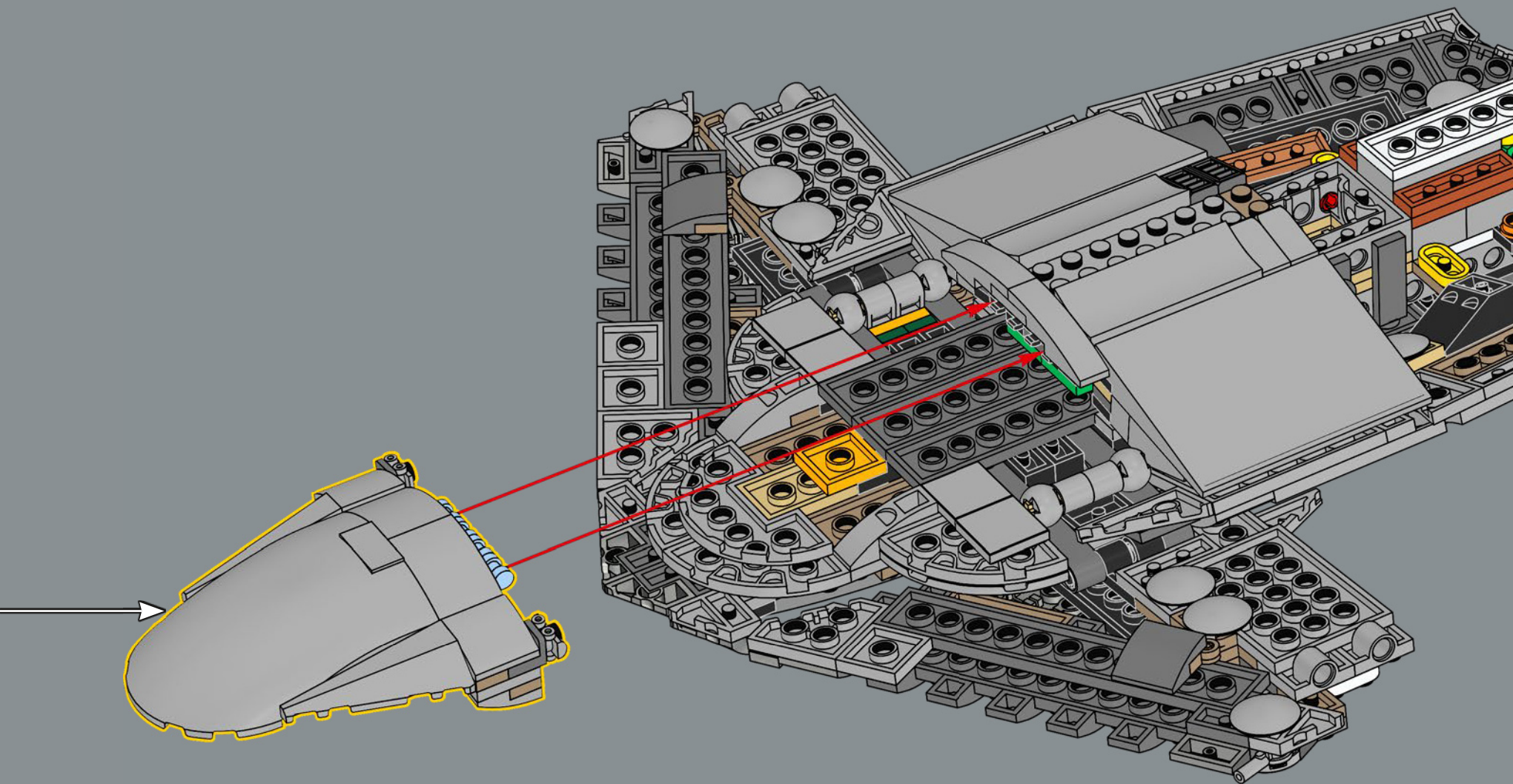

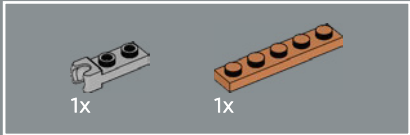
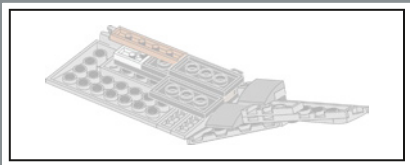

290

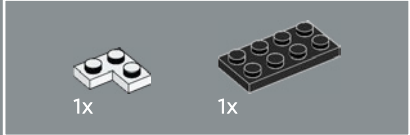
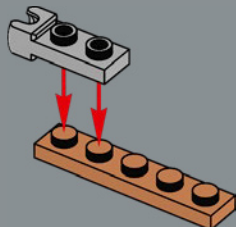

291

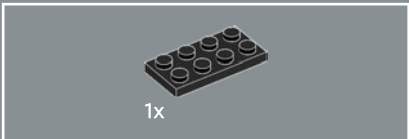
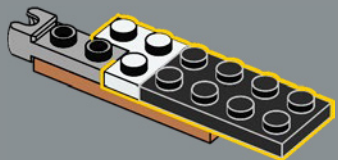

292

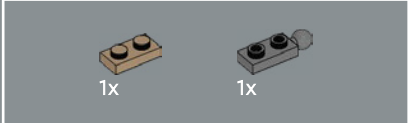
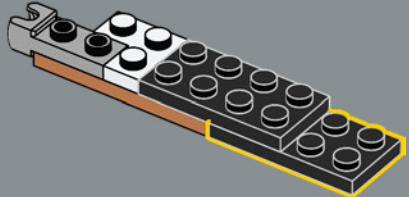

293

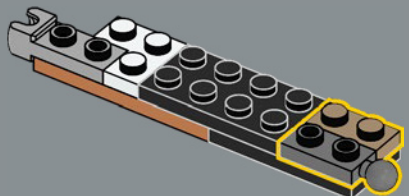

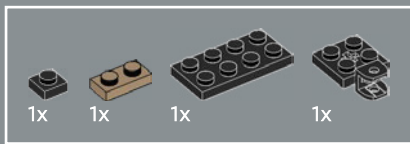

294

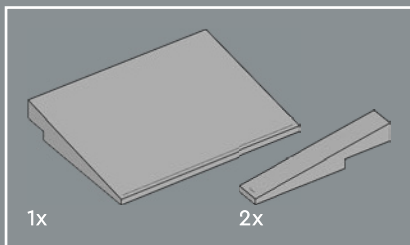
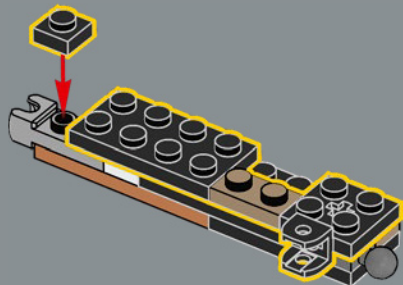

295

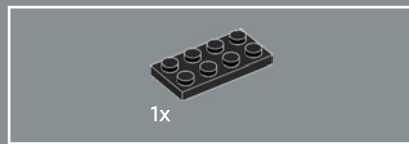
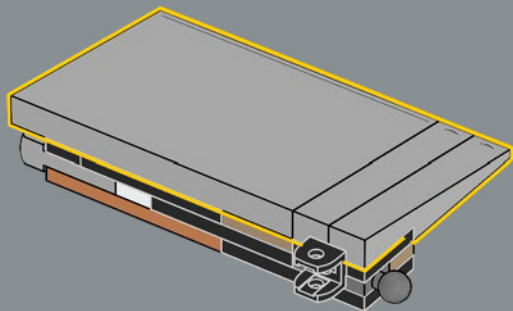

296

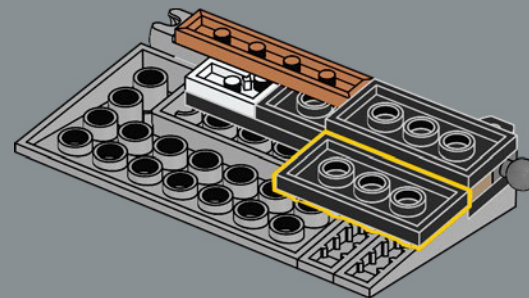

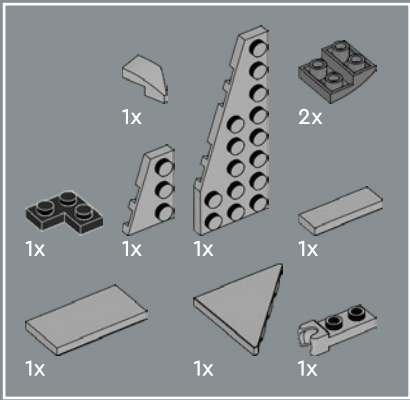

297

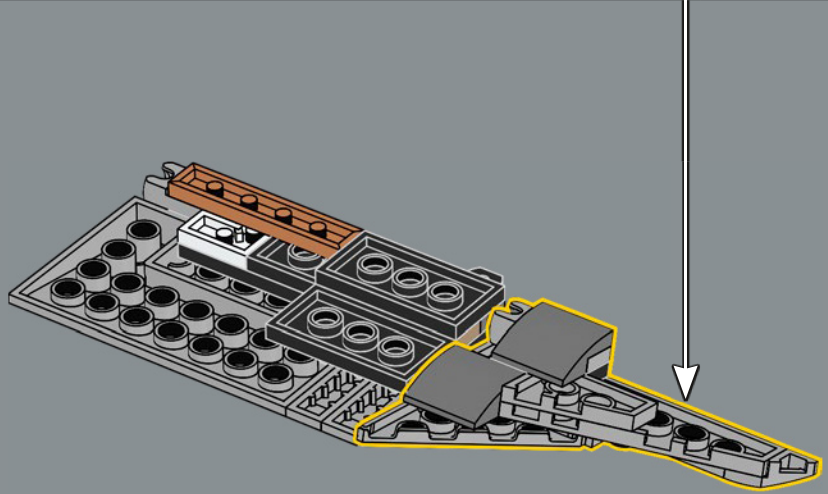
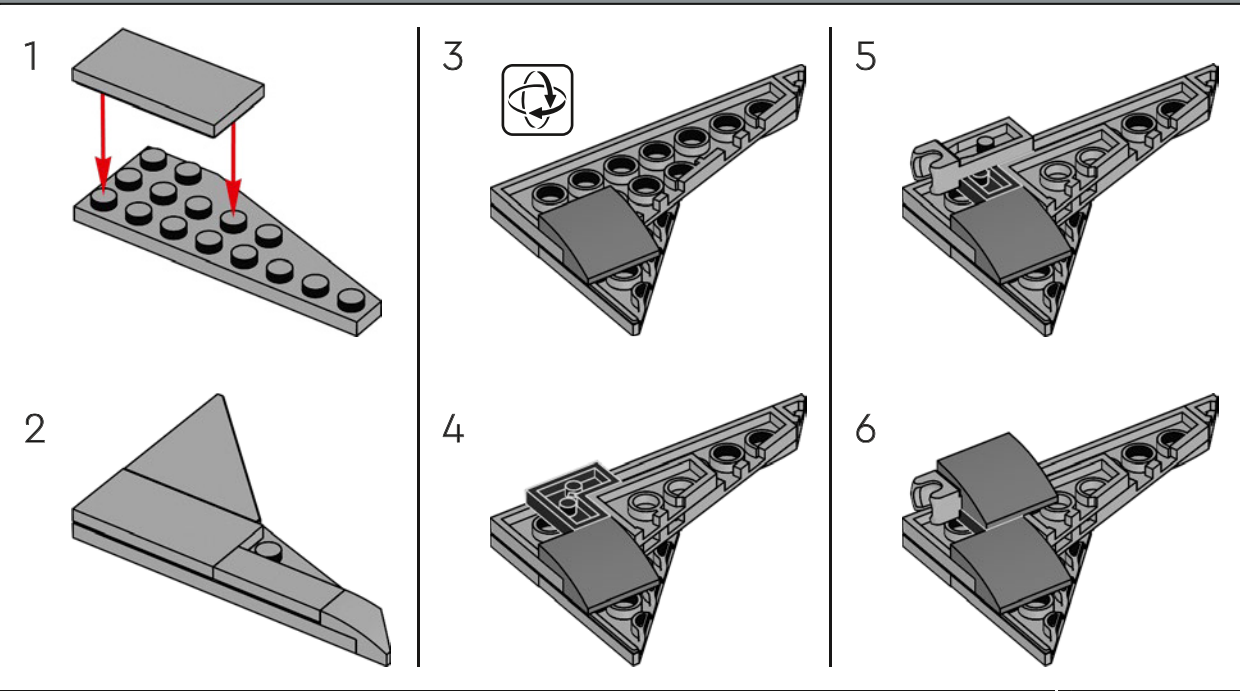

298

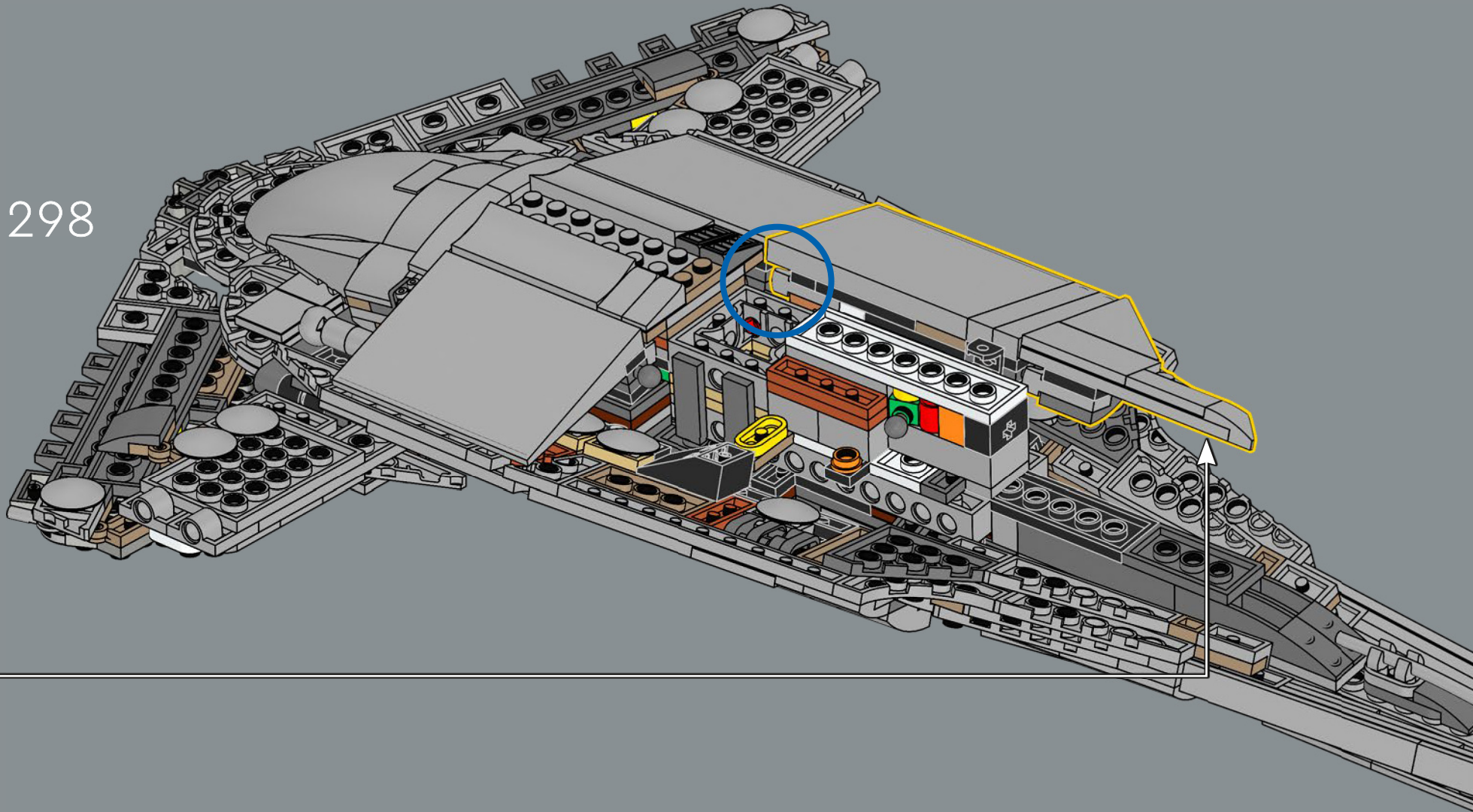

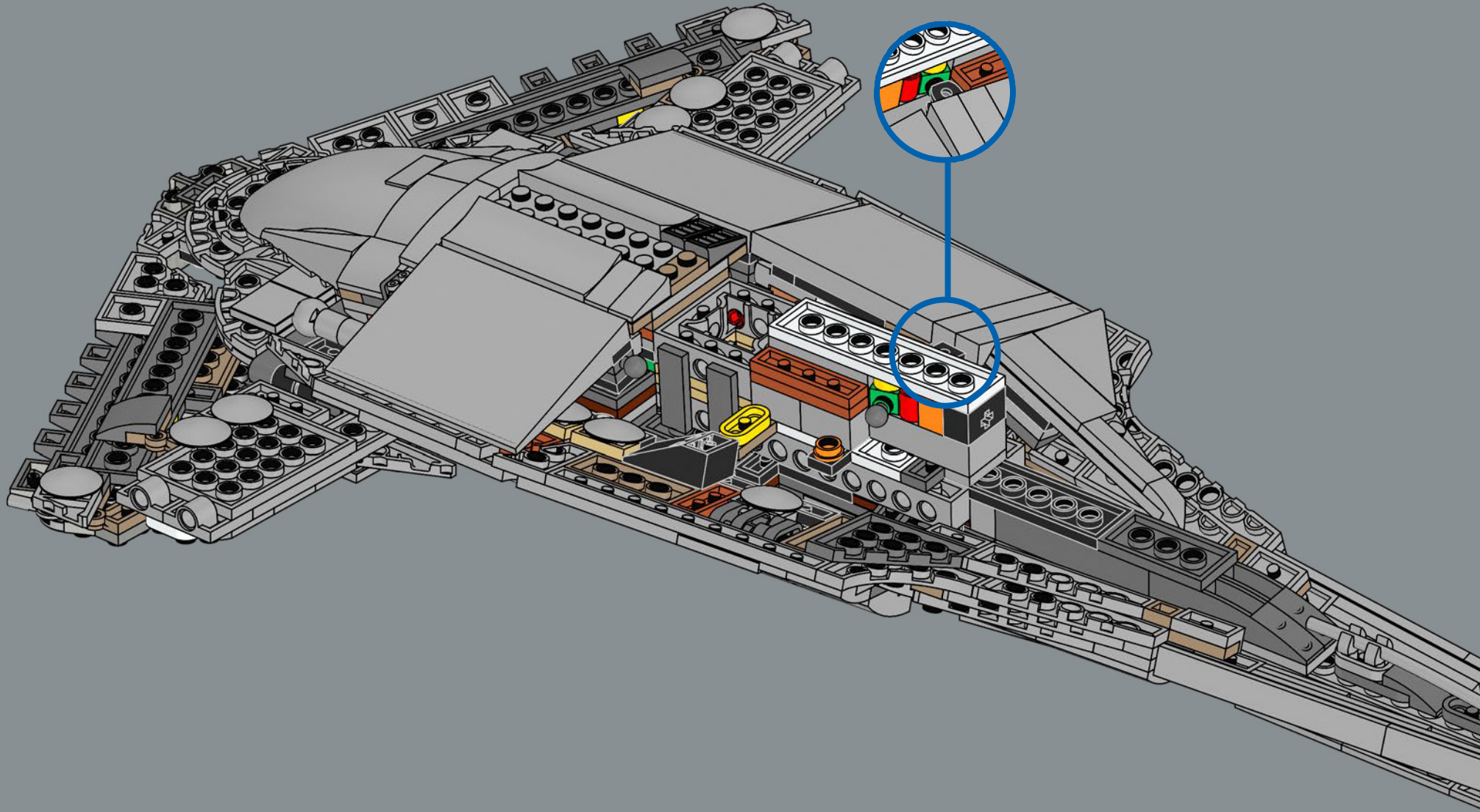

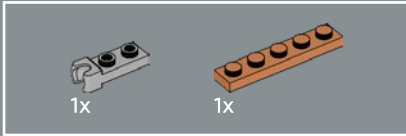
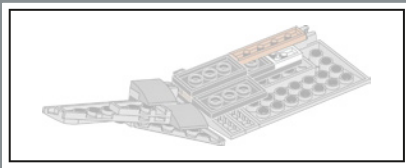

300

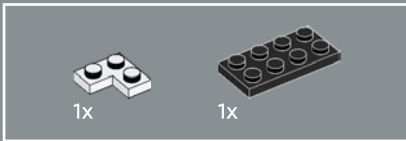
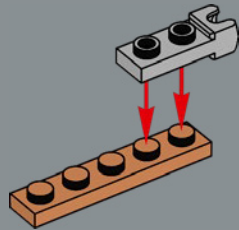

301

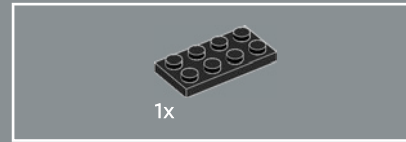
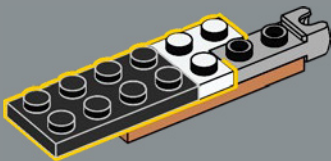

302

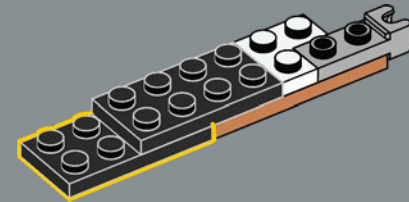

303



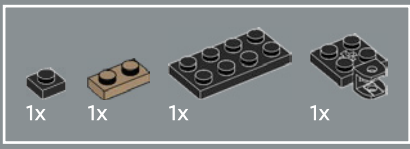

304

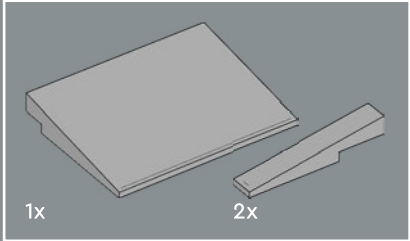
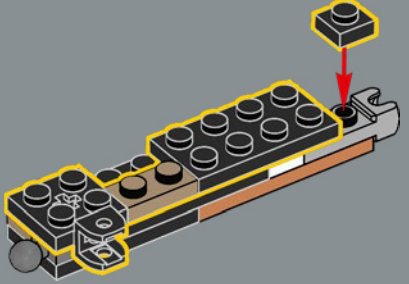

305

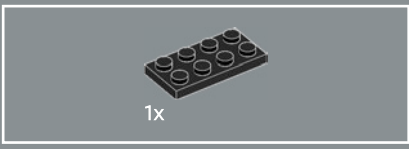
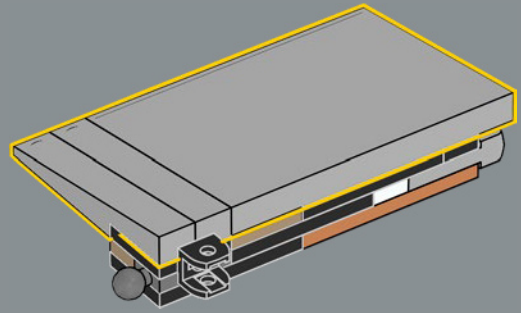

306

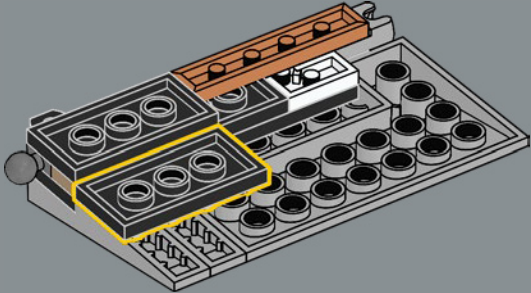

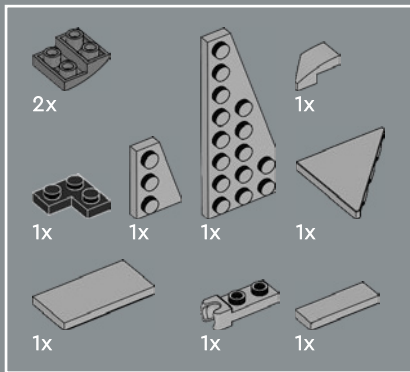

307

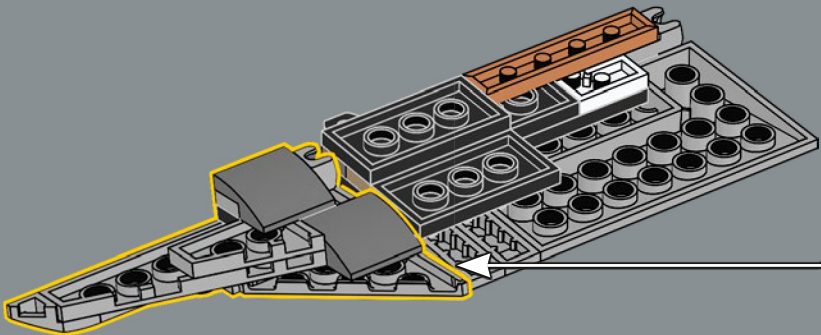
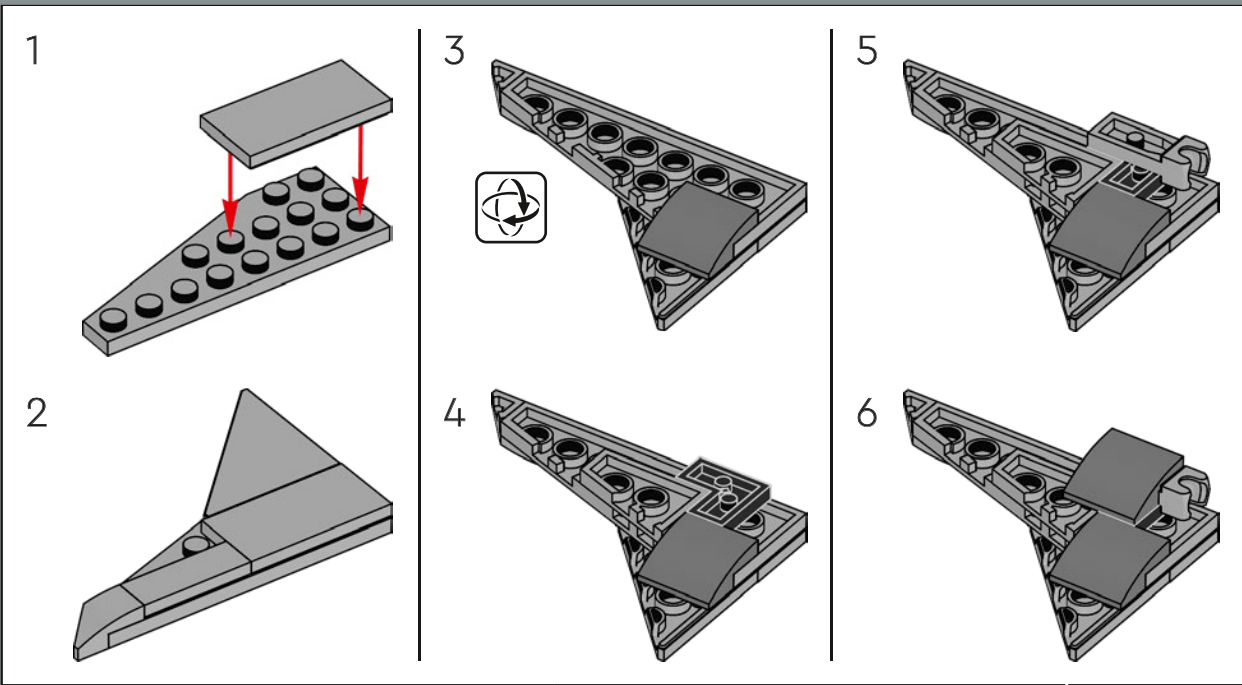

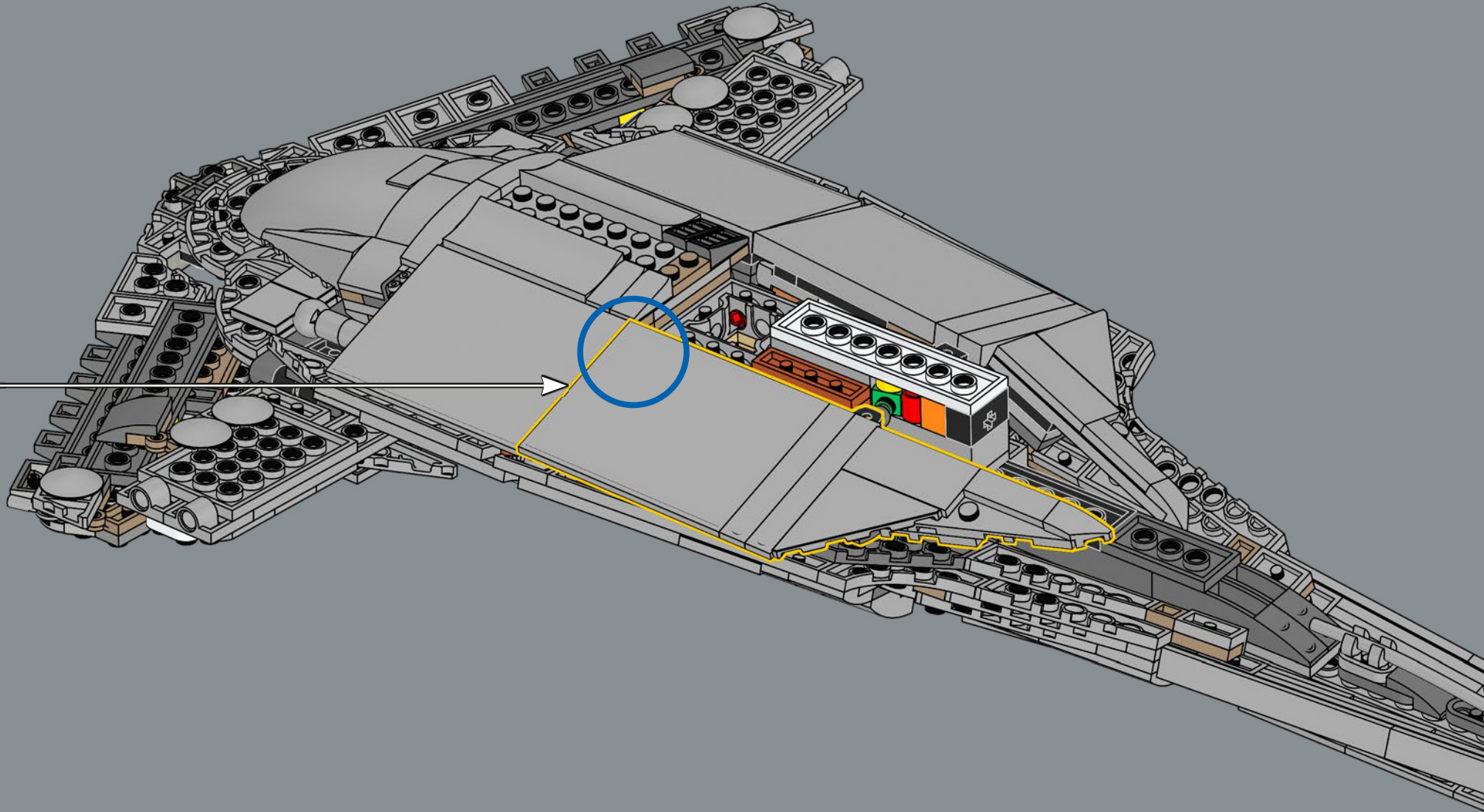

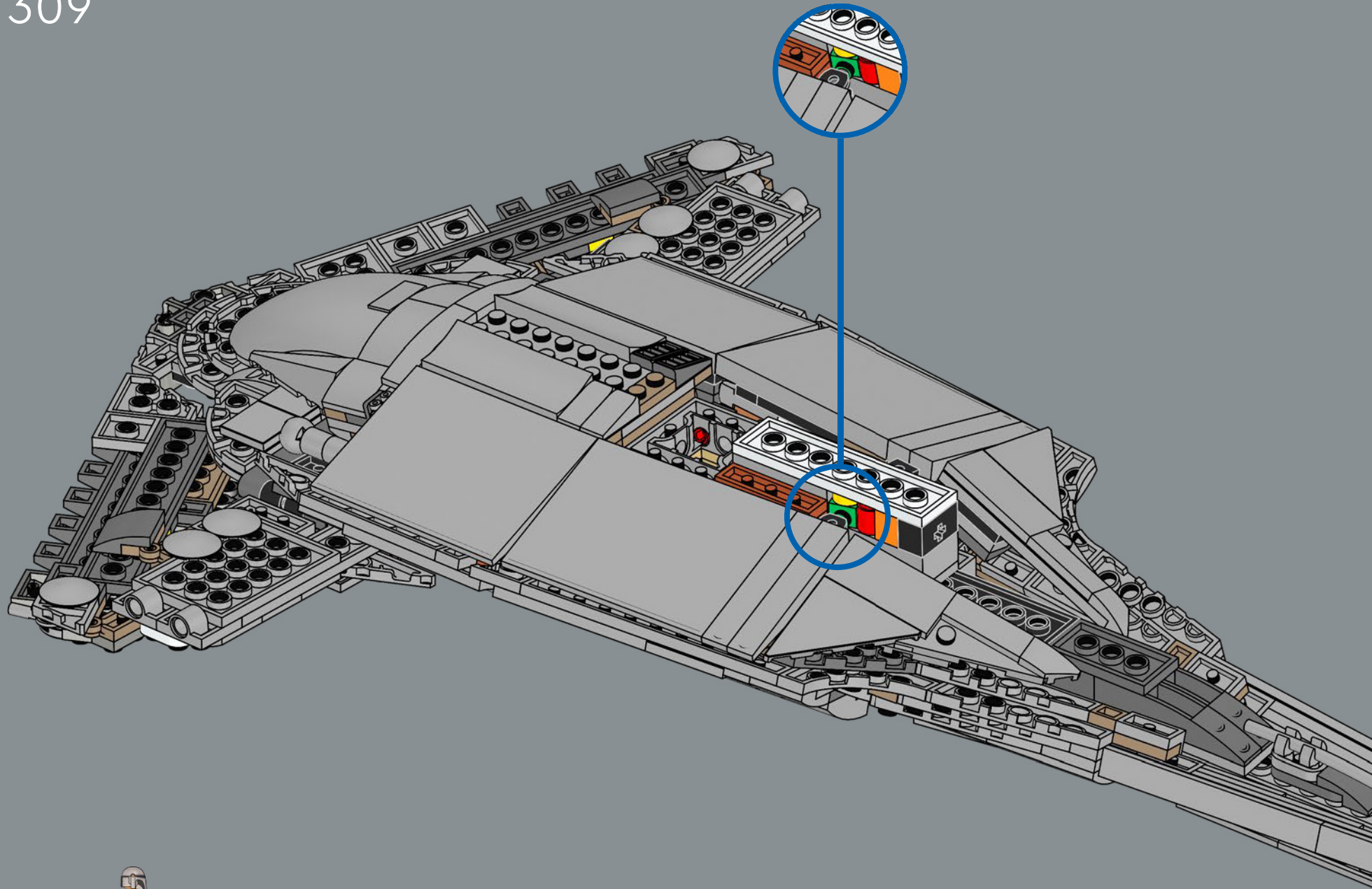

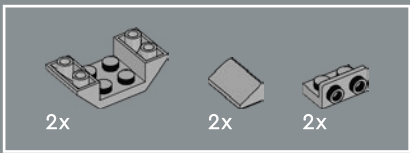

310

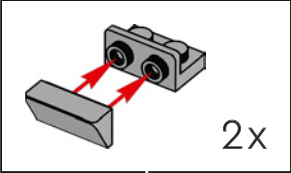
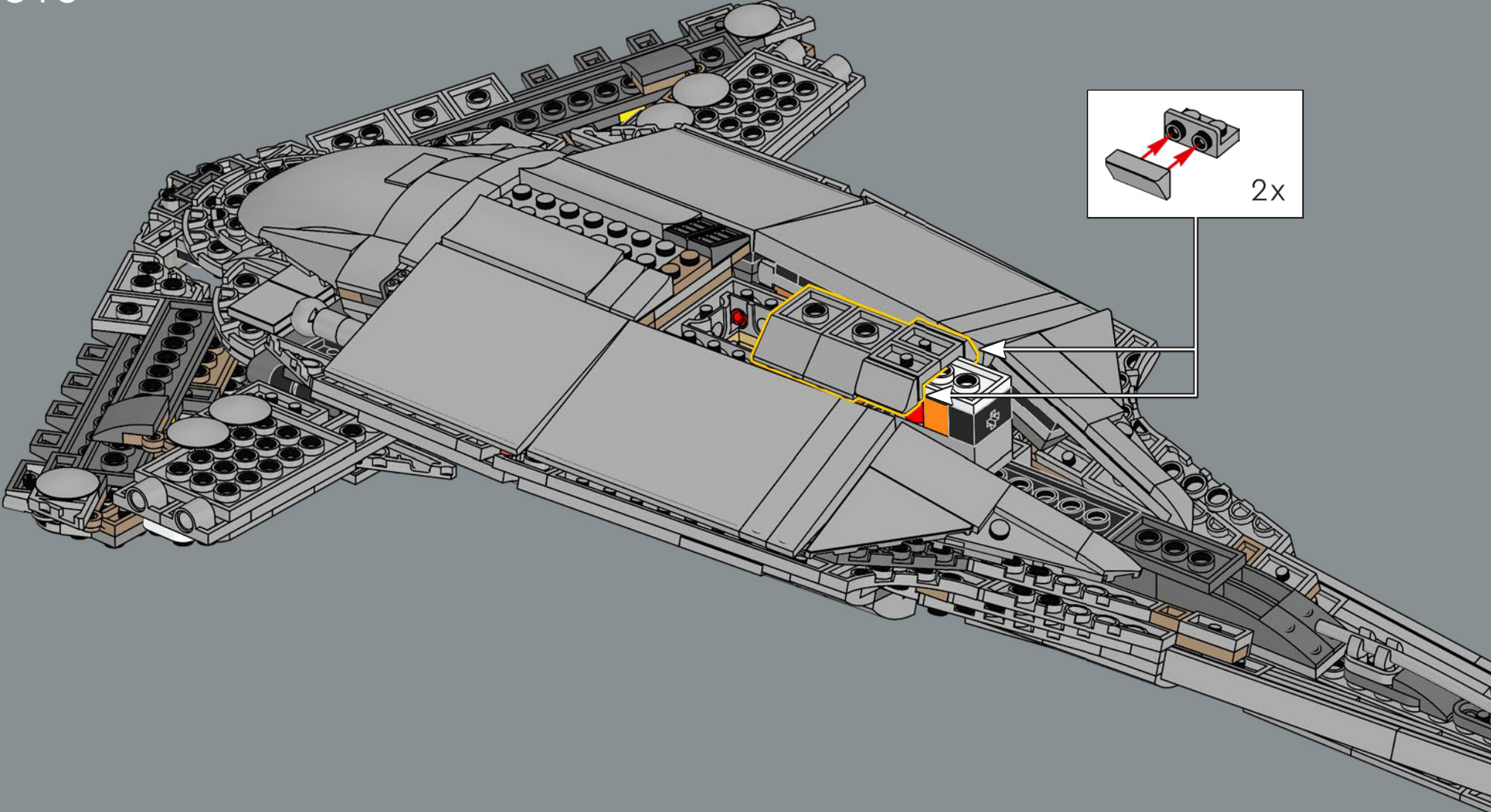

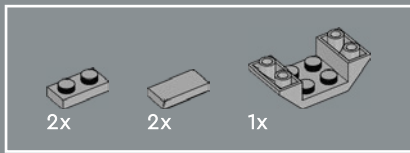

311

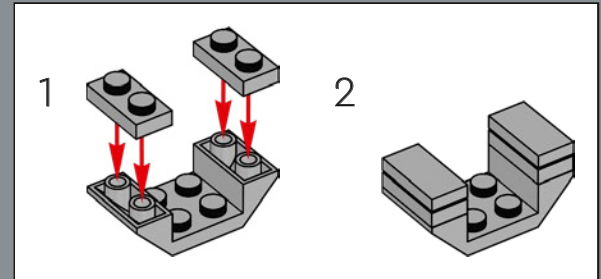
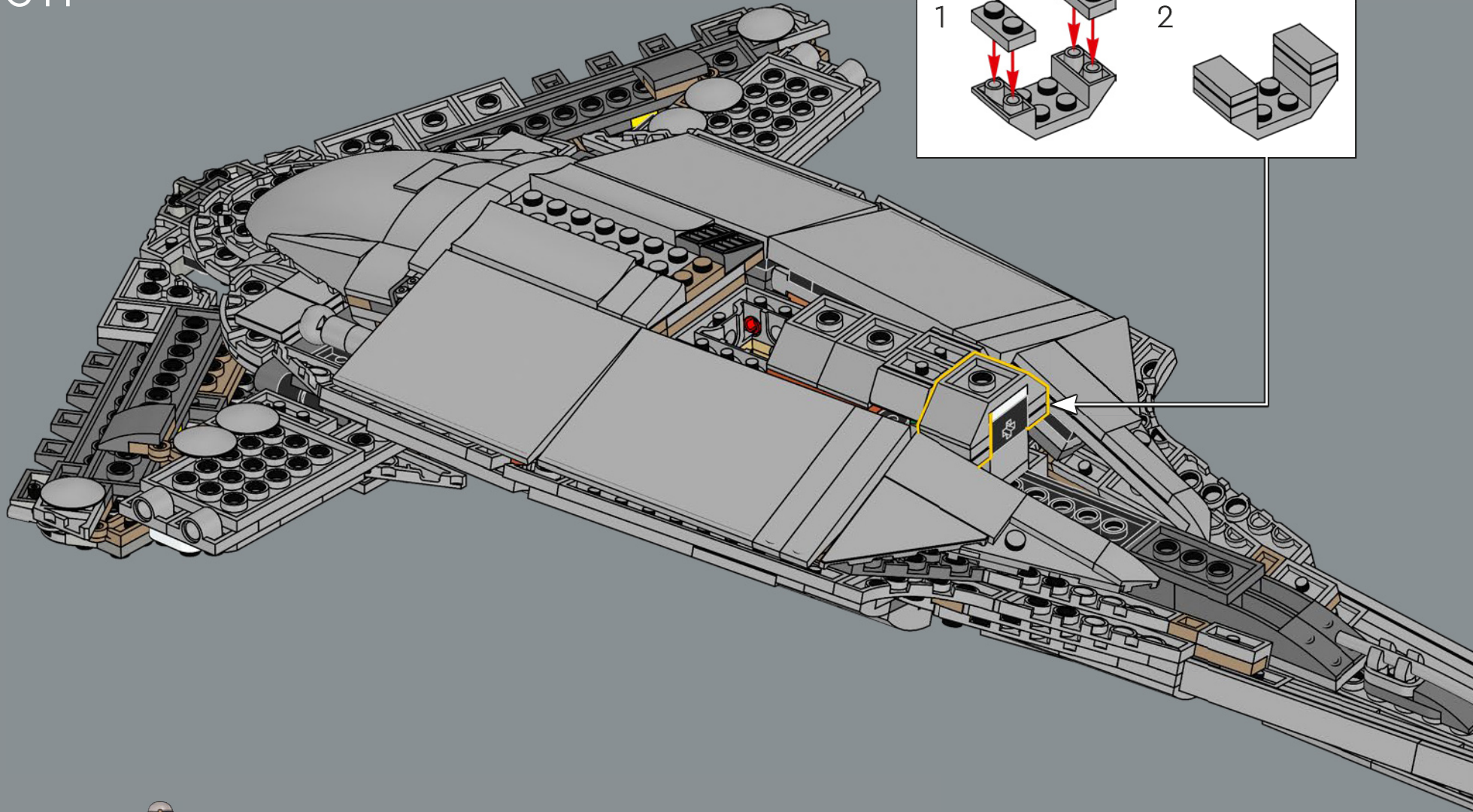

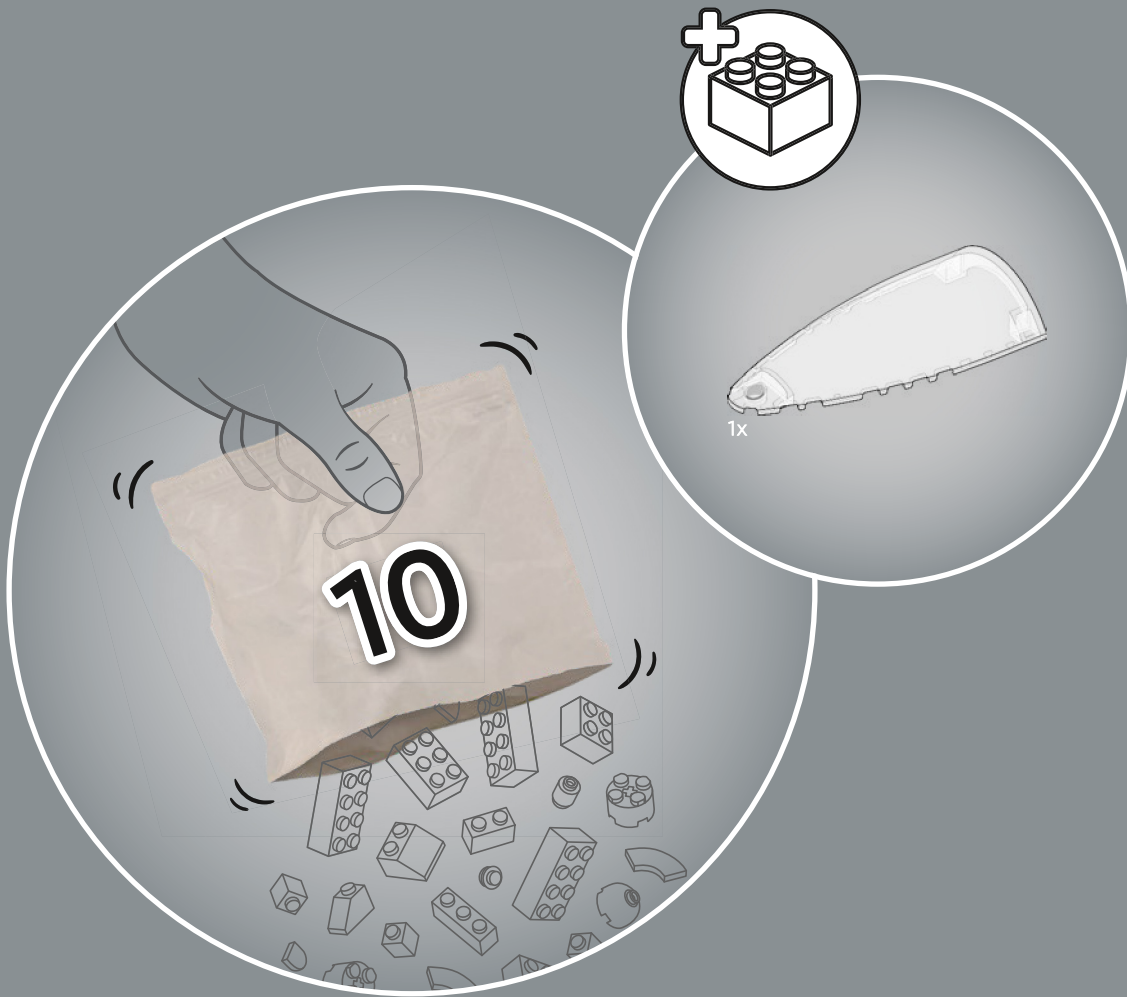

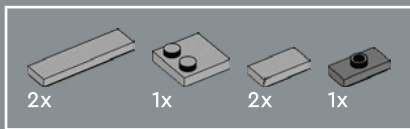

312

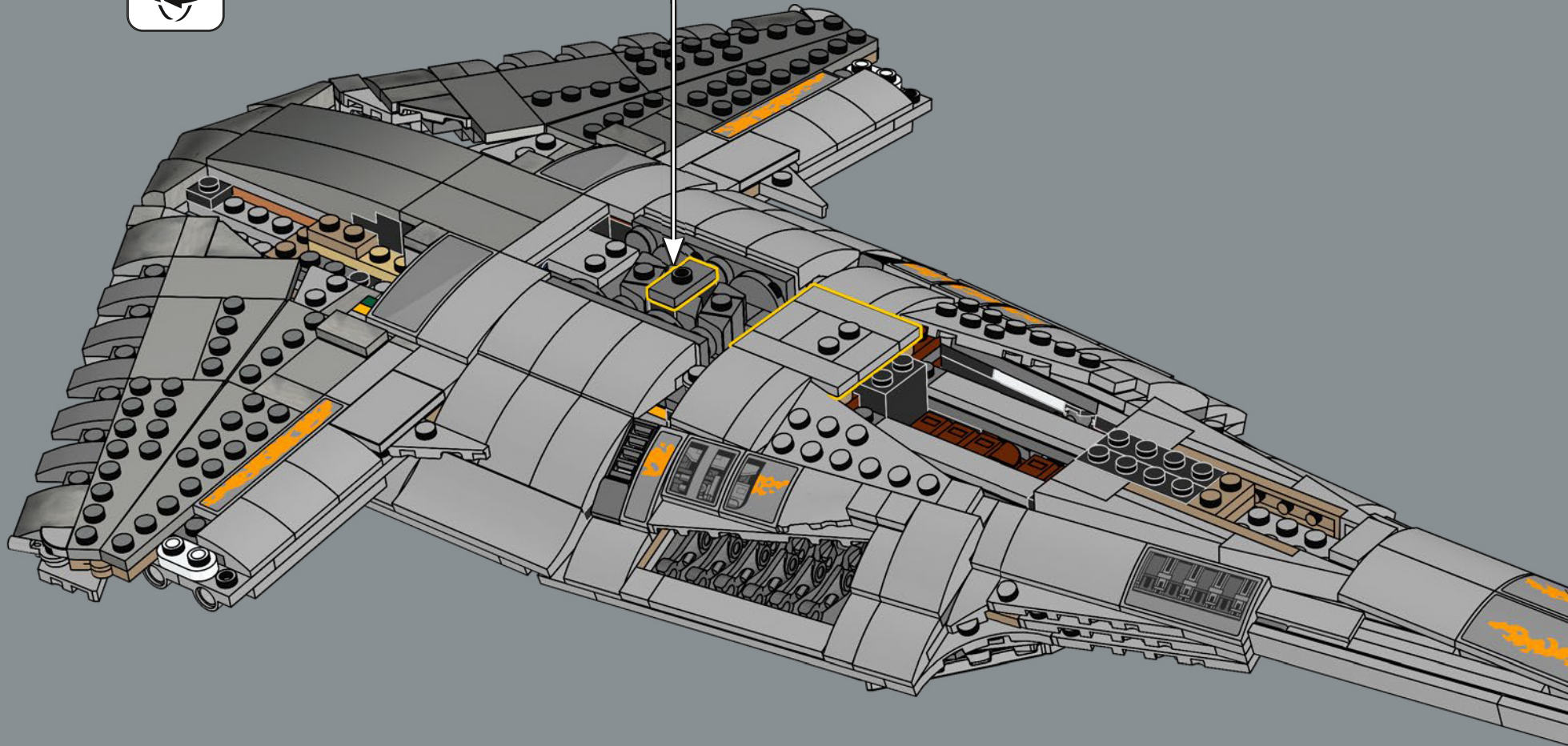
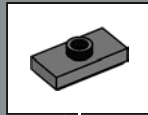

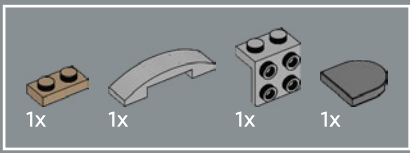

313

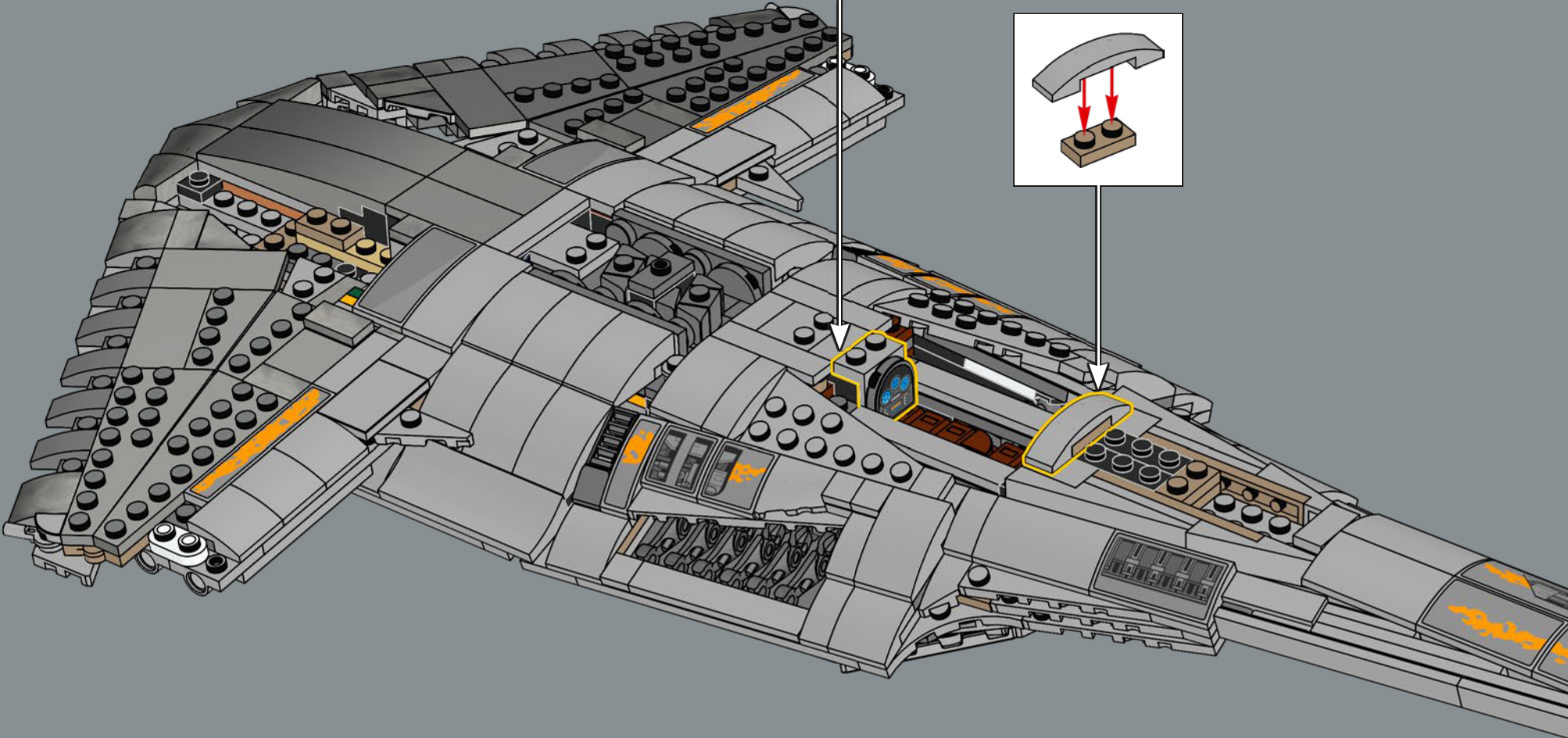
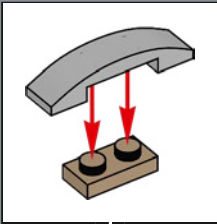
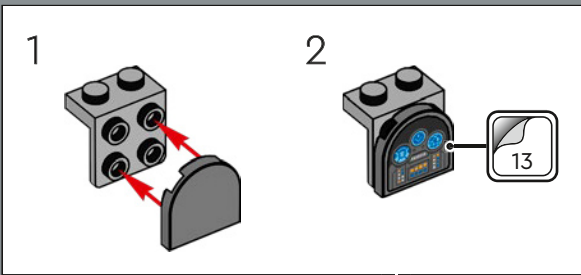



2x



6x

314

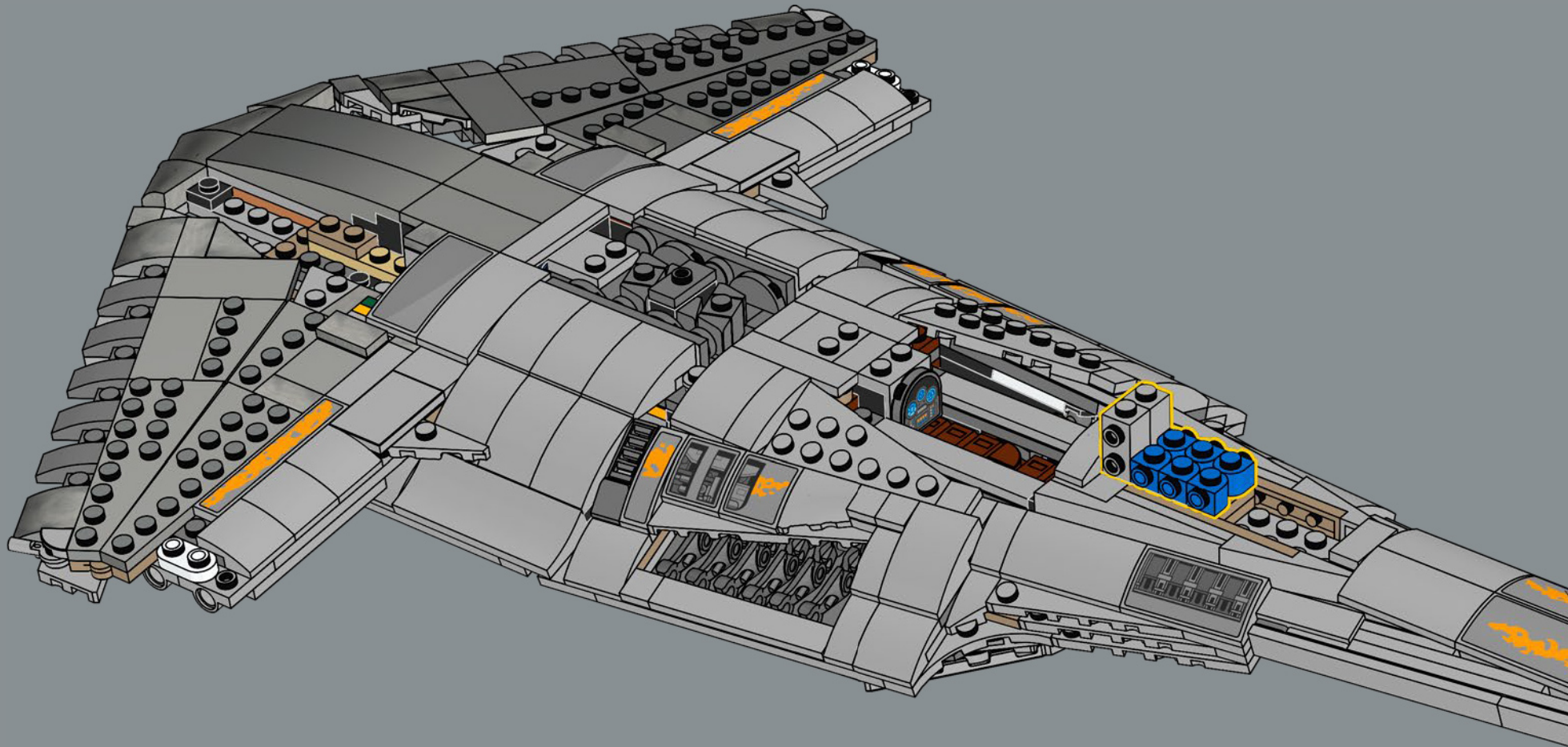

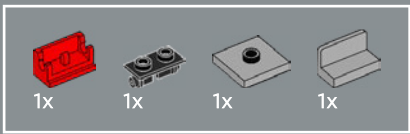

315

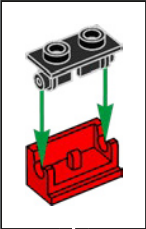
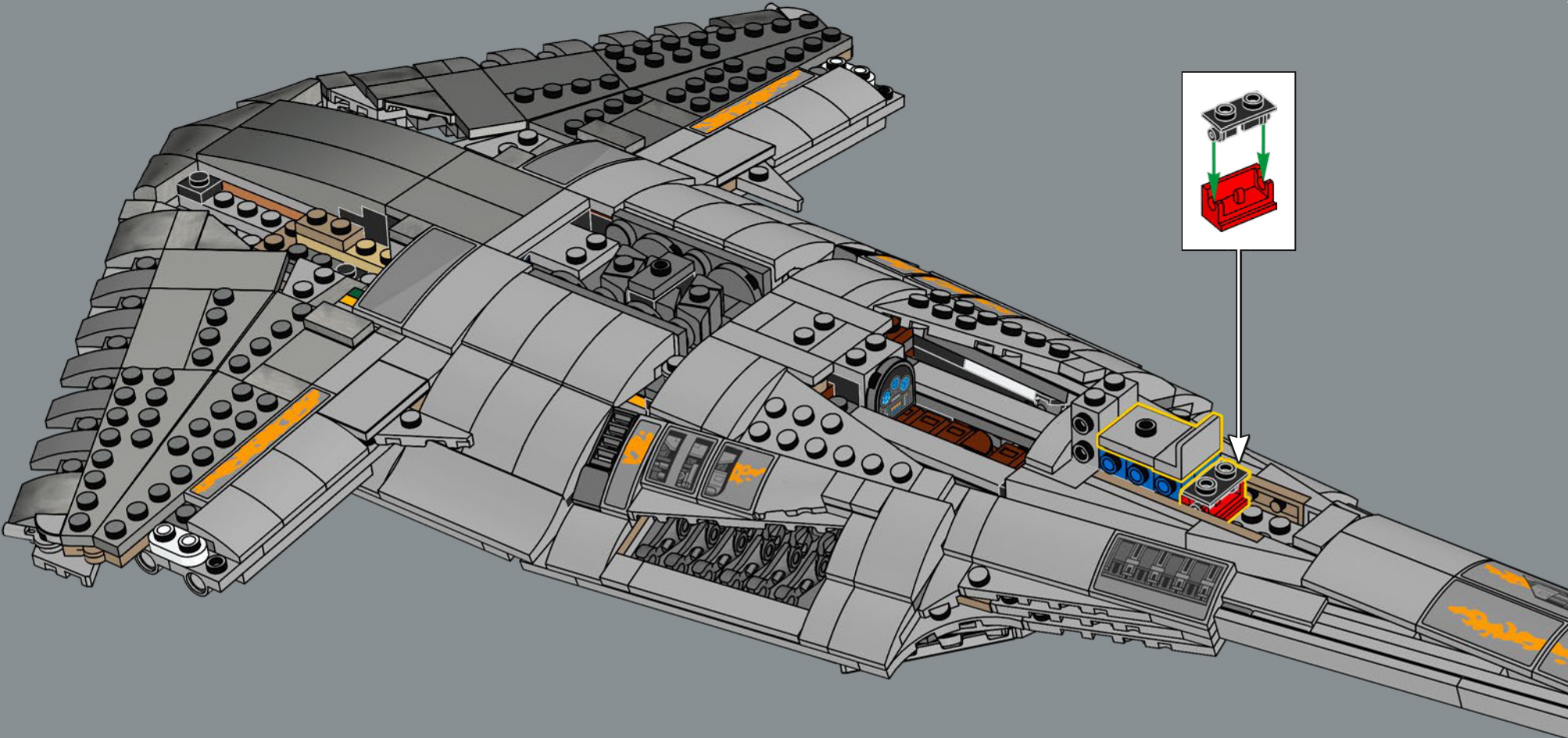

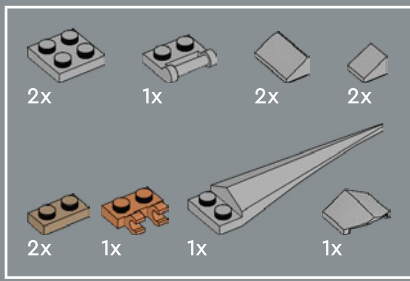

316

1

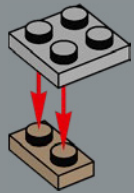

2

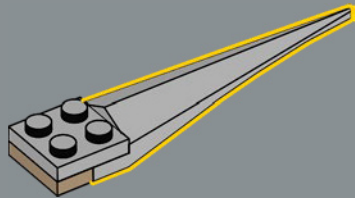

3

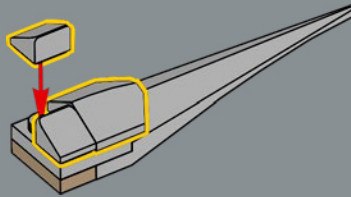

4

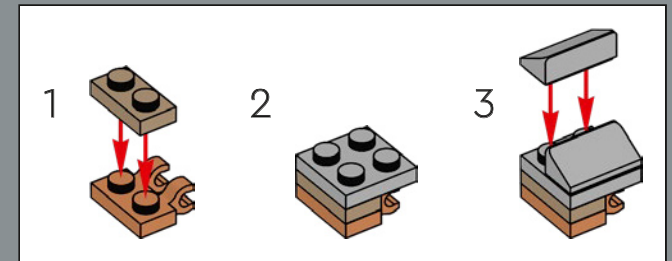
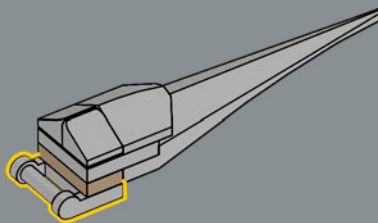

5

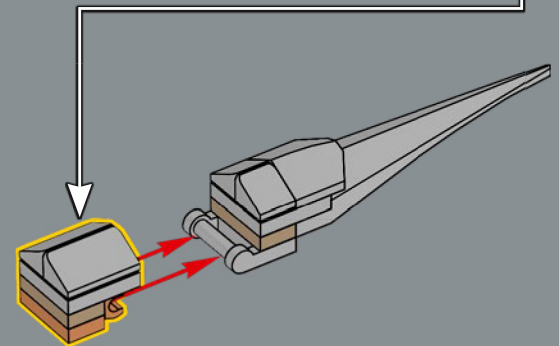

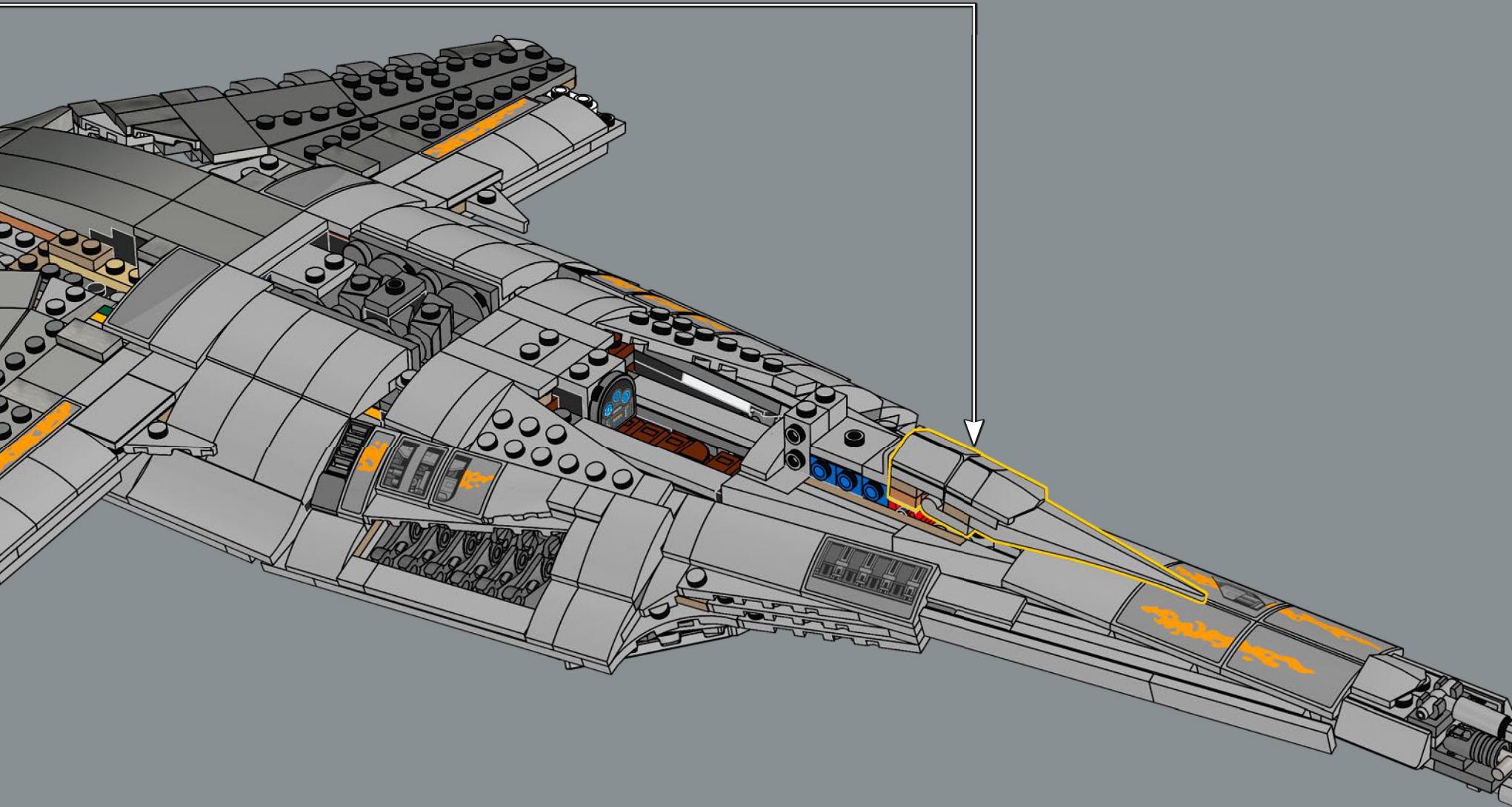

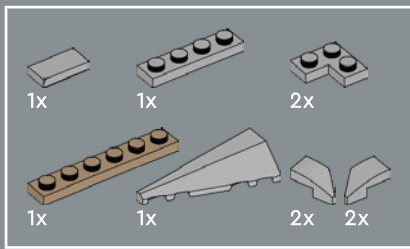

317

1

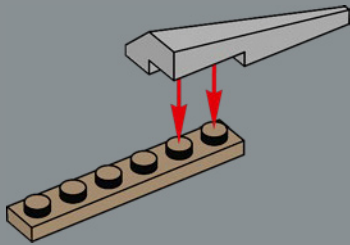

2

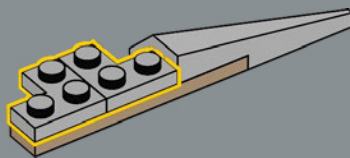

3

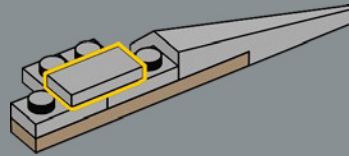

4

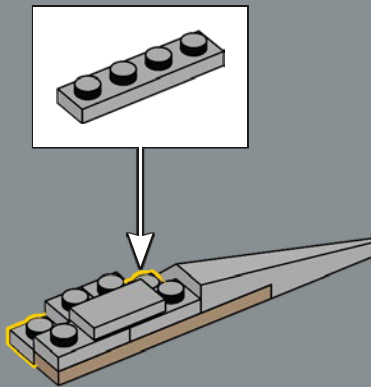

5

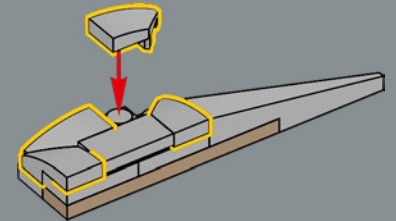

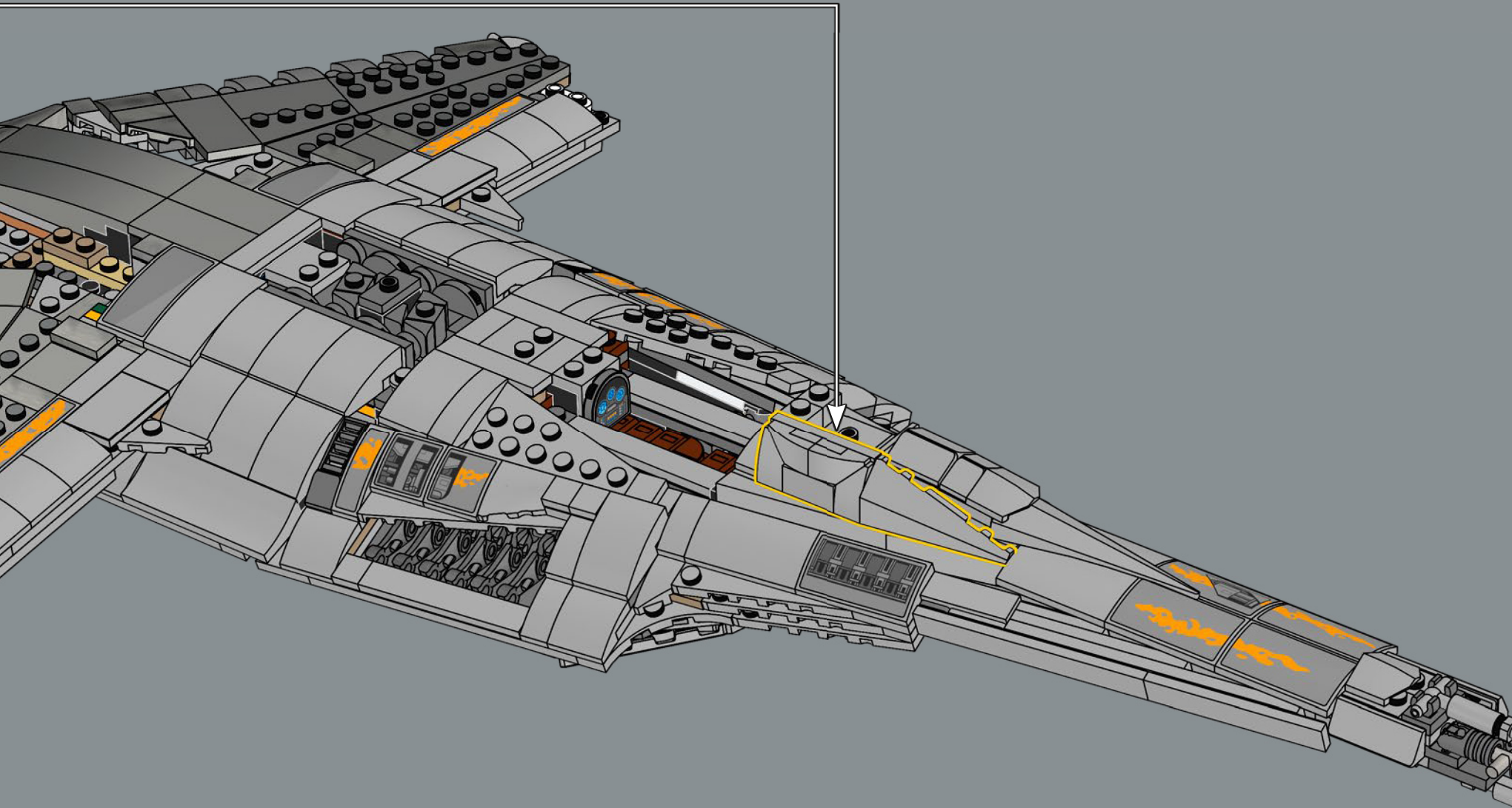

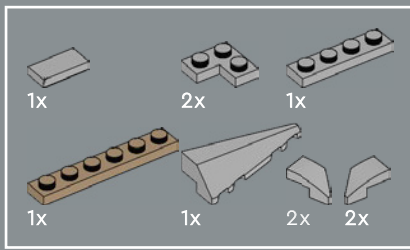

318

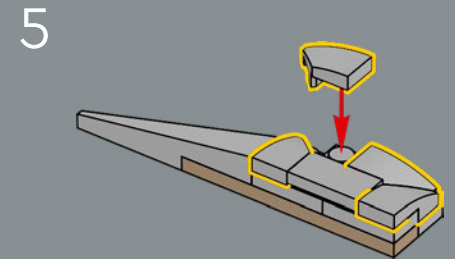
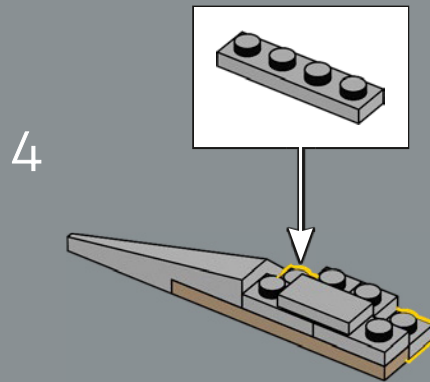
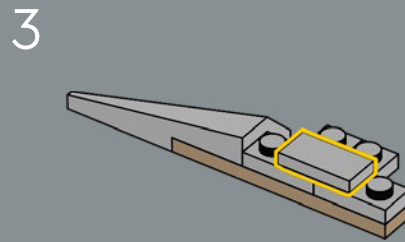
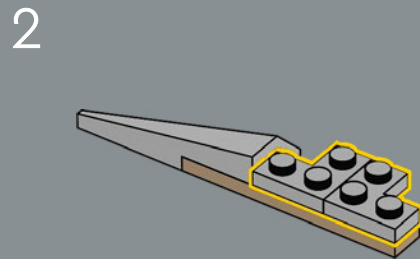
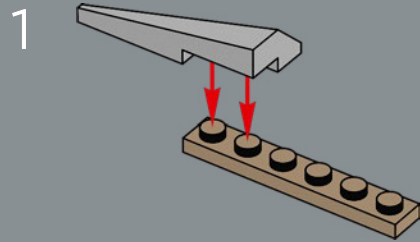

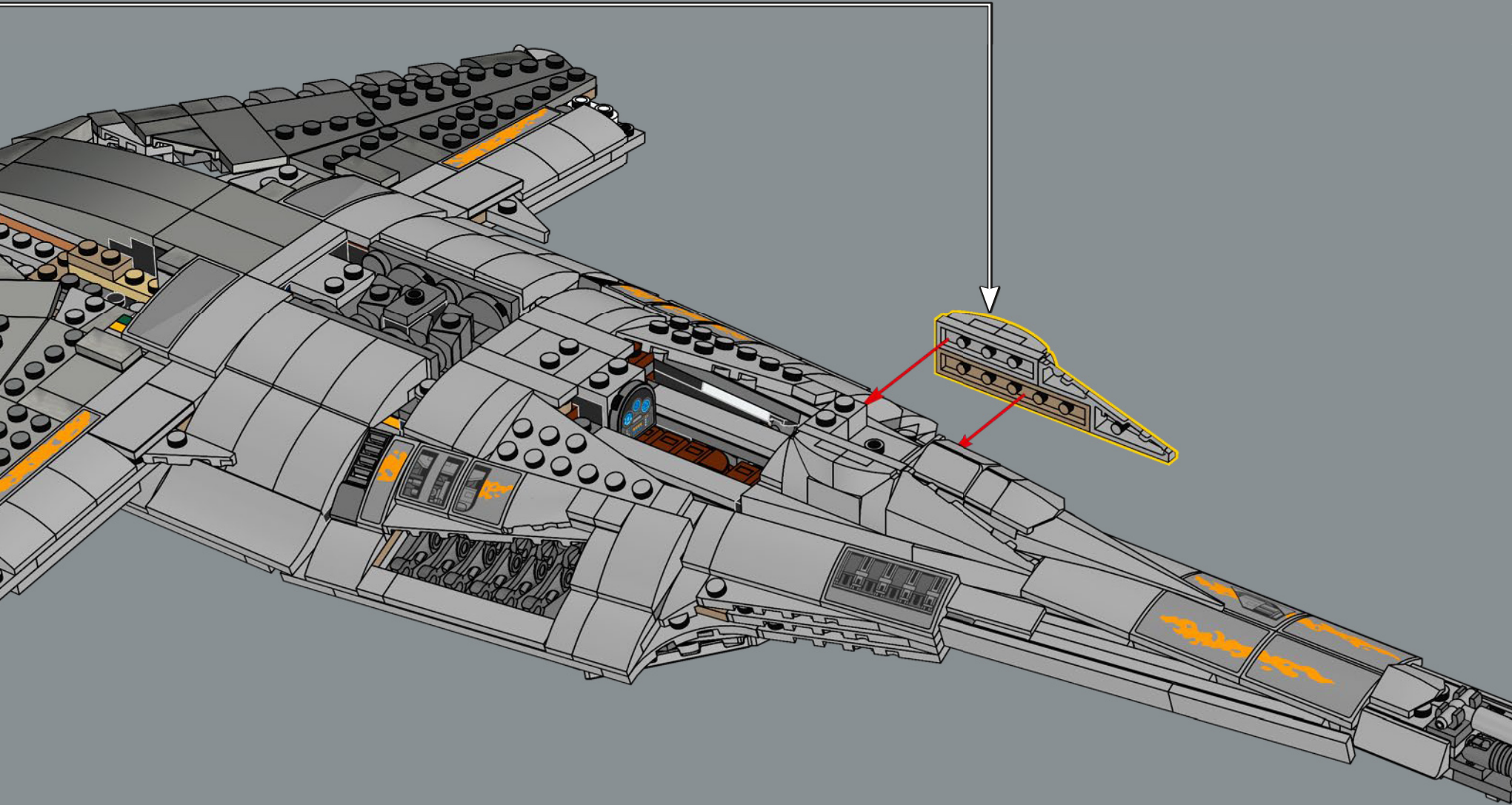

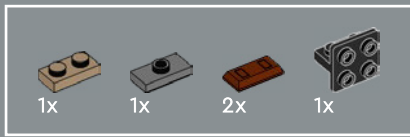

319

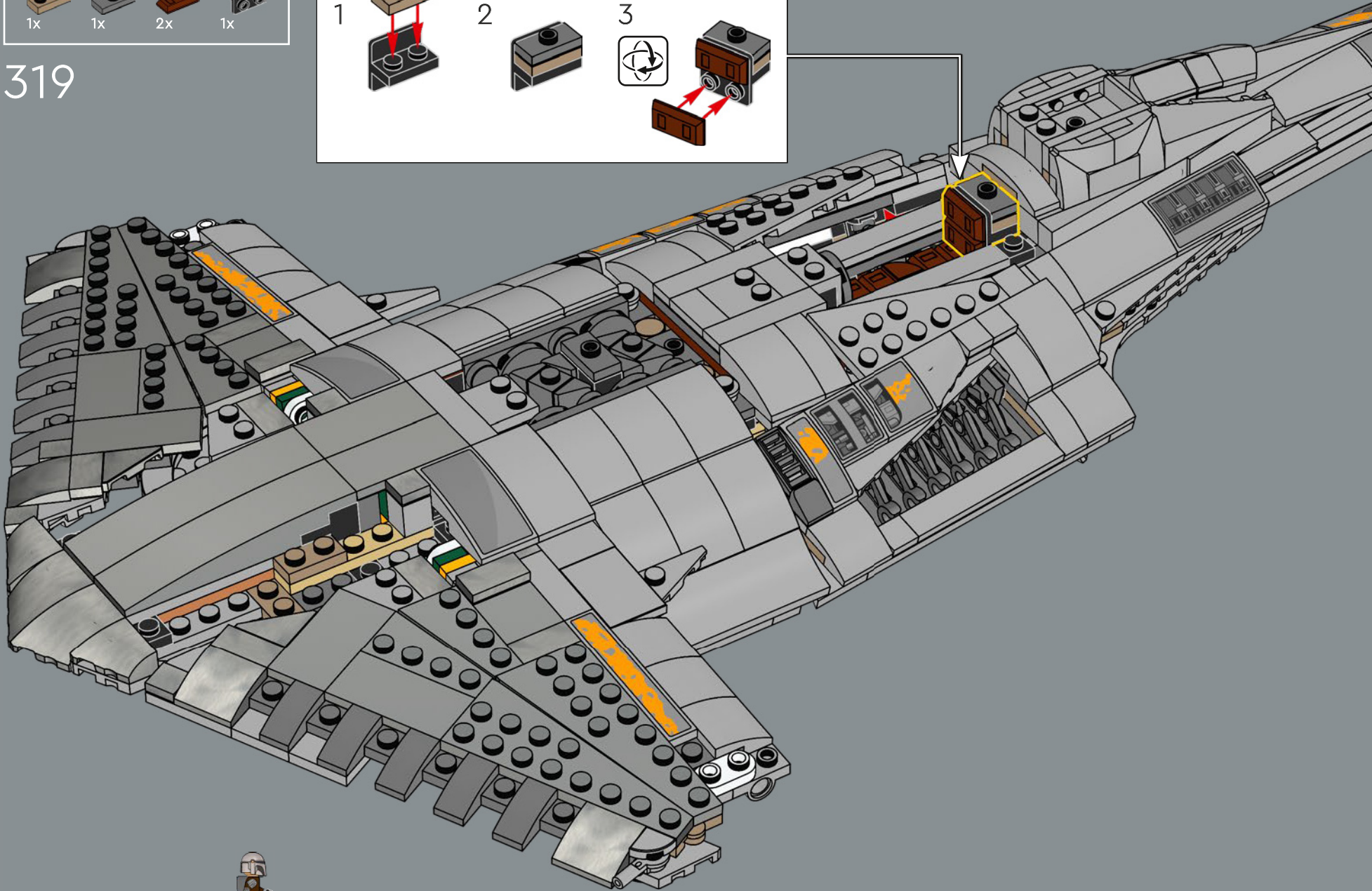
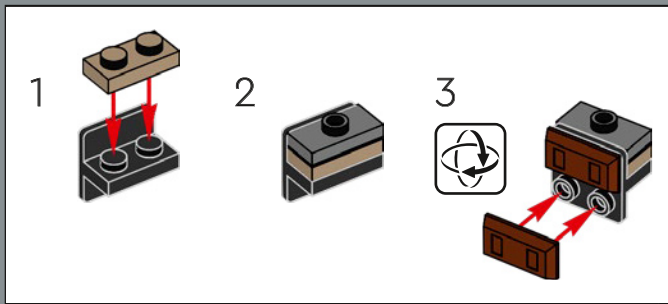

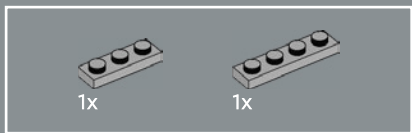

320

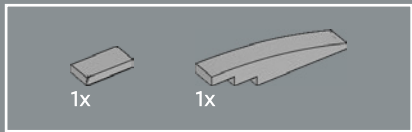
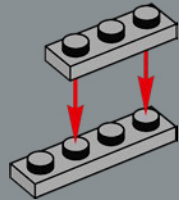

321

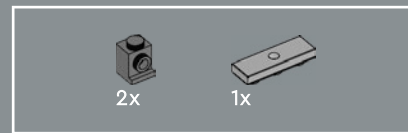
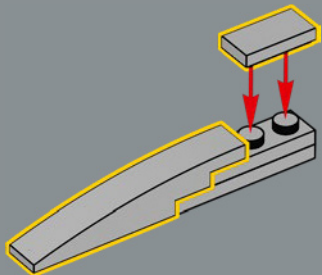

322

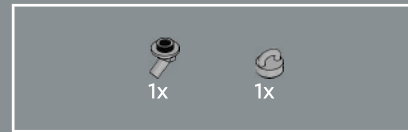
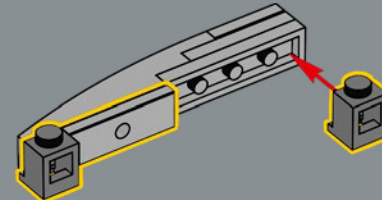

323

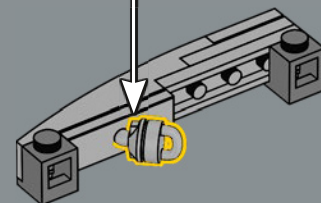
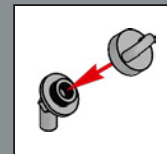

324

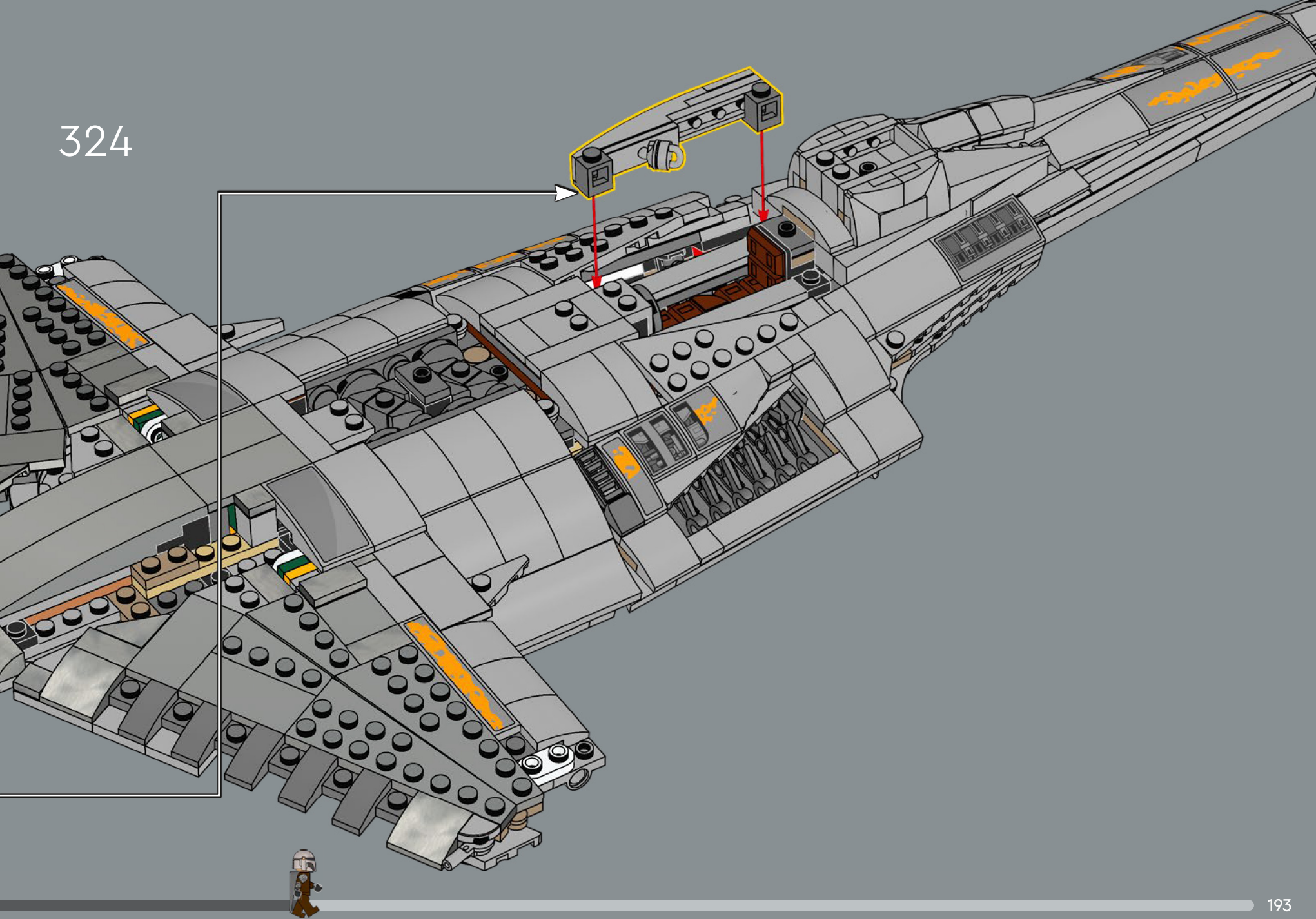

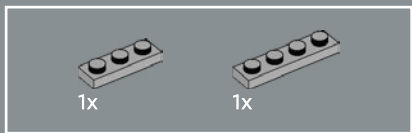

325

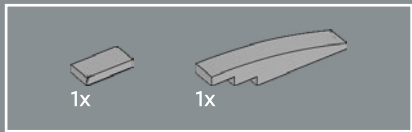
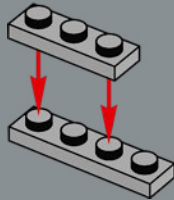

326

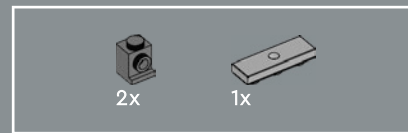
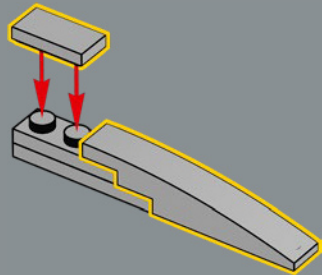

327

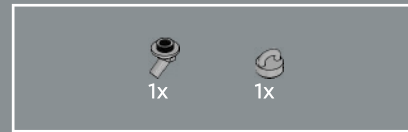
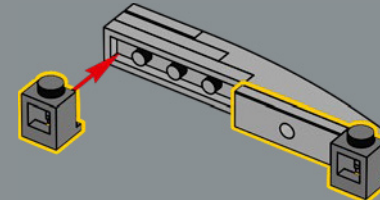

328

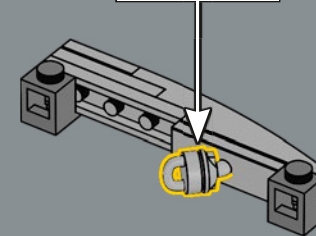
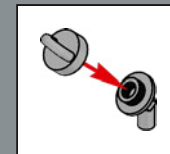

329

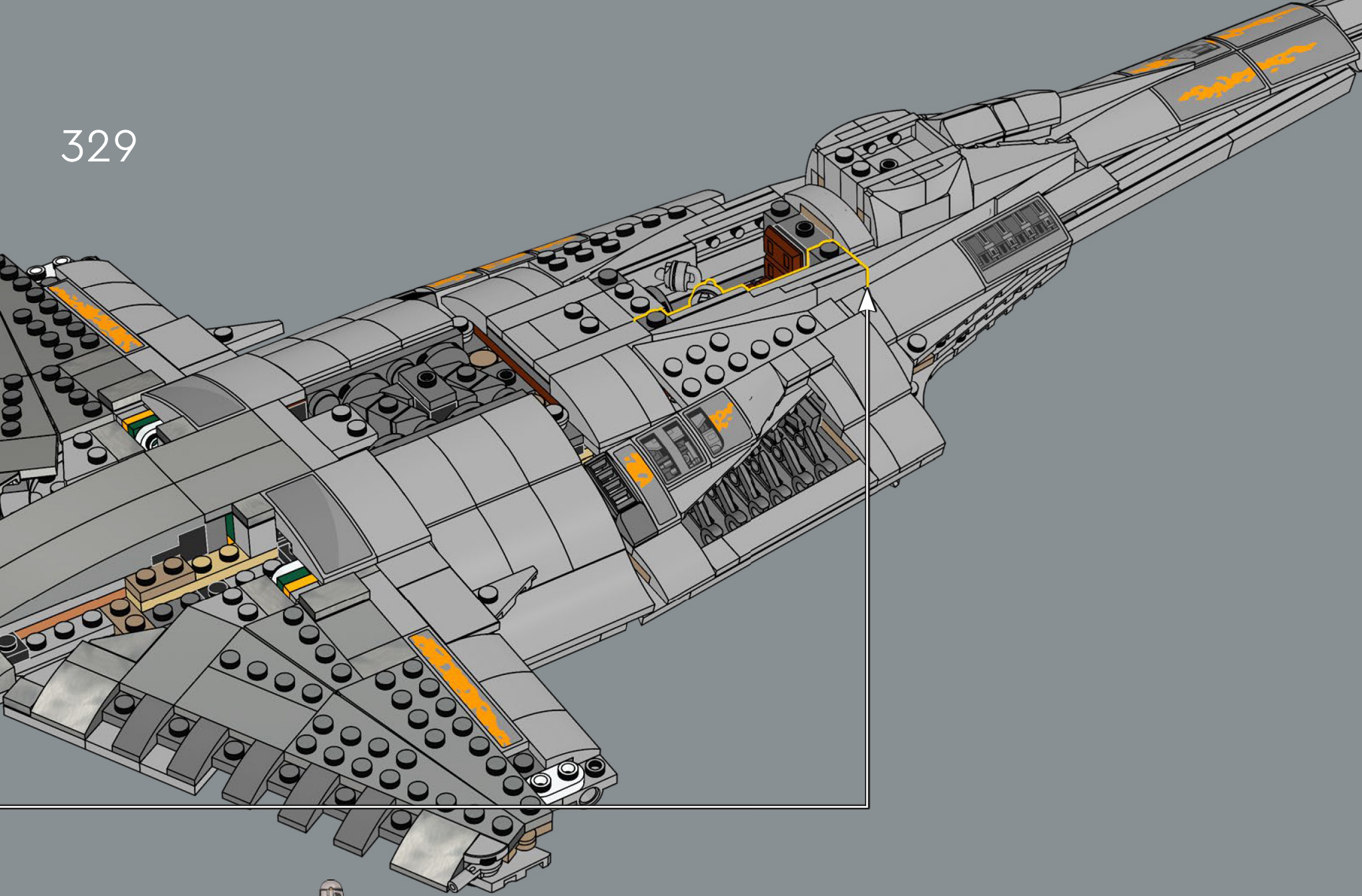



330

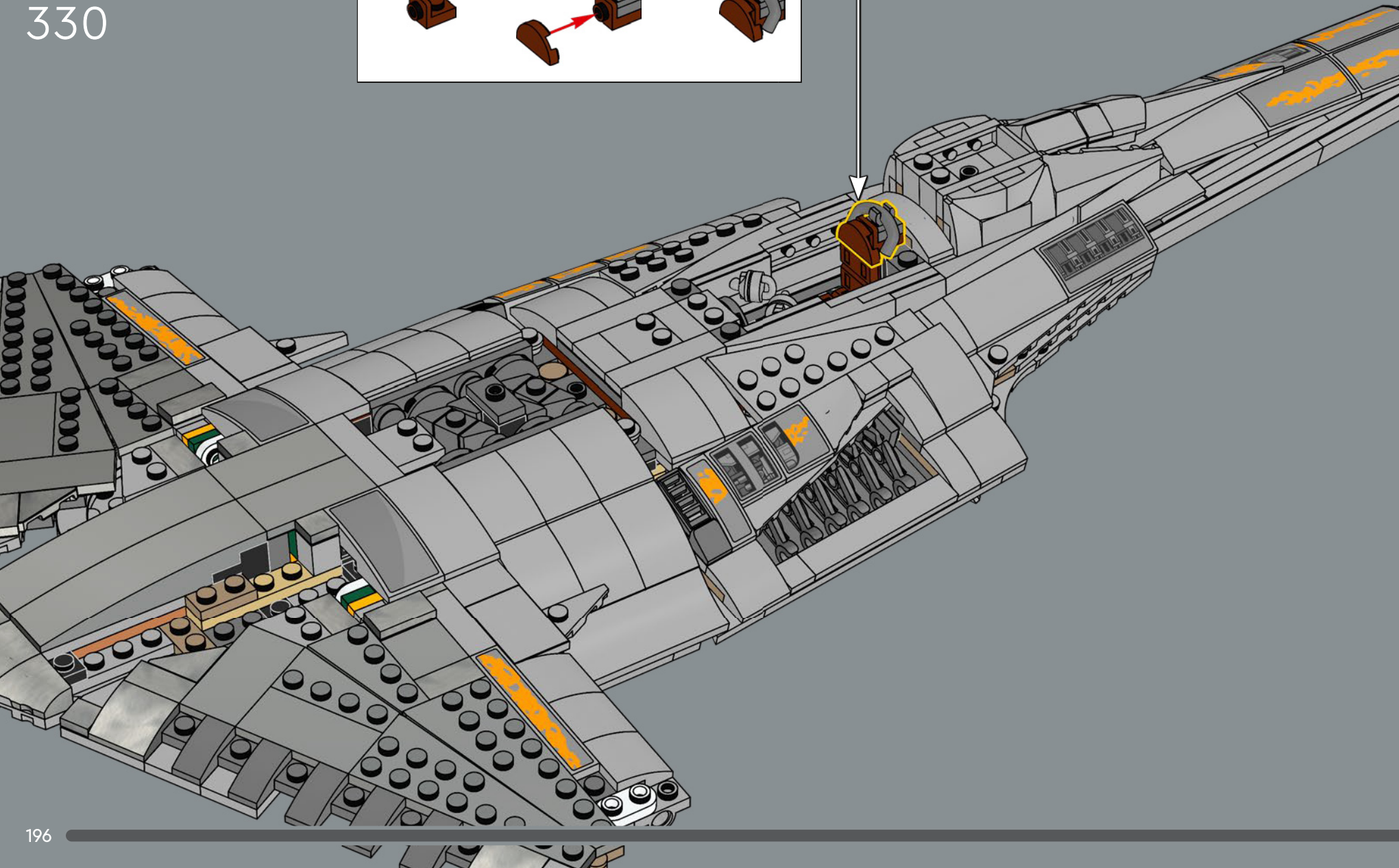
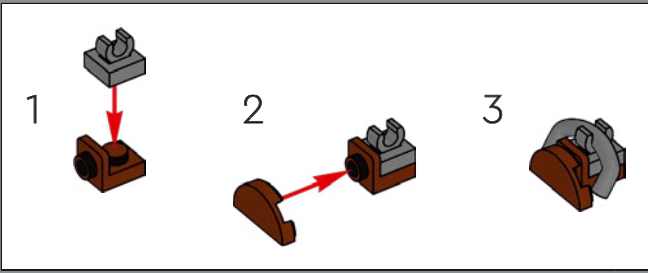



331

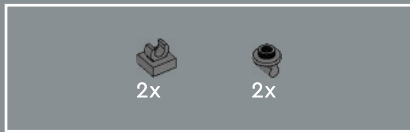
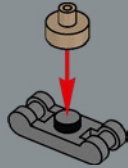

332

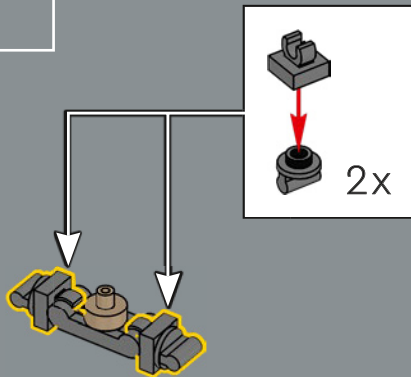

333

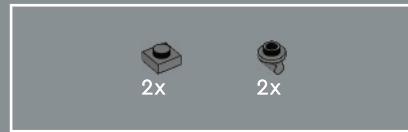
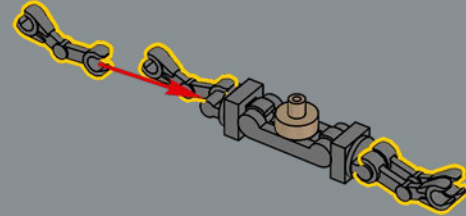

334

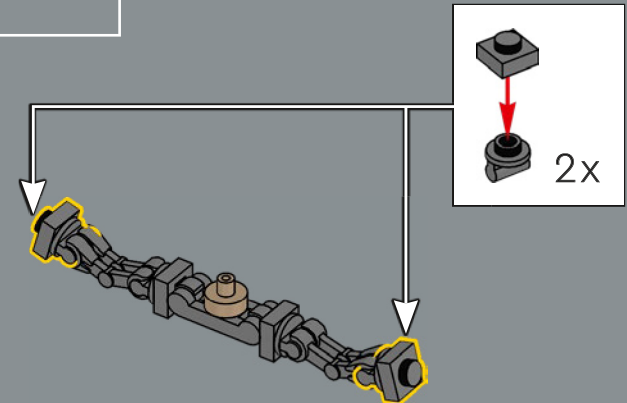

335

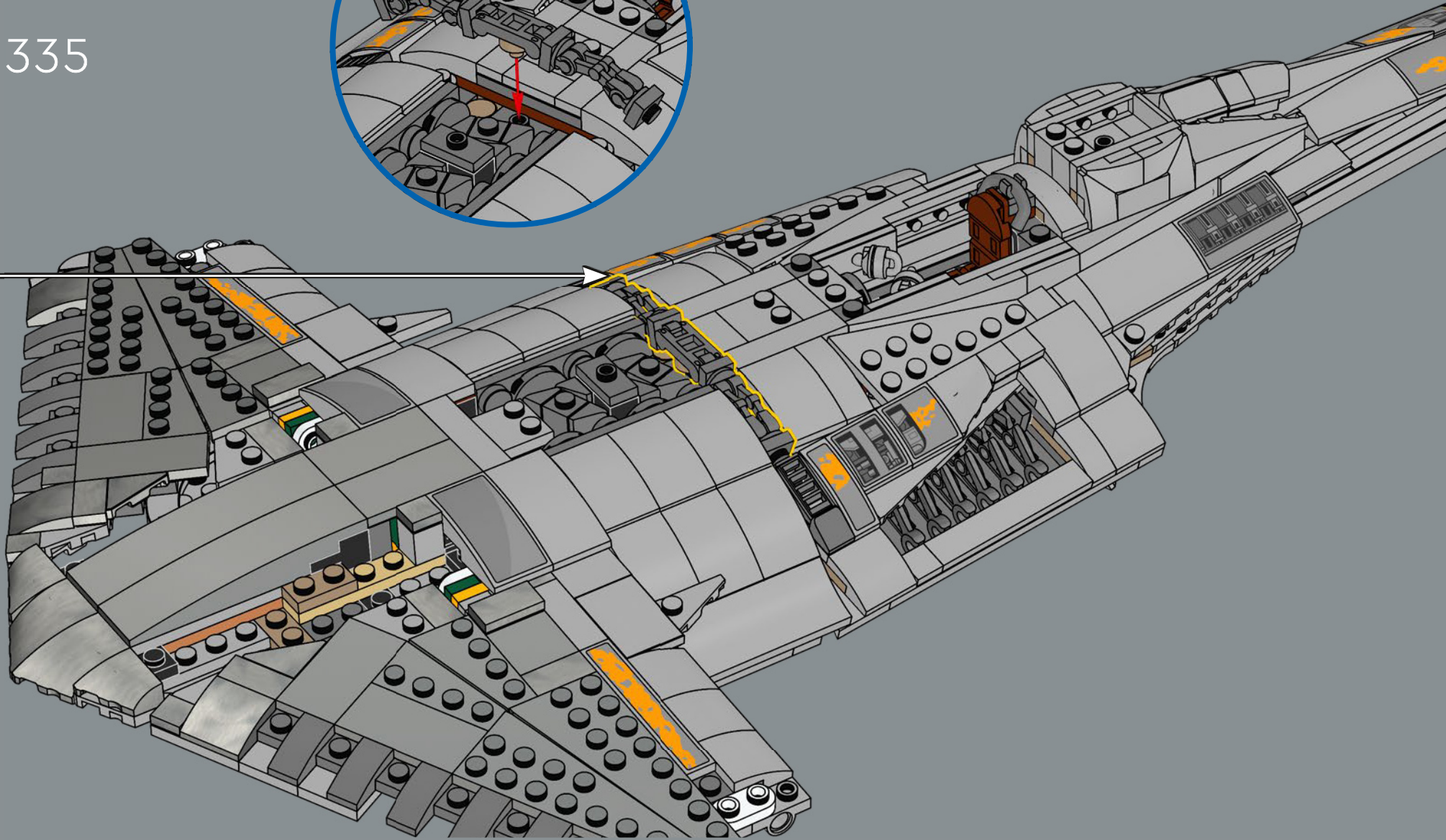
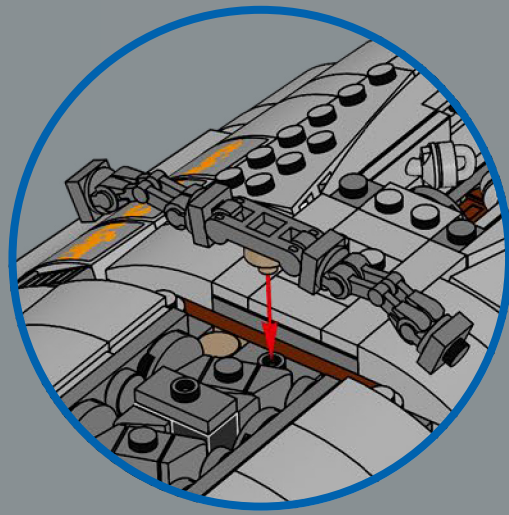

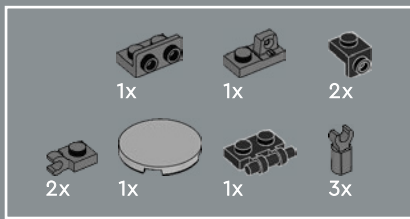

336

1

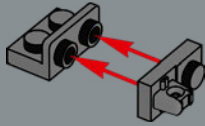

2

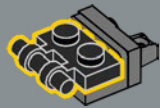

3

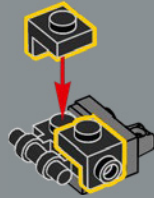

4



5

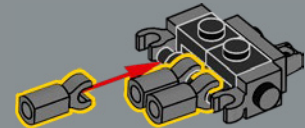

6

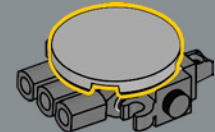

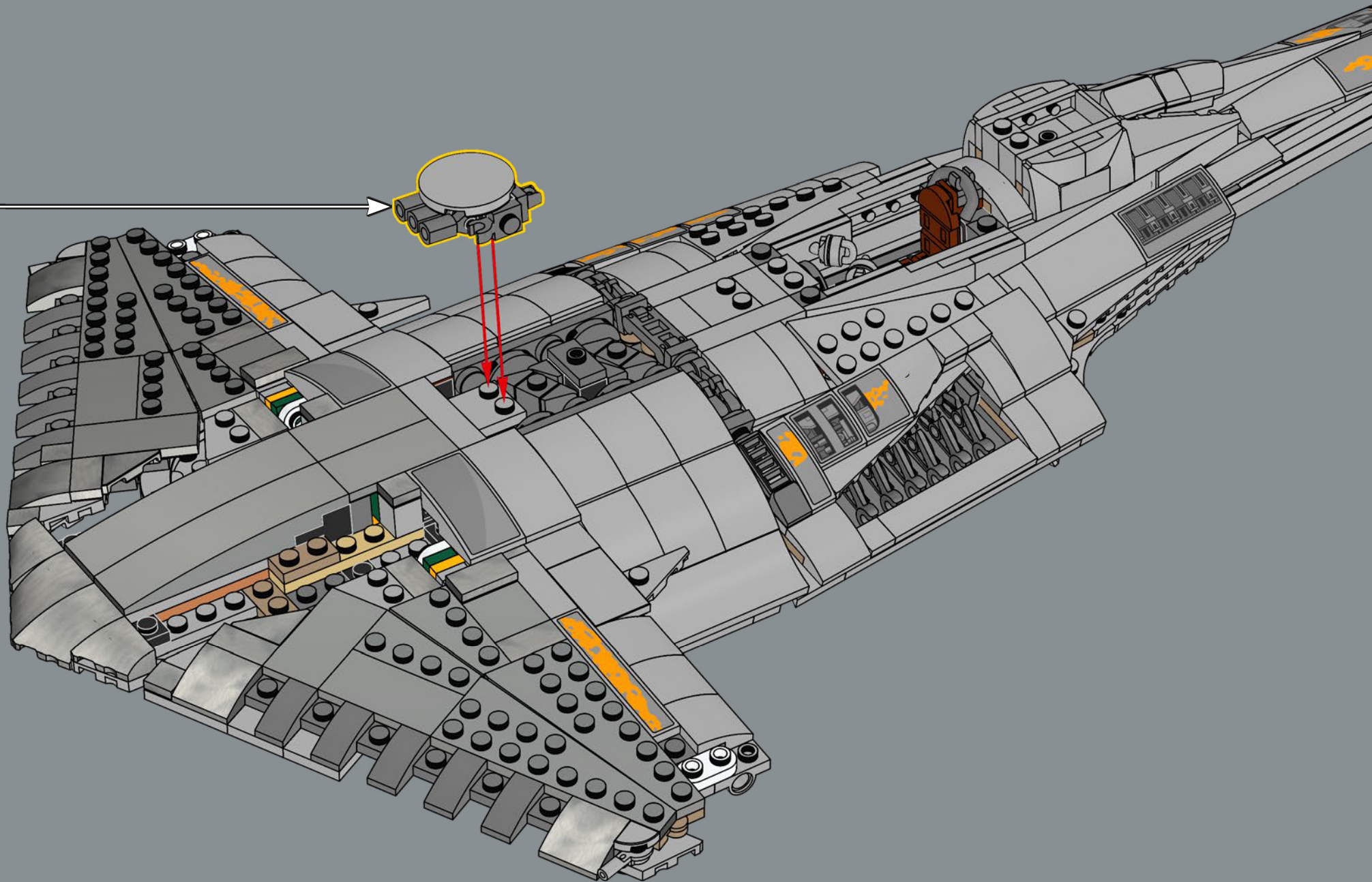

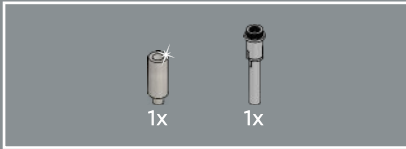
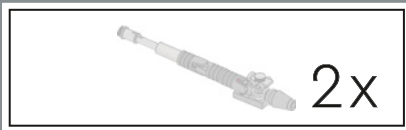

337

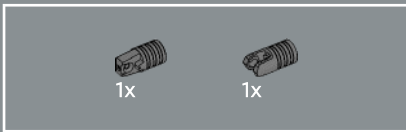
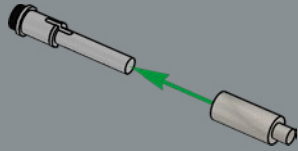

338

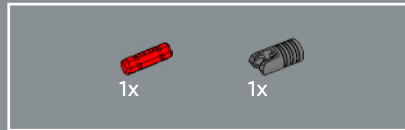
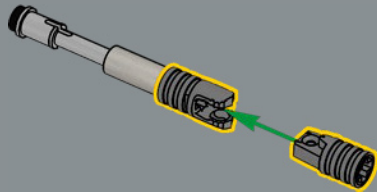

339

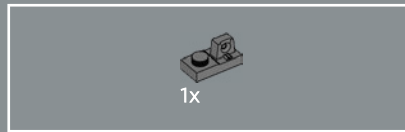
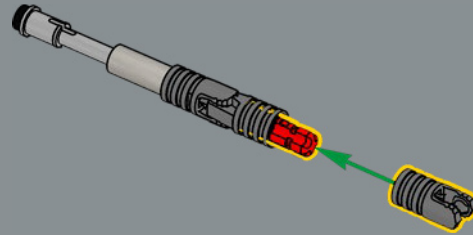

340

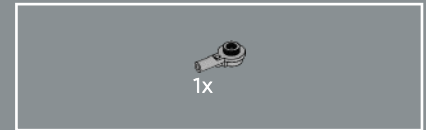
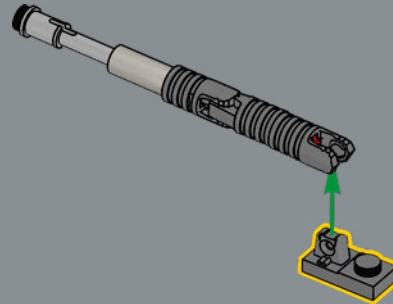

341

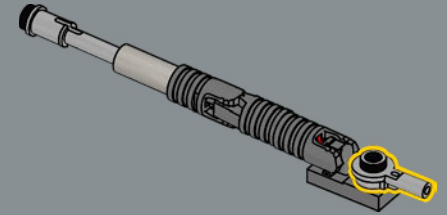

342

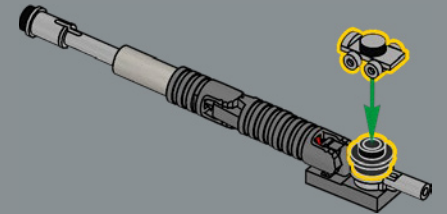

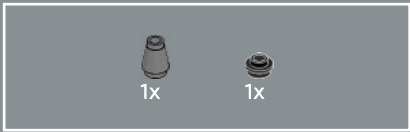

343

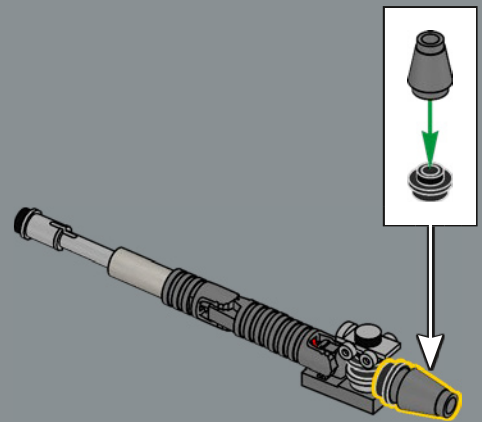

2x

344

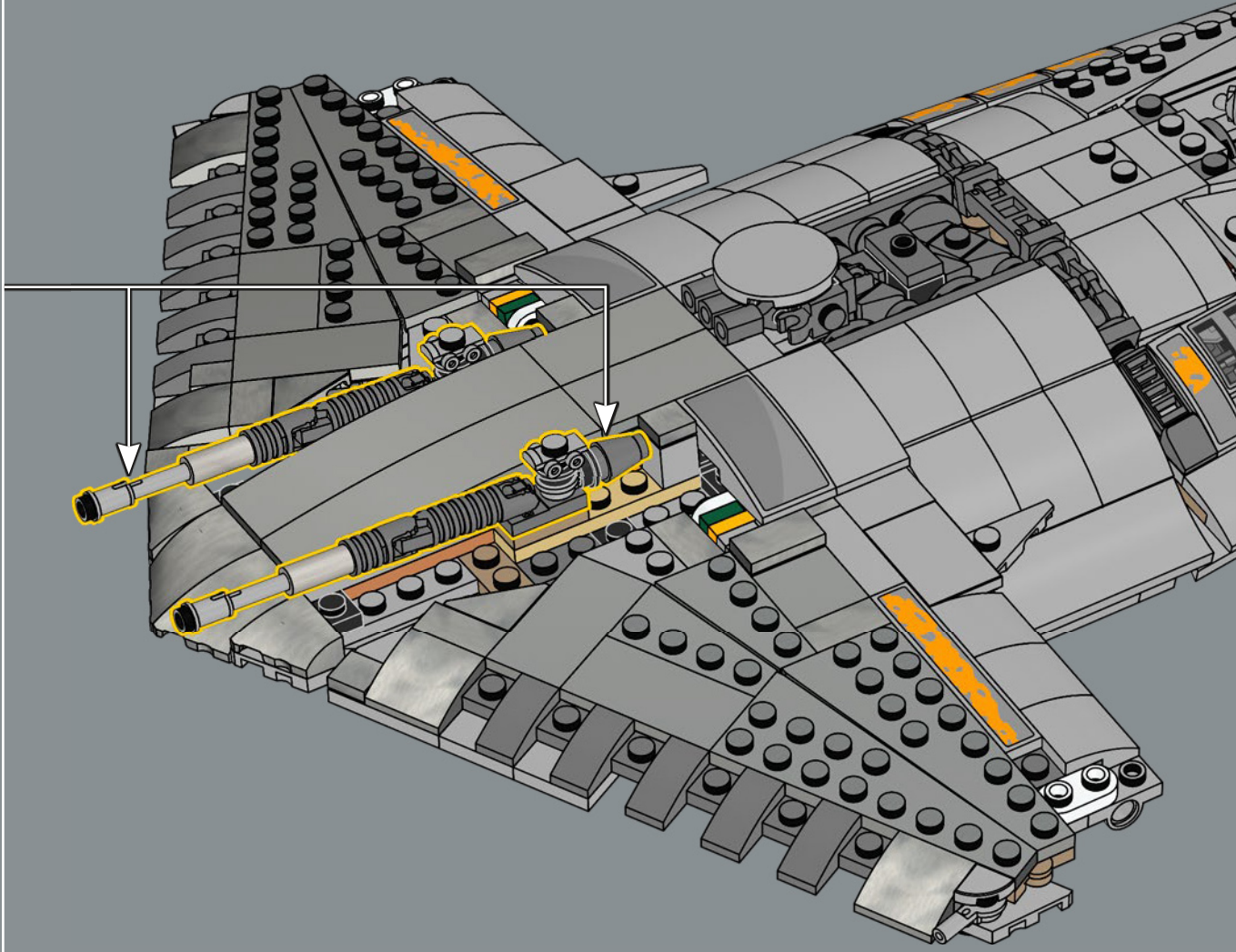

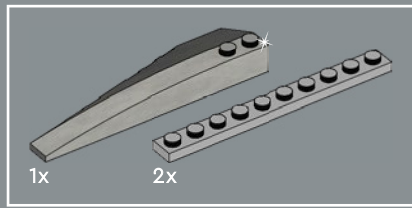

345

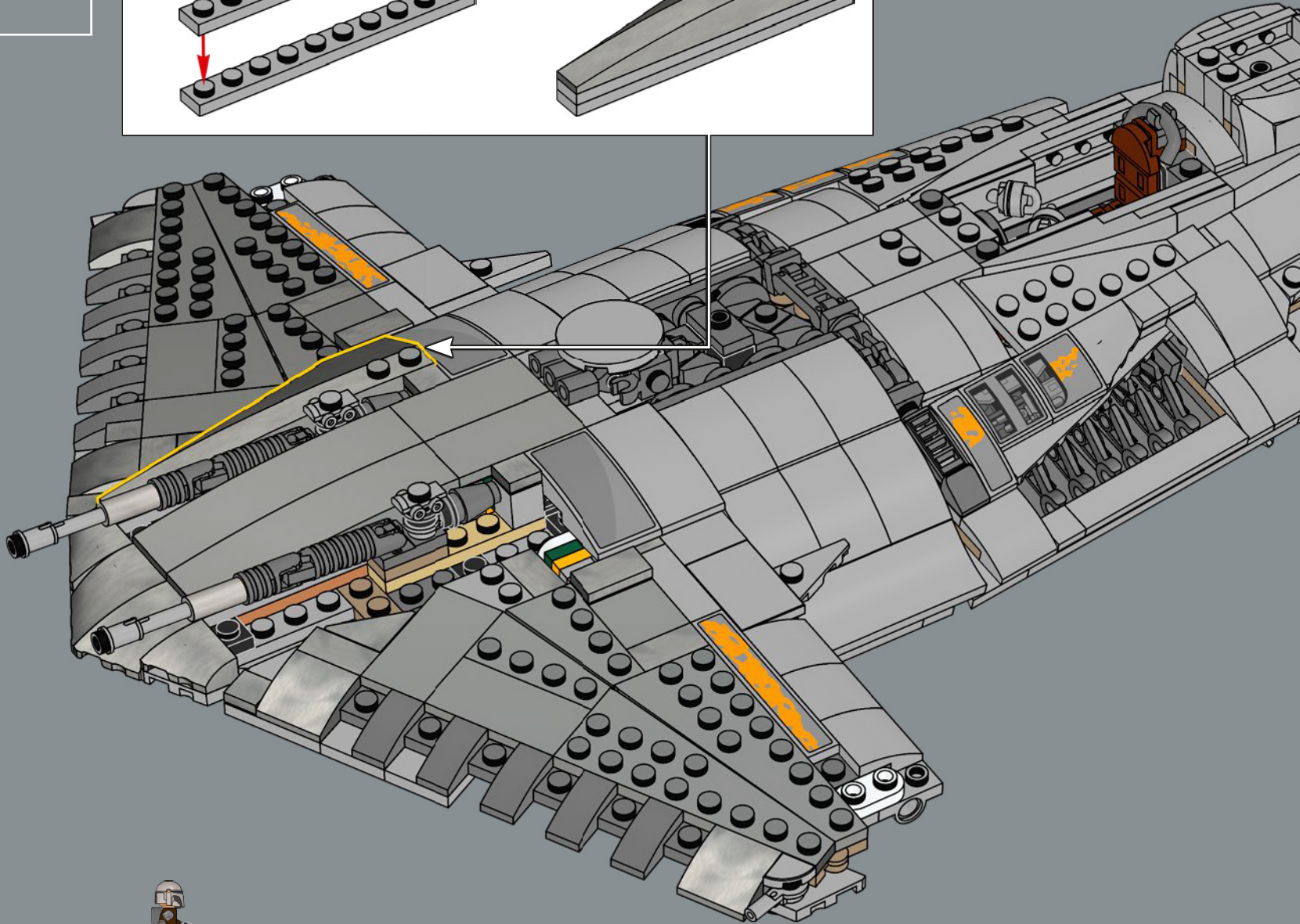
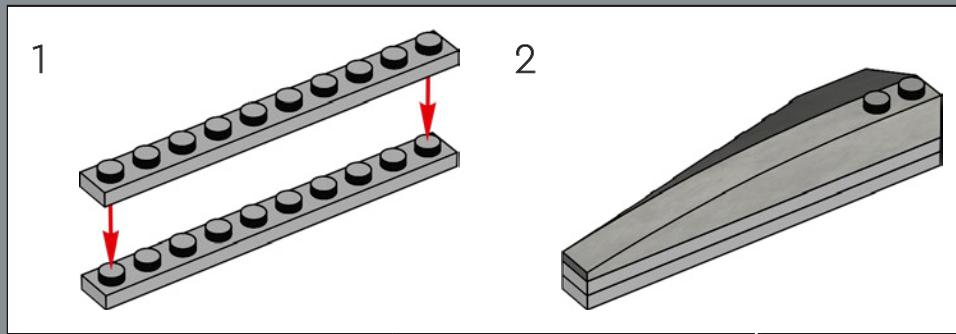

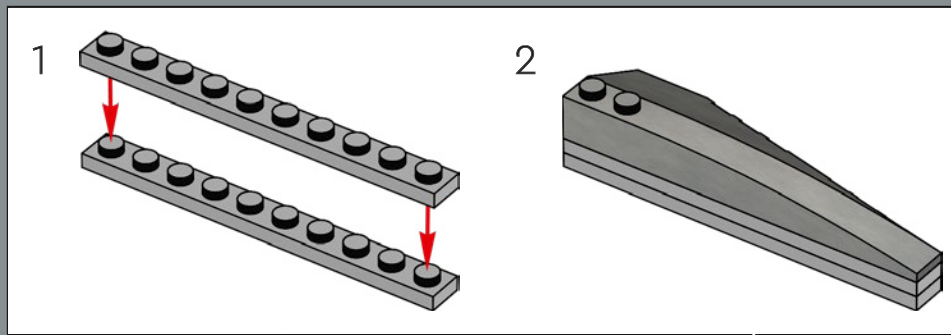
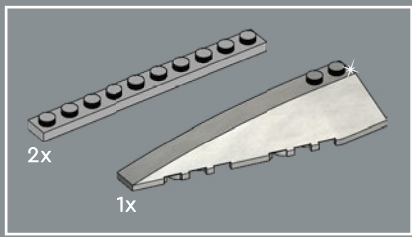

346

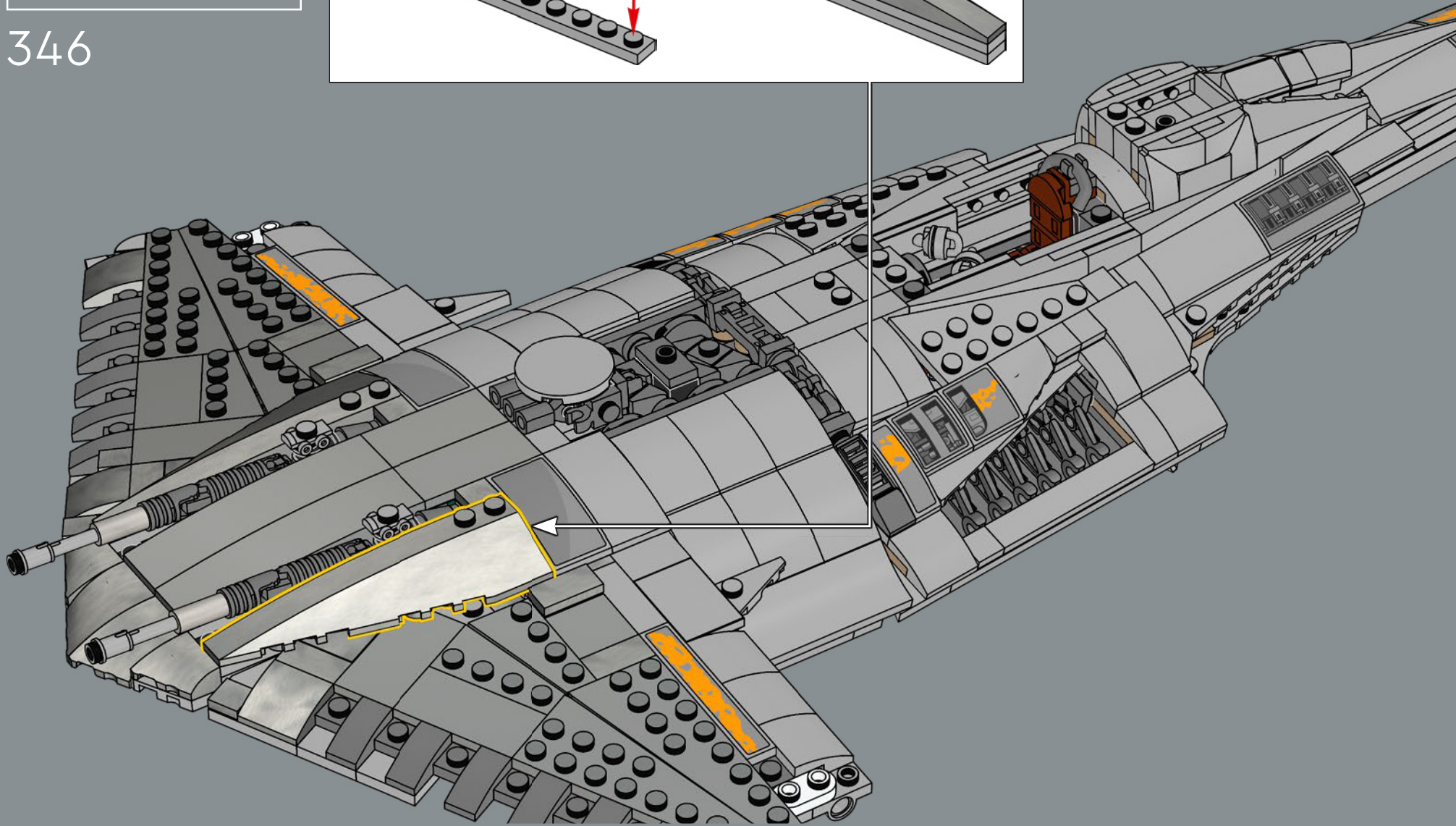

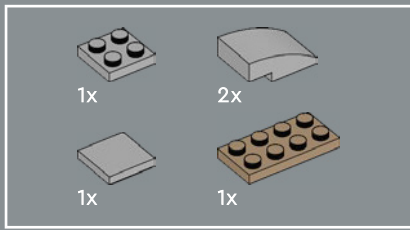

347

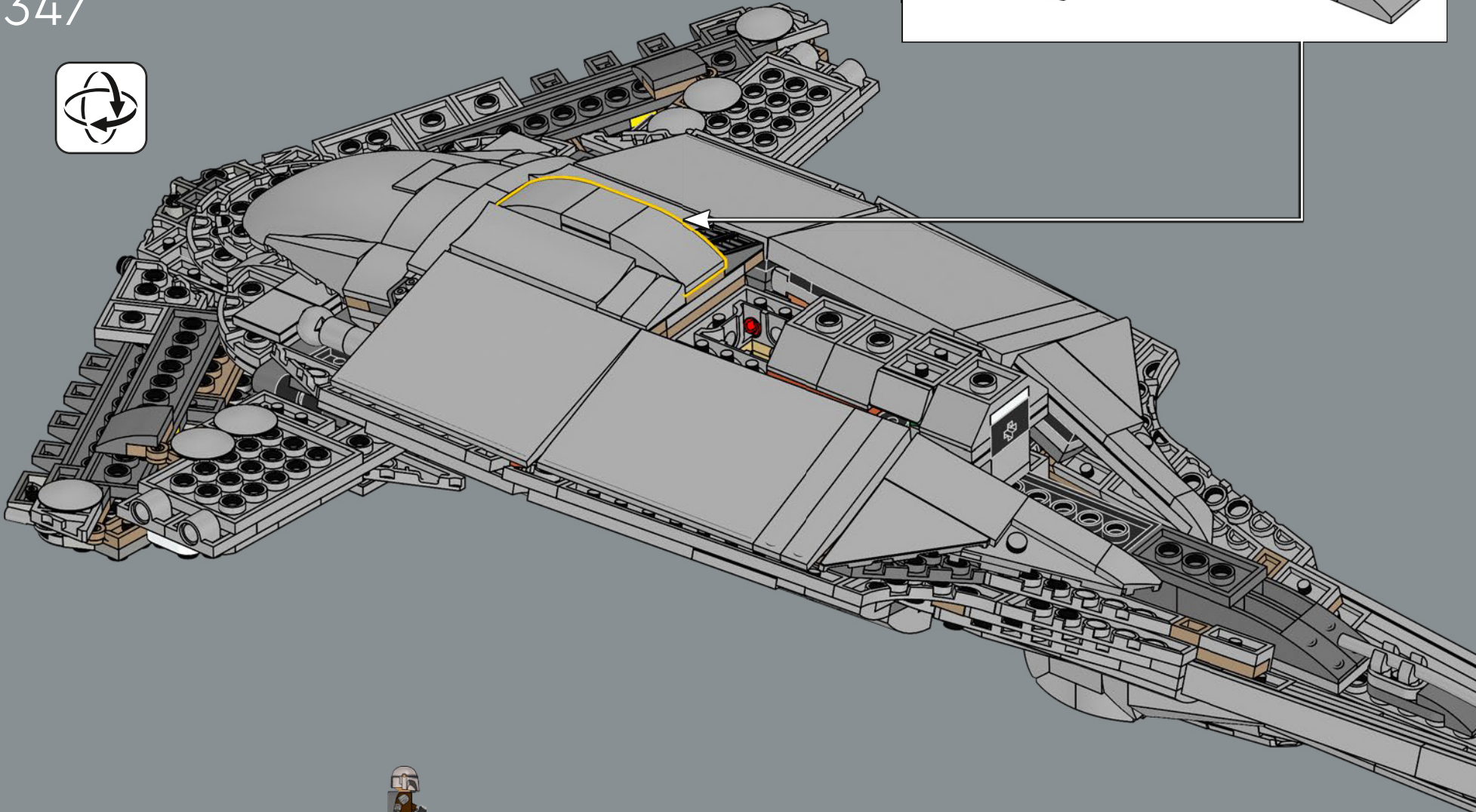
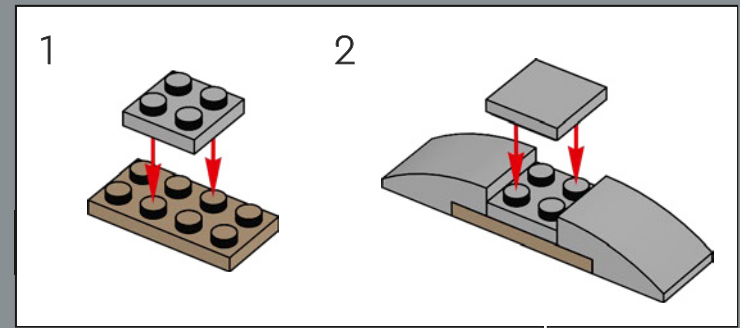

348

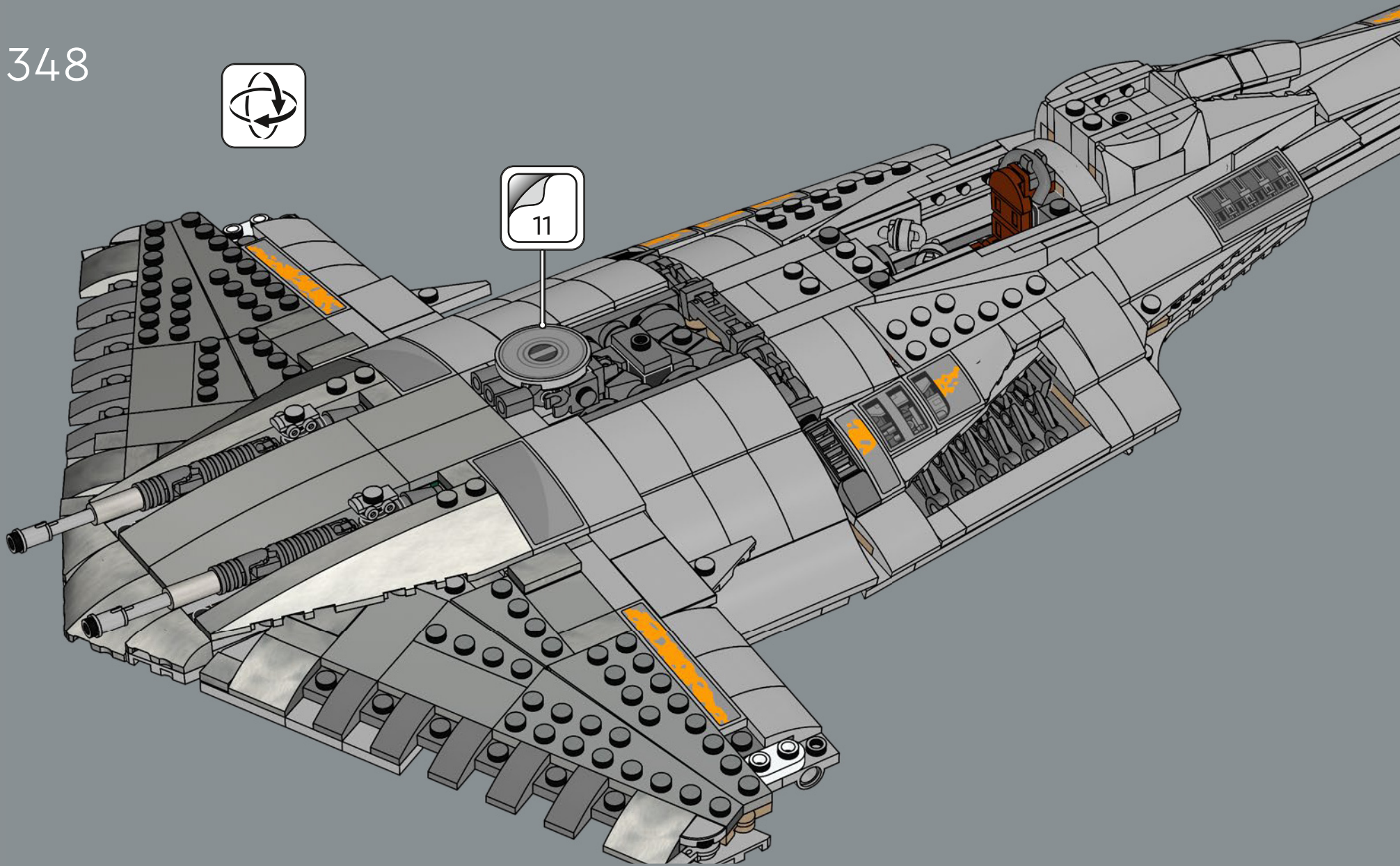

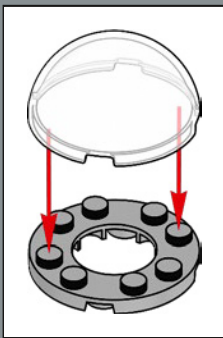
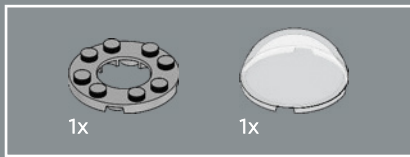

349

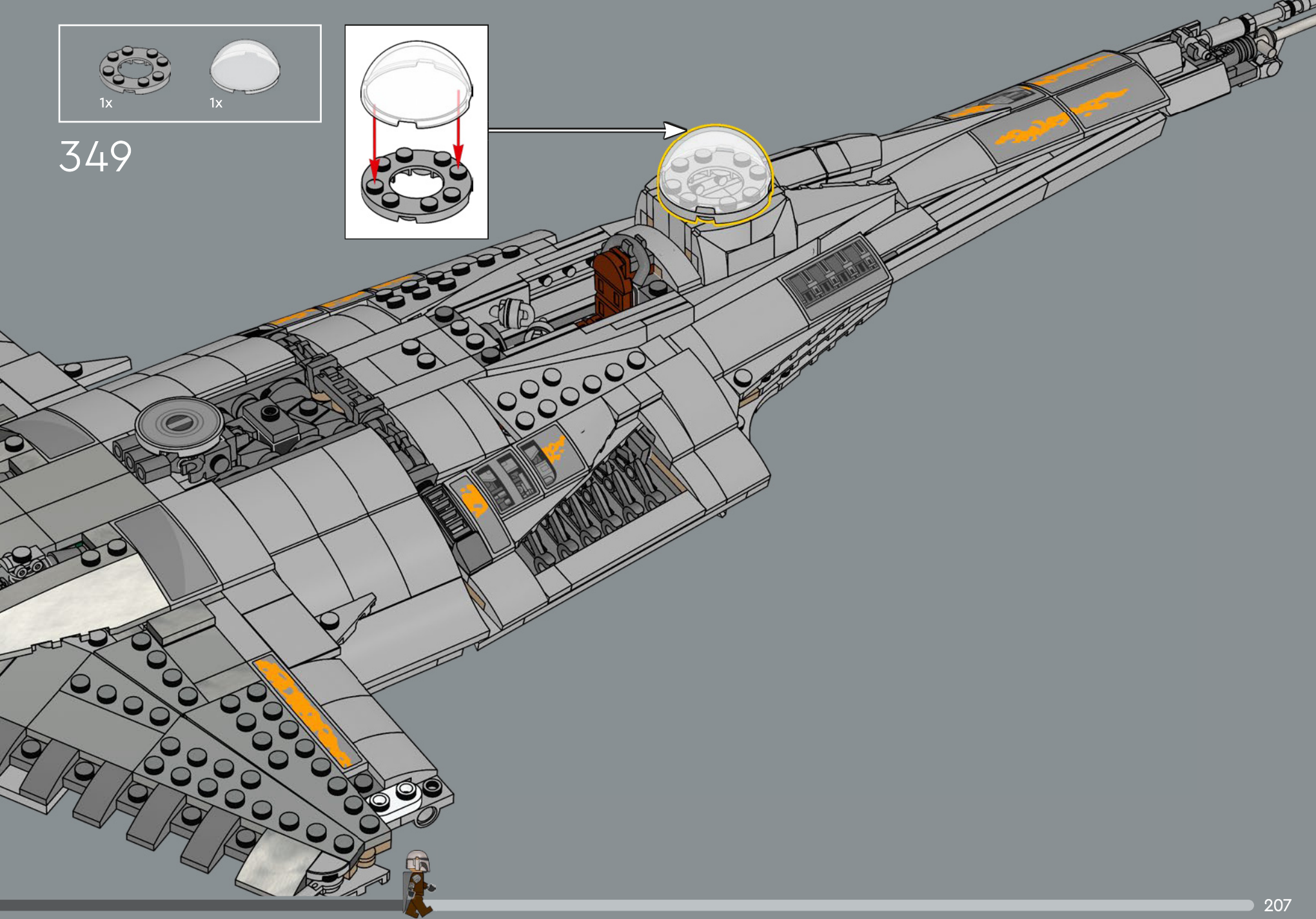

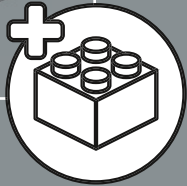
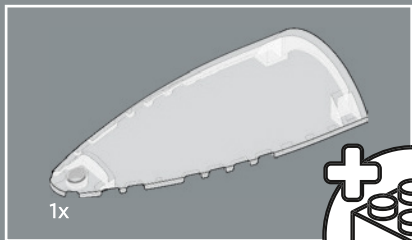

350

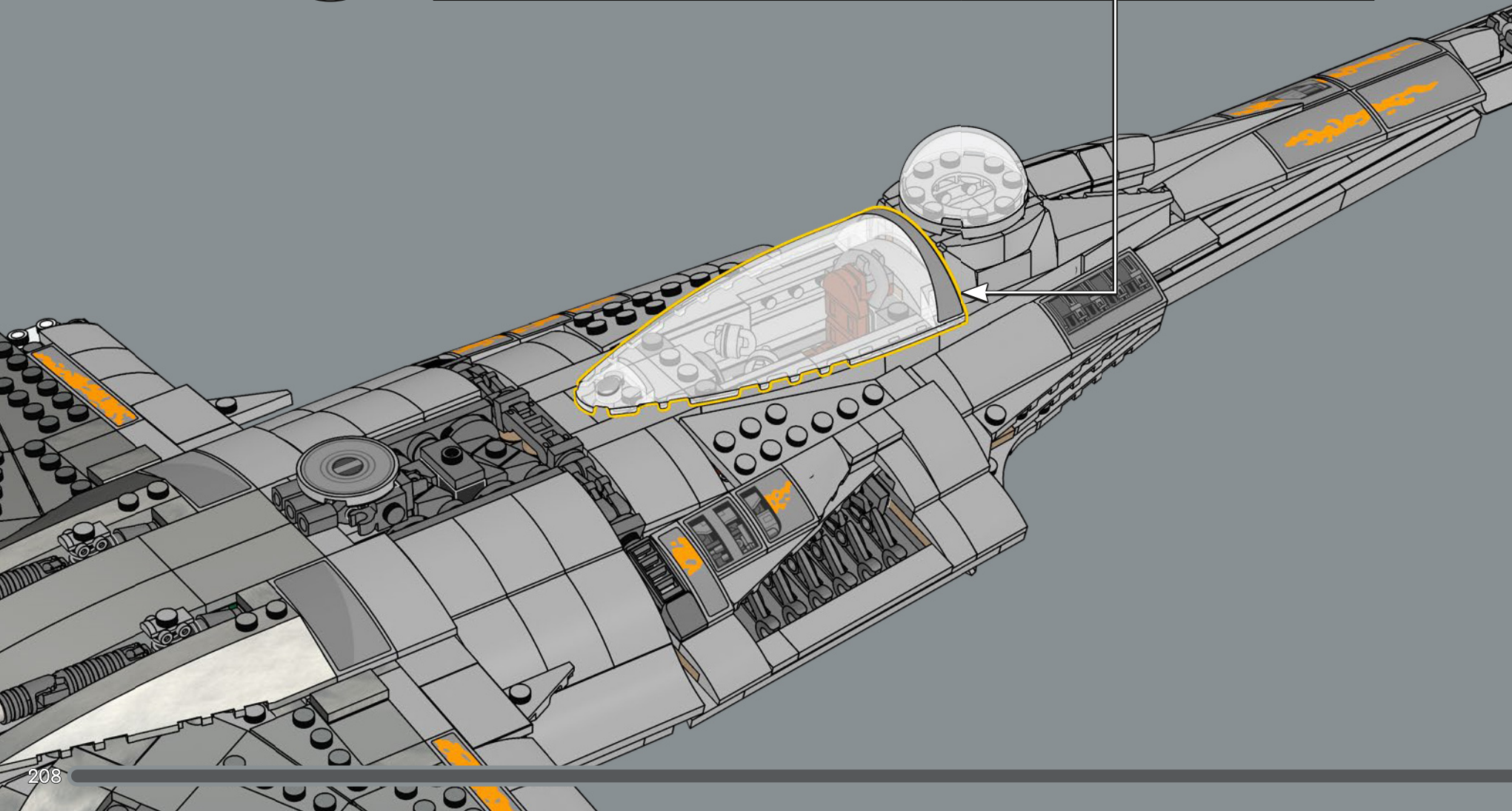
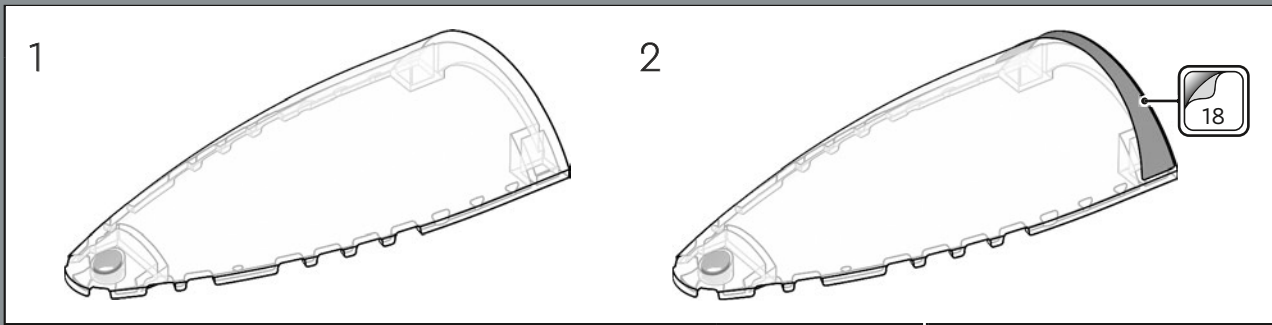

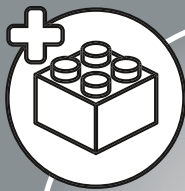

1x

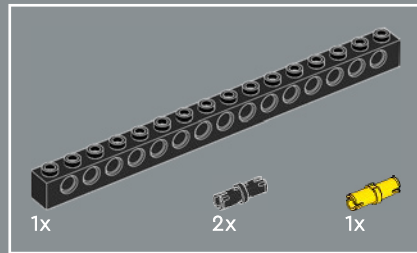
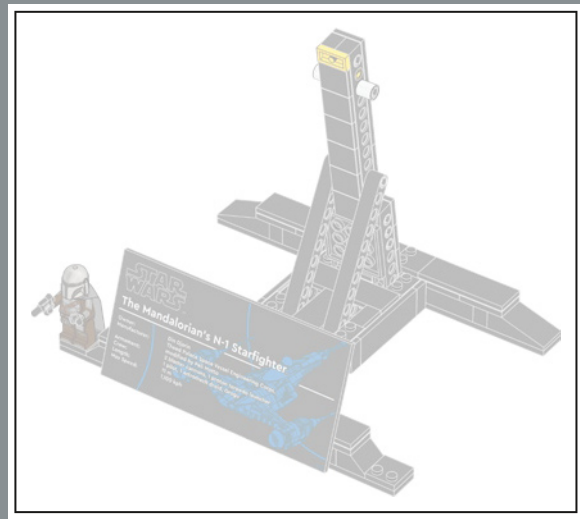
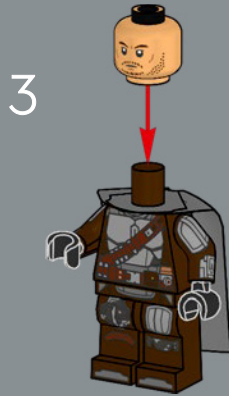
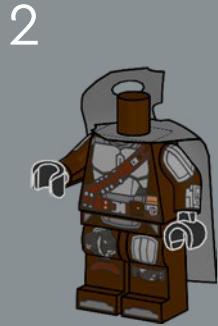
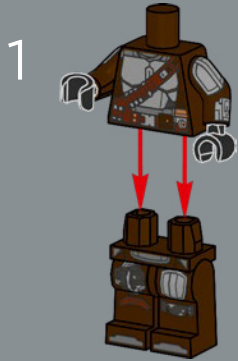

351

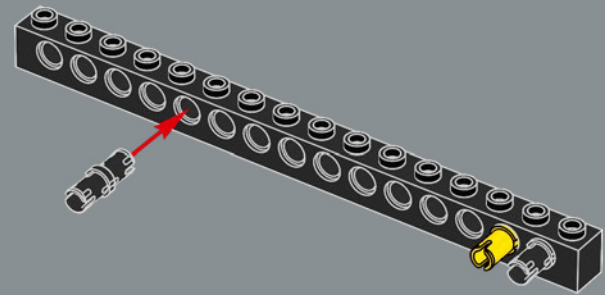

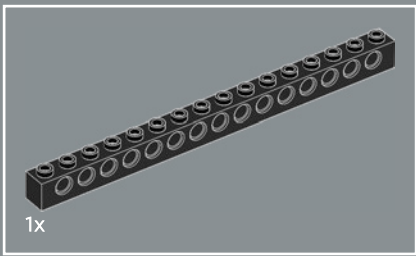

352

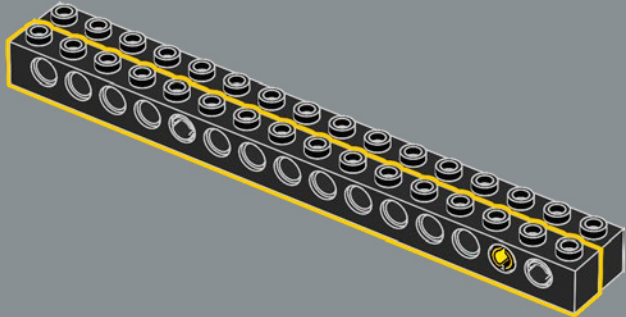

353

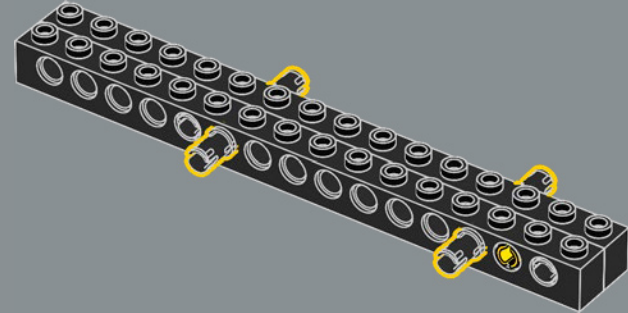

354

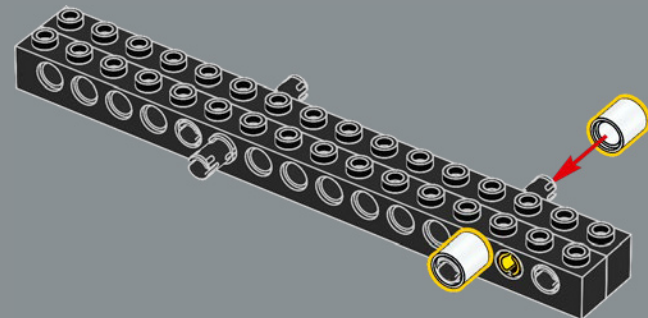

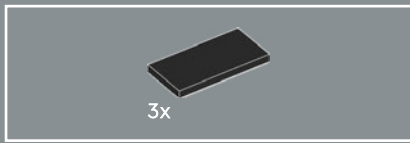

355

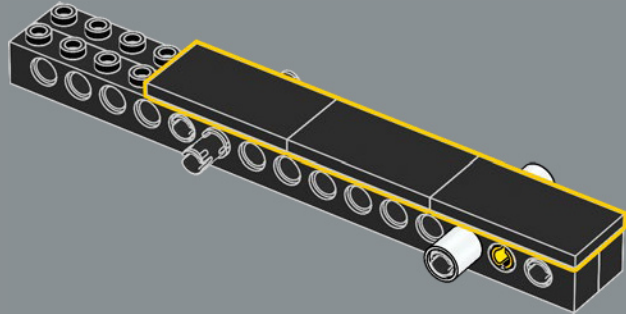

356

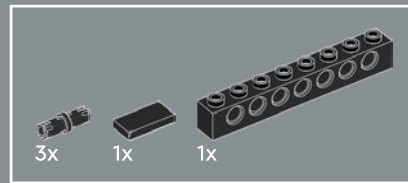
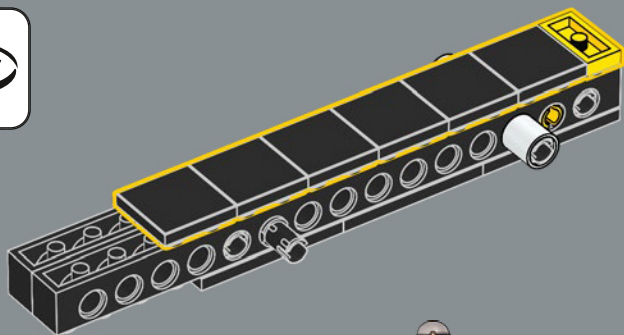

357

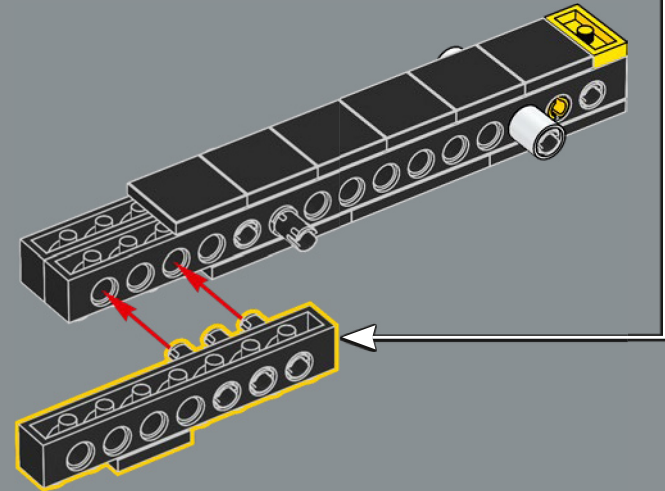
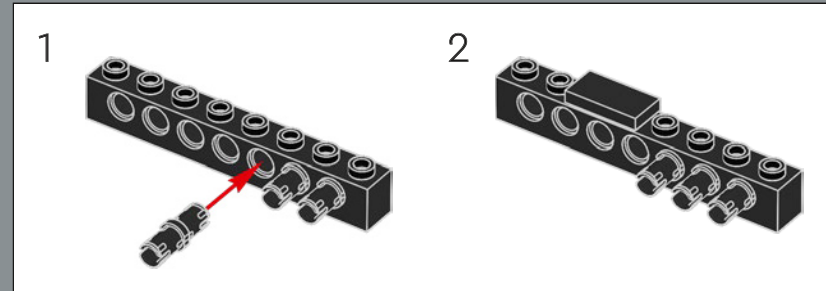

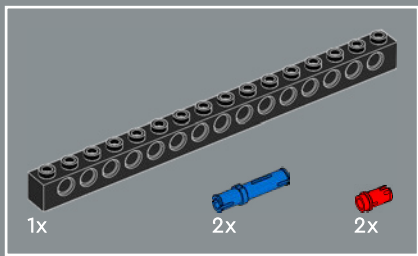

358

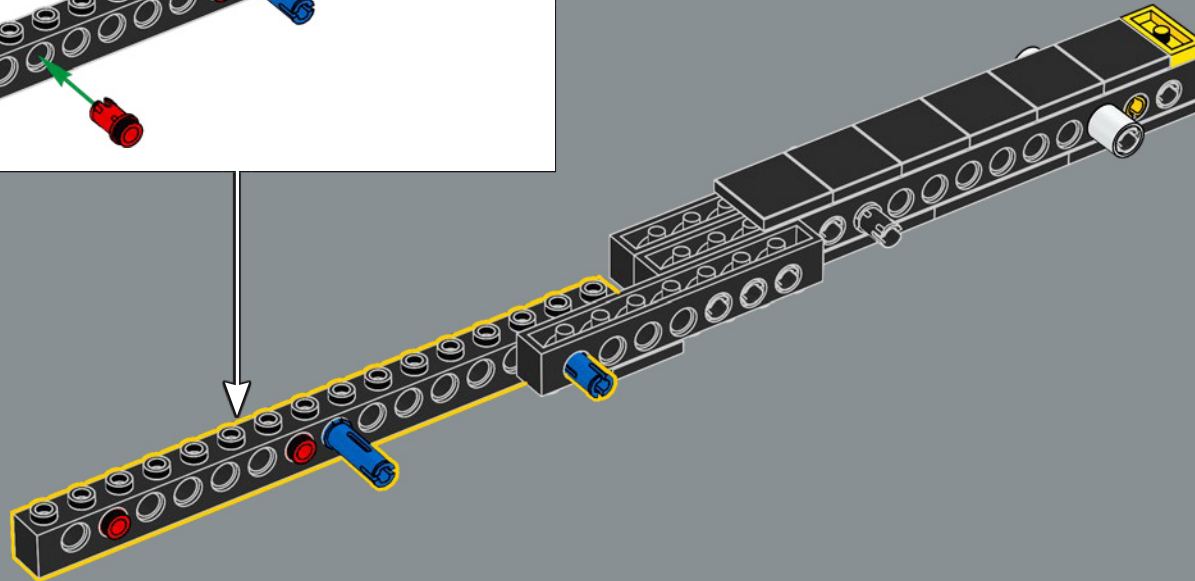
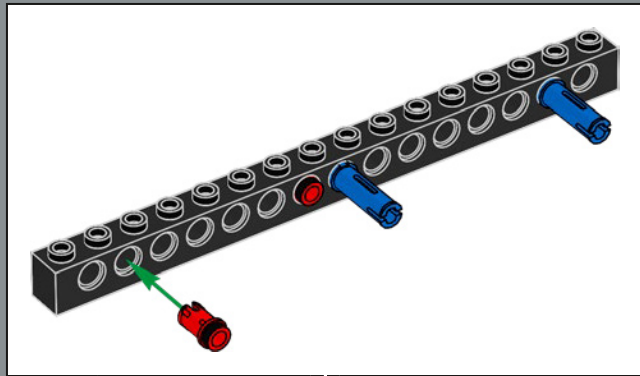

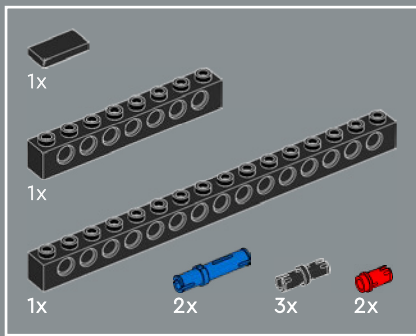

359

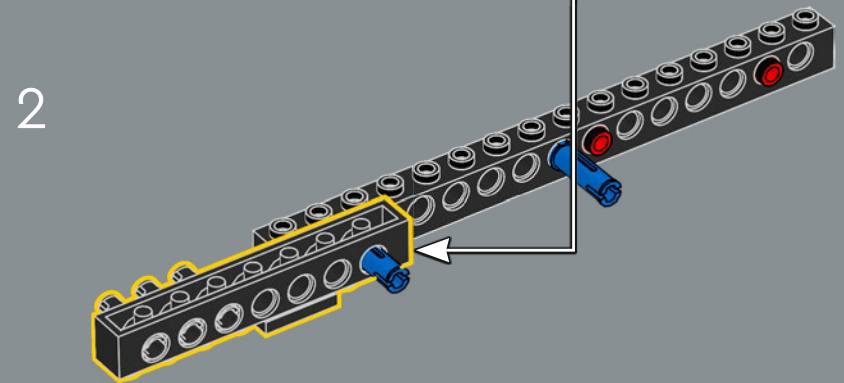
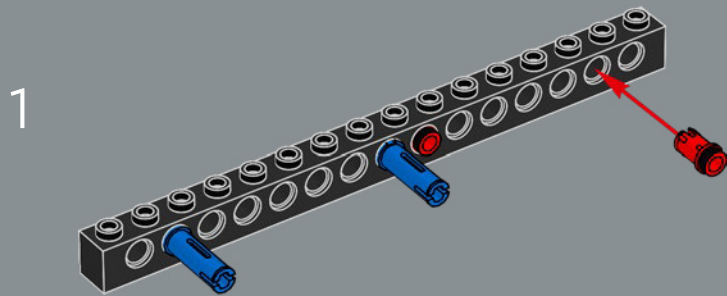
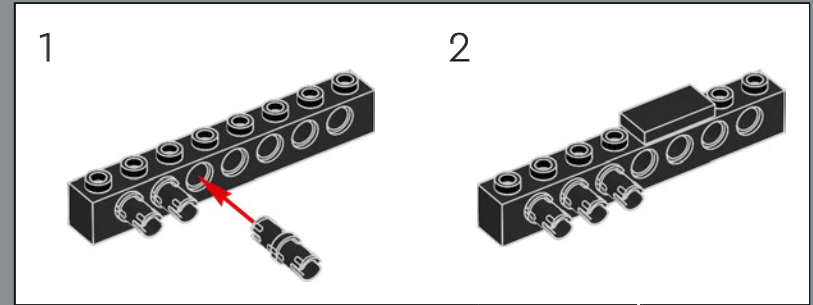

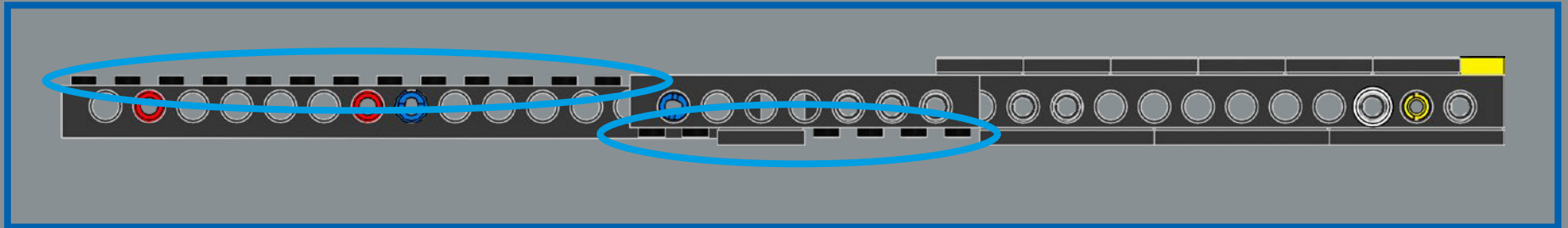
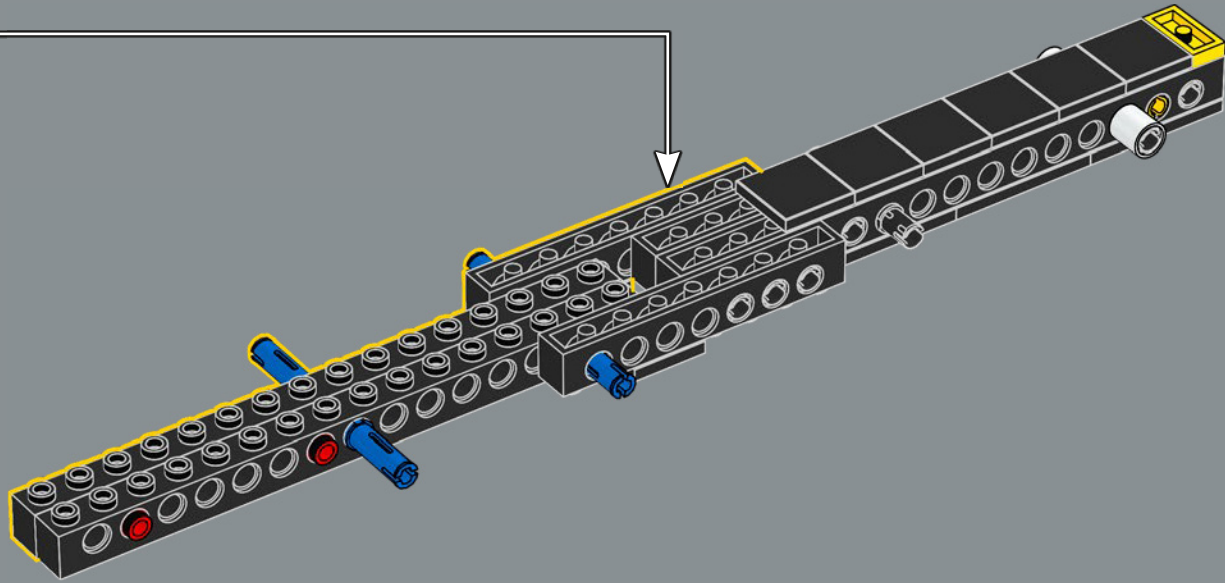

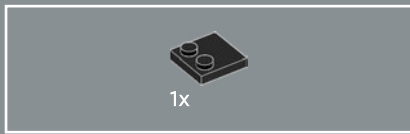

360

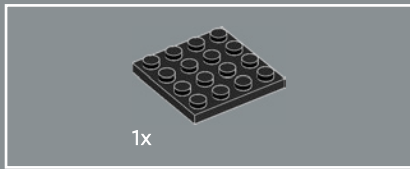
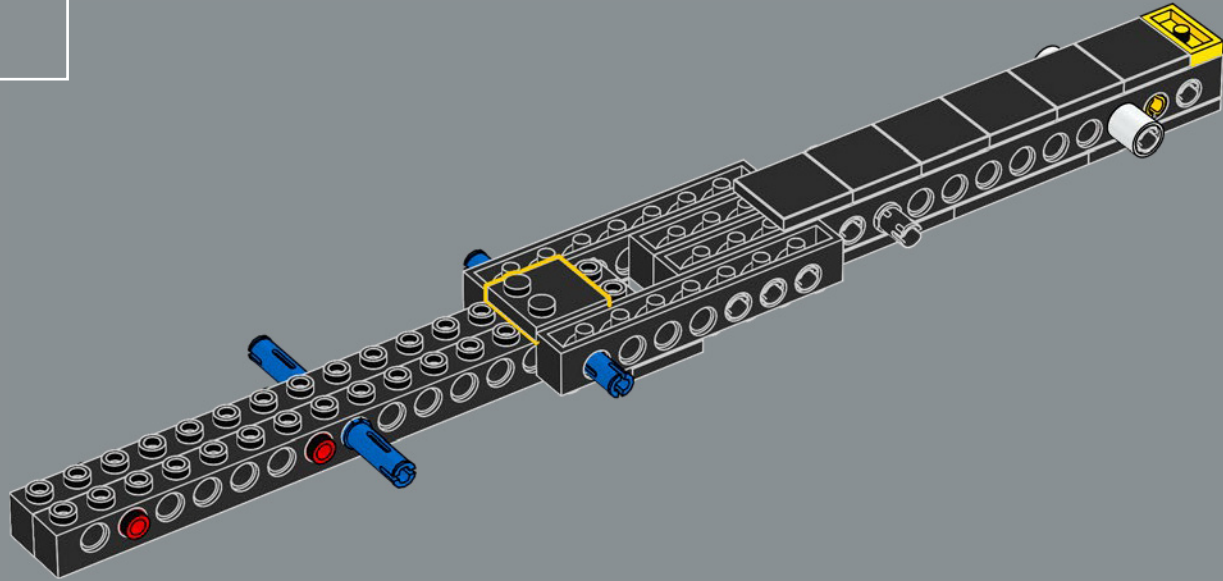

361

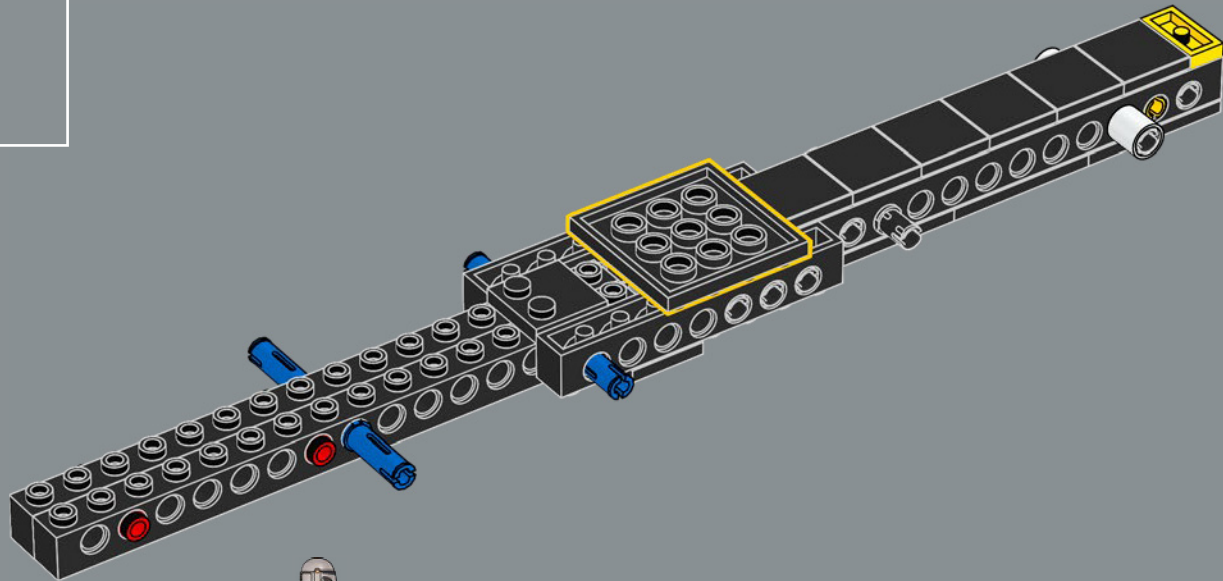

362

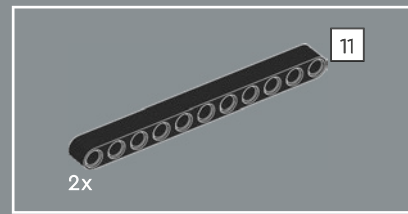
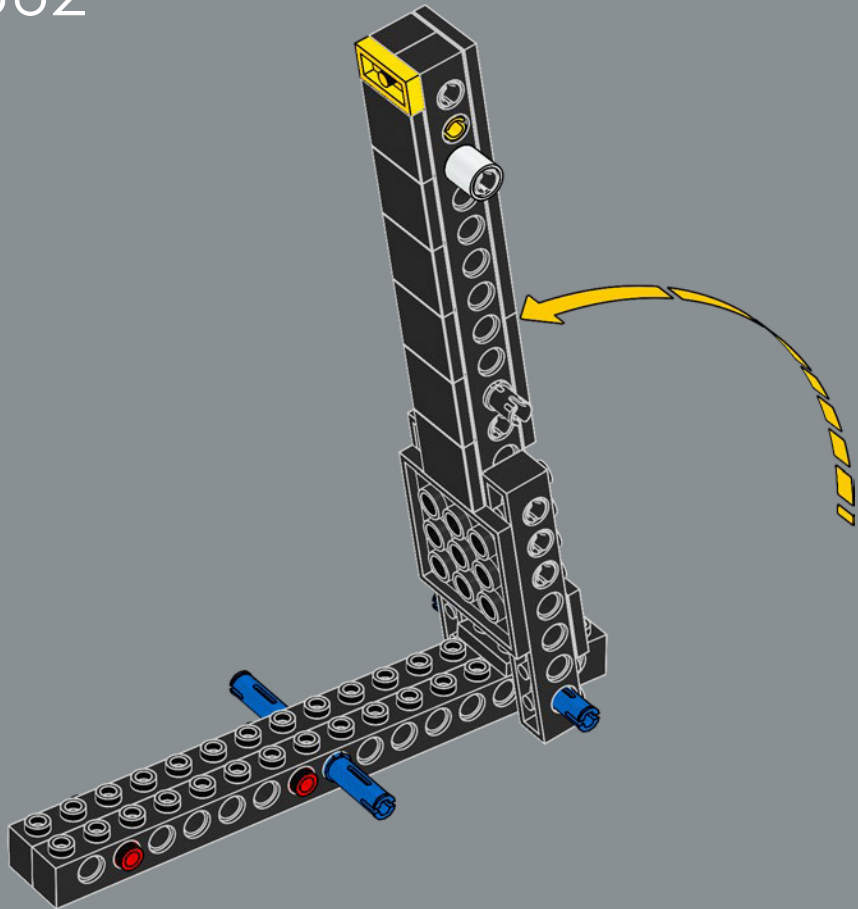

363

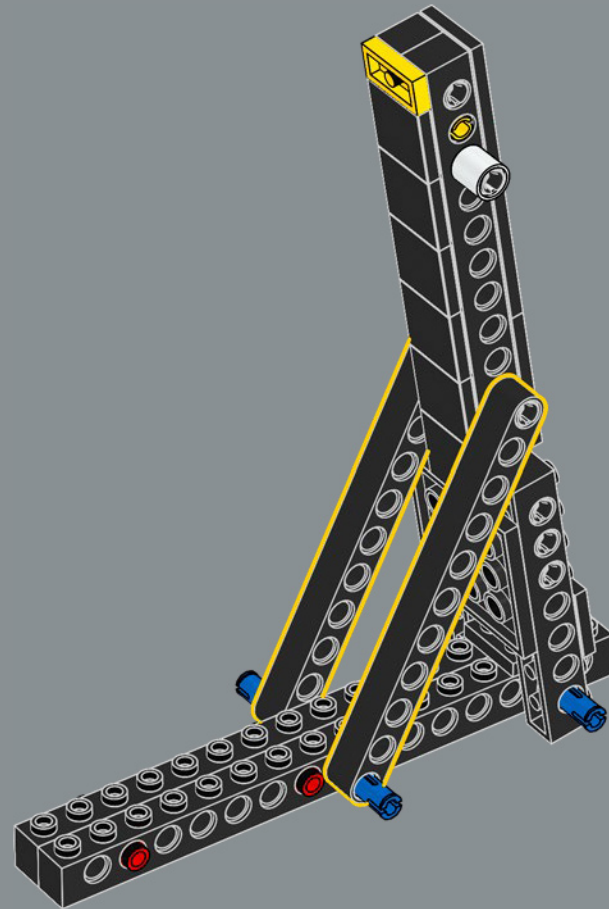

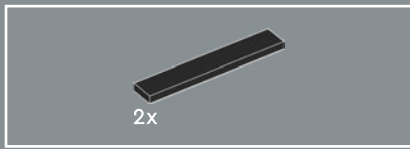

364

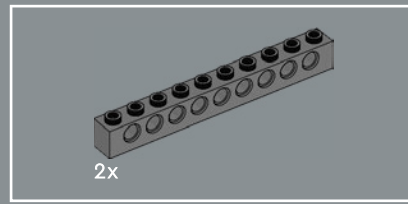
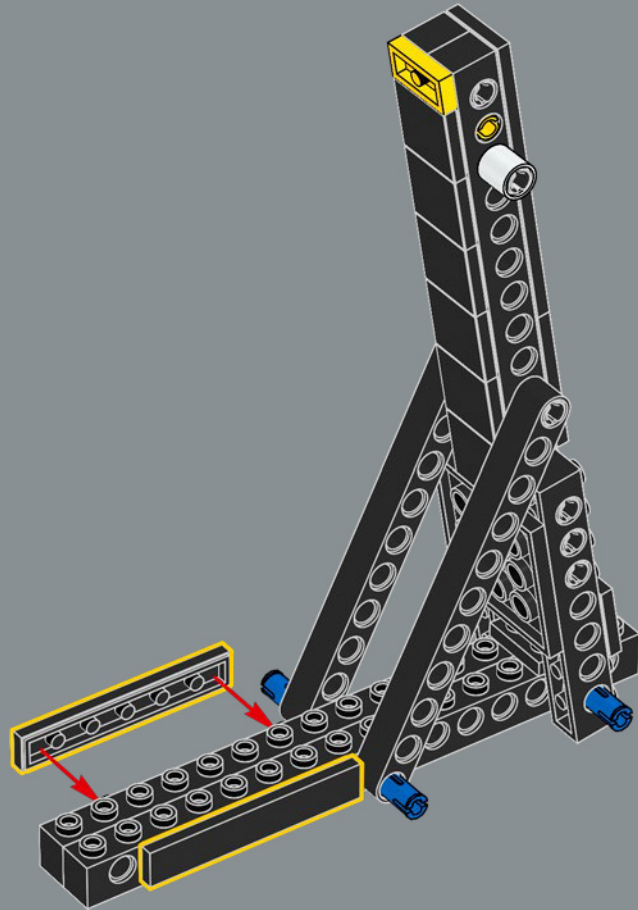

365

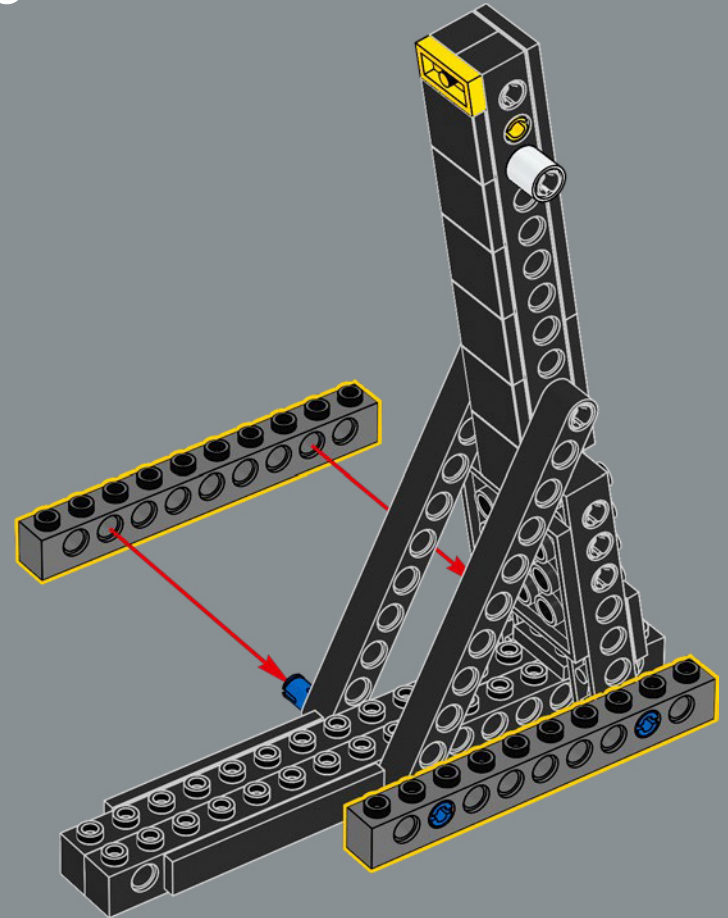

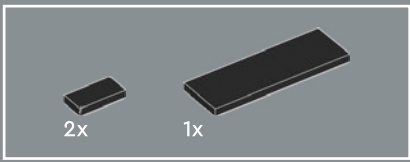

366

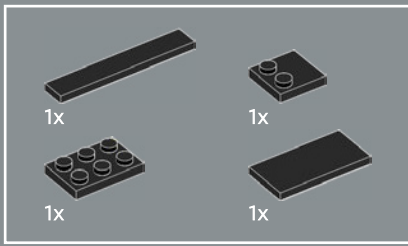
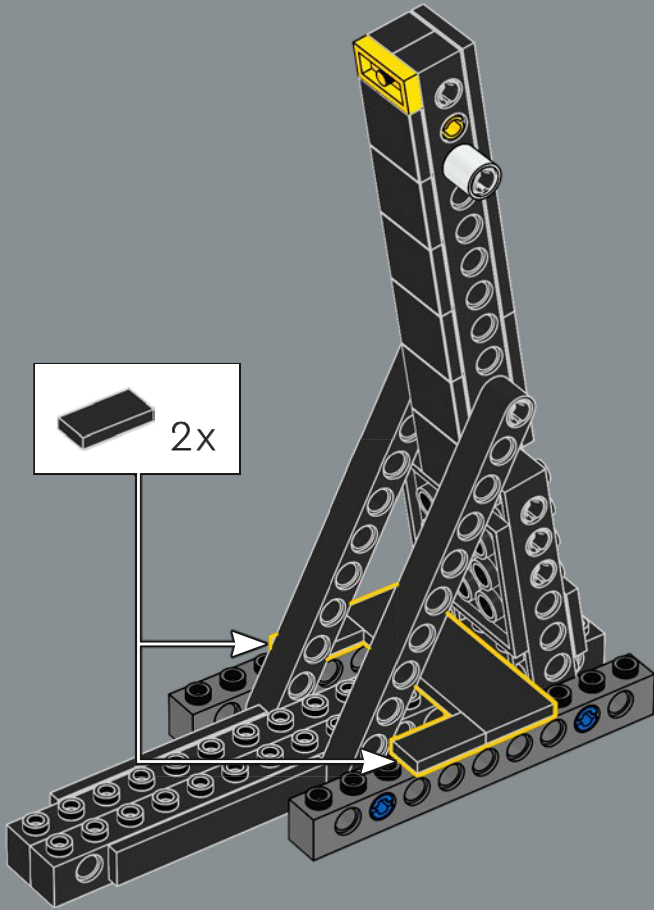

367

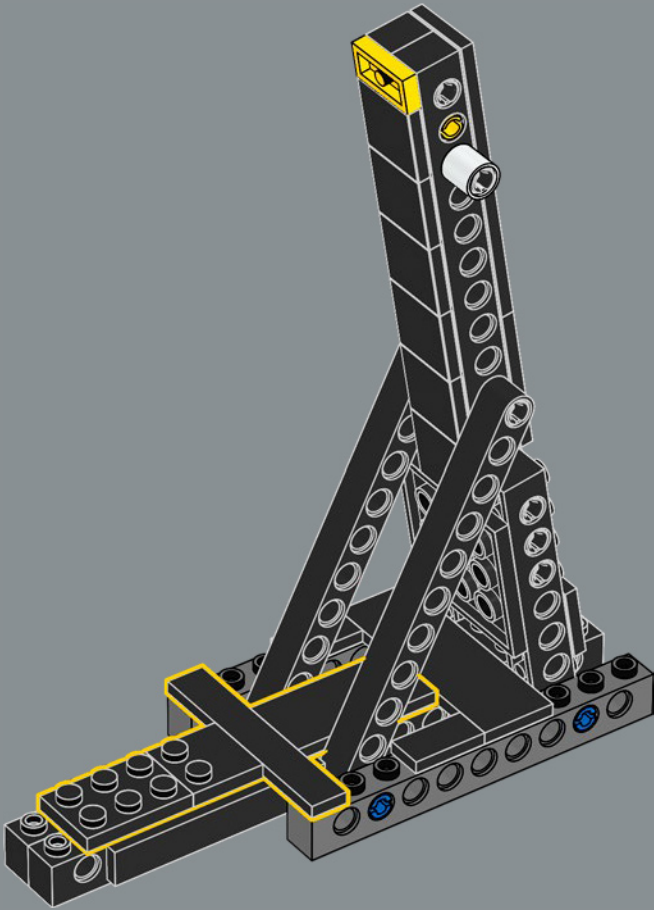

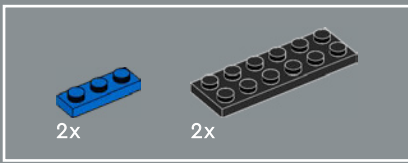

368

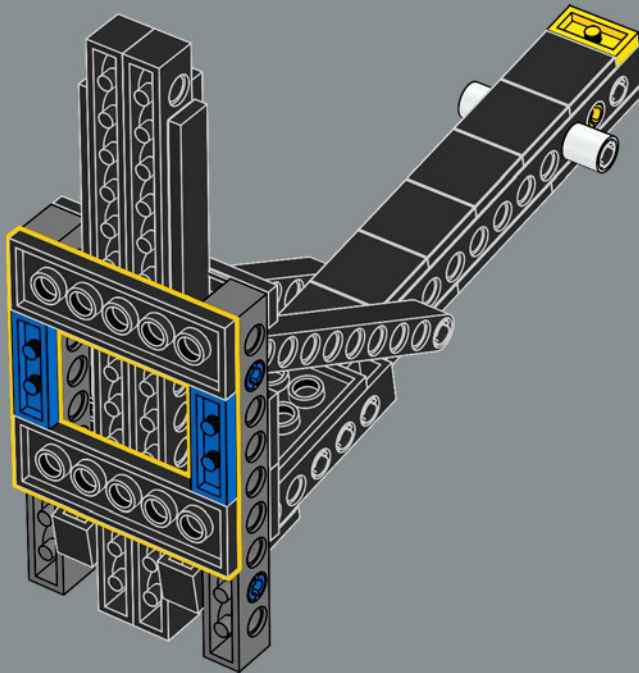

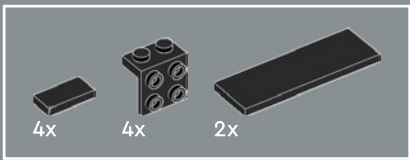

369

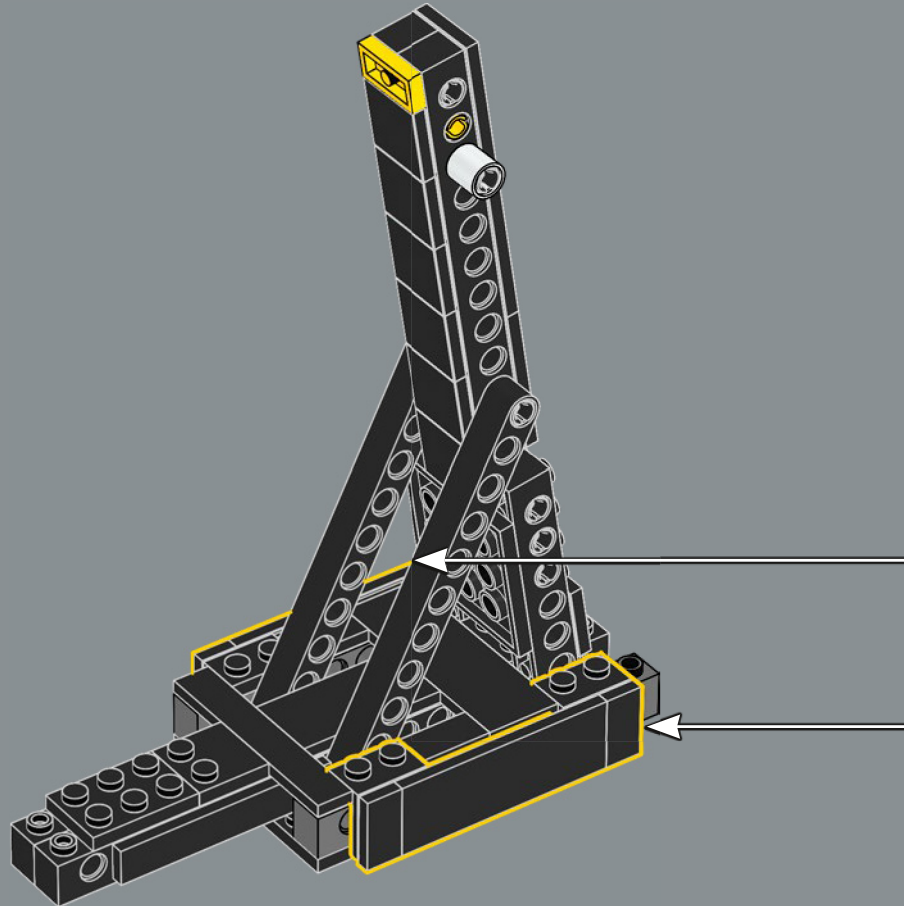
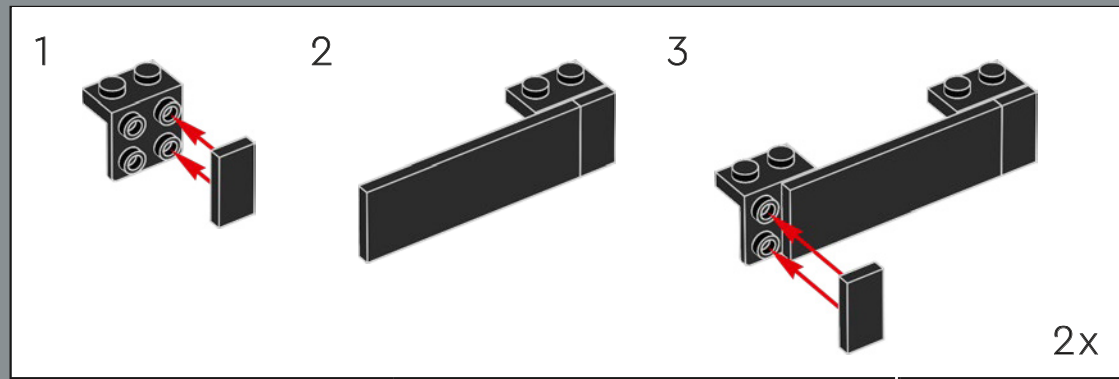

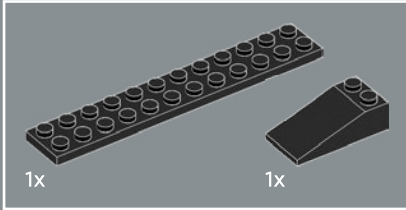
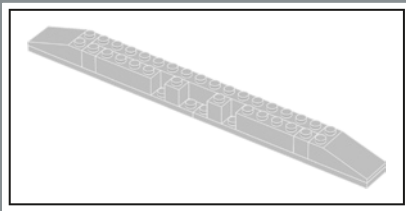

370

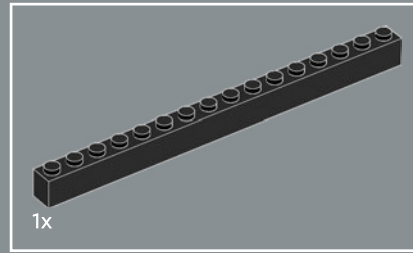
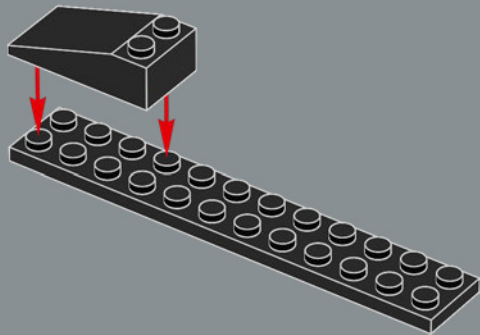

371

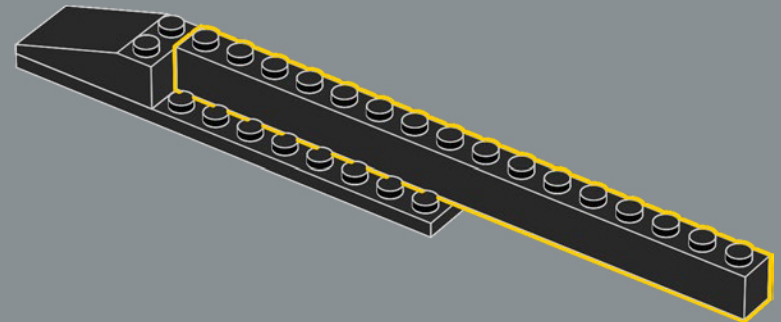

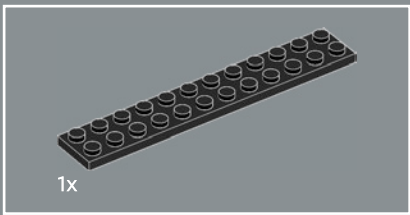

372

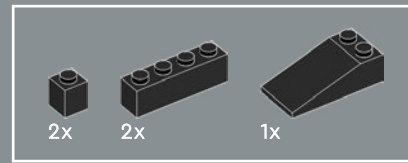
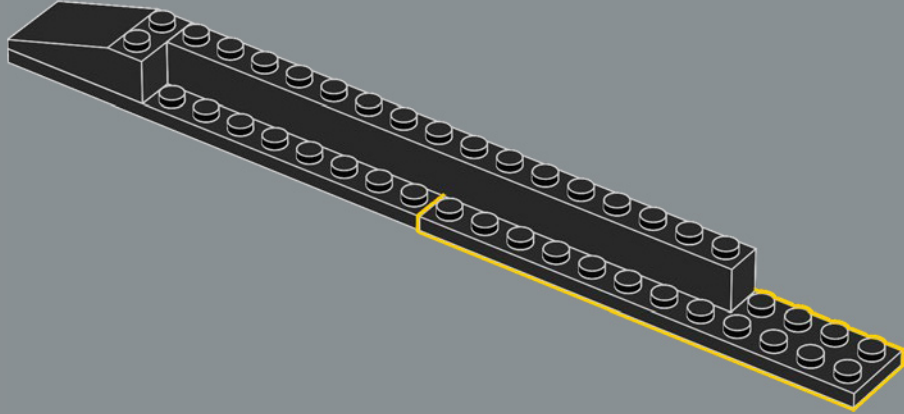

373

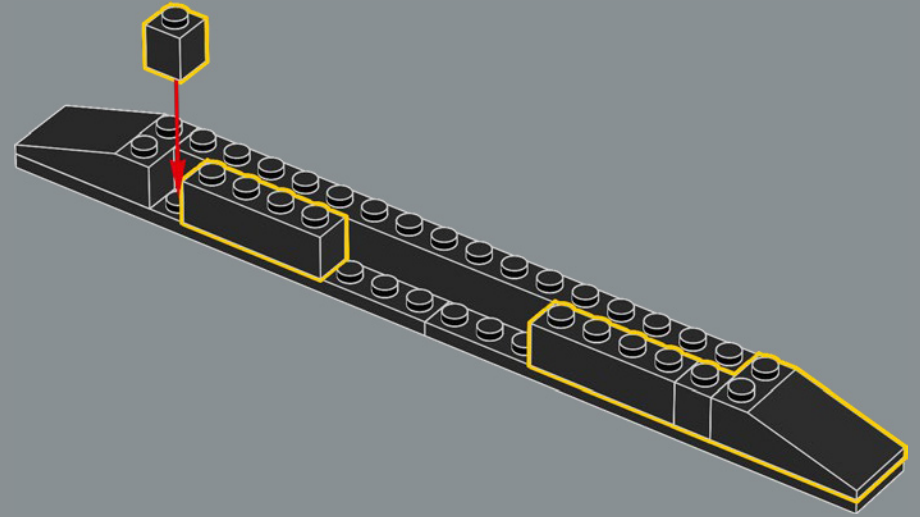



2x

374

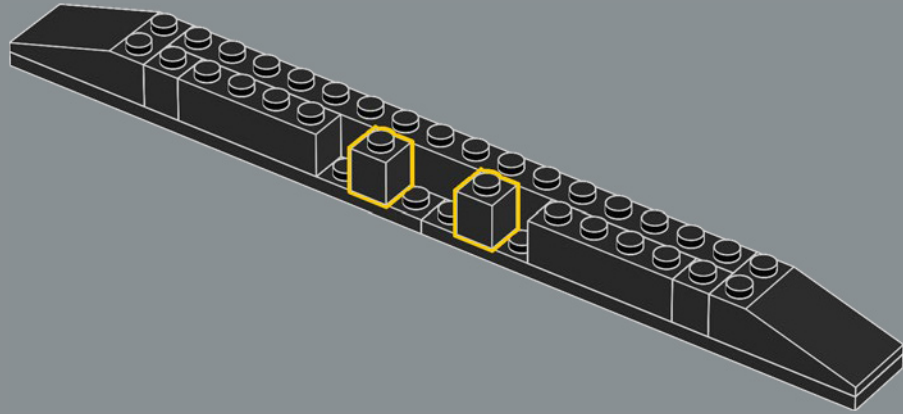

375

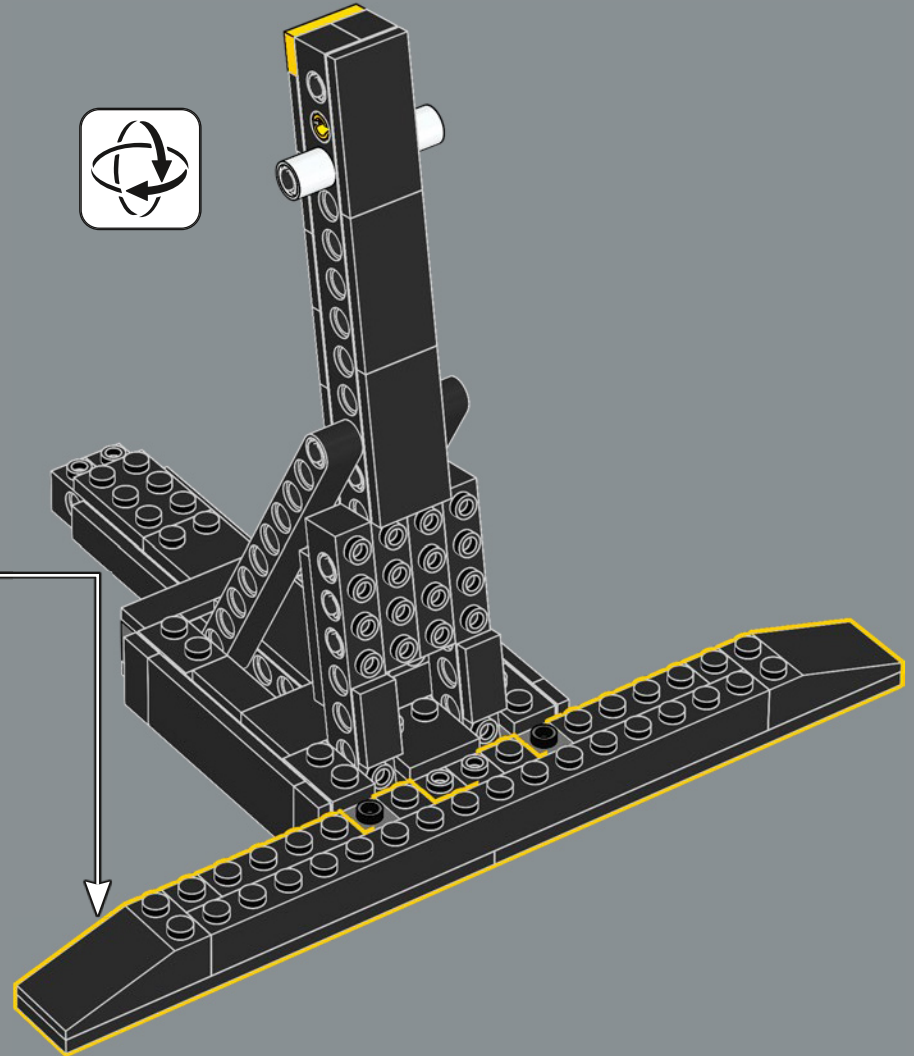

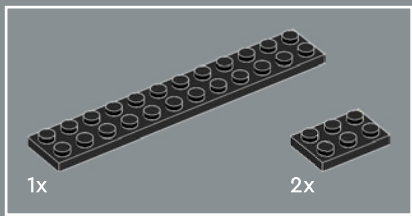

376

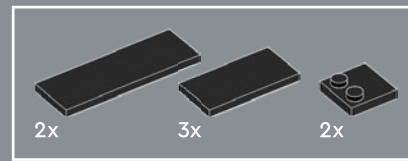
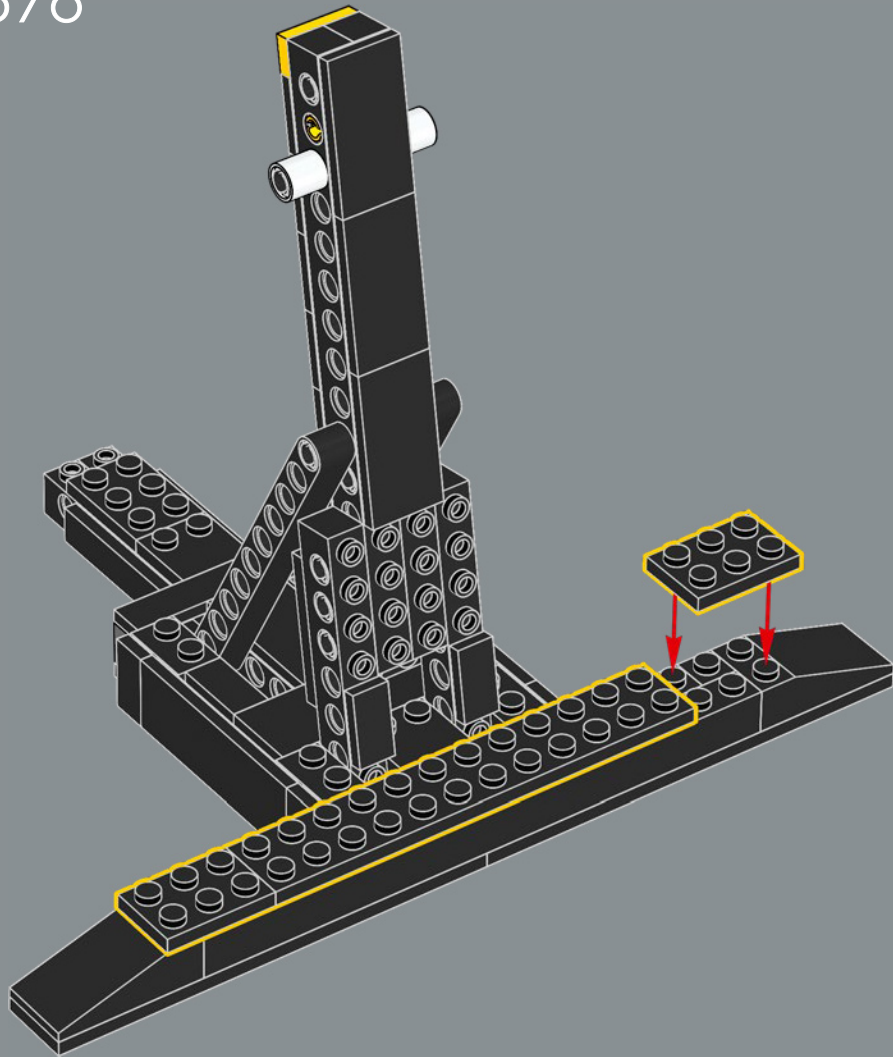

377

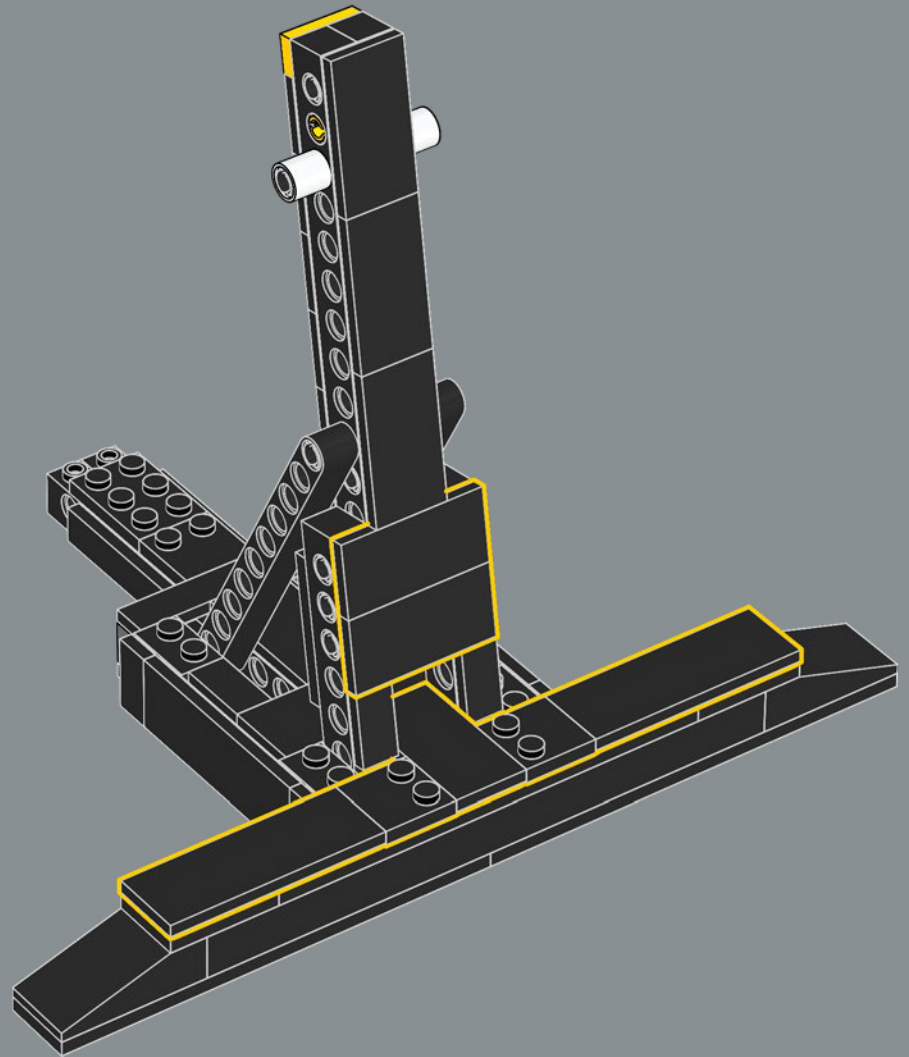

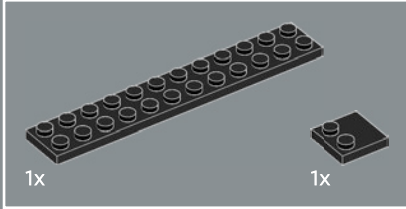
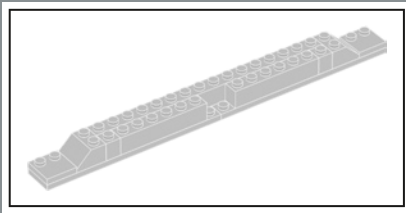

378

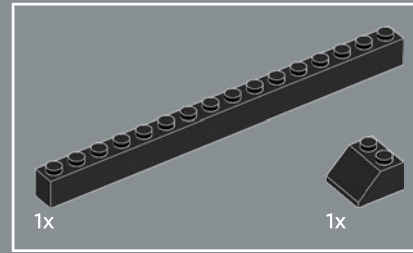
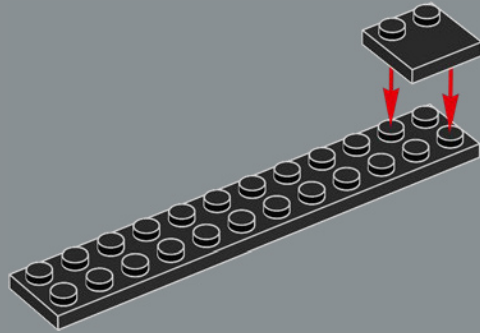

379

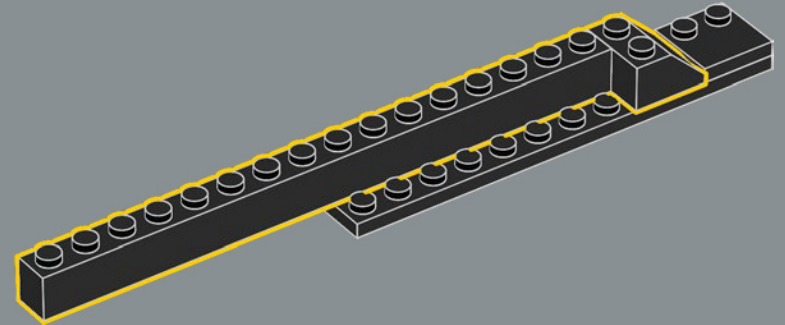

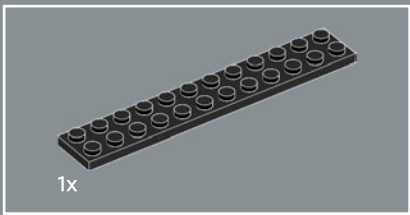

380

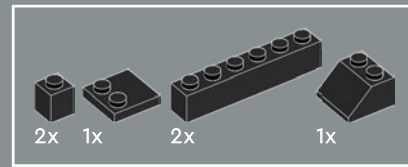
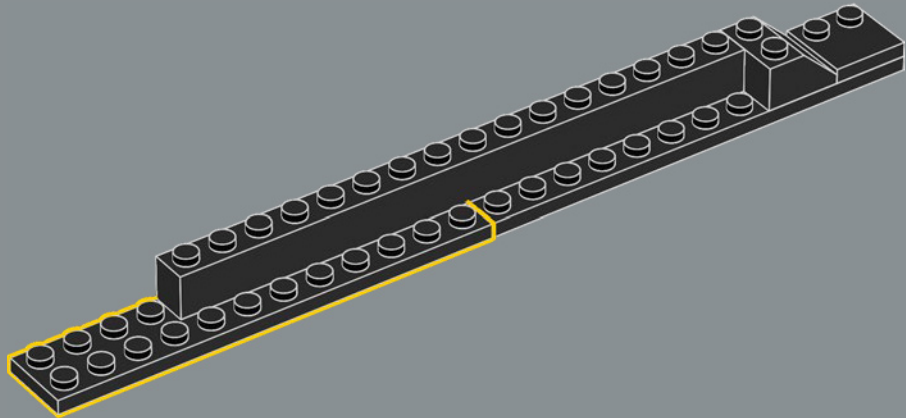

381

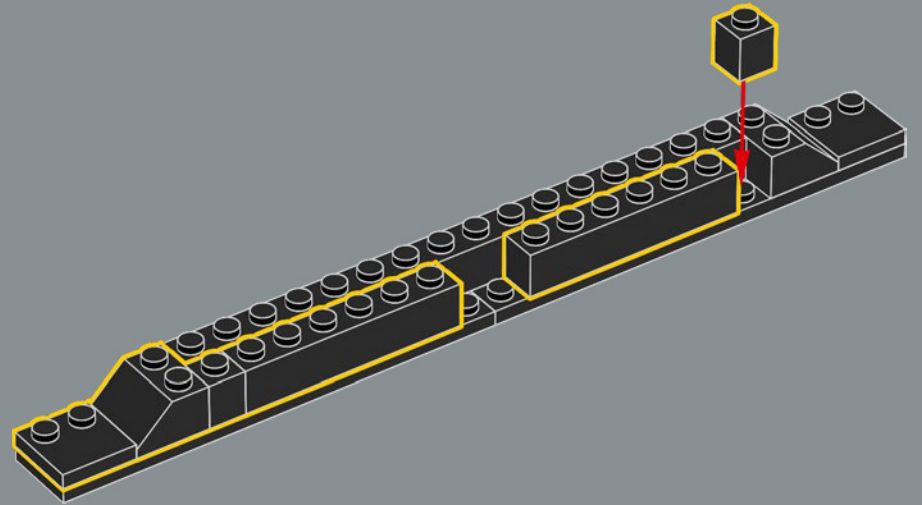

382

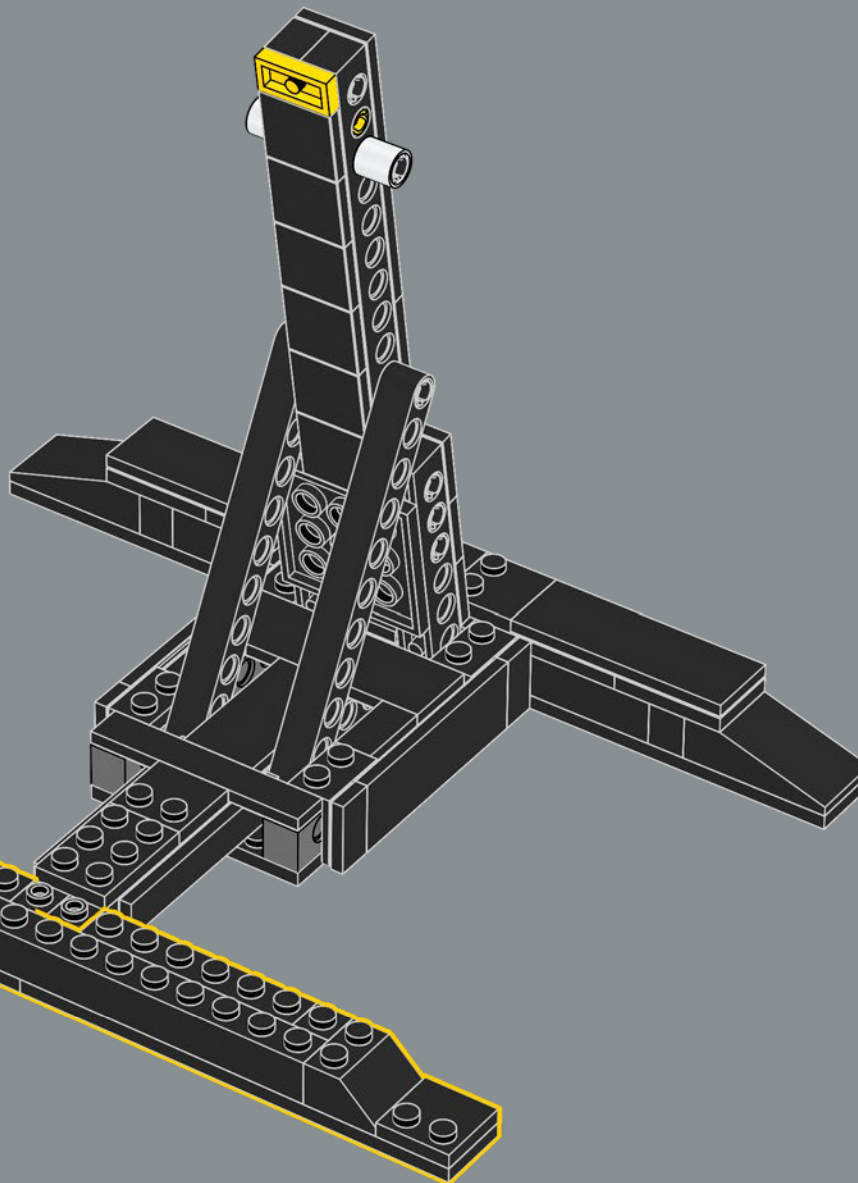

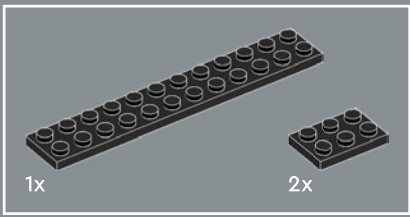

383

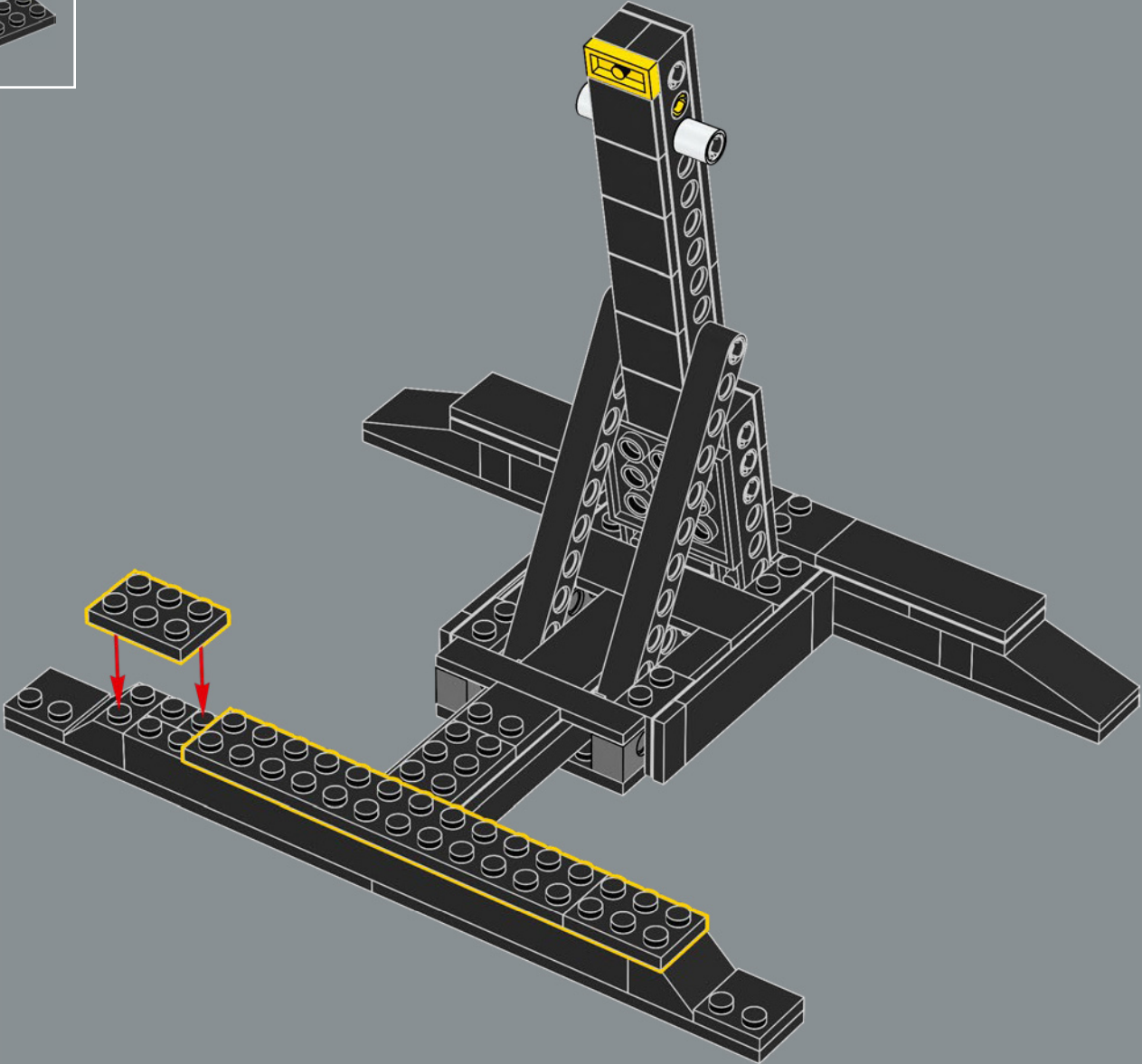

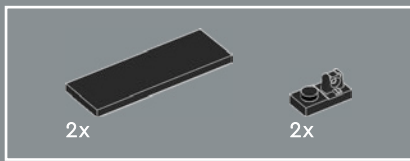

384

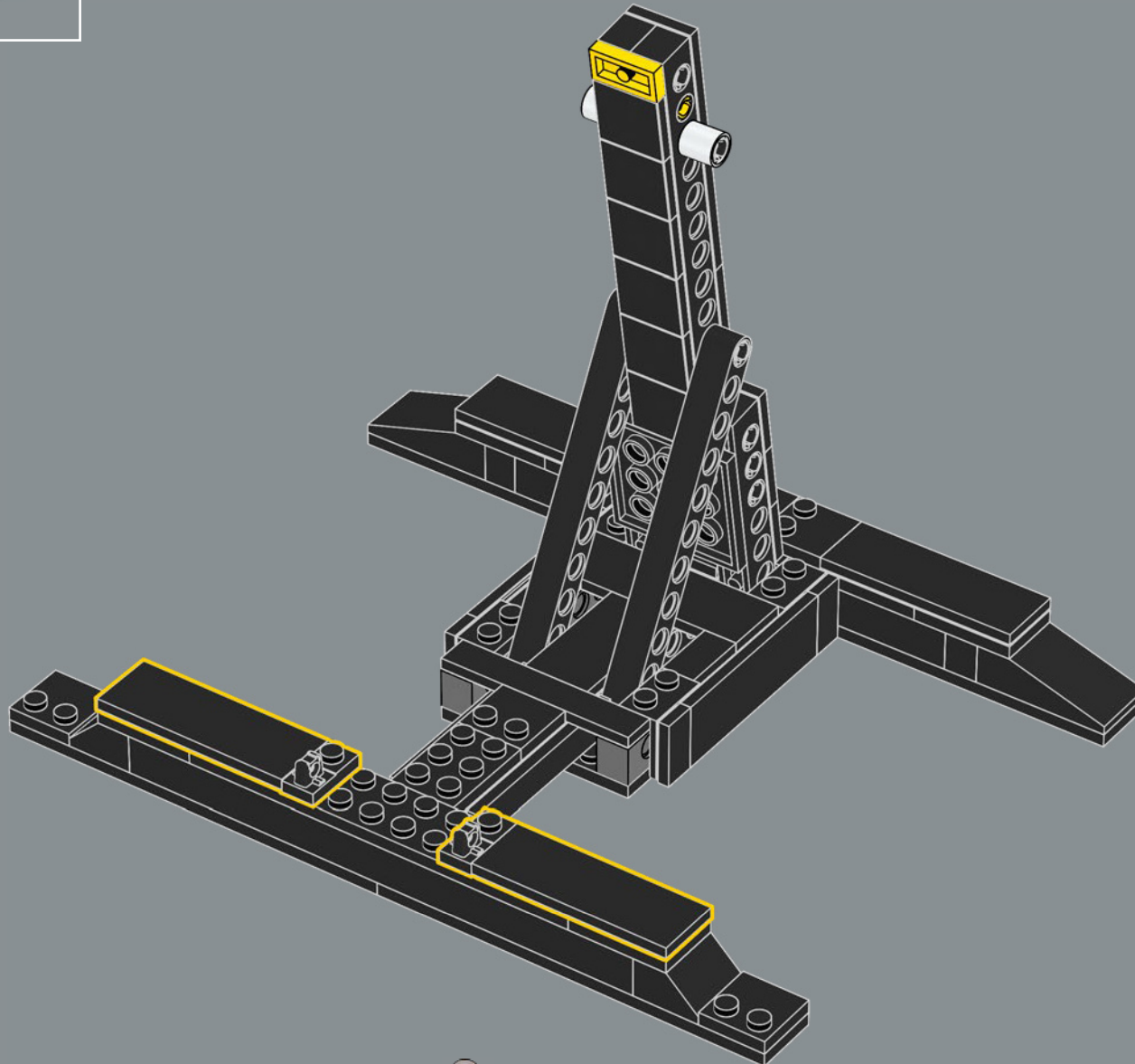

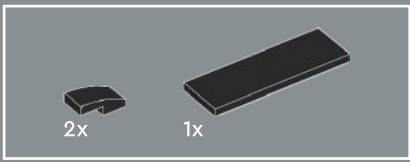

385

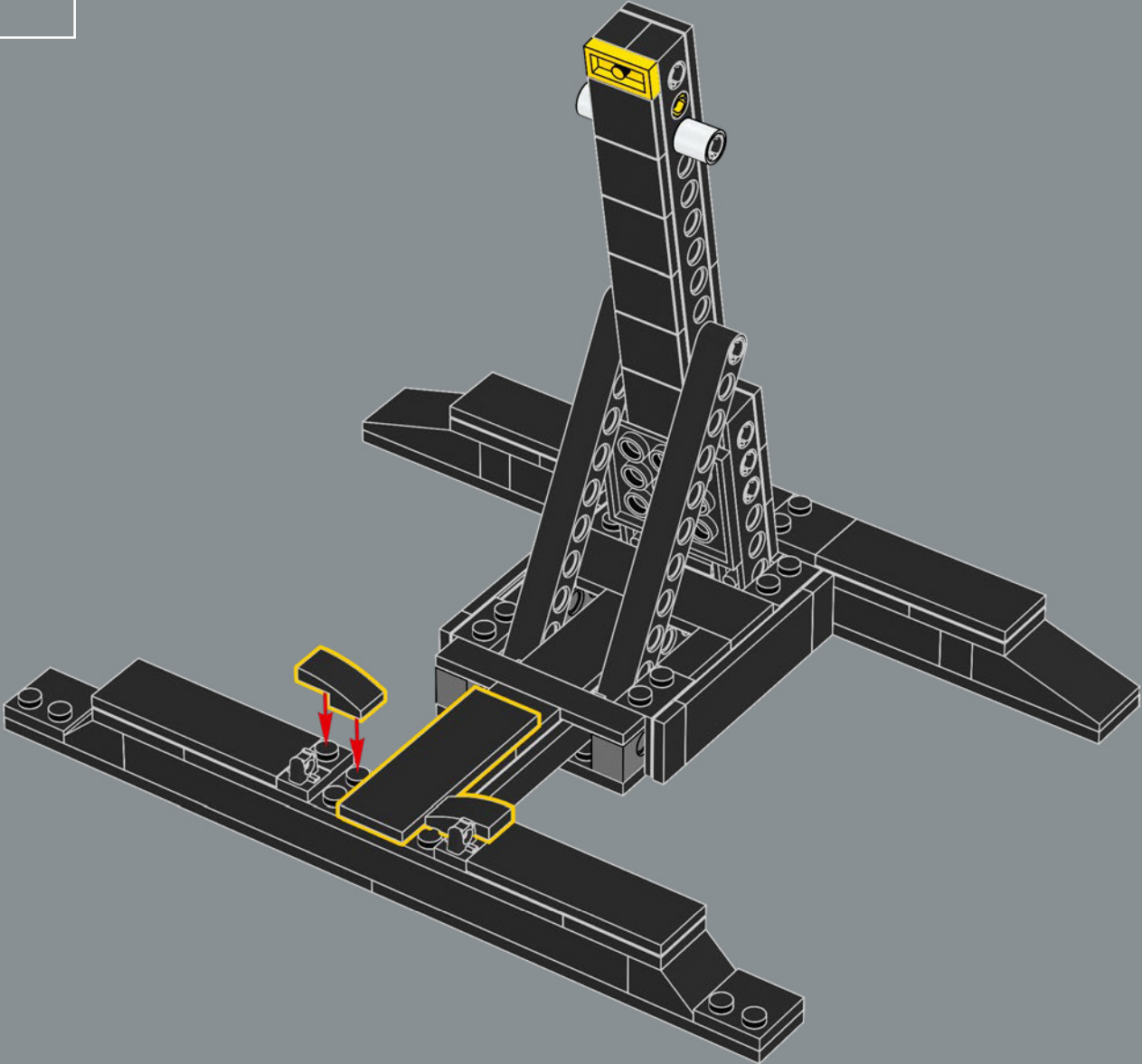

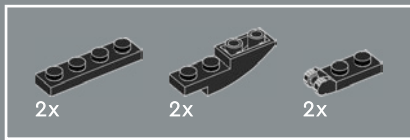

386

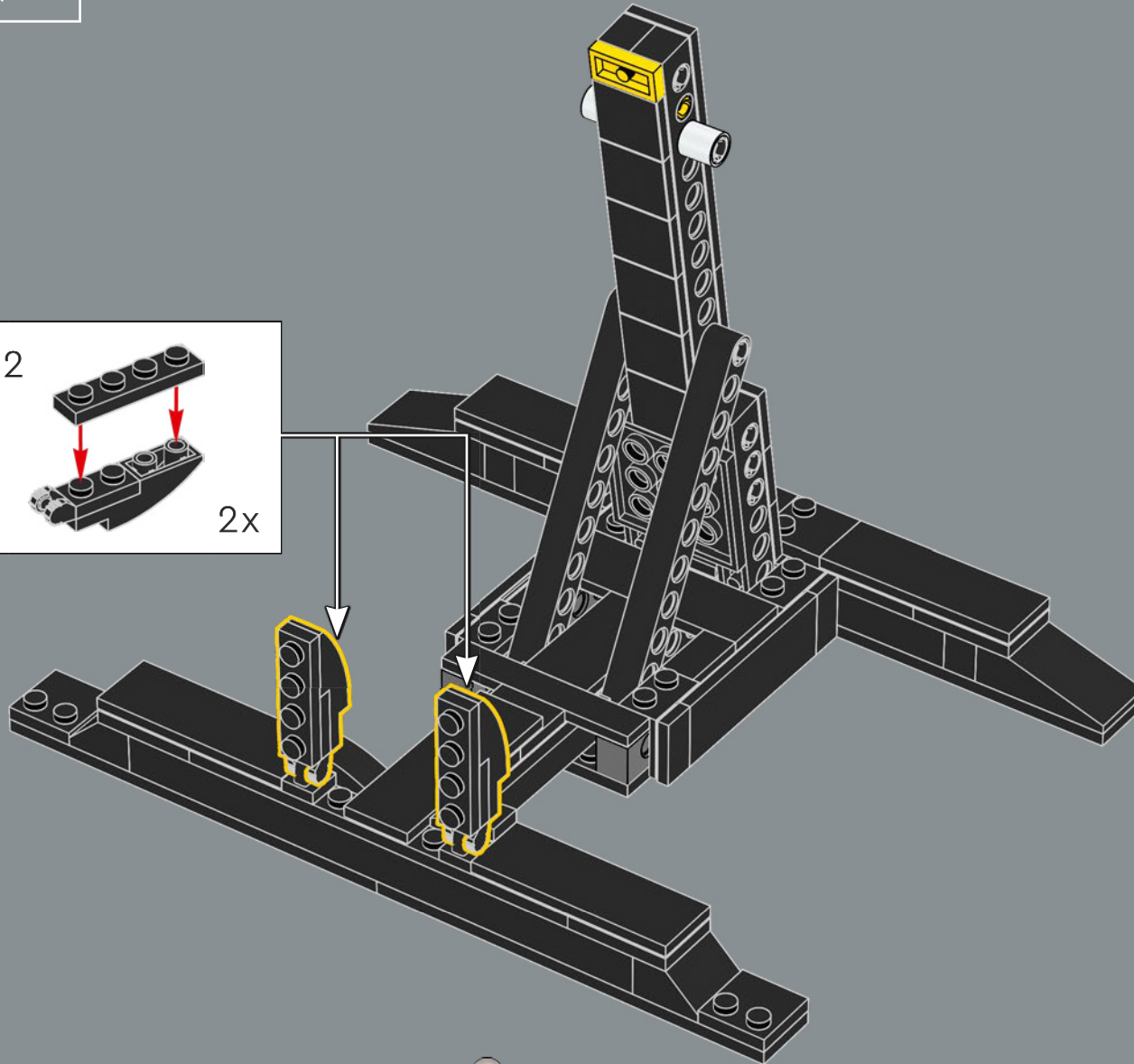
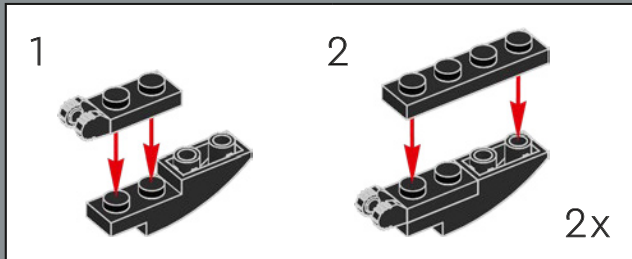

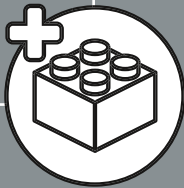
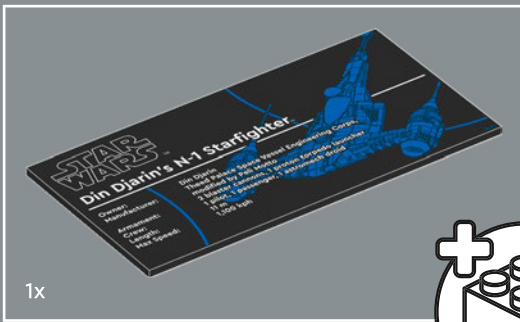

387

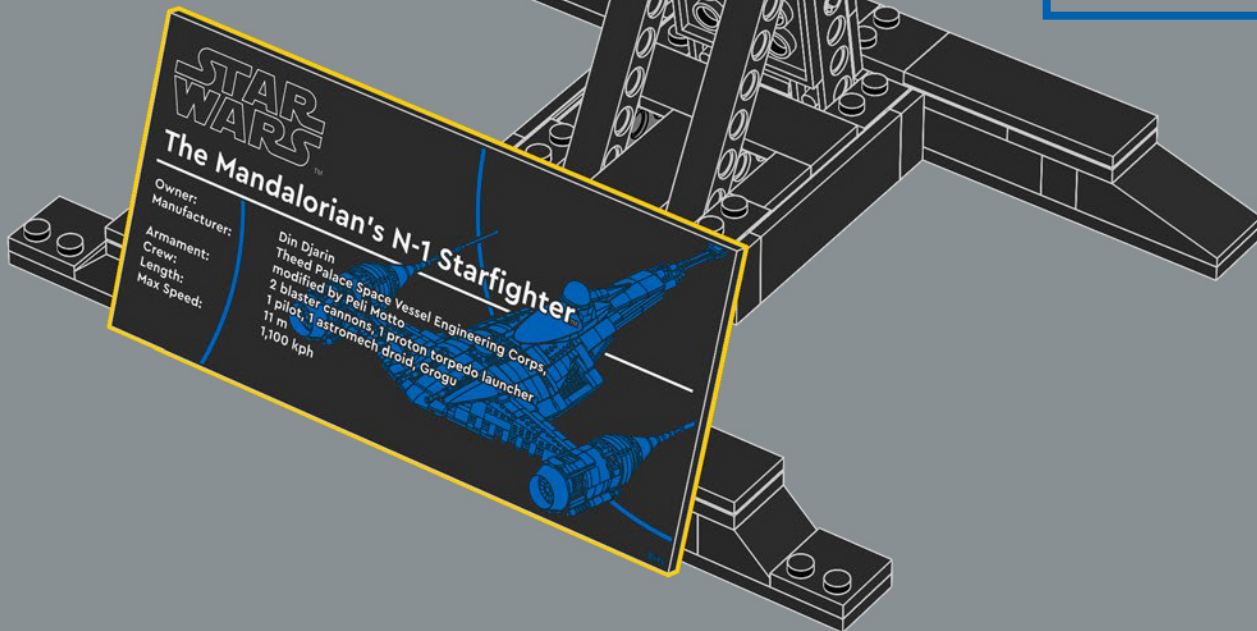
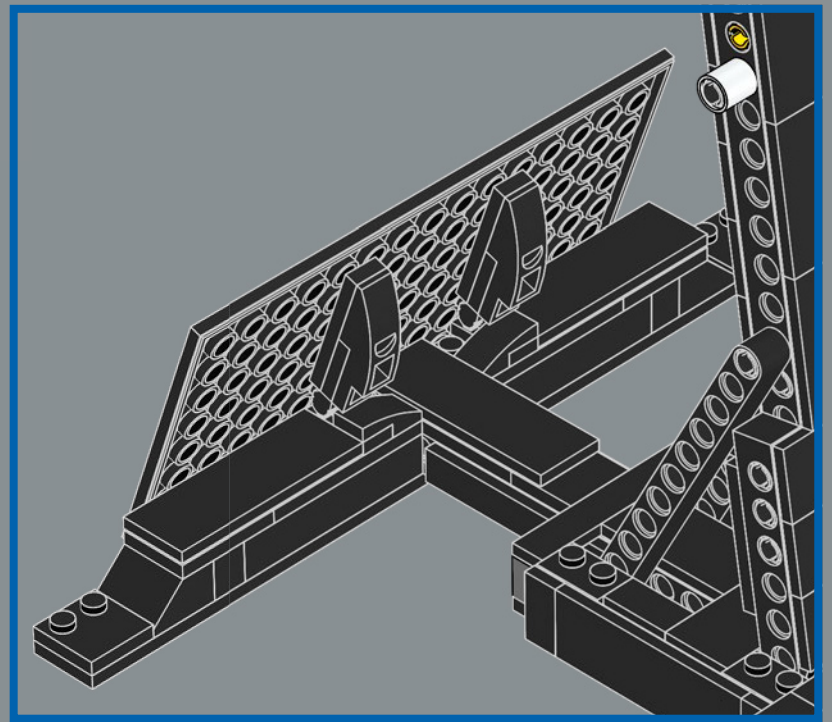

388



**STAR WARS**

### The Mandalorian's N-1 Starfighter

**Owner:**  
Din Djarin

**Manufacturer:**  
Theed Palace Space Vessel Engineering Corps, modified by Peli Motto

**Armament:**  
2 blaster cannons, 1 proton torpedo launcher

**Crew:**  
1 pilot, 1 astromech droid, Grogu

**Length:**  
11 m

**Max Speed:**  
1,100 kph

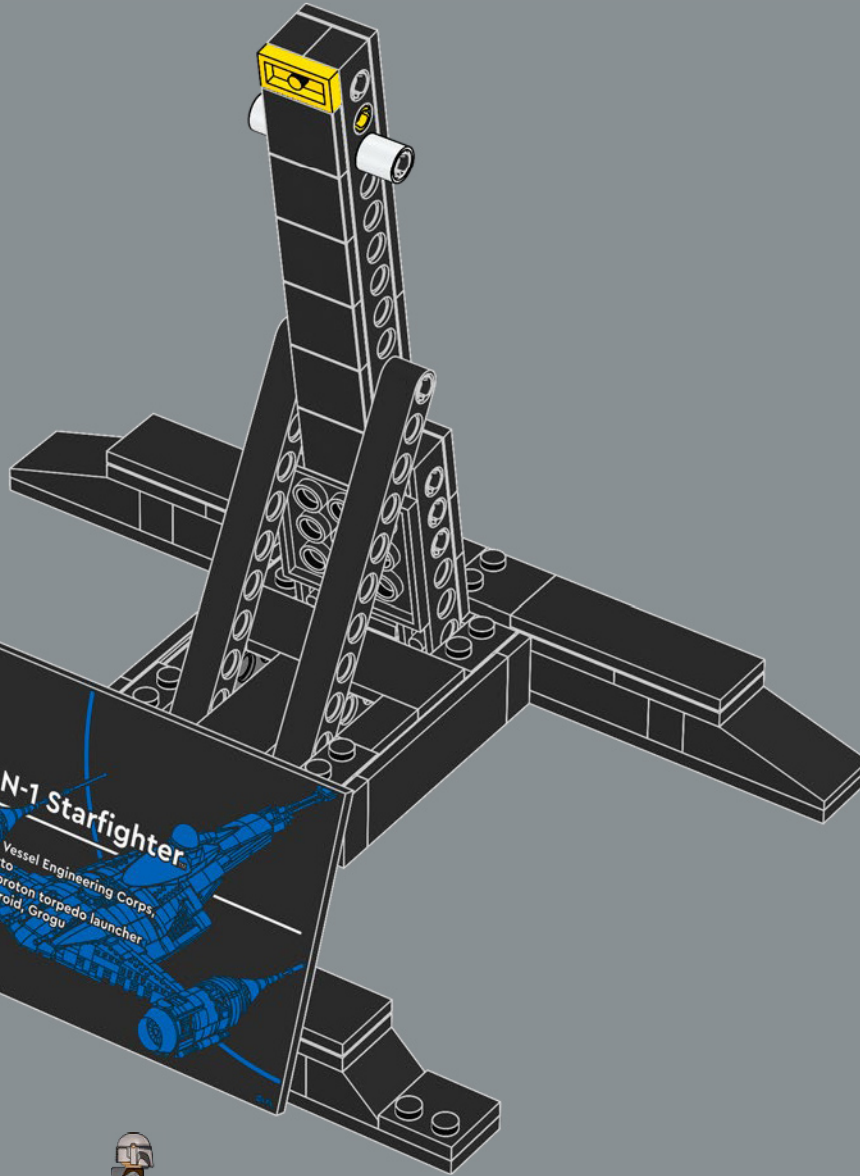
A blue line-art illustration of the N-1 Starfighter is shown on the right side of the information panel.

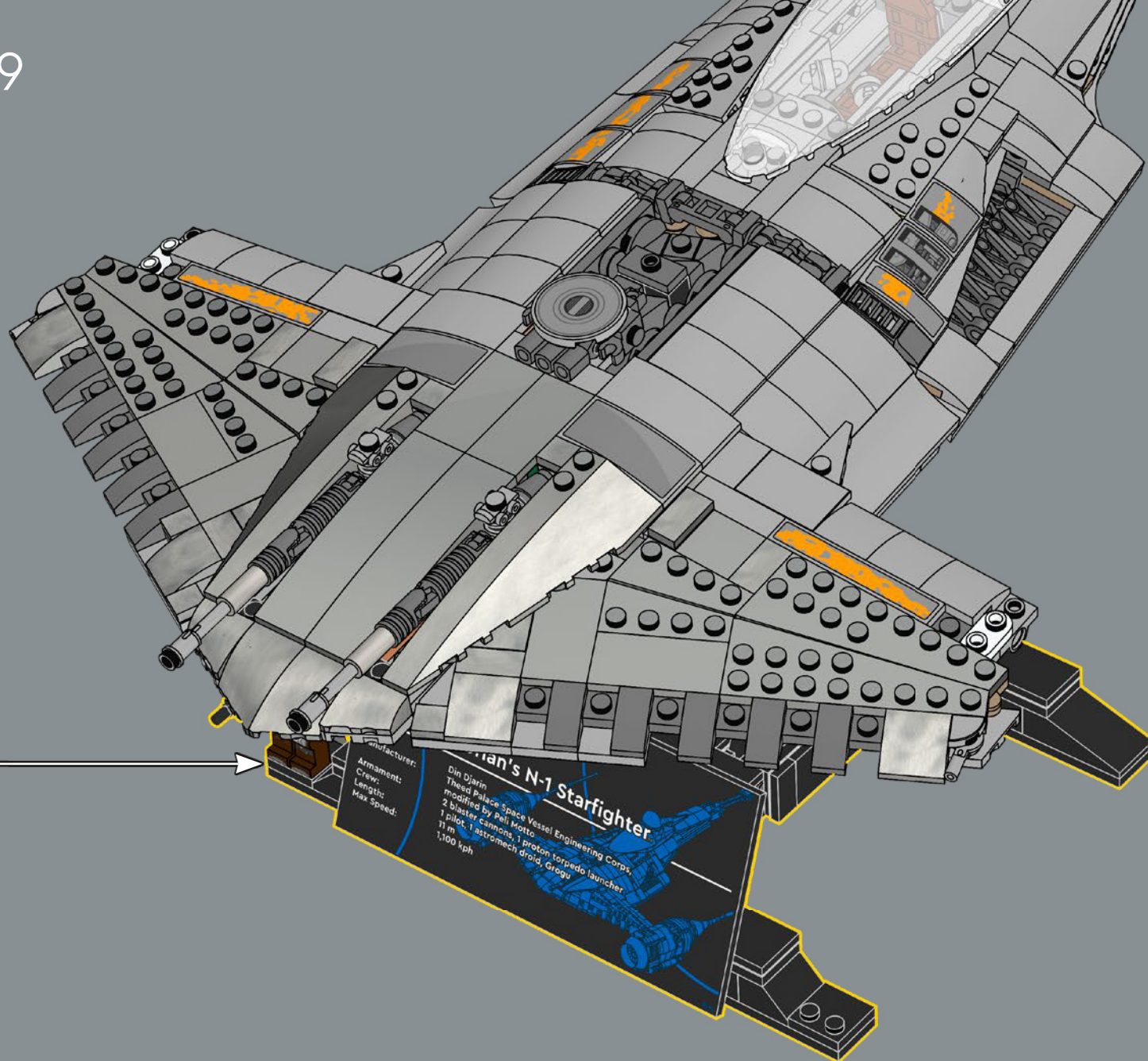

Manufacturer:  
Armament:  
Crew:  
Length:  
Max Speed:

**Djarin's N-1 Starfighter**

Theed Palace Space Vessel Engineering Corps.  
modified by Peli Motto  
2 blaster cannons, 1 proton torpedo launcher  
1 pilot, 1 astromech droid, Groggu

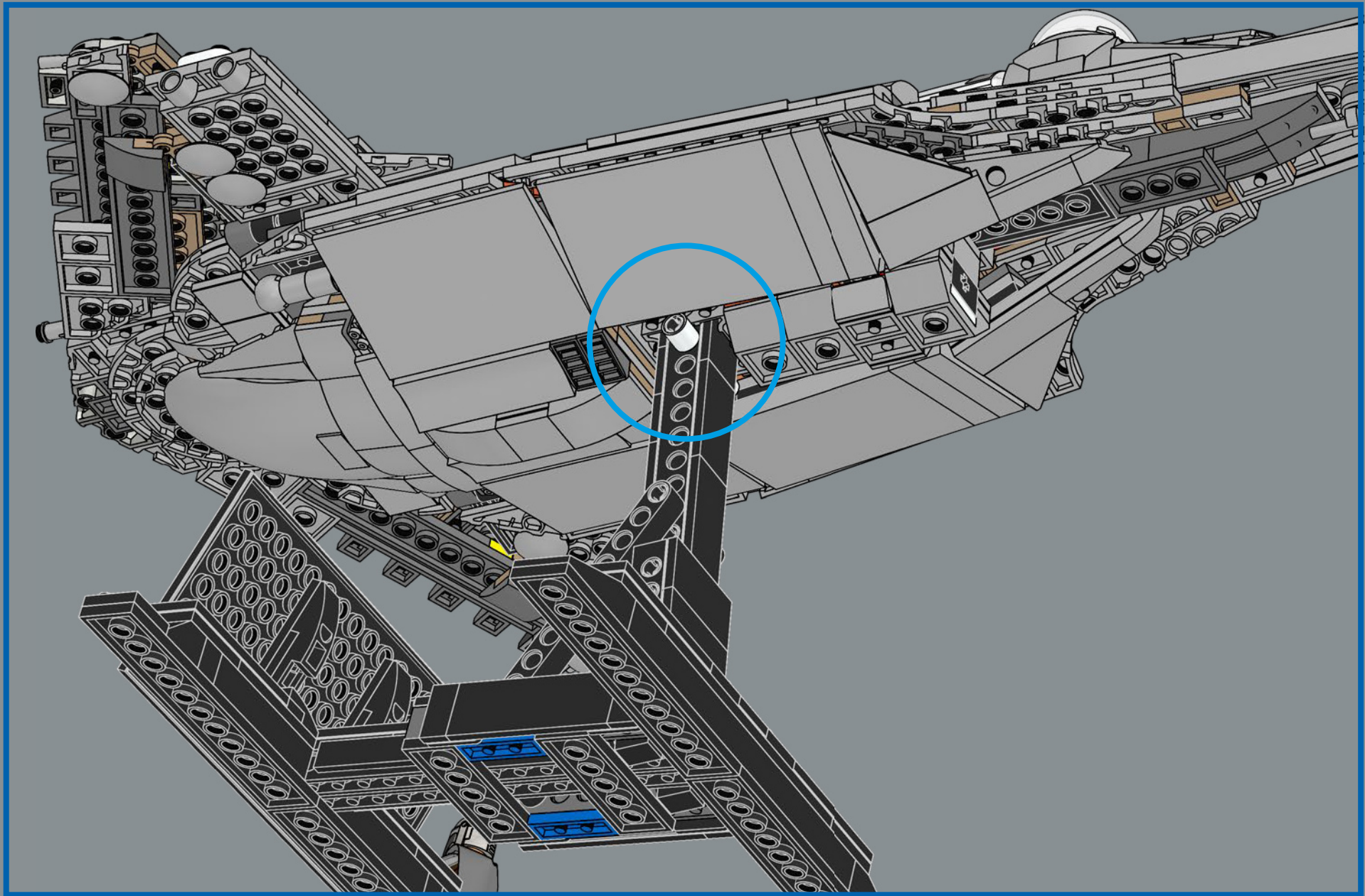



390

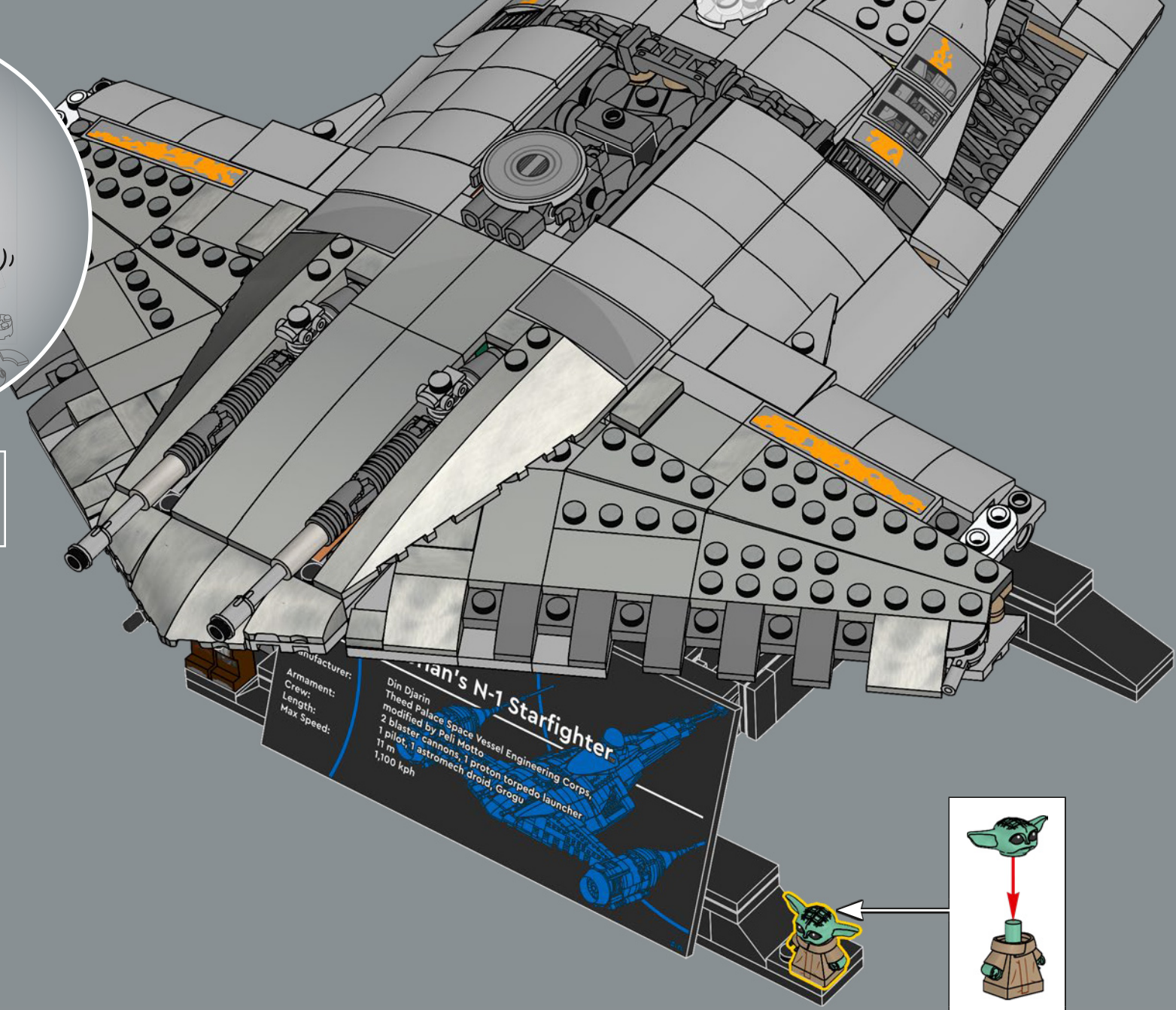

Manufacturer: **Wan's N-1 Starfighter**  
Armament: Theed Palace space Vessel Engineering Corps.  
Crew: modified by Paji Motto  
Length: 2 blaster cannons, 1 proton torpedo launcher  
Max Speed: 11 m  
1 pilot, 1 astromech droid, Gregu  
1,100 kph

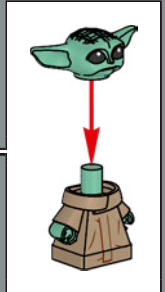

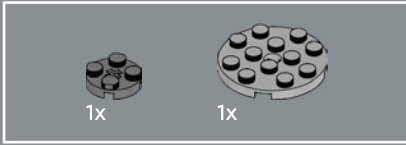
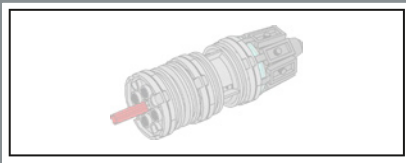

391

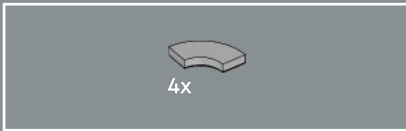

392

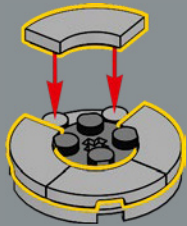

393

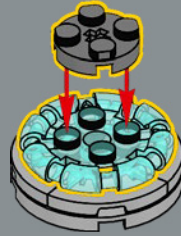

394

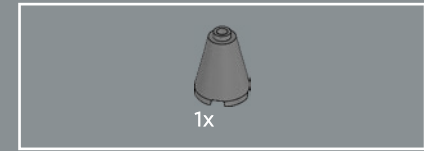
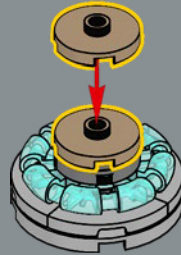

395

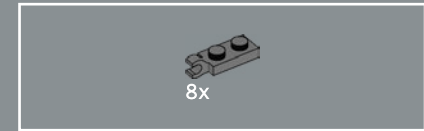

396

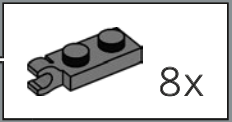
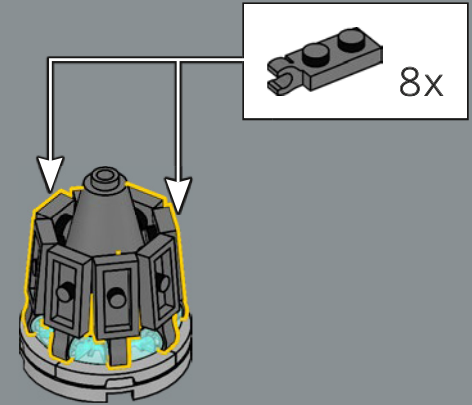

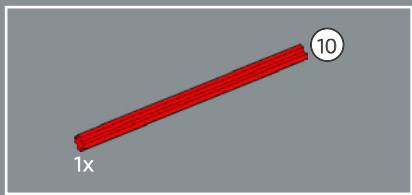

397

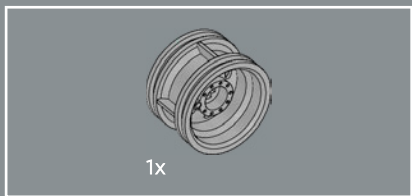
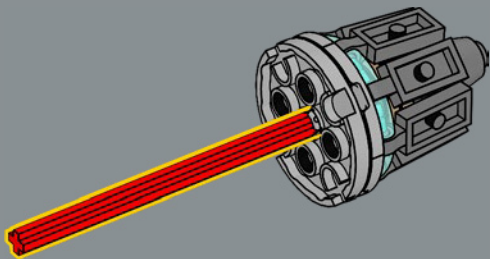

398

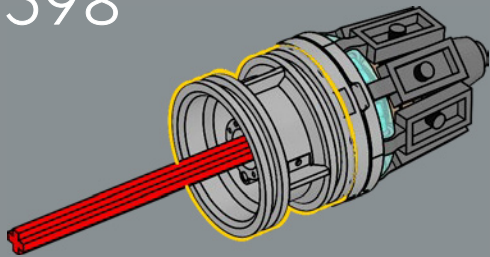

399

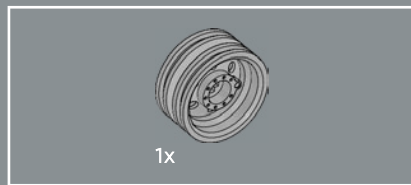
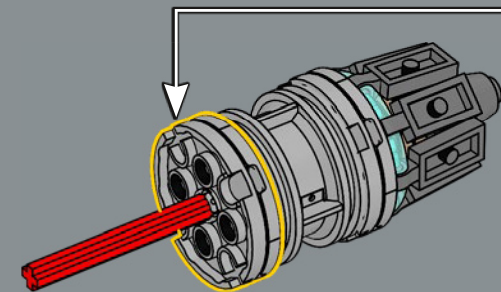

400

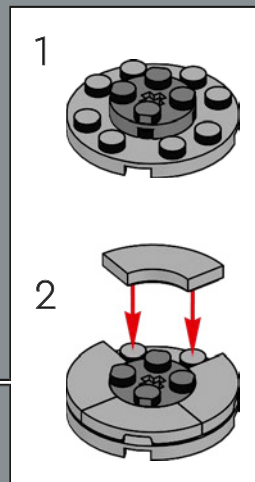
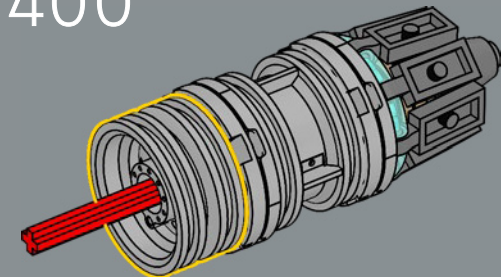

401

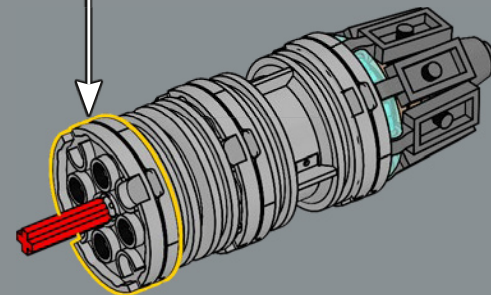
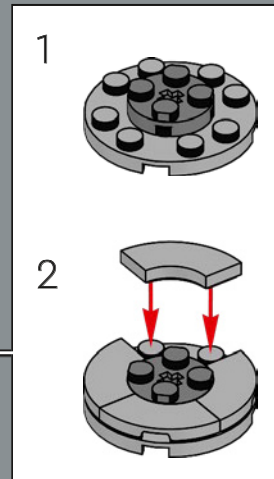

402

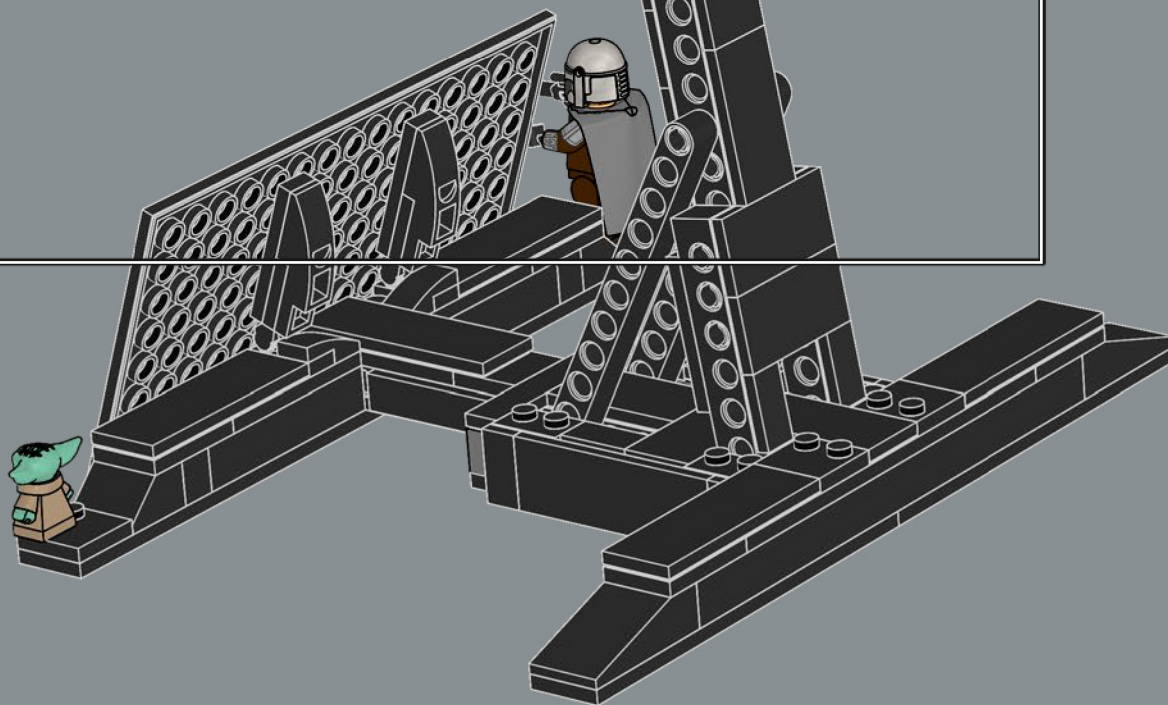
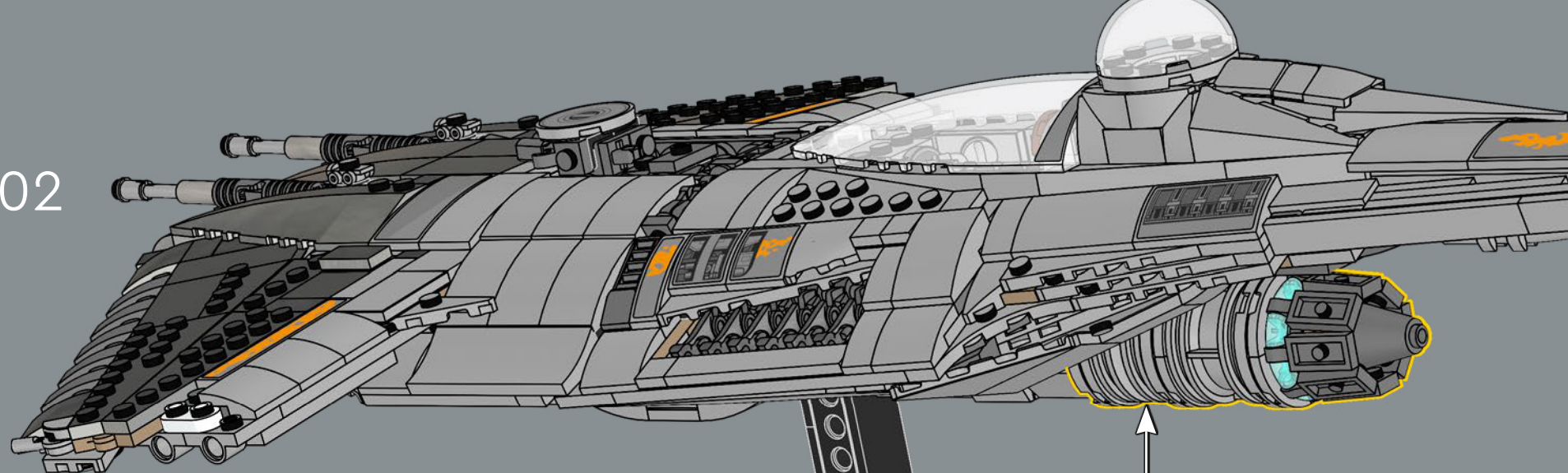

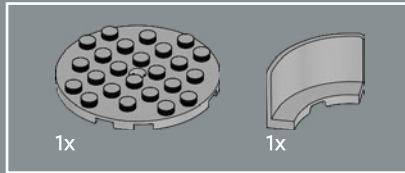
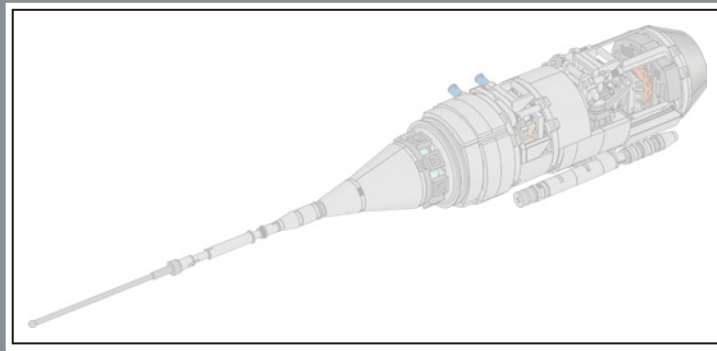

403

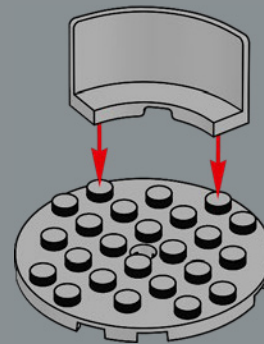

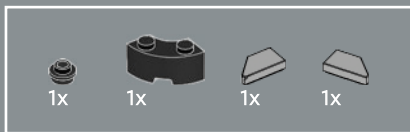

404

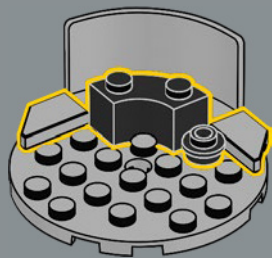

405

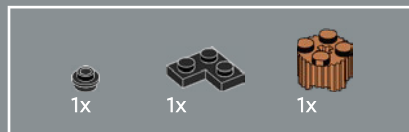
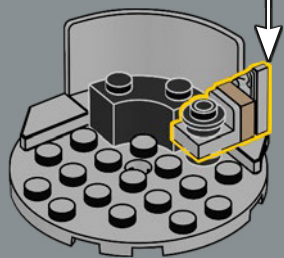
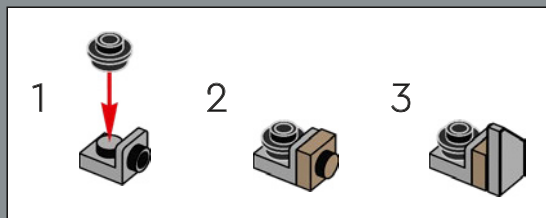

406

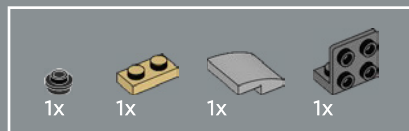
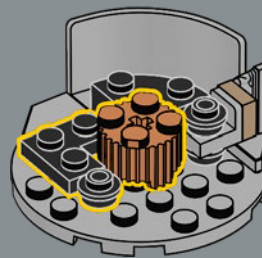

407

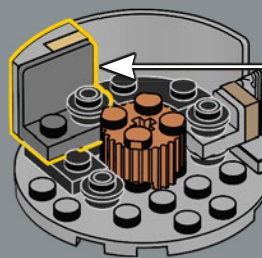
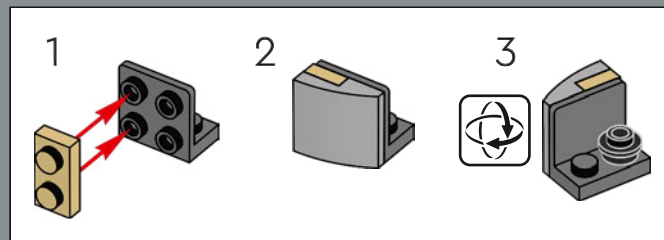

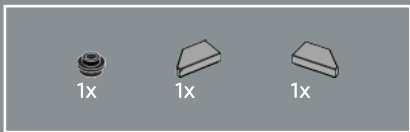

408

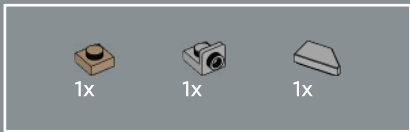
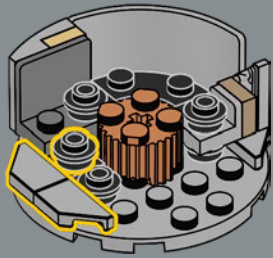

409

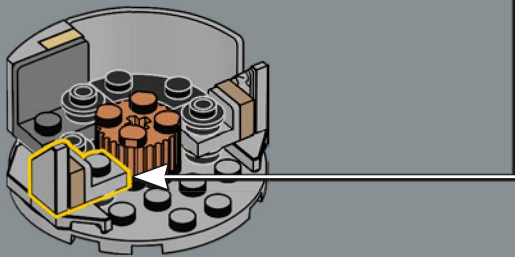
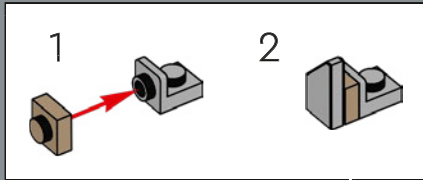

410

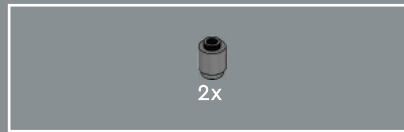
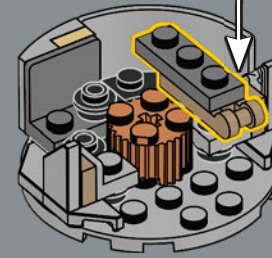
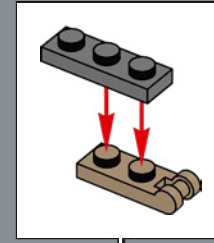

411

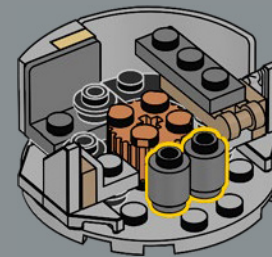

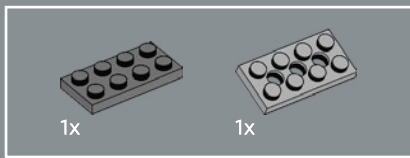

412

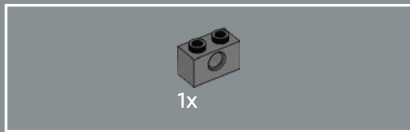
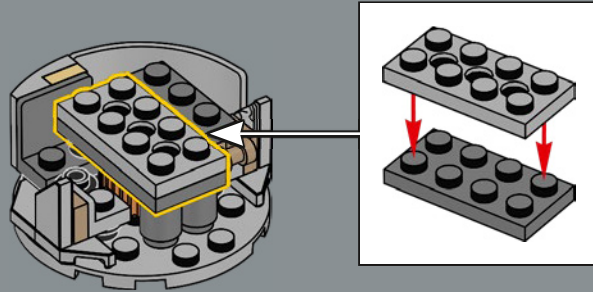

413

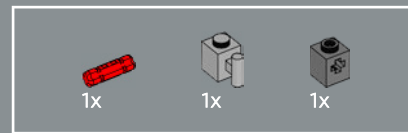
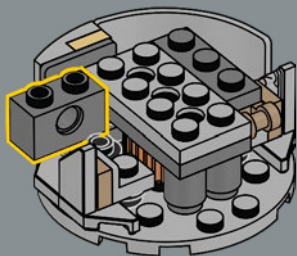

414

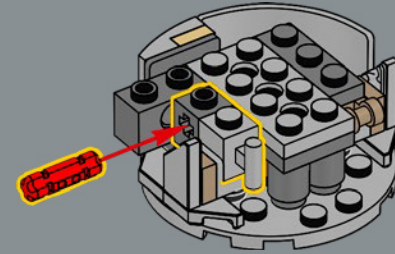

415

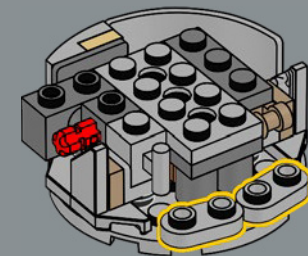

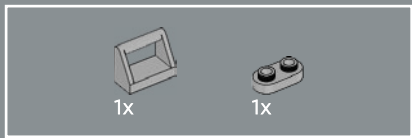

416

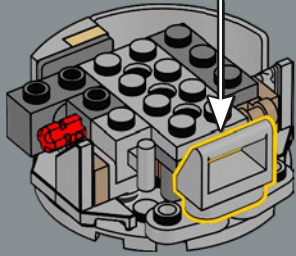
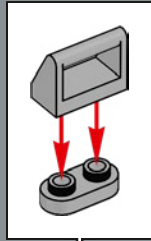

417

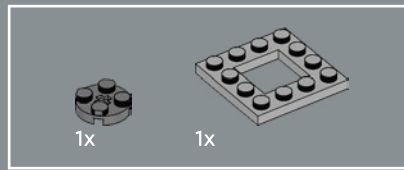
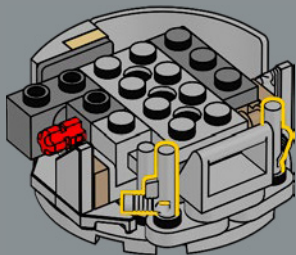

418

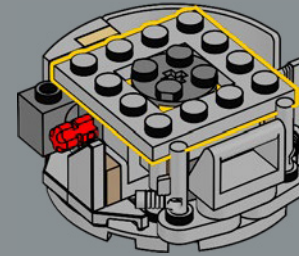

419

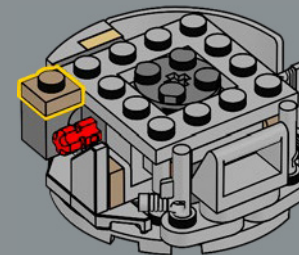

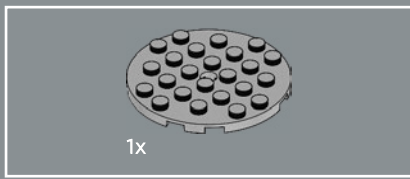

420

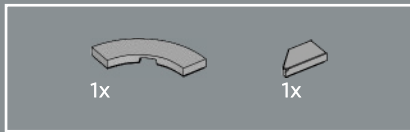
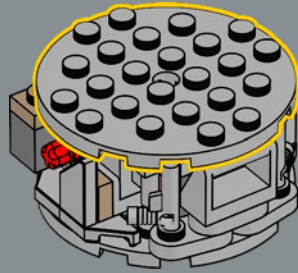

421

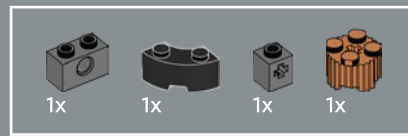
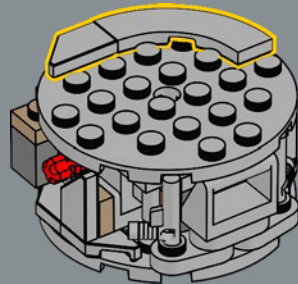

422

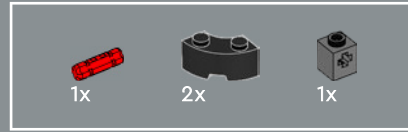
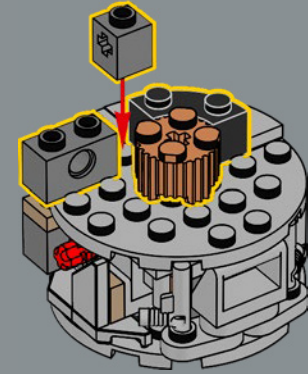

423

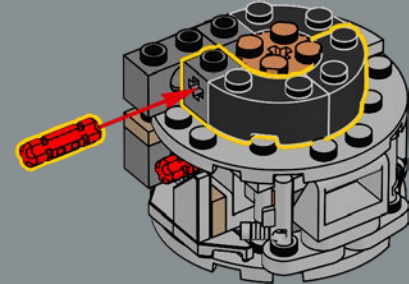

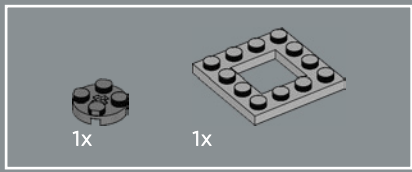

424

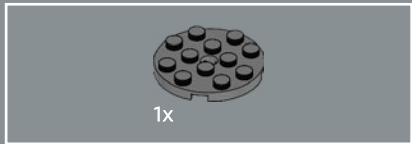
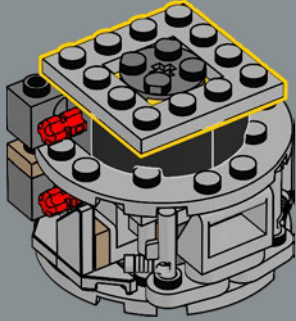

425

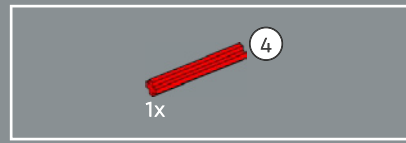
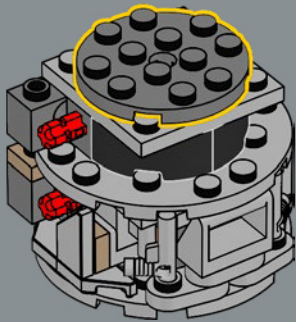

426

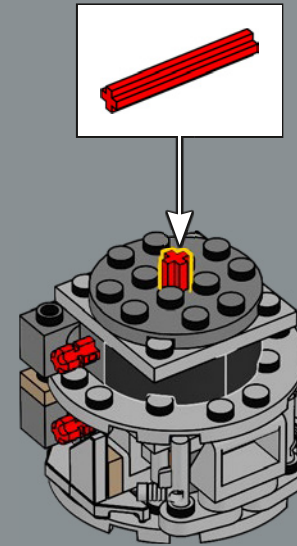

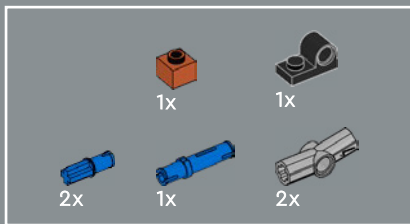

427

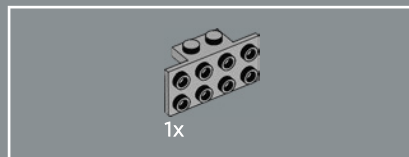
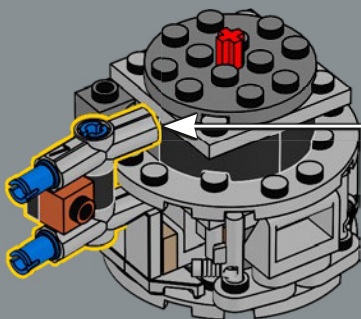
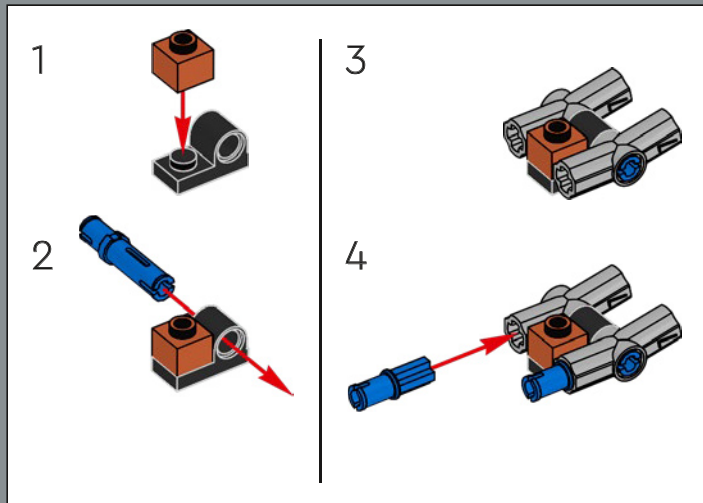

428

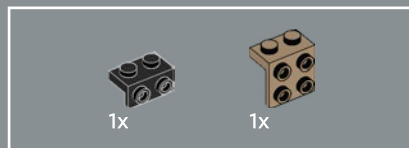
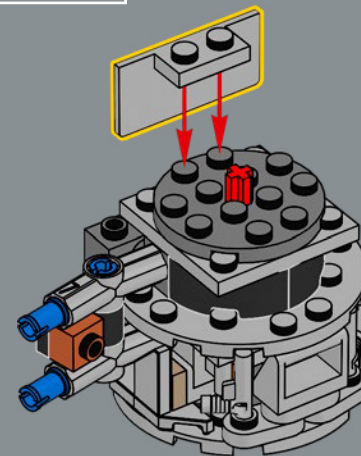

429

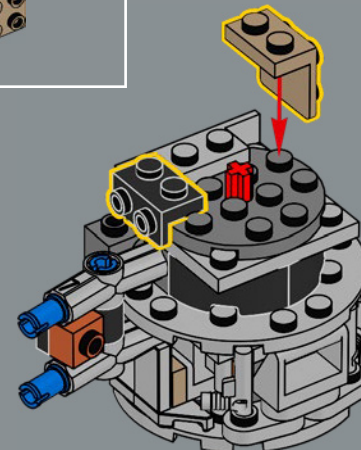

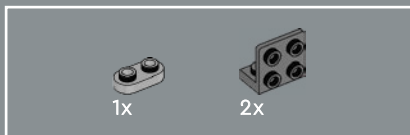

430

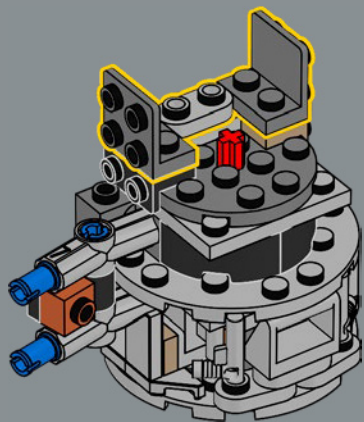

432

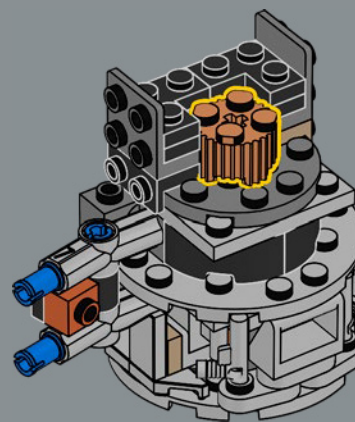

431

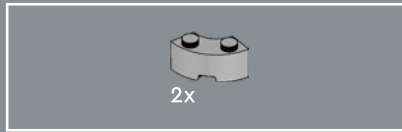
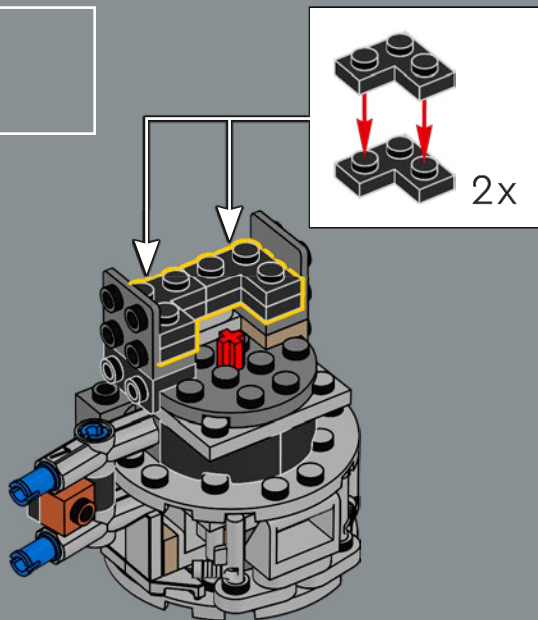

433

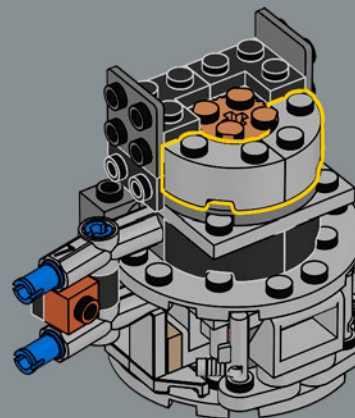

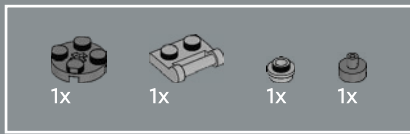

434

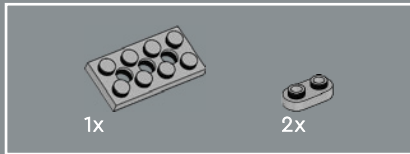
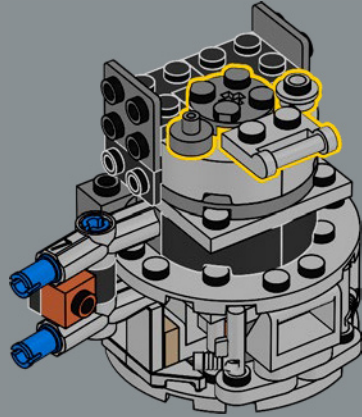

435

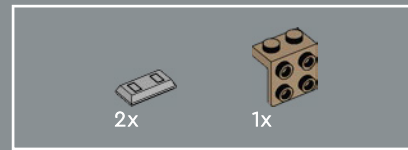
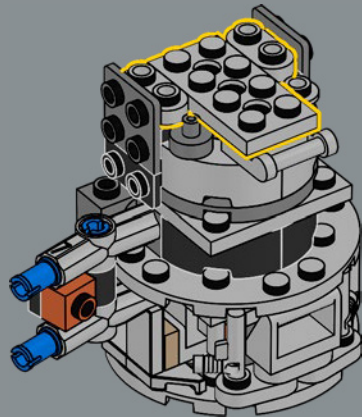

436

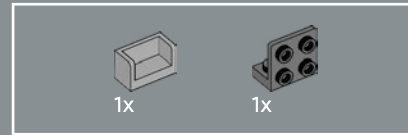
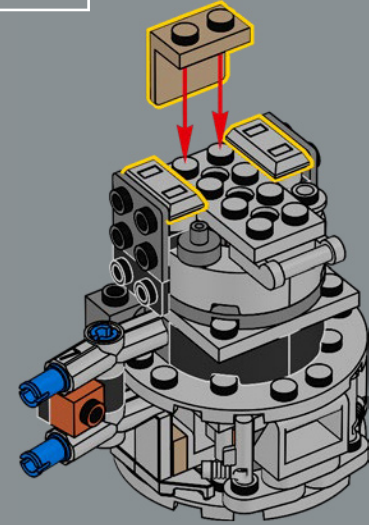

437

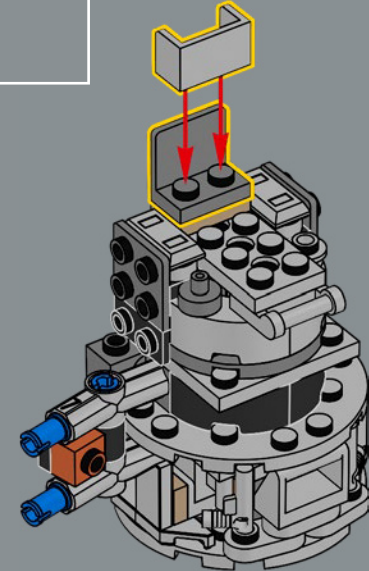

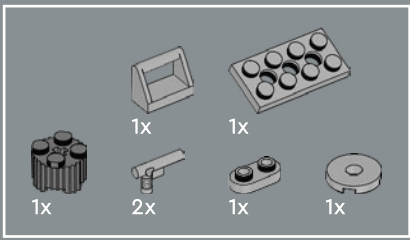

438

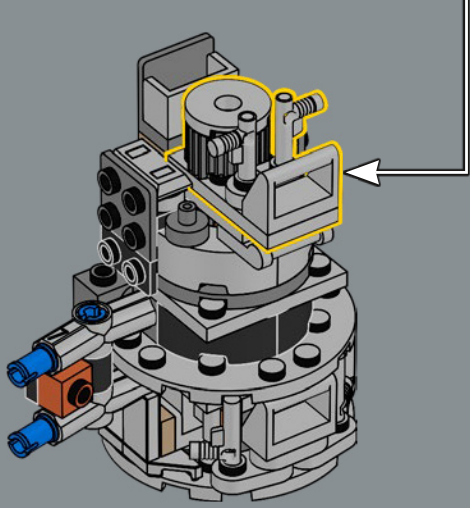
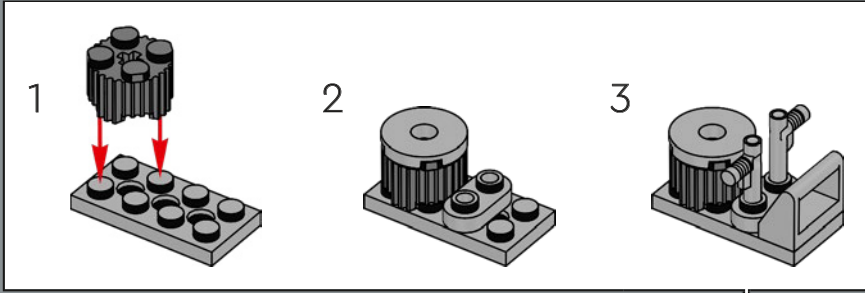

439

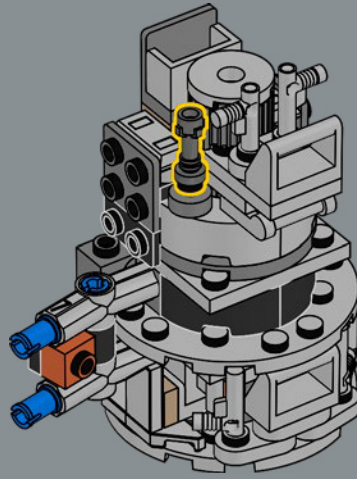

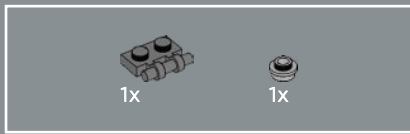

440

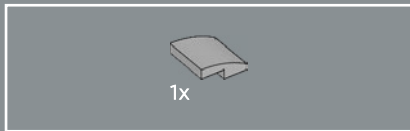
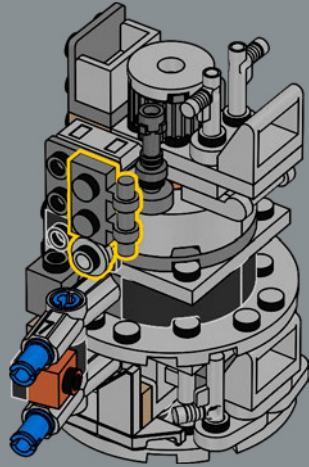

441

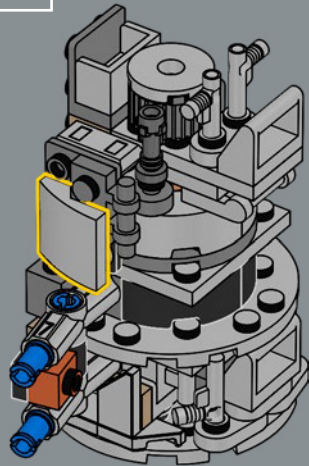

442

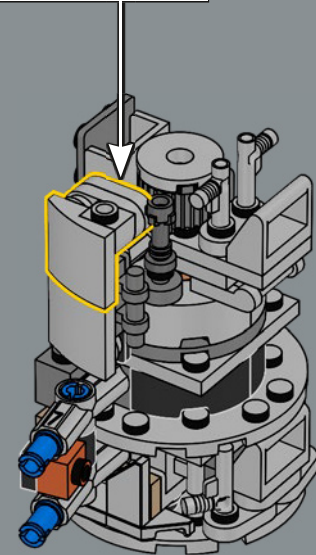
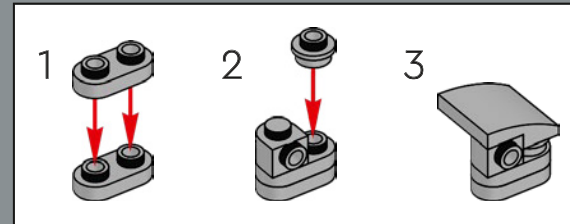



443

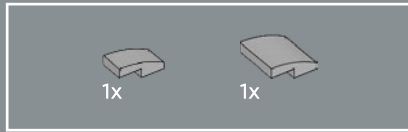
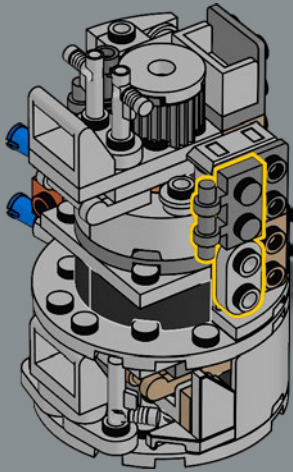

444

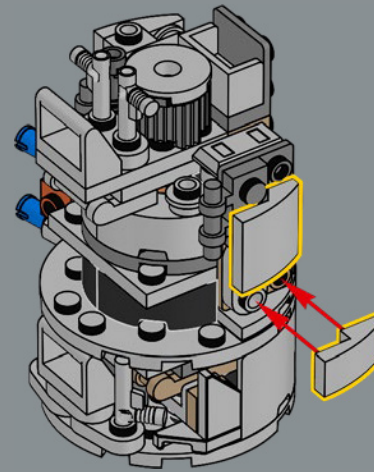

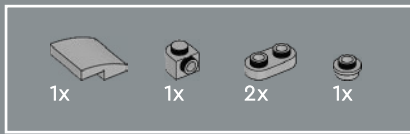

445

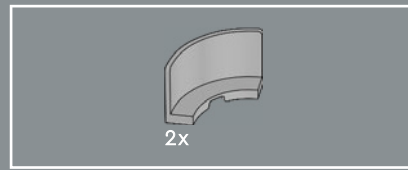
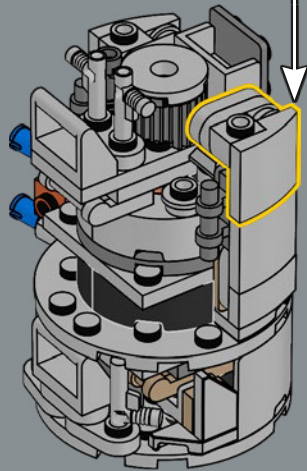
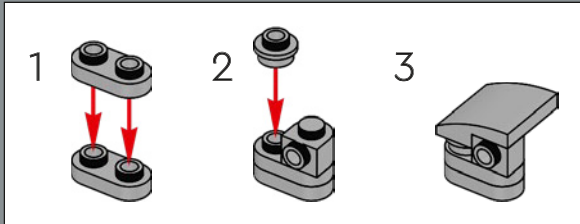

446

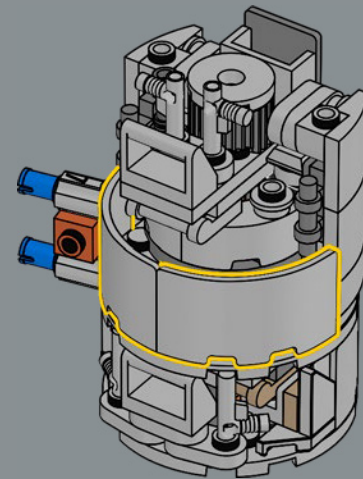

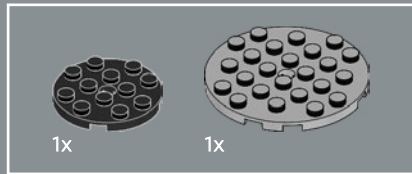
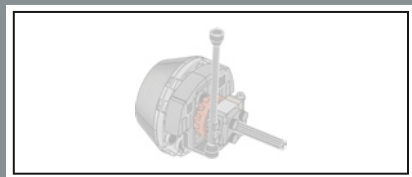

447

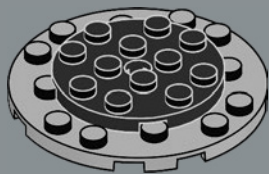

448

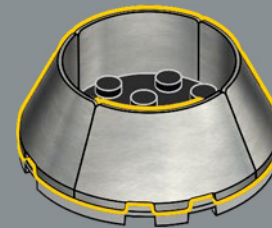

449

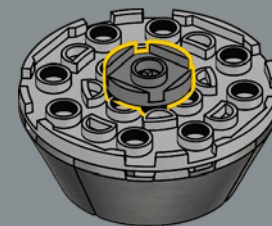

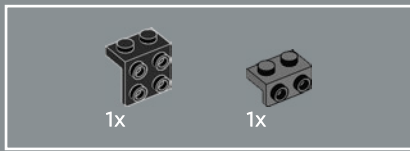

450

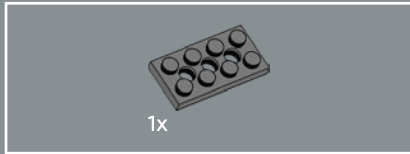
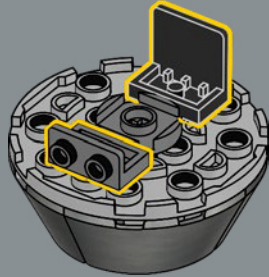

451

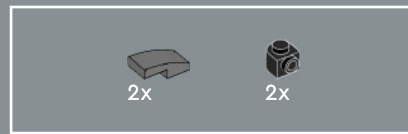
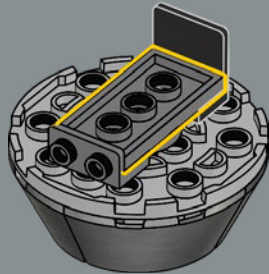

452

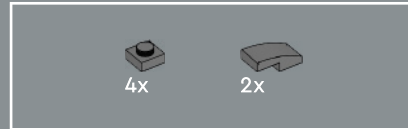
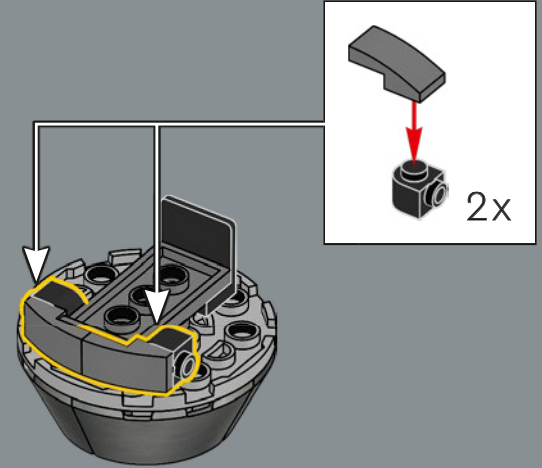

453

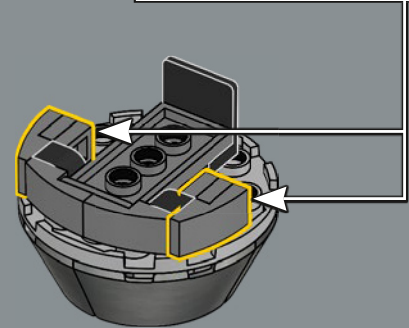
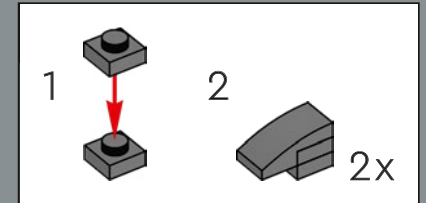

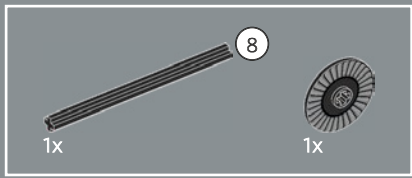

454

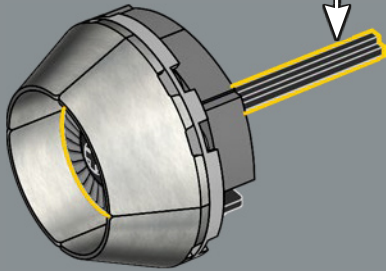
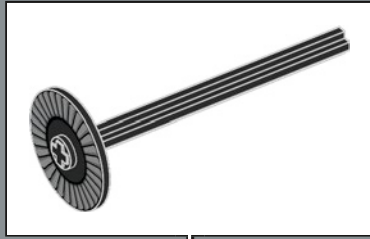

455

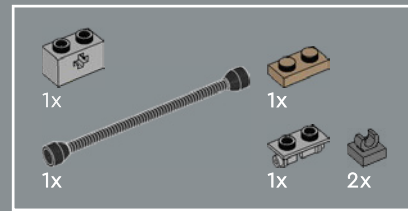
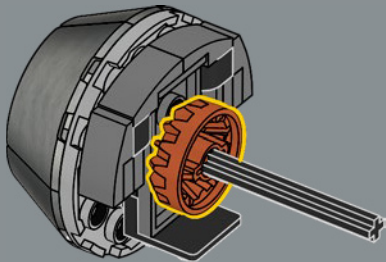

456

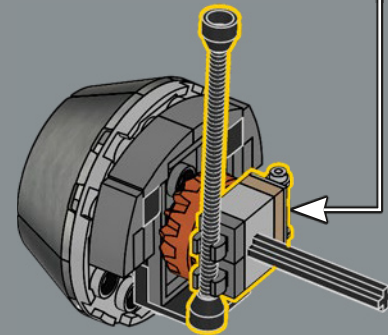
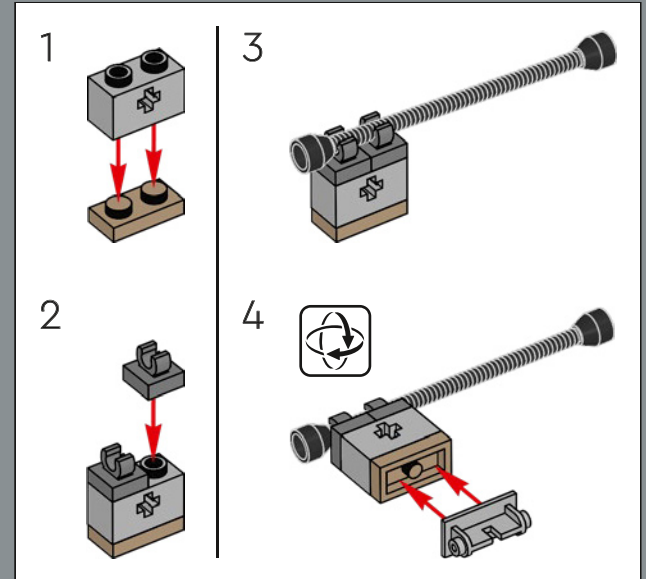



1x

457

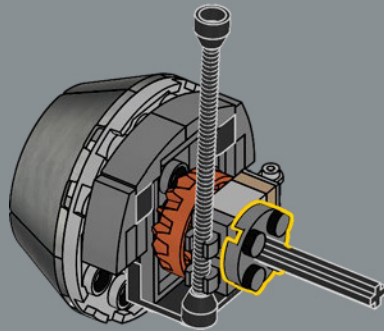

458

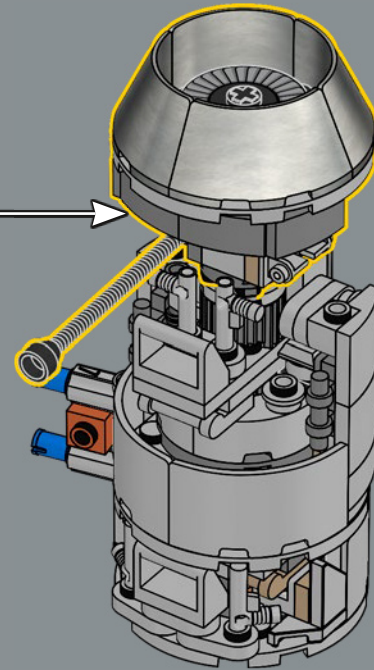

459

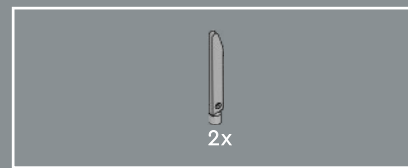
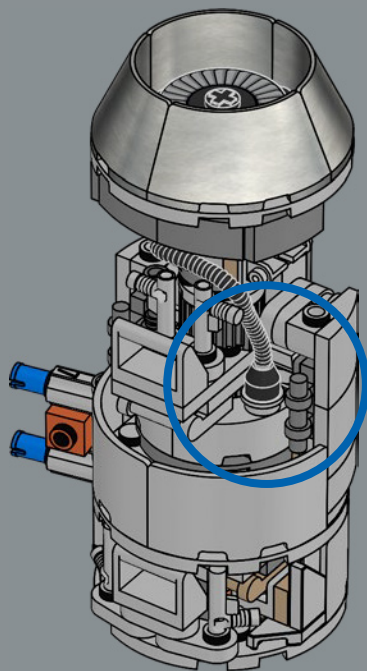

460

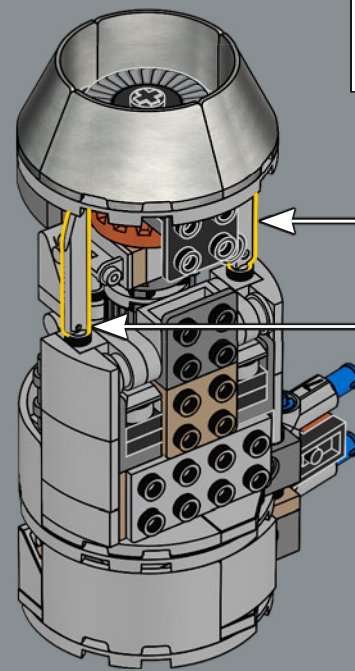
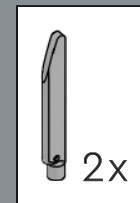

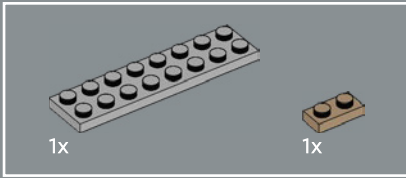
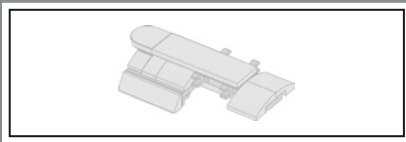

461

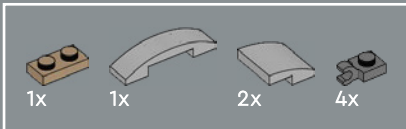
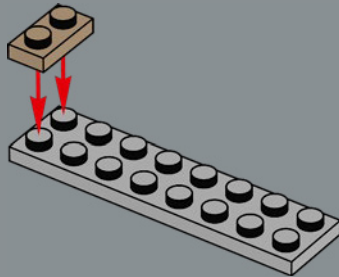

462

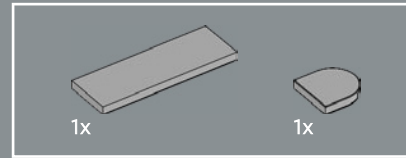
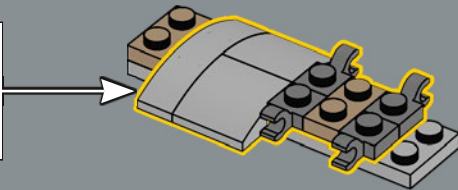
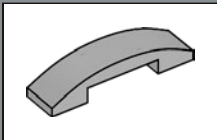

463

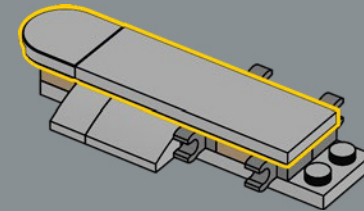

464

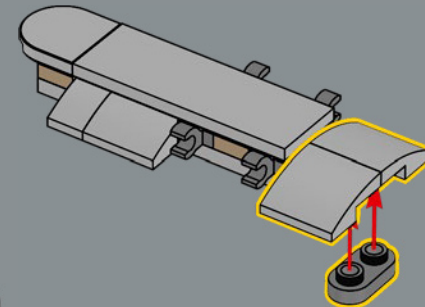

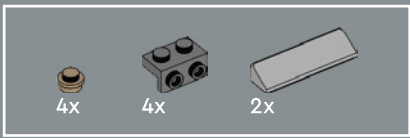

465

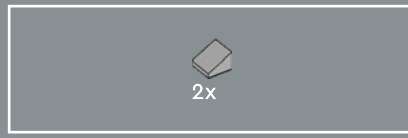
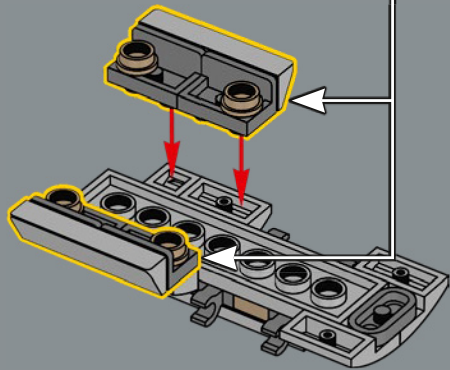
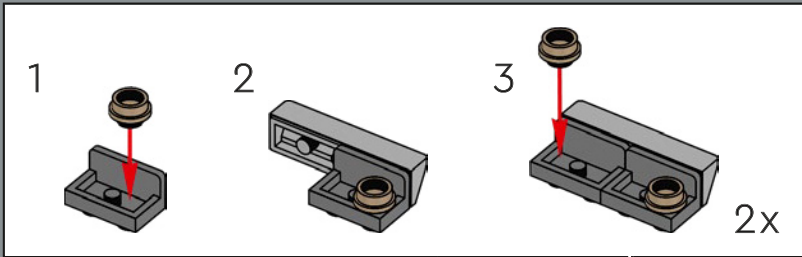

466

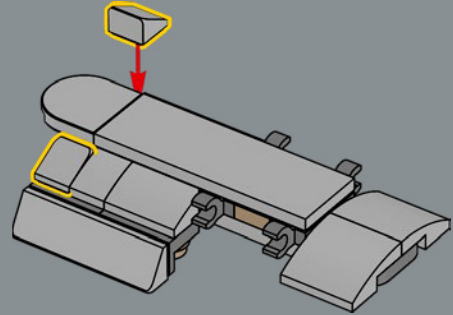

467

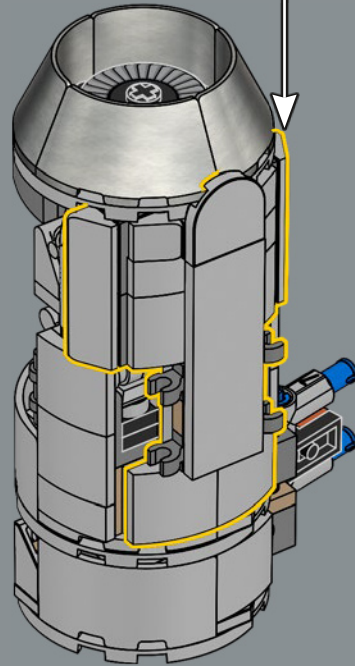

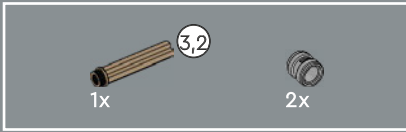
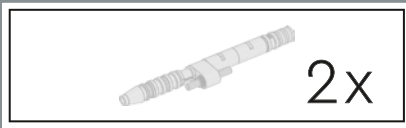

468

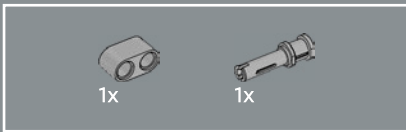
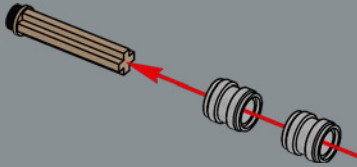

469

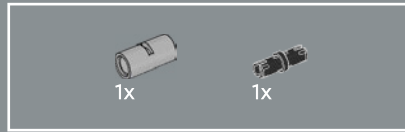
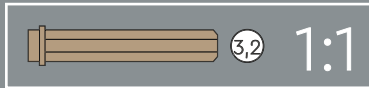
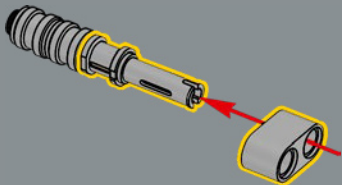

470

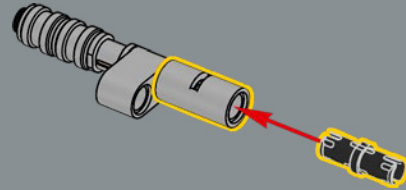

471

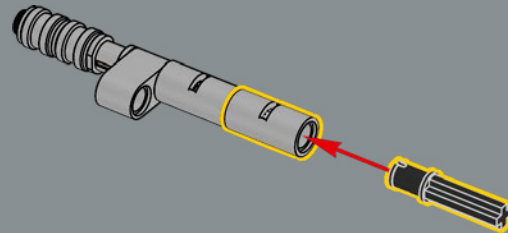

472

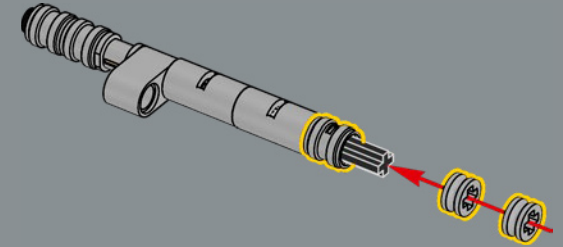

473

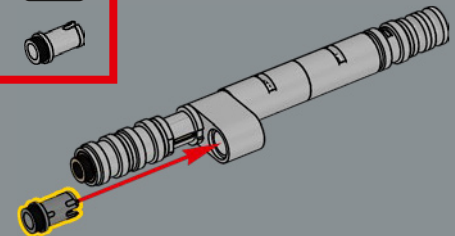
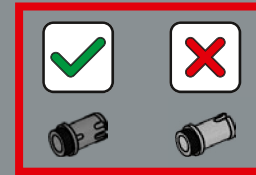

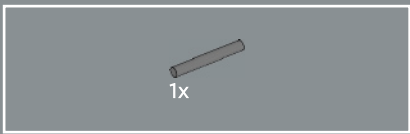

474

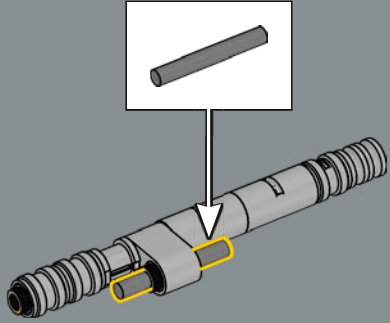

475

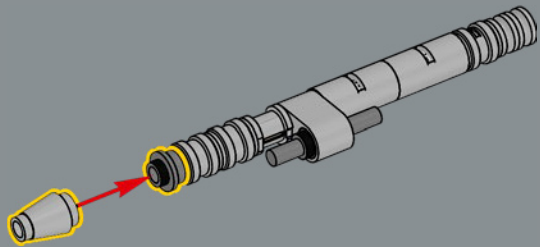

2x

476

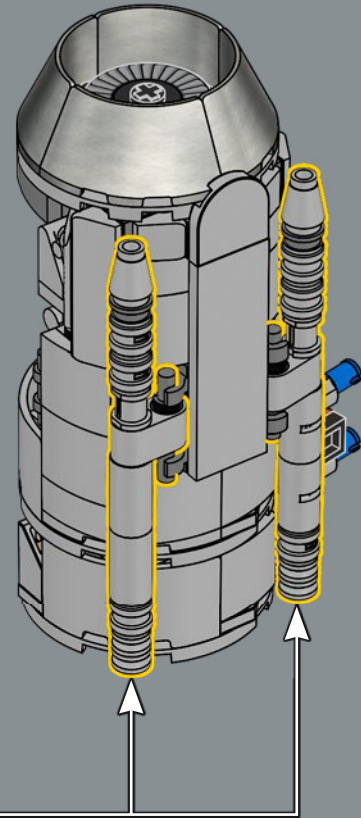

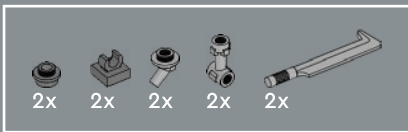

477

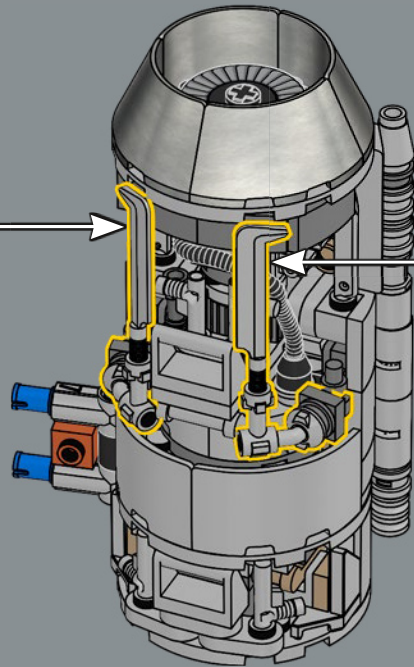
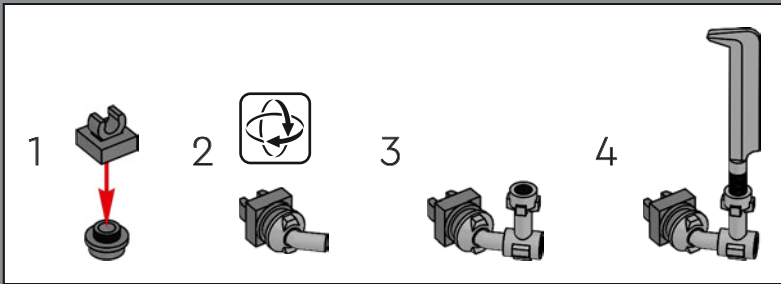
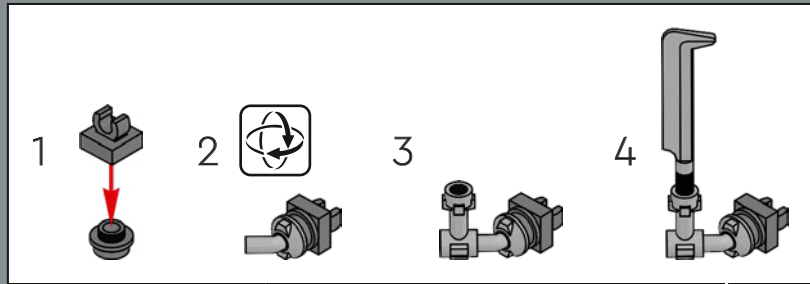

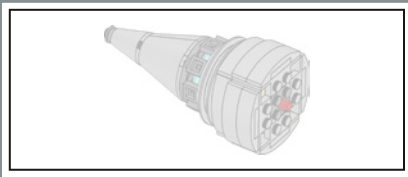

478

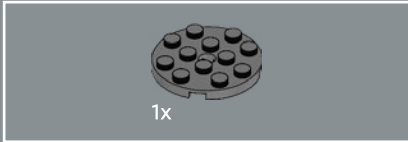

479

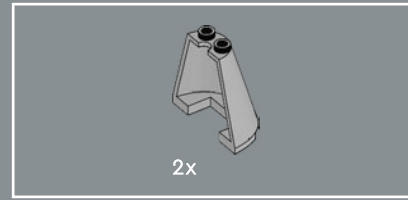

480

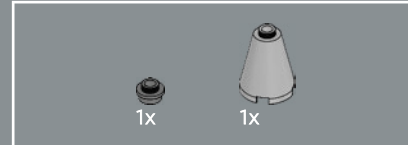
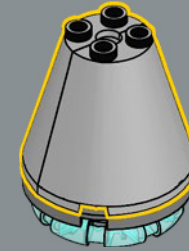

481

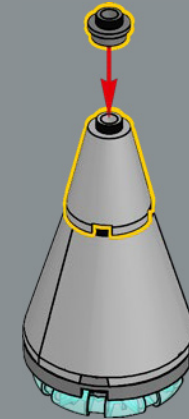

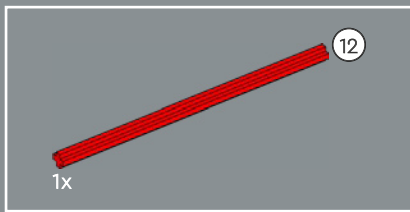

482

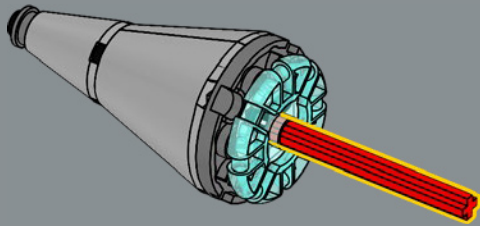

483

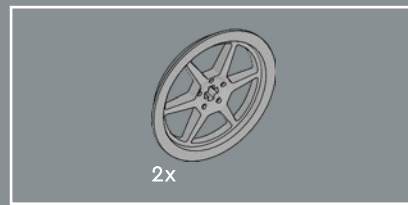
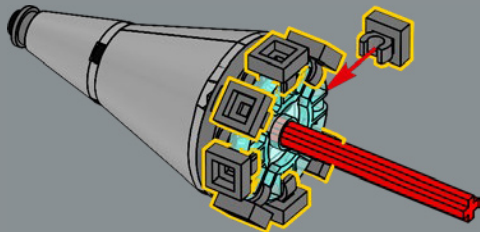

484

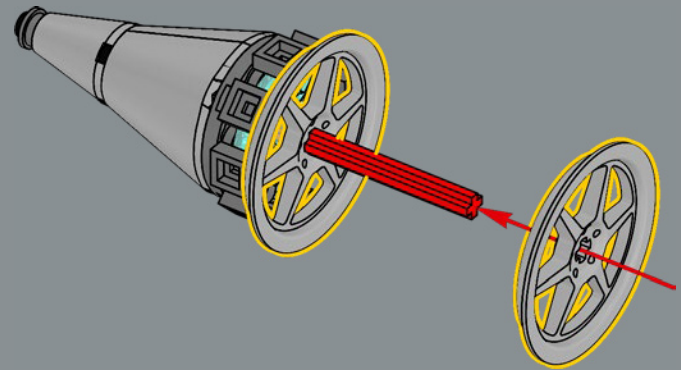

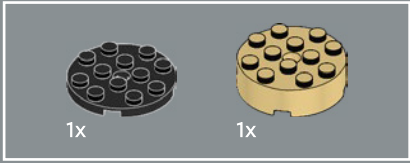
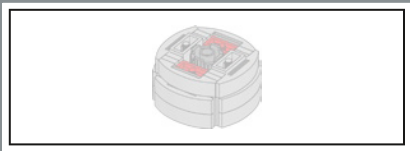

485

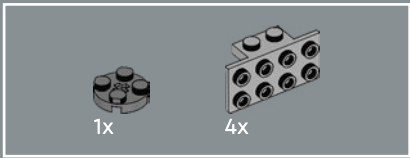
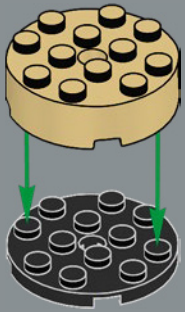

486

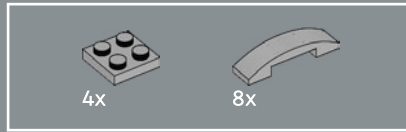
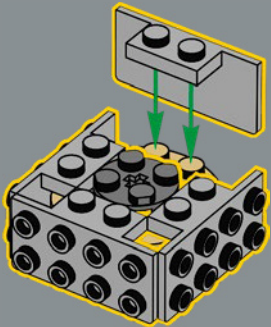

487

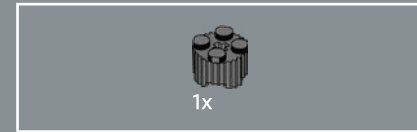
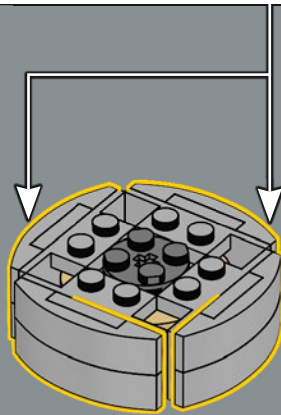
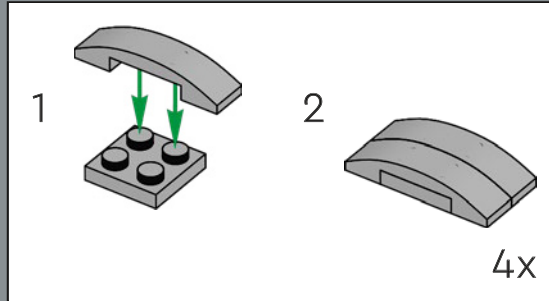

488

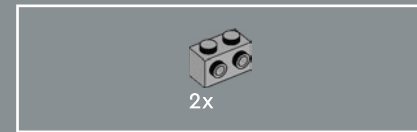
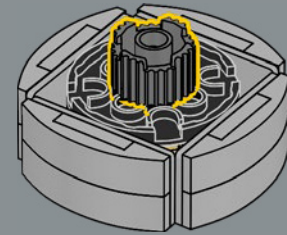

489

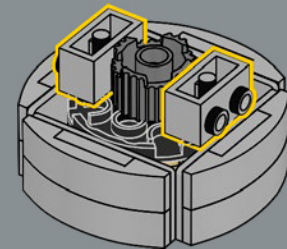

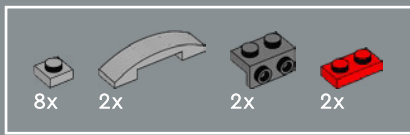

490

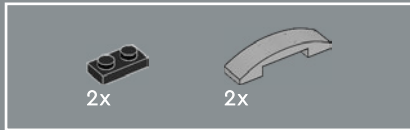
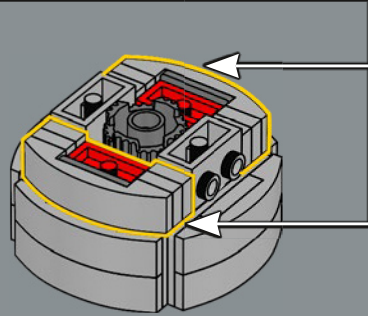
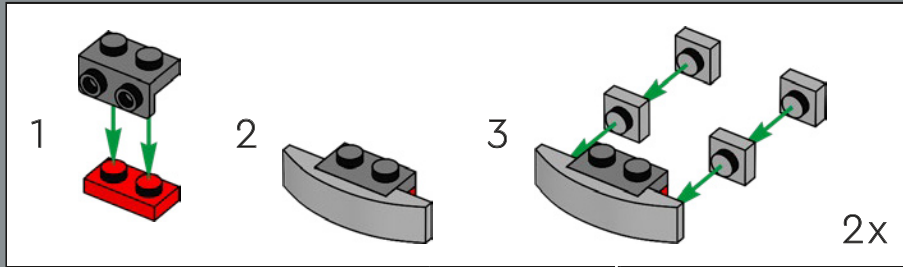

491

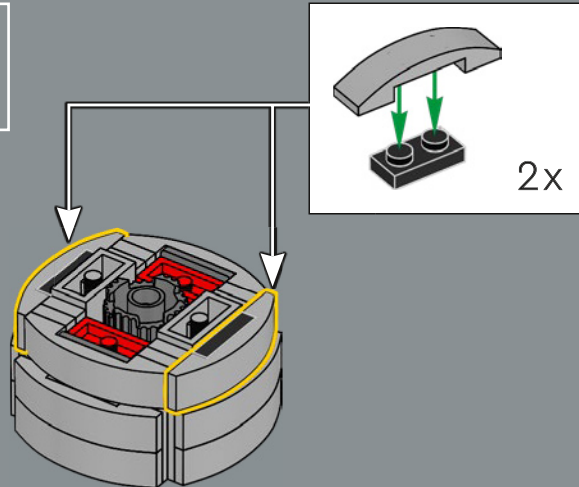

492

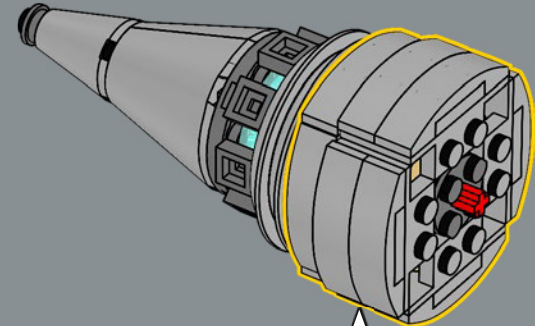

493

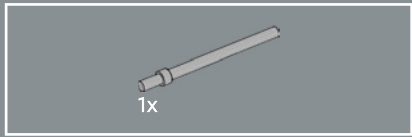
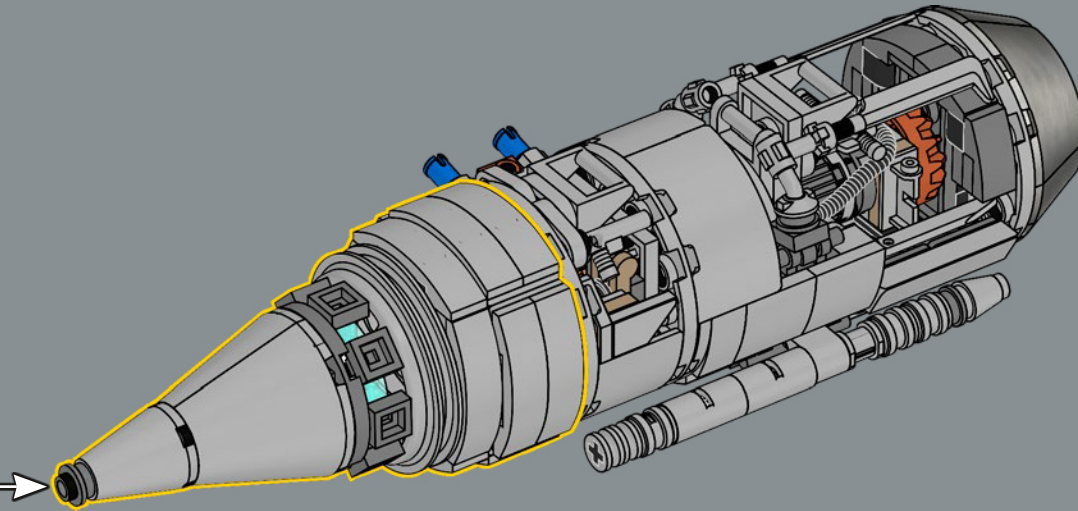

494

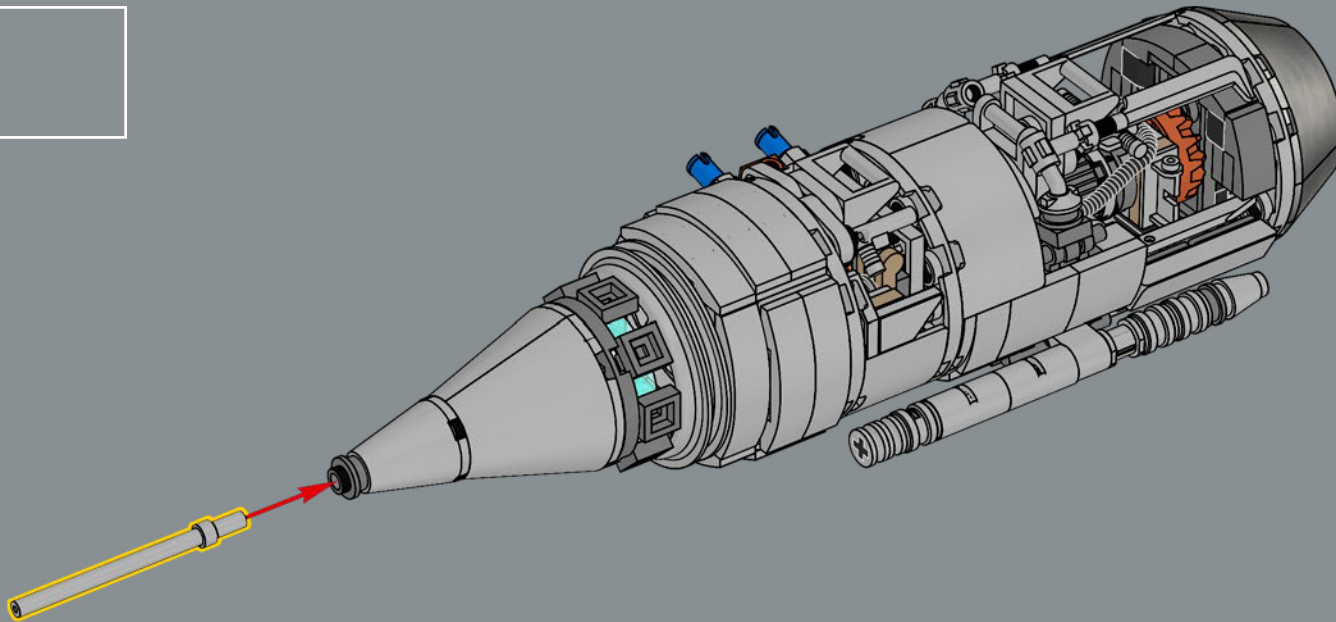

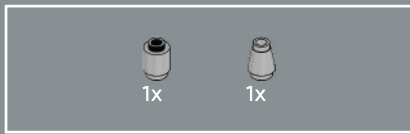

495

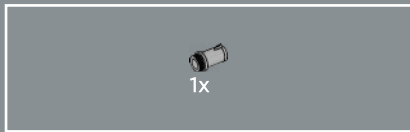
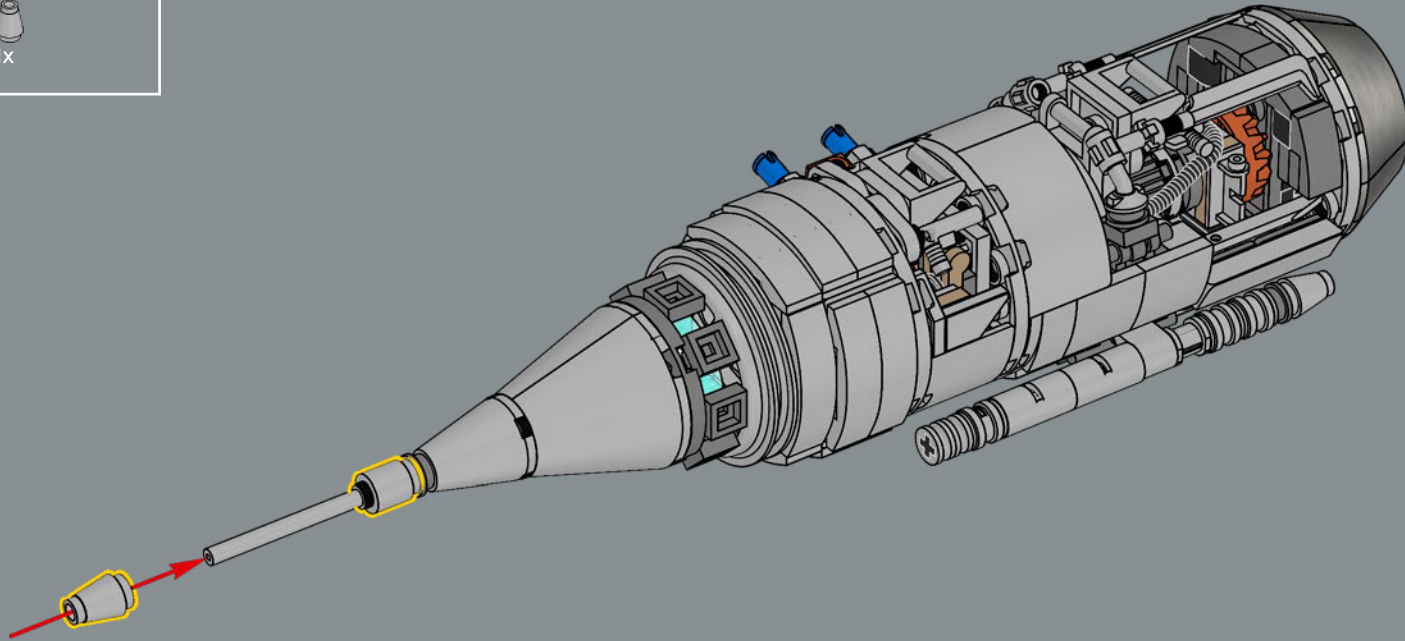

496

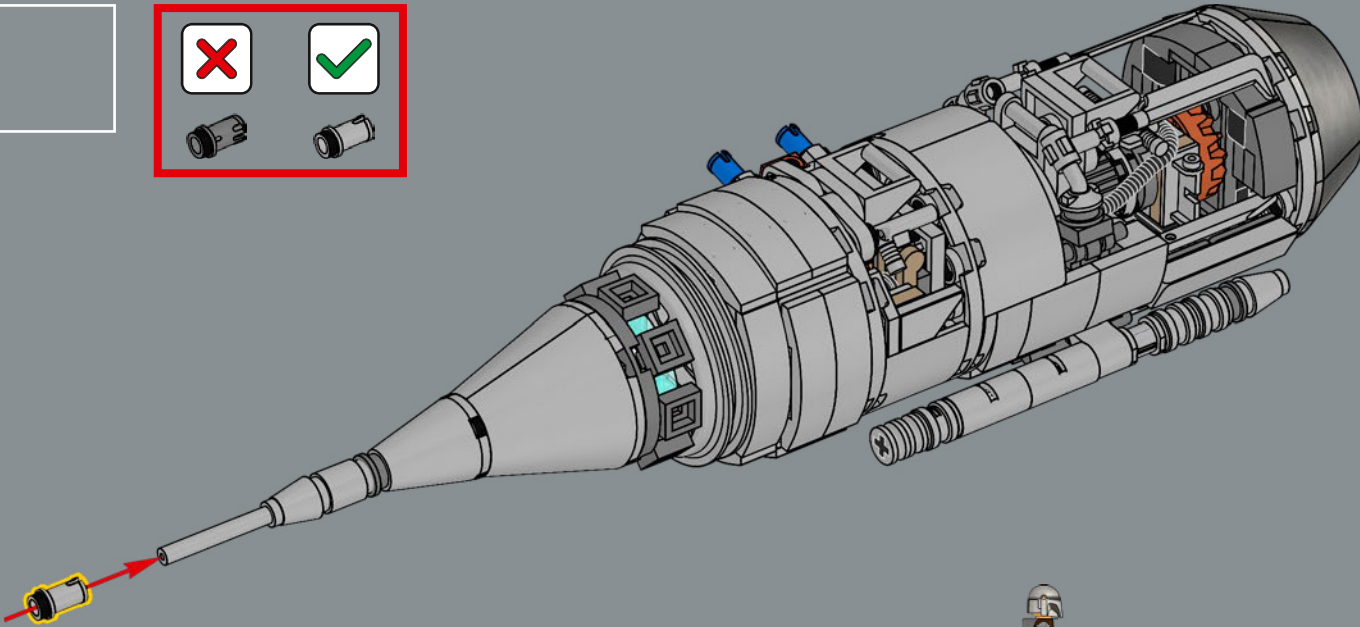
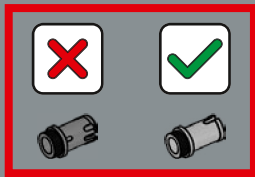

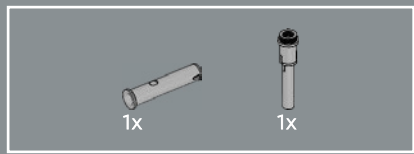

497

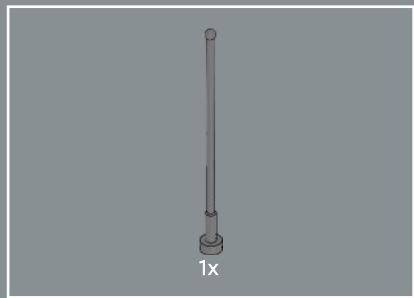
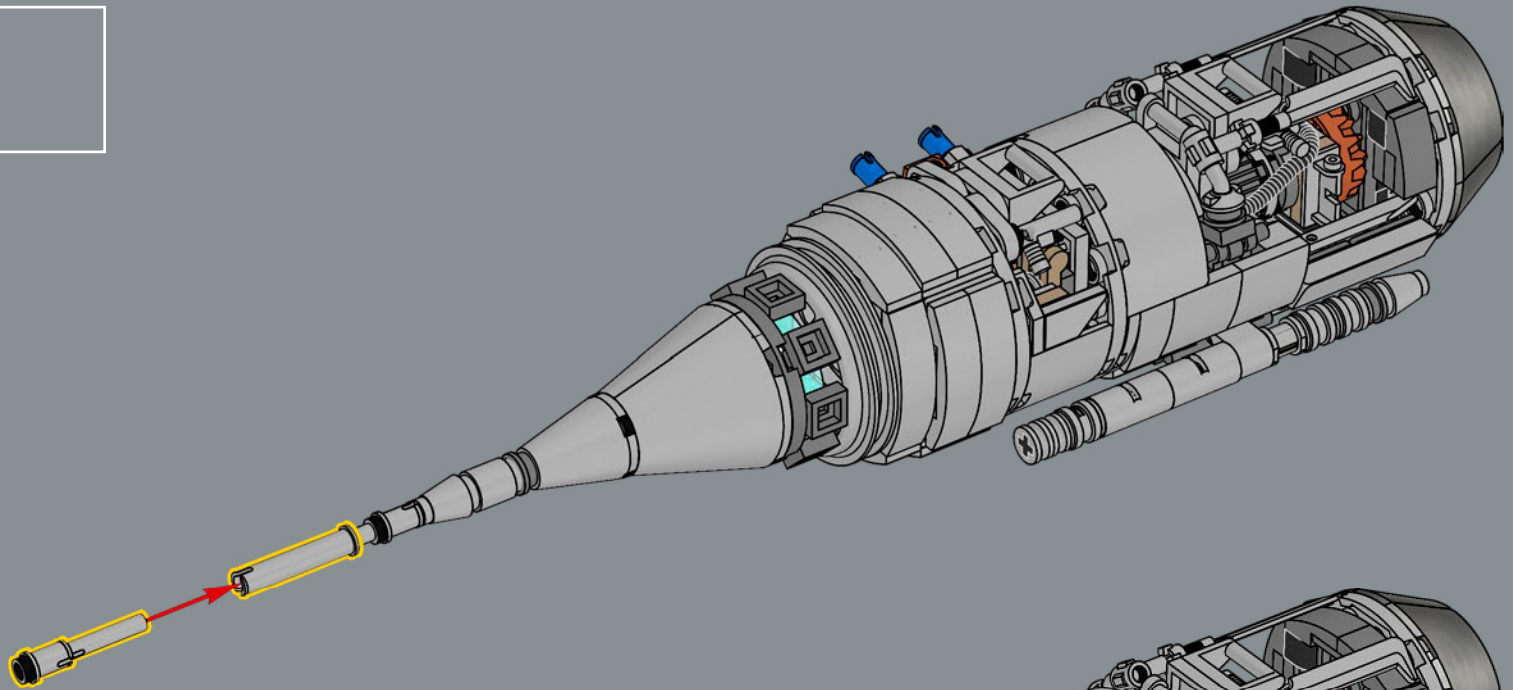

498

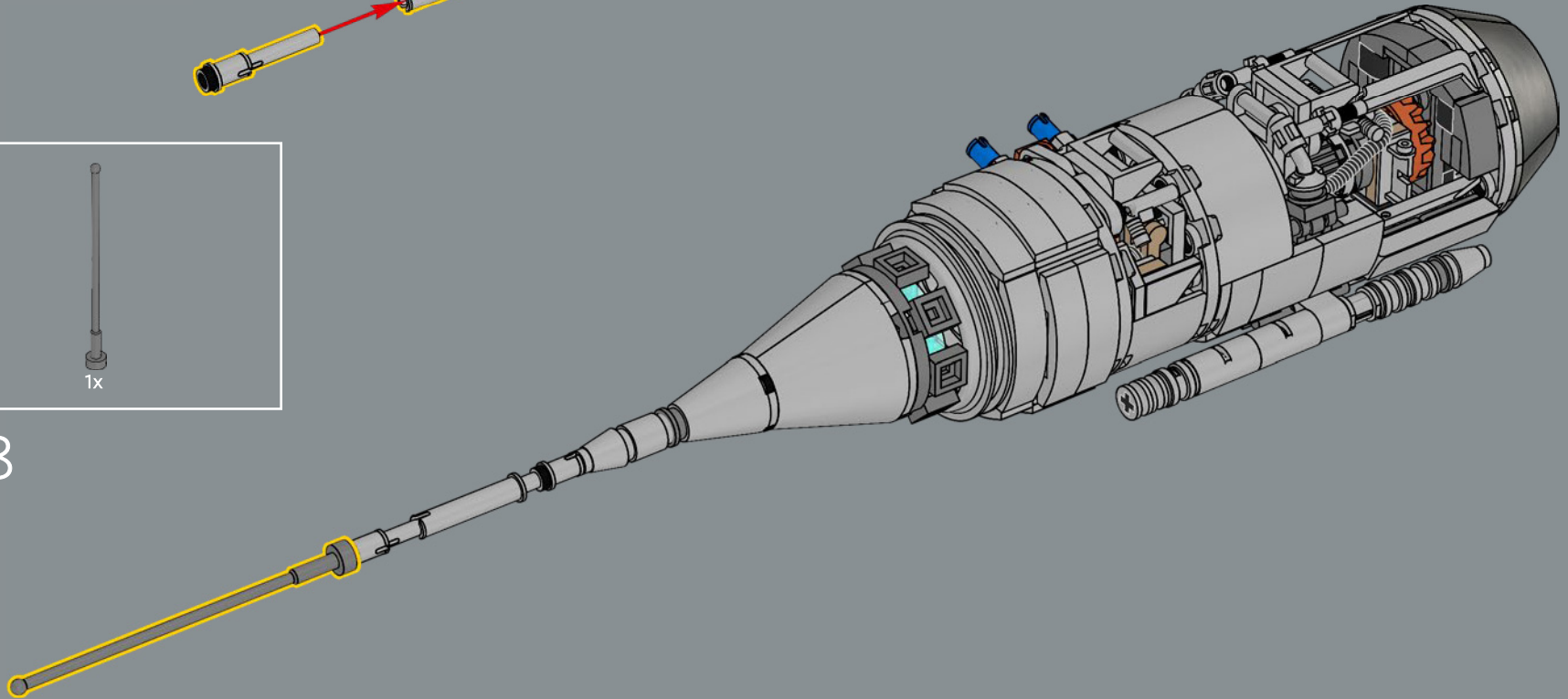

499

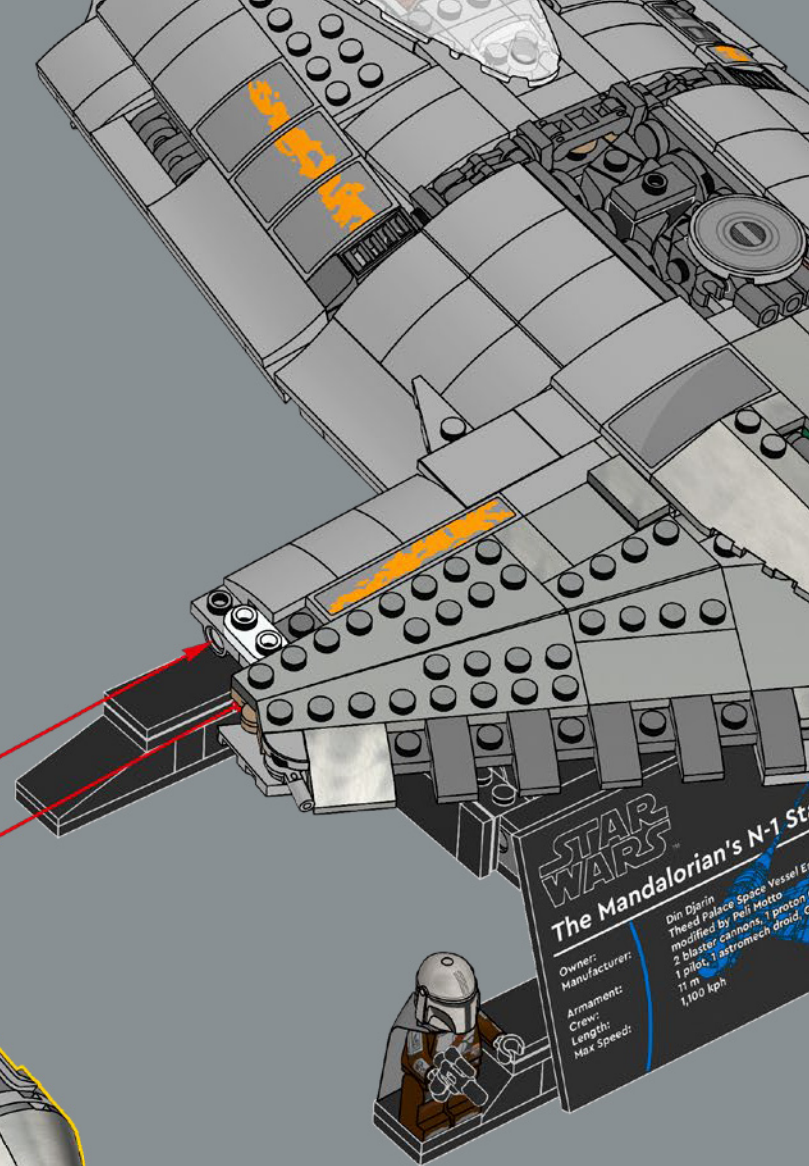
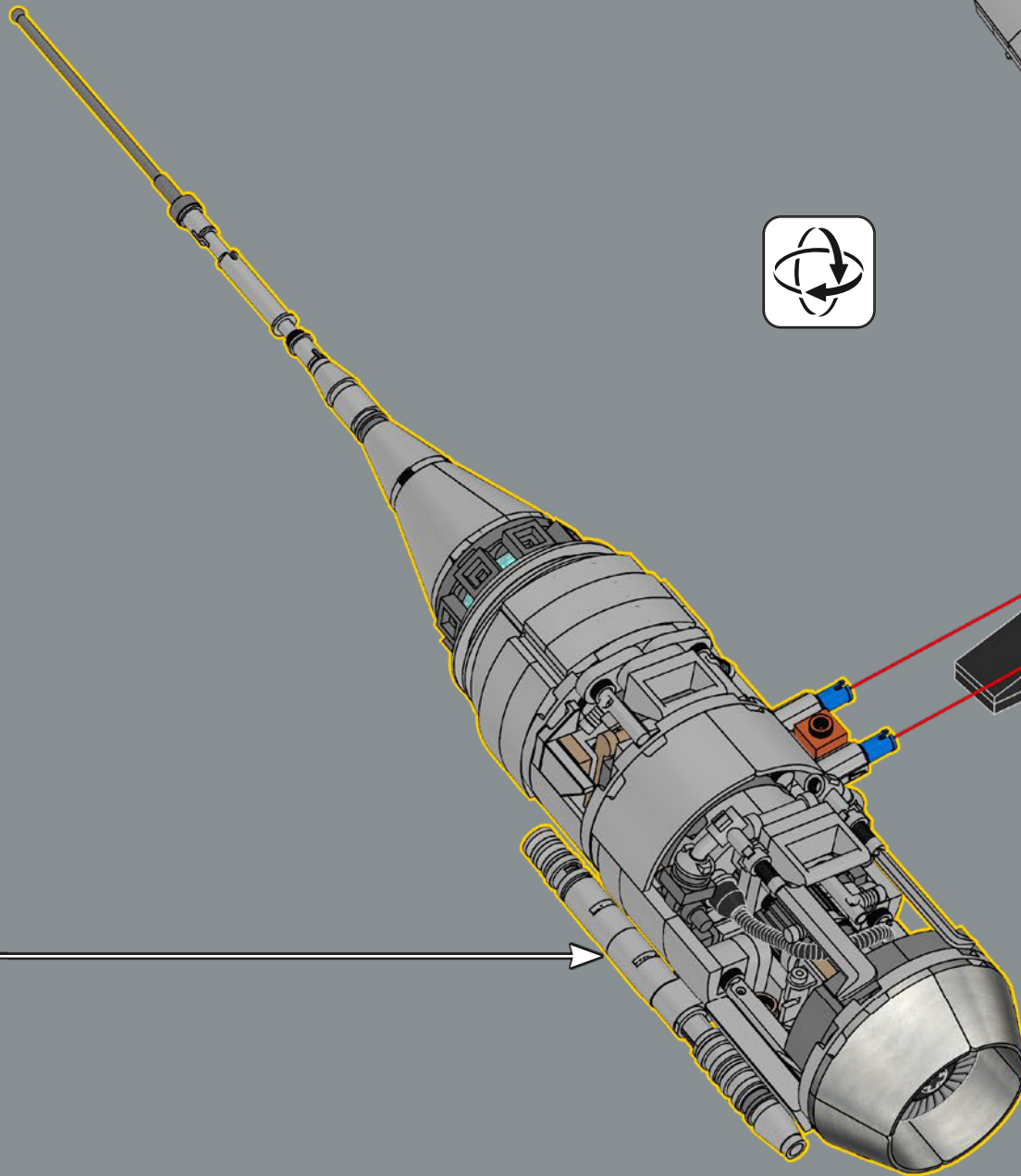

**STAR WARS**  
**The Mandalorian's N-1 Starfighter**

Owner: Din Djarin  
Manufacturer: Theed Palace Space Vessel Engineering  
modified by Peli Motto

Armament: 2 blaster cannons, 1 proton torpedoes  
Crew: 1 pilot, 1 astromech droid  
Length: 11 m  
Max Speed: 1,100 kph



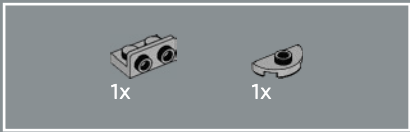

500

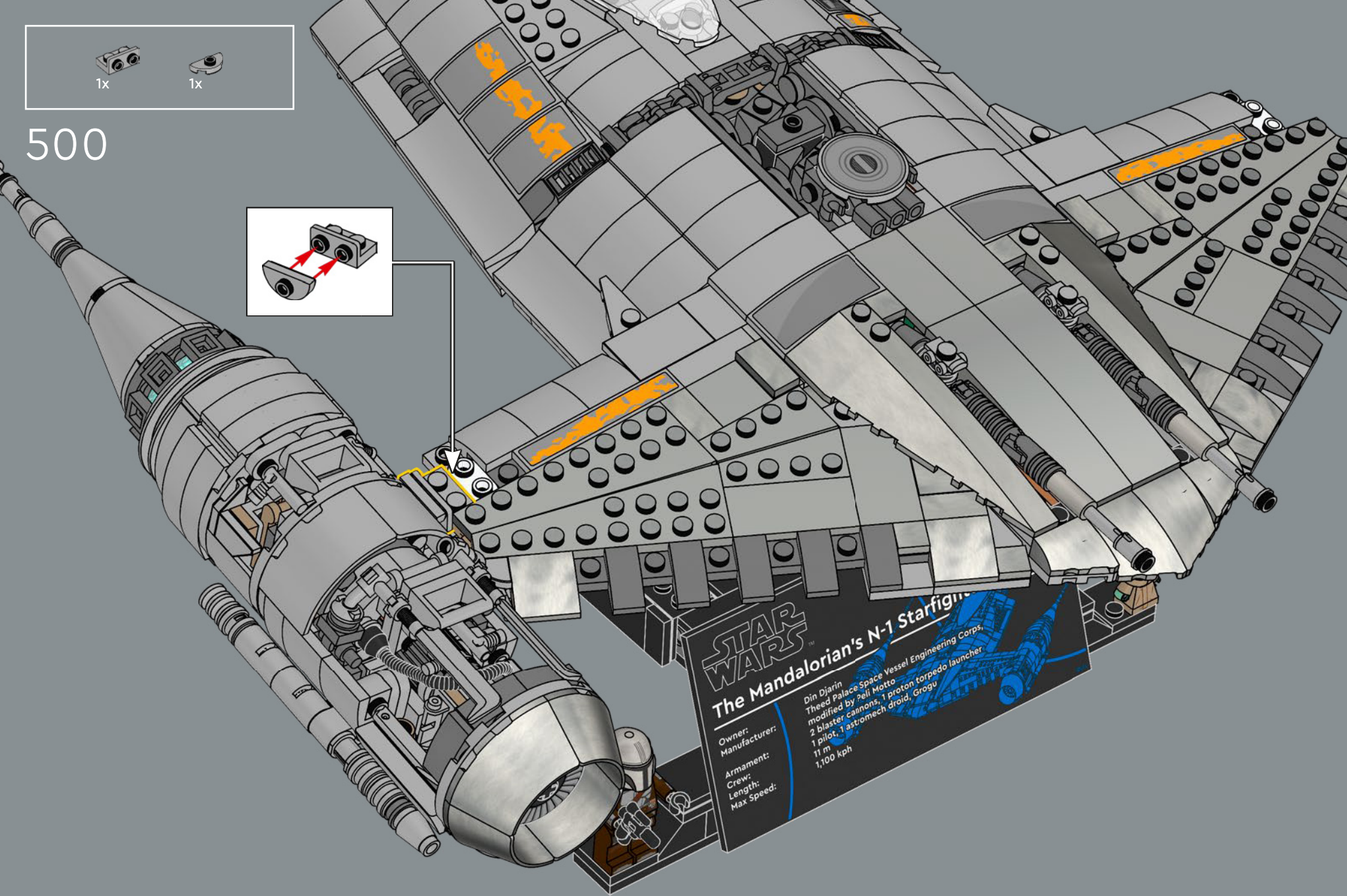
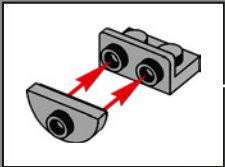

**STAR WARS**  
**The Mandalorian's N-1 Starfighter**

Owner: Din Djarin  
 Manufacturer: Theed Palace Space Vessel Engineering Corps, modified by Pelli Motto  
 Armament: 2 blaster cannons, 1 proton torpedo launcher  
 Crew: 1 pilot, 1 astromech droid, Grogu  
 Length: 11 m  
 Max Speed: 1,100 kph

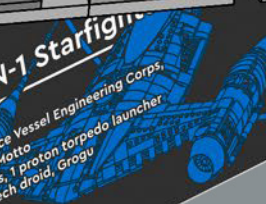

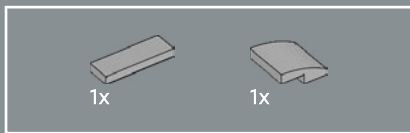

501

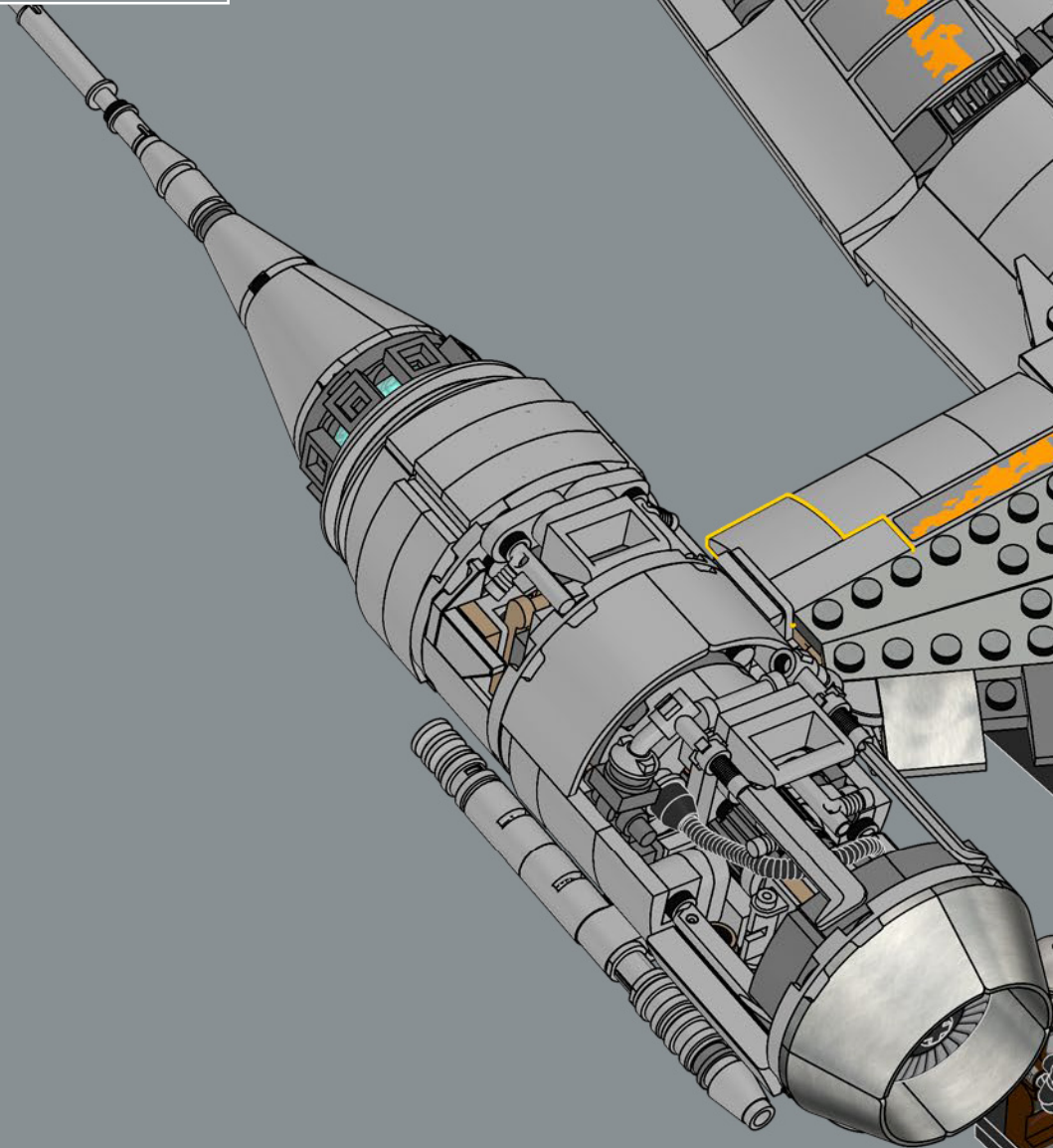

**STAR WARS™**  
**The Mandalorian's N-1 Starfighter**

Din Djarin  
Theed Palace Space Vessel Engineering Corps,  
modified by Peli Motto

2 blaster cannons, 1 proton torpedo launcher  
1 pilot, 1 astromech droid, Grogu

Owner:  
Manufacturer:  
Armament:  
Crew:  
Length:  
Max Speed:





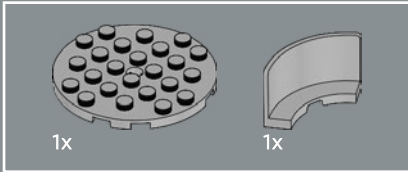
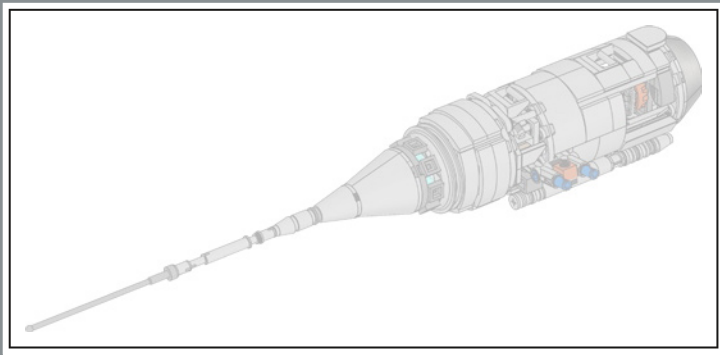

502

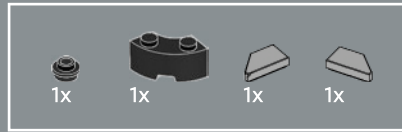
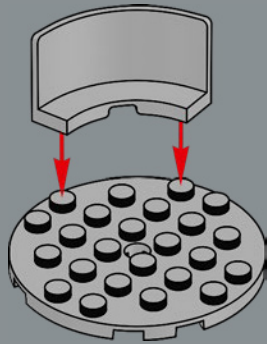

503

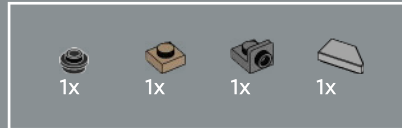
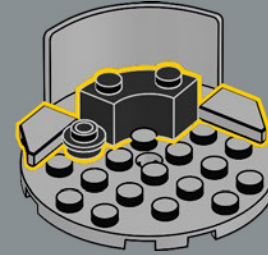

504

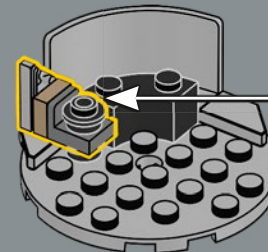
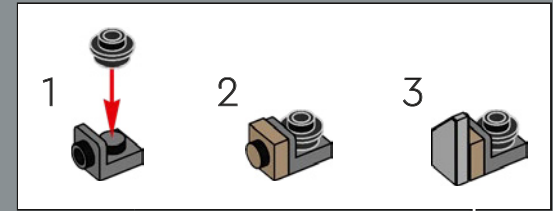



505

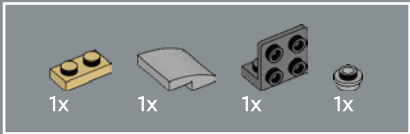
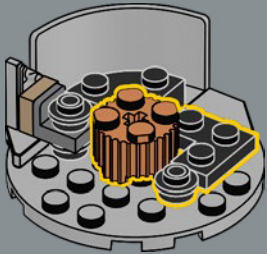

506

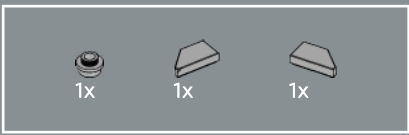
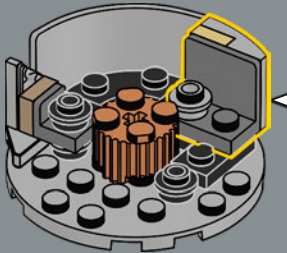
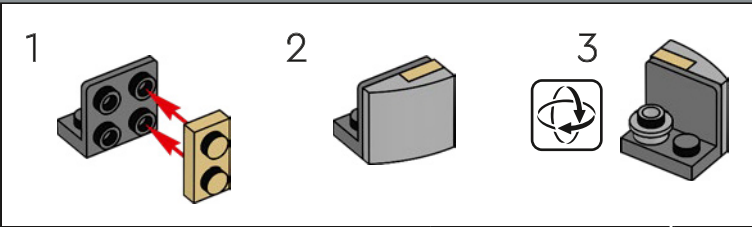

507

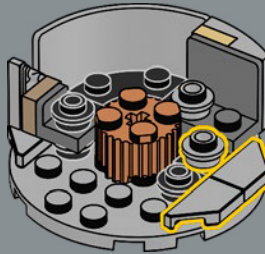

508

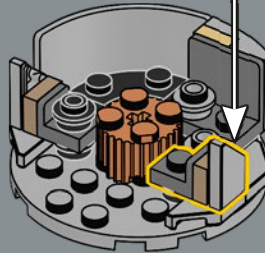
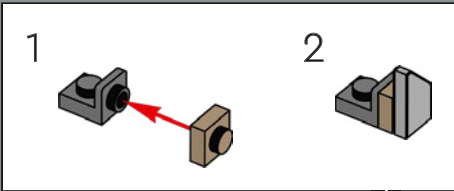

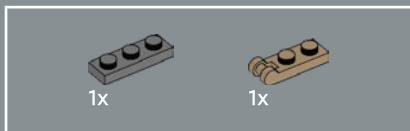

509

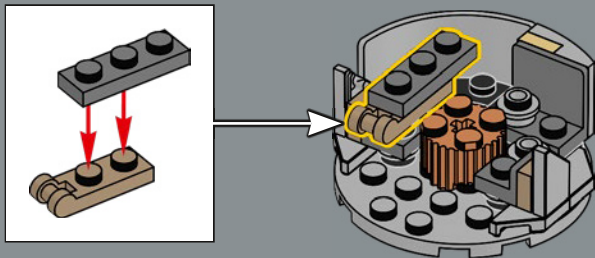

510

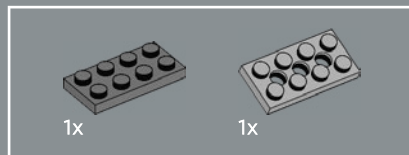
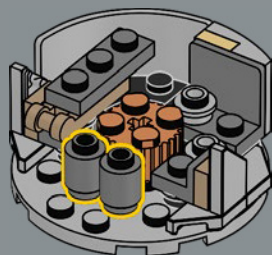

511

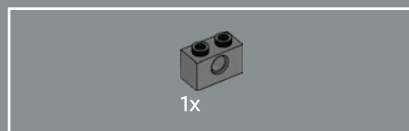
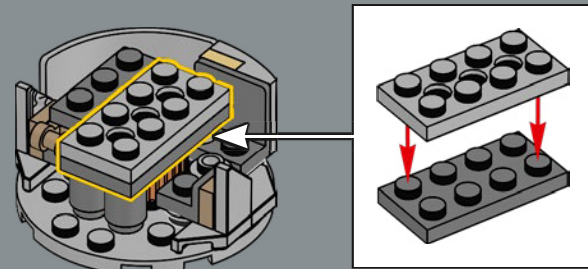

512

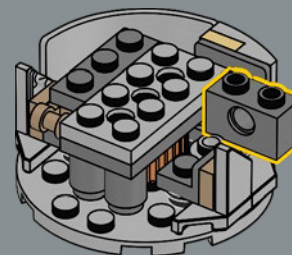



513

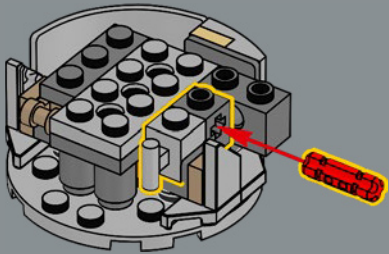

514

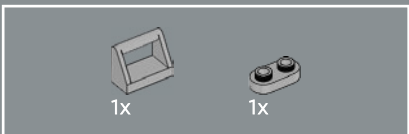
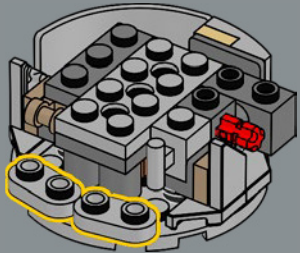

515

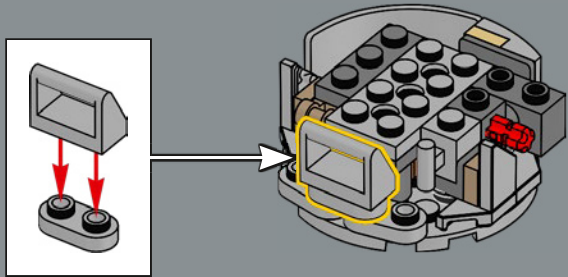

516

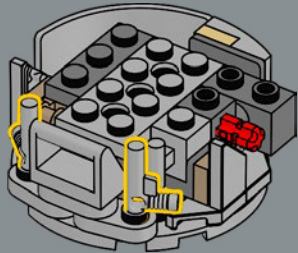

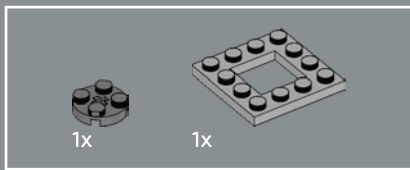

517

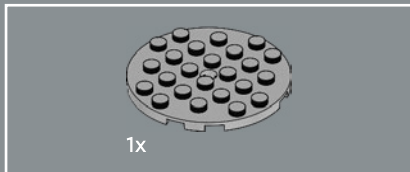
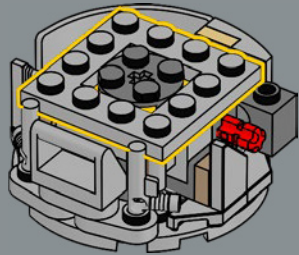

518

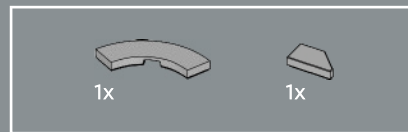
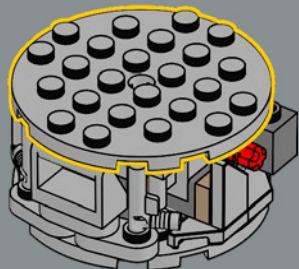

519

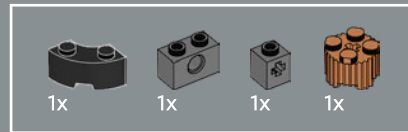
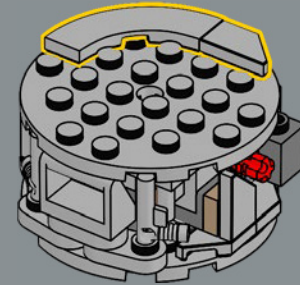

520

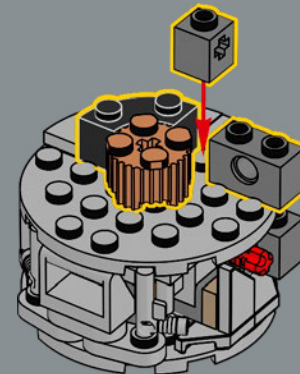

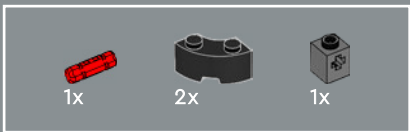

521

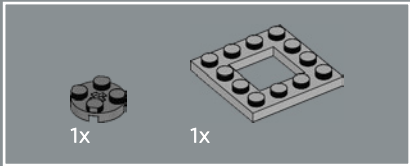
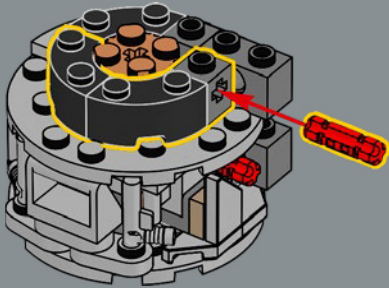

522

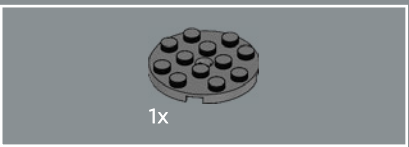
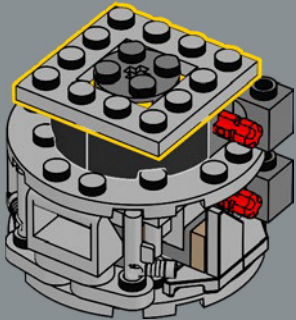

523

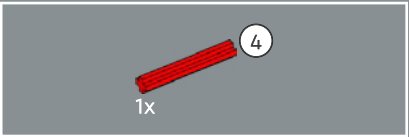
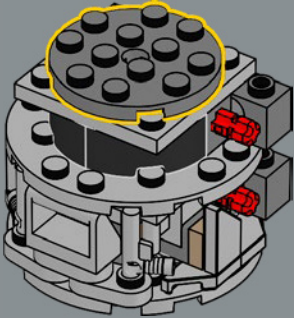

524

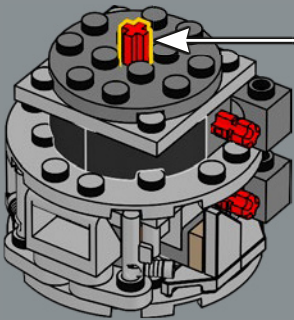

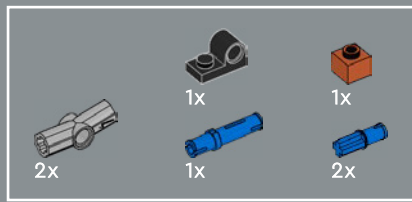

525

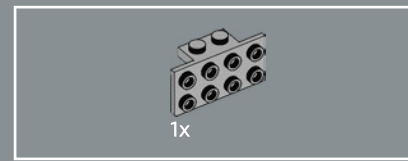
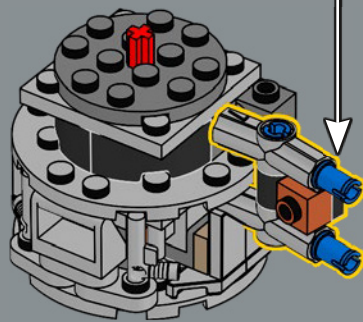
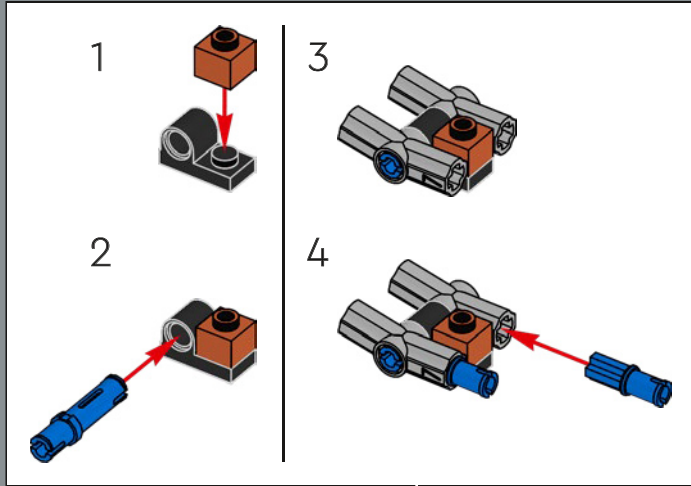

526

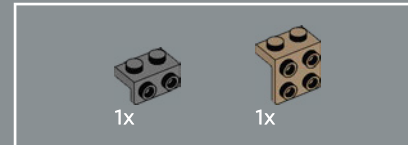
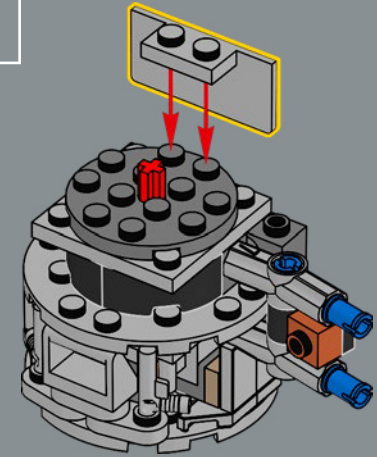

527

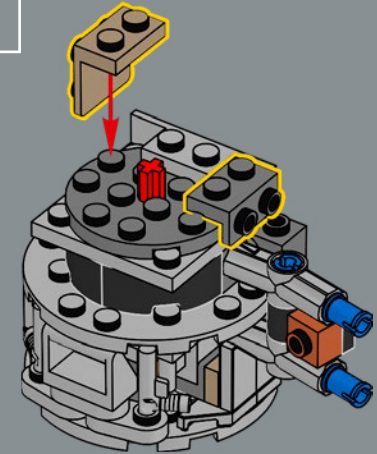

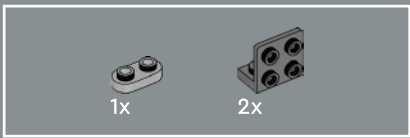

528

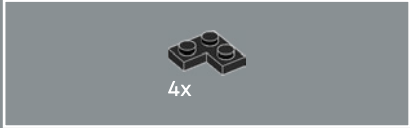
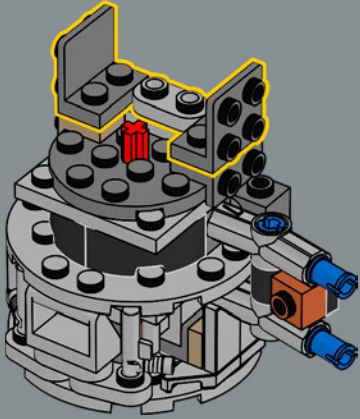

529

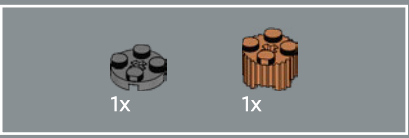
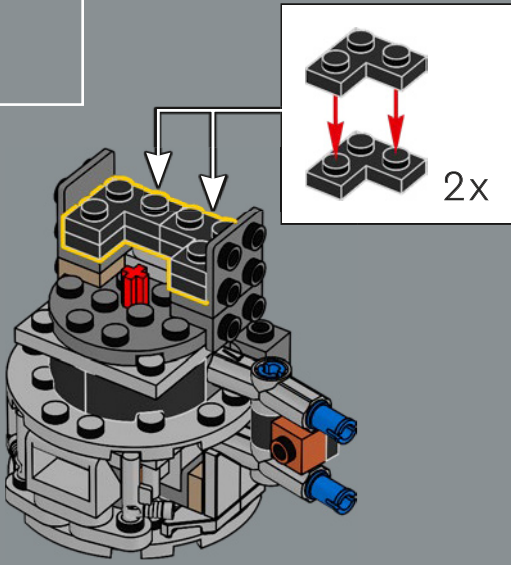

530

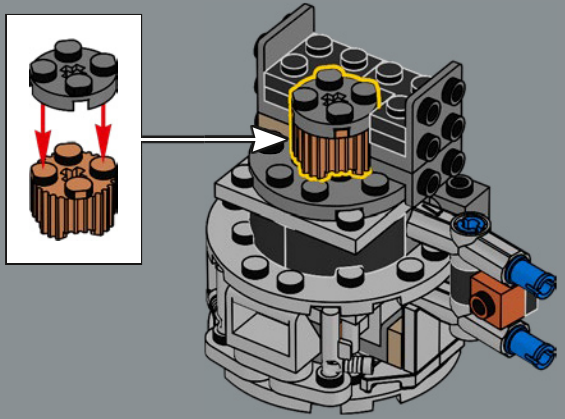

531

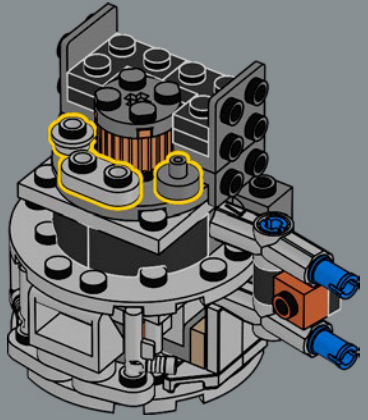

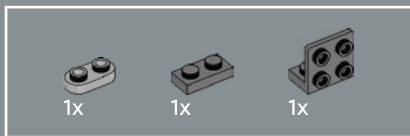

532

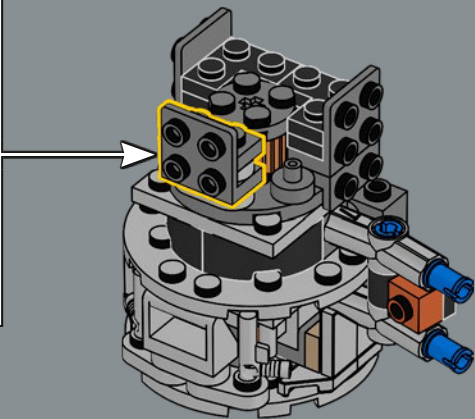
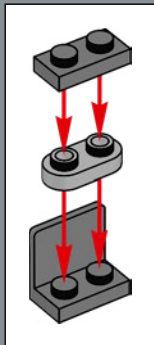

533

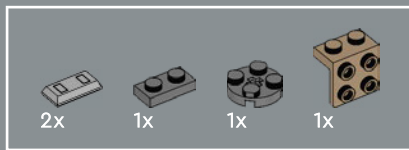
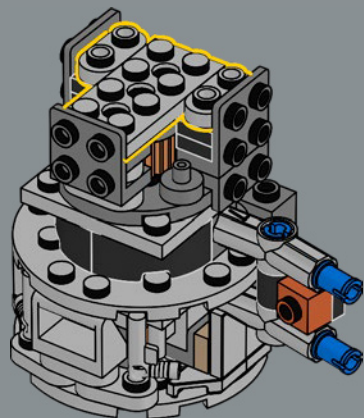

534

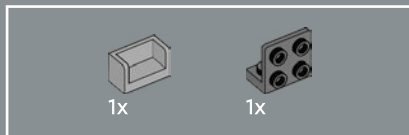
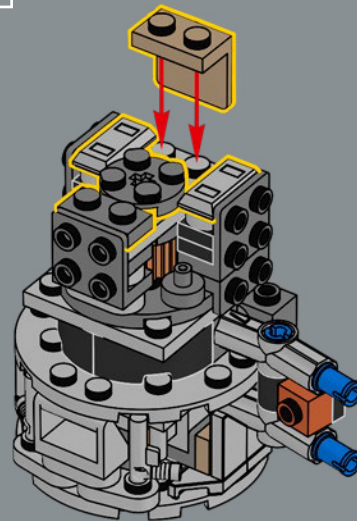

535

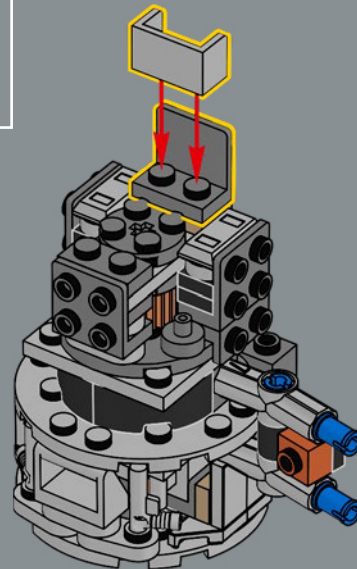

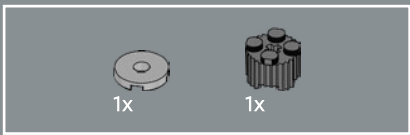

536

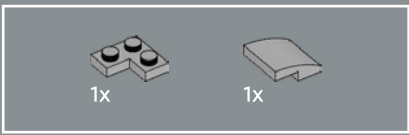
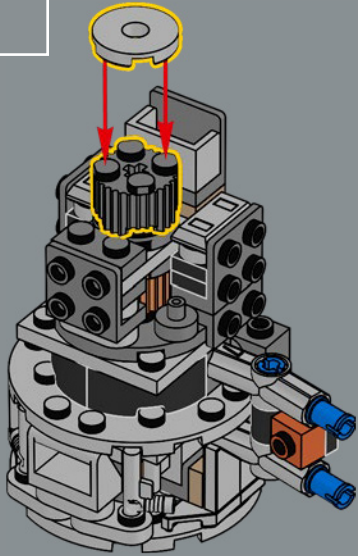

538

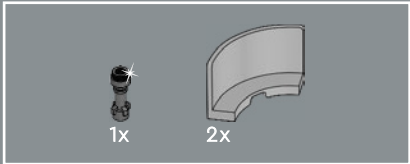
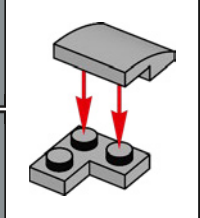
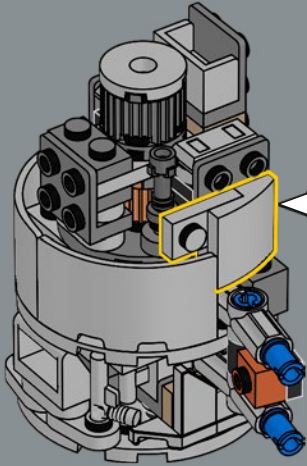

537

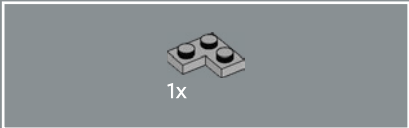
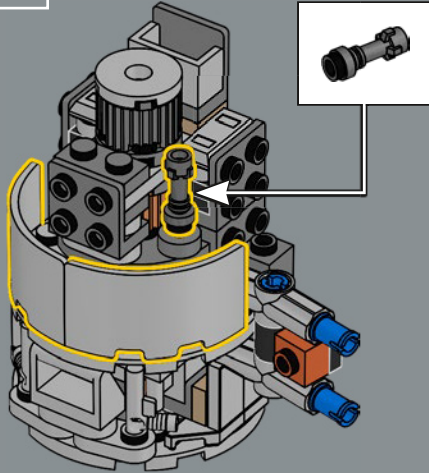

539

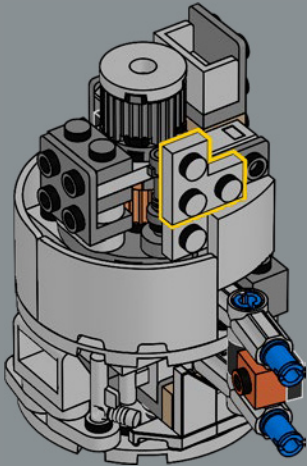

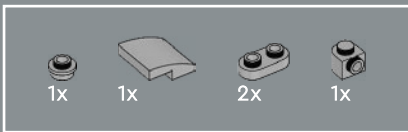

540

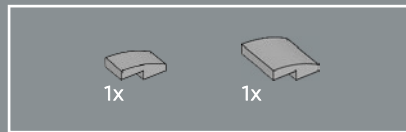
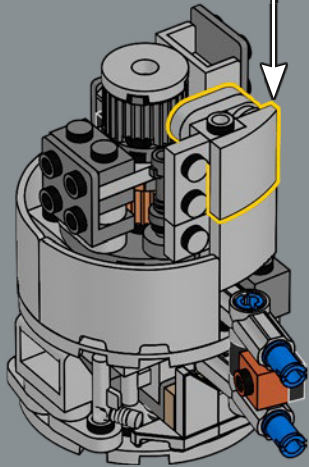
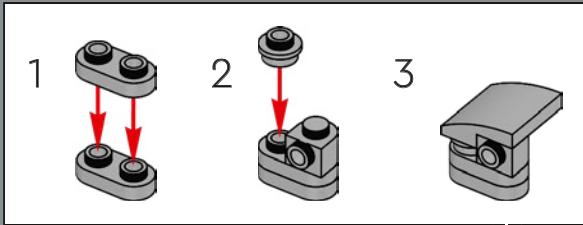

541

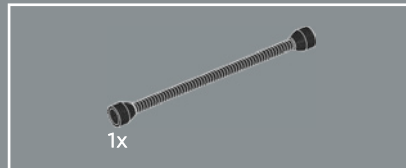
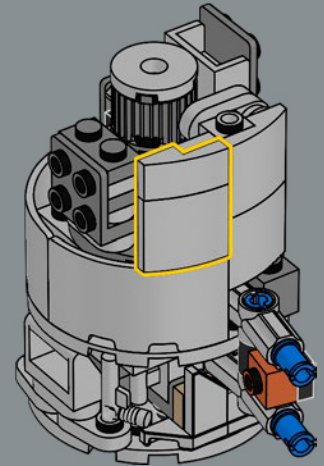

542

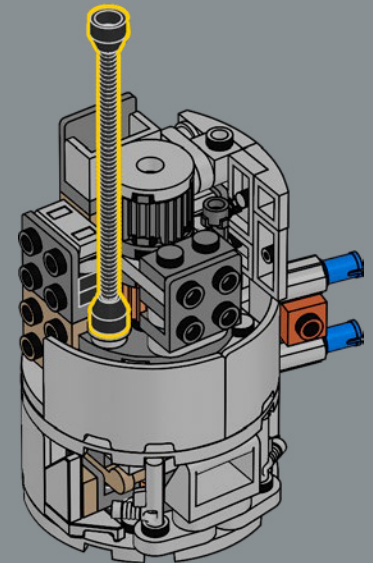

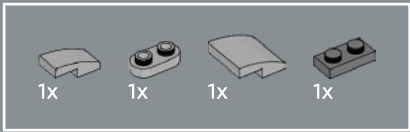

543

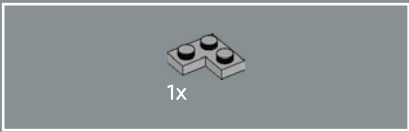
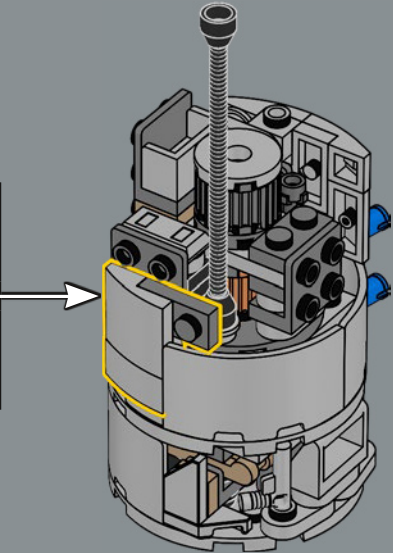
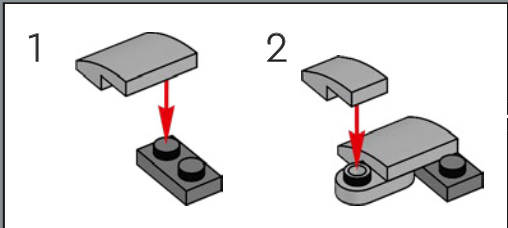

544

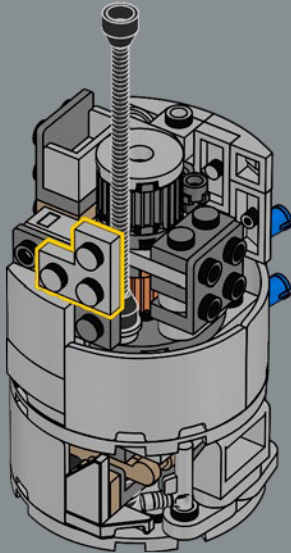

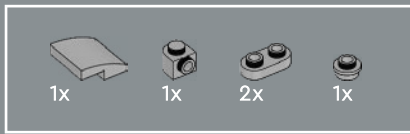

545

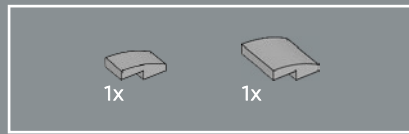
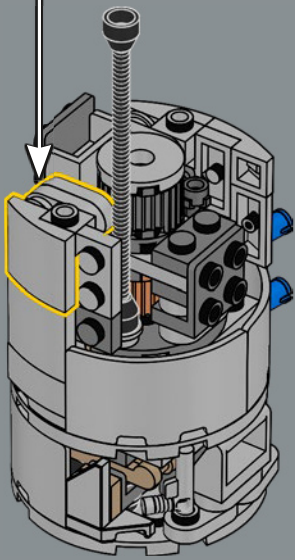
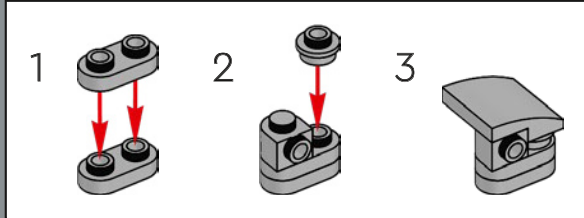

546

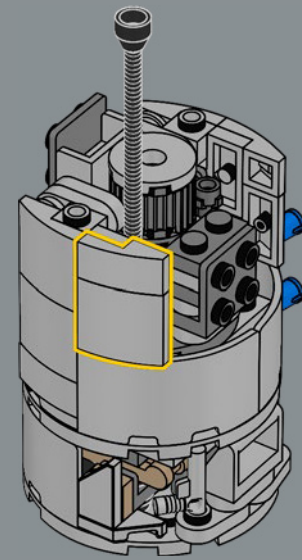

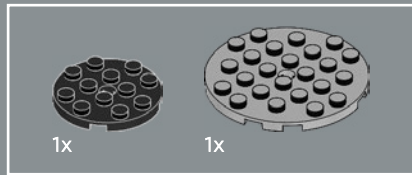
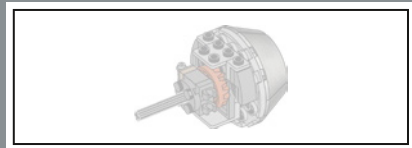

547

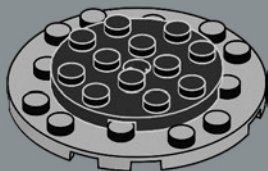

548

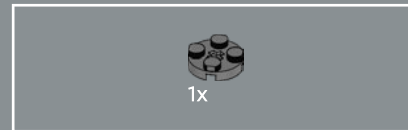
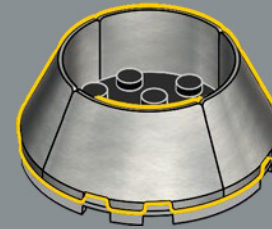

549

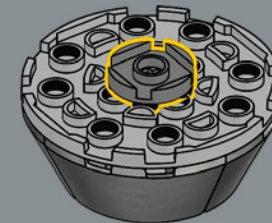



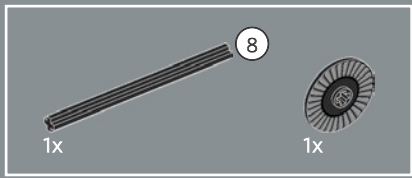

554

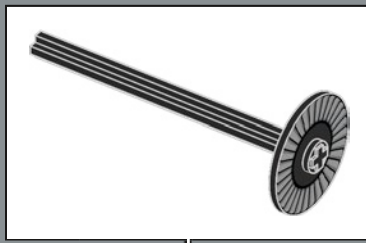
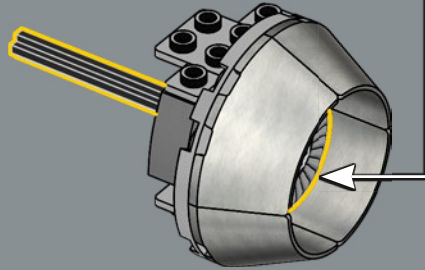

555

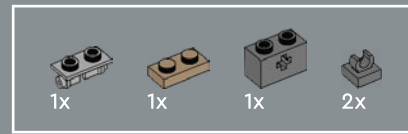
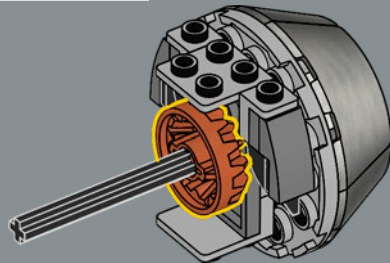

556

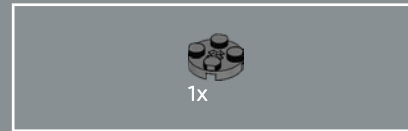
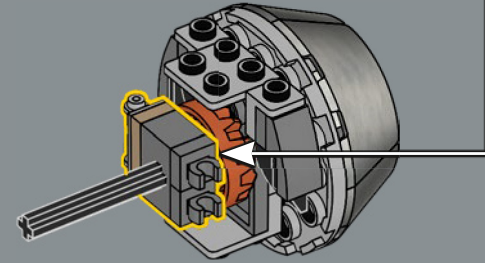
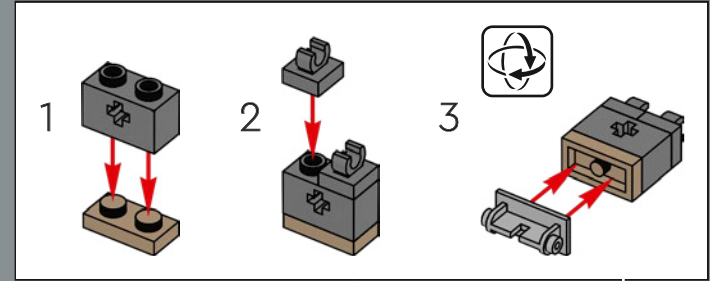

557

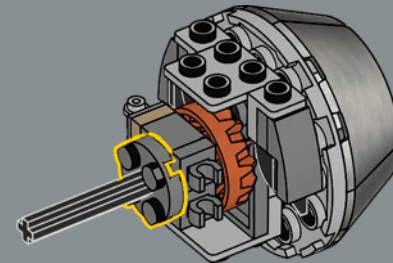

558

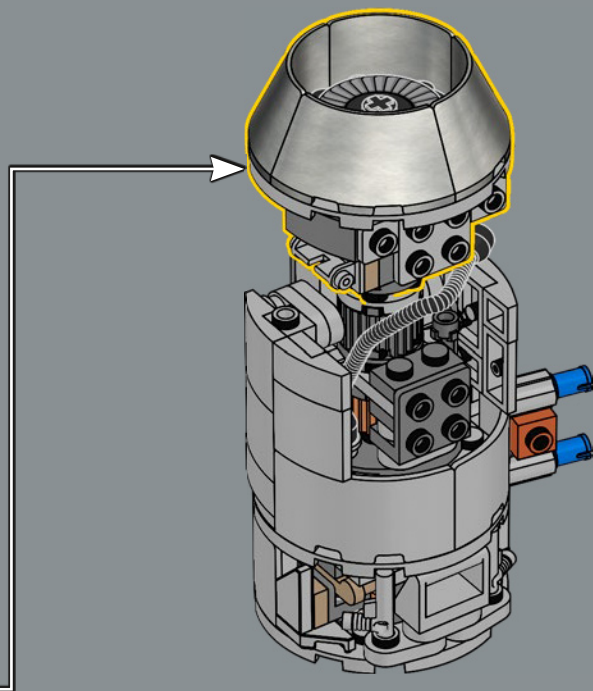

559

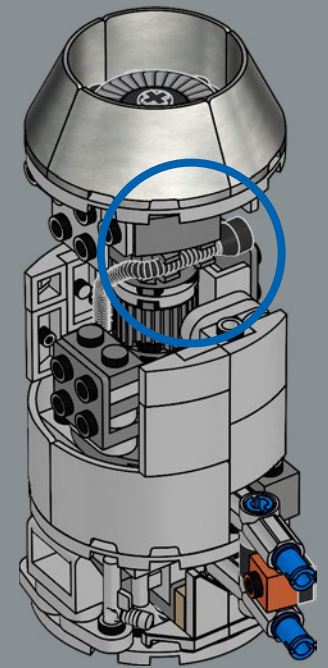

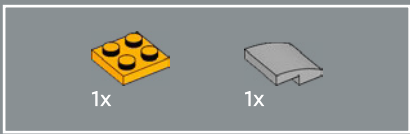

560

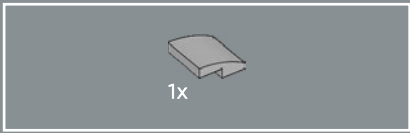
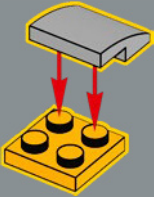

561

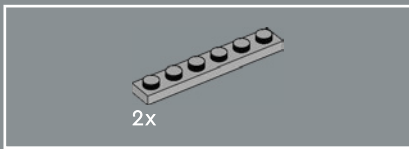
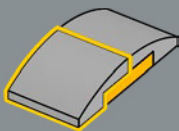

562

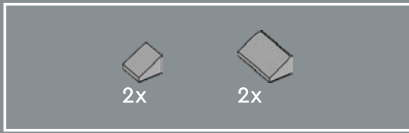
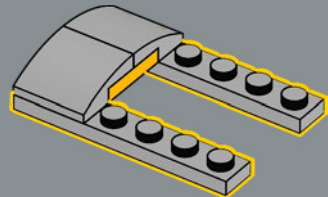

563

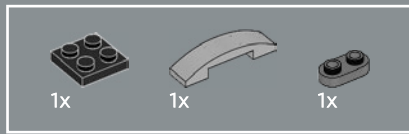
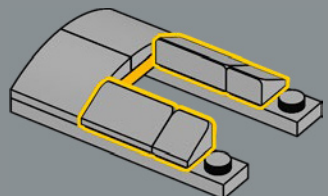

564

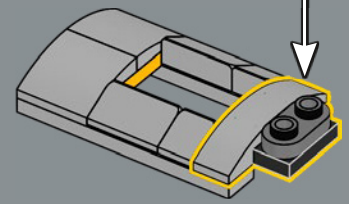
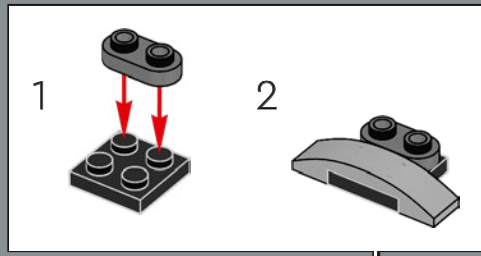

565

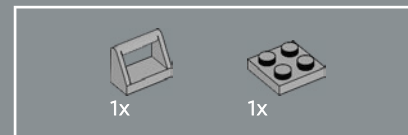
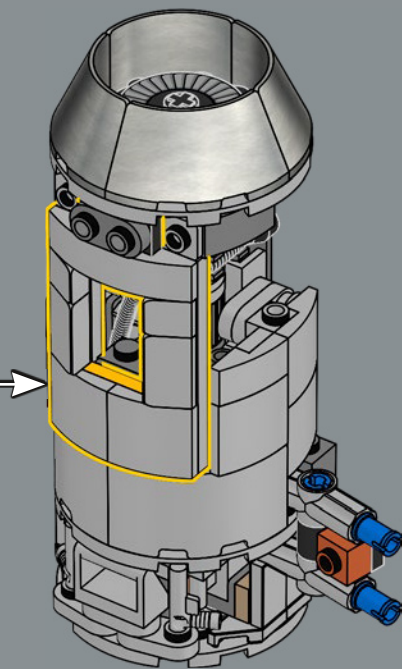

566

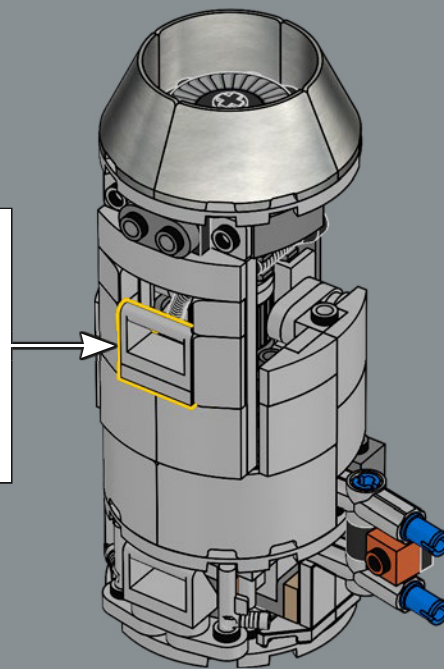
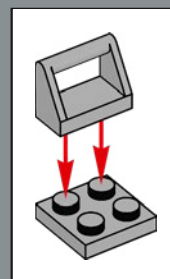

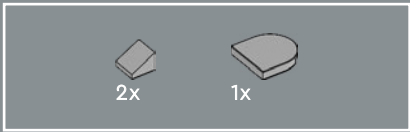

567

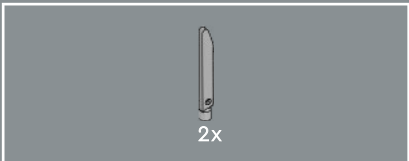
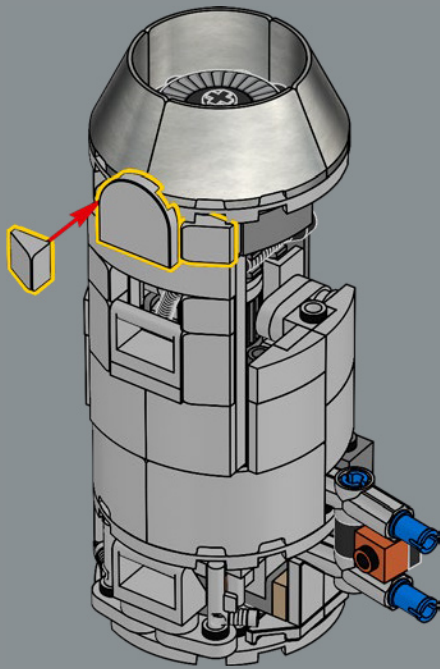

568

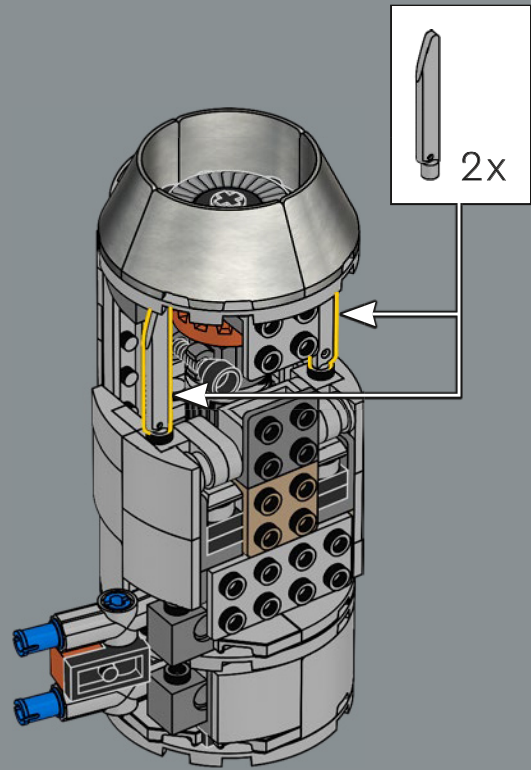

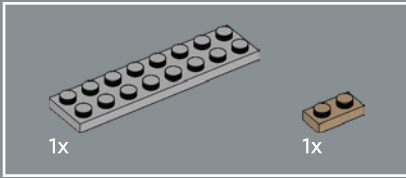
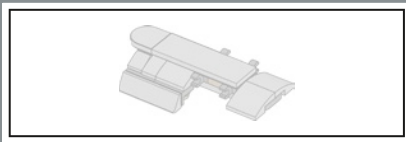

569

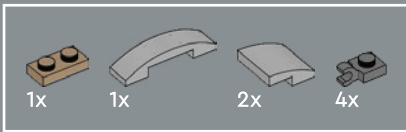
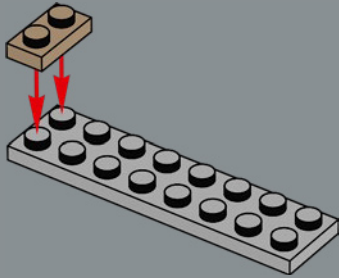

570

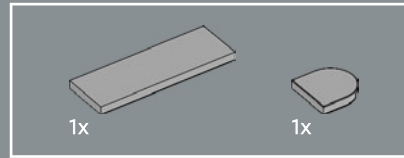
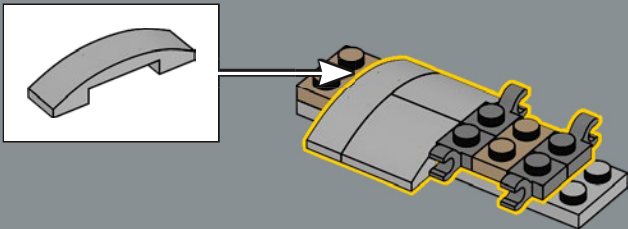

571

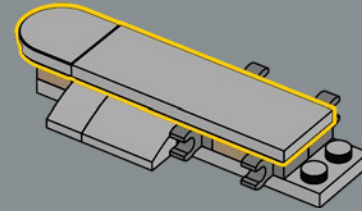

572

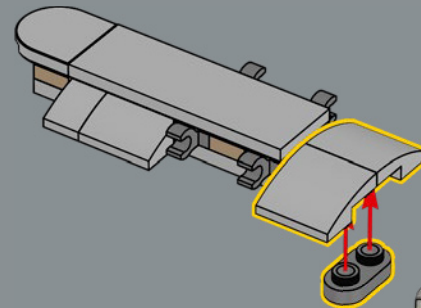

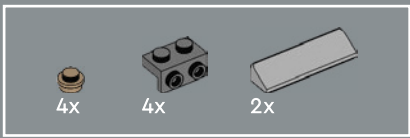

573

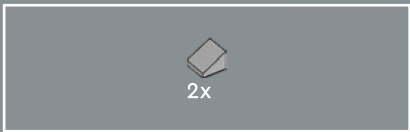
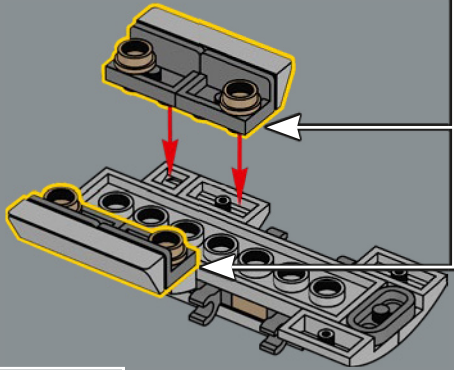
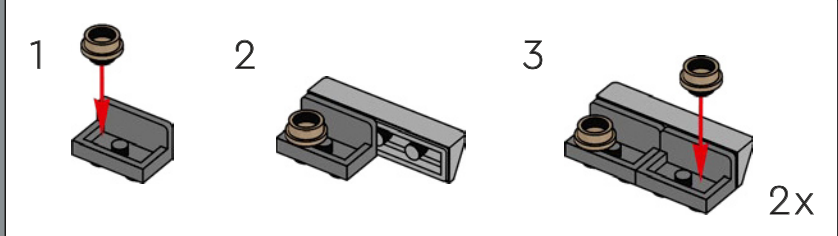

574

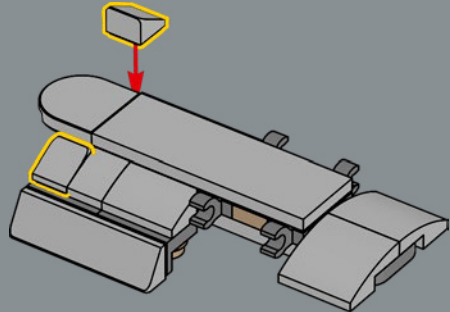

575

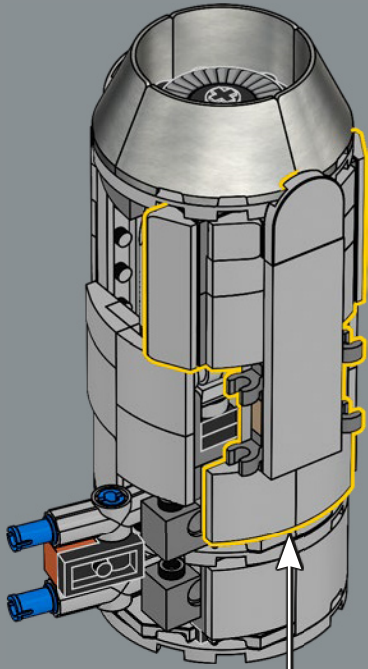

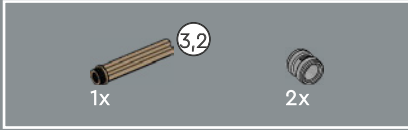
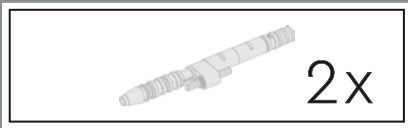

576

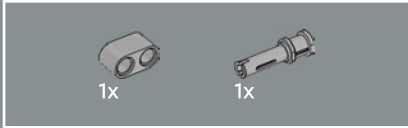
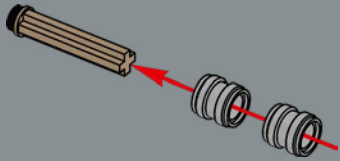

577

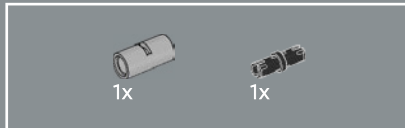
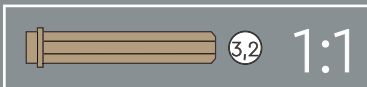
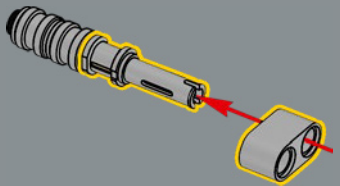

578

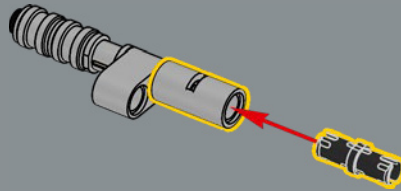

579

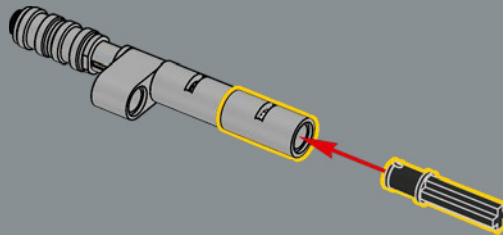

580

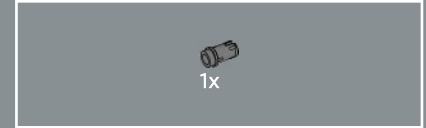
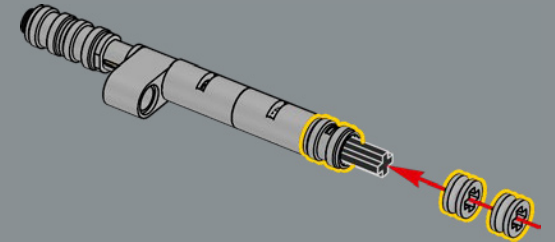

581

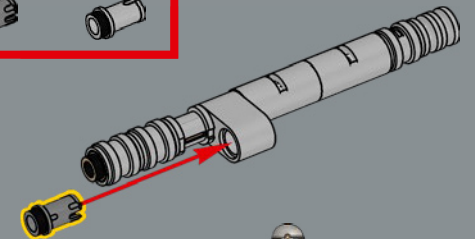
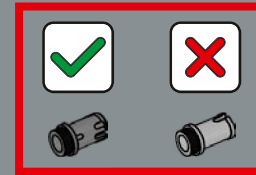

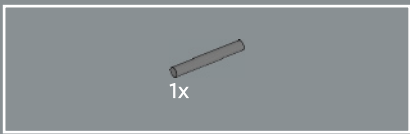

582

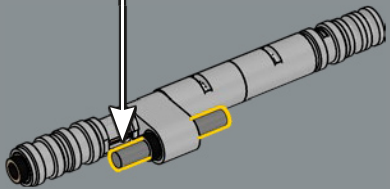
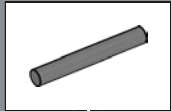

583

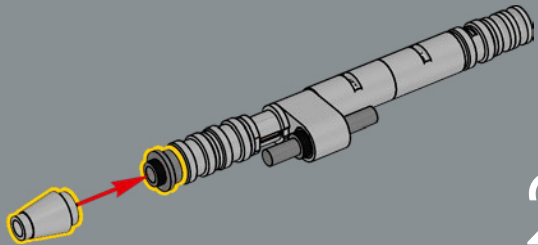

2x

584

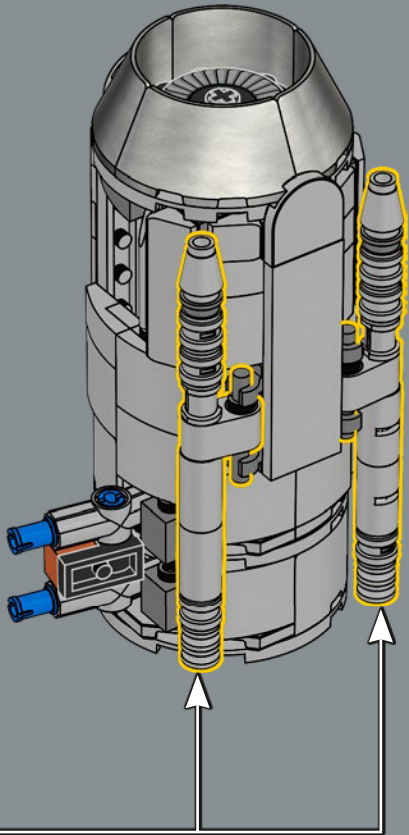

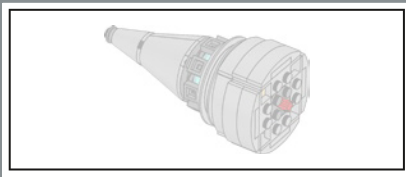

585



586

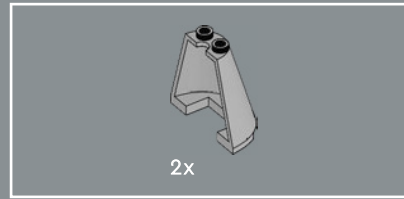

587

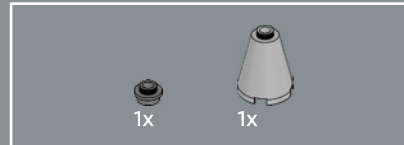
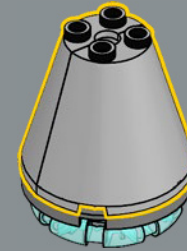

588

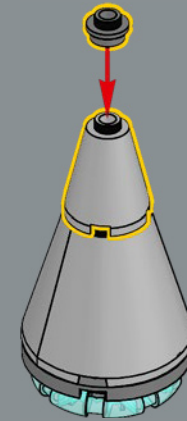

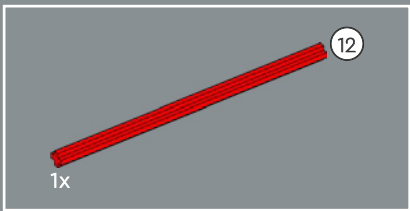

589

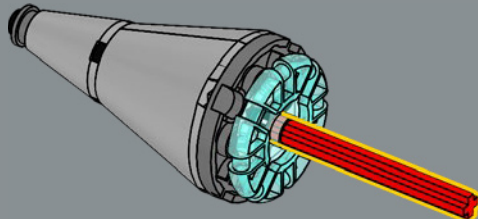

590

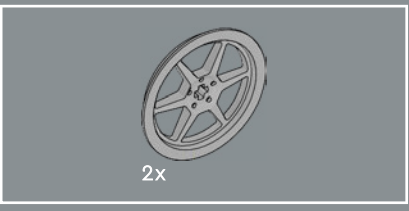
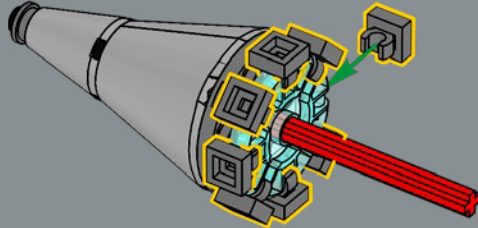

591

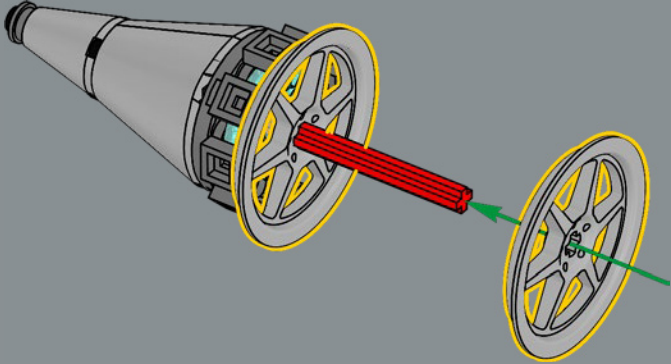





600

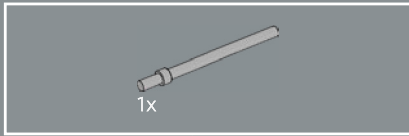
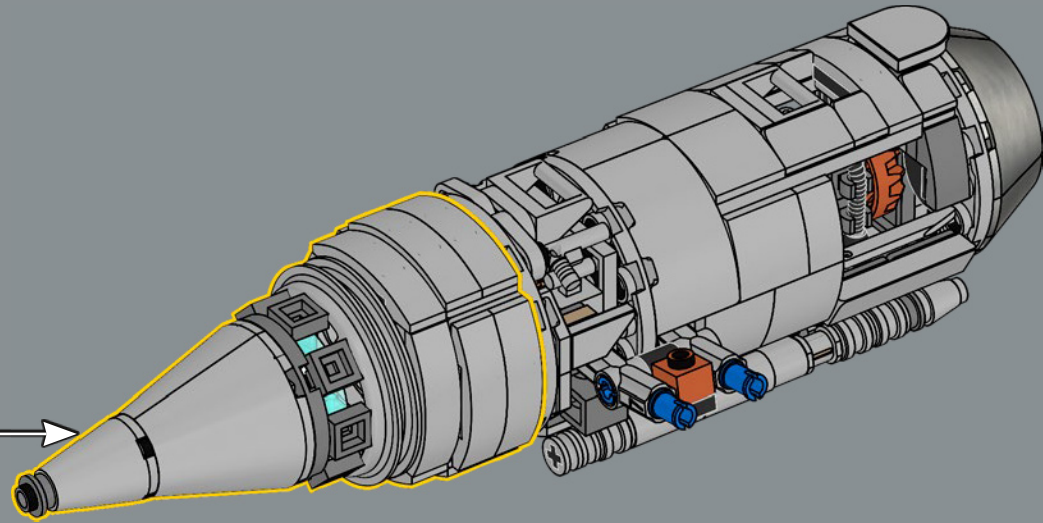

601

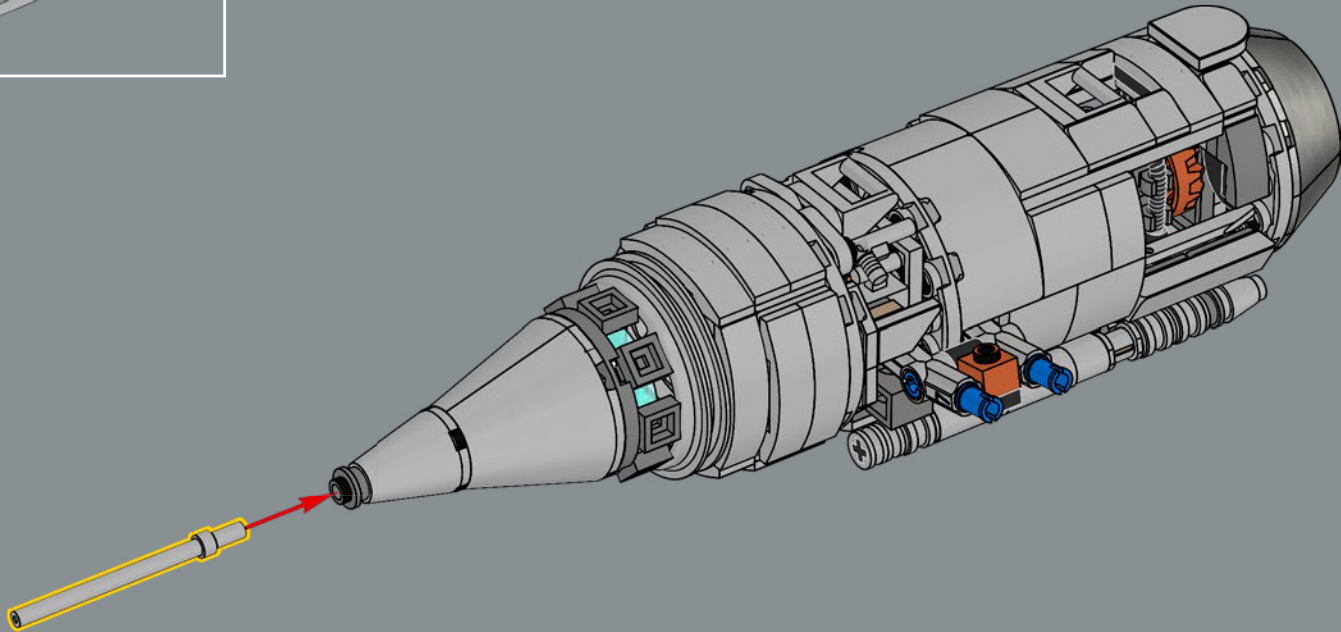

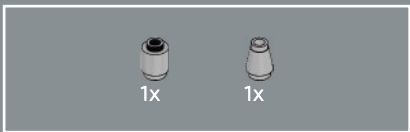

602

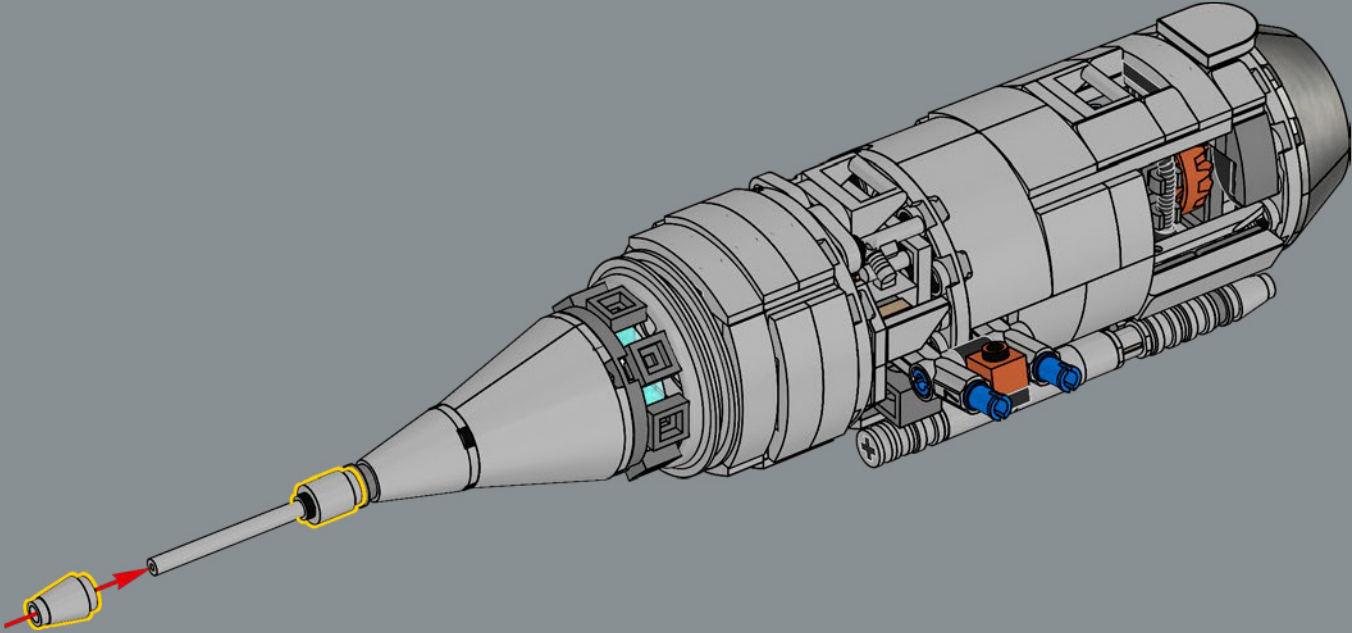

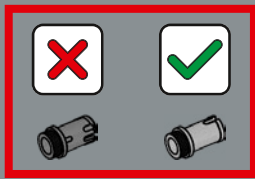
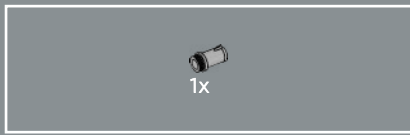

603

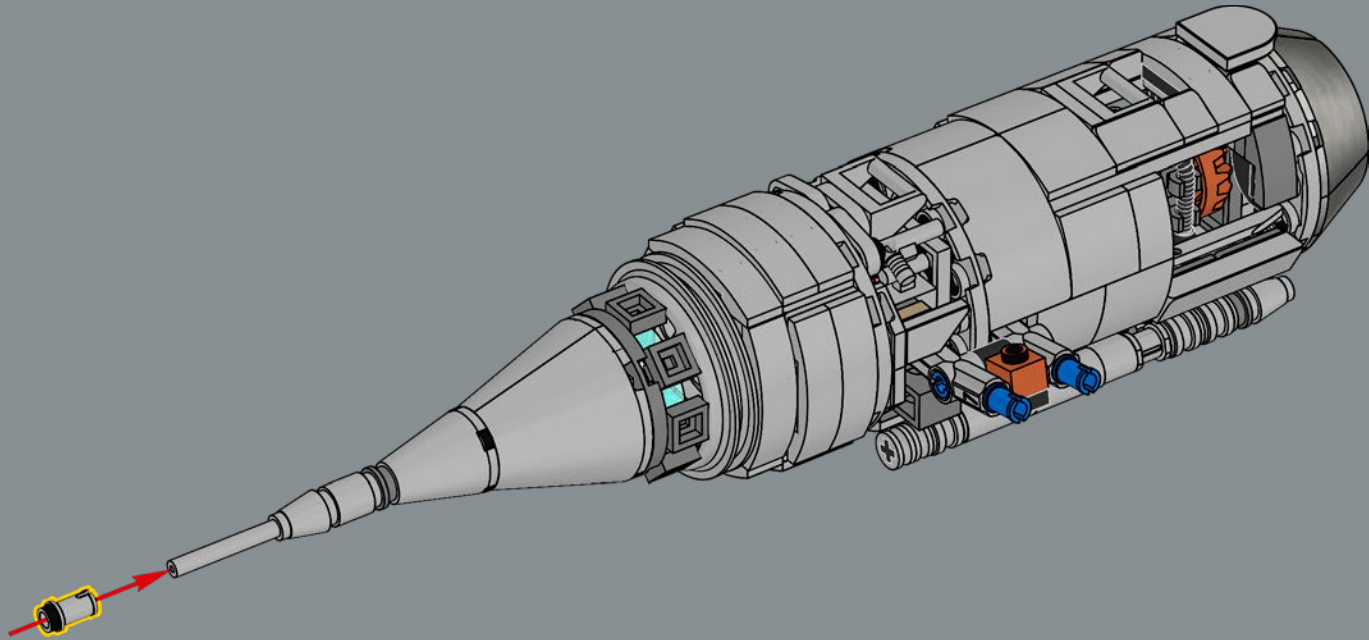

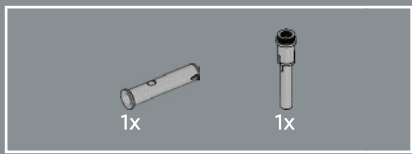

604

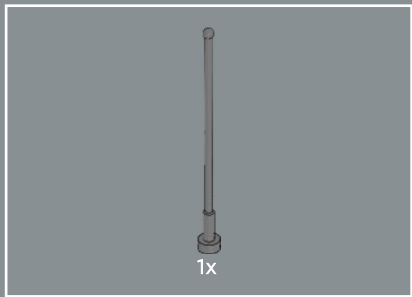
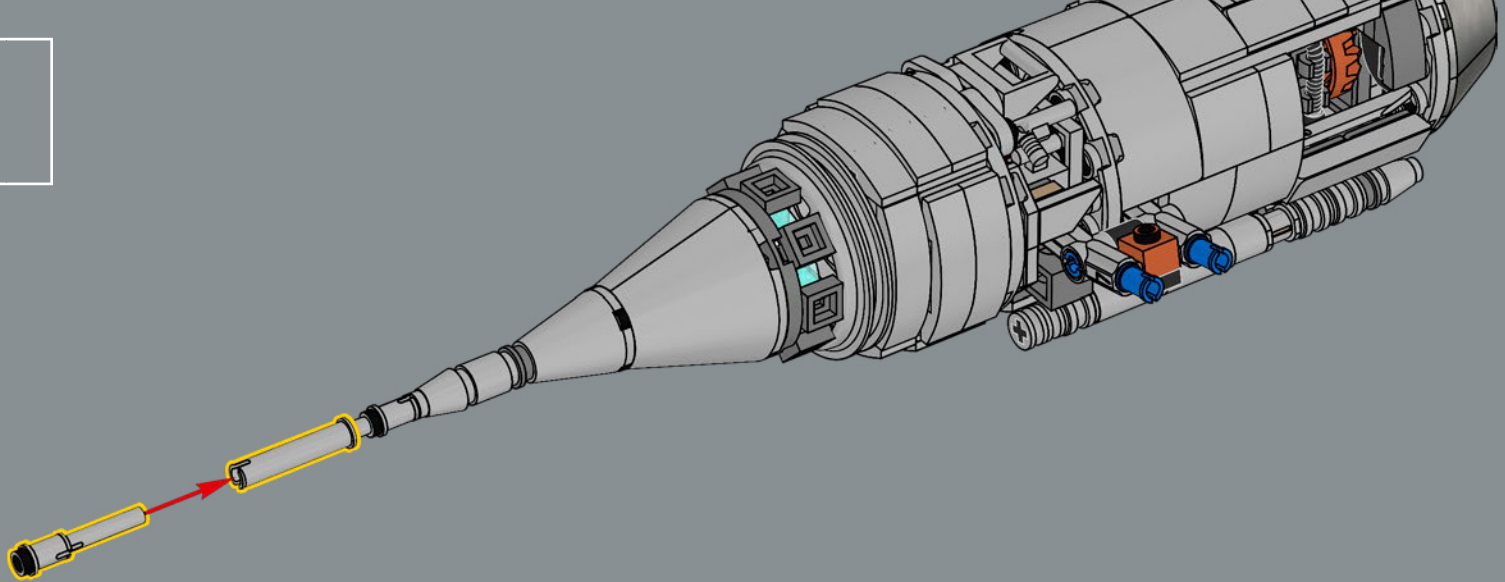

605

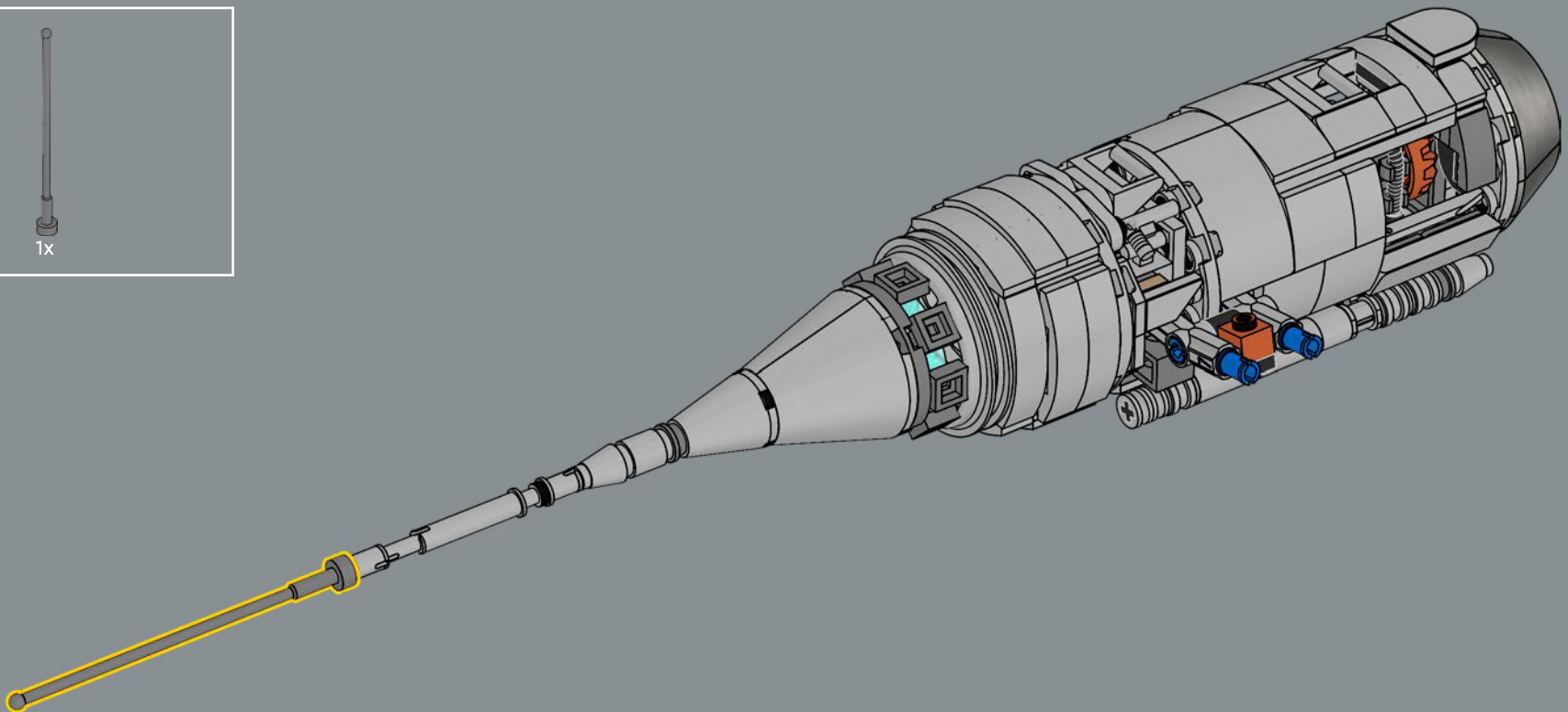

606

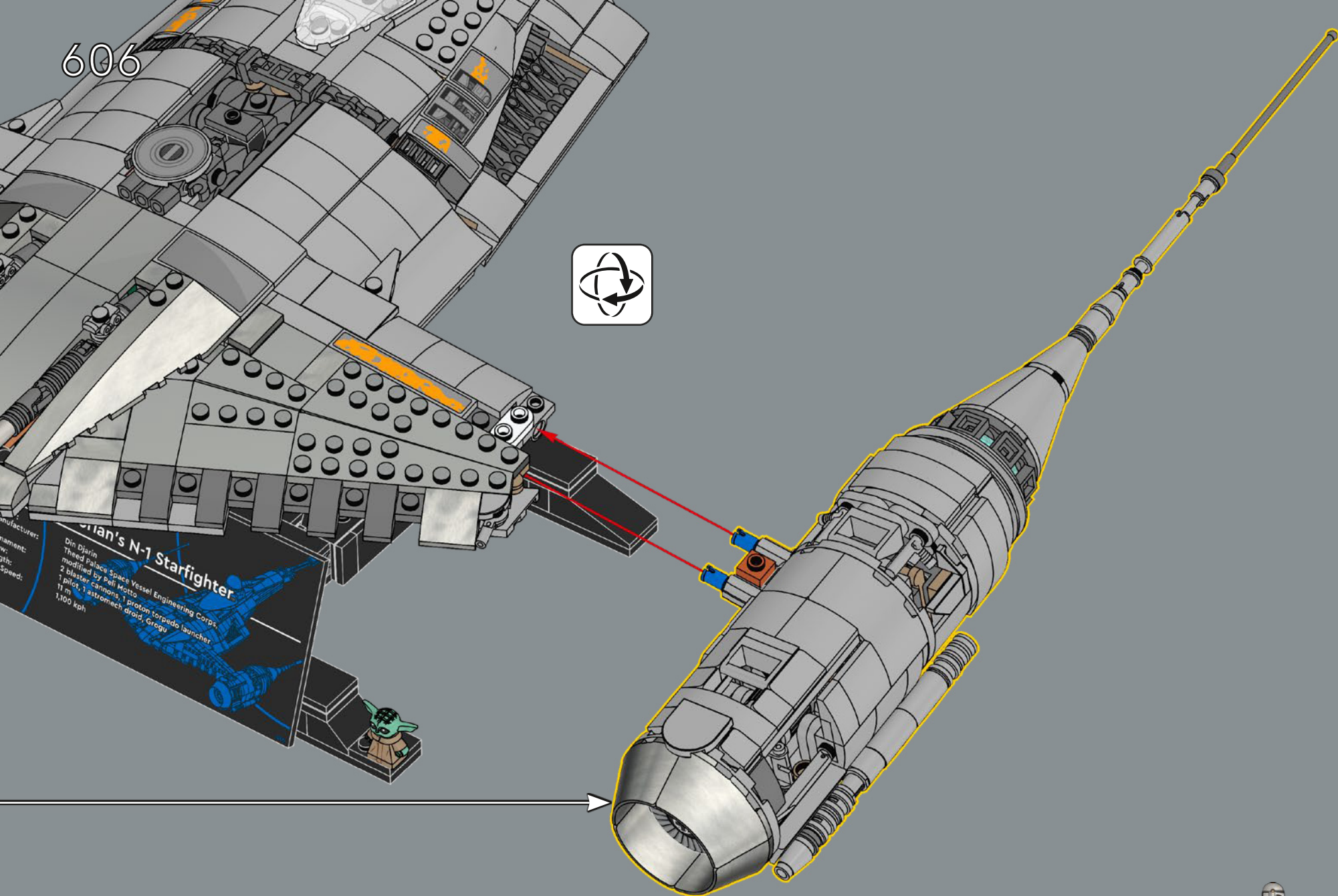

Manufacturer:  
Name:  
Length:  
Speed:  
**Djarin's N-1 Starfighter**  
Manufacturer: Theed Palace Space Vessel Engineering Corp.  
Modified by: Pelli Motto  
Crew: 2 blaster cannons, 1 proton torpedo launcher  
Length: 11 m  
Features: astromech droid, Groggu  
Speed: 1,100 kph



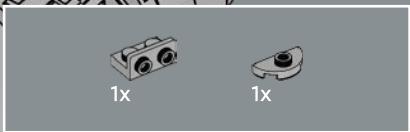

607

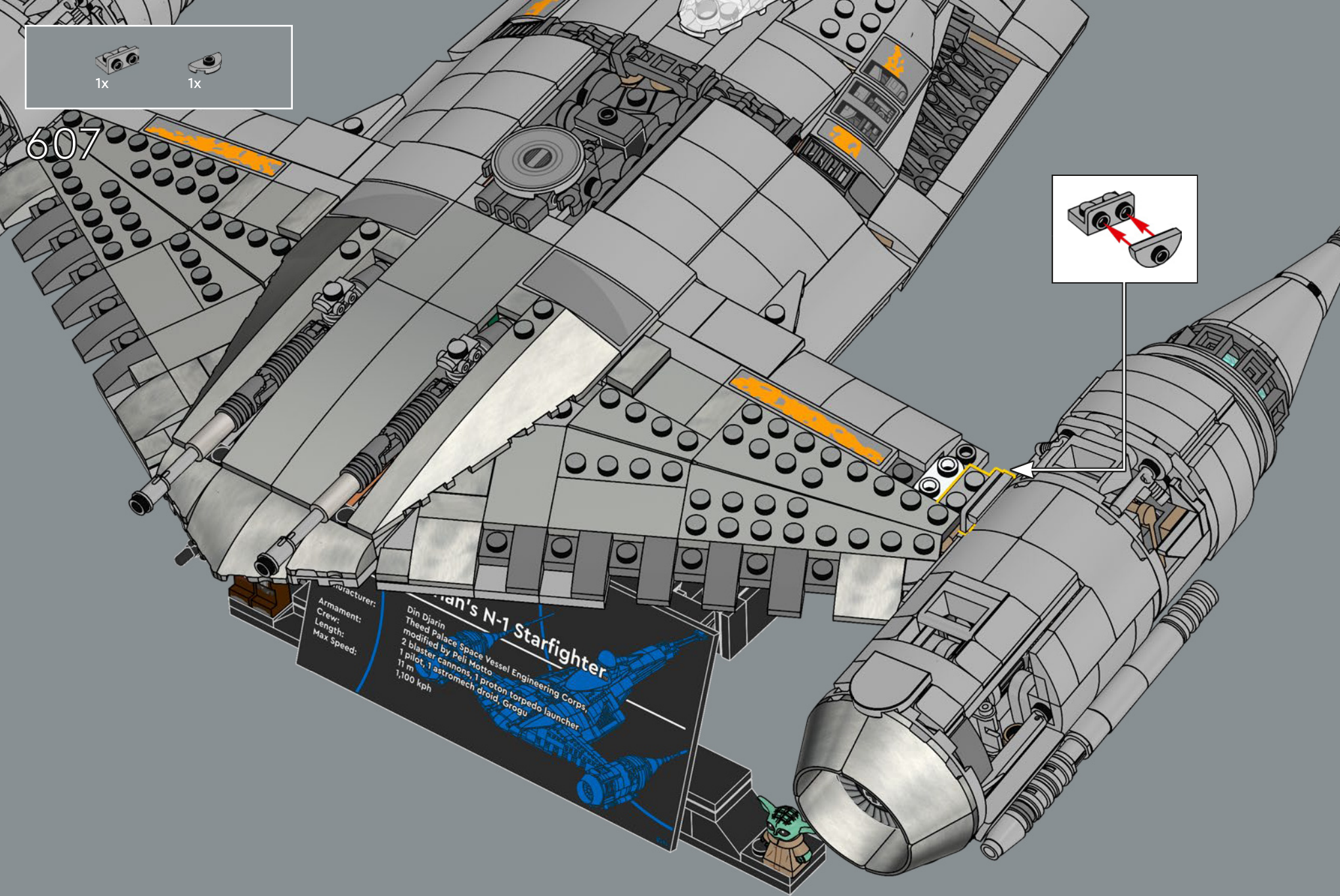
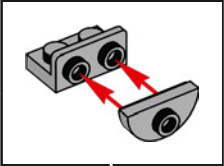

Manufacturer:  
Armament:  
Crew:  
Length:  
Max Speed:

Din Djarin  
Theed Palace Space Vessel Engineering Corps  
modified by Peli Motto  
2 blaster cannons, 1 proton torpedo launcher  
1 pilot, 1 astromech droid, Grogu

**Djarin's N-1 Starfighter**



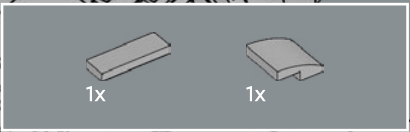

608

Manufacturer:  
Arms and Armaments  
Crew:  
Length:  
Max Speed:

Din Djarin  
Theed Palace Space Vessel Engineering Corps  
modified by Peli Motto  
2 blaster cannons, 1 proton torpedo launcher  
1 pilot, 1 astromech droid, Grogu  
11 m  
1,100 kph

**Din Djarin's N-1 Starfighter**

A detailed illustration of the N-1 Starfighter, showing its sleek, angular design and various armaments. The ship is shown from a three-quarter perspective, highlighting its compact size and intricate details.

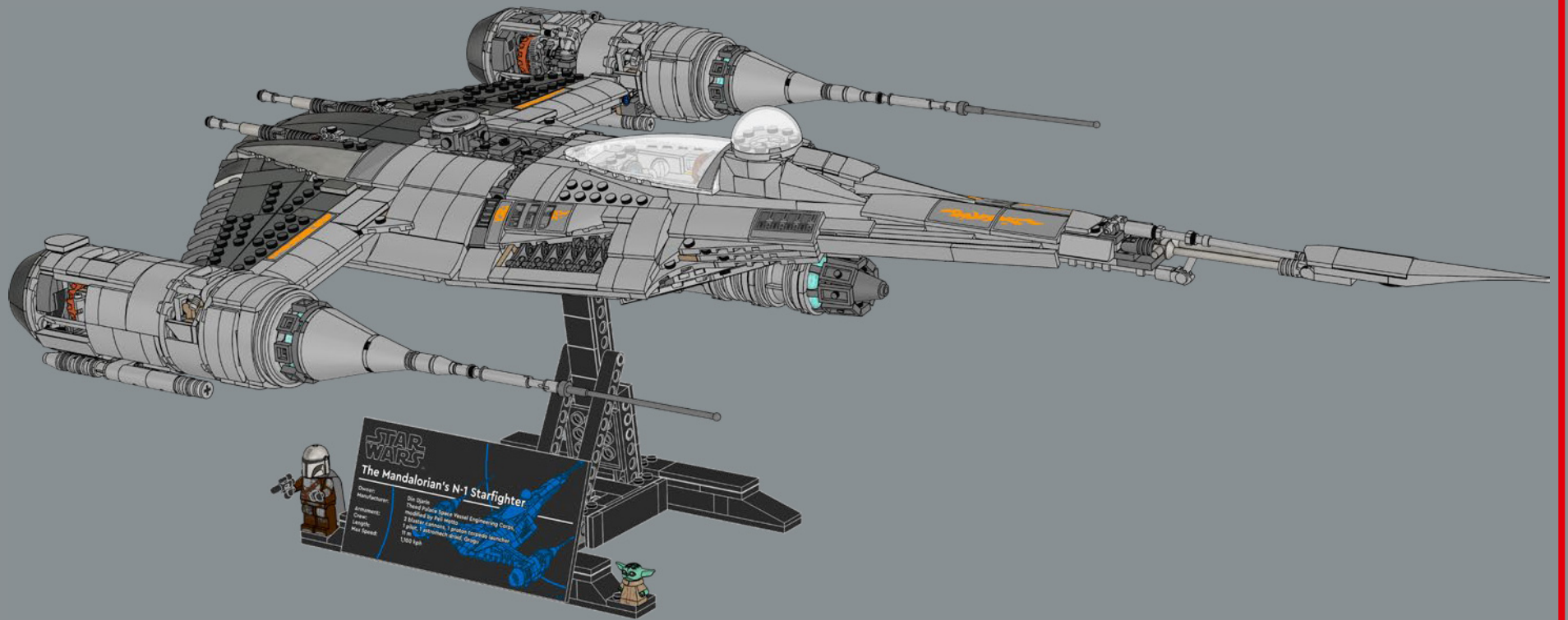

**STAR WARS**  
**The Mandalorian's N-1 Starfighter**

Character: Din Djarin  
Manufacturer: Mandalorian Space Vehicle Engineering Corps  
Equipment: 2 Laser cannons, 1 proton torpedo launcher  
Height: 1 pilot, 1 attachment point, 1 display  
Max Speed: 1,000 kph

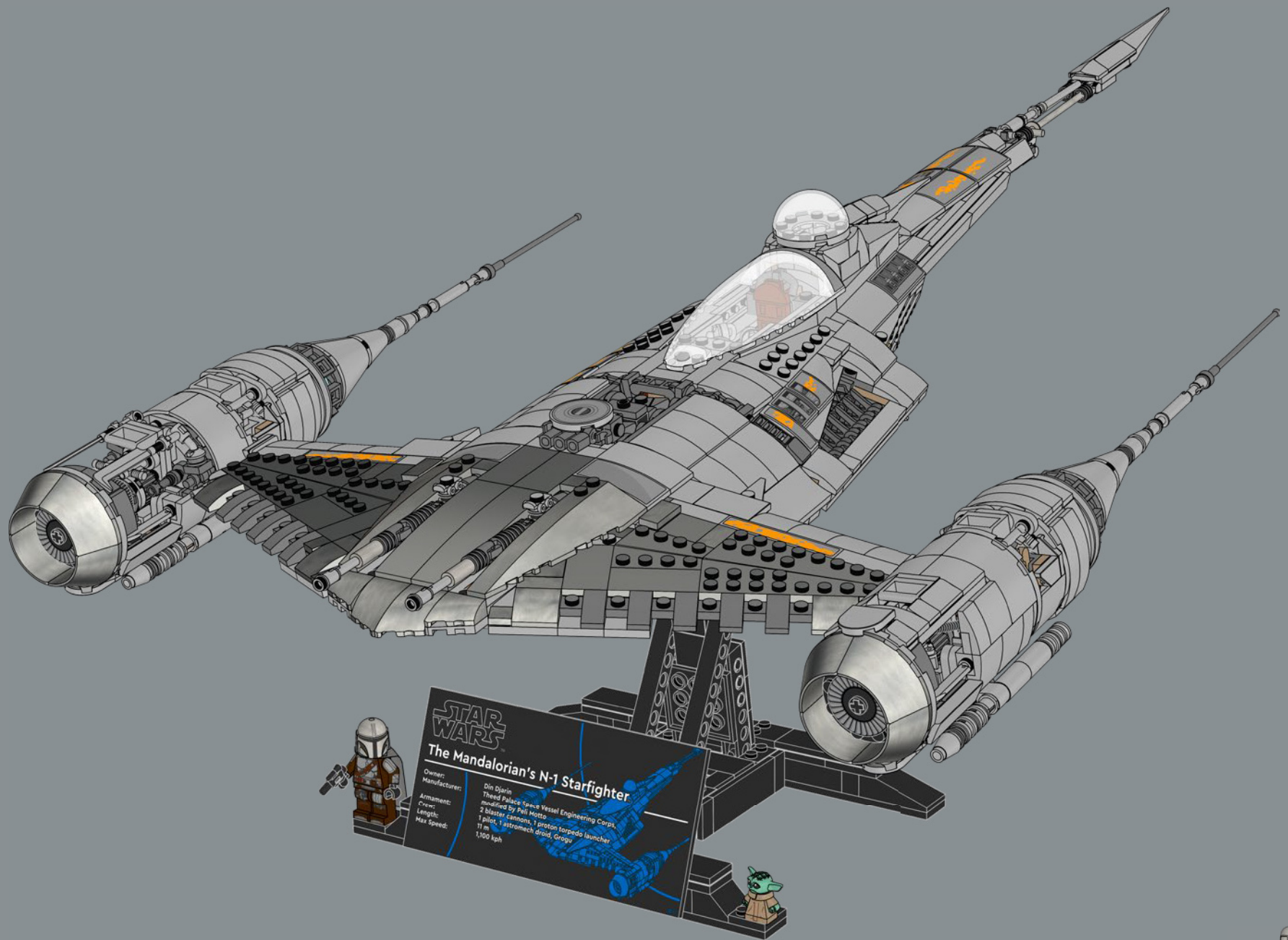

**STAR WARS**  
**The Mandalorian's N-1 Starfighter**

Owner: Din Djarin  
Manufacturer: Theed Palace Space Vessel Engineering Corps  
Arms: 2 blaster cannons, 1 proton torpedo launcher  
Crew: 1 pilot, 1 astromech droid, Grogu  
Length: 11 m  
Max Speed: 1,100 kph

- 2x 6177114
- 4x 6210272
- 2x 403201
- 2x 242001
- 1x 302101
- 4x 302001
- 1x 303401
- 3x 4161734
- 2x 4666579
- 2x 4218749
- 10x 4113917
- 6x 4118790
- 2x 4159739
- 2x 6294592
- 2x 6223291
- 3x 4124067
- 2x 6156462
- 2x 306221
- 12x 6378120
- 2x 6399645
- 6x 4142865
- 1x 393721
- 4x 302321
- 2x 6129995
- 4x 371021
- 2x 346021
- 1x 6130005
- 2x 6147702
- 6x 6482573
- 6x 4206482
- 20x 6299413
- 2x 362323
- 2x 302424
- 3x 6248971
- 1x 6331822
- 1x 302324
- 1x 300324
- 1x 4514844
- 12x 6168646
- 2x 6186675
- 2x 614126
- 2x 6424674
- 6x 300526
- 2x 4558954
- 2x 302426
- 4x 6299338
- 1x 6335317
- 1x 6360207
- 21x 6279875
- 2x 6338799
- 8x 306926
- 2x 6047276
- 4x 393726
- 1x 6178922
- 4x 302326
- 2x 6114987
- 1x 393826
- 2x 6147050
- 5x 6117973
- 1x 6563402
- 1x 6016172
- 2x 6306819
- 1x 4140588
- 4x 6336989
- 6x 6192346
- 2x 303926
- 6x 6013867
- 4x 6273226
- 16x 242026
- 3x 6506032
- 1x 6061032
- 1x 302226
- 8x 4567436
- 4x 6089119
- 2x 6267045
- 5x 362326
- 5x 302126
- 1x 6435928
- 2x 301026
- 2x 6039869
- 5x 370126
- 2x 4162443
- 4x 4515350
- 2x 6174917
- 4x 6416444
- 7x 4560182
- 2x 6194233
- 10x 302026
- 2x 4185583
- 1x 6171066
- 2x 6020193
- 2x 371026
- 2x 300926
- 3x 663626
- 7x 366626
- 1x 4243819
- 8x 6318582
- 5x 379526
- 2x 370726
- 9x 346026
- 3x 370226
- 1x 303426
- 2x 6327402
- 2x 6029578
- 3x 4514845
- 6x 244526
- 1x 6001494
- 4x 370326
- 2x 246526
- 1x 6614514
- 2x 6493351
- 2x 6347288
- 2x 303428
- 2x 6382577
- 2x 6228840
- 2x 6628591
- 1x 6186007
- 9x 6074892
- 3x 6585259
- 2x 4157103
- 1x 6136553
- 1x 6293710
- 1x 6240515
- 1x 6561723
- 2x 6322841
- 8x 6315781
- 1x 6300320
- 26x 4549436
- 2x 6231386

11

8

4

10

12



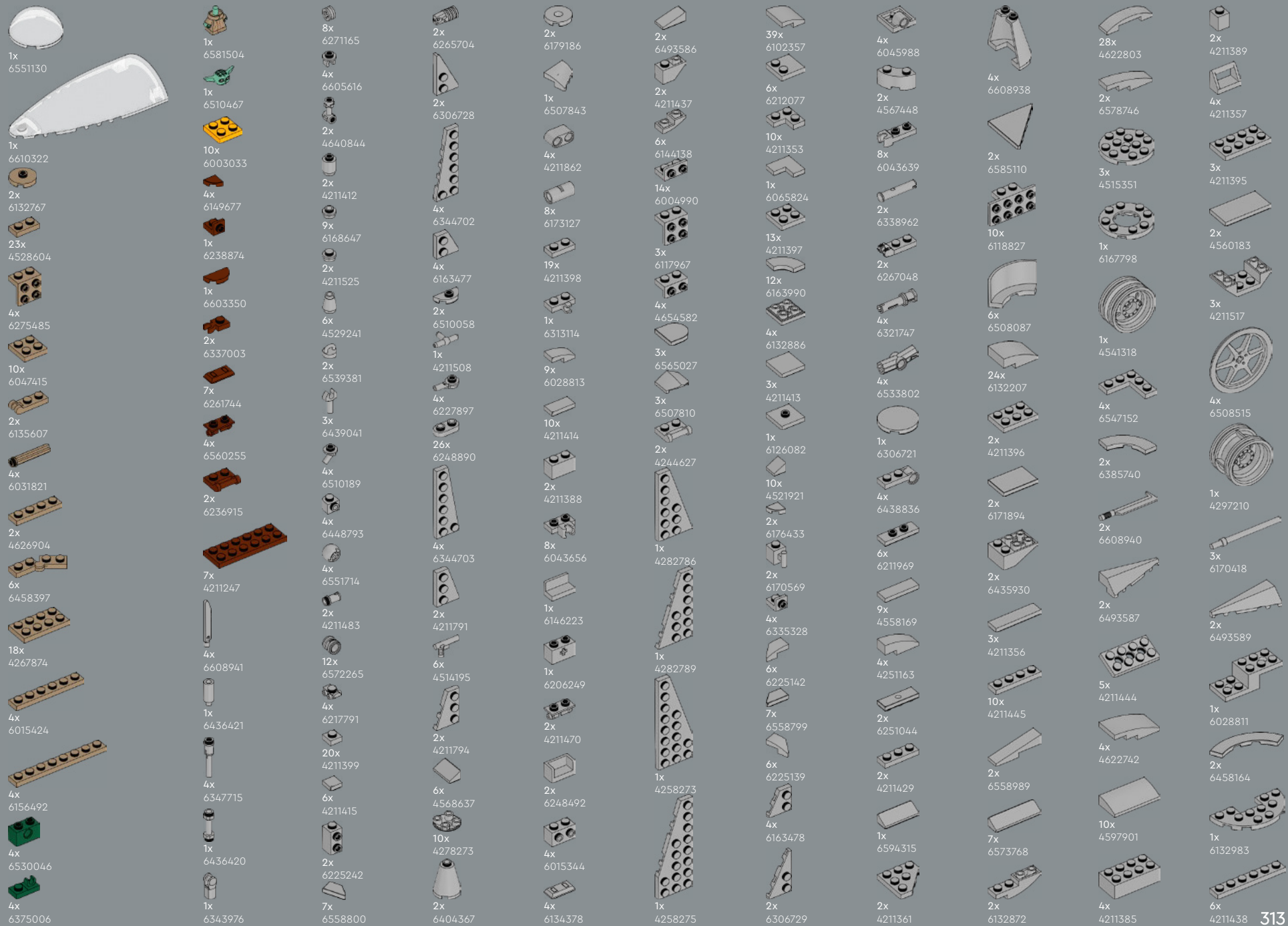

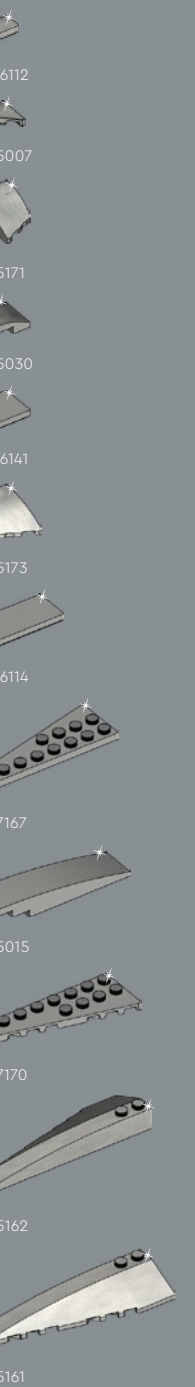
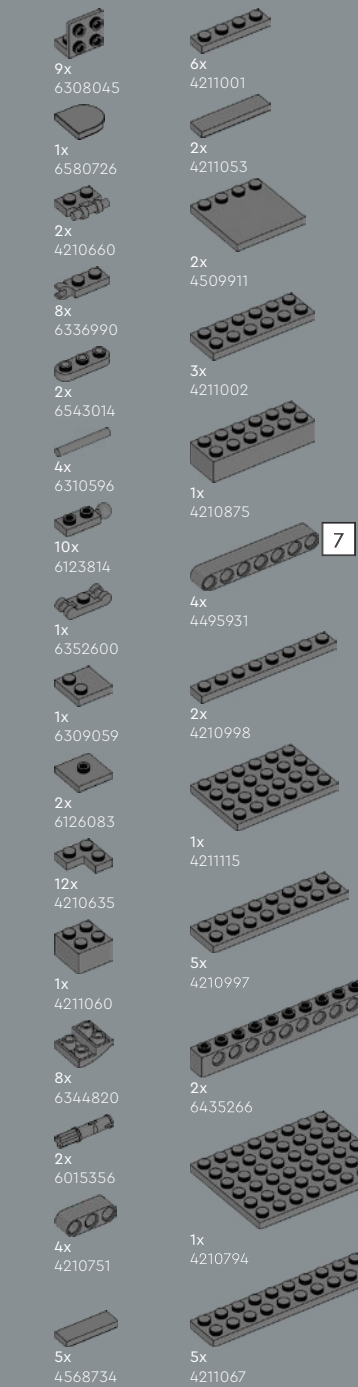
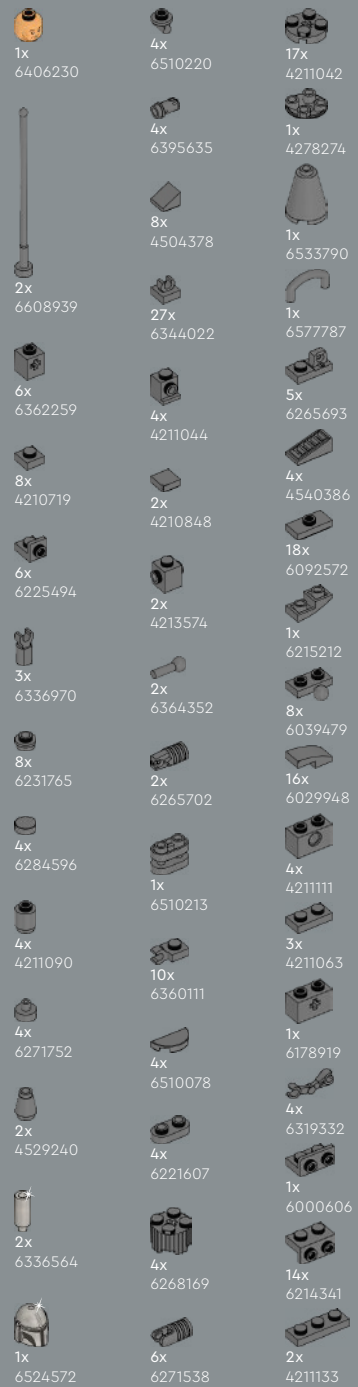
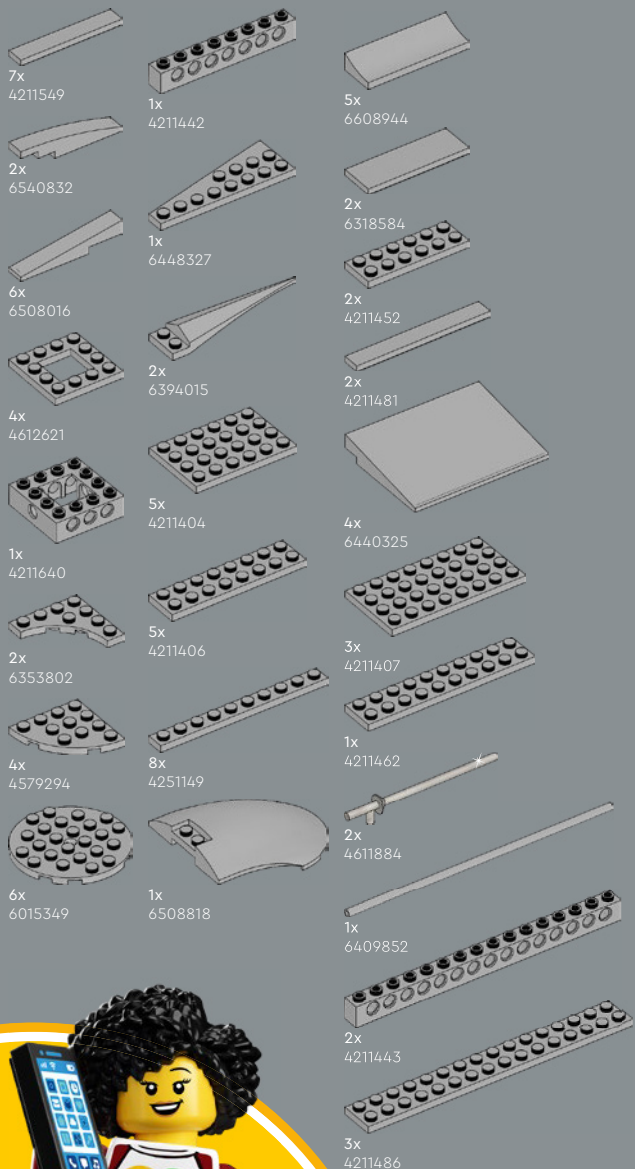

 [LEGO.com/service](https://www.LEGO.com/service)

7



**YOU COULD  
WIN**



**YOU COULD  
WIN**

Your feedback will help shape the future development of this product series.

Visit:

**DU KÖNNTEST  
GEWINNEN**

Dein Feedback trägt zur Weiterentwicklung dieser Produktreihe bei.

Geh auf:

**VOUS POURRIEZ  
GAGNER**

Vos commentaires nous aideront à concevoir les futurs produits de cette gamme.

Visitez :

**POTRESTI  
VINCERE TU**

La tua opinione ci aiuterà a migliorare la creazione futura di questa linea di prodotti.

Visita:

**PUEDES  
GANAR**

Tu opinión contribuirá al futuro de esta serie de productos.

Visita:

**轻松获奖**

您的反馈将有助于我们在今后改进本产品系列。

请访问:

---

**[LEGO.com/productfeedback](https://LEGO.com/productfeedback)**

---

You also have the chance to win a LEGO® set.

Terms and conditions apply.\*

Außerdem hast du die Chance, ein LEGO® Set zu gewinnen.

Es gelten die Teilnahmebedingungen.\*

Vous pourriez également gagner un ensemble LEGO®.

Des conditions s'appliquent.\*

Hai anche la possibilità di vincere un set LEGO®.

Termini e condizioni sono applicabili.\*

También tienes la oportunidad de ganar un set LEGO®.

Aplican términos y condiciones.\*

您还有机会赢取乐高®套装。

条款和条件适用。\*

\*[LEGO.com/productfeedback-terms](https://LEGO.com/productfeedback-terms)

