



40955



MAERSK





LEGO.com/sustainable-packaging



FR

DONNEZ
OU
RECYCLEZ



OU



OU



ASSOCIATION

MAGASIN

DÉCHÈTERIE

Adresses sur quefairedemesdechets.fr

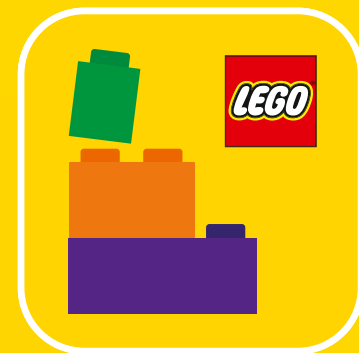

🔍 LEGO® Builder

BUILDER



Apple and the Apple logo are trademarks of Apple Inc., registered in the U.S. and other countries and regions. App Store is a service mark of Apple Inc. Google Play and the Google Play logo are trademarks of Google LLC. Tencent and the Tencent logo are trademarks of Tencent Inc.

🔍 LEGO.com/devicecheck

EN Ask parents' permission before going online | DE Eltern um Erlaubnis bitten, bevor du online gehst | FR Demande l'autorisation d'un parent avant d'aller en ligne | IT Chiedi il permesso ai tuoi genitori prima di andare online | ES Pídeles permiso a tus papás antes de conectarte a Internet | PT Peça autorização aos pais antes de acederes online | ZH 上网前应先征得父母的同意 | PL Poproś rodziców o zgodę, zanim wejdiesz do Internetu | CS Než půjdeš na internet, požádej rodiče o svolení | SK Skôr než pôjdeš na internet, vypoťaj si povolenie od rodičov | HU Kérj szülői engedélyt, mielőtt online csatlakoznál! | UA Запитуйте дозволу батьків, перш ніж користуватися інтернетом | RO Cere permisiunea părinților înainte de a te conecta online | BG Поискайте разрешение от родител, преди да влезете онлайн | LV Pirms došanās tiešsaistē palūdz atļauju vecākiem | ET Enne Interneti kasutamist küsi vanematelt luba | LT Prieš prisijungdami prie interneto, atsiklauskite tėvų

ȚI-O PREZENTĂM PE ANE MÆRSK

ANE MÆRSK este prima navă din categoria portcontainerelor de dimensiuni mari capabile să funcționeze pe bază de combustibil cu emisii reduse, cum ar fi biometanolul și e-metanolul. De când ANE MÆRSK a fost lansată la apă în ianuarie 2024, multe alte nave cu combustibil dual au fost puse în funcțiune, marcând un capitol nou și important în decarbonizarea transportului maritim și a comerțului mondial.

ANE MÆRSK are o lungime de 350 de metri și o lățime de 53,5 metri. Când este goală, nava cântărește 47.700 de tone, iar când este complet încărcată cu marfă, combustibil și echipaj, nava poate transporta o cantitate uimitoare de 190.000 de tone, echivalentul a 29.000 de elefanți africani.

Nava are capacitate pentru 16.592 de containere TEU (unitate echivalentă douăzeci de picioare), iar dacă le-ai alinia pe toate, acestea s-ar întinde pe 100,5 km, adică lungimea a 959 de terenuri de fotbal.





 MAERSK

ALL THE 10 ZERO WAY



TRANSFORMAREA NAVIGAȚIEI – ISTORIA TRANSPORTULUI MARITIM

Oamenii transportă mărfuri pe mare de peste 5.000 de ani, dar până la Revoluția Industrială și inventarea motorului cu aburi, depindeam de vreme. Dacă nu exista vânt, nu se putea naviga. Odată cu introducerea puterii aburului, pentru prima dată în istoria omenirii, echipajul unei nave nu mai depindea de vreme sau de propulsia manuală. Această invenție a revoluționat complet transportul maritim, făcând posibile noi rute și dând comerțului maritim un impuls major.

Deși motoarele cu aburi au reprezentat o îmbunătățire considerabilă față de pânze, acestea erau încă ineficiente și nu a trecut mult timp până când transportul maritim a fost din nou transformat odată cu inventarea motorului diesel. Cu toate acestea, revoluțiile în domeniul transportului naval necesită timp și au mai trecut câteva decenii până când motorina a înlocuit complet puterea aburului. Maersk a achiziționat prima sa navă cu motor diesel, LEISE MÆRSK, în 1921, la doar nouă ani după lansarea primei nave comerciale de navigație oceanică cu motor diesel.



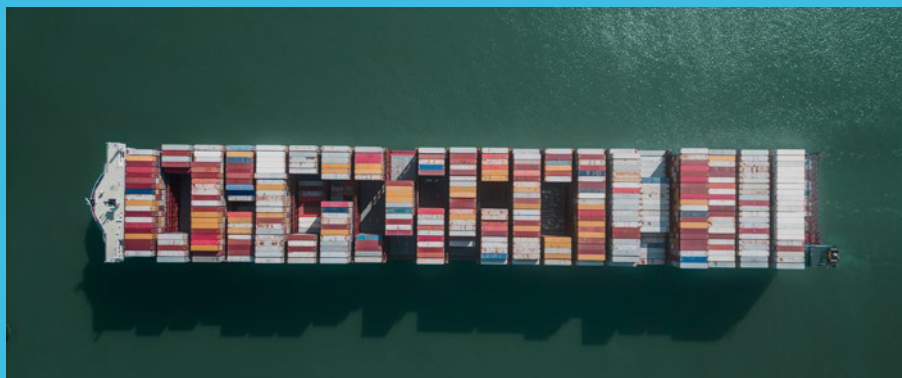

În 1956, a avut loc o nouă transformare în acest domeniu odată cu introducerea „încărcăturii containerizate” eficiente, prin care remorcile de camion sunt încărcate direct pe nave. Folosirea containerelor a redus timpul necesar pentru încărcarea și descărcarea navelor de la câteva zile la câteva ore.

Datorită containerelor și a codurilor de bare – mecanismele ascunse din spatele comerțului global – un producător din orice parte a lumii își poate vinde mărfurile pe toate piețele, făcând globalizarea posibilă din punct de vedere fizic. Lumea, așa cum o știm astăzi, depinde foarte mult de lanțurile de aprovizionare globale. De la cultivatorul de banane din Columbia la copilul din Danemarca pe care ni-l putem imagina curățând o banană la prânz, lanțurile de aprovizionare mențin lumea conectată și asigură fluxul de alimente, medicamente, bunuri și materiale către oamenii din întreaga lume.





 MAER

 MAERS

 MAERSK

 MAERSK

CARE ESTE SEMNIFICAȚIA UNUI NUME?

Din 1906, toate navele din flota Maersk au inclus cuvântul „MÆRSK” în denumirea lor. Majoritatea navelor inițiale aveau denumiri care făceau referire la familia fondatoare, dar, pe măsură ce flota a depășit numărul de nume disponibile, tradiția a trebuit să fie ajustată. Astăzi poți vedea și nave Maersk denumite, de exemplu, după orașe și râuri.

Atunci când a decis cum să numească noua serie de nave cu combustibil dual, Maersk a revenit la tradiția de a numi navele după membrii familiei fondatoare, de data aceasta începând cu litera A pentru a anunța o nouă eră.

ANE MÆRSK este denumită după Ane Mærsk Mc-Kinney Uggla, președinta A.P. Moller Holding, care este societatea-mamă A.P. Moller-Maersk. A.P. Moller-Maersk a fost fondată în 1904 de Arnold Peter Møller. Ane este nepoata fondatorului Grupului, Arnold Peter Møller, și a soției acestuia, Chastine Mc-Kinney Møller.



ANE MAERSK





STEAUA ALBĂ – UN SIMBOL AL SPERANȚEI

Emblematica stea de culoare albă, cu șapte vârfuri, a făcut parte din patrimoniul Maersk încă dinaintea de înființarea companiei în 1904 și este un simbol durabil al legăturilor puternice de familie, care încă reprezintă esența companiei după mai bine de 100 de ani.

La începutul carierei sale, căpitanul Peter Mærsk Møller, tatăl lui A.P. Møller, a lucrat pentru un armator englez, iar soția sa, Anna, îl însoțea uneori în călătorii. Într-una dintre aceste călătorii, Anna s-a îmbolnăvit grav. Temându-se că nu va supraviețui, Peter Mærsk Møller a urcat pe punte și s-a rugat la Dumnezeu pentru un semn că soția sa își va reveni. În acel moment, a văzut o singură stea luminând cerul, de altminteri gri.

Anna și-a revenit, iar în 1886 Peter Mærsk Møller a achiziționat primul vapor cu aburi, denumit LAURA, și a împodobit coșul navei cu o stea albă cu șapte vârfuri pe un fundal albastru deschis, ca omagiu adus soției sale iubite. Pentru Peter Maersk Møller, steaua reprezenta recuperarea ei și simbolul norocului lor.

De atunci, steaua albă cu șapte vârfuri pe emblematicul fundal albastru a fost sinonimă cu Maersk, însă logoul în sine a evoluat de-a lungul anilor. Au existat multe versiuni ale logoului, dar logoul Maersk din prezent datează de la începutul anilor 1970, când s-a decis că este nevoie de o abordare mai modernă.



ALL THE WAY
TO ZERO



ÎMBUNĂTĂȚIREA VIEȚII TUTUROR PRIN INTEGRAREA LUMII

Ca lider mondial în domeniul serviciilor logistice, Maersk are peste 100.000 de clienți, operează în aproape 130 de țări și are peste 100.000 de angajați. De la începuturile sale modeste ca o companie de nave cu aburi, până la a deveni o companie de logistică integrată care lucrează pentru a conecta și a simplifica lanțurile de aprovizionare ale clienților săi, Maersk utilizează peste 700 de nave și transportă aproape 20% din alimentele, materialele și bunurile lumii.





MAERSK
MAERSK
MAERSK
MAERSK
MAERSK
MAERSK
MAERSK

MAERSK
MAERSK
MAERSK
MAERSK
MAERSK
MAERSK
MAERSK

ALL
THE T
WAY

ANE MAERSK

SPREADERS
TSP98
MAERSK
MAERSK
MAERSK
MAERSK
MAERSK

PTP
T414
65 TOP'S SWL
P423 PTP

DRUMUL PÂNĂ LA ZERO EMISII: ANGAJAMENTUL PENTRU UN VIITOR DECARBONIZAT

Pe măsură ce lumea se confruntă cu urgențe climatice, viitorul lanțurilor de aprovizionare și al comerțului global depinde de capacitatea de a inova și de a promova noi surse de energie. Maersk și-a asumat o obligație serioasă de a atinge nivelul net de zero emisii de gaze cu efect de seră până în 2040, în cadrul tuturor operațiunilor sale. În timp ce își decarbonizează operațiunile, Maersk și-a asumat totodată un angajament social de a fi lider în abordarea crizei climatice prin decarbonizarea lanțurilor de aprovizionare globale și prin facilitarea unei tranziții corecte către o economie cu emisii nete zero.

Maersk a stabilit obiective ambițioase până în 2040 pentru a asigura progrese semnificative în acest deceniu: în cadrul sectoarelor maritime, terestre, aeriene, precum și la terminalele noastre. În contextul comandării și livrării de numeroase nave cu combustibil dual care pot naviga cu emisii reduse, cum ar fi biometanolul și e-metanolul, precum și biometanolul, misiunea de decarbonizare a flotei este în grafic.



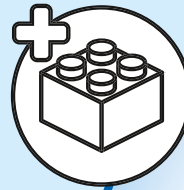
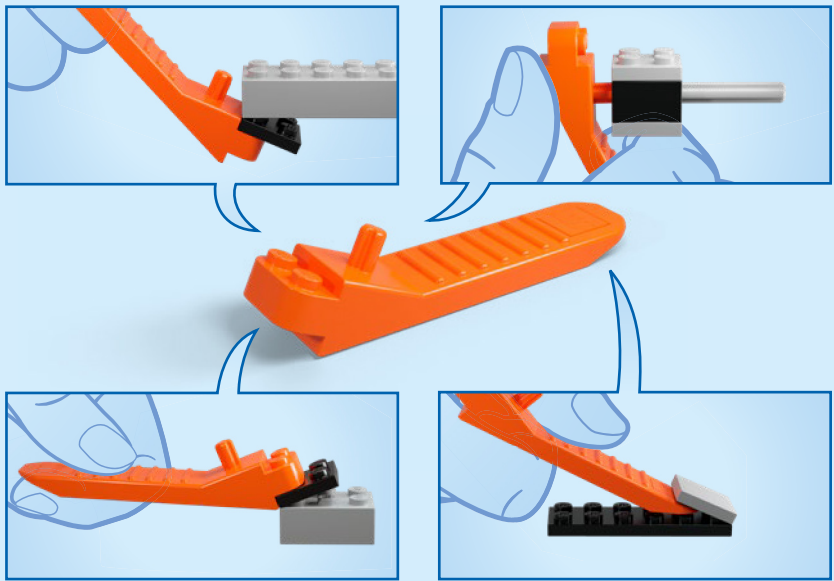

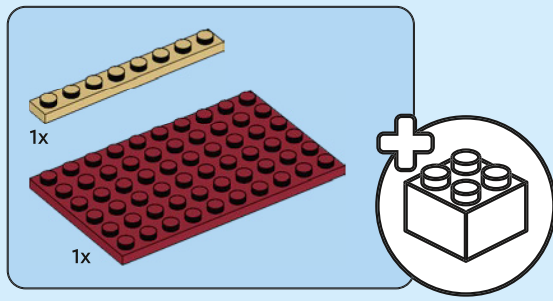

1

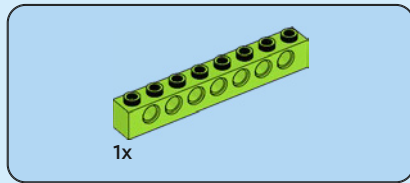
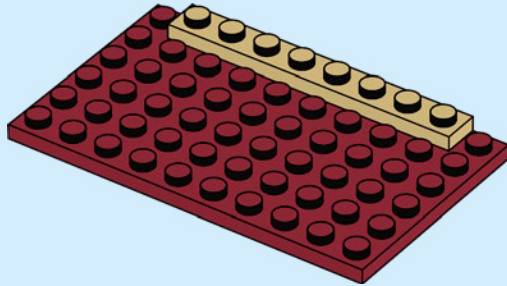

2

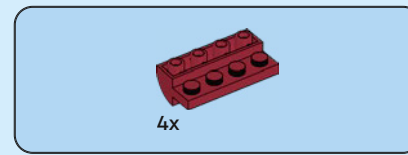
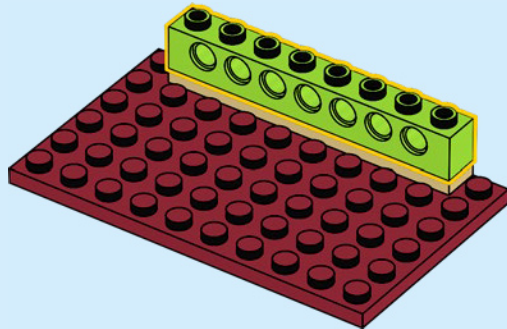

3

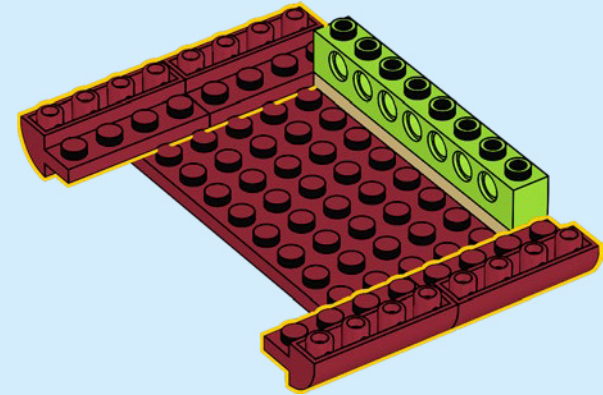

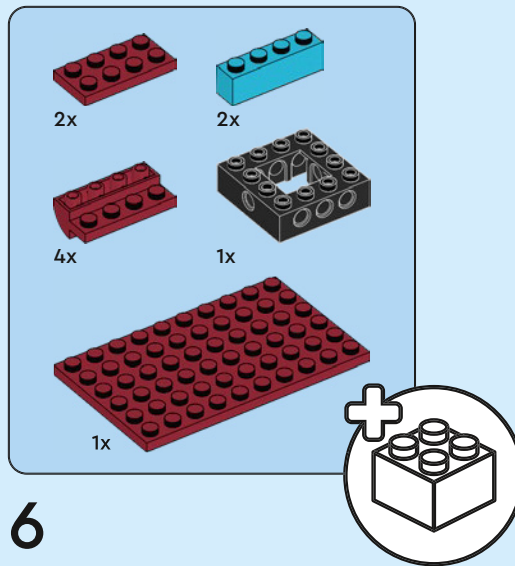
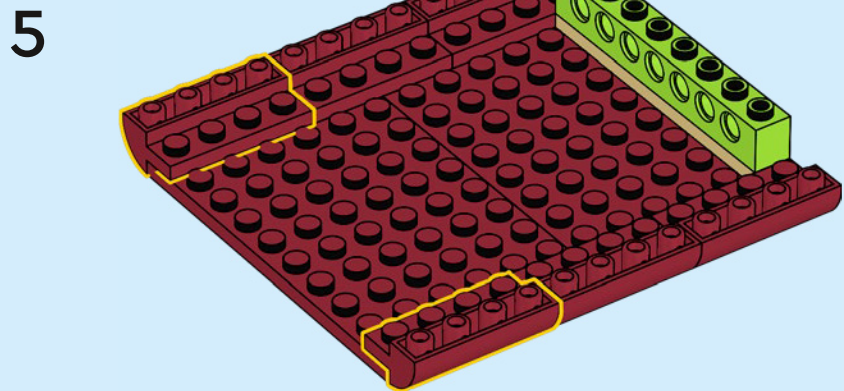
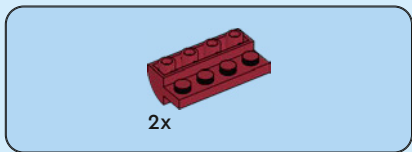
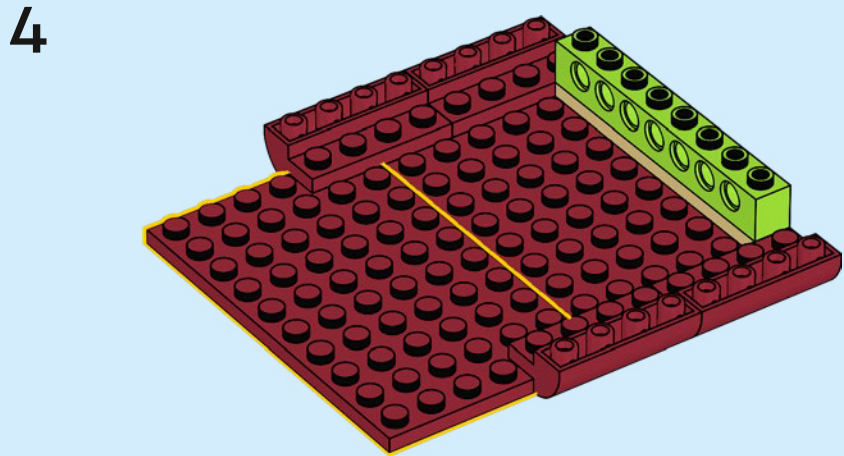
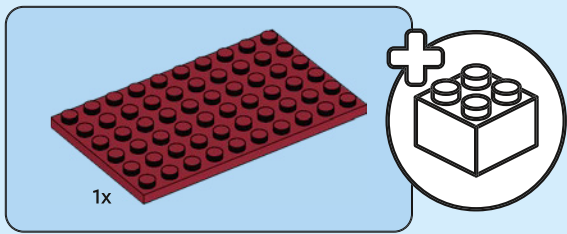

6

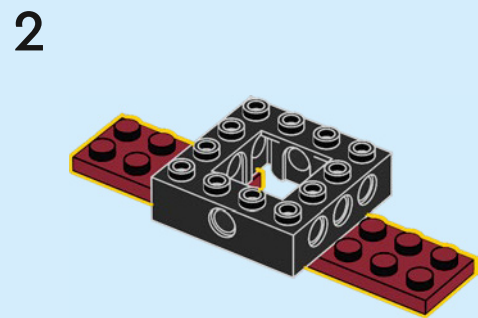
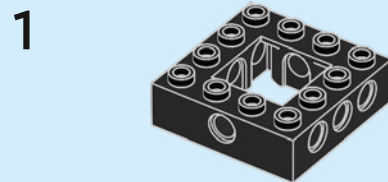

3

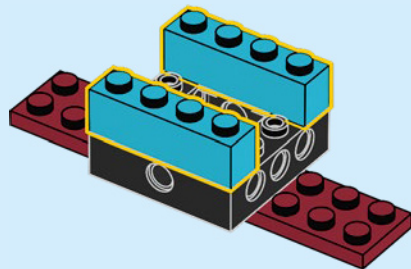

4

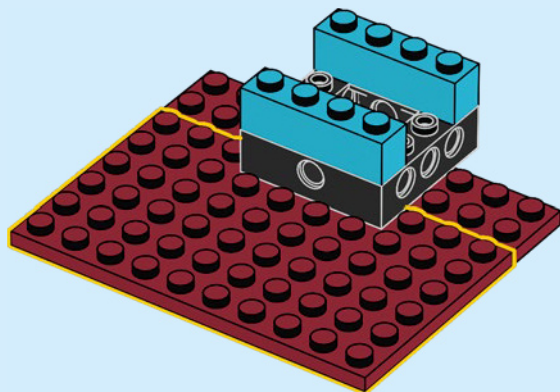

5

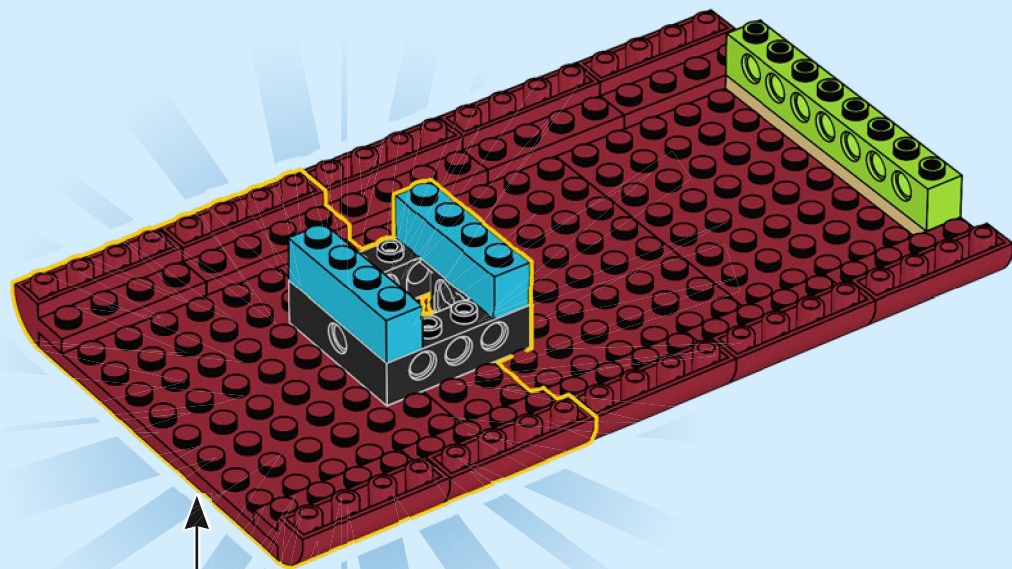
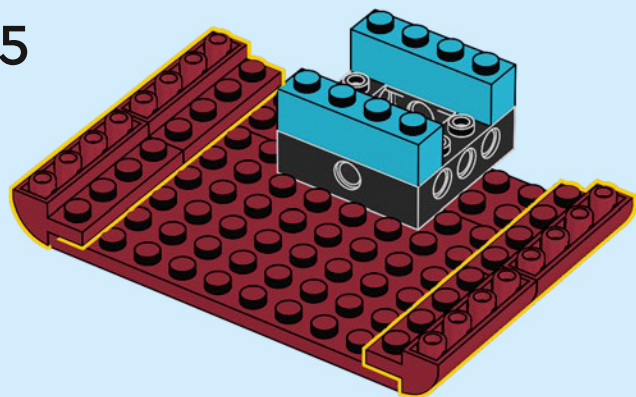

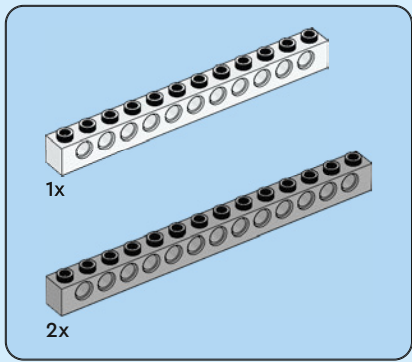

7

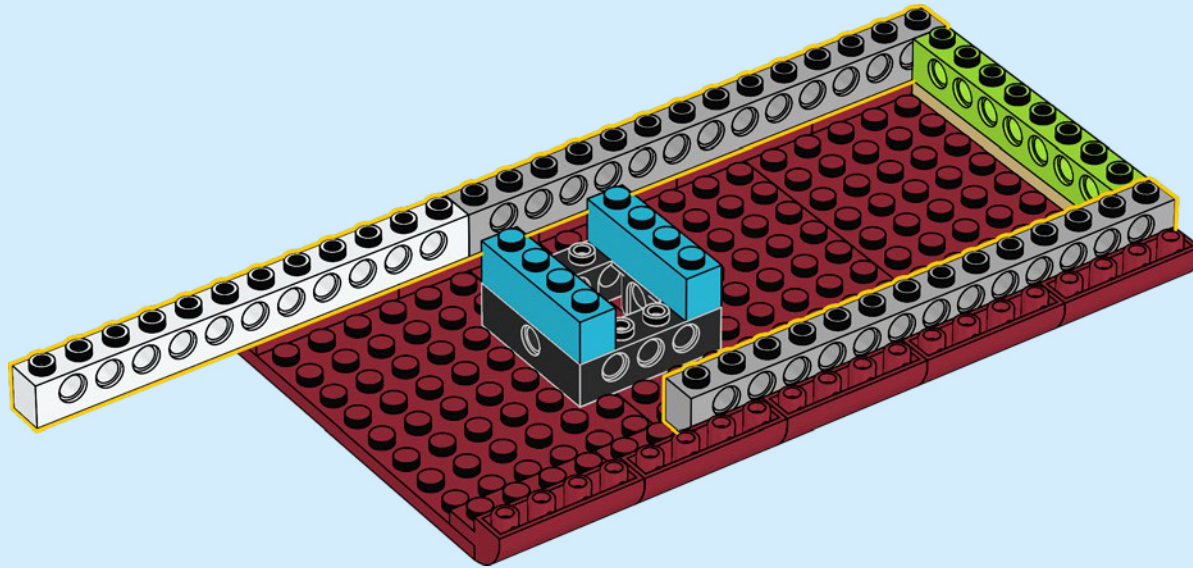

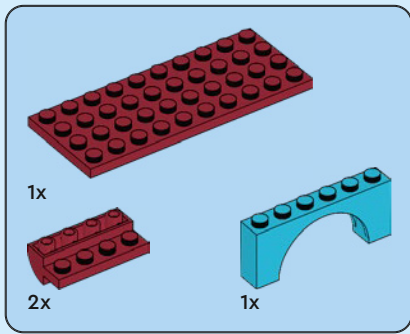

8

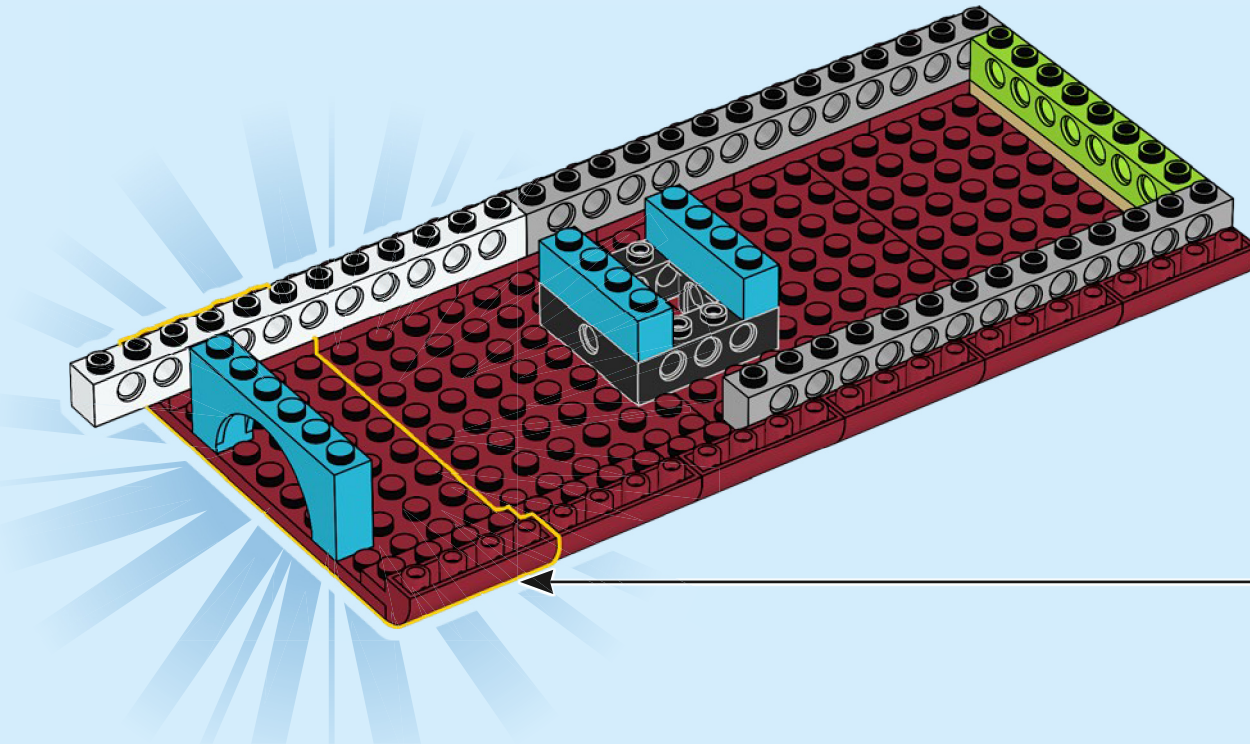
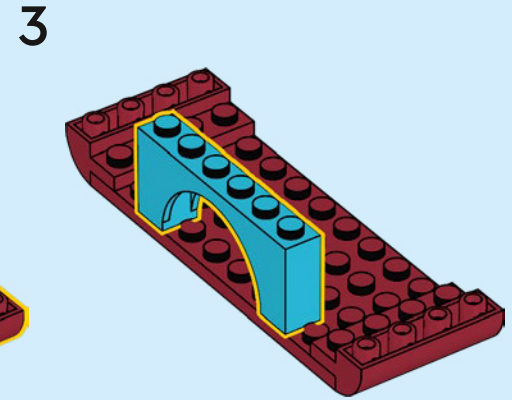
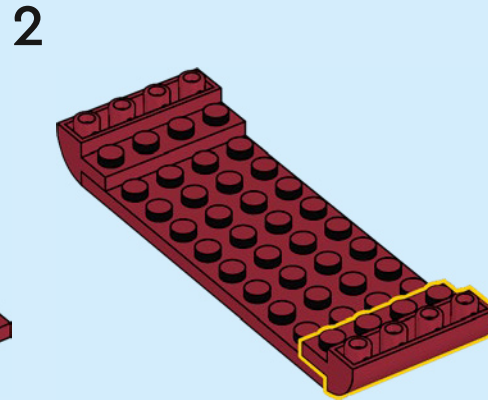
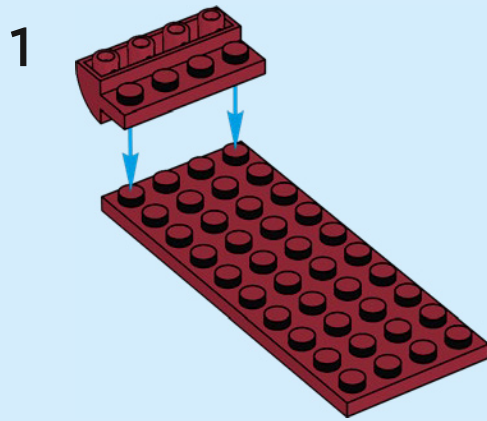

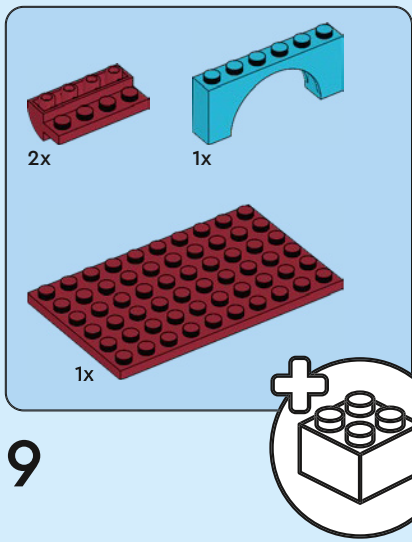

9

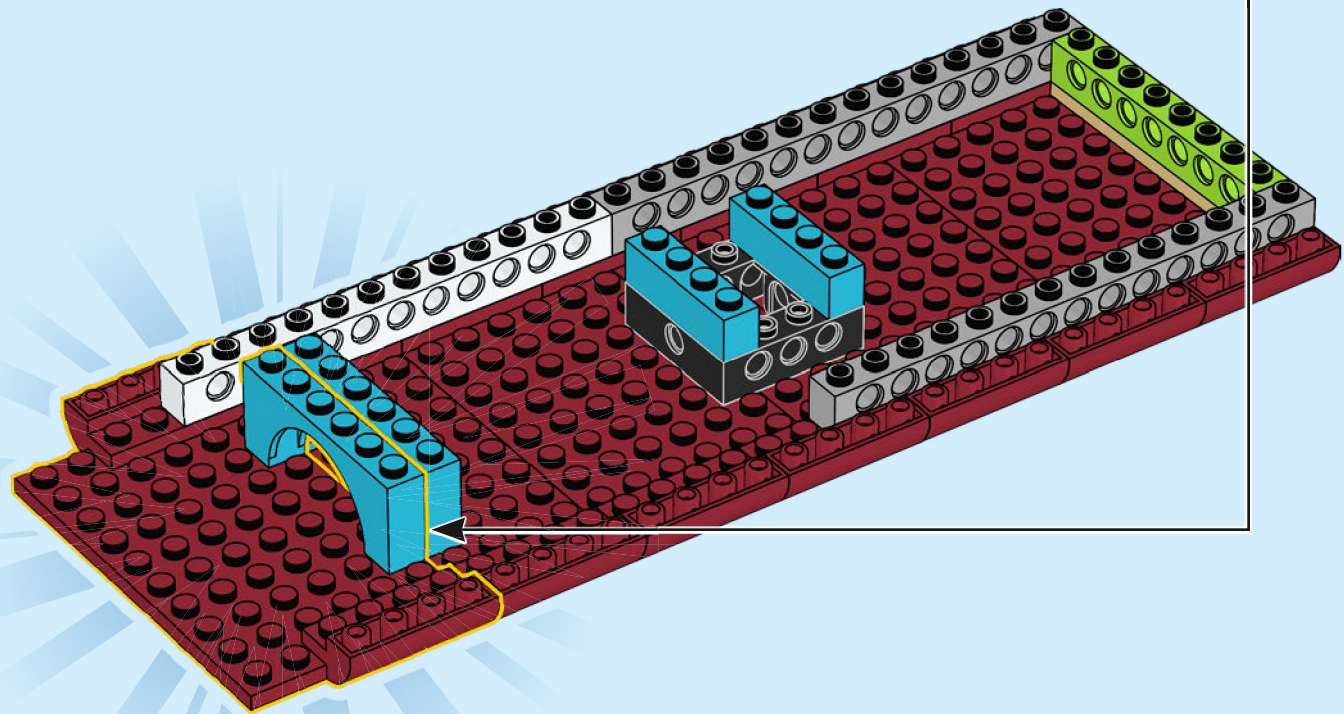
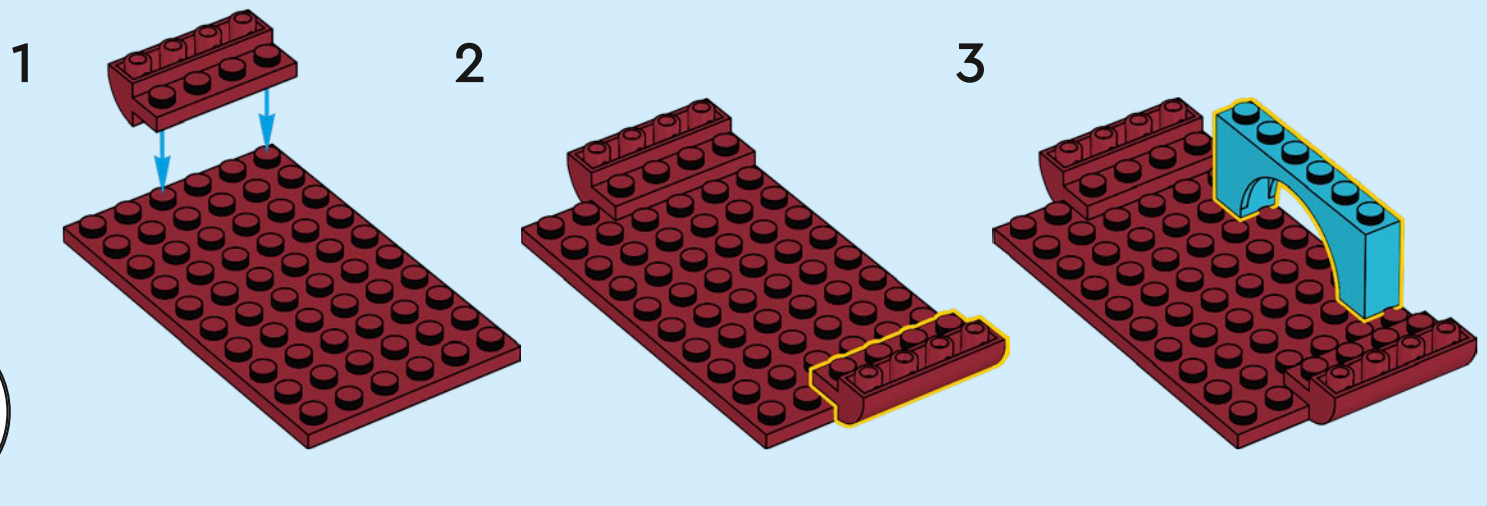

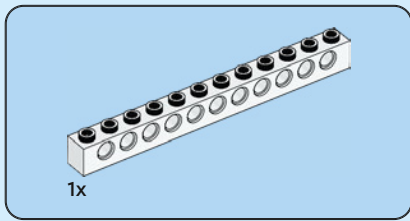

10

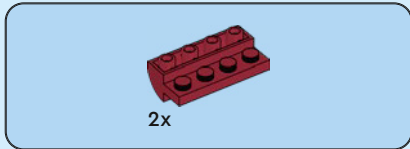
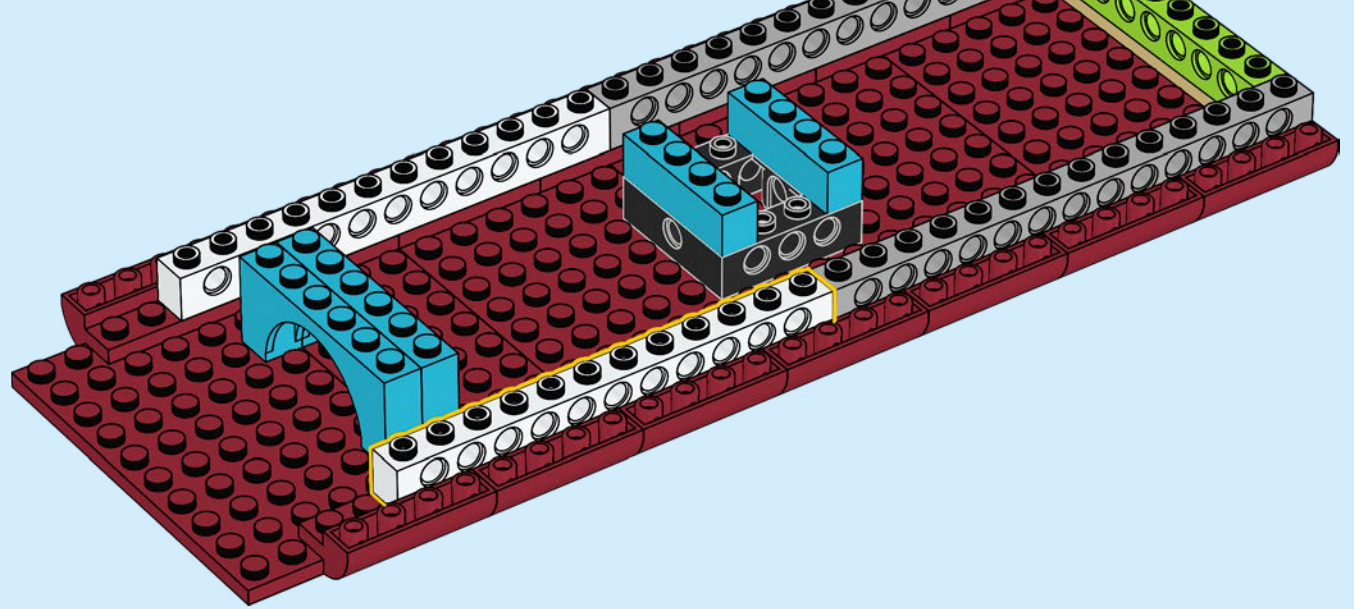

11

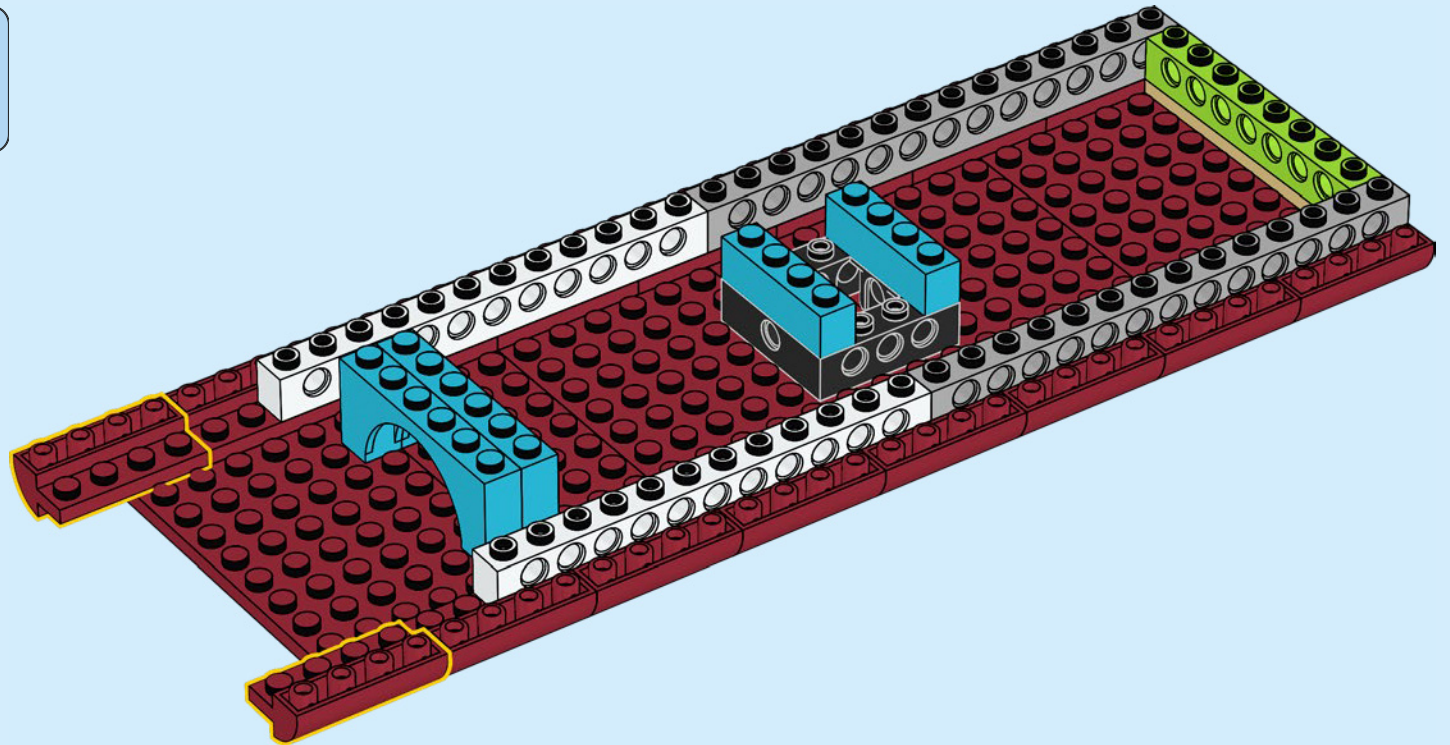

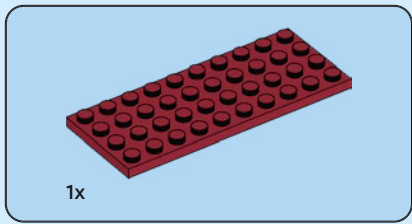

12

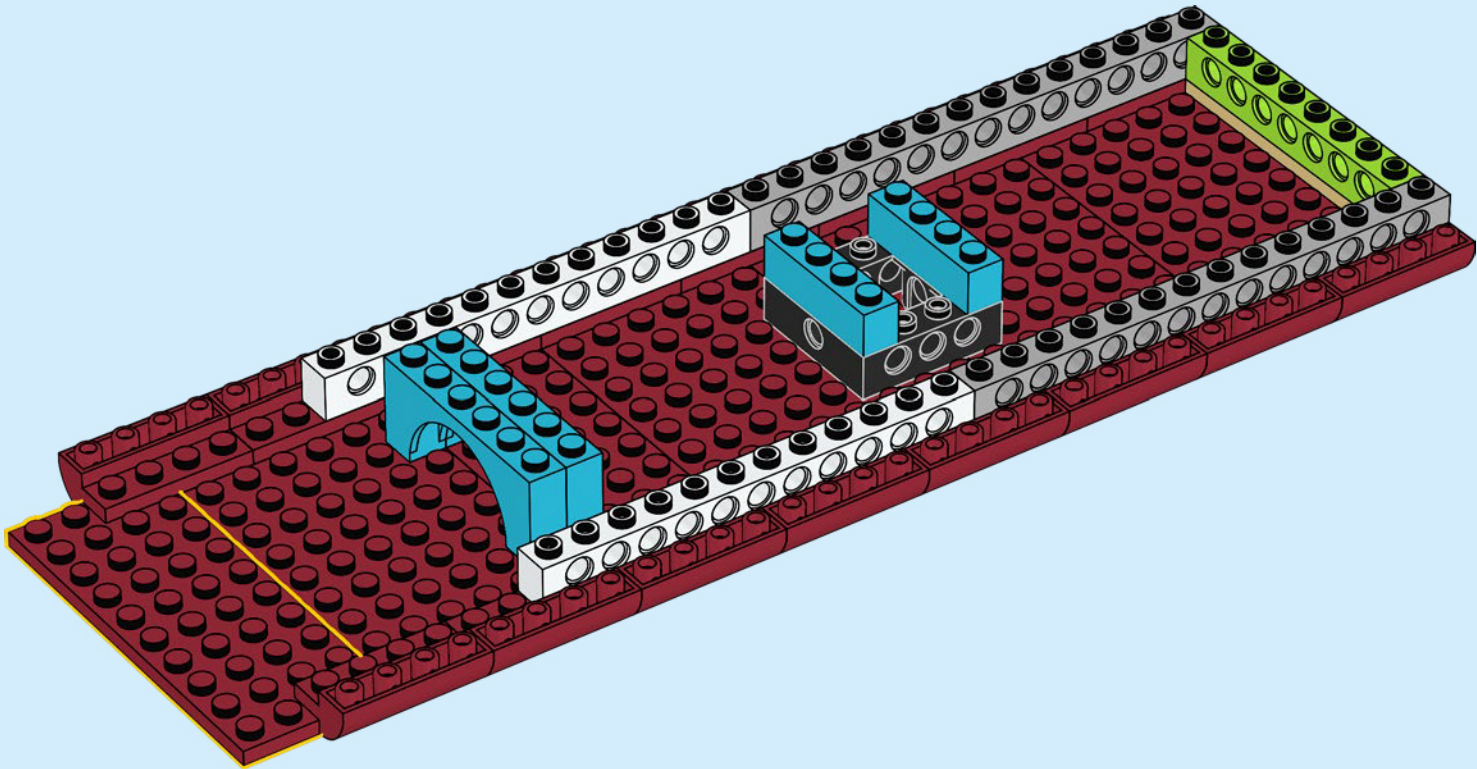

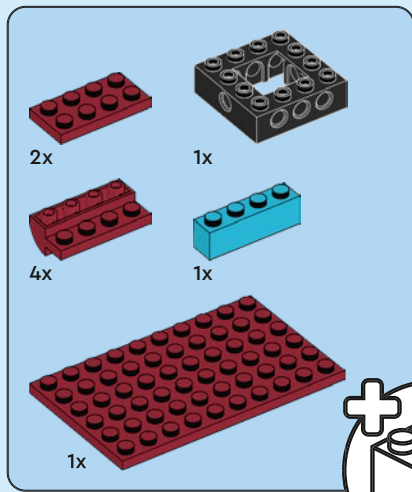

13

1

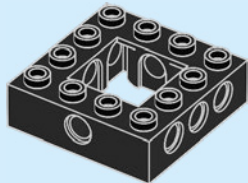

2

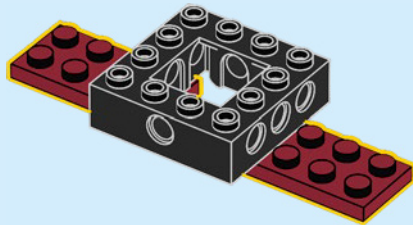

3

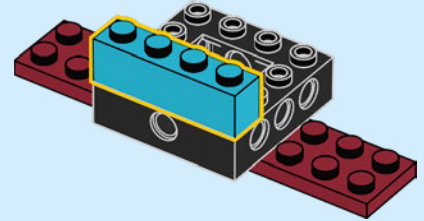

4

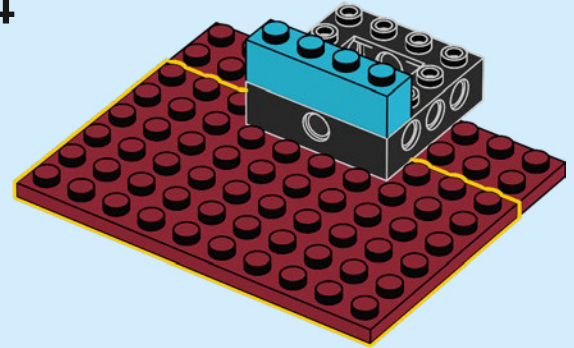

5

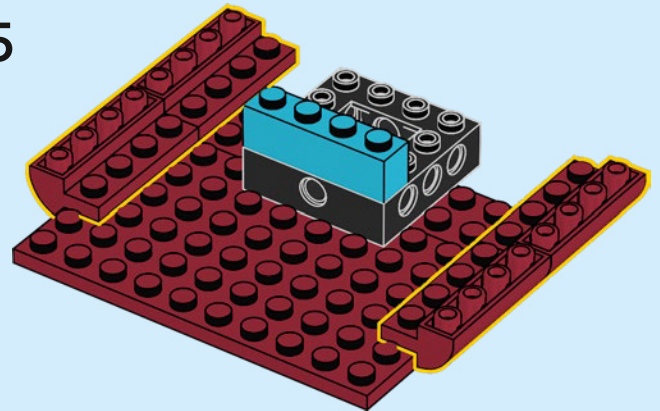

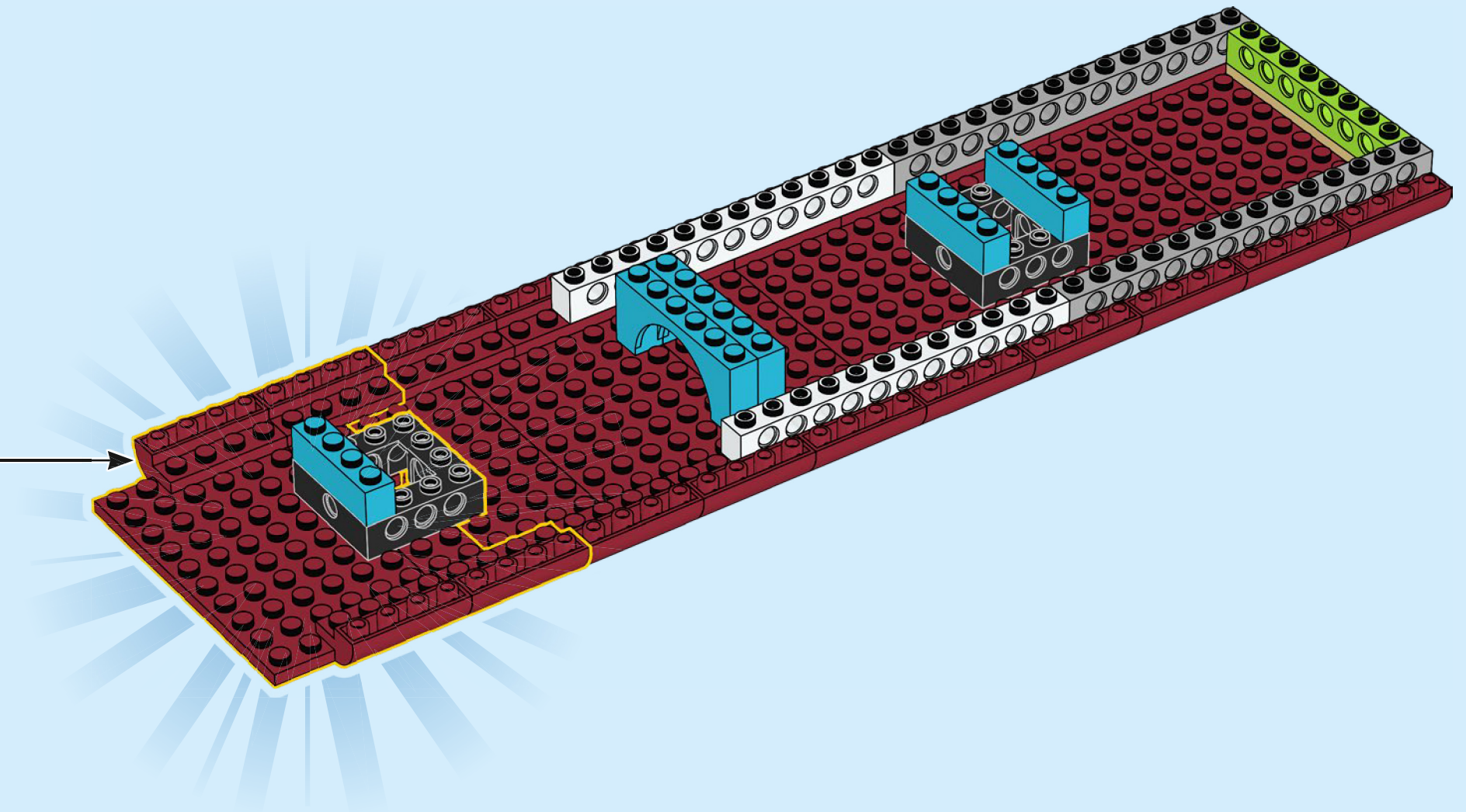

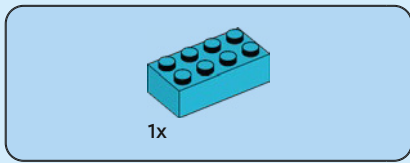

14

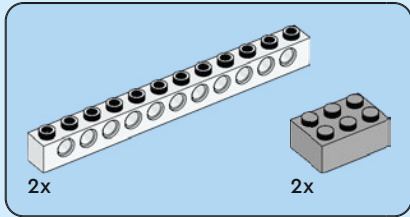
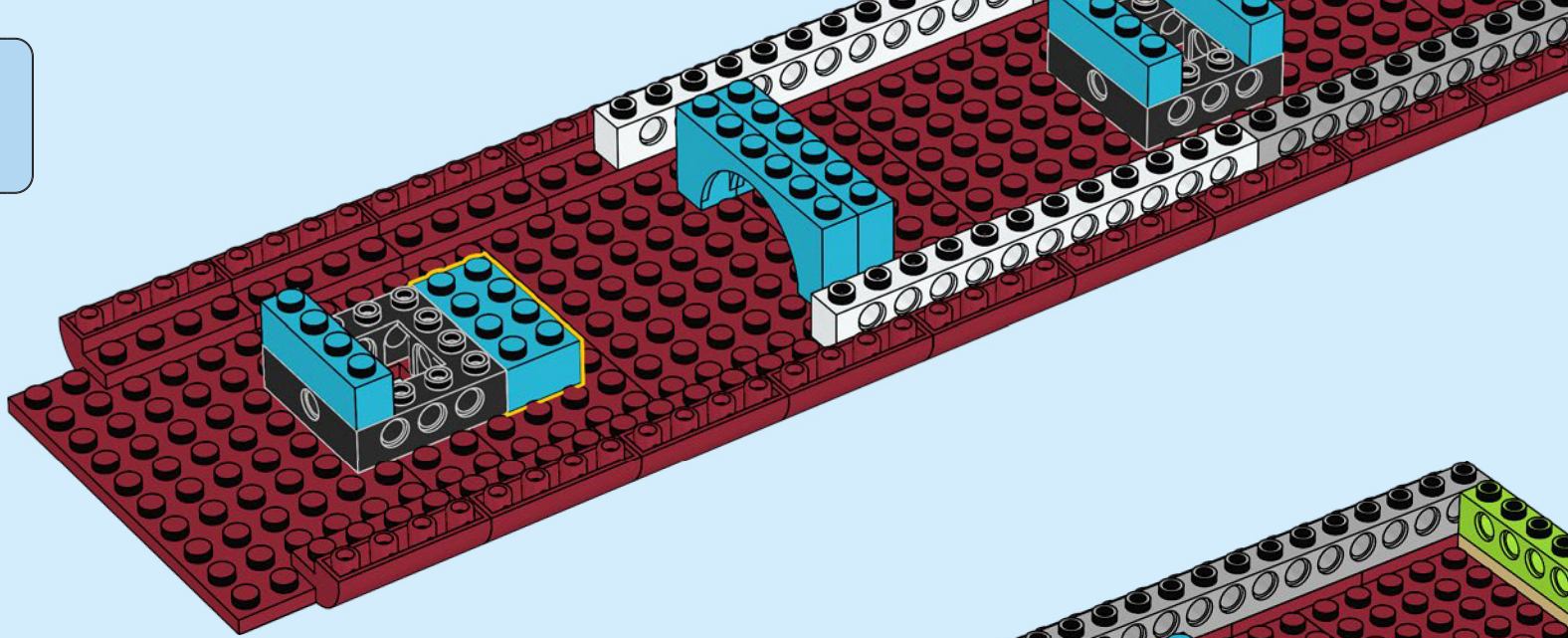

15

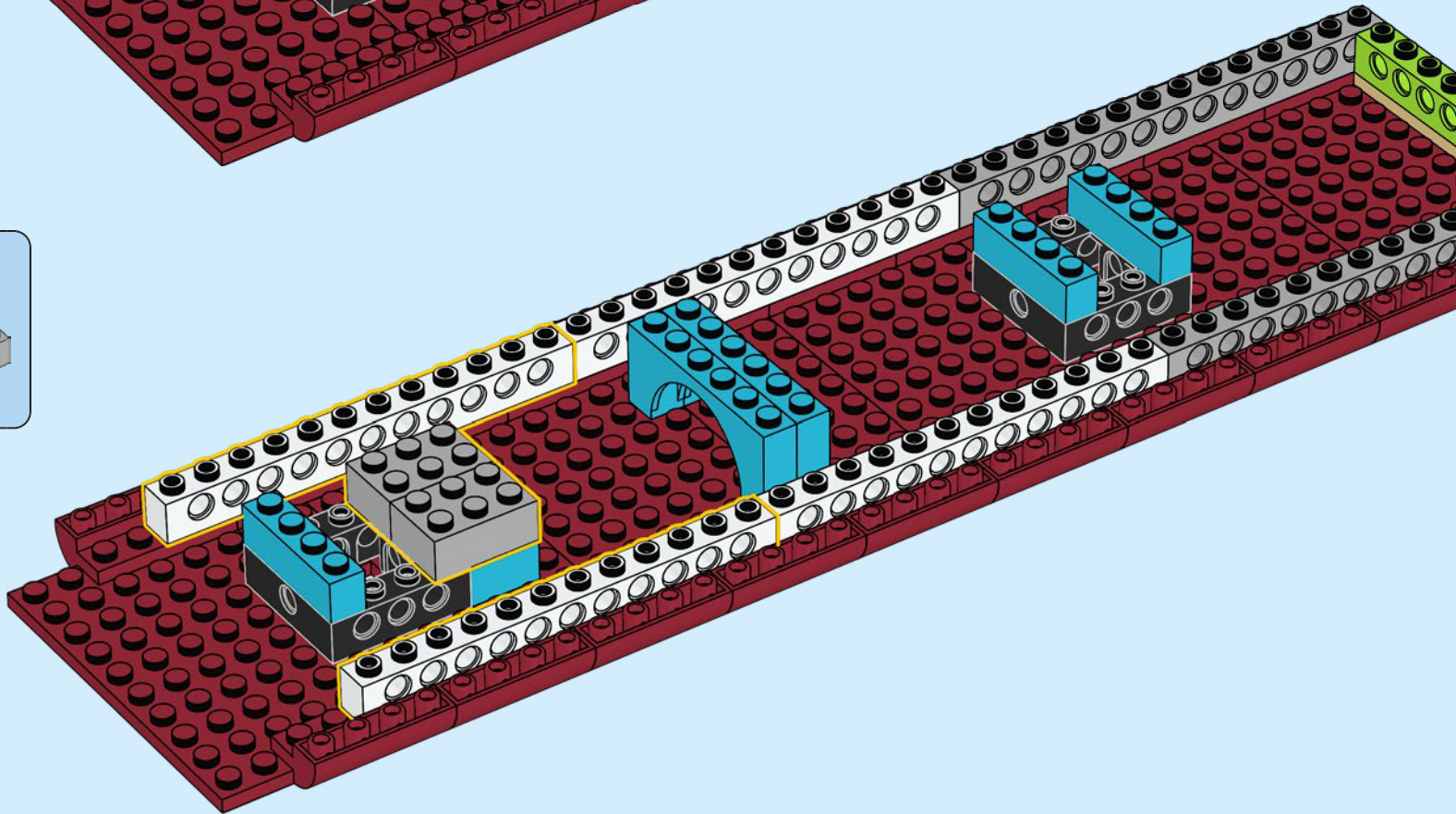

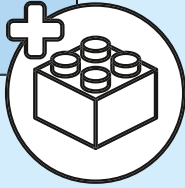
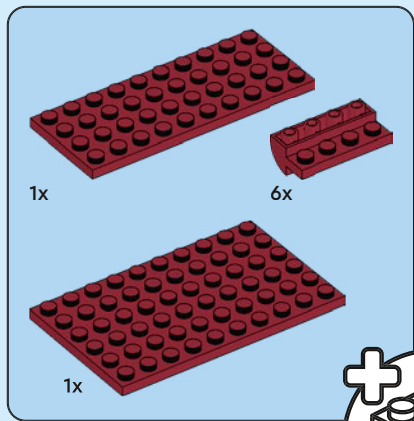

16

1

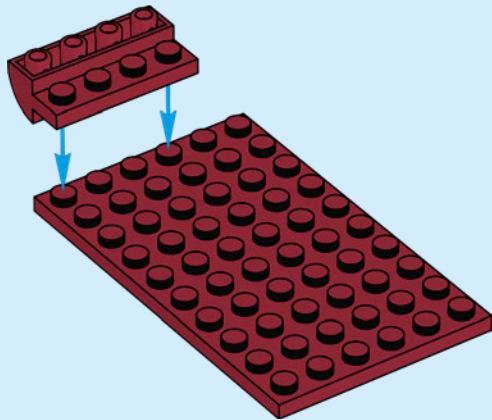

2

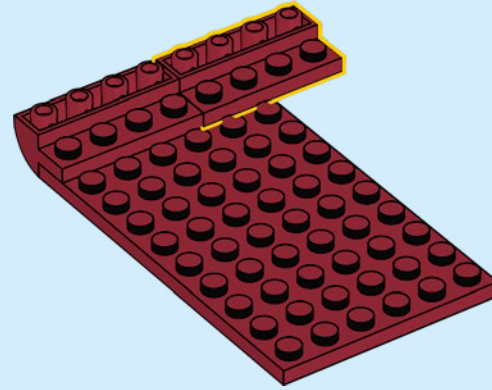

3

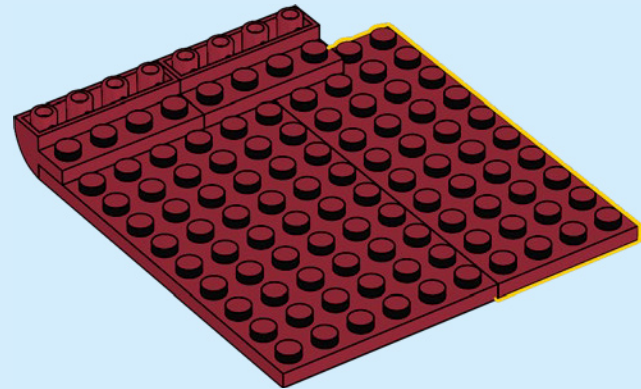

4

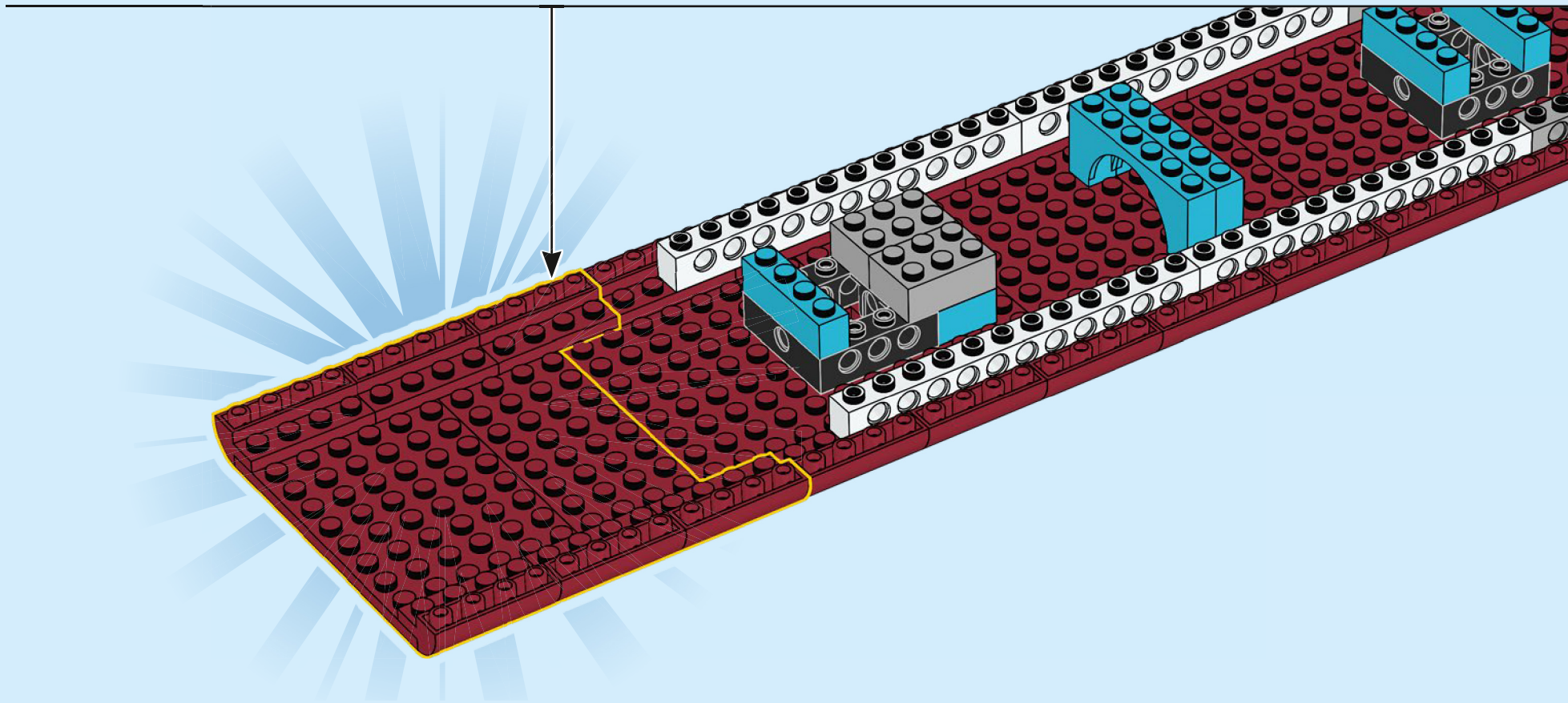
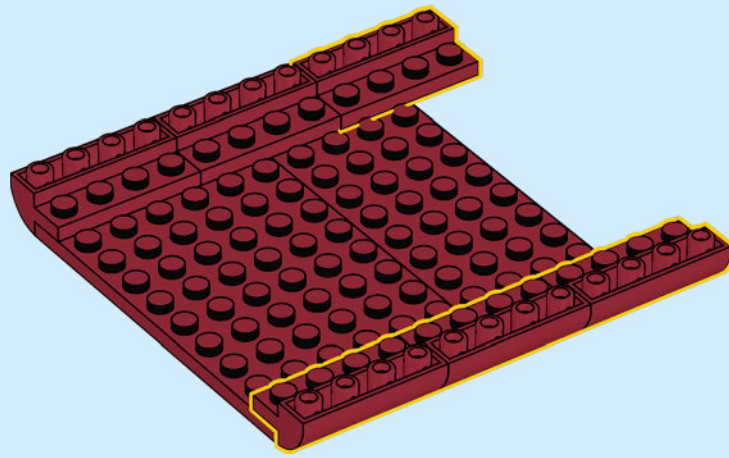

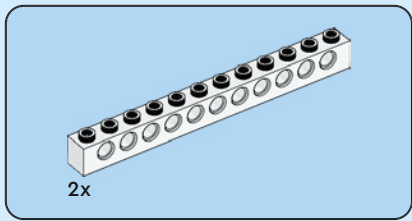

17

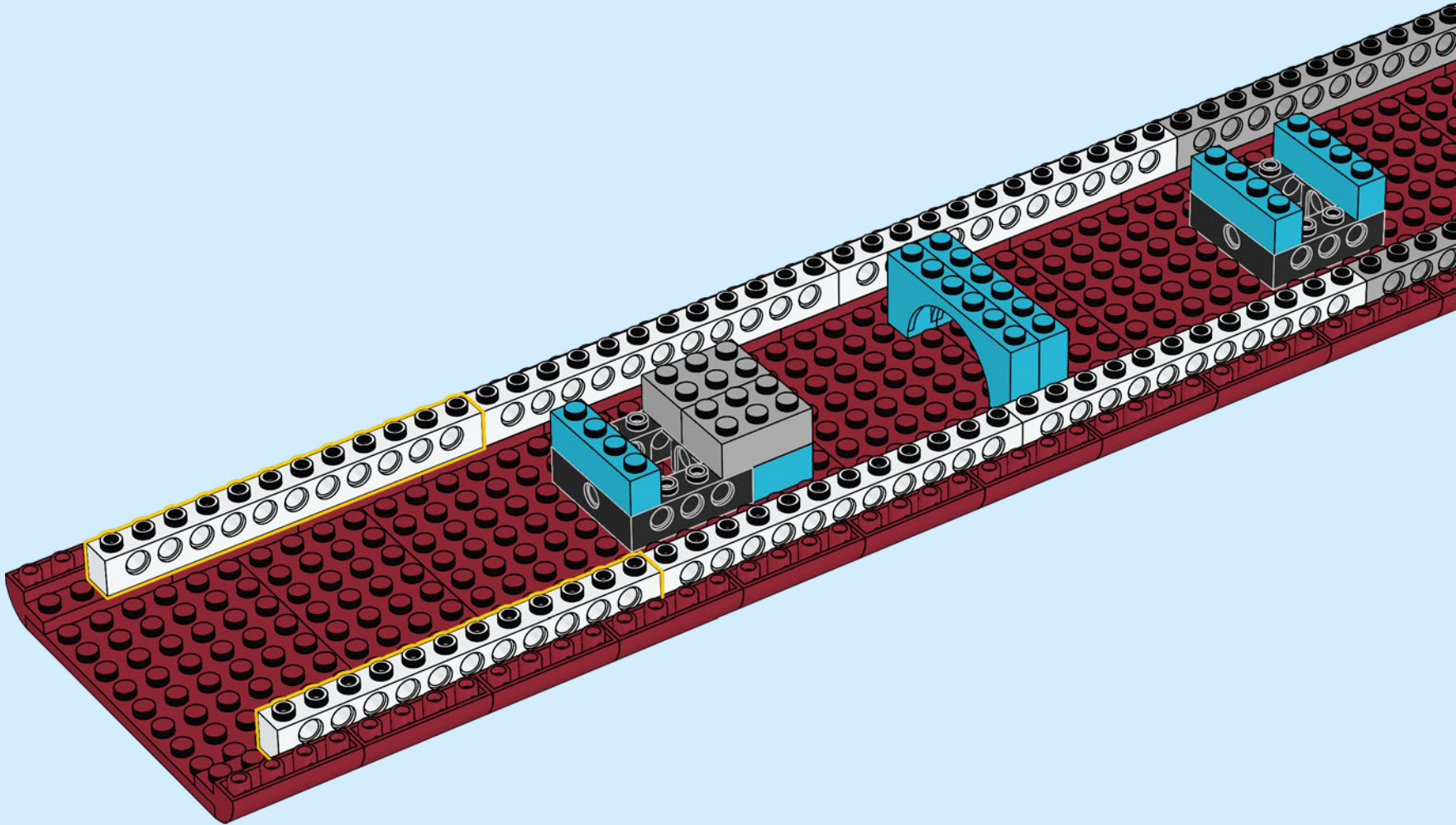

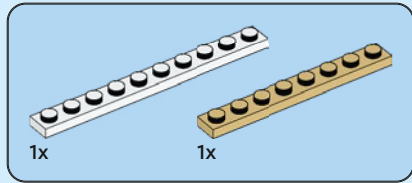

18

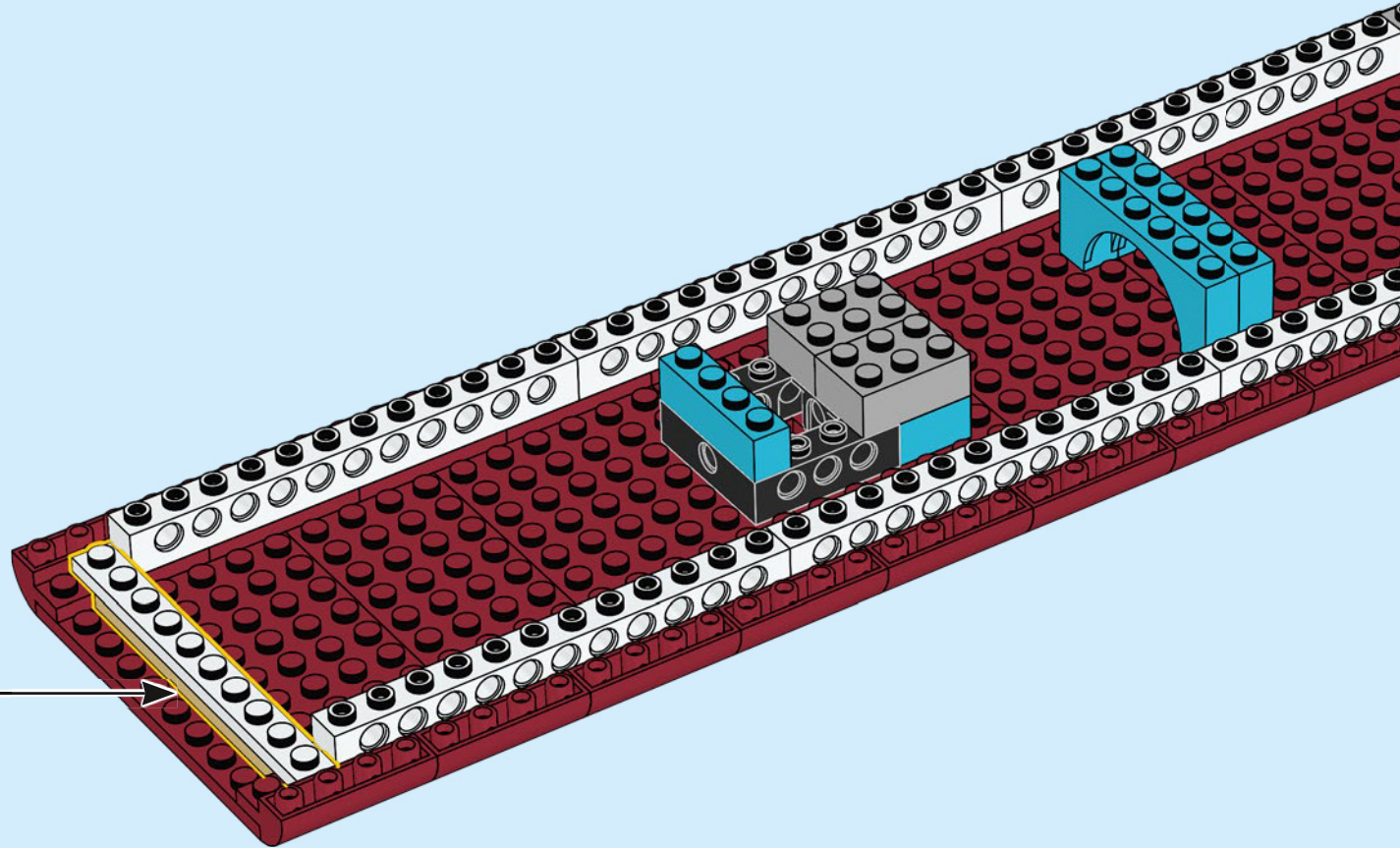
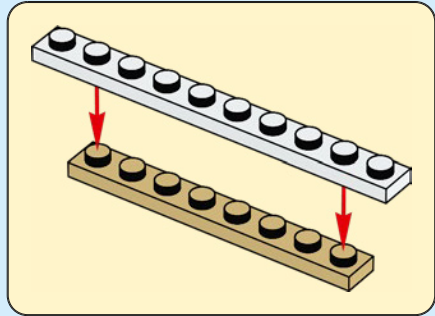



2x



3x

19

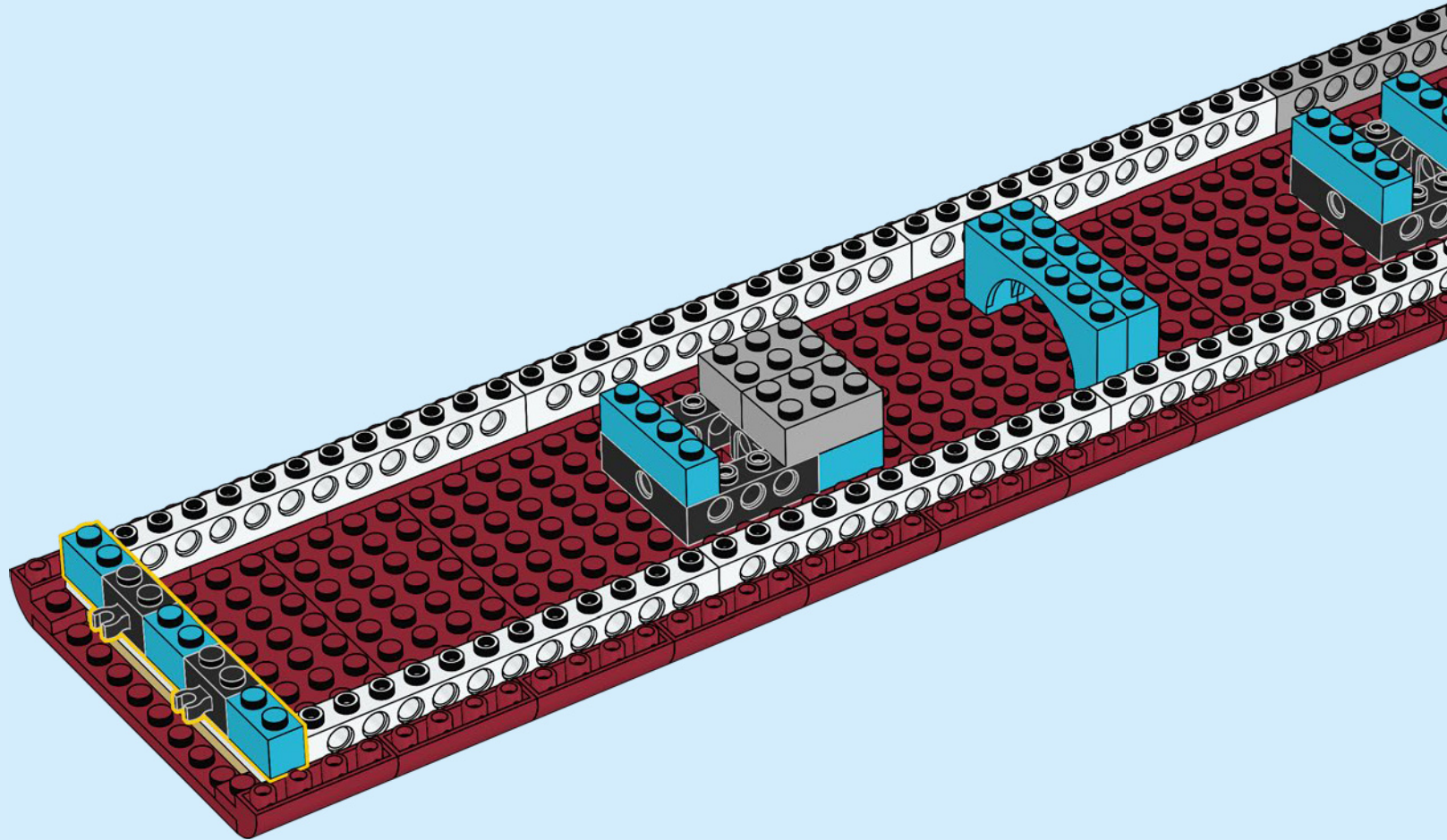

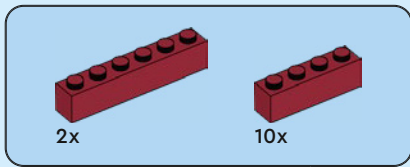

20

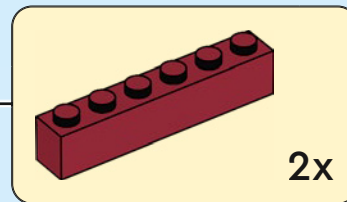
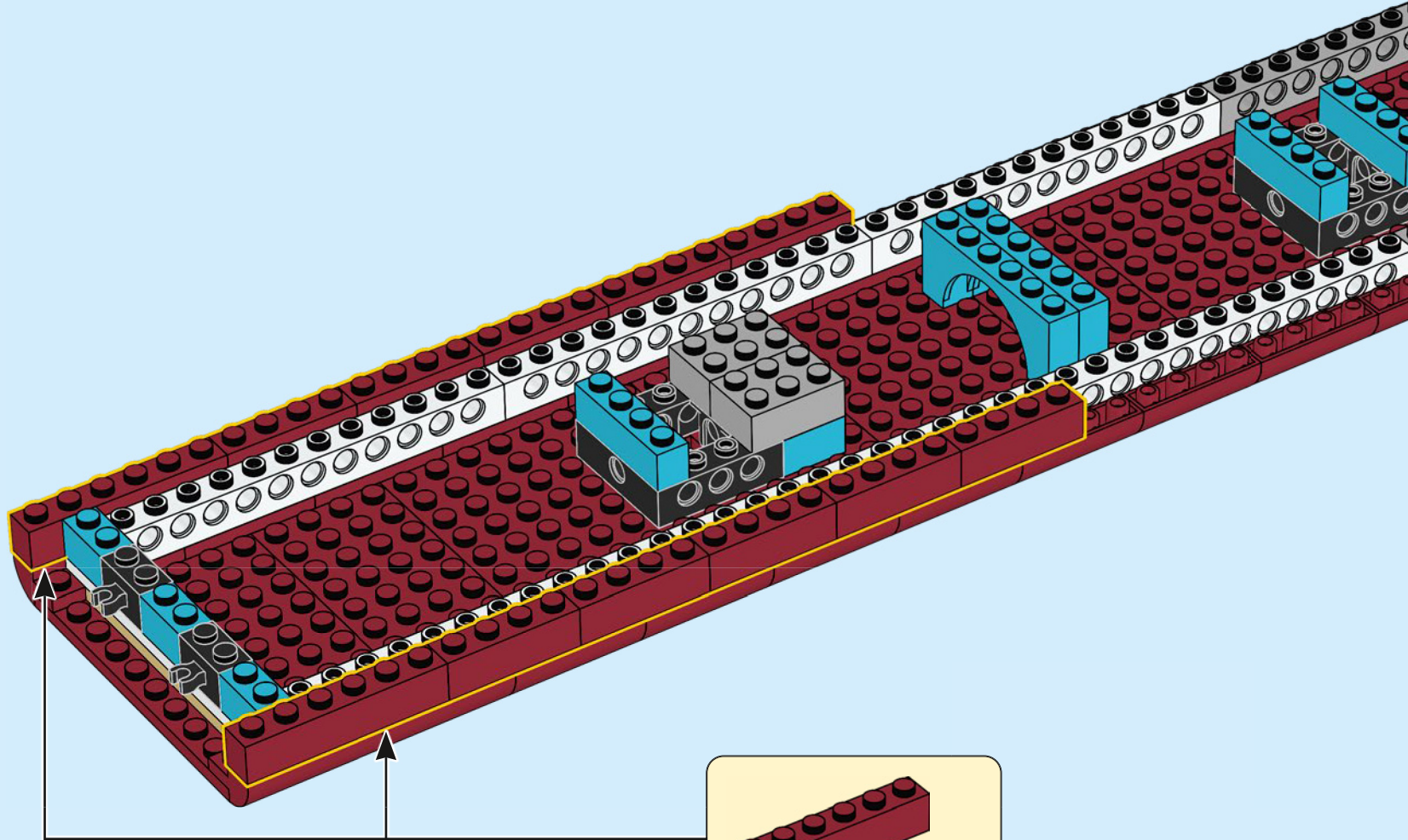

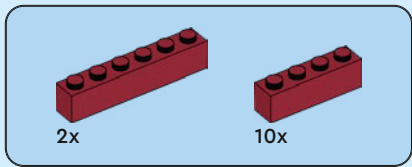

21

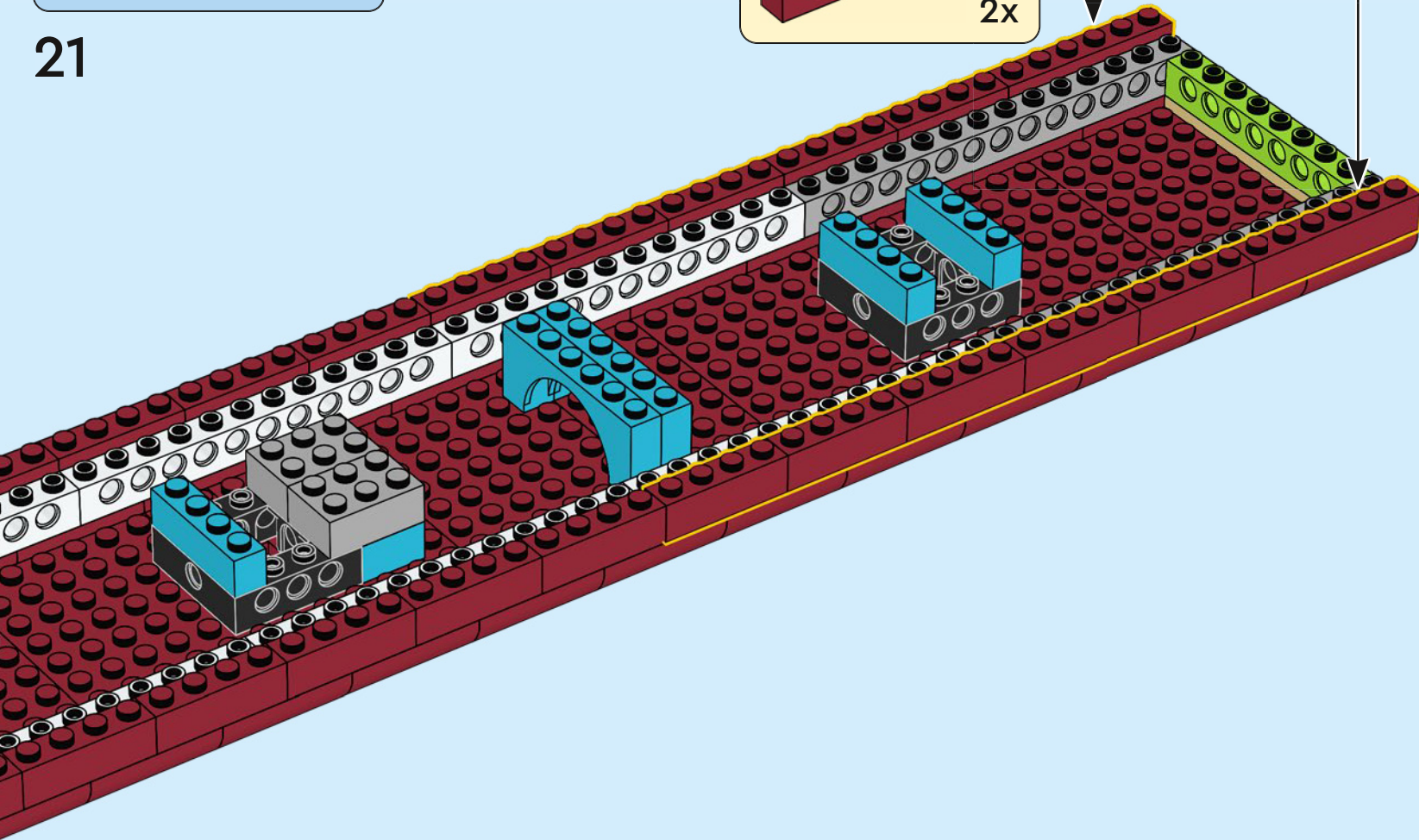
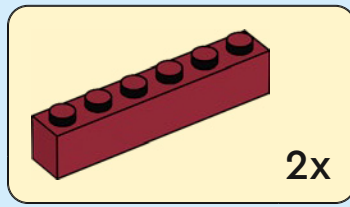

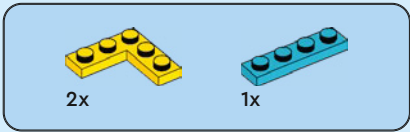

22

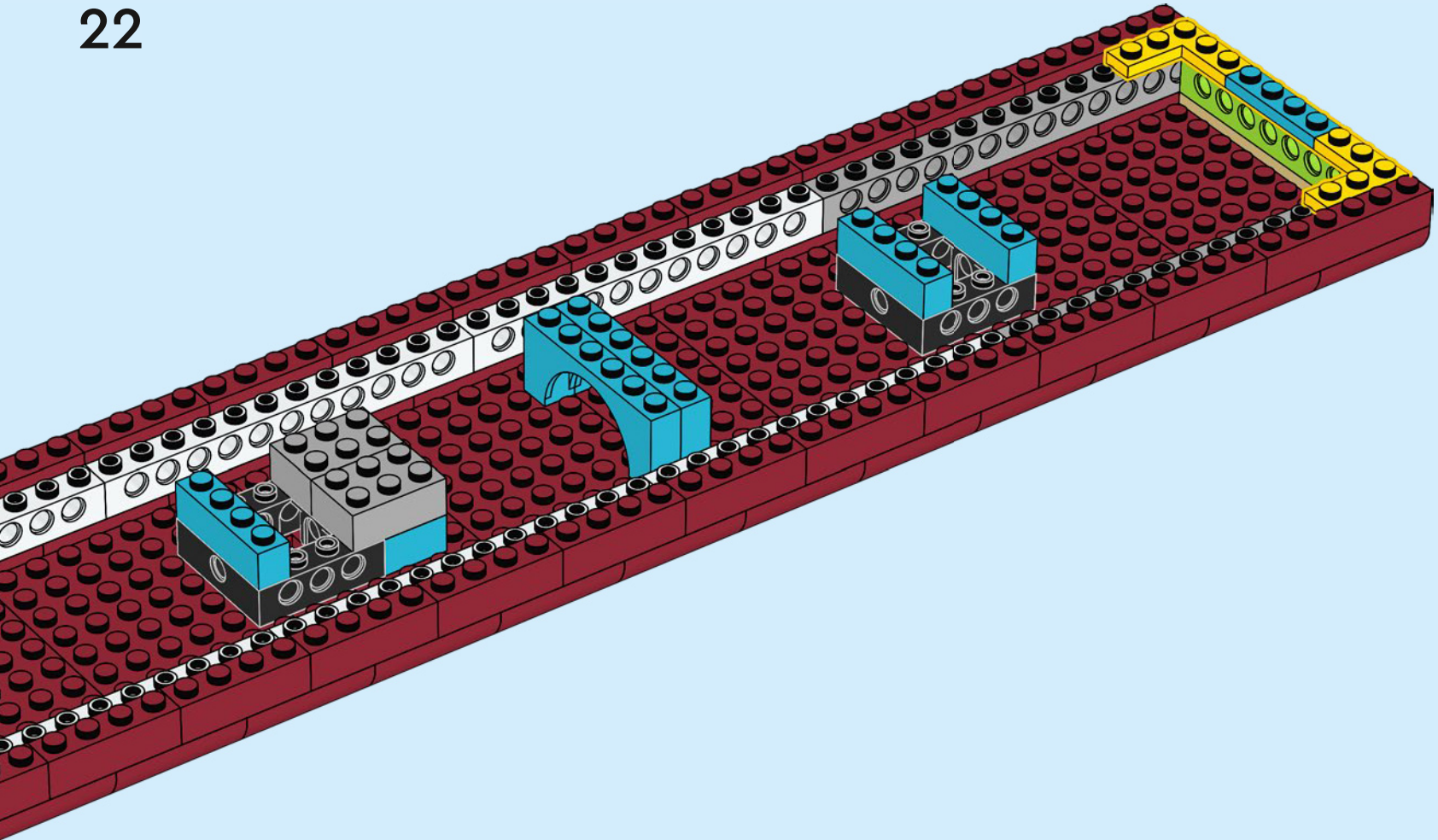

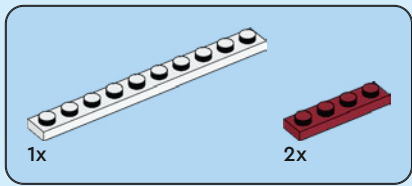

23

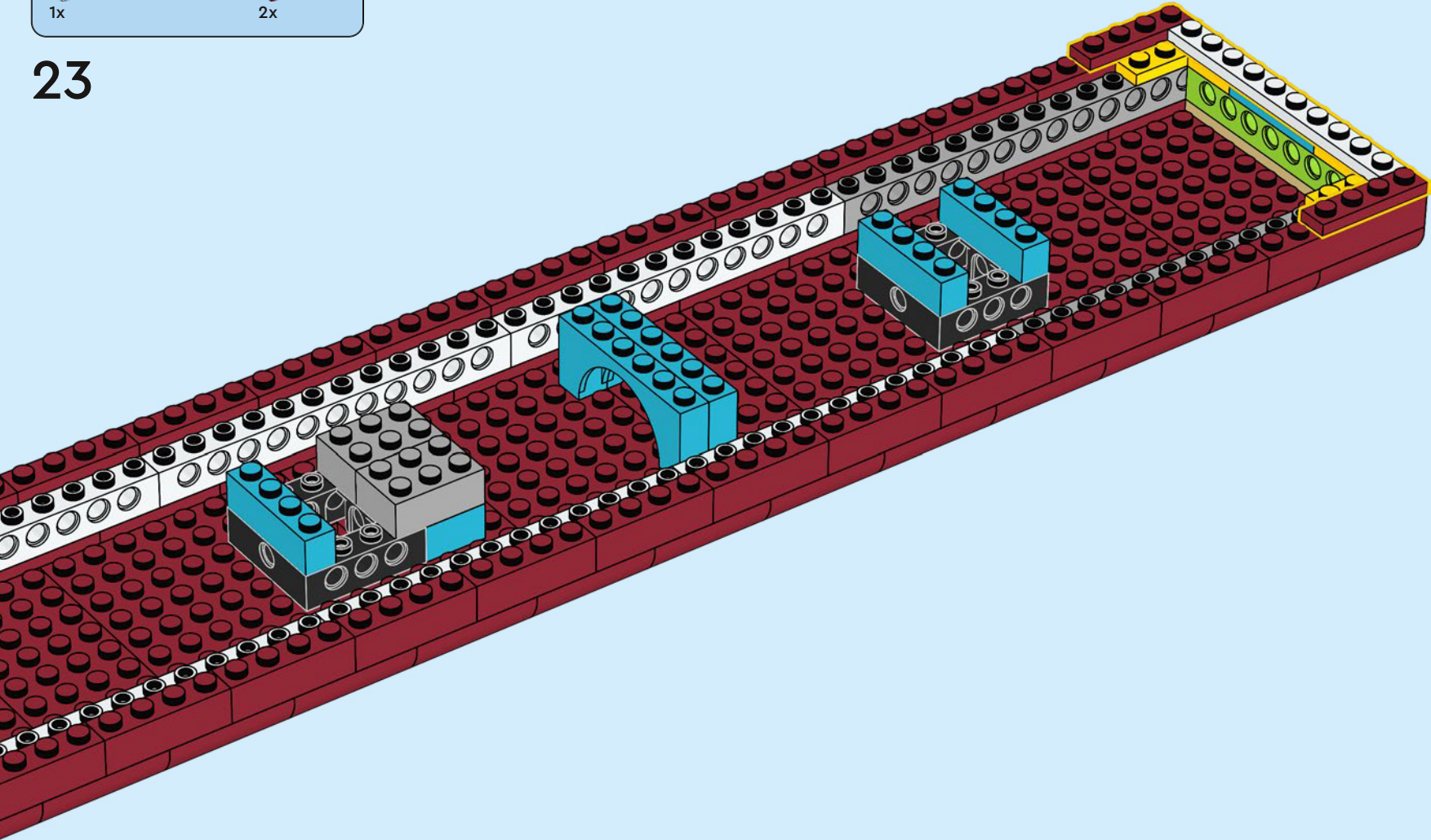

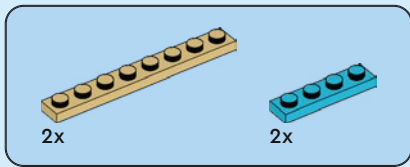

24

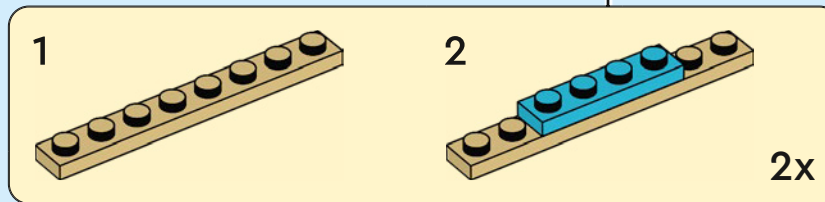
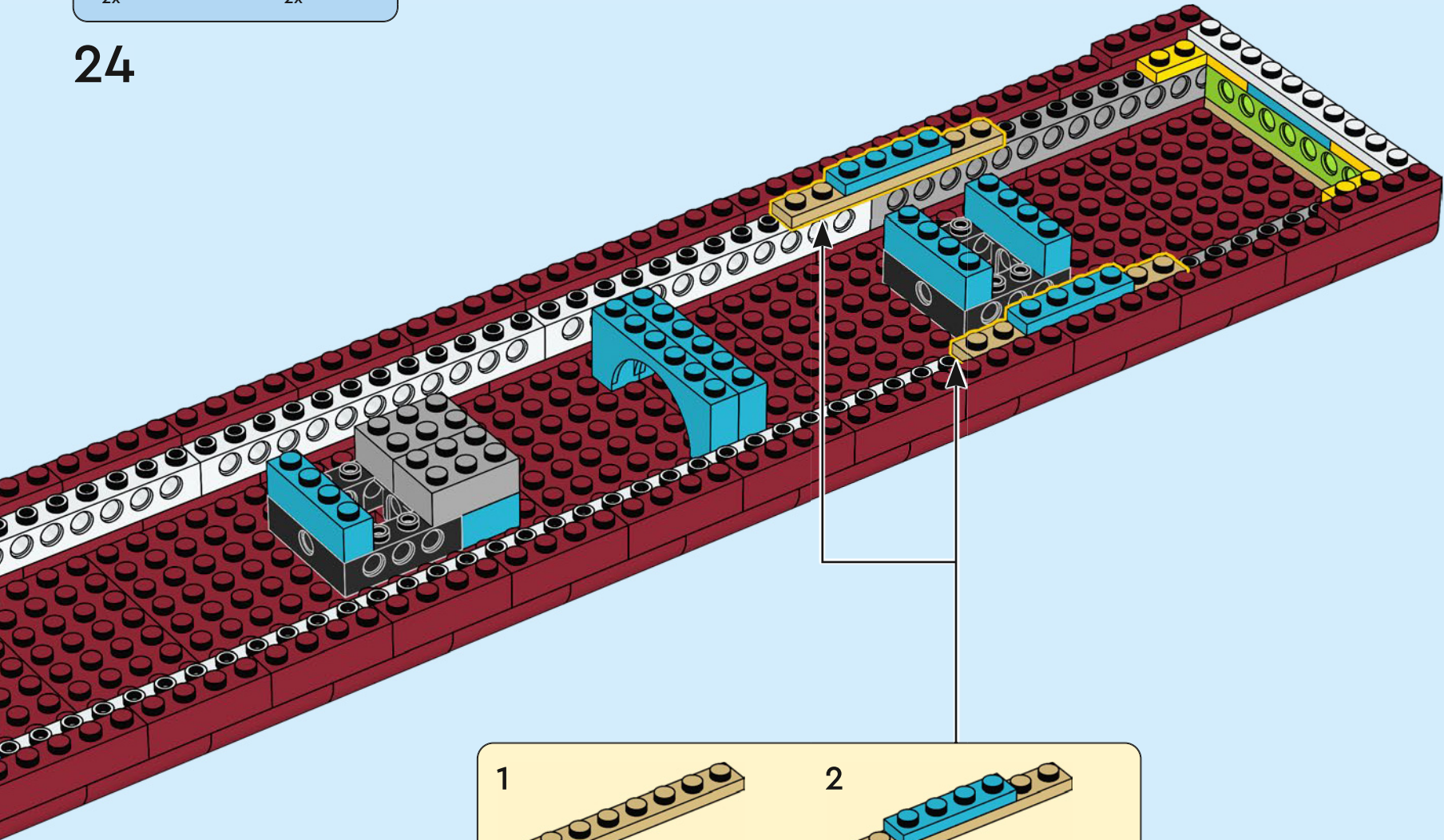

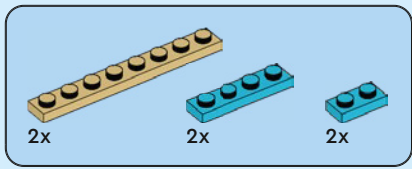

25

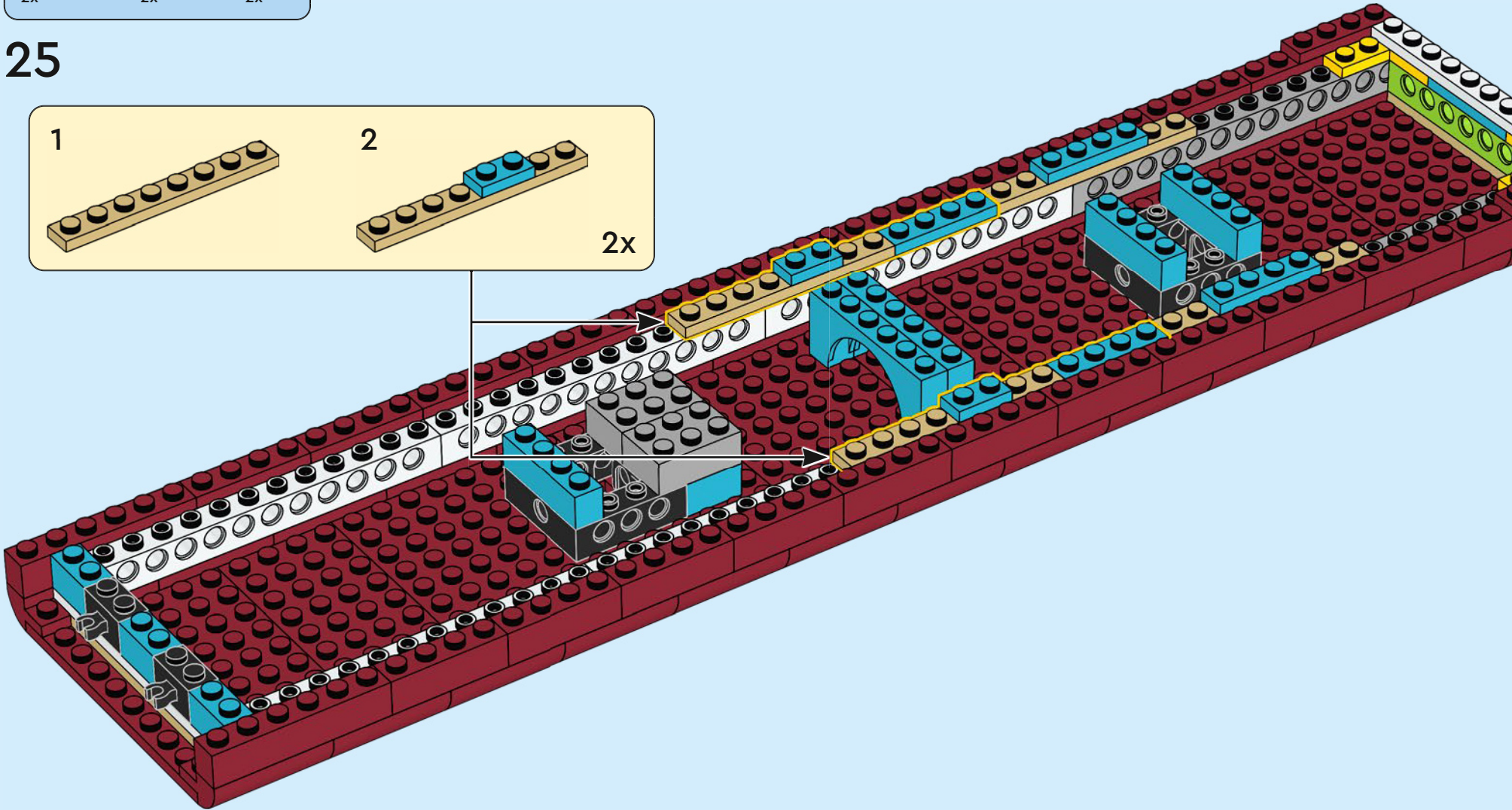
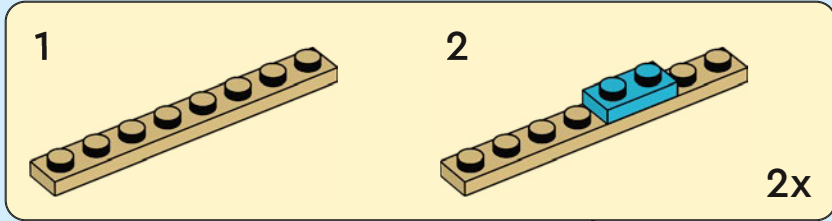

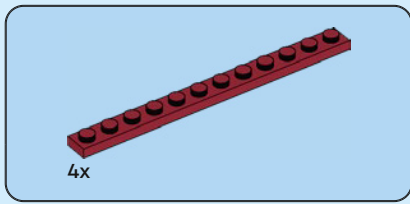

26

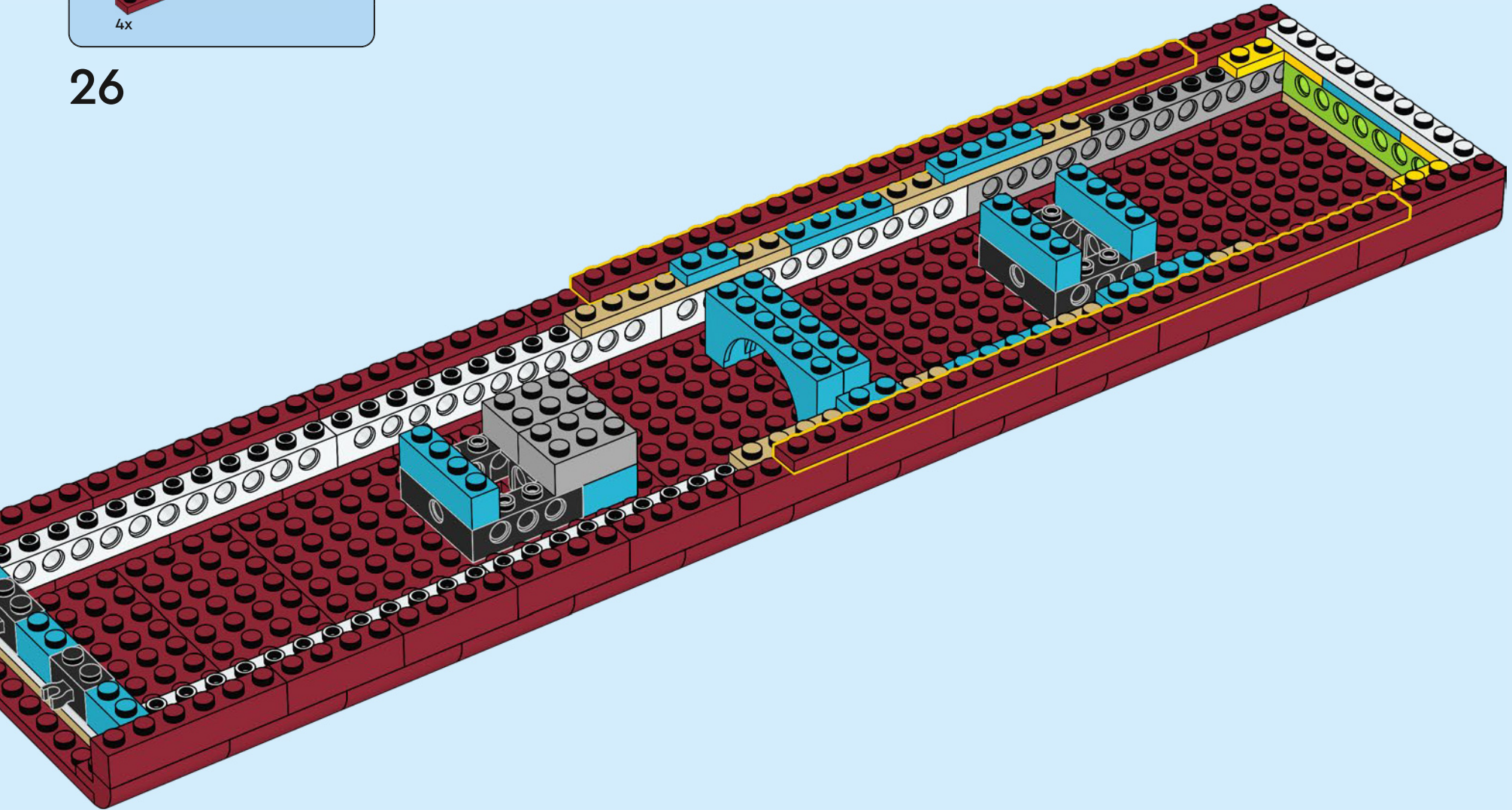

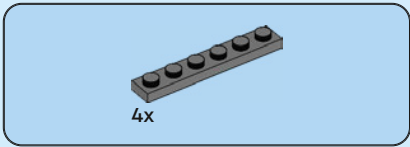

27

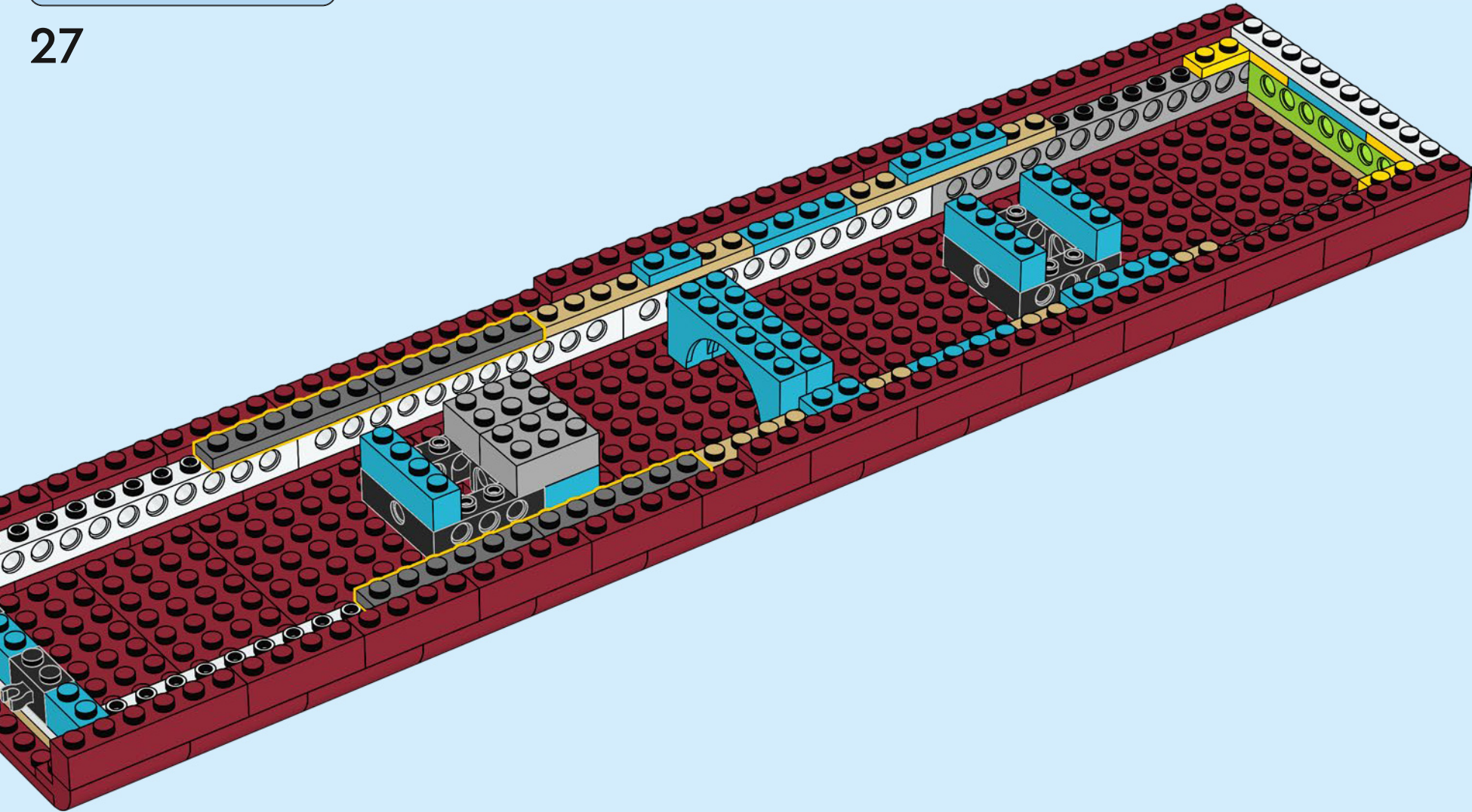

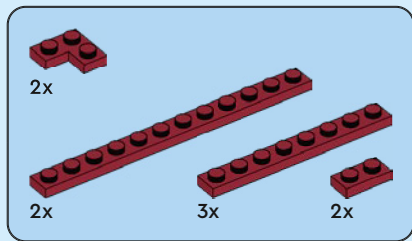

28

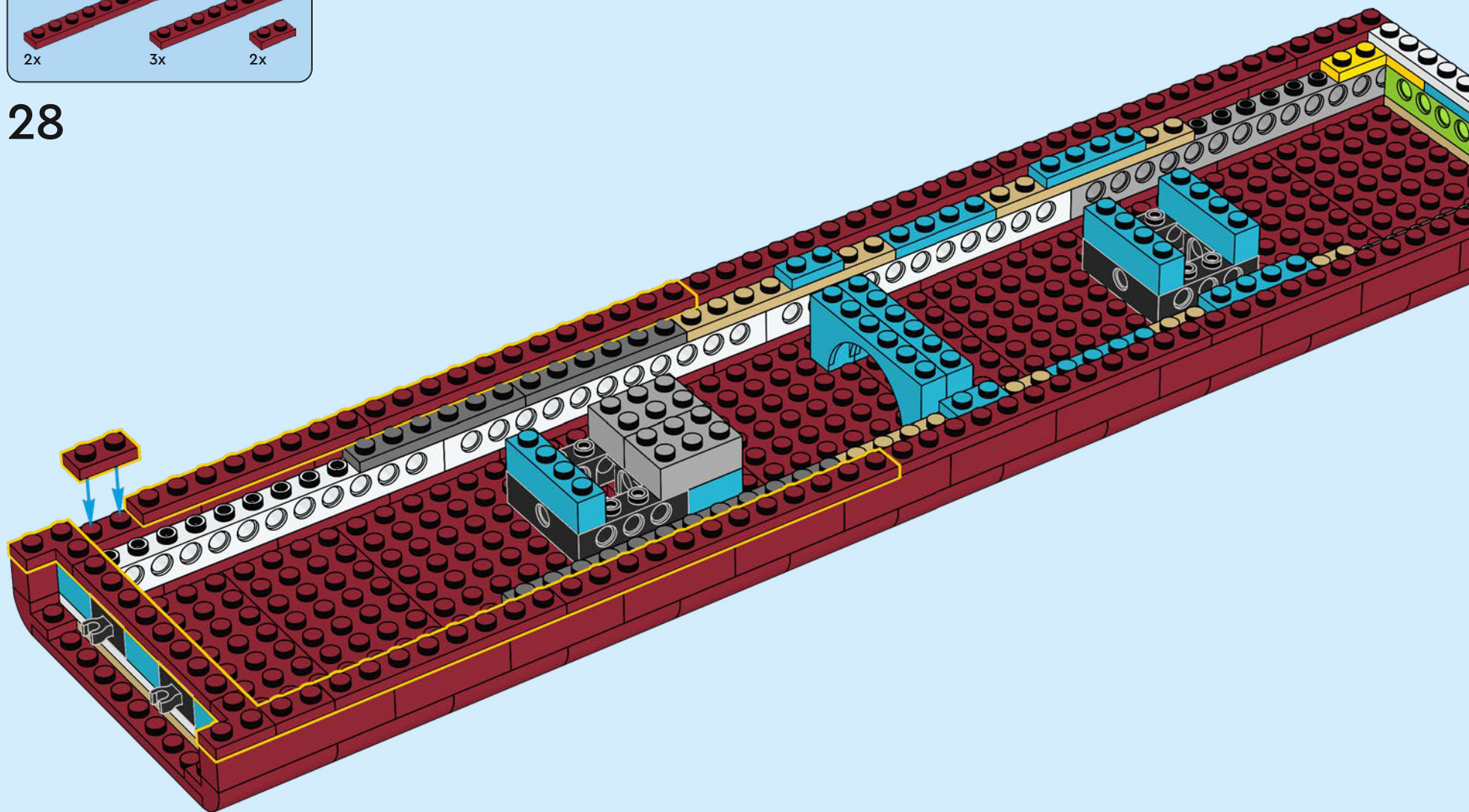

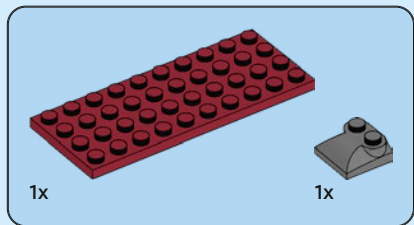
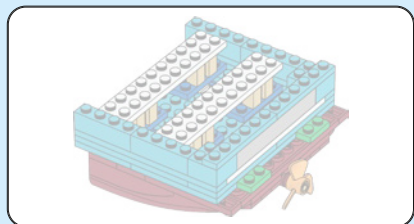

29

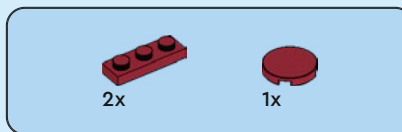
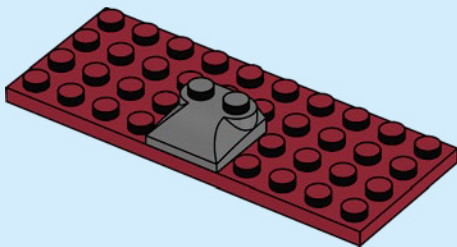

30

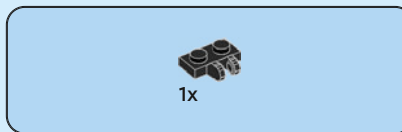
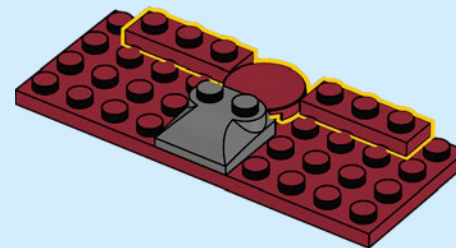

31

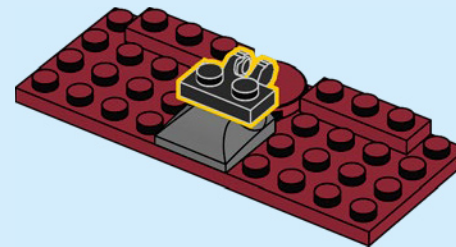

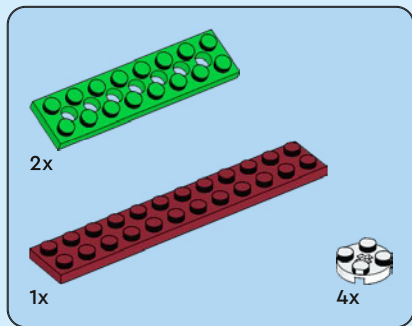

32

1

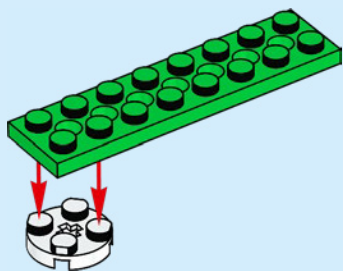

2

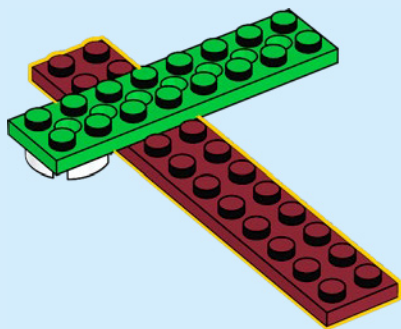

3

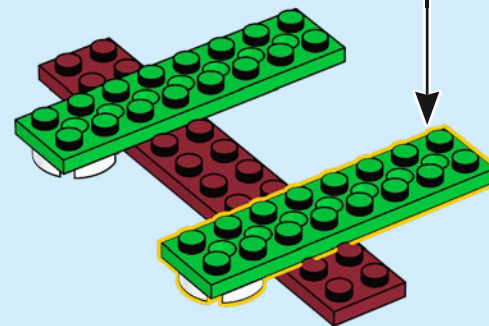
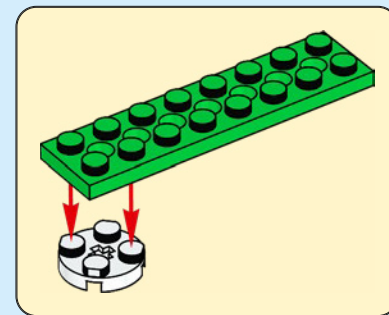

4

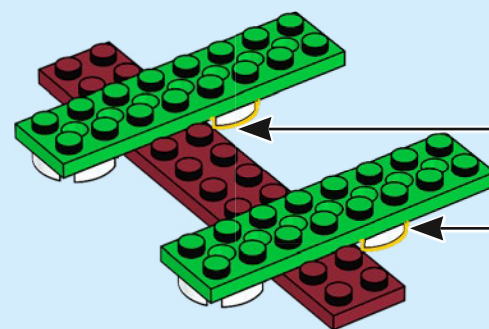

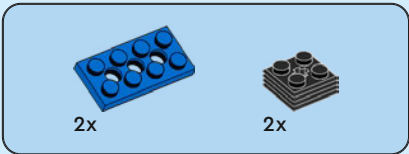

33

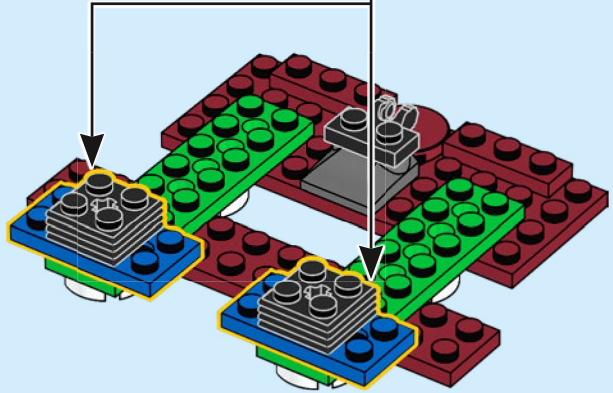
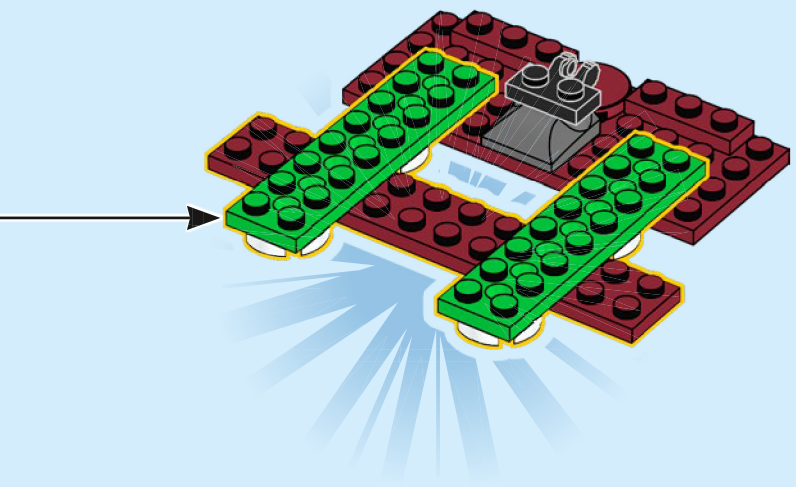
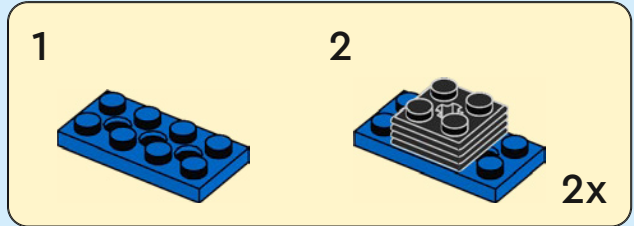

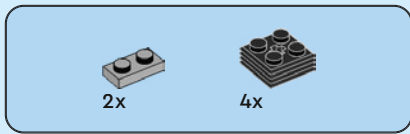

34

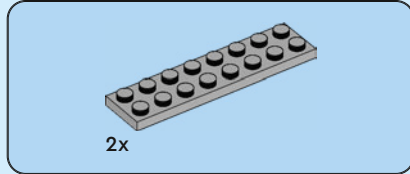
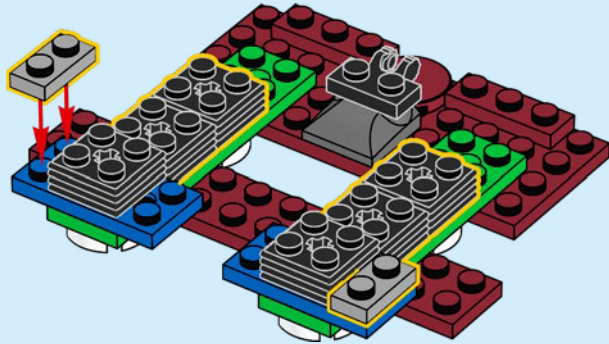

35

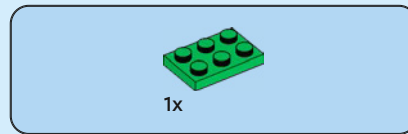
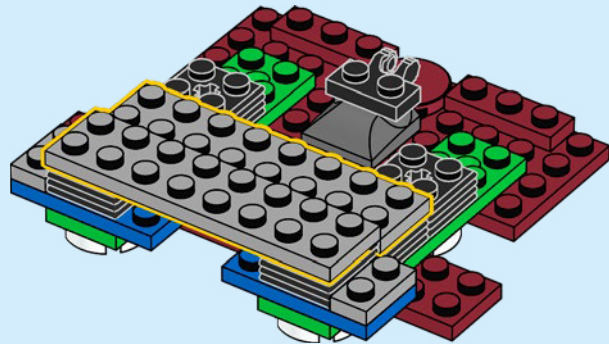

36

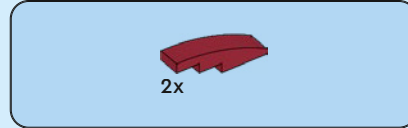
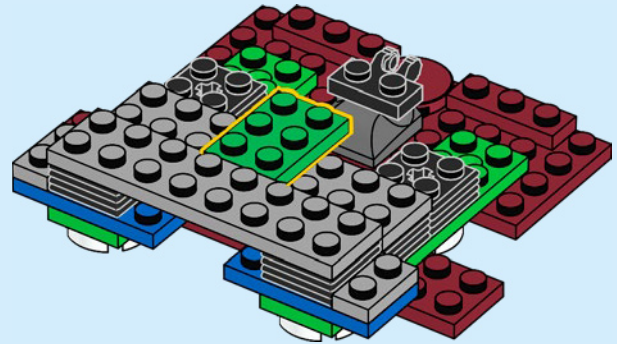

37

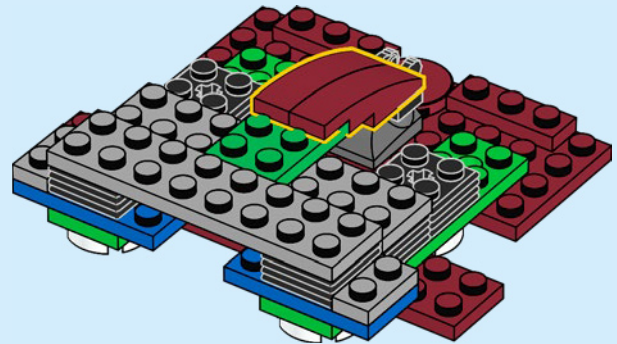

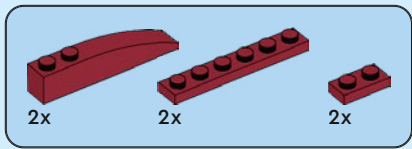

38

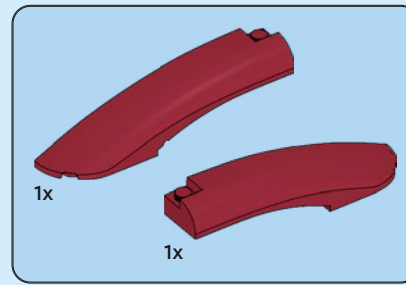
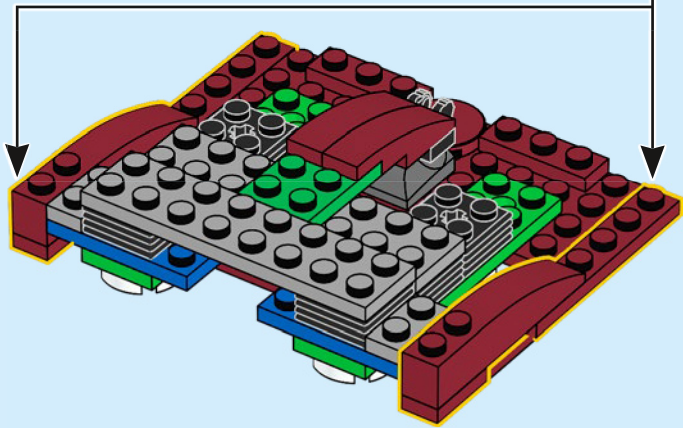
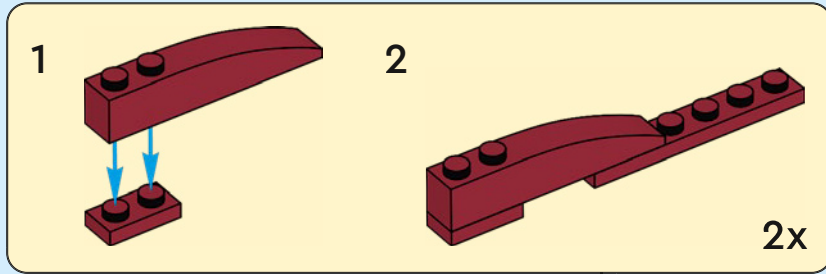

39

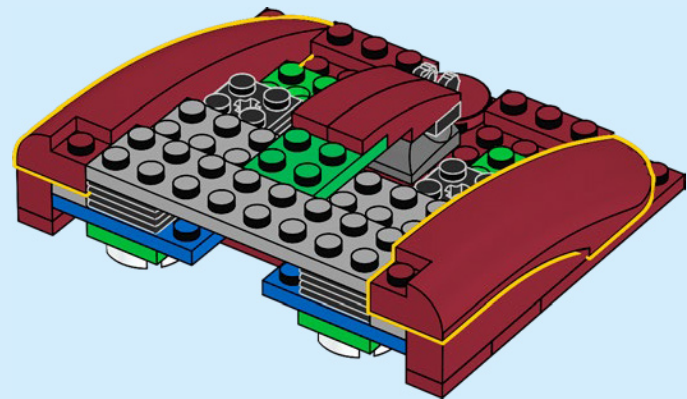

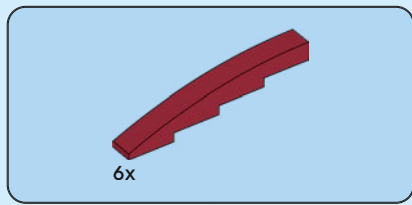

40

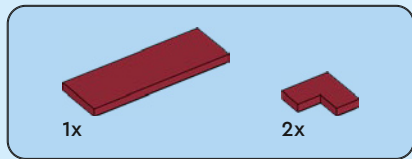
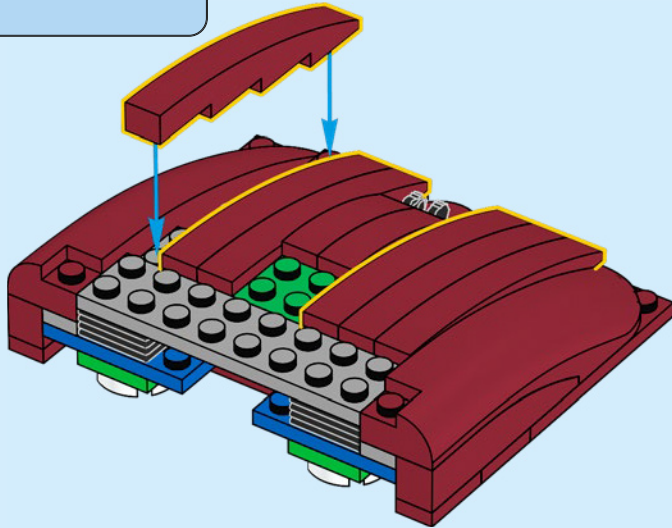

41

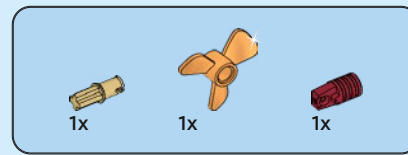
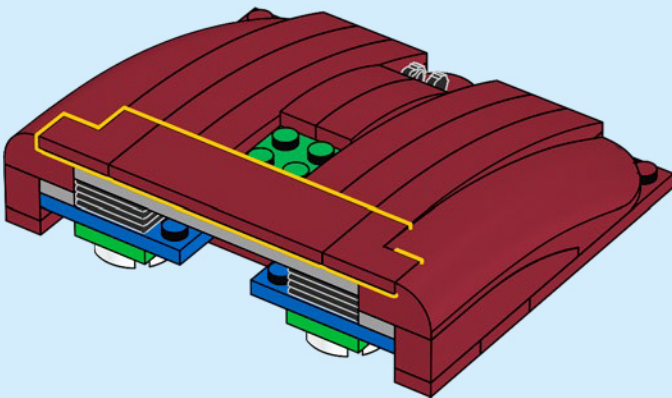

42

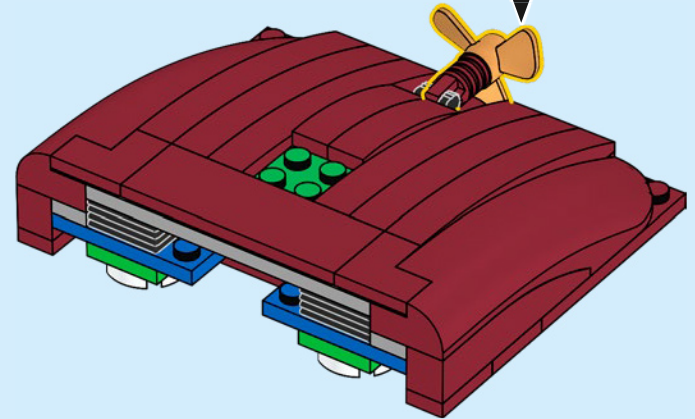
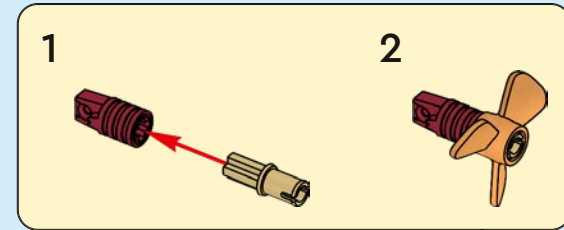

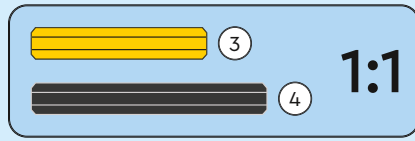
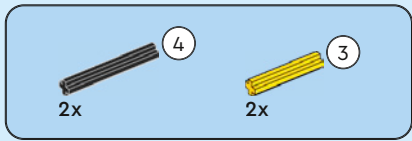

43

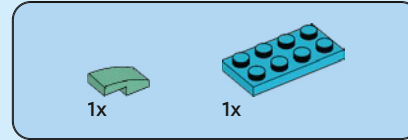
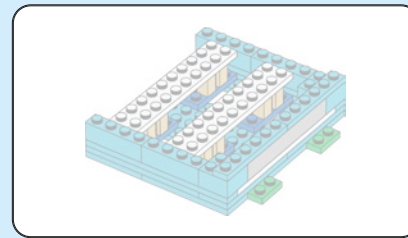
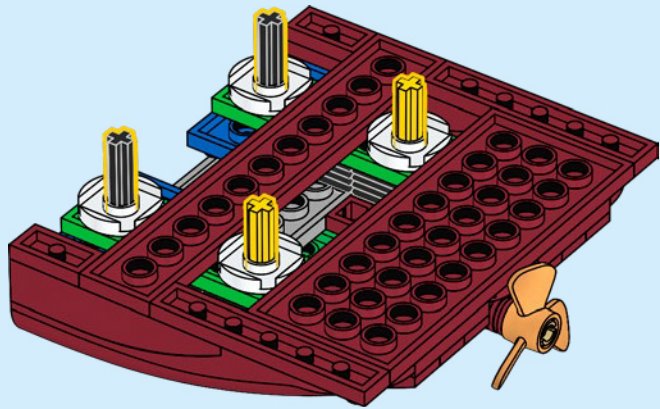

44

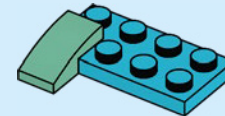

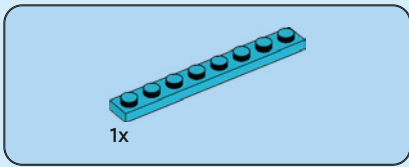

45

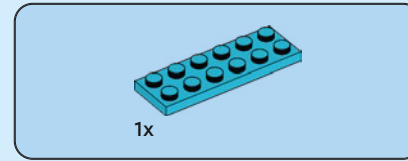
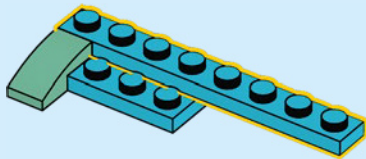
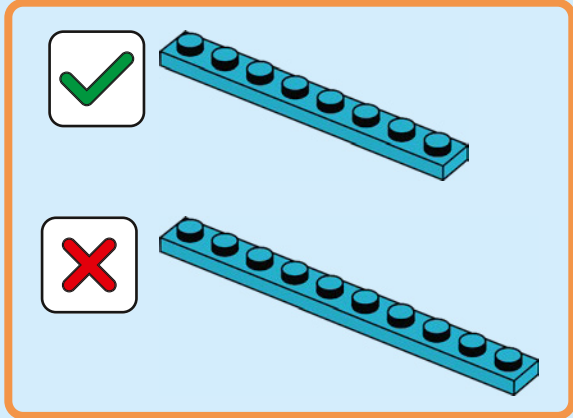

46

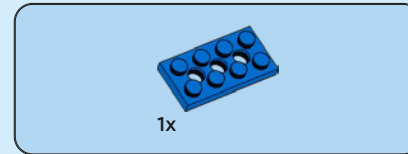
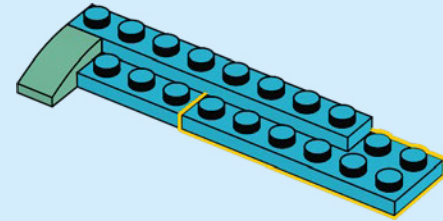

47

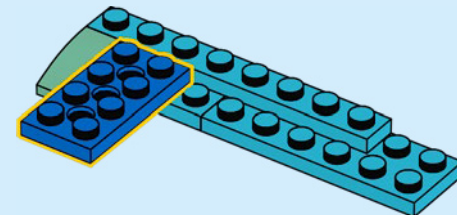

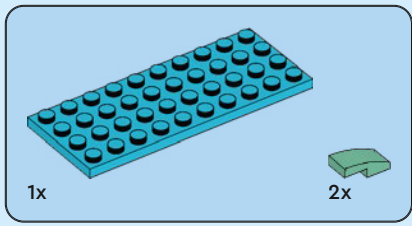

48

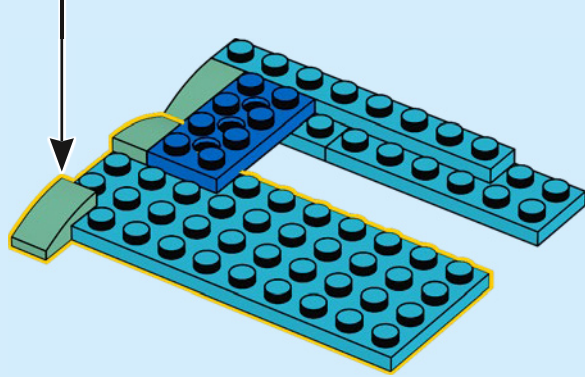
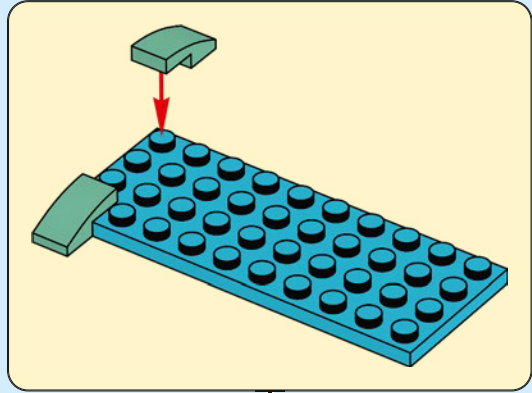

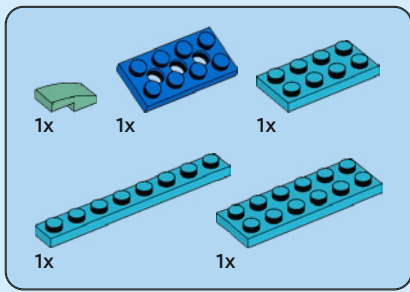

49

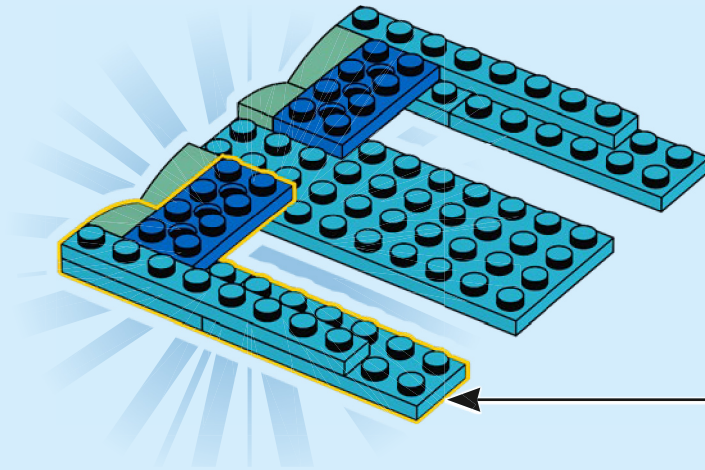
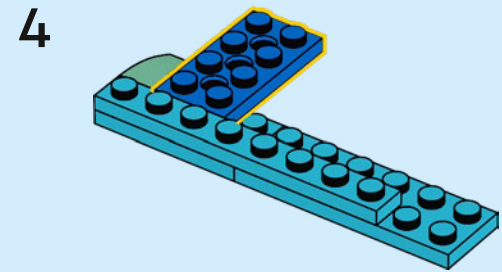
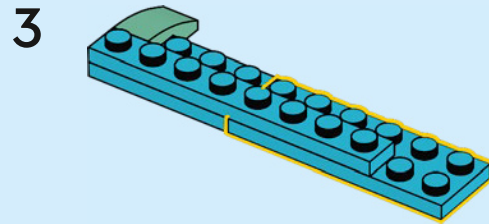
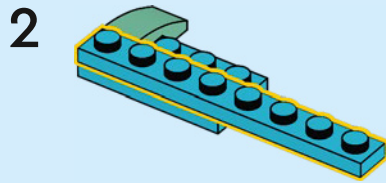
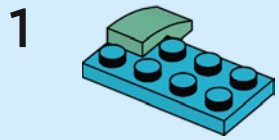
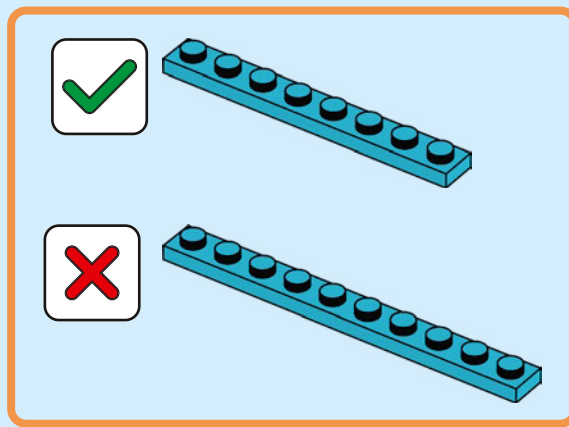



50

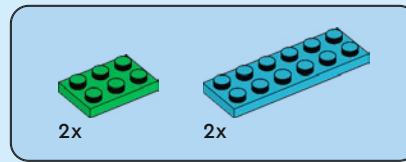
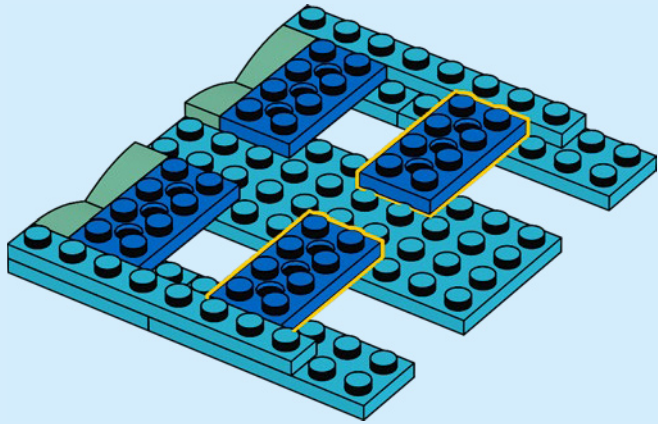

51

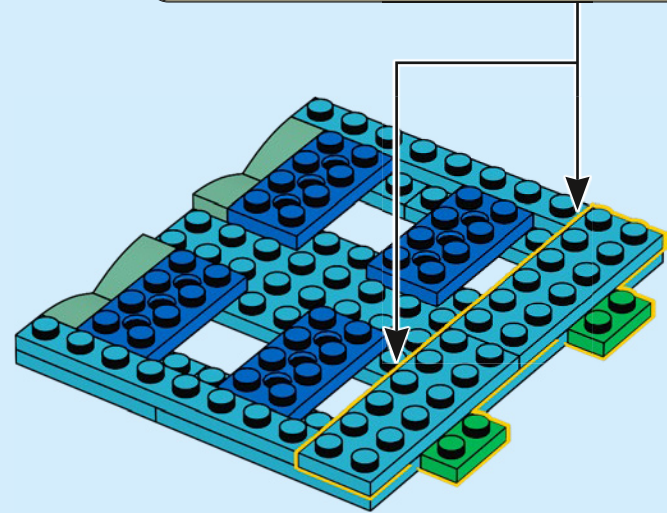
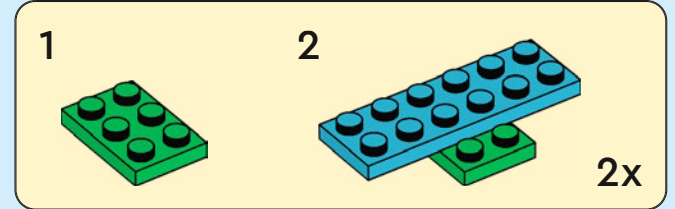

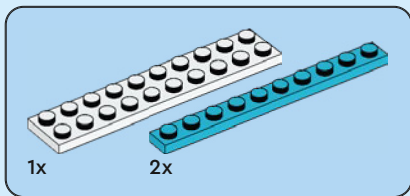

52

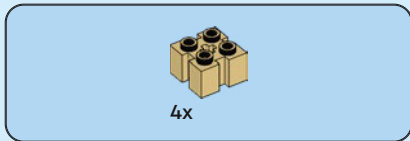
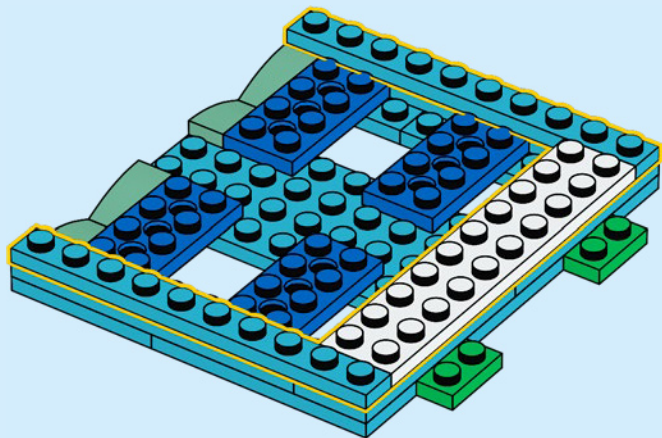

53

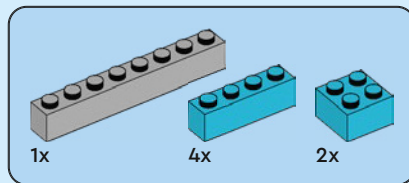
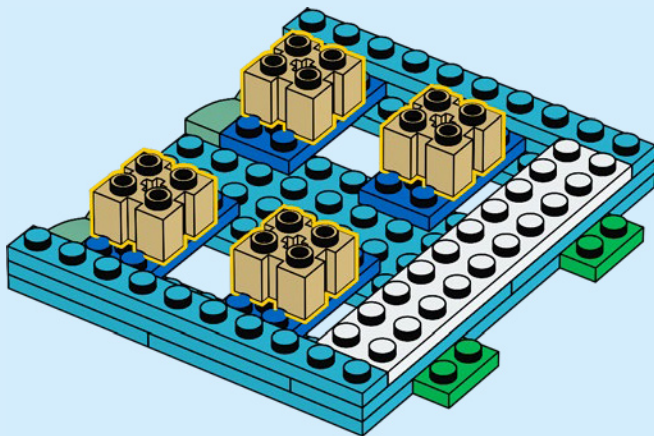

54

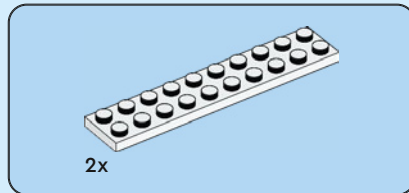
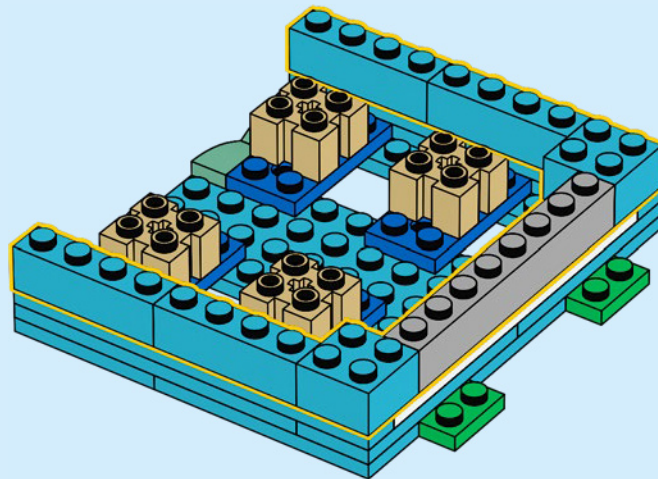

55

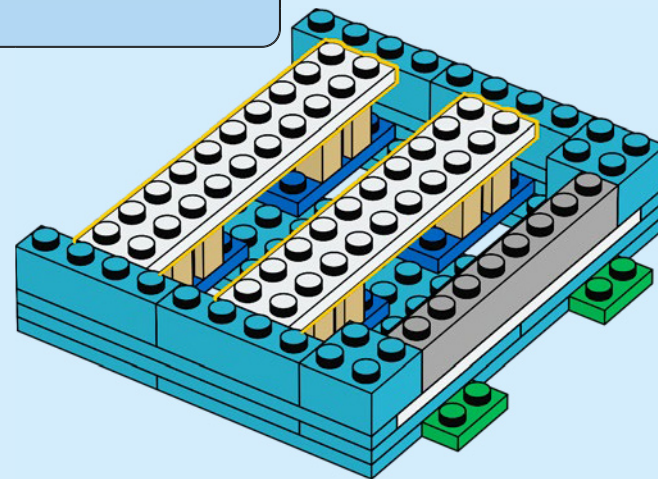

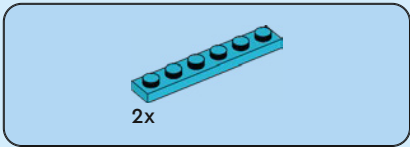

56

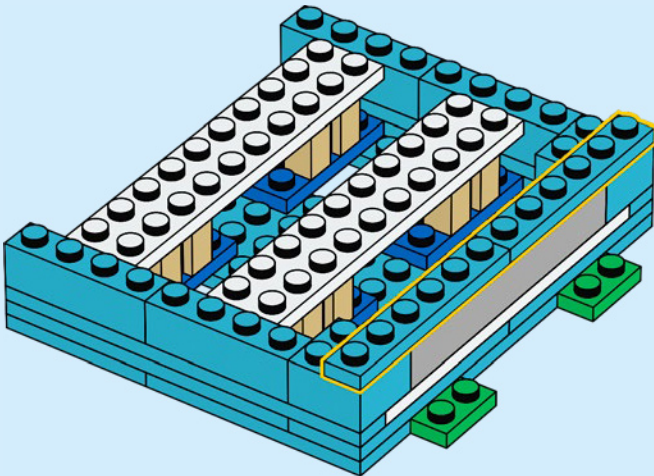

57

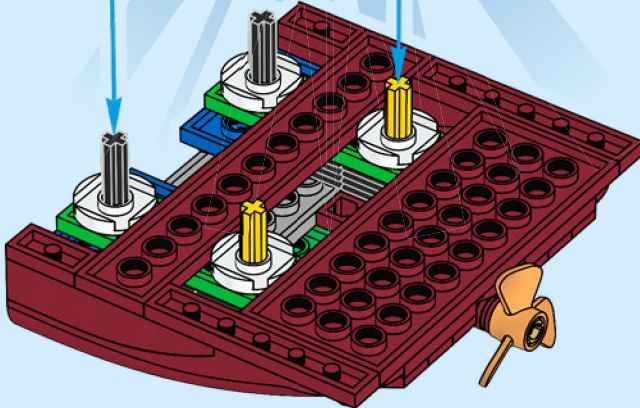
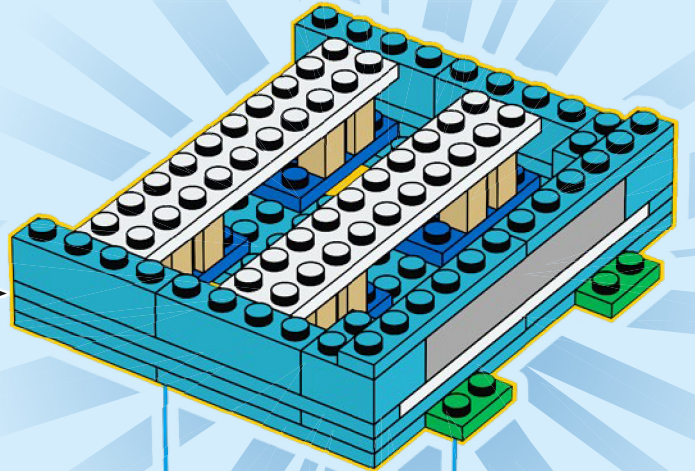

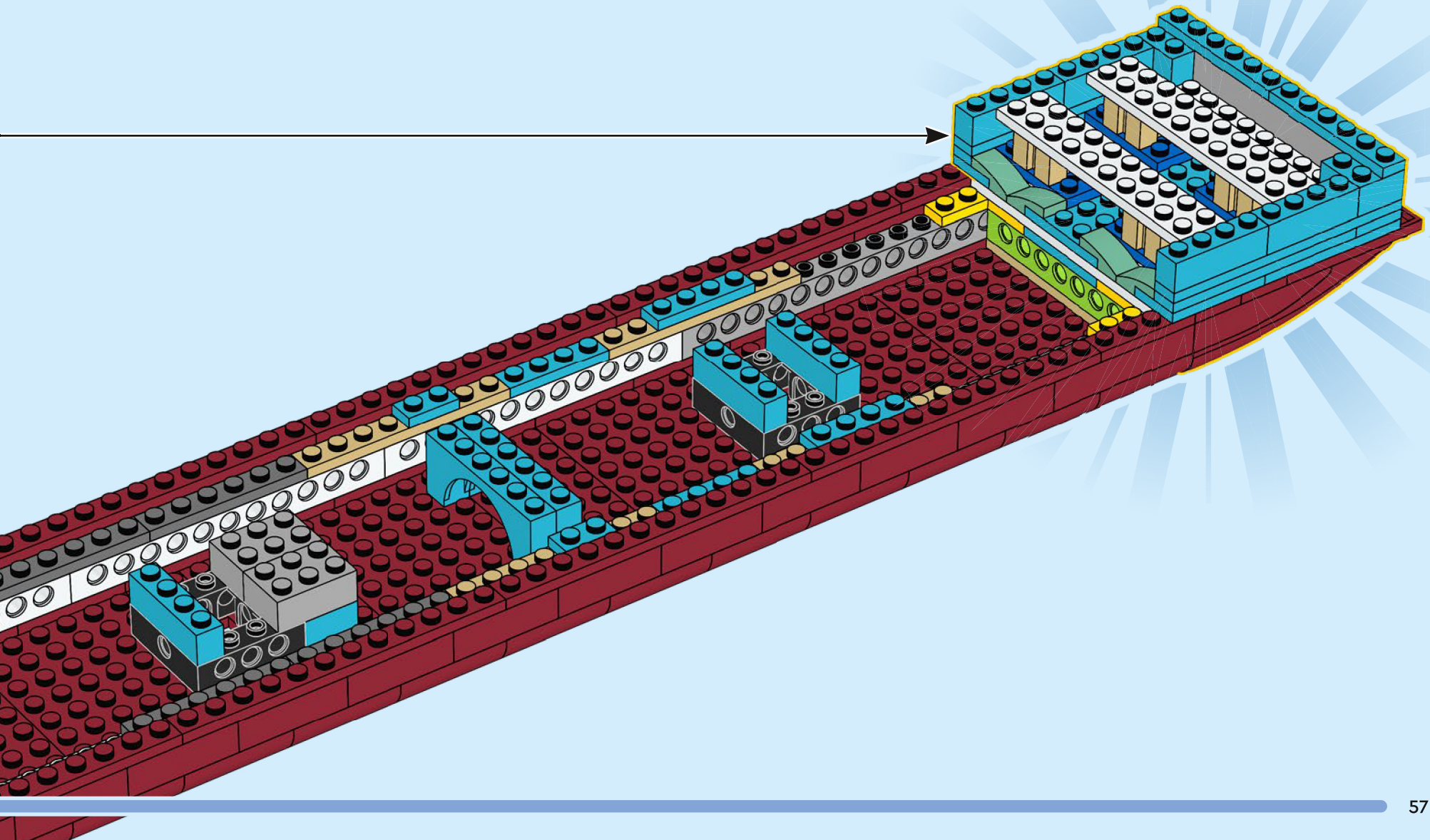

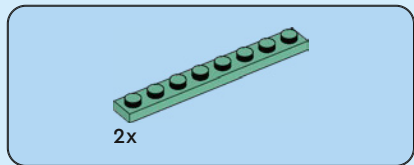
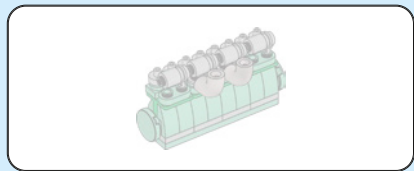

59

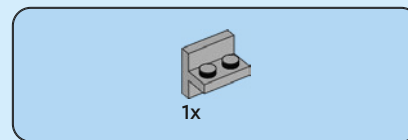
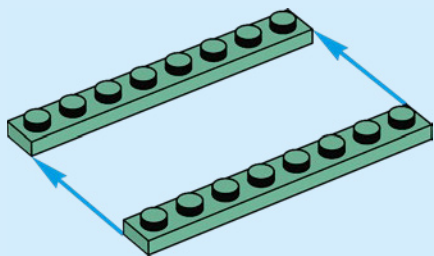

1x

60

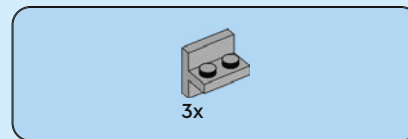
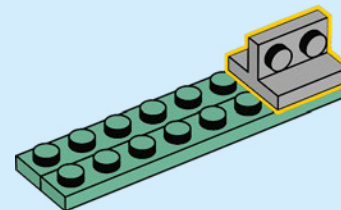

3x

61

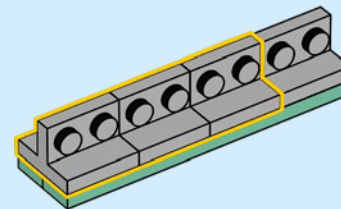



62

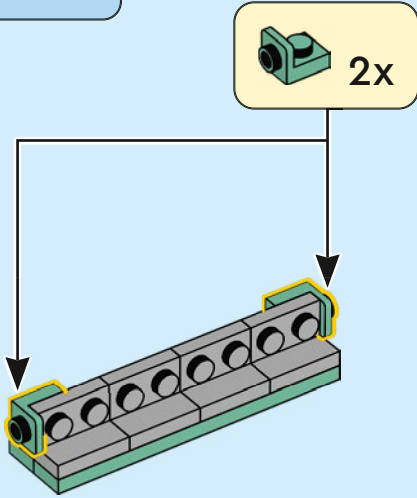

63

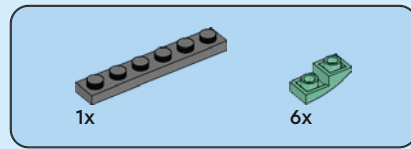
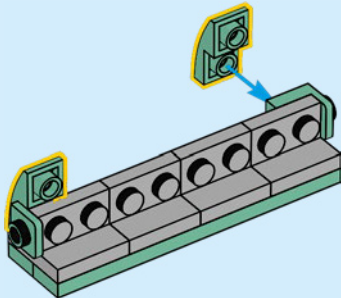

64

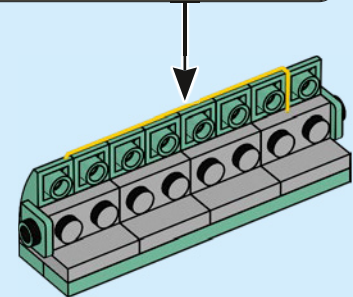
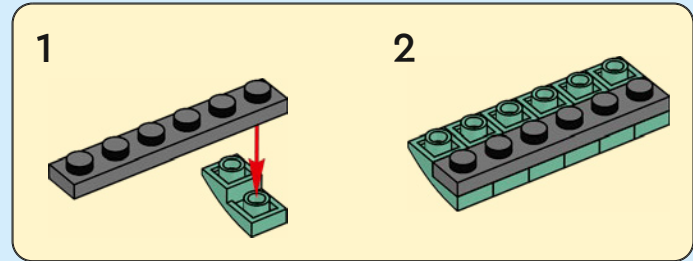

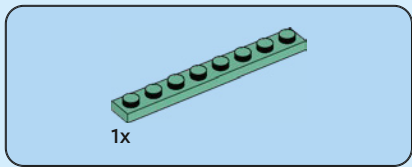

65

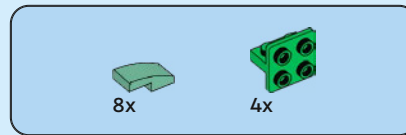
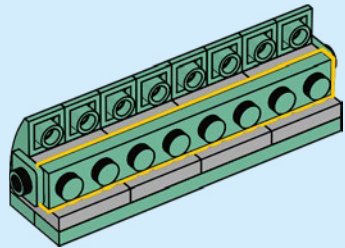

66

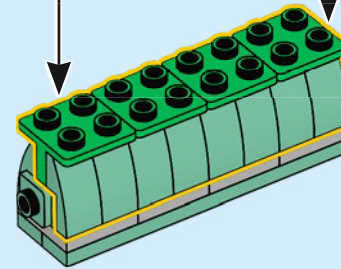
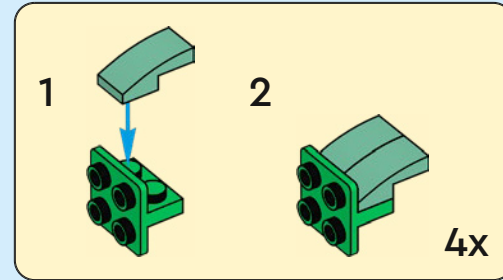

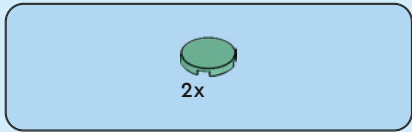

67

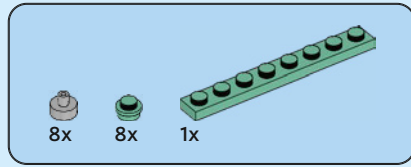
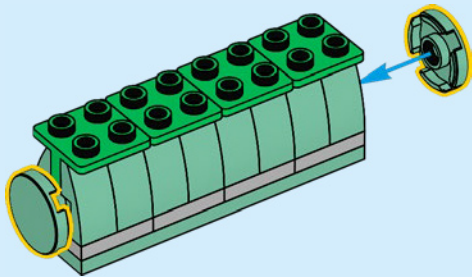

68

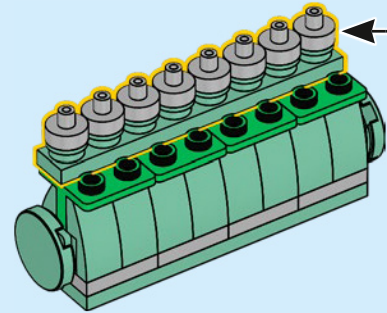
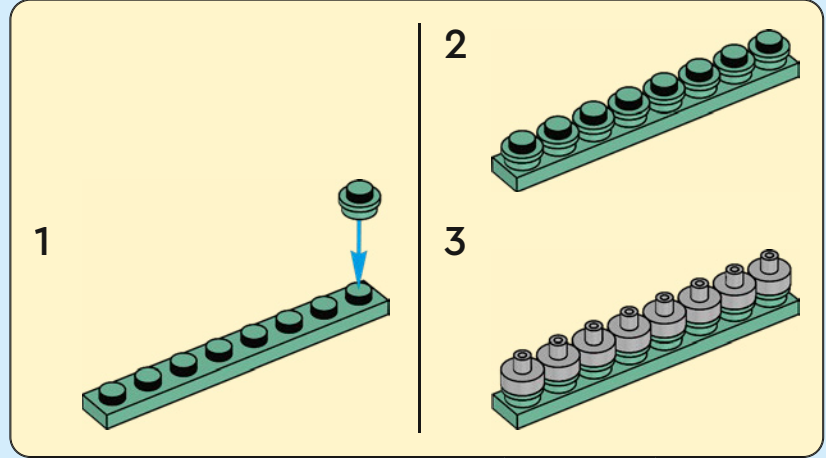



2x

69

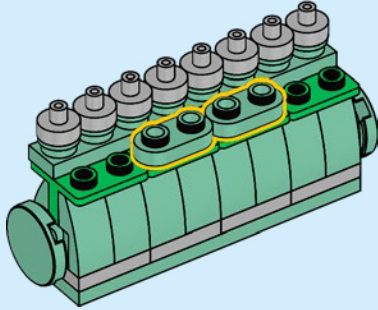

2x



2x

70

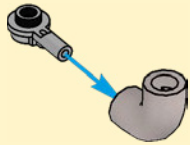
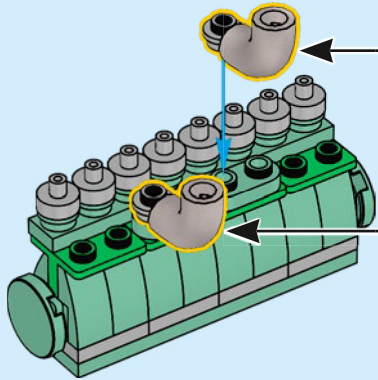

2x



2x

71

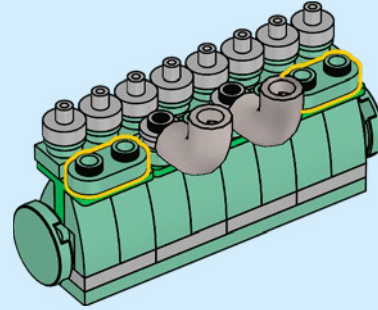

4x



4x

72

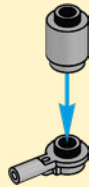
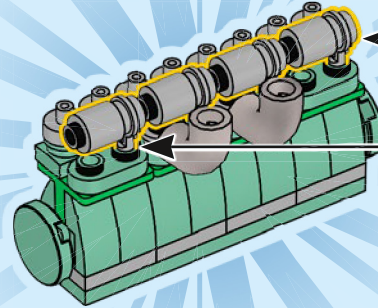

4x

73

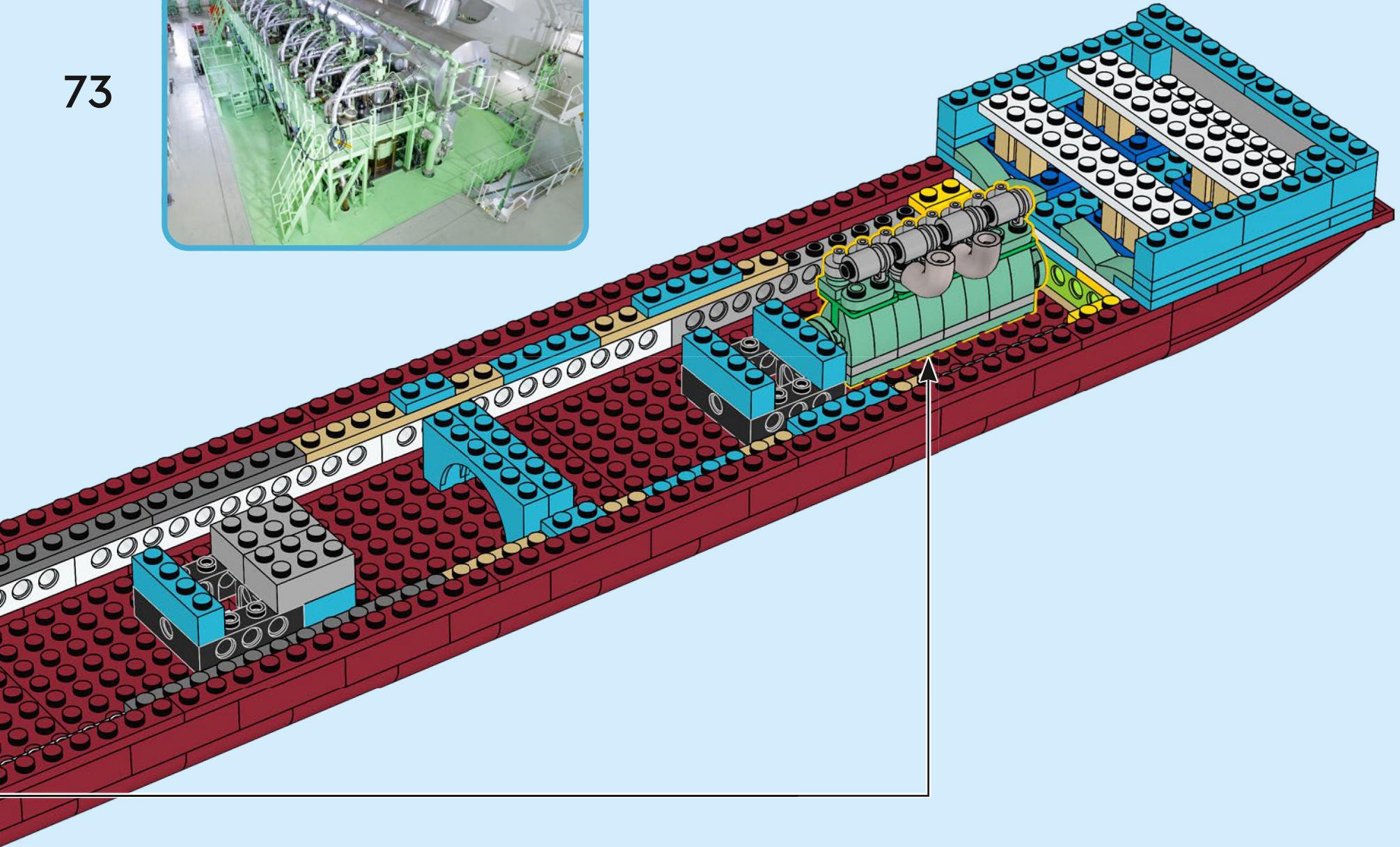

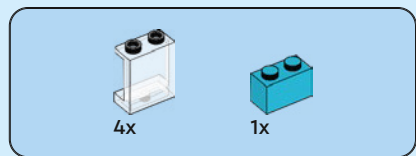

74

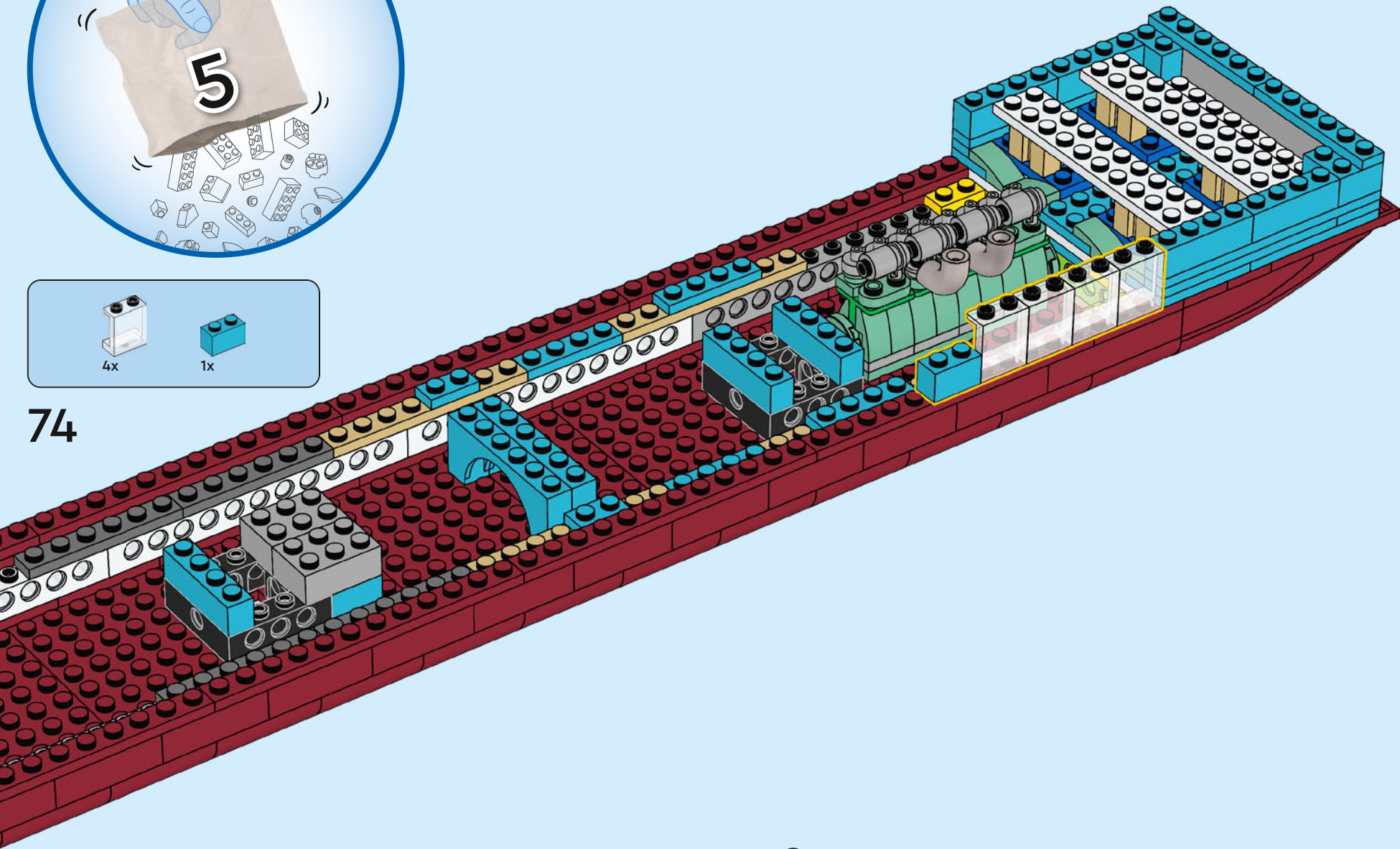

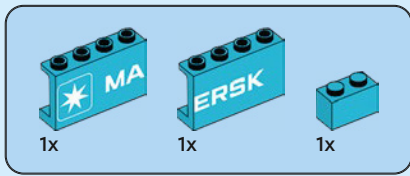

75

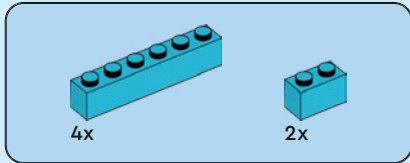
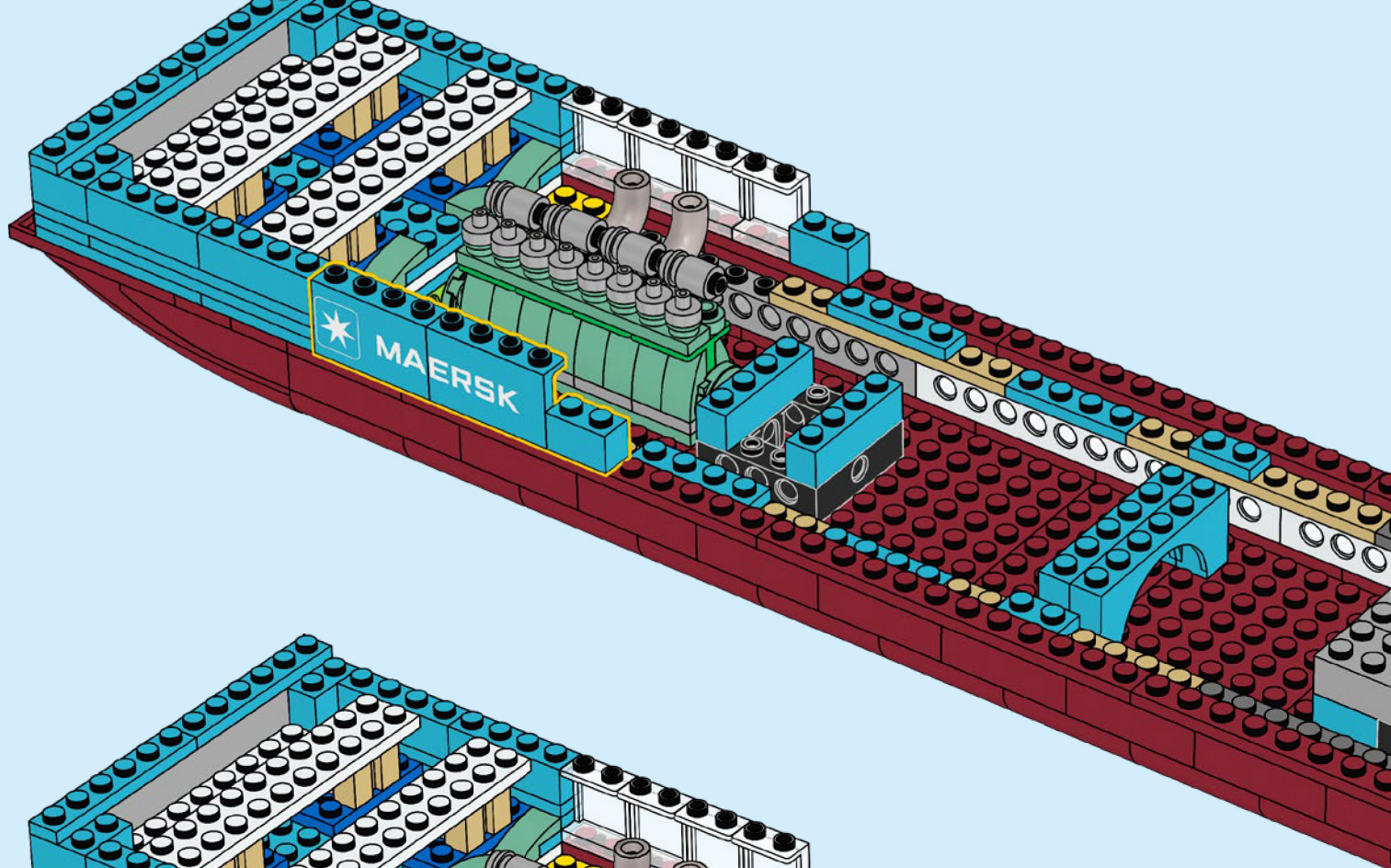

76

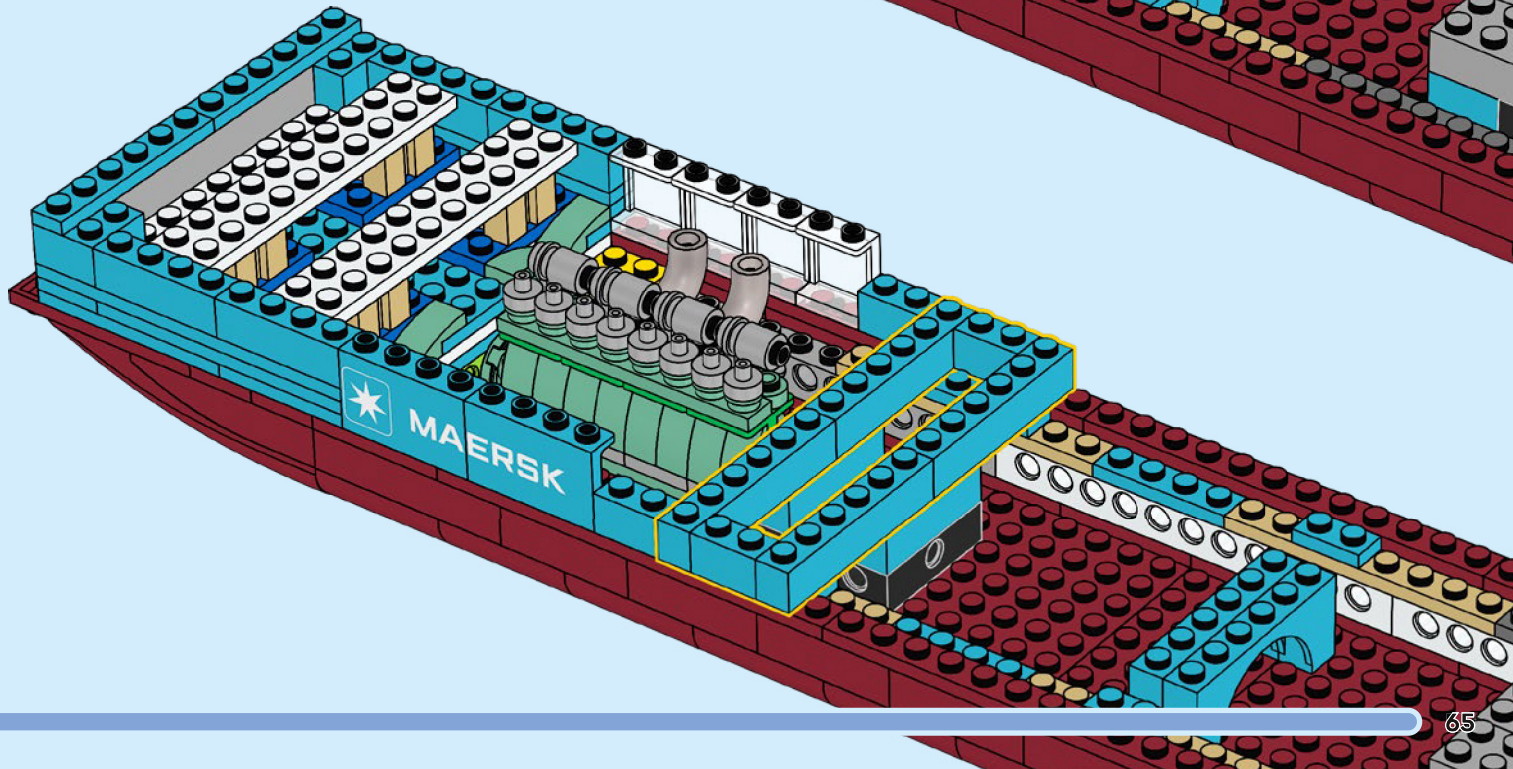

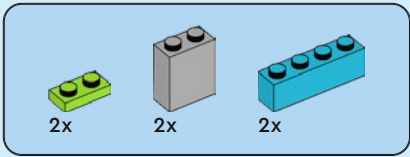

77

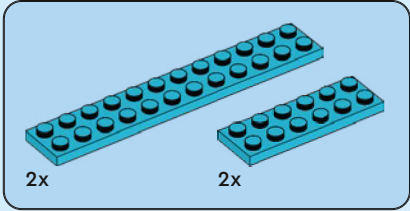
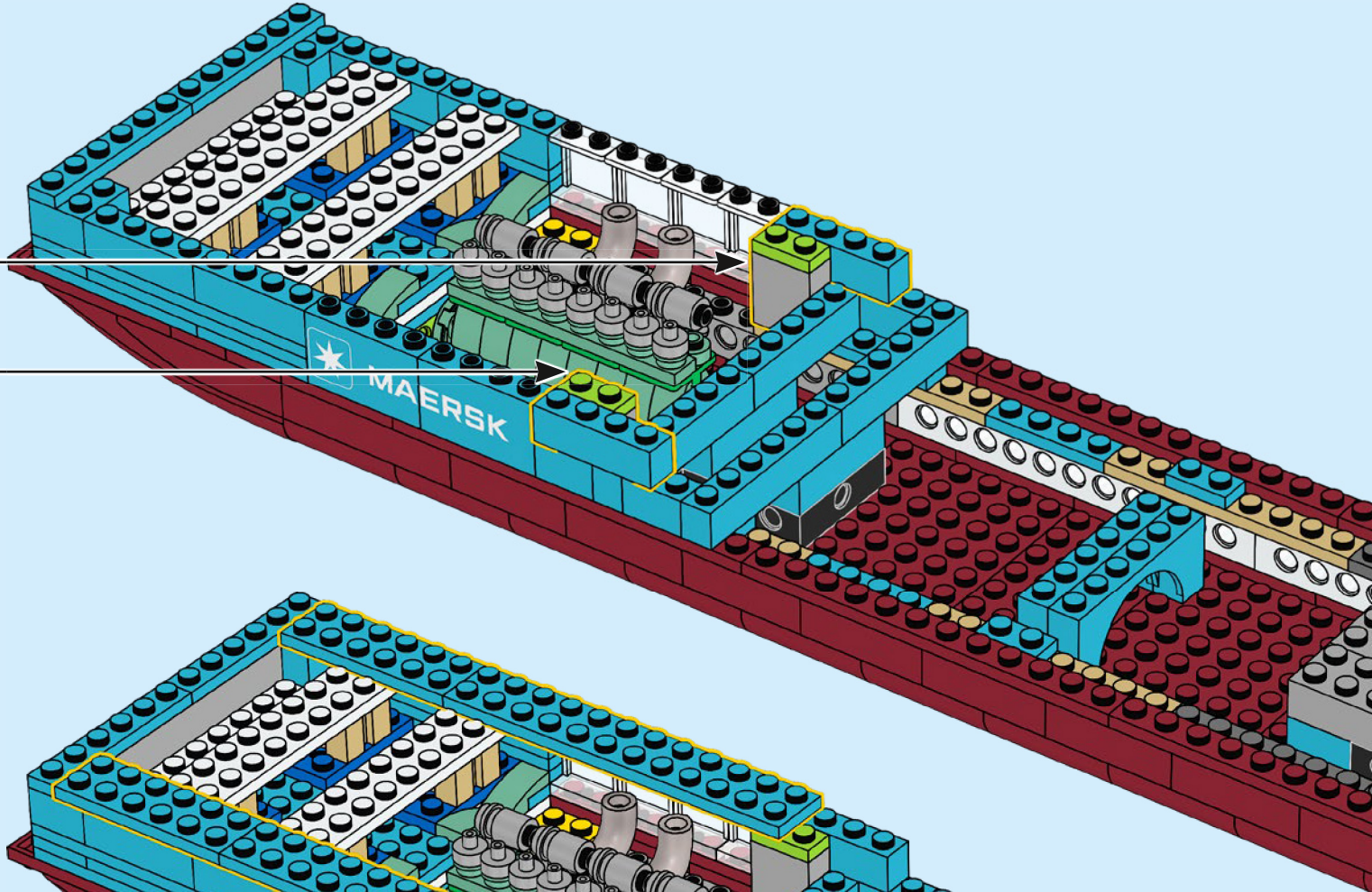
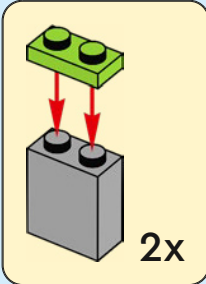

78

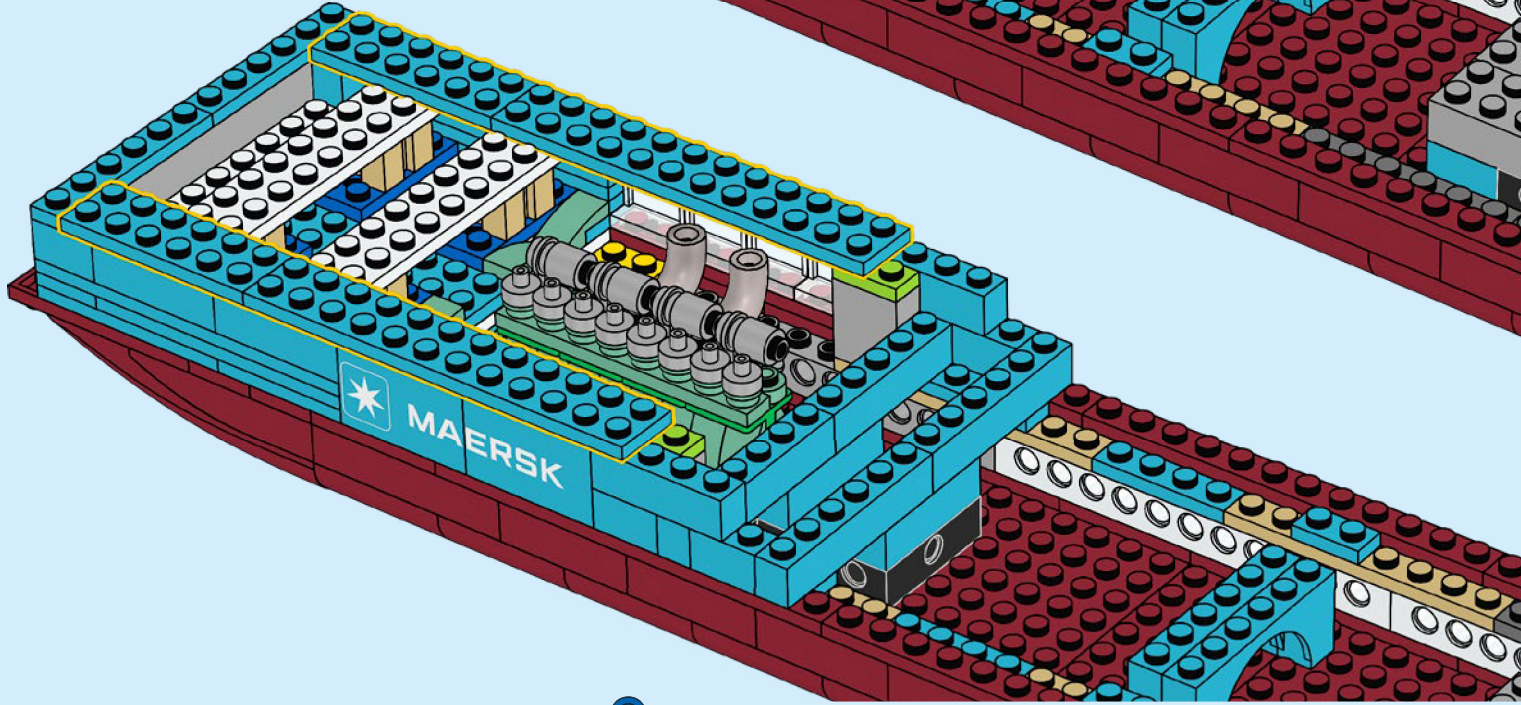

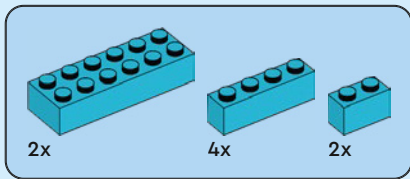

79

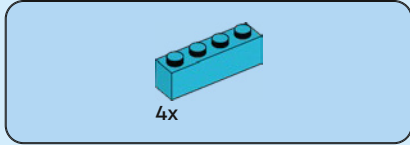
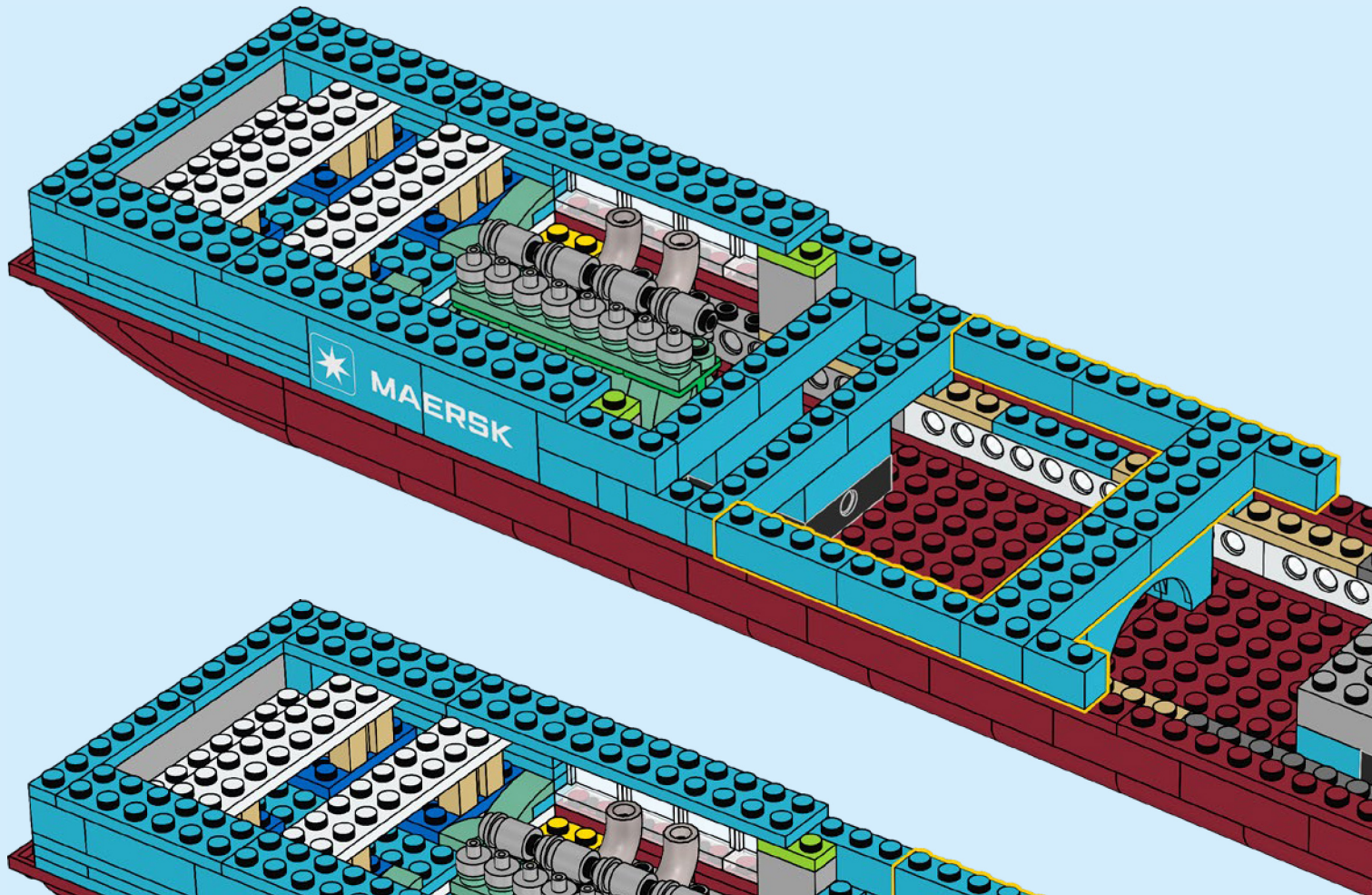

80

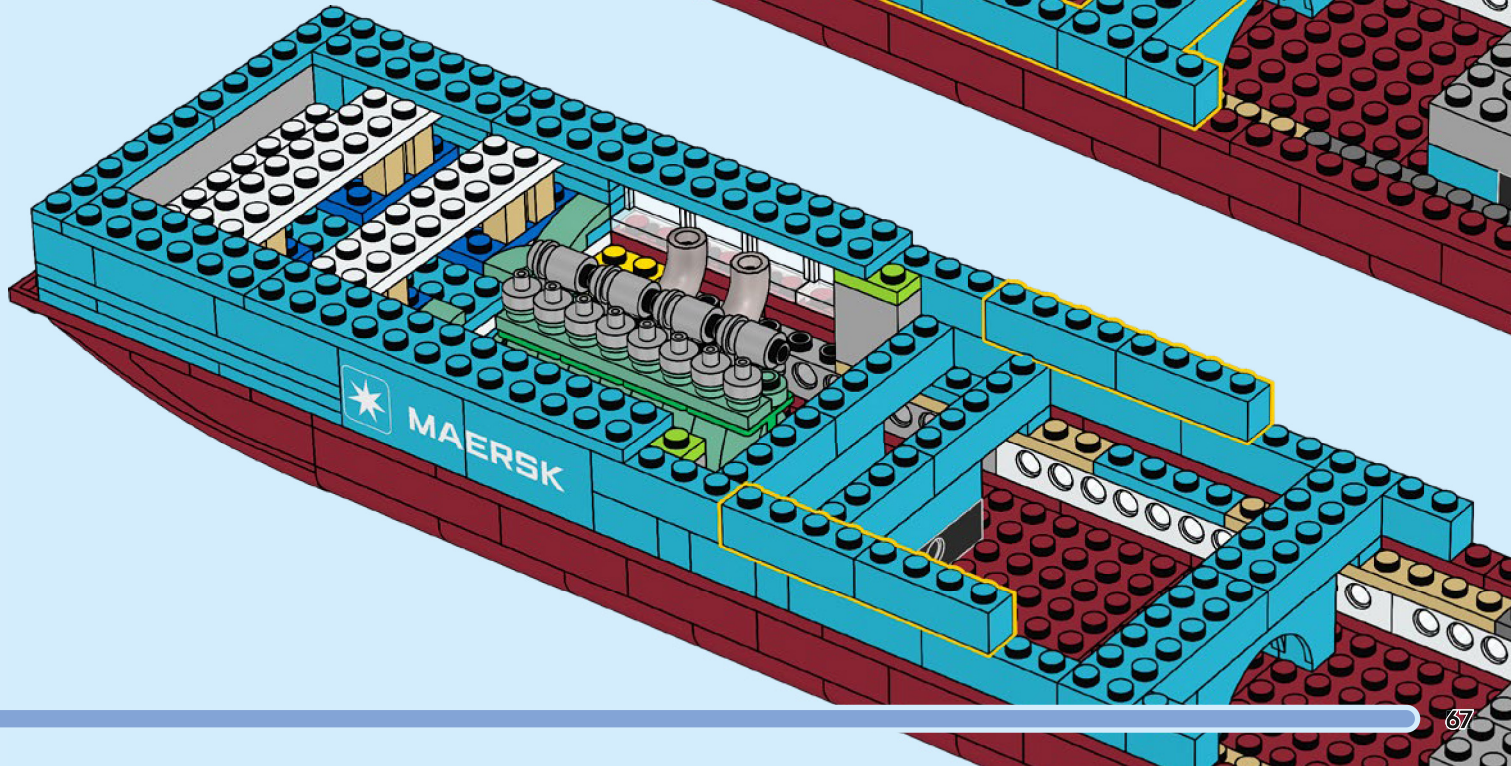

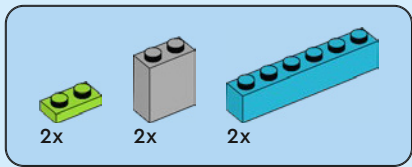

81

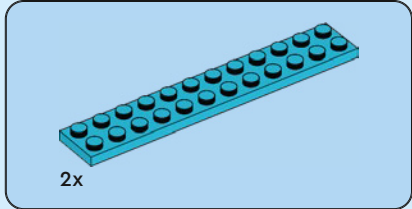
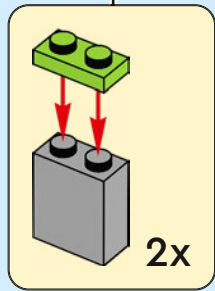
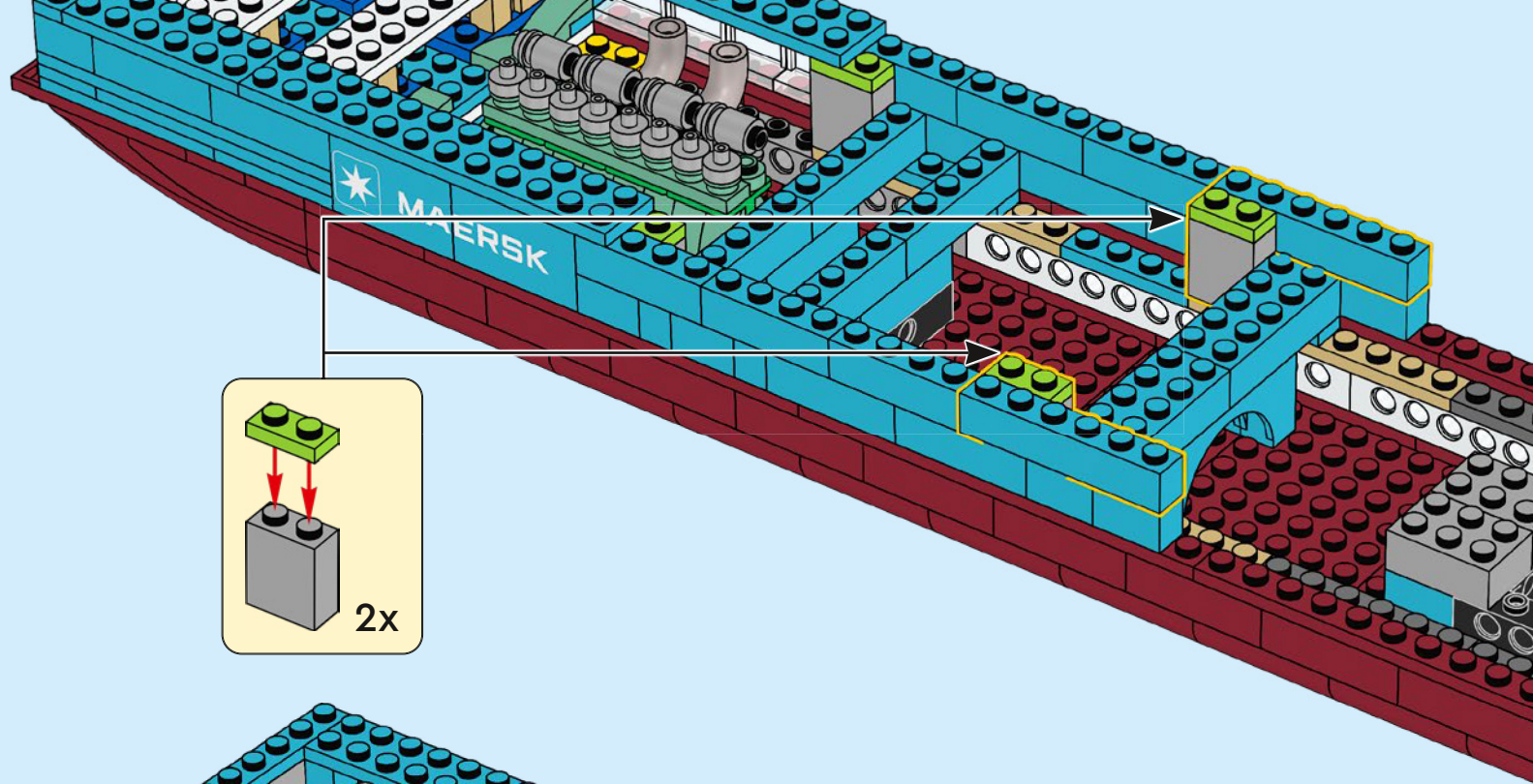

82

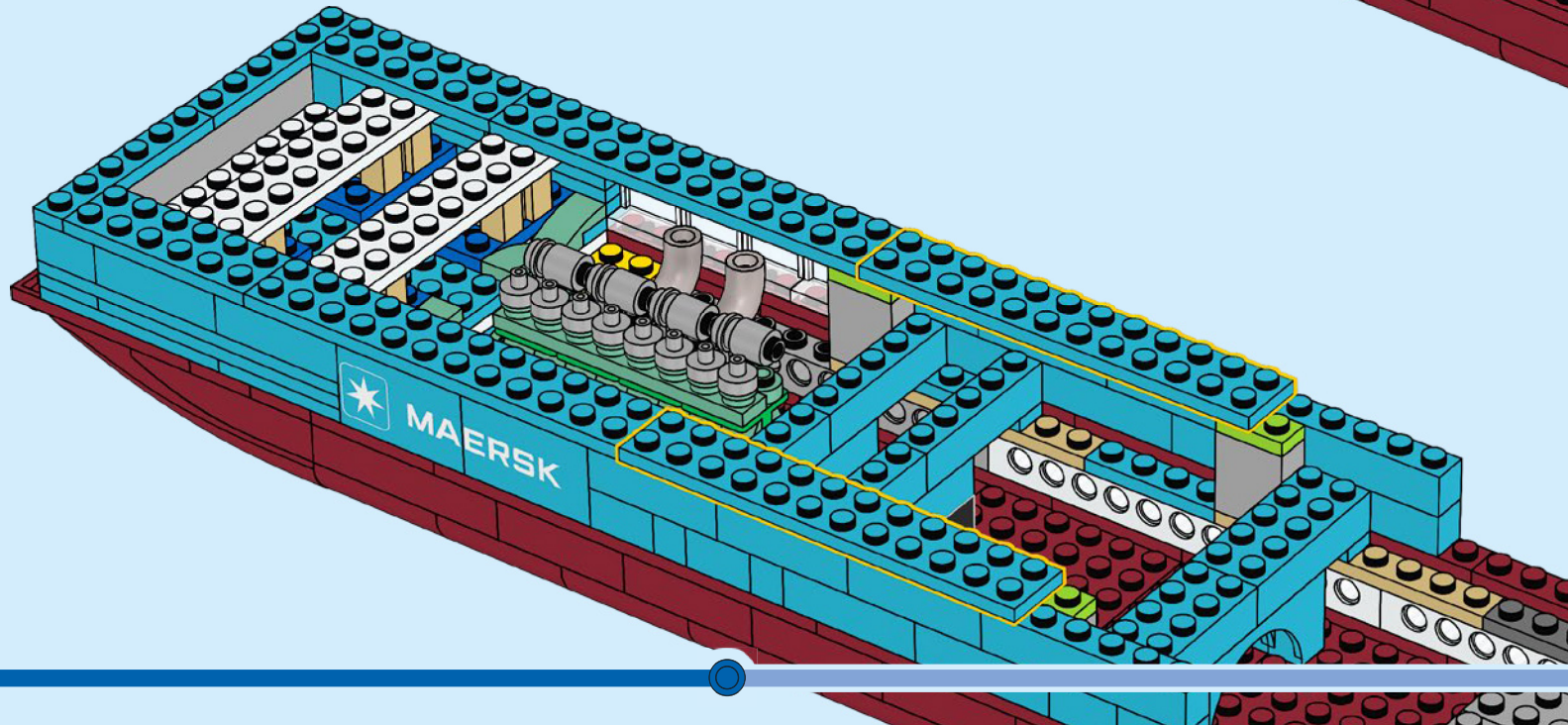

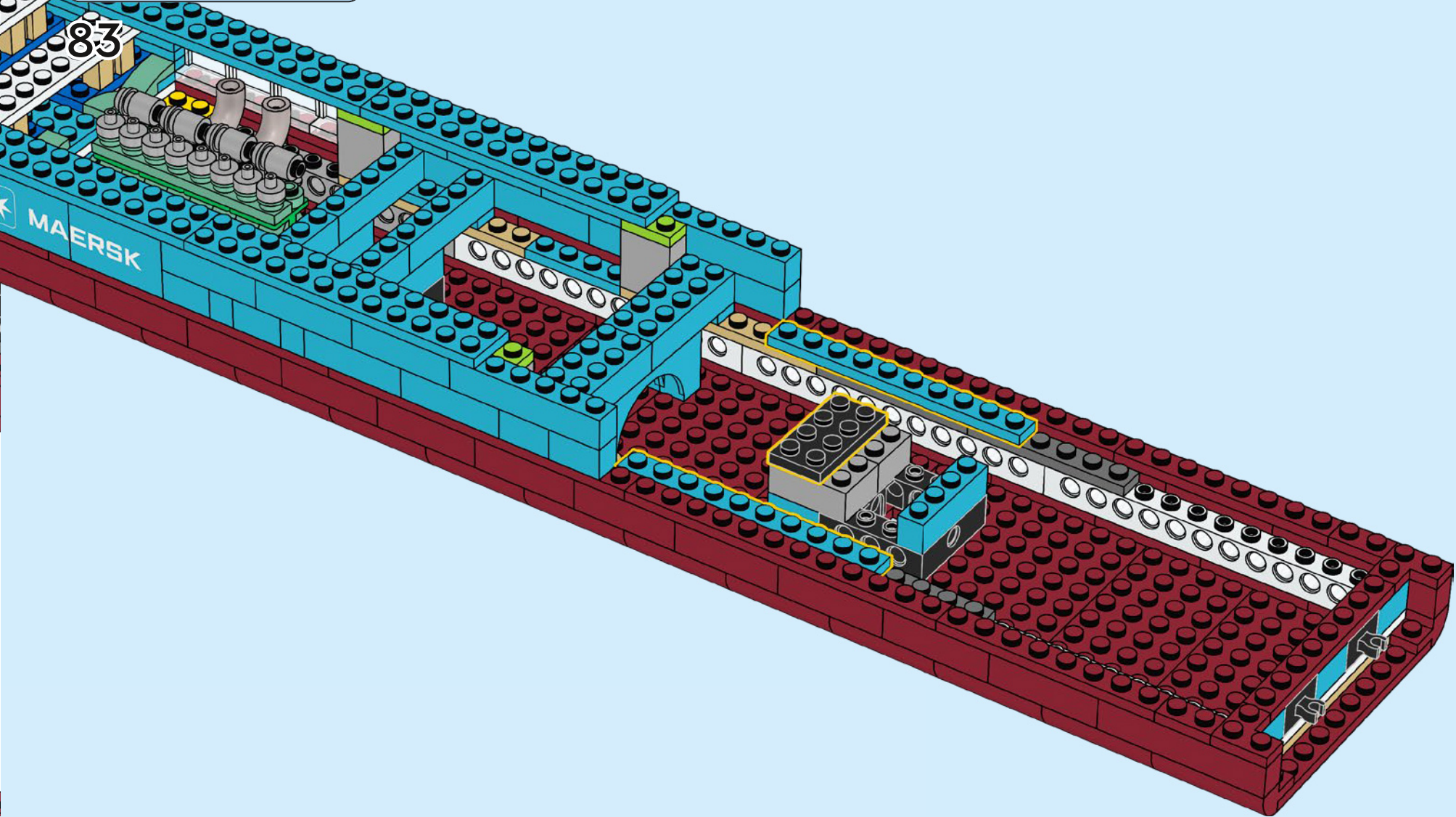
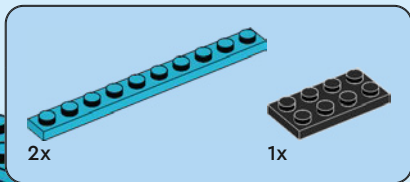

84

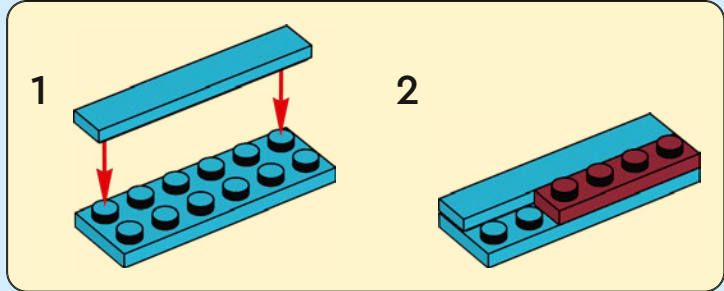
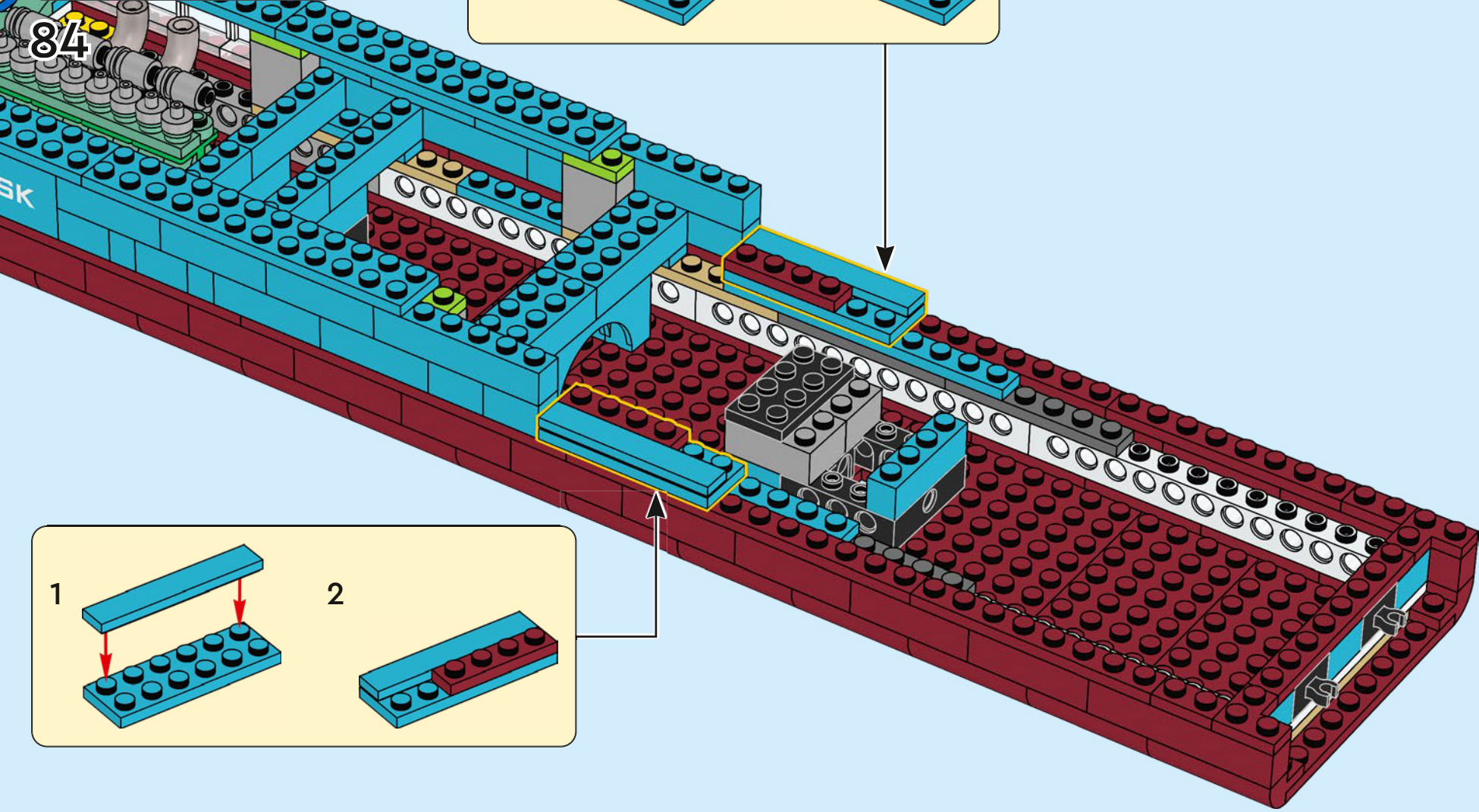
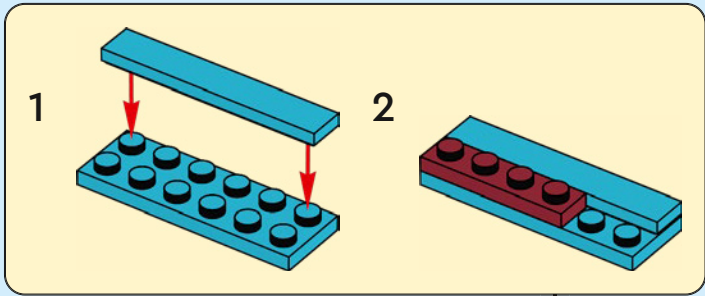
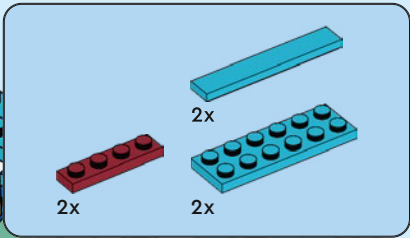

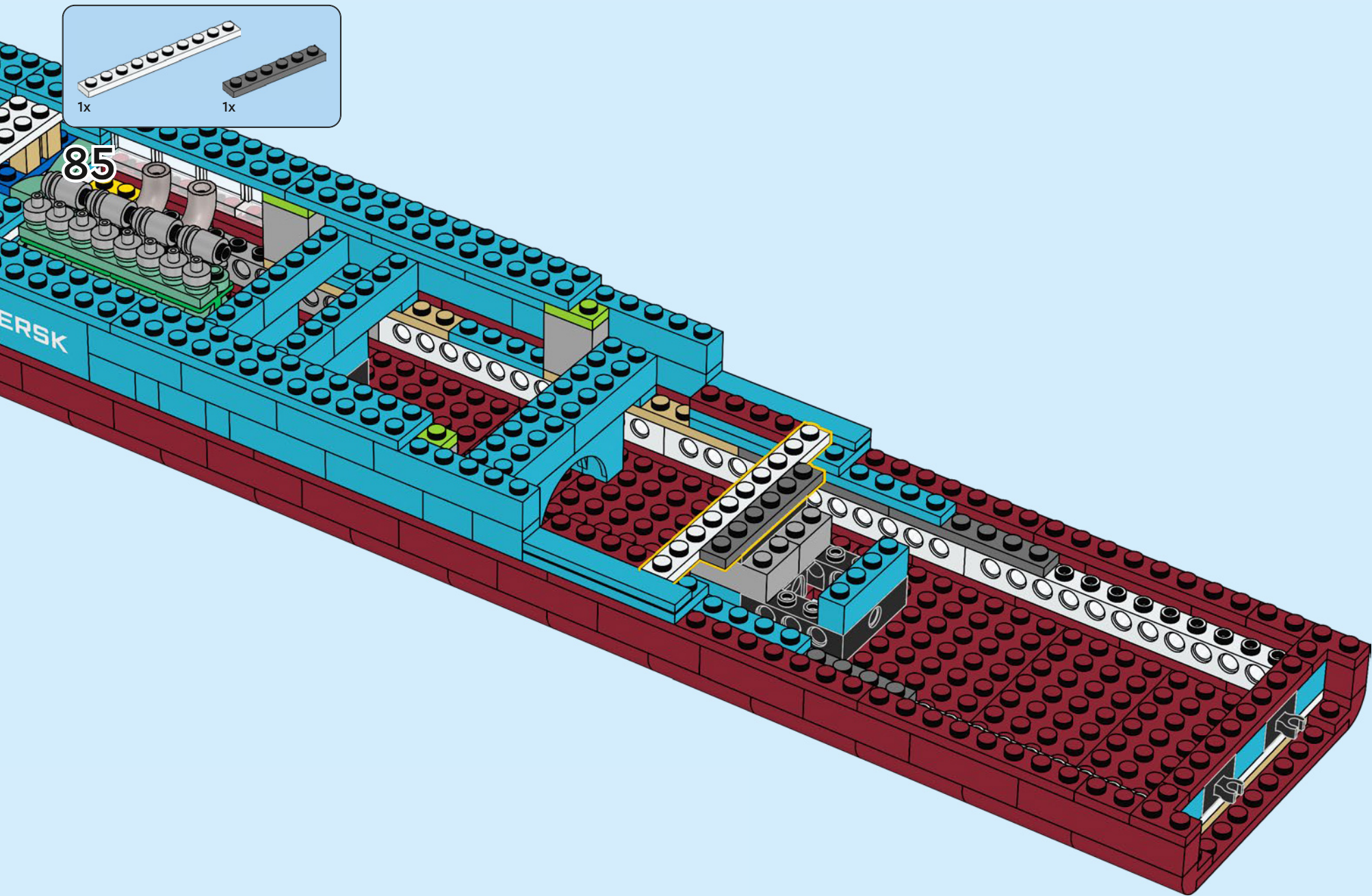

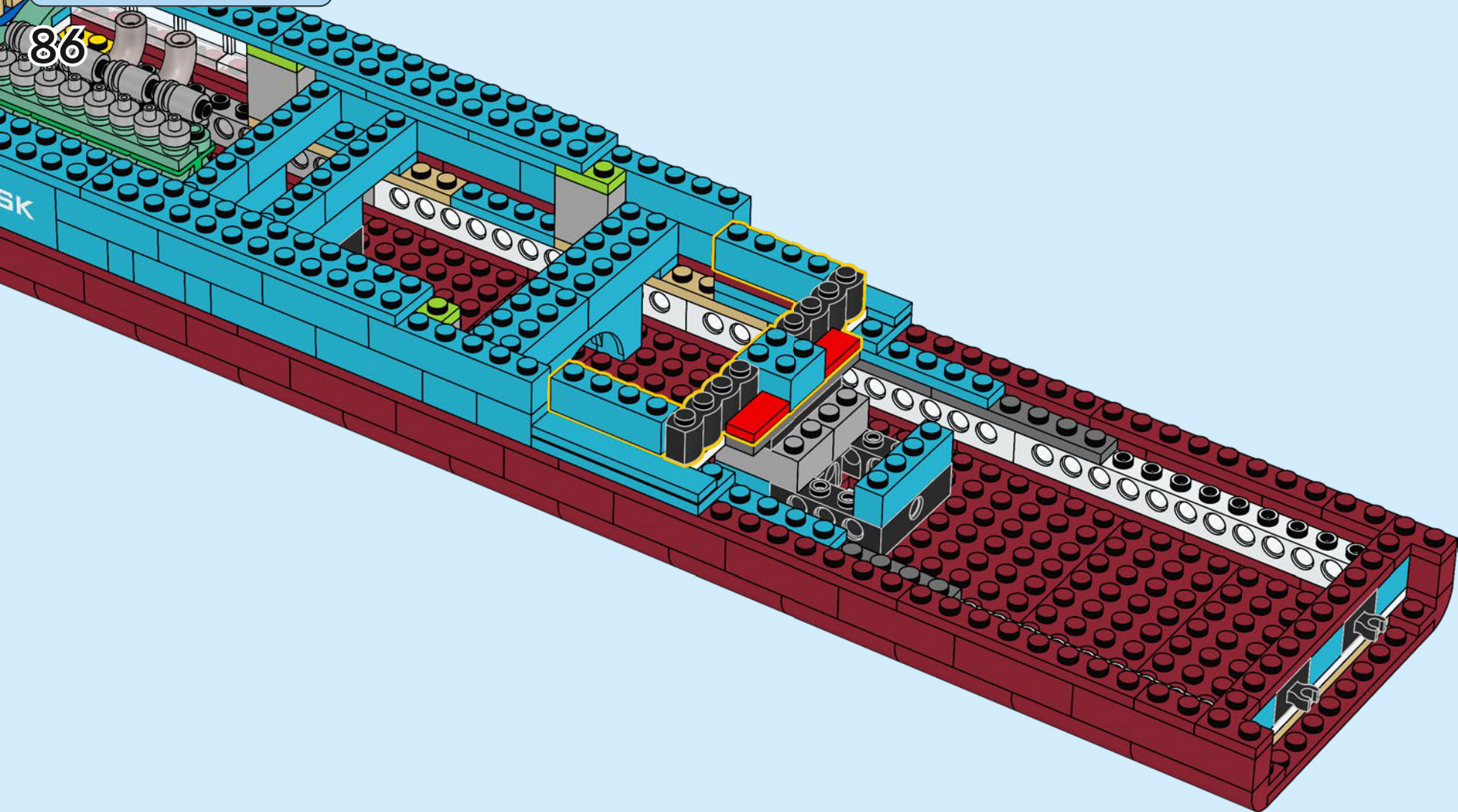
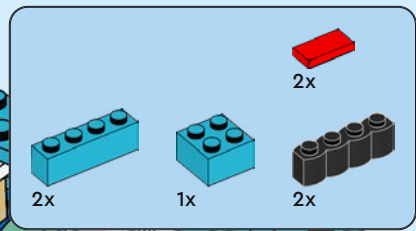

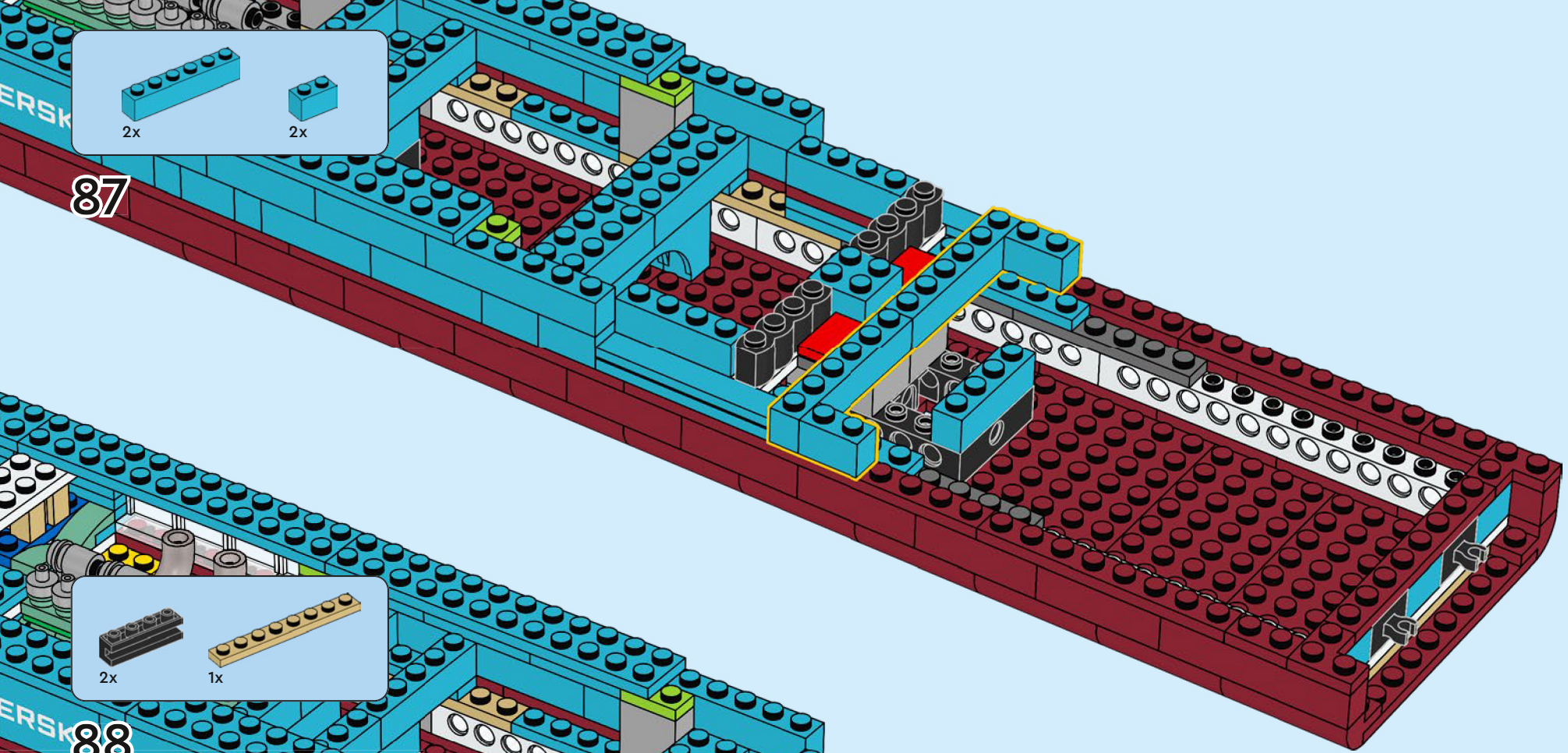

87



88

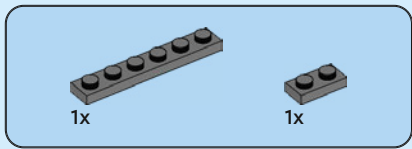

89

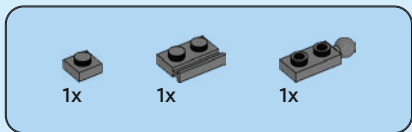
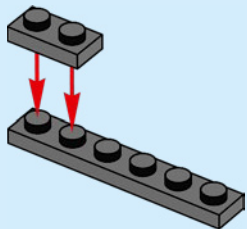

90

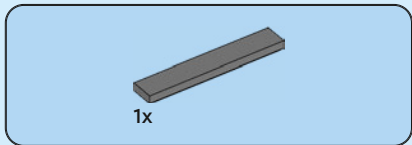
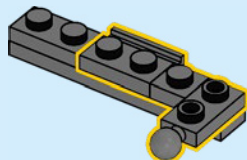

91

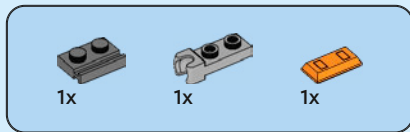
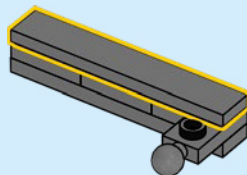

92

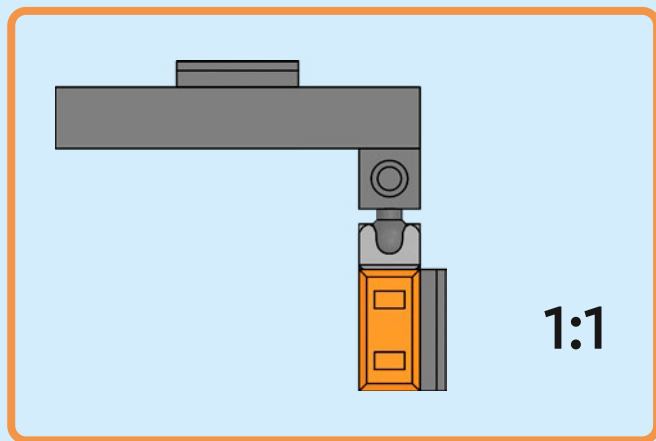
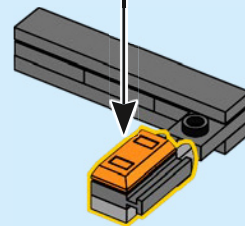
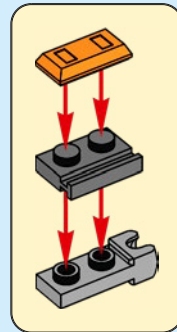

93

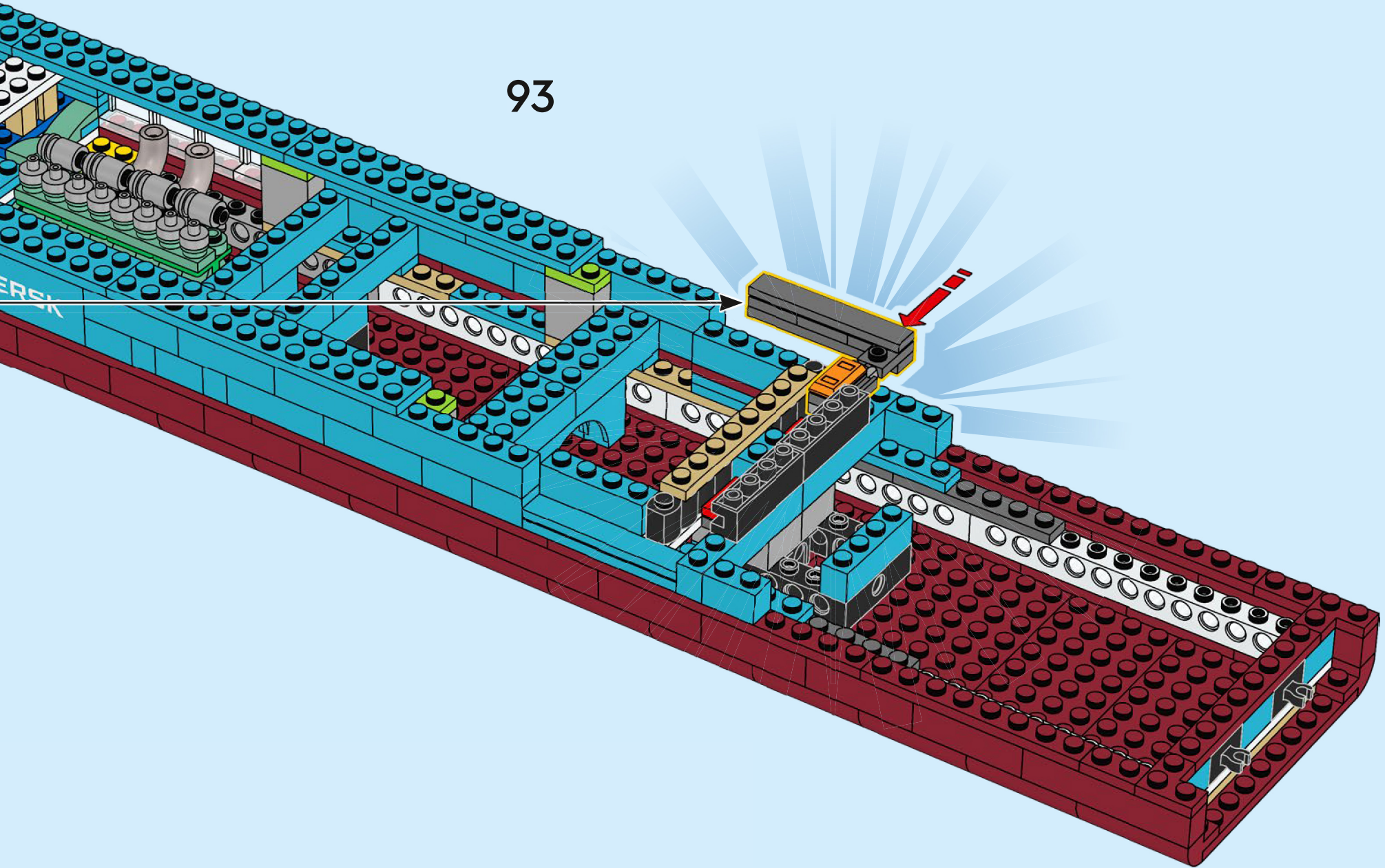

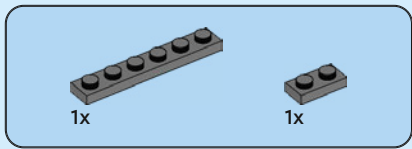

94

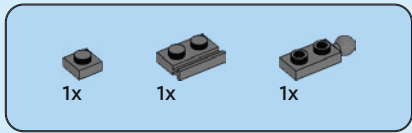
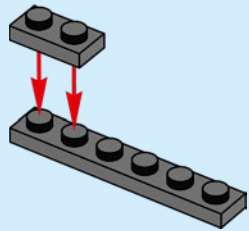

95

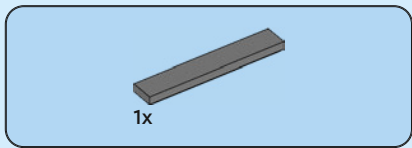
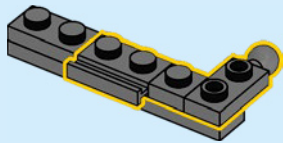

96

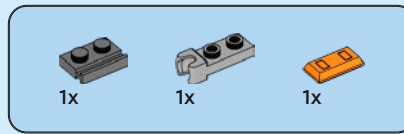
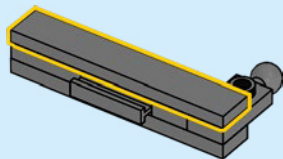

97

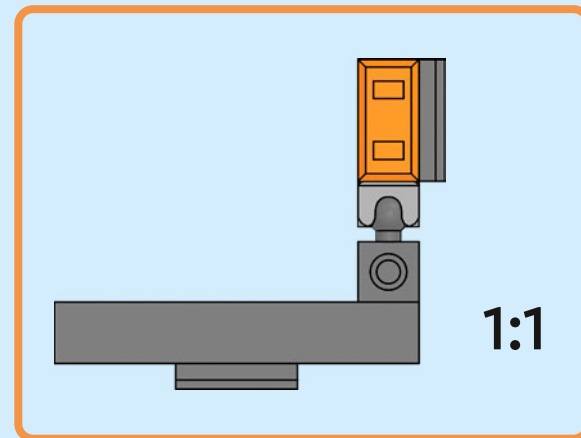
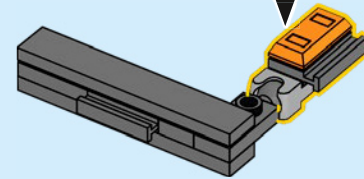
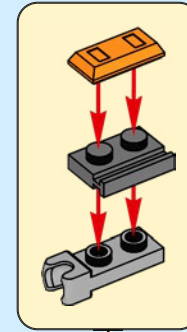

98

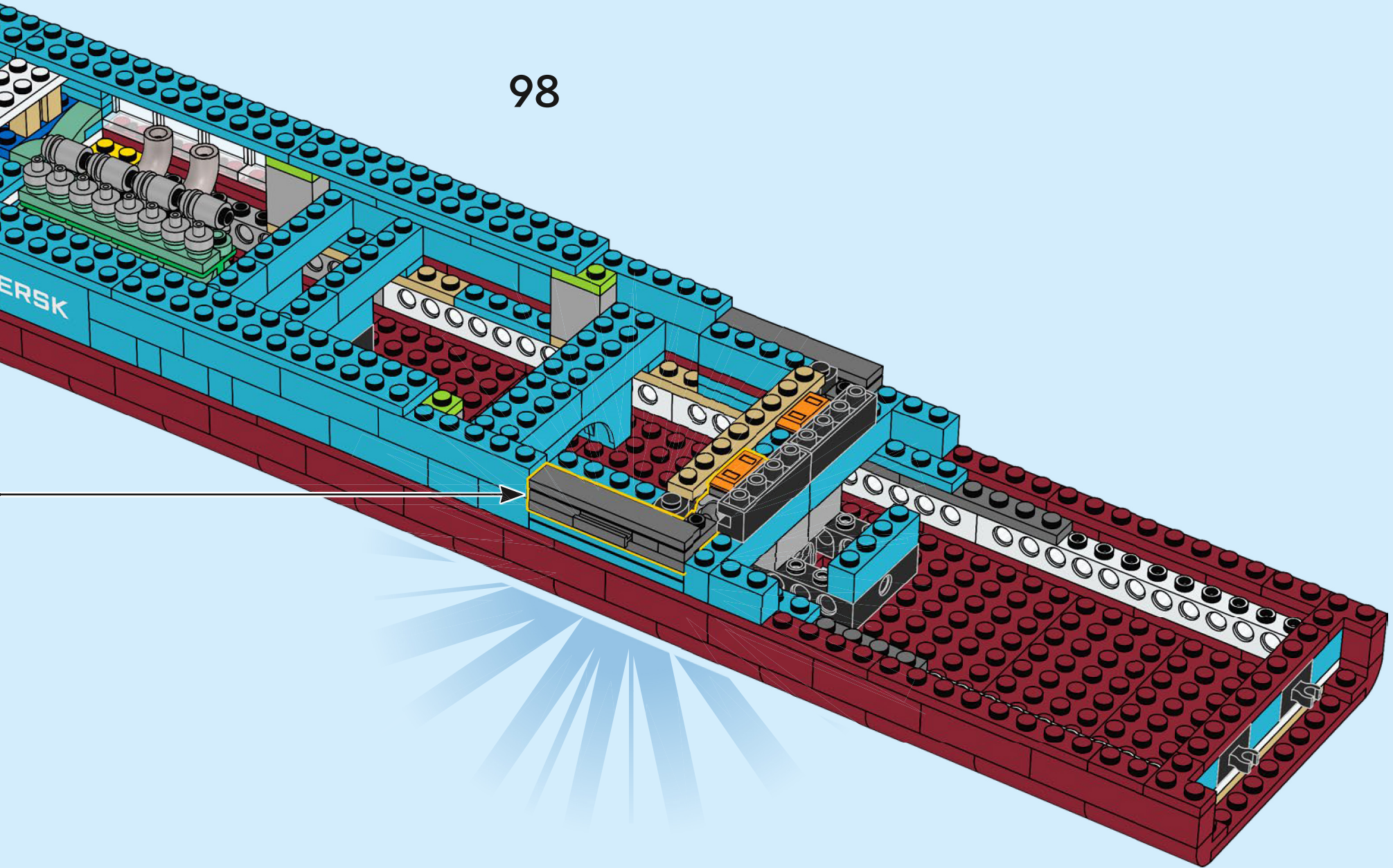

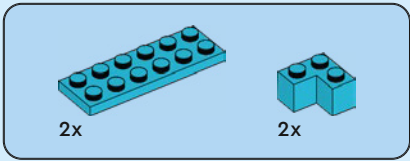

99

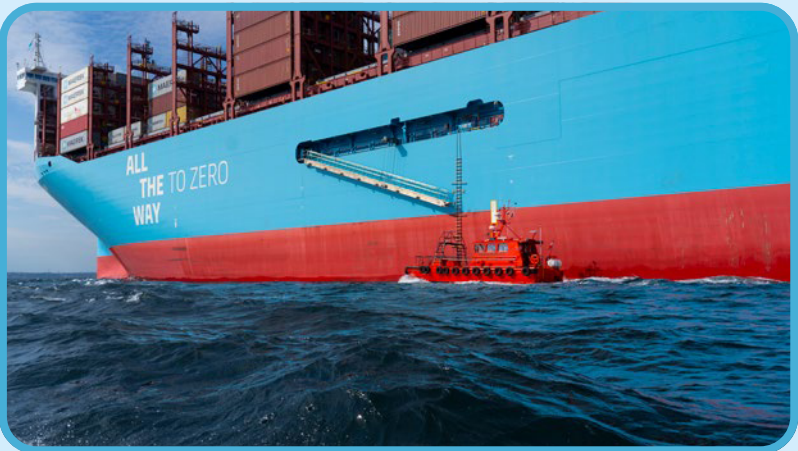
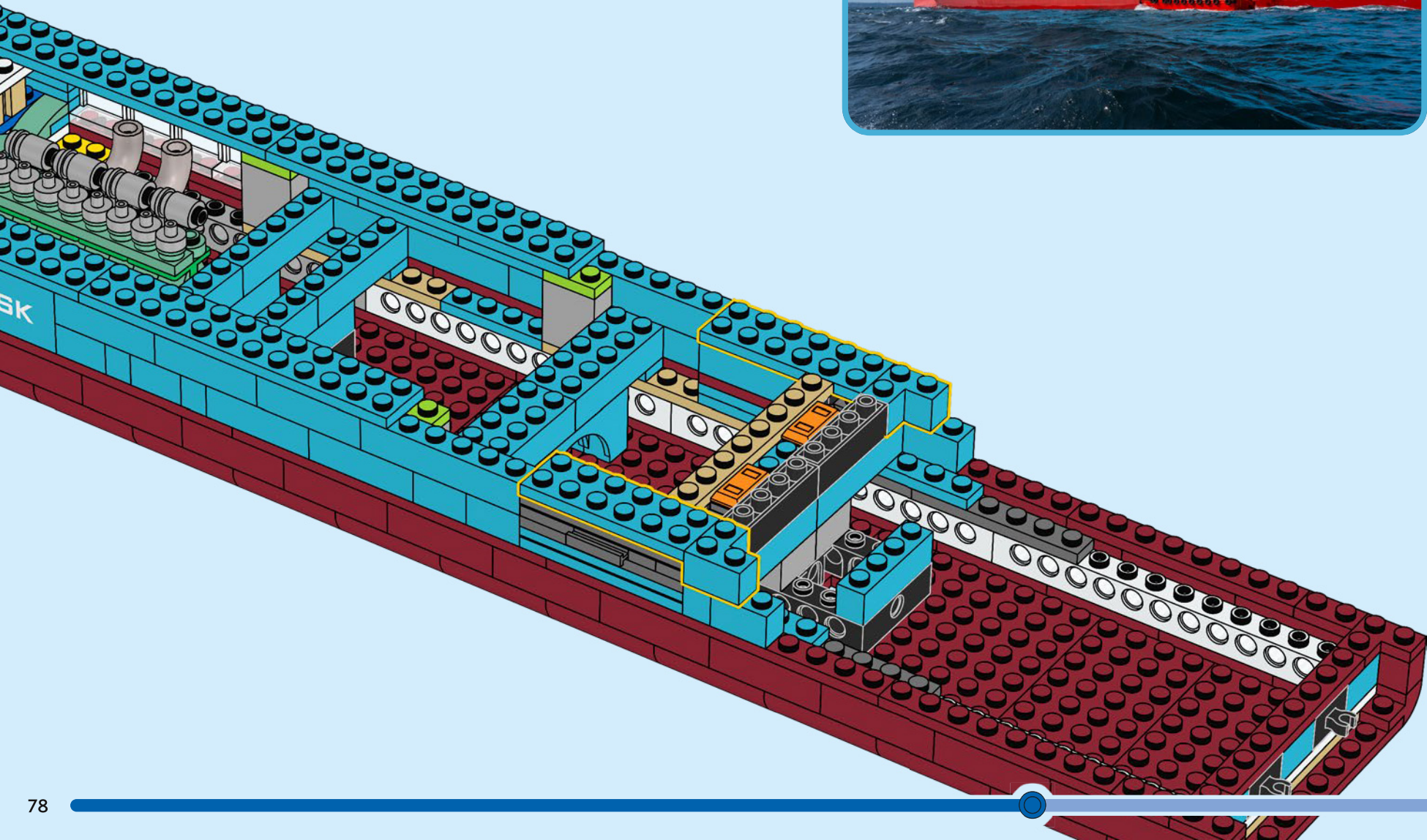

1

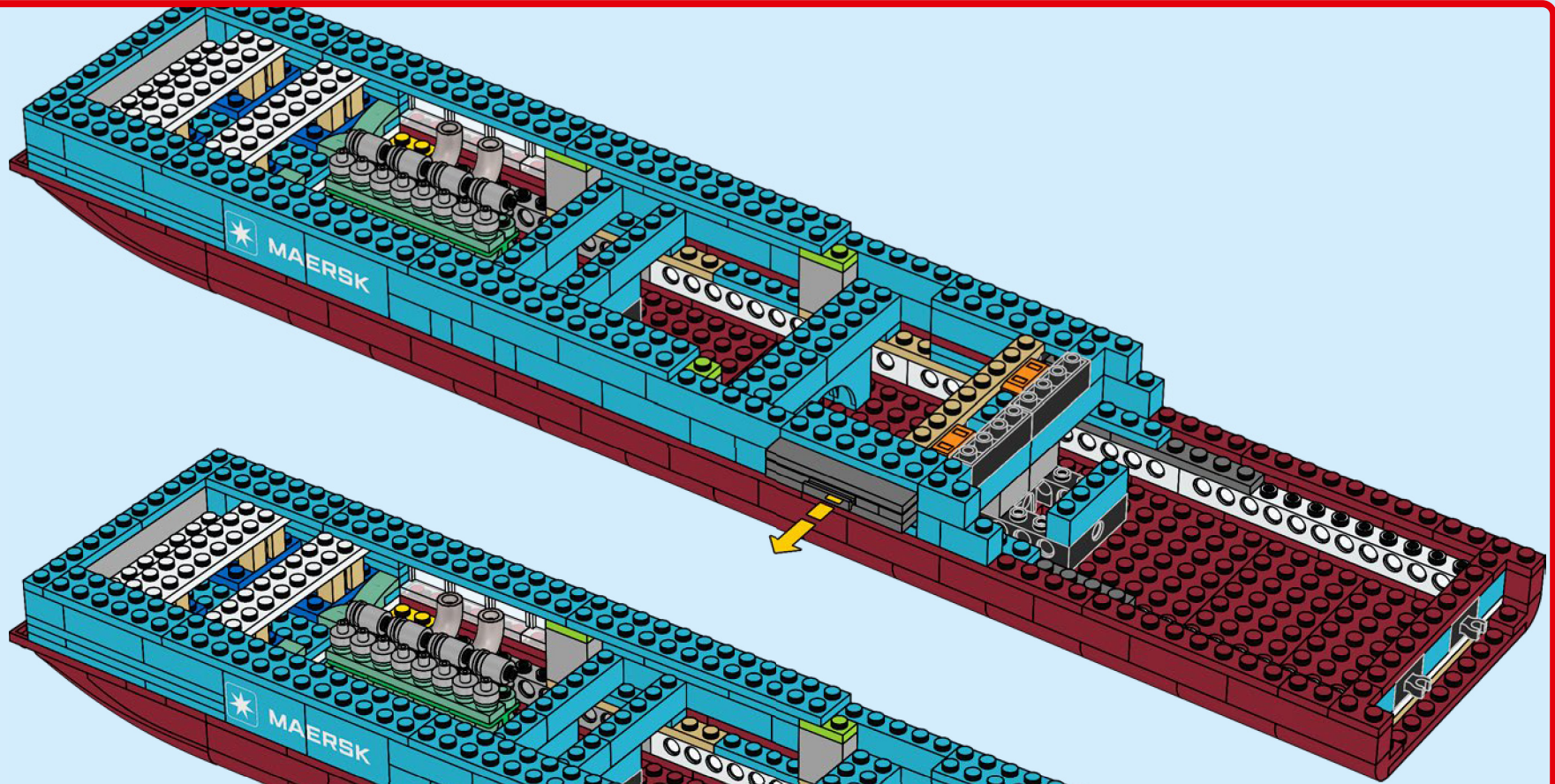

2

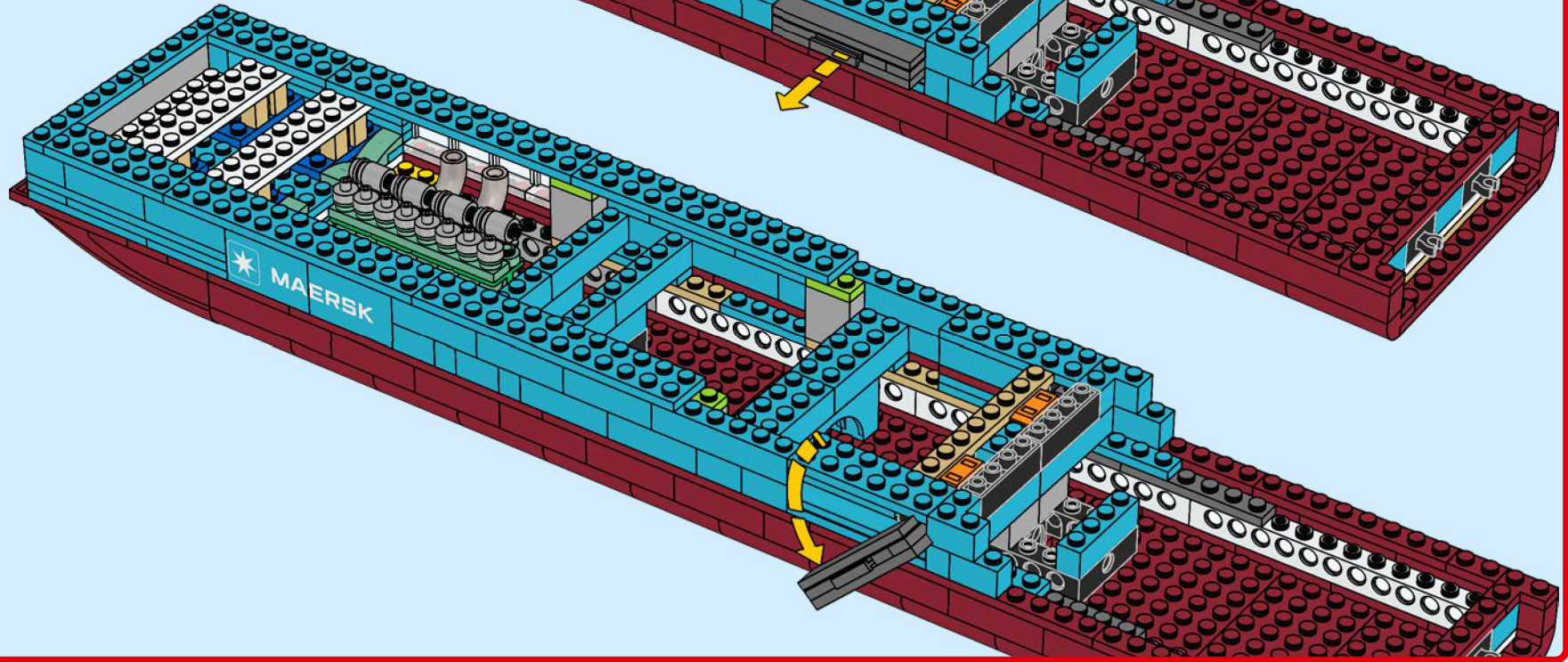

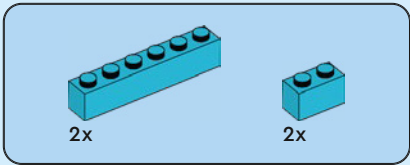

100

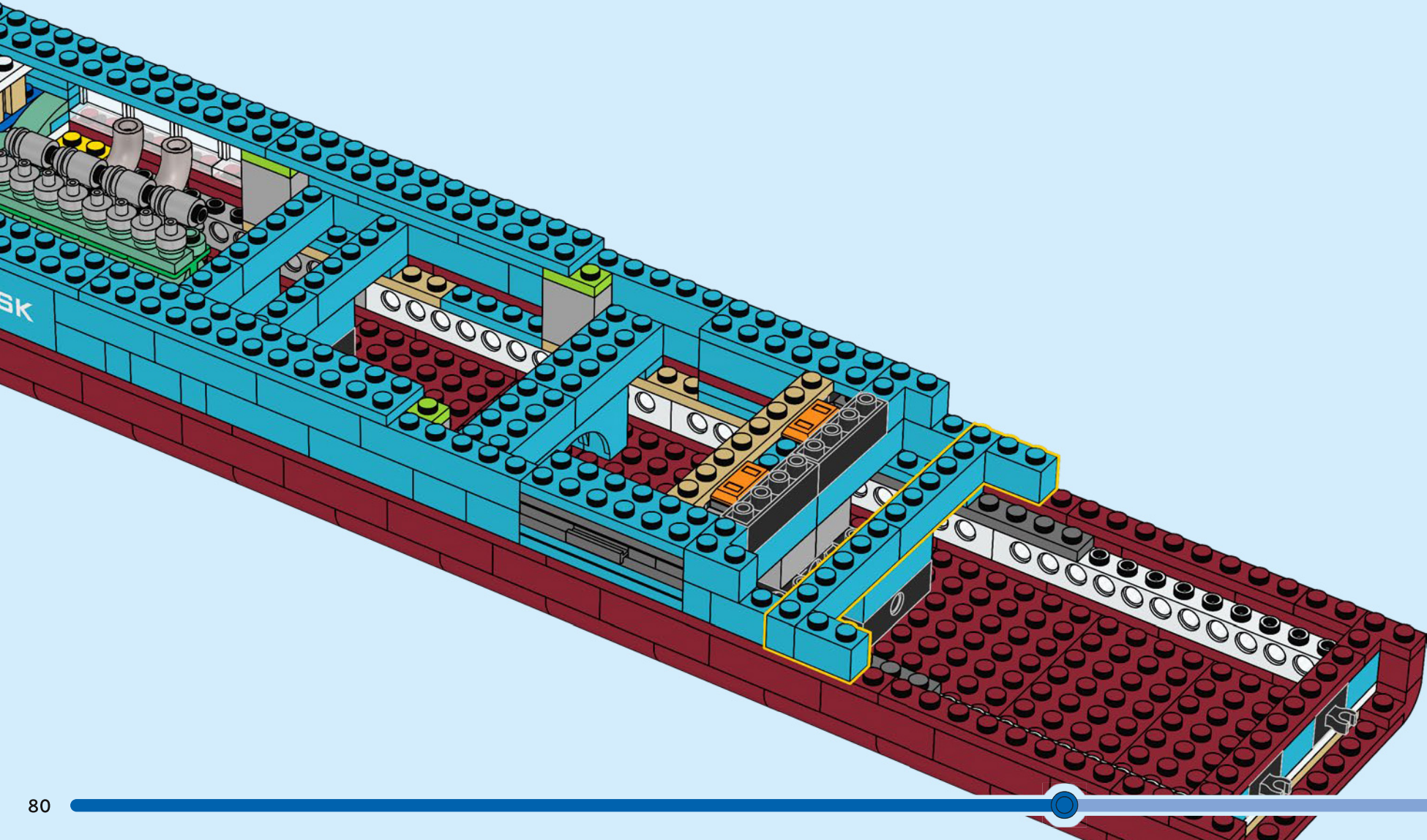

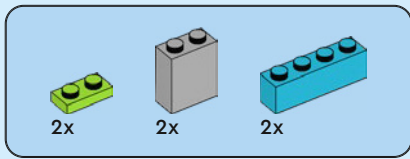

101

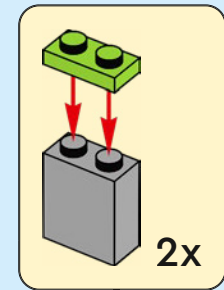
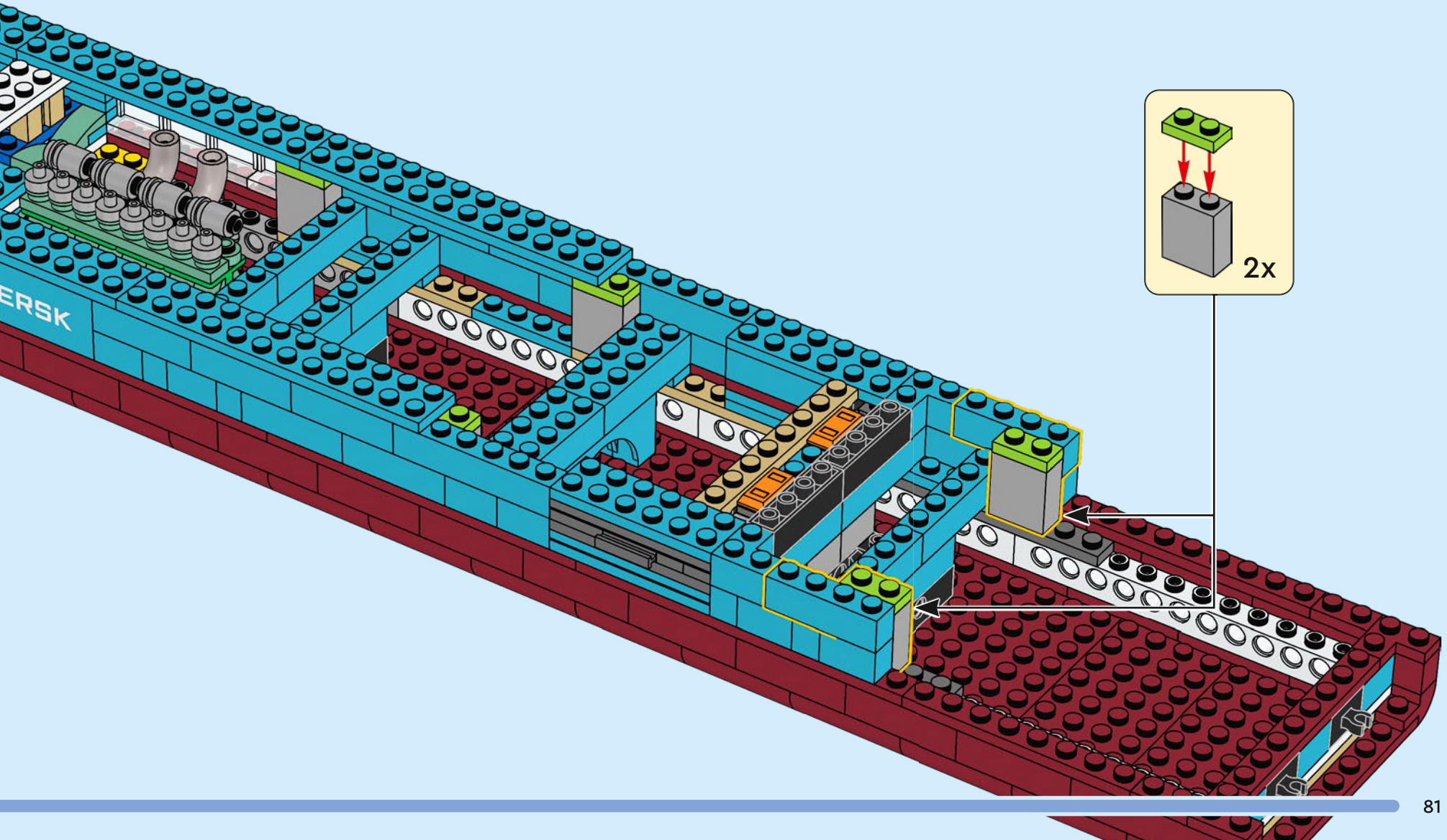

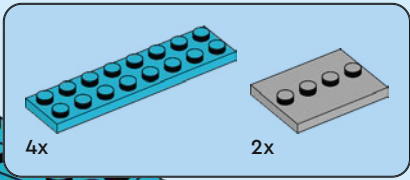

102

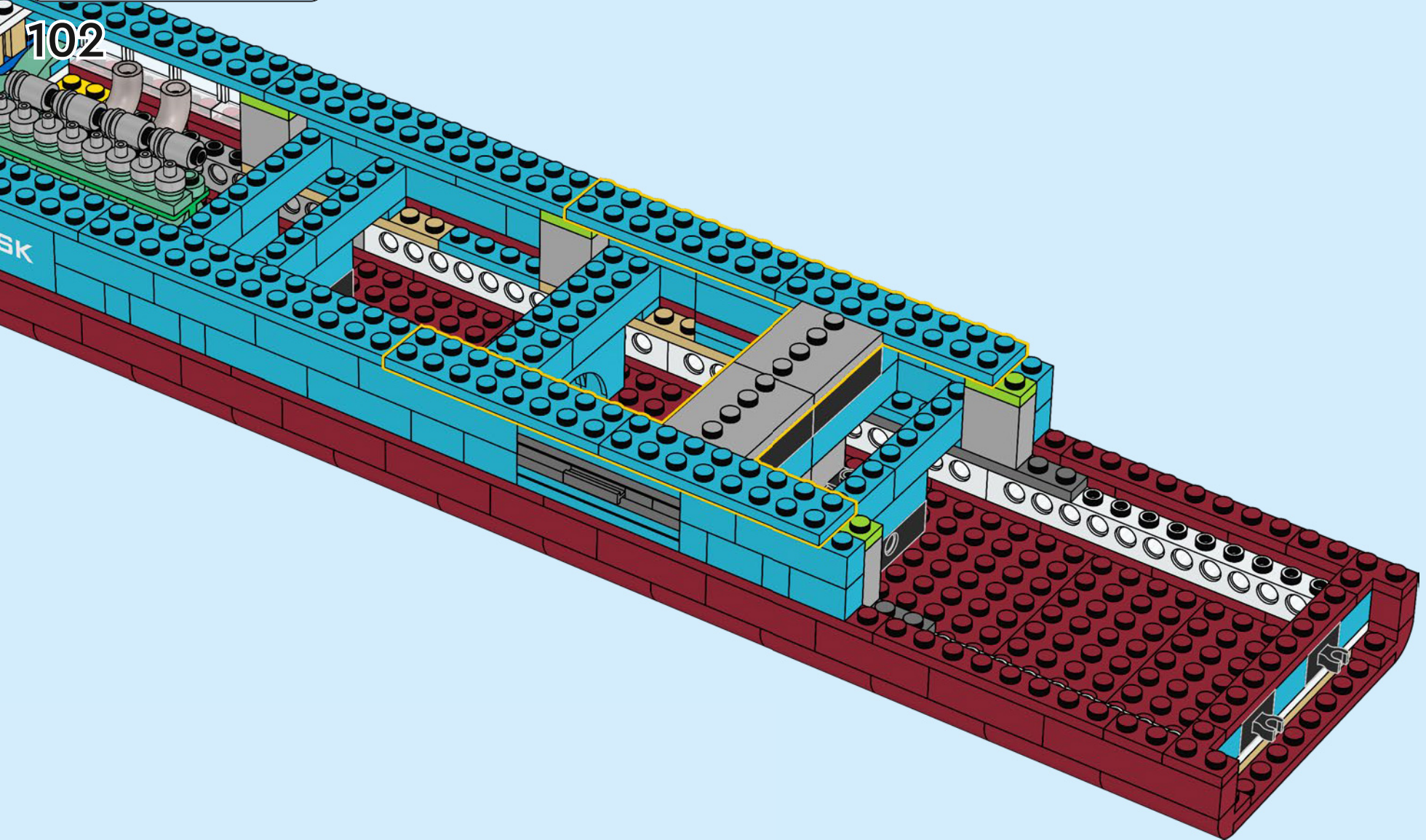

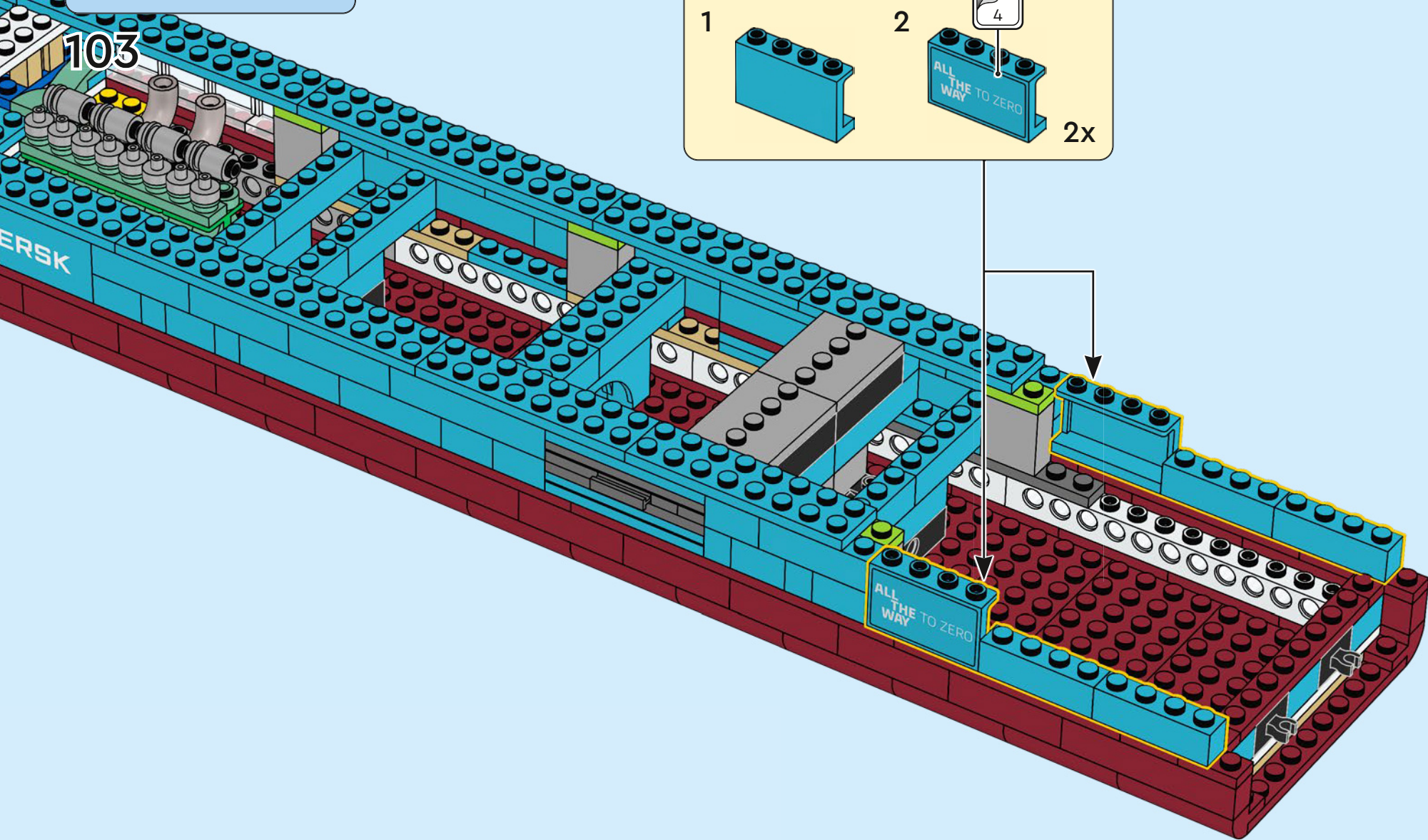
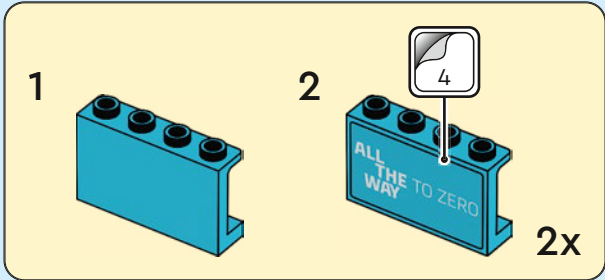
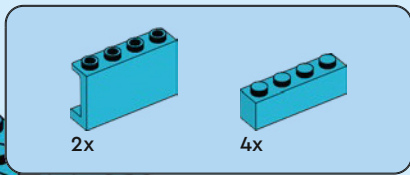

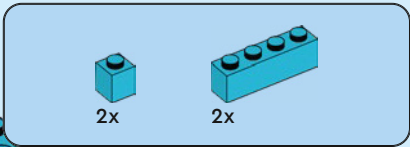

104

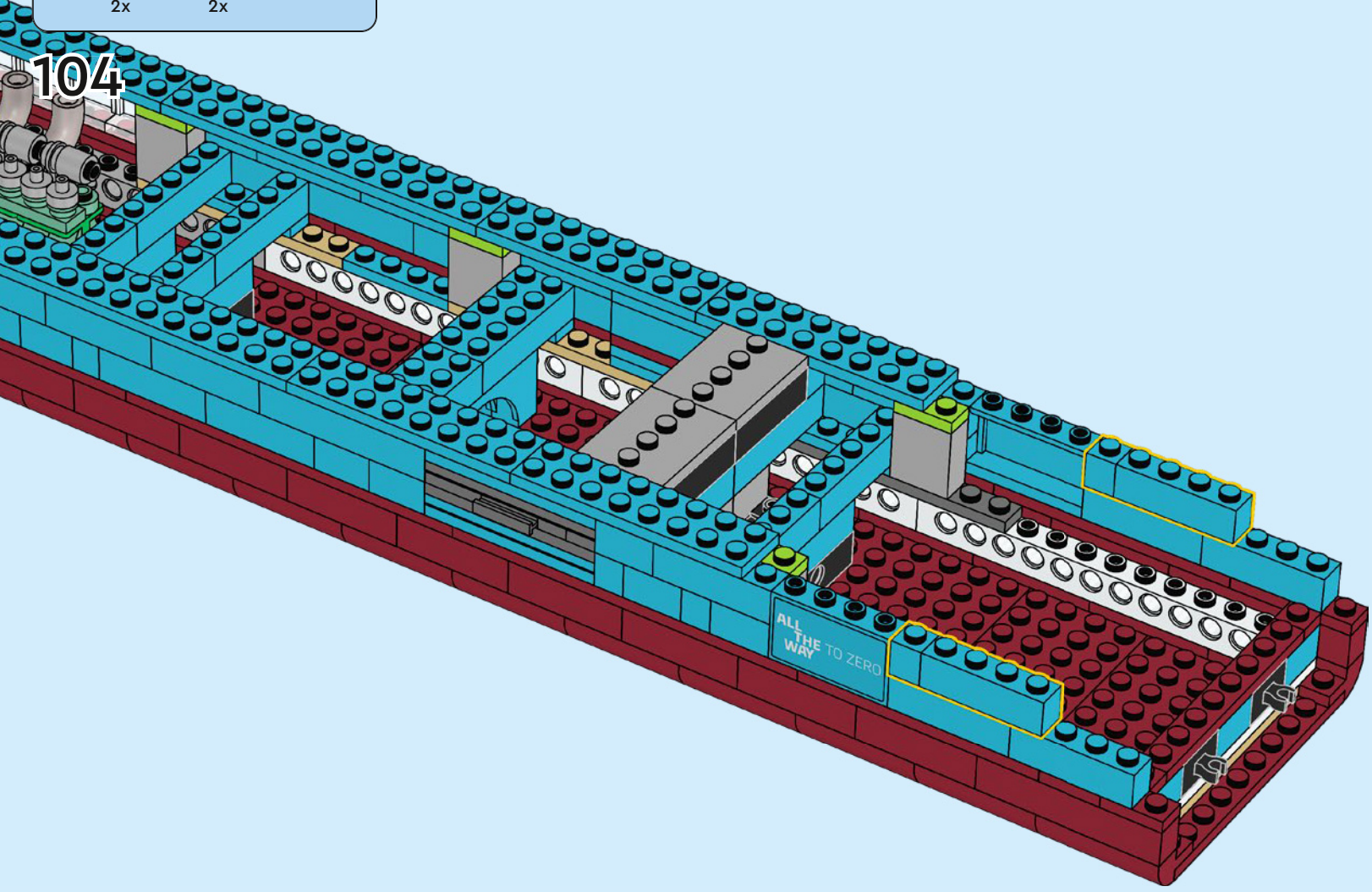

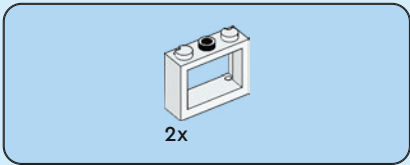

105

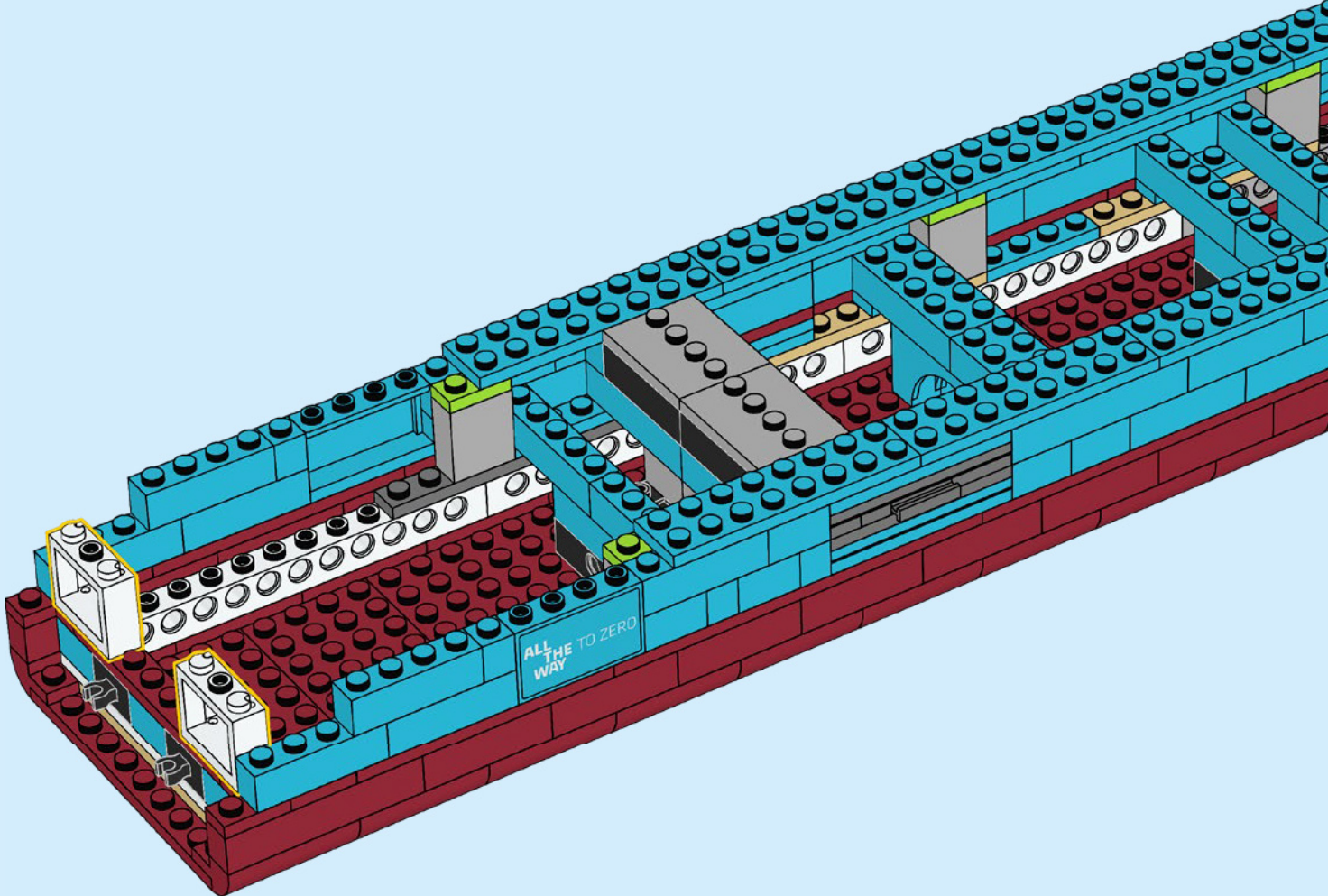

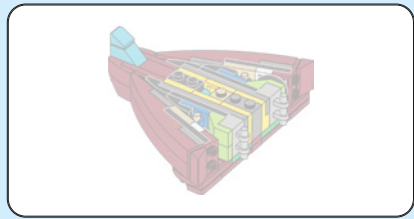
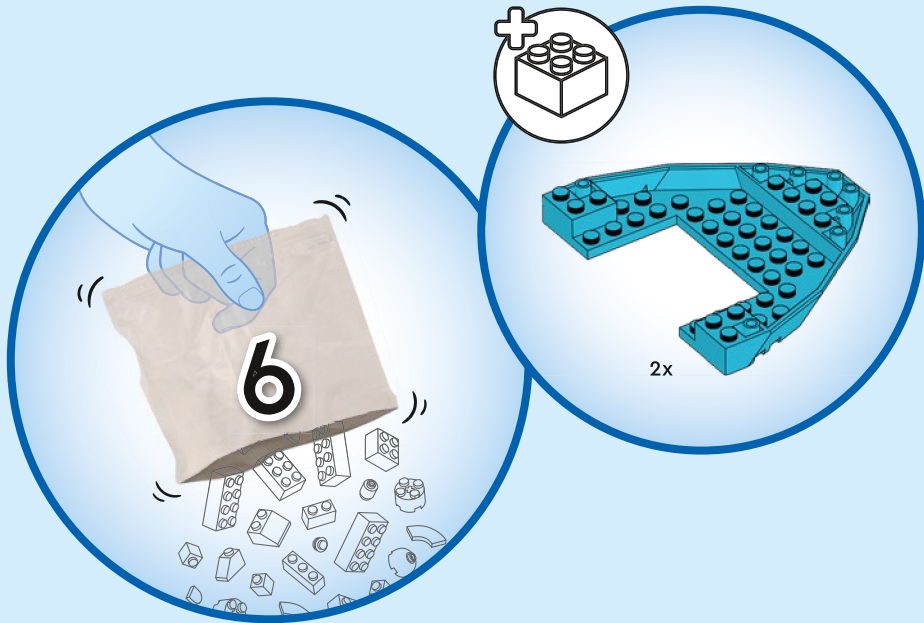

106

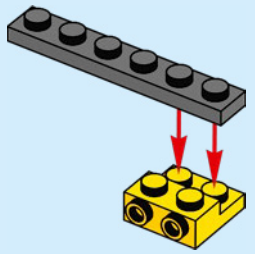

107

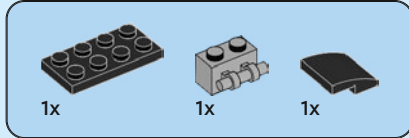
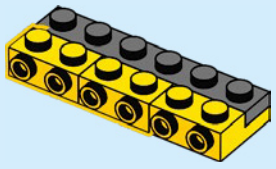

108

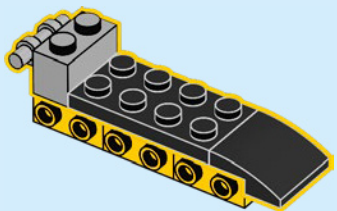

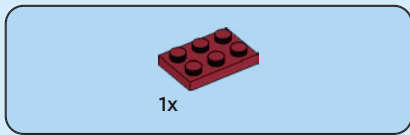

109

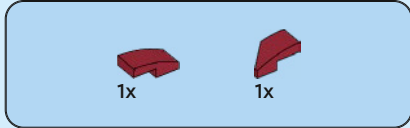
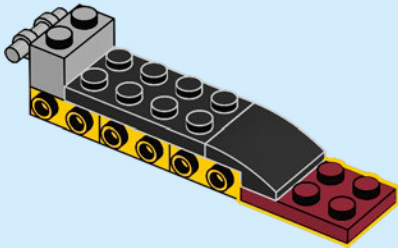

110

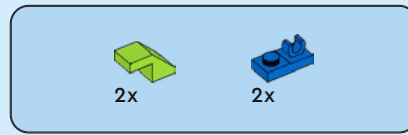
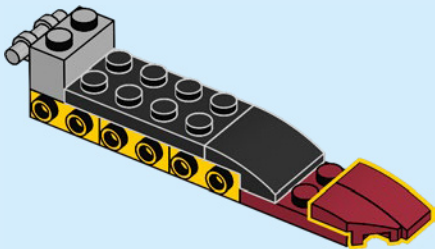

111

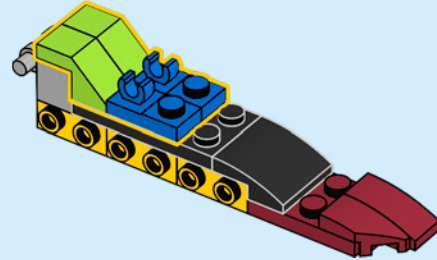

112

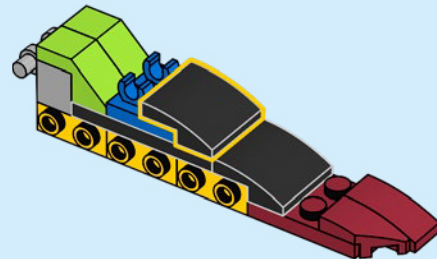

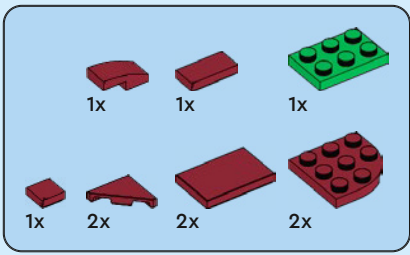

113

1

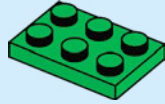

2

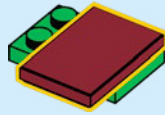

3

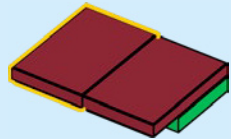

4

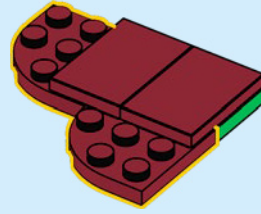

5

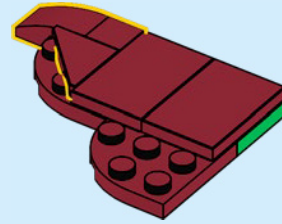

6

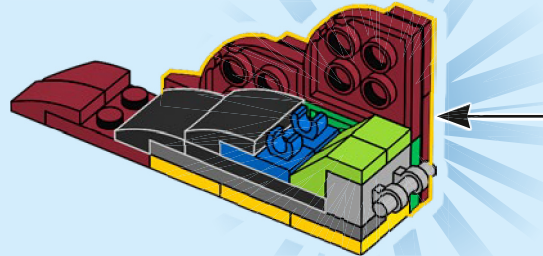
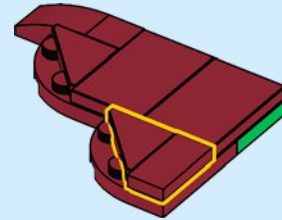

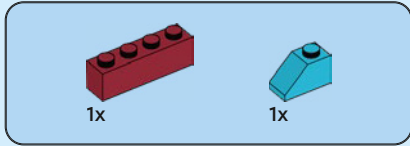
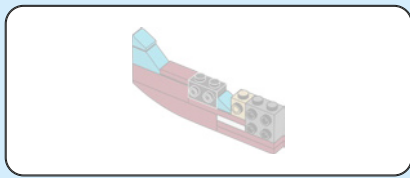

114

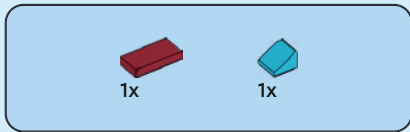
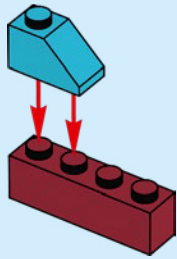

115

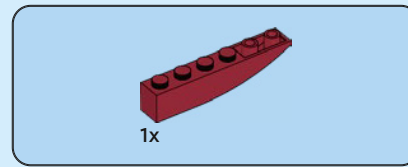
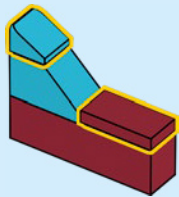

116

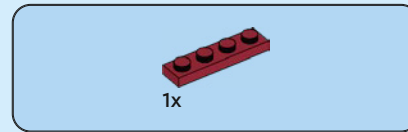
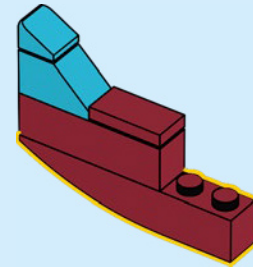

117

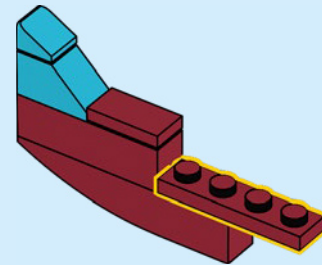

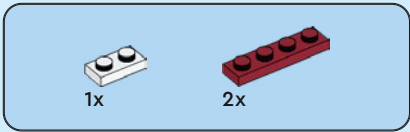

118

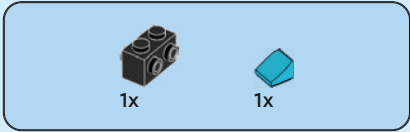
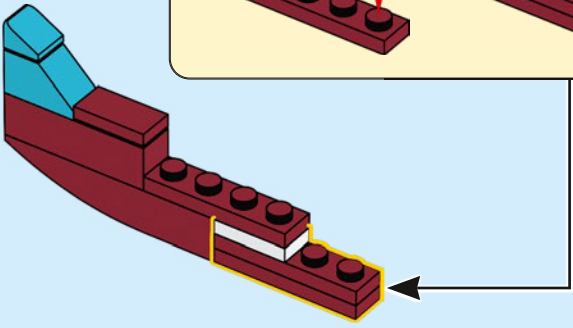
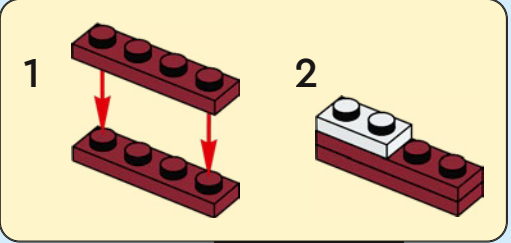

119

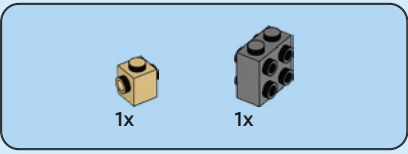
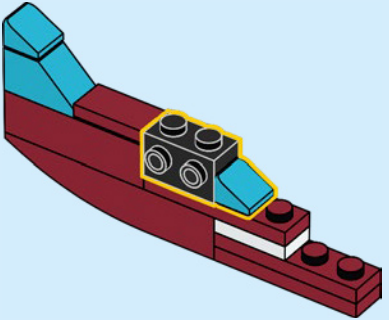

120

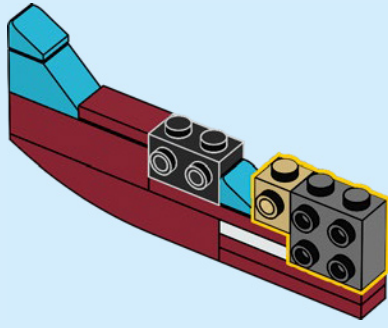

121

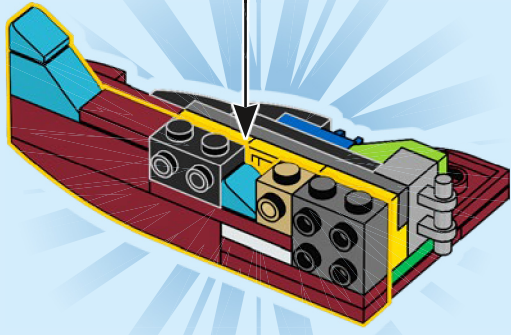

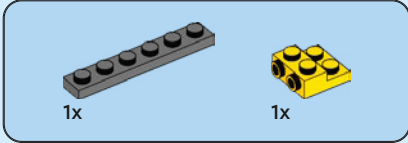
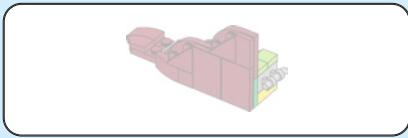

122

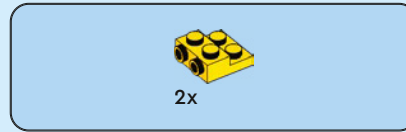
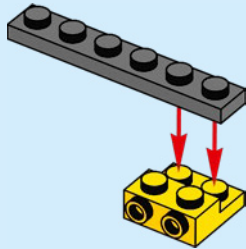

123

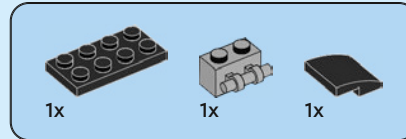
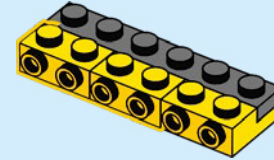

124

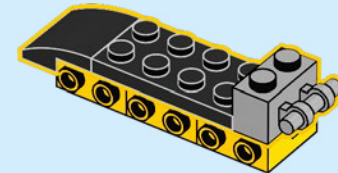

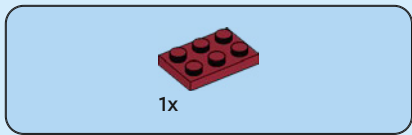

125

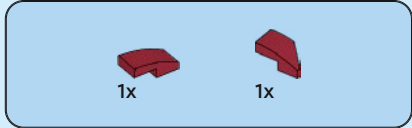
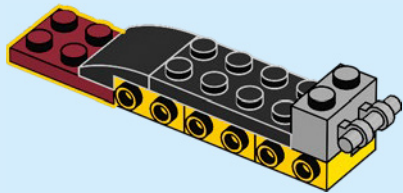

126

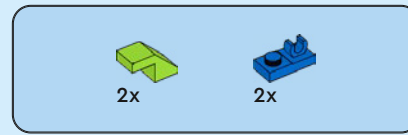
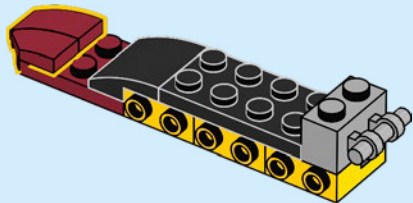

127

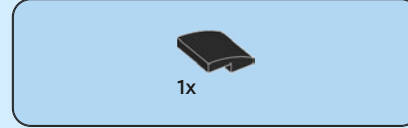
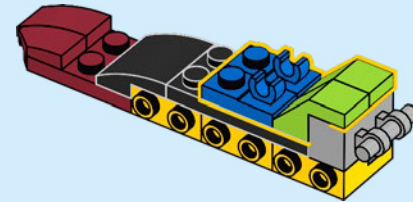

128

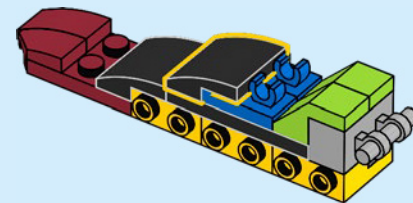

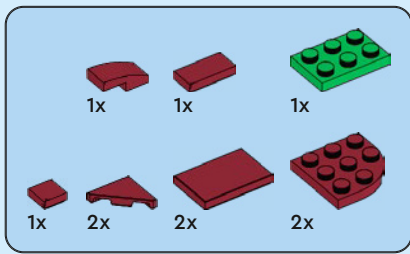

129

1

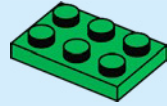

2

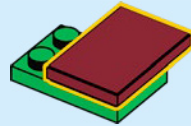

3

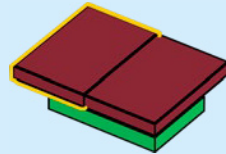

4

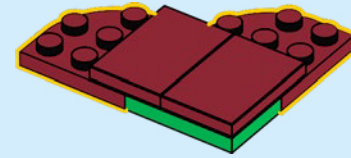

5

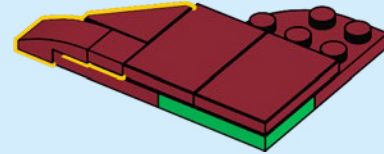

6

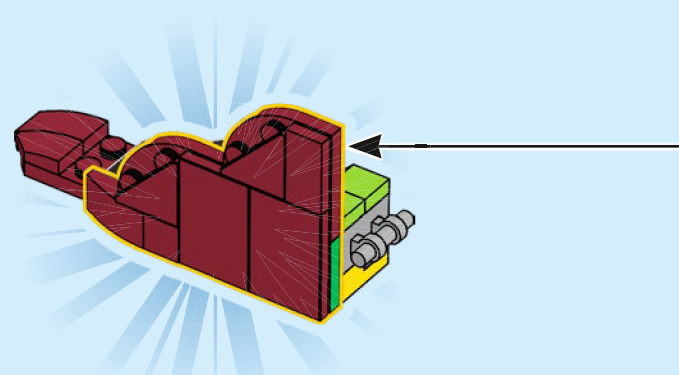
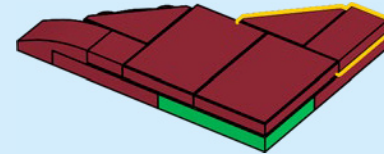

130

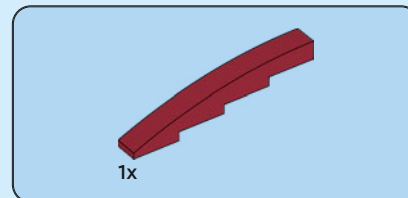
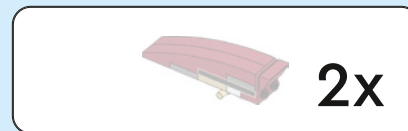
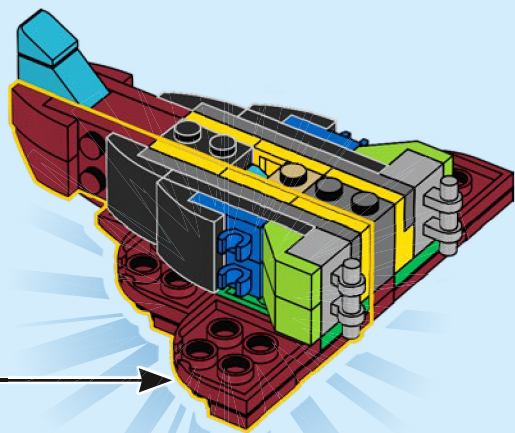

131

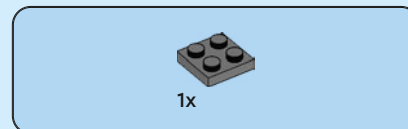
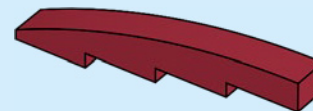

132

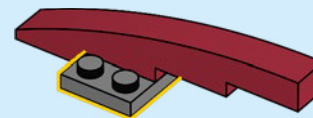

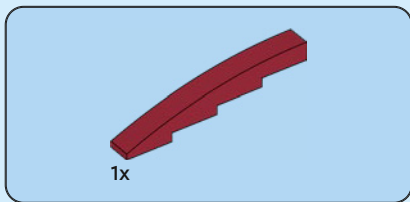

133

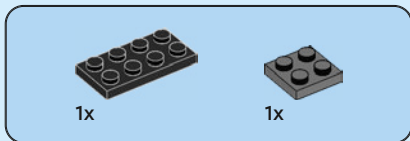
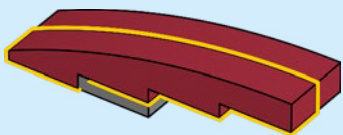

134

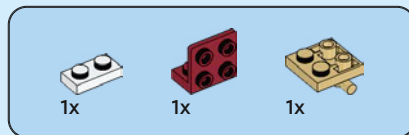
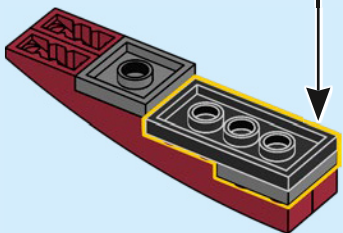
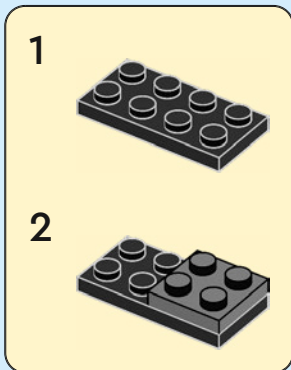

135

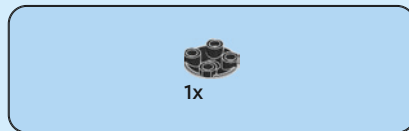
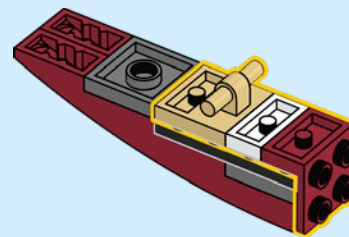

136

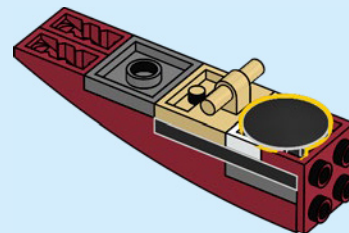



1x

137

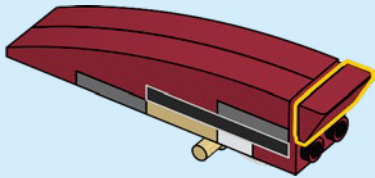

2x

138

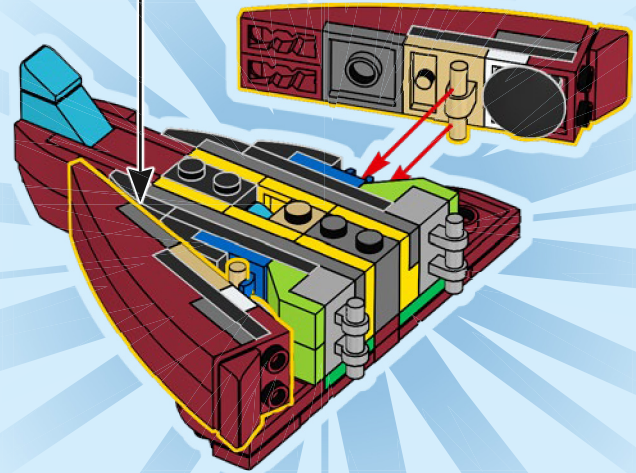

139

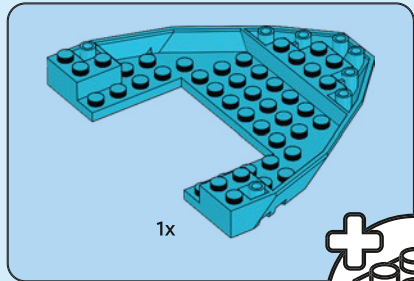
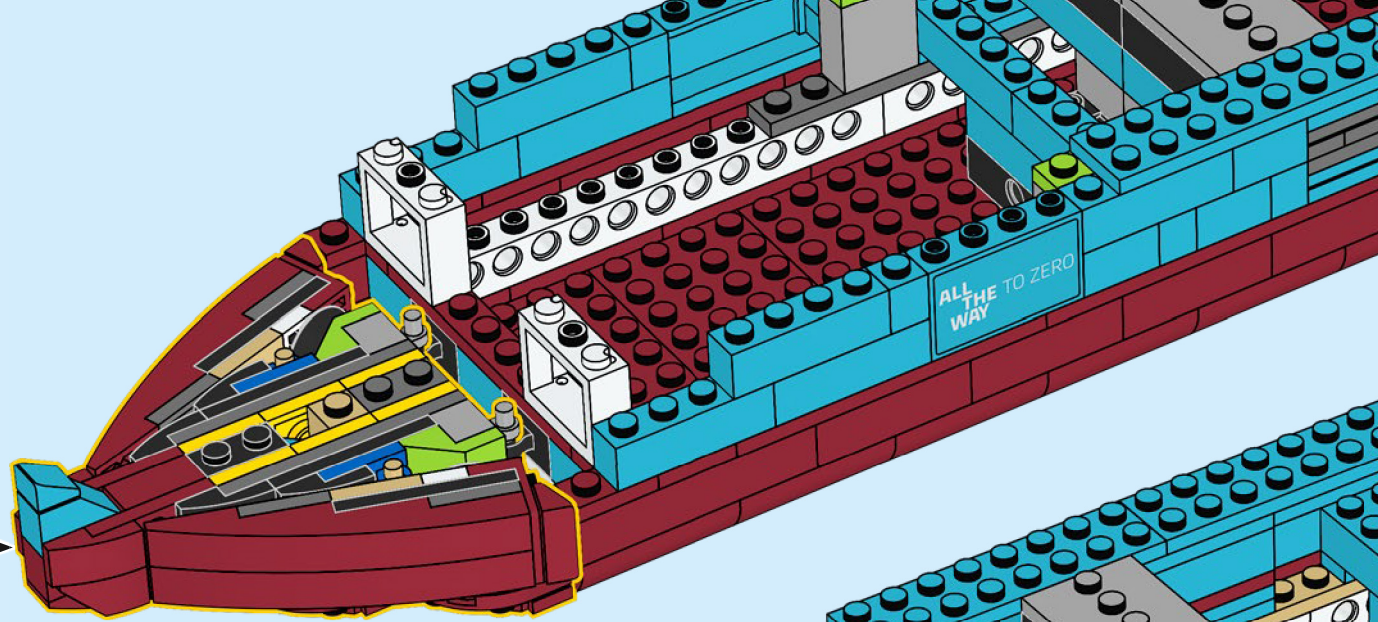

1x

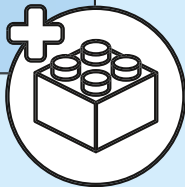

140

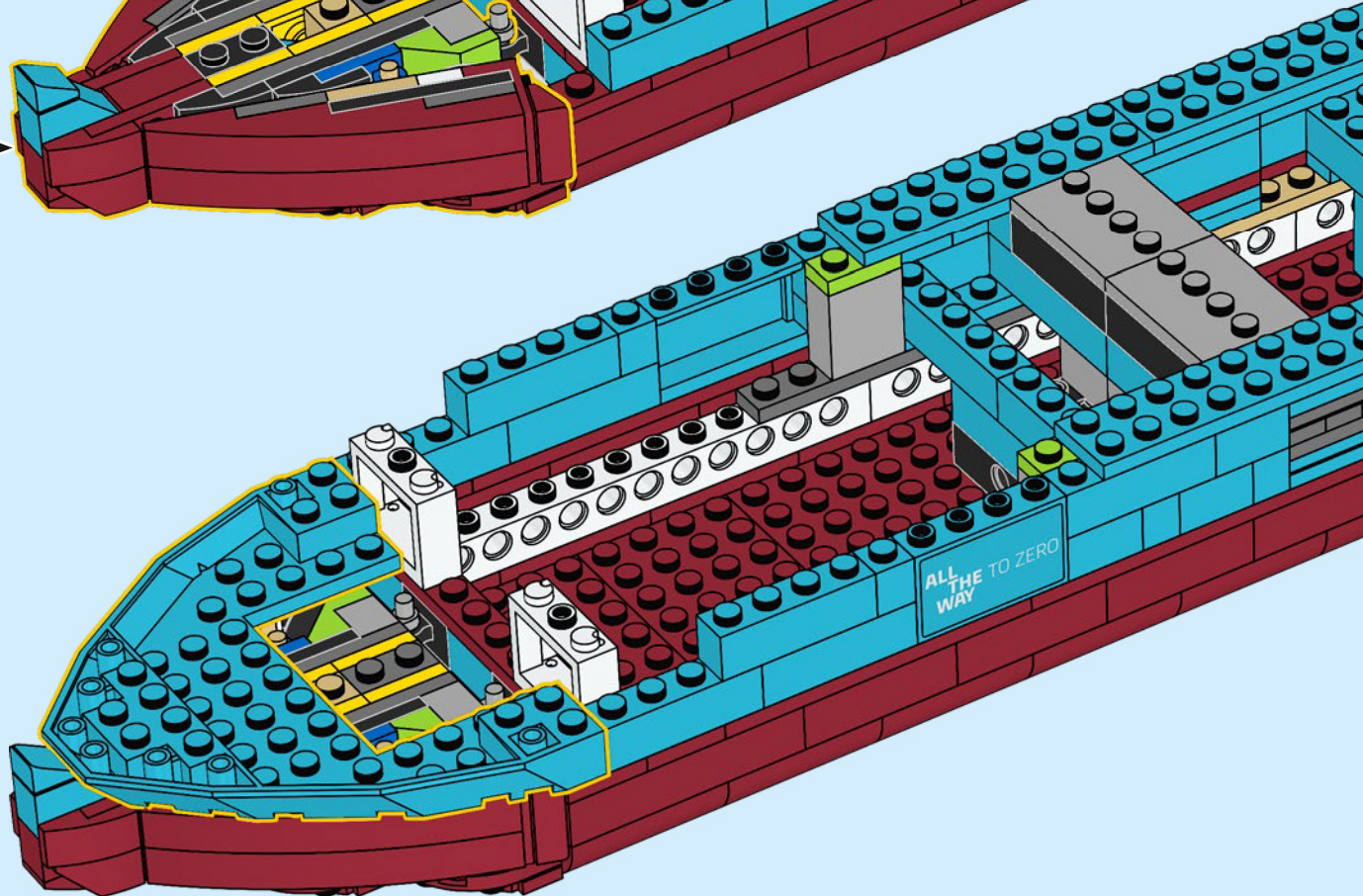

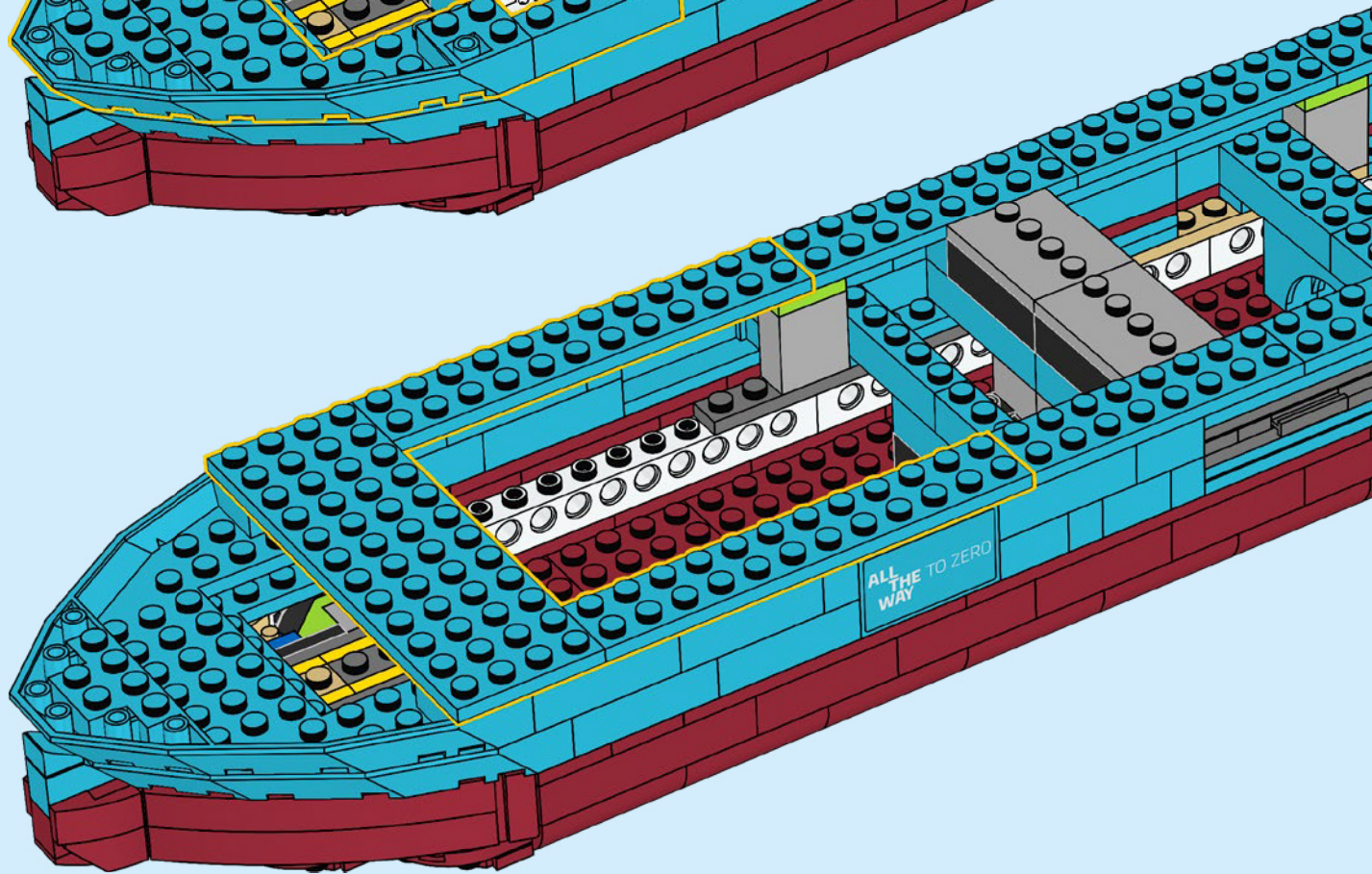
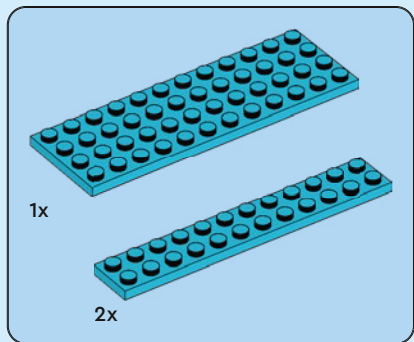
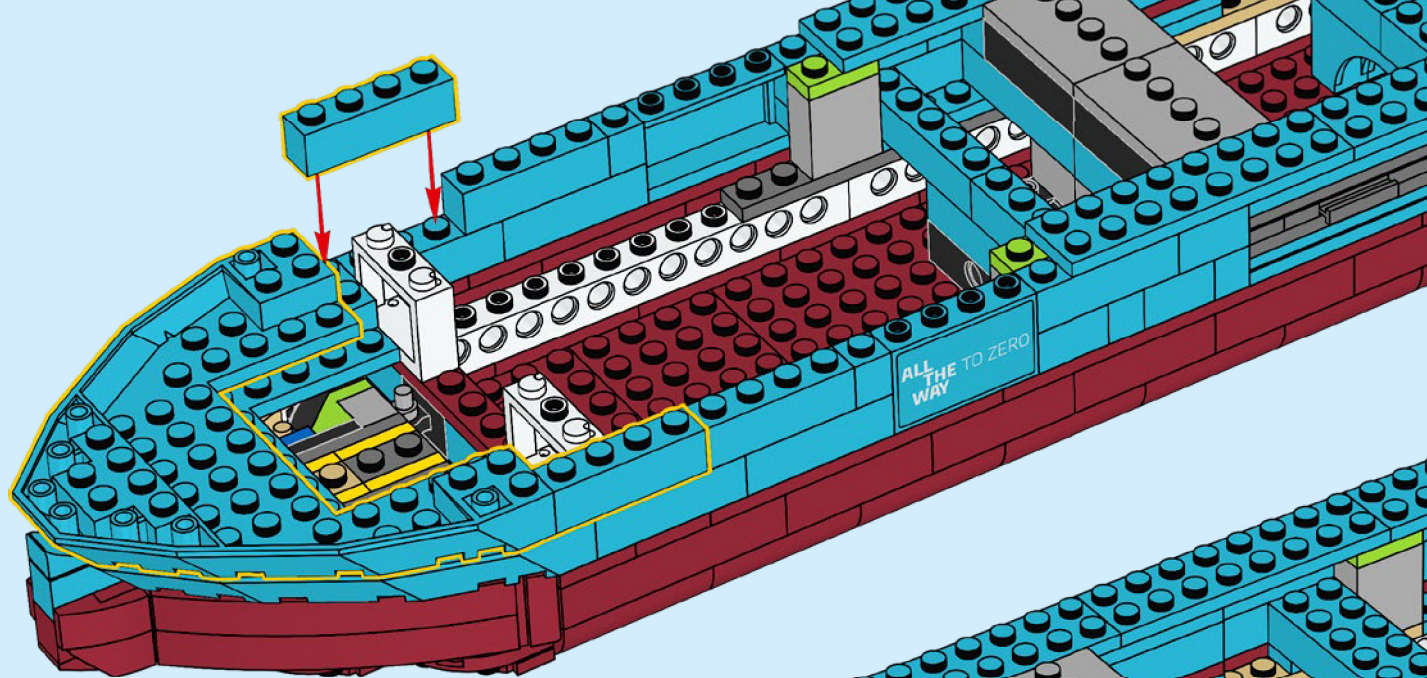
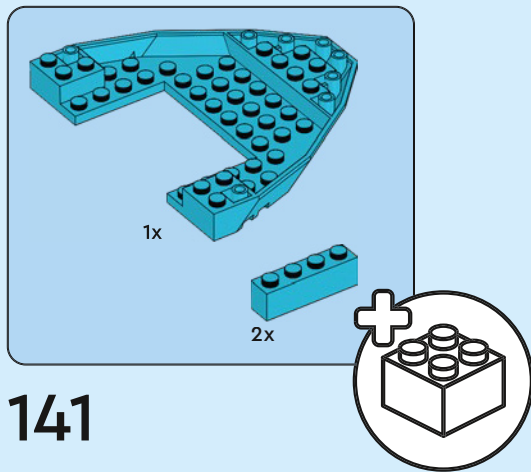

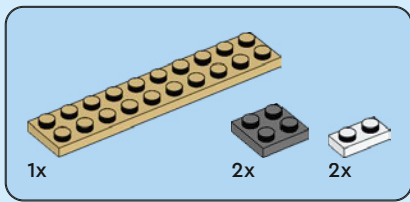

143

1

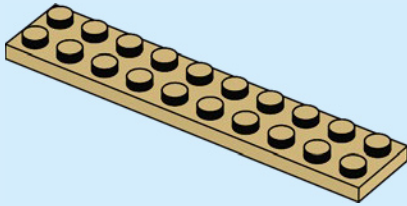

2

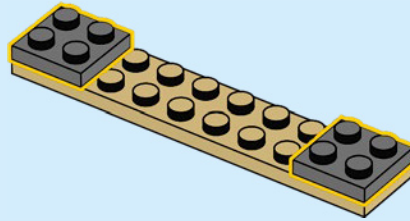

3

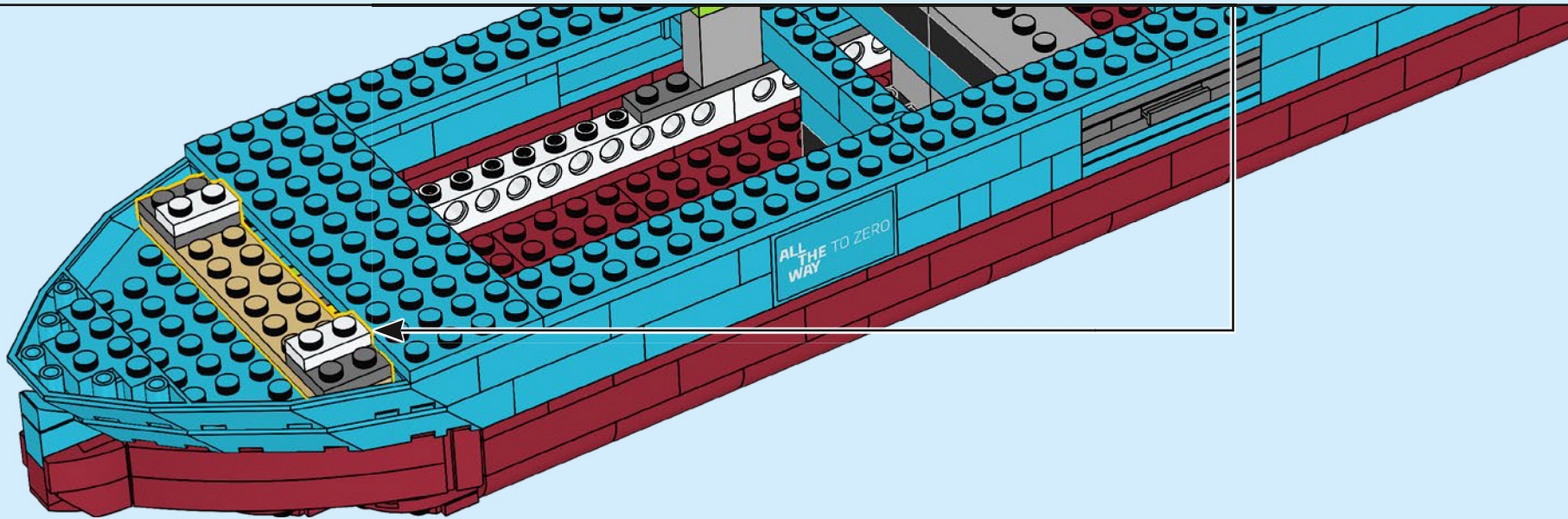
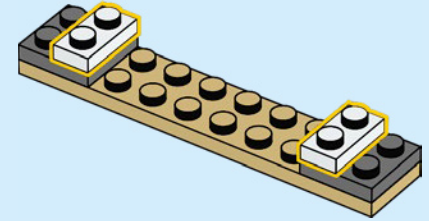

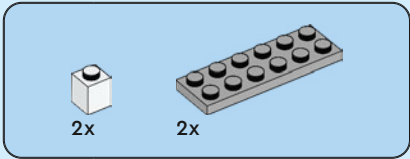

144

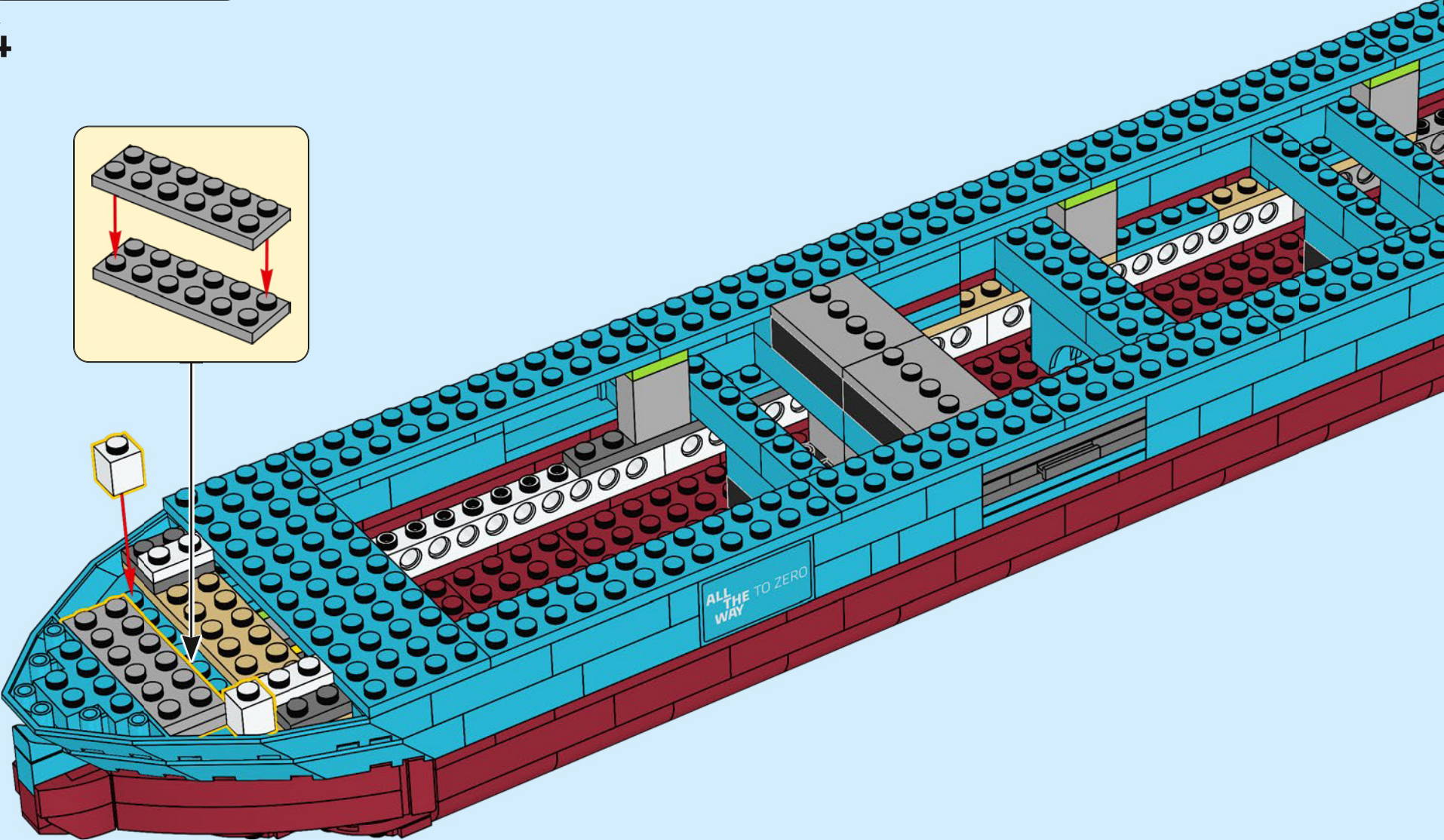
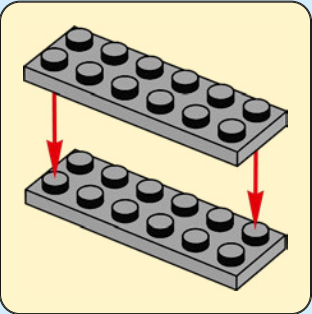

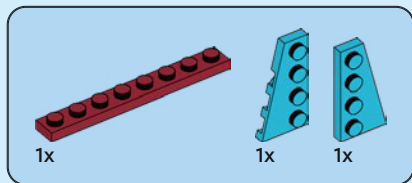

145

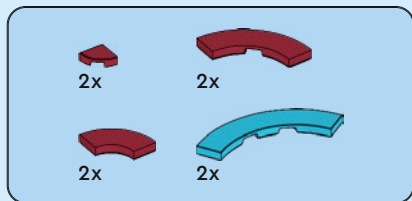
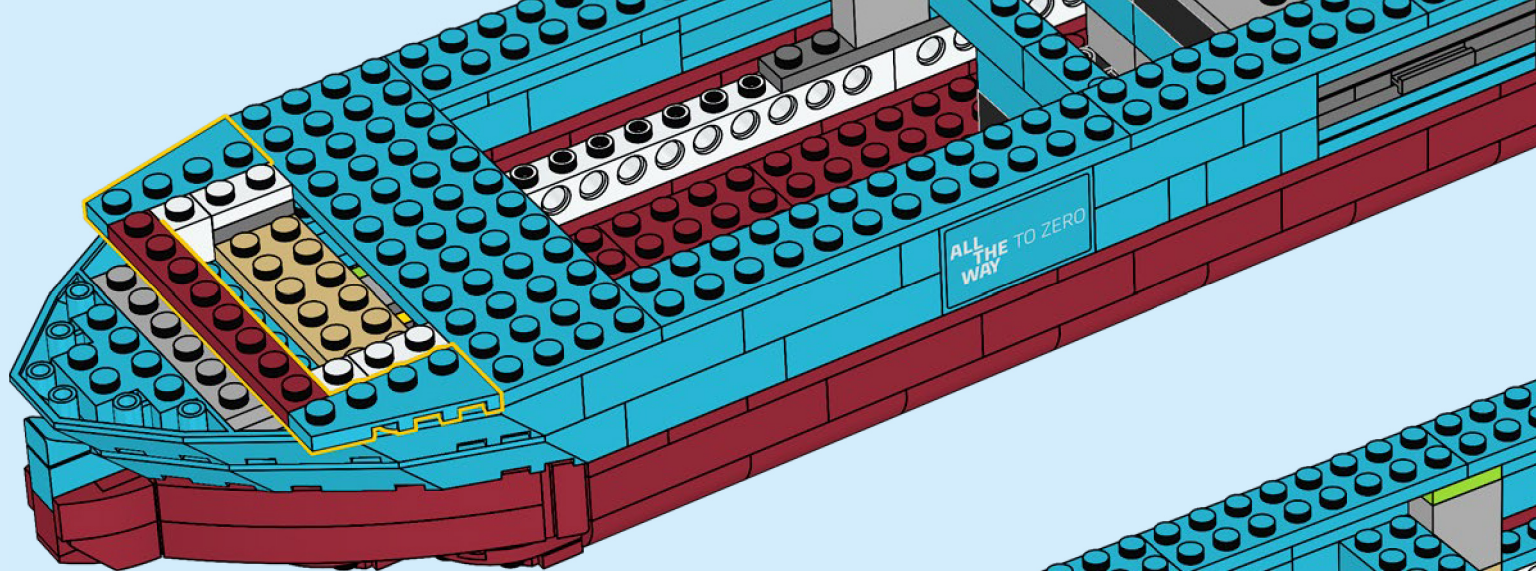

146

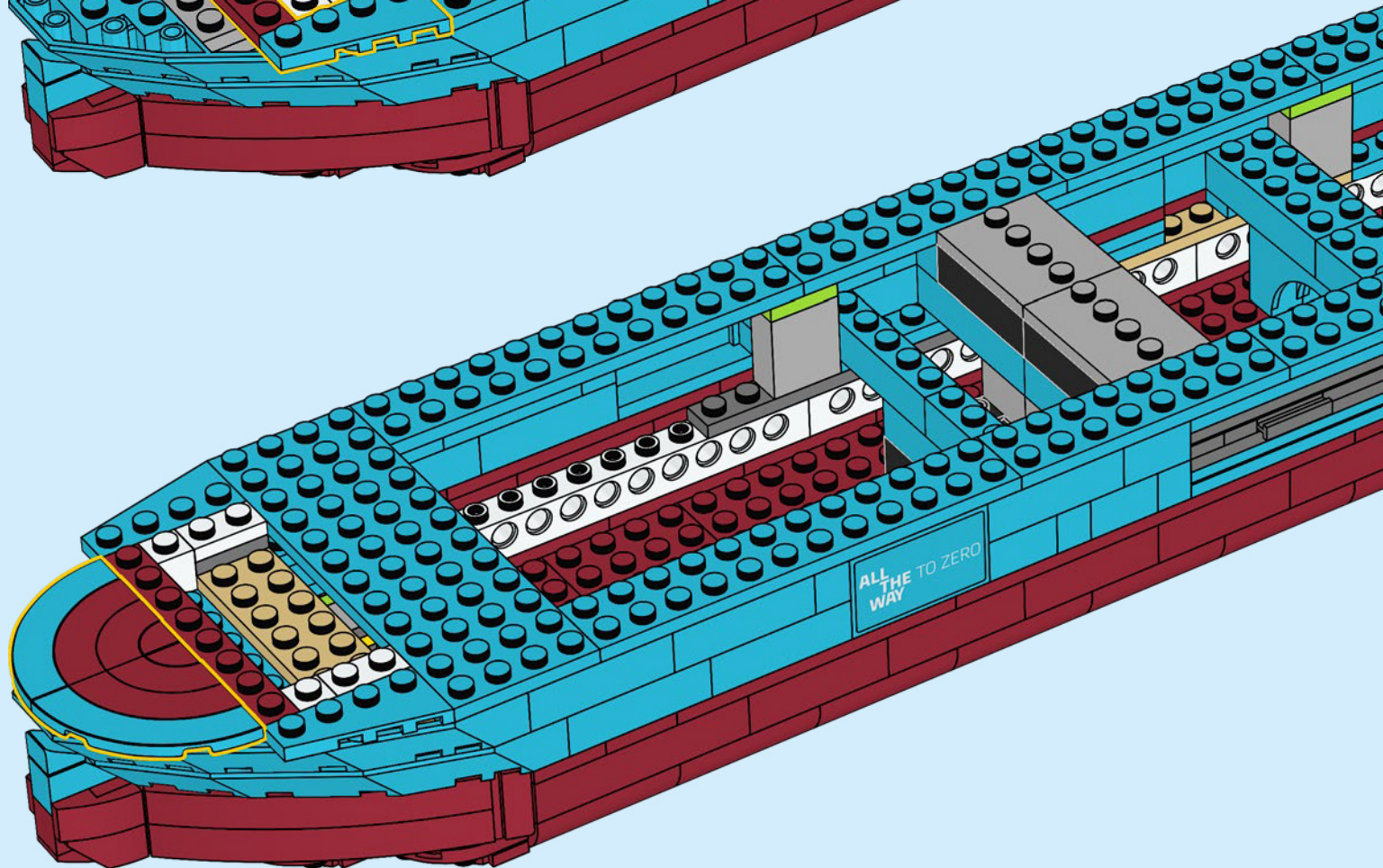

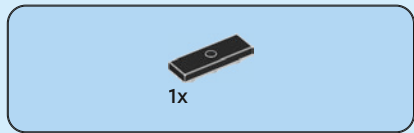

147

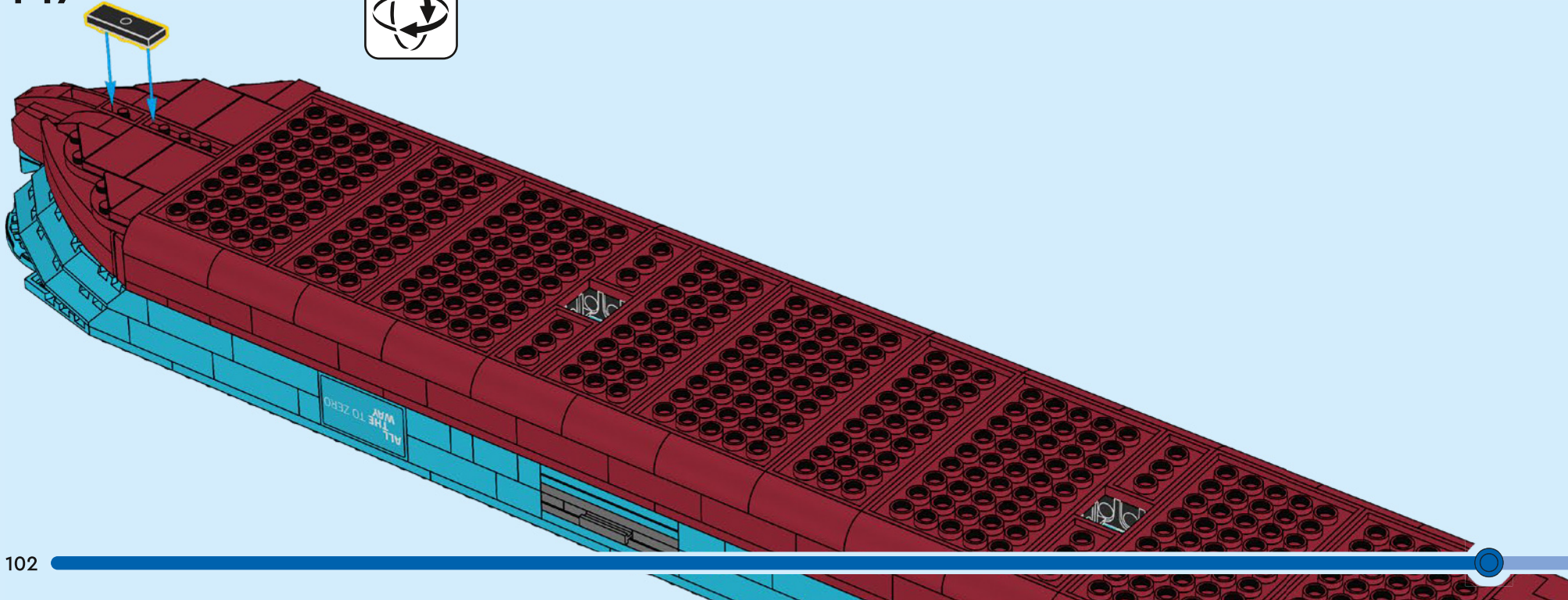



24x

148

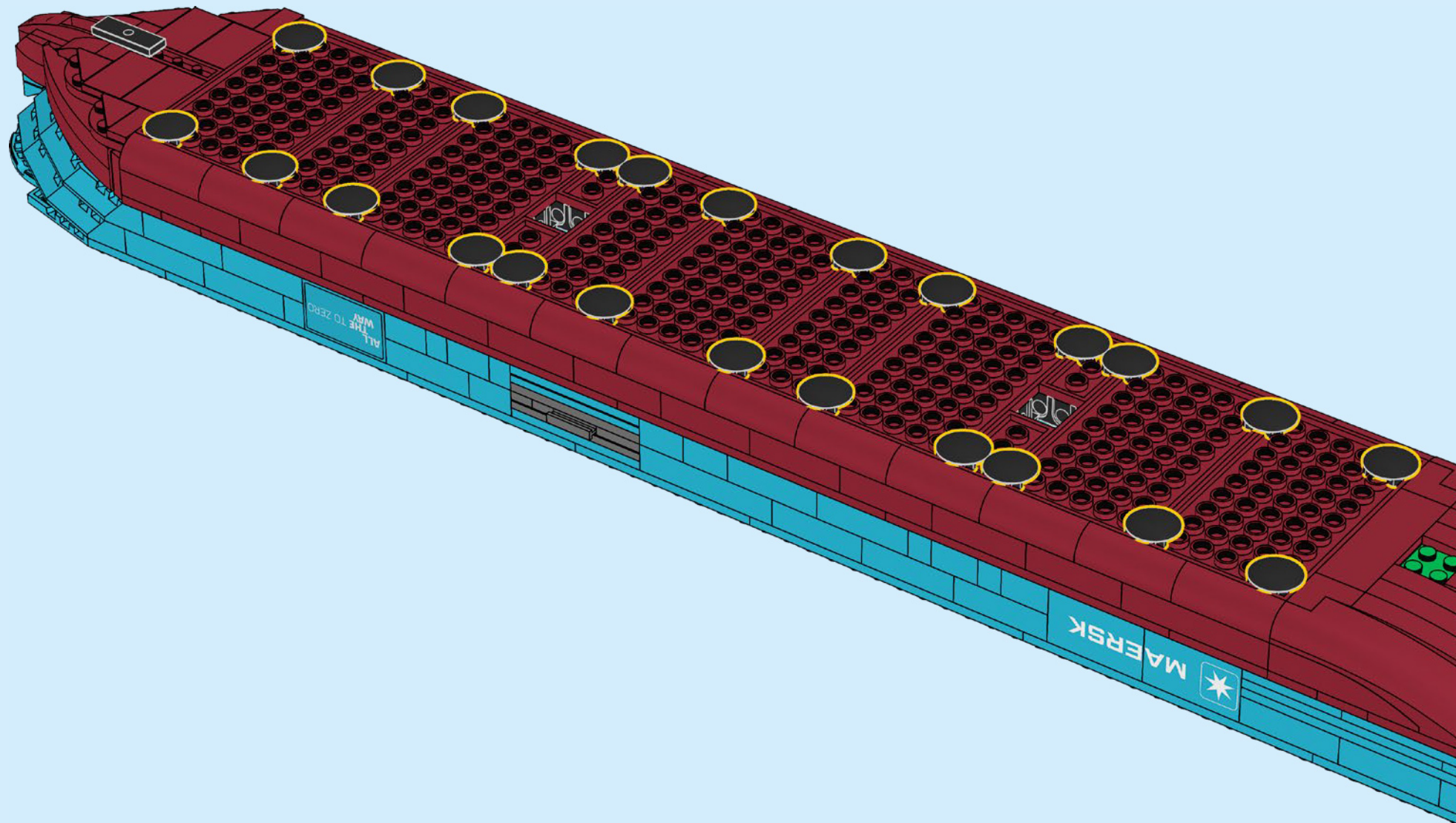

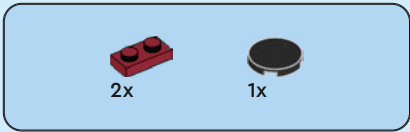

149

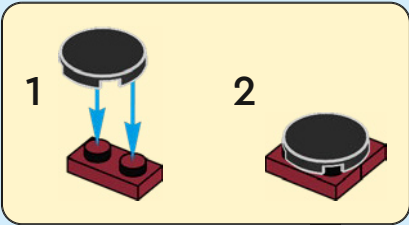
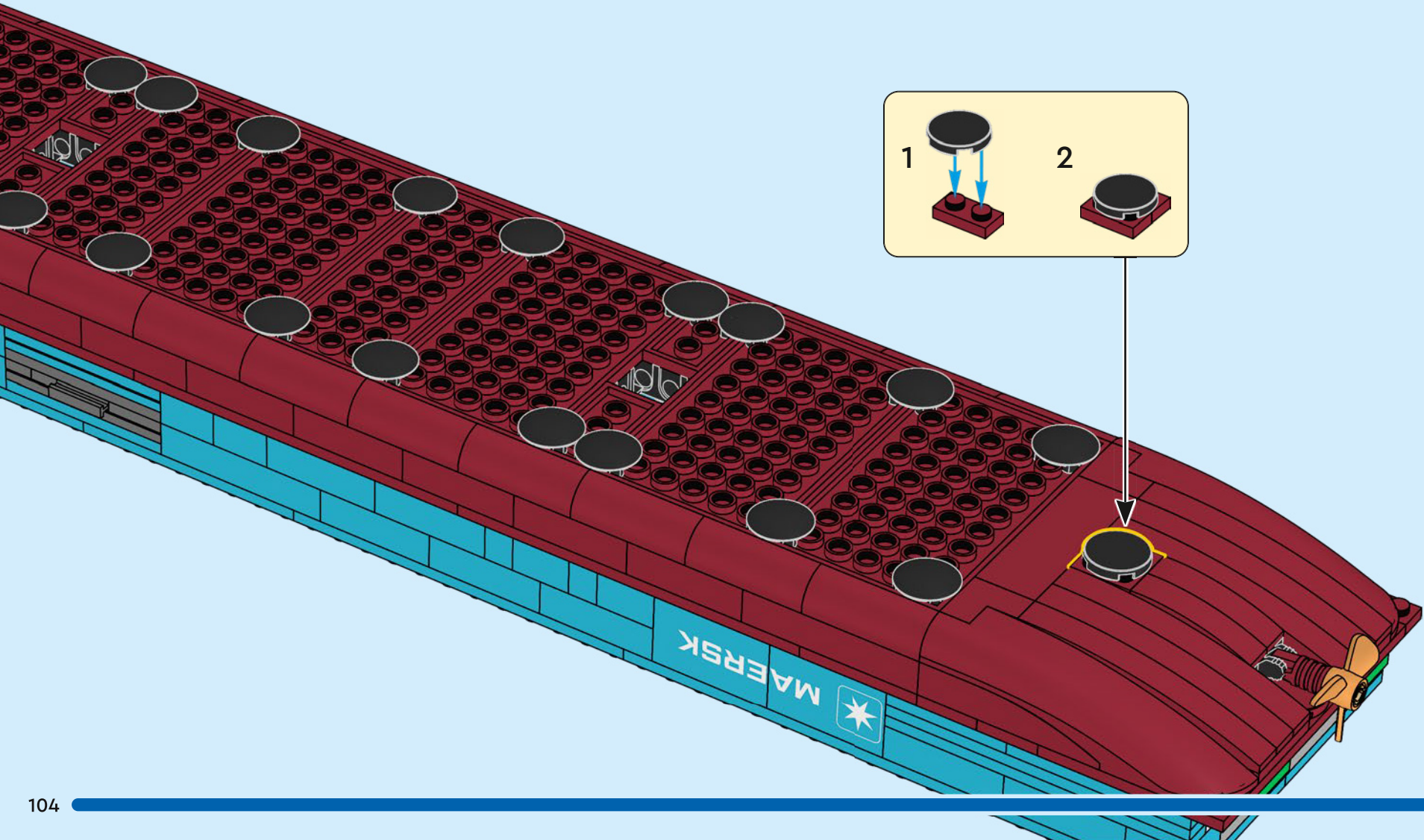

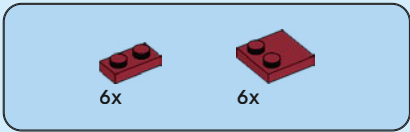

150

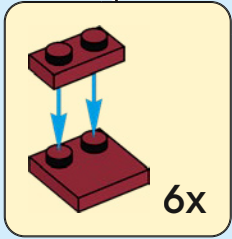
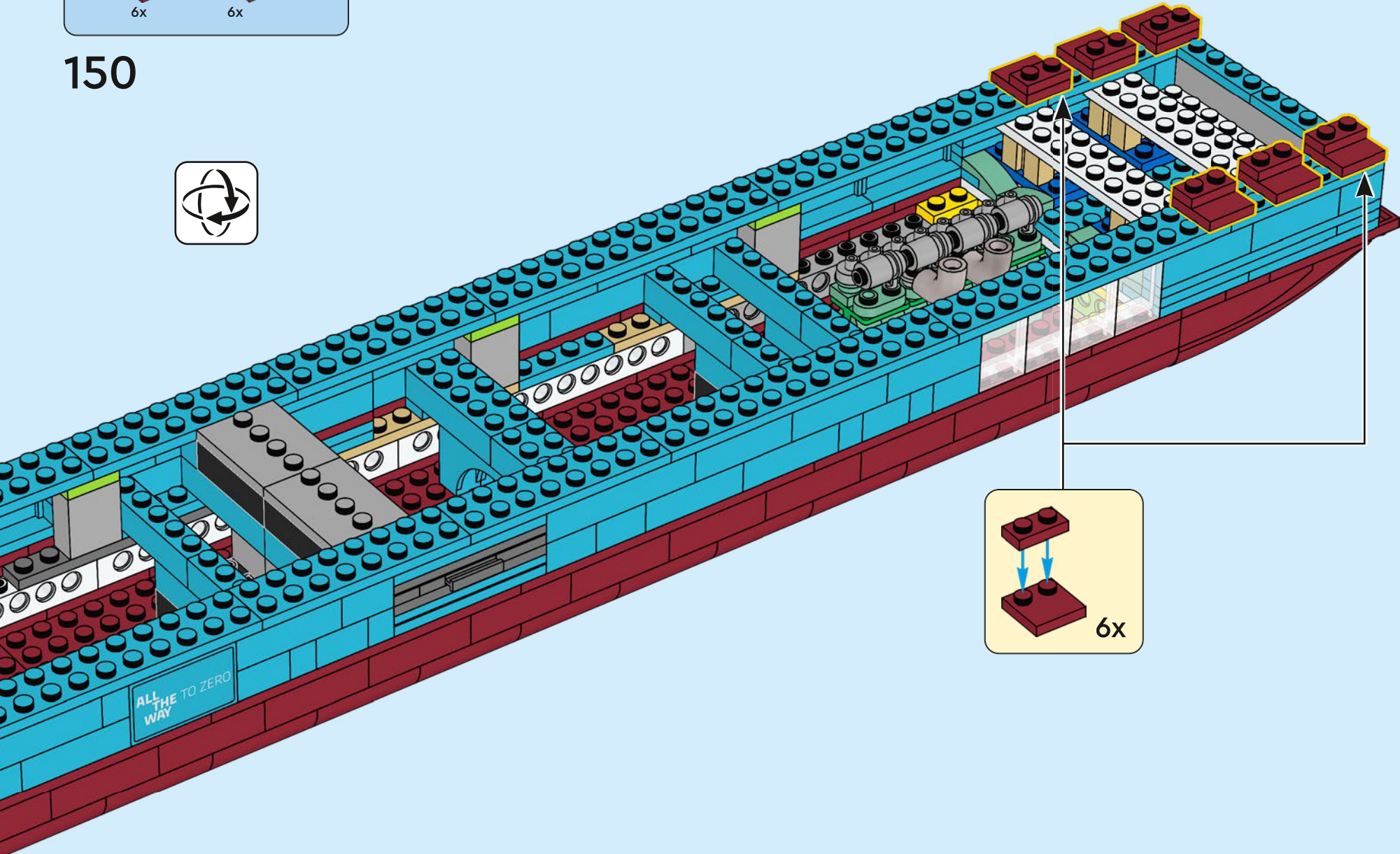

ALL
THE
WAY TO ZERO

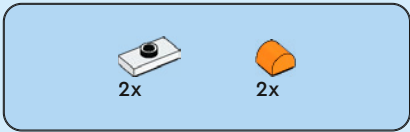

151

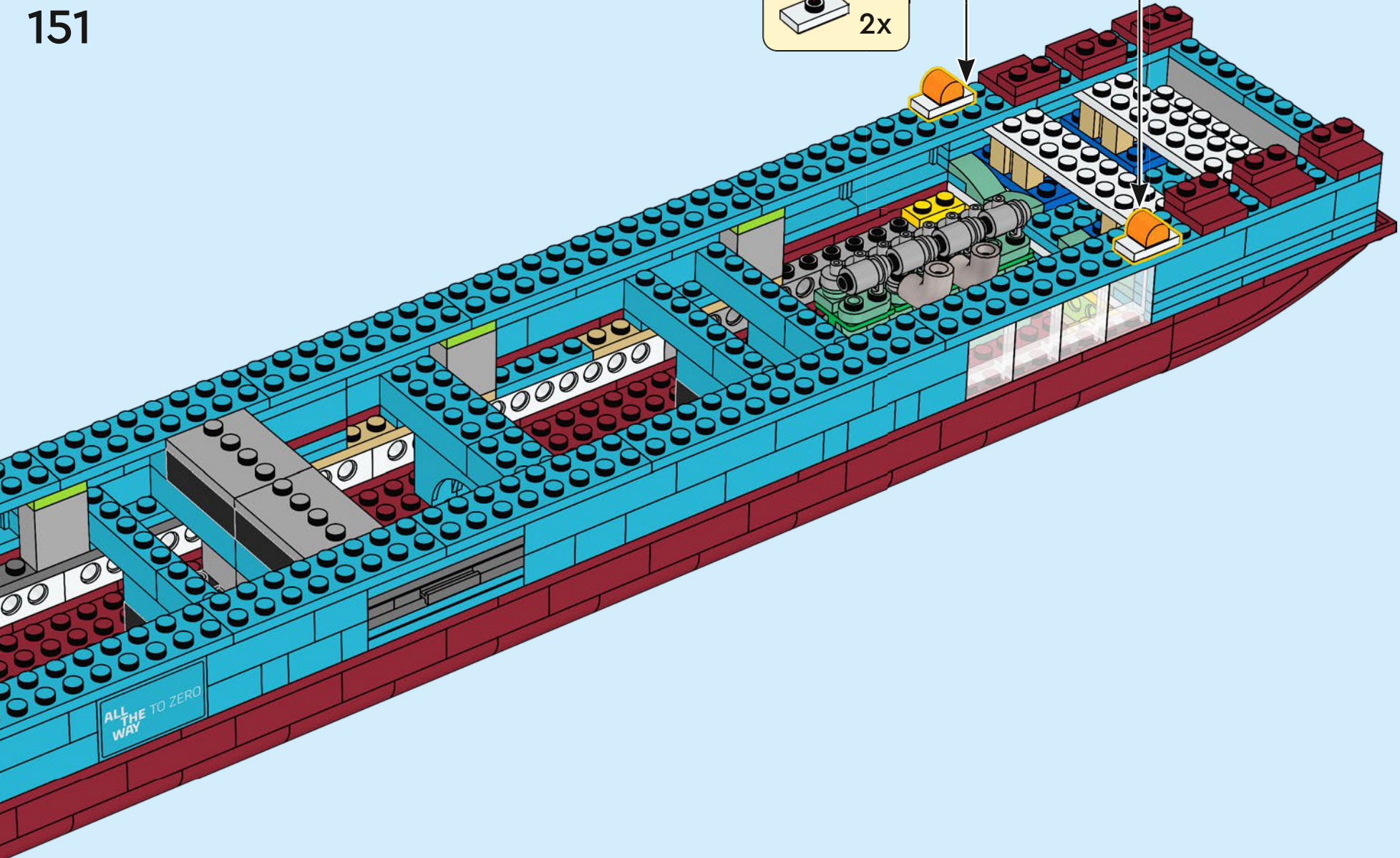
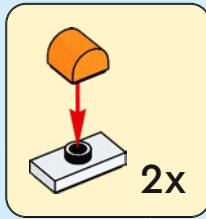

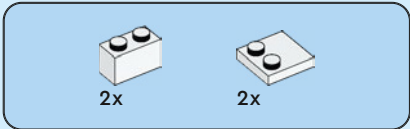

152

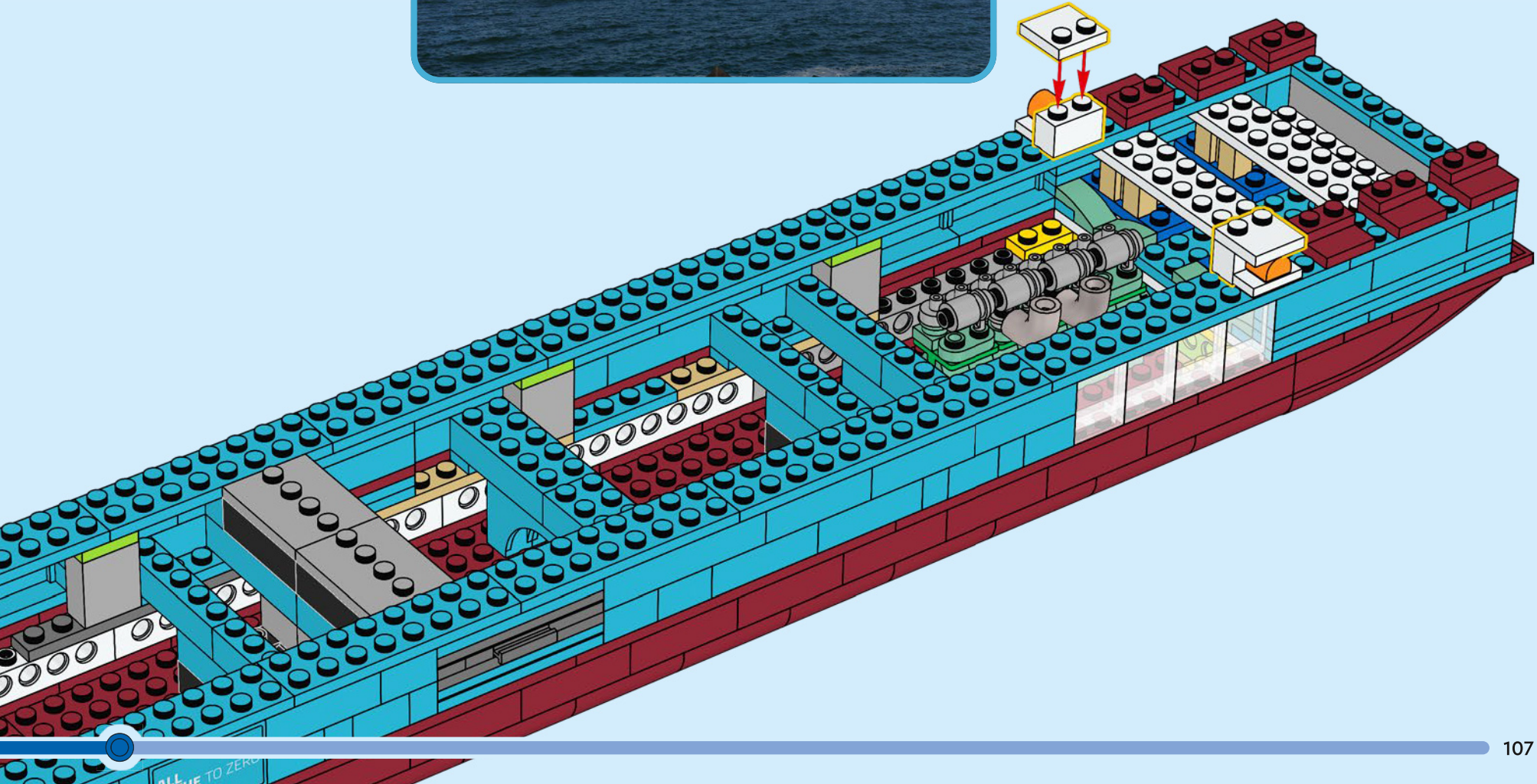
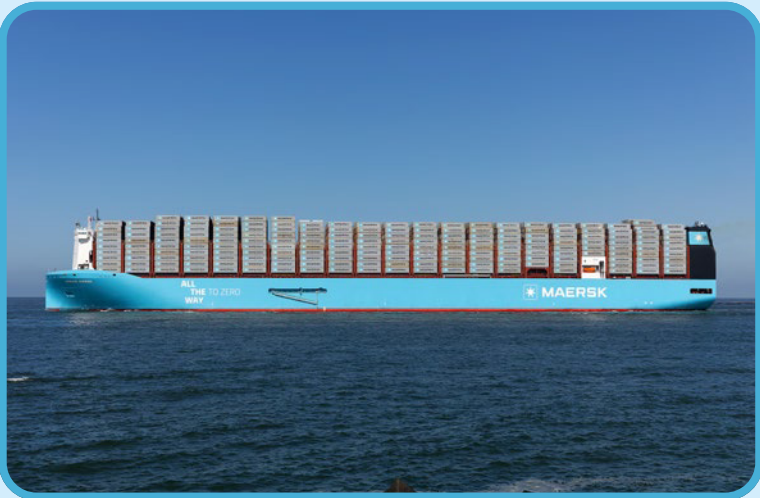

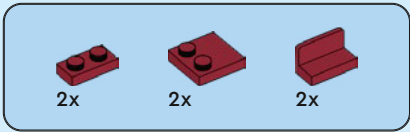

153

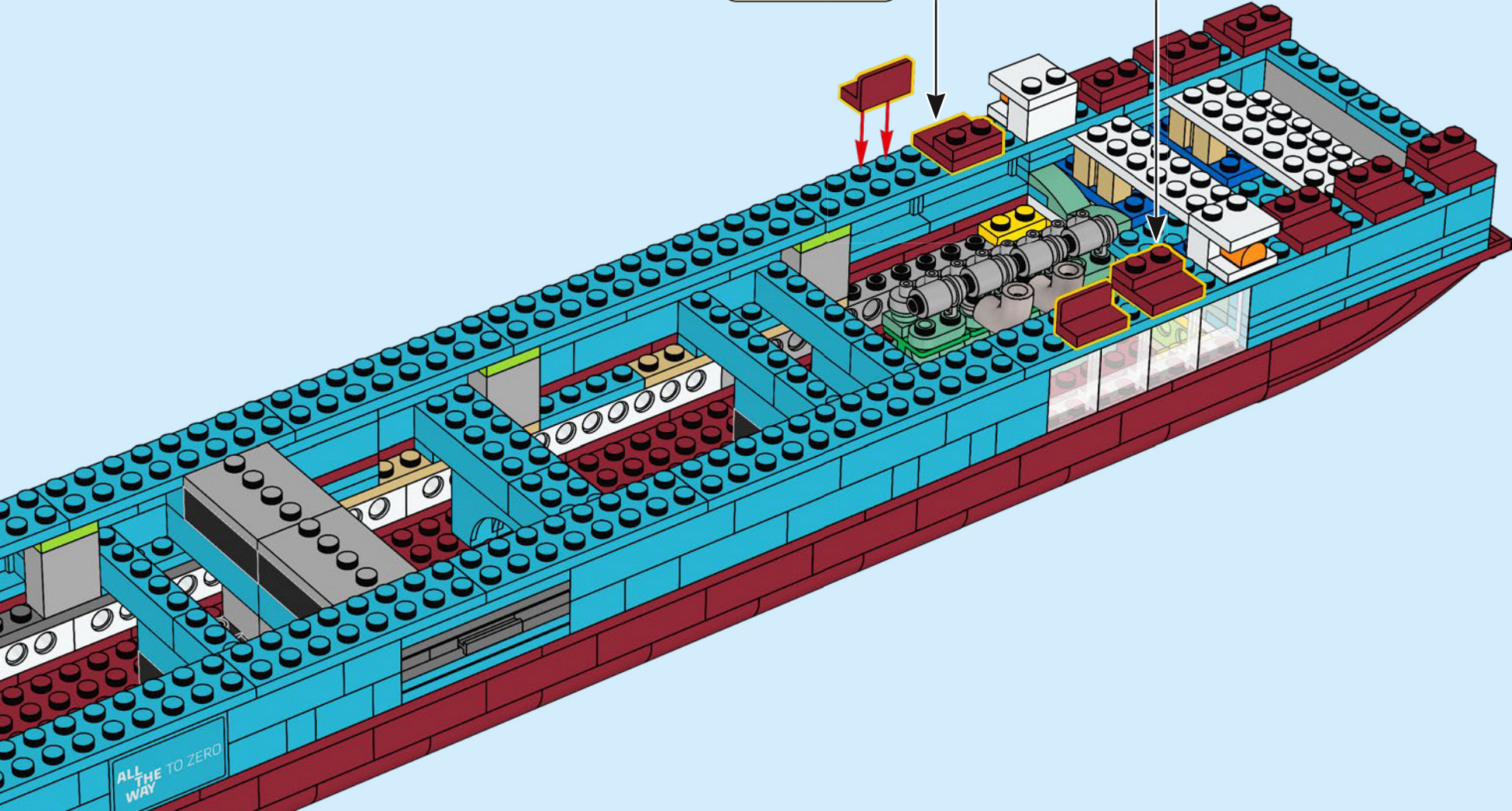
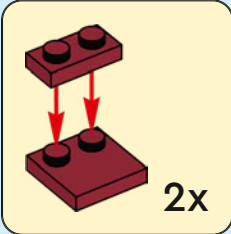

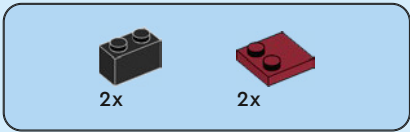

154

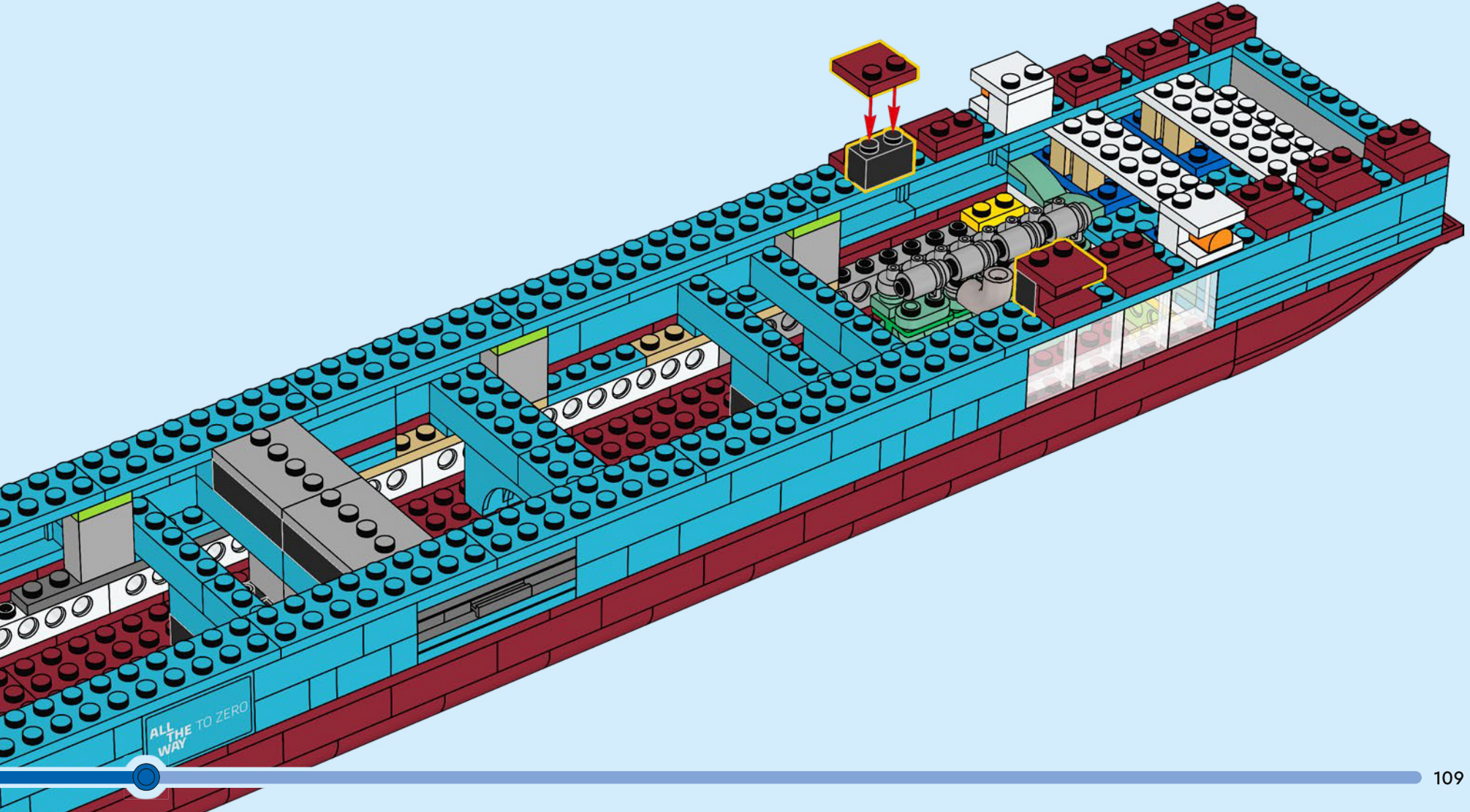

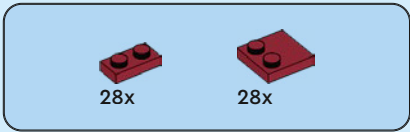

155

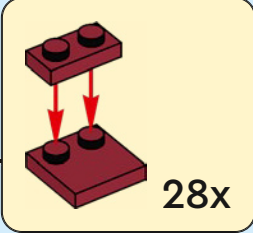
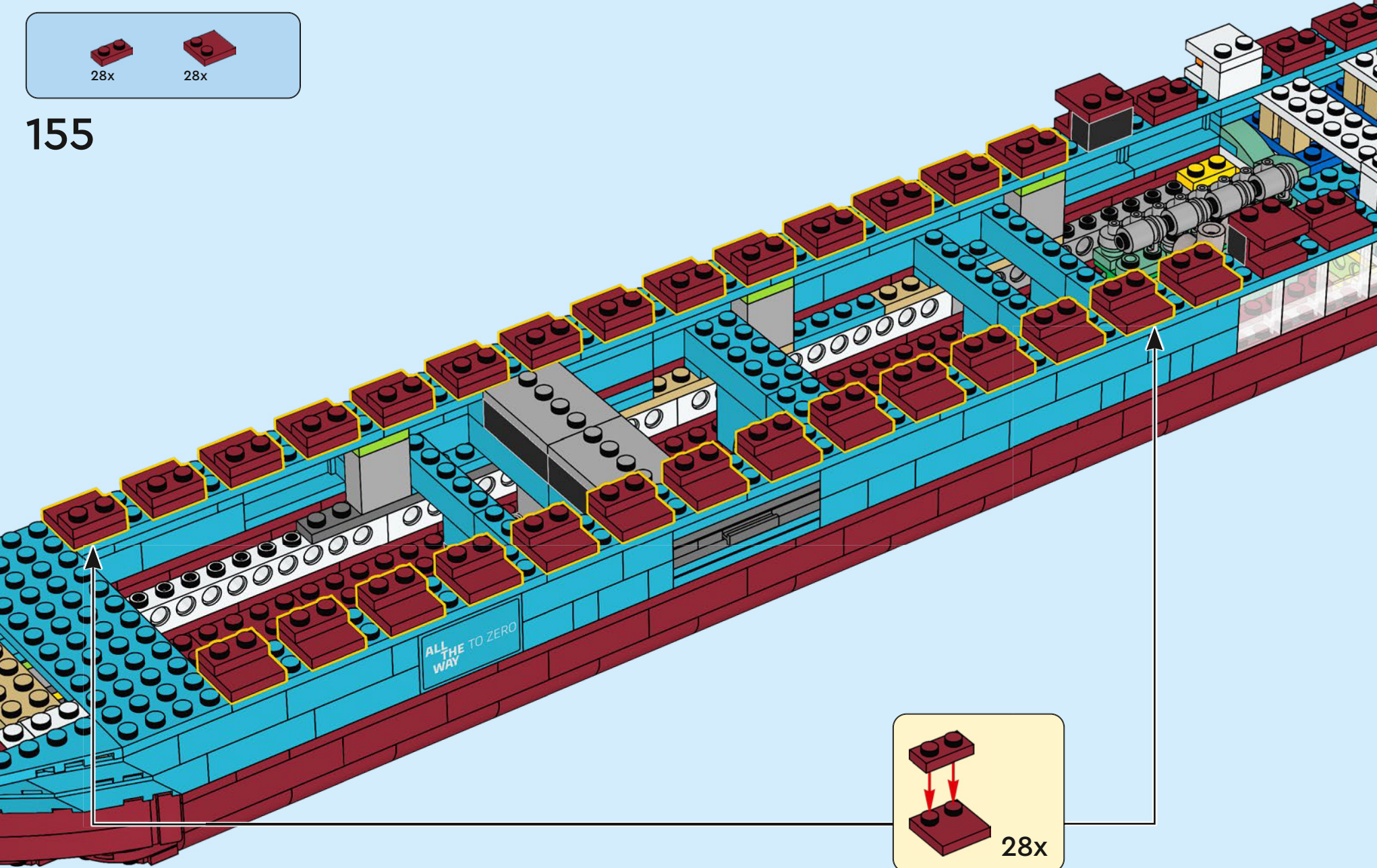

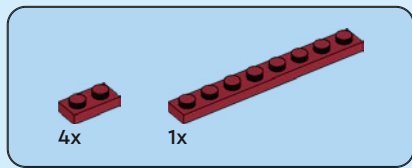

156

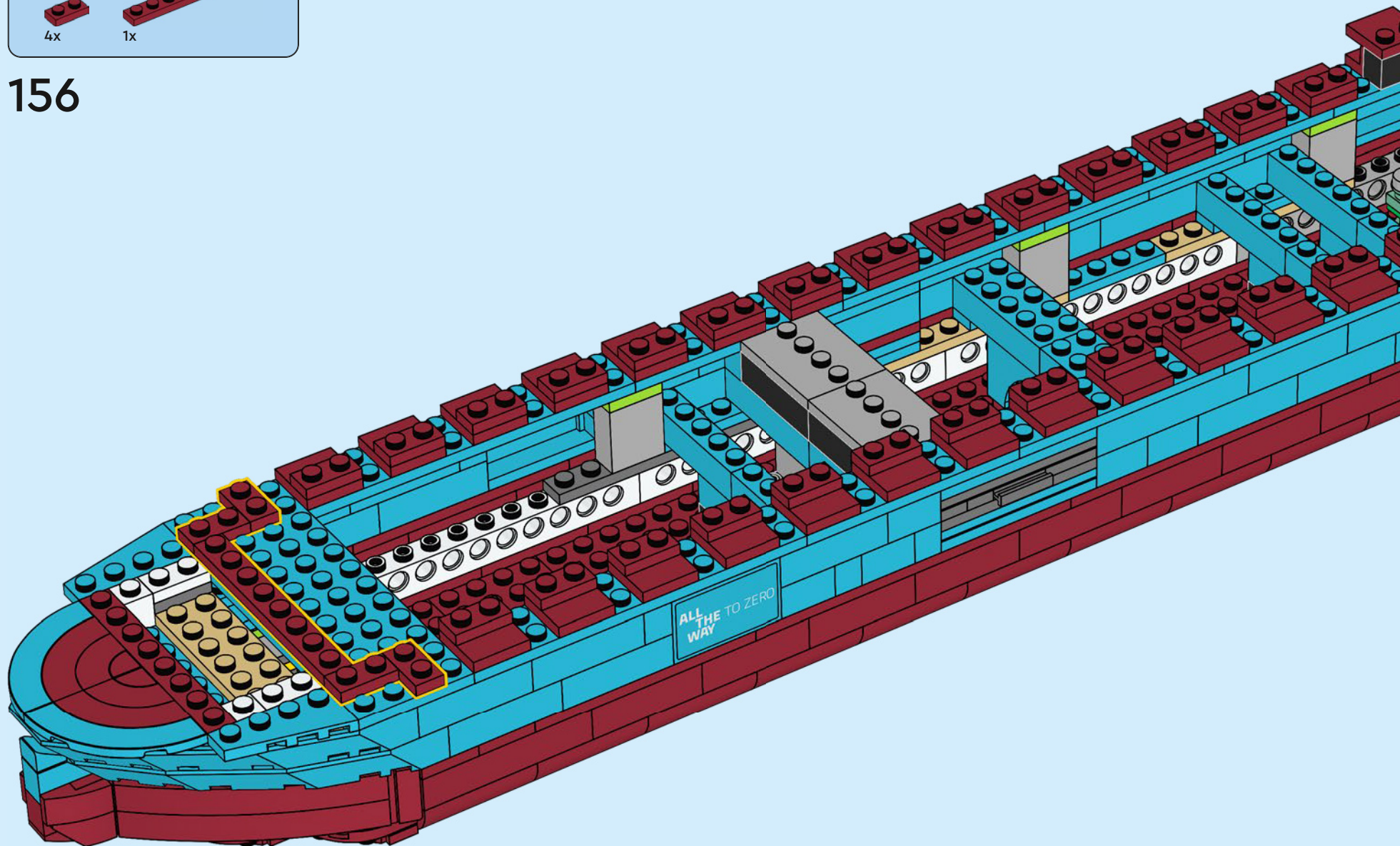

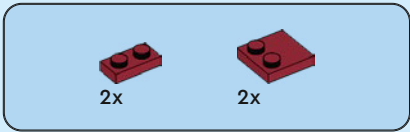

157

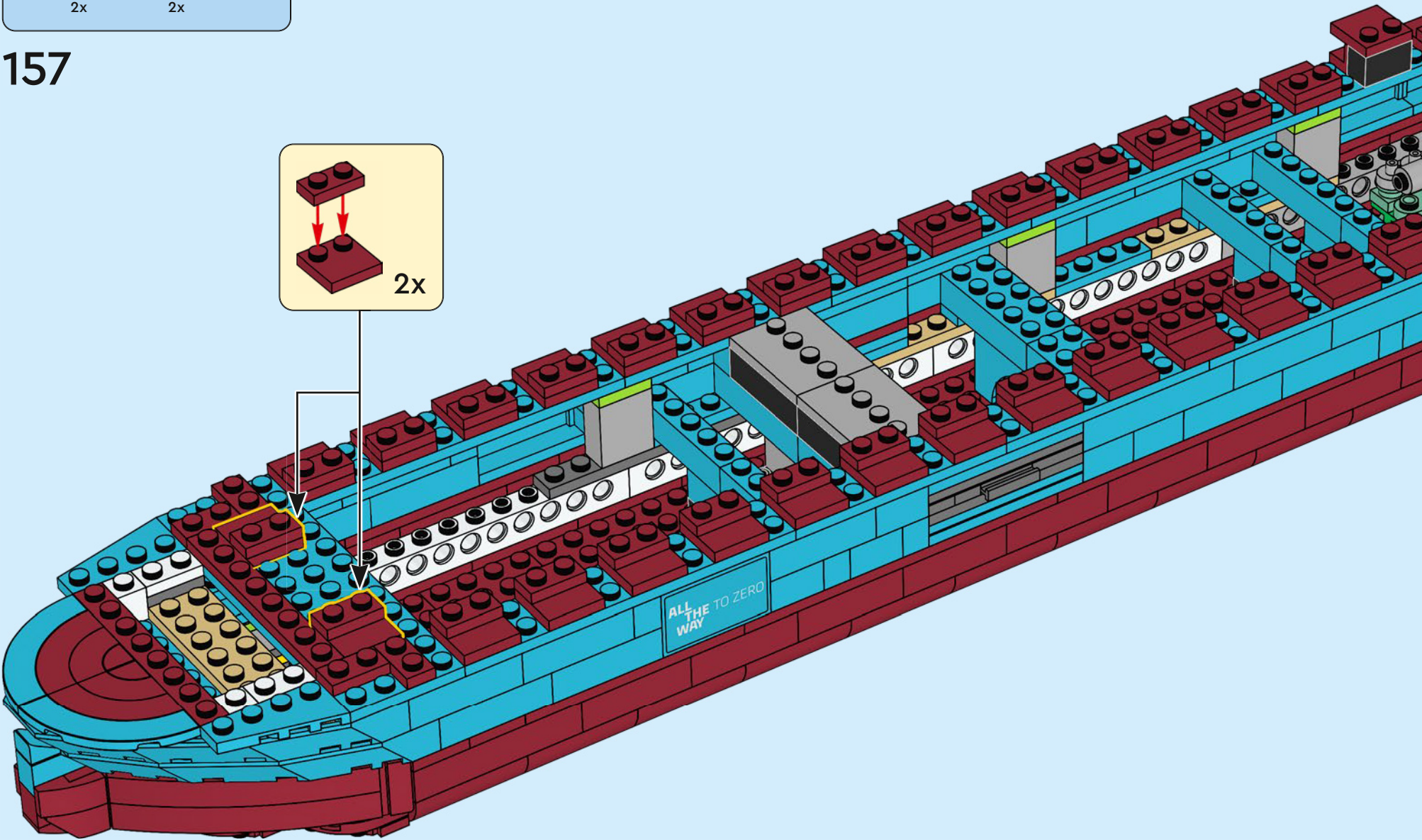
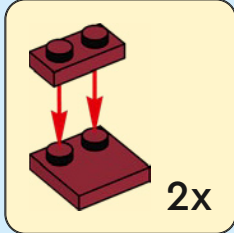

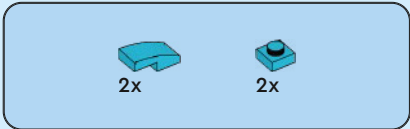

158

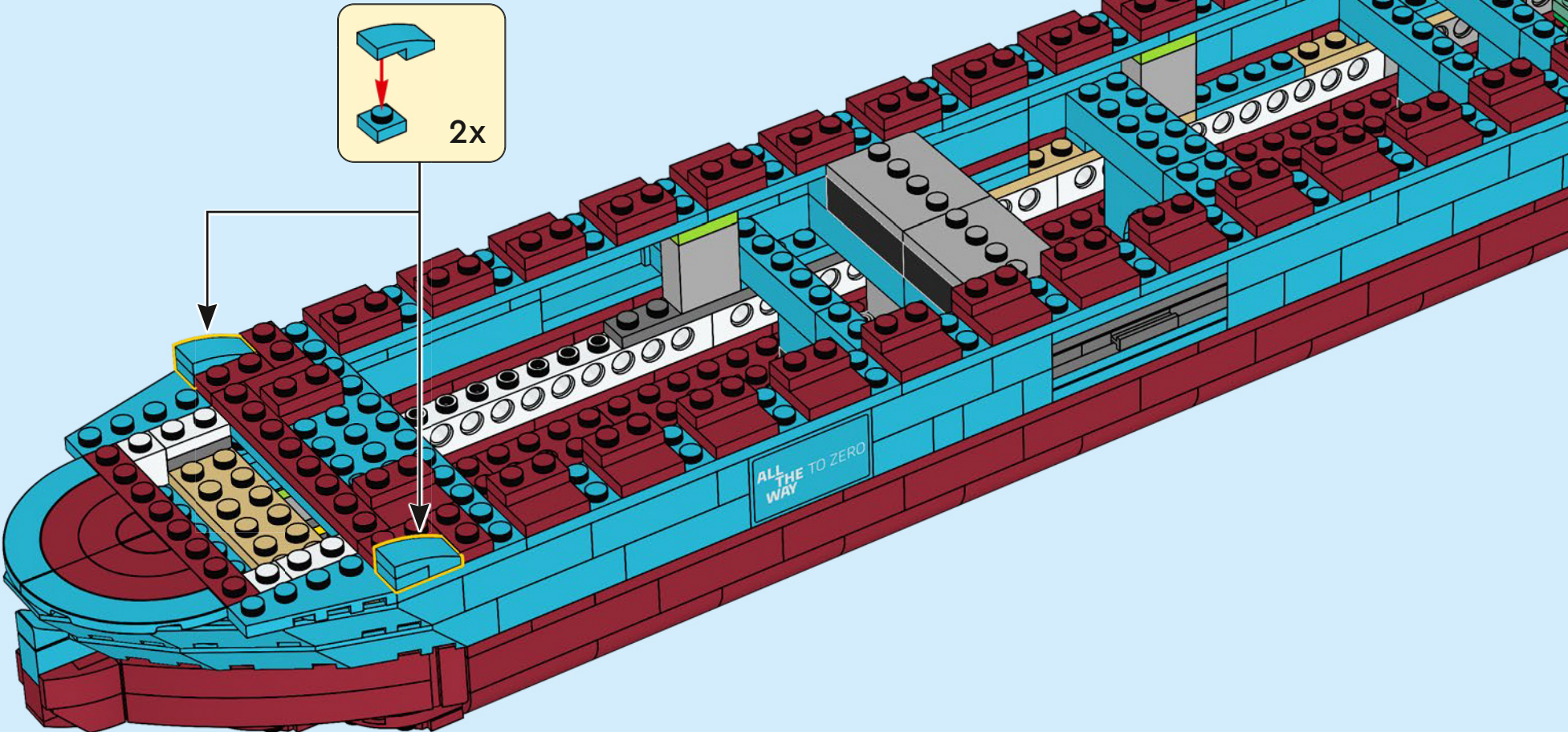

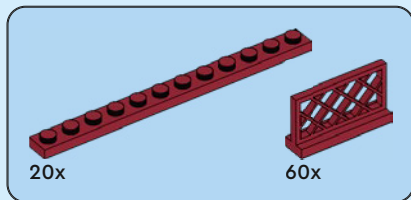
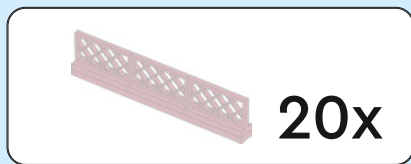

159

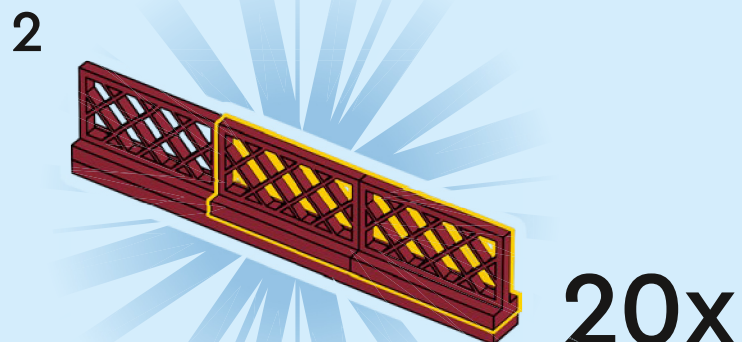
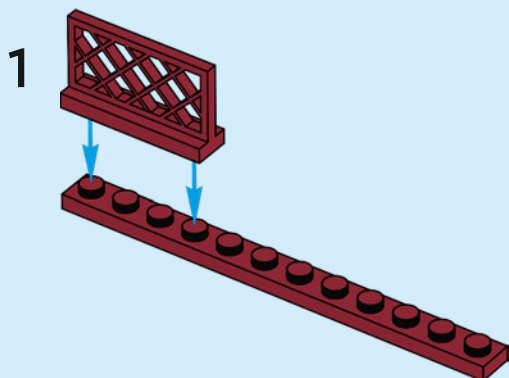
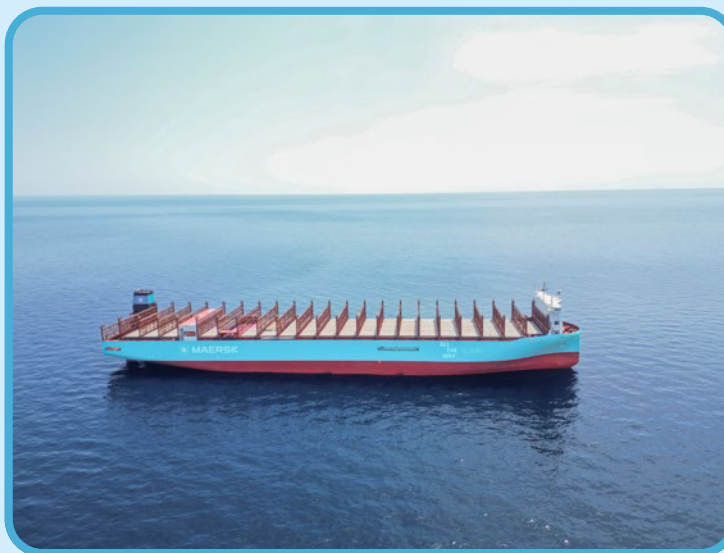

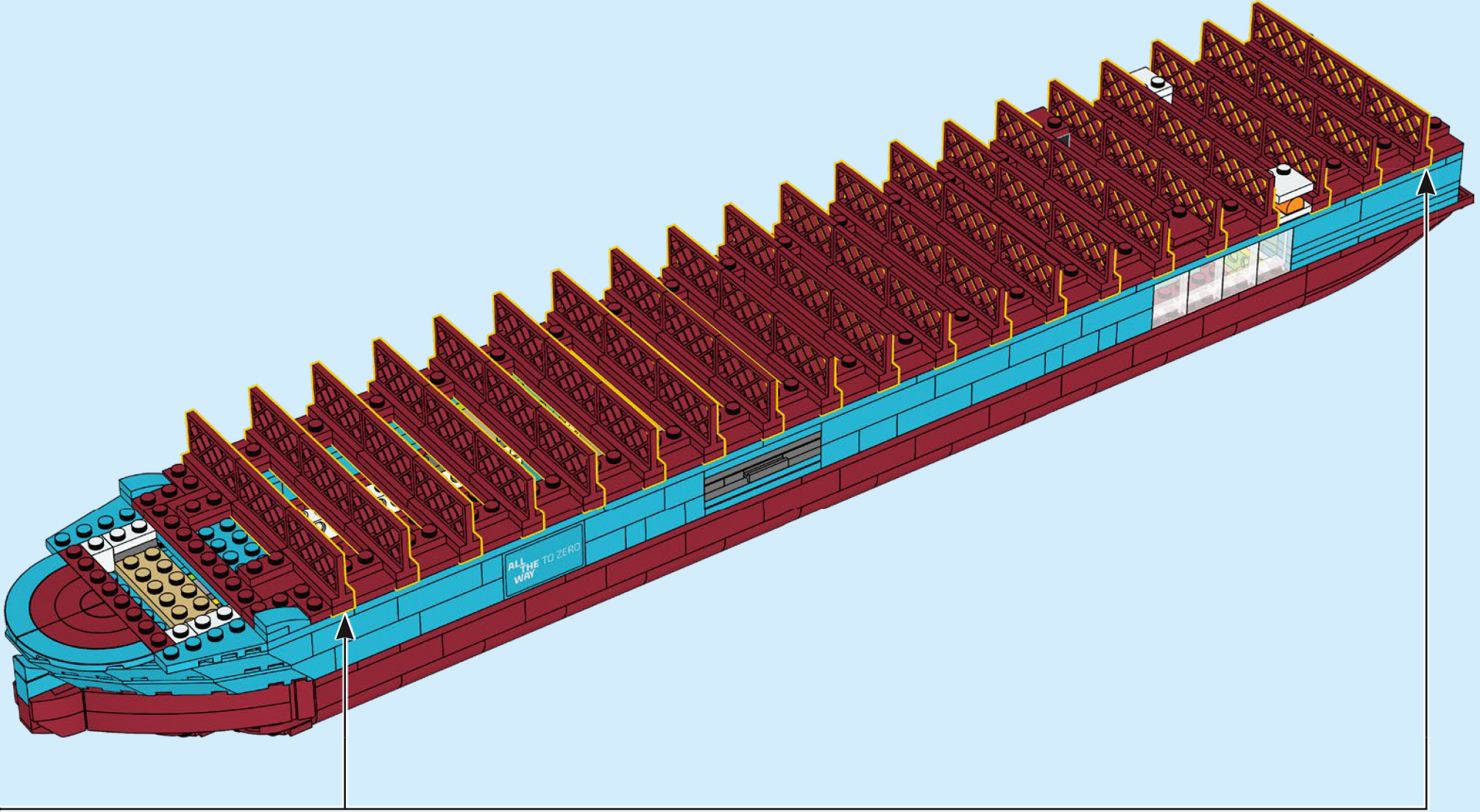

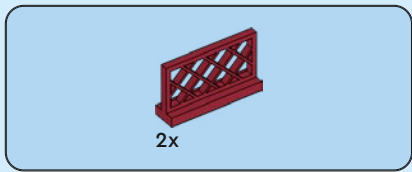

160

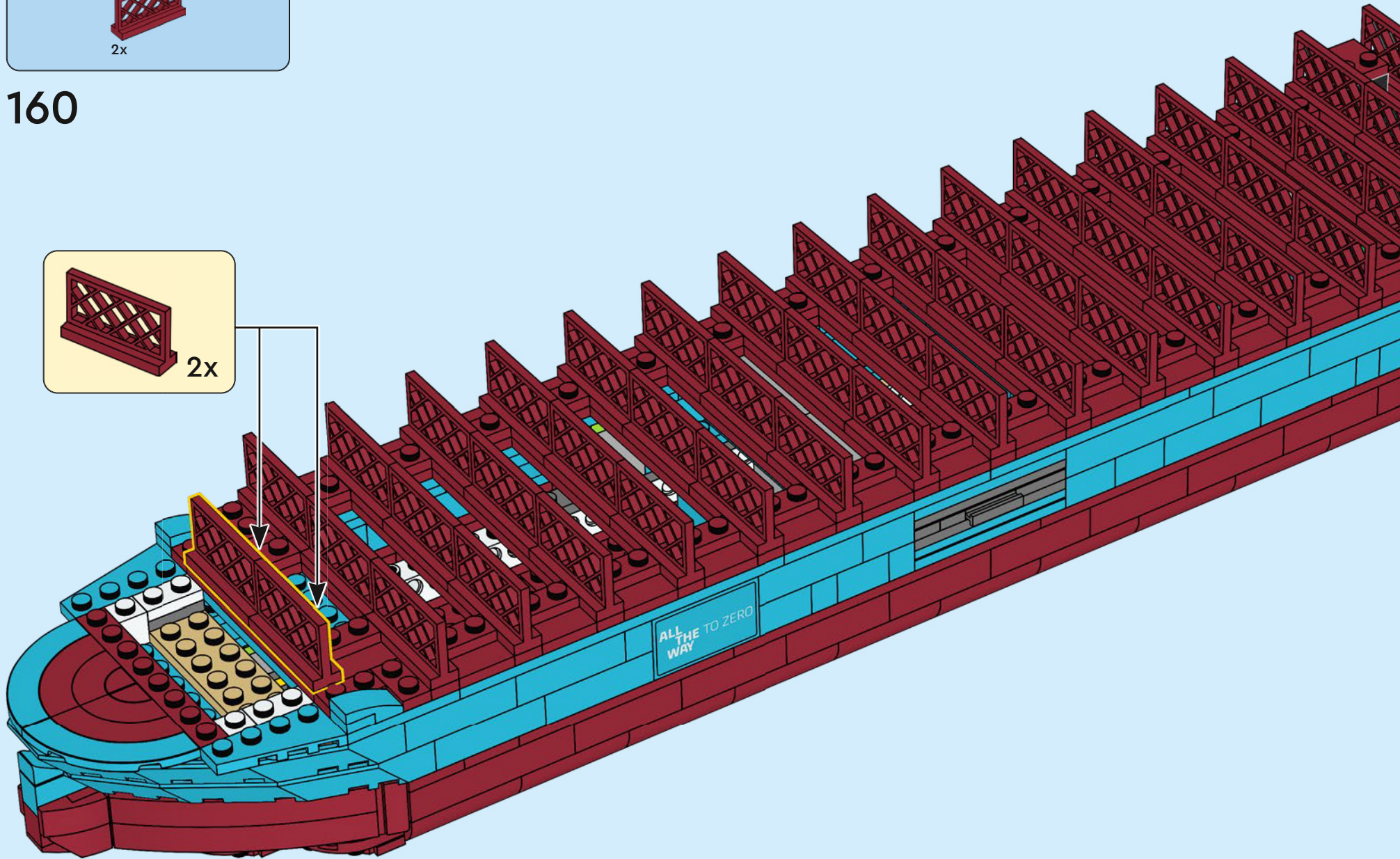
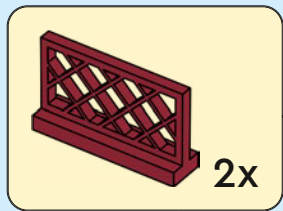

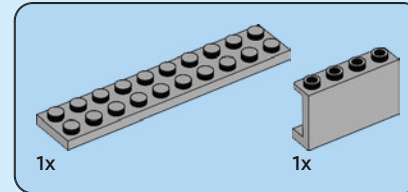
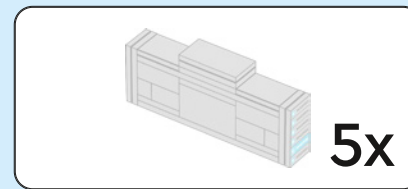

161

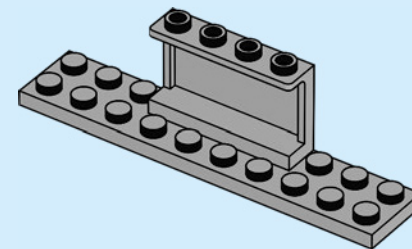
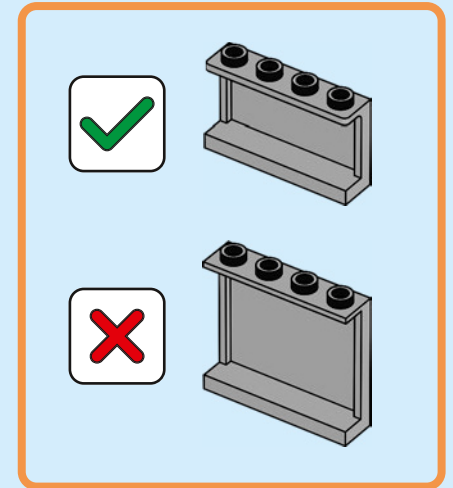

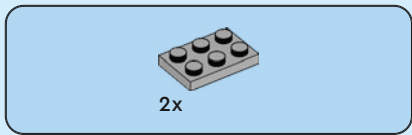

162

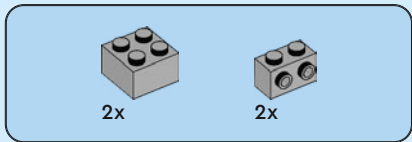
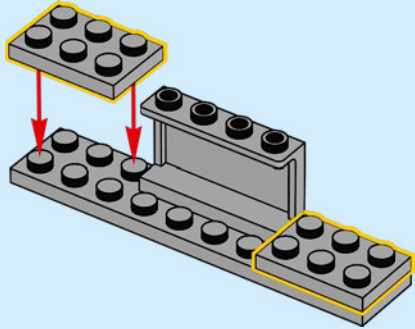

163

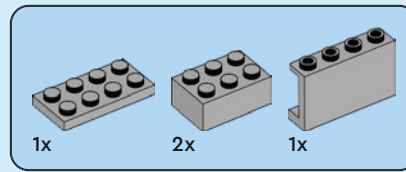
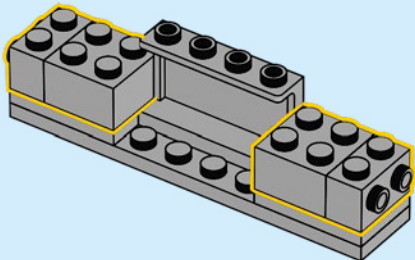

164

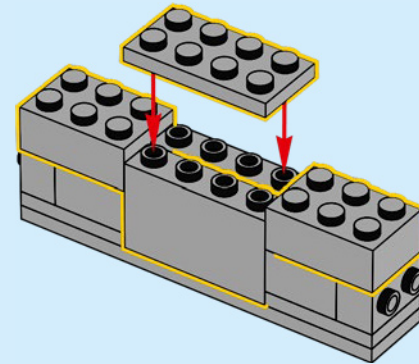

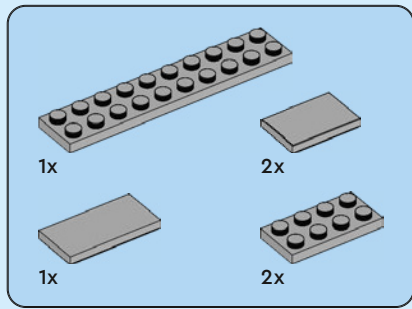

165

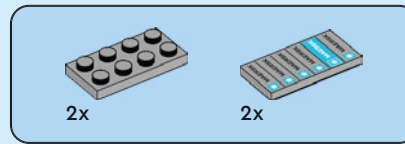
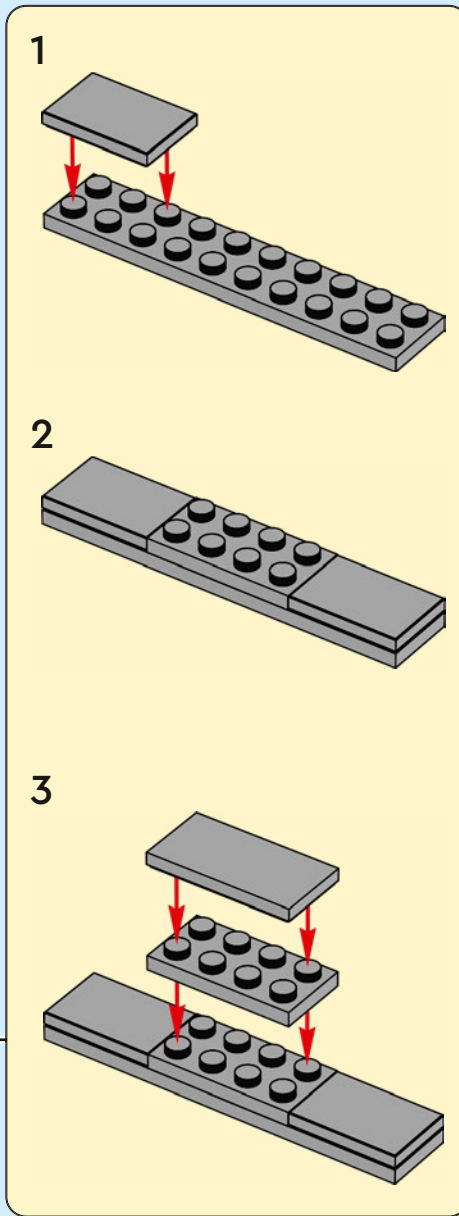
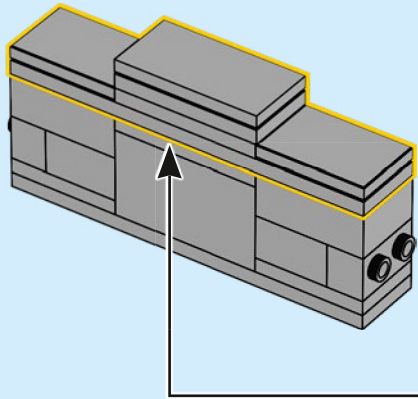

166

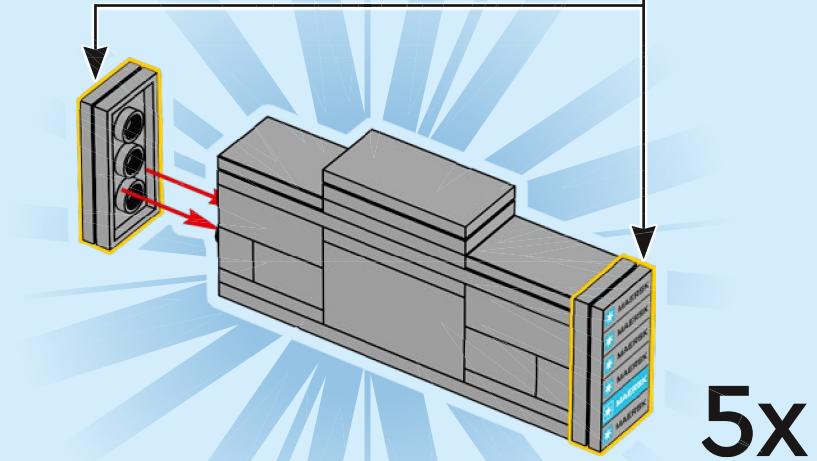
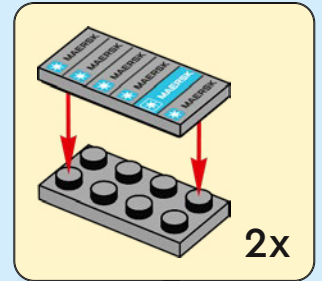

5x



167

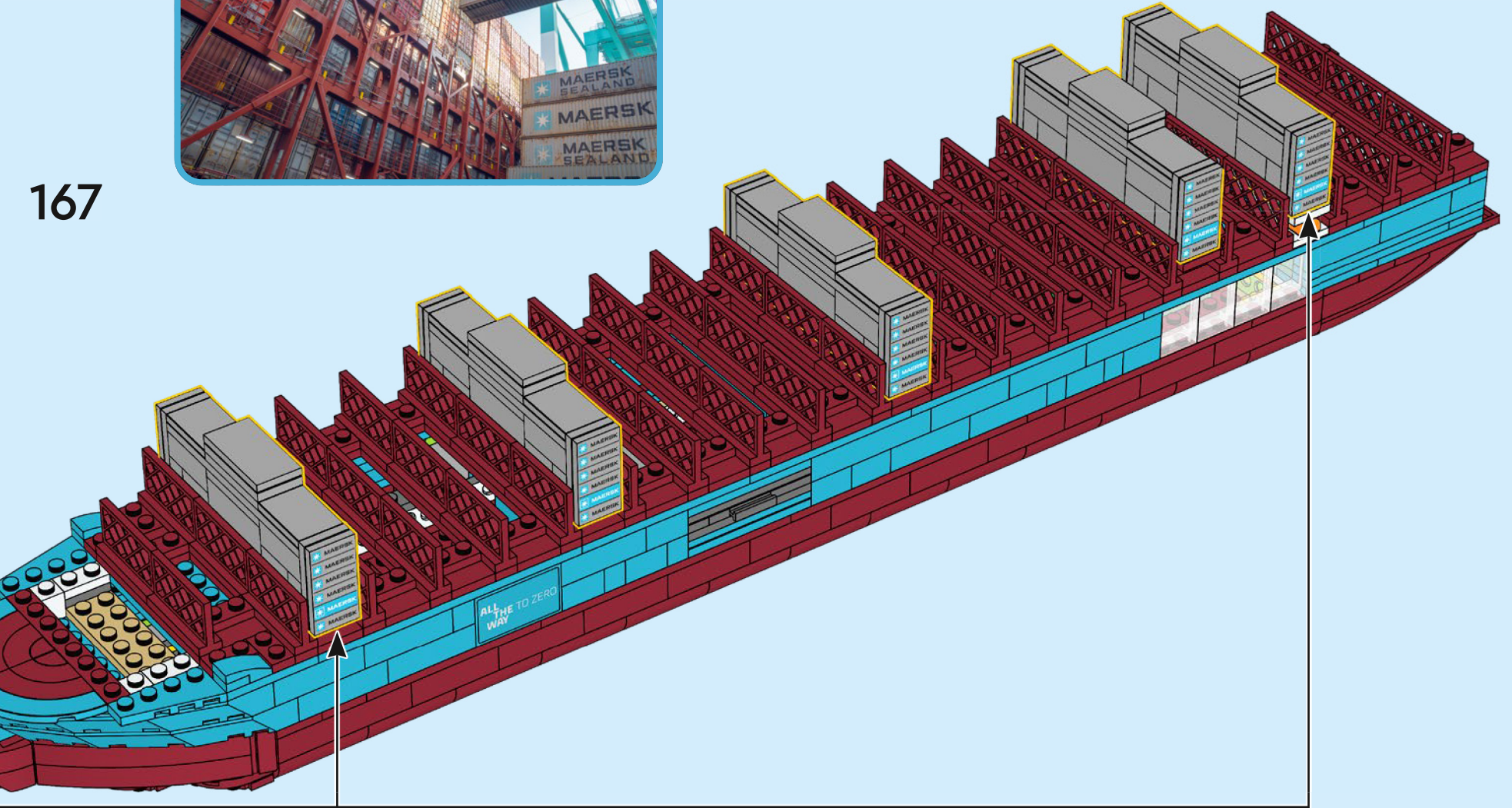

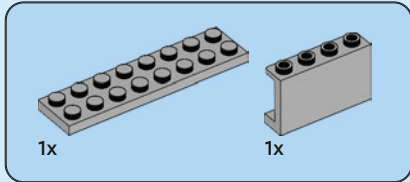
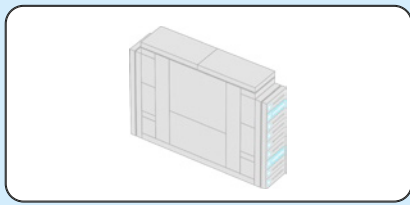

168

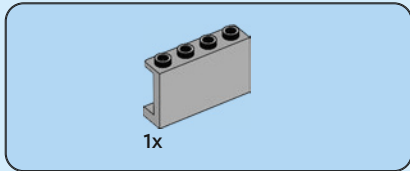
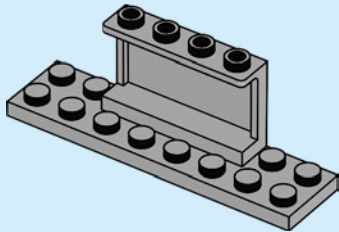

169

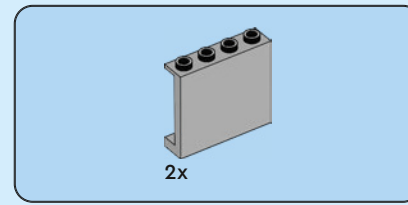
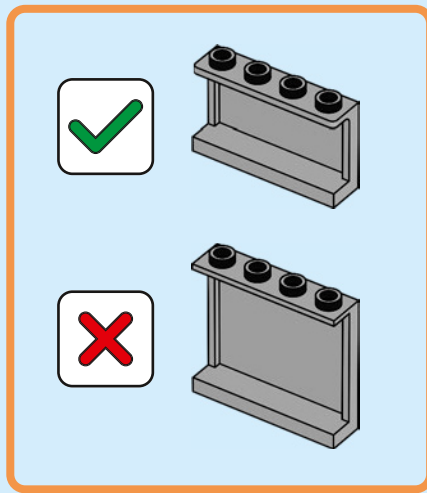
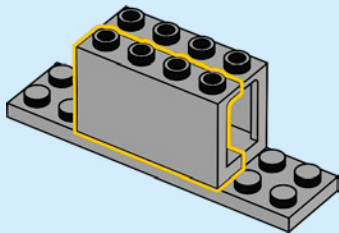

170

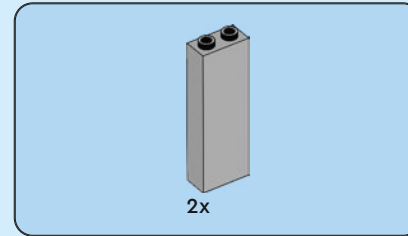
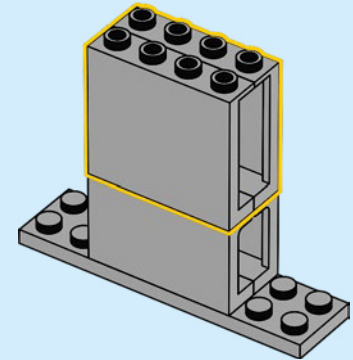

171

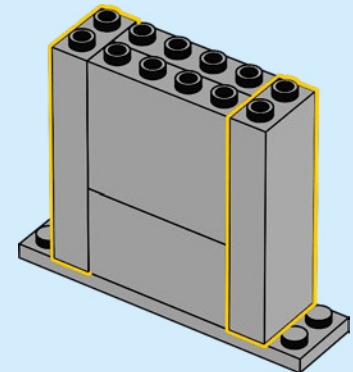

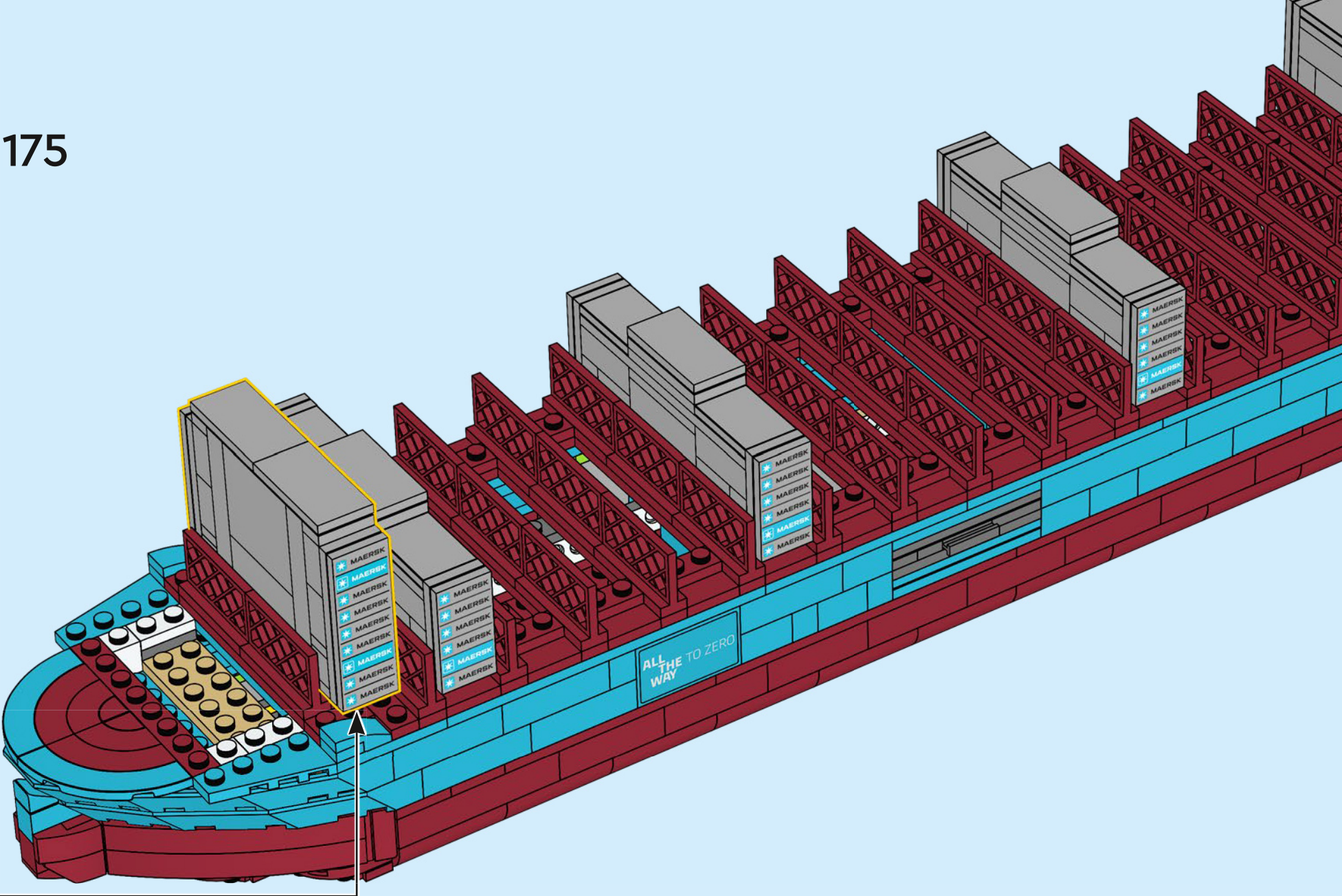

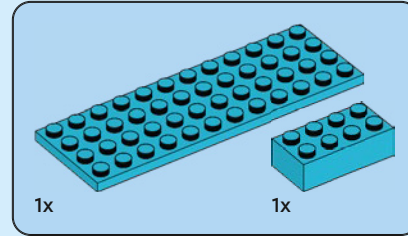
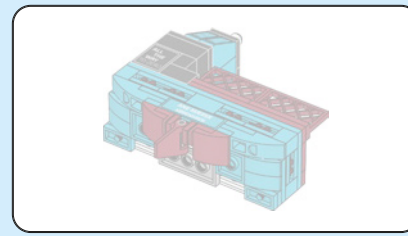

176

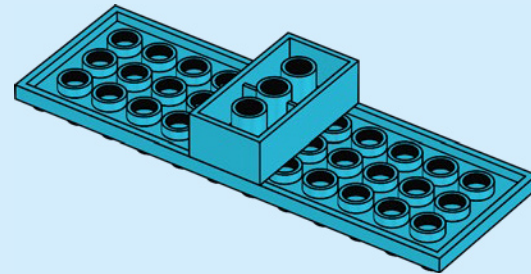

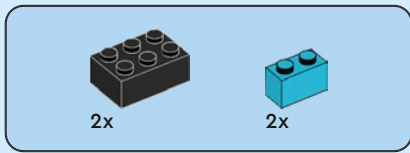

177

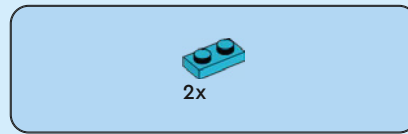
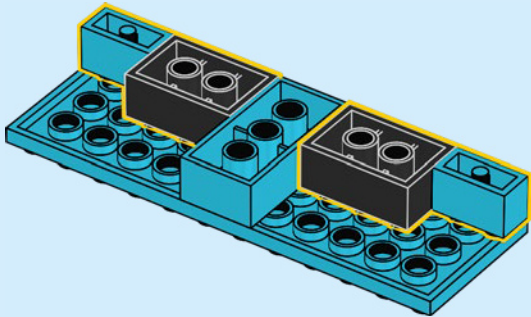

178

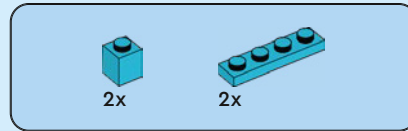
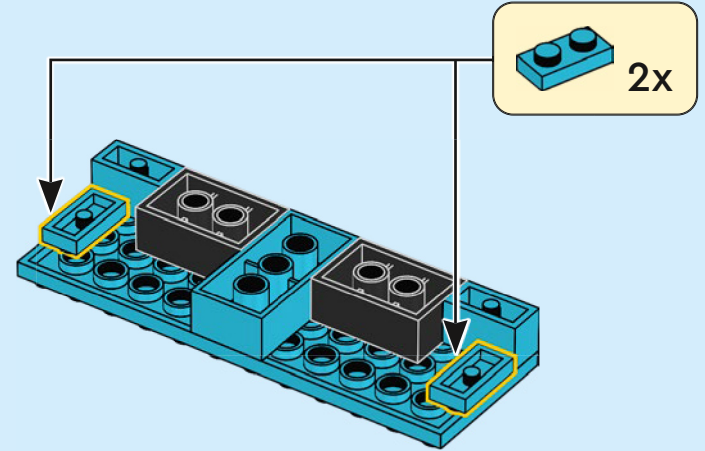

179

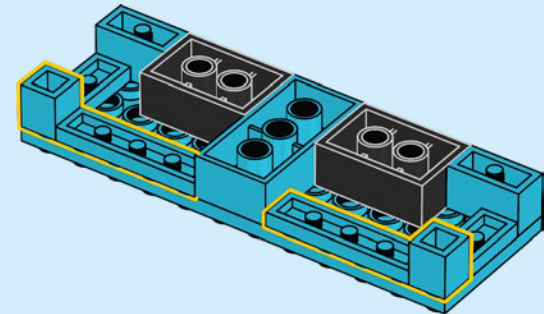

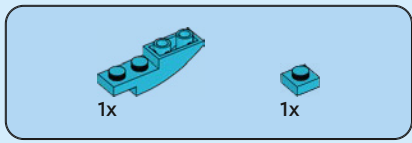

180

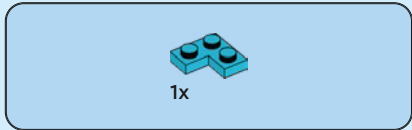
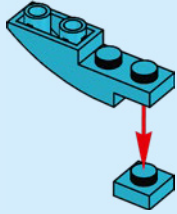

181

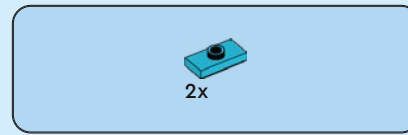
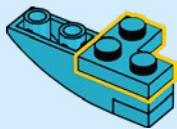

182

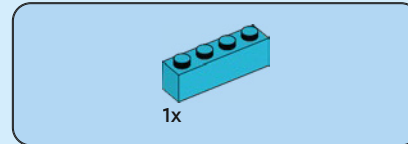
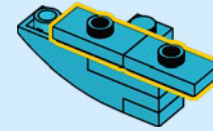

183

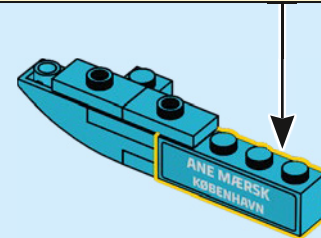
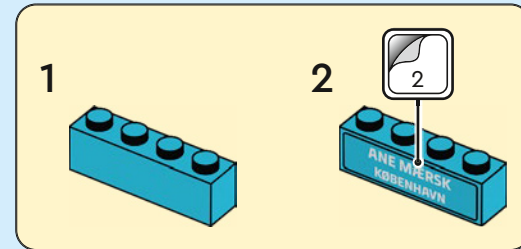

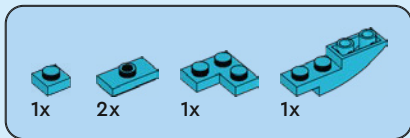

184

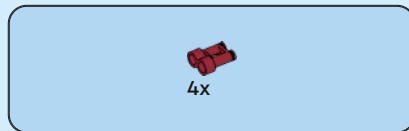
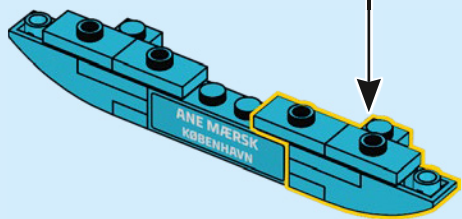
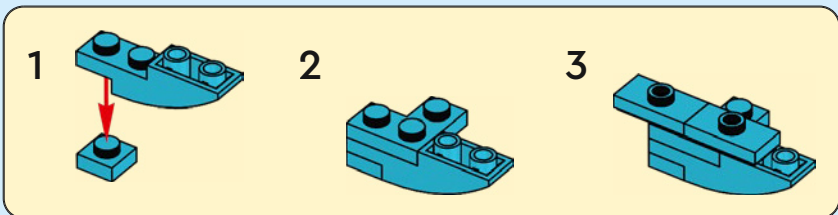

185

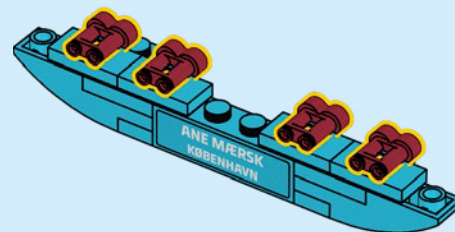

186

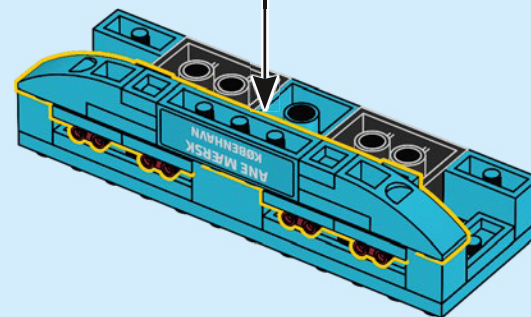

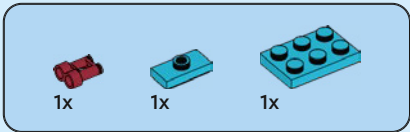

187

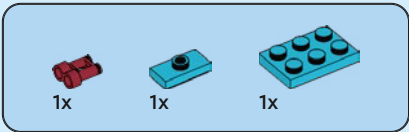
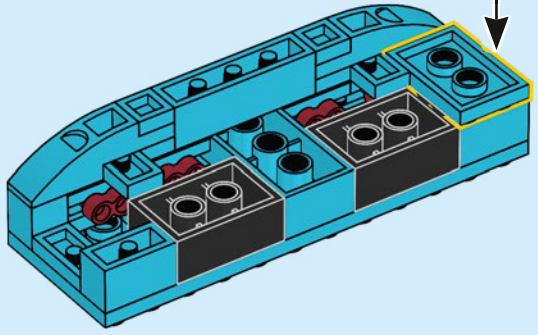
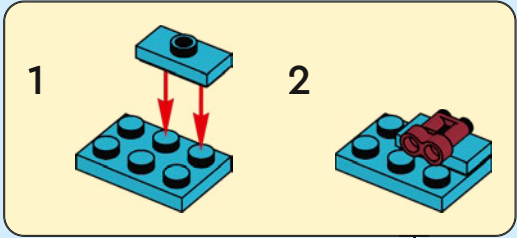

188

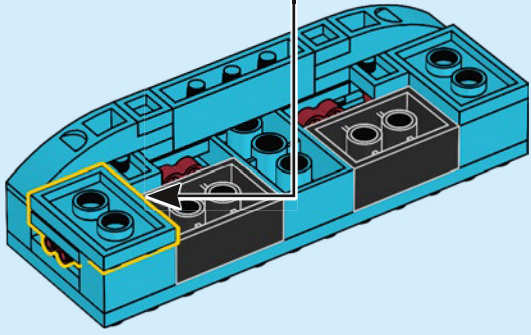
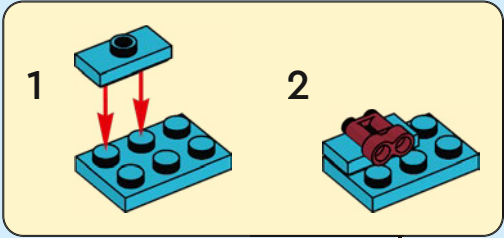

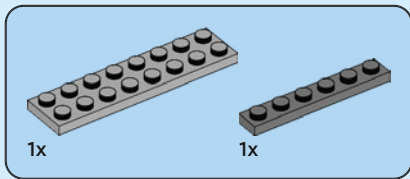

189

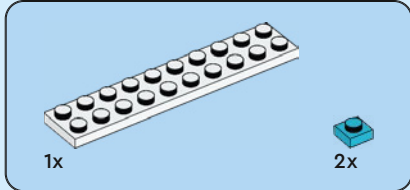
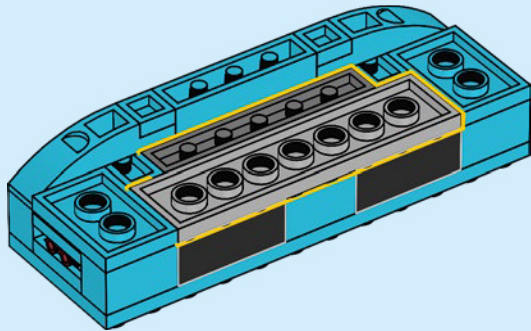

190

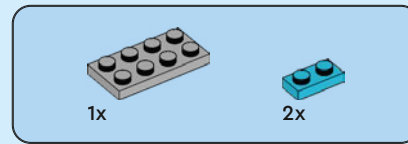
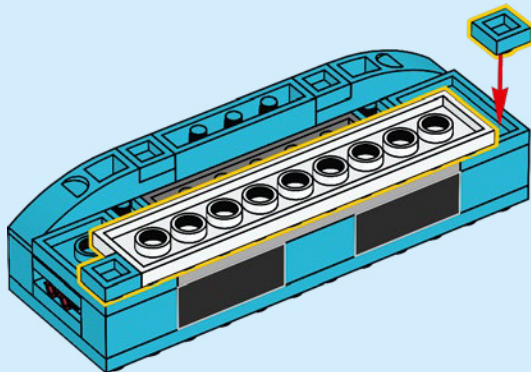

191

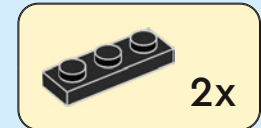
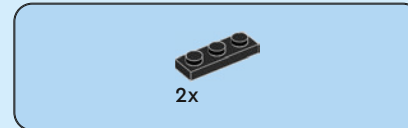
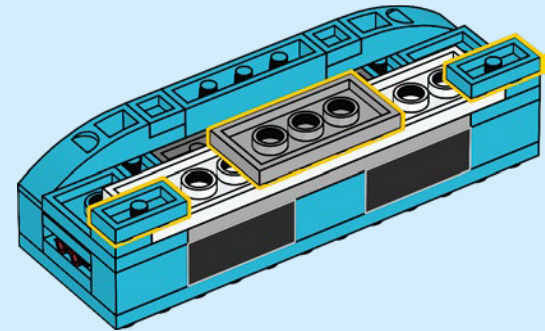

192

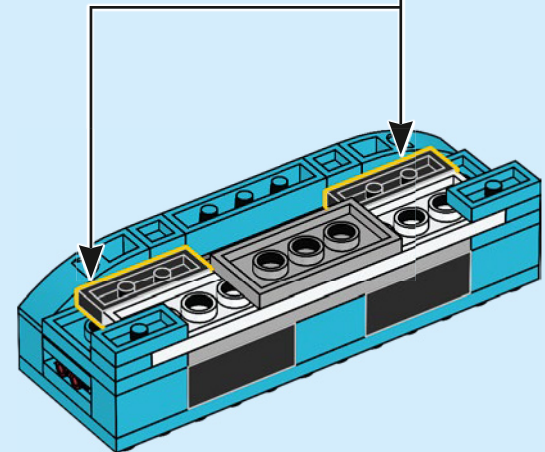



4x

193

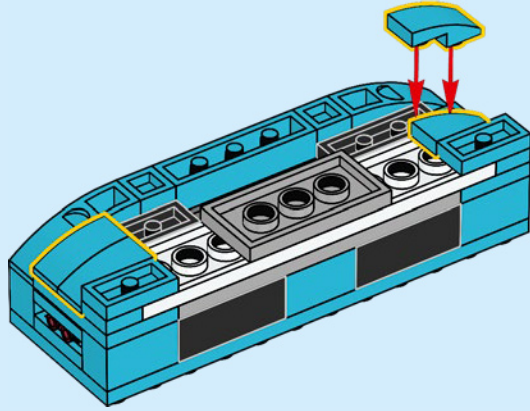

2x

194

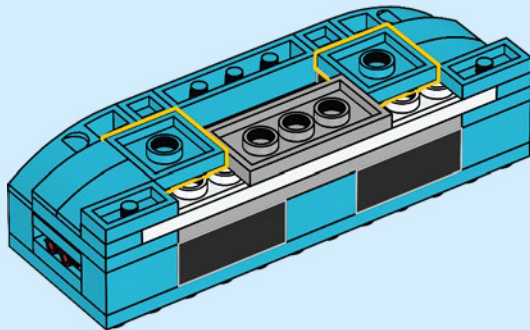

1x



1x



1x

195

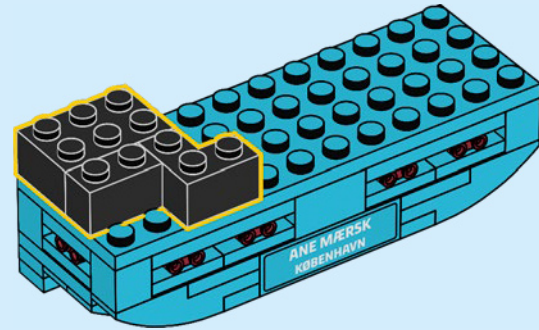
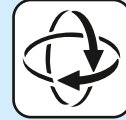

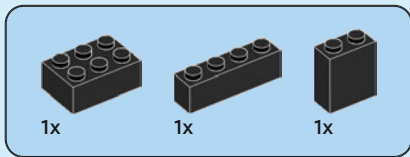

196

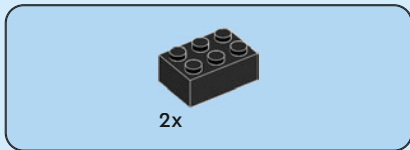
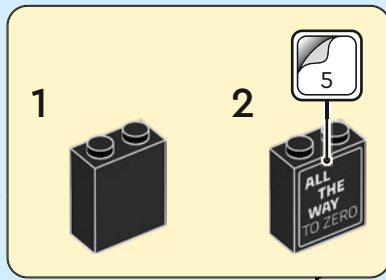
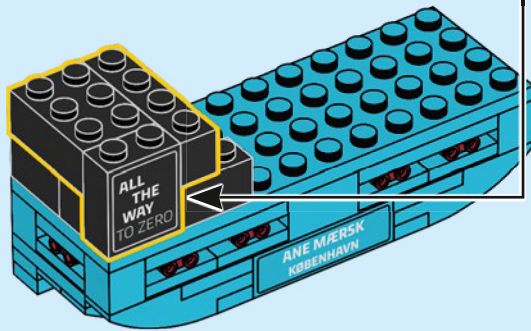

197

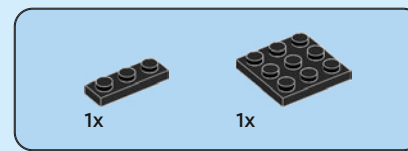
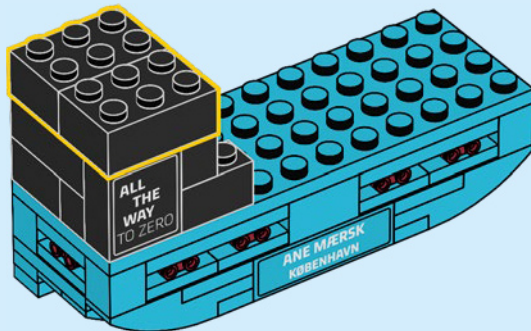

198

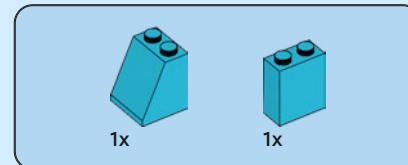
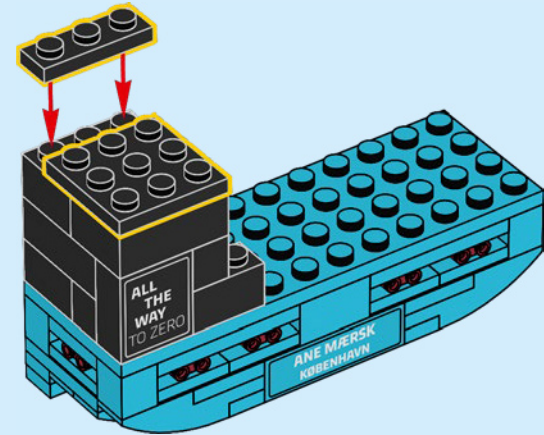

199

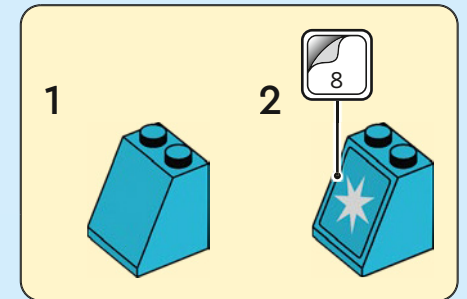
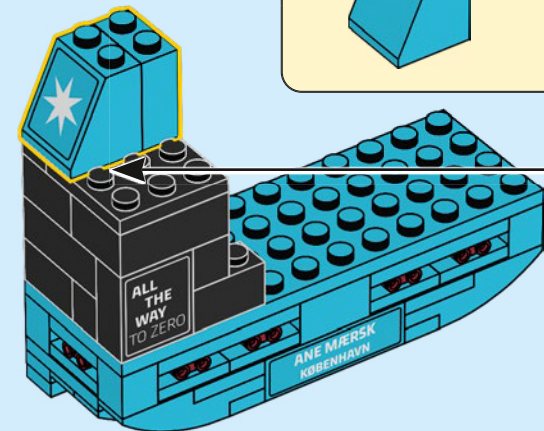

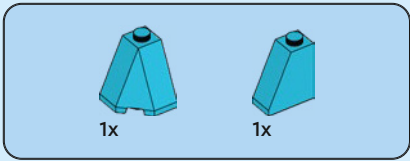

200

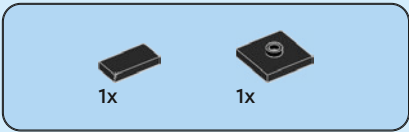
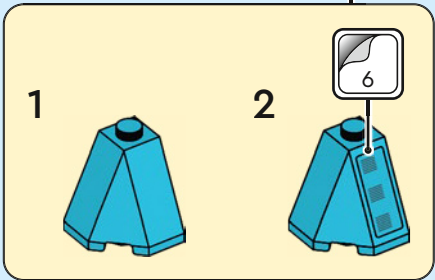
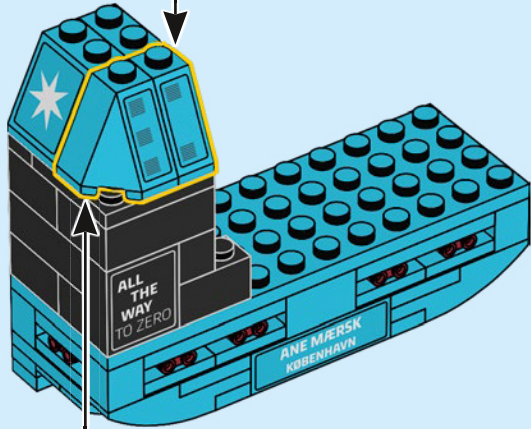
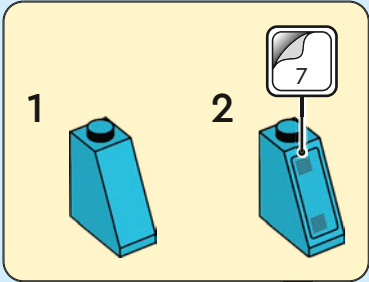

201

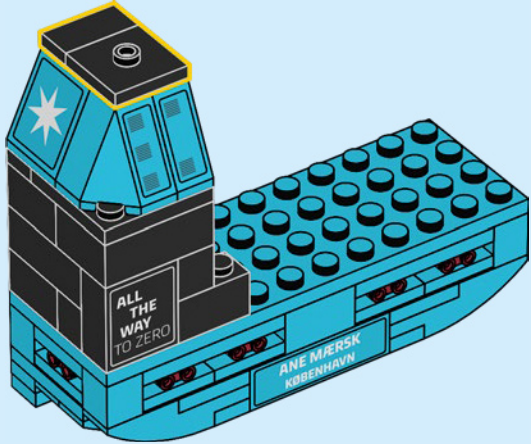



1x



1x

202

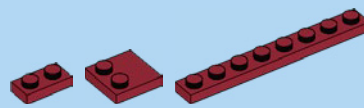
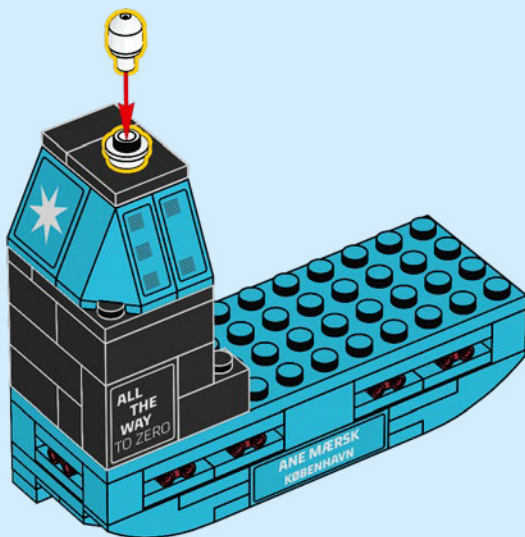

1x

2x

1x

203

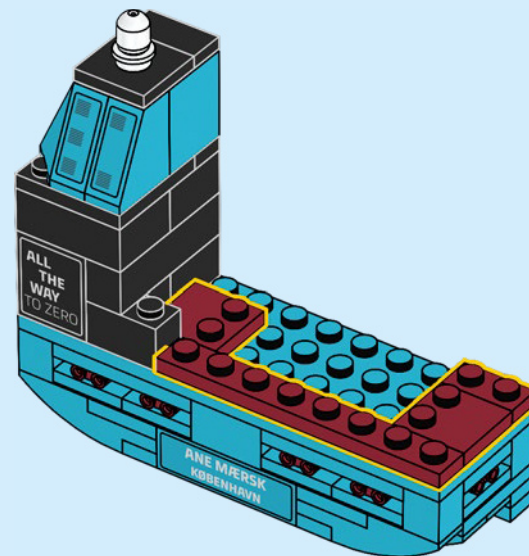



2x

204

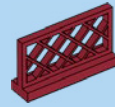
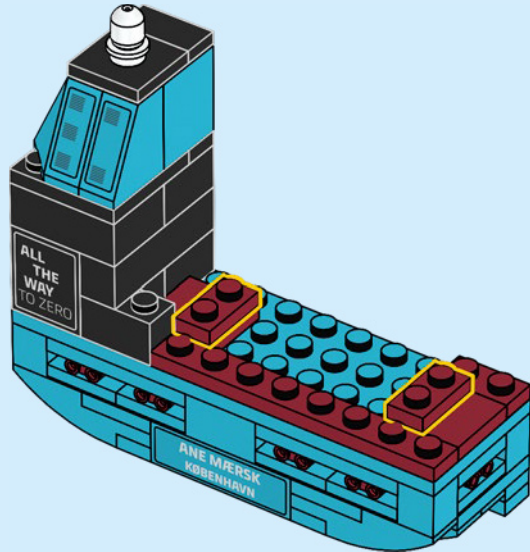

2x

205

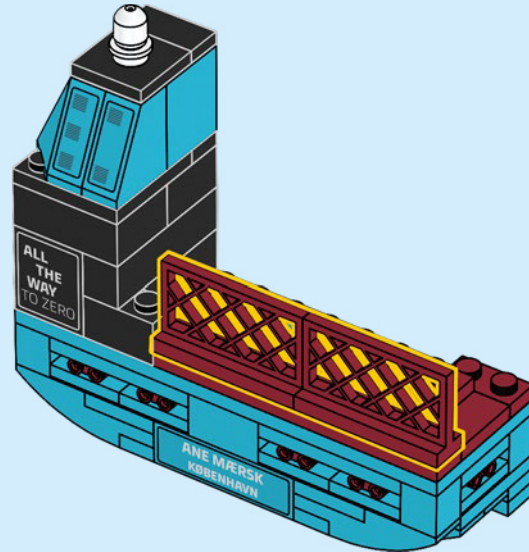

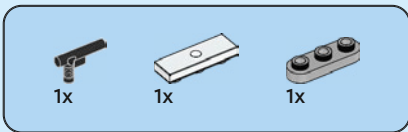

206

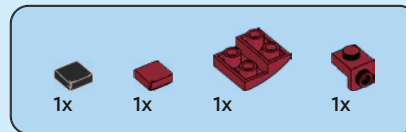
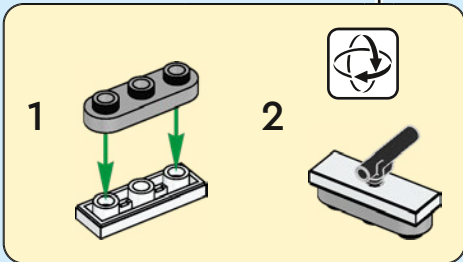
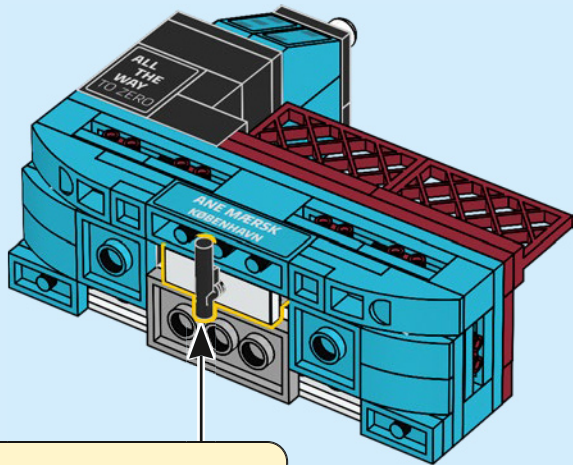

207

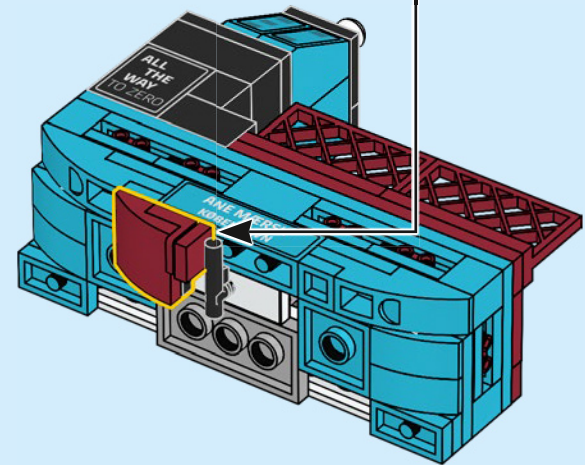
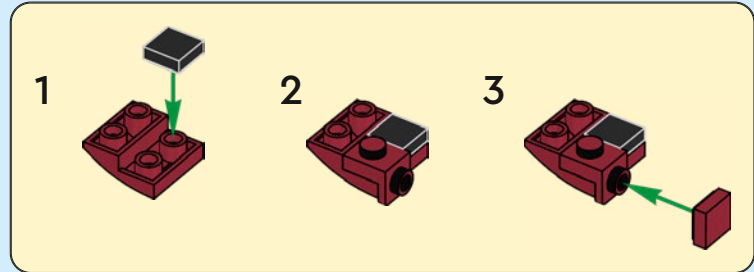

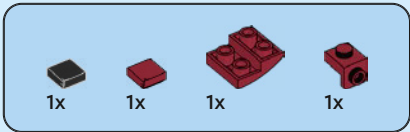

208

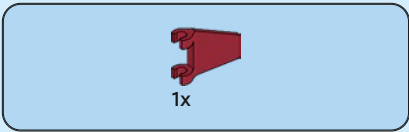
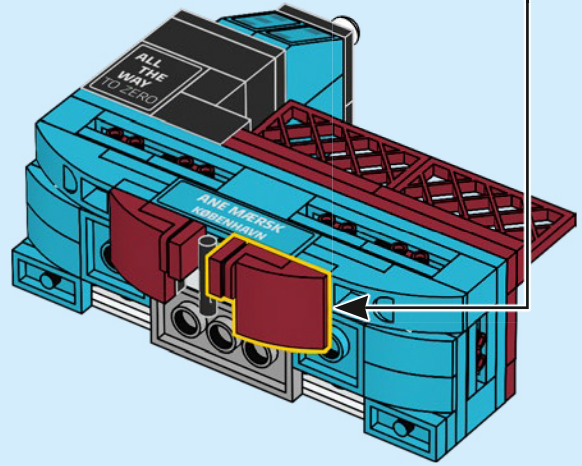

209

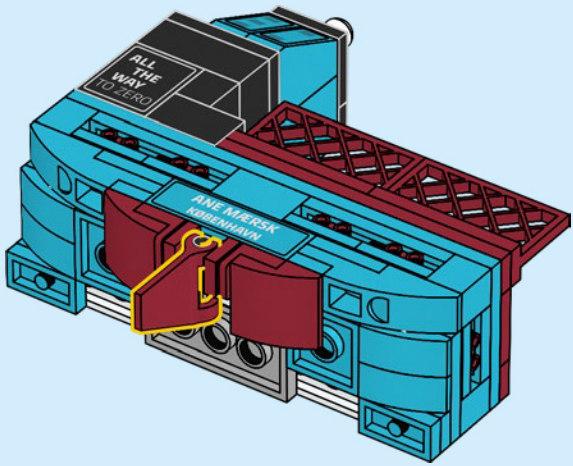

210

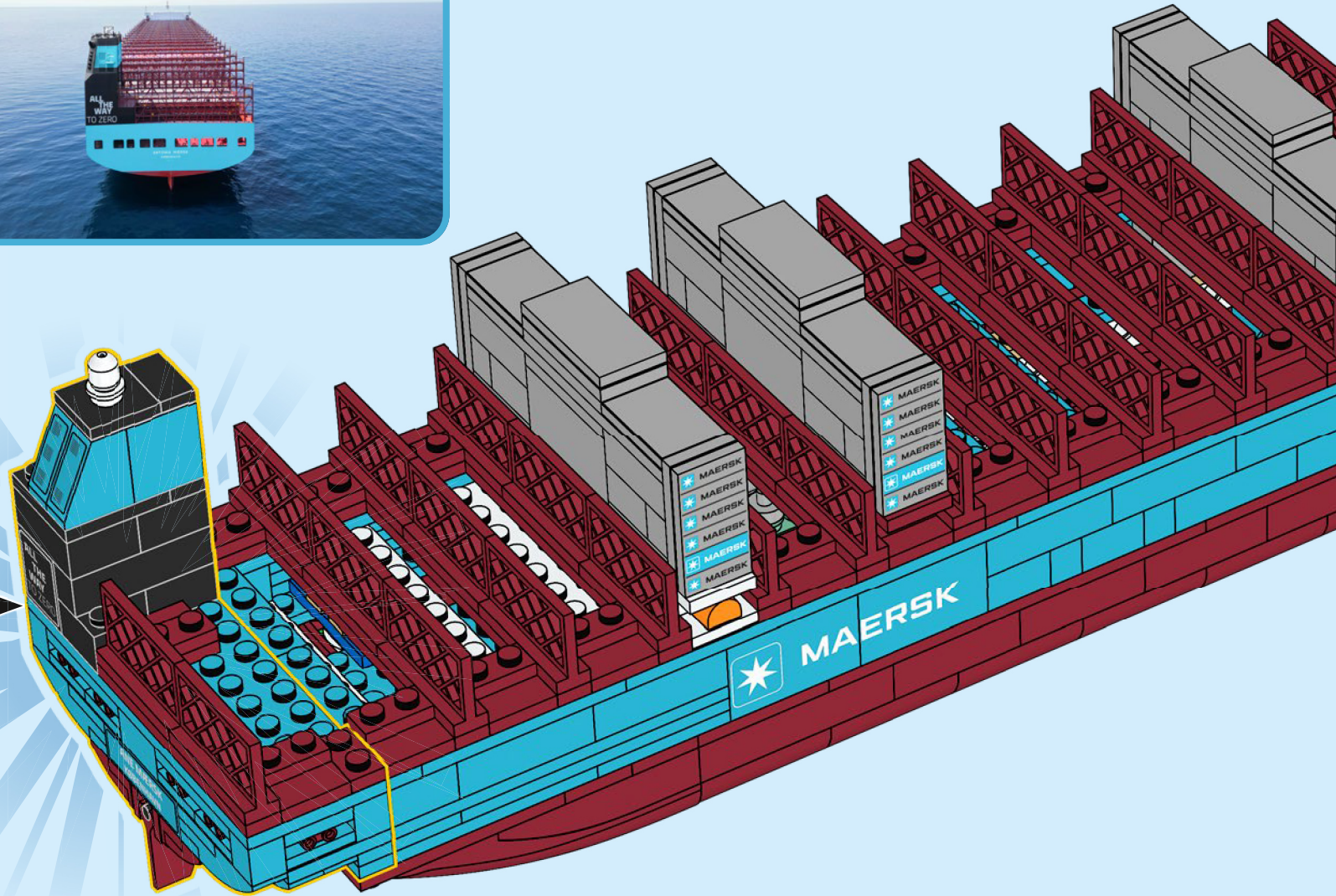
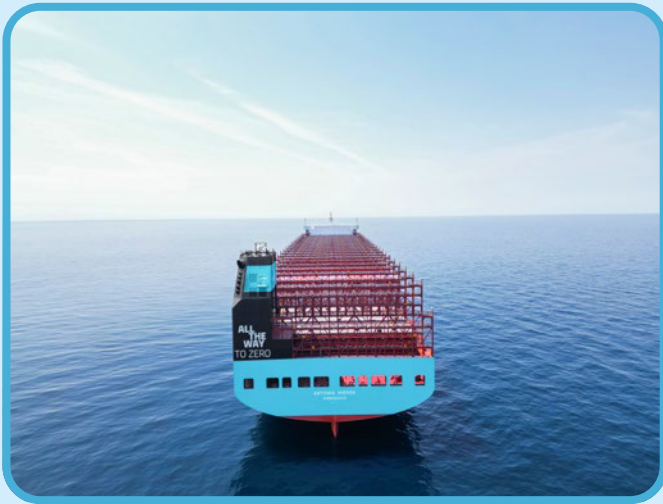

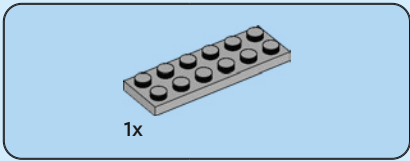

211

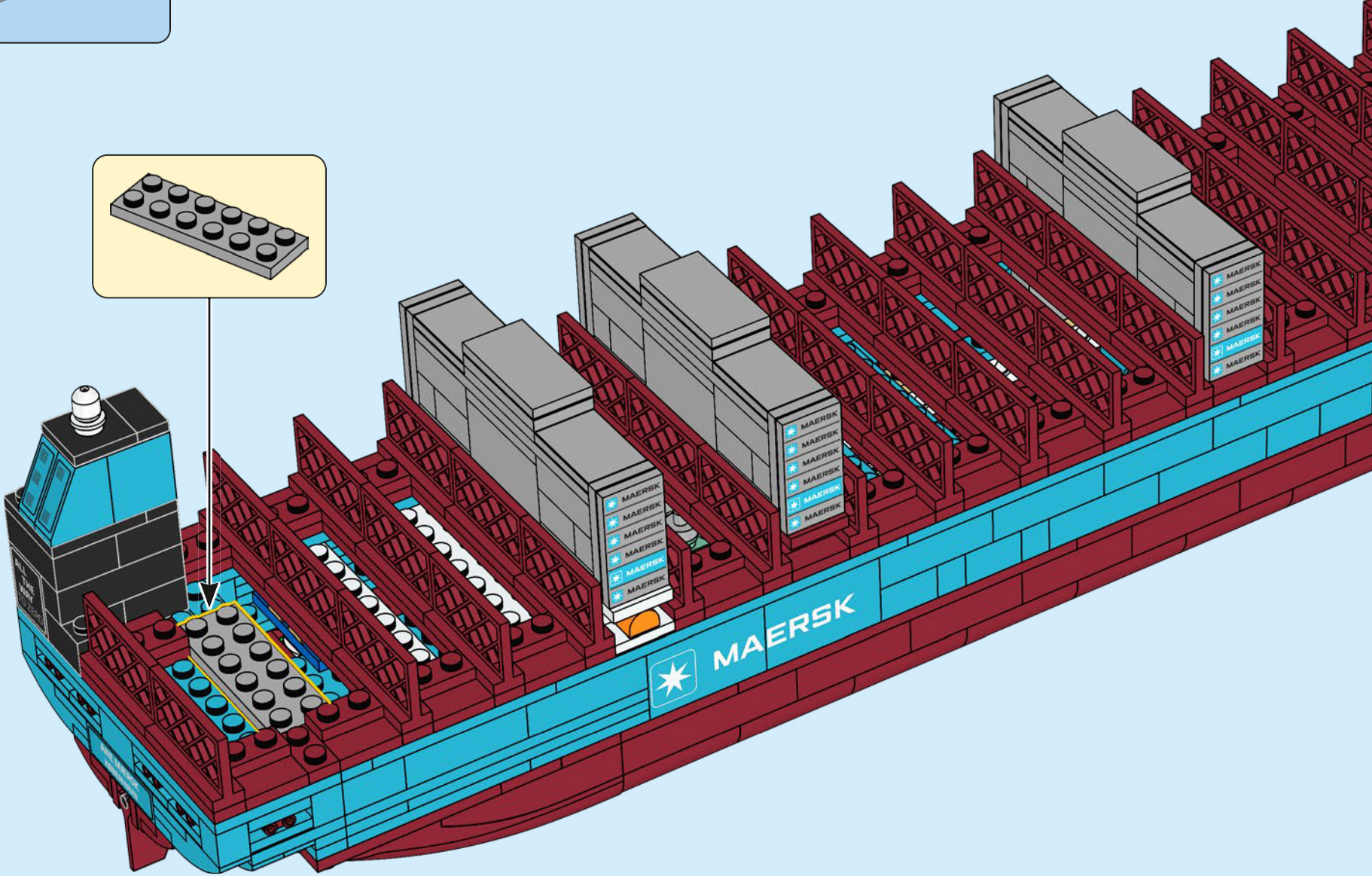
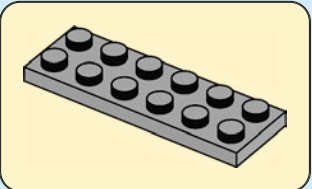

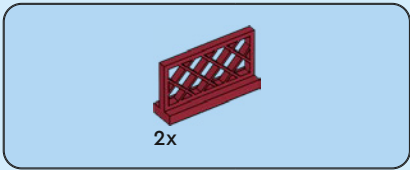

212

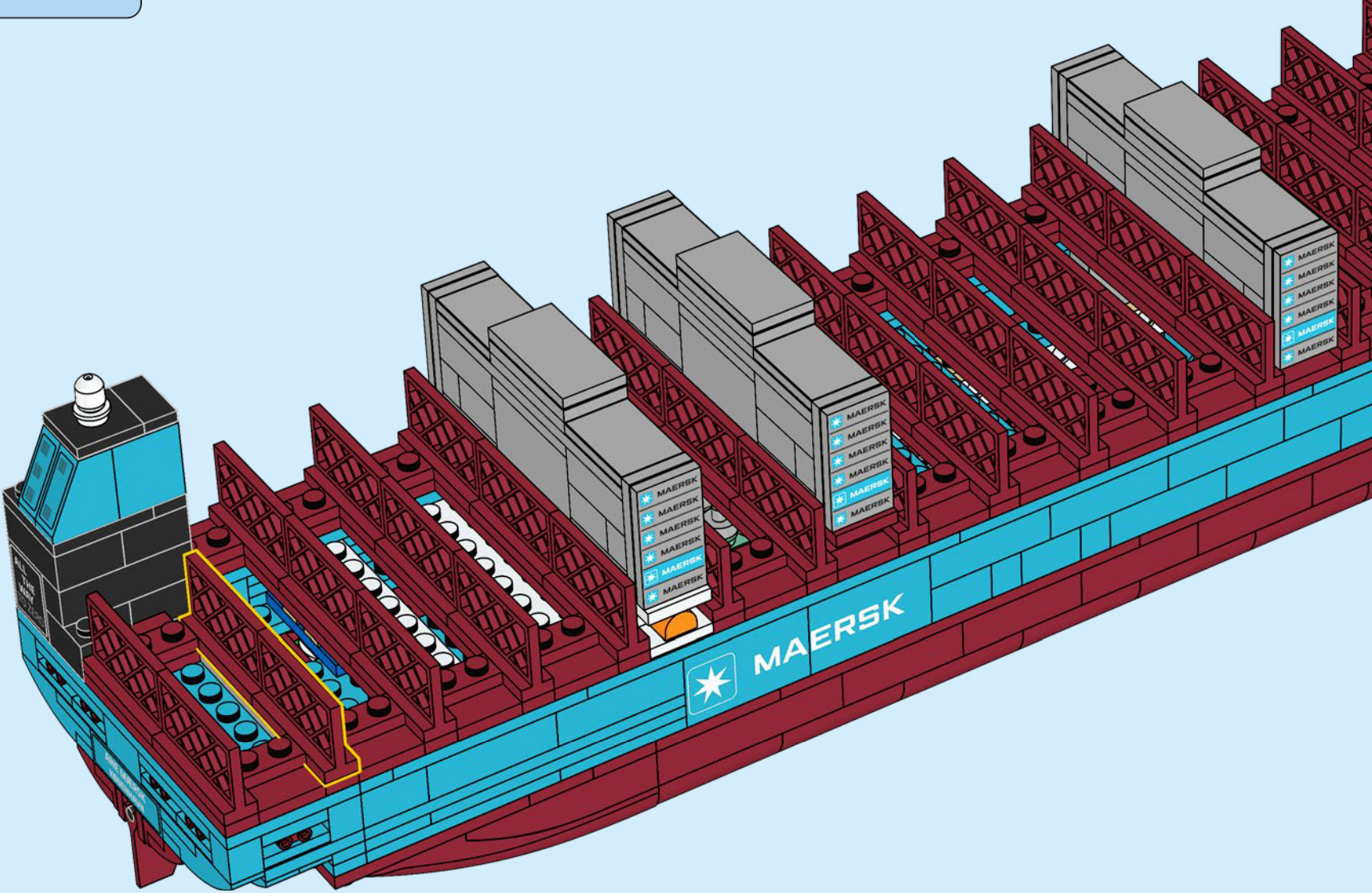

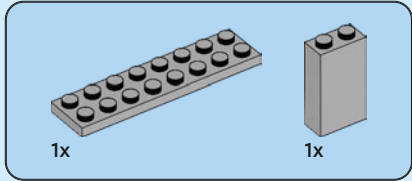
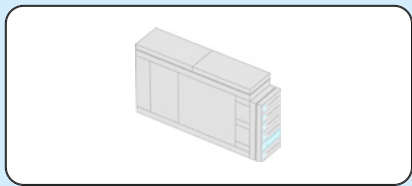

213

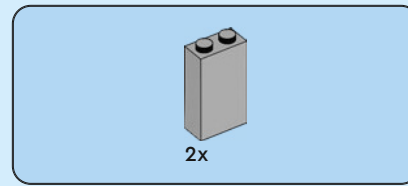
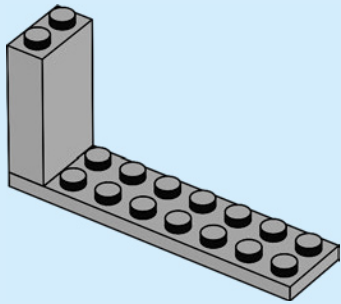

214

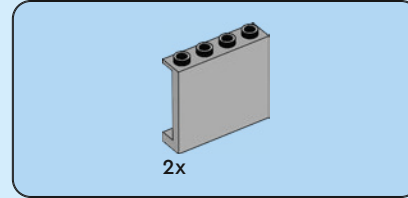
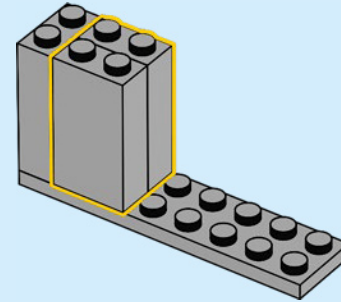

215

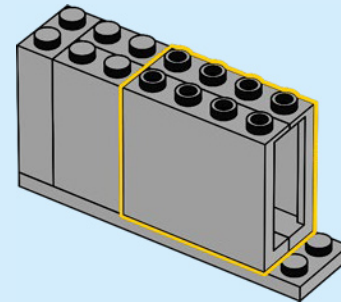

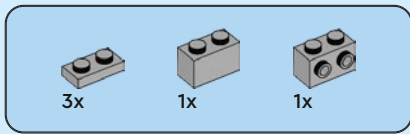

216

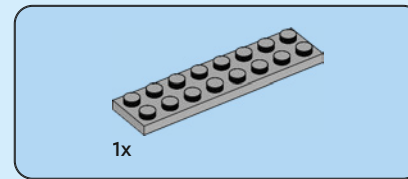
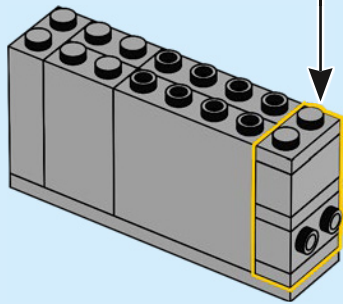
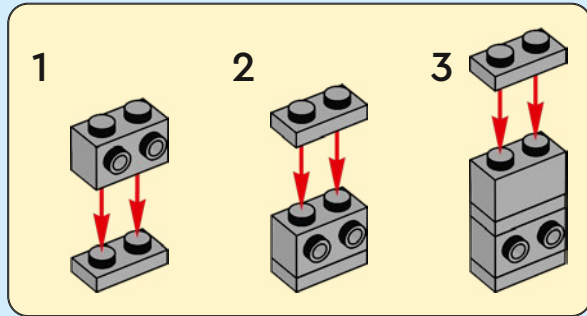

217

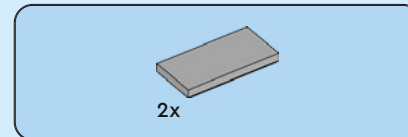
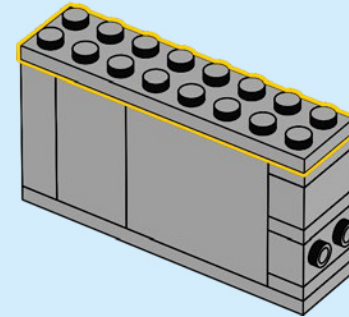

218

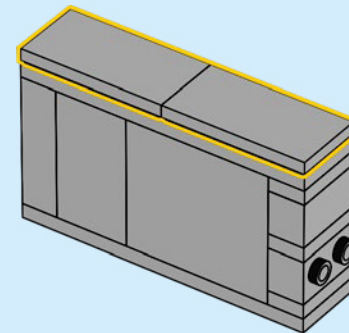

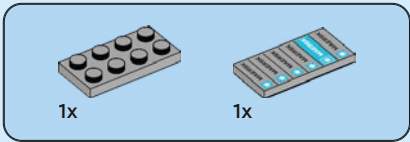

219

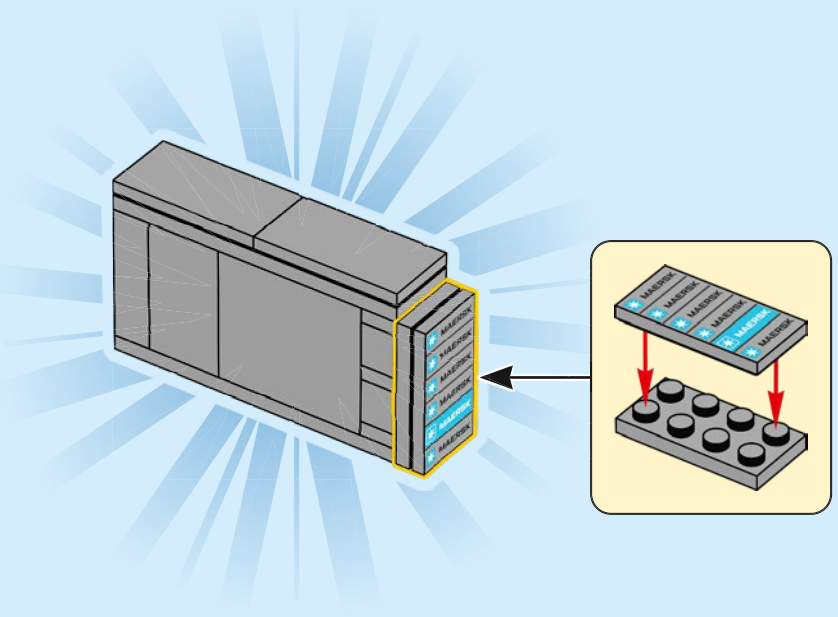

220

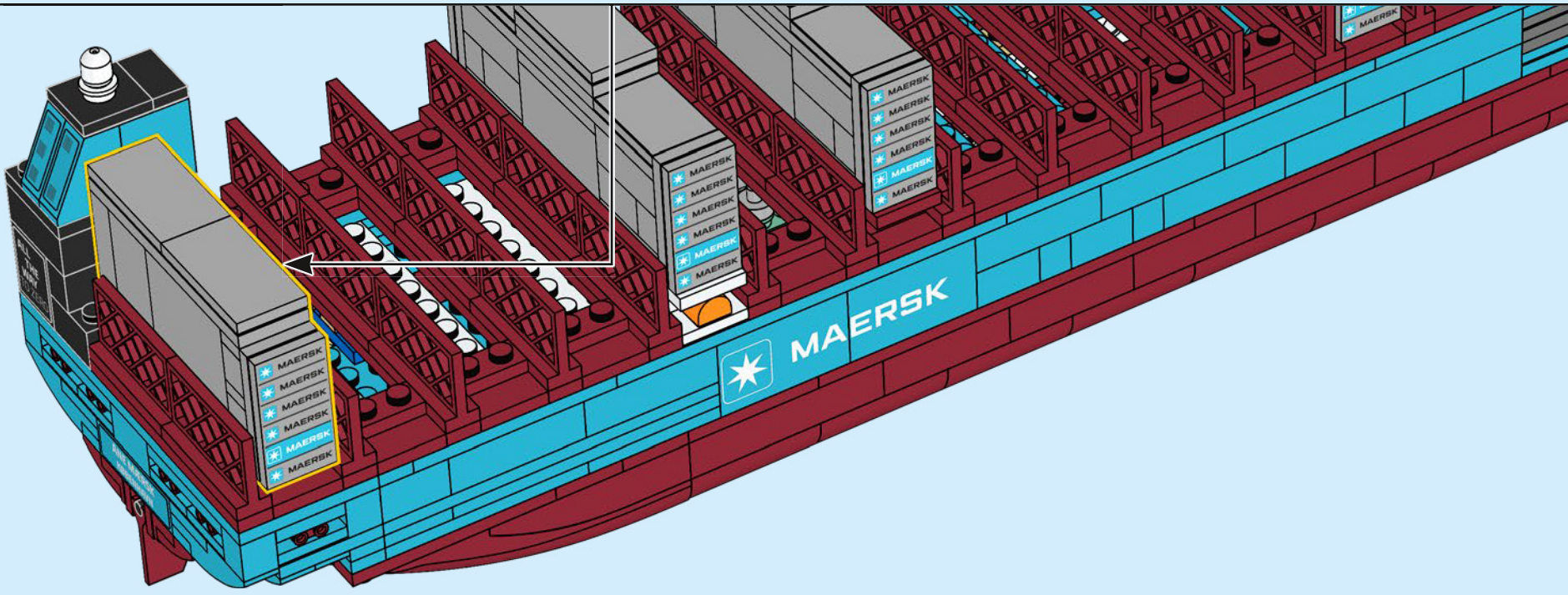

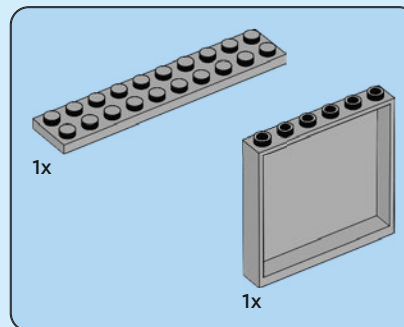
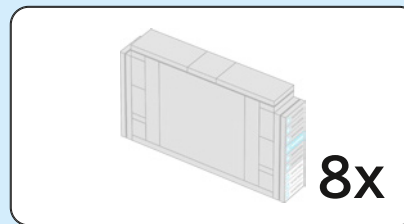

221

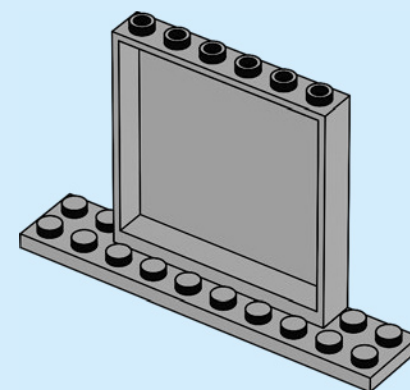

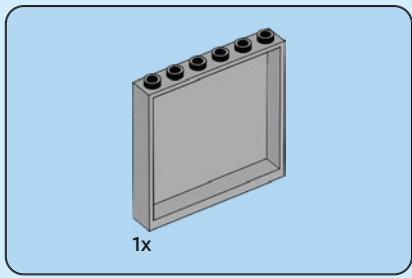

222

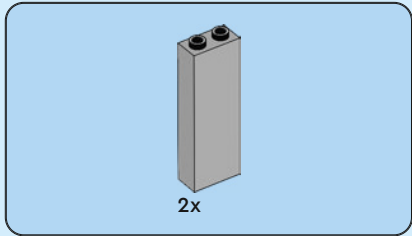
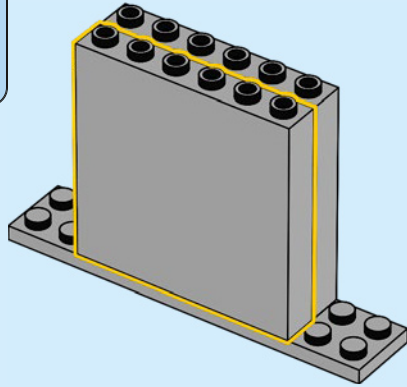

223

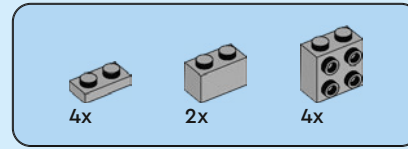
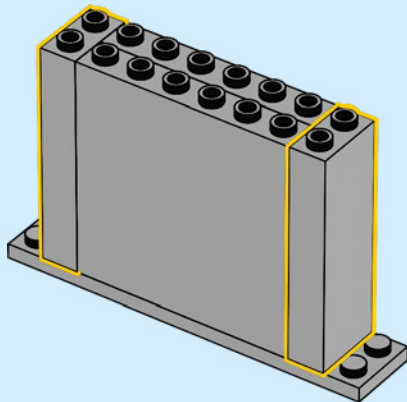

224

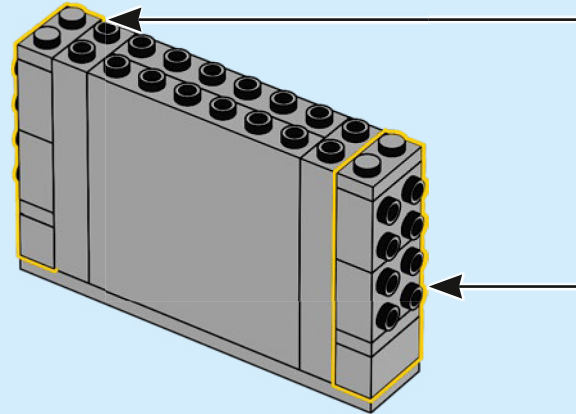
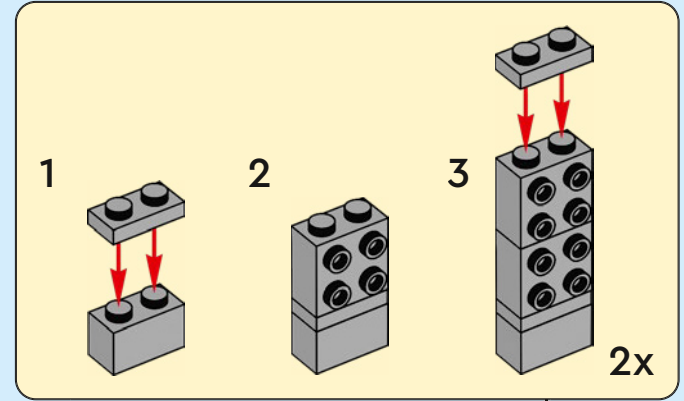

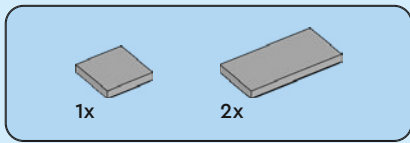

225

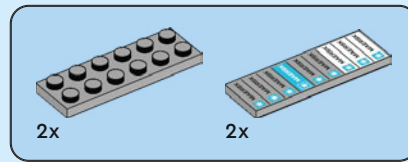
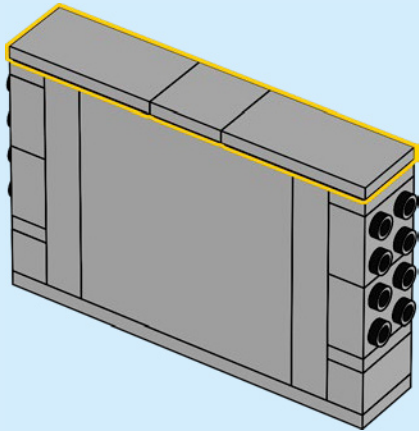

226

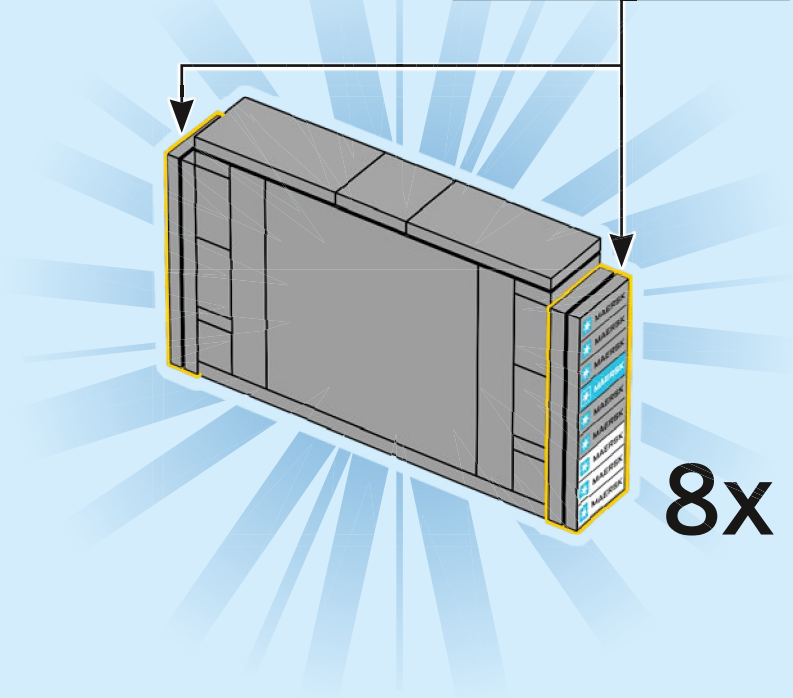
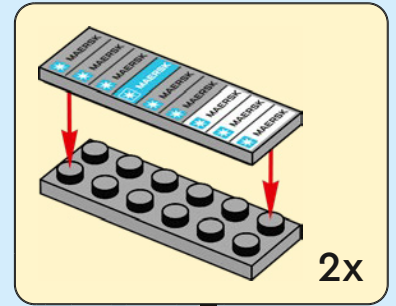

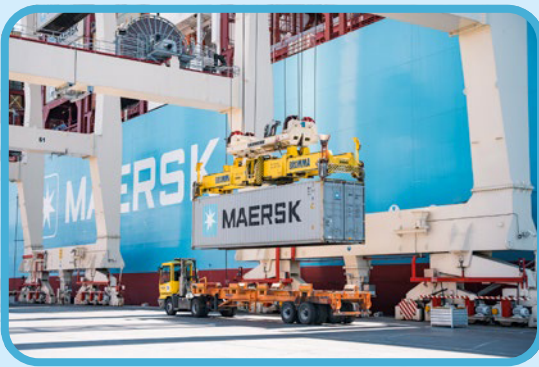

227

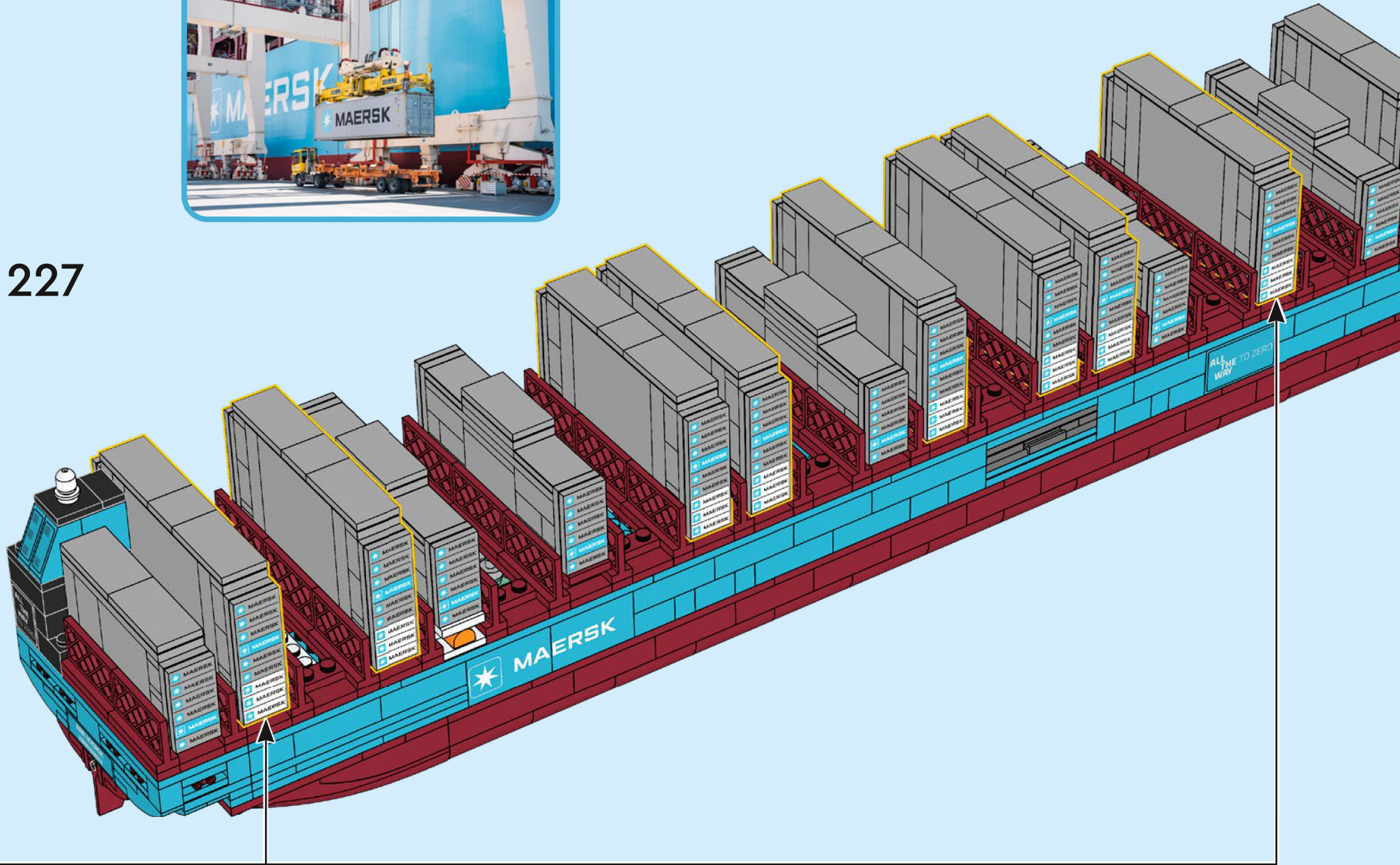





228

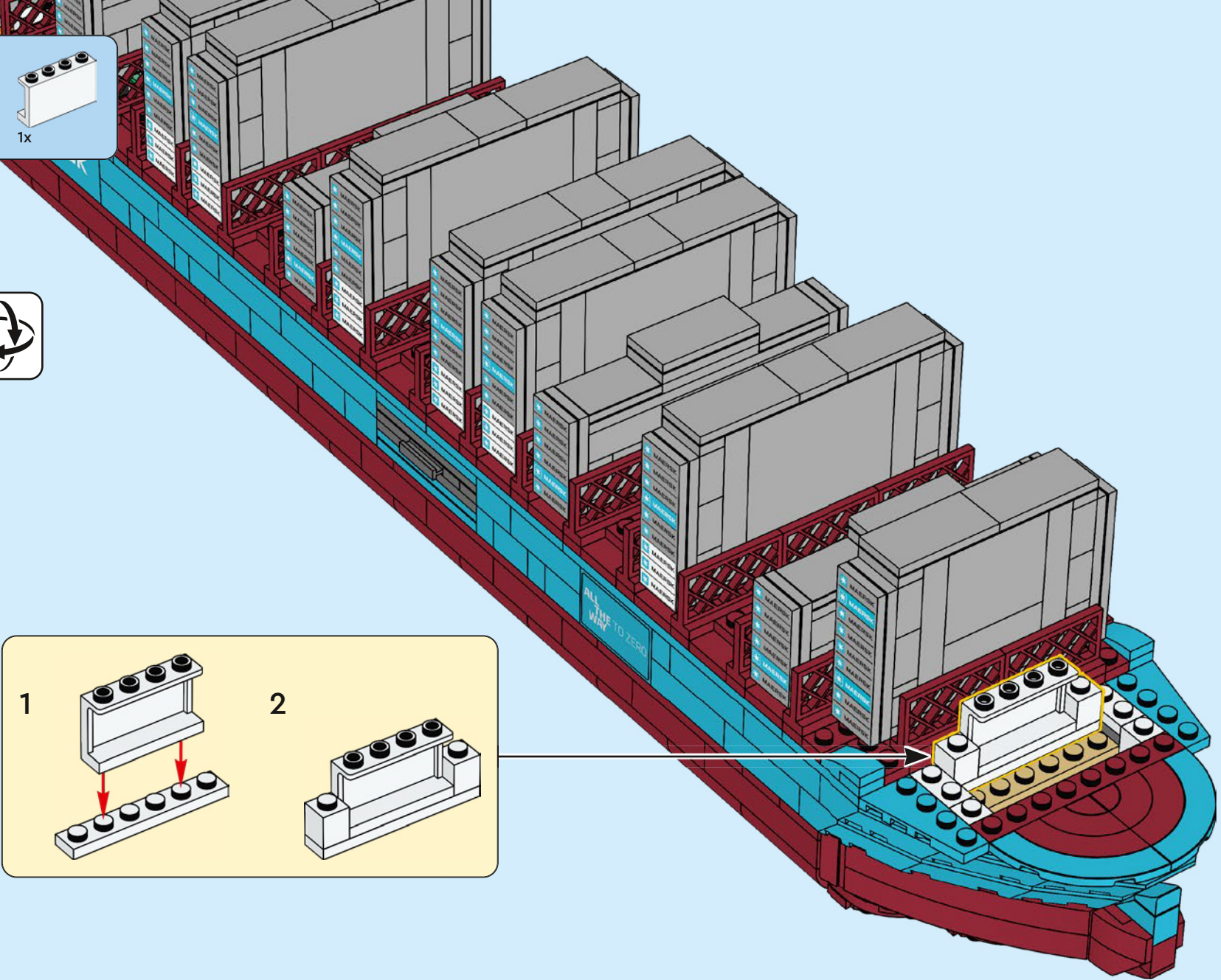
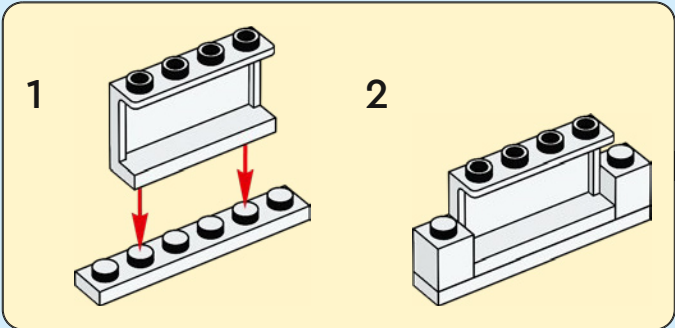

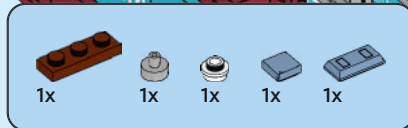

229

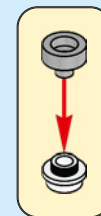
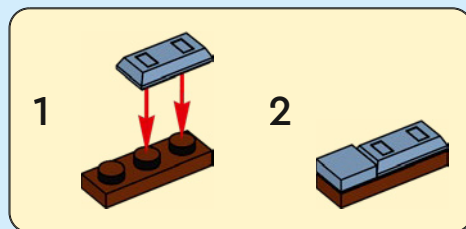



4x

230

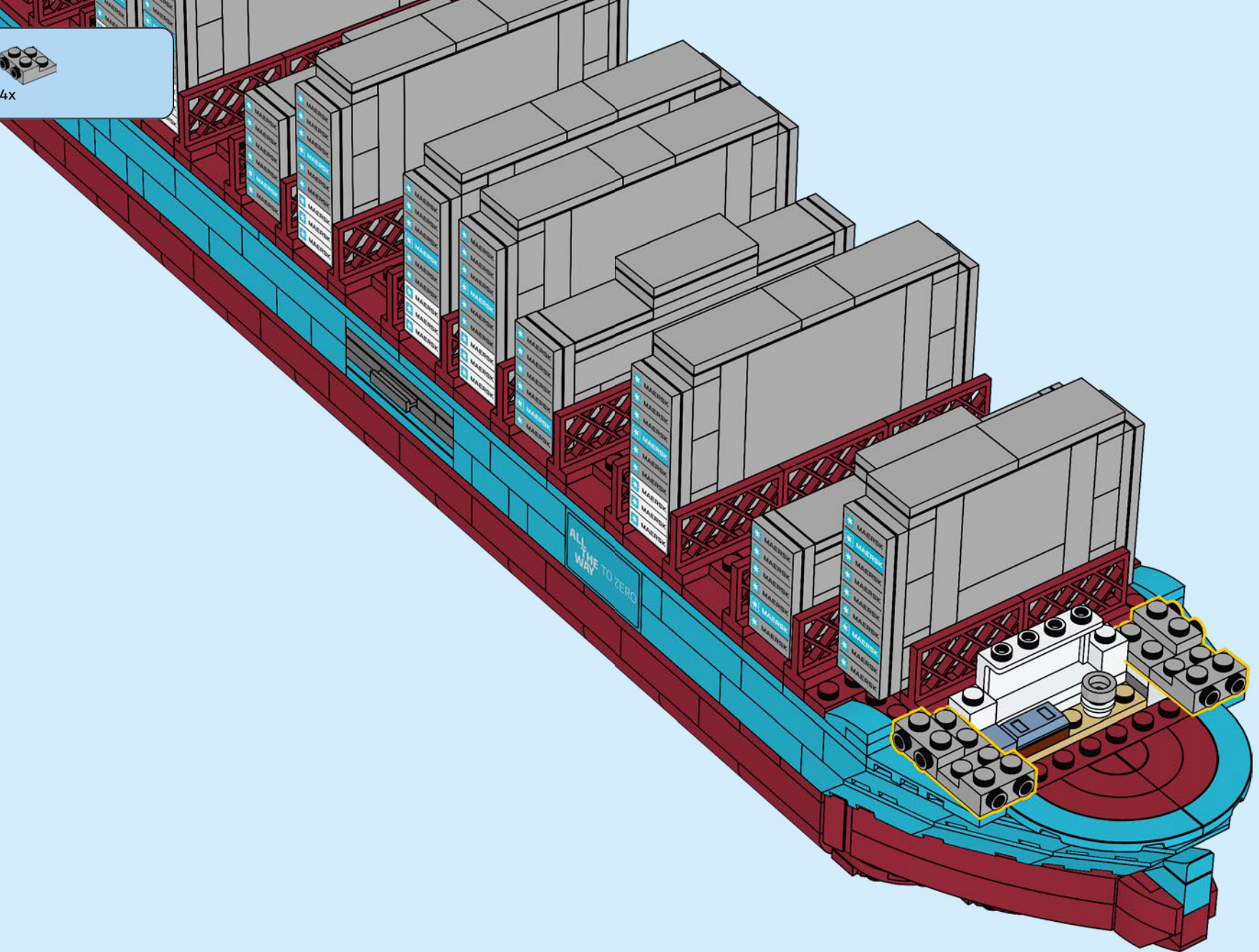

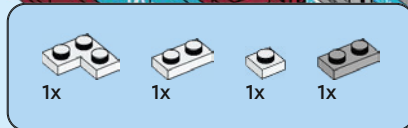

231

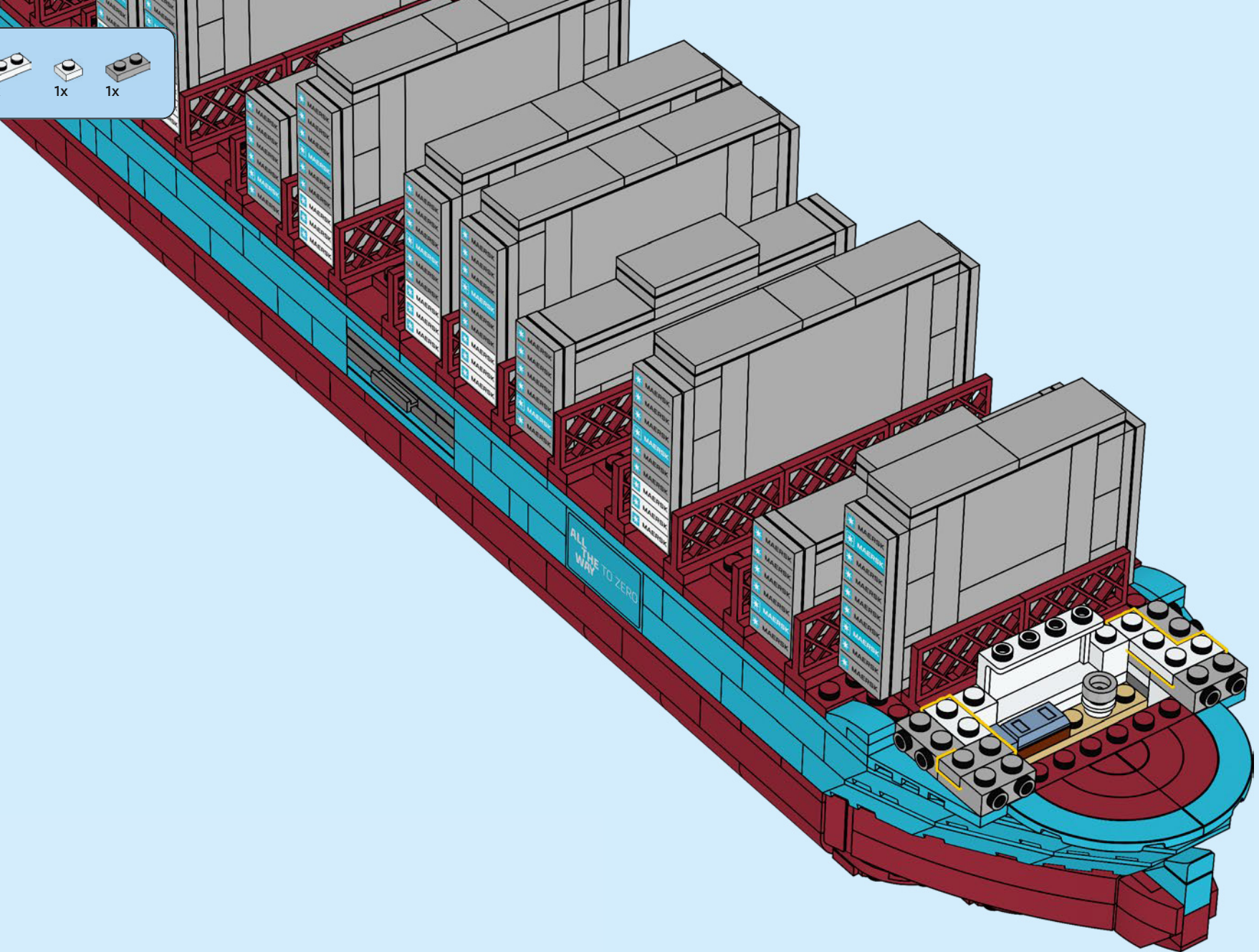

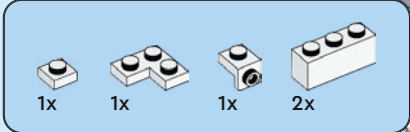

232

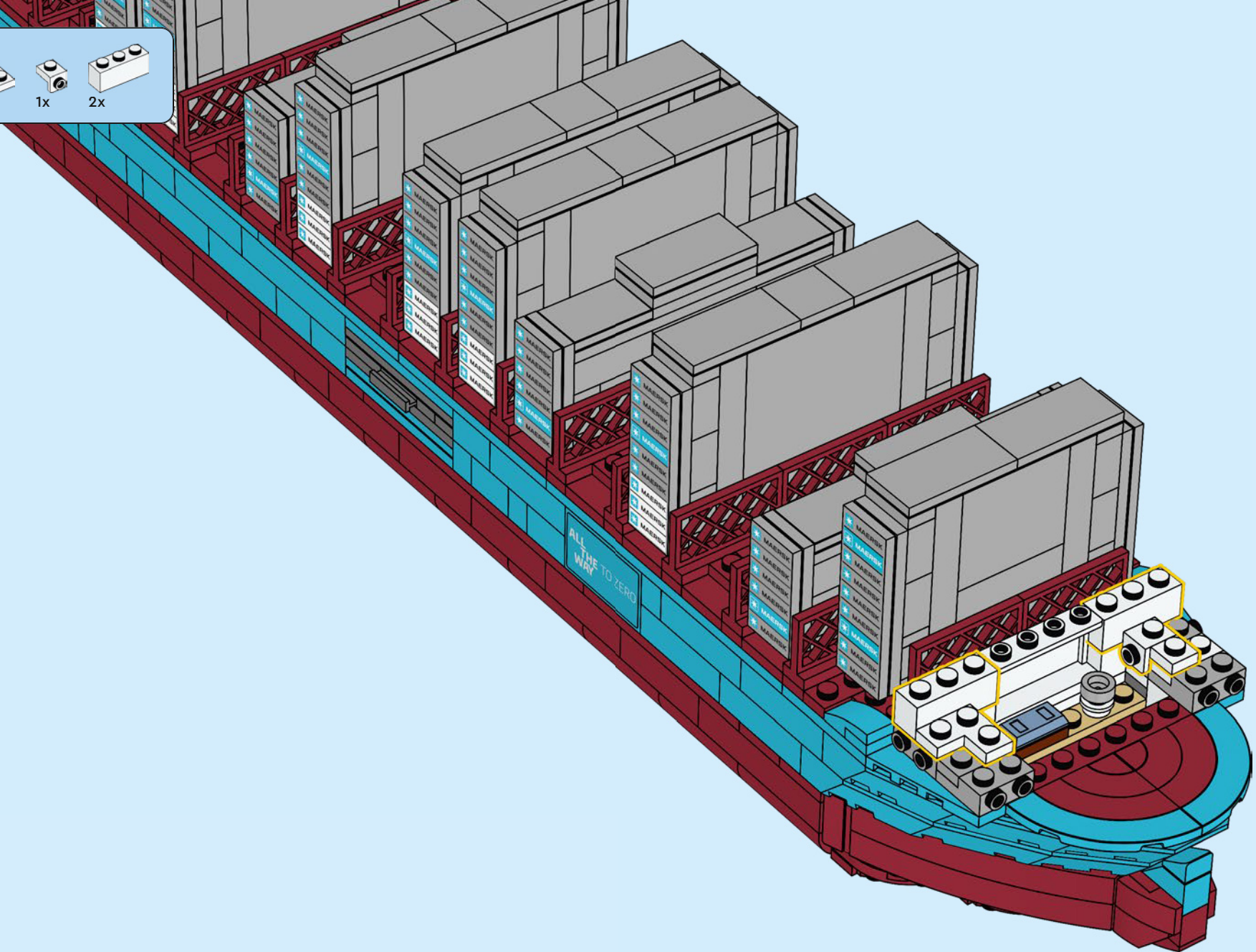

1x 1x 4x

233

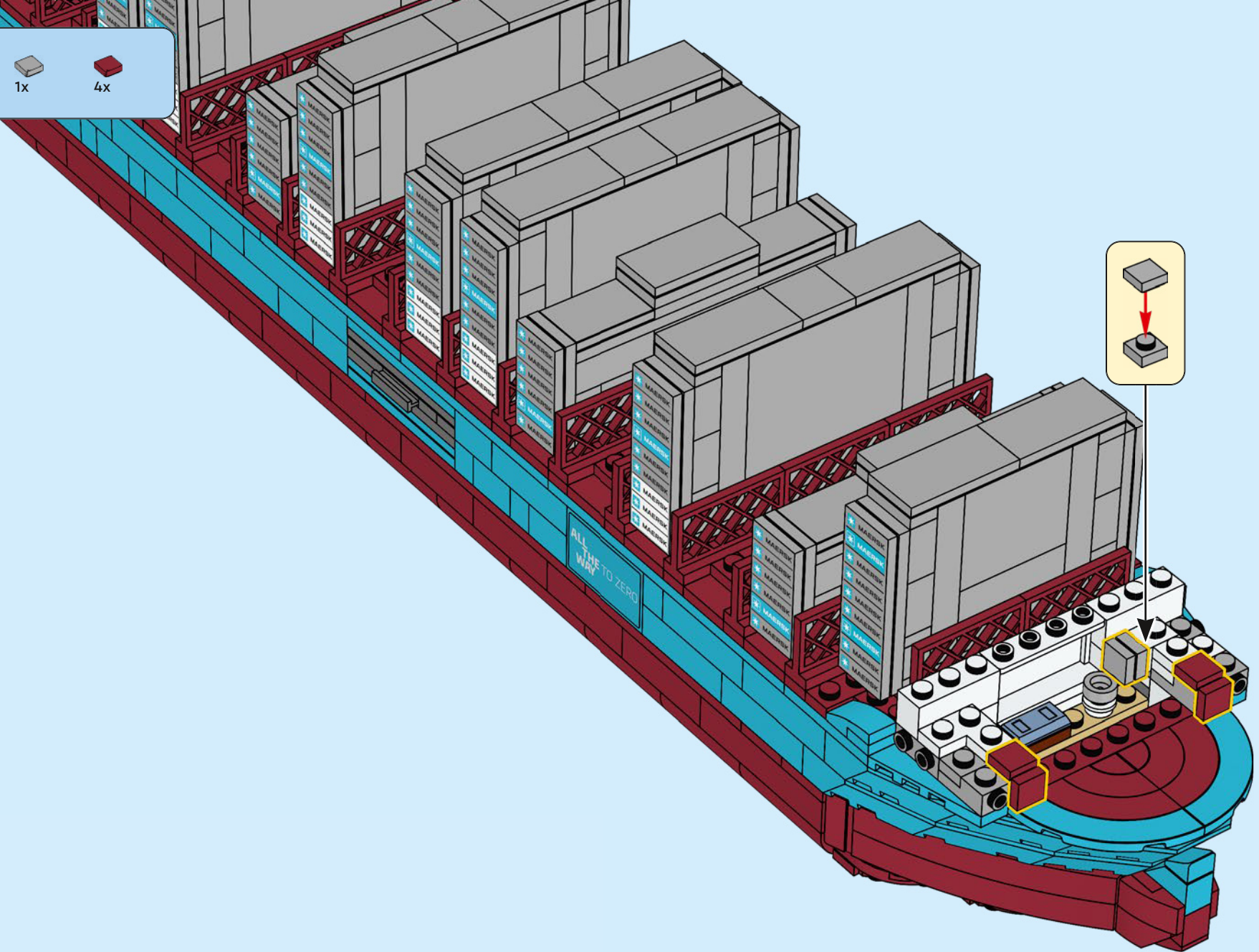

3x 2x 2x

234

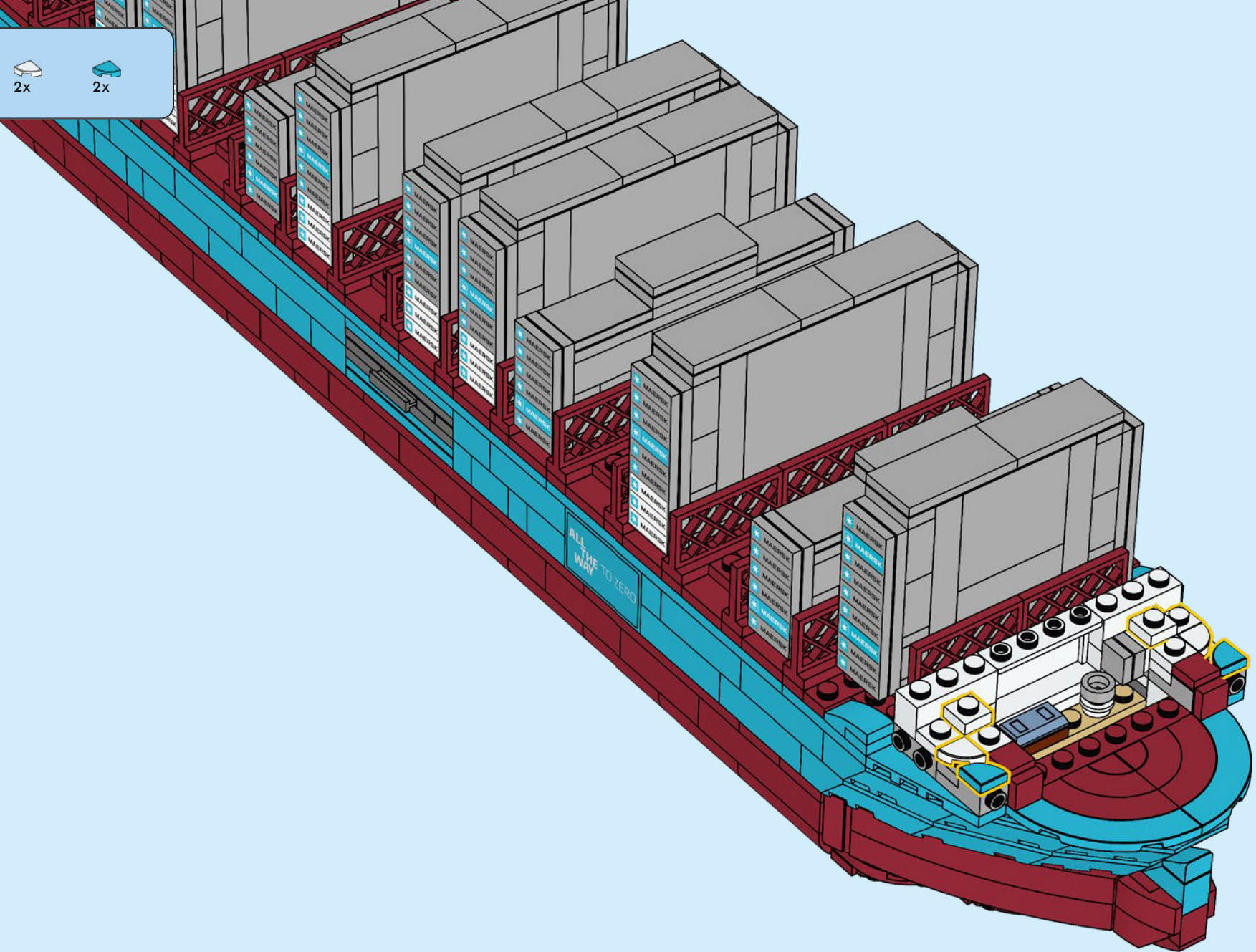

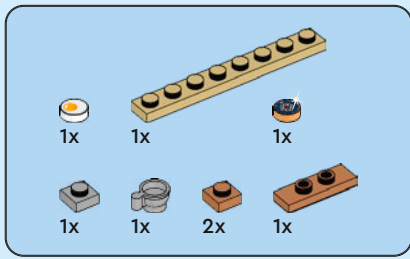

235

1

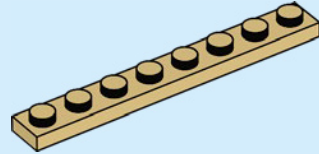

2

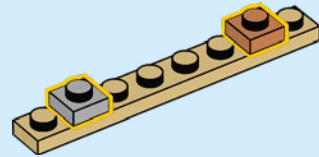

3

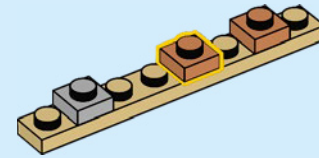

4

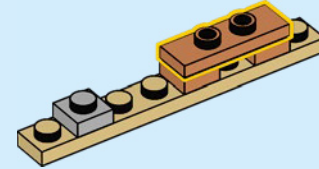

5

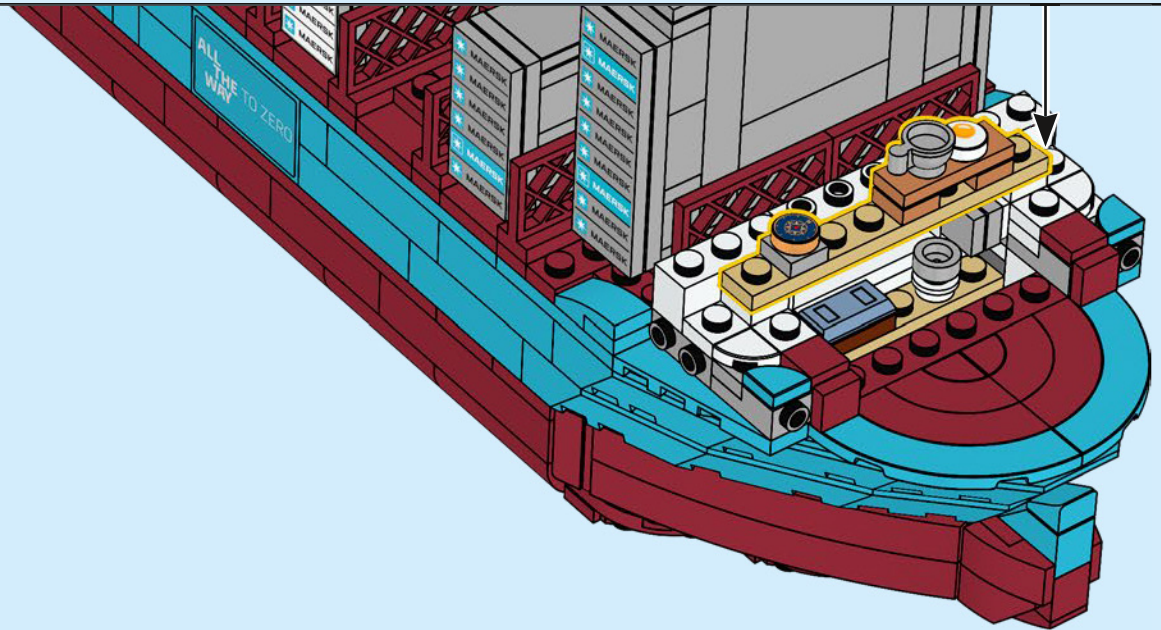
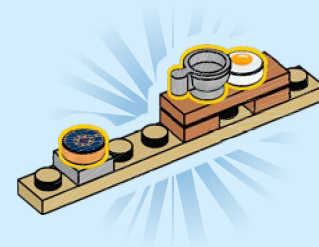

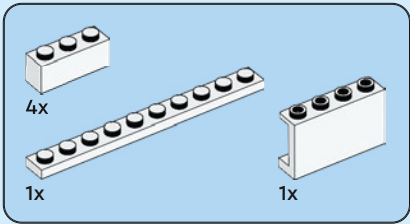

236

1

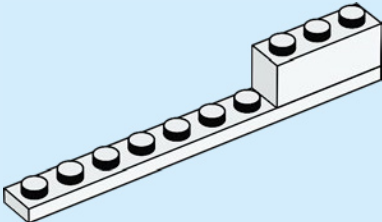

2

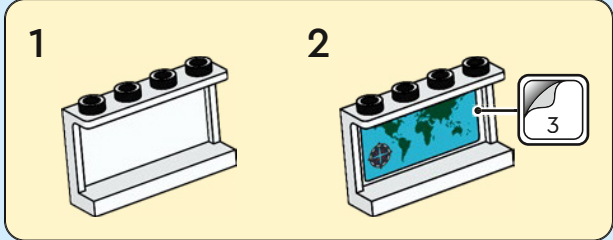
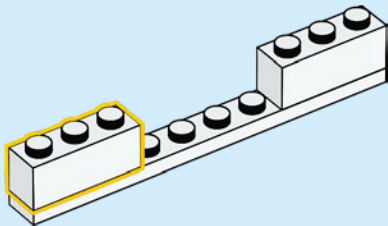

3

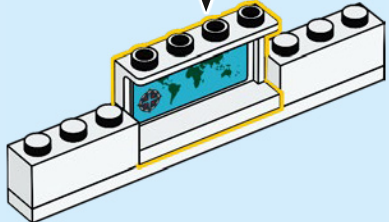

4

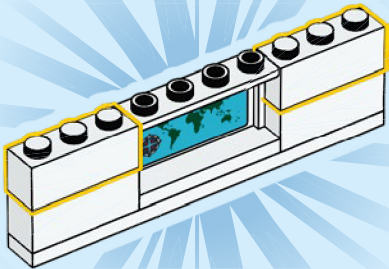

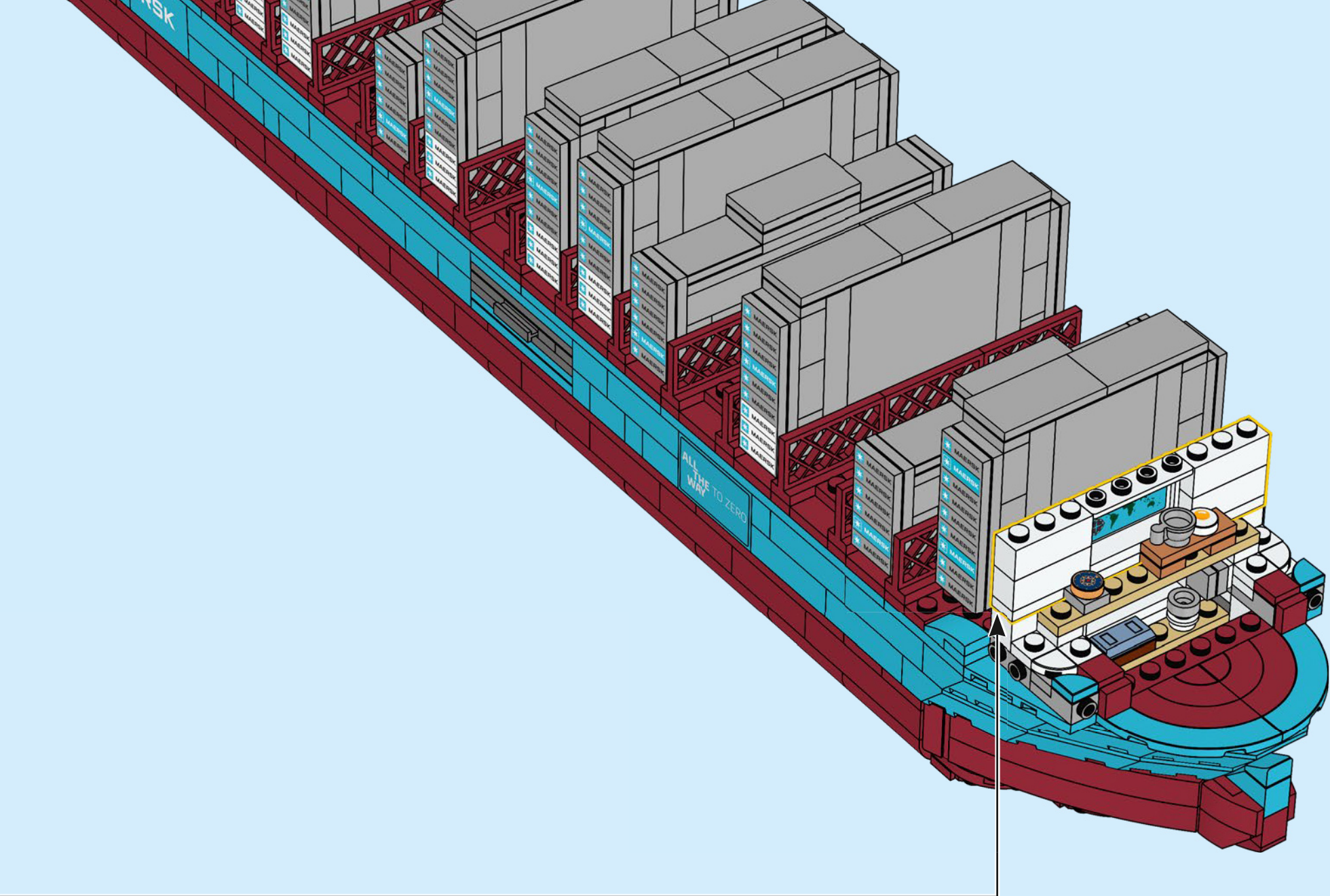

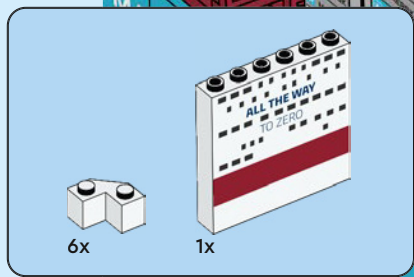

237

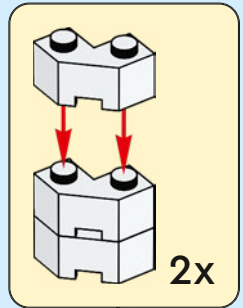
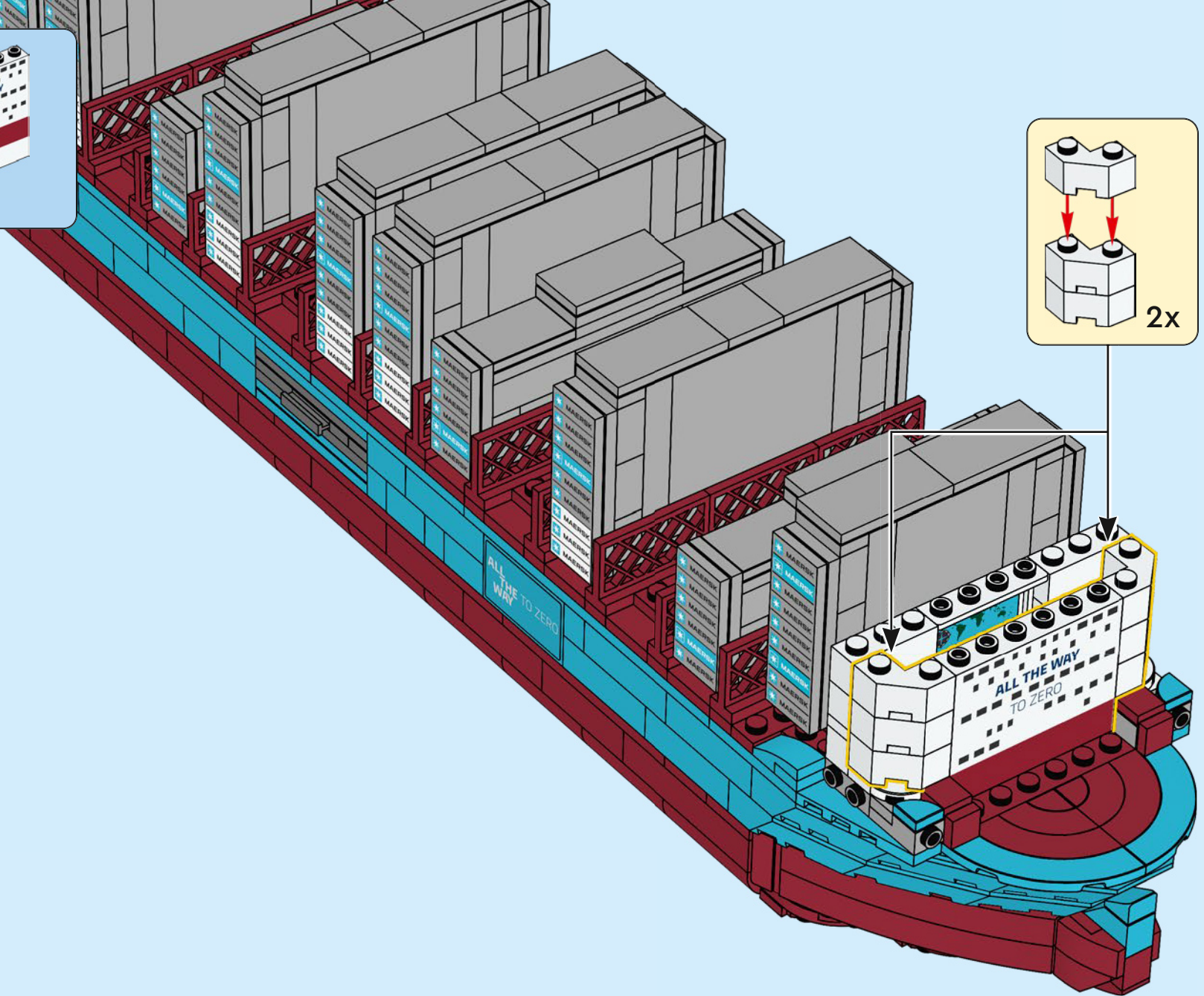



238

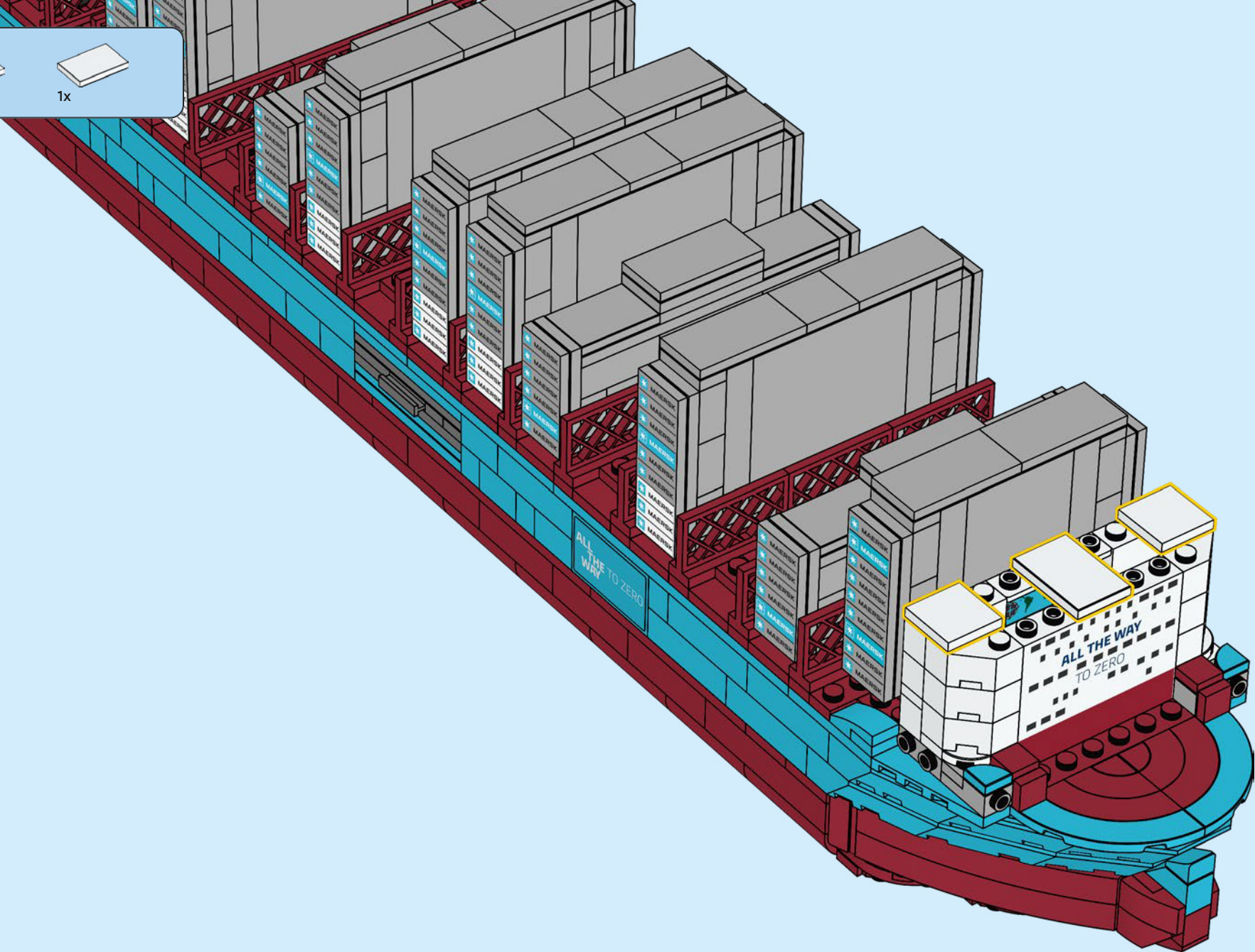

2x 1x 1x

239

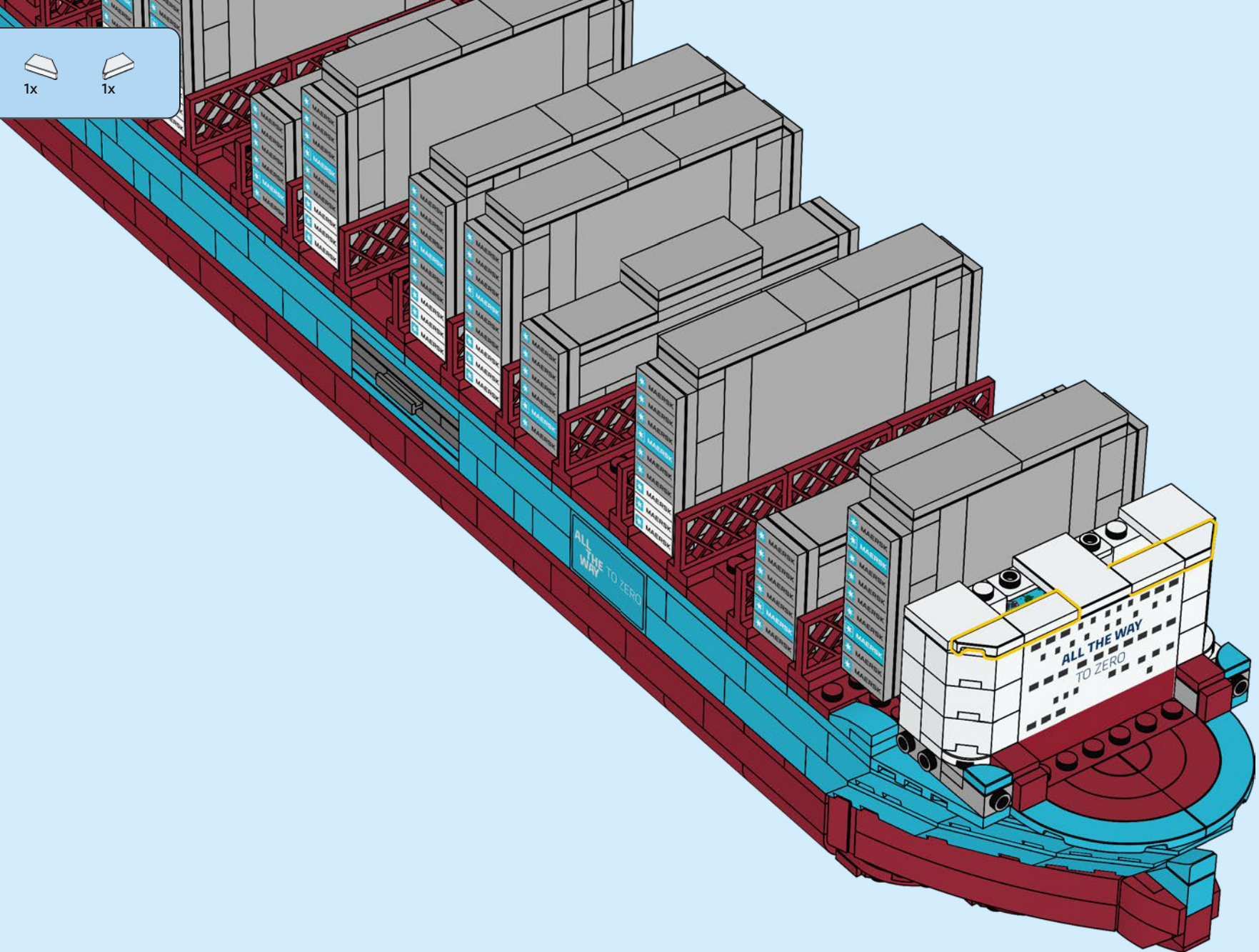

2x 2x 2x

240

1 2 2x

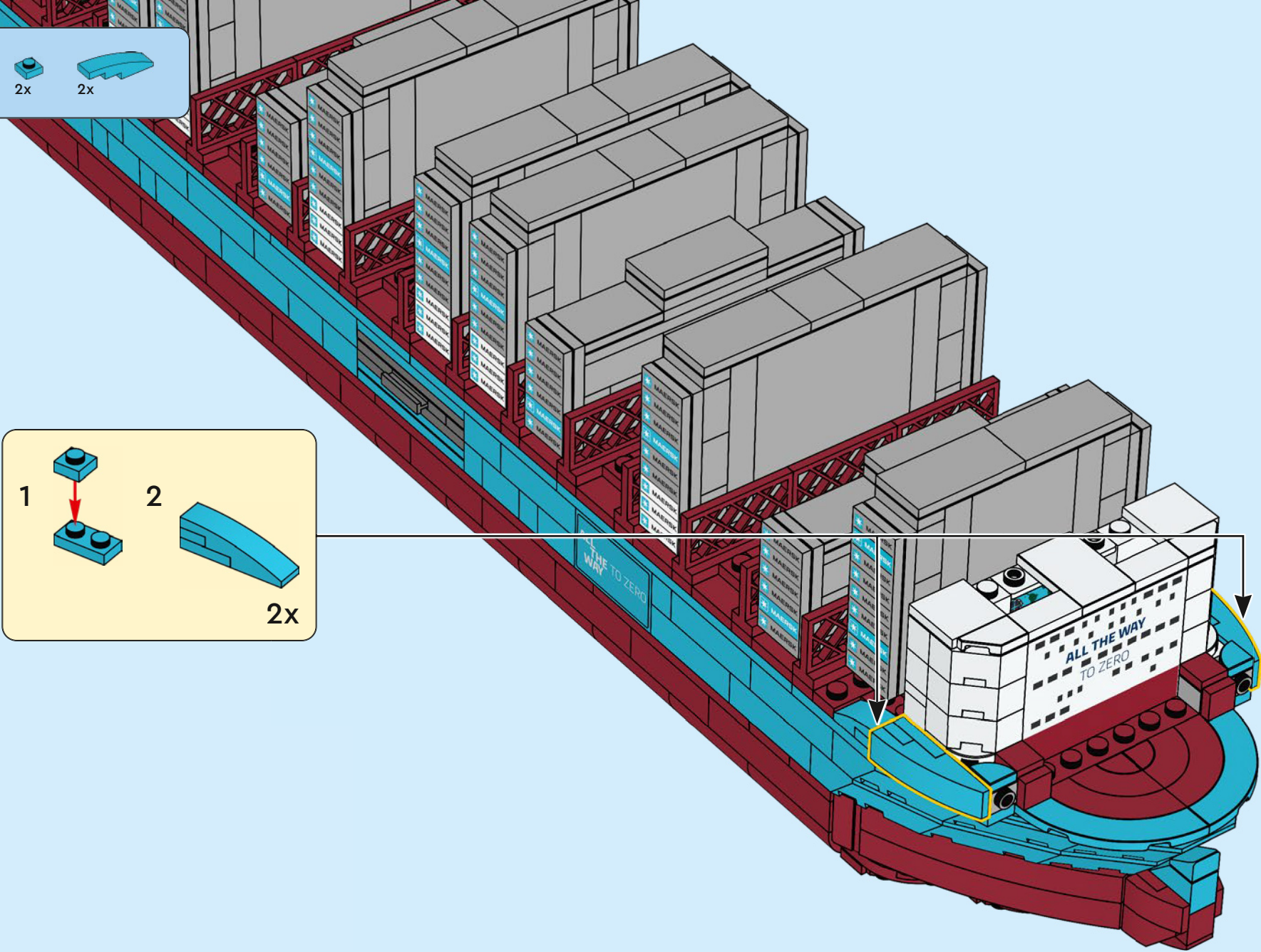

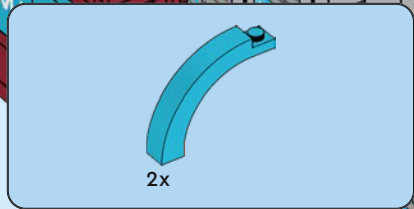

241

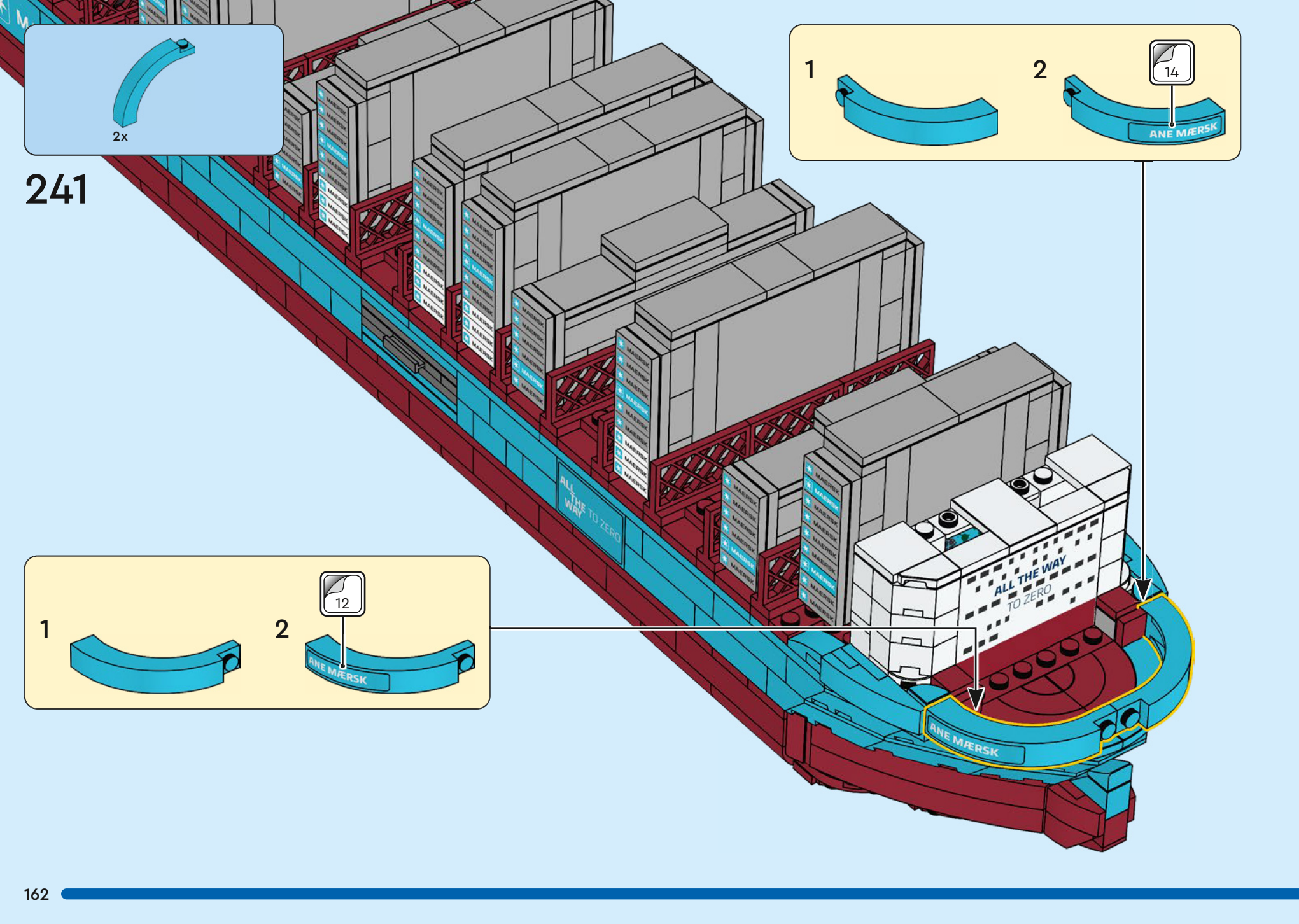
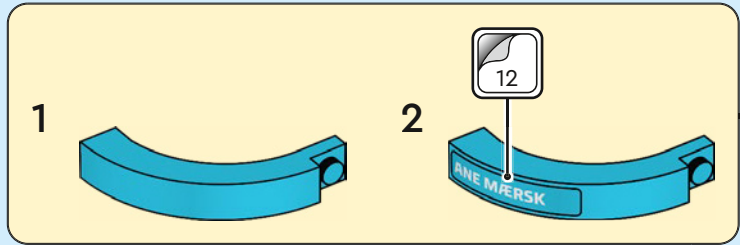
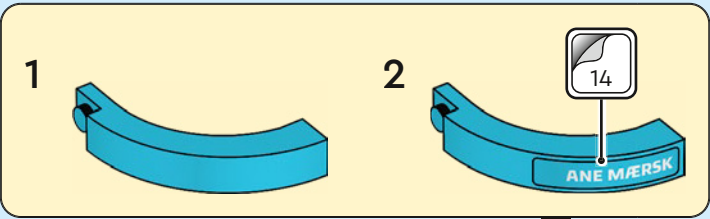

1x

242

1

2

13

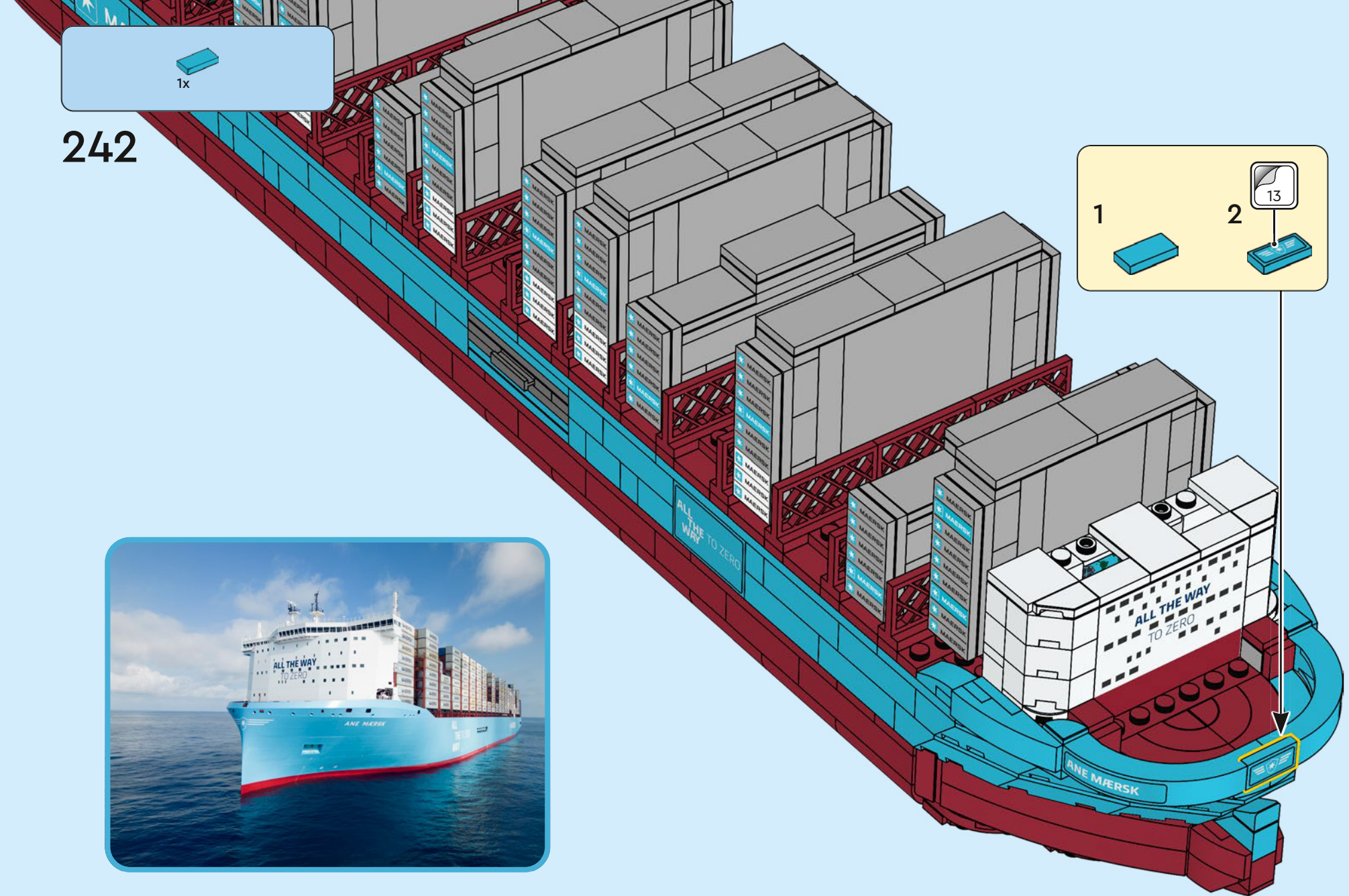

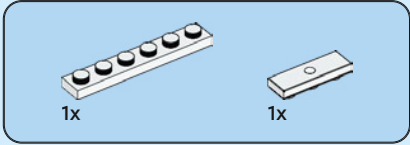
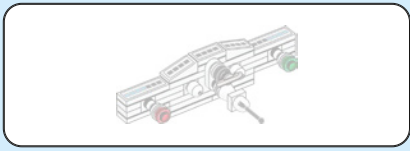

243

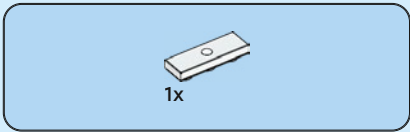
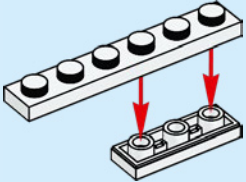

244

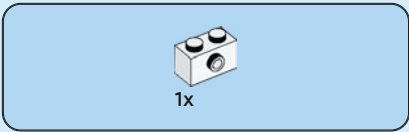
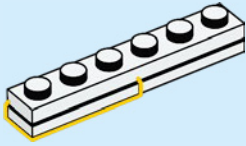

245

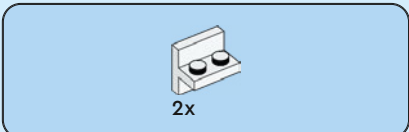
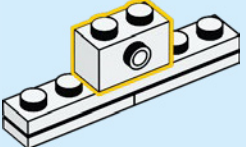

246

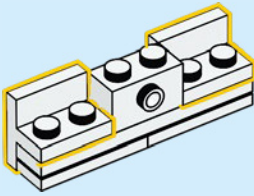



2x

247

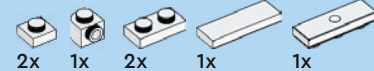
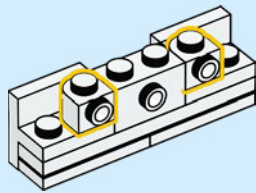

248

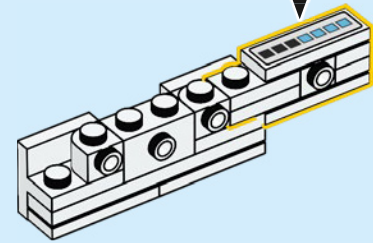
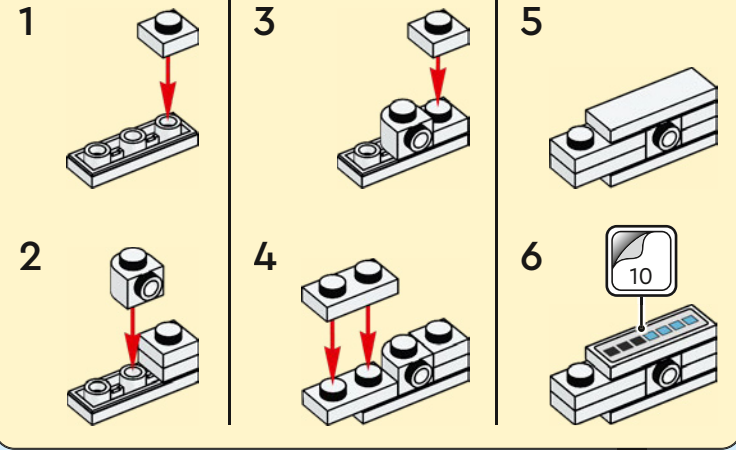

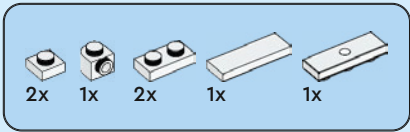

249

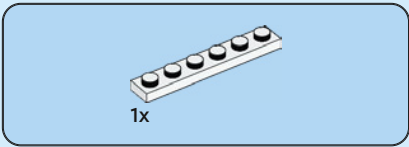
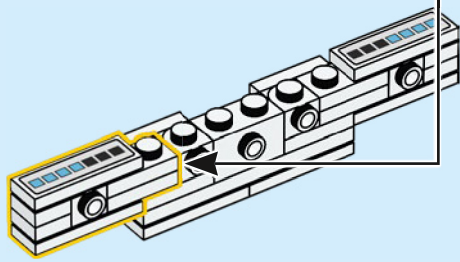
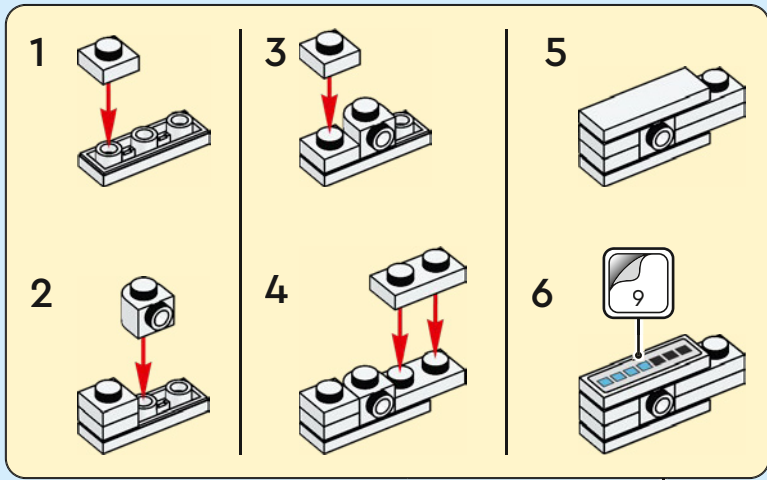

250

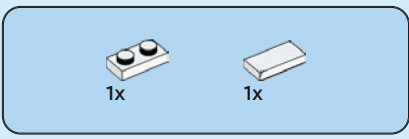
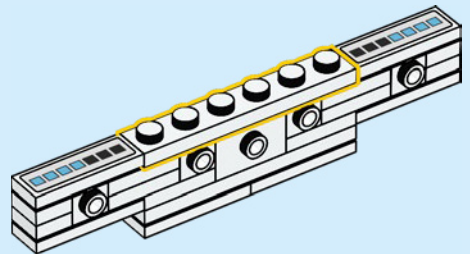

251

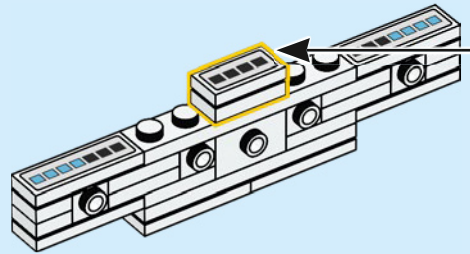
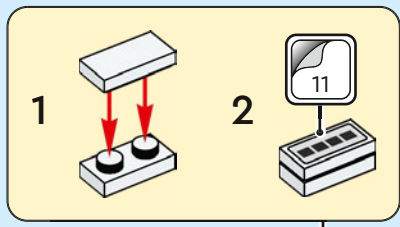

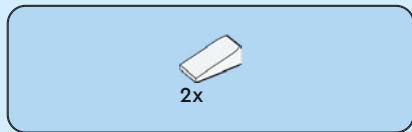

252

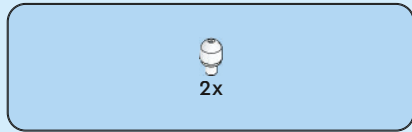
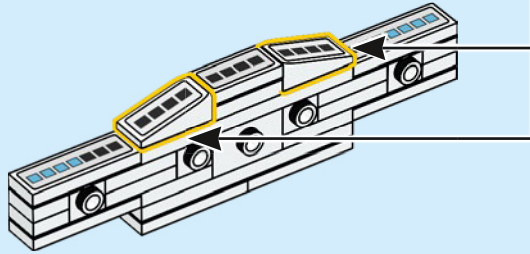
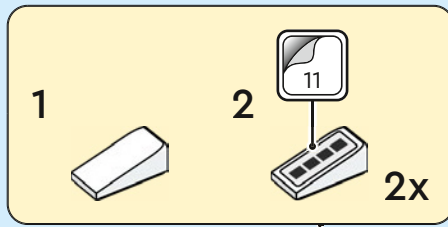

253

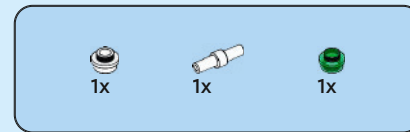
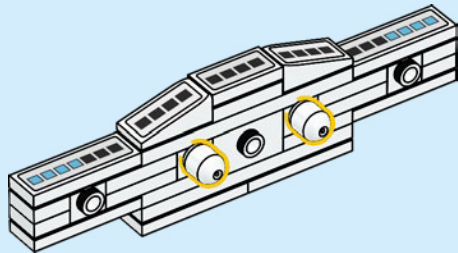

254

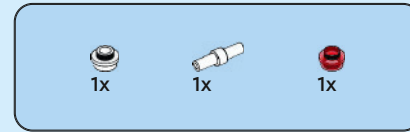
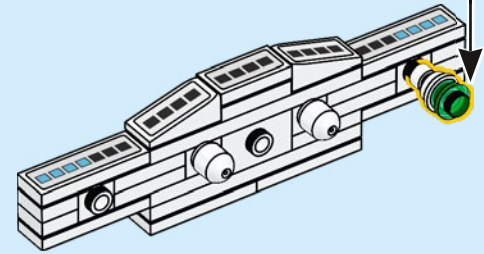
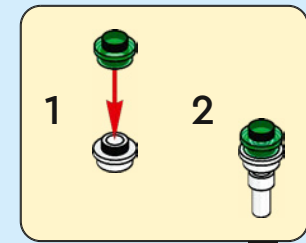

255

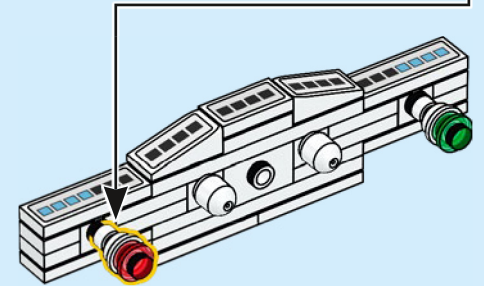
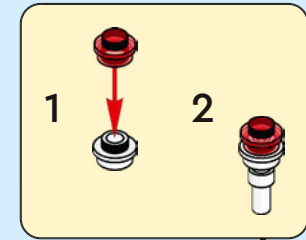

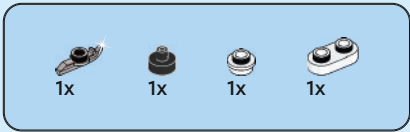

256

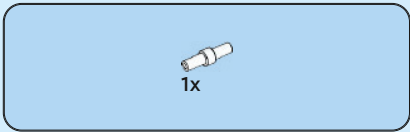
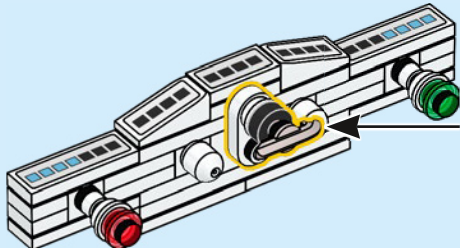
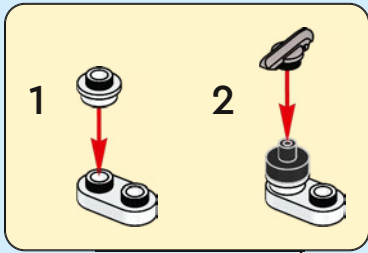

257

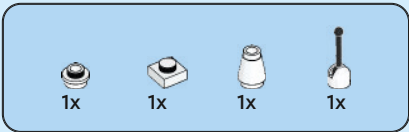
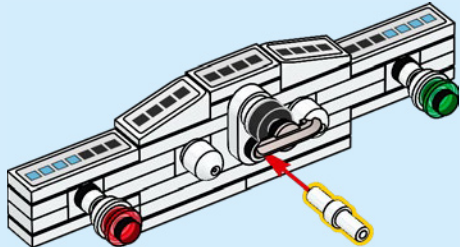

258

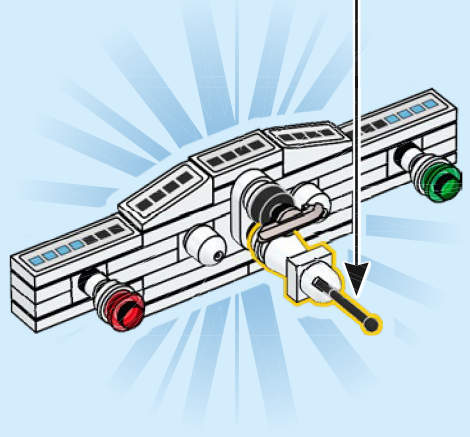
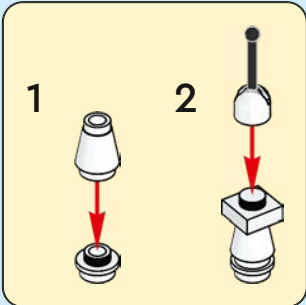

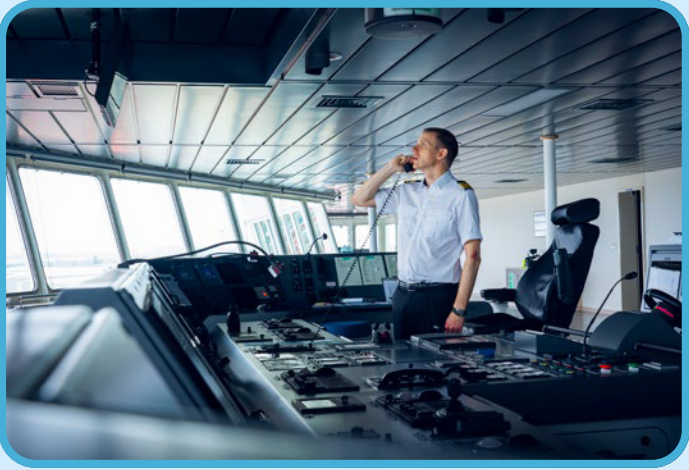
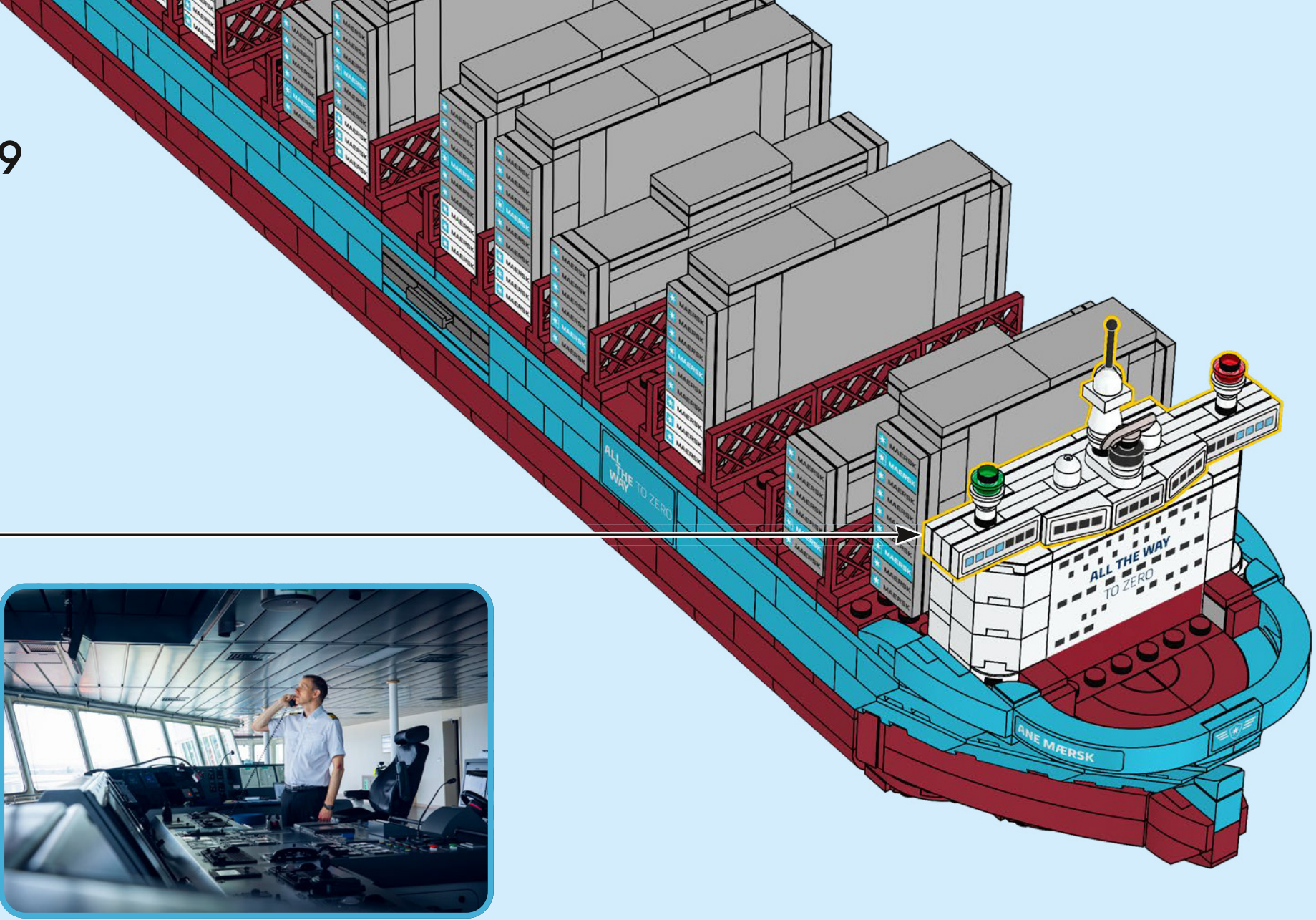

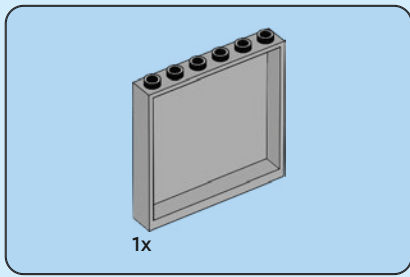

261

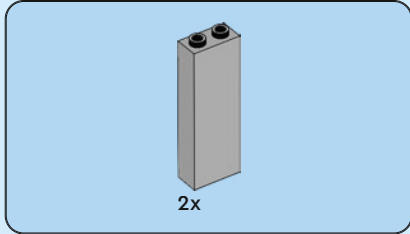
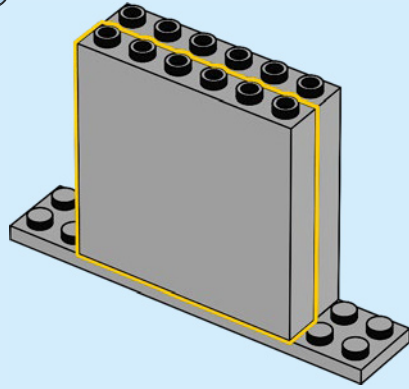

262

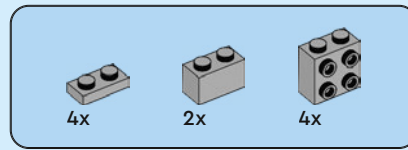
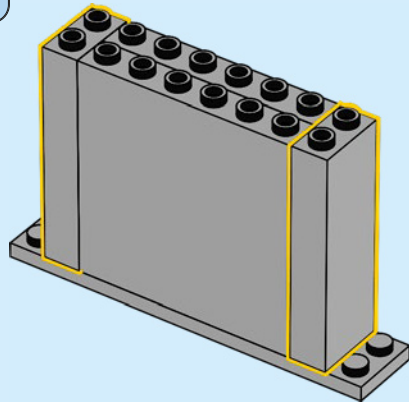

263

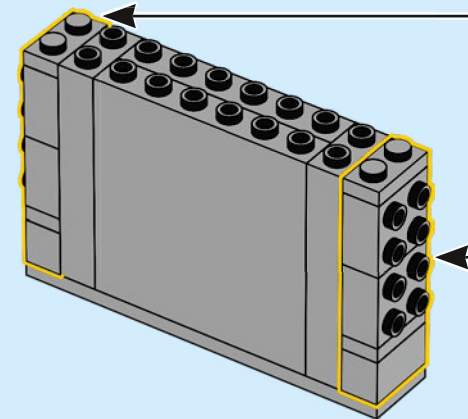
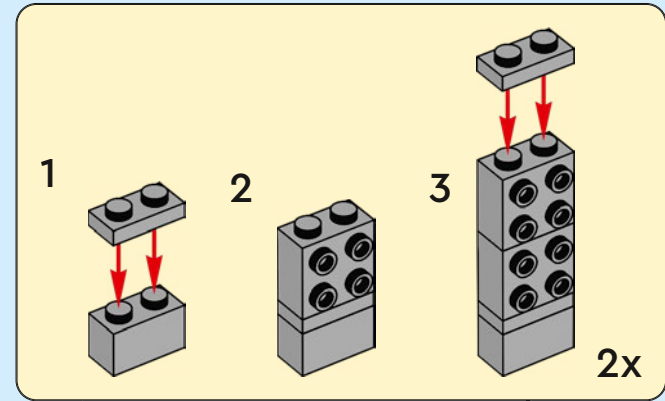

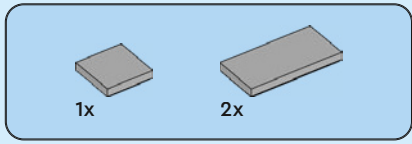

264

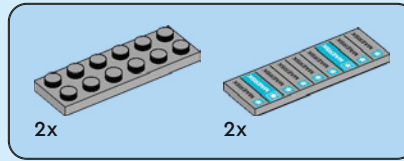
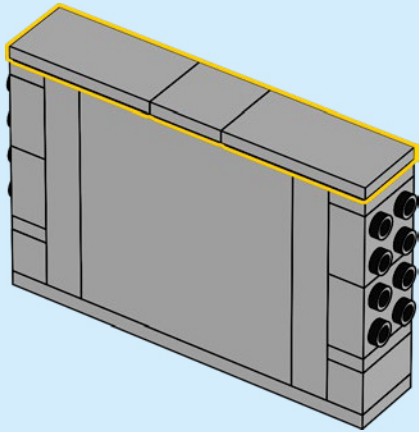

265

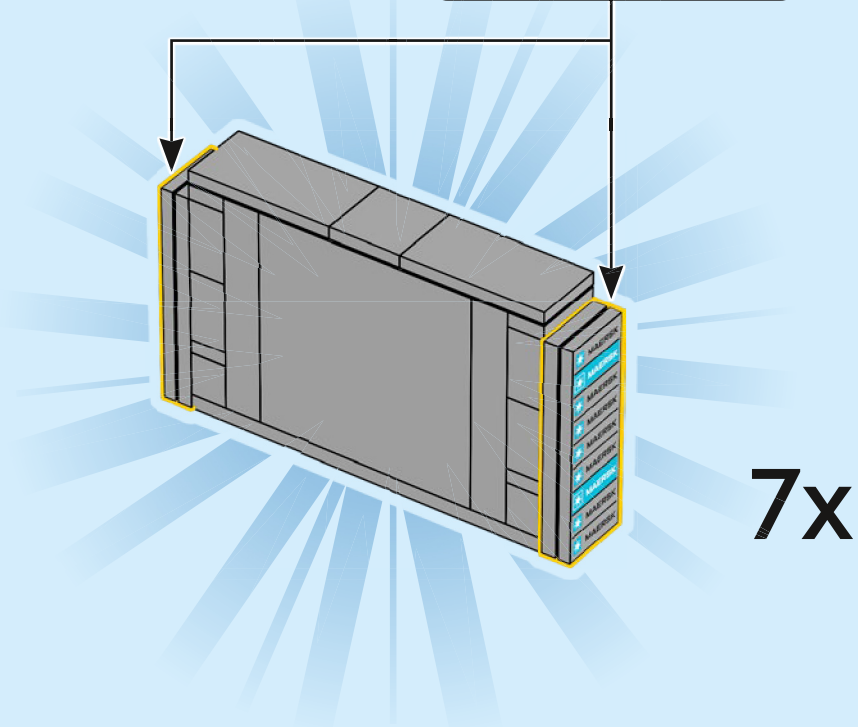
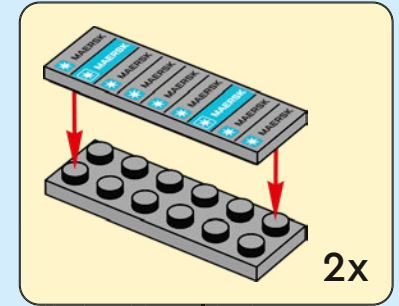

266

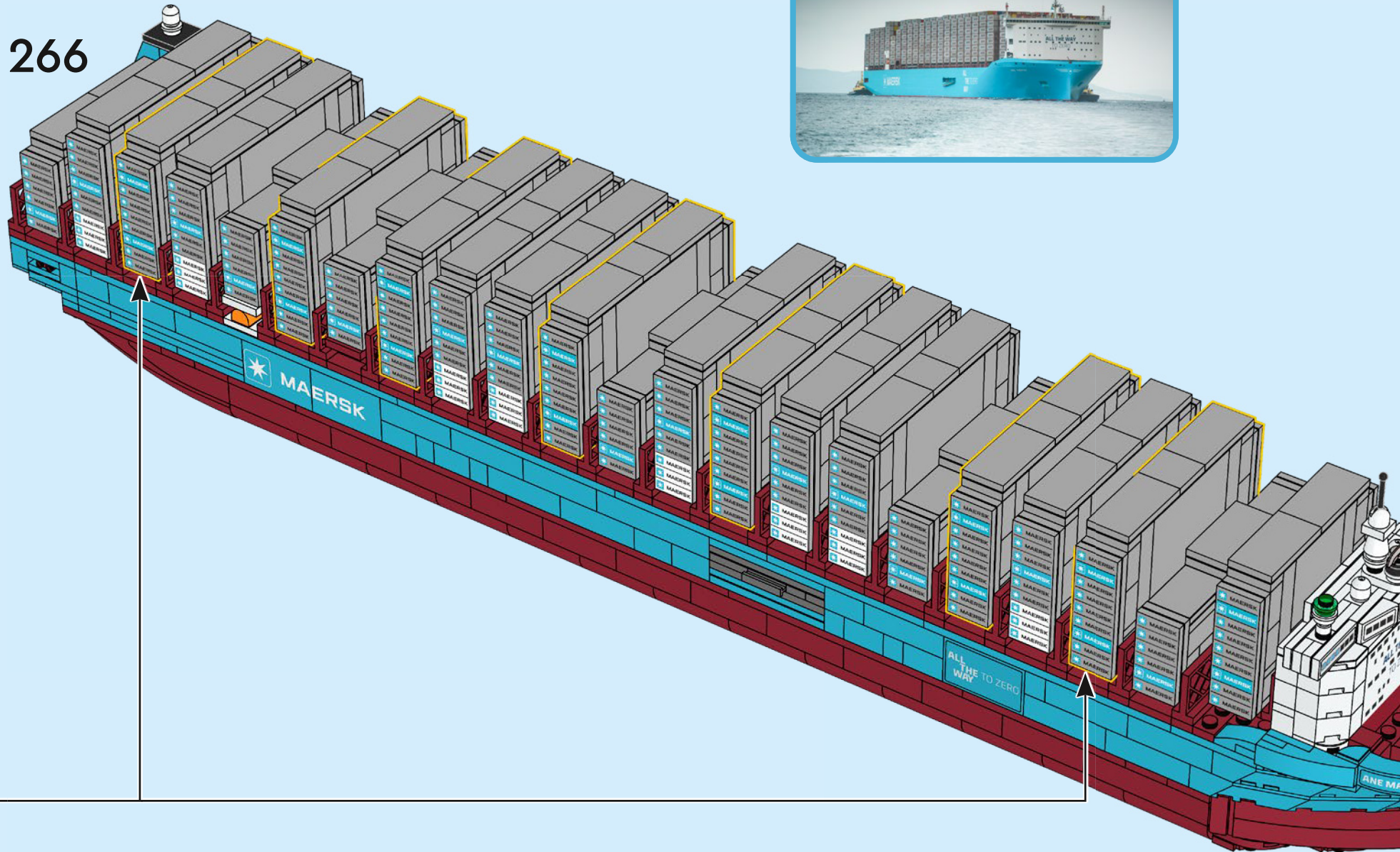

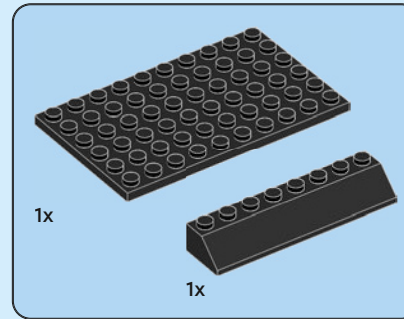
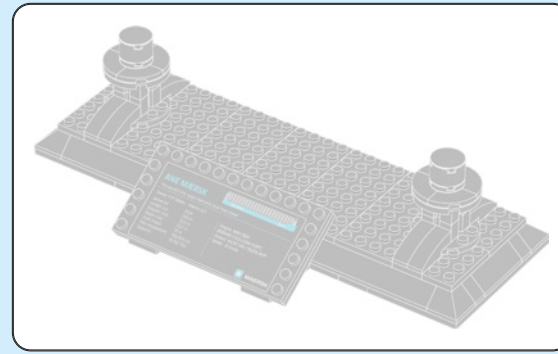

267

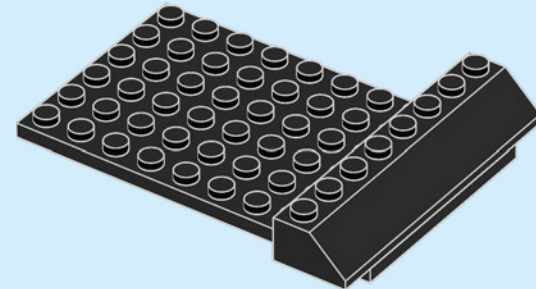

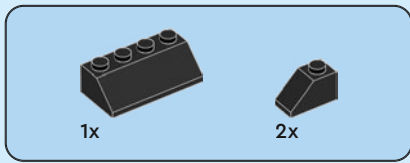

268

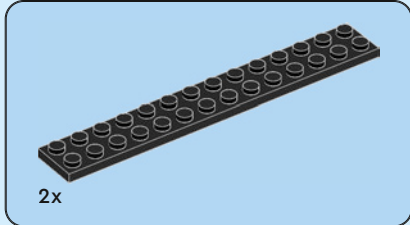
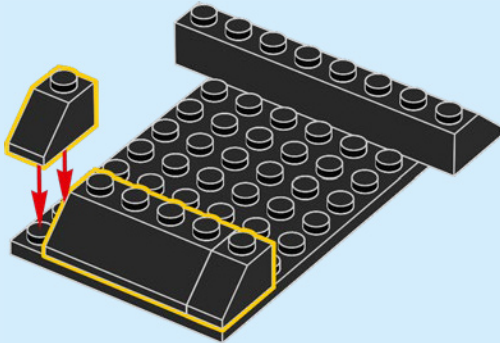

269

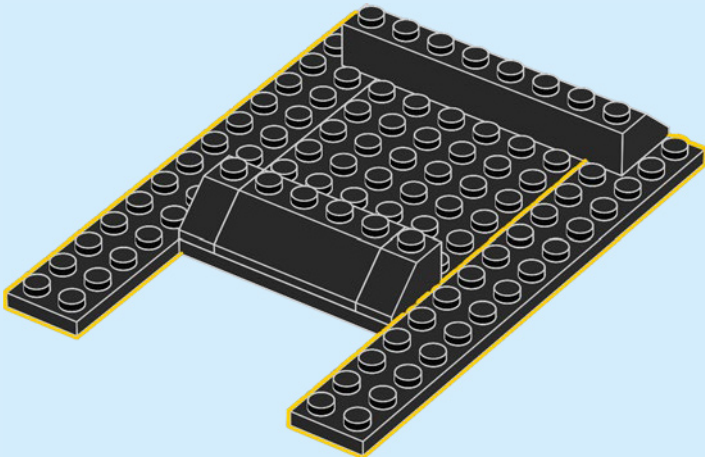

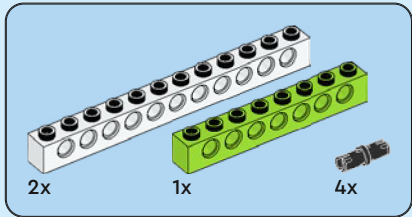
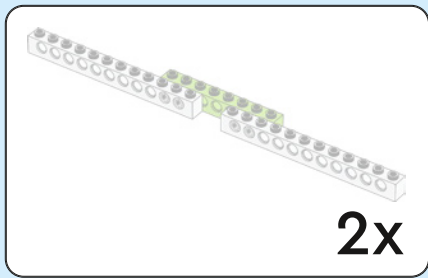

270

1

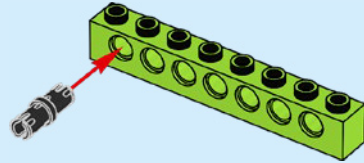

2

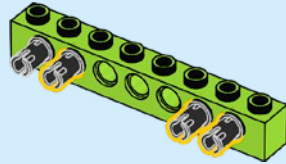

3

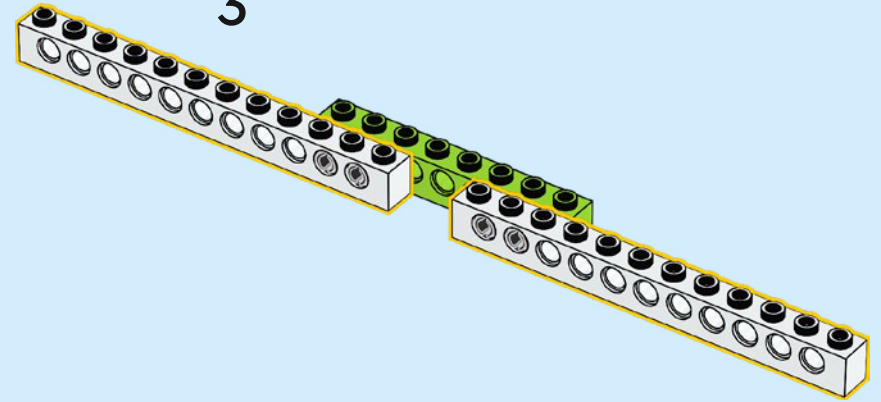

2x

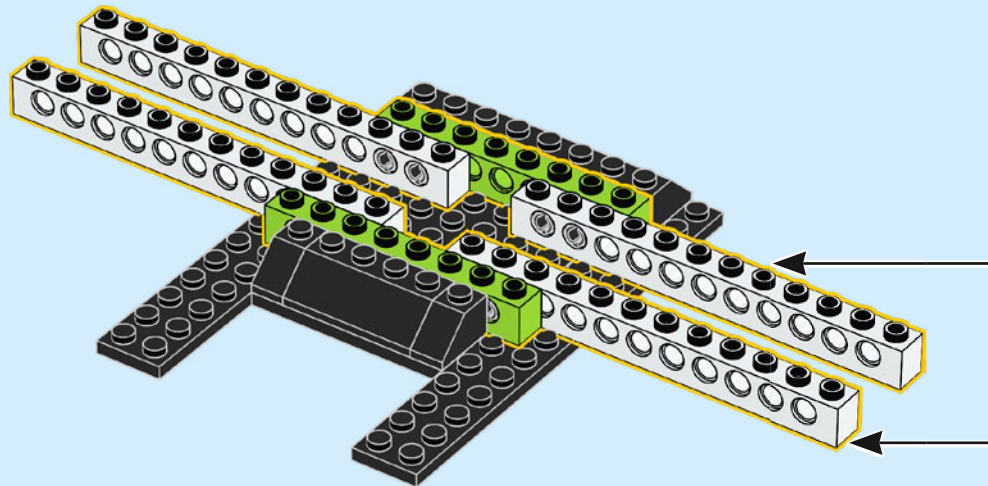

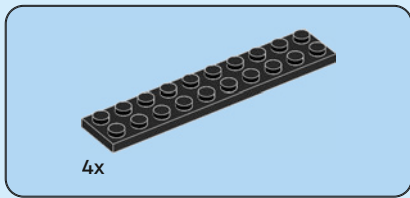

271

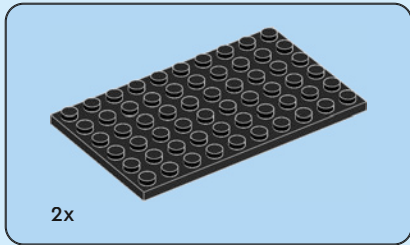
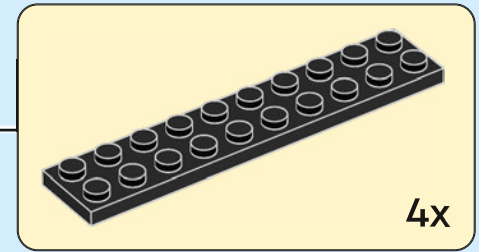
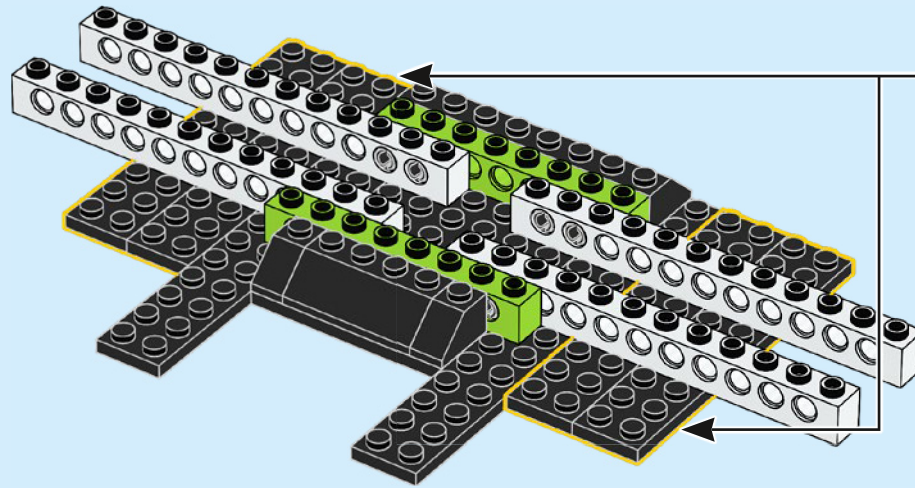

272

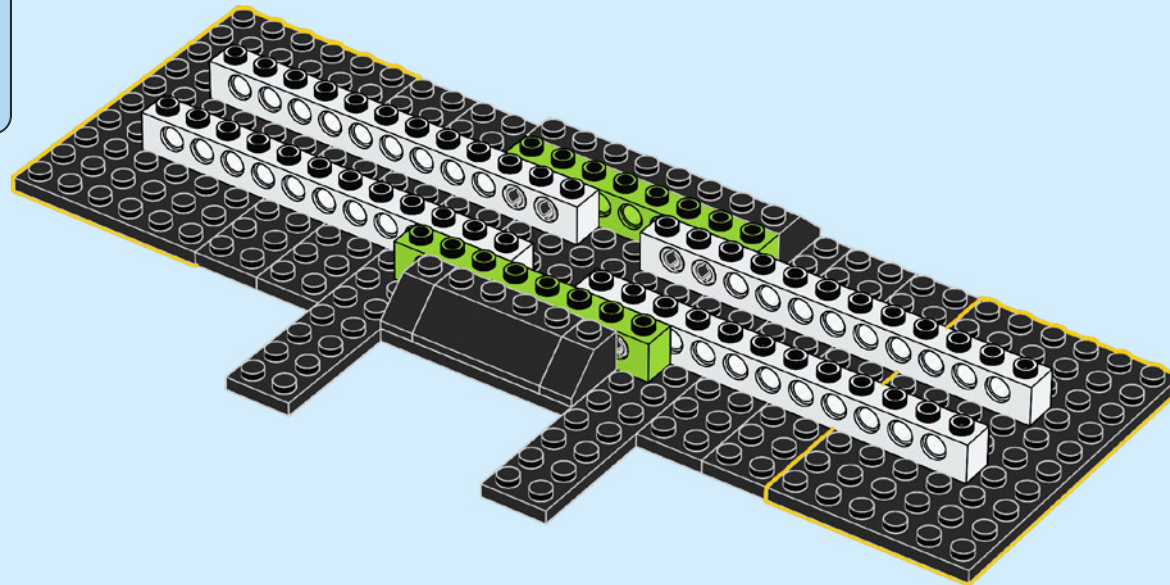

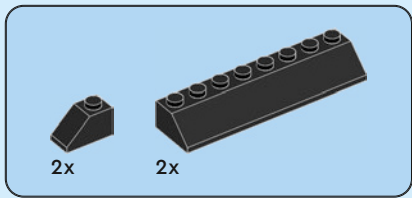

273

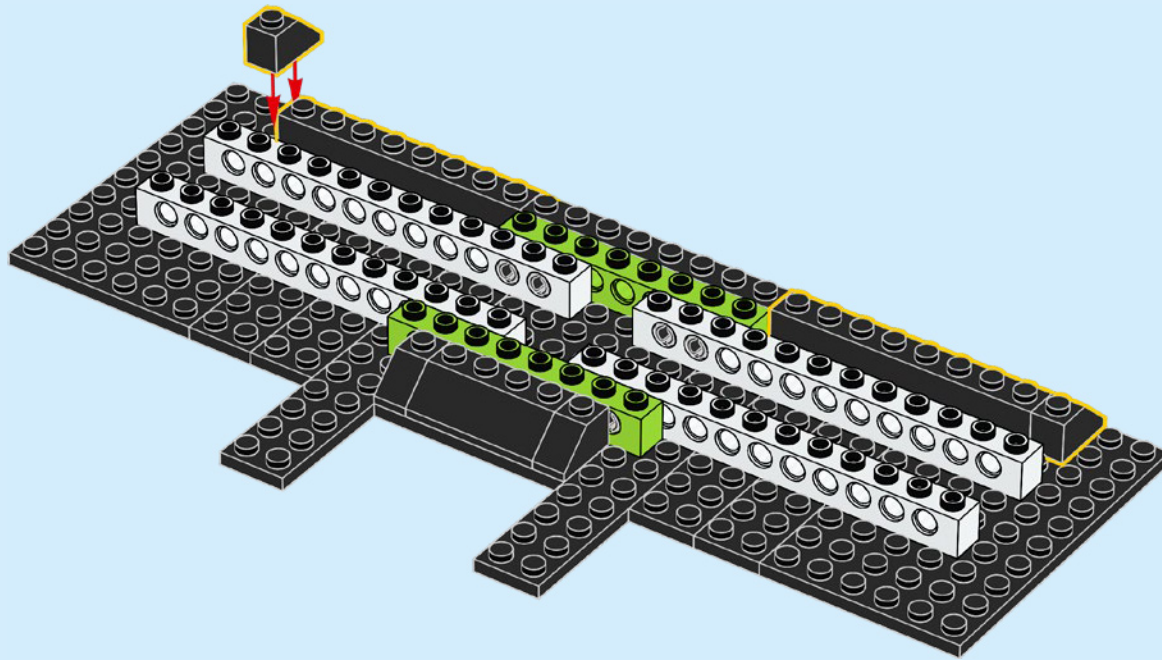

274

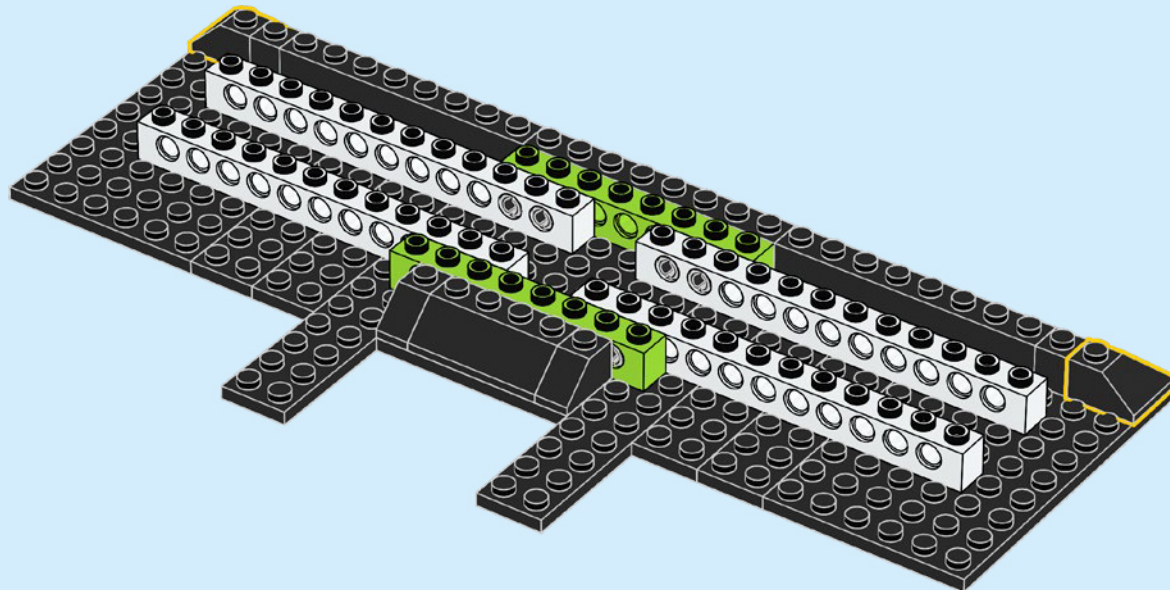

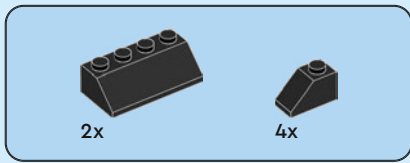

275

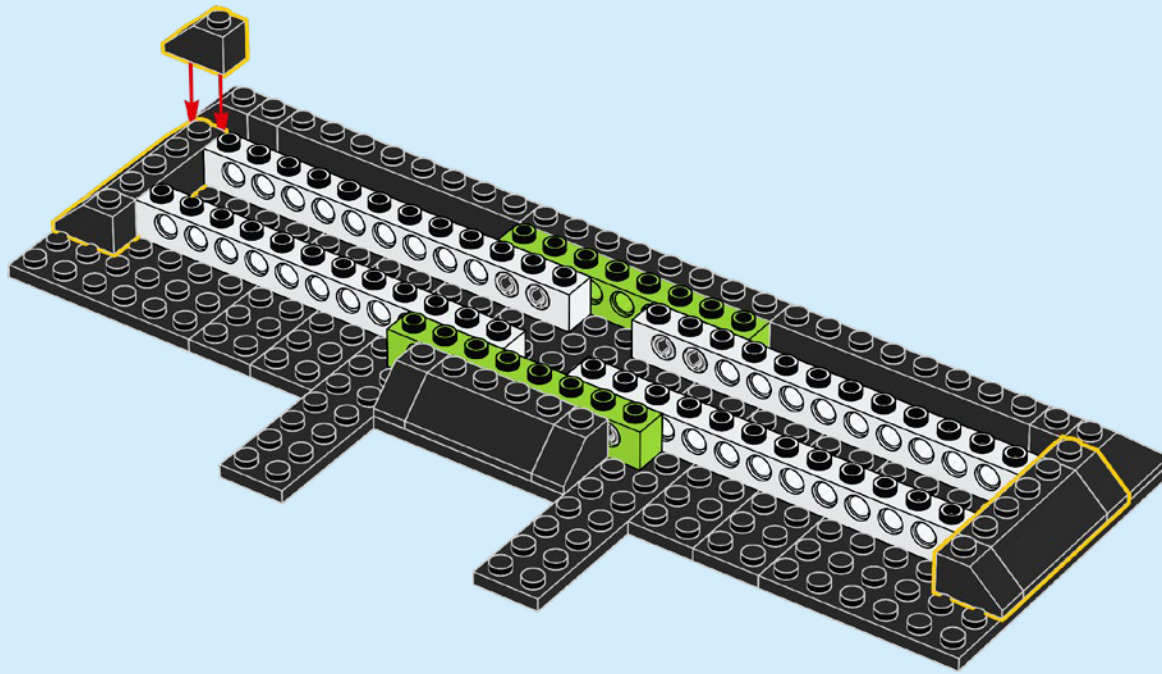

276

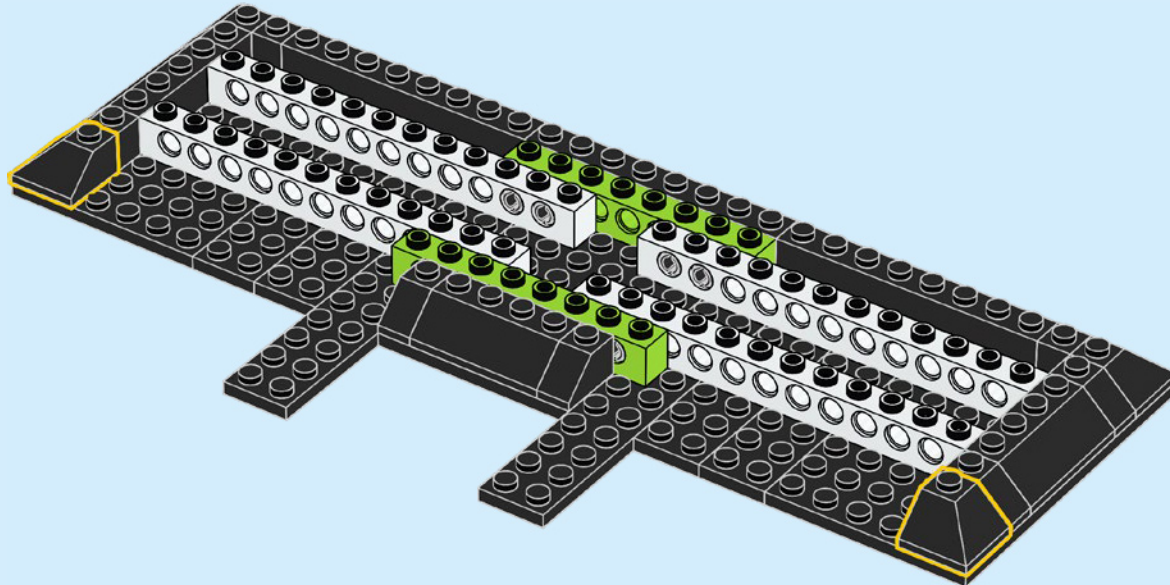



2x



2x

277

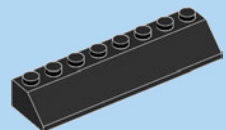
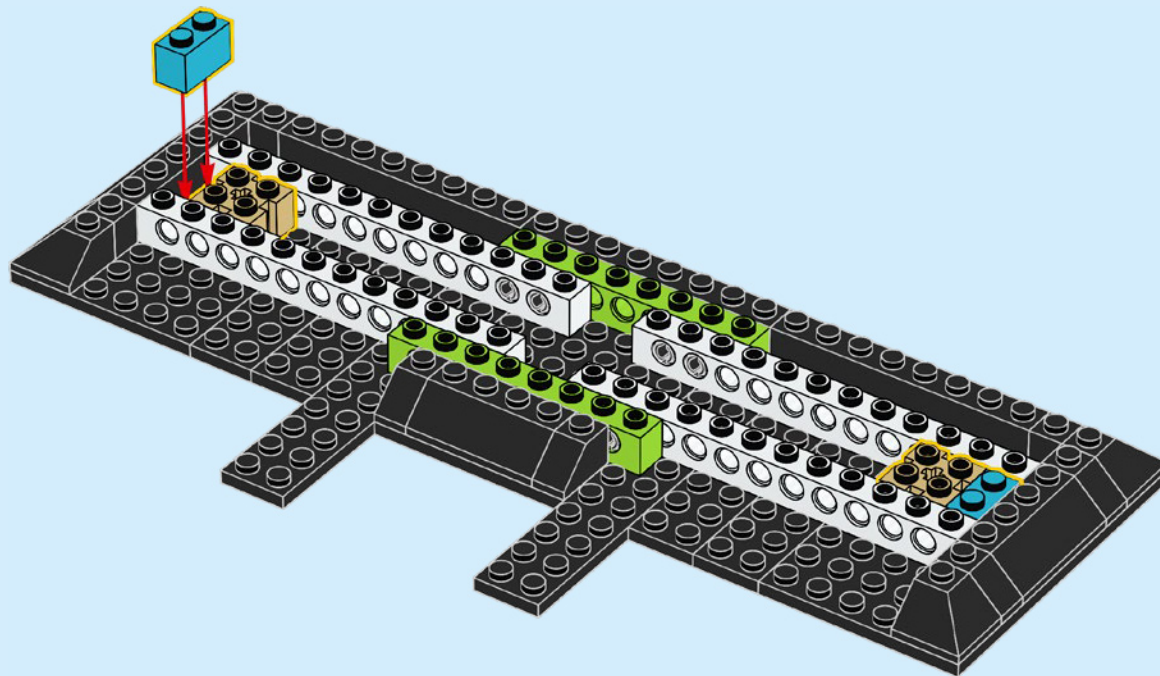

2x

278

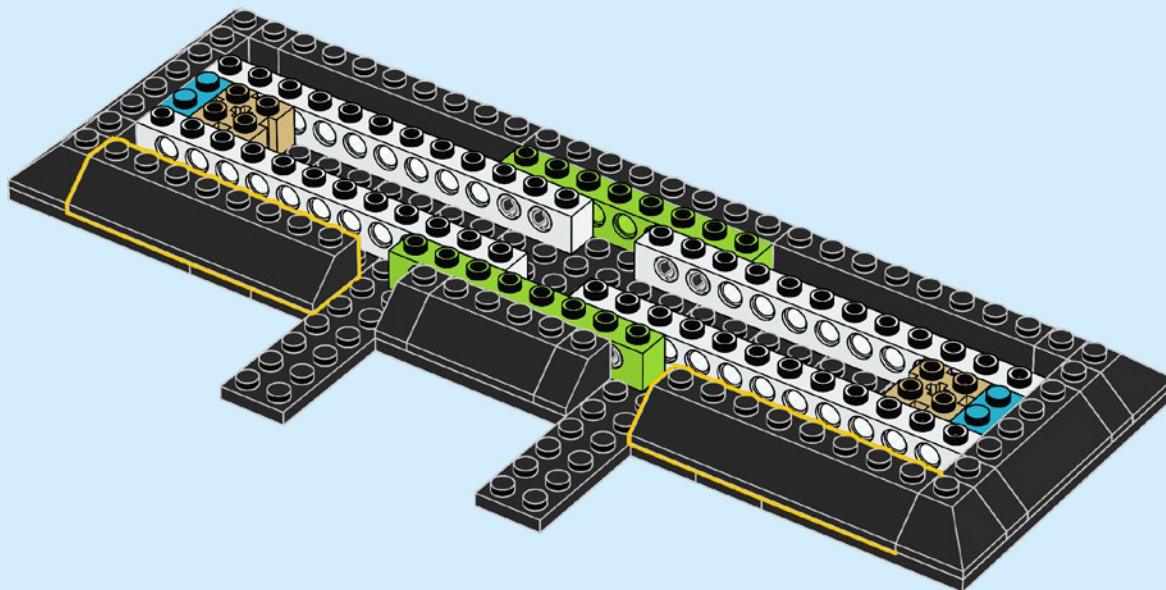

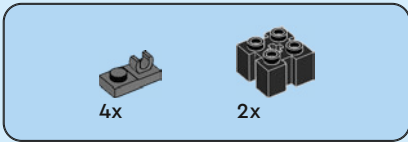

279

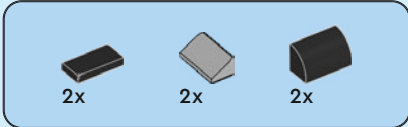
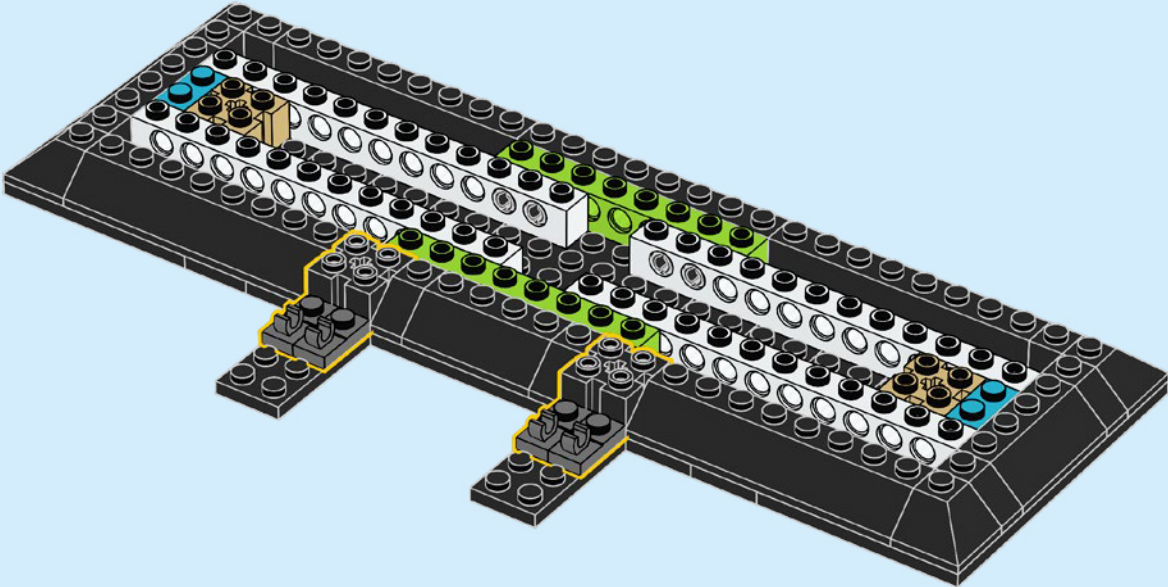

280

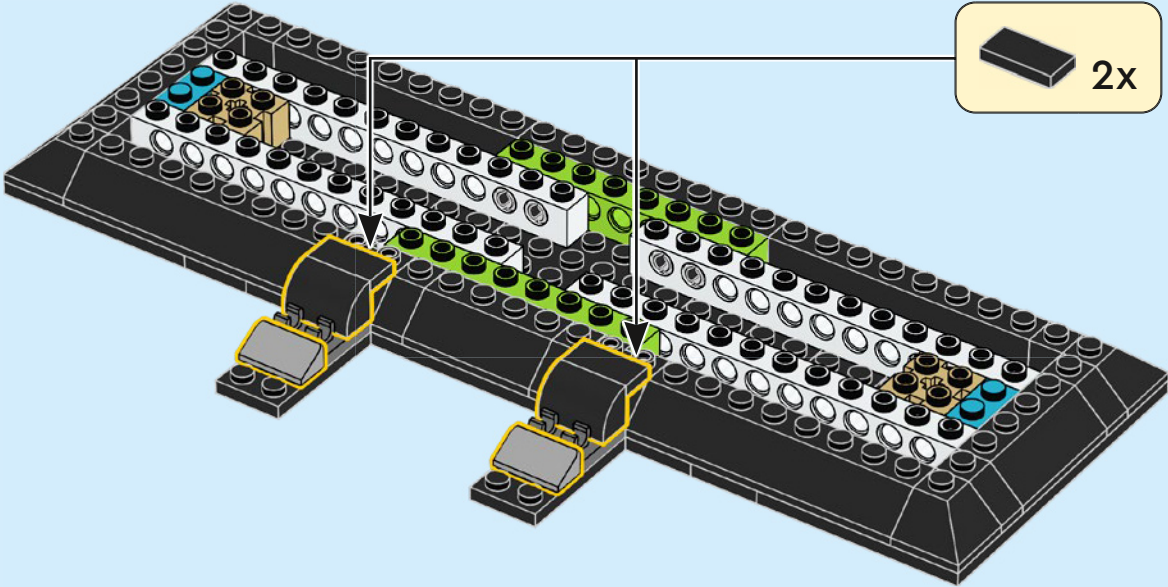

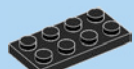

4x

281

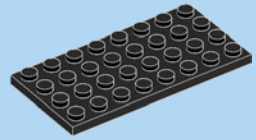
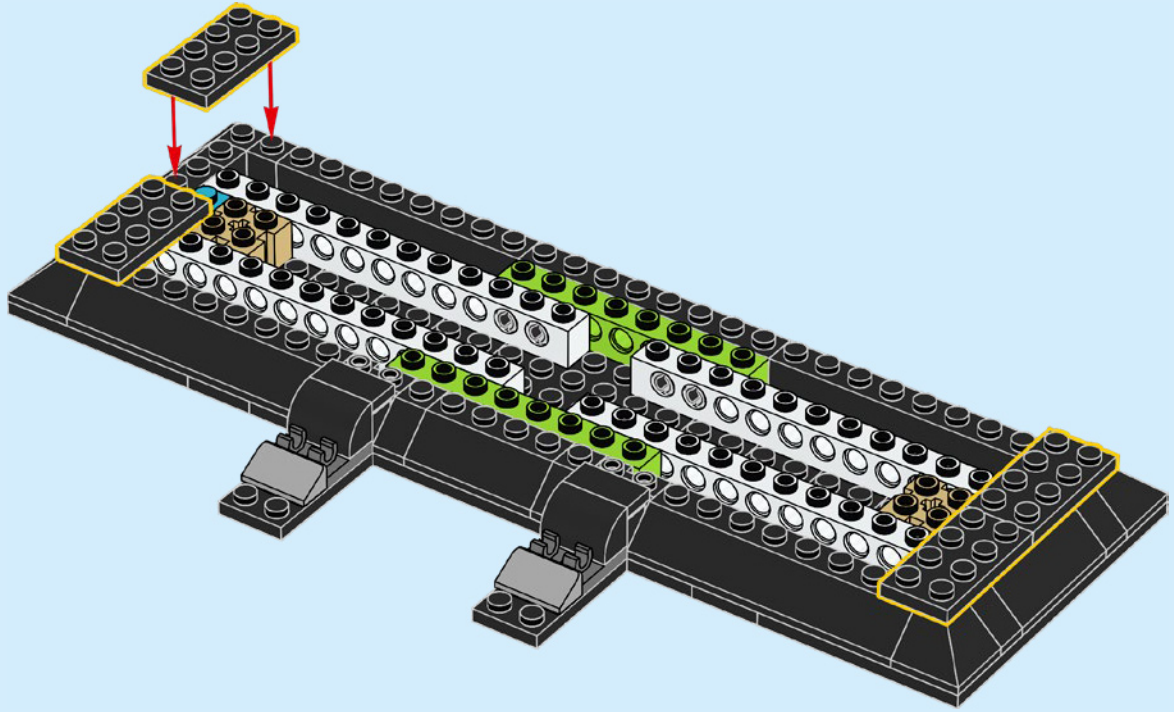

5x

282

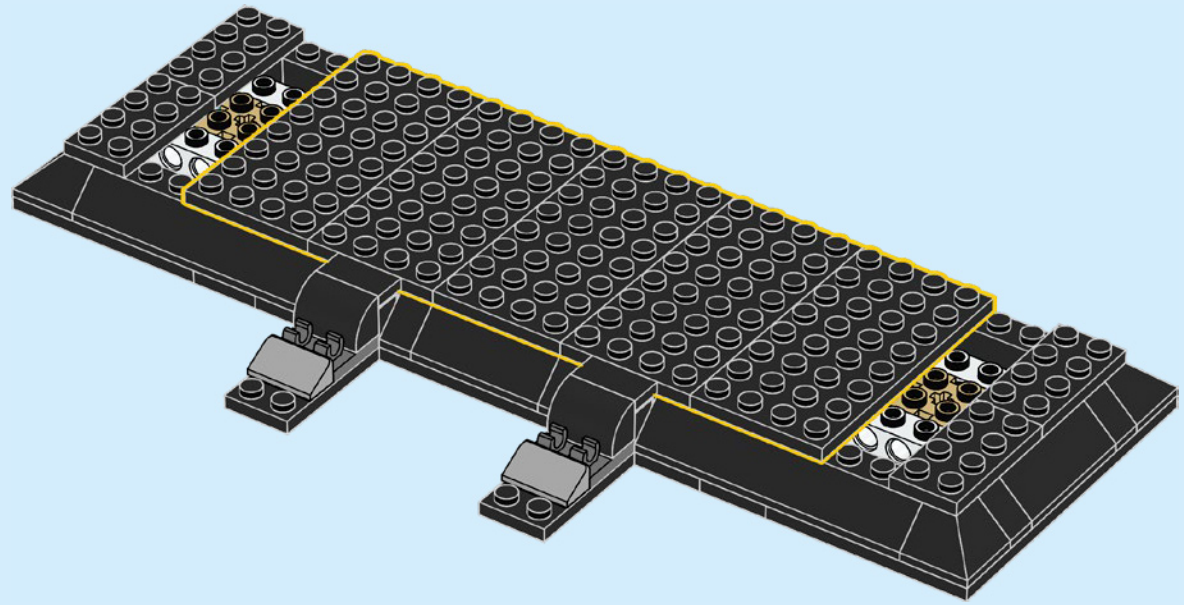

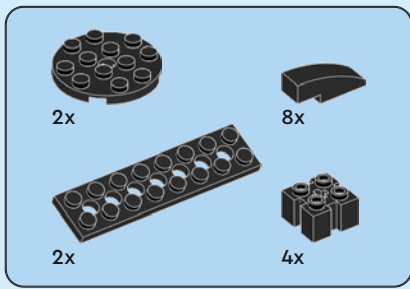

283

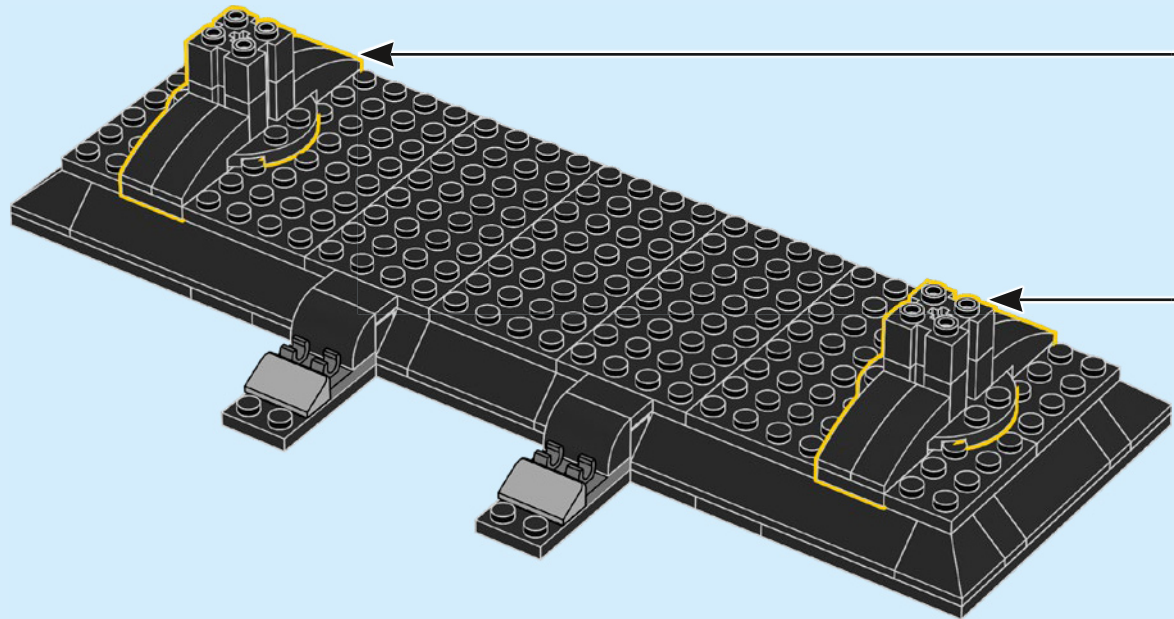
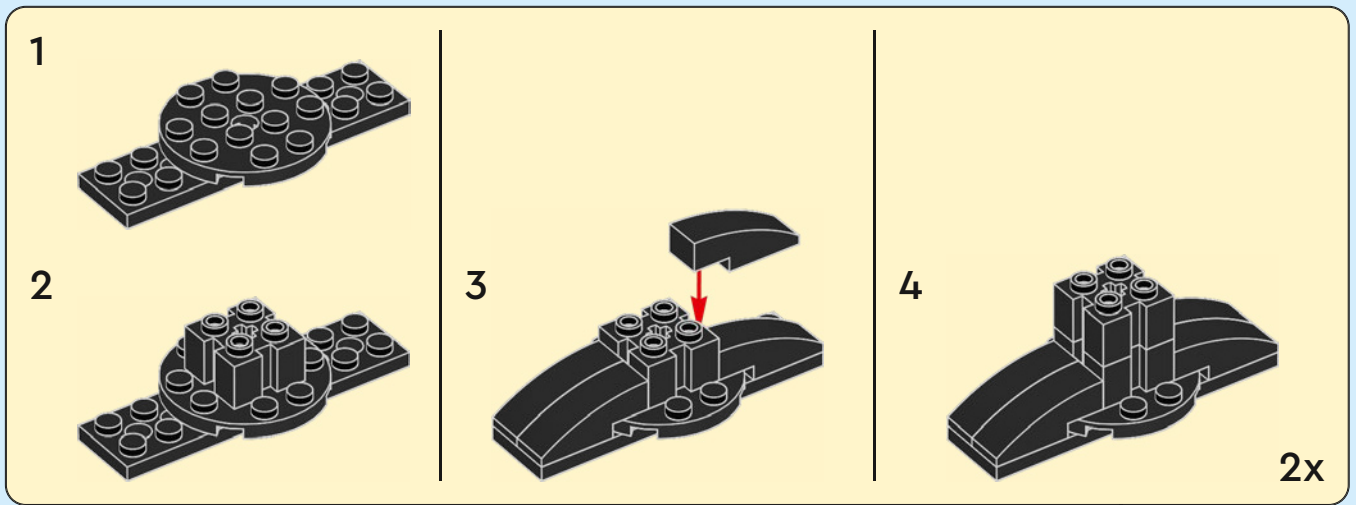

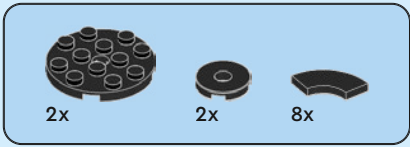

284

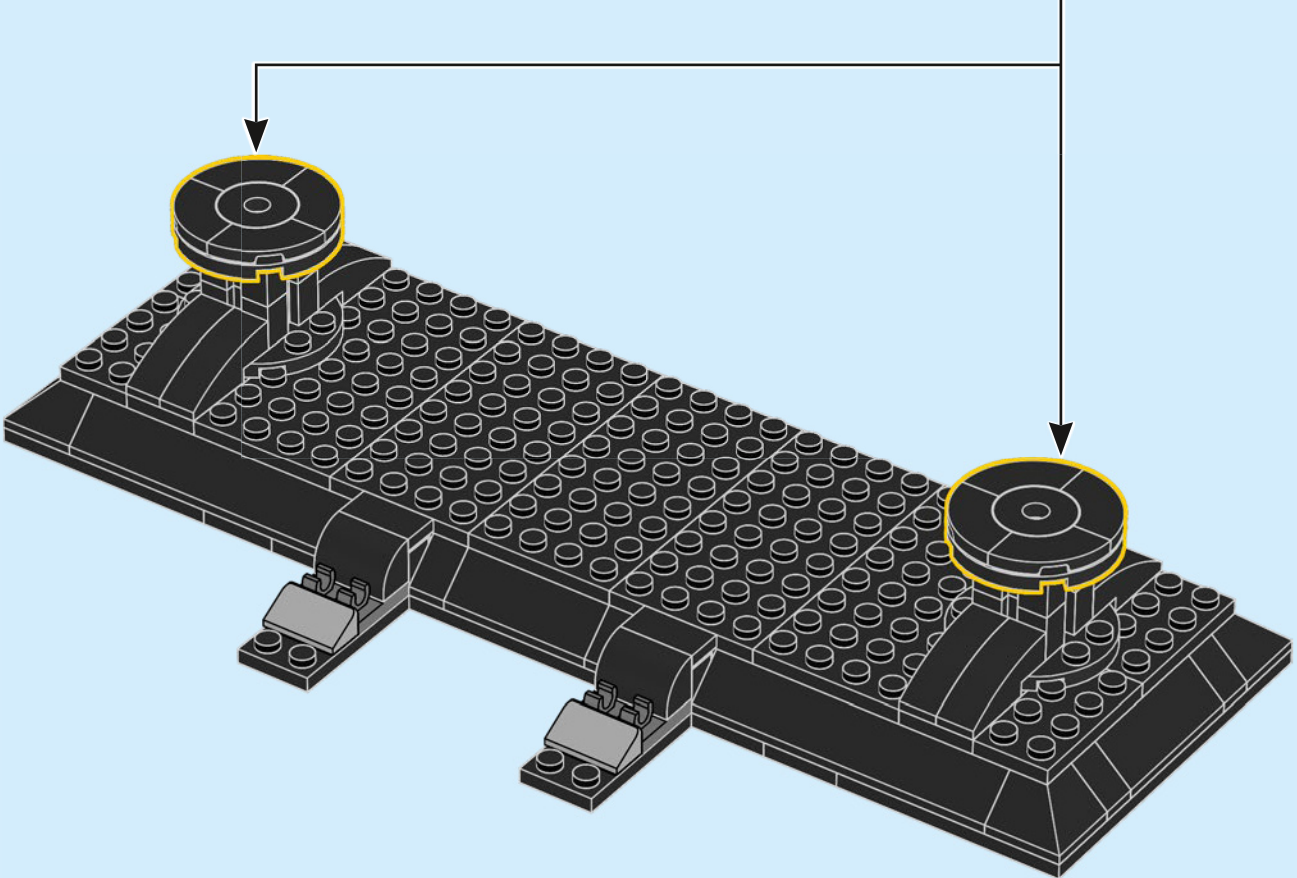
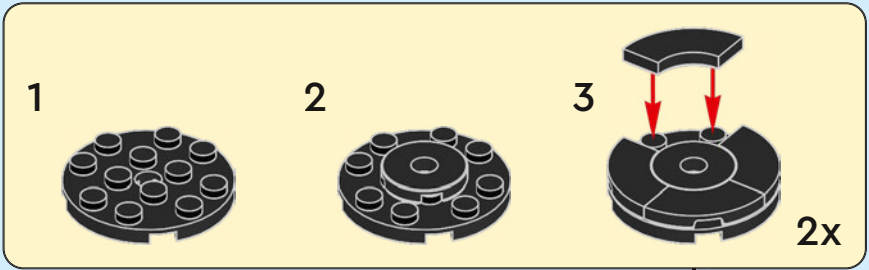

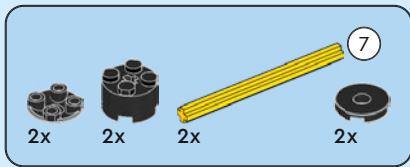

285

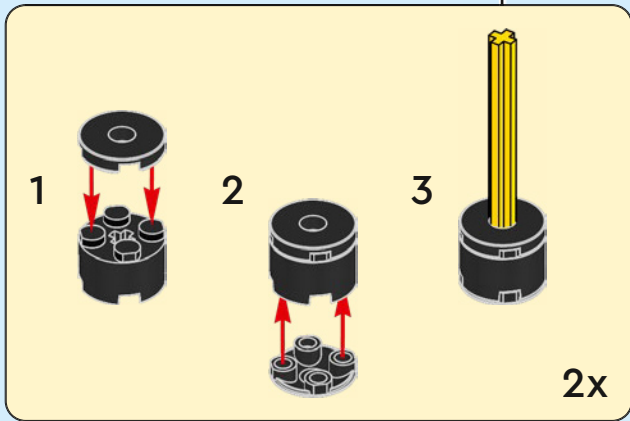
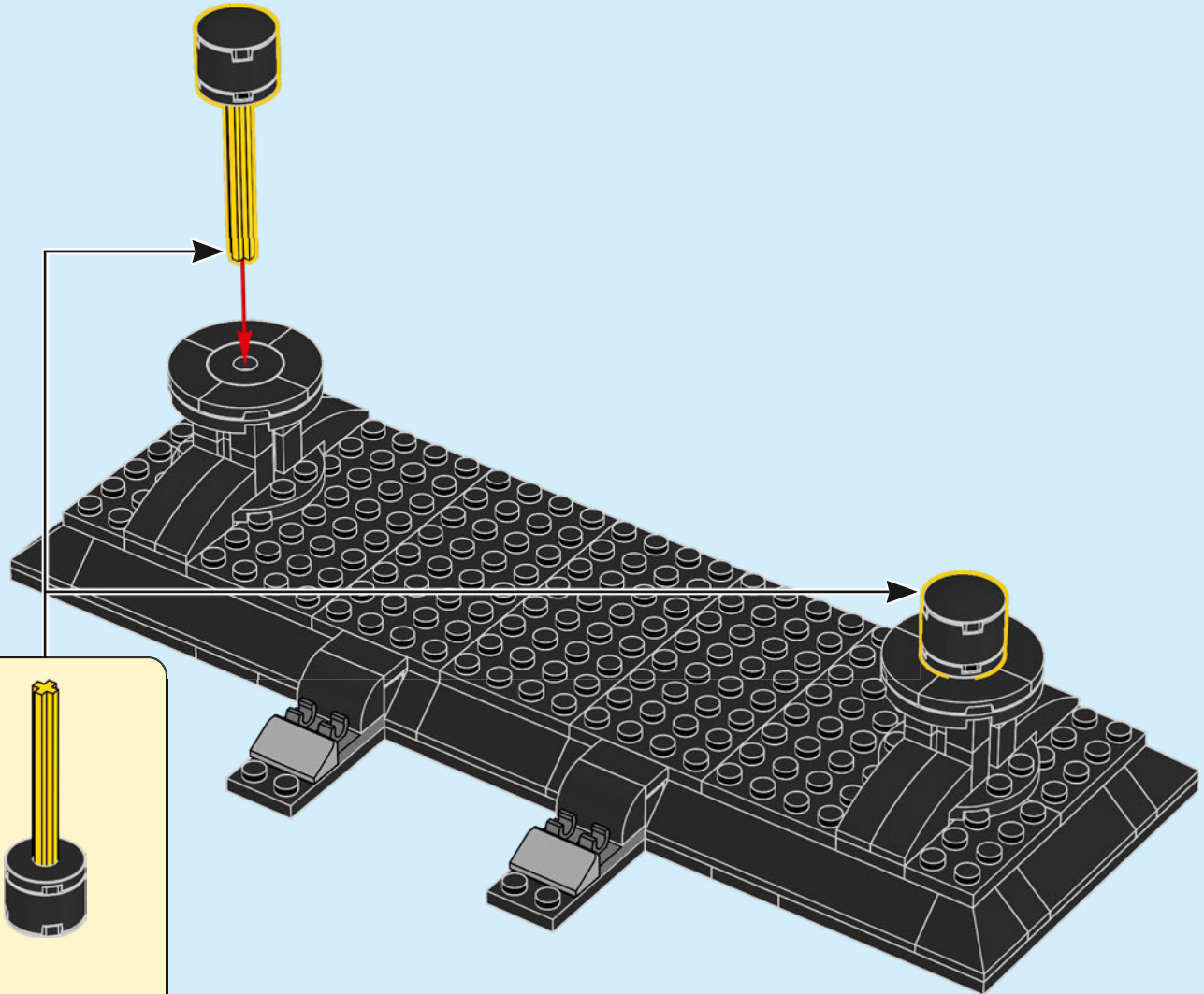

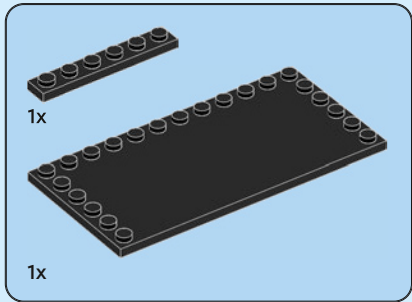

286

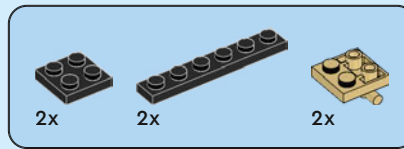
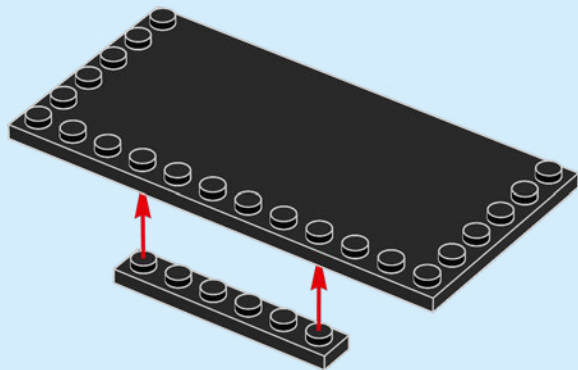

287

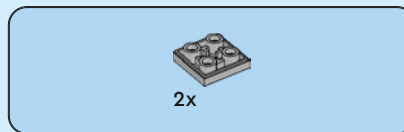
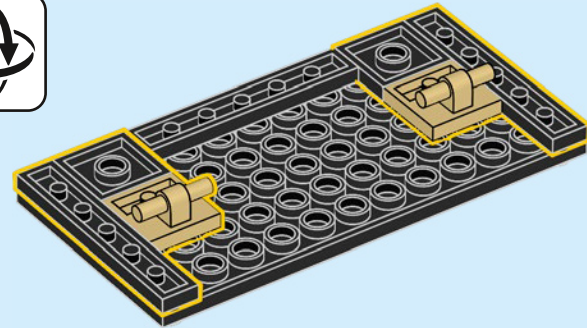

288

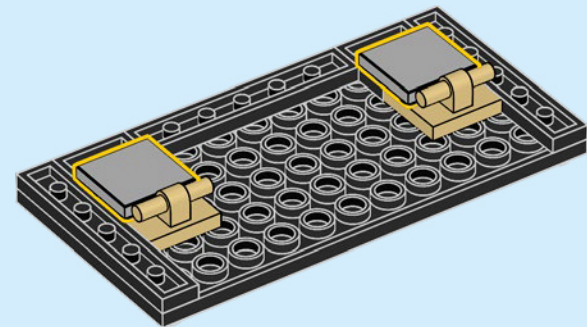

289

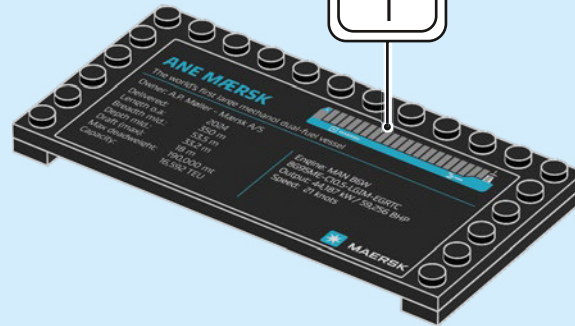

290

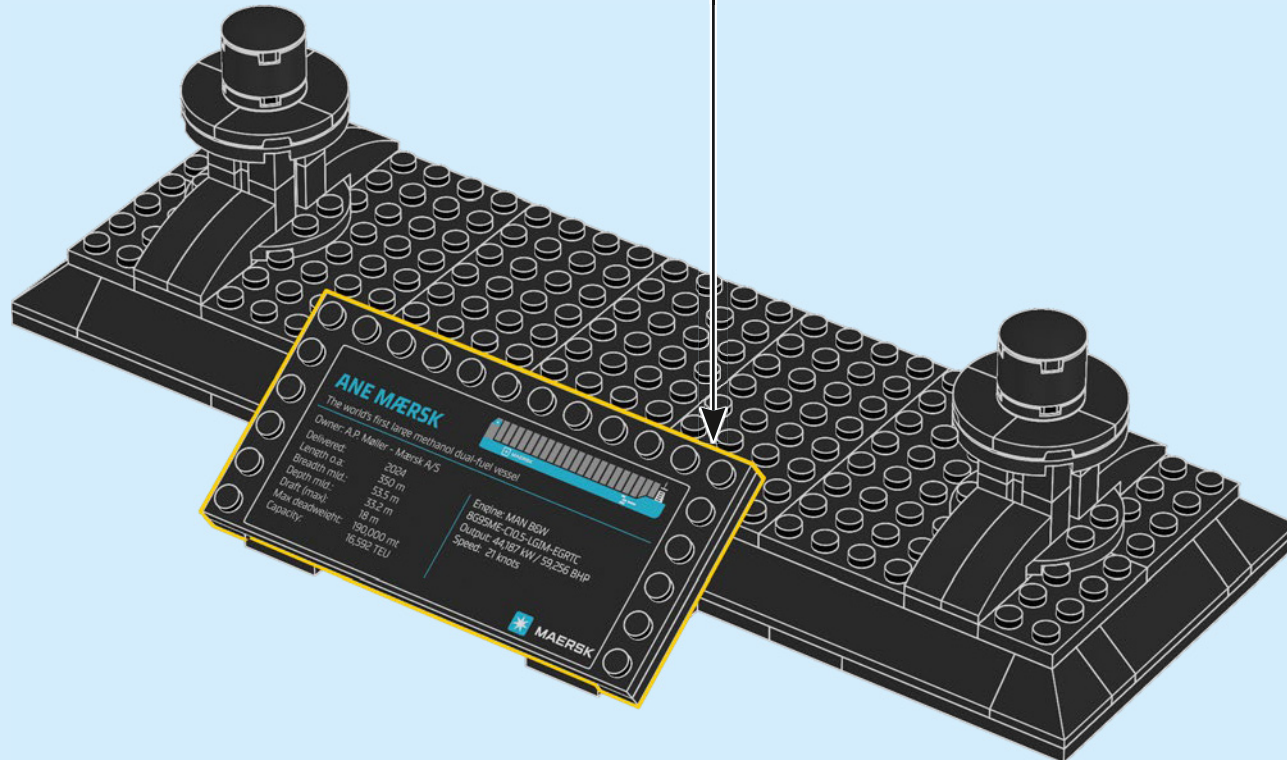

- 4x 6584062
- 4x 4541528
- 2x 6586652
- 1x 6335319
- 21x 6052777
- 6x 4541507
- 4x 4539071
- 10x 6576807
- 66x 6584063
- 1x 6465734
- 2x 6602414
- 2x 4539062
- 1x 6476042
- 1x 6350339
- 26x 6253142
- 4x 6186106
- 1x 6544174
- 6x 6440979
- 1x 4211392
- 6x 4211406
- 25x 4211462
- 2x 4211705
- 1x 6539385
- 11x 6015344
- 9x 6258831
- 2x 4568637
- 1x 4211415
- 2x 4568637
- 4x 4211412
- 33x 4211388
- 2x 4211399
- 11x 6598026
- 6x 6227897
- 70x 4211398
- 27x 4211395
- 12x 6061675
- 4x 6059033
- 2x 6079461
- 30x 4527174
- 16x 6598025
- 16x 6595947
- 35x 4211452
- 64x 6123809
- 6x 4211564
- 3x 6170387
- 32x 4211363
- 4x 6469440
- 1x 6446028
- 2x 6132886
- 2x 6043639
- 2x 4211580
- 15x 4211413
- 4x 6258820
- 10x 4211387
- 10x 6171894
- 10x 4211396
- 12x 4211386
- 1x 6514057
- 1x 6514051
- 2x 4210719
- 2x 4211063
- 4x 6344754
- 1x 6514456
- 2x 6123814
- 4x 4543086
- 1x 4218696
- 6x 4211094
- 11x 4211056
- 2x 4210651
- 1x 6287847
- 1x 6322046
- 2x 6215606
- 1x 6292145
- 1x 6088641
- 2x 6335563
- 1x 6593293
- 2x 6603341
- 8x 6603339
- 2x 6603283
- 4x 6603285
- 6x 6603587
- 8x 6603337
- 2x 6603334
- 1x 6603315
- 4x 6603598
- 17x 6603336
- 1x 6603301
- 1x 6603600
- 1x 6603591
- 1x 6603586
- 1x 6603585
- 2x 6603590
- 2x 6603344
- 2x 6603309
- 3x 6603316
- 1x 6593286
- 2x 6604733
- 2x 6603601
- 7x 6603965
- 30x 6603319
- 2x 6603317
- 2x 6576809
- 2x 6603313
- 1x 6598028
- 2x 6576810
- 1x 6598027
- 2x 6603599
- 2x 6603596
- 2x 6603342
- 2x 6603312
- 10x 6603286
- 2x 6603333
- 10x 6603340
- 2x 6603318
- 4x 6603343
- 2x 6603335
- 4x 6603595
- 1x 6603594
- 6x 6603589
- 2x 6603332
- 2x 6576813



[LEGO.com/service](https://www.LEGO.com/service)

YOU COULD WIN



Scan this QR code or go to
LEGO.COM/PRODUCTFEEDBACK and give us
your short feedback about this LEGO® set
for a chance to win a cool LEGO prize.

Terms and Conditions apply*

EN: YOU COULD WIN. Terms and Conditions apply* **DE: Du könntest GEWINNEN.** Es gelten die Teilnahmebedingungen* **FR: Tu pourrais GAGNER.** Des conditions s'appliquent* **IT: Potresti VINCERE tu.** Termini e condizioni sono applicabili* **ES: Puedes GANAR.** Aplican términos y condiciones* **PT: PODERÁ GANHAR.** Aplicam-se Termos e Condições* **ZH: 轻松获奖.** 条款和条件适用* **PL: Szansa na WYGRANĄ.** Obowiązuje regulamin* **CS: Máte šanci VYHRÁT.** Platí všeobecné smluvní podmínky* **SK: Máte šancu VYHRÁT.** Platia všeobecné zmluvné podmienky* **HU: TE IS NYERHETSZ.** Felhasználási feltételek érvényesek* **UA: ВИ МОЖЕТЕ ВИГРАТИ.** Застосовуються загальні положення та умови* **RO: Ai putea CÂȘTIGA.** Se aplică termenii și condiții* **BG: Можете да СПЕЧЕЛИТЕ.** Има определени правила и условия* **LV: Tu vari LAIMĒT.** Ir spēkā noteikumi un nosacījumi.* **ET: Sul on võimalus VÕITA.** Kehtivad tingimused* **LT: Jūs galite LAIMĖTI.** Taikomos sąlygos*

*[LEGO.com/productfeedback-terms](https://www.lego.com/productfeedback-terms)

