



40955



# MAERSK





LEGO.com/sustainable-packaging



FR

**DONNEZ**  
OU  
**RECYCLEZ**



OU



OU



ASSOCIATION

MAGASIN

DÉCHÈTERIE

Adresses sur [quefairedemesdechets.fr](http://quefairedemesdechets.fr)

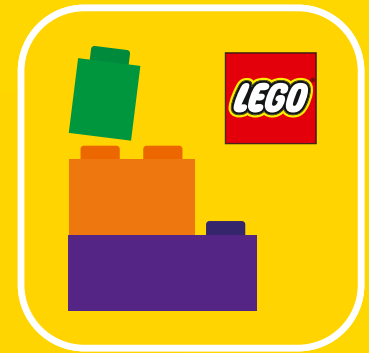

🔍 LEGO® Builder

# BUILDER



Apple and the Apple logo are trademarks of Apple Inc., registered in the U.S. and other countries and regions. App Store is a service mark of Apple Inc. Google Play and the Google Play logo are trademarks of Google LLC. Tencent and the Tencent logo are trademarks of Tencent Inc.

🔍 [LEGO.com/devicecheck](https://LEGO.com/devicecheck)

EN Ask parents' permission before going online | DE Eltern um Erlaubnis bitten, bevor du online gehst | FR Demande l'autorisation d'un parent avant d'aller en ligne | IT Chiedi il permesso ai tuoi genitori prima di andare online | ES Pídeles permiso a tus papás antes de conectarte a Internet | PT Peça autorização aos pais antes de acederes online | ZH 上网前应先征得父母的同意 | PL Poproś rodziców o zgodę, zanim wejdiesz do Internetu | CS Než půjdeš na internet, požádej rodiče o svolení | SK Skôr než pôjdeš na internet, vypoťaj si povolenie od rodičov | HU Kérj szülői engedélyt, mielőtt online csatlakoznál! | UA Запитуйте дозволу батьків, перш ніж користуватися інтернетом | RO Cere permisiunea părinților înainte de a te conecta online | BG Поискайте разрешение от родител, преди да влезете онлайн | LV Pirms došanās tiešsaistē palūdz atļauju vecākiem | ET Enne Interneti kasutamist küsi vanematelt luba | LT Prieš prisijungdami prie interneto, atsiklauskite tėvų



## OTO ANE MÆRSK

ANE MÆRSK jest pierwszym statkiem tego typu – to pierwszy duży kontenerowiec, który może być napędzany paliwem niskoemisyjnym, takim jak biometanol i e-metanol. Od momentu, gdy ANE MÆRSK po raz pierwszy wypłynął na wody w styczniu 2024 r., wiele innych statków z silnikiem dwupaliwowym wyruszyło w rejs, otwierając nowy, ważny rozdział w procesie dekarbonizacji żeglugi i światowego handlu.

ANE MÆRSK ma 350 metrów długości i 53,5 metra szerokości. Pusta jednostka bez załadunku waży 47 700 ton, a po obciążeniu towarami, paliwem i załogą może zabrać na pokład aż 190 000 ton, co odpowiada masie 29 tysięcy słoni afrykańskich.

Statek może pomieścić 16 592 kontenery TEU, a gdyby ustawić je wszystkie w rzędzie, miałyby niebagatelną długość 100,5 km, czyli długość 959 boisk piłkarskich.





 MAERSK

ALL THE 10 ZERO WAY



# KURS NA ZMIANY – HISTORIA ŻEGLUGI

Ludzie transportują towary drogą morską od ponad 5000 lat, ale aż do rewolucji przemysłowej i wynalezienia silnika parowego byliśmy uzależnieni od pogody. Bez wiatru nie ma rejsu. Wraz z wprowadzeniem napędu parowego załoga statku po raz pierwszy w historii ludzkości nie była już uzależniona od pogody ani siły rąk. Wynalazek ten całkowicie zrewolucjonizował transport morski – umożliwił tworzenie nowych tras i znacznie ożywił handel morski.

Chociaż silniki parowe stanowiły ogromny postęp w stosunku do żagli, nadal były nieefektywne i nie minęło dużo czasu, zanim transport morski ponownie uległ transformacji dzięki wynalezieniu silnika wysokoprężnego. Jednak rewolucje w żegludze wymagają czasu i minęło kilkadziesiąt lat, zanim silniki diesla całkowicie zastąpiły napęd parowy. Maersk zakupił swój pierwszy statek z napędem dieslowskim, LEISE MÆRSK, w 1921 roku, zaledwie dziewięć lat po zwodowaniu pierwszego w historii oceanicznego statku handlowego z silnikiem wysokoprężnym.



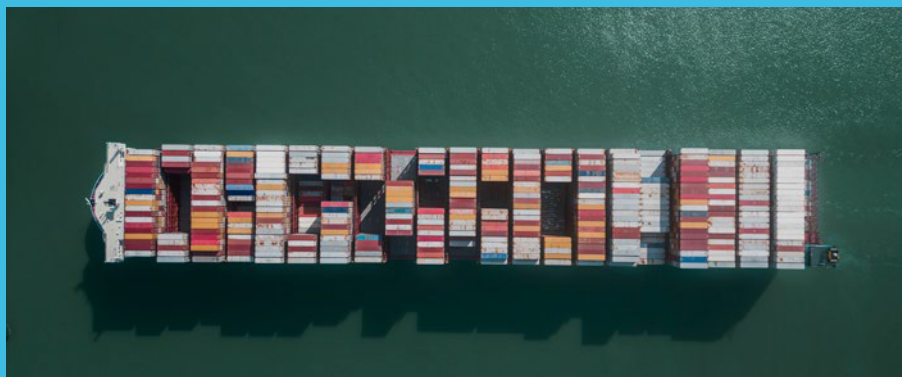

W 1956 r. branża ponownie przeszła transformację, kiedy to wprowadzono wydajny system „ładunków kontenerowych”, w ramach którego naczepy ciężarówek są ładowane bezpośrednio na statki. Wprowadzenie kontenerów skróciło czas załadunku i rozładunku statków z kilku dni do kilku godzin.

Dzięki kontenerom i kodom kreskowym – ukrytym „przepustkom” umożliwiającym światowy handel – producent z dowolnego miejsca na świecie może sprzedawać swoje towary na wszystkich rynkach, co sprawia, że globalizacja staje się fizycznie możliwa. Świat, jaki znamy dzisiaj, jest głęboko uzależniony od globalnych łańcuchów dostaw. Od plantatora bananów z Kolumbii po małego Polaka zjadającego banany na drugie śniadanie – łańcuchy dostaw łączą świat i zapewniają przepływ żywności, leków, towarów i materiałów do ludzi na całym świecie.





 MAER

 MAERS

 MAERSK

 MAERSK

## SKĄD TAKA NAZWA?

Od 1906 roku wszystkie statki floty Maersk mają w swojej nazwie słowo „MÆRSK”. Większość pierwszych statków miała imiona związane z rodziną, która założyła przedsiębiorstwo, ale gdy flota przerosła liczbę dostępnych imion rodzinnych, tradycja ta musiała zostać zmieniona. Obecnie można również spotkać statki Maersk nazwane na cześć miast i rzek.

Podjmując decyzję o nazwie nowej serii statków z silnikiem dwupaliwowym, firma Maersk powróciła do tradycji nadawania statkom imion członków rodziny założycieli – tym razem zaczynając od litery A, symbolizującą nową erę.

Nazwa ANE MÆRSK pochodzi od imienia Ane Mærsk Mc-Kinney Uggla, prezeski A.P. Moller Holding, spółki macierzystej A.P. Moller-Maersk. Firma A.P. Moller-Maersk została założona w 1904 roku przez Arnolda Petera Møllera. Ane jest wnuczką Arnolda i jego żony, Chastine Mc-Kinney Møller.



# ANE MAERSK





## BIAŁA GWIAZDA – SYMBOL NADZIEI

Kultowa biała siedmioramienna gwiazda stała się częścią dziedzictwa firmy Maersk jeszcze przed jej założeniem w 1904 roku i stanowi trwały symbol silnych więzi rodzinnych, które nadal stanowią sedno działalności firmy ponad 100 lat później.

Na początku swojej kariery kapitan Peter Mærsk Møller, ojciec A.P. Møllera, pracował dla angielskiego armatora, a jego żona Anna czasami towarzyszyła mu w podróżach. To właśnie podczas jednej z tych podróży Anna poważnie zachorowała. W obawie, że nie przeżyje, Peter Mærsk Møller wyszedł na pokład i modlił się do Boga o znak, że jego żona wyzdrowieje. Właśnie wtedy ujrzął pojedynczą gwiazdę rozświetlającą szare niebo.

Anna wyzdrowiała, a w 1886 roku, kiedy Peter Mærsk Møller kupił swój pierwszy parowiec o nazwie LAURA, ozdobił komin statku białą siedmioramienną gwiazdą na jasnoniebieskim tle na cześć swojej ukochanej żony. Dla Petera Maerska Møllera gwiazda stała się symbolem jej powrotu do zdrowia i ich szczęścia.

Od tego czasu biała siedmioramienna gwiazda na charakterystycznym błękitnym tle jest synonimem firmy Maersk, ale samo logo przeszło przez lata pewną ewolucję. Istniało wiele wersji logo, ale obecne logo Maersk pochodzi z początku lat 70. XX wieku, kiedy to zdecydowano, że potrzebne jest bardziej nowoczesne podejście.



ALL THE WAY  
TO ZERO



# POPRAWA JAKOŚCI ŻYCIA POPRZĘZ INTEGRACJĘ ŚWIATA

Jako światowy lider w dziedzinie usług logistycznych, firma Maersk ma ponad 100 000 klientów, działa w prawie 130 krajach i zatrudnia ponad 100 000 osób. Od skromnych początków jako firma żeglugaowa po przekształcenie się w zintegrowaną firmę logistyczną, która zajmuje się łączeniem i upraszczaniem łańcuchów dostaw swoich klientów, Maersk dysponuje ponad 700 statkami i transportuje prawie 20% światowej żywności, materiałów i towarów.







# OD BOHATERA DO ZERA, CZYLI ZOBOWIĄZANIE DO DEKARBONIZACJI PRZYSZŁOŚCI

W obliczu globalnych wyzwań związanych ze zmianami klimatycznymi przyszłość łańcuchów dostaw i światowego handlu zależy od zdolności do wprowadzania innowacji i promowania nowych źródeł energii. Firma Maersk podjęła poważne zobowiązanie, aby do 2040 r. osiągnąć zerowy poziom emisji gazów cieplarnianych w całej swojej działalności. Oprócz dekarbonizacji własnych działań firma Maersk podjęła również zobowiązanie wobec społeczeństwa, aby przewodzić działaniom na rzecz rozwiązania kryzysu klimatycznego poprzez dekarbonizację globalnych łańcuchów dostaw i umożliwienie sprawiedliwego przejścia na gospodarkę zeroemisyjną.

Maersk wyznaczył sobie ambitne cele do 2040 roku. Przedsiębiorstwo chce poczynić znaczący postęp w tej dekadzie: na morzu, lądzie, w powietrzu i w naszych terminalach. Dzięki zamówieniom i dostawie wielu statków z silnikiem dwupaliwowym, które mogą pływać na paliwach niskoemisyjnych, takich jak bio- i e-metanol oraz biometan, misja dekarbonizacji floty jest na najlepszej drodze do sukcesu.





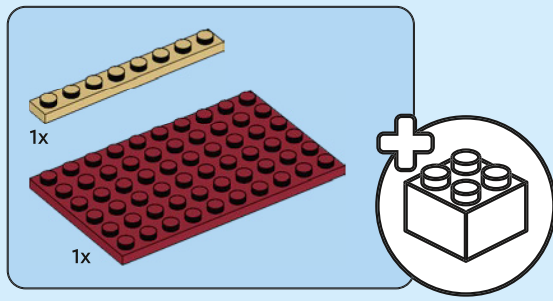

1

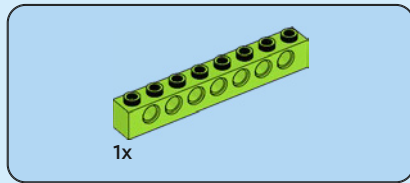
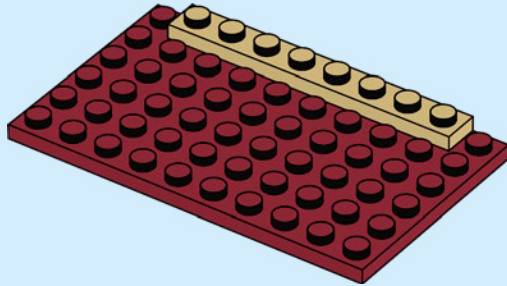

2

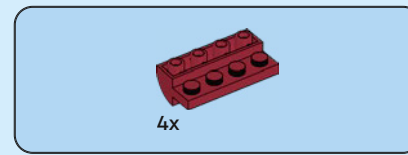
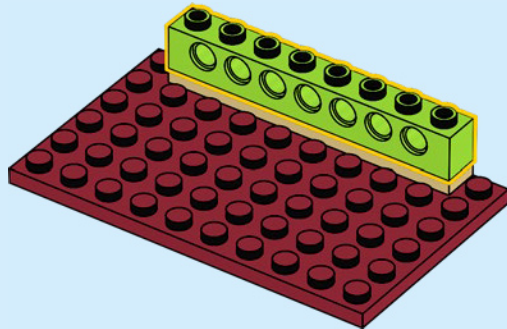

3

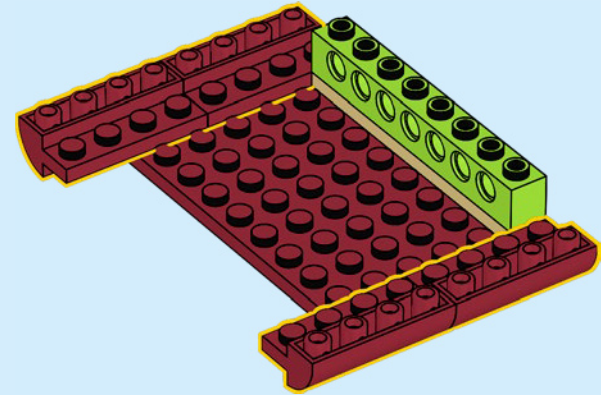

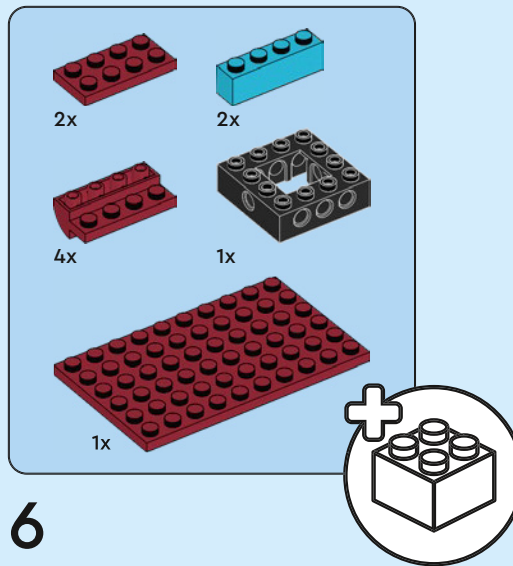
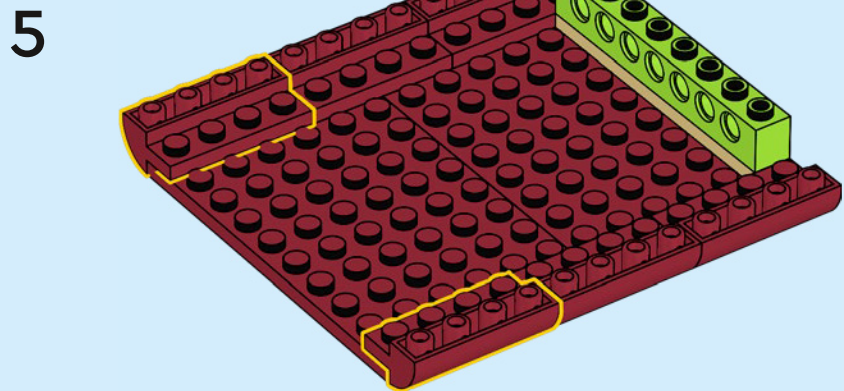
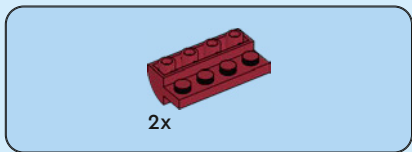
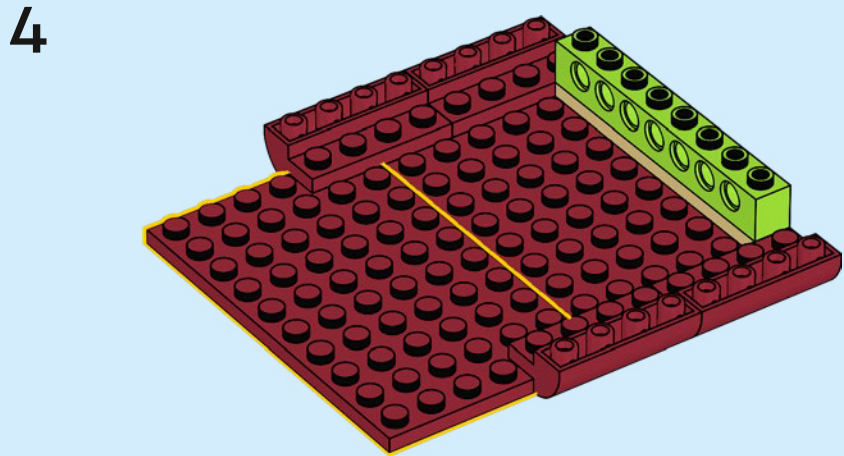
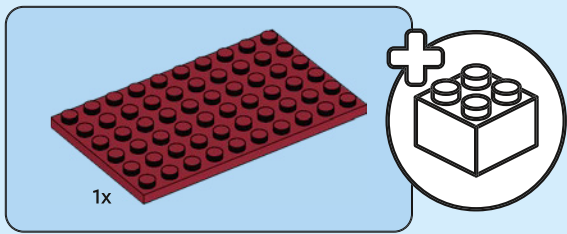

6

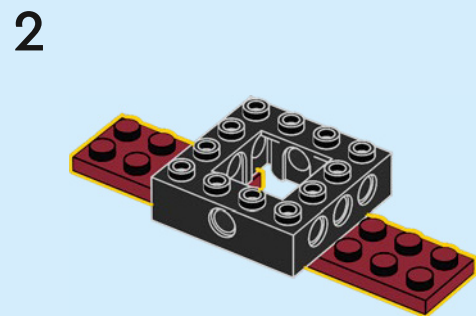
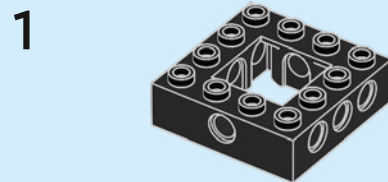

3

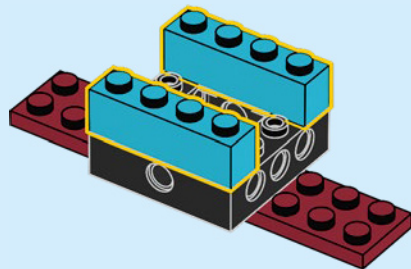

4

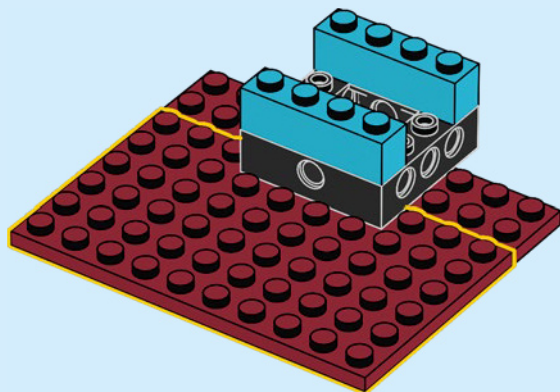

5

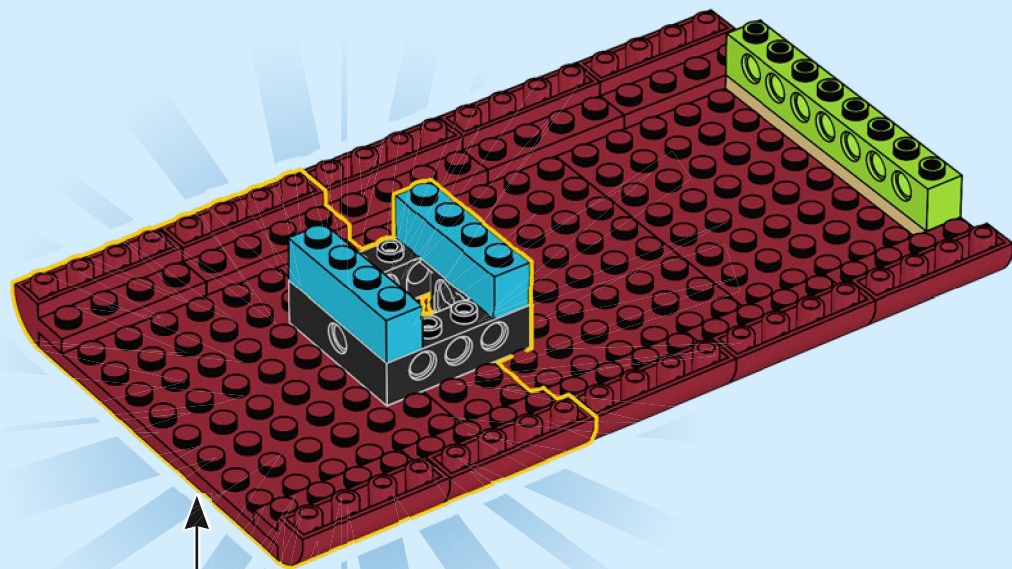
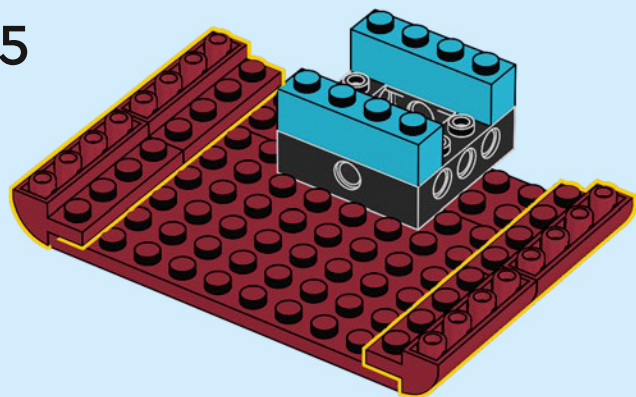

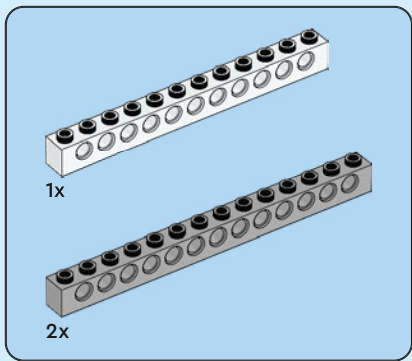

7

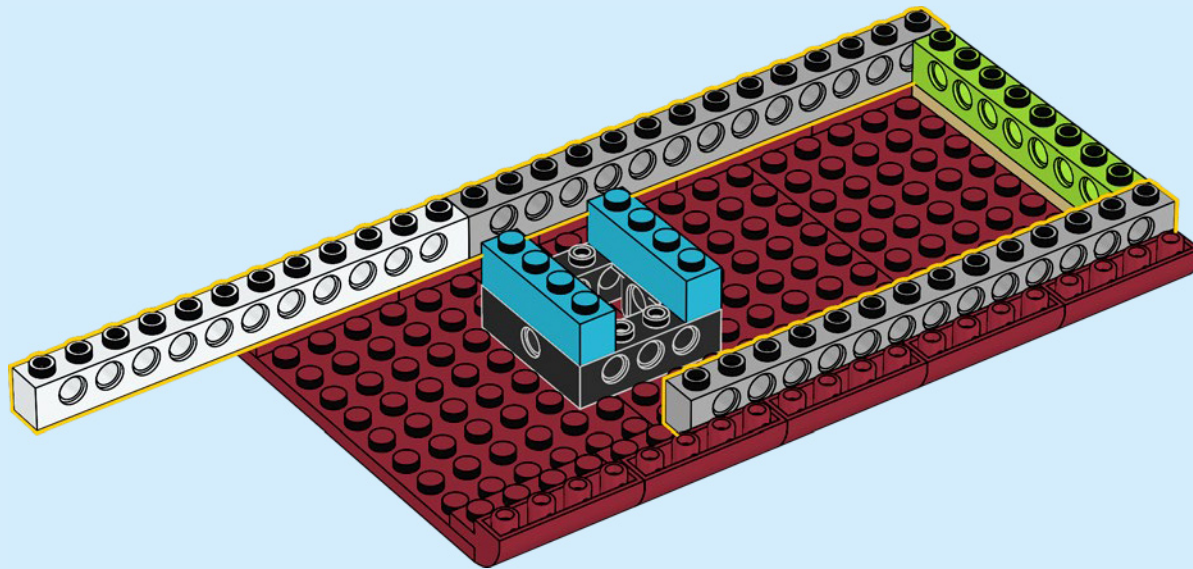



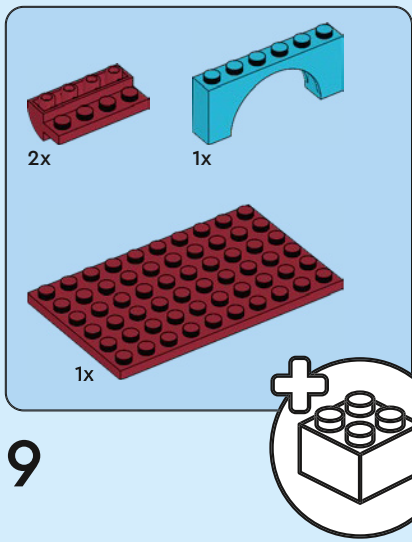

9

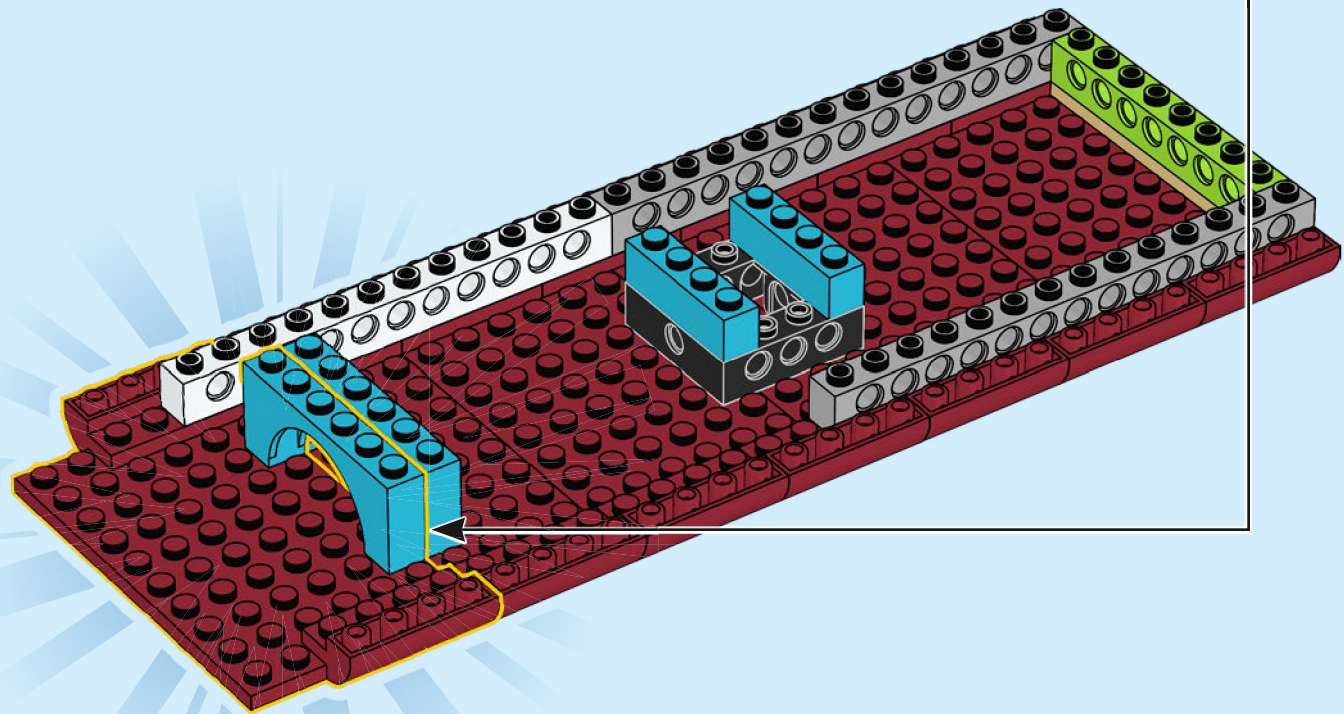
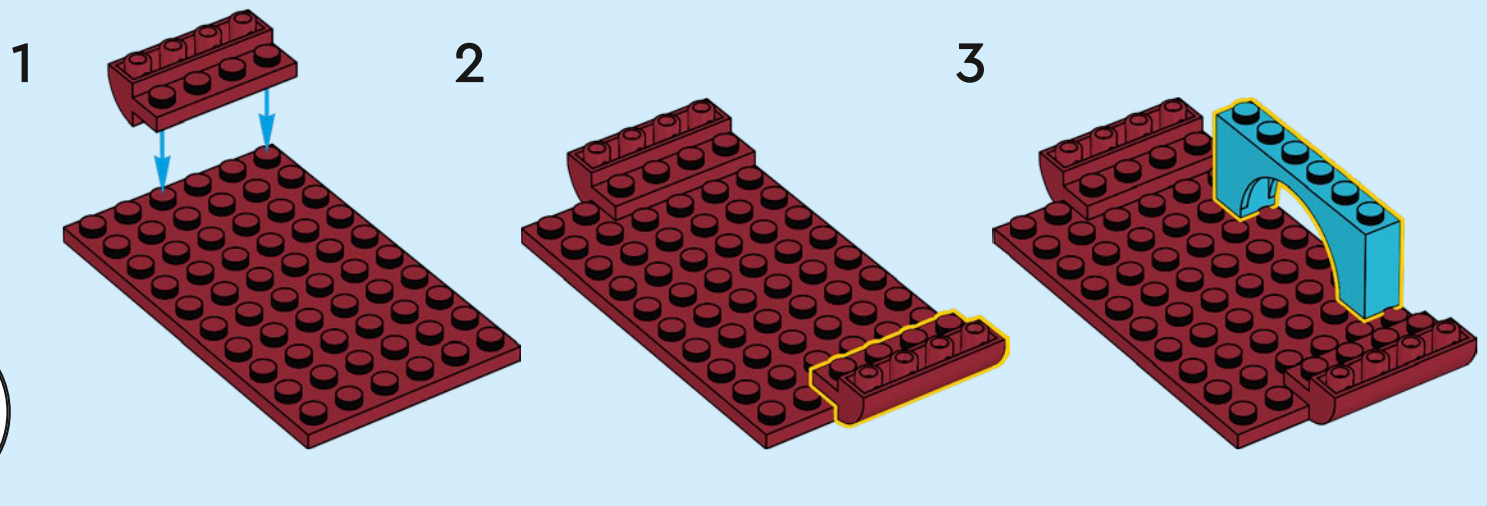

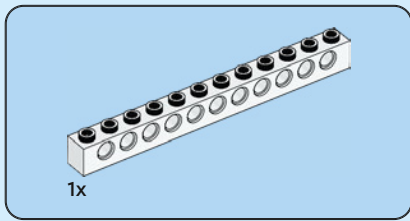

10

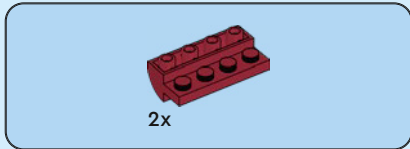
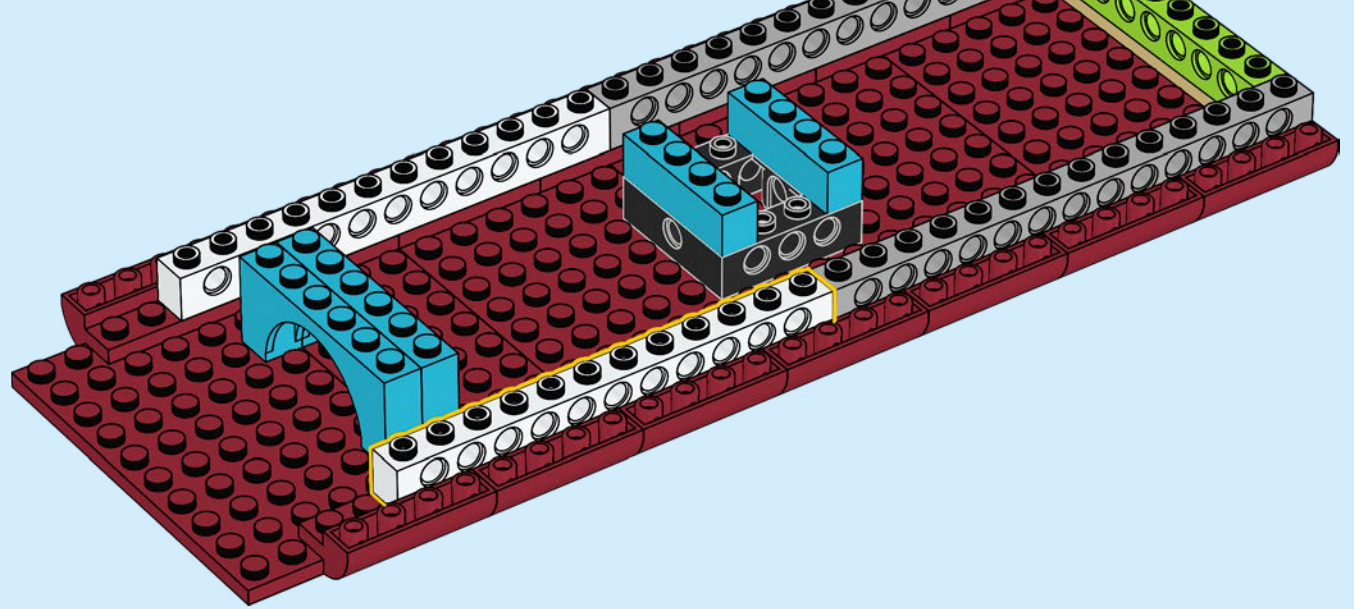

11

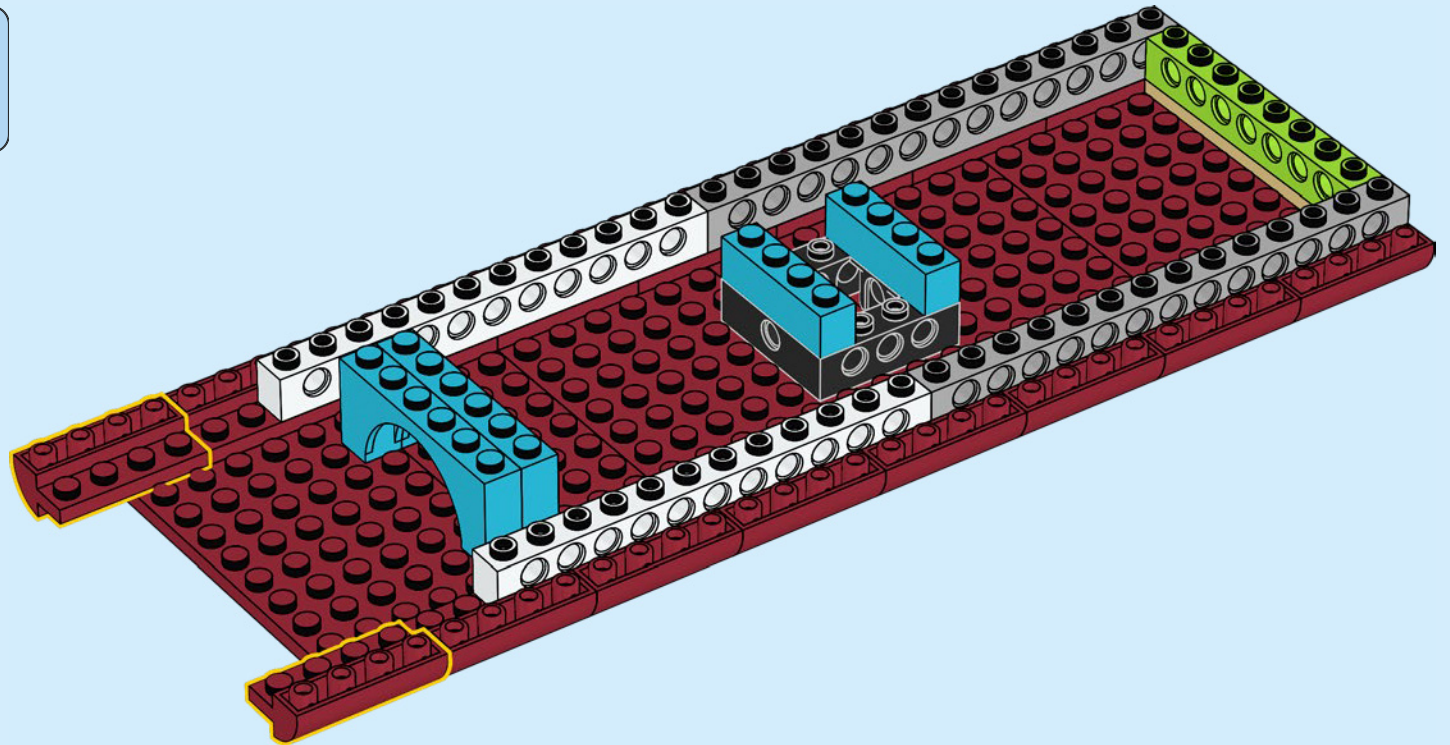

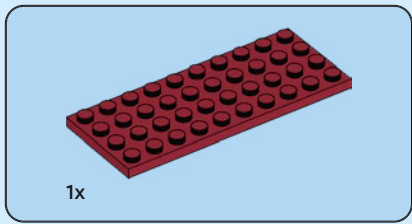

12

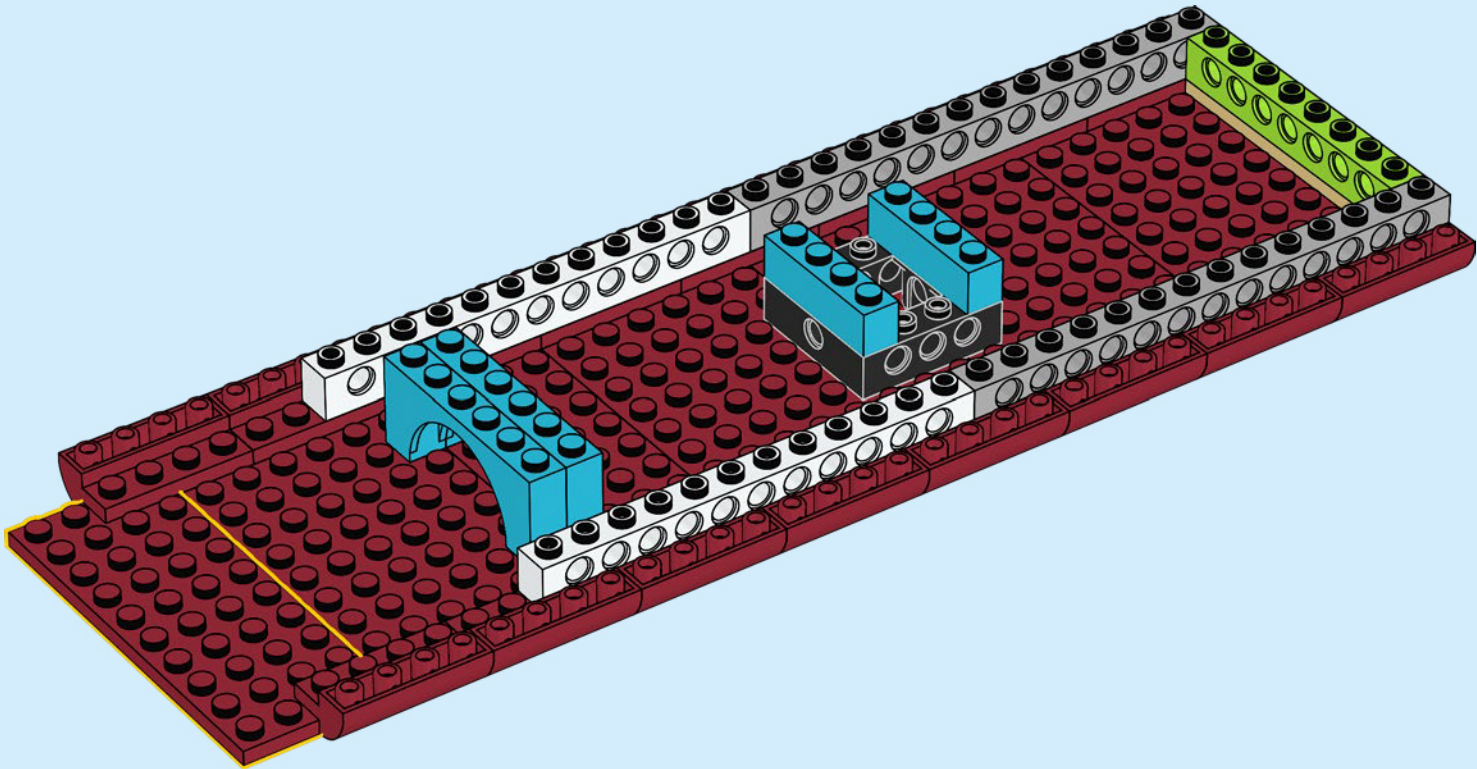

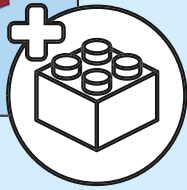
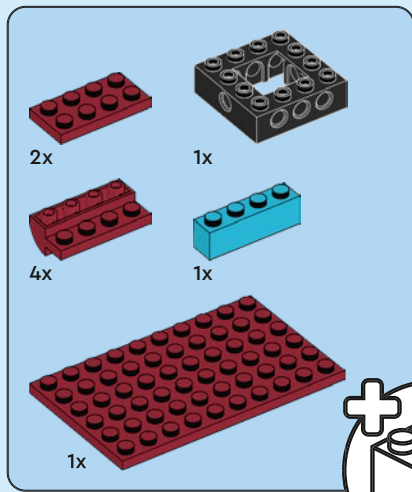

13

1

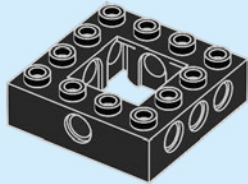

2

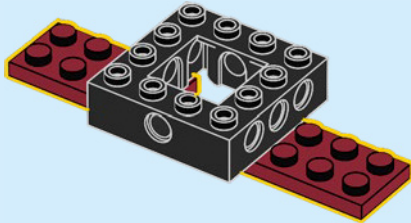

3

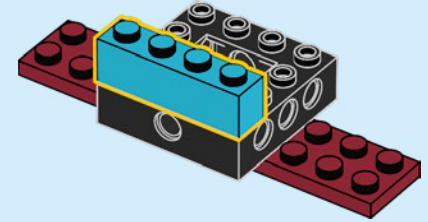

4

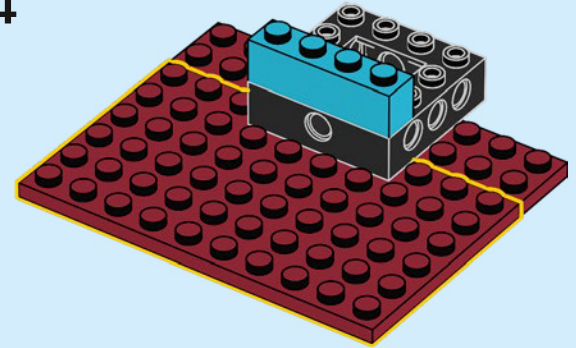

5

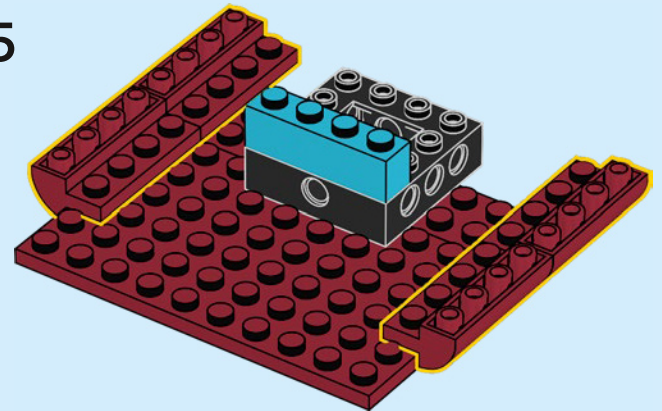

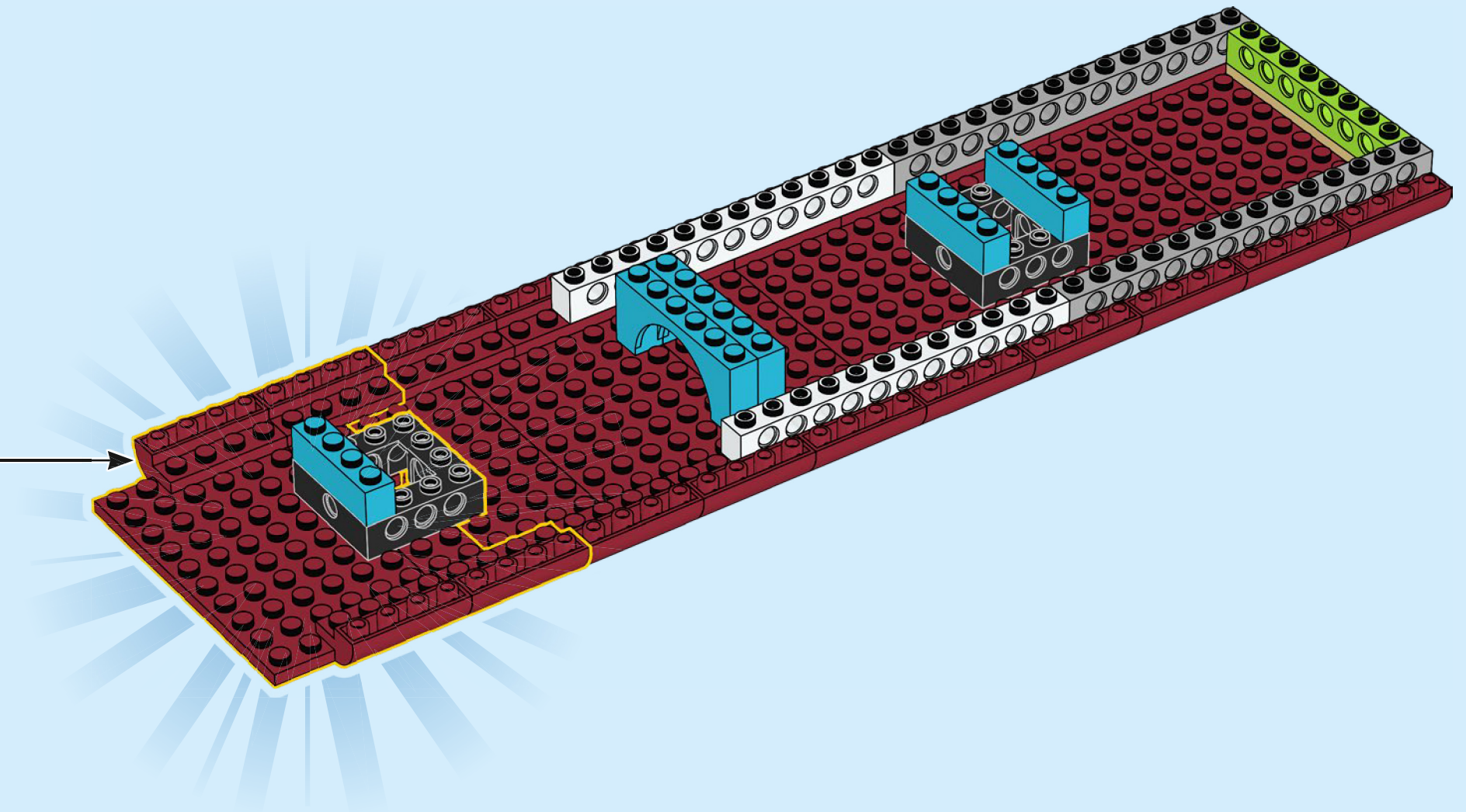

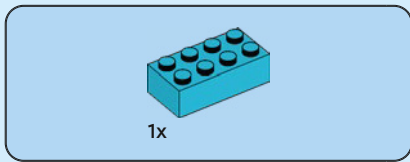

14

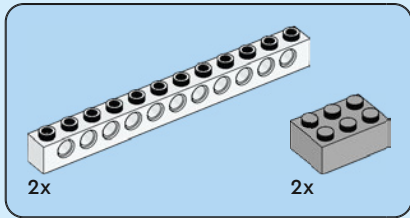
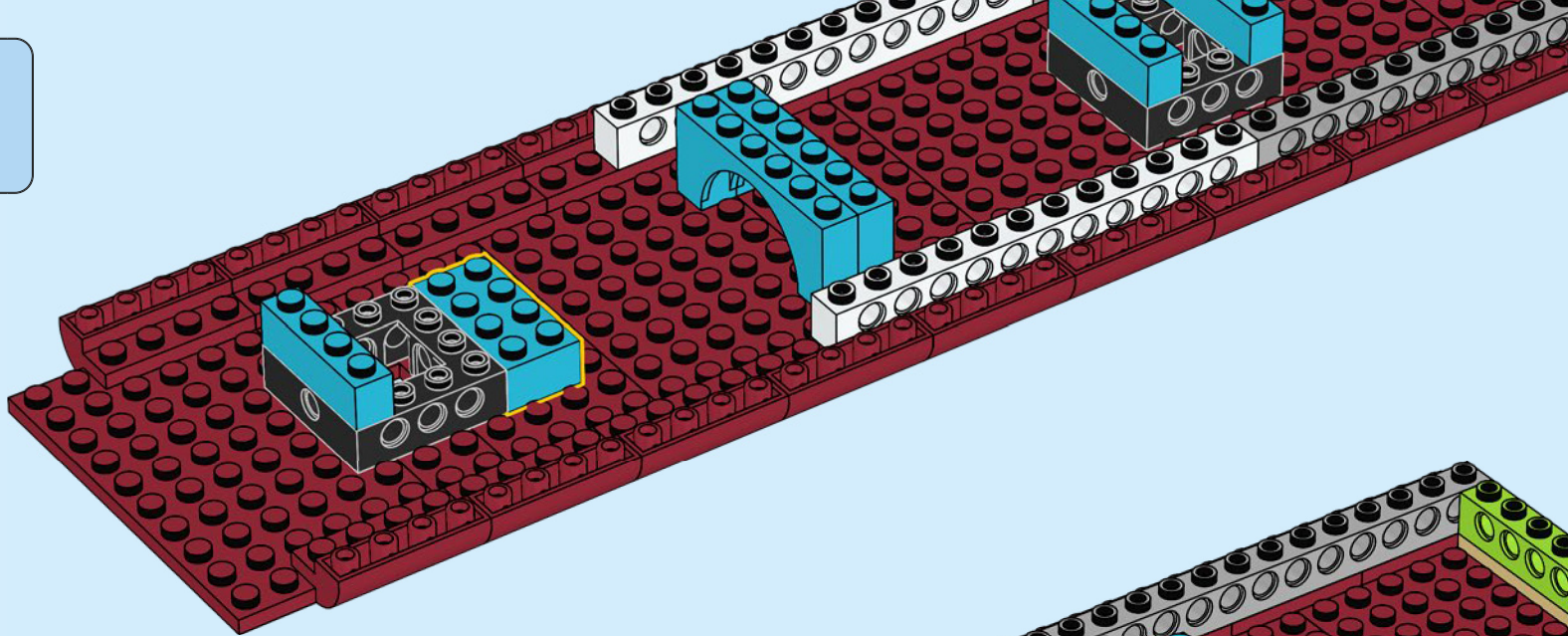

15

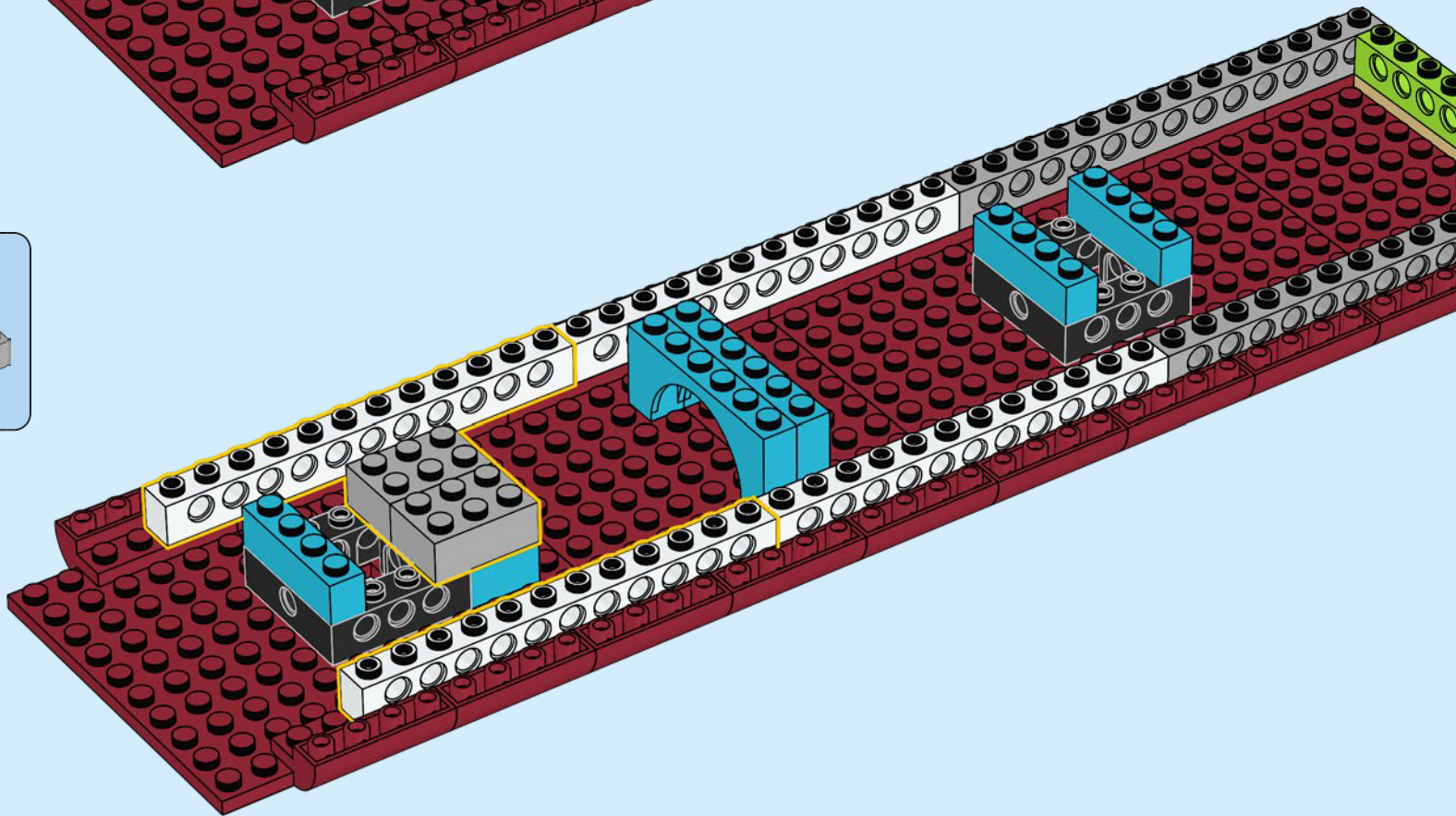

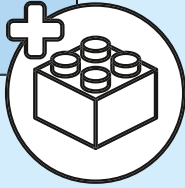
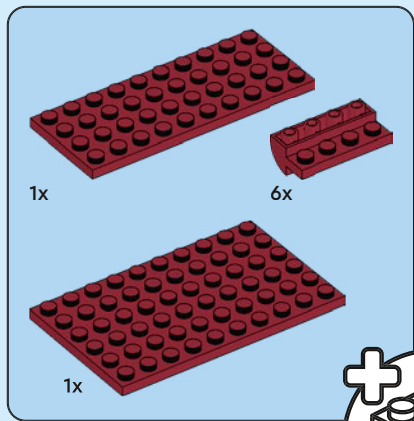

16

1

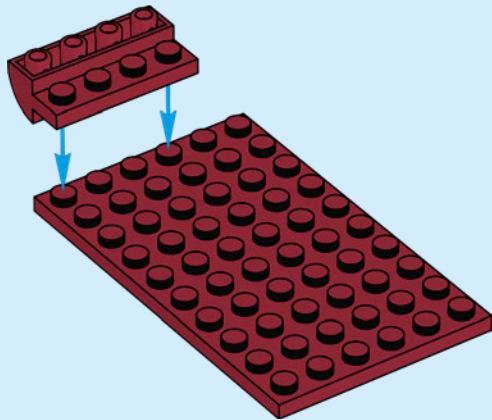

2

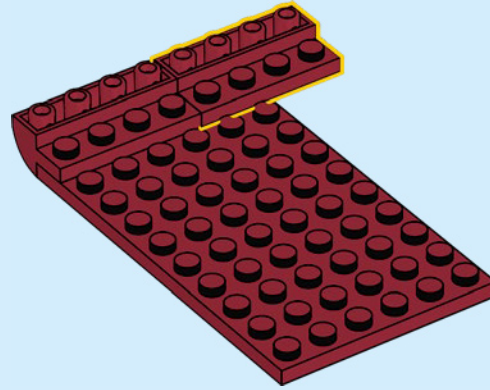

3

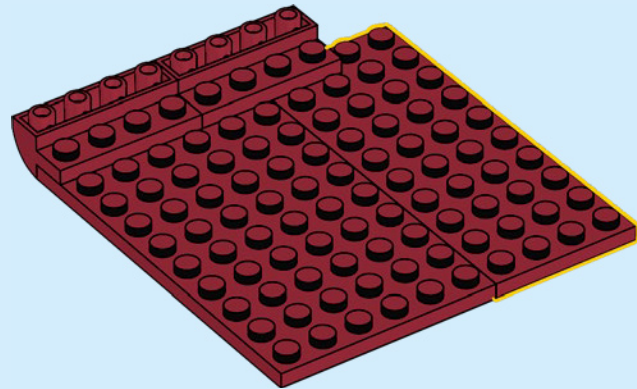

4

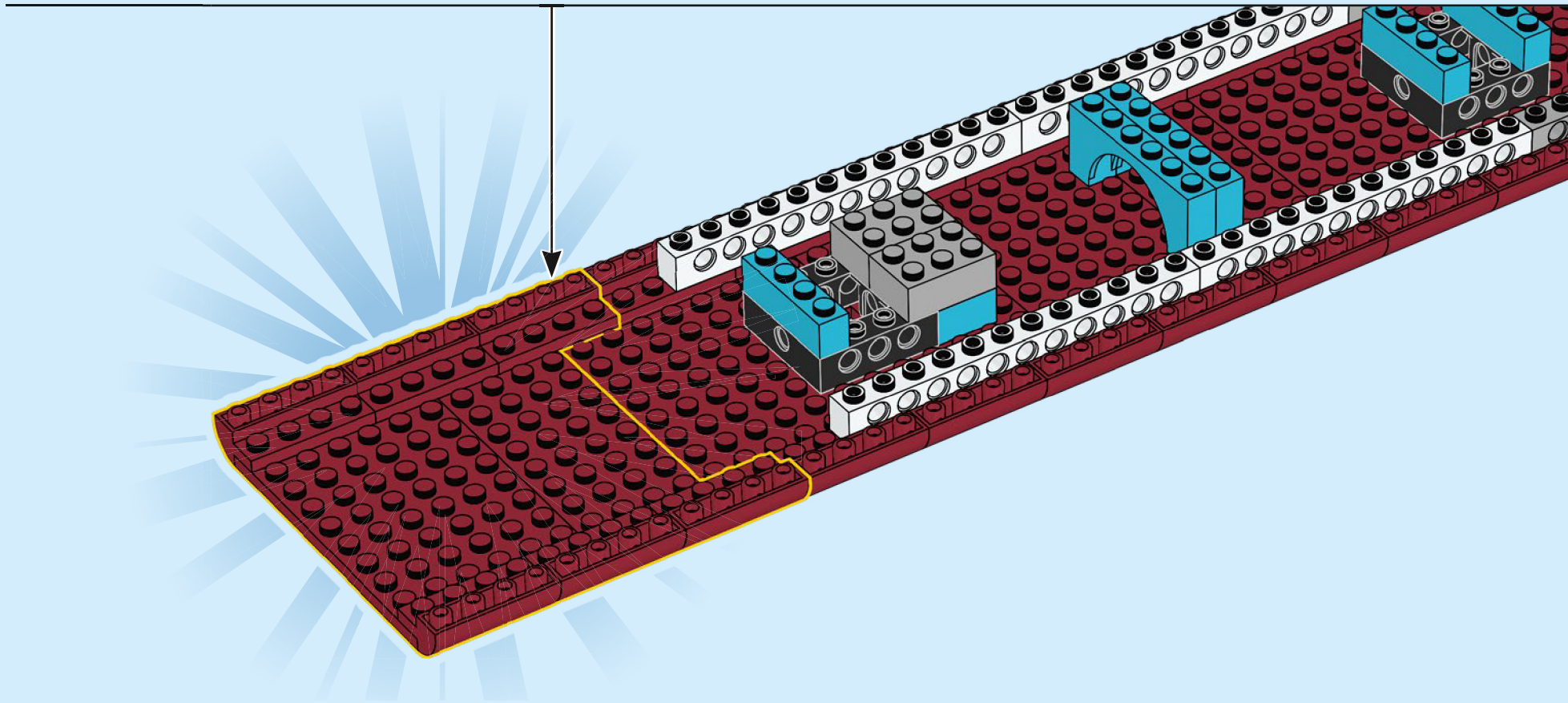
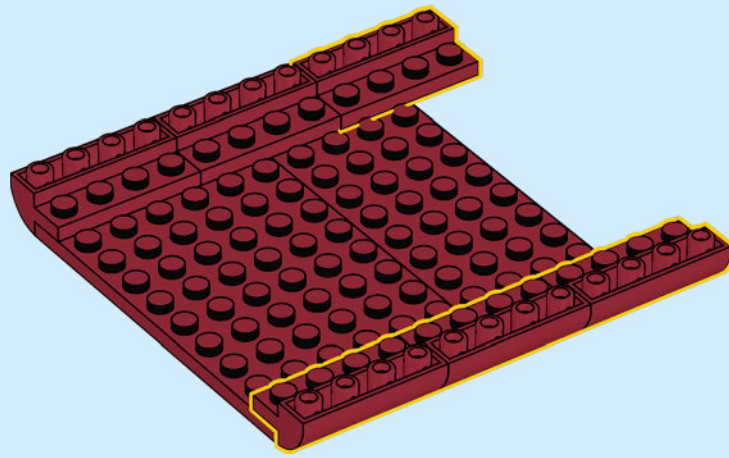

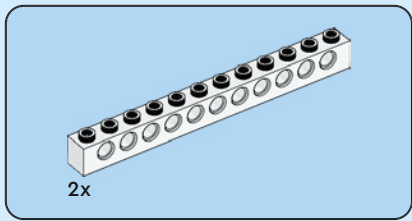

17

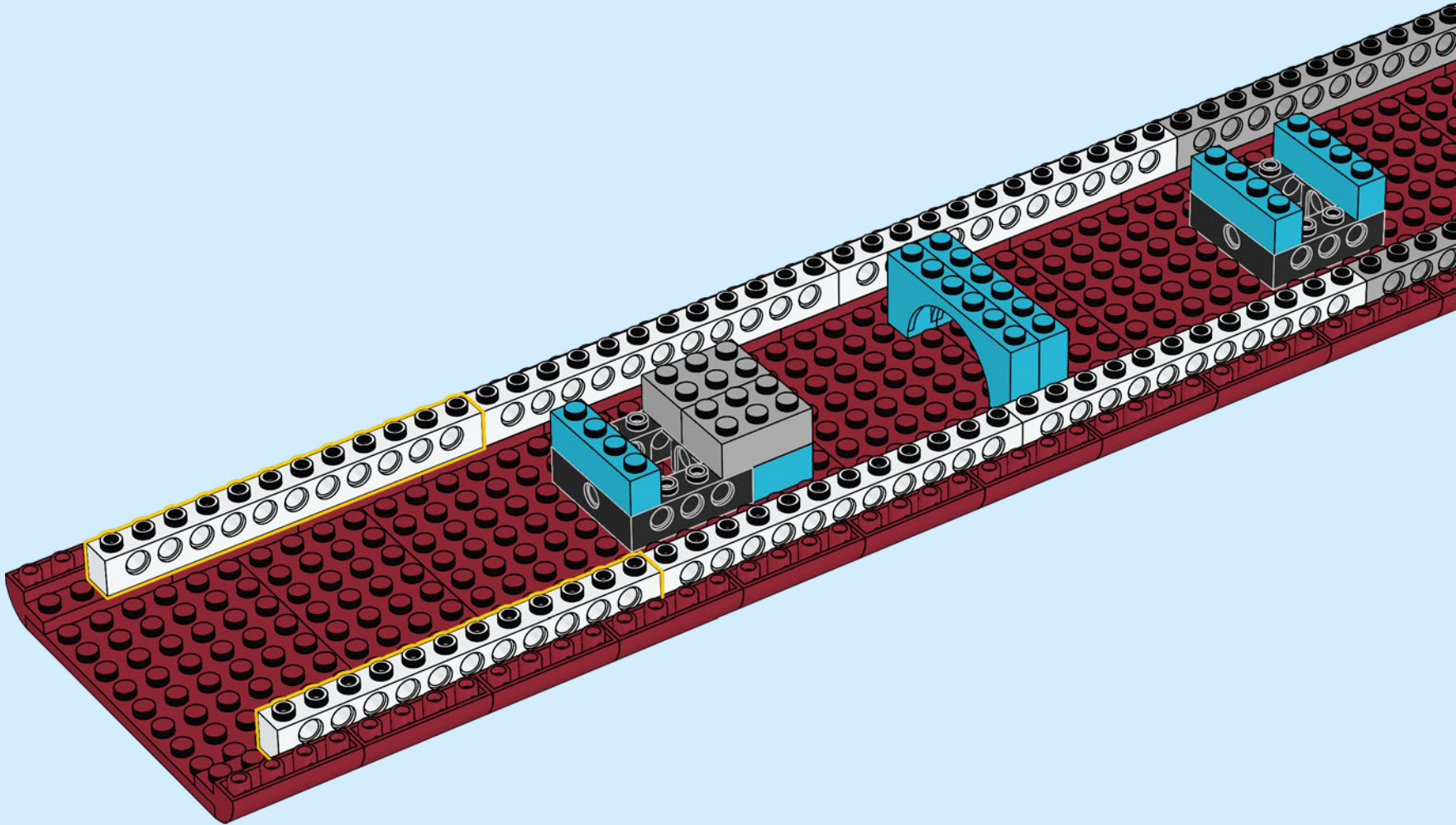

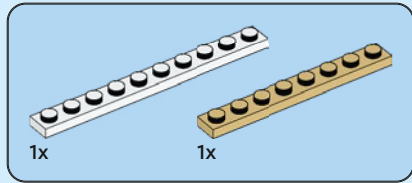

18

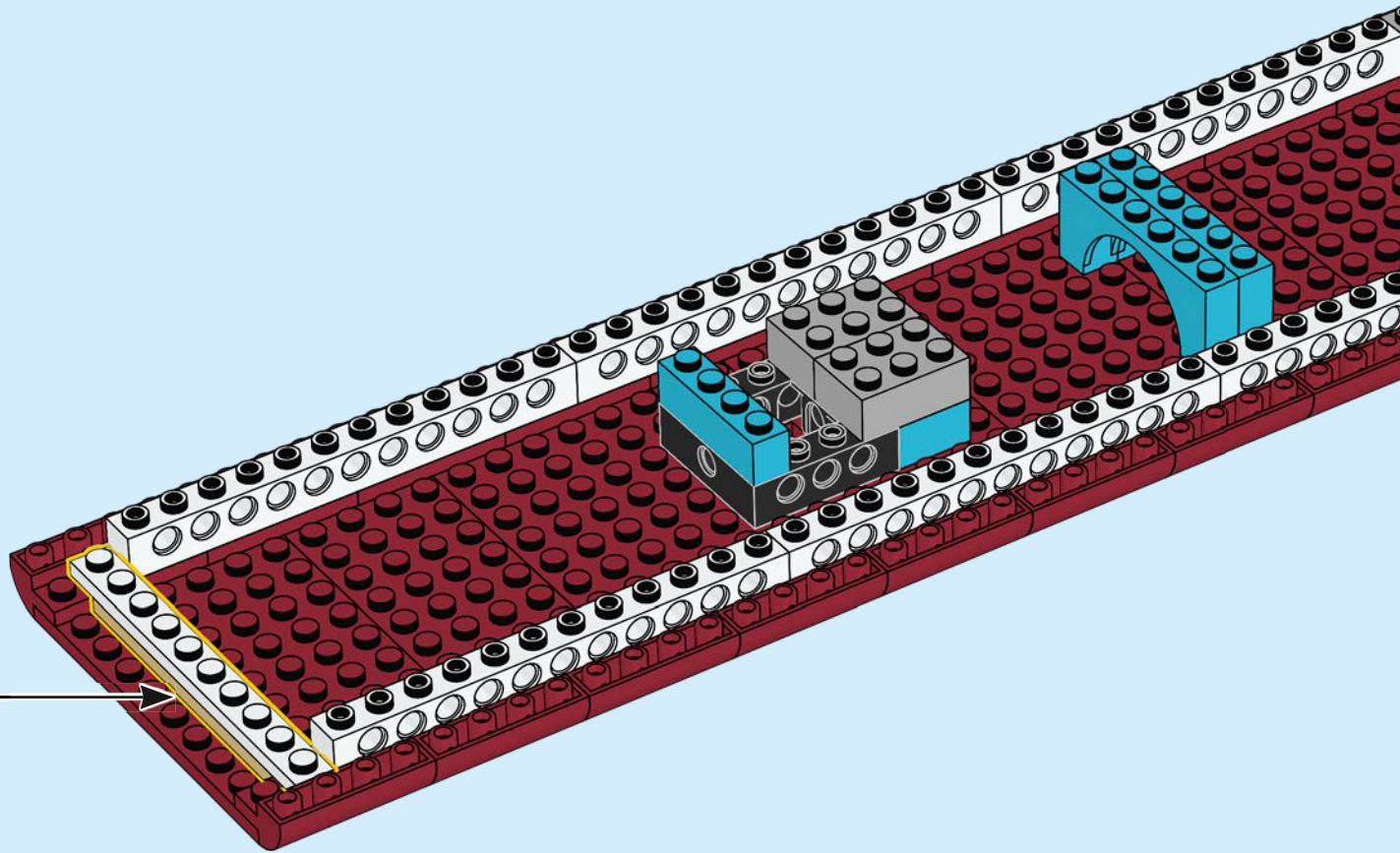
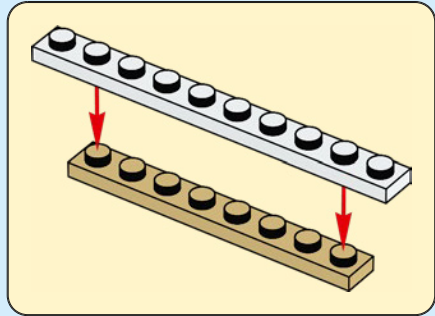

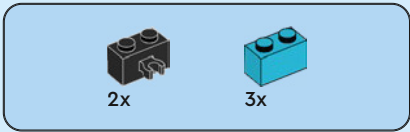

19

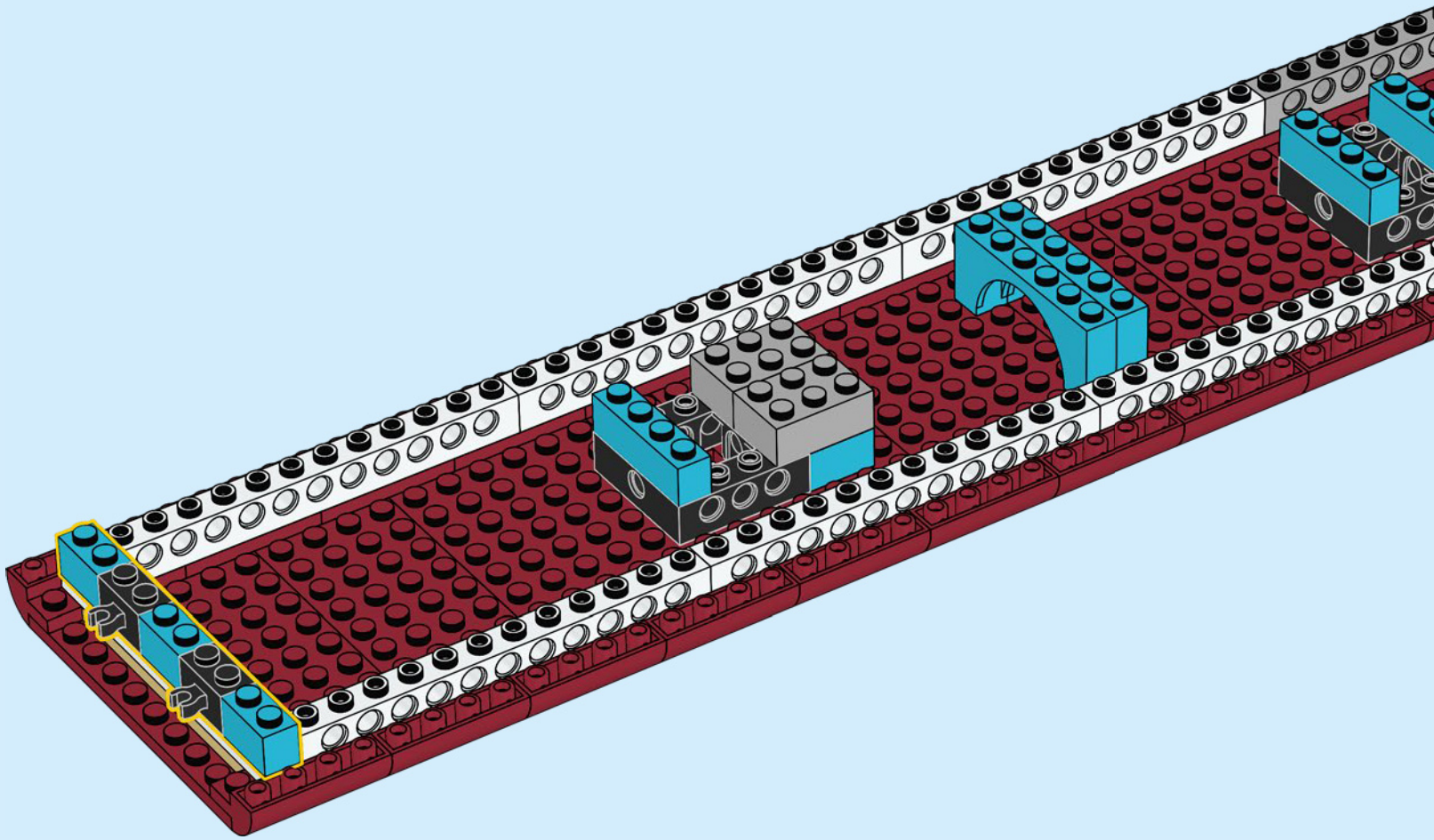

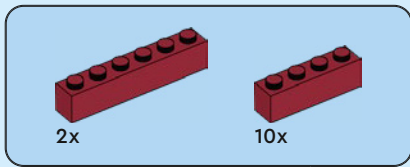

20

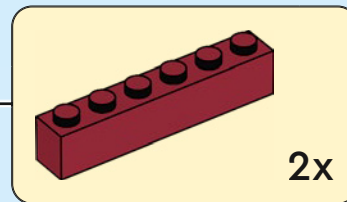
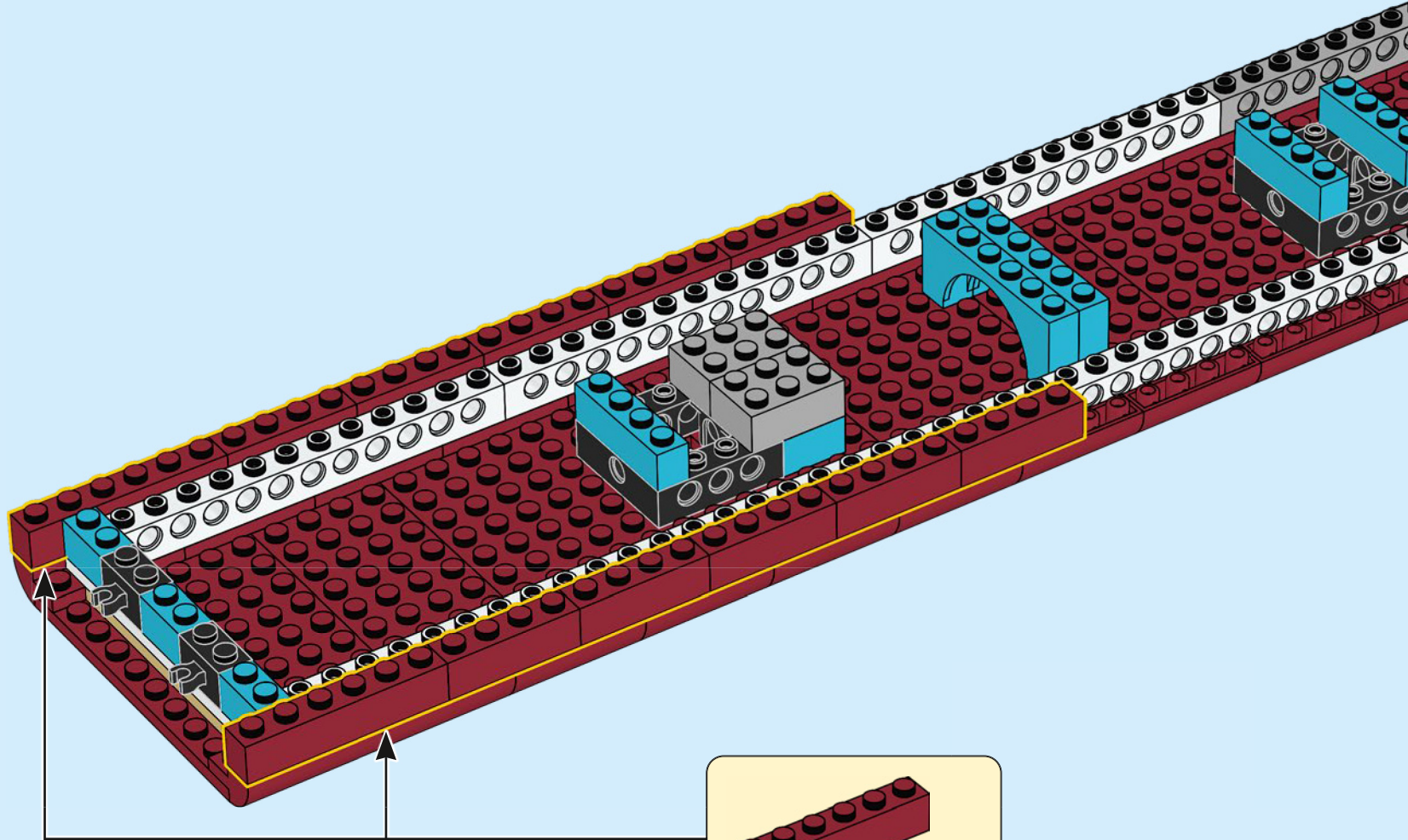

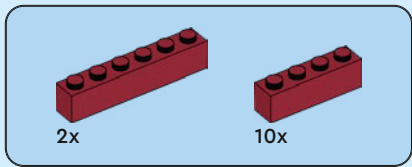

21

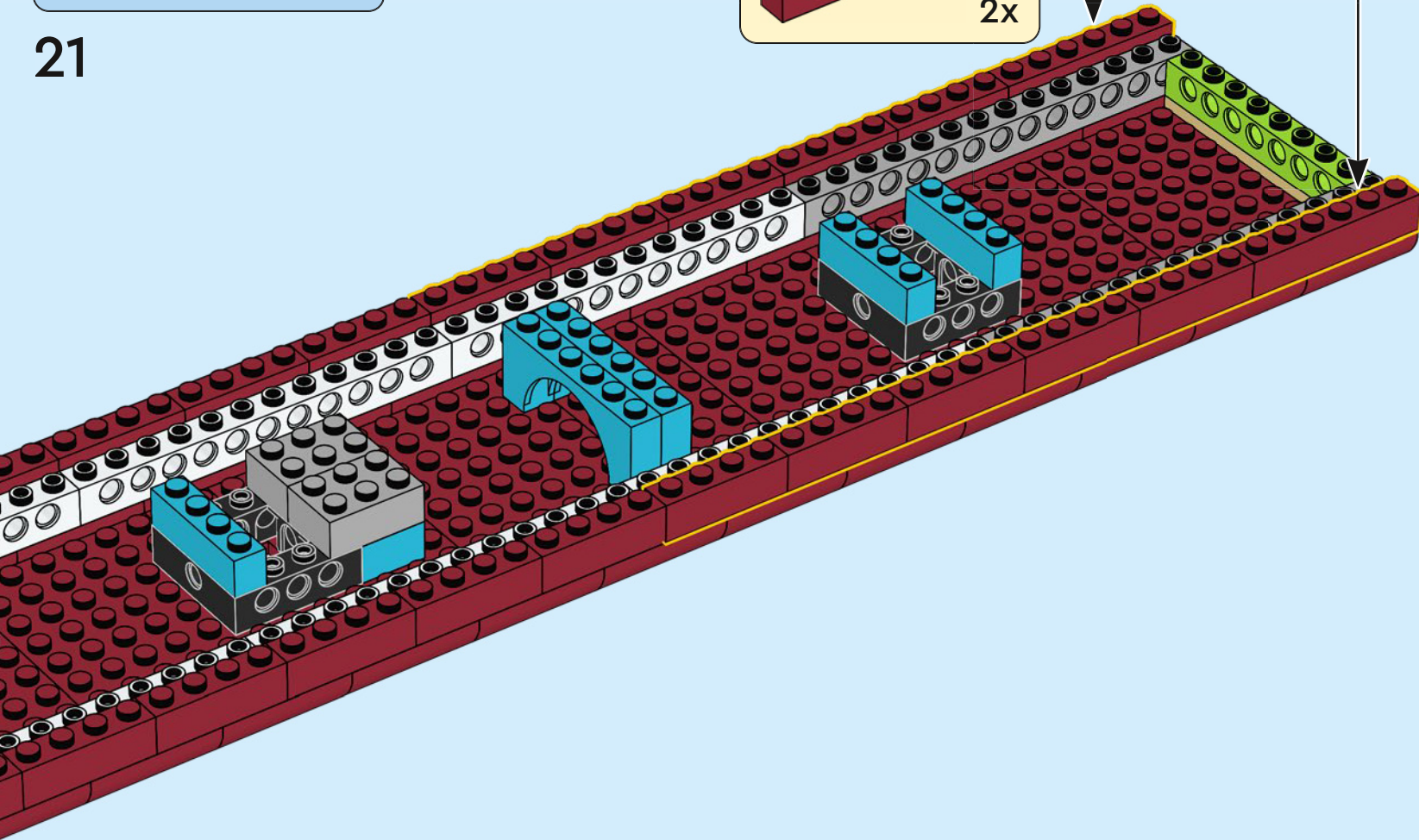
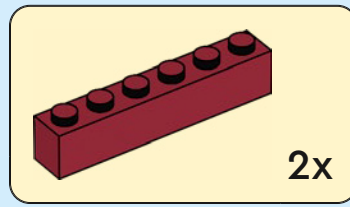

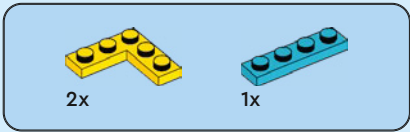

22

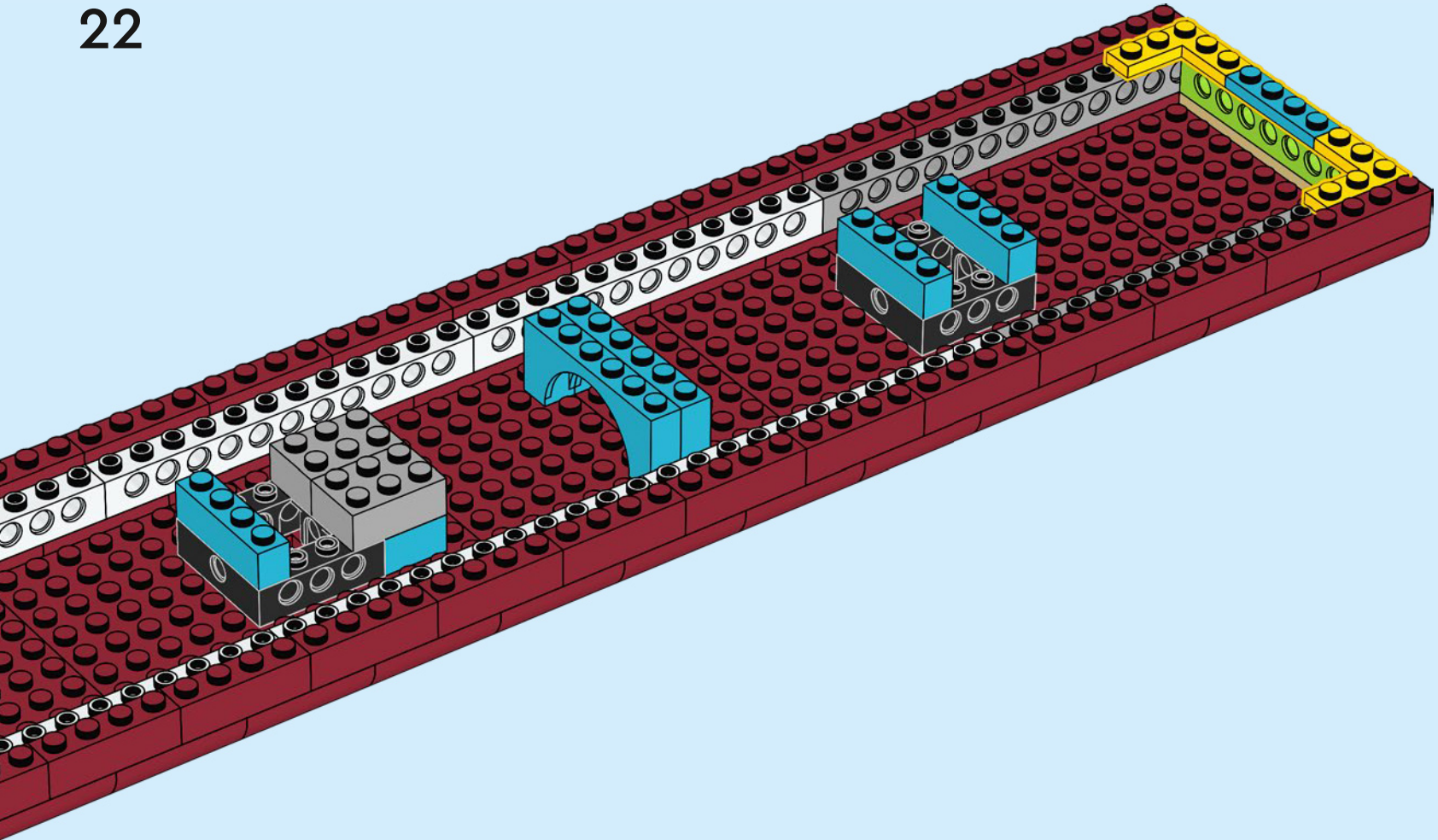



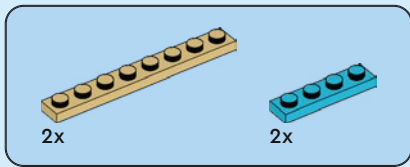

24

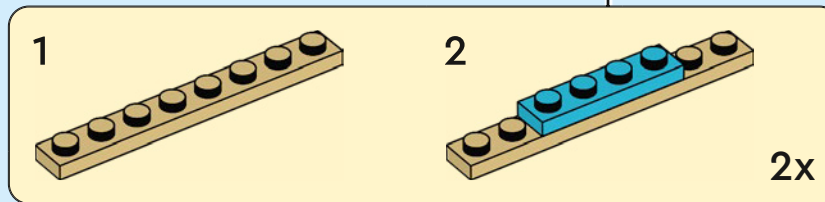
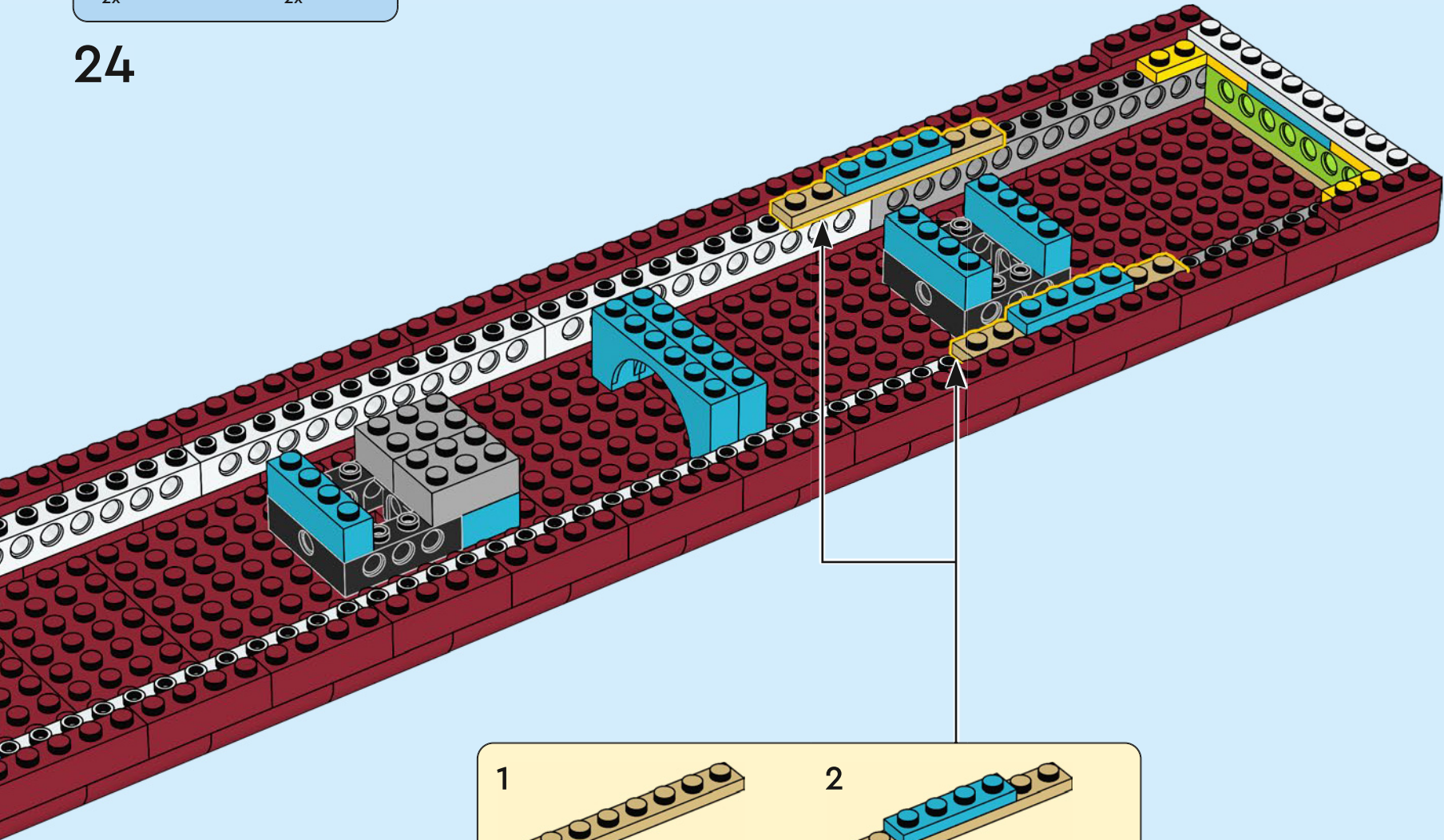



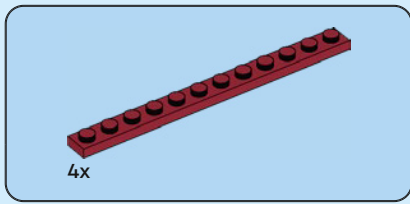

26

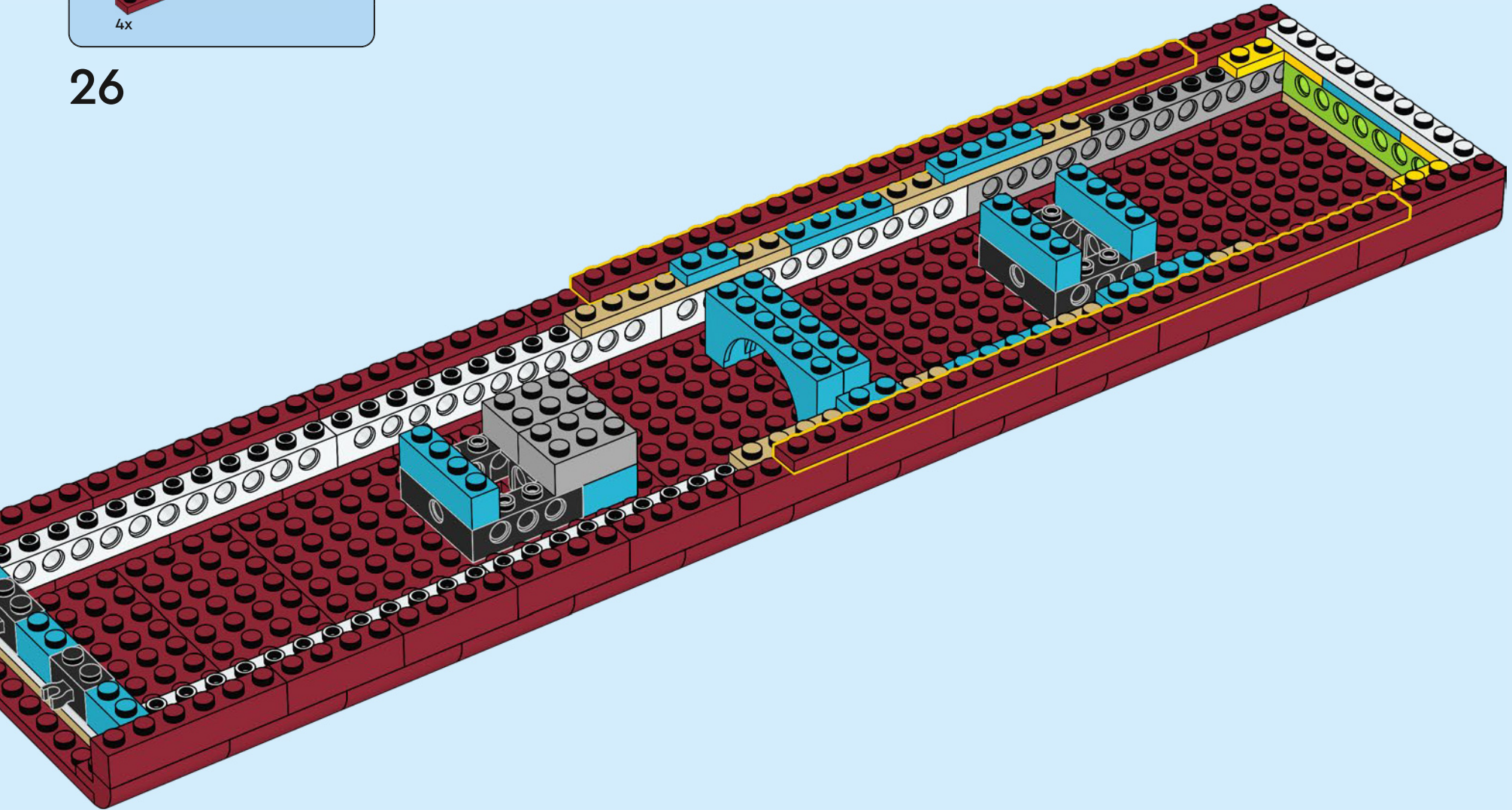

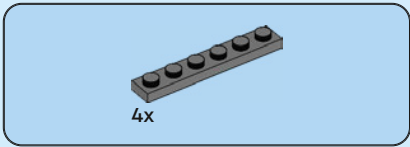

27

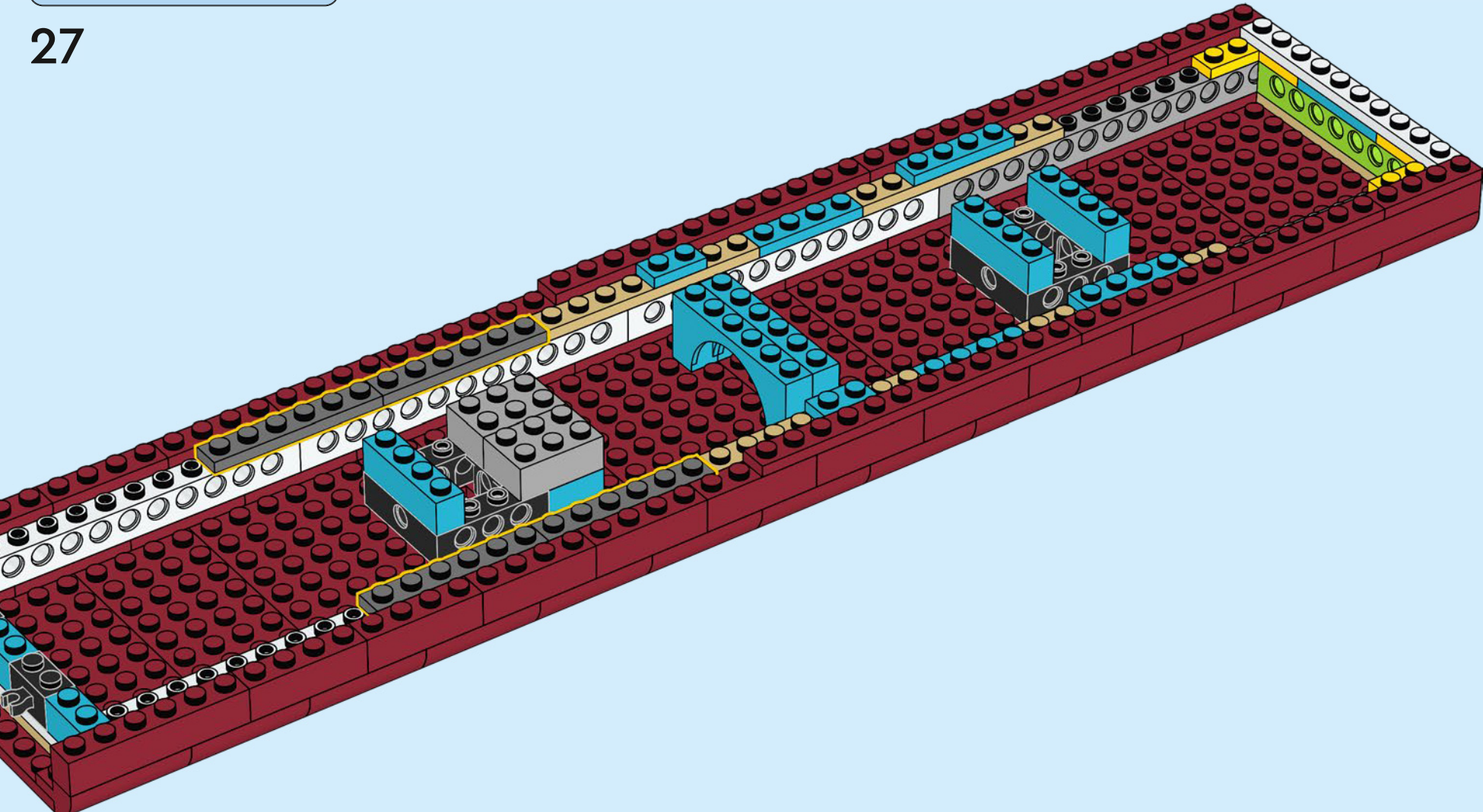

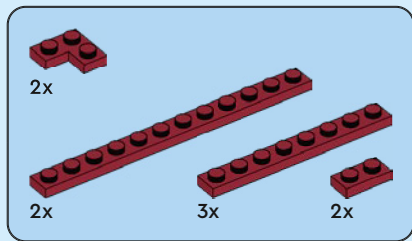

28

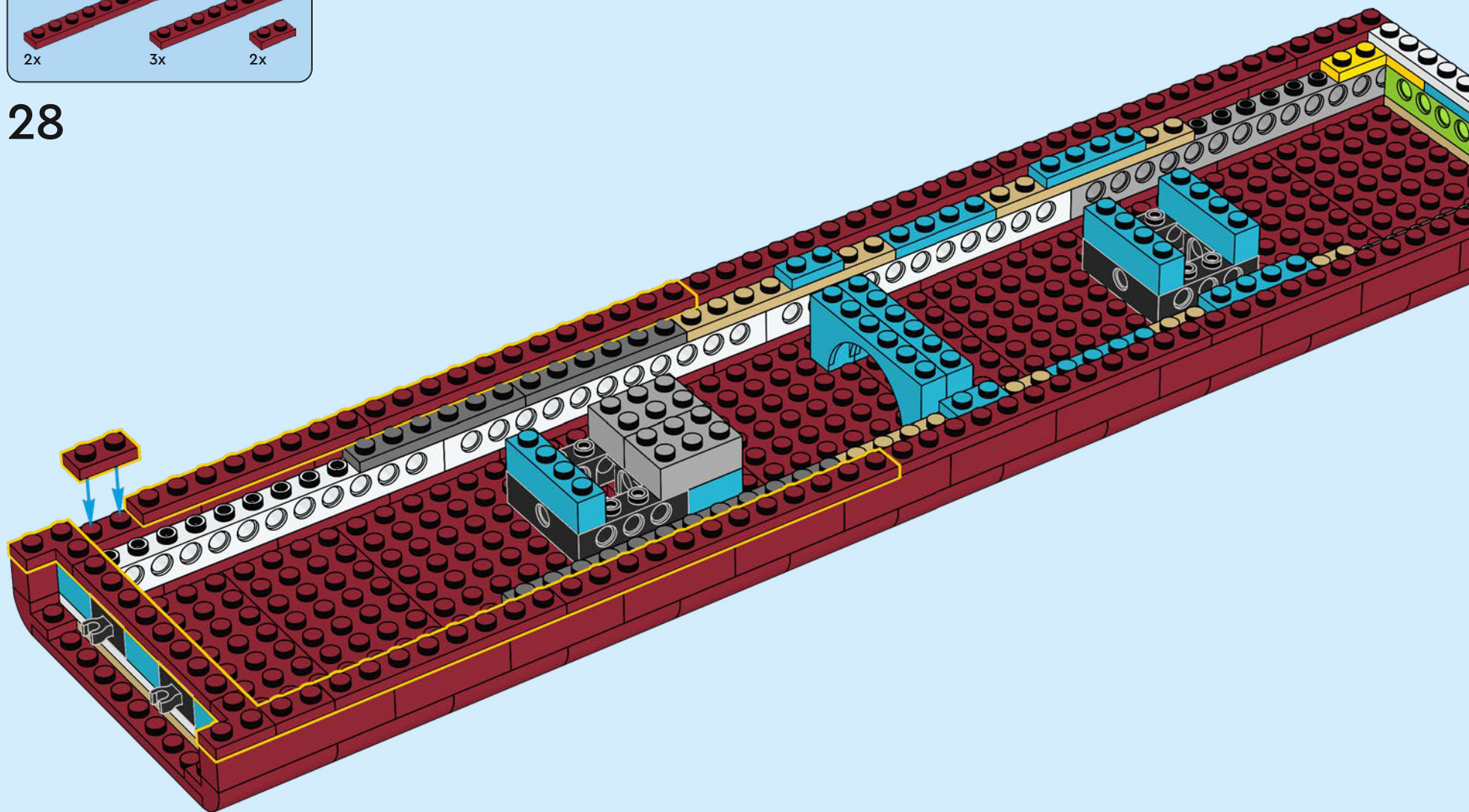

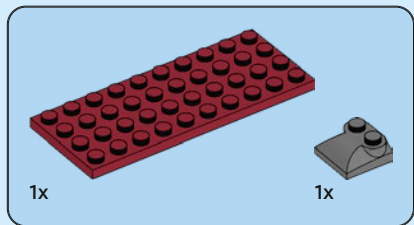
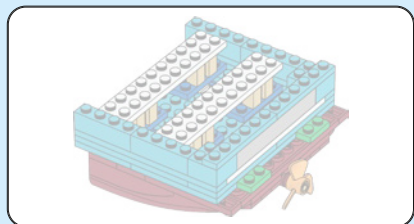

29

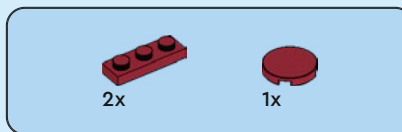
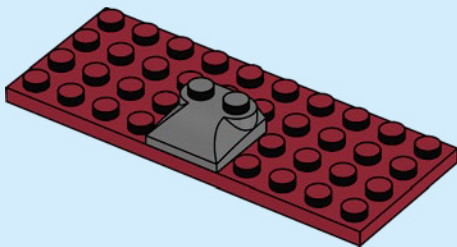

30

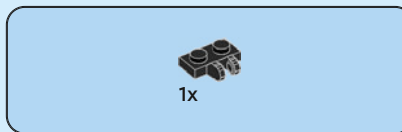
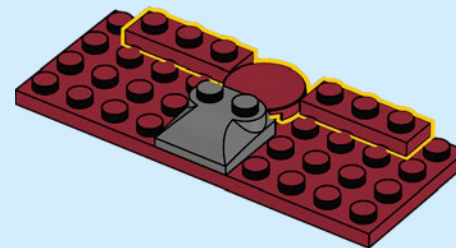

31

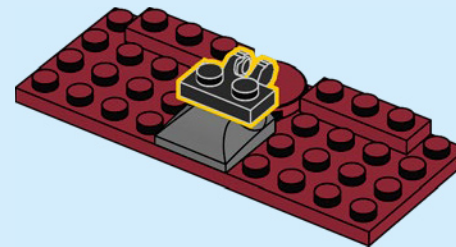

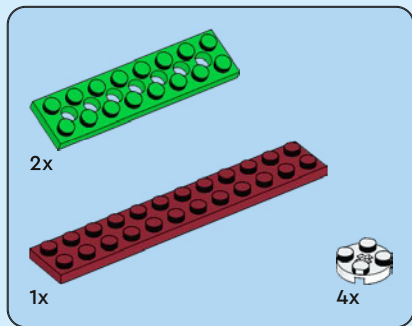

32

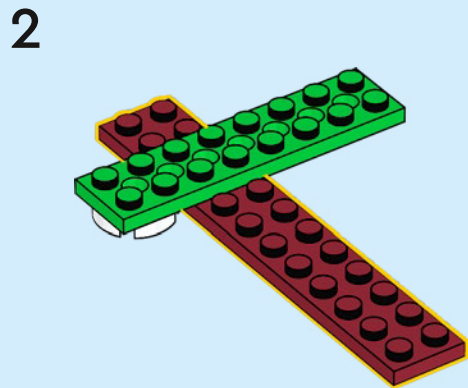
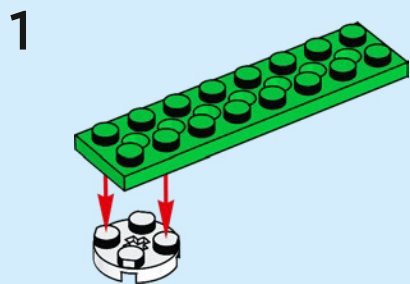

3

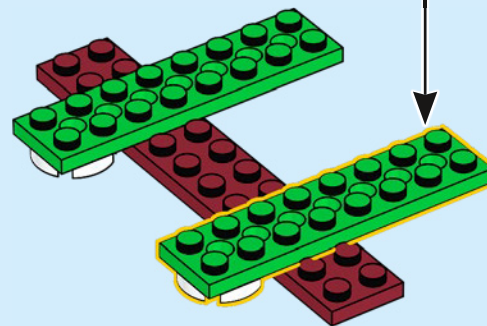

4

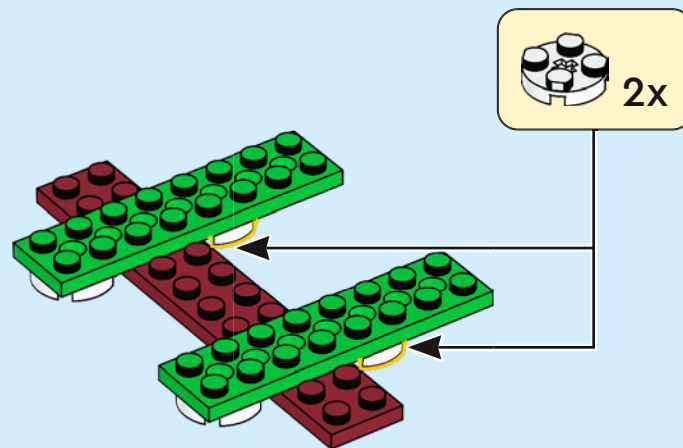

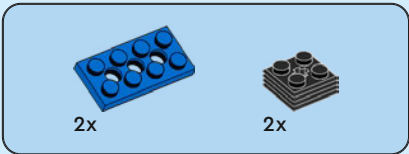

# 33

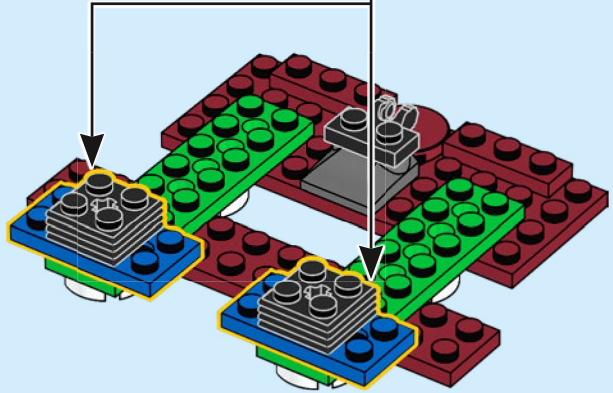
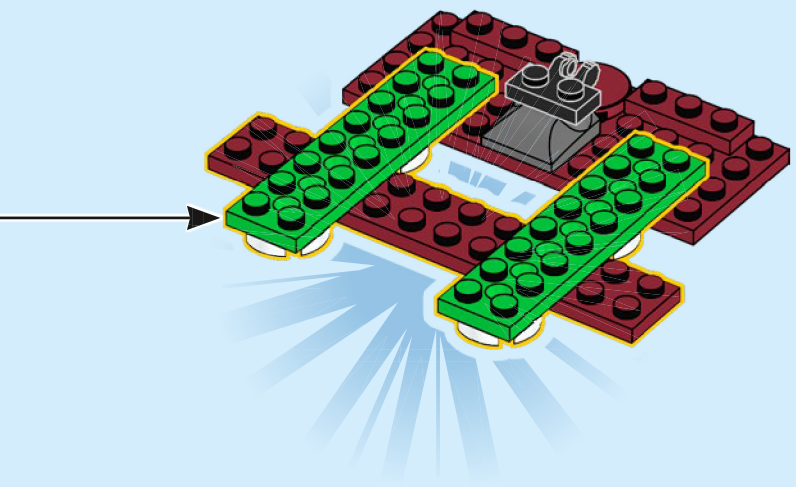
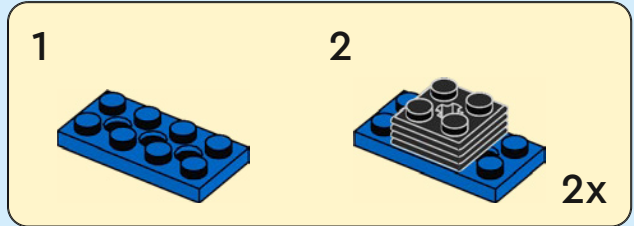

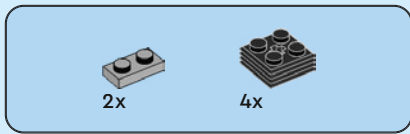

34

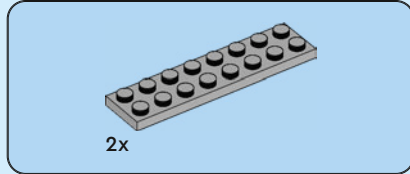
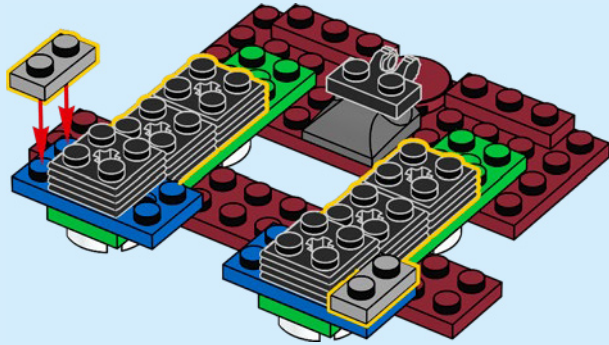

35

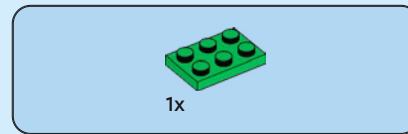
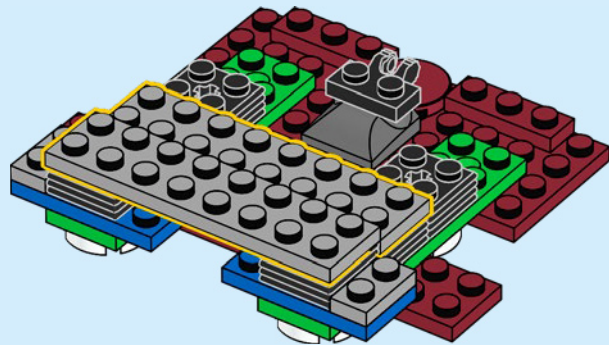

36

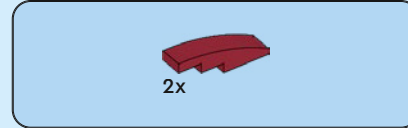
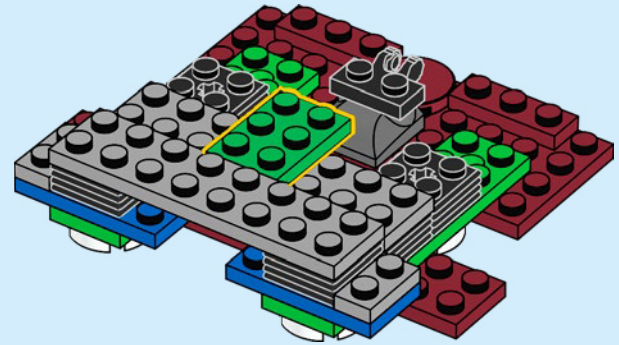

37

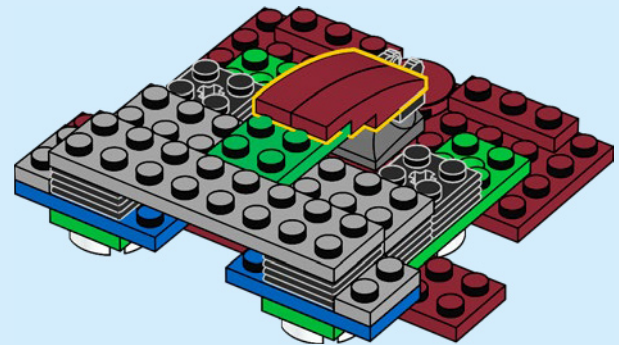

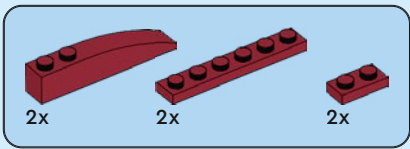

38

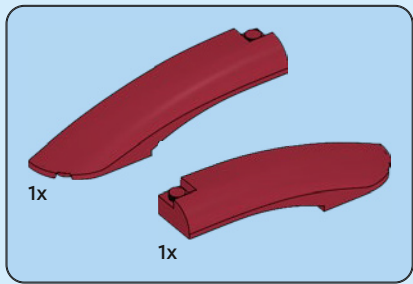
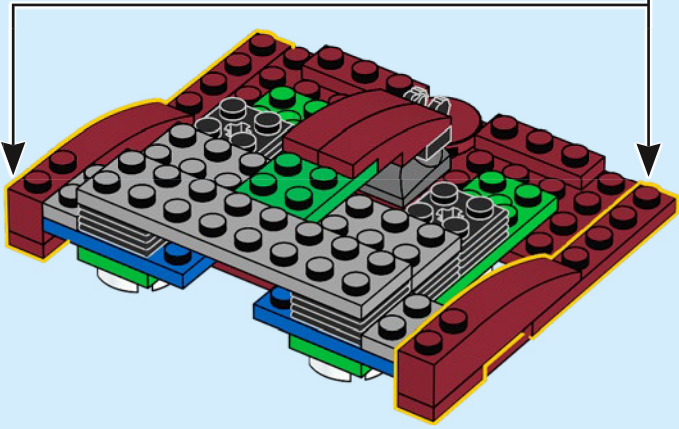
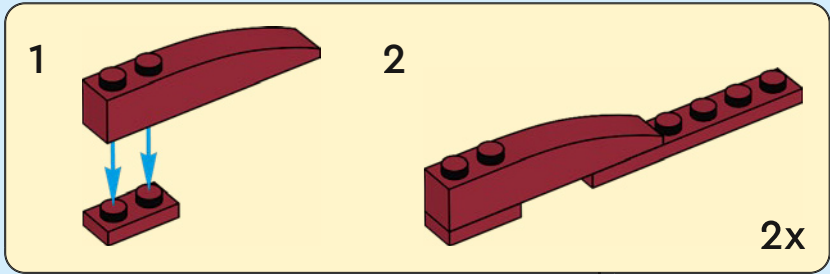

39

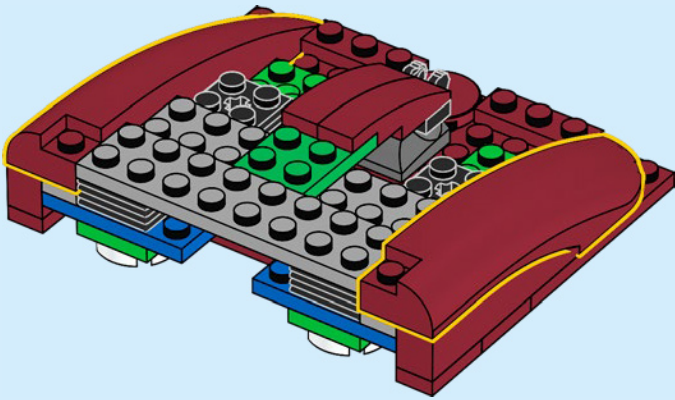

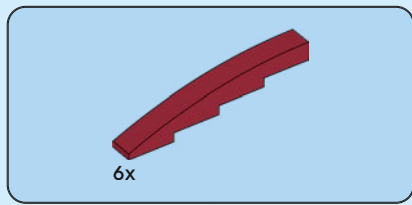

40

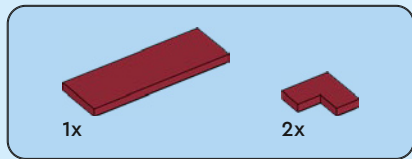
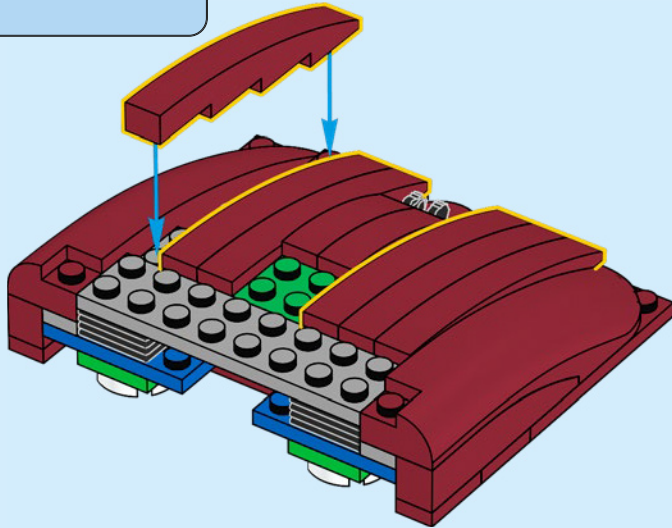

41

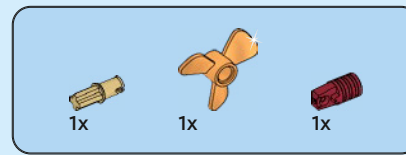
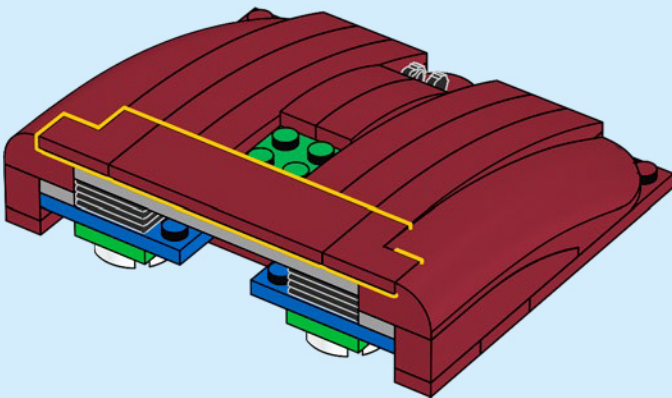

42

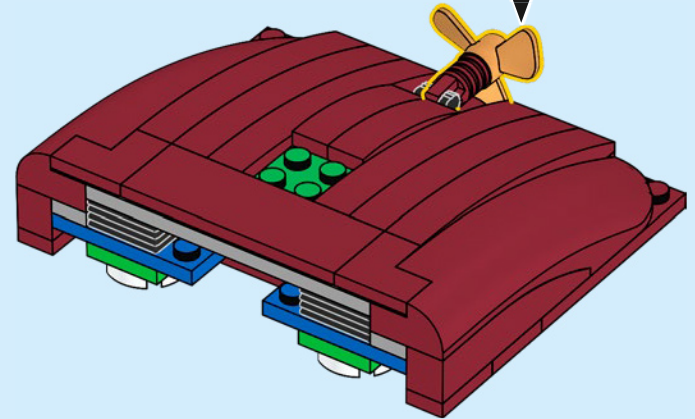
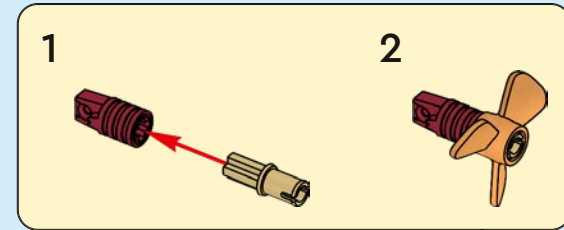

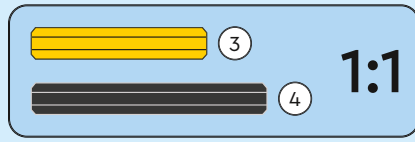
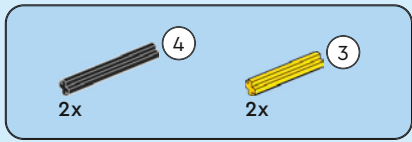

43

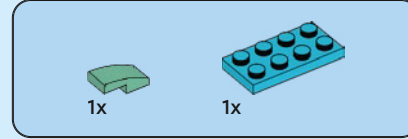
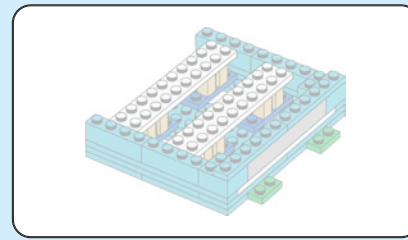
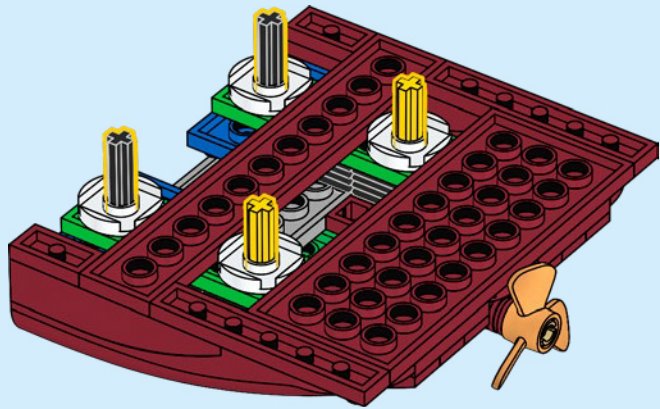

44

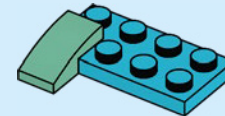

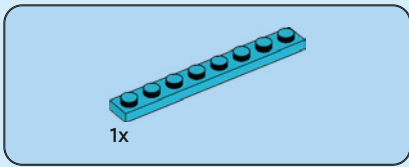

45

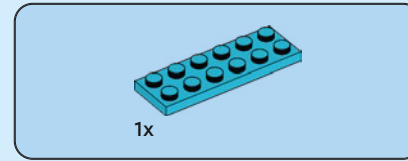
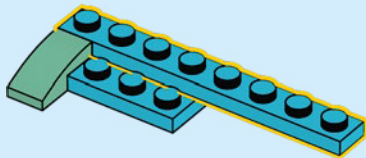
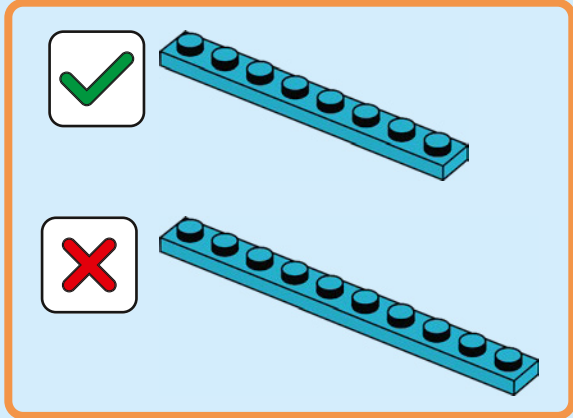

46

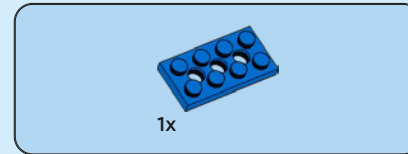
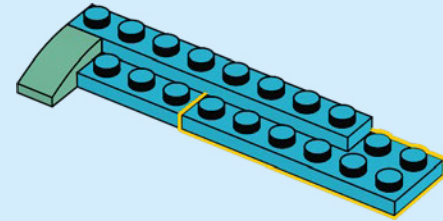

47

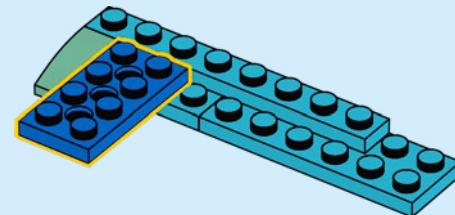

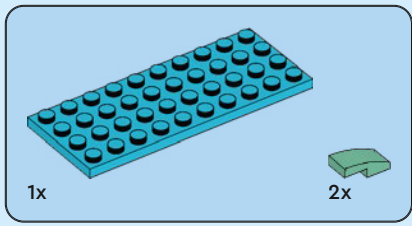

48

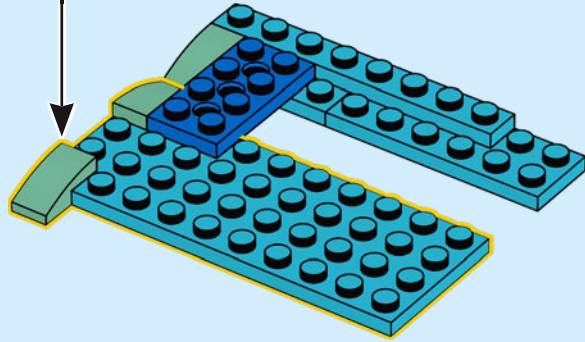
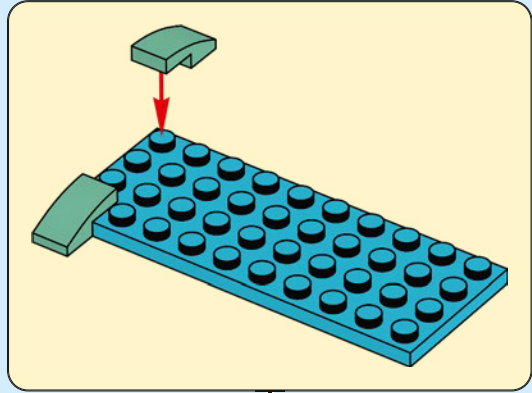

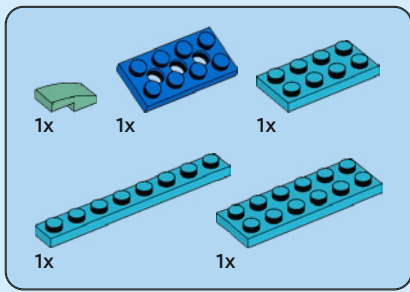

49

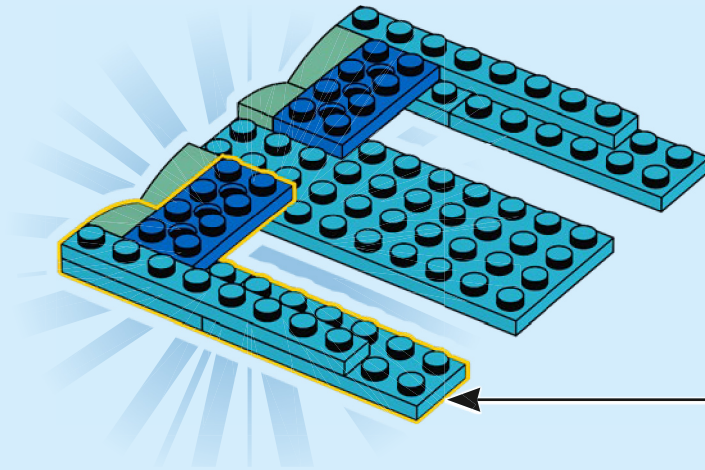
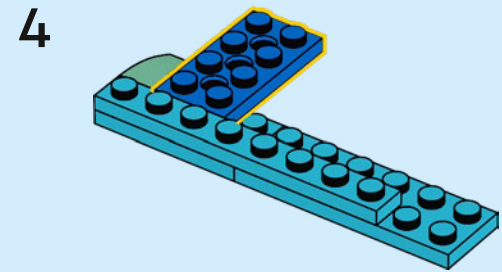
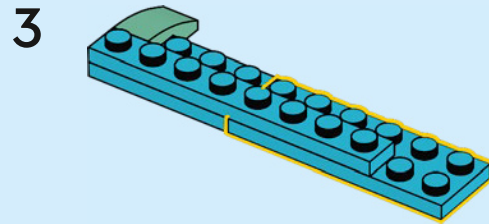
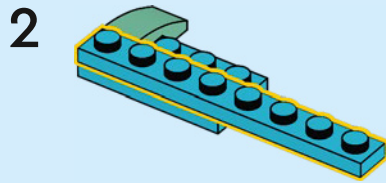
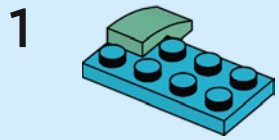
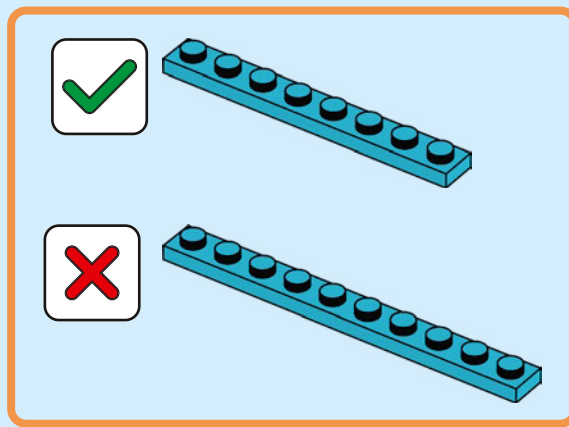



50

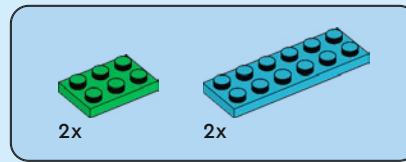
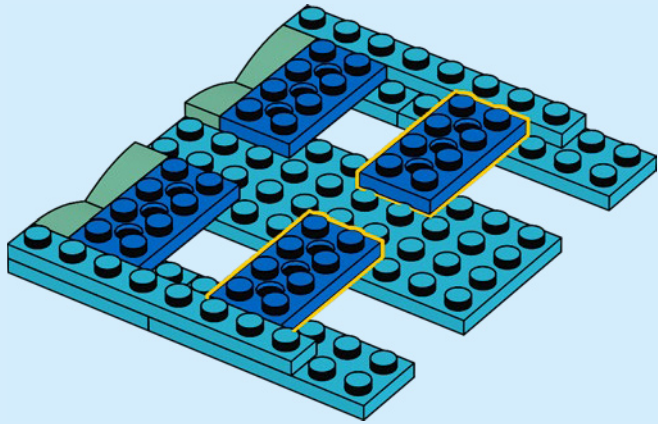

51

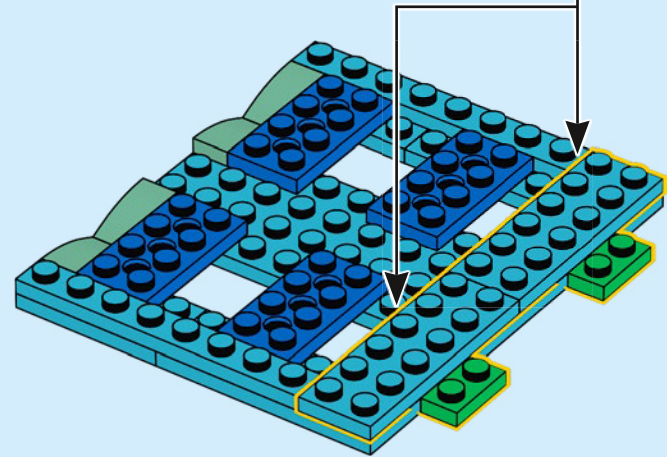
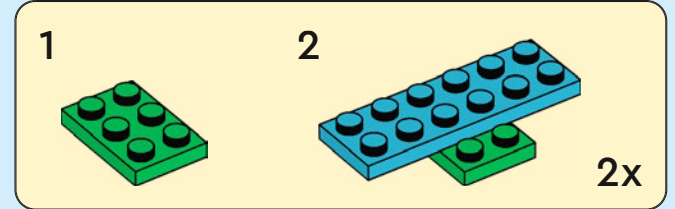

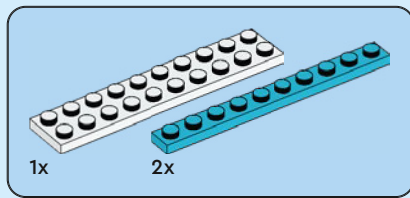

52

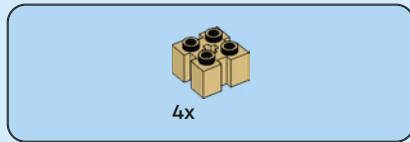
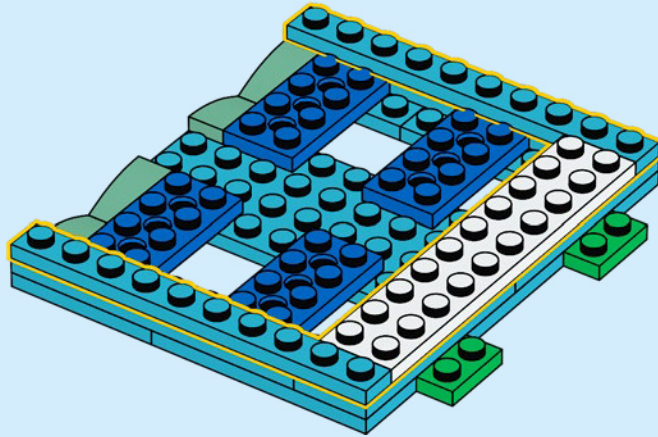

53

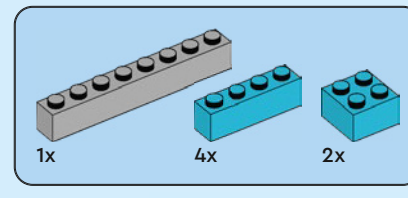
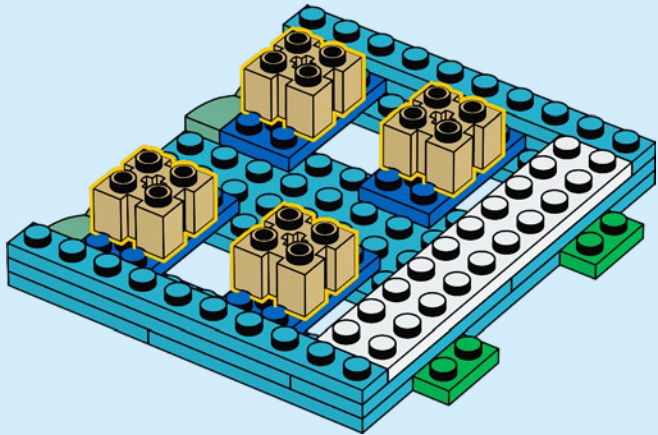

54

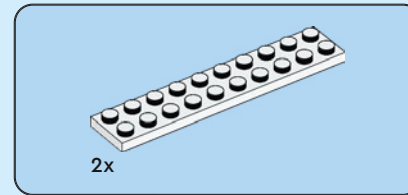
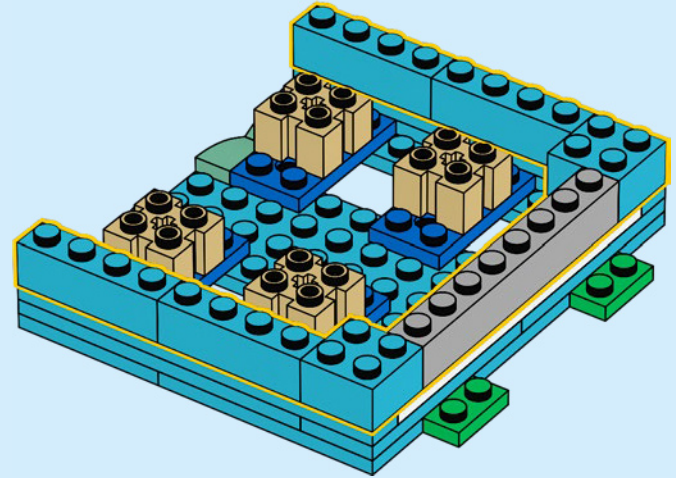

55

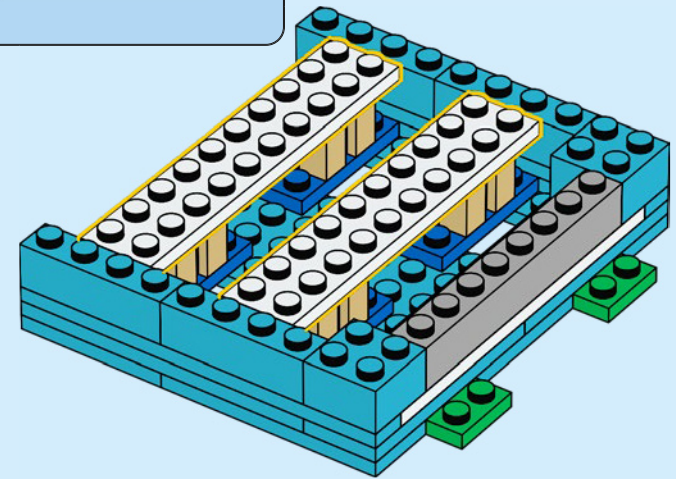

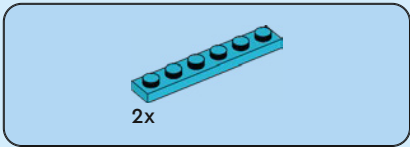

56

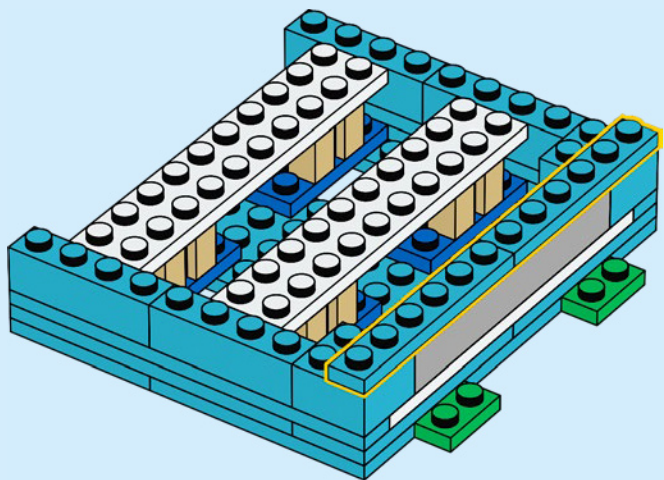

57

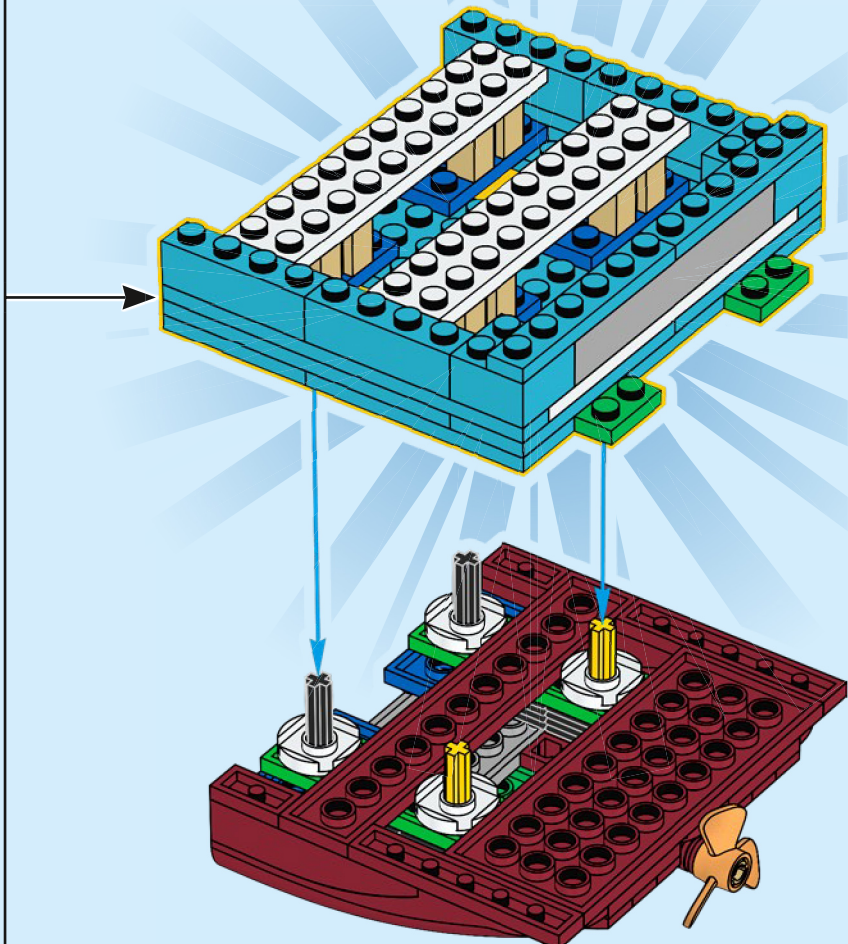

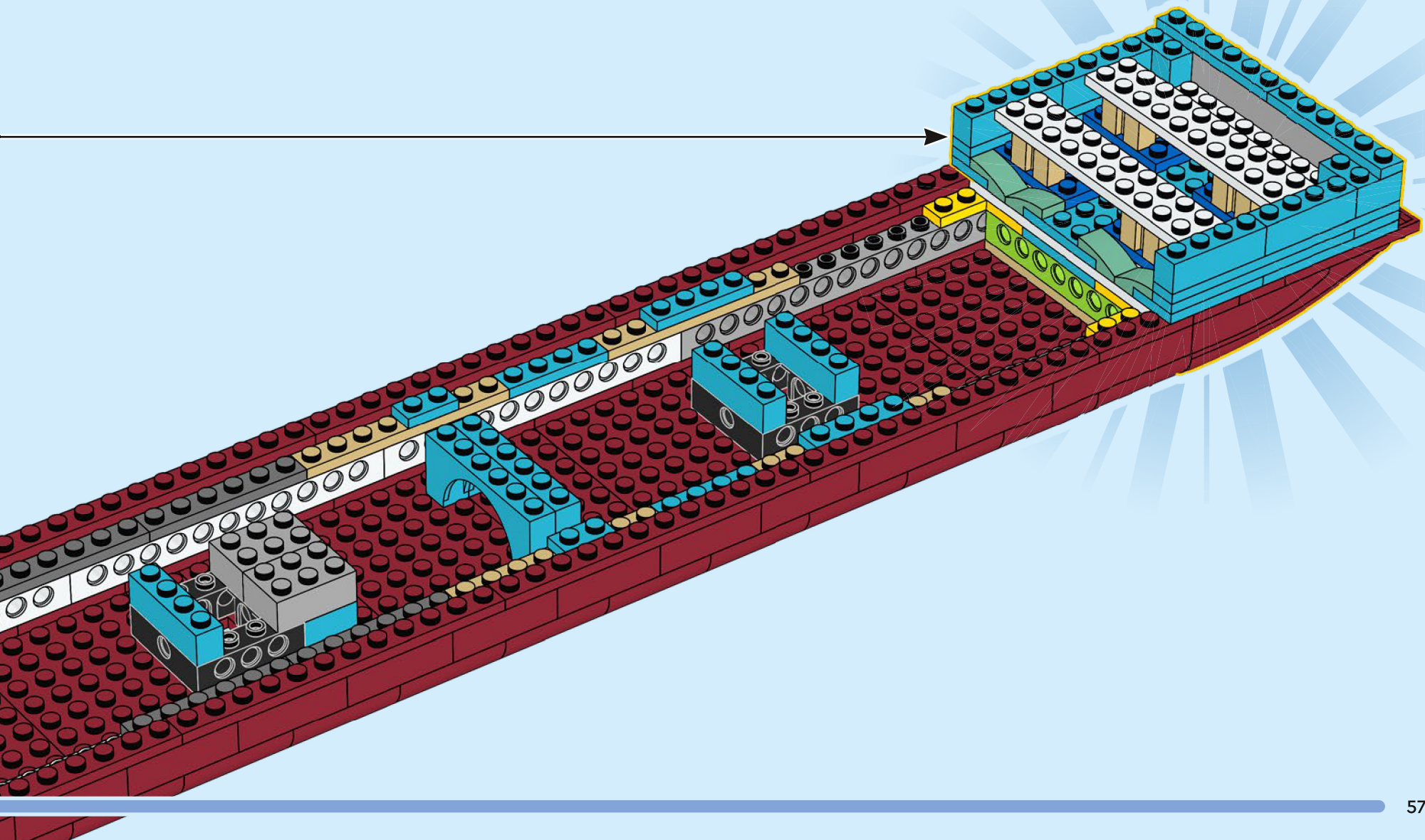

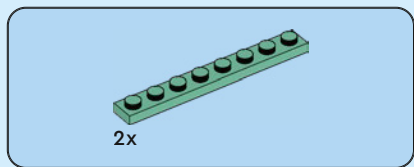
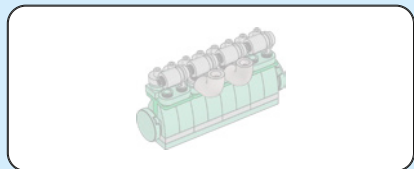

59

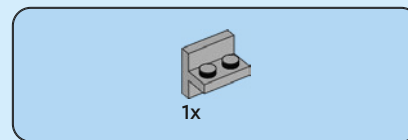
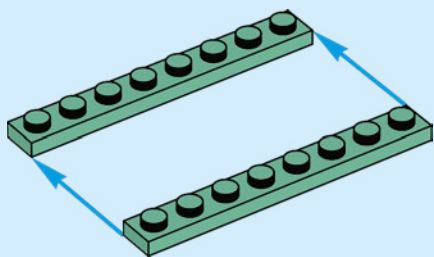

60

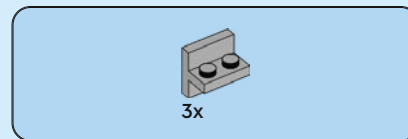
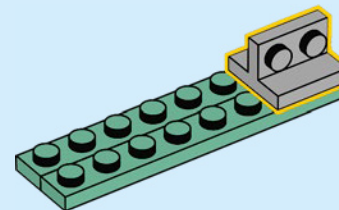

61

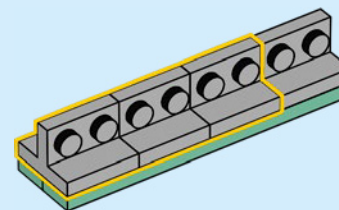



62

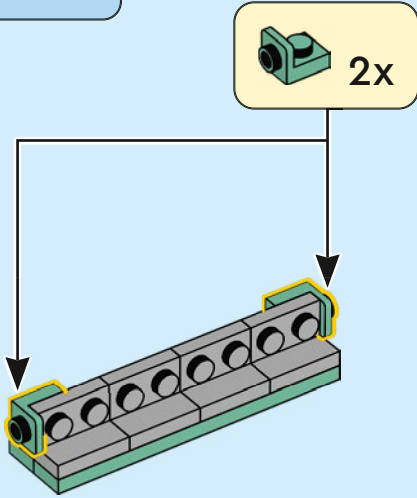

63

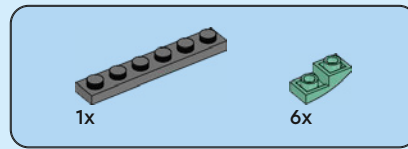
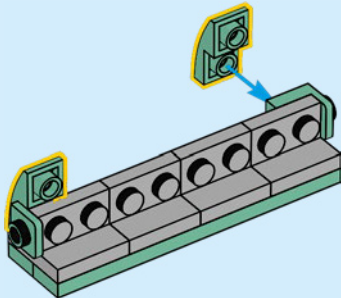

64

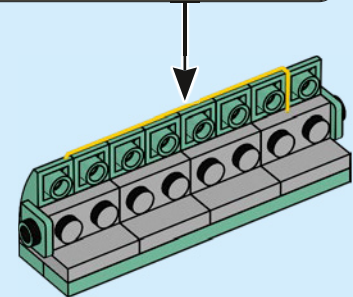
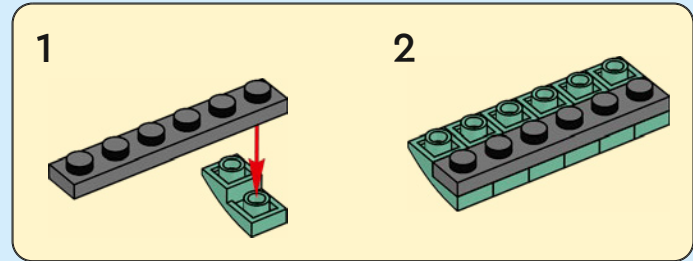

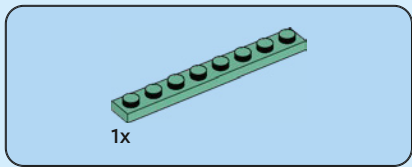

65

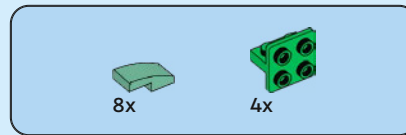
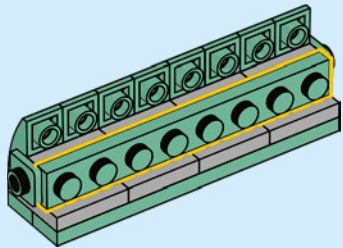

66

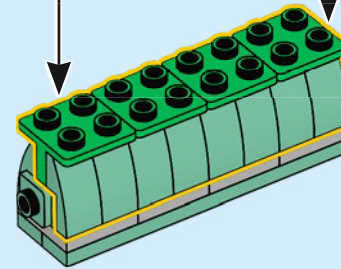
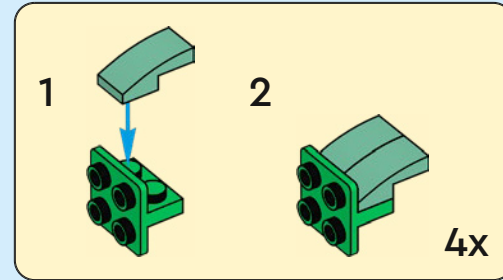

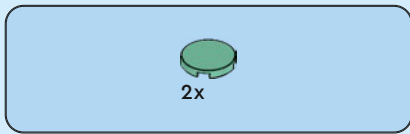

67

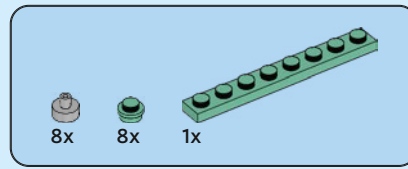
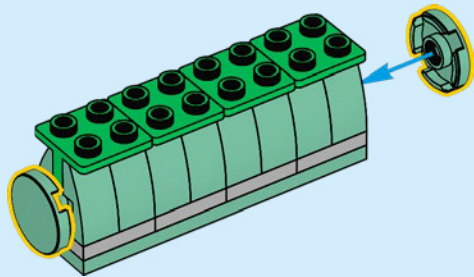

68

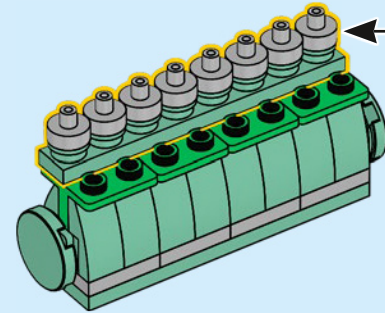
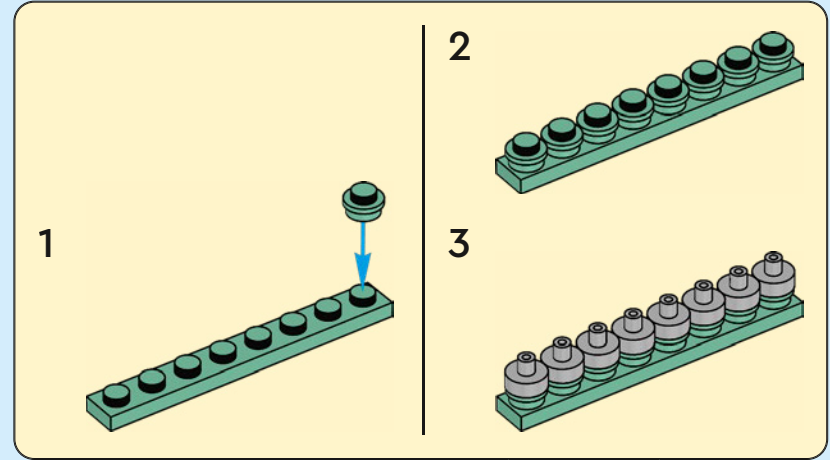



2x

69

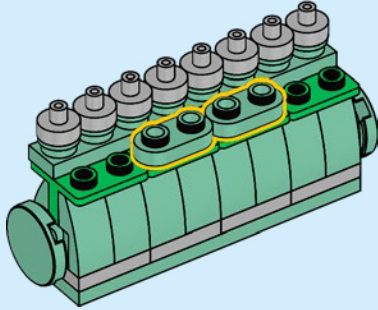

2x



2x

70

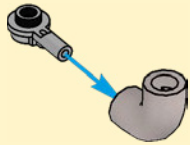
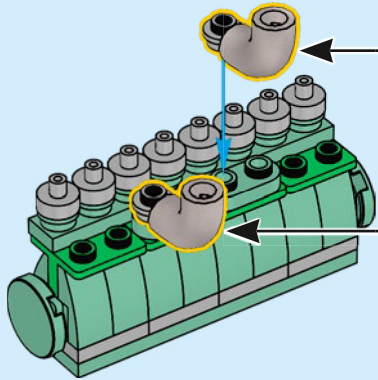

2x



2x

71

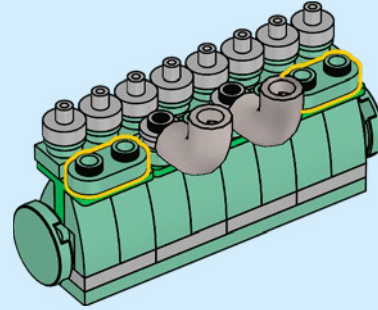

4x



4x

72

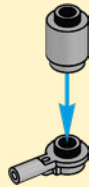
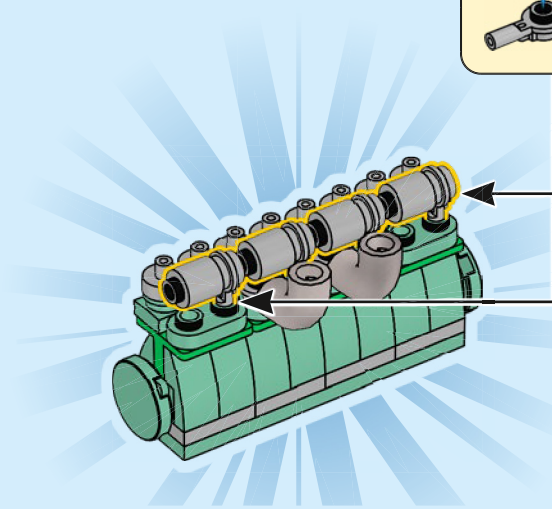

4x

73

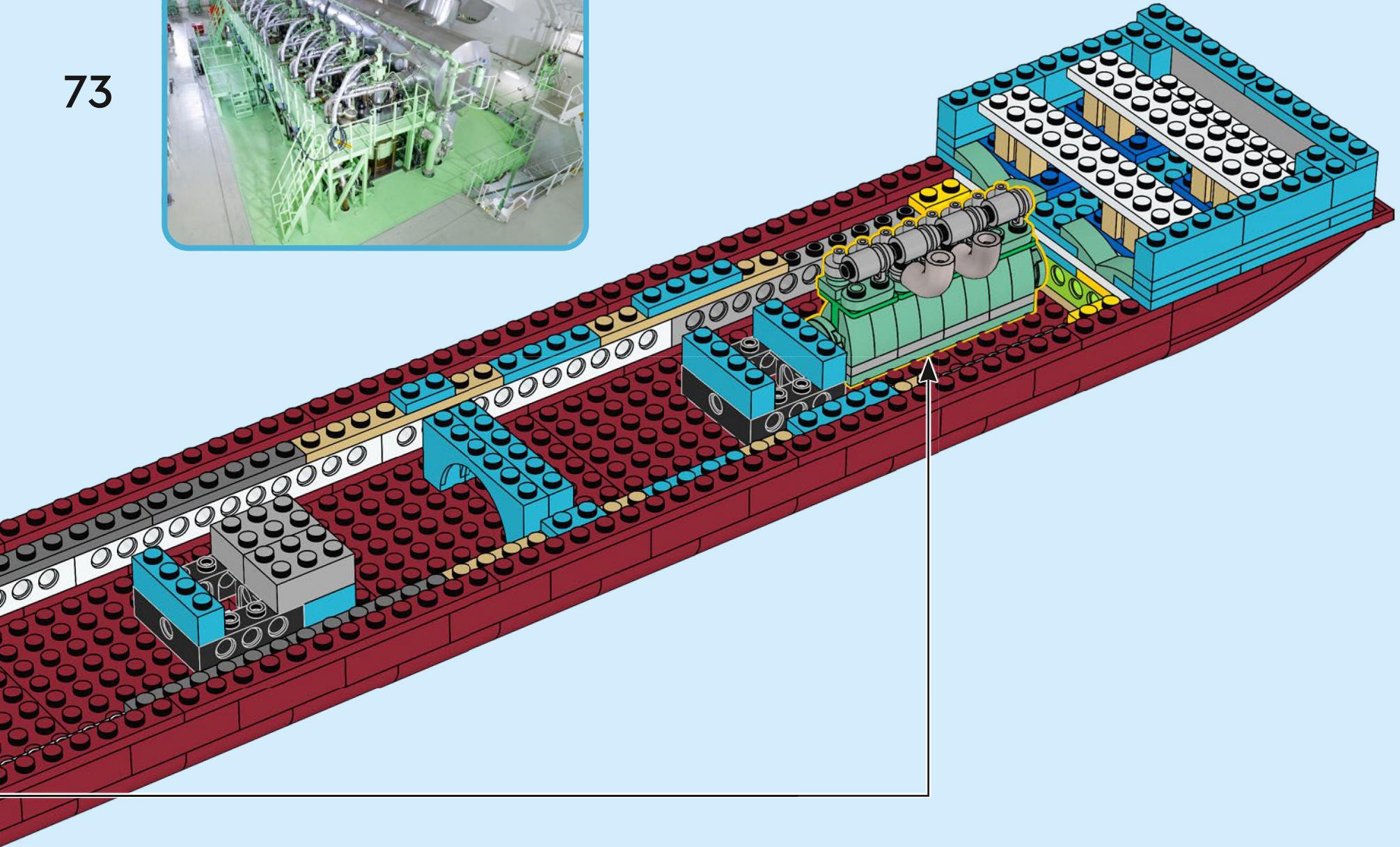

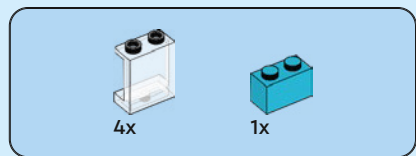

74

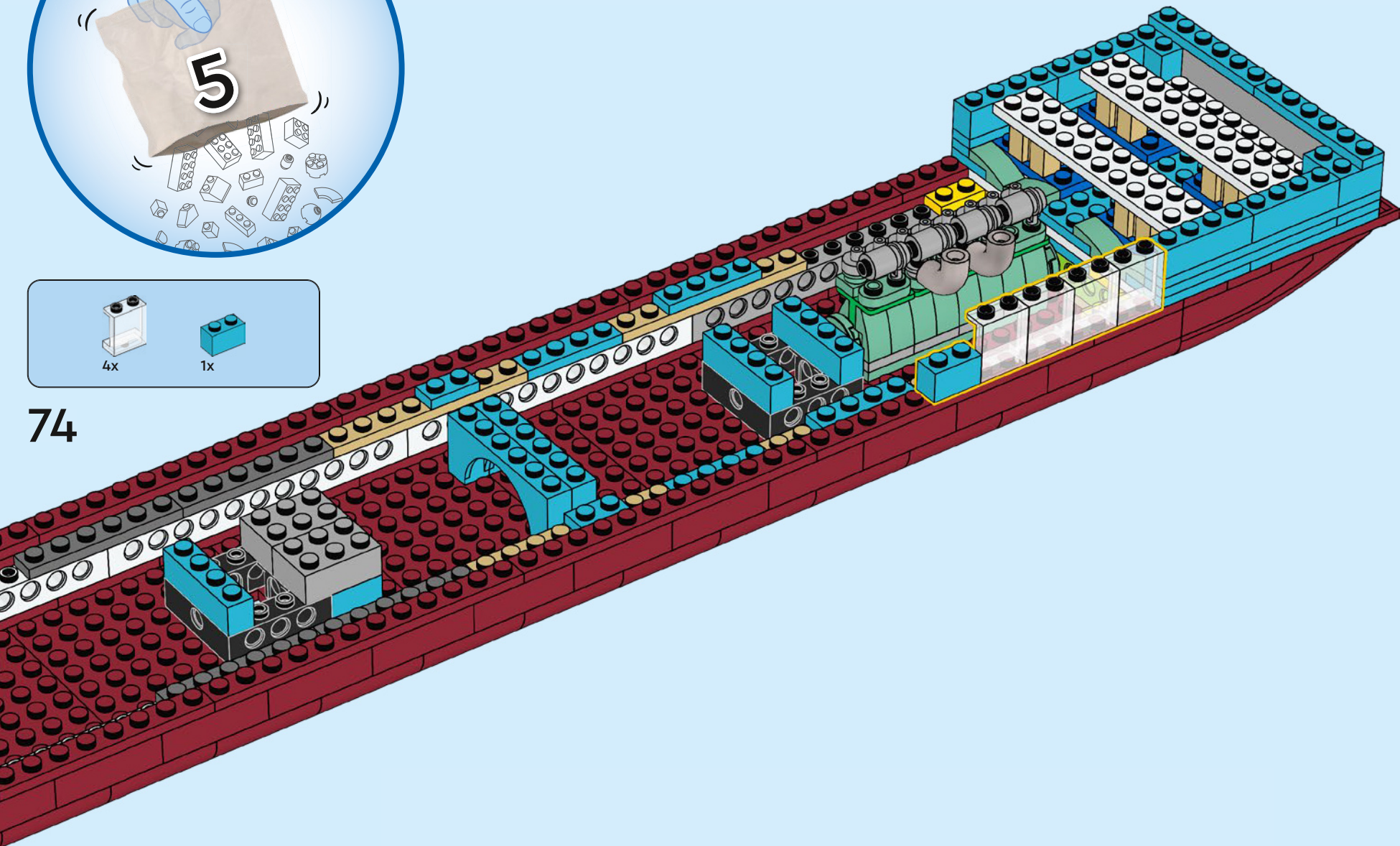

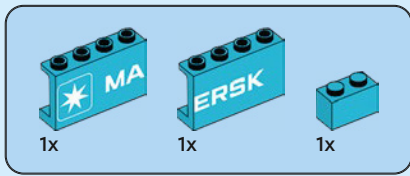

75

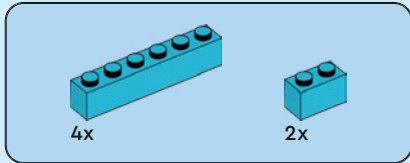
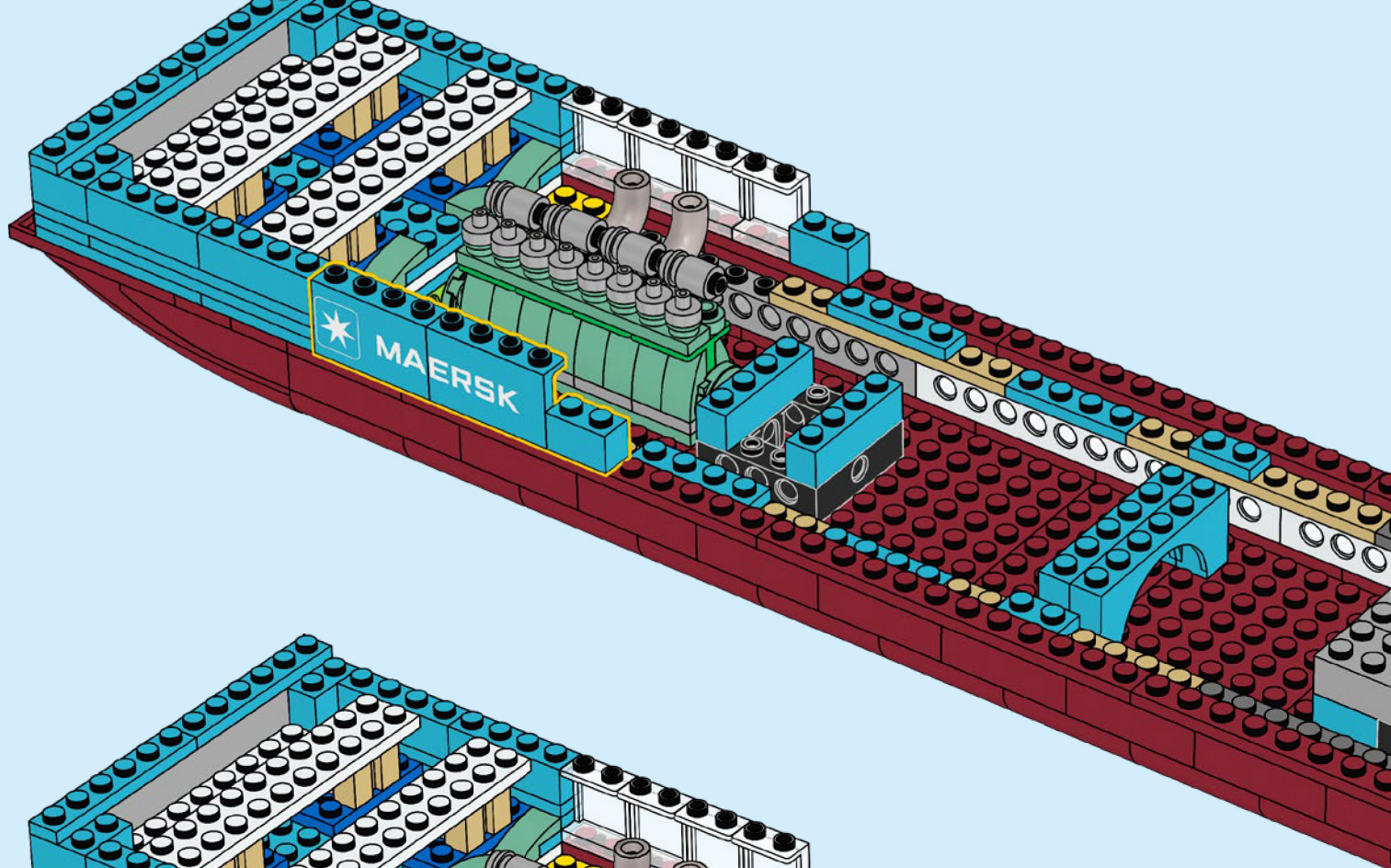

76

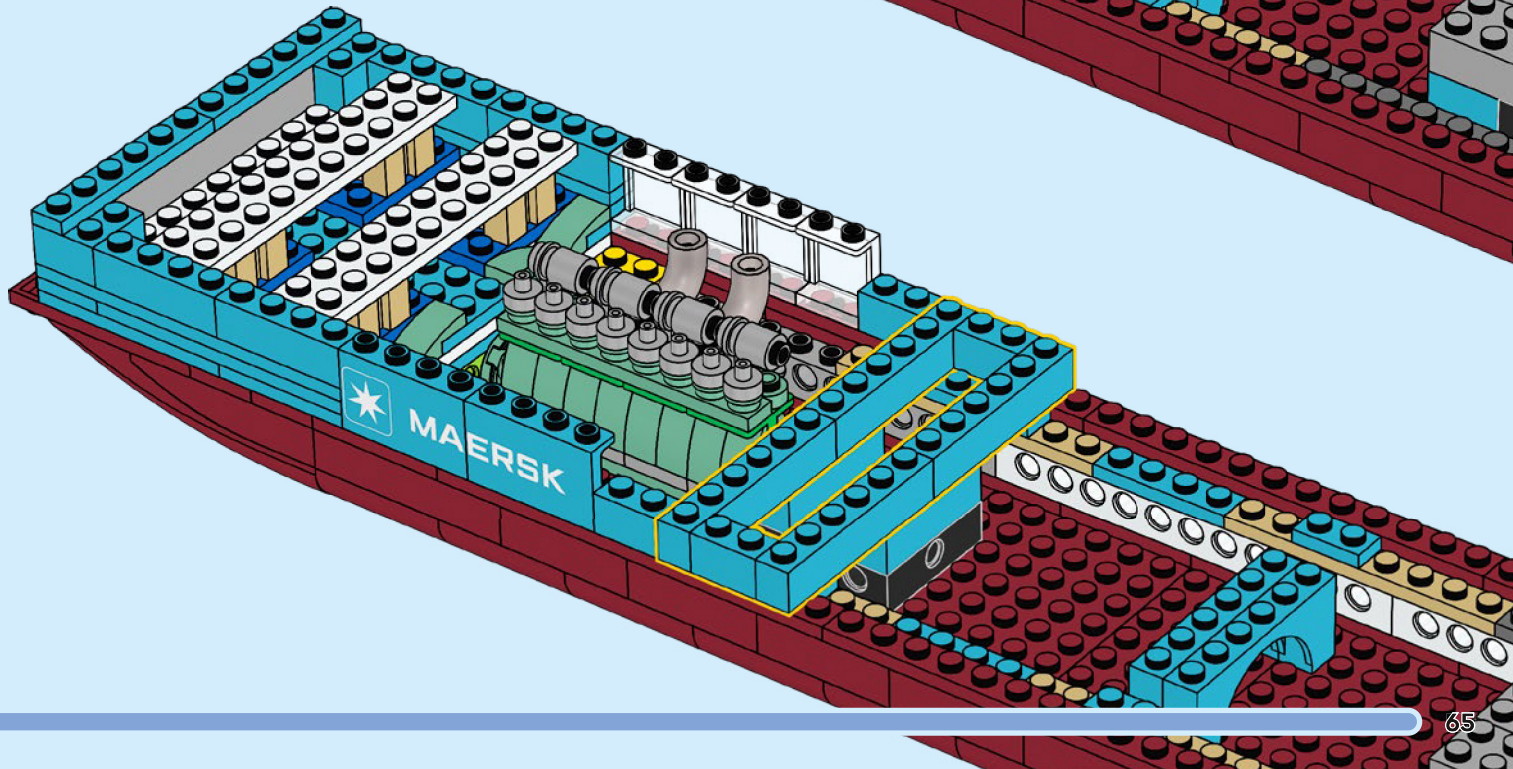

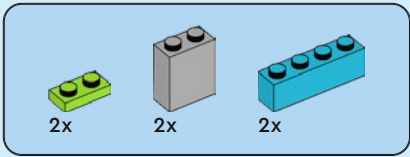

77

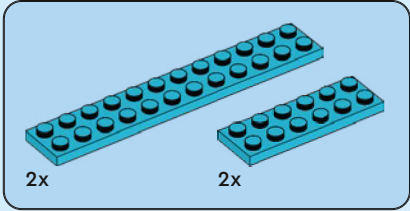
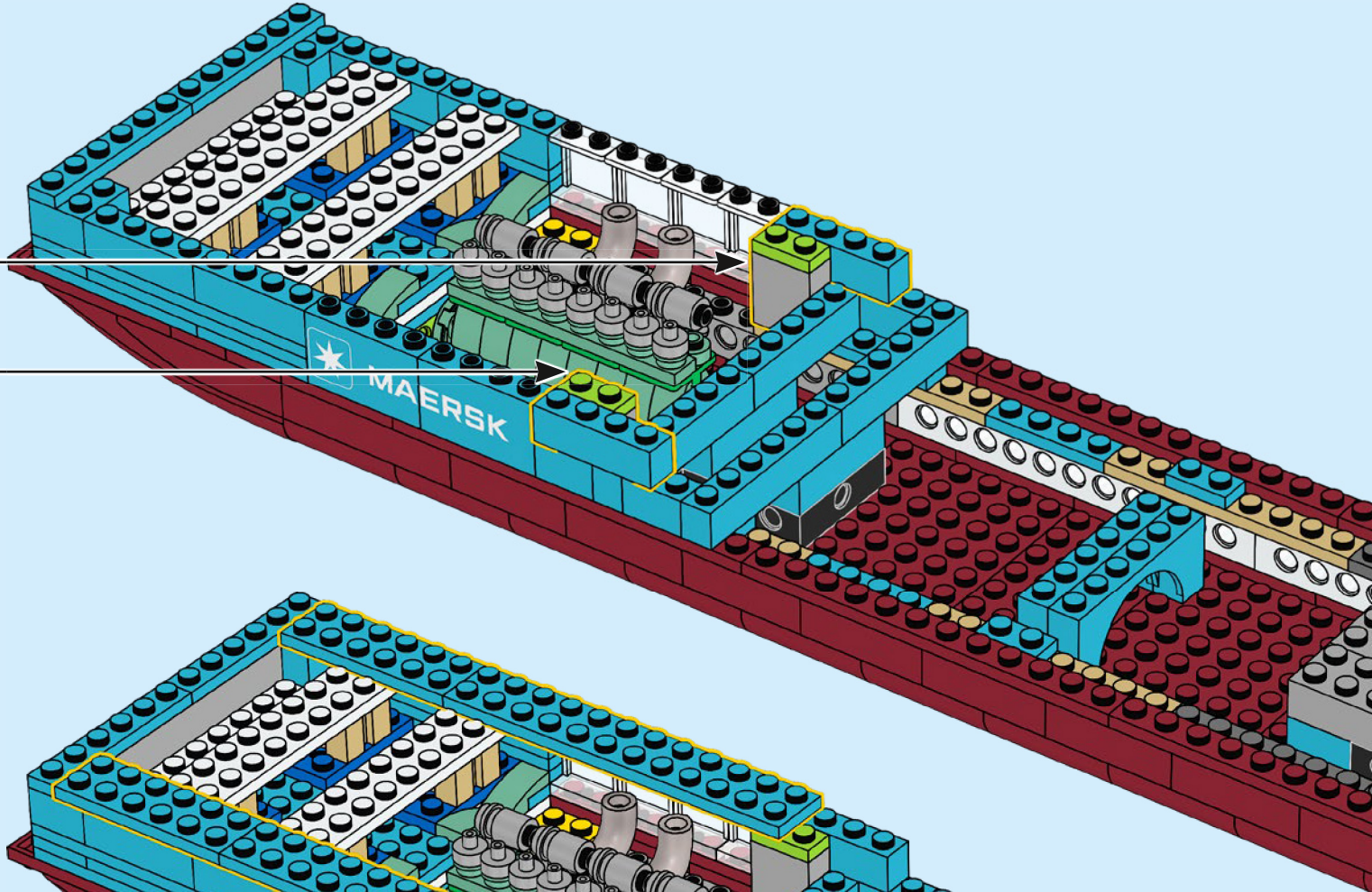
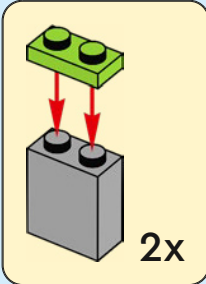

78

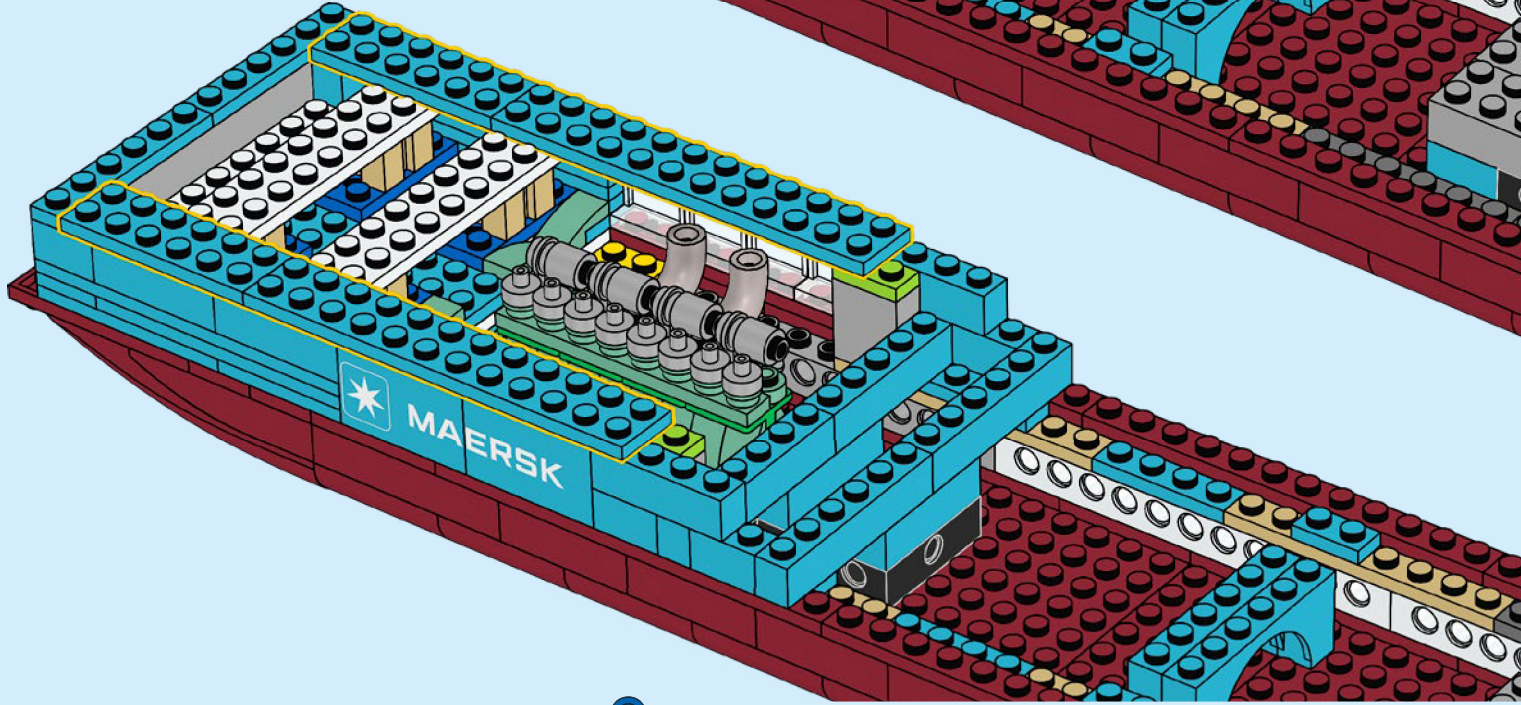

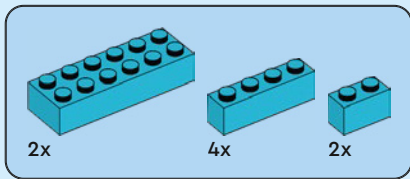

79

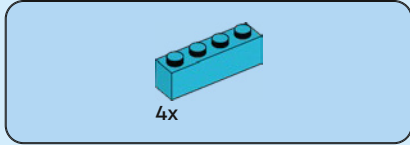
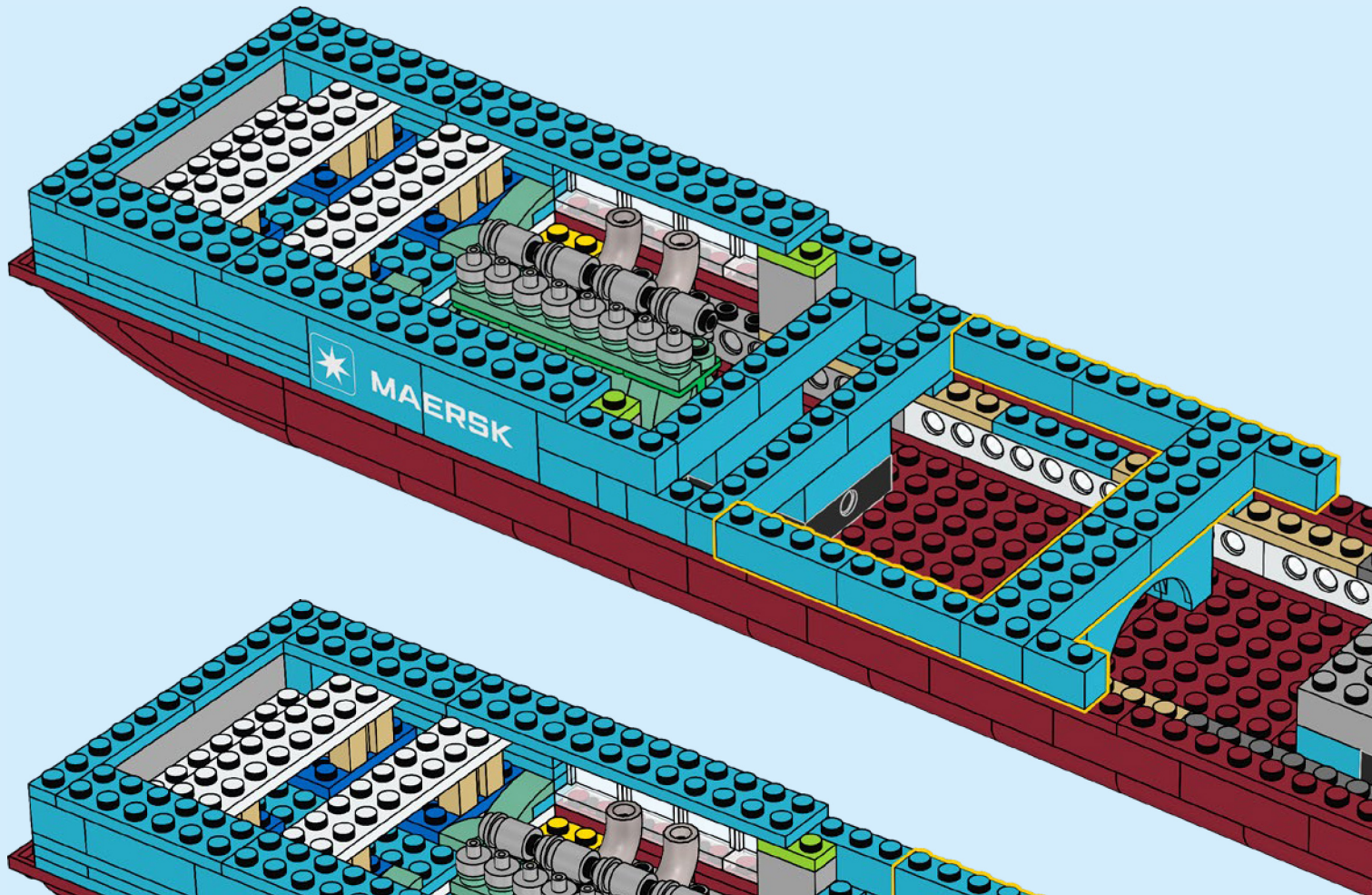

80

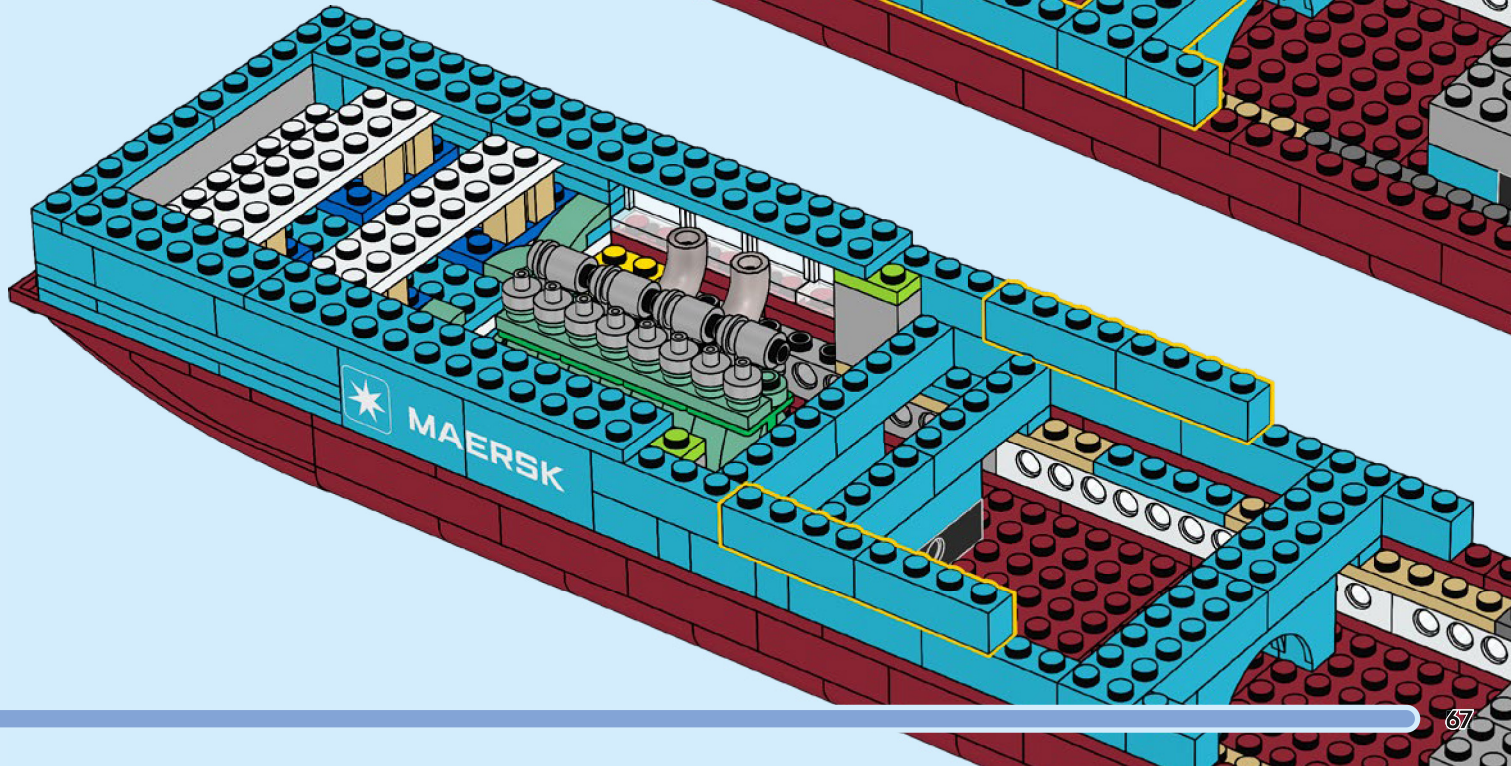

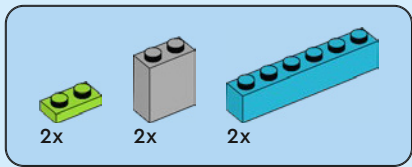

81

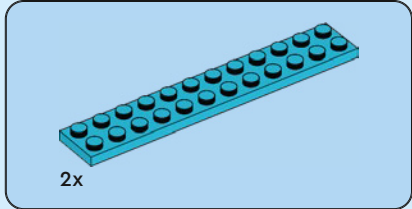
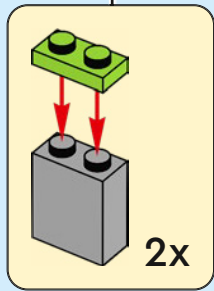
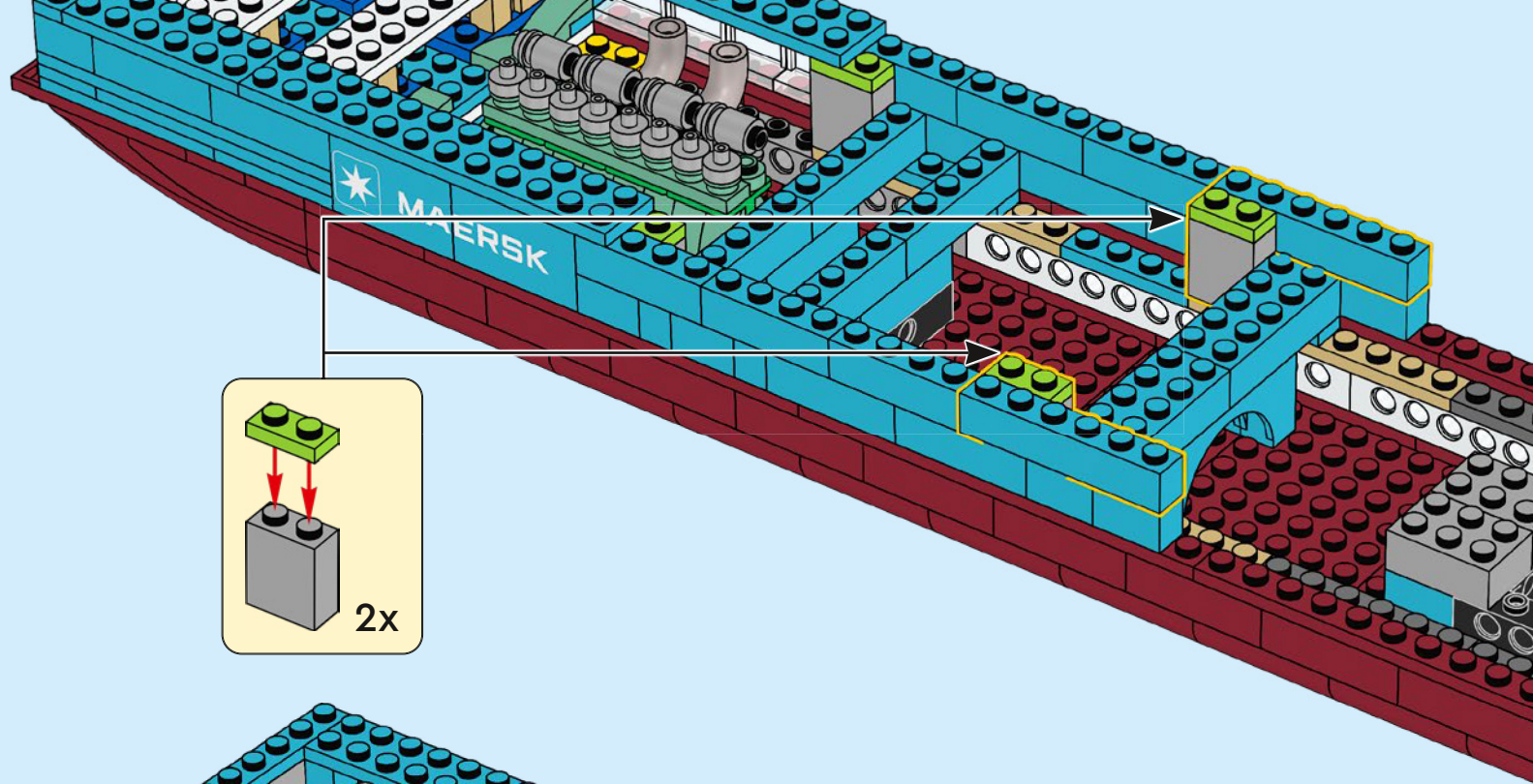

82

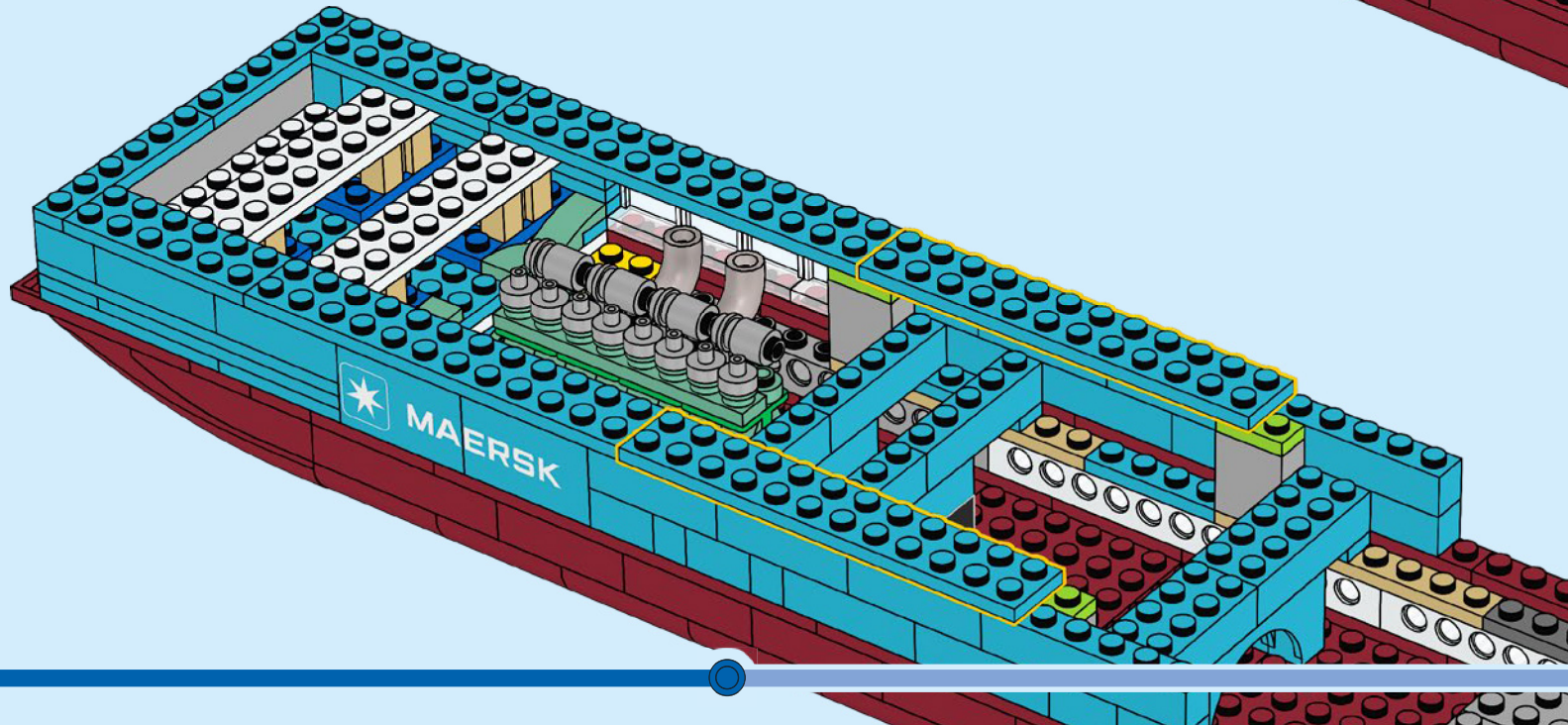

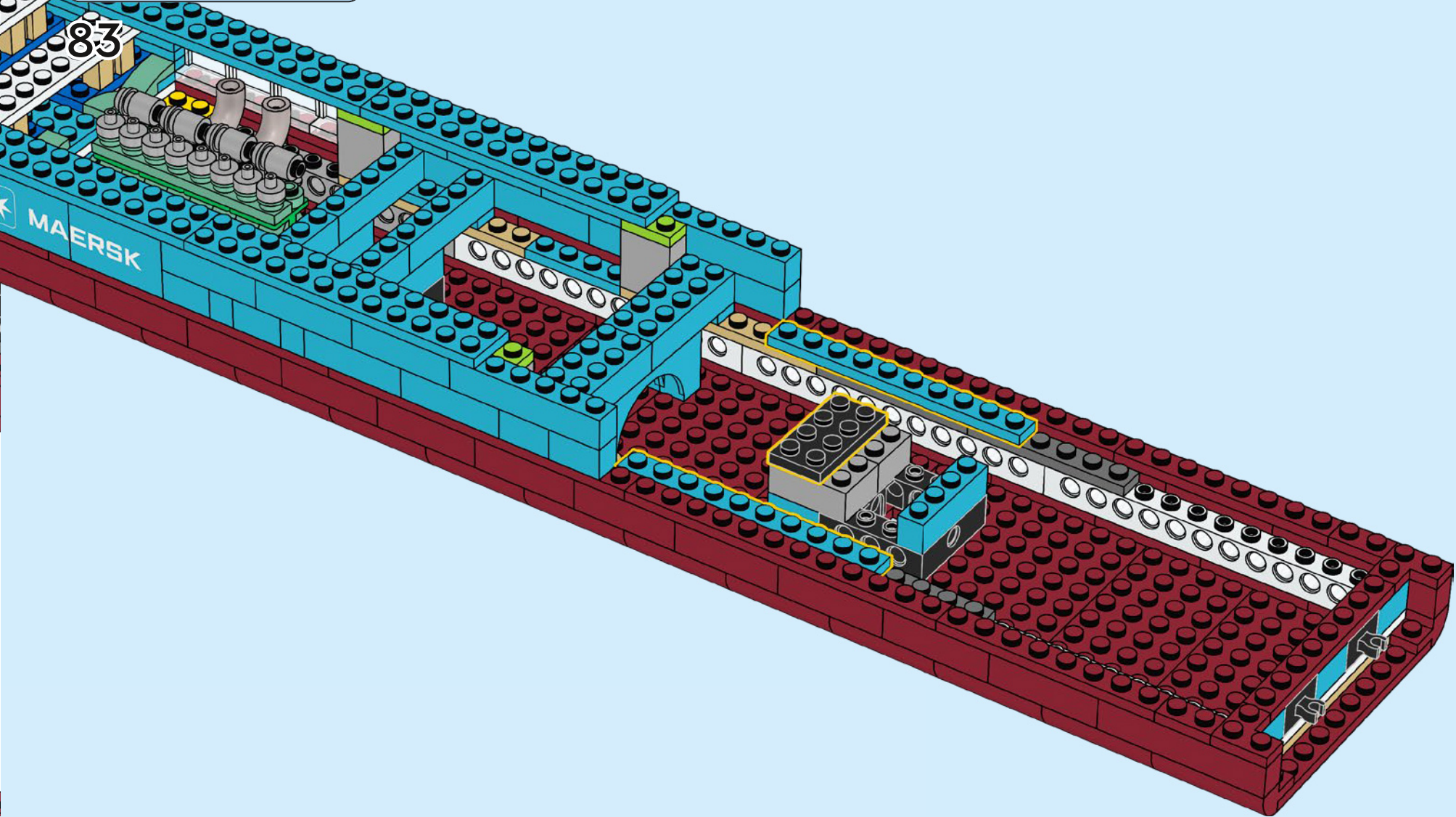
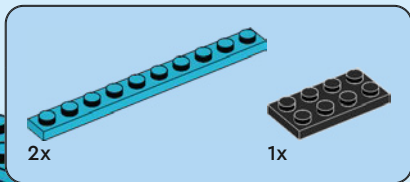

84

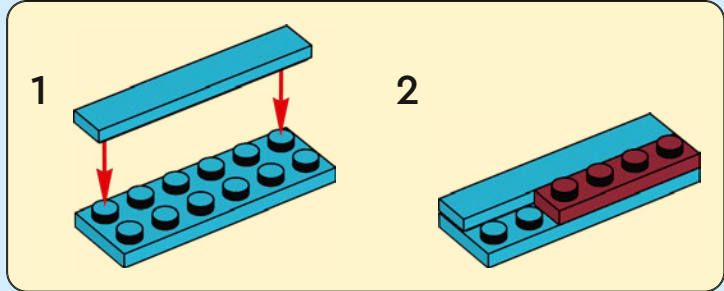
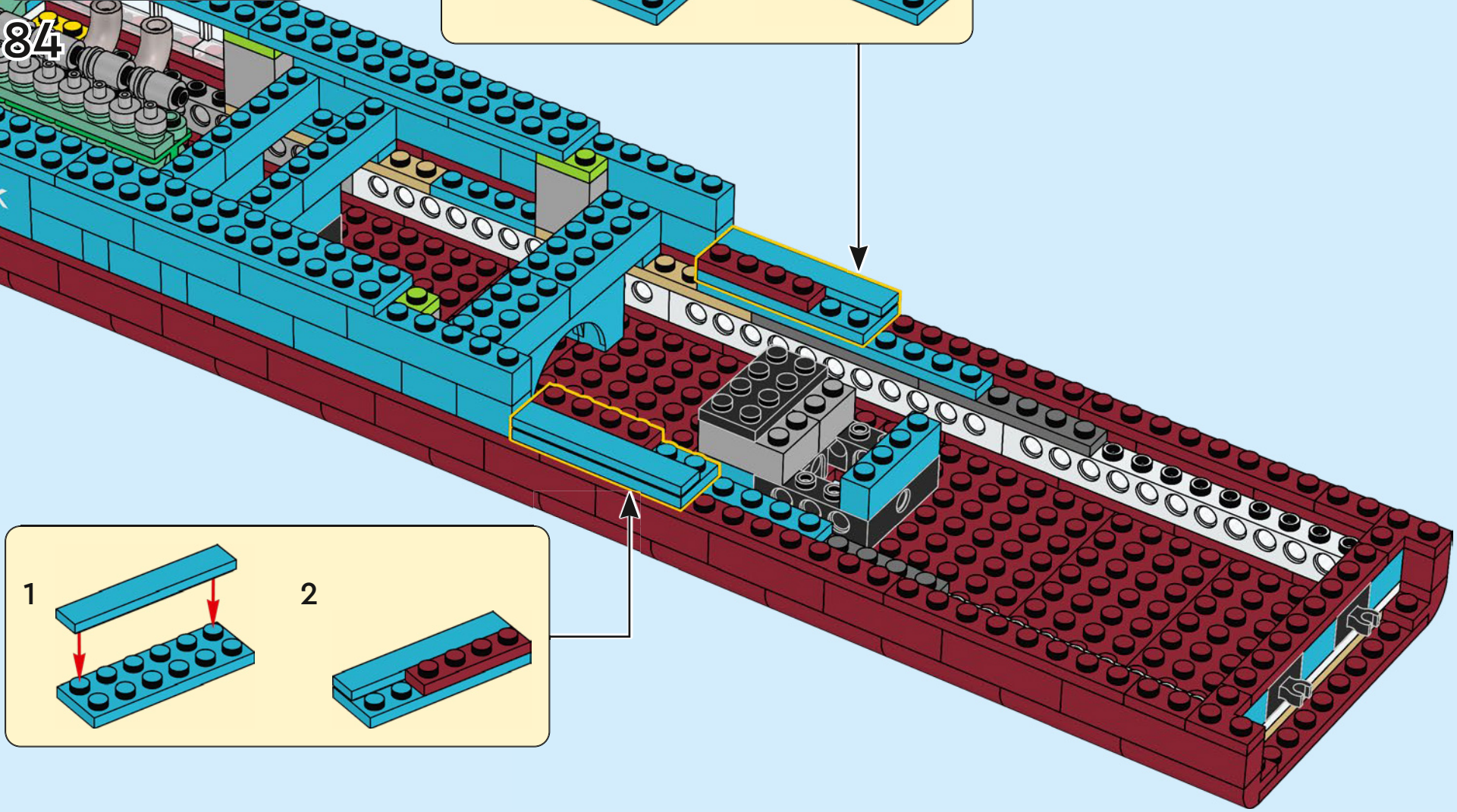
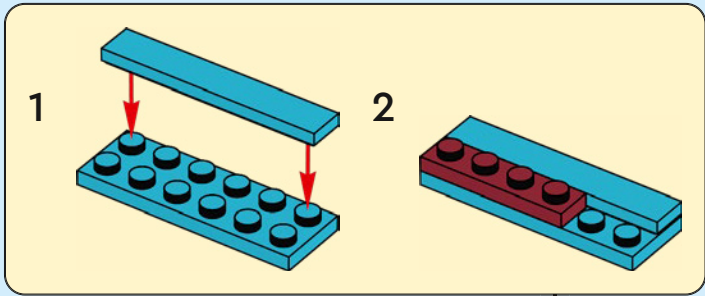
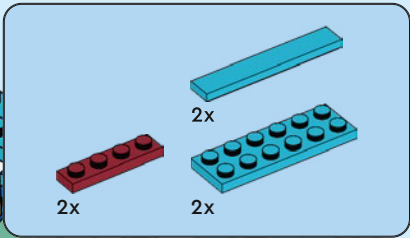

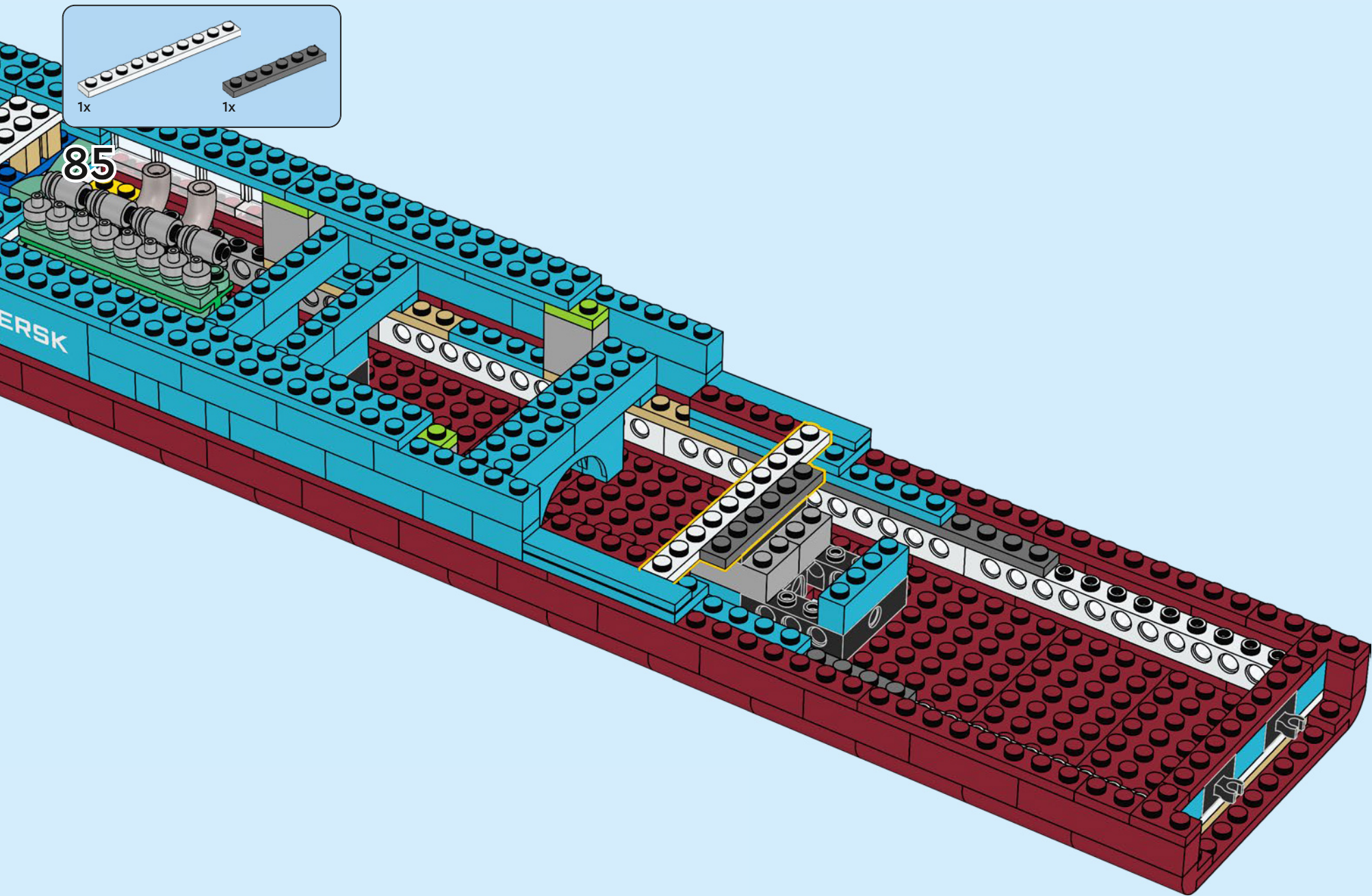

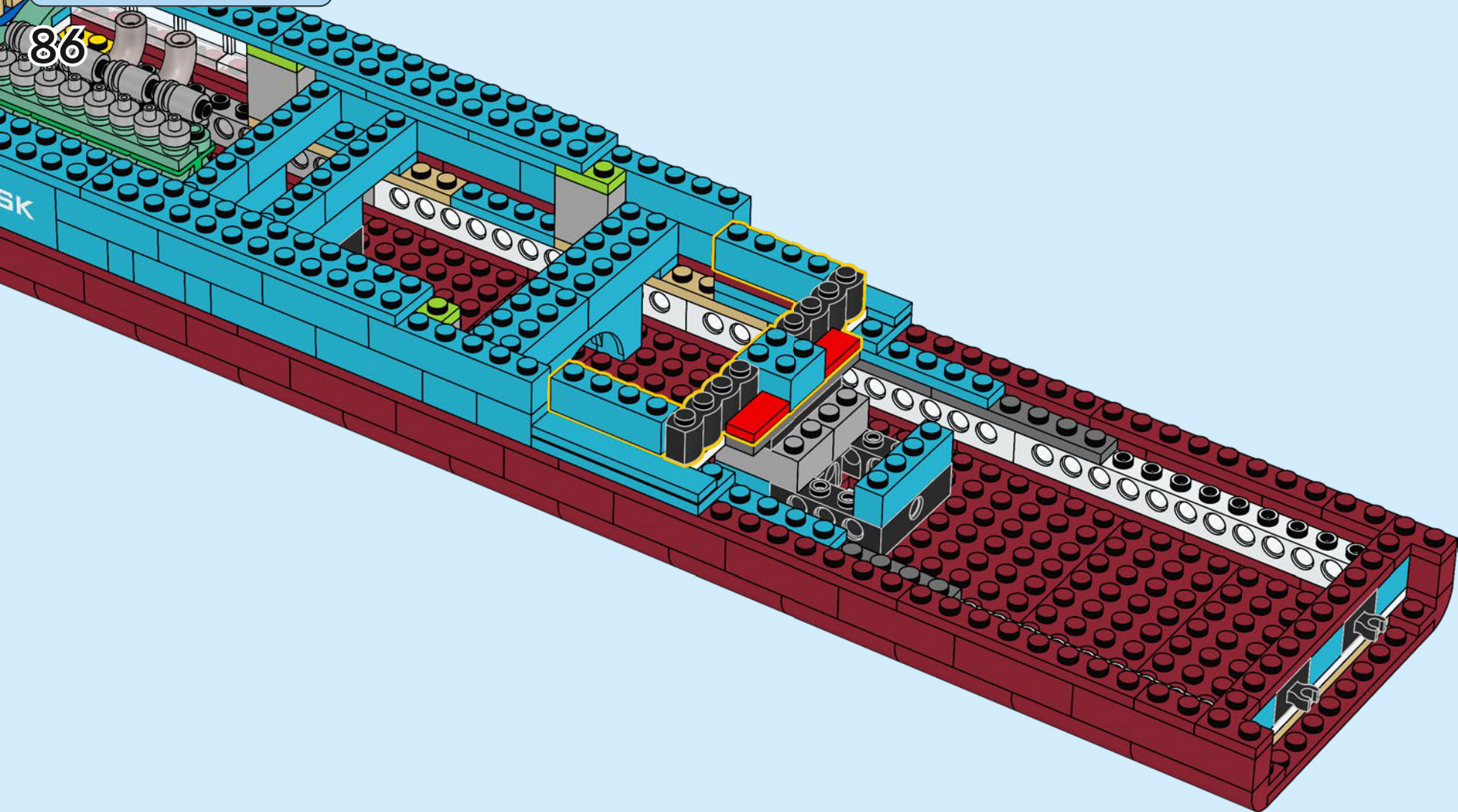
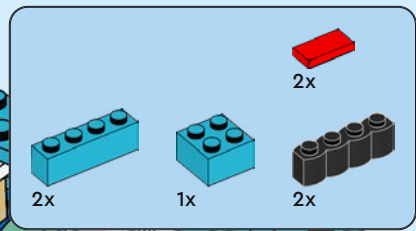

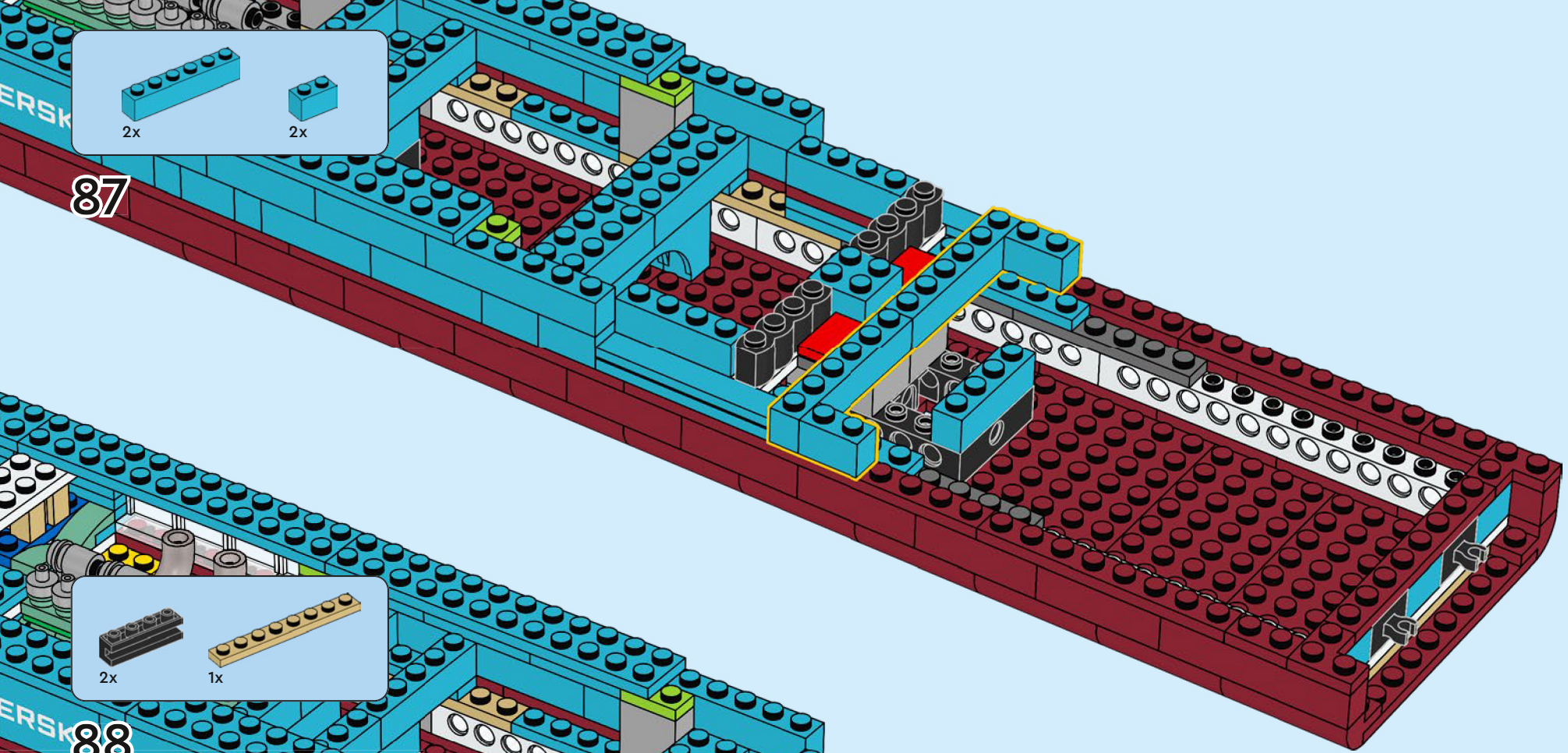

87

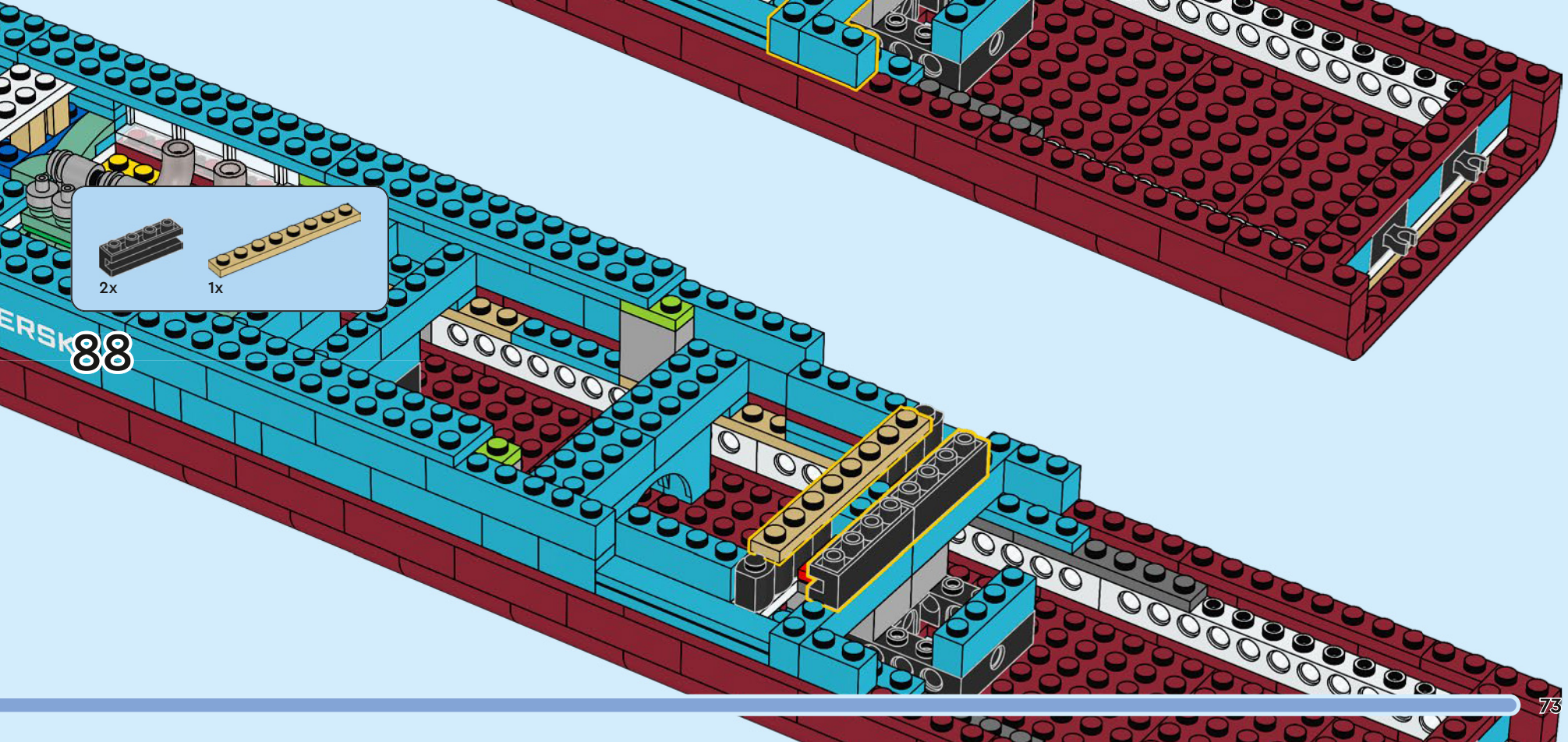

88

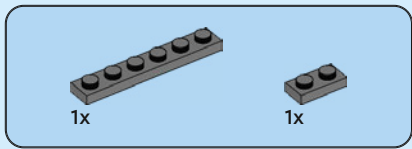

89

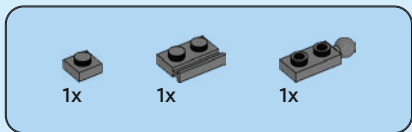
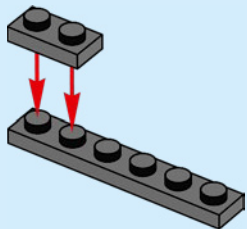

90

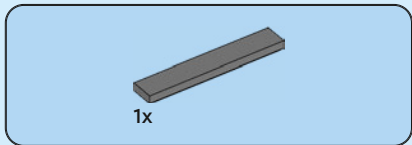
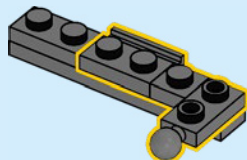

91

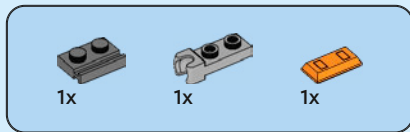
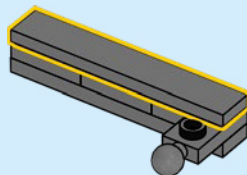

92

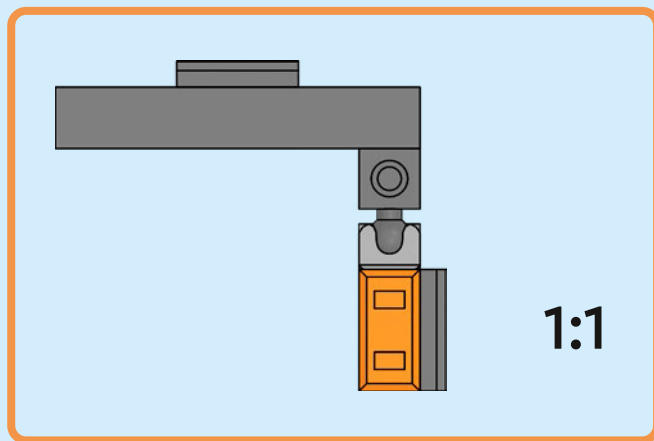
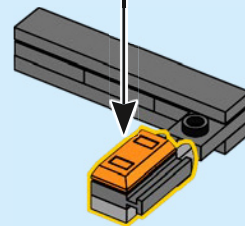
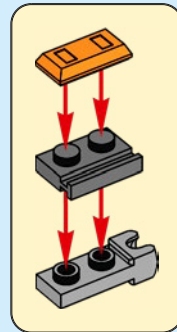

93

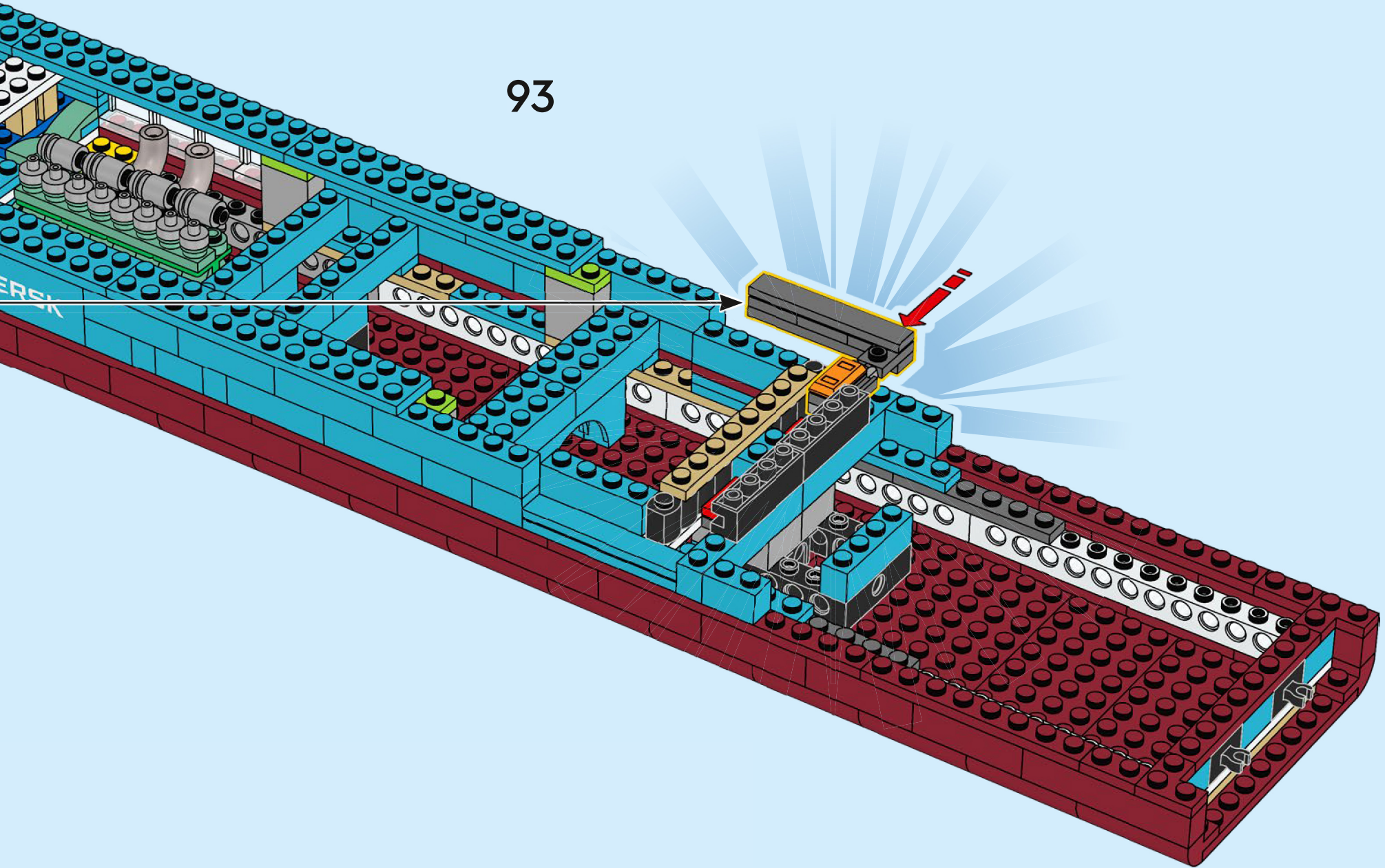

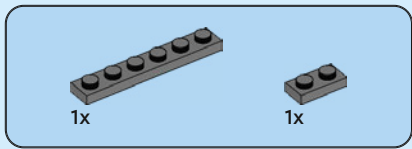

94

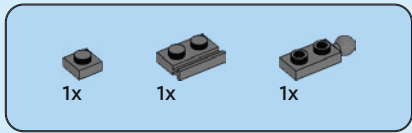
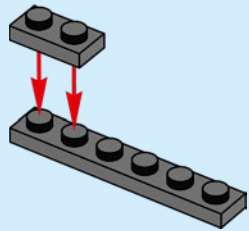

95

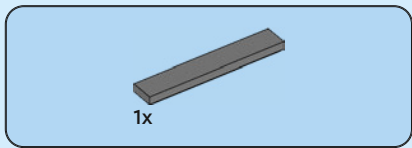
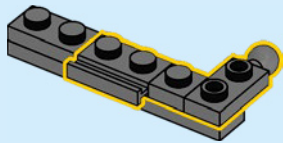

96

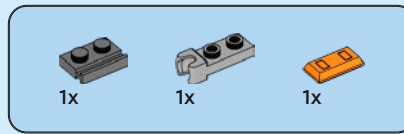
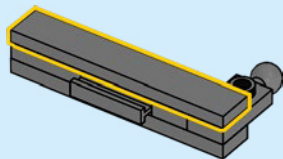

97

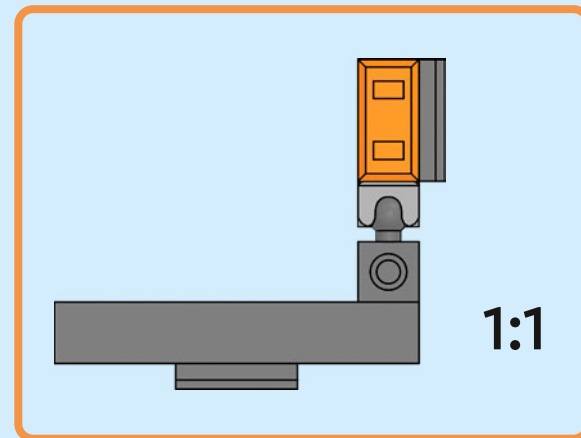
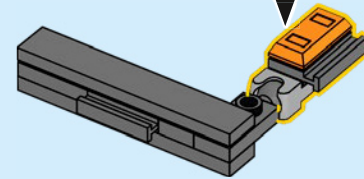
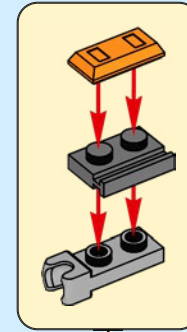

98

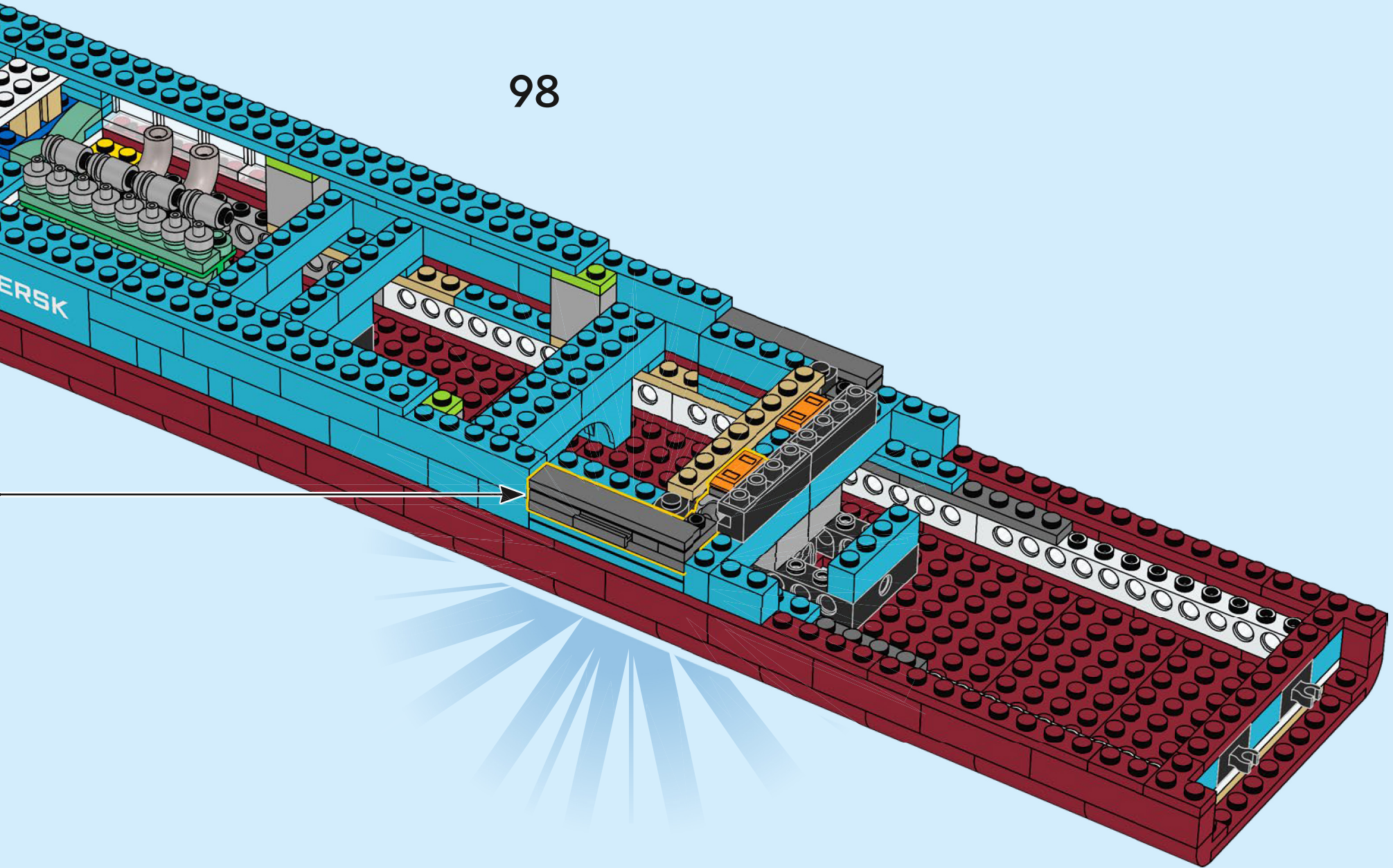

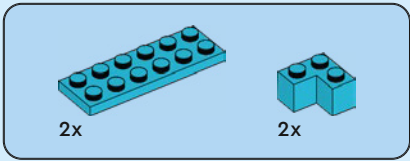

99

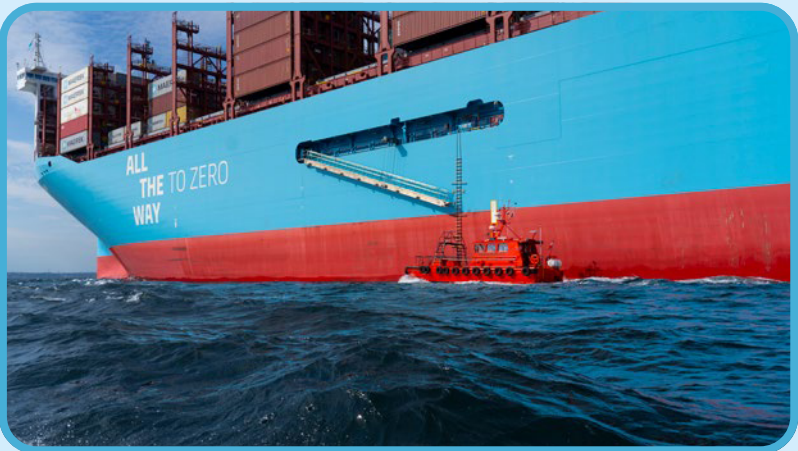
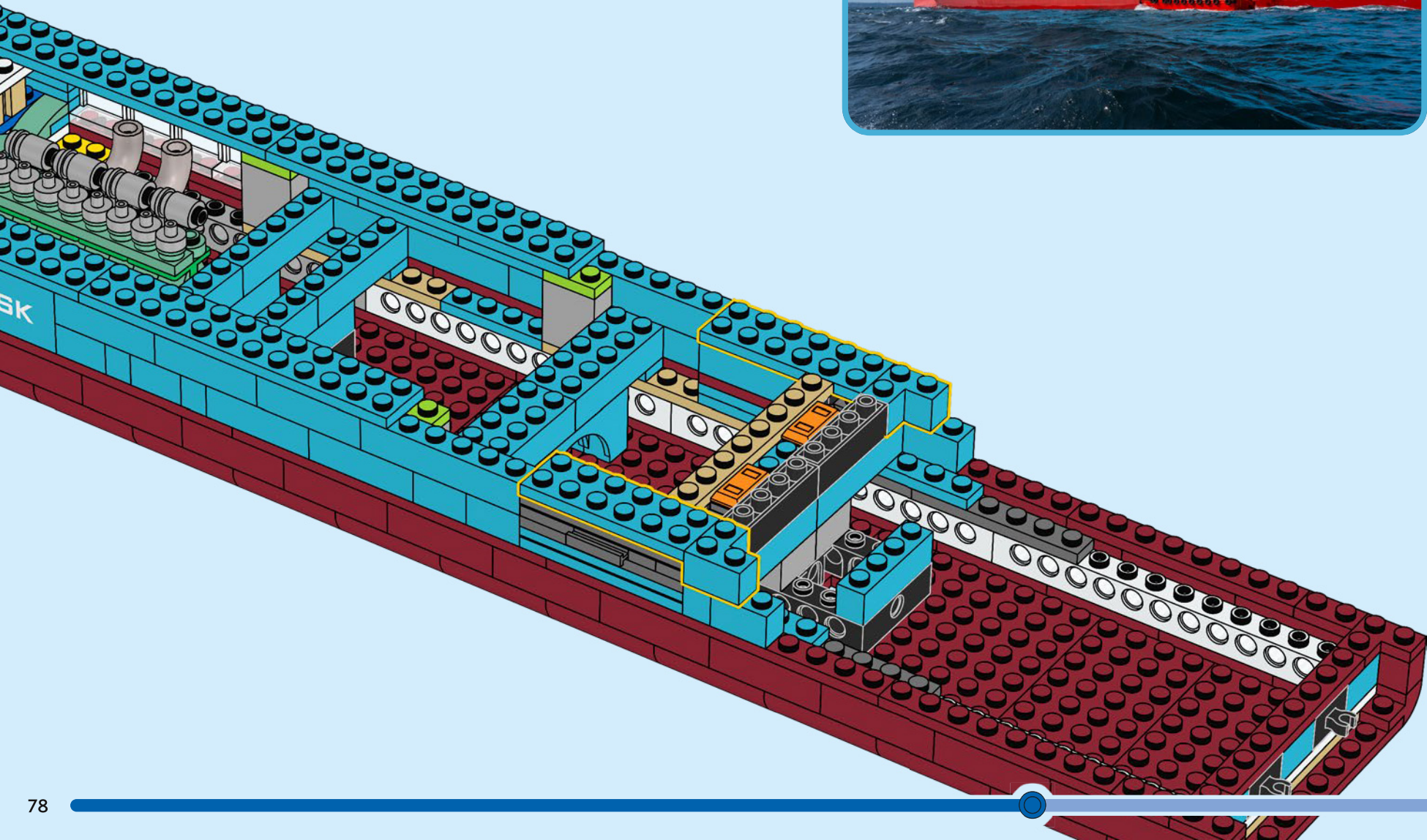

1

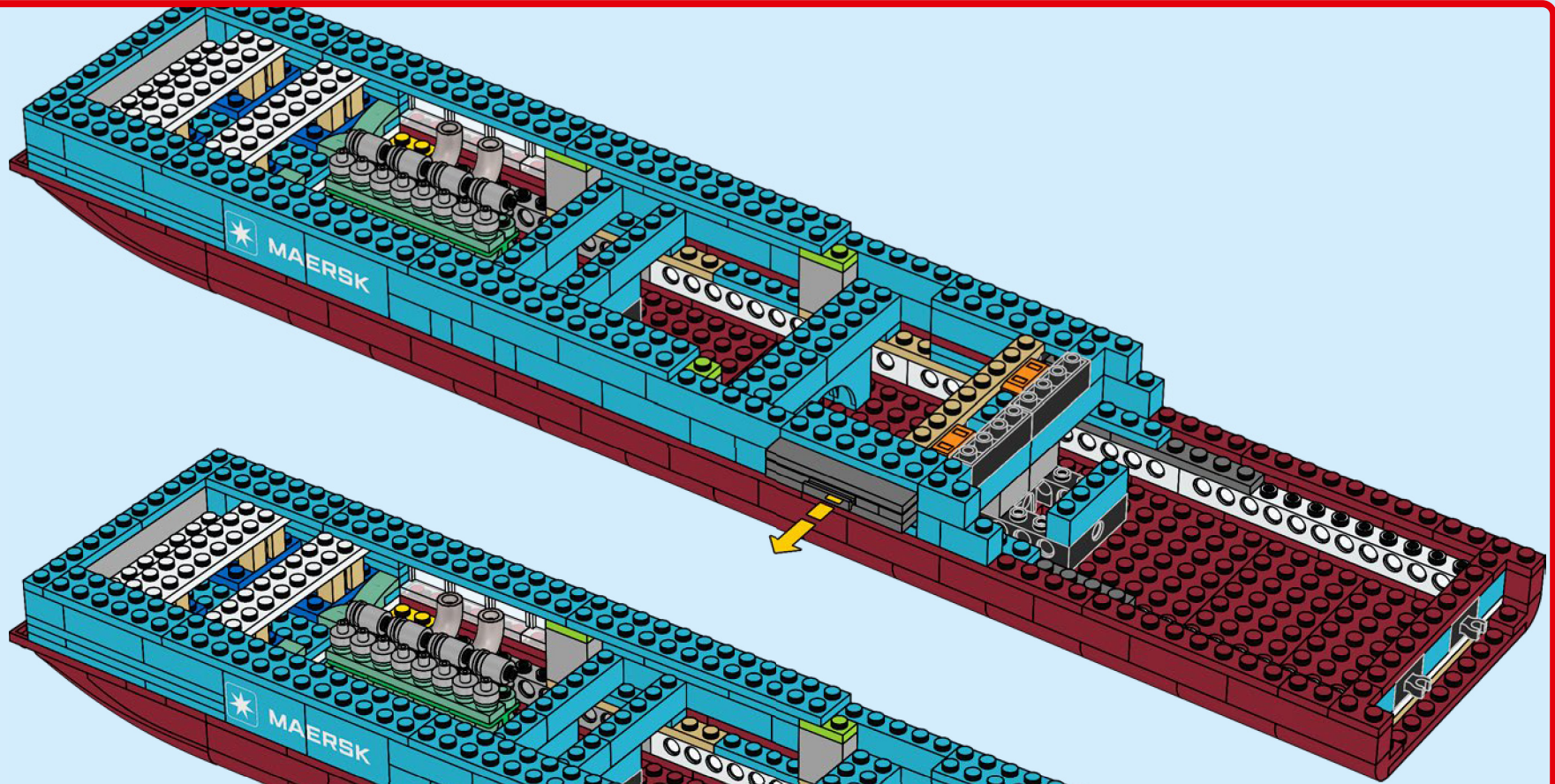

2

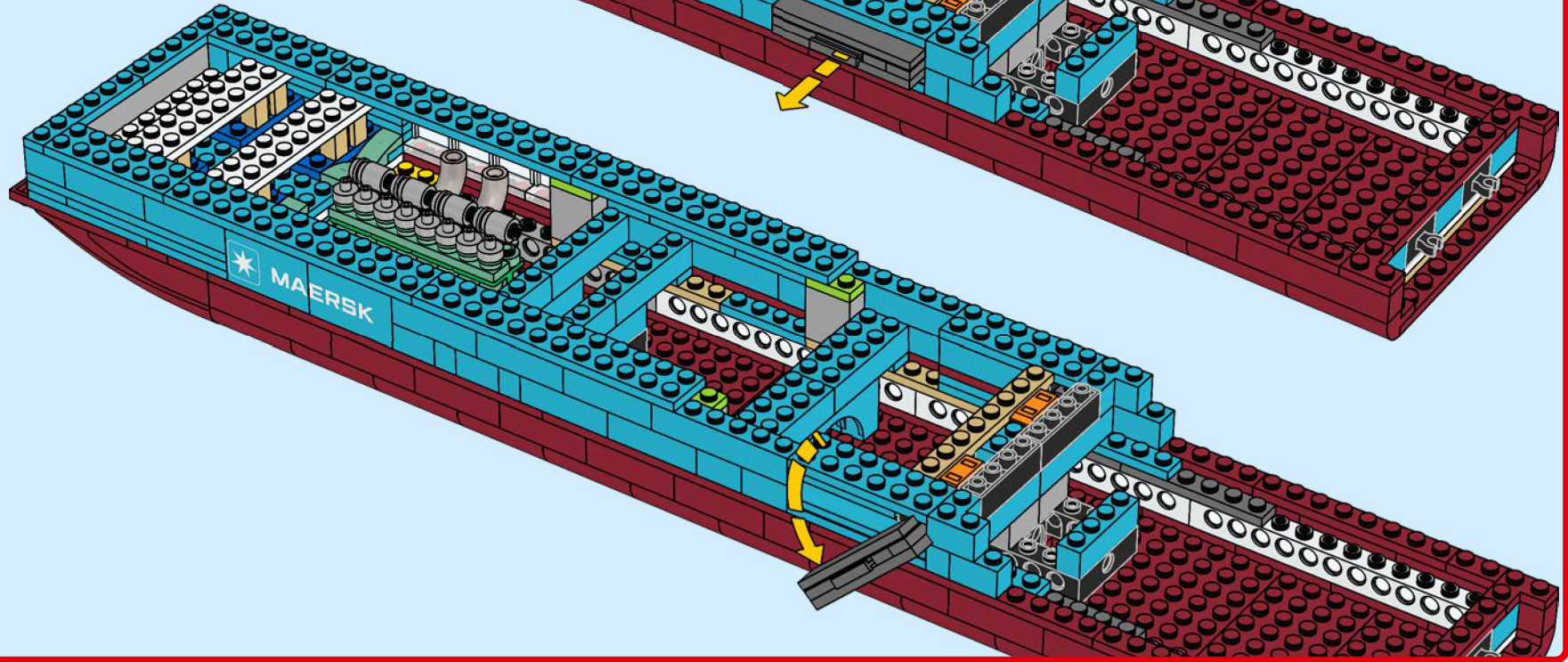

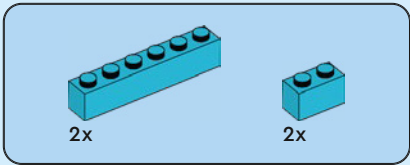

100

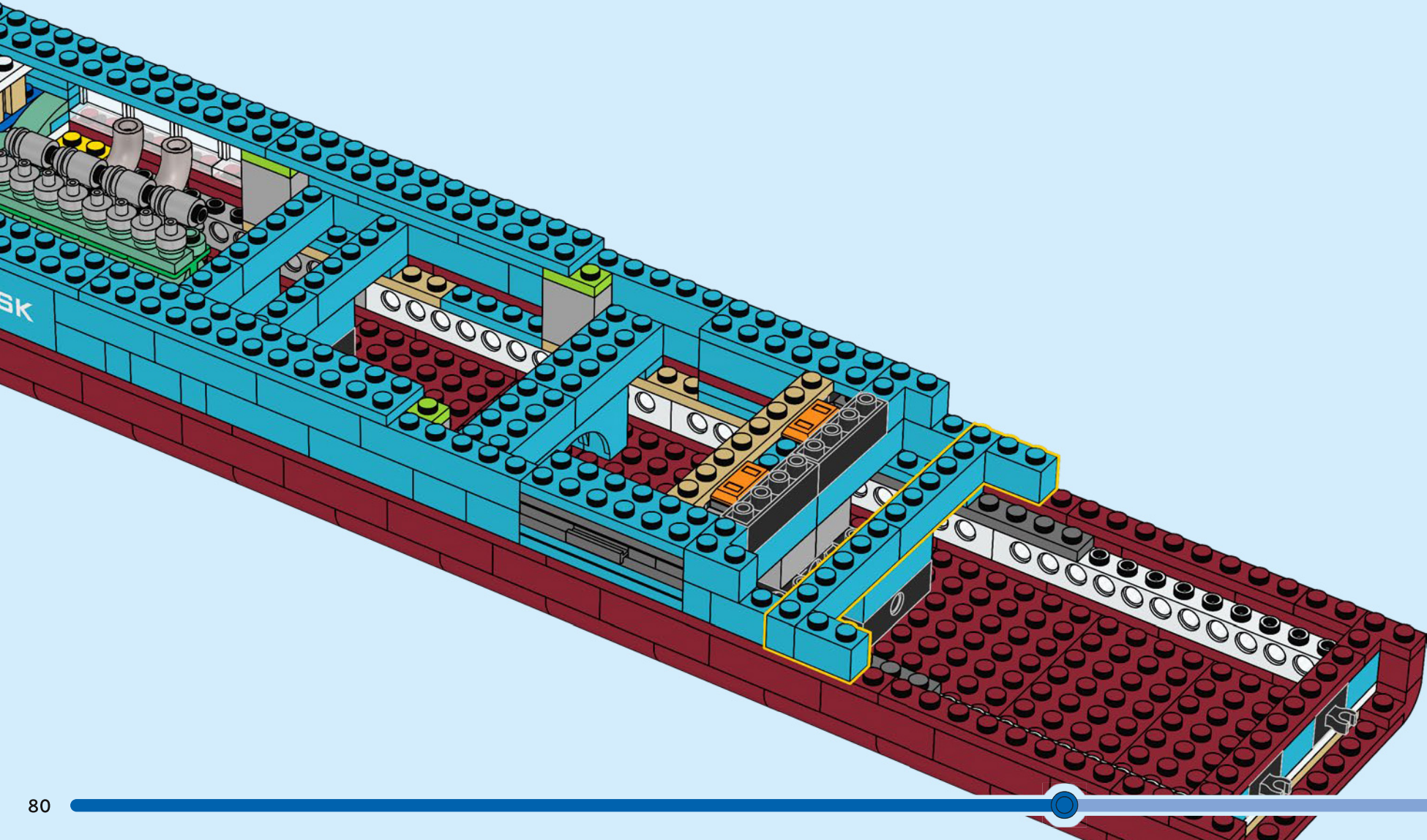

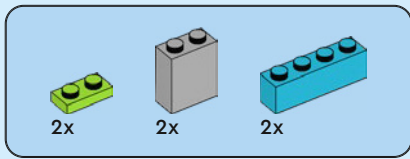

101

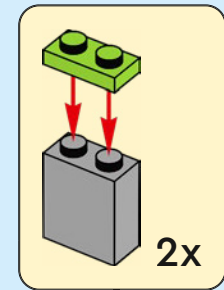
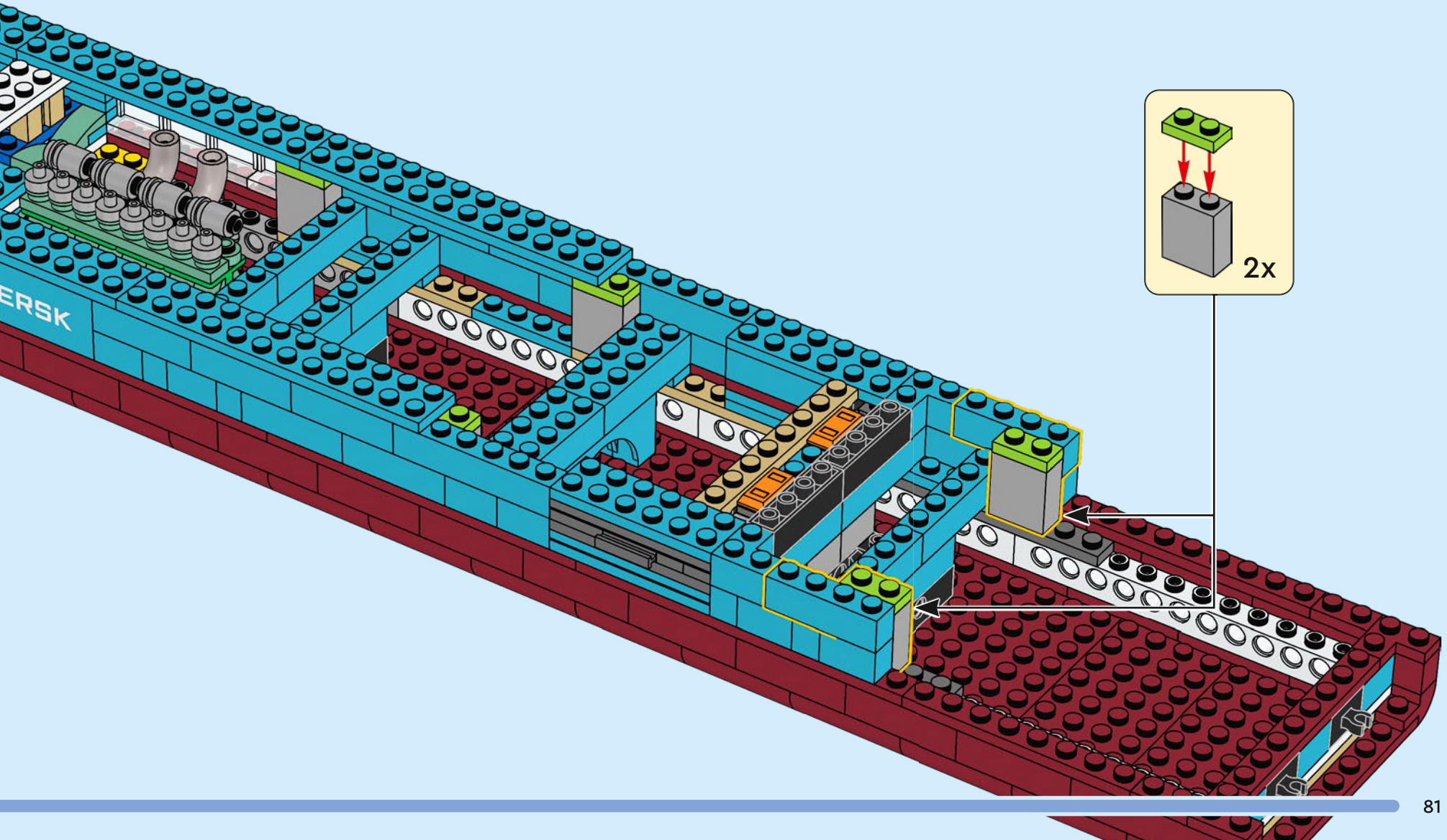

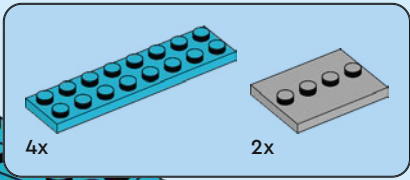

102

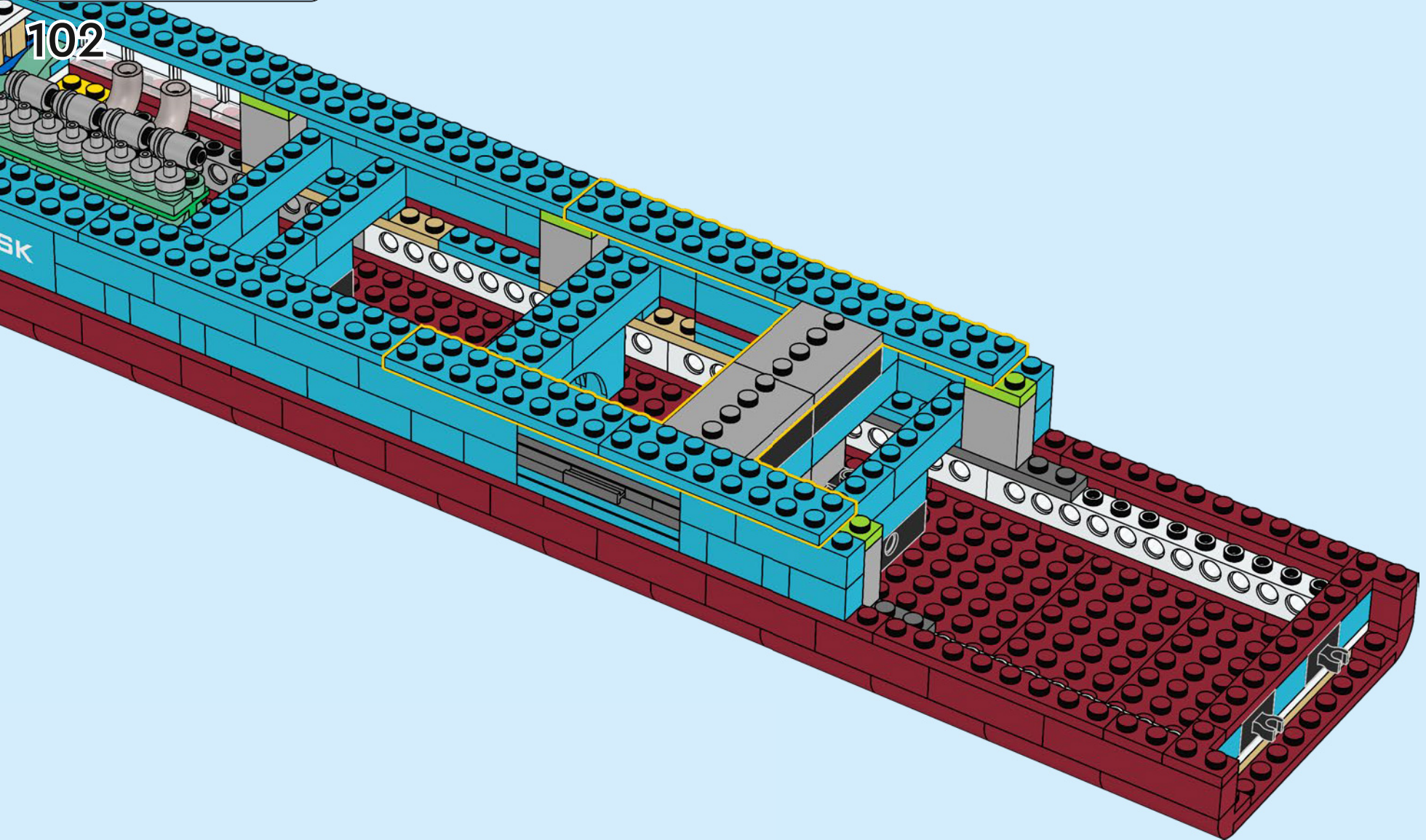

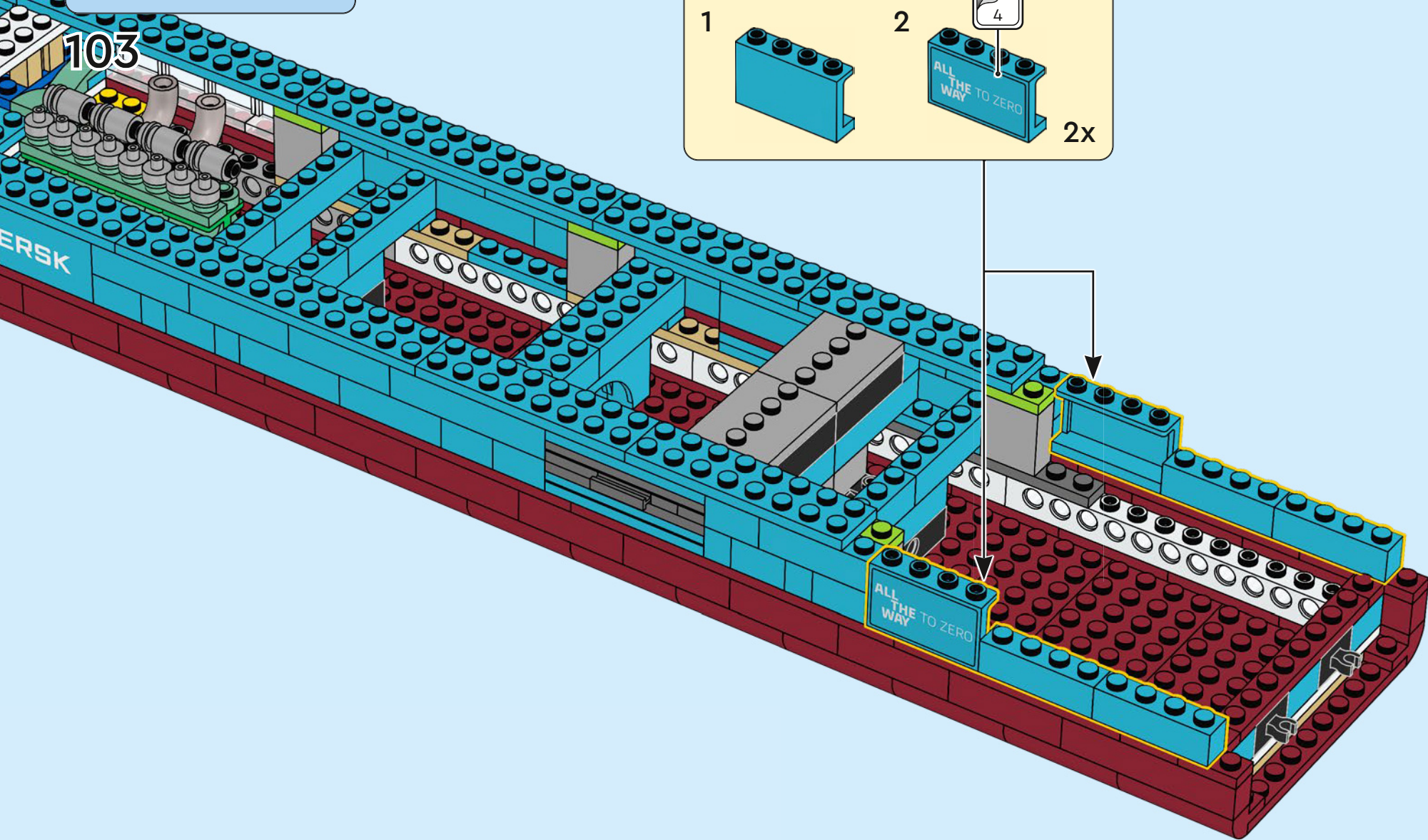
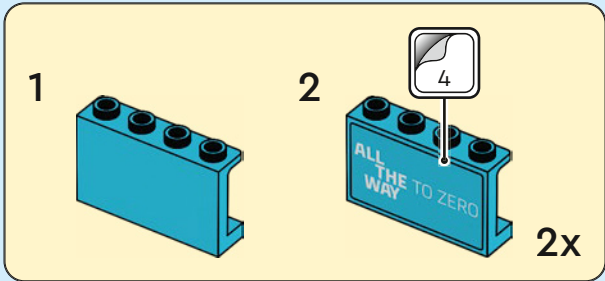
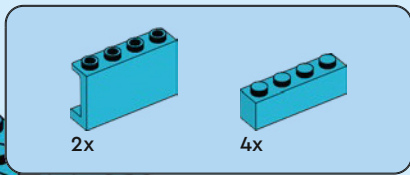

ERSK

103

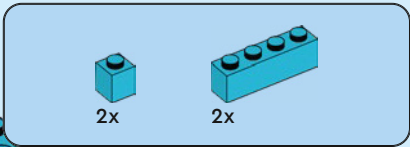

104

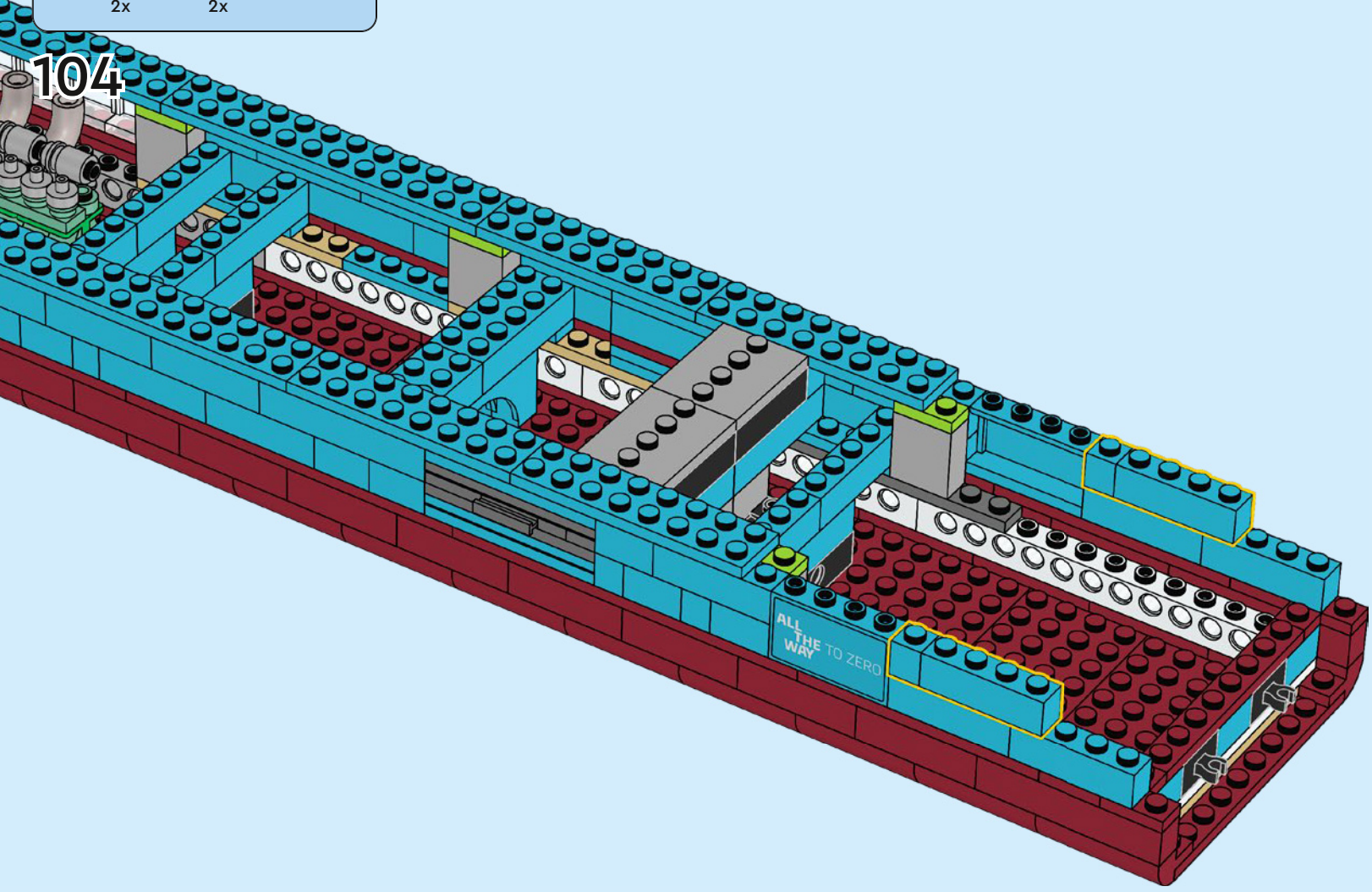

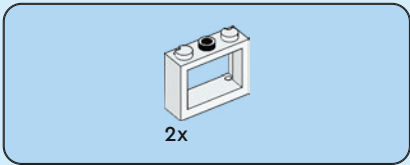

105

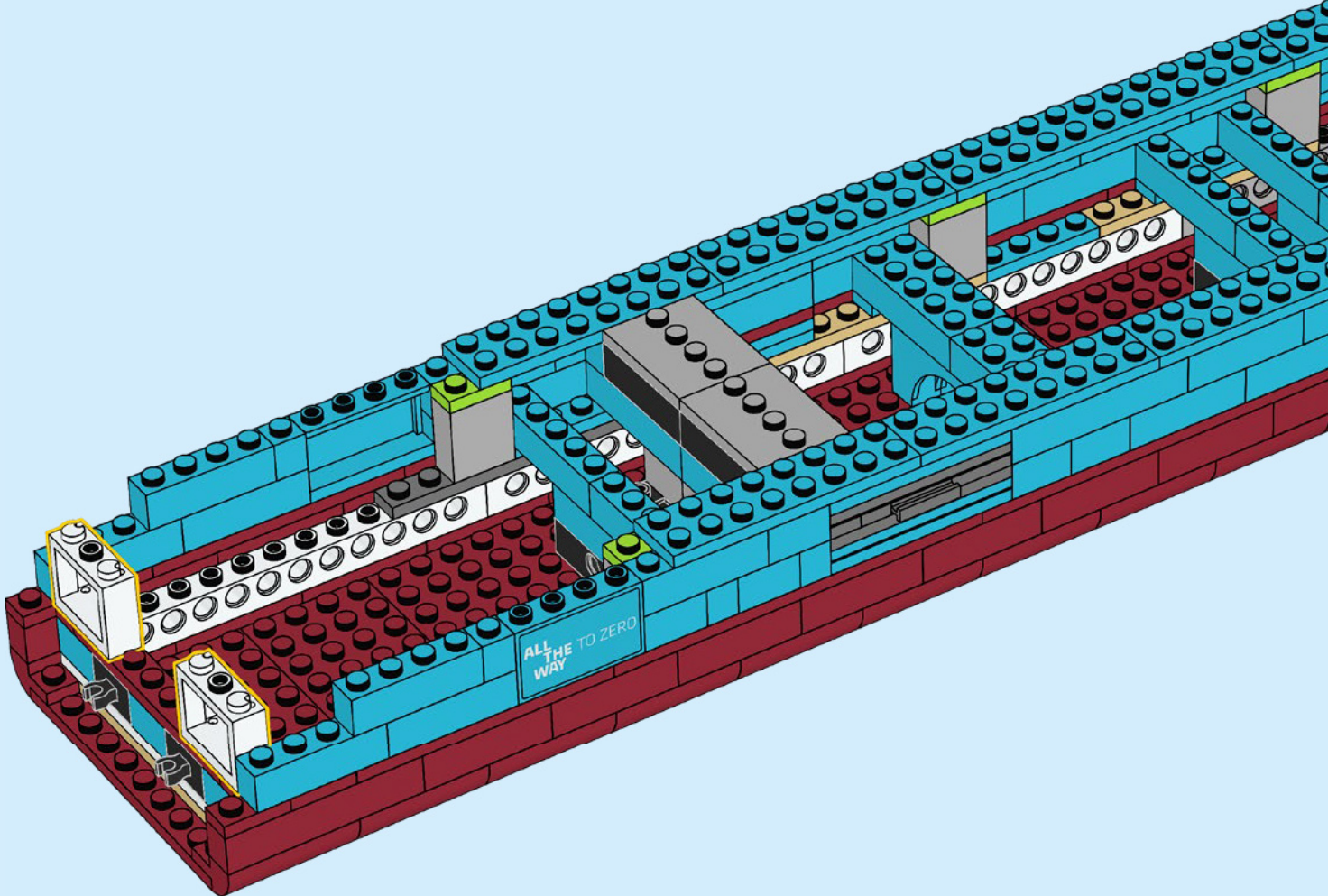

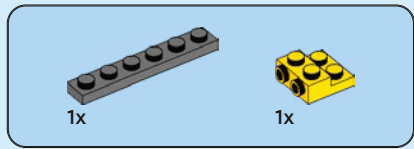
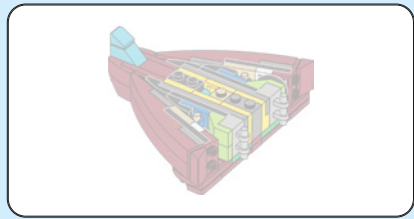
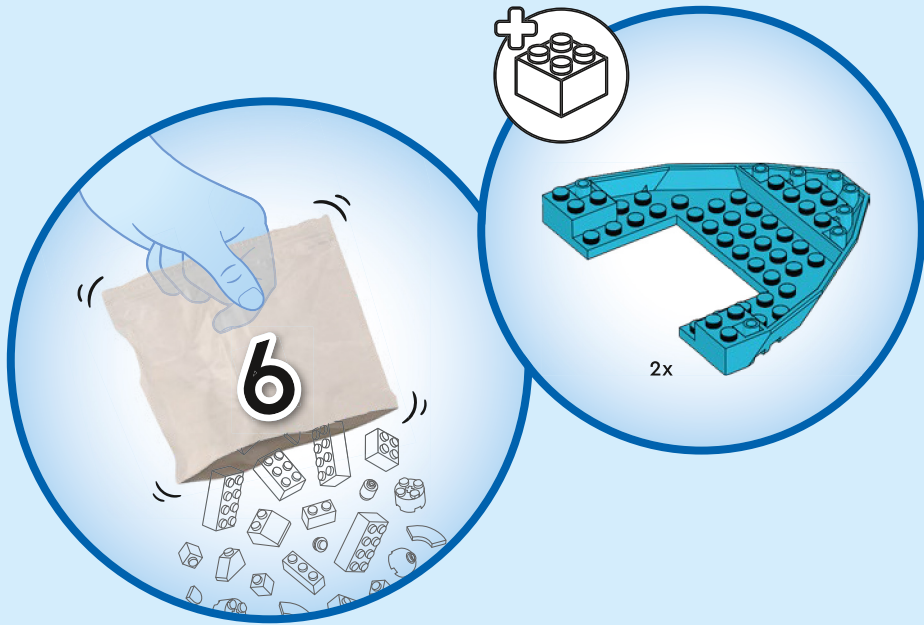

106

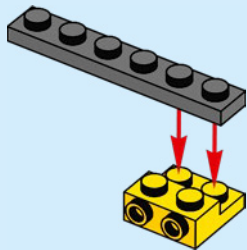

107

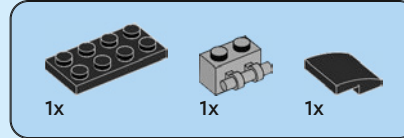
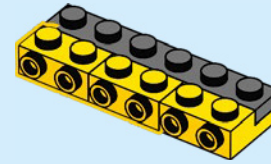

108

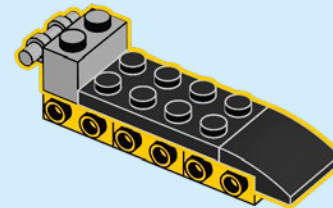

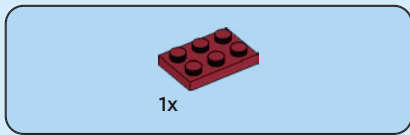

109

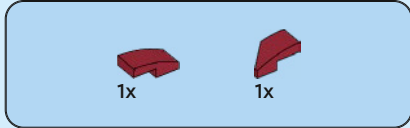
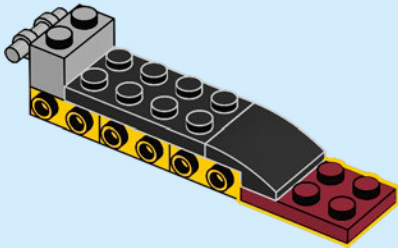

110

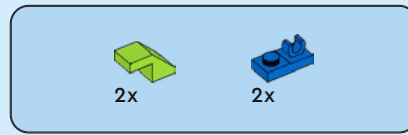
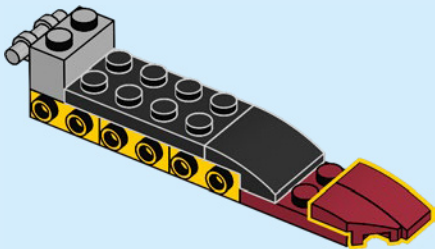

111

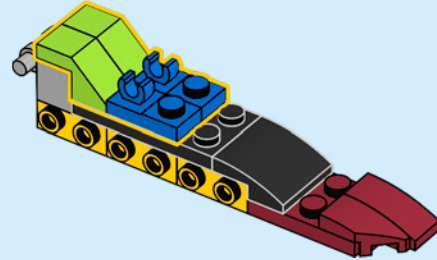

112

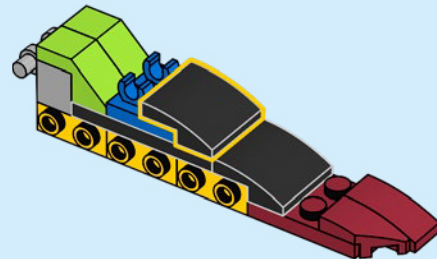

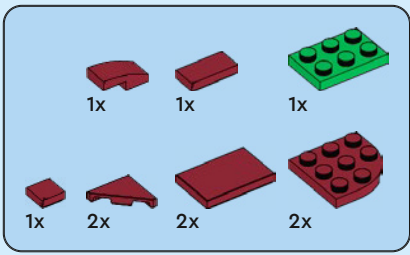

# 113

1

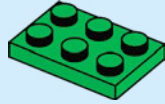

2

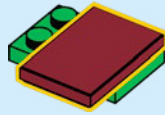

3

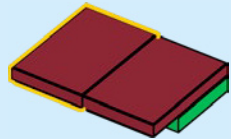

4

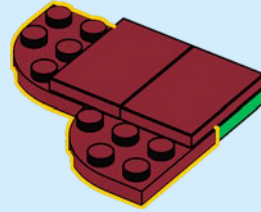

5

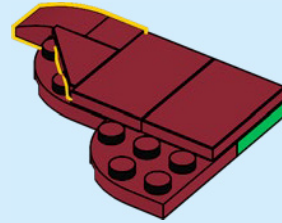

6

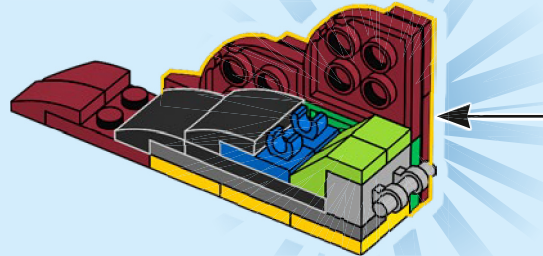
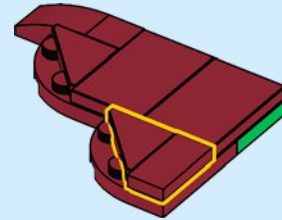

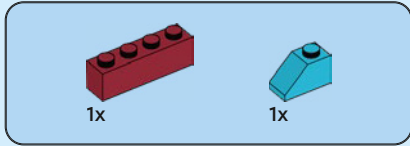
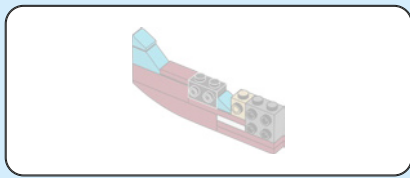

114

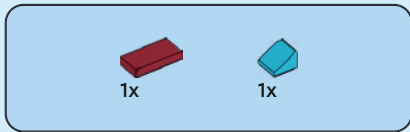
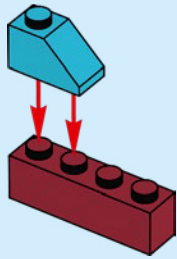

115

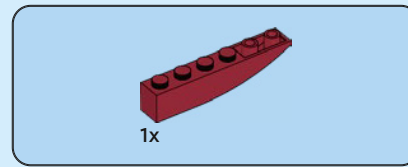
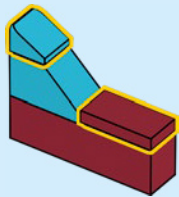

116

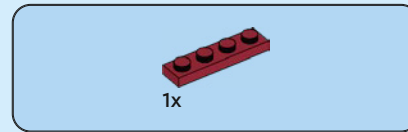
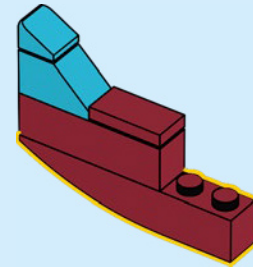

117

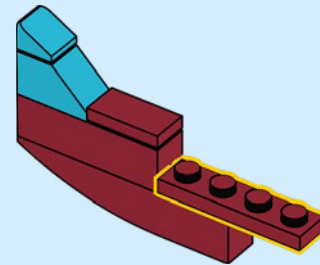

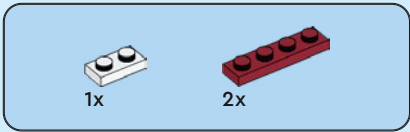

118

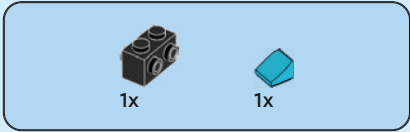
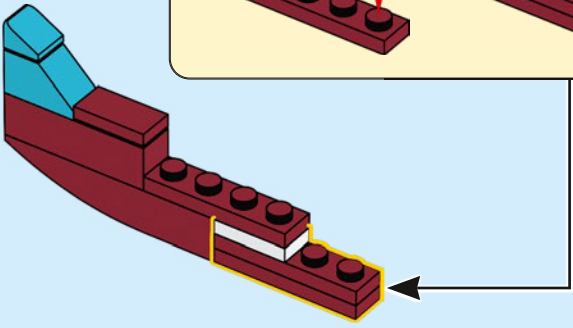
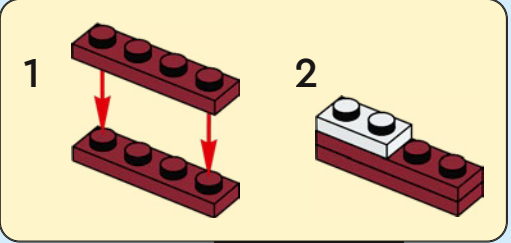

119

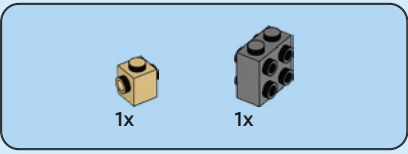
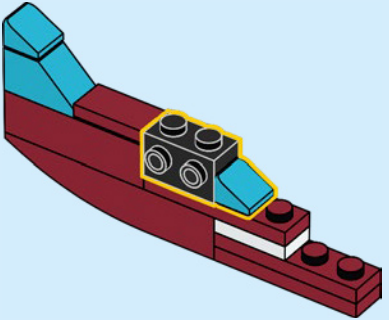

120

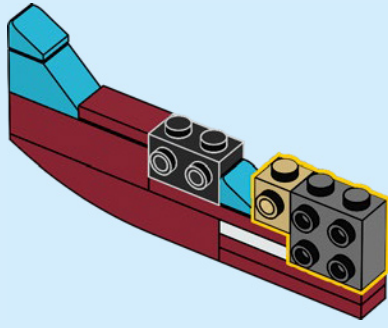

121

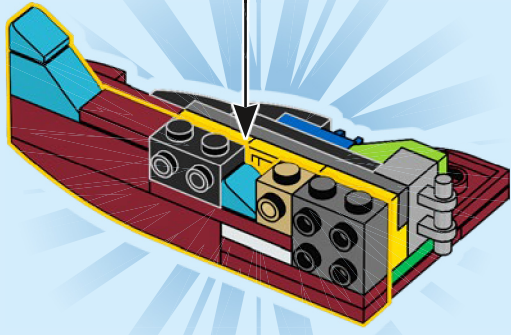

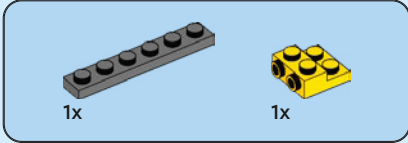
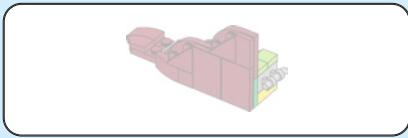

122

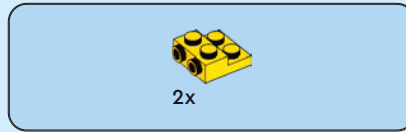
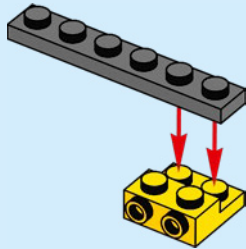

123

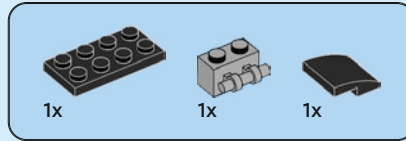
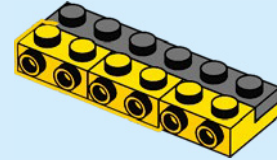

124

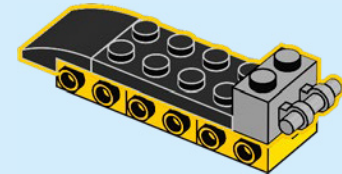

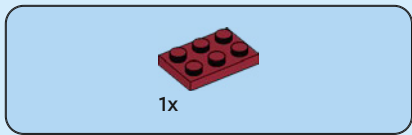

125

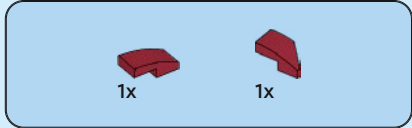
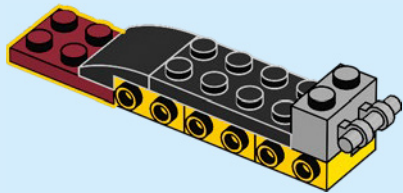

126

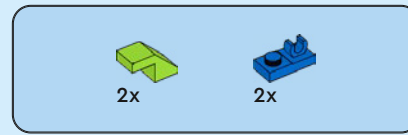
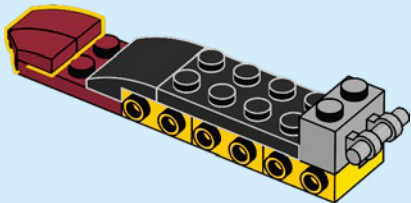

127

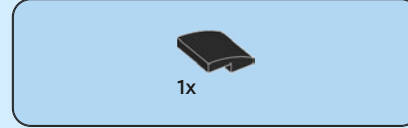
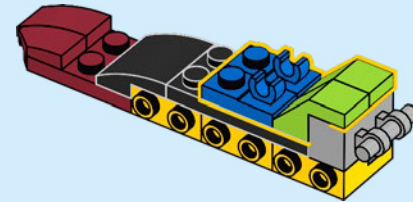

128

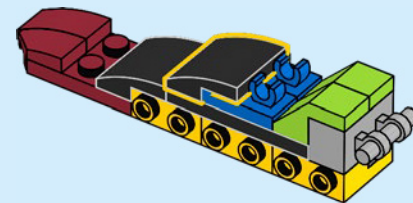

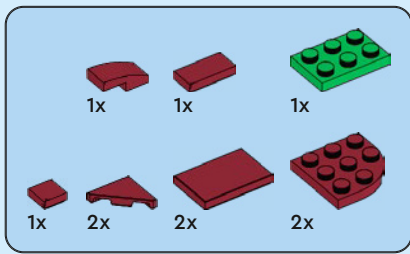

129

1

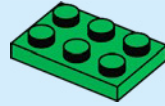

2

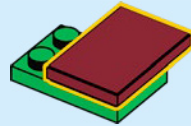

3

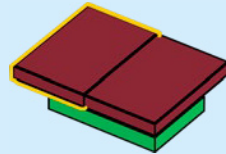

4

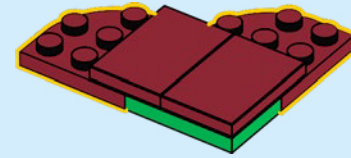

5

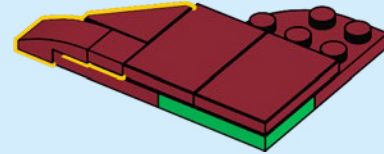

6

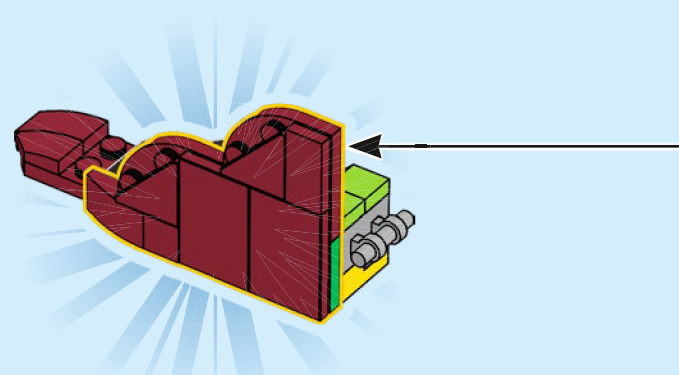
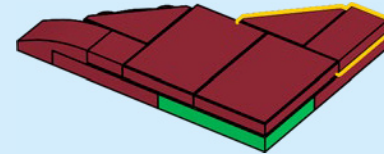

130

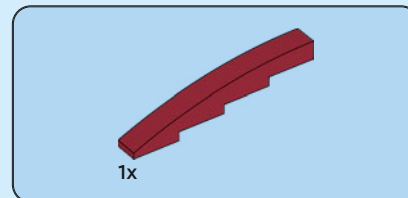
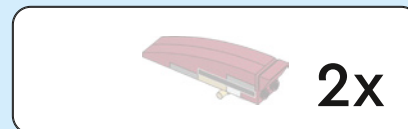
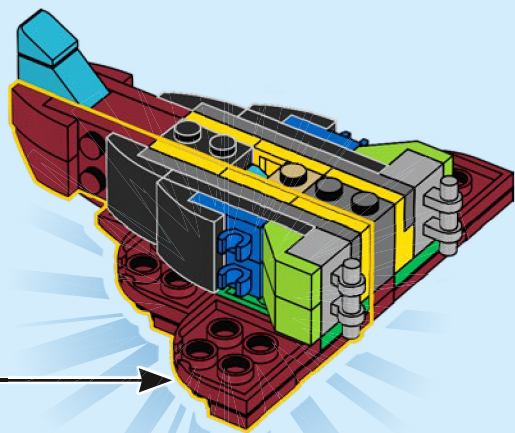

131

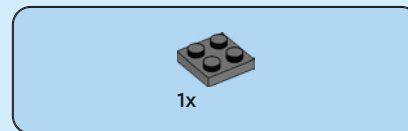
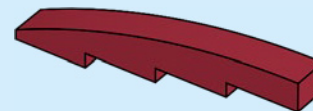

132

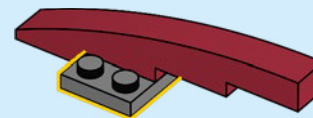

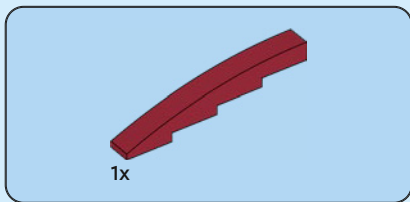

133

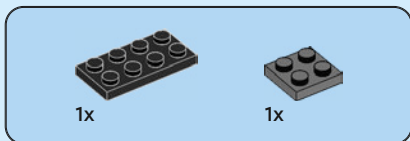
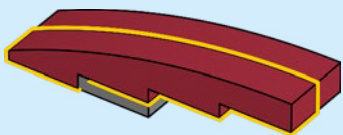

134

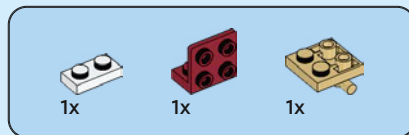
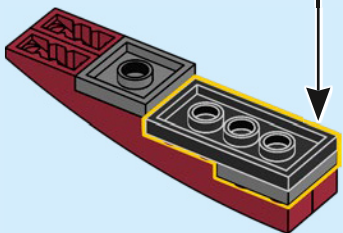
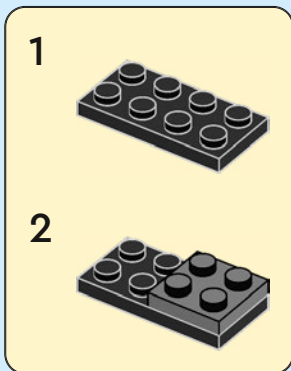

135

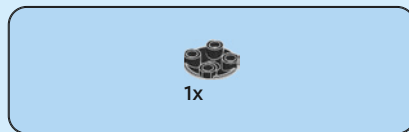
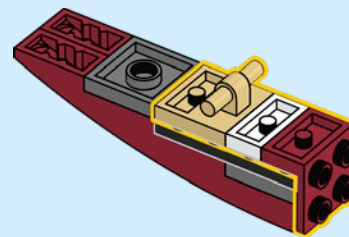

136

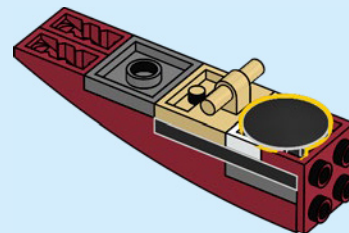



1x

137

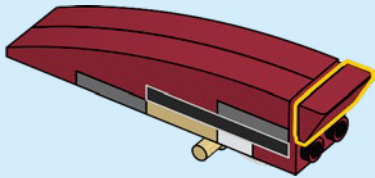

2x

138

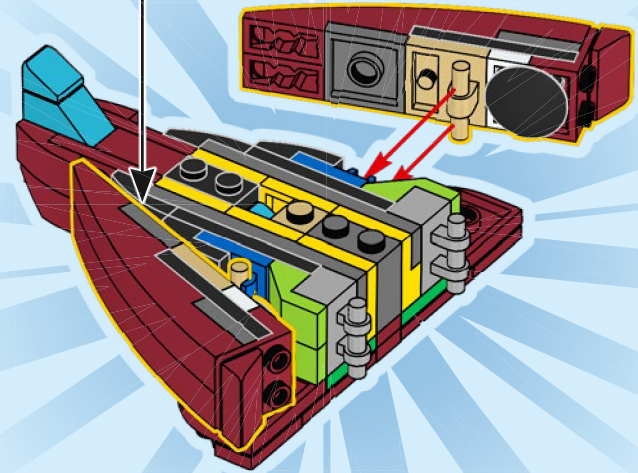

139

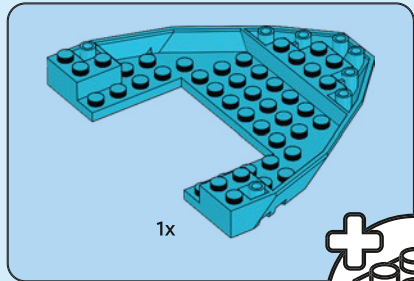
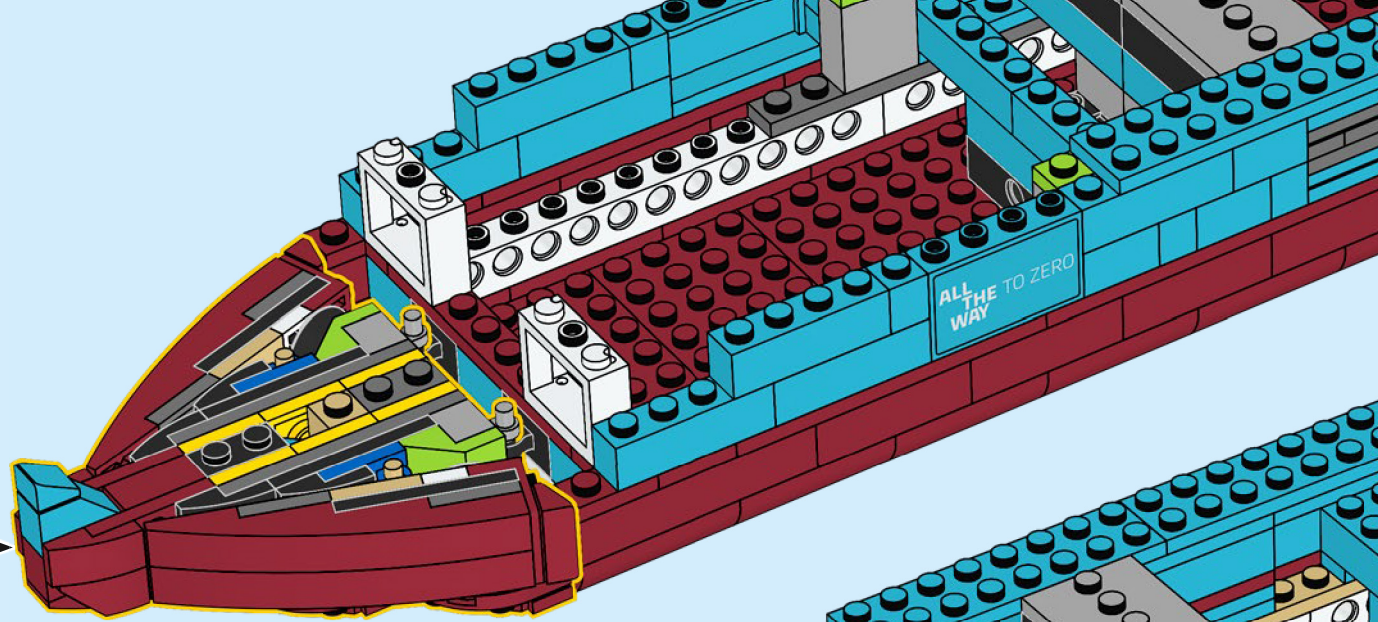

1x

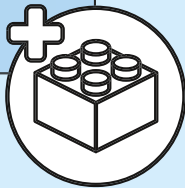

140

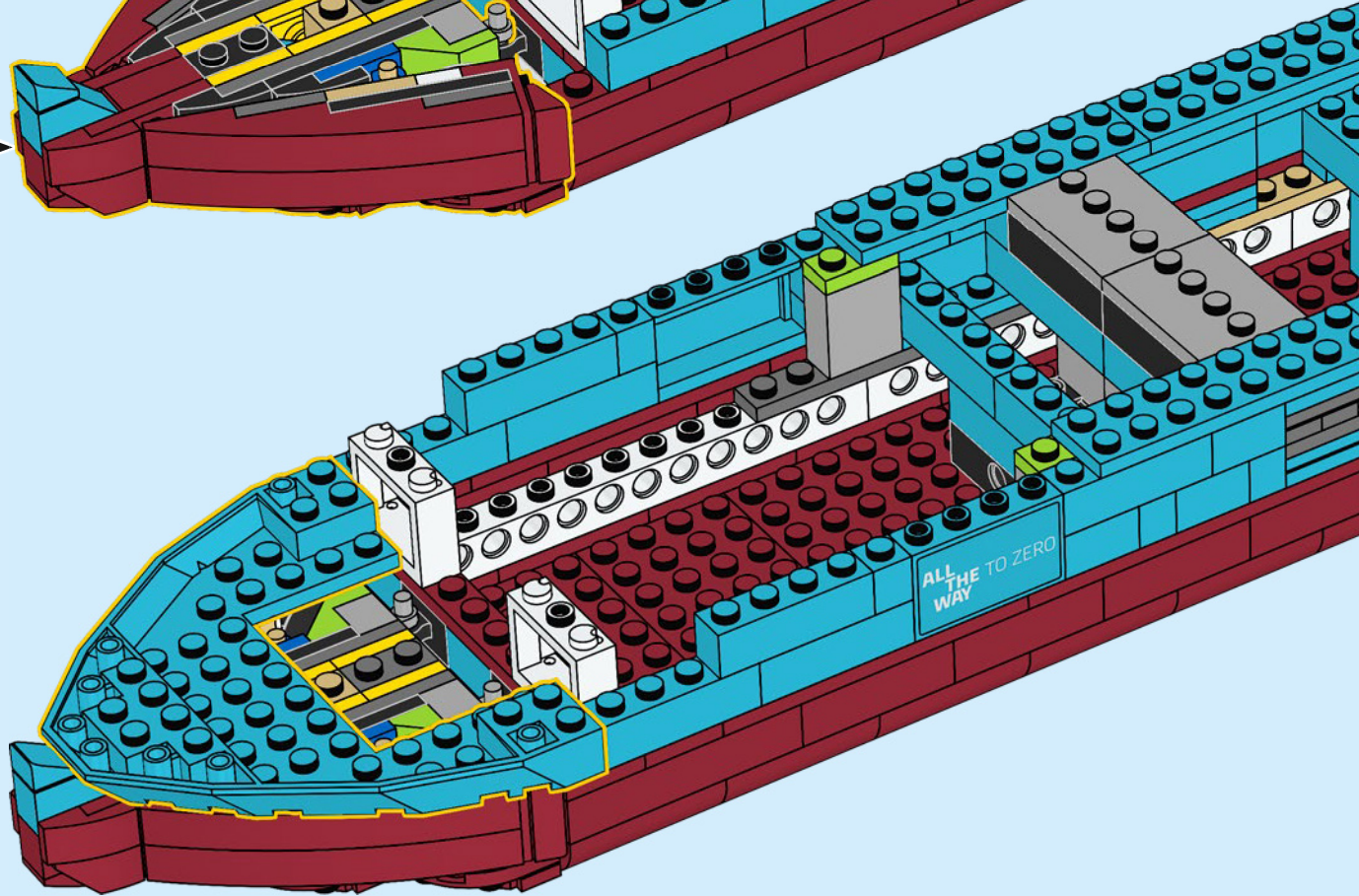



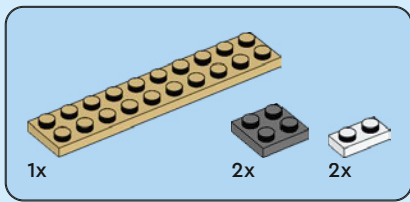

143

1

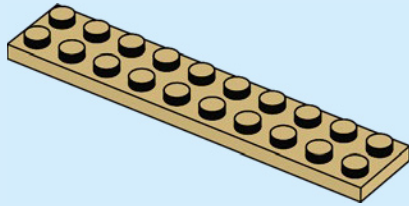

2

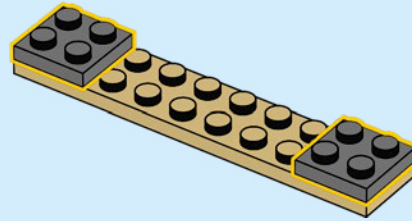

3

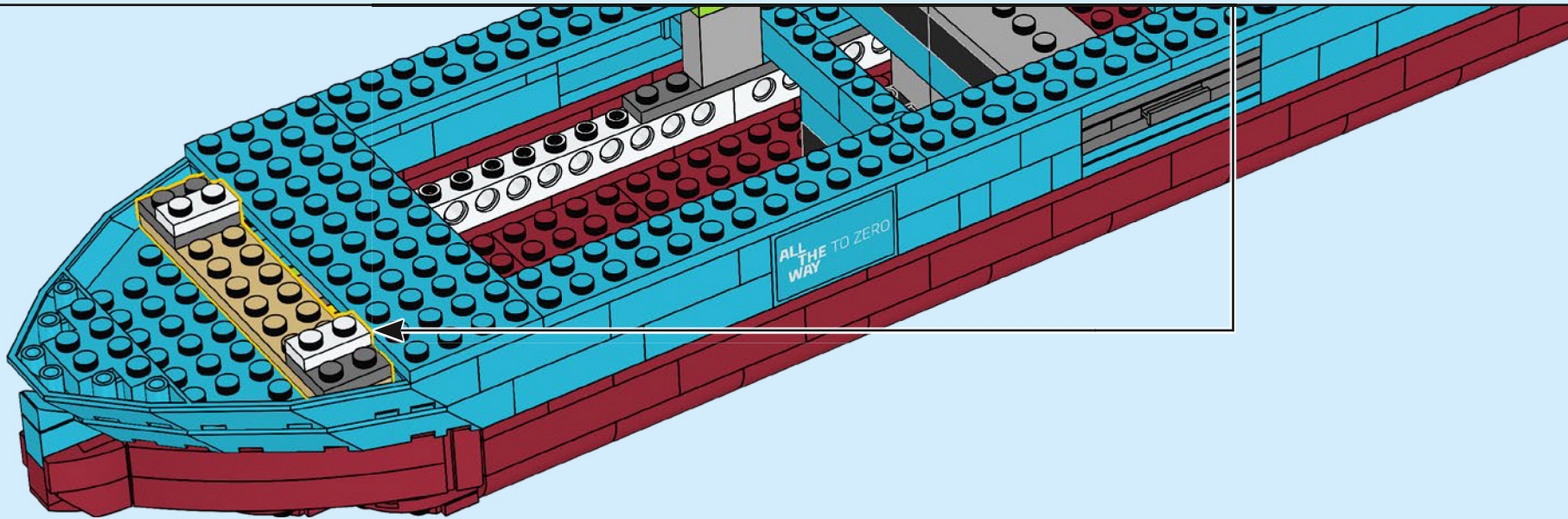
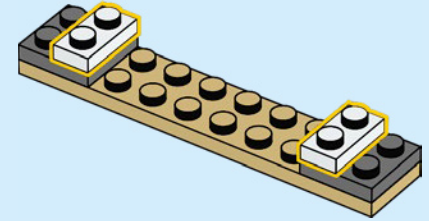

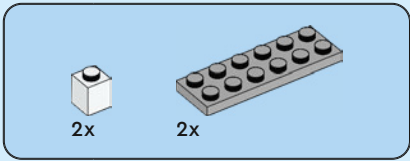

144

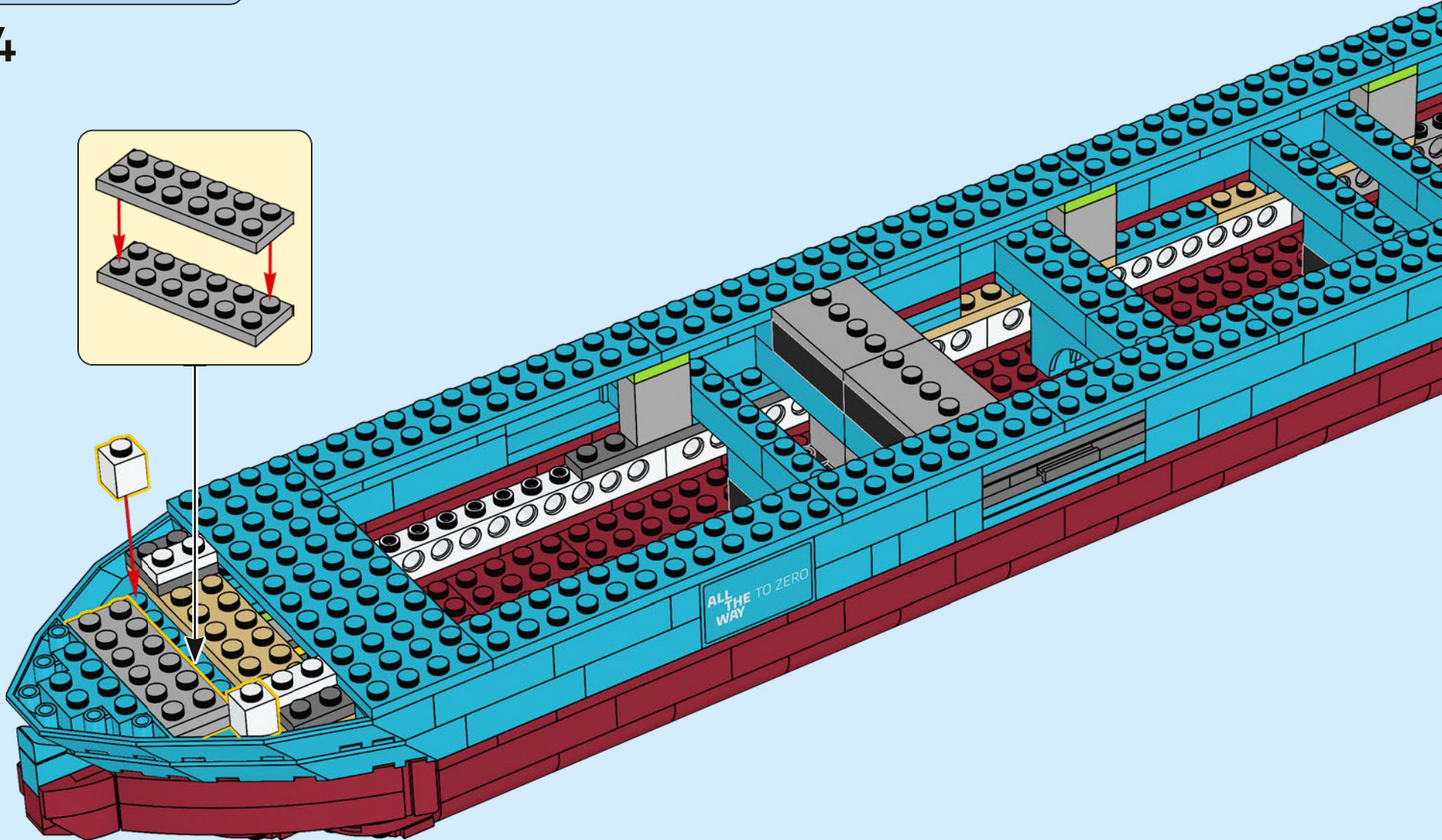
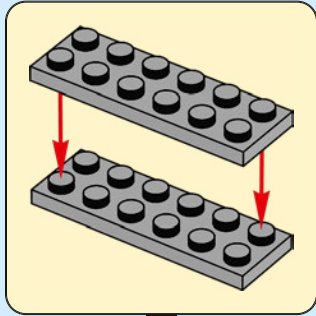

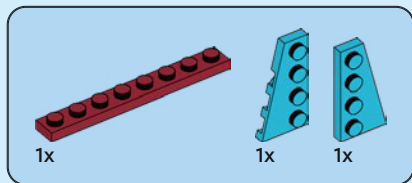

145

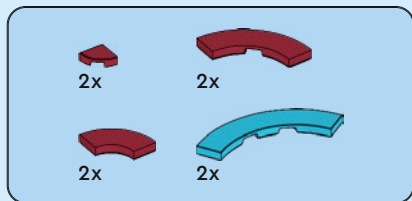
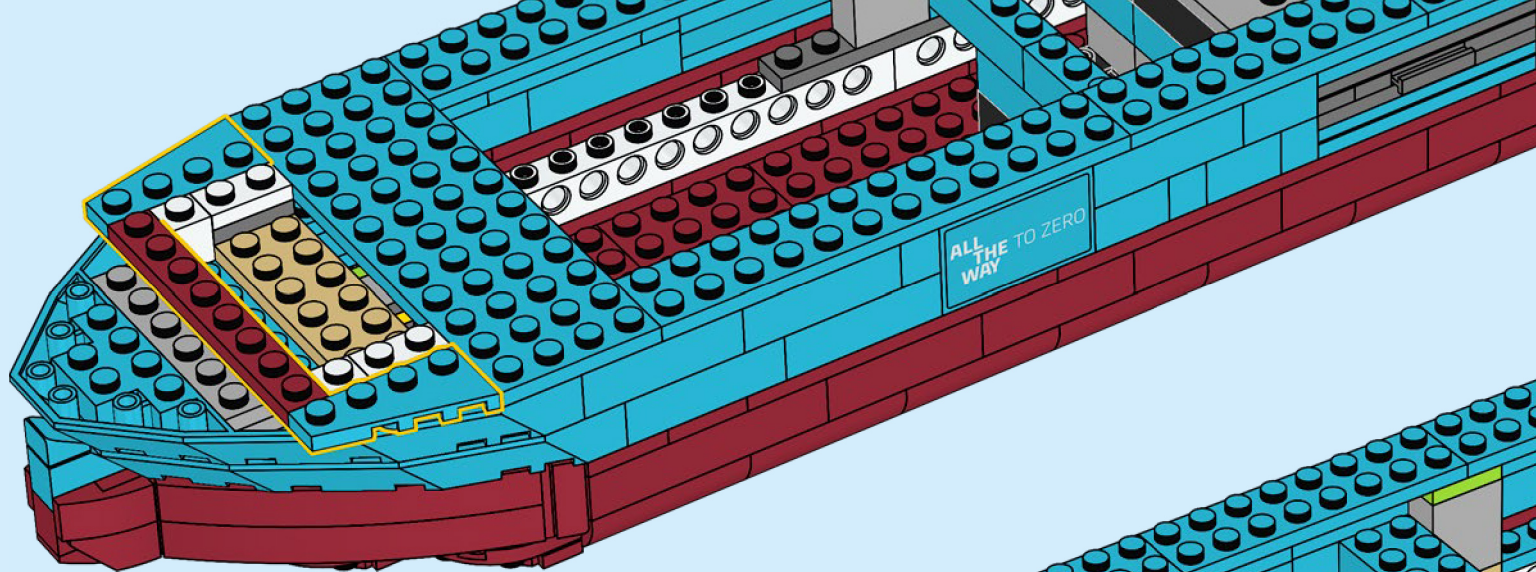

146

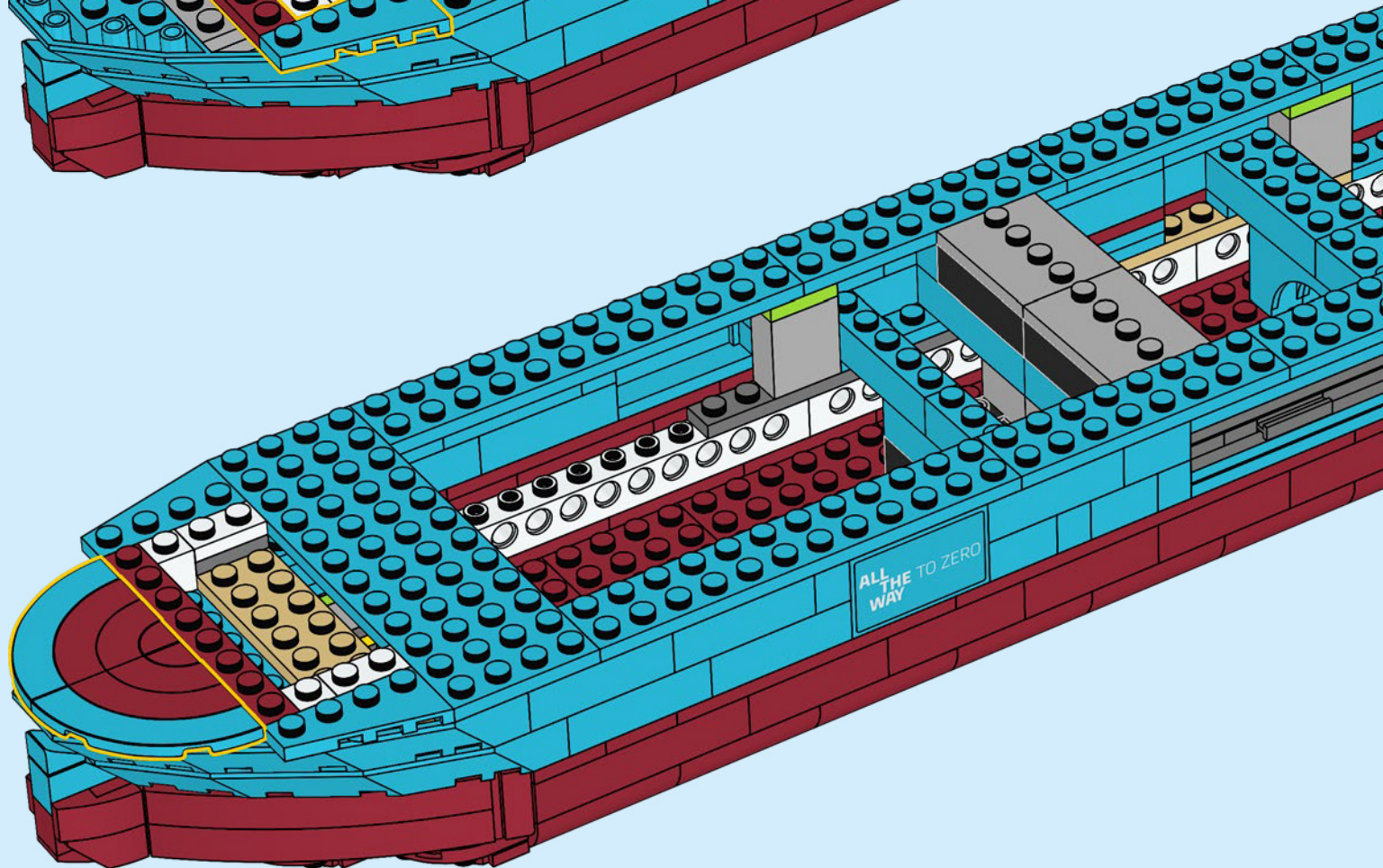

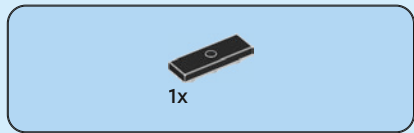

147

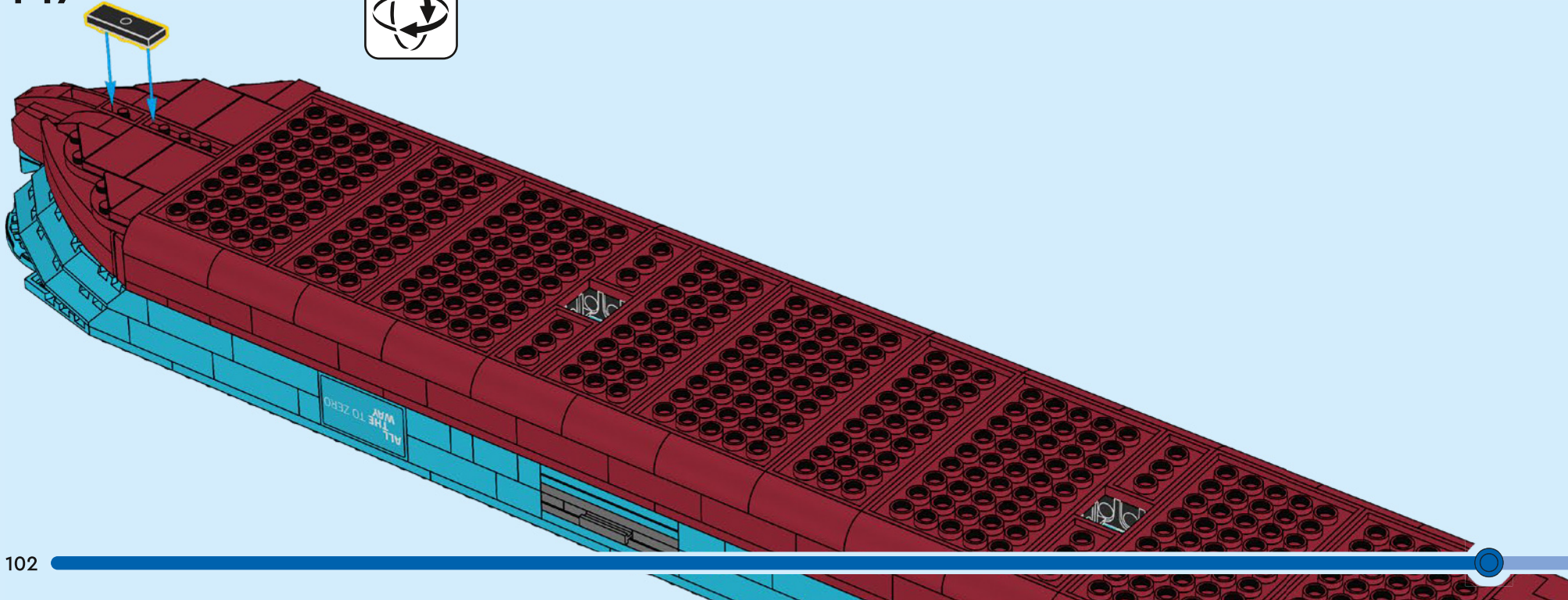



24x

# 148

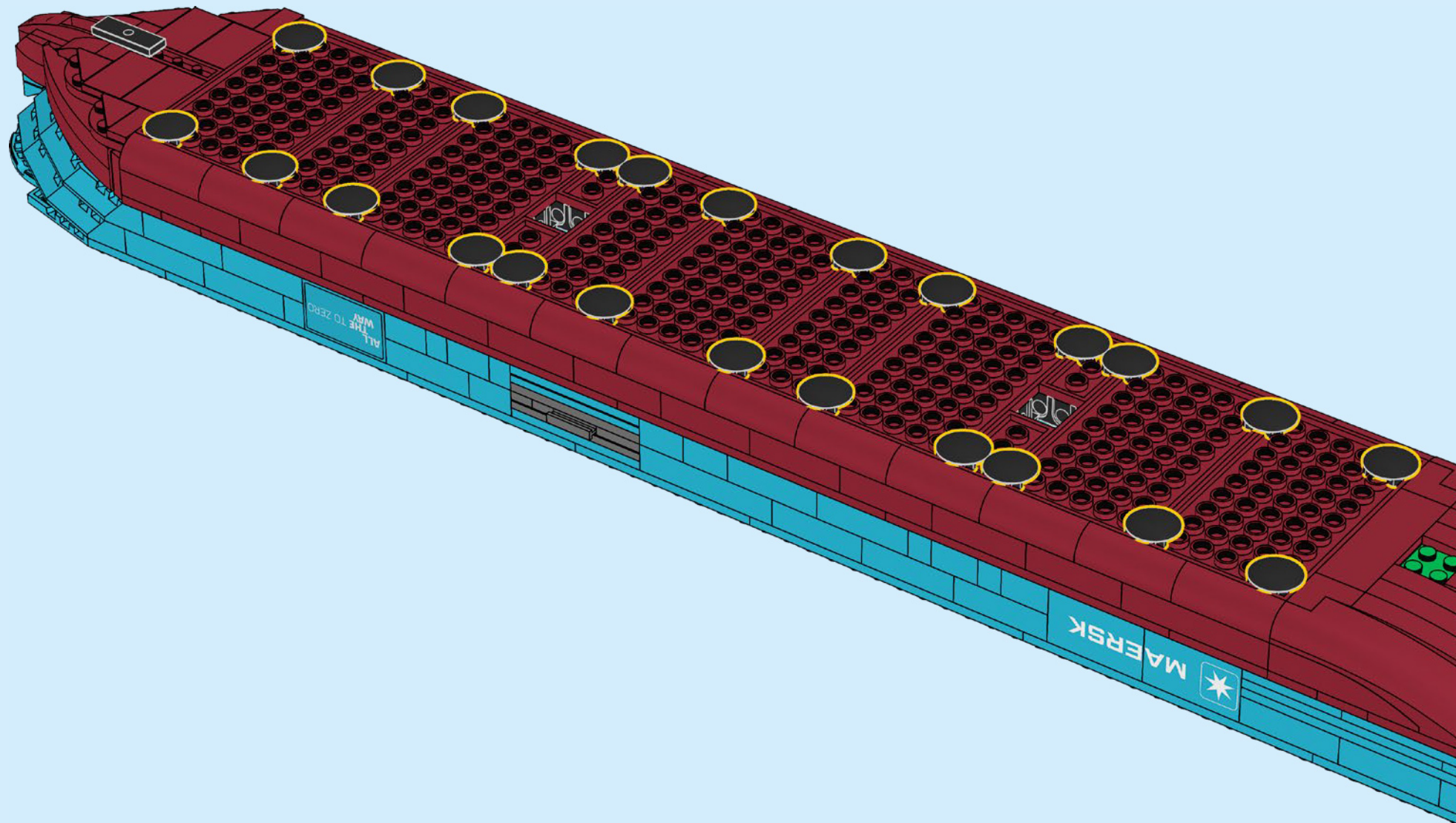

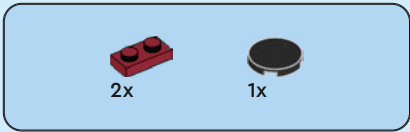

149

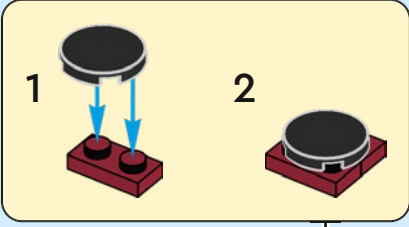
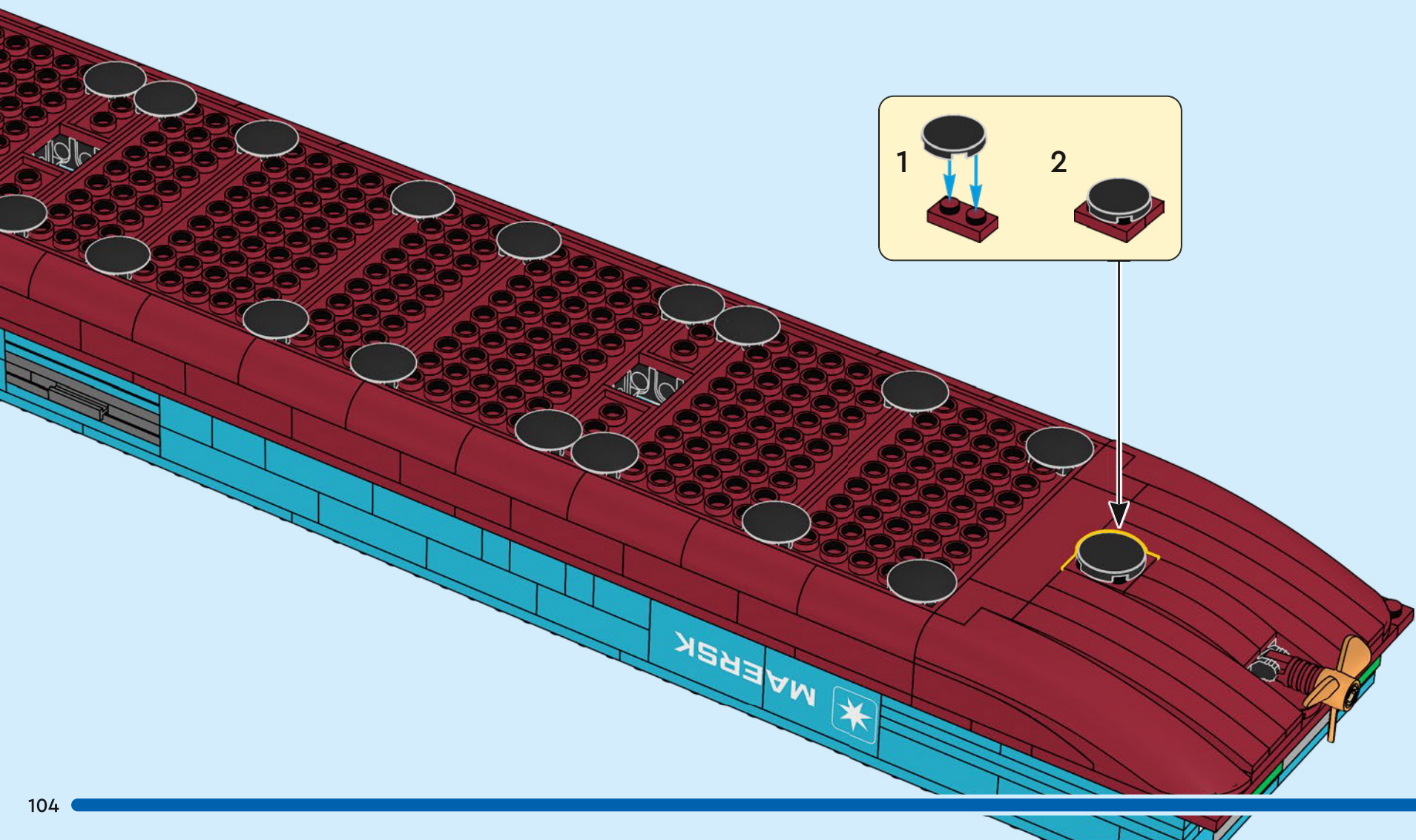

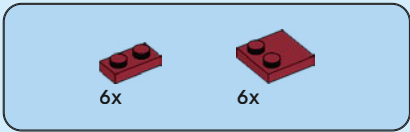

150

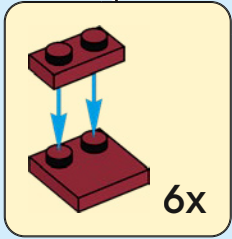
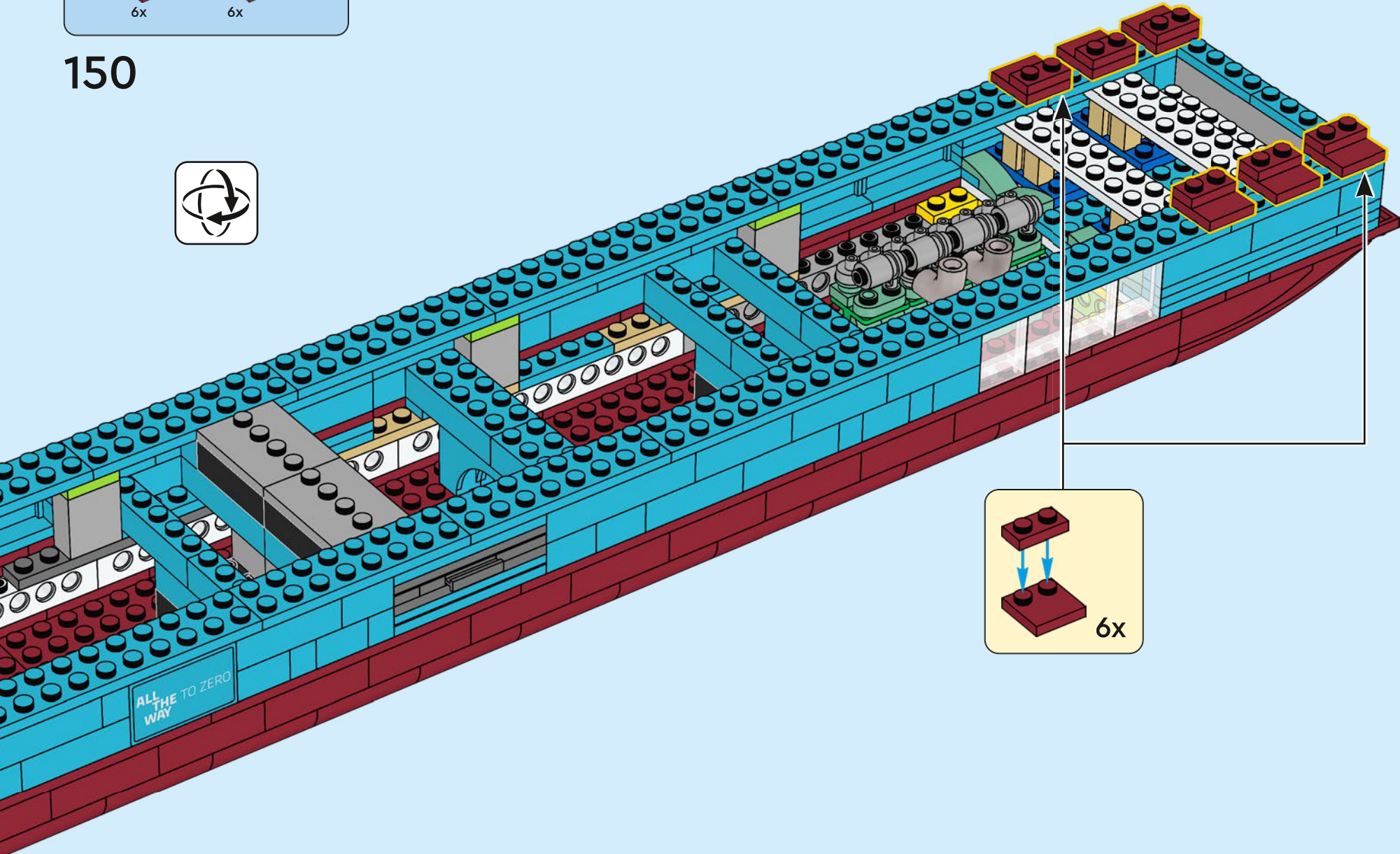

ALL  
THE  
WAY TO ZERO

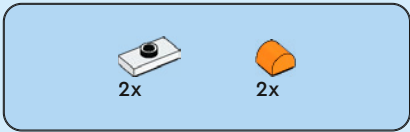

151

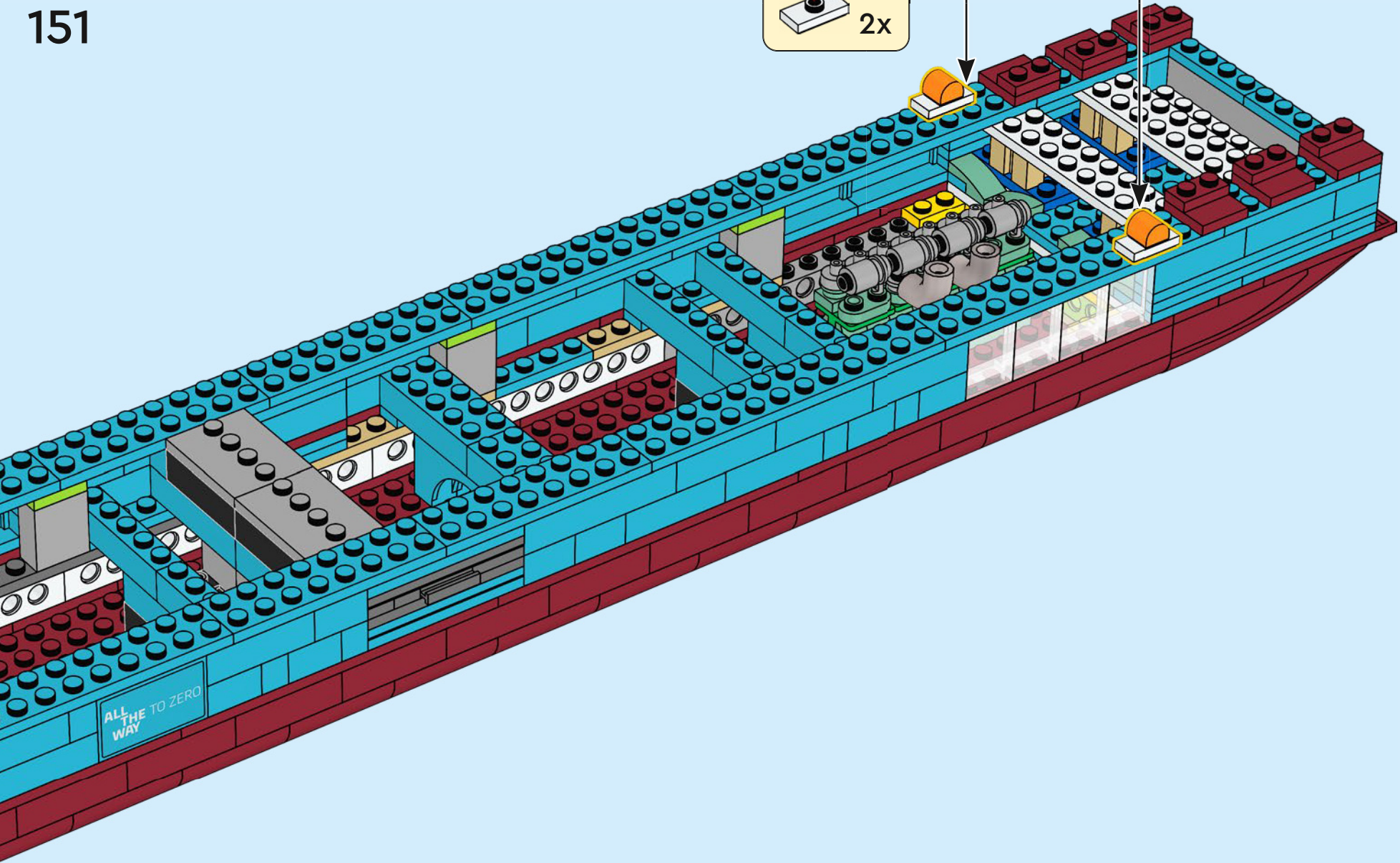
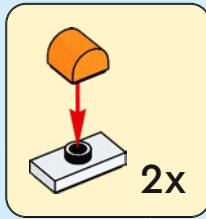

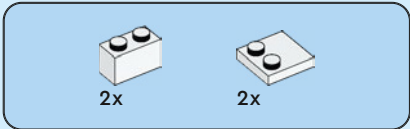

152

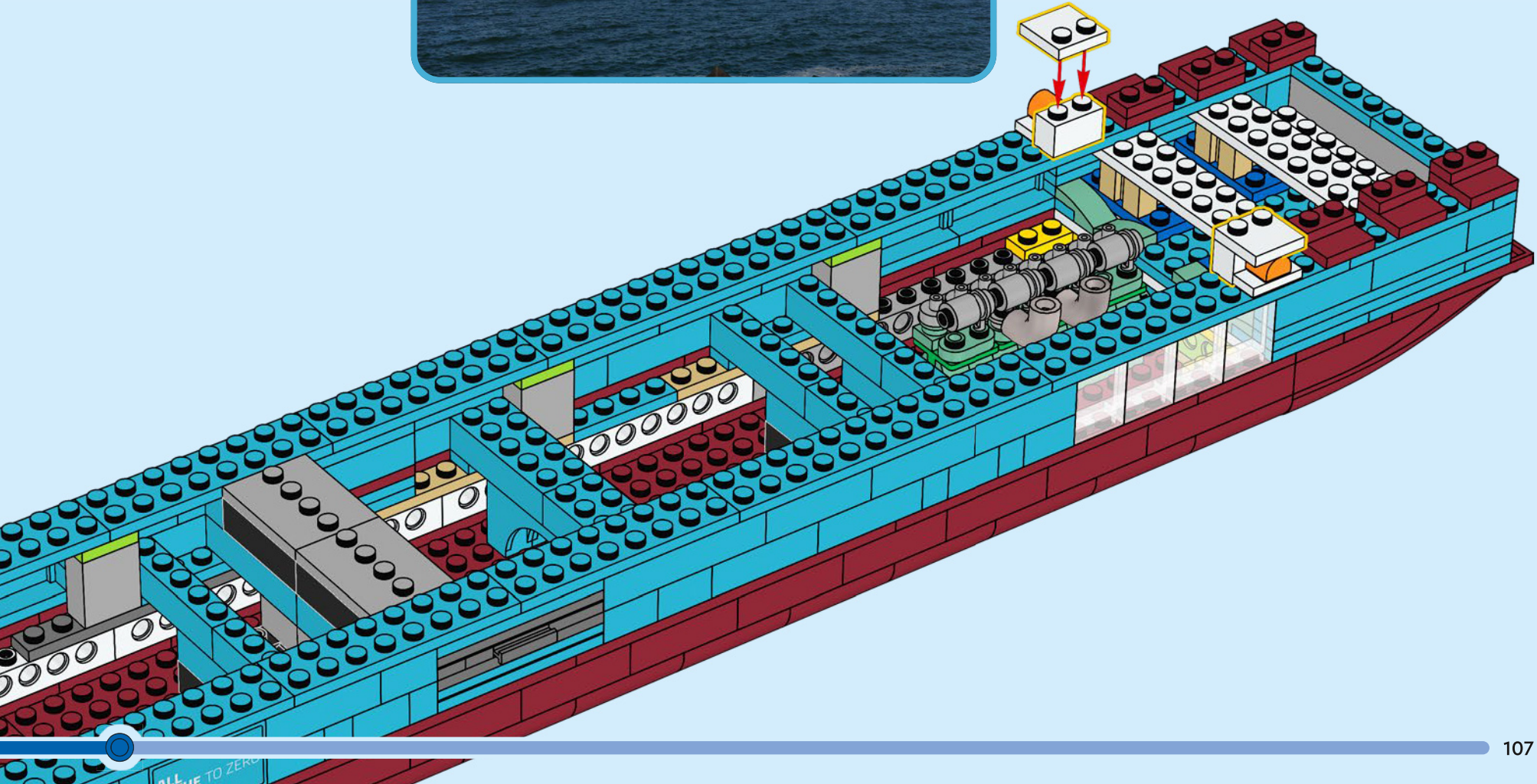
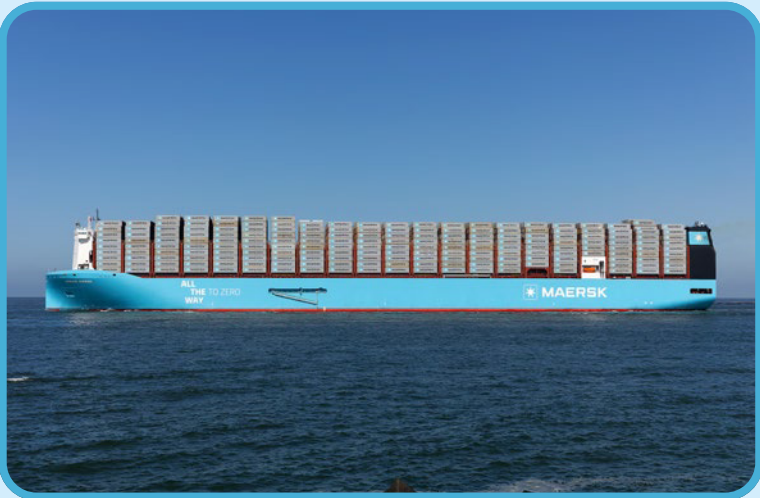

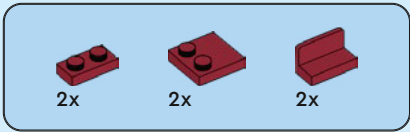

153

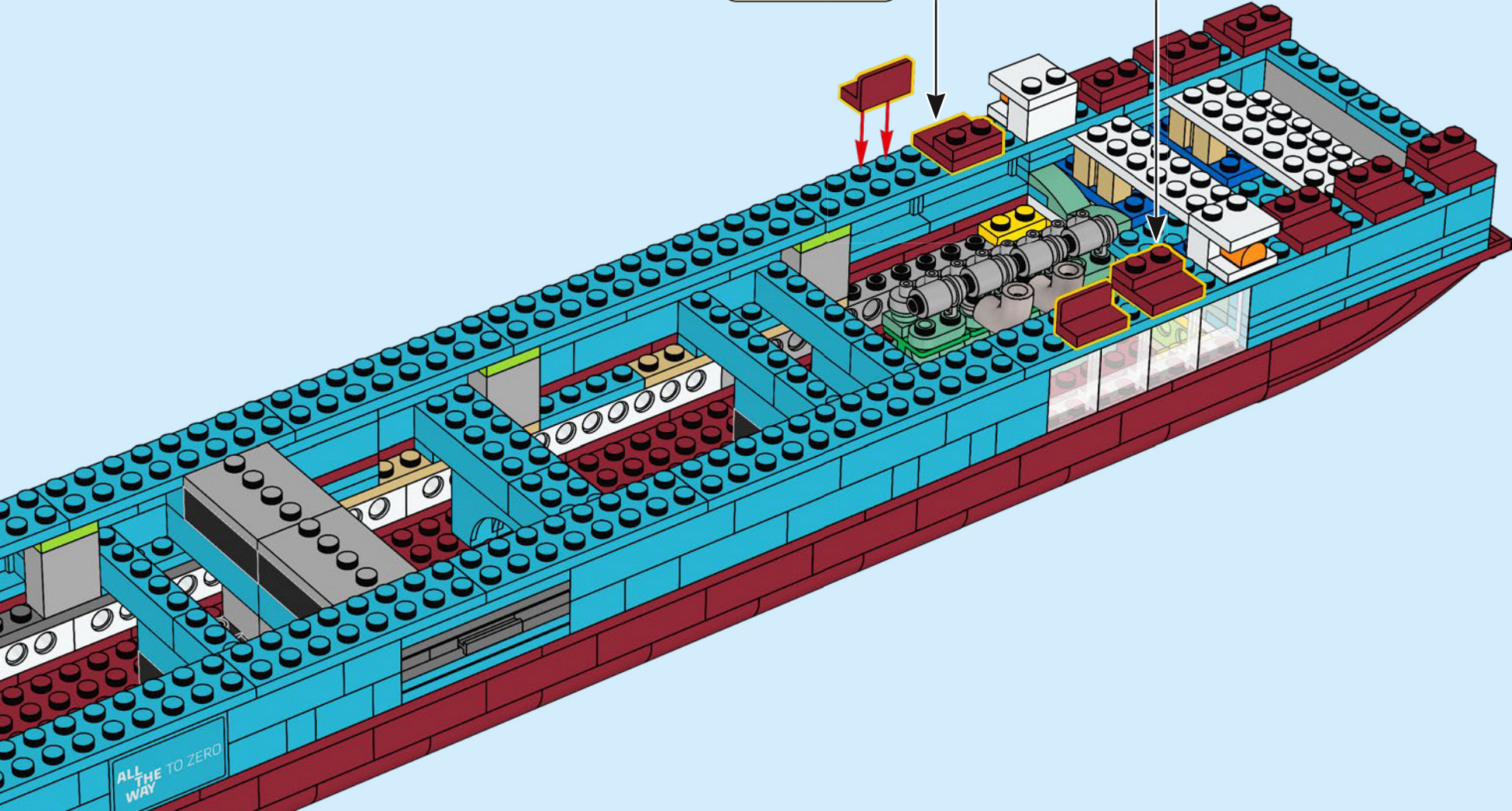
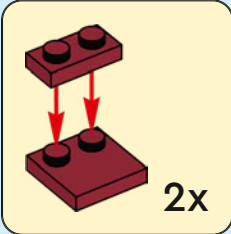

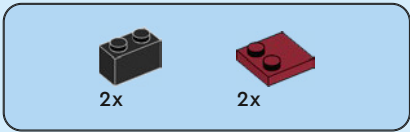

154

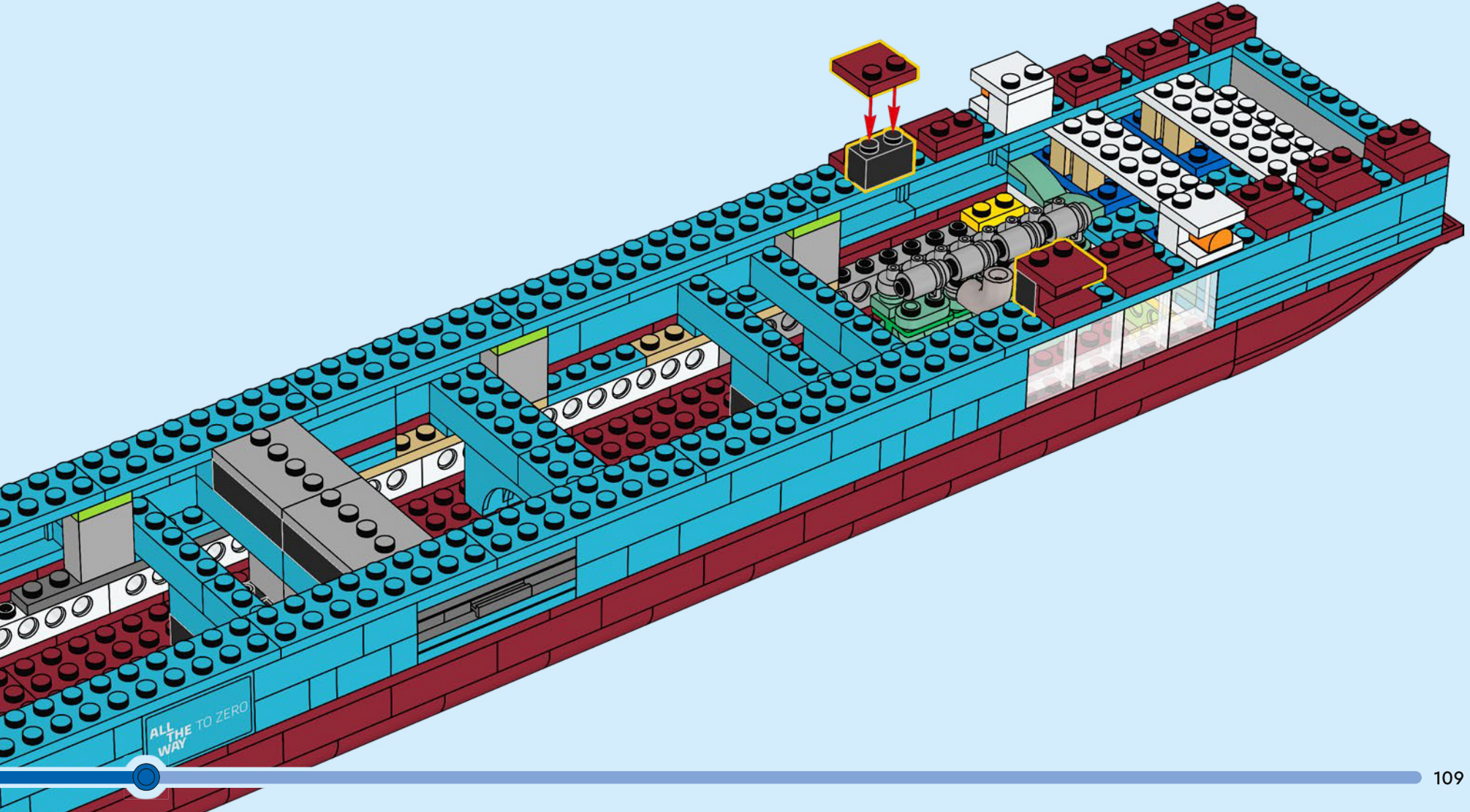

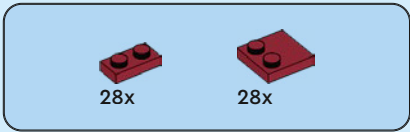

155

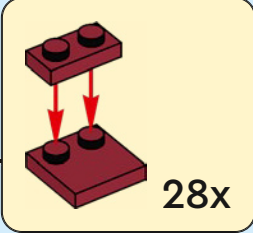
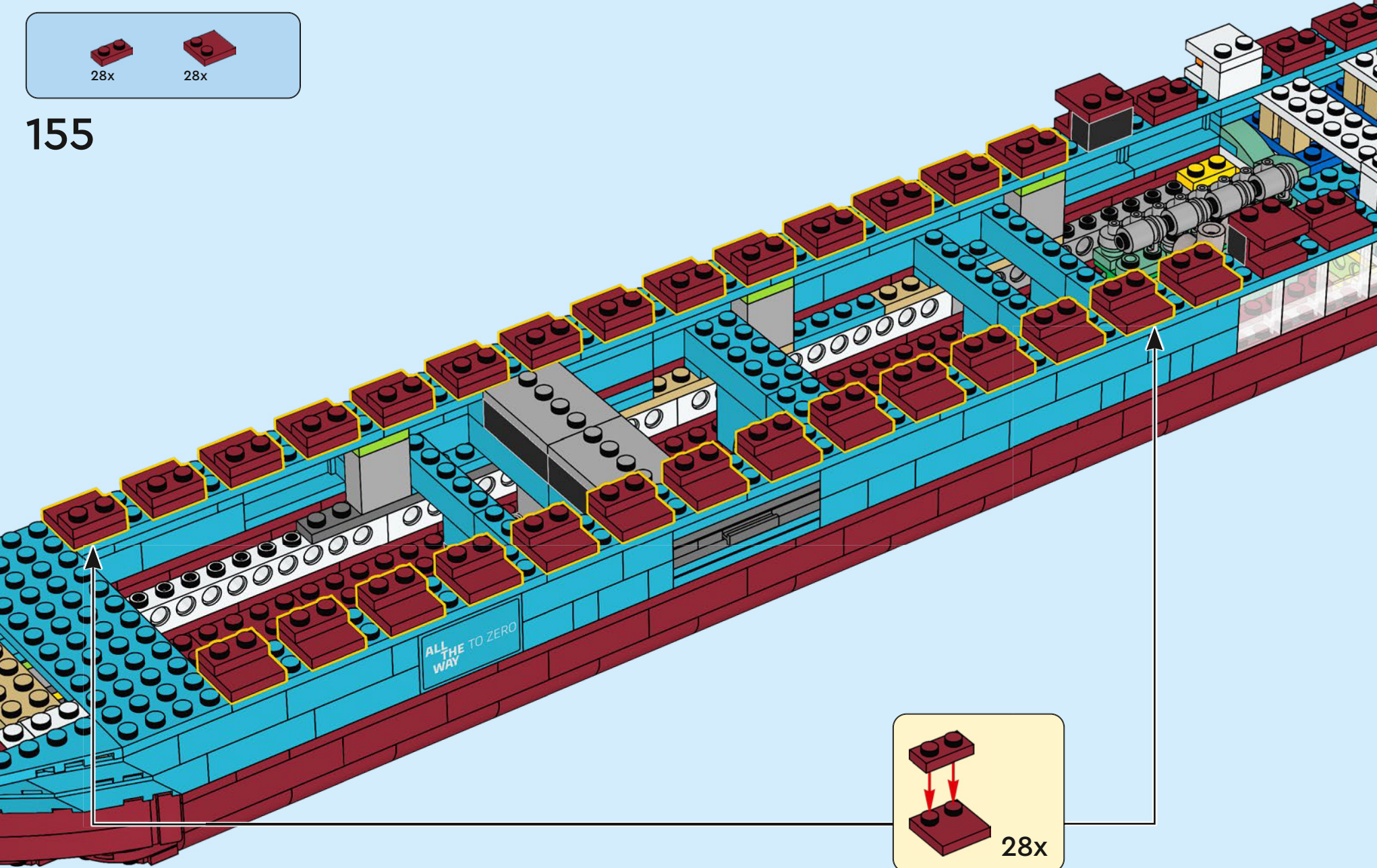

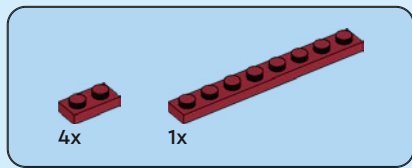

156

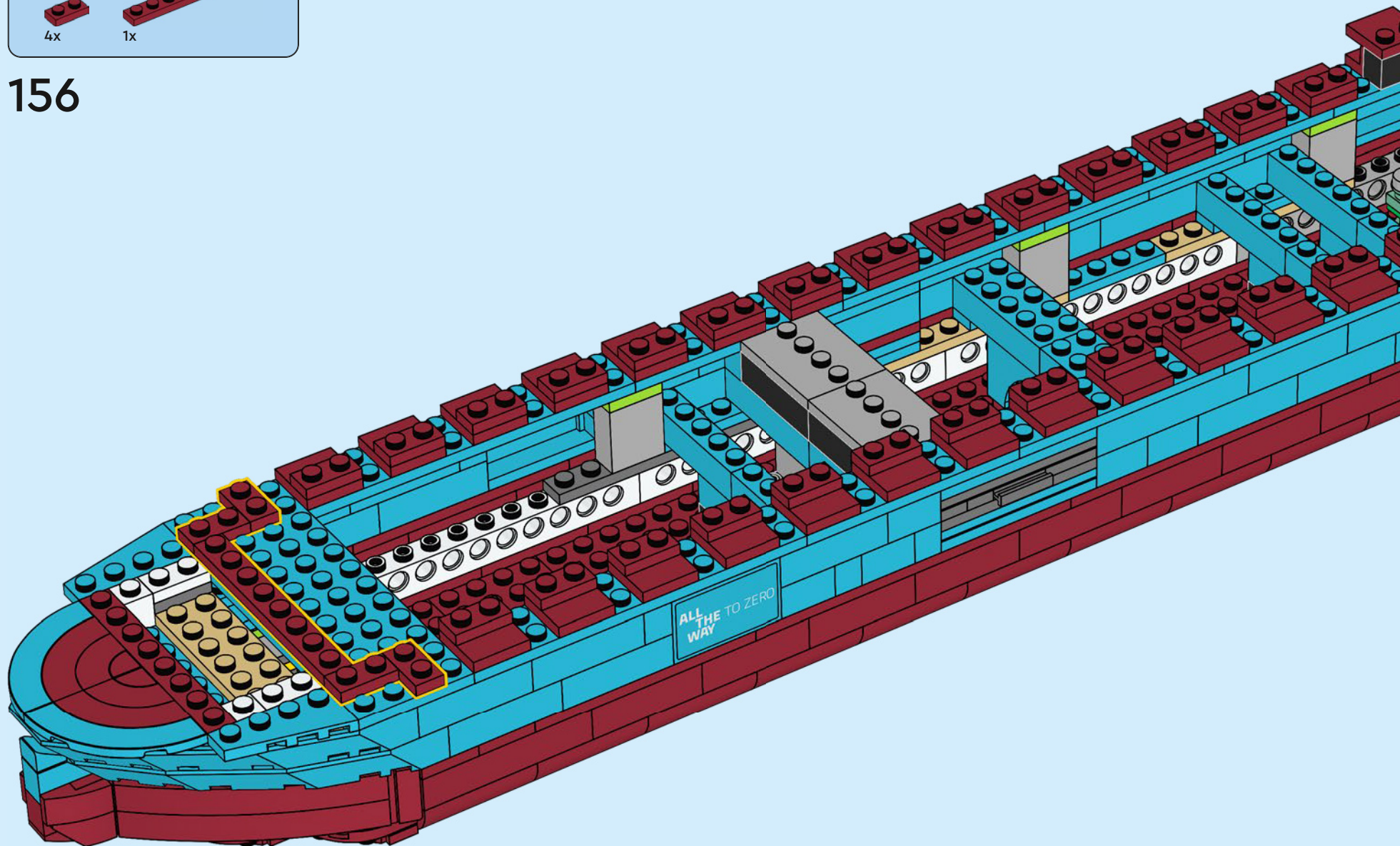

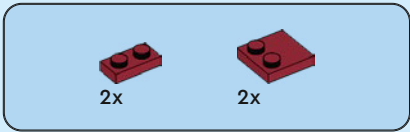

157

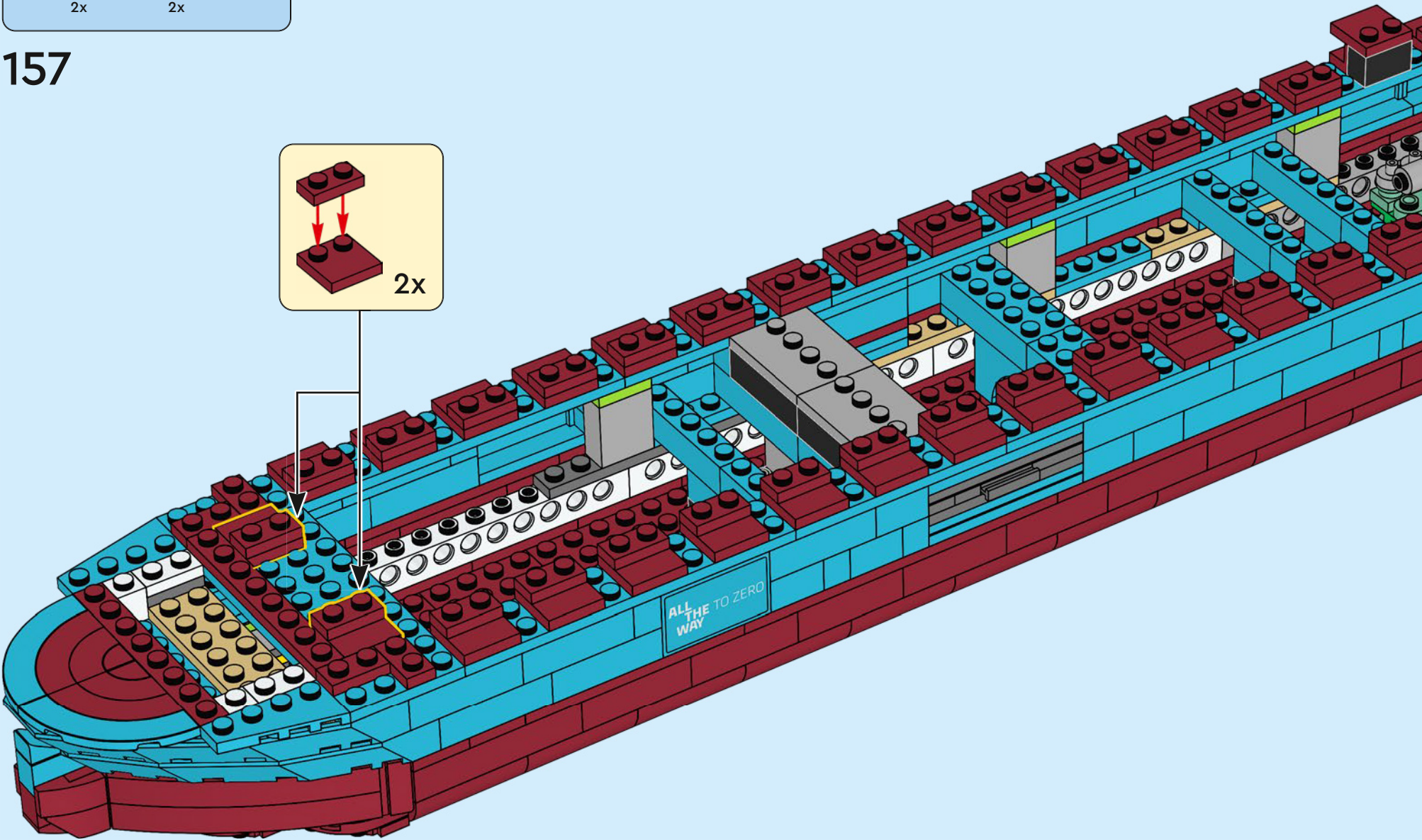
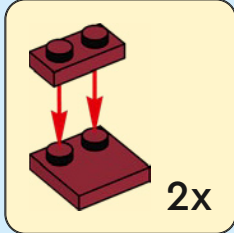

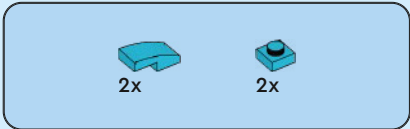

158

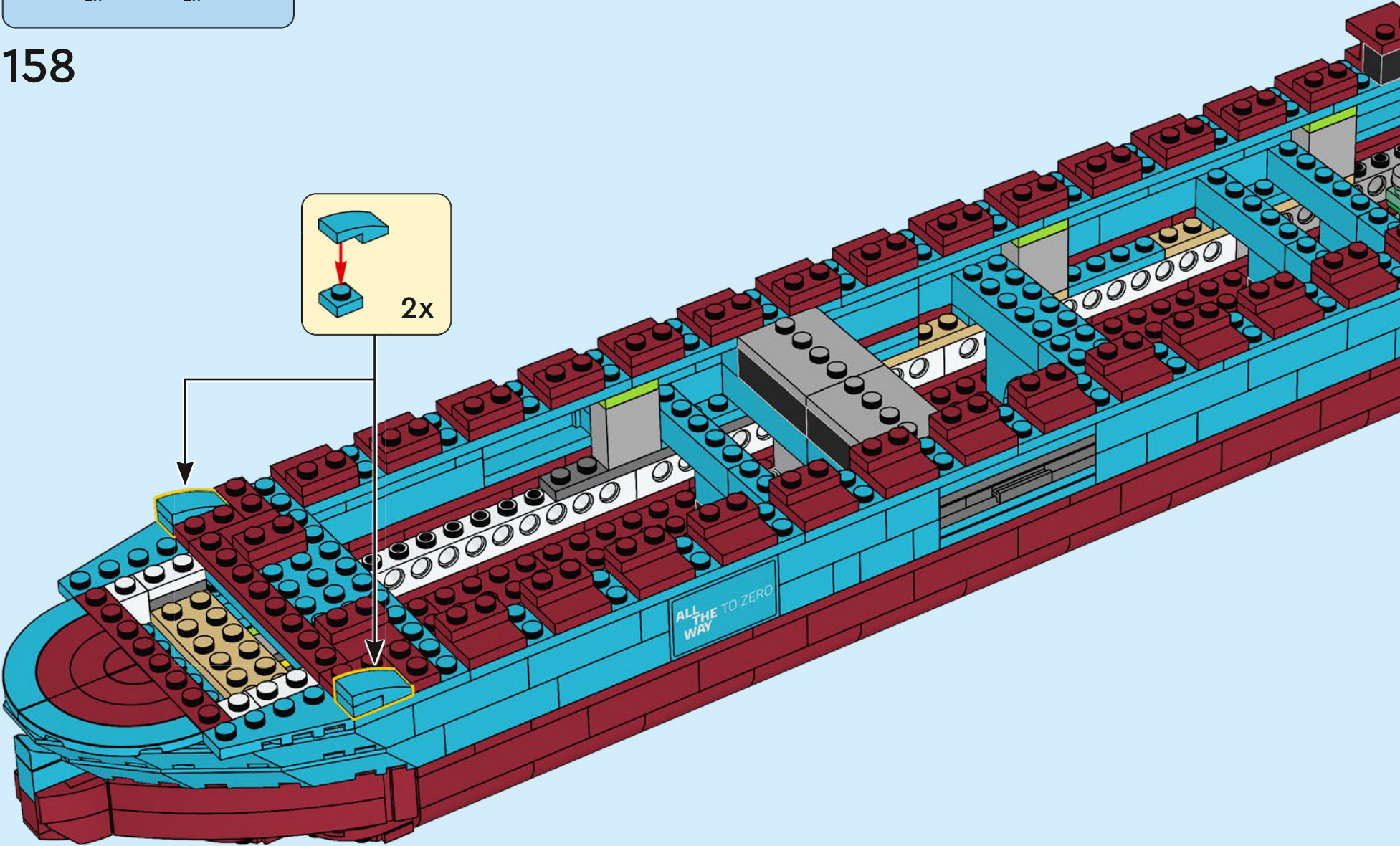
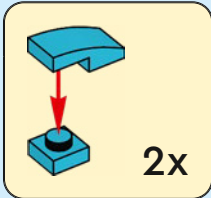

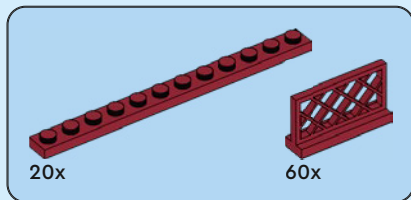
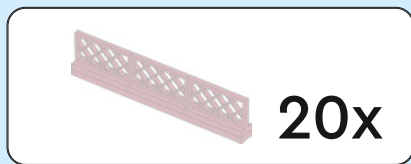

159

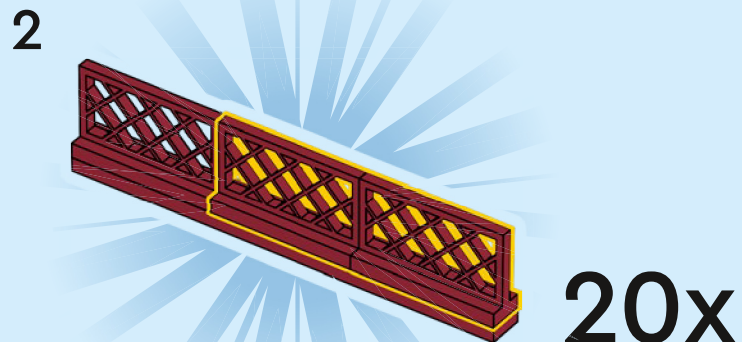
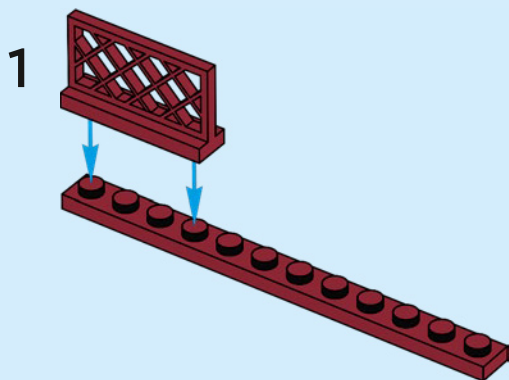
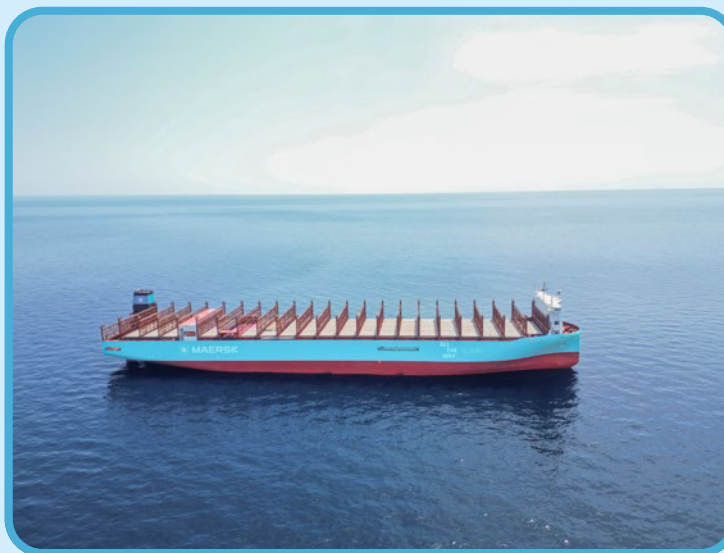

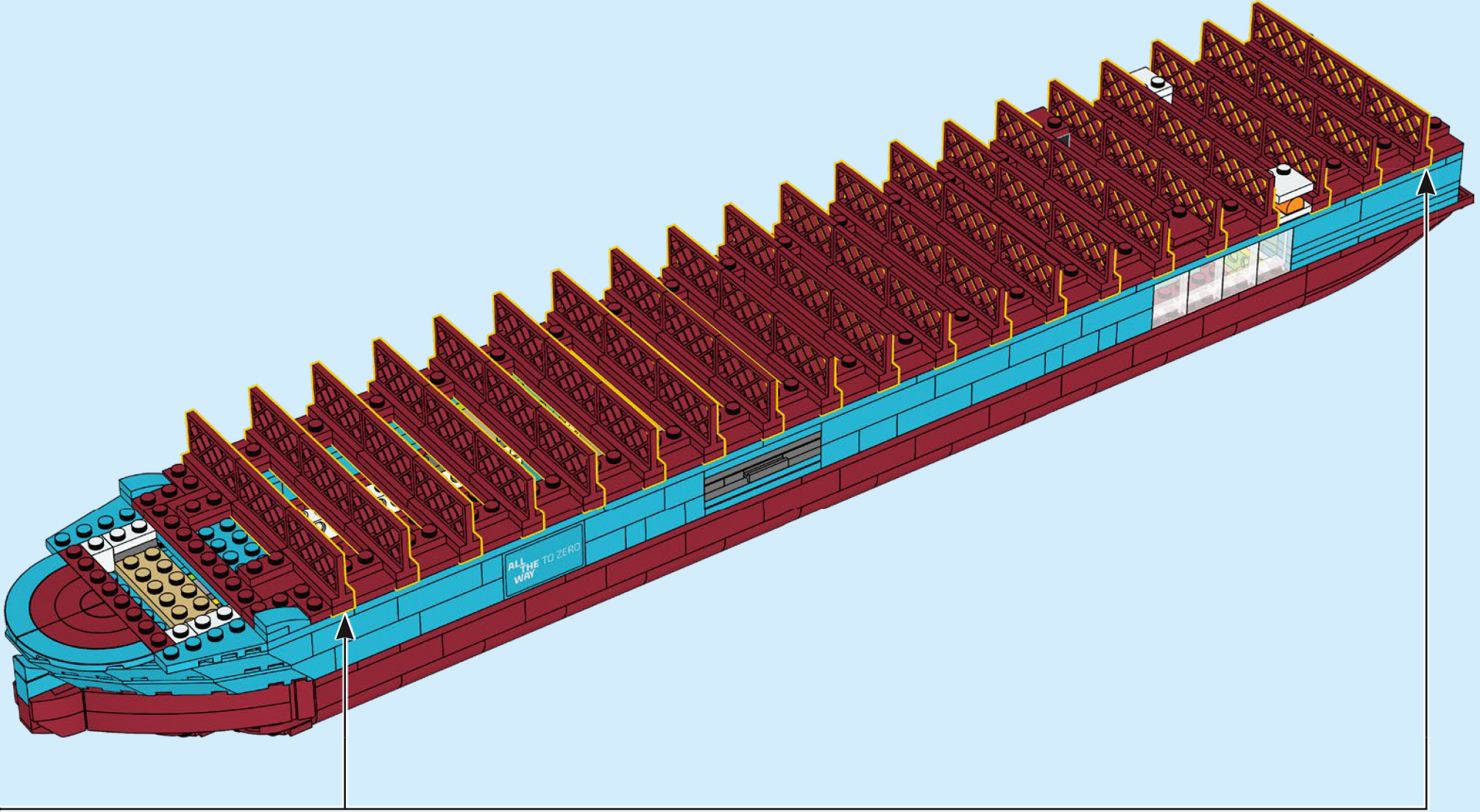

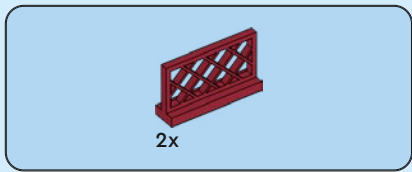

160

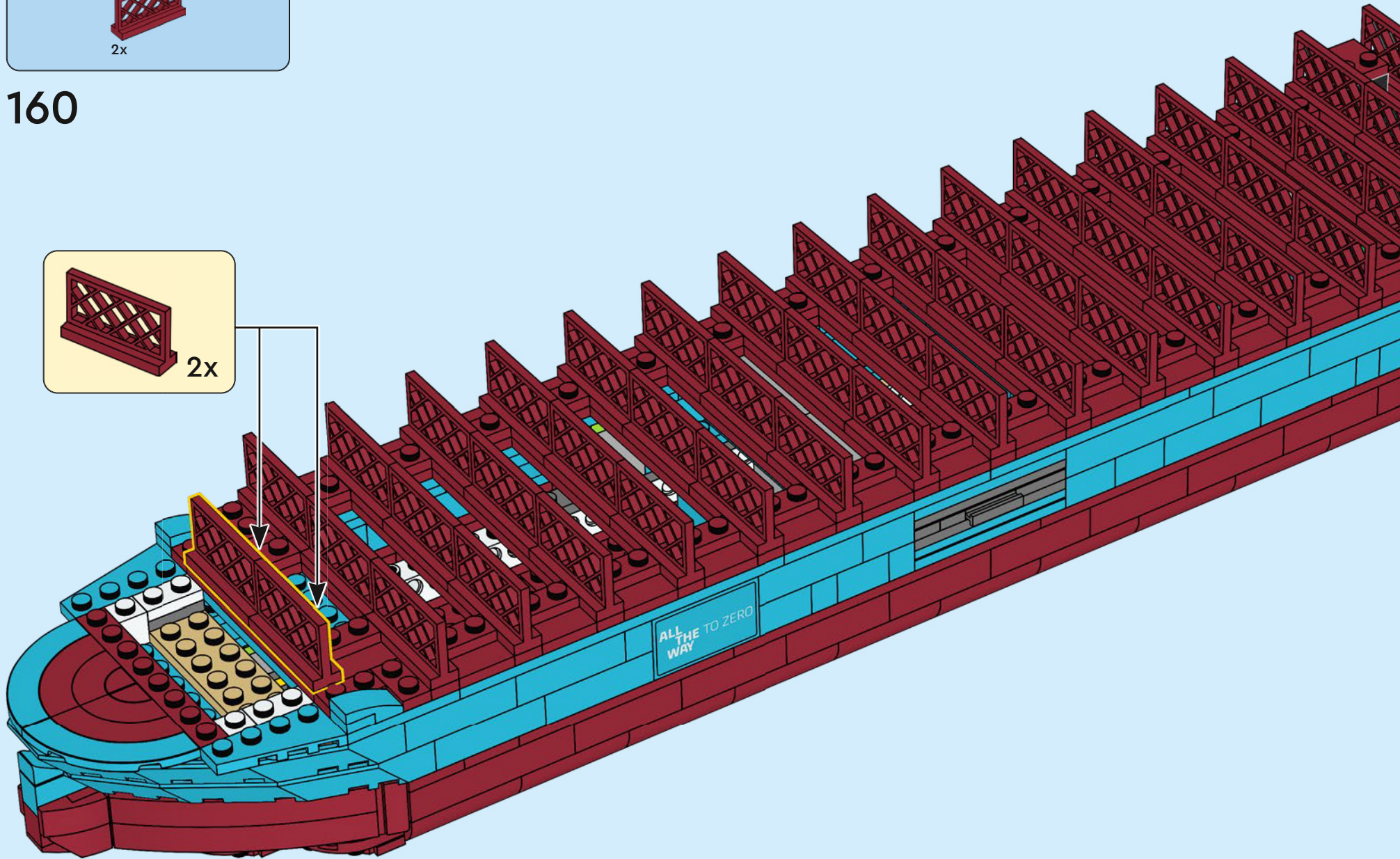
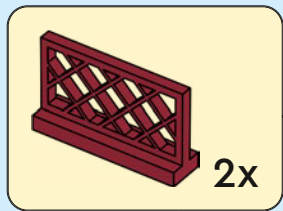

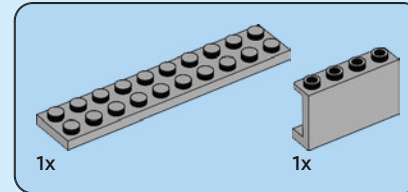
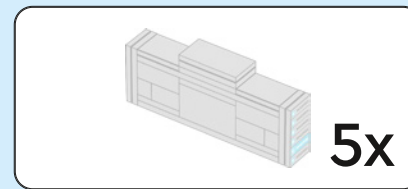

161

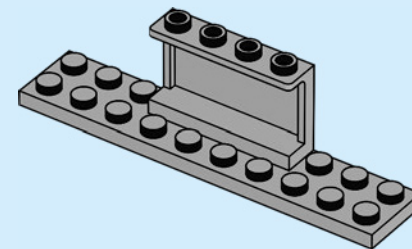
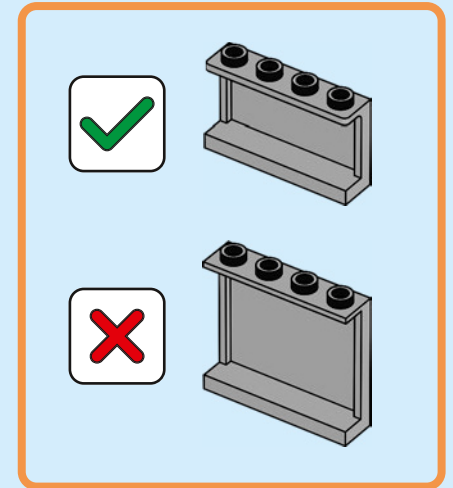

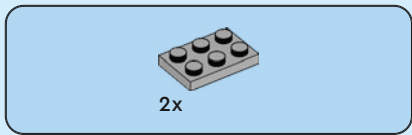

162

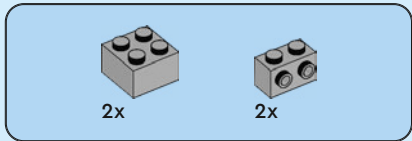
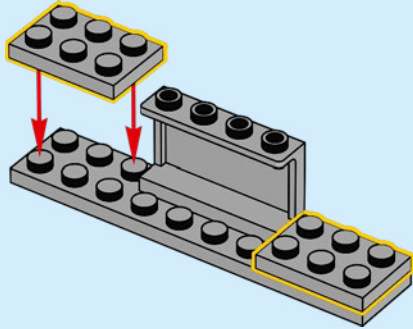

163

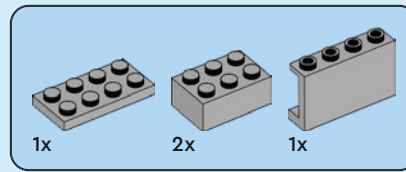
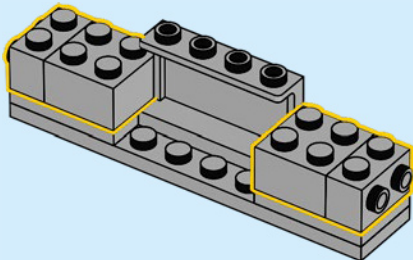

164

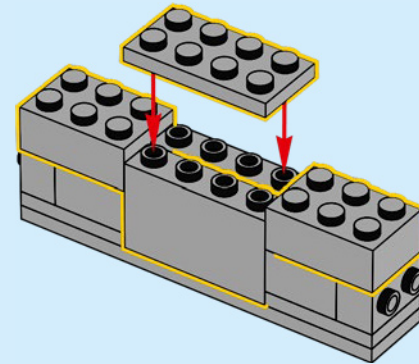

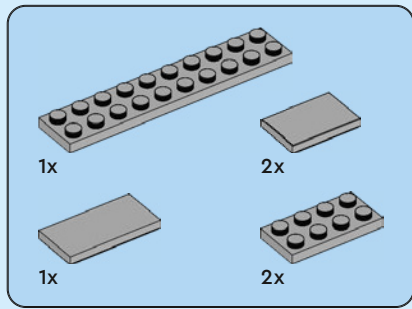

165

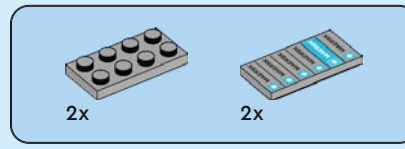
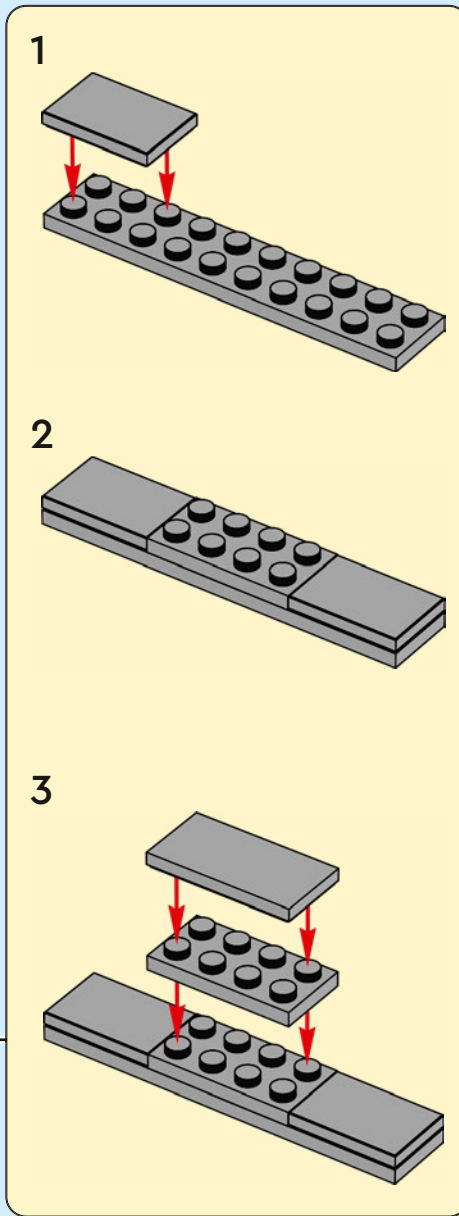
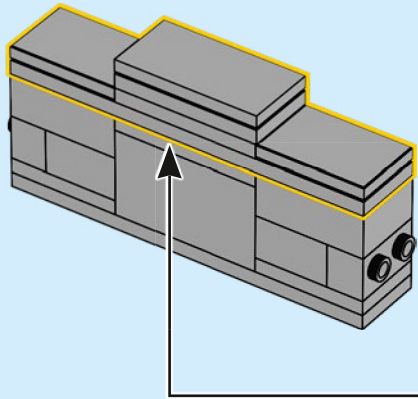

166

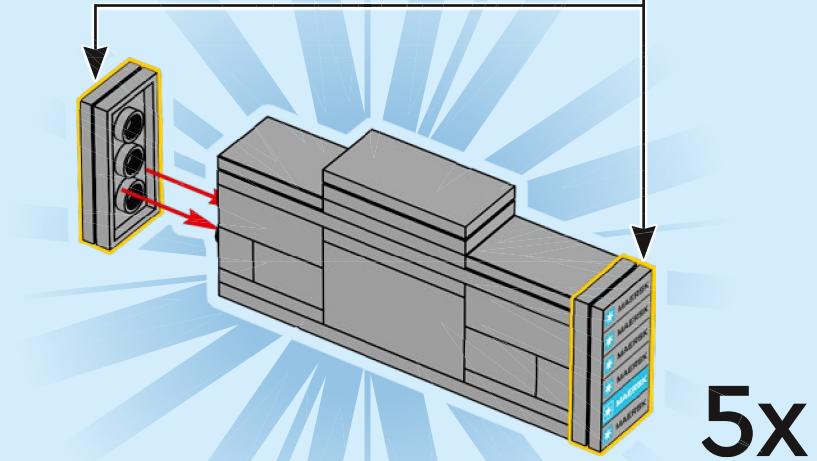
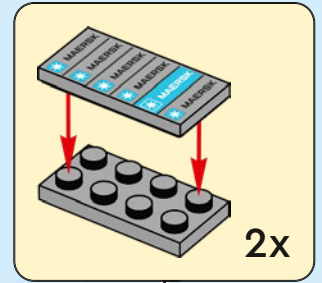

5x



167

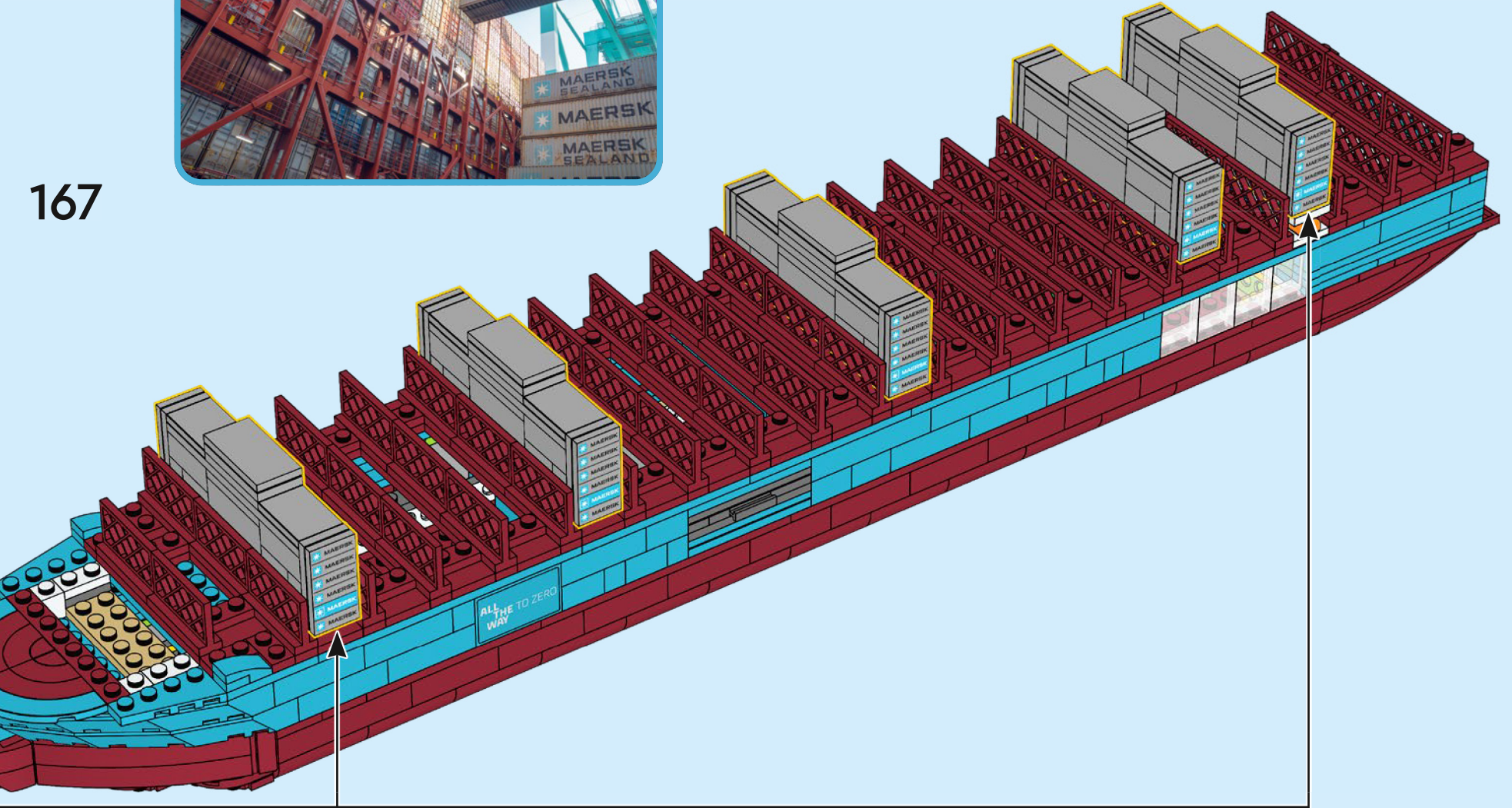

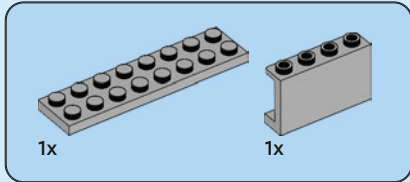
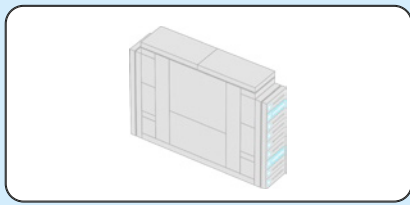

168

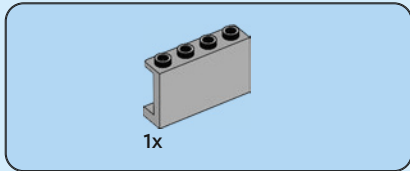
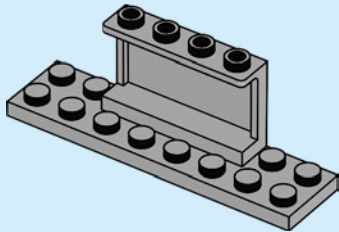

169

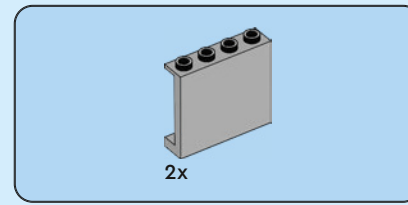
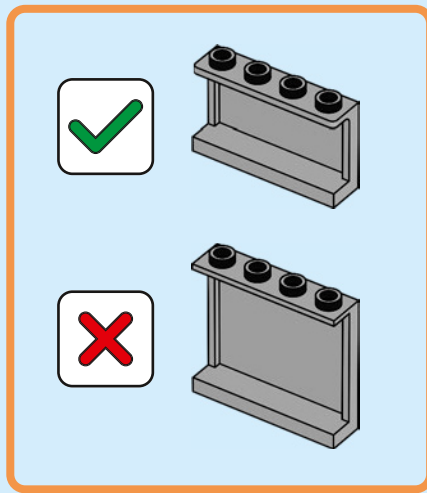
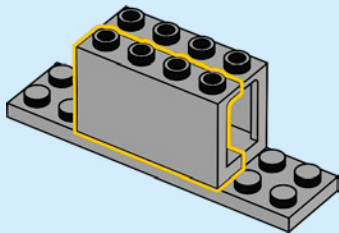

170

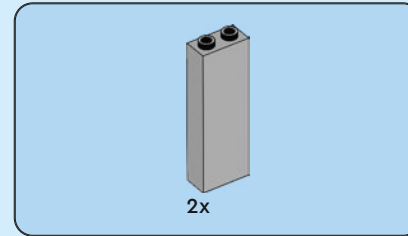
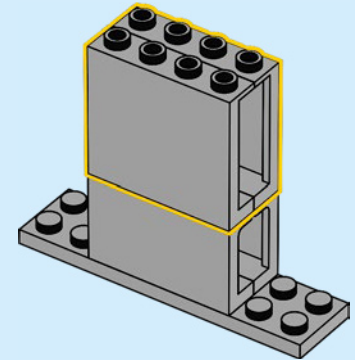

171

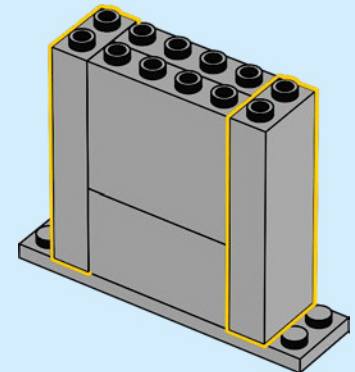



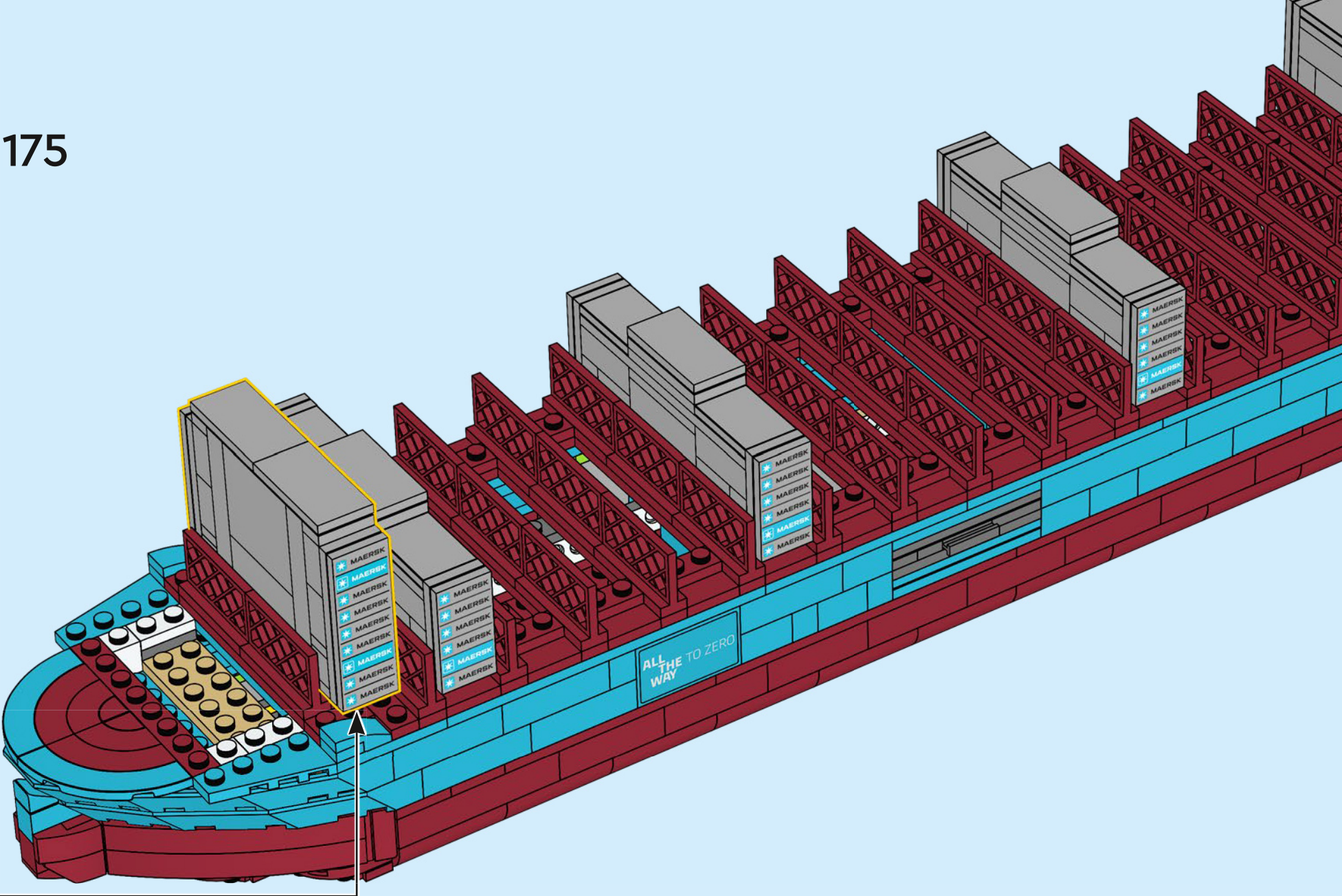

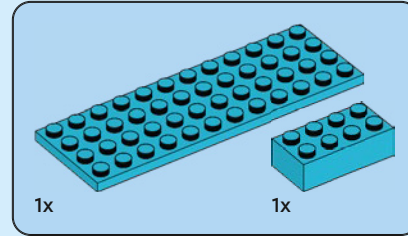
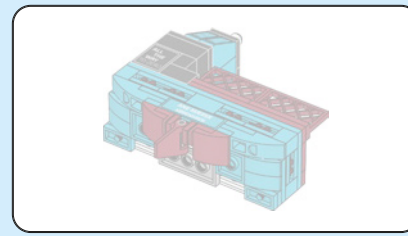

176

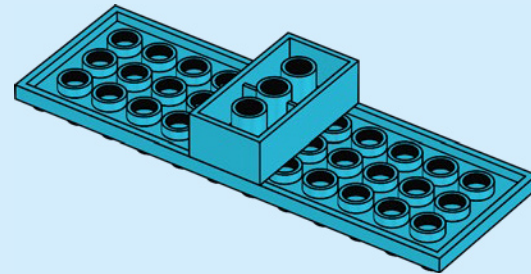

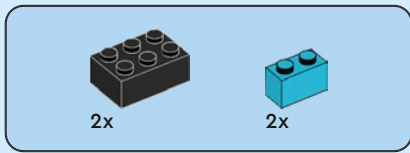

177

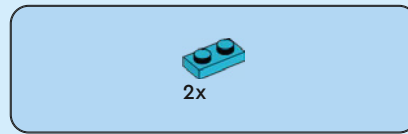
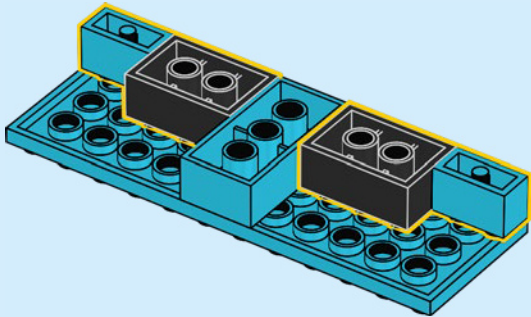

178

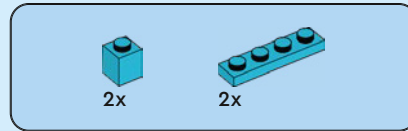
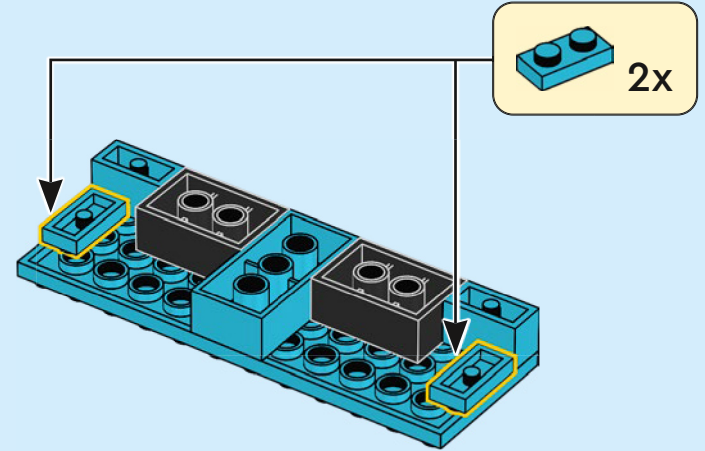

179

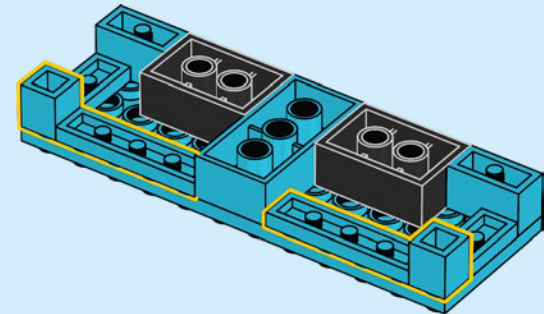

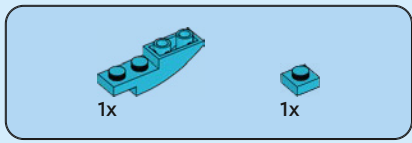

180

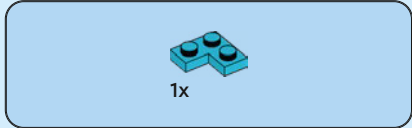
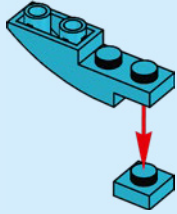

181

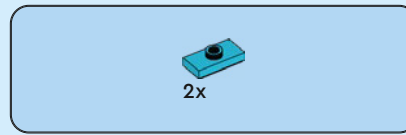
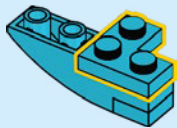

182

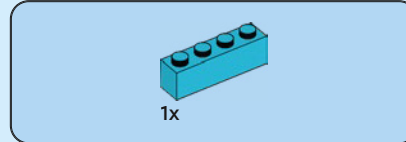
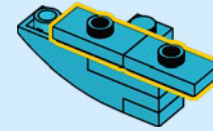

183

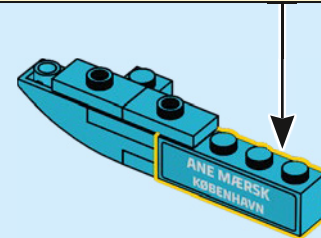
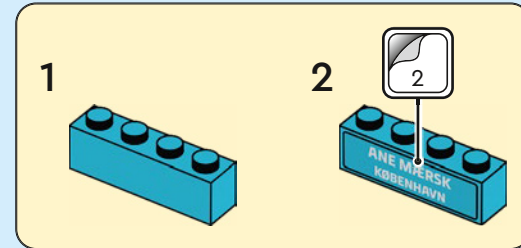

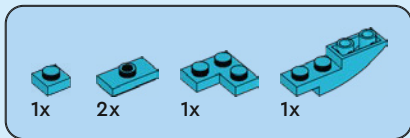

184

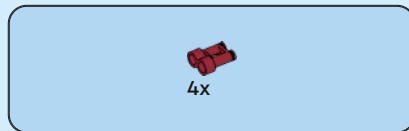
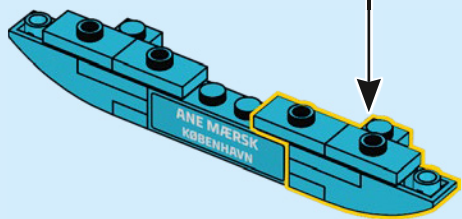
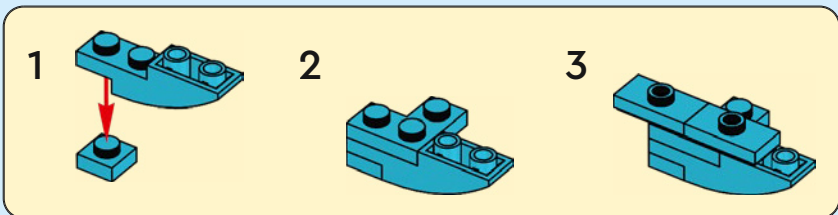

185

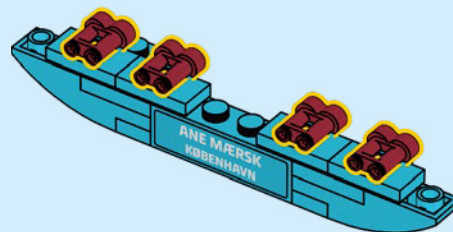

186

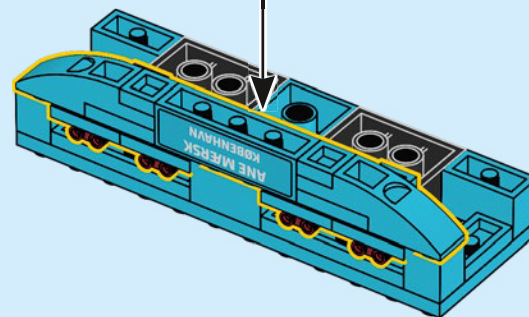

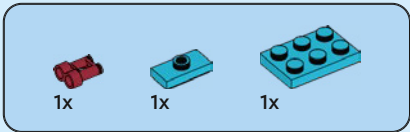

187

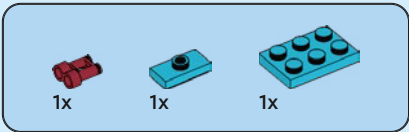
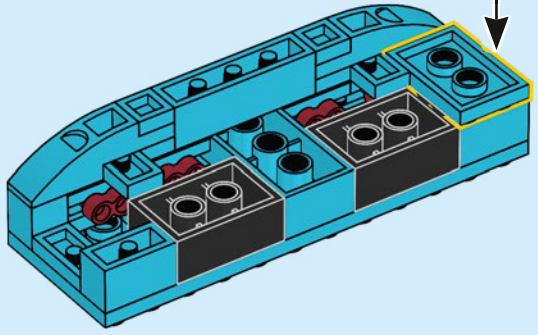
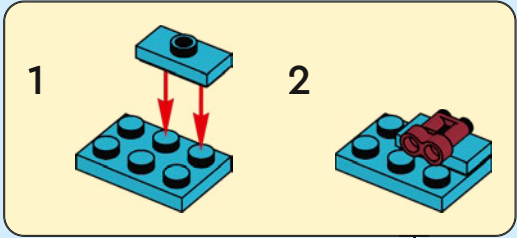

188

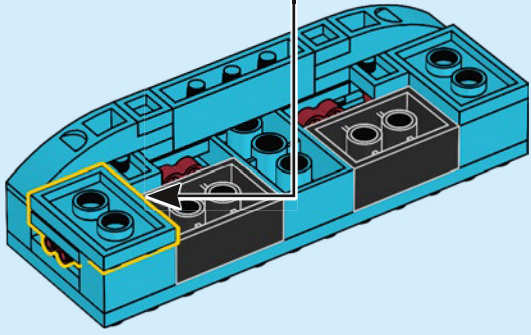
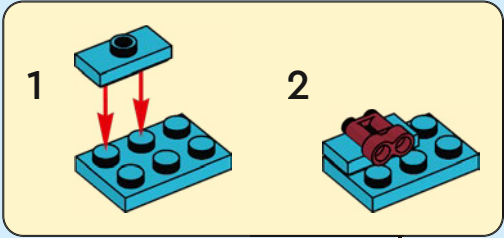

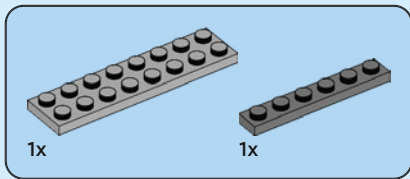

189

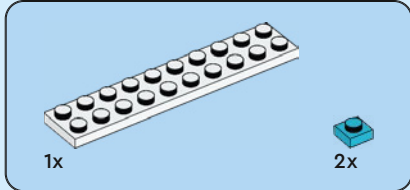
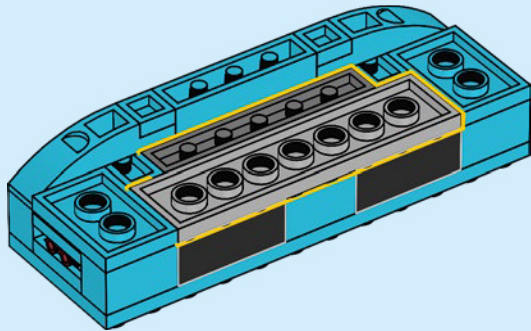

190

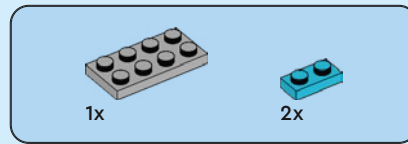
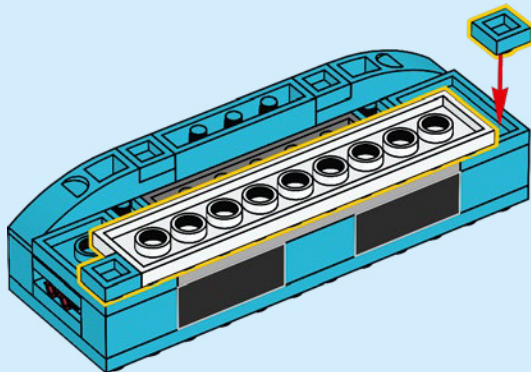

191

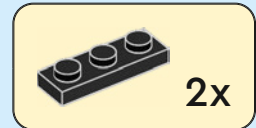
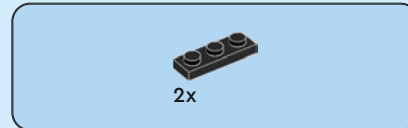
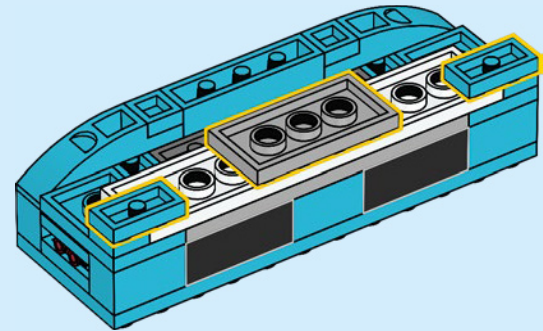

192

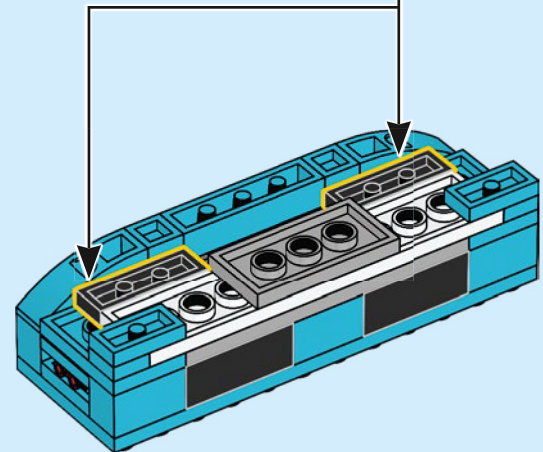



4x

# 193

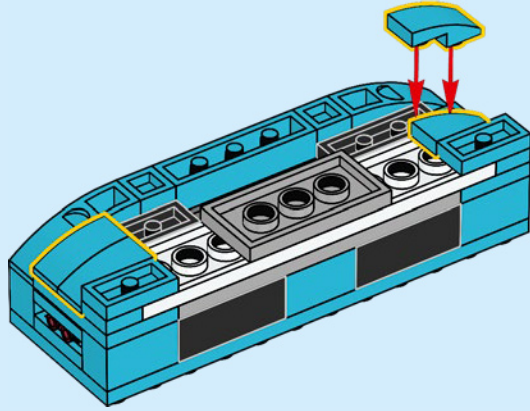

2x

# 194

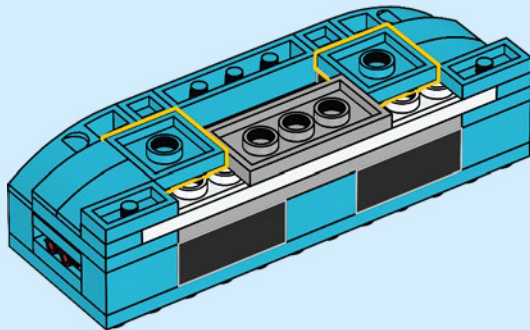

1x

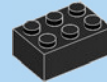

1x



1x

# 195

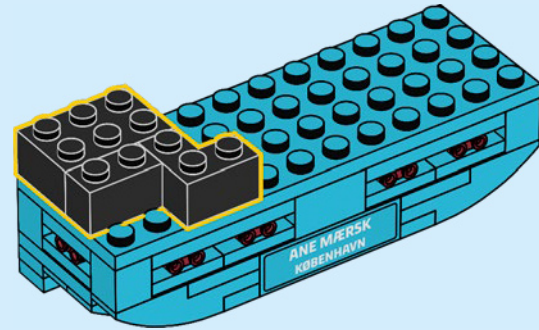
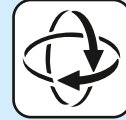

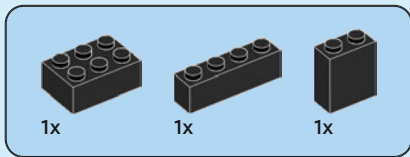

196

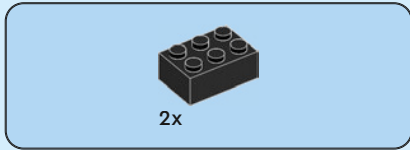
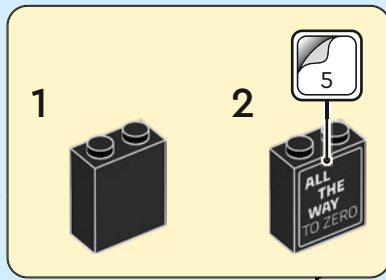
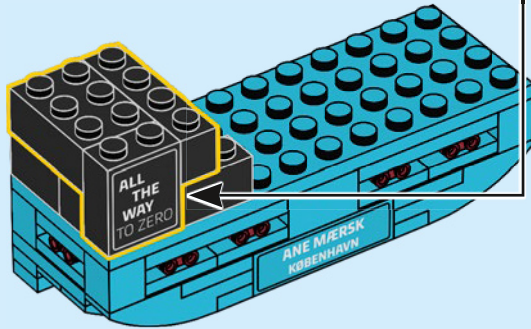

197

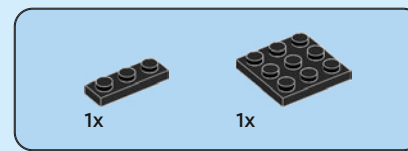
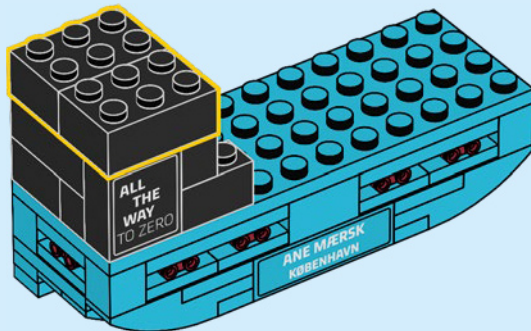

198

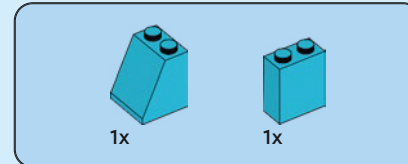
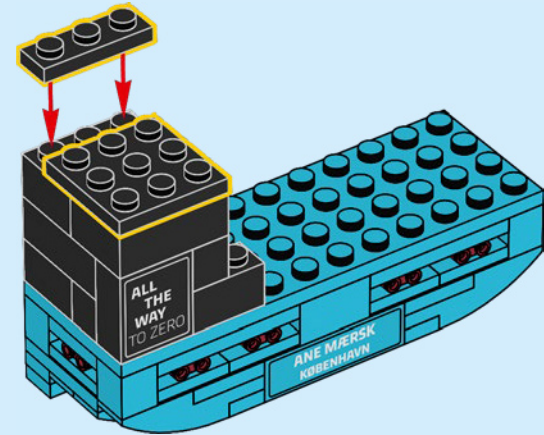

199

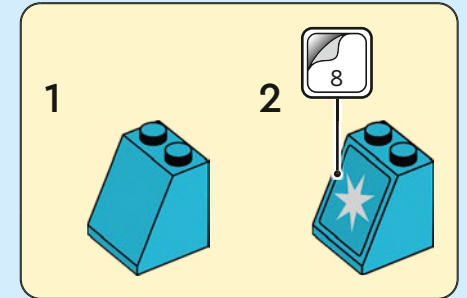
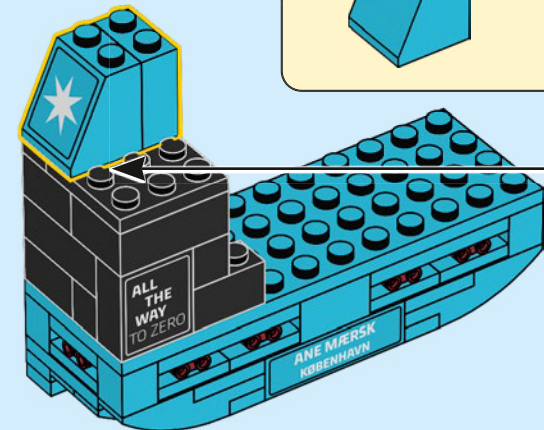

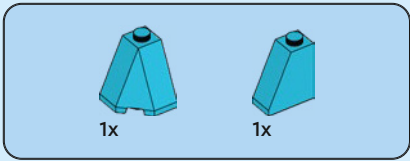

# 200

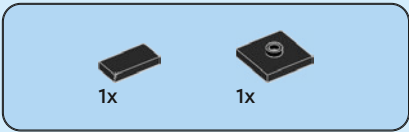
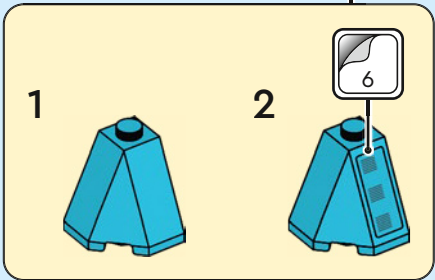
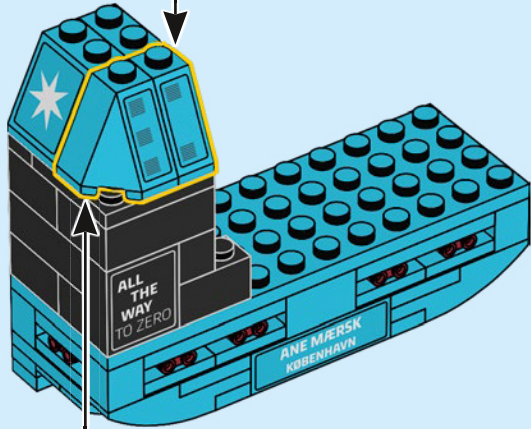
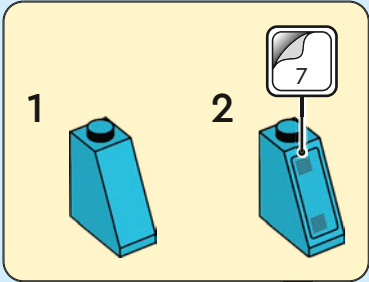

# 201

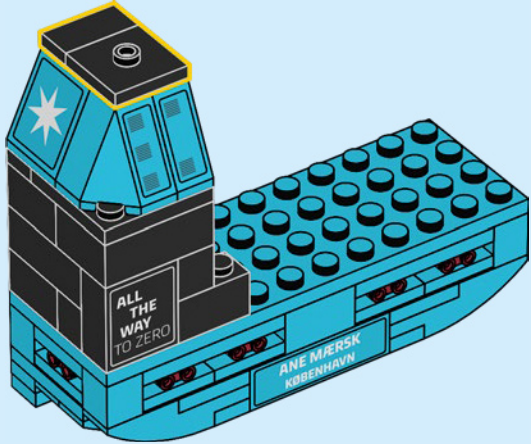



1x



1x

# 202

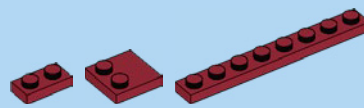
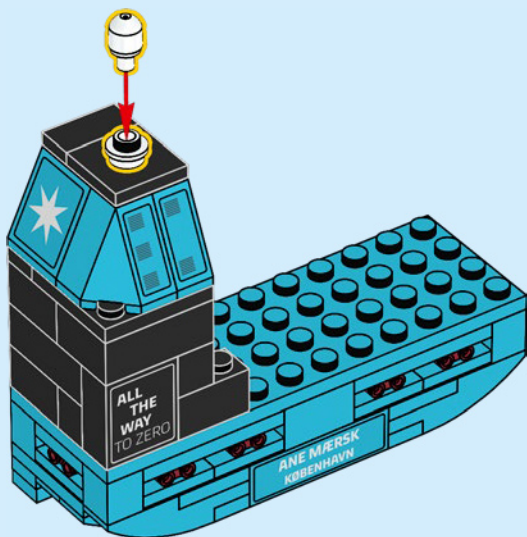

1x

2x

1x

# 203

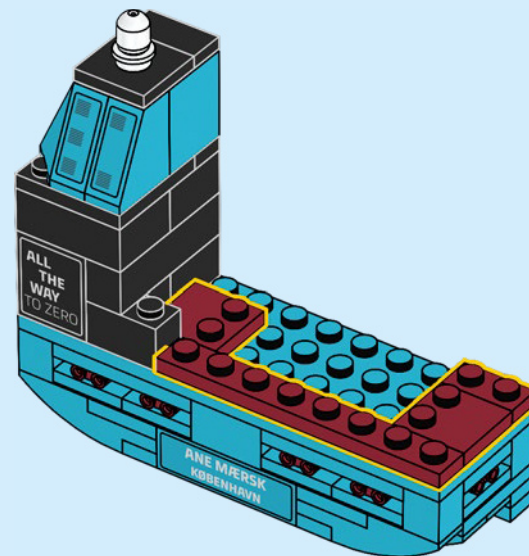



2x

204

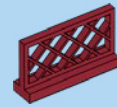
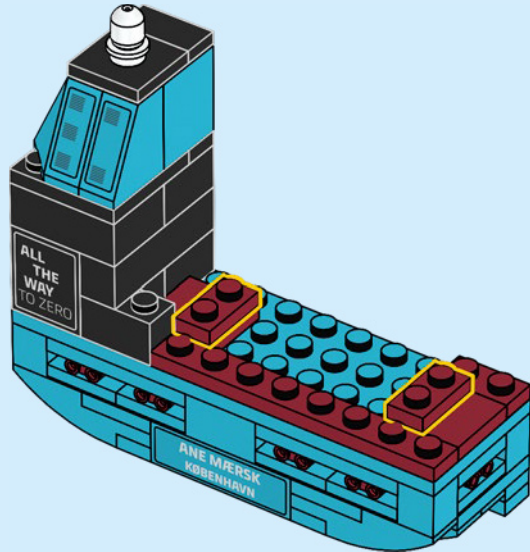

2x

205

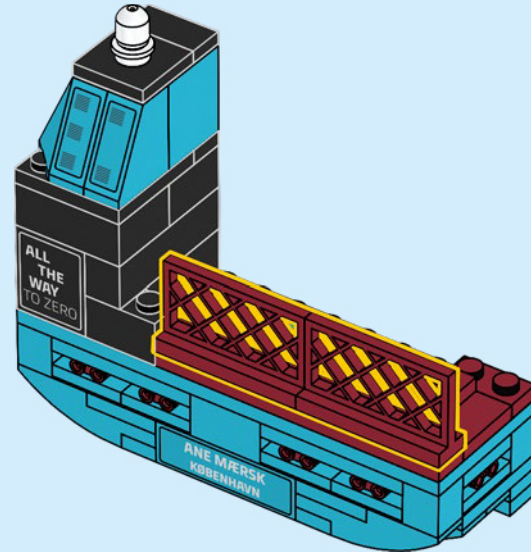

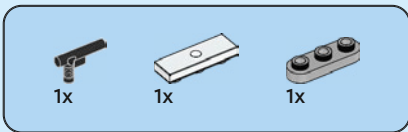

# 206

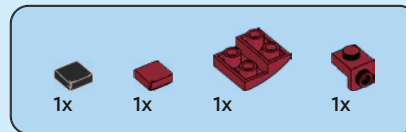
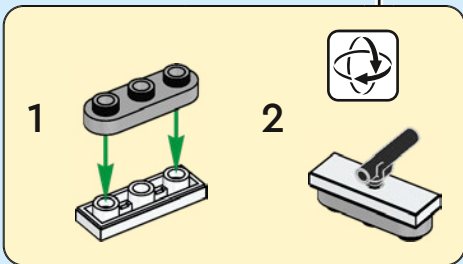
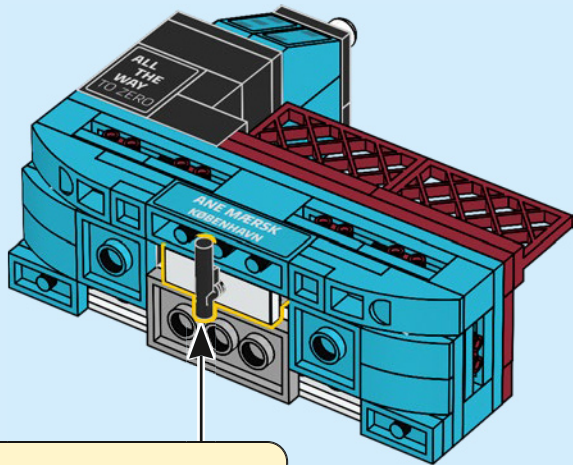

# 207

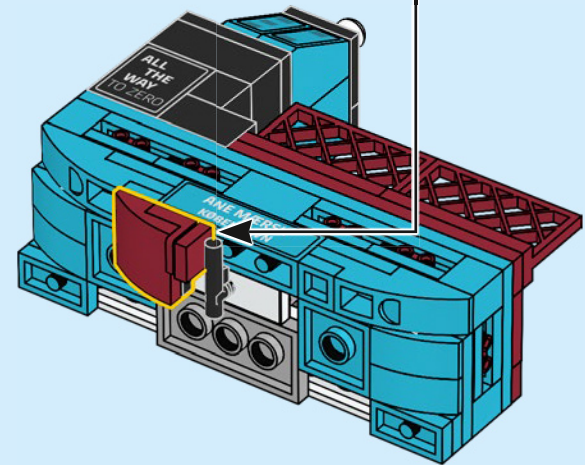
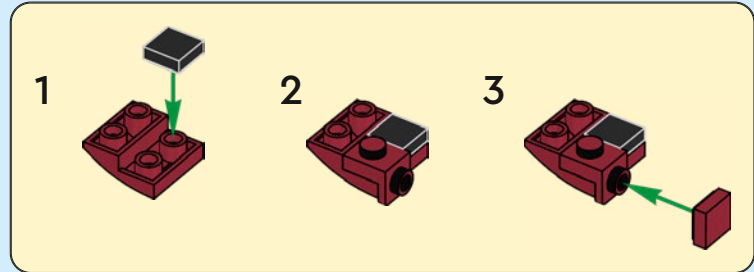

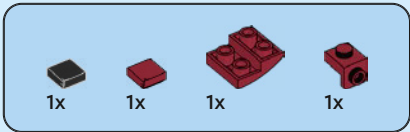

# 208

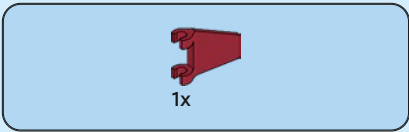
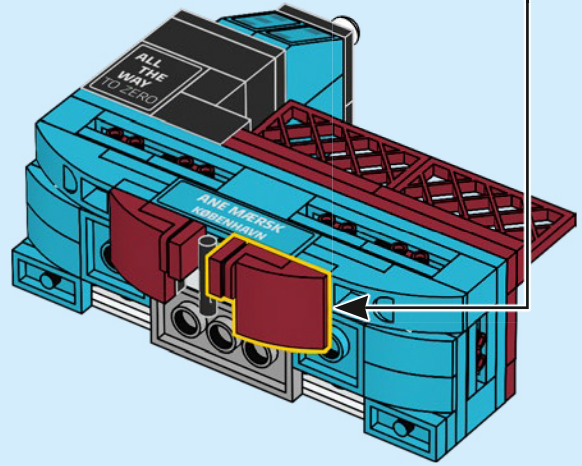

# 209

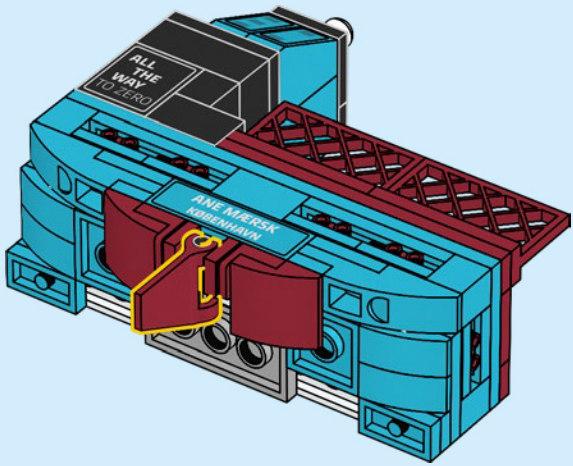

210

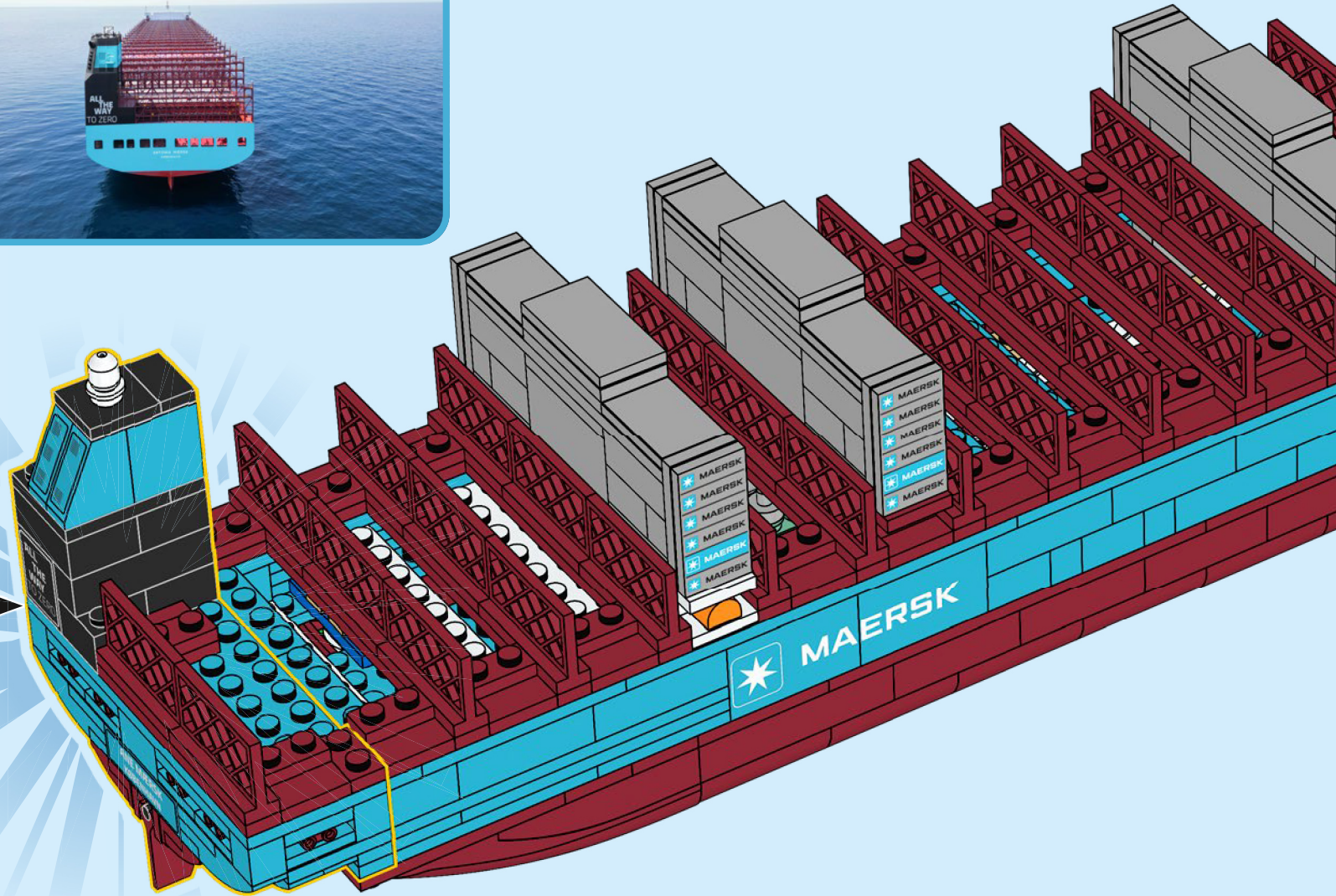
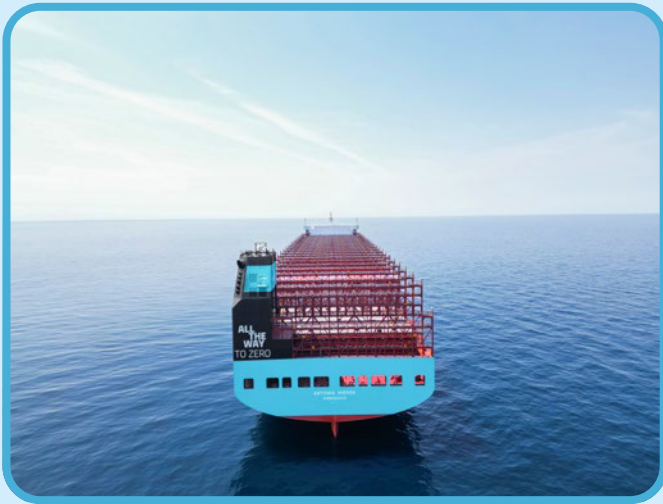

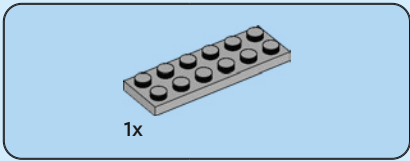

211

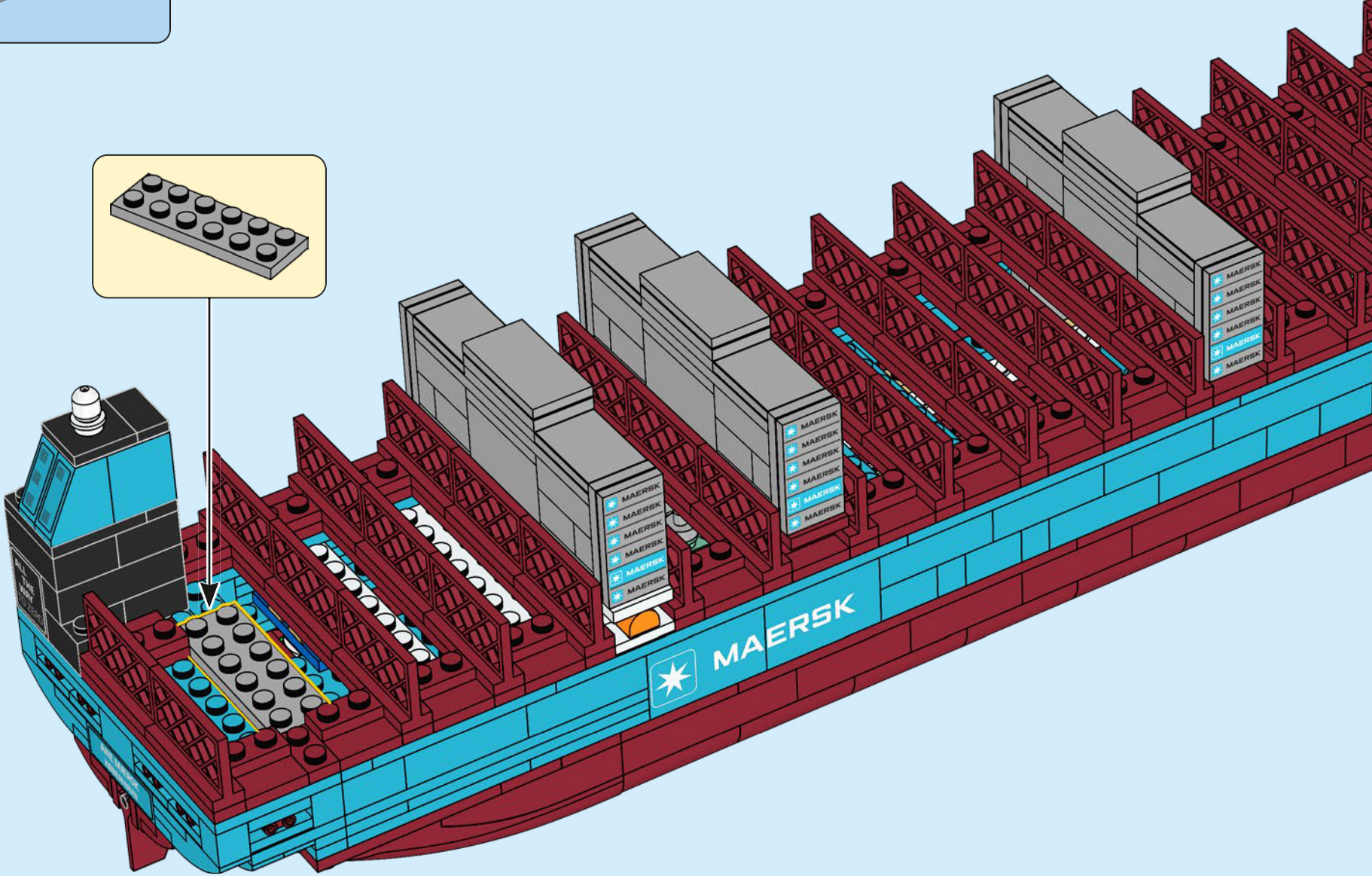
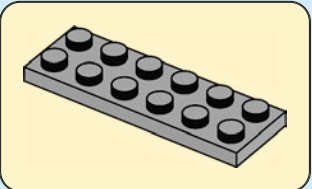

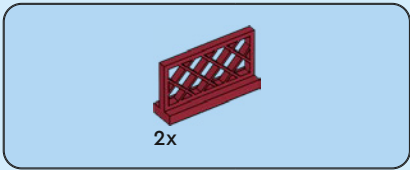

212

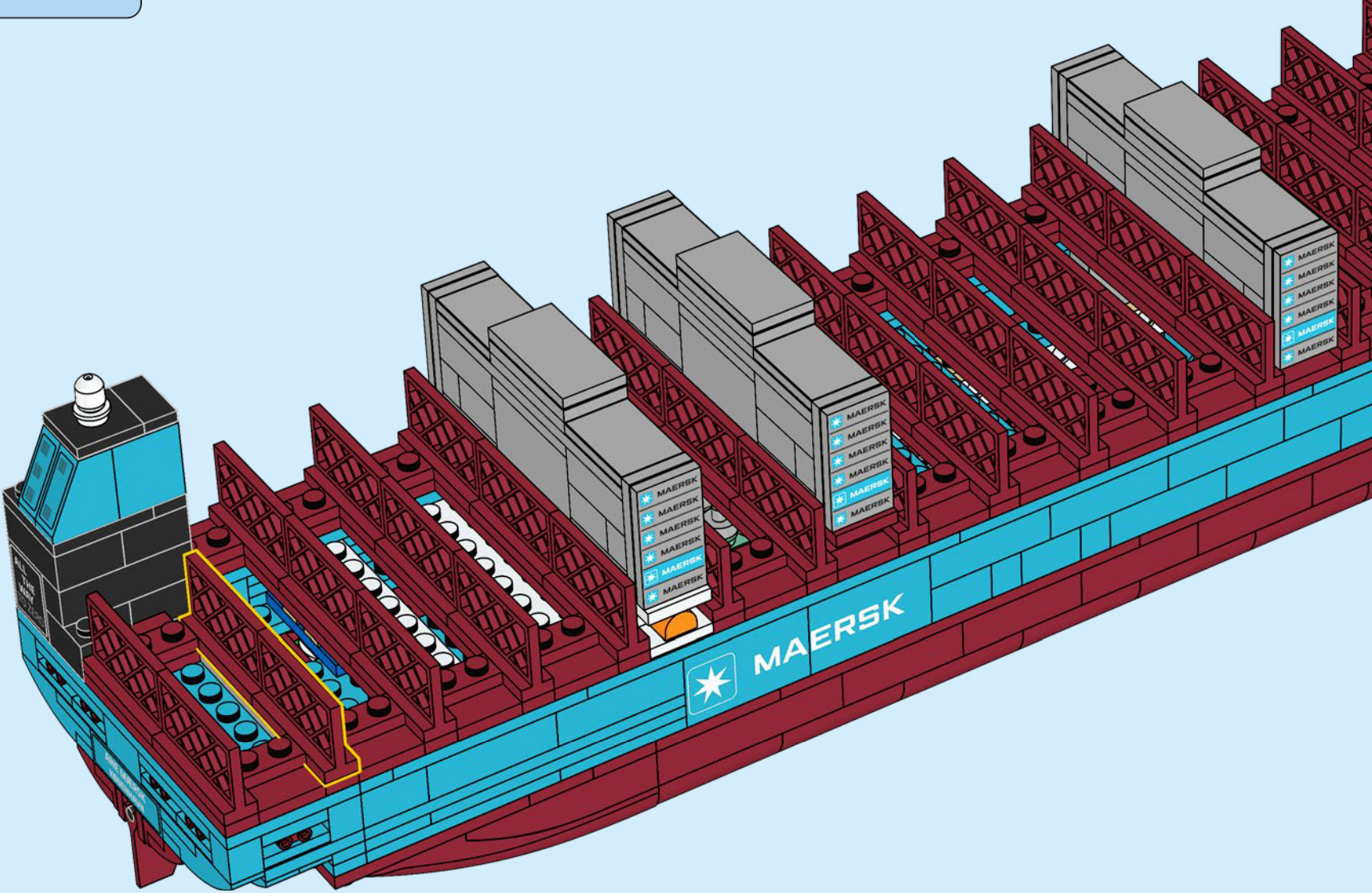

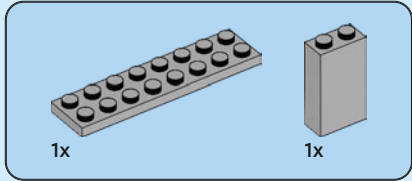
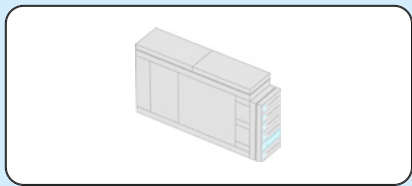

213

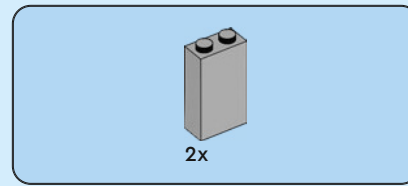
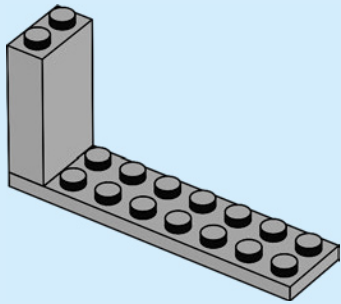

214

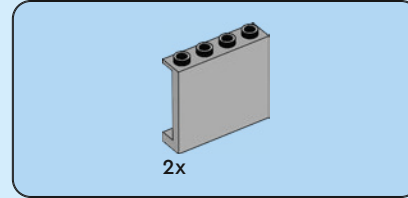
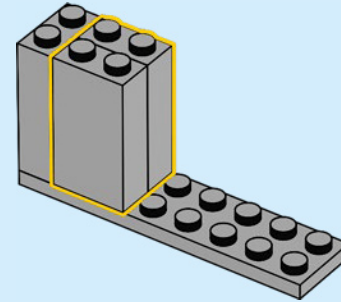

215

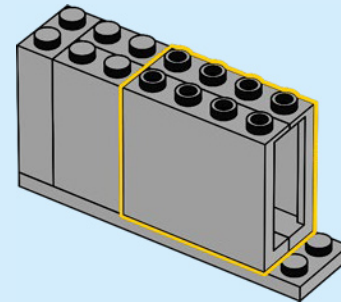

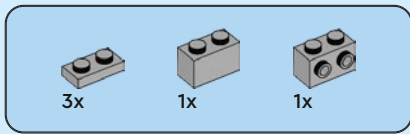

216

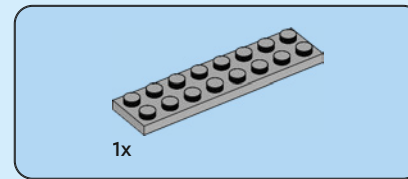
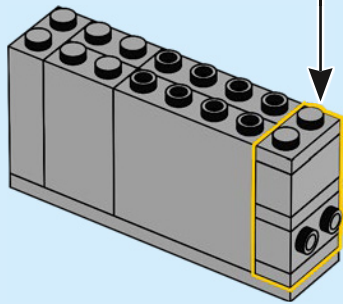
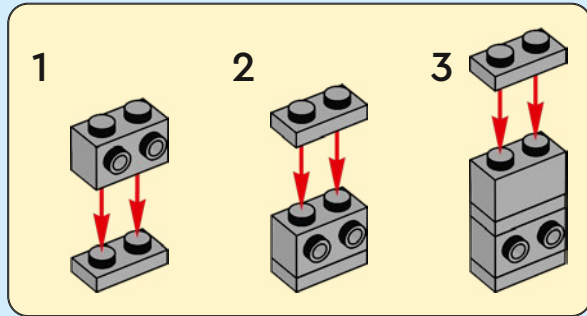

217

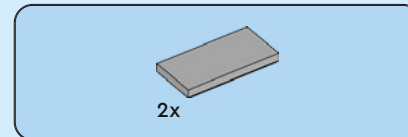
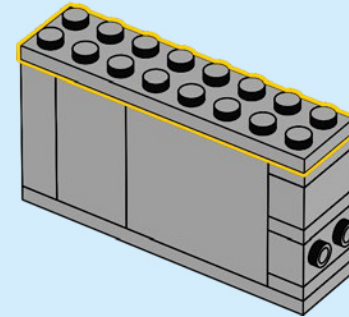

218

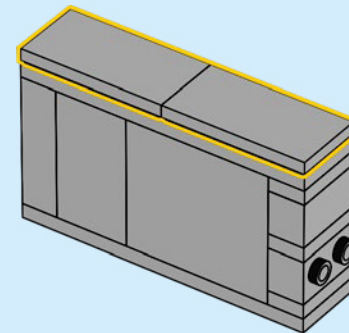

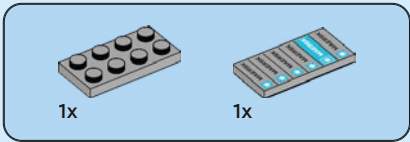

219

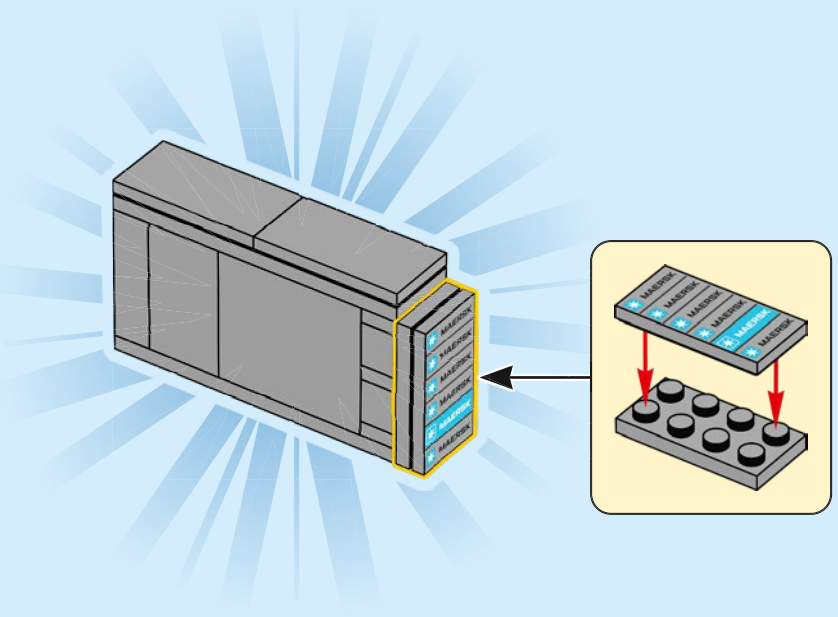

220

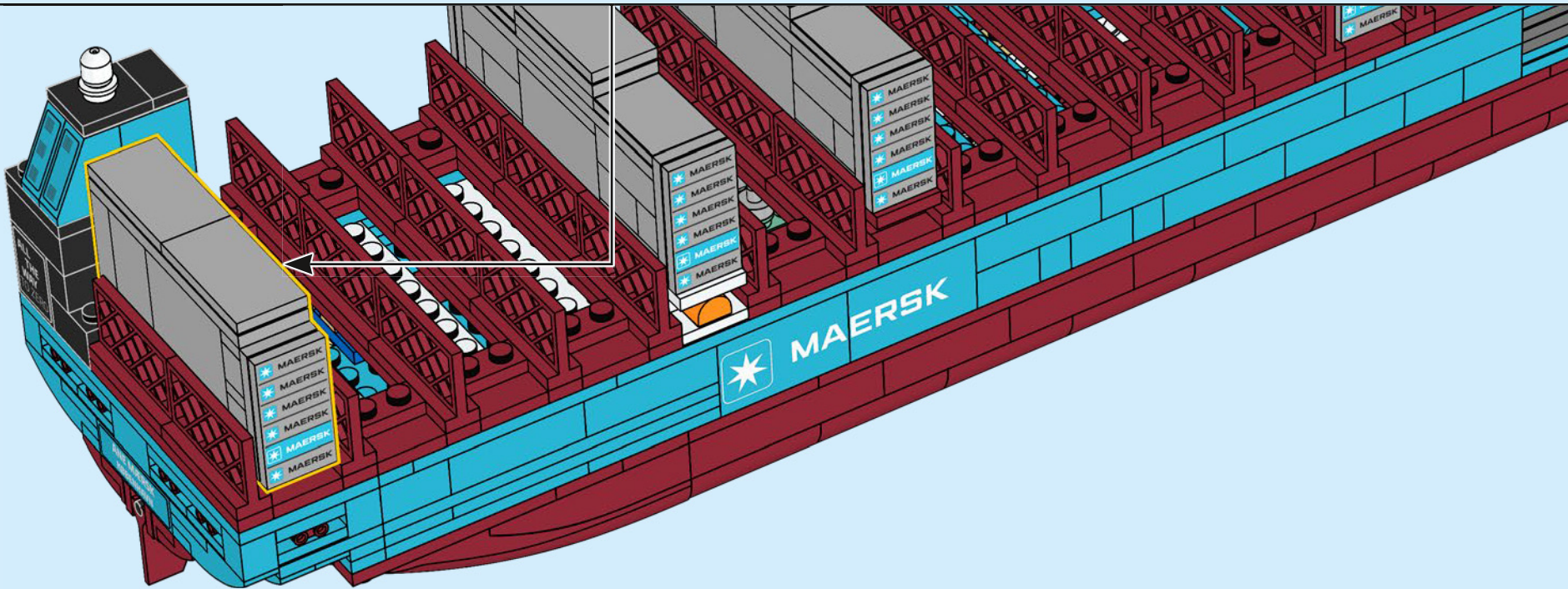

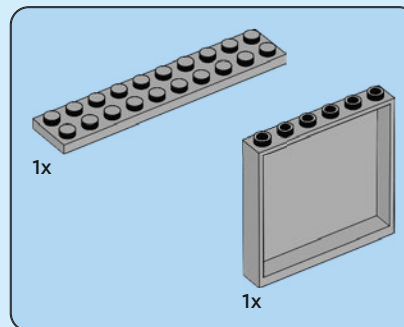
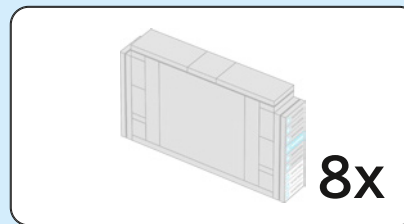

221

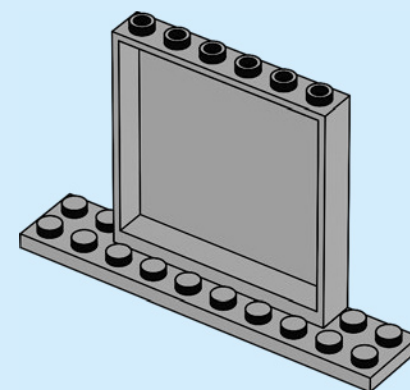

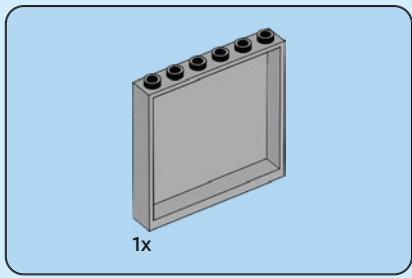

222

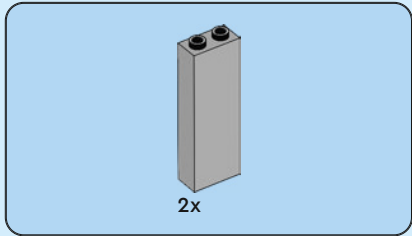
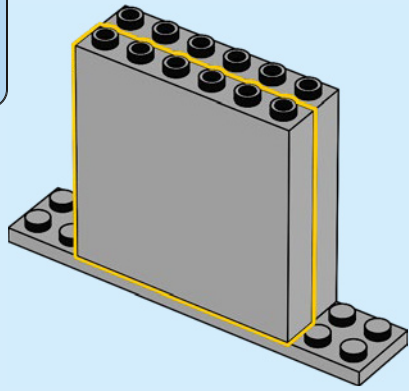

223

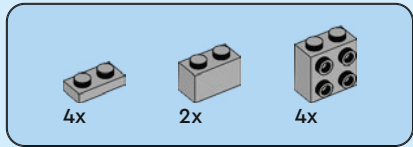
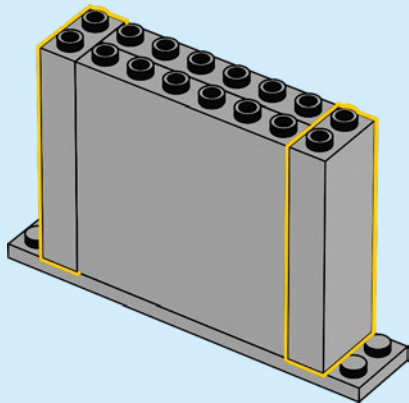

224

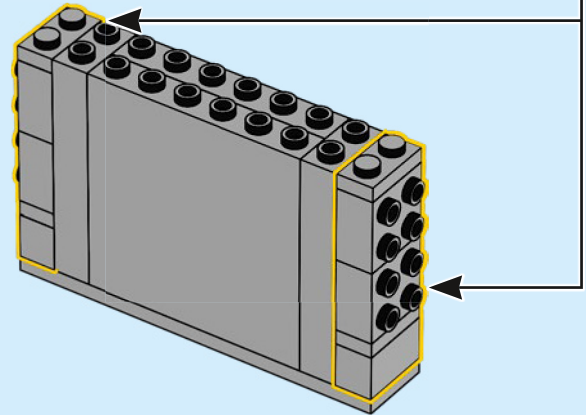
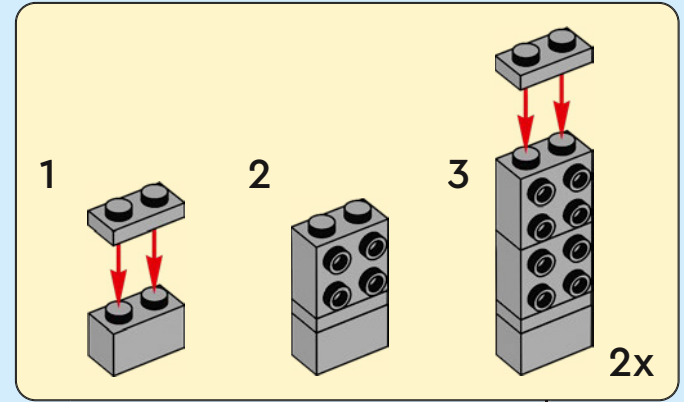

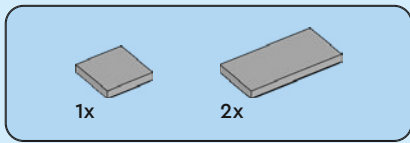

225

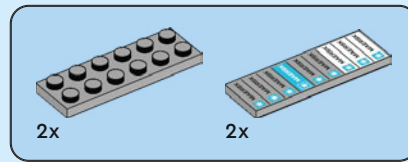
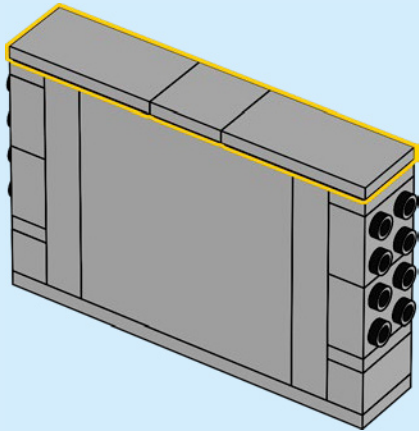

226

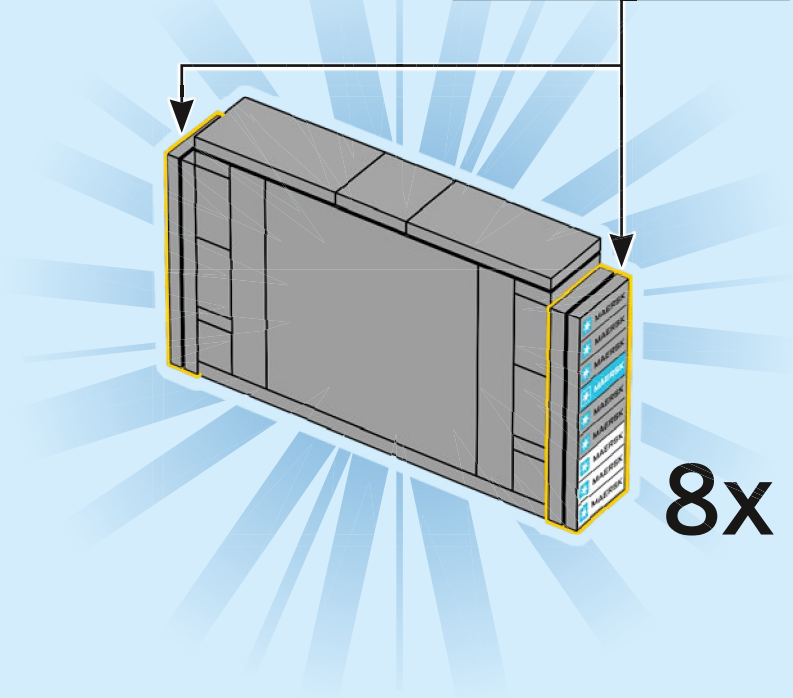
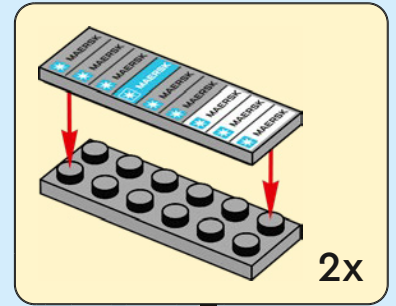

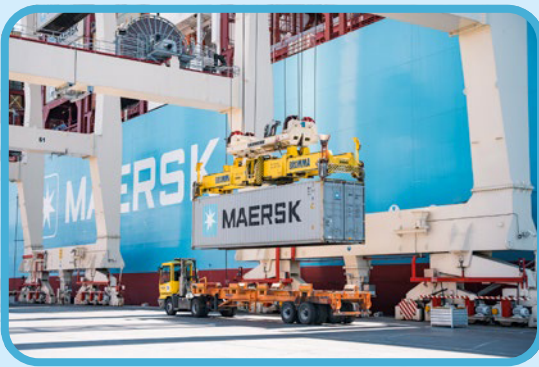

227

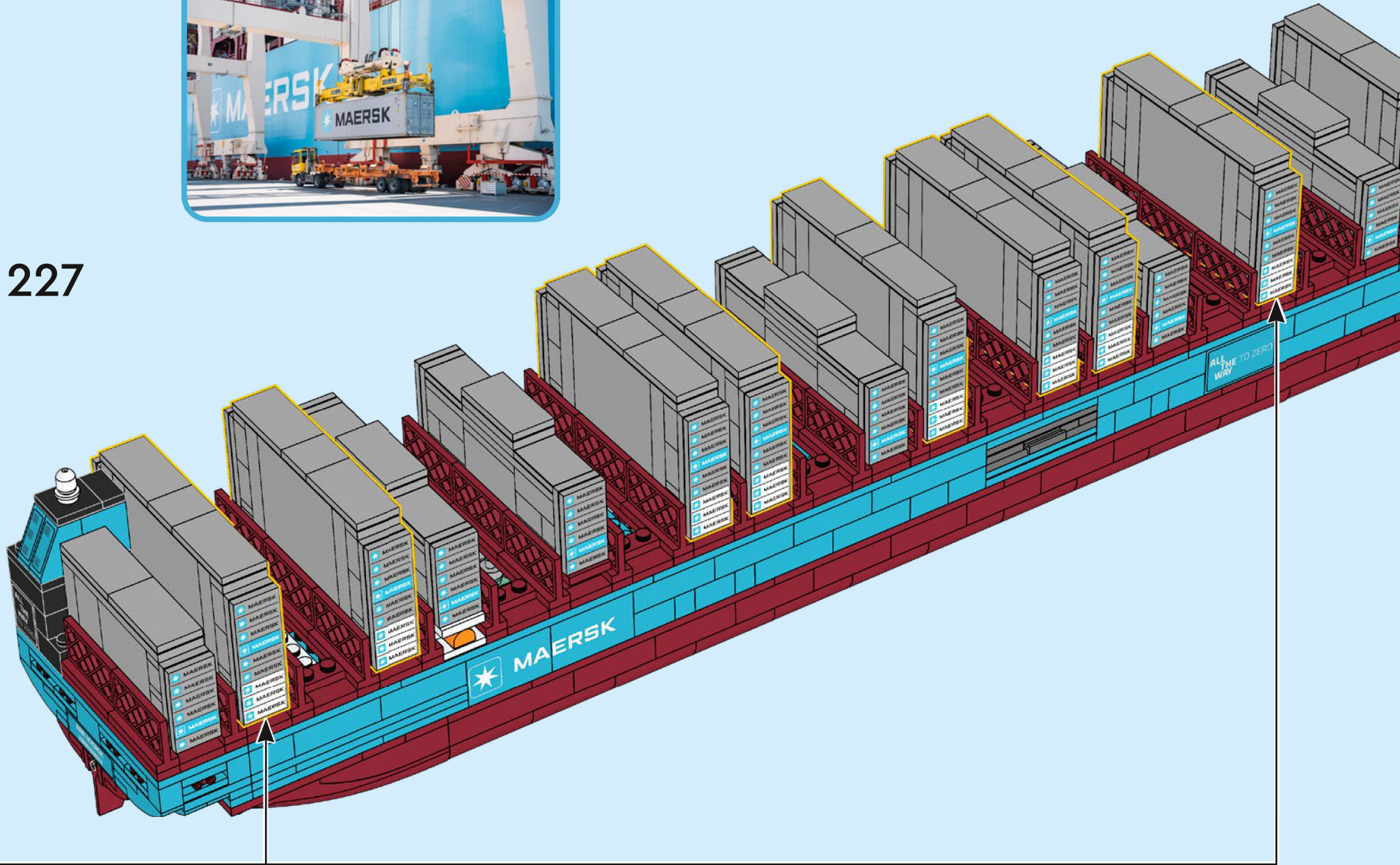





228

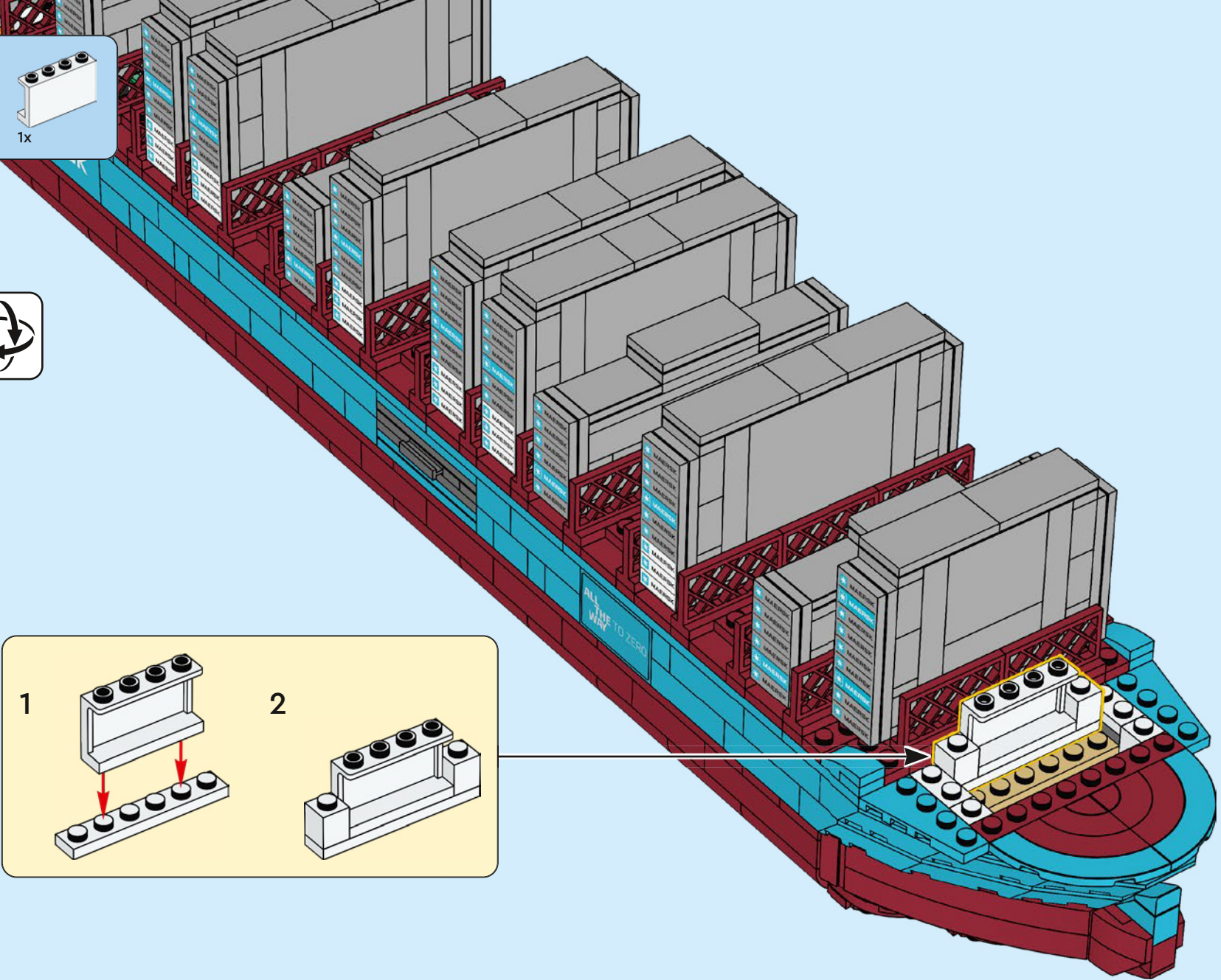
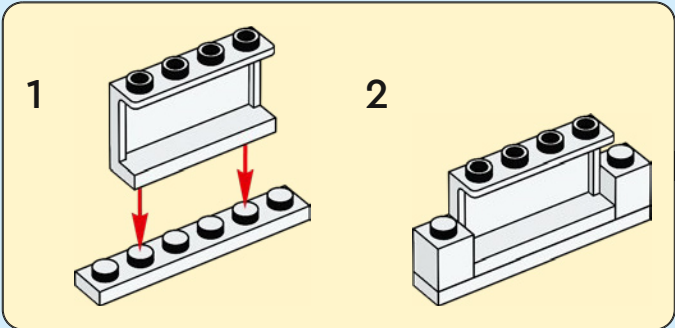

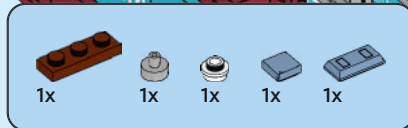

229

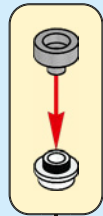
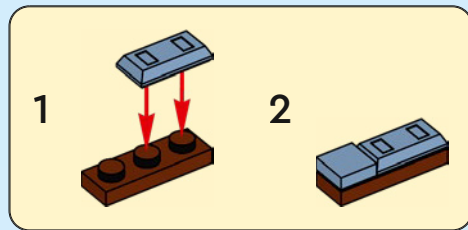



4x

230

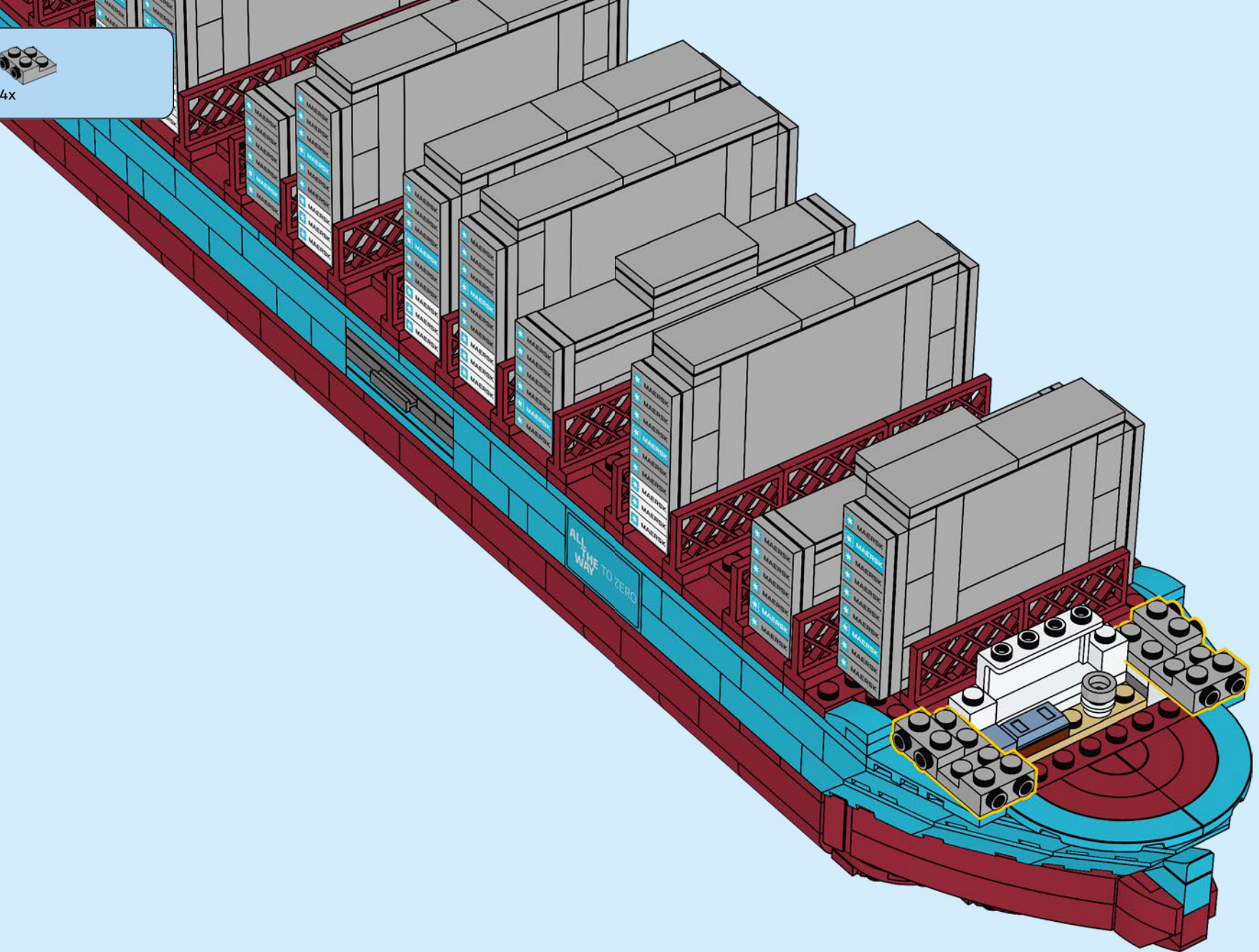

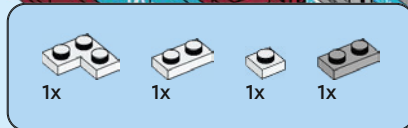

231

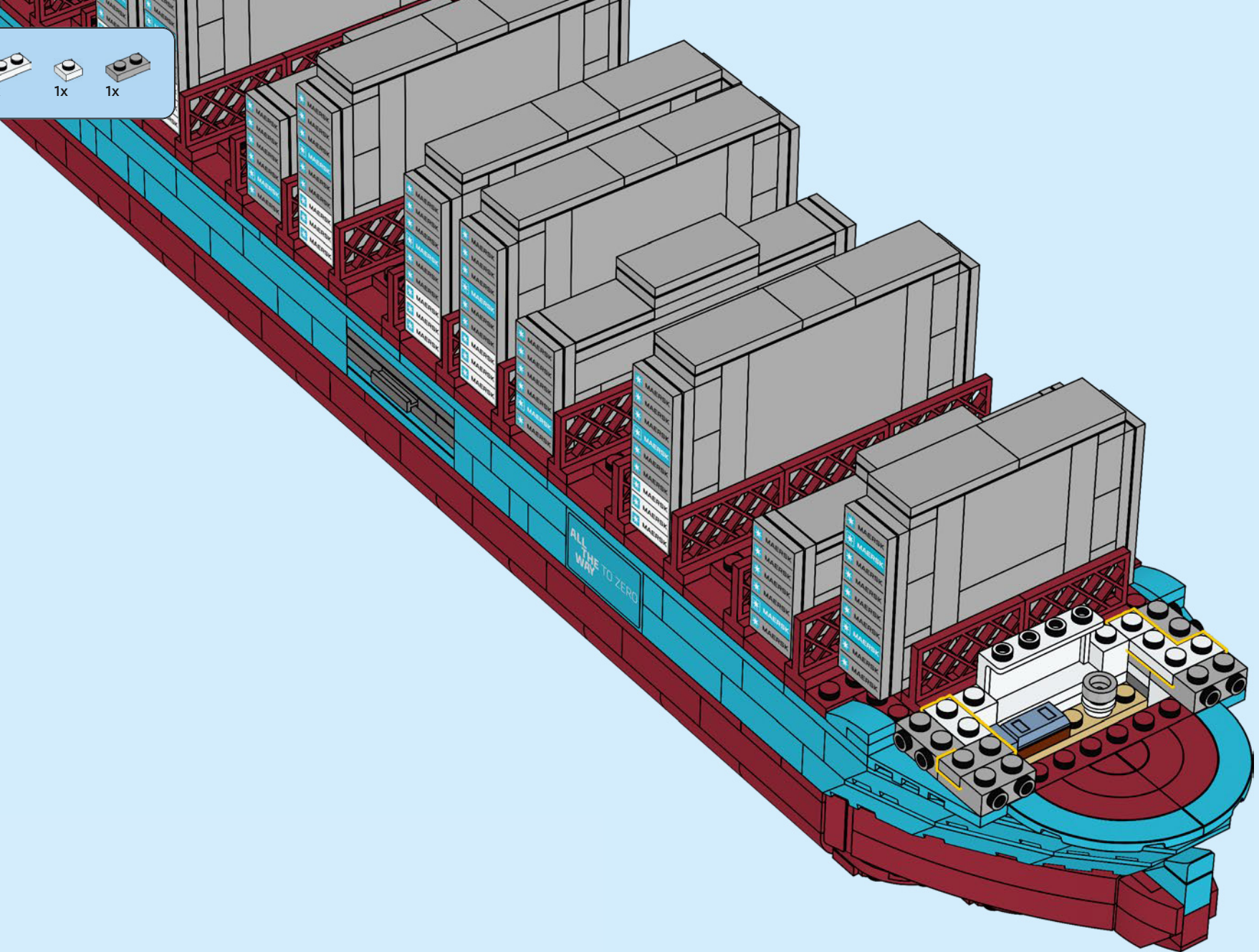

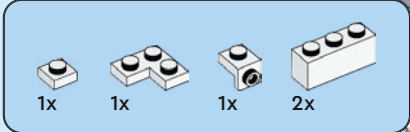

232

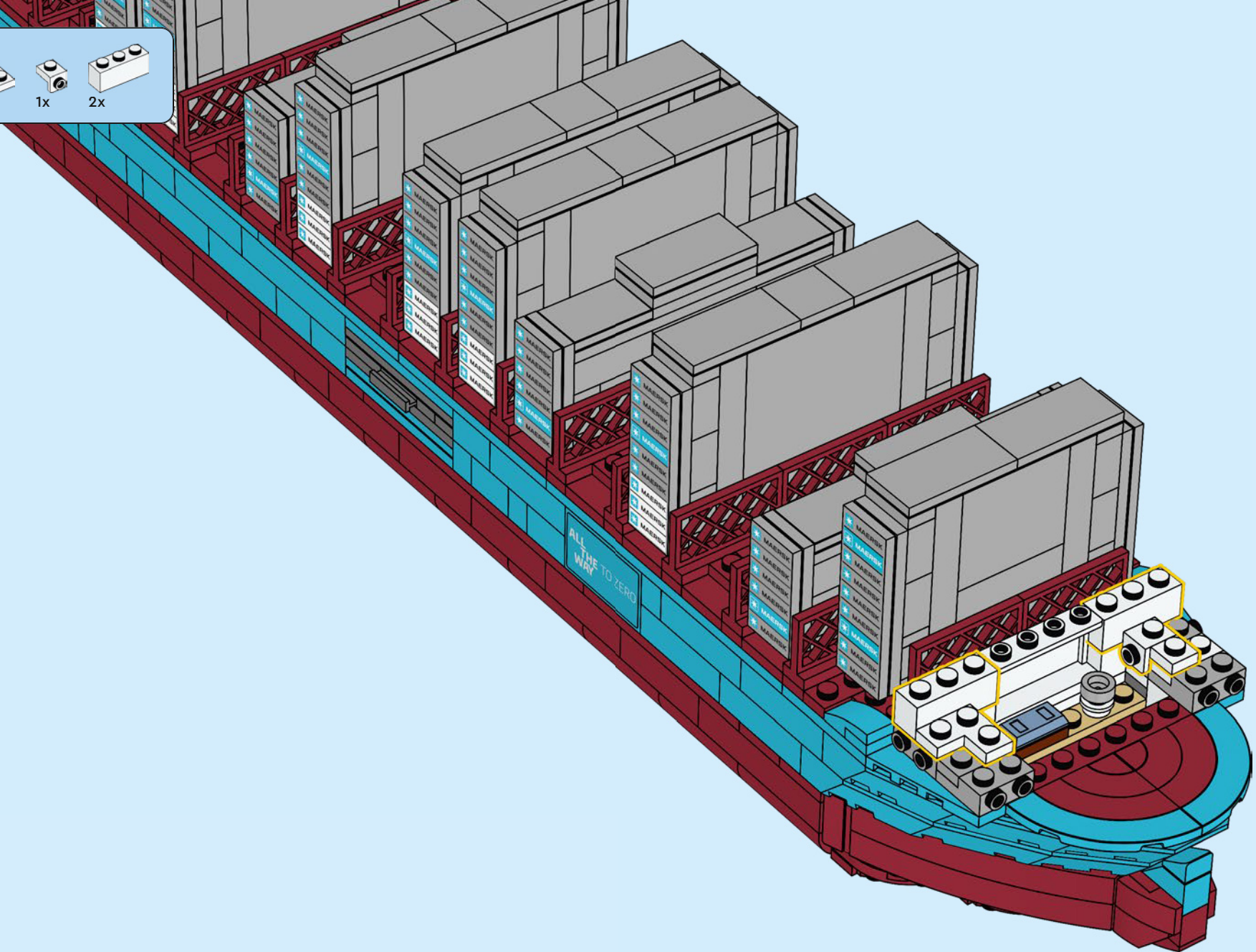

1x 1x 4x

233

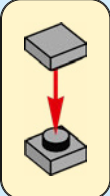
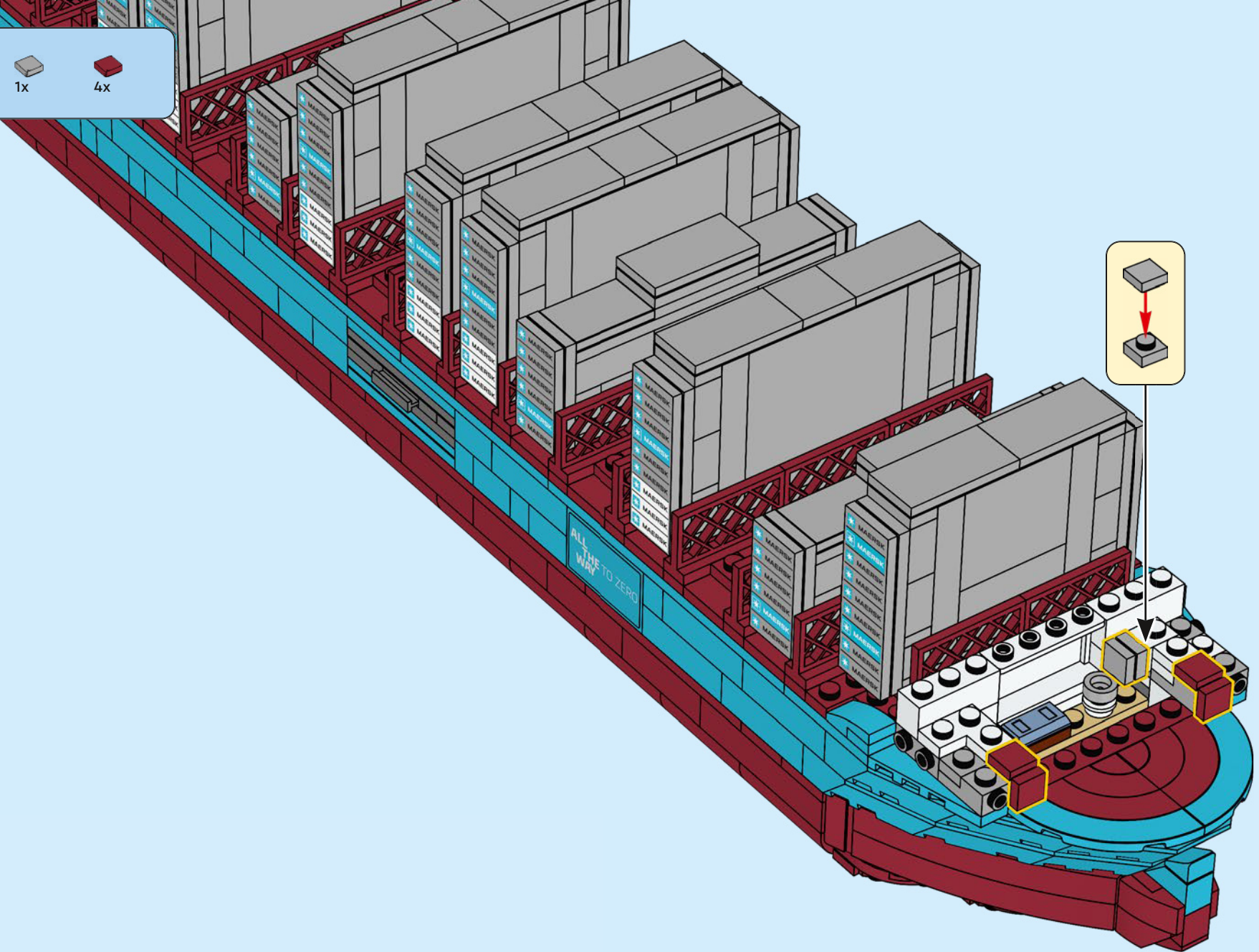

3x 2x 2x

234

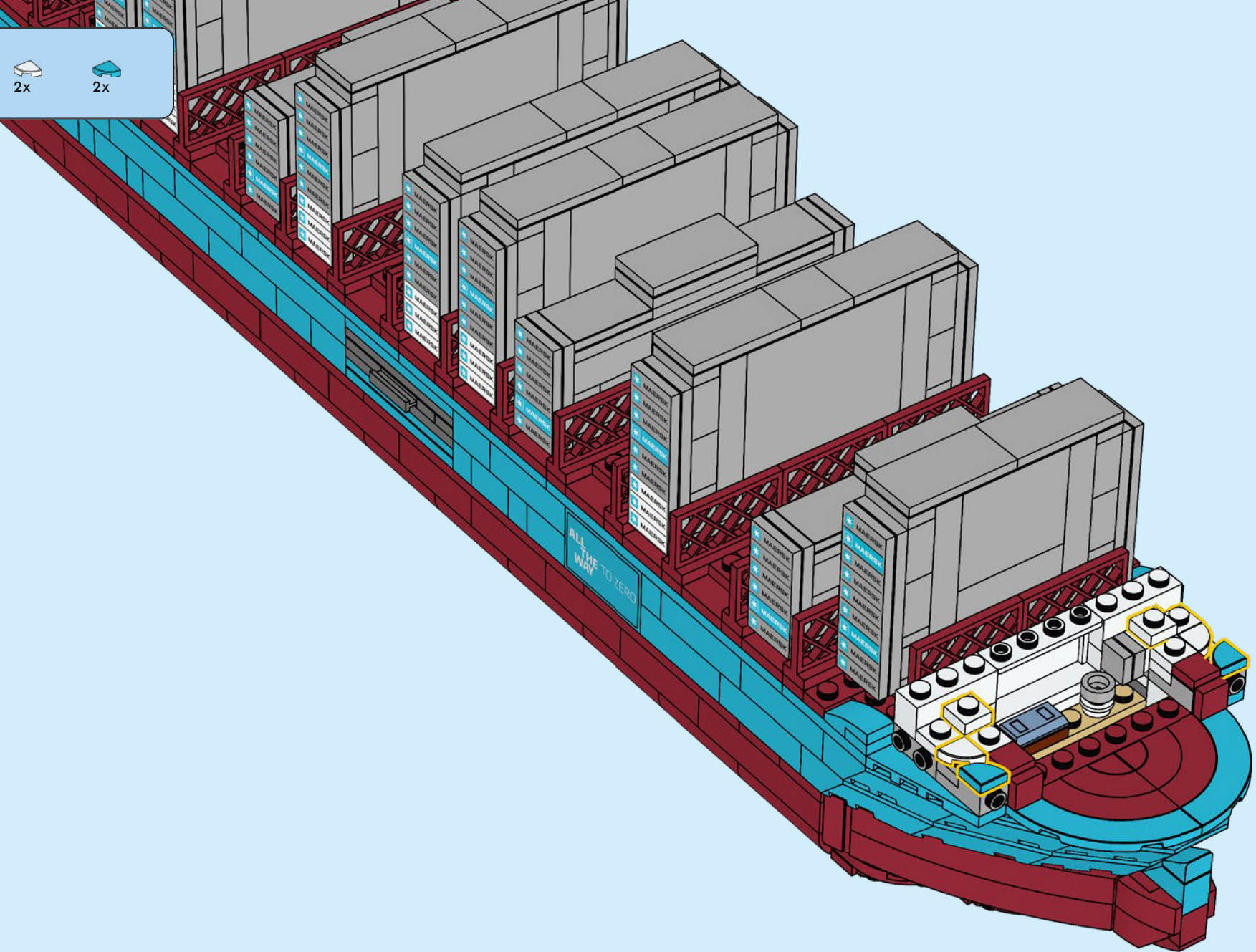

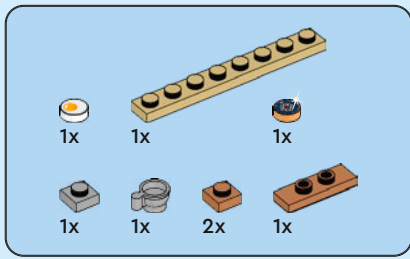

235

1

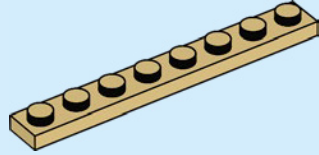

2

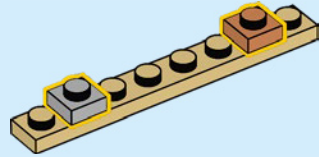

3

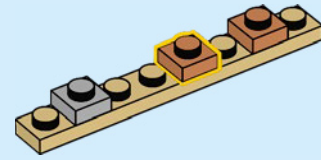

4

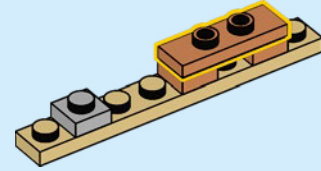

5

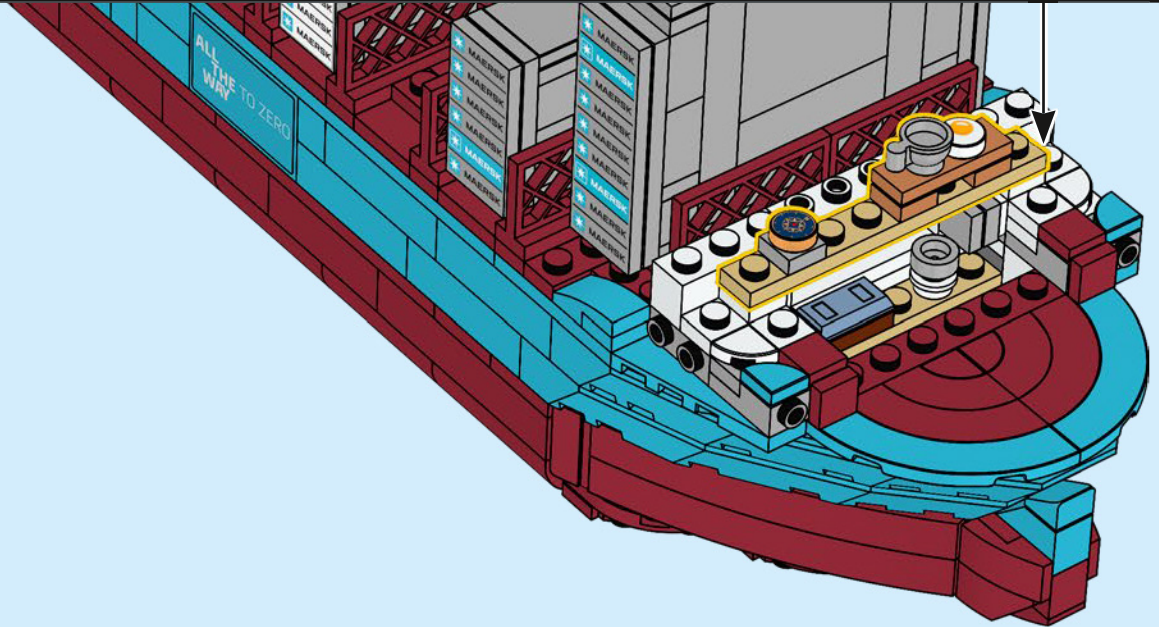

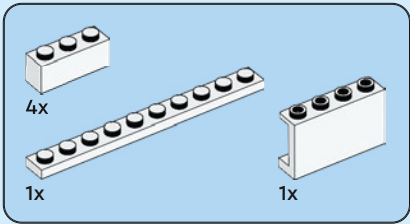

# 236

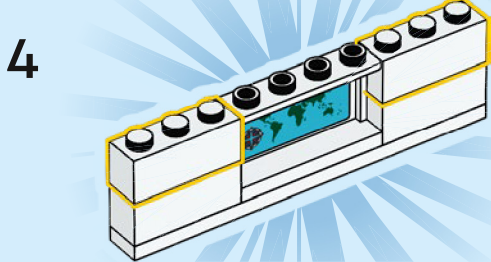
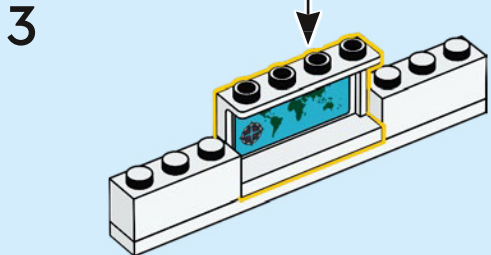
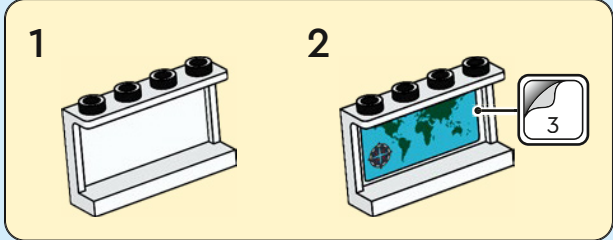
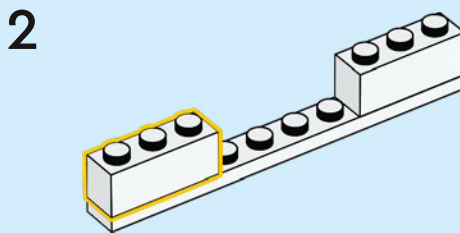
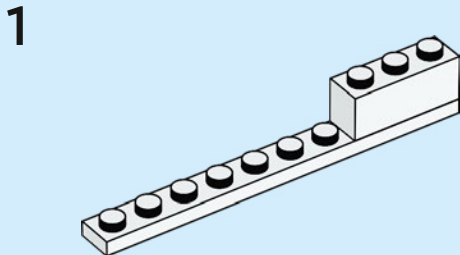

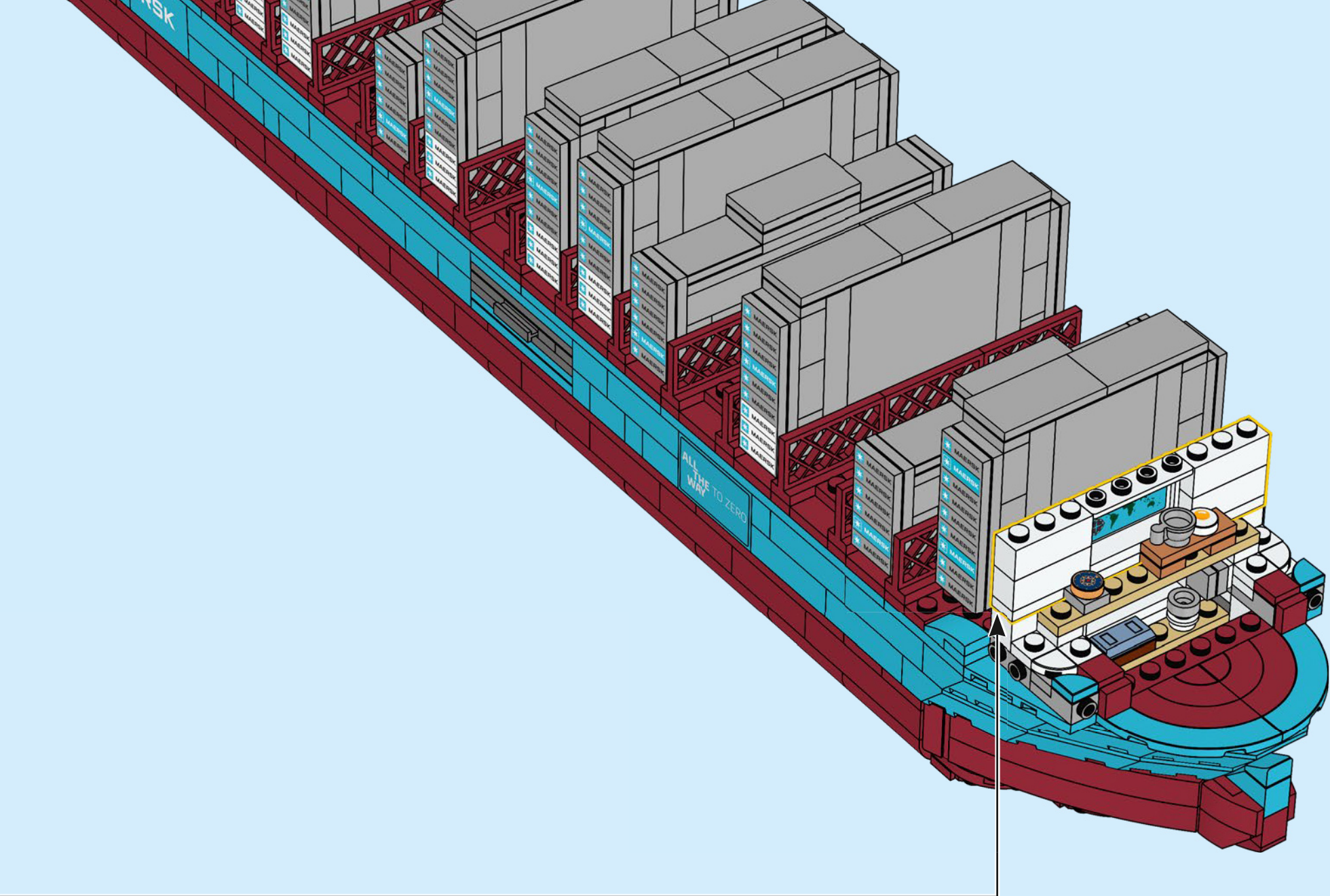

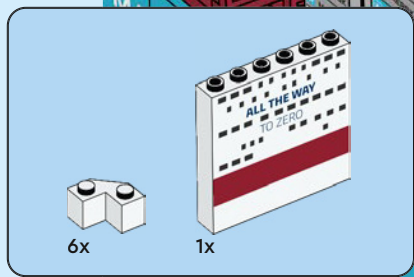

237

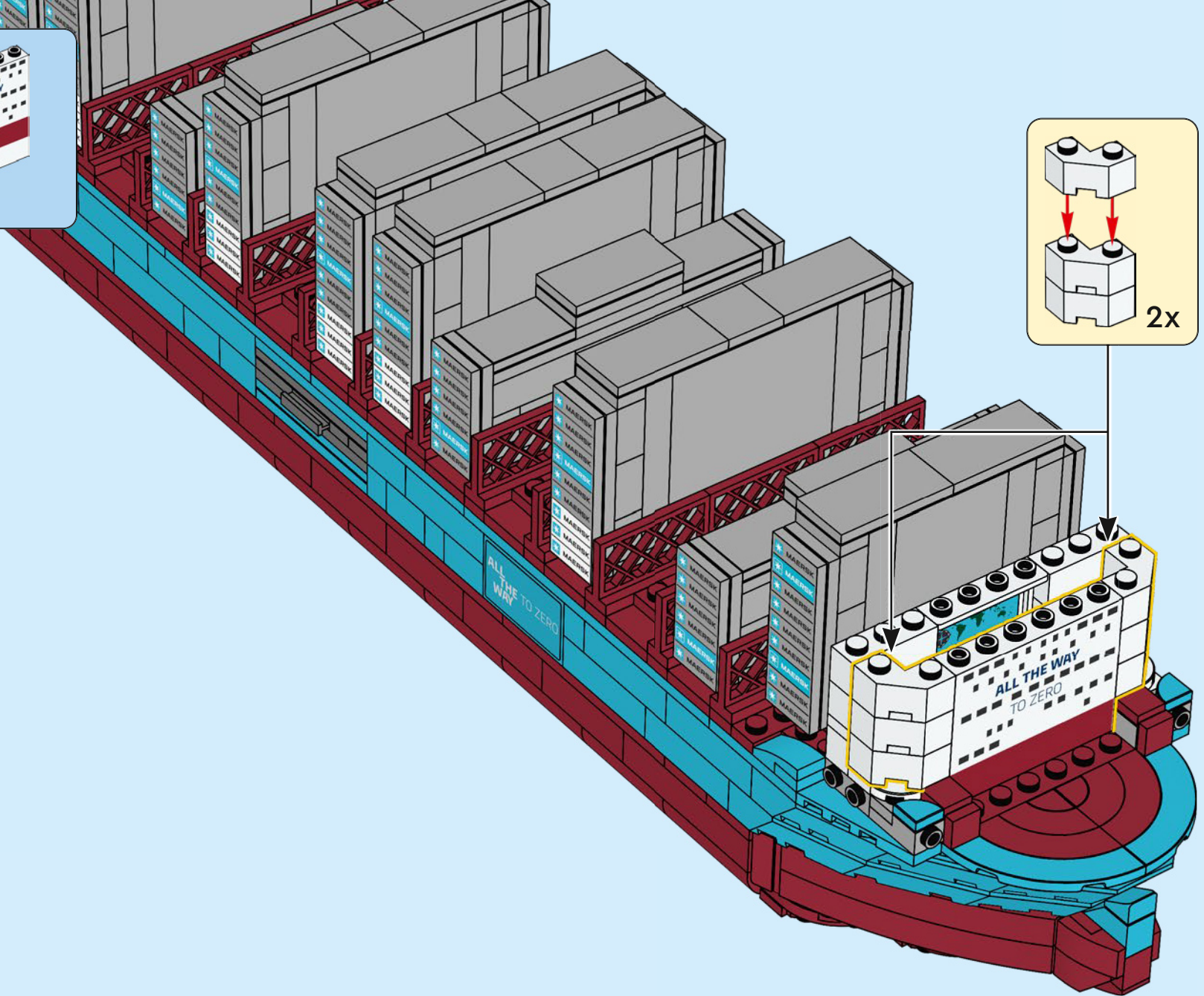



2x 1x 1x

239

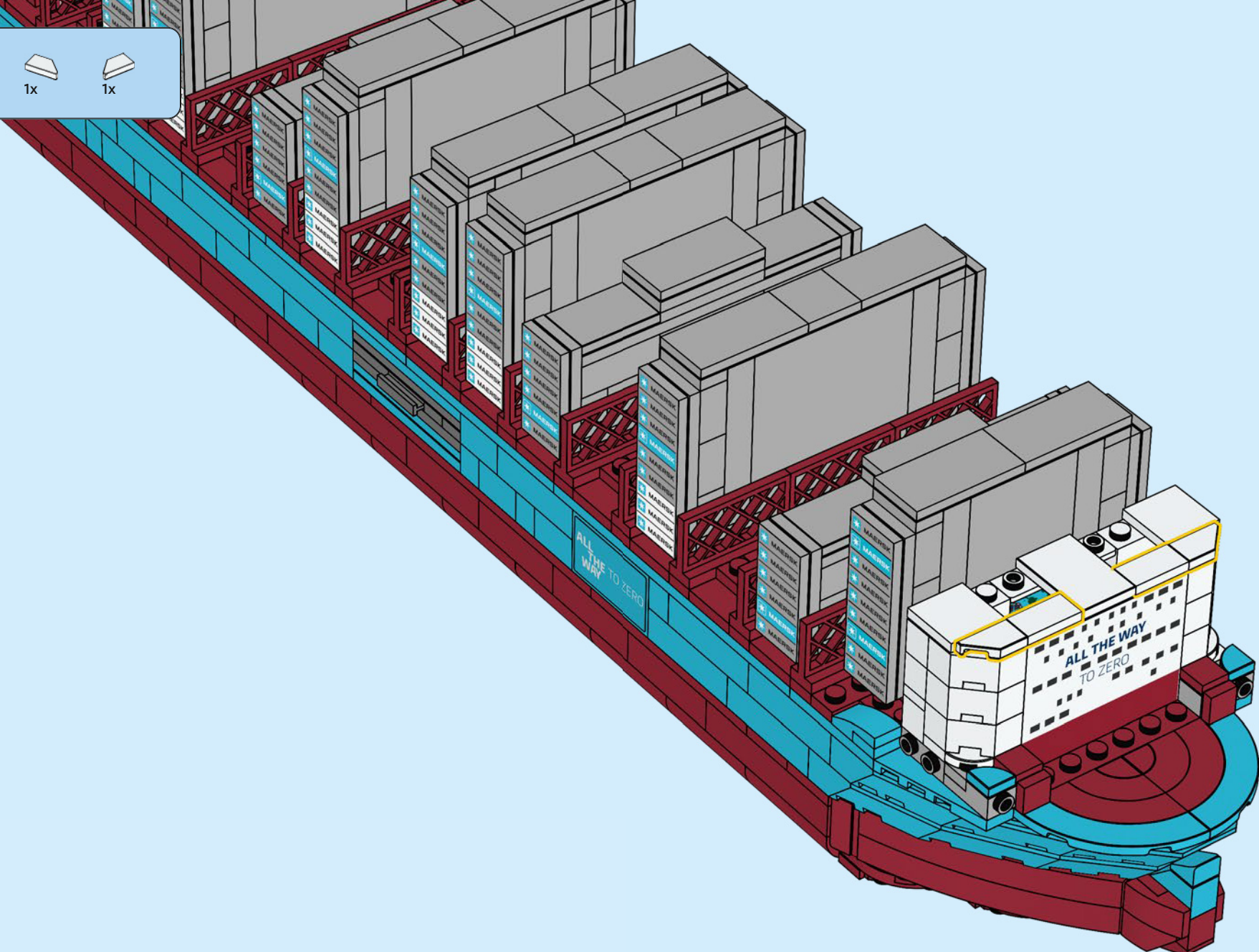

2x 2x 2x

240

1 2 2x

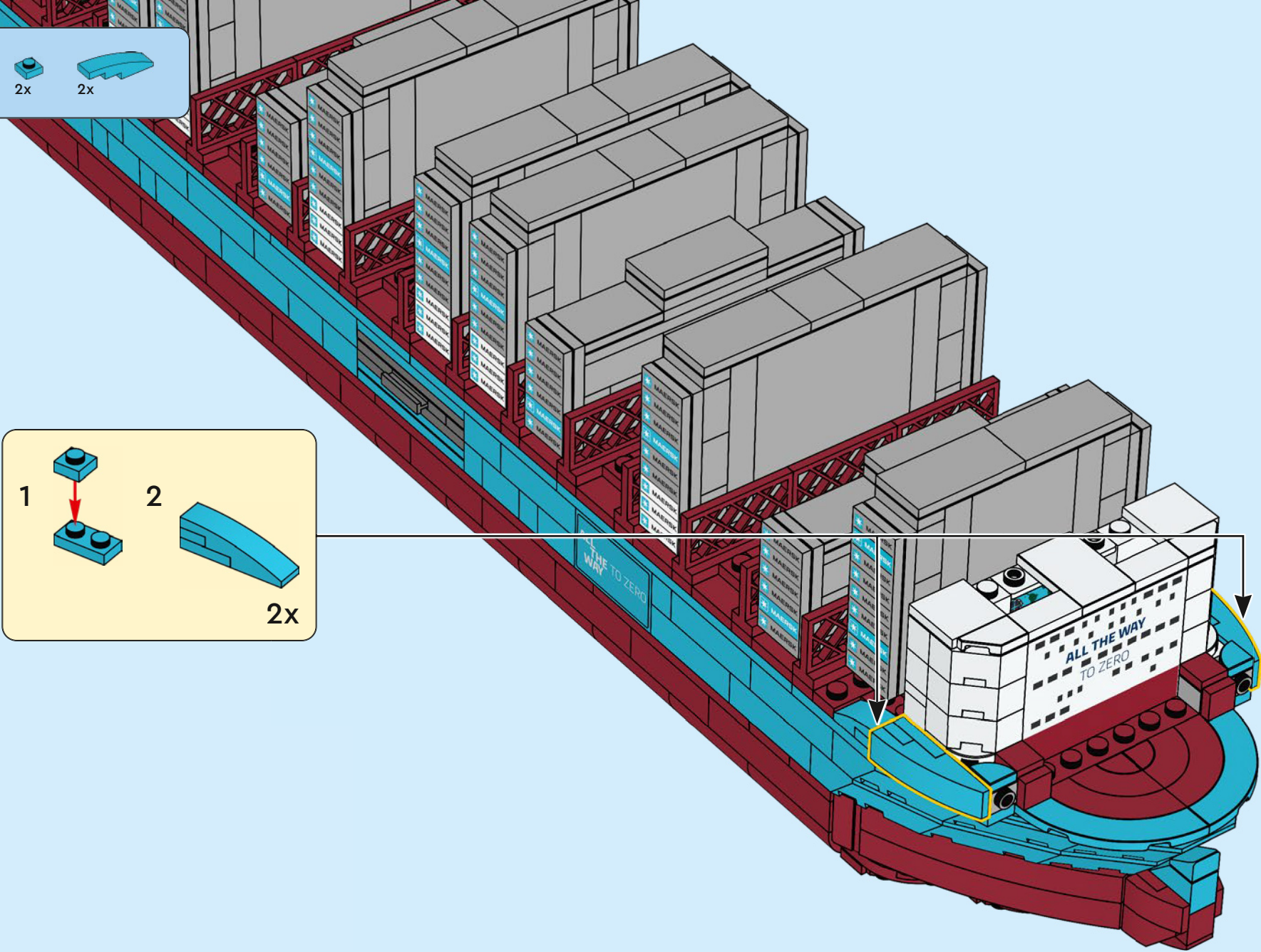

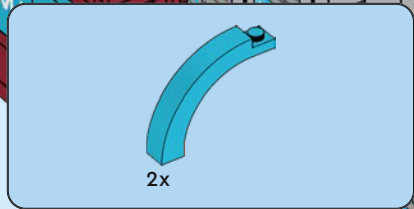

241

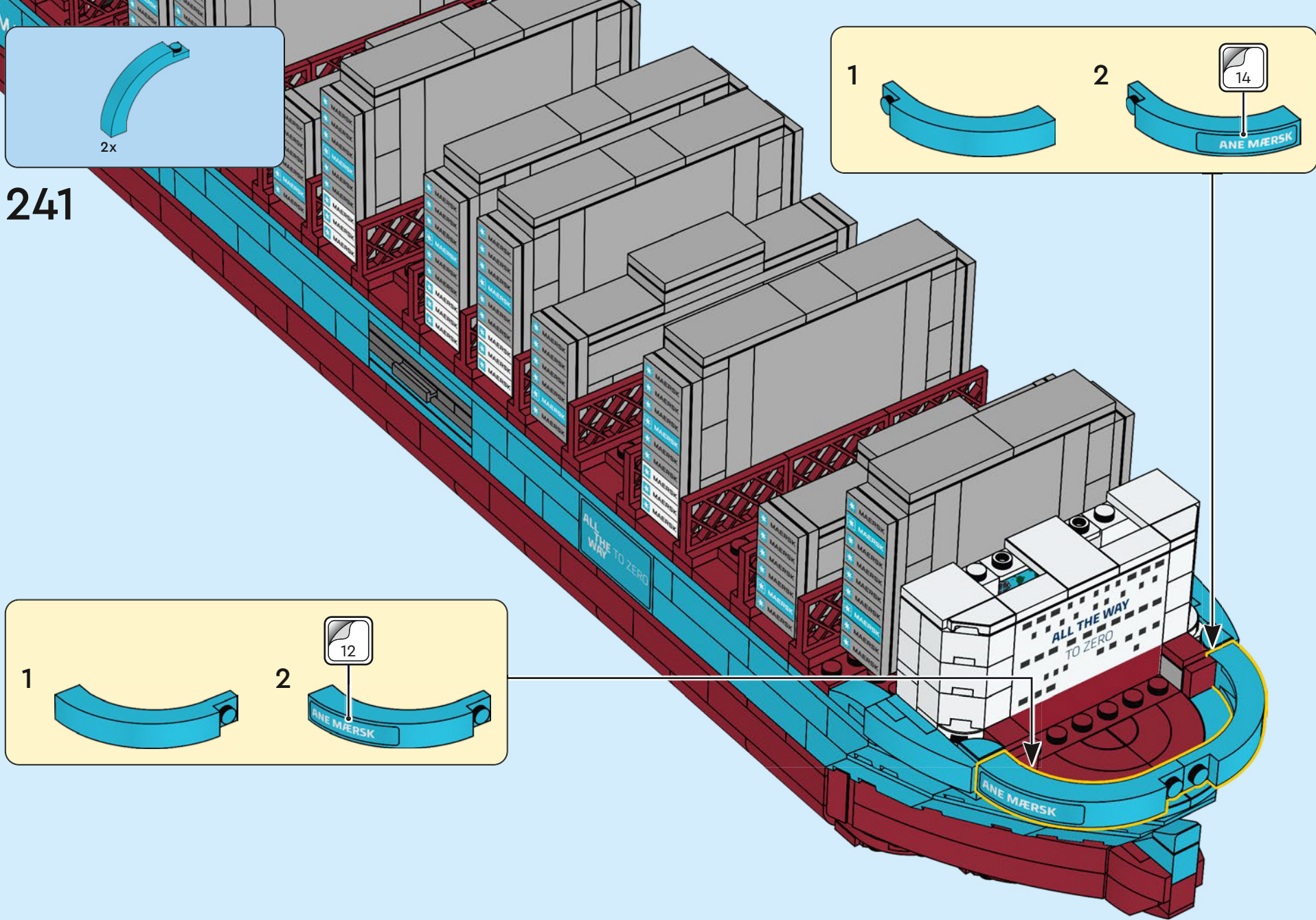
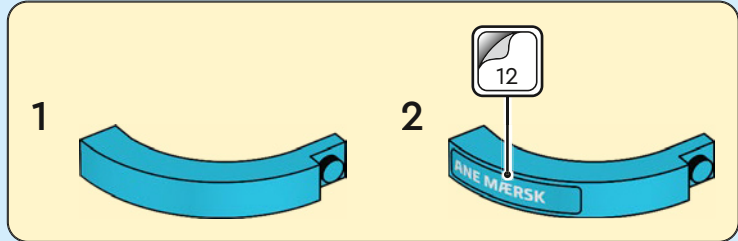
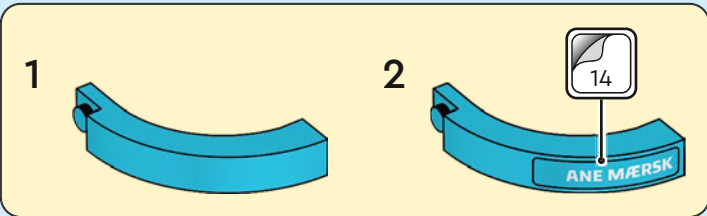

1x

242

1

2

13

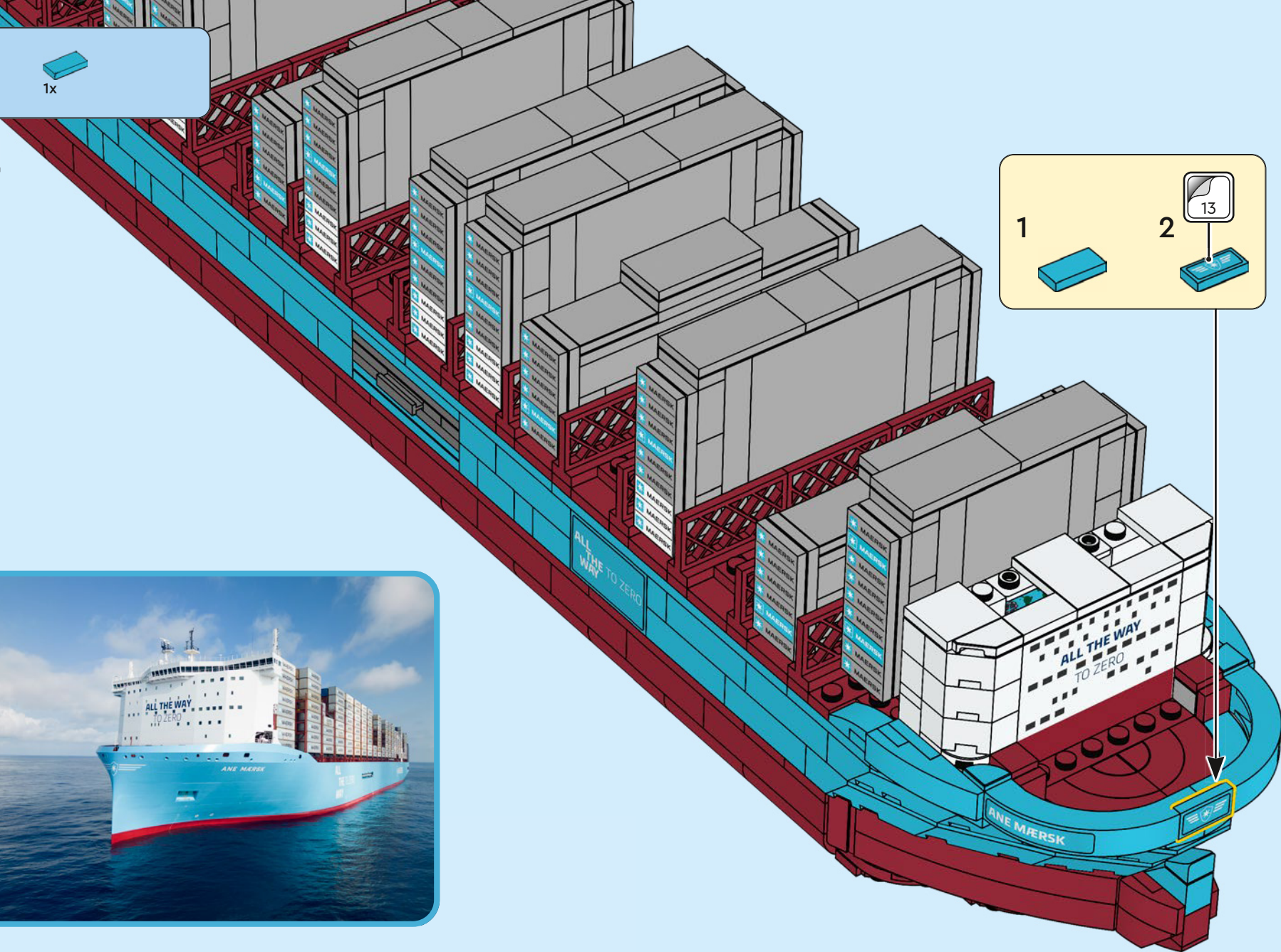

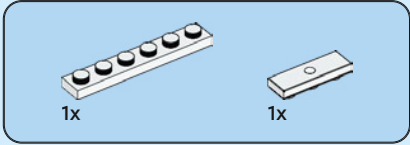
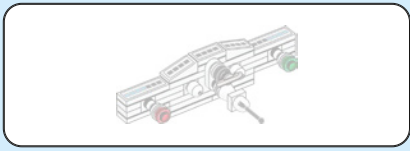

243

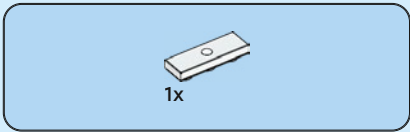
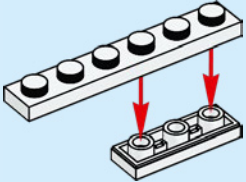

244

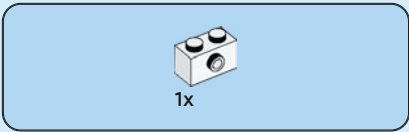
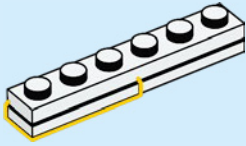

245

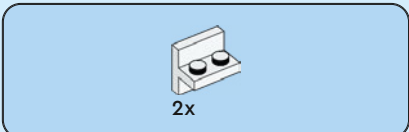
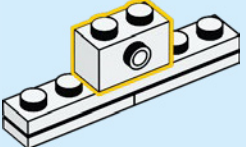

246

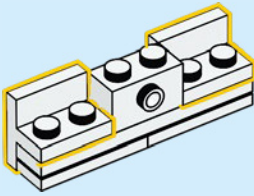



2x

# 247

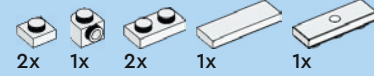
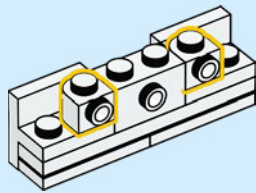

# 248

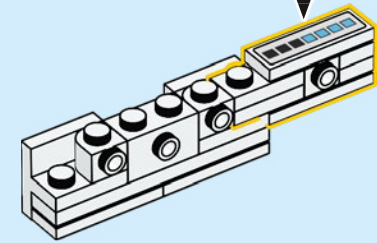
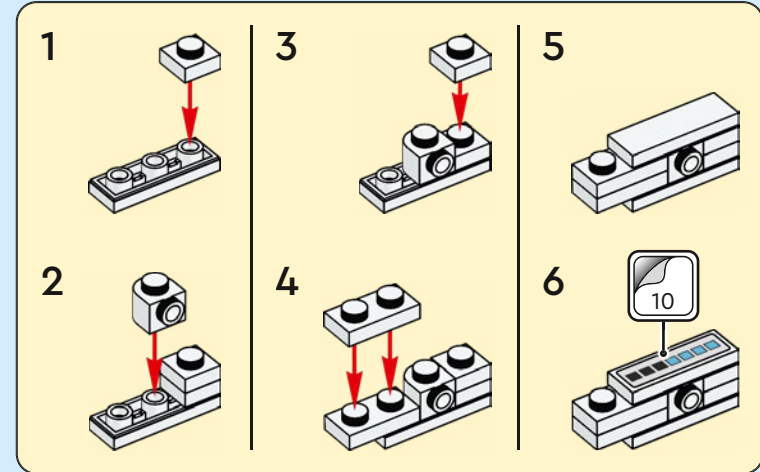

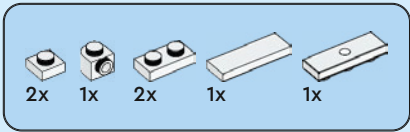

# 249

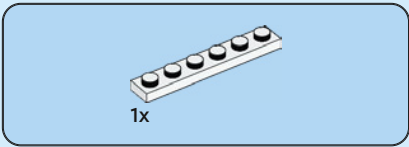
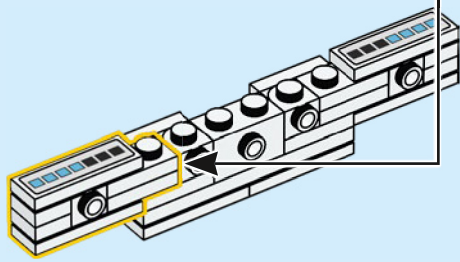
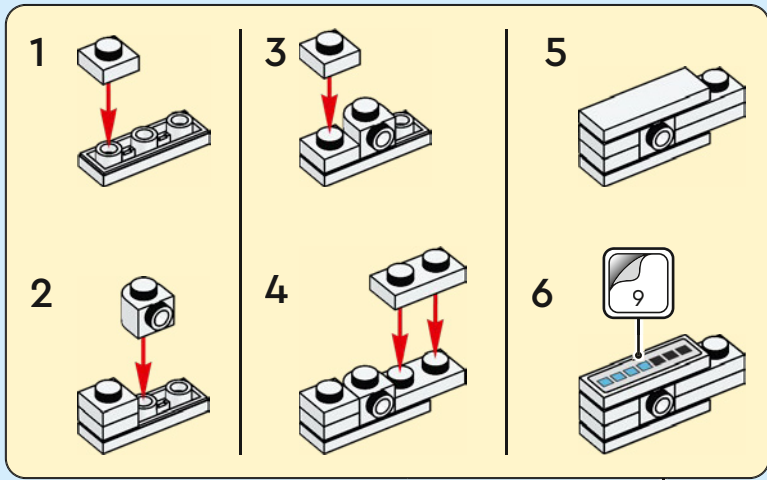

# 250

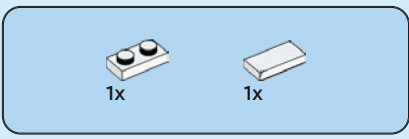
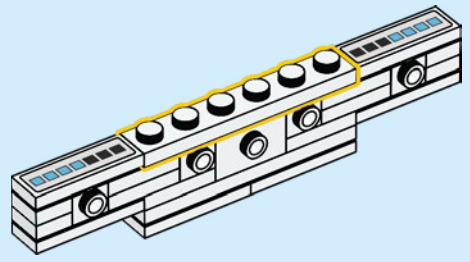

# 251

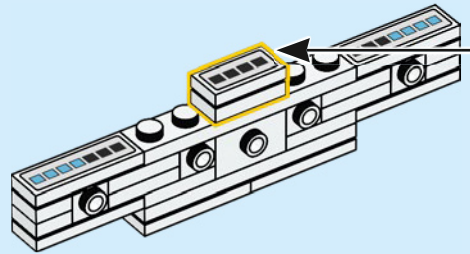
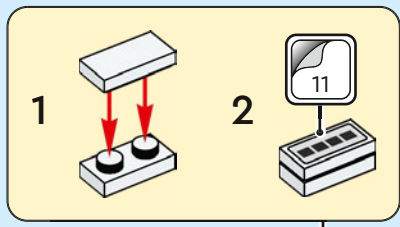

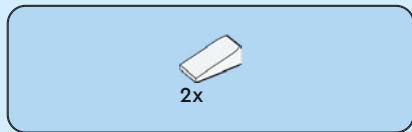

252

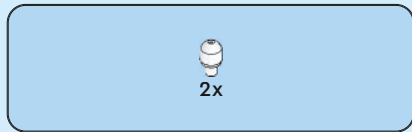
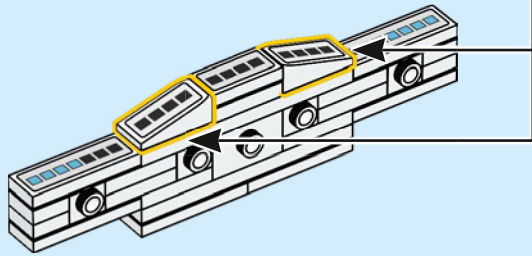
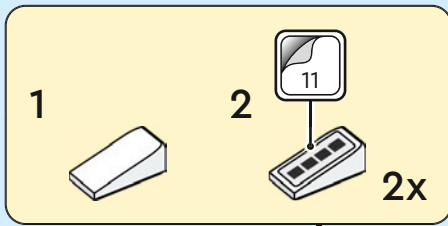

253

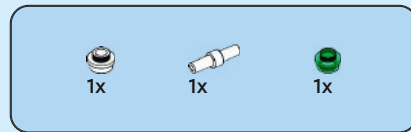
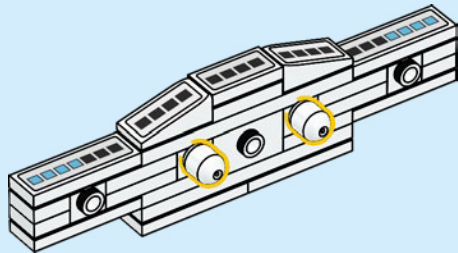

254

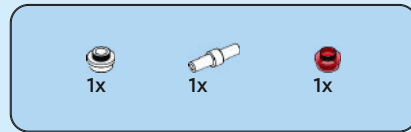
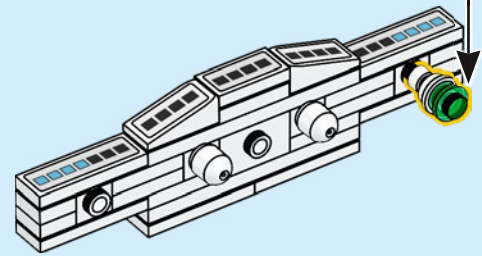
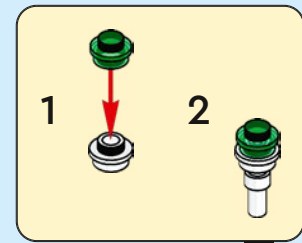

255

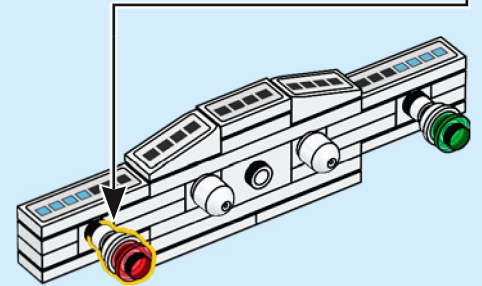
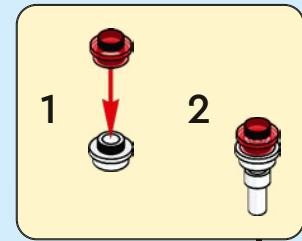

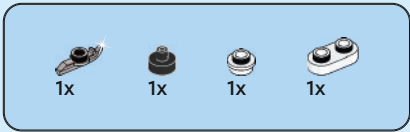

256

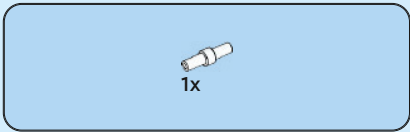
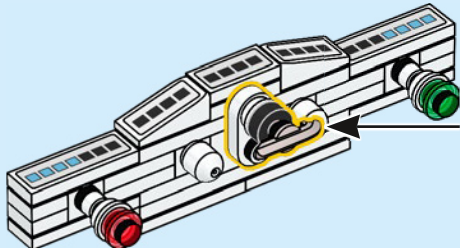
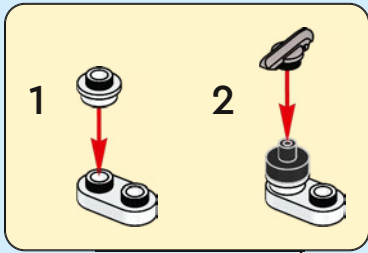

257

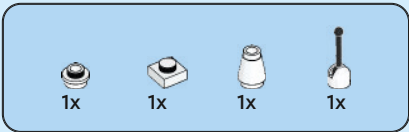
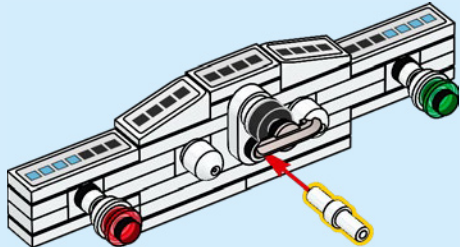

258

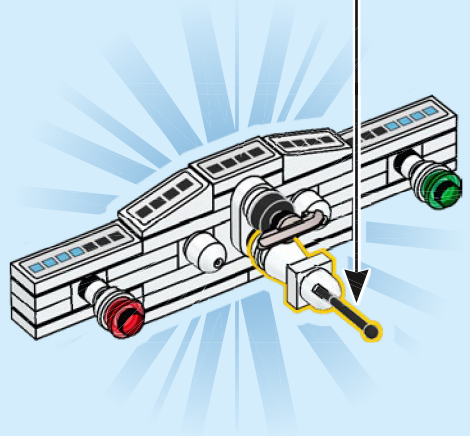
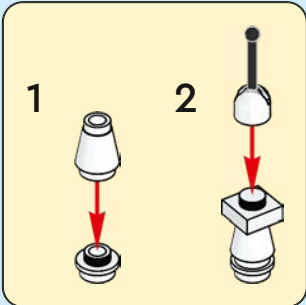

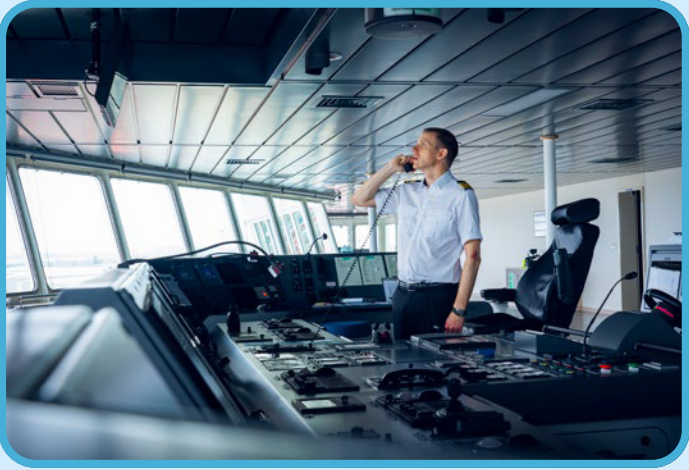
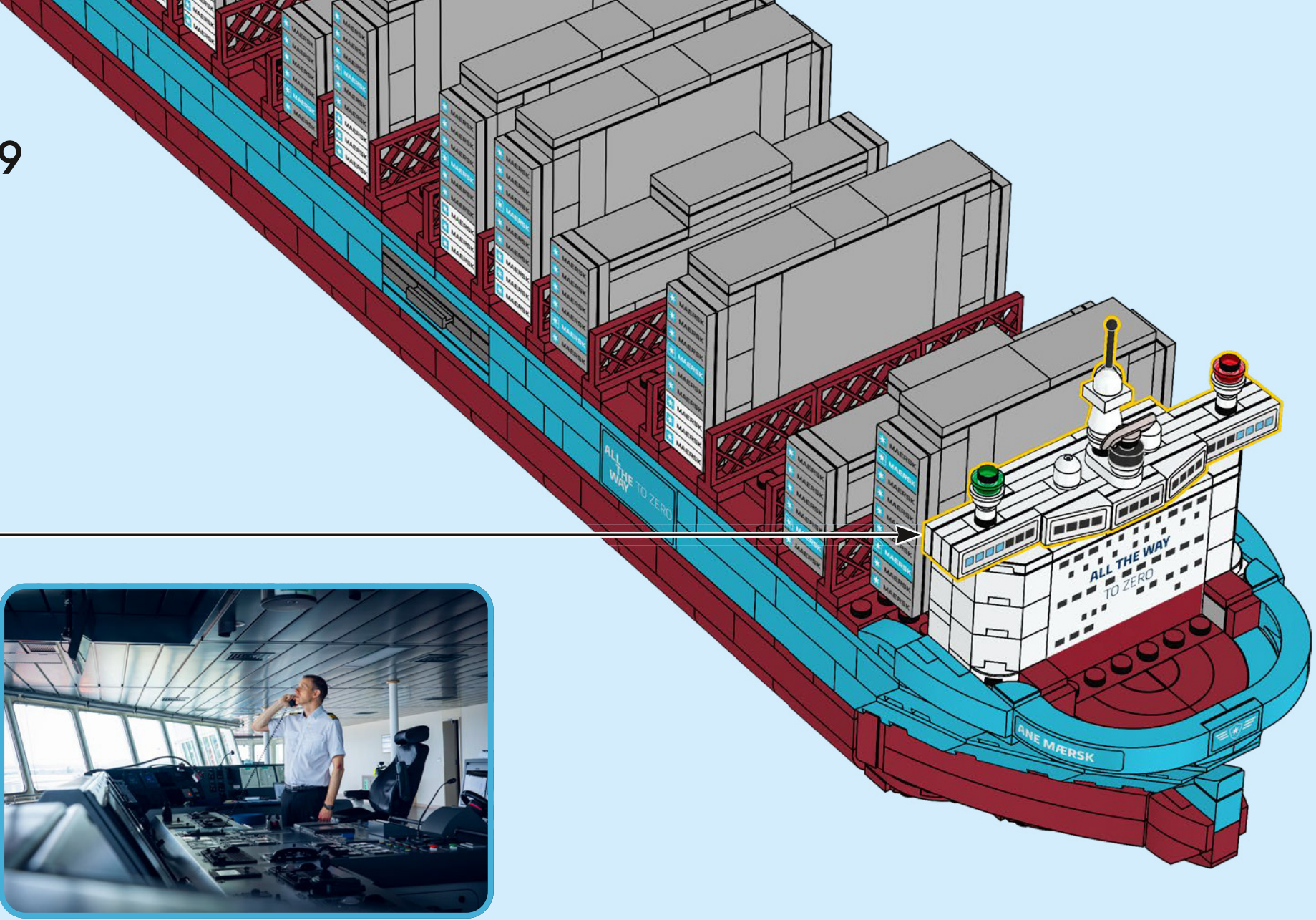

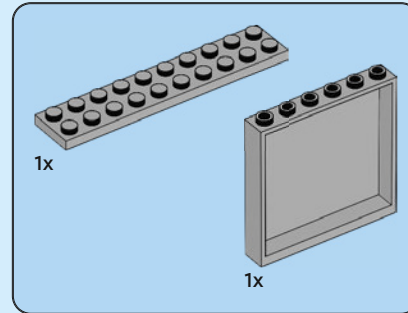
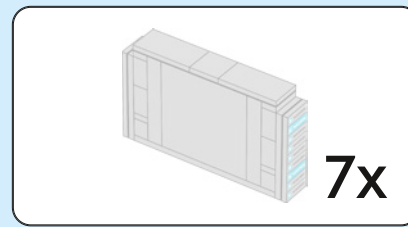

260

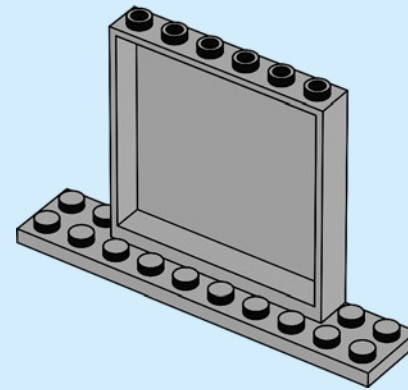

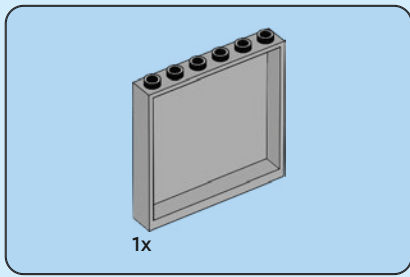

261

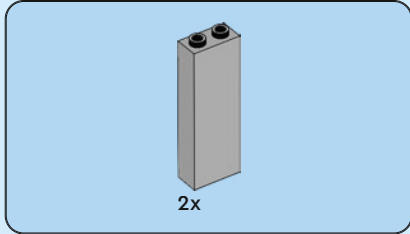
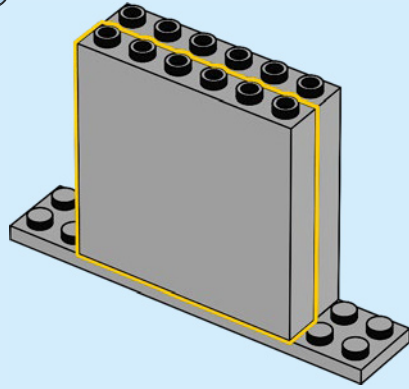

262

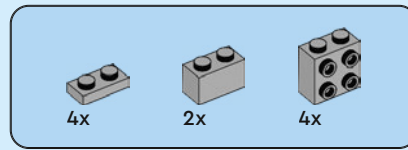
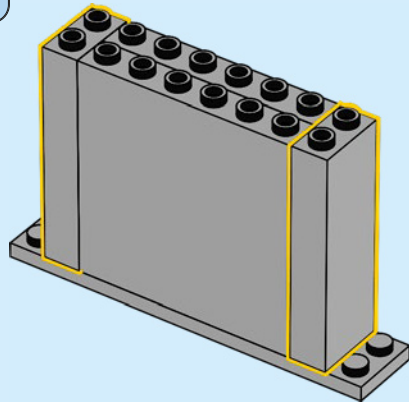

263

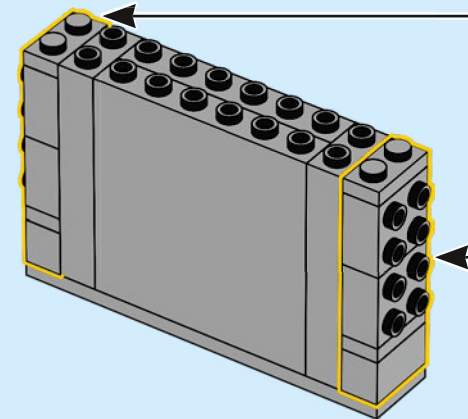
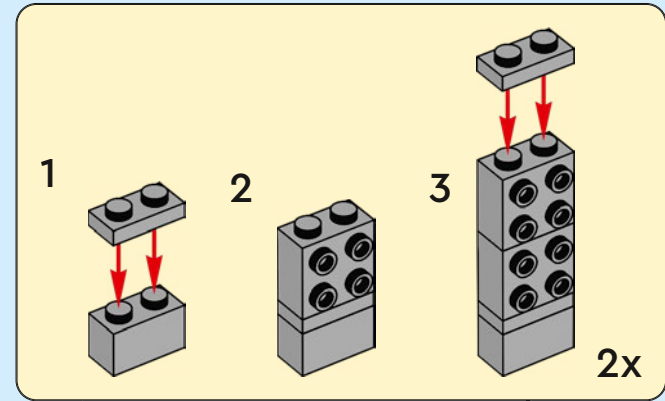

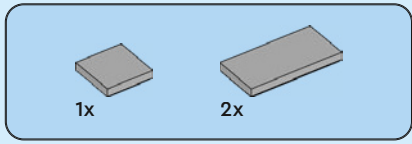

264

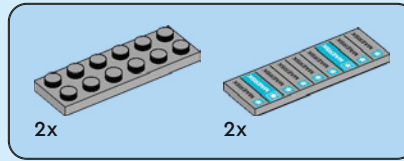
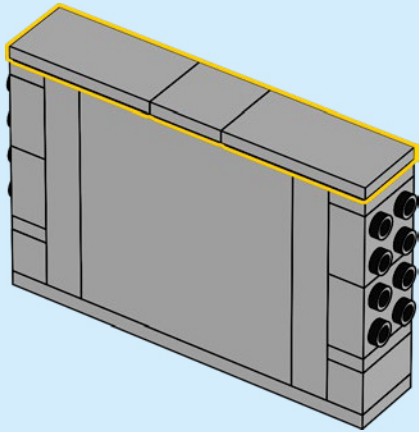

265

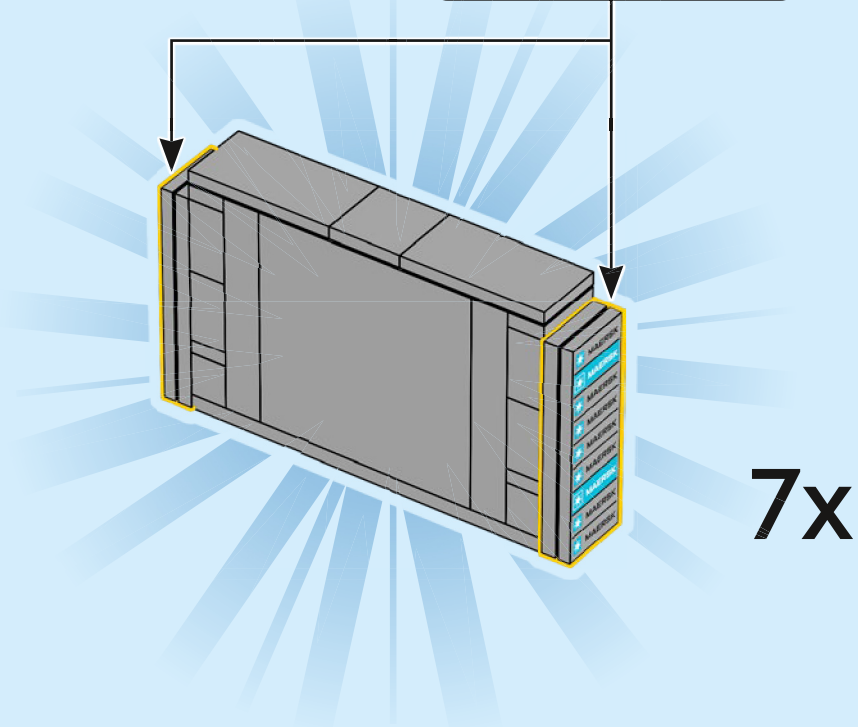
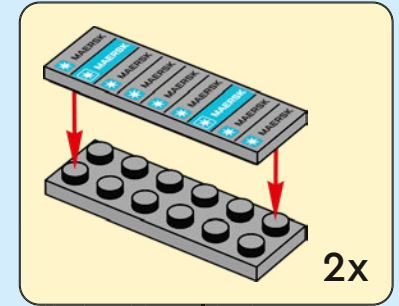

266

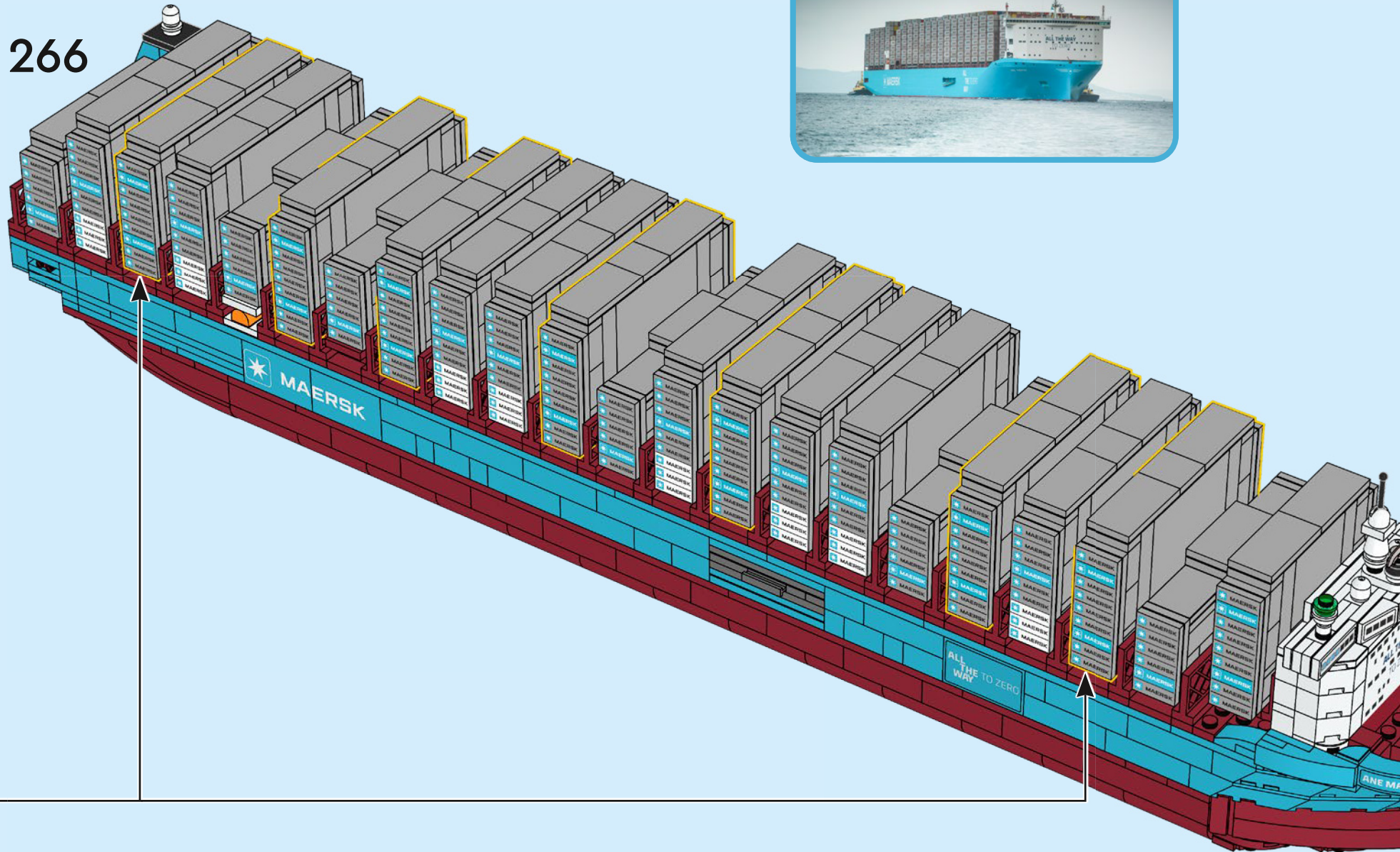

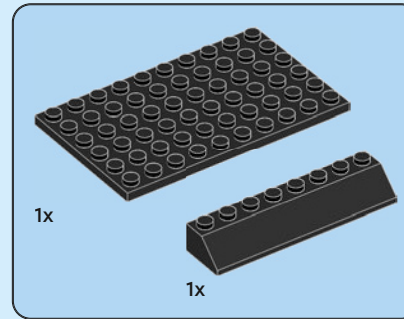
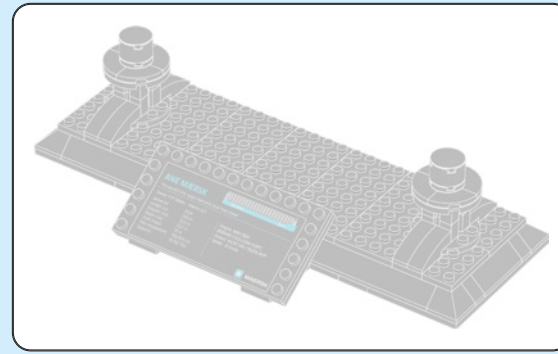

267

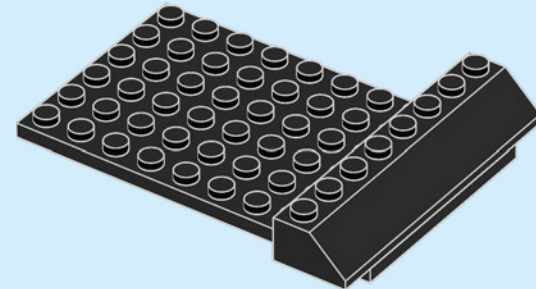

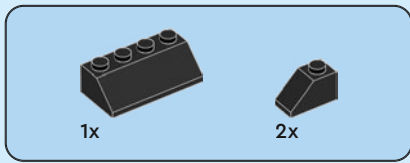

268

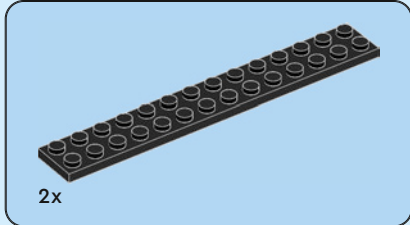
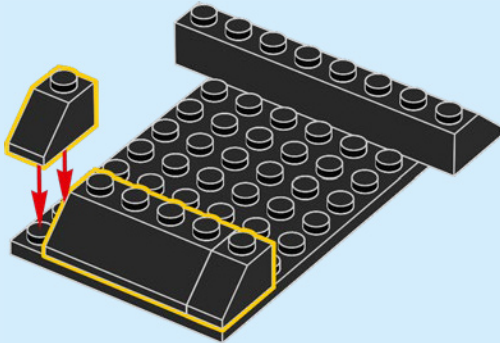

269

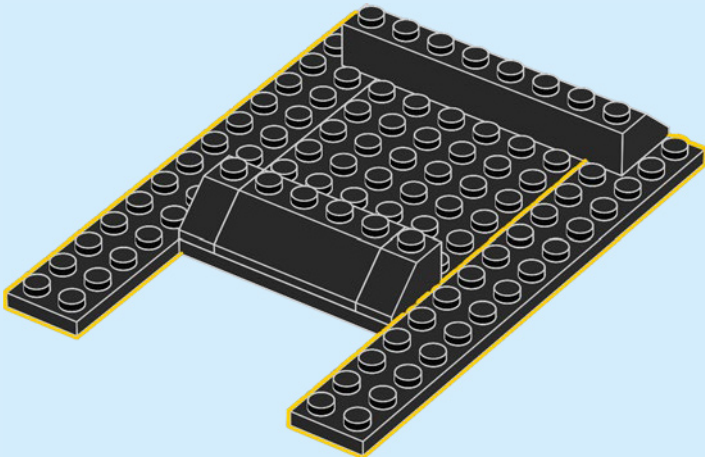

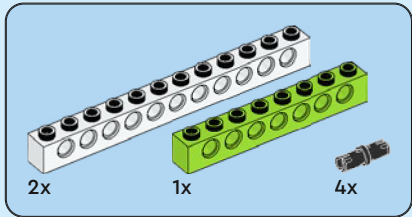
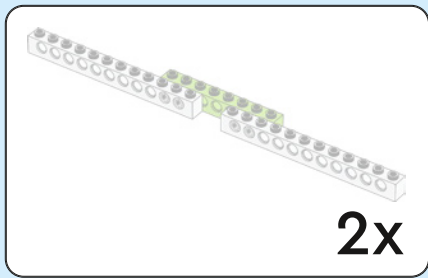

270

1

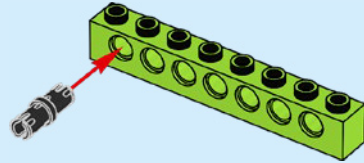

2

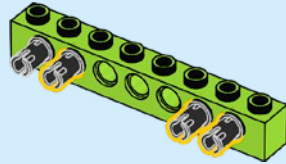

3

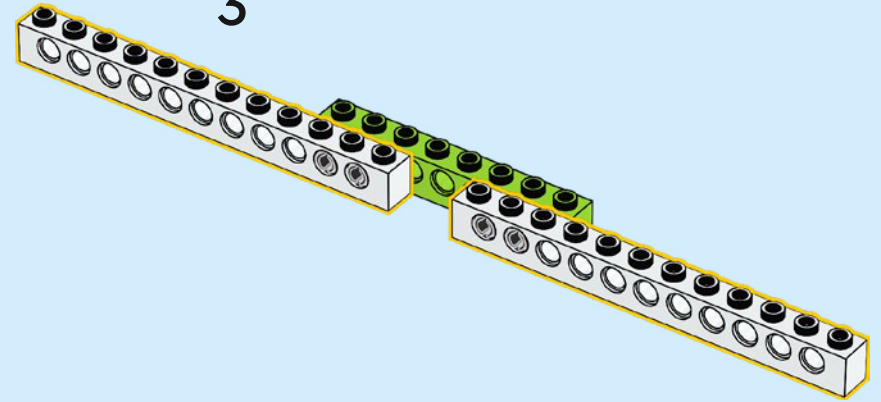

2x

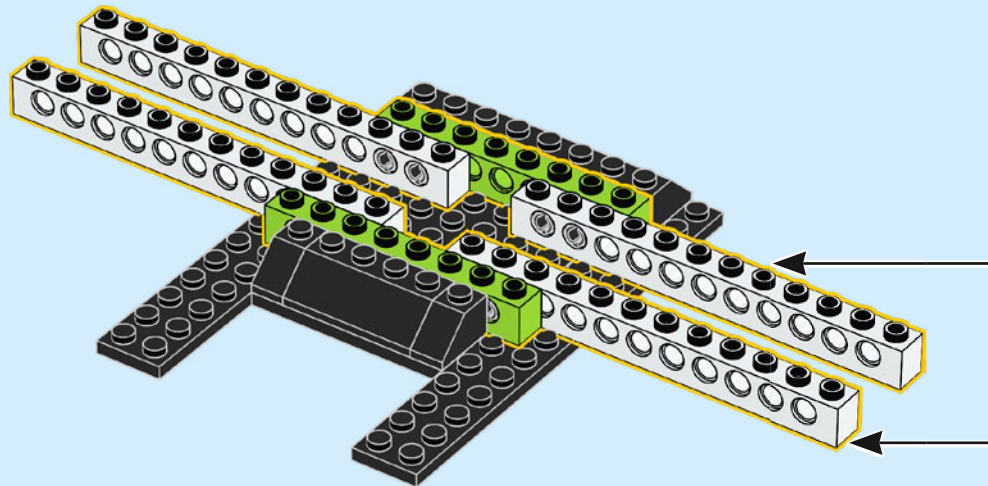

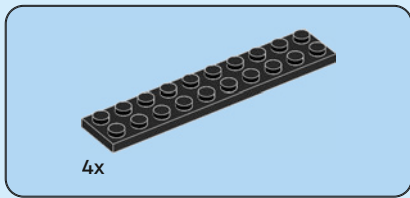

271

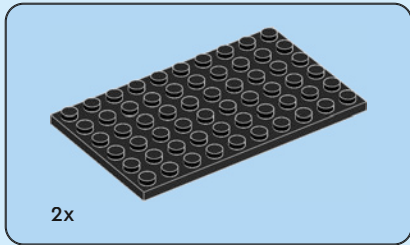
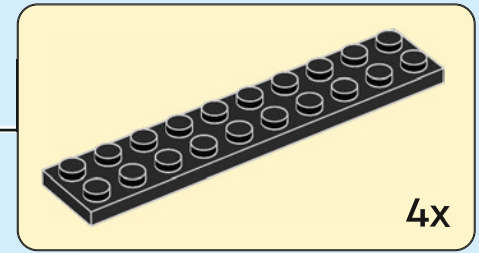
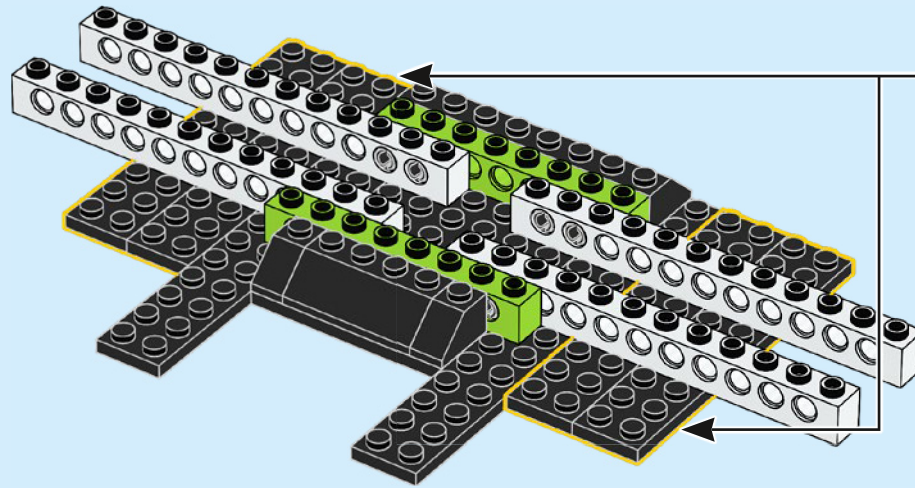

272

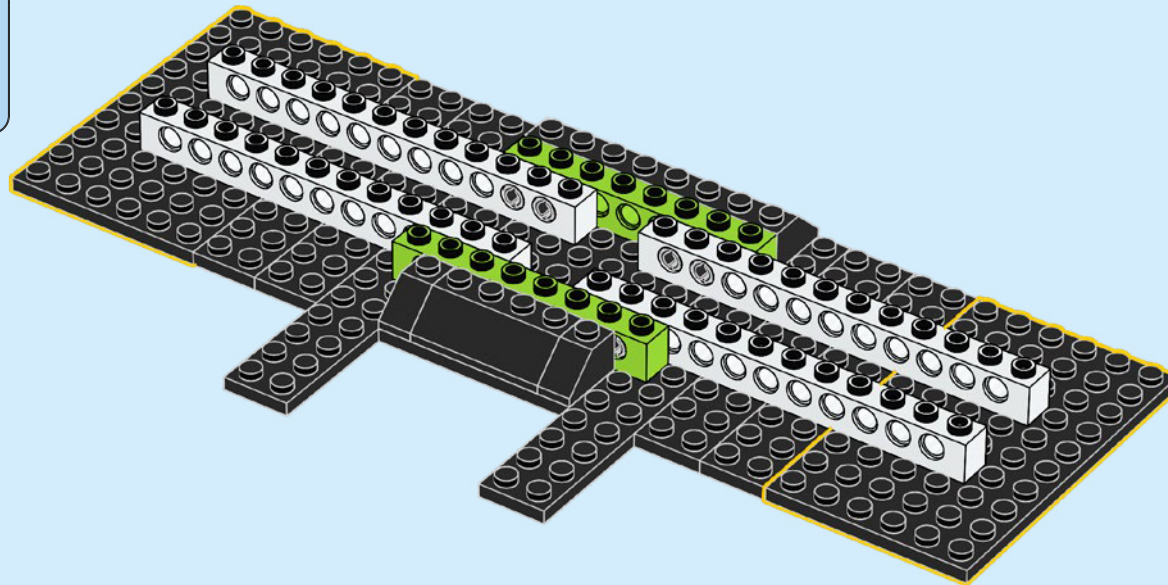

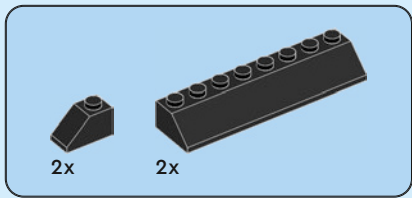

273

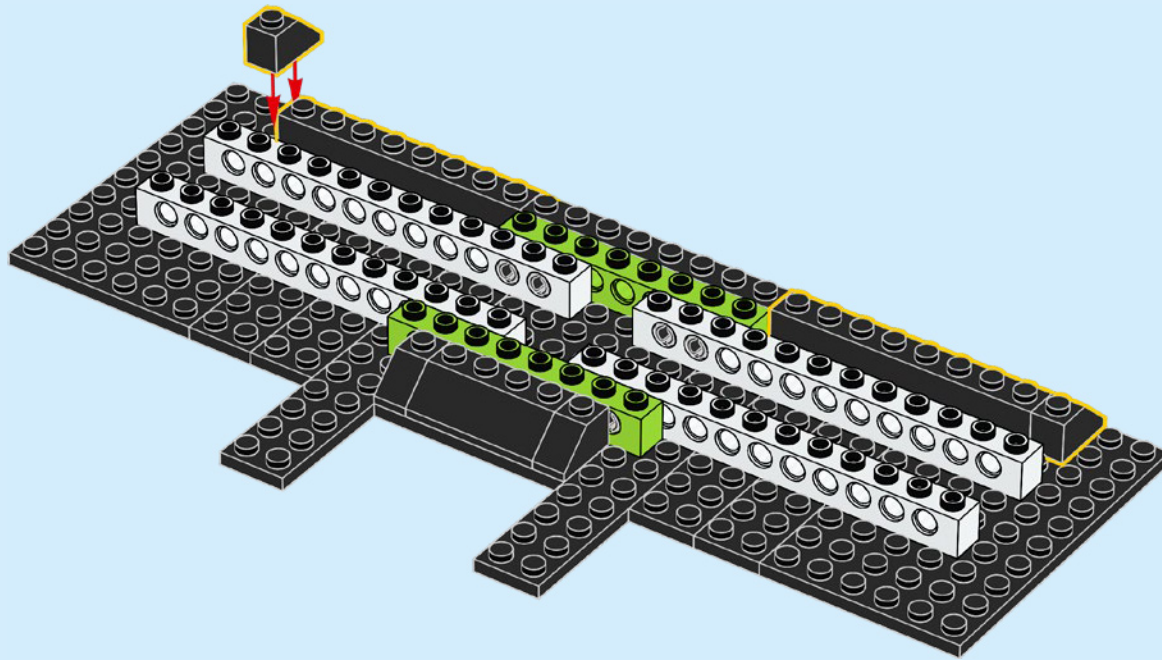

274

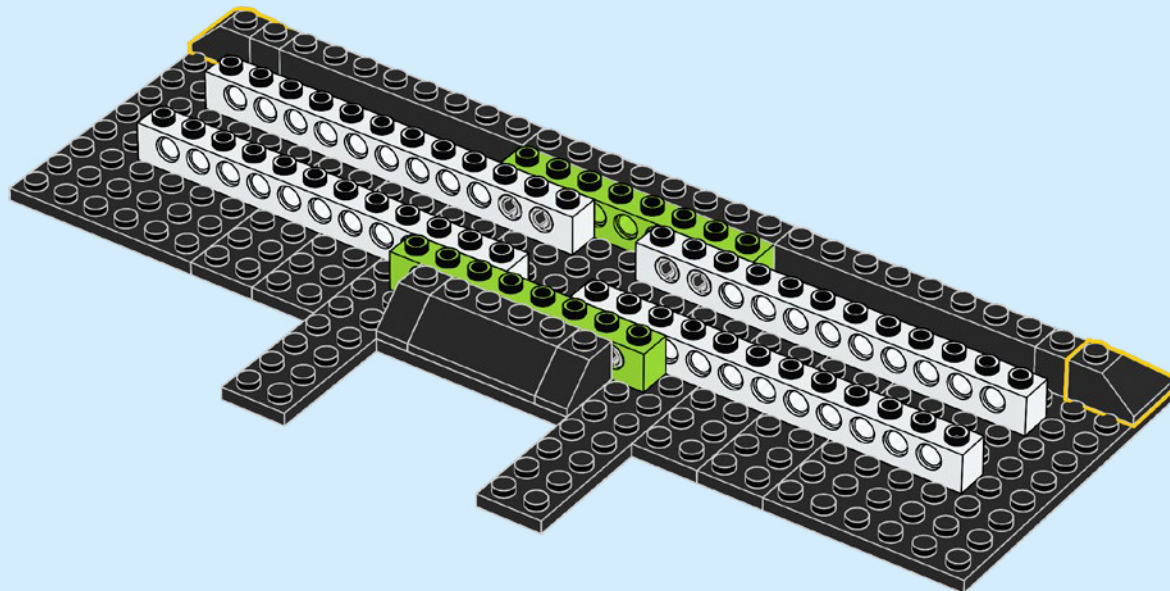

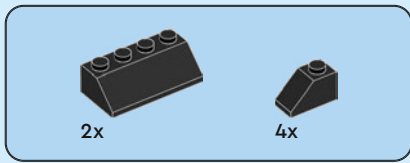

275

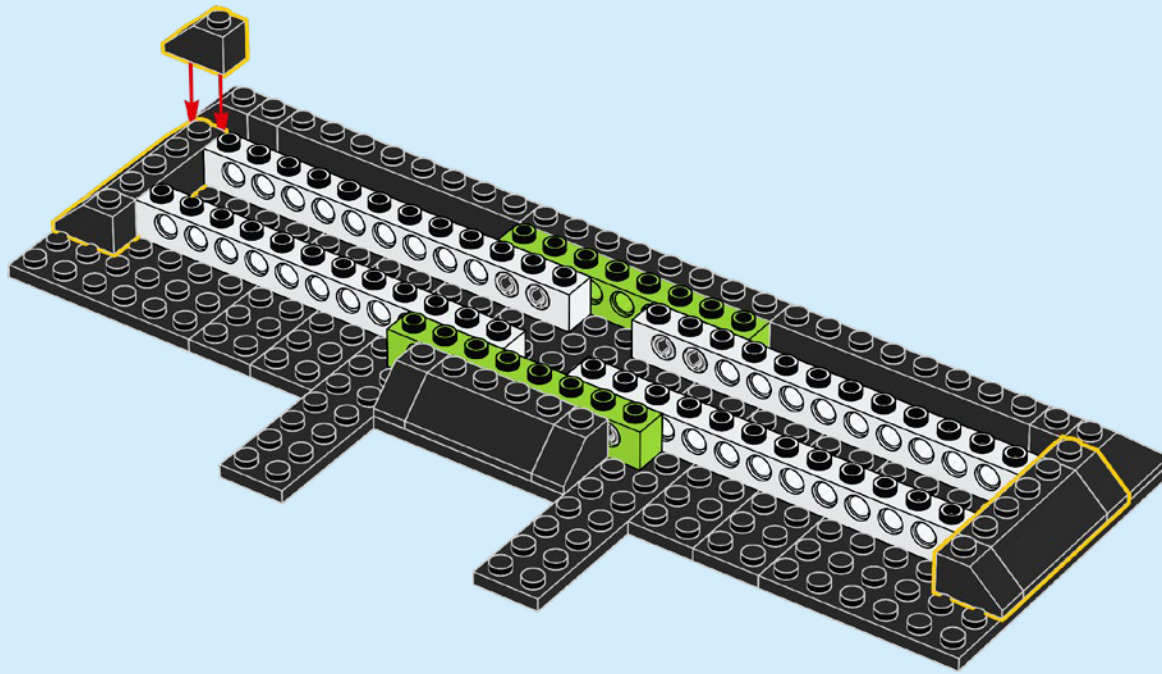

276

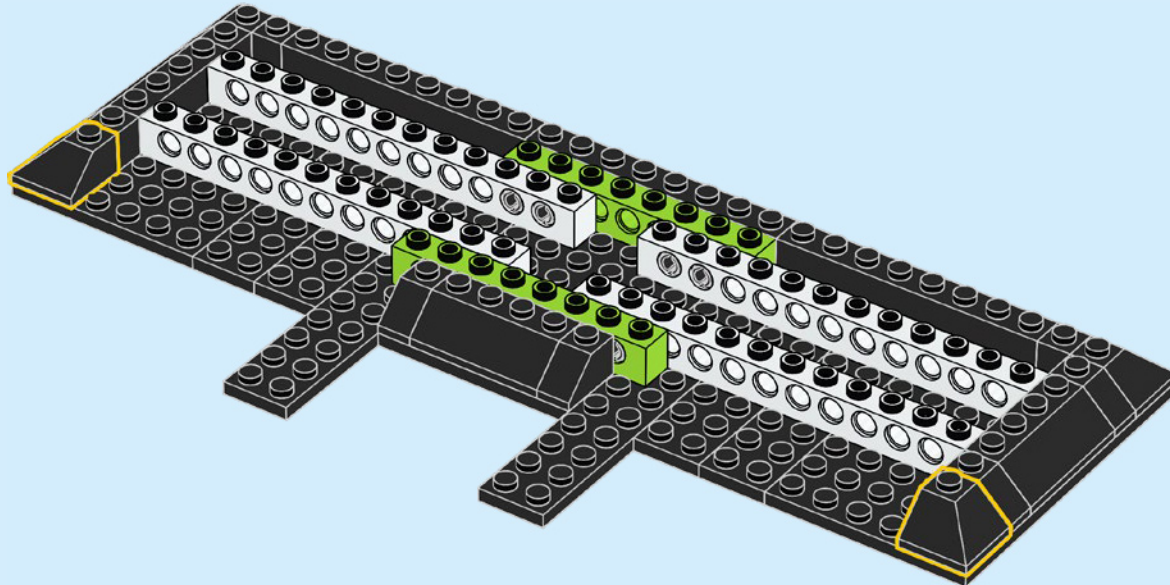



2x



2x

# 277

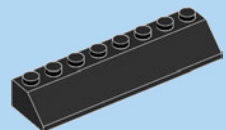
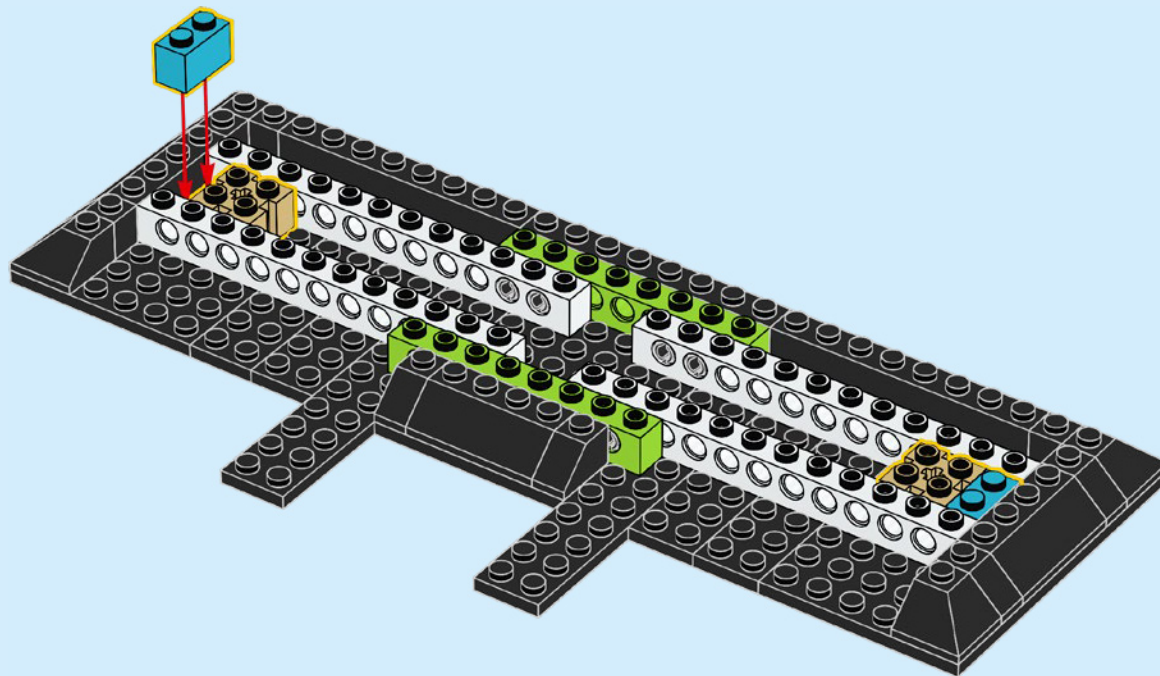

2x

# 278

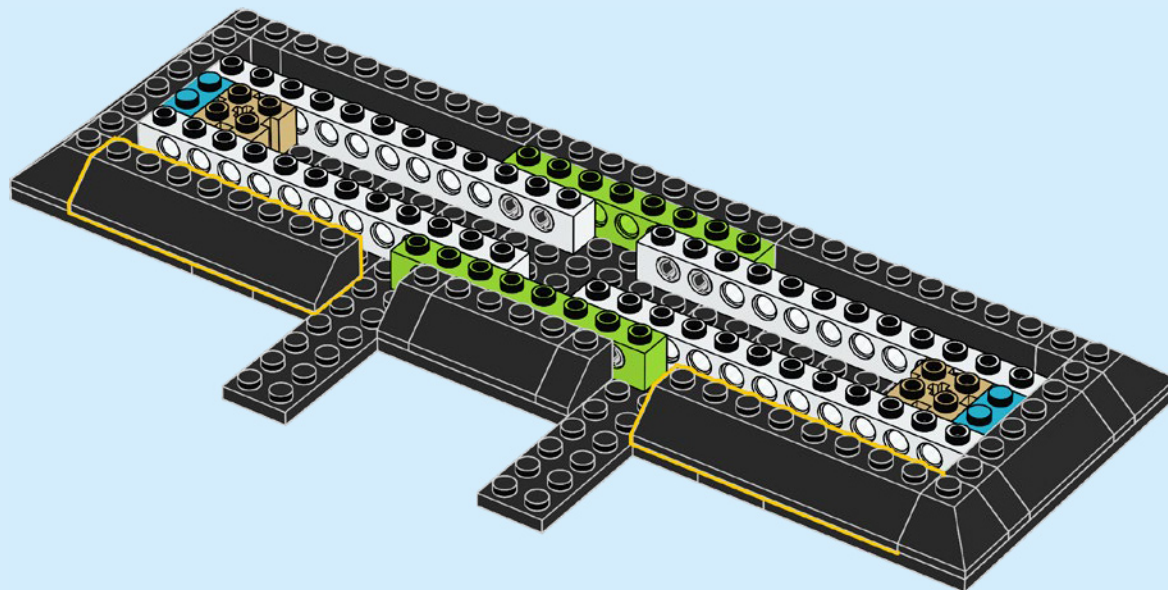

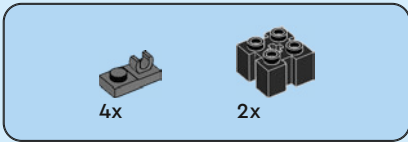

279

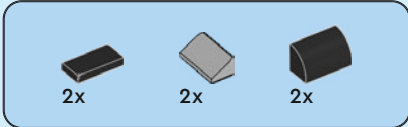
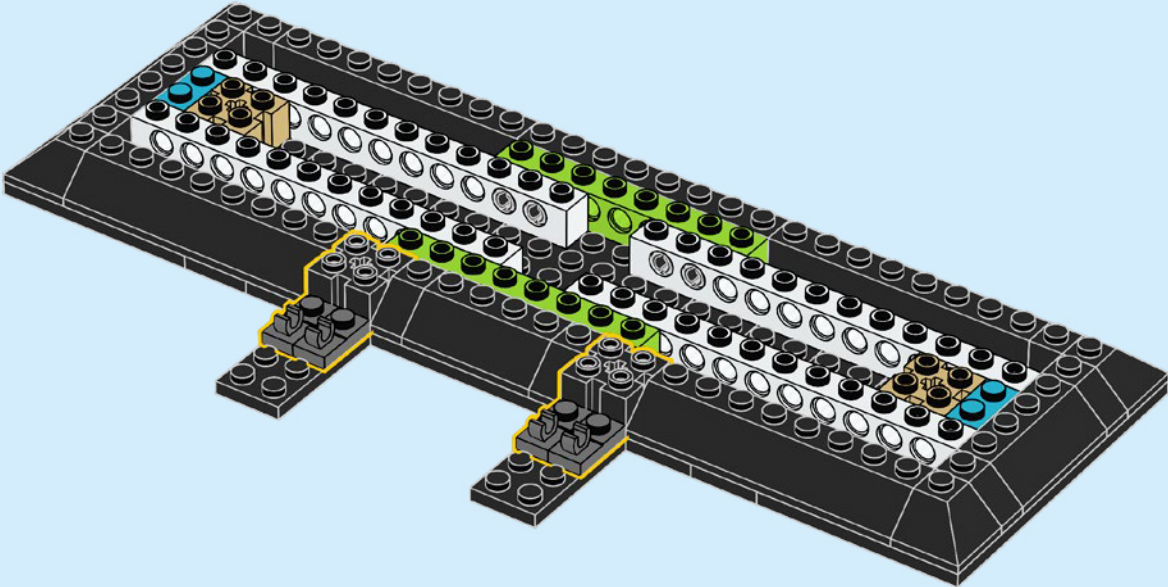

280

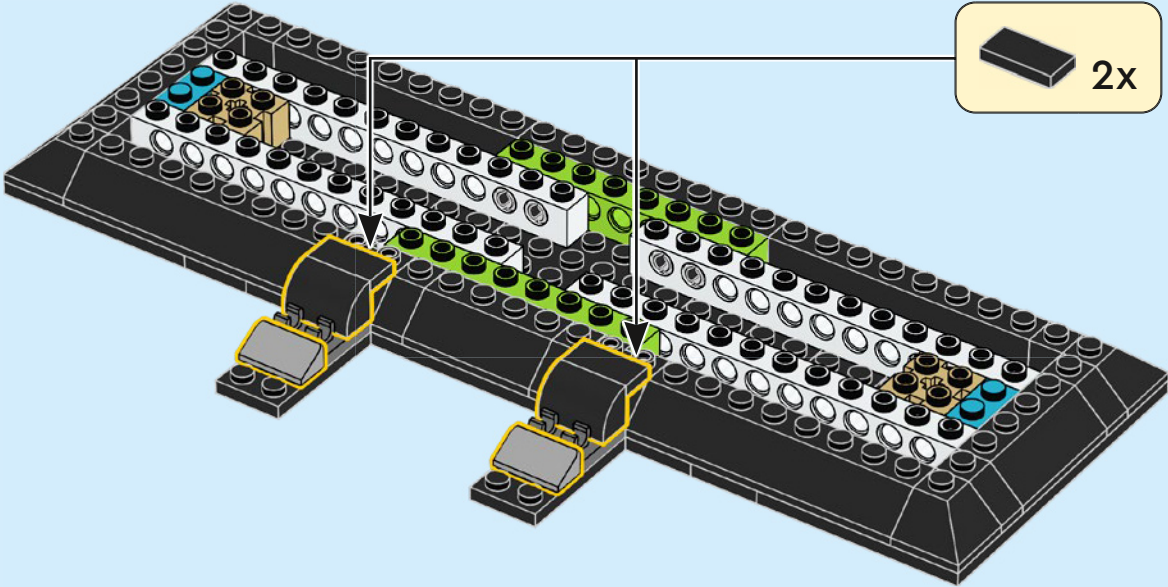

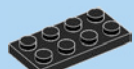

4x

281

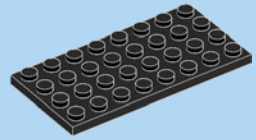
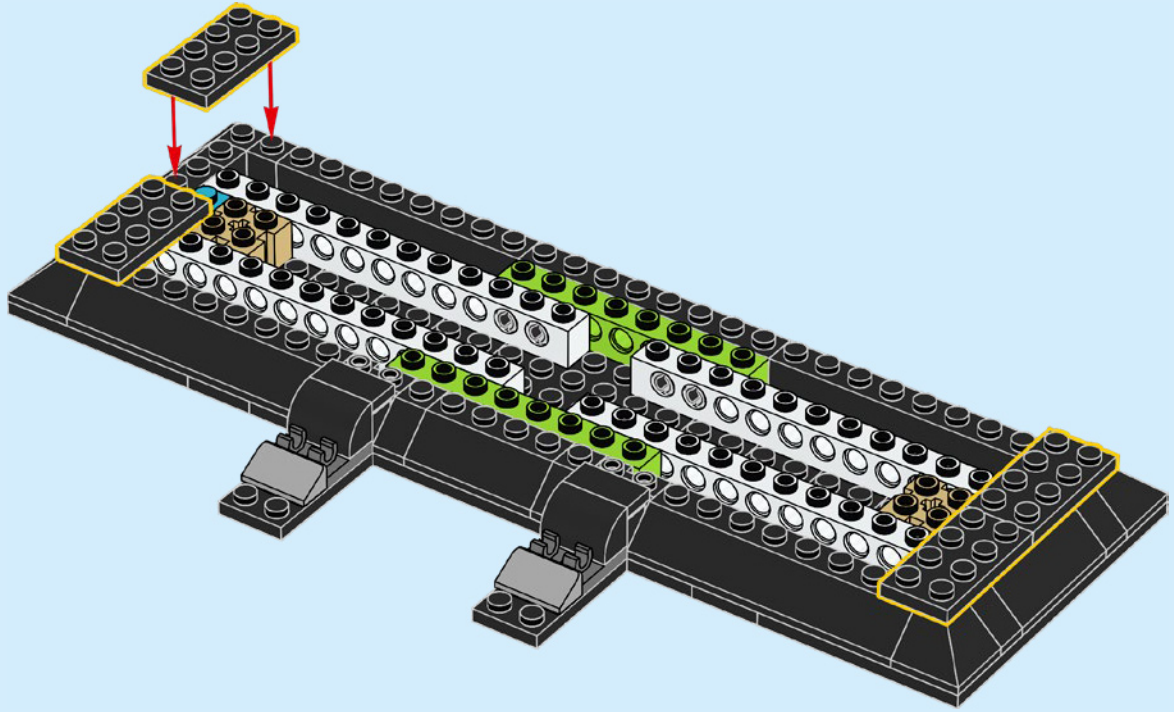

5x

282

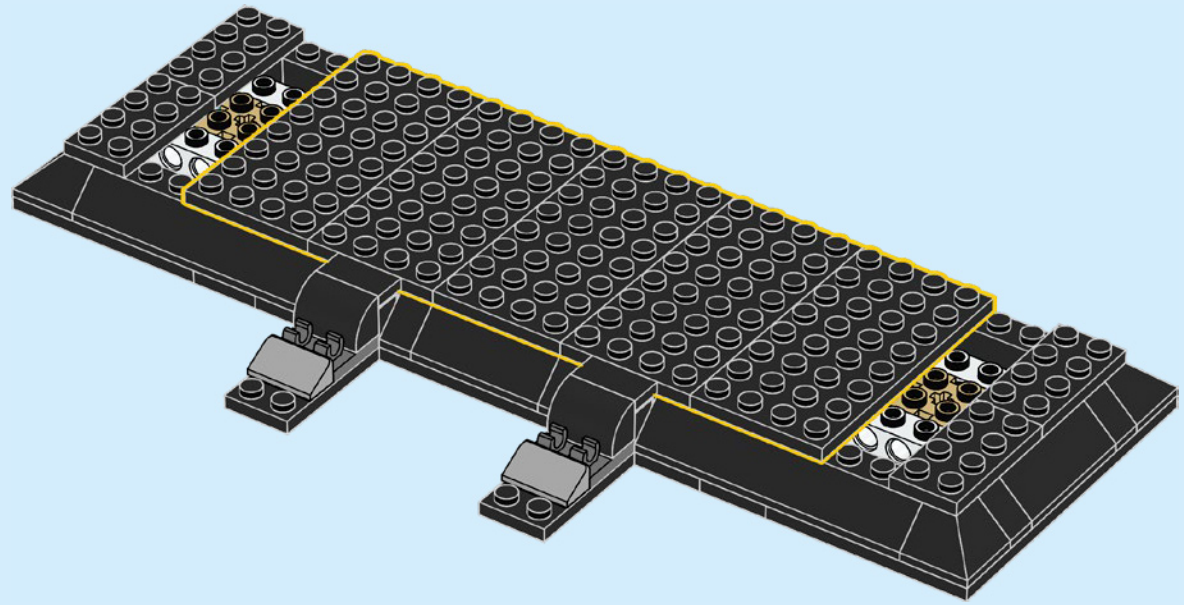

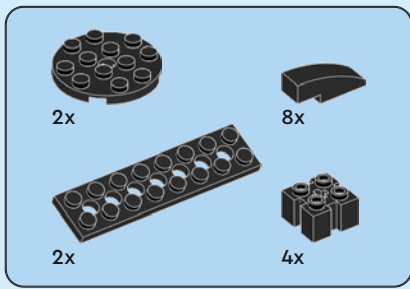

283

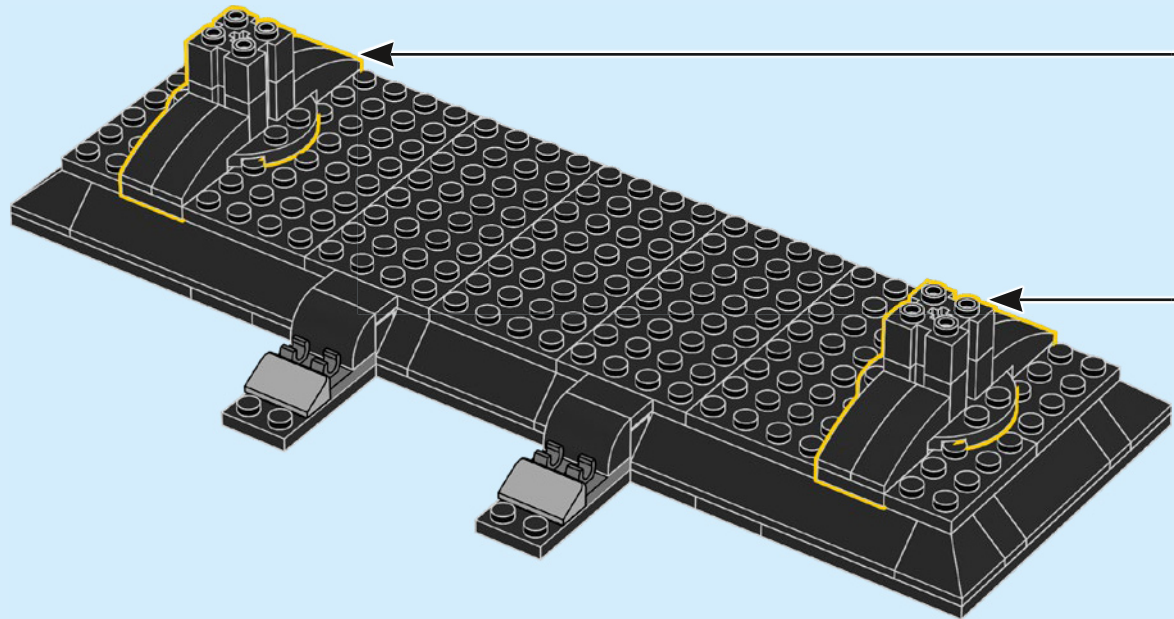
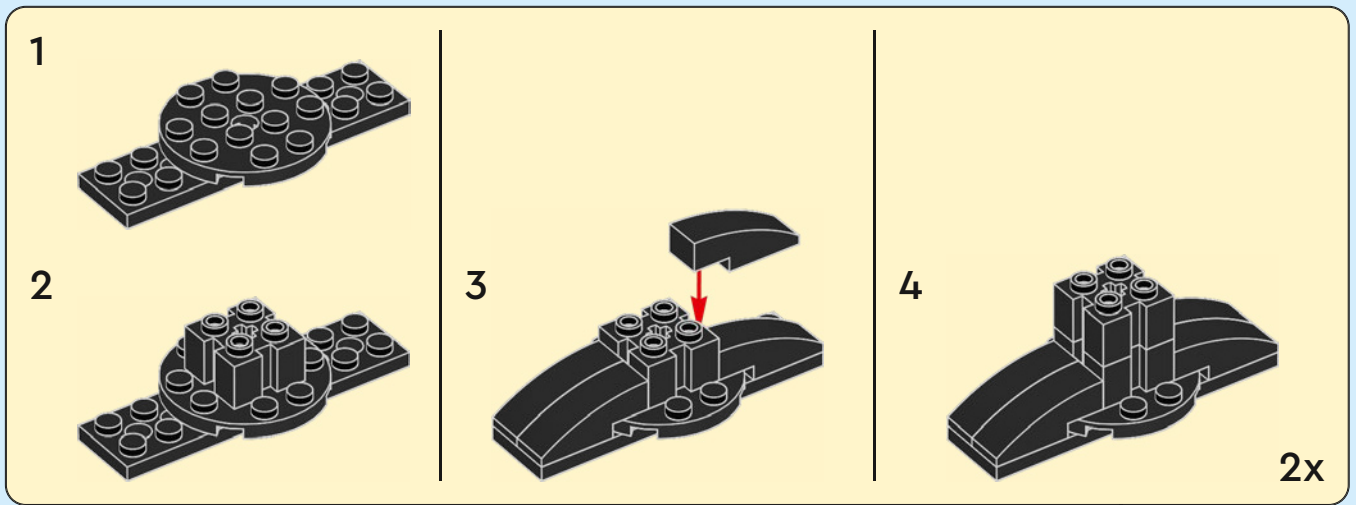

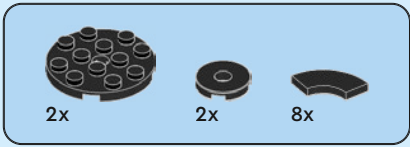

284

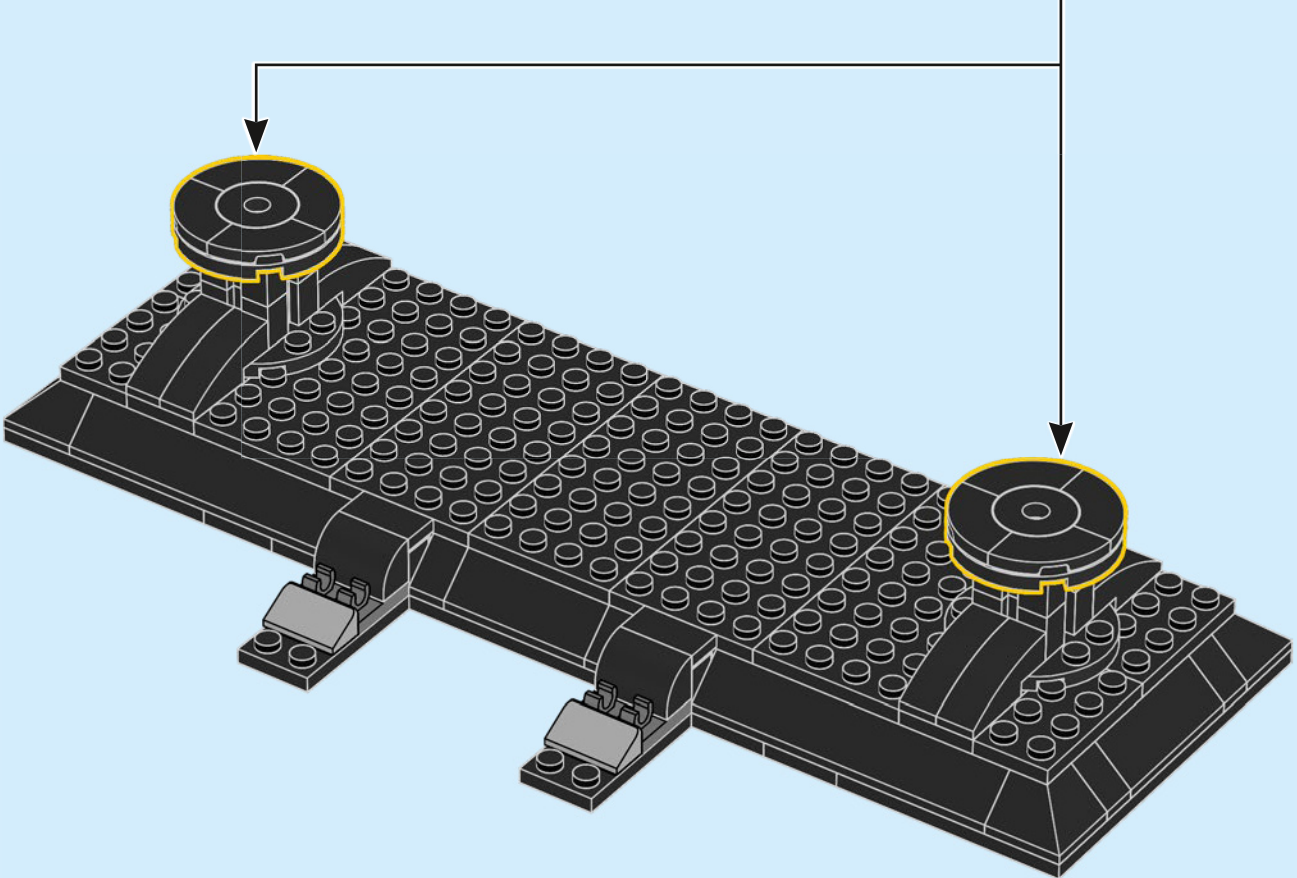
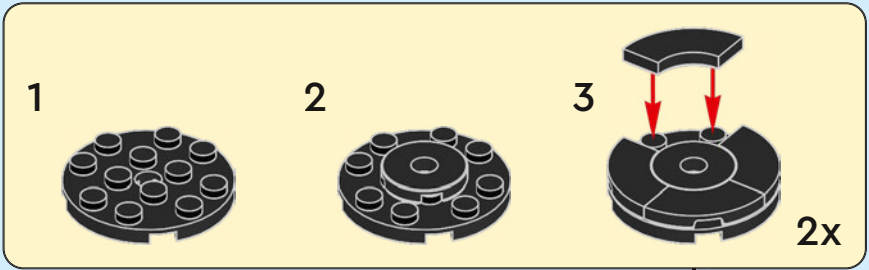

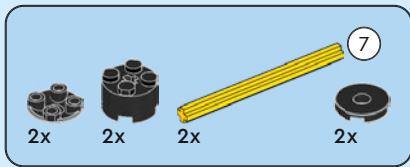

285

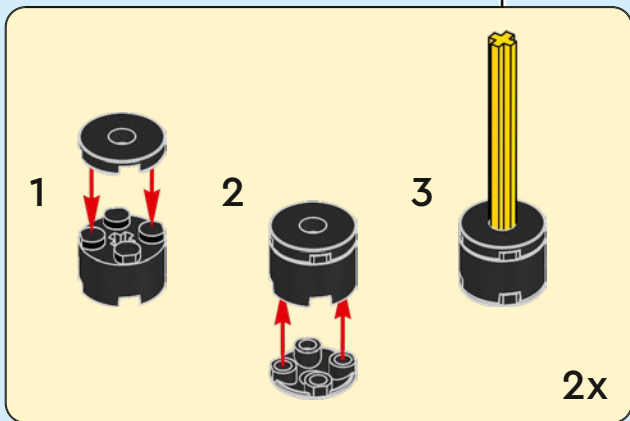
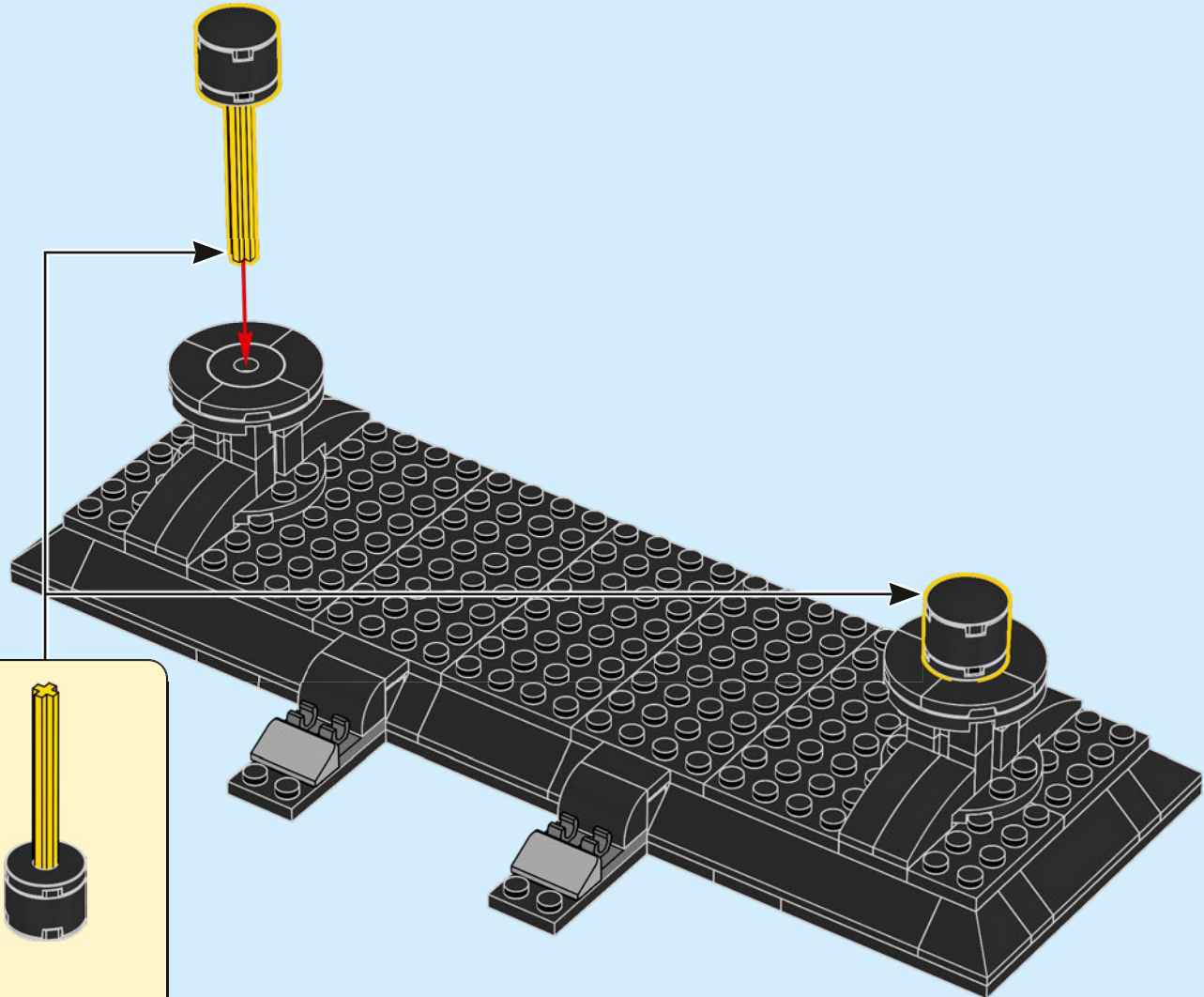

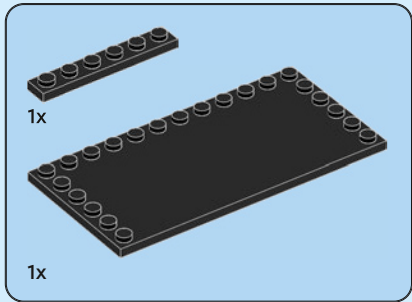

286

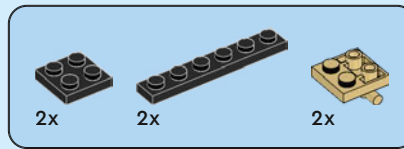
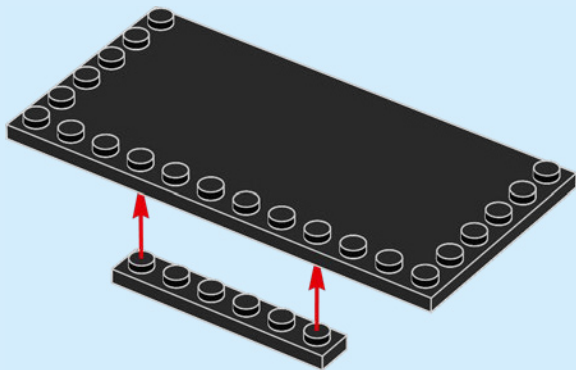

287

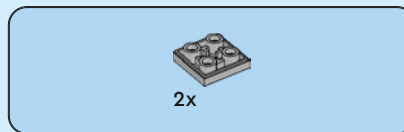
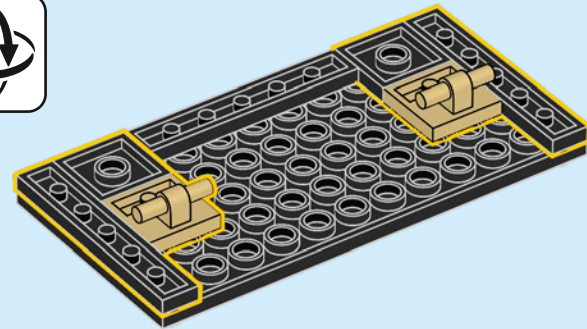

288

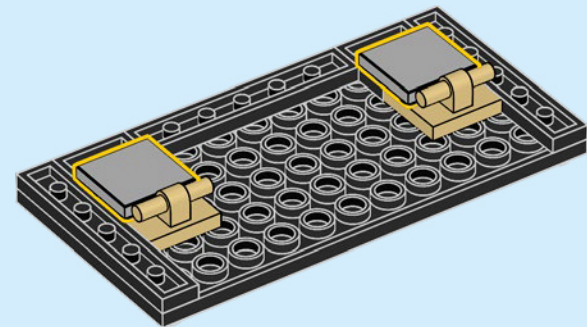

289

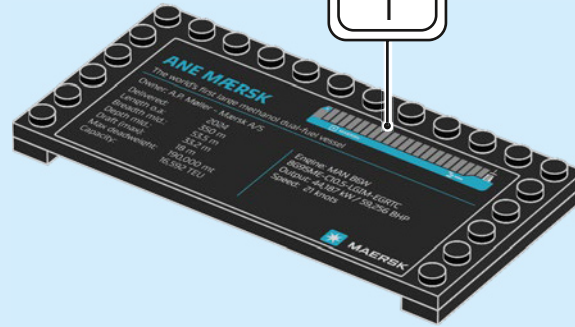

290

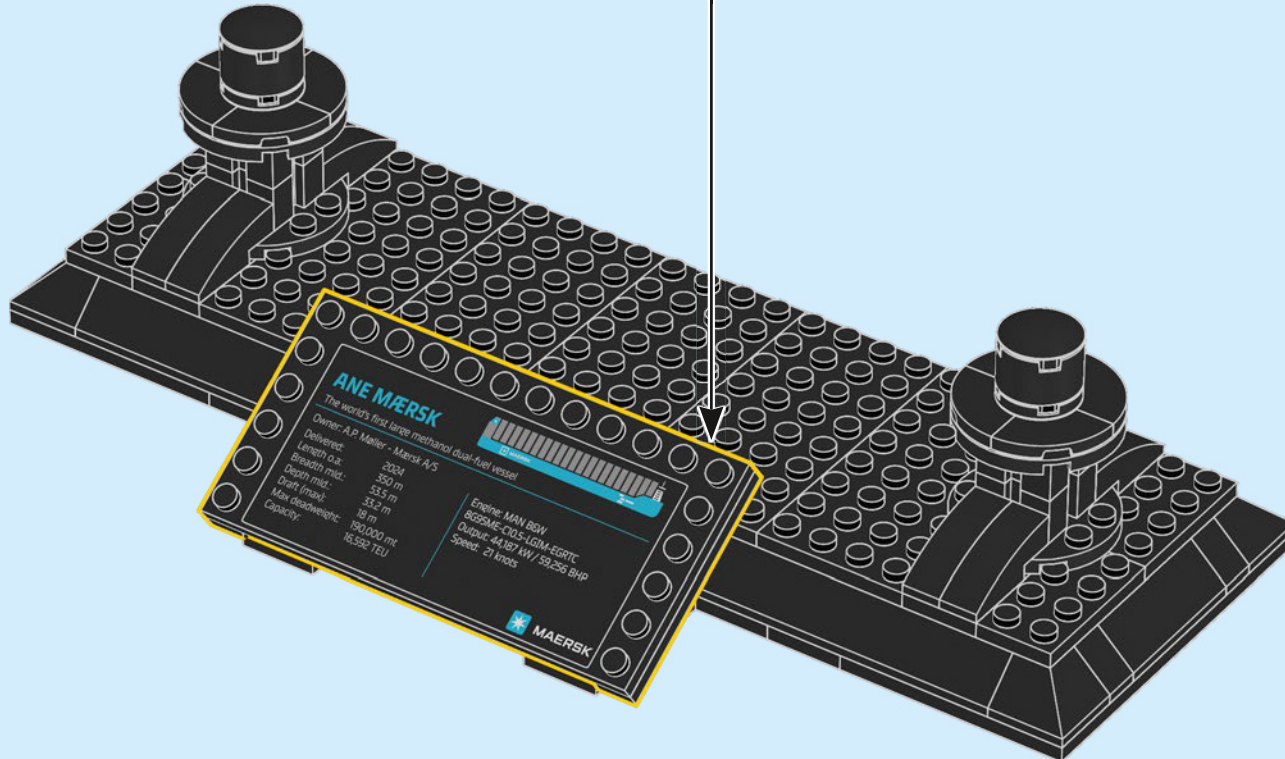

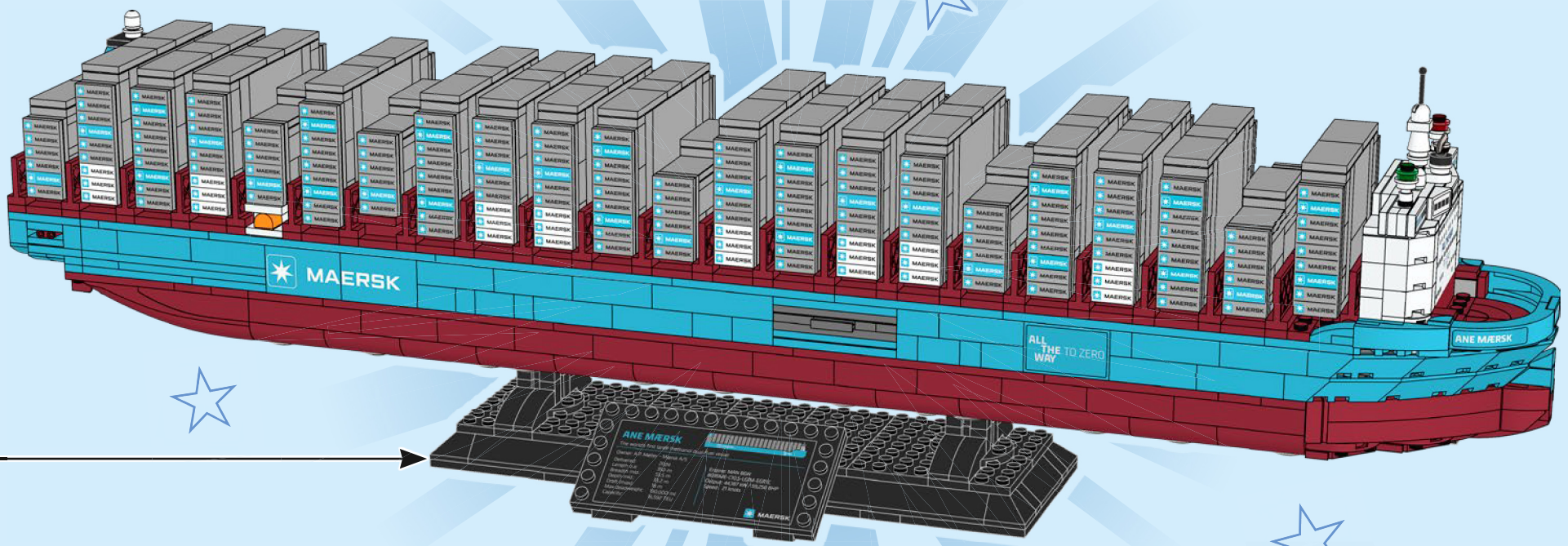
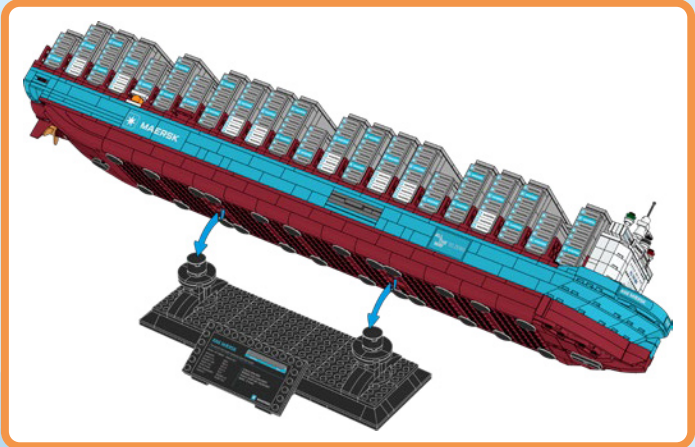

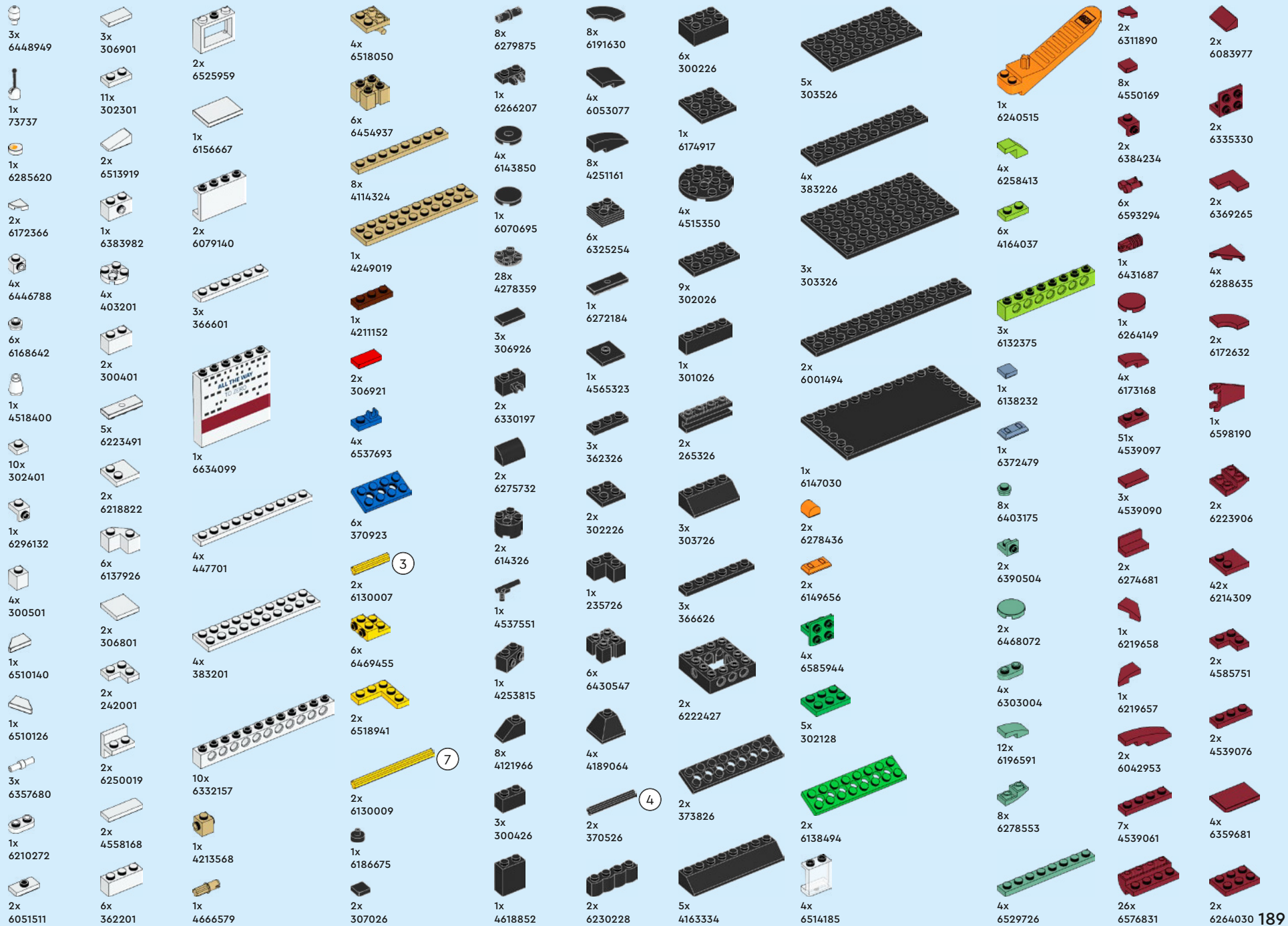

- 4x 6584062
- 4x 4541528
- 2x 6586652
- 1x 6335319
- 21x 6052777
- 6x 4541507
- 4x 4539071
- 10x 6576807
- 66x 6584063
- 1x 6465734
- 2x 6602414
- 2x 4539062
- 1x 6476042
- 1x 6350339
- 26x 6253142
- 4x 6186106
- 1x 6544174
- 6x 6440979
- 1x 4211392
- 6x 4211406
- 25x 4211462
- 2x 4211705
- 1x 6539385
- 11x 6015344
- 9x 6258831
- 2x 4568637
- 1x 4211415
- 2x 4568637
- 4x 4211412
- 33x 4211388
- 2x 4211399
- 11x 6598026
- 6x 6227897
- 70x 4211398
- 27x 4211395
- 12x 6061675
- 4x 6059033
- 2x 6079461
- 30x 4527174
- 16x 6598025
- 16x 6595947
- 35x 4211452
- 64x 6123809
- 6x 4211564
- 3x 6170387
- 32x 4211363
- 4x 6469440
- 1x 6446028
- 2x 6132886
- 2x 6043639
- 2x 4211580
- 15x 4211413
- 4x 6258820
- 10x 4211387
- 10x 6171894
- 10x 4211396
- 12x 4211386
- 1x 6514057
- 1x 6514051
- 2x 4210719
- 2x 4211063
- 4x 6344754
- 1x 6514456
- 2x 6123814
- 4x 4543086
- 1x 4218696
- 6x 4211094
- 11x 4211056
- 2x 4210651
- 1x 6287847
- 1x 6322046
- 2x 6215606
- 1x 6292145
- 1x 6088641
- 2x 6335563
- 1x 6593293
- 2x 6603341
- 8x 6603339
- 2x 6603283
- 4x 6603285
- 6x 6603587
- 8x 6603337
- 2x 6603334
- 1x 6603315
- 4x 6603598
- 17x 6603336
- 1x 6603301
- 1x 6603600
- 1x 6603591
- 1x 6603586
- 1x 6603585
- 2x 6603590
- 2x 6603344
- 2x 6603309
- 3x 6603316
- 1x 6593286
- 2x 6604733
- 2x 6603601
- 7x 6603965
- 30x 6603319
- 2x 6603317
- 2x 6576809
- 2x 6603313
- 1x 6598028
- 2x 6576810
- 1x 6598027
- 2x 6603599
- 2x 6603596
- 2x 6603342
- 2x 6603312
- 10x 6603286
- 2x 6603333
- 10x 6603340
- 2x 6603318
- 4x 6603343
- 2x 6603335
- 4x 6603595
- 1x 6603594
- 6x 6603589
- 2x 6603332
- 2x 6576813



[LEGO.com/service](https://www.LEGO.com/service)

**YOU COULD WIN**



Scan this QR code or go to  
**LEGO.COM/PRODUCTFEEDBACK** and give us  
your short feedback about this LEGO® set  
for a chance to win a cool LEGO prize.

Terms and Conditions apply\*

**EN: YOU COULD WIN.** Terms and Conditions apply\* **DE: Du könntest GEWINNEN.** Es gelten die Teilnahmebedingungen\* **FR: Tu pourrais GAGNER.** Des conditions s'appliquent\* **IT: Potresti VINCERE tu.** Termini e condizioni sono applicabili\* **ES: Puedes GANAR.** Aplican términos y condiciones\* **PT: PODERÁ GANHAR.** Aplicam-se Termos e Condições\* **ZH: 轻松获奖.** 条款和条件适用\* **PL: Szansa na WYGRANĄ.** Obowiązuje regulamin\* **CS: Máte šanci VYHRÁT.** Platí všeobecné smluvní podmínky\* **SK: Máte šancu VYHRÁT.** Platia všeobecné zmluvné podmienky\* **HU: TE IS NYERHETSZ.** Felhasználási feltételek érvényesek\* **UA: ВИ МОЖЕТЕ ВИГРАТИ.** Застосовуються загальні положення та умови\* **RO: Ai putea CÂȘTIGA.** Se aplică termenii și condiții\* **BG: Можете да СПЕЧЕЛИТЕ.** Има определени правила и условия\* **LV: Tu vari LAIMĒT.** Ir spēkā noteikumi un nosacījumi.\* **ET: Sul on võimalus VÕITA.** Kehtivad tingimused\* **LT: Jūs galite LAIMĖTI.** Taikomos sąlygos\*

\*[LEGO.com/productfeedback-terms](https://www.lego.com/productfeedback-terms)

