



40955



MAERSK





LEGO.com/sustainable-packaging



FR

**DONNEZ
OU
RECYCLEZ**



OU



OU



ASSOCIATION MAGASIN DÉCHÈTERIE

Adresses sur quefairedemesdechets.fr

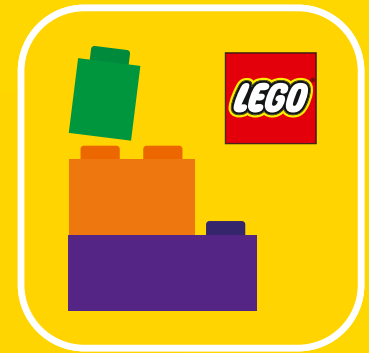

🔍 LEGO® Builder

BUILDER



Apple and the Apple logo are trademarks of Apple Inc., registered in the U.S. and other countries and regions. App Store is a service mark of Apple Inc. Google Play and the Google Play logo are trademarks of Google LLC. Tencent and the Tencent logo are trademarks of Tencent Inc.

🔍 LEGO.com/devicecheck

EN Ask parents' permission before going online | DE Eltern um Erlaubnis bitten, bevor du online gehst | FR Demande l'autorisation d'un parent avant d'aller en ligne | IT Chiedi il permesso ai tuoi genitori prima di andare online | ES Pídeles permiso a tus papás antes de conectarte a Internet | PT Peça autorização aos pais antes de acederes online | ZH 上网前应先征得父母的同意 | PL Poproś rodziców o zgodę, zanim wejdiesz do Internetu | CS Než půjdeš na internet, požádej rodiče o svolení | SK Skôr než pôjdeš na internet, vypoťaj si povolenie od rodičov | HU Kérj szülői engedélyt, mielőtt online csatlakoznál! | UA Запитуйте дозволу батьків, перш ніж користуватися інтернетом | RO Cere permisiunea părinților înainte de a te conecta online | BG Поискайте разрешение от родител, преди да влезете онлайн | LV Pirms došanās tiešsaistē palūdz atļauju vecākiem | ET Enne Interneti kasutamist küsi vanematelt luba | LT Prieš prisijungdami prie interneto, atsiklauskite tėvų

PRÉSENTATION DU ANE MÆRSK

Le ANE MÆRSK est le premier navire porte-conteneurs de grande taille capable de fonctionner avec des carburants à faibles émissions, tels que le bio-méthanol et l'e-méthanol. Depuis que le ANE MÆRSK a pris la mer pour la première fois en janvier 2024, de nombreux autres navires à double carburant ont levé l'ancre, marquant ainsi un nouveau chapitre important dans la décarbonation du transport maritime et du commerce mondial.

Le ANE MÆRSK mesure 350 mètres (1 148,2 pieds) de long et 53,5 mètres (175,5 pieds) de large. À vide, le navire pèse 47 700 tonnes (52 580,25 tonnes anglaises) et lorsqu'il est entièrement chargé de marchandises, de carburant et d'équipage, il peut transporter pas moins de 190 000 tonnes (209 439,1 tonnes anglaises), soit l'équivalent de 29 000 éléphants d'Afrique.

Le navire peut charger 16 592 conteneurs EVP (chacun mesurant plus de 6 mètres de large) et si on les alignait tous, ils s'étendraient sur 100,5 km (62,4 miles), soit la longueur de 959 terrains de football.





 MAERSK

ALL THE 10 ZERO WAY



NAVIGUER DANS LE CHANGEMENT : L'HISTOIRE DU TRANSPORT MARITIME

Les hommes transportent des marchandises par voie maritime depuis plus de 5 000 ans, mais jusqu'à la révolution industrielle et l'invention de la machine à vapeur, nous étions à la merci des conditions météorologiques. Pas de vent, pas de traversée. Avec l'introduction de la vapeur, l'équipage d'un navire n'est plus tributaire des conditions météorologiques ou de la propulsion manuelle pour la première fois dans l'histoire de l'homme. Cette invention a complètement révolutionné le transport maritime, ouvrant de nouveaux itinéraires et donnant un coup de fouet au commerce maritime.

Bien que les machines à vapeur aient constitué une amélioration considérable par rapport aux voiles, elles restaient inefficaces, et il ne fallut pas longtemps avant que le transport maritime ne soit à nouveau transformé par l'invention du moteur diesel. Cependant, les révolutions dans ce domaine prennent du temps, et il aura fallu plusieurs décennies avant que le diesel ne remplace complètement la vapeur. Maersk a acheté son premier navire à moteur diesel, le LEISE MÆRSK, en 1921, neuf ans seulement après le lancement du tout premier navire marchand océanique à moteur diesel.



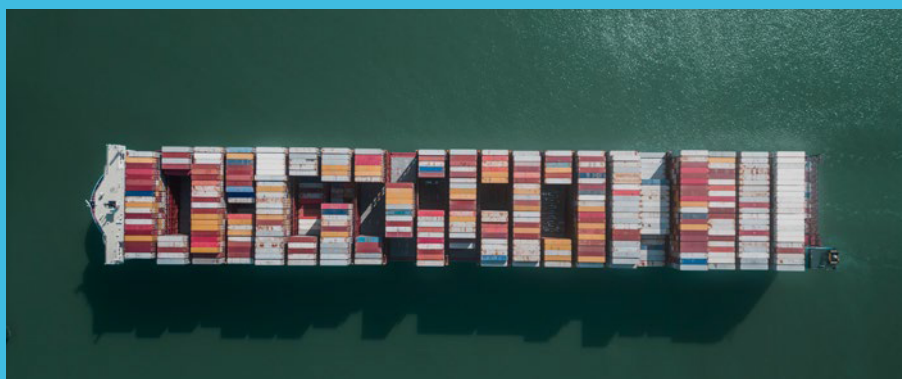

En 1956, l'industrie a connu une nouvelle transformation avec l'introduction du « fret conteneurisé », qui permet de charger directement les remorques de camions sur les navires. L'introduction du conteneur a permis de réduire le temps de chargement et de déchargement des navires de plusieurs jours à quelques heures.

Grâce au conteneur et au code-barres, ces catalyseurs cachés du commerce mondial, un fabricant situé n'importe où dans le monde peut vendre ses produits sur tous les marchés, rendant ainsi la mondialisation physiquement possible. Le monde tel que nous le connaissons aujourd'hui est fortement tributaire des chaînes d'approvisionnement mondiales. Du producteur de bananes en Colombie à l'enfant danois qui épluche une banane pour son déjeuner, les chaînes d'approvisionnement maintiennent le monde connecté et assurent la circulation des denrées alimentaires, des médicaments, des marchandises et des matériaux vers les populations du monde entier.





 MAER

 MAERS

 MAERSK

 MAERSK

QU'Y A-T-IL DANS UN NOM ?

Depuis 1906, tous les navires de la flotte Maersk portent le nom « MÆRSK ». La plupart des premiers navires étaient baptisés d'après les prénoms des membres de la famille fondatrice, mais au fur et à mesure que la flotte s'agrandissait, les noms disponibles dans la famille ne suffisaient plus et il fallut adapter la tradition. Aujourd'hui, les navires Maersk portent également le nom de villes ou de rivières, par exemple.

Au moment de décider comment nommer la nouvelle série de navires à double carburant, Maersk est revenu à la tradition de donner aux navires les noms des membres de la famille fondatrice, en commençant cette fois-ci par la lettre A pour marquer le début d'une nouvelle ère.

Le ANE MÆRSK porte le nom d'Ane Mærsk Mc-Kinney Uggle, présidente de A.P. Moller Holding, qui est la société mère de A.P. Moller - Maersk. A.P. Moller - Maersk a été fondée en 1904 par Arnold Peter Møller. Ane est la petite-fille du fondateur du groupe, Arnold Peter Møller, et de son épouse, Chastine Mc-Kinney Møller.



ANE MAERSK





LE WHITE STAR : UNE LUEUR D'ESPOIR

L'étoile blanche à sept branches emblématique fait partie de l'héritage de Maersk depuis avant même la création de l'entreprise en 1904. Elle est le symbole durable des liens familiaux solides qui continuent d'animer l'entreprise plus de 100 ans plus tard.

Au début de sa carrière, le capitaine Peter Mærsk Møller, père d'A.P. Møller, travaillait pour un armateur anglais, et sa femme, Anna, l'accompagnait parfois dans ses voyages. C'est au cours de l'un de ces voyages qu'Anna tombe gravement malade. Craignant qu'elle ne s'en sorte pas, Peter Mærsk Møller monta sur le pont et pria Dieu de lui donner un signe que sa femme se remettrait. C'est alors qu'il aperçoit une étoile unique qui illumine le ciel gris.

Anna se rétablit et, en 1886, lorsque Peter Mærsk Møller acheta son premier navire à vapeur, le LAURA, il orna la cheminée du navire d'une étoile blanche à sept branches sur fond bleu pâle, en hommage à sa femme adorée. Pour Peter Maersk Møller, l'étoile symbolisait son rétablissement et leur bonne fortune.

Depuis, l'étoile blanche à sept branches sur son emblématique fond bleu ciel est synonyme de Maersk, mais le logo lui-même a évolué au fil des ans. Il existe de nombreuses versions du logo, mais le logo Maersk actuel remonte au début des années 1970, lorsqu'il a été décidé qu'une approche plus moderne était nécessaire.



ALL THE WAY
TO ZERO



AMÉLIORER LA VIE DE TOUS EN INTÉGRANT LE MONDE

Leader mondial des services logistiques, Maersk compte plus de 100 000 clients, opère dans près de 130 pays et emploie plus de 100 000 personnes. Depuis ses modestes débuts en tant que compagnie maritime jusqu'à son évolution vers une entreprise de logistique intégrée qui s'efforce de connecter et de simplifier les chaînes d'approvisionnement de ses clients, Maersk déploie plus de 700 navires et transporte près de 20 % des denrées alimentaires, des matériaux et des marchandises dans le monde.





ALL
THE WAY TO ZERO

EN ROUTE VERS LA NEUTRALITÉ CARBONE : UN ENGAGEMENT POUR UN AVENIR DÉCARBONÉ

Alors que le monde est confronté à des urgences climatiques, l'avenir des chaînes d'approvisionnement et du commerce mondial repose sur la capacité à innover et à promouvoir de nouvelles sources d'énergie. Maersk s'est engagé à atteindre la neutralité carbone d'ici 2040 dans l'ensemble de ses activités. Tout en décarbonisant ses propres opérations, Maersk s'est également engagé socialement à montrer la voie dans la lutte contre la crise climatique en décarbonisant les chaînes d'approvisionnement mondiales et en favorisant une transition juste vers une économie neutre en carbone.

Maersk s'est fixé des objectifs ambitieux pour 2040 afin de garantir des progrès considérables au cours de cette décennie, que ce soit en mer, sur terre, dans les airs ou dans ses terminaux. Et grâce à la commande et à la livraison de nombreux navires à double carburant, capables de naviguer avec des carburants à faibles émissions tels que le bio-méthanol, l'e-méthanol et le biométhane, la mission de décarbonation de la flotte est jusqu'à présent en bonne voie.



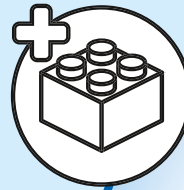
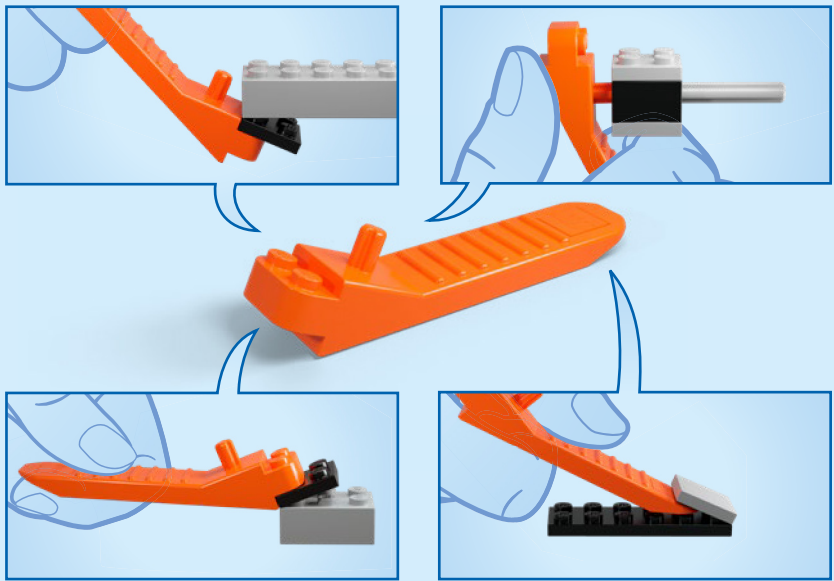

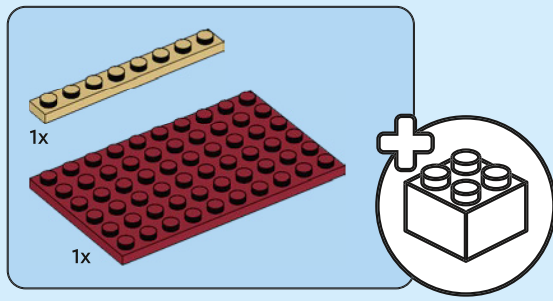

1

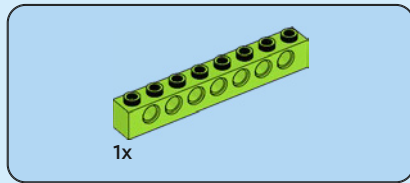
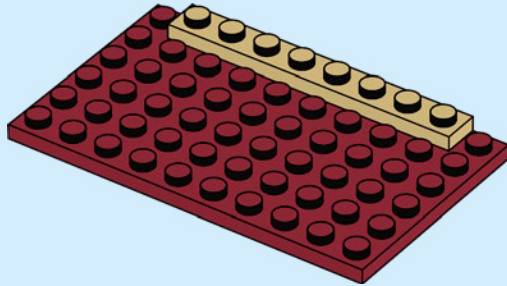

2

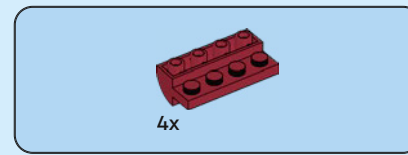
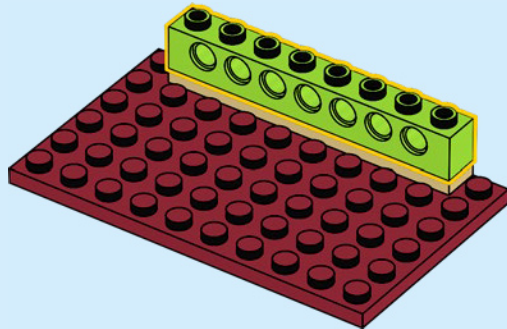

3

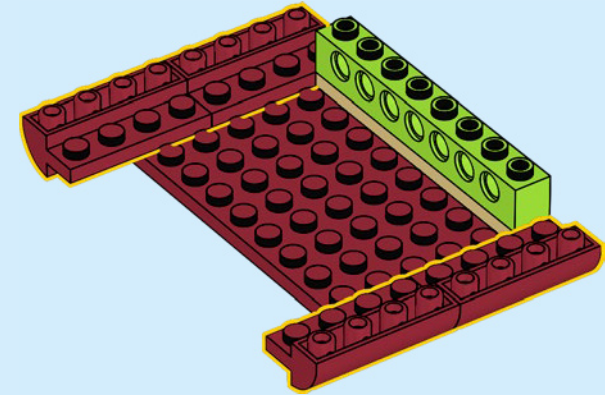

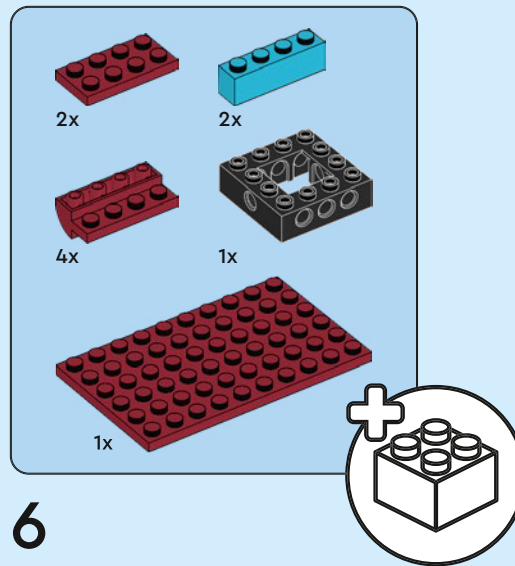
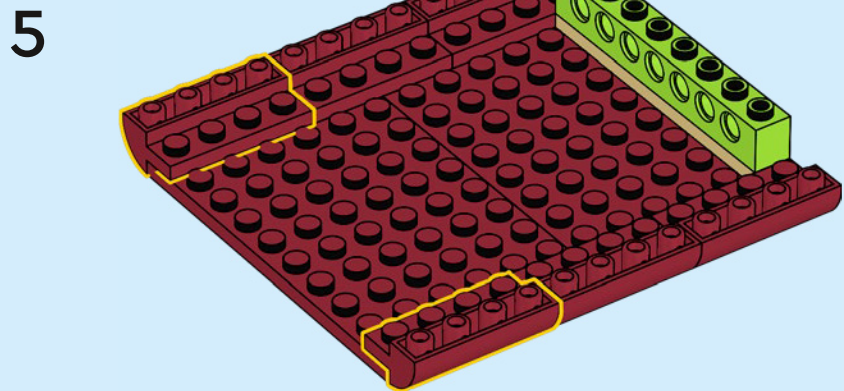
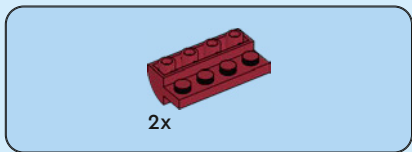
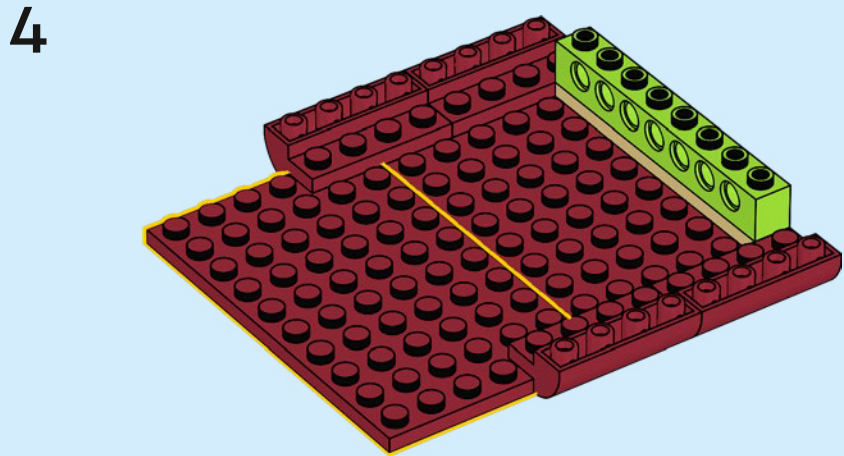
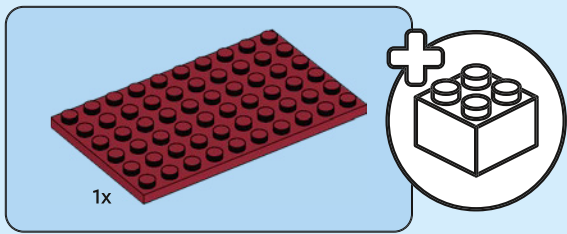

6

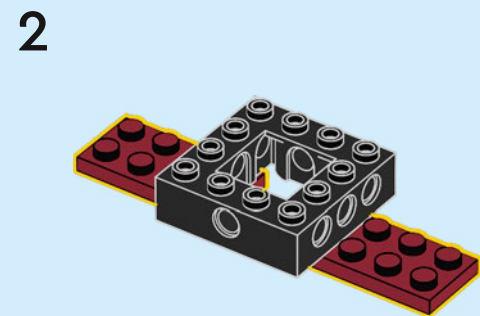
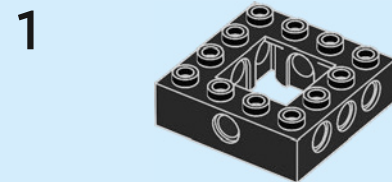

3

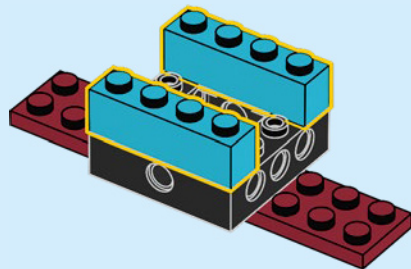

4

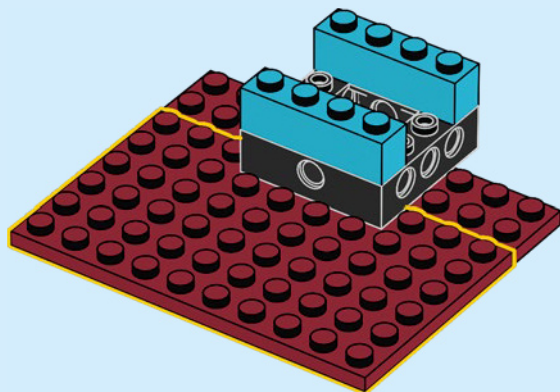

5

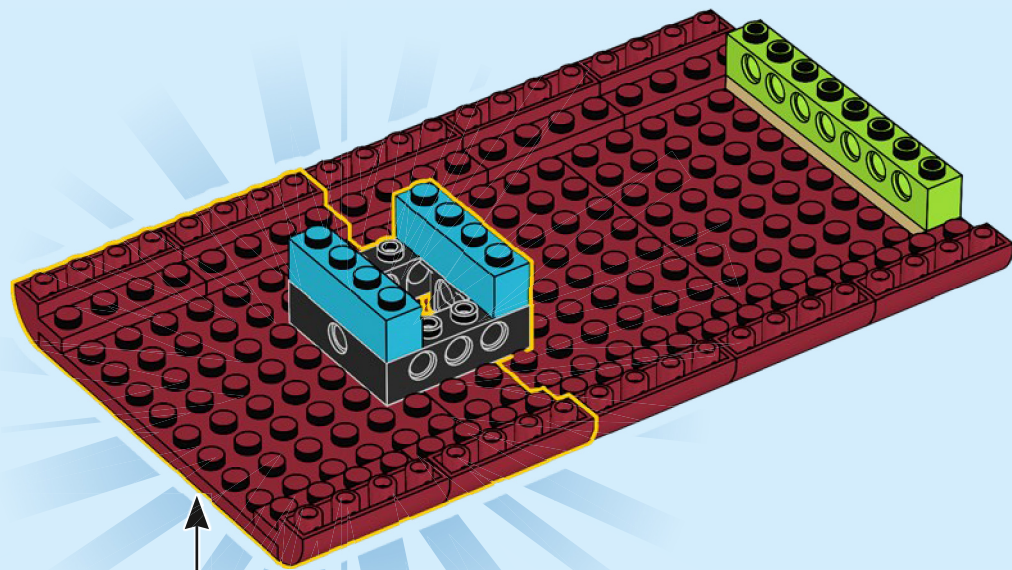
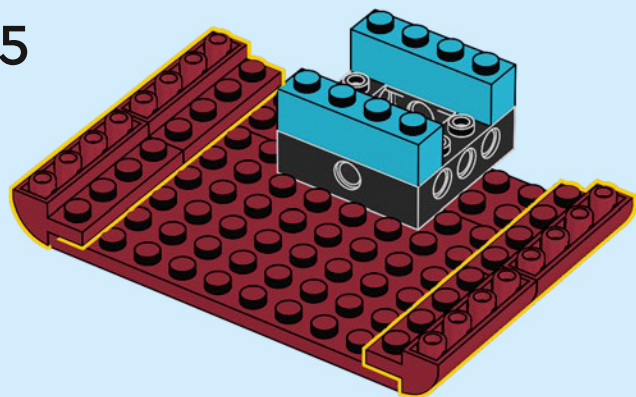

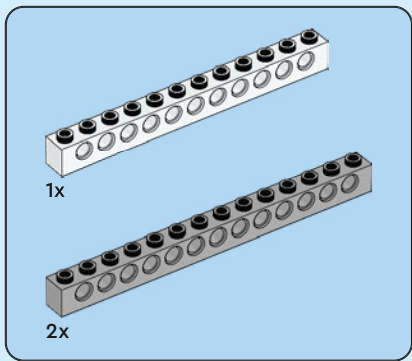

7

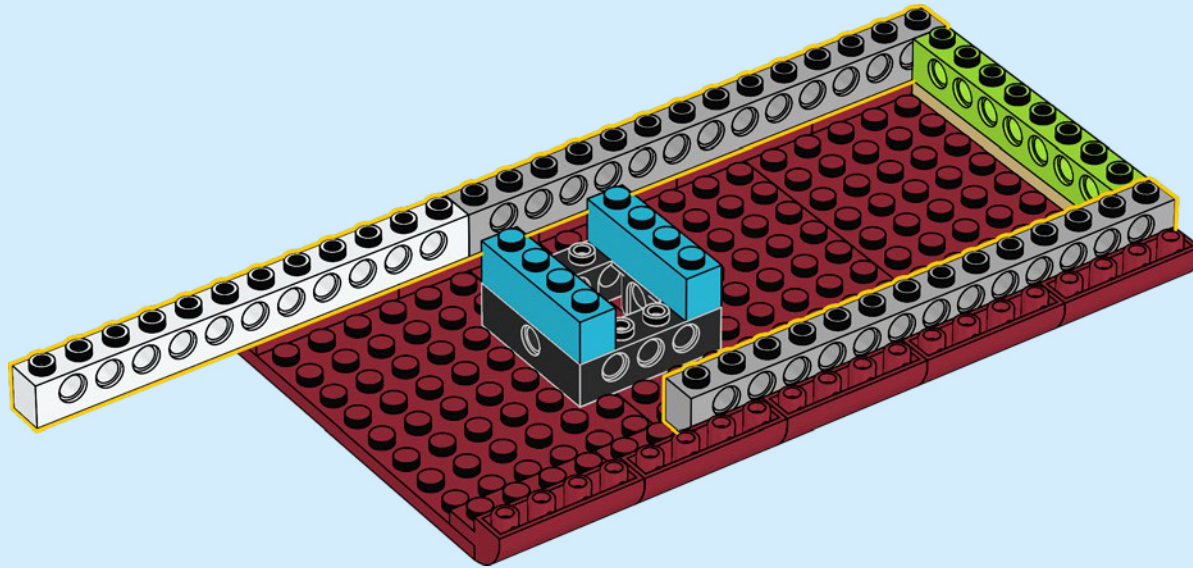

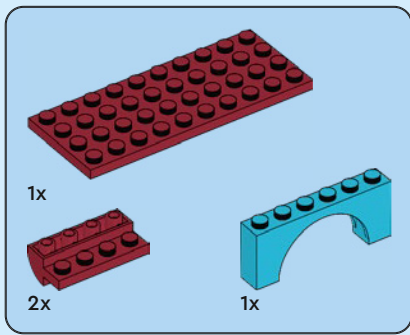

8

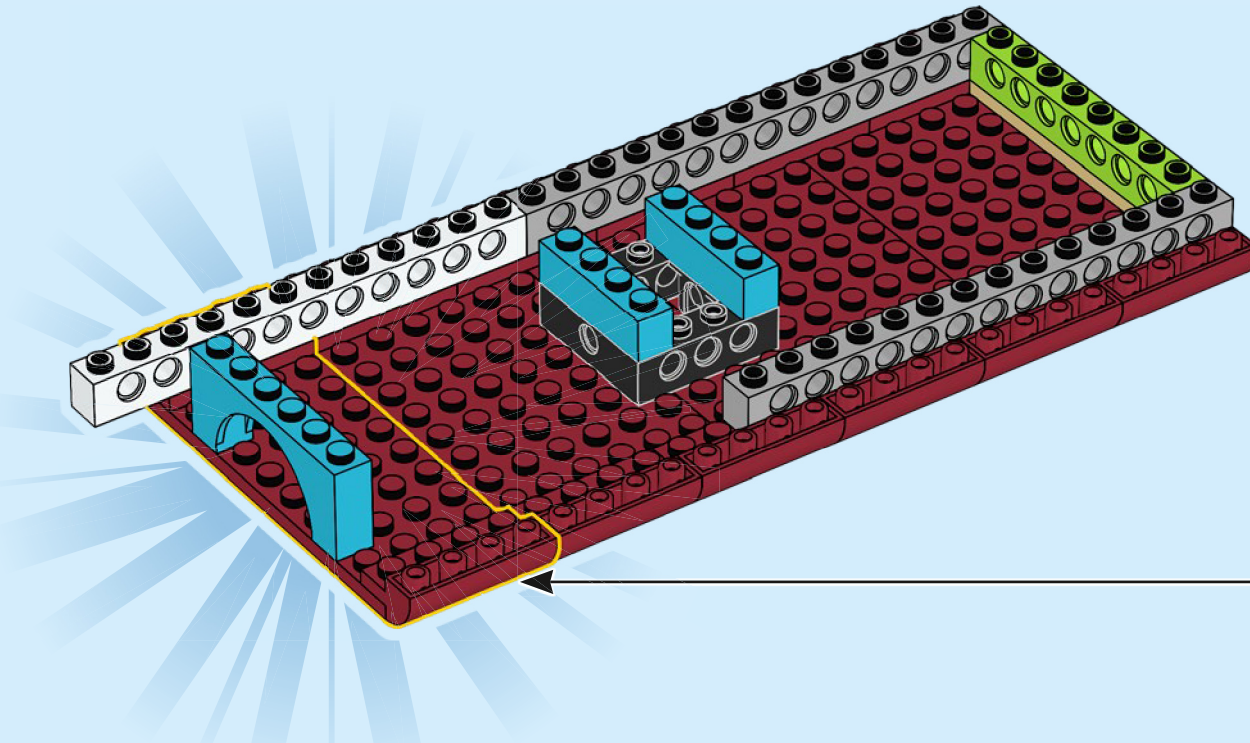
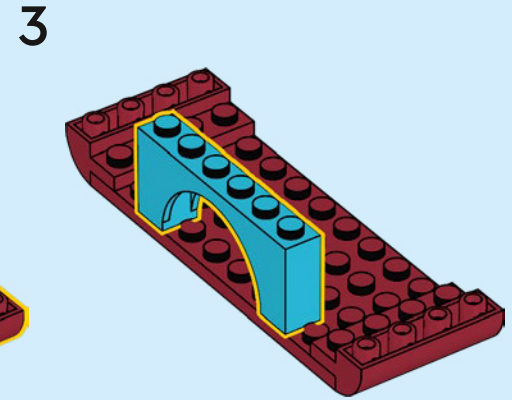
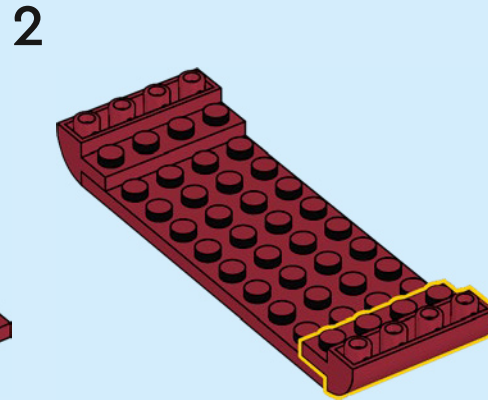
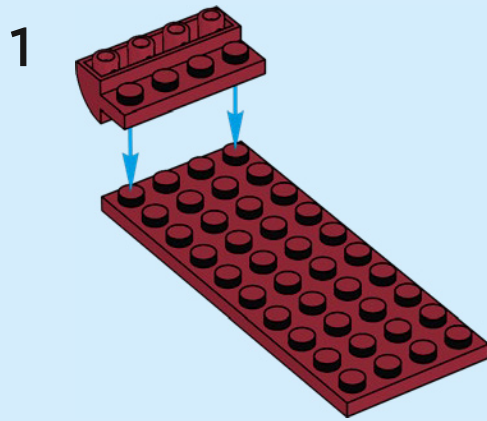

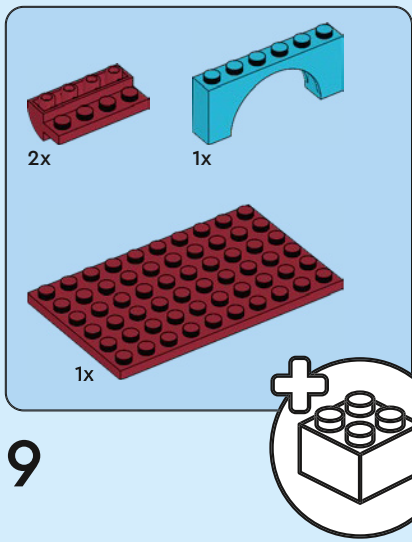

9

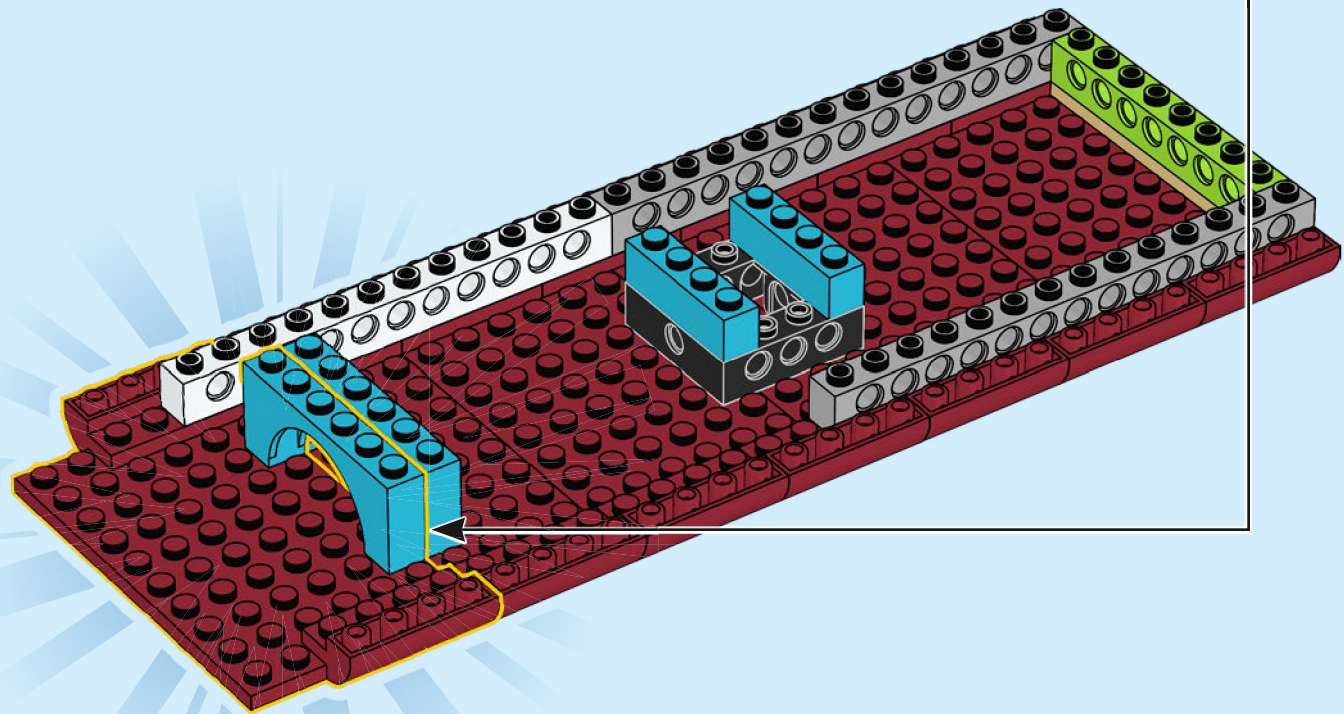
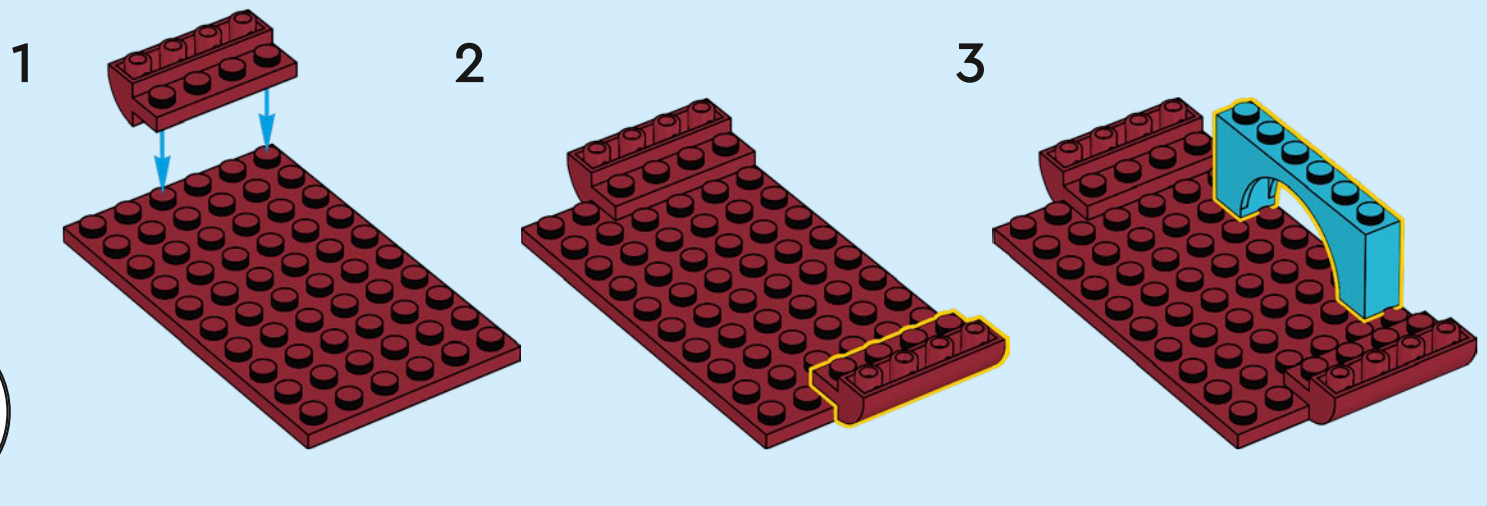

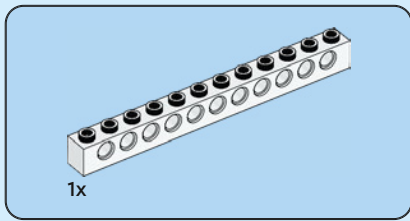

10

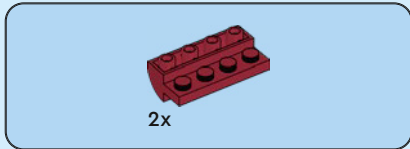
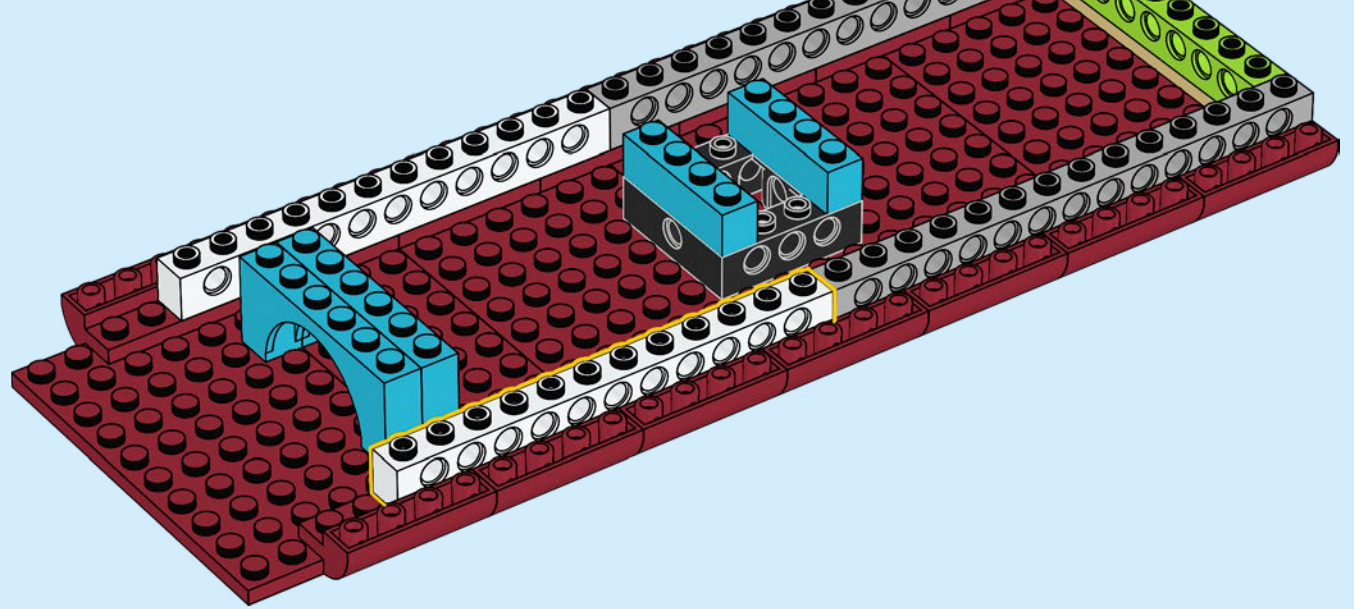

11

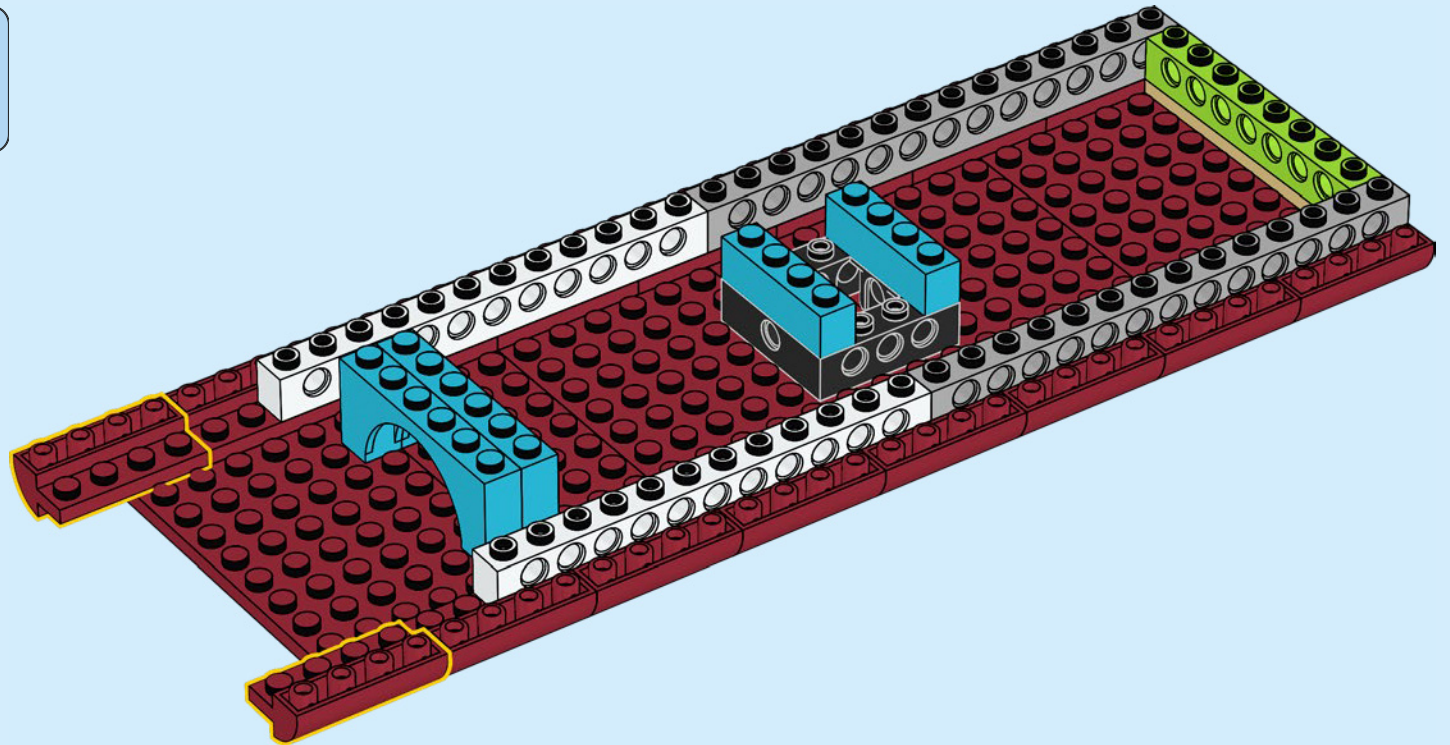

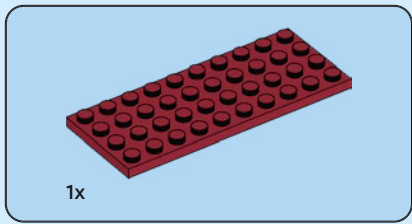

12

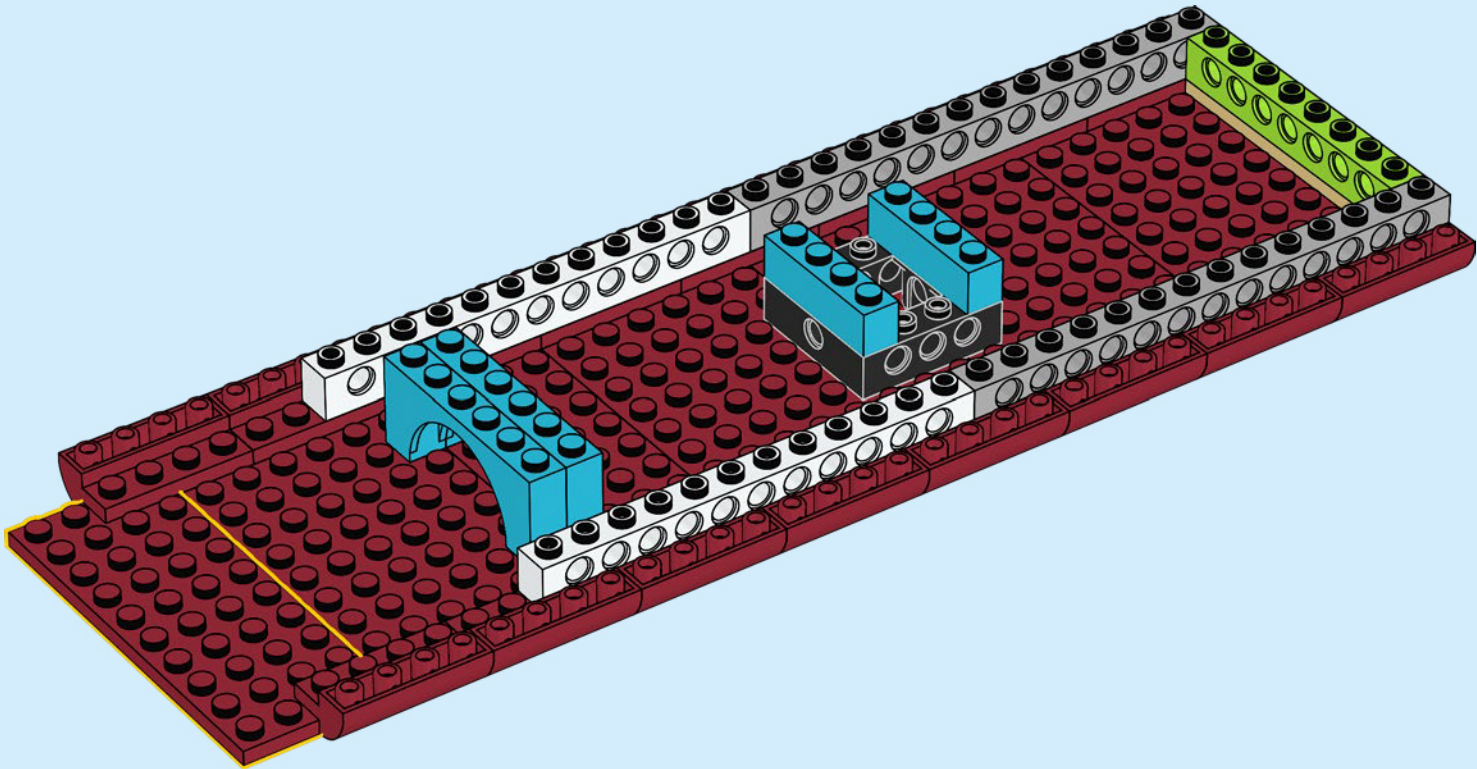

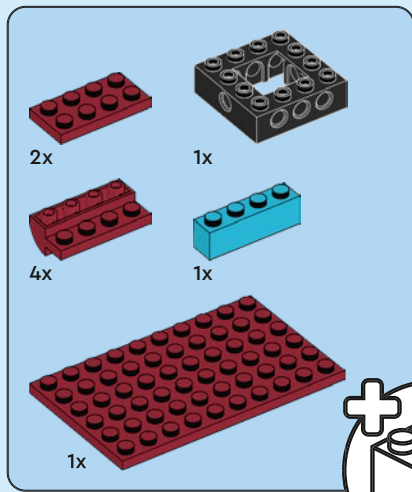

13

1

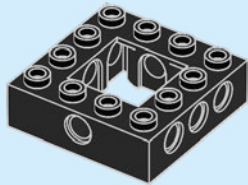

2

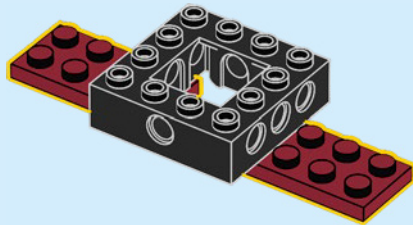

3

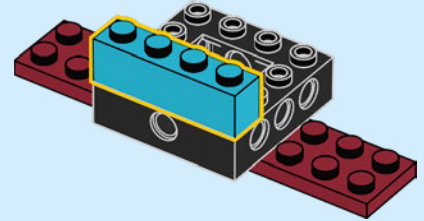

4

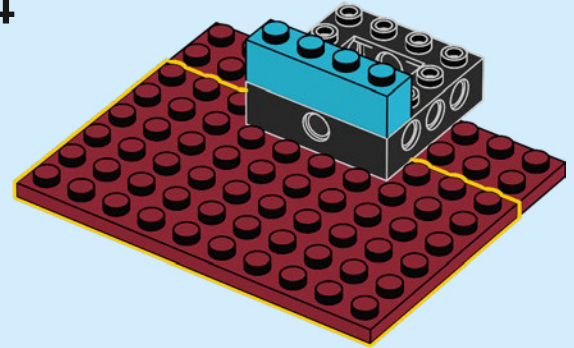

5

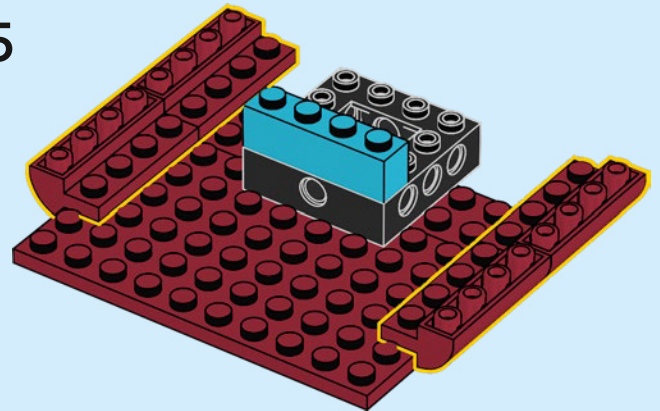

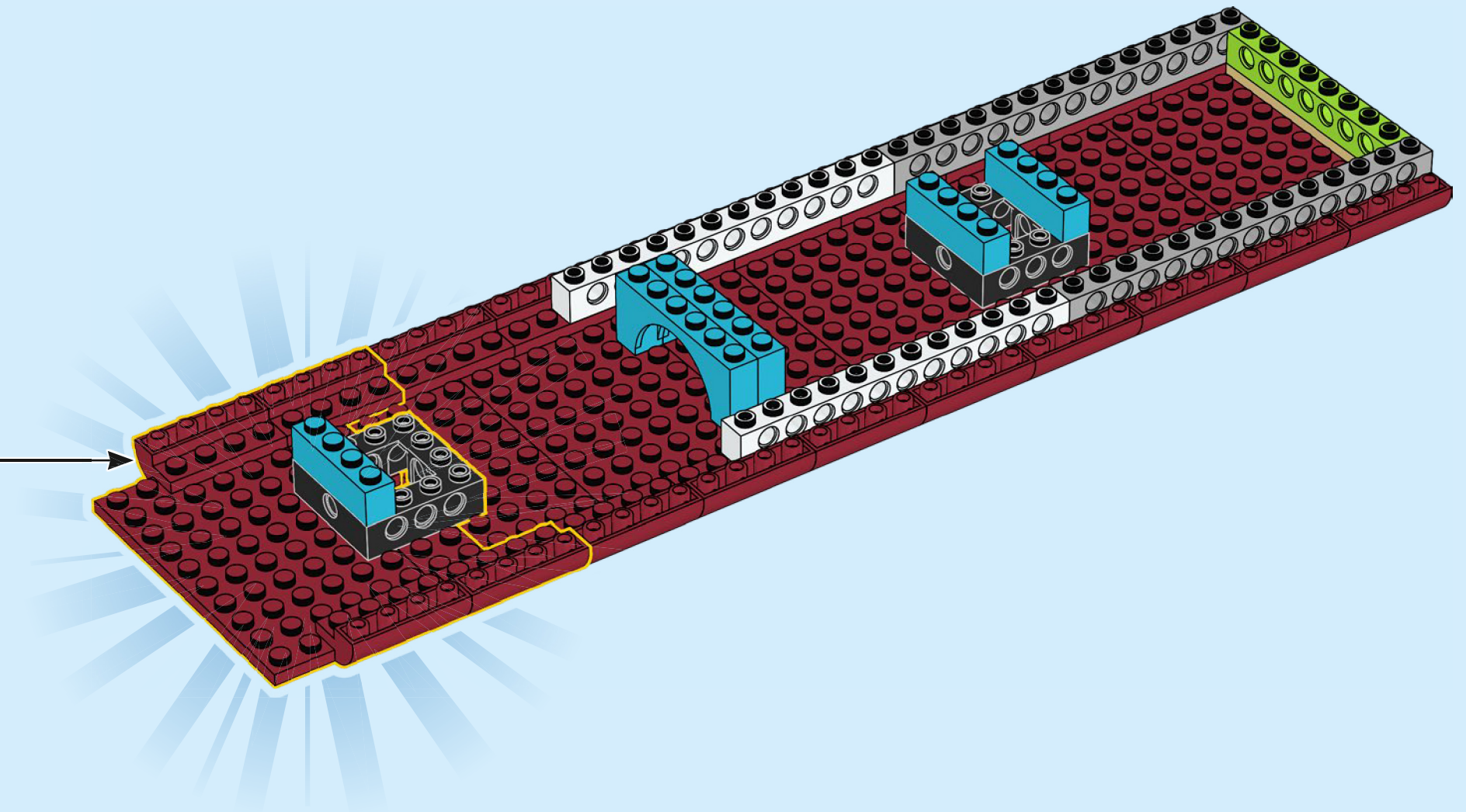

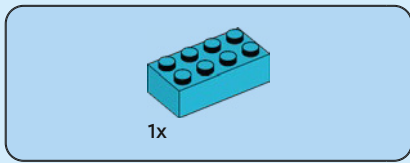

14

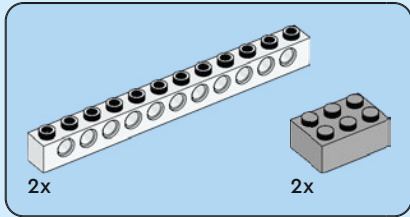
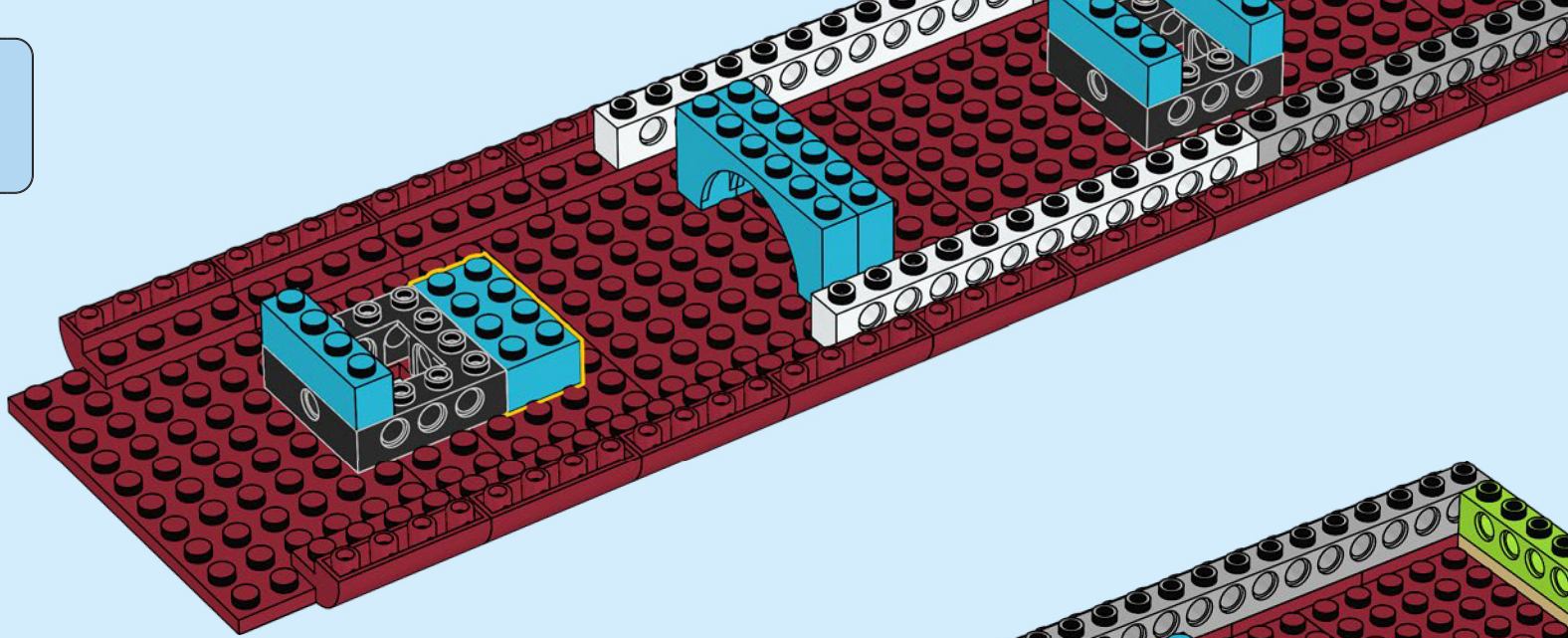

15

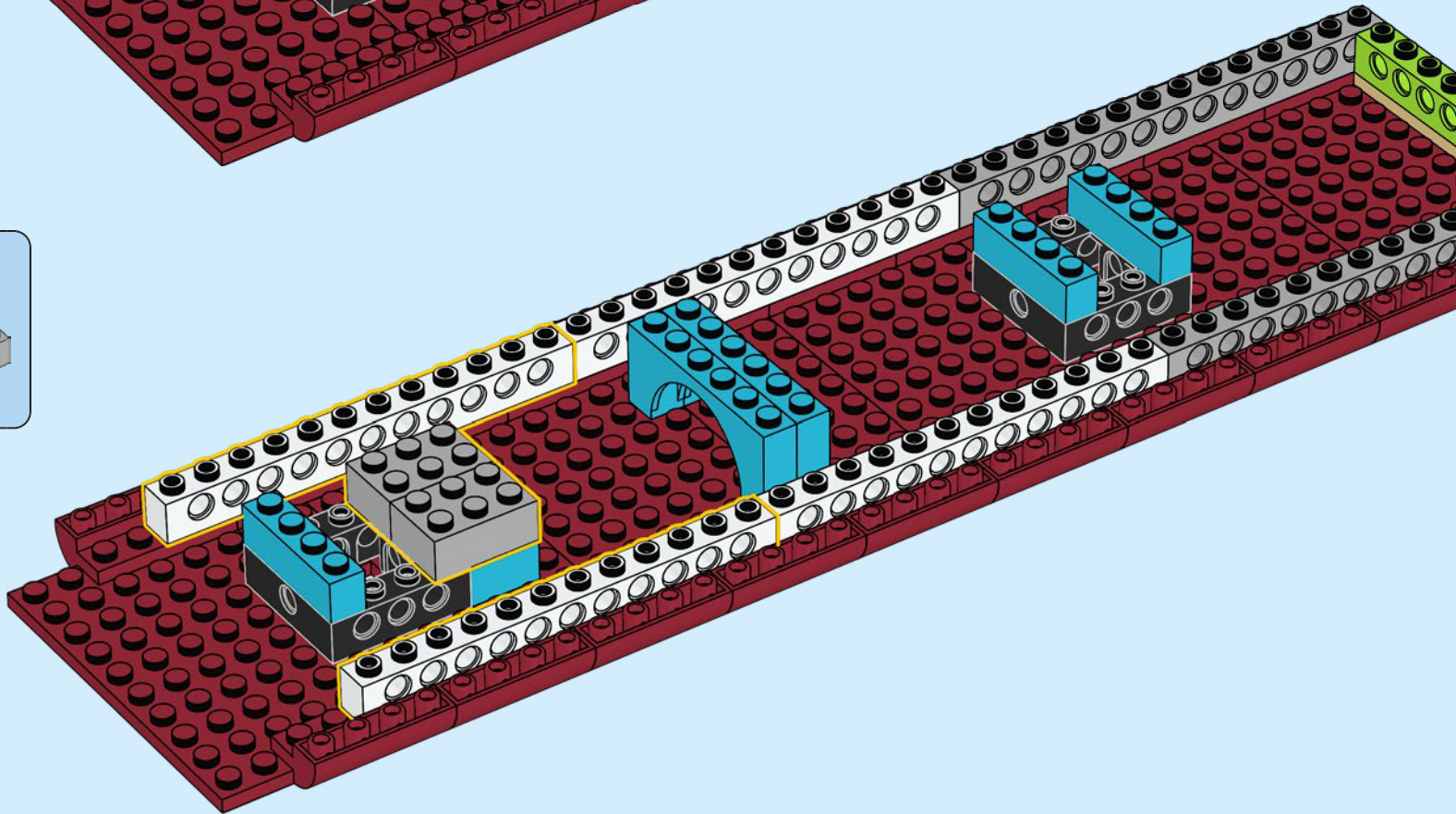

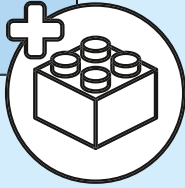
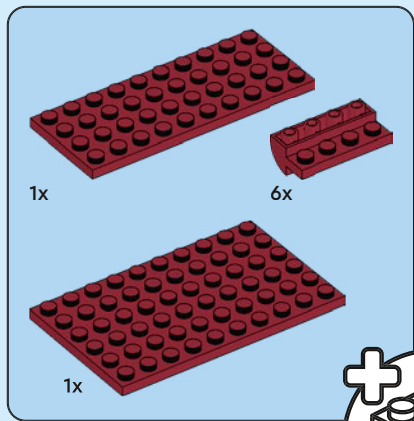

16

1

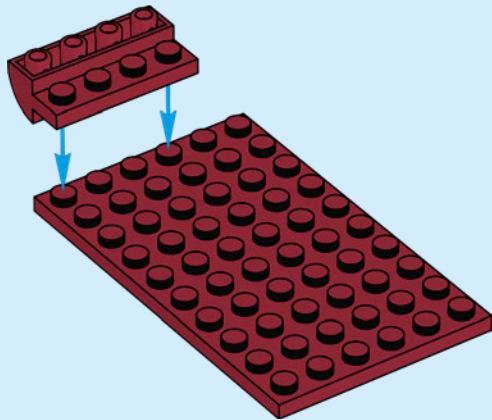

2

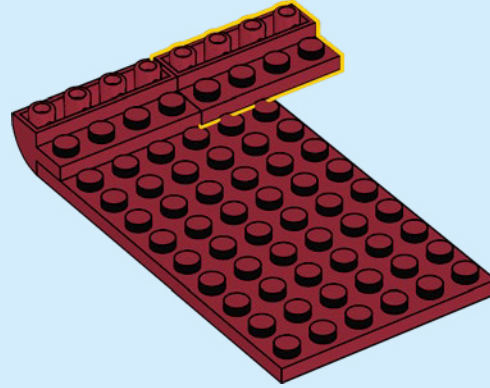

3

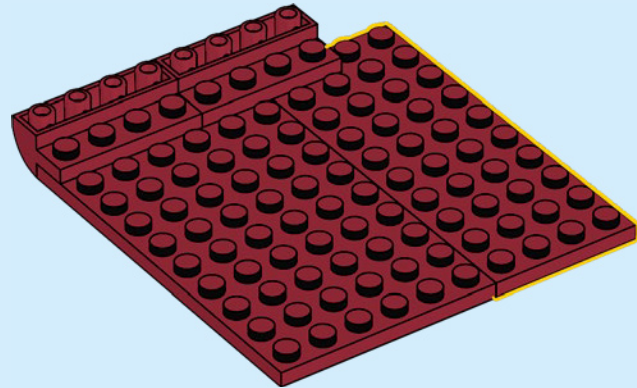

4

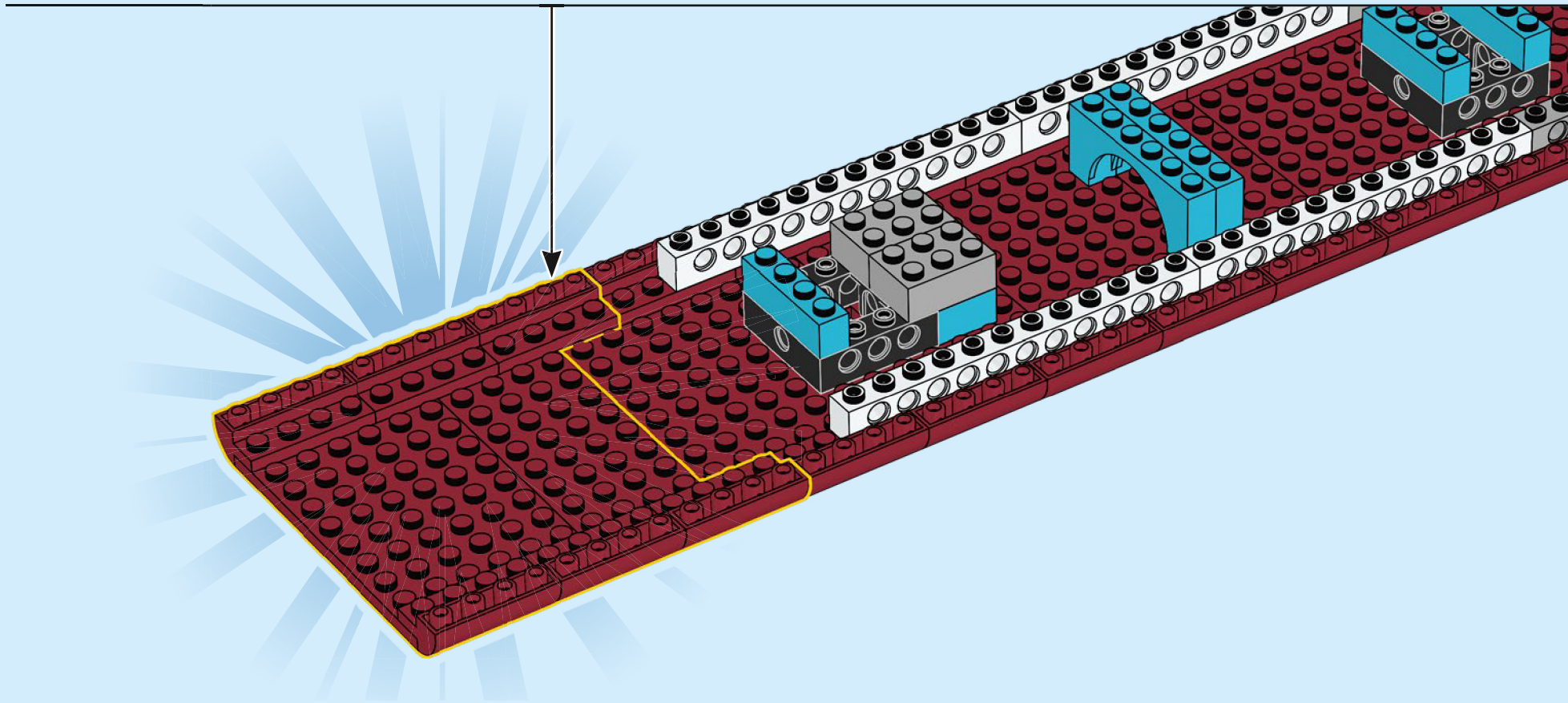
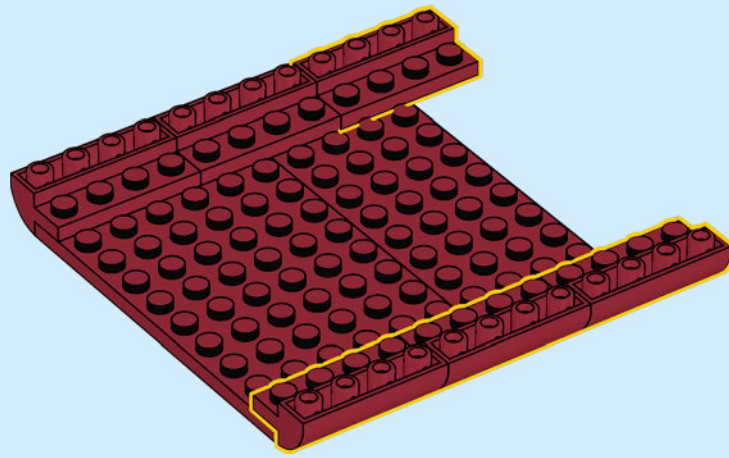

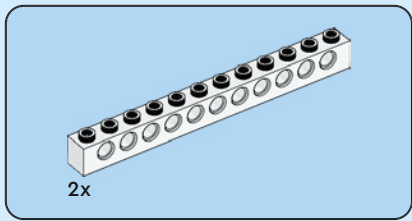

17

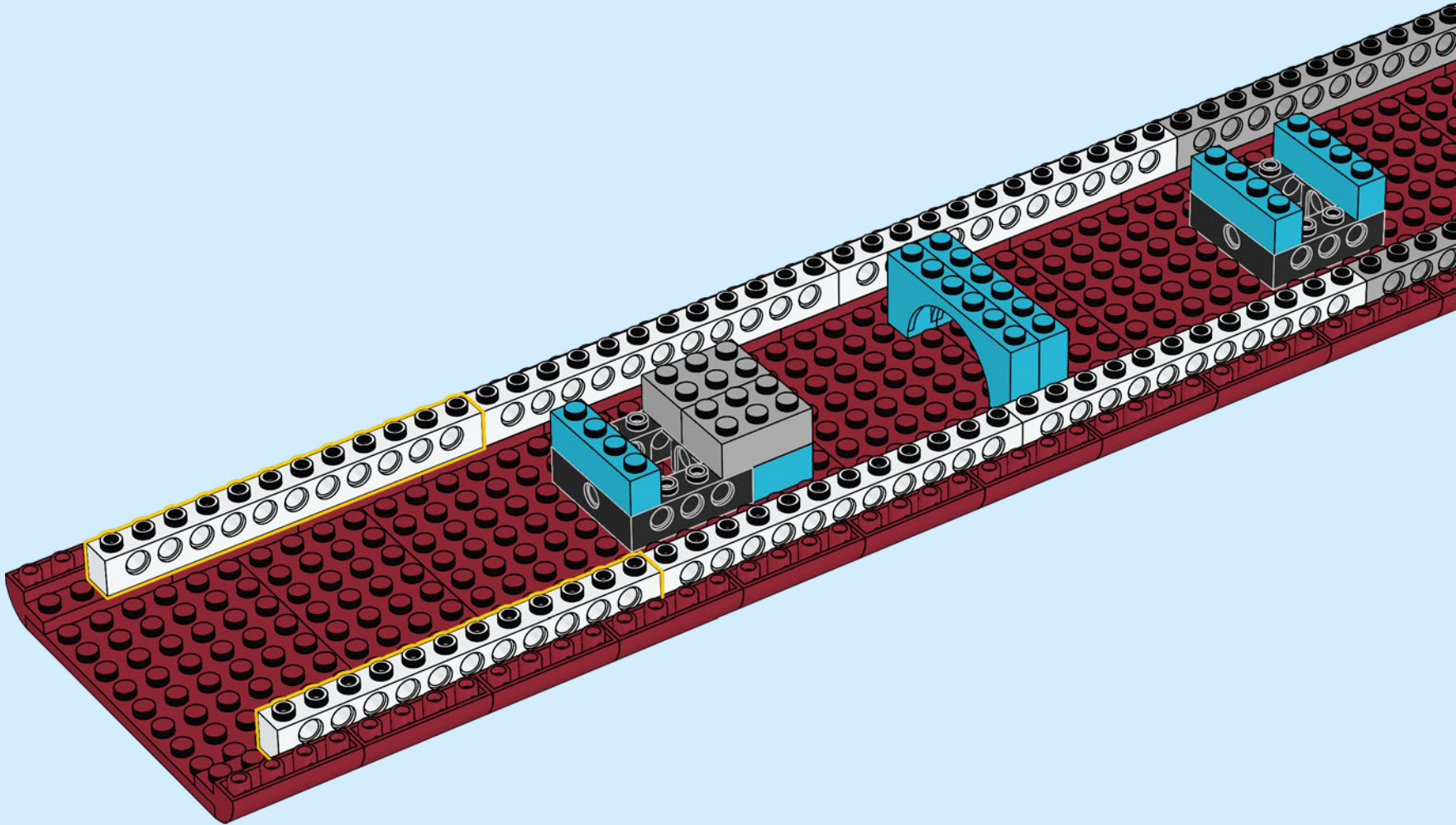

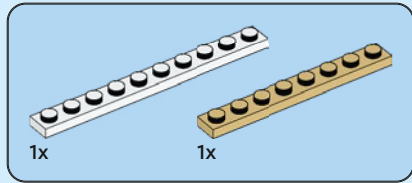

18

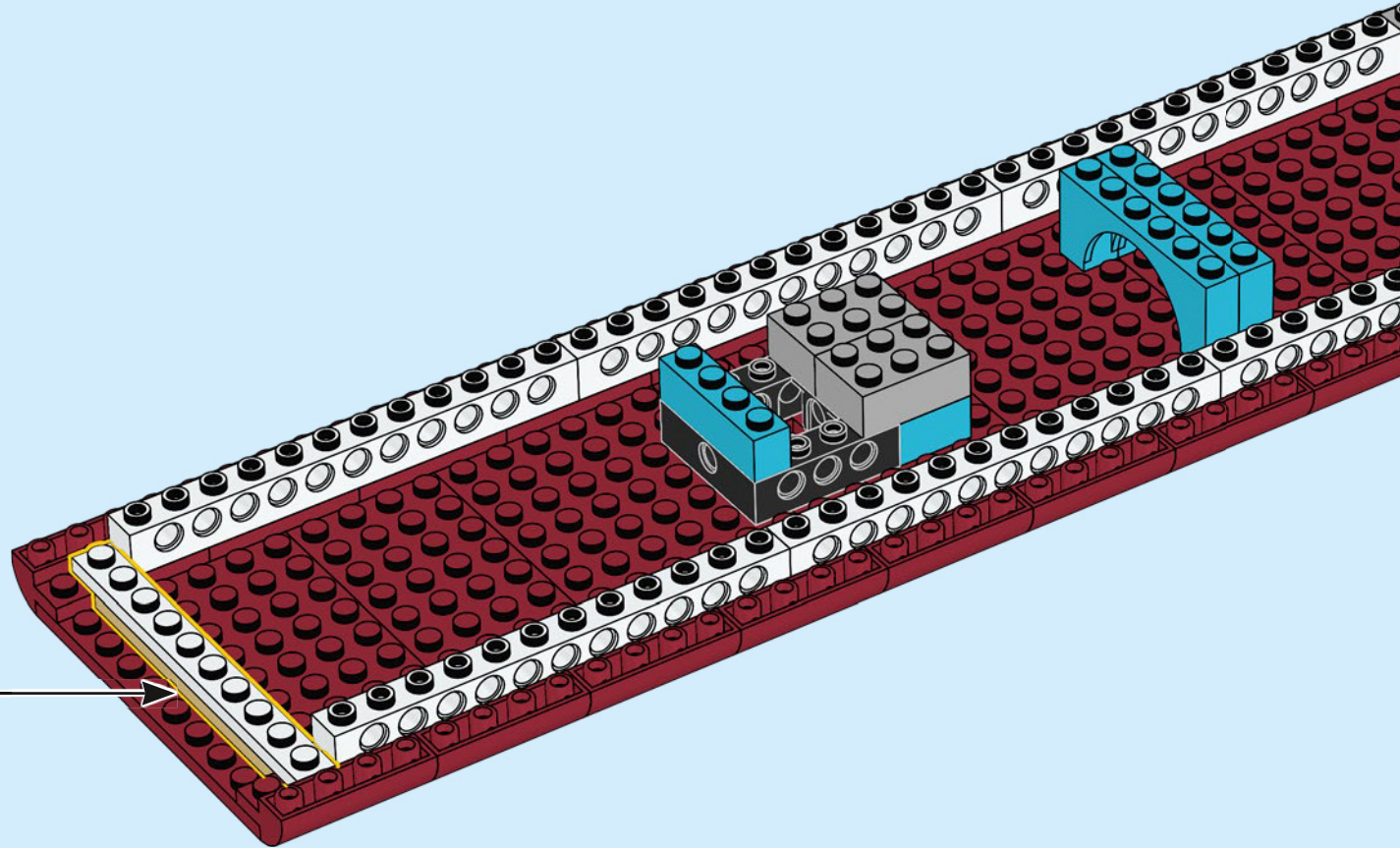
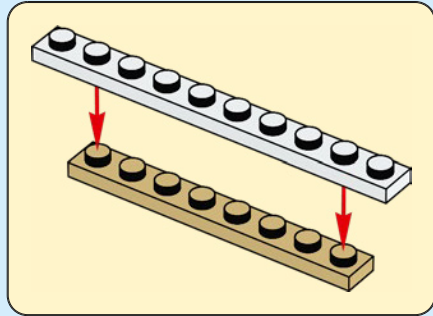

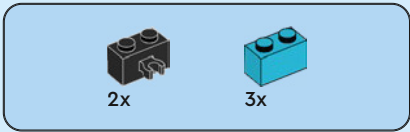

19

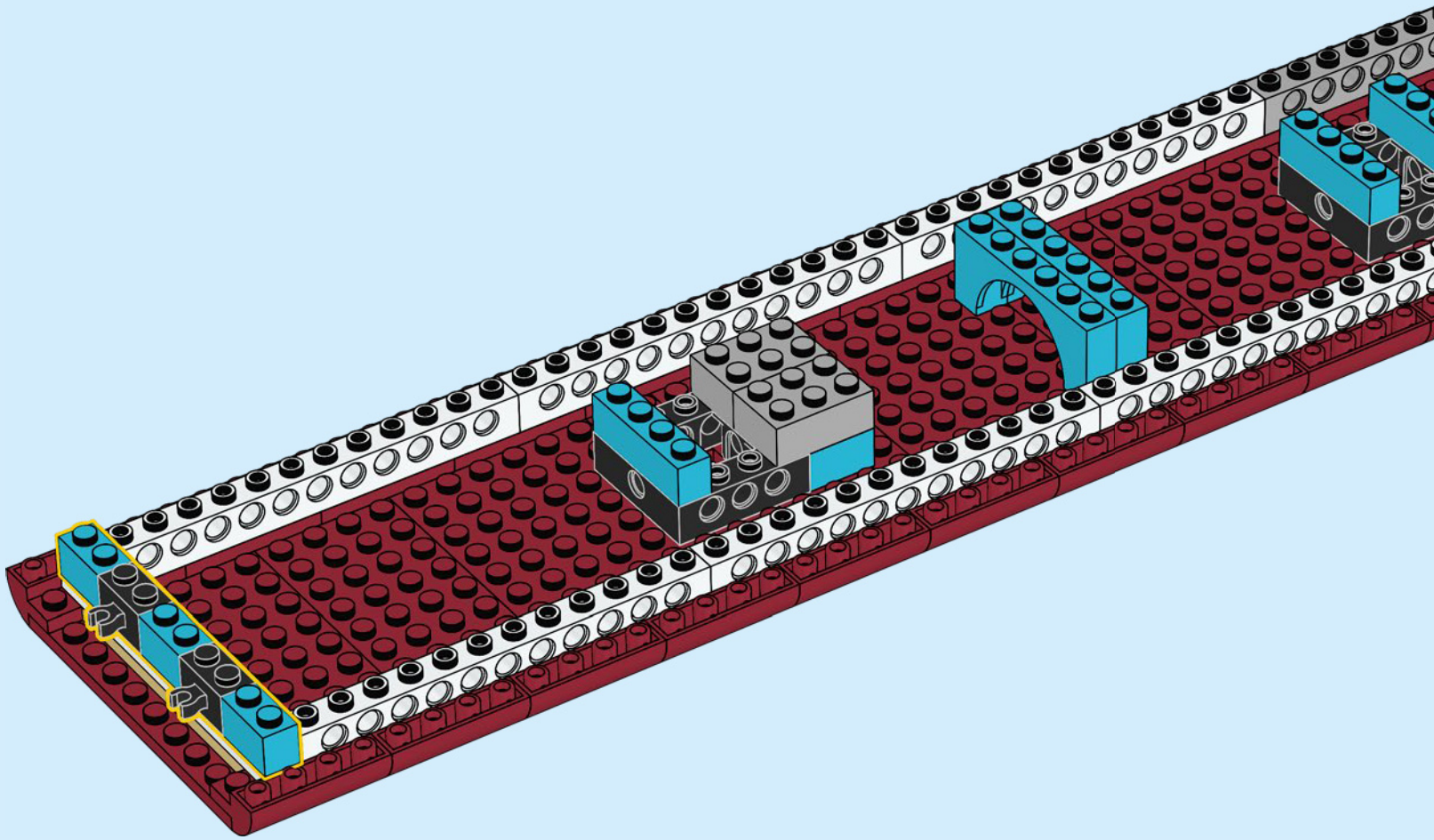

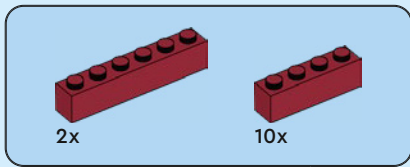

20

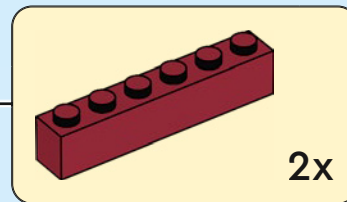
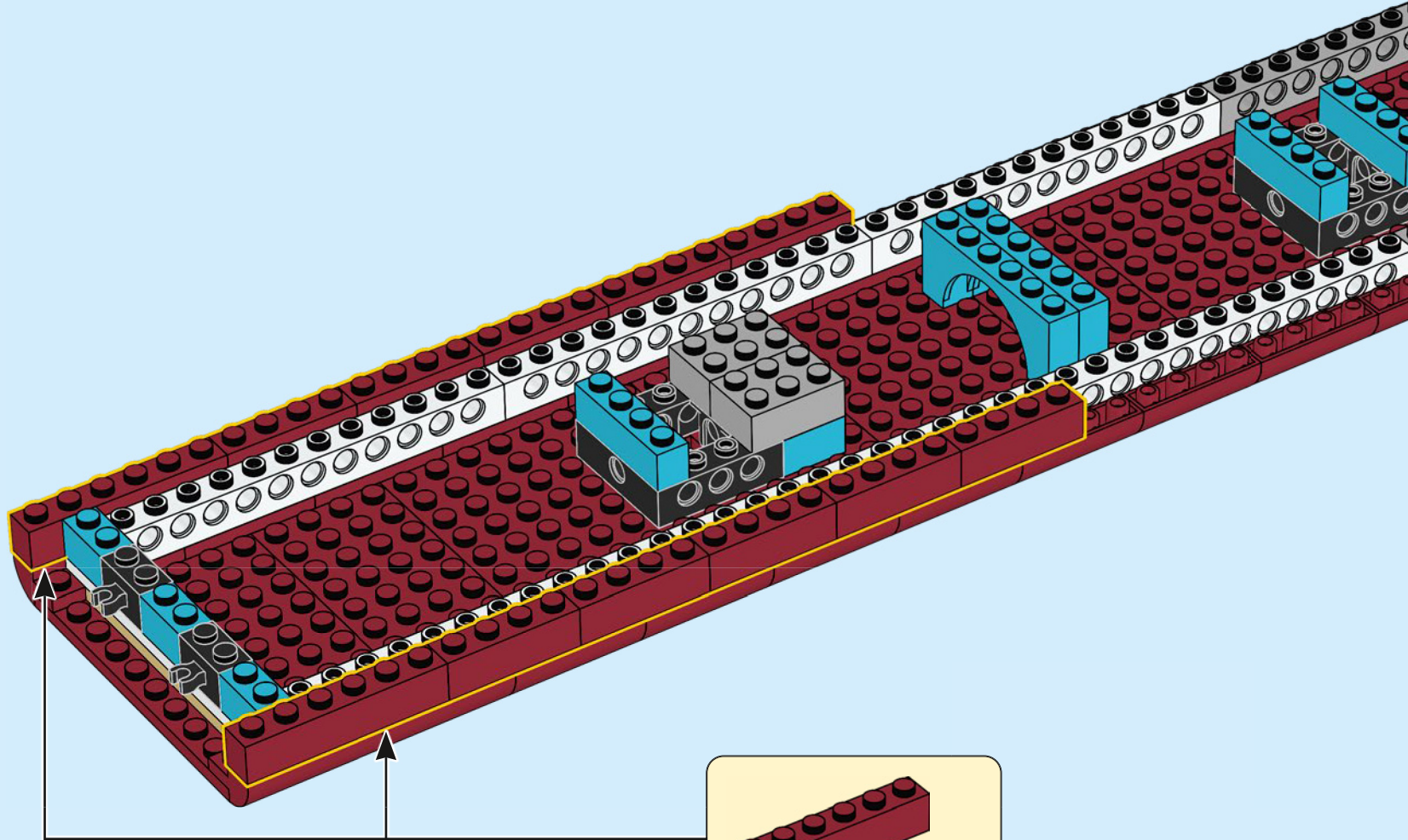

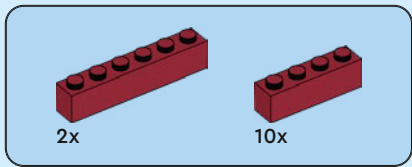

21

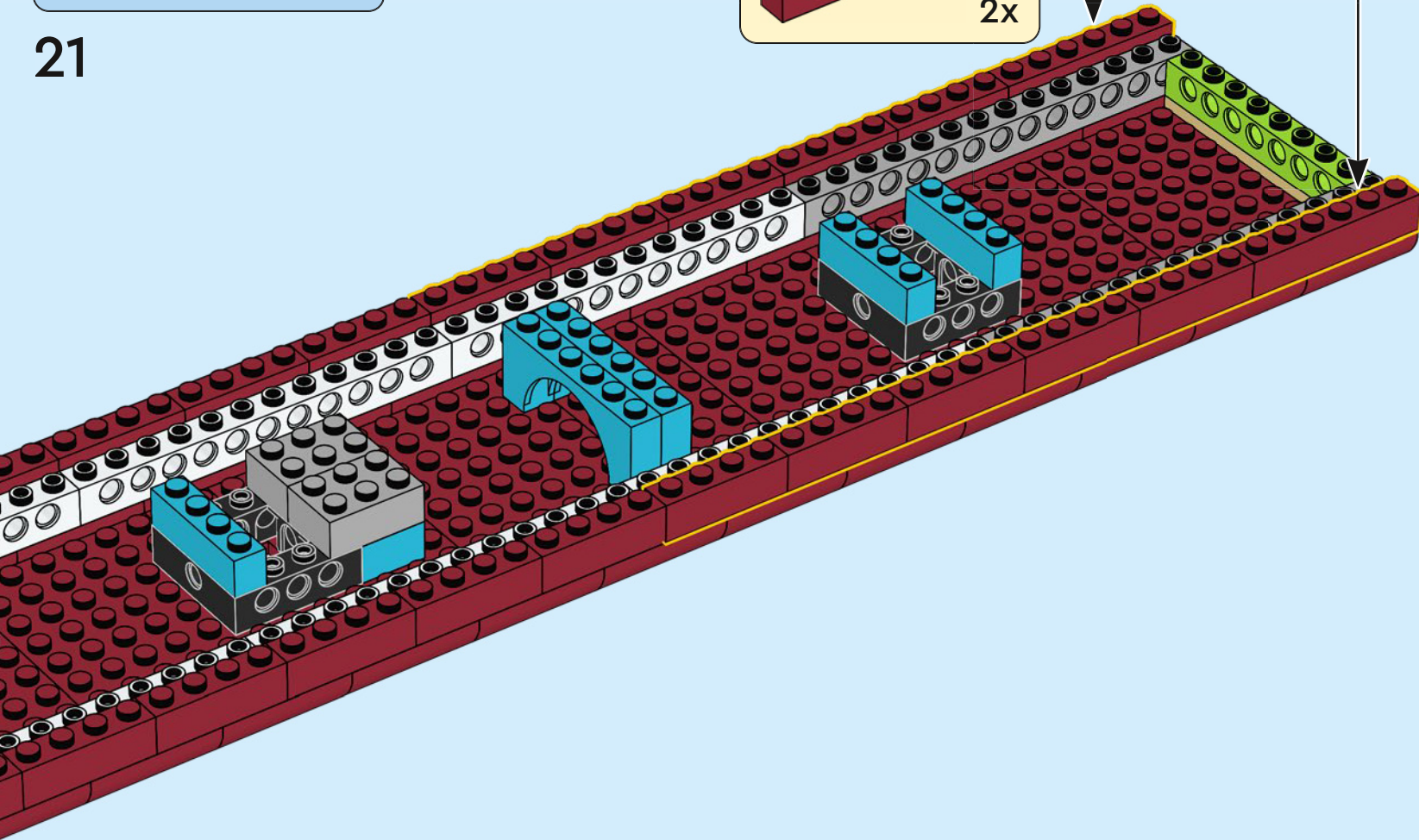
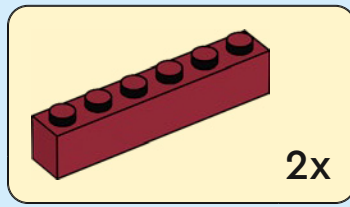

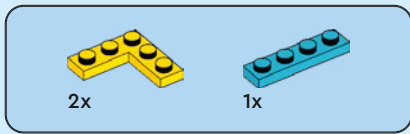

22

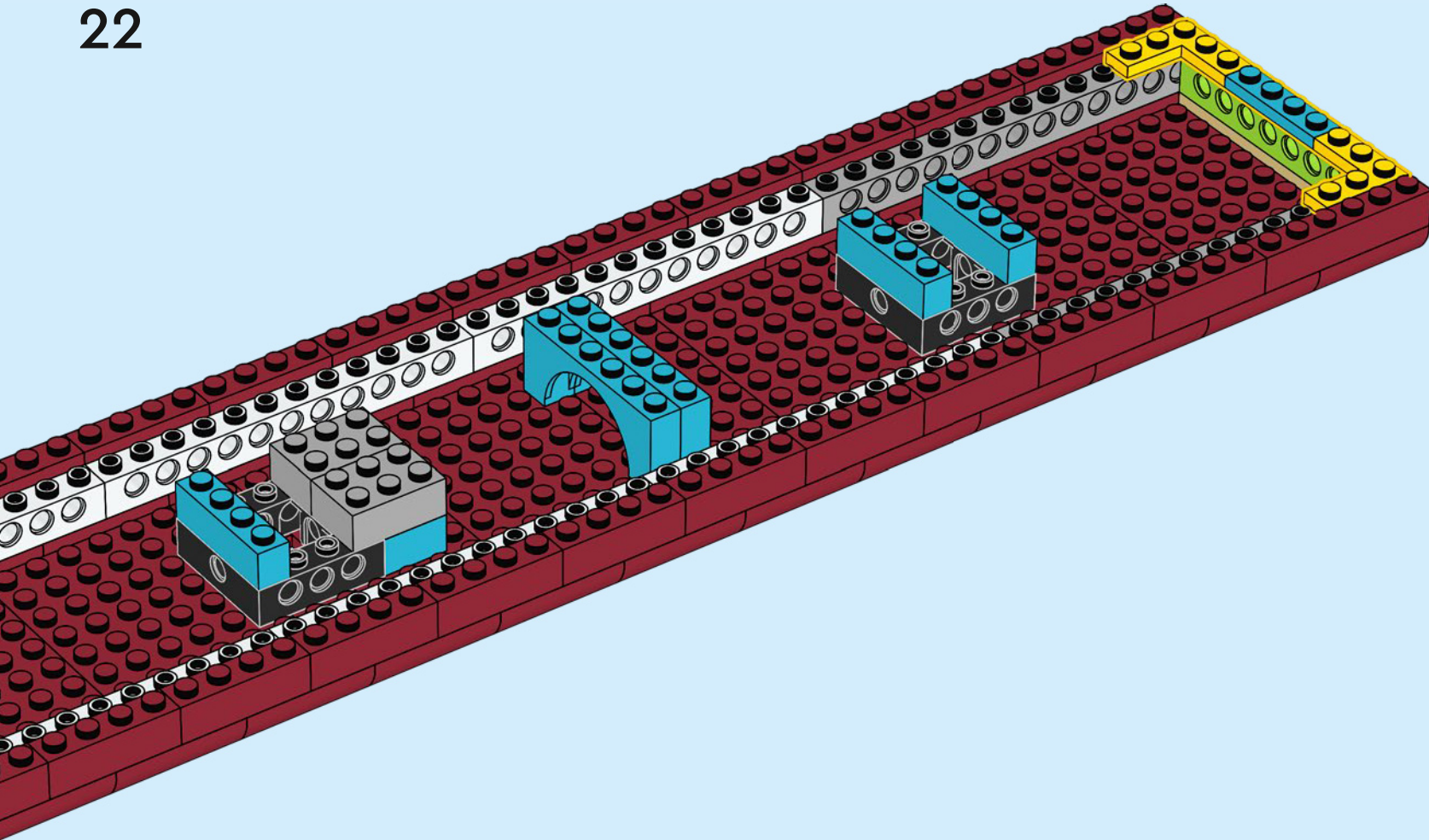

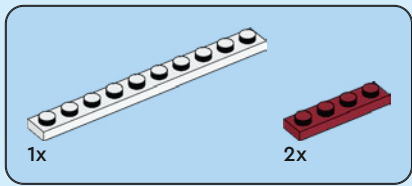

23

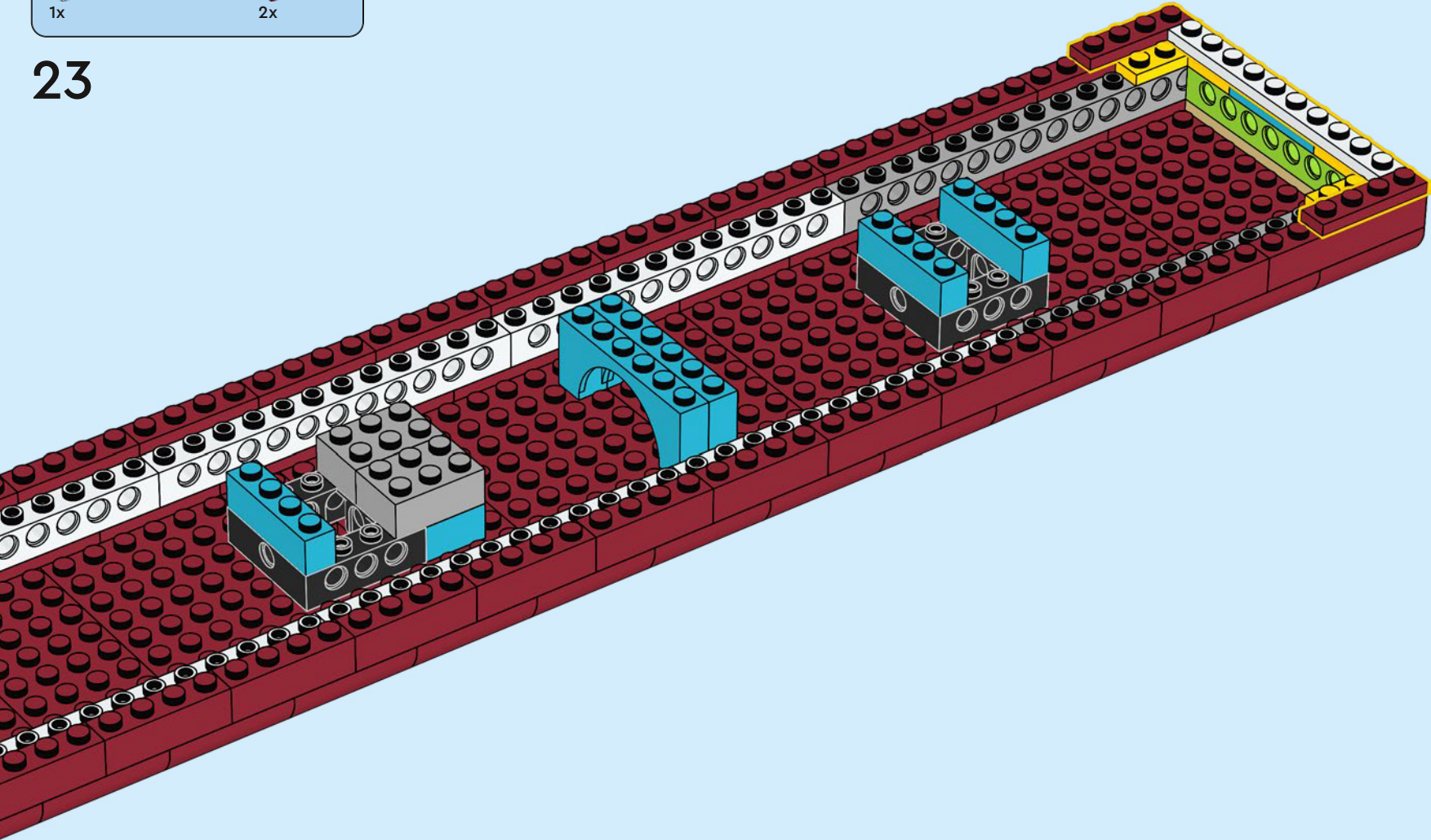

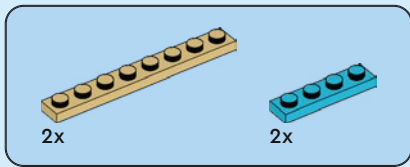

24

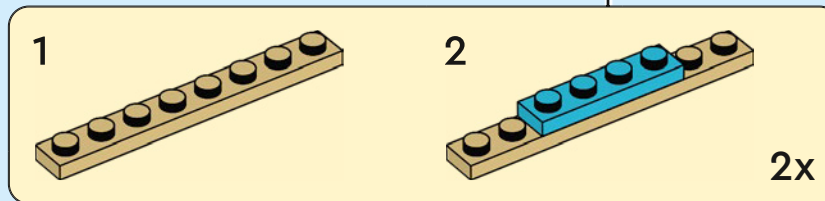
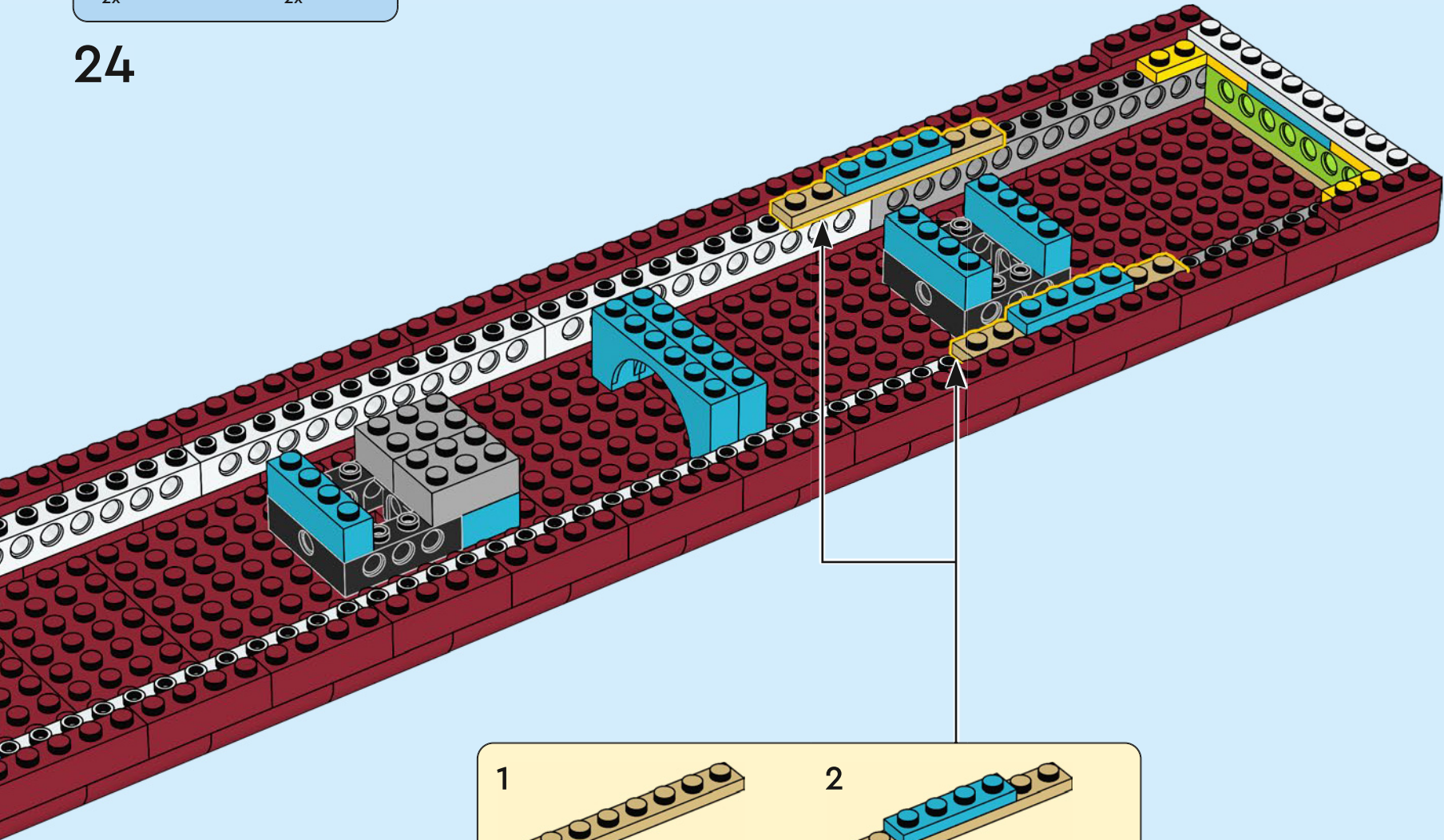

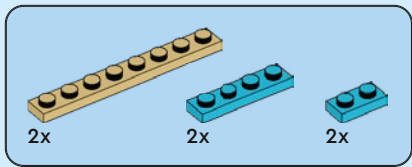

25

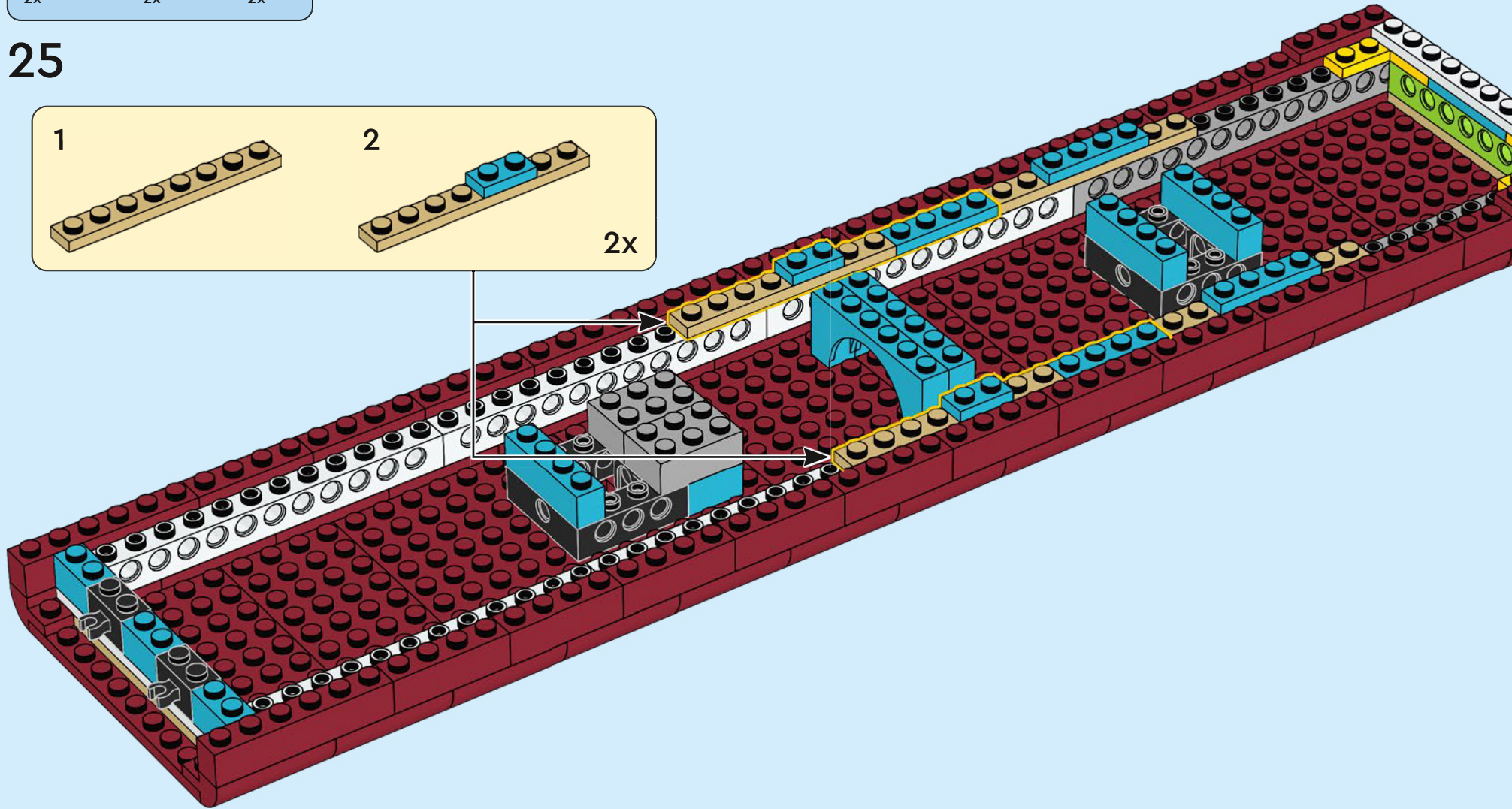
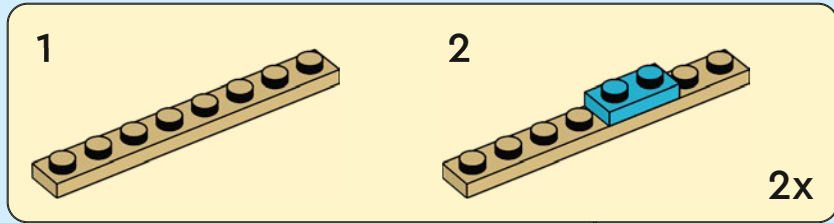

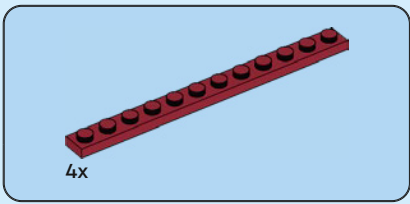

26

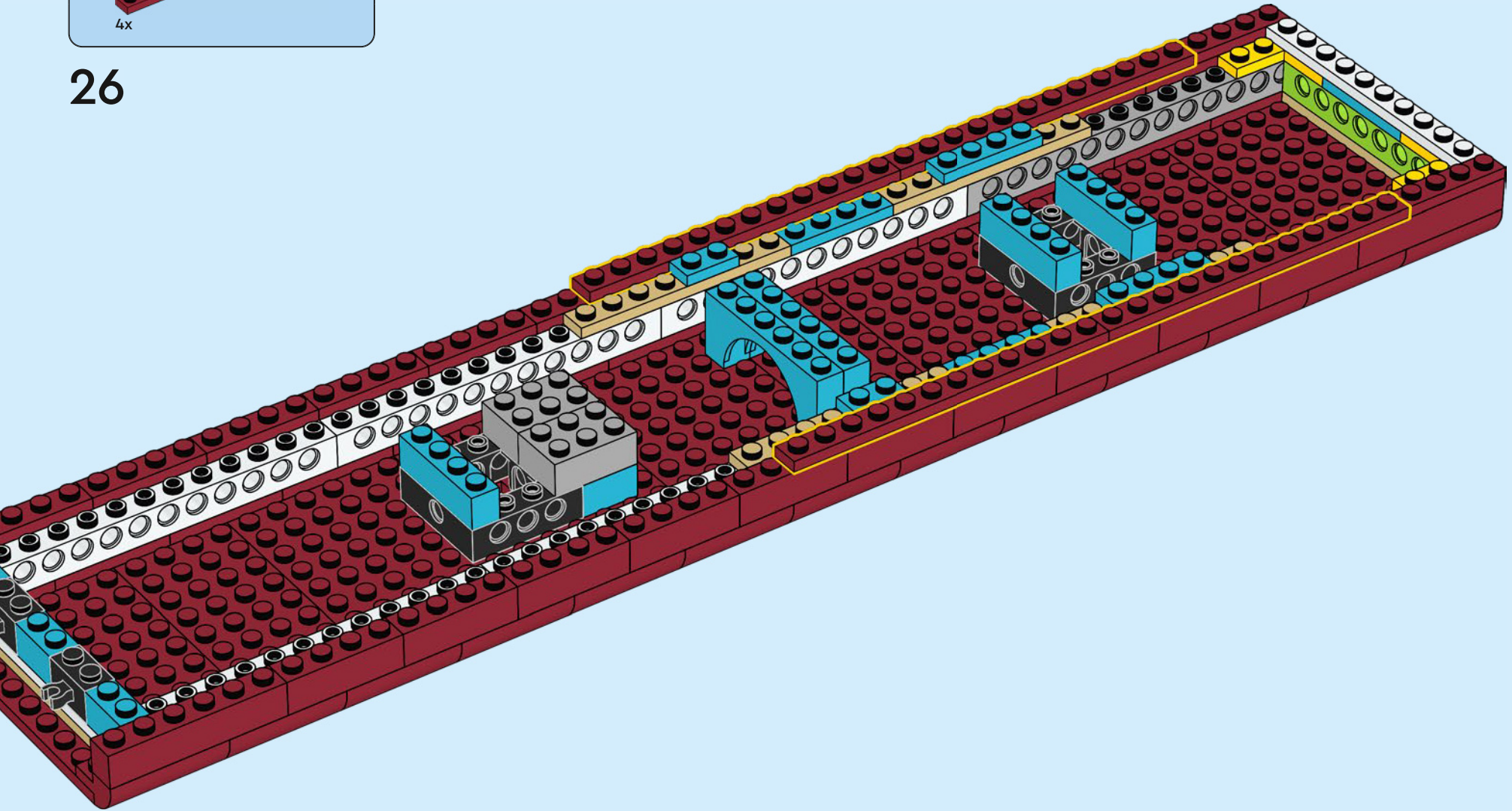

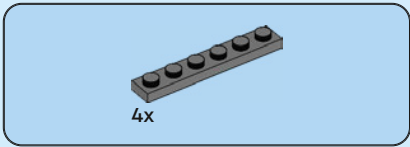

27

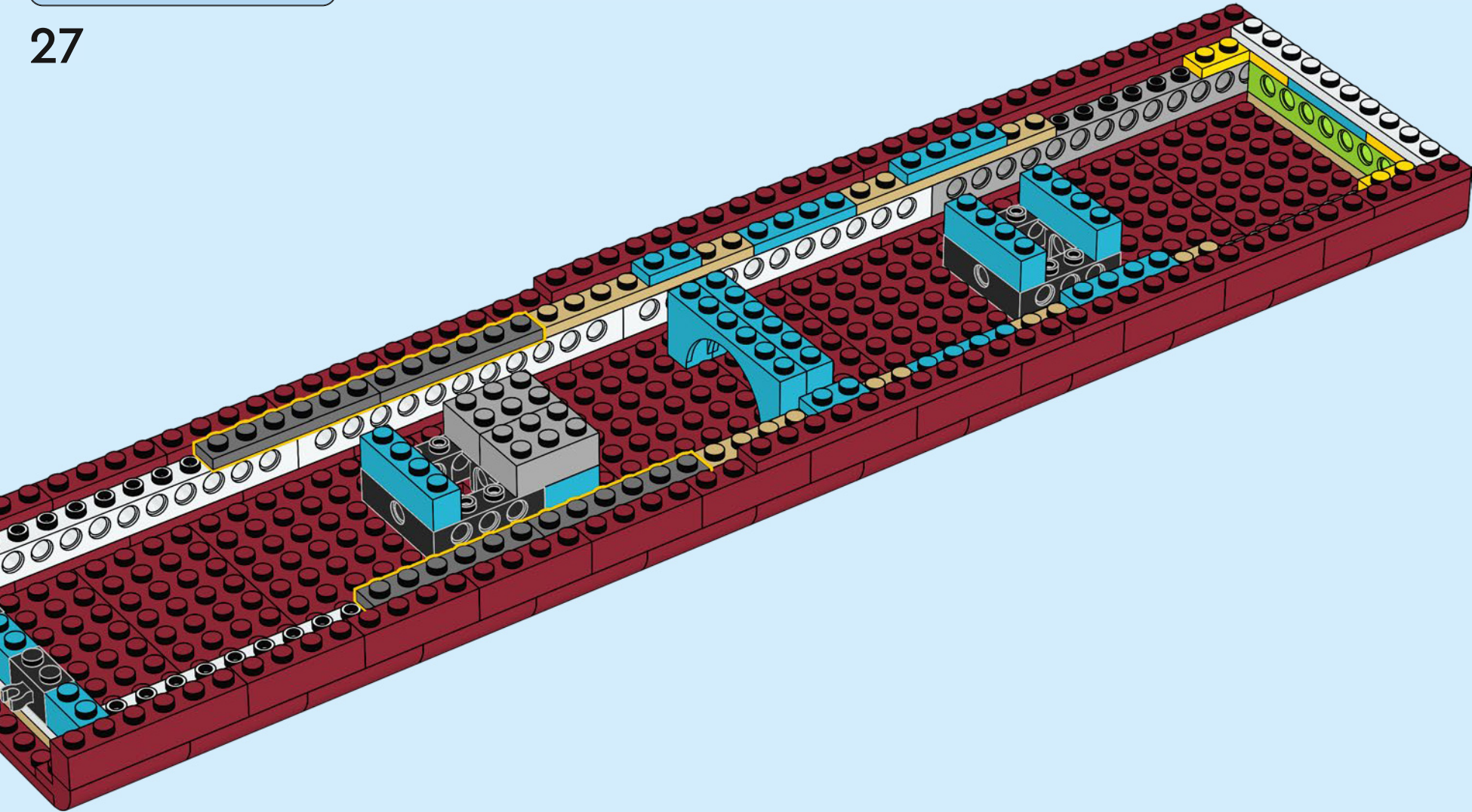

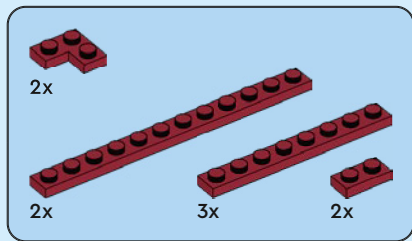

28

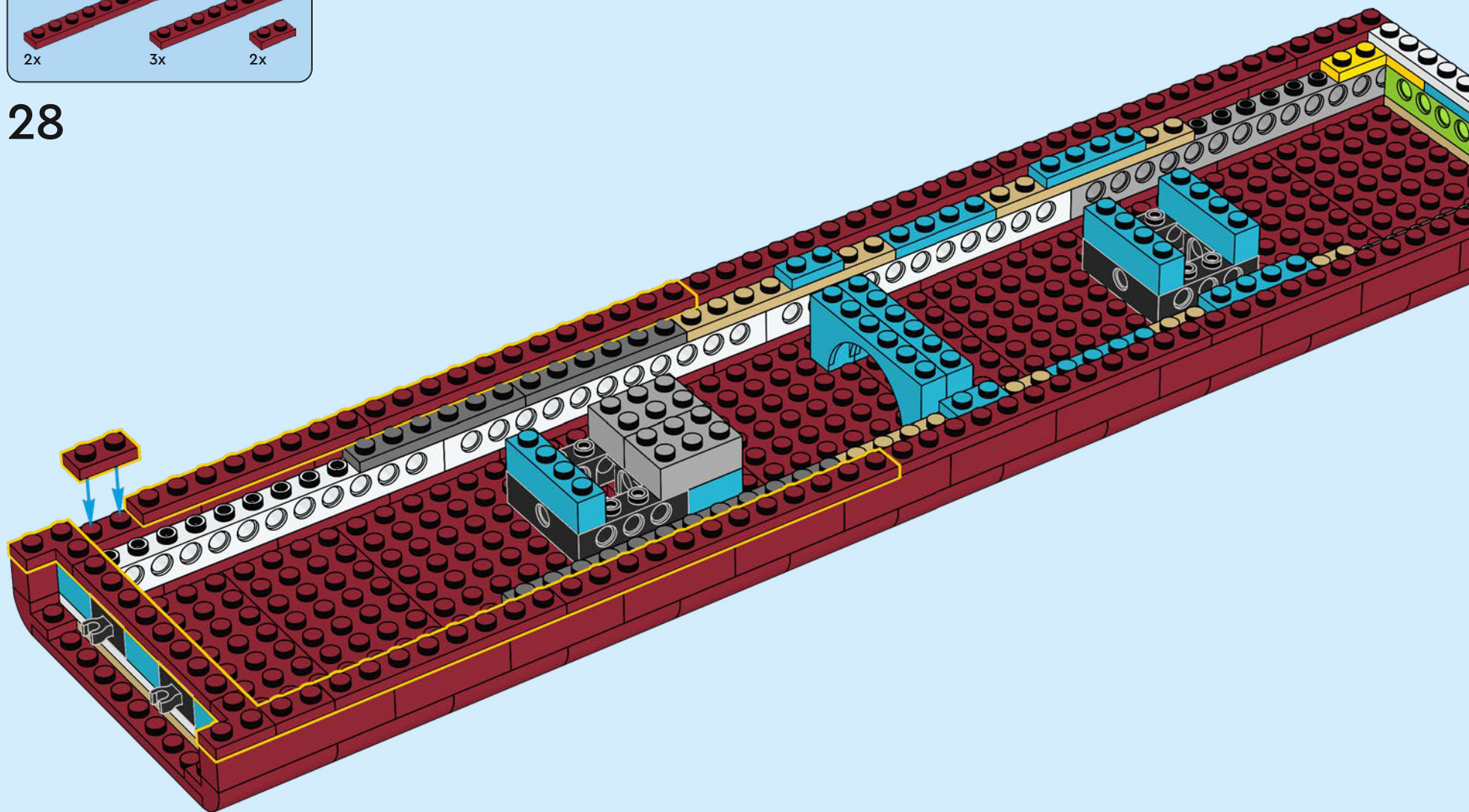

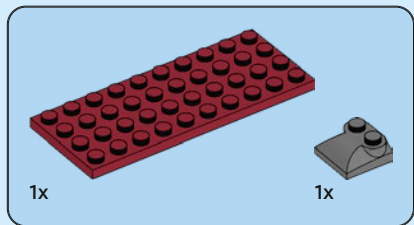
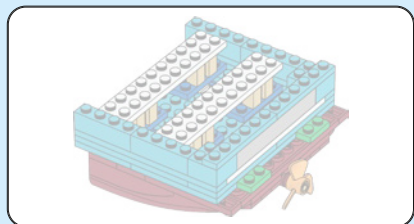

29

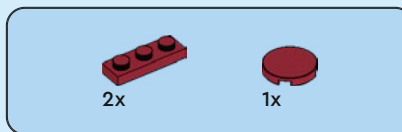
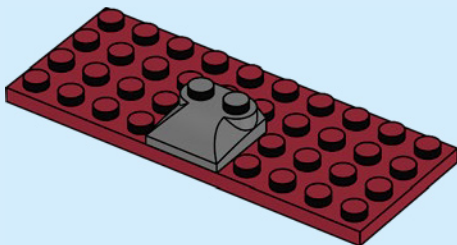

30

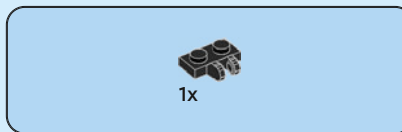
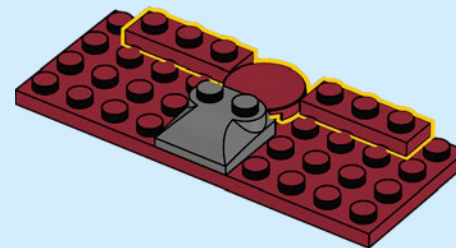

31

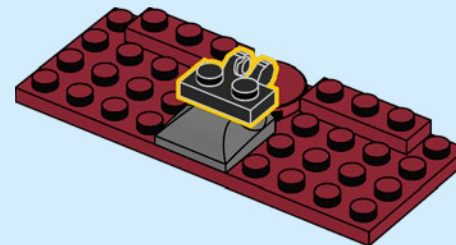

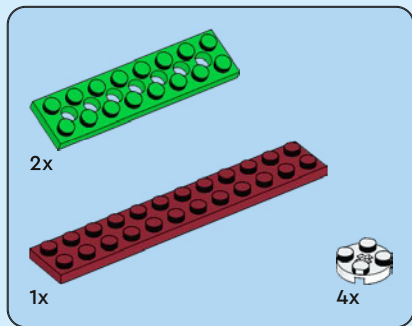

32

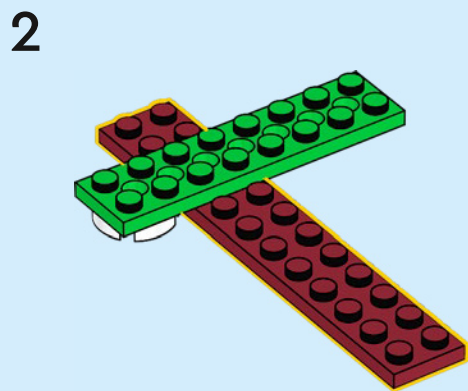
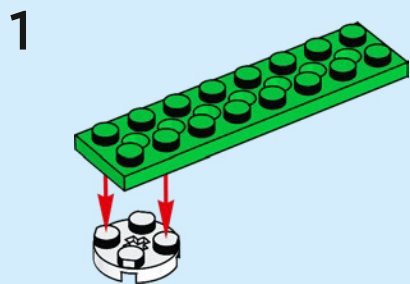

3

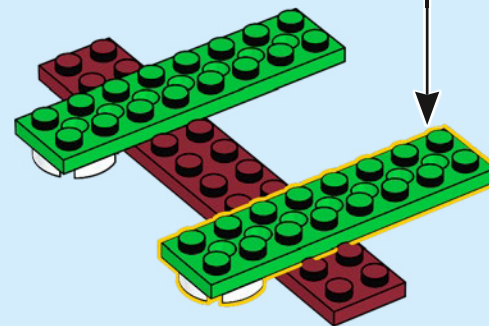
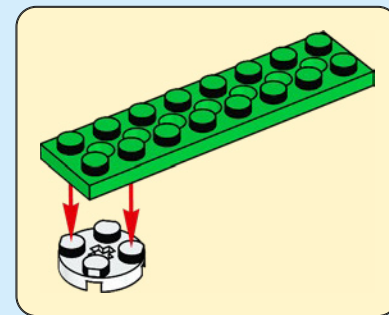

4

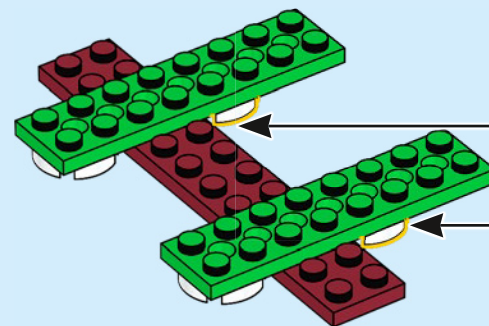

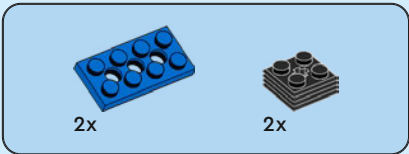

33

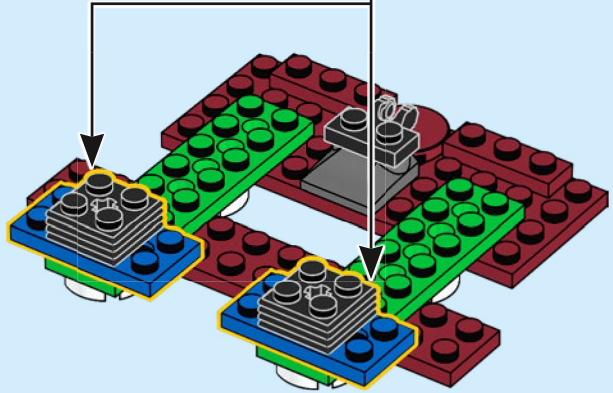
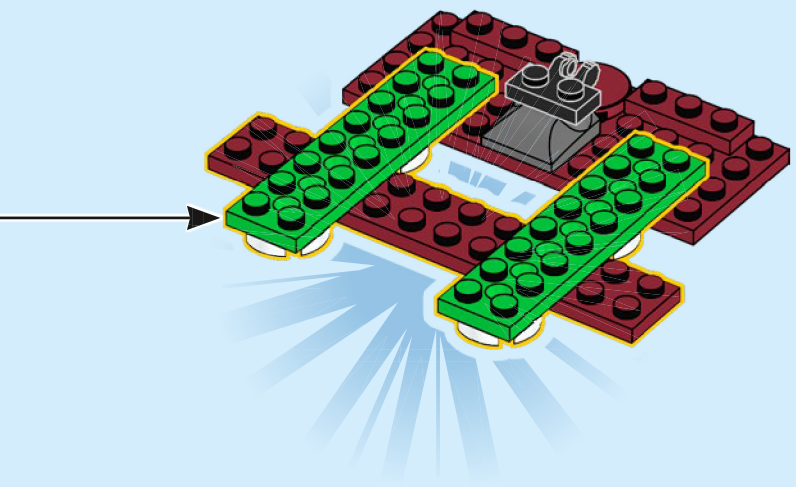
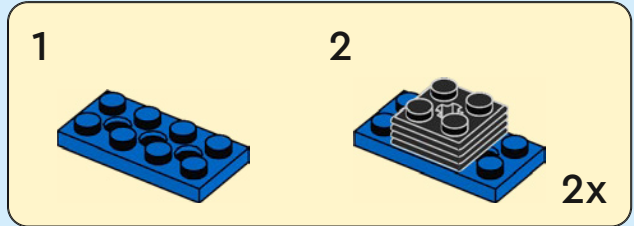

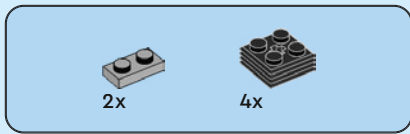

34

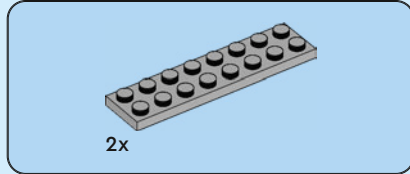
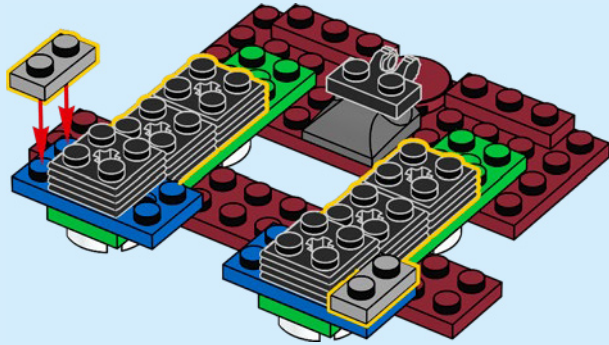

35

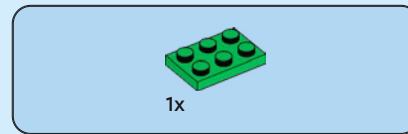
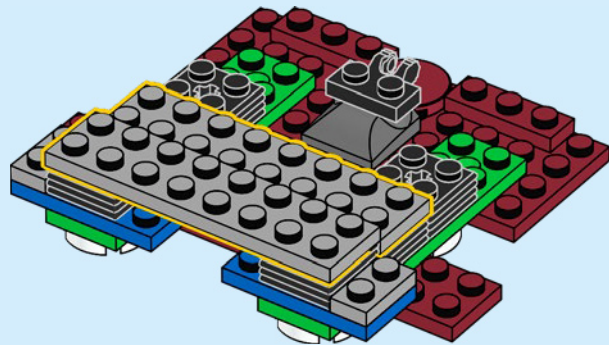

36

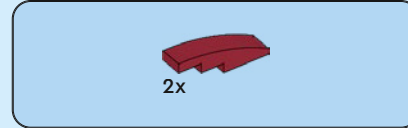
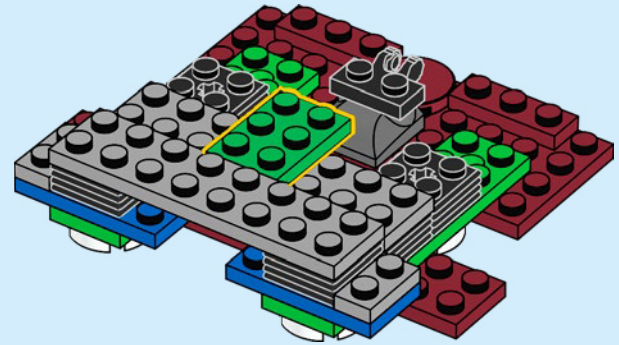

37

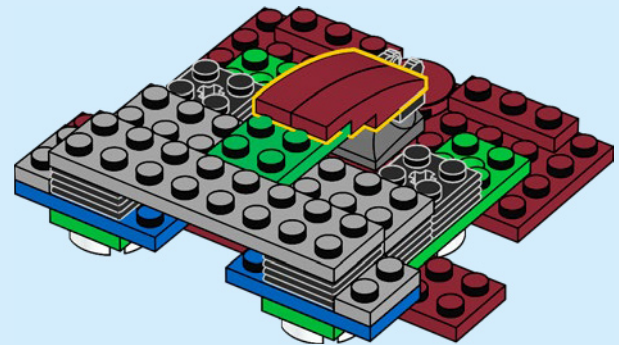

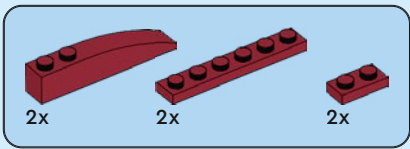

38

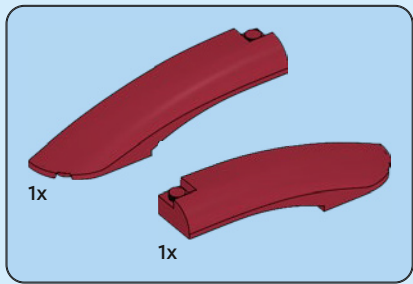
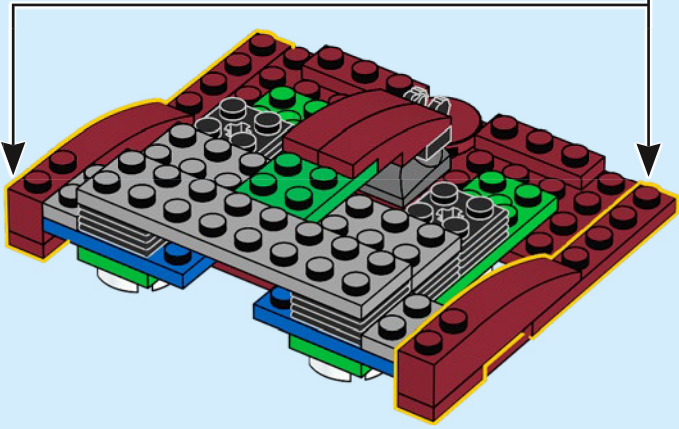
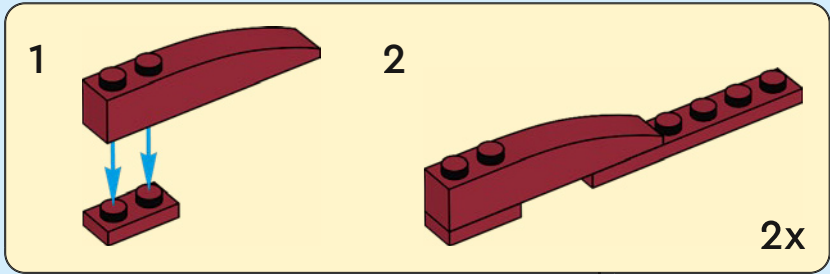

39

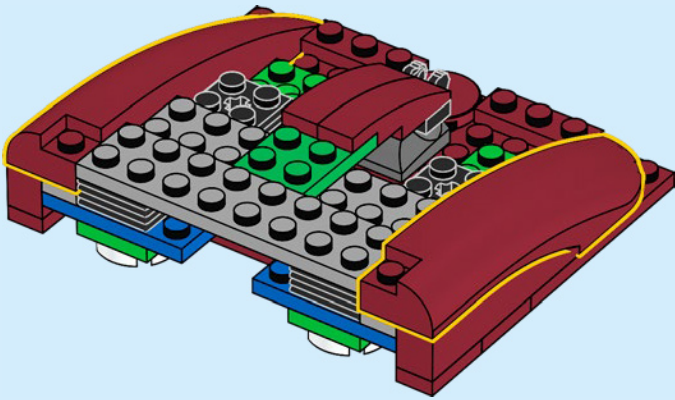

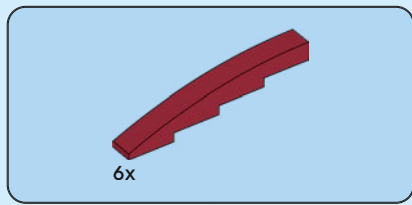

40

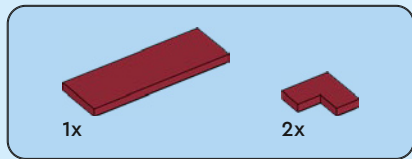
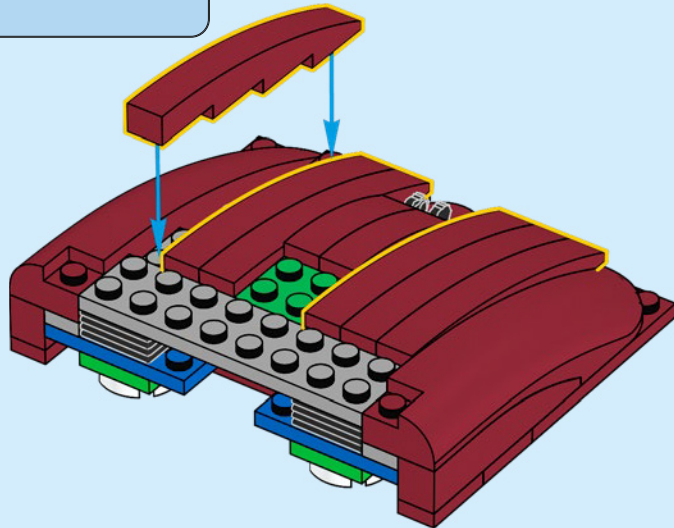

41

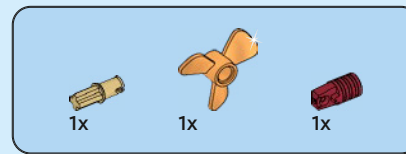
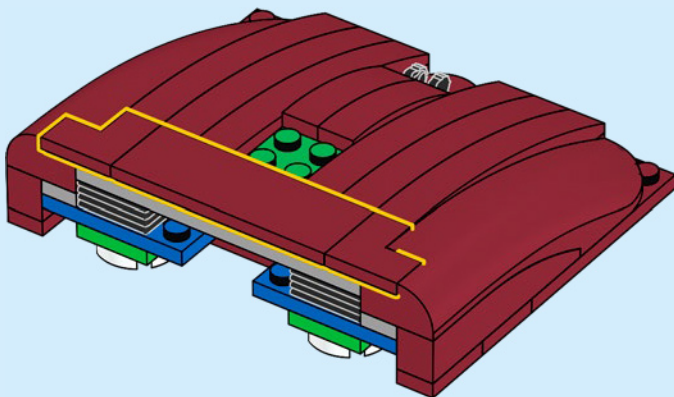

42

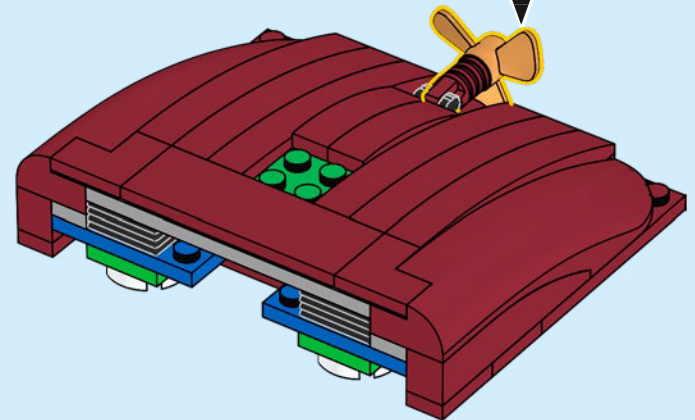
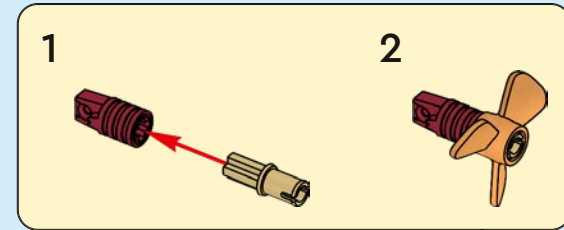

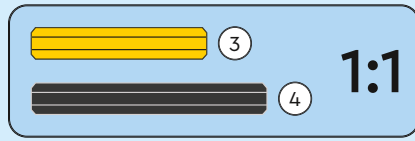
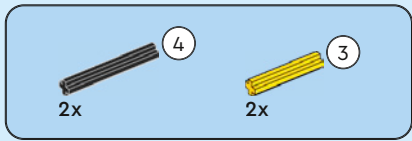

43

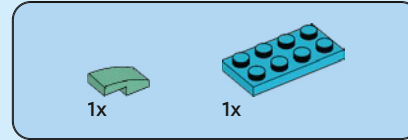
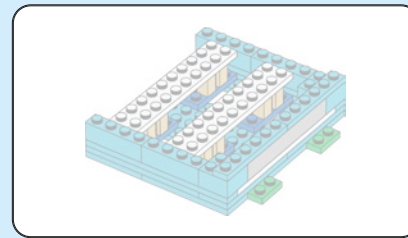
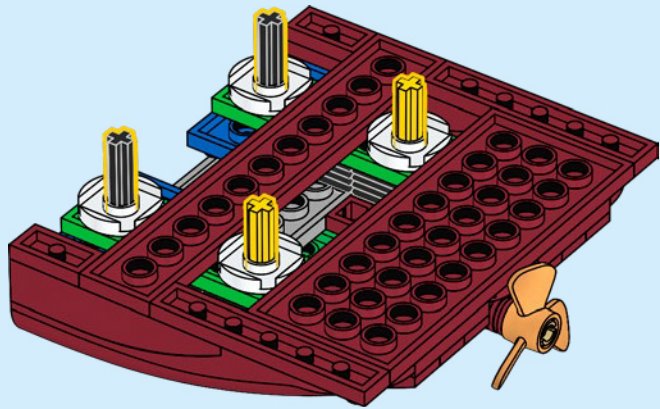

44

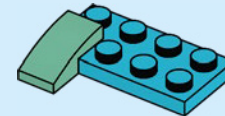

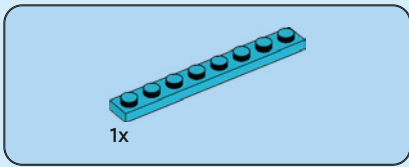

45

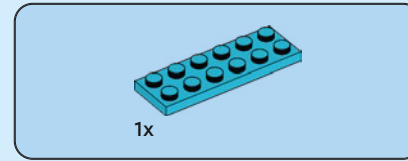
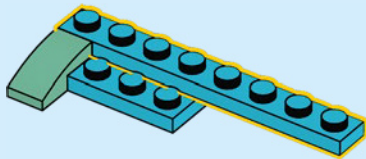
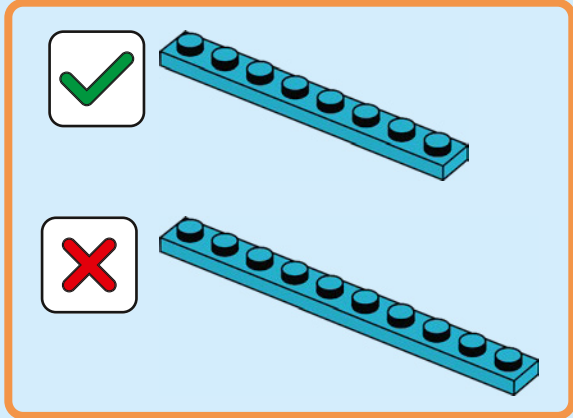

46

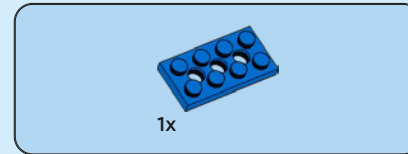
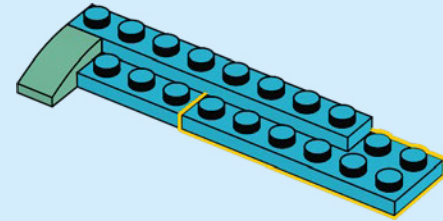

47

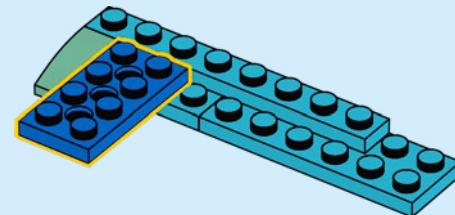

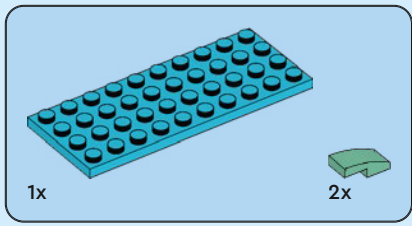

48

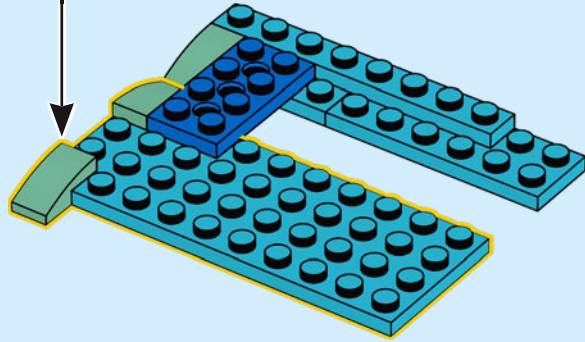
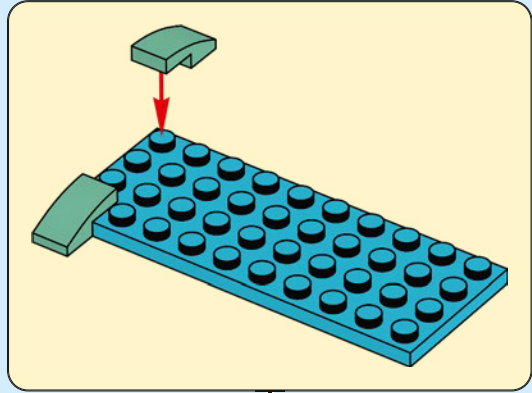

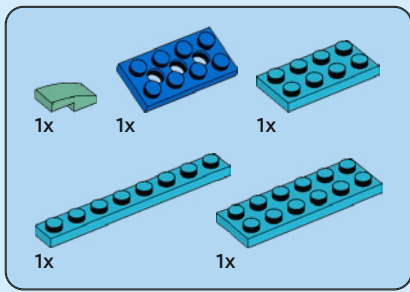

49

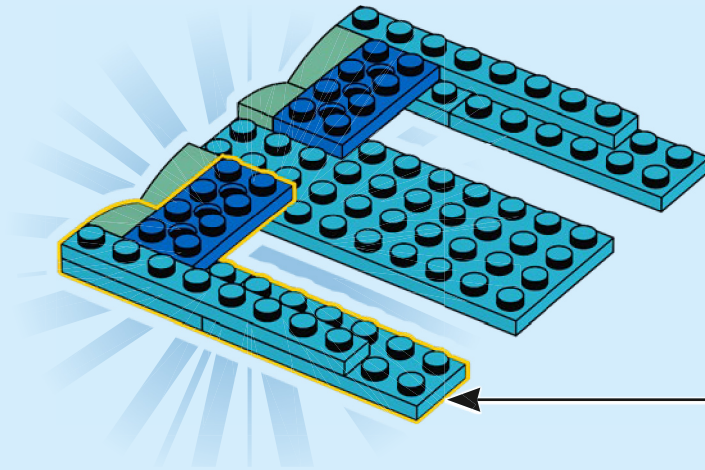
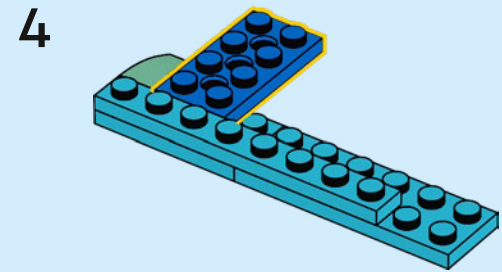
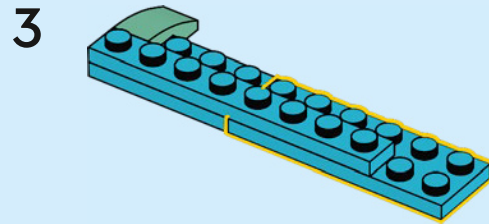
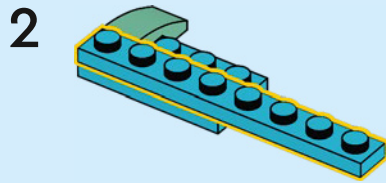
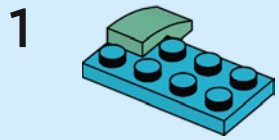
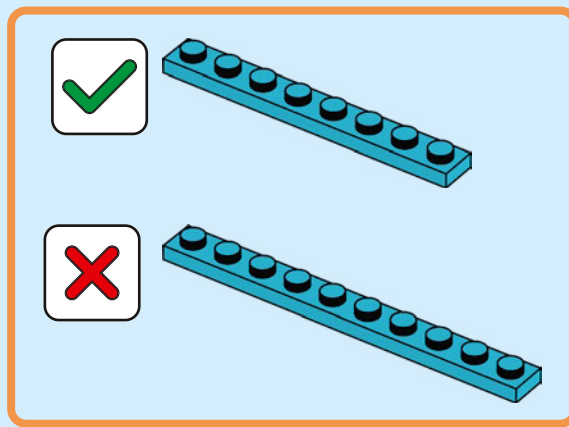



50

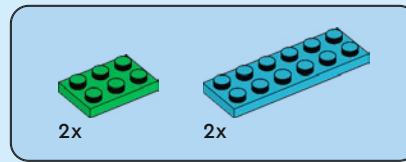
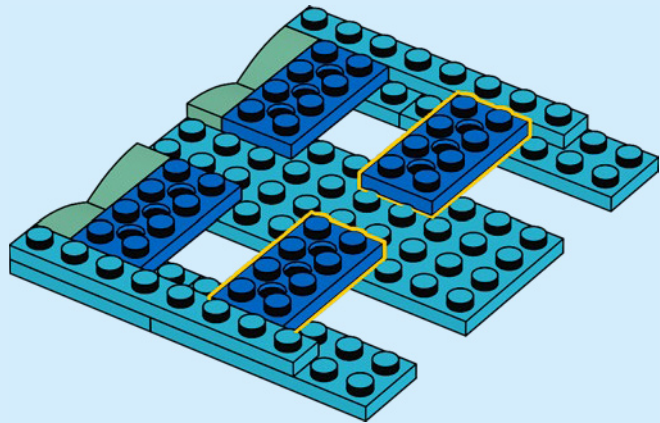

51

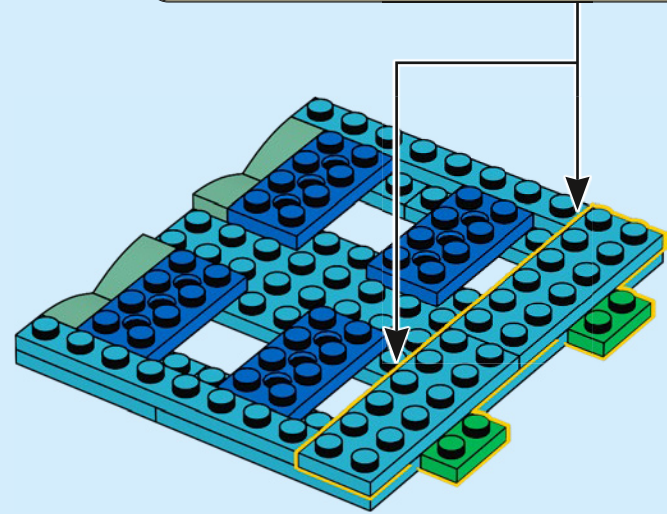
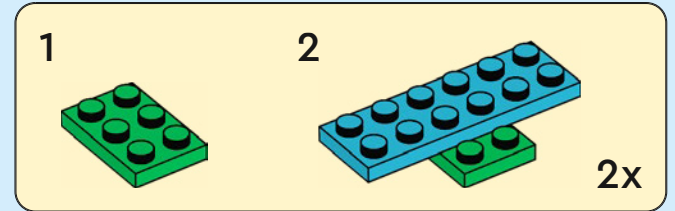

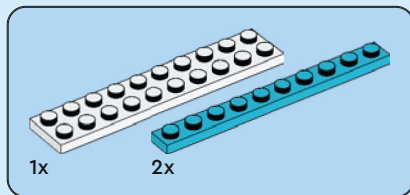

52

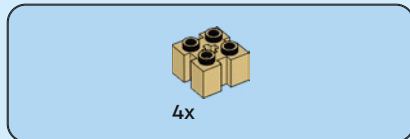
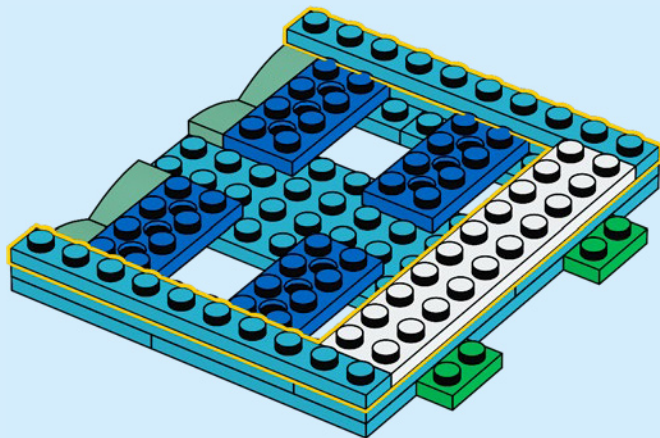

53

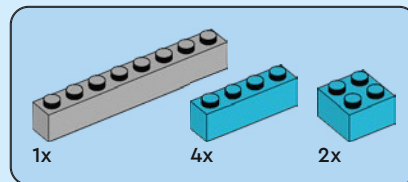
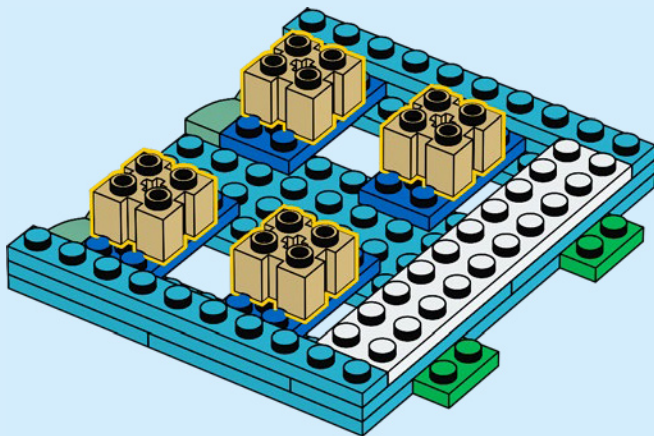

54

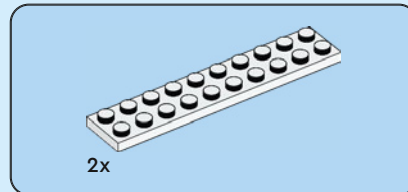
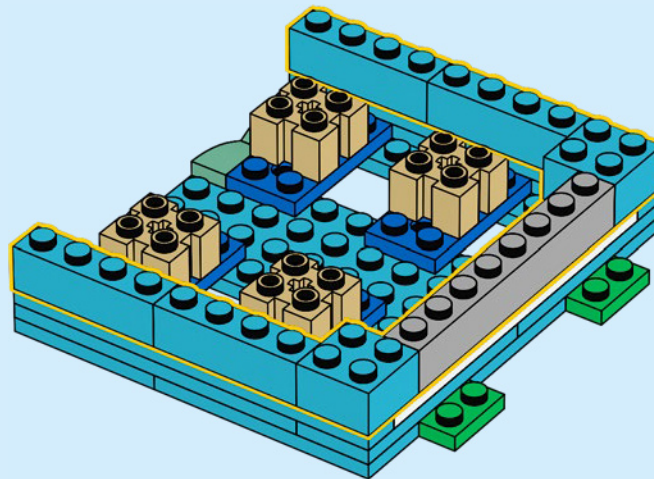

55

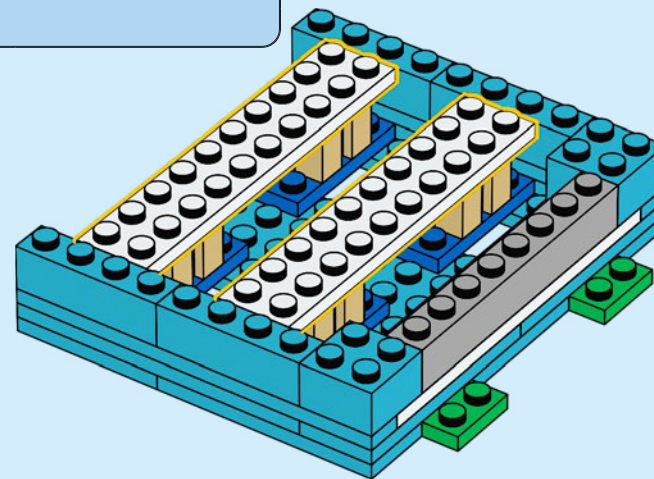

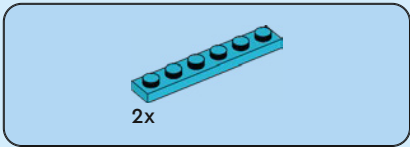

56

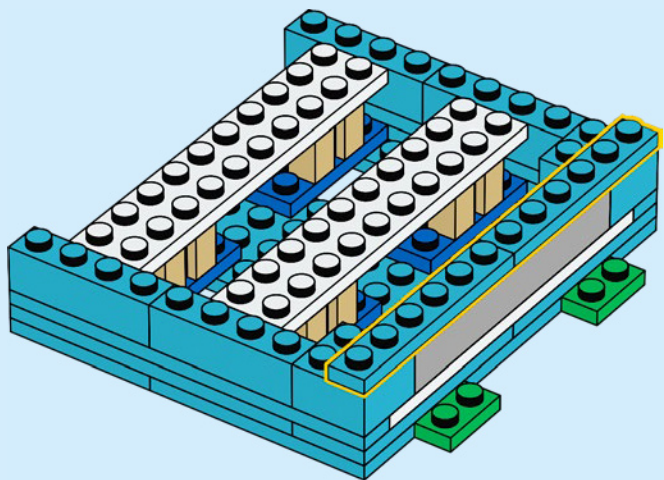

57

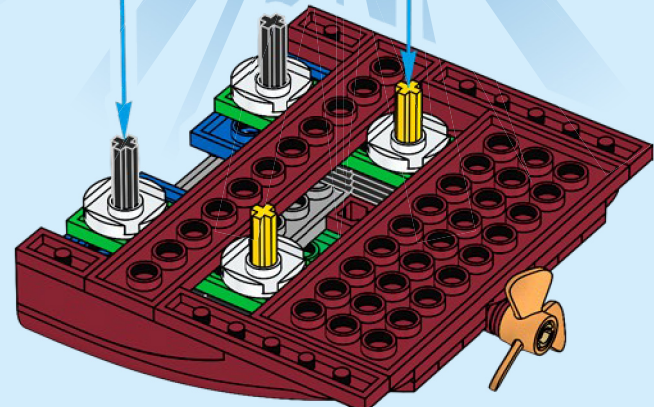
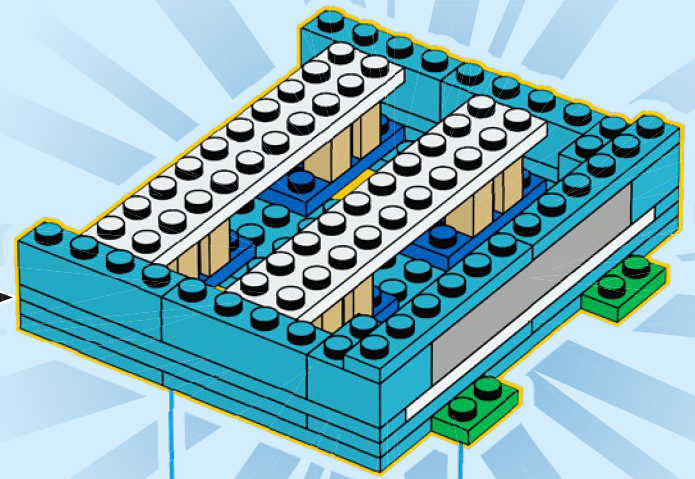

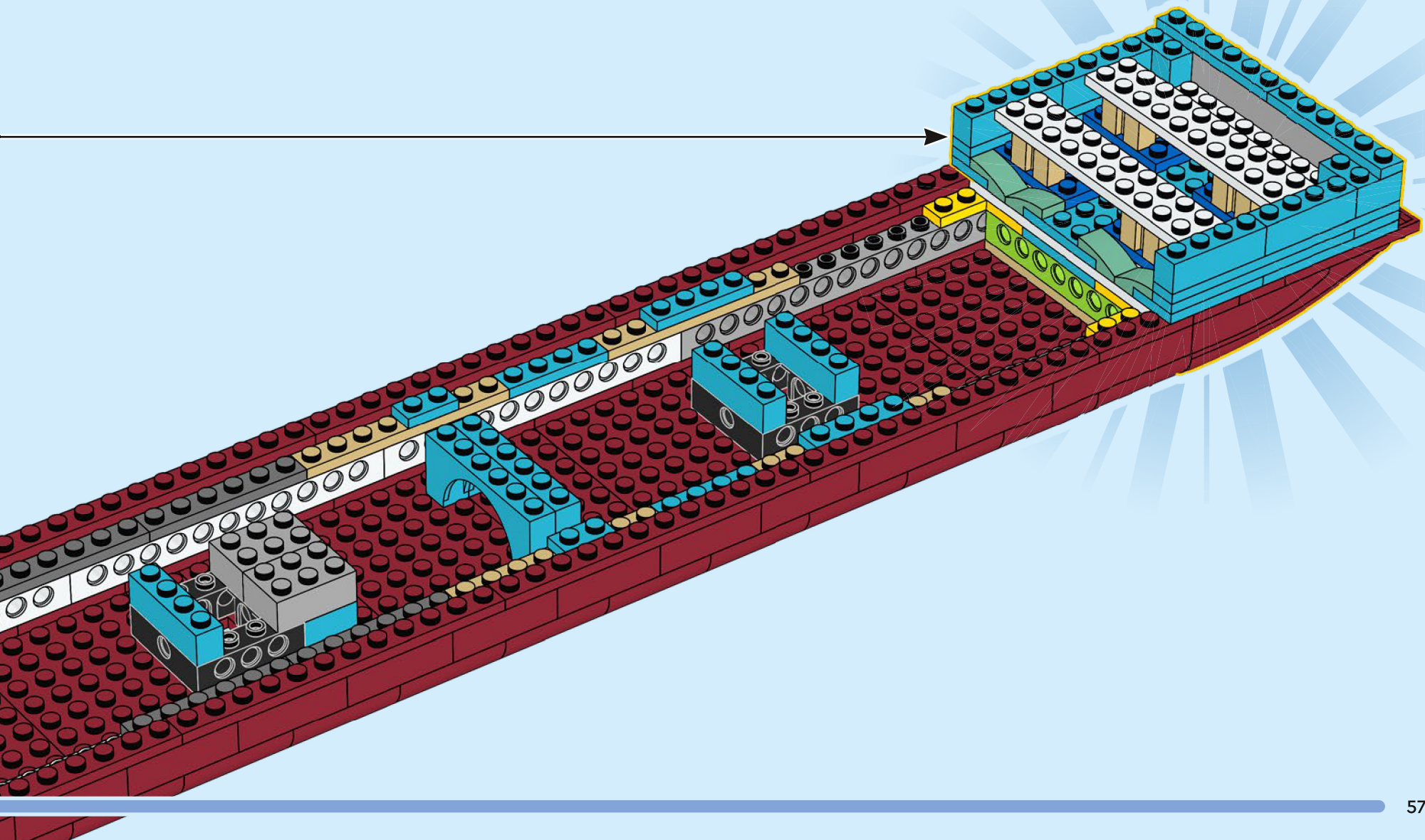

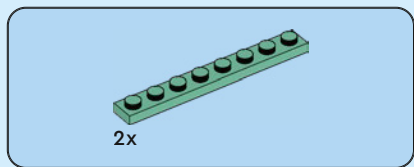
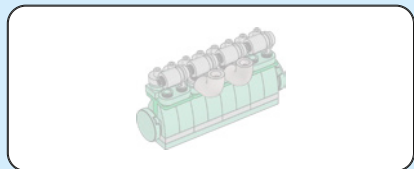

59

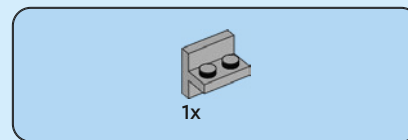
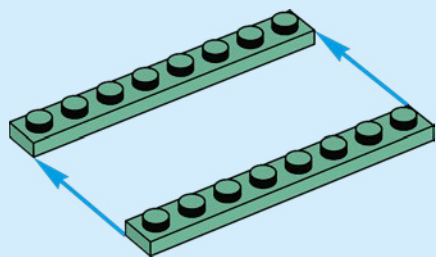

60

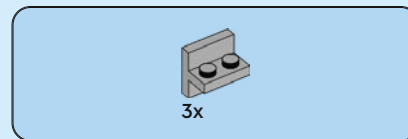
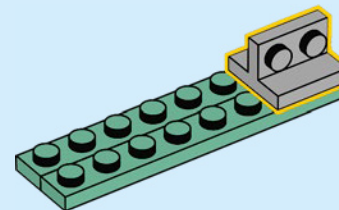

61

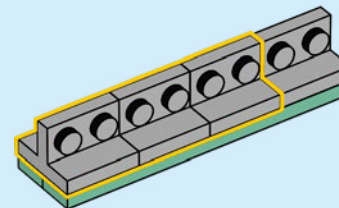



62

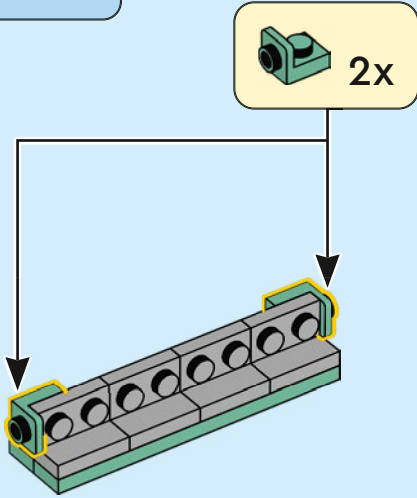

63

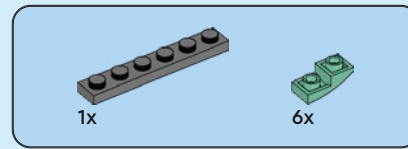
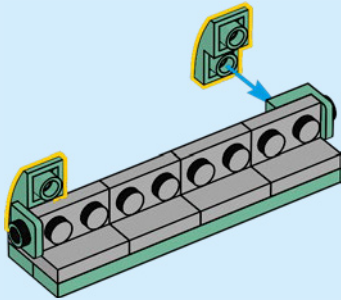

64

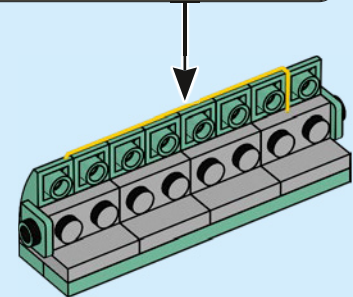
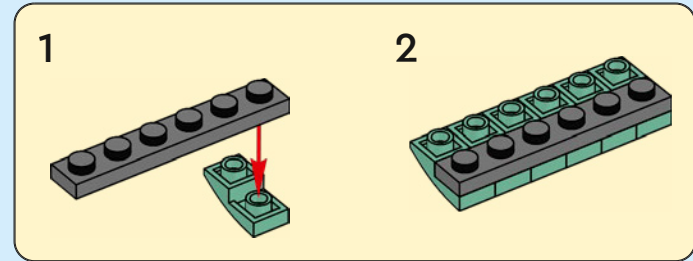

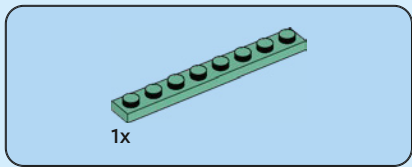

65

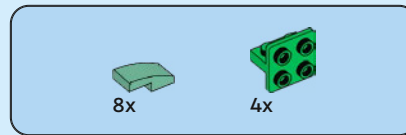
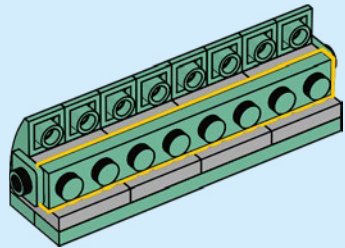

66

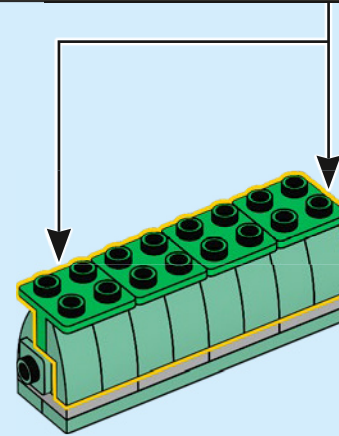
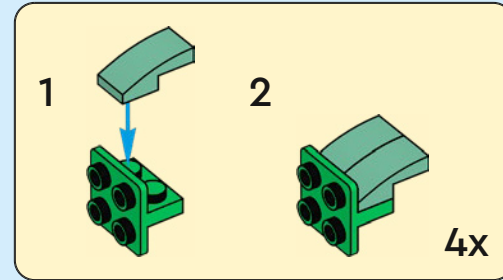

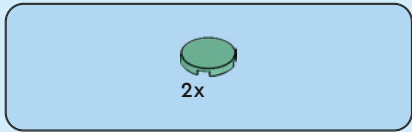

67

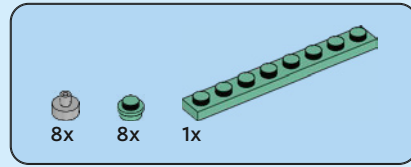
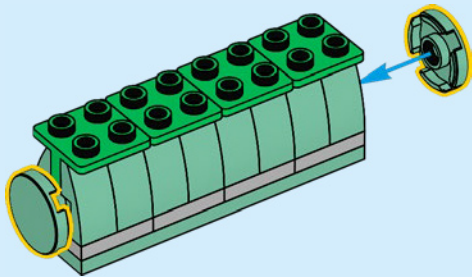

68

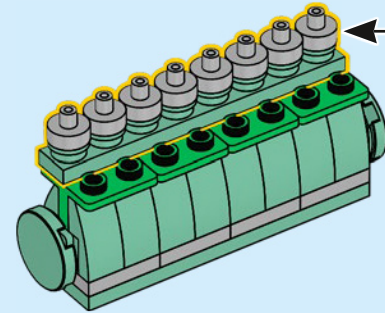
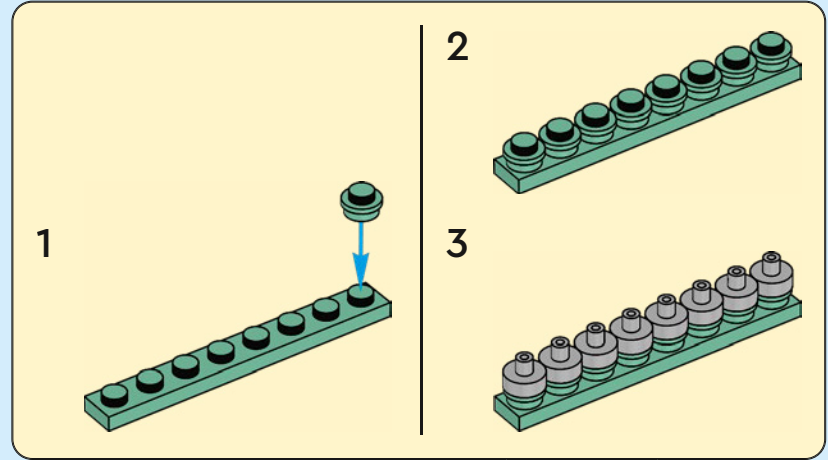



2x

69

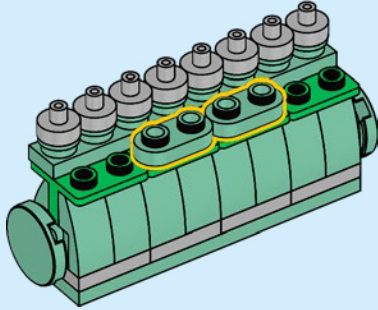

2x



2x

70

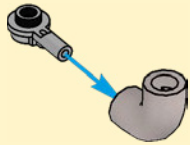
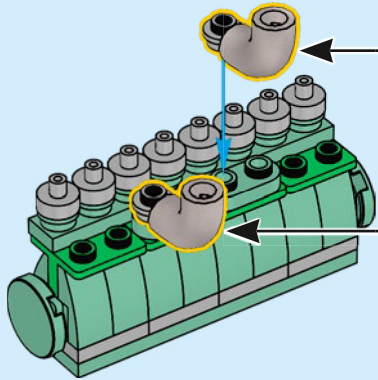

2x



2x

71

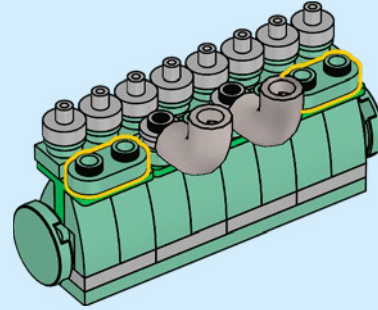

4x



4x

72

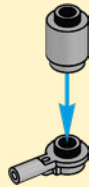
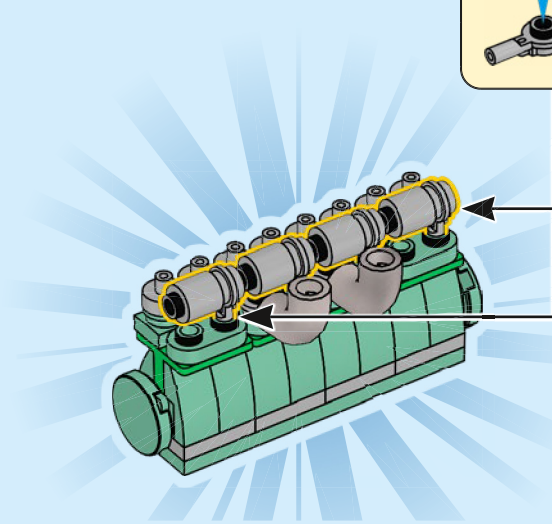

4x

73

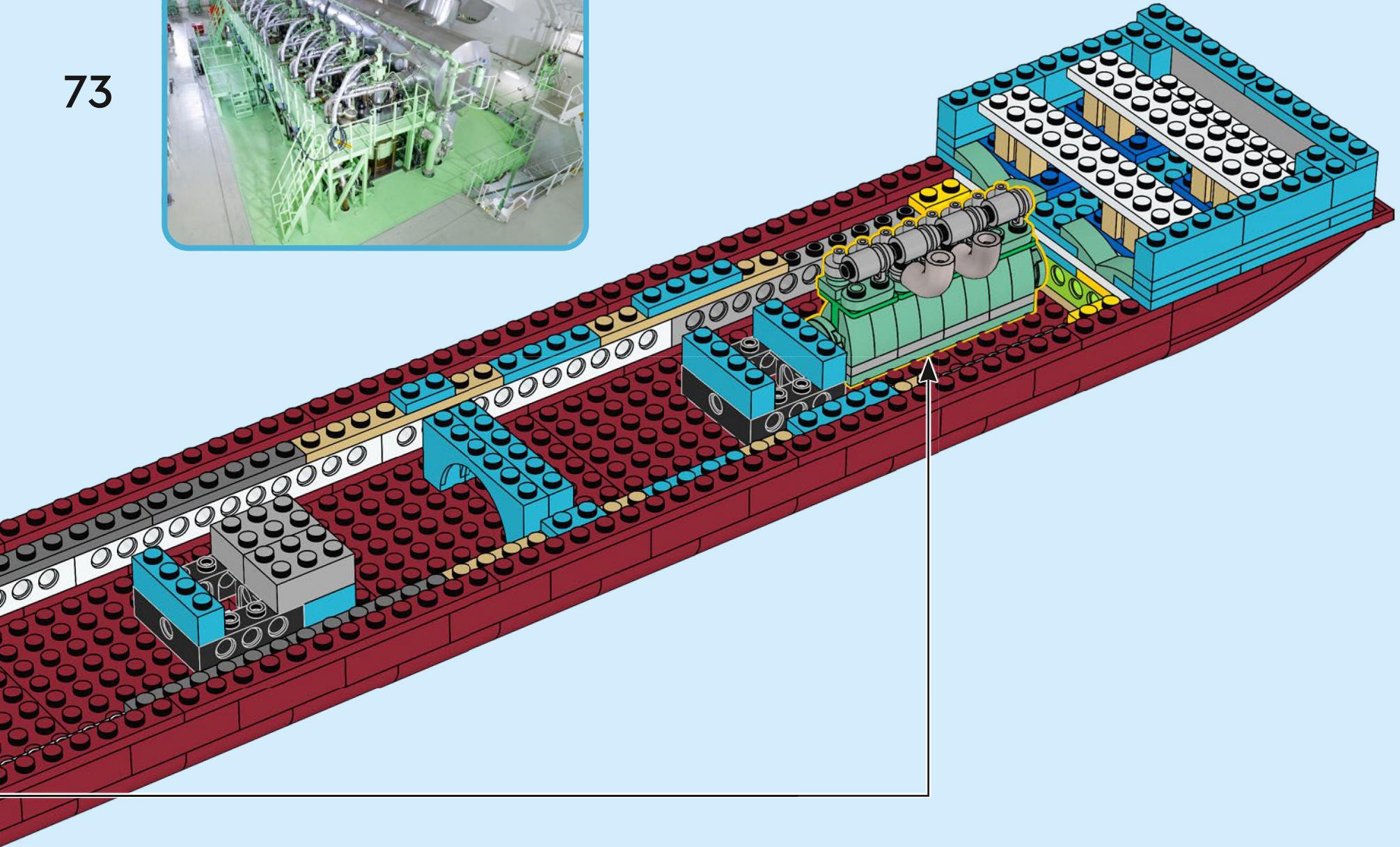

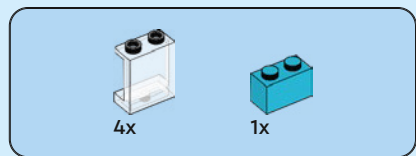

74

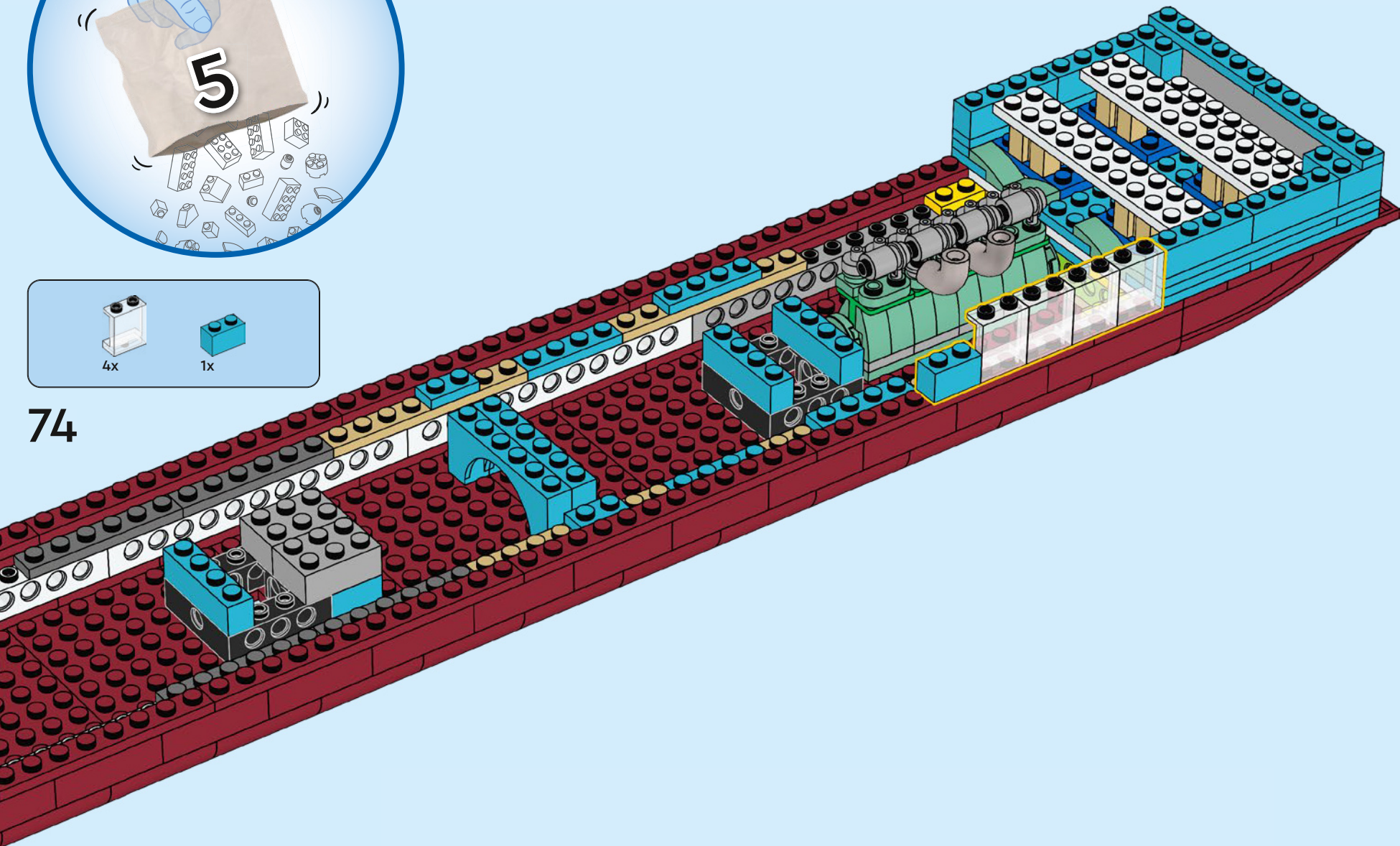

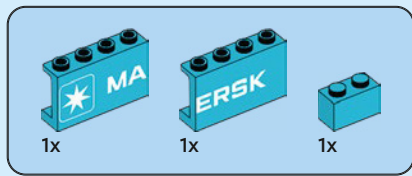

75

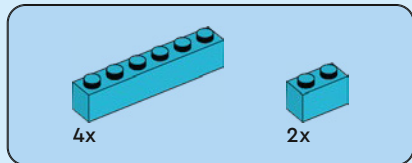
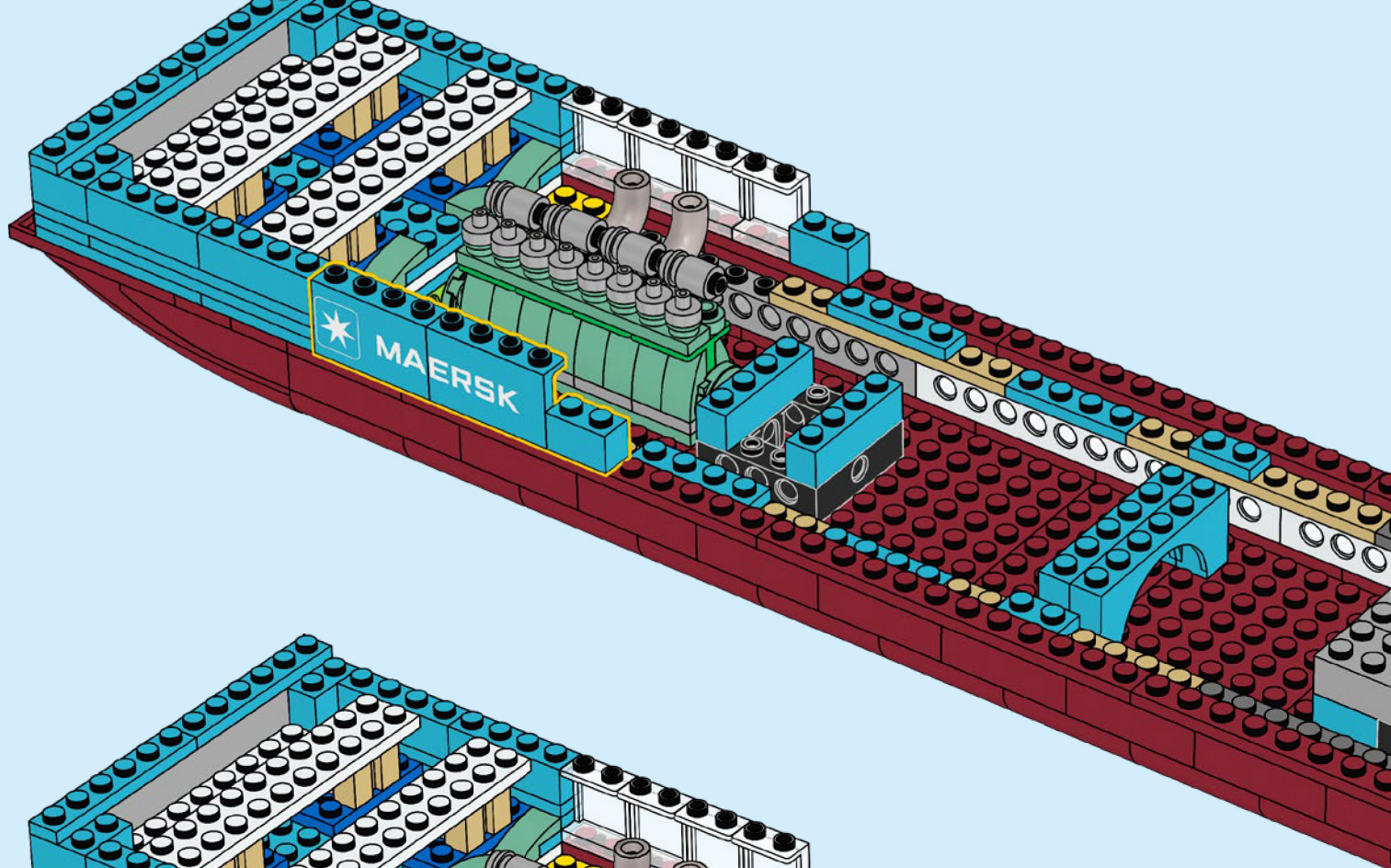

76

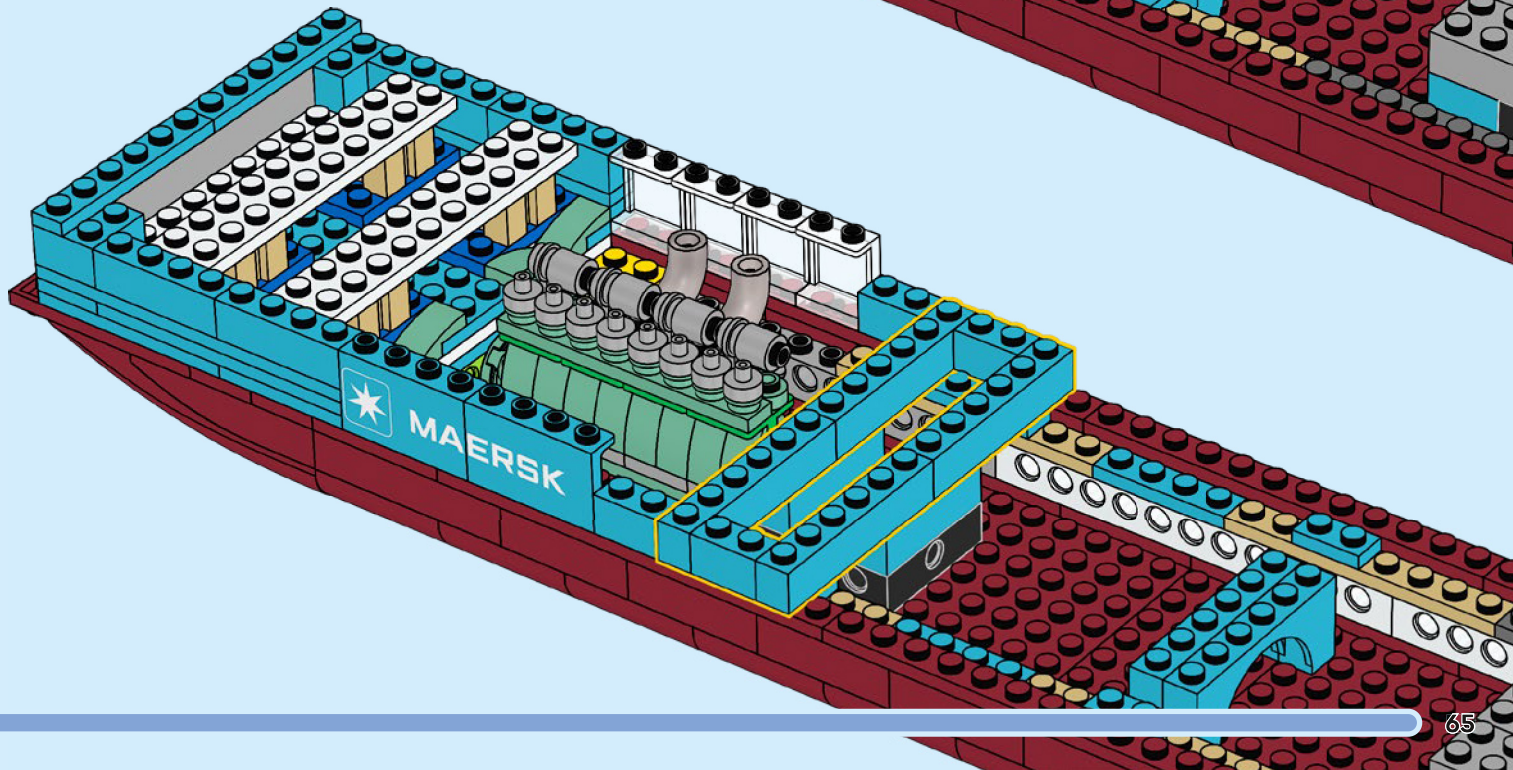

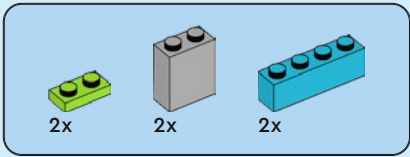

77

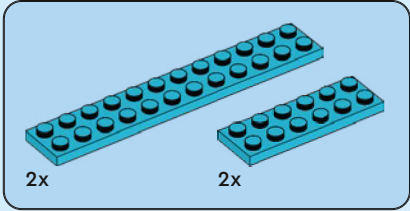
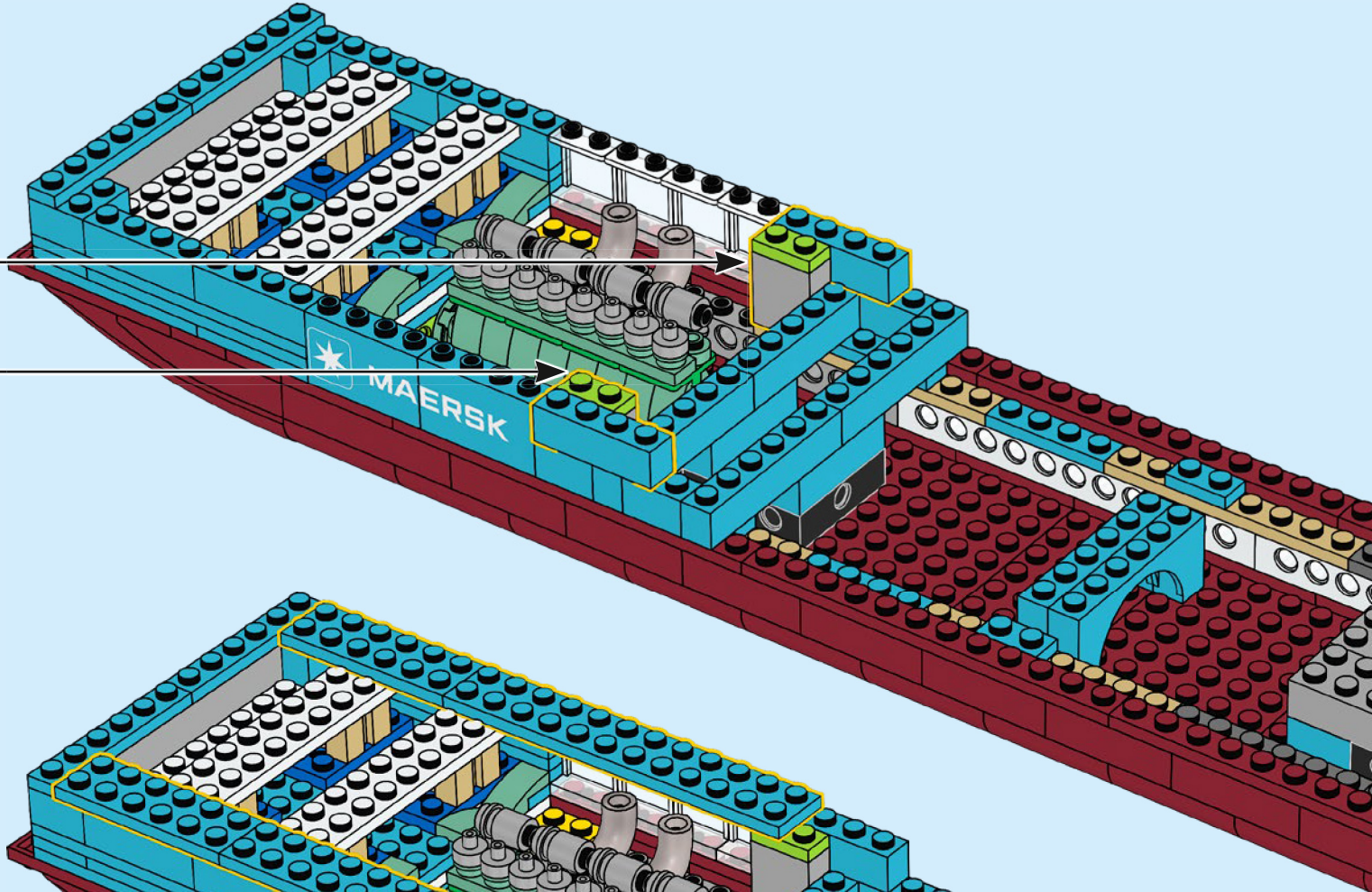
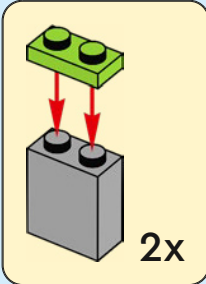

78

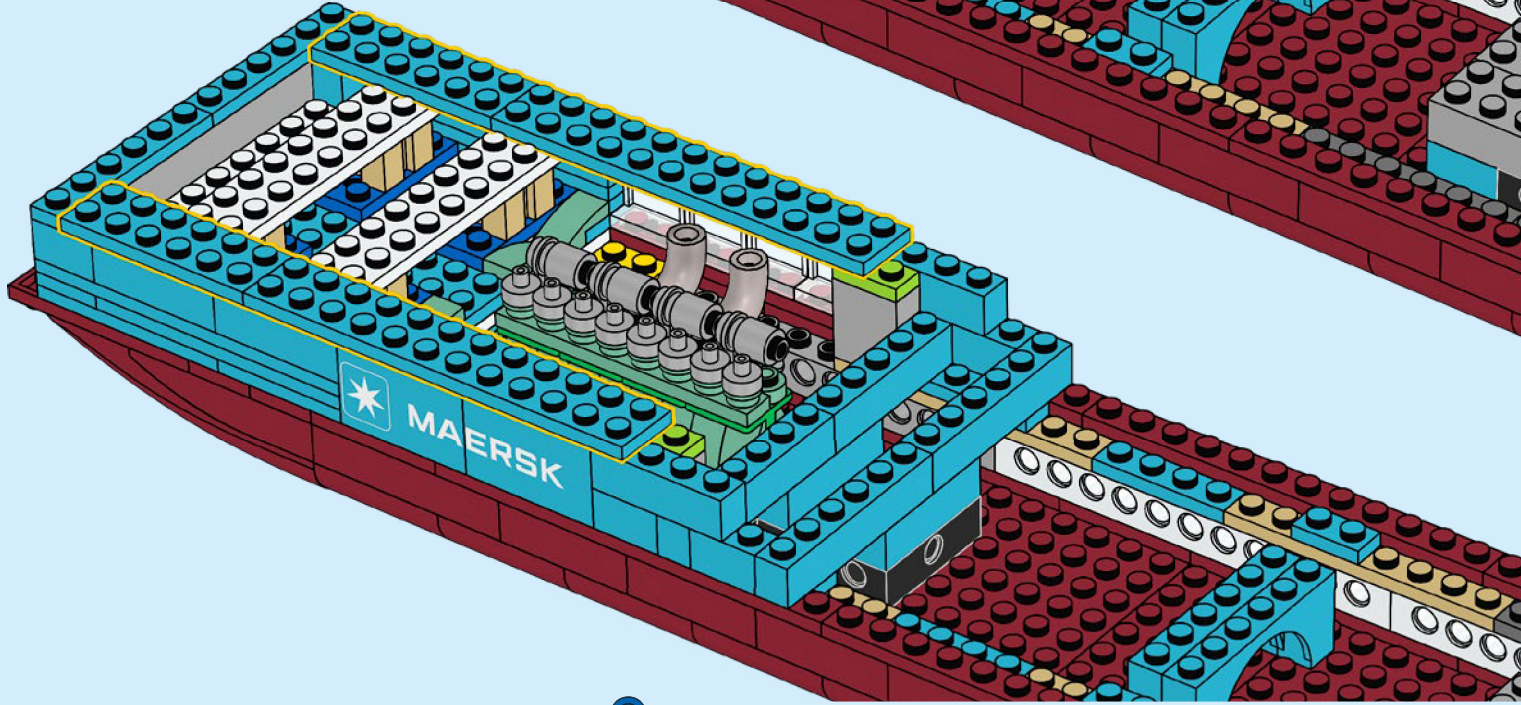

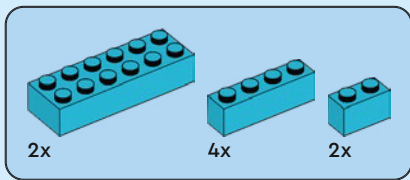

79

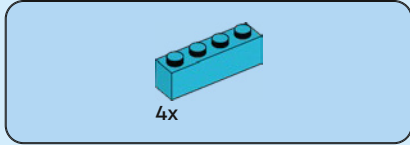
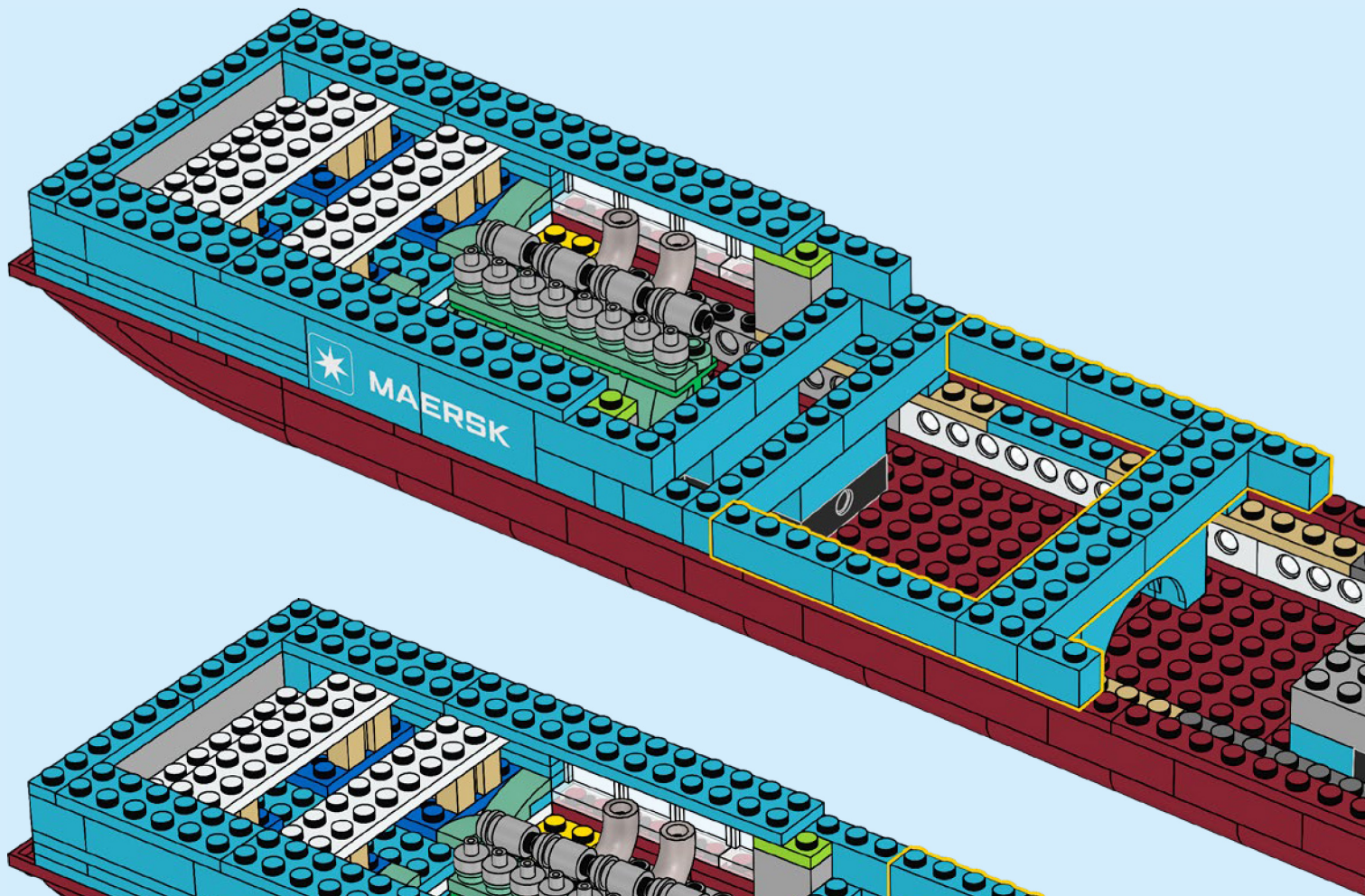

80

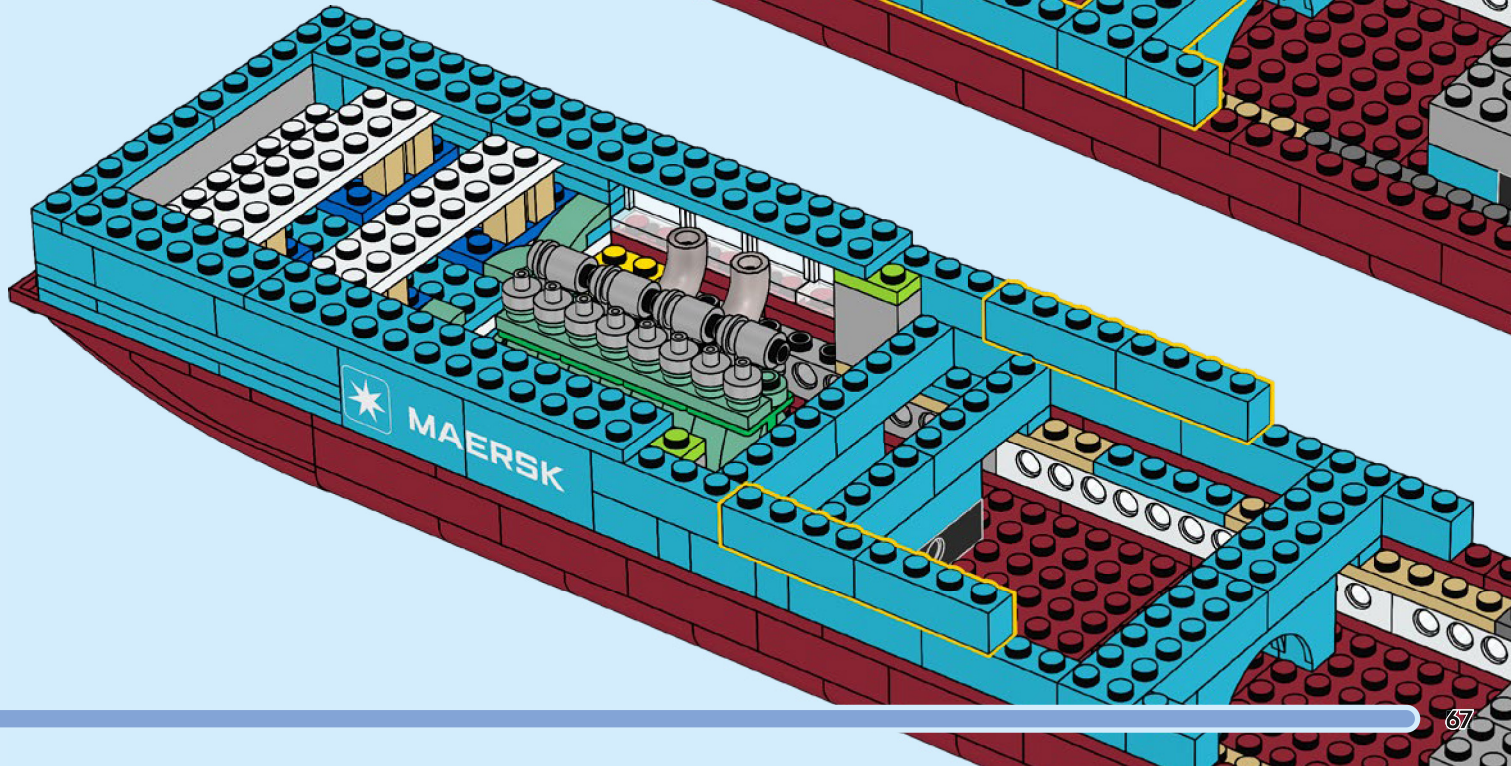

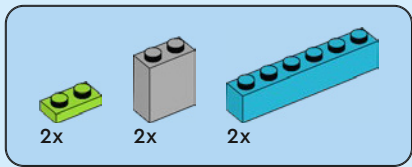

81

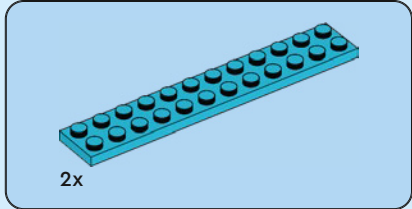
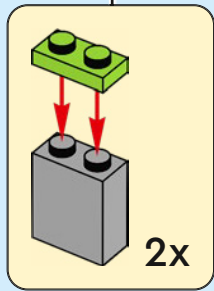
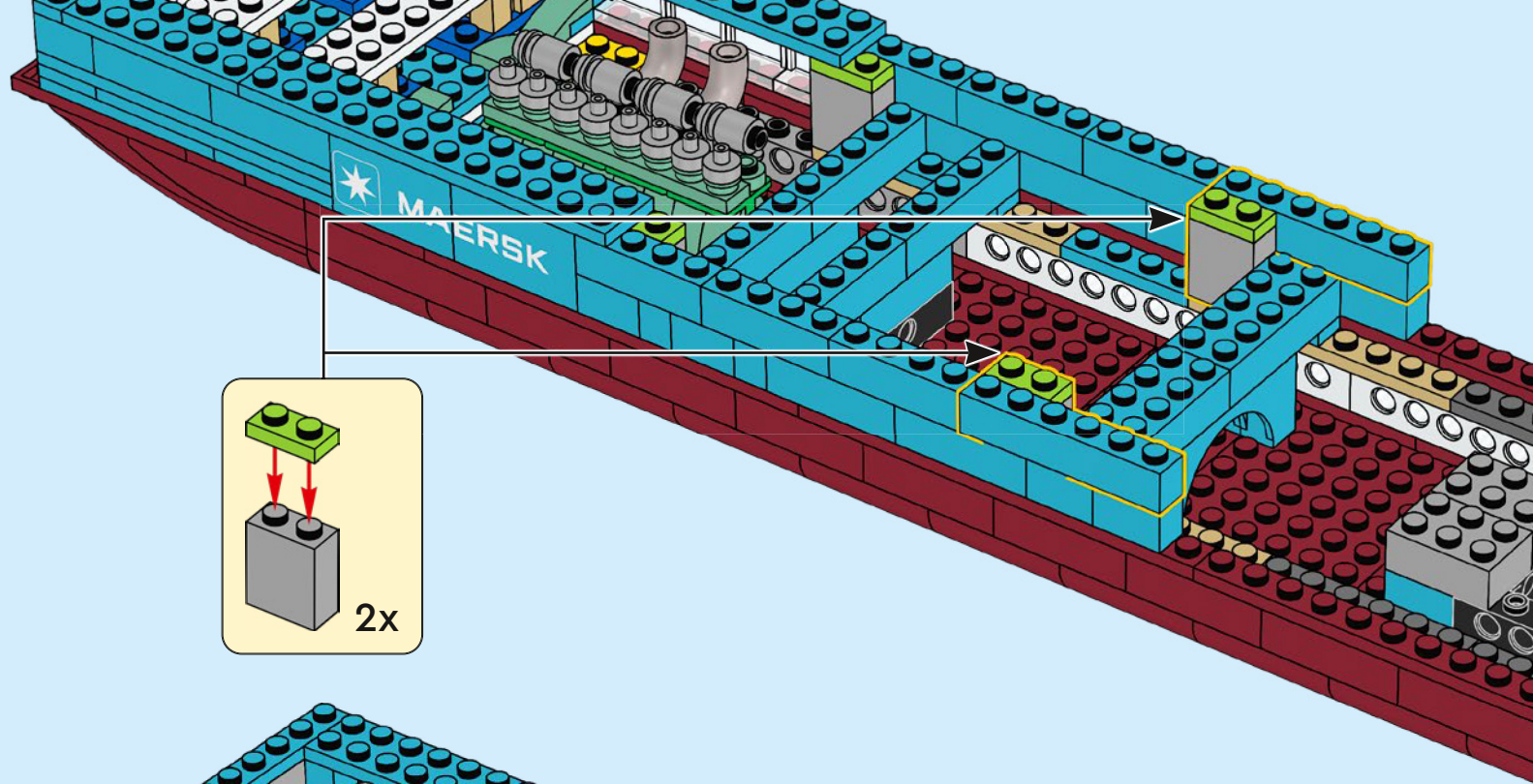

82

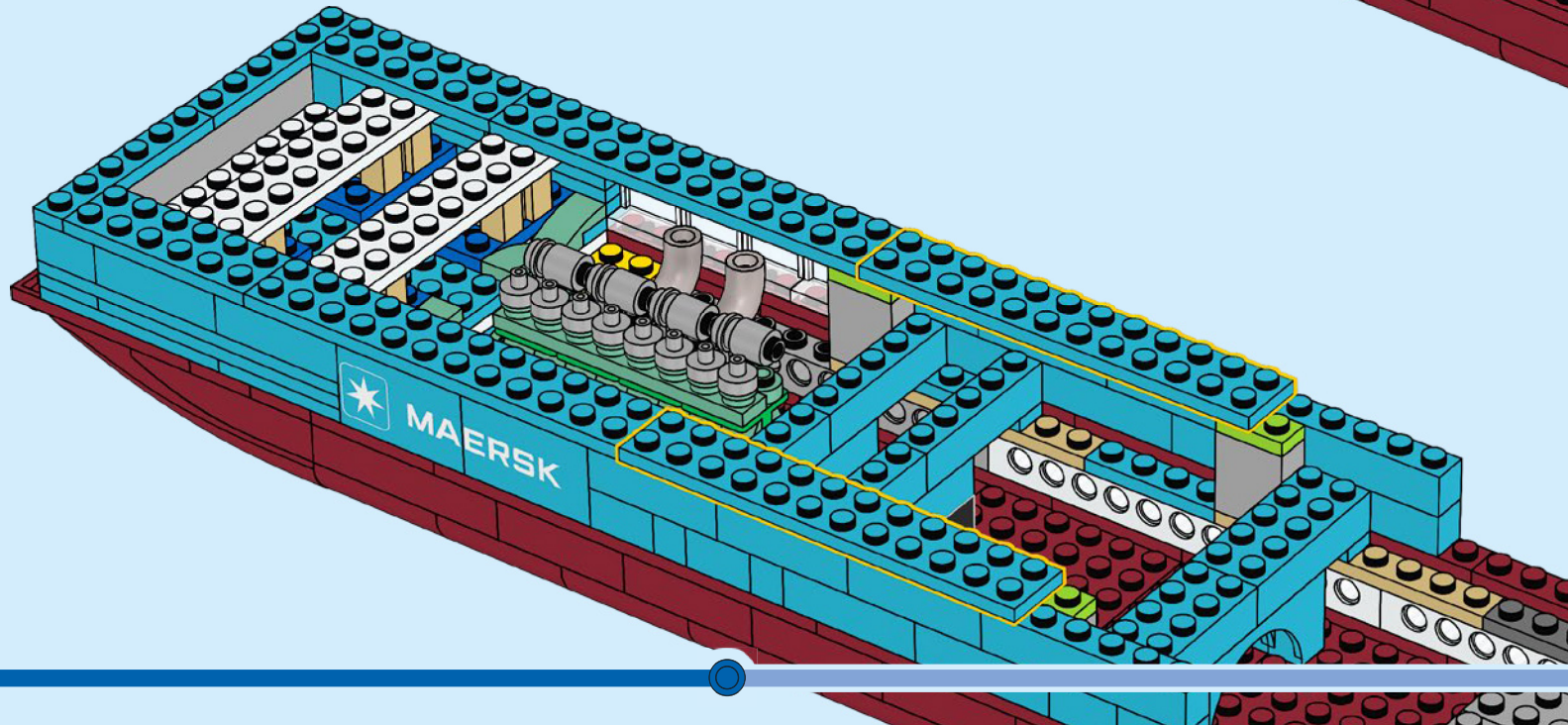

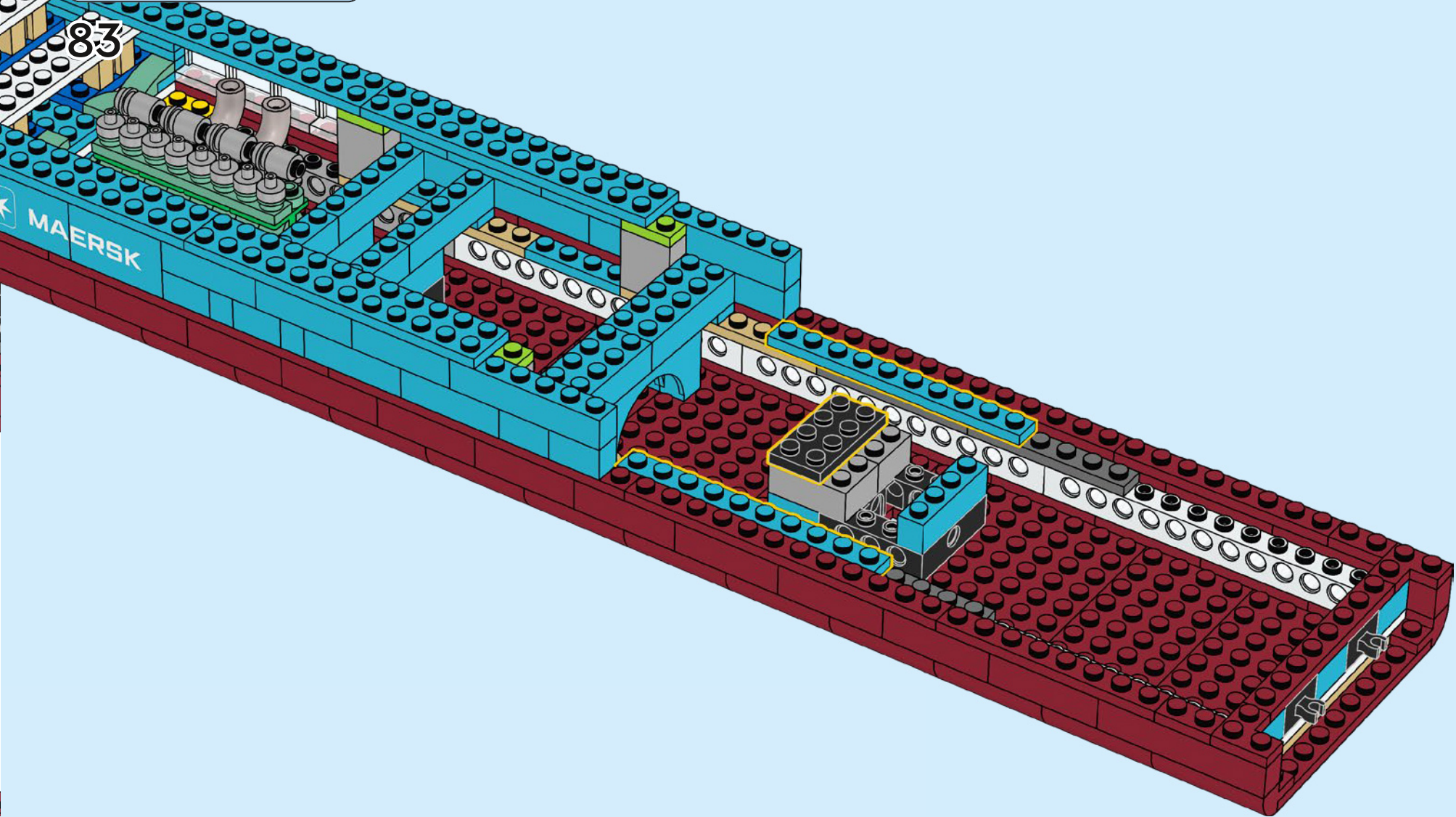
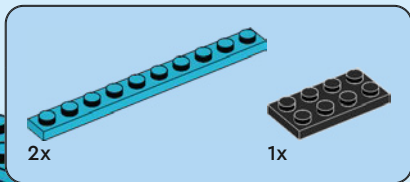

84

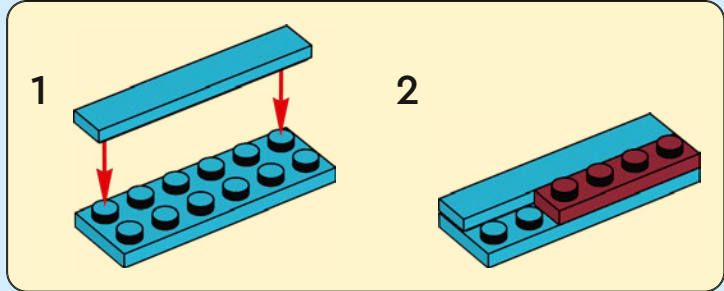
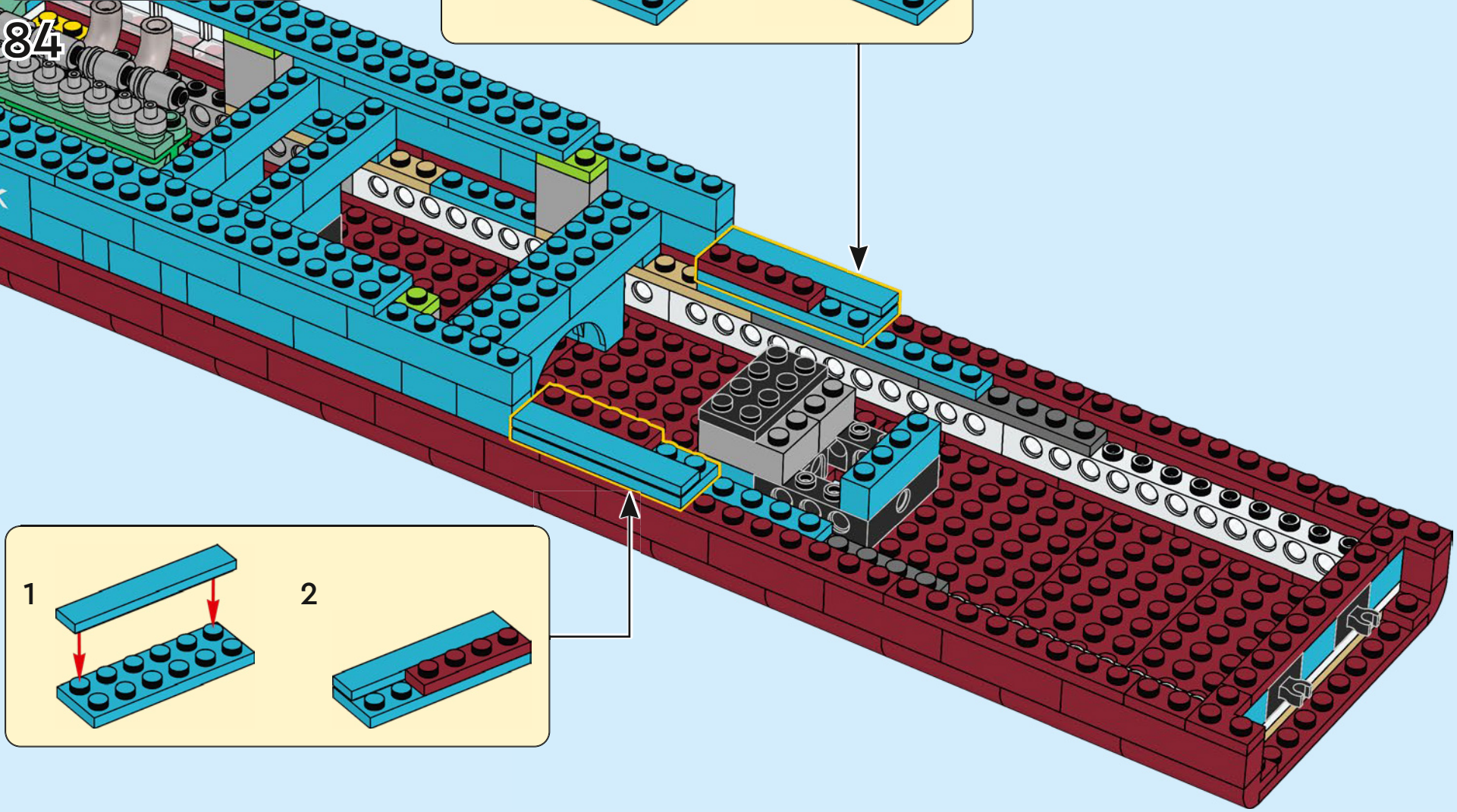
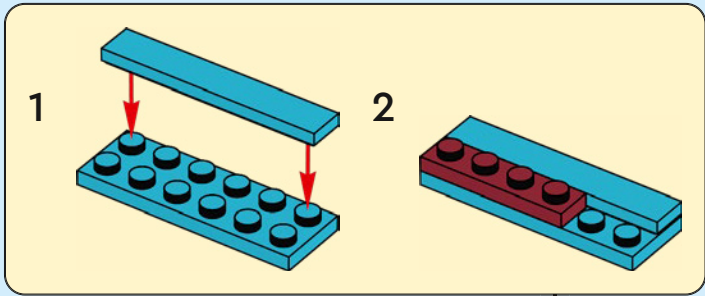
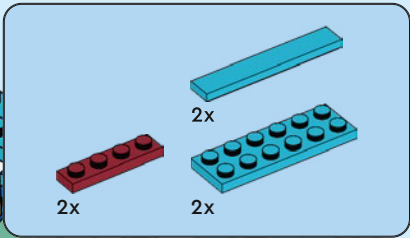

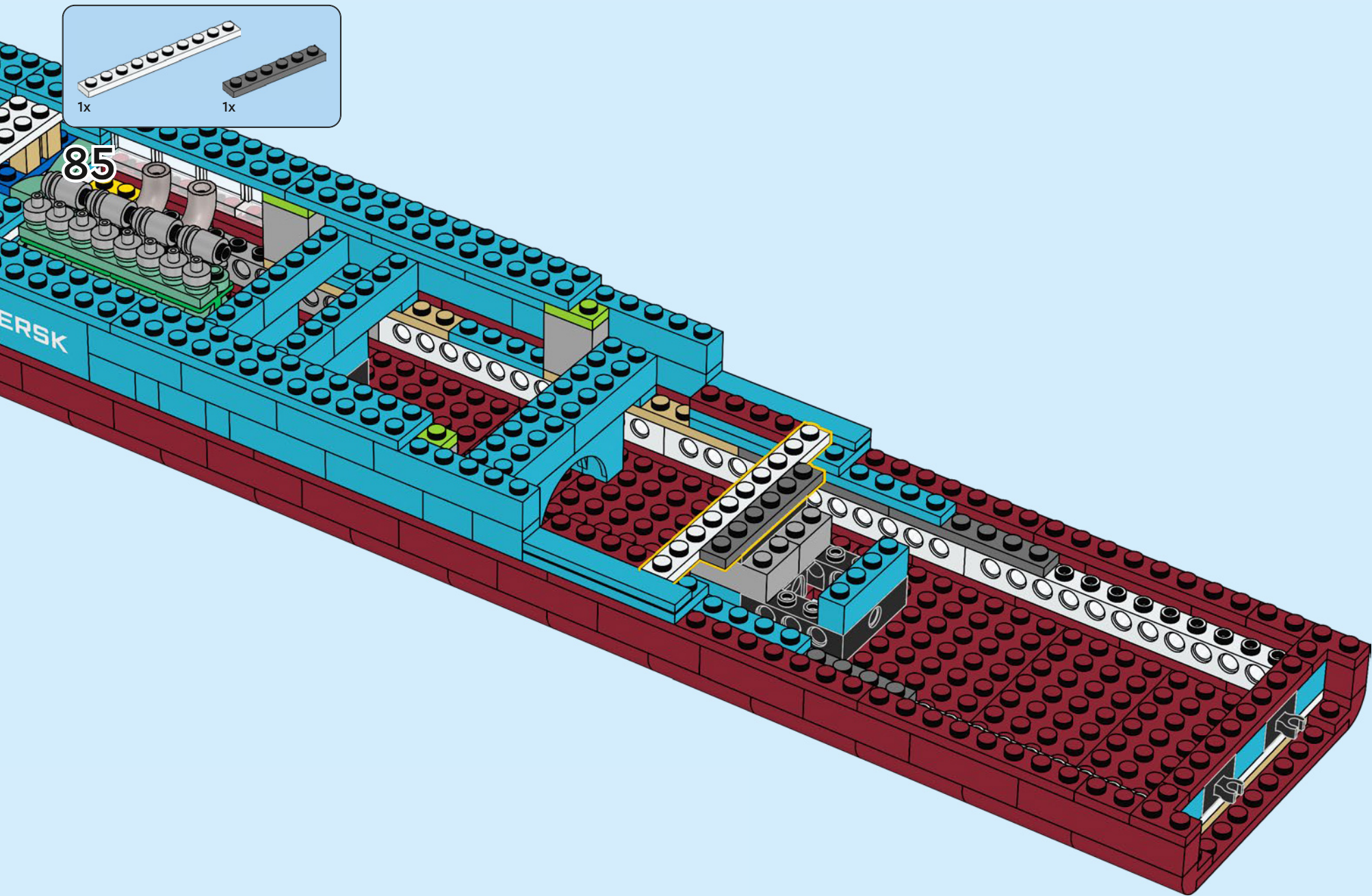

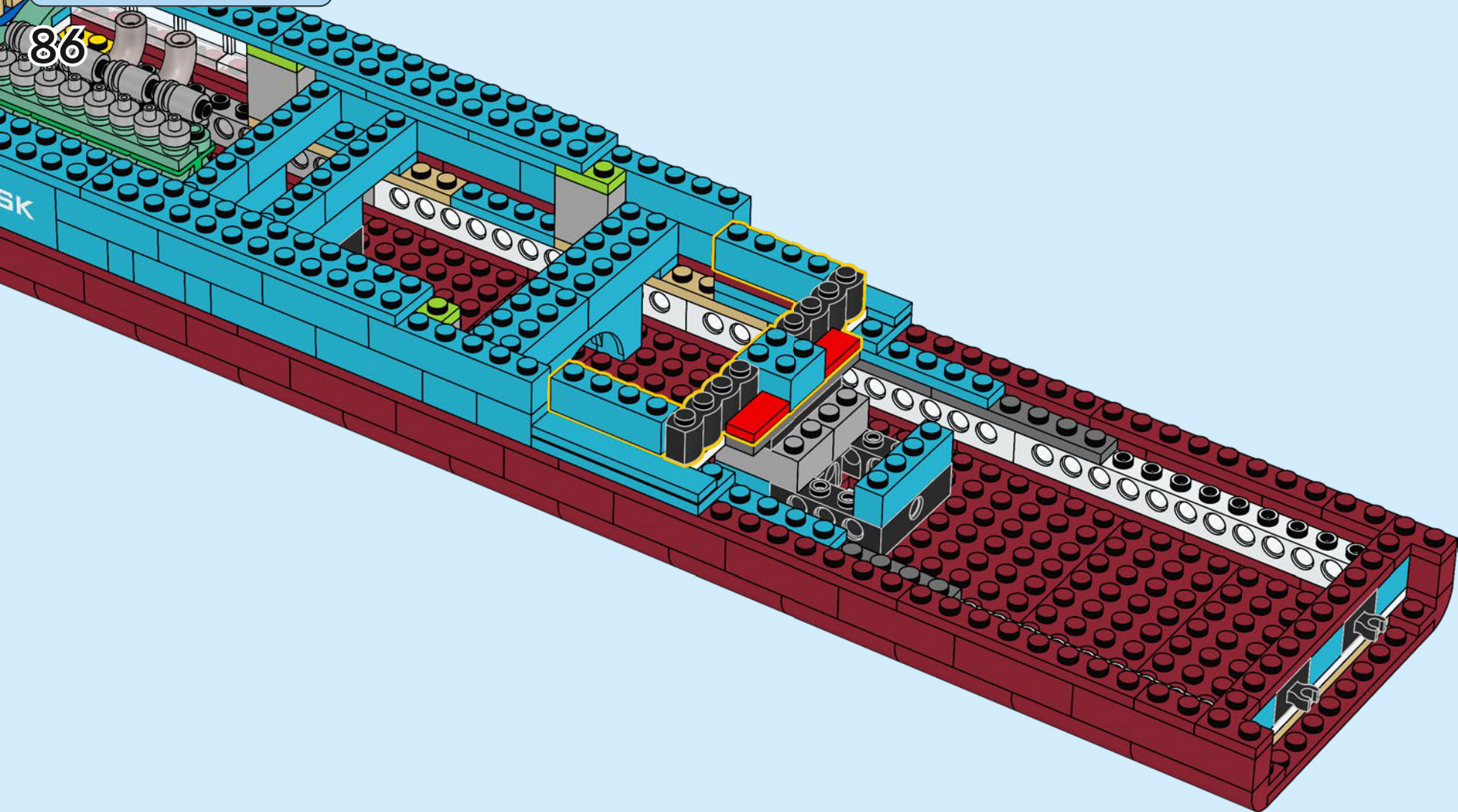
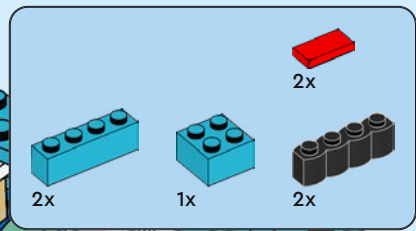

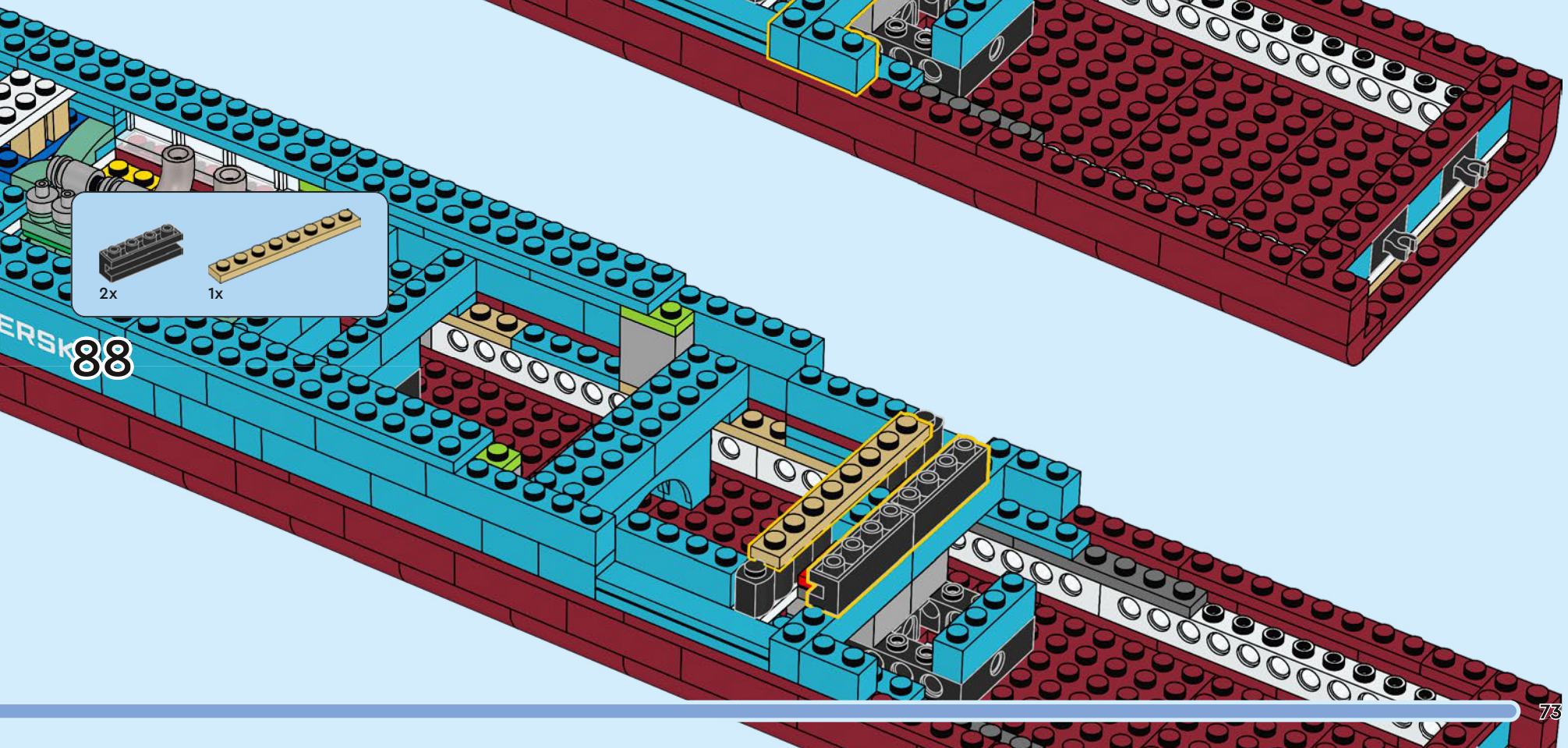
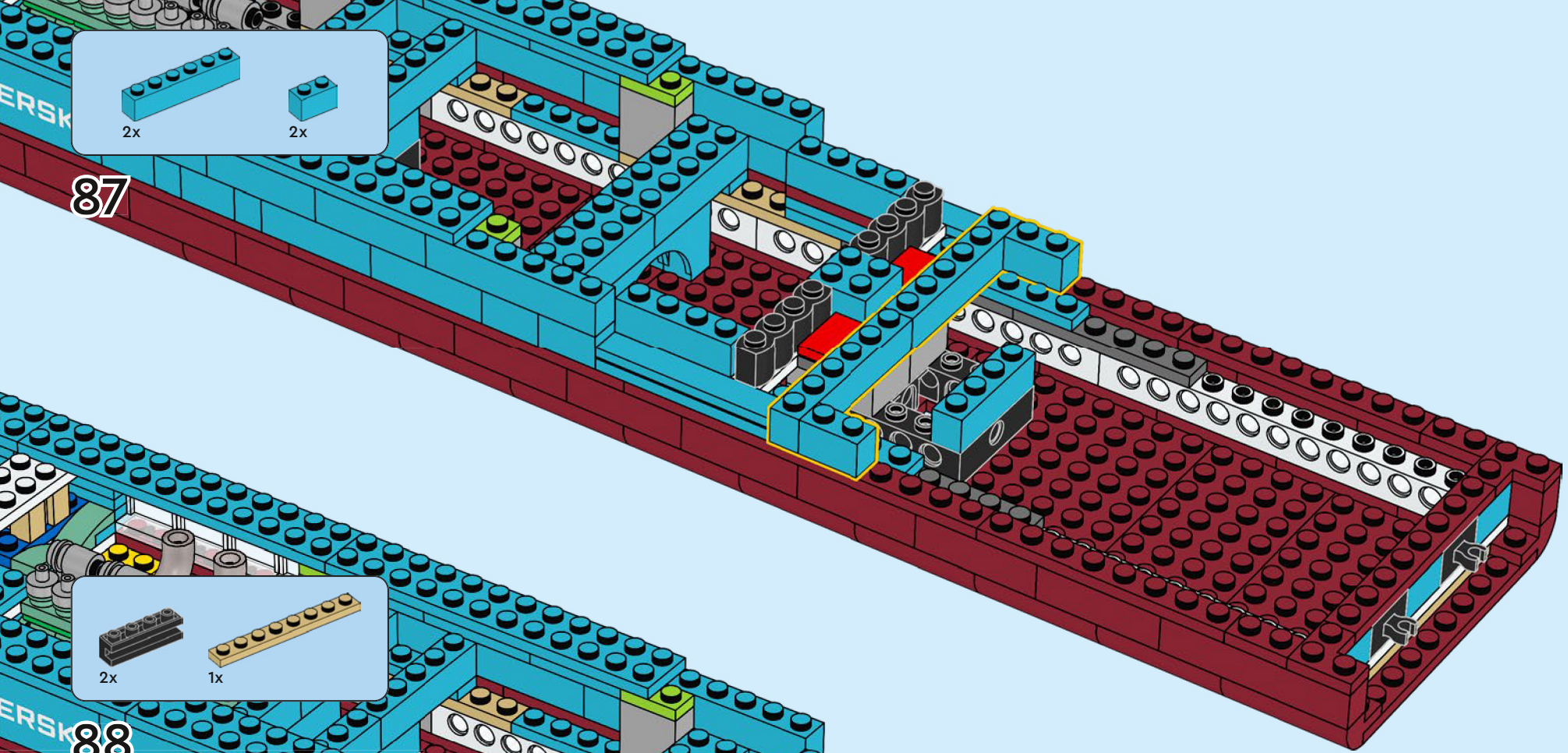

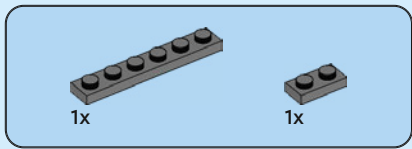

89

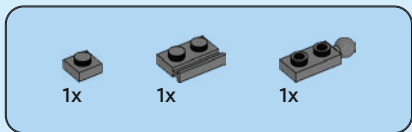
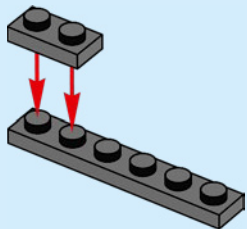

90

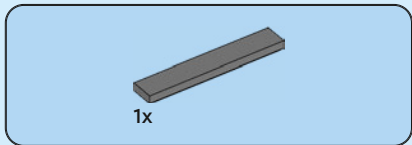
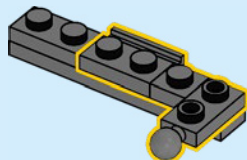

91

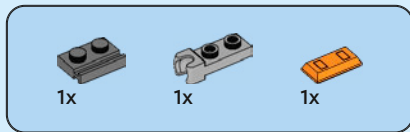
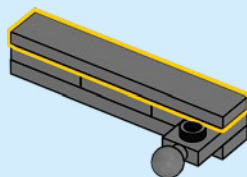

92

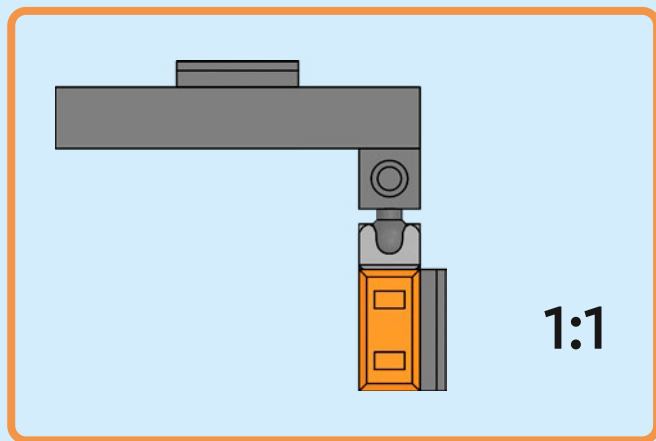
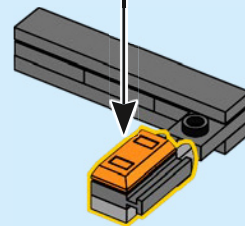
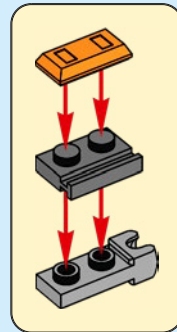

93

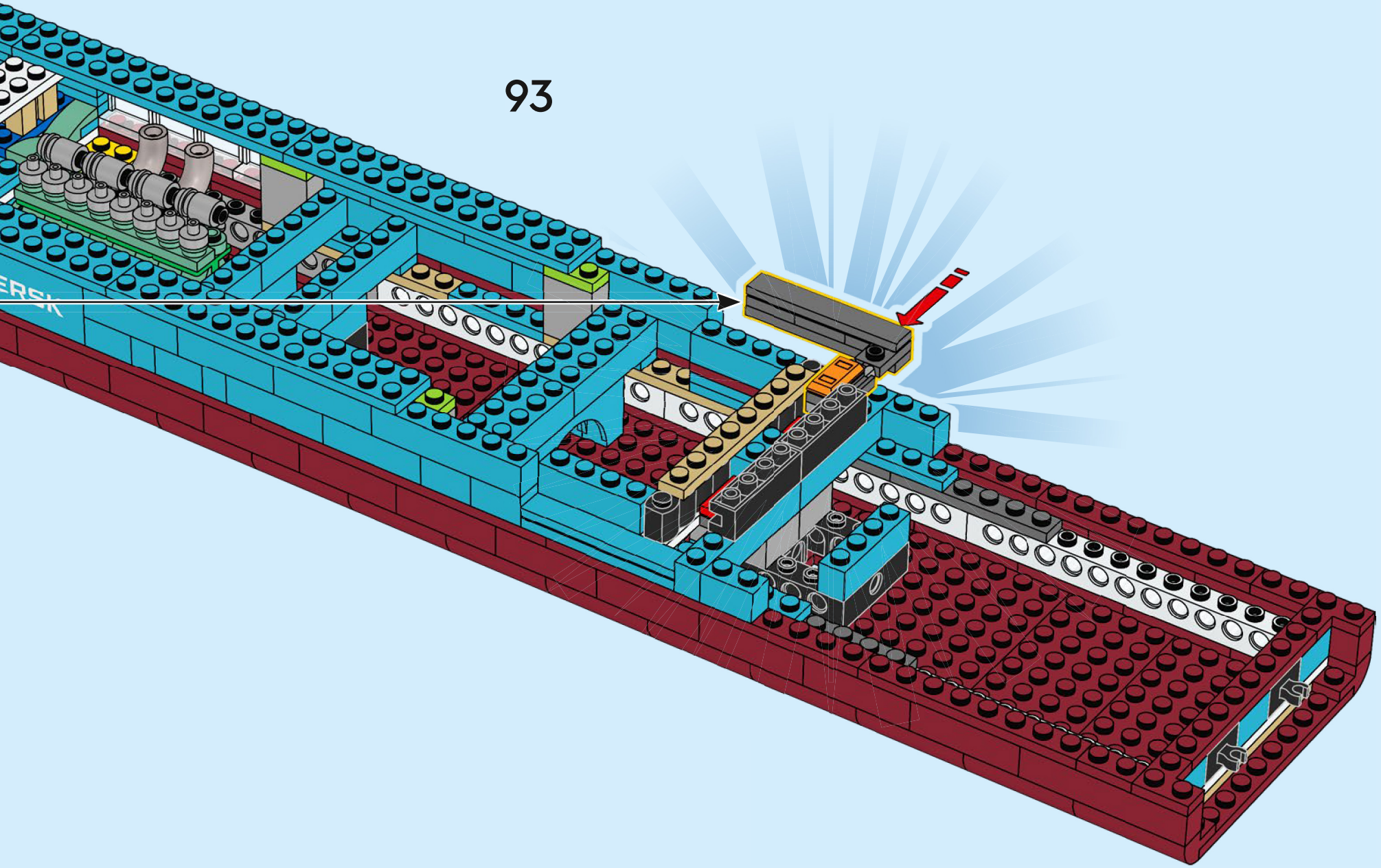

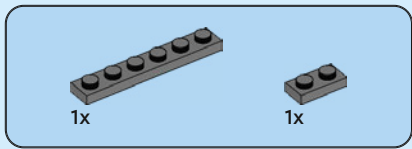

94

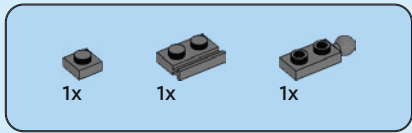
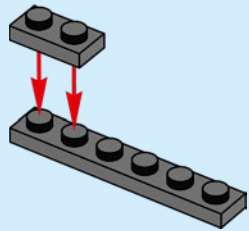

95

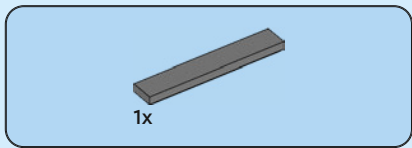
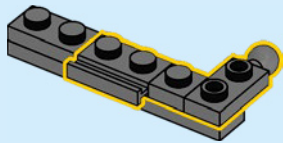

96

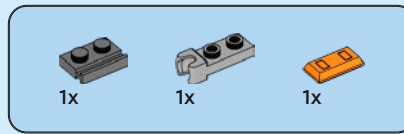
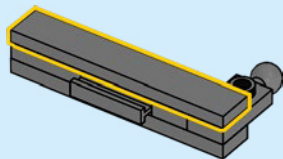

97

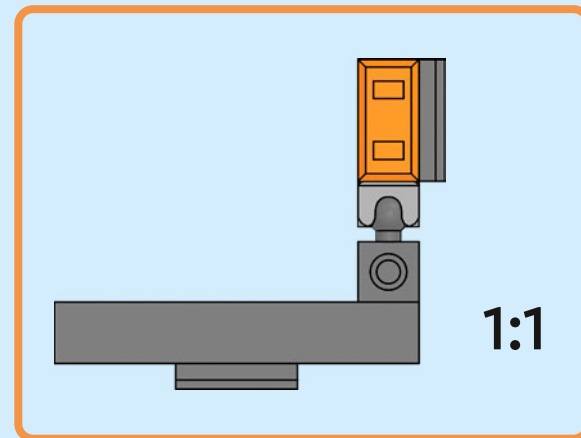
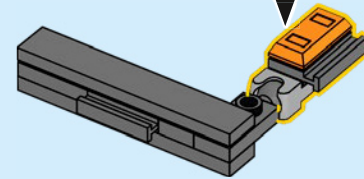
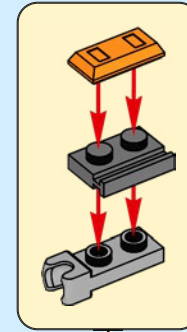

98

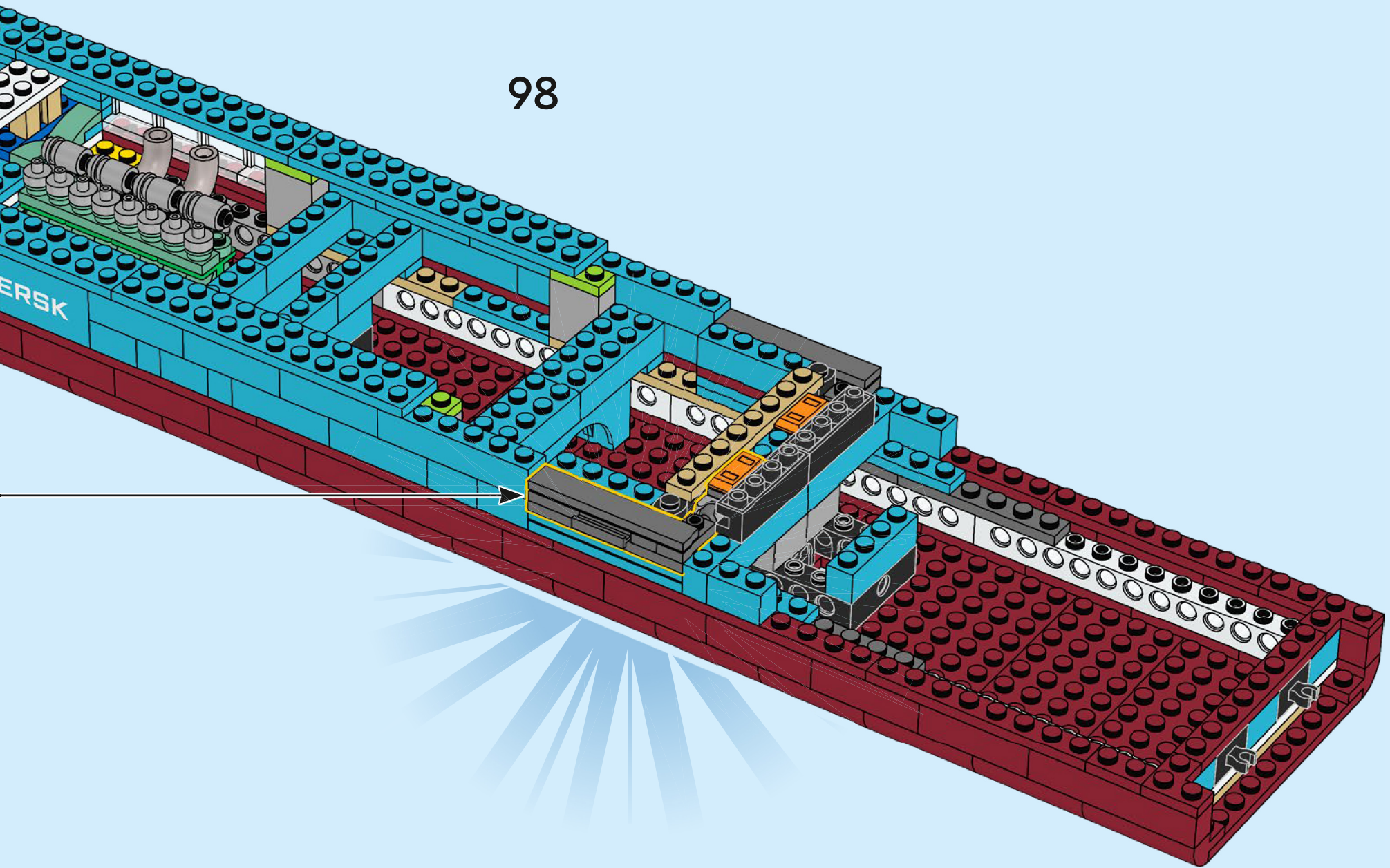

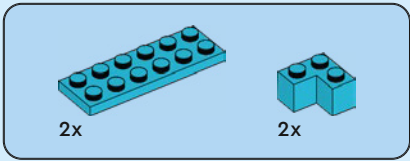

99

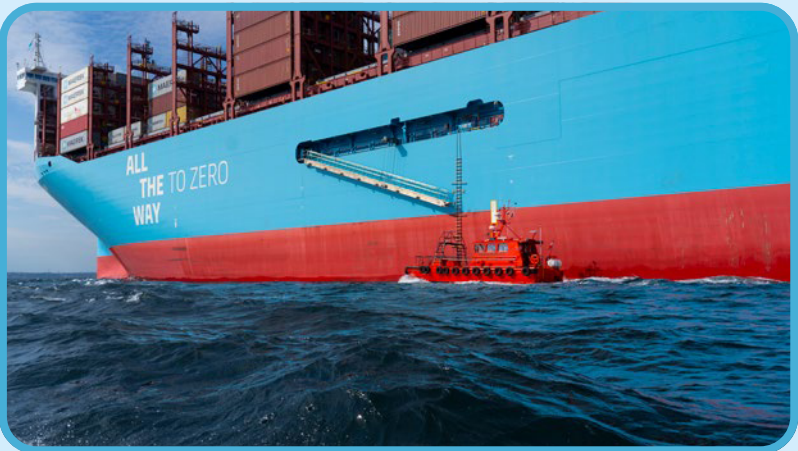
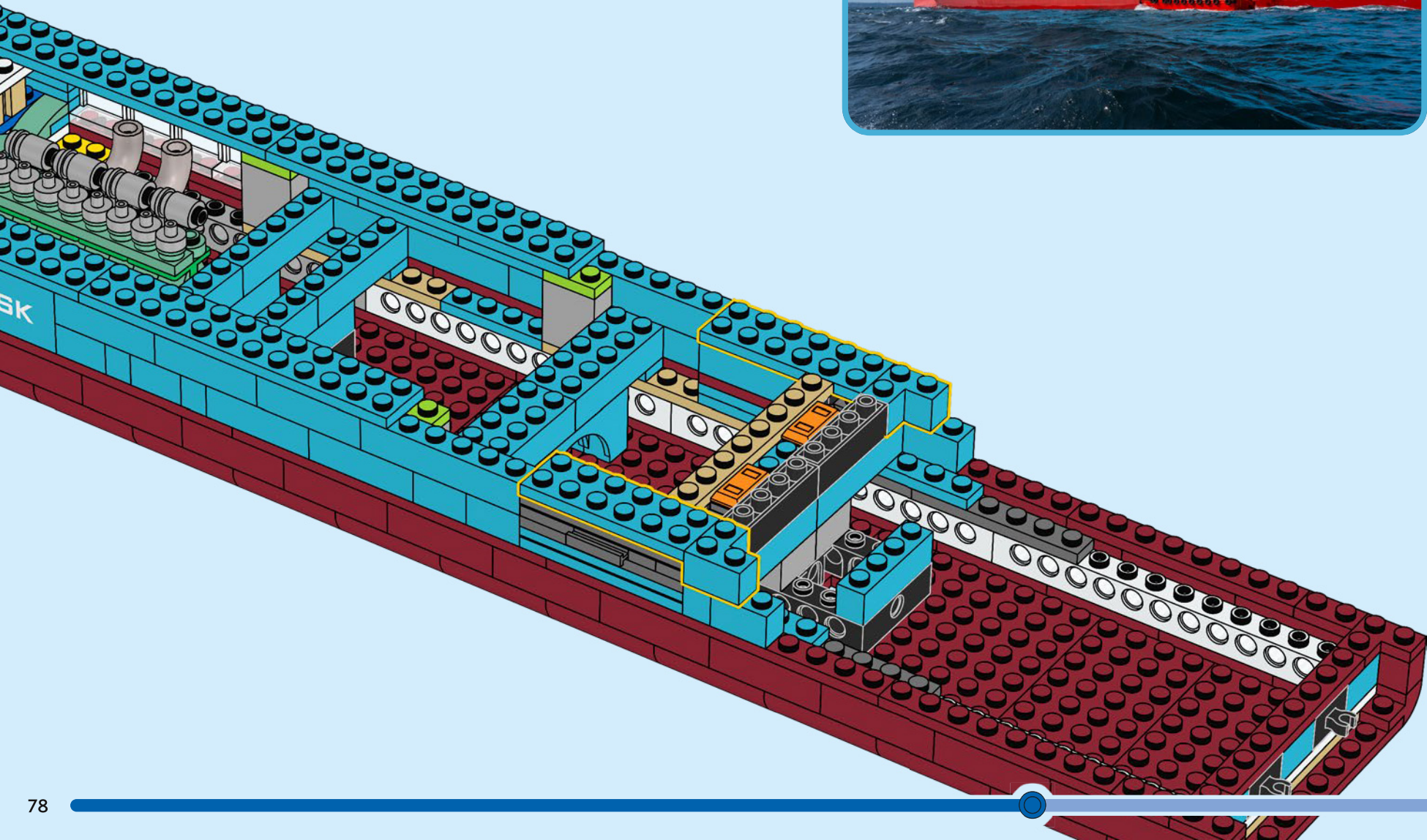

1

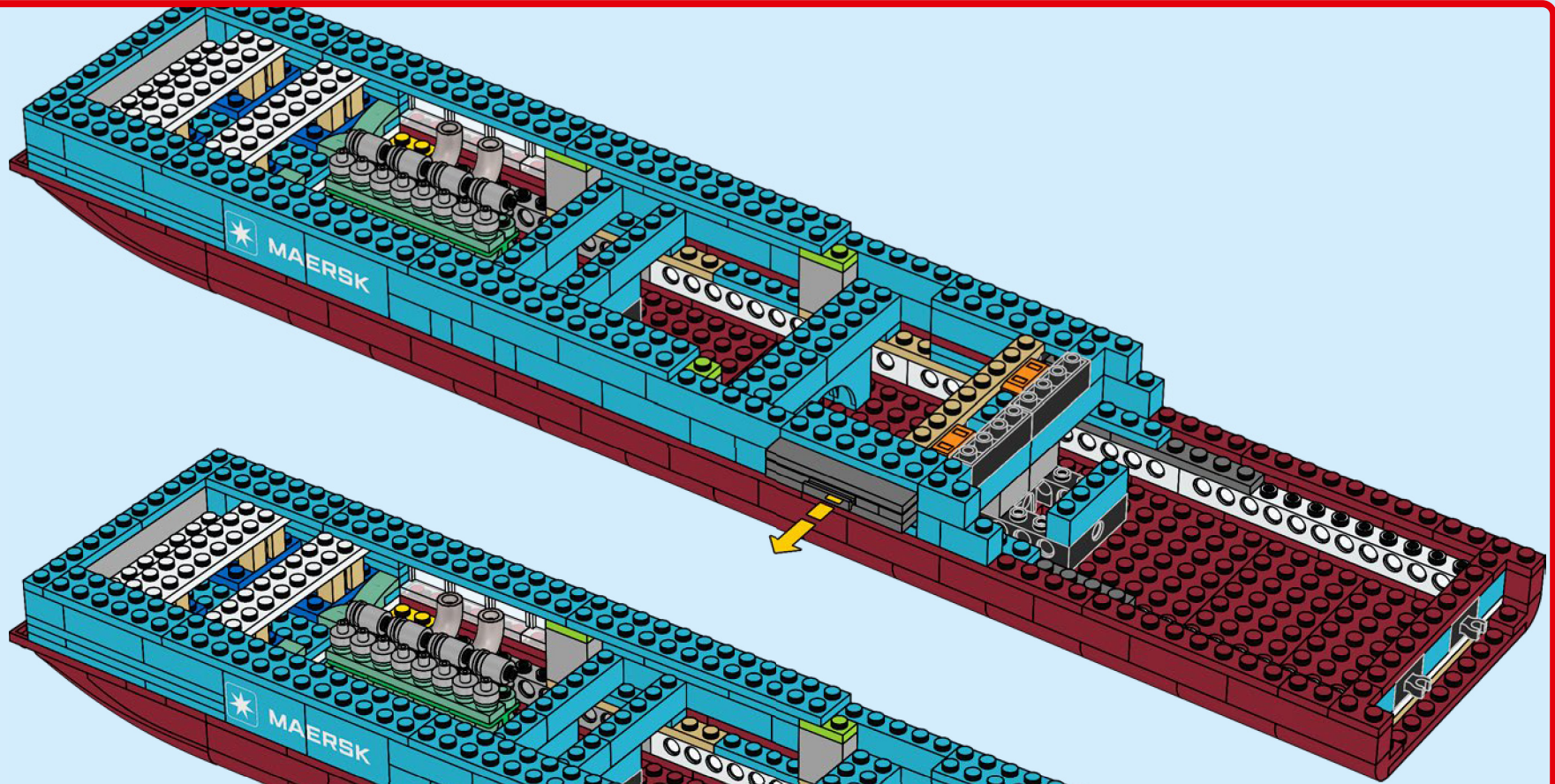

2

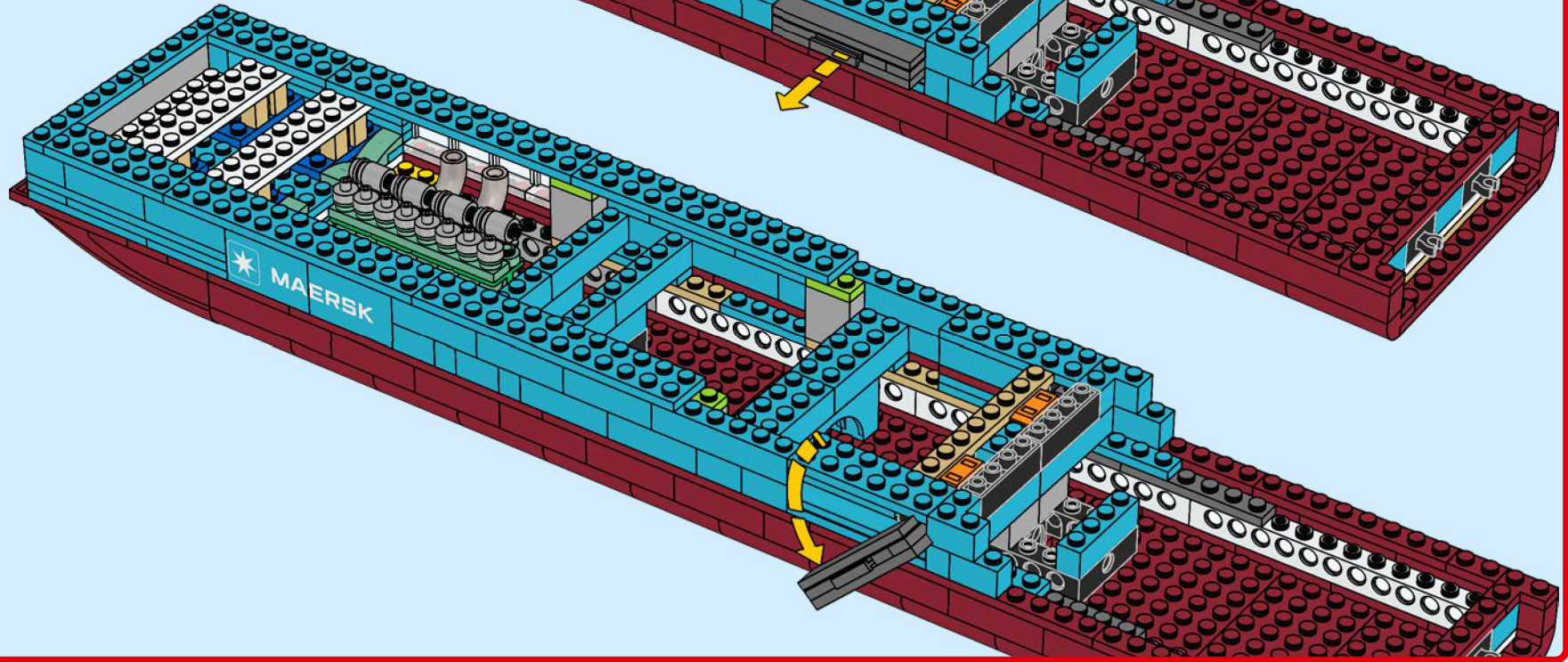

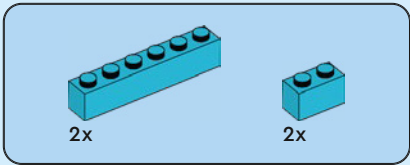

100

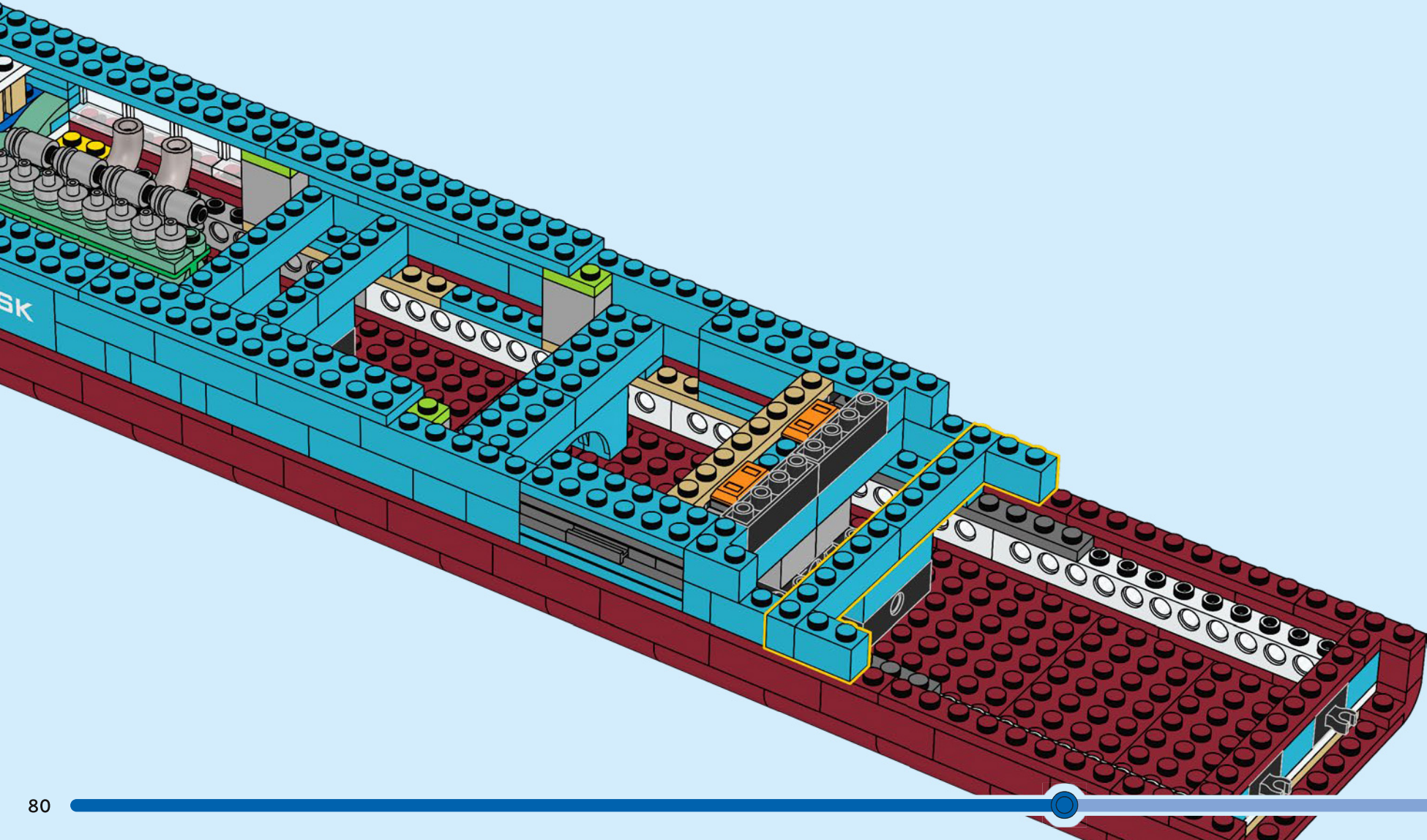

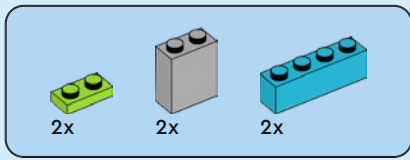

101

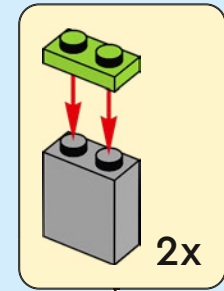
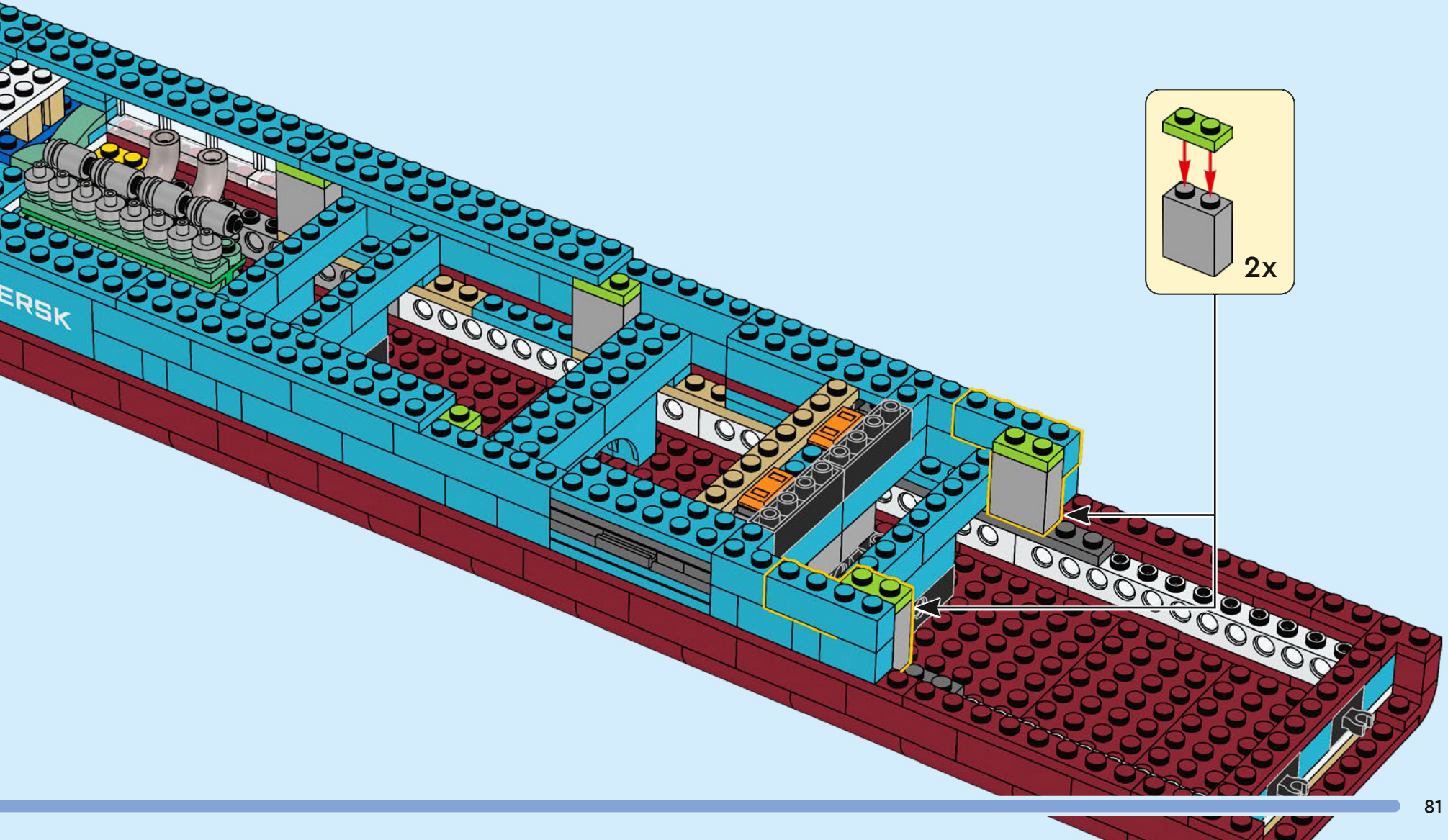

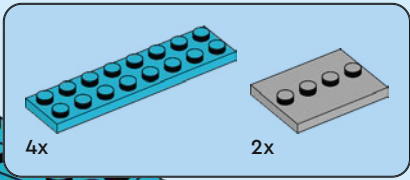

102

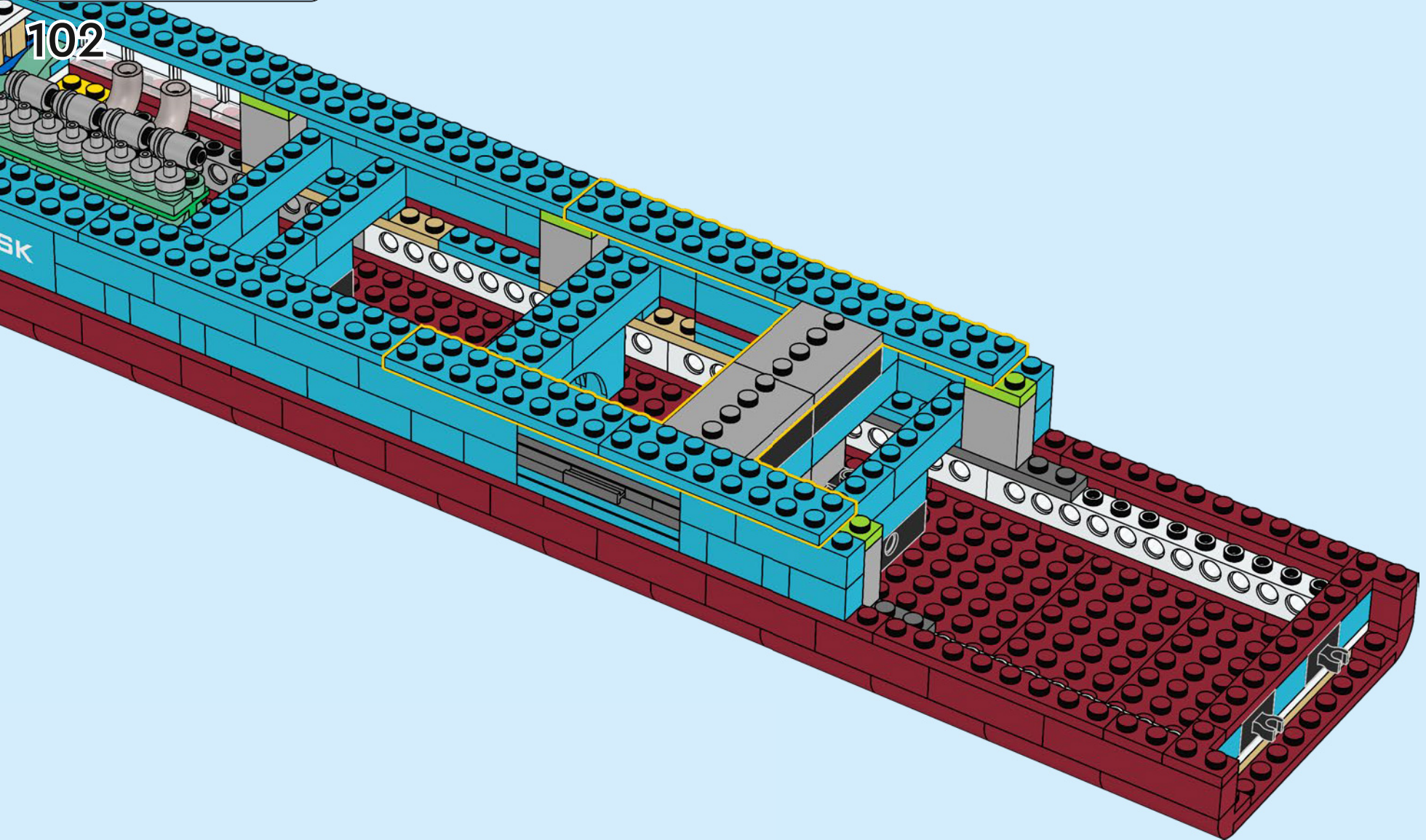

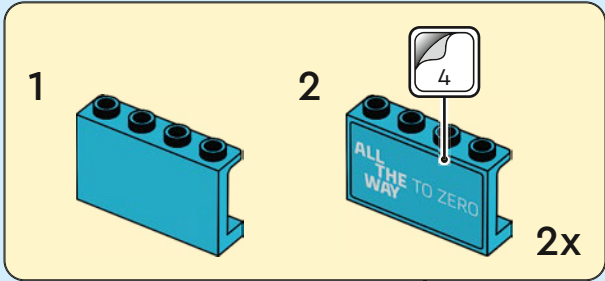
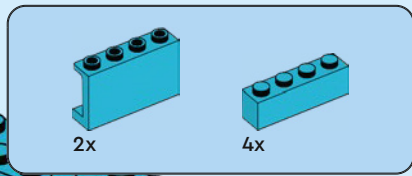

103

ERSK

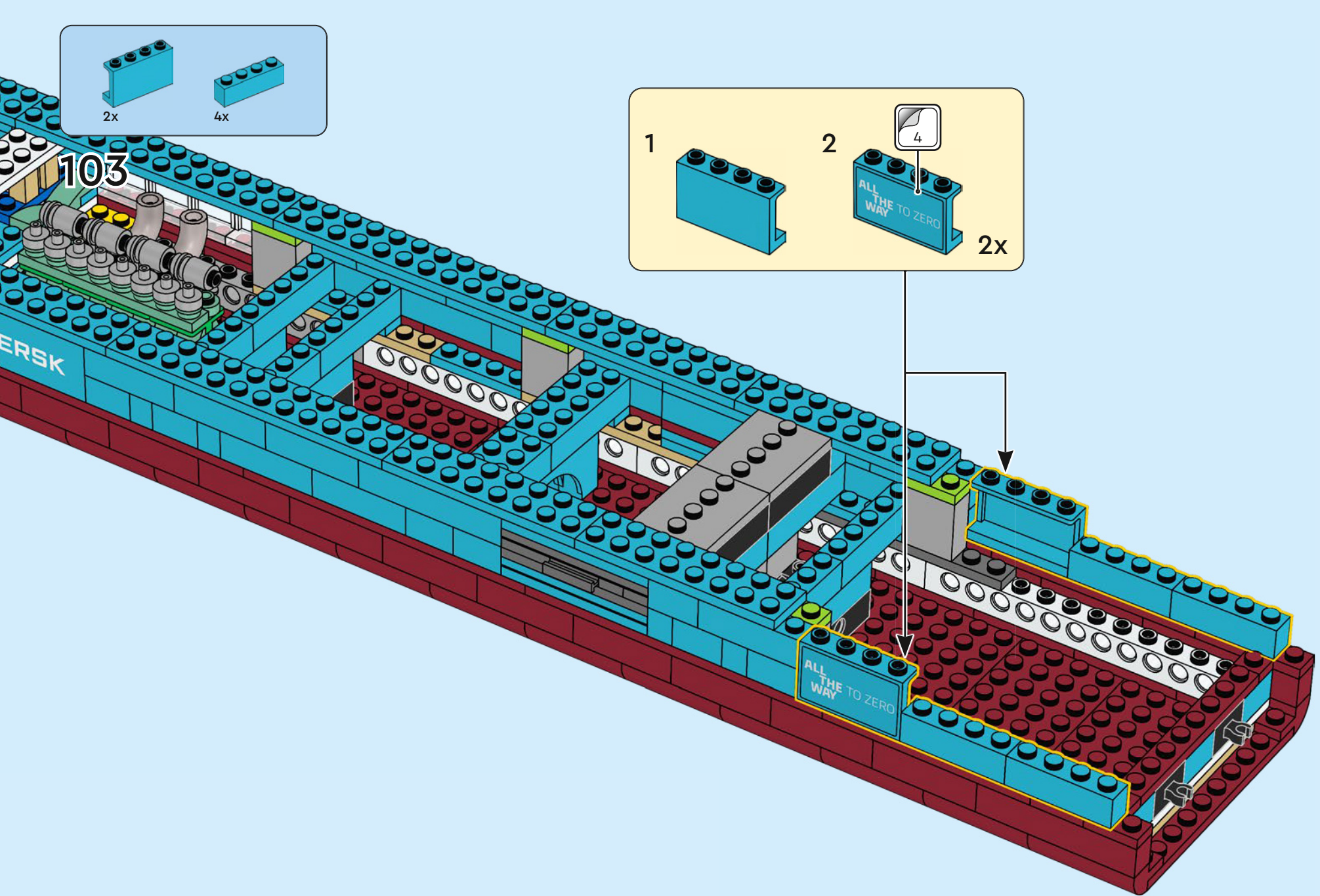

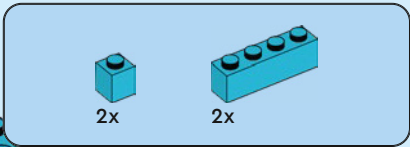

104

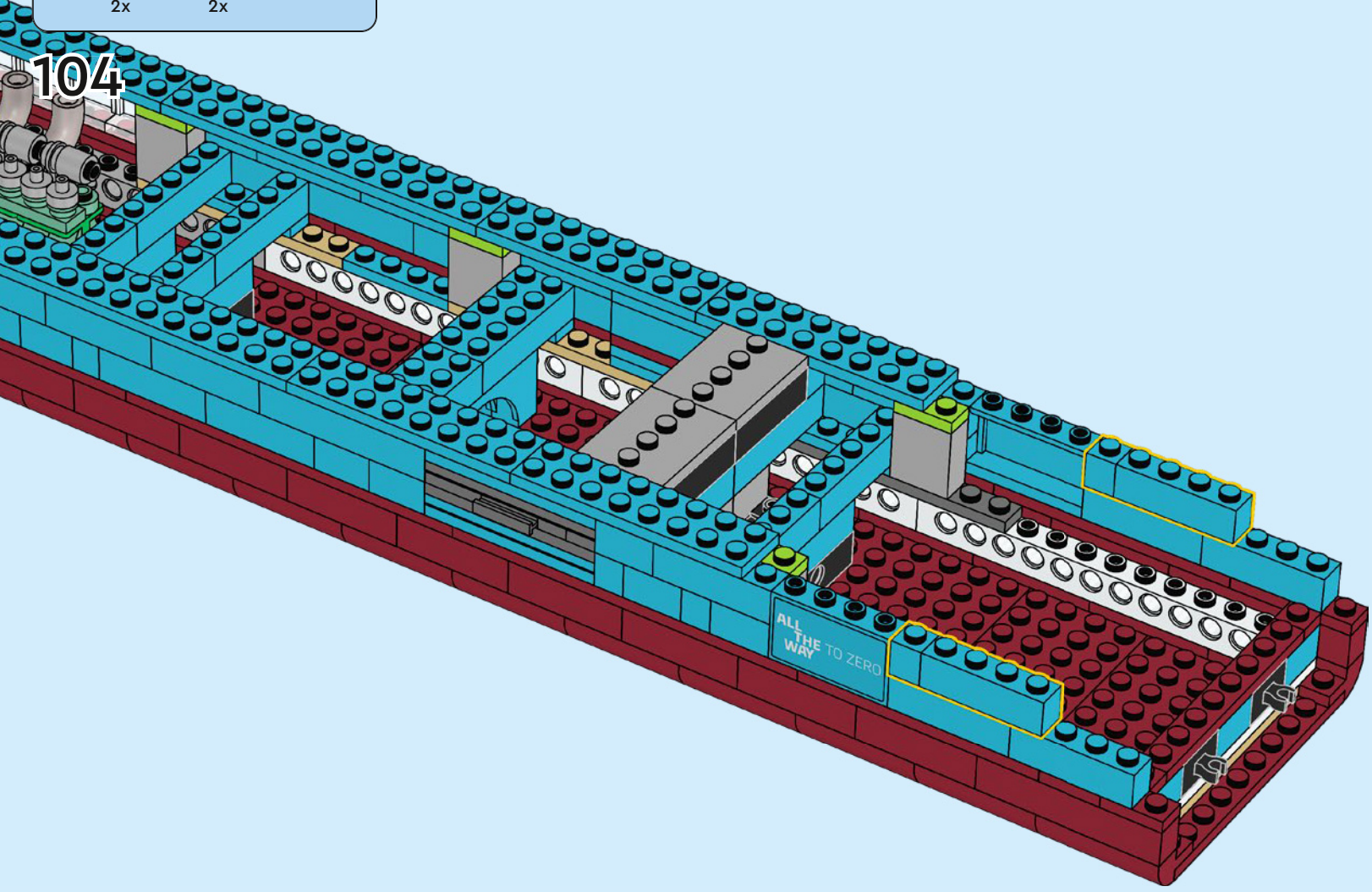

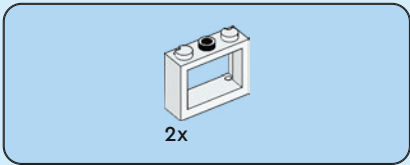

105

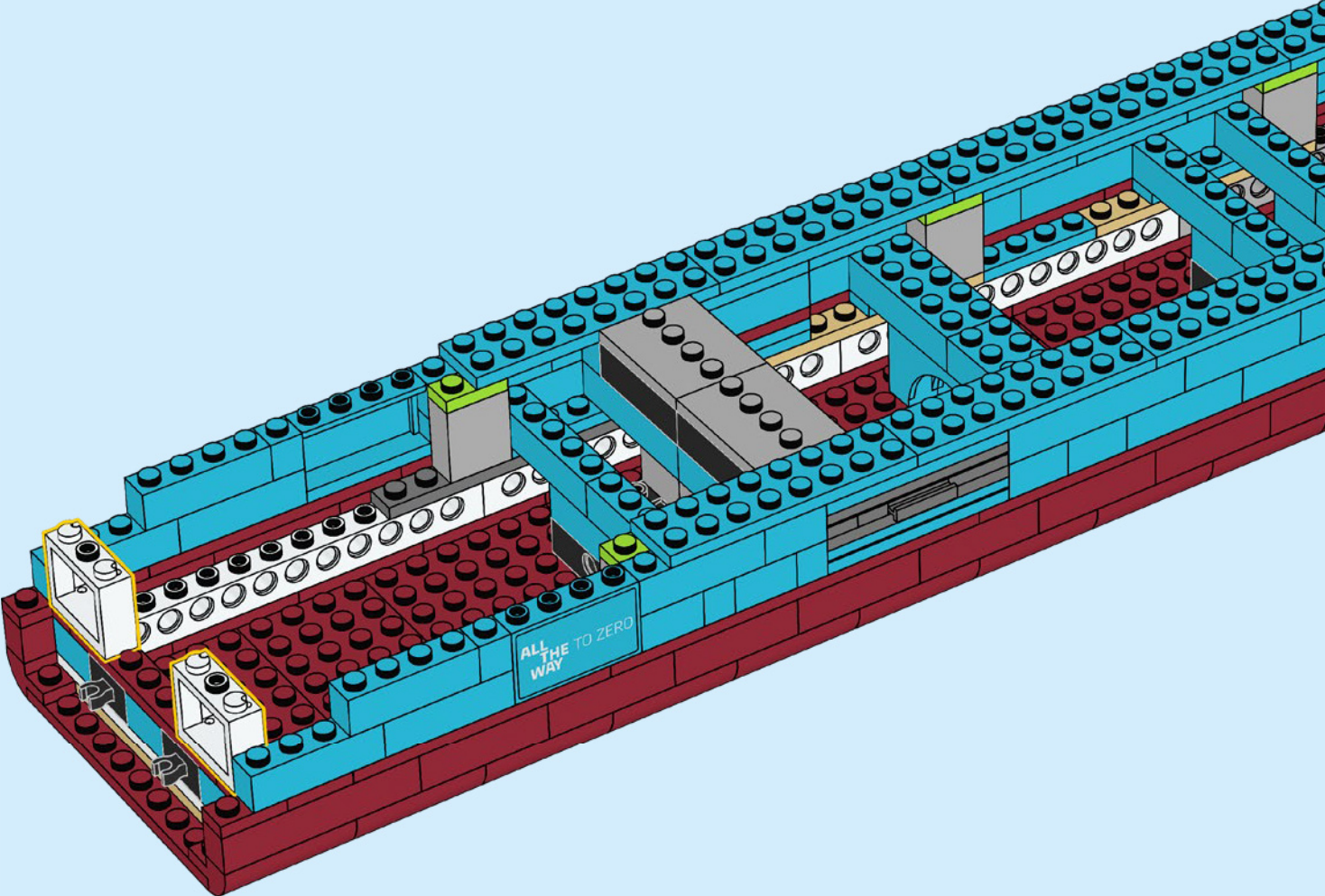

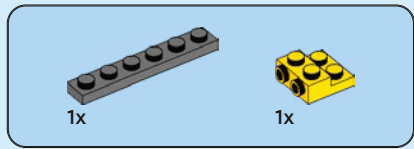
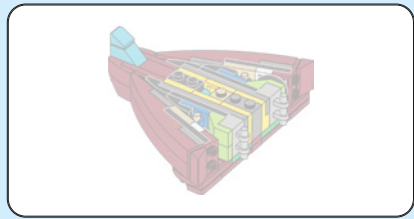
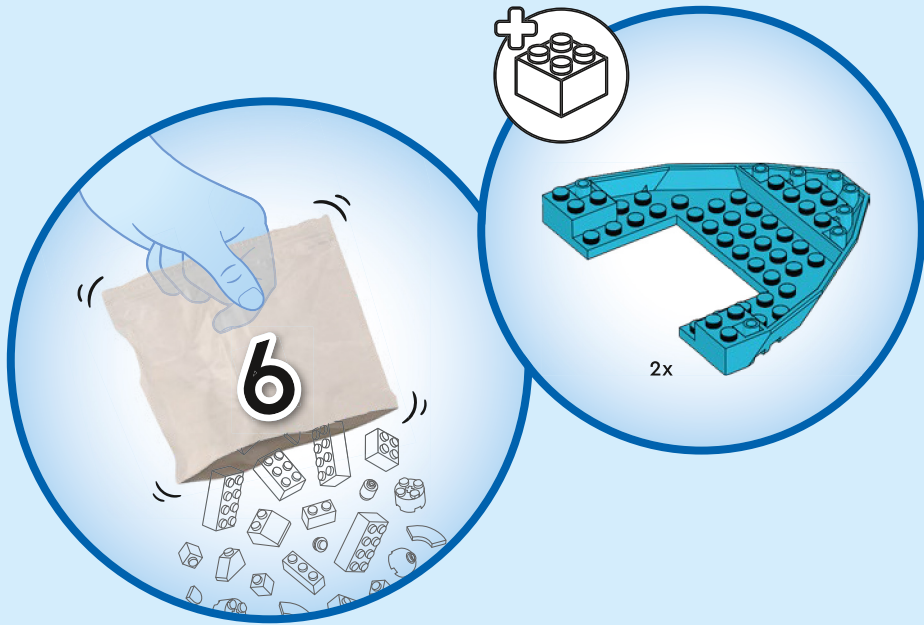

106

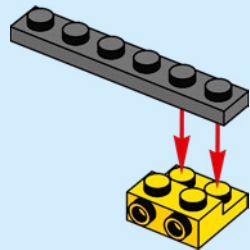

107

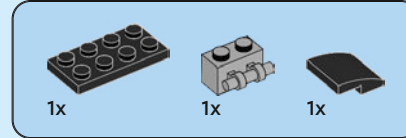
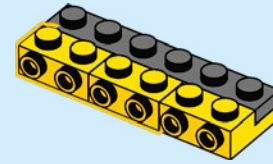

108

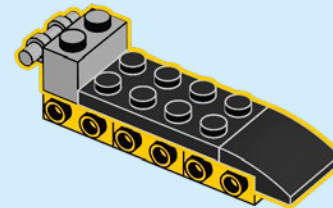

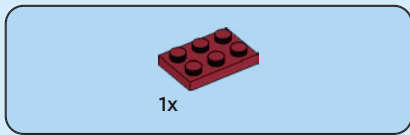

109

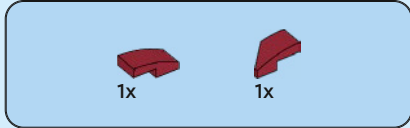
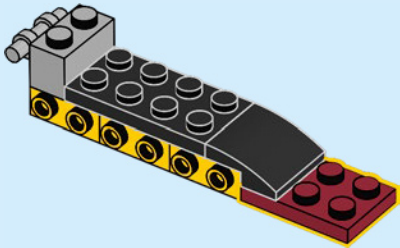

110

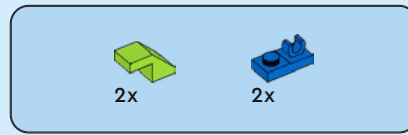
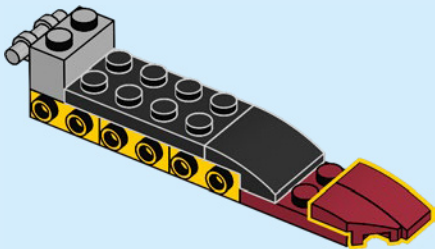

111

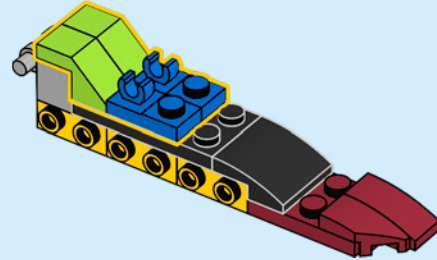

112

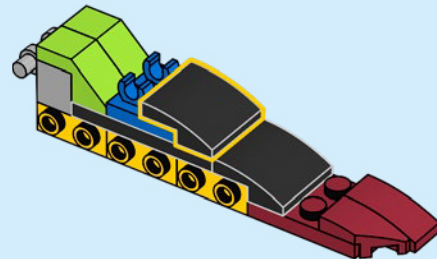

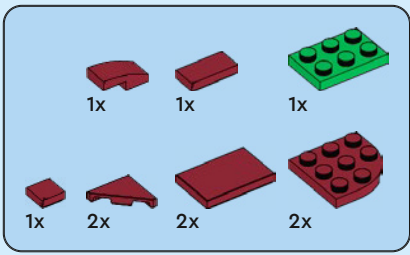

113

1

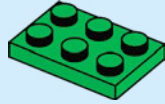

2

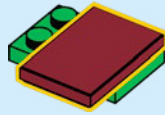

3

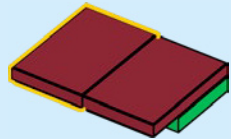

4

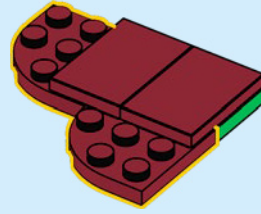

5

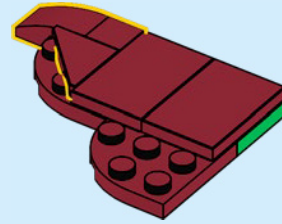

6

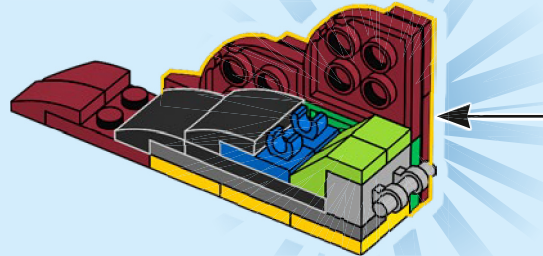
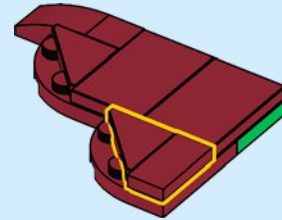

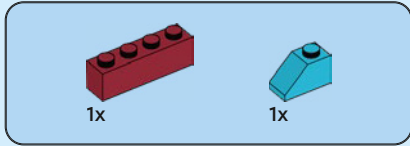
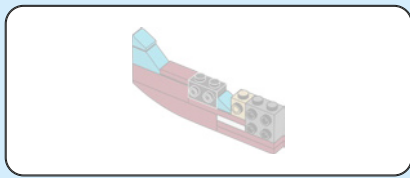

114

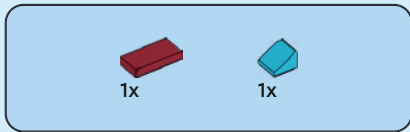
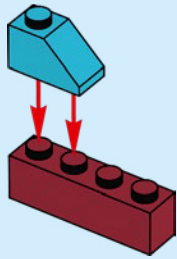

115

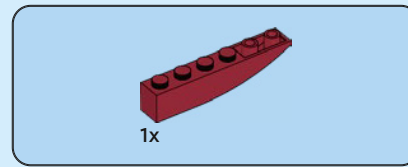
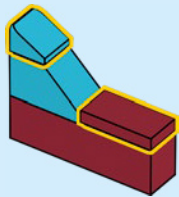

116

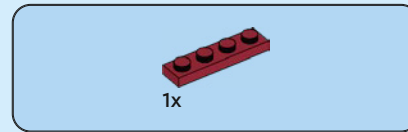
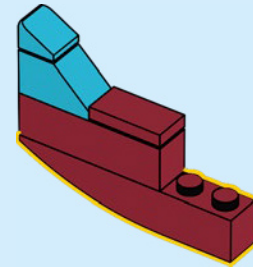

117

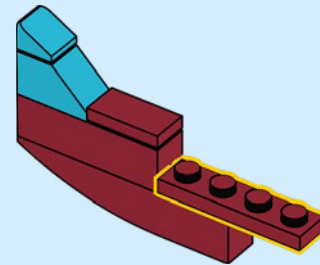

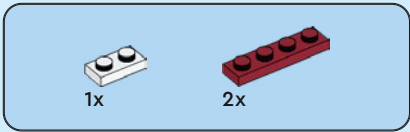

118

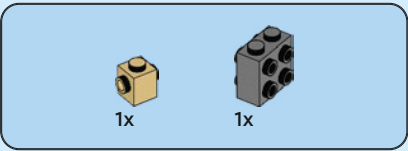
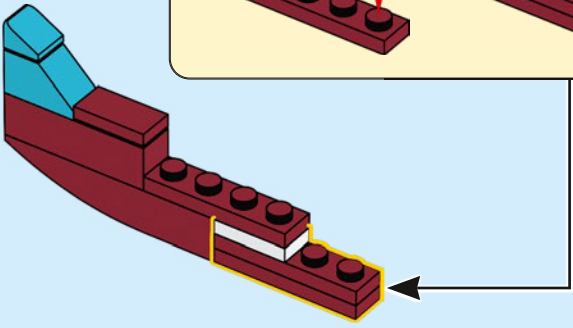
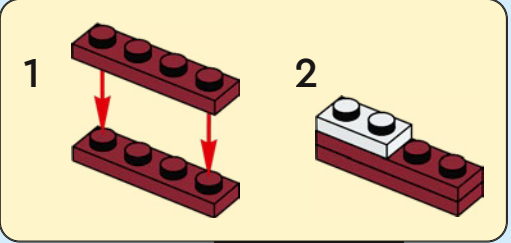

120

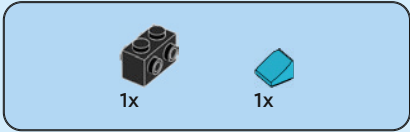
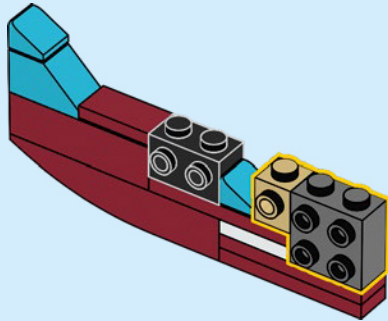

119

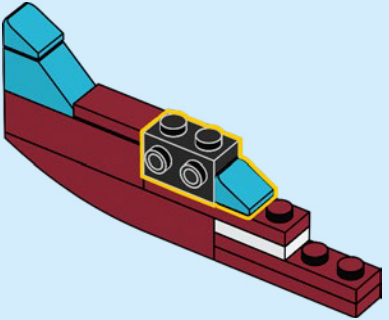

121

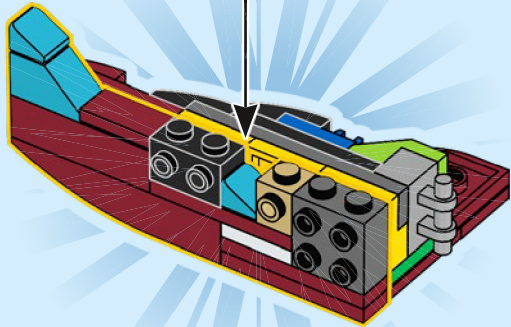

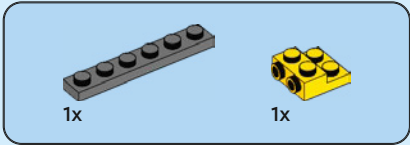
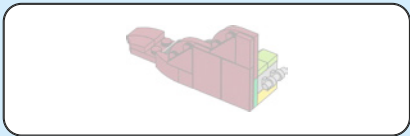

122

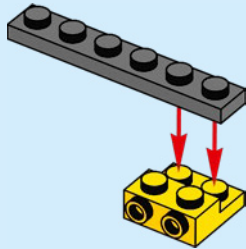

123

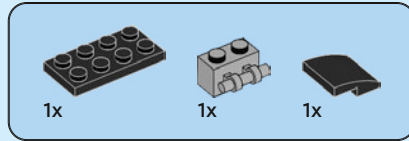
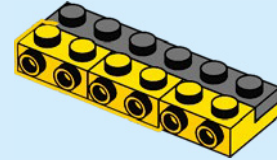

124

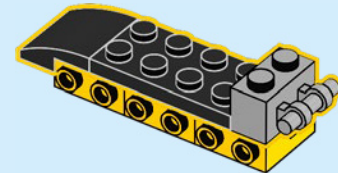

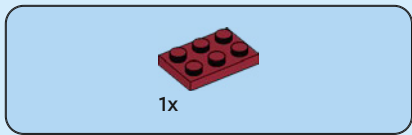

125

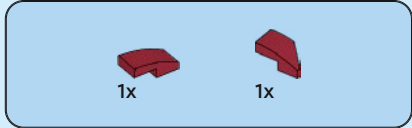
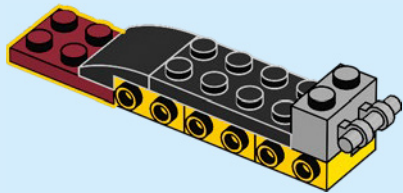

126

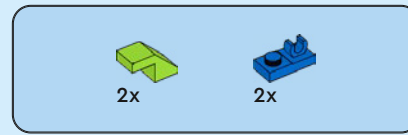
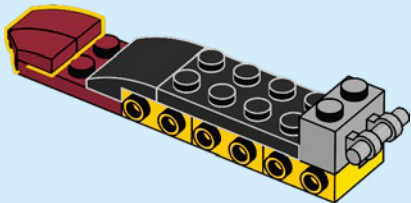

127

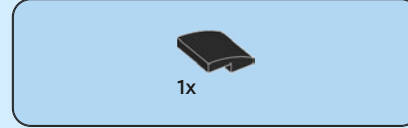
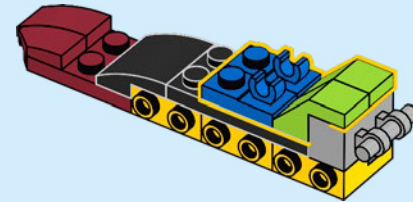

128

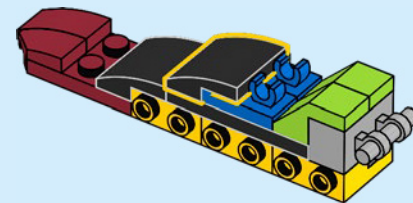

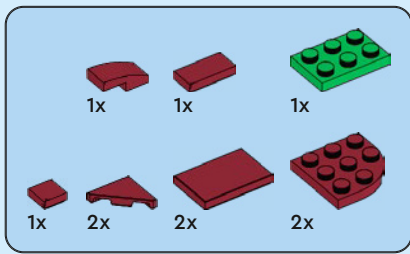

129

1

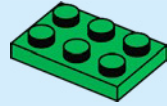

2

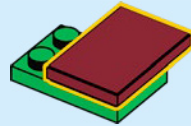

3

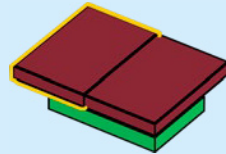

4

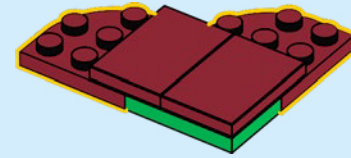

5

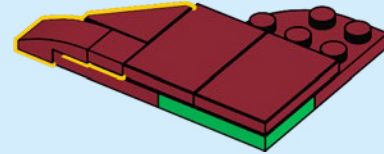

6

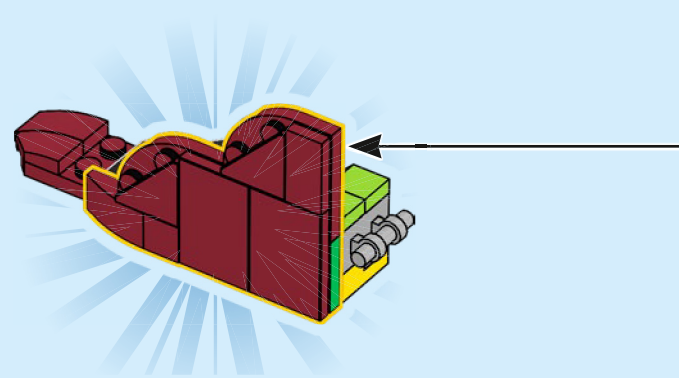
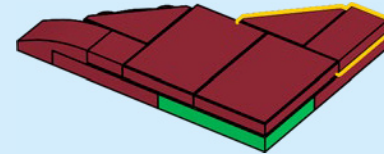

130

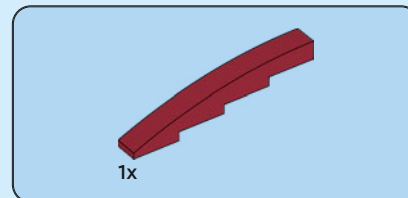
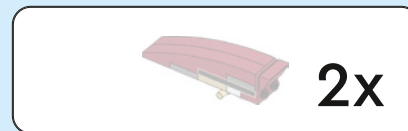
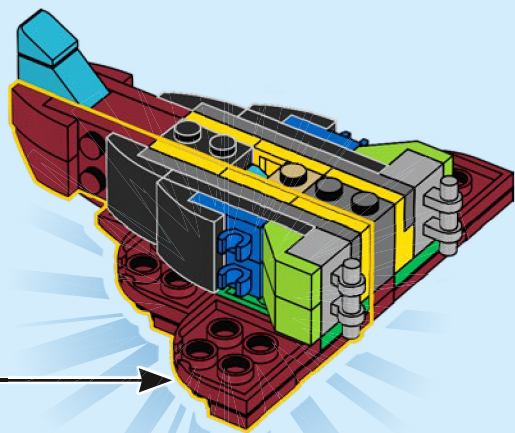

131

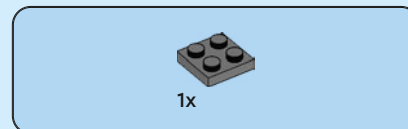
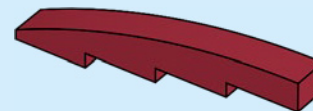

132

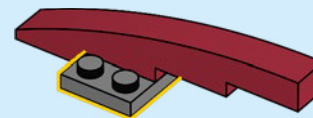

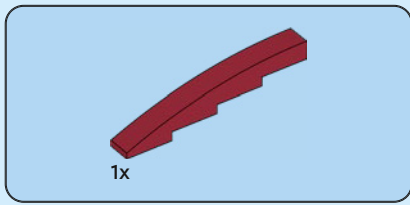

133

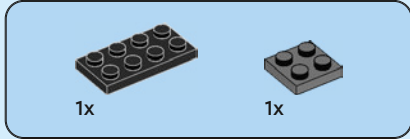
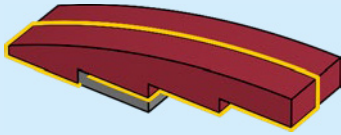

134

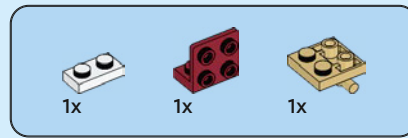
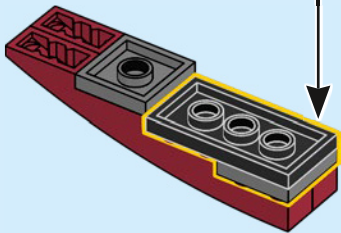
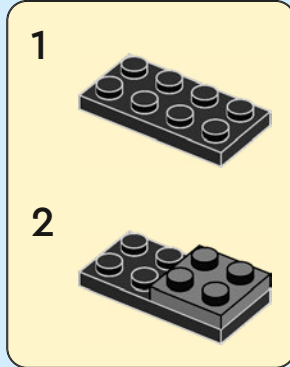

135

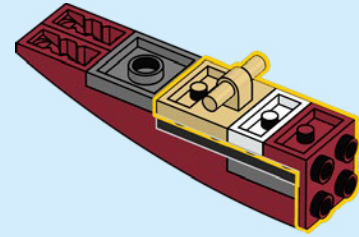

136

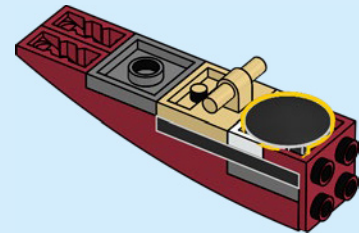



1x

137

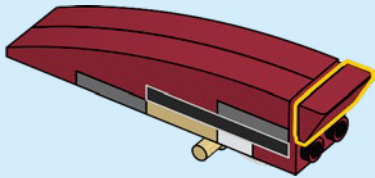

2x

138

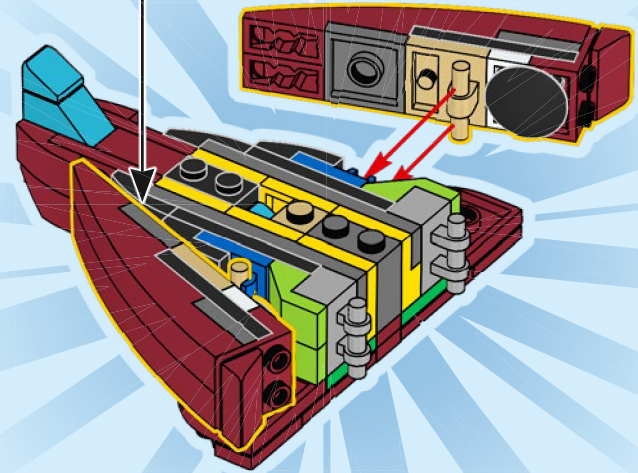

139

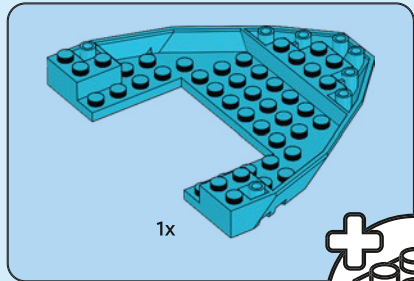
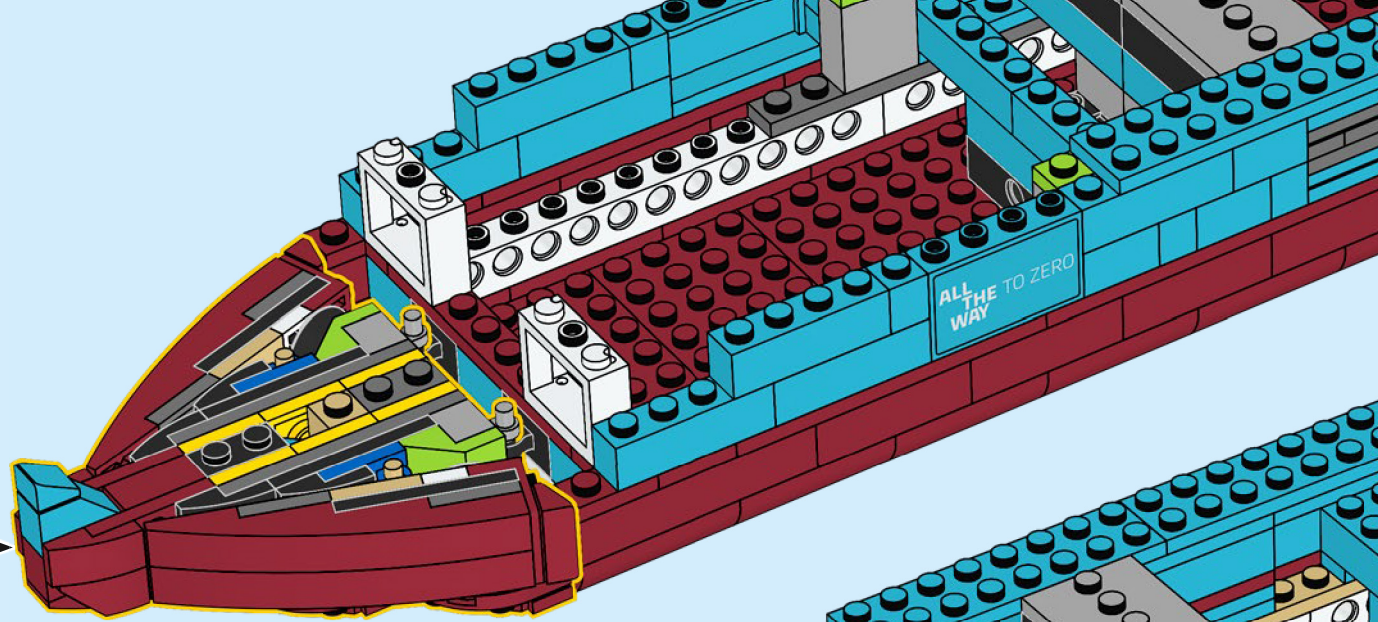

1x

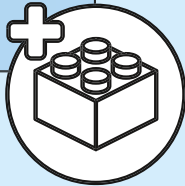

140

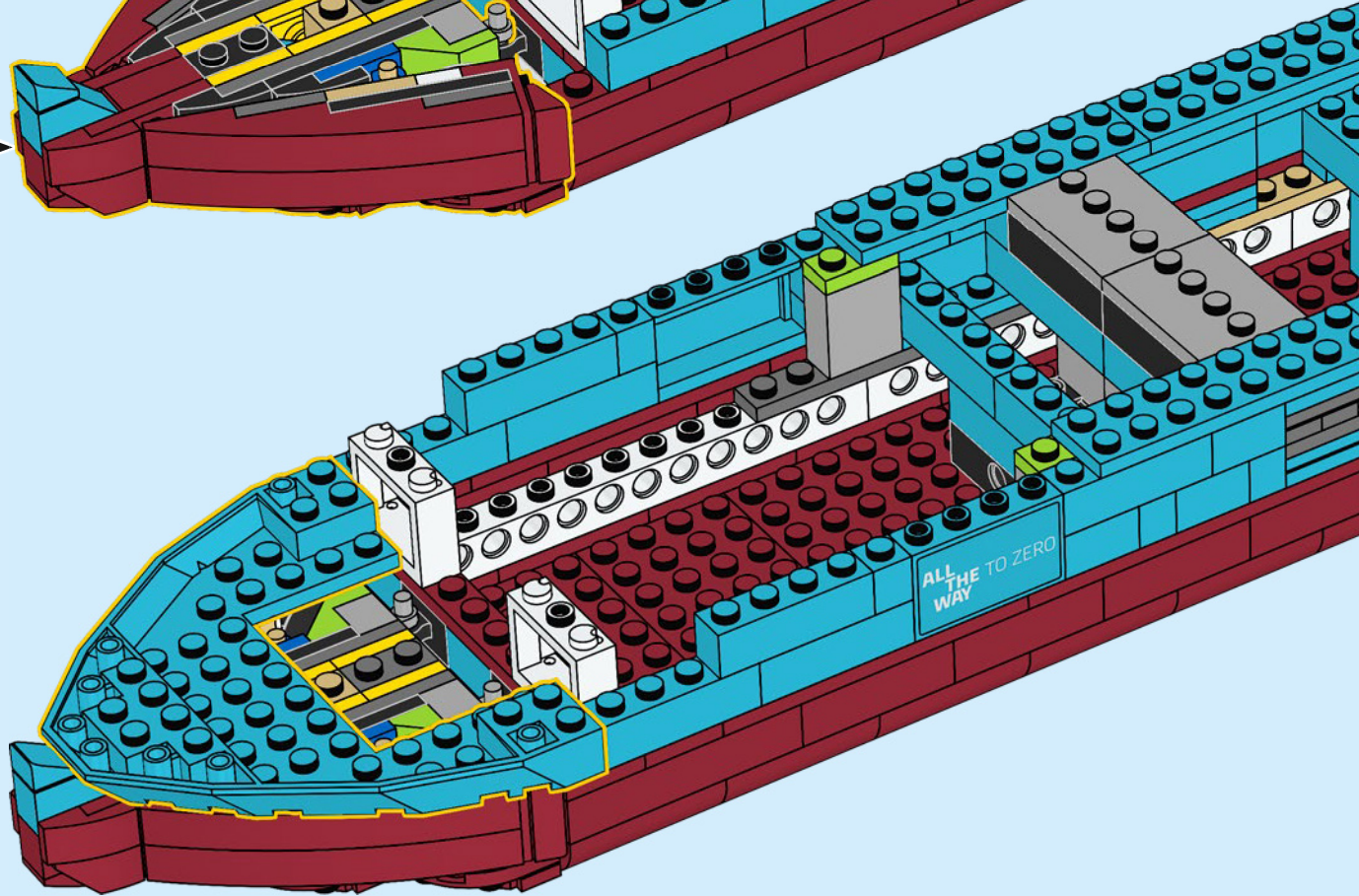

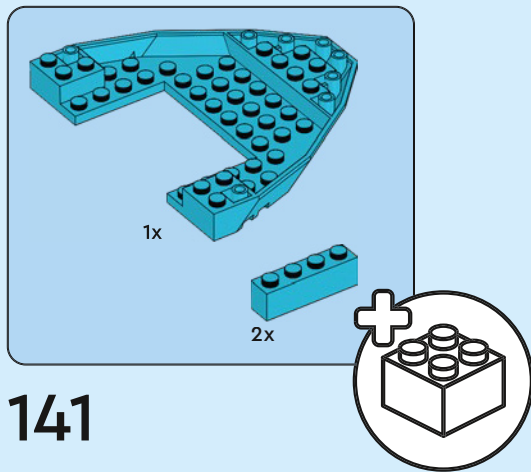

141

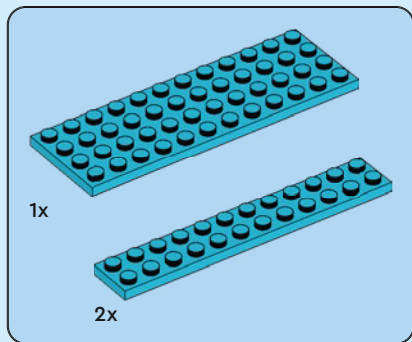
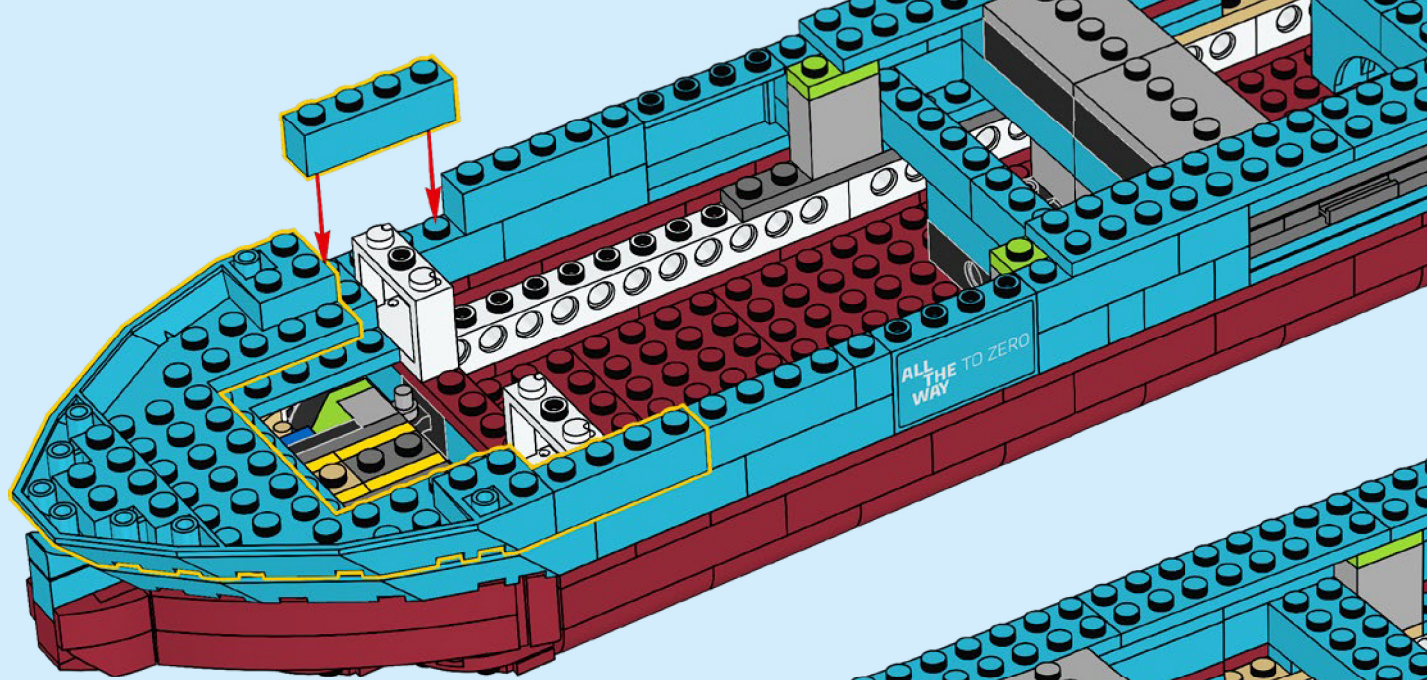

142

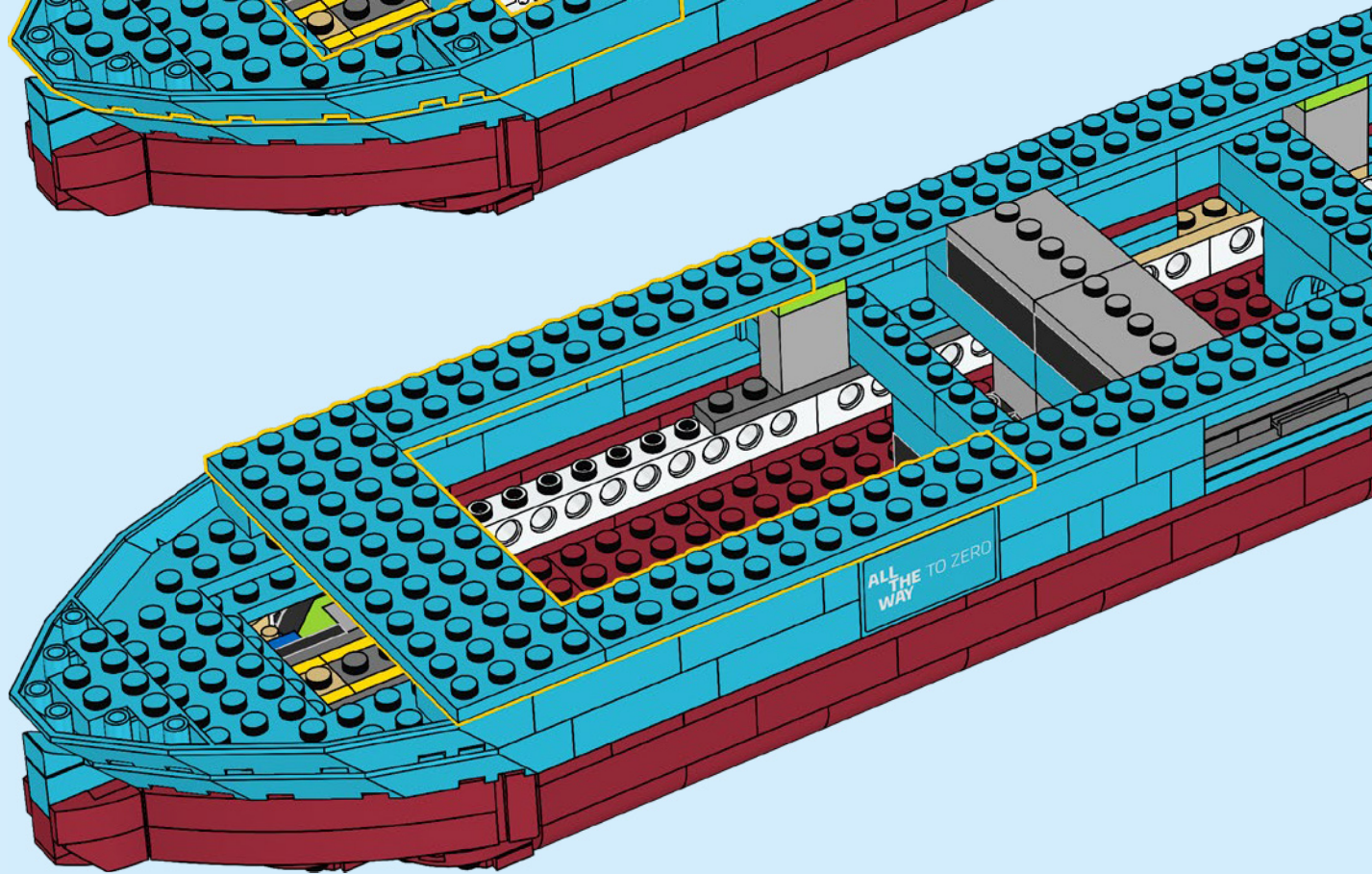

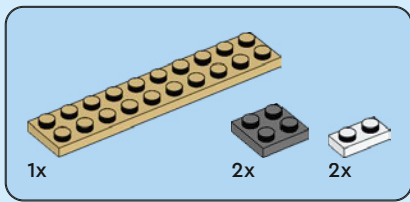

143

1

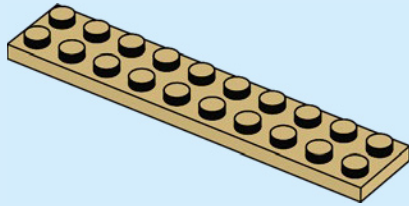

2

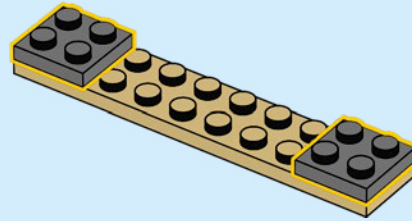

3

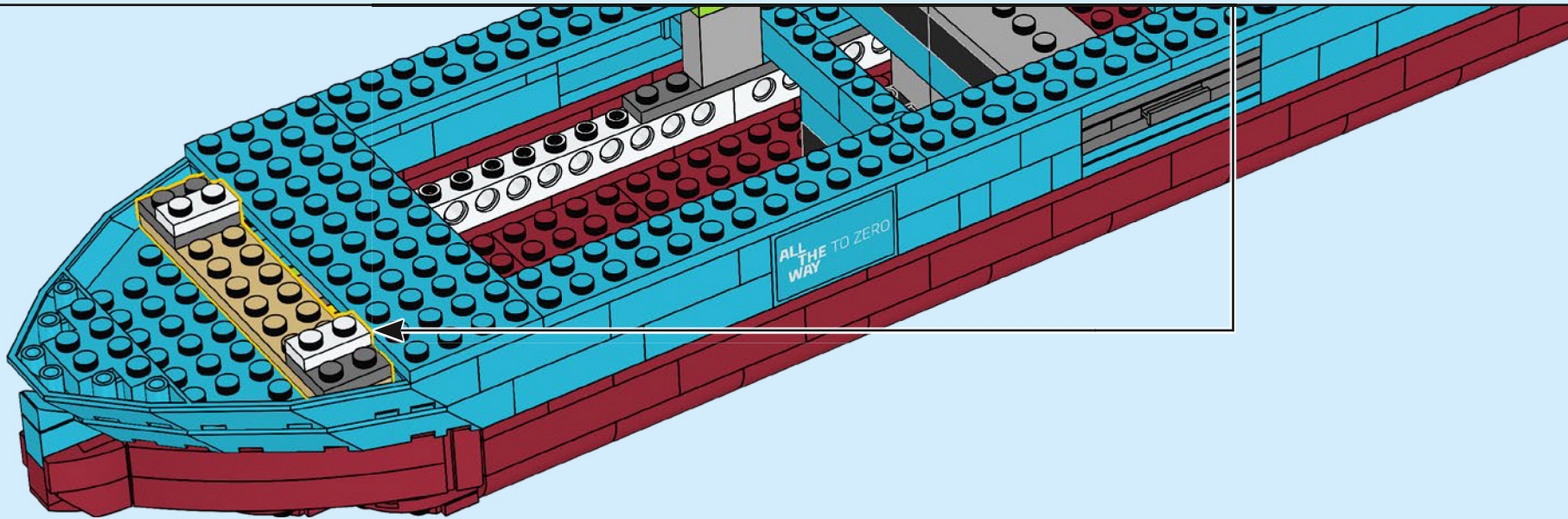
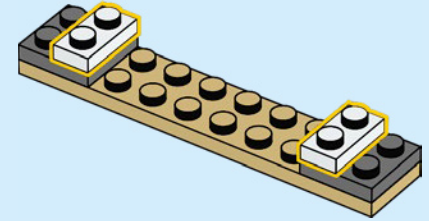

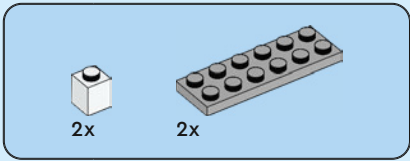

144

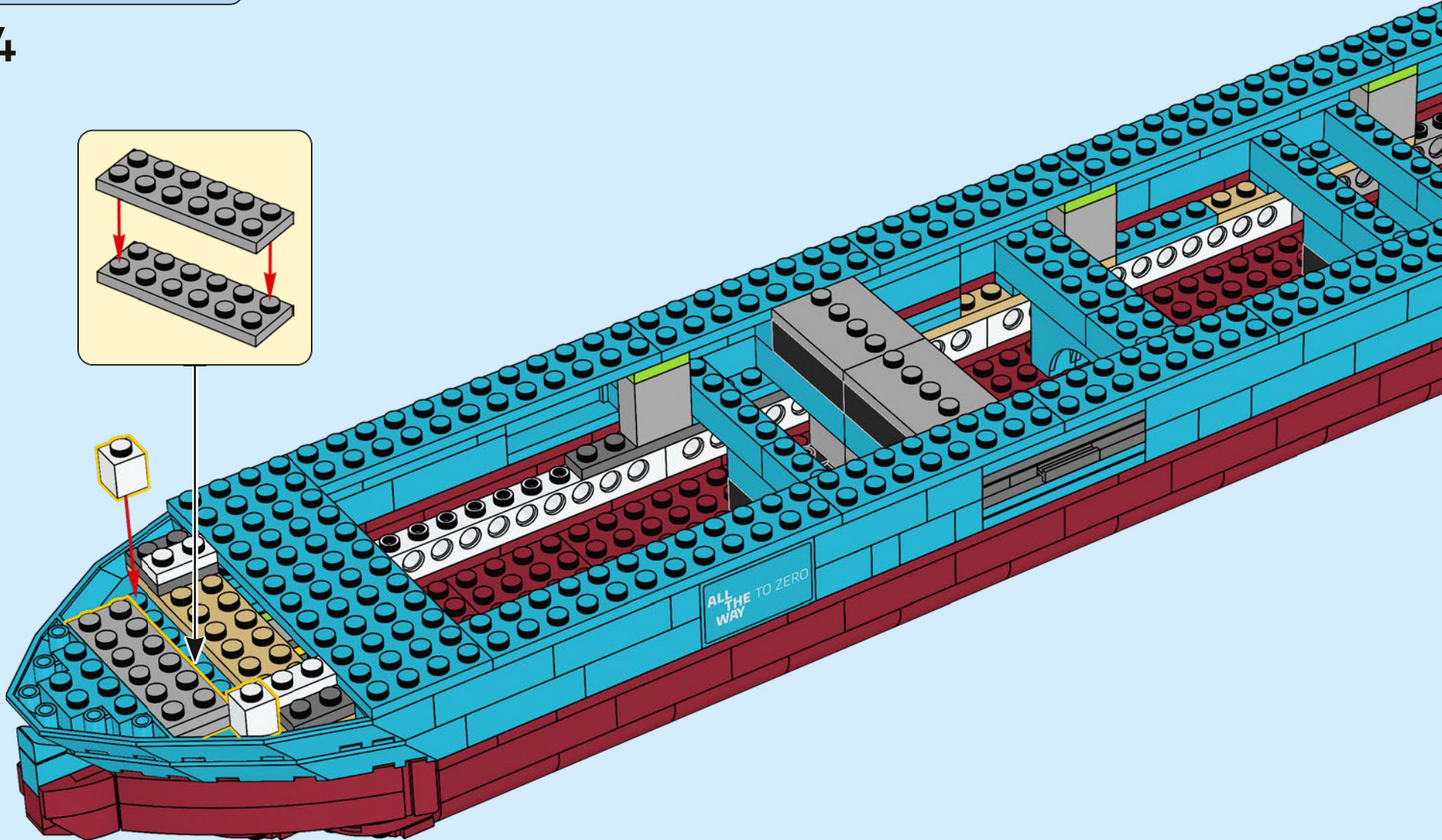
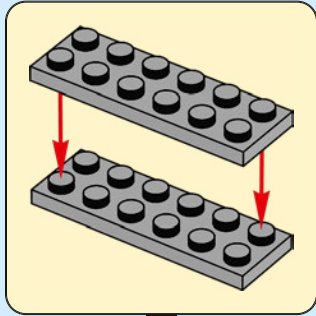

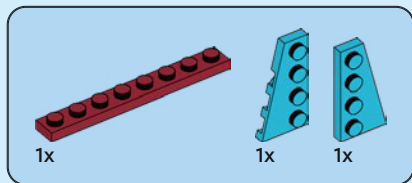

145

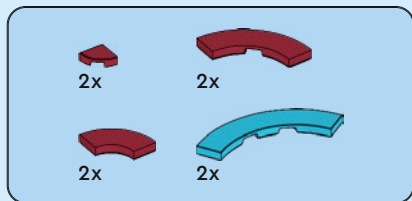
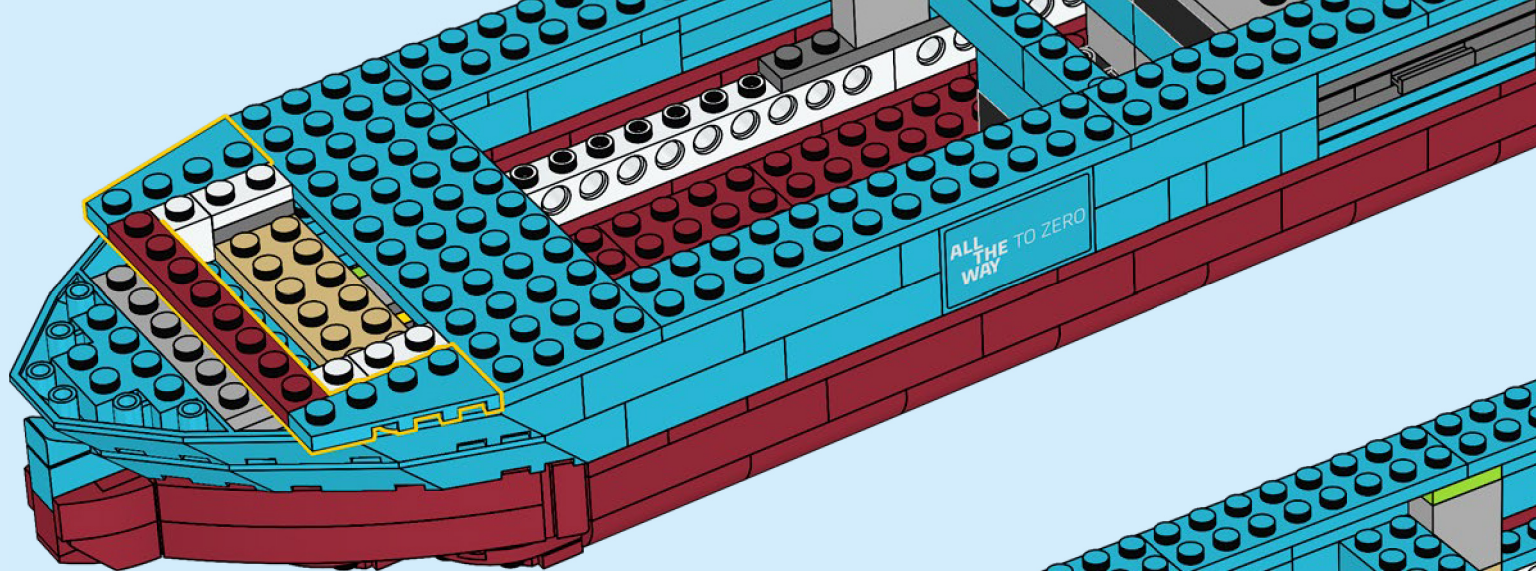

146

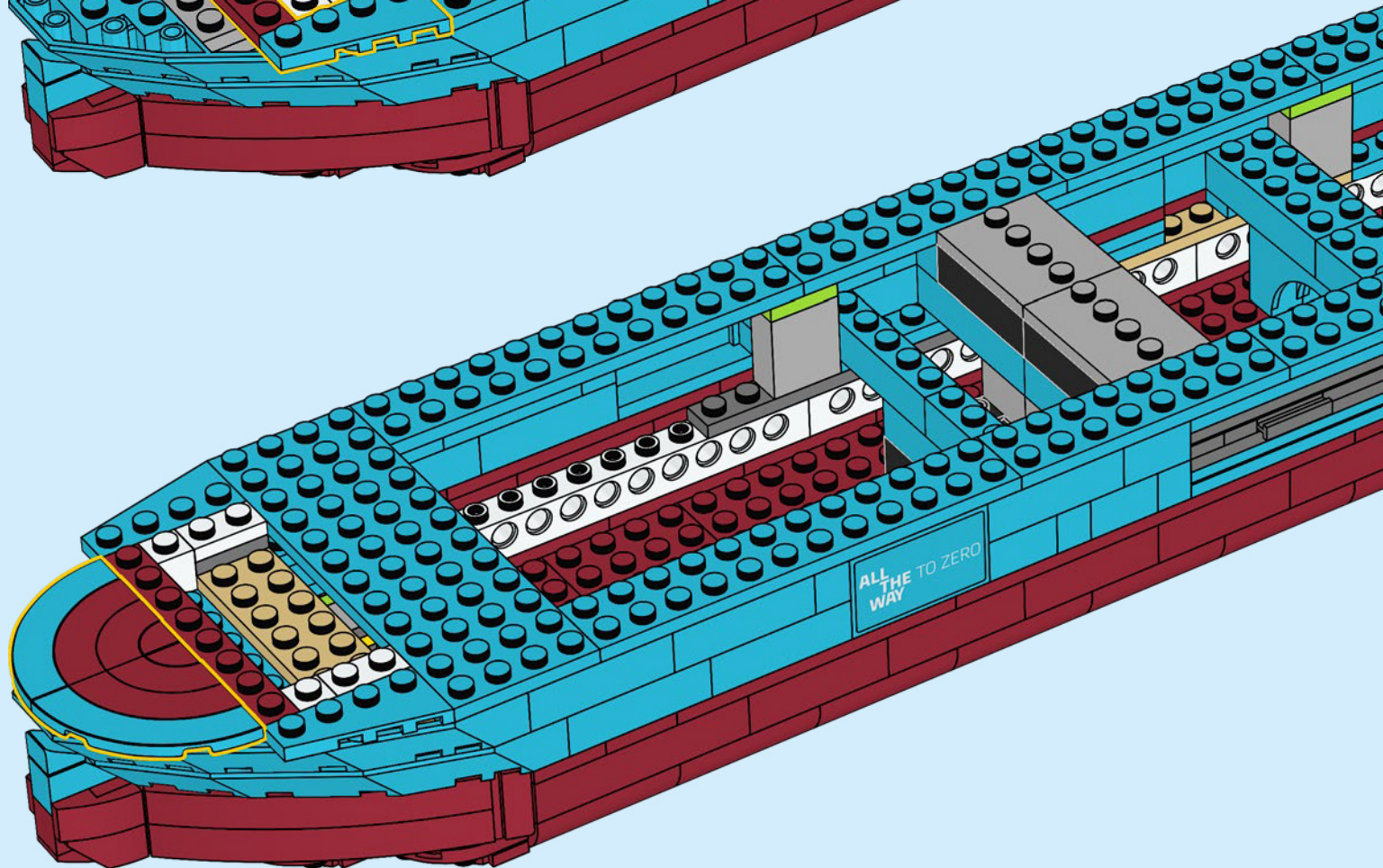

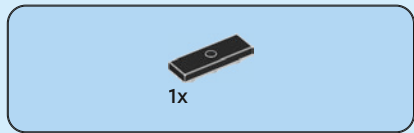

147

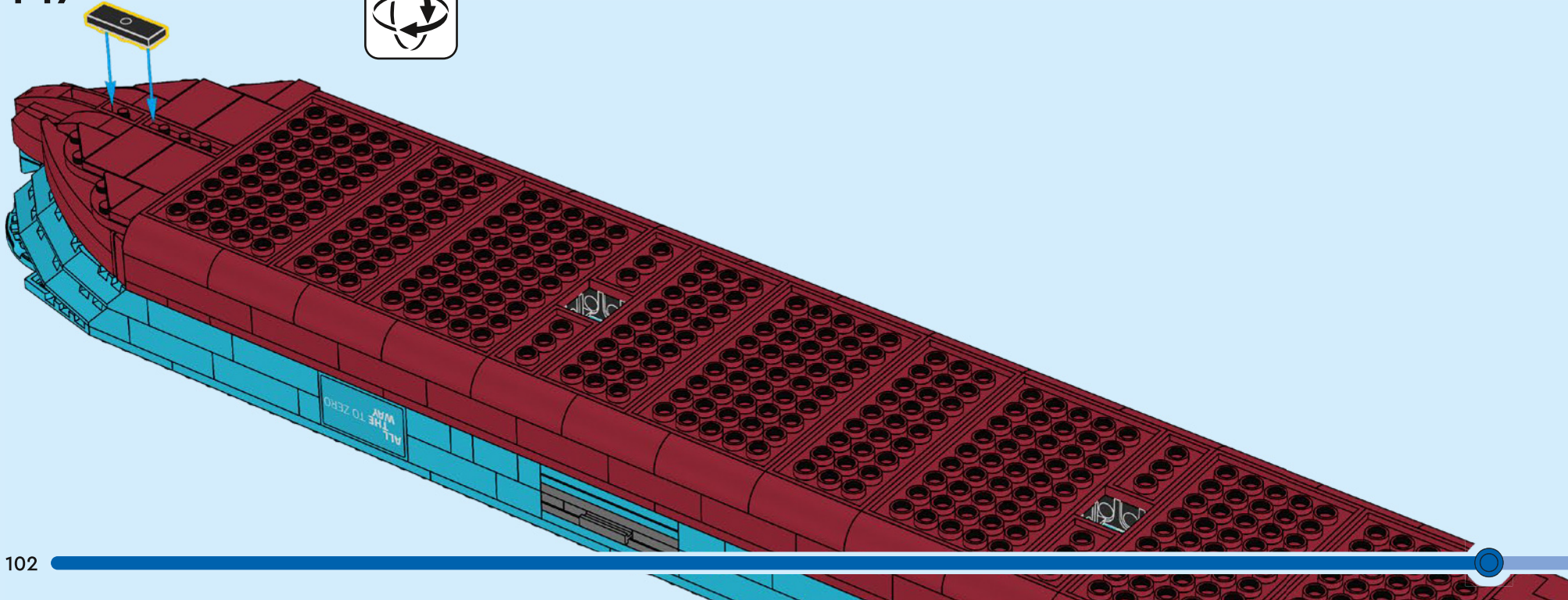



24x

148

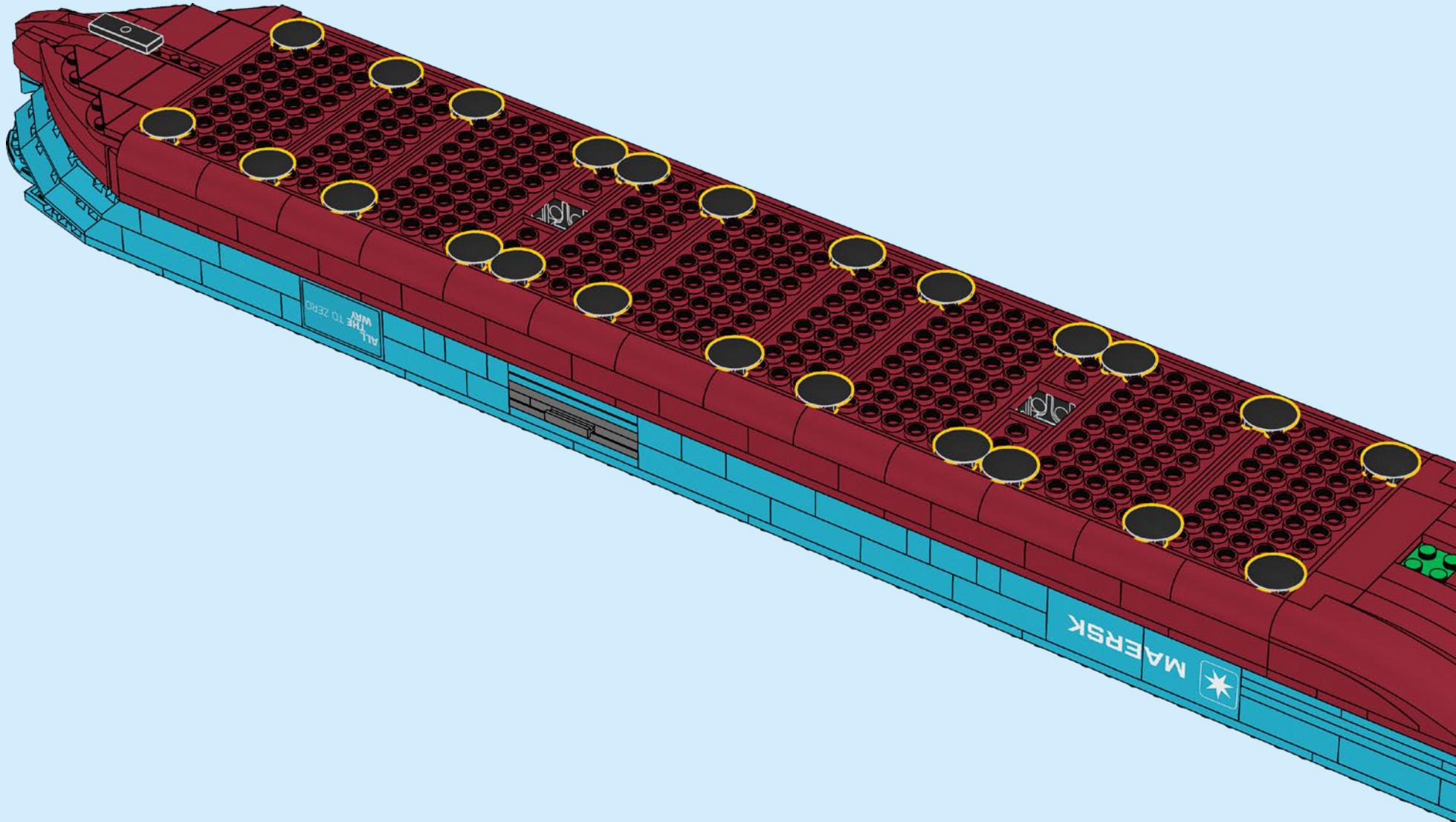

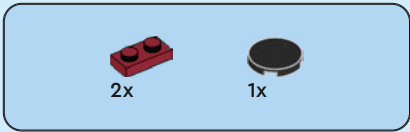

149

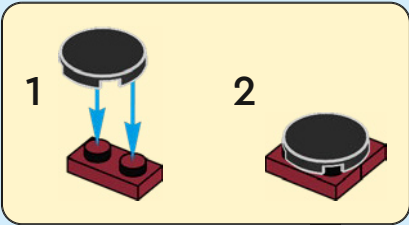
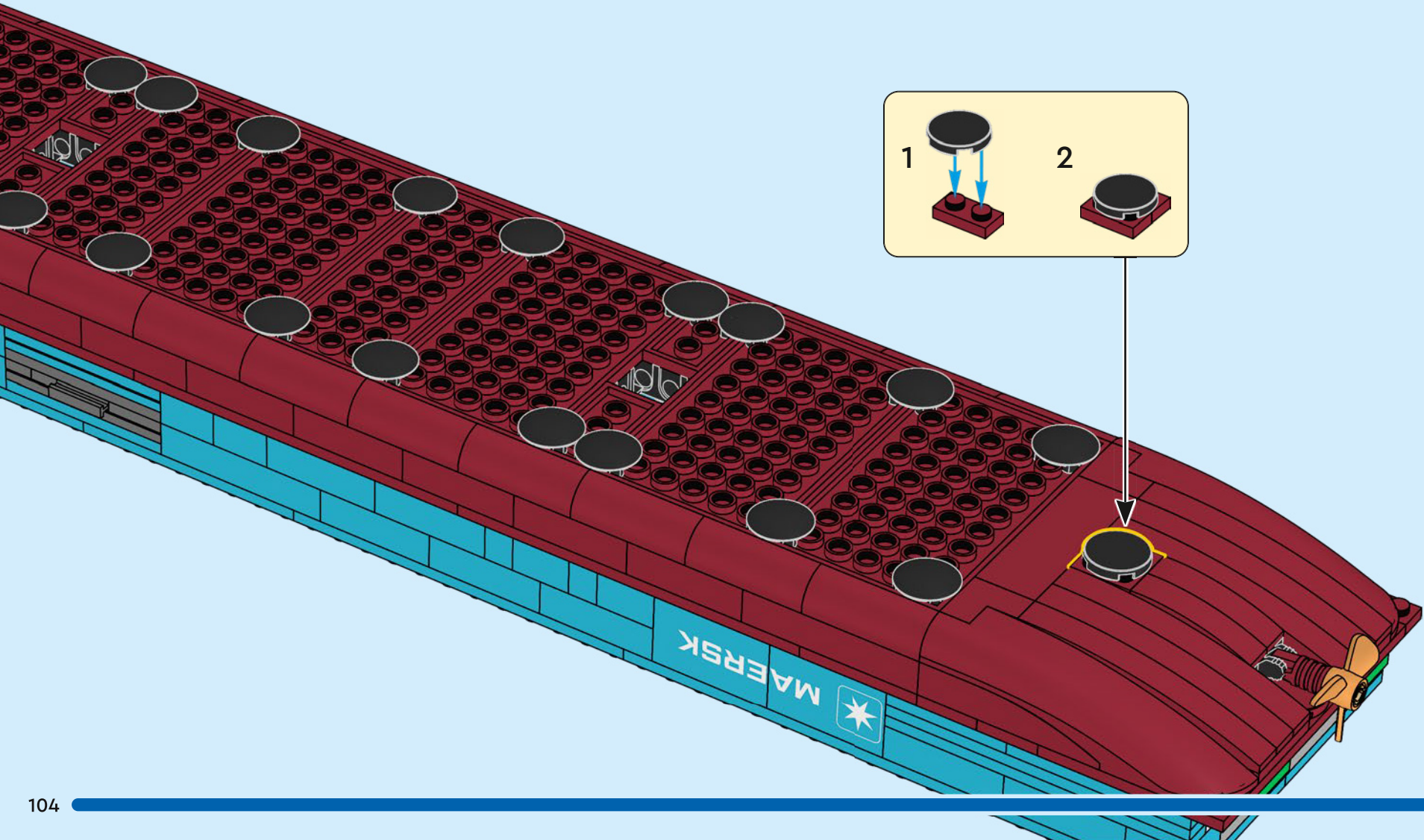

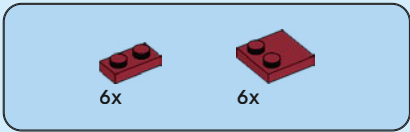

150

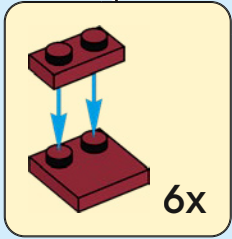
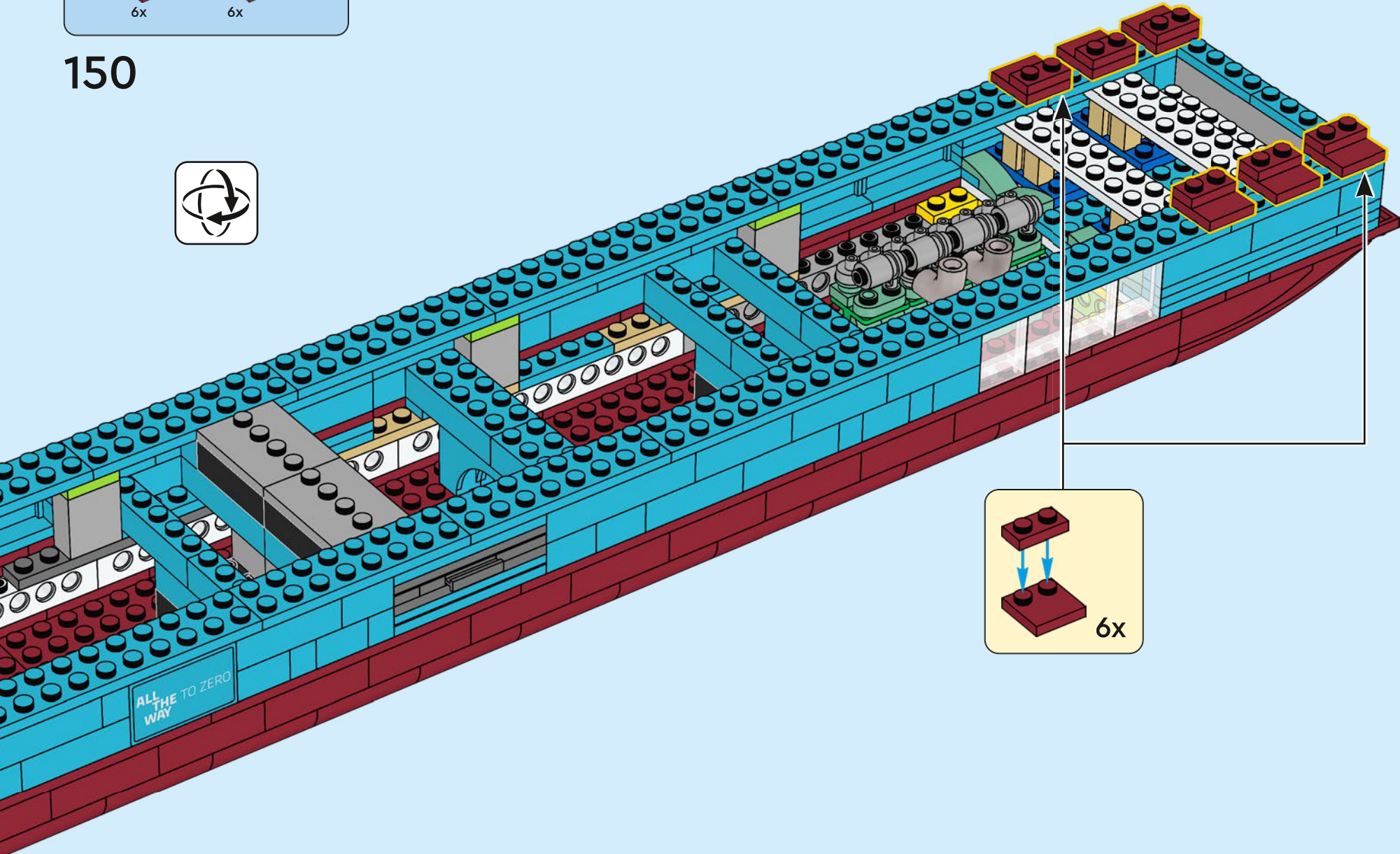

ALL THE WAY TO ZERO

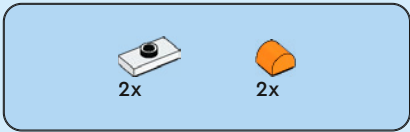

151

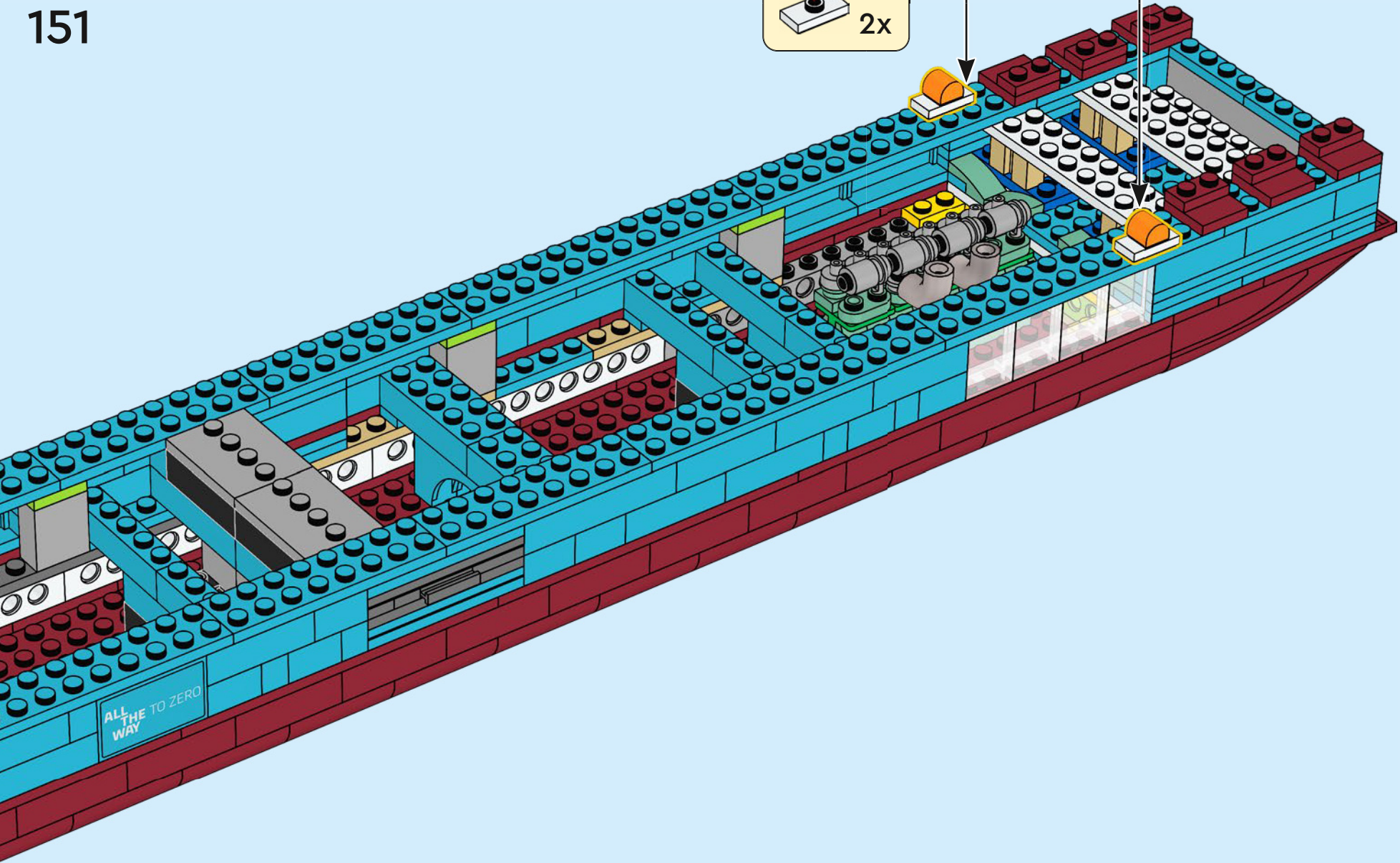
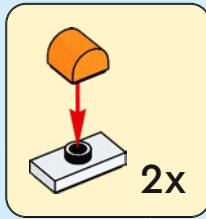

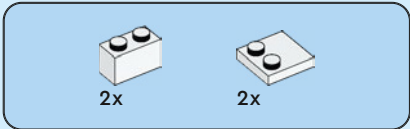

152

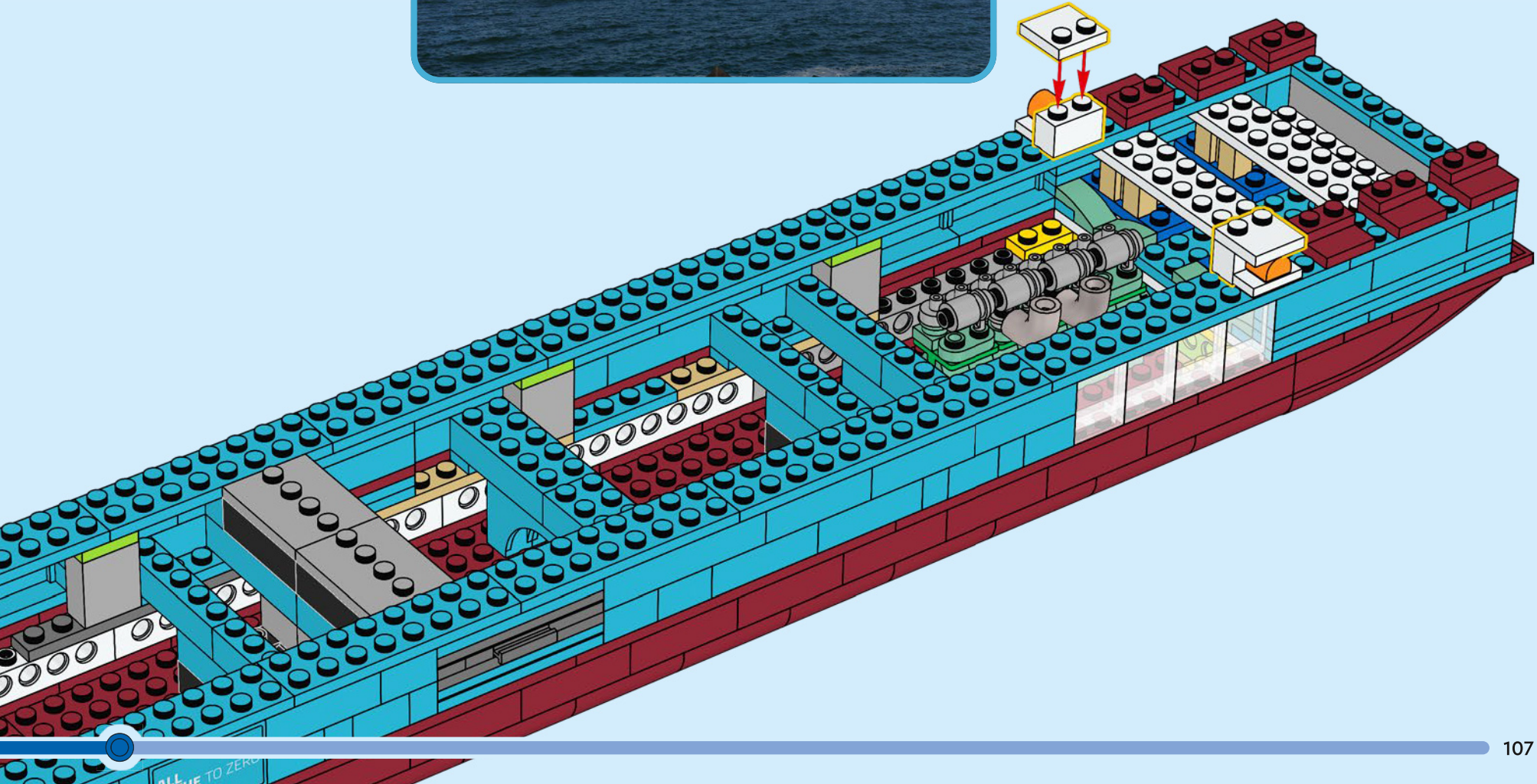
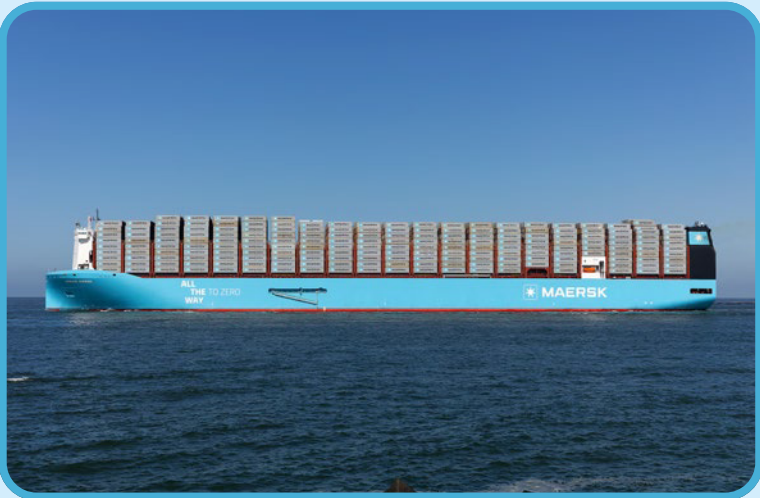

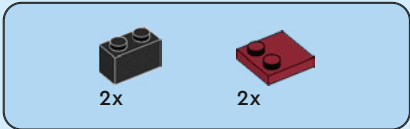

154

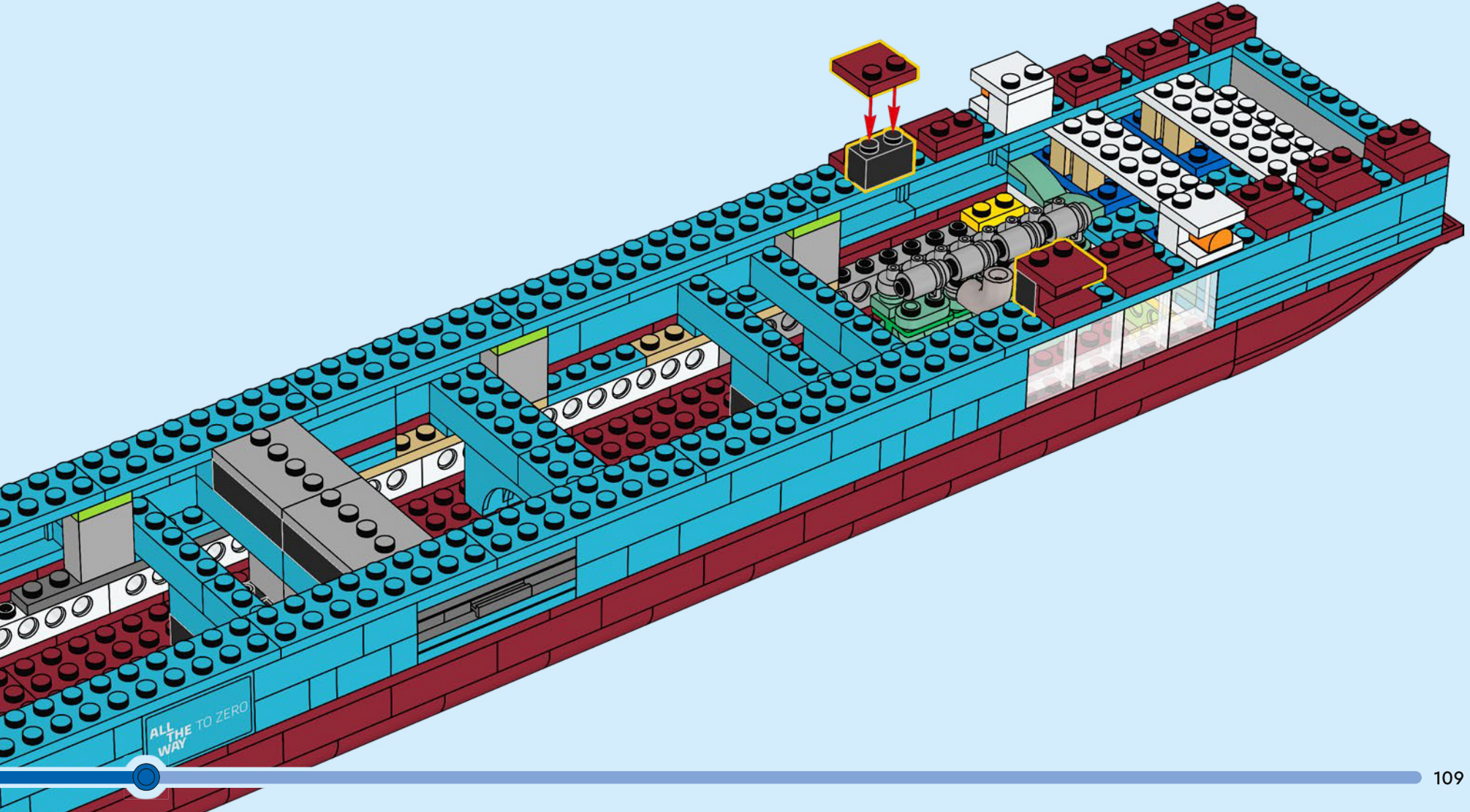

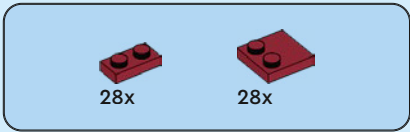

155

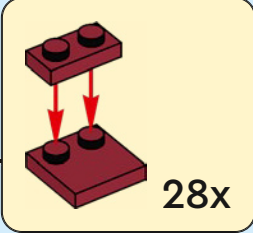
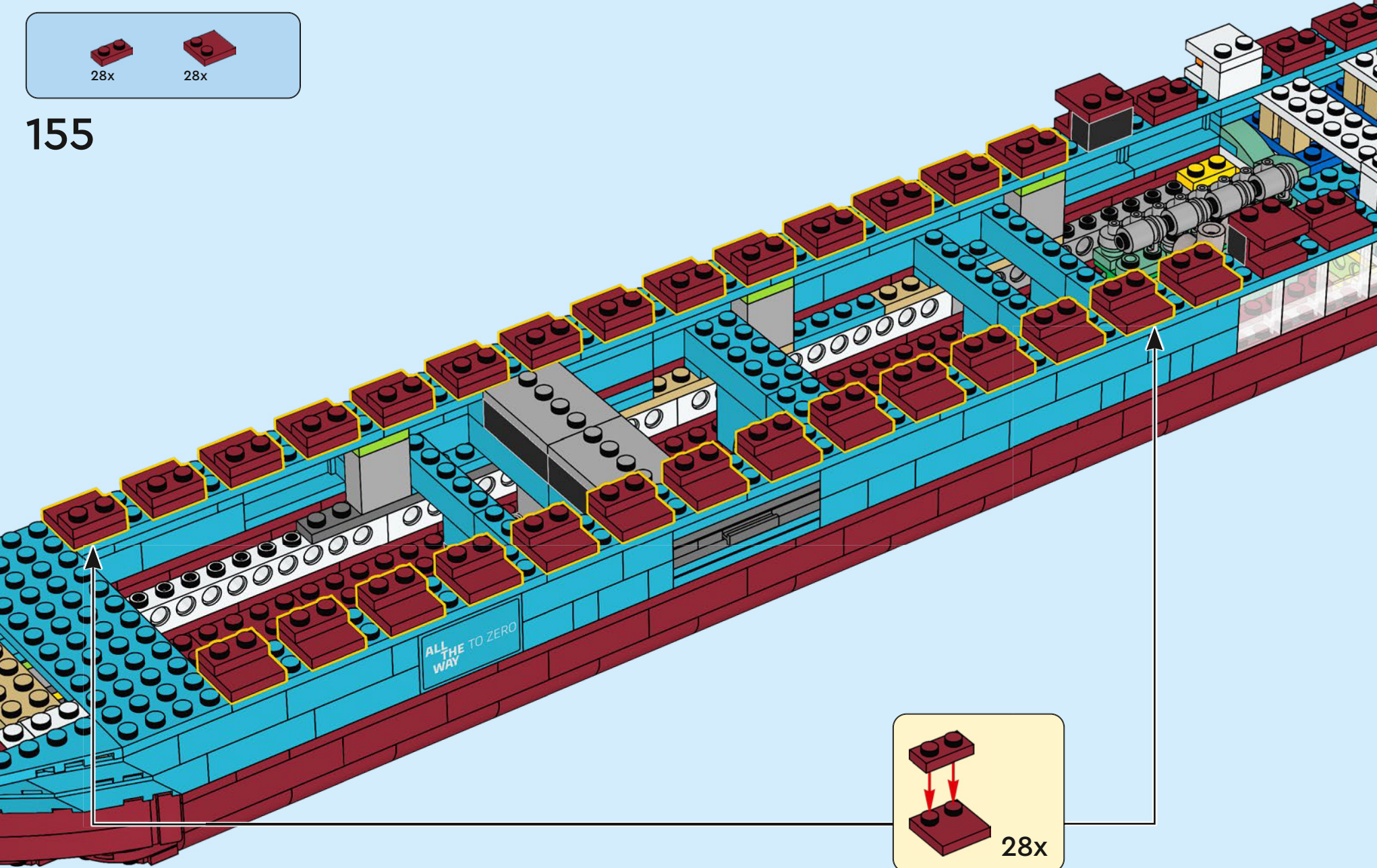

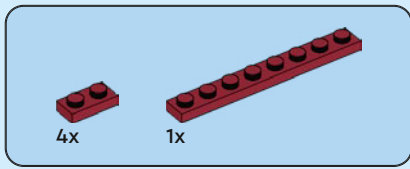

156

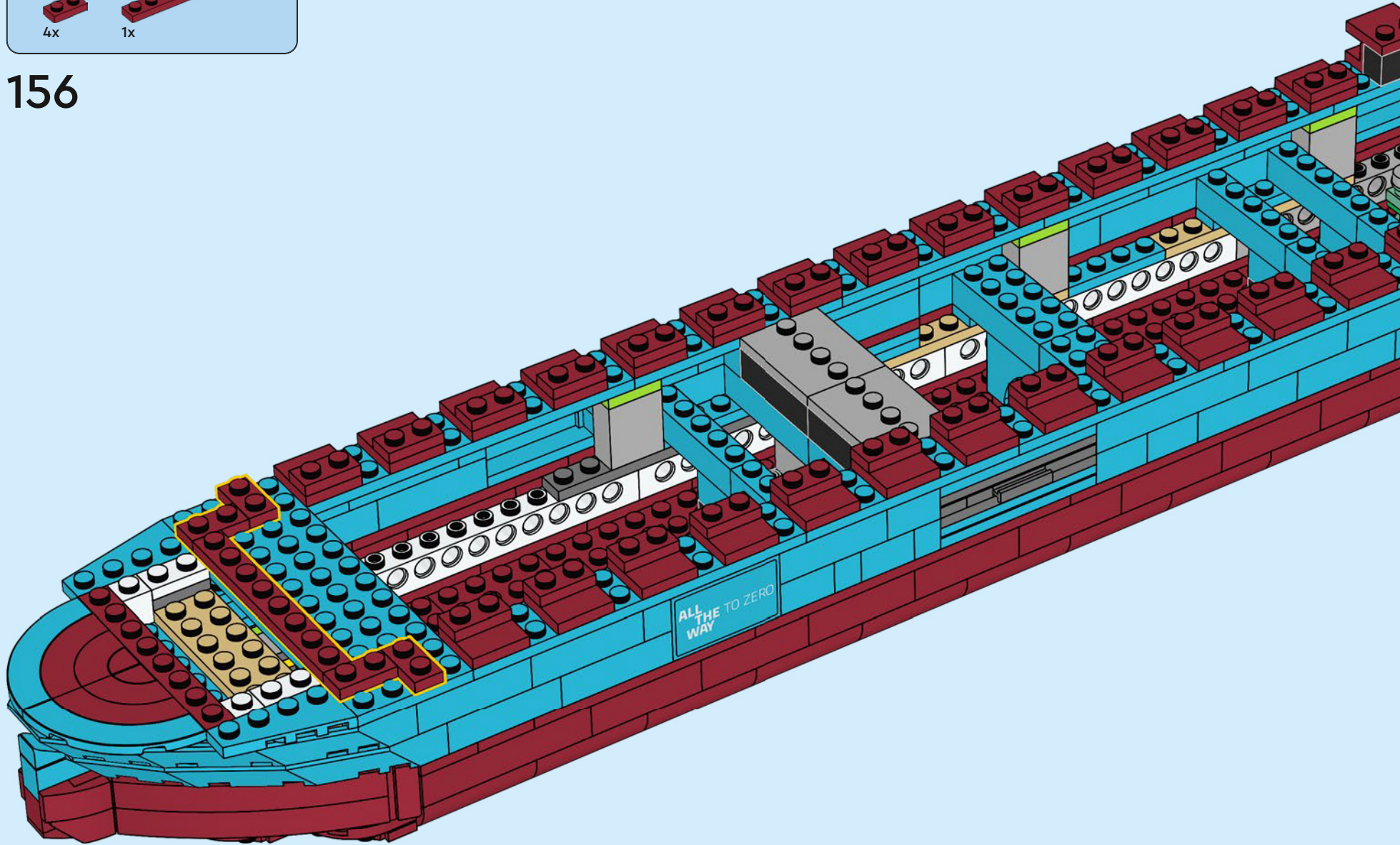

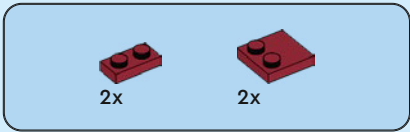

157

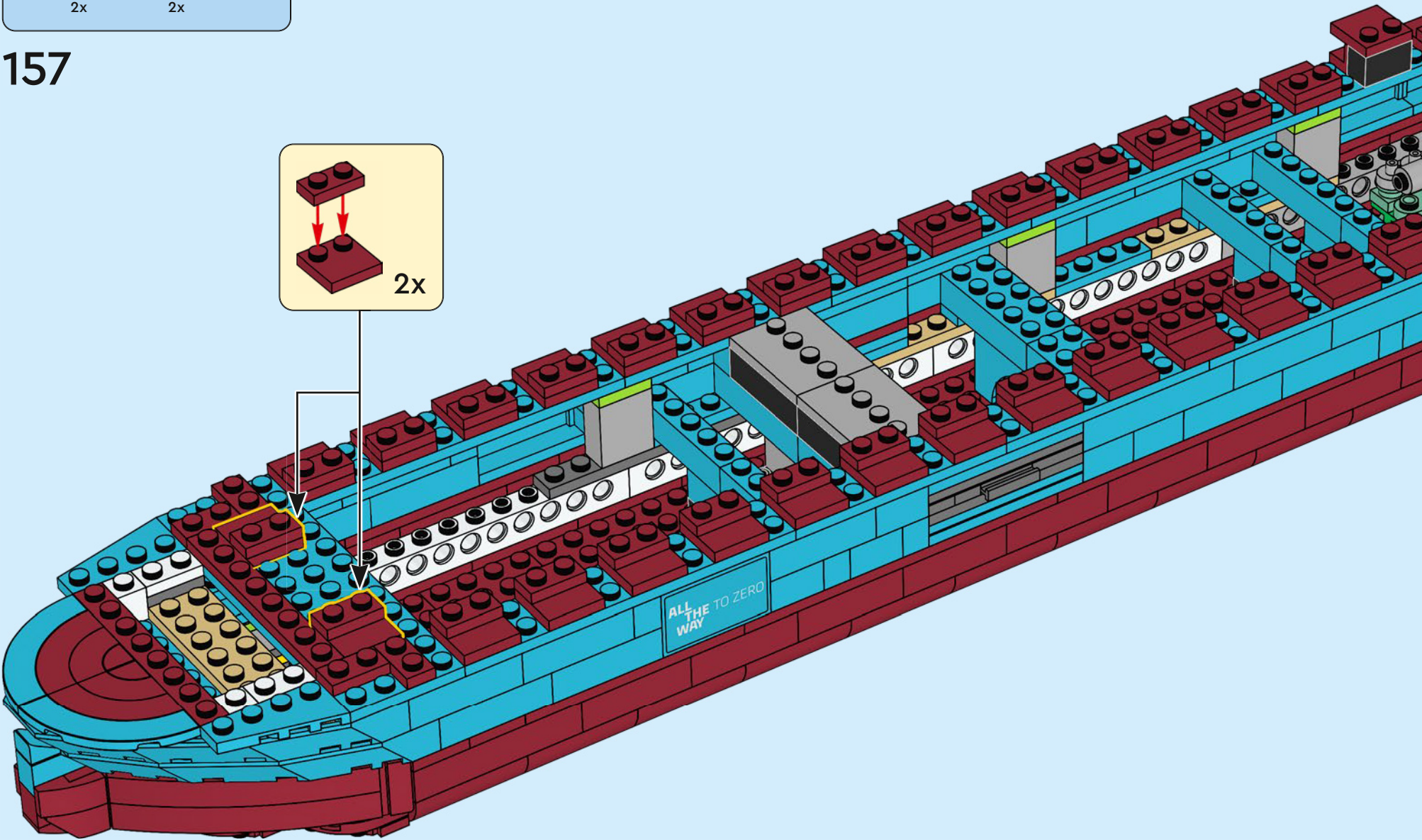
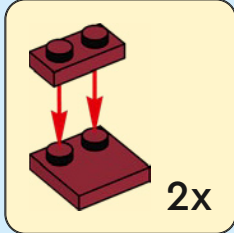

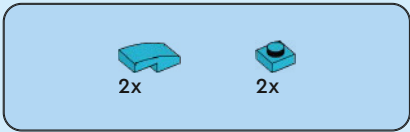

158

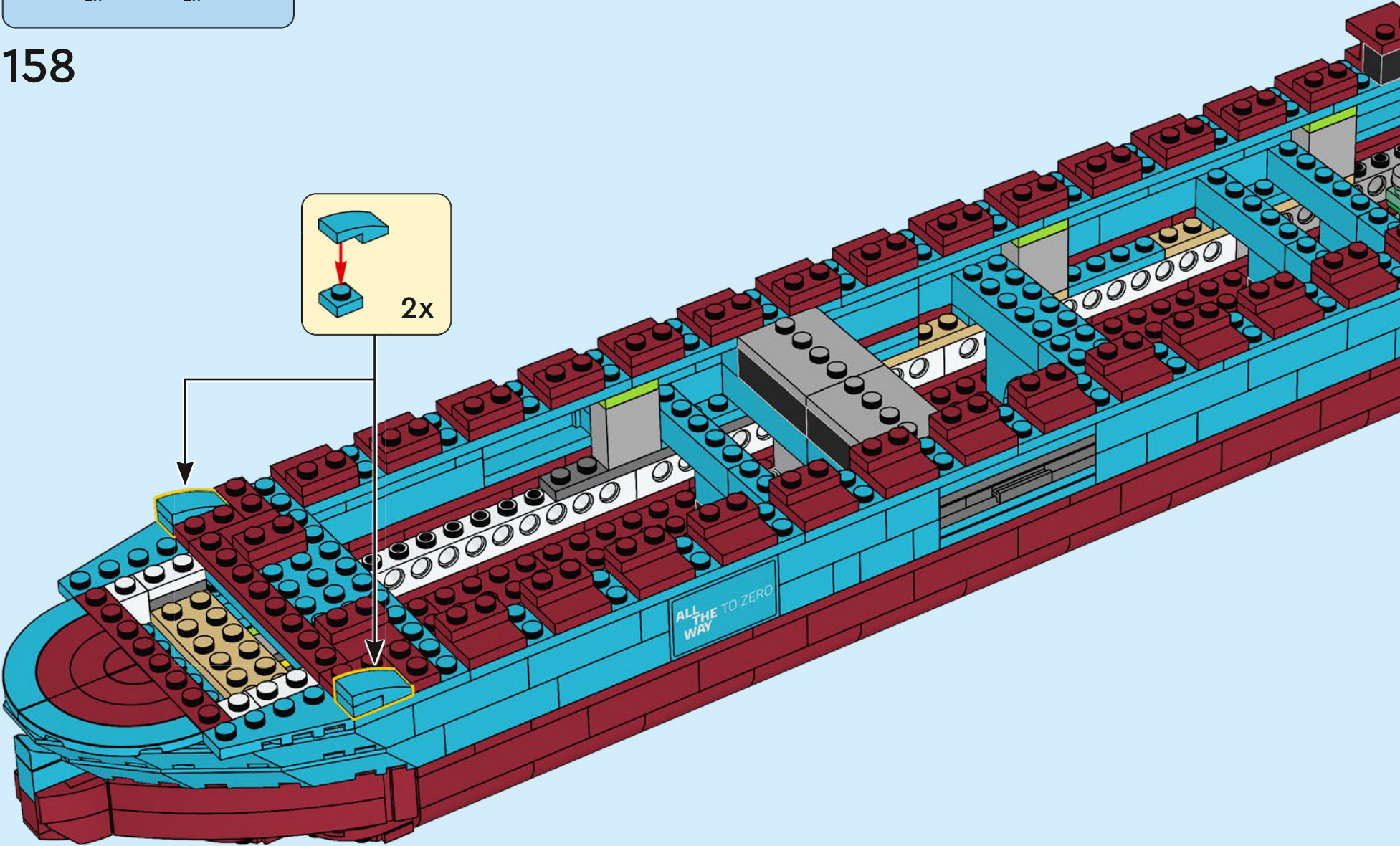
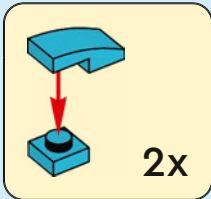

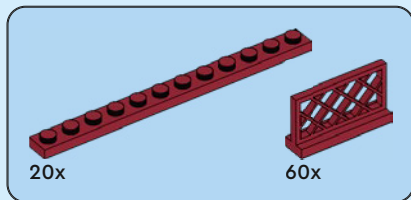
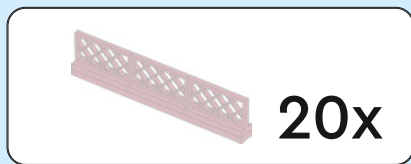

159

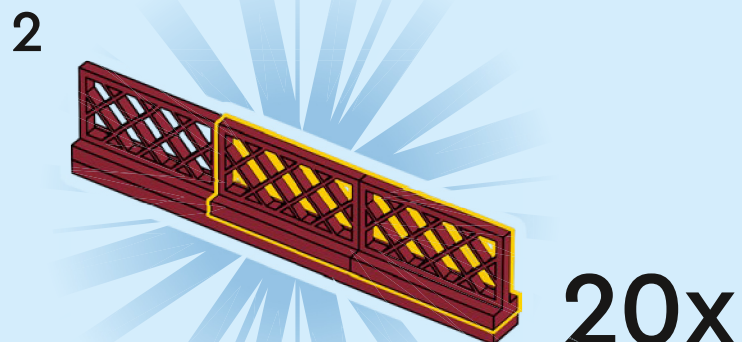
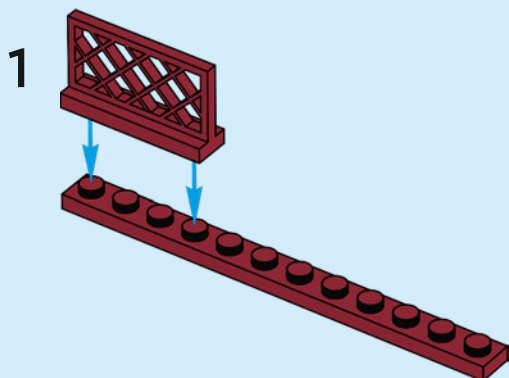
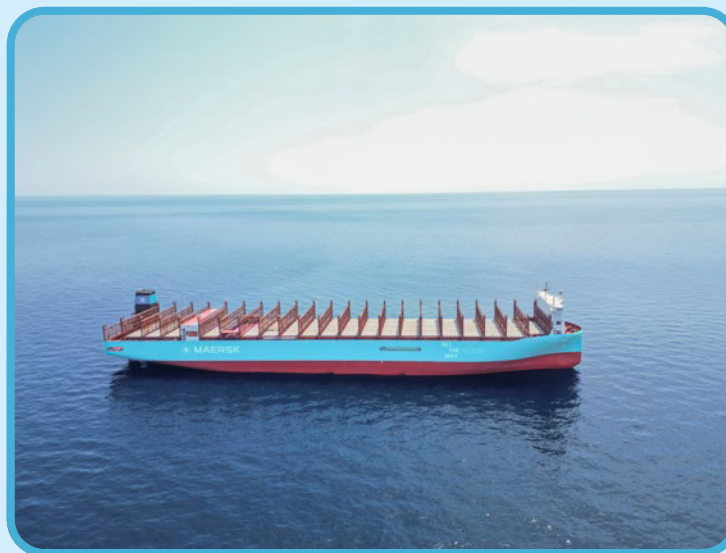

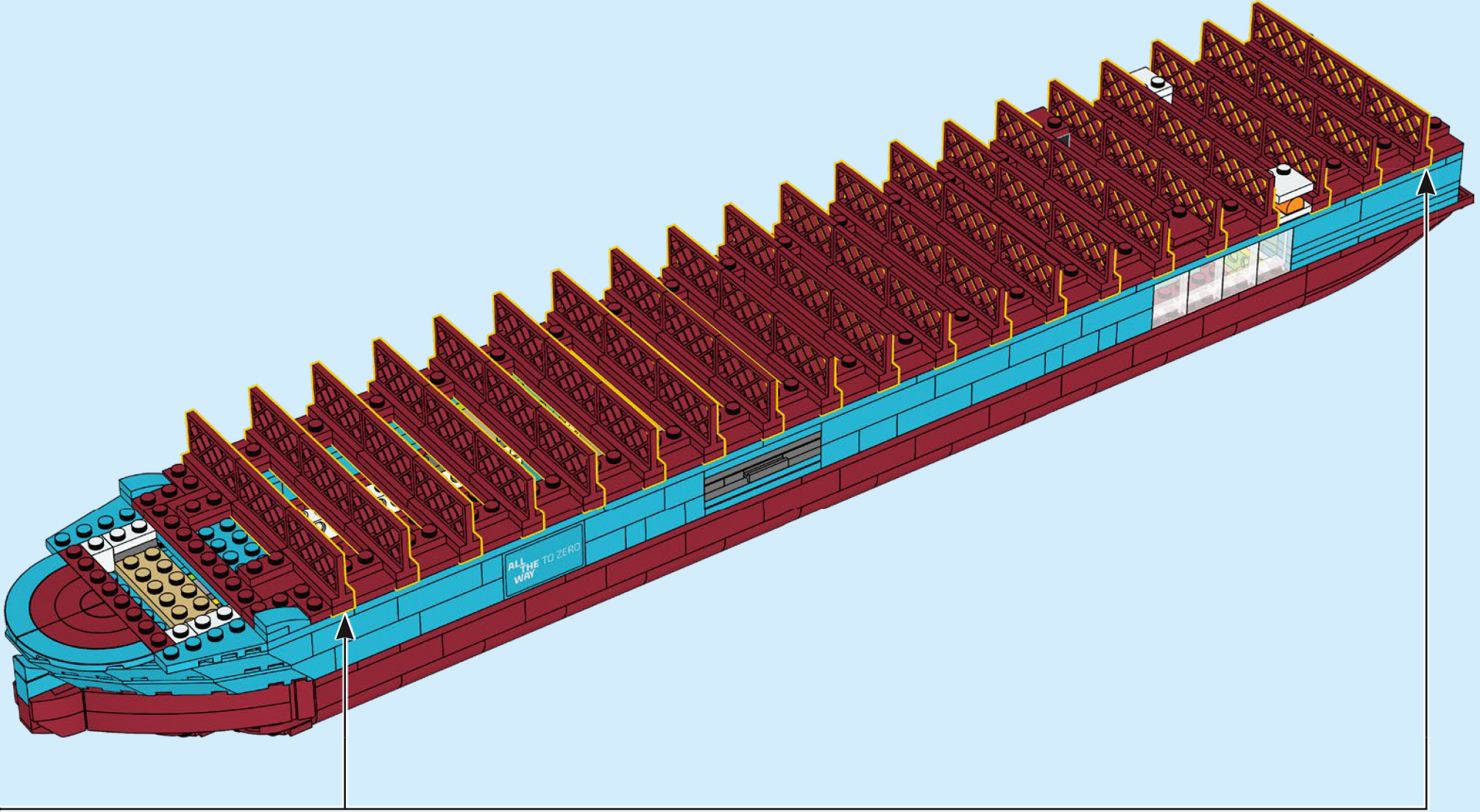

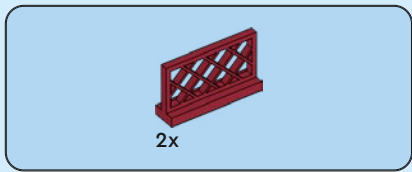

160

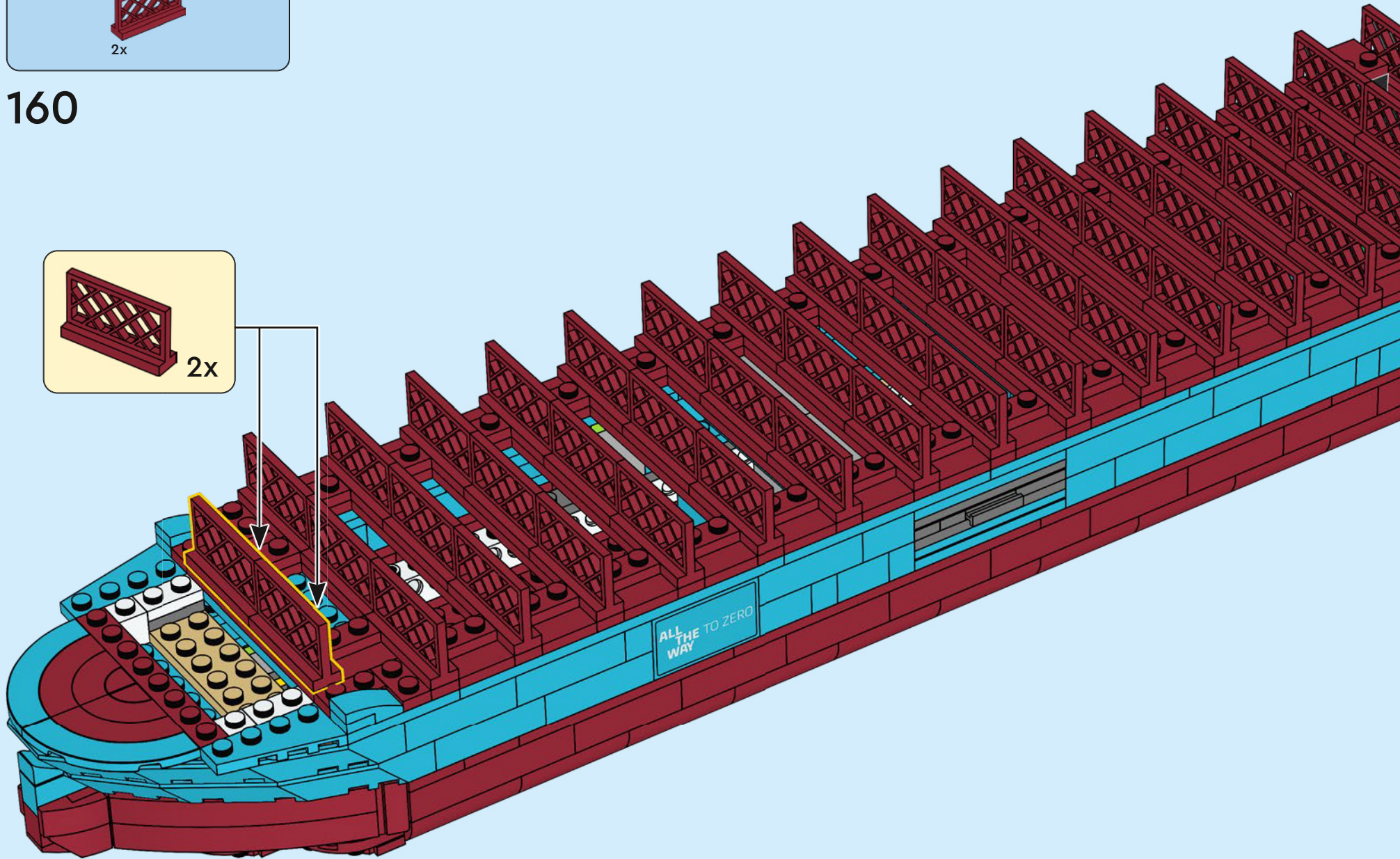
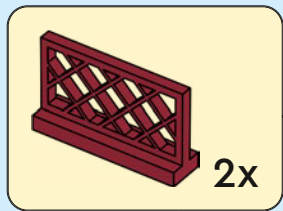

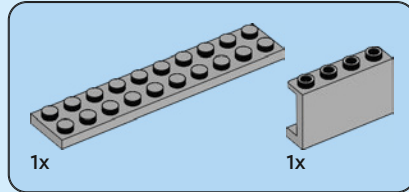
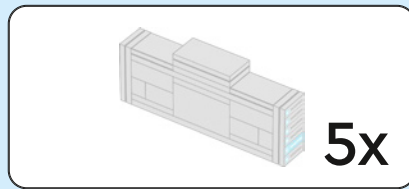

161

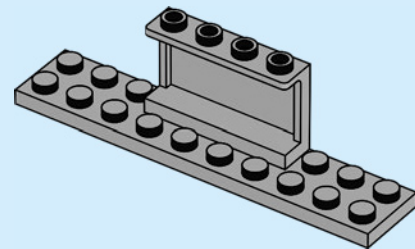
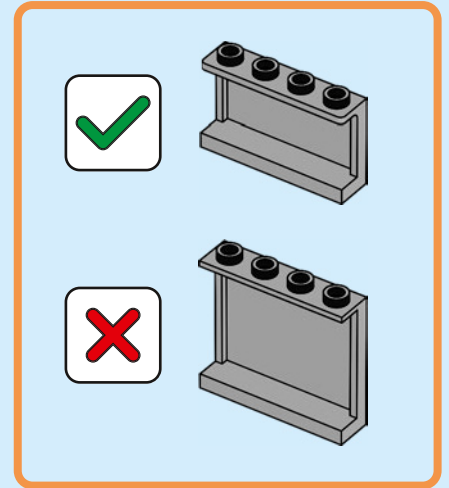

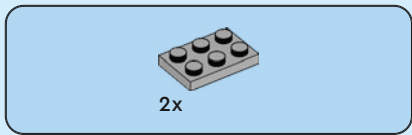

162

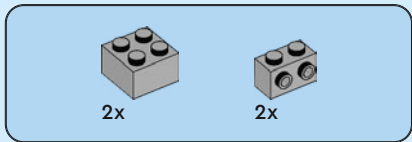
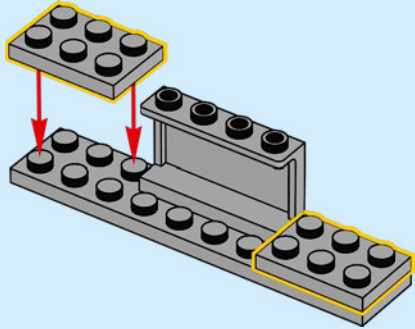

163

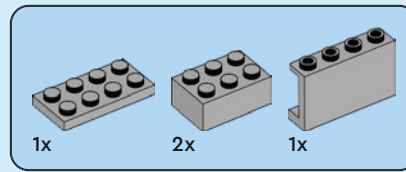
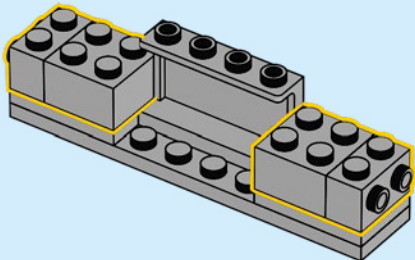

164

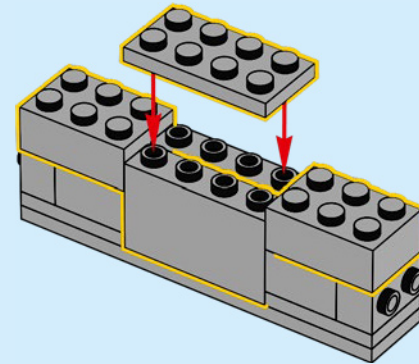

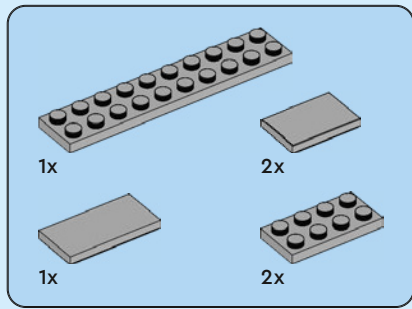

165

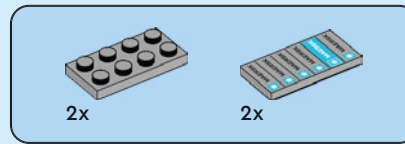
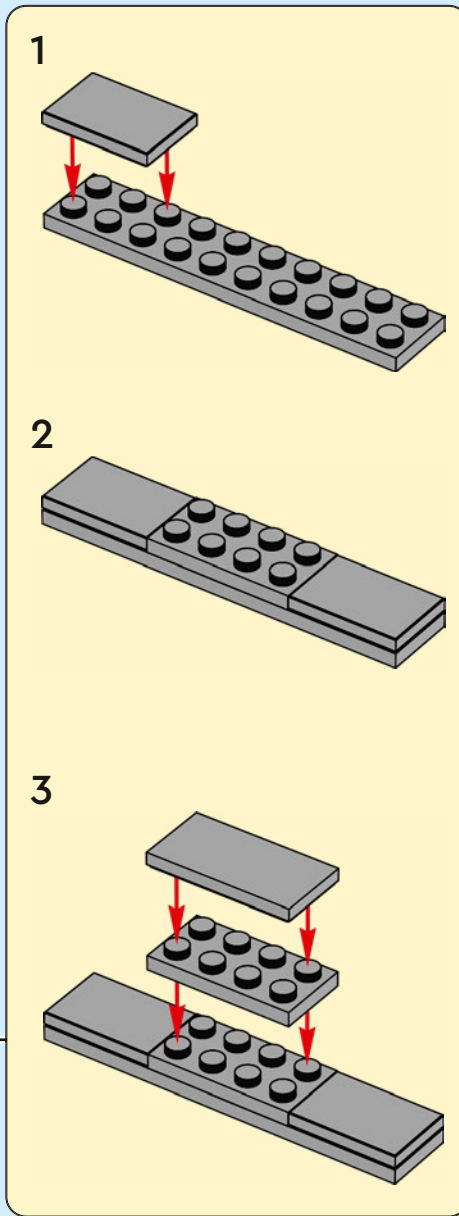
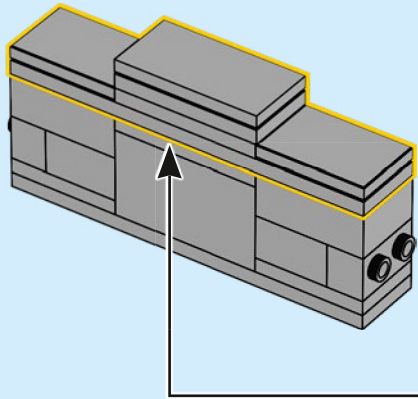

166

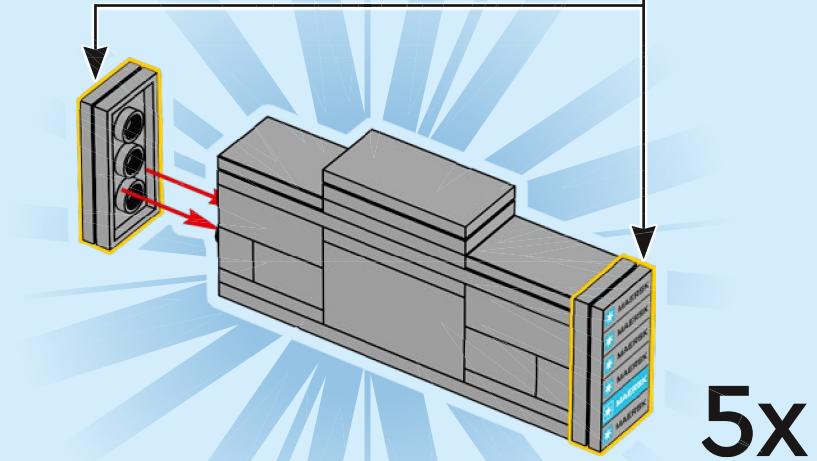
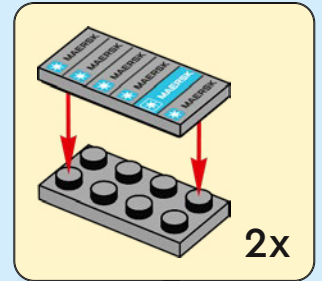



167

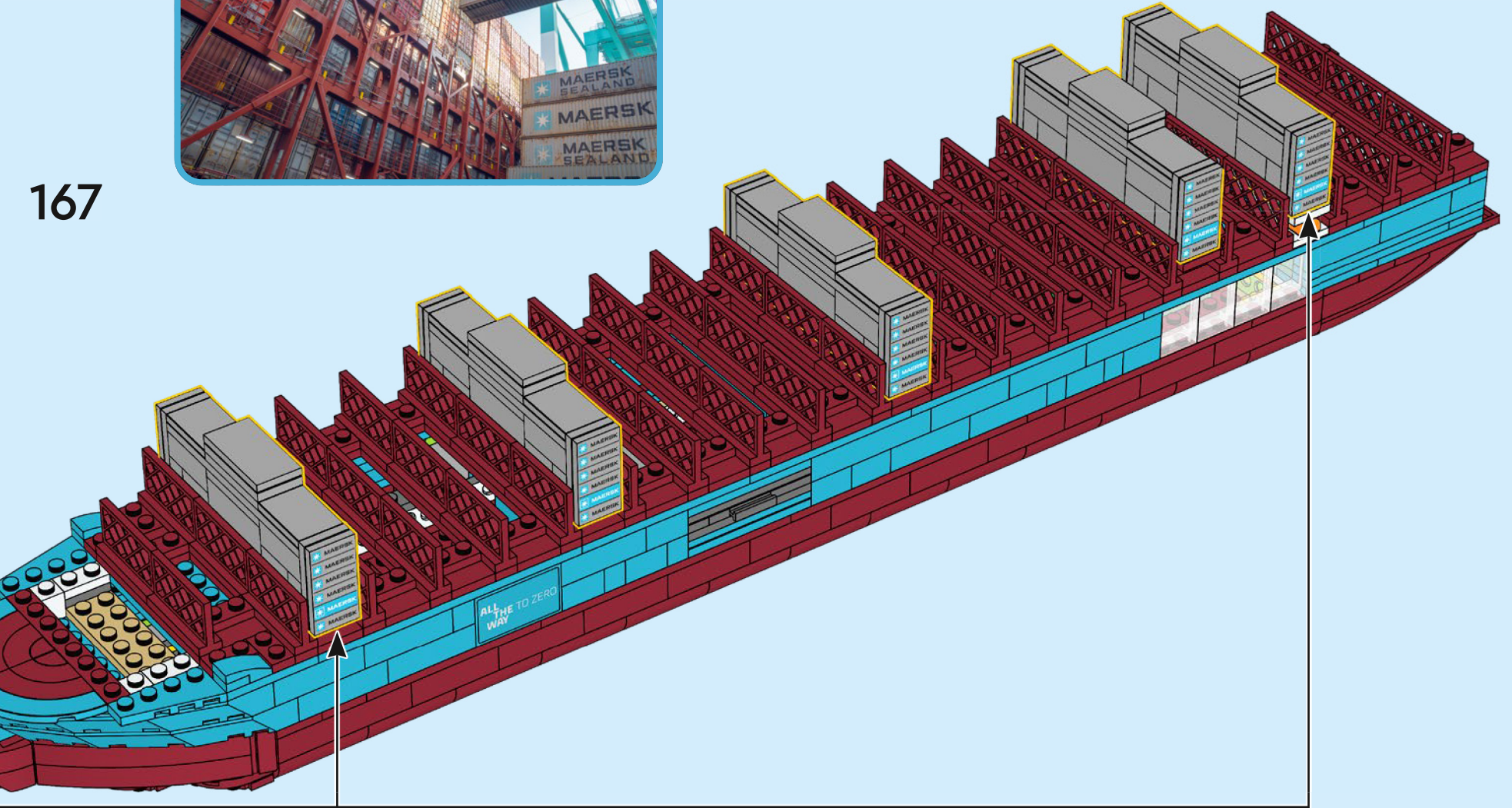

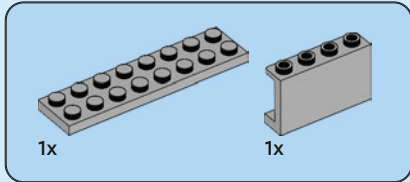
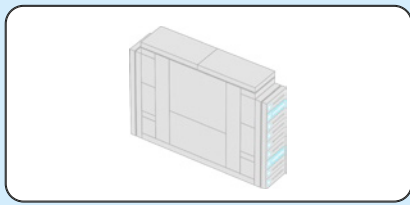

168

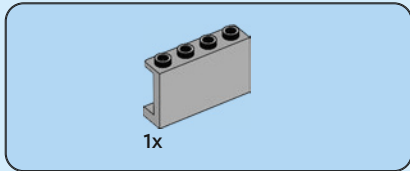
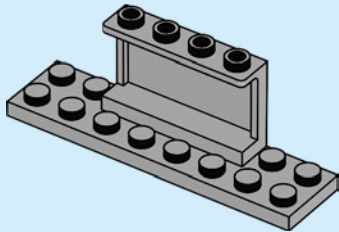

169

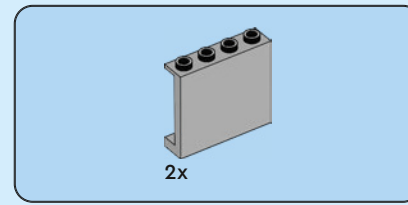
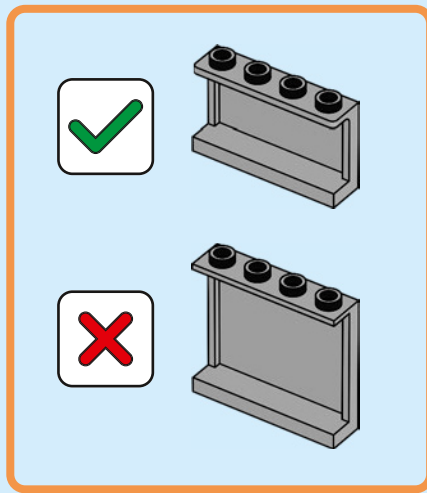
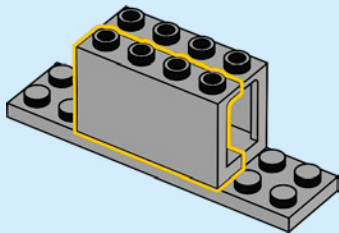

170

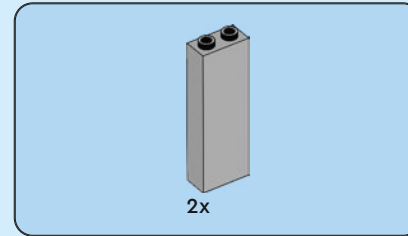
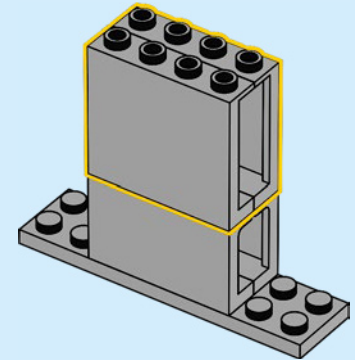

171

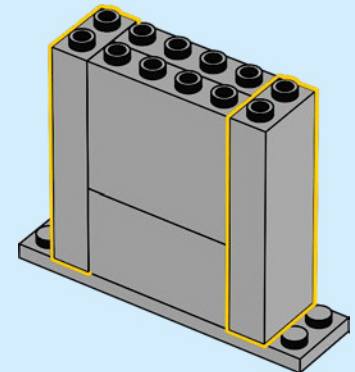

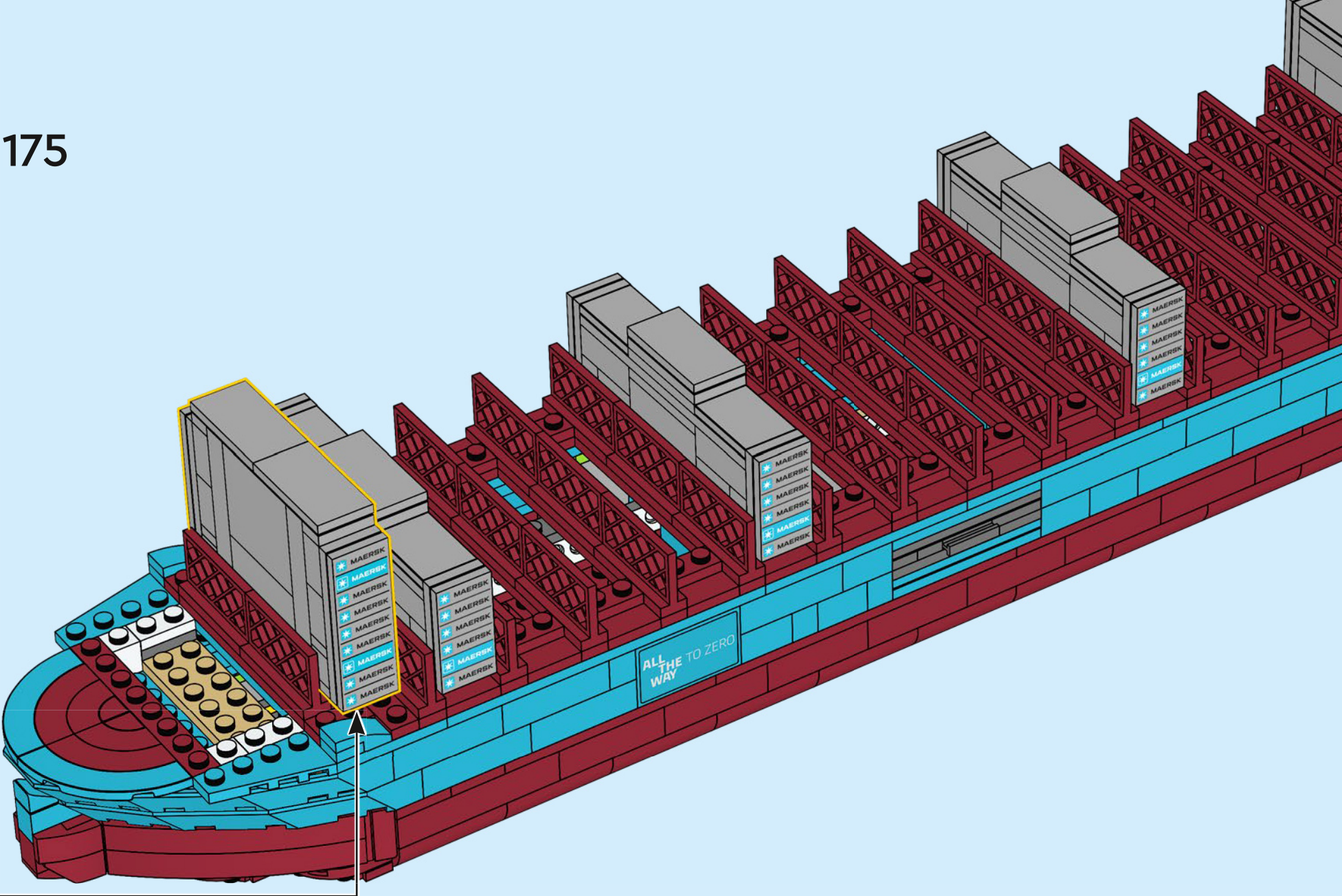

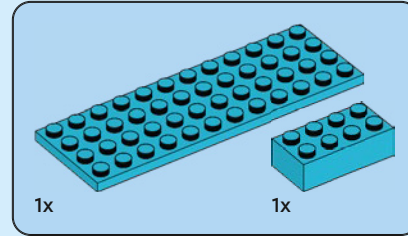
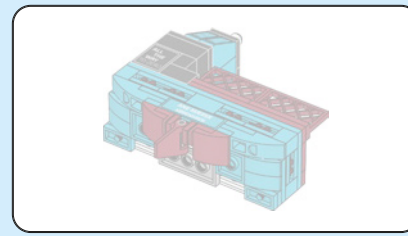

176

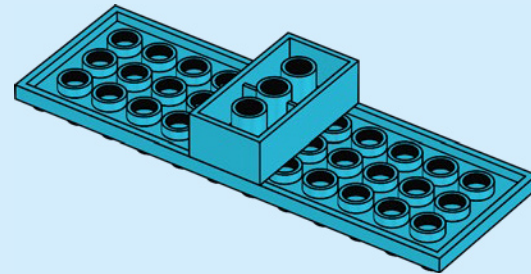

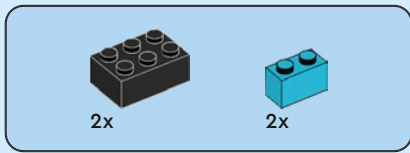

177

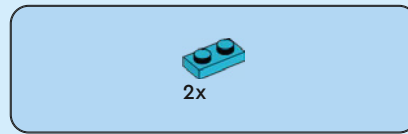
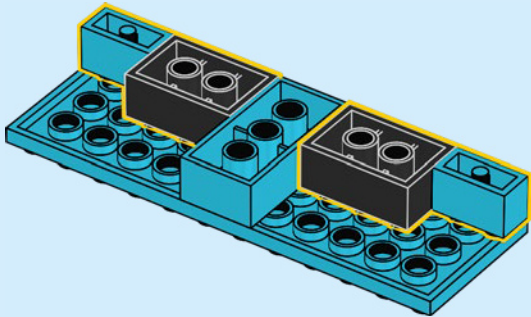

178

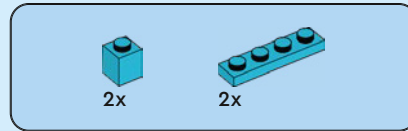
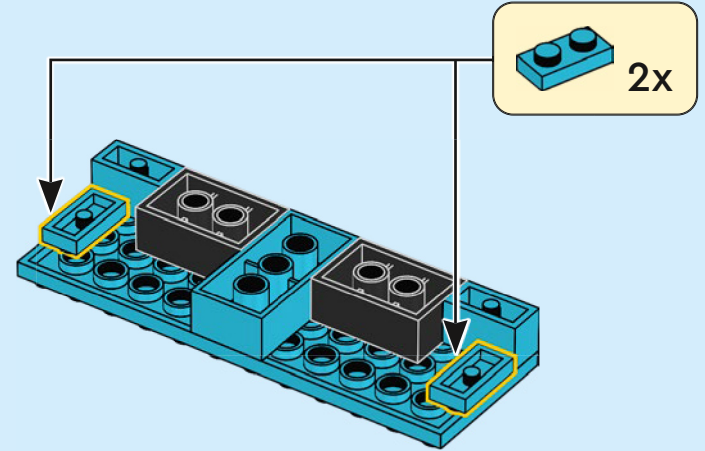

179

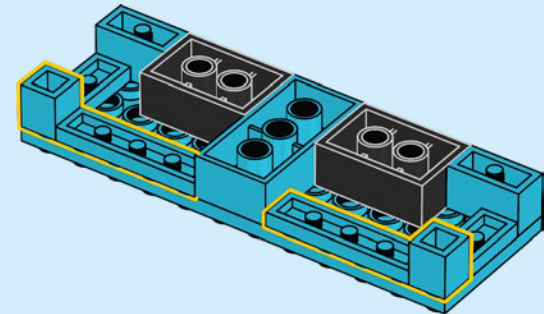

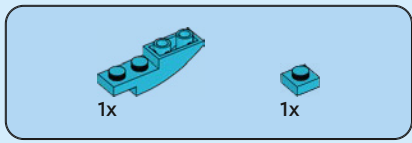

180

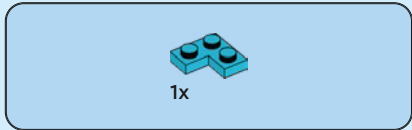
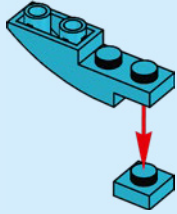

181

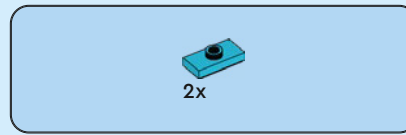
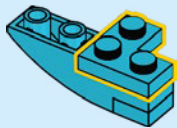

182

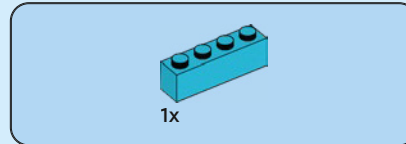
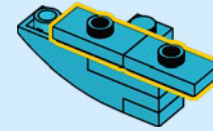

183

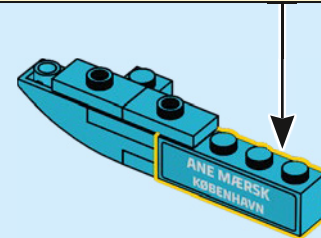
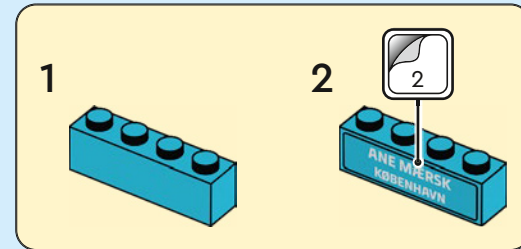

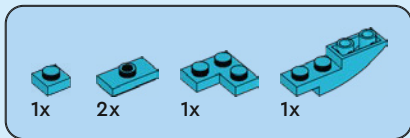

184

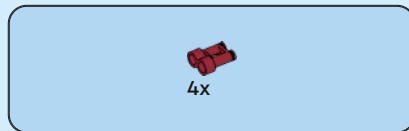
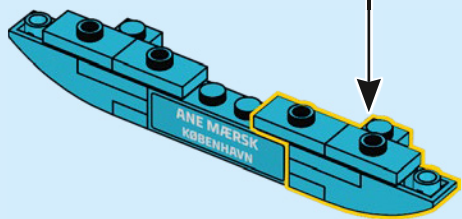
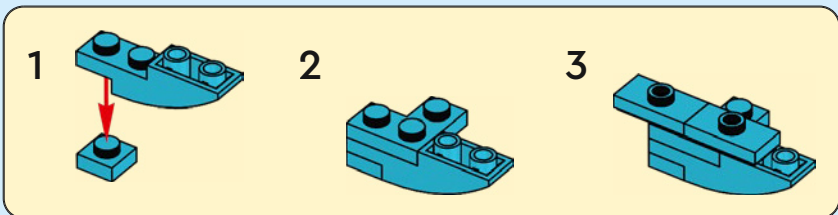

185

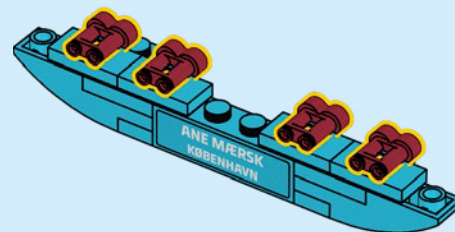

186

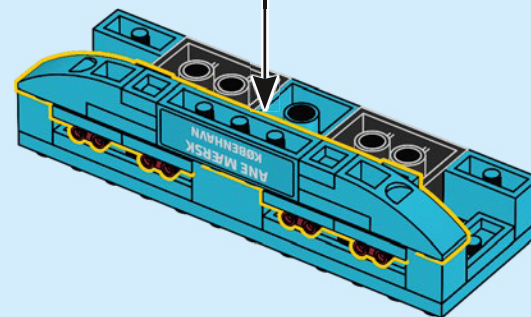

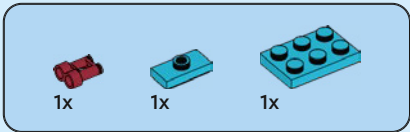

187

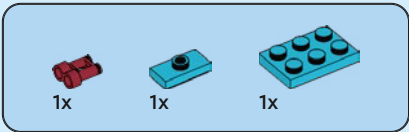
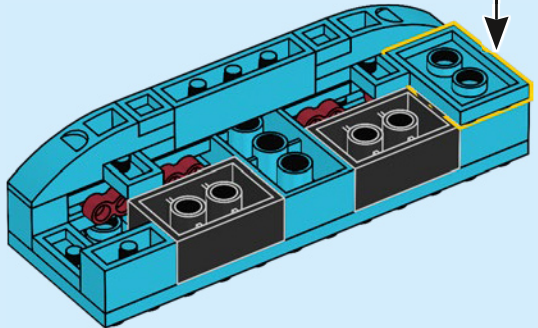
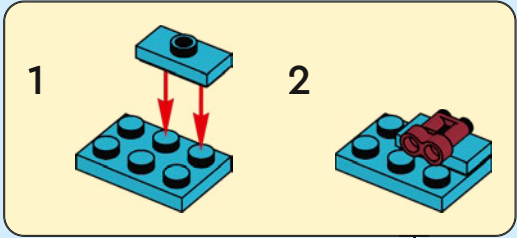

188

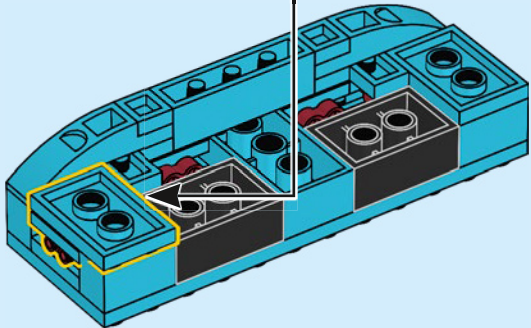
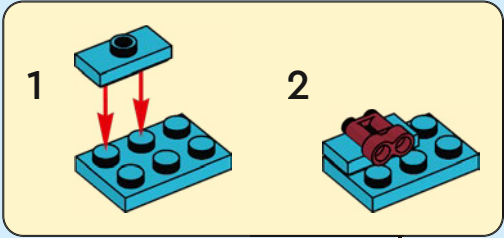

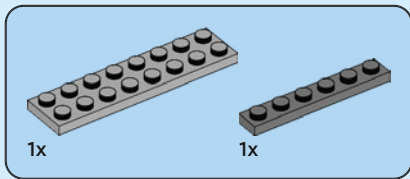

189

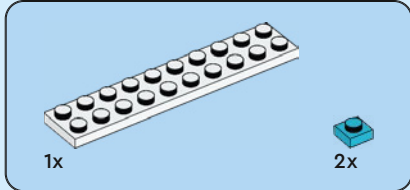
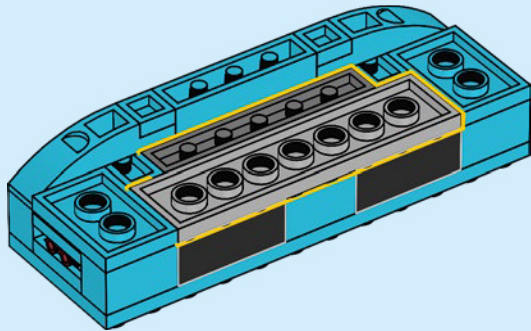

190

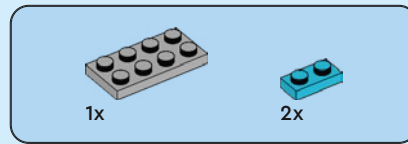
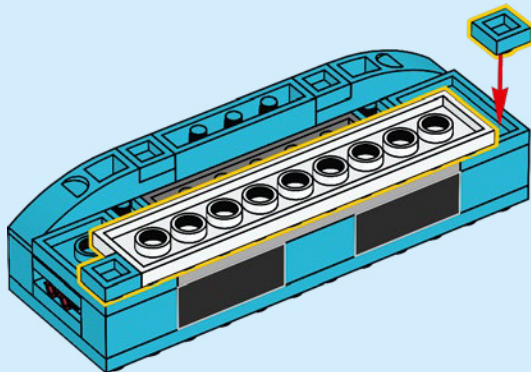

191

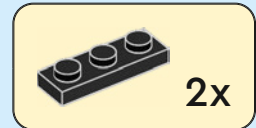
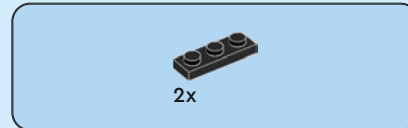
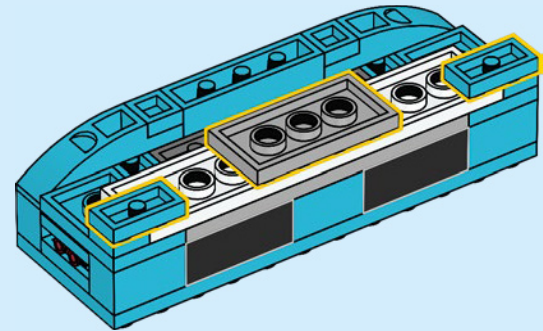

192

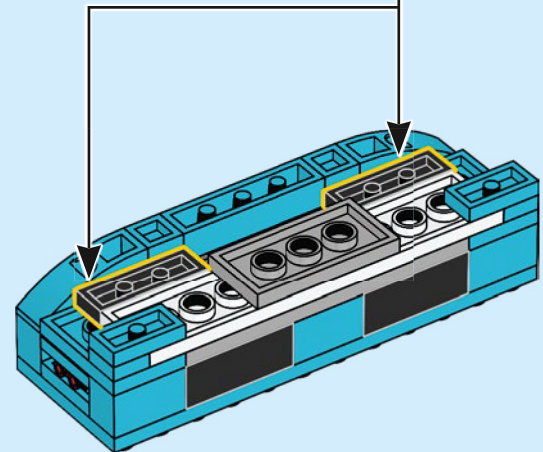



4x

193

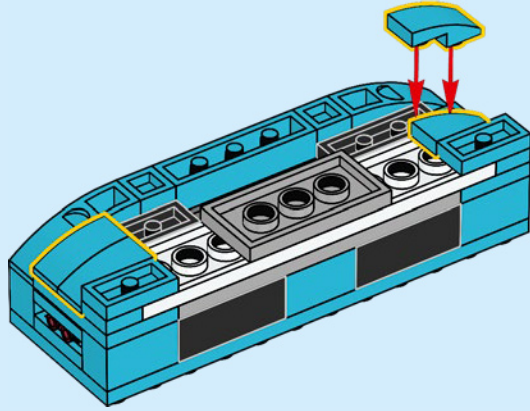

2x

194

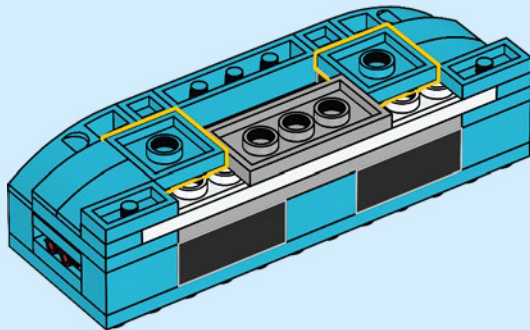

1x

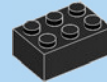

1x



1x

195

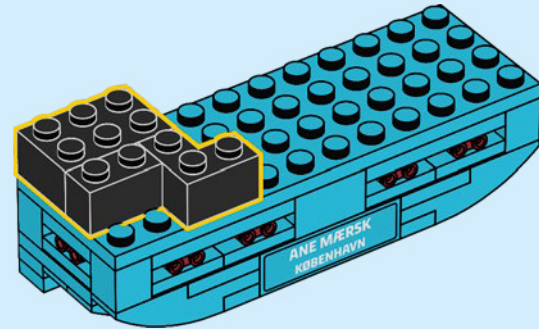
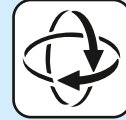

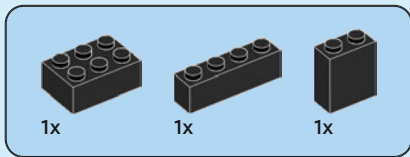

196

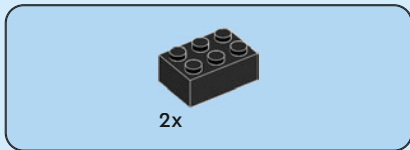
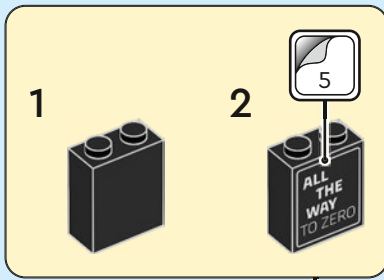
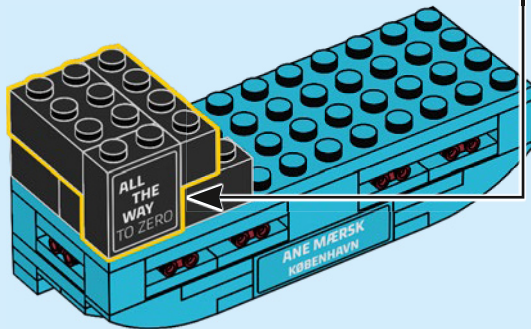

197

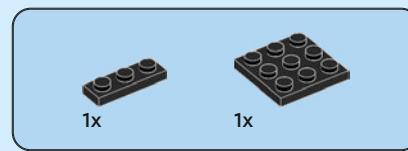
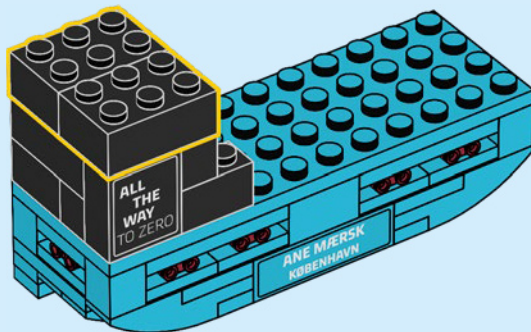

198

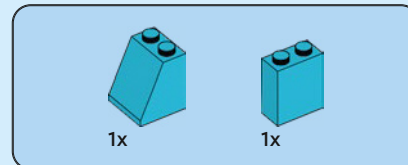
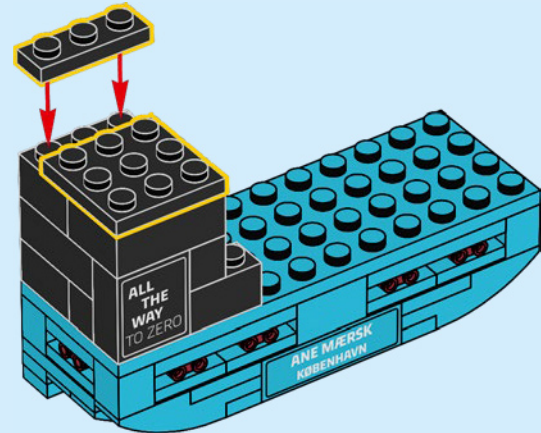

199

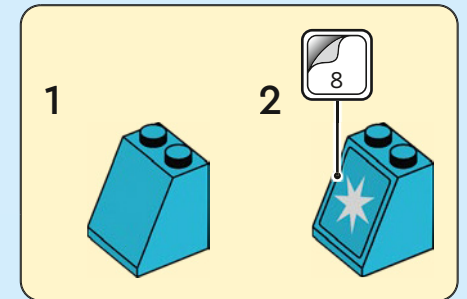
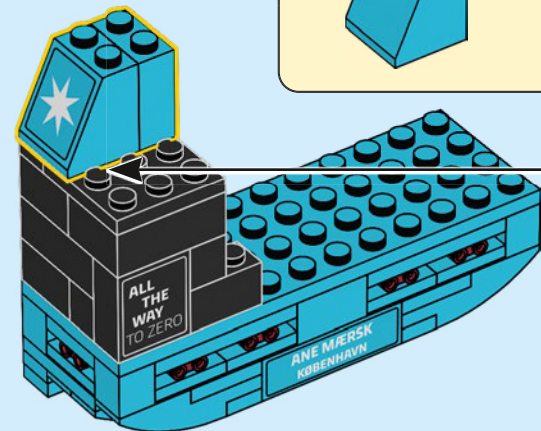

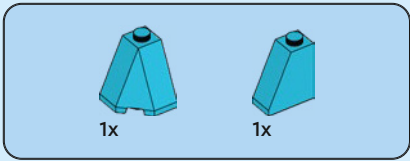

200

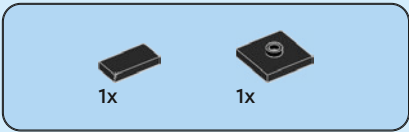
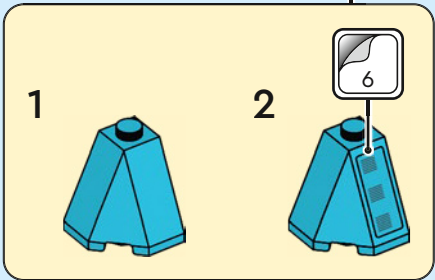
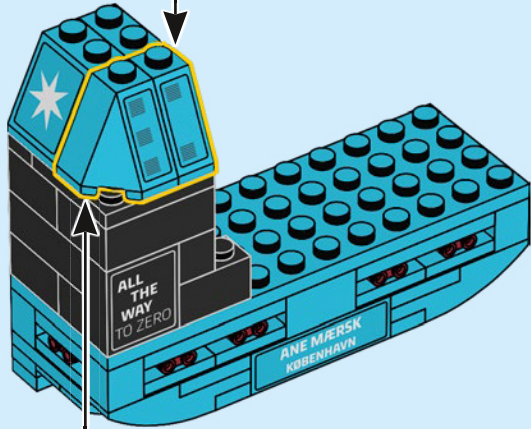
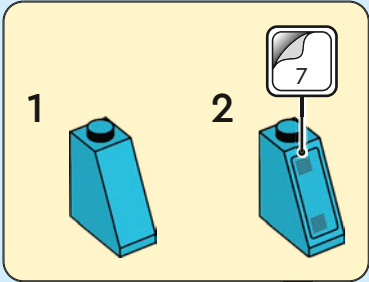

201

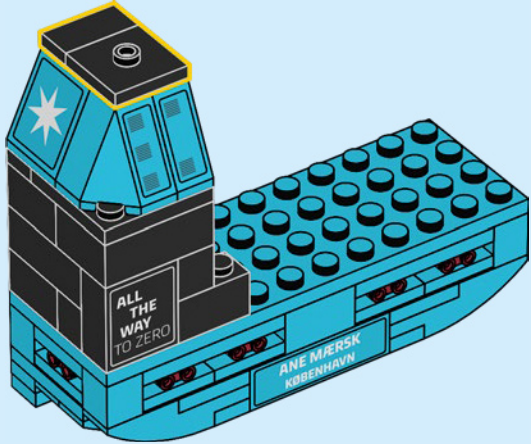



1x



1x

202

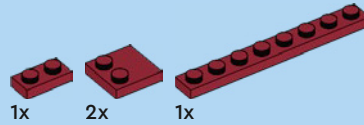
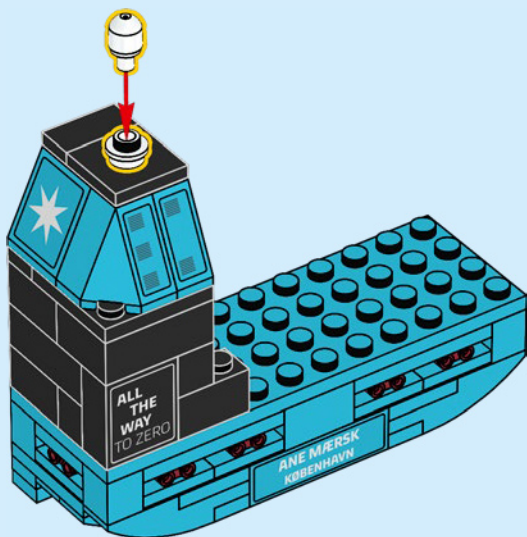

1x

2x

1x

203

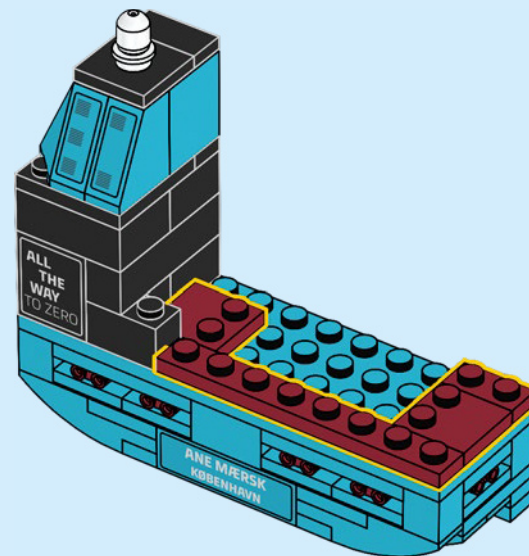



2x

204

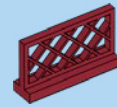
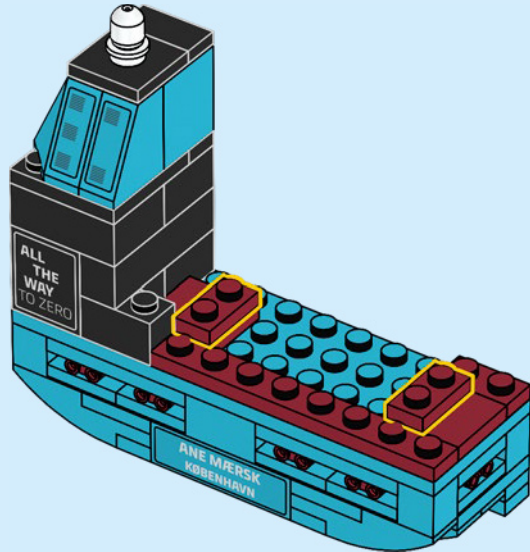

2x

205

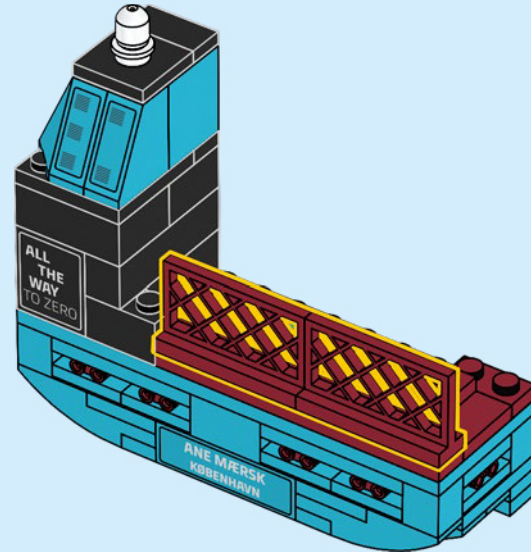

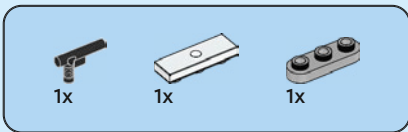

206

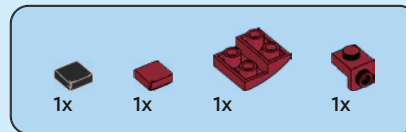
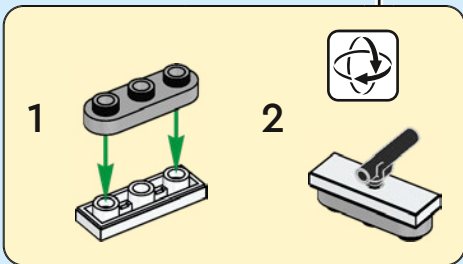
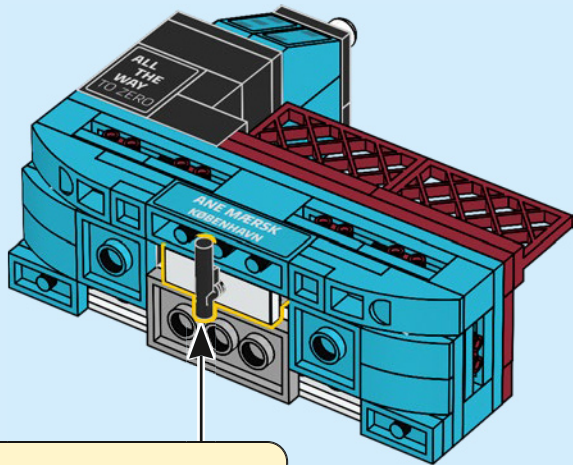

207

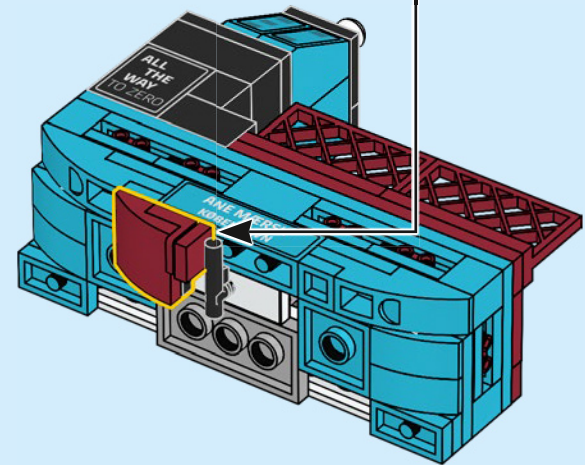
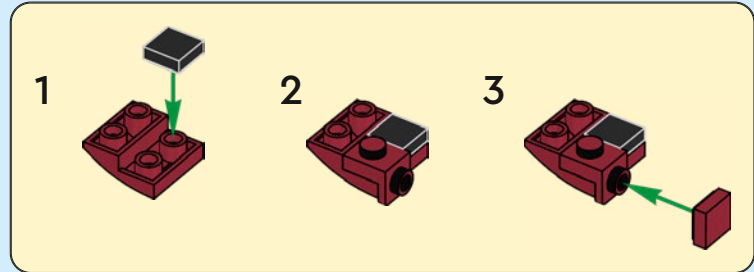

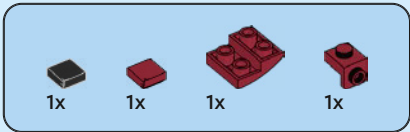

208

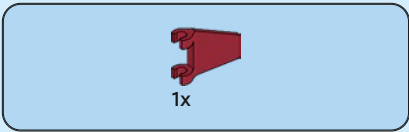
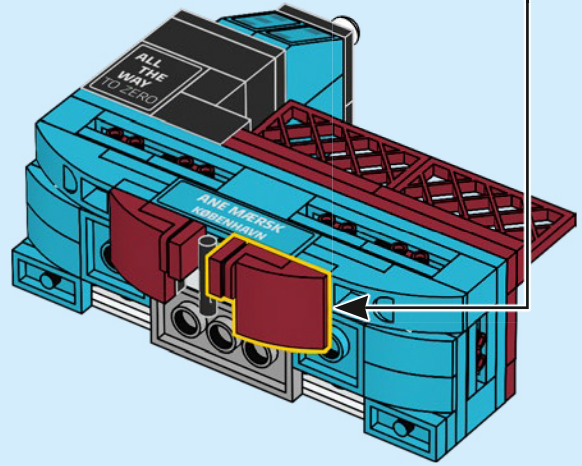

209

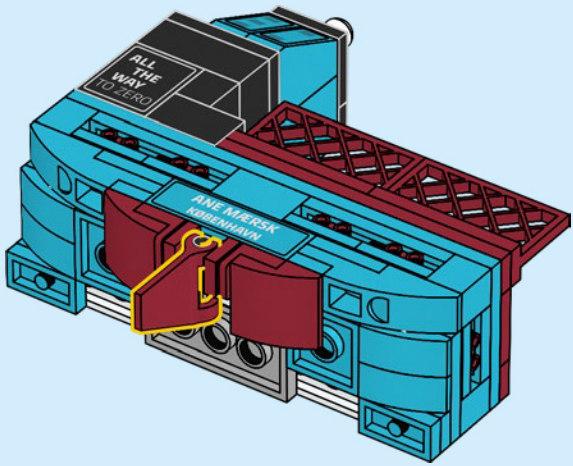

210

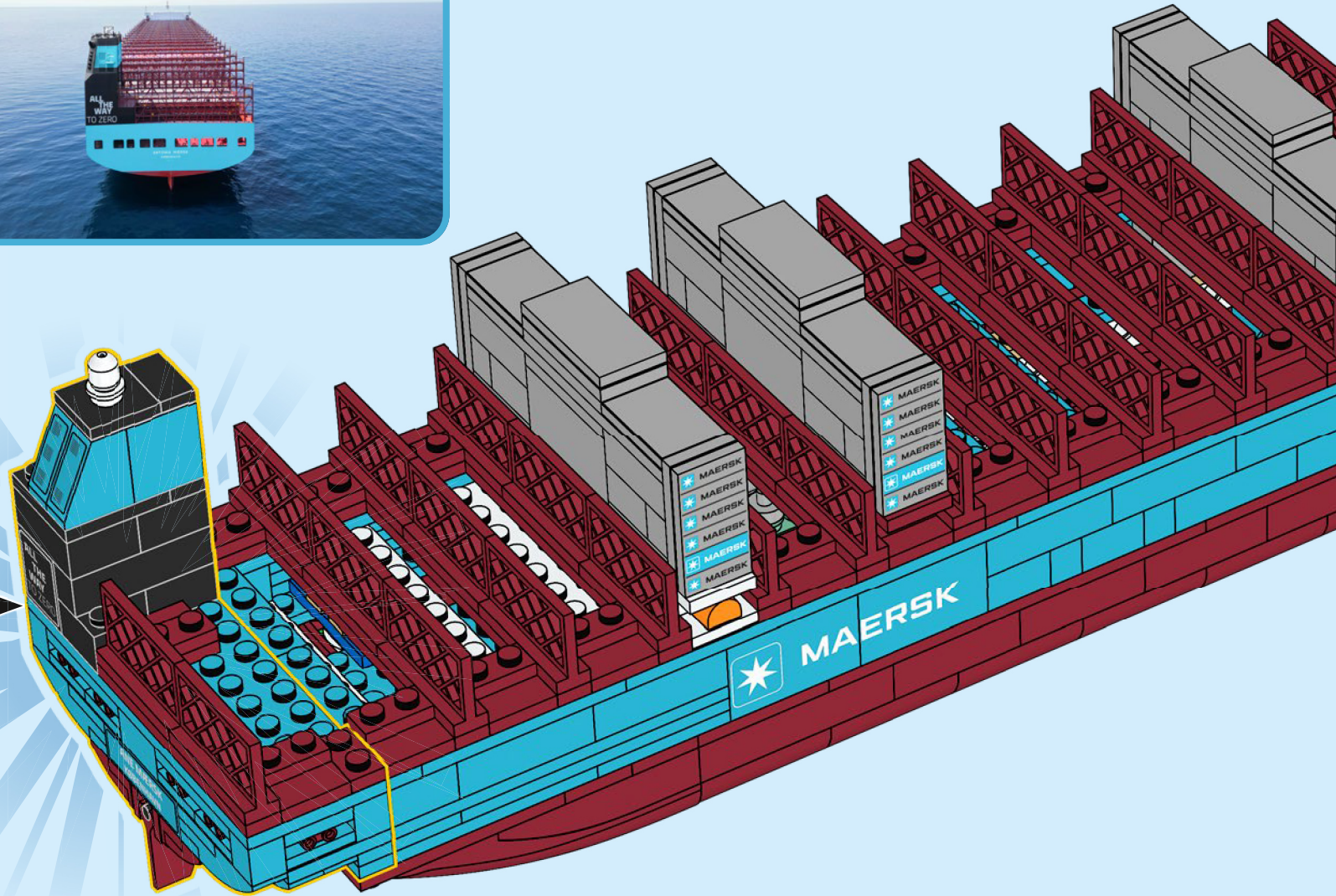
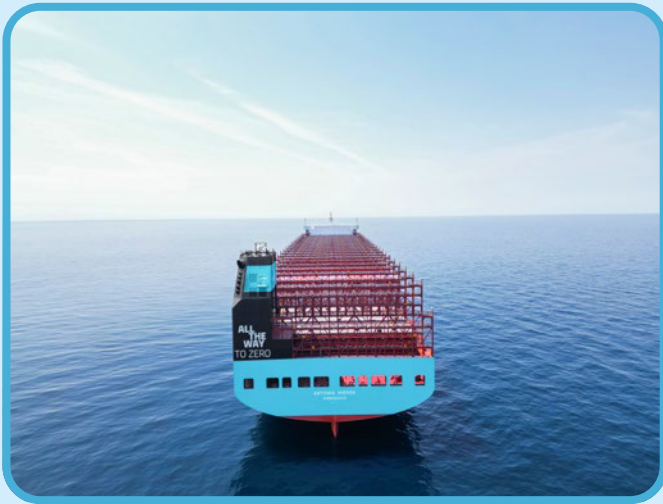

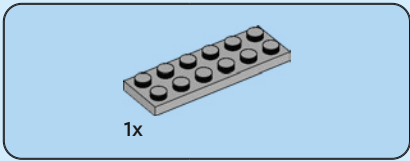

211

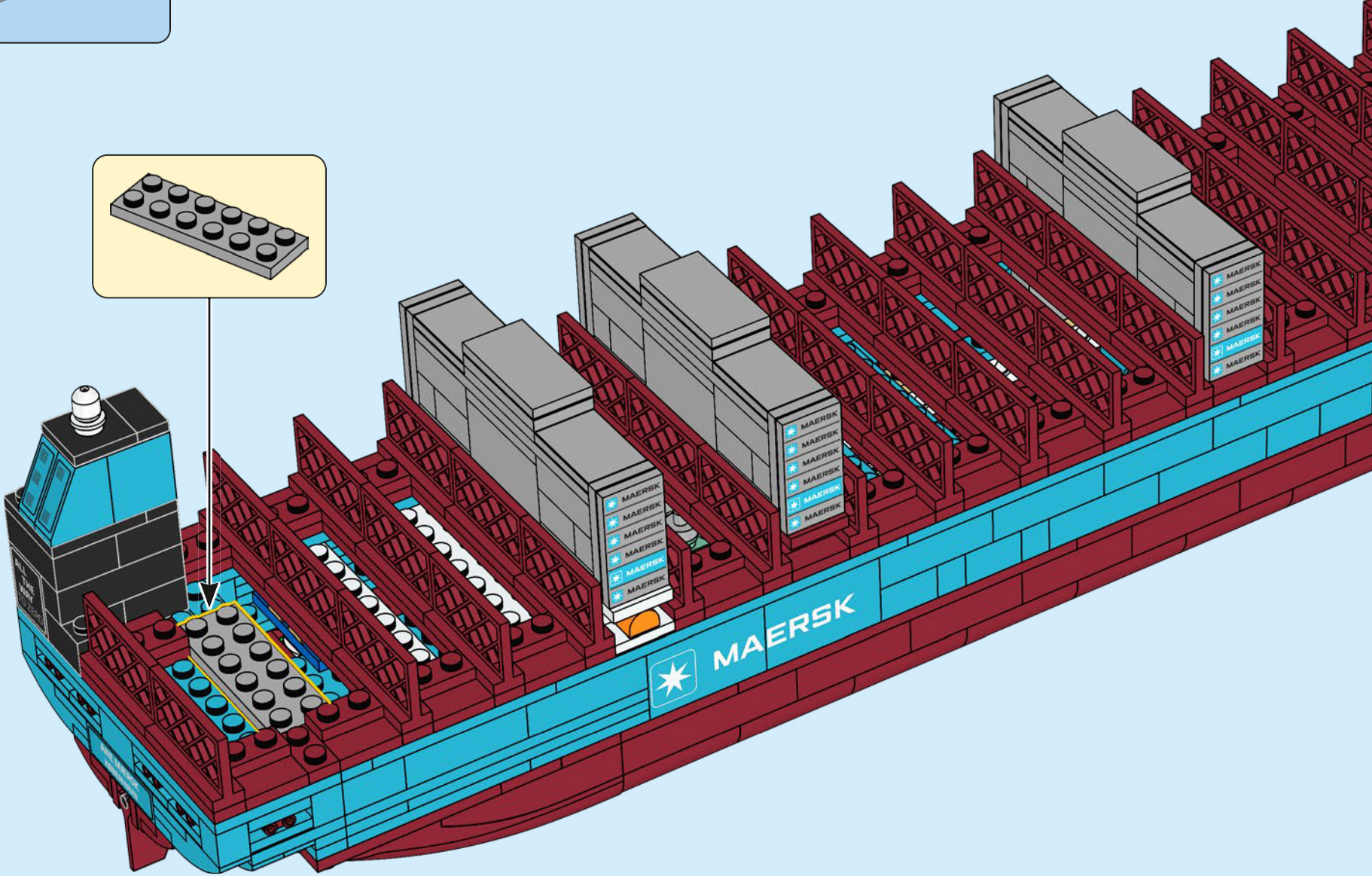
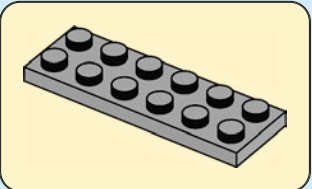

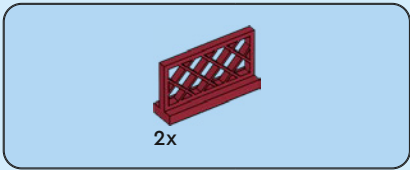

212

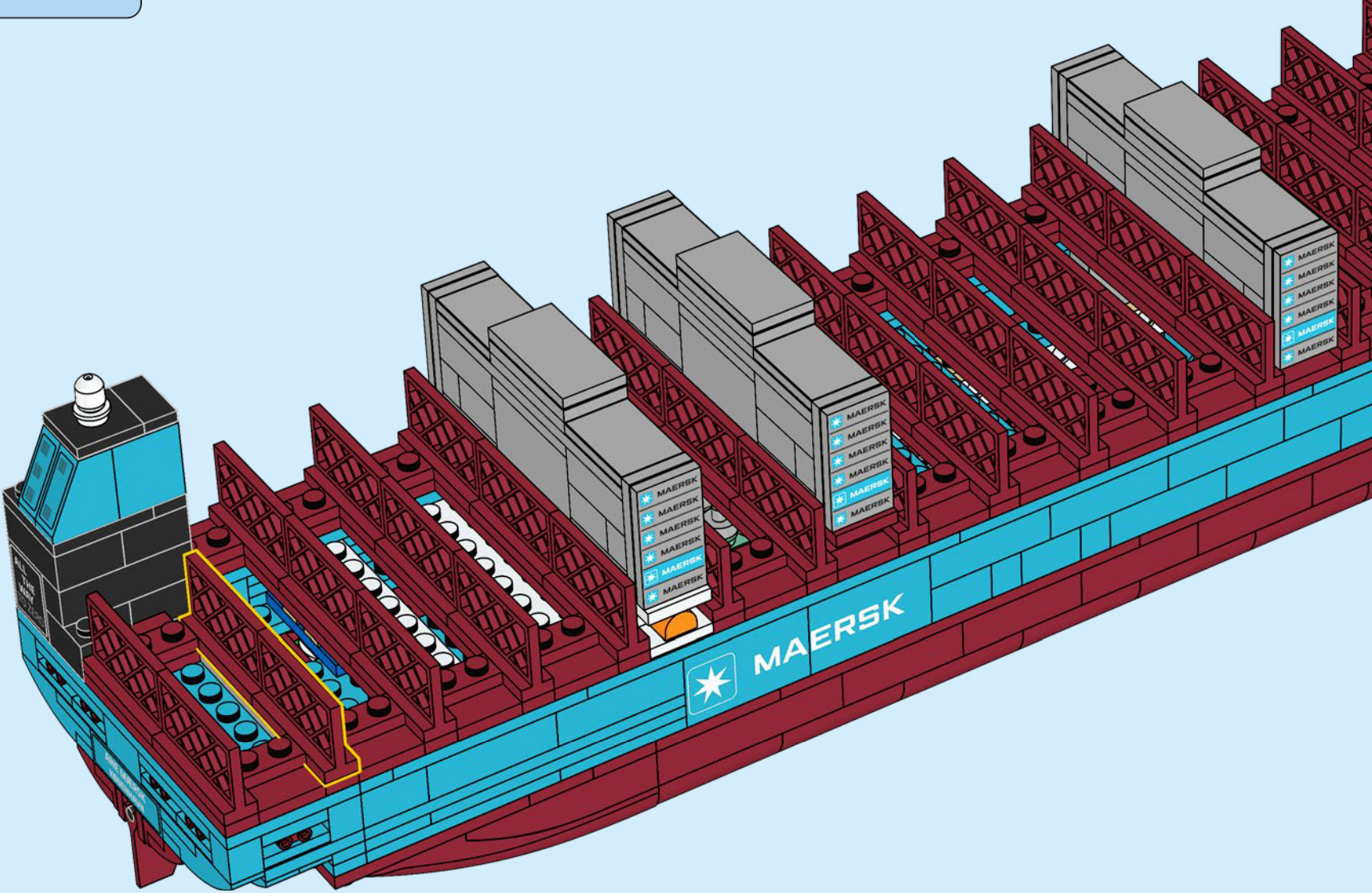

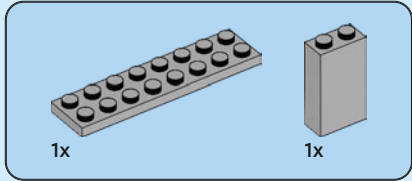
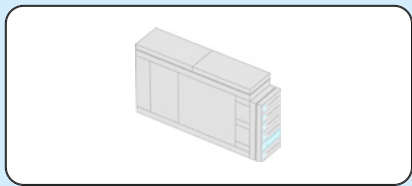

213

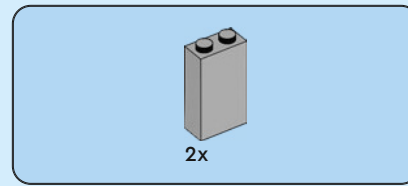
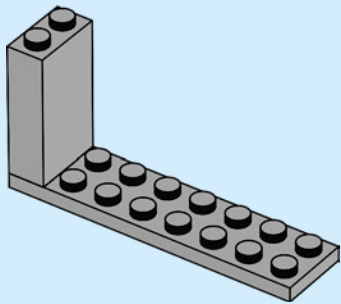

214

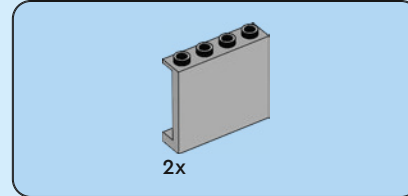
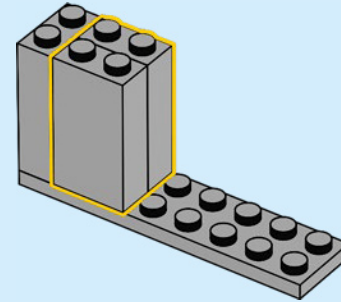

215

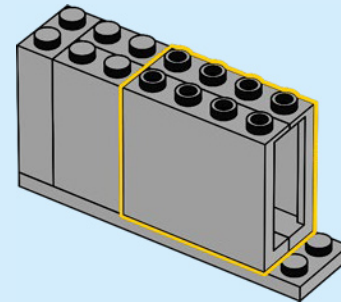

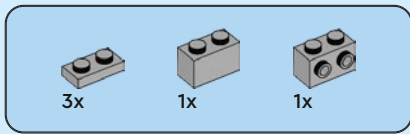

216

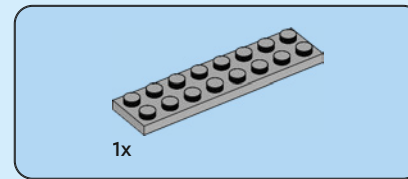
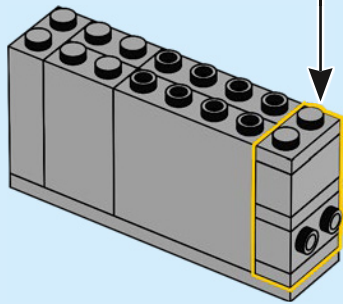
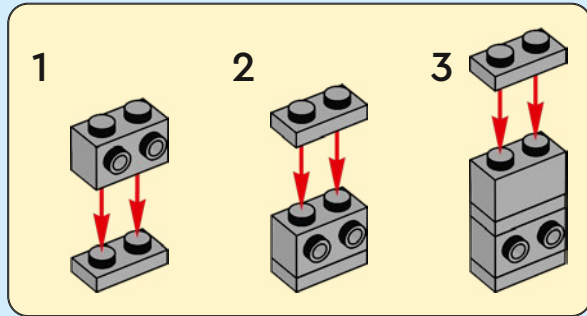

217

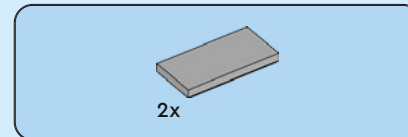
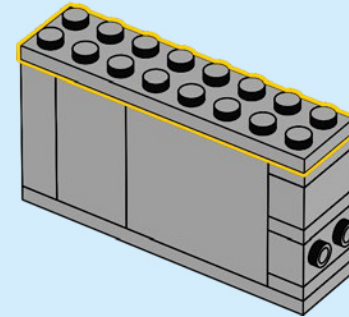

218

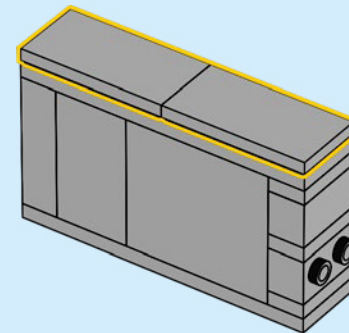

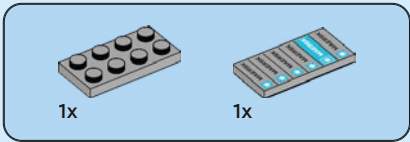

219

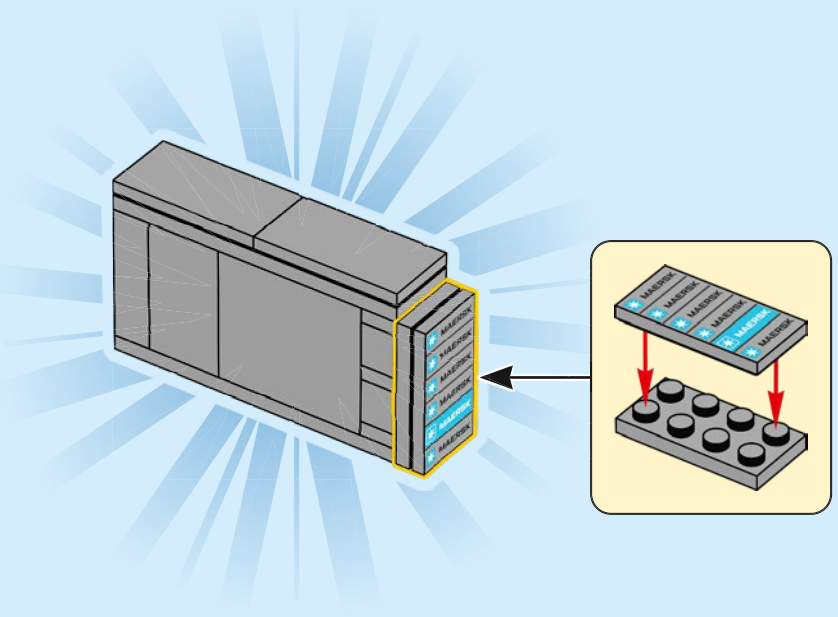

220

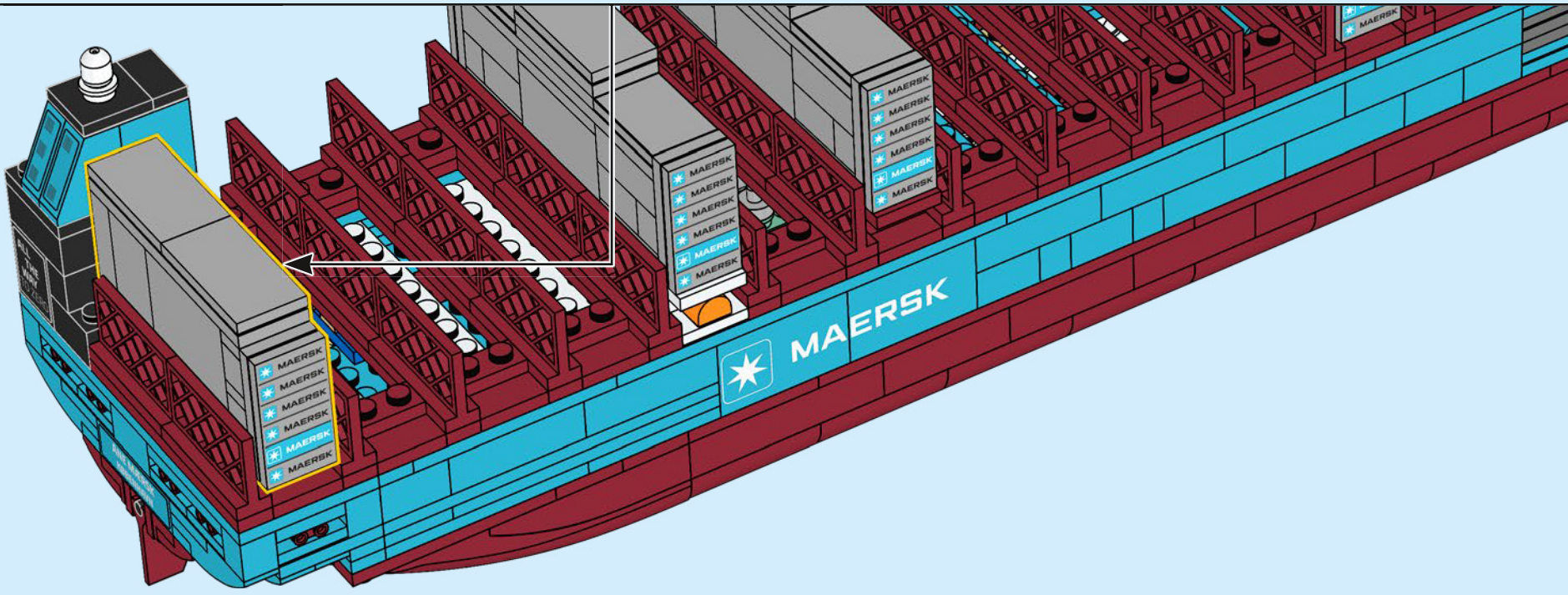

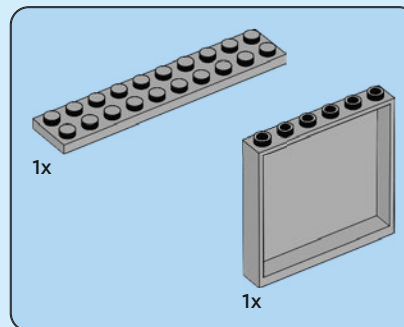
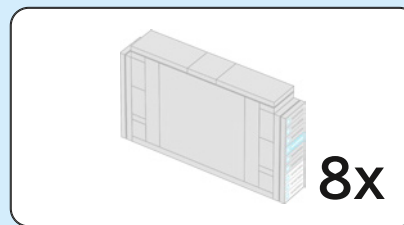

221

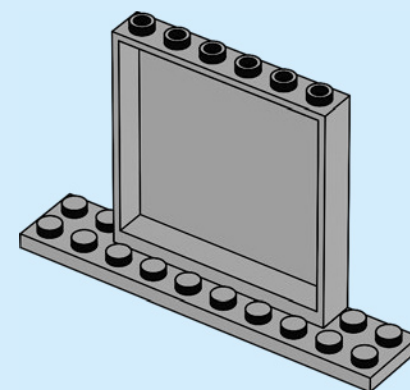

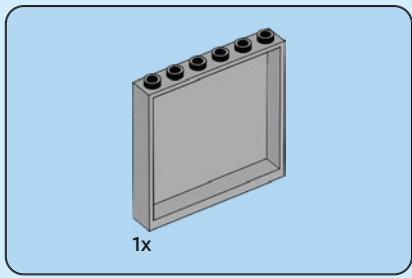

222

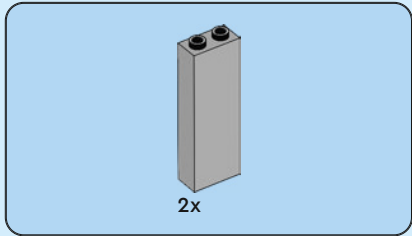
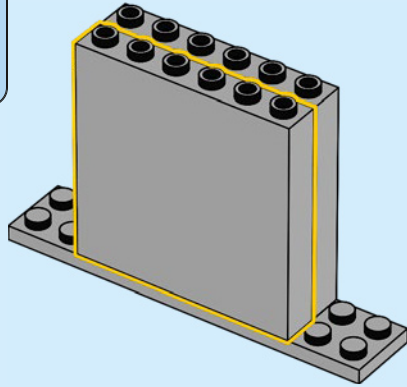

223

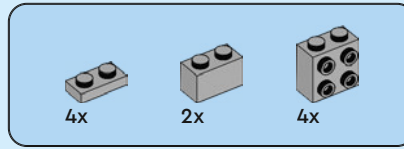
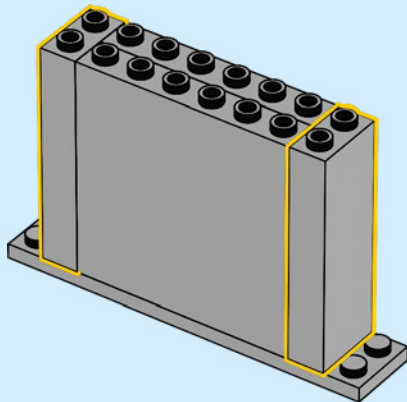

224

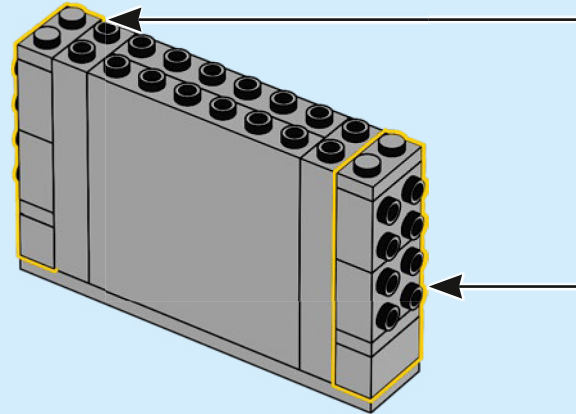
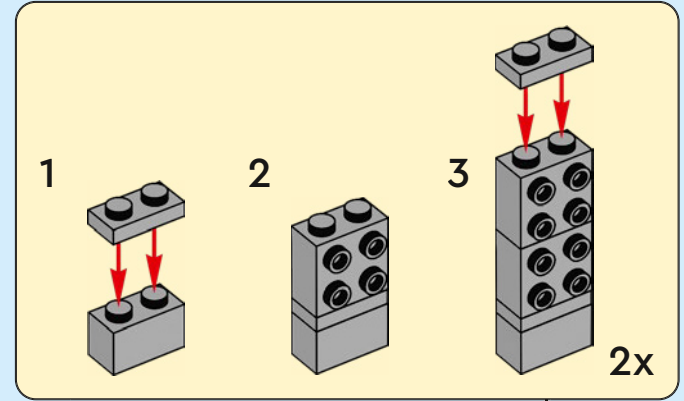

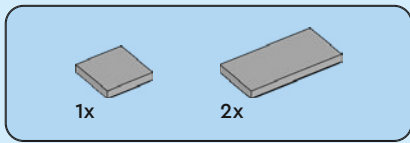

225

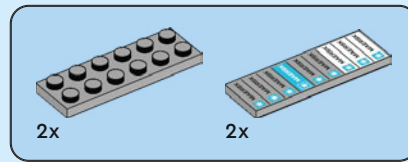
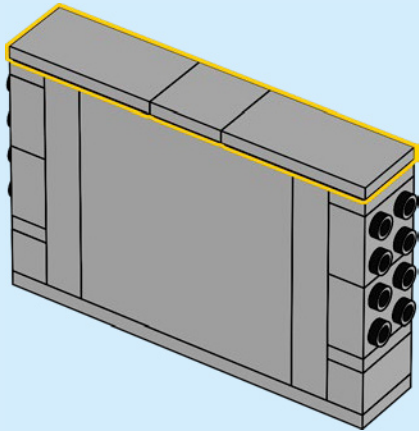

226

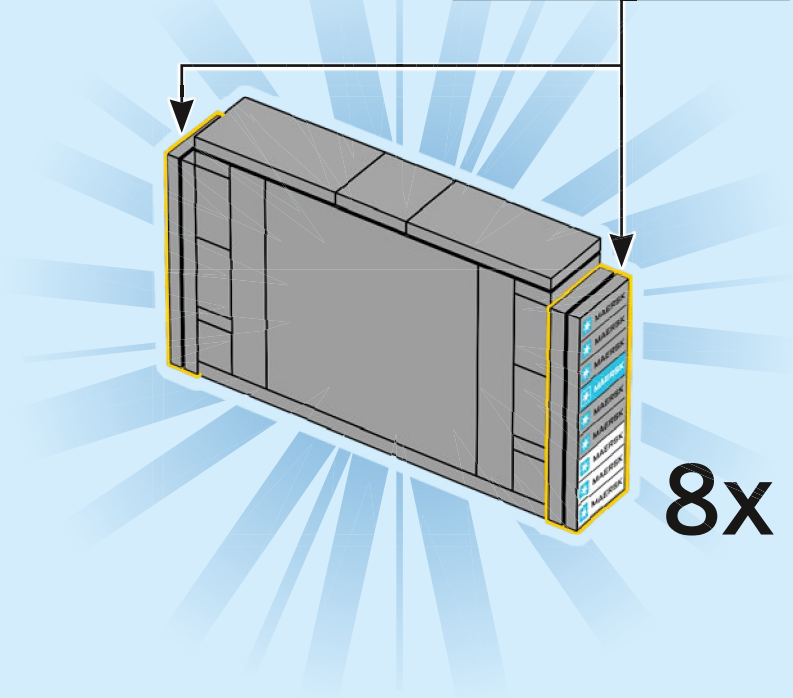
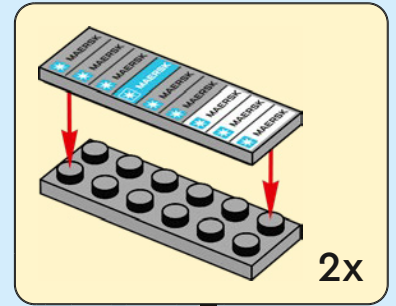

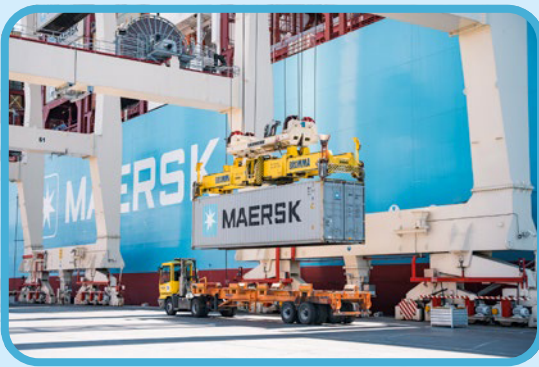

227

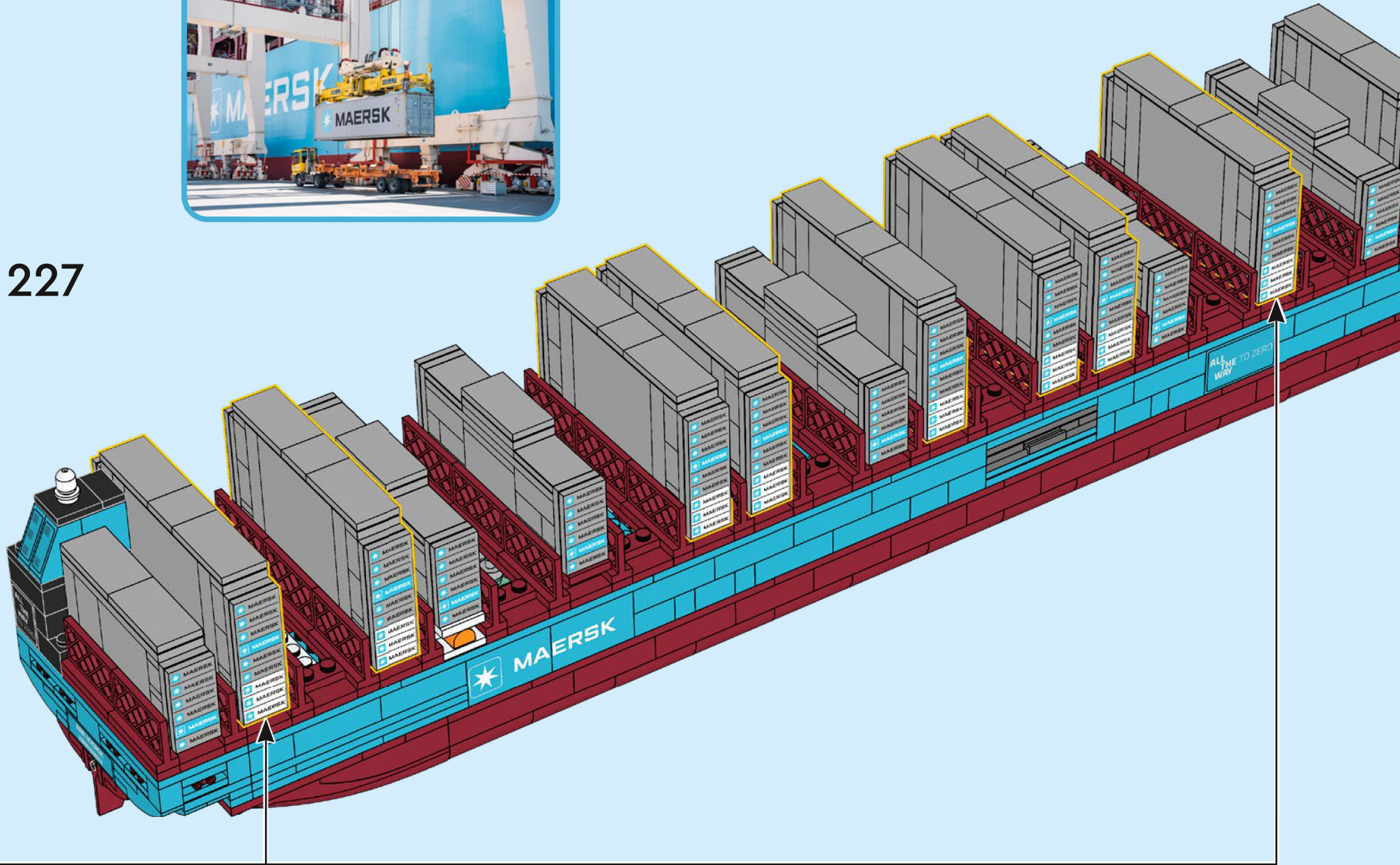





228

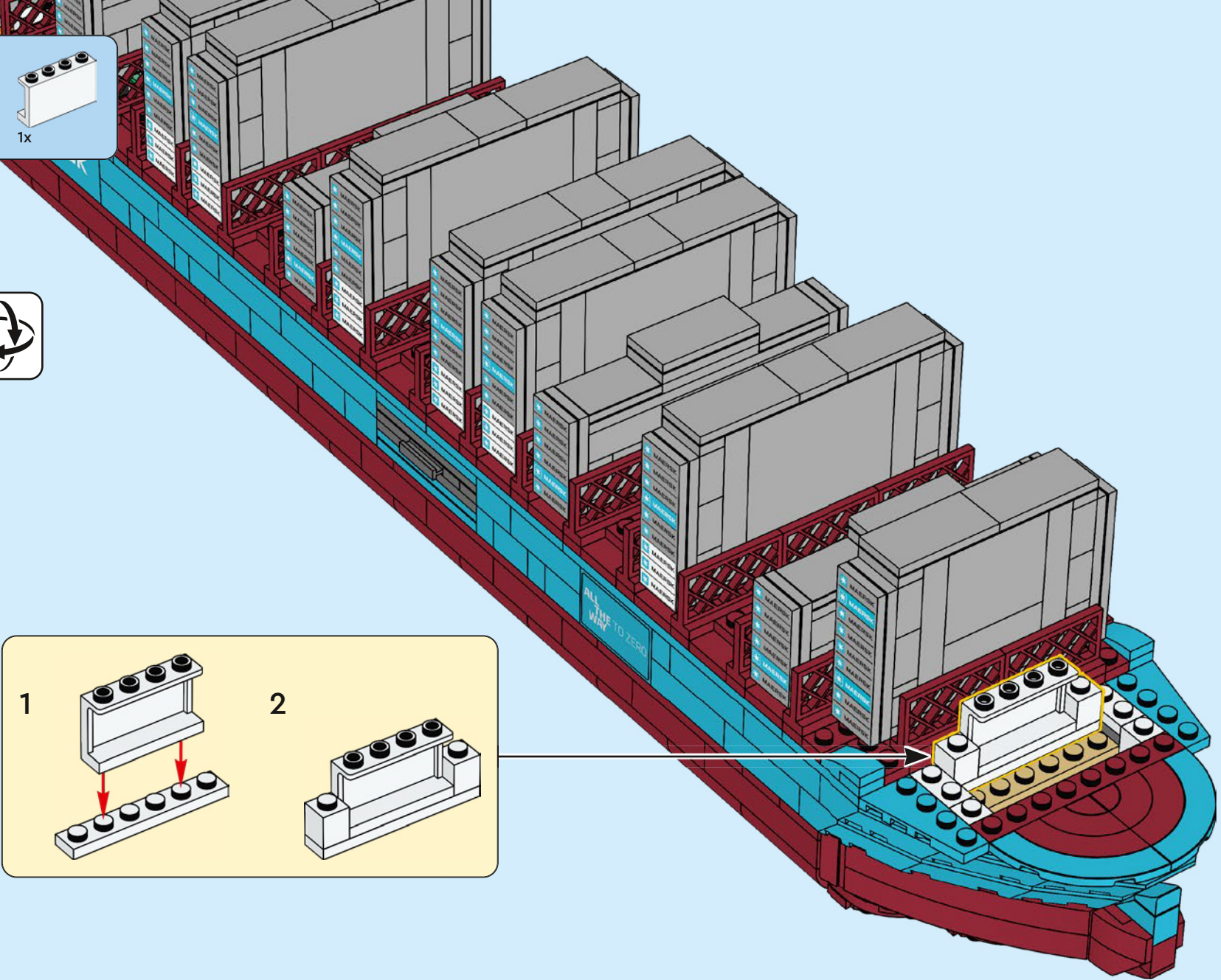
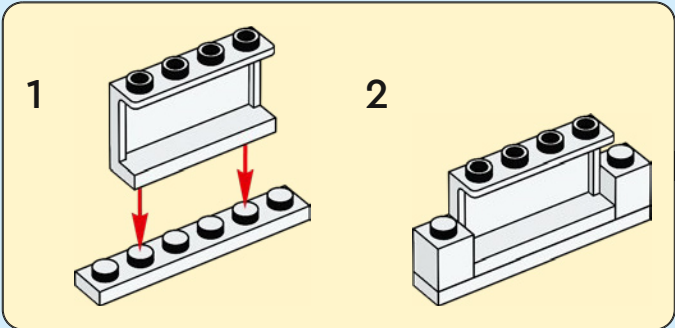

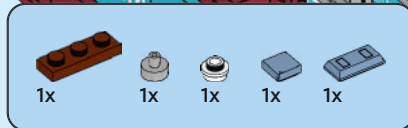

229

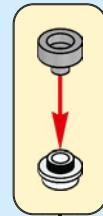
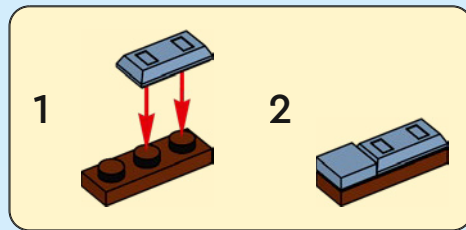



4x

230

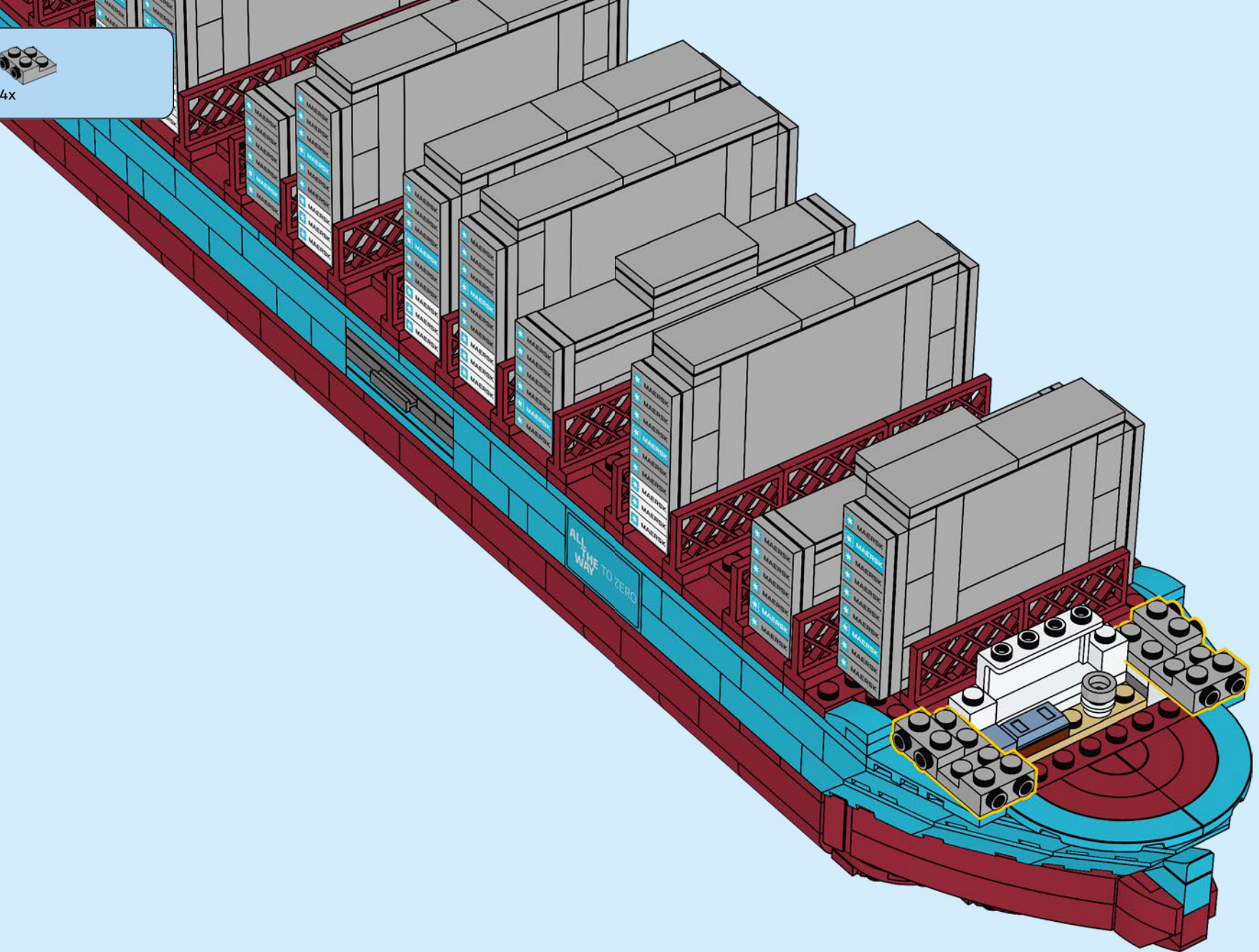

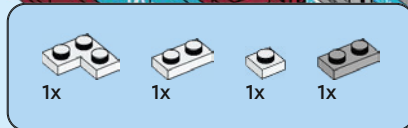

231

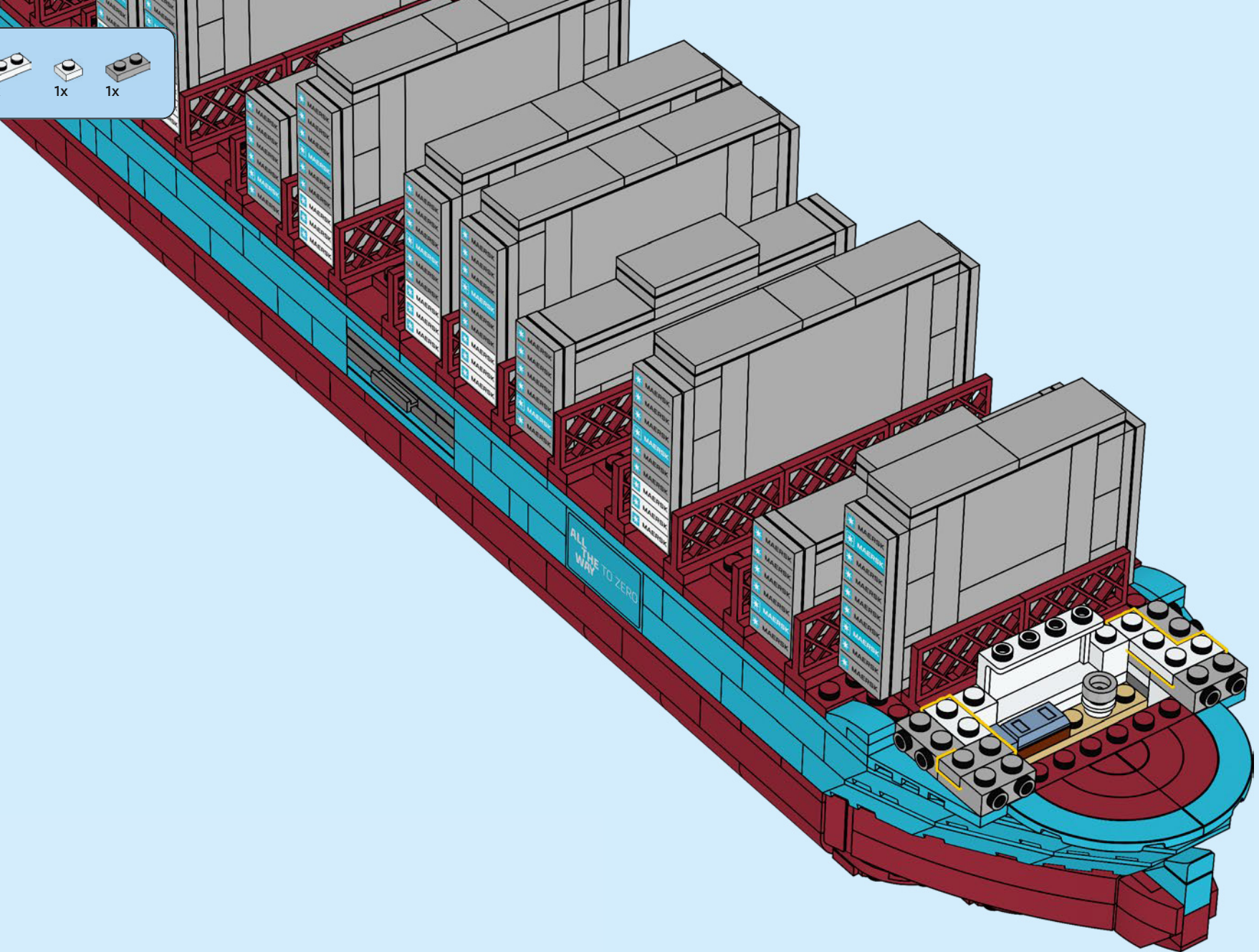

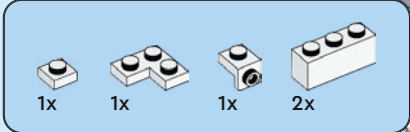

232

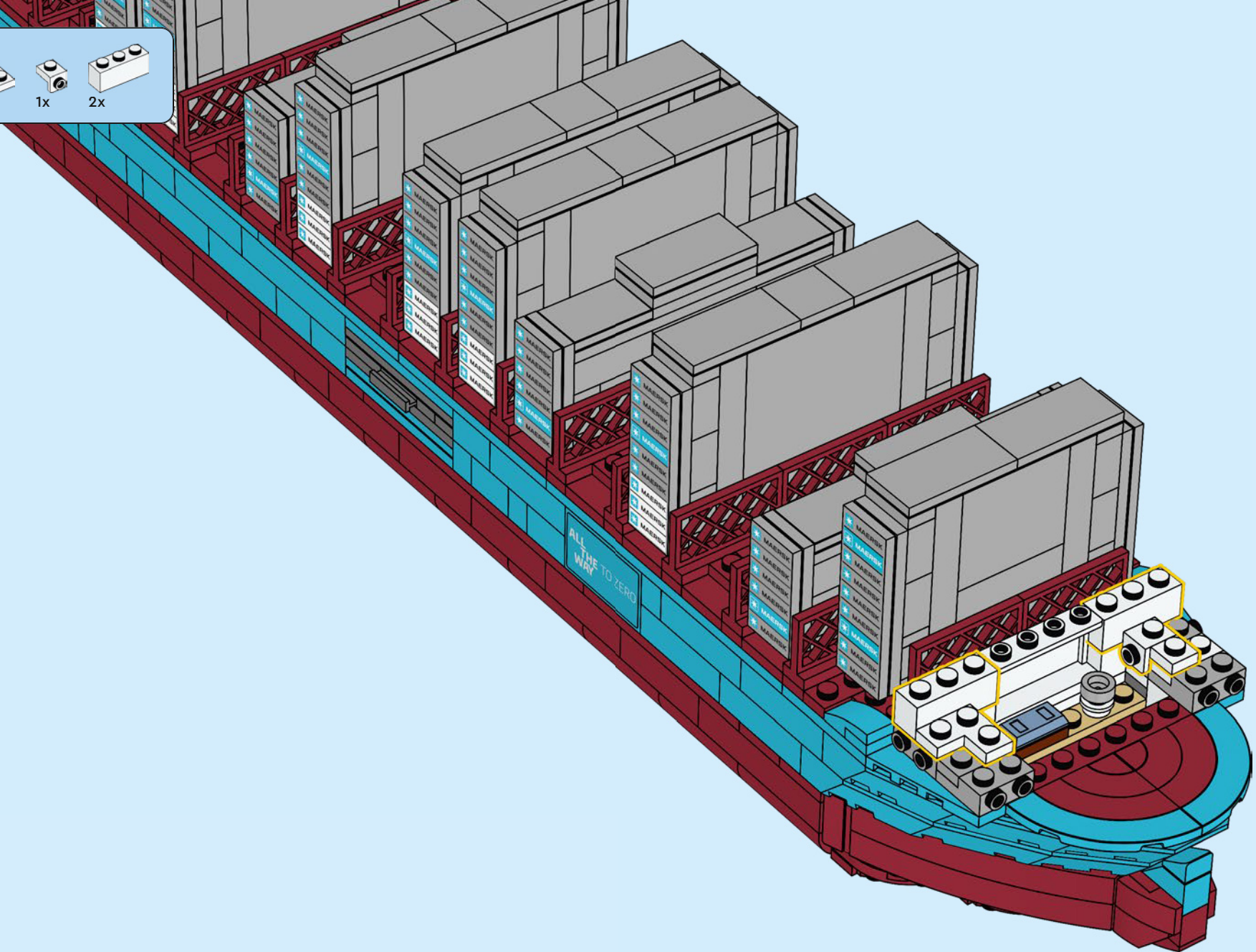

1x 1x 4x

233

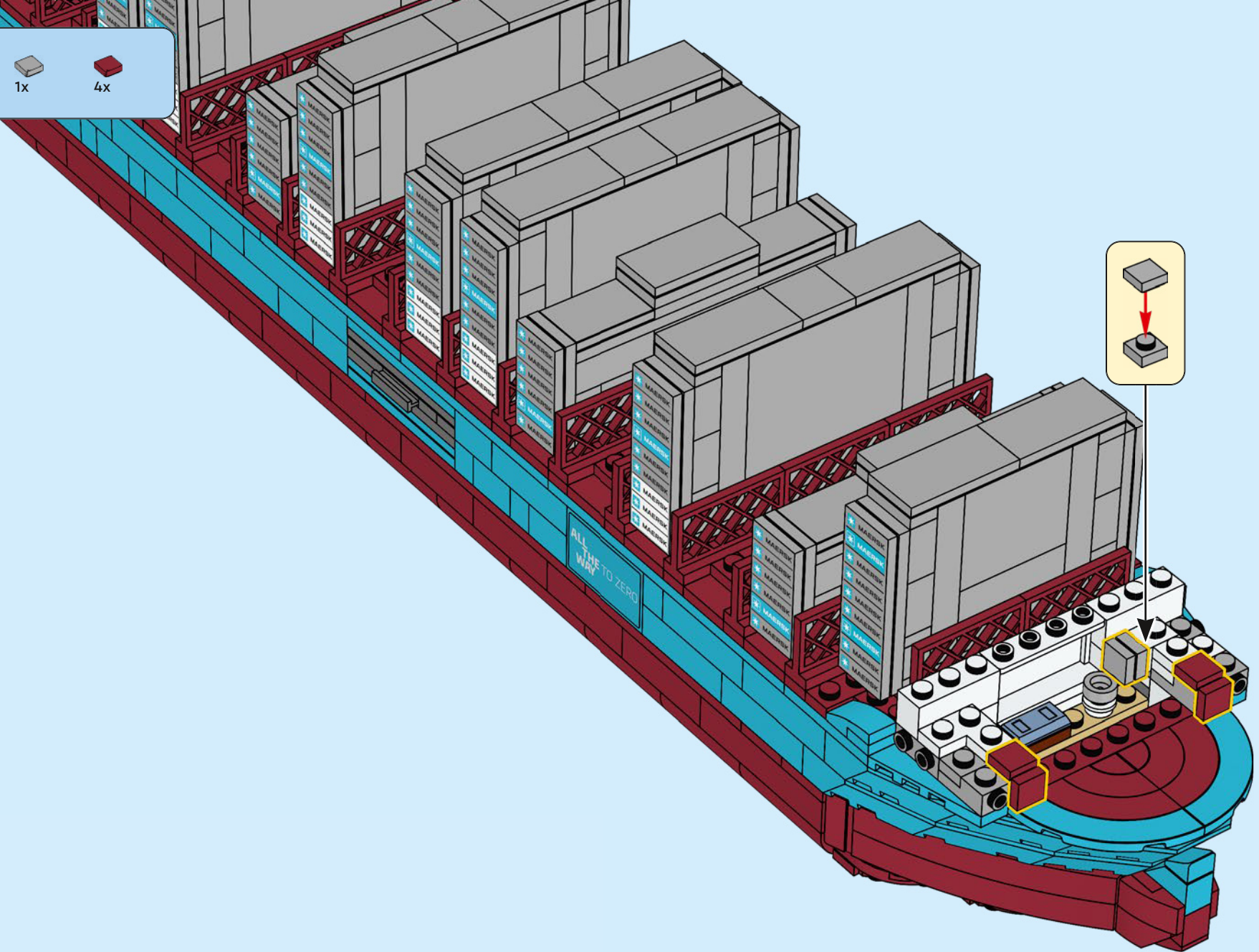

3x 2x 2x

234

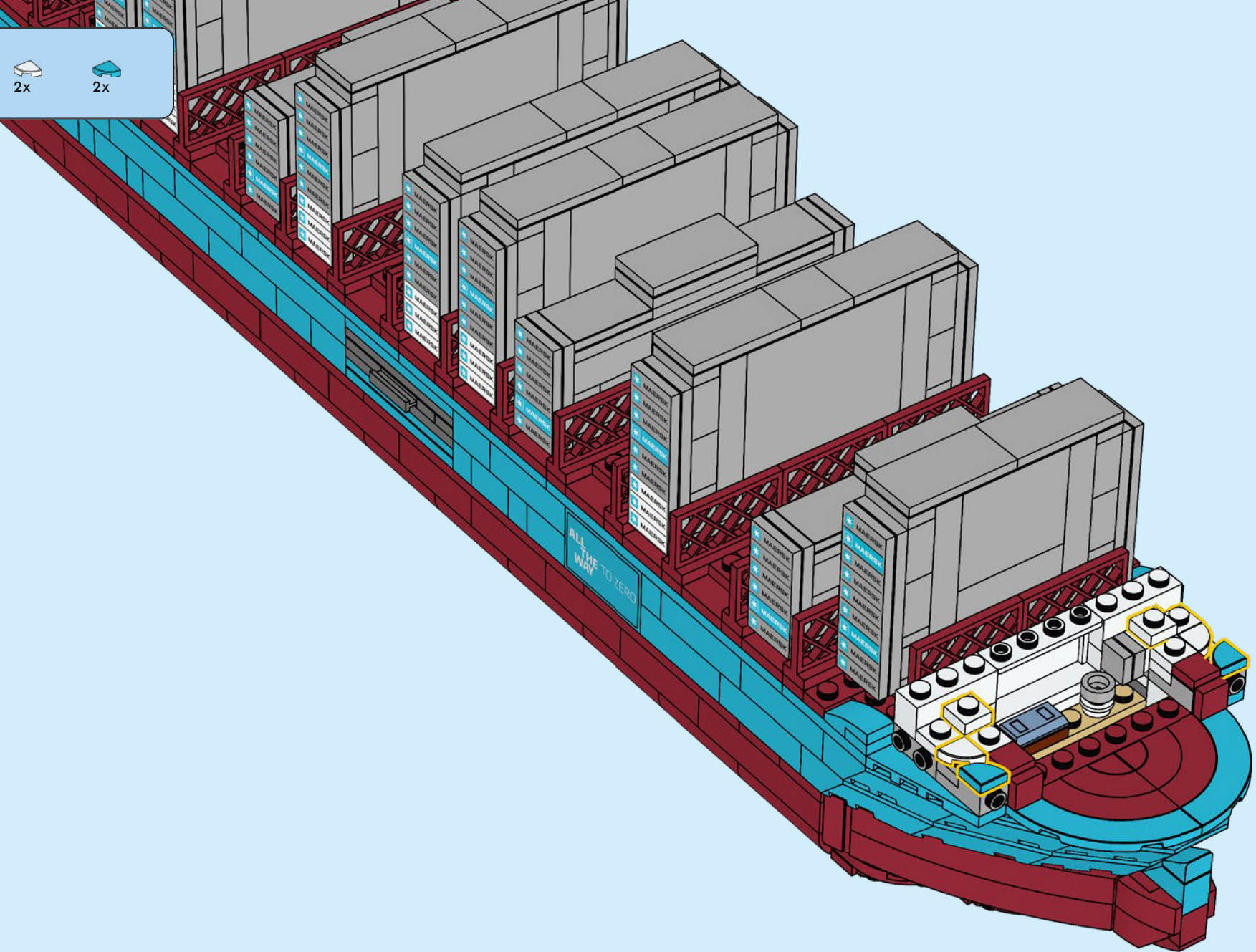

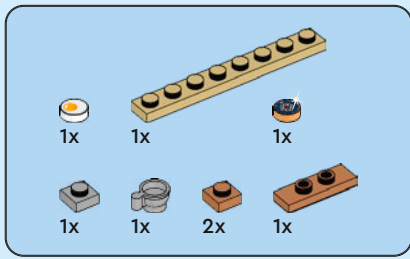

235

1

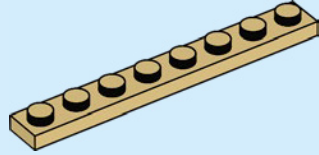

2

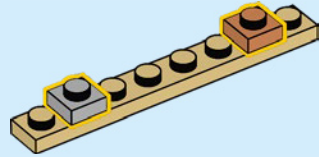

3

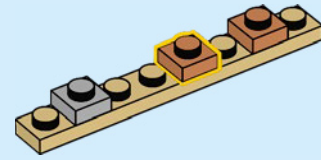

4

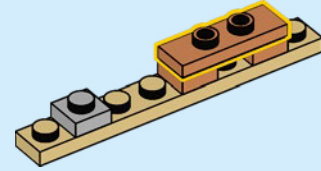

5

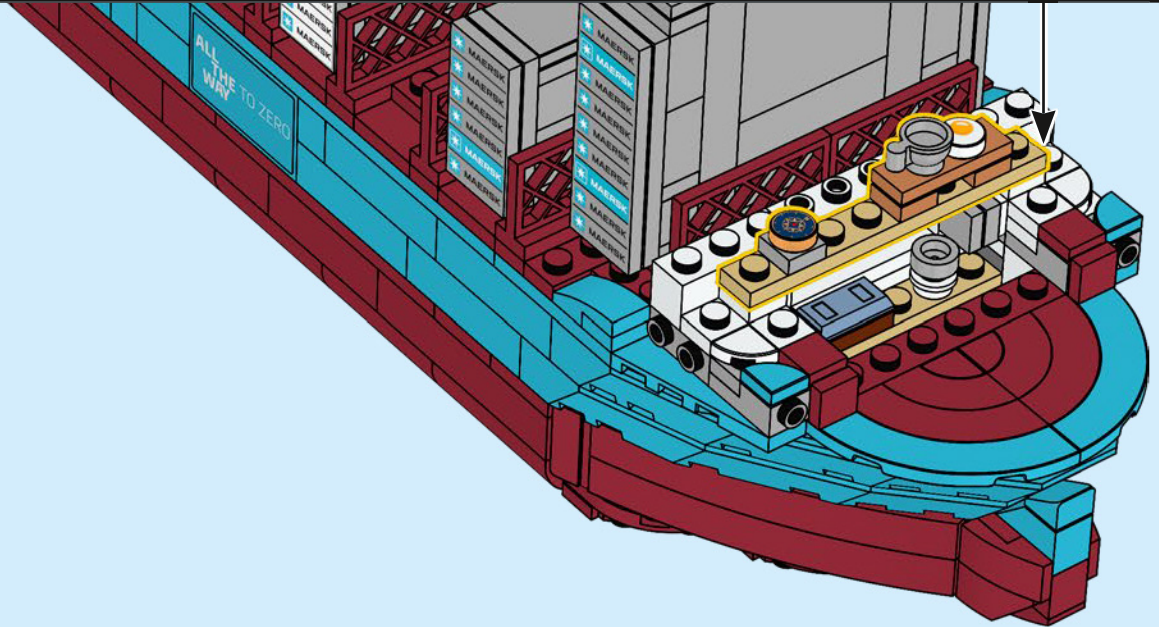

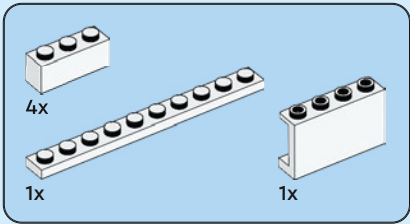

236

1

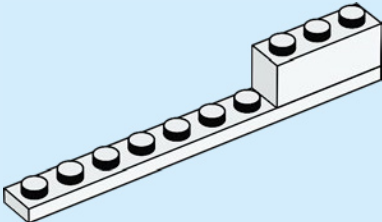

2

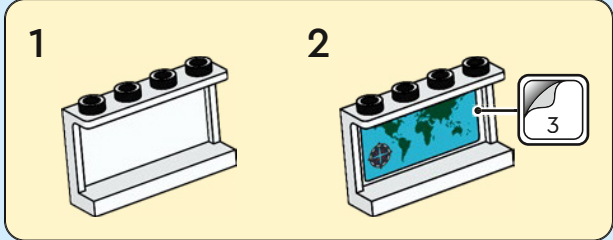
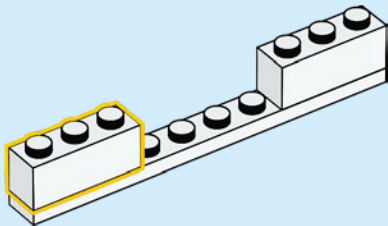

3

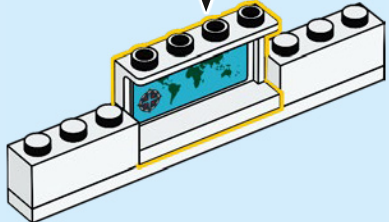

4

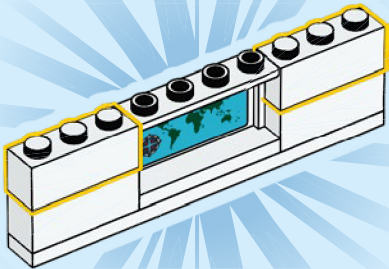

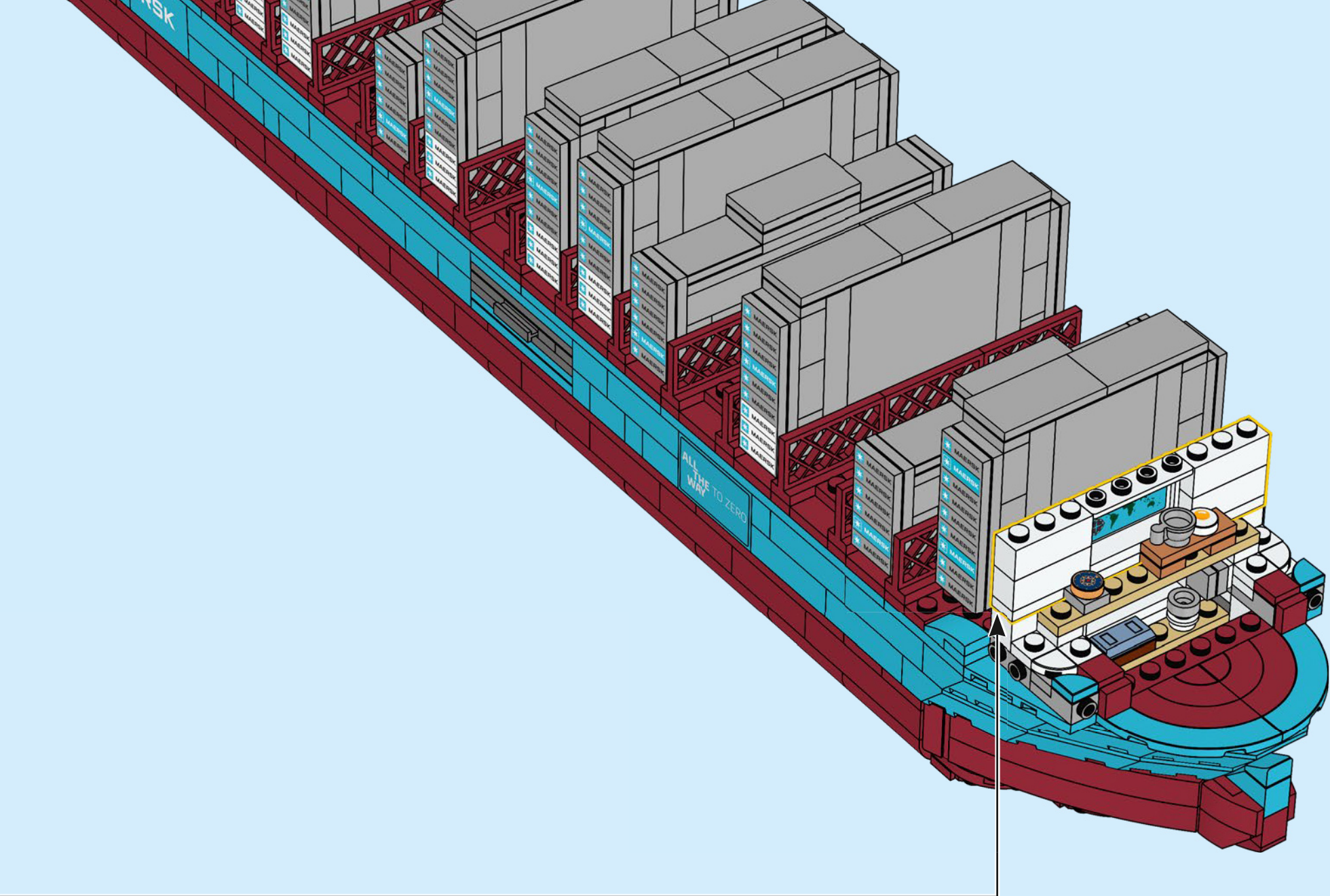

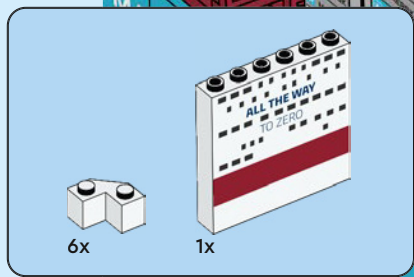

237

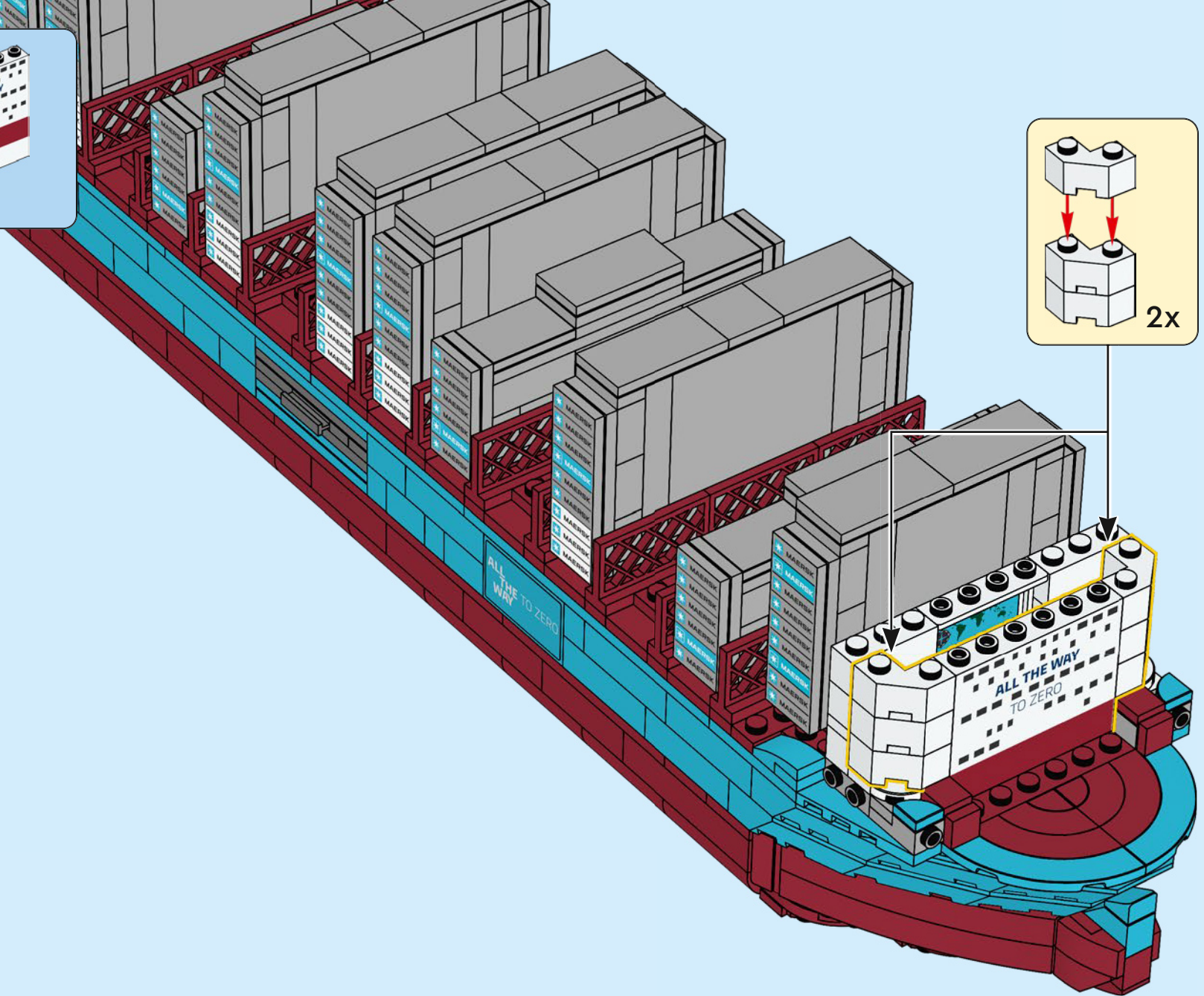



238

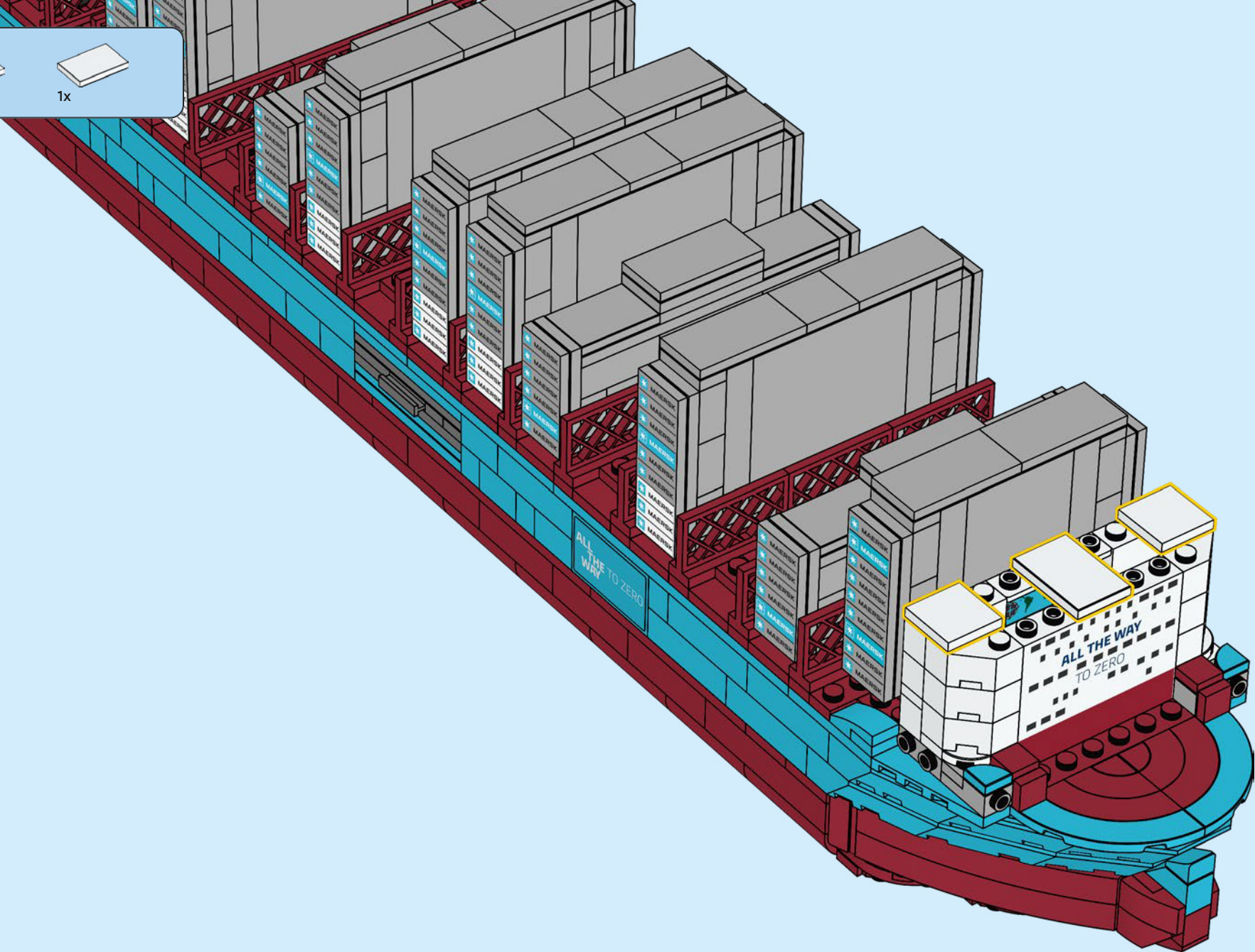

2x 1x 1x

239

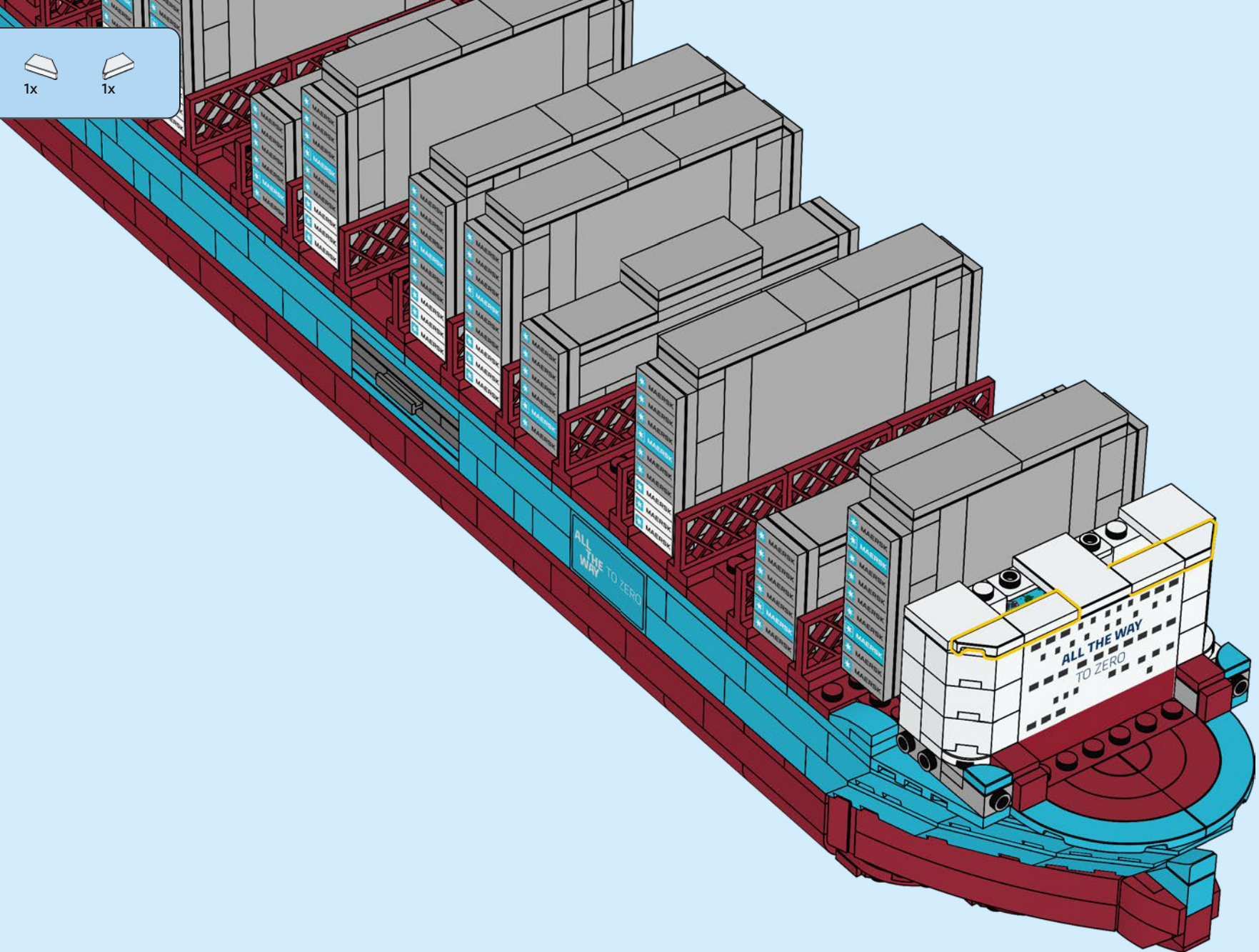

2x 2x 2x

240

1 2 2x

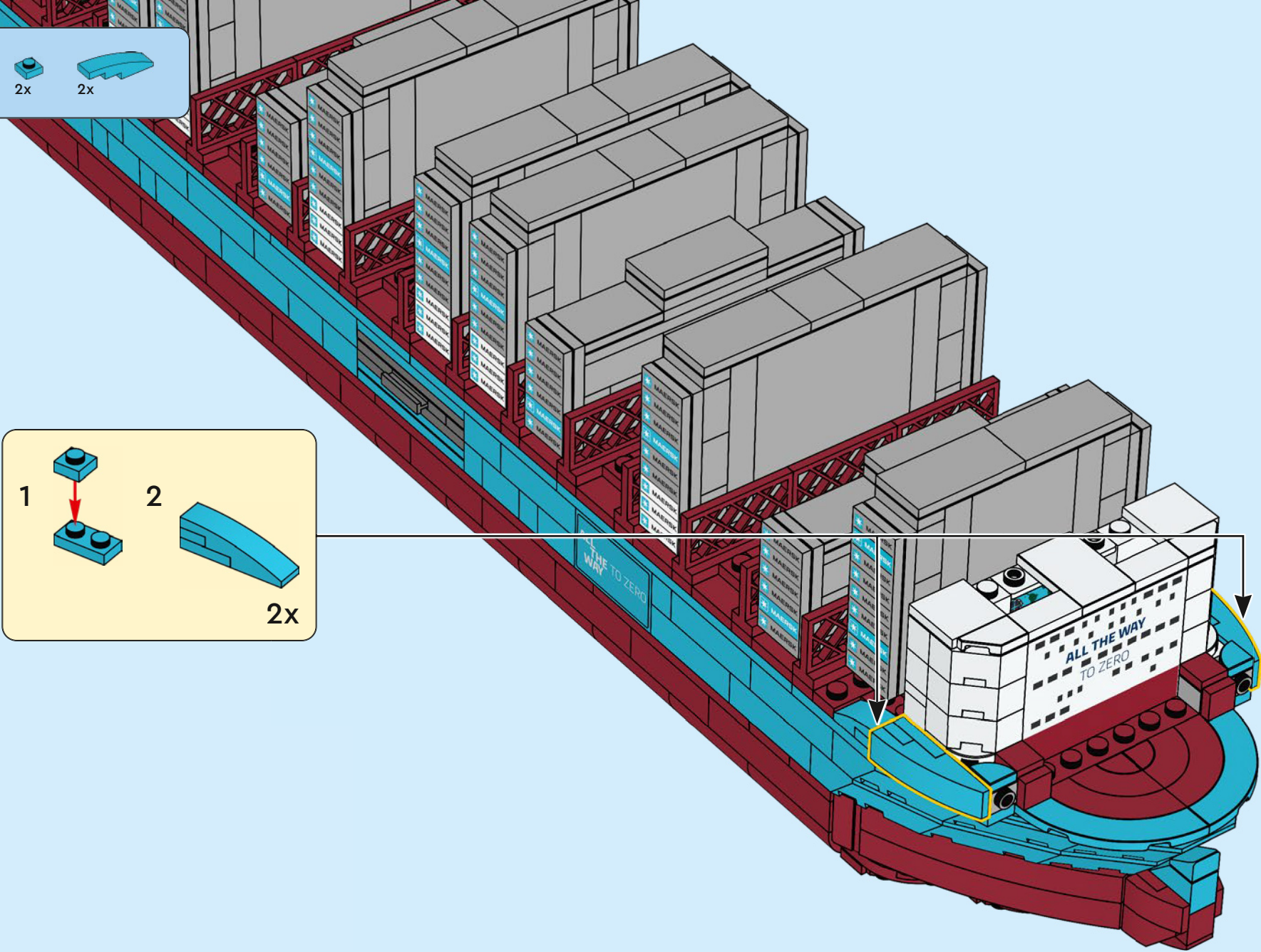

241

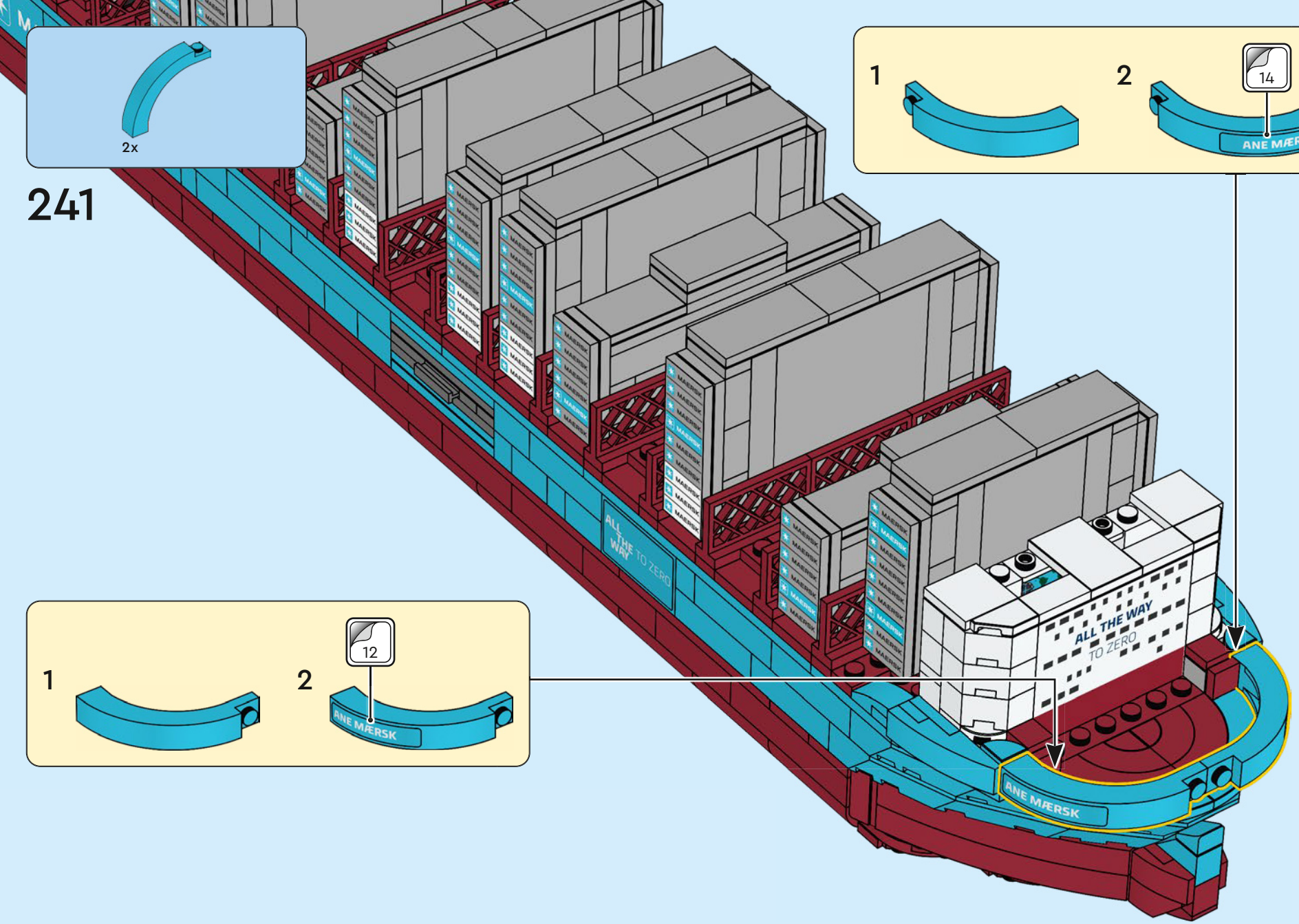
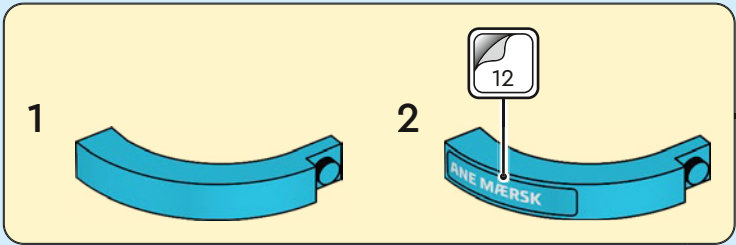
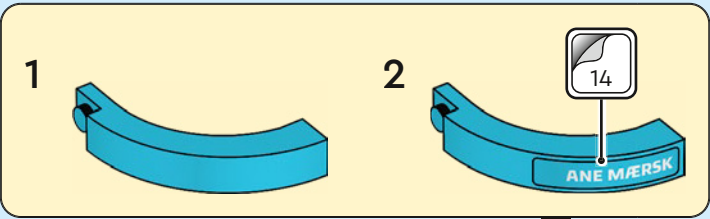
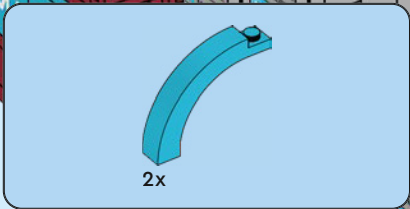

1x

242

1

2

13

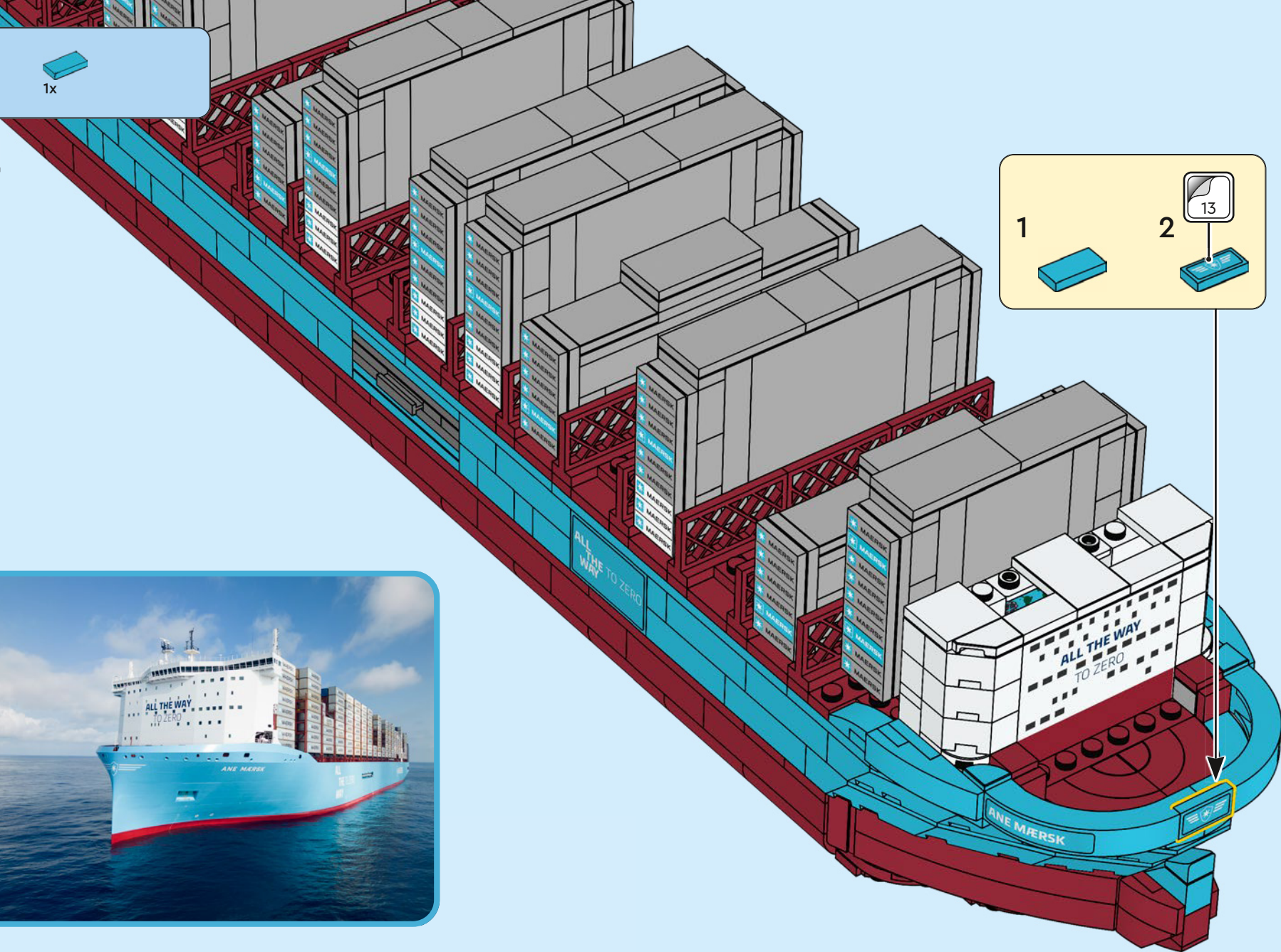

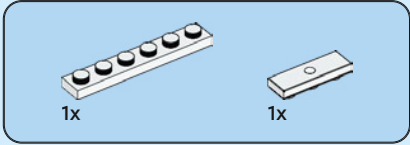
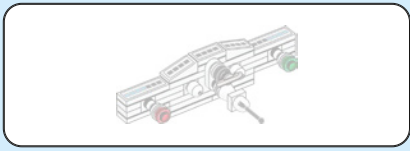

243

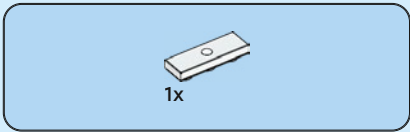
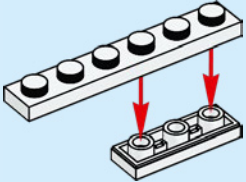

244

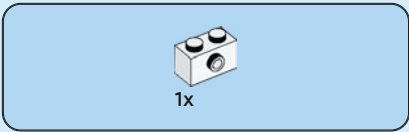
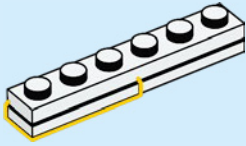

245

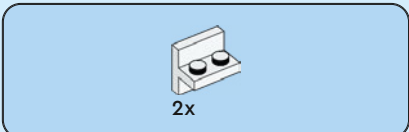
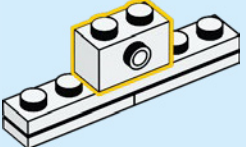

246

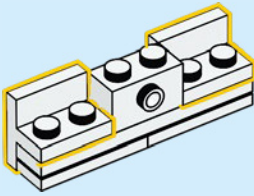



2x

247

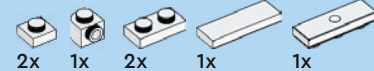
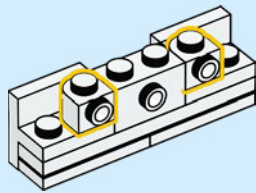

248

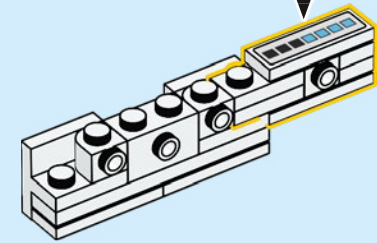
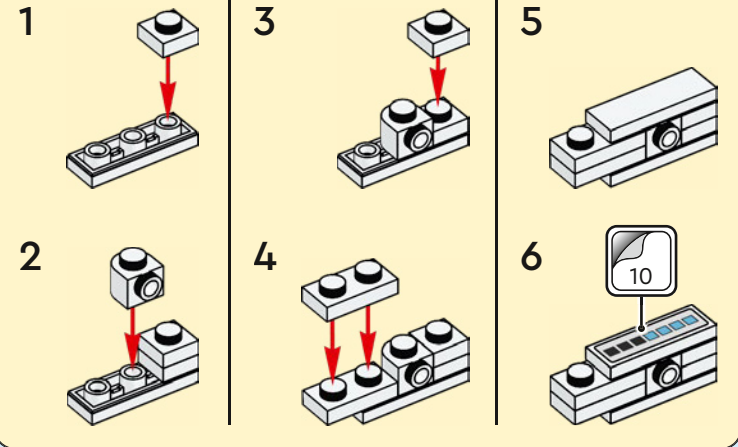

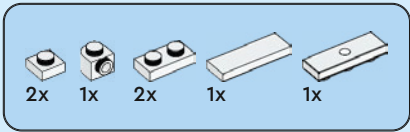

249

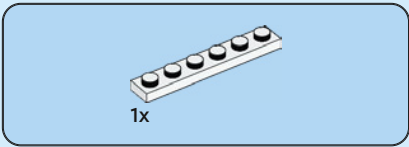
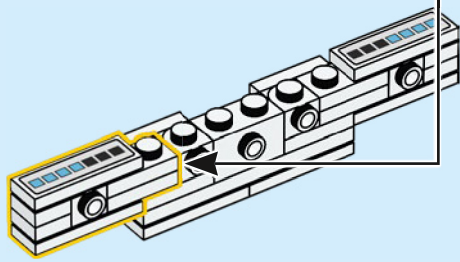
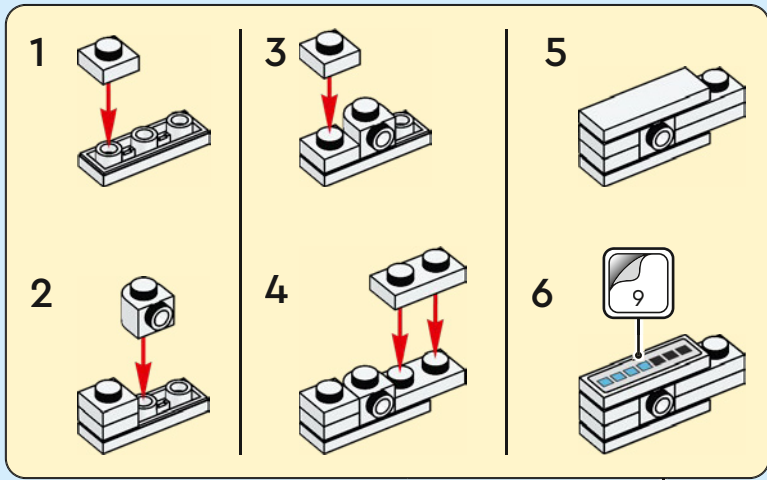

250

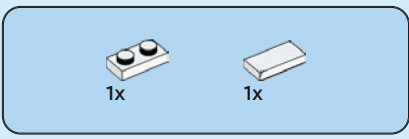
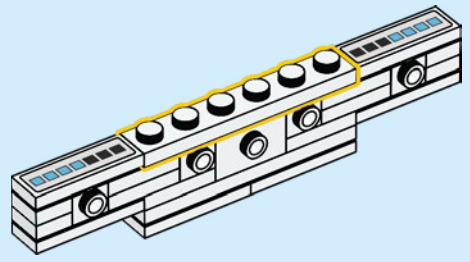

251

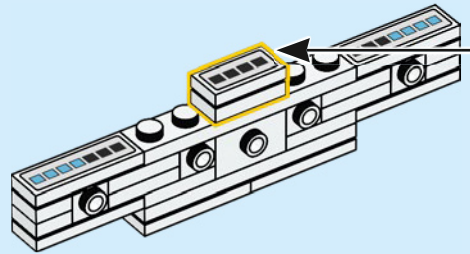
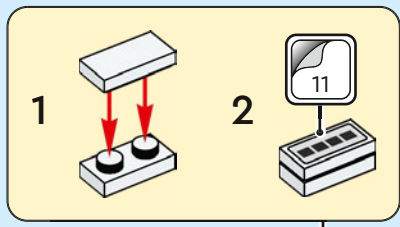

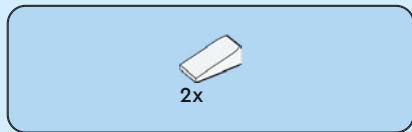

252

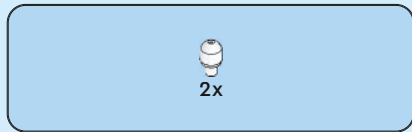
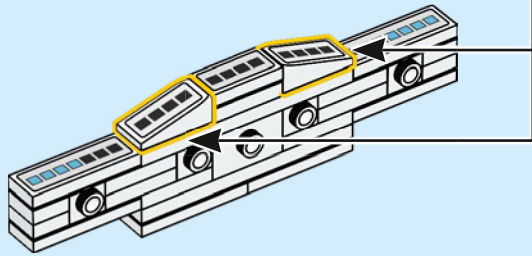
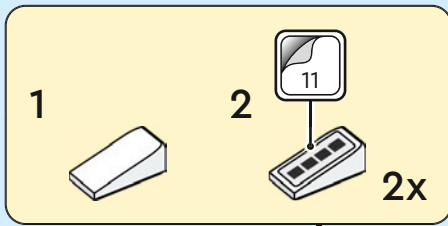

253

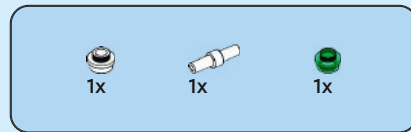
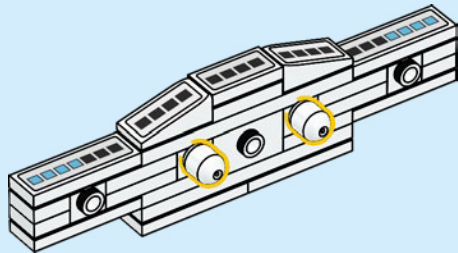

254

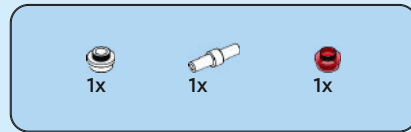
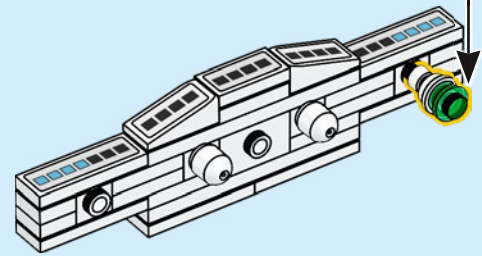
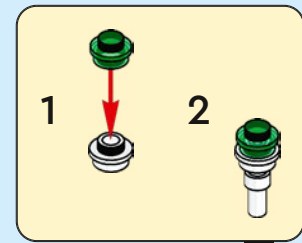

255

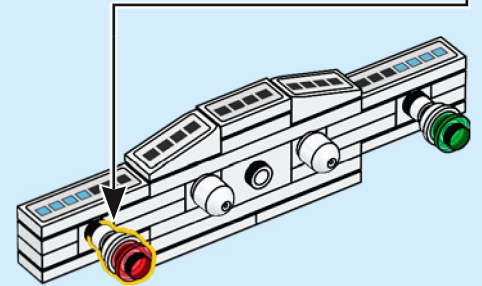
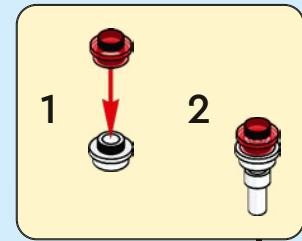

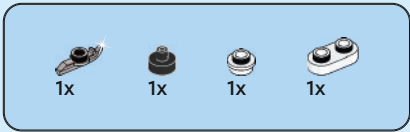

256

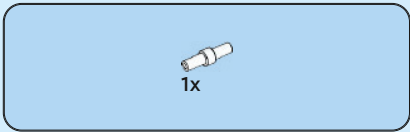
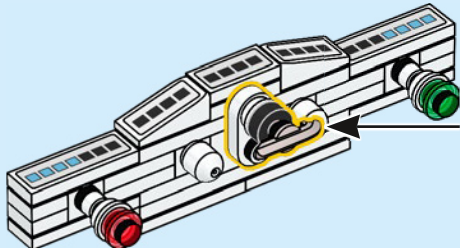
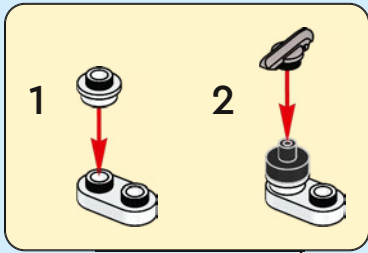

257

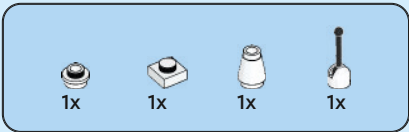
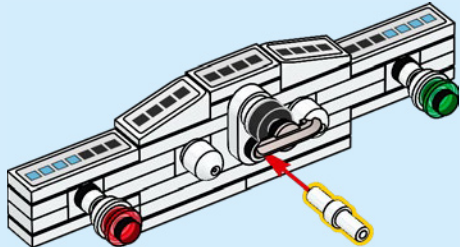

258

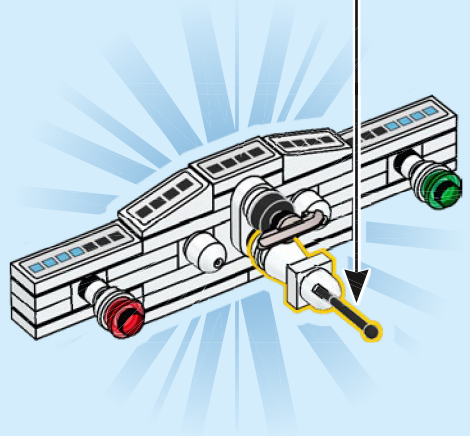
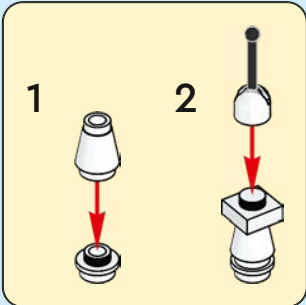

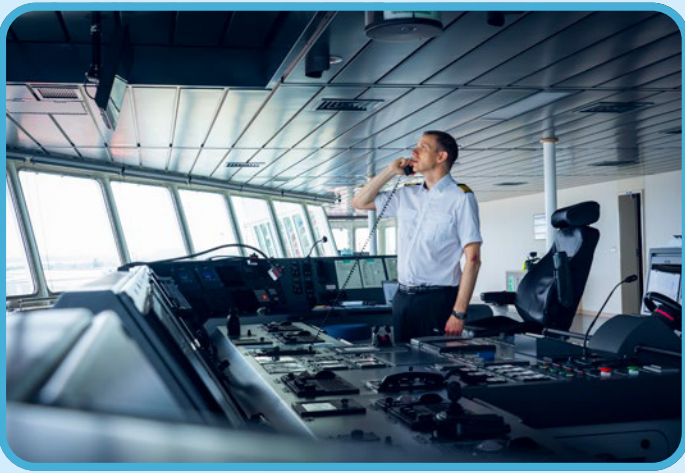
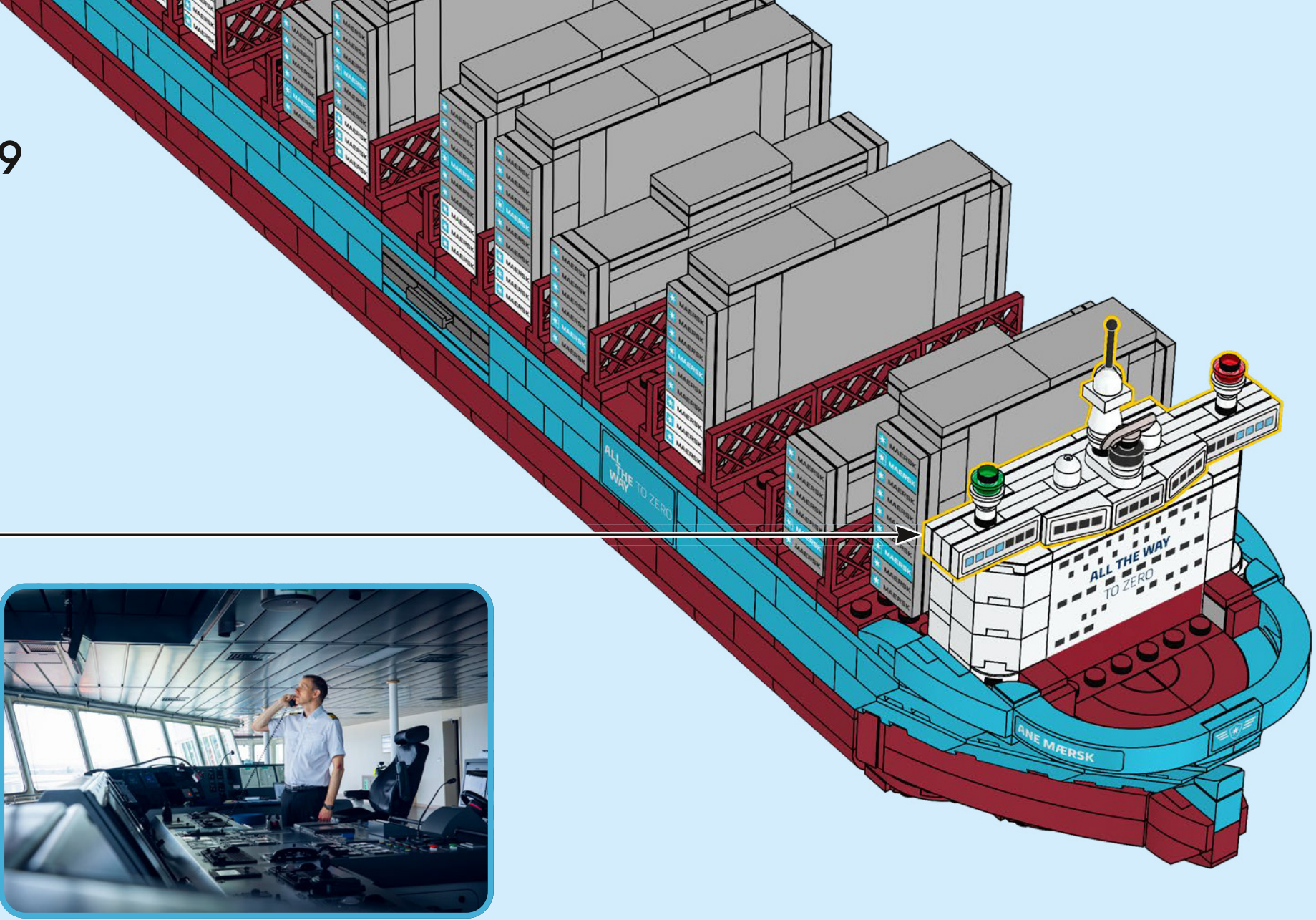

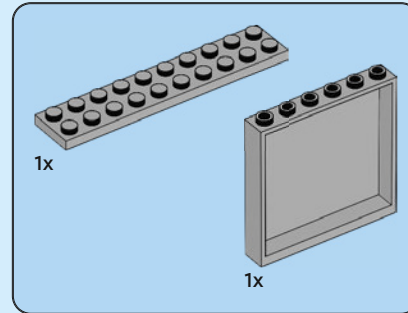
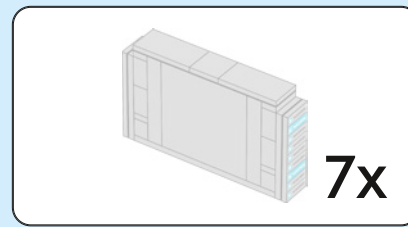

260

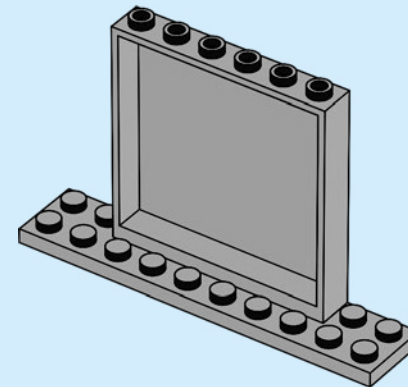

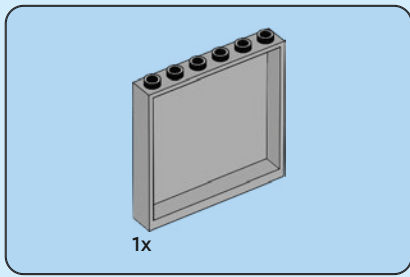

261

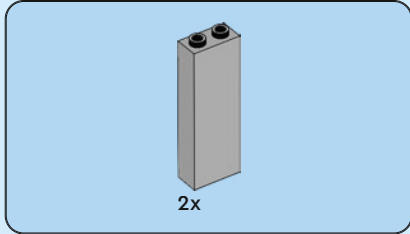
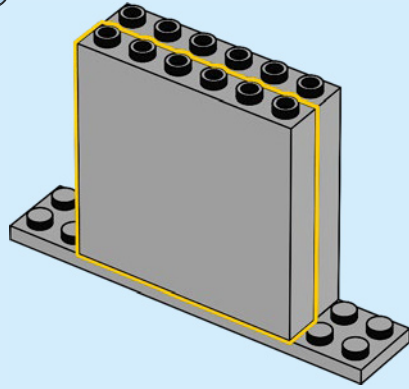

262

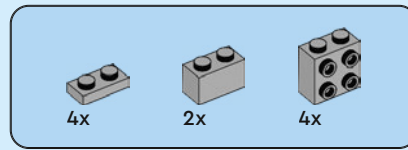
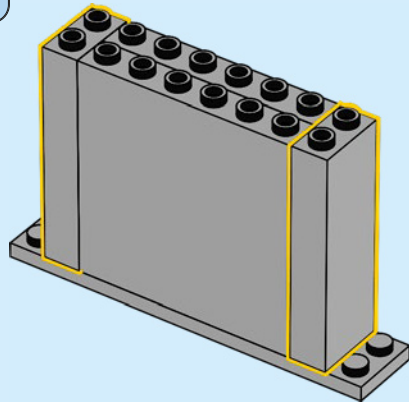

263

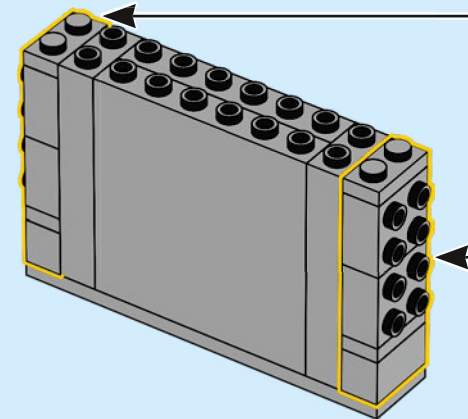
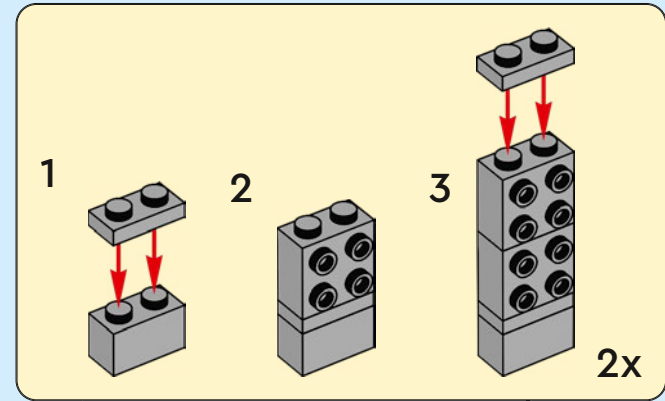

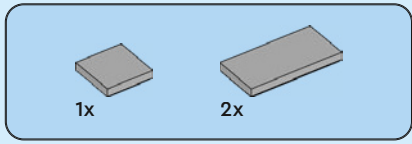

264

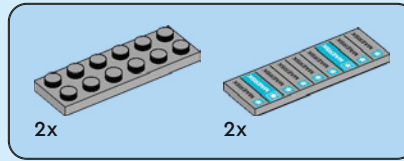
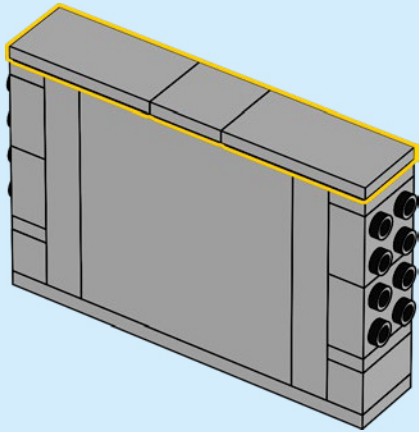

265

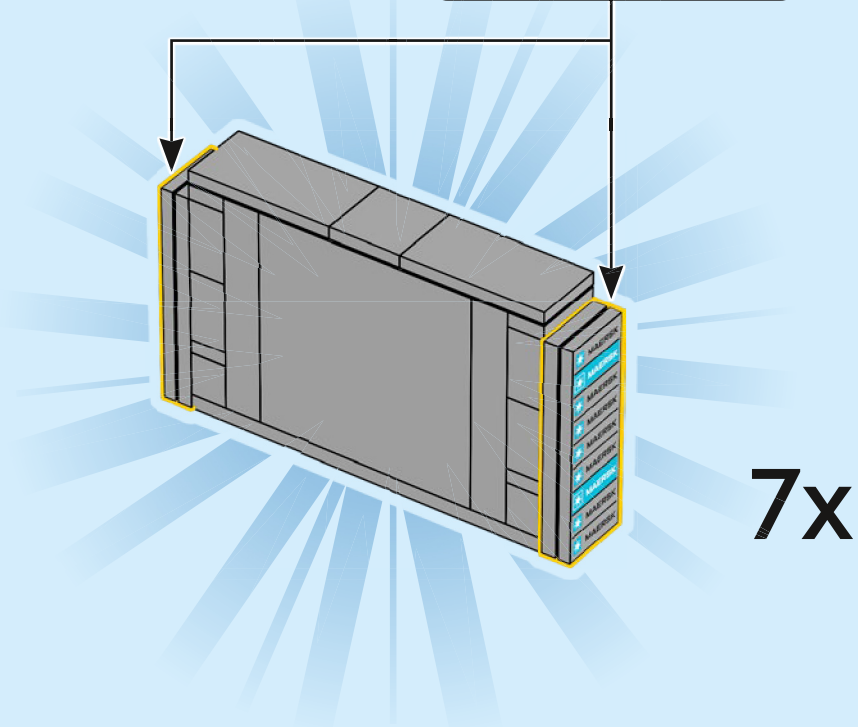
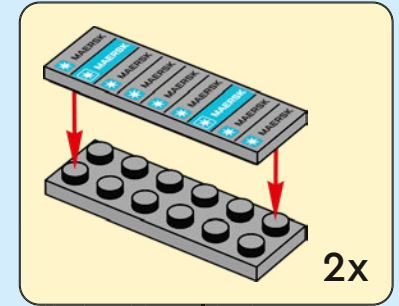

266

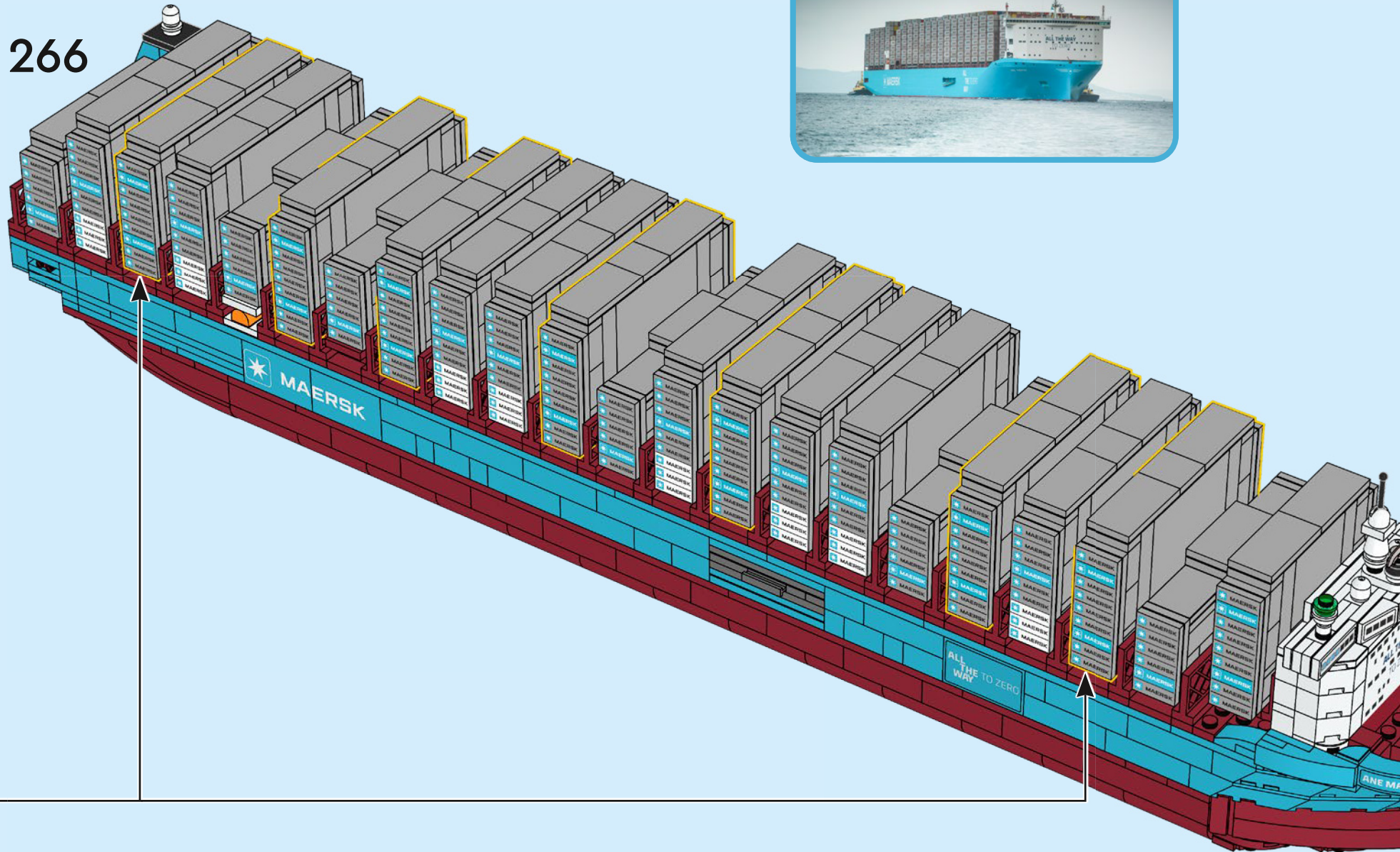

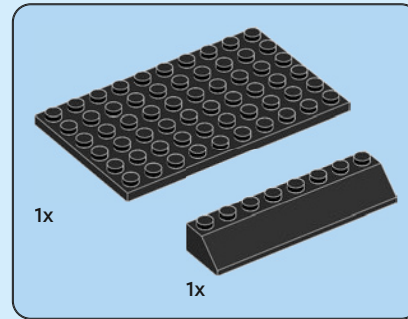
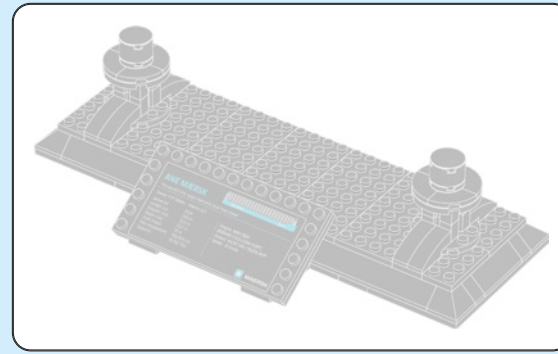

267

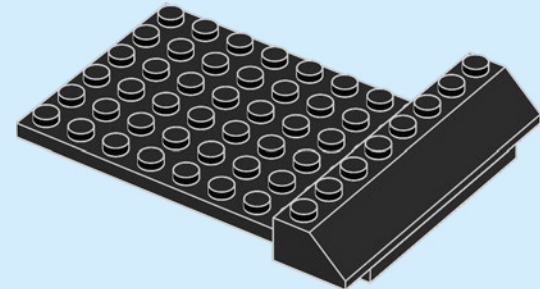

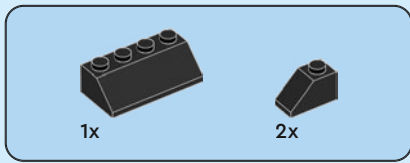

268

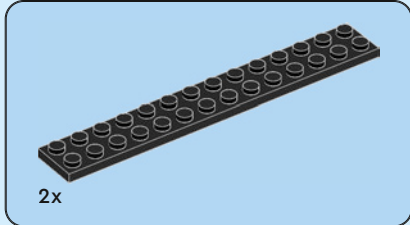
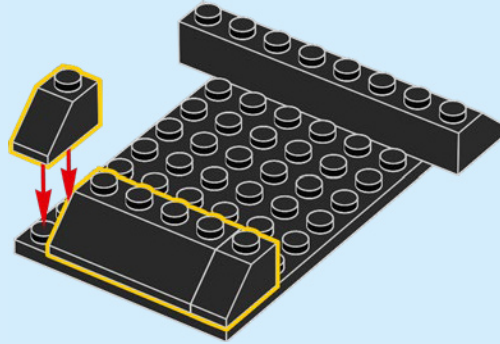

269

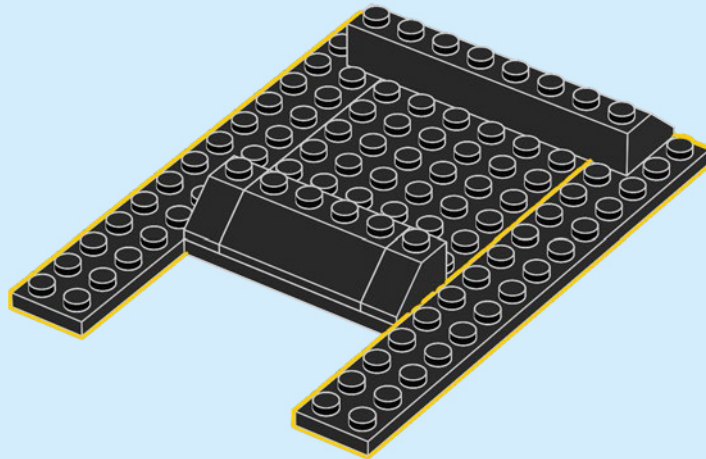

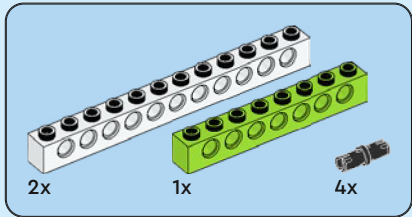
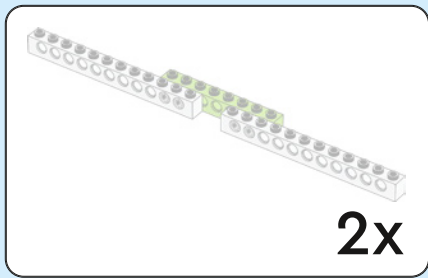

270

1

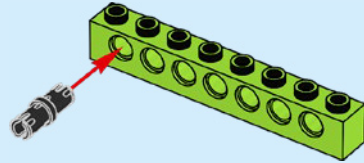

2

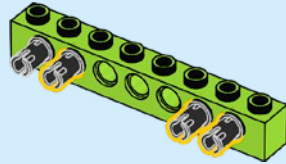

3

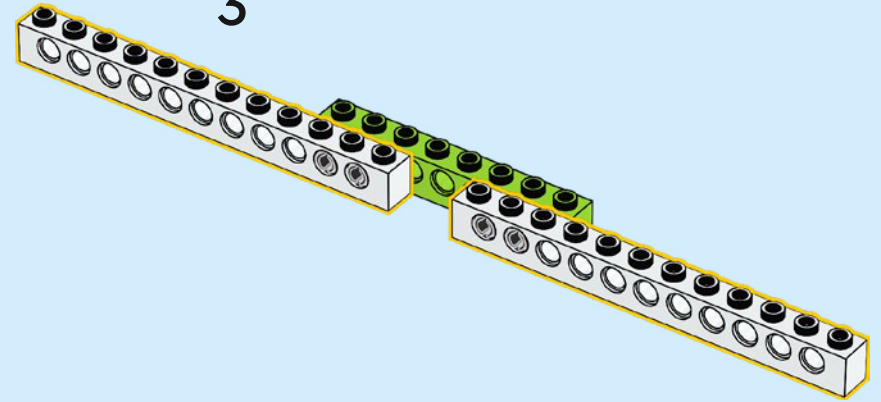

2x

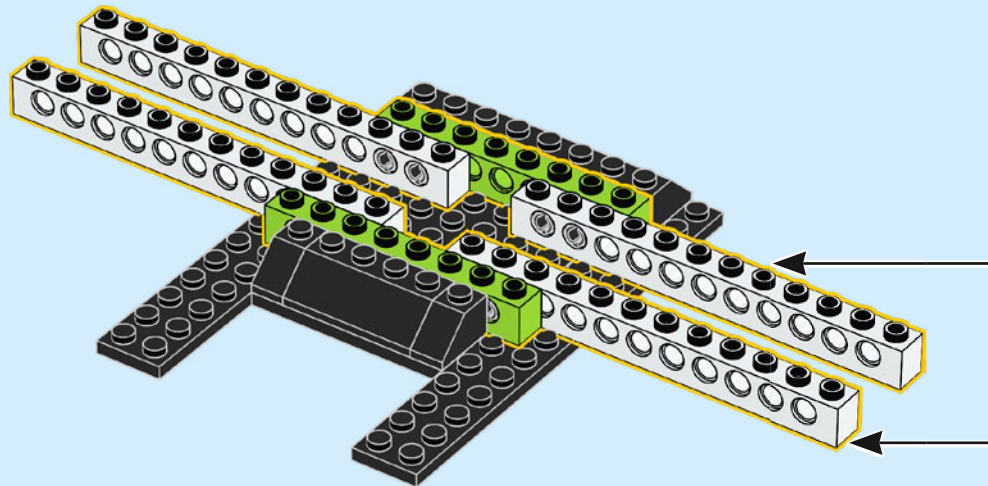

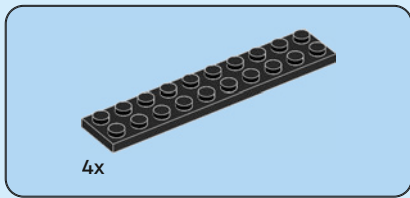

271

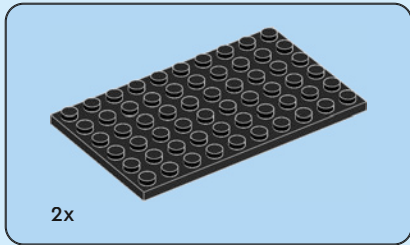
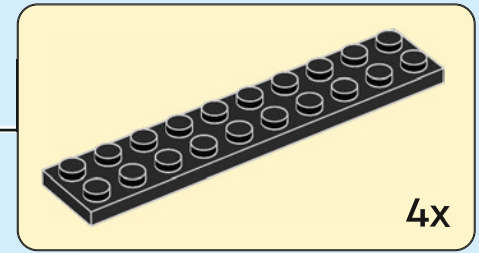
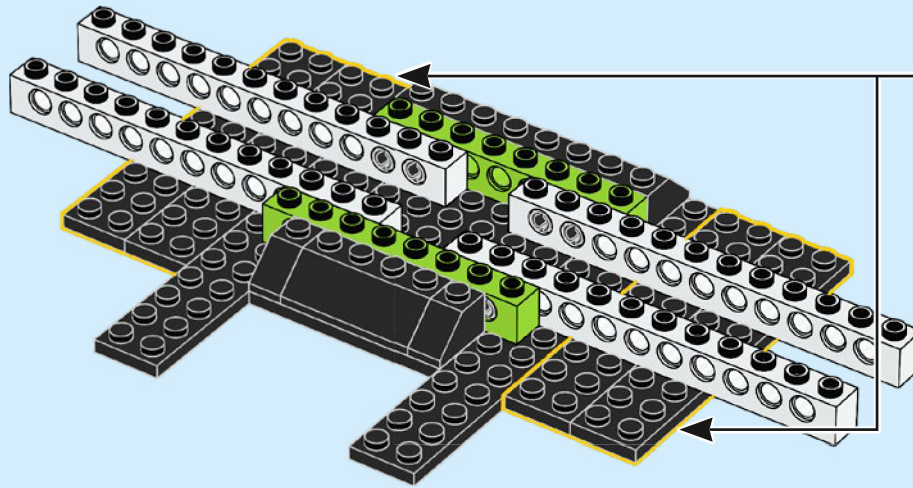

272

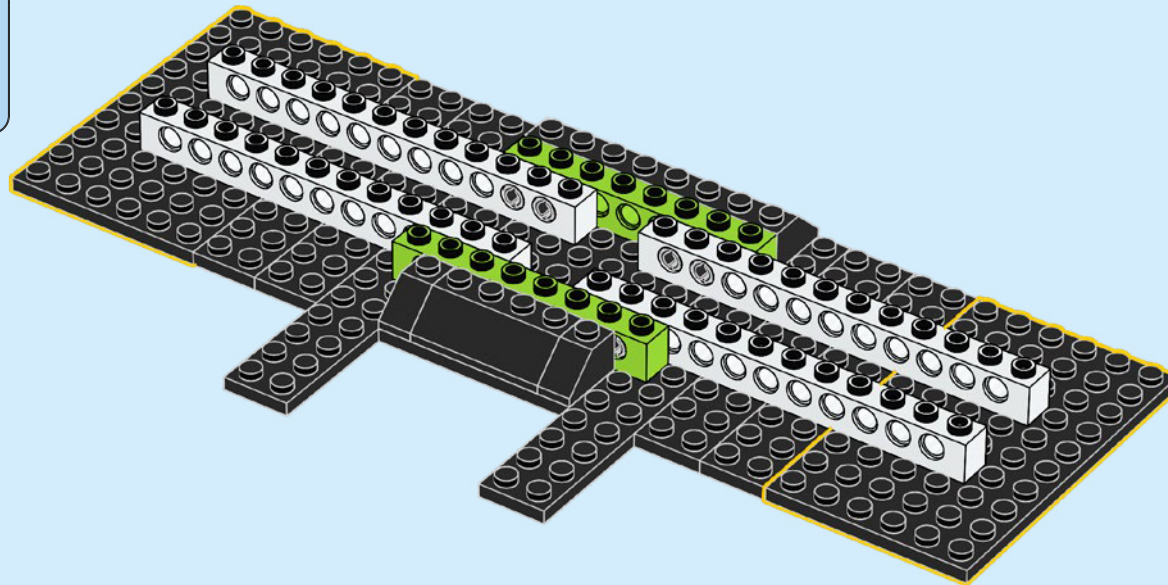

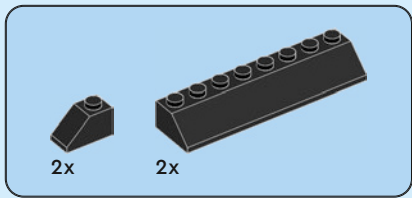

273

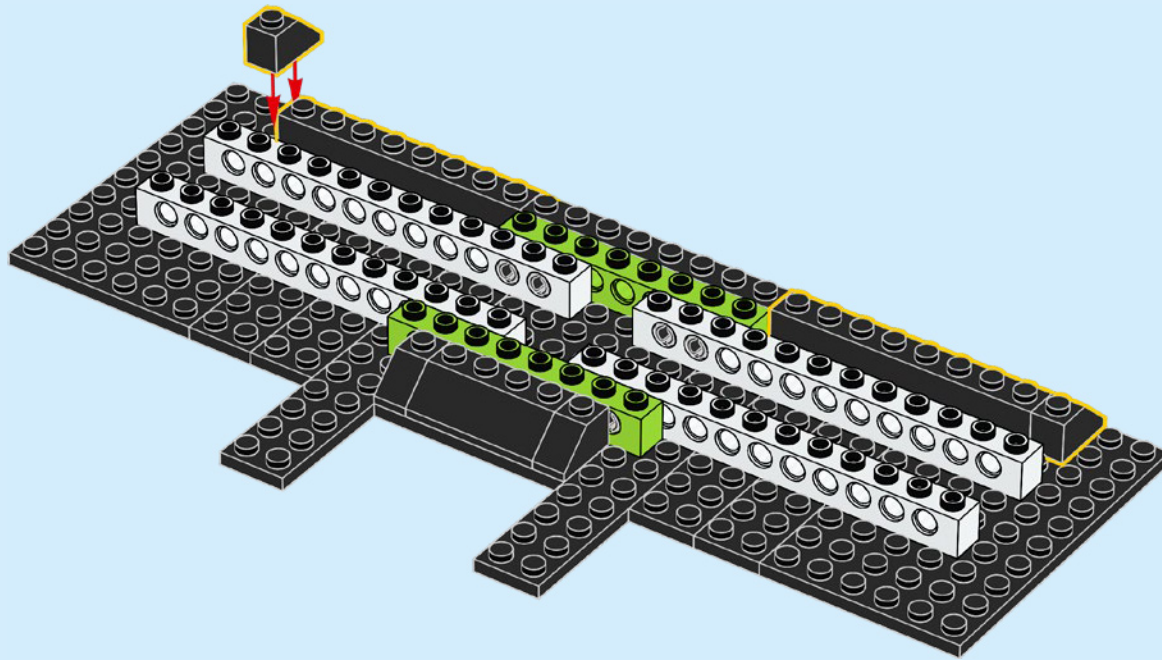

274

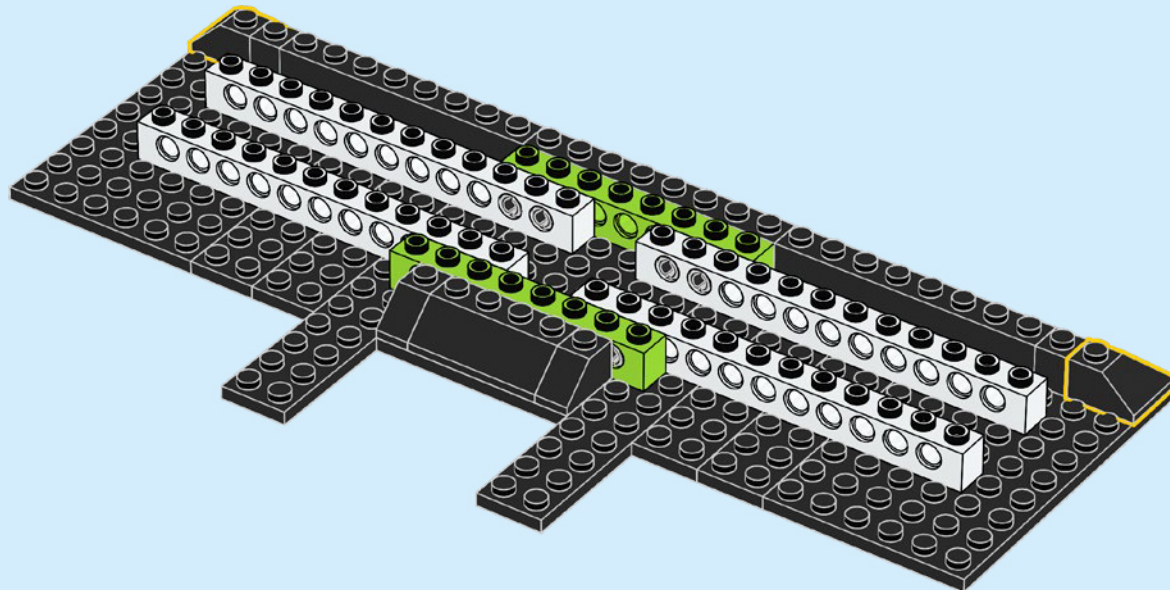

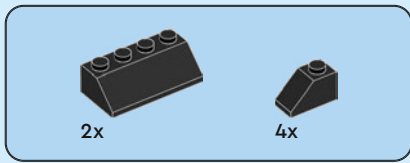

275

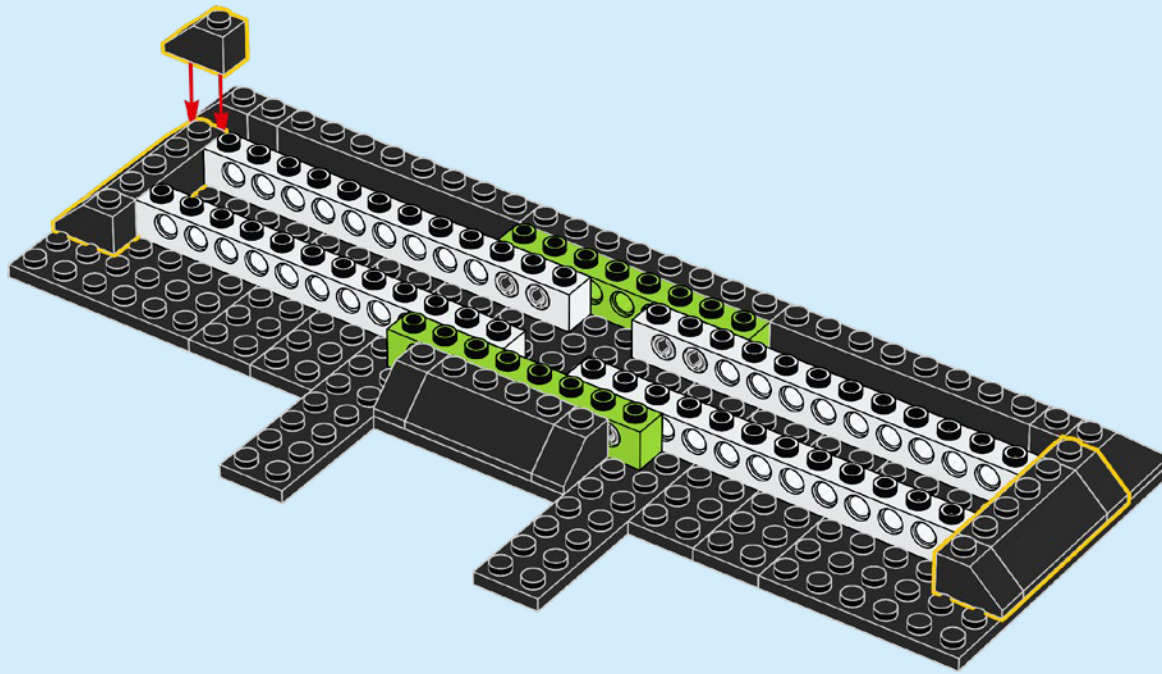

276

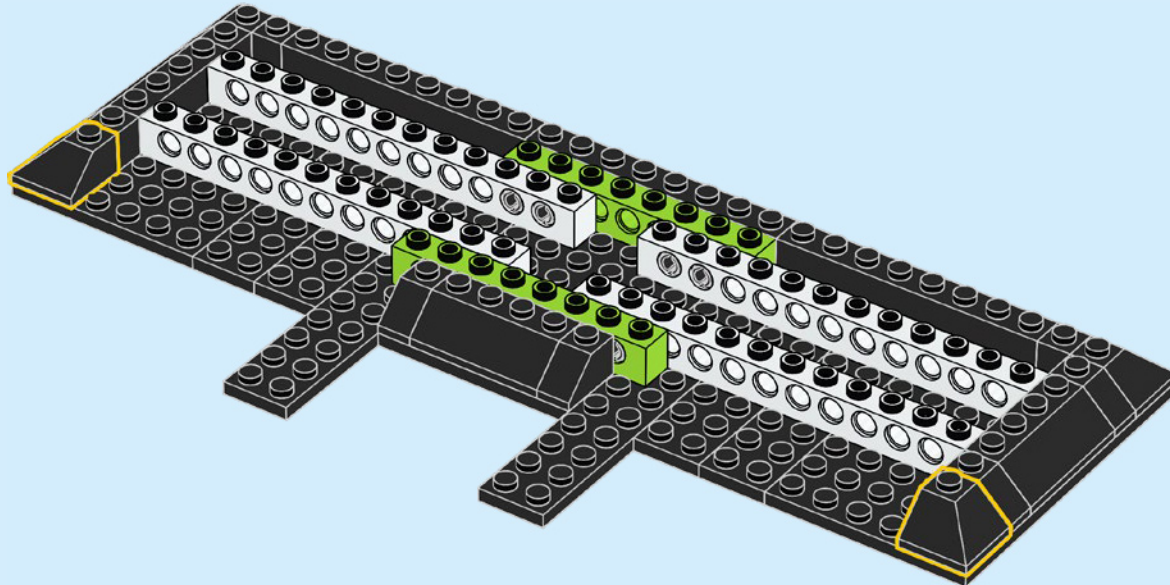



2x



2x

277

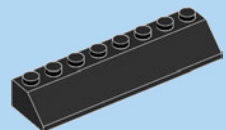
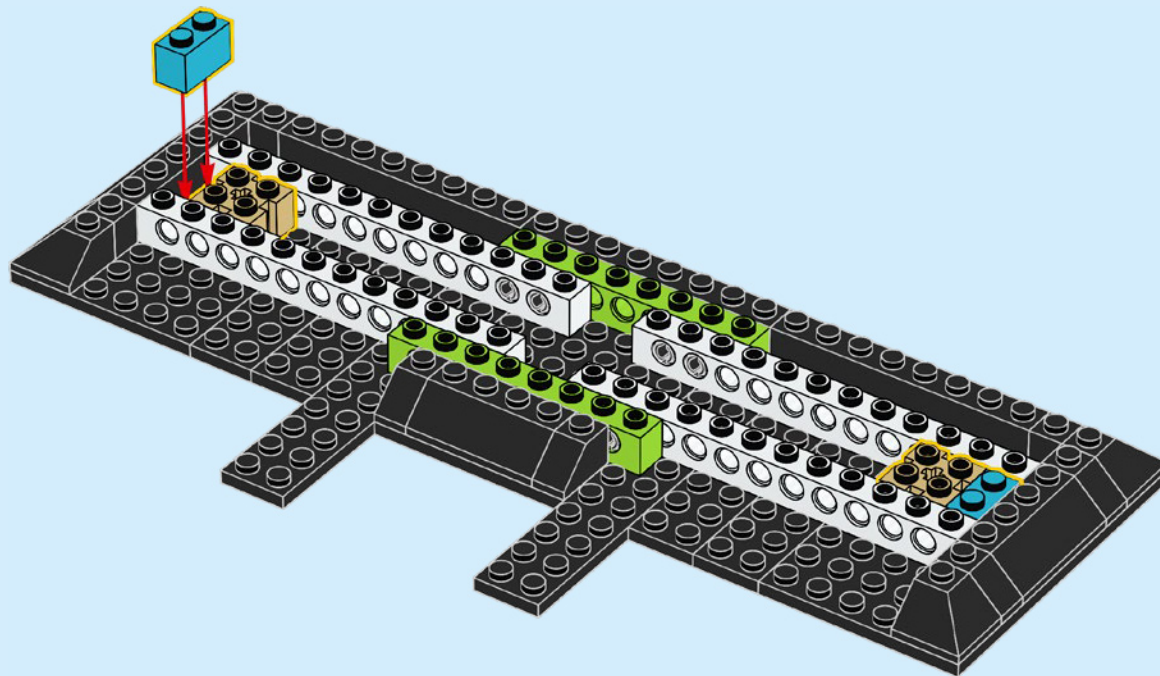

2x

278

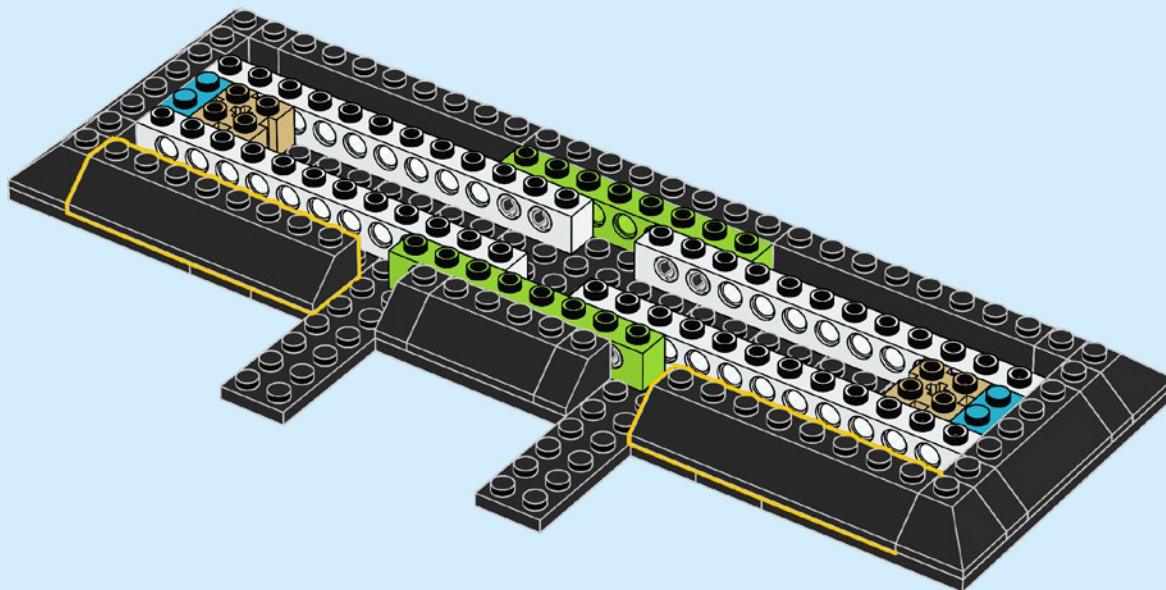

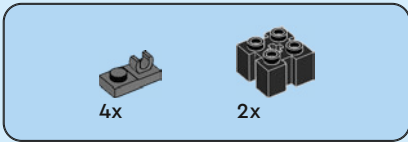

279

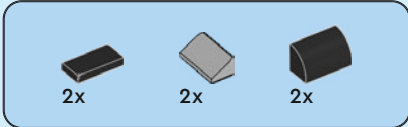
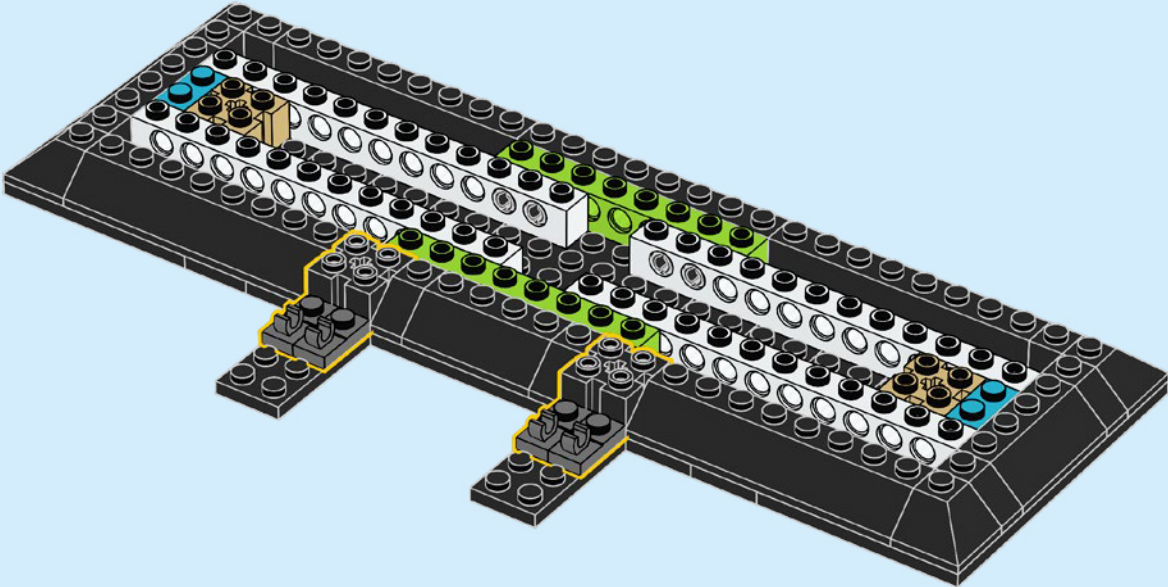

280

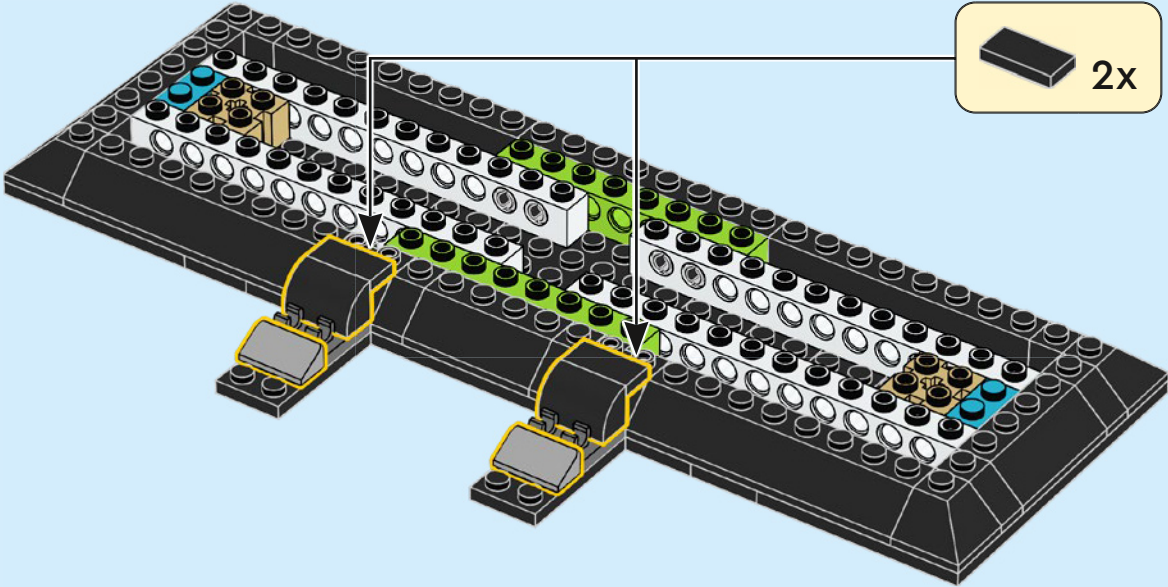

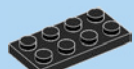

4x

281

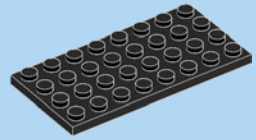
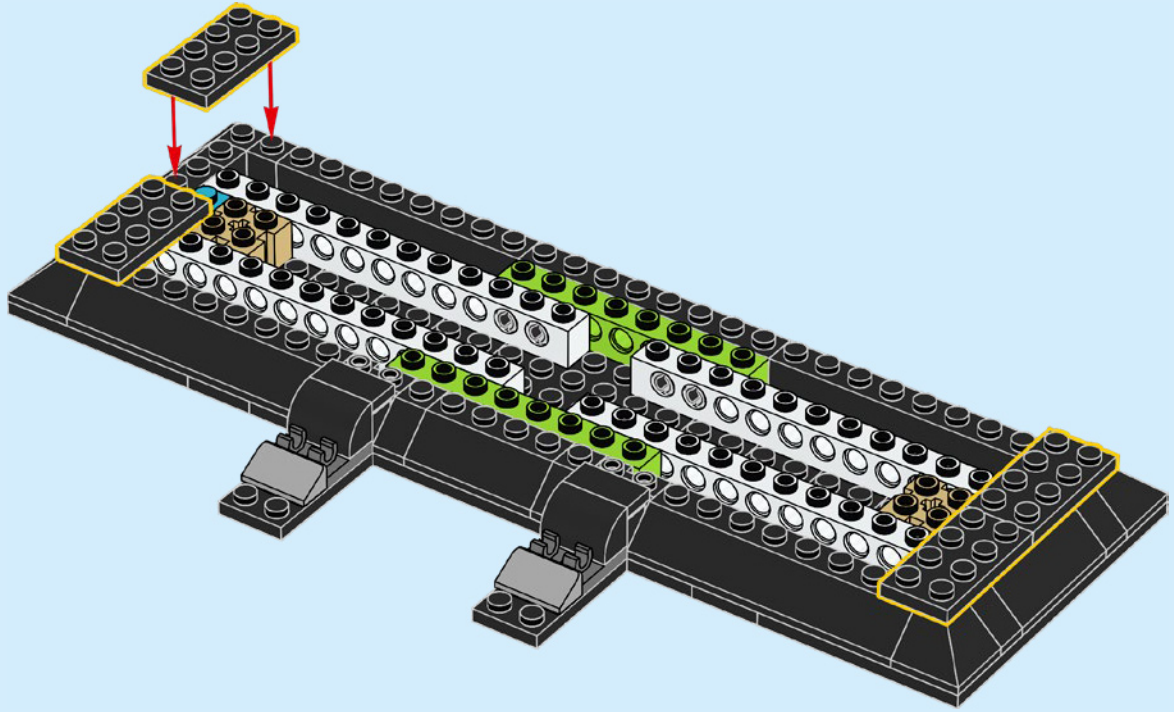

5x

282

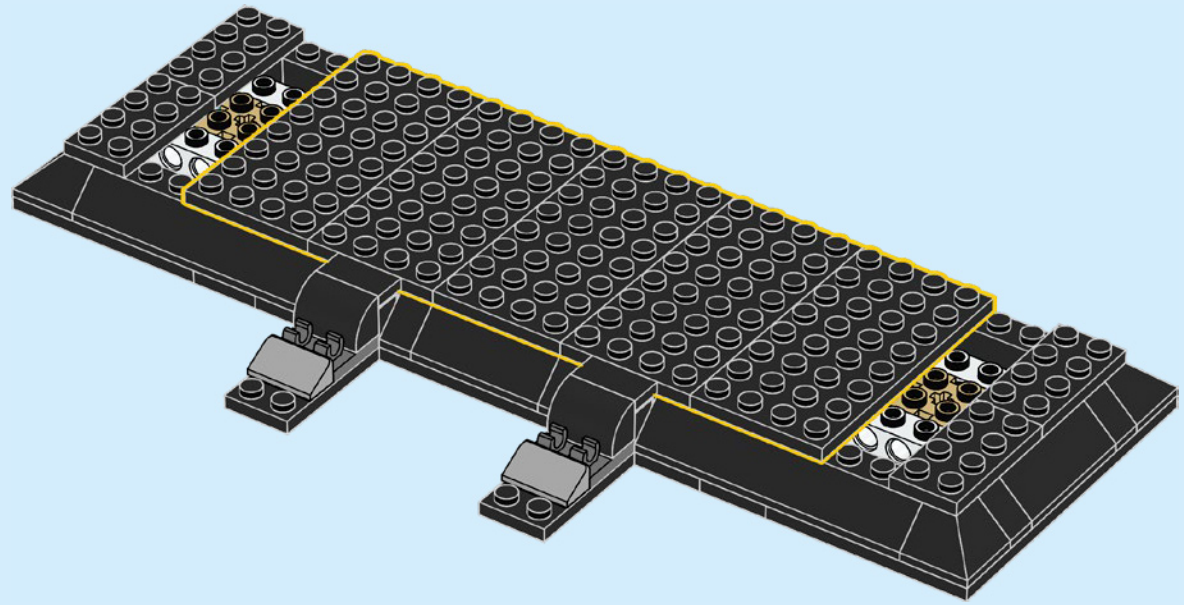

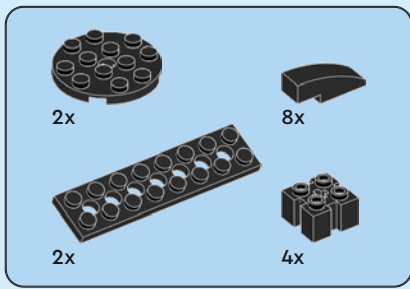

283

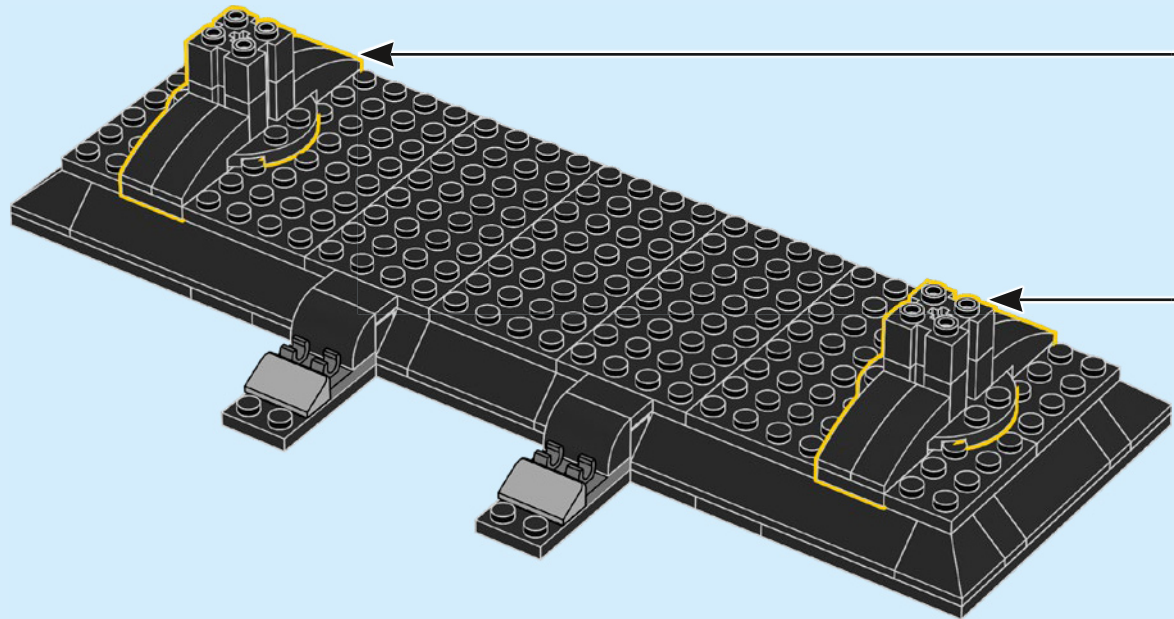
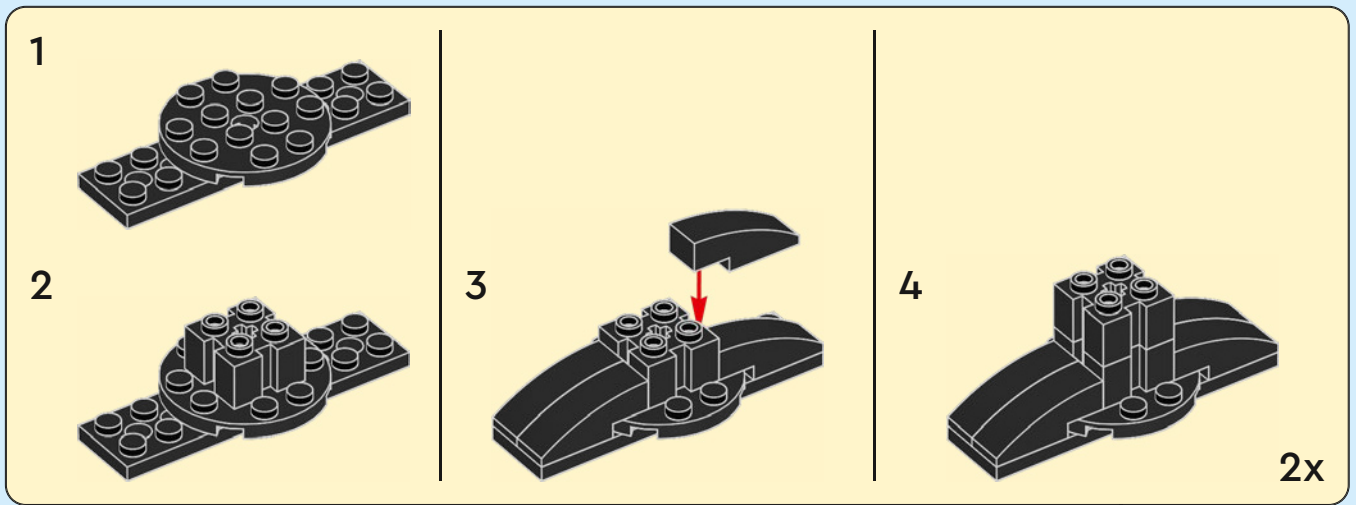

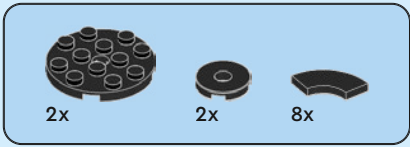

284

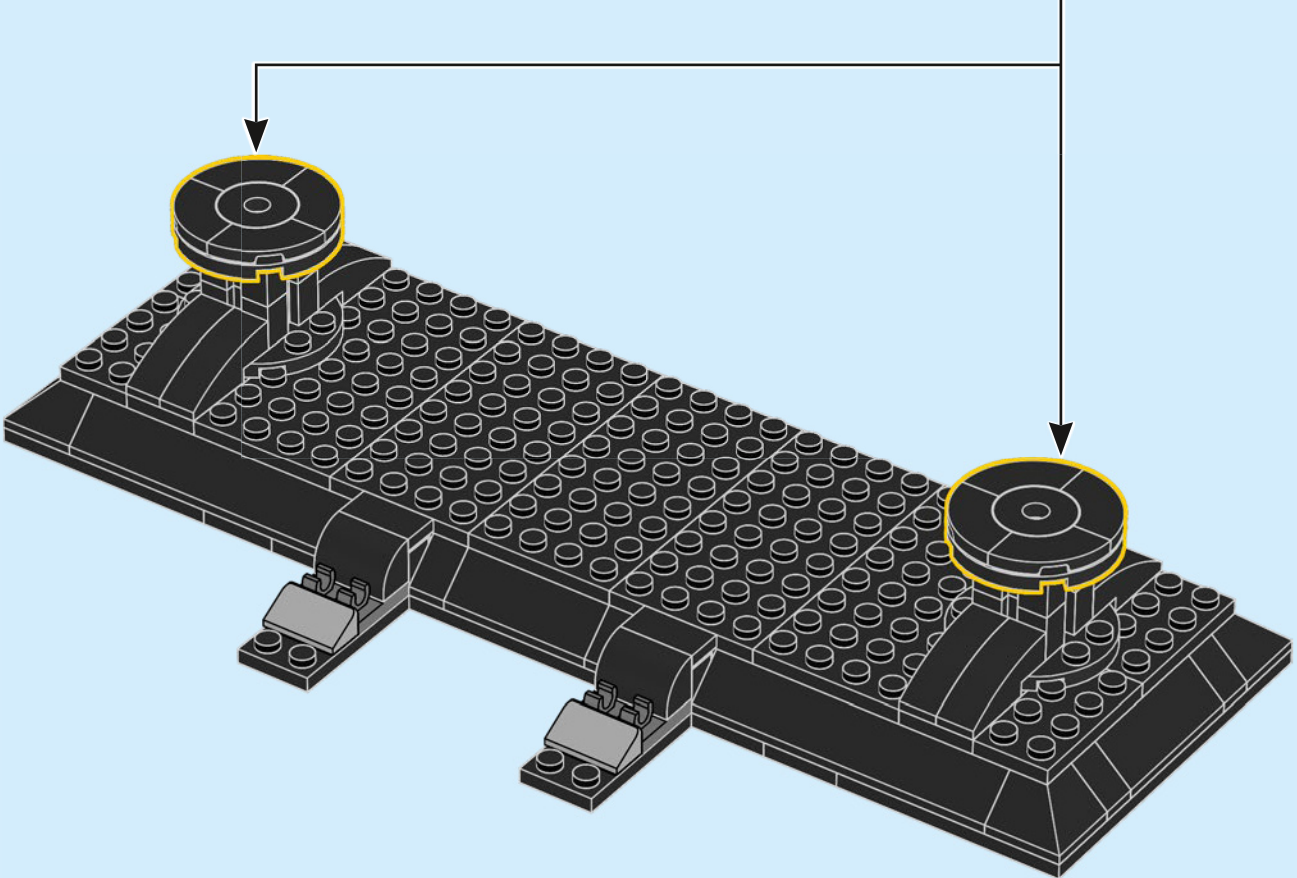
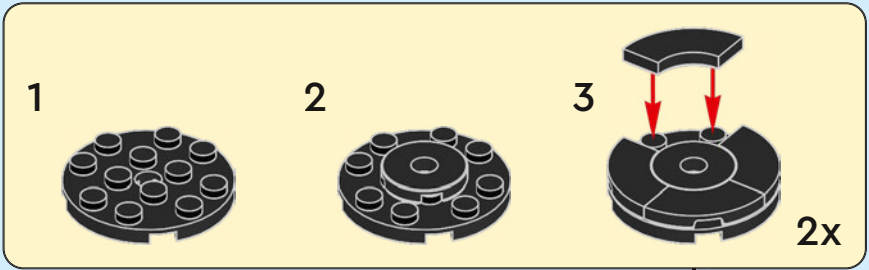

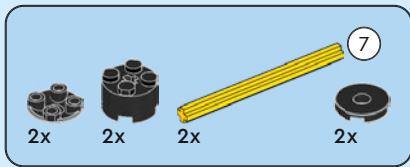

285

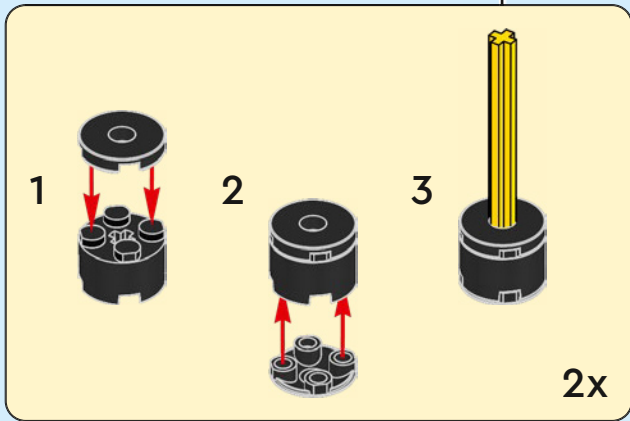
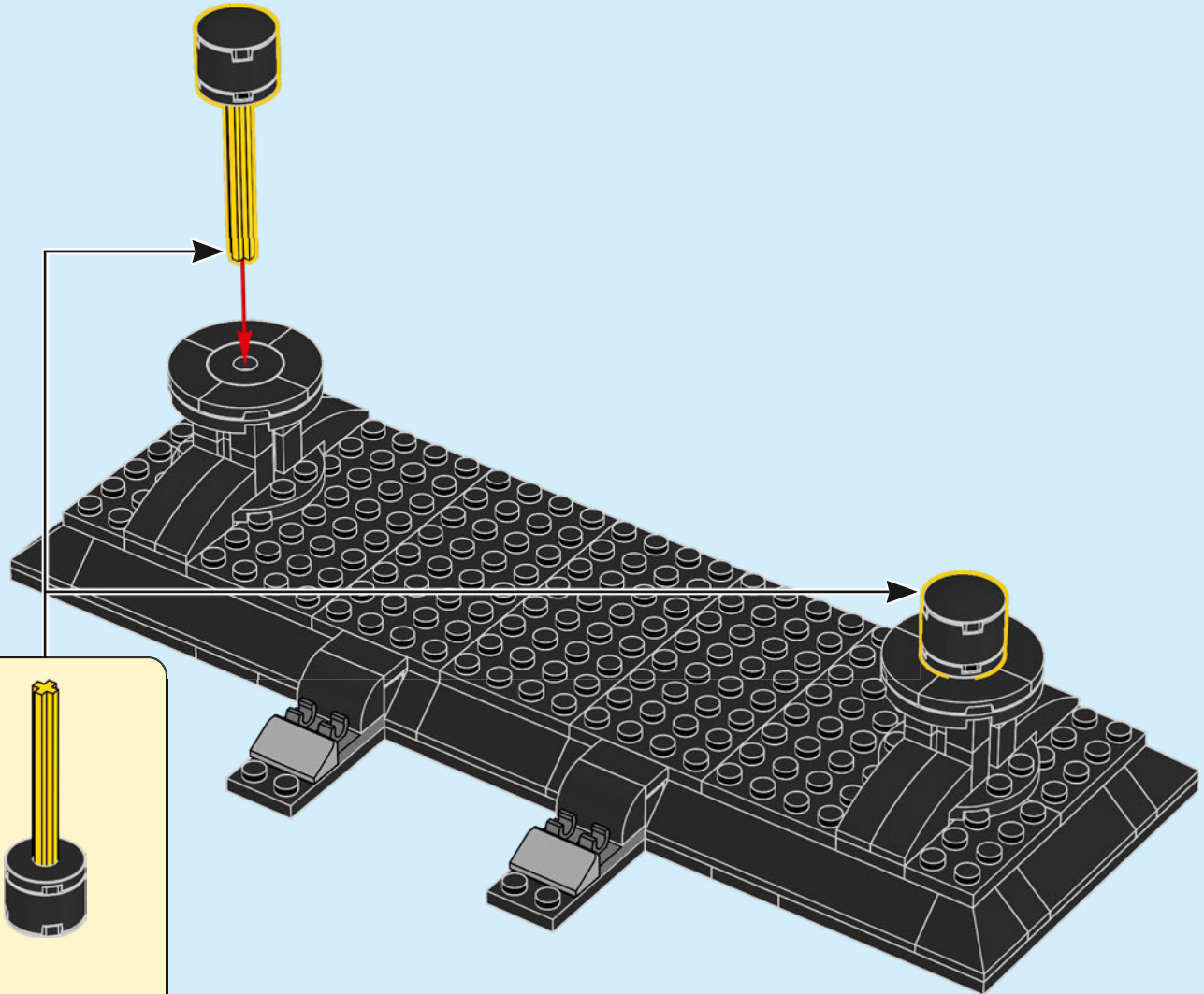

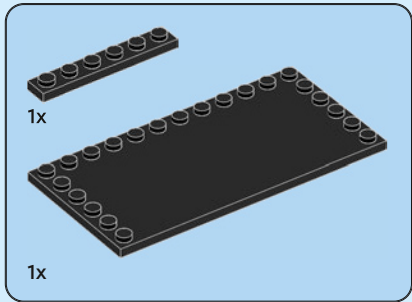

286

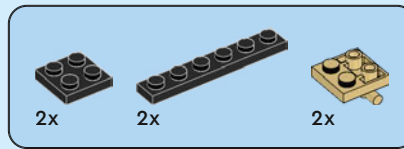
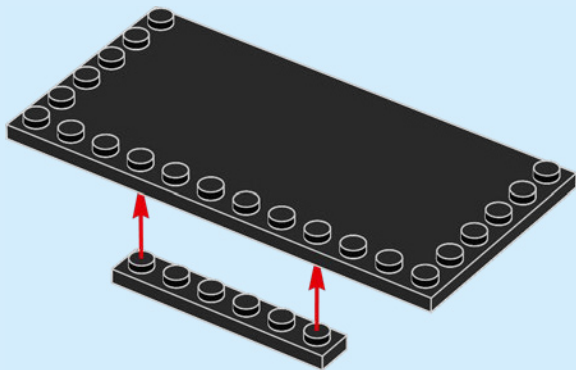

287

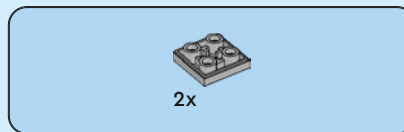
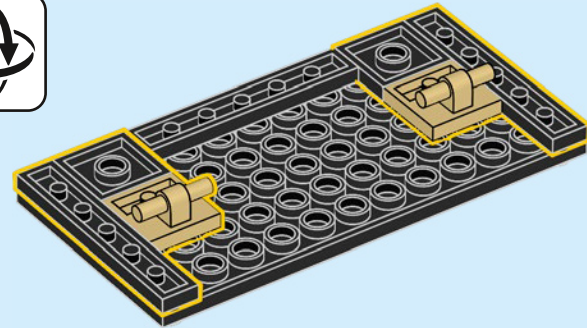

288

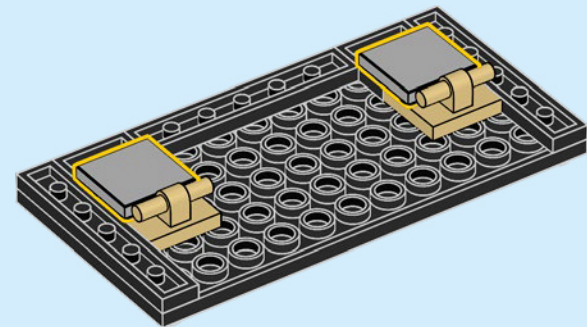

289

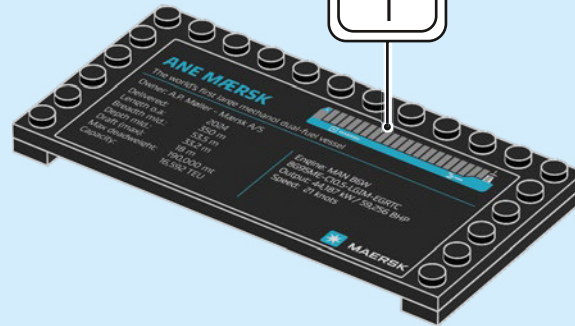

290

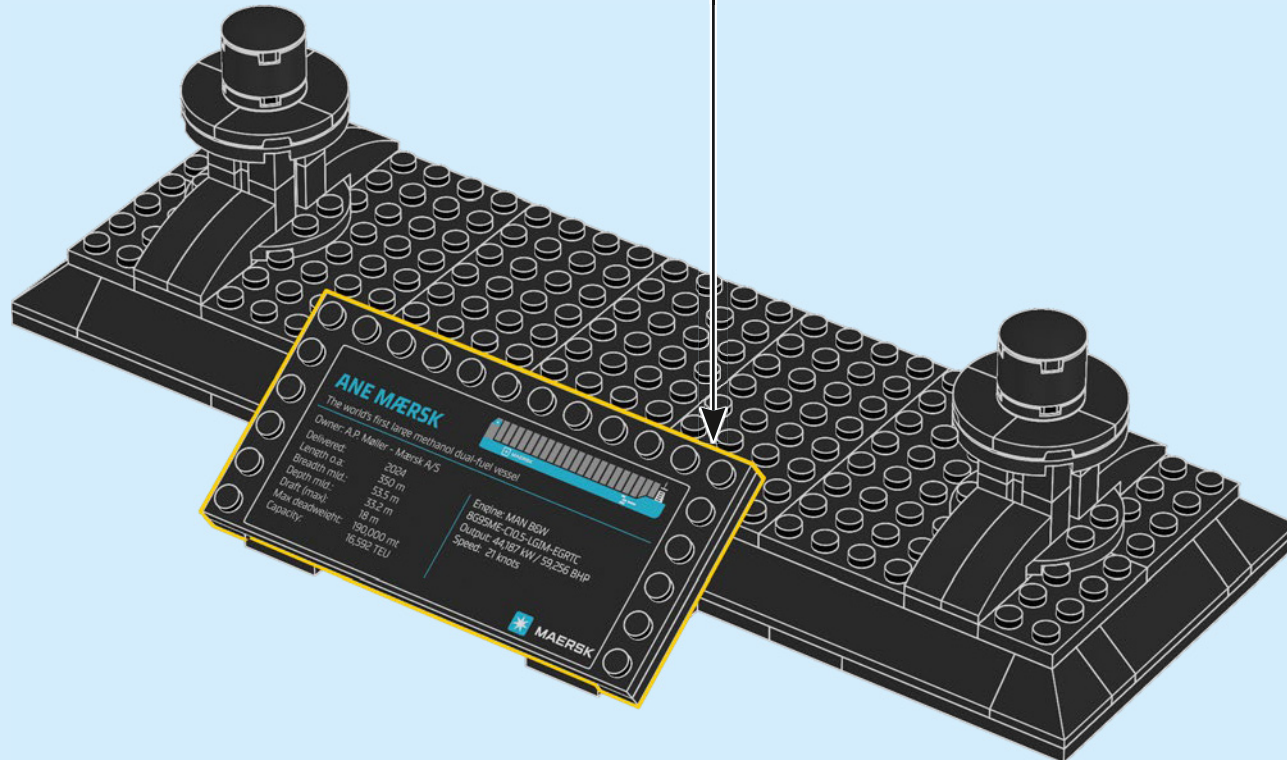

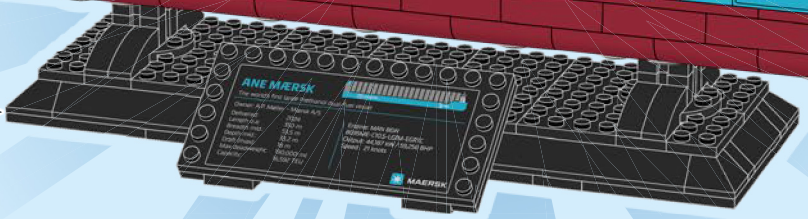
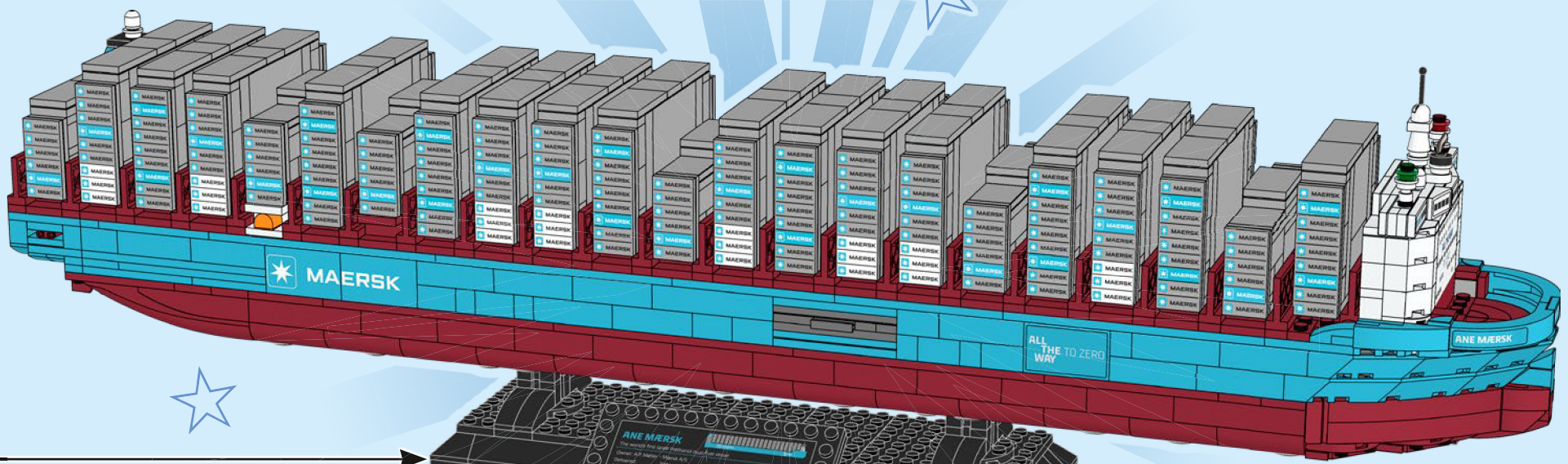
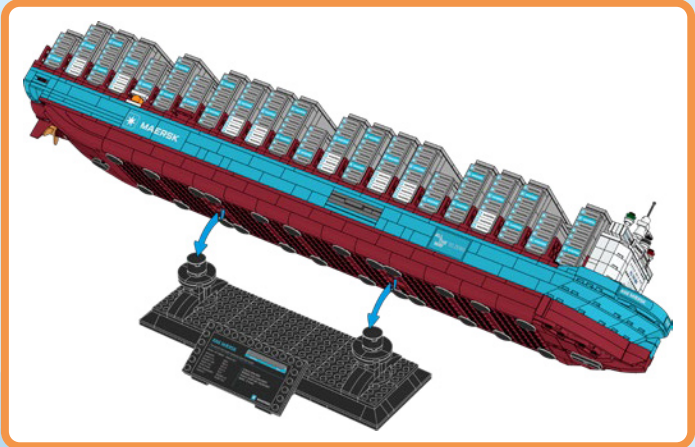

- 4x 6584062
- 4x 4541528
- 2x 6586652
- 1x 6335319
- 21x 6052777
- 6x 4541507
- 4x 4539071
- 10x 6576807
- 66x 6584063
- 1x 6465734
- 2x 6602414
- 2x 4539062
- 1x 6476042
- 1x 6350339
- 26x 6253142
- 4x 6186106
- 1x 6544174
- 6x 6440979
- 1x 4211392
- 6x 4211406
- 25x 4211462
- 2x 4211705
- 1x 6539385
- 11x 6015344
- 9x 6258831
- 2x 4568637
- 1x 4211415
- 2x 4568637
- 4x 4211412
- 33x 4211388
- 2x 4211399
- 11x 6598026
- 6x 6227897
- 70x 4211398
- 27x 4211395
- 12x 6061675
- 4x 6059033
- 2x 6079461
- 30x 4527174
- 16x 6598025
- 16x 6595947
- 35x 4211452
- 64x 6123809
- 6x 4211564
- 3x 6170387
- 32x 4211363
- 4x 6469440
- 1x 6446028
- 2x 6132886
- 2x 6043639
- 2x 4211580
- 15x 4211413
- 4x 6258820
- 10x 4211387
- 10x 6171894
- 10x 4211396
- 12x 4211386
- 1x 6514057
- 1x 6514051
- 2x 4210719
- 2x 4211063
- 4x 6344754
- 1x 6514456
- 2x 6123814
- 4x 4543086
- 1x 4218696
- 6x 4211094
- 11x 4211056
- 2x 4210651
- 1x 6287847
- 1x 6322046
- 2x 6215606
- 1x 6292145
- 1x 6088641
- 2x 6335563
- 1x 6593293
- 2x 6603341
- 8x 6603339
- 2x 6603283
- 4x 6603285
- 6x 6603587
- 8x 6603337
- 2x 6603334
- 1x 6603315
- 4x 6603598
- 17x 6603336
- 1x 6603301
- 1x 6603600
- 1x 6603591
- 1x 6603586
- 1x 6603585
- 2x 6603590
- 2x 6603344
- 2x 6603309
- 3x 6603316
- 1x 6593286
- 2x 6604733
- 2x 6603601
- 7x 6603965
- 30x 6603319
- 2x 6603317
- 2x 6576809
- 2x 6603313
- 1x 6598028
- 2x 6576810
- 1x 6598027
- 2x 6603599
- 2x 6603596
- 2x 6603342
- 2x 6603312
- 10x 6603286
- 2x 6603333
- 10x 6603340
- 2x 6603318
- 4x 6603343
- 2x 6603335
- 4x 6603595
- 1x 6603594
- 6x 6603589
- 2x 6603332
- 2x 6576813



[LEGO.com/service](https://www.LEGO.com/service)

YOU COULD WIN



Scan this QR code or go to
LEGO.COM/PRODUCTFEEDBACK and give us
your short feedback about this LEGO® set
for a chance to win a cool LEGO prize.

Terms and Conditions apply*

EN: YOU COULD WIN. Terms and Conditions apply* **DE: Du könntest GEWINNEN.** Es gelten die Teilnahmebedingungen* **FR: Tu pourrais GAGNER.** Des conditions s'appliquent* **IT: Potresti VINCERE tu.** Termini e condizioni sono applicabili* **ES: Puedes GANAR.** Aplican términos y condiciones* **PT: PODERÁ GANHAR.** Aplicam-se Termos e Condições* **ZH: 轻松获奖.** 条款和条件适用* **PL: Szansa na WYGRANĄ.** Obowiązuje regulamin* **CS: Máte šanci VYHRÁT.** Platí všeobecné smluvní podmínky* **SK: Máte šancu VYHRÁT.** Platia všeobecné zmluvné podmienky* **HU: TE IS NYERHETSZ.** Felhasználási feltételek érvényesek* **UA: ВИ МОЖЕТЕ ВИГРАТИ.** Застосовуються загальні положення та умови* **RO: Ai putea CÂȘTIGA.** Se aplică termenii și condiții* **BG: Можете да СПЕЧЕЛИТЕ.** Има определени правила и условия* **LV: Tu vari LAIMĒT.** Ir spēkā noteikumi un nosacījumi.* **ET: Sul on võimalus VÕITA.** Kehtivad tingimused* **LT: Jūs galite LAIMĖTI.** Taikomos sąlygos*

*[LEGO.com/productfeedback-terms](https://www.lego.com/productfeedback-terms)

