



40955



MAERSK





LEGO.com/sustainable-packaging



FR

DONNEZ
OU
RECYCLEZ



OU



OU



ASSOCIATION

MAGASIN

DÉCHÈTERIE

Adresses sur quefairedemesdechets.fr

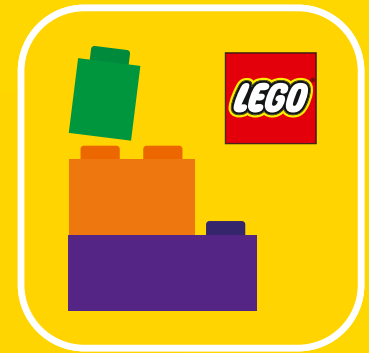

🔍 LEGO® Builder

BUILDER



Apple and the Apple logo are trademarks of Apple Inc., registered in the U.S. and other countries and regions. App Store is a service mark of Apple Inc. Google Play and the Google Play logo are trademarks of Google LLC. Tencent and the Tencent logo are trademarks of Tencent Inc.

🔍 LEGO.com/devicecheck

EN Ask parents' permission before going online | DE Eltern um Erlaubnis bitten, bevor du online gehst | FR Demande l'autorisation d'un parent avant d'aller en ligne | IT Chiedi il permesso ai tuoi genitori prima di andare online | ES Pídeles permiso a tus papás antes de conectarte a Internet | PT Peça autorização aos pais antes de acederes online | ZH 上网前应先征得父母的同意 | PL Poproś rodziców o zgodę, zanim wejdiesz do Internetu | CS Než půjdeš na internet, požádej rodiče o svolení | SK Skôr než pôjdeš na internet, vypoťaj si povolenie od rodičov | HU Kérj szülői engedélyt, mielőtt online csatlakoznál! | UA Запитуйте дозволу батьків, перш ніж користуватися інтернетом | RO Cere permisiunea părinților înainte de a te conecta online | BG Поискайте разрешение от родител, преди да влезете онлайн | LV Pirms došanās tiešsaistē palūdz atļauju vecākiem | ET Enne Interneti kasutamist küsi vanematelt luba | LT Prieš prisijungdami prie interneto, atsiklauskite tėvų



PRESENTAMOS EL ANE MÆRSK

El ANE MÆRSK es el primero de su clase: se trata del primer buque portacontenedores de gran tamaño capaz de funcionar con combustibles de bajas emisiones como el biometanol y el e-metanol. Desde la botadura del ANE MÆRSK en enero de 2024, muchos más buques de combustible dual han comenzado a navegar, lo que marca un nuevo e importante capítulo en la descarbonización del transporte marítimo y el comercio mundial.

El ANE MÆRSK tiene 350 m de eslora y 53,5 m de manga. Cuando está vacío, pesa 47.700 t y, a plena carga, con mercancías, combustible y tripulación, puede transportar nada menos que 190.000 t, lo que equivale a 29.000 elefantes africanos.

El buque tiene capacidad para 16.592 contenedores TEU (de veinte pies) y, si se alinearan todos ellos, alcanzarían una longitud de 100,5 km, lo que equivale a 959 campos de fútbol.





 MAERSK

ALL THE 10 ZERO WAY



NAVEGAR EN AGUAS CAMBIANTES: LA HISTORIA DEL TRANSPORTE MARÍTIMO

Los seres humanos llevan más de 5000 años transportando mercancías por mar, pero, hasta la Revolución Industrial y la invención de la máquina de vapor, se dependía del clima. Sin viento no hay travesía. Con la introducción de la energía de vapor, la tripulación de los barcos dejó de depender de la meteorología y la propulsión manual por primera vez en la historia de la humanidad. El invento revolucionó por completo el transporte marítimo, haciendo posibles nuevas rutas y dando un gran impulso al comercio por mar.

Aunque las máquinas de vapor supusieron una gran mejora con respecto a las velas, seguían siendo poco eficientes, y no pasó mucho tiempo antes de que el transporte marítimo volviera a transformarse con la invención del motor diésel. Sin embargo, las revoluciones en el transporte marítimo llevan su tiempo, y pasarían varias décadas antes de que el diésel sustituyera por completo a la energía del vapor. Maersk adquirió su primer buque propulsado por diésel, el LEISE MÆRSK, en 1921, solo nueve años después del lanzamiento del primer buque mercante oceánico propulsado por este combustible.



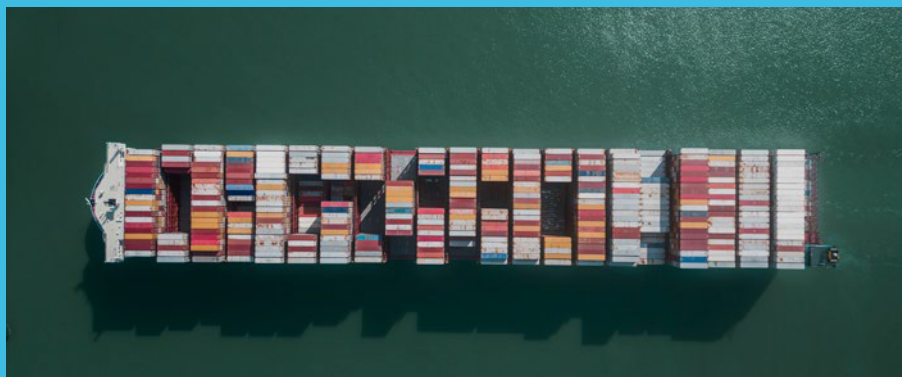

En 1956, el sector volvió a transformarse con la introducción de la *carga contenedorizada*, con la que los remolques de los camiones se cargan directamente en los buques. Esta introducción del contenedor redujo el tiempo necesario para cargar y descargar los buques de varios días a unas pocas horas.

Gracias al contenedor y al código de barras, las dos tecnologías silenciosas que han hecho posible el comercio mundial, un fabricante de cualquier parte del mundo puede vender sus productos en todos los mercados, haciendo físicamente posible la globalización. El mundo tal y como lo conocemos hoy depende en gran medida de las cadenas de suministro globales. Desde el productor de plátanos en Colombia hasta el niño danés que pela uno de ellos para su almuerzo, las cadenas de suministro mantienen al mundo conectado y garantizan el flujo de alimentos, medicinas, bienes y materiales a personas de todo el mundo.





 MAER

 MAERS

 MAERSK

 MAERSK

¿QUÉ HAY DETRÁS DEL NOMBRE?

Desde 1906, todos los buques de la flota Maersk incluyen "MÆRSK" como parte de su nombre. La mayoría de los primeros buques tenían nombres relacionados con la familia fundadora, pero, a medida que la flota superaba en número a la cantidad de familiares existentes, la tradición tuvo que adaptarse. Hoy en día también se pueden ver buques Maersk que llevan, por ejemplo, nombres de ciudades y ríos.

A la hora de decidir cómo bautizar la nueva serie de buques de combustible dual, Maersk regresó a la tradición de dedicar los buques a los miembros de la familia fundadora, pero esta vez comenzando por la letra A para señalar una nueva era.

ANE MÆRSK debe su nombre a Ane Mærsk Mc-Kinney Uggle, presidenta de A.P. Moller Holding, la empresa matriz de A.P. Moller - Maersk. A.P. Moller - Maersk fue fundada en 1904 por Arnold Peter Møller. Ane es la nieta del fundador del grupo, Arnold Peter Møller, y de su esposa, Chastine Mc-Kinney Møller.



ANE MAERSK





LA ESTRELLA BLANCA: UN FARO DE ESPERANZA

La emblemática estrella blanca de siete puntas forma parte del legado de Maersk desde antes de la fundación de la empresa en 1904 y es un símbolo perdurable de los fuertes lazos familiares que siguen arraigados en ella más de 100 años después.

Al principio de su carrera, el capitán Peter Mærsk Møller, padre de A.P. Møller, trabajaba para un armador inglés, y su esposa Anna lo acompañaba a veces en sus viajes. Fue en uno de esos viajes cuando Anna enfermó gravemente. Temiendo que no sobreviviera, Peter Mærsk Møller subió a cubierta y le rezó a Dios para que le diera una señal de que su esposa se recuperaría. Entonces vio una sola estrella iluminando el cielo, por lo demás gris.

Anna se recuperó y, en 1886, cuando Peter Mærsk Møller se hizo con su primer barco de vapor, el LAURA, adornó la chimenea con una estrella blanca de siete puntas sobre un fondo azul pálido en homenaje a su amada esposa. Para Peter Mærsk Møller, la estrella pasó a simbolizar su recuperación y su buena suerte.

Desde entonces, la estrella blanca de siete puntas sobre el emblemático fondo azul celeste ha sido sinónimo de Maersk, pero el logotipo en sí ha experimentado cierta evolución a lo largo de los años. Aunque ha habido muchas otras versiones, el logotipo actual de Maersk data de principios de la década de los 70, cuando se decidió adoptar un enfoque más moderno.



ALL THE WAY
TO ZERO



MEJORAR LA VIDA DE TODOS INTEGRANDO EL MUNDO

Como líder mundial en servicios logísticos, Maersk cuenta con más de 100.000 clientes, opera en casi 130 países y da empleo a más de 100.000 personas. Desde sus humildes comienzos con los barcos de vapor, Maersk se ha convertido en una empresa de logística integrada que trabaja para conectar y simplificar las cadenas de suministro de sus clientes, cuenta con más de 700 buques y transporta casi el 20 % de los alimentos, materiales y mercancías del mundo.



“ALL THE WAY TO ZERO”: COMPROMETIDOS CON UN FUTURO DESCARBONIZADO

Mientras el mundo se enfrenta a emergencias climáticas, el futuro de las cadenas de suministro y el comercio mundial depende de la capacidad de innovar y promover nuevas fuentes de energía. Maersk se ha impuesto la obligación de alcanzar cero emisiones netas de gases de efecto invernadero para 2040 en toda su actividad. Además de descarbonizar sus propias operaciones, Maersk también se ha comprometido socialmente a liderar la lucha contra la crisis climática promoviendo la descarbonización de las cadenas de suministro globales y una transición justa hacia una economía con cero emisiones netas.

En su camino hacia el 2040, Maersk se ha fijado unos objetivos ambiciosos para garantizar un progreso significativo en esta misma década: en el océano, en tierra, en el aire y en las terminales. Y con el pedido y la entrega de muchos buques de combustible dual, capaces de navegar con combustibles de bajas emisiones como el biometanol y el e-metanol, así como el biometano, la misión de descarbonizar la flota marcha viento en popa.



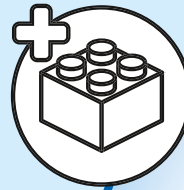
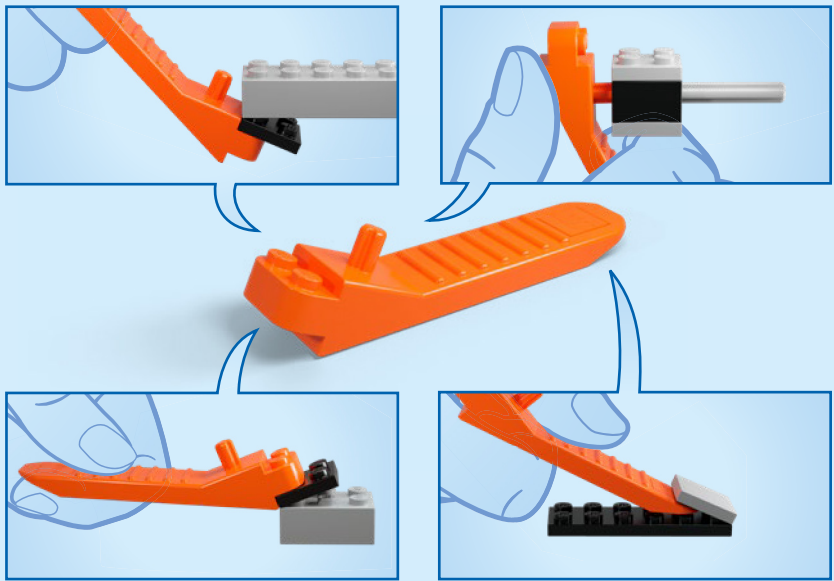

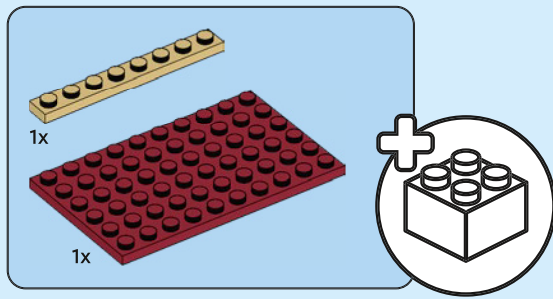

1

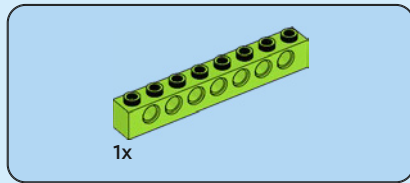
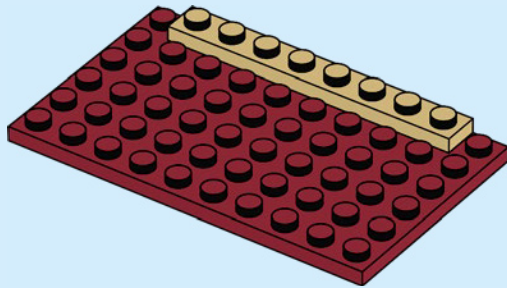

2

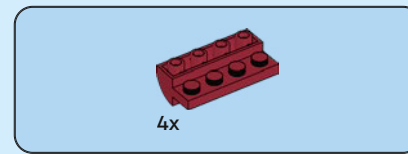
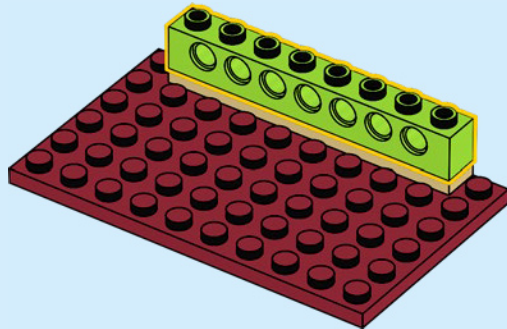

3

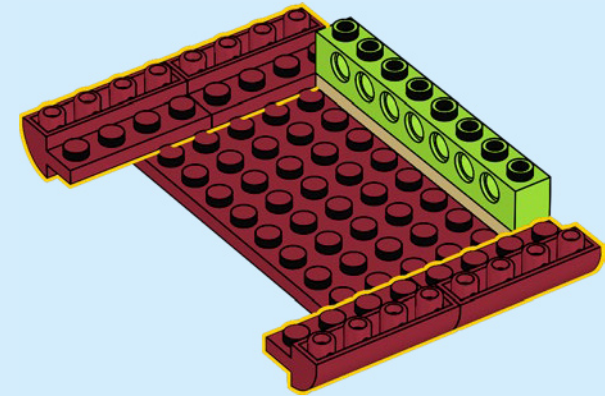

3

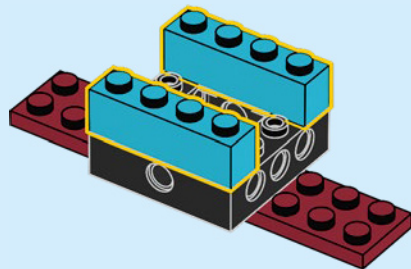

4

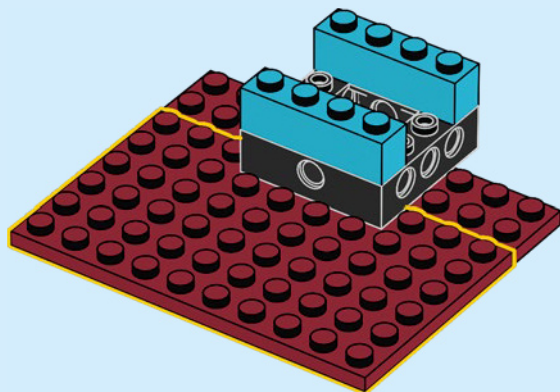

5

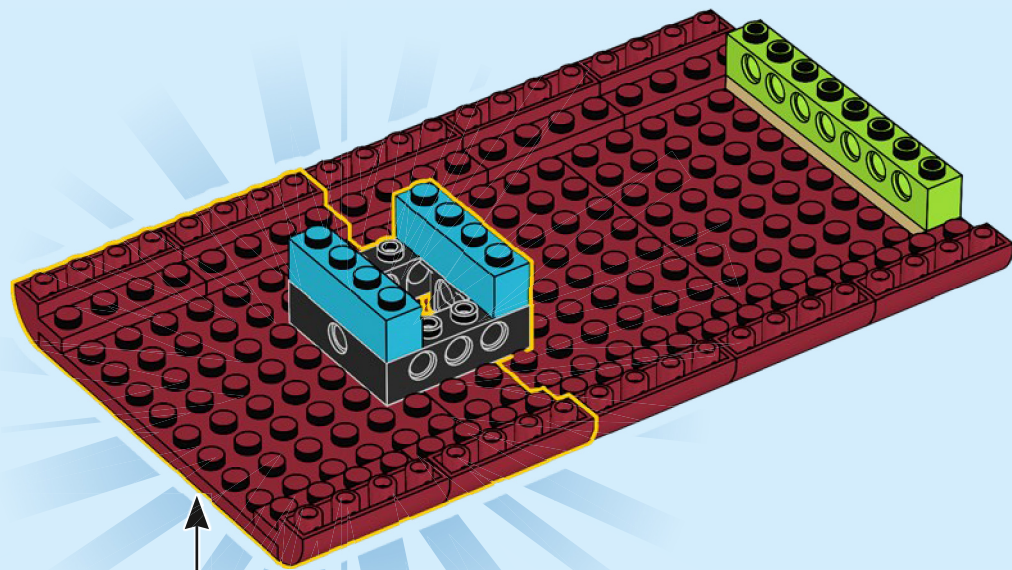
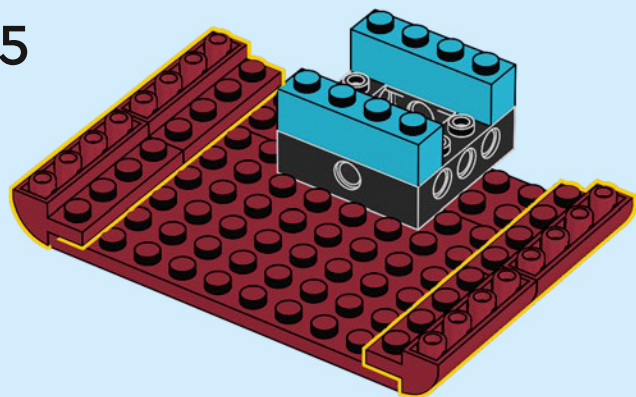

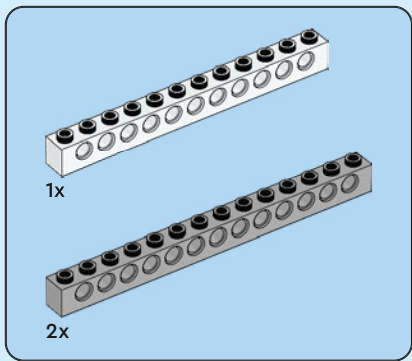

7

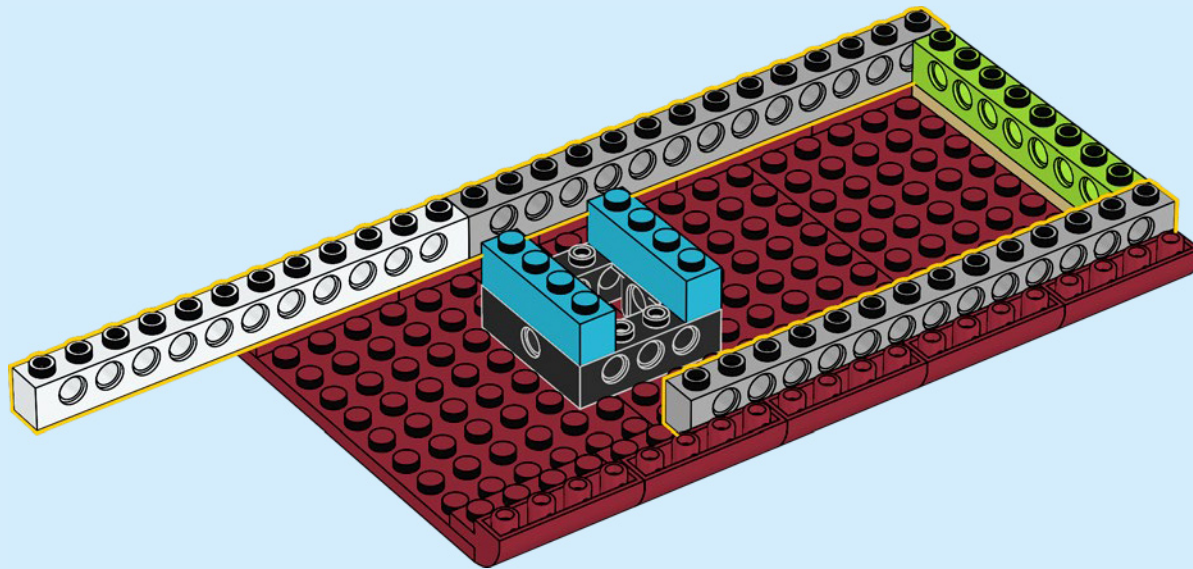

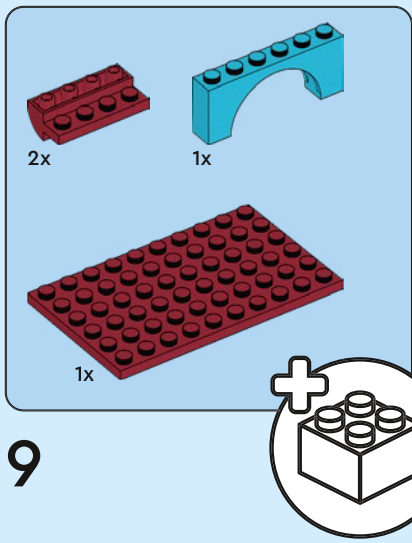

9

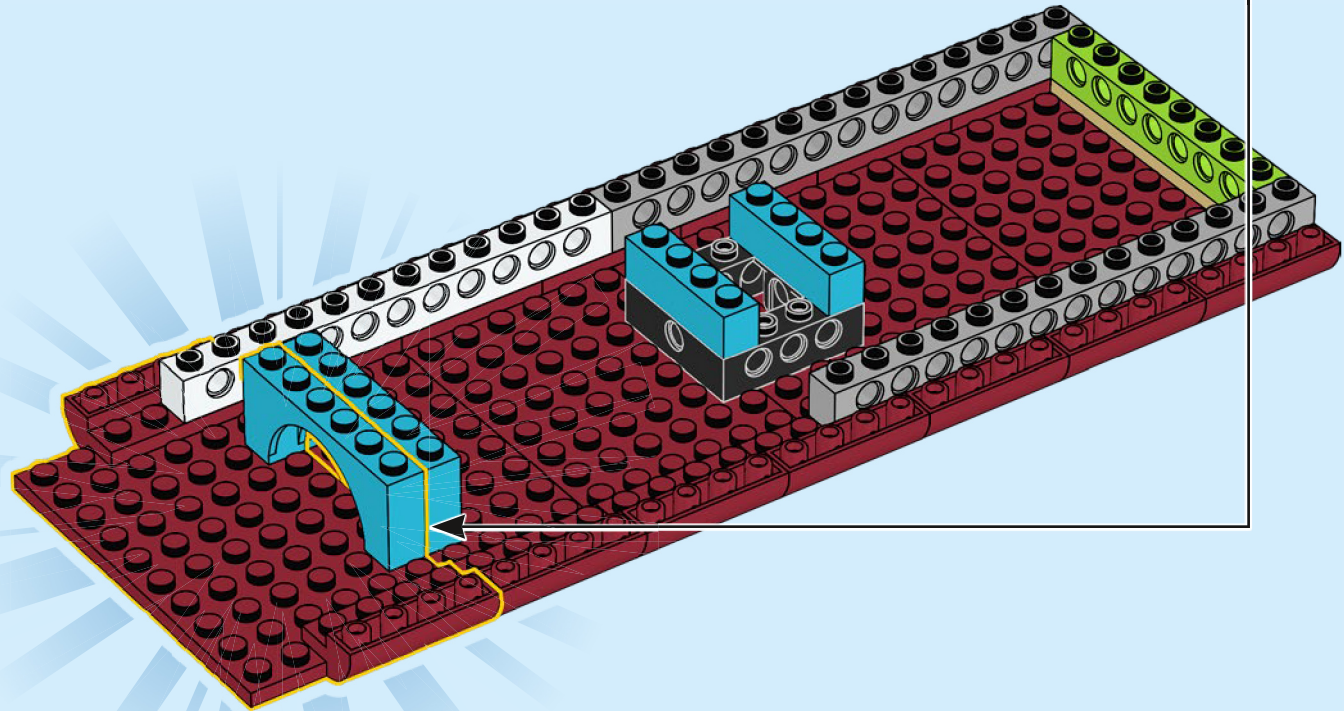
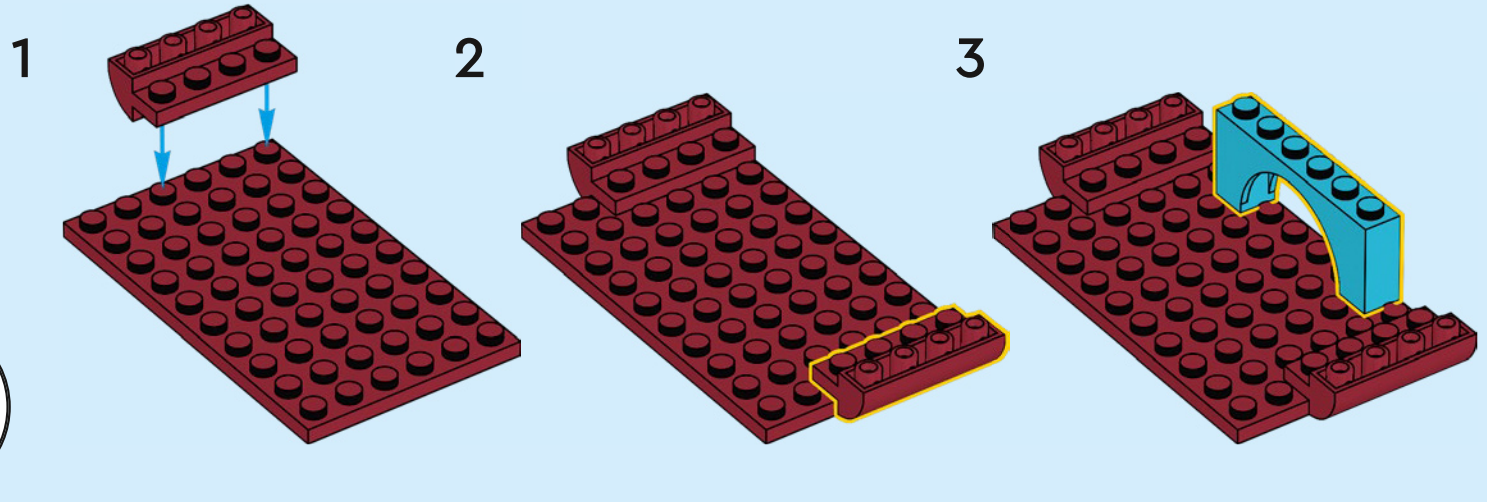

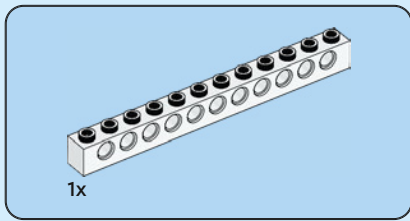

10

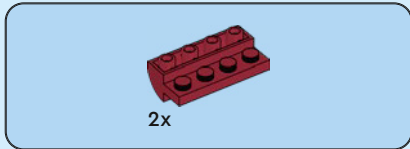
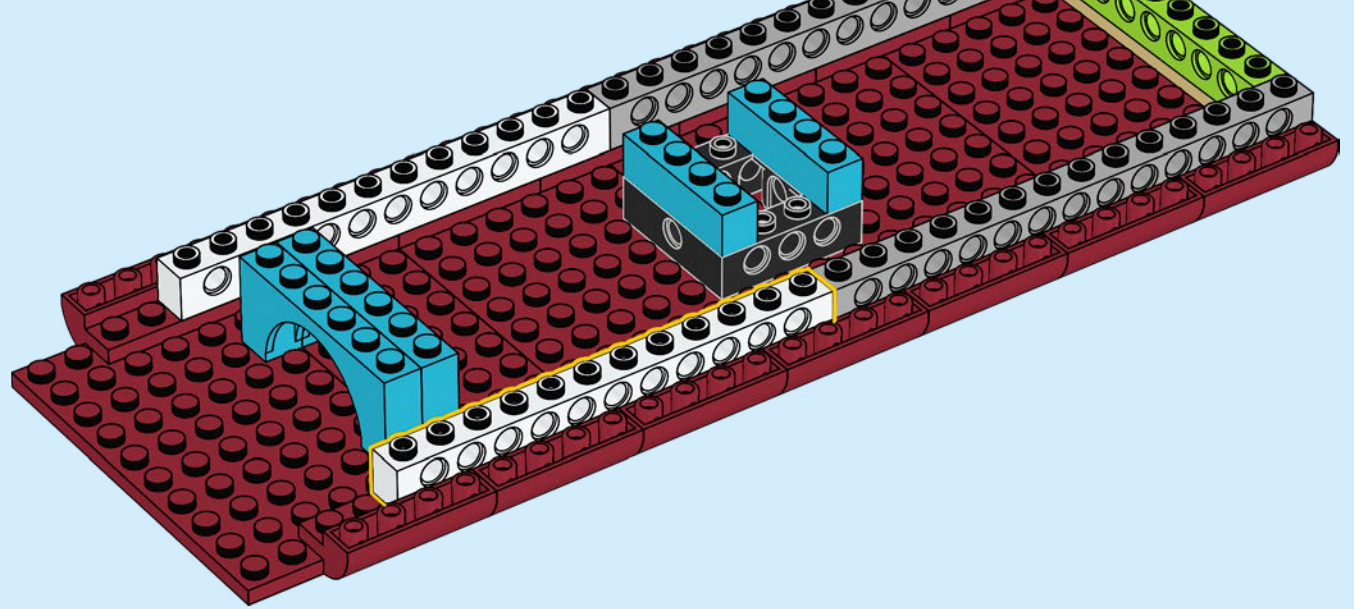

11

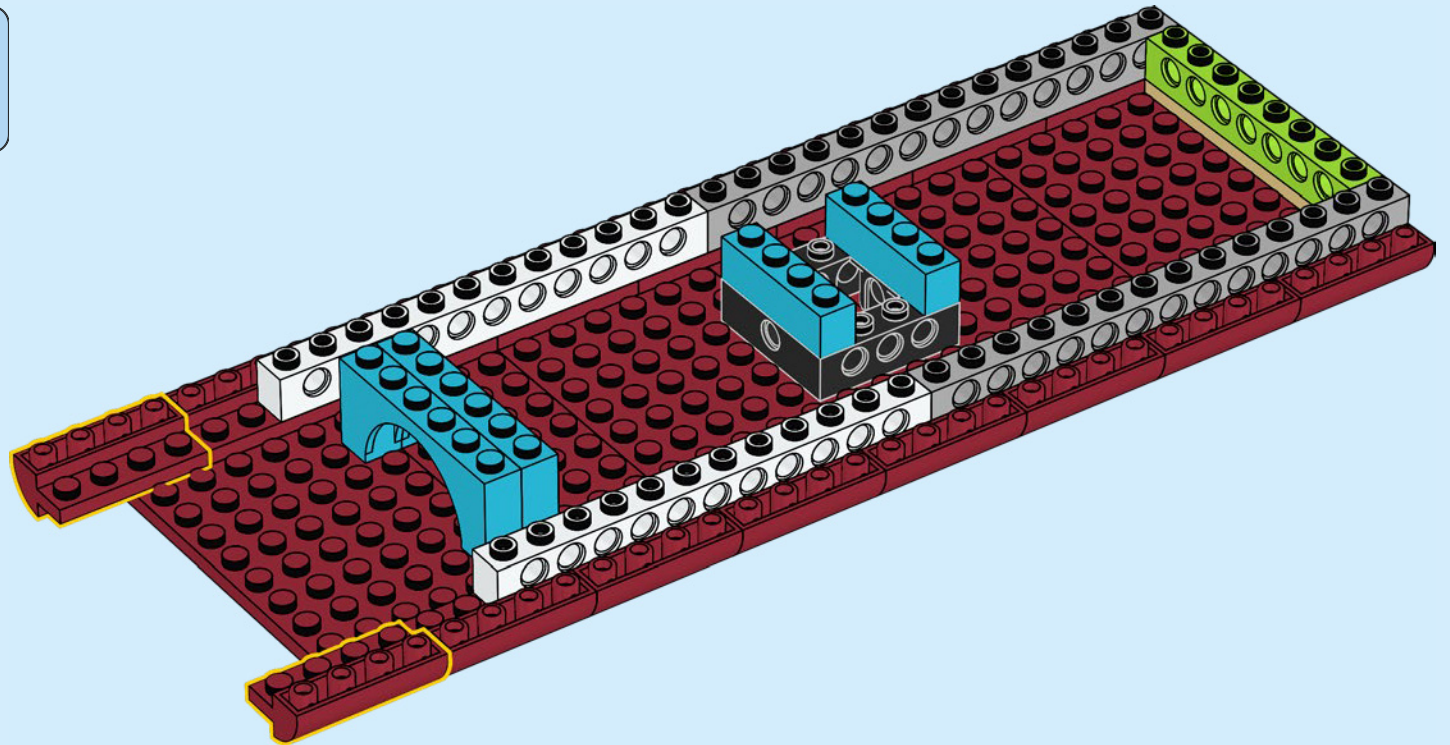

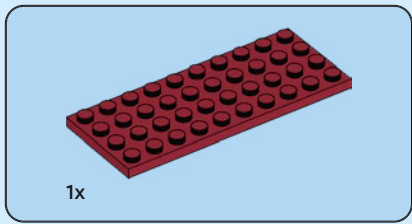

12

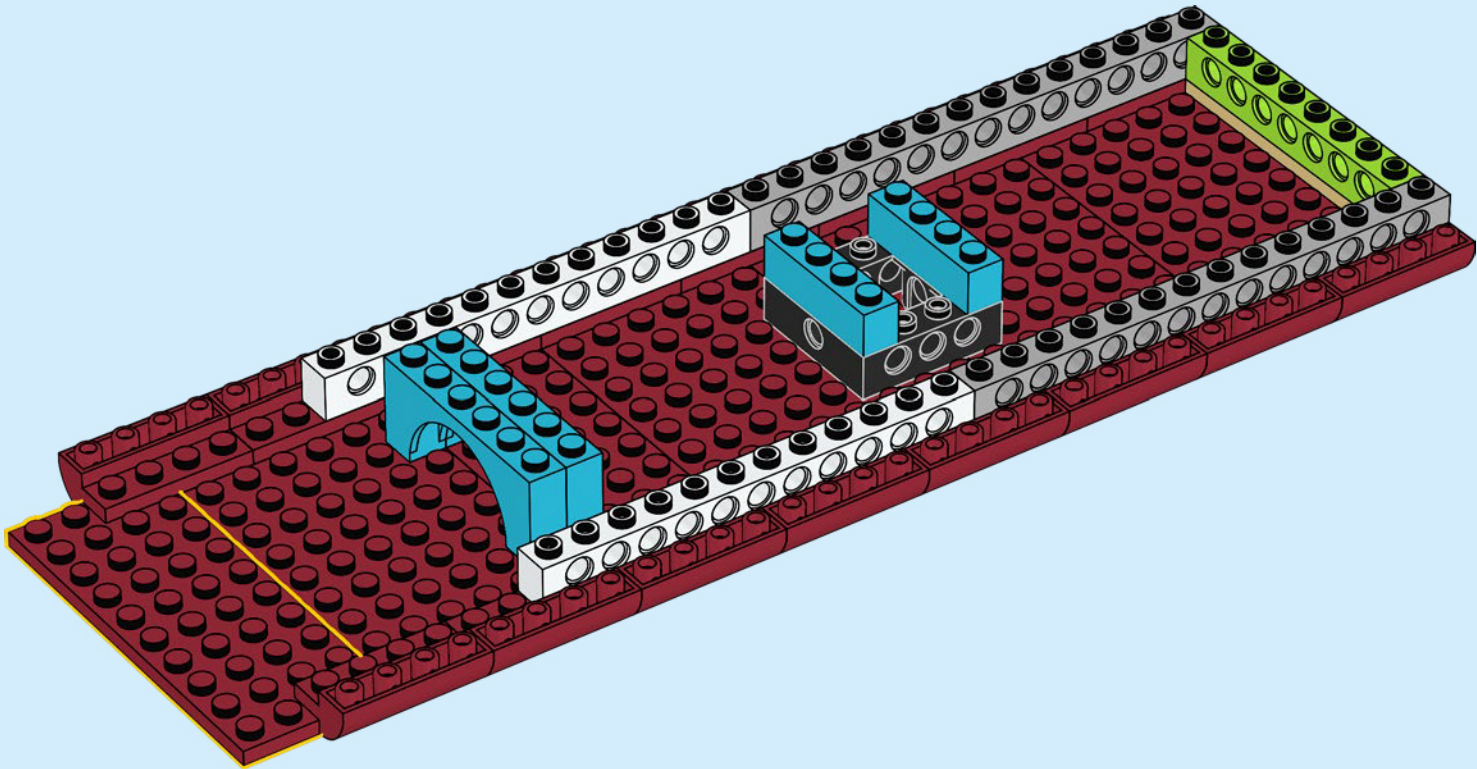

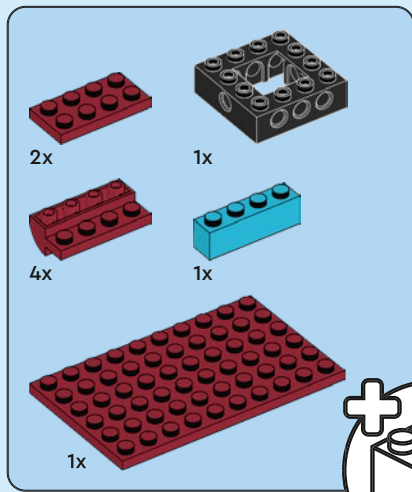

13

1

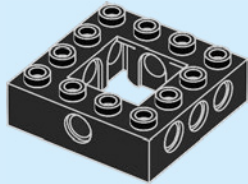

2

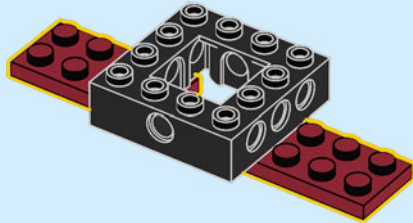

3

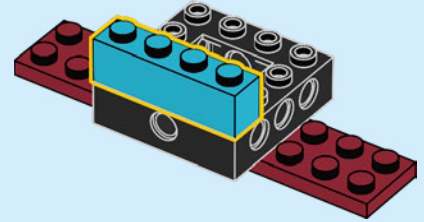

4

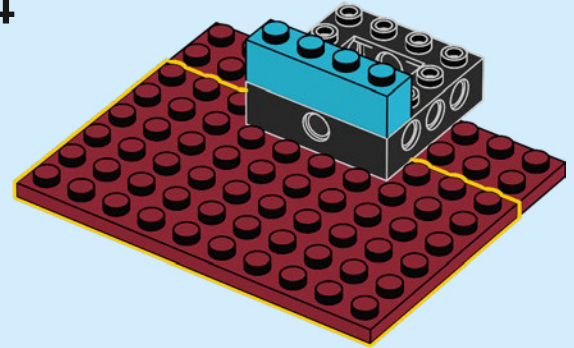

5

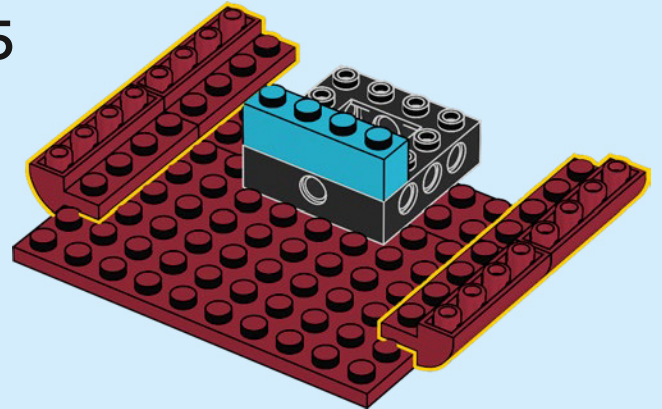

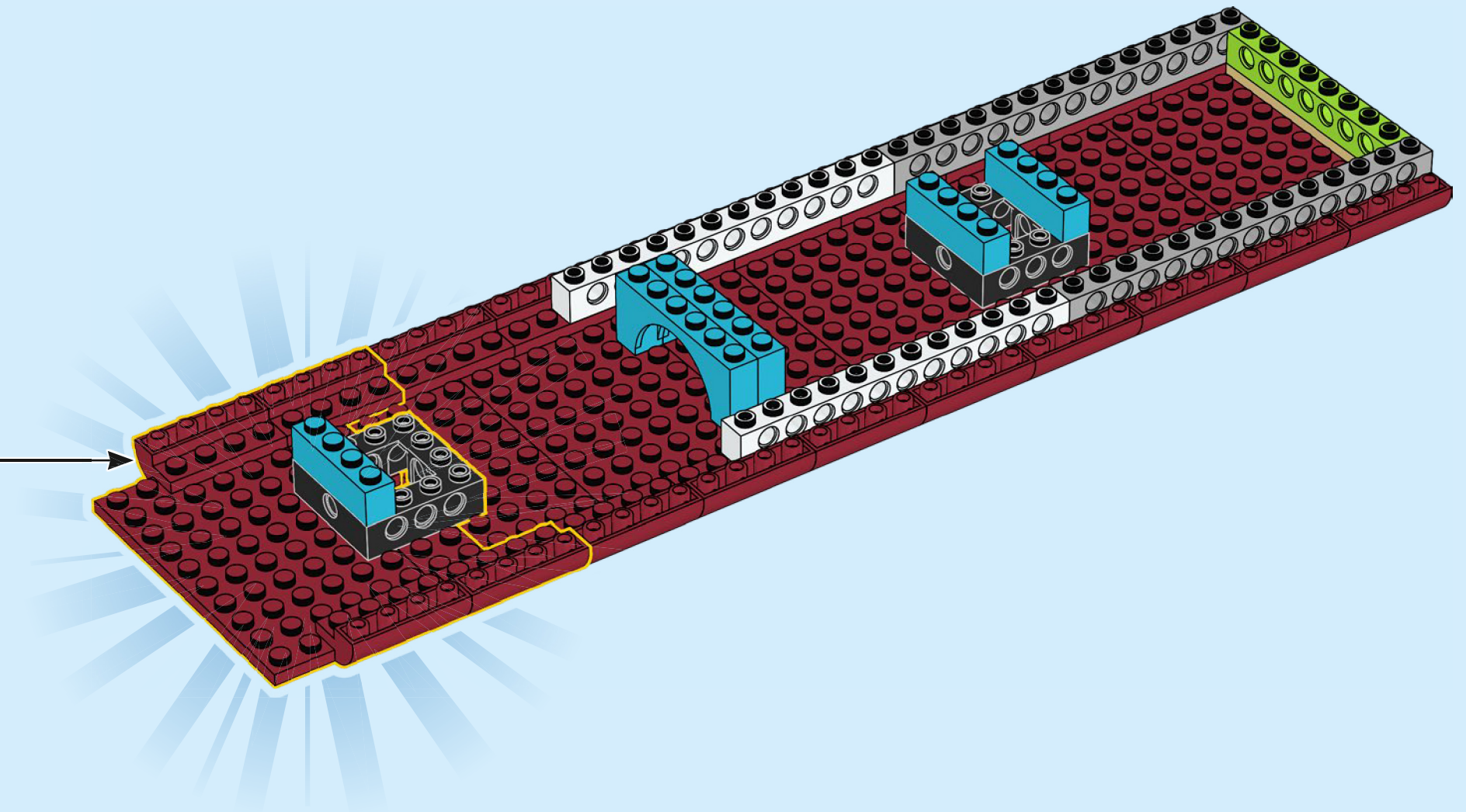

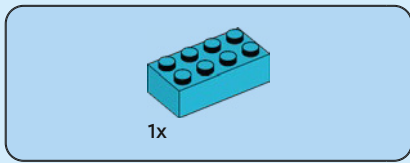

14

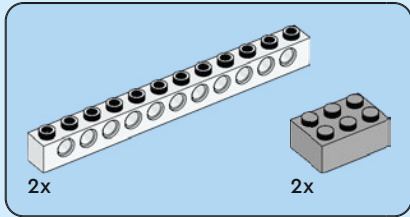
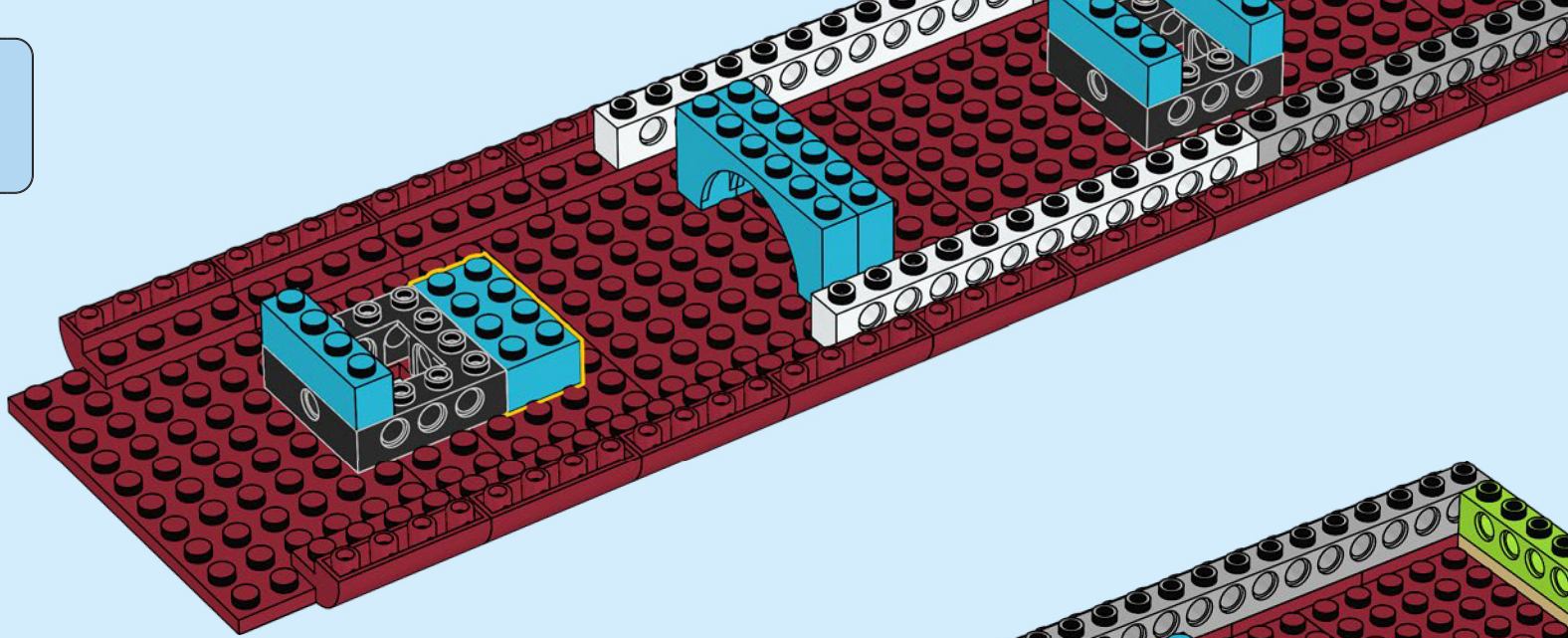

15

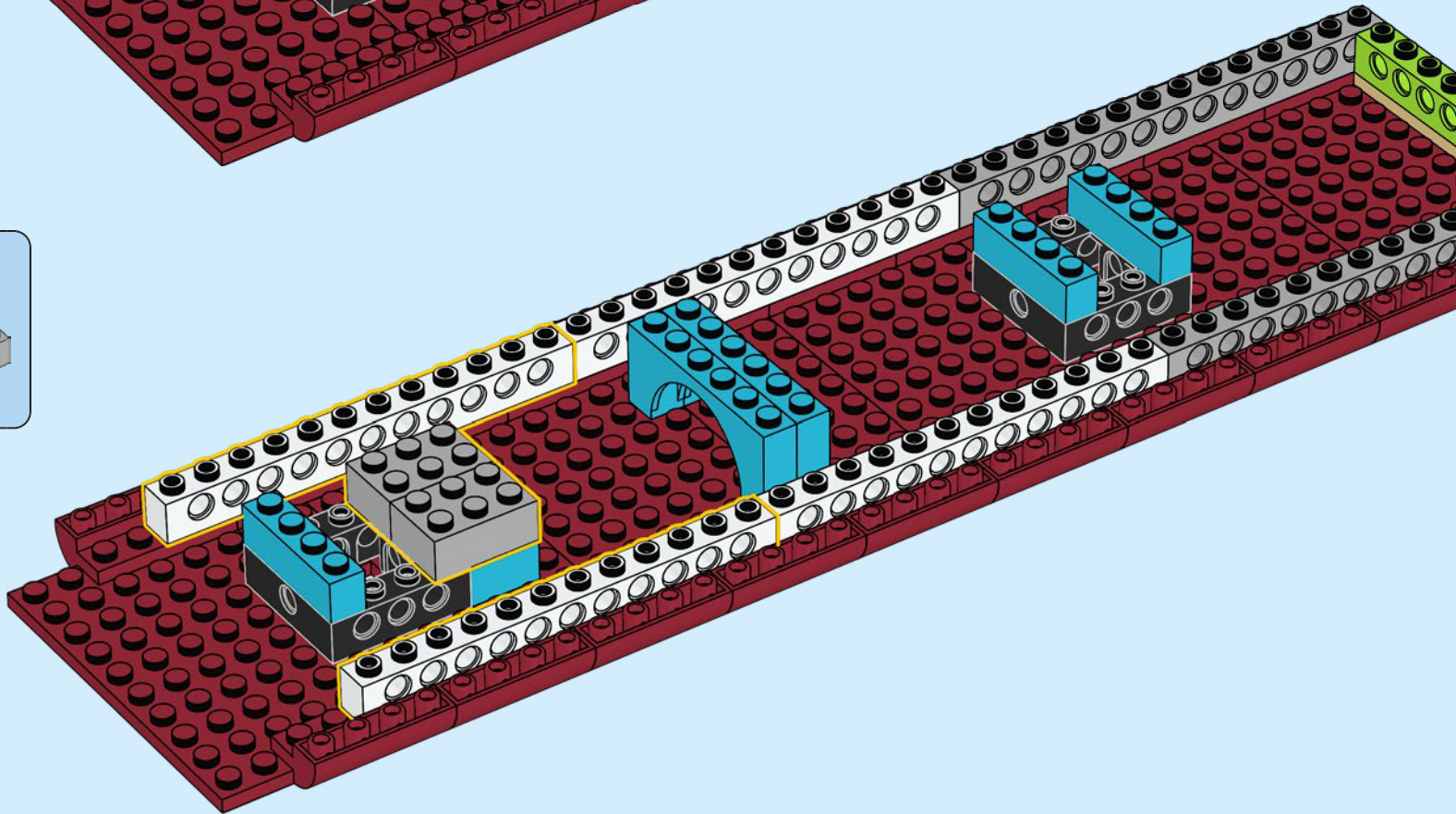

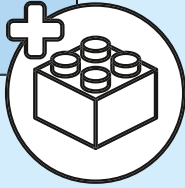
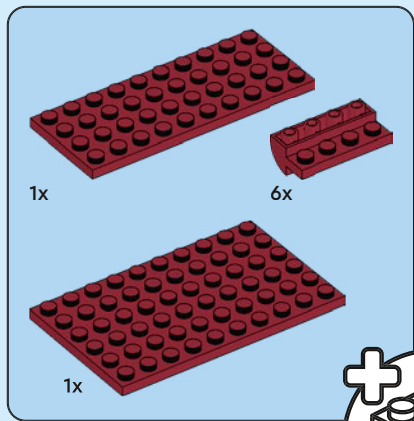

16

1

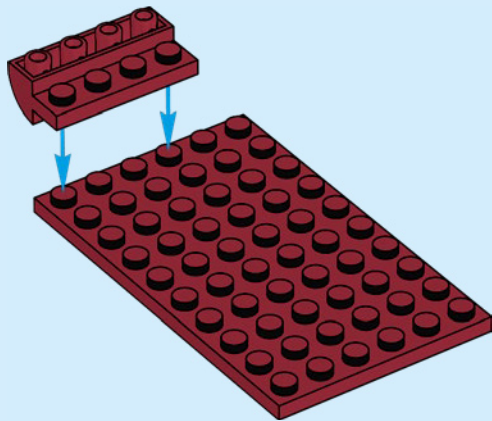

2

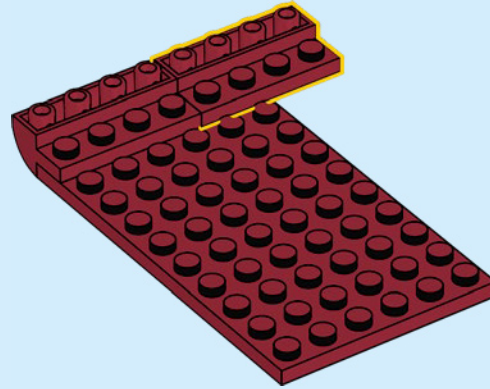

3

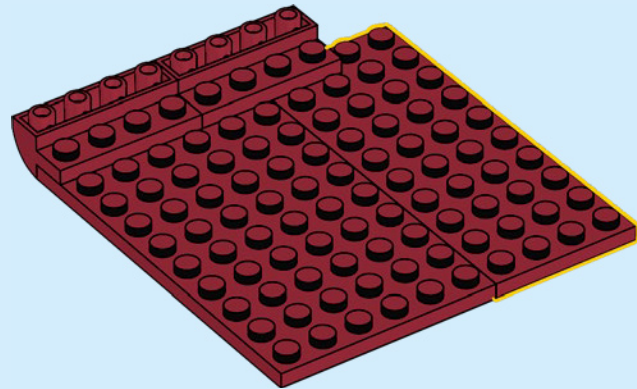

4

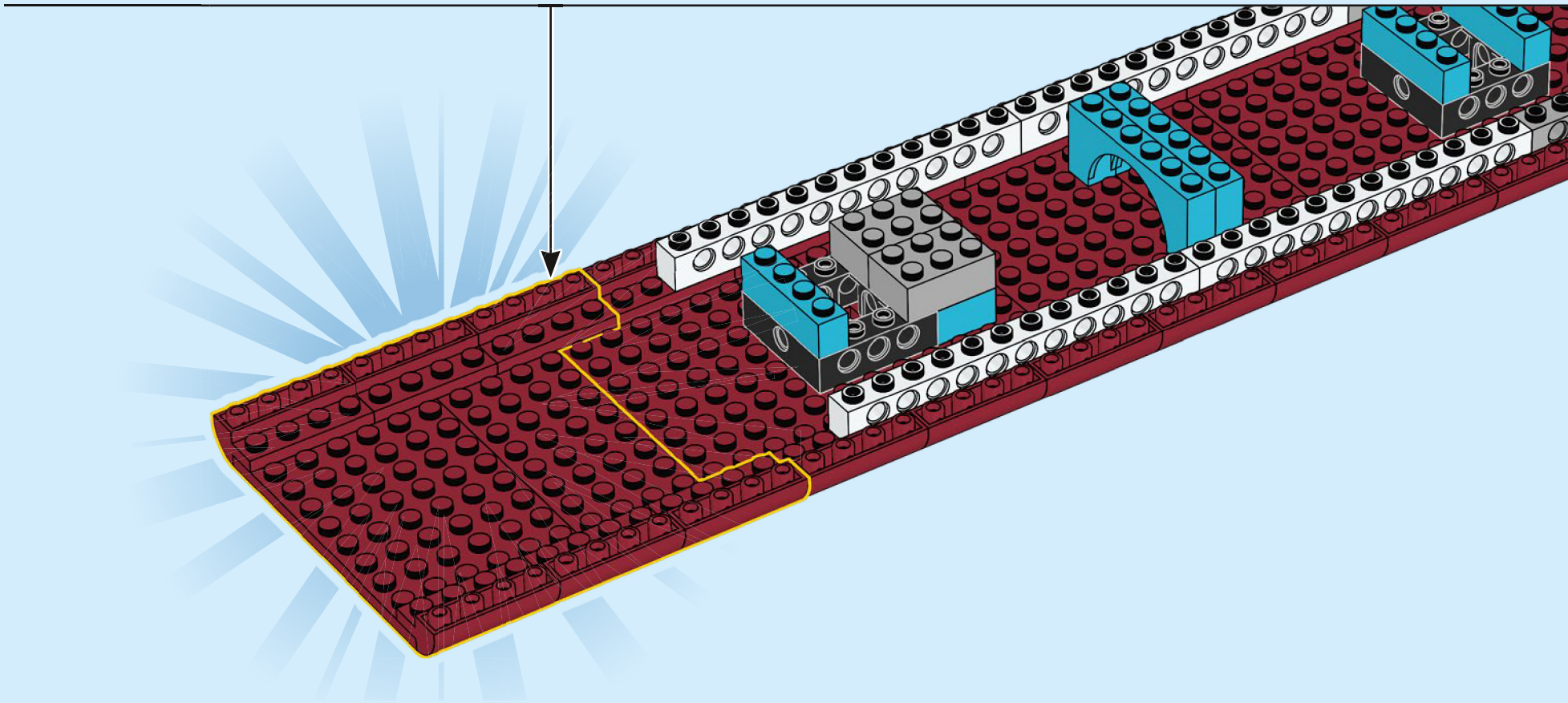
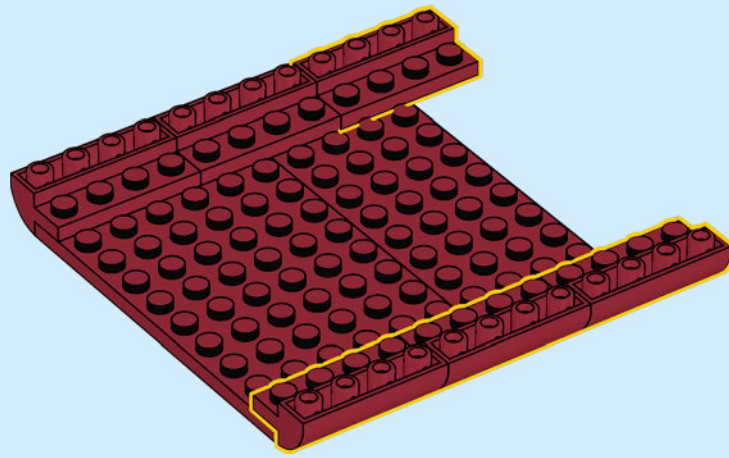

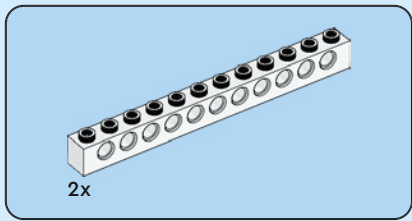

17

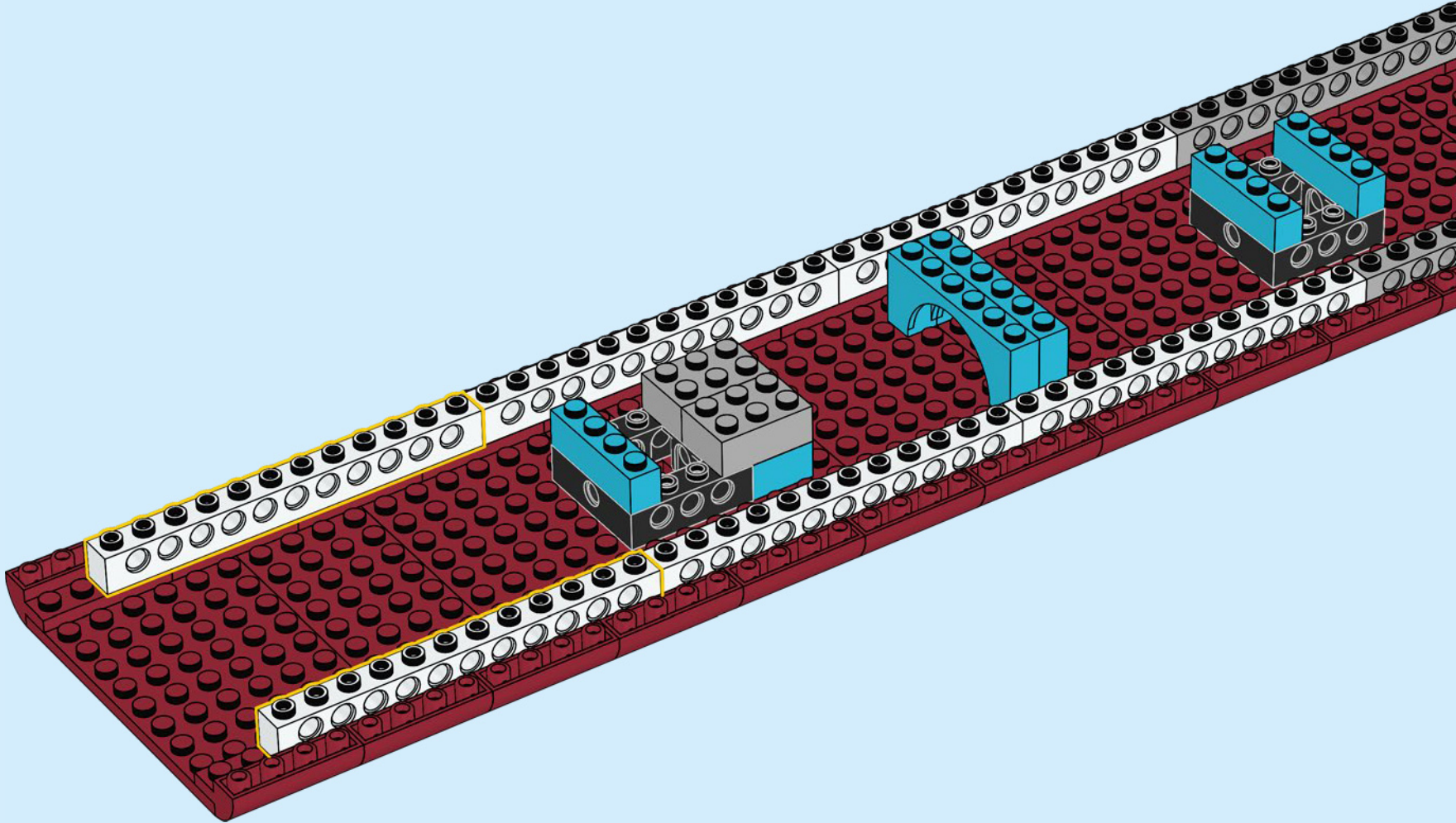

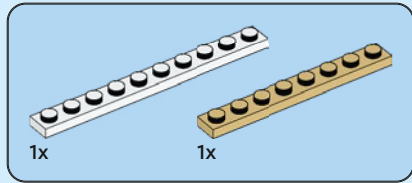

18

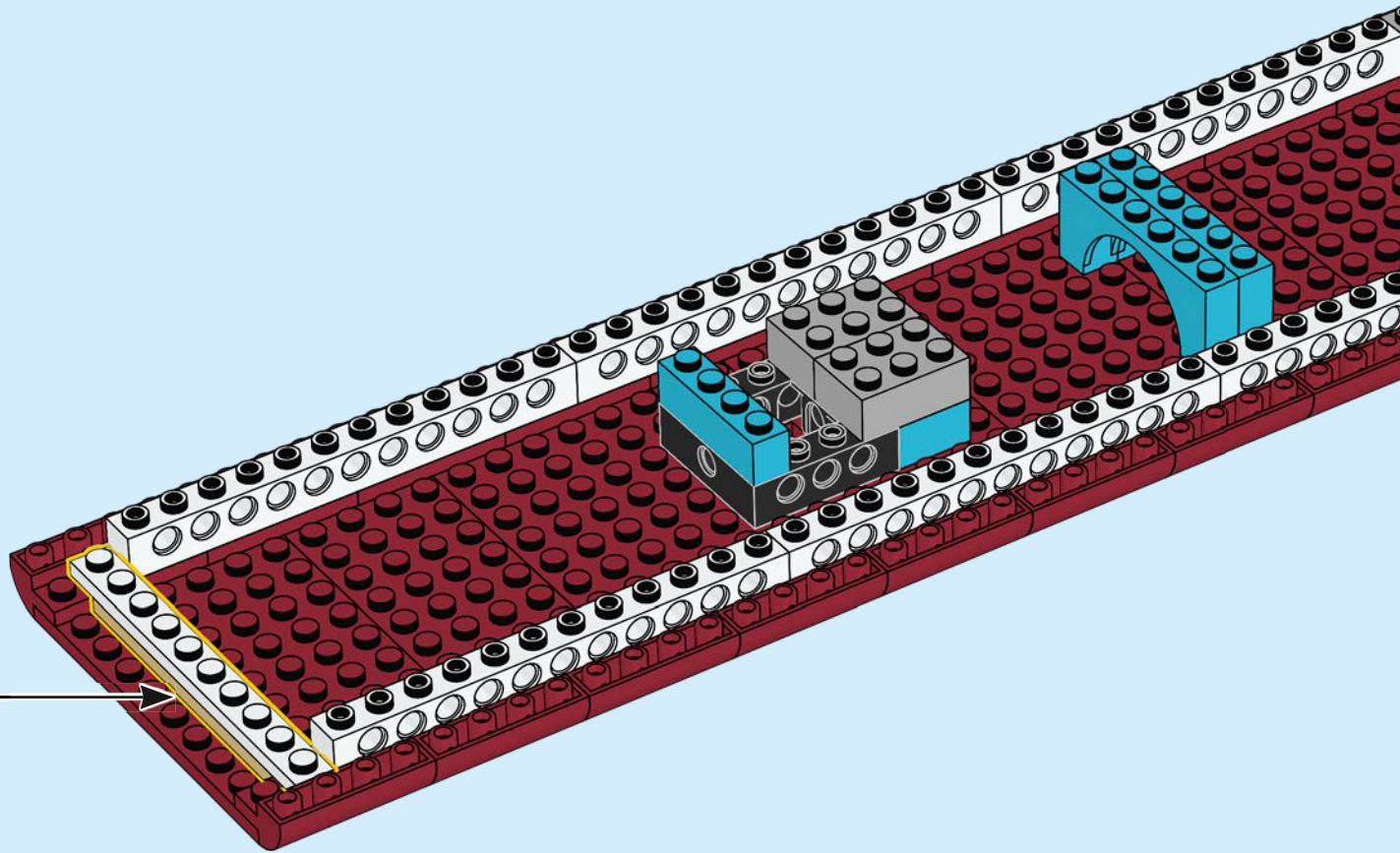
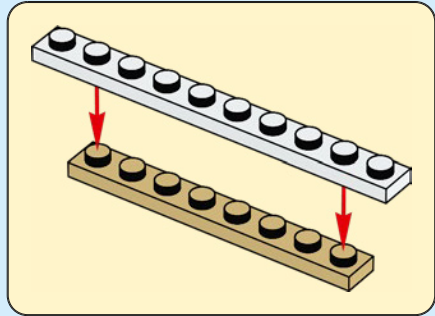

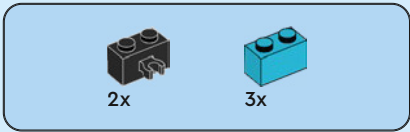

19

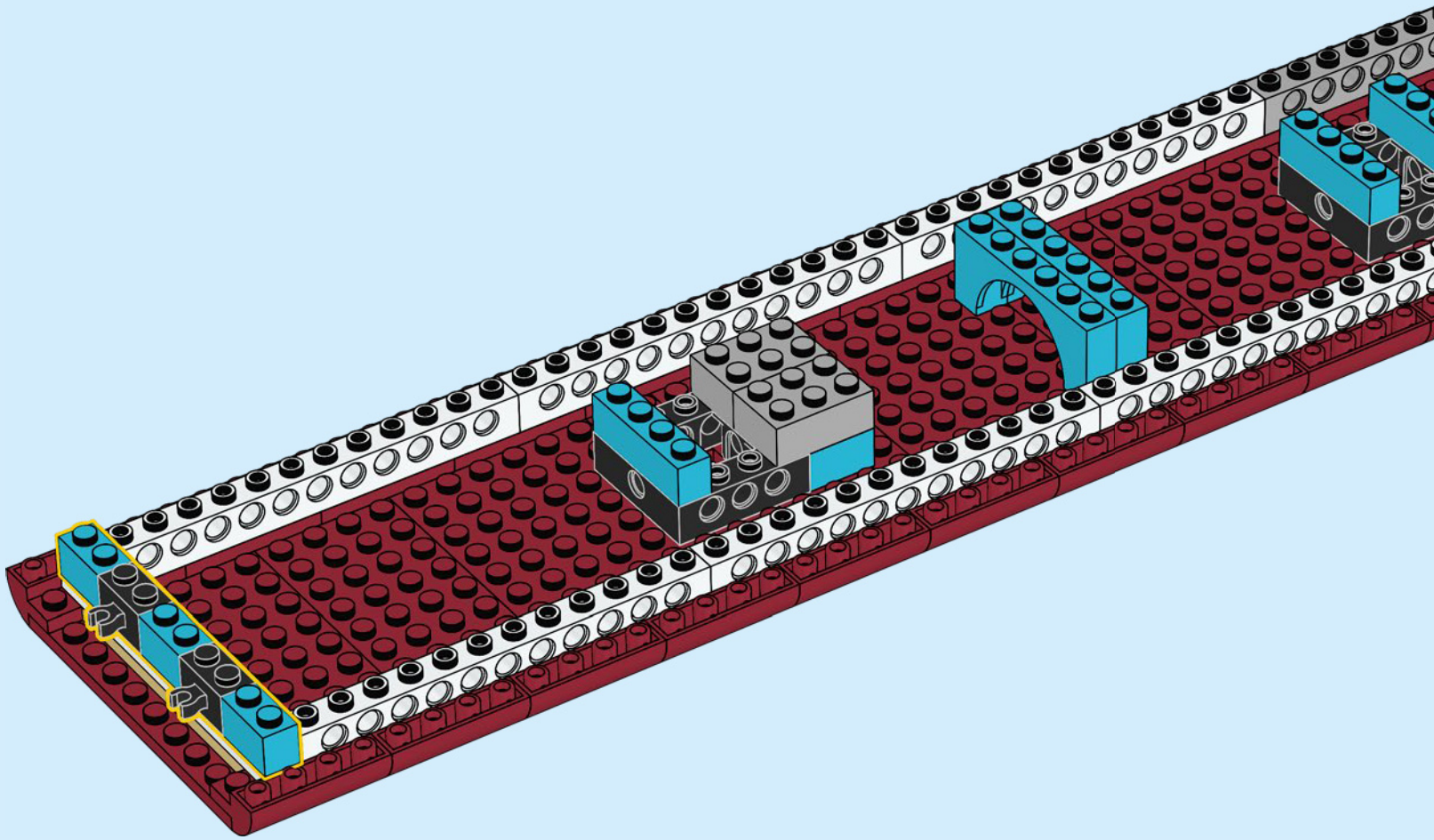

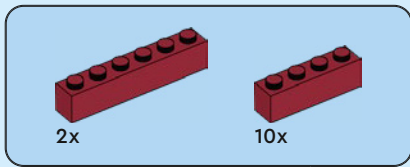

20

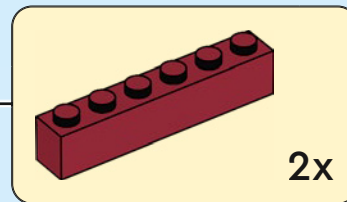
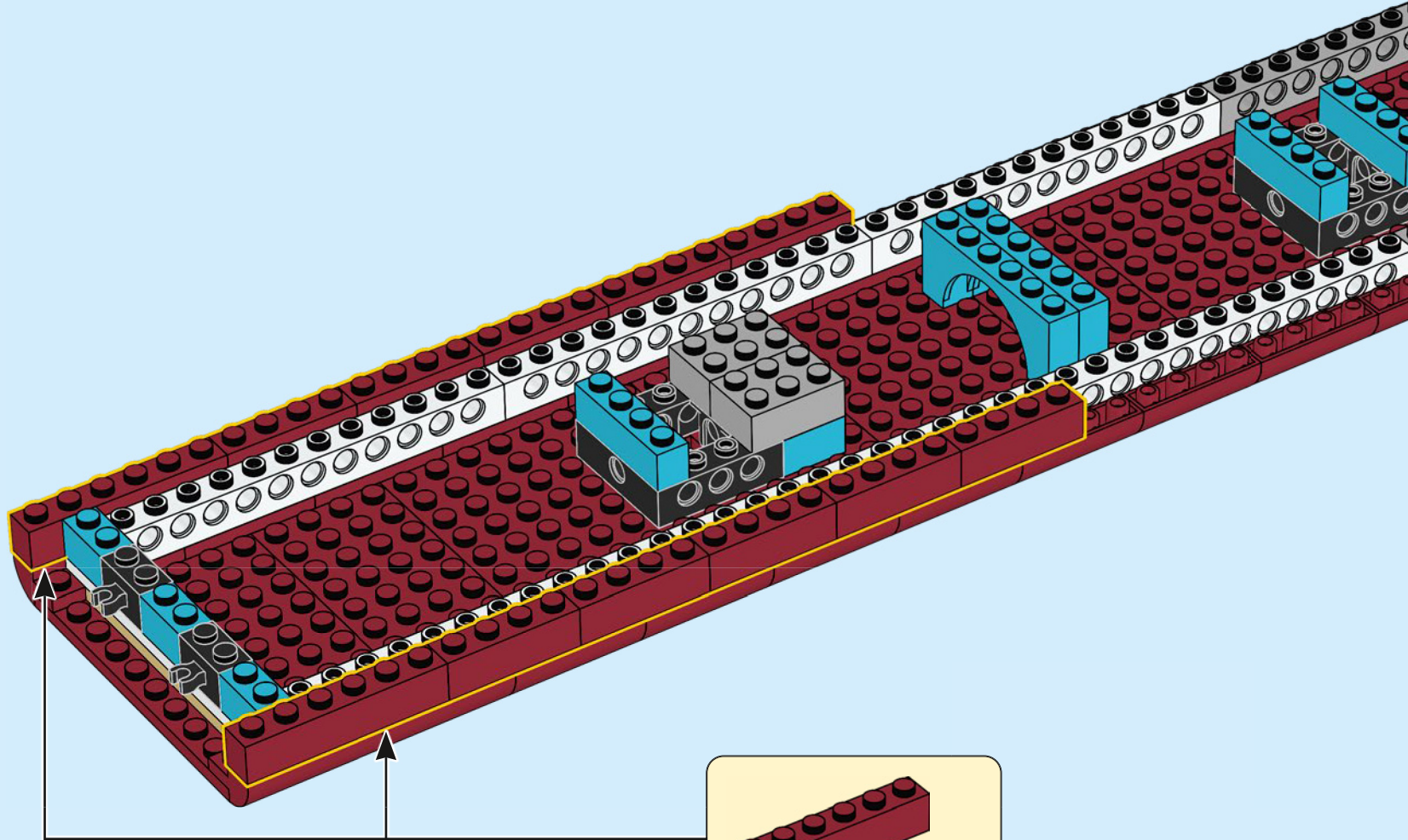

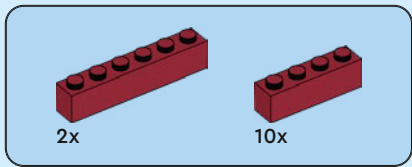

21

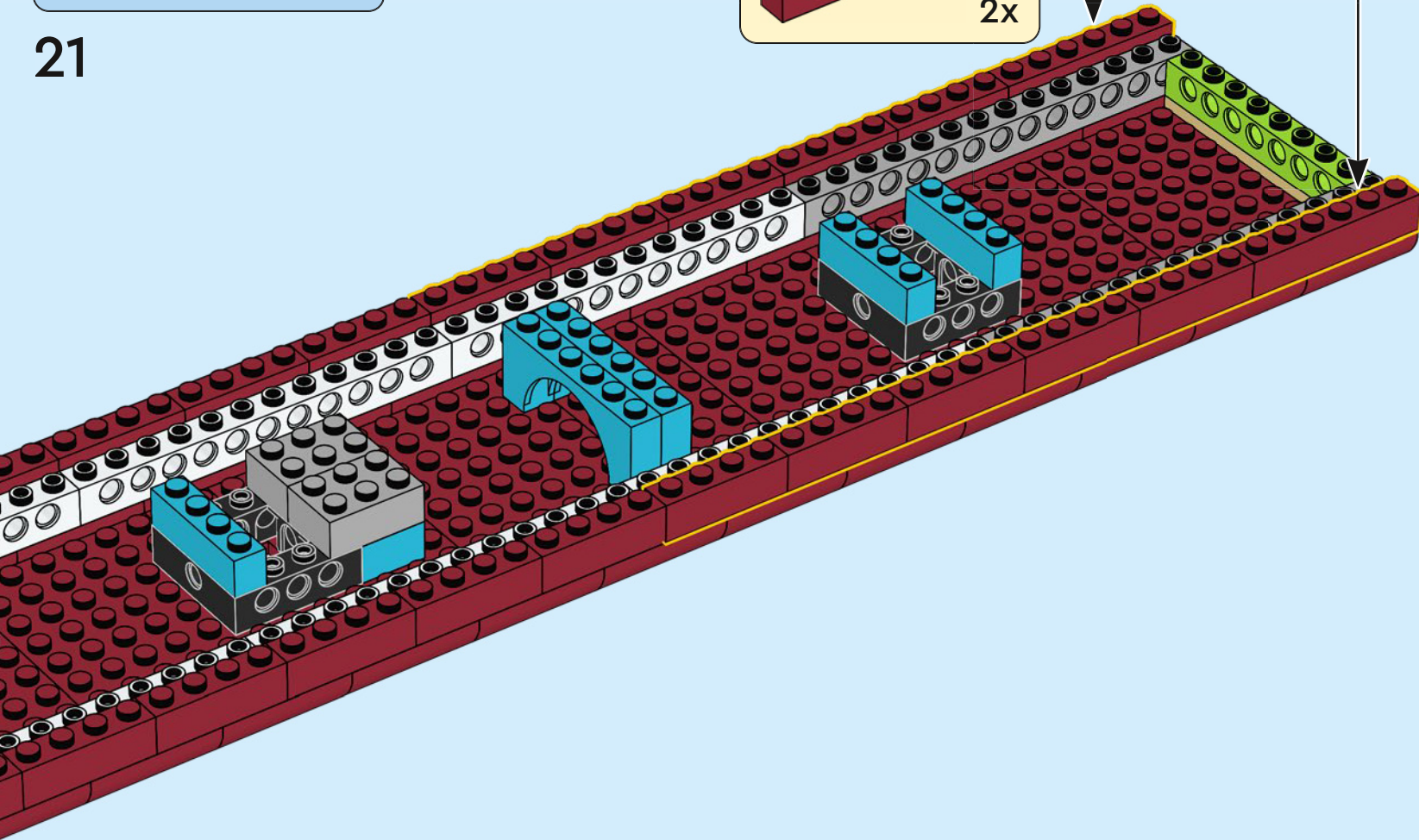
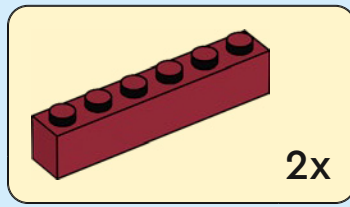

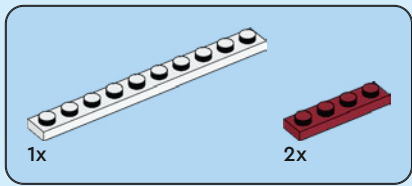

23

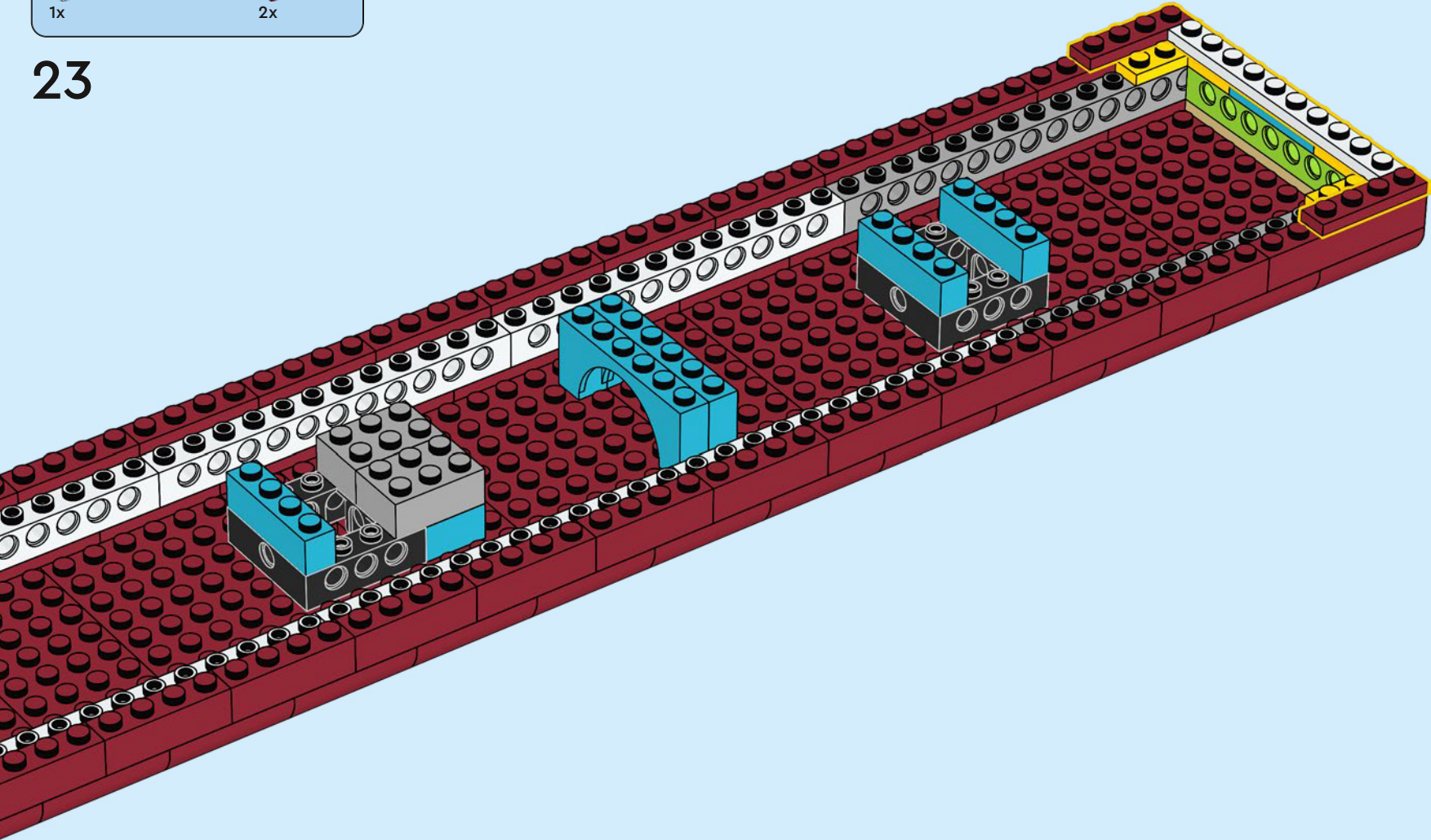

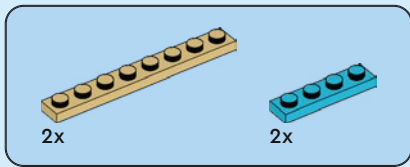

24

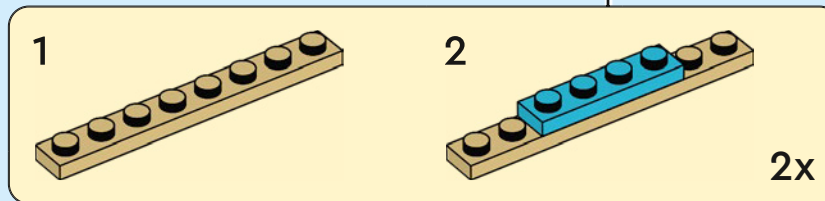
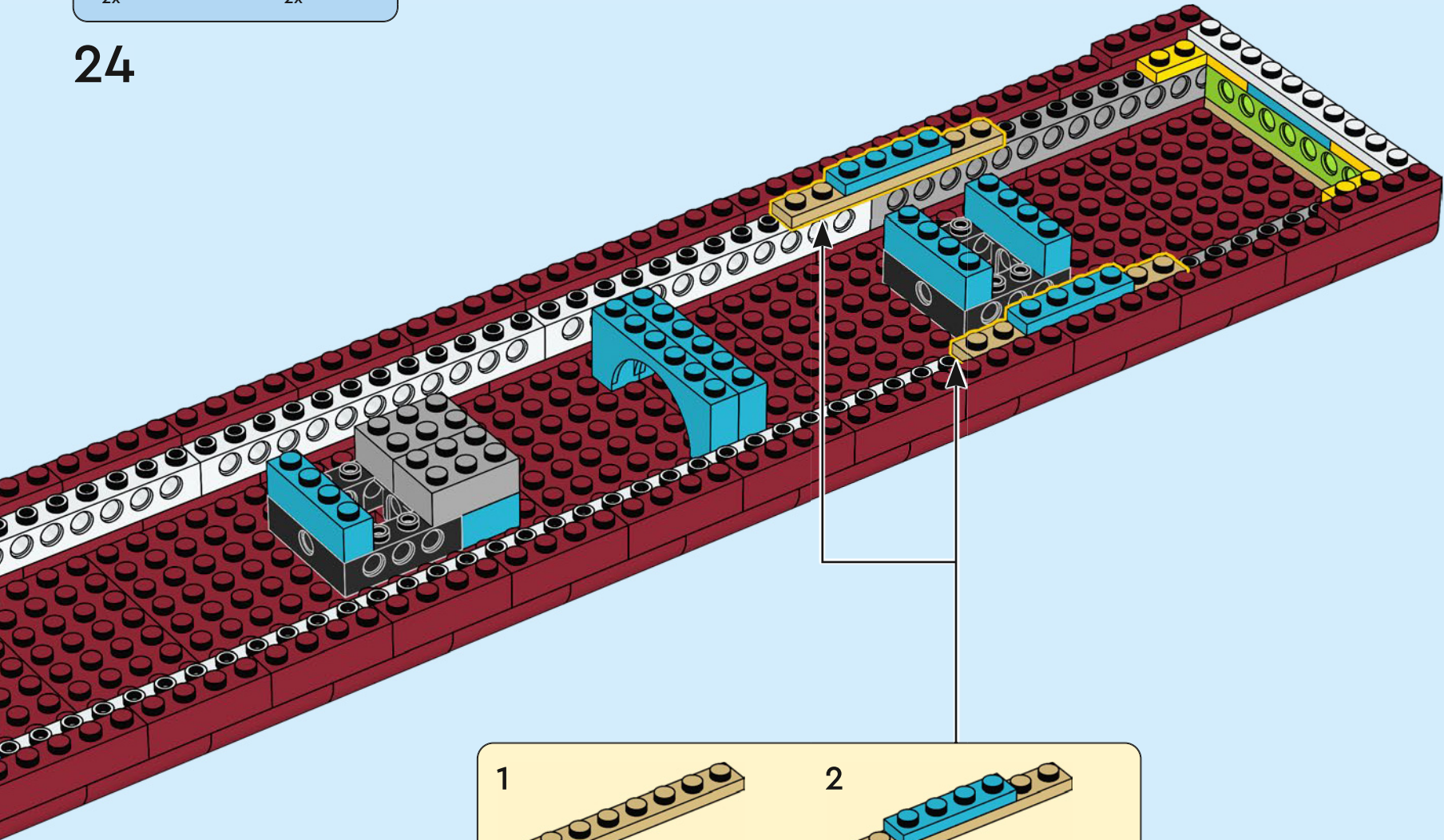

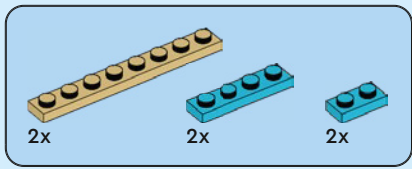

25

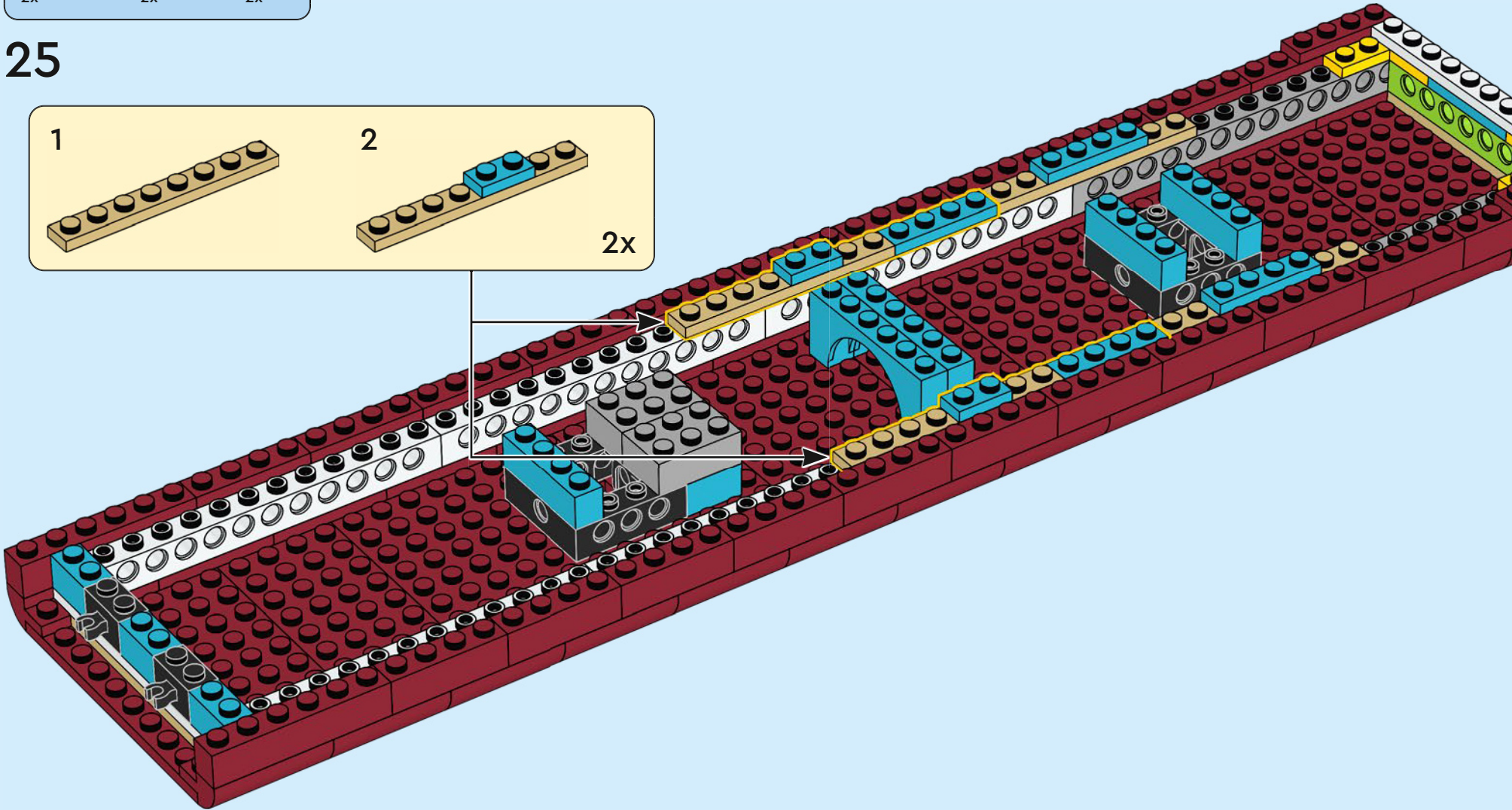
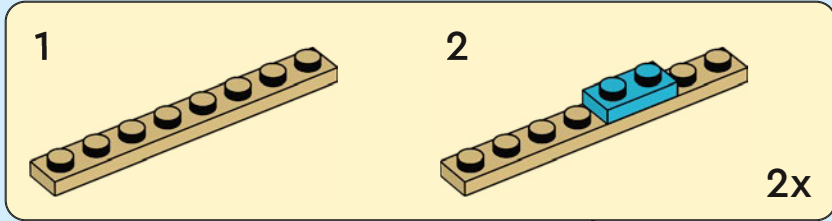

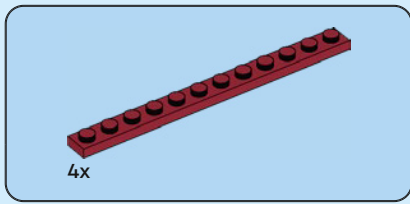

26

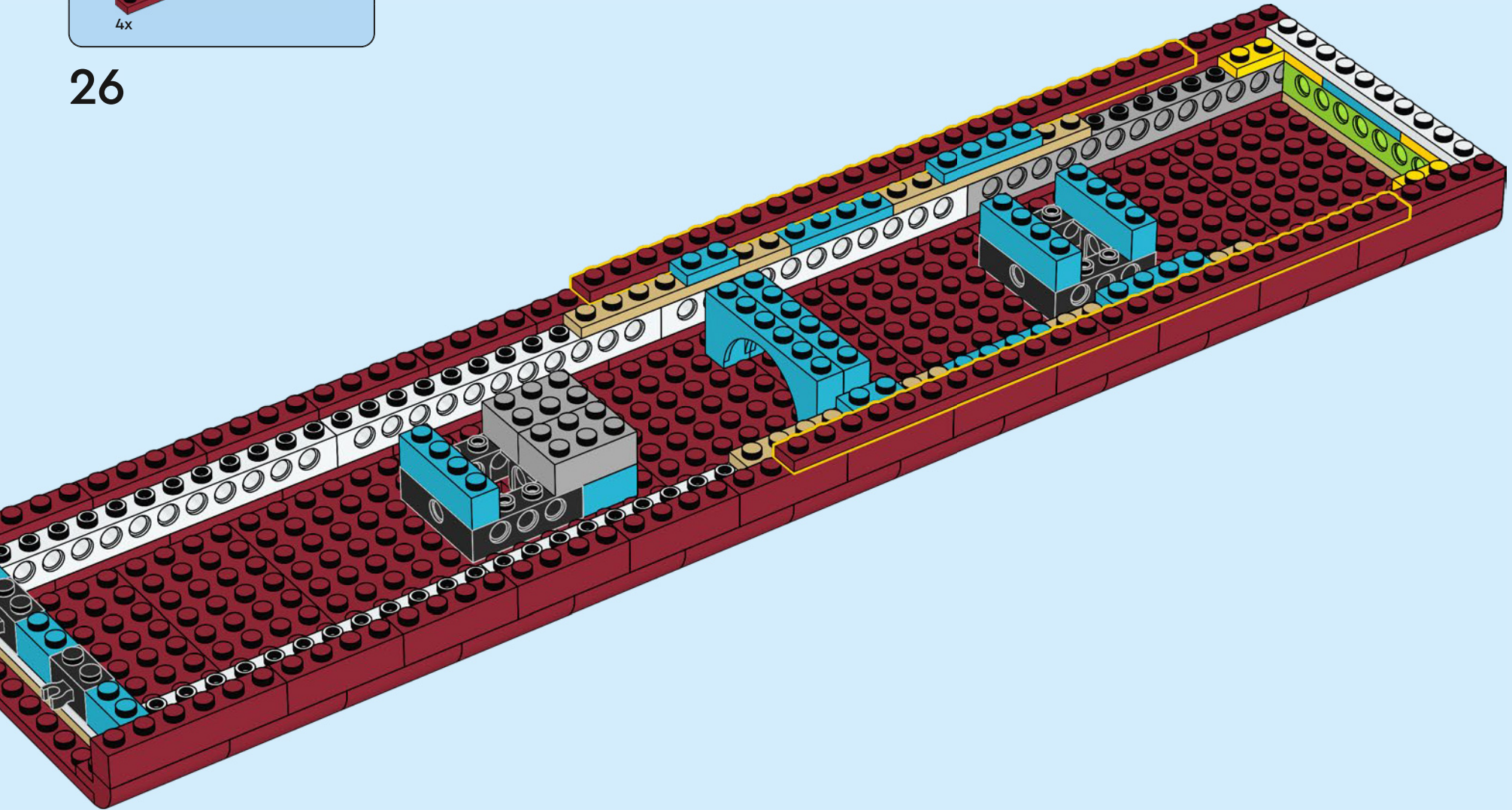

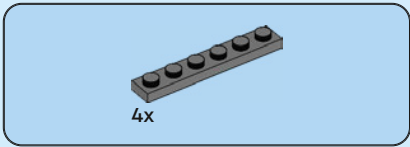

27

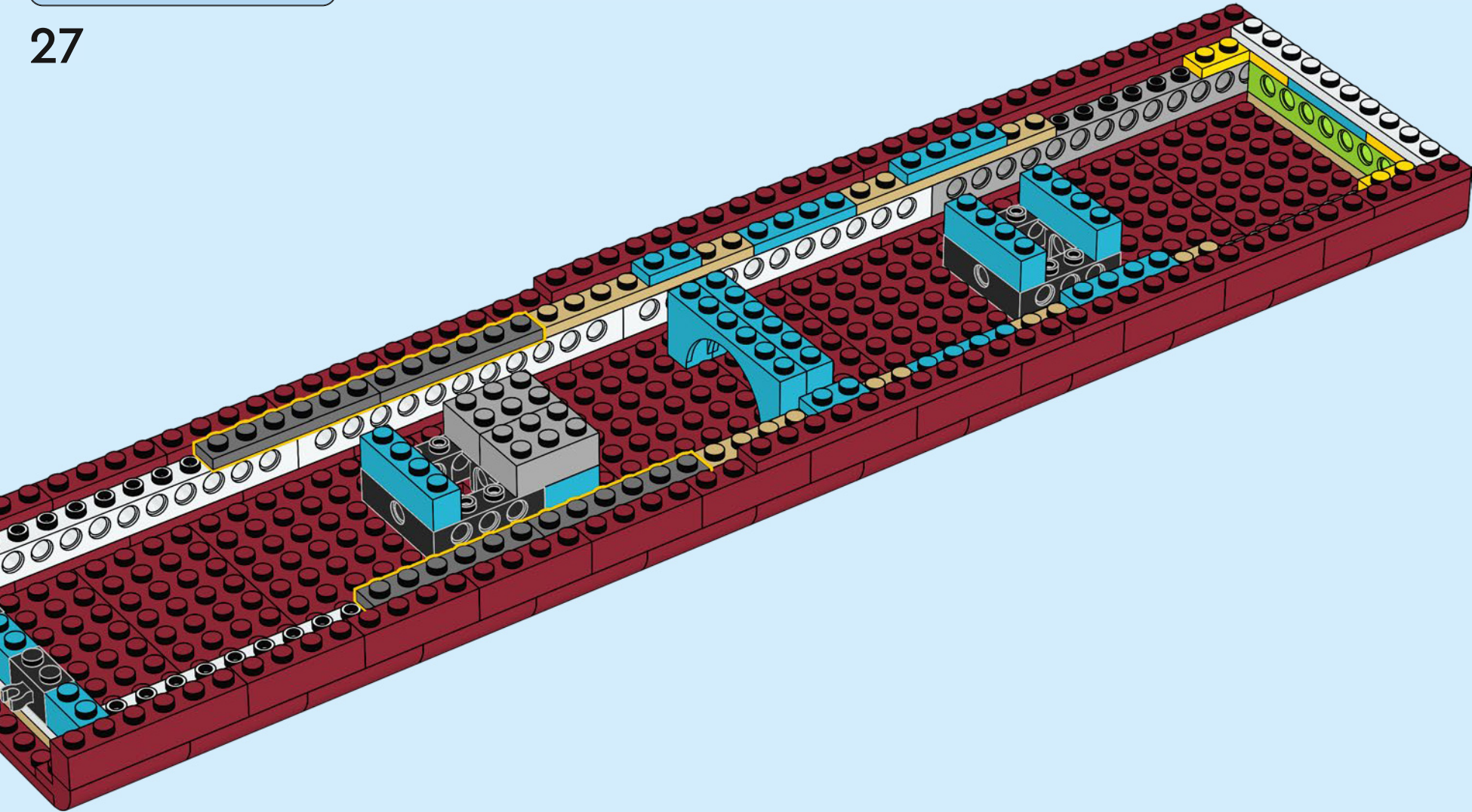

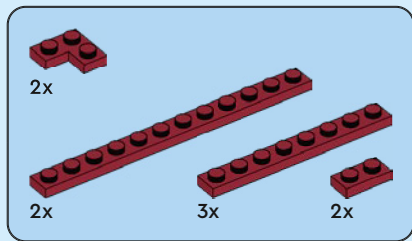

28

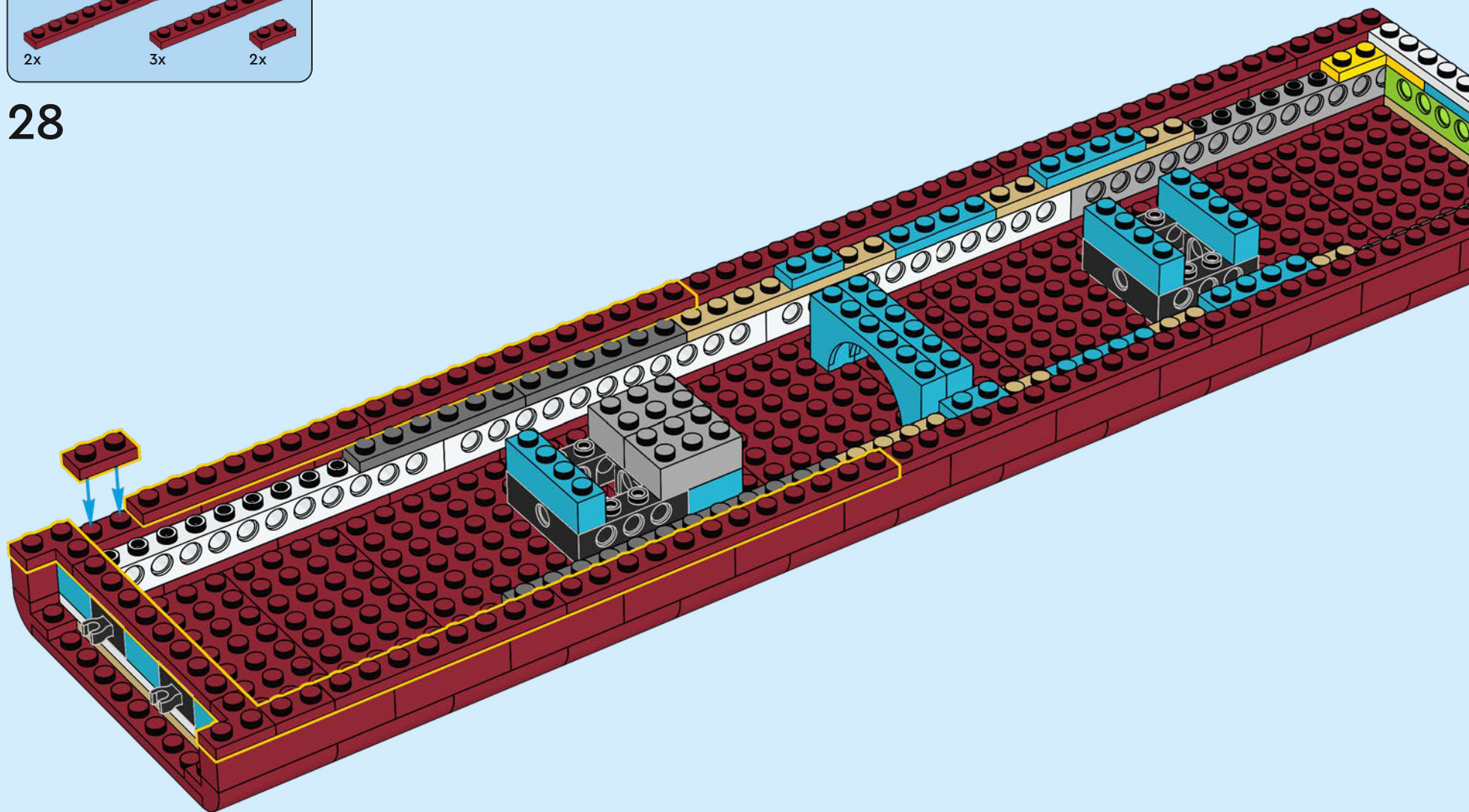

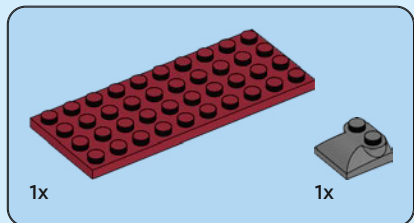
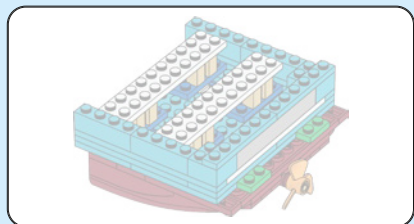

29

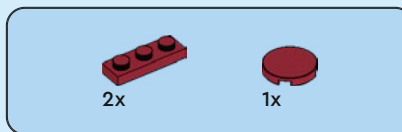
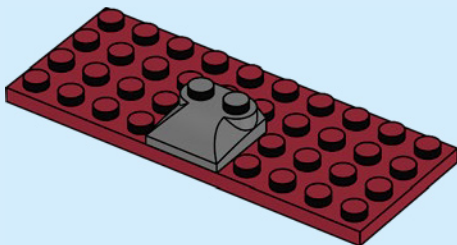

30

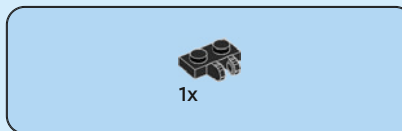
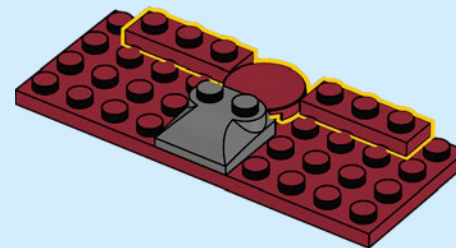

31

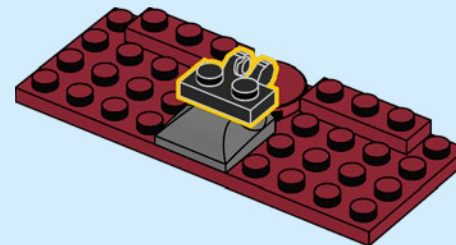

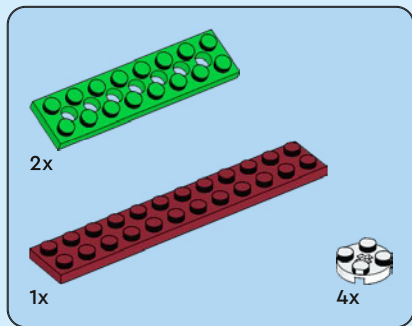

32

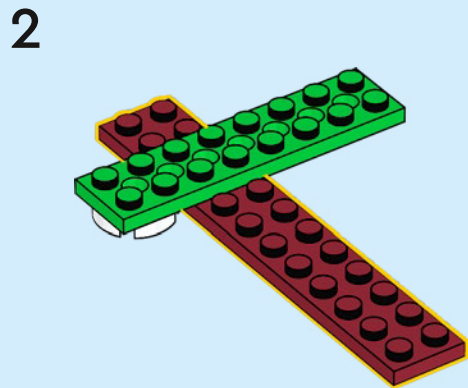
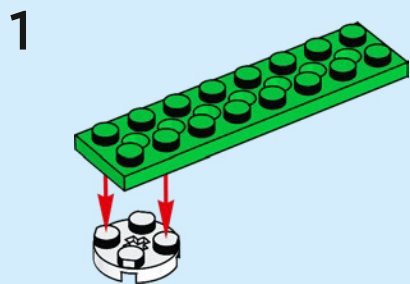

3

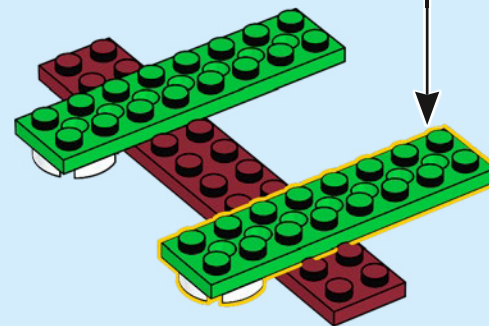
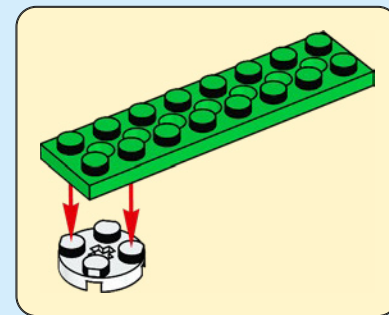

4

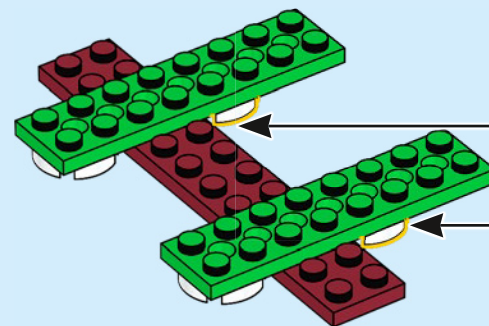

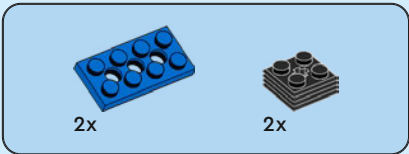

33

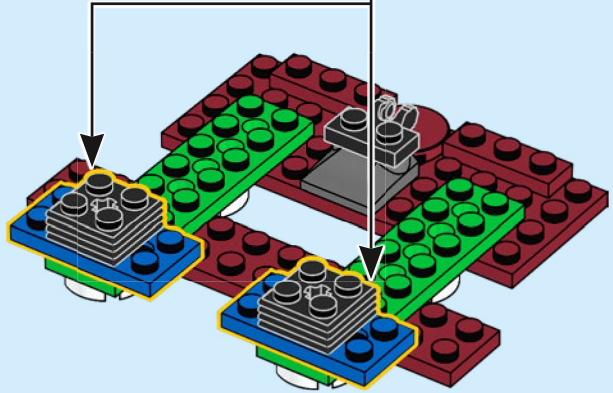
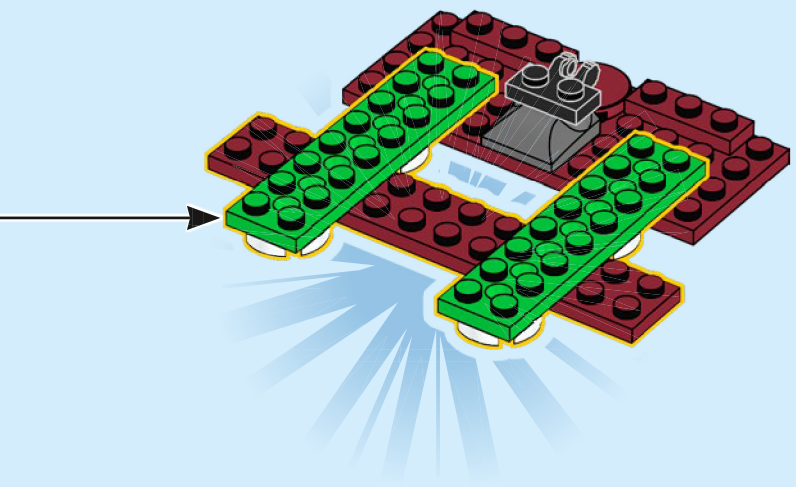
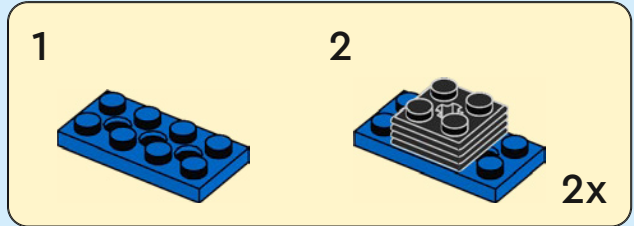

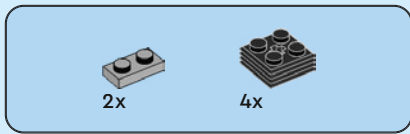

34

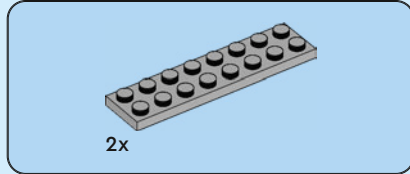
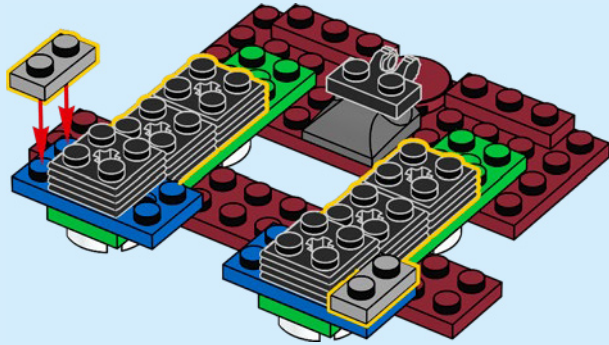

35

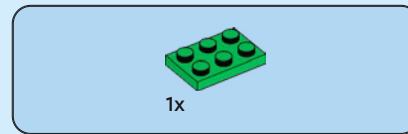
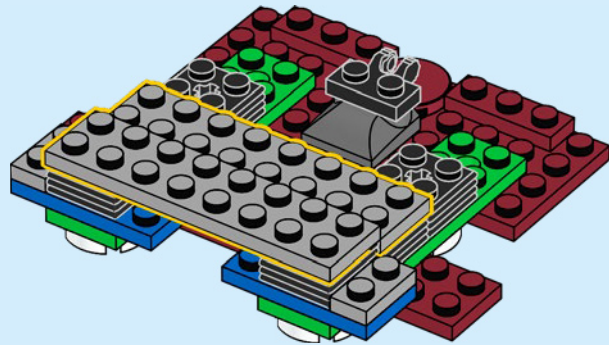

36

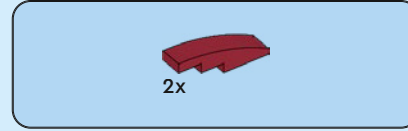
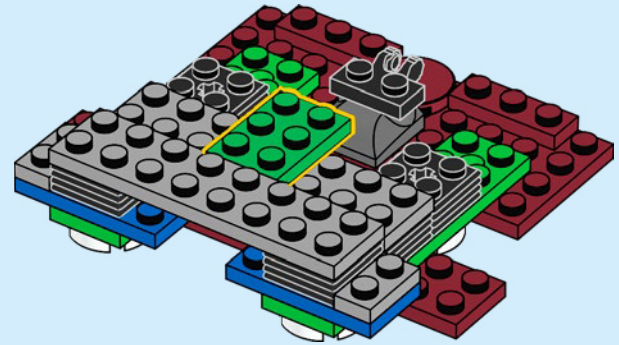

37

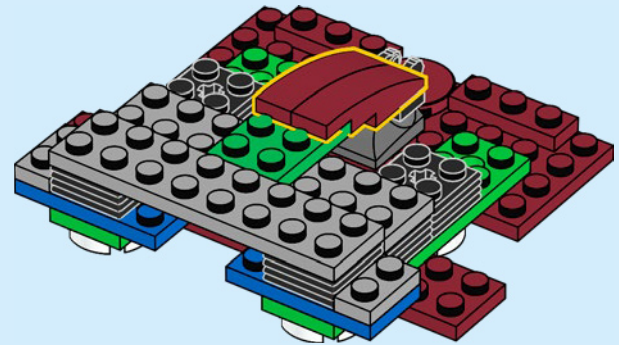

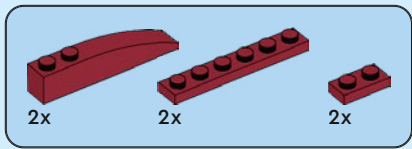

38

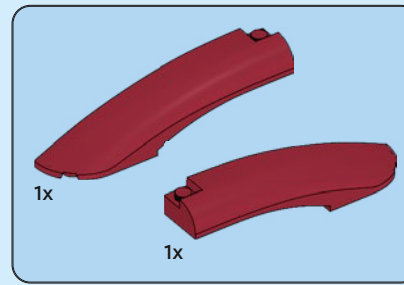
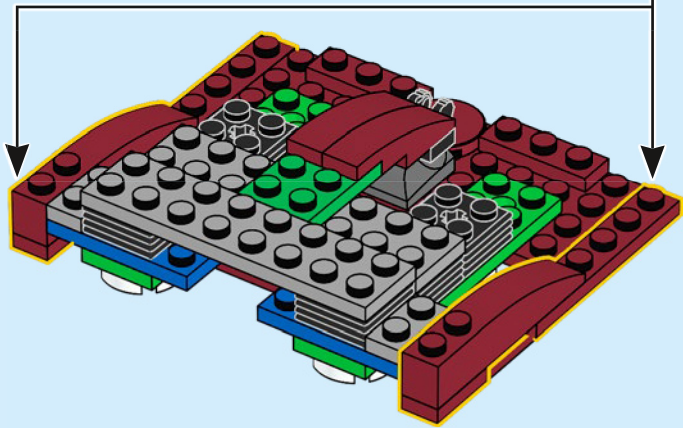
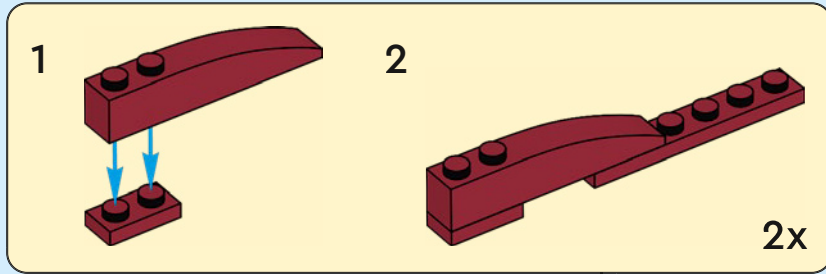

39

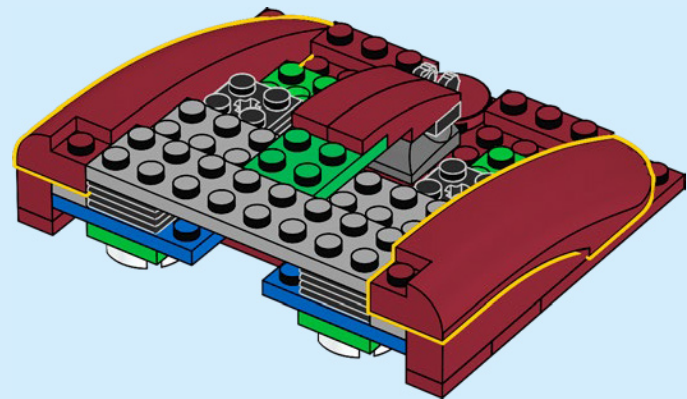

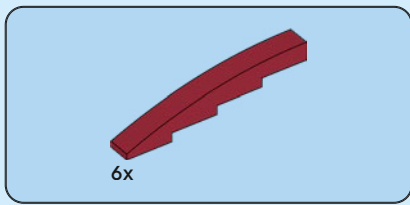

40

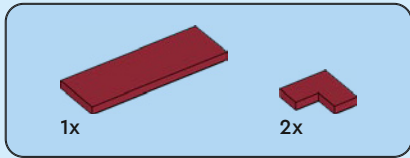
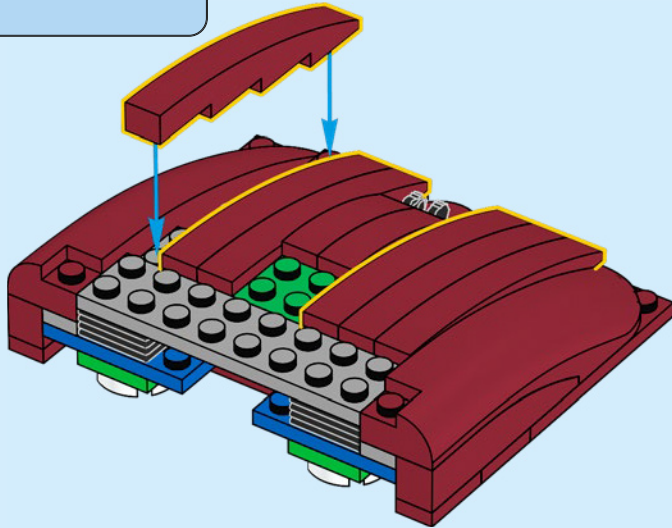

41

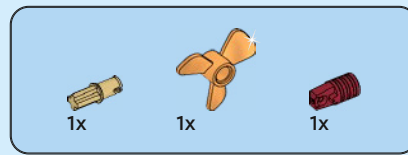
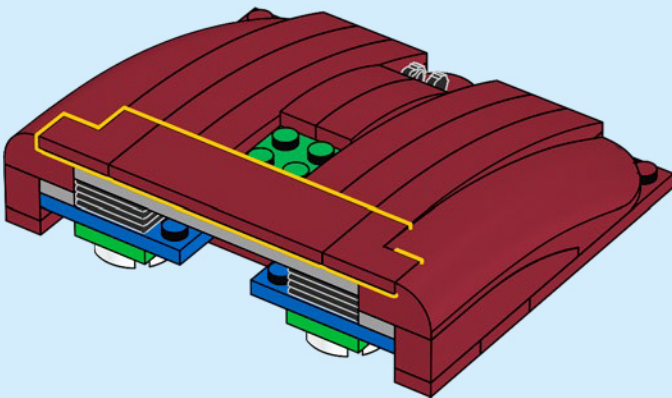

42

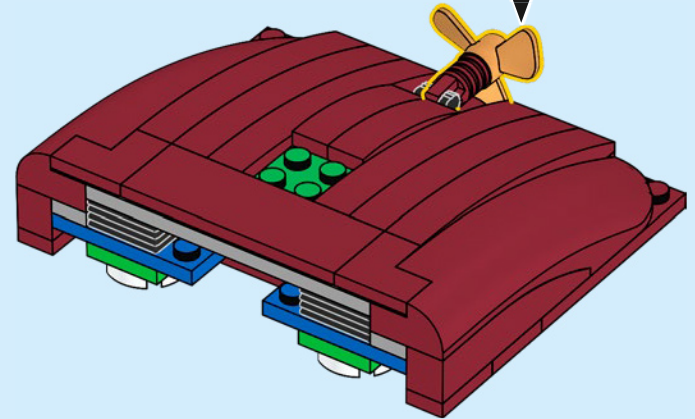
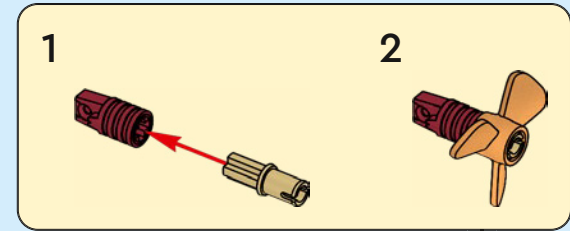

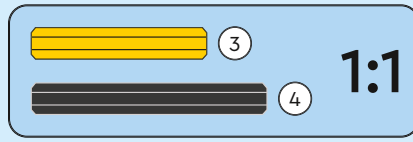
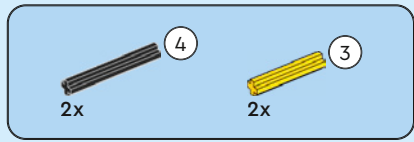

43

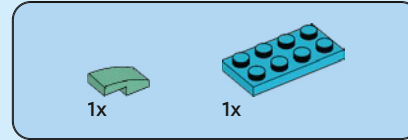
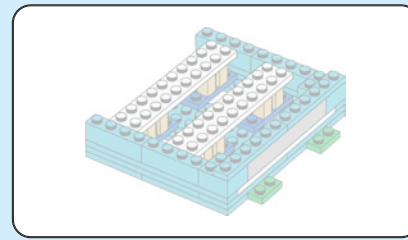
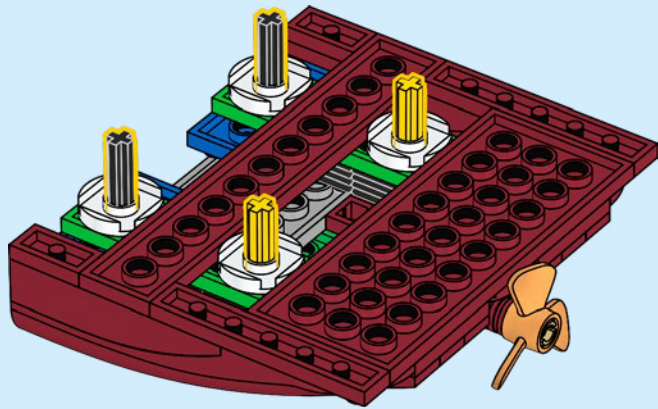

44

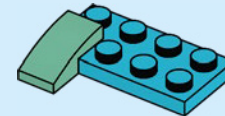

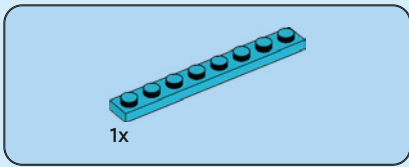

45

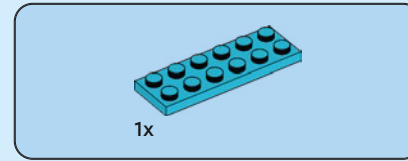
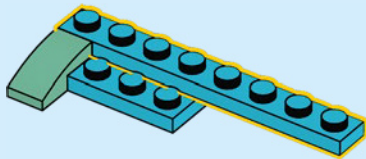
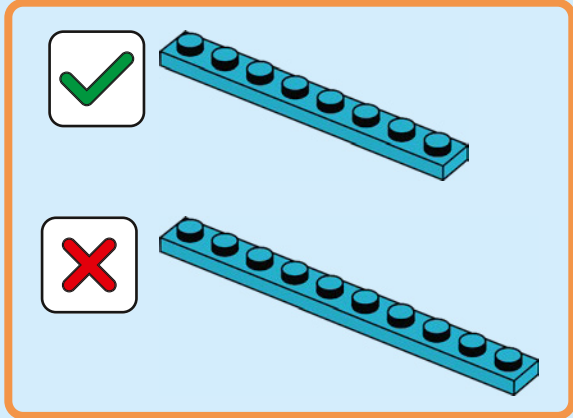

46

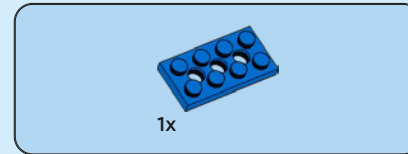
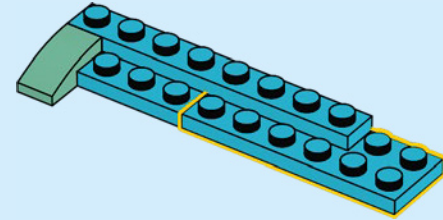

47

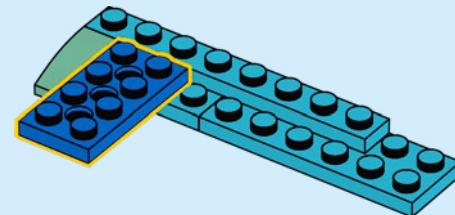

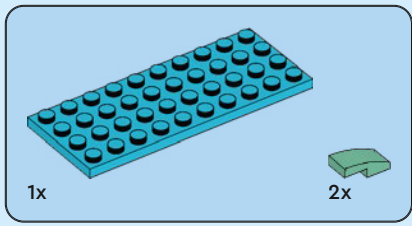

48

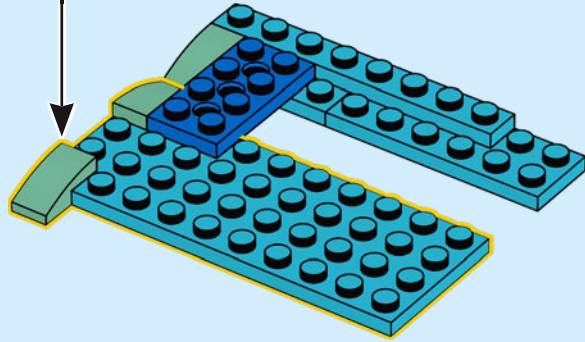
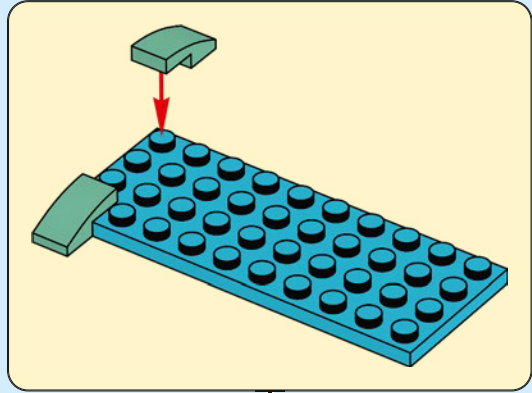

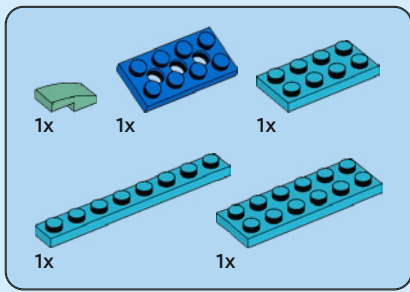

49

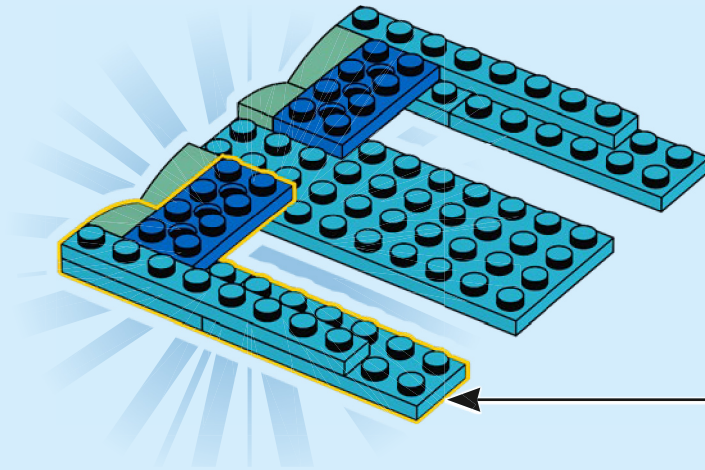
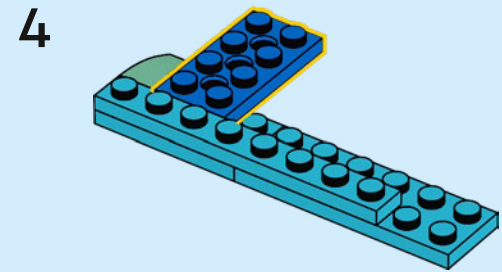
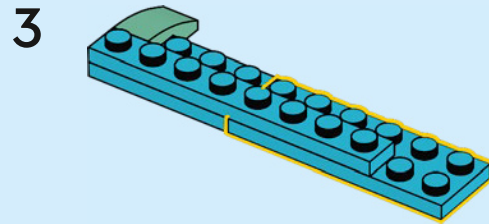
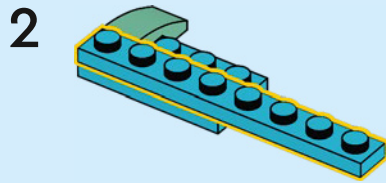
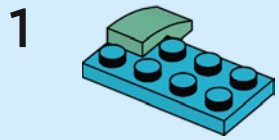
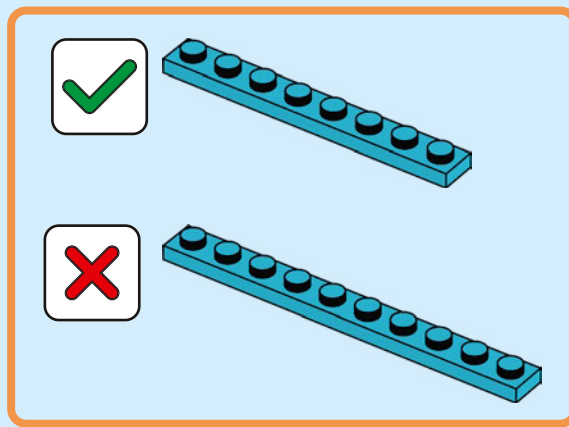



50

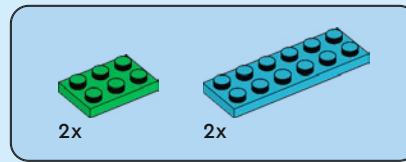
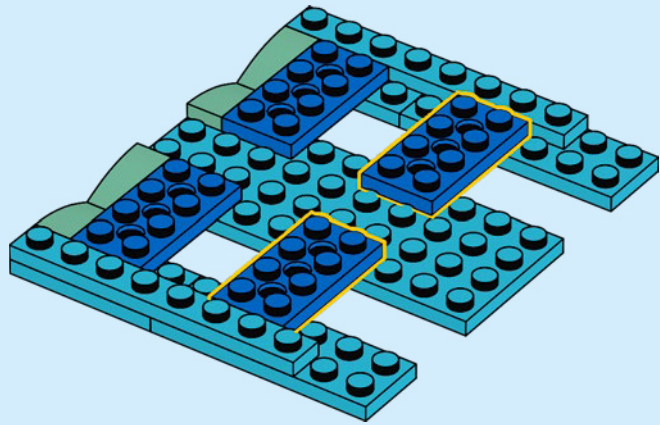

51

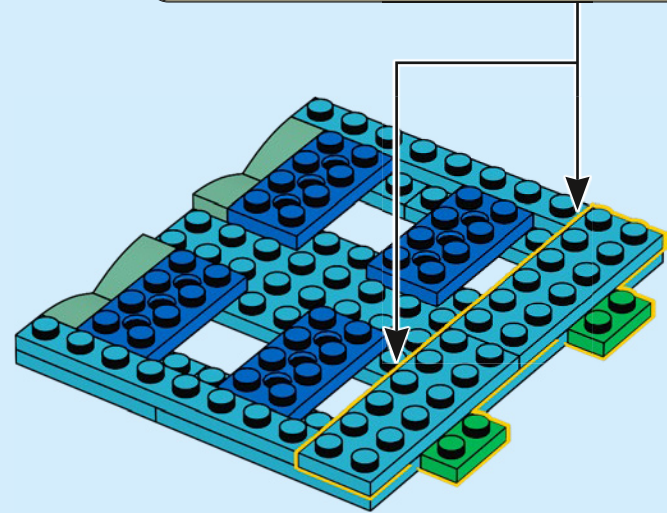
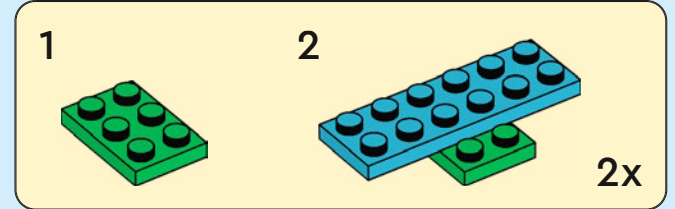

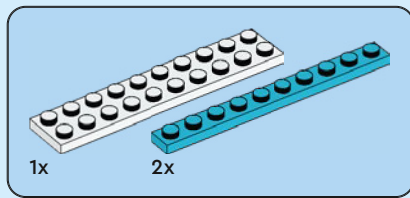

52

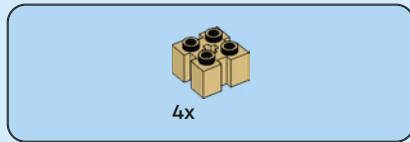
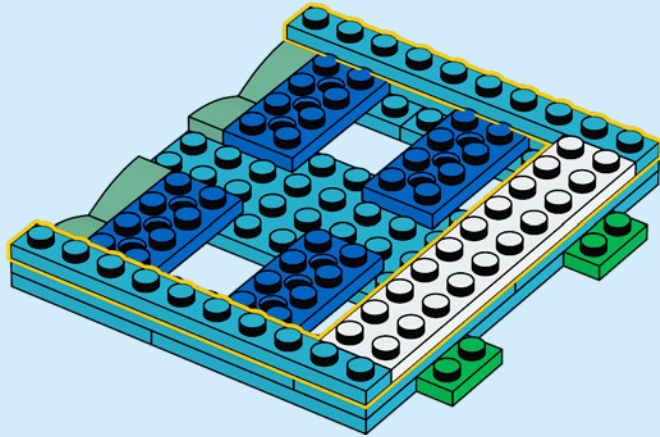

53

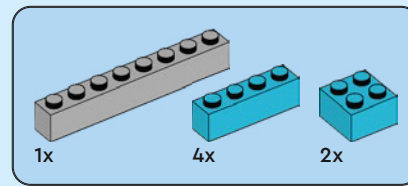
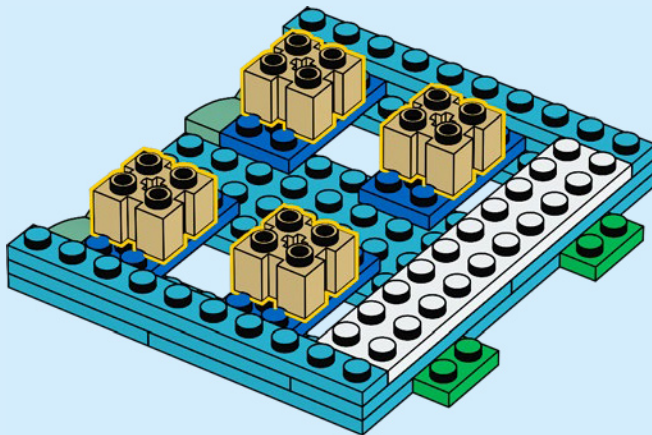

54

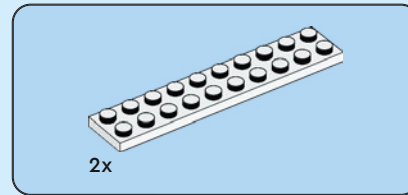
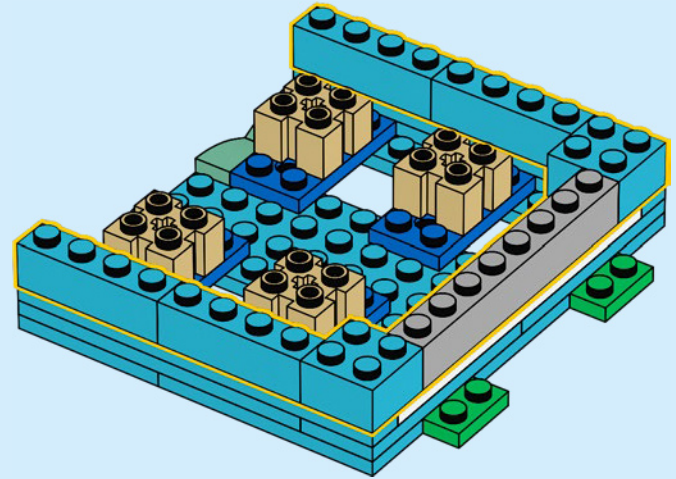

55

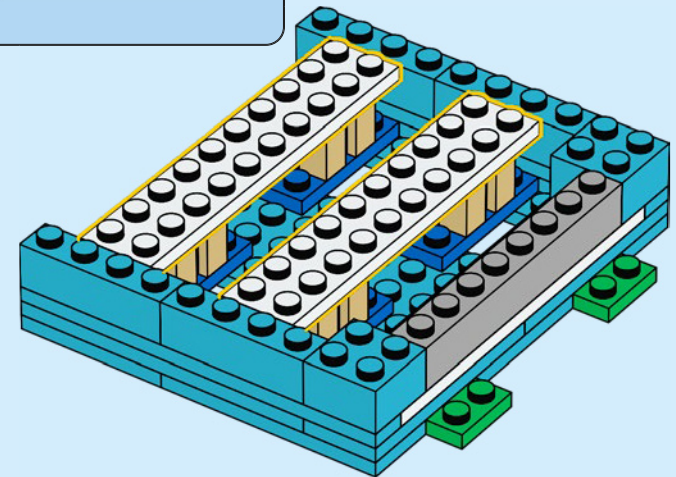

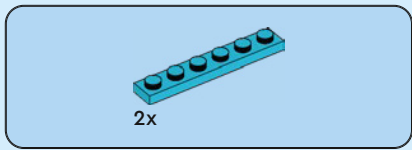

56

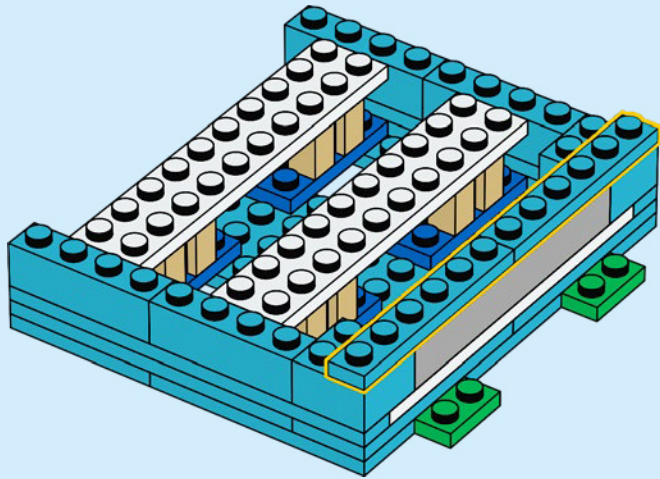

57

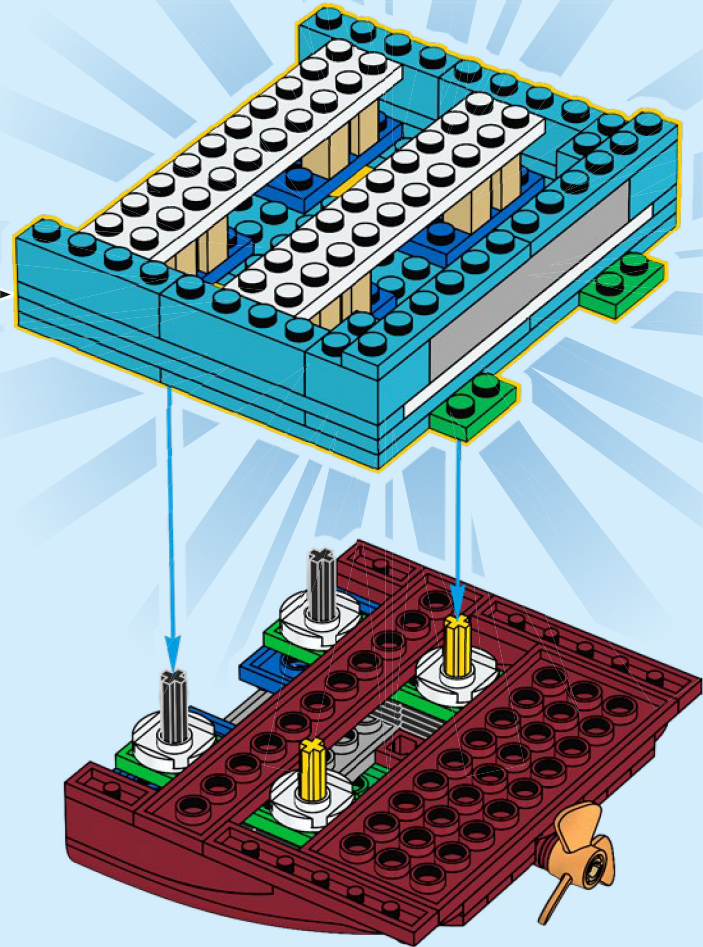

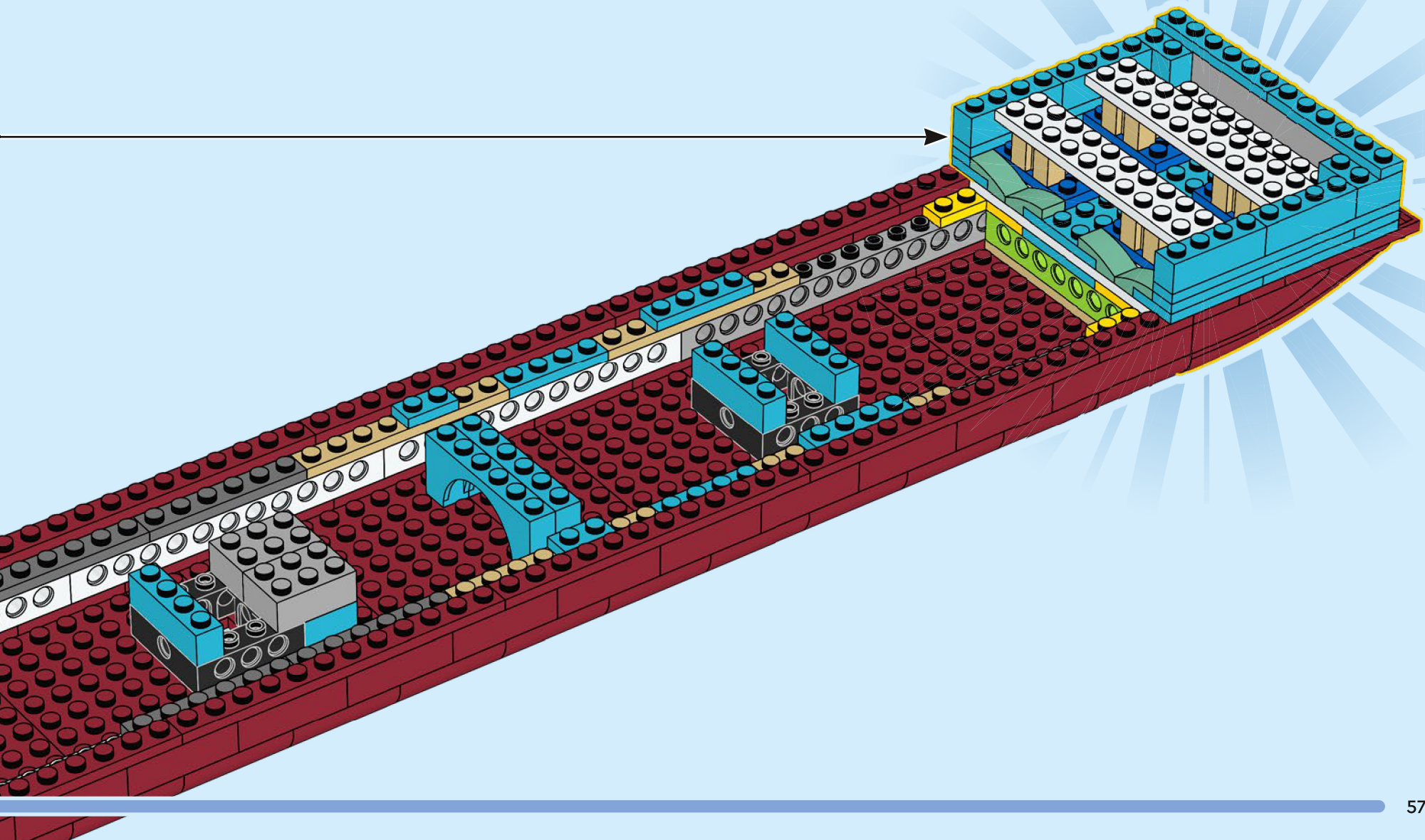

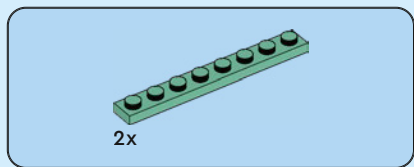
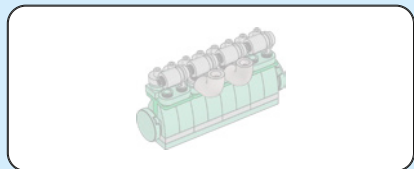

59

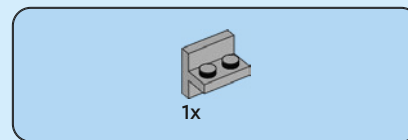
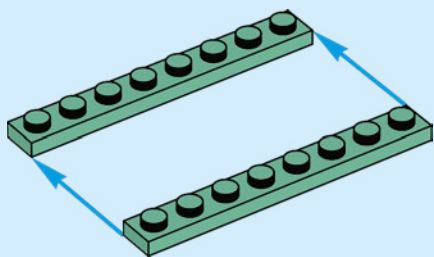

1x

60

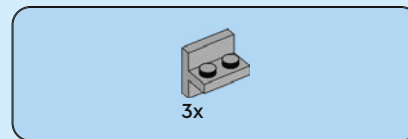
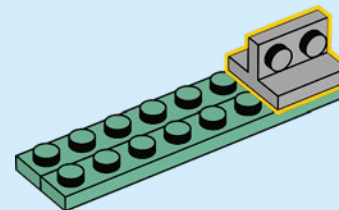

3x

61

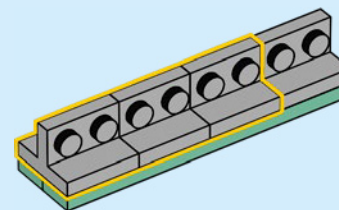



62

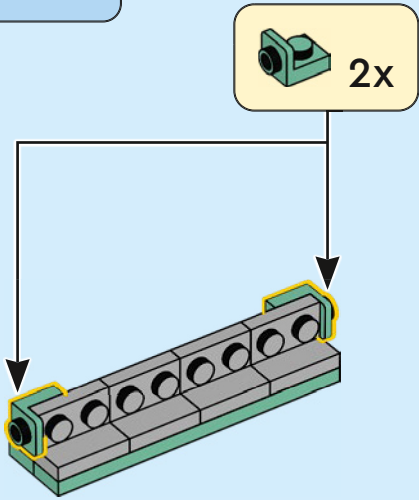

63

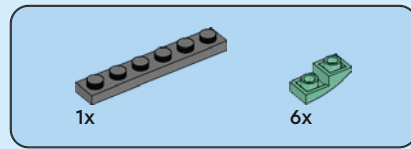
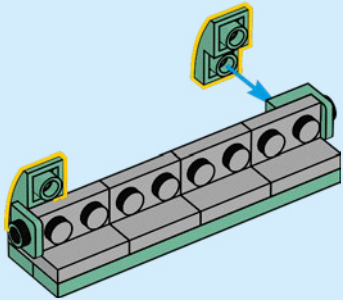

64

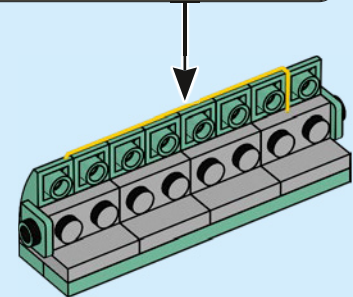
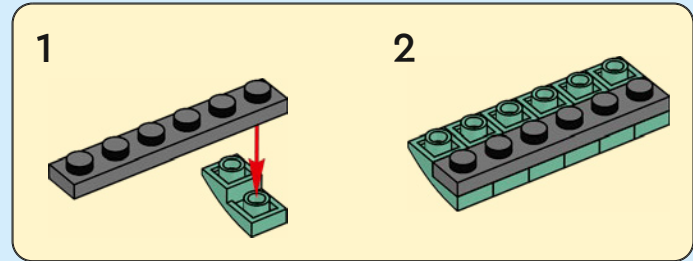

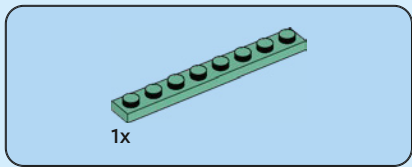

65

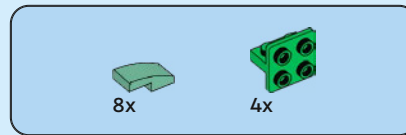
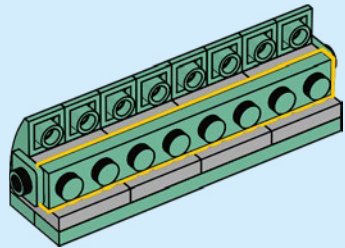

66

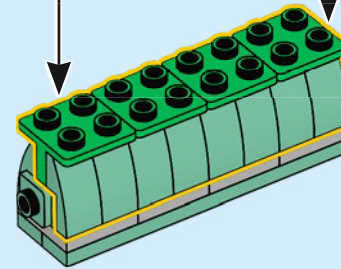
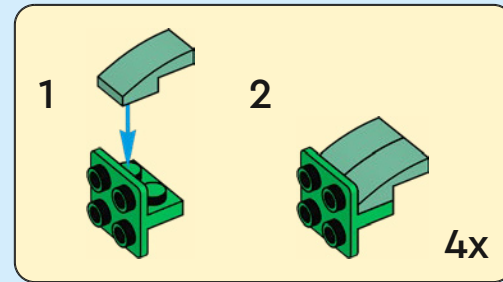

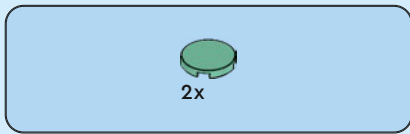

67

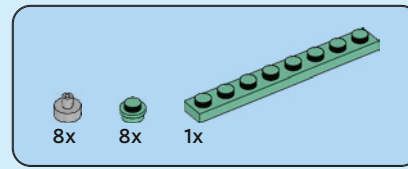
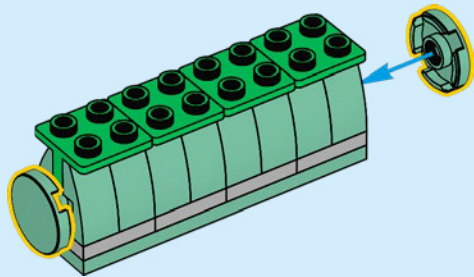

68

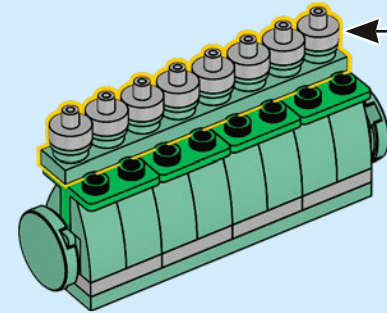
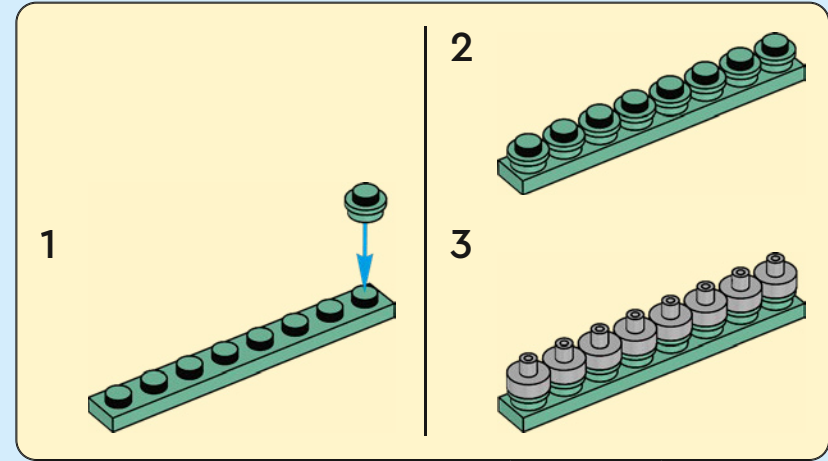



2x

69

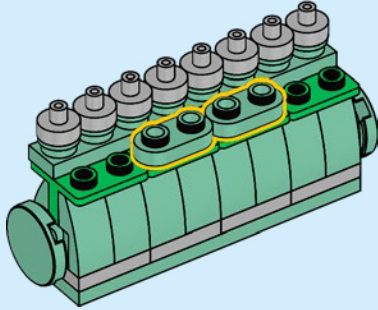

2x



2x

70

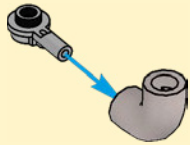
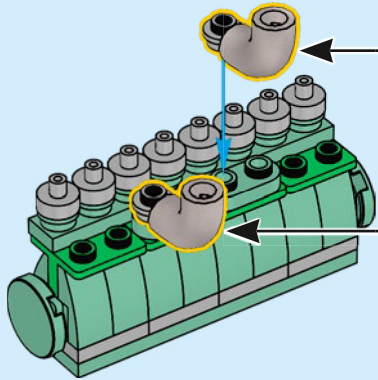

2x



2x

71

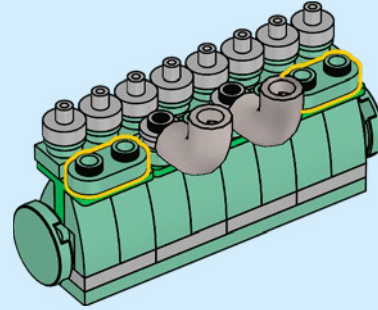

4x



4x

72

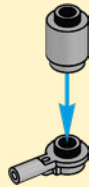
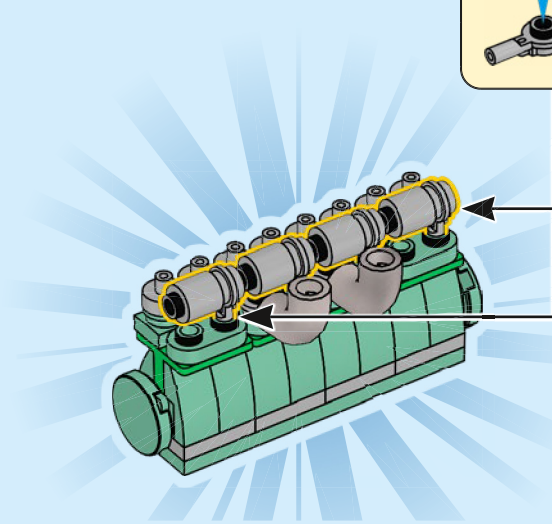

4x

73

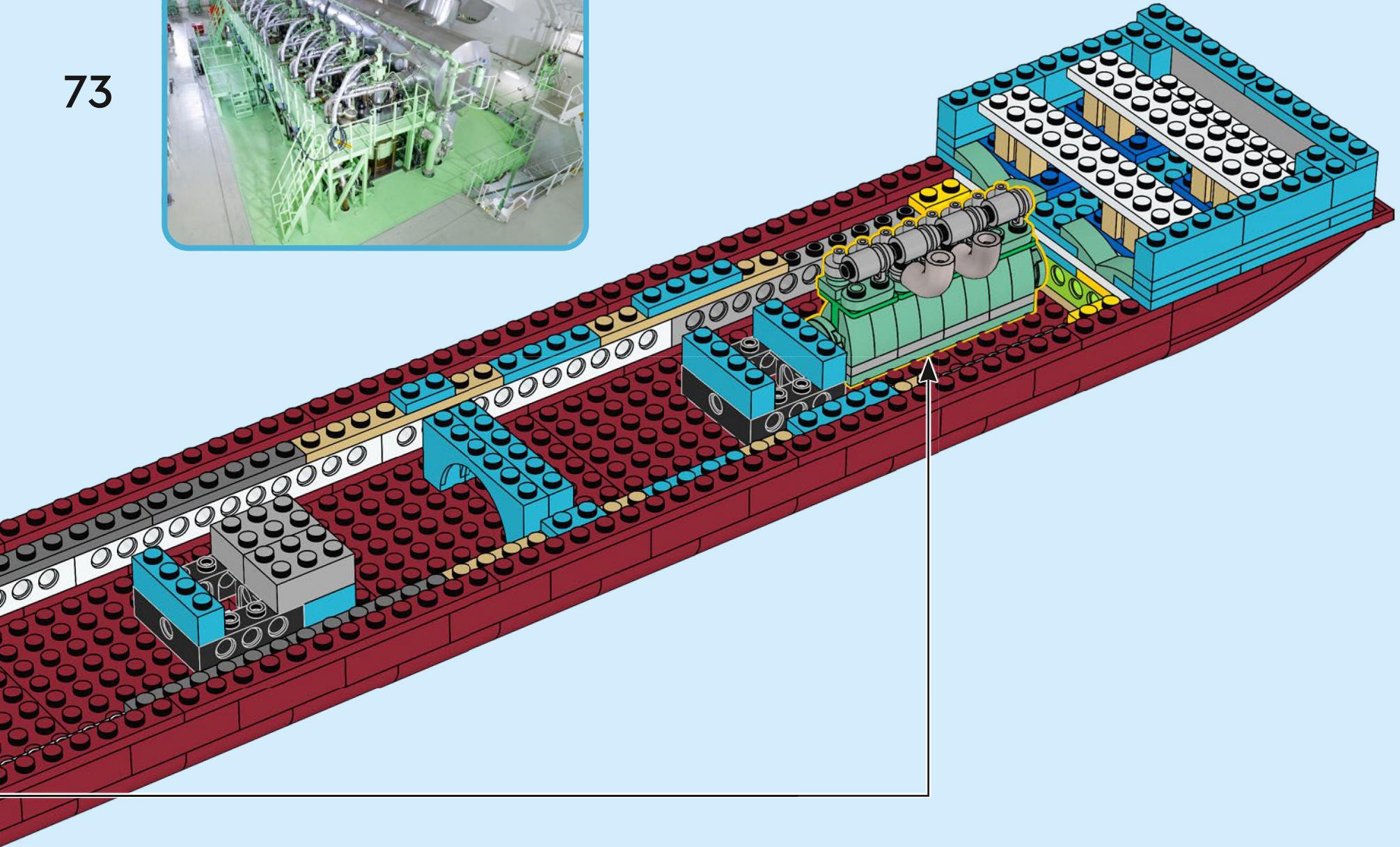
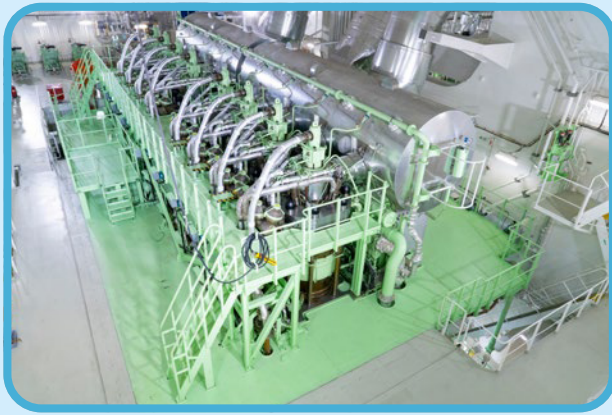

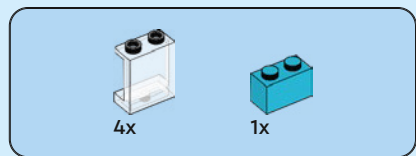

74

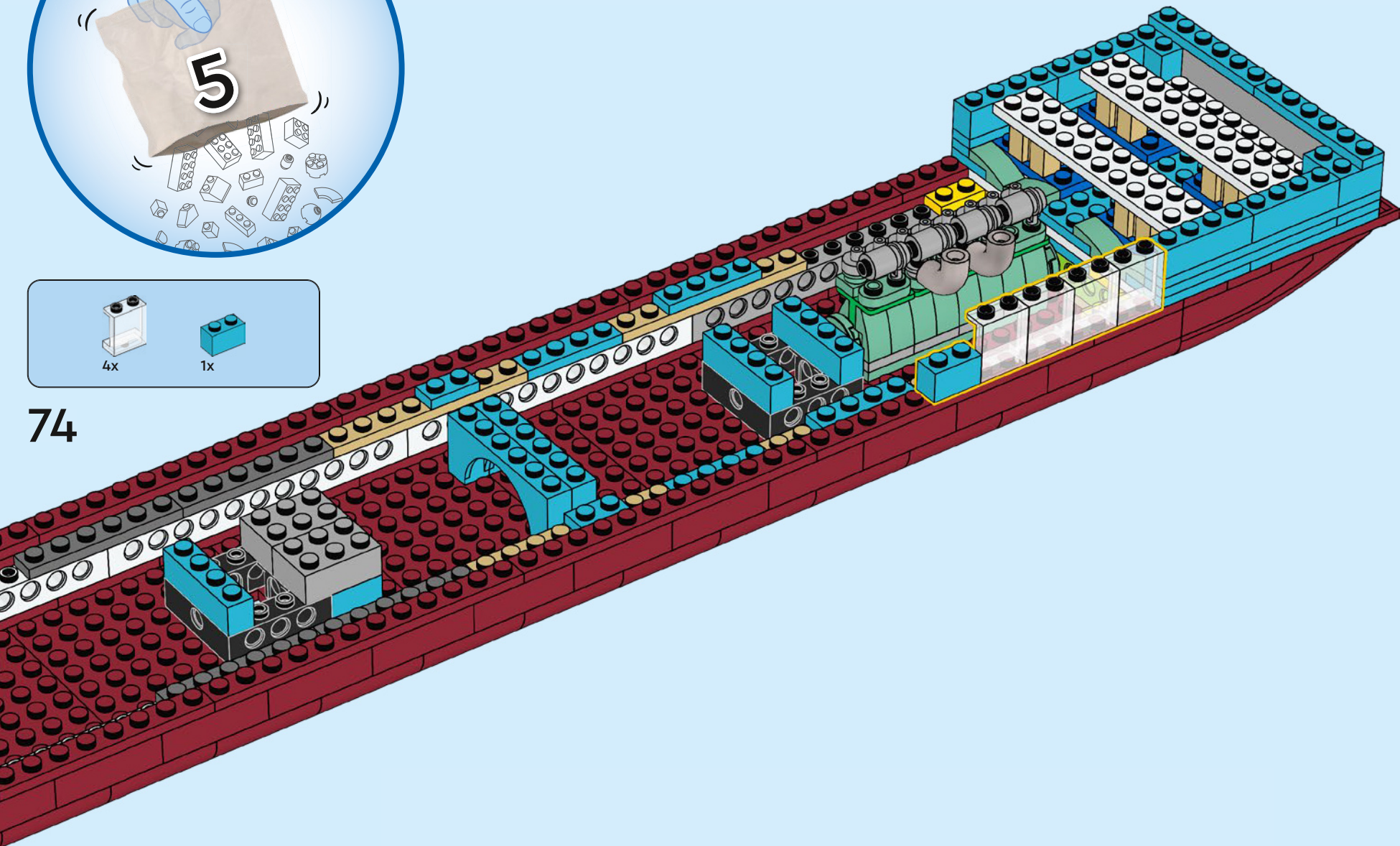

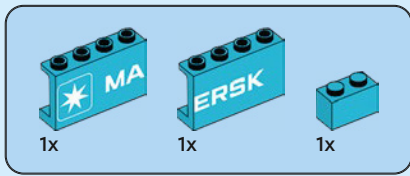

75

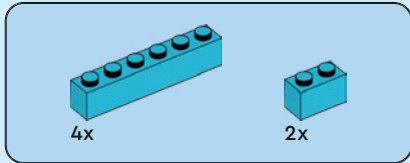
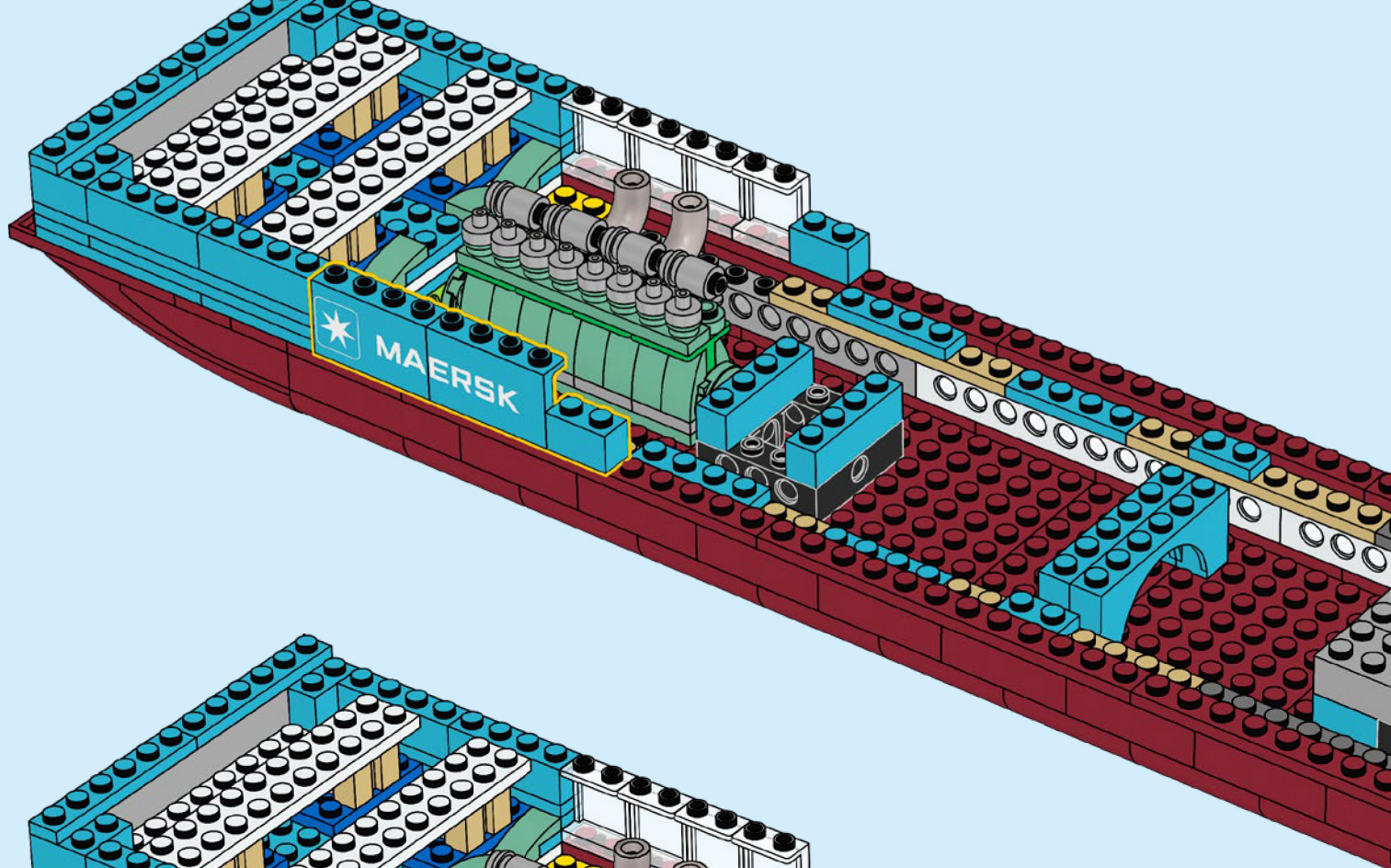

76

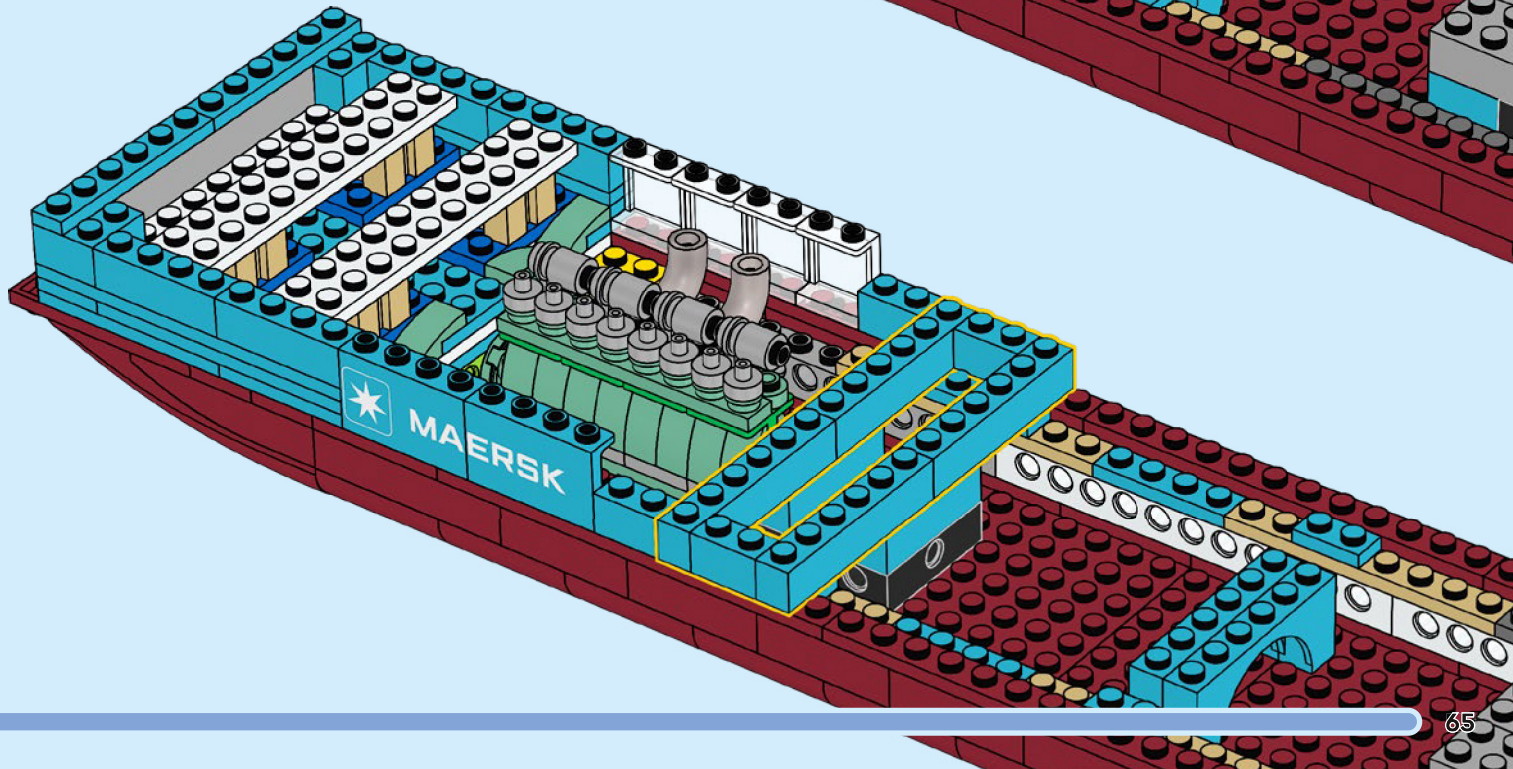

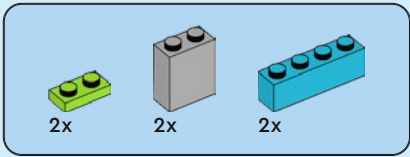

77

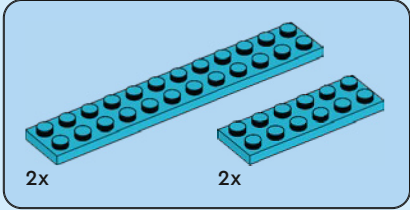
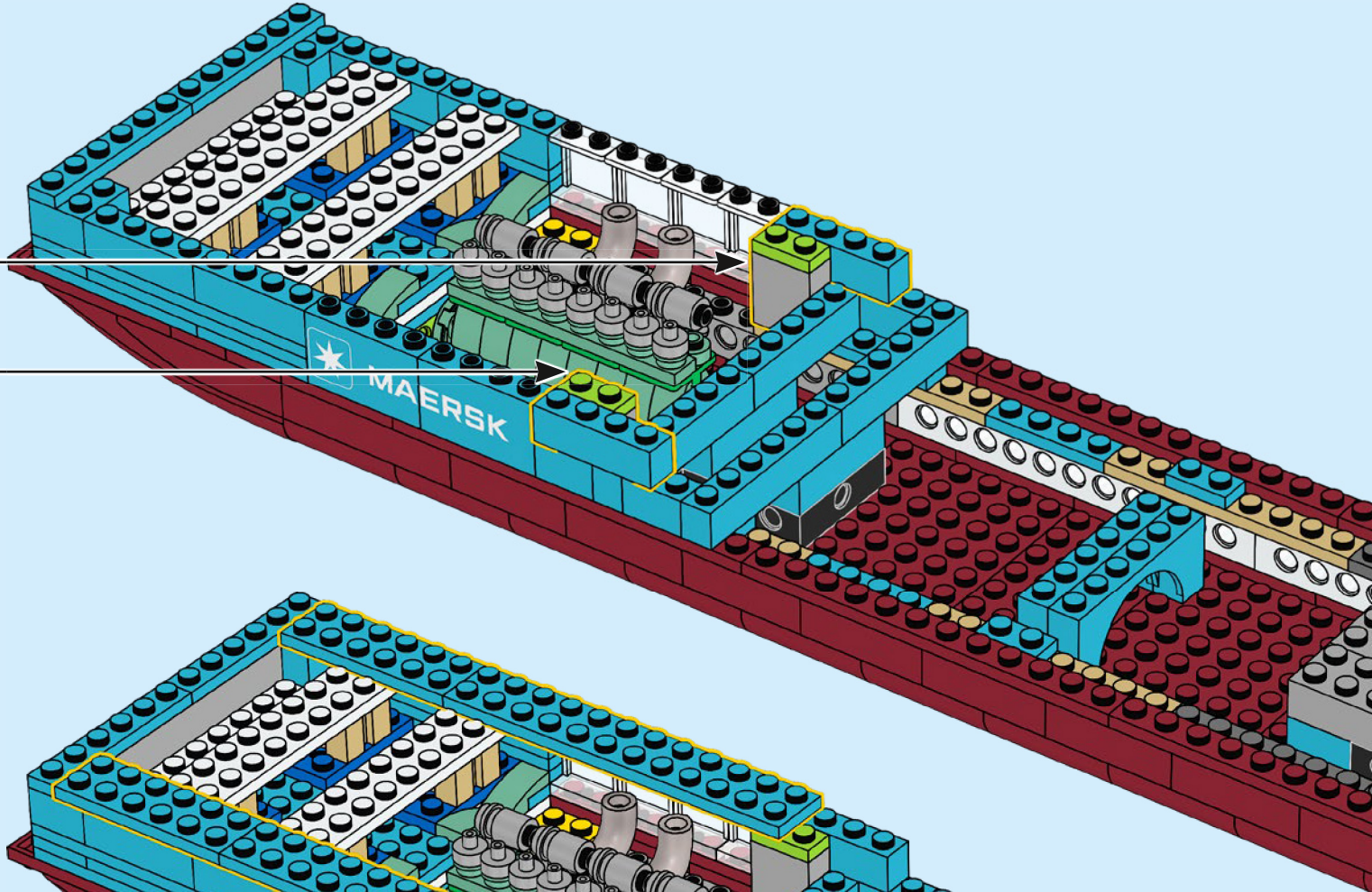
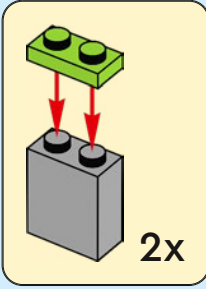

78

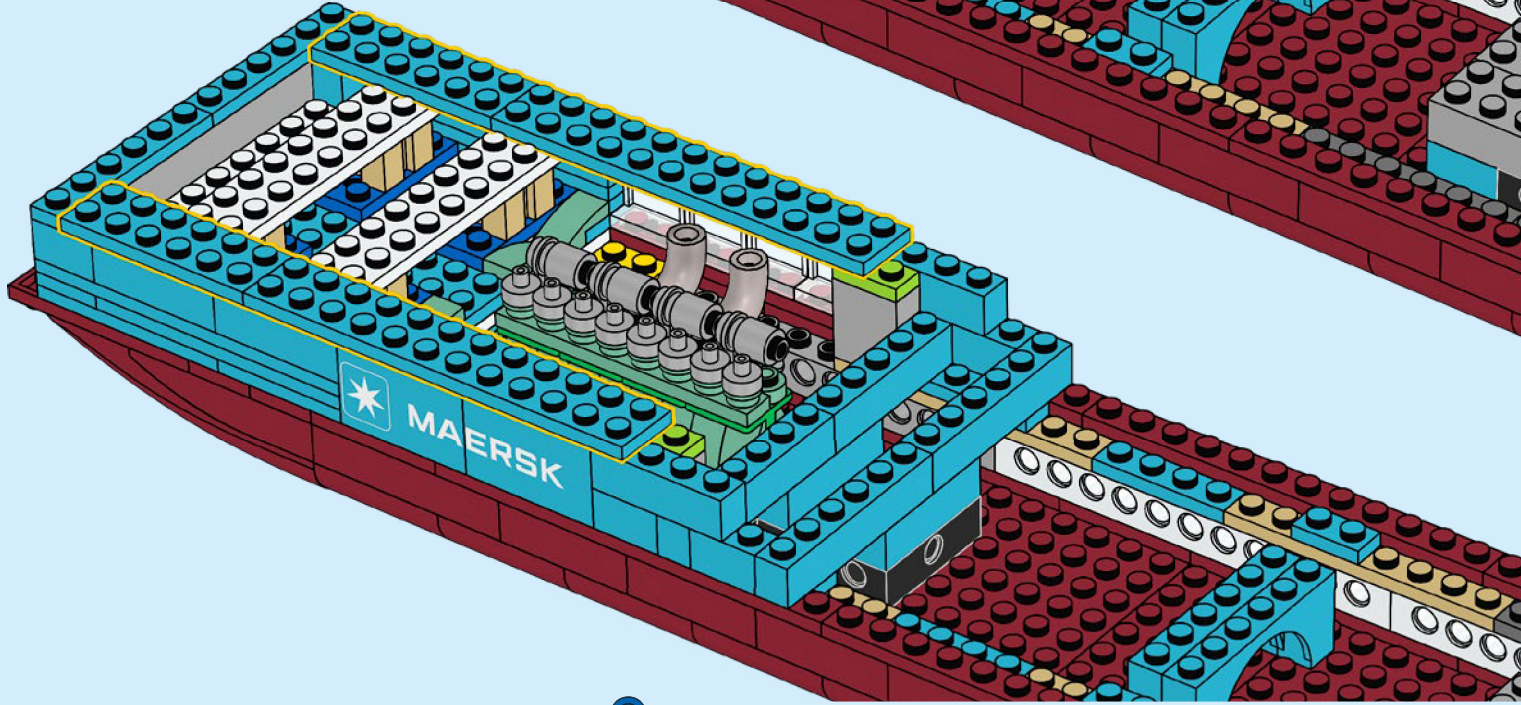

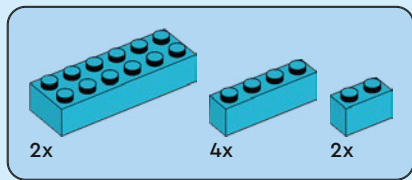

79

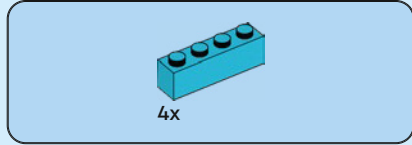
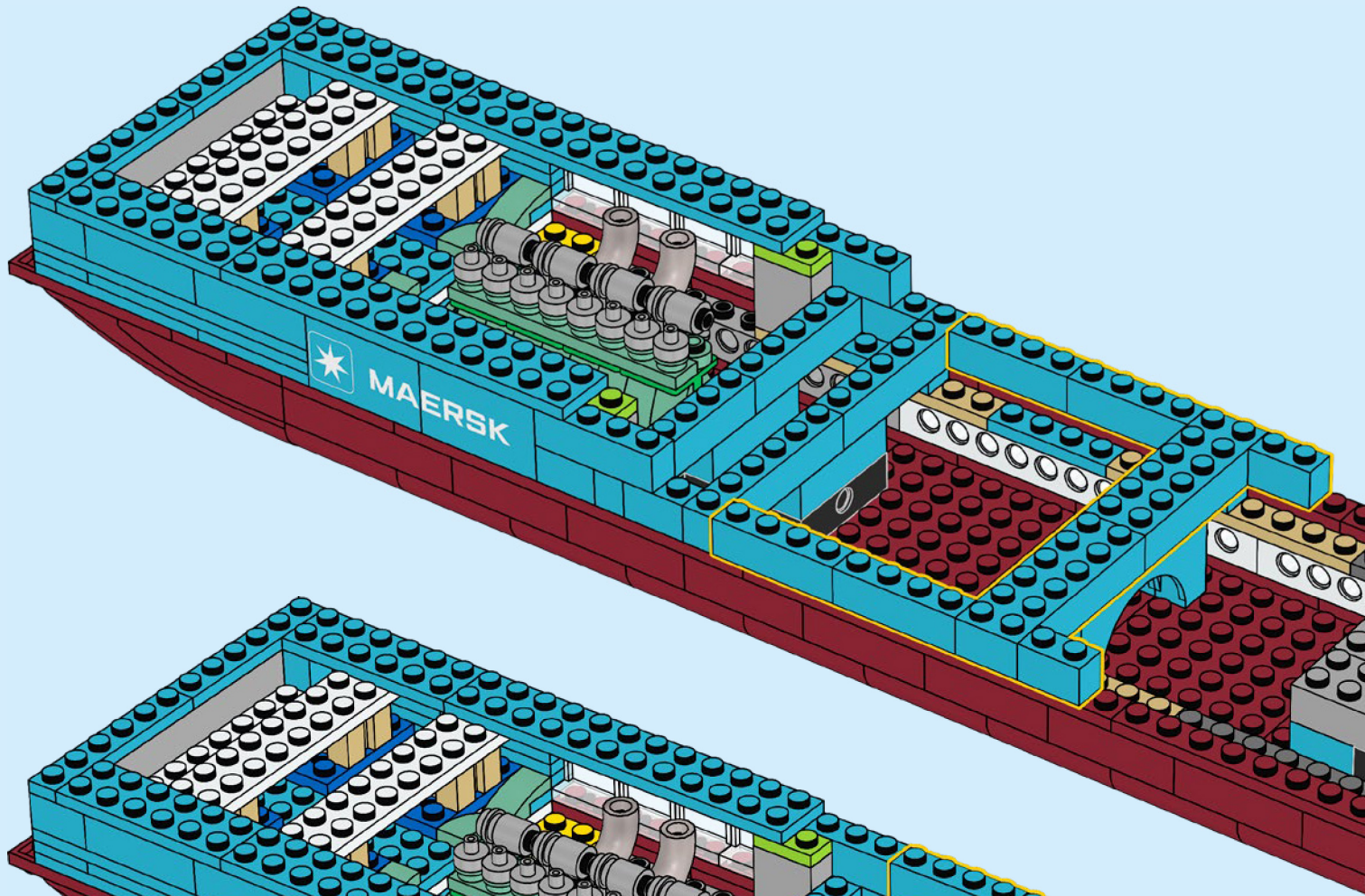

80

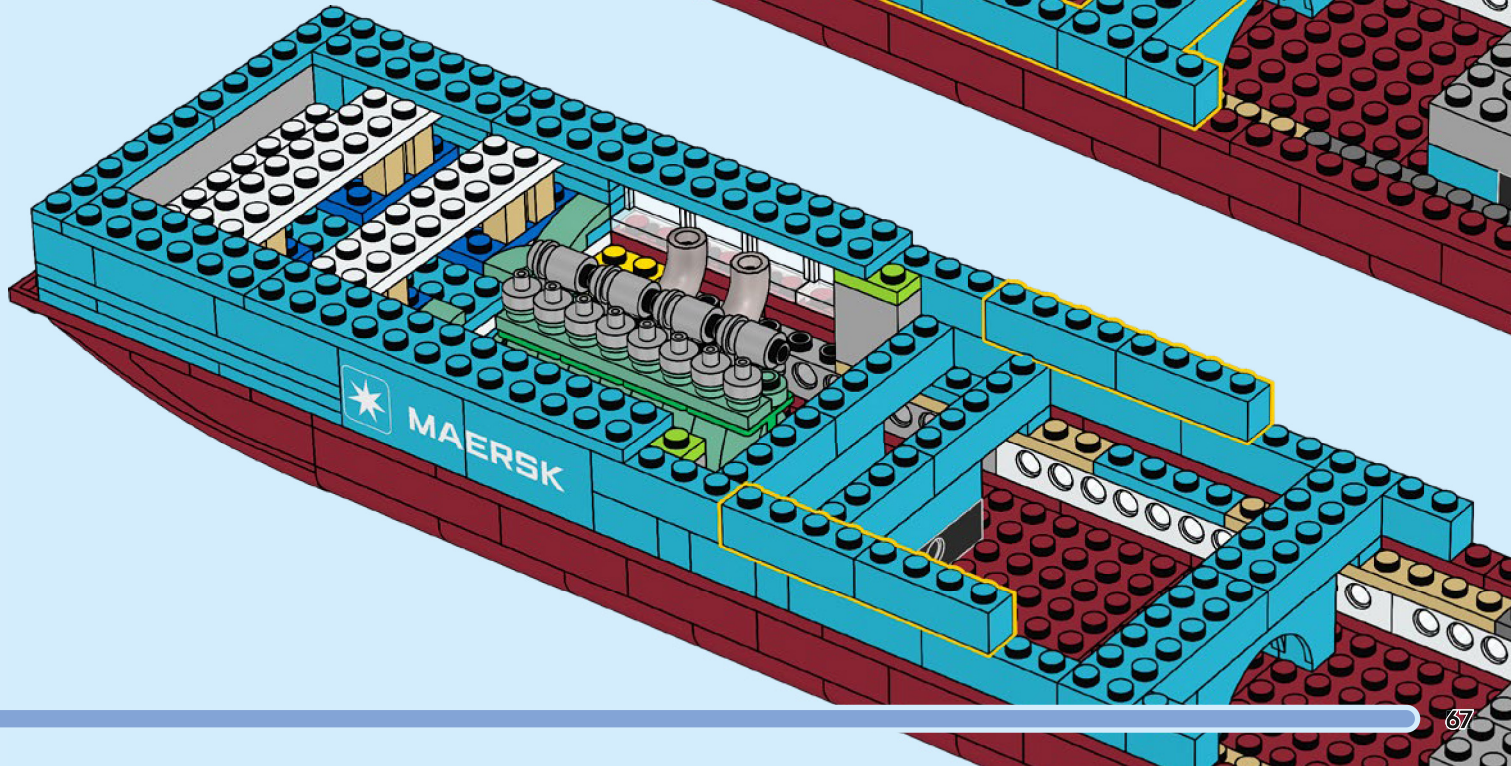

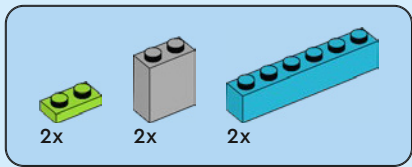

81

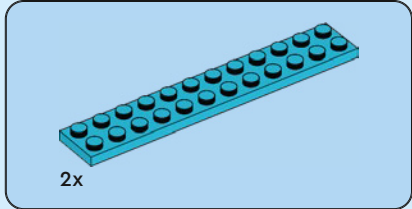
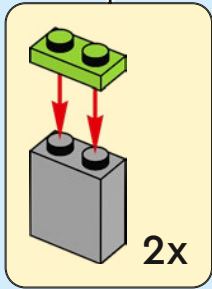
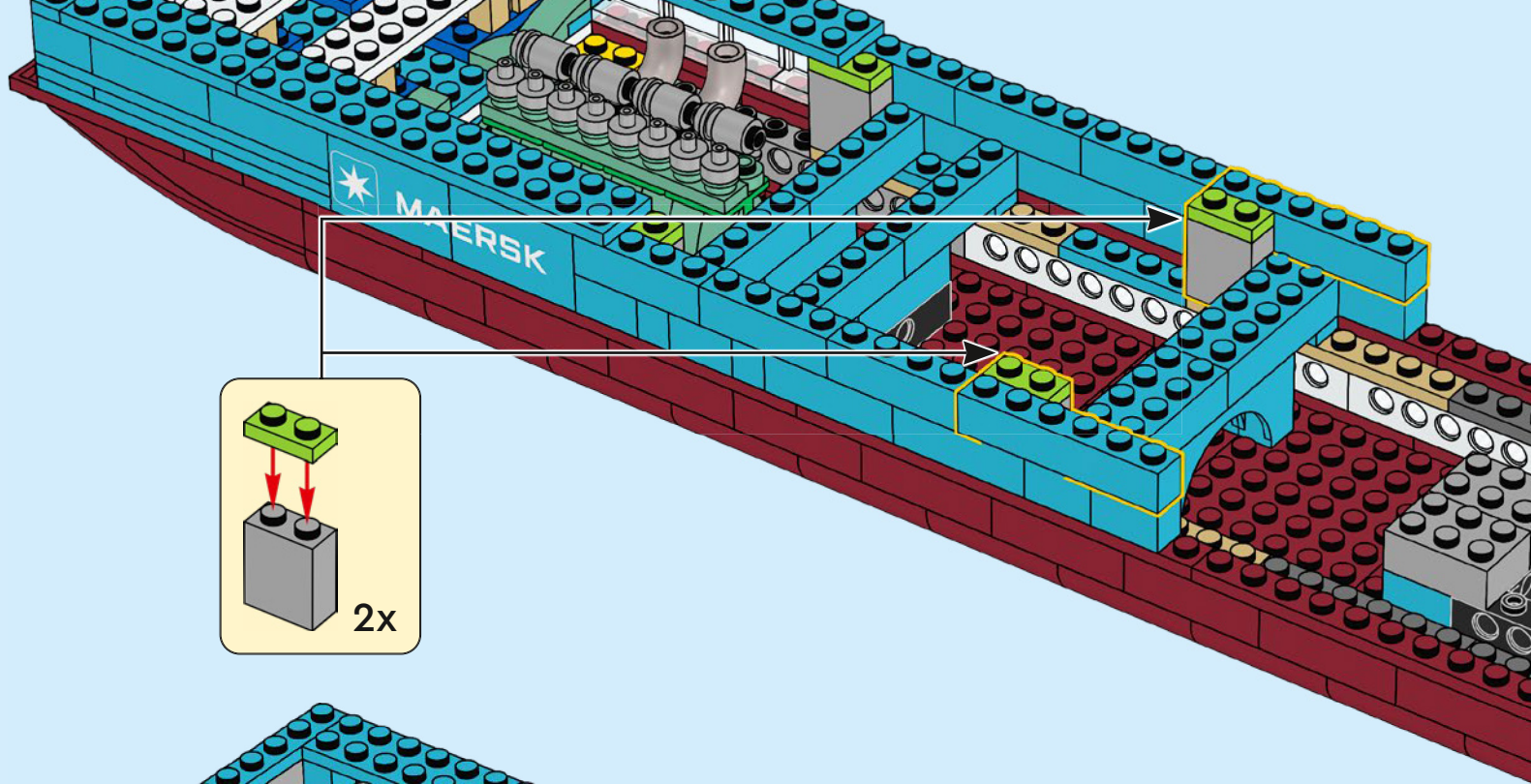

82

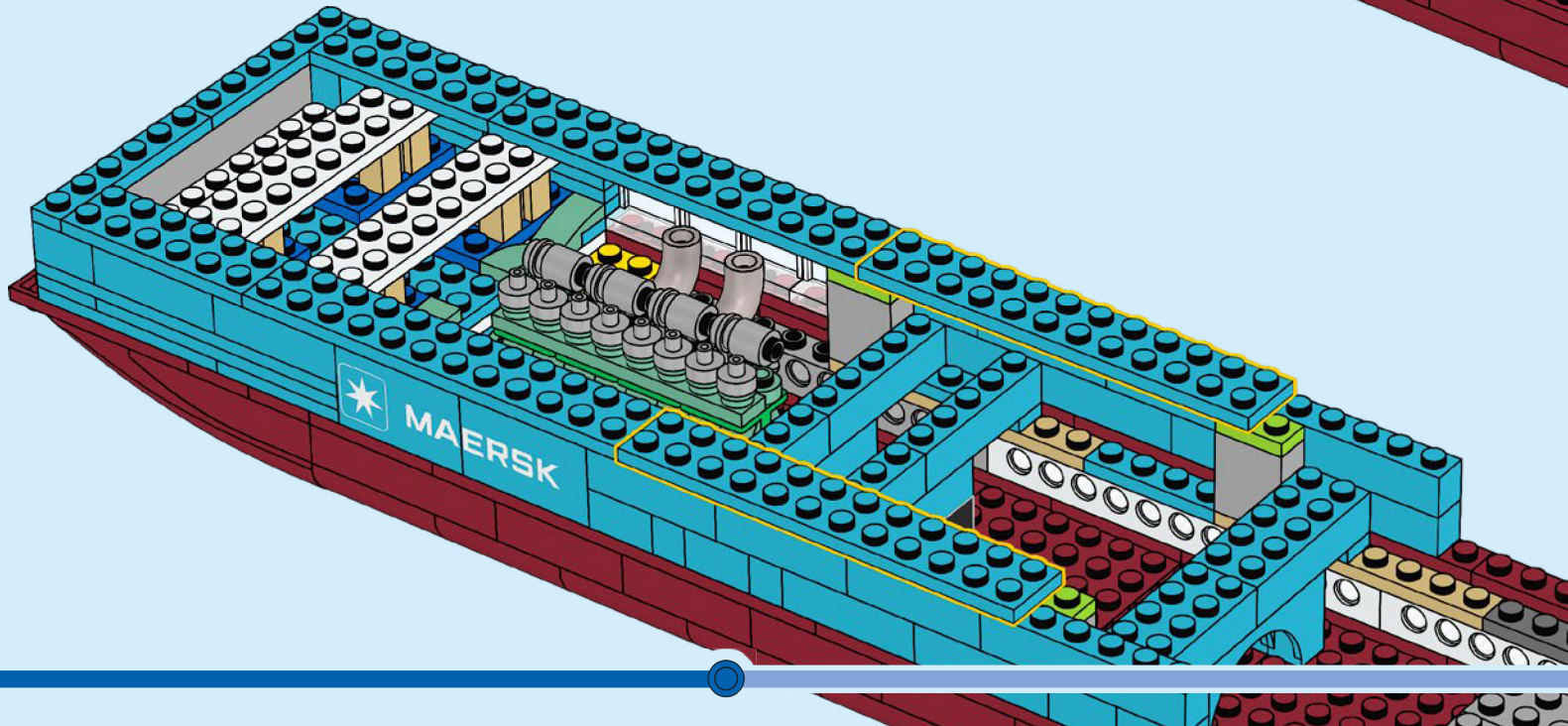

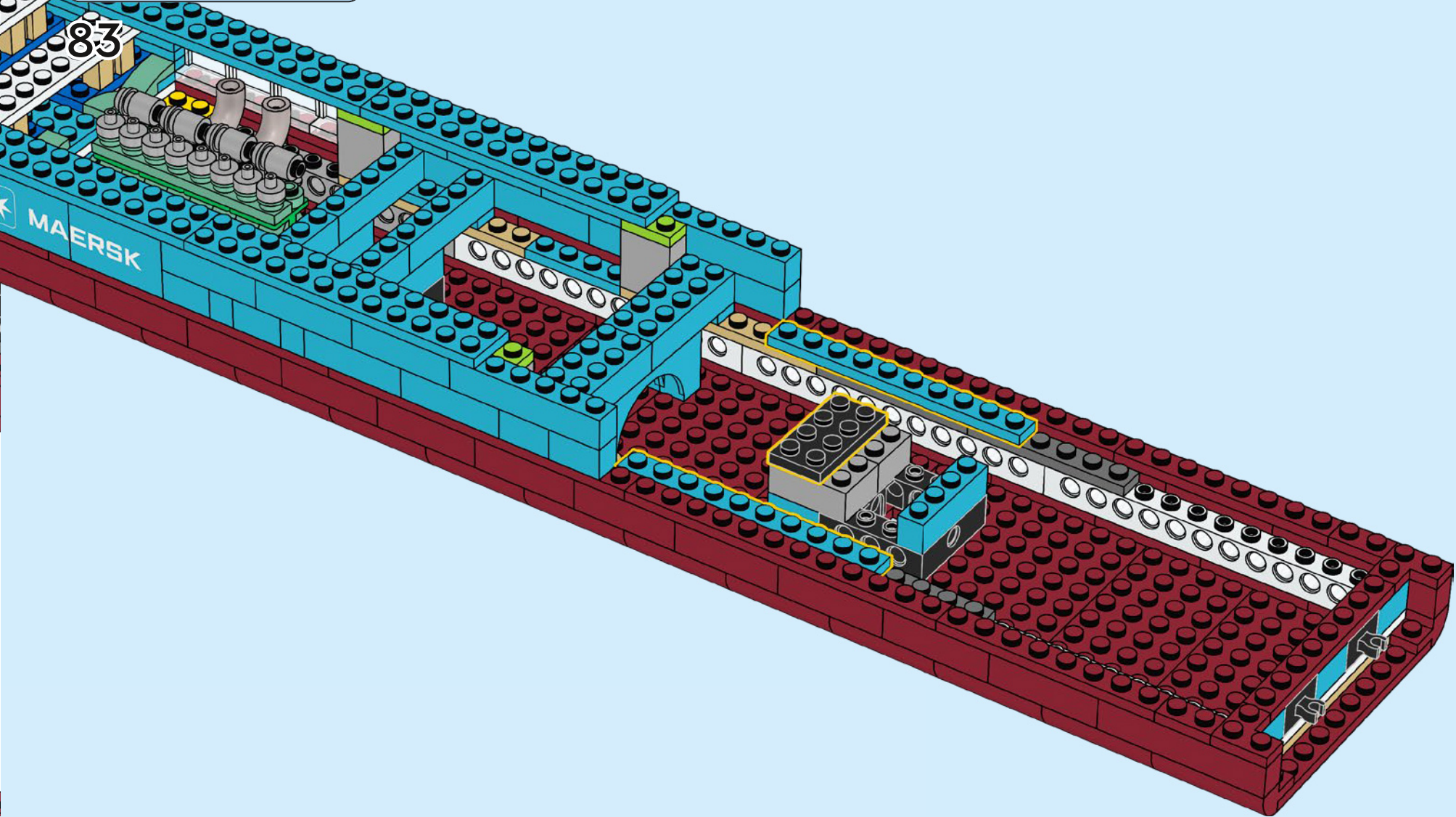
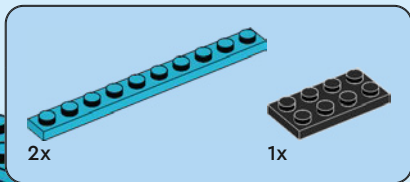

84

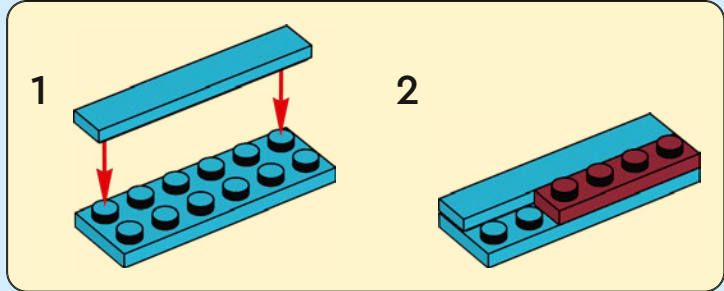
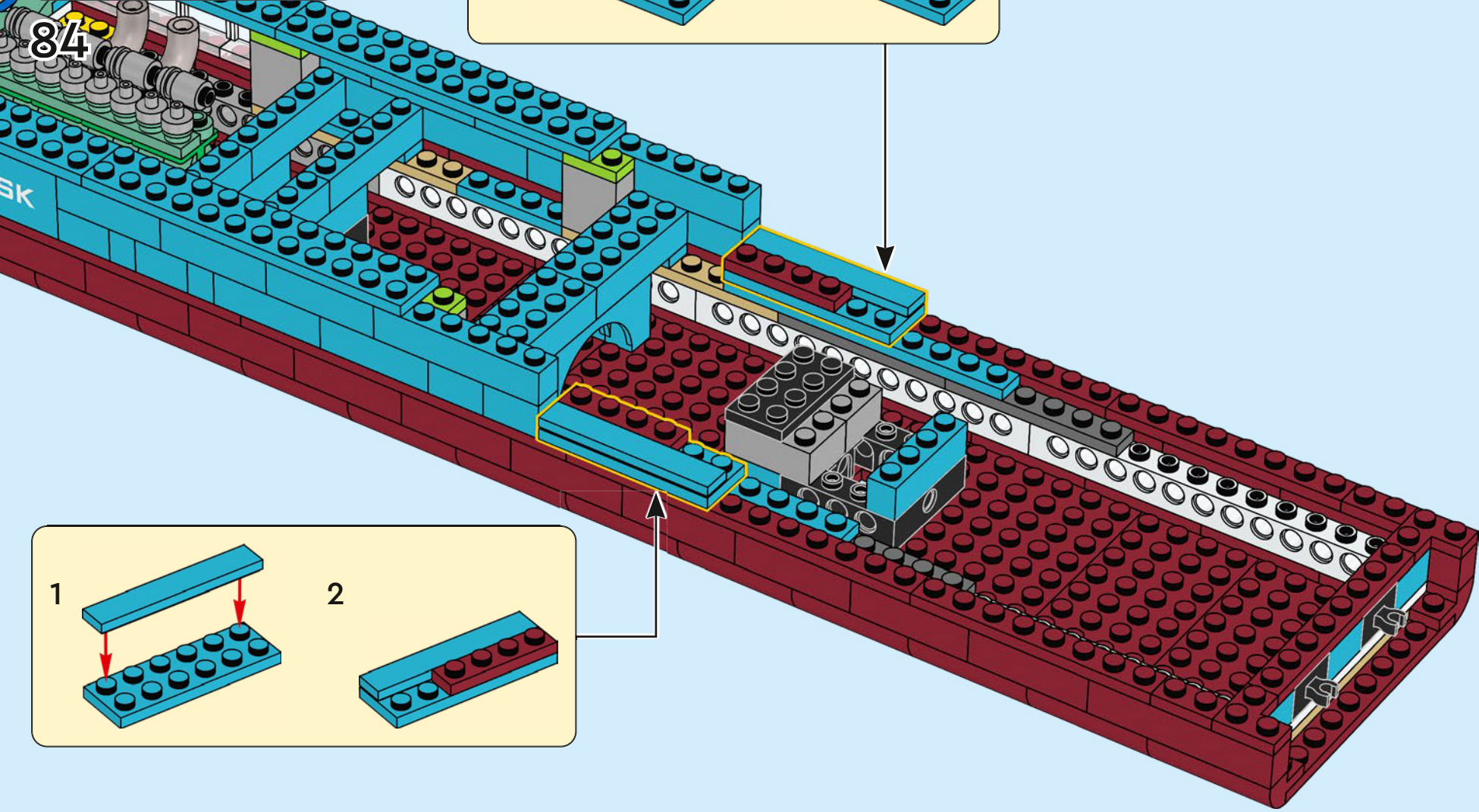
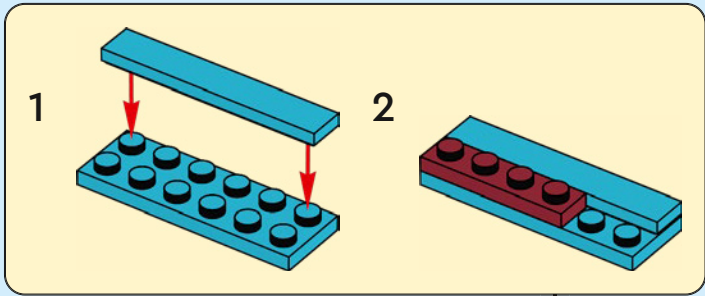
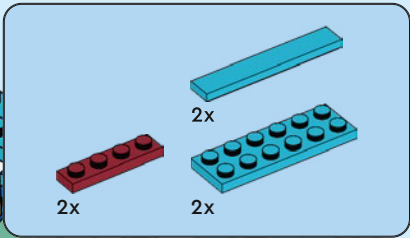

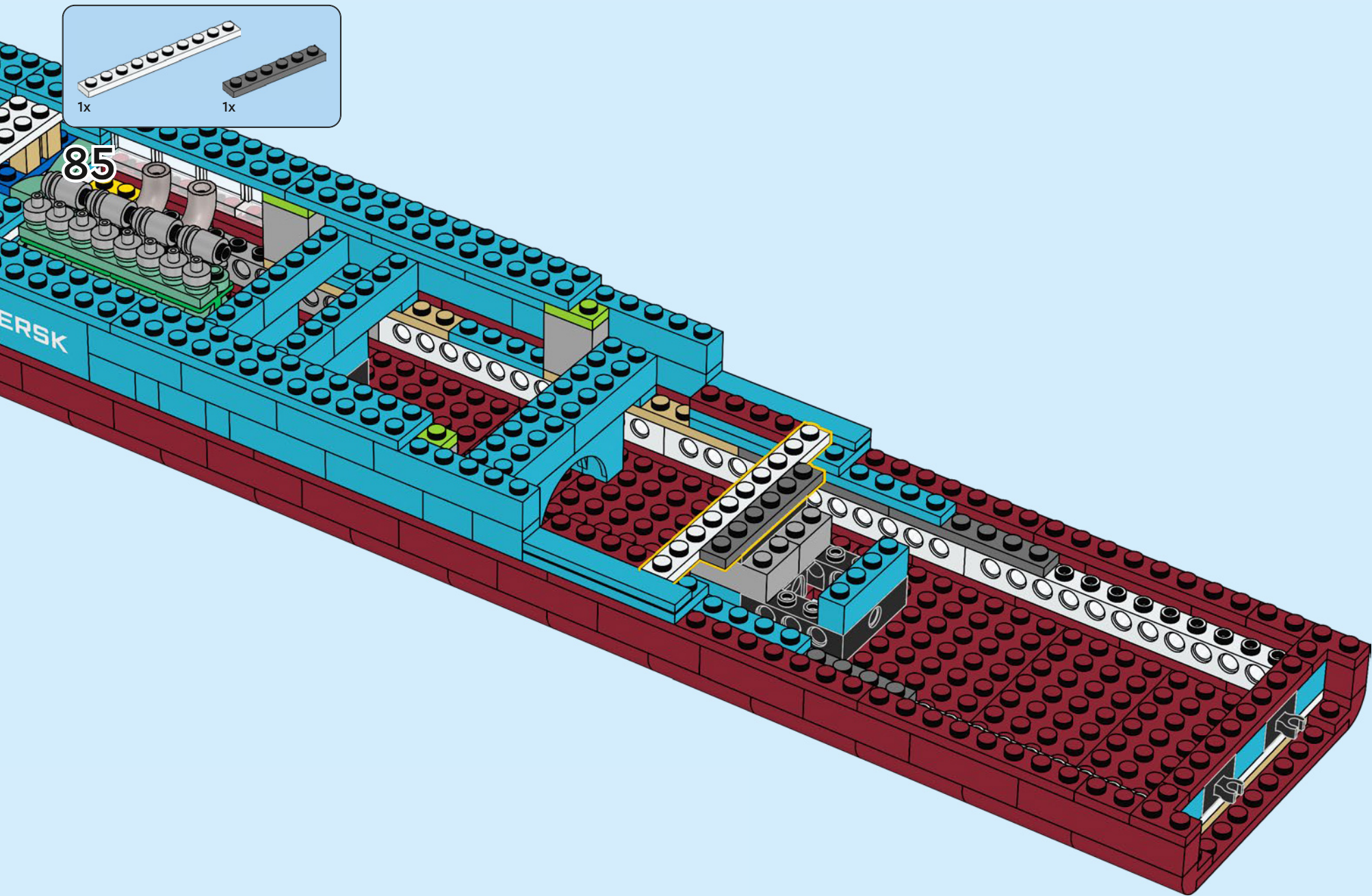

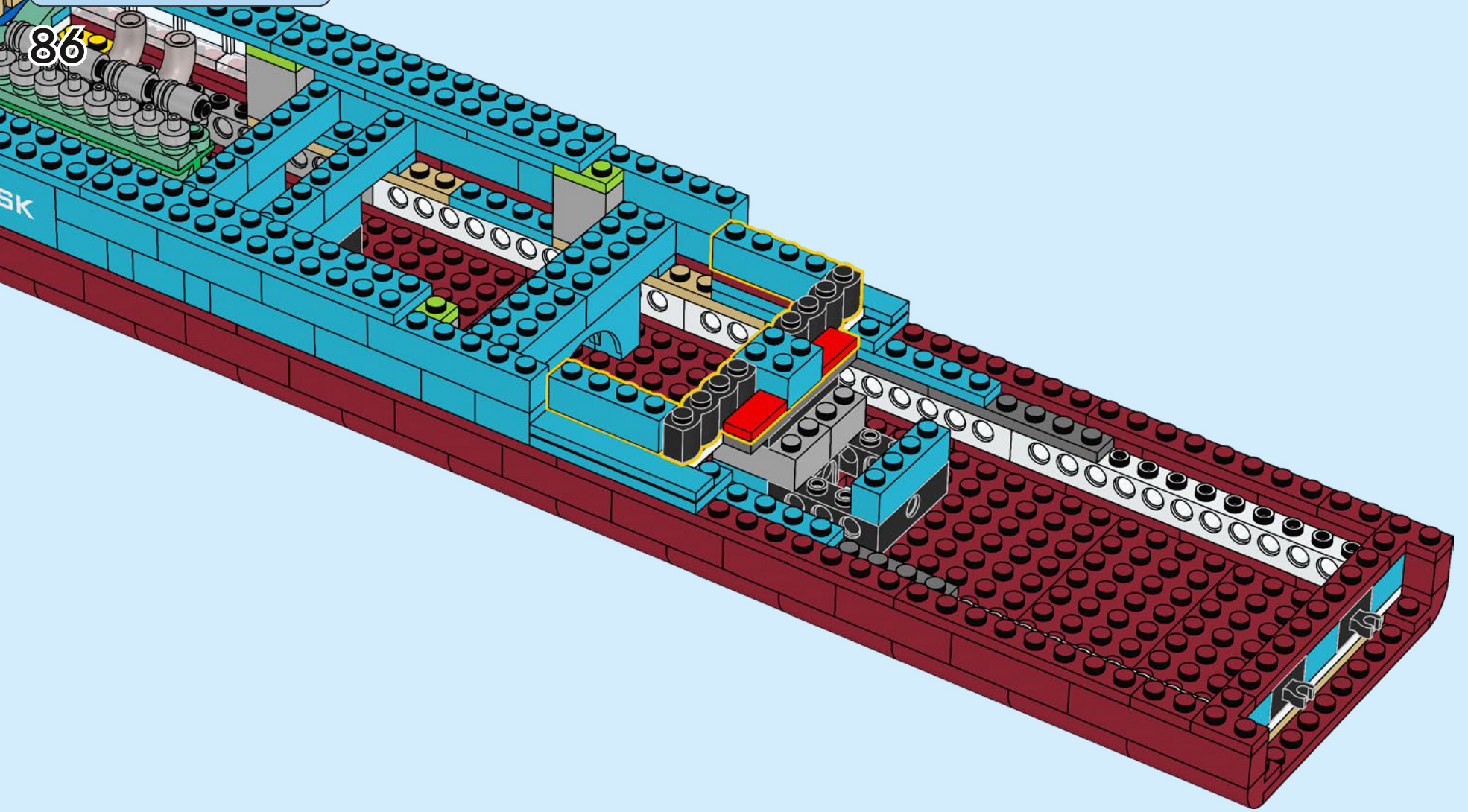
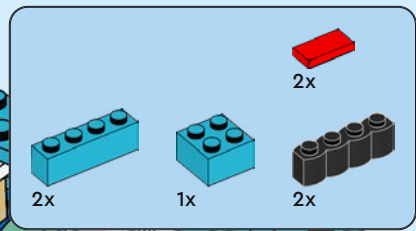

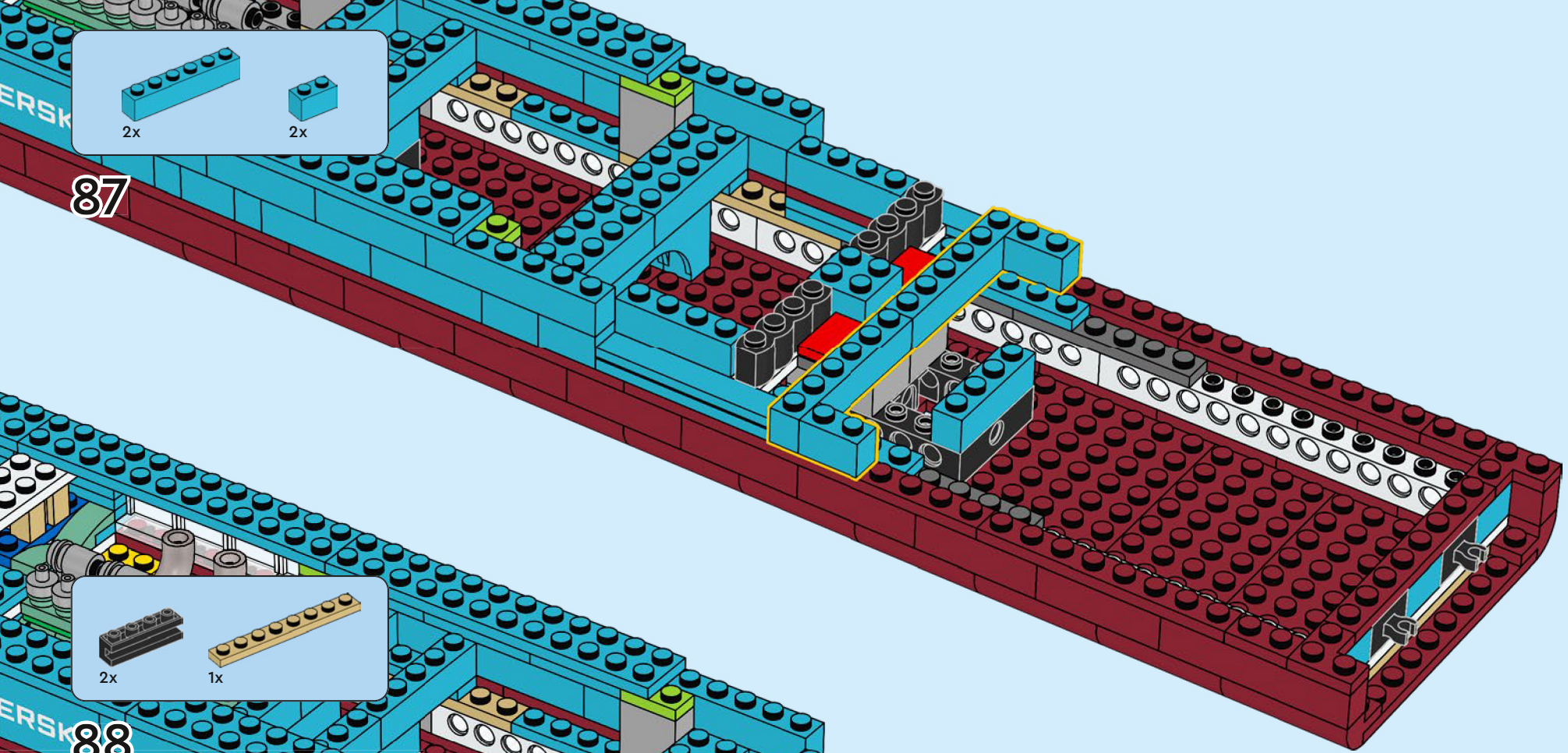

87



88

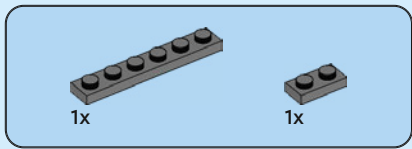

89

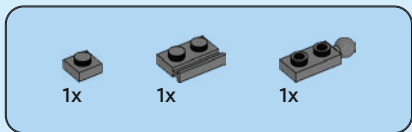
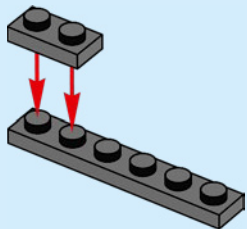

90

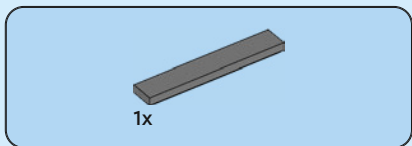
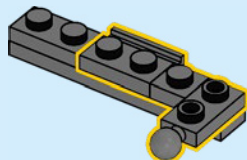

91

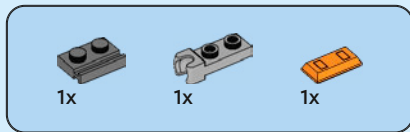
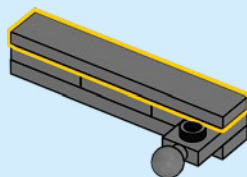

92

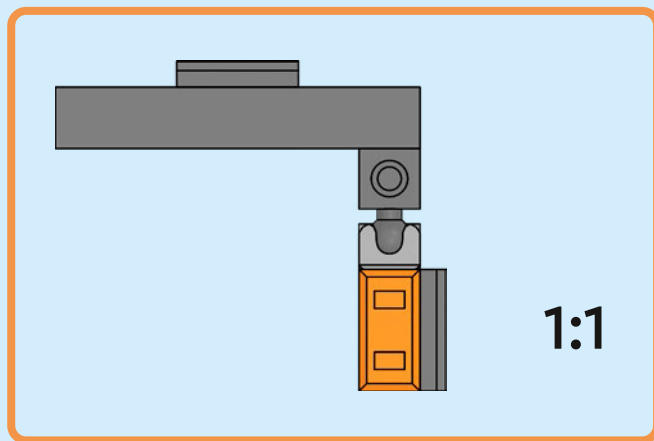
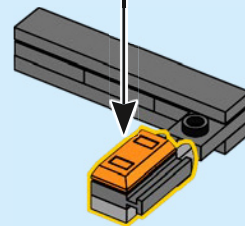
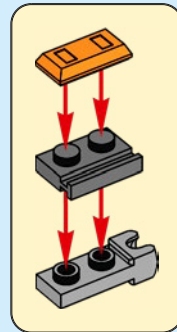

93

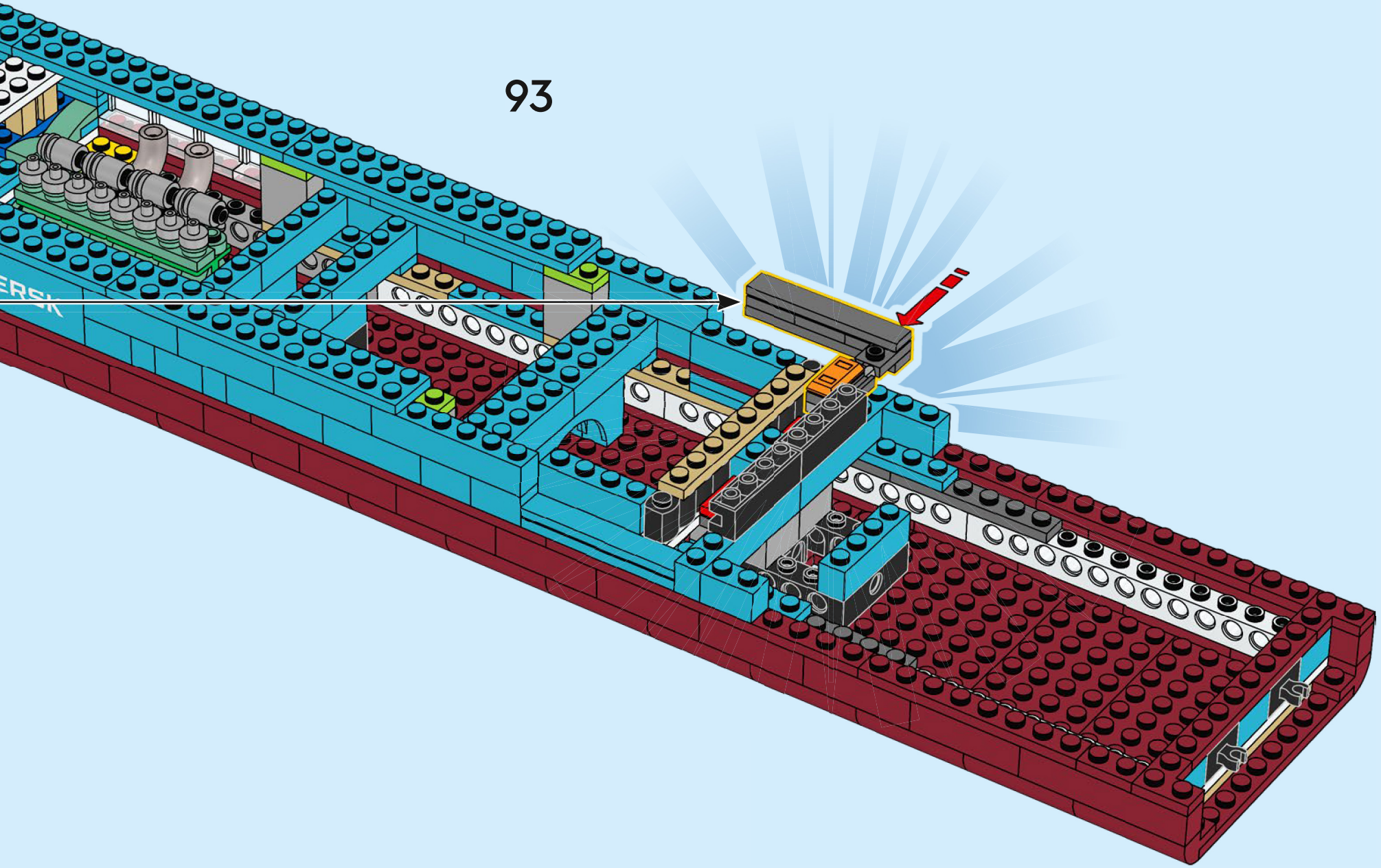

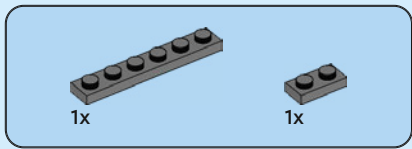

94

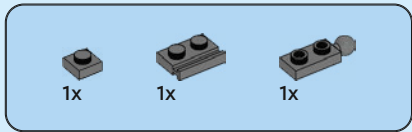
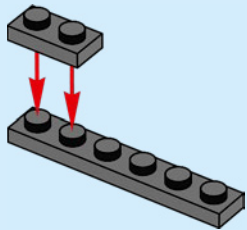

95

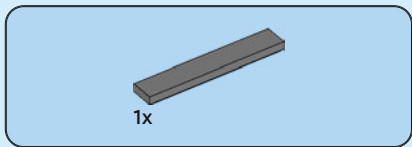
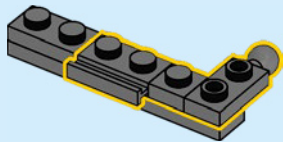

96

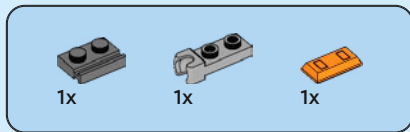
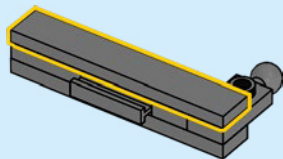

97

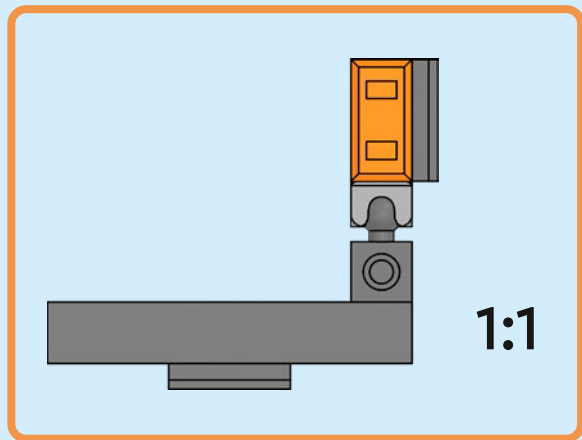
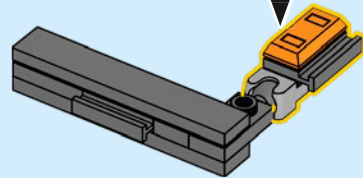
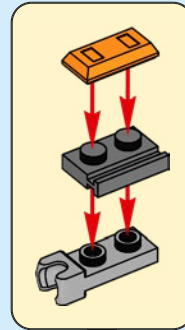

98

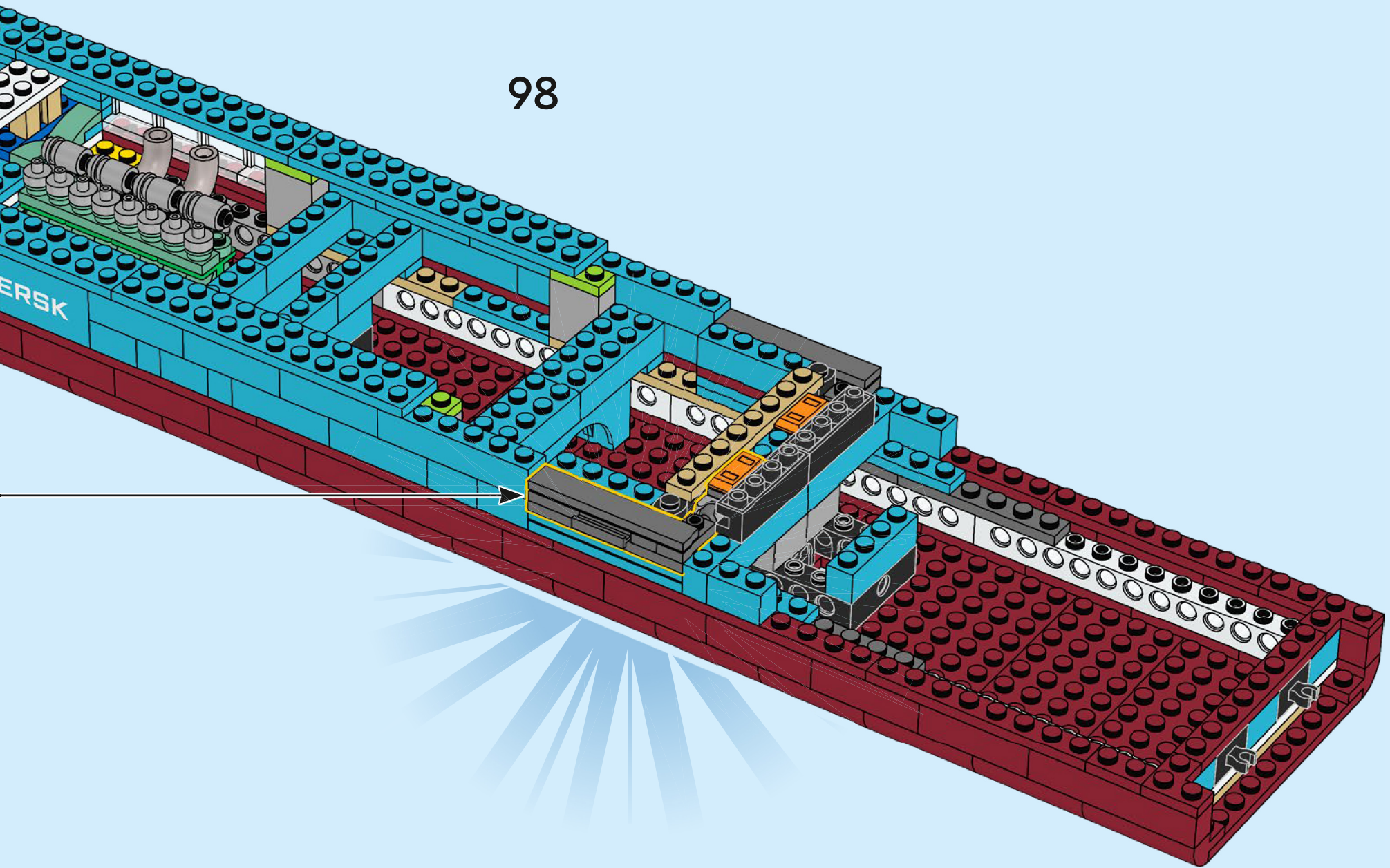

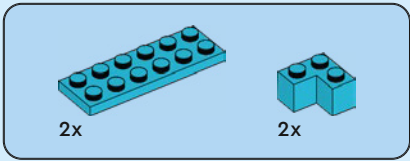

99

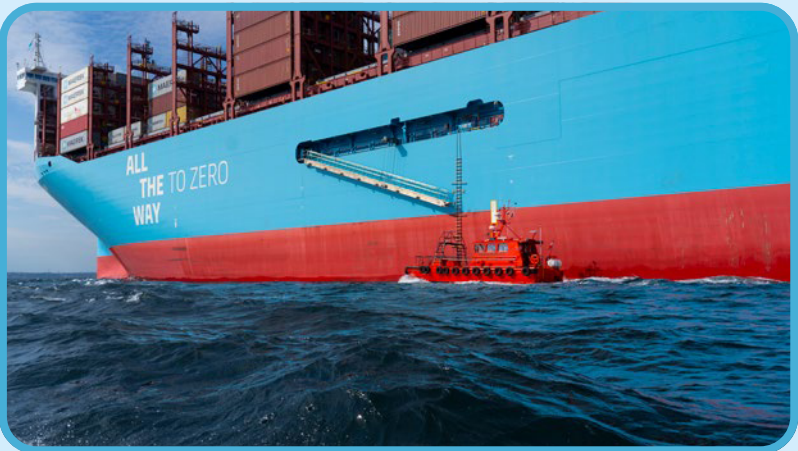
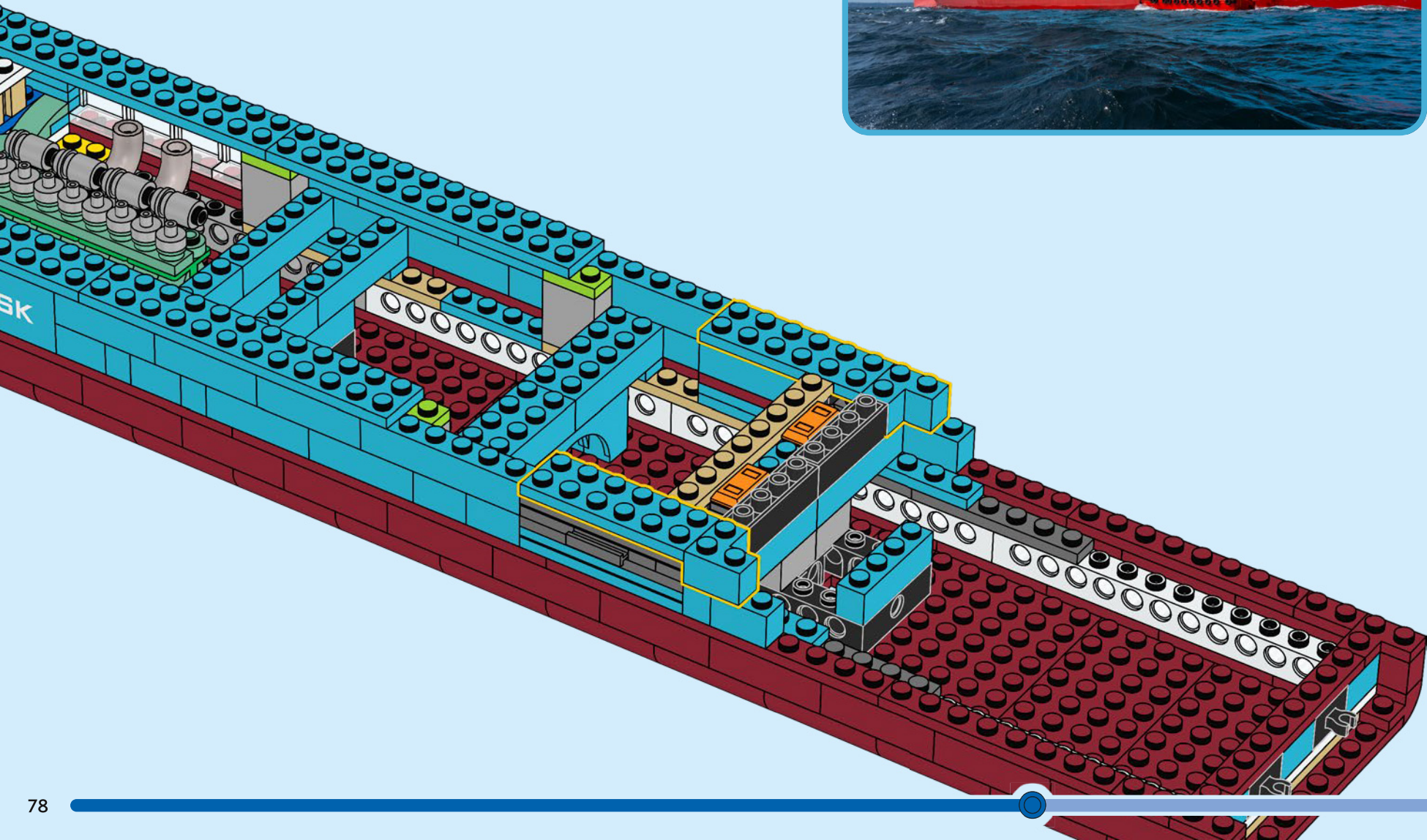

1

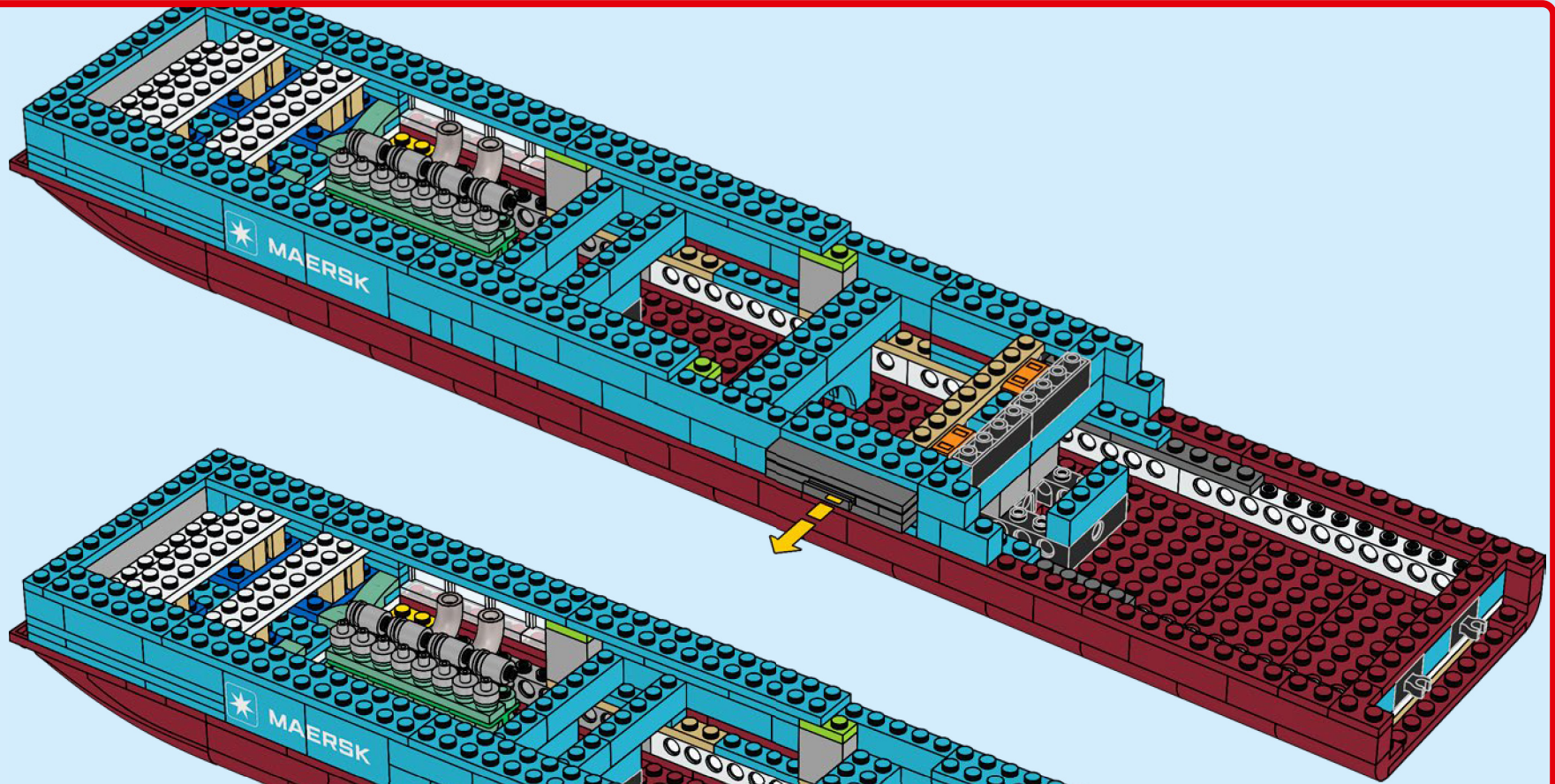

2

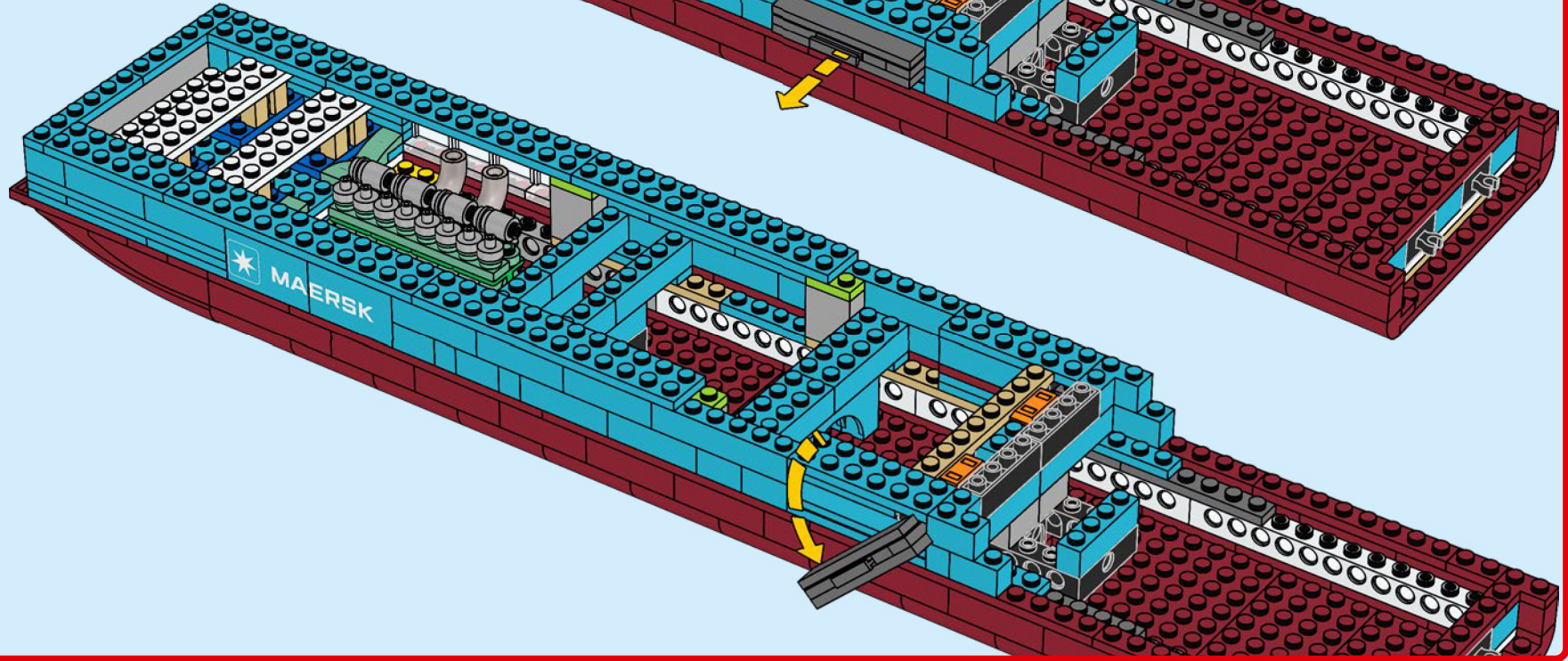

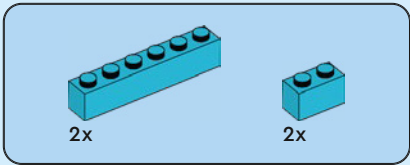

100

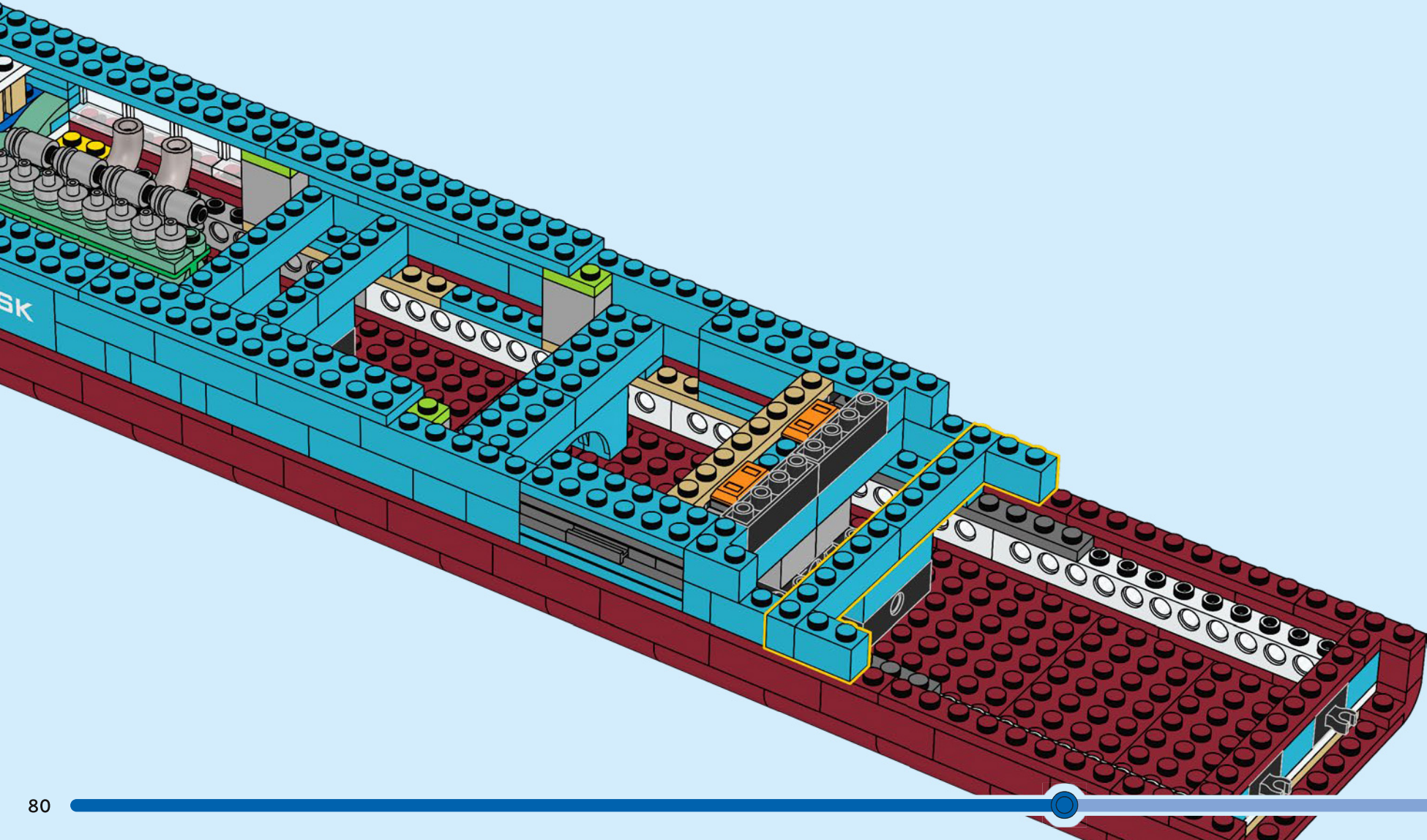

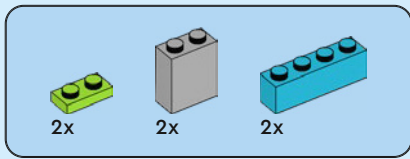

101

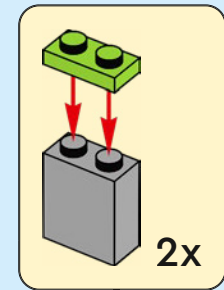
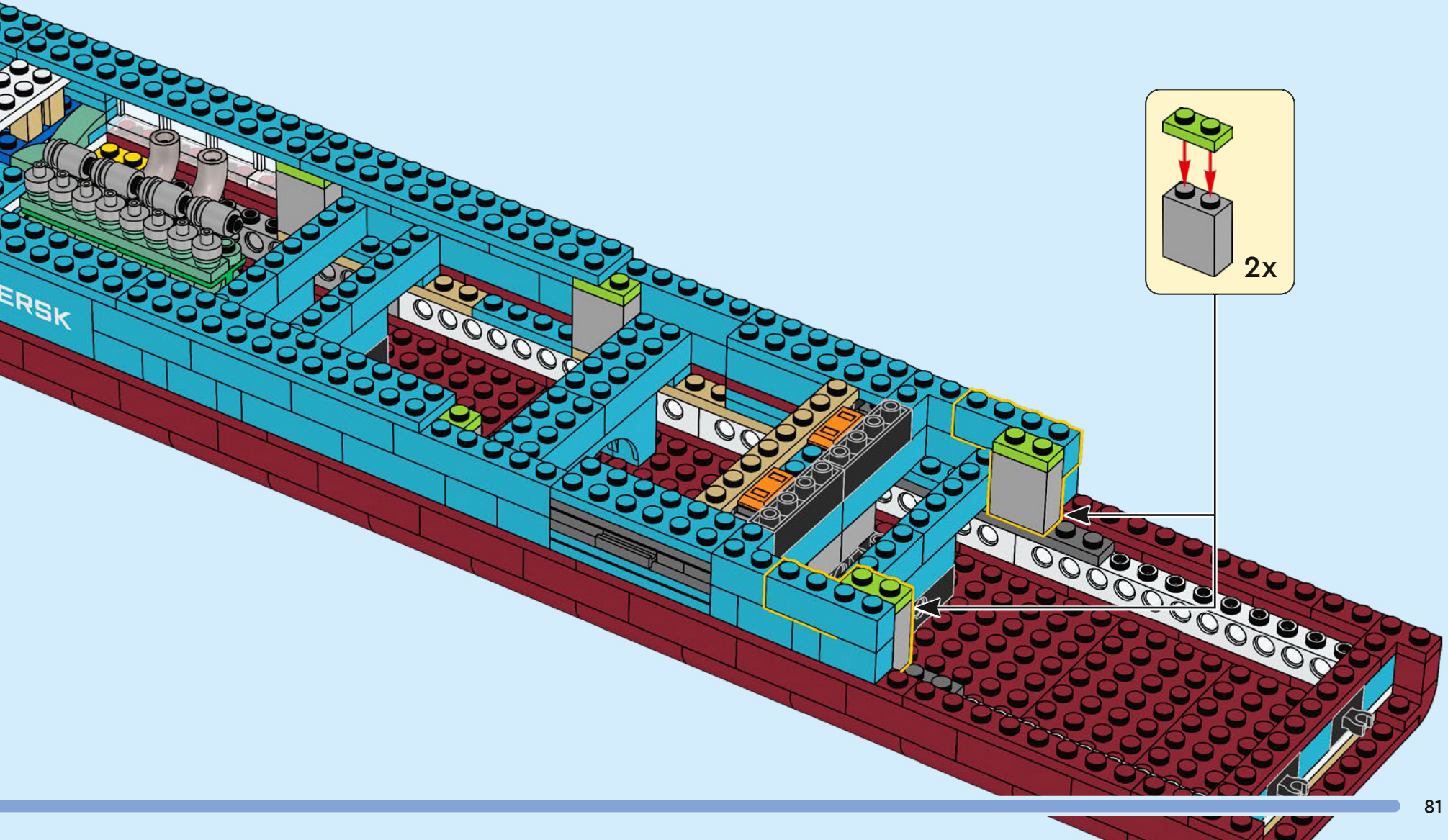

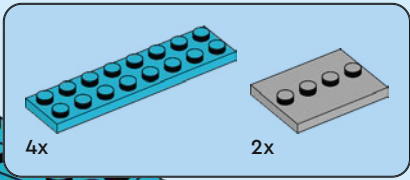

102

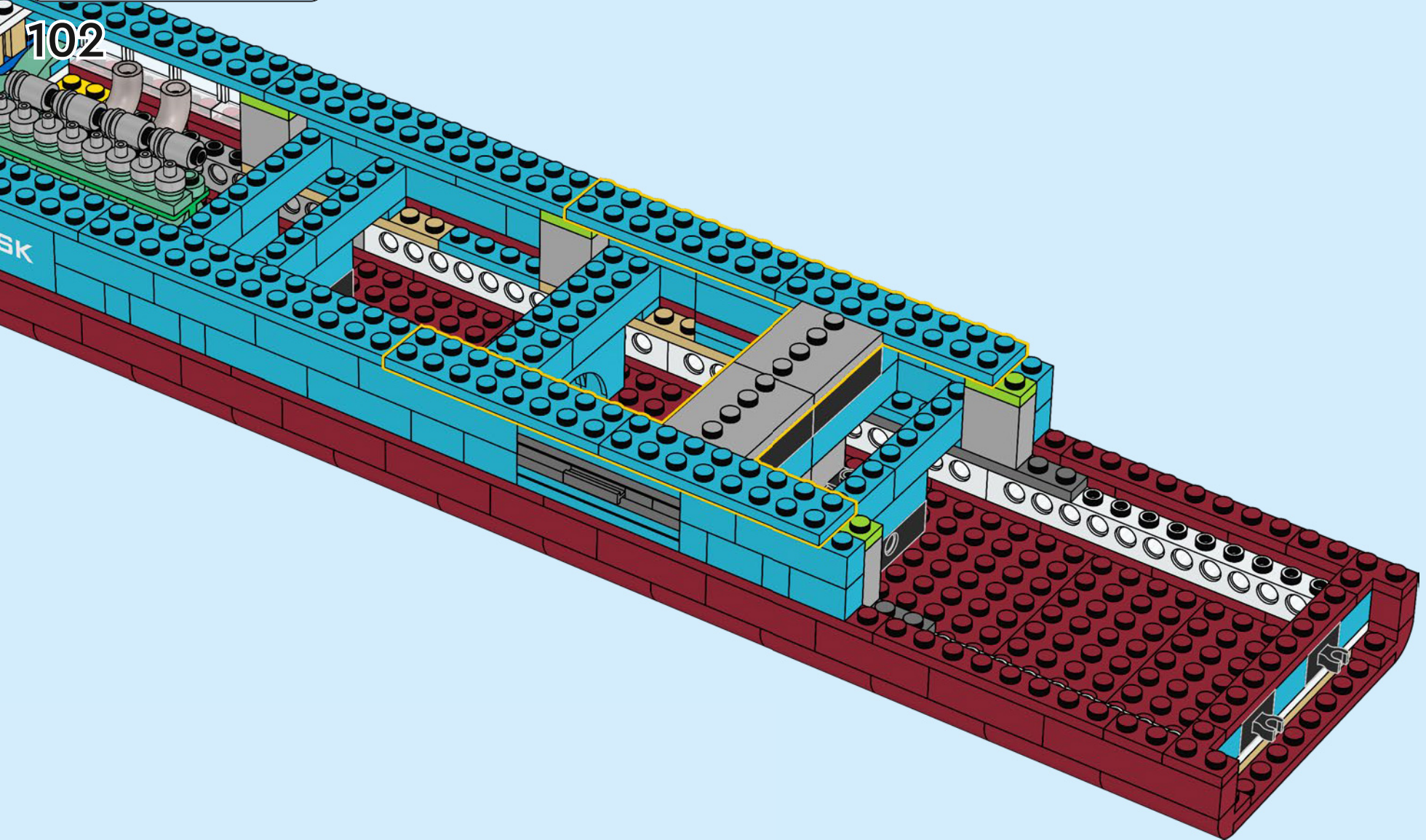

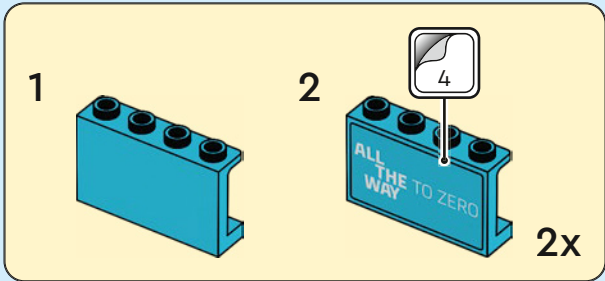
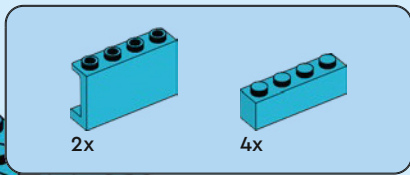

103
ERSK

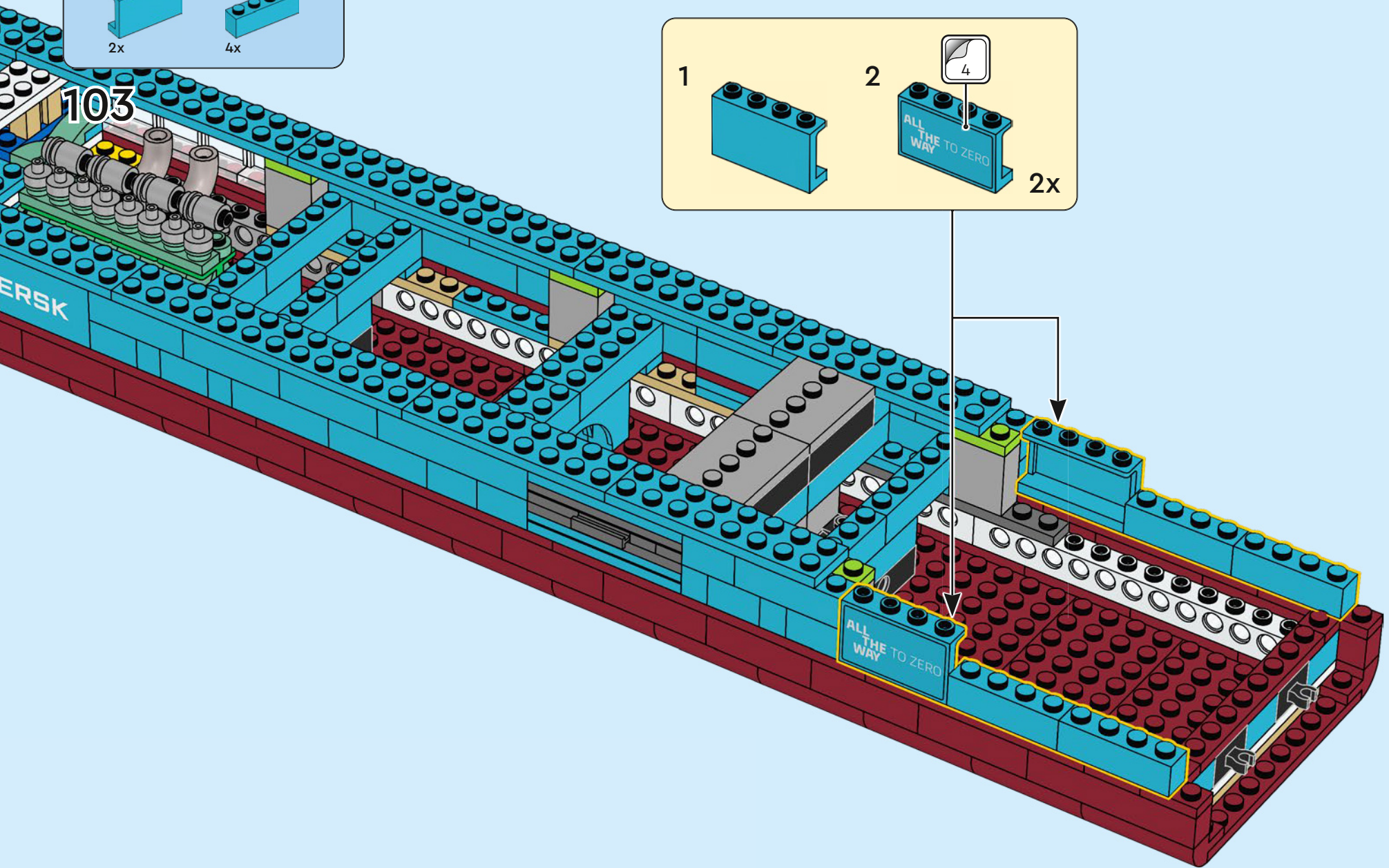

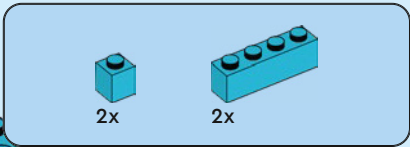

104

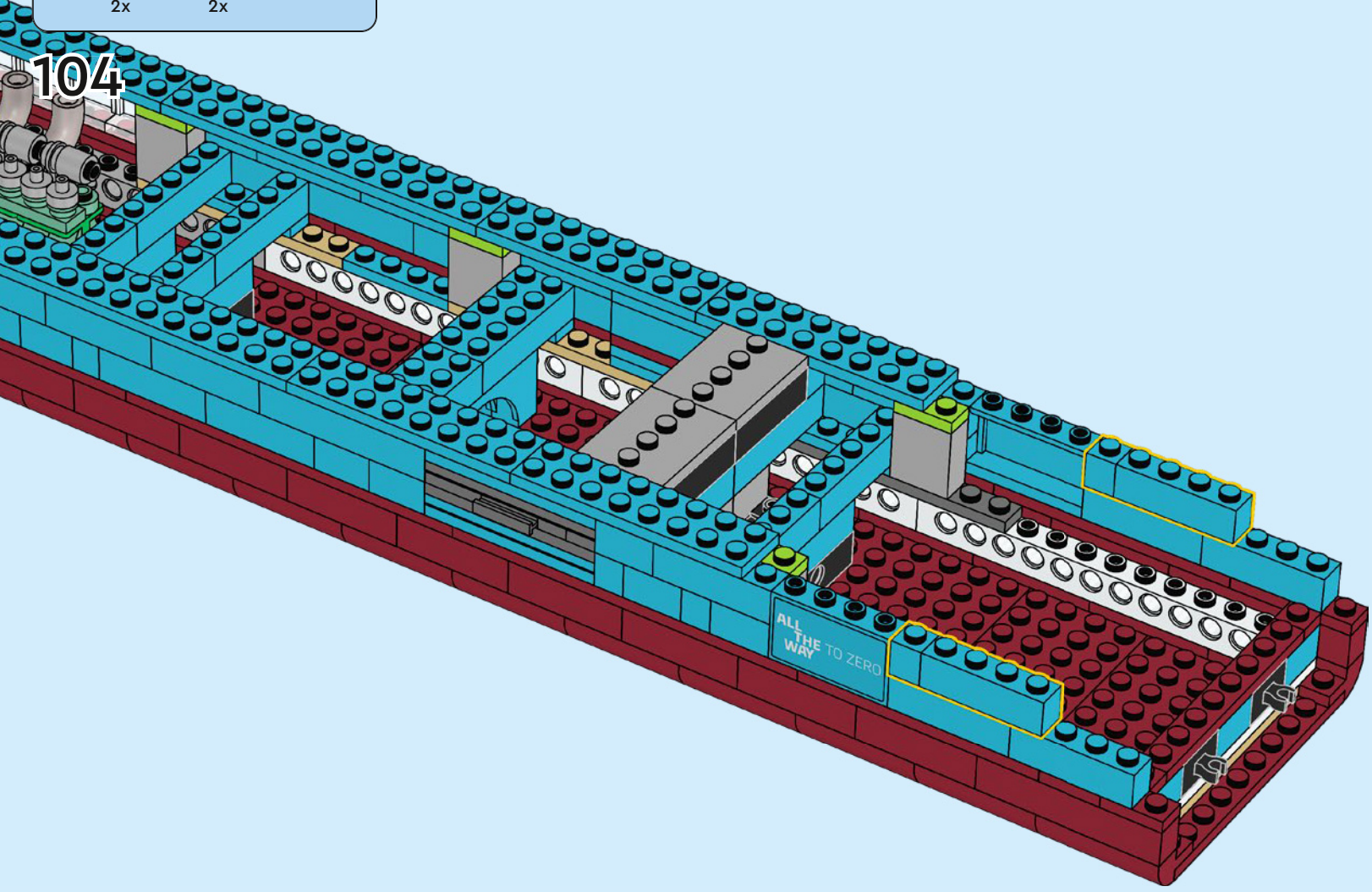

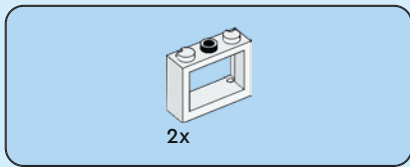

105

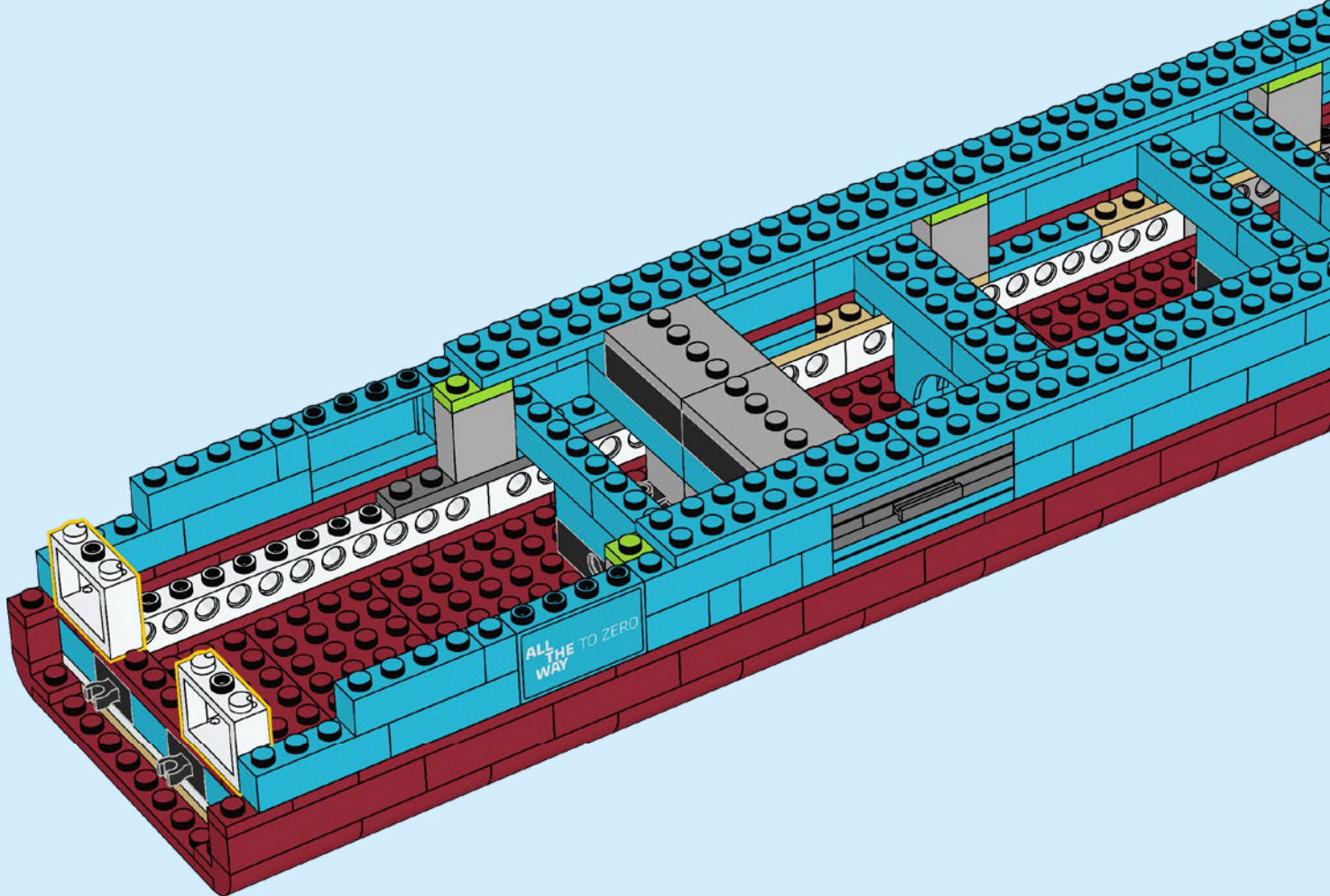

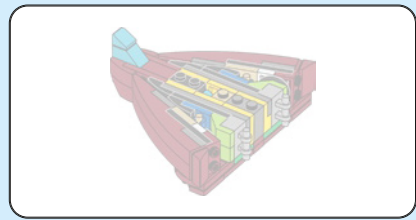
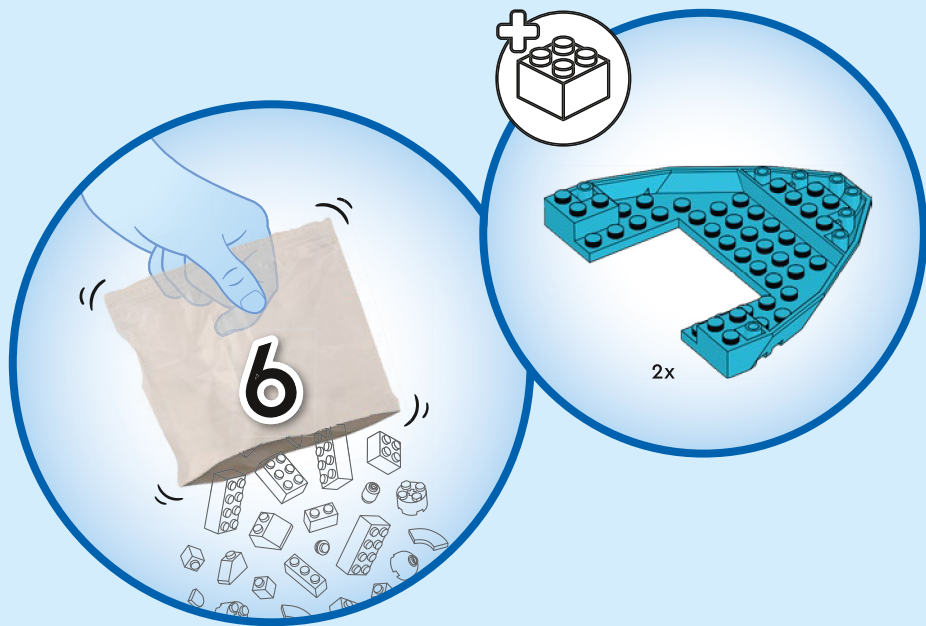

106

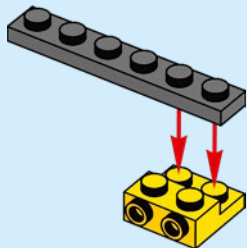

107

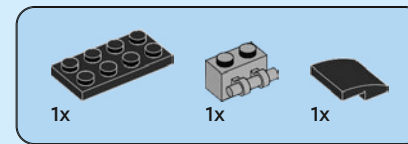
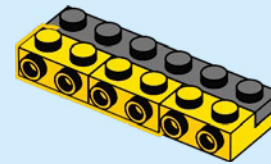

108

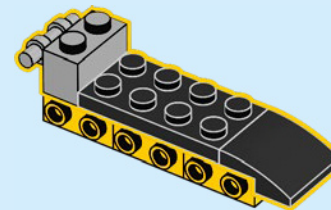

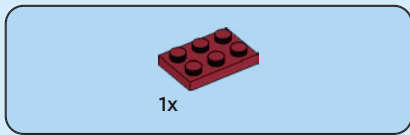

109

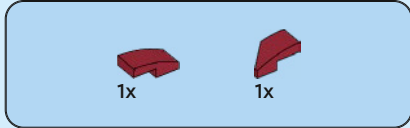
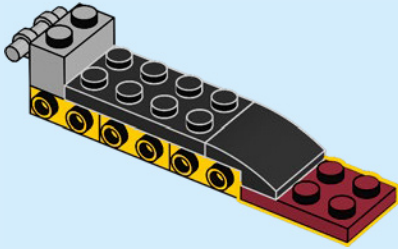

110

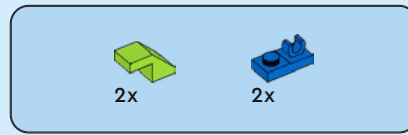
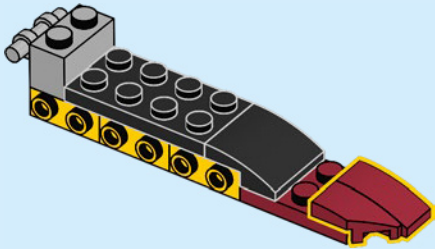

111

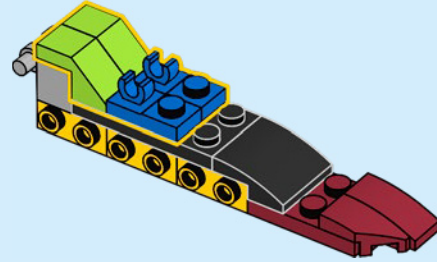

112

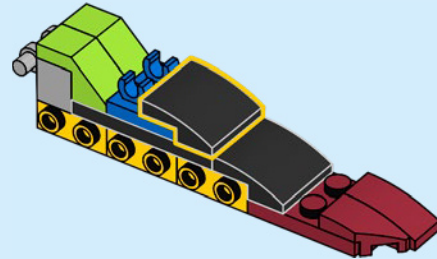

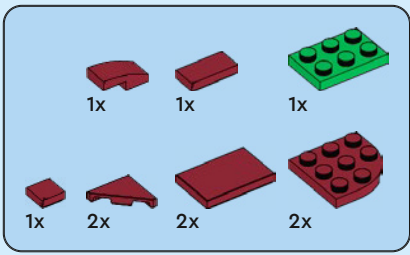

113

1

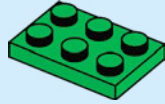

2

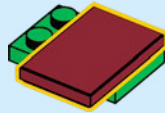

3

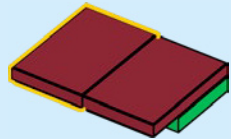

4

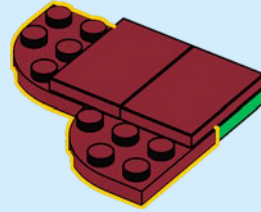

5

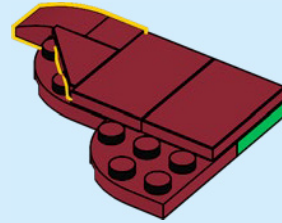

6

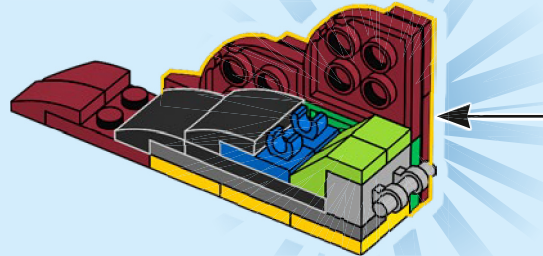
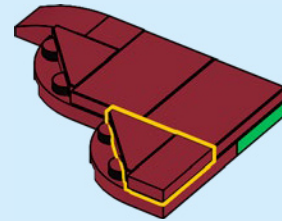

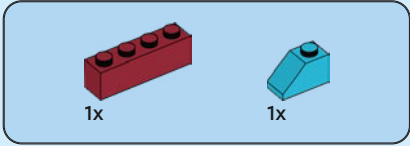
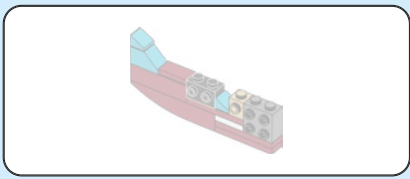

114

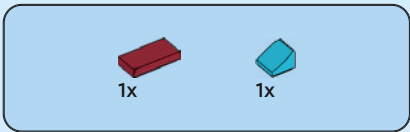
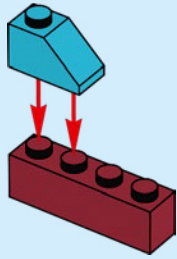

115

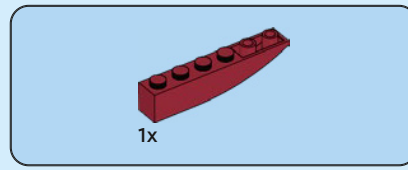
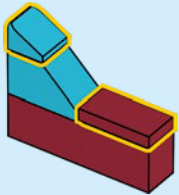

116

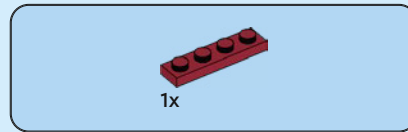
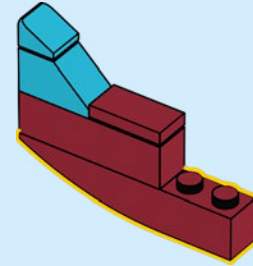

117

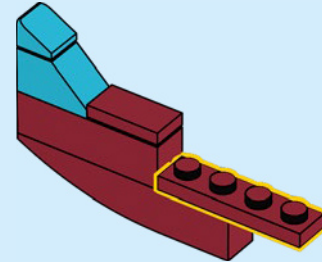

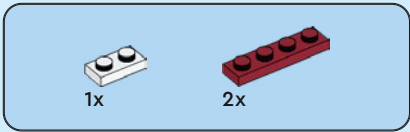

118

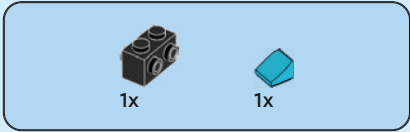
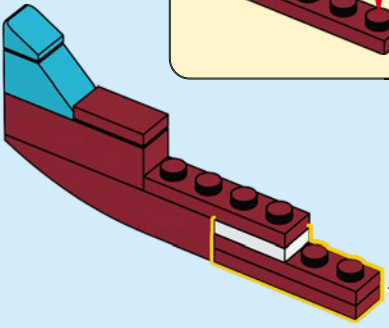
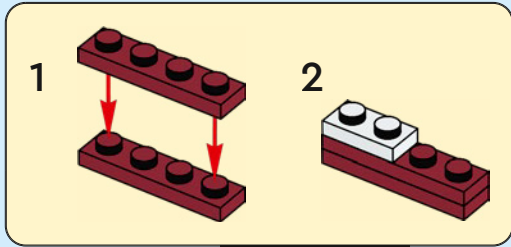

119

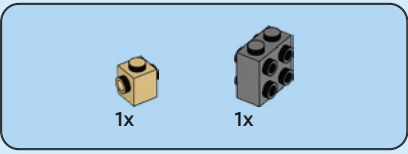
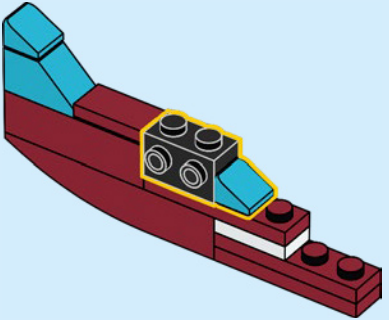

120

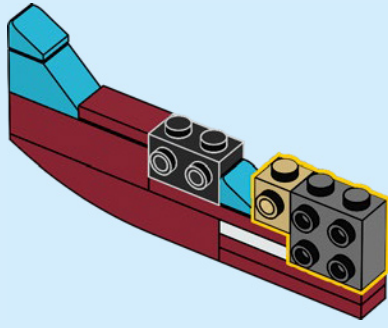

121

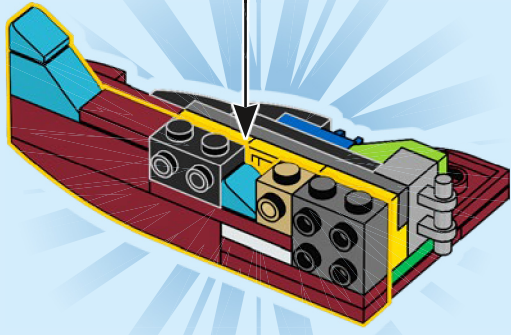

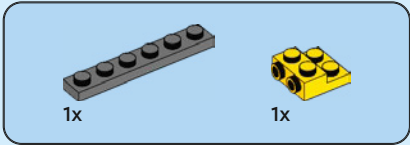
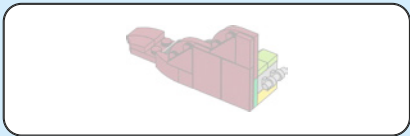

122

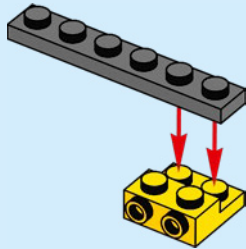

123

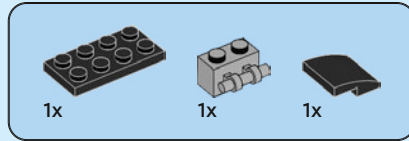
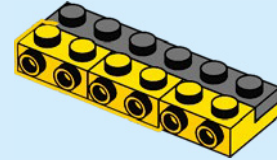

124

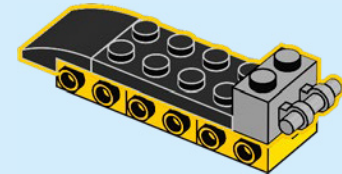

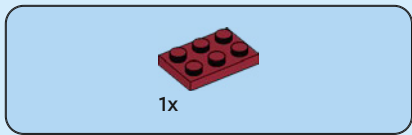

125

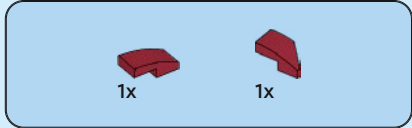
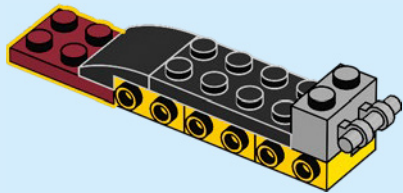

126

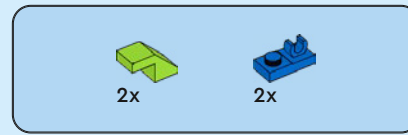
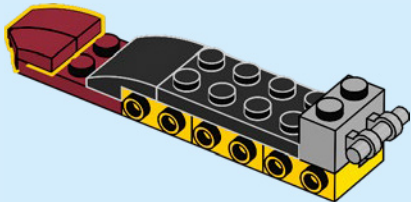

127

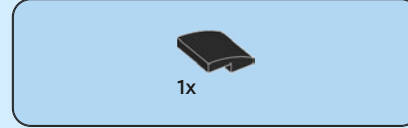
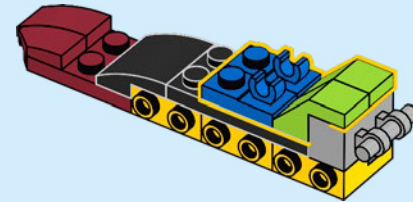

128

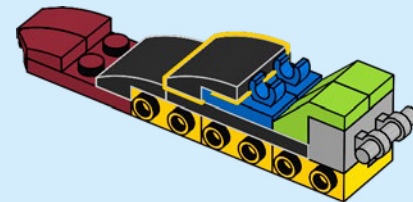

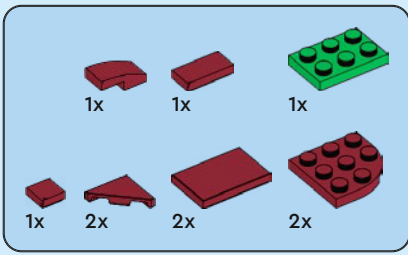

129

1

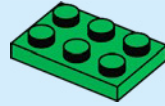

2

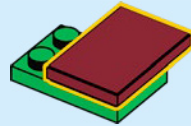

3

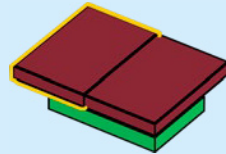

4

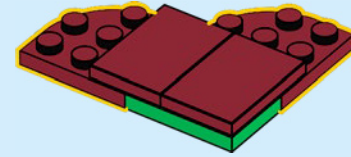

5

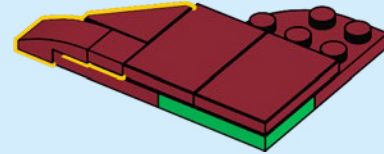

6

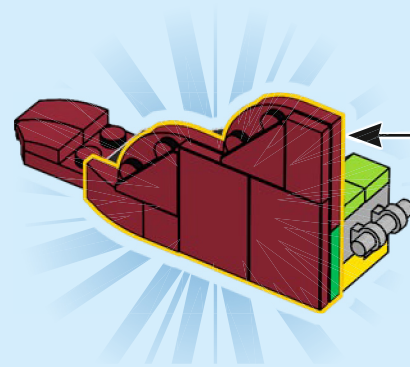
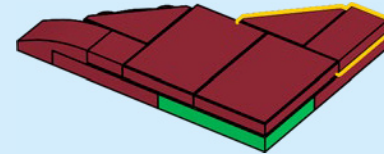

130

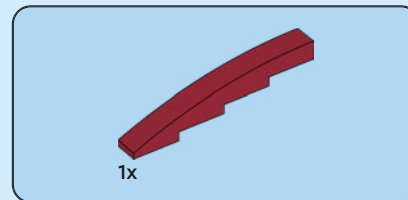
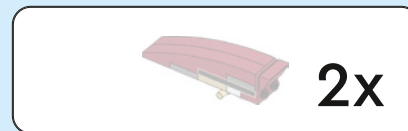
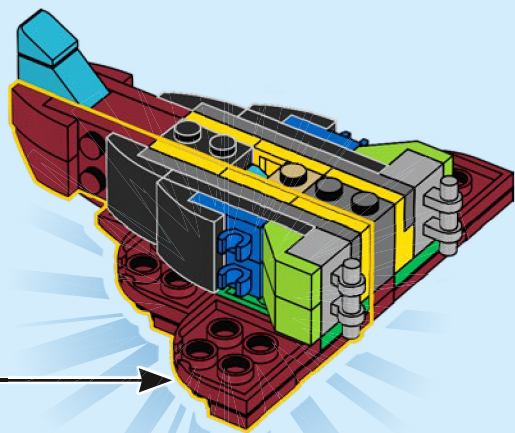

131

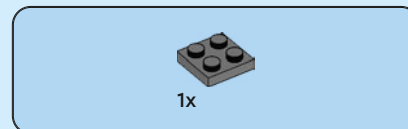
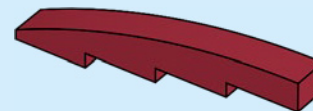

132

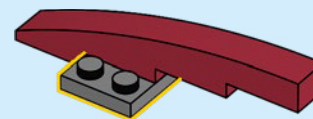

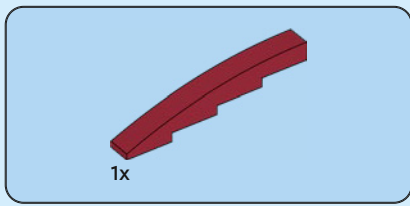

133

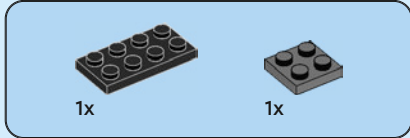
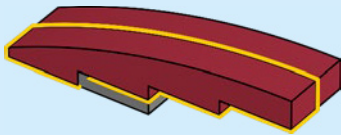

134

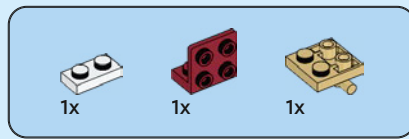
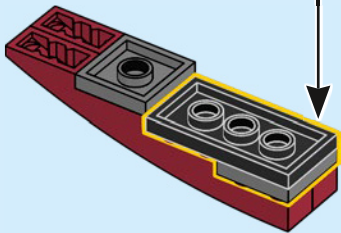
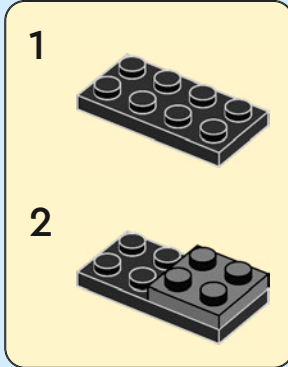

135

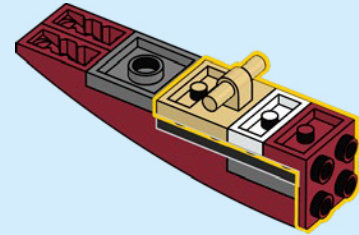

136

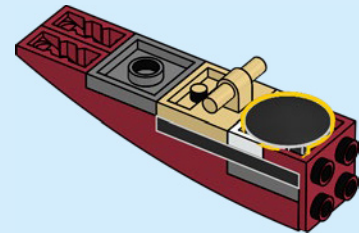



1x

137

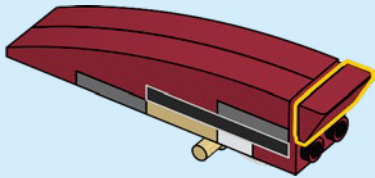

2x

138

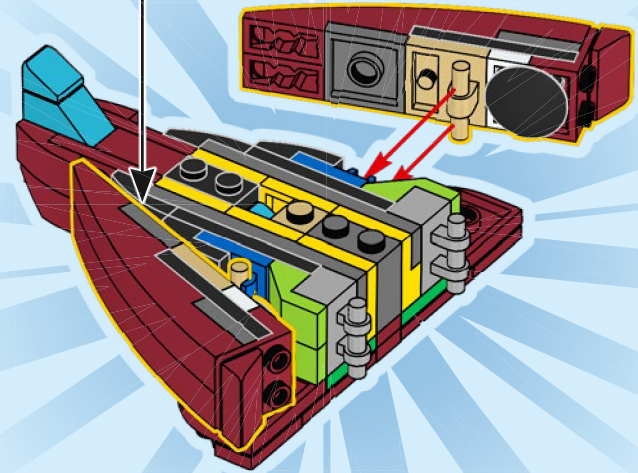

139

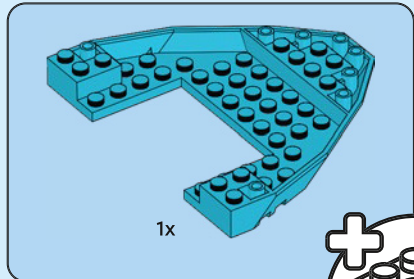
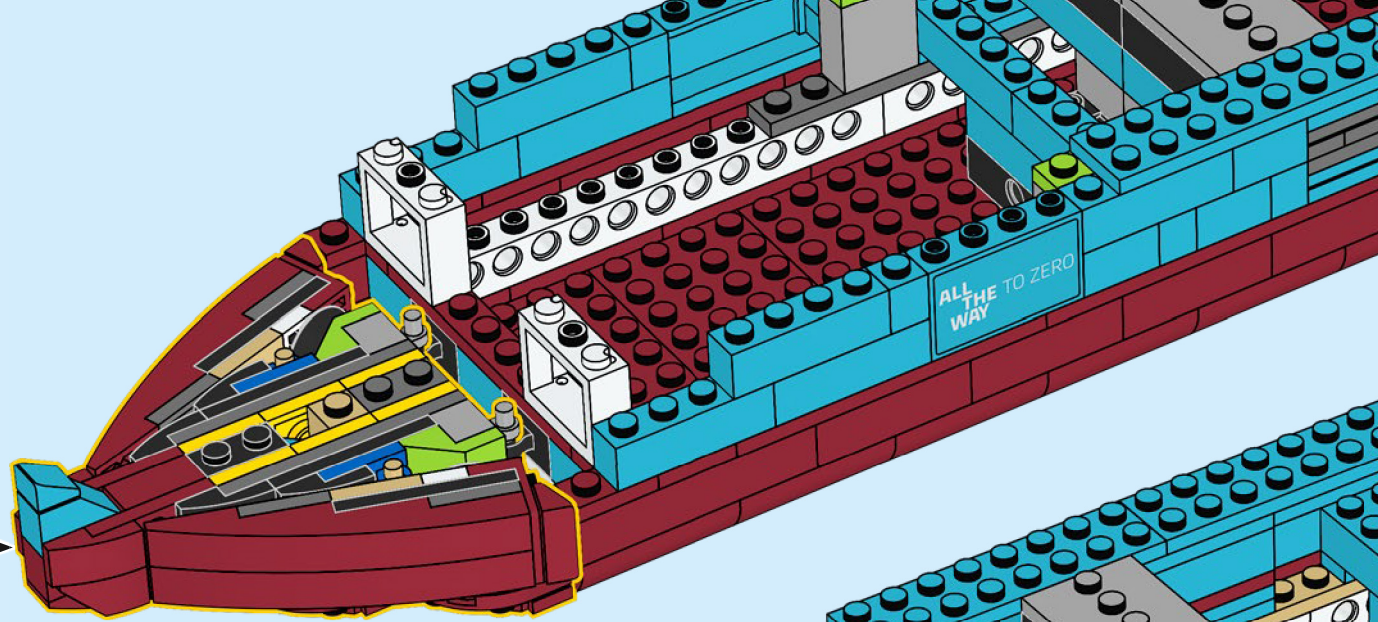

1x

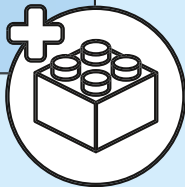

140

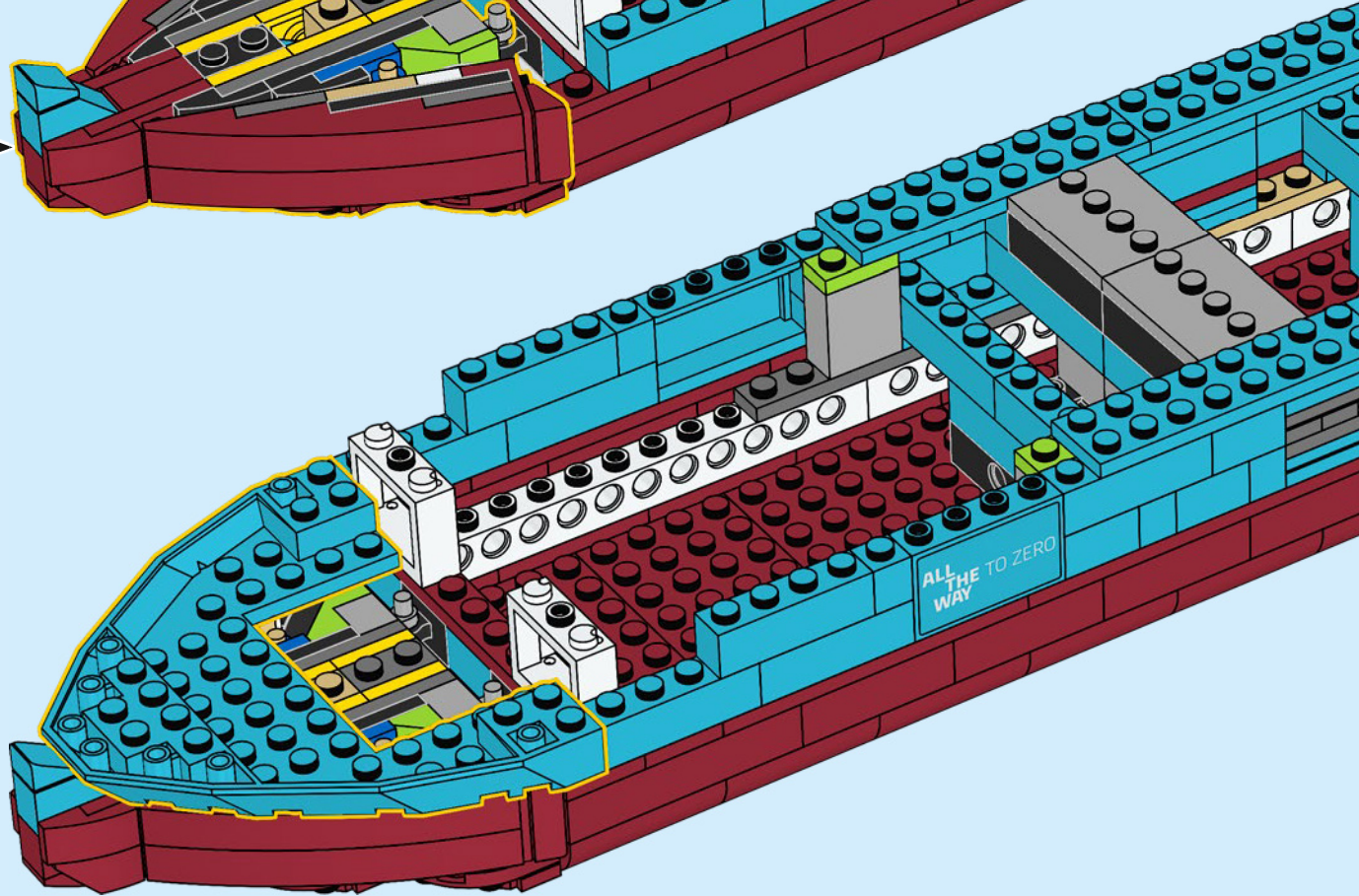

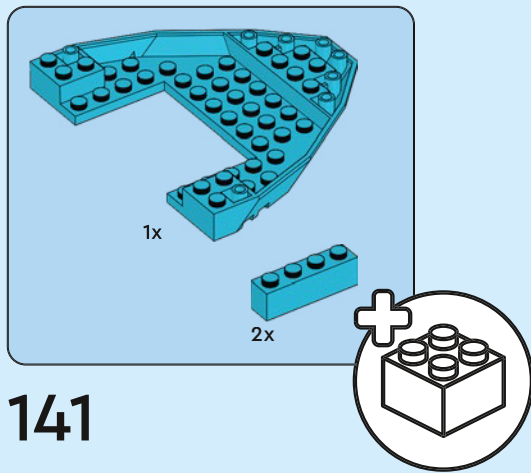

141

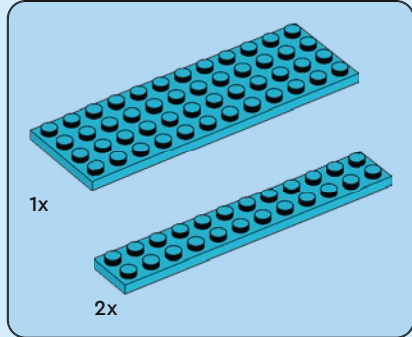
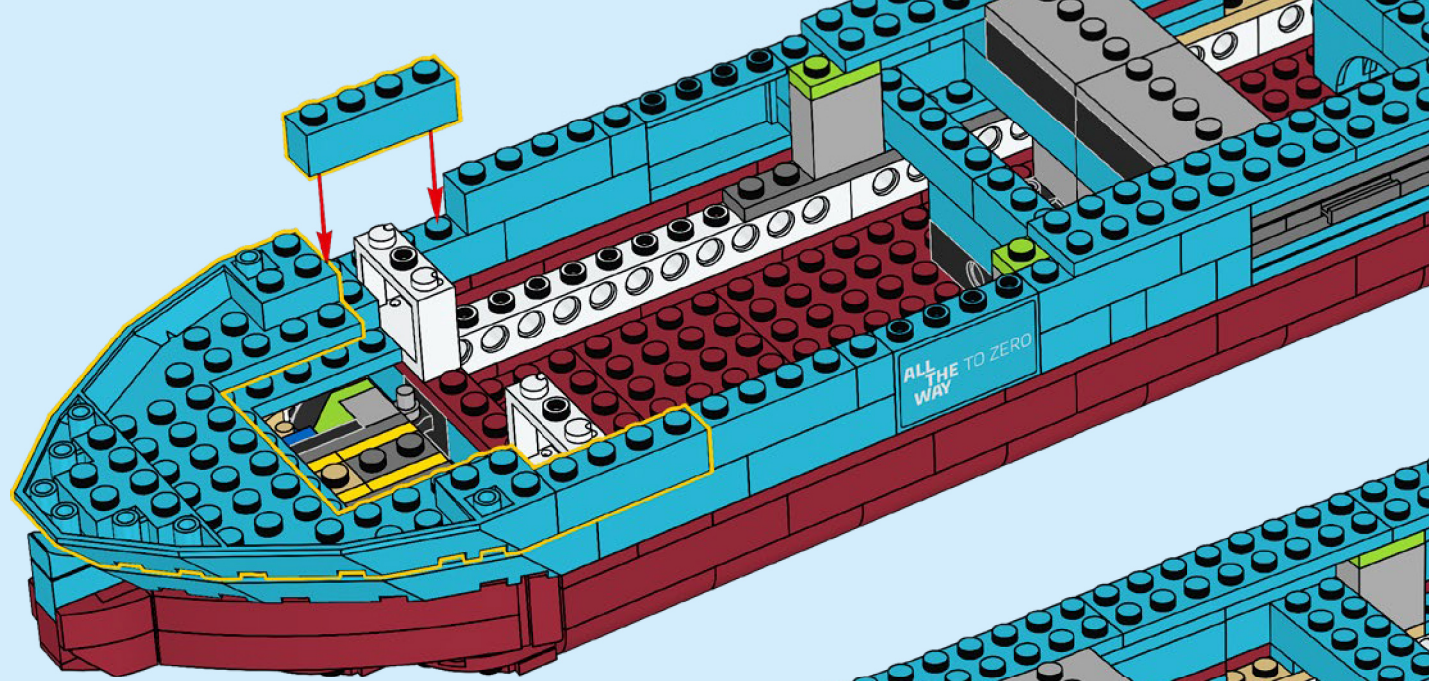

142

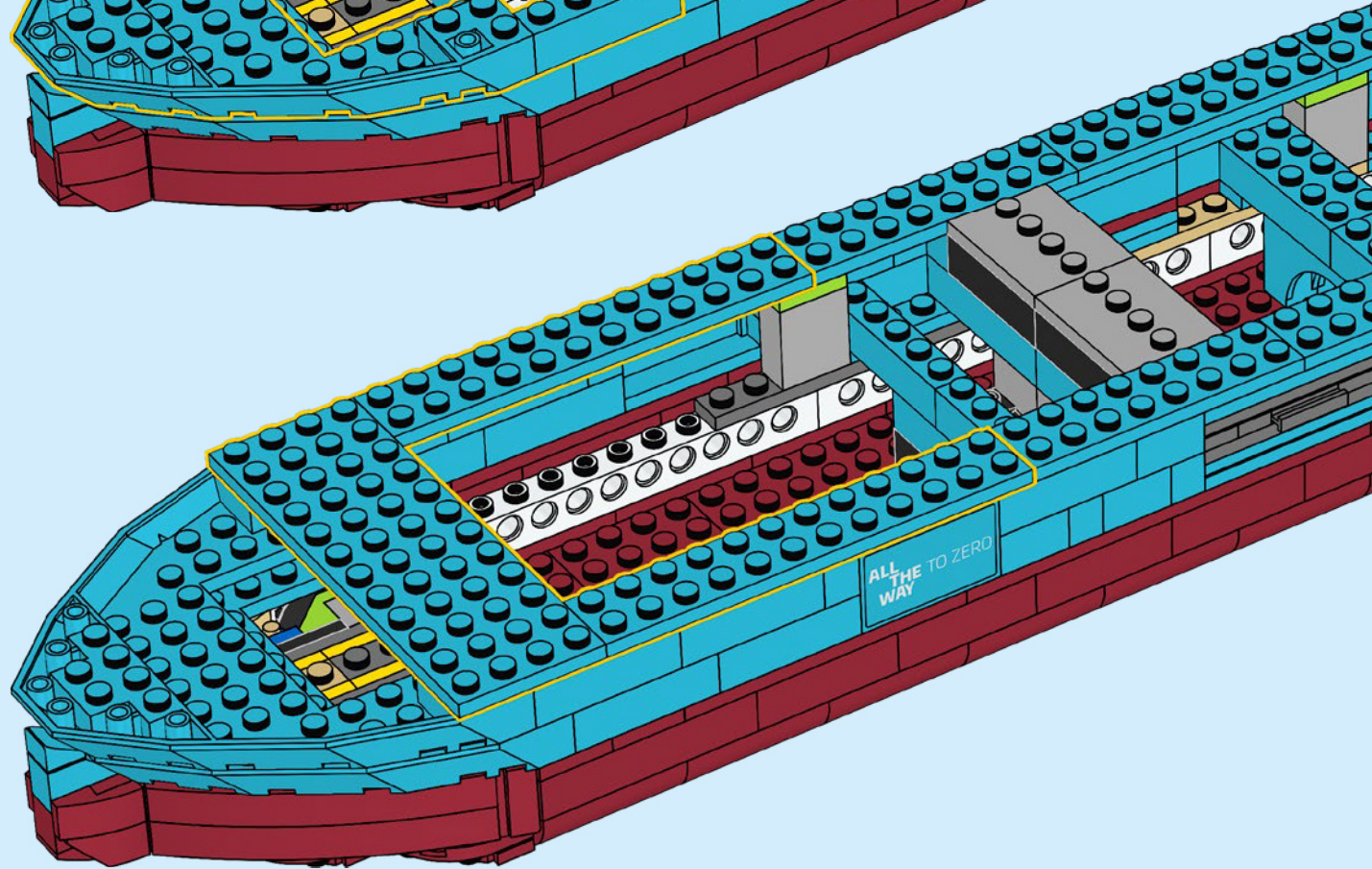

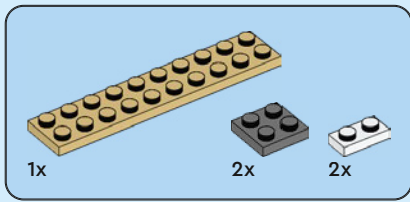

143

1

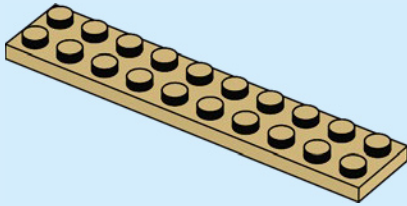

2

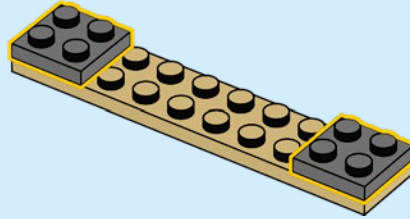

3

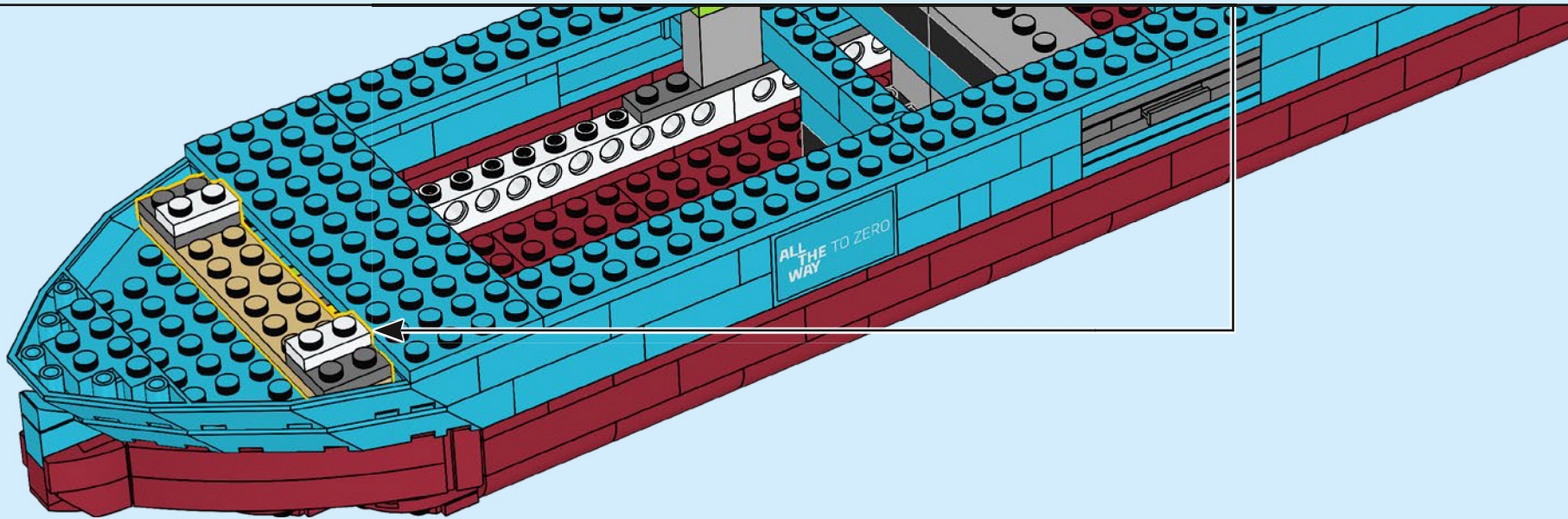
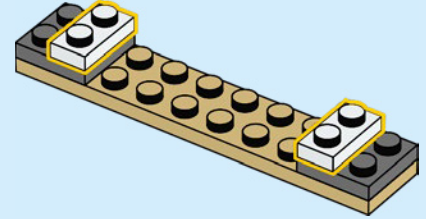

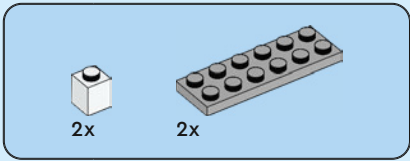

144

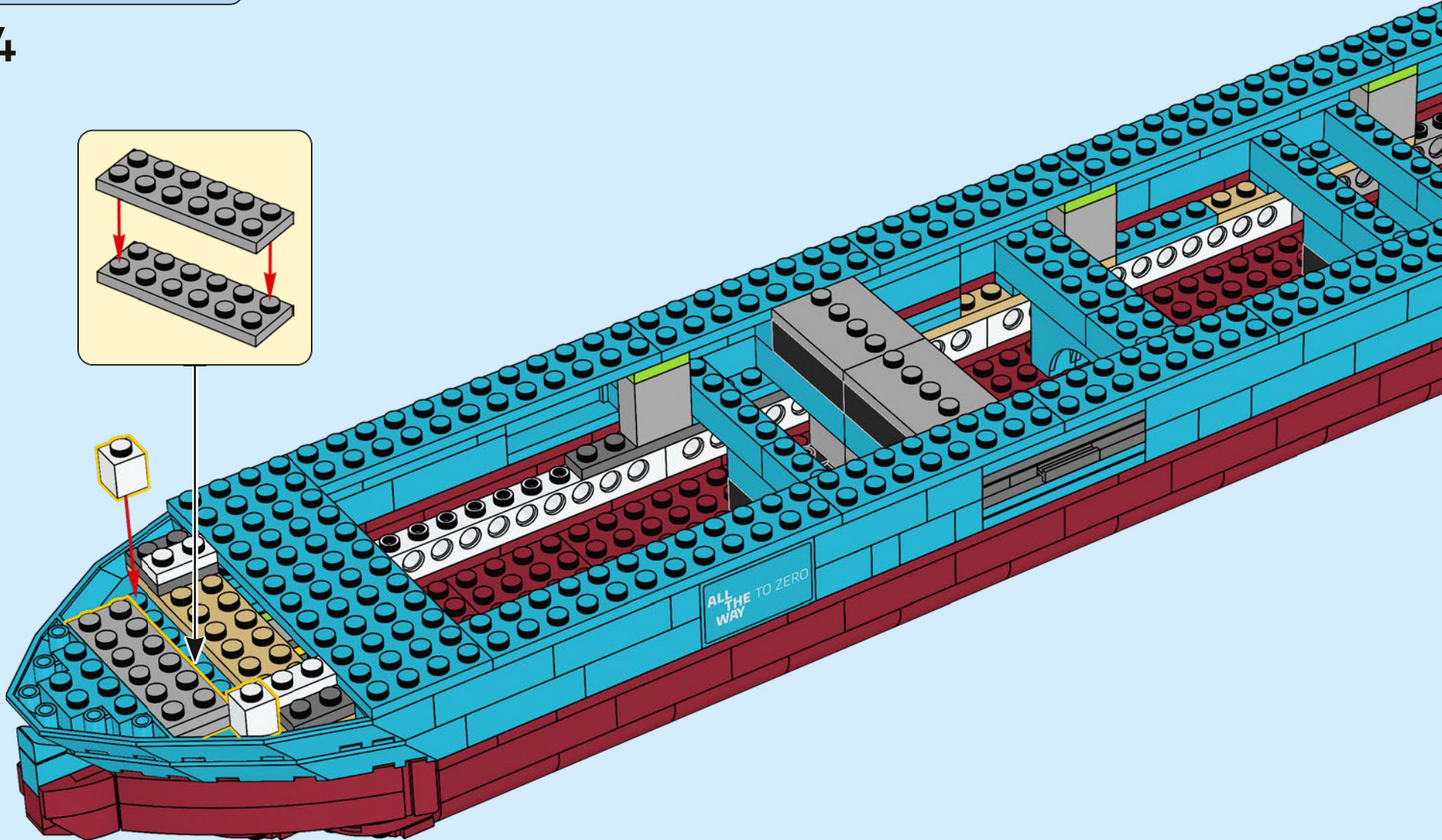
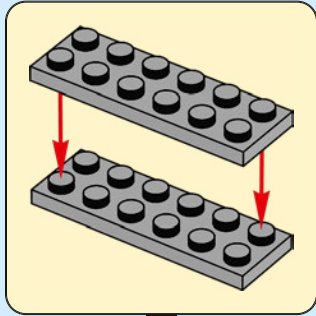

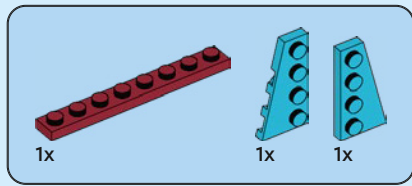

145

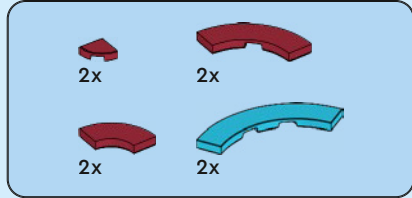
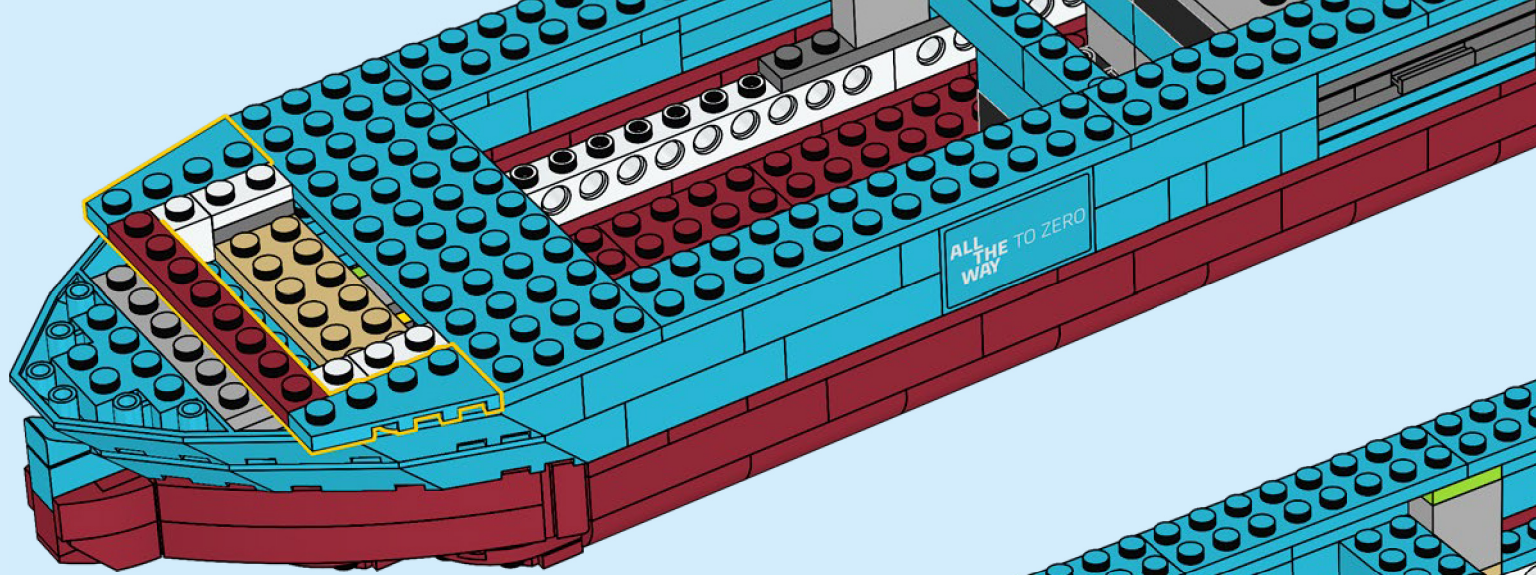

146

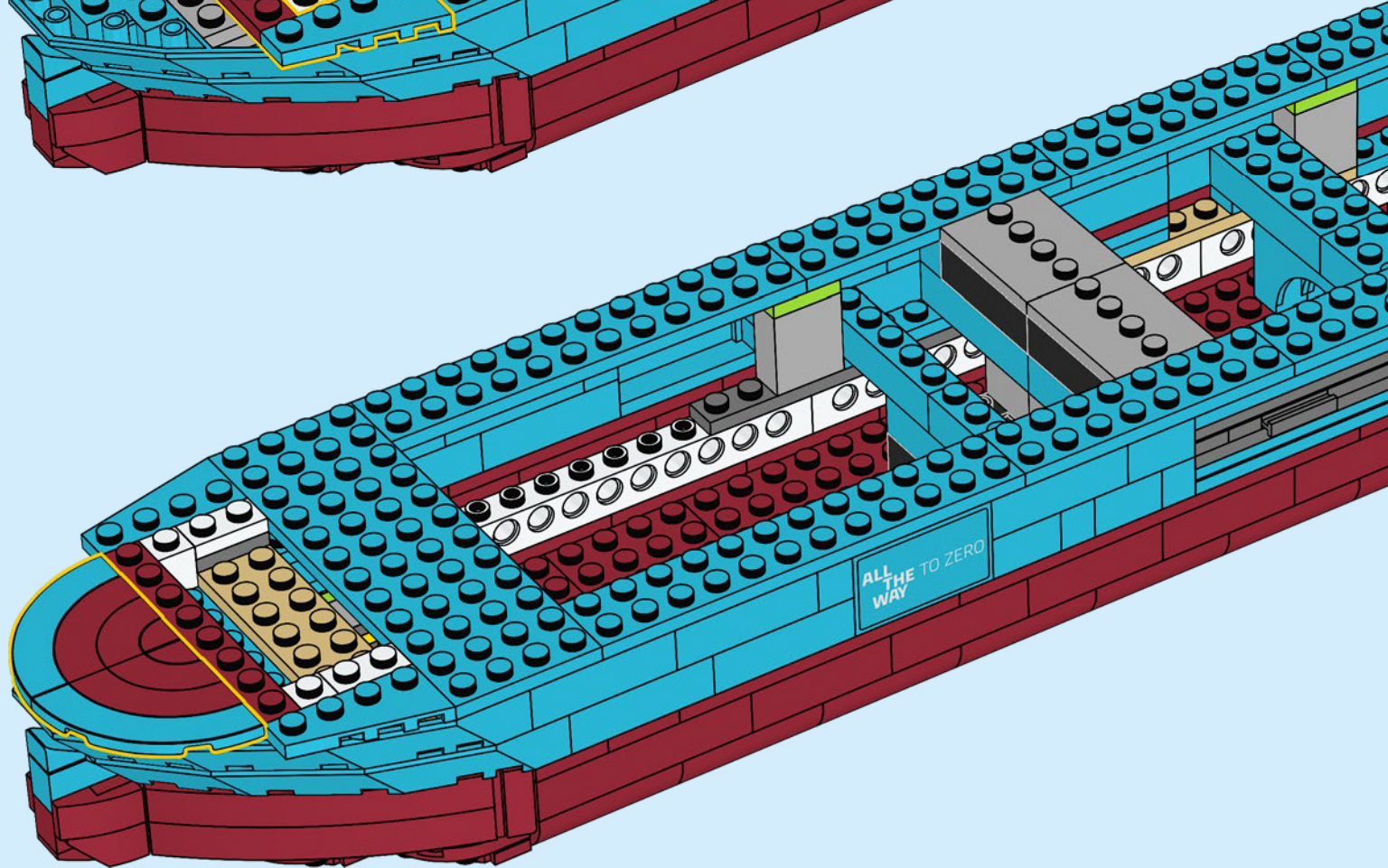

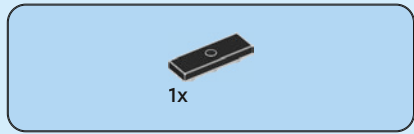

147

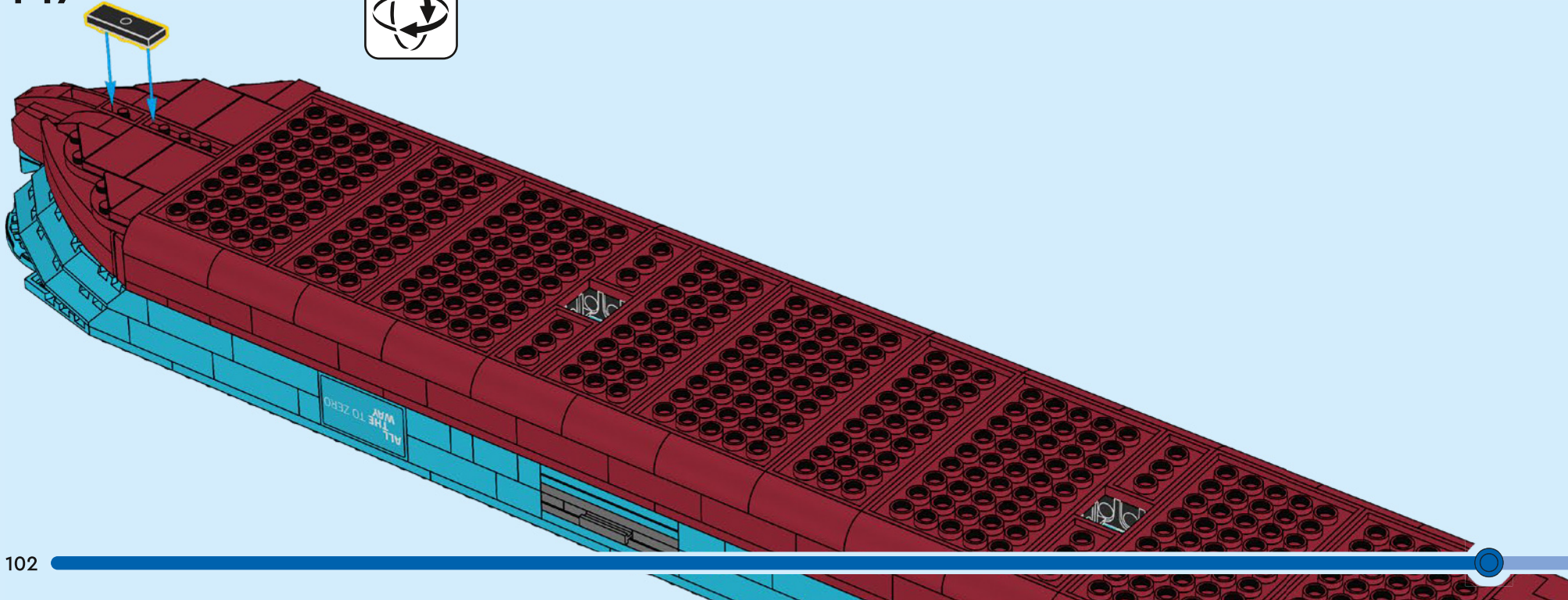



24x

148

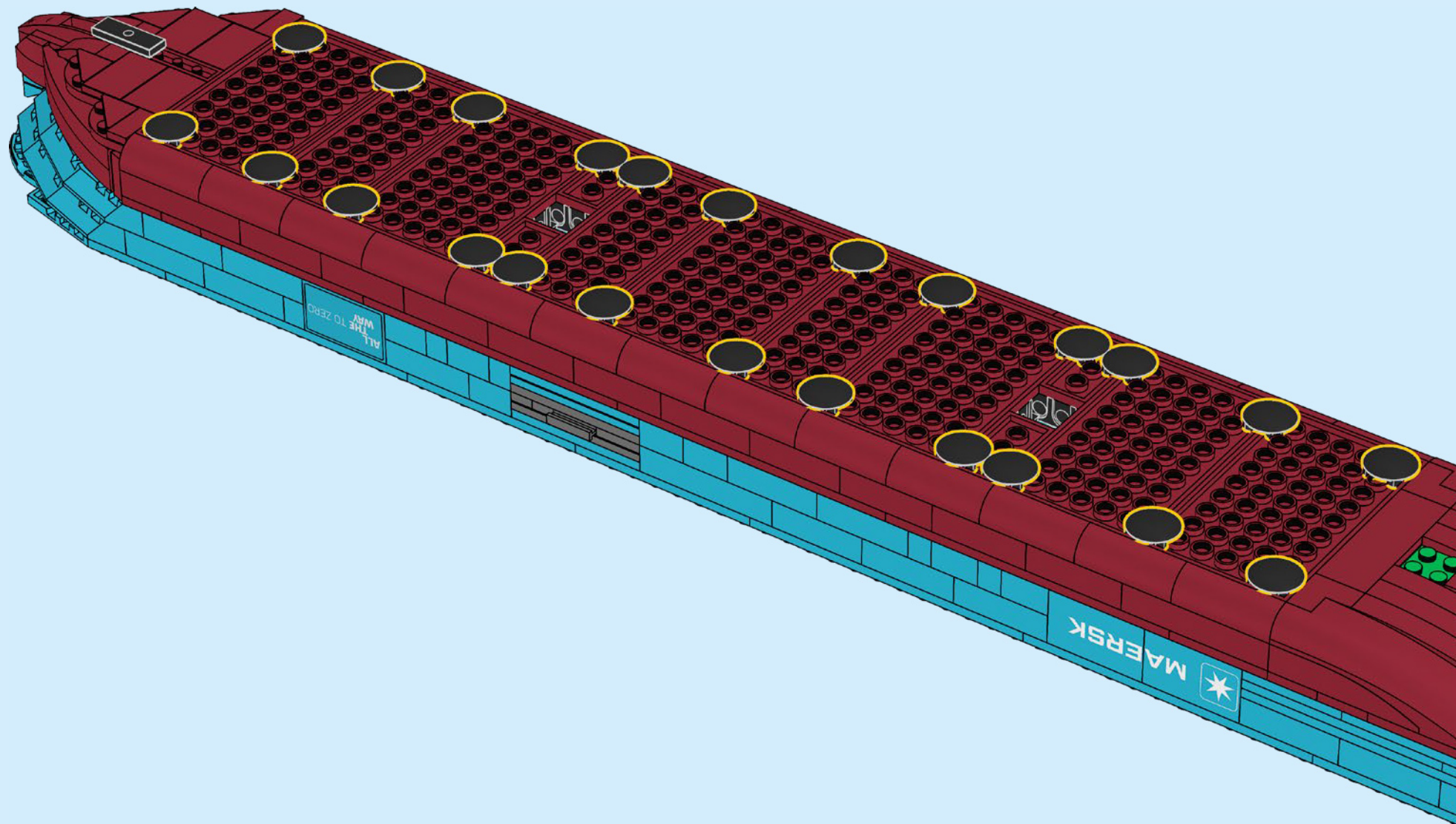

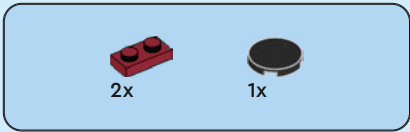

149

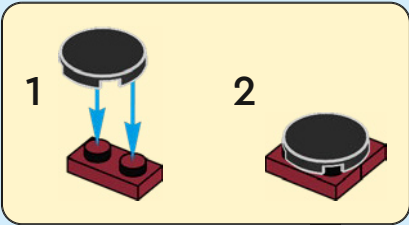
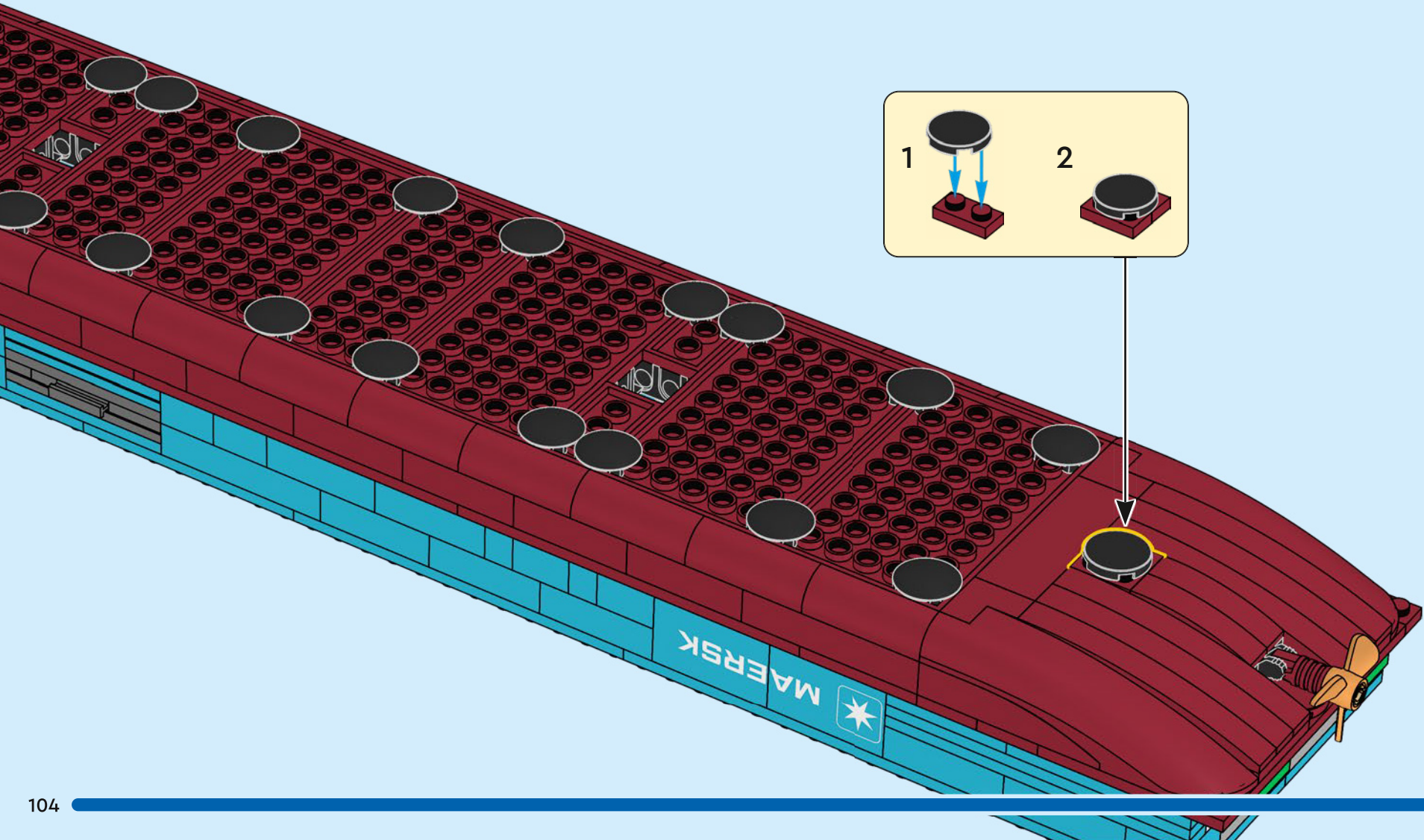

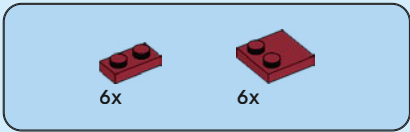

150

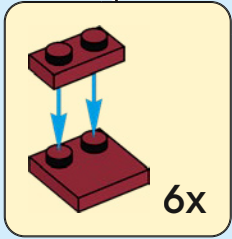
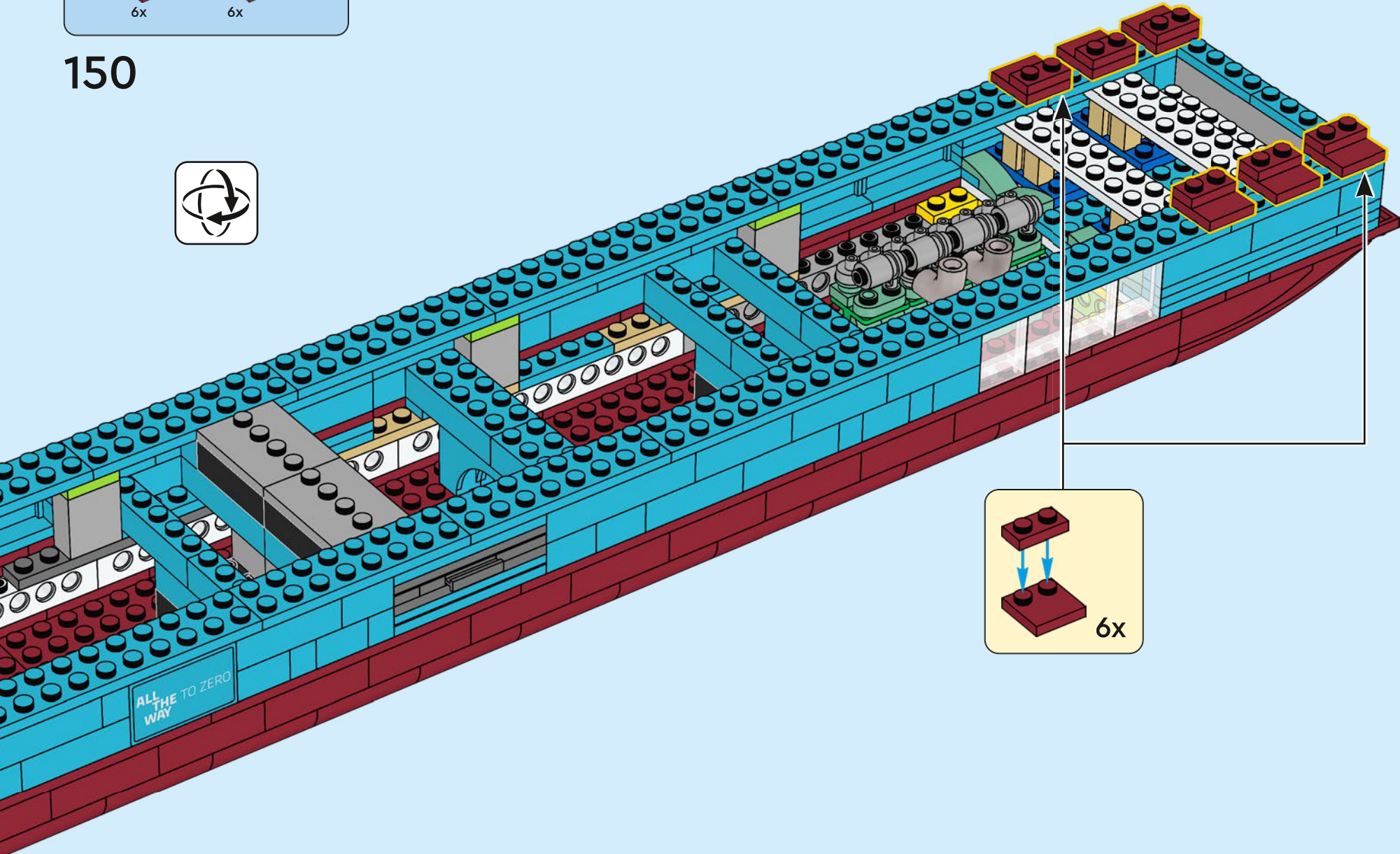

ALL
THE
WAY TO ZERO

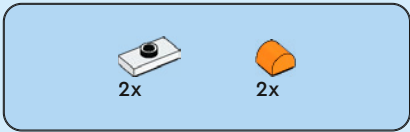

151

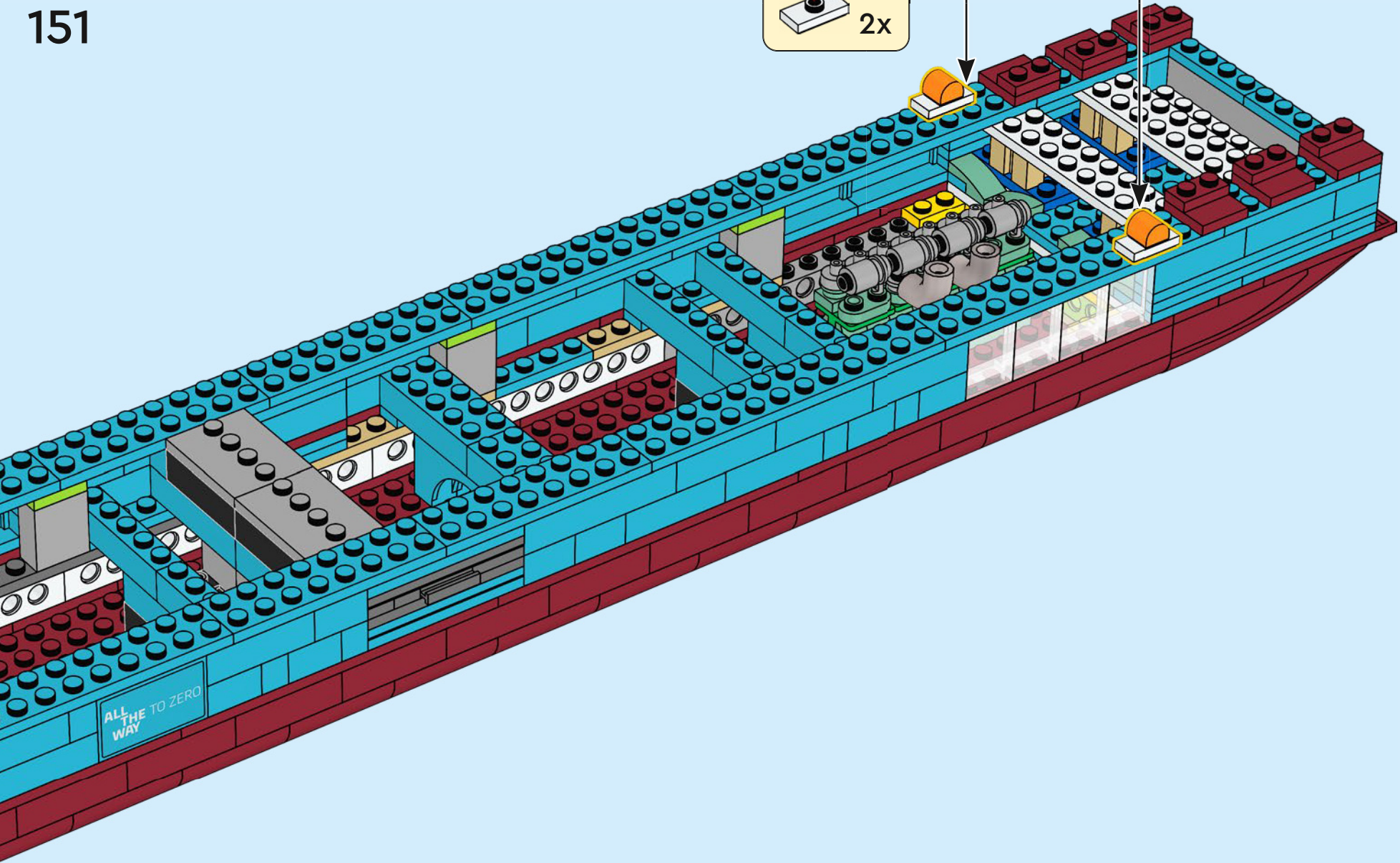
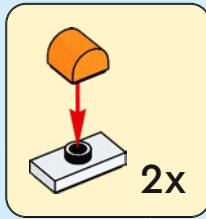

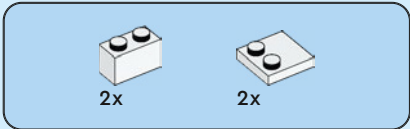

152

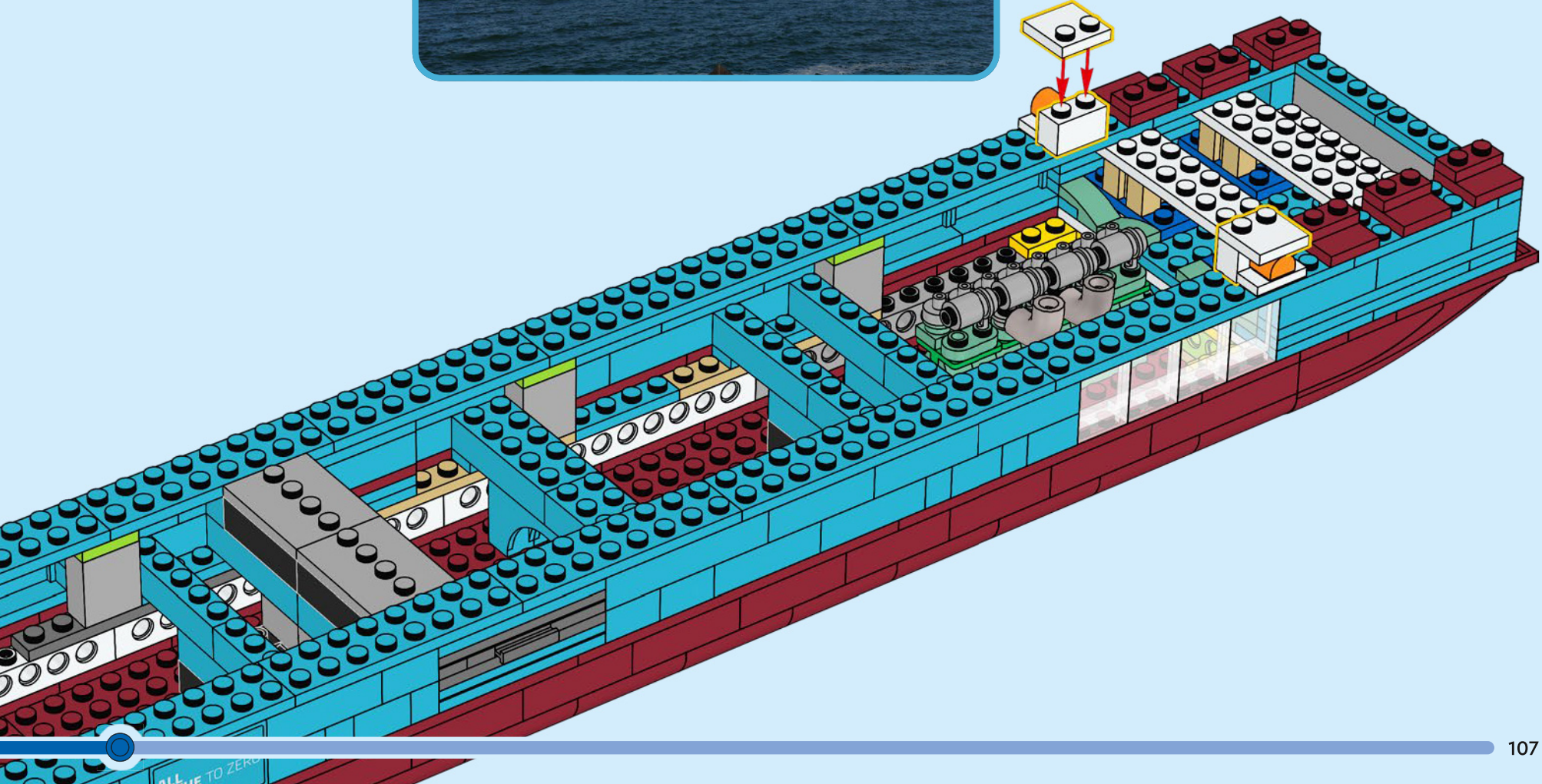
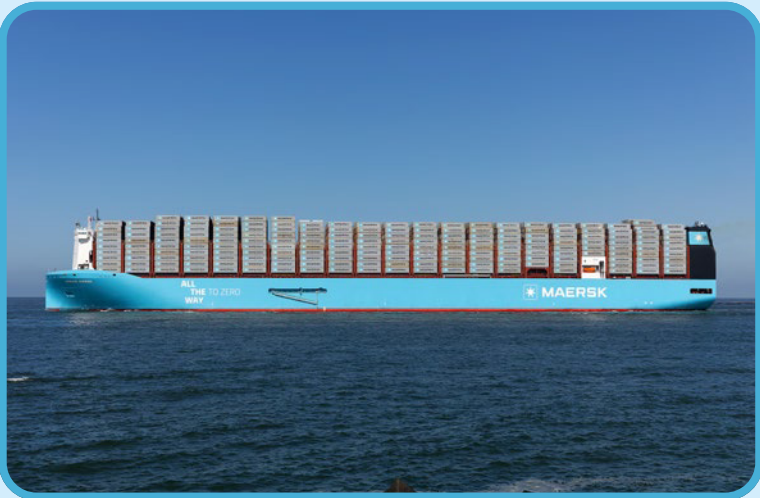

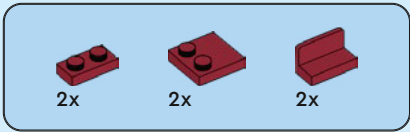

153

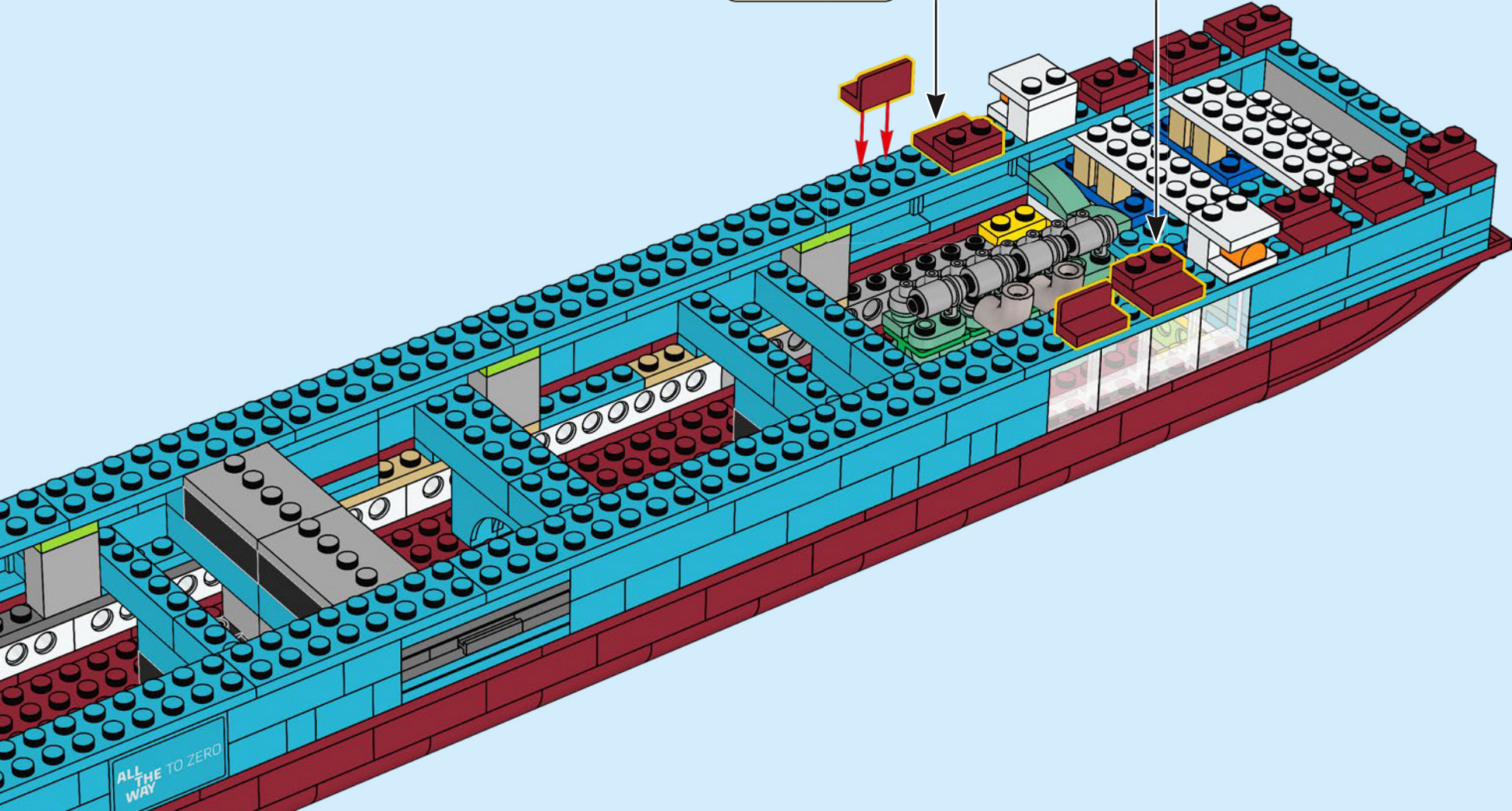
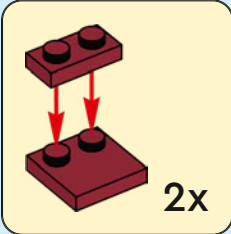

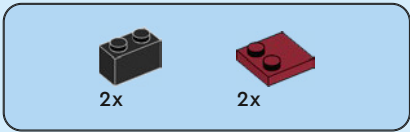

154

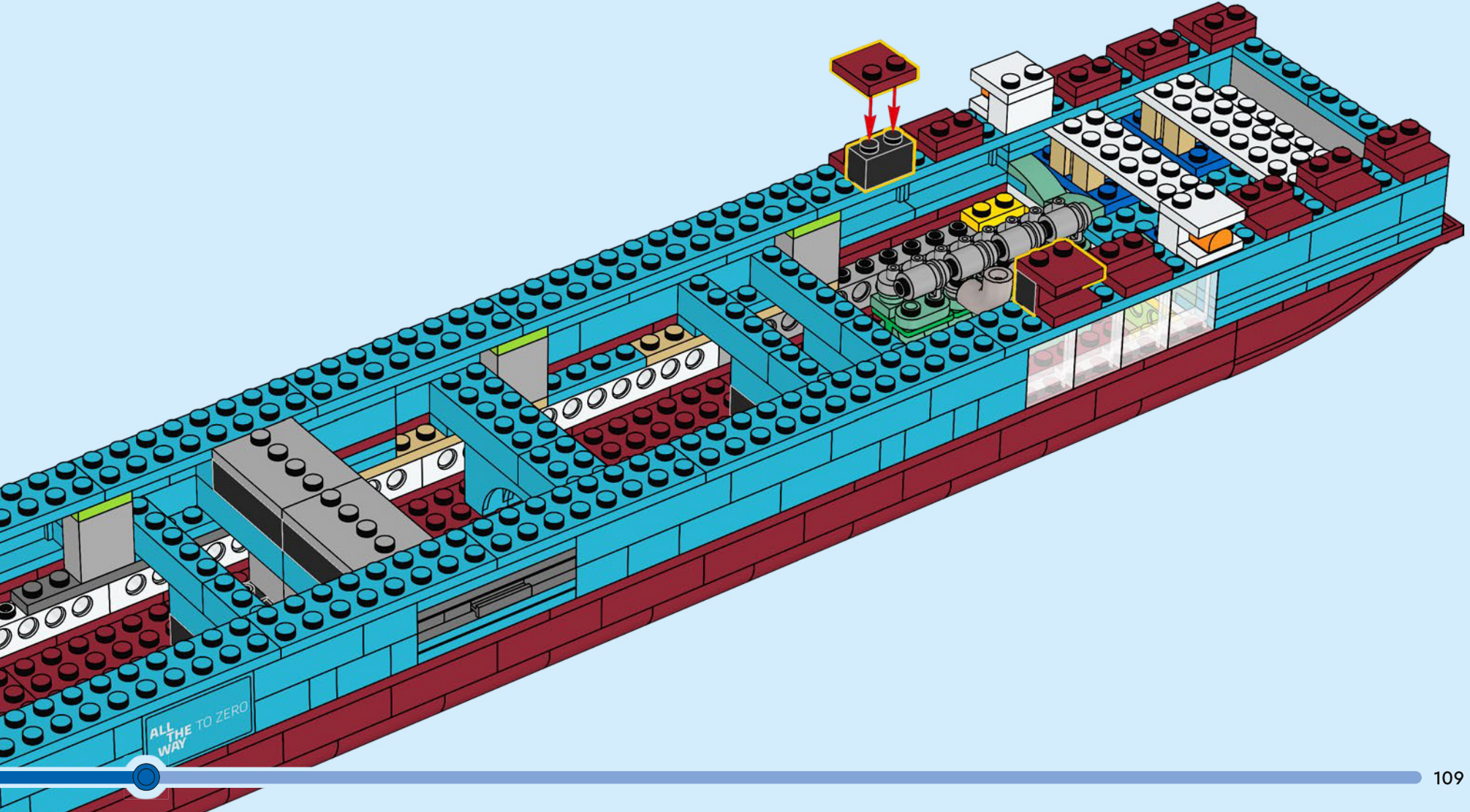

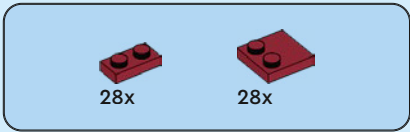

155

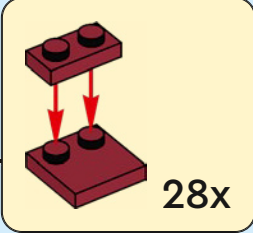
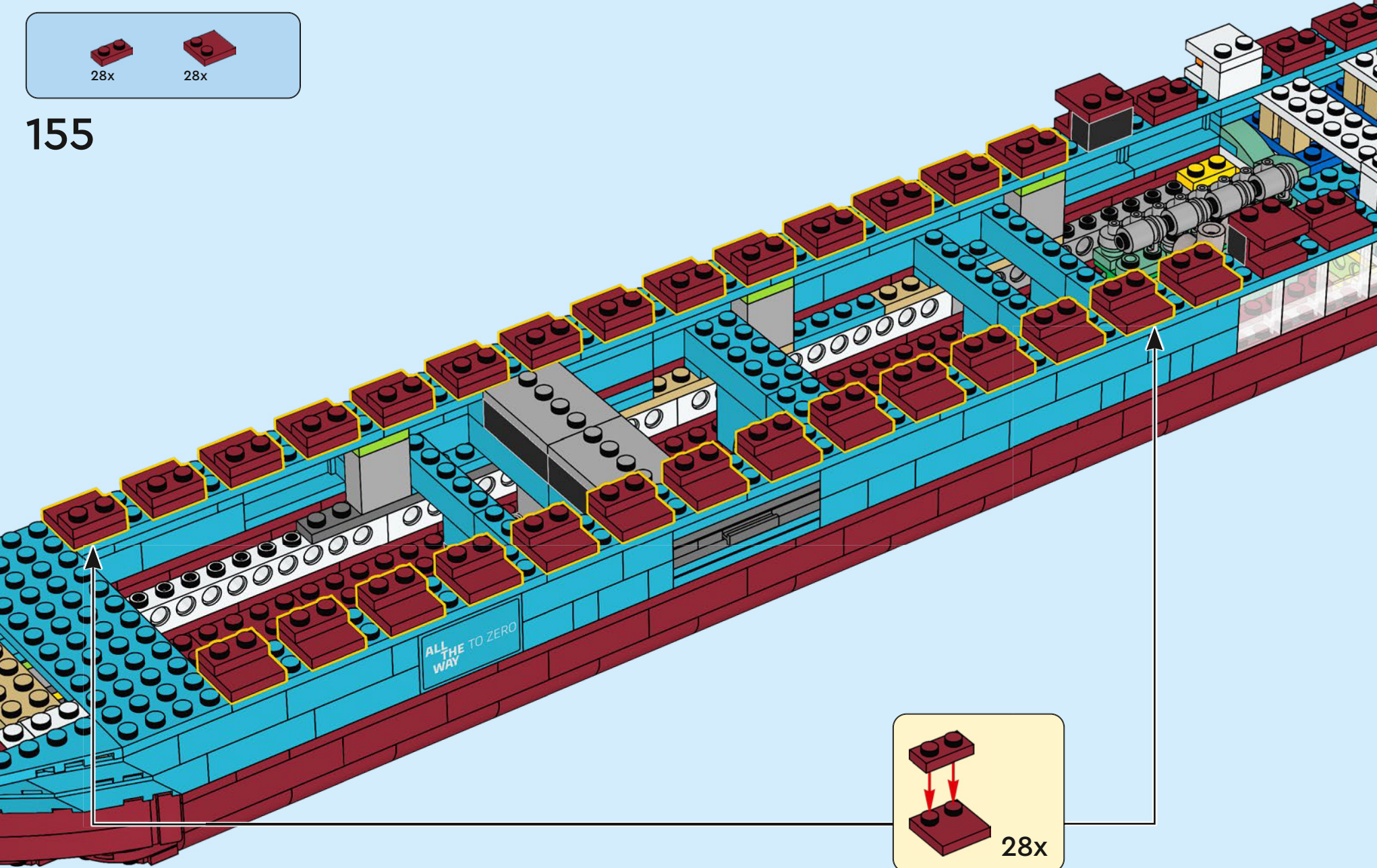

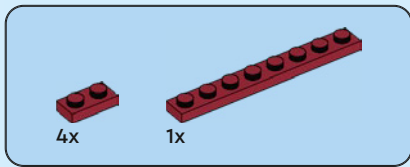

156

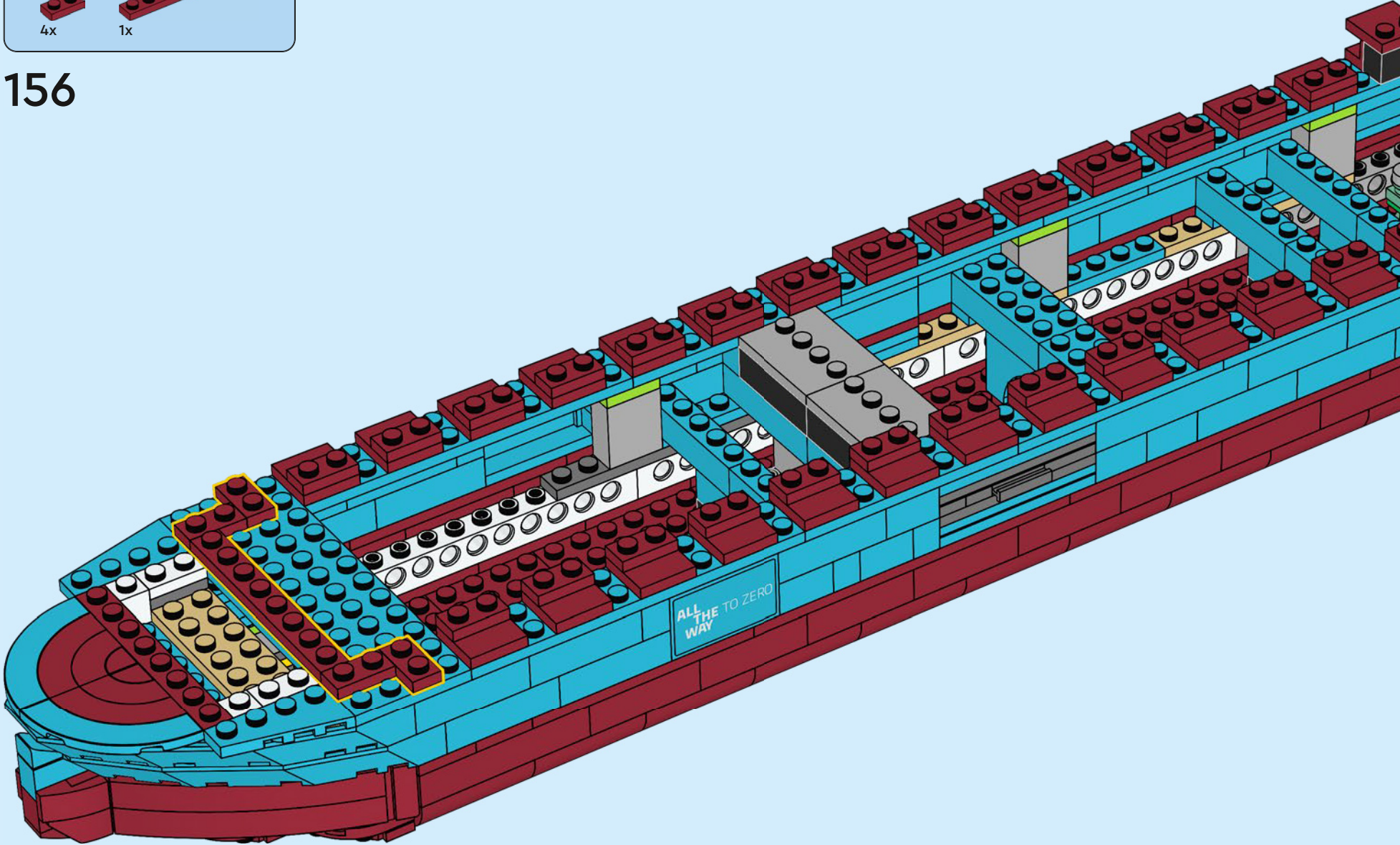

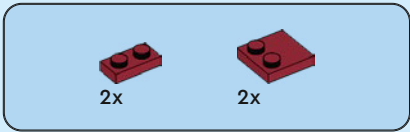

157

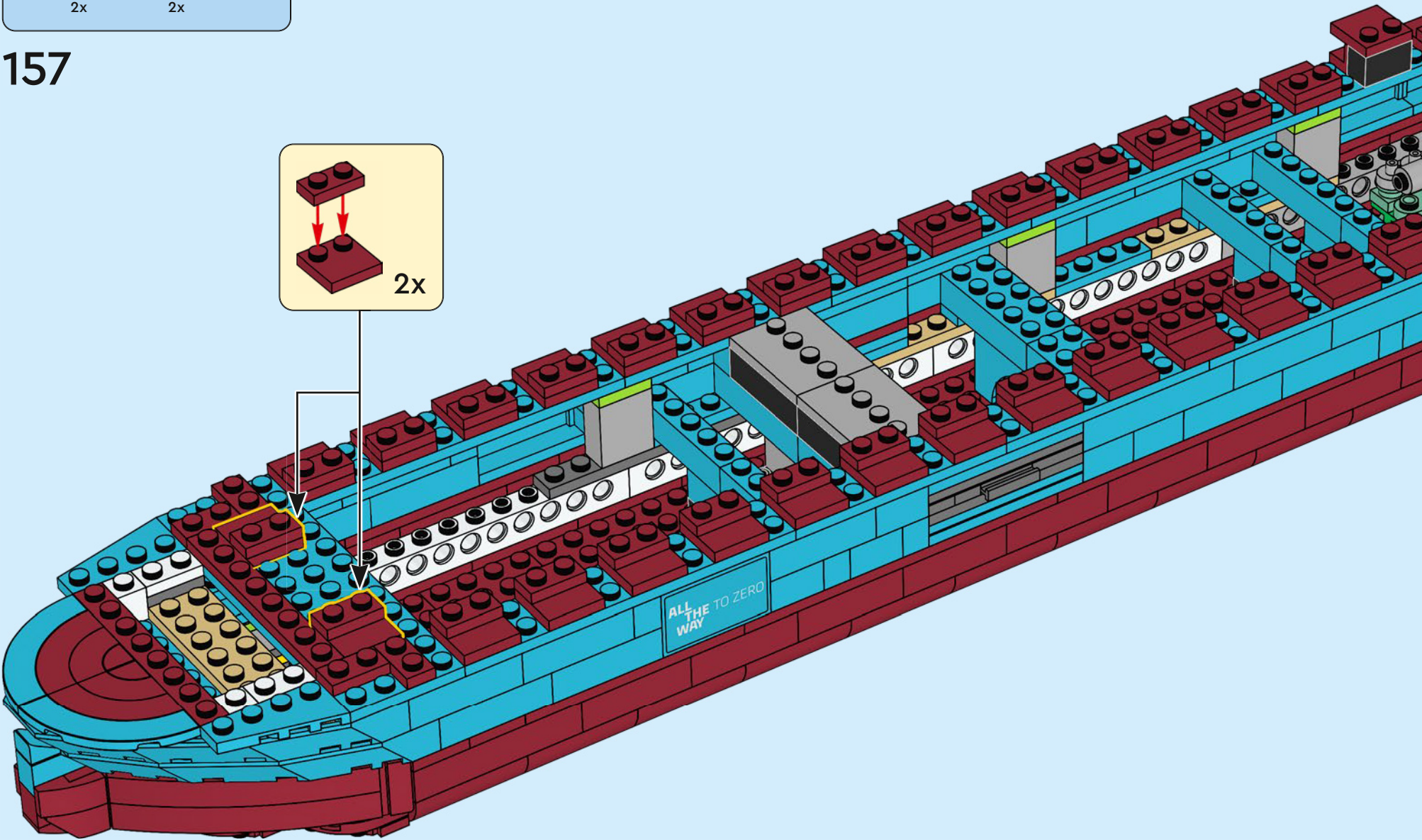
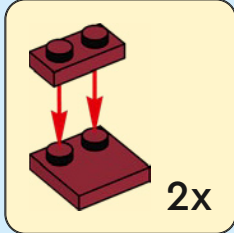

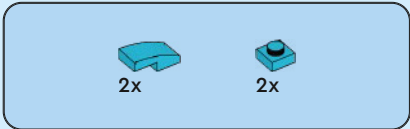

158

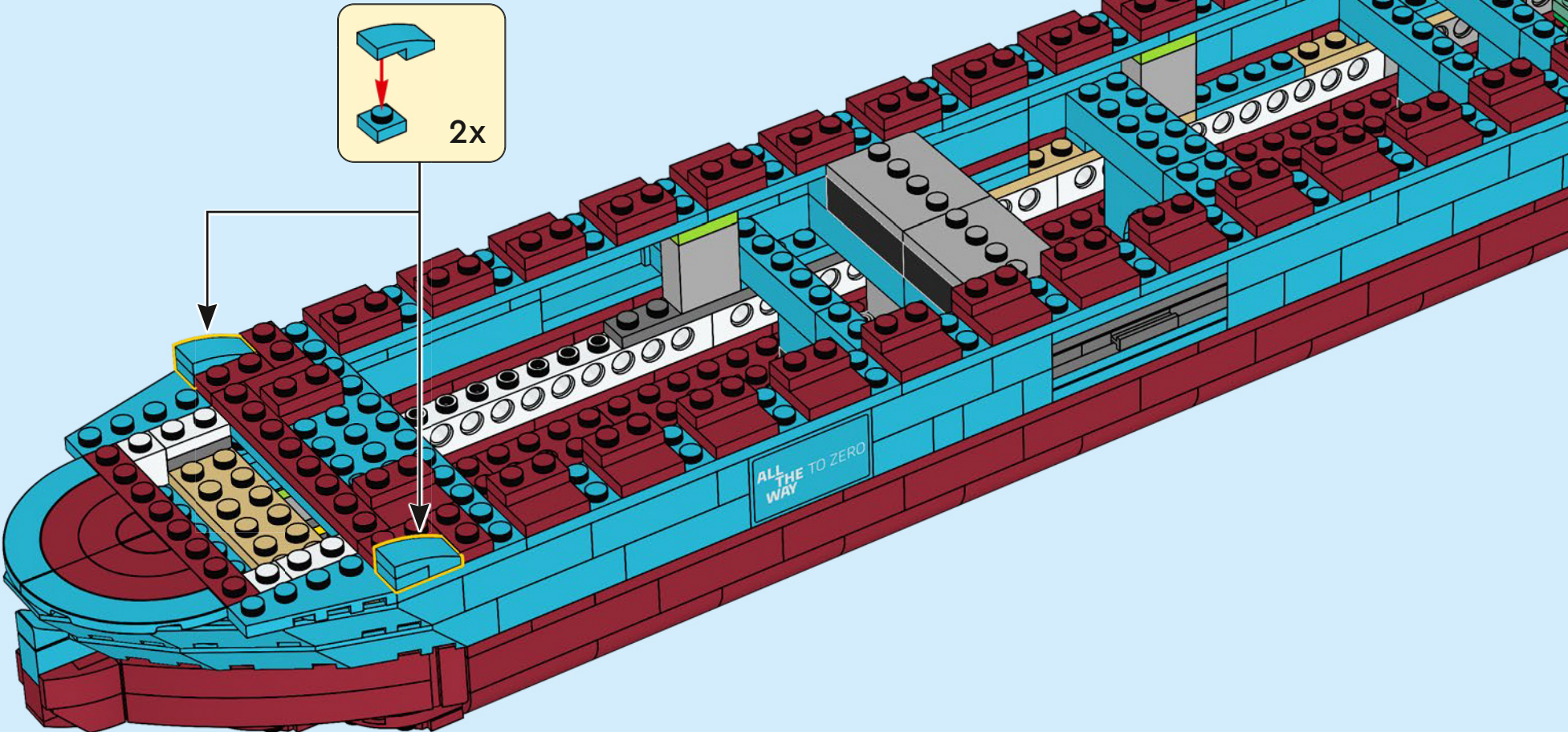

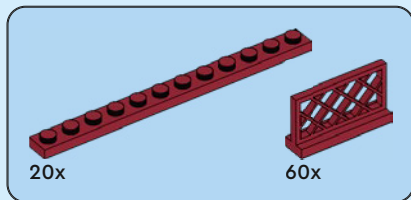
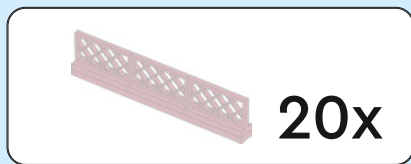

159

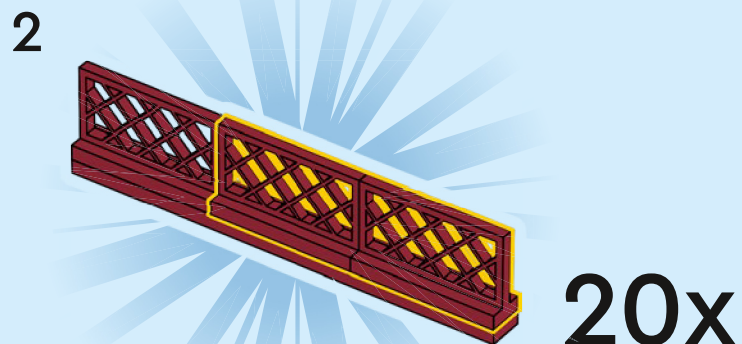
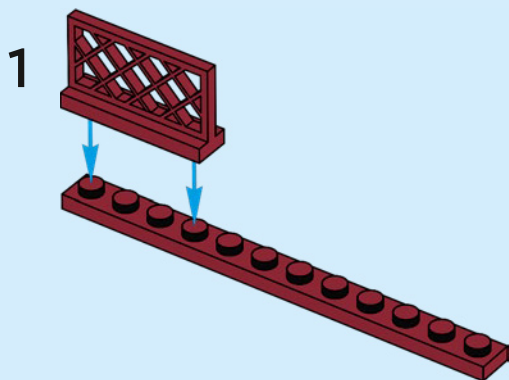
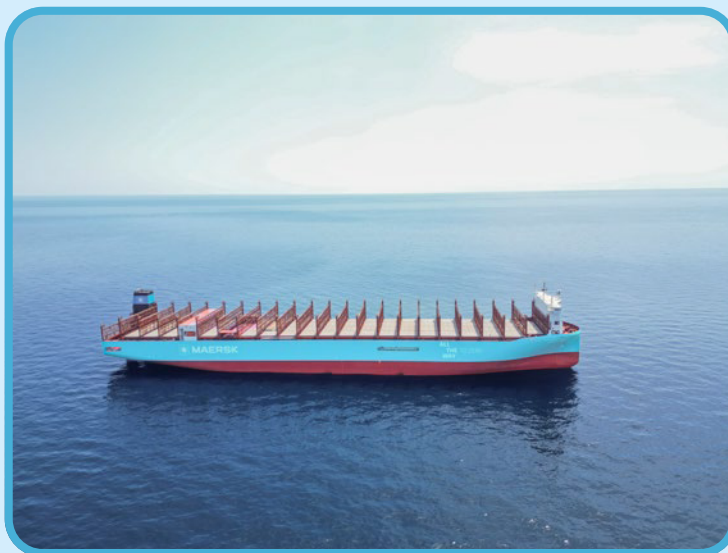

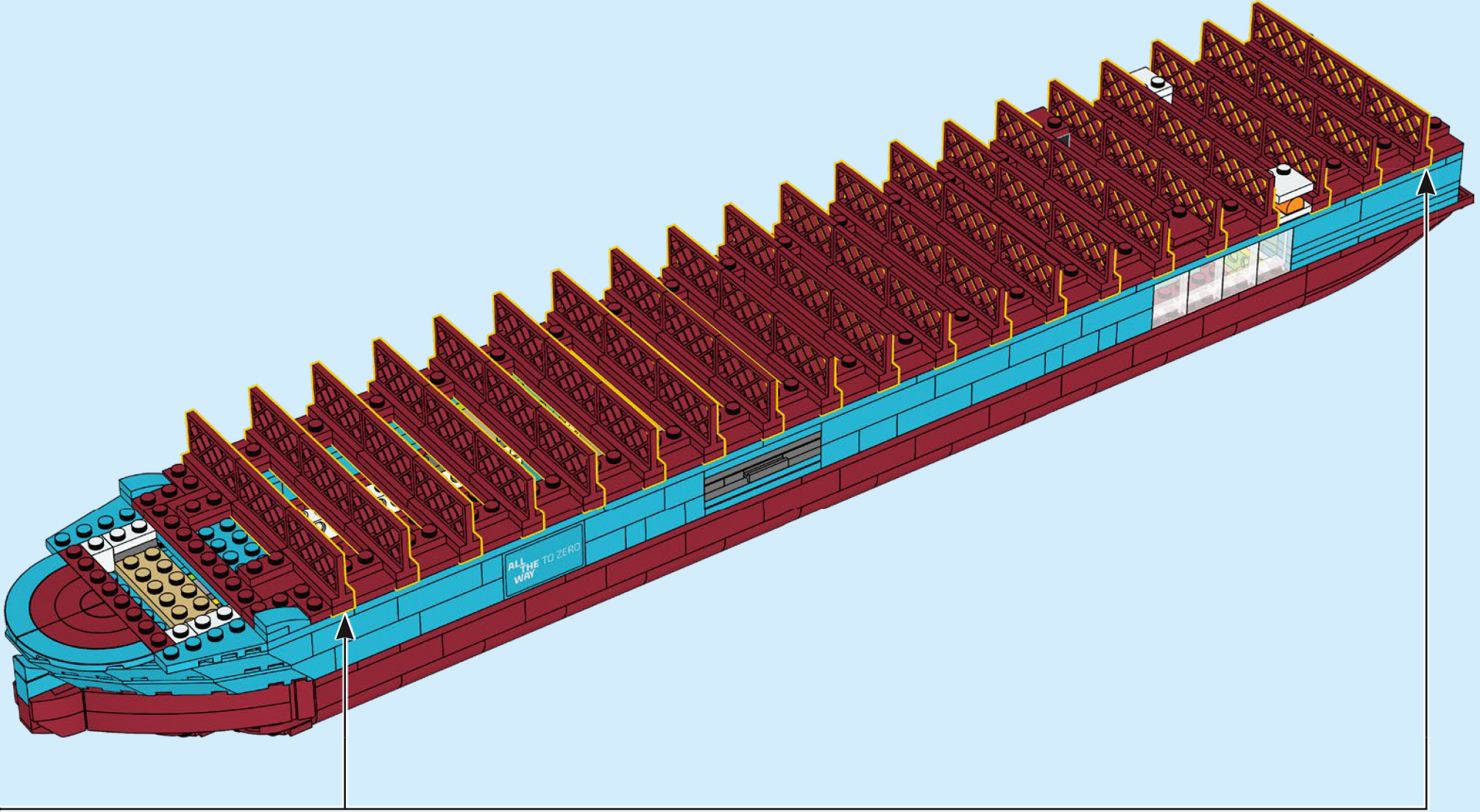

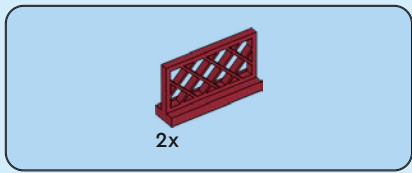

160

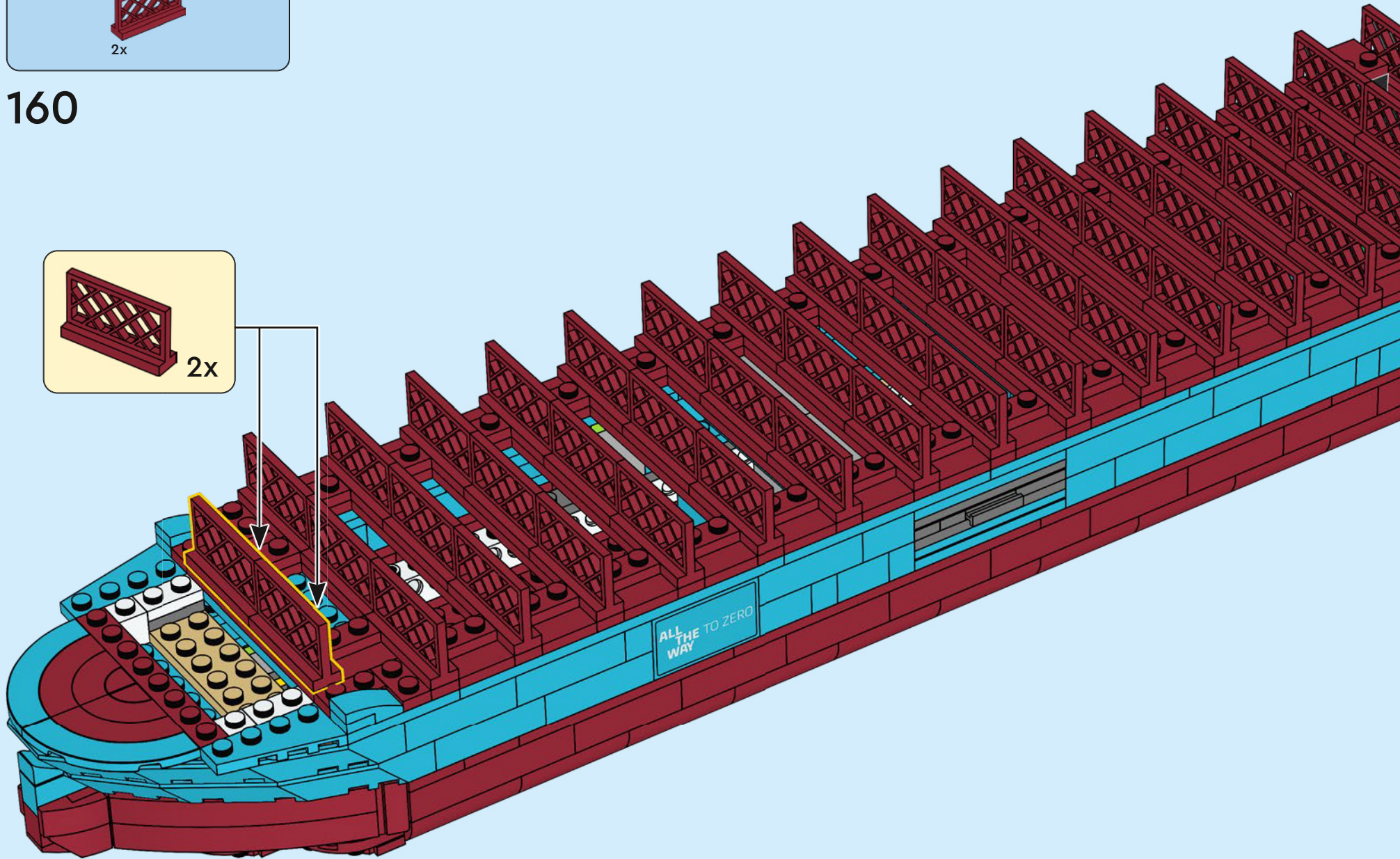
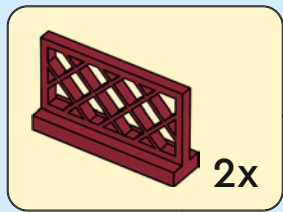

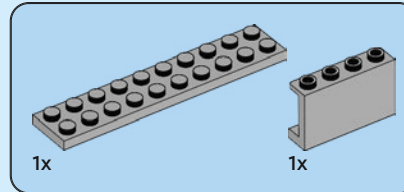
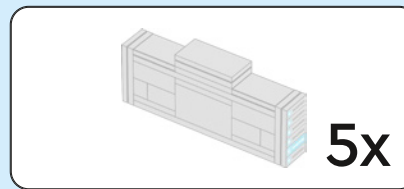

161

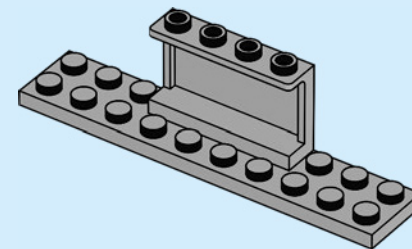
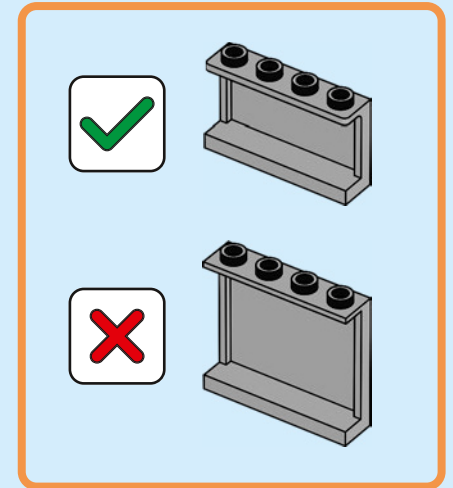

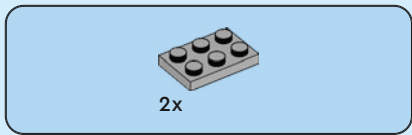

162

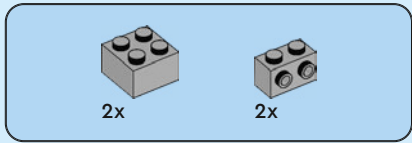
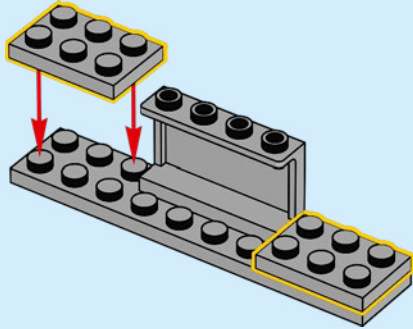

163

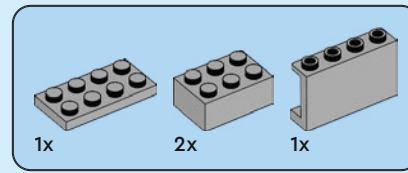
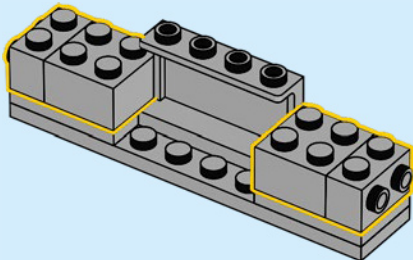

164

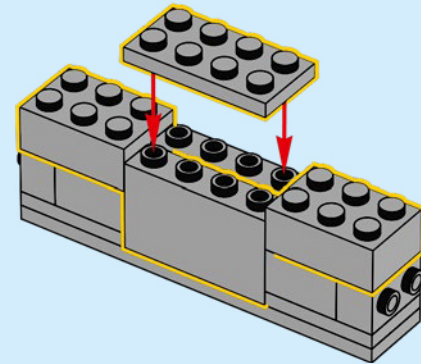

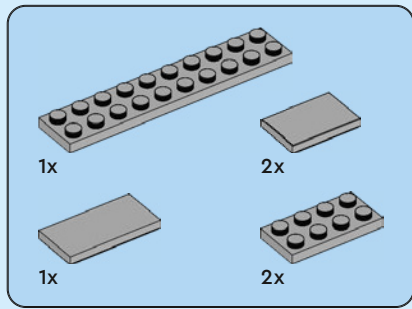

165

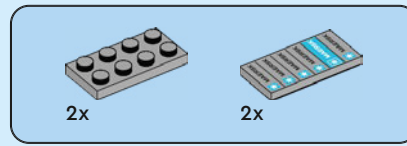
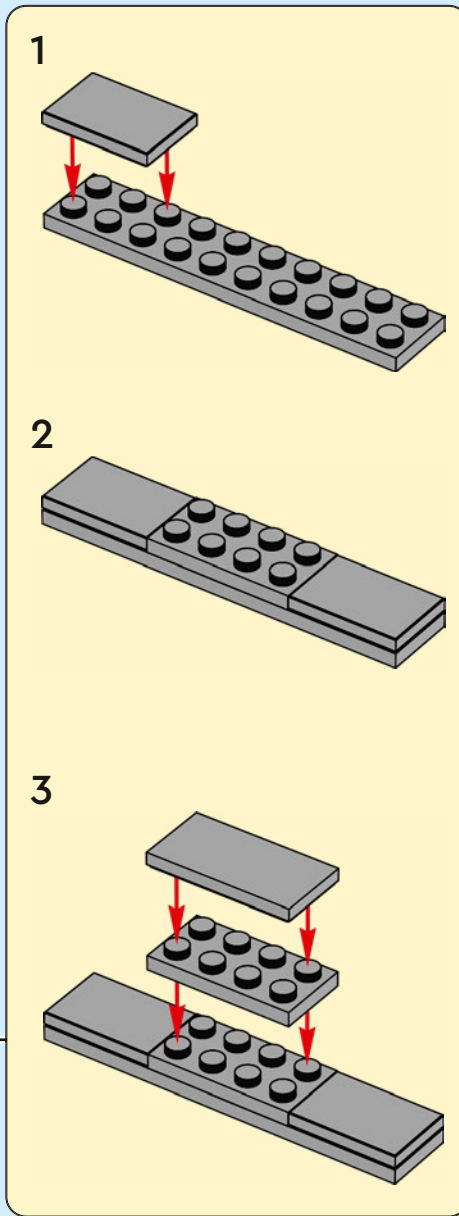
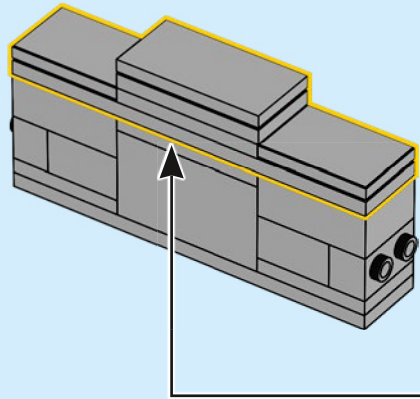

166

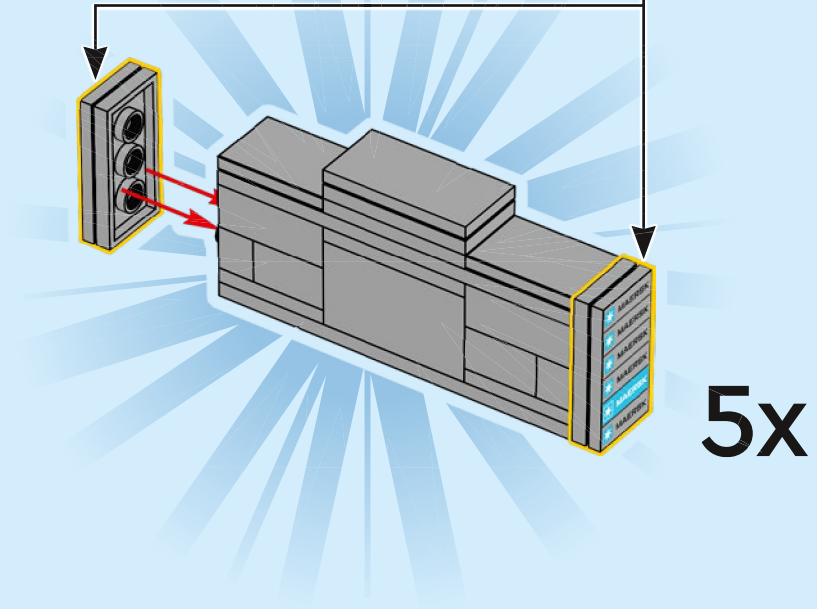
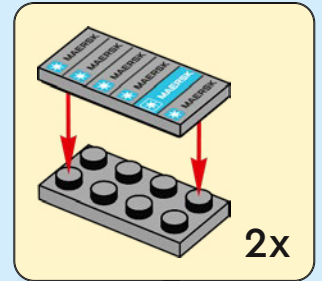

5x



167

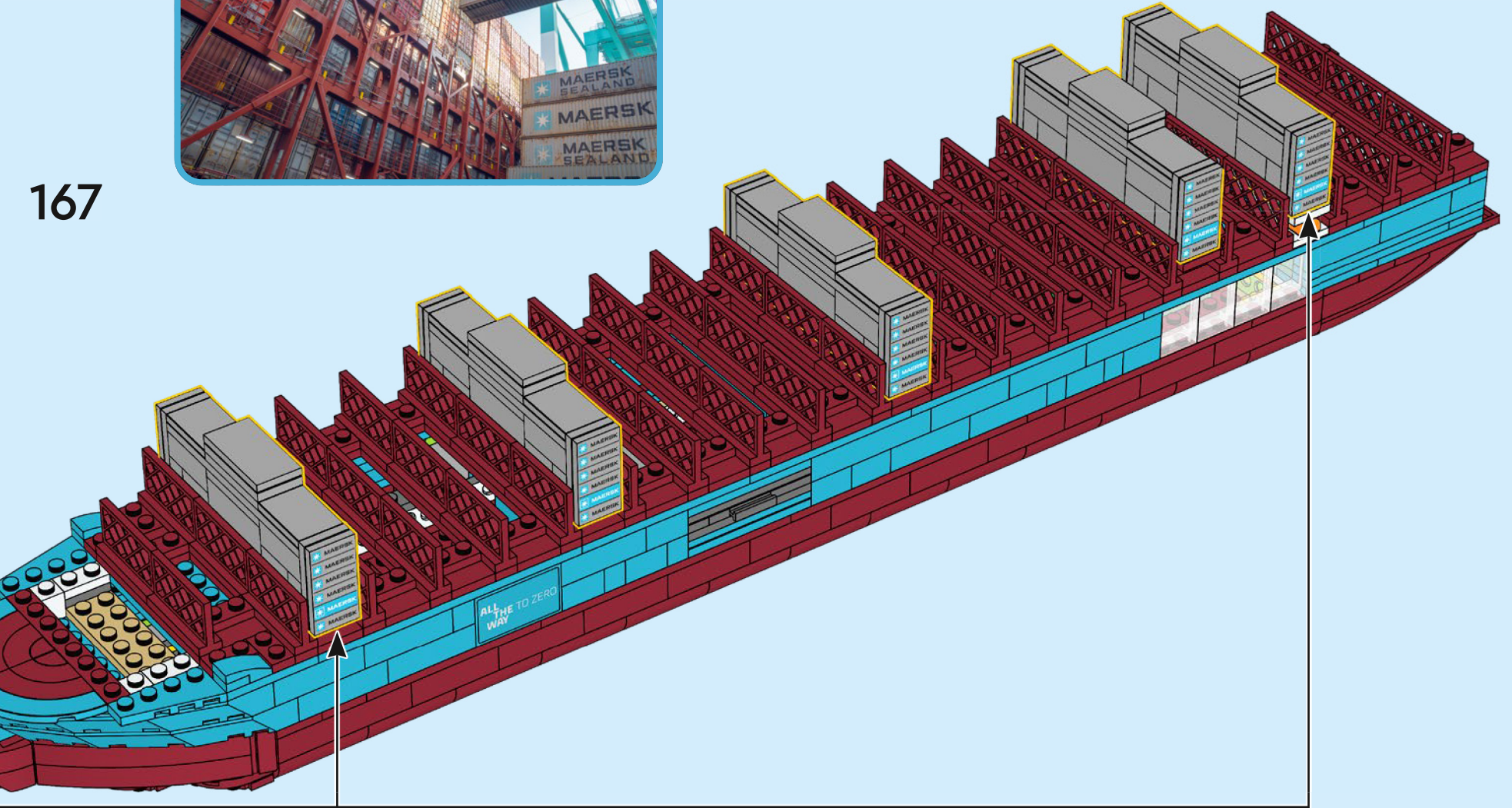

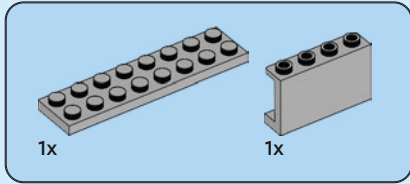
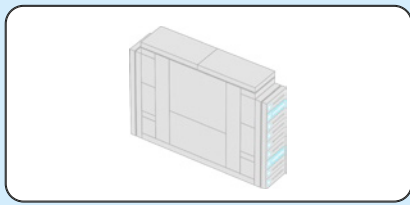

168

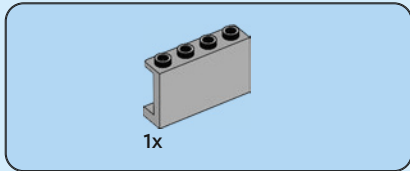
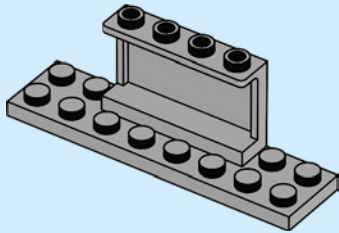

169

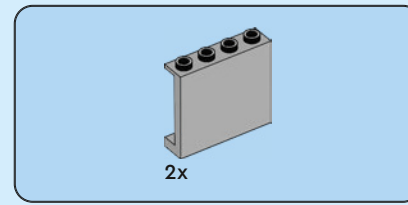
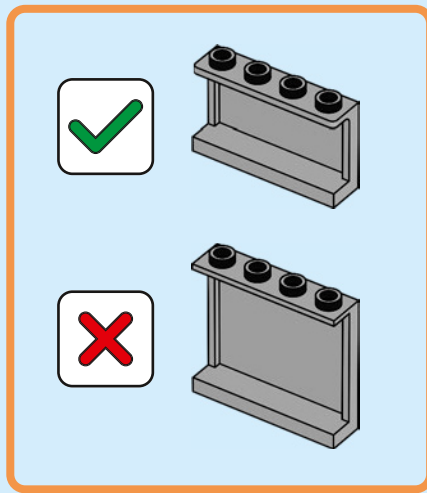
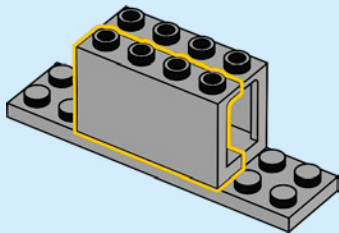

170

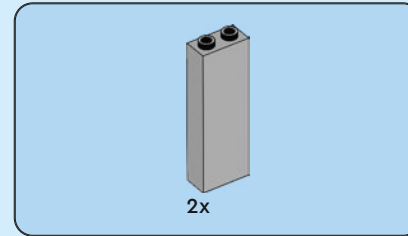
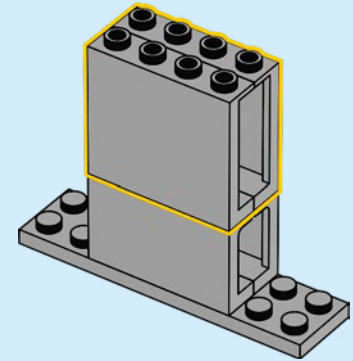

171

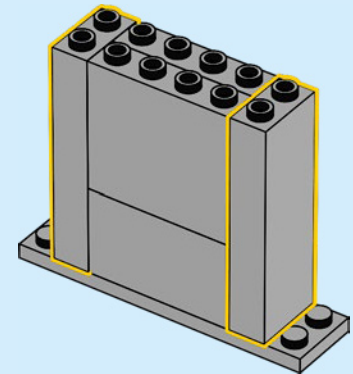

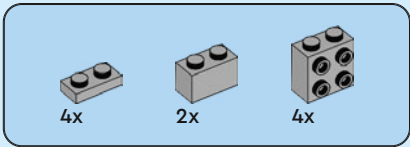

172

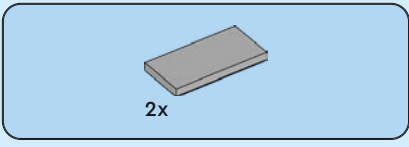
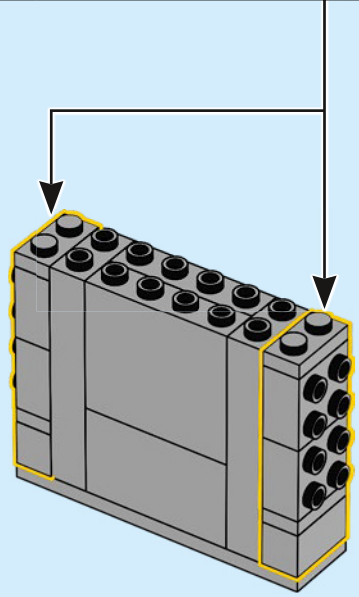
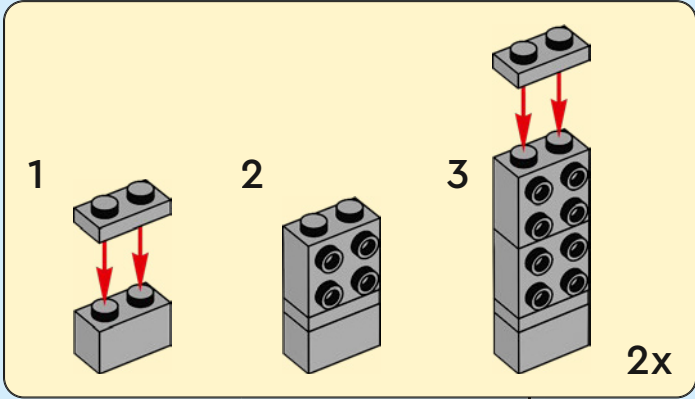

173

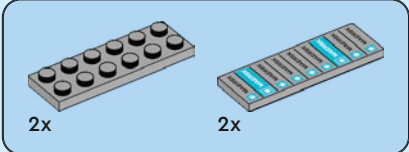
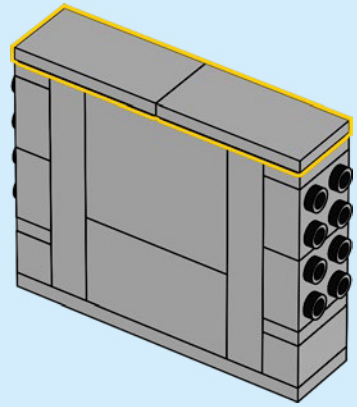

174

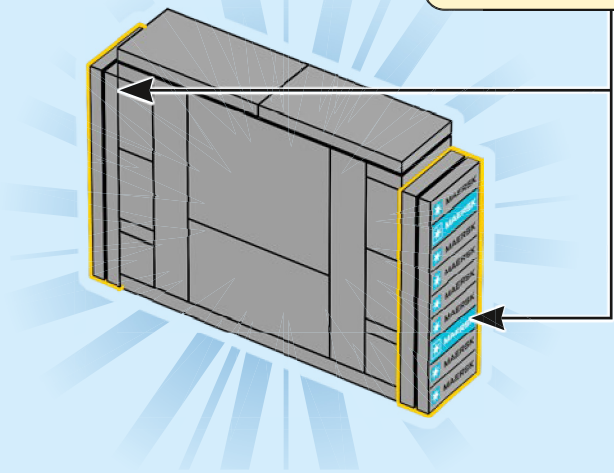
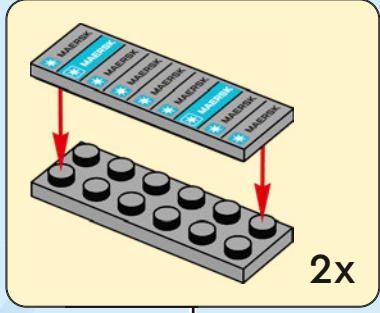

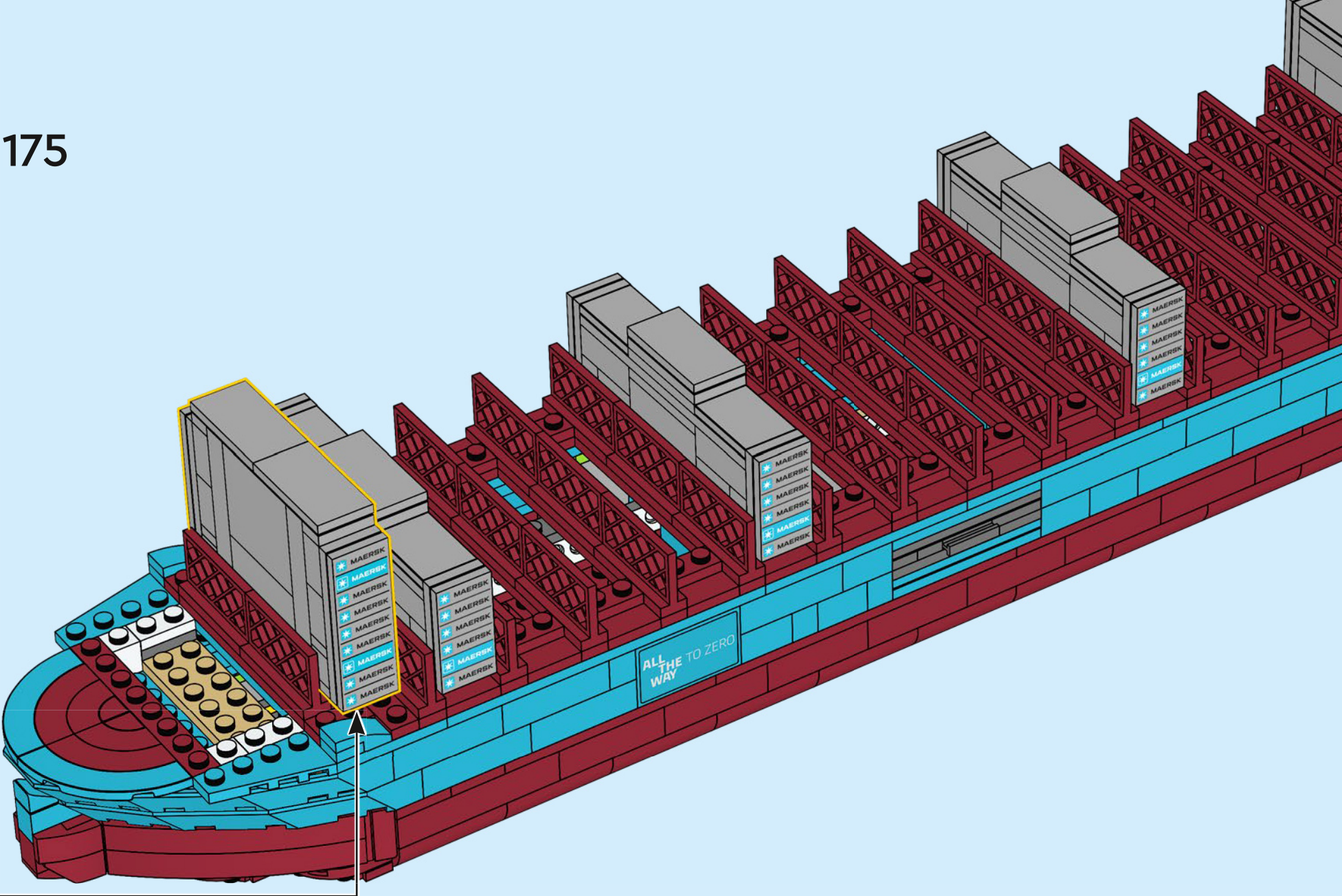

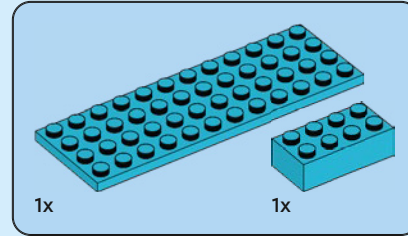
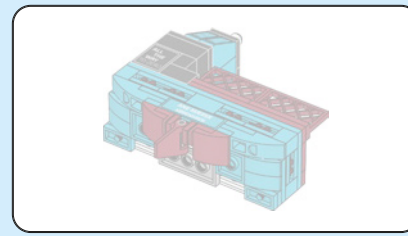

176

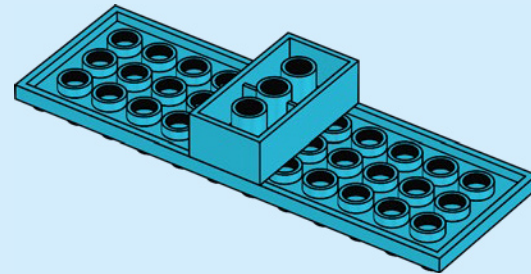

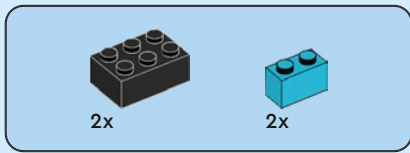

177

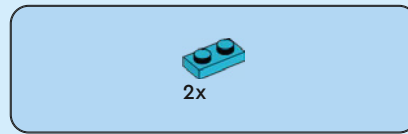
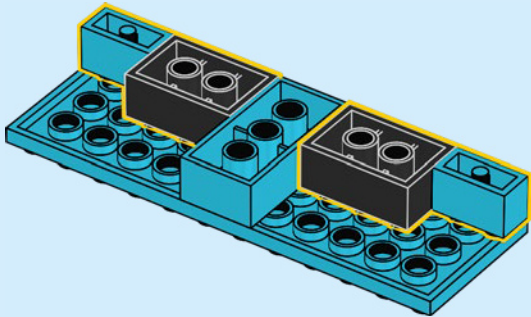

178

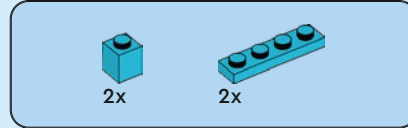
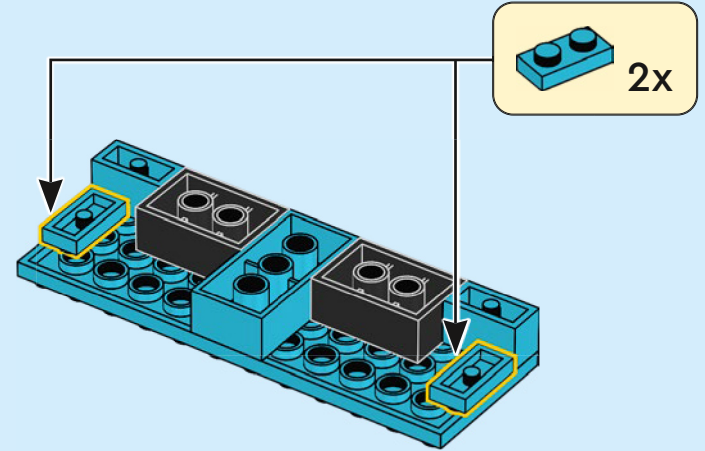

179

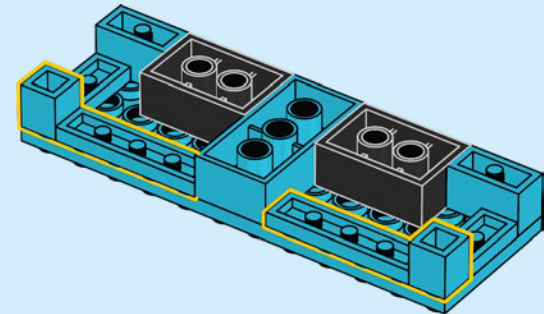

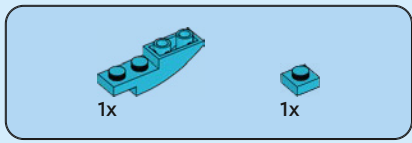

180

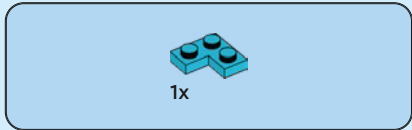
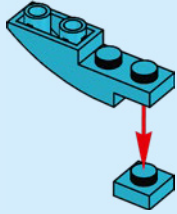

181

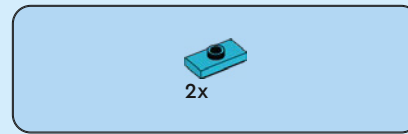
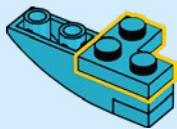

182

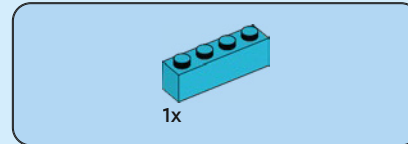
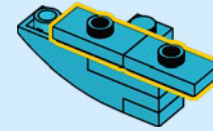

183

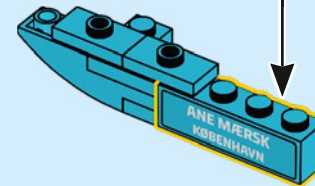
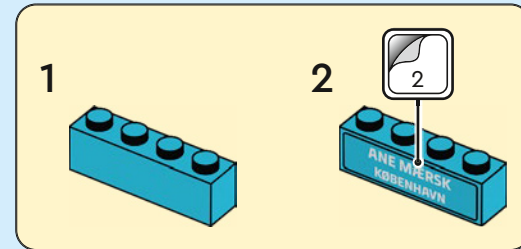

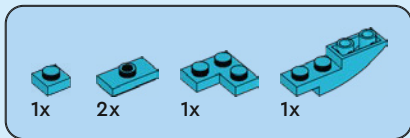

184

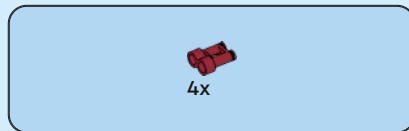
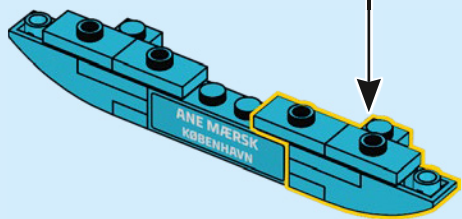
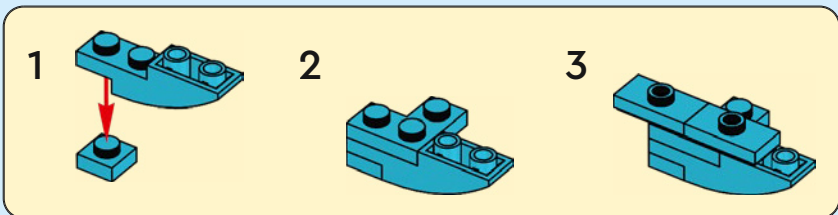

185

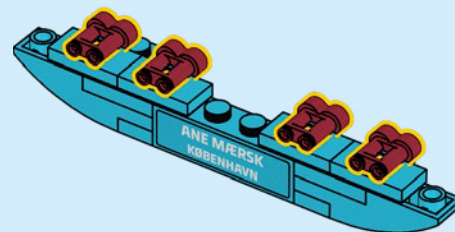

186

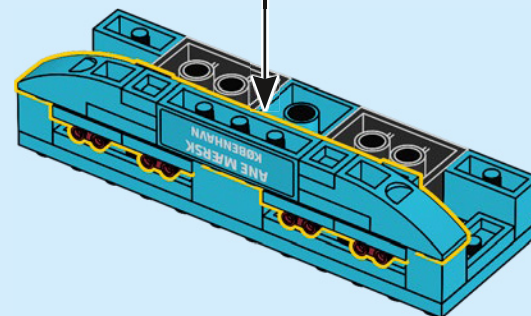

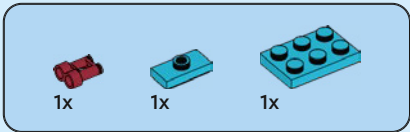

187

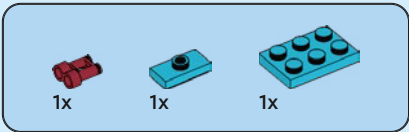
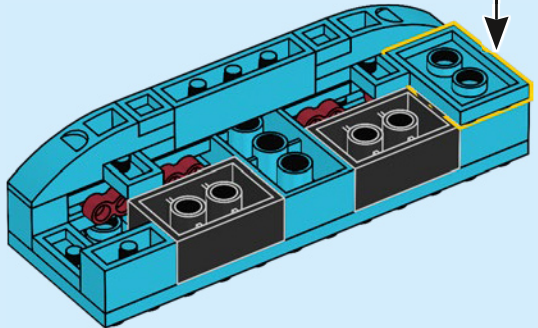
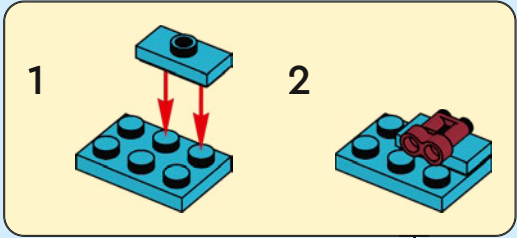

188

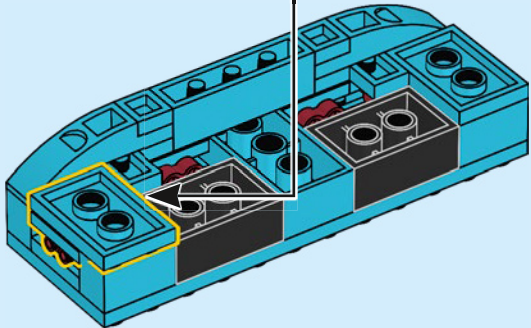
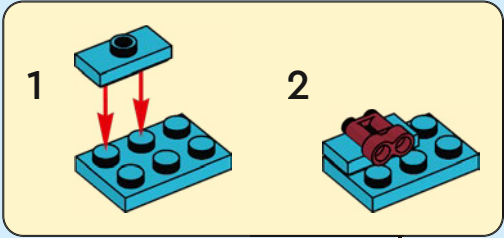

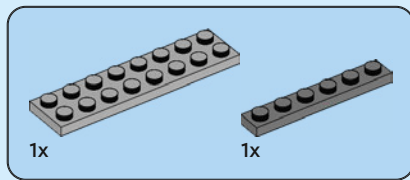

189

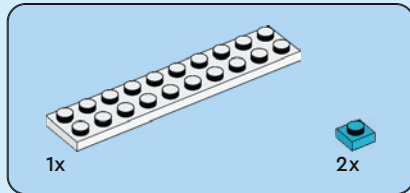
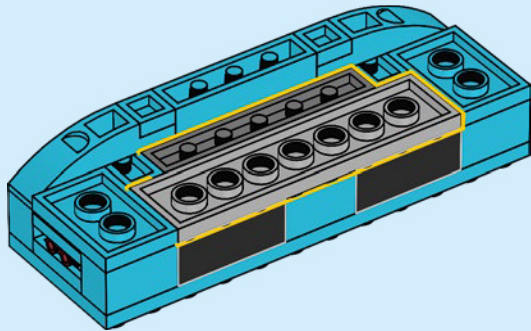

190

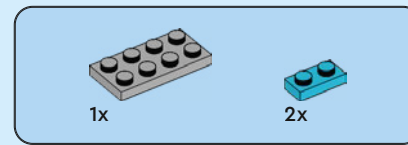
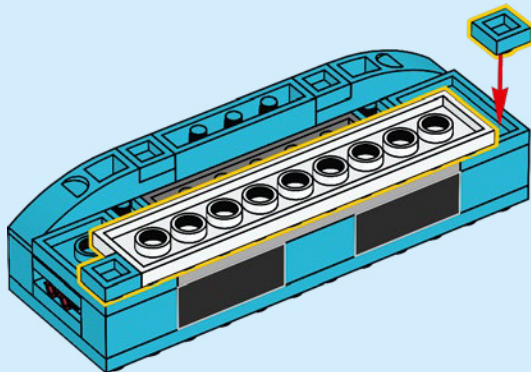

191

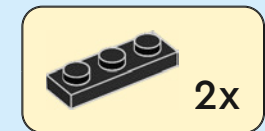
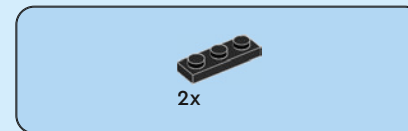
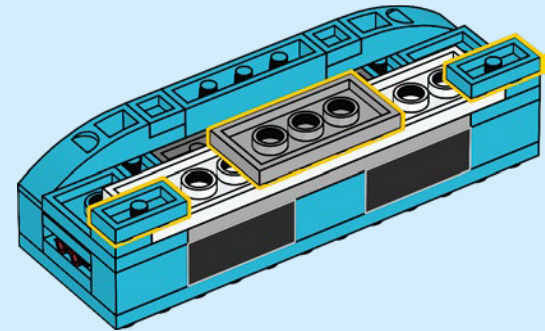

192

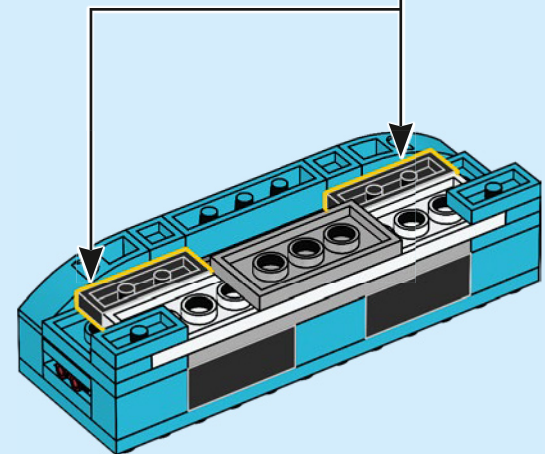



4x

193

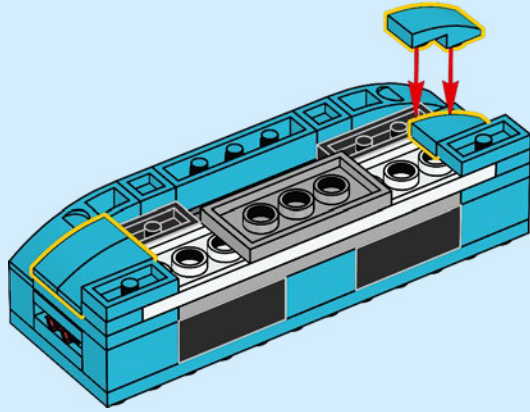

2x

194

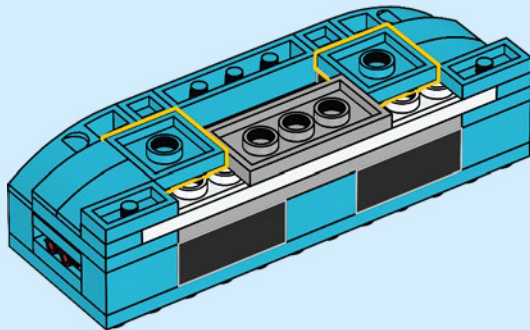

1x



1x



1x

195

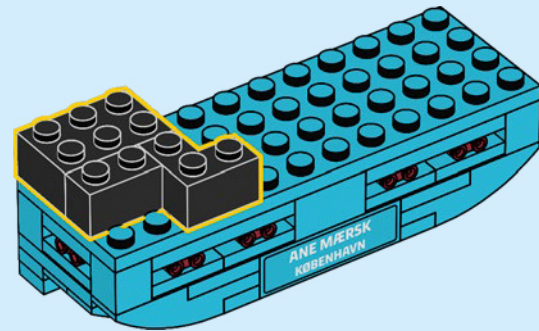

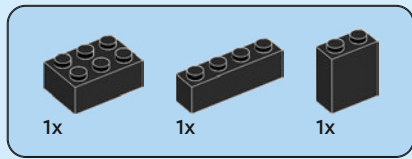

196

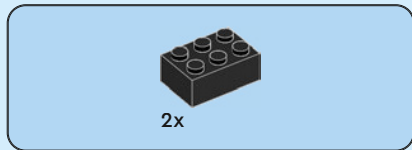
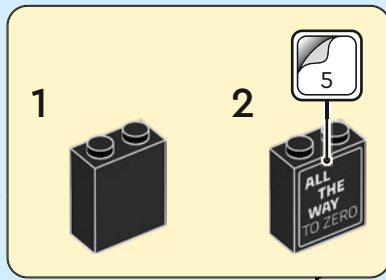
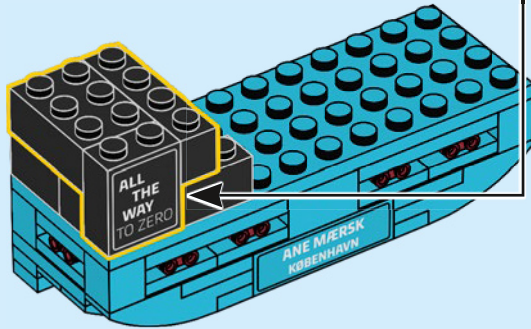

197

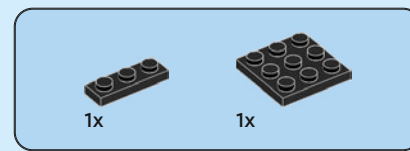
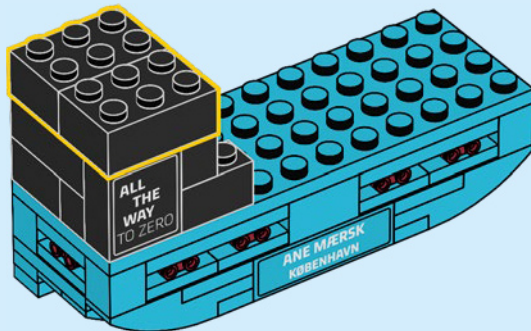

198

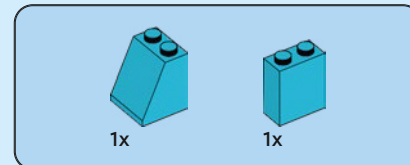
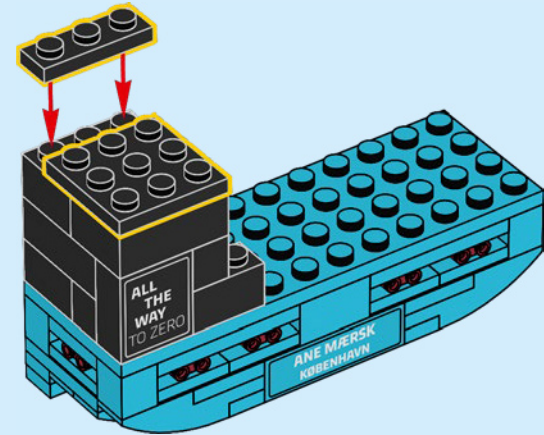

199

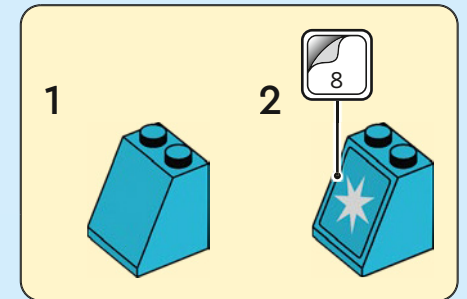
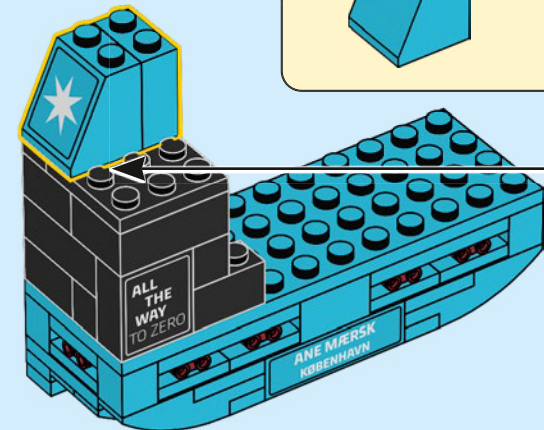

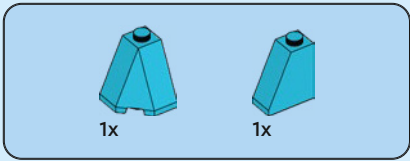

200

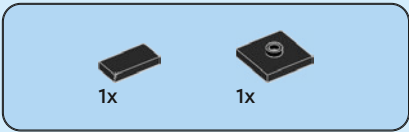
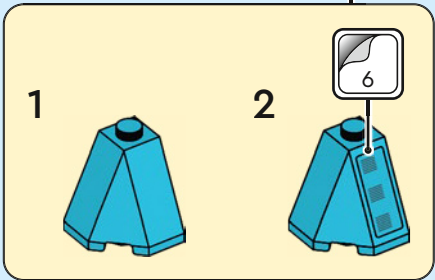
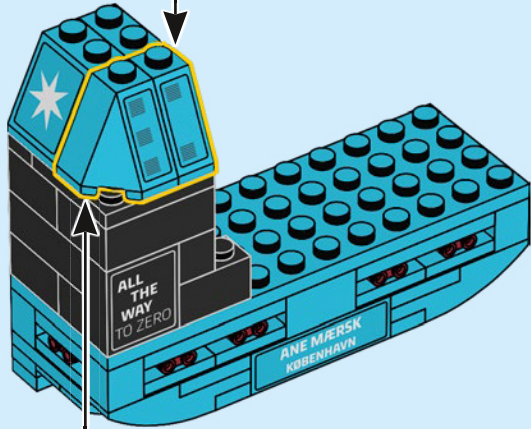
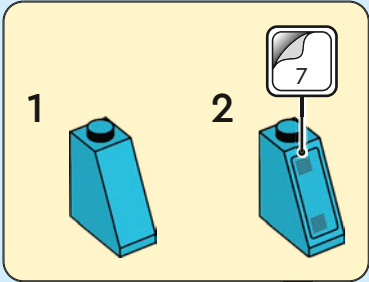

201

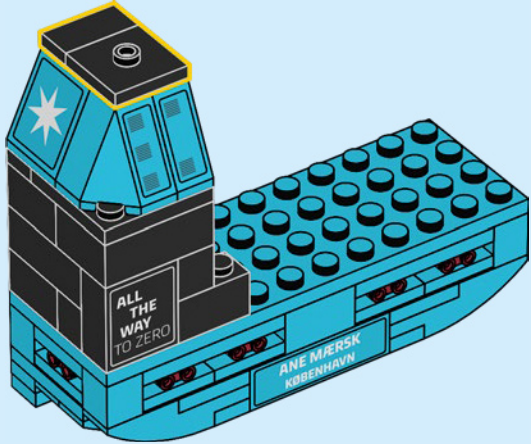



1x



1x

202

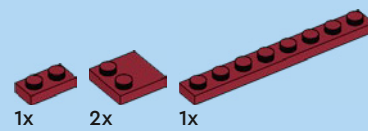
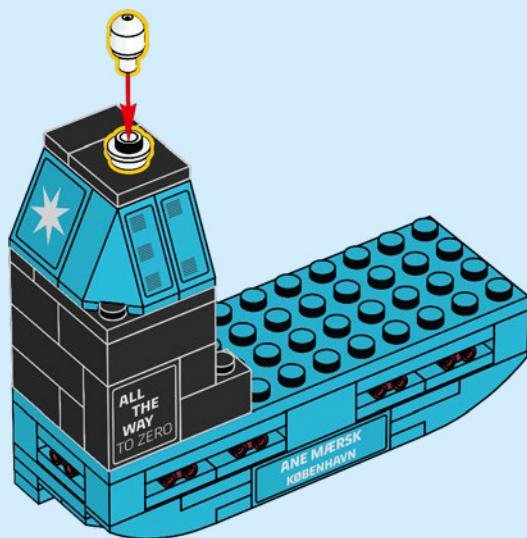

1x

2x

1x

203

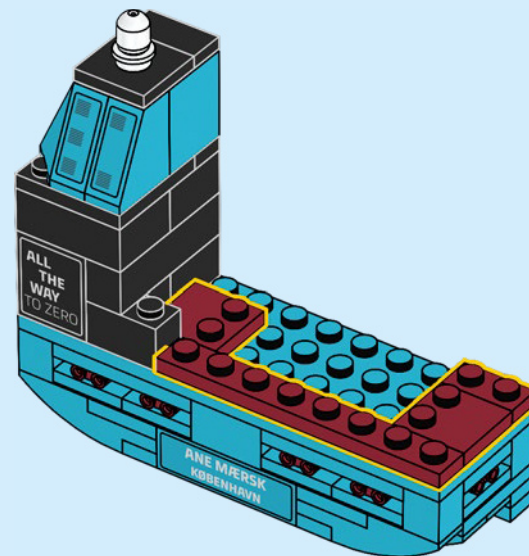



2x

204

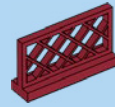
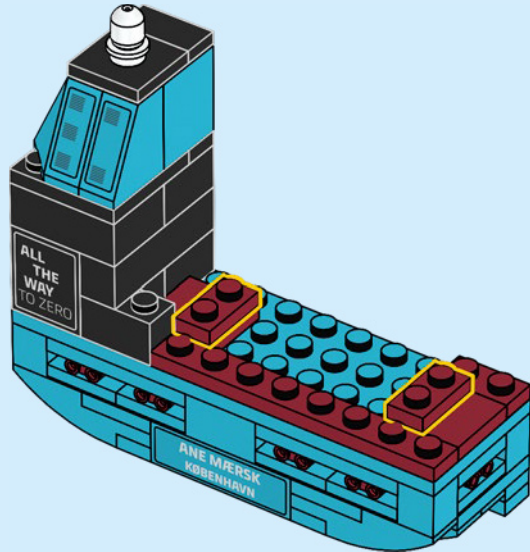

2x

205

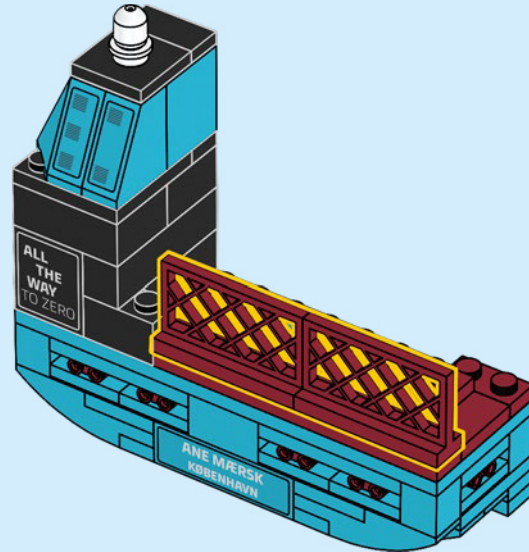

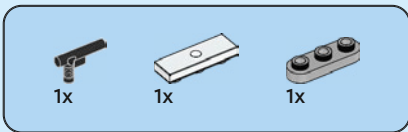

206

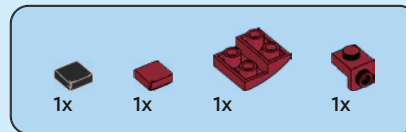
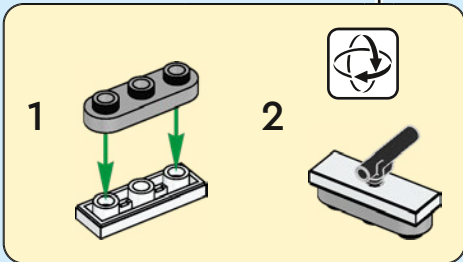
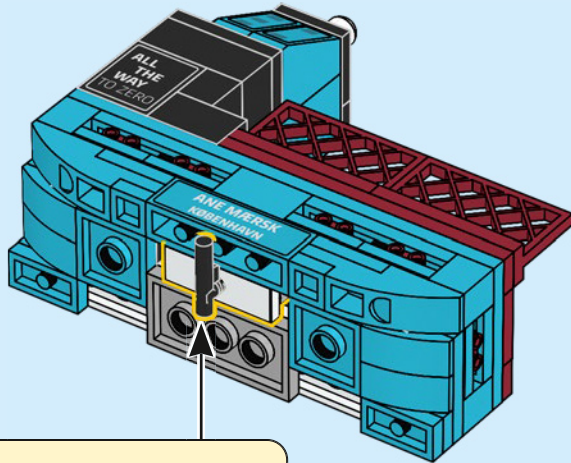

207

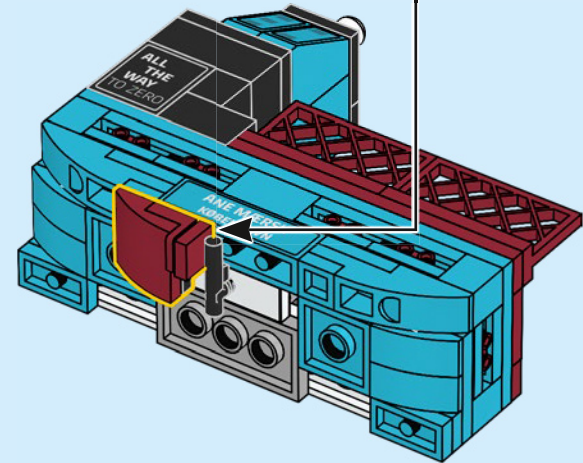
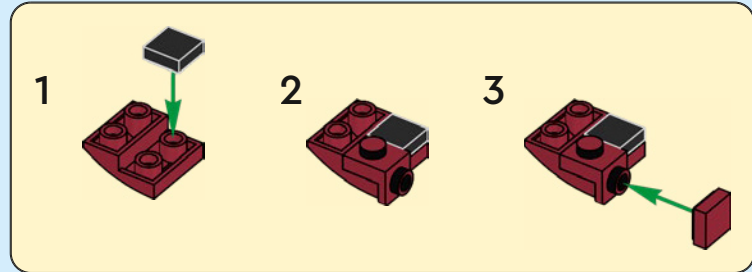

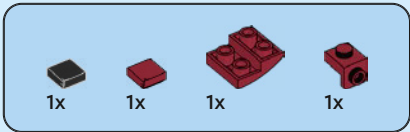

208

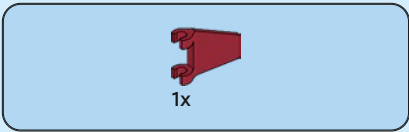
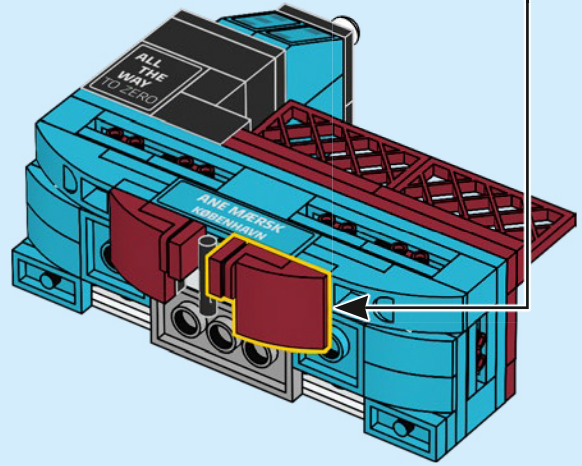

209

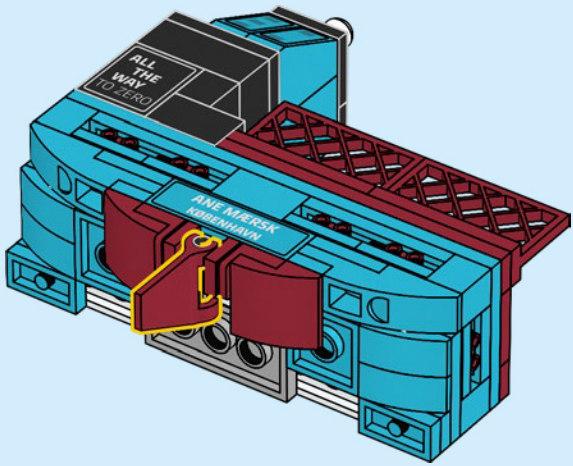

210

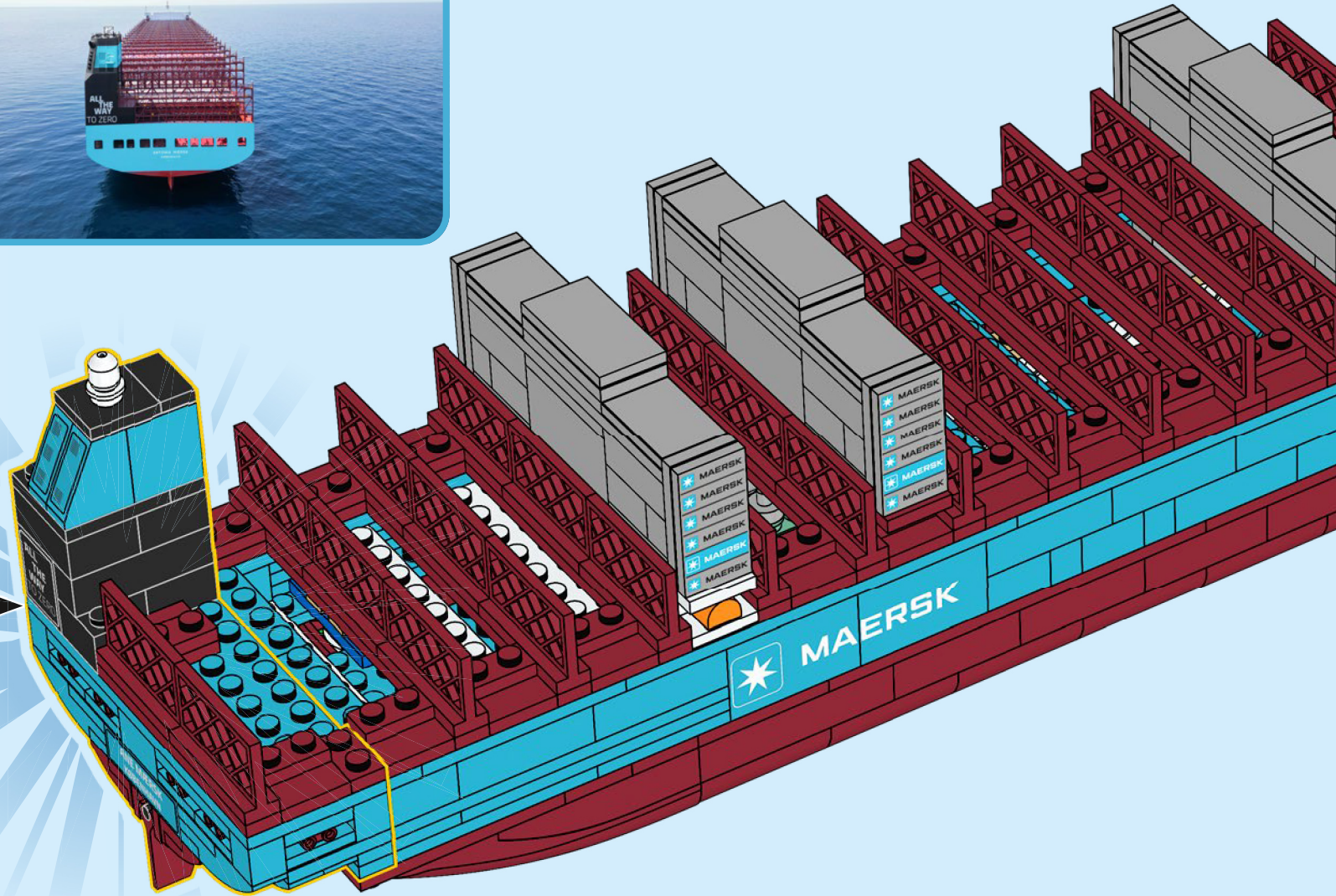
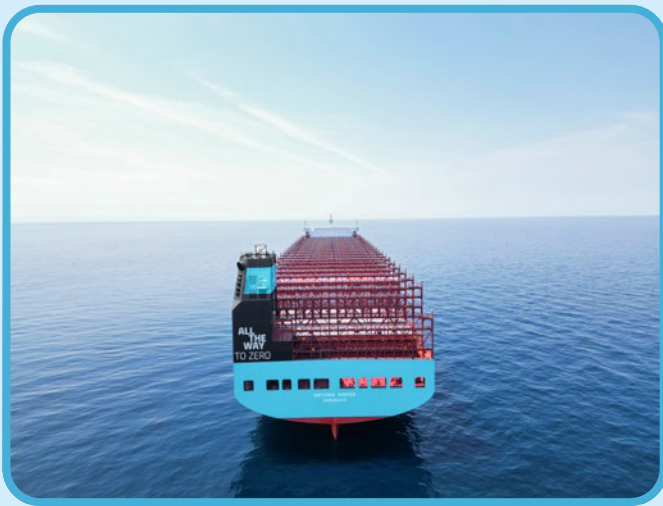

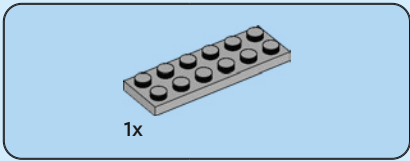

211

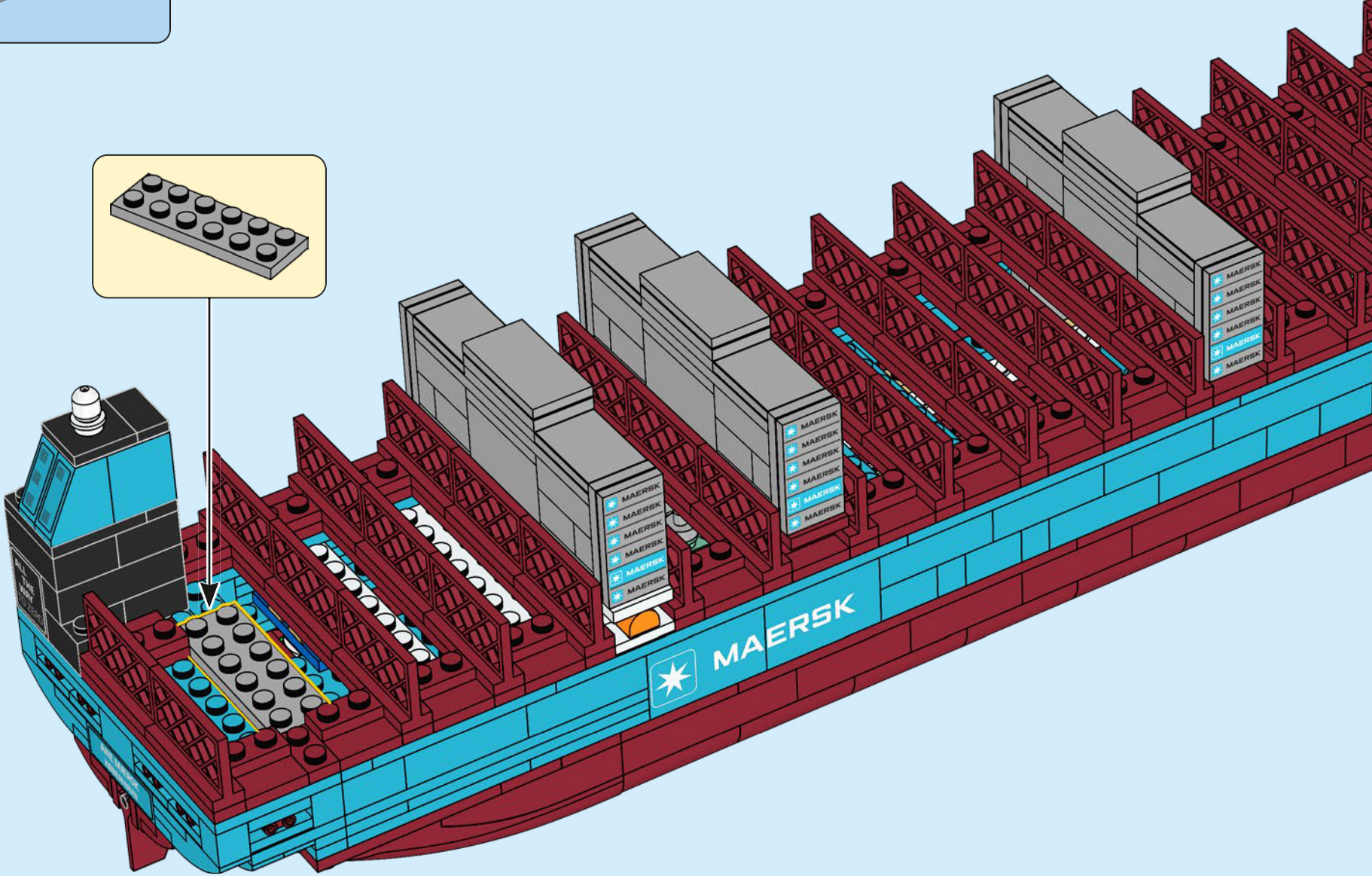
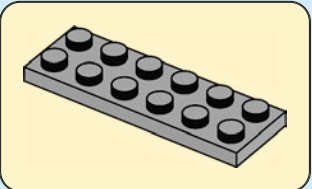

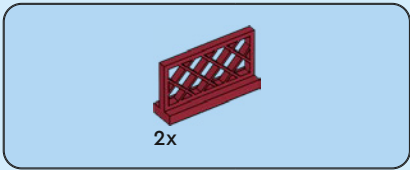

212

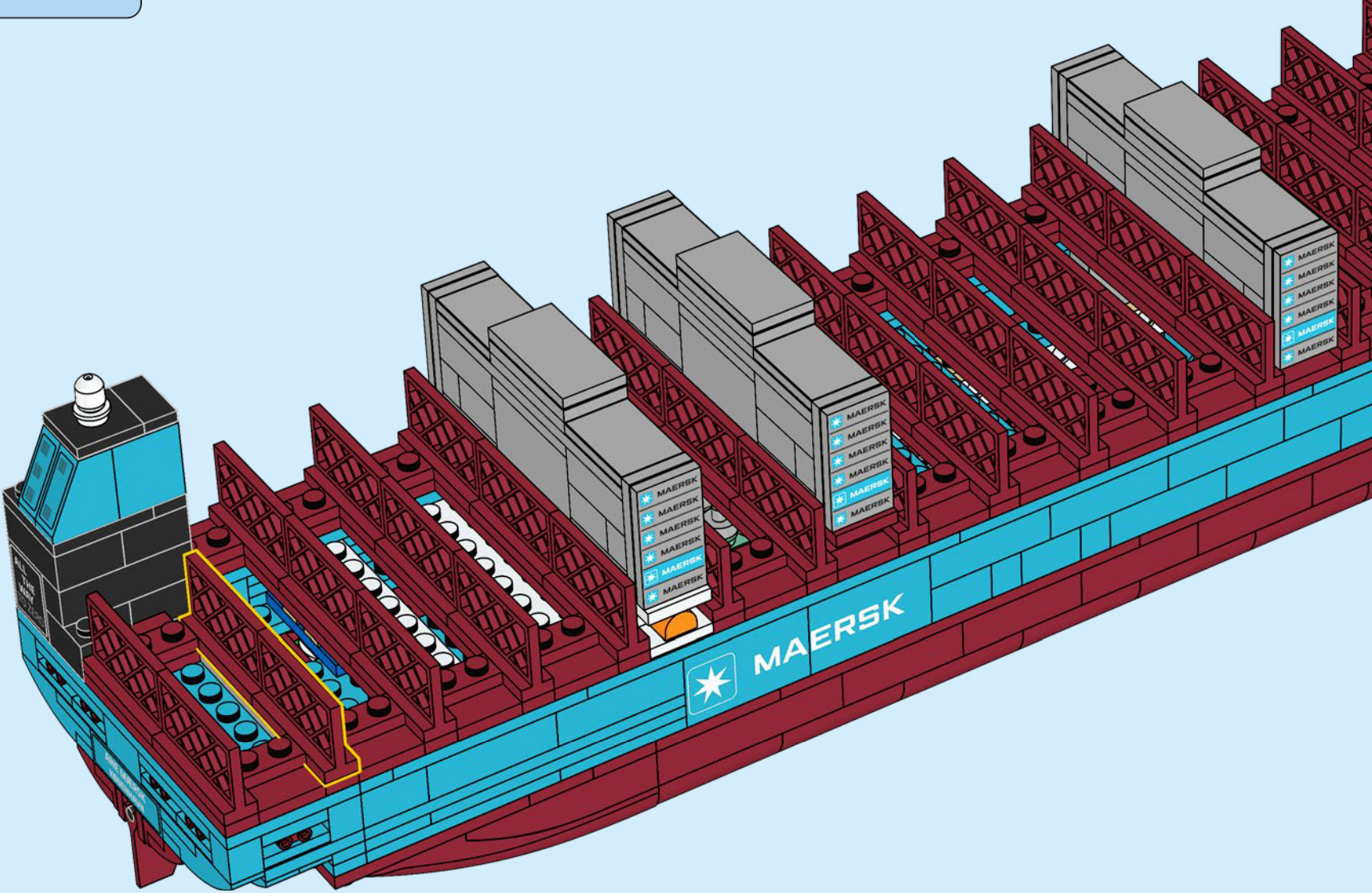

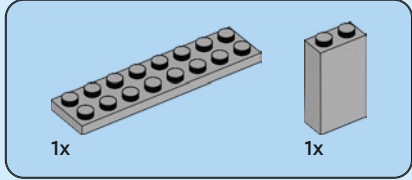
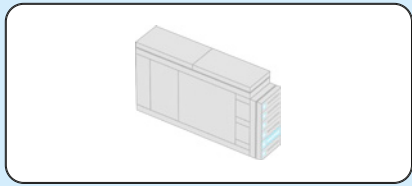

213

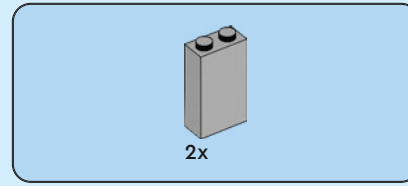
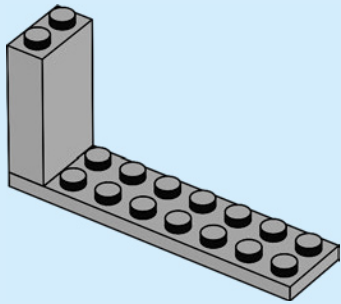

214

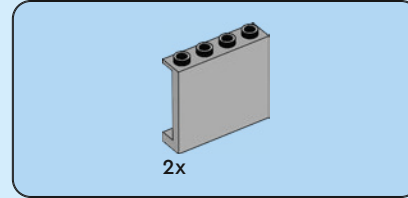
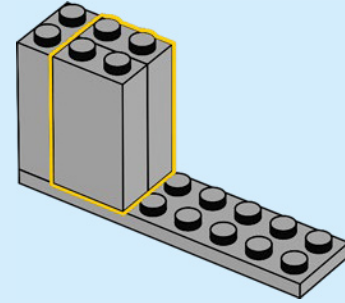

215

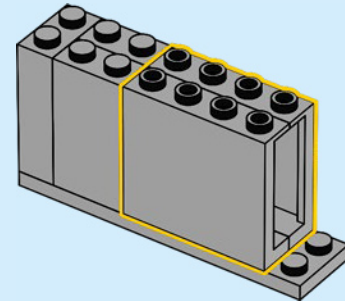

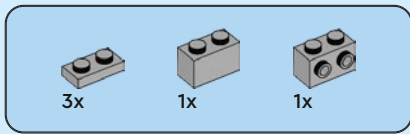

216

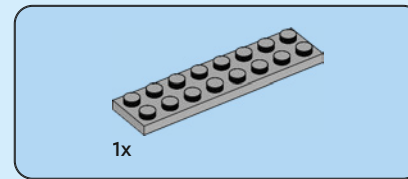
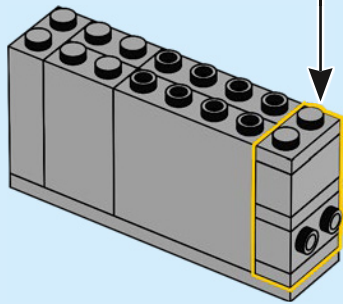
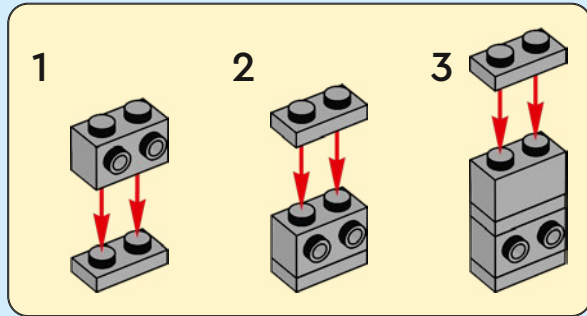

217

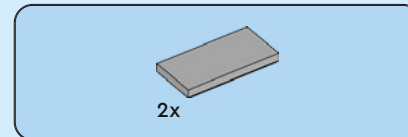
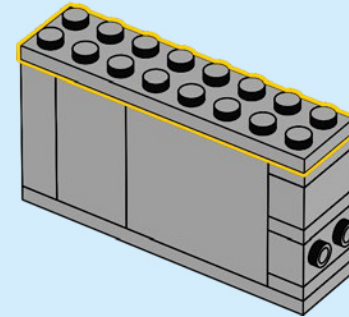

218

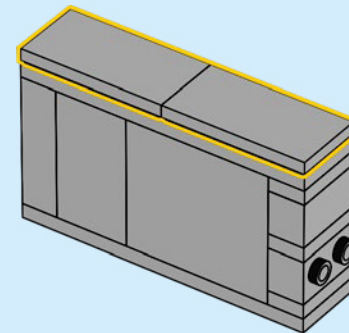

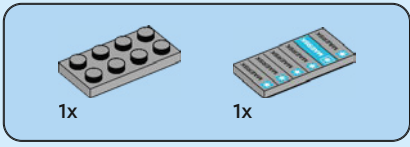

219

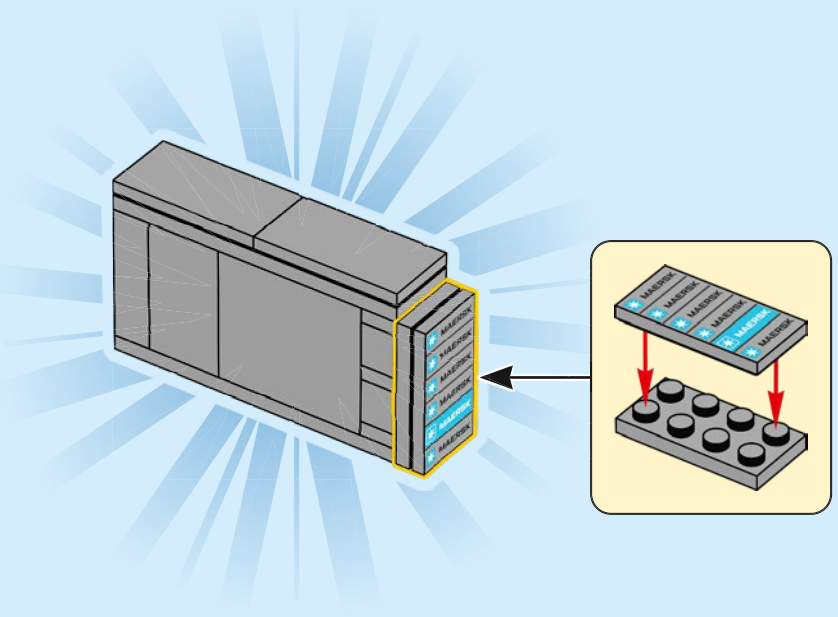

220

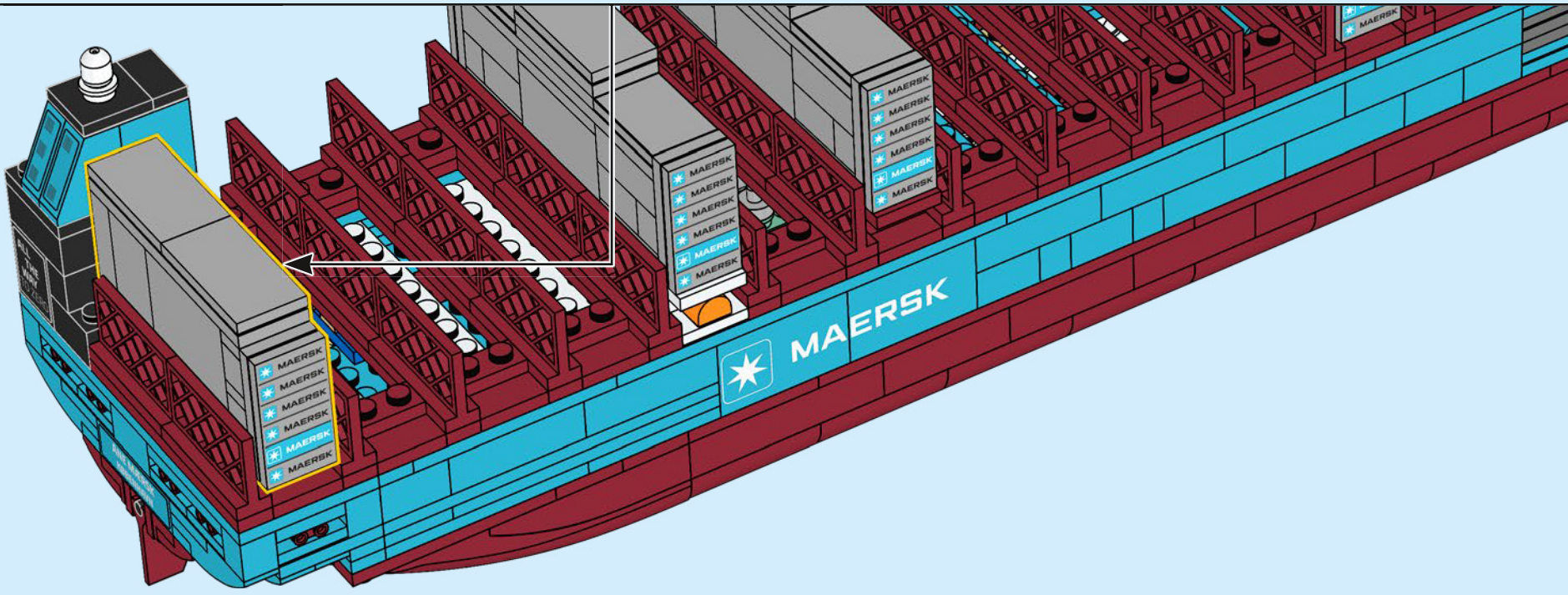

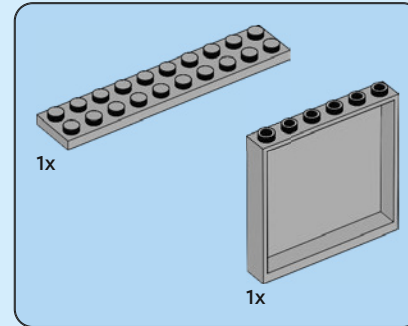
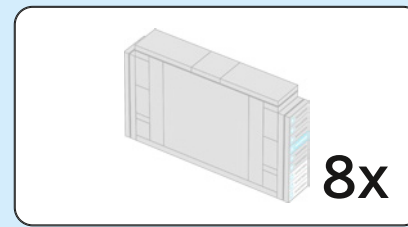

221

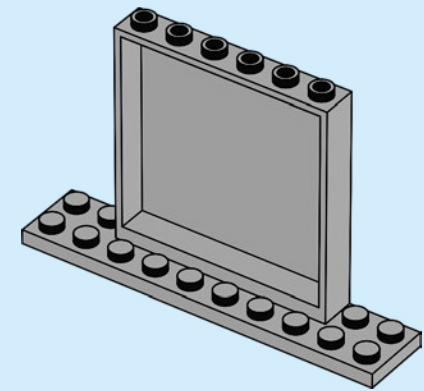

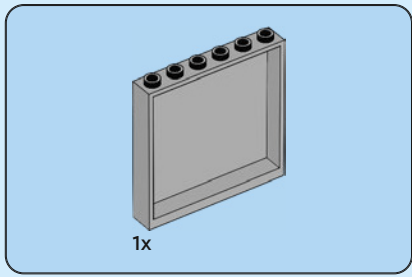

222

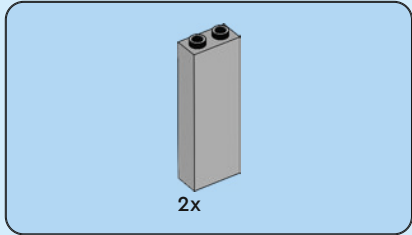
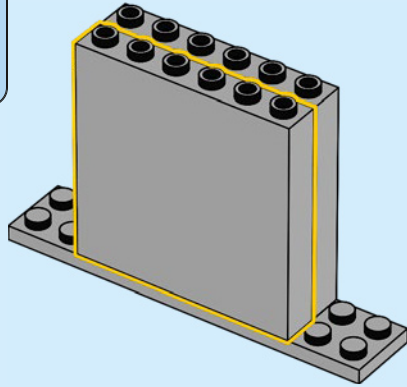

223

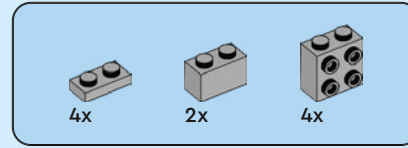
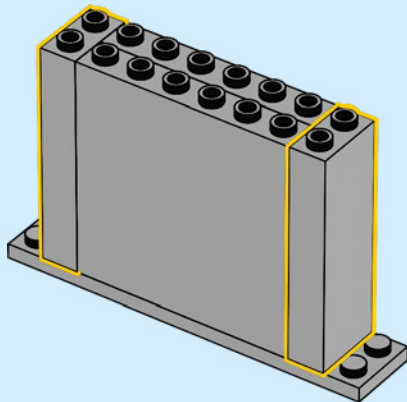

224

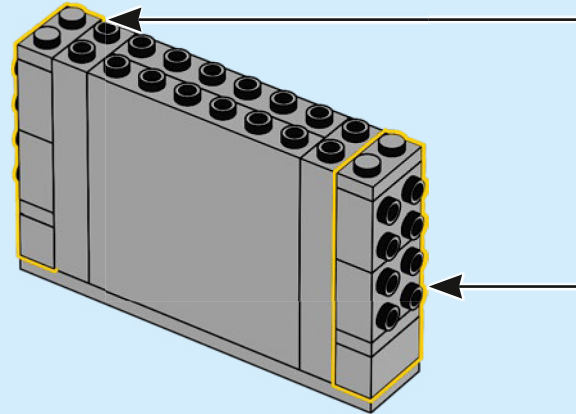
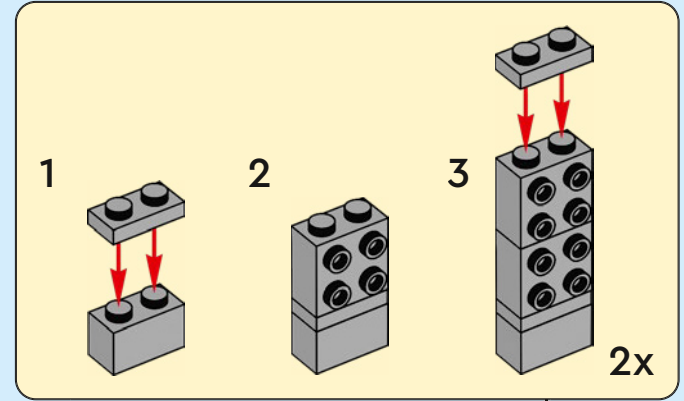

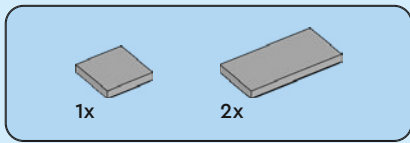

225

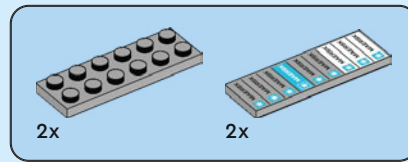
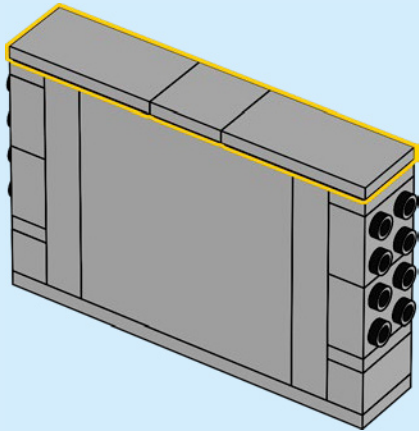

226

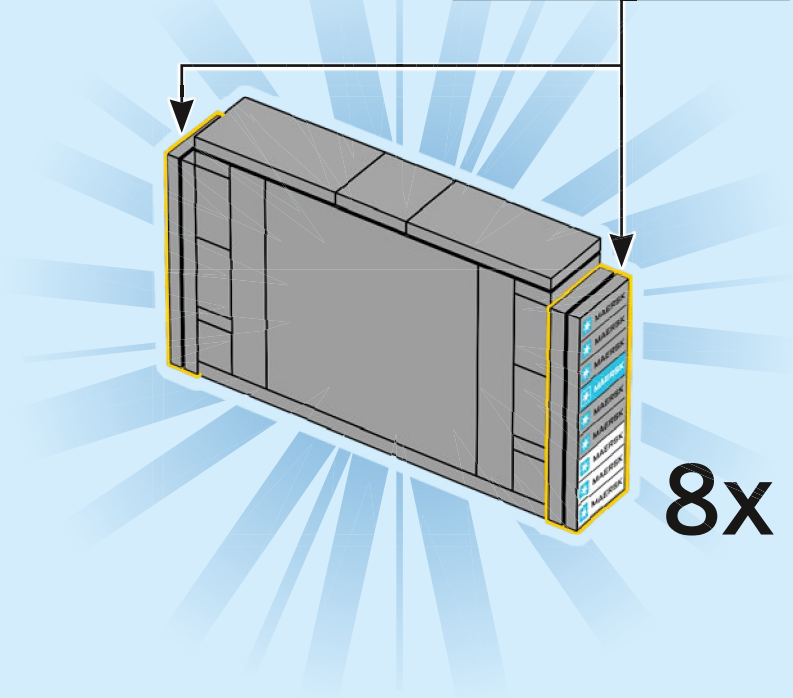
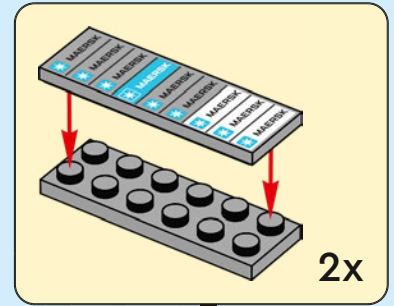

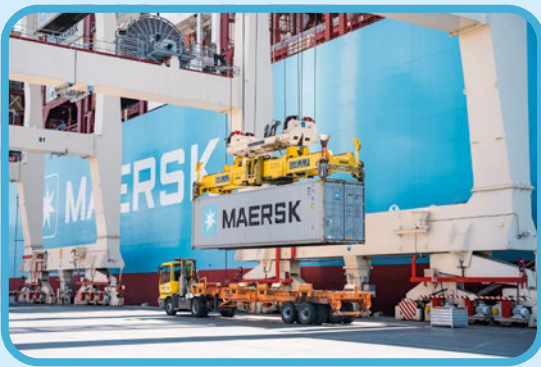

227

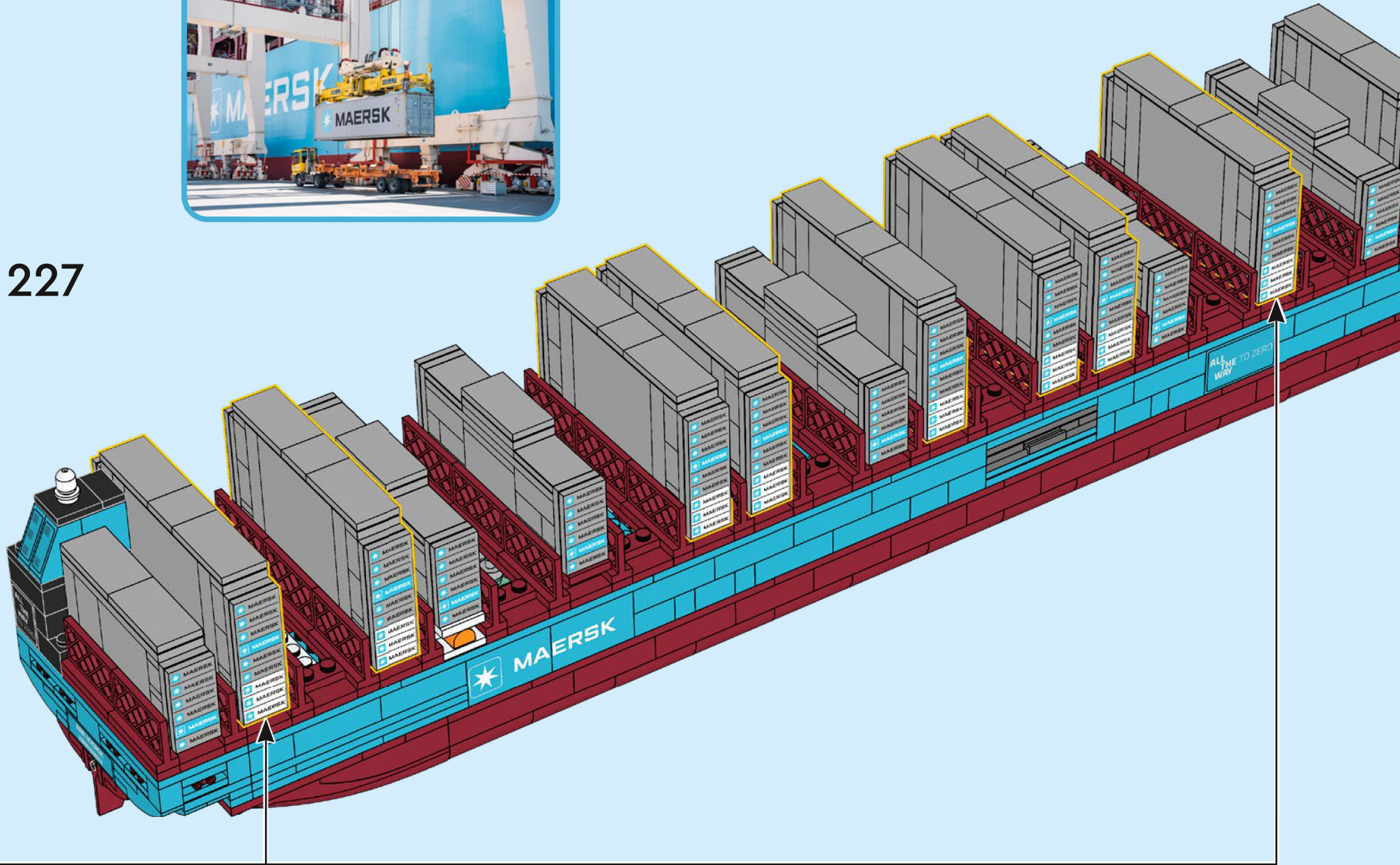





228

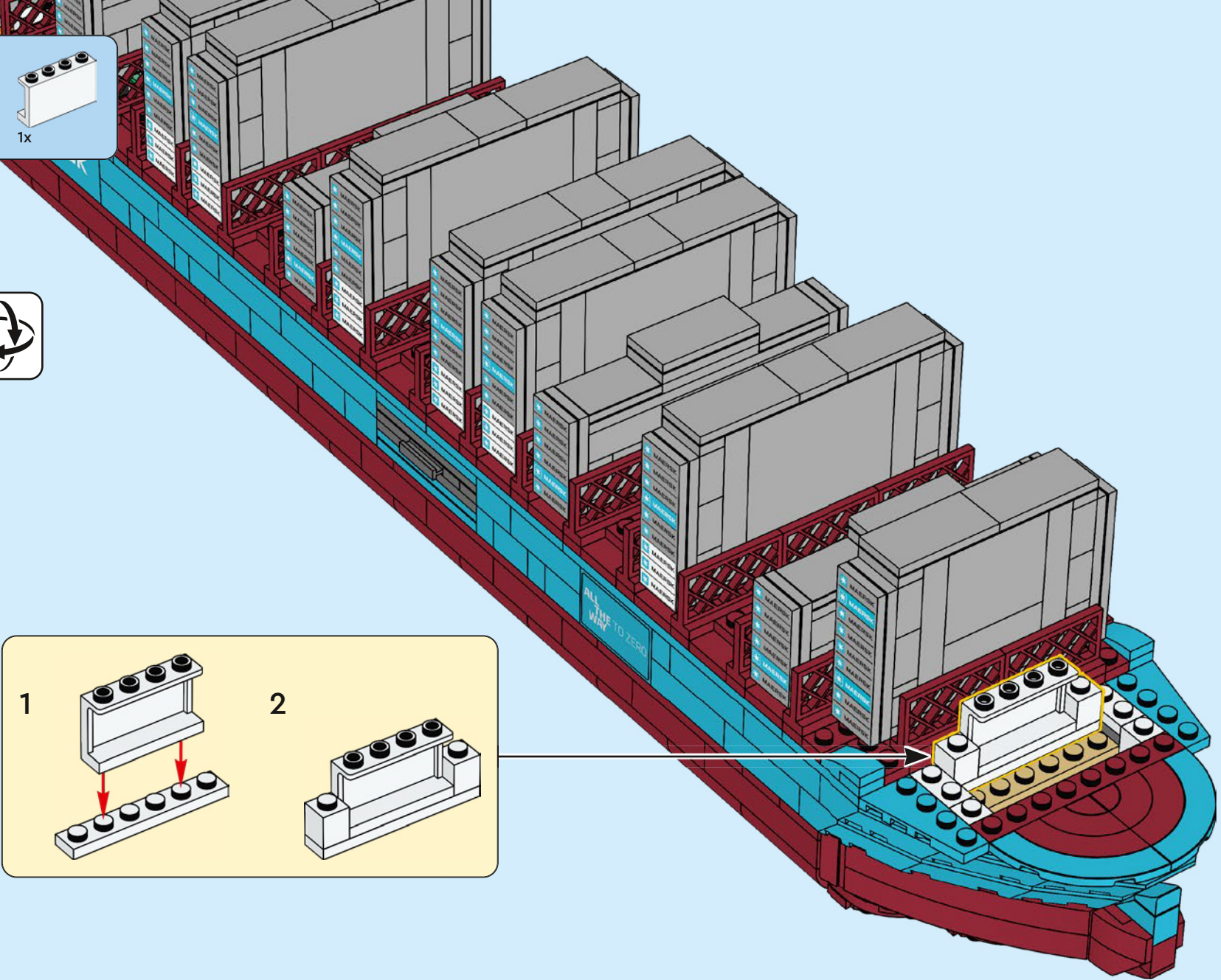
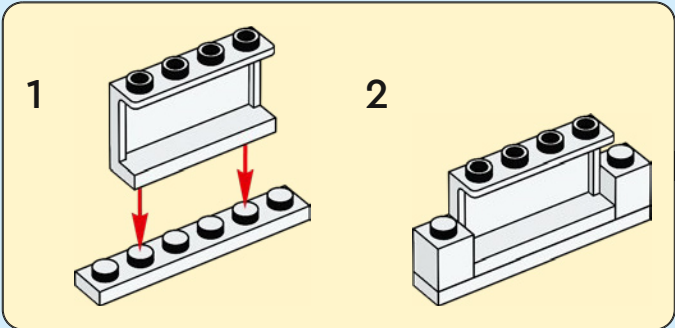

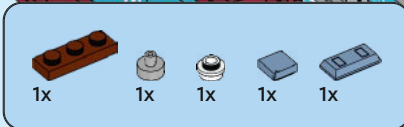

229

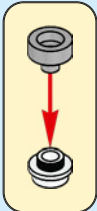
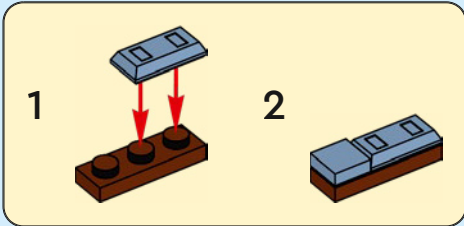



4x

230

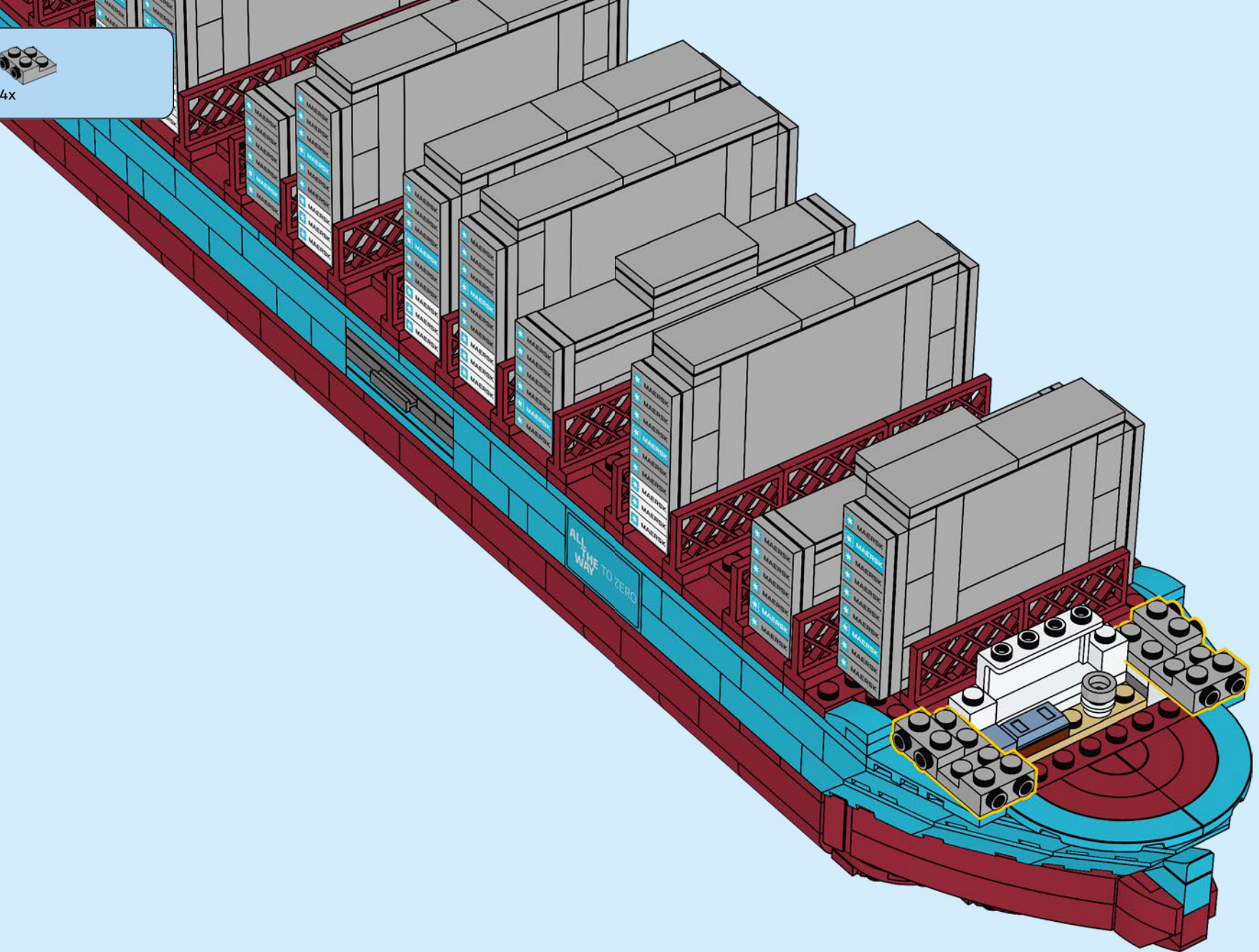

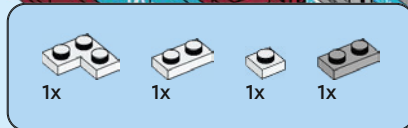

231

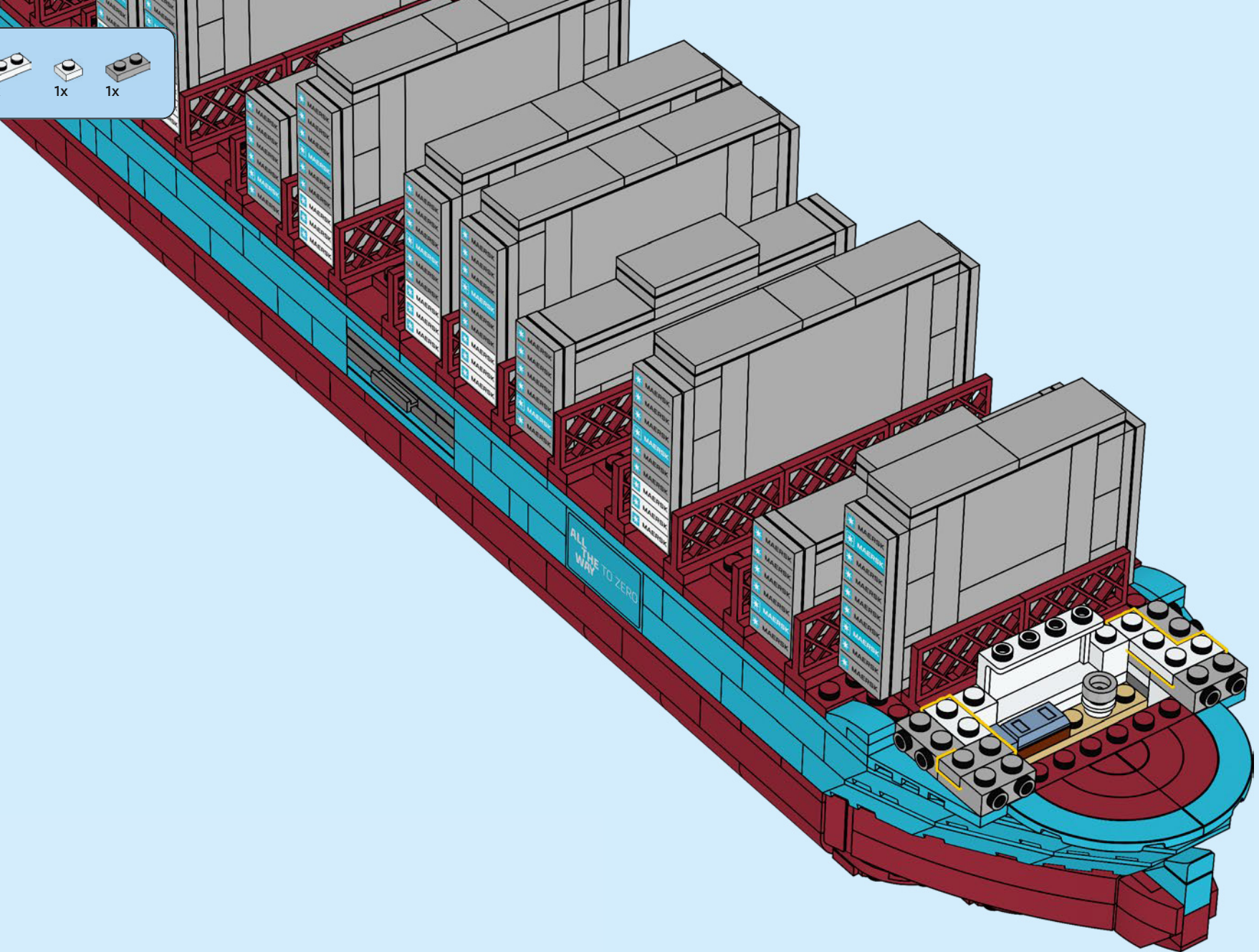

1x 1x 1x 2x

232

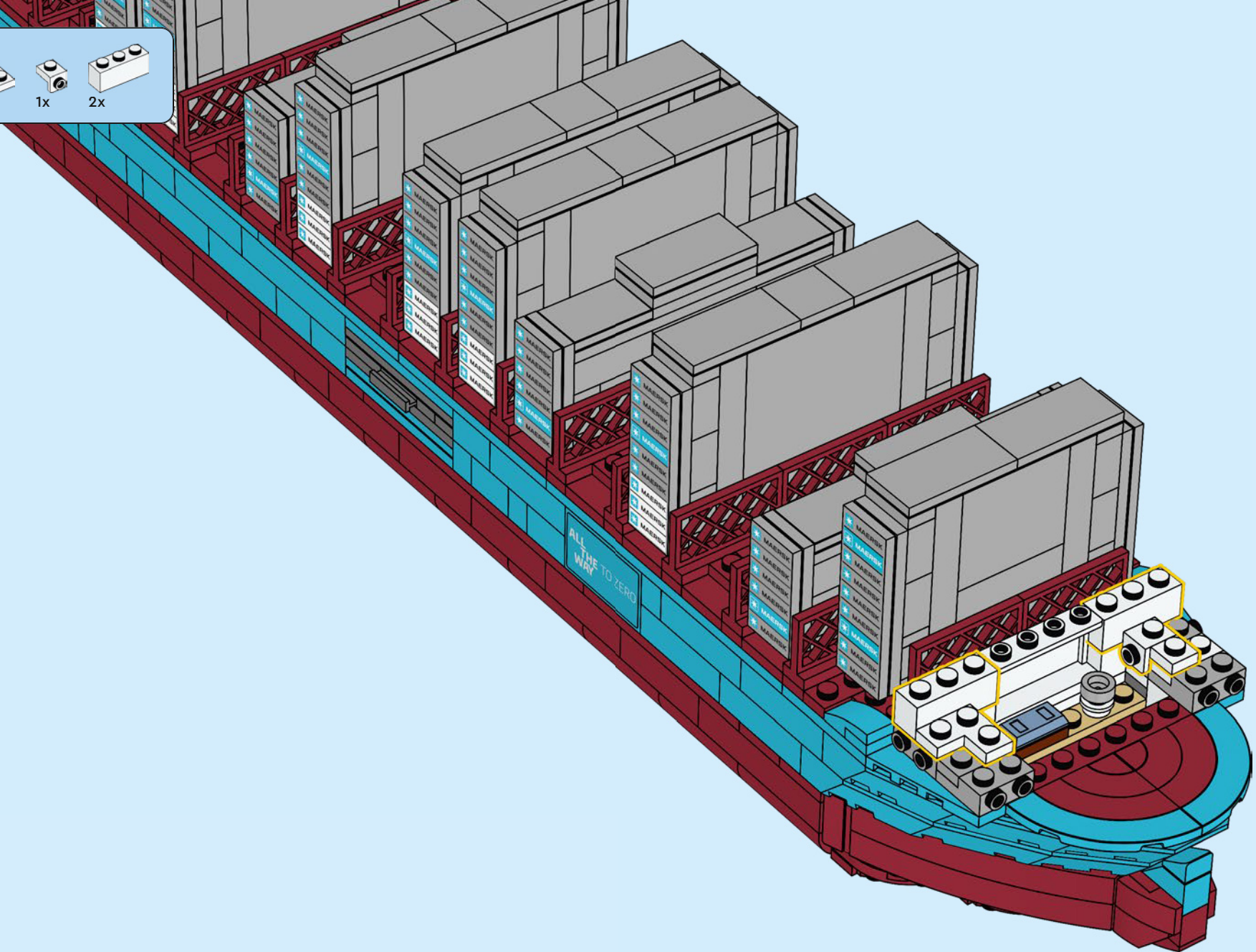

1x 1x 4x

233

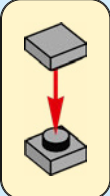
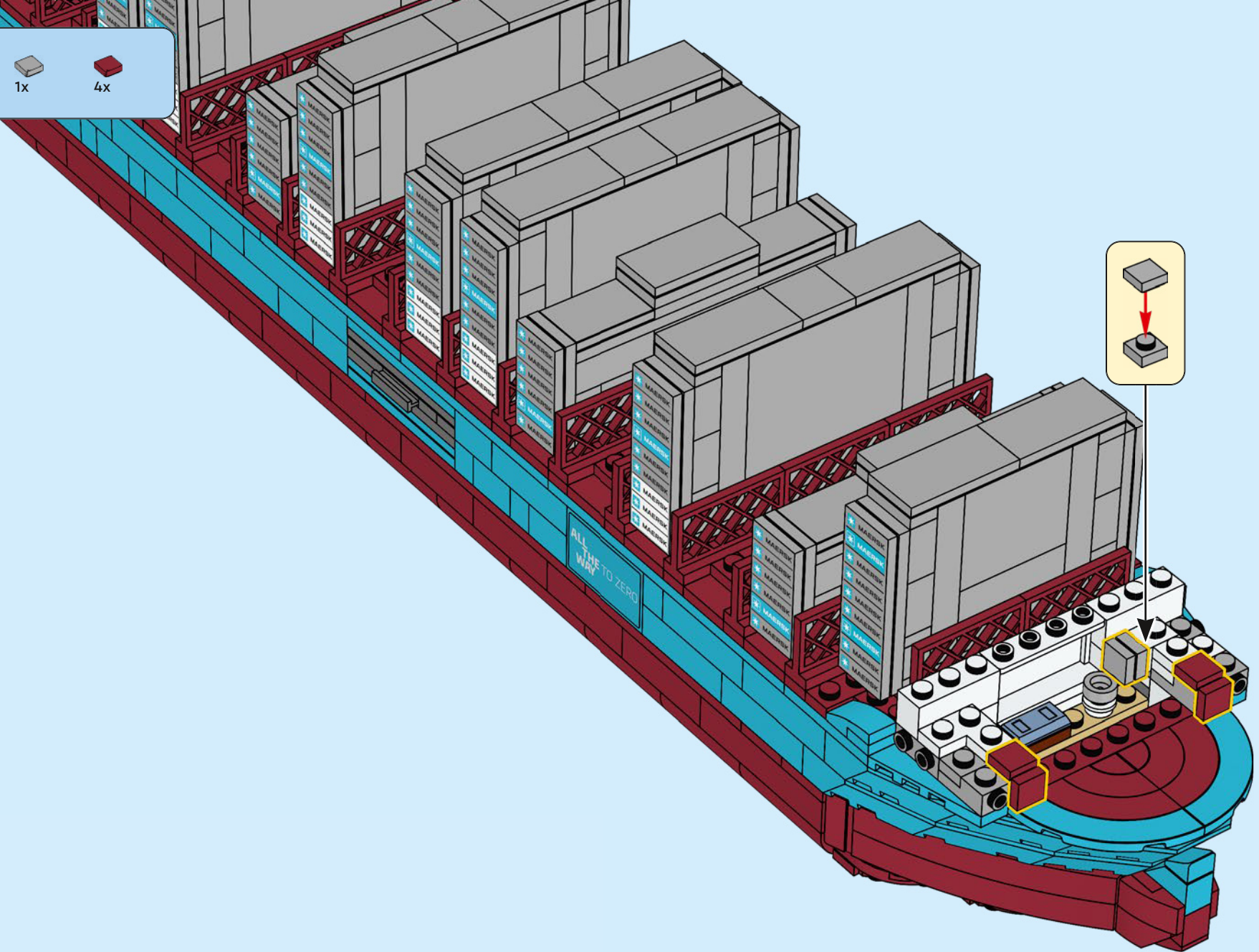

3x 2x 2x

234

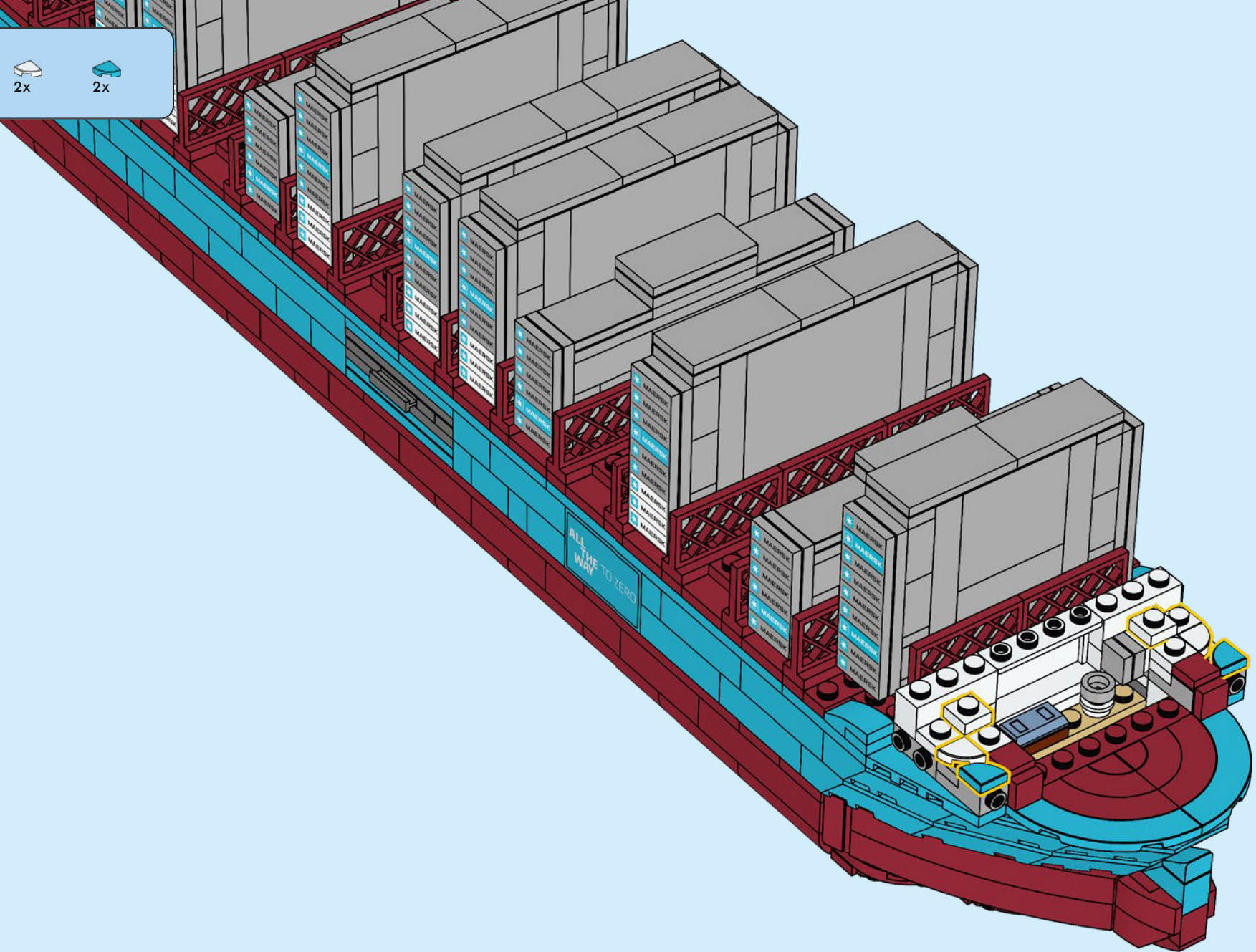

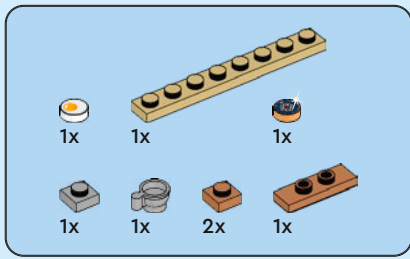

235

1

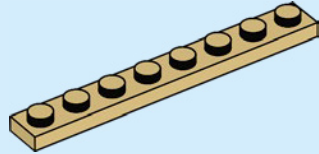

2

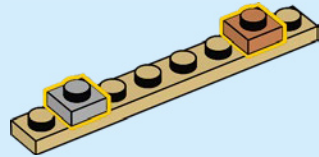

3

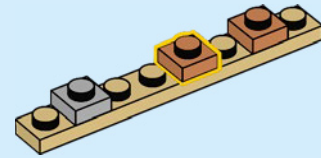

4

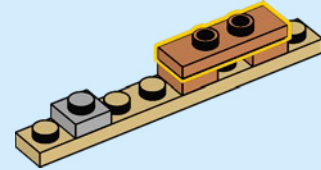

5

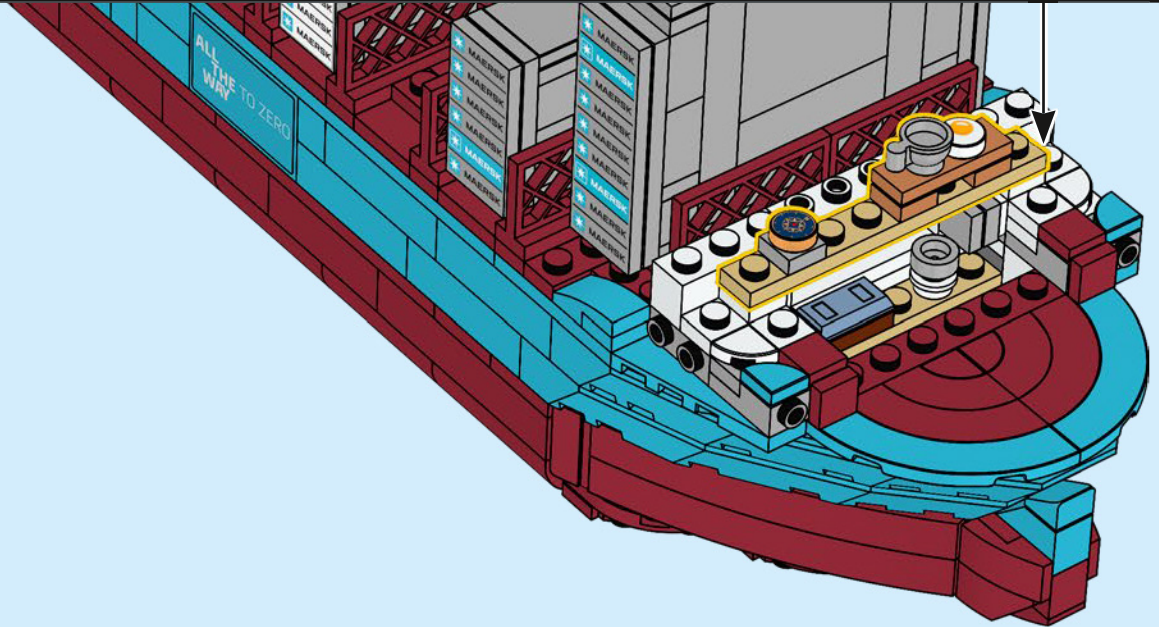
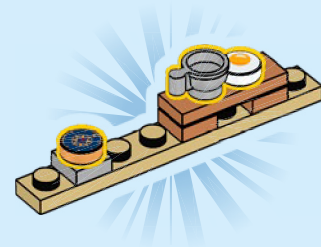

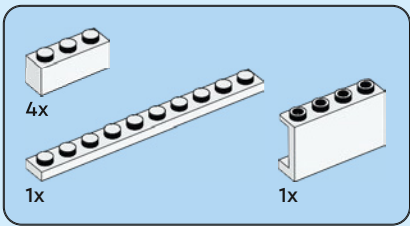

236

1

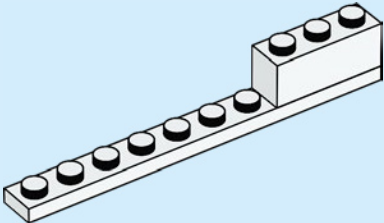

2

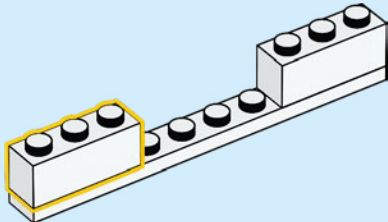

1

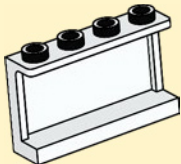

2

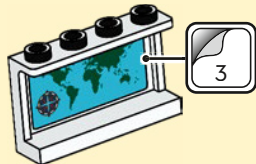

3

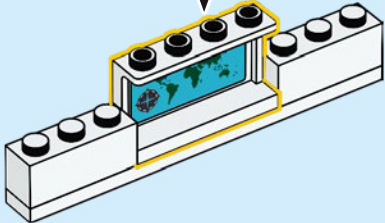

4

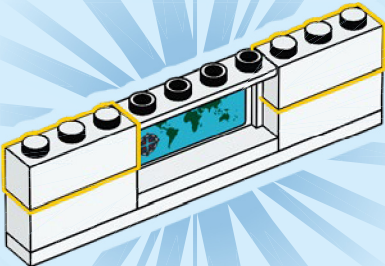

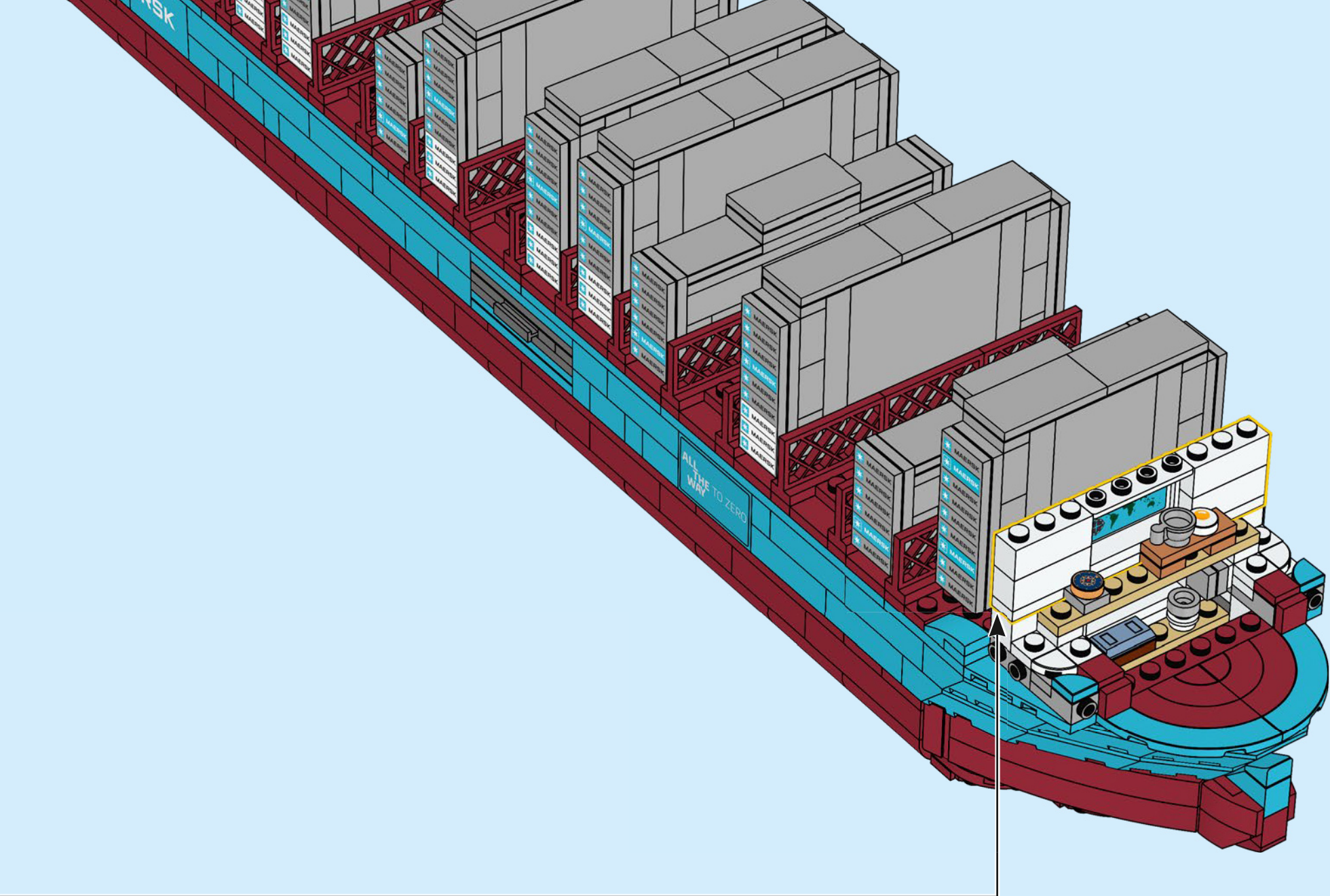

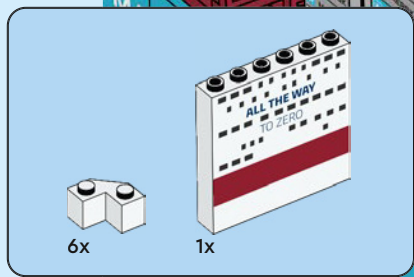

237

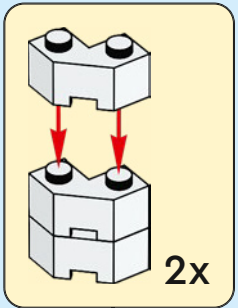
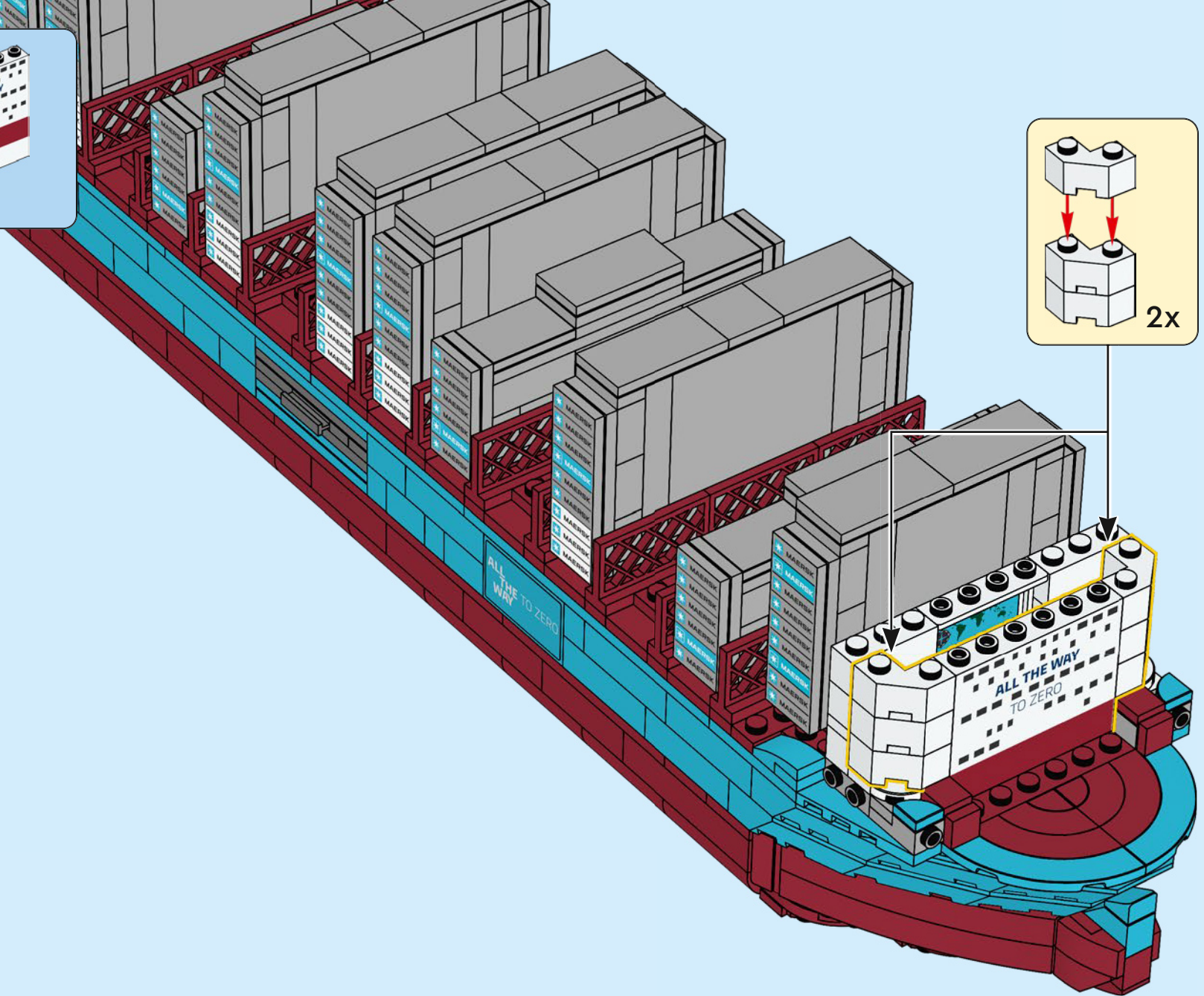

2x 1x

238

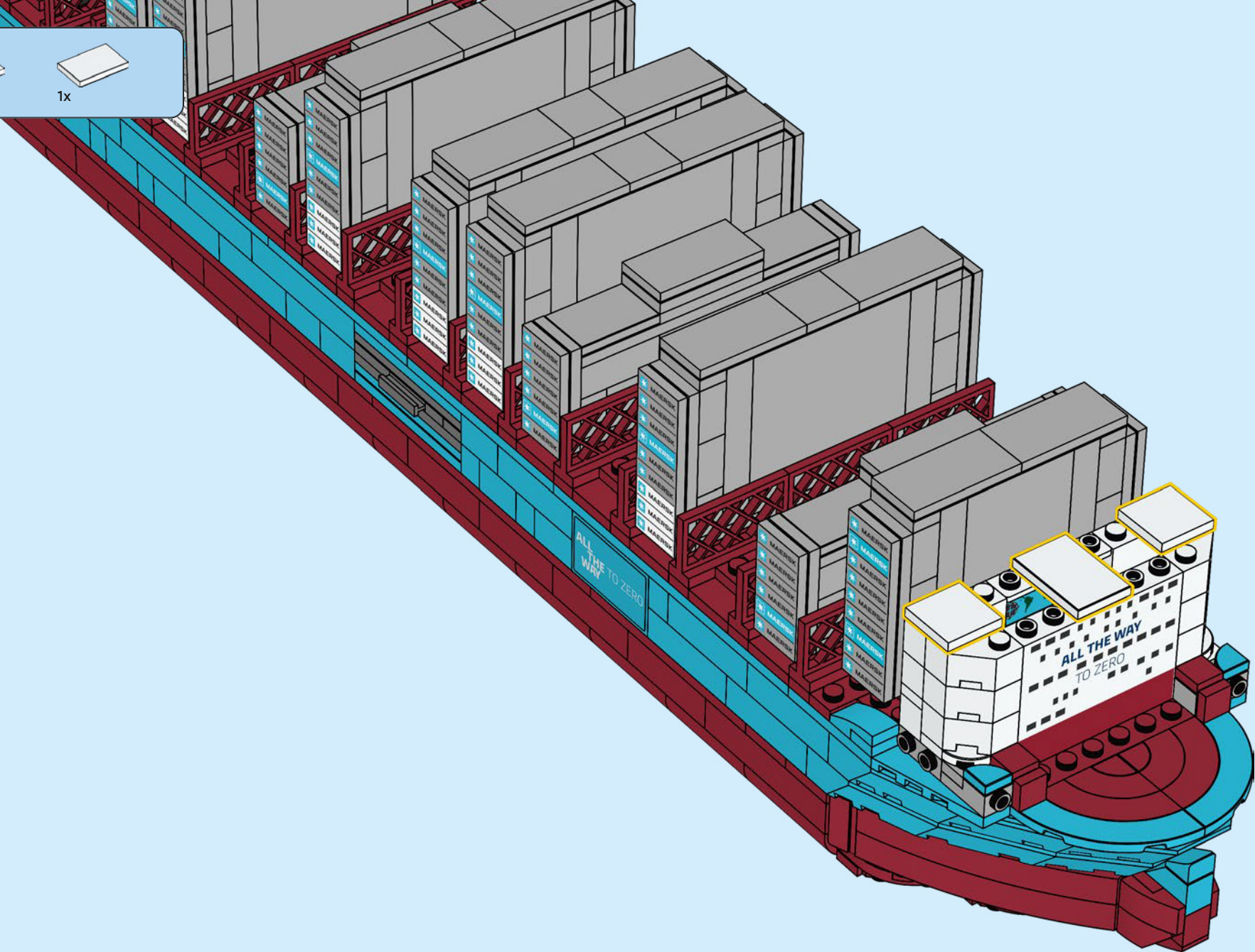

2x 1x 1x

239

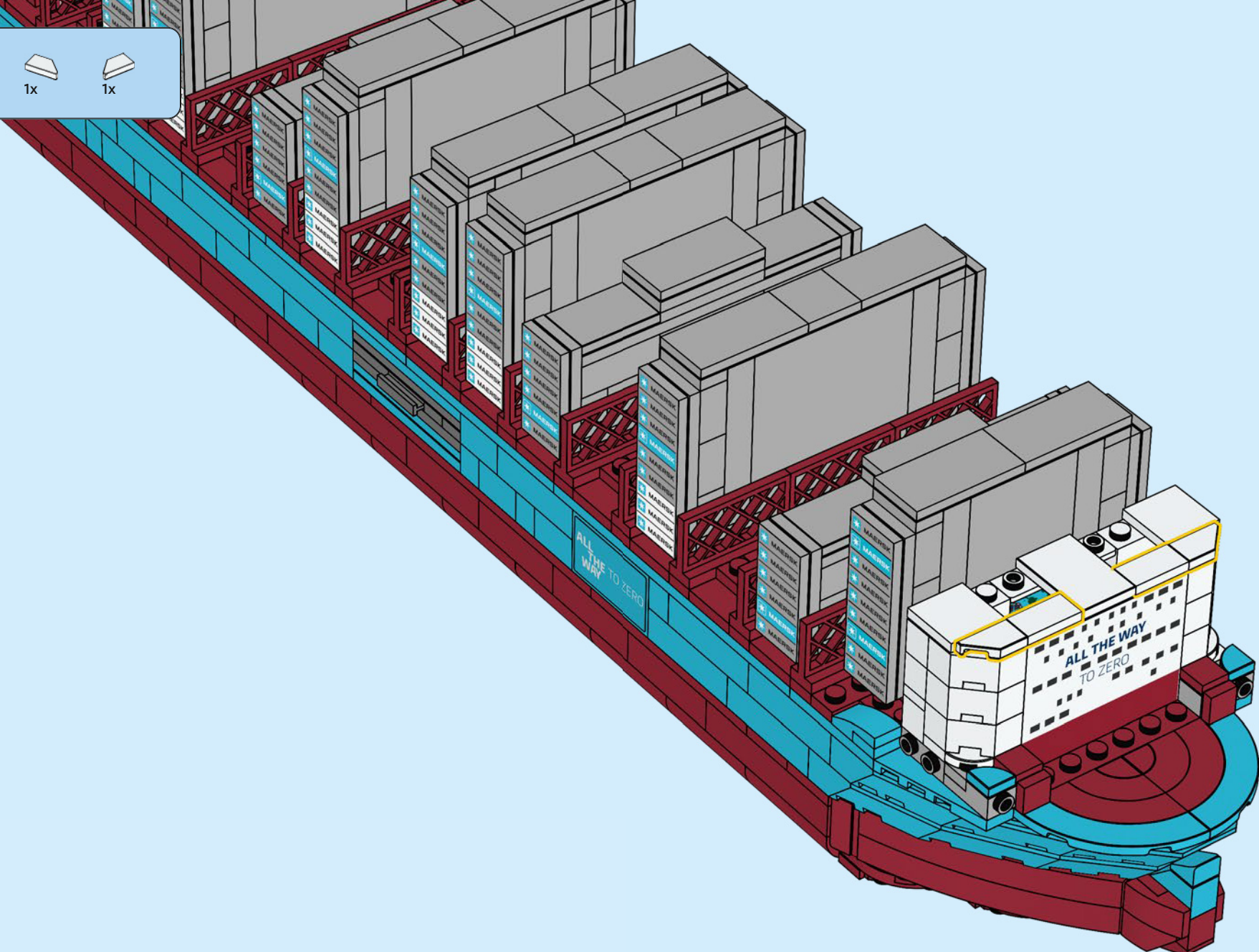

2x 2x 2x

240

1 2 2x

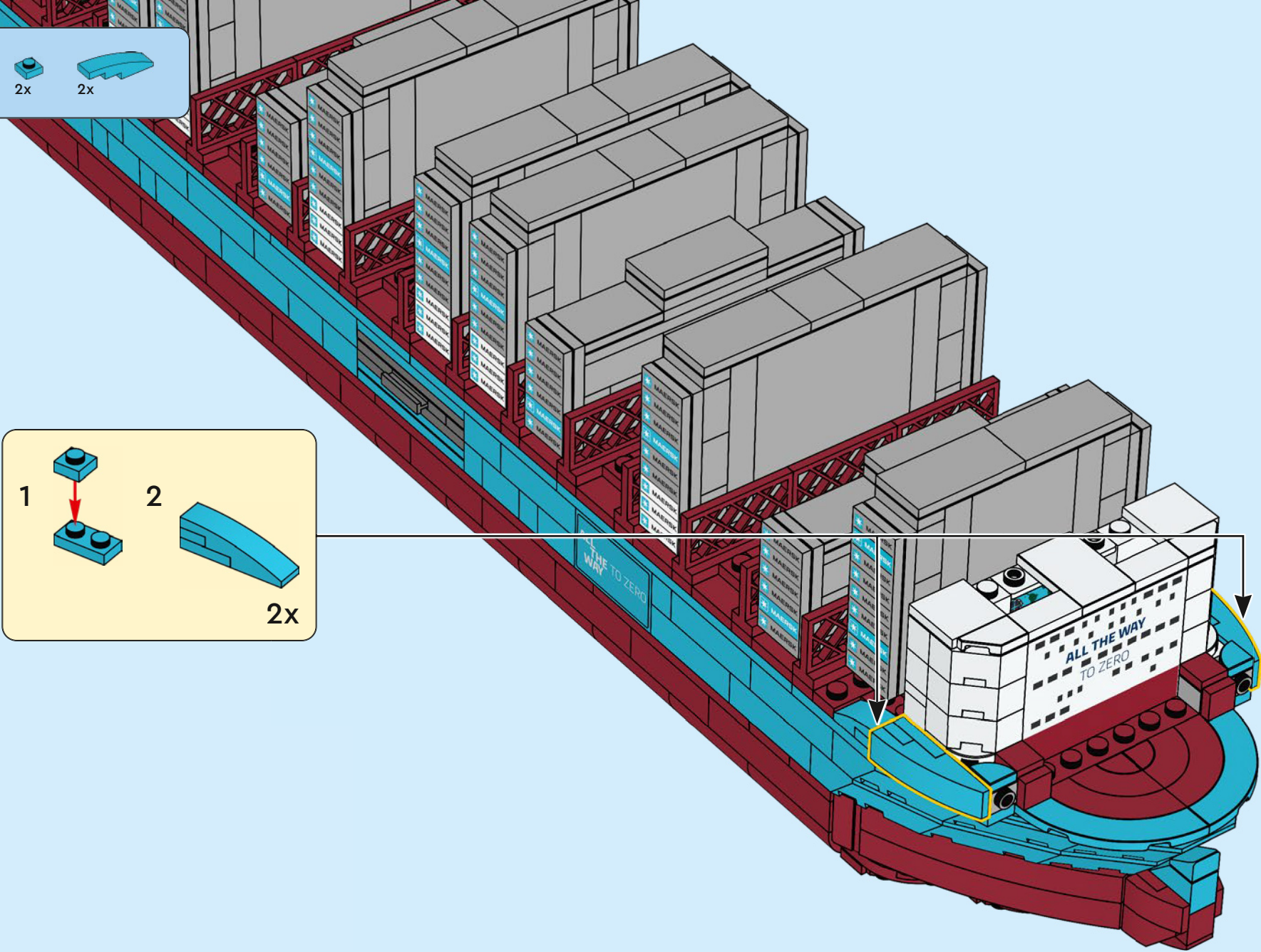

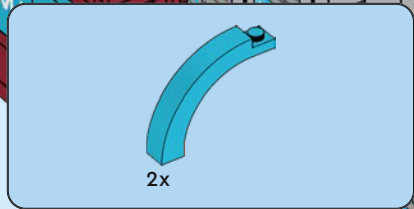

241

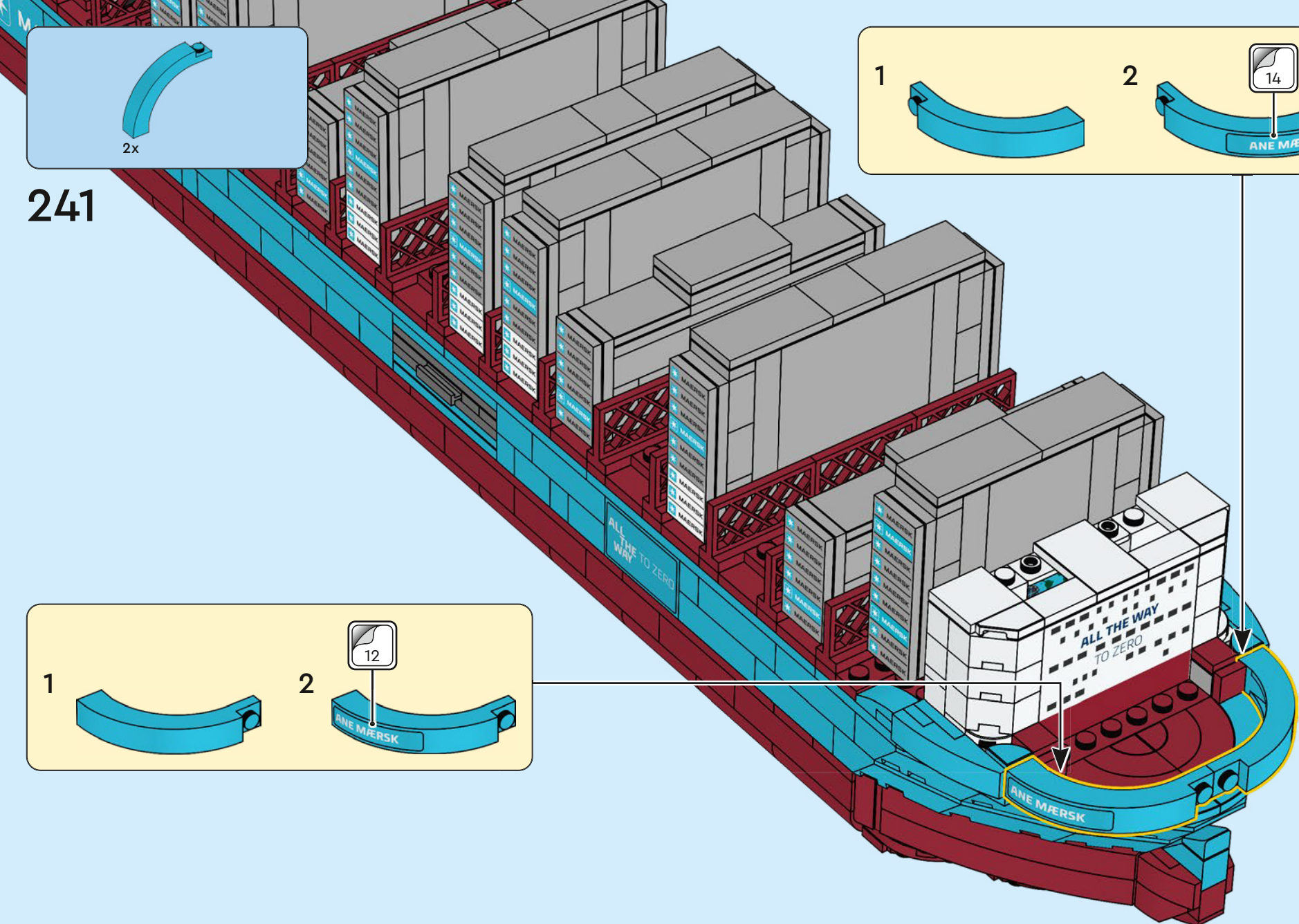
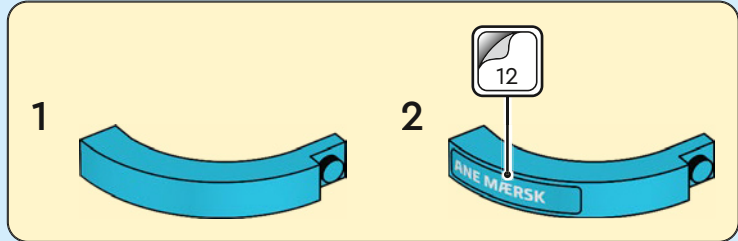
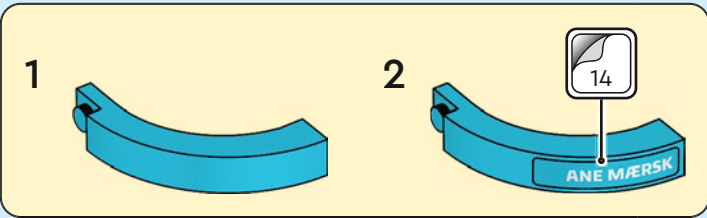



1x

242

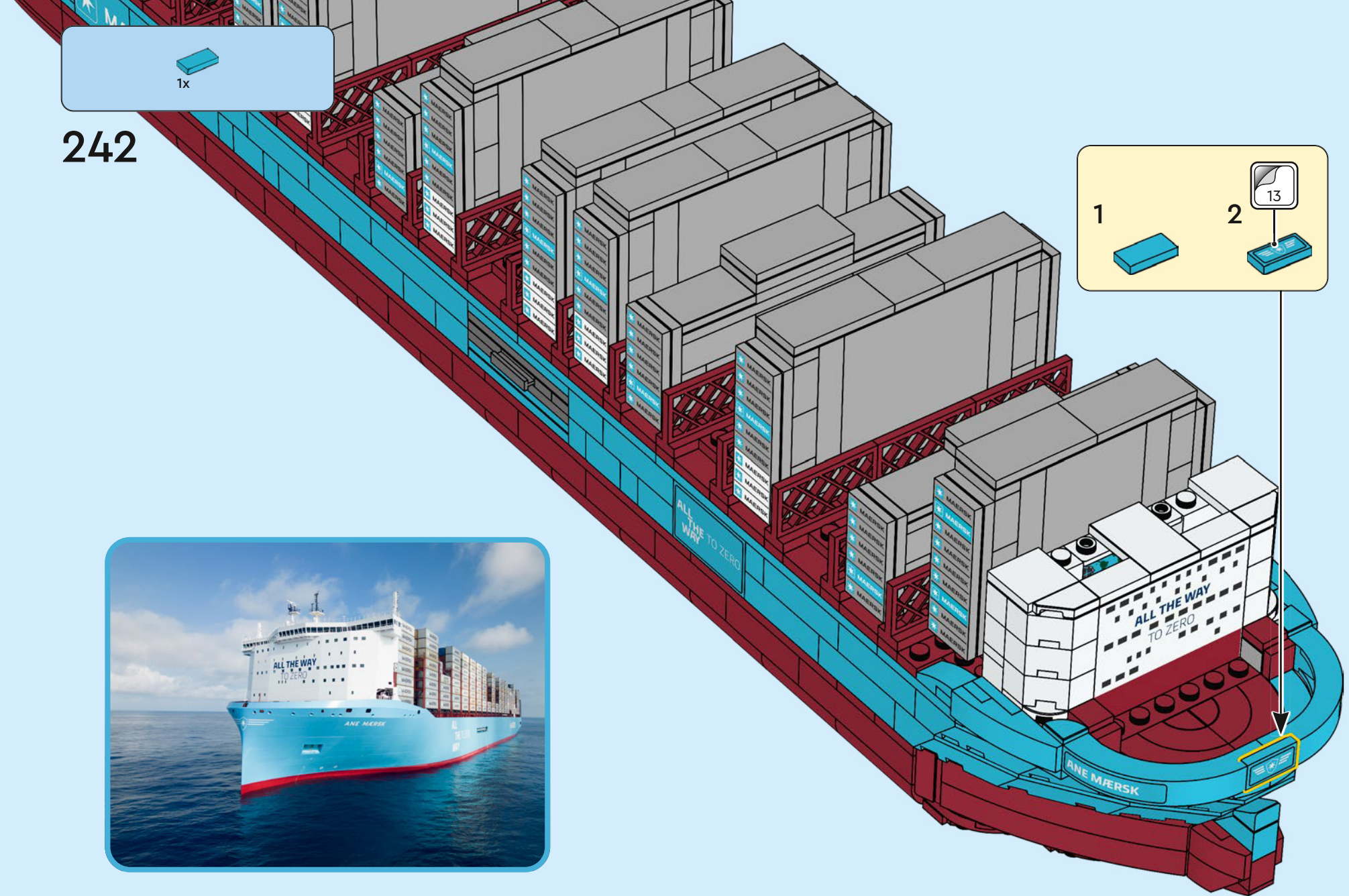
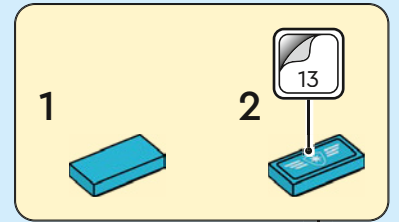

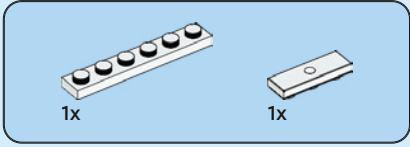
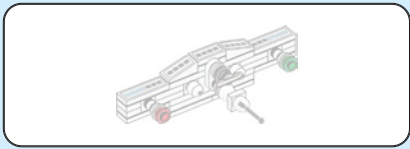

243

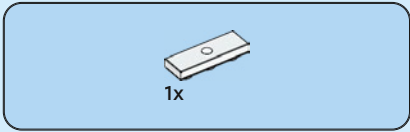
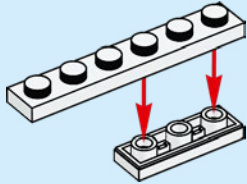

244

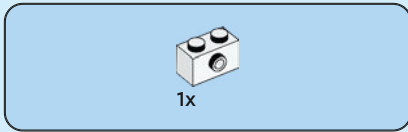
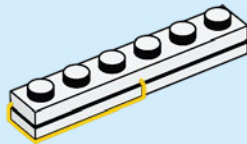

245

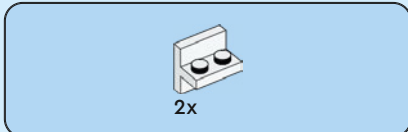
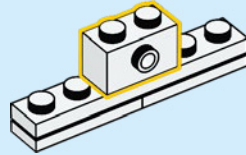

246

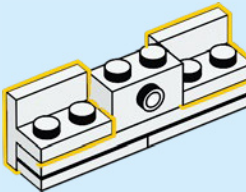



2x

247

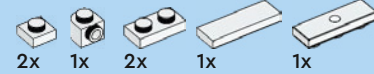
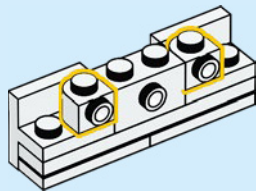

248

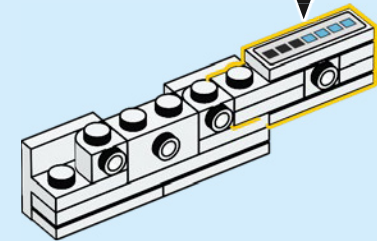
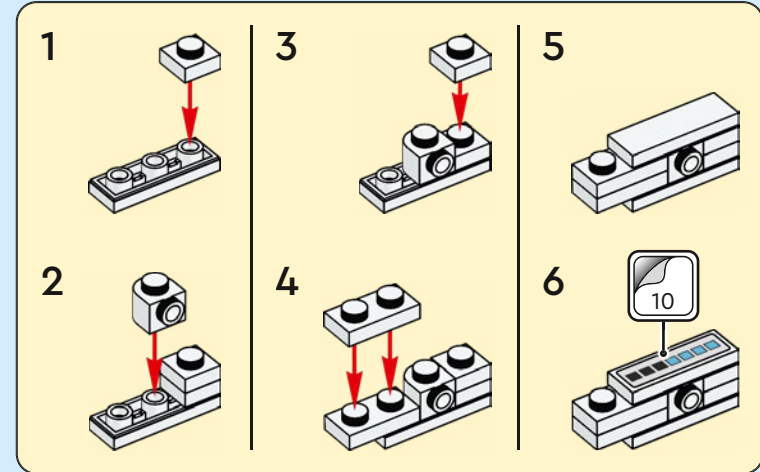

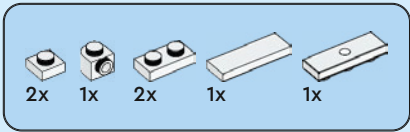

249

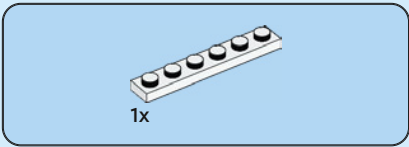
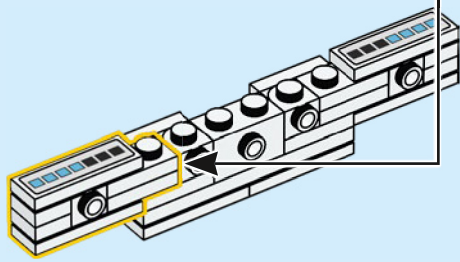
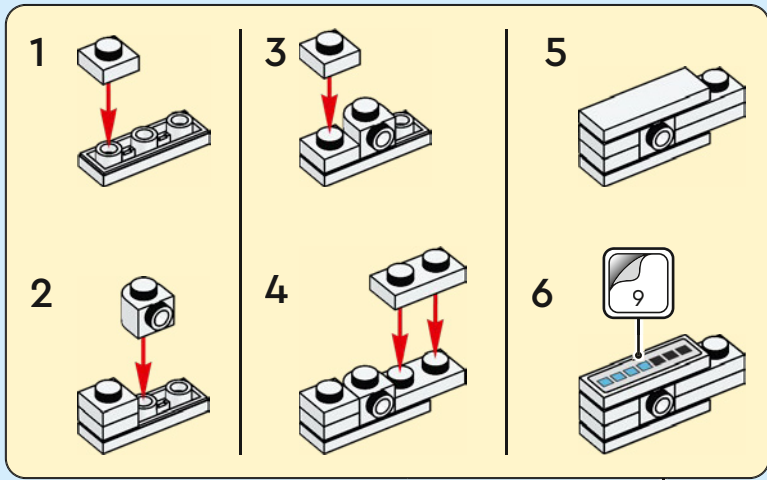

250

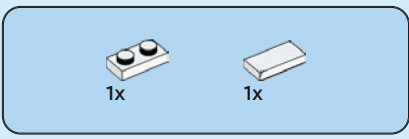
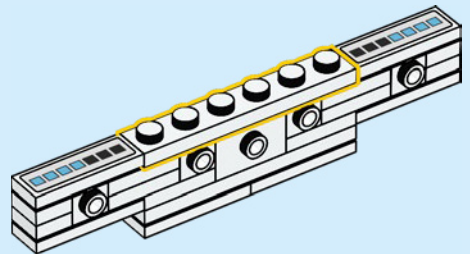

251

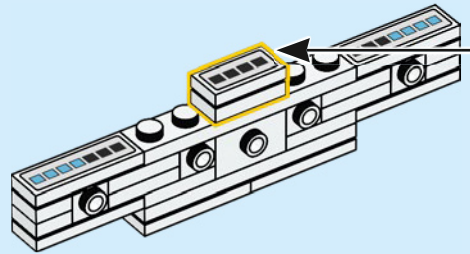
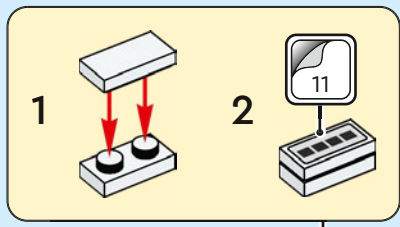

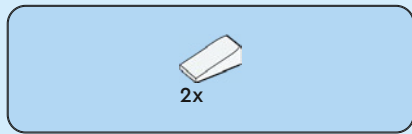

252

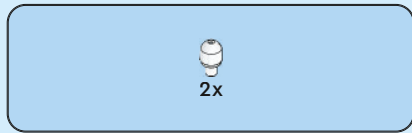
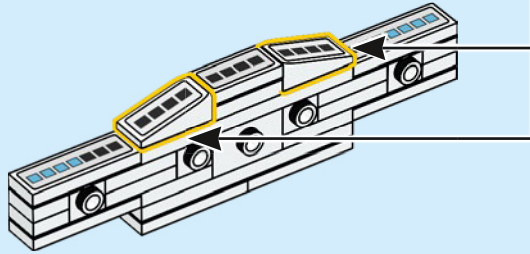
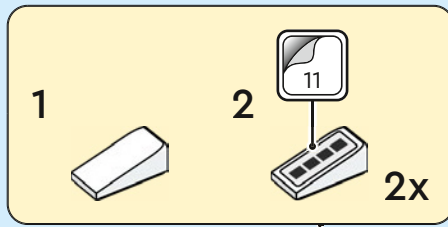

253

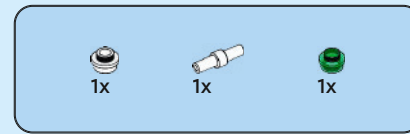
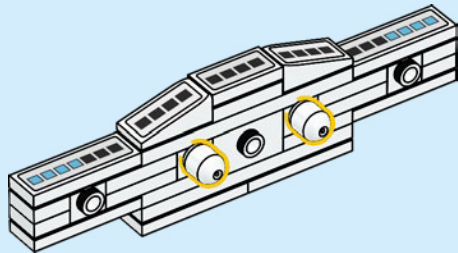

254

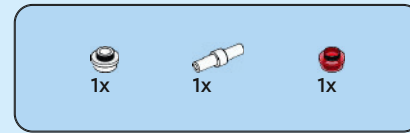
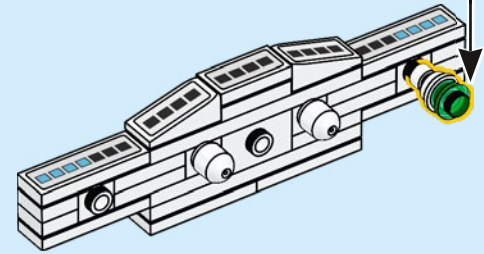
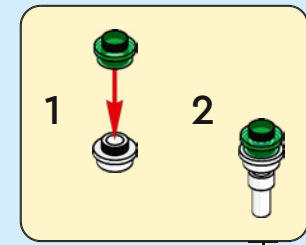

255

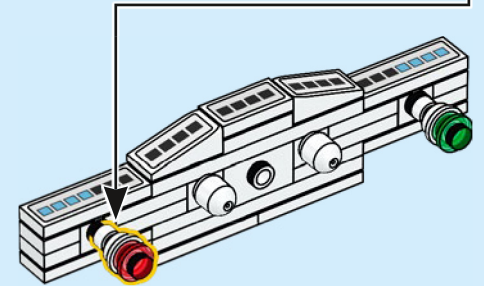
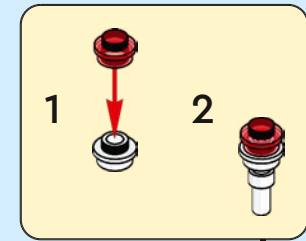

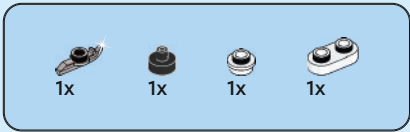

256

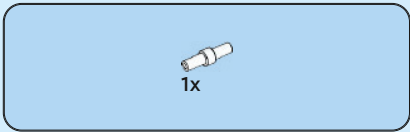
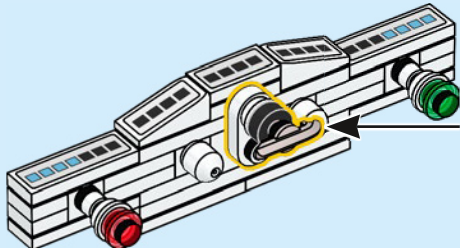
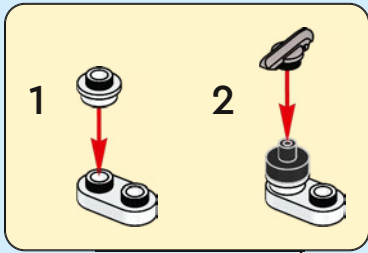

257

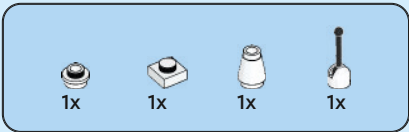
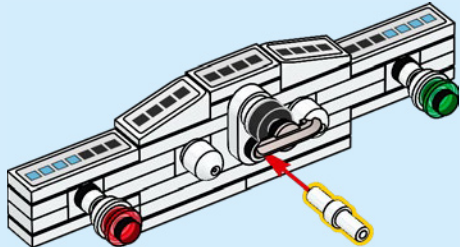

258

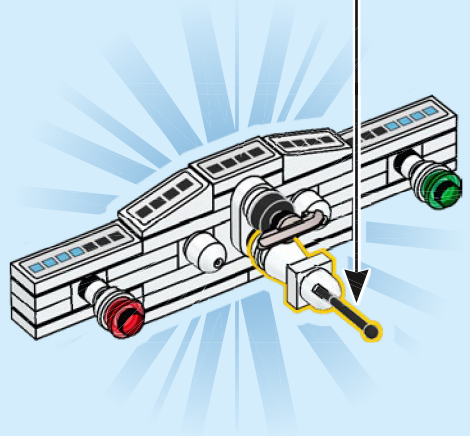
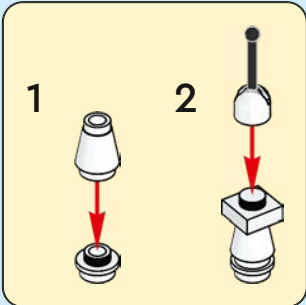

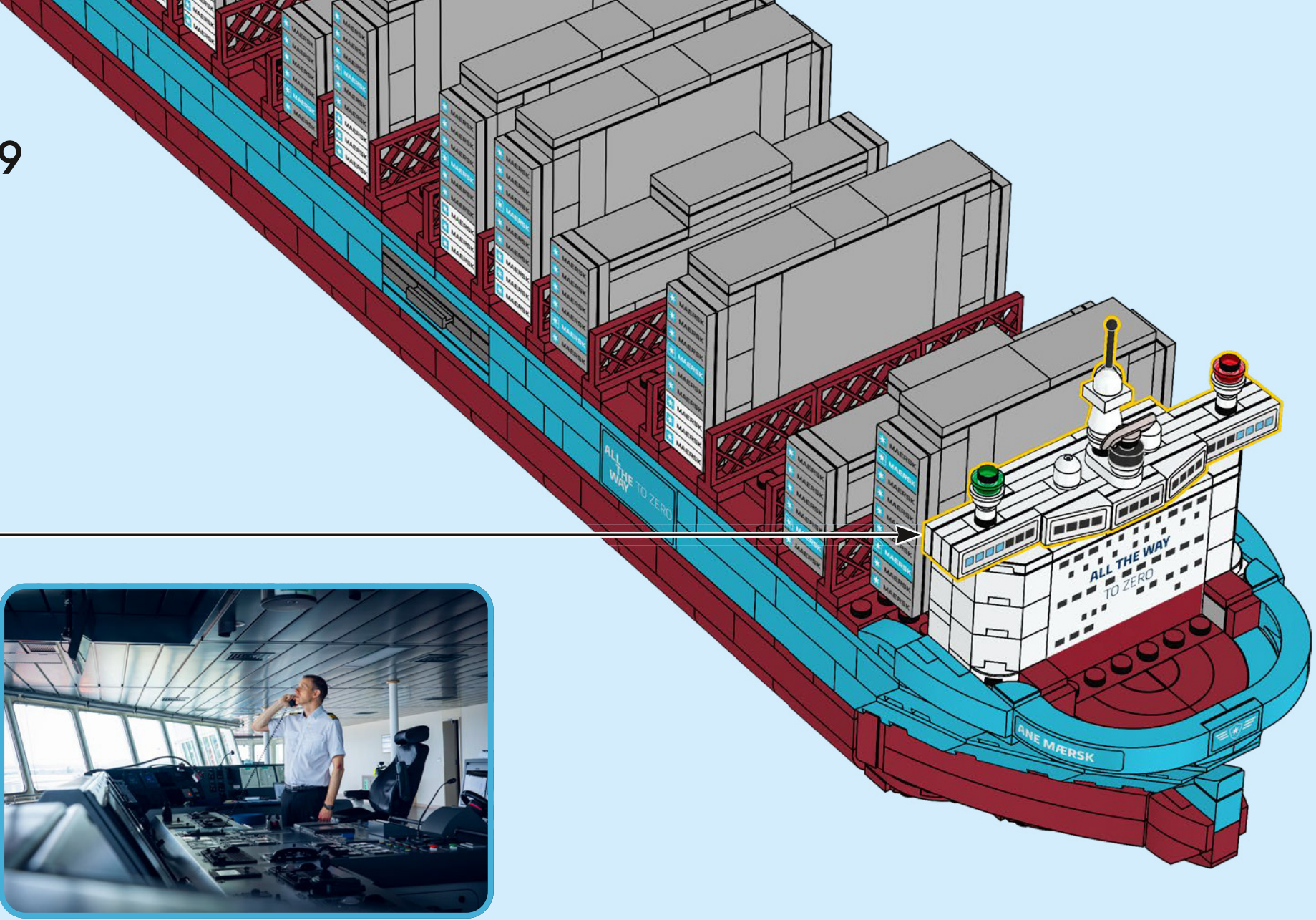

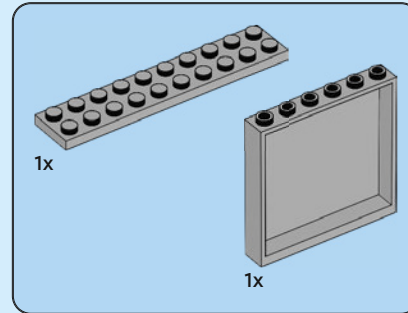
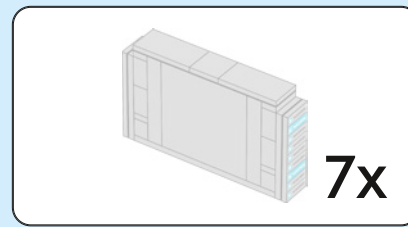

260

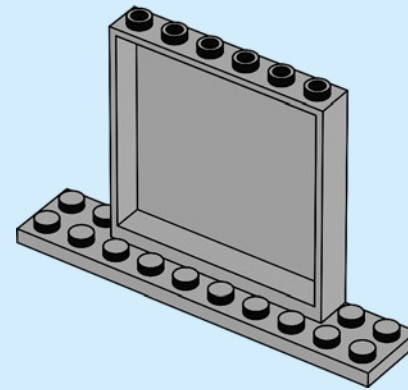

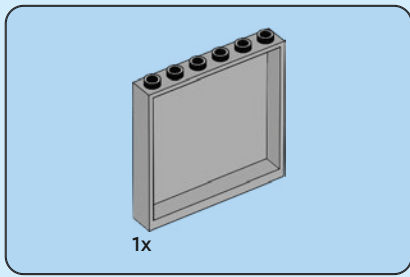

261

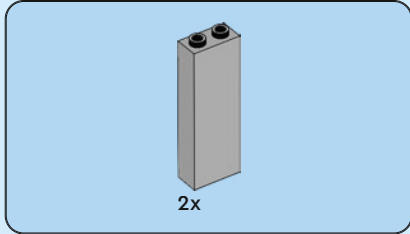
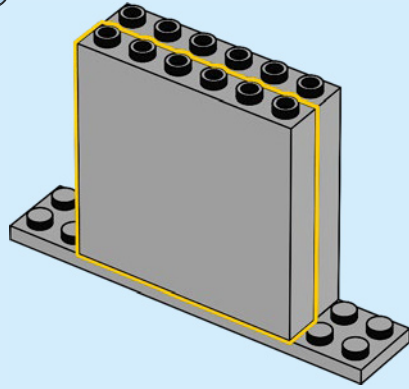

262

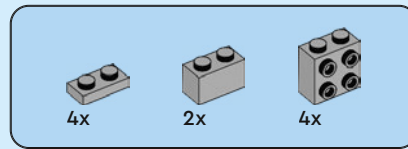
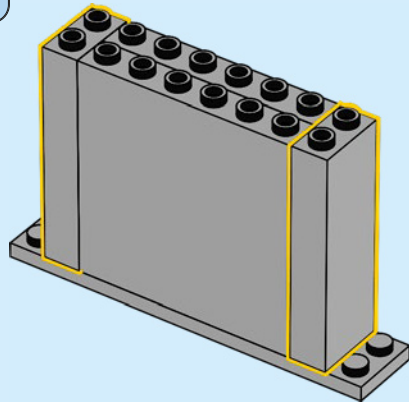

263

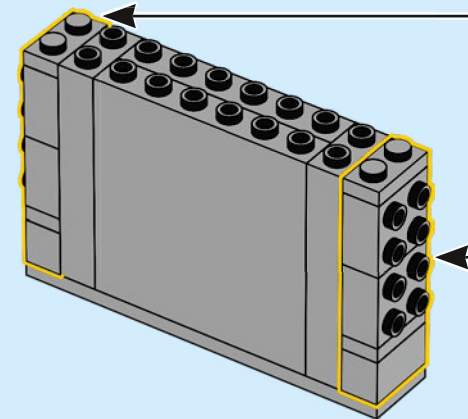
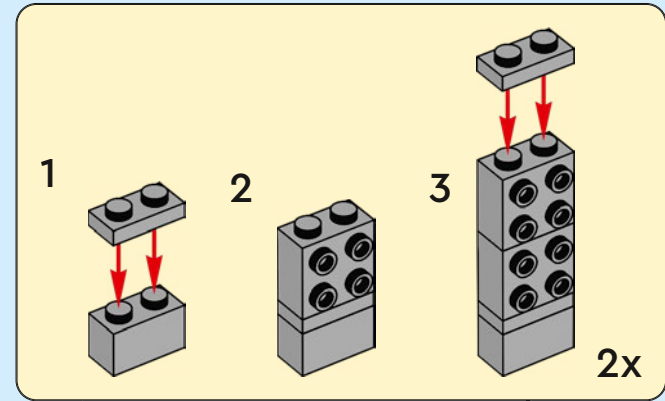

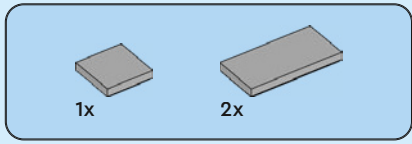

264

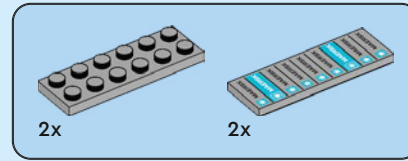
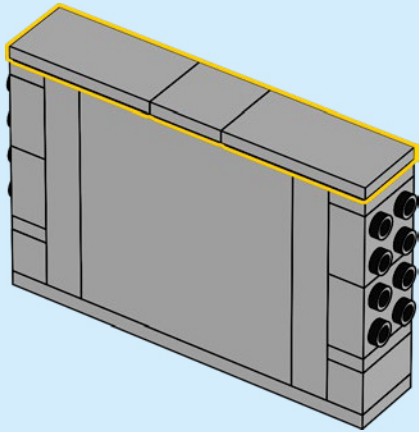

265

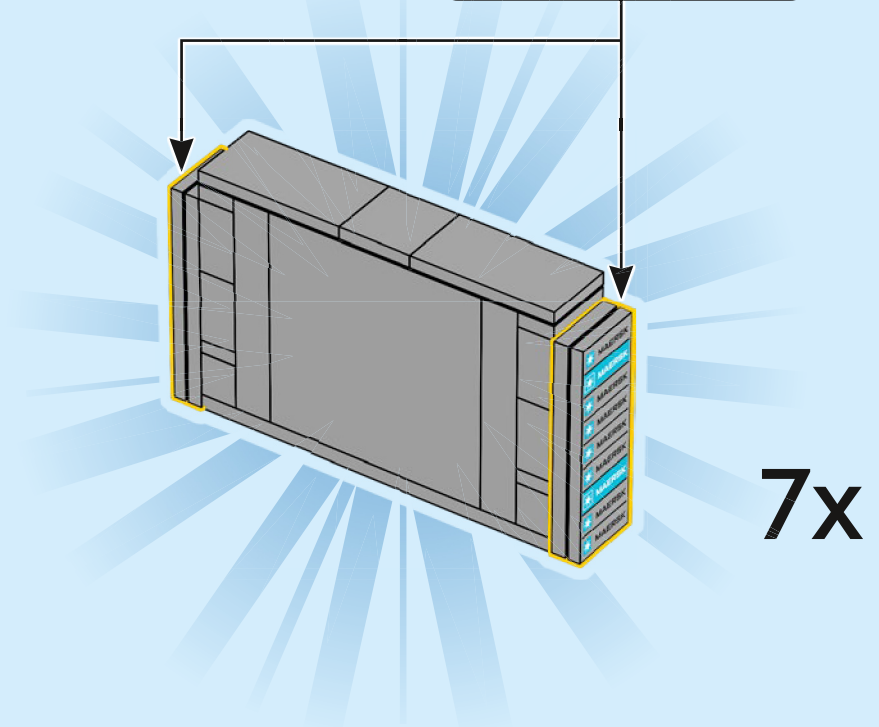
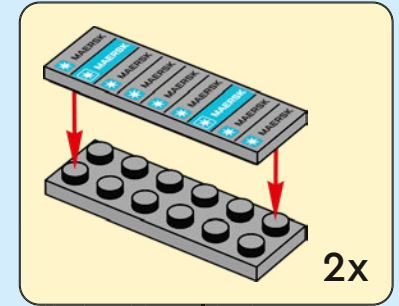

266

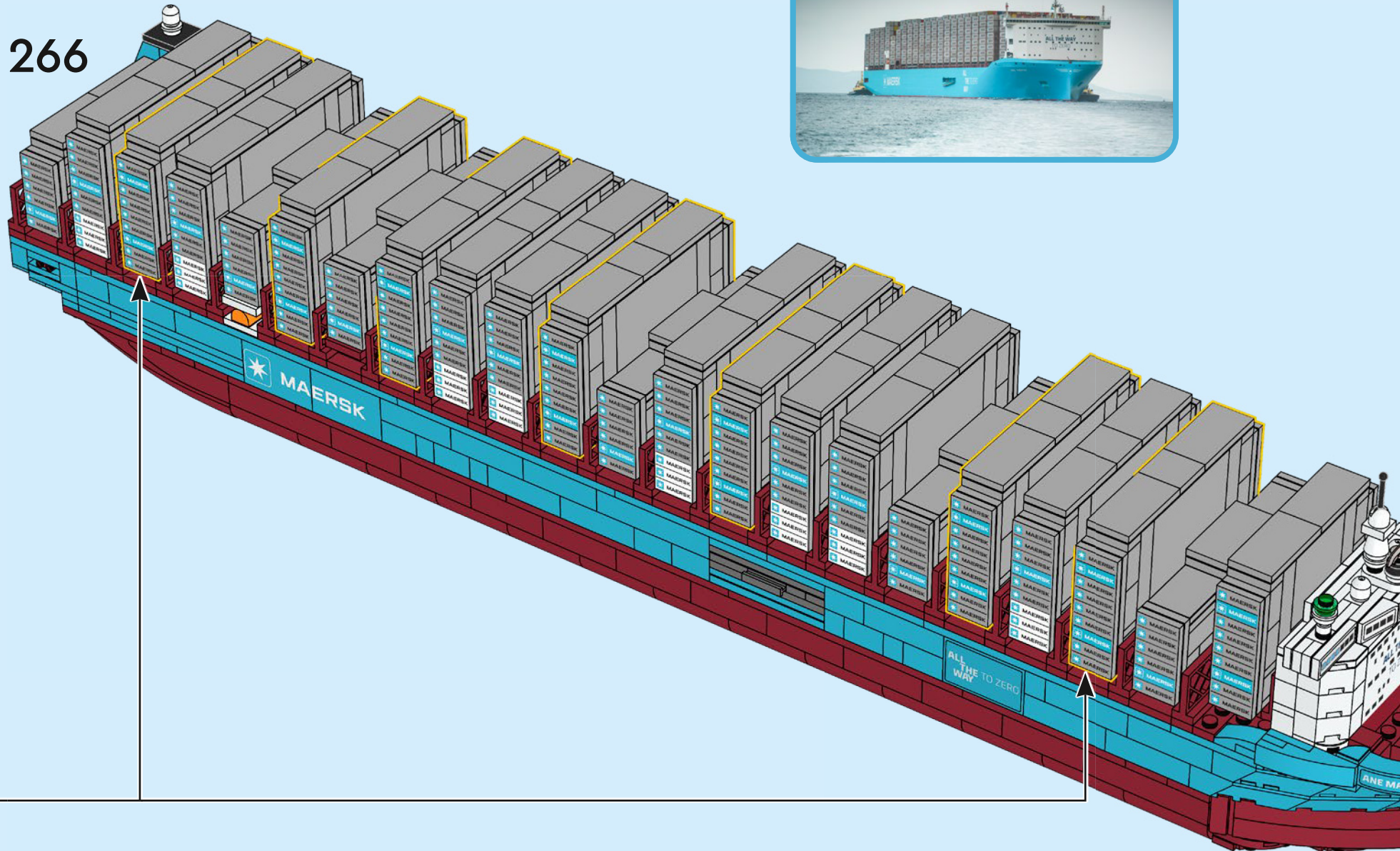

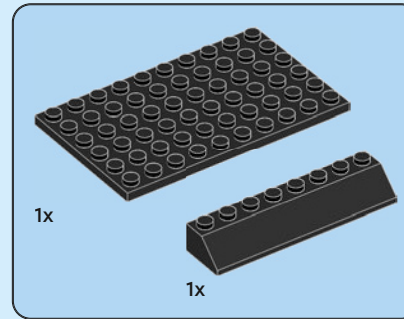
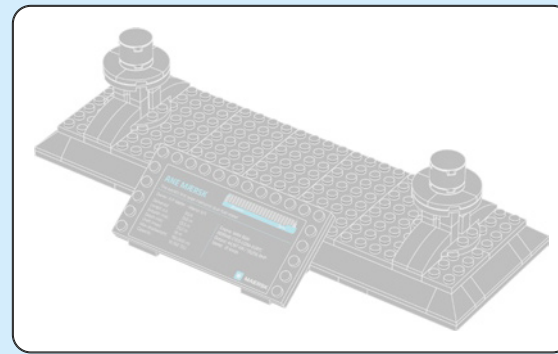

267

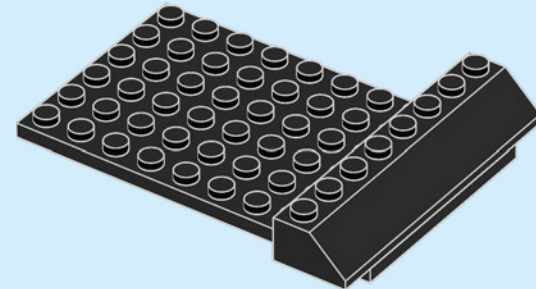

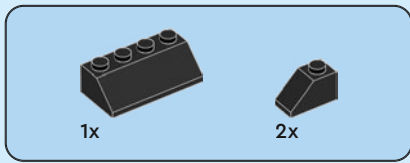

268

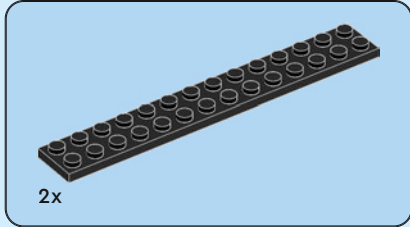
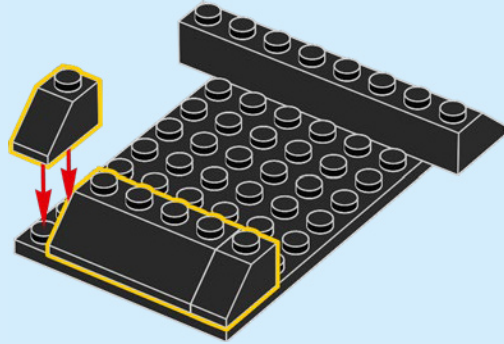

269

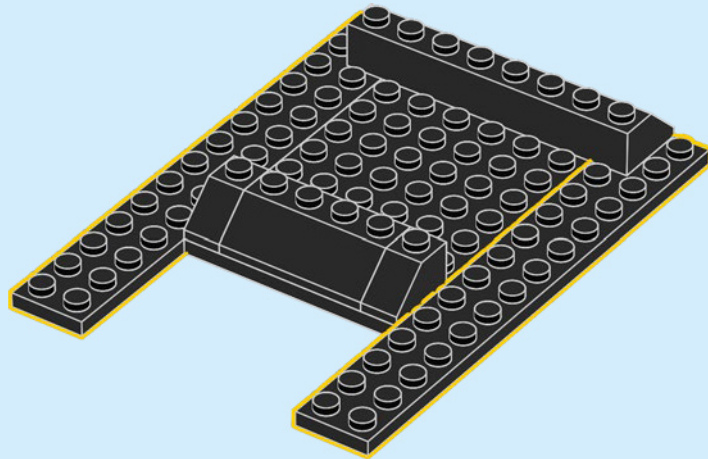

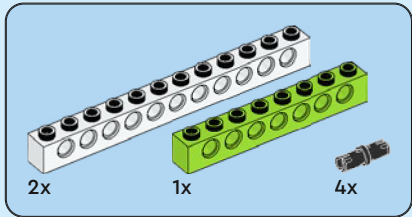
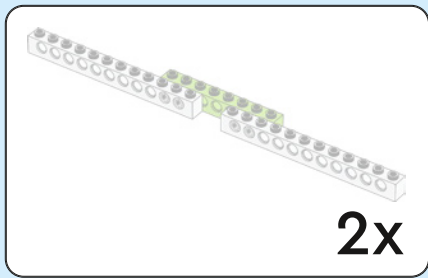

270

1

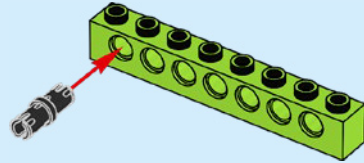

2

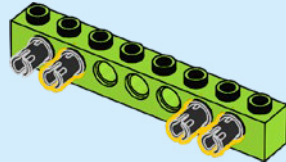

3

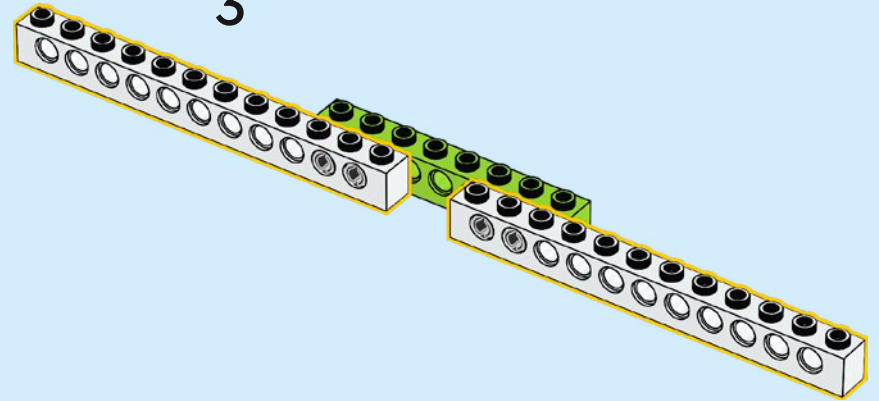

2x

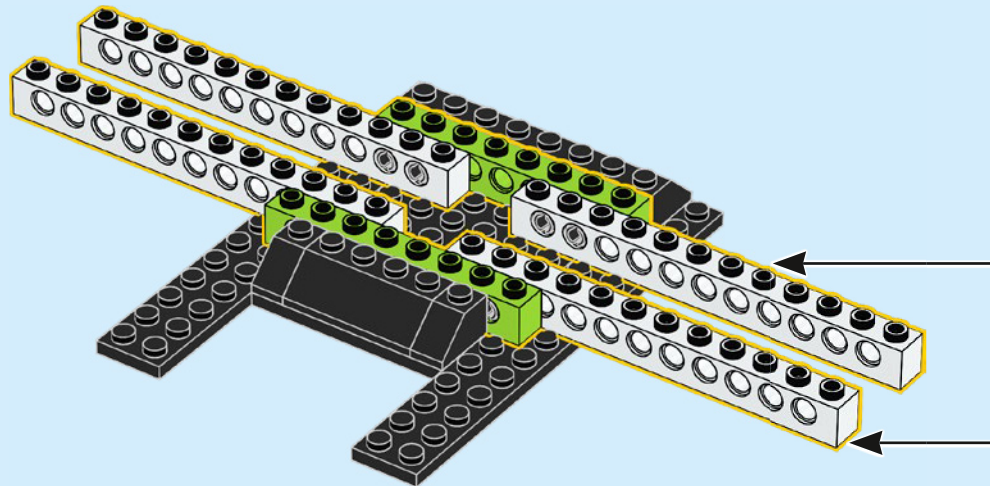

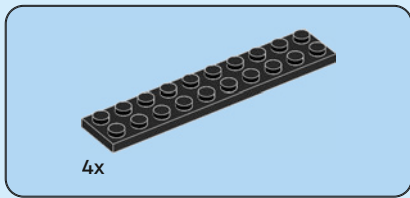

271

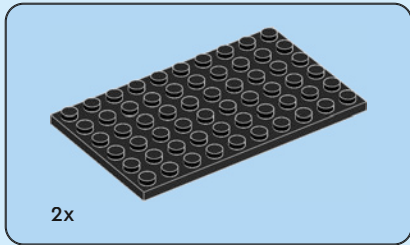
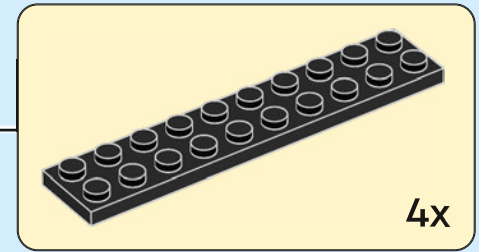
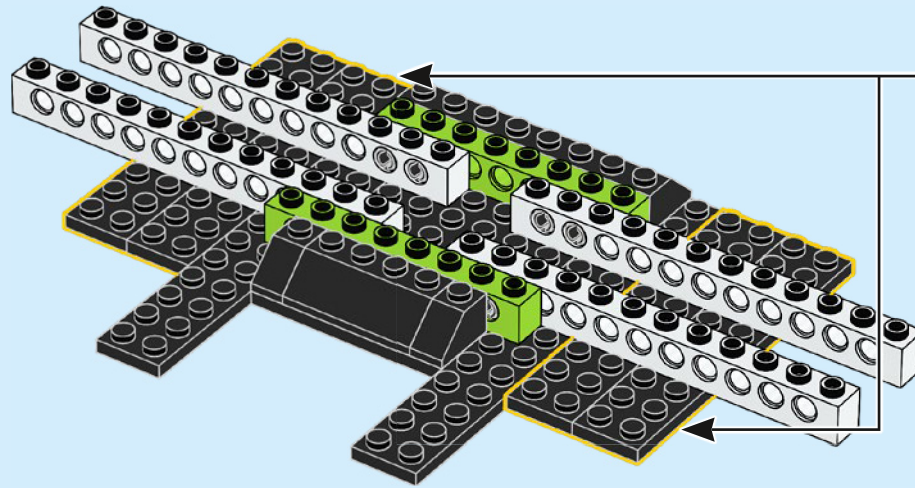

272

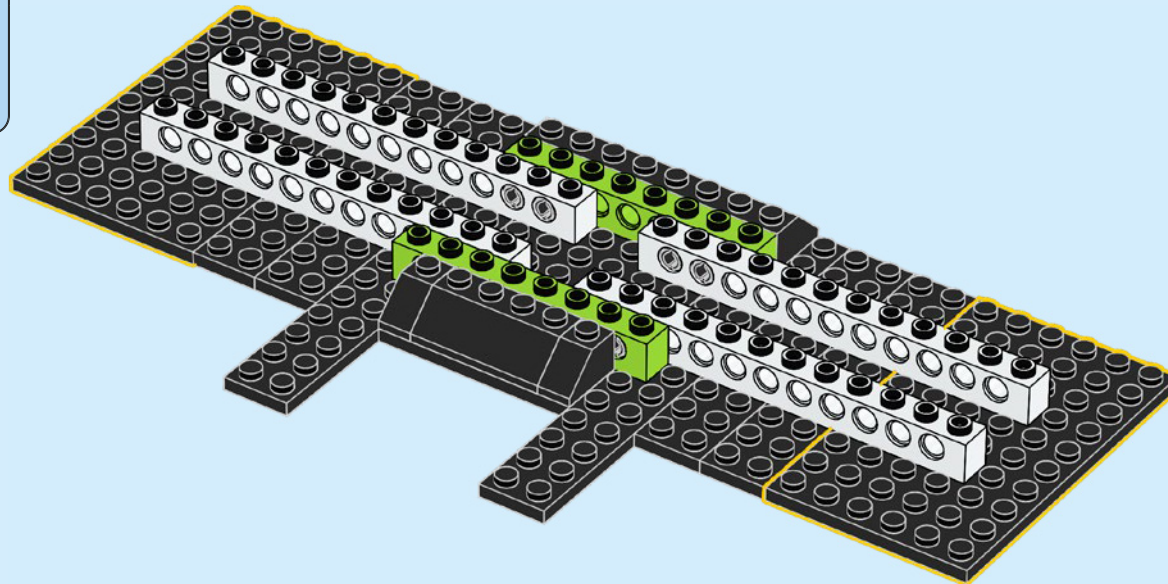

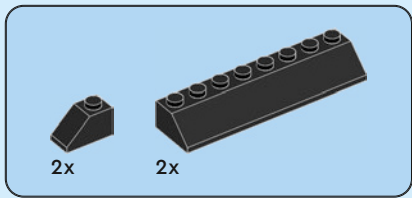

273

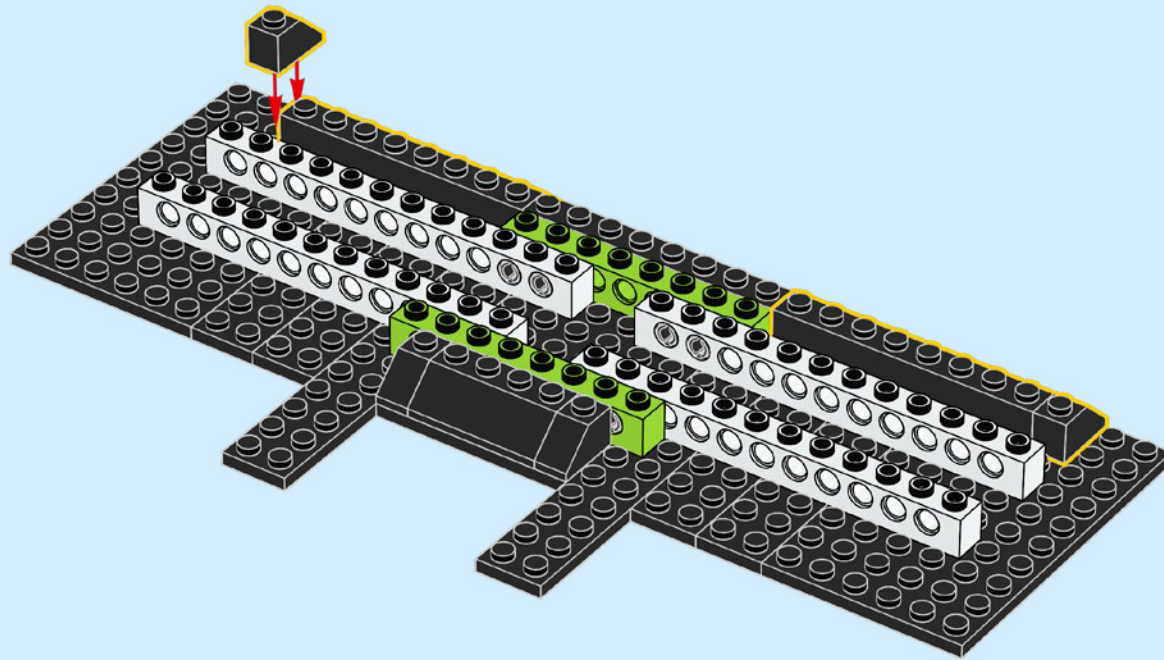

274

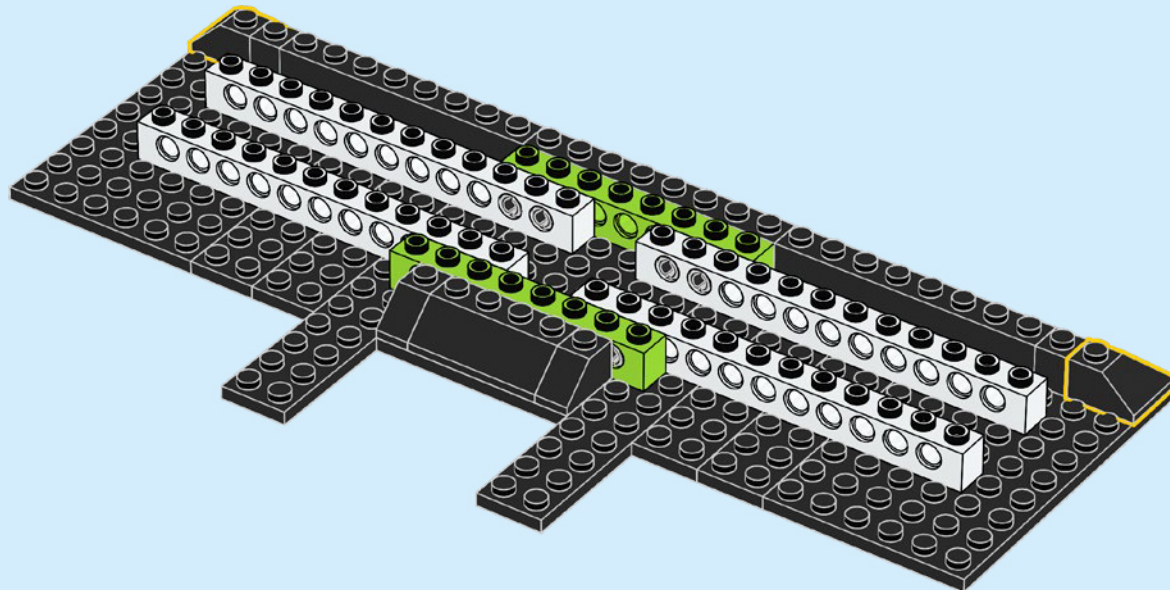

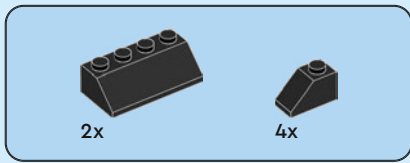

275

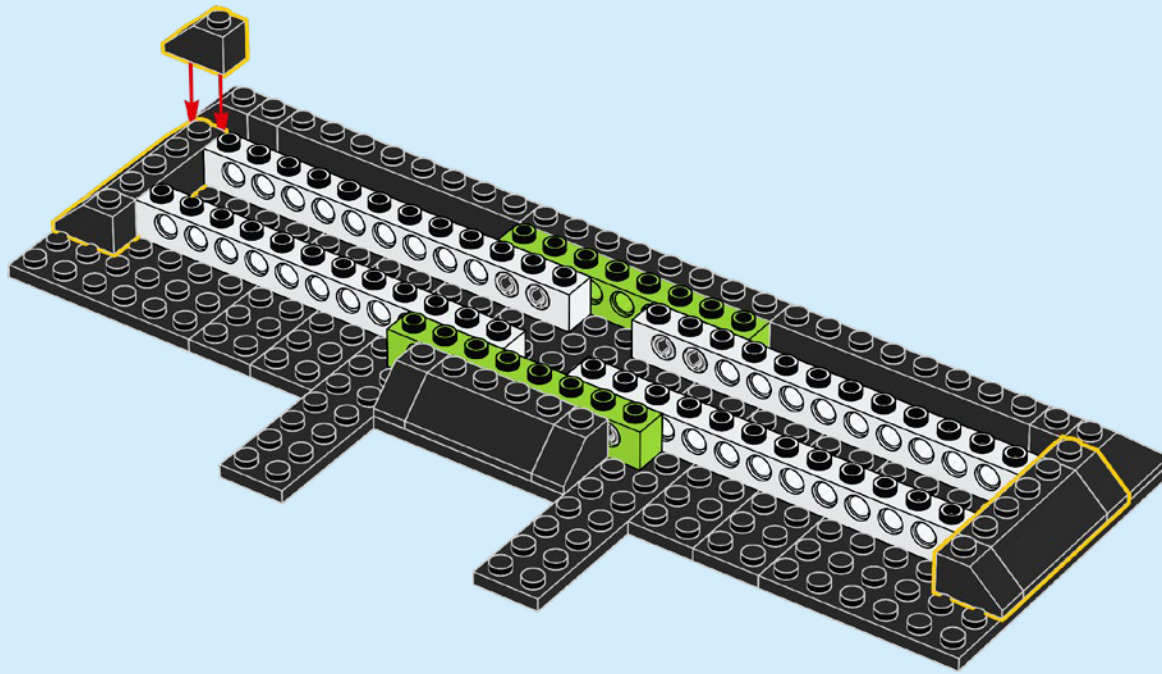

276

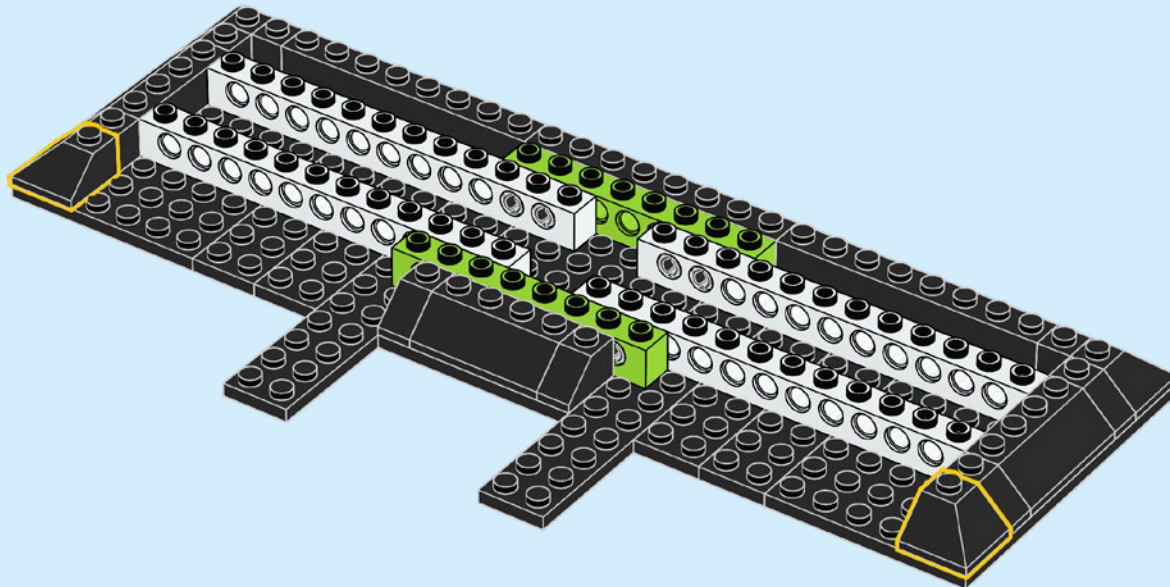



2x



2x

277

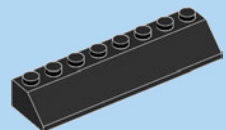
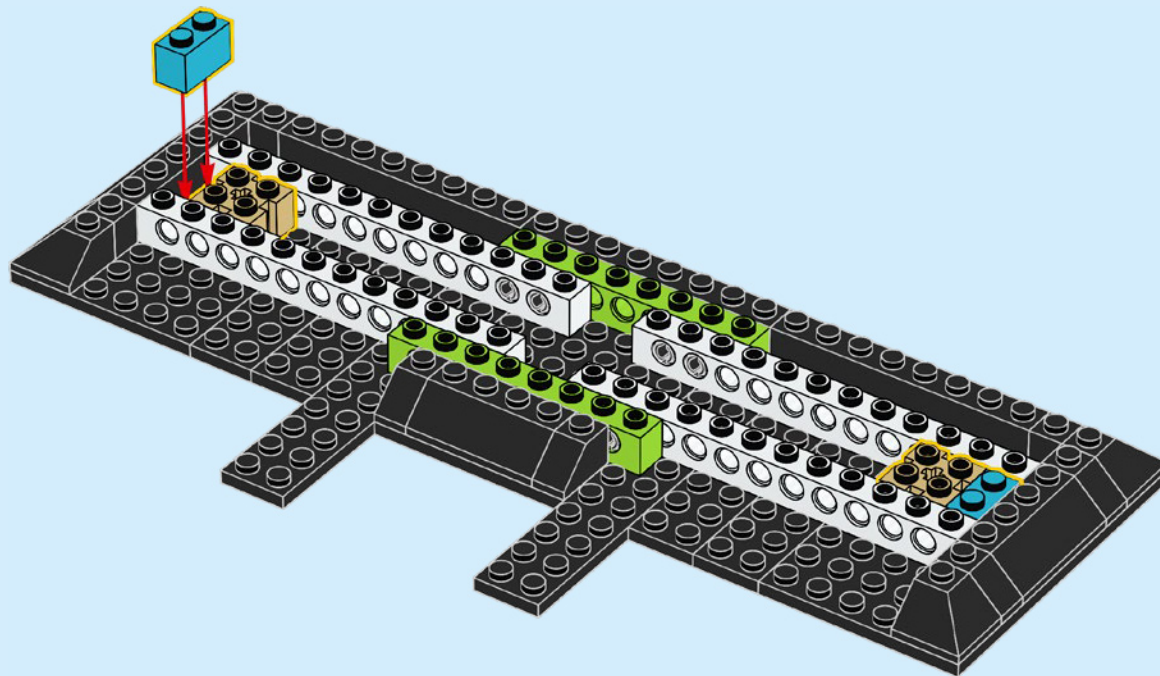

2x

278

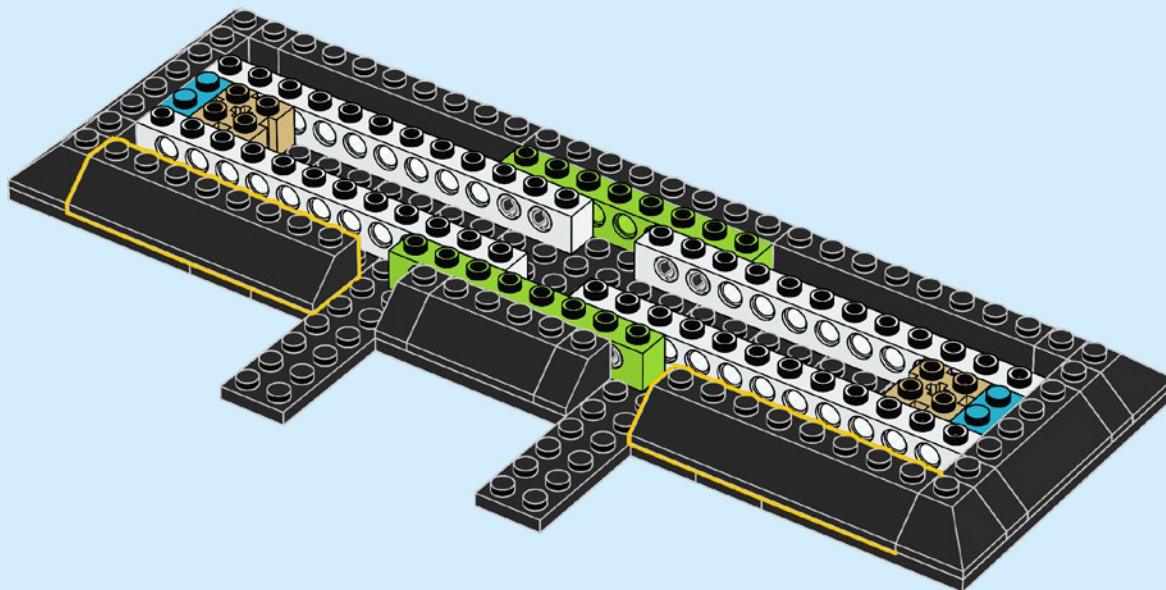

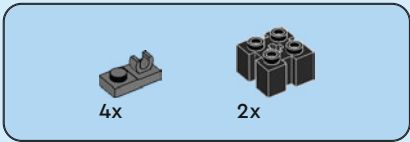

279

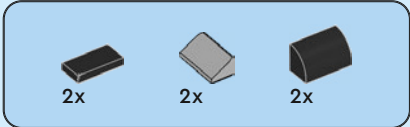
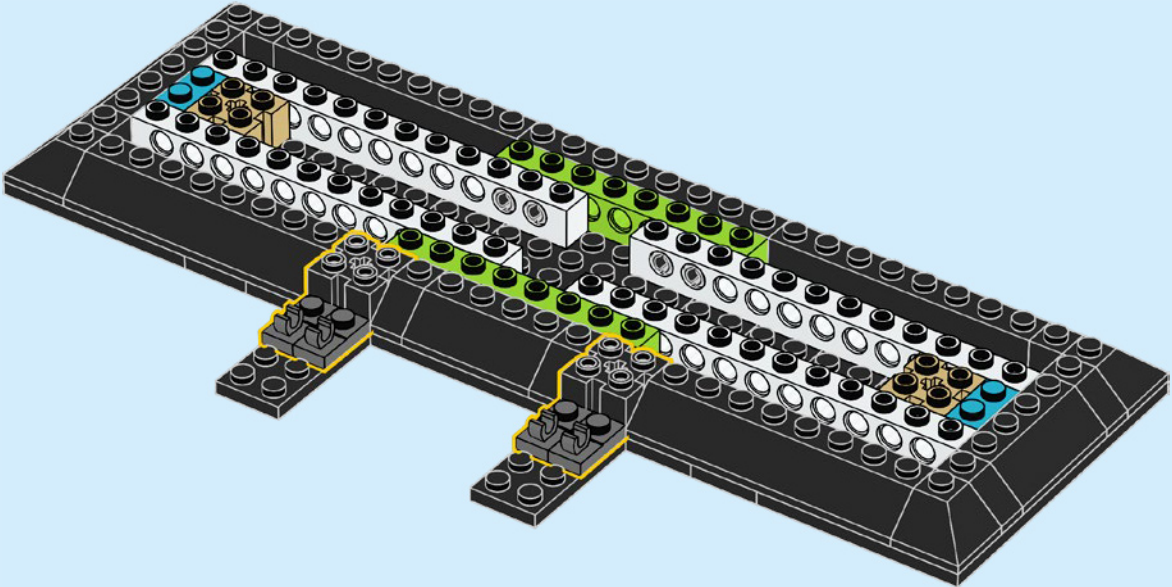

280

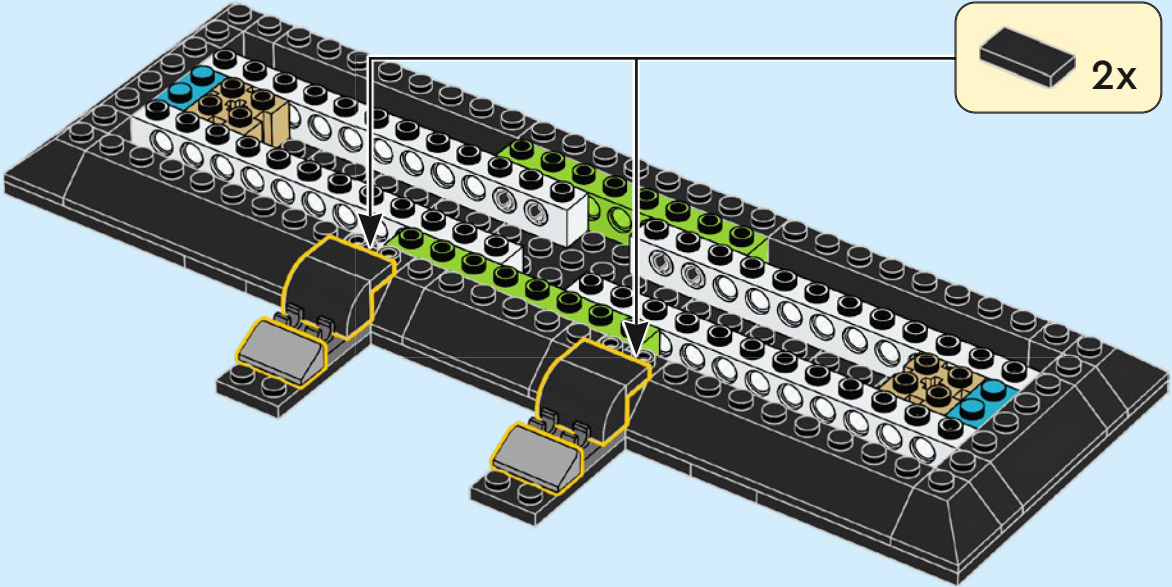

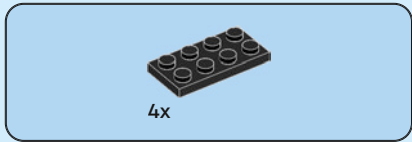

281

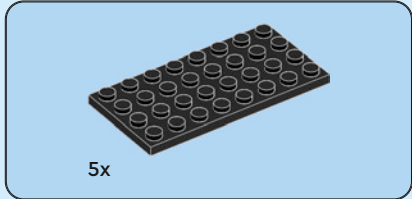
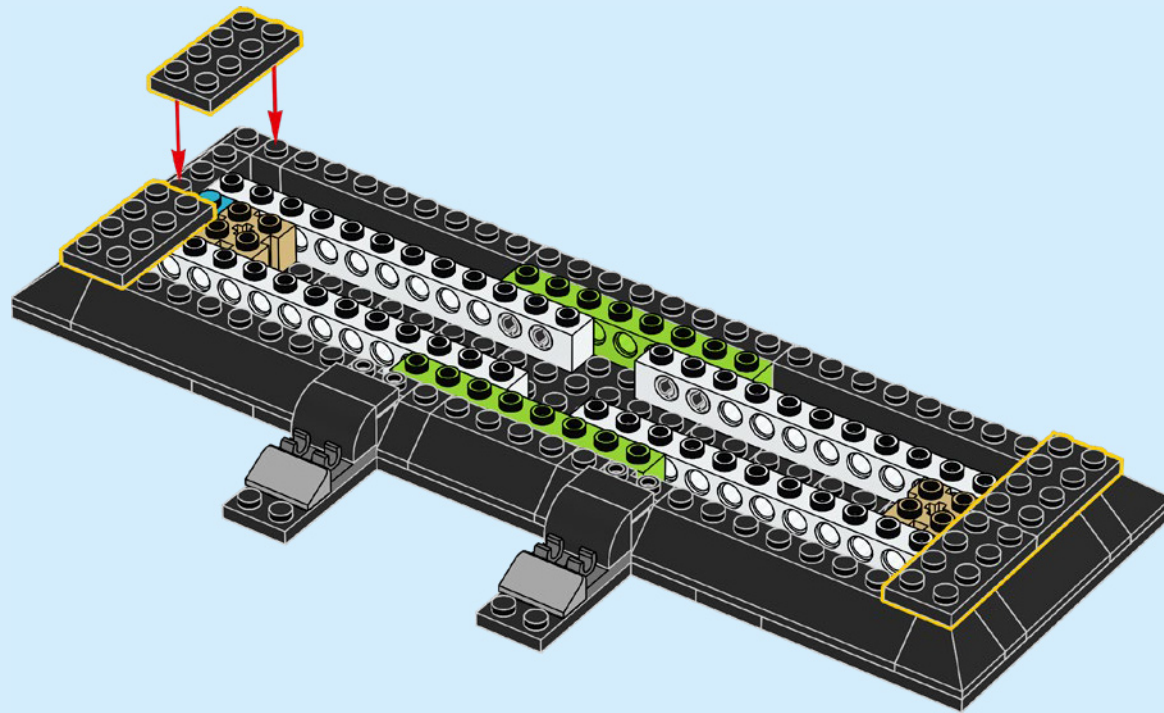

282

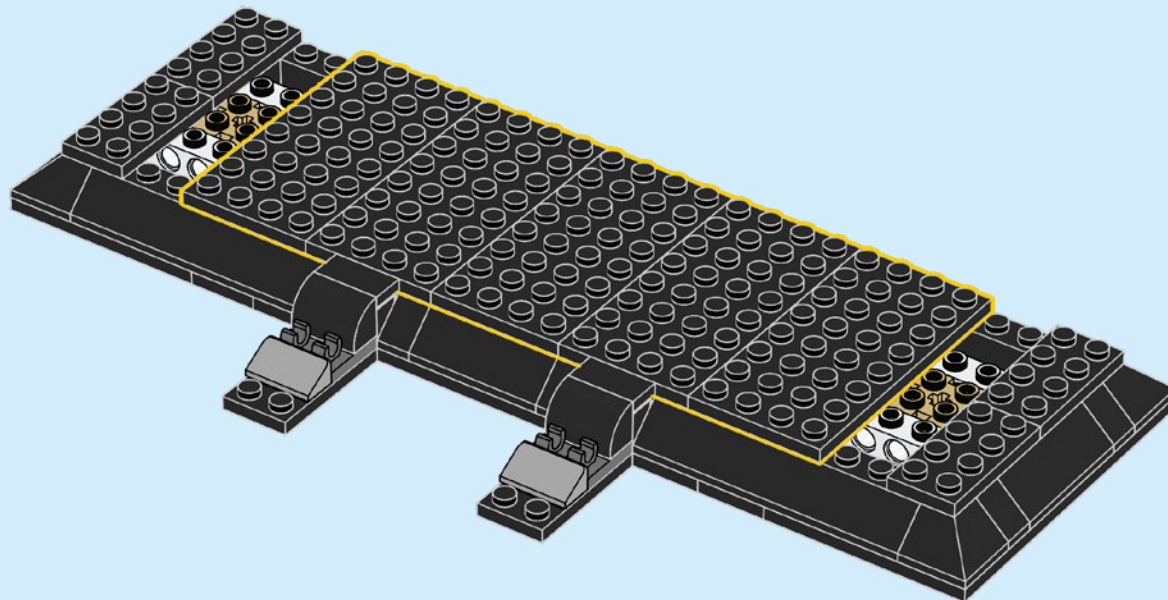

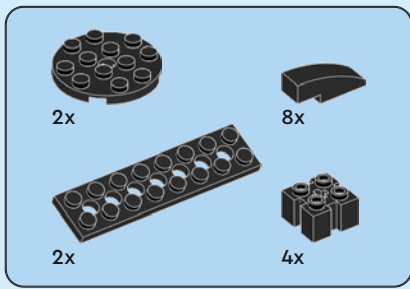

283

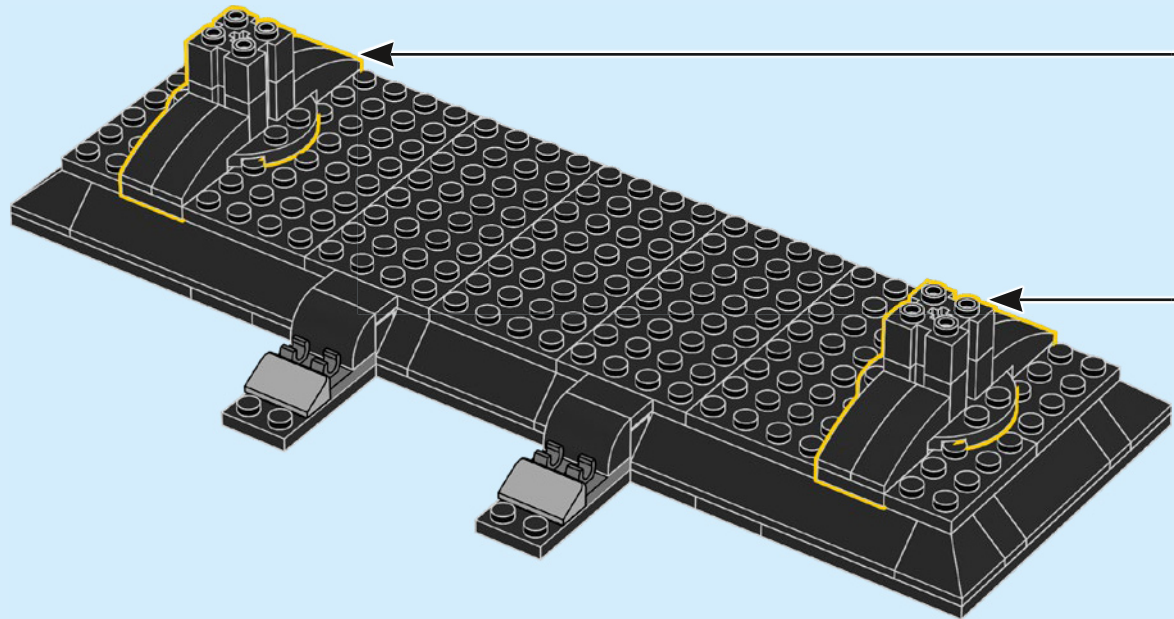
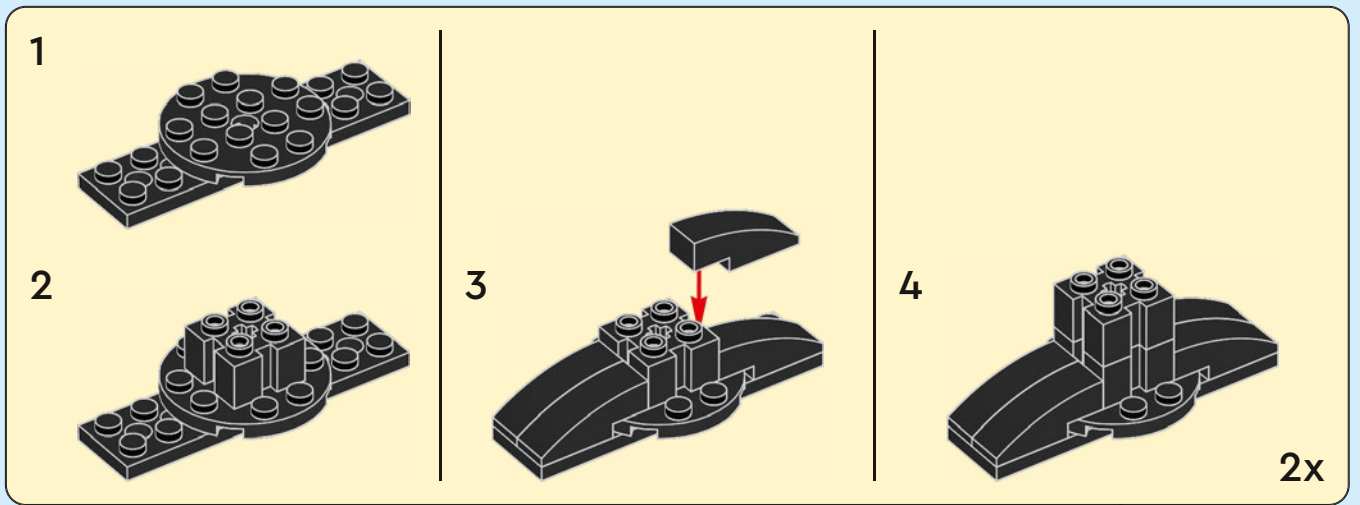

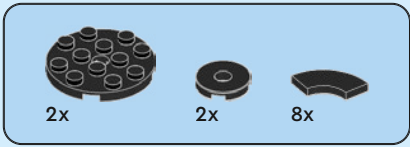

284

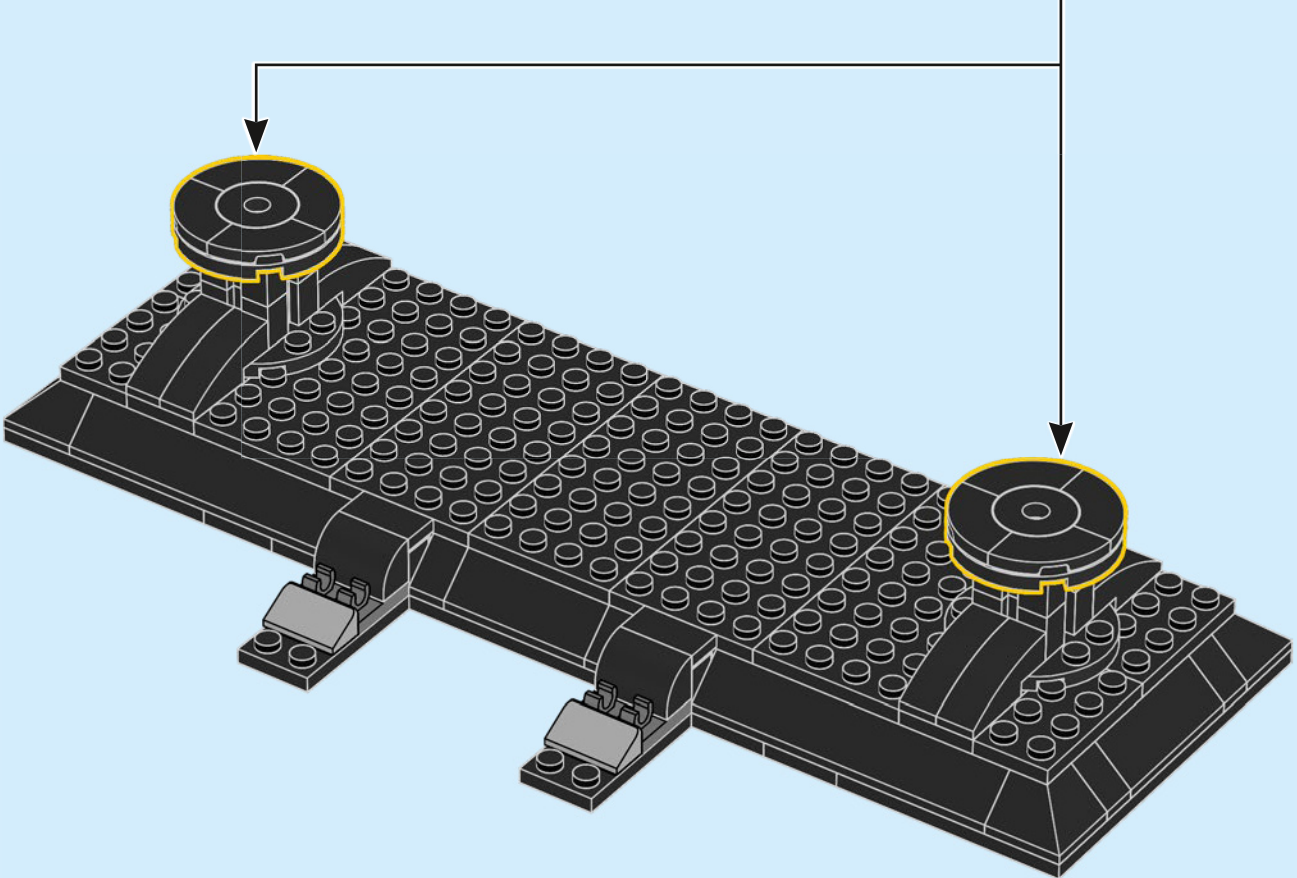
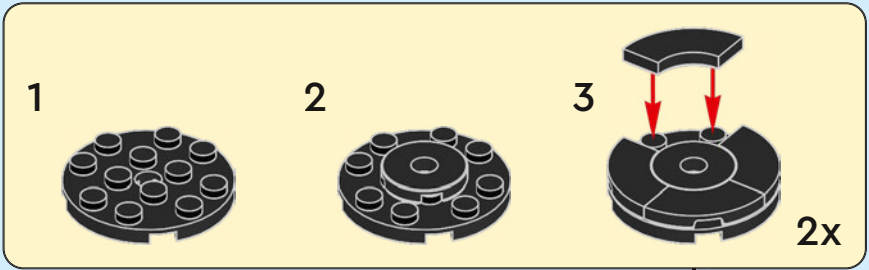

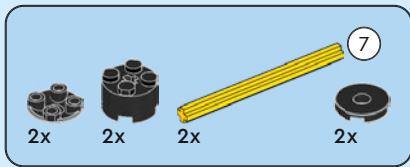

285

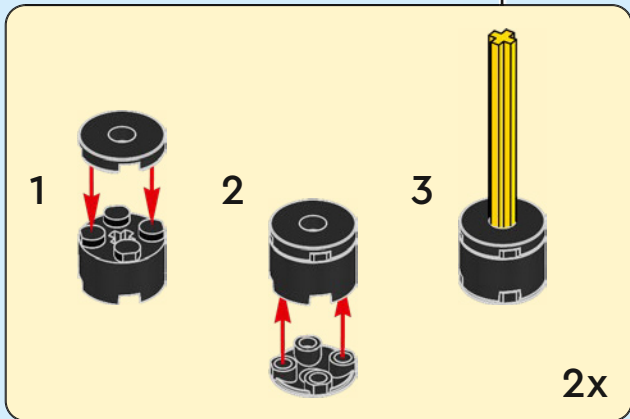
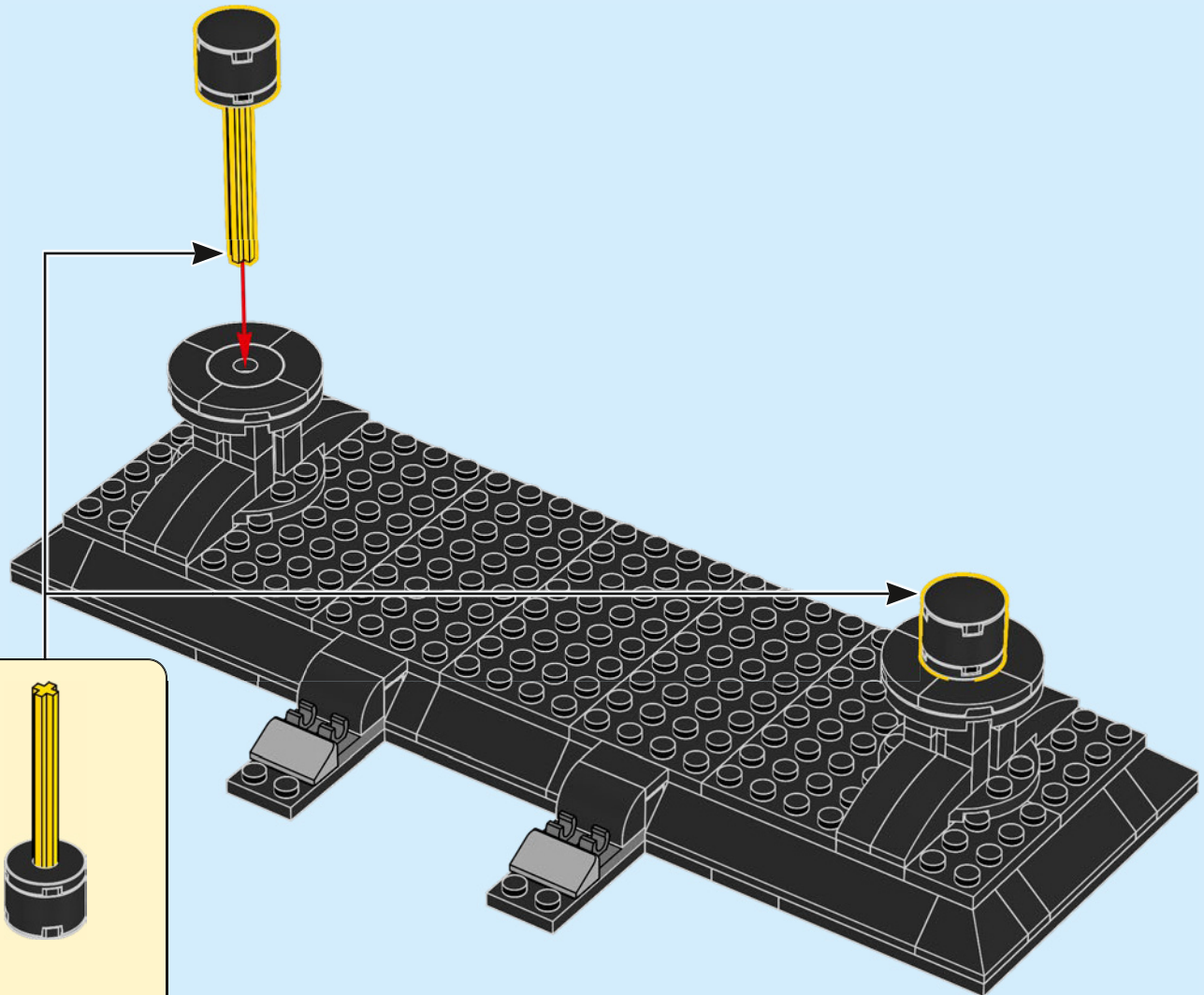

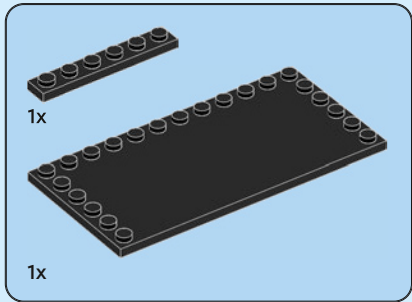

286

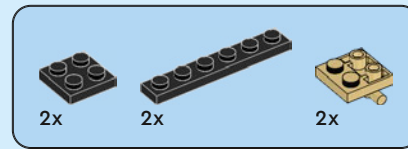
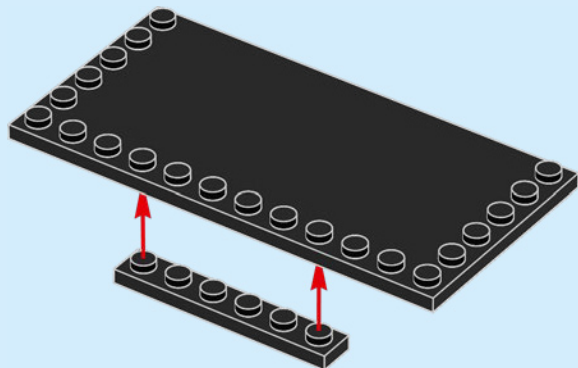

287

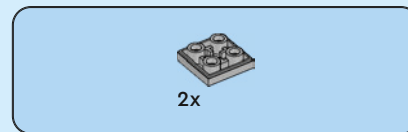
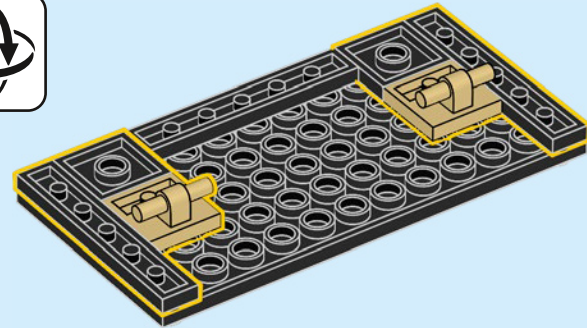

288

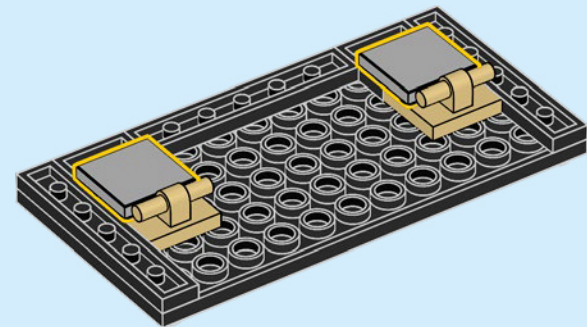

289

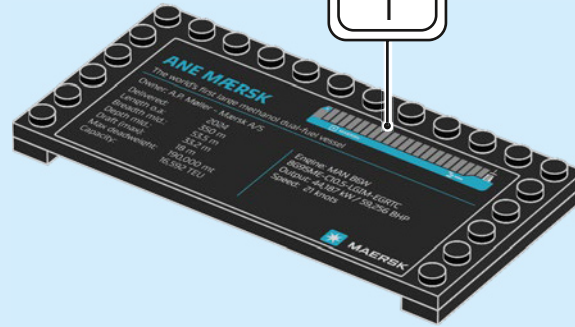

290

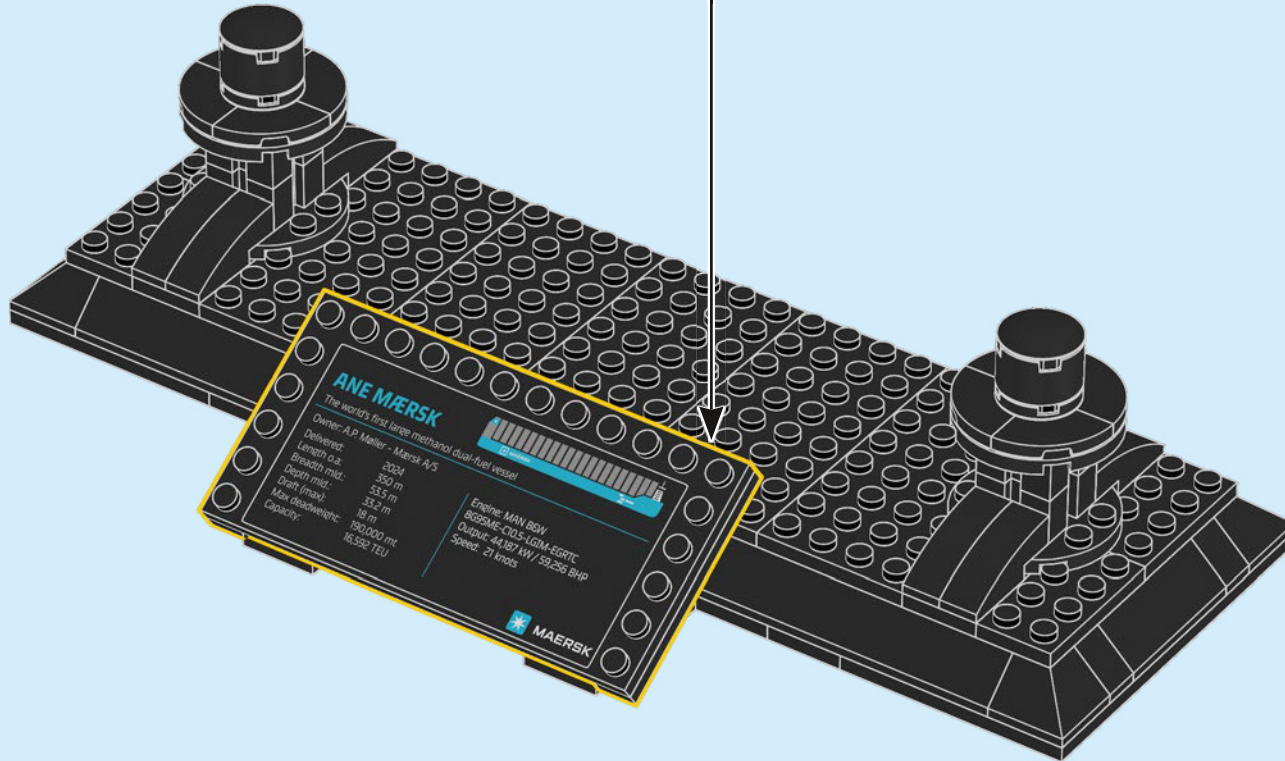

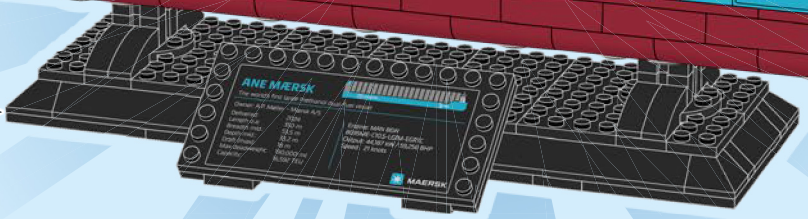
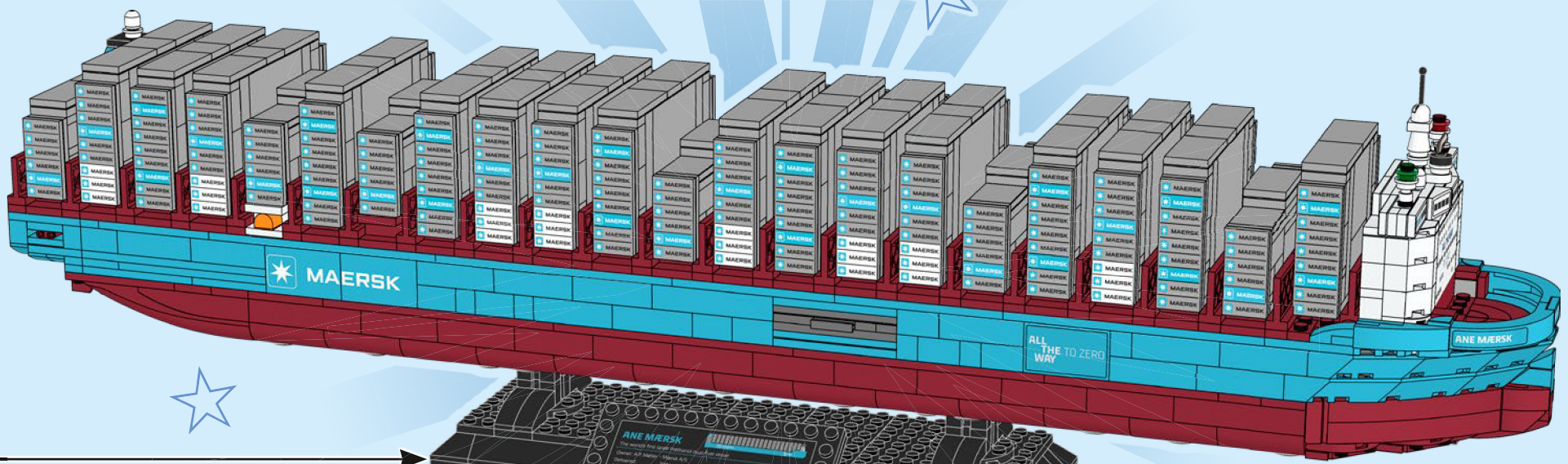
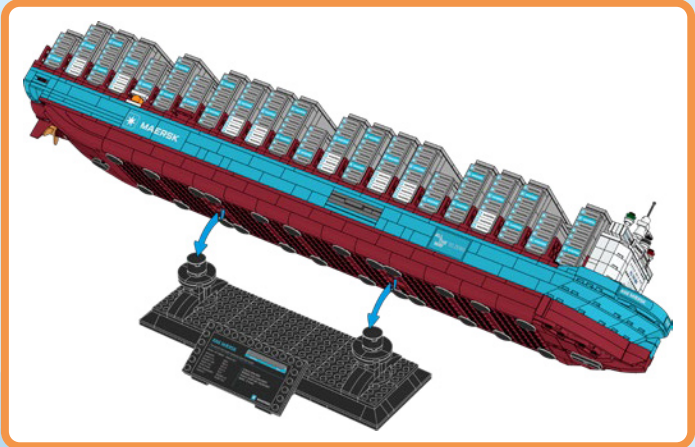

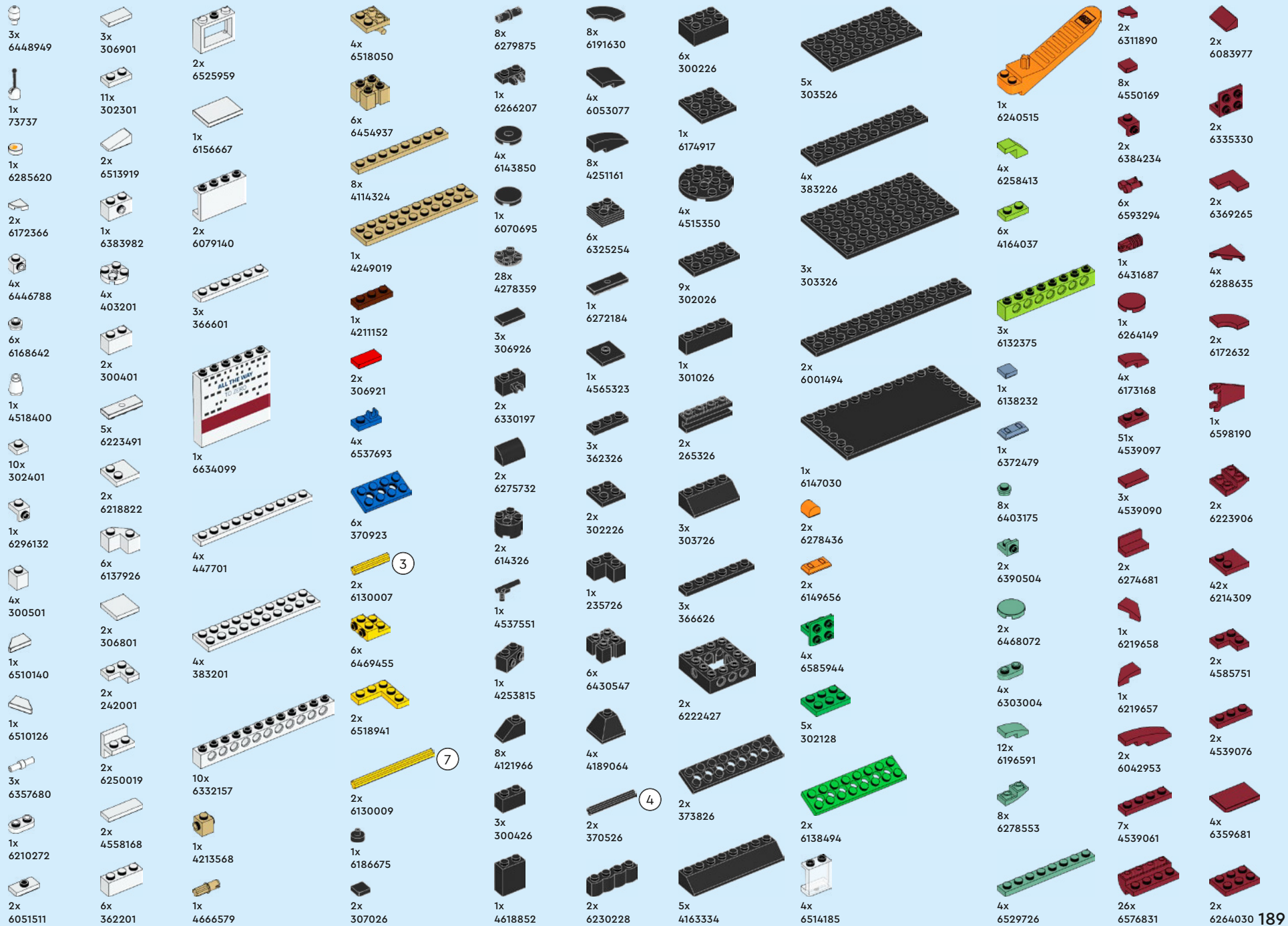

- 4x 6584062
- 4x 4541528
- 2x 6586652
- 1x 6335319
- 21x 6052777
- 6x 4541507
- 4x 4539071
- 10x 6576807
- 66x 6584063
- 1x 6465734
- 2x 6602414
- 2x 4539062
- 1x 6476042
- 1x 6350339
- 26x 6253142

- 4x 6186106
- 1x 6544174
- 6x 6440979
- 1x 4211392
- 6x 4211406
- 25x 4211462
- 2x 4211705
- 1x 6539385
- 9x 6258831
- 1x 4211415
- 4x 4211412
- 2x 4211399
- 6x 6227897
- 70x 4211398
- 11x 6015344
- 2x 4568637
- 33x 4211388
- 11x 6598026
- 39x 4560183

- 27x 4211395
- 12x 6061675
- 4x 6059033
- 2x 6079461
- 30x 4527174
- 16x 6598025
- 16x 6595947
- 35x 4211452
- 64x 6123809
- 6x 4211564

- 3x 6170387
- 32x 4211363
- 4x 6469440
- 1x 6446028
- 2x 6132886
- 2x 6043639
- 2x 4211580
- 15x 4211413
- 4x 6258820
- 10x 4211387
- 10x 6171894
- 10x 4211396
- 12x 4211386

- 1x 6514057
- 1x 6514051
- 2x 4210719
- 2x 4211063
- 4x 6344754
- 1x 6514456
- 2x 6123814
- 4x 4543086
- 1x 4218696
- 6x 4211094
- 11x 4211056
- 2x 4210651
- 1x 6287847
- 1x 6322046

- 2x 6215606
- 1x 6292145
- 1x 6088641
- 2x 6335563
- 1x 6593293
- 2x 6603341
- 8x 6603339
- 2x 6603283
- 4x 6603285
- 6x 6603587
- 8x 6603337
- 2x 6603334
- 1x 6603315
- 4x 6603598
- 17x 6603336

- 1x 6603301
- 1x 6603600
- 1x 6603591
- 1x 6603586
- 1x 6603585
- 2x 6603590
- 2x 6603344
- 2x 6603309
- 3x 6603316
- 1x 6593286
- 2x 6604733
- 2x 6603601
- 7x 6603965

- 30x 6603319
- 2x 6603317
- 2x 6576809
- 2x 6603313
- 1x 6598028
- 2x 6576810
- 1x 6598027
- 2x 6603599
- 2x 6603596
- 2x 6603342
- 2x 6603312
- 10x 6603286

- 2x 6603333
- 10x 6603340
- 2x 6603318
- 4x 6603343
- 2x 6603335
- 4x 6603595
- 1x 6603594
- 6x 6603589
- 2x 6603332
- 2x 6576813
- 2x 6576813



[LEGO.com/service](https://www.LEGO.com/service)

YOU COULD WIN



Scan this QR code or go to
LEGO.COM/PRODUCTFEEDBACK and give us
your short feedback about this LEGO® set
for a chance to win a cool LEGO prize.

Terms and Conditions apply*

EN: YOU COULD WIN. Terms and Conditions apply* **DE: Du könntest GEWINNEN.** Es gelten die Teilnahmebedingungen* **FR: Tu pourrais GAGNER.** Des conditions s'appliquent* **IT: Potresti VINCERE tu.** Termini e condizioni sono applicabili* **ES: Puedes GANAR.** Aplican términos y condiciones* **PT: PODERÁ GANHAR.** Aplicam-se Termos e Condições* **ZH: 轻松获奖.** 条款和条件适用* **PL: Szansa na WYGRANA.** Obowiązuje regulamin* **CS: Máte šanci VYHRÁT.** Platí všeobecné smluvní podmínky* **SK: Máte šancu VYHRÁT.** Platia všeobecné zmluvné podmienky* **HU: TE IS NYERHETSZ.** Felhasználási feltételek érvényesek* **UA: ВИ МОЖЕТЕ ВИГРАТИ.** Застосовуються загальні положення та умови* **RO: Ai putea CÂȘTIGA.** Se aplică termenii și condiții* **BG: Можете да СПЕЧЕЛИТЕ.** Има определени правила и условия* **LV: Tu vari LAIMĒT.** Ir spēkā noteikumi un nosacījumi.* **ET: Sul on võimalus VÕITA.** Kehtivad tingimused* **LT: Jūs galite LAIMĖTI.** Taikomos sąlygos*

*[LEGO.com/productfeedback-terms](https://www.lego.com/productfeedback-terms)

