



21367





LEGO.com/sustainable-packaging



FR
DONNEZ
OU
RECYCLEZ



OU



OU



ASSOCIATION MAGASIN DÉCHÈTERIE

Adresses sur quefairedemesdechets.fr



BUILDER



LEGO® Builder



Apple and the Apple logo are trademarks of Apple Inc., registered in the U.S. and other countries and regions. App Store is a service mark of Apple Inc. Google Play and the Google Play logo are trademarks of Google LLC. Tencent and the Tencent logo are trademarks of Tencent Inc.

LEGO.com/devicecheck



*Il Fan Designer di
LEGO® Ideas Alexis
Dos Santos con il suo
modello originale*

CONOSCIAMO IL FAN-DESIGNER

Come il portoghese Alexis Dos Santos (nome LEGO® Ideas Tkel86) riesca a trovare abbastanza ore al giorno per il suo lavoro di programmatore e web designer è per noi un mistero. Con un vasto portfolio di intricati MOC (My Own Creation), questo fan designer ha sempre qualcosa da fare!

Nel mio tempo libero, amo fare qualsiasi cosa che unisca creatività e ingegno: costruzioni LEGO, progetti elettronici, lavorare il legno, disegnare, progettare grafica, modelli 3D e scolpire. Adoro riutilizzare i materiali per nuovi scopi, come smontare un set LEGO per crearne un altro. Ricordo sempre di aver giocato con i mattoncini LEGO: da bambino ho ereditato una scatola piena di pezzi da un cugino e da allora ho ampliato la mia collezione fino all'adolescenza. Ho attraversato quella che chiamano l'"età oscura", lontano dai mattoncini, dai 16 ai 26 anni. Poi ho riscoperto la mia passione quando, per caso, ho visitato una mostra di fan LEGO creata da una comunità. Ho finito per unirmi a loro e questo hobby è cresciuto esponenzialmente. Questo progetto ha richiesto circa sei mesi. Ho sempre

ammirato Tintin e un collega mi ha ispirato a ricreare questo modello in mattoncini LEGO. Ho usato alcune parti Technic per realizzare elementi per le gambe e il cono superiore. Mi piace il fatto che il modello utilizzi elementi rotondi e conici realizzati con più pezzi, poiché è sempre una sfida riuscire a ridurre gli spazi visibili con soluzioni relativamente complesse. Alcuni di questi elementi in rosso sono stati difficili da trovare! Dopo averlo condiviso sul sito LEGO Ideas, il mio piano era di continuare a perfezionarlo, ma a poco a poco, mentre ero impegnato a lavorare ad altri progetti, ha raggiunto 10.000 sostenitori. Mi piace quando i modelli combinano movimenti meccanici e una bella estetica. Spero che i fan adoreranno il fattore Wow del modello finale".



Il modello di Alexis e l'immagine del libro che ha dato origine alla sua idea

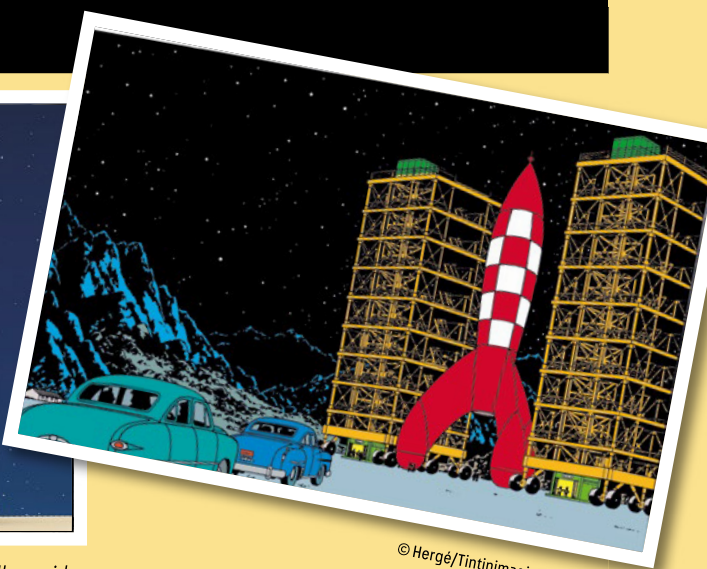

© Hergé/Tintinimagnatio 2026

UN ESPORATORE SULLA LUNA!

Il razzo a scacchi rosso e bianco di *Obiettivo Luna* (1953) e *Uomini sulla Luna* (1954) rimane uno dei simboli più riconoscibili de *Le avventure di Tintin*. Nella storia, Tintin, Capitano Haddock, Snowy e il Professor Calculus intraprendono un audace viaggio per esplorare il lato oscuro della Luna, lanciando un razzo rivoluzionario dal paese immaginario di Syldavia. Quando fu pubblicata per la prima volta, l'avventura trasportò i lettori in un futuro in cui i viaggi spaziali umani sembravano a portata di mano, in un'epoca in cui un vero e proprio allunaggio era ancora solo un sogno. Il razzo divenne rapidamente un'immagine simbolo del progresso e dell'innovazione tecnologica, poiché Tintin e i suoi amici catturarono l'immaginazione di milioni di persone con un mix di avventura, suspense e scienza moderna.

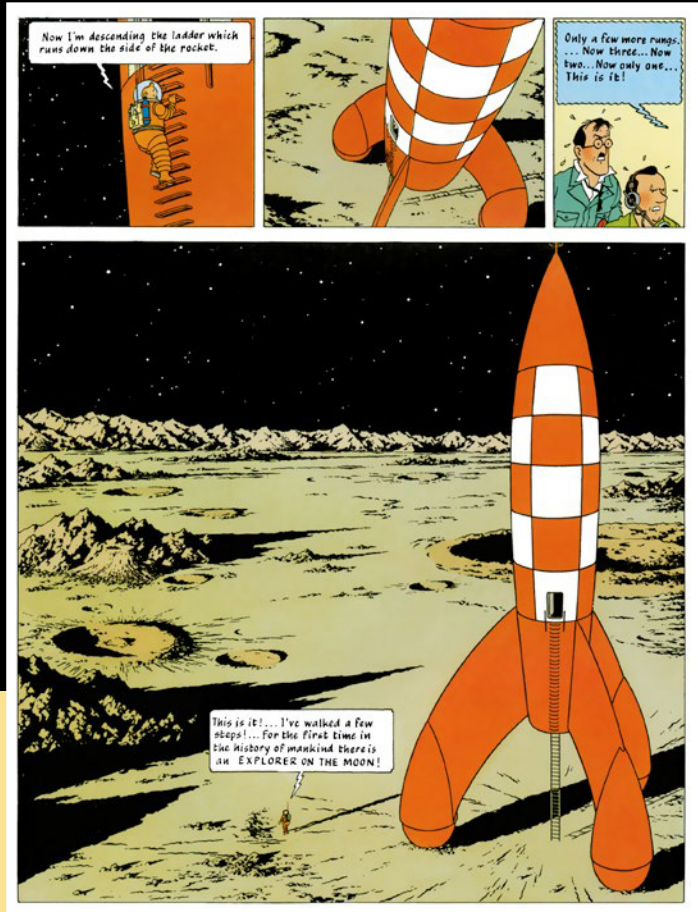

© Hergé/Tintinimagination 2026



L'ARTE INCONTRA LA SCIENZA

La storia intreccia in modo impeccabile le battute, l'arguzia e l'umorismo dei personaggi in un racconto ricco di suspense, di spionaggio e di scoperte scientifiche. Poiché il progetto del razzo, il centro di ricerca atomica Sprodj e i dettagli tecnici del viaggio erano tutti basati su ricerche reali disponibili all'epoca, la storia risultò al tempo stesso nuova e convincente e le scene ricche di dettagli introdussero la scienza avanzata a un pubblico più vasto. L'eredità di Tintin è oggi custodita in luoghi come il Musée Hergé e lo spirito pionieristico del suo razzo continua a ispirare sognatori ed esploratori.

© Hergé/Tintinimagination 2026



Molti dettagli erano basati sulla scienza reale.



© Danny Gys - Atelier Christian de Portzamparc Hergé-Tintinimagination 2026

Hergé creò un'ampia collezione di materiali di ricerca e documenti. Alcune avevano un'origine poco chiara, come queste foto in bianco e nero, classificate in una categoria separata, "Documentazione Hergé".

IL LEGO® IDEAS TEAM

Il modello del fan è davvero ben fatto ed era anche enorme! Abbiamo quindi deciso di rimuovere la torre, di concentrarci sul razzo, di portare il modello di Alexis dalla Terra allo spazio e di presentare i personaggi nelle loro iconiche tute spaziali, tra cui, ovviamente, un personaggio di LEGO® Snowy! Hergé era noto per la sua grande attenzione ai dettagli e alla precisione, e noi volevamo rendere giustizia al suo lavoro. Il razzo ha una forma a 6 lati con una curva sottile dall'alto verso il basso. Abbiamo esplorato innumerevoli tecniche di costruzione e angoli diversi per ottenere questa forma. I quadrati del motivo a scacchi sulla superficie del razzo sono

trapezoidali e, per rimanere fedeli al design, la superficie liscia e il motivo autentico sono stati una sfida emozionante. Le alette sono state un'altra parte molto tecnica del modello. La soluzione a questo problema è stata quella di utilizzare un triangolo "riflesso" per ciascuna delle alette, per creare l'angolazione corretta e bloccarle per conferire maggiore resistenza al modello. Per il cono superiore del razzo, abbiamo creato un nuovo elemento conico simile ai piedi del razzo, per omogeneità.

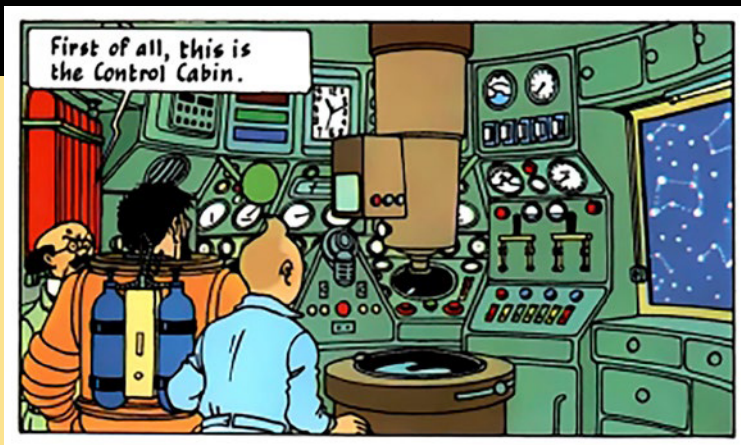

© Hergé/Tintinmagazine 2026





Abbiamo incluso una sala di controllo in cima al razzo per mostrare una scena iconica dopo il decollo, quando i personaggi vedono la Terra dallo spazio per la prima volta. L'abbiamo resa quanto più accurata possibile, con decorazioni, dettagli e adesivi, e siamo persino riusciti ad aggiungere il portello che conduce al livello successivo del razzo.

“Tradurre” i personaggi in minifigure è stato un processo molto divertente. Hanno così tanta personalità e una storia fumettistica che abbiamo ristretto il campo a espressioni che riflettessero questa trama. Le tute spaziali sono ispirate a *Uomini sulla Luna* e i capelli verdi di Dupont e Dupont richiamano una scena esilarante nel fumetto!

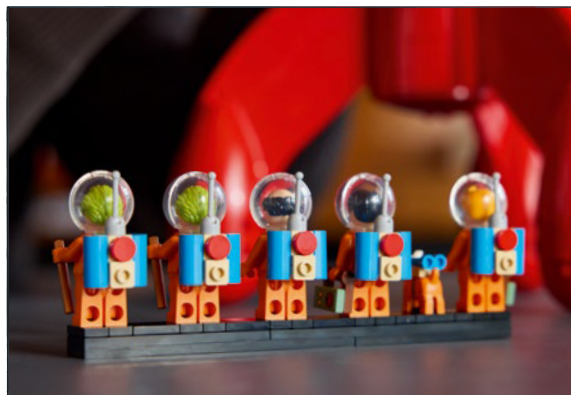

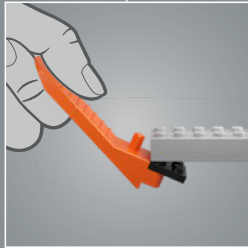
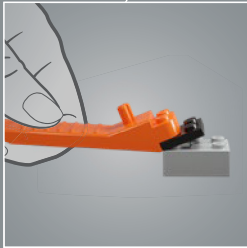
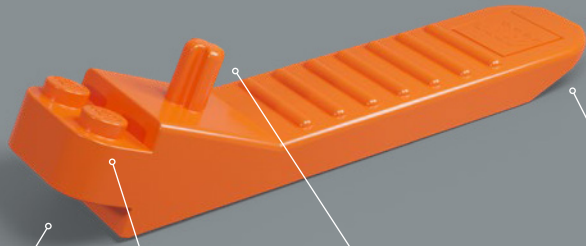

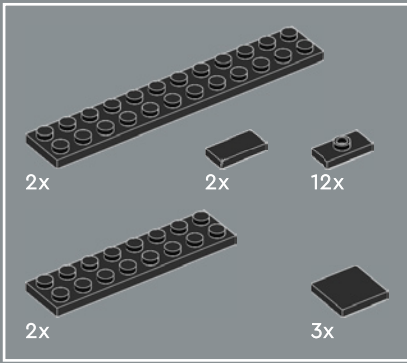
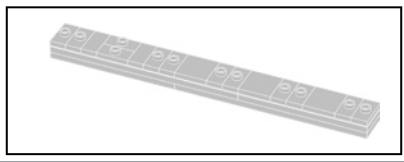

1

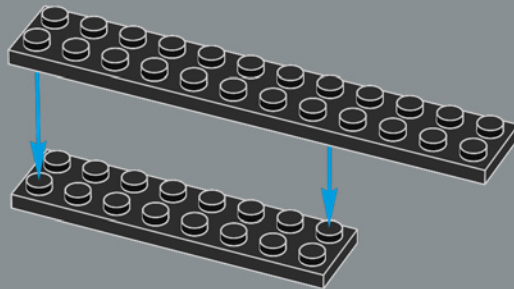

2

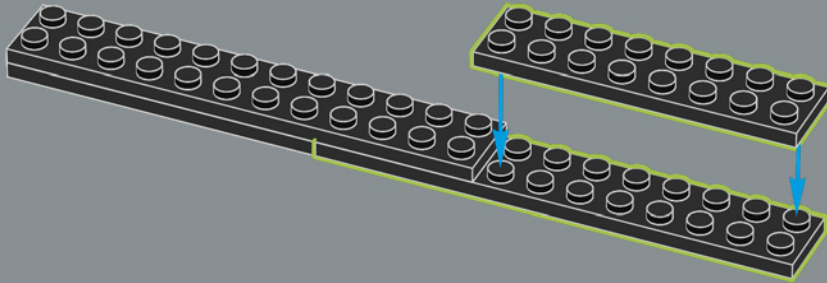

3

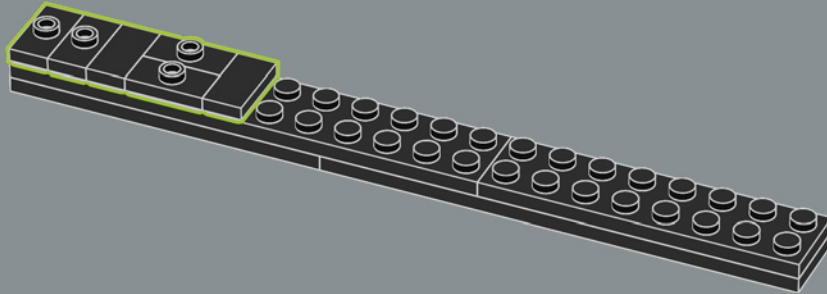

4

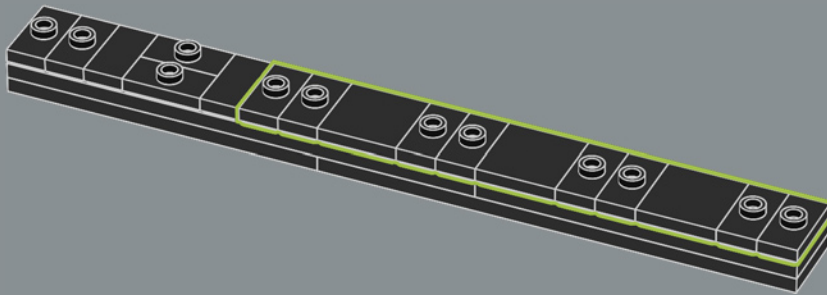

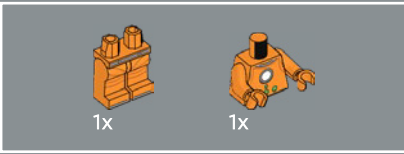
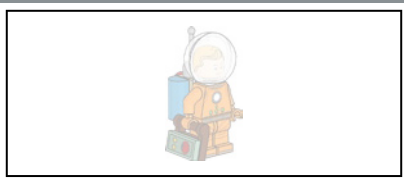

1

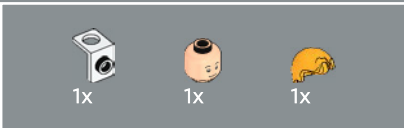
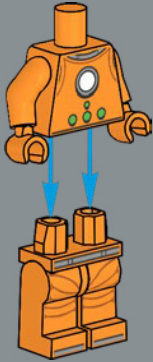

2

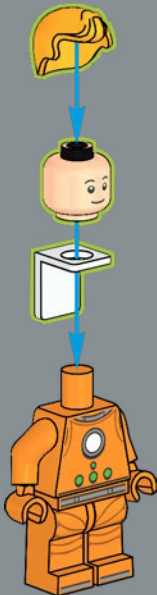

3

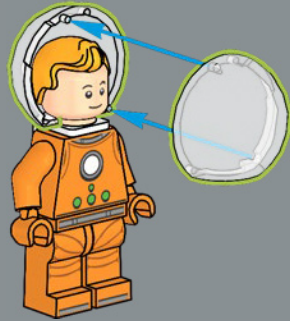

4

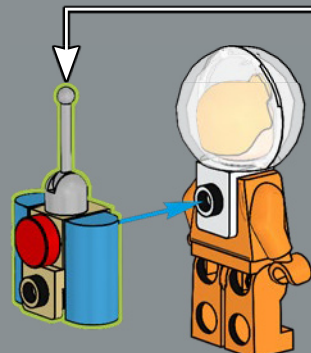
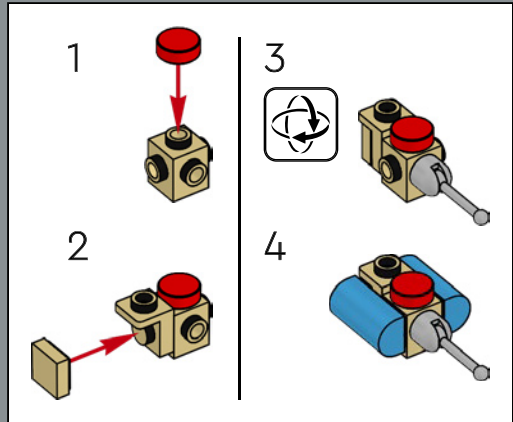



5

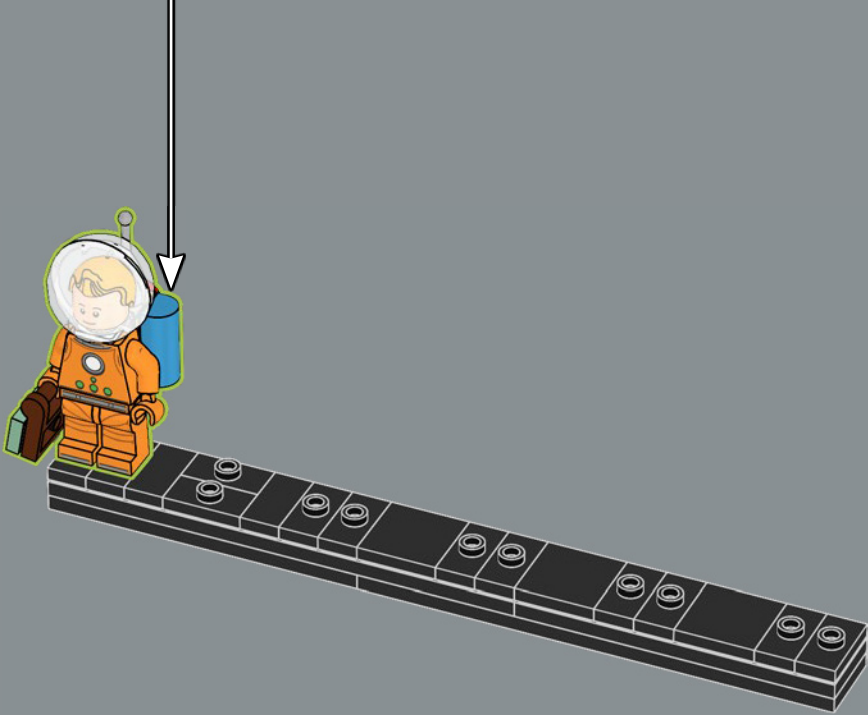
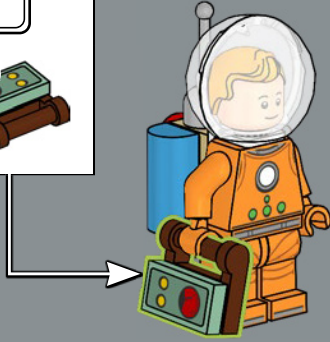
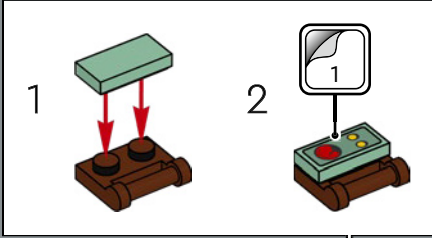

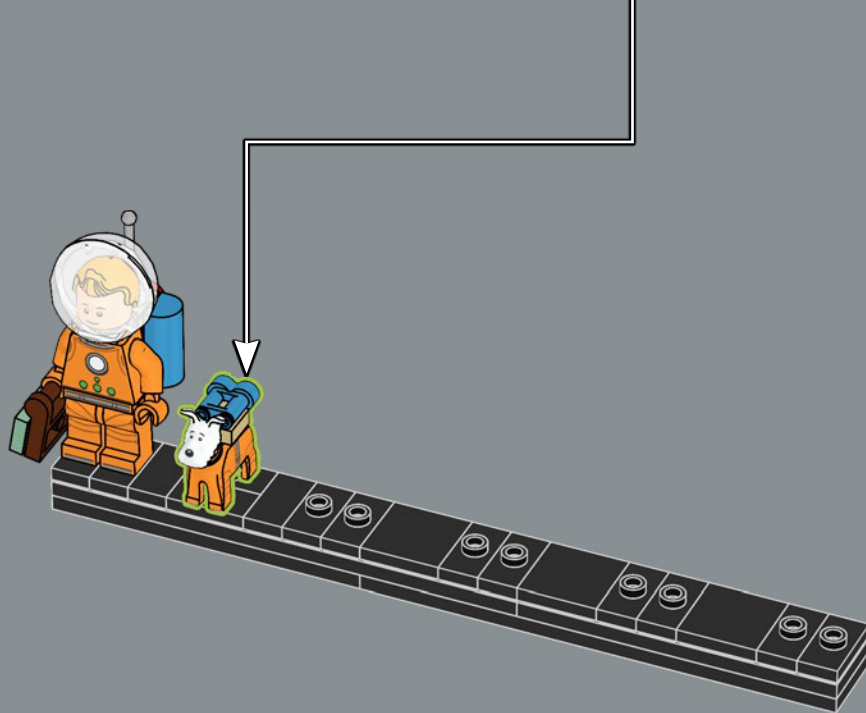
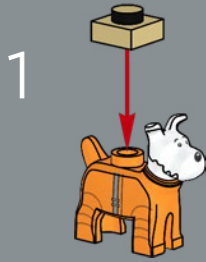

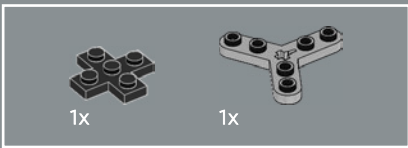
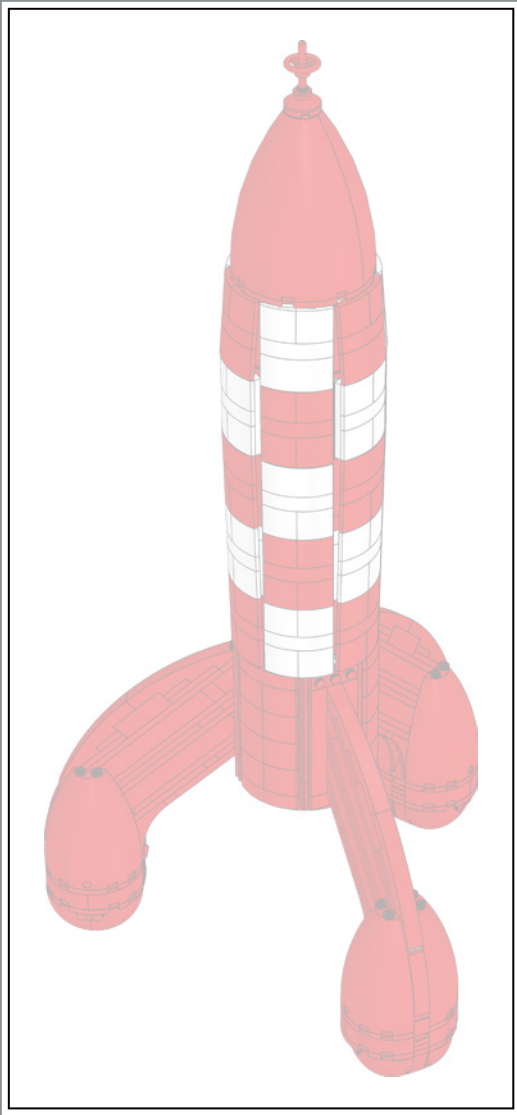

1

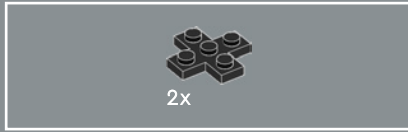
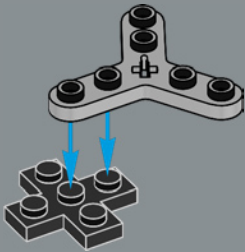

2

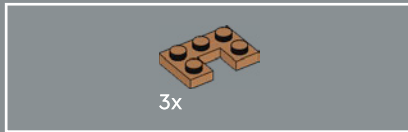
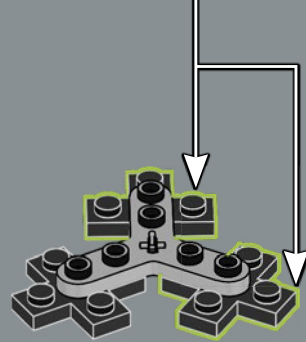

3

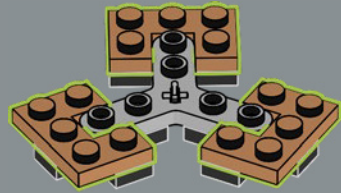

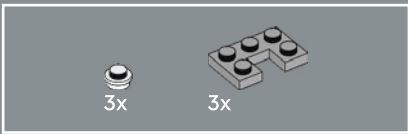

8

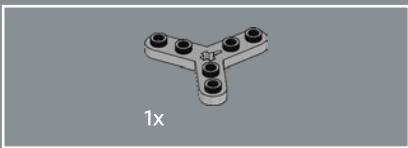

9

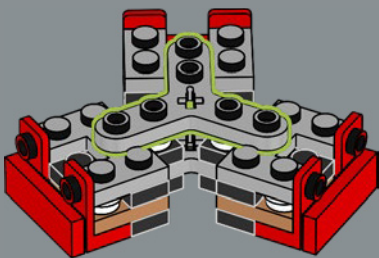

10

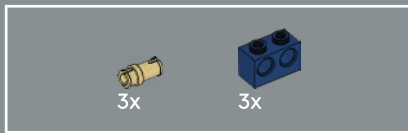
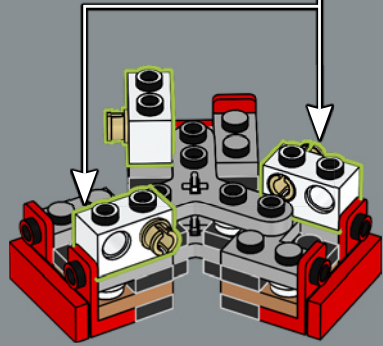
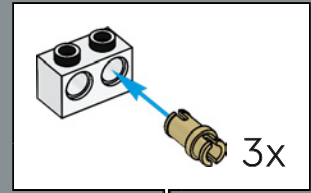

11

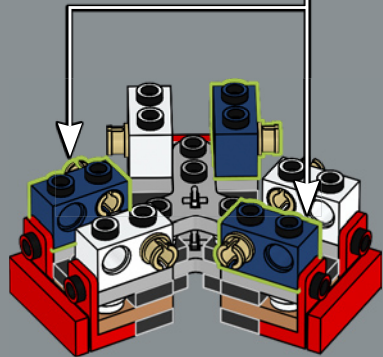
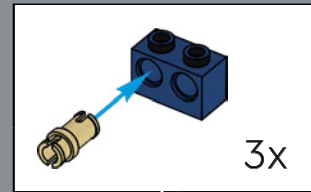



12

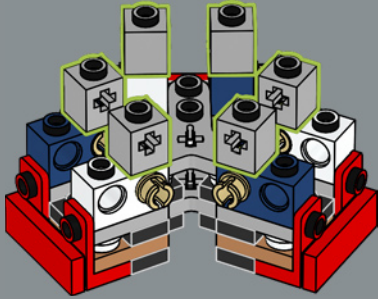

14

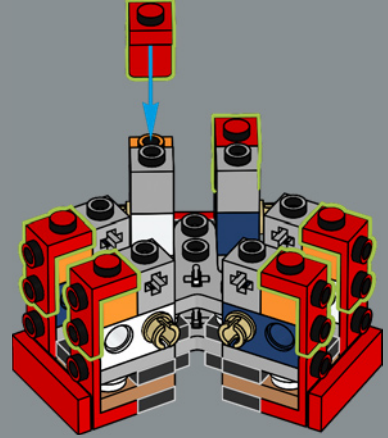

13

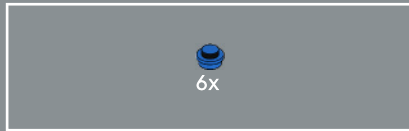
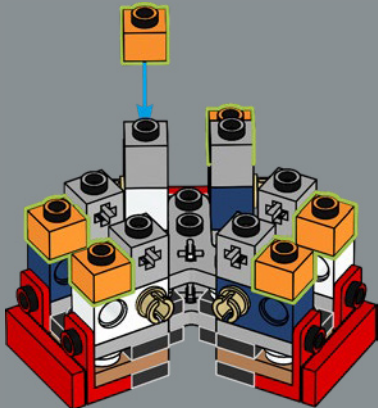

15

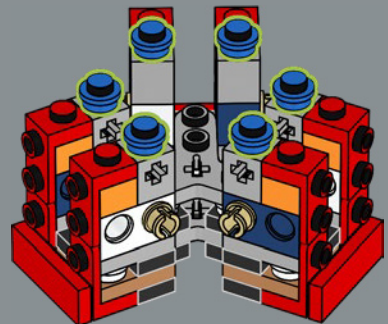

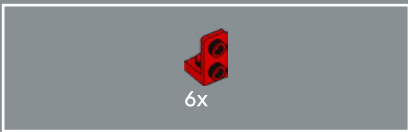

16

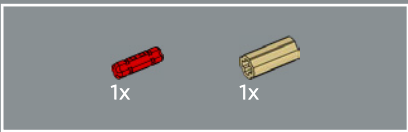
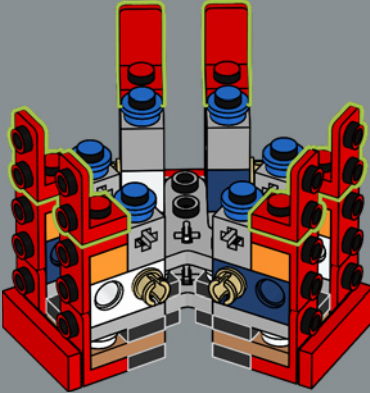

18

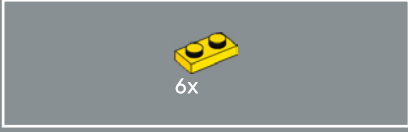
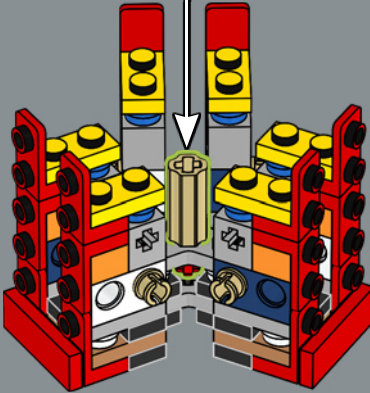
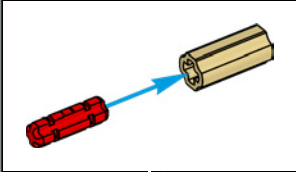

17

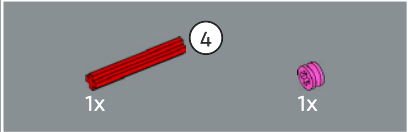
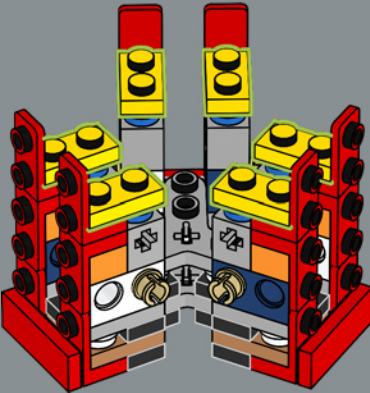

19

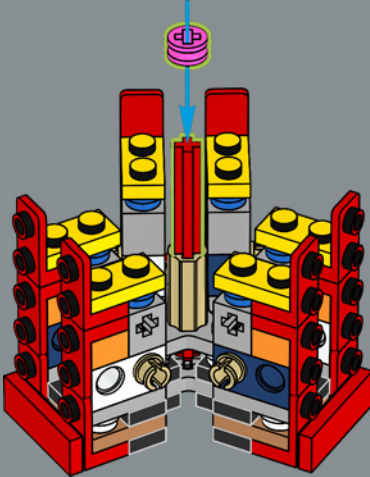

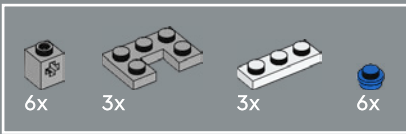

20

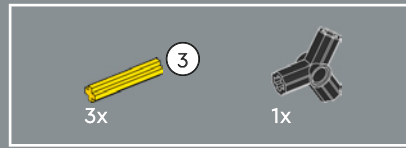
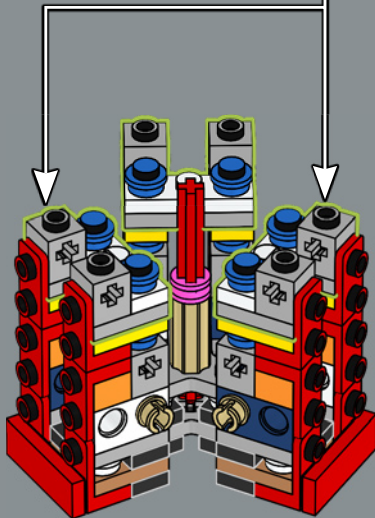
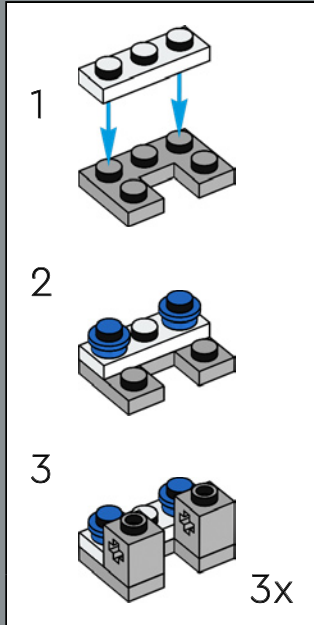

21

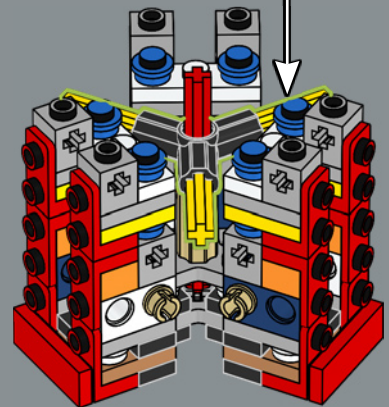
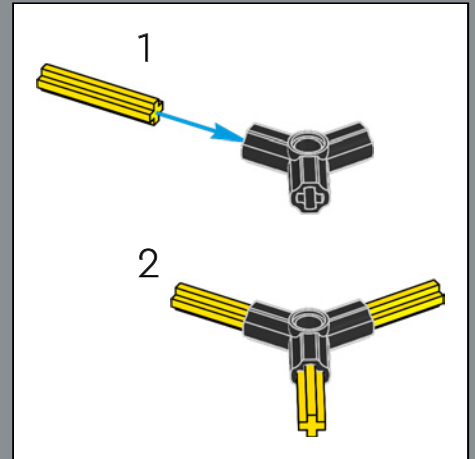

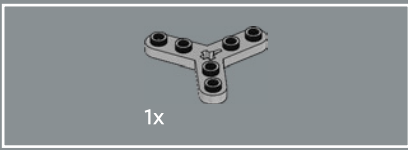

22

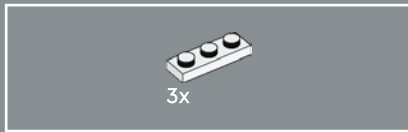
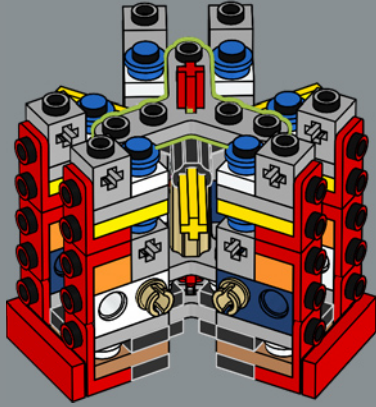

23

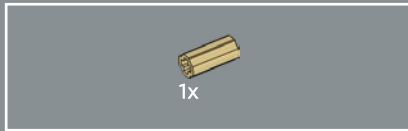
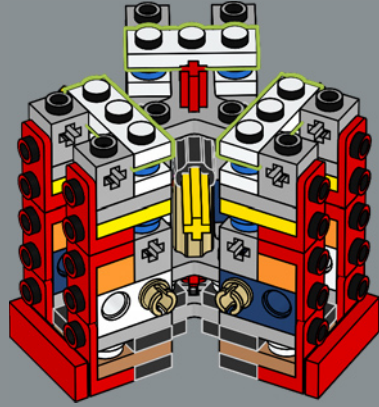

24

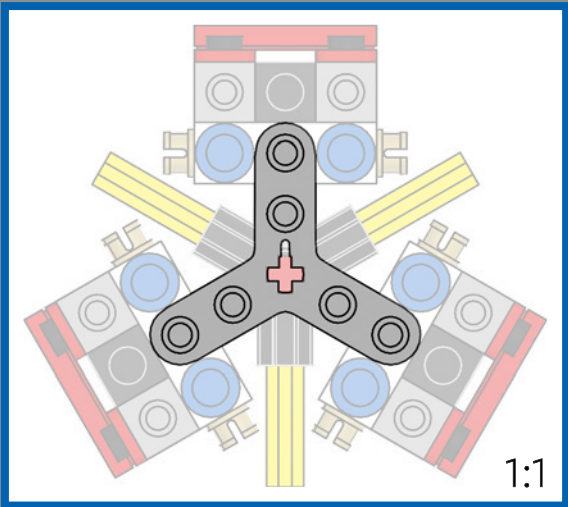
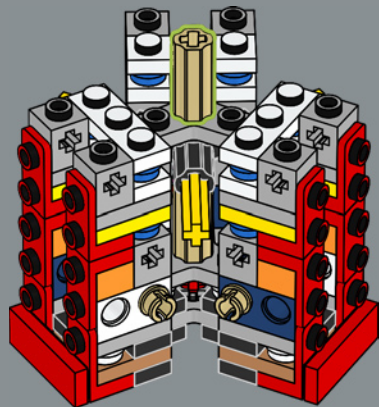

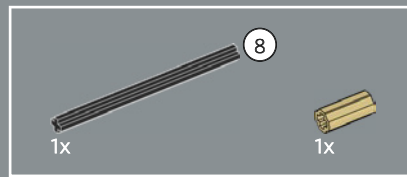

25

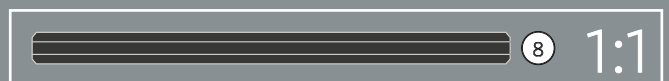
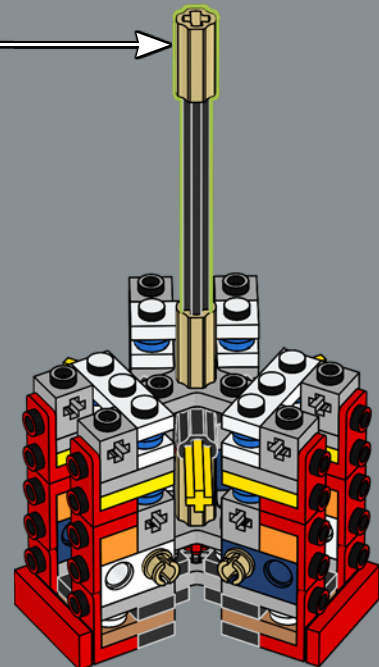
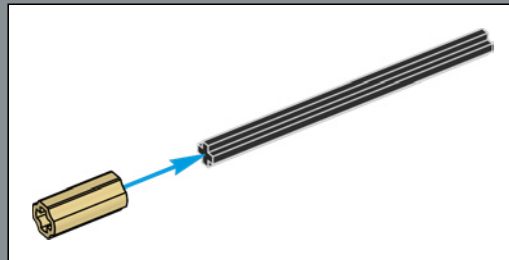

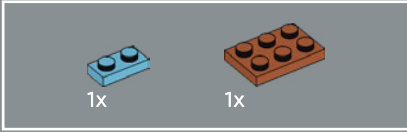
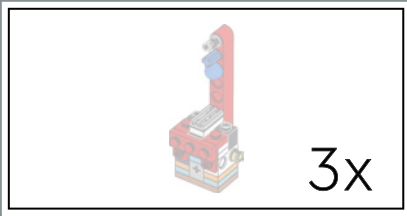

26

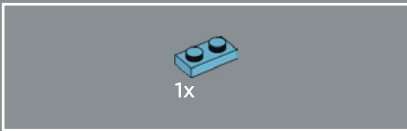
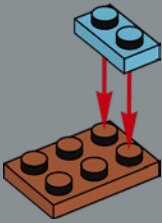

27

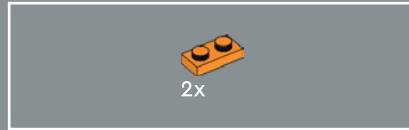
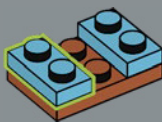

28

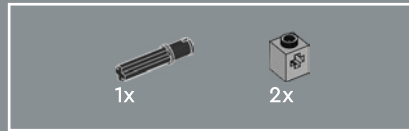
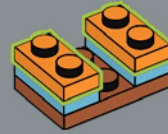

29

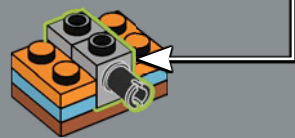
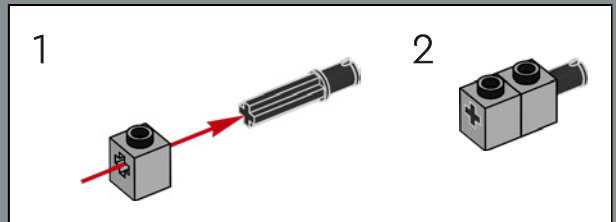

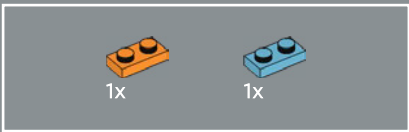

30

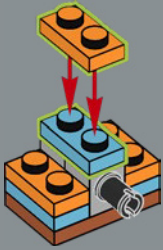

32

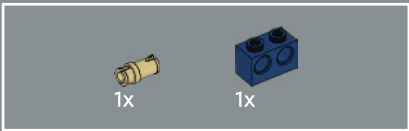
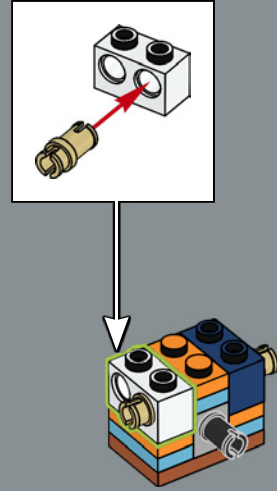

31

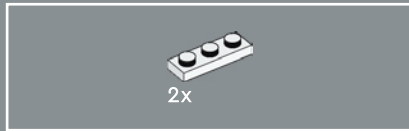
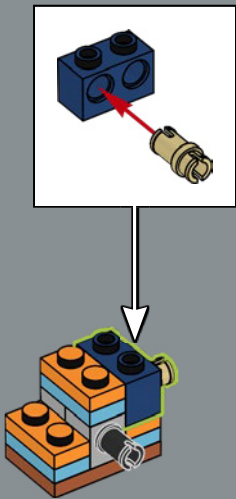

33

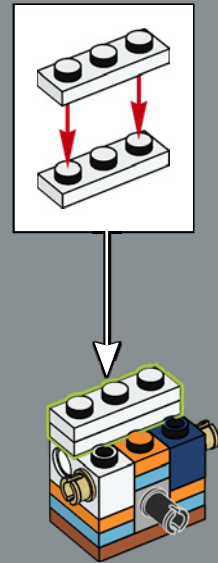

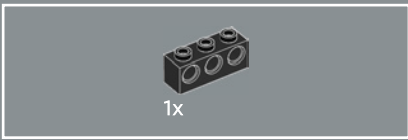

34

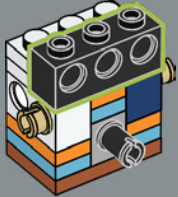

35

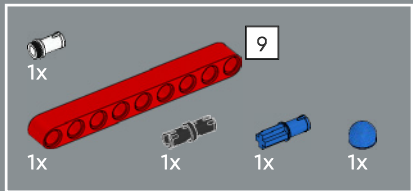
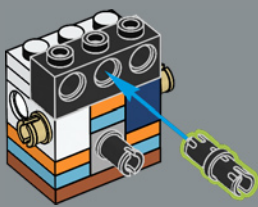

36

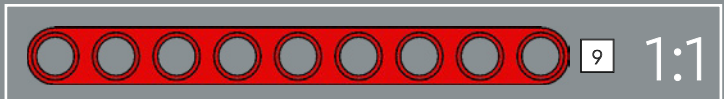
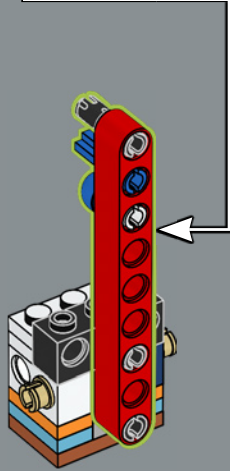
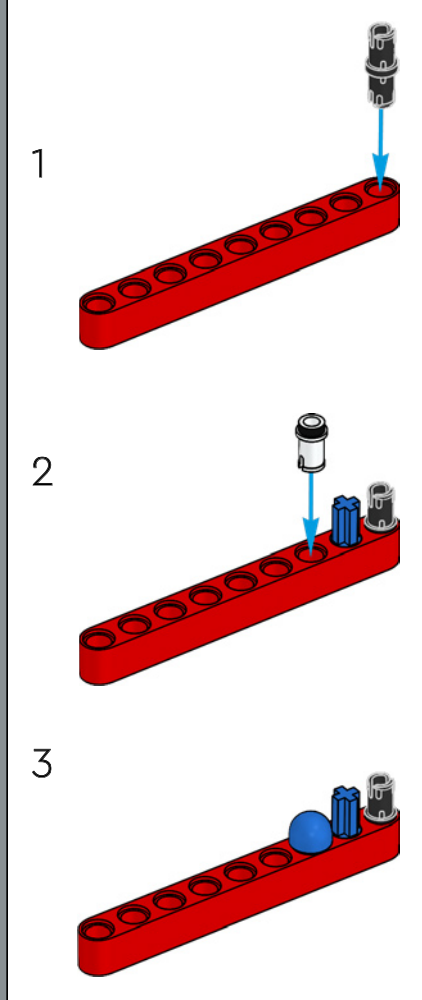

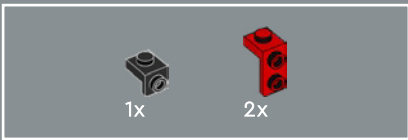

37

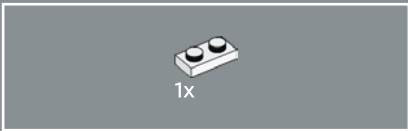
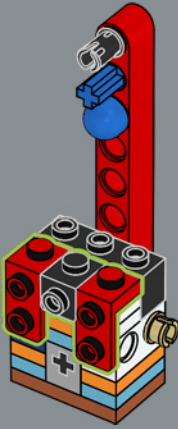

38

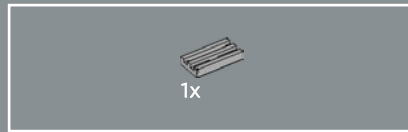
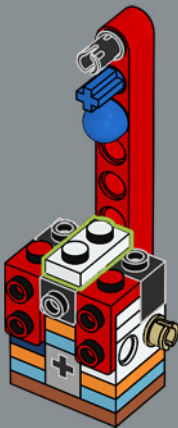

39

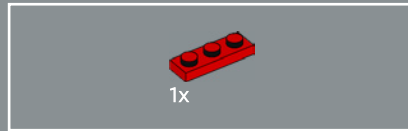
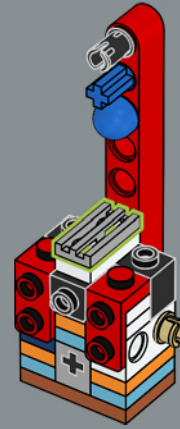

40

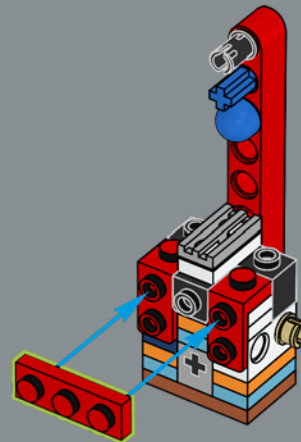

3x

41

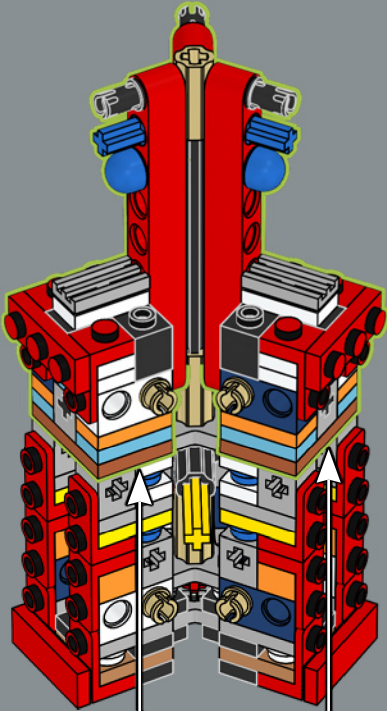

42

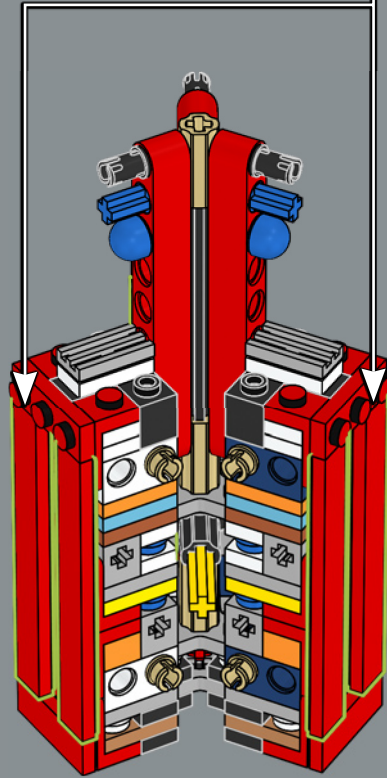
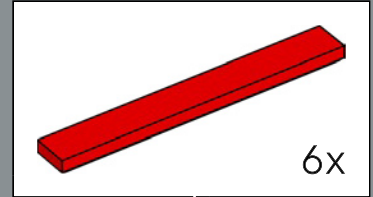
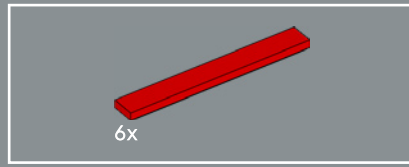



2

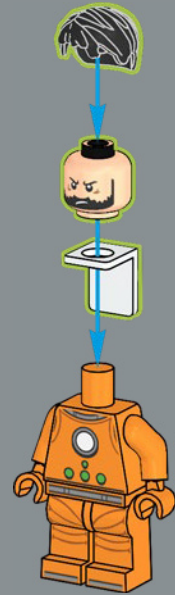

3

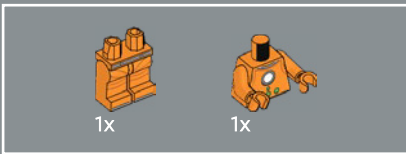
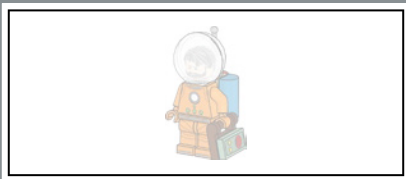
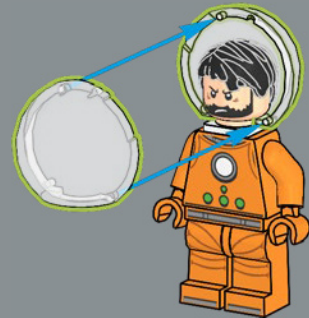

1

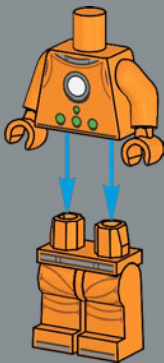



4

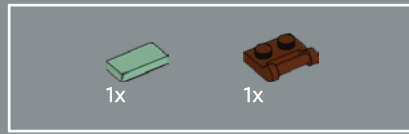
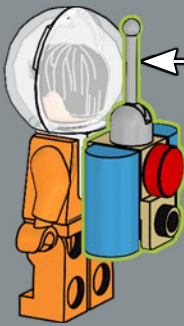
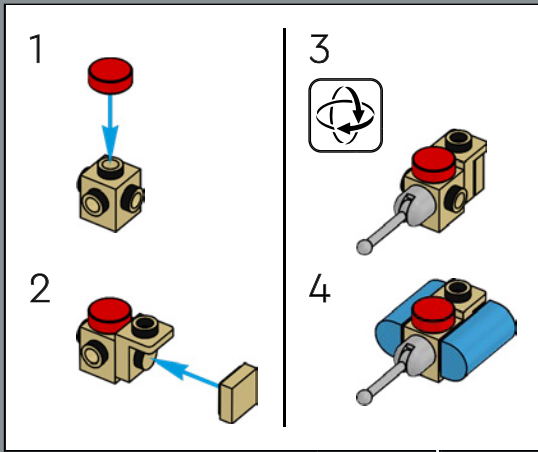

5

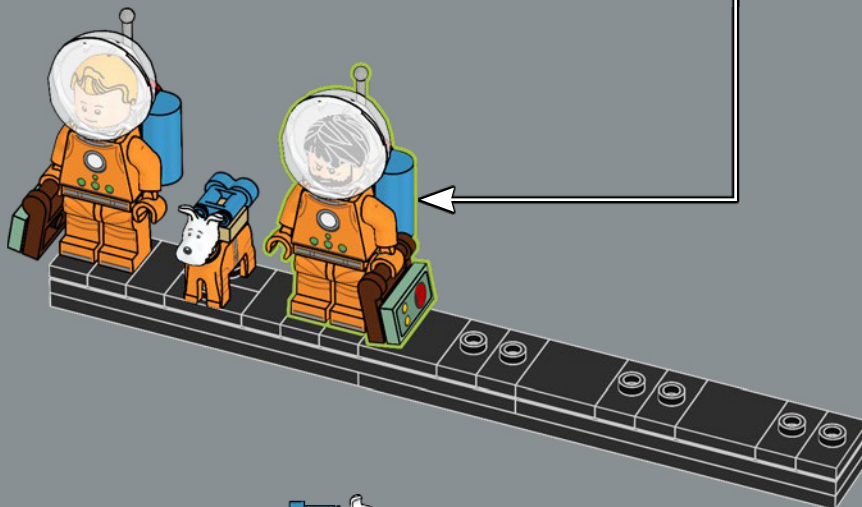
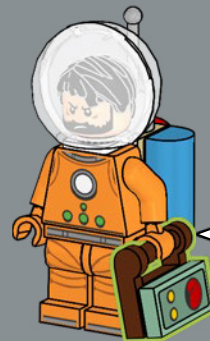
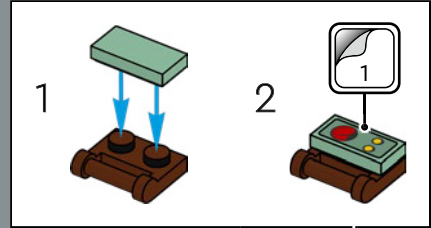

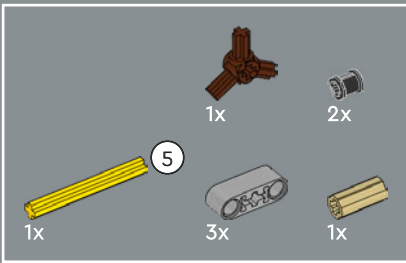

43

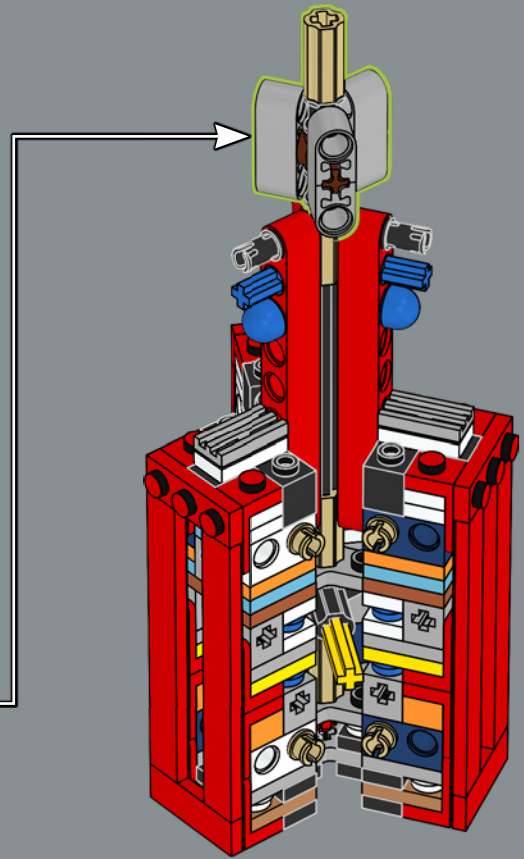
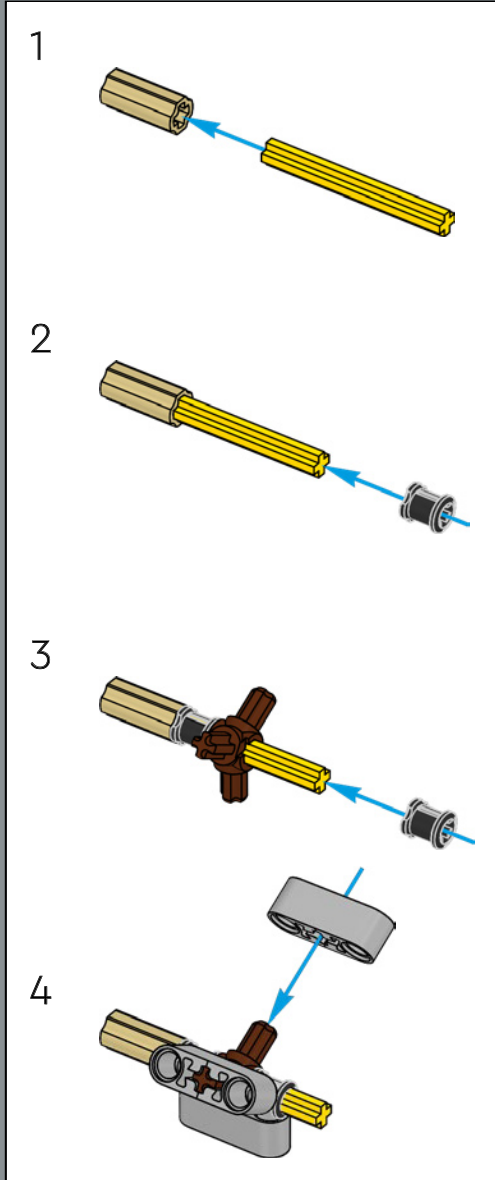
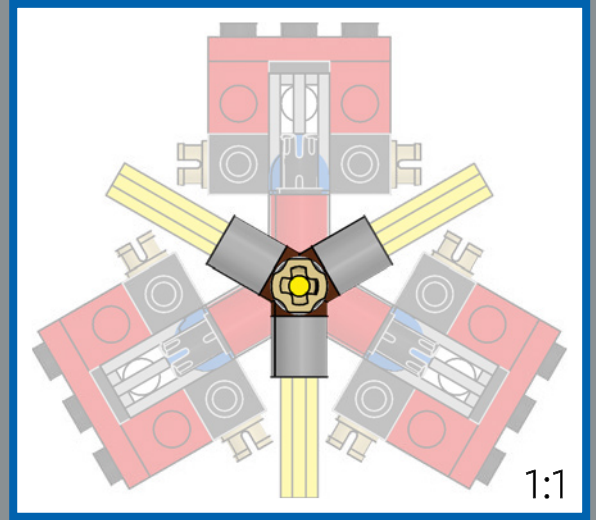

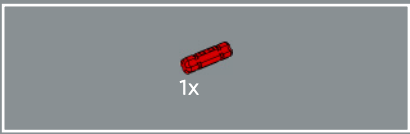

44

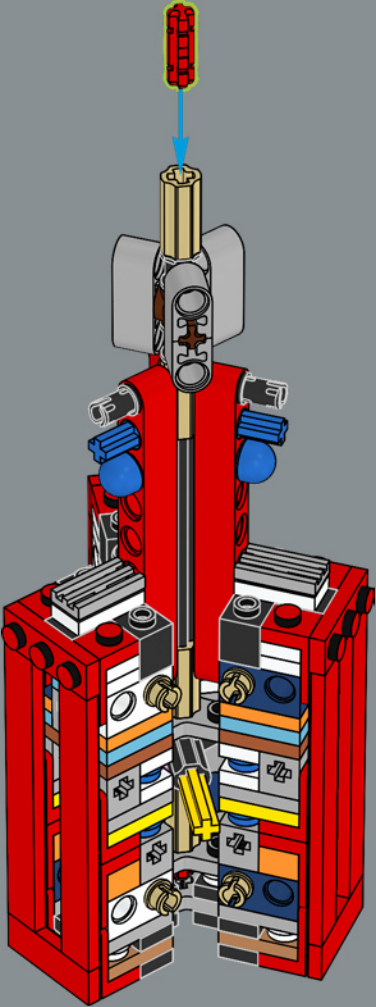

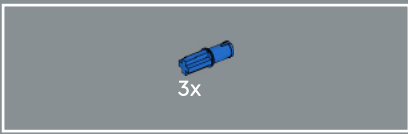

45

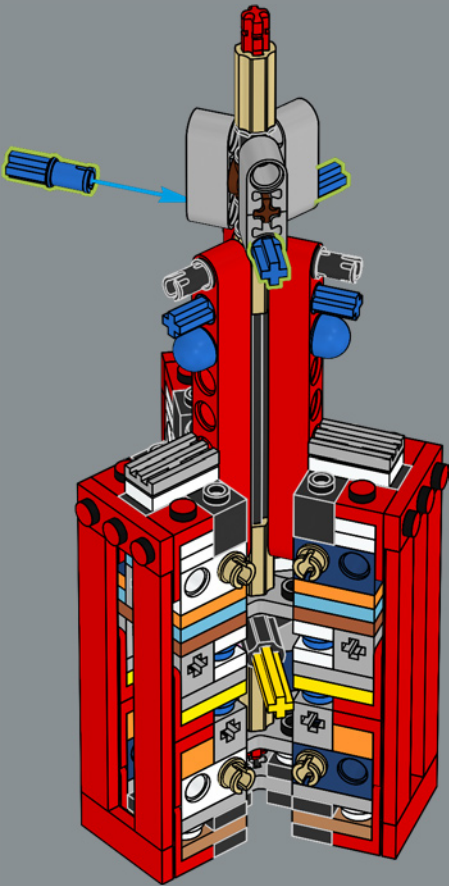

46

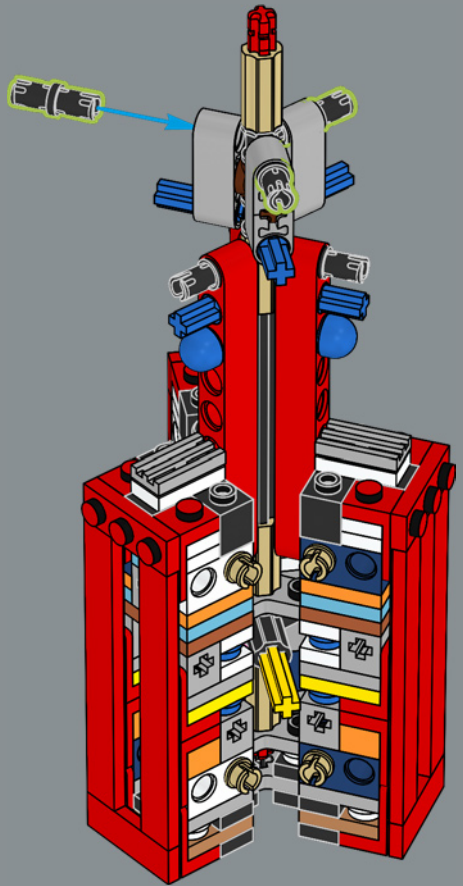

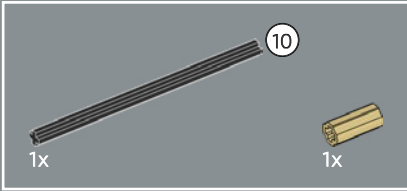
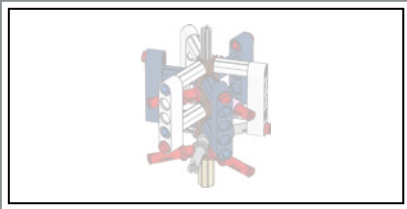

47

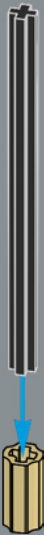

48

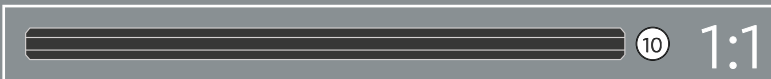
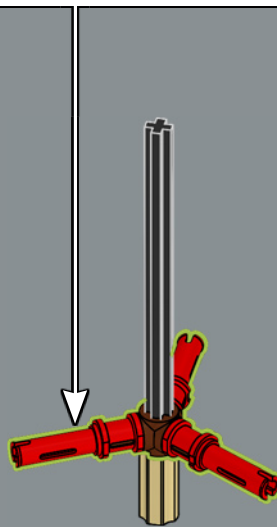
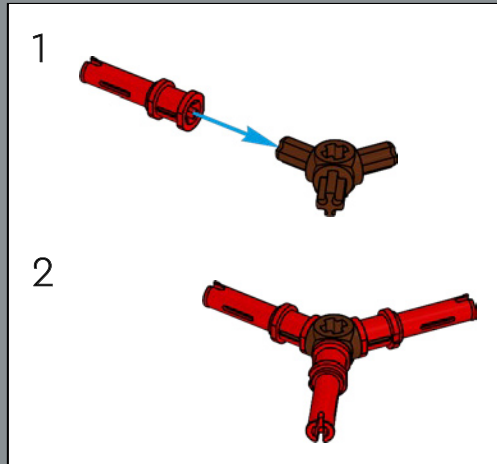

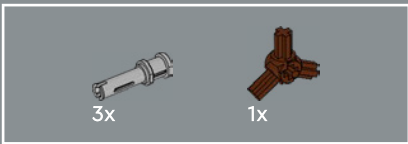

49

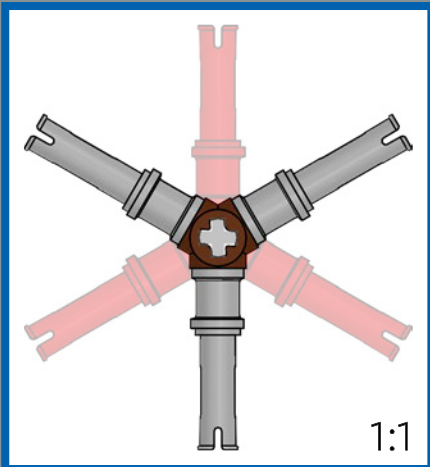
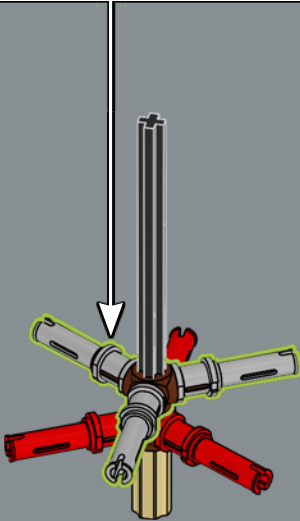
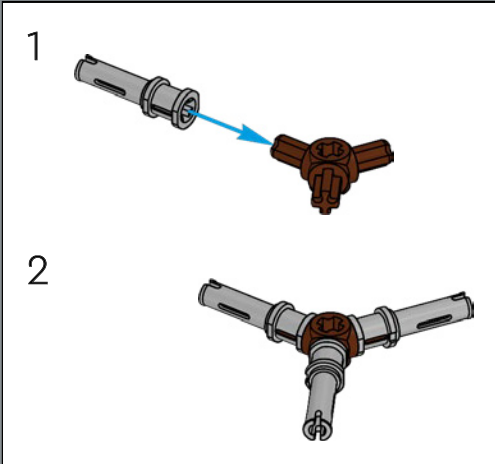

50

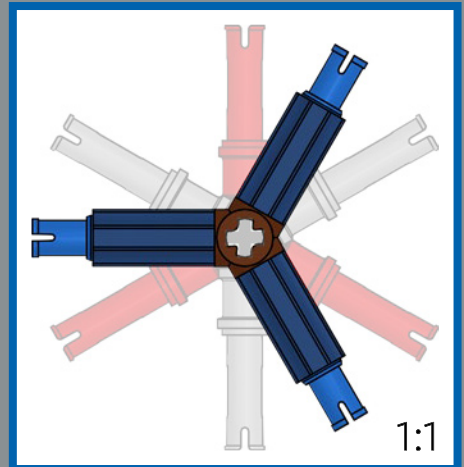
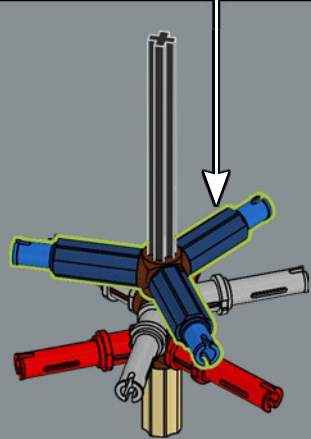
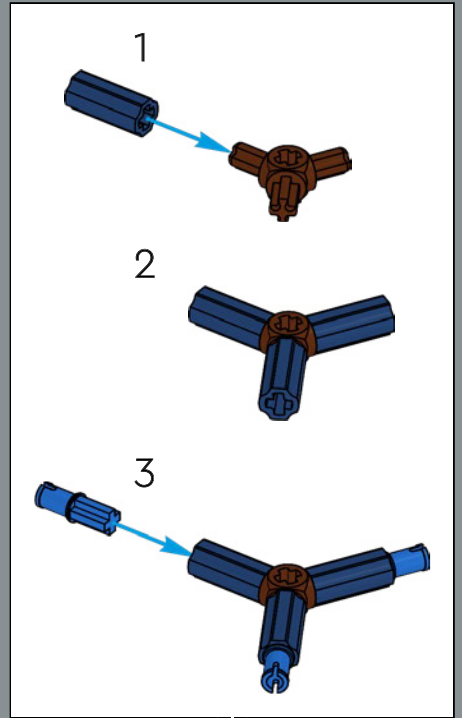

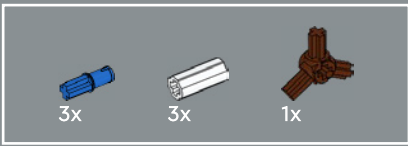

51

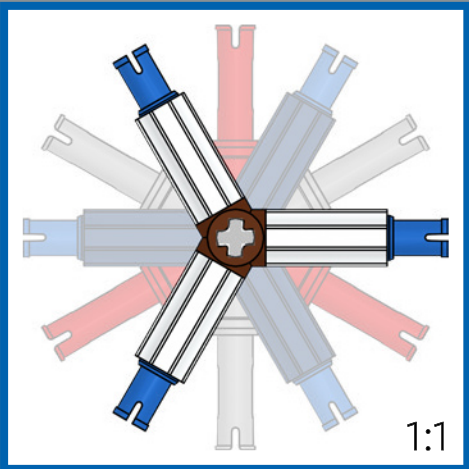
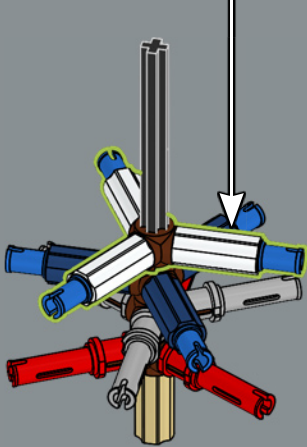
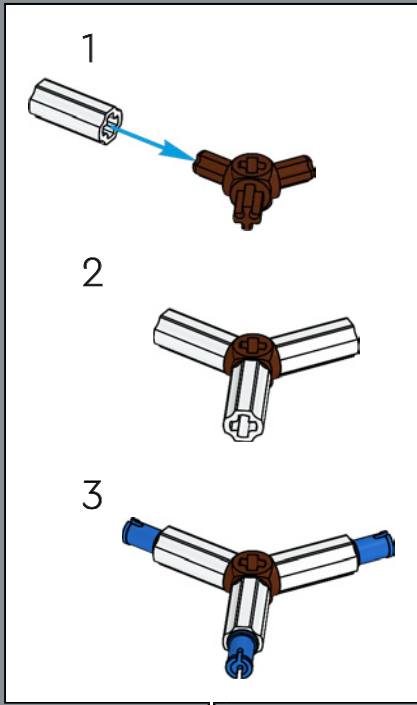

1:1

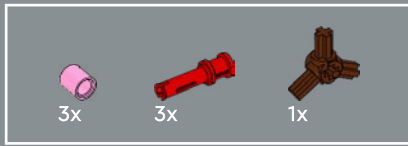

52

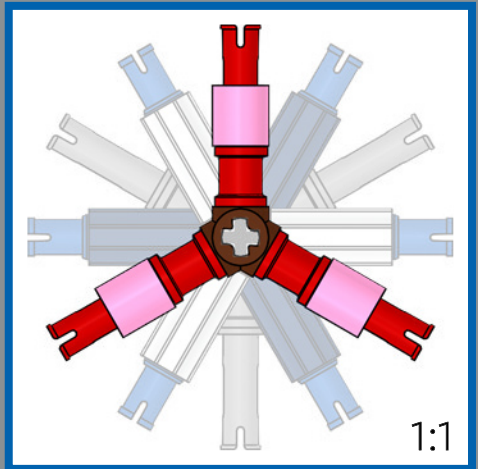
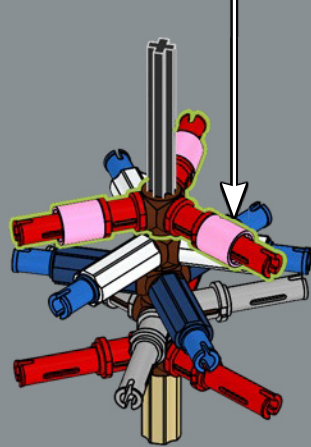
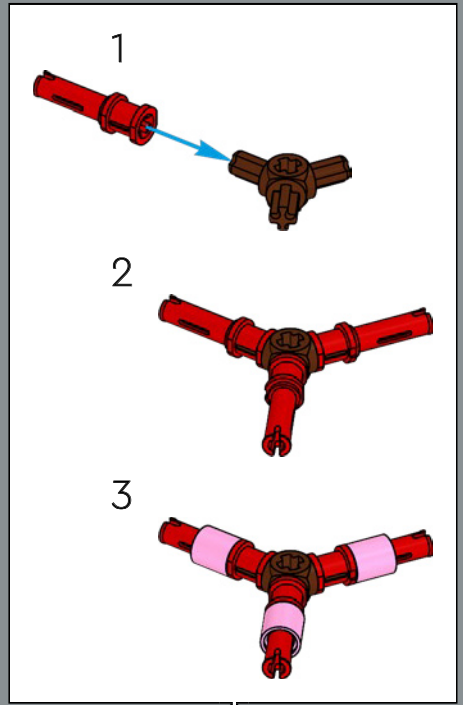

1:1



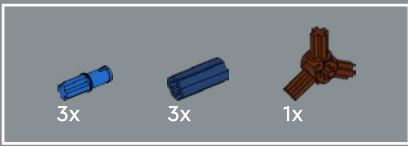

53

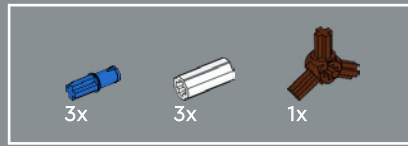
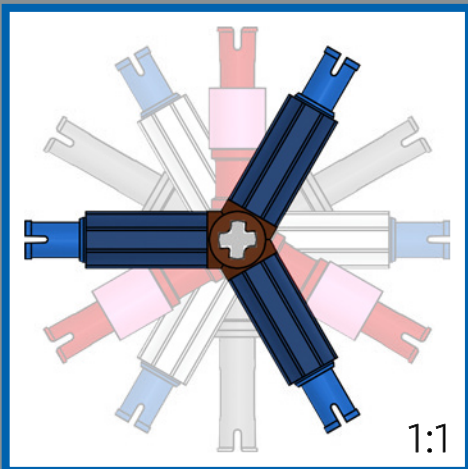
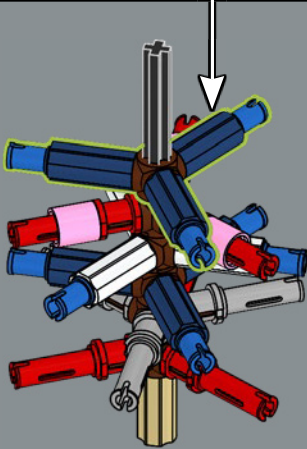
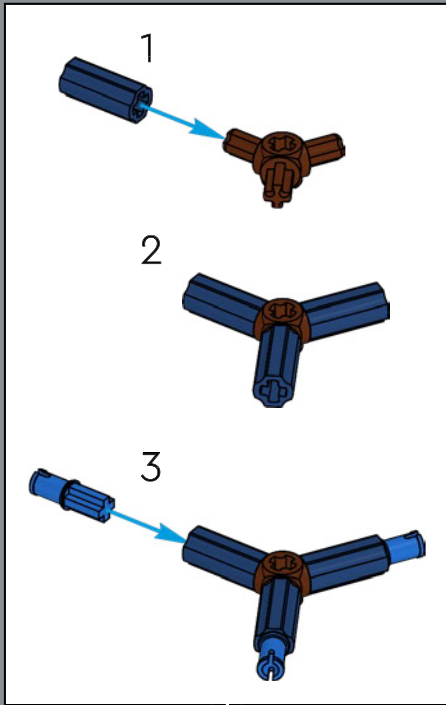

54

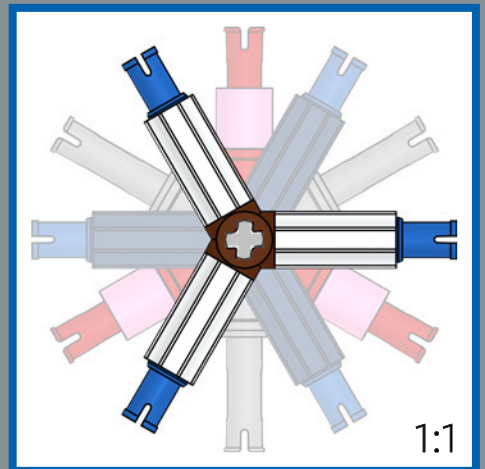
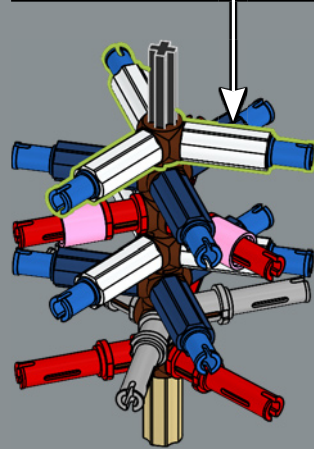
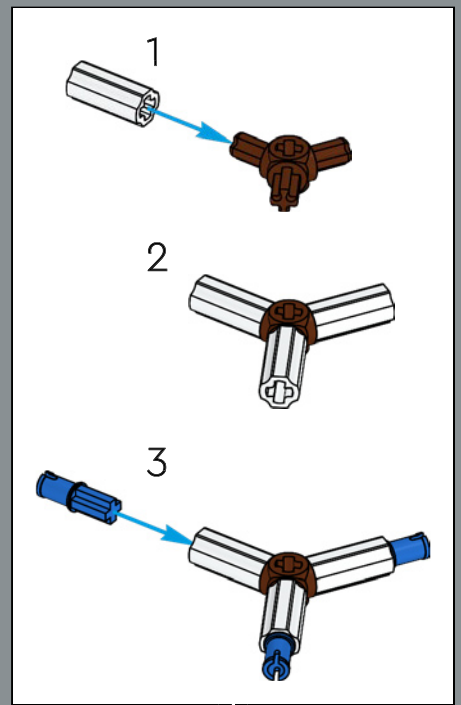

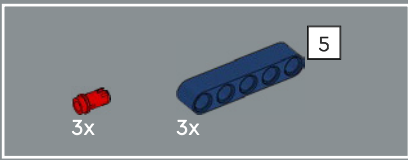

55

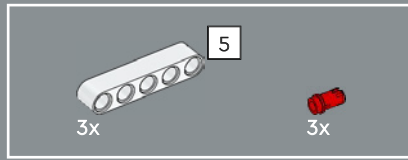
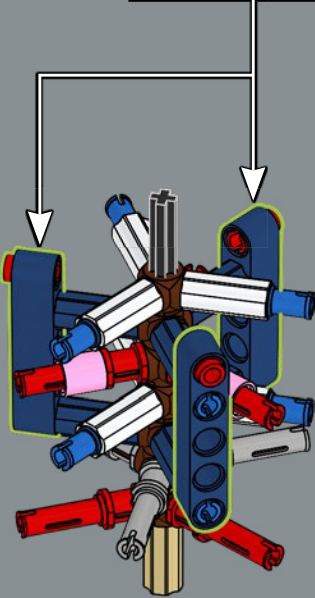
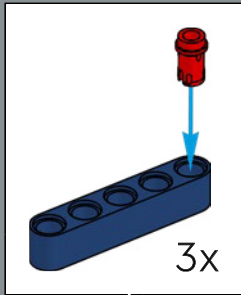

56

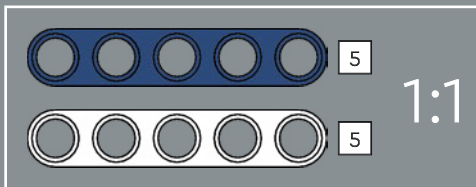
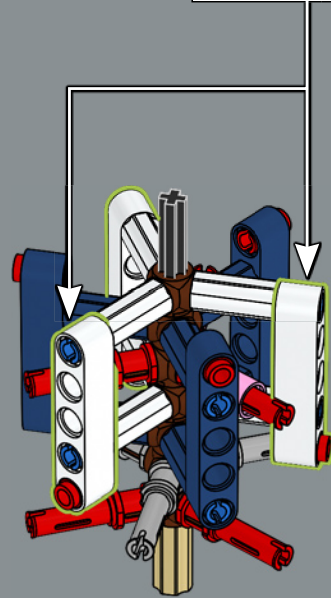
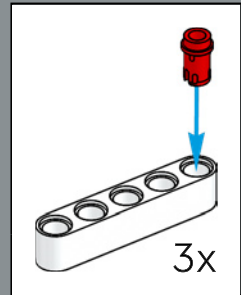

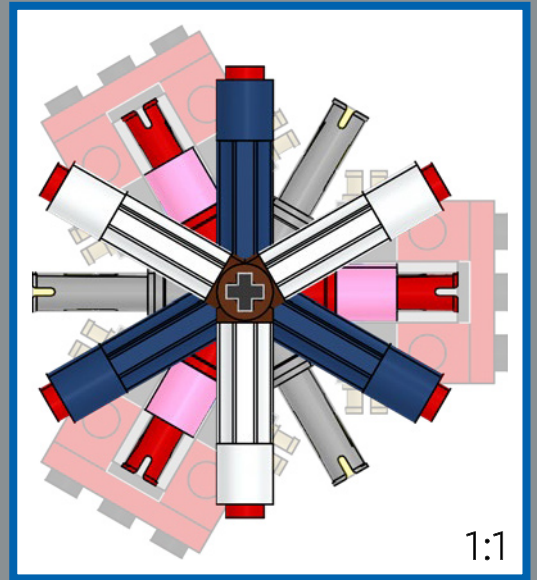
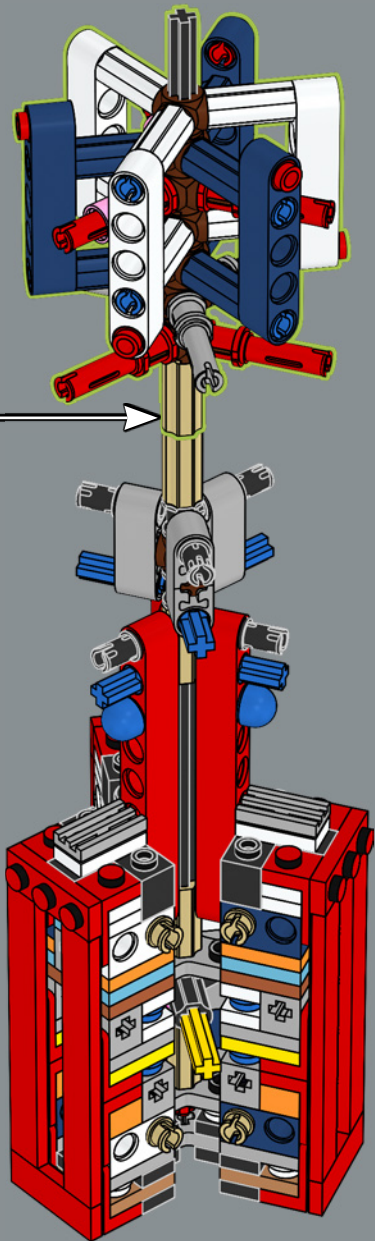

1:1

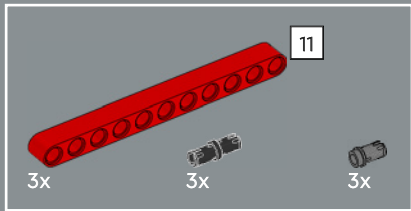

58

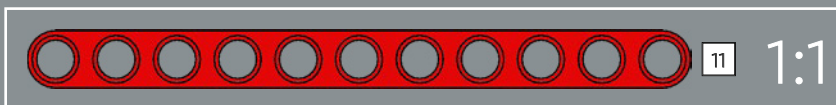
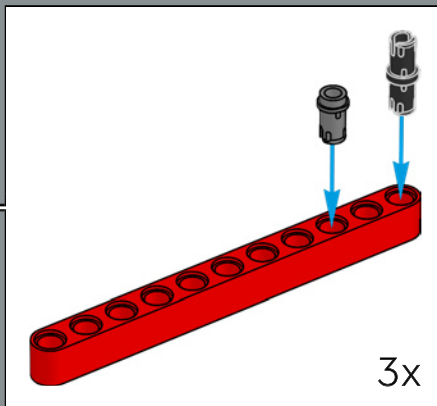
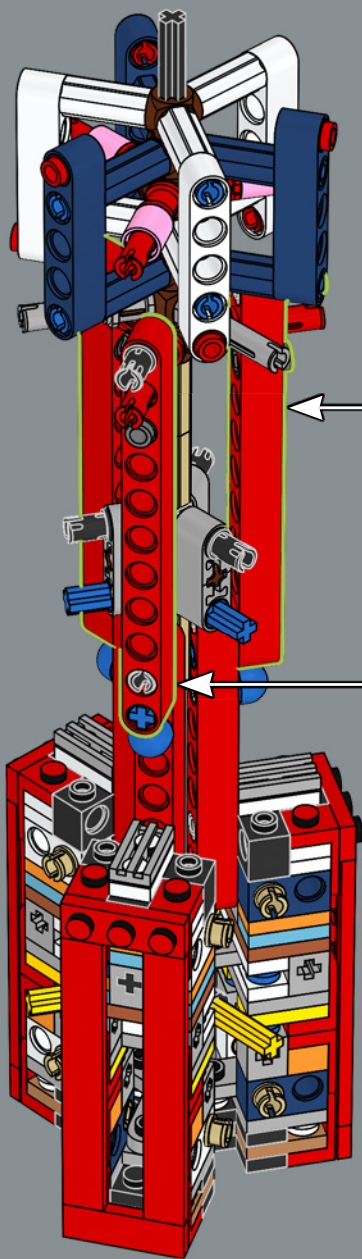

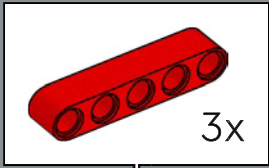
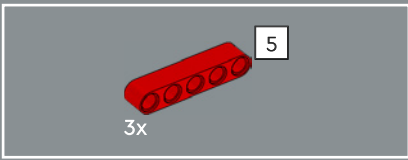

59

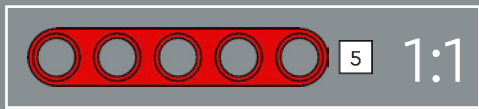
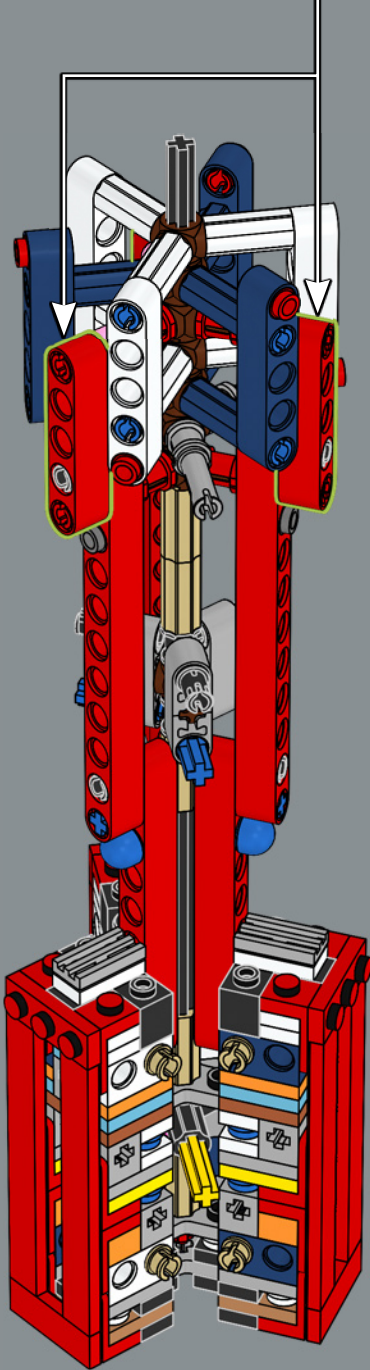

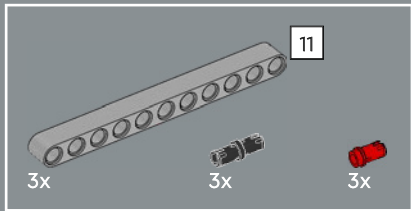

60

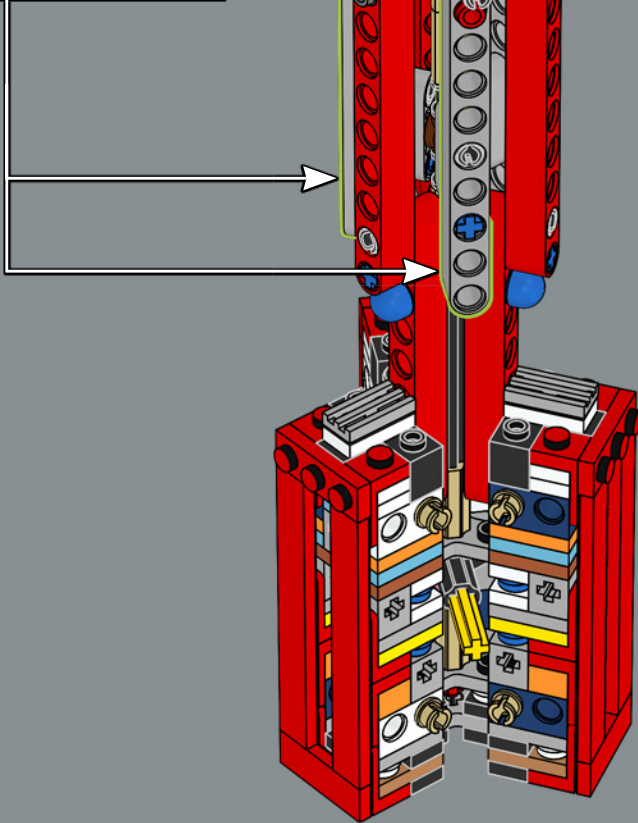
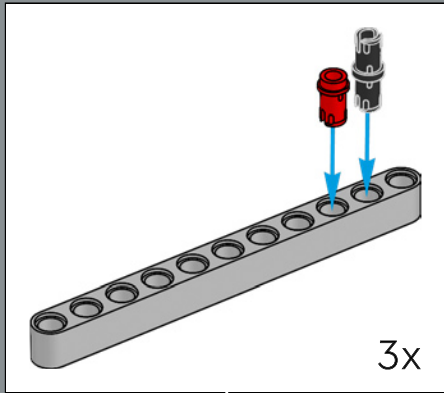



61

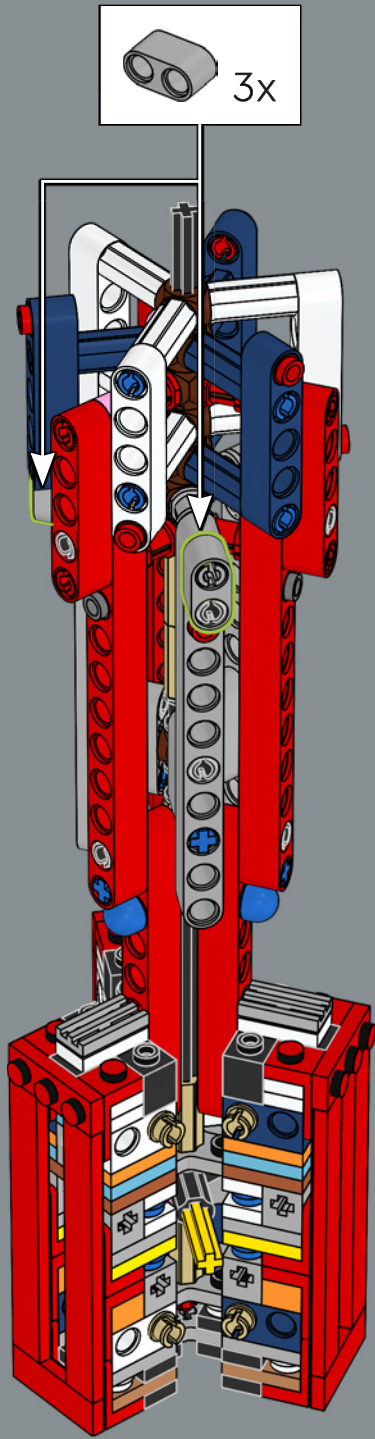

62

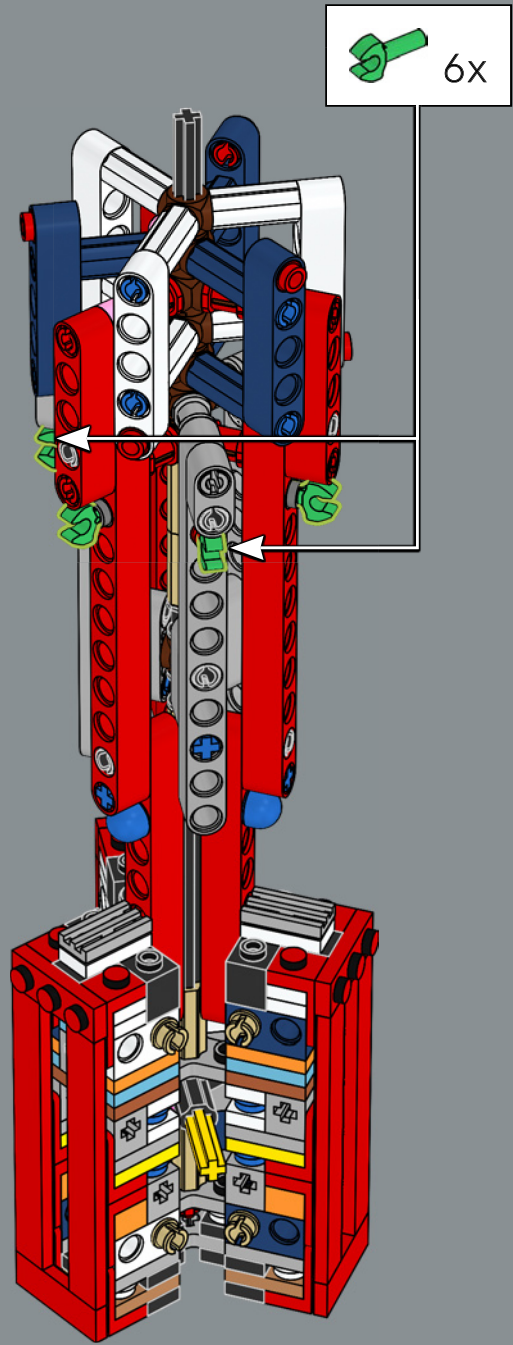



63

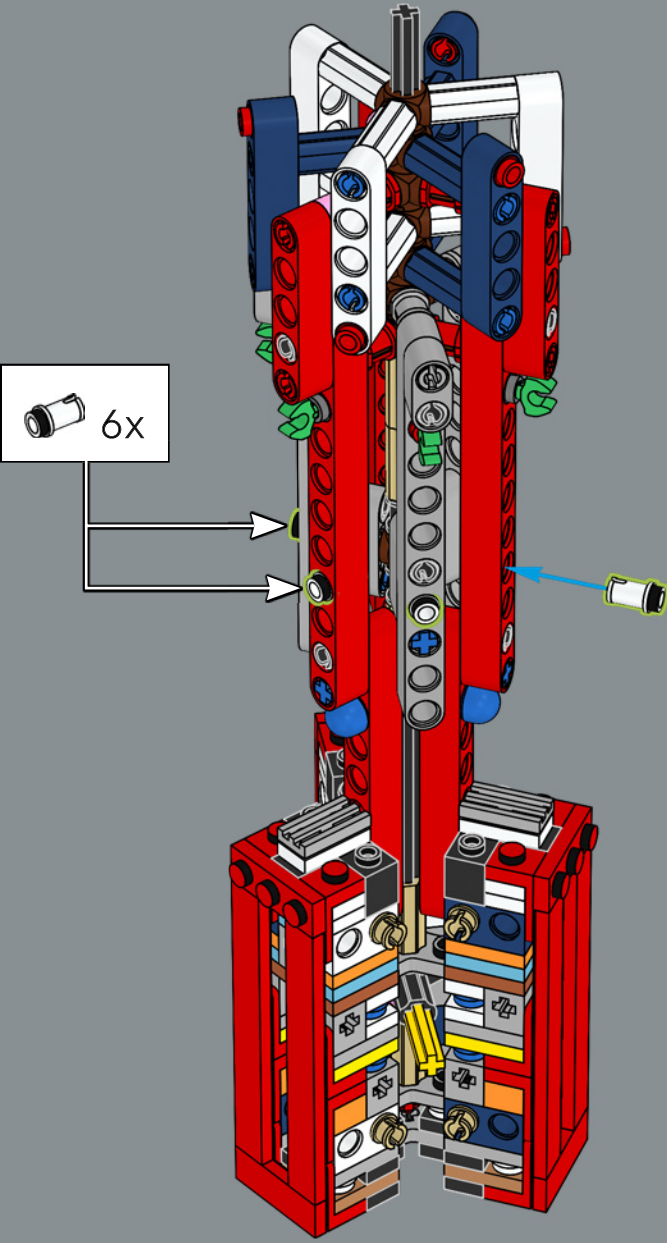



65

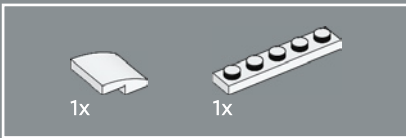
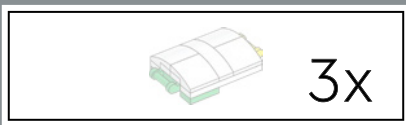
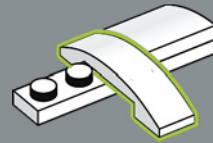

64

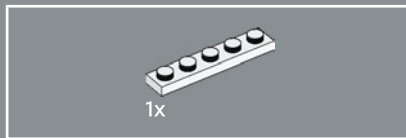
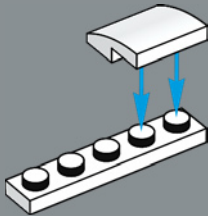

66

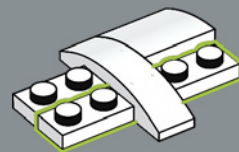



67

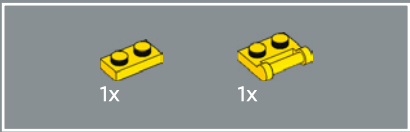
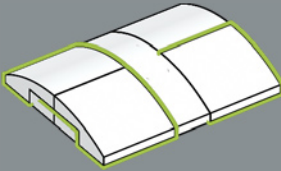

68

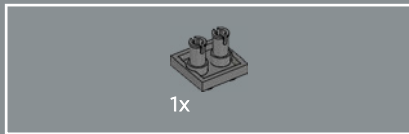
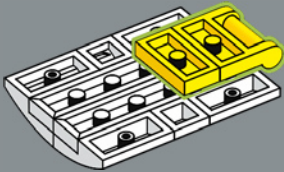

69

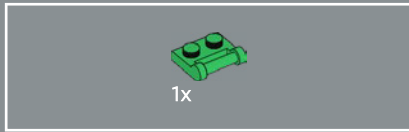
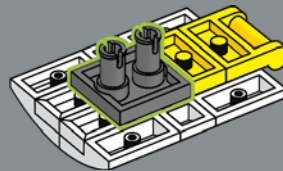

70

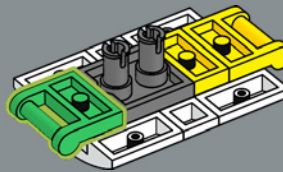

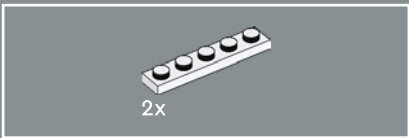

71

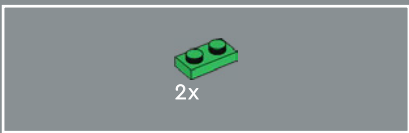
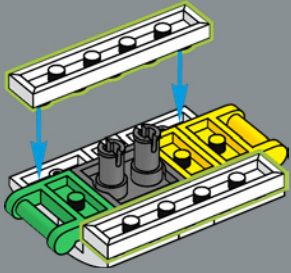

72

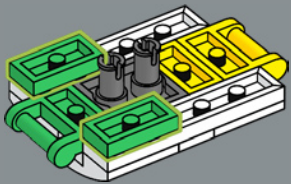

3x

73

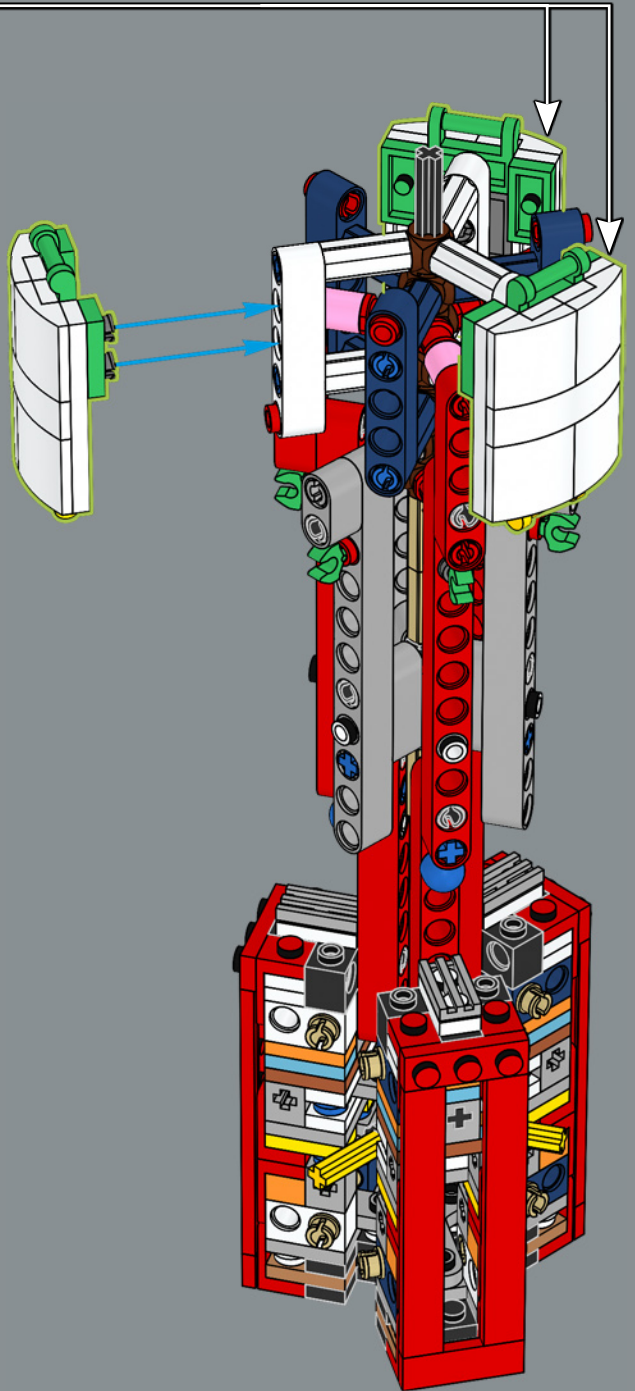

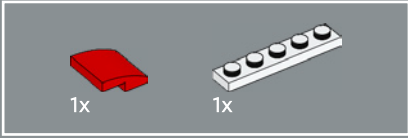
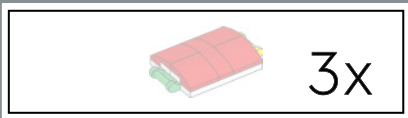

74

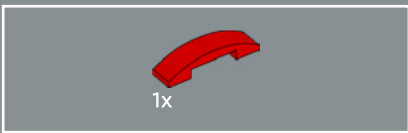
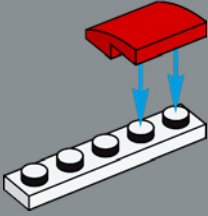

75

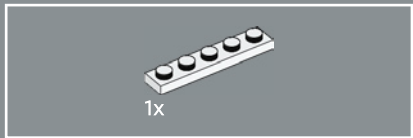
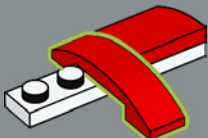

76

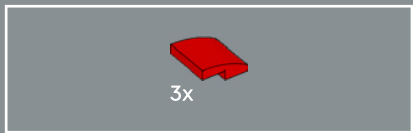
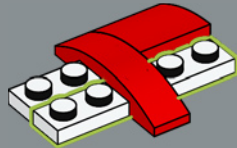

77

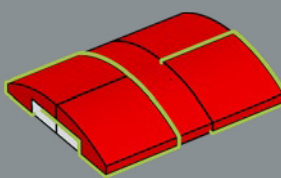

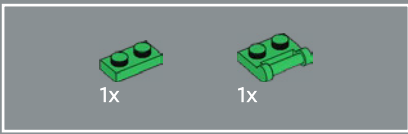

78

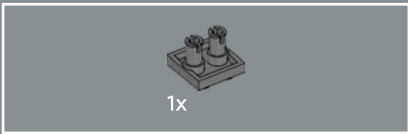
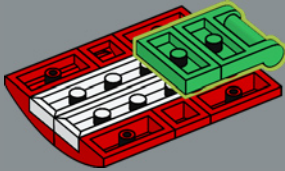

79

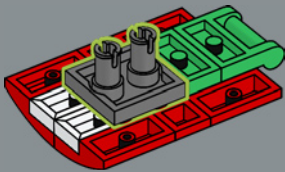

80

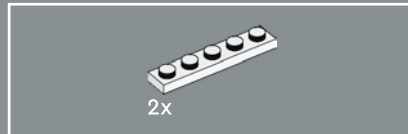
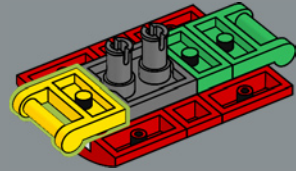

81

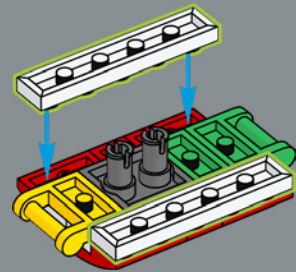

3x

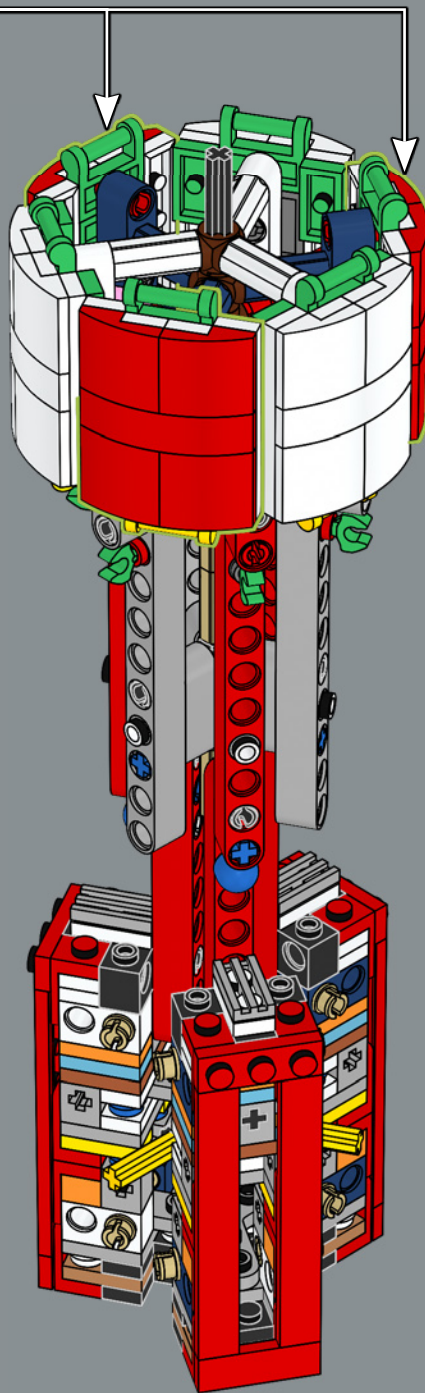



1x



1x



1x

2

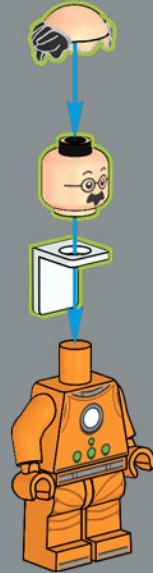

1x



1x

1

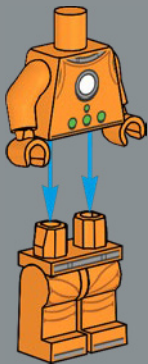

2x

3

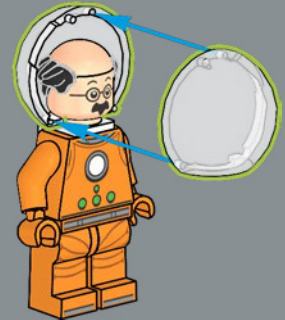



4

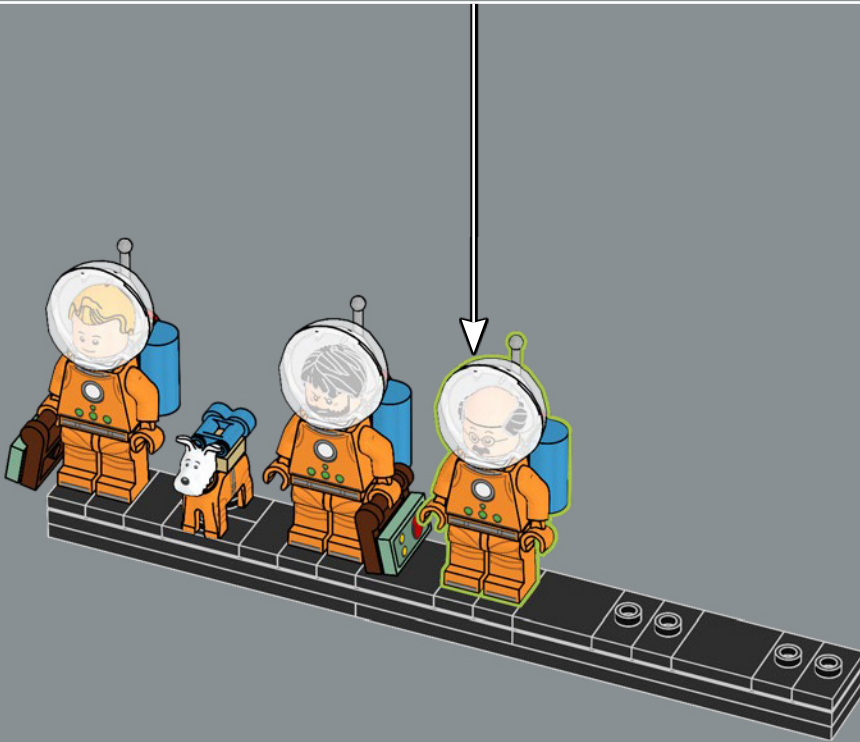
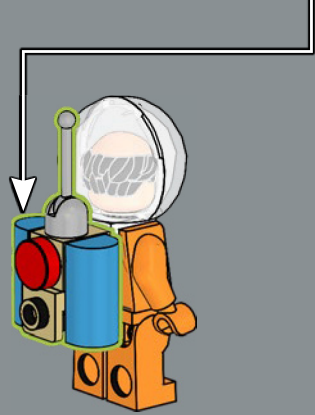
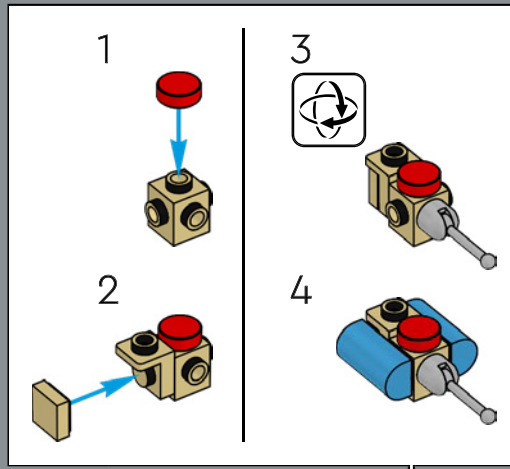

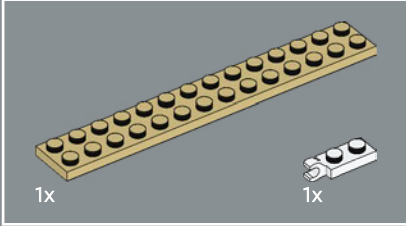
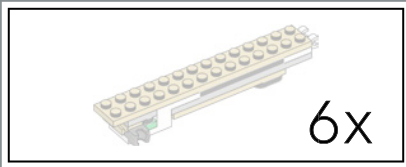

83

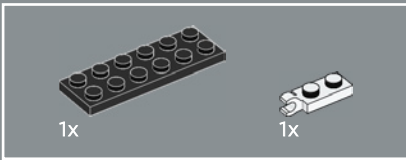
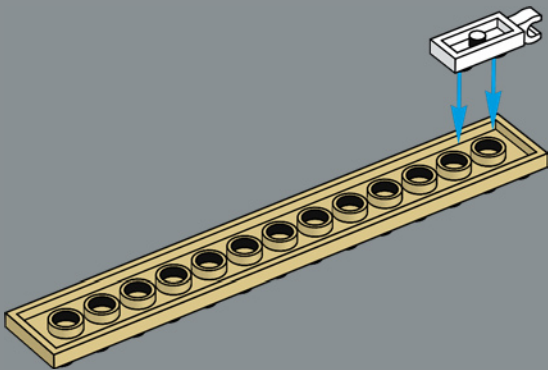

84

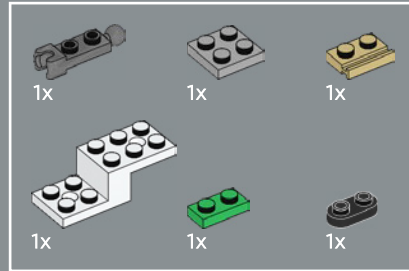
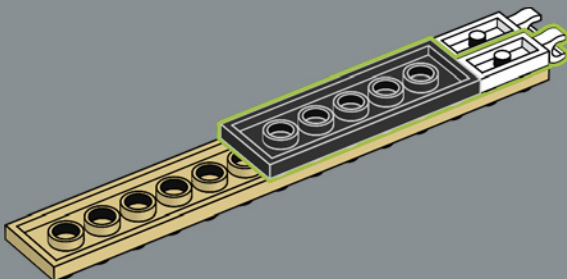

85

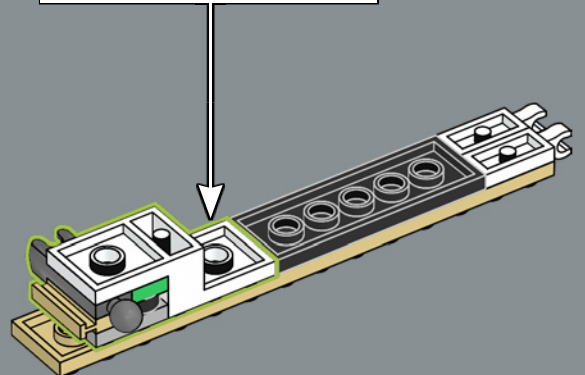
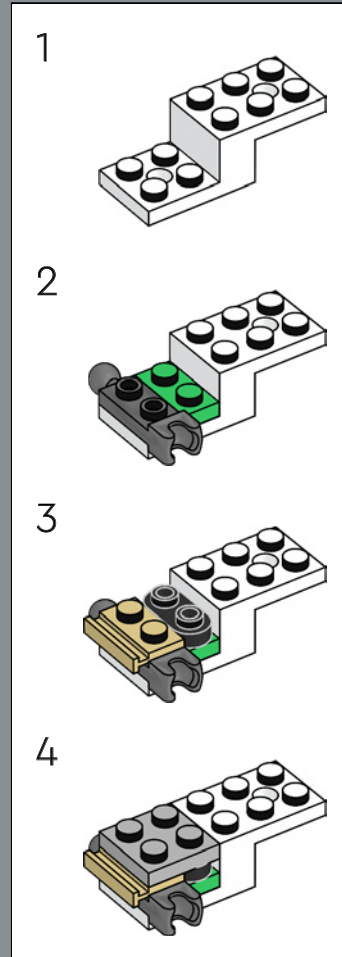

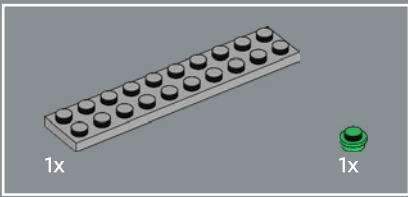

86

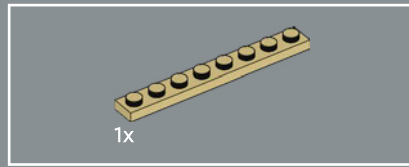
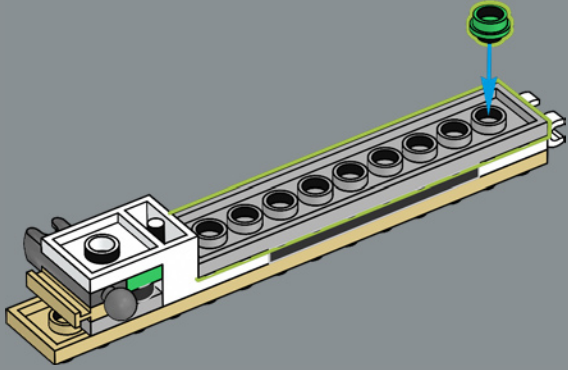

88

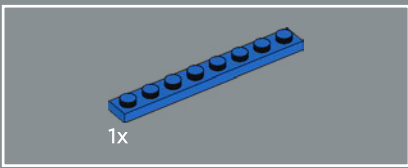
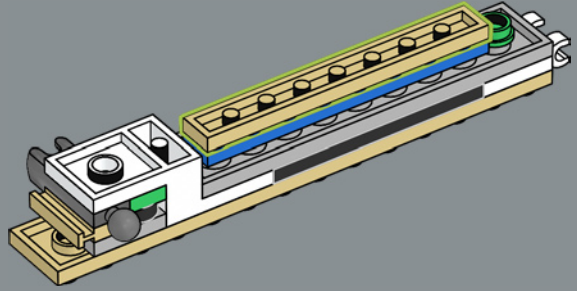

87

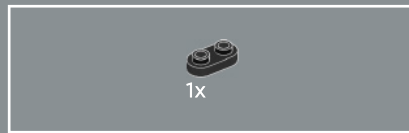
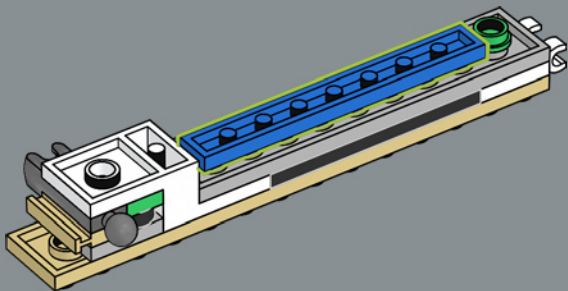

89

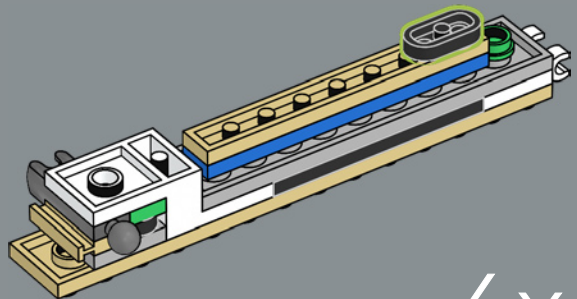

6x



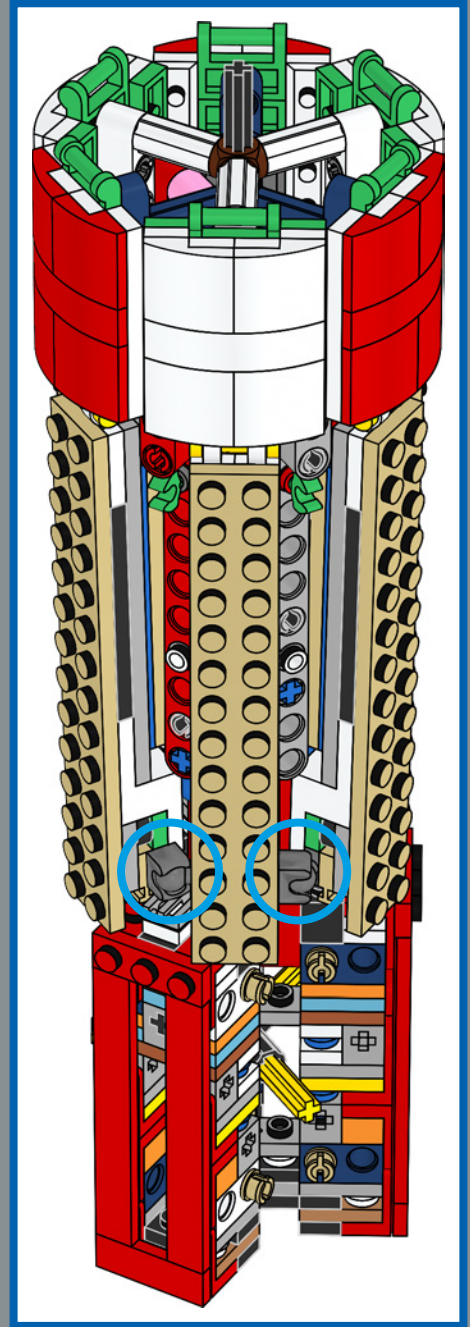
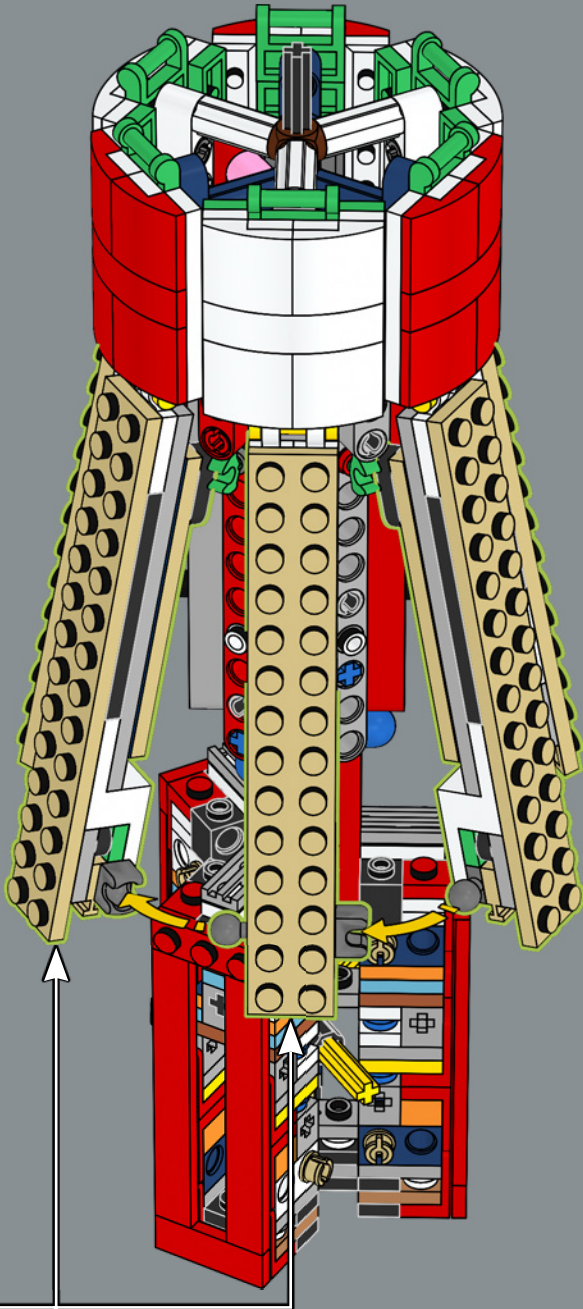

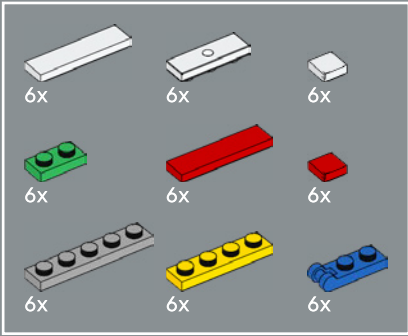
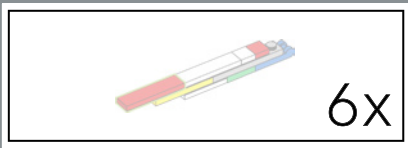

91

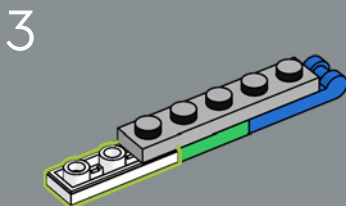
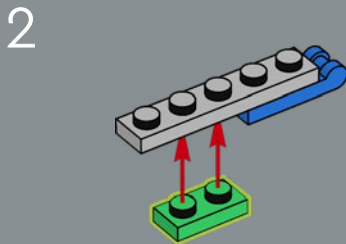
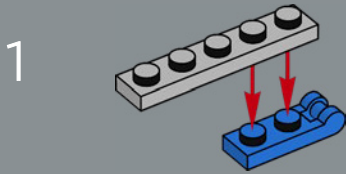

4

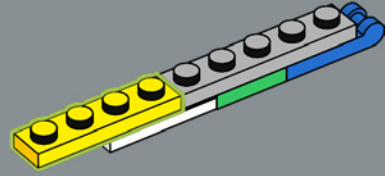

5

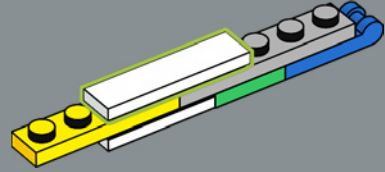

6

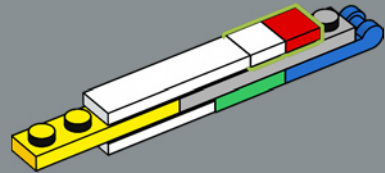

7

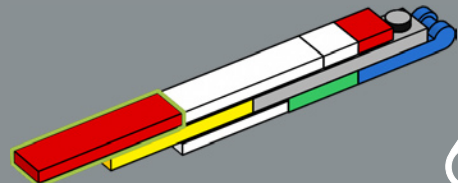

6x



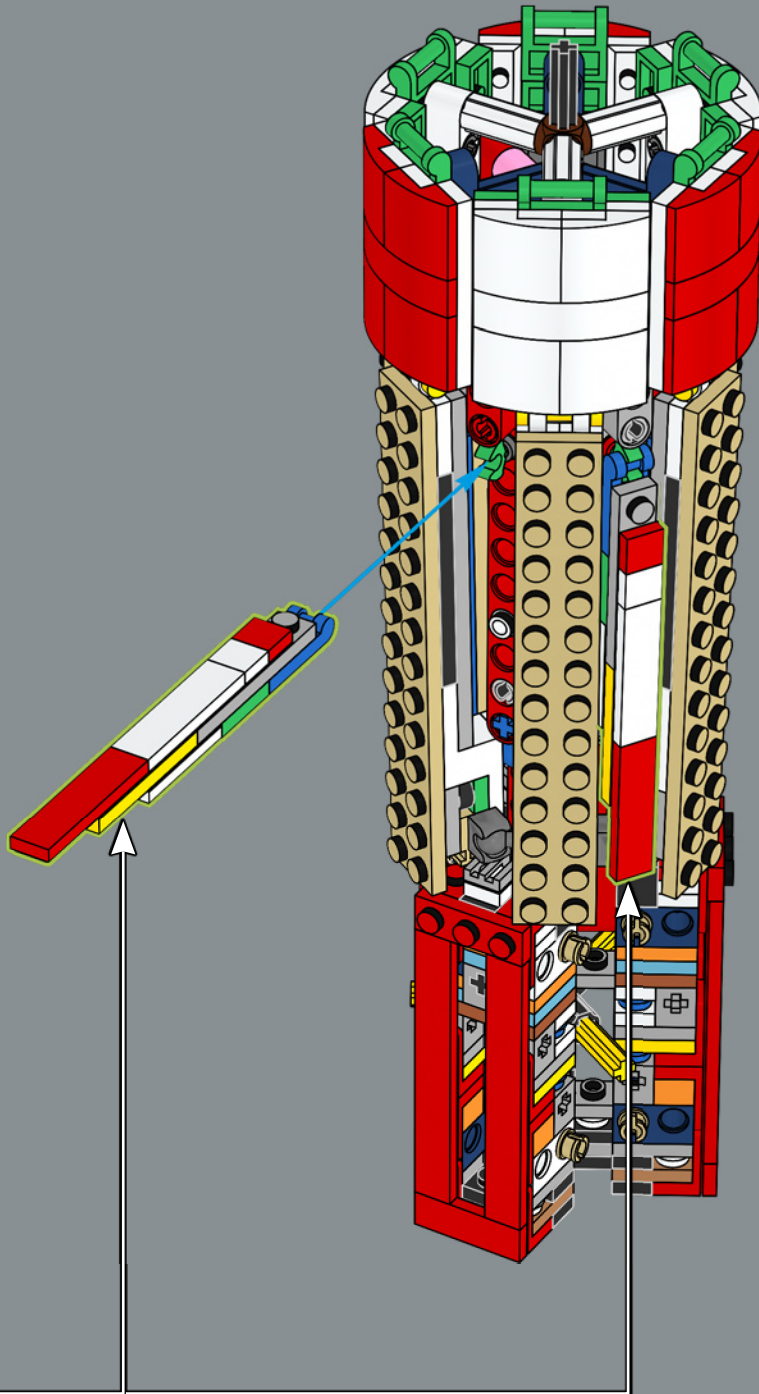

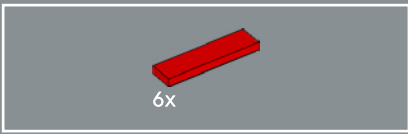

92

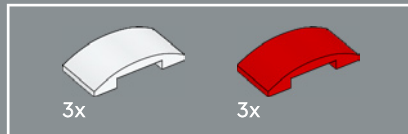
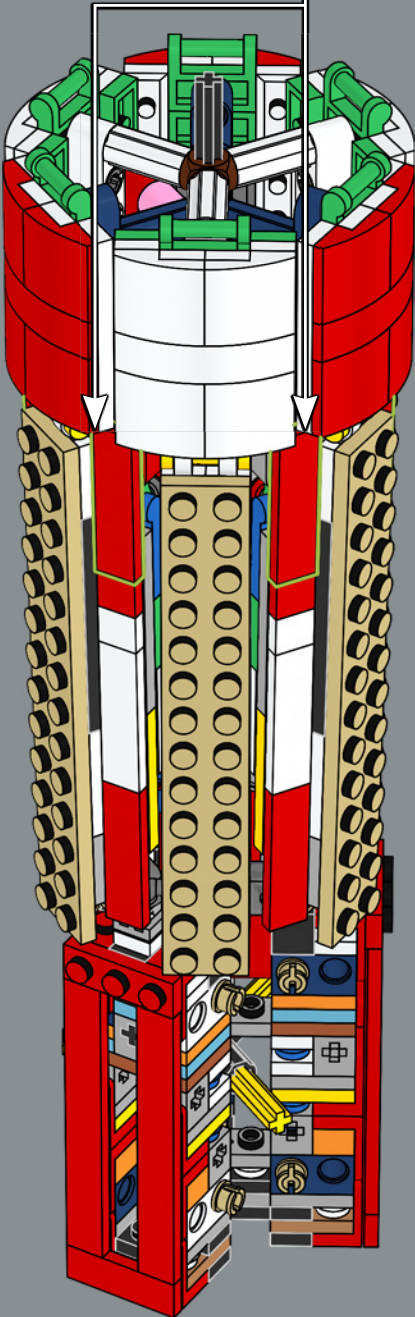
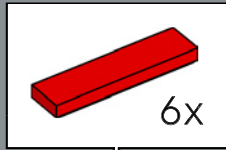

93

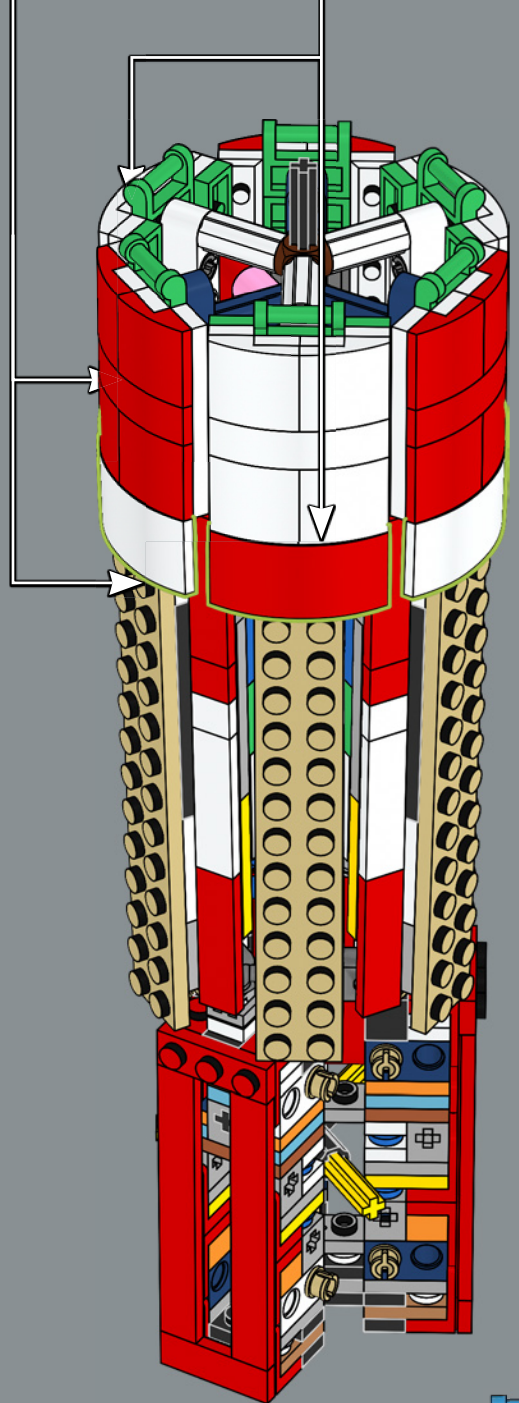
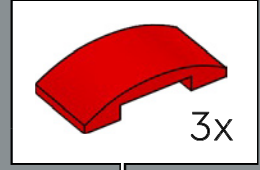
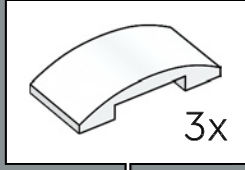

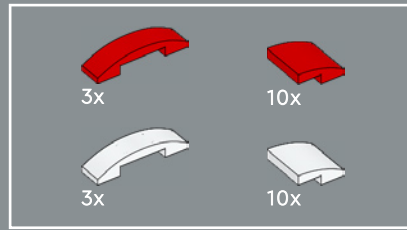

94

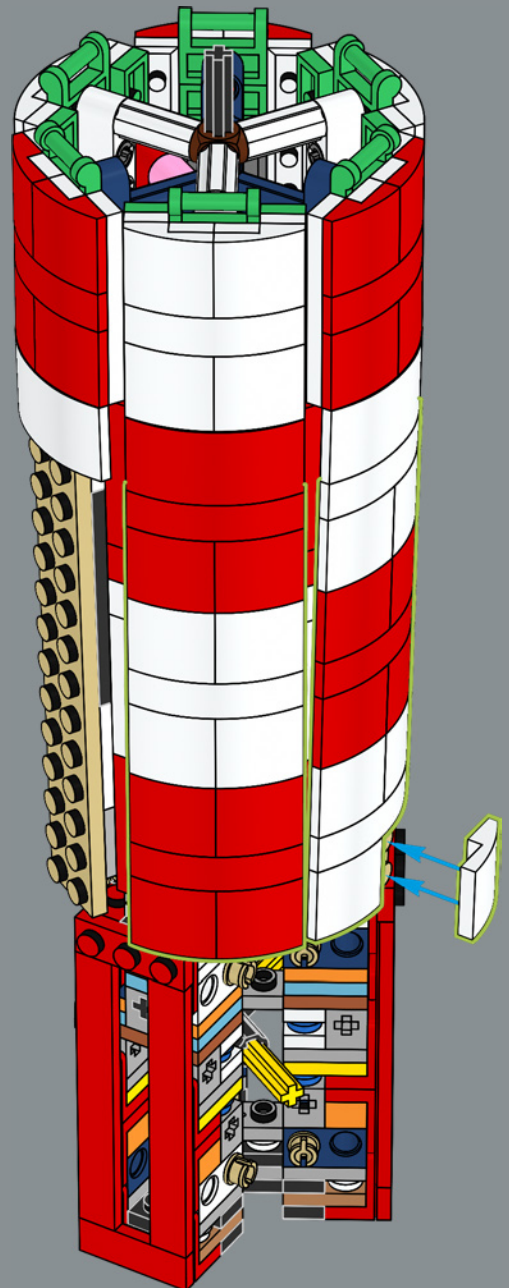

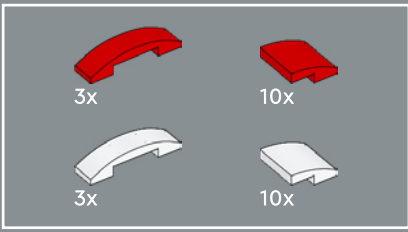

95

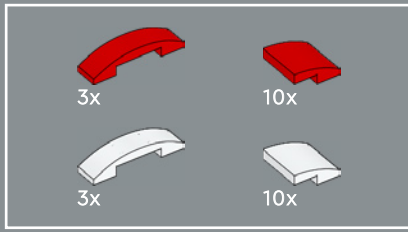
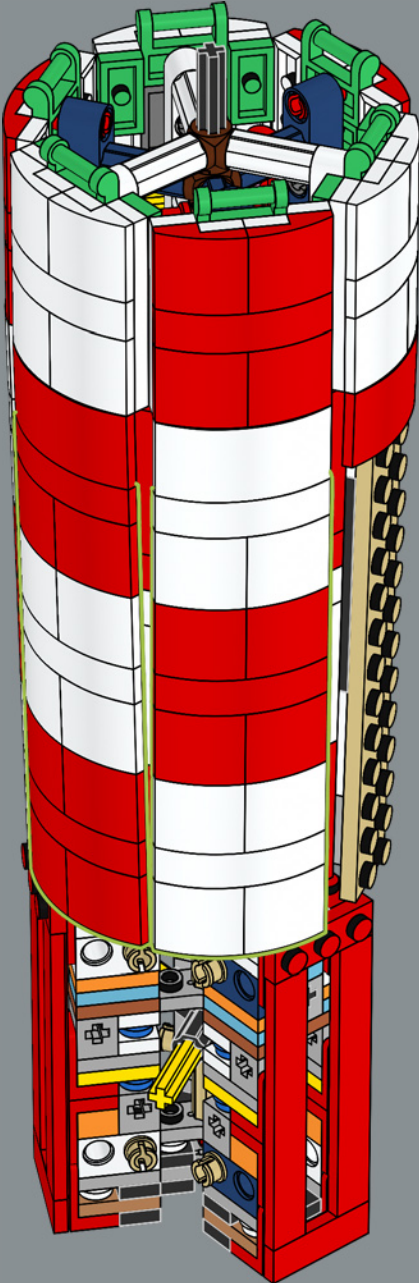

96

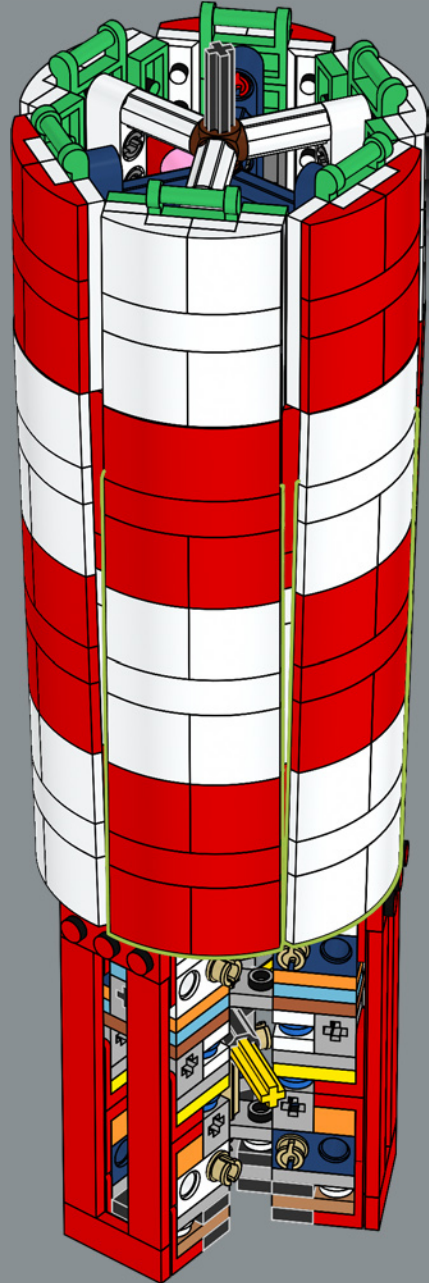





97

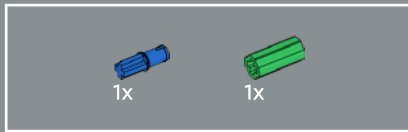
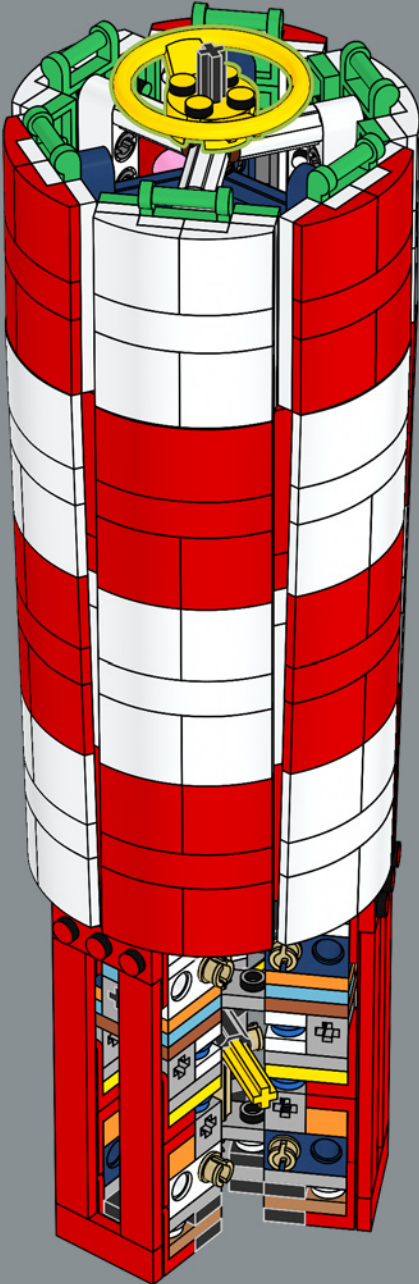

98

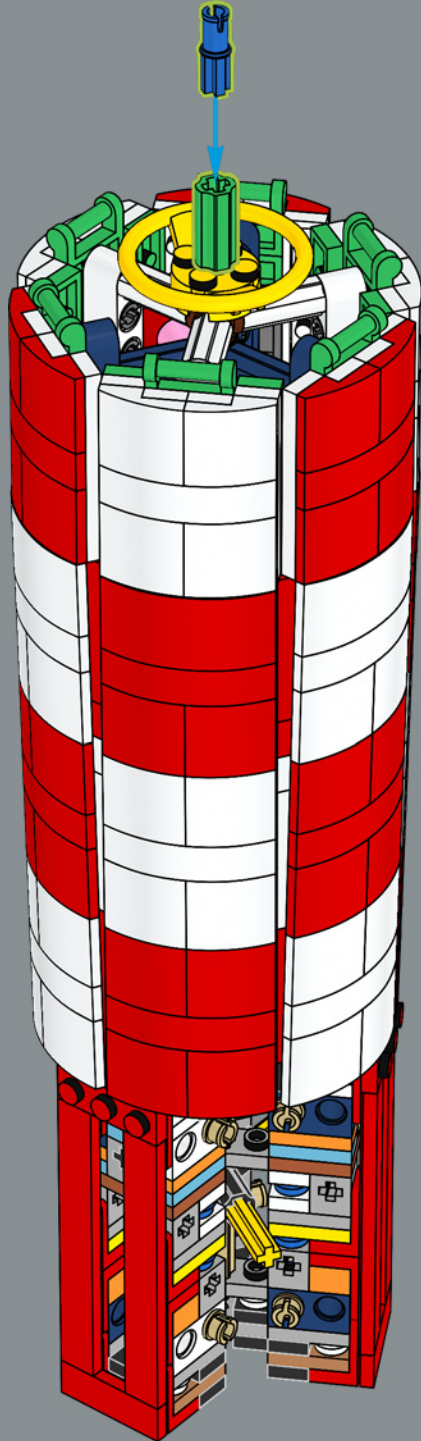

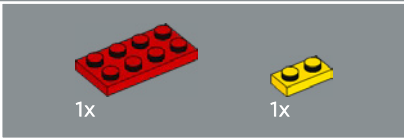
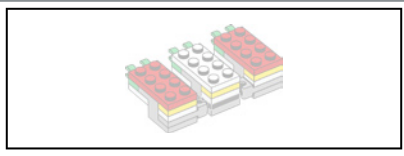

99

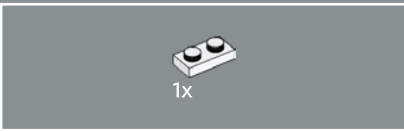
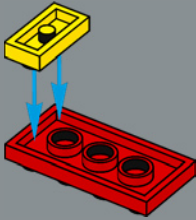

100

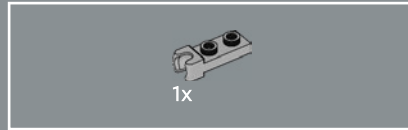
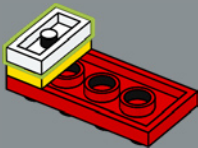

101

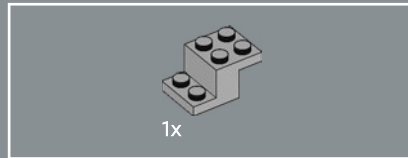
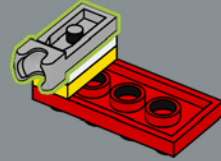

102

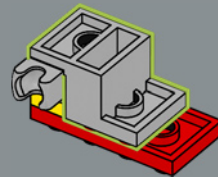

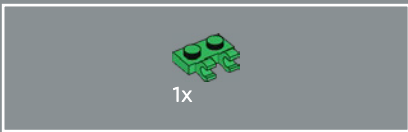

103

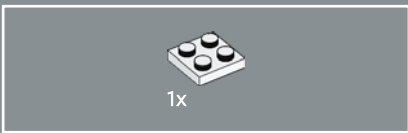
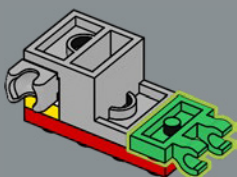

104

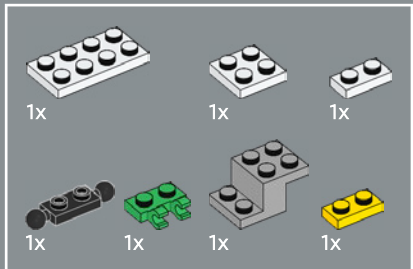
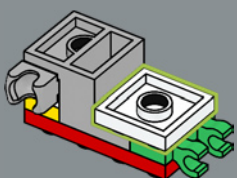

105

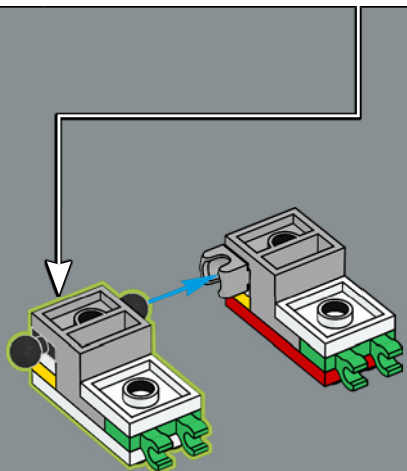
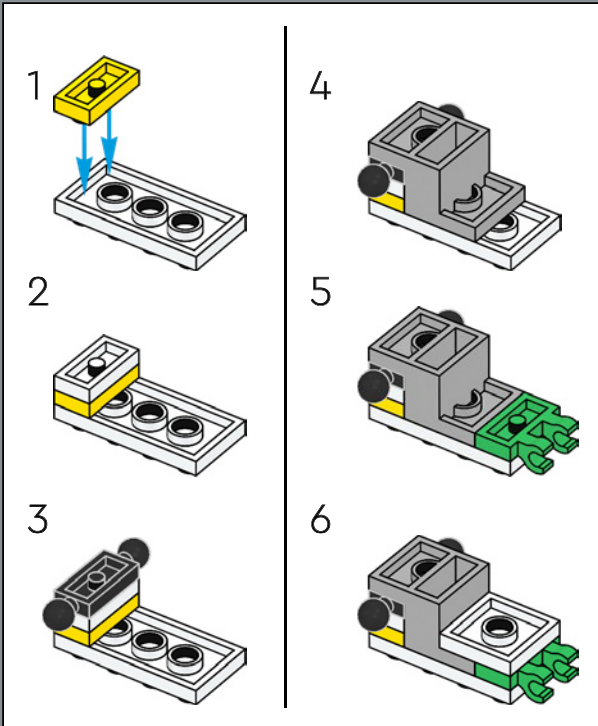

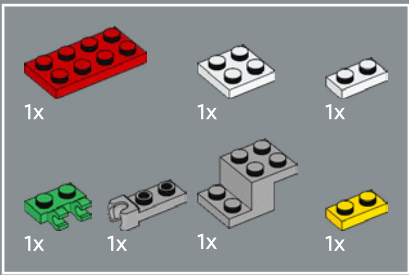

106

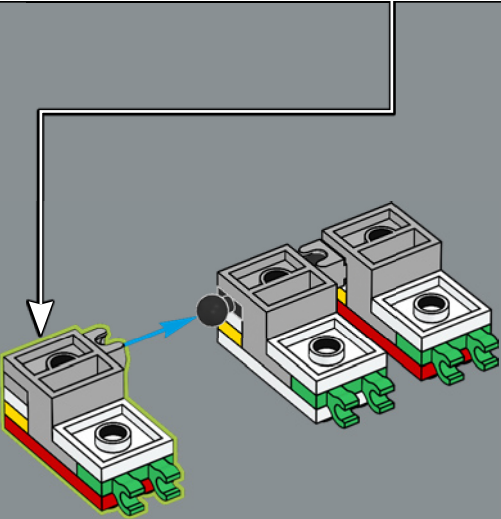
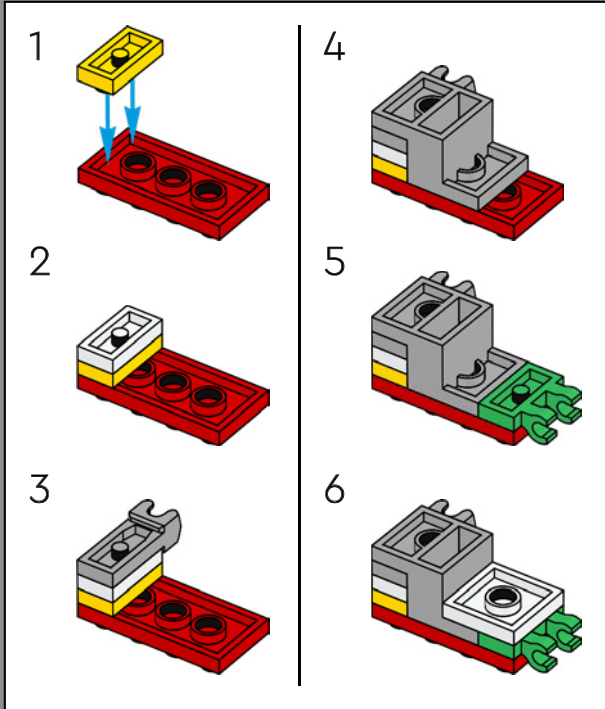

107

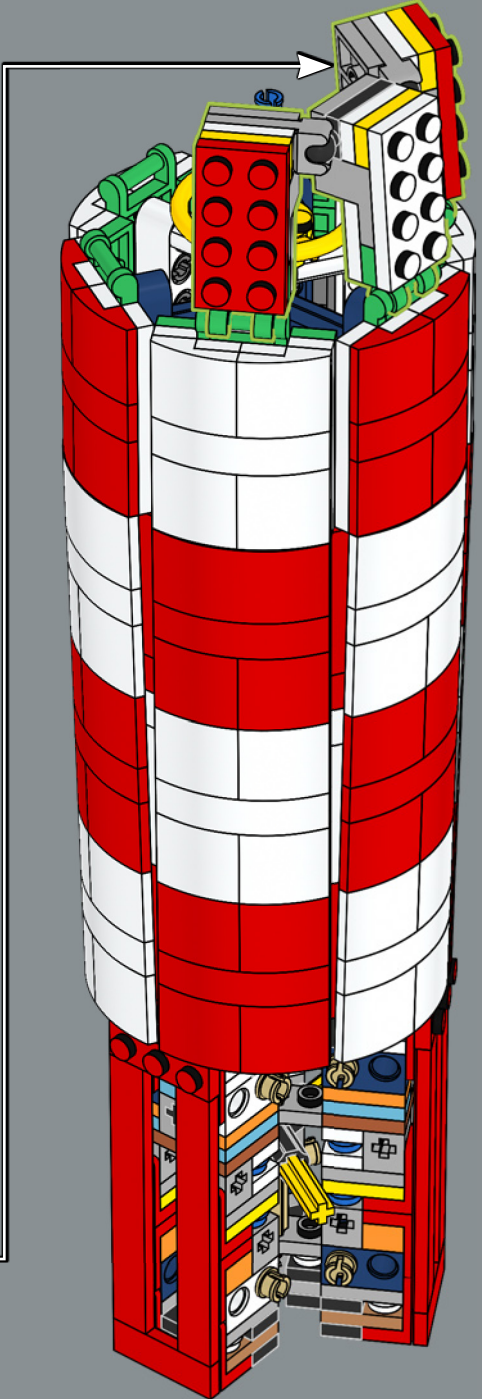

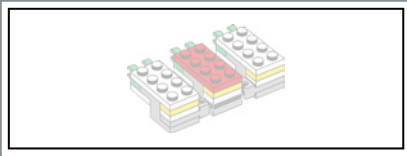

108

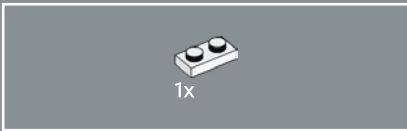
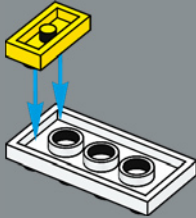

109

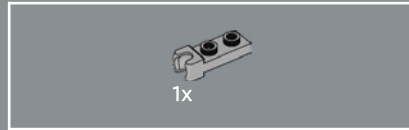

110

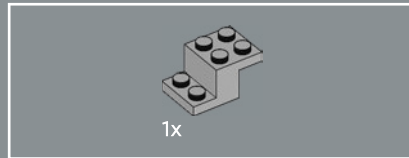
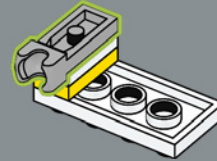

111

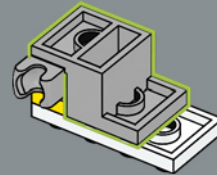

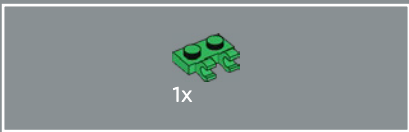

112

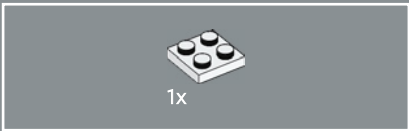
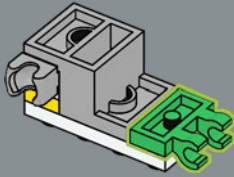

113

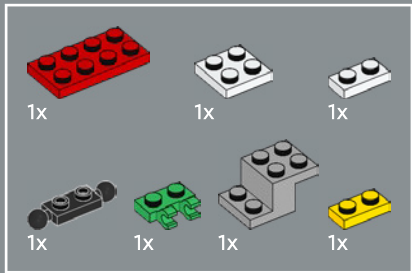
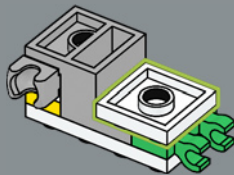

114

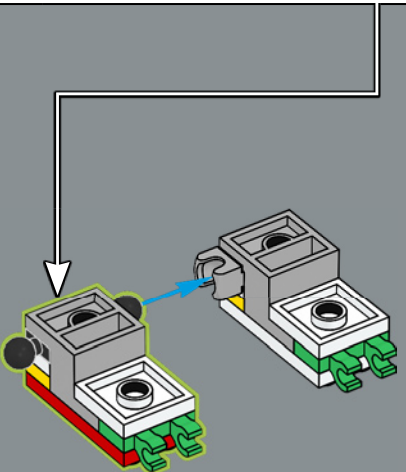
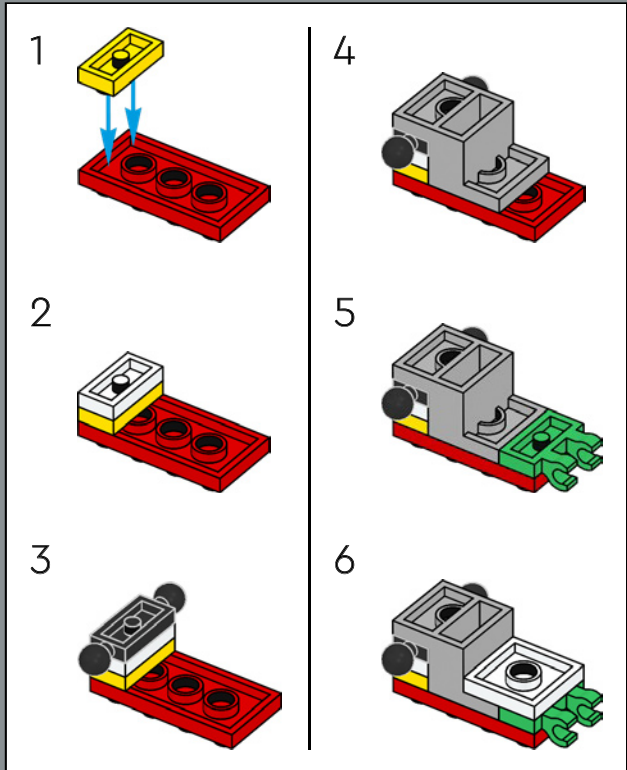

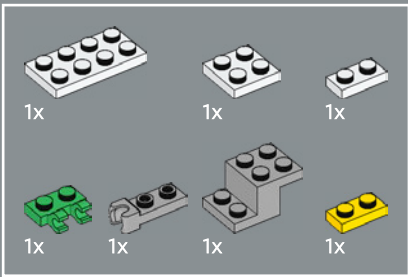

115

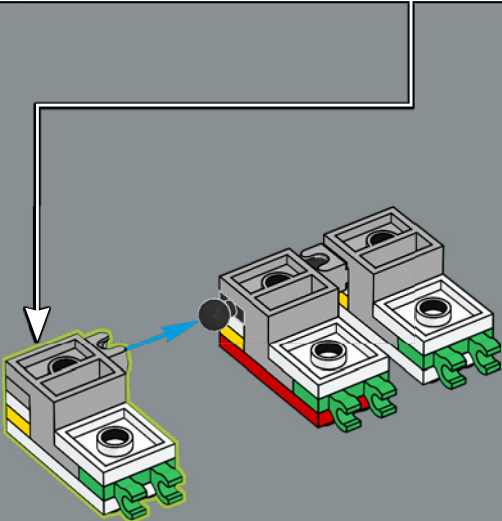
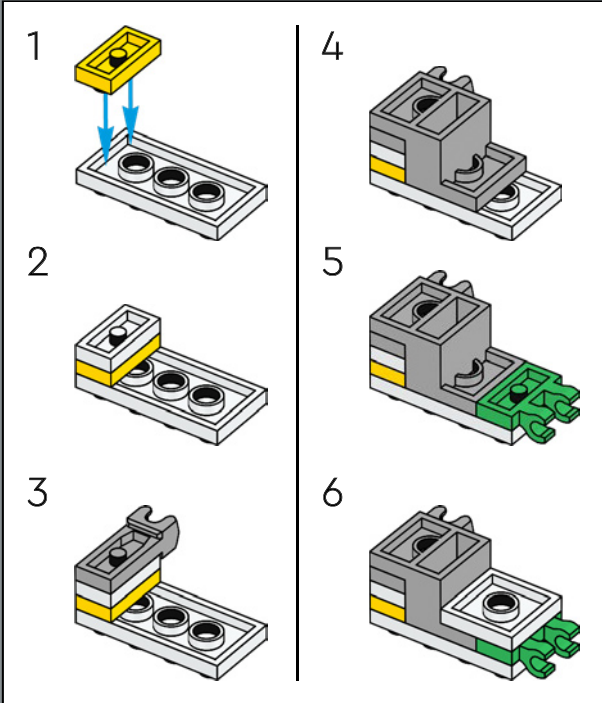

116

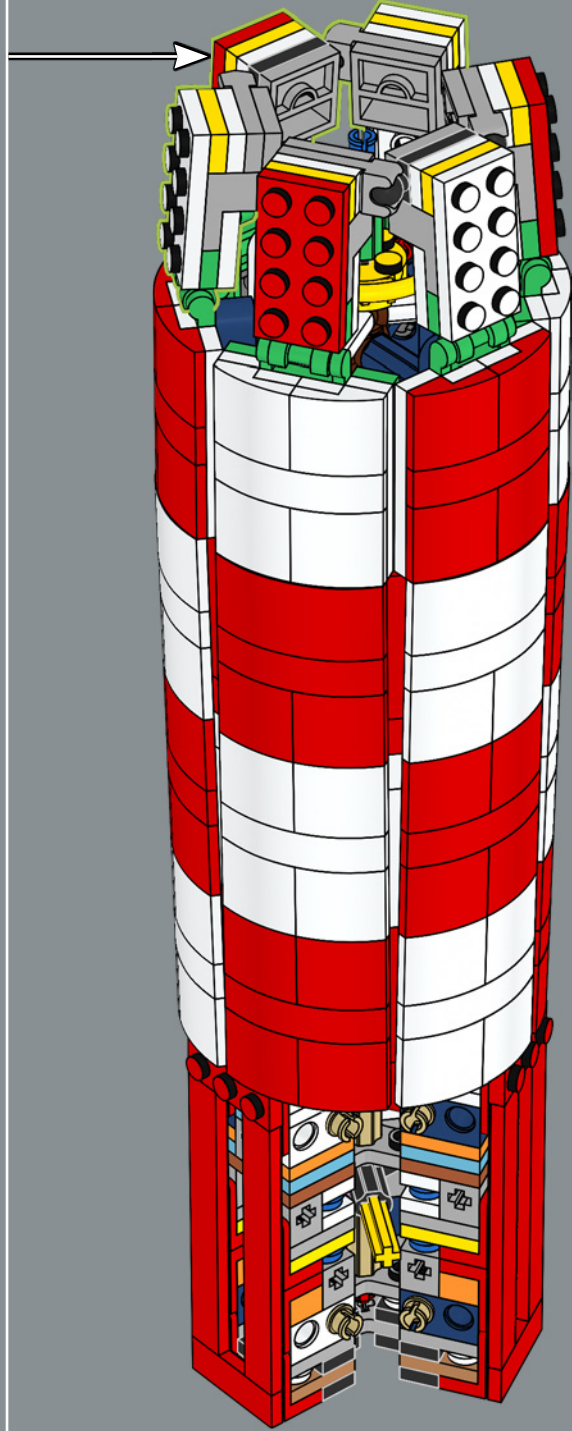

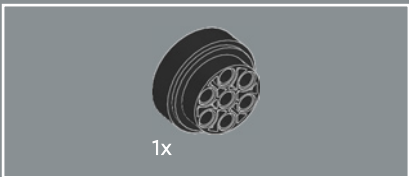

117

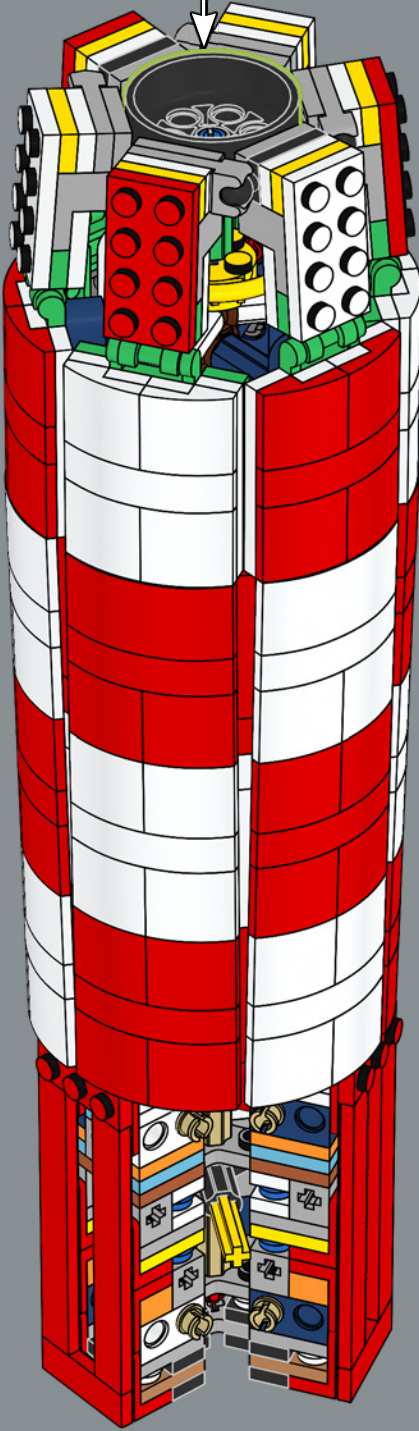

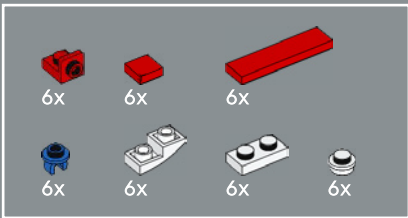

118

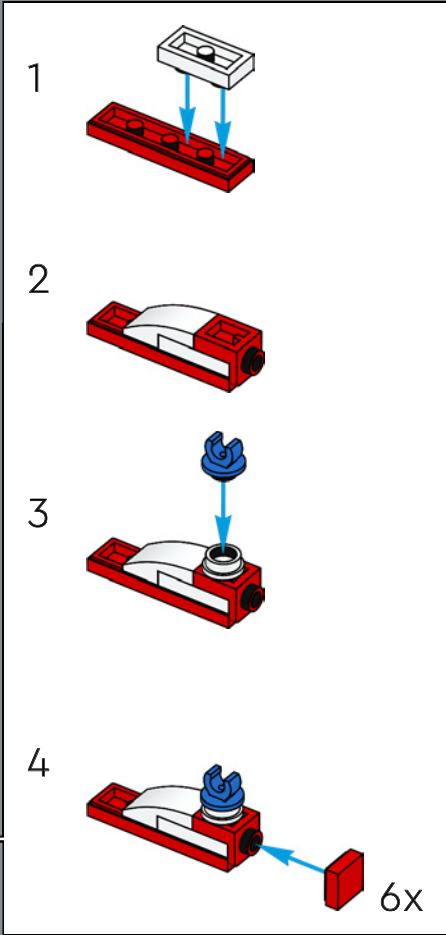
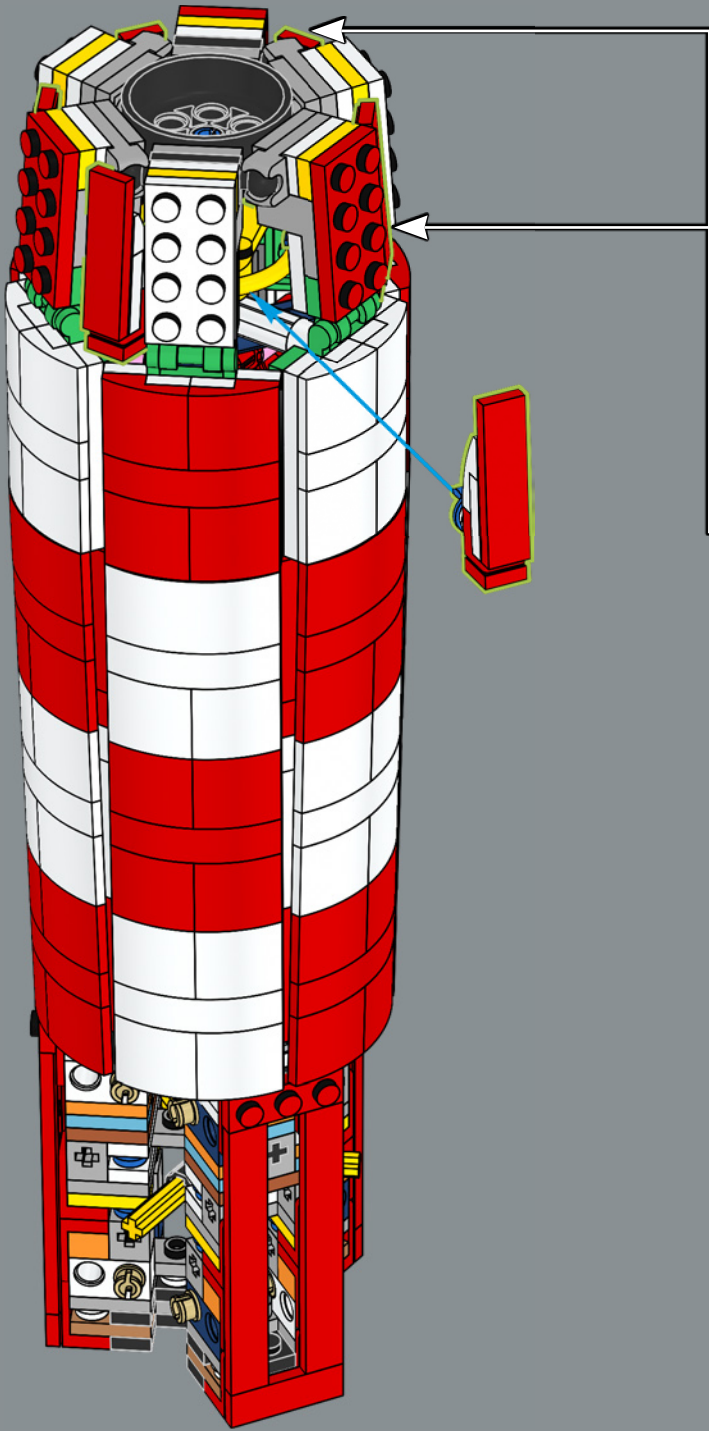

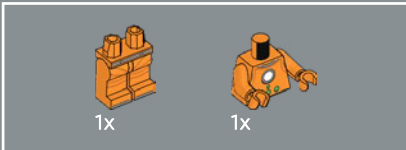
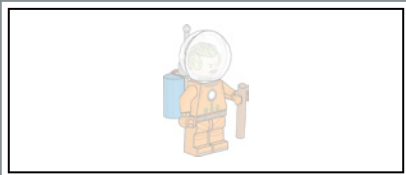

1x

1x

1

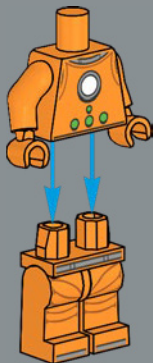

1x



1x



1x

2

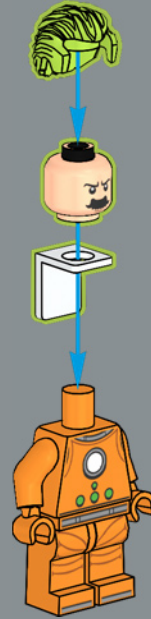

3



2x

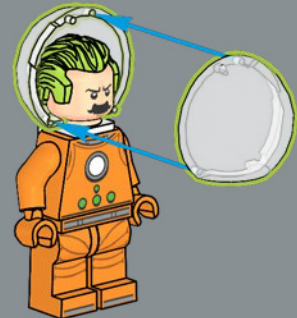



4

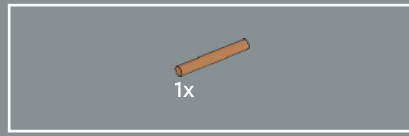
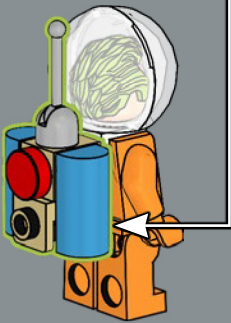
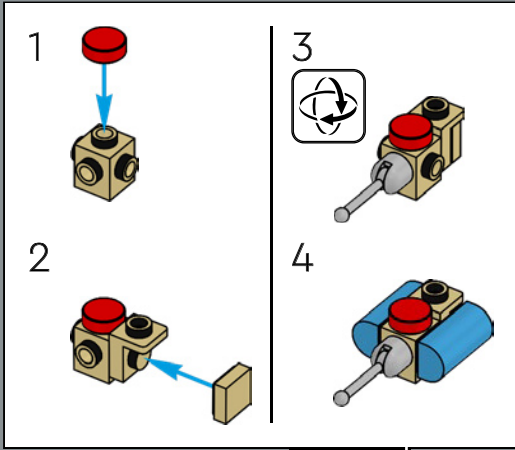

5

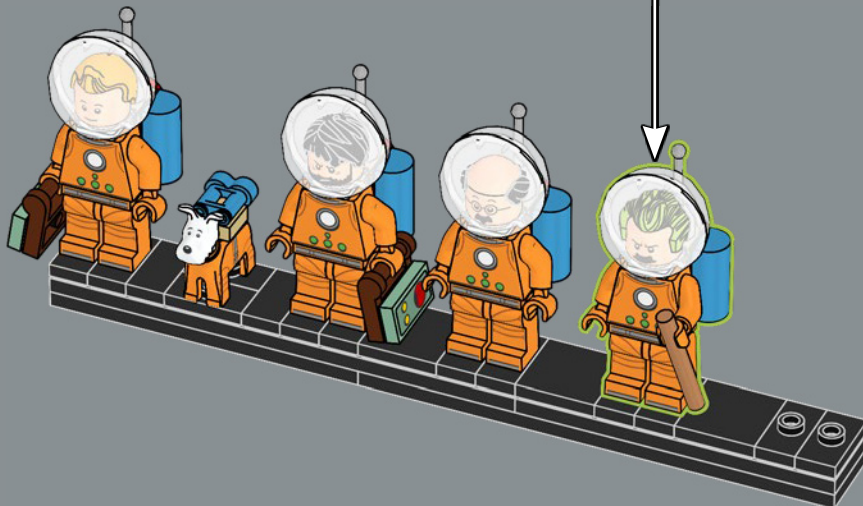

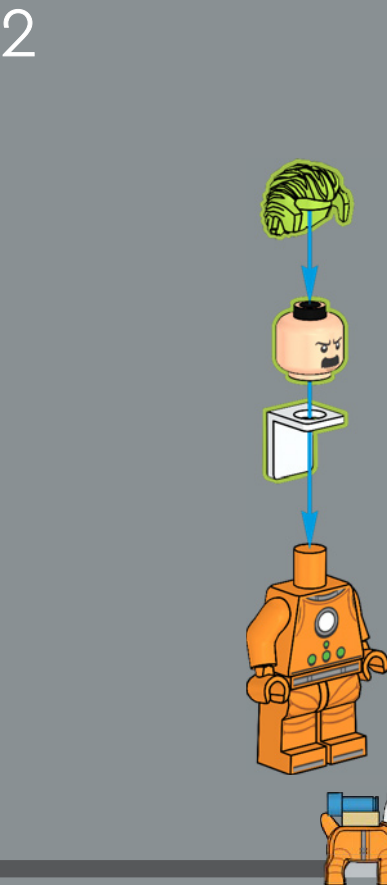
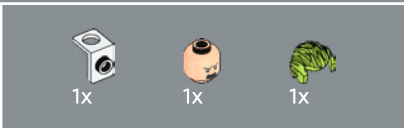
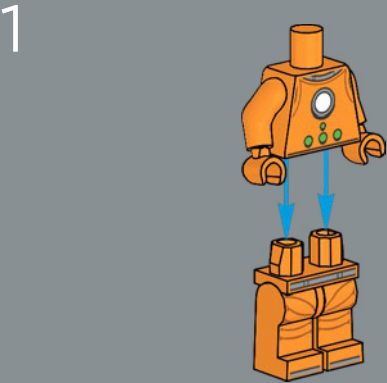
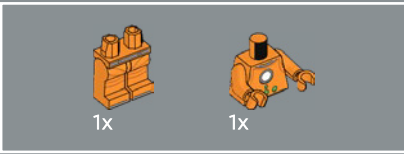
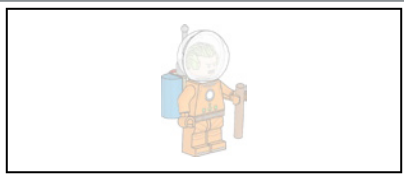

3

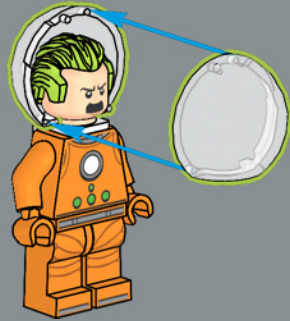

4

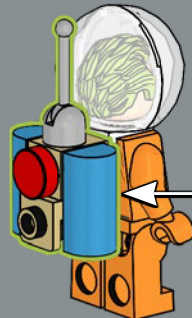
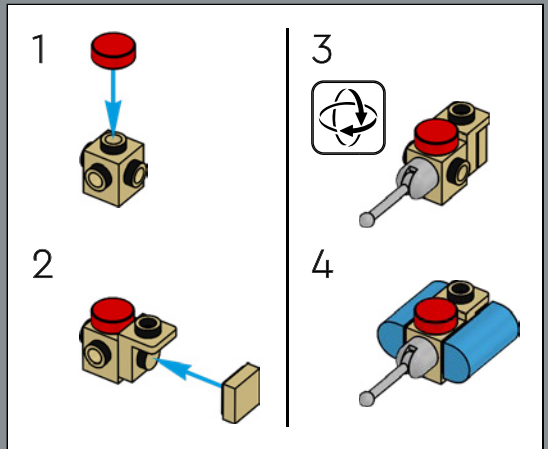

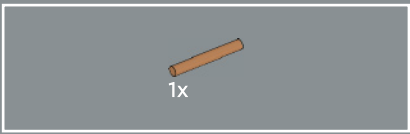

5

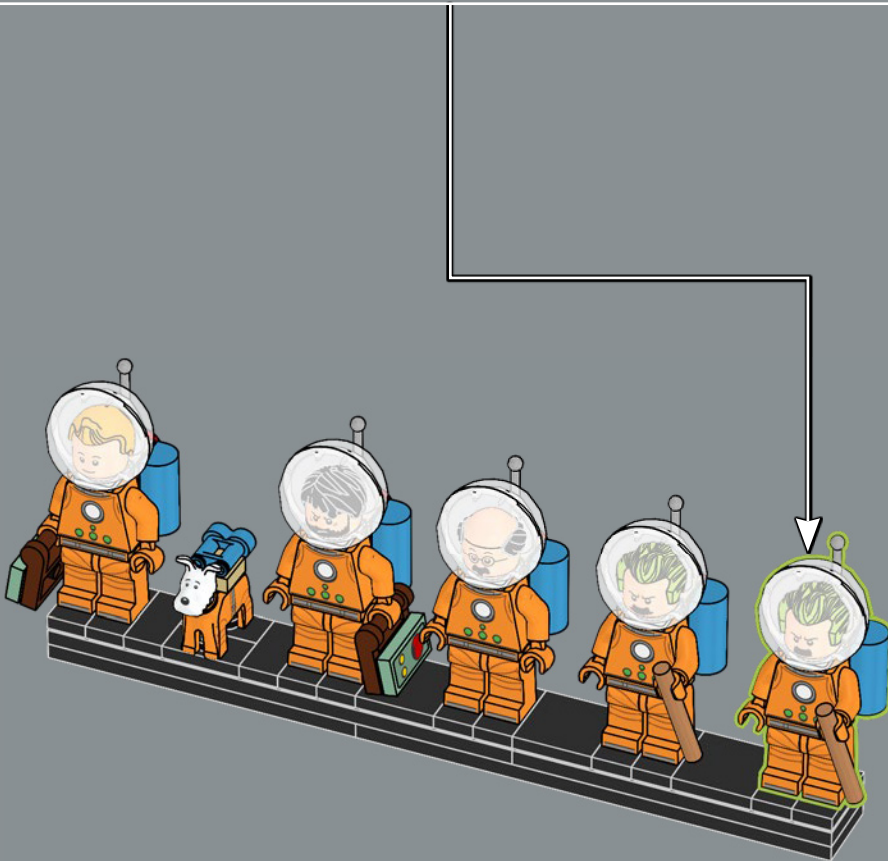
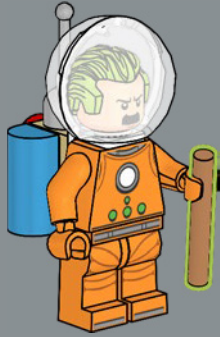

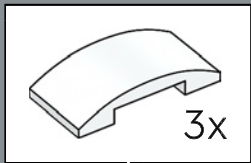
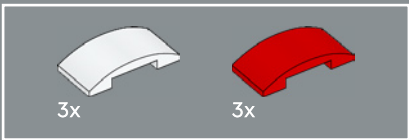

119

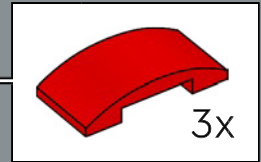
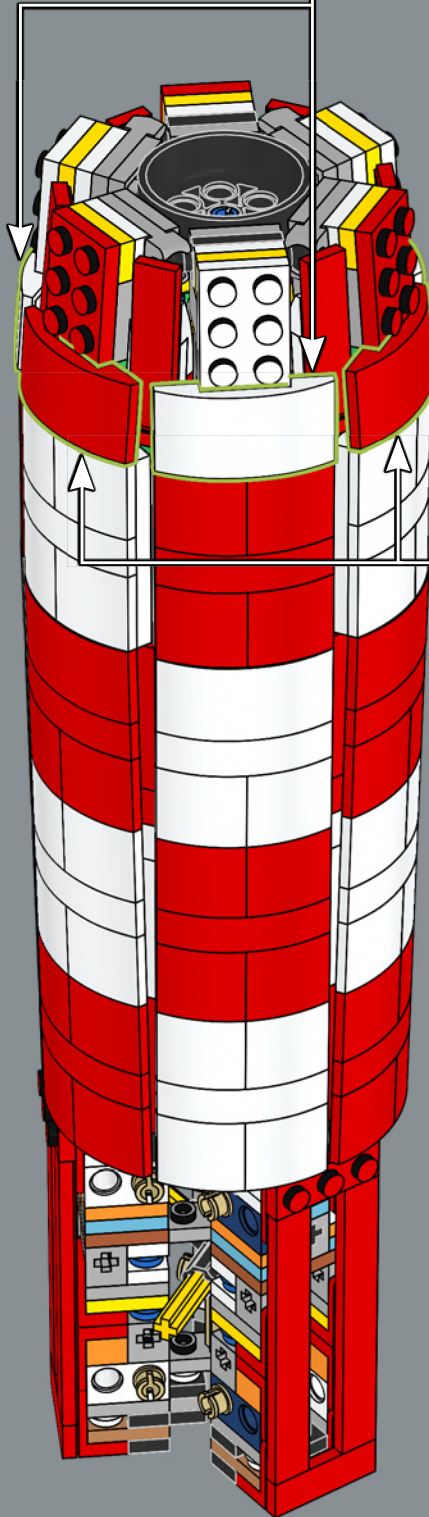

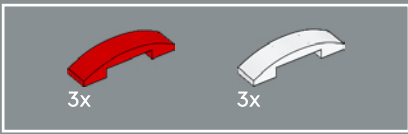

120

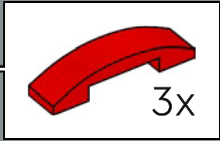
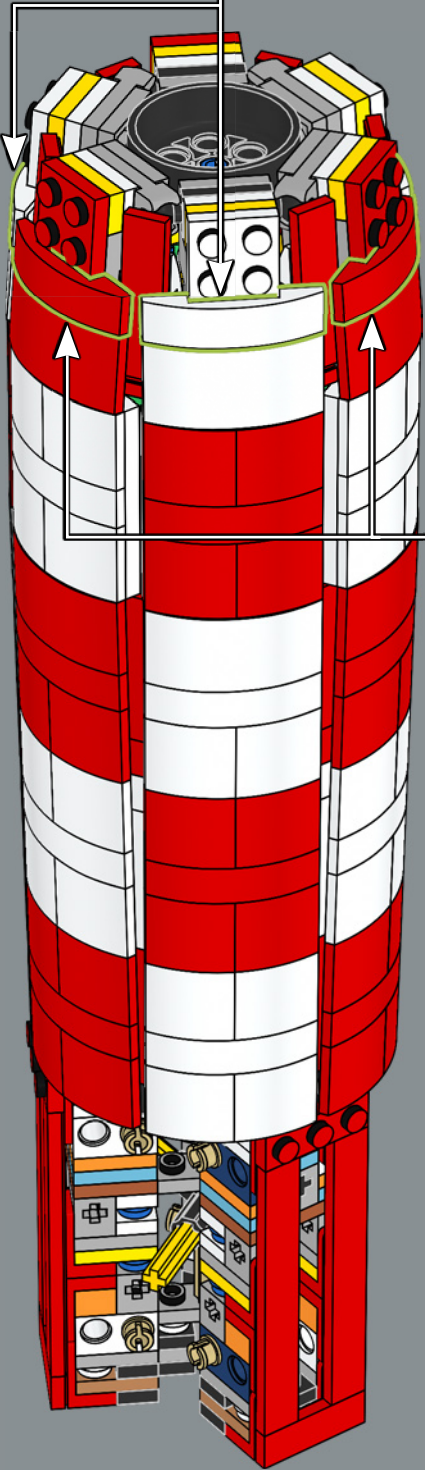
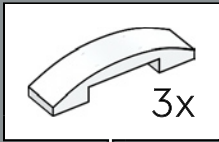

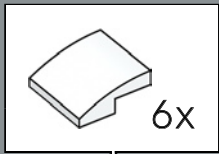
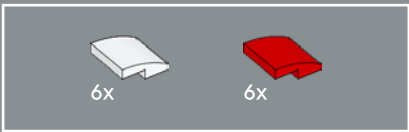

121

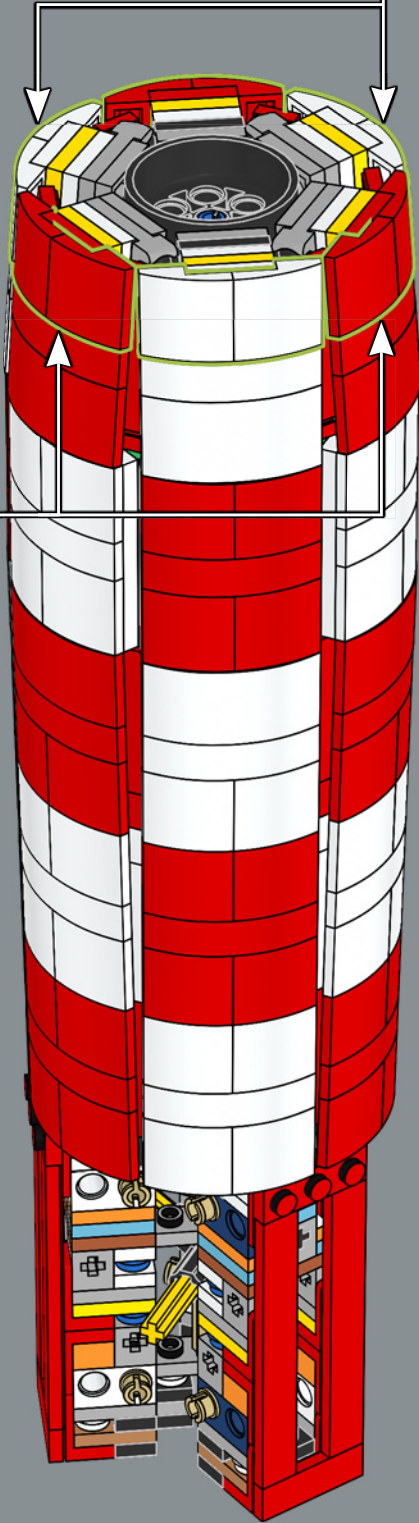
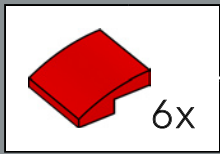

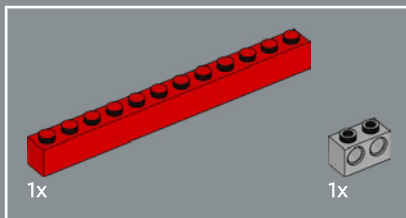
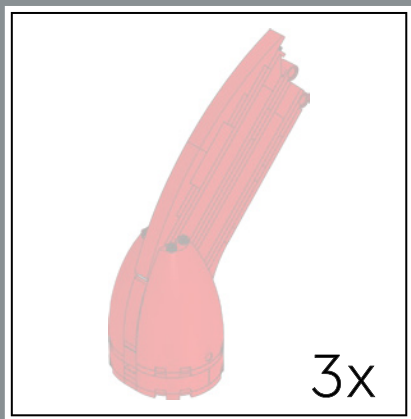

122

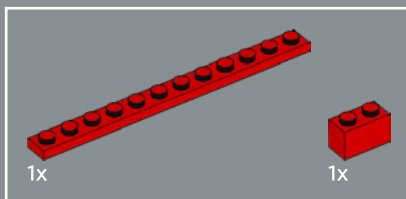
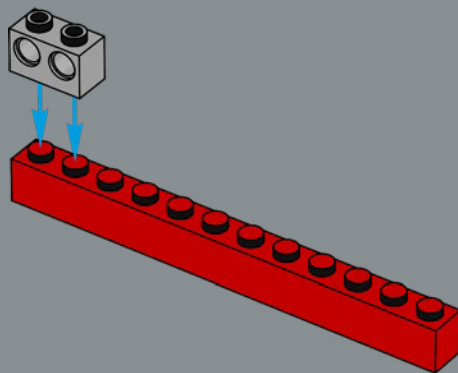

123

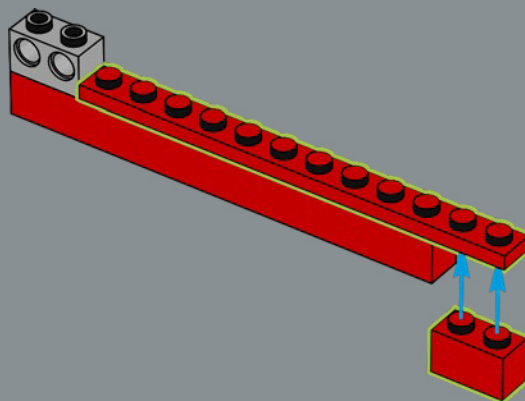

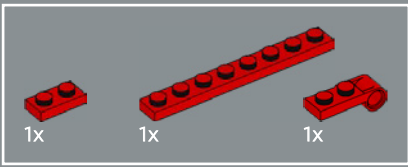

124

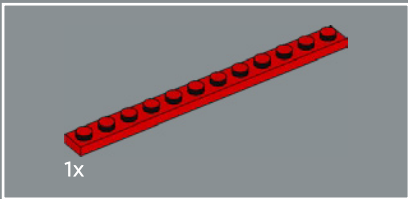
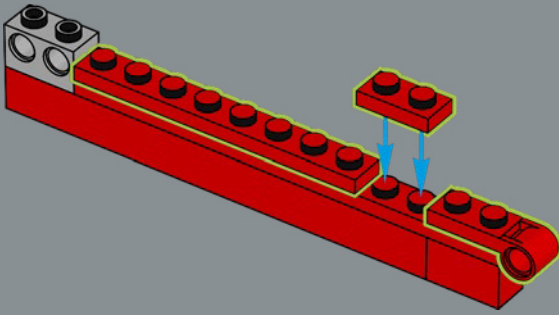

125

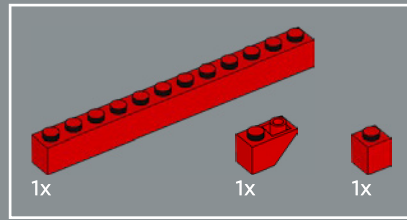
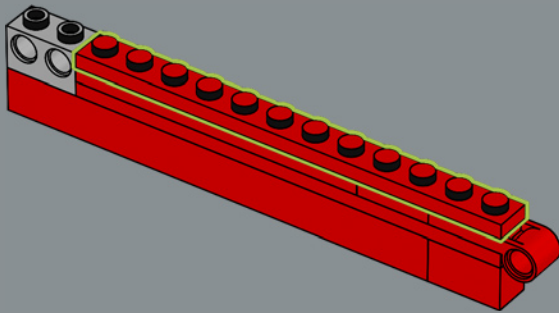

126

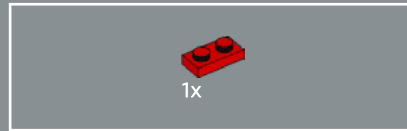
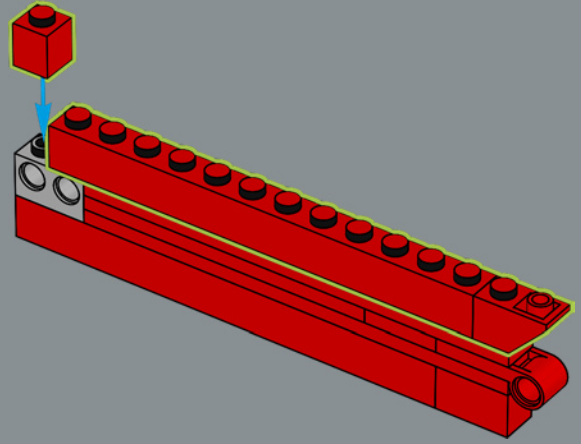

127

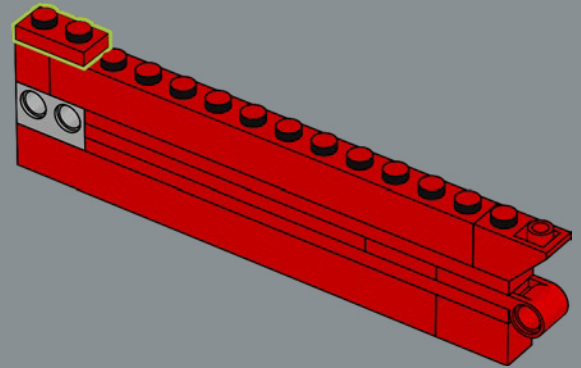

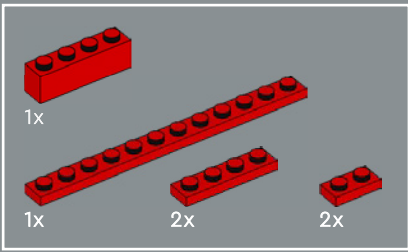

128

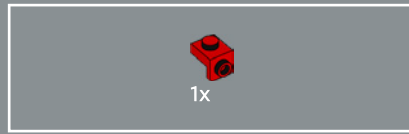
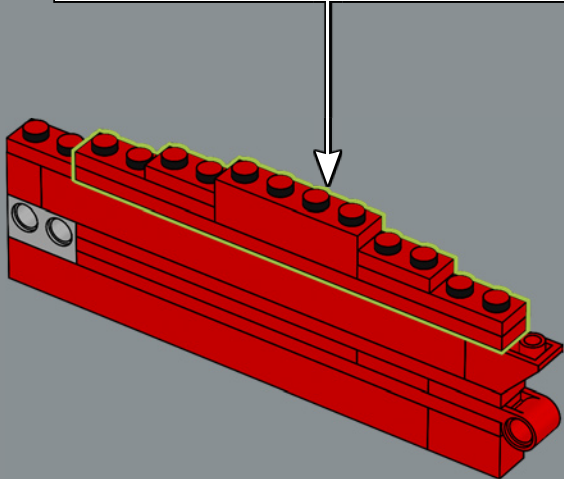
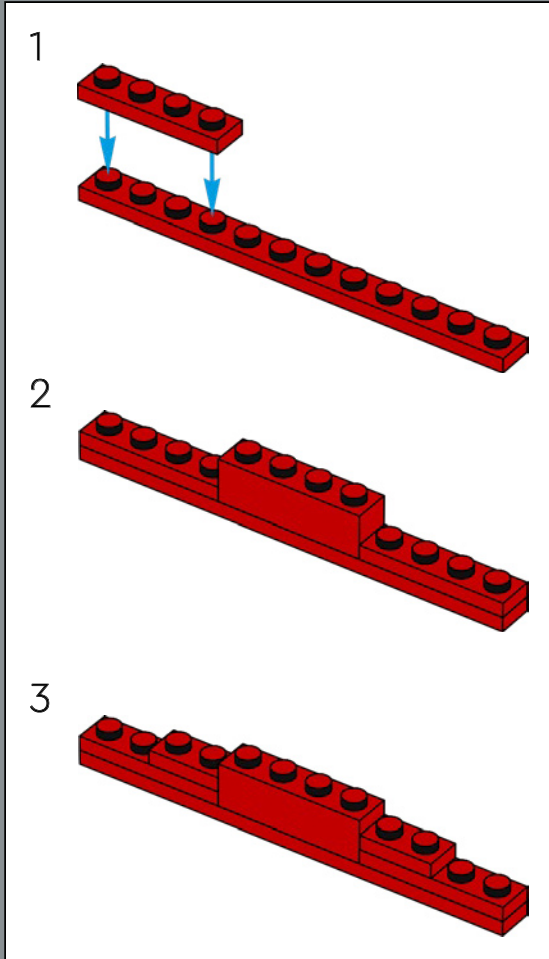

129

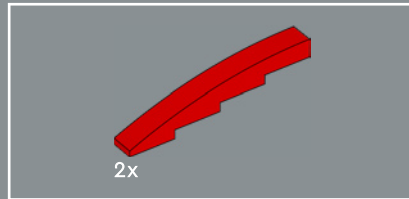
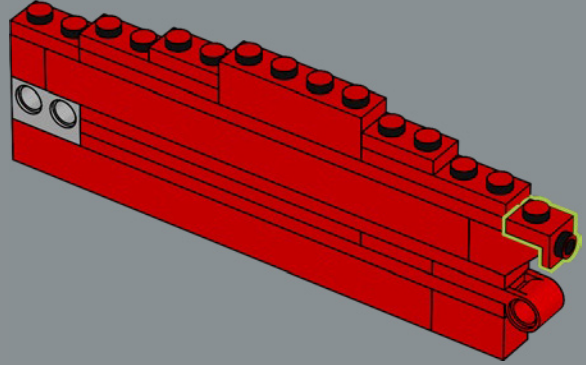

130

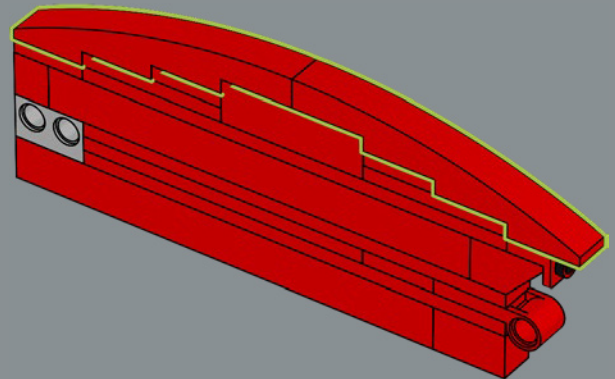

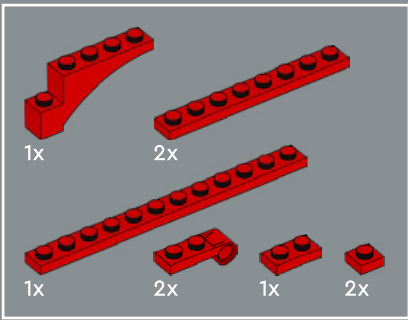

131

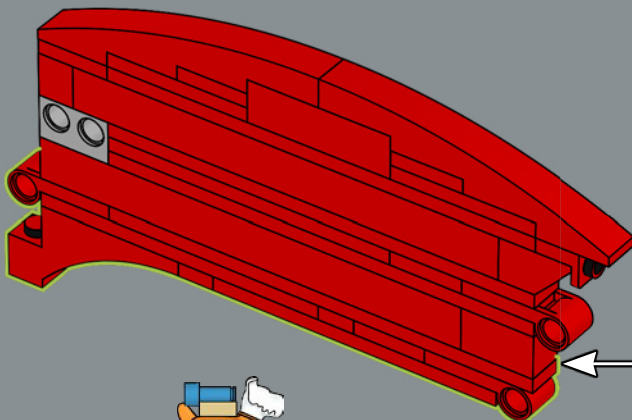
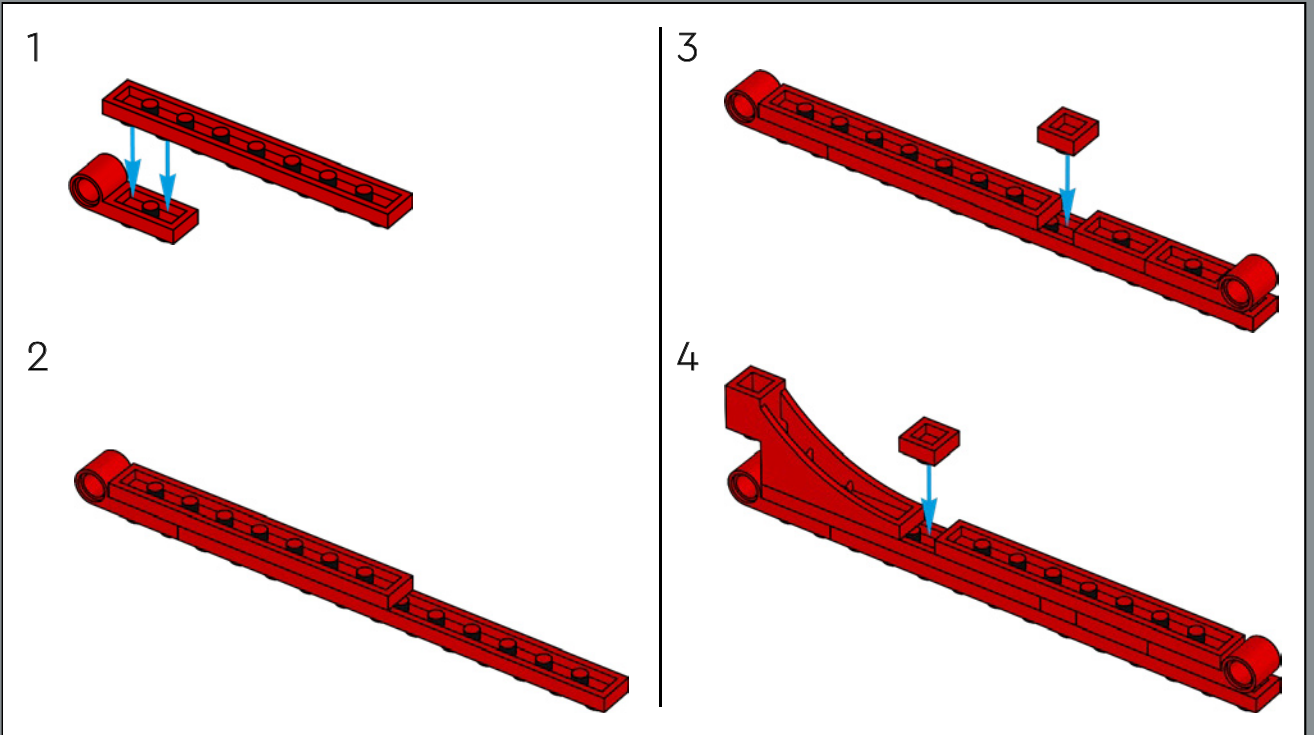

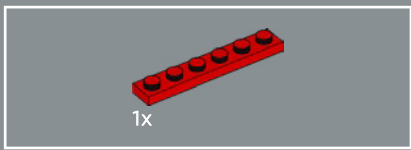

133

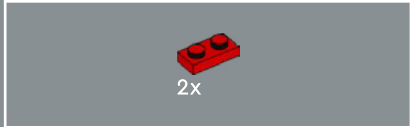
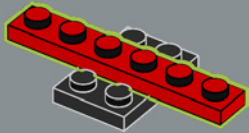

134

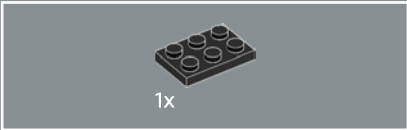
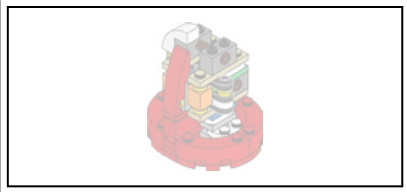
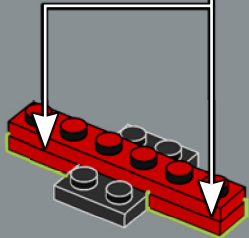
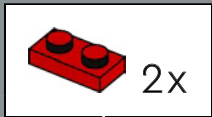

132

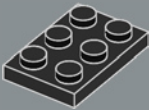



135

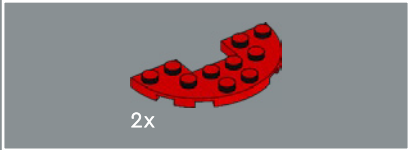
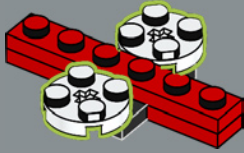

136

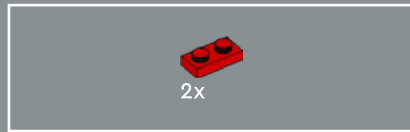
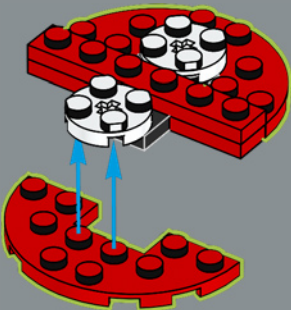

137

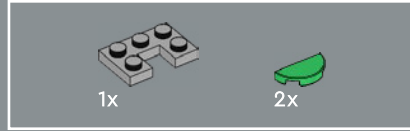
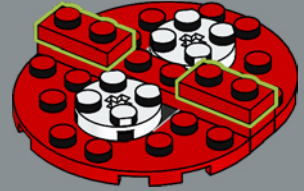

138

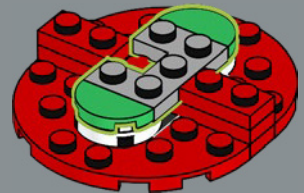

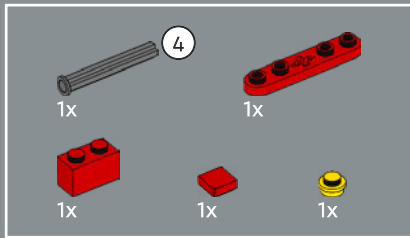

139

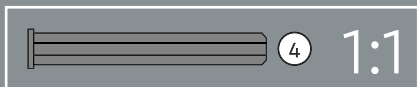
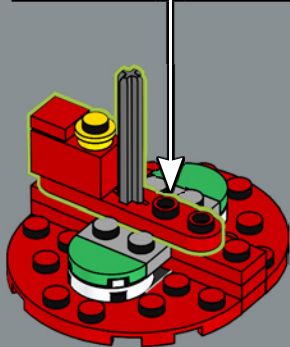
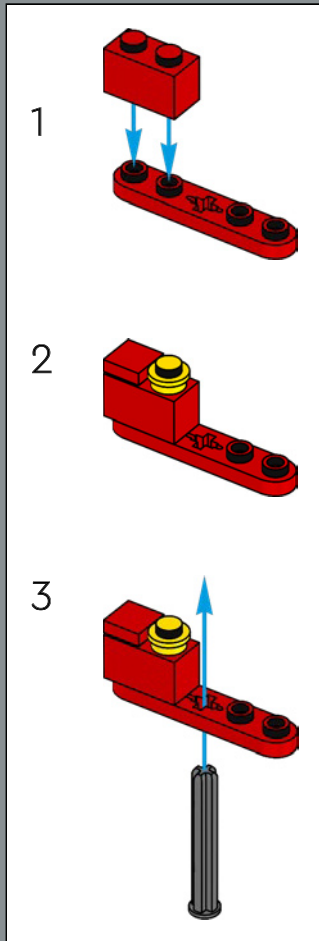

140

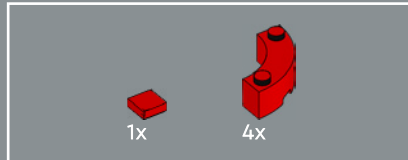
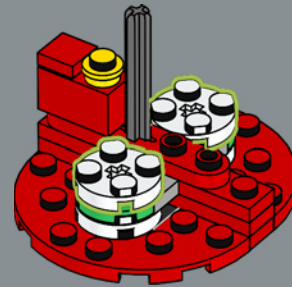

141

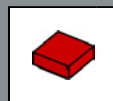
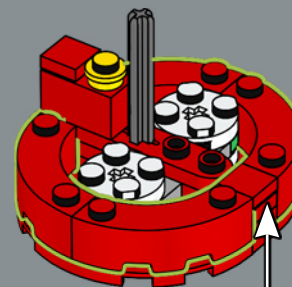

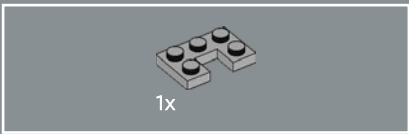

142

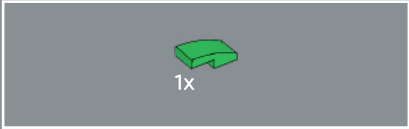
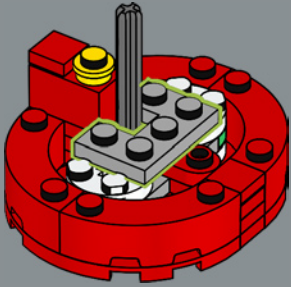

143

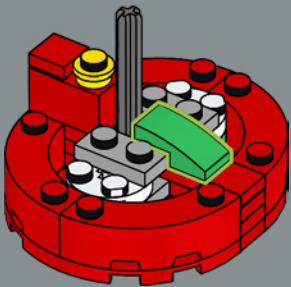

144

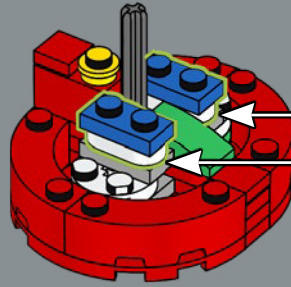
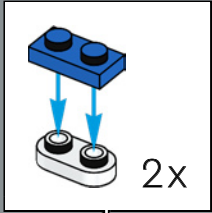

145

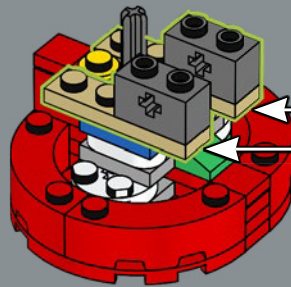
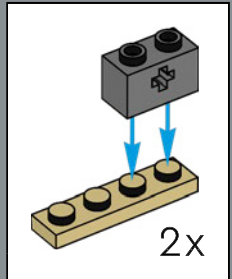

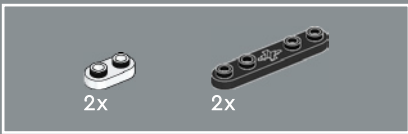

146

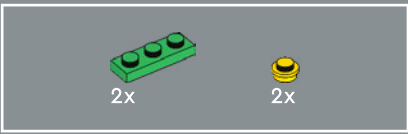
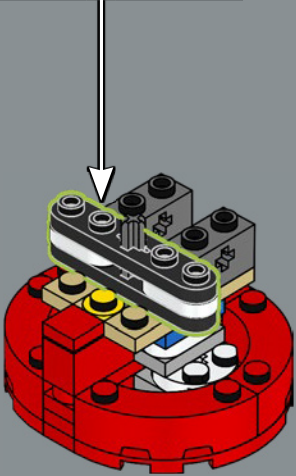
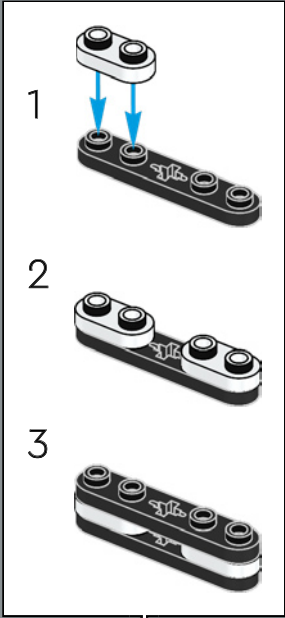

147

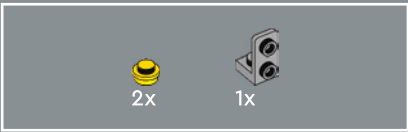
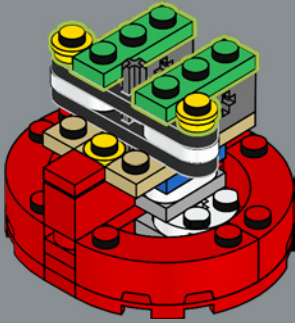

148

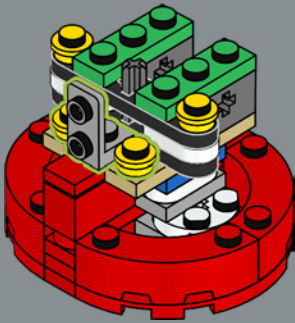

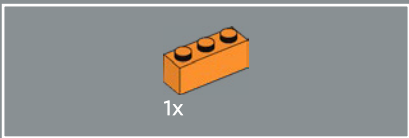

149

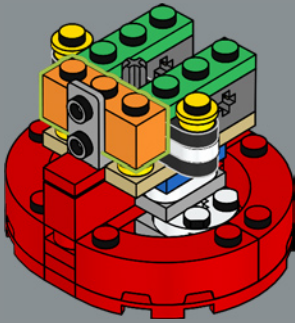

151

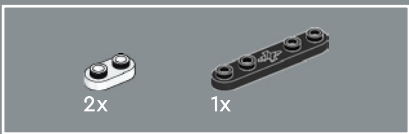
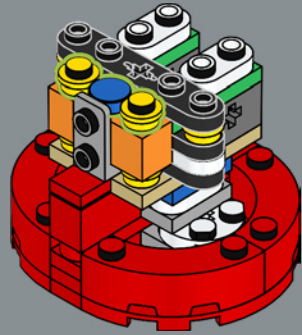

150

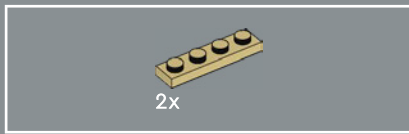
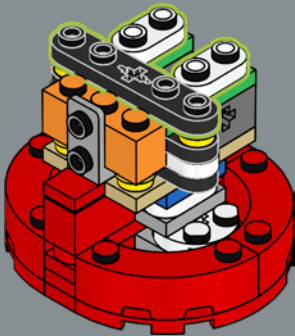

152

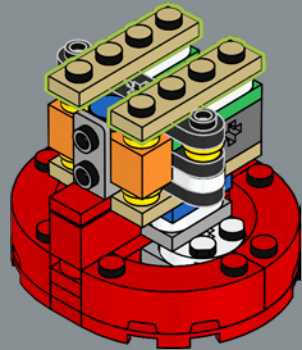

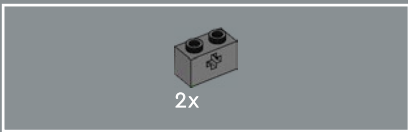

153

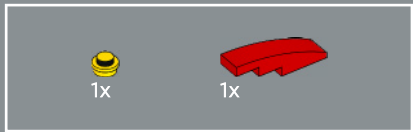
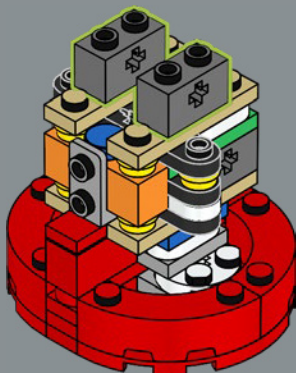

155

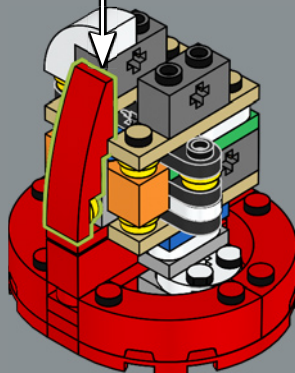
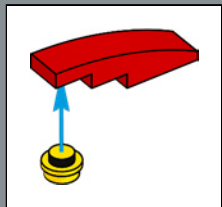

154

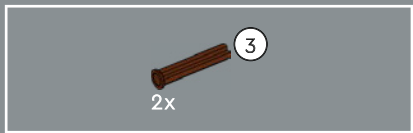
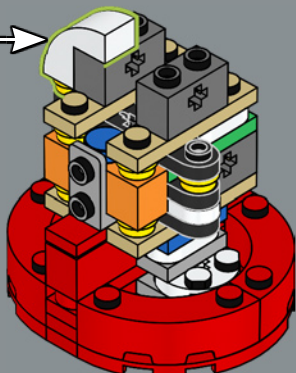
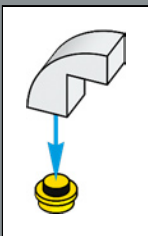

156

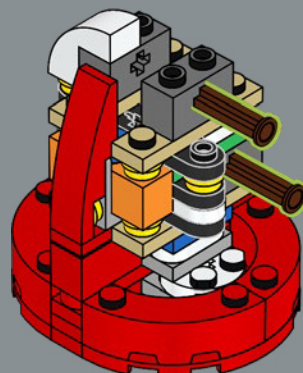

157

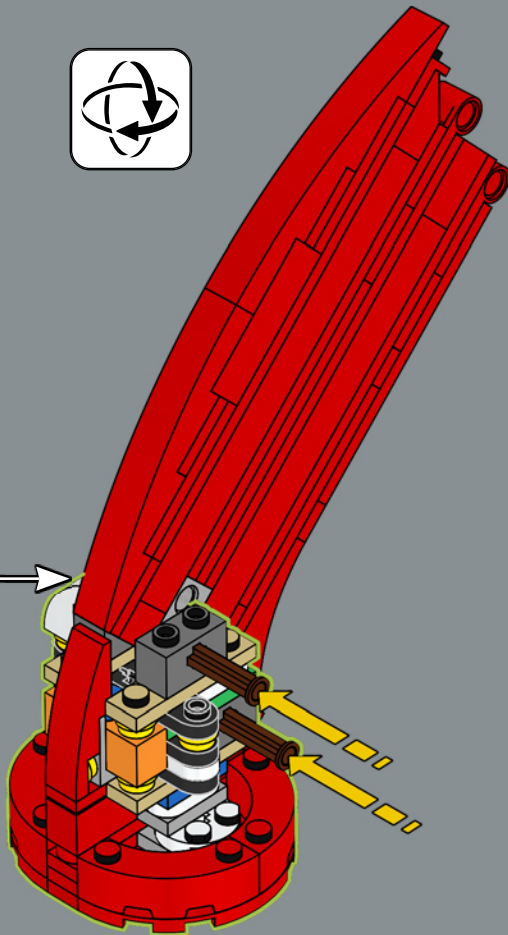

158

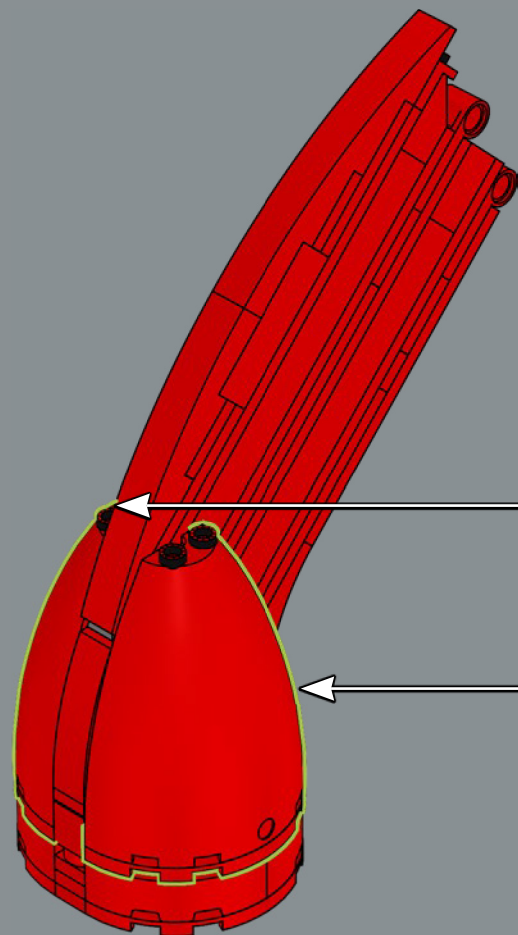
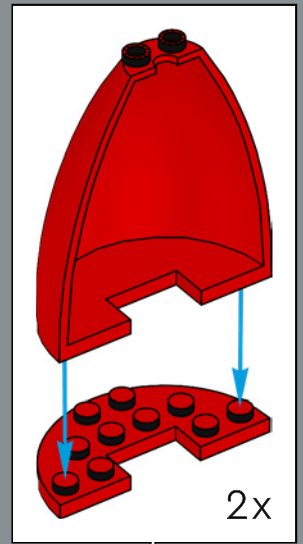
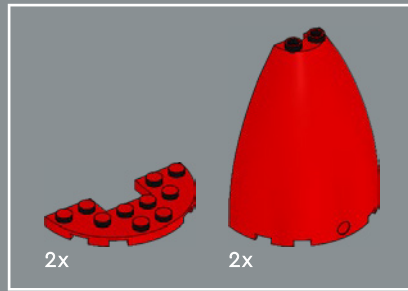

3x



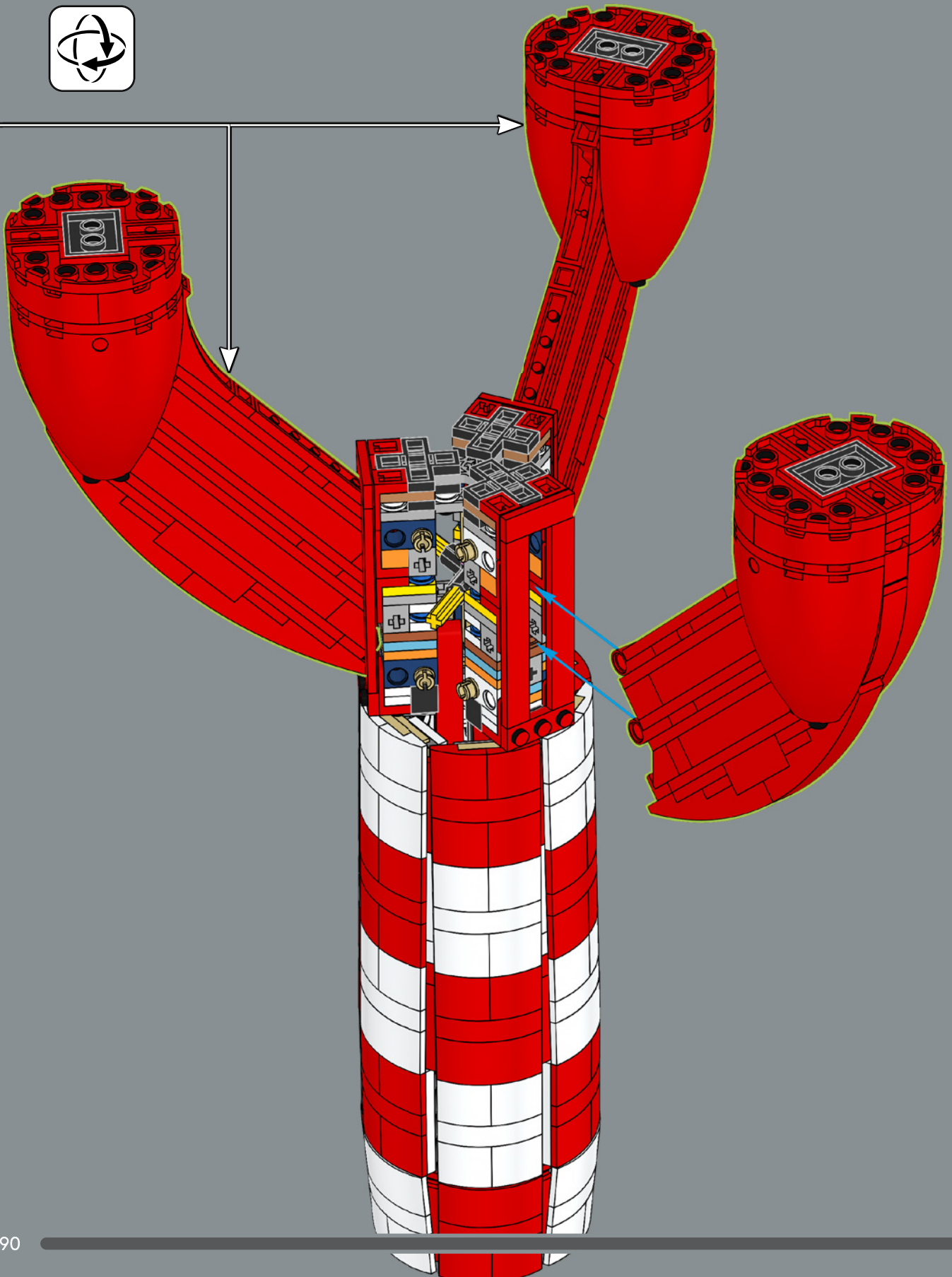

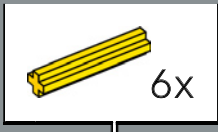
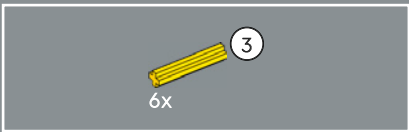

160

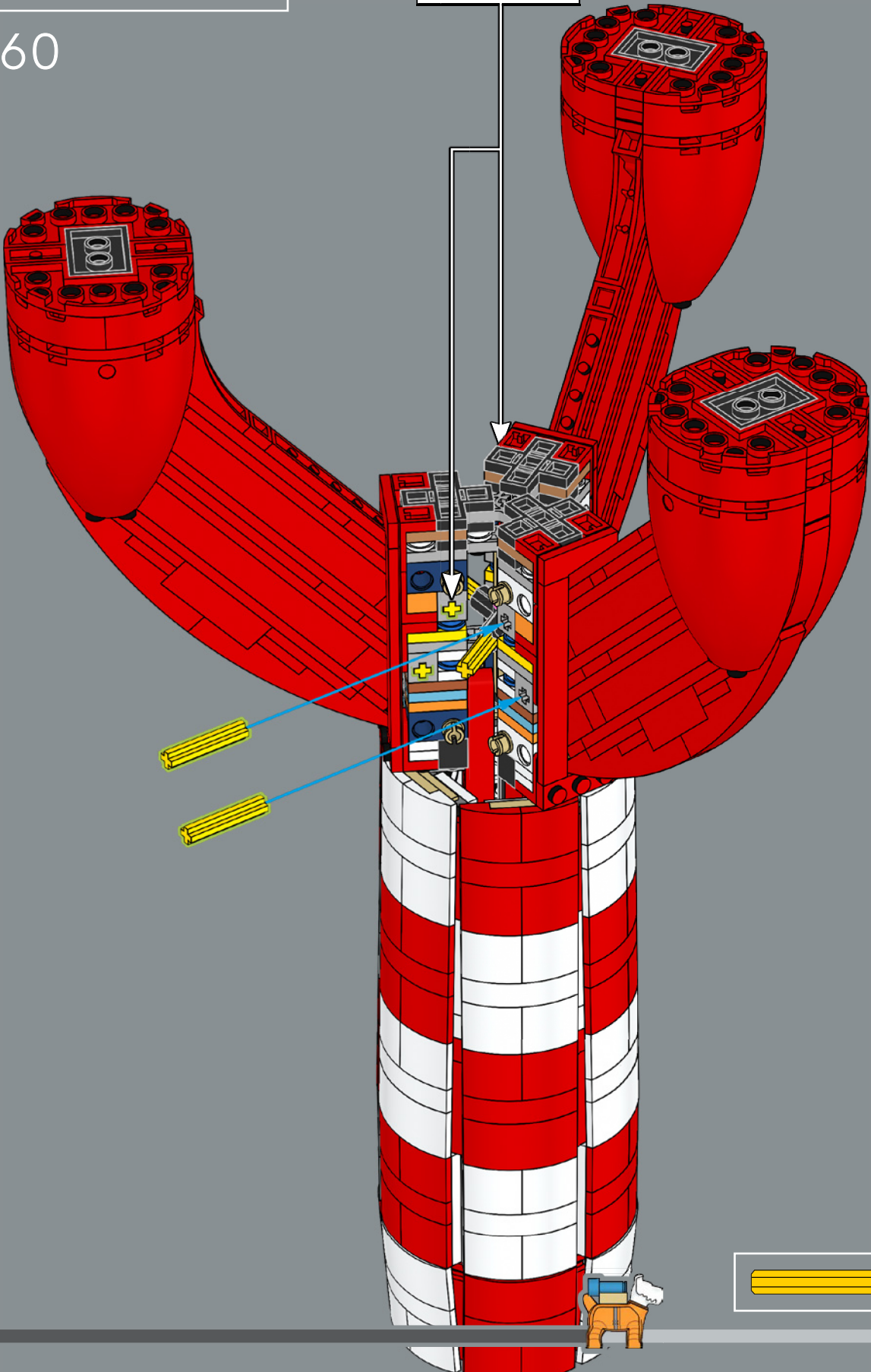

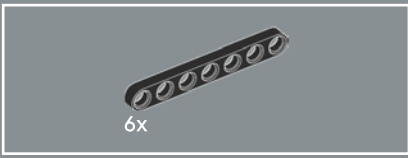

161

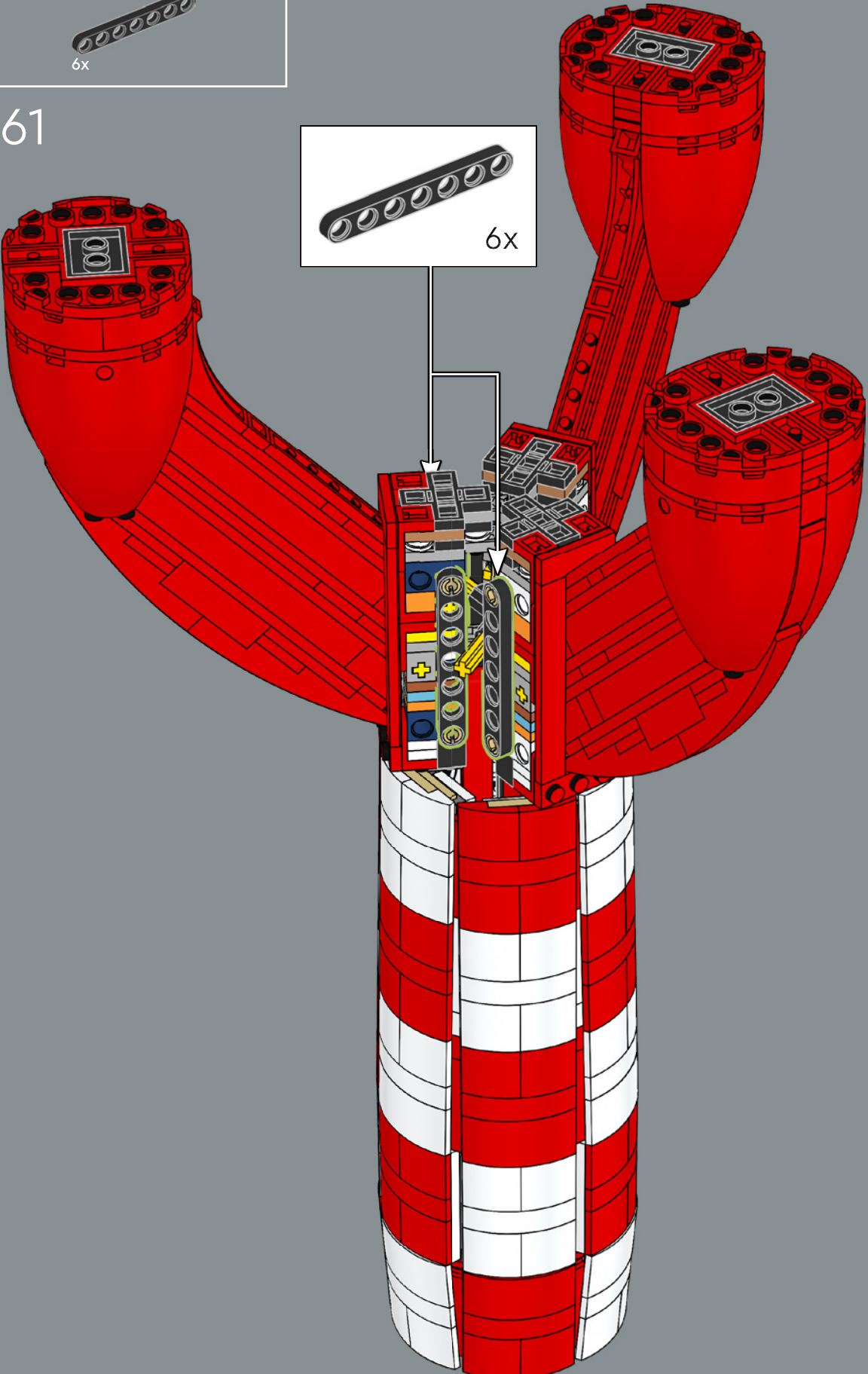
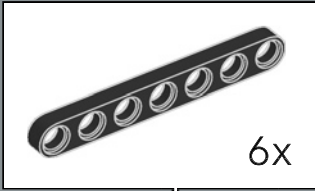

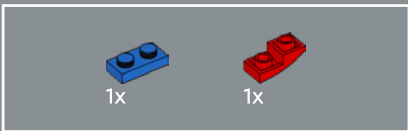
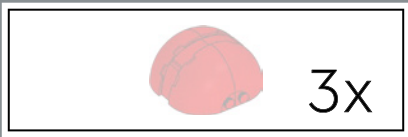
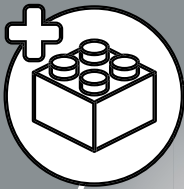

162

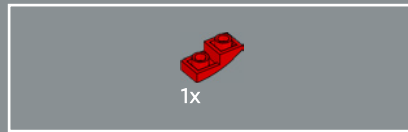
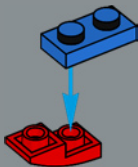

163

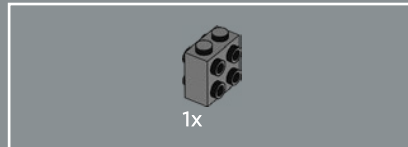
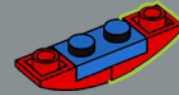

164

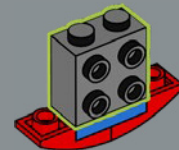



165

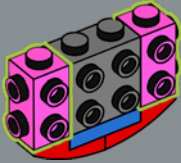

166

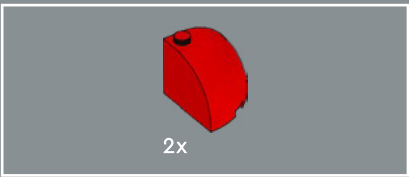
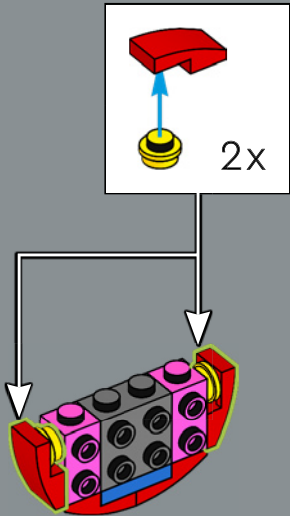

167

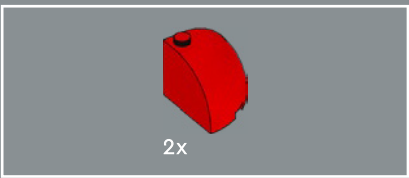
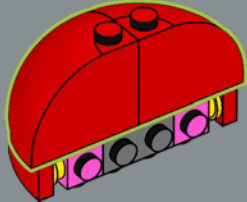

168

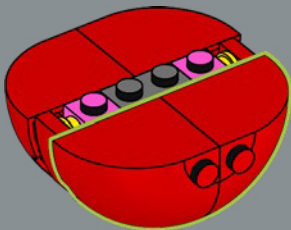

3x

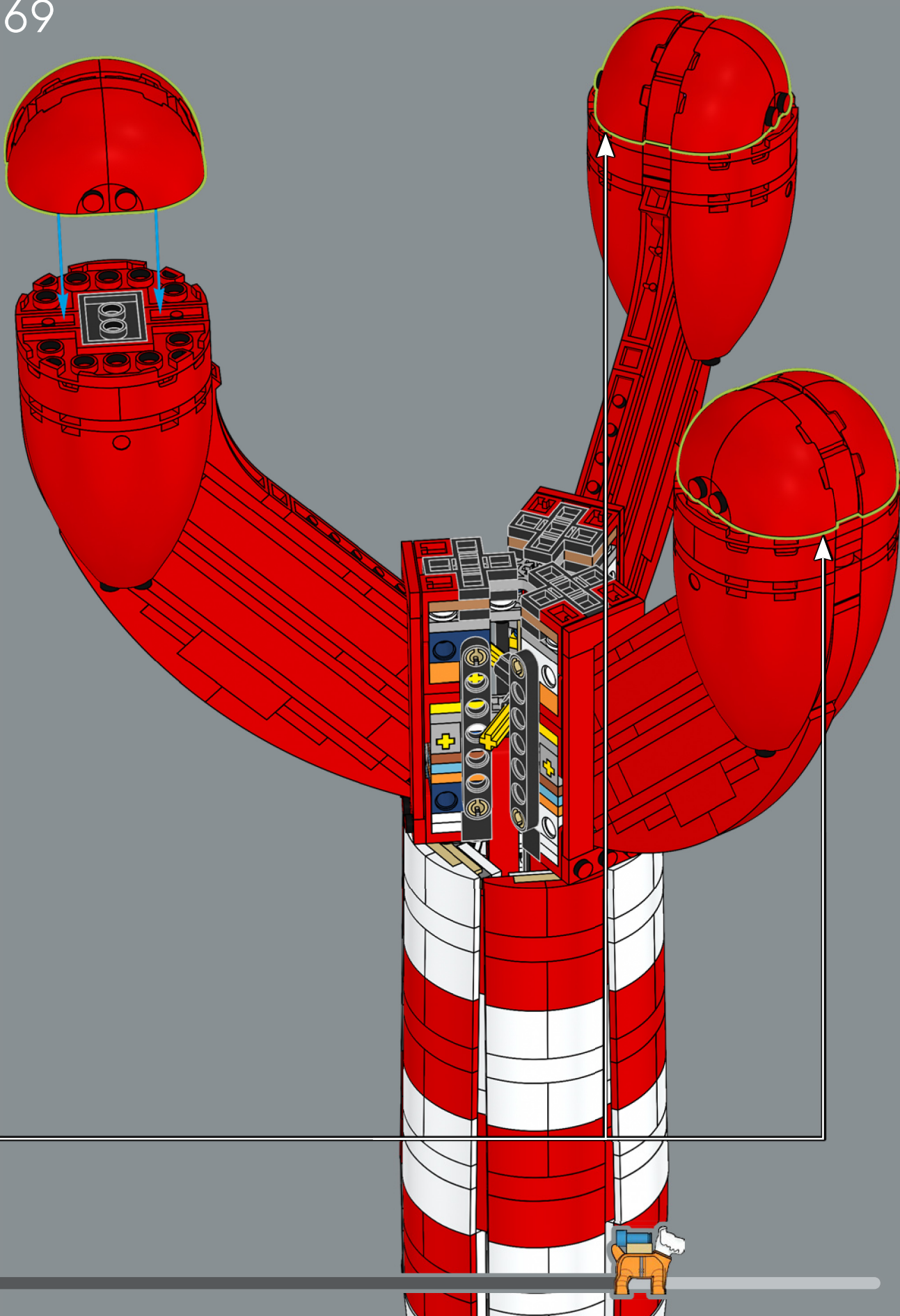

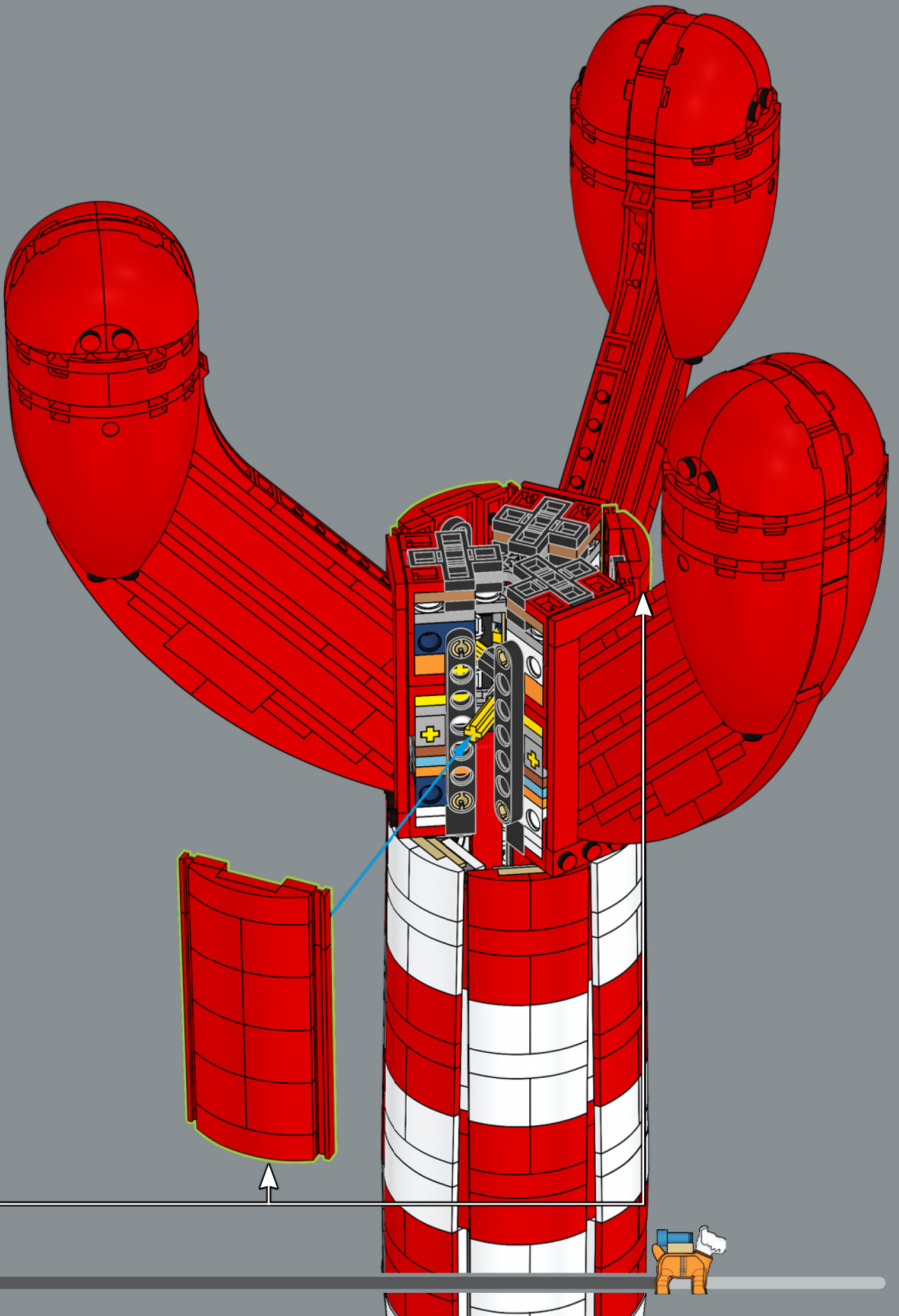

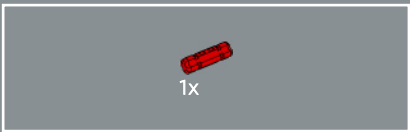

171

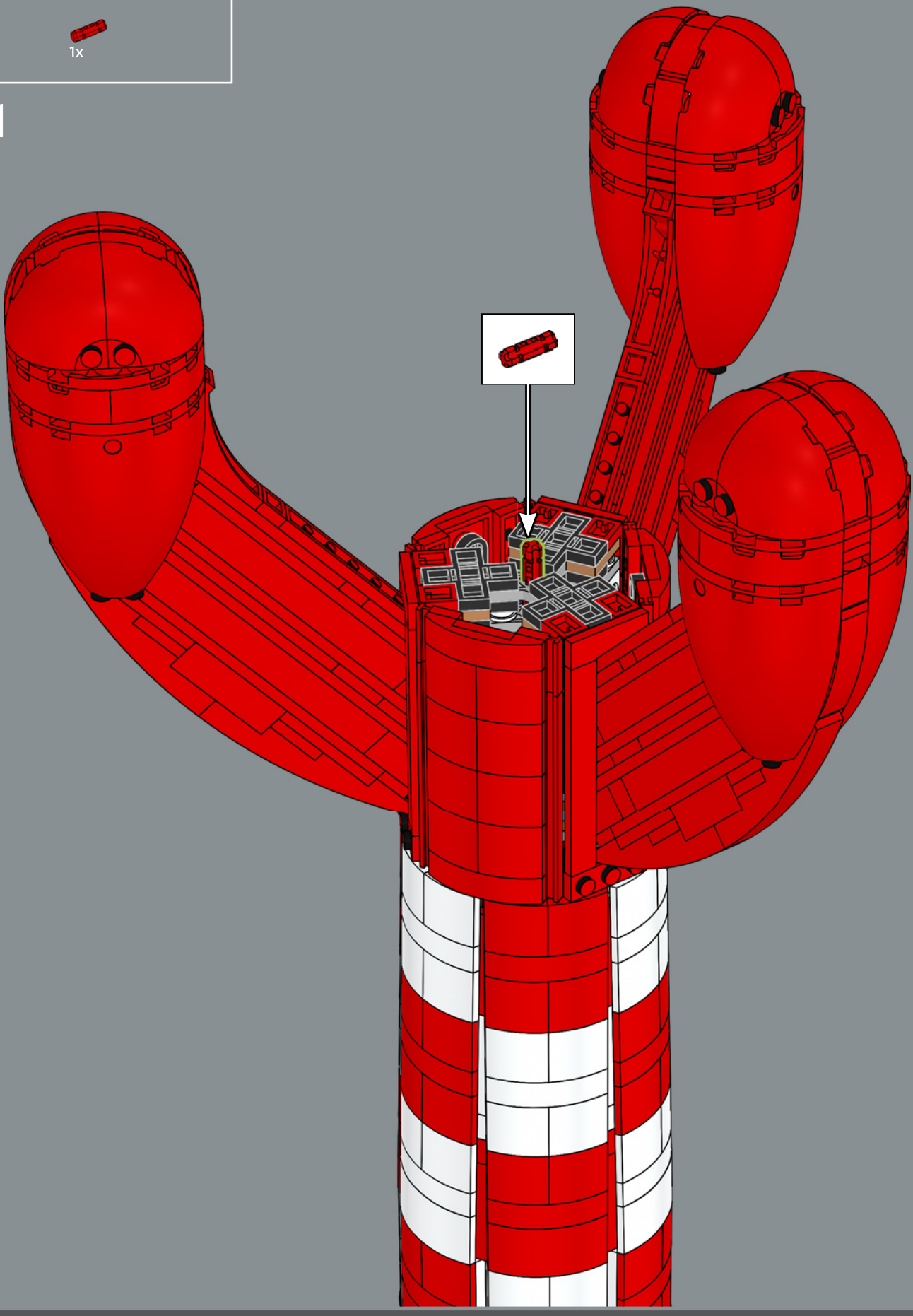

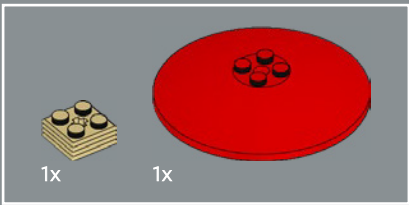

172

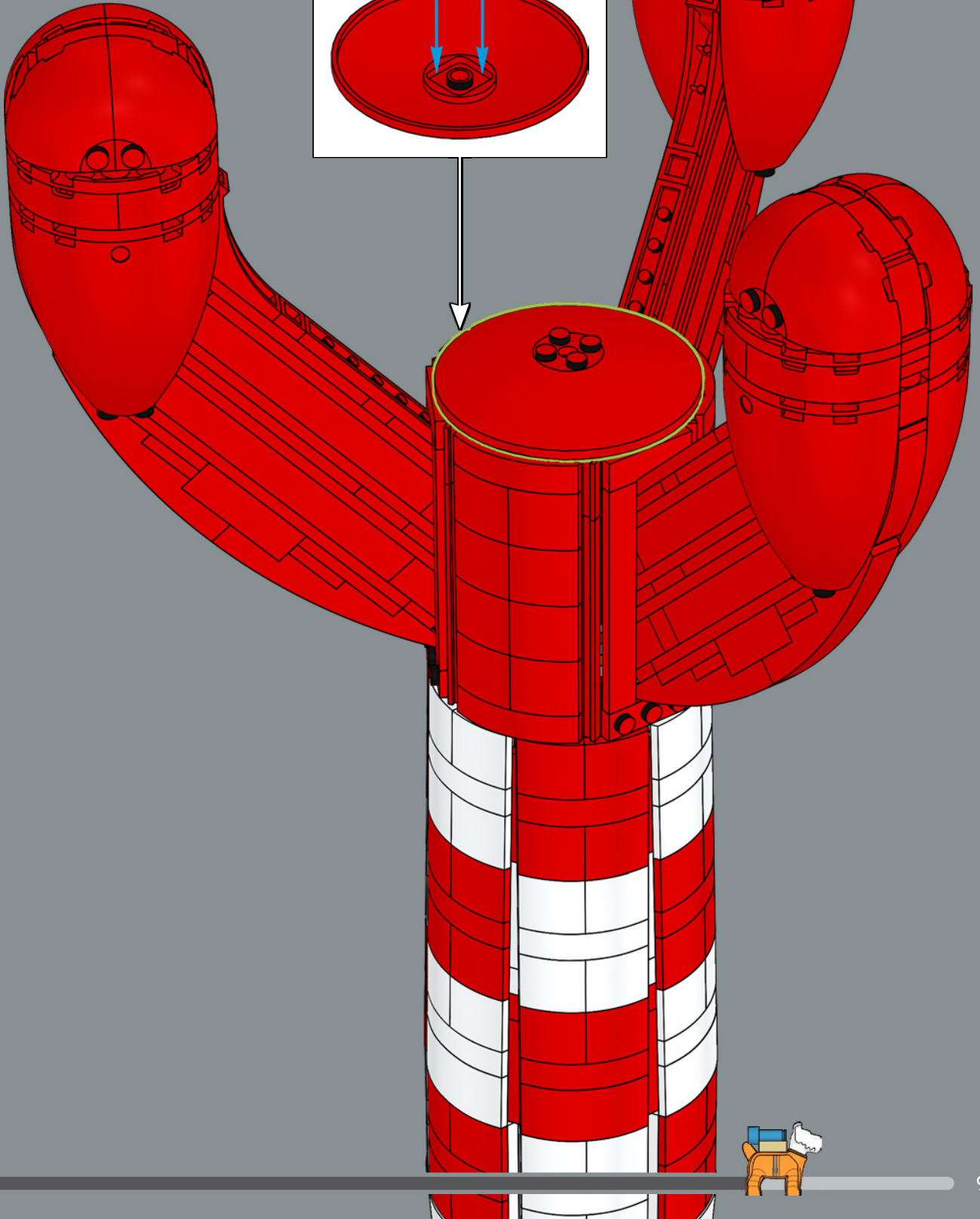
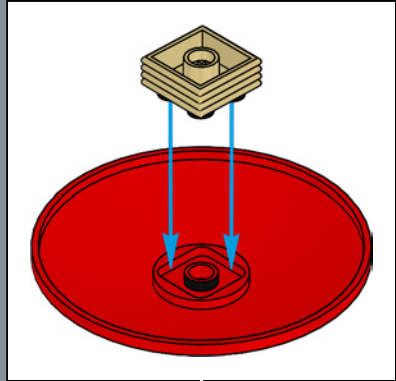

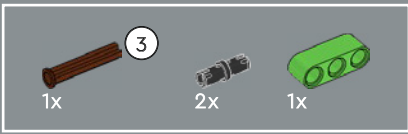

173

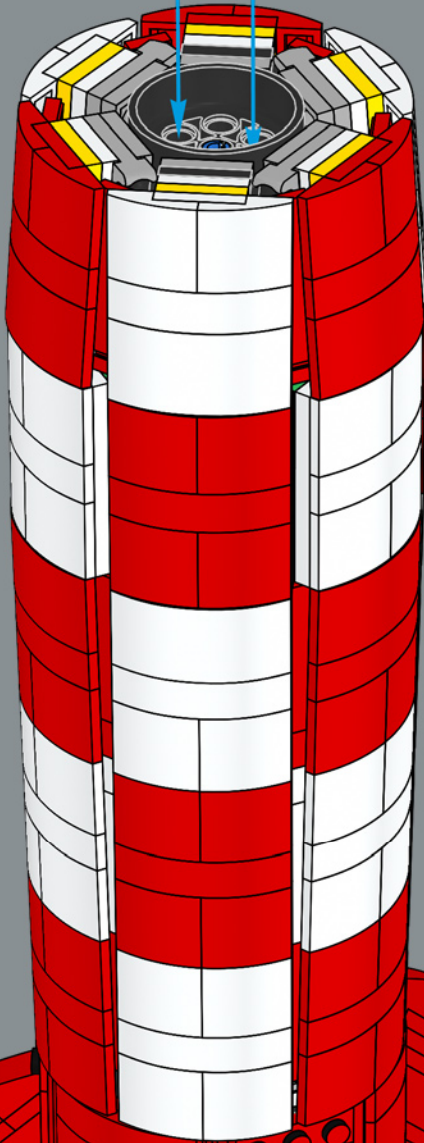
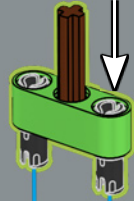
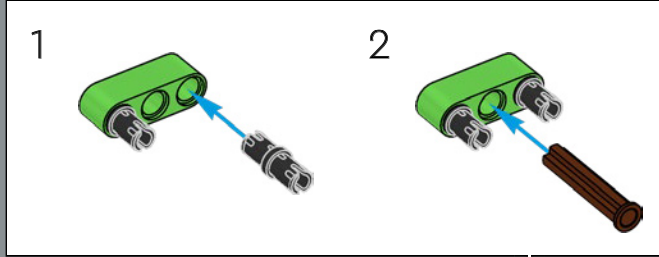

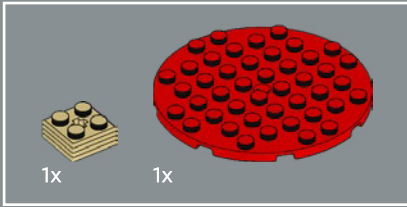

174

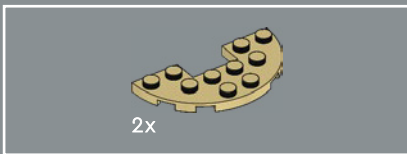
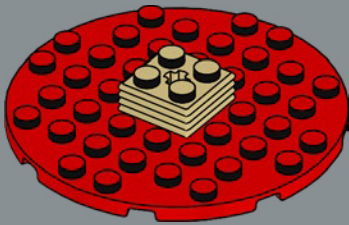

175

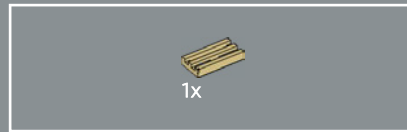
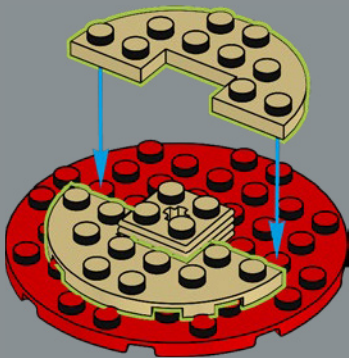

176

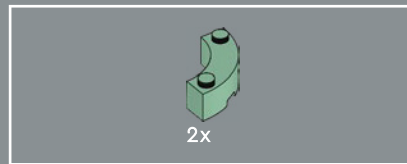
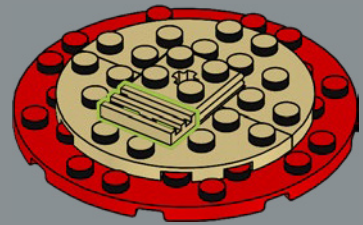

177

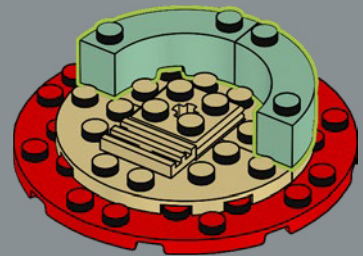



178

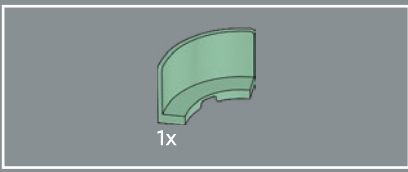
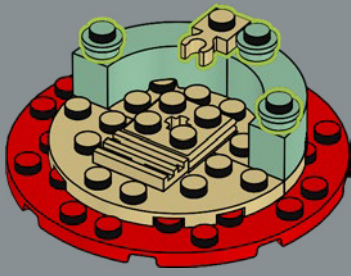

179

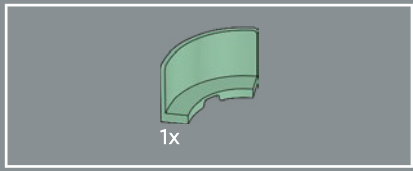
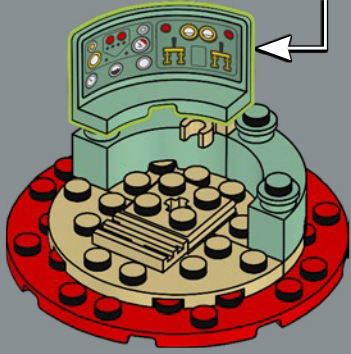
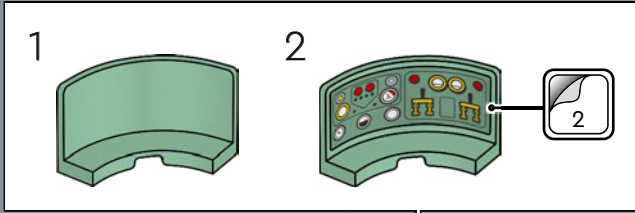

180

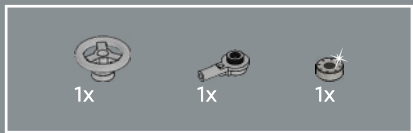
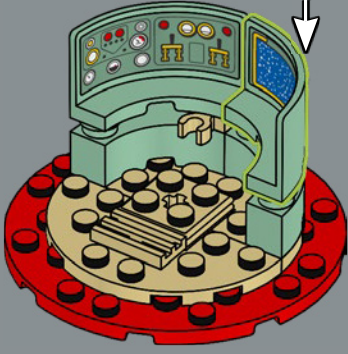
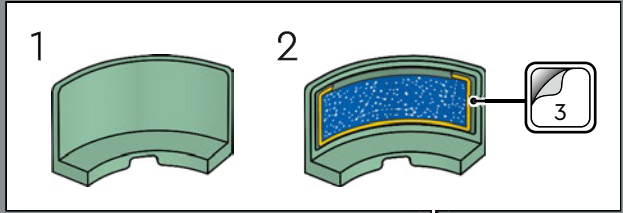

181

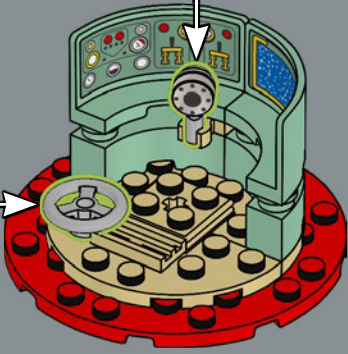
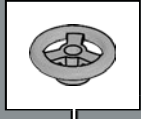
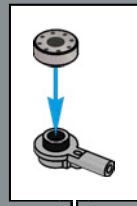

182

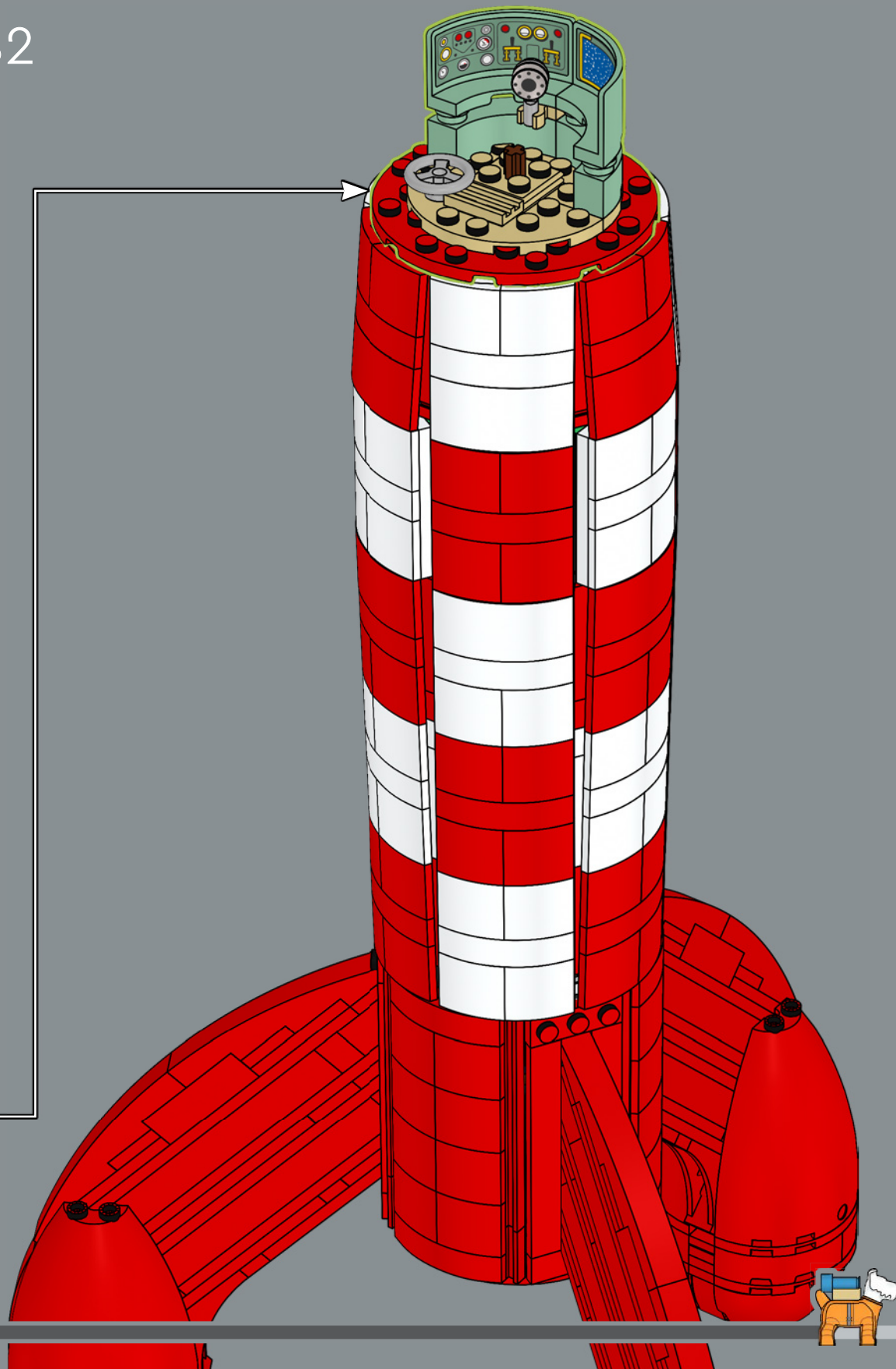

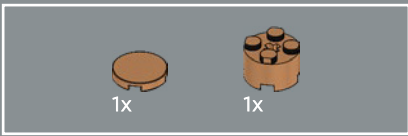

183

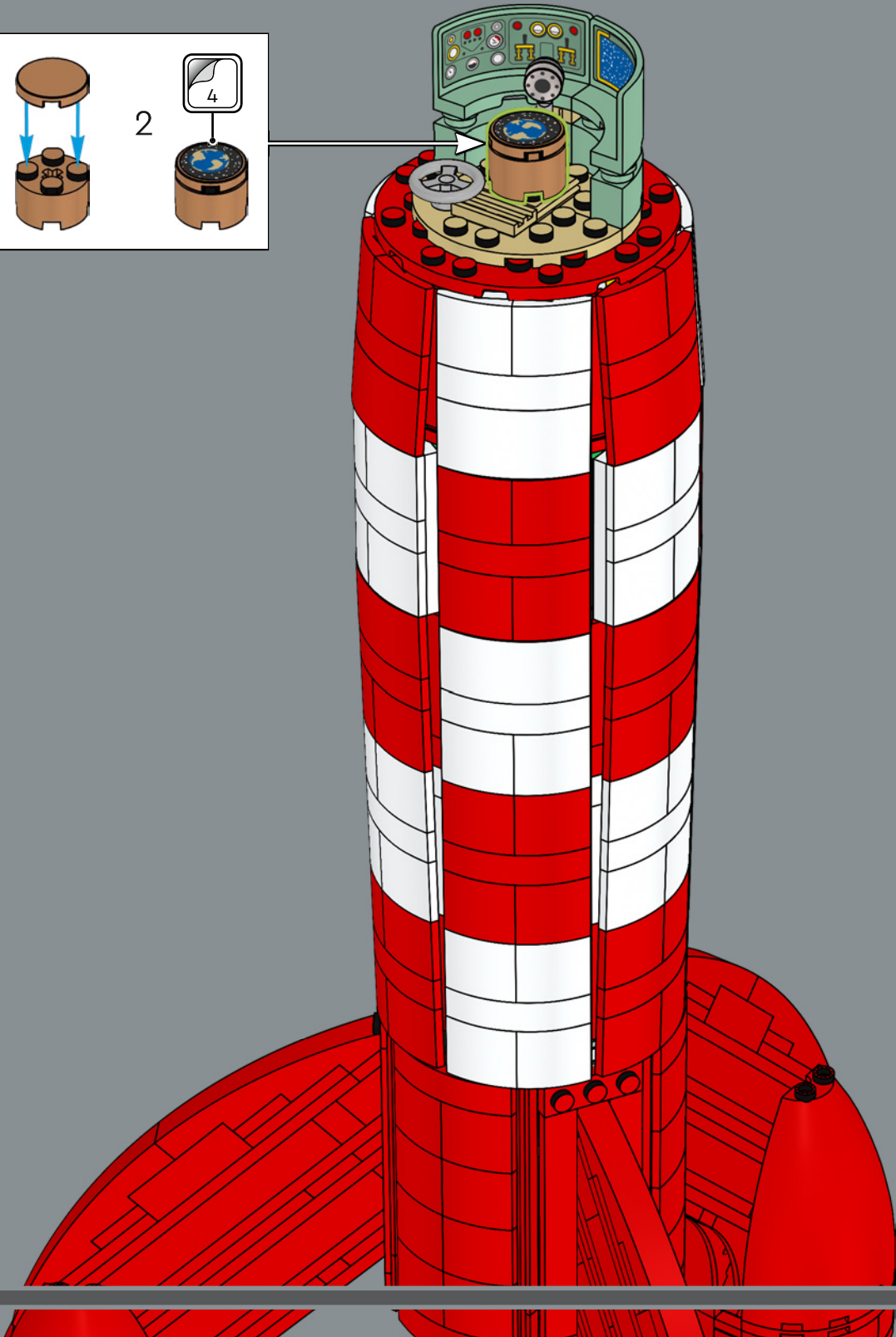
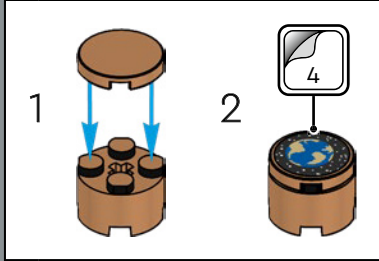

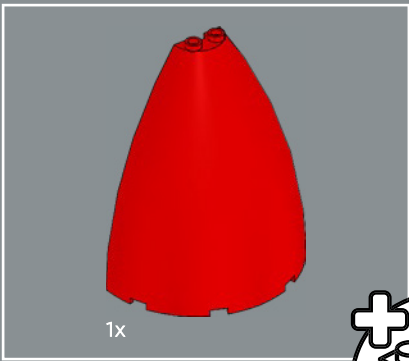

184

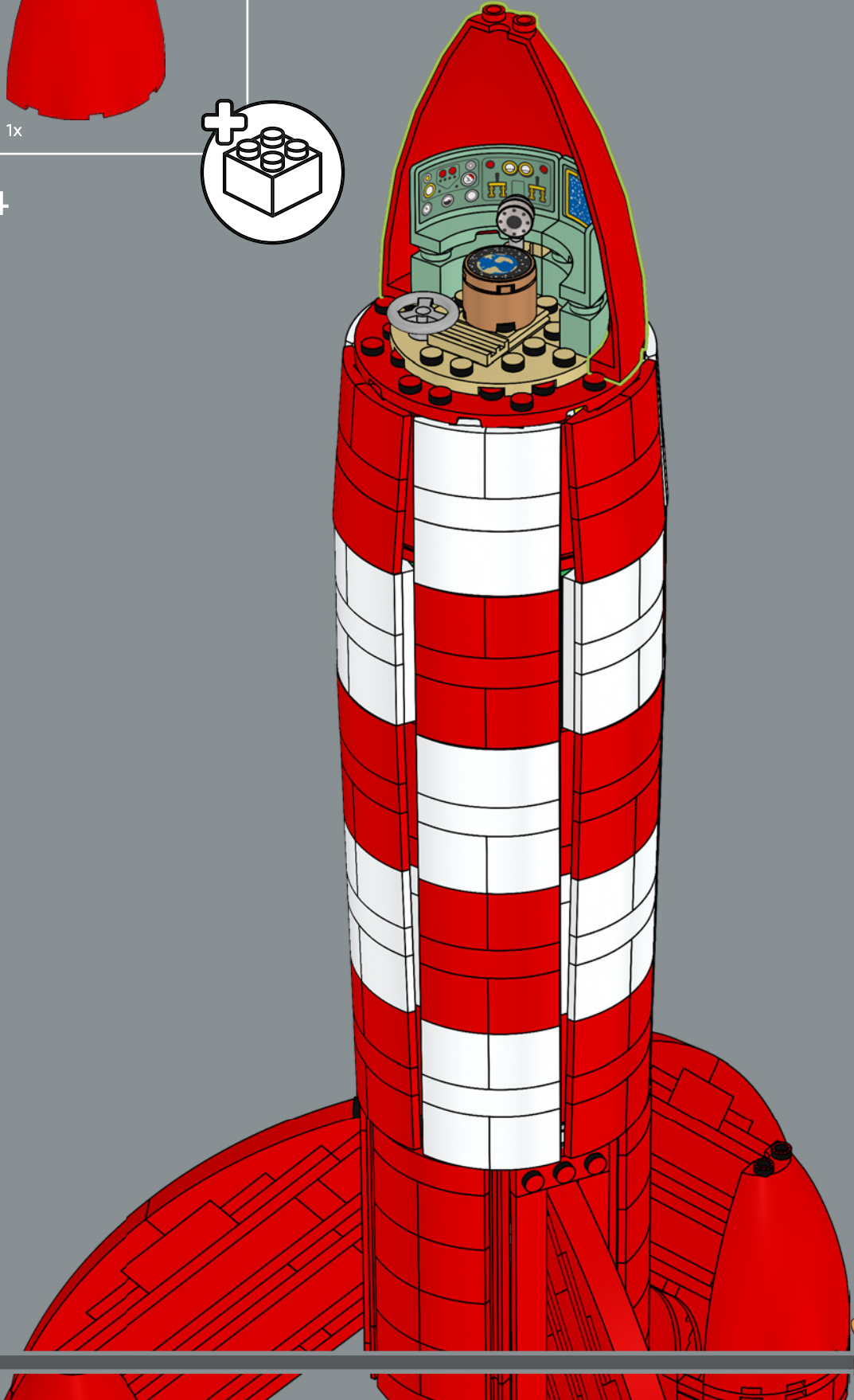
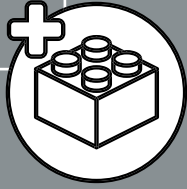

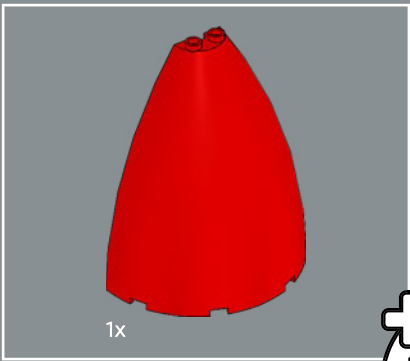

1x

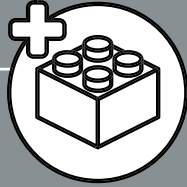

185

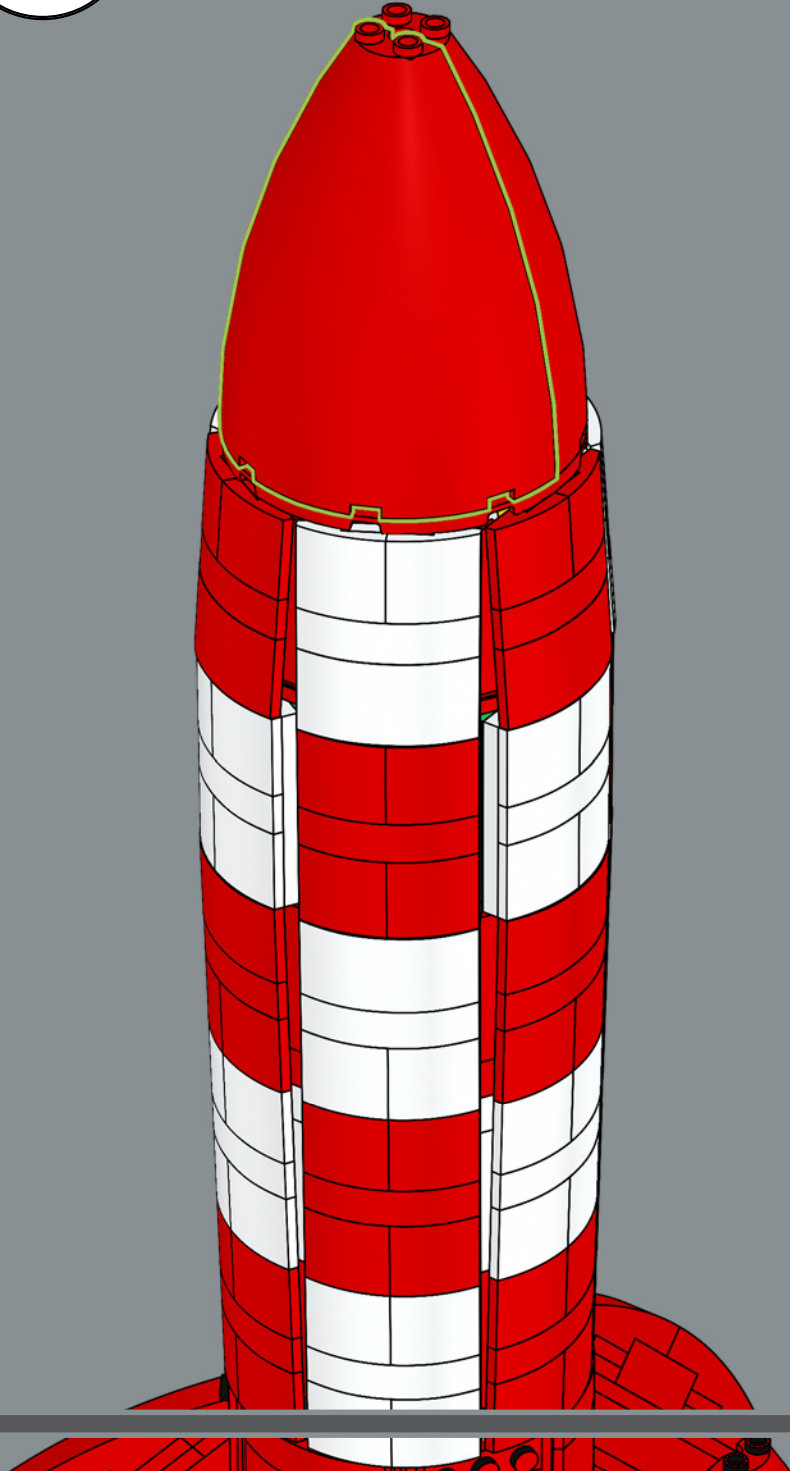

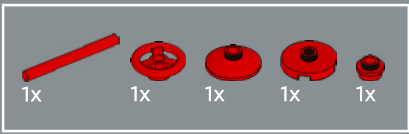

186

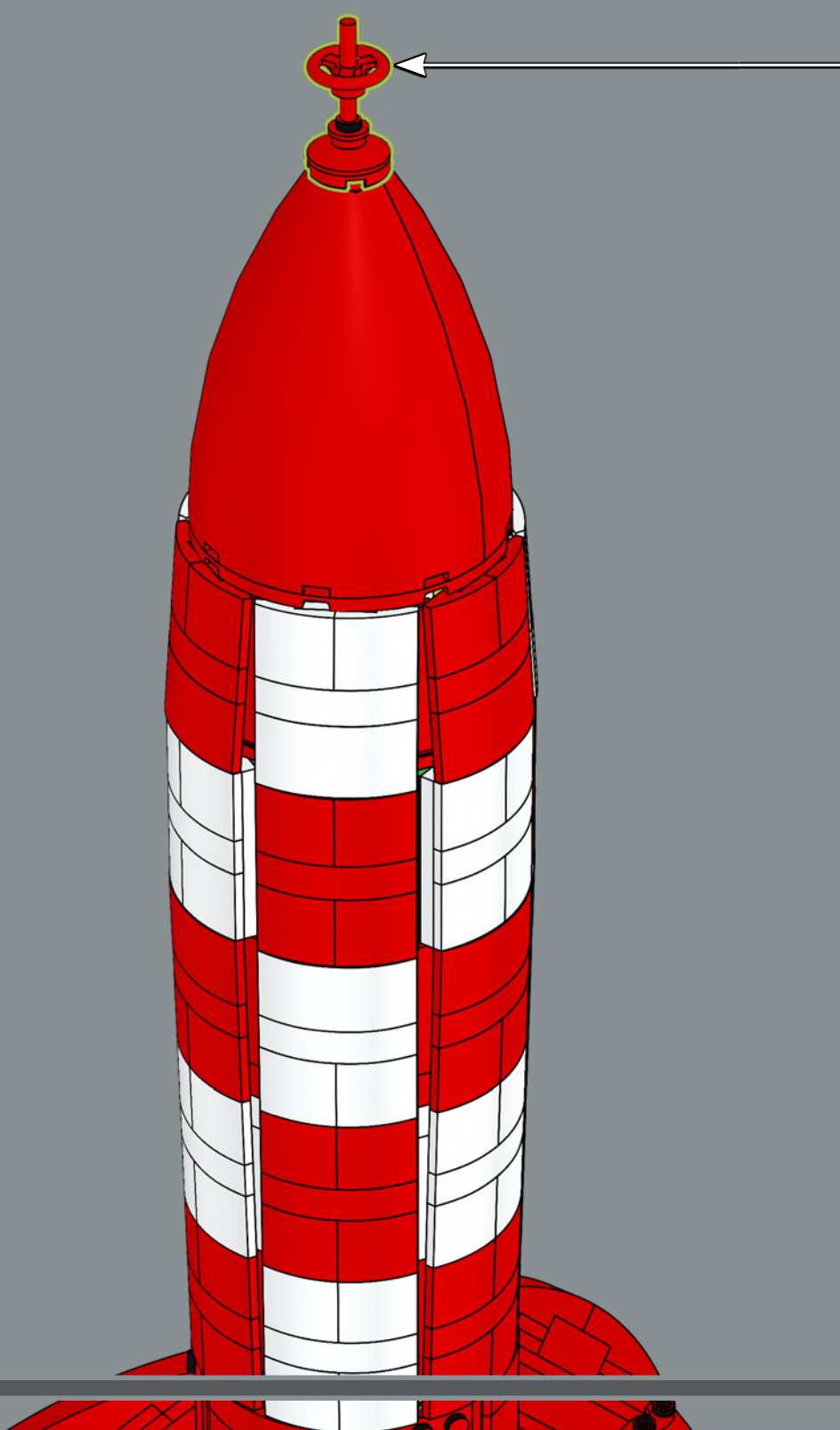
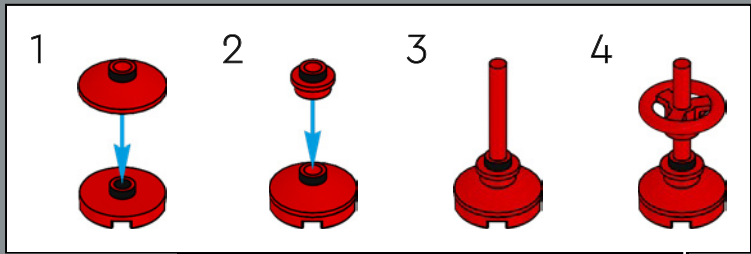

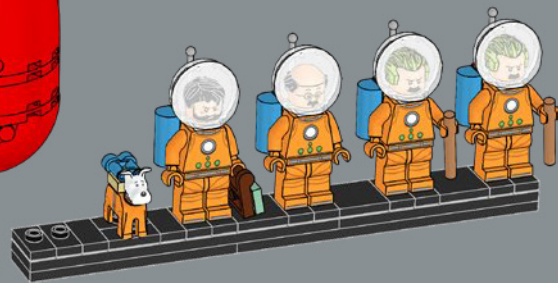
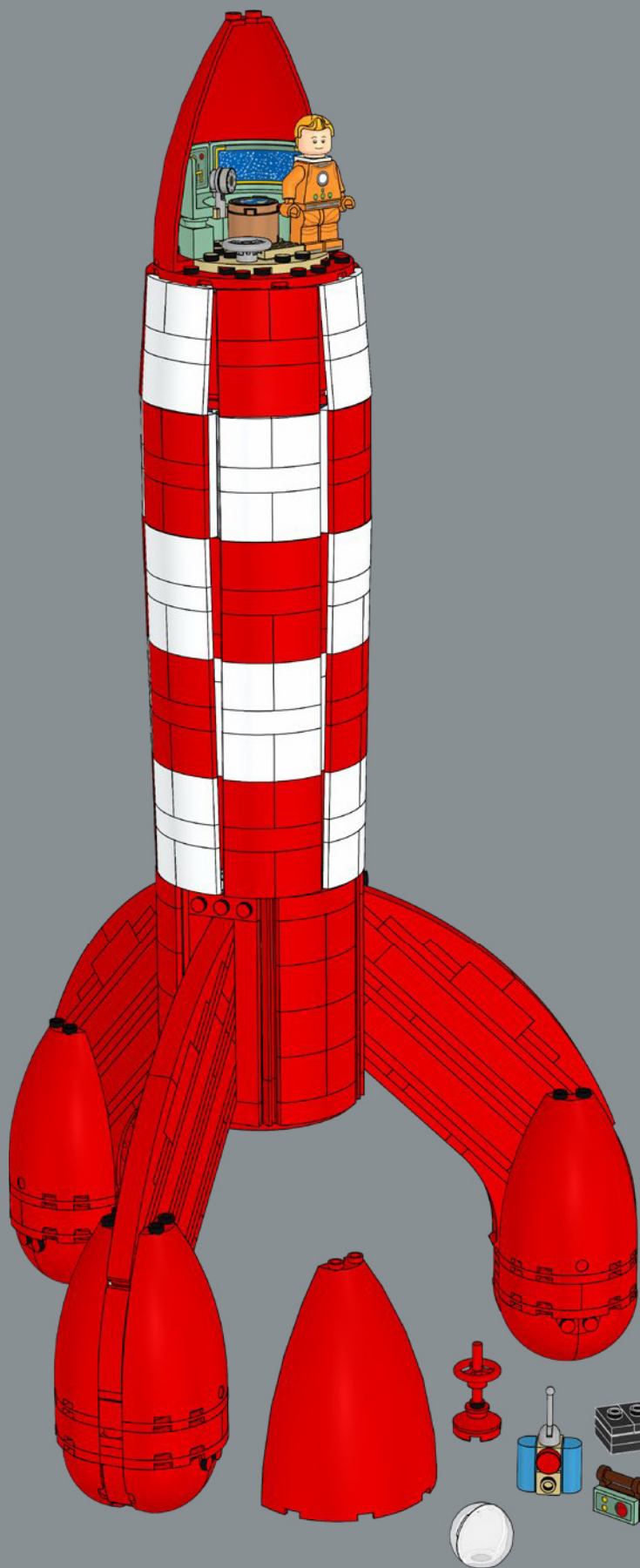

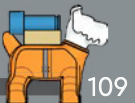
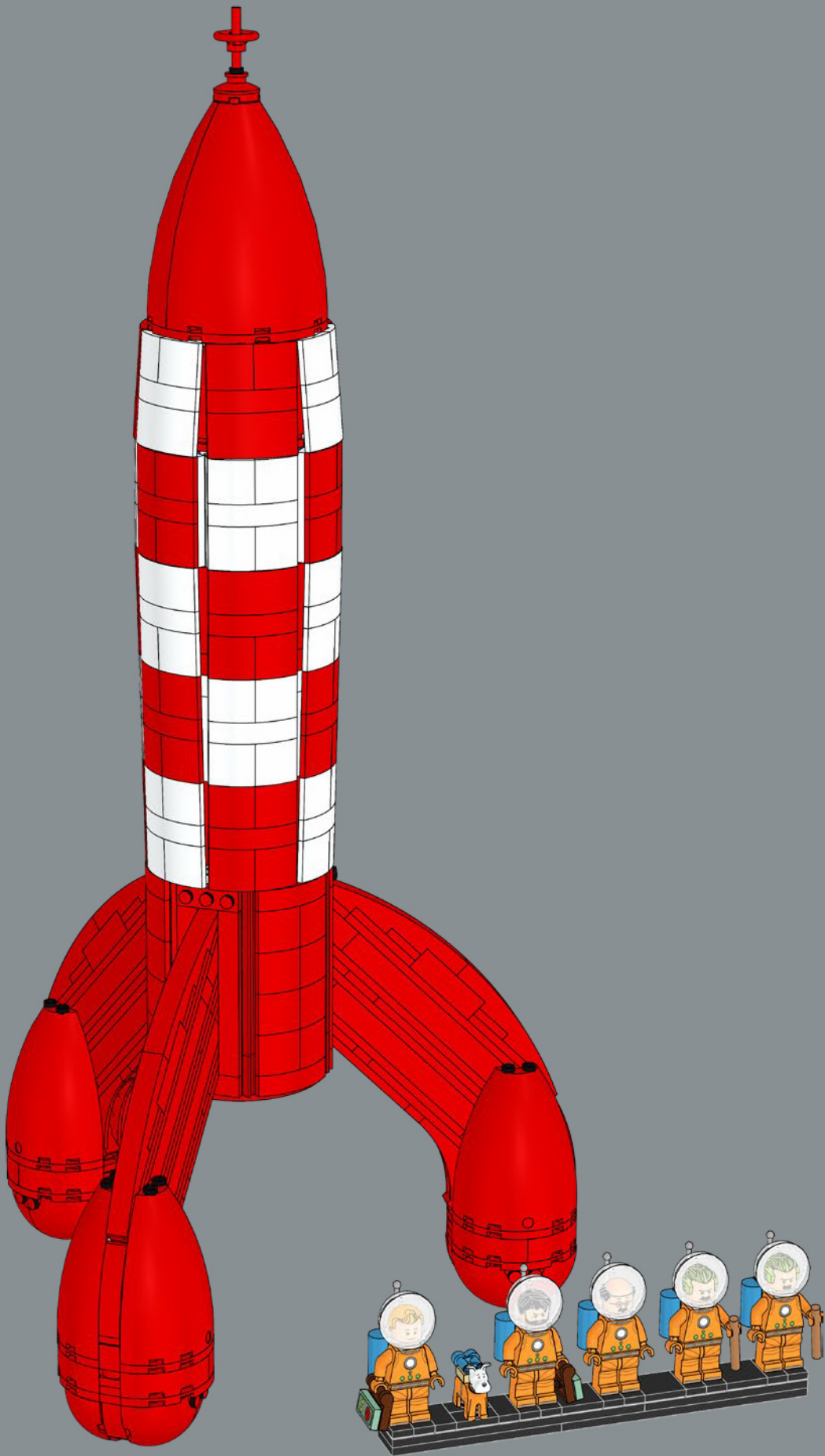



IDEAS

GATHER SUPPORT
HOL DIR UNTERSTÜTZUNG
RECUEILLENZ DES VOTES
CHIEDI DI ESSERE SUPPORTATO
CONSIGUE APOYOS
OBTÉM APOIO
爭取支持
ZDOBĄDŹ GŁOSY
ZÍSKEJTE PODPORU
ZÍSKAJTE PODPORU
SZEREZZ TÁMOGATÁST!
ЗБЕРІТЬ ПІДТРИМКУ
CERE SPRIJIN
ПОЛУЧЕТЕ ПОДКРЕПА
IEGŪSTI ATBALSTU
KOGU TOETUST
RINK PALAIKYMA

SHARE YOUR IDEA
TEILE DEINE IDEE
PARTAGEZ VOTRE IDÉE
CONDIVIDI LA TUA IDEA
COMPARTE TU IDEA
PARTILHA A TUA IDEIA
分享创意
PODZIEL SIĘ POMYSŁEM
SDÍLEJTE SVÉ NÁPADY
ZDIEĽAJTE SVOJE NÁPADY
OSZD MEG AZ ÖTLETED!
ПОДІЛІТЬСЯ СВОЮ ІДЕЮ
İMPARTÁŞEŞTE IDEEA TA
СПОДЕЛЕТЕ ИДЕИТЕ СИ
PARĀDI SAVU IDEJU
JAGA OMA IDEED
PASIDALINK SAVO IDĖJA

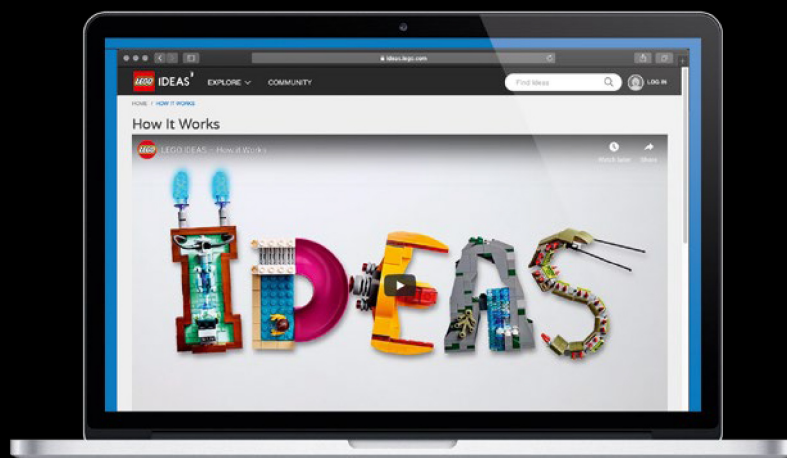
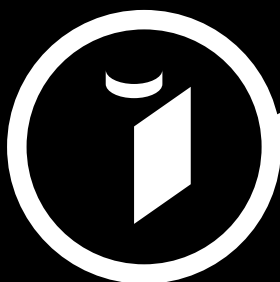
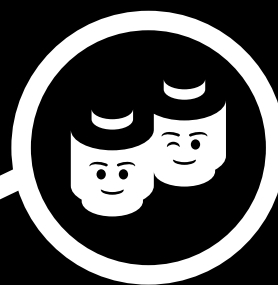

LEGO® REVIEW
LEGO® PRÜFUNG
EXAMEN PAR LEGO®
REVIEW LEGO®
REVISIÓN DE LEGO®
AVALIAÇÃO LEGO®
乐高®审核
OCENA LEGO®
POSOUZENÍ DESIGNÉRY LEGO®
POSÚDENÉ DIZAJNÉRMÍ LEGO®
LEGO® VÉLEMÉNYEZÉS
ОГЛЯД LEGO®
VERIFICARE LEGO®
ΠΡΕΓΛΕΔ ΗΑ LEGO®
LEGO® RECENZIJA
LEGO® ARVUSTUS
LEGO® APŽVALGA

NEW LEGO® PRODUCT
NEUES LEGO® PRODUKT
NOUVEAU PRODUIT LEGO®
NUOVO PRODOTTO LEGO®
NUEVO PRODUCTO LEGO®
NOVO PRODUTO LEGO®
全新乐高®产品
NOWY PRODUKT LEGO®
NOVÁ STAVEBNICE LEGO®
NOVÁ STAVEBNICA LEGO®
ÚJ LEGO® TERMÉK
НОВИЙ ПРОДУКТ LEGO®
PRODUS LEGO® NOU
НОВ ПРОДУКТ LEGO®
JAUNS LEGO® PRODUKTS
UUS LEGO® TOODE
NAUJAS LEGO® PRODUKTAS

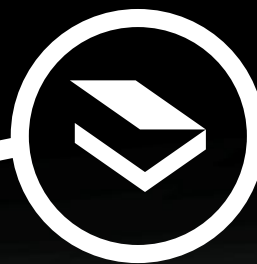

ideas.LEGO.com

- 9x 6388018
- 15x 614101
- 6x 307001
- 5x 6277181
- 6x 6212049
- 18x 6210272
- 6x 393801
- 15x 302301
- 3x 6548968
- 6x 6172927
- 12x 403201
- 6x 3200001
- 12x 6361170
- 48x 6047220
- 6x 6223491
- 12x 362301
- 6x 302201
- 15x 6023806
- 6x 243101
- 6x 6554416
- 3x 302001
- 24x 6350399
- 3x 4249021
- 6x 6053026
- 5x 6365720
- 1x 4159553
- 5x 4125253
- 5x 6609636
- 1x 6352222
- 5x 6262188
- 12x 6013938
- 1x 4124456
- 2x 6330903
- 6x 4160483
- 12x 4113233
- 2x 6099893
- 6x 4114324
- 6x 6036487

5

- 5x 6284574
- 9x 6378120
- 6x 6249907
- 1x 6223427
- 18x 307021
- 6x 302421
- 3x 6372478
- 12x 6345637
- 3x 300521
- 12x 6435047
- 1x 6527648
- 1x 6132541
- 6x 6029946
- 1x 4585146
- 3x 4142865
- 27x 302321
- 6x 6186398
- 3x 366521
- 6x 300421
- 6x 6540808
- 72x 6105976
- 9x 6433069
- 6x 6347789
- 6x 4612575
- 3x 4533742
- 3x 362321
- 12x 6334053
- 1x 6296954
- 1x 6129995
- 3x 6583512
- 3x 6547141
- 21x 4633914
- 6x 371021
- 18x 243121
- 6x 6592314
- 3x 302021
- 3x 301021
- 3x 4142132

4

5

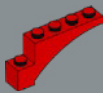

3x
6594986



12x
6295298



3x
366621



6x
6594751

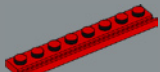

6x
6078594



6x
416221



9x
346021



6x
6594753



2x
6595787

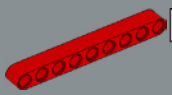

3x
4645733



1x
6603363



1x
6594752

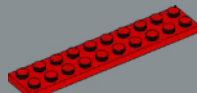

3x
383221

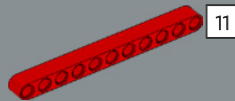

3x
4562805



12x
4514843

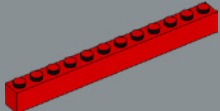

6x
611221



3x
6284575



3x
6584954



6x
6537695



12x
614123



19x
4206482



9x
302323



6x
6073890

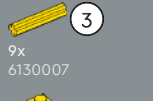

6x
346023



33x
614124



15x
302324



9x
6130007

6x
4501232

1x
6130008

6x
371024



1x
6389951



2x
6332148



1x
4526110



3x
6299338



17x
6279875



12x
6210270



12x
6092585



2x
306926



3x
6089119



6x
6097283



3x
306826



3x
306826



3x
6572774



1x
6460708



6x
6428167



2x
6416838

3x
302126

9x
6280168

1x
6438426

6x
6271573



6x
379526

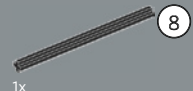

1x
370726

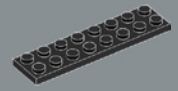

2x
303426

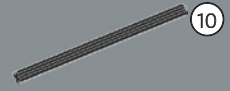

1x
373726

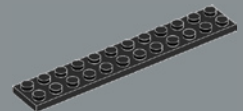

2x
244526



6x
4569058



6x
6541878



6x
6510079



1x
6374076



3x
6047426



21x
302328



6x
6347288



6x
4521931



6x
4107758



1x
6573947

3x
6359717

10x
6414564

6x
6442359

9

3

5

8

10



9x
4177932



5x
6593094



1x
6593089



3x
4118787



5x
6607486

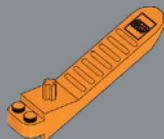

1x
6240515



6x
6539419



6x
6574771

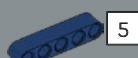

3x
6420960



3x
6403175



2x
4616578



2x
6599347



2x
6599346



2x
6599346



2x
6607967



1x
6595785



2x
6236915



7x
6135494



8x
6441316



5x
6267587



3x
6345639



18x
6336539



1x
6227897



3x
4211350



1x
6092956



3x
4211862



3x
4211541



3x
6540763



3x
6321747



3x
6321747



4x
6043639



6x
4211397



12x
6421522



6x
6347992



3x
6549304



3x
6307999



6x
6372029



6x
4211462



3x
4611705



3x
6395635



12x
6178919



3x
6514456



6x
6284702



3x
6083620



6x
6039482



3x
6083620



6x
6039482



3x
6083620



6x
6039482



1x
6443852



6x
6574782



3x
6573660



1x
6593099



1x
6593098



1x
6593097



1x
6593096



1x
6593095



1x
6593095



1x
6593090



1x
6368592



1x
6454167



2x
6600809



3x
6336665



1x
6551965



1x
6603200



10x
6601287



9x
6097419

3

5

11

4



YOU COULD WIN



YOU COULD WIN

Your feedback will help shape the future development of this product series.

Visit:

DU KÖNNTEST GEWINNEN

Dein Feedback trägt zur Weiterentwicklung dieser Produktreihe bei.

Geh auf:

VOUS POURRIEZ GAGNER

Vos commentaires nous aideront à concevoir les futurs produits de cette gamme.

Visitez :

POTRESTI VINCERE TU

La tua opinione ci aiuterà a migliorare la creazione futura di questa linea di prodotti.

Visita:

PUEDES GANAR

Tu opinión contribuirá al futuro de esta serie de productos.

Visita:

轻松获奖

您的反馈将有助于我们在今后改进本产品系列。

请访问:

LEGO.com/productfeedback

You also have the chance to win a LEGO® set.

Terms and conditions apply.*

Außerdem hast du die Chance, ein LEGO® Set zu gewinnen.

Es gelten die Teilnahmebedingungen.*

Vous pourriez également gagner un ensemble LEGO®.

Des conditions s'appliquent.*

Hai anche la possibilità di vincere un set LEGO®.

Termini e condizioni sono applicabili.*

También tienes la oportunidad de ganar un set LEGO®.

Aplican términos y condiciones.*

您还有机会赢取乐高®套装。

条款和条件适用。*

*LEGO.com/productfeedback-terms



In partnership with the Hergé Museum
In Partnerschaft mit dem Hergé-Museum
En partenariat avec le Musée Hergé
In collaborazione con l'Hergé Museum
En colaboración con el Museo Hergé
Em parceria com o Museu Hergé
与埃尔热博物馆合作
We współpracy z Muzeum Hergé
Ve spolupráci s Muzeem Hergé
V spolupráci s Muzeom Hergé
A Hergé Museummal együttműködésben
У партнерстві з музеєм Ерже
În parteneriat cu Muzeul Hergé
Съвместно с музей „Ерже”
Sadarbībā ar Hergé muzeju
Koostöös Hergé muuseumiga
Sukurta bendradarbiaujant su Hergé muziejumi
Hergé Müzesi ile iş birliği içinde

