



21367





LEGO.com/sustainable-packaging



FR  
**DONNEZ**  
OU  
**RECYCLEZ**



OU



OU



ASSOCIATION    MAGASIN    DÉCHÈTERIE

Adresses sur [quefairedemesdechets.fr](http://quefairedemesdechets.fr)

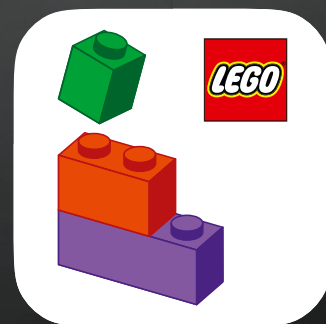

LEGO® Builder



# BUILDER

Download on the  
App Store

GET IT ON  
Google Play

腾讯应用宝  
安卓应用商店

Apple and the Apple logo are trademarks of Apple Inc., registered in the U.S. and other countries and regions. App Store is a service mark of Apple Inc. Google Play and the Google Play logo are trademarks of Google LLC. Tencent and the Tencent logo are trademarks of Tencent Inc.

[LEGO.com/devicecheck](https://LEGO.com/devicecheck)



LEGO® Fandesigner Alexis  
Dos Santos mit seinem  
Originalmodell

# LERNE DEN FANDESIGNER KENNEN

Wie Alexis Dos Santos (LEGO® Ideas Name Tkel86) aus Portugal genug Zeit für seinen Beruf als Programmierer und Webdesigner findet, ist uns ein Rätsel. Mit einem umfangreichen Portfolio an komplexen MOCs (My Own Creations) ist dieser Fandesigner ständig beschäftigt!

„In meiner Freizeit liebe ich alles, was Kreativität und Einfallsreichtum verbindet – LEGO Bauwerke, Elektronikprojekte, Holzarbeiten, Zeichnen, Grafikdesign, 3D-Modelle und Bildhauerei. Ich liebe es, Materialien für neue Zwecke wiederzuverwenden, zum Beispiel indem ich ein LEGO Set auseinandernehme, um ein Neues zu bauen. Ich erinnere mich noch gut daran, wie ich mit LEGO Steinen gespielt habe – als Kind habe ich von einem Cousin eine Kiste voller Steine geerbt und von da an meine Sammlung erweitert, bis ich ein Teenager war. Ich hatte eine sogenannte „dunkle Phase“, in der ich mich im Alter von 16 bis 26 Jahren von den LEGO Steinen fernhielt. Dann entdeckte ich meine Leidenschaft wieder, als ich zufällig eine LEGO Fanausstellung besuchte, die von einer Community organisiert worden war. Am Ende schloss ich mich ihnen an, und dieses Hobby wuchs exponentiell. Dieses Projekt dauerte etwa sechs Monate. Ich habe Tim

schon immer bewundert, und ein Kollege hat mich dazu inspiriert, dieses Modell mit LEGO Steinen nachzubauen. Ich habe einige Technic-Teile verwendet, um die Befestigungen für die Beine und den oberen Kegel zu gestalten. Mir gefällt, dass das Modell runde und konische Elemente aus mehreren Teilen verwendet, da es immer eine Herausforderung ist, sichtbare Lücken mit relativ komplexen Verbindungsstücken zu reduzieren. Einige dieser rot markierten Elemente waren schwer zu finden! Nachdem ich mein Modell auf der LEGO Ideas Website geteilt hatte, wollte ich es noch etwas verfeinern, aber während ich mit anderen Projekten beschäftigt war, erreichte es nach und nach 10.000 Unterstützer. Ich liebe es, wenn Modelle mechanische Bewegungen und schöne Ästhetik kombinieren. Ich hoffe, dass die Fans vom Wow-Faktor des endgültigen Modells begeistert sein werden.“



Alexis' Modell und das Bild aus dem Buch, das ihn zu seiner Idee inspirierte

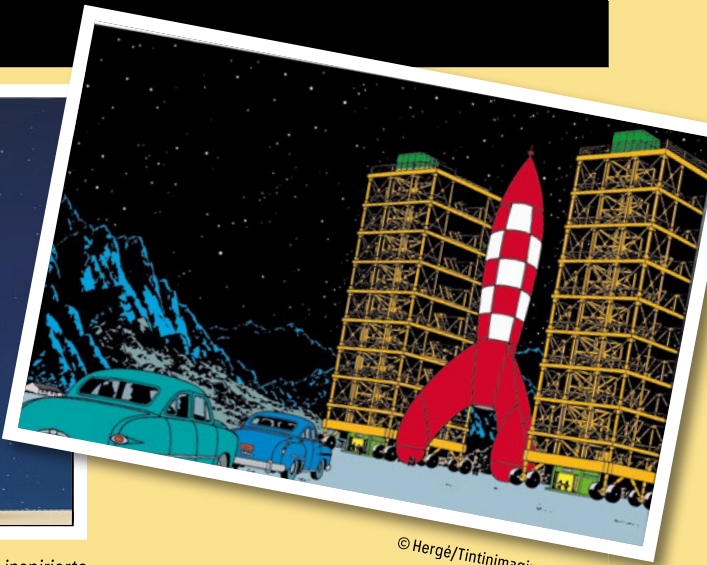

© Hergé/Tintinimagnatio 2026

# EIN ENTDECKER AUF DEM MOND!

Die rot-weiß karierte Rakete aus *Reiseziel Mond* (1953) und *Schritte auf dem Mond* (1954) ist nach wie vor eines der bekanntesten Symbole aus *Tim und Struppi*. In der Geschichte begeben sich Tim, Kapitän Haddock, Struppi und Professor Calculus auf eine gewagte Reise, um die dunkle Seite des Mondes zu erkunden, und starten dazu eine bahnbrechende Rakete aus dem fiktiven Land Syldavien. Bei der ersten Veröffentlichung des Abenteuers wurden die Leser in eine Zukunft entführt, in der die bemannte Raumfahrt zum Greifen nah schien, zu einer Zeit, als eine tatsächliche Mondlandung noch ein Traum war. Die Rakete wurde schnell zu einem Symbol für technologischen Fortschritt und Innovation, da Tim und seine Freunde mit einer Mischung aus Abenteuer, Spannung und modernen Naturwissenschaften die Fantasie von Millionen Menschen beflügelten.

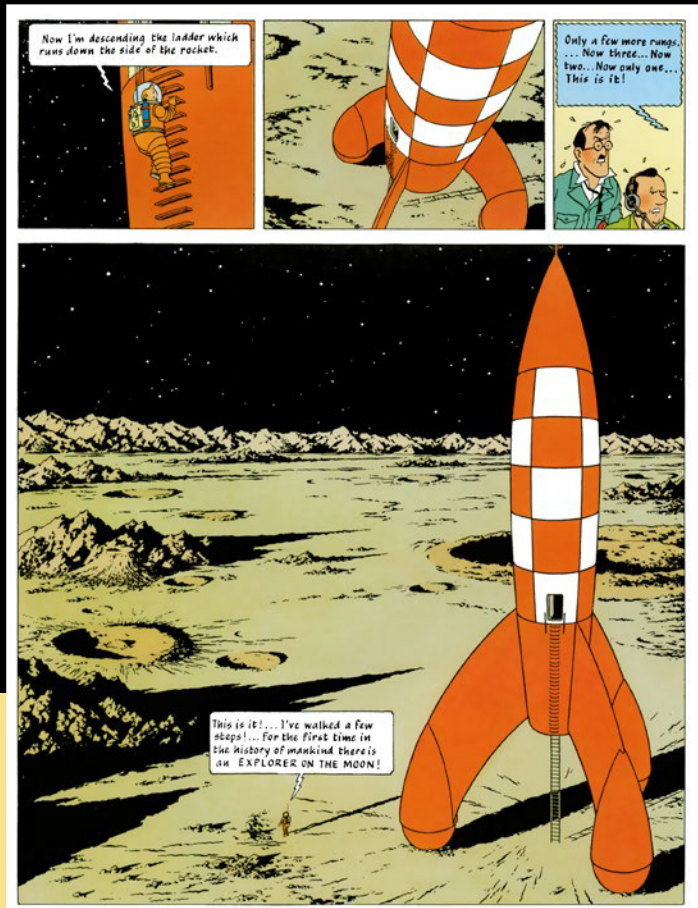

© Hergé/Tintinimaginatio 2026



# KUNST TRIFFT NATURWISSENSCHAFTEN

Die Geschichte verwebt die vertrauten Wortgefechte, den Witz und Humor der Figuren nahtlos zu einer spannenden Erzählung über Spionage und wissenschaftliche Entdeckungen. Da das Raketendesign, das Sprodj Atomic Research Centre und die technischen Details der Reise alle auf realen, damals verfügbaren Forschungsergebnissen basierten, wirkte die Geschichte sowohl neuartig als auch überzeugend, und die detailreichen Szenen brachten einem breiteren Publikum die fortgeschrittene Wissenschaft näher. Das Erbe von Tim und Struppi wird heute an Orten wie dem Hergé-Museum bewahrt, und der Pioniergeist seiner Rakete inspiriert weiterhin Träumer und Entdecker gleichermaßen.

© Hergé/Tintinimagination 2026



Viele Details basierten auf realen Naturwissenschaften.



© Danny Gys - Atelier Christian de Portzamparc Hergé-Tintinimagination 2026

Hergé stellte umfangreiches Forschungsmaterial und Dokumente zusammen. Einige sind unklarer Herkunft, wie diese Schwarz-Weiß-Fotos, die unter einer separaten Kategorie „Hergé-Dokumentation“ klassifiziert sind.

# DAS LEGO® IDEAS TEAM

Das Ventilatormodell war wirklich gut gemacht – und außerdem riesig! Also einigten wir uns darauf, den Turm zu entfernen und uns auf die Rakete selbst zu konzentrieren. Alexis' Modell von der Erde ins Weltall zu bringen und die Figuren in ihren legendären Raumanzügen zu zeigen, darunter natürlich auch eine LEGO® Struppi-Figur! Hergé war bekannt für seine Liebe zum Detail und seine Genauigkeit, und wir wollten seinem Werk gerecht werden. Die Rakete hat eine sechseckige Form mit einer leichten Krümmung von oben nach unten. Wir haben unzählige verschiedene Bautechniken und Winkel erforscht, um diese Form zu erreichen. Die Quadrate des Schachbrettmusters auf der Raketenoberfläche sind trapezförmig,

und um dem Entwurf treu zu bleiben, stellten die glatte Oberfläche und das authentische Muster eine spannende Herausforderung dar. Die Flossen waren ein weiterer technischer Bestandteil des Modells. Die Lösung hierfür bestand darin, für jede der Flossen ein gespiegeltes Dreieck zu verwenden, um den richtigen Winkel zu erzeugen und diese zu fixieren, um dem Modell zusätzliche Stabilität zu verleihen. Für den oberen Kegel der Rakete haben wir ein neues Kegelement erstellt, das den Füßen der Rakete ähnelt, um die Konsistenz zu gewährleisten.

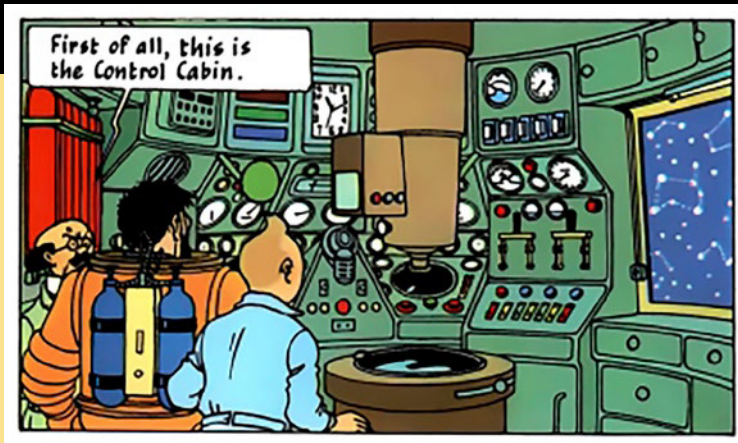

© Hergé/Tintinmagazine 2026





Wir haben oben auf der Rakete einen Kontrollraum eingebaut, um eine berühmte Szene nach dem Start zu zeigen, in der die Figuren zum ersten Mal die Erde aus dem Weltraum sehen. Wir haben es so genau wie möglich gestaltet, mit Dekorationen, Details und Aufklebern, und es ist uns sogar gelungen, die Luke für die Tür zum nächsten Level in der Rakete unterzubringen.

Die Figuren in Minifiguren zu „übersetzen“ war ein sehr unterhaltsamer Prozess. Sie haben so viel Persönlichkeit und Comic-Geschichte, dass wir uns auf Ausdrücke beschränkt haben, die diese Handlung widerspiegeln. Die Raumanzüge sind inspiriert durch *Schritte auf dem Mond*, und Thomson and Thompson haben ihr grünes Haar als Anspielung auf eine lustige Szene im Comic!



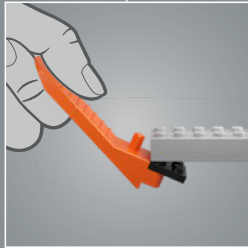
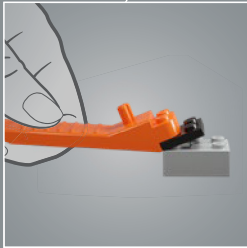
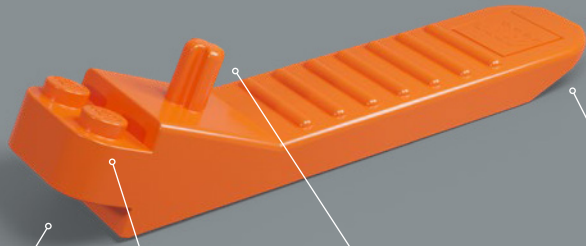

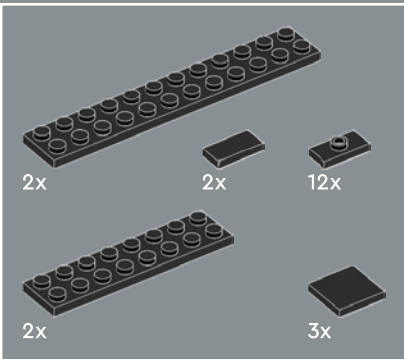
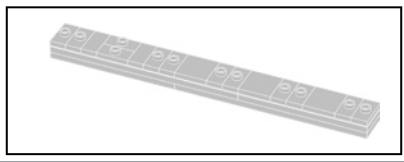

1

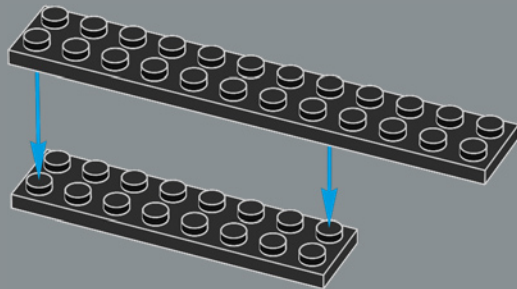

2

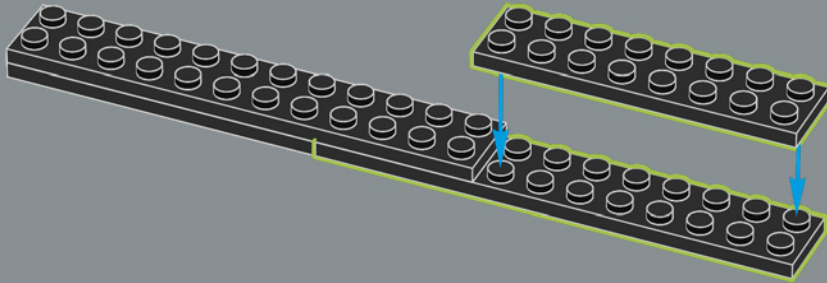

3

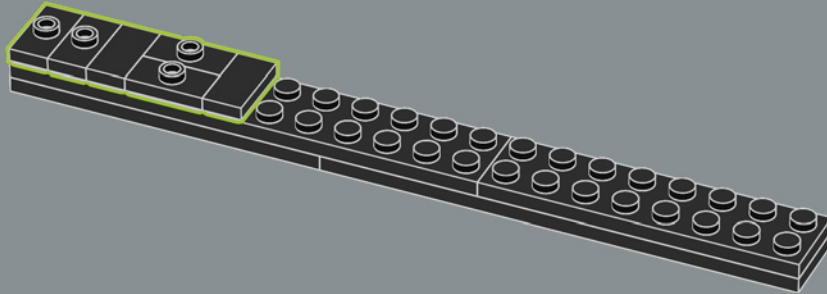

4

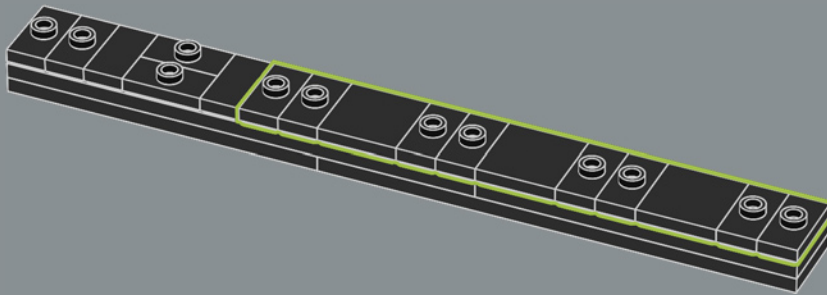

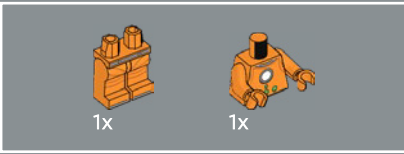
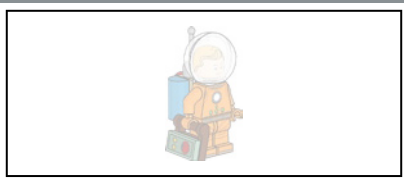

1

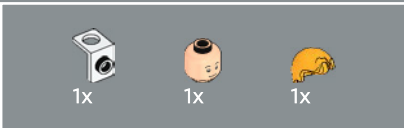
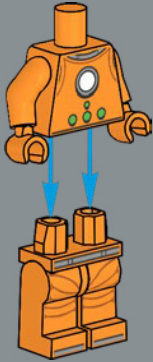

2

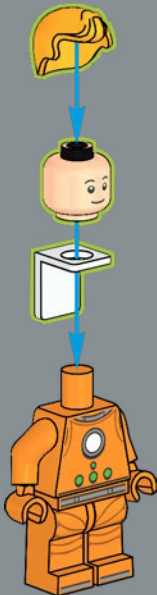

3

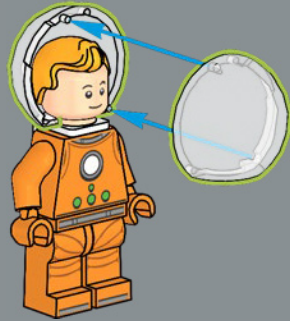

4

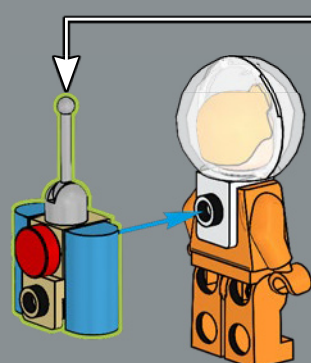
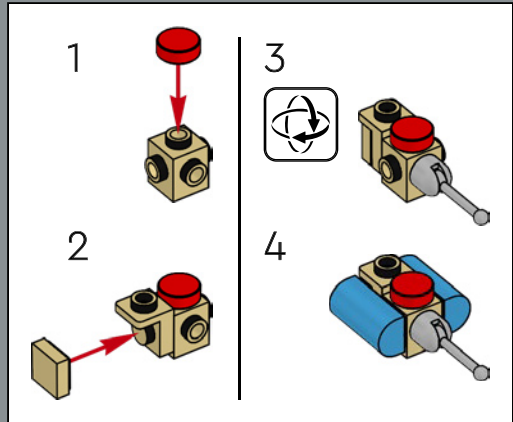



5

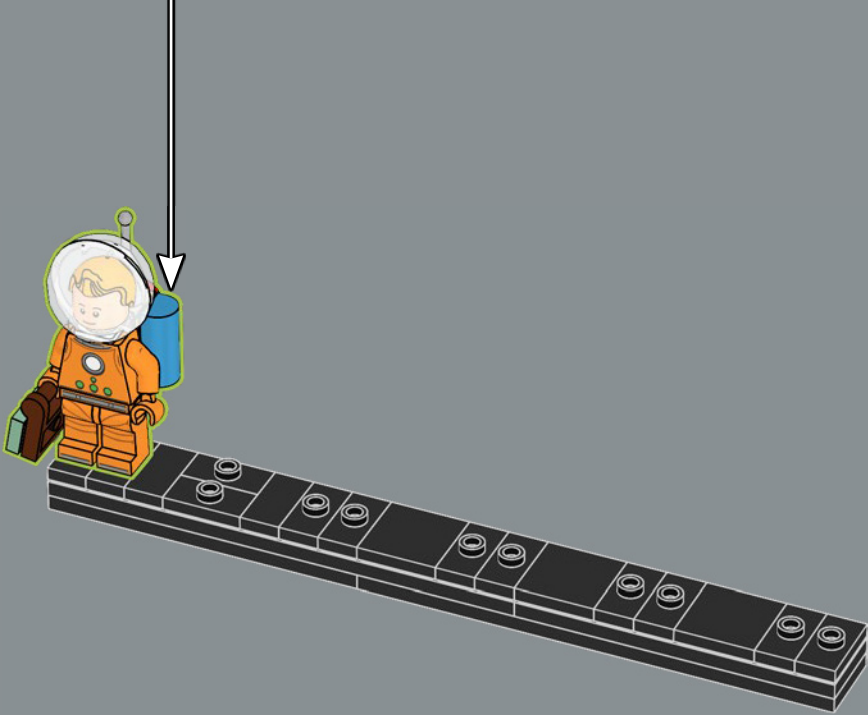
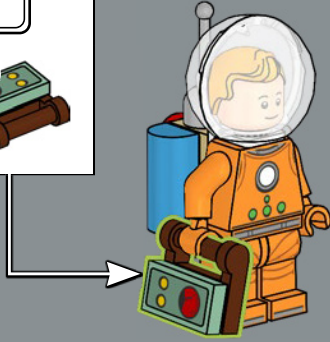
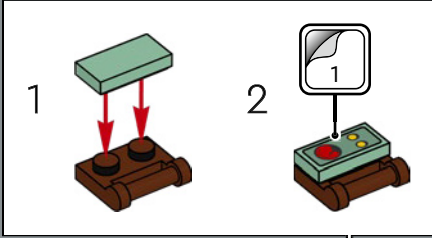

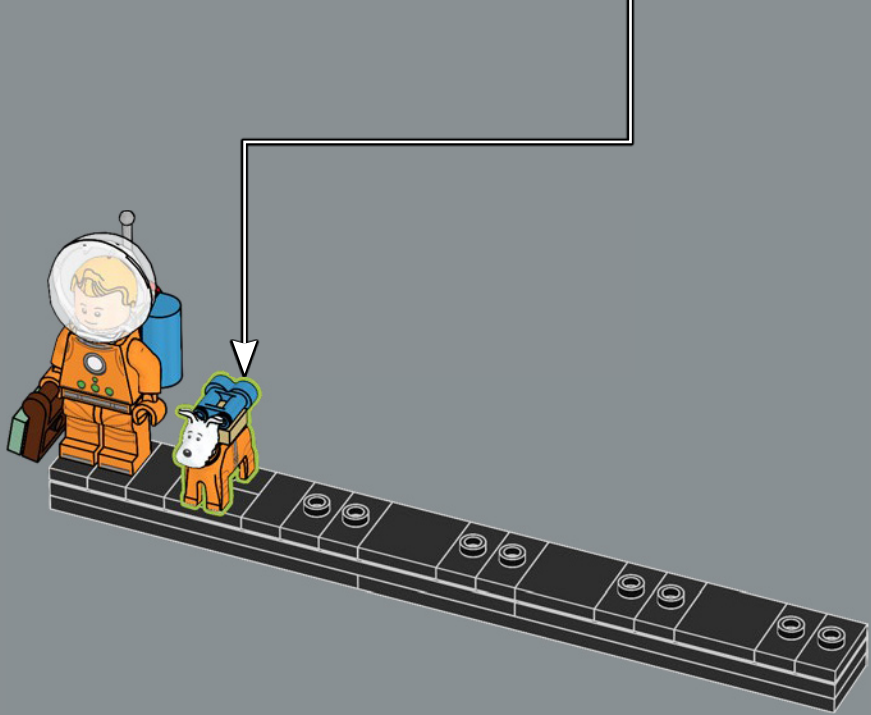
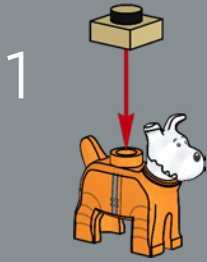

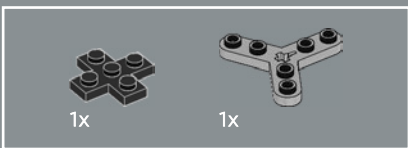
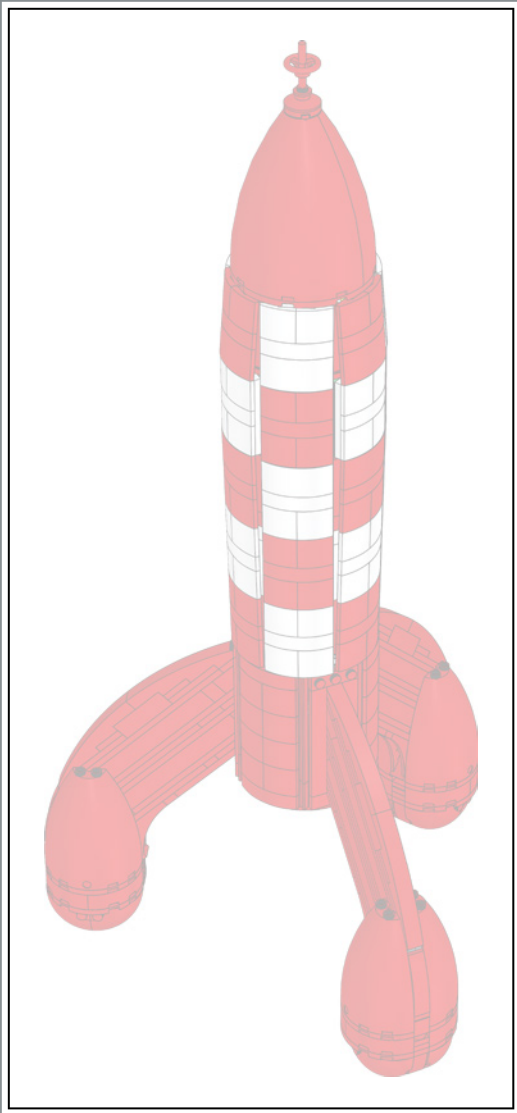

1

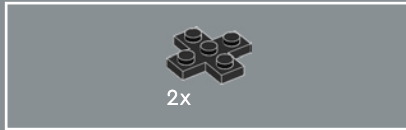
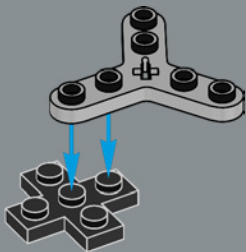

2

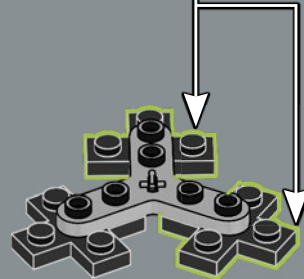
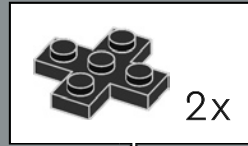

3

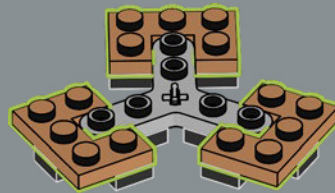

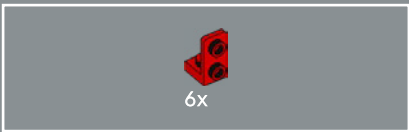

4

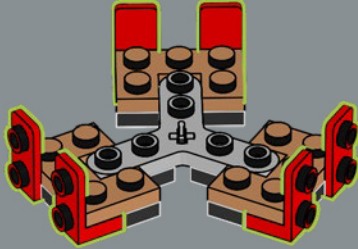

6

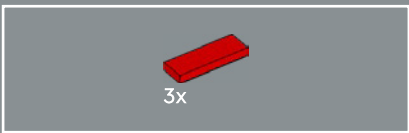

5

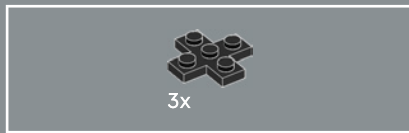
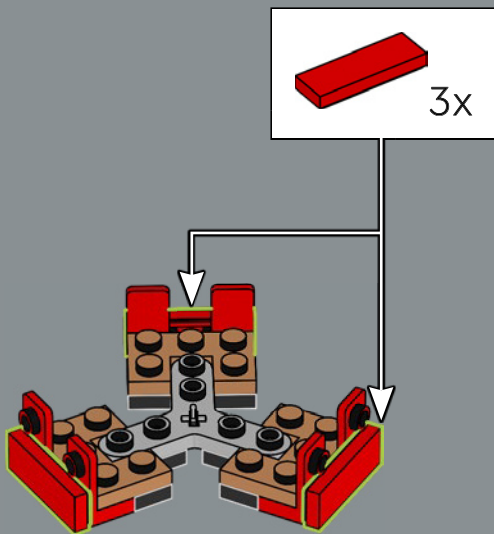

7

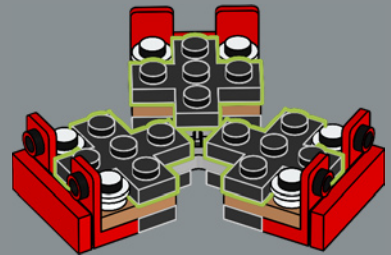

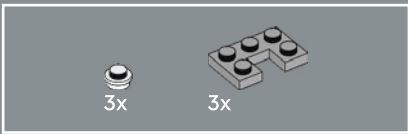

8



10

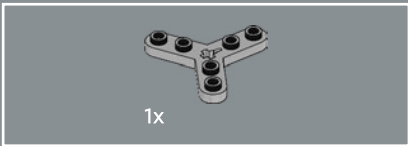
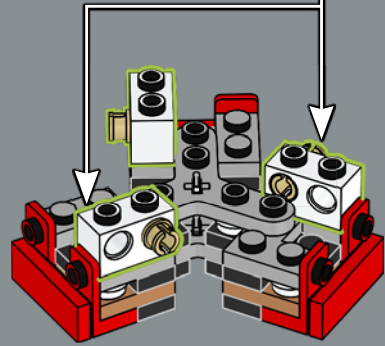
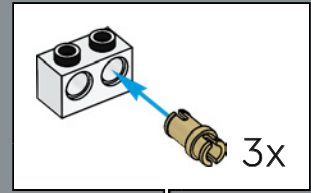

9

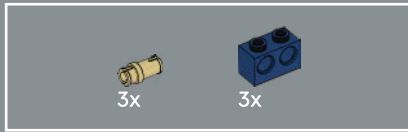
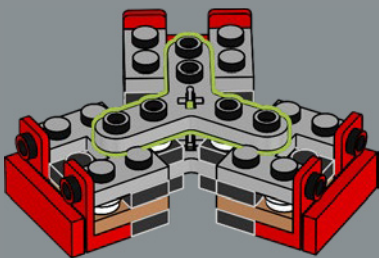

11

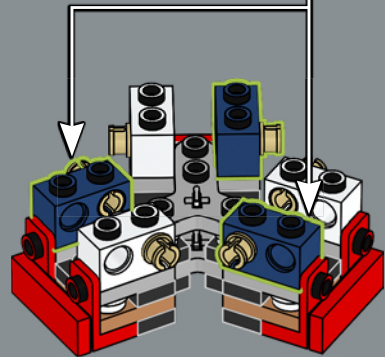
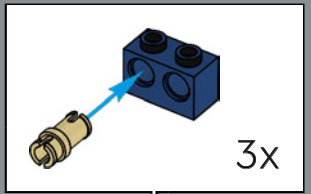



12

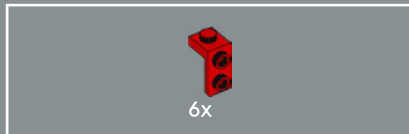
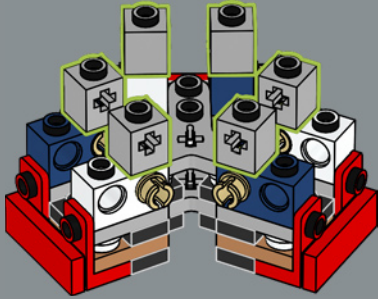

14

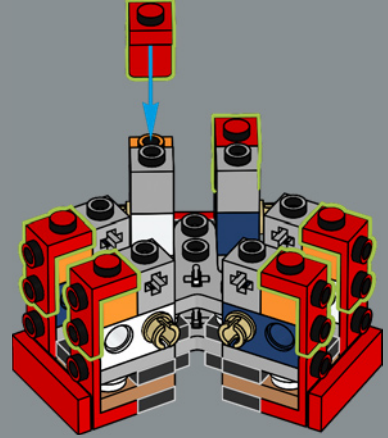

13

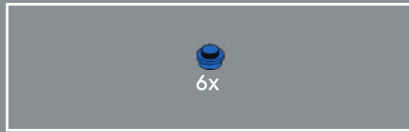
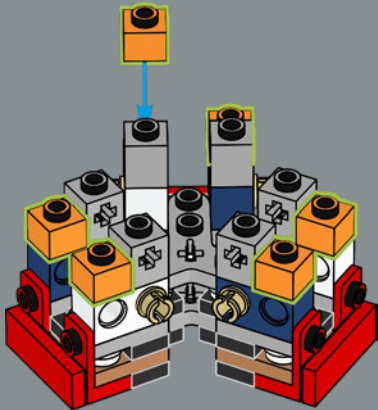

15

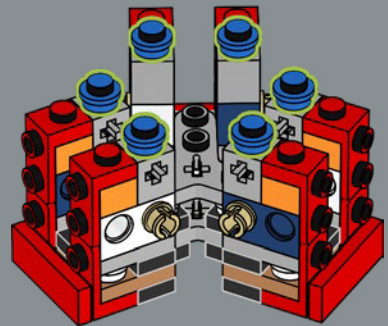

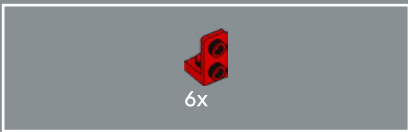

16

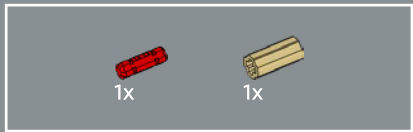
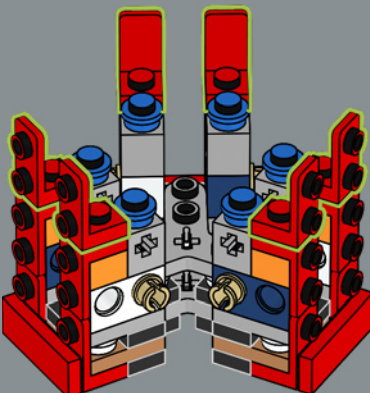

18

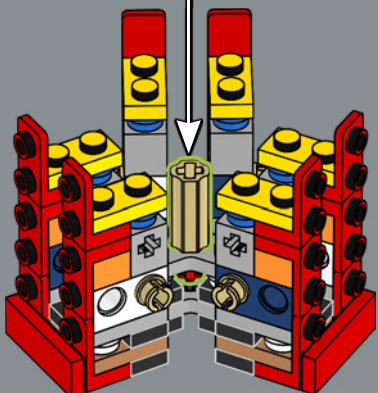
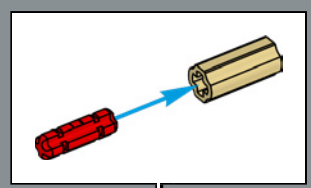

17

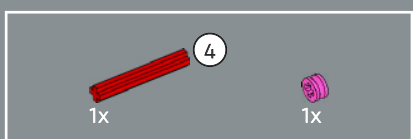
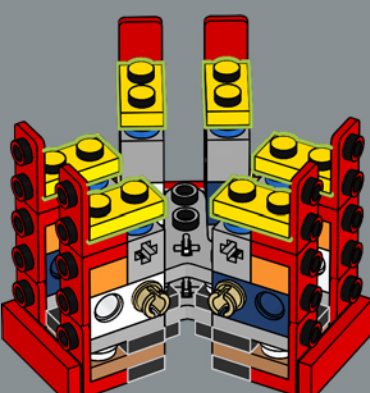

19

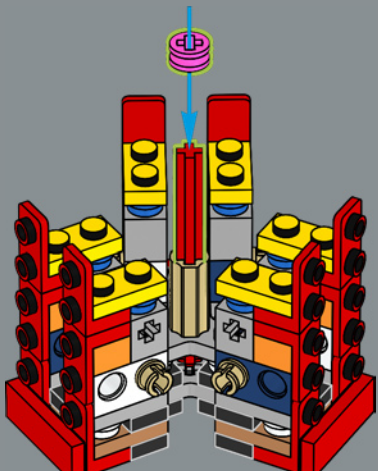

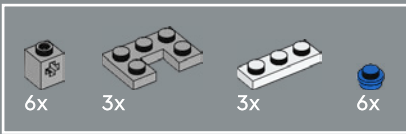

20

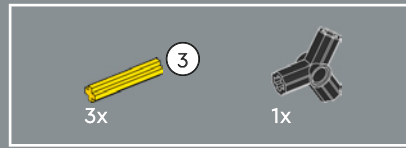
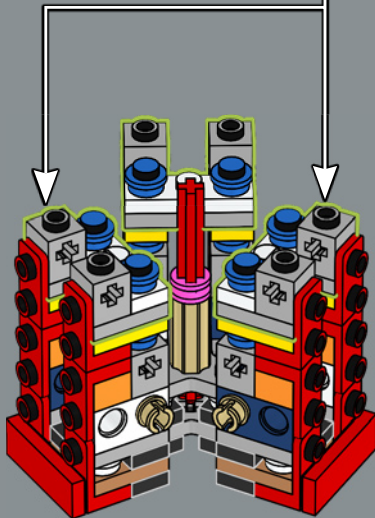
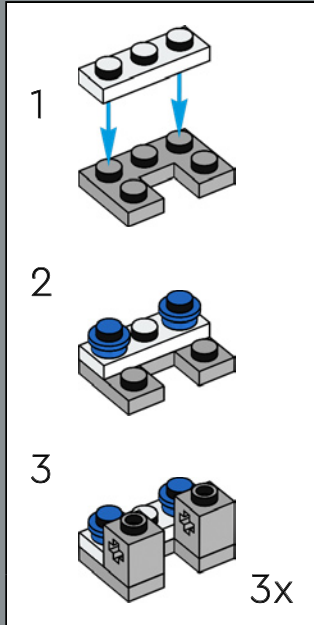

21

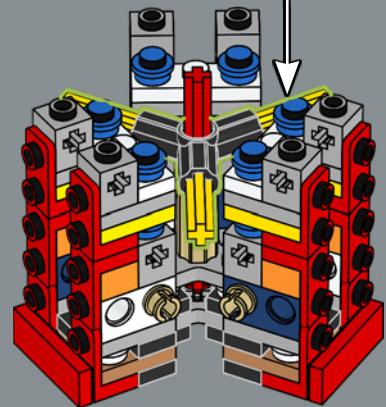
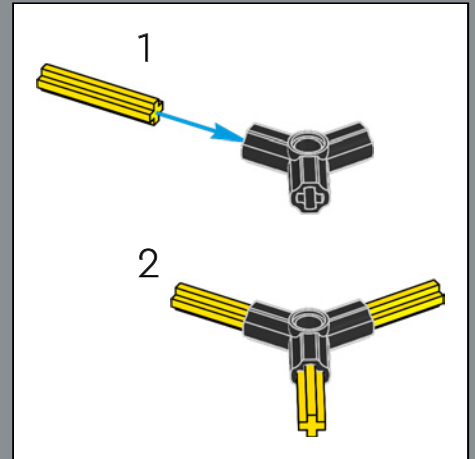

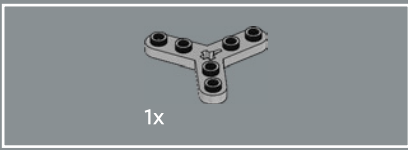

22

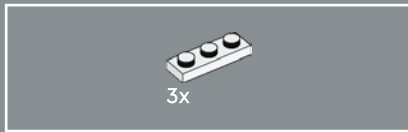
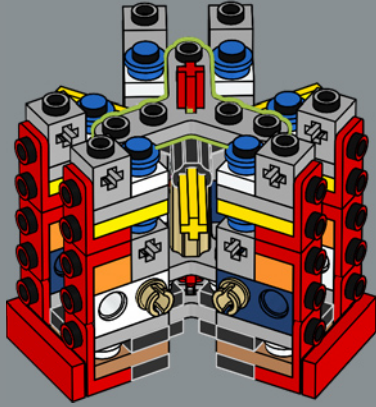

23

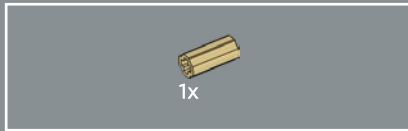
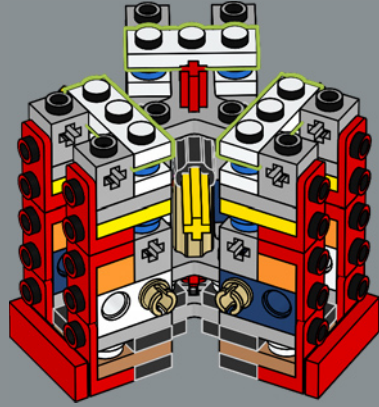

24

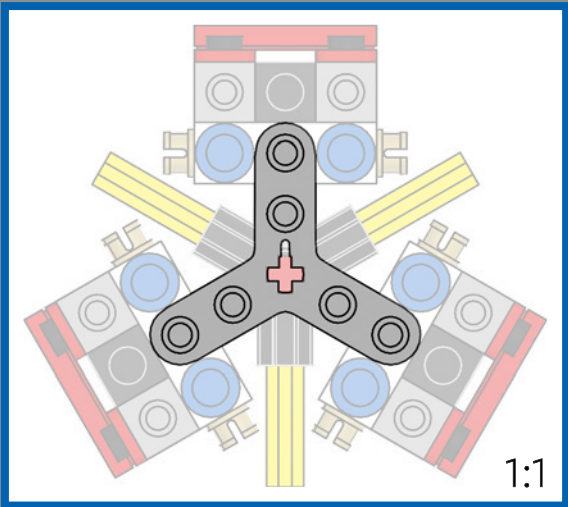
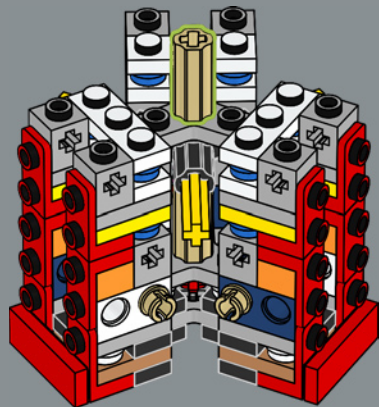

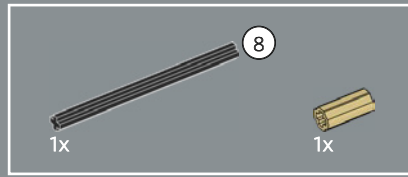

25

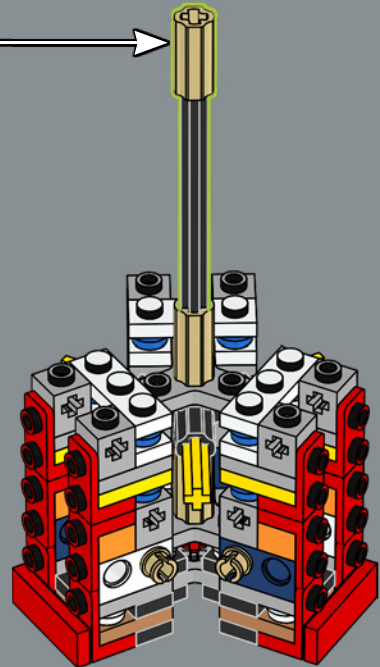
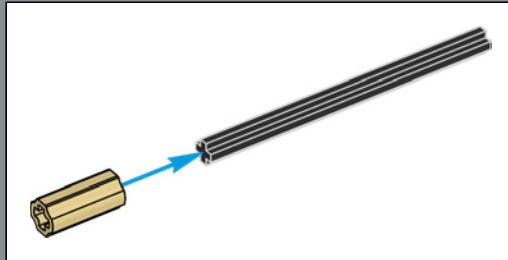

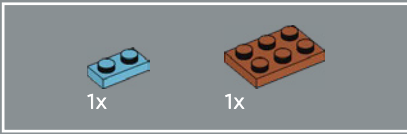
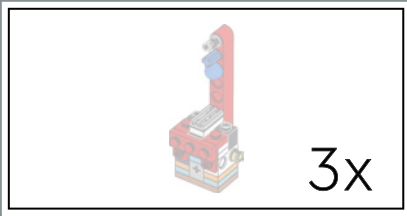

26

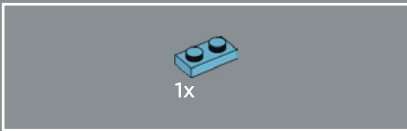
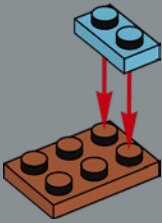

27

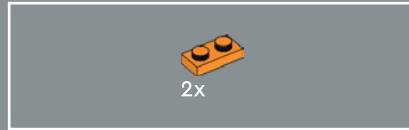
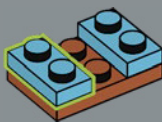

28

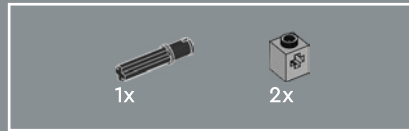
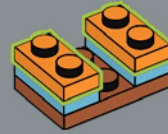

29

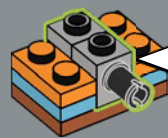
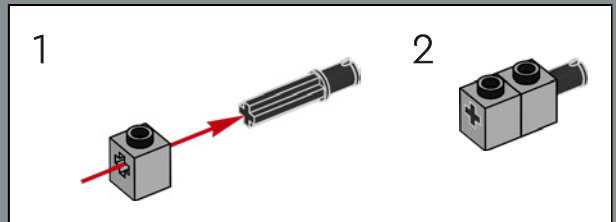

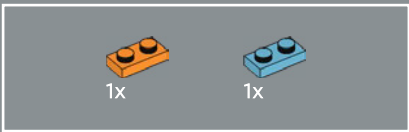

30

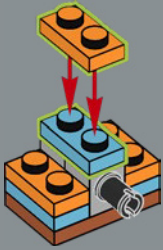

32

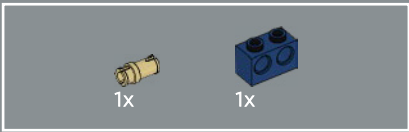
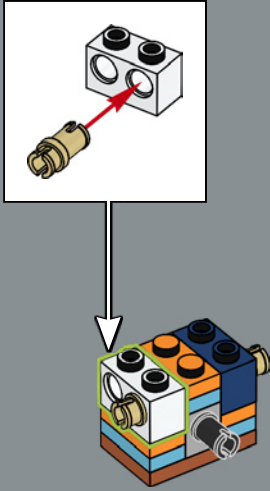

31

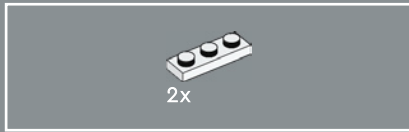
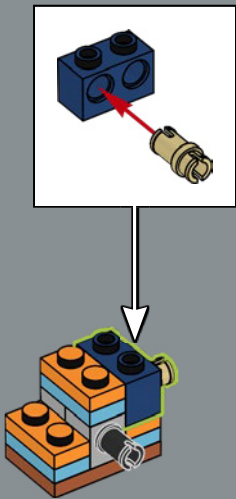

33

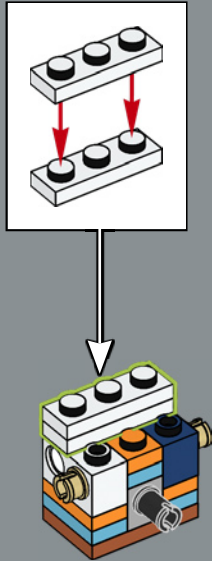

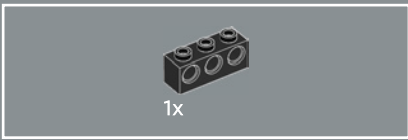

34

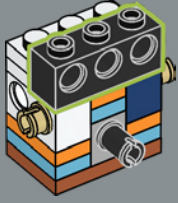

35

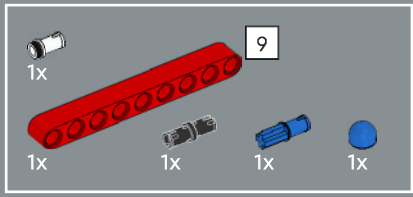
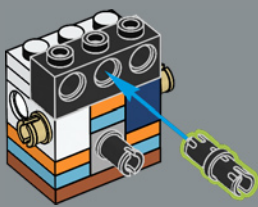

36

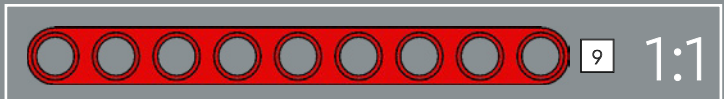
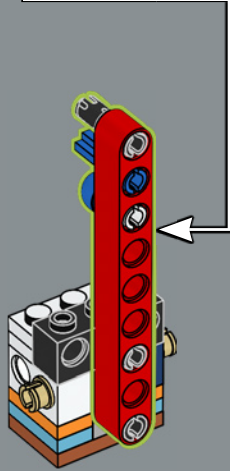
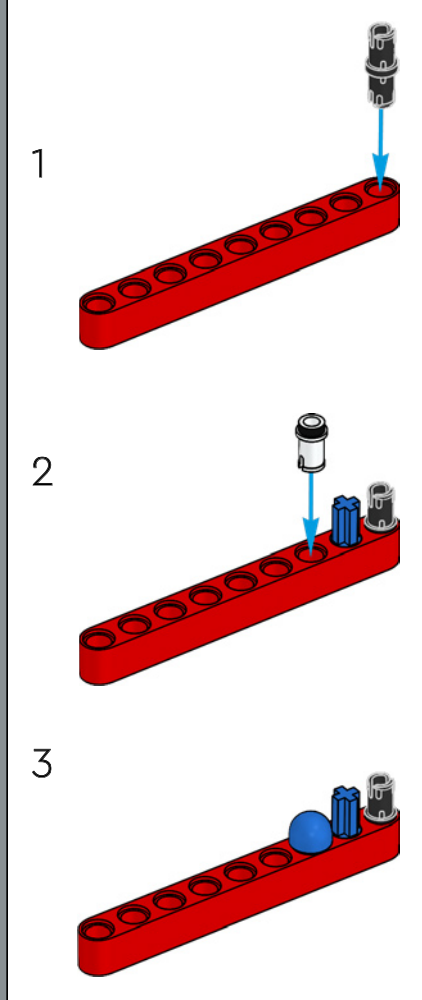

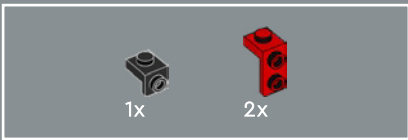

37

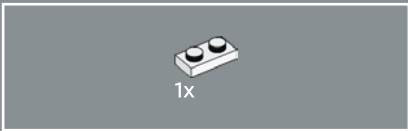
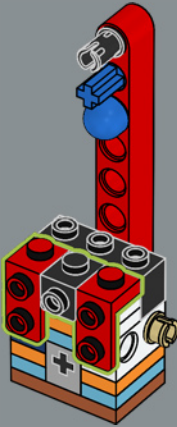

38

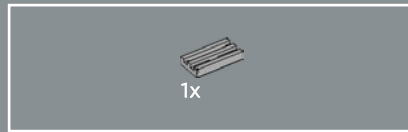
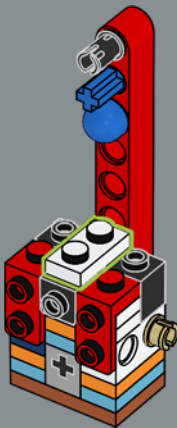

39

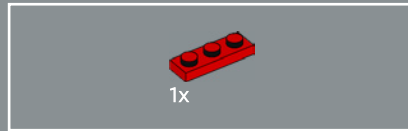
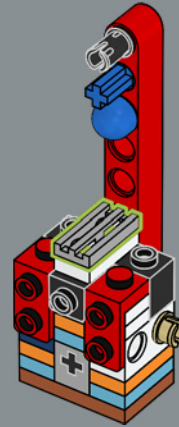

40

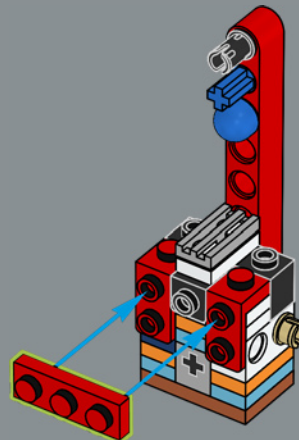

3x

41

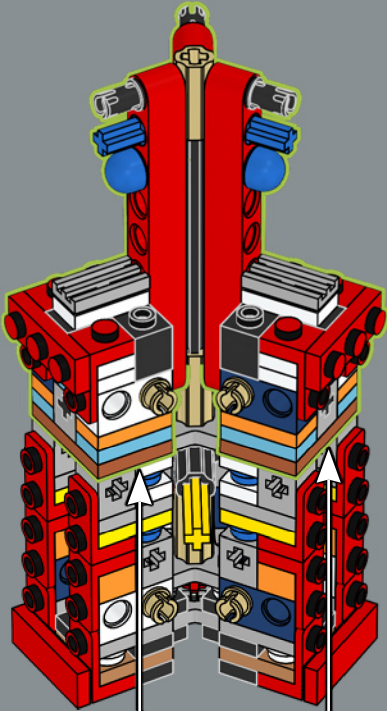

42

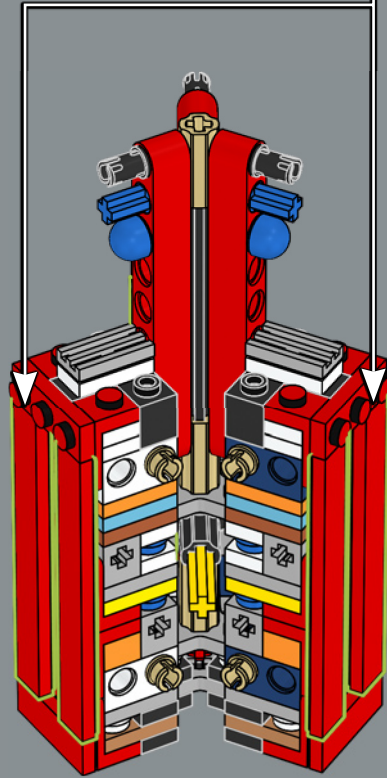
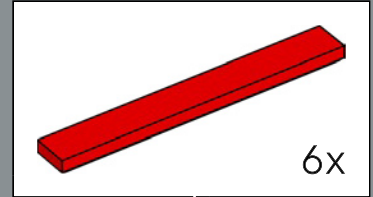
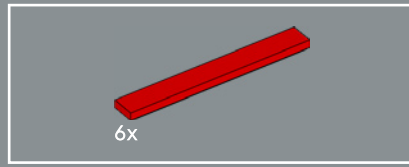



2

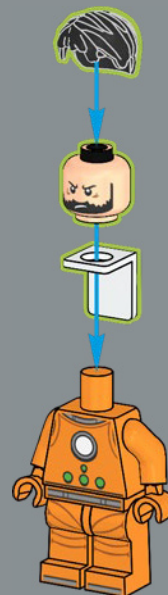

3

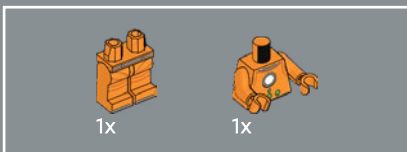
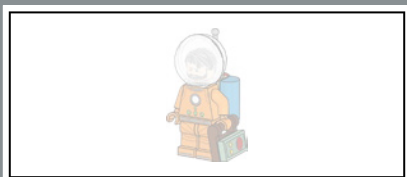
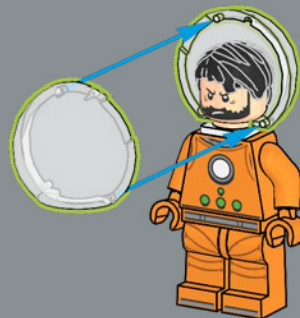

1

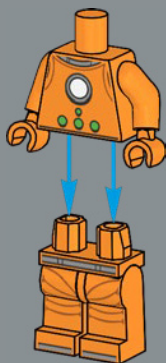



4

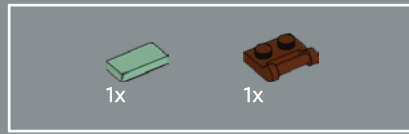
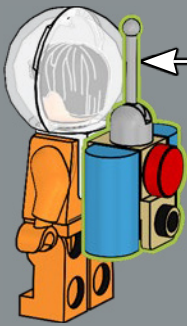
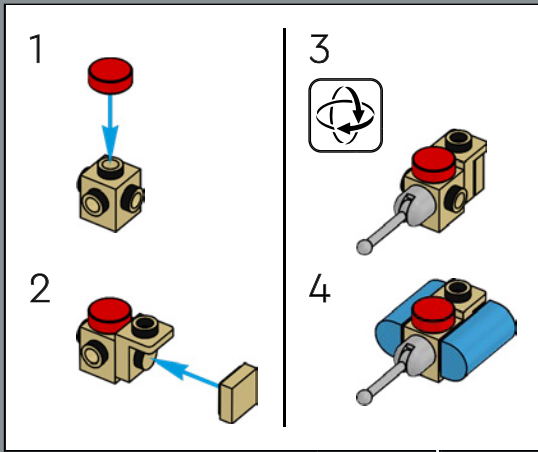

5

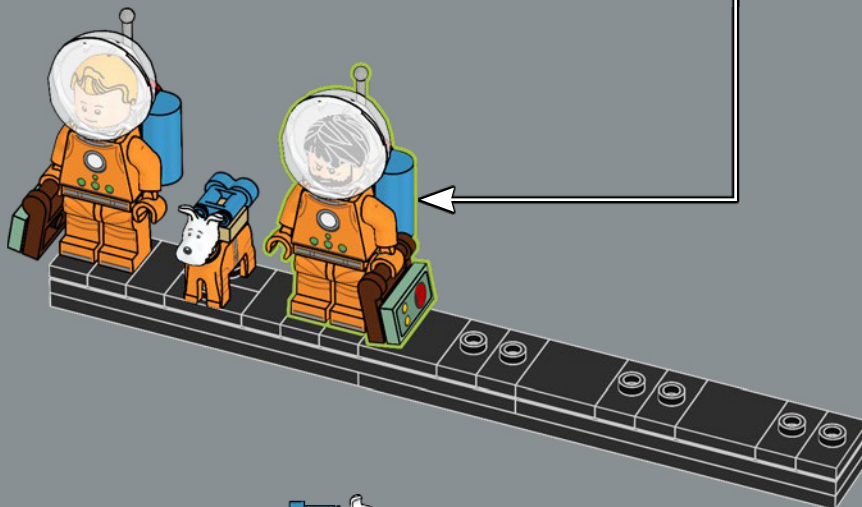
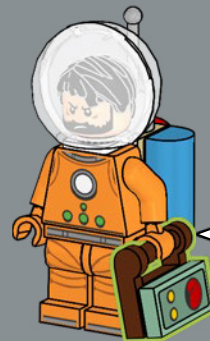
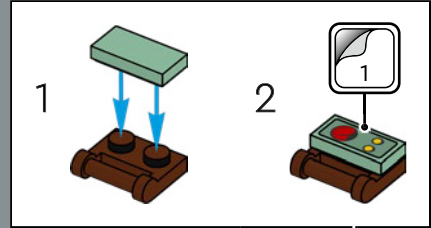

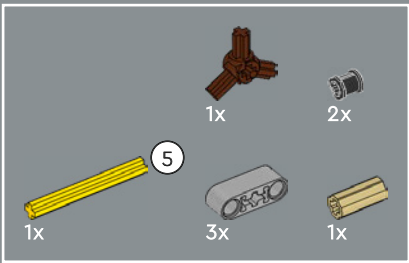

43

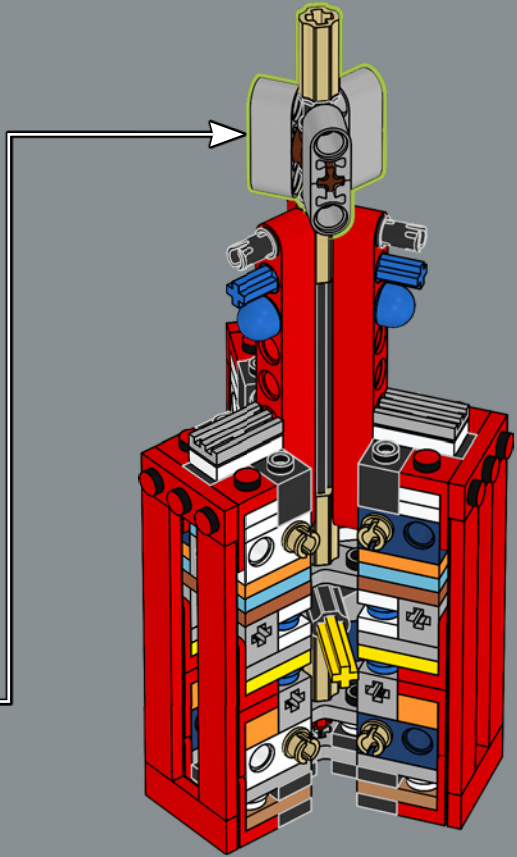
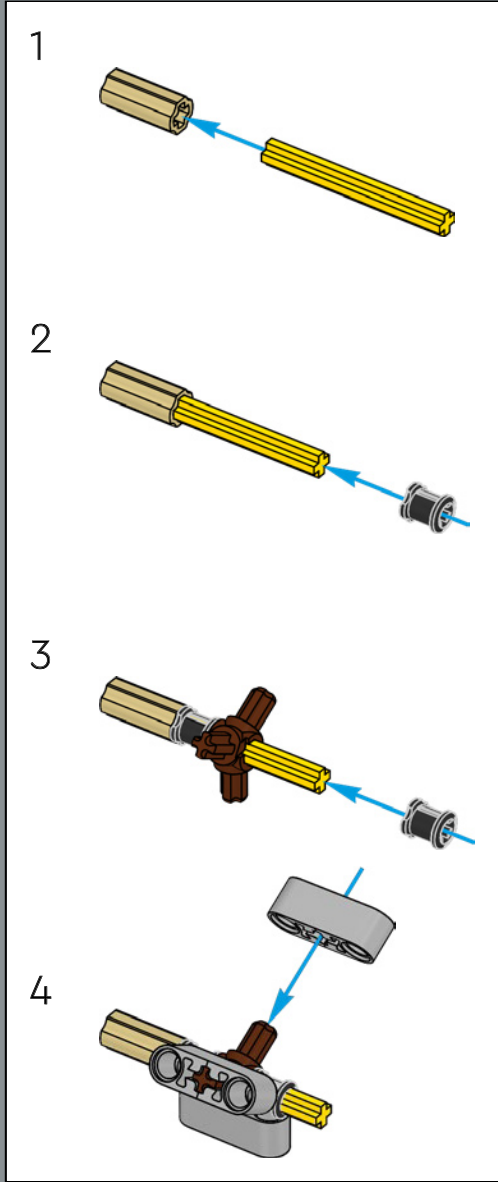
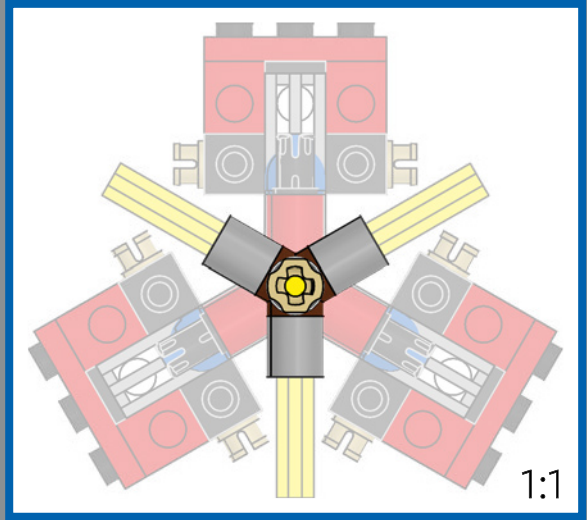

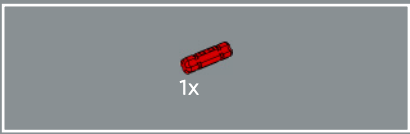

44

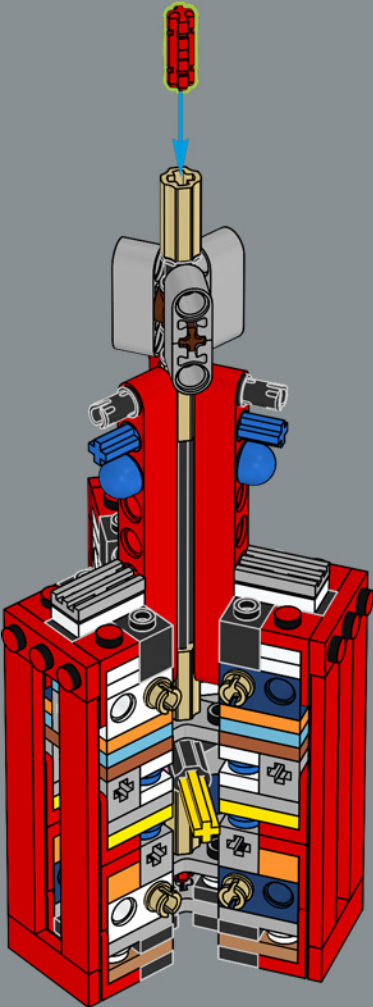

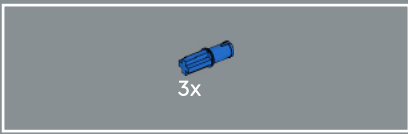

45

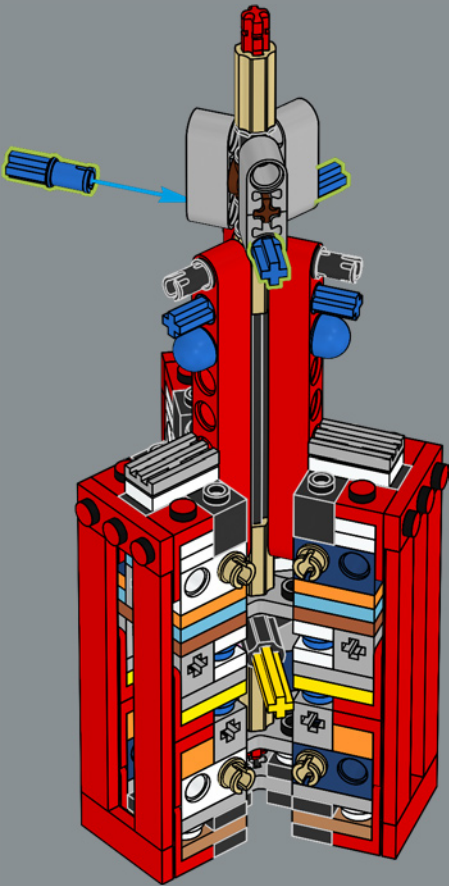

46

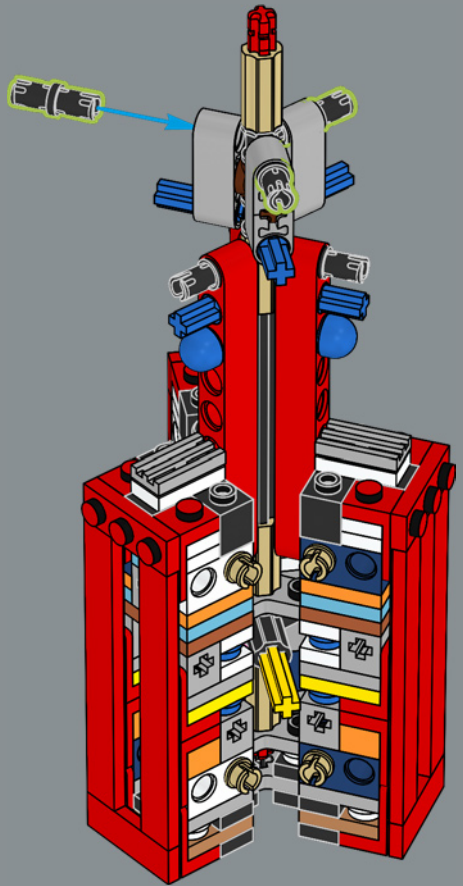

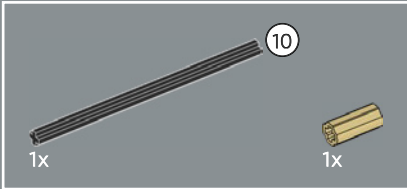
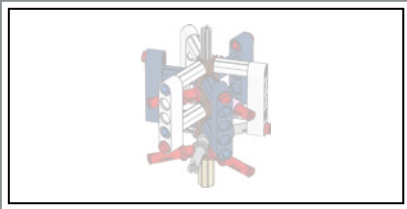

47

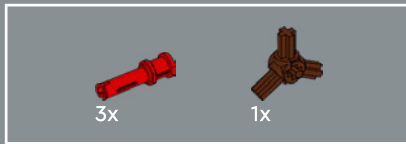
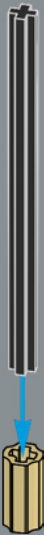

48

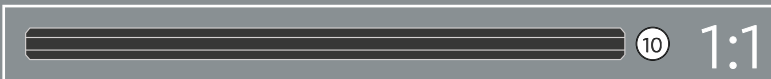
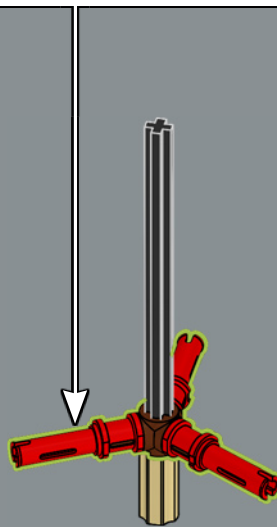
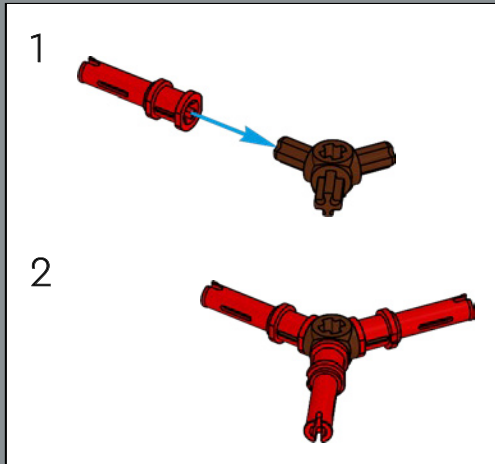

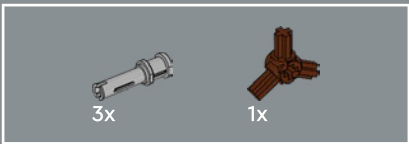

49

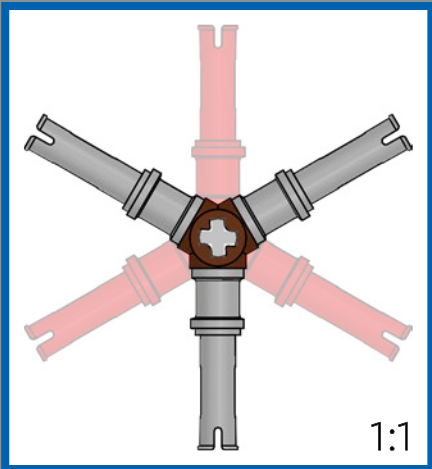
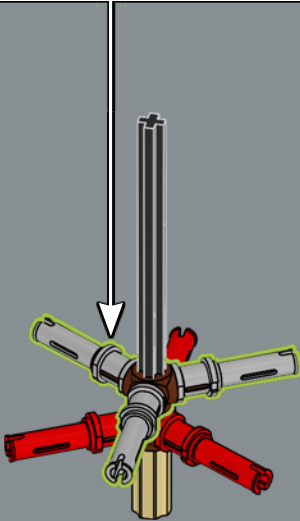
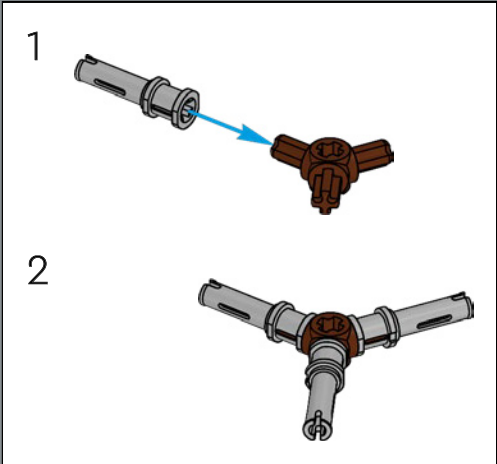

50

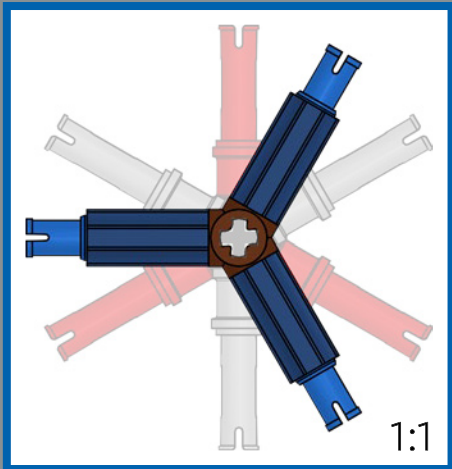
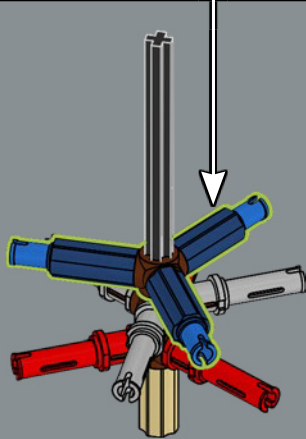
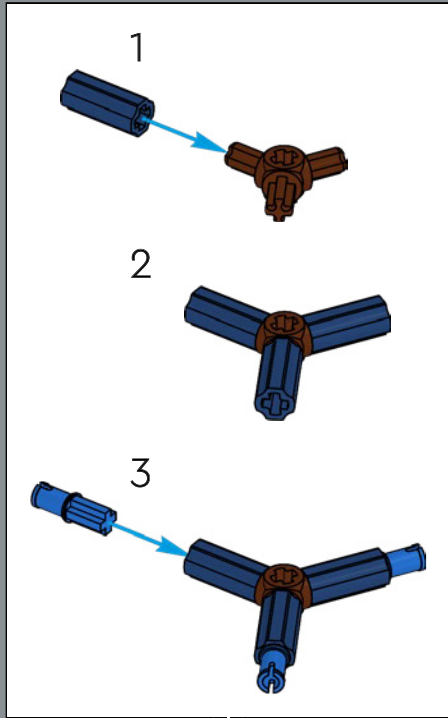

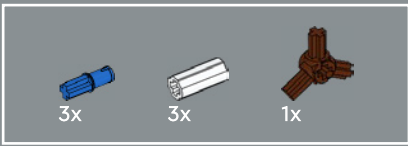

51

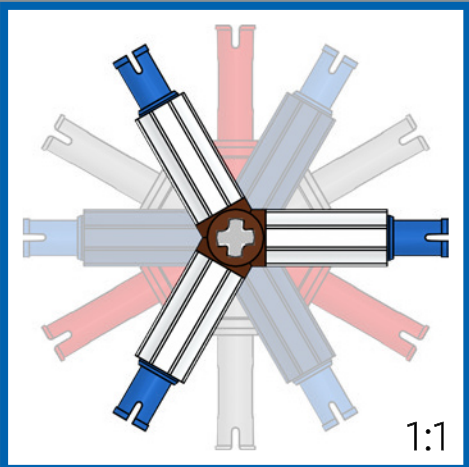
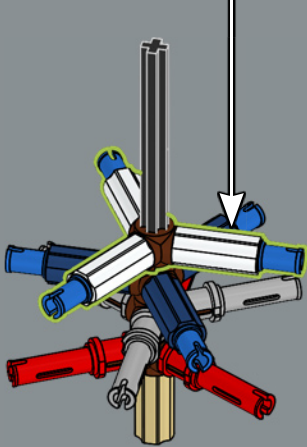
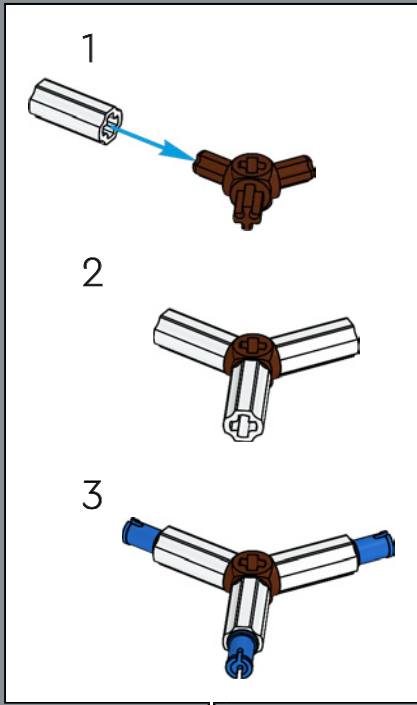

1:1

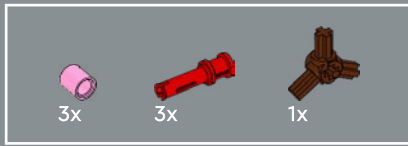

52

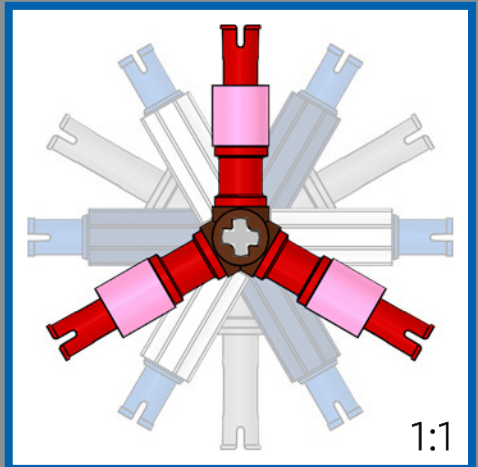
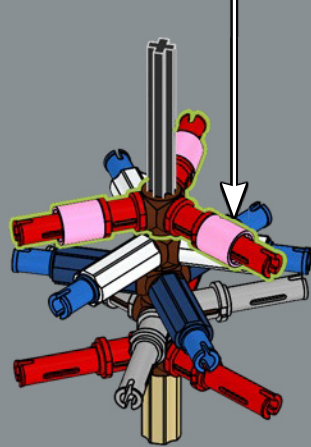
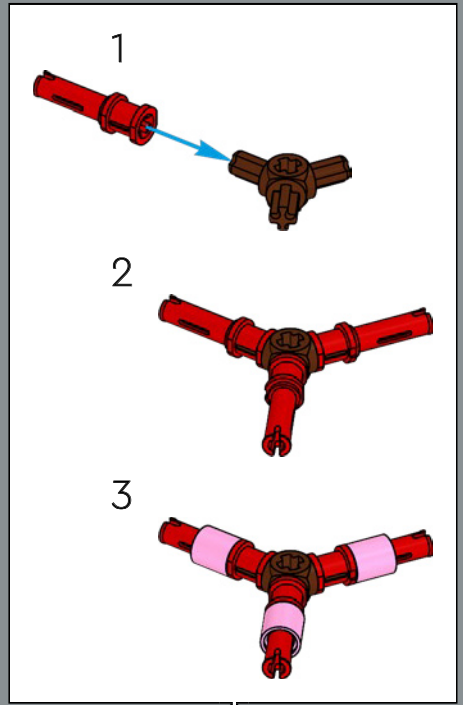

1:1



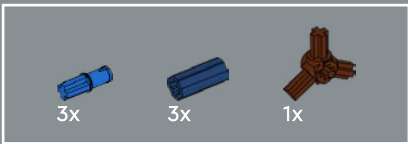

53

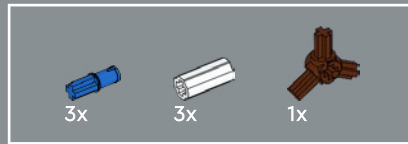
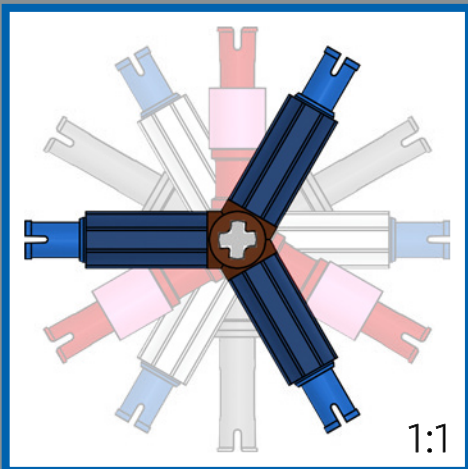
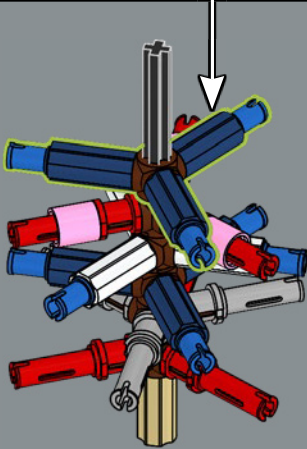
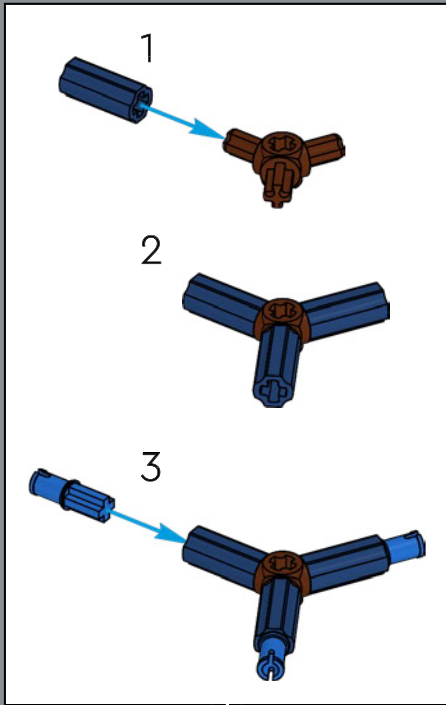

54

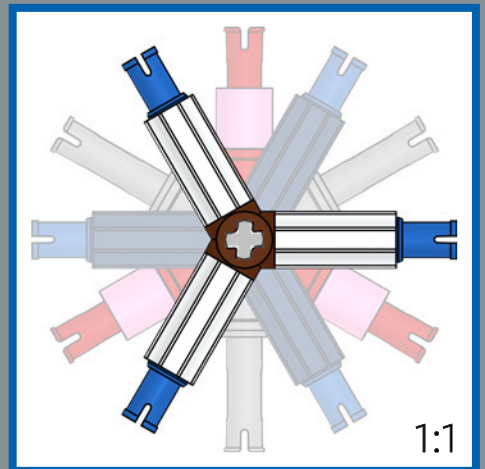
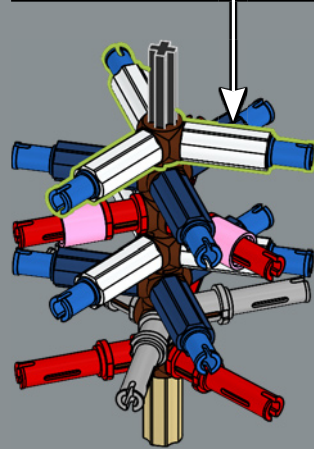
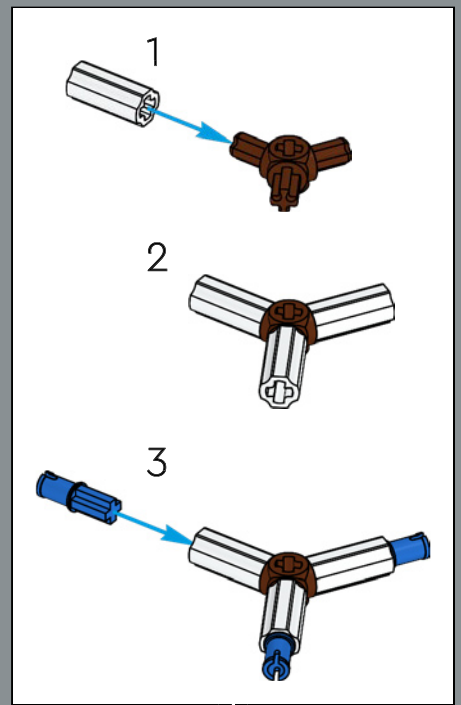

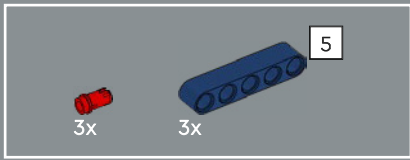

55

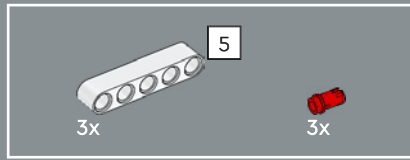
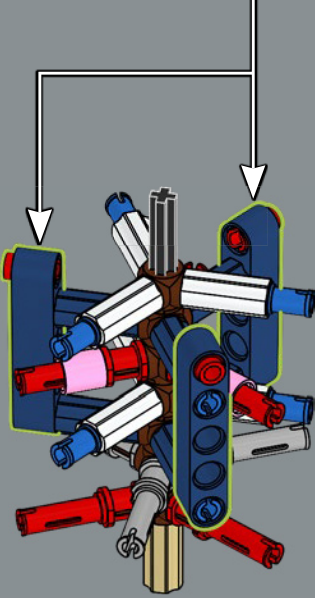
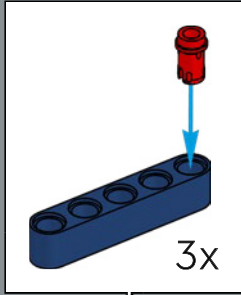

56

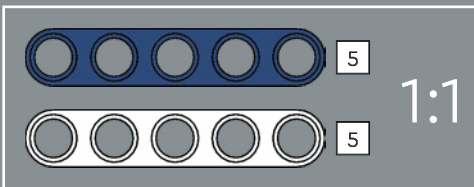
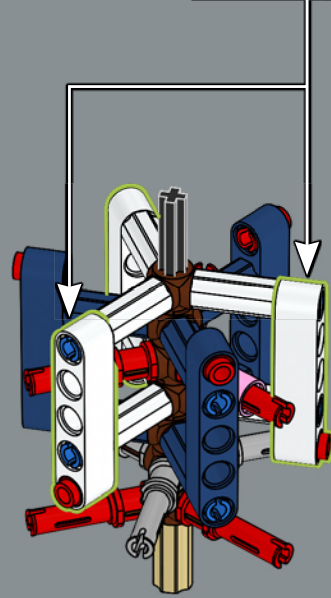
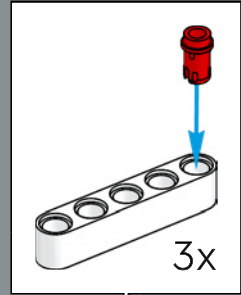

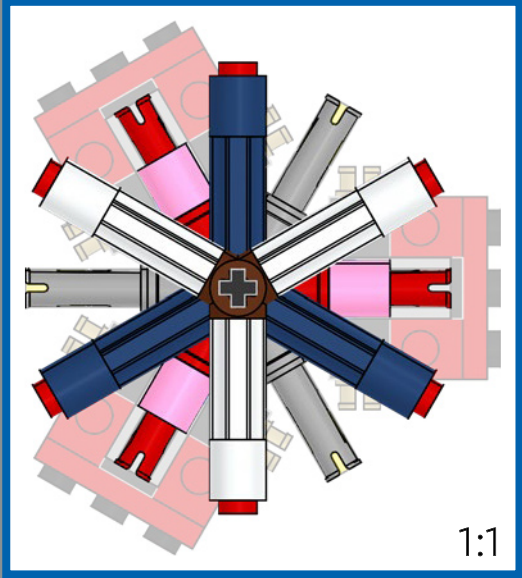
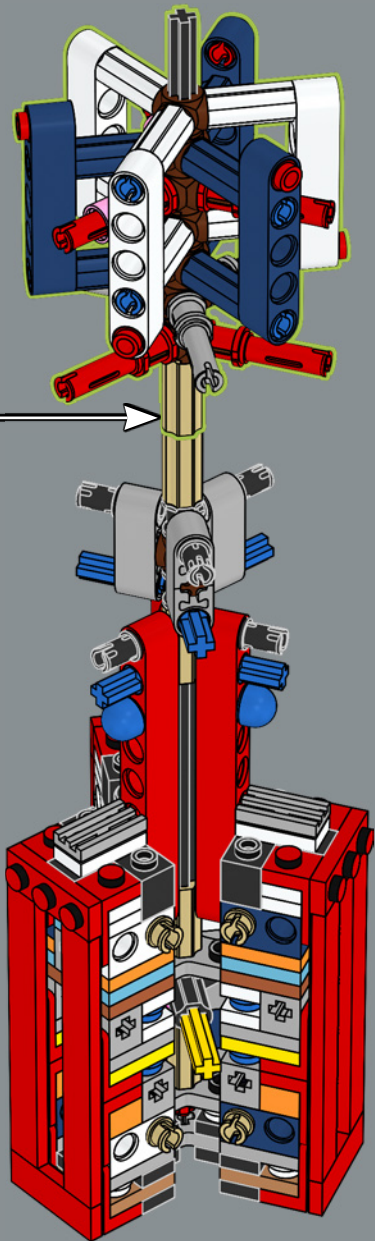

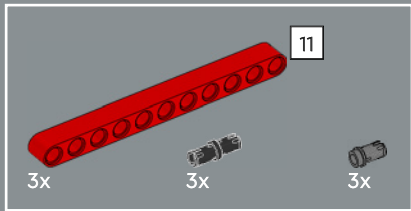

58

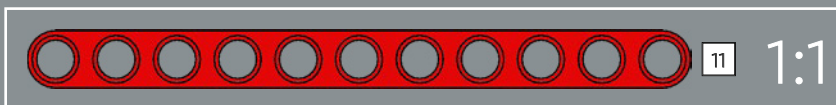
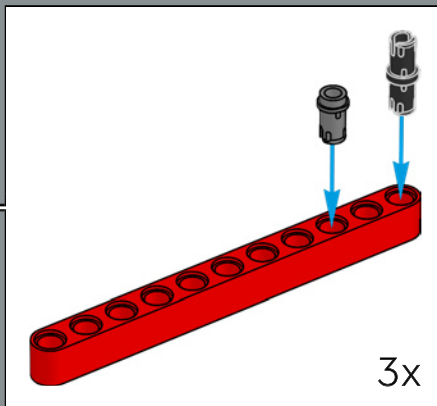
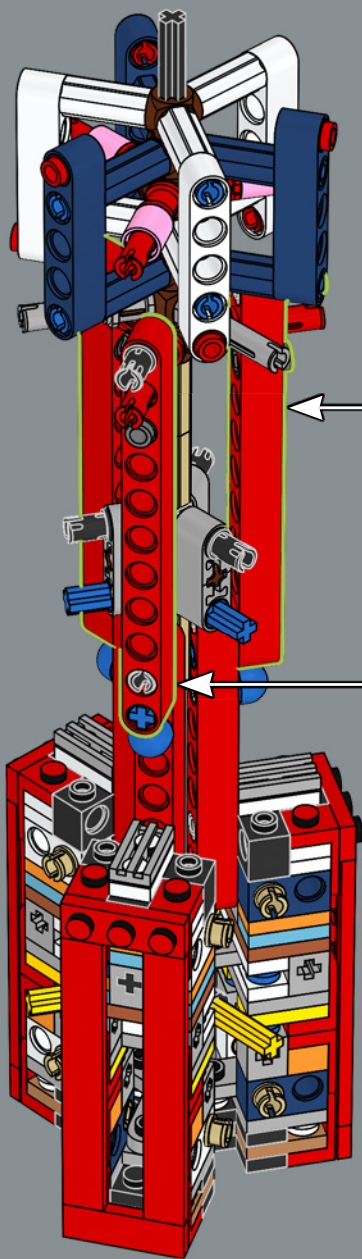

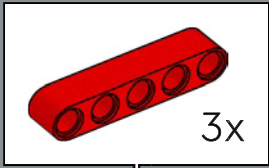
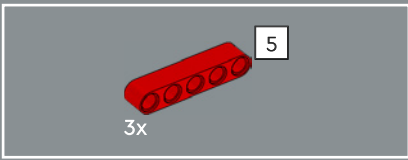

59

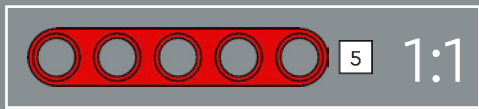
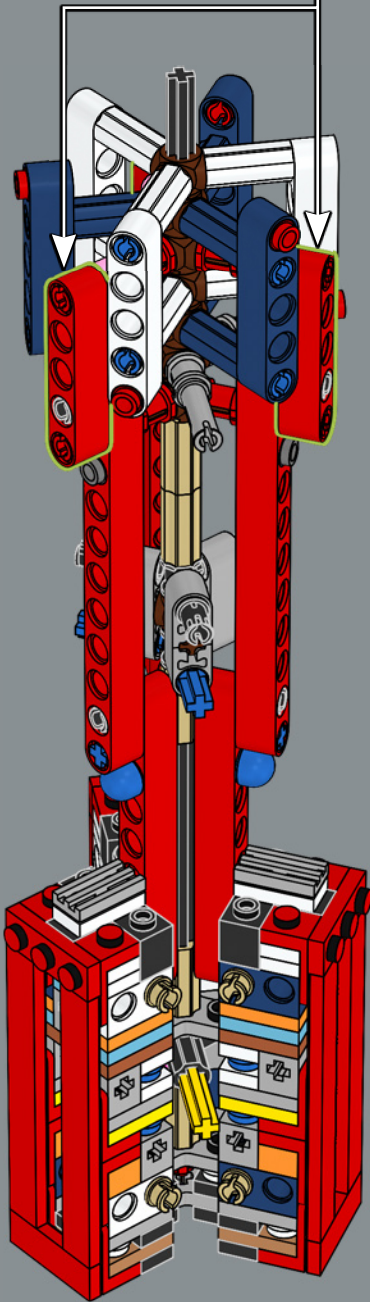

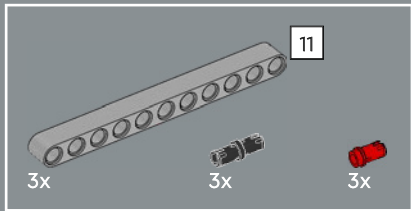

60

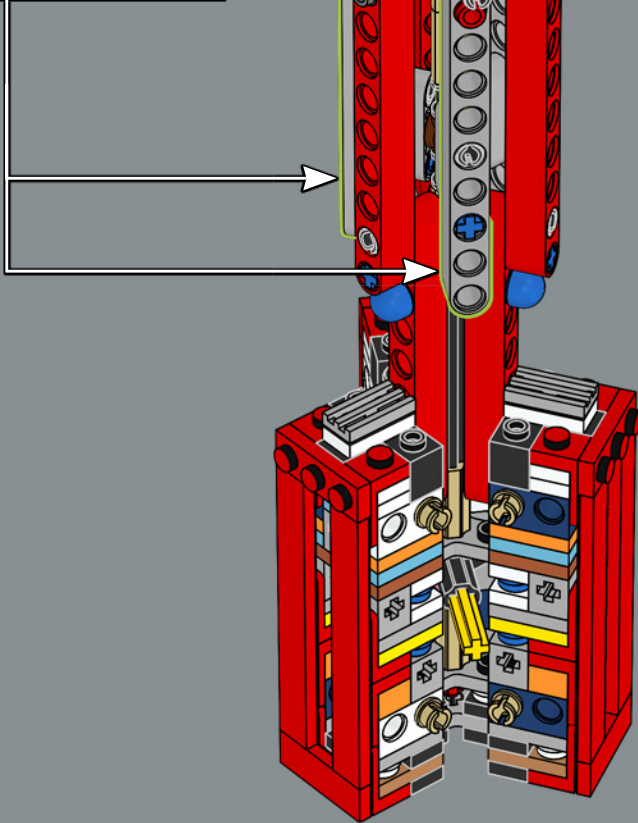
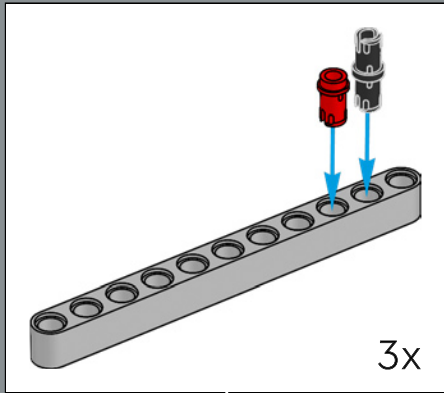



61

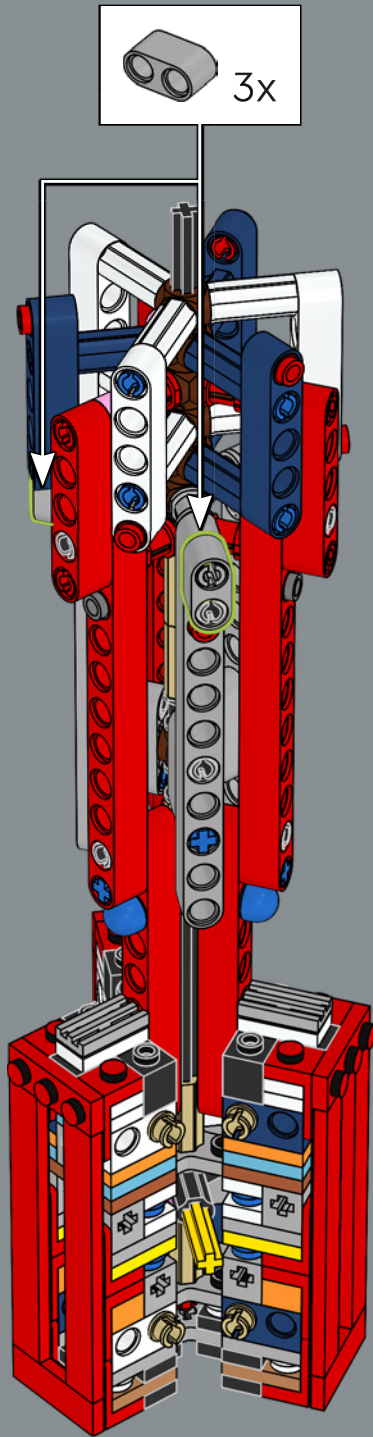

62

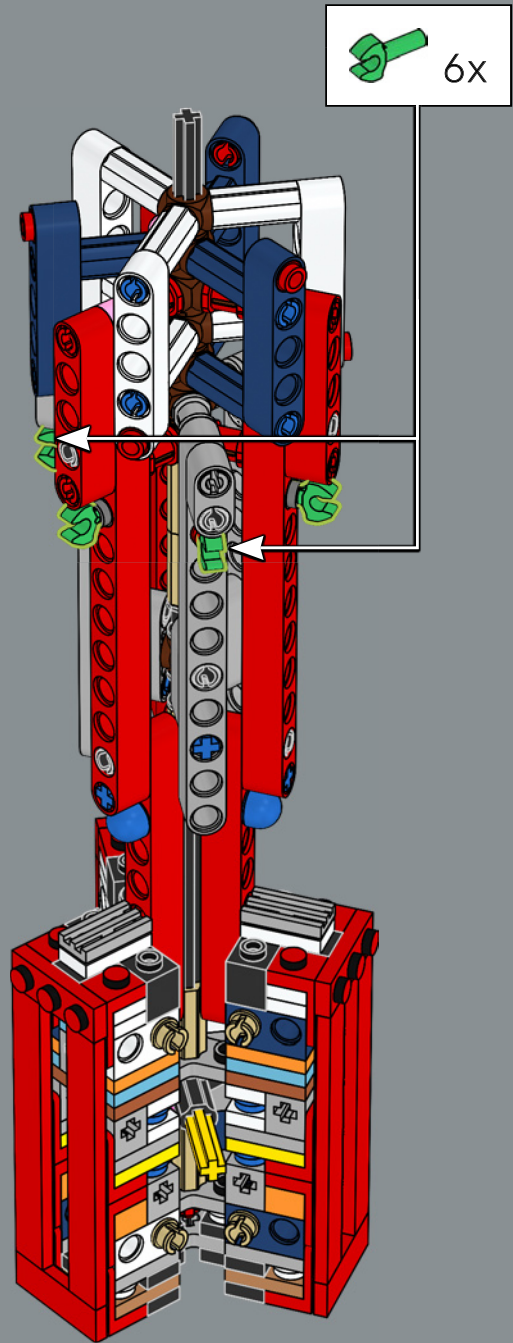



63

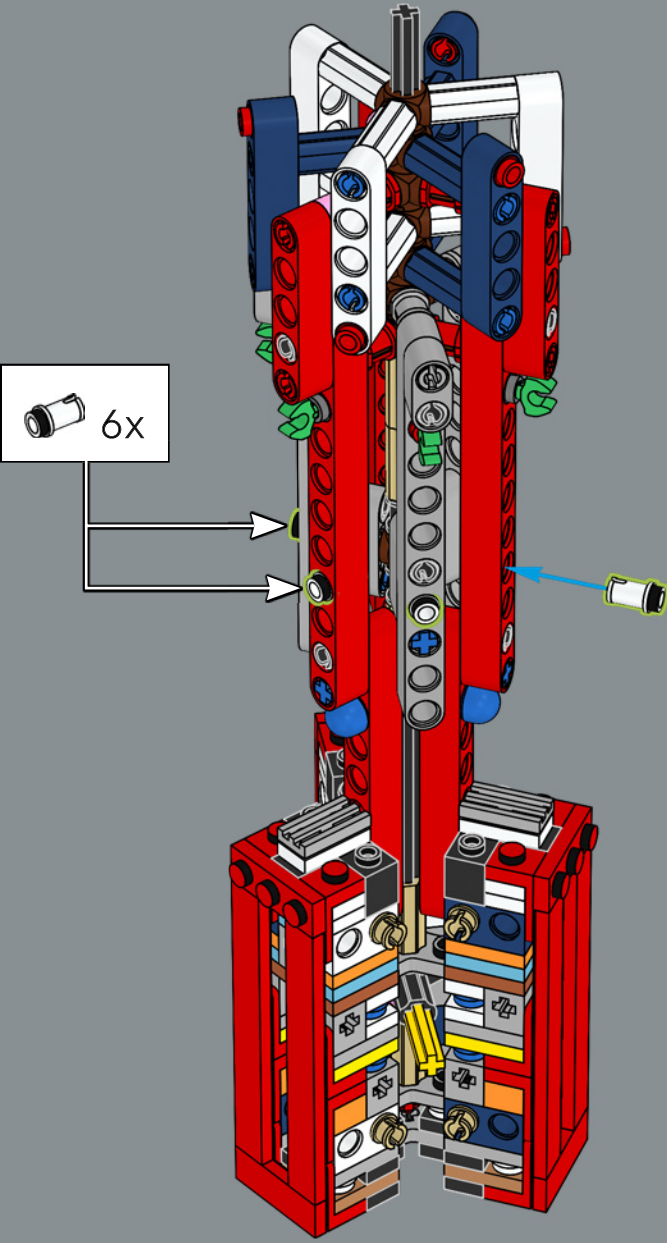



65

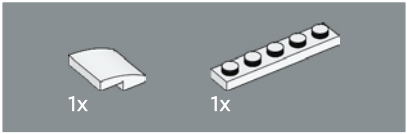
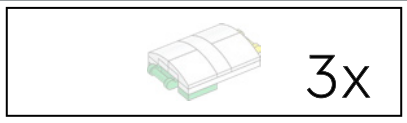
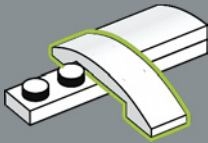

64

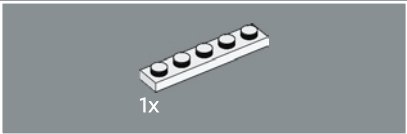
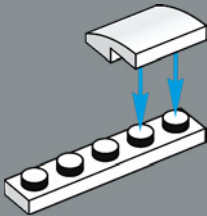

66

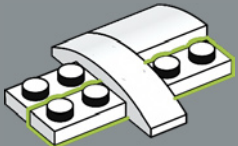



67

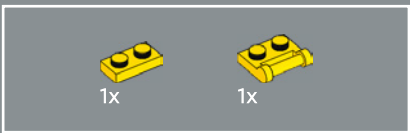
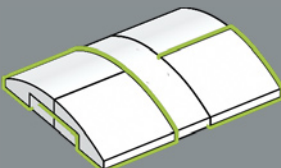

68

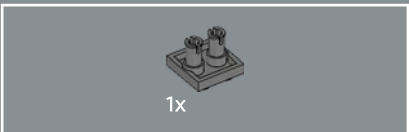
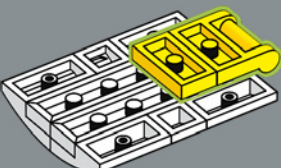

69

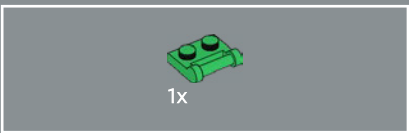
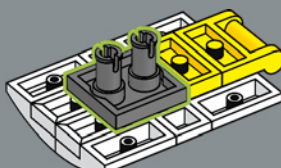

70

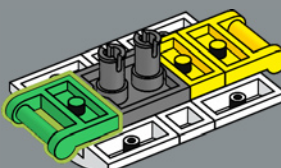

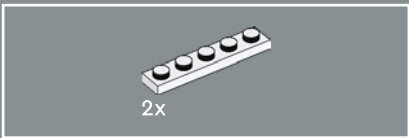

71

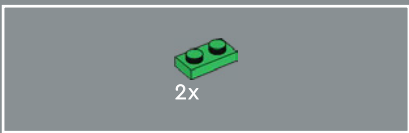
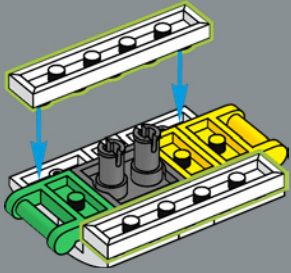

72

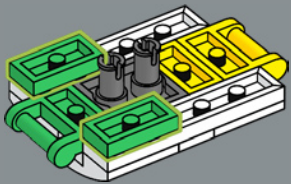

3x

73

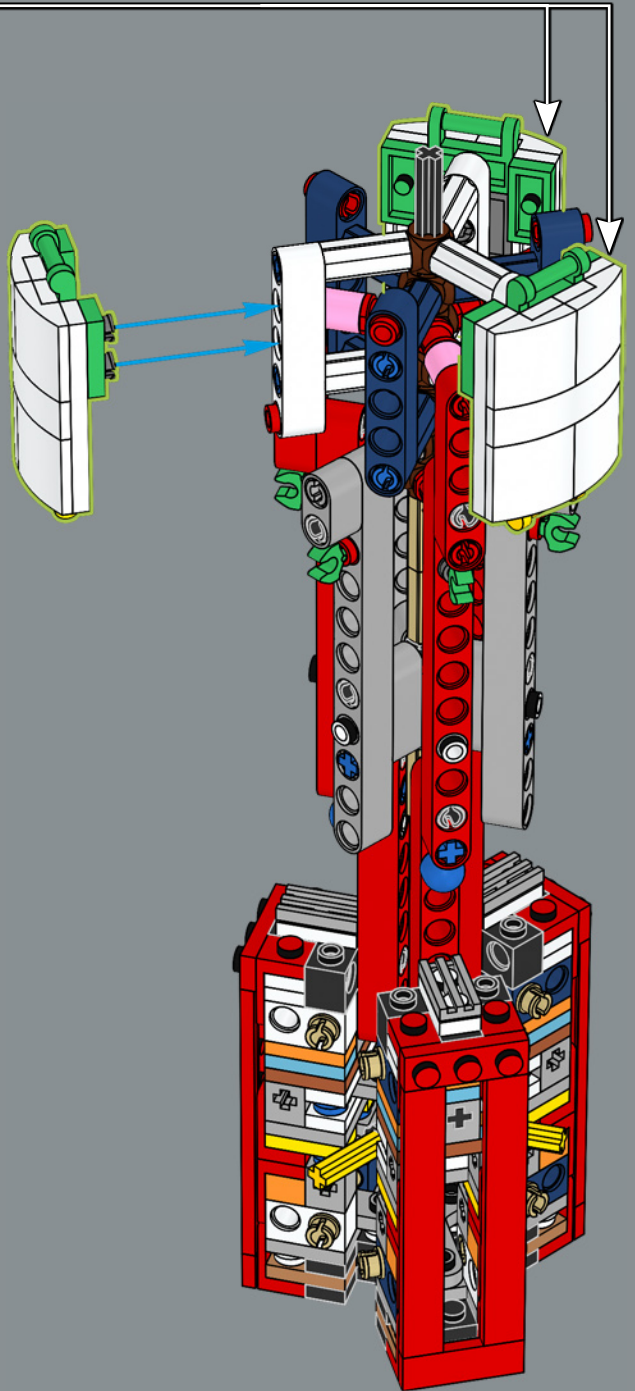

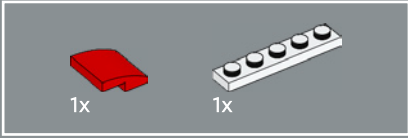
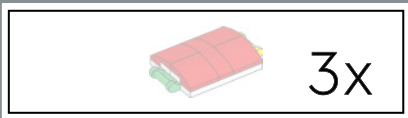

74

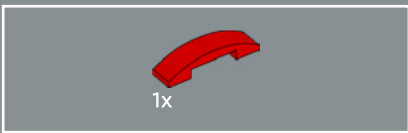
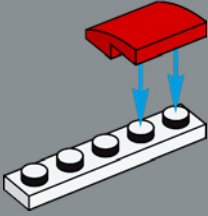

75

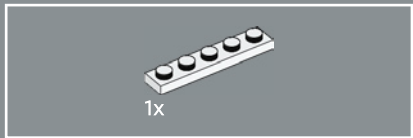
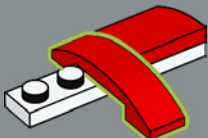

76

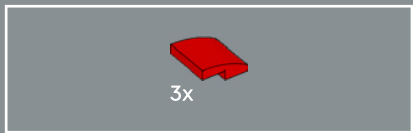
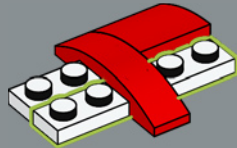

77

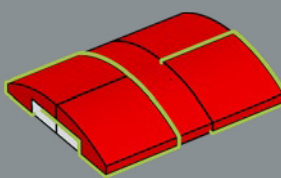

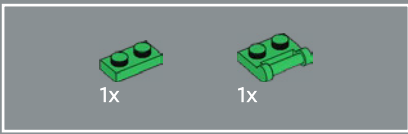

78

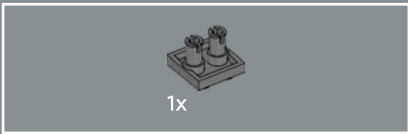
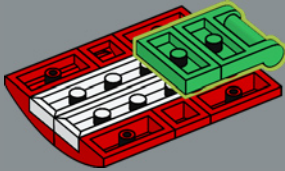

79

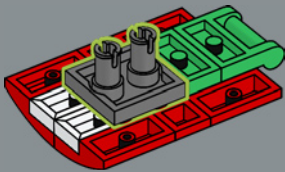

80

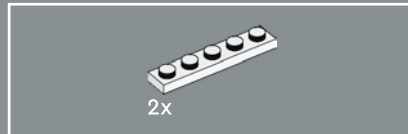
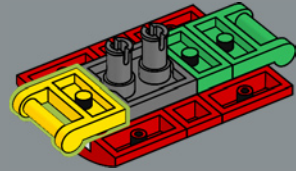

81

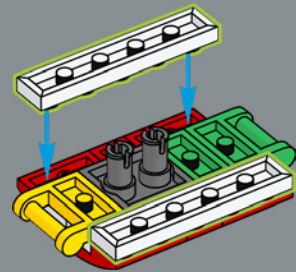

3x

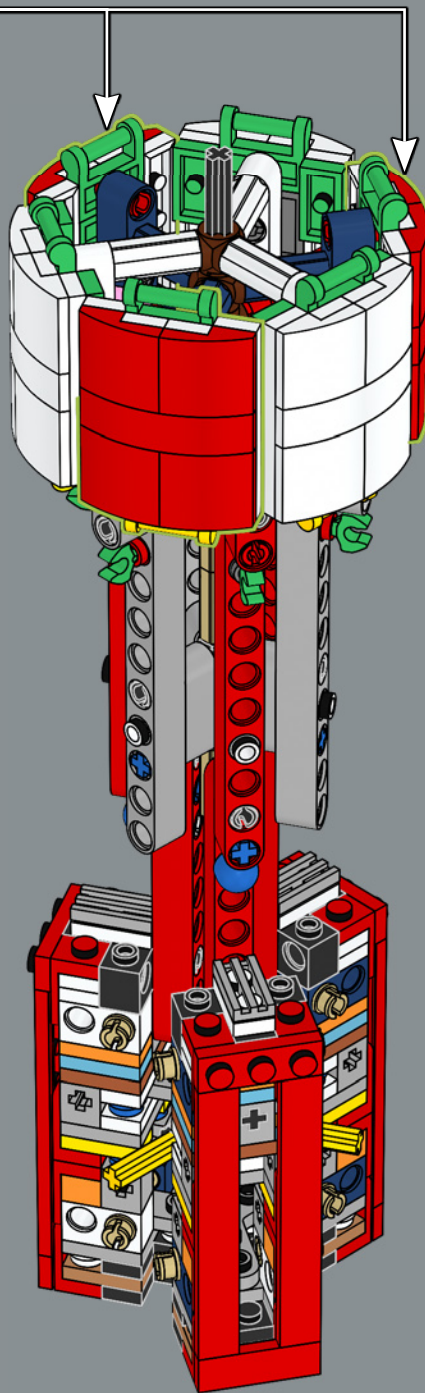



1x



1x



1x

2

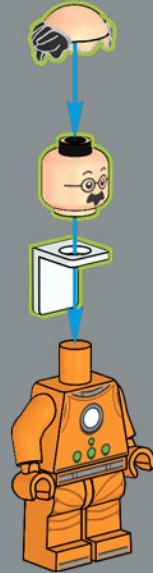

1x



1x

1

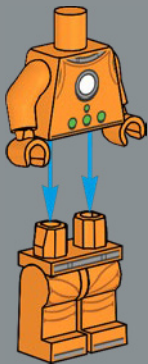

2x

3

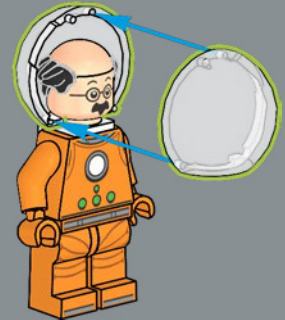



4

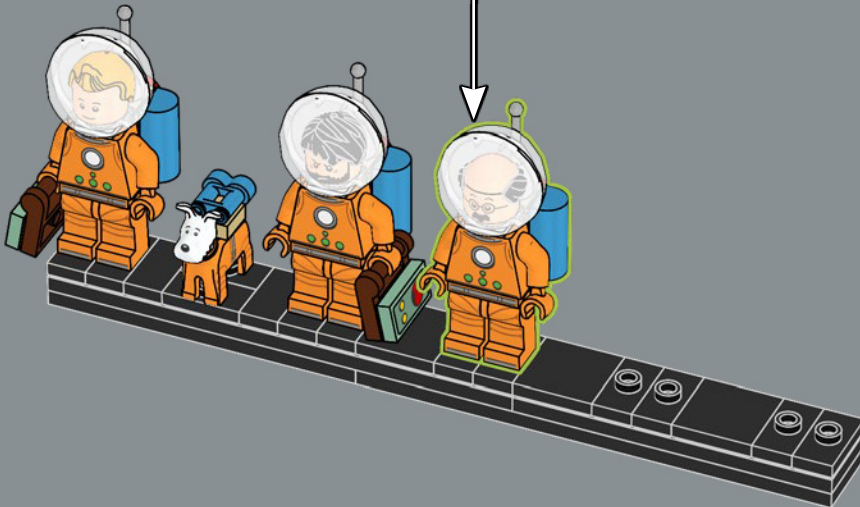
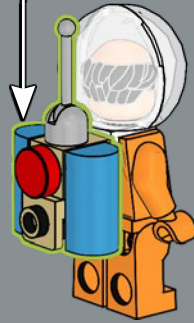
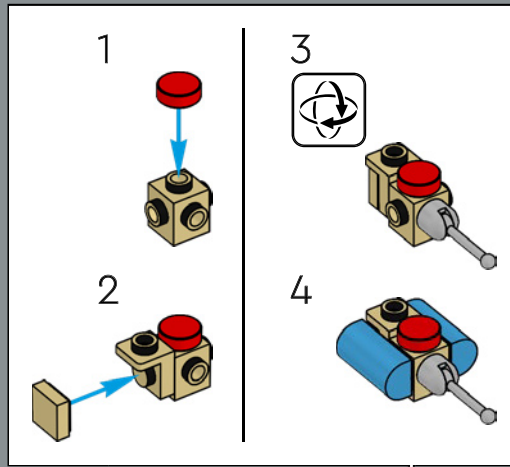

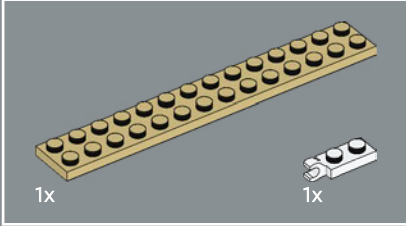
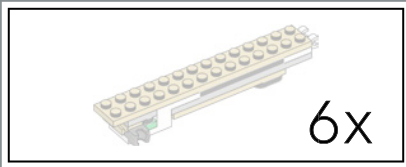

83

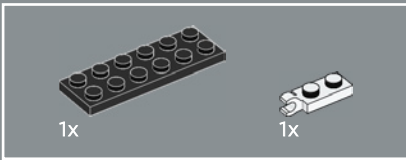
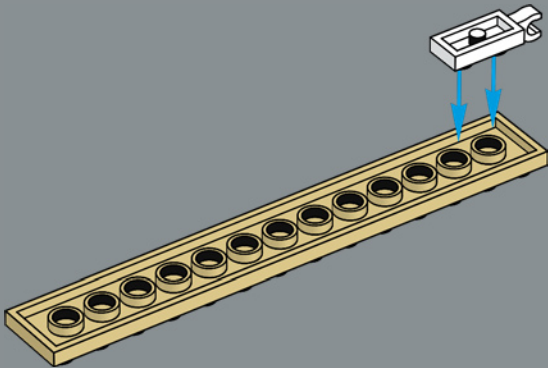

84

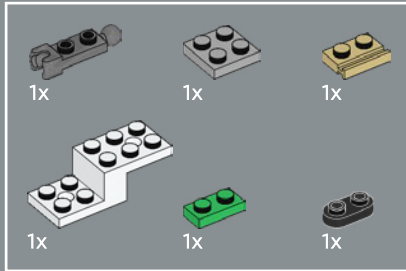
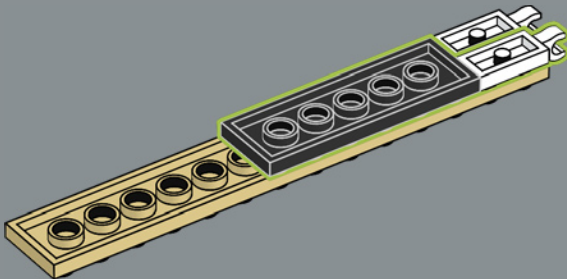

85

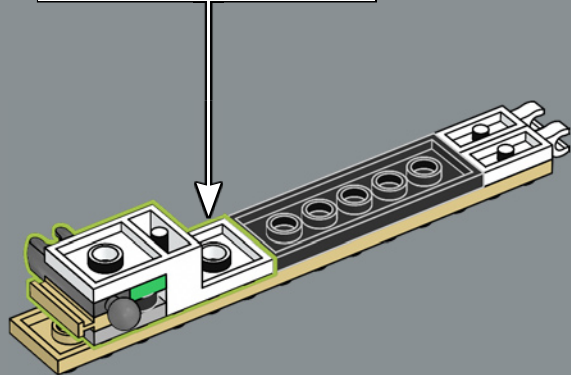
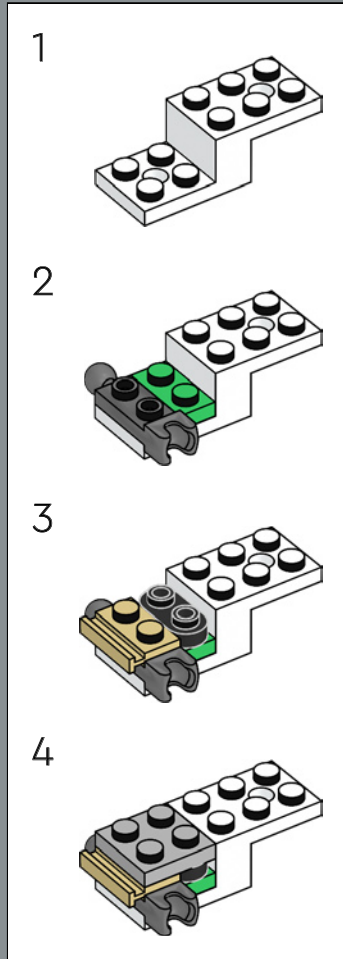

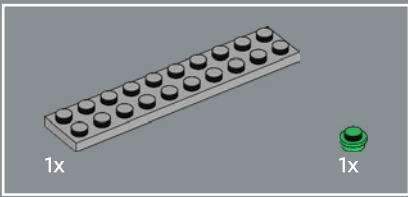

86

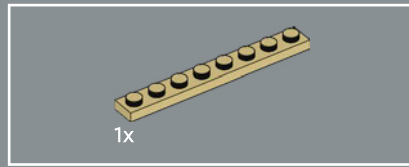
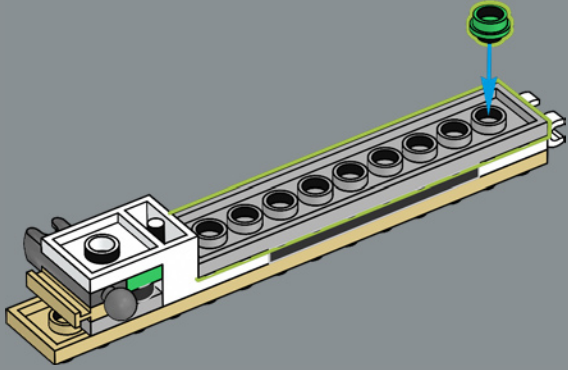

88

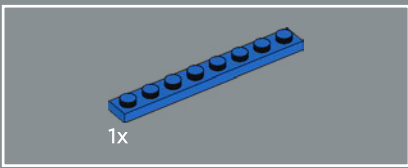
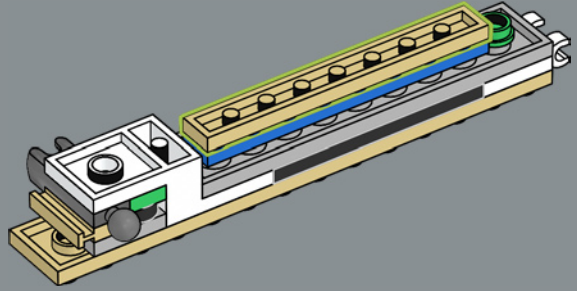

87

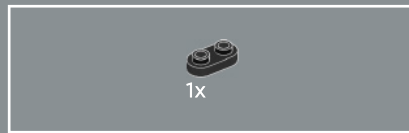
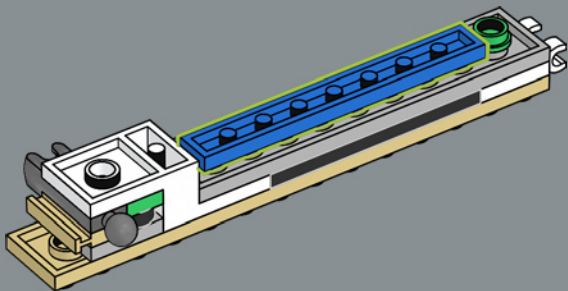

89

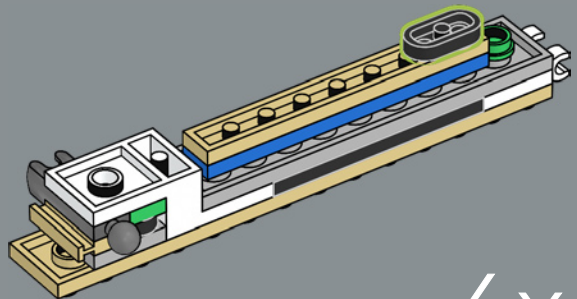

6x



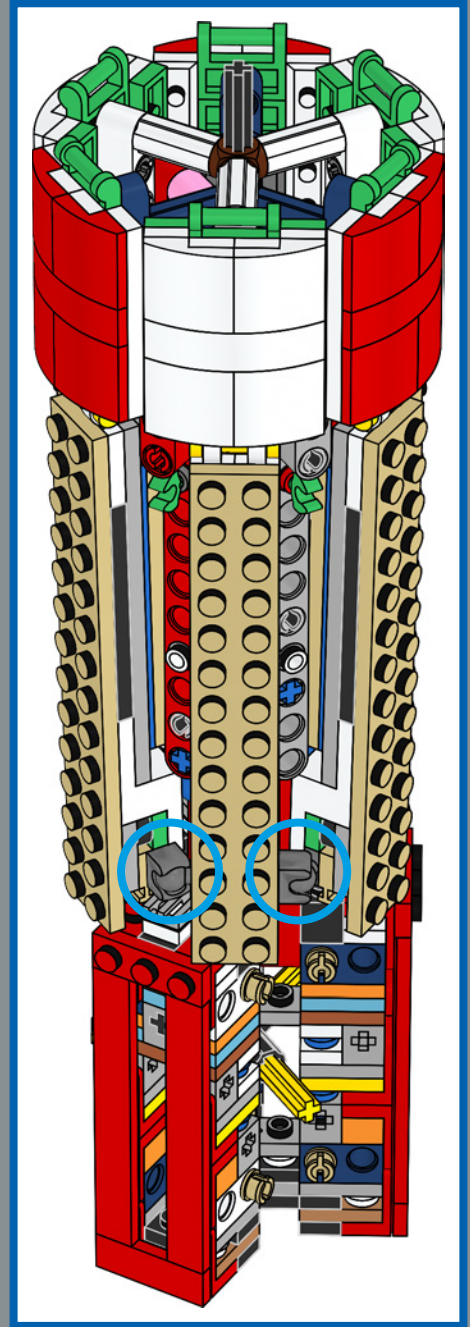
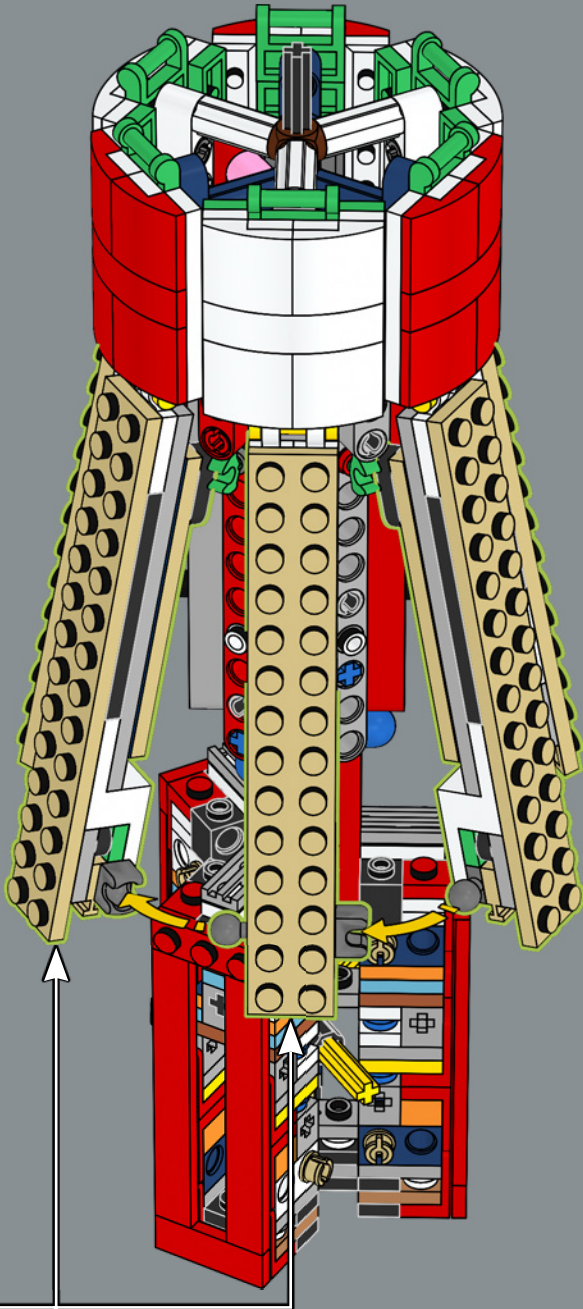

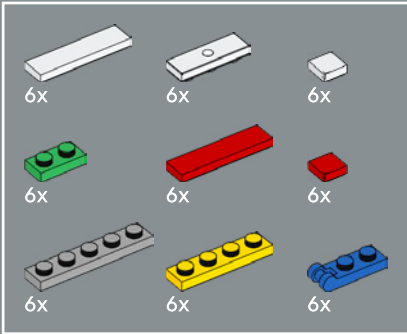
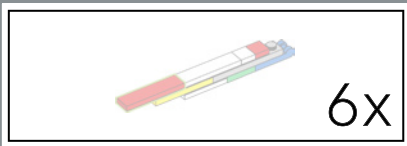

91

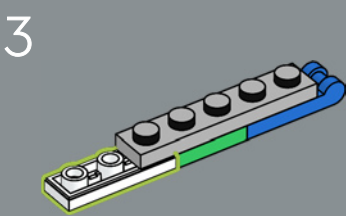
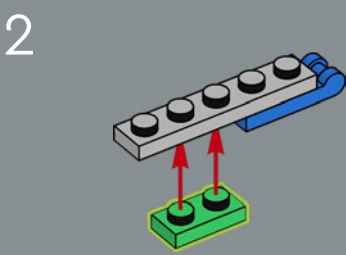
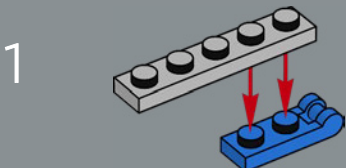

4

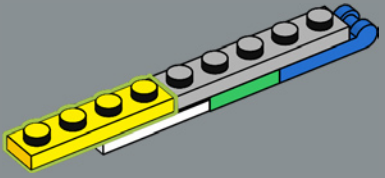

5

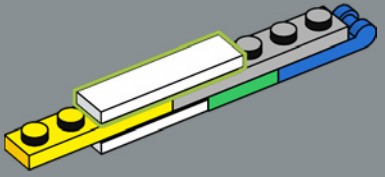

6

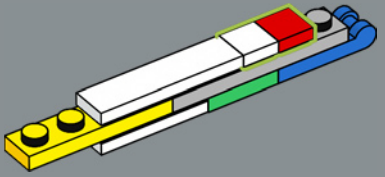

7

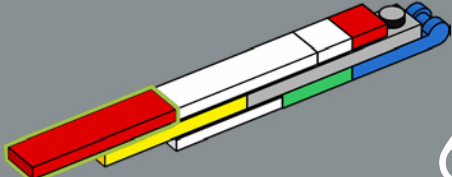

6x



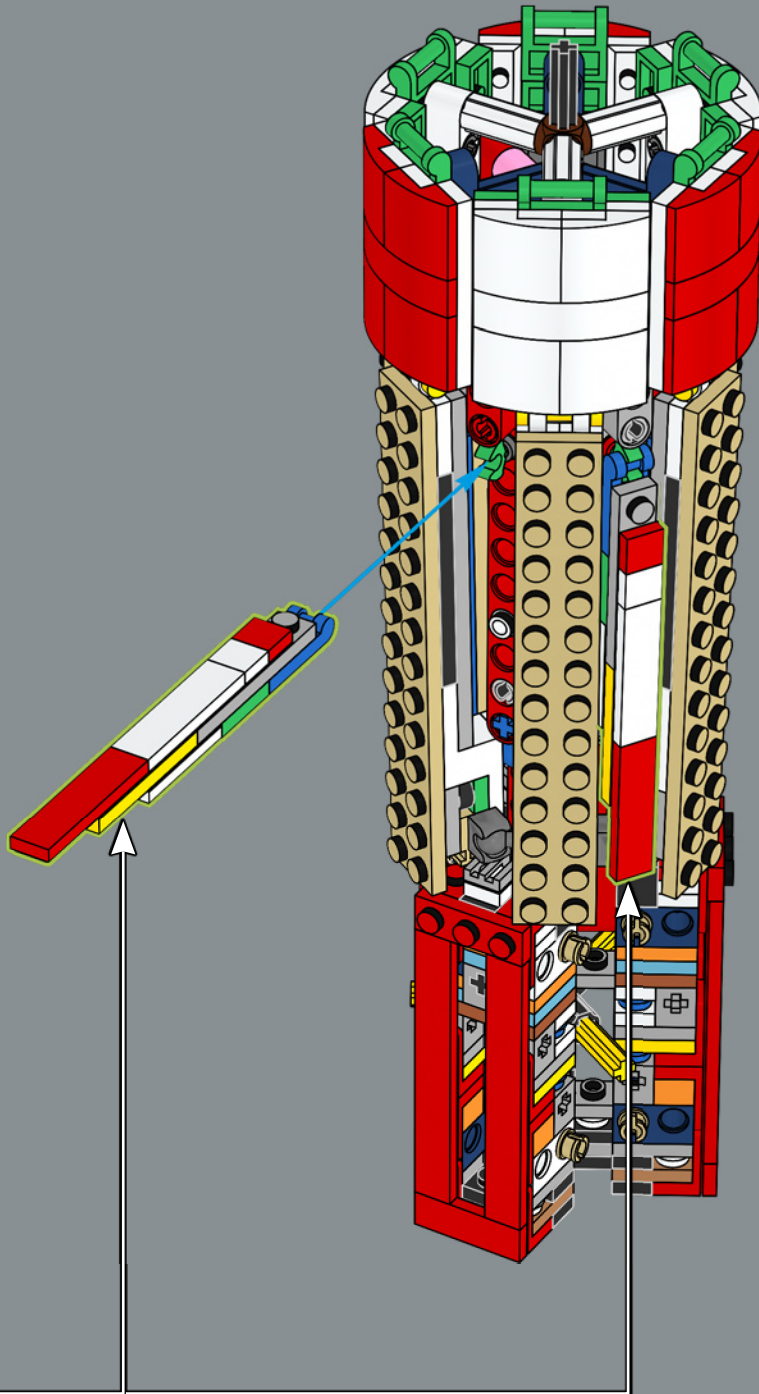

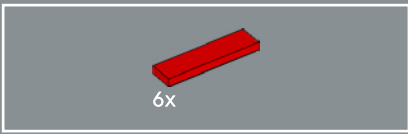

92

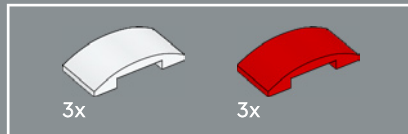
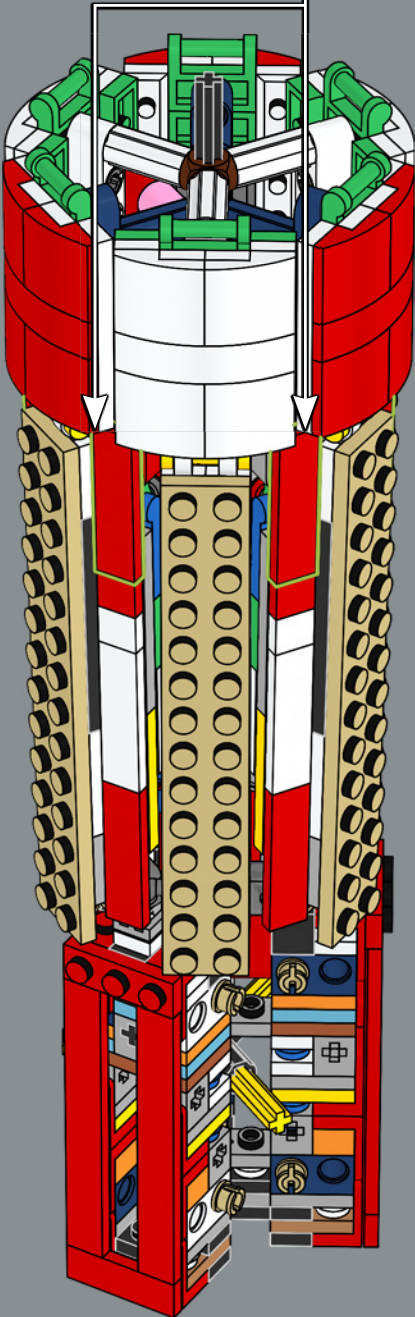
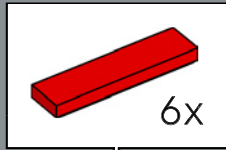

93

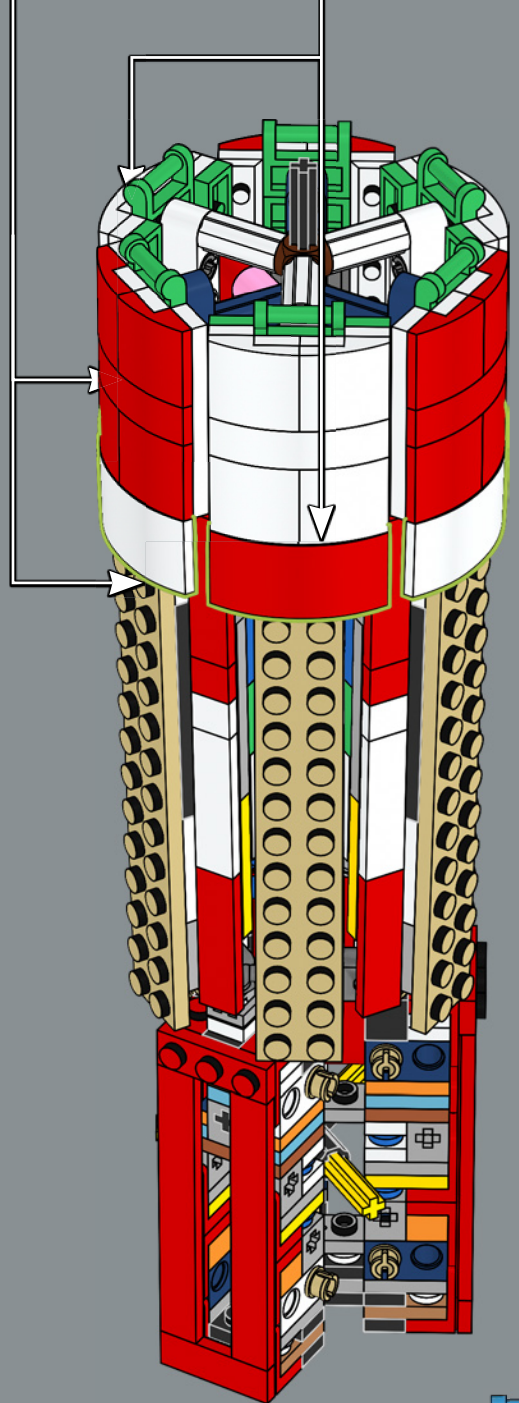
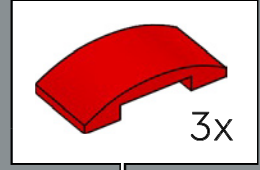
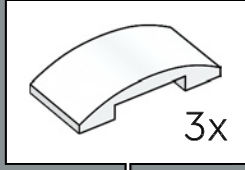

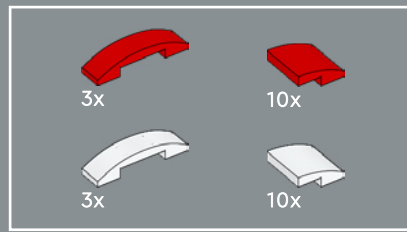

94

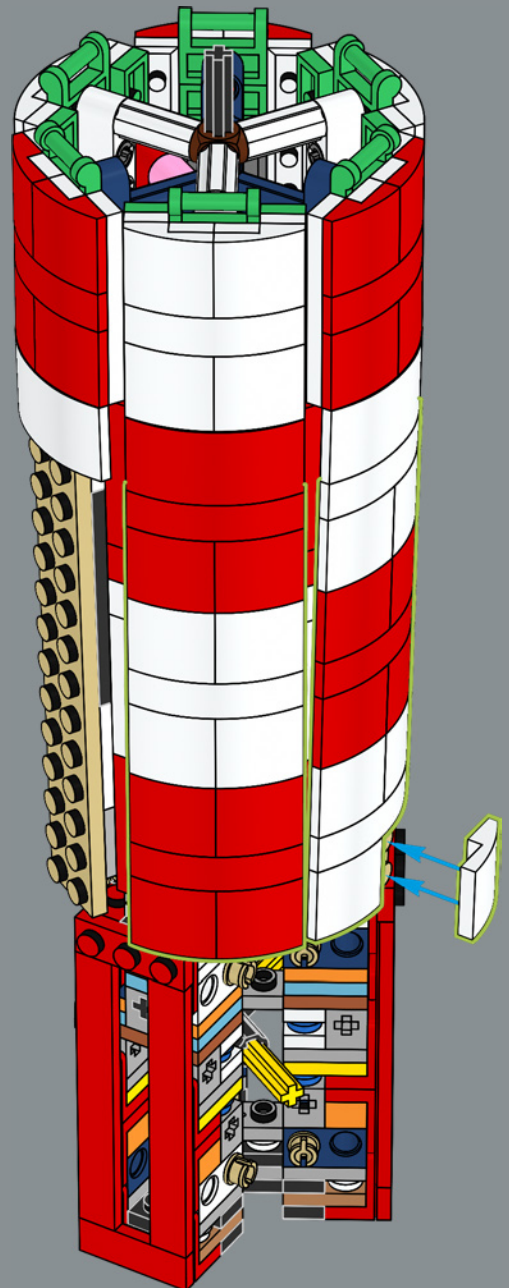

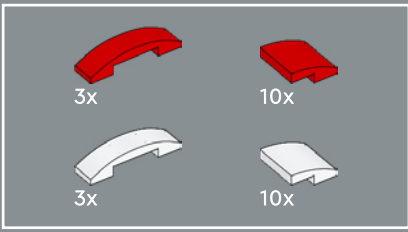

95

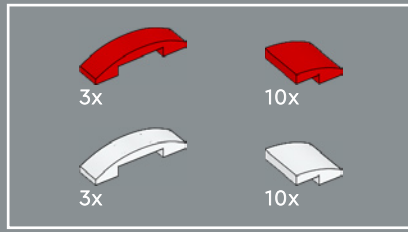
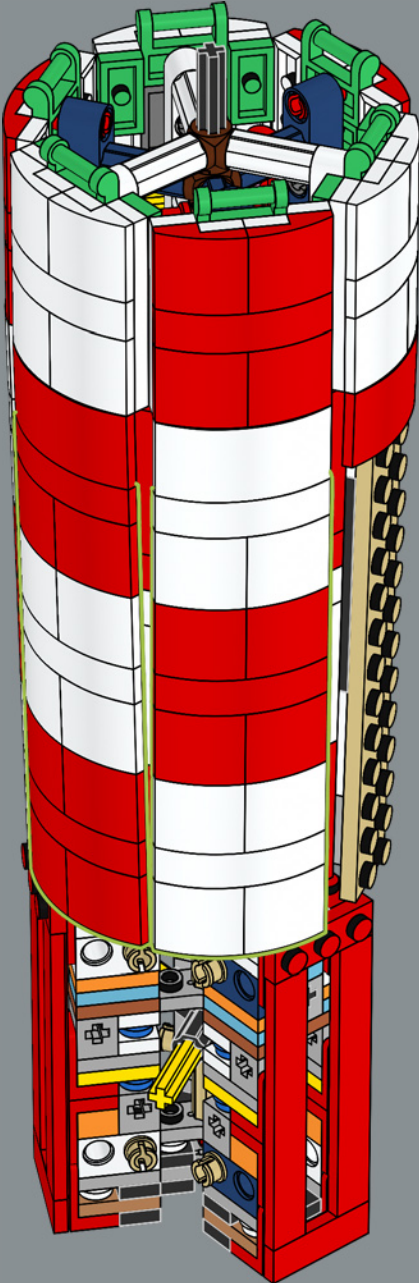

96

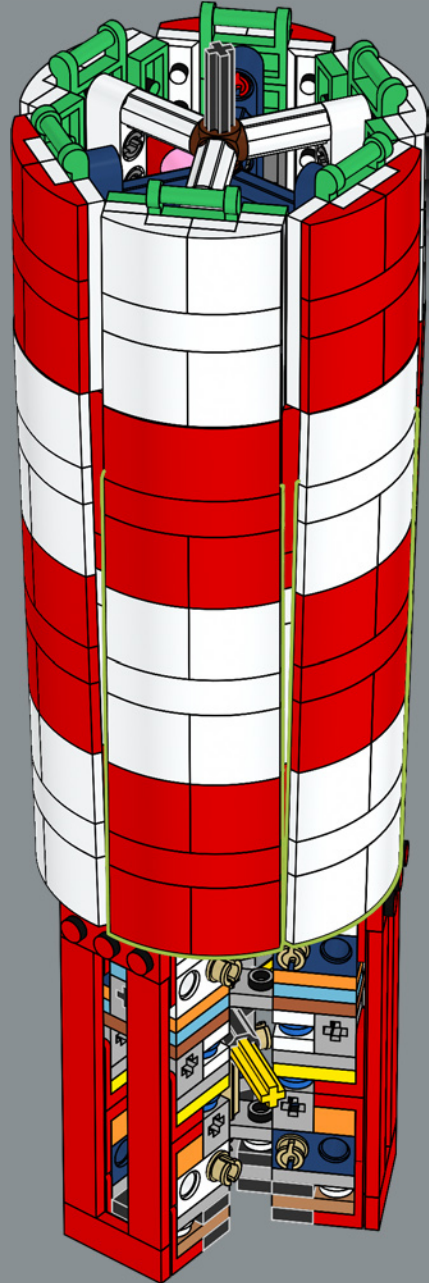





97

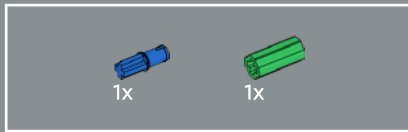
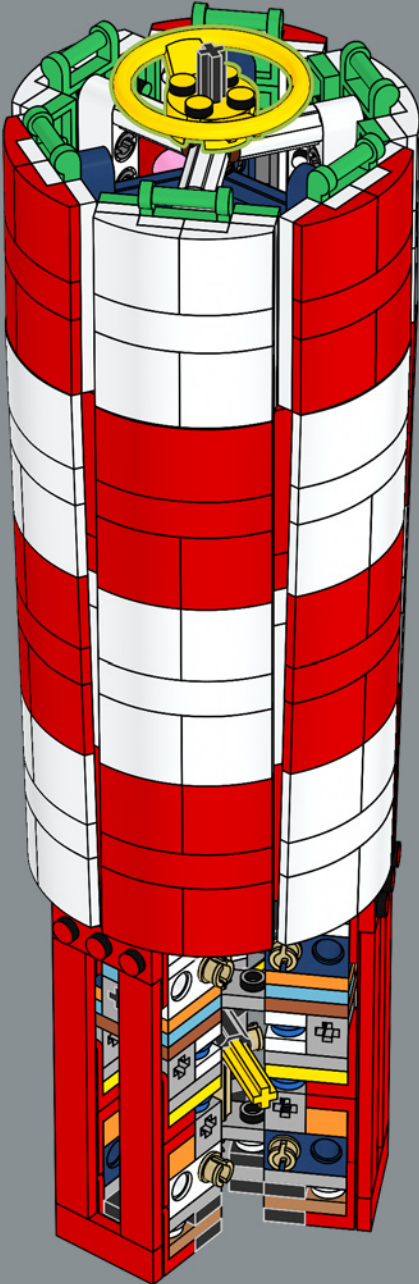

98

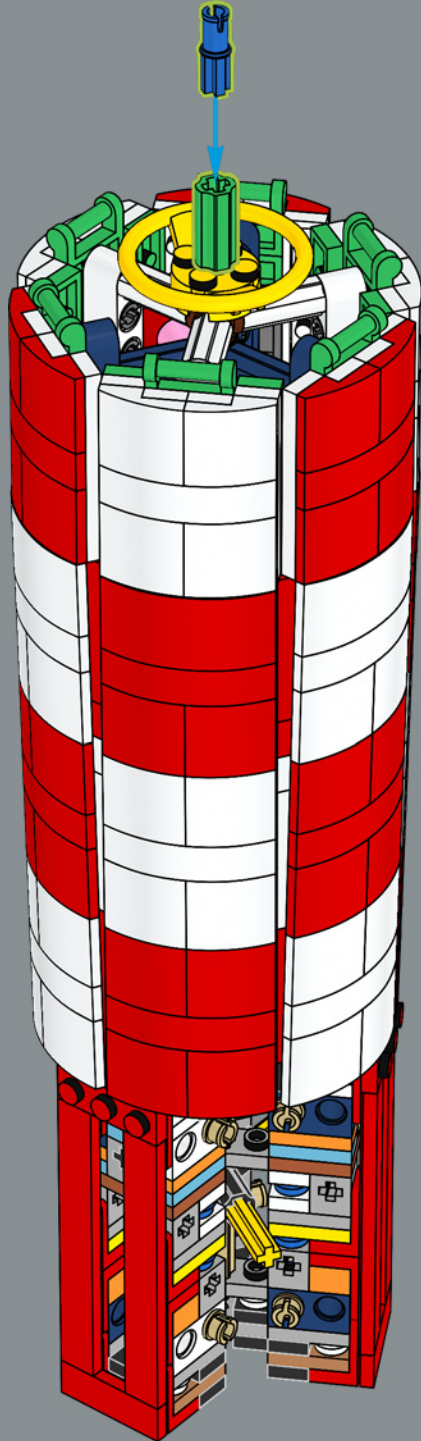

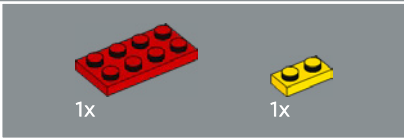
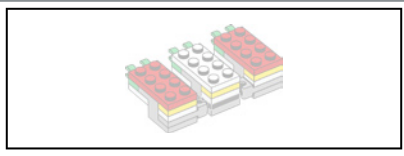

99

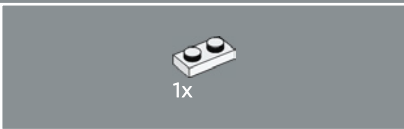
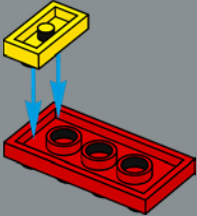

100

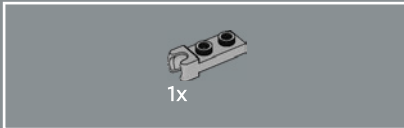
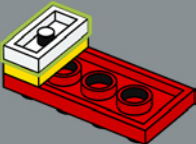

101

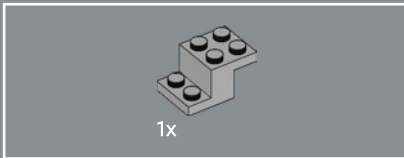
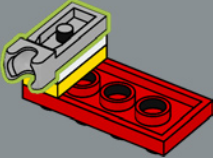

102

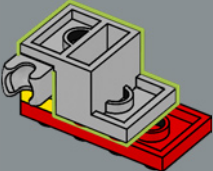

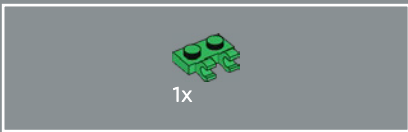

103

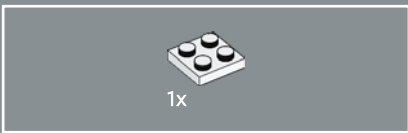
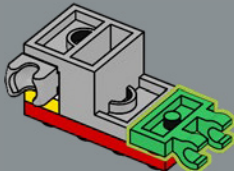

104

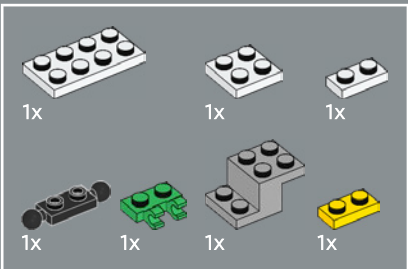
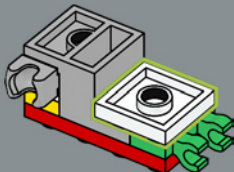

105

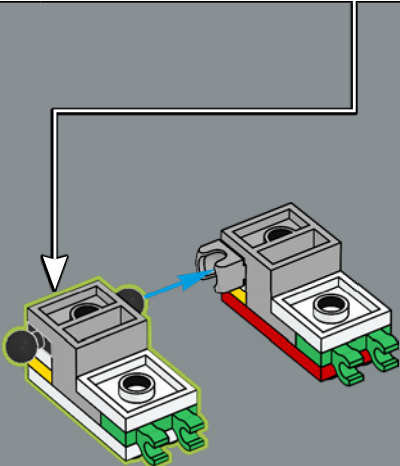
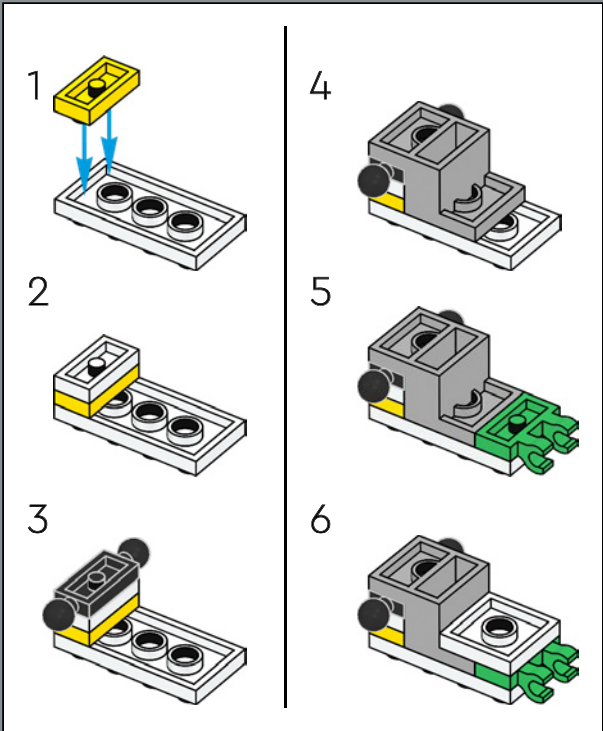

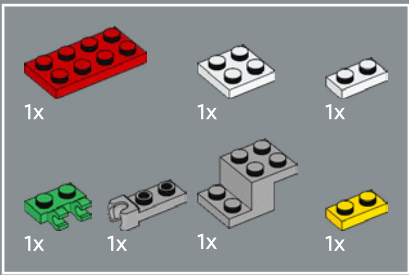

# 106

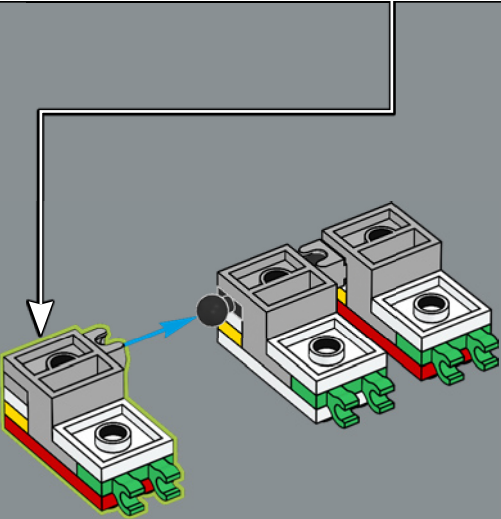
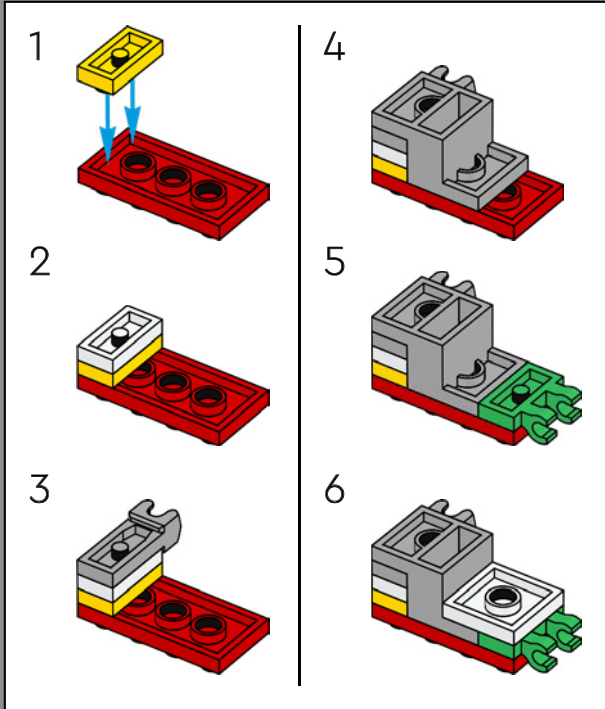

# 107

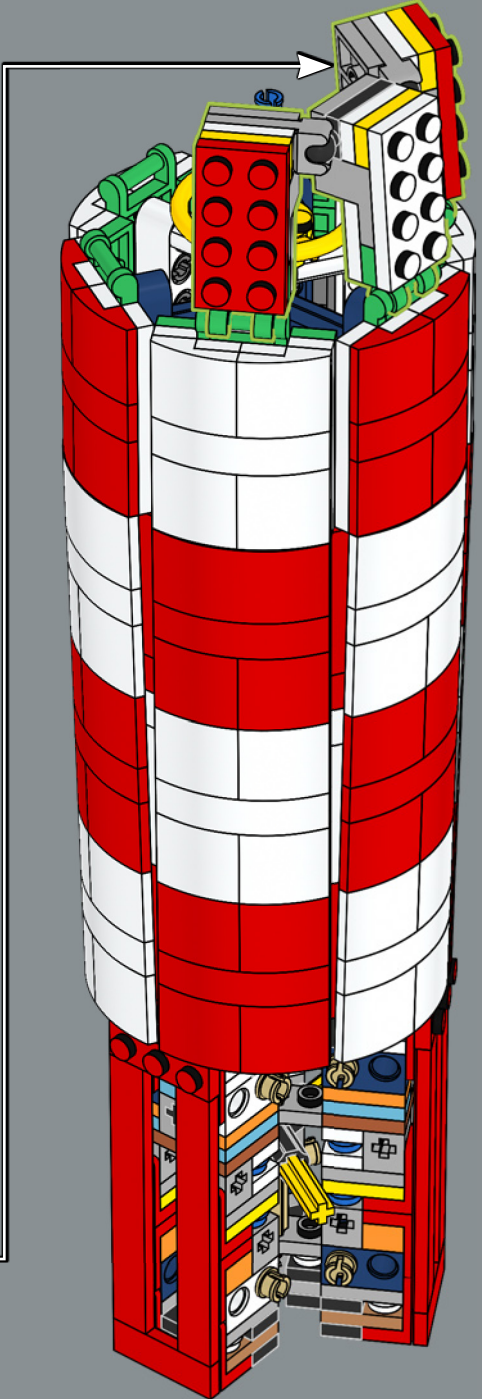

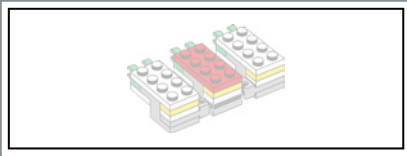

108

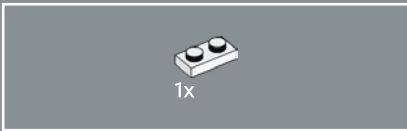
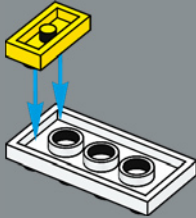

109

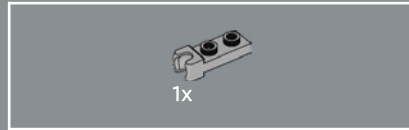

110

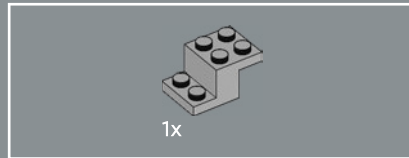
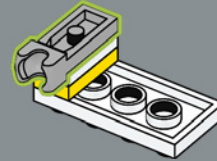

111

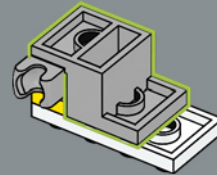

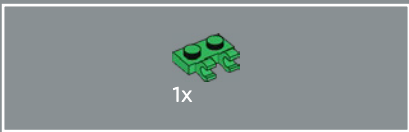

112

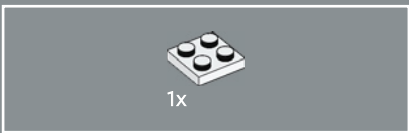
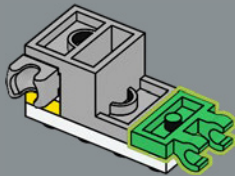

113

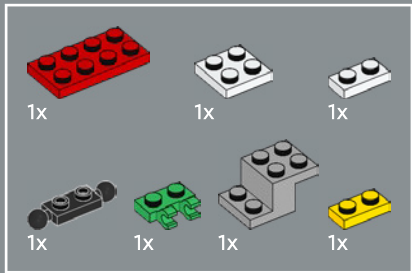
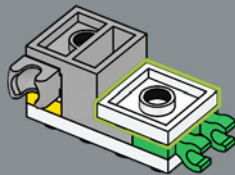

114

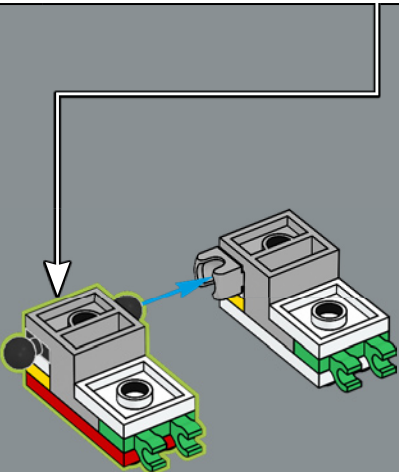
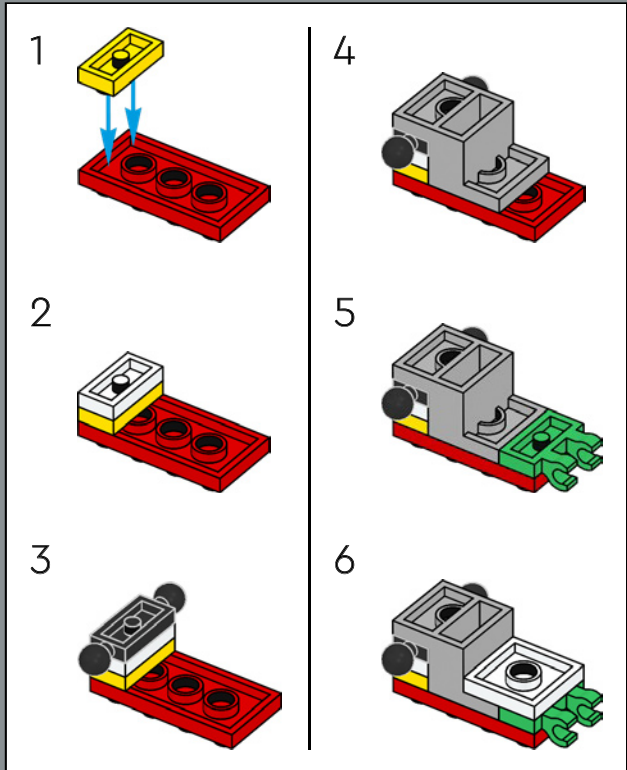

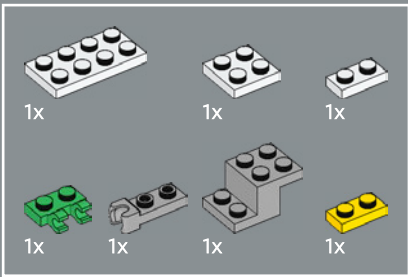

115

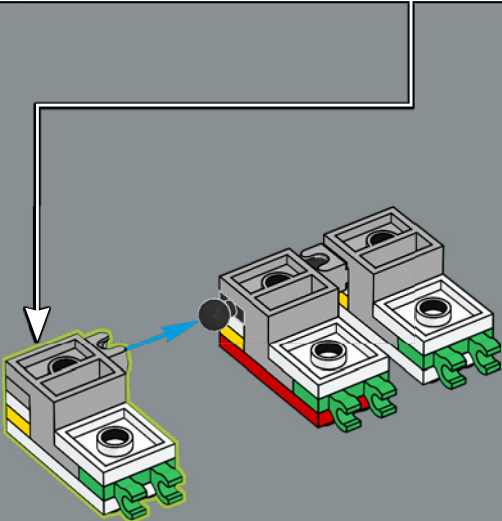
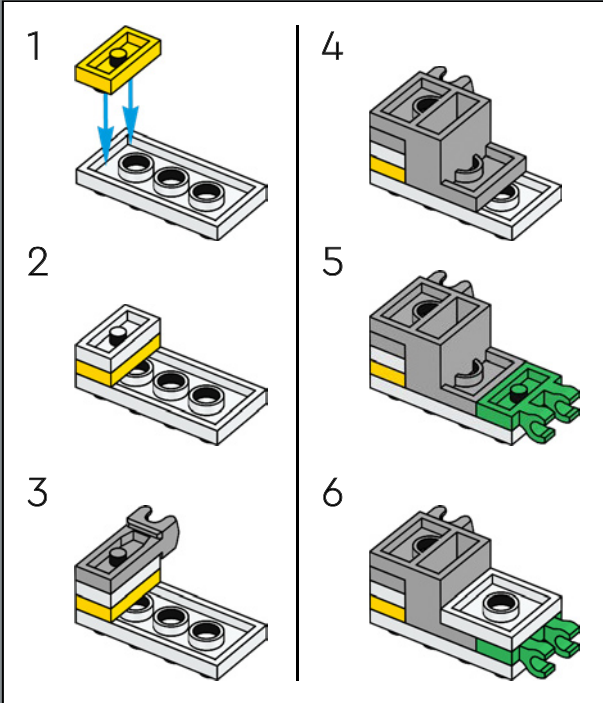

116

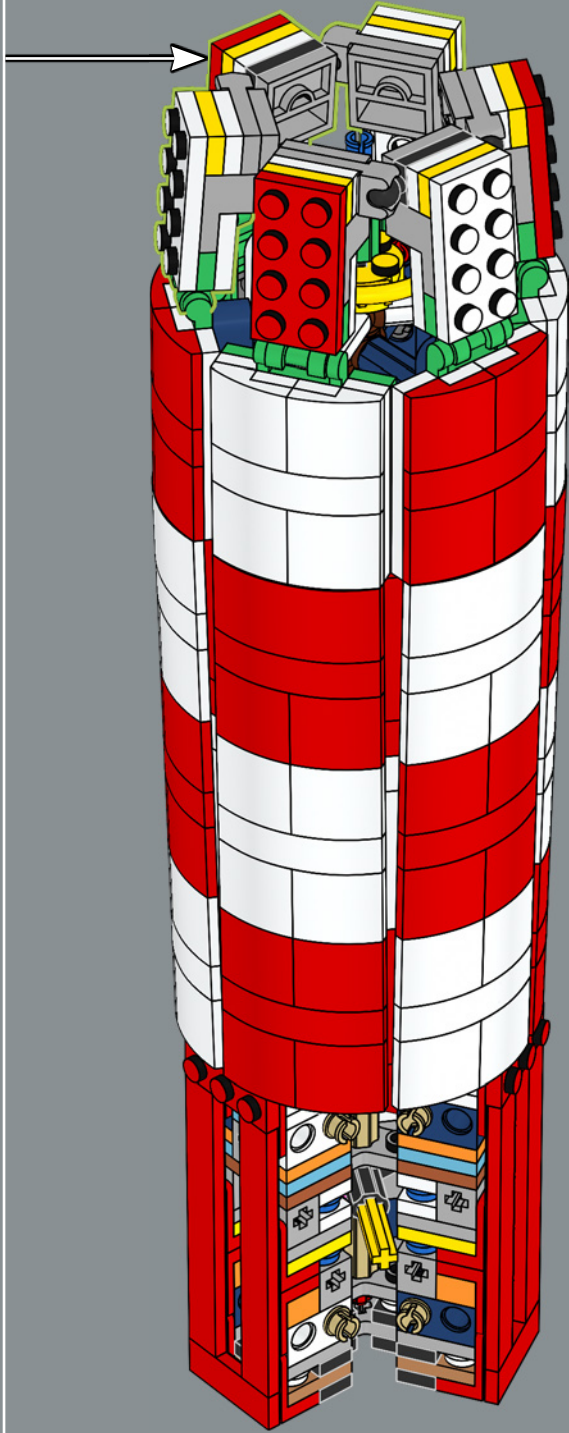

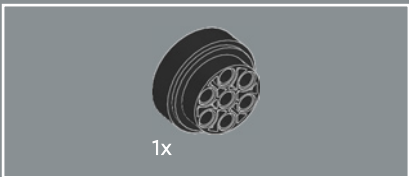

117

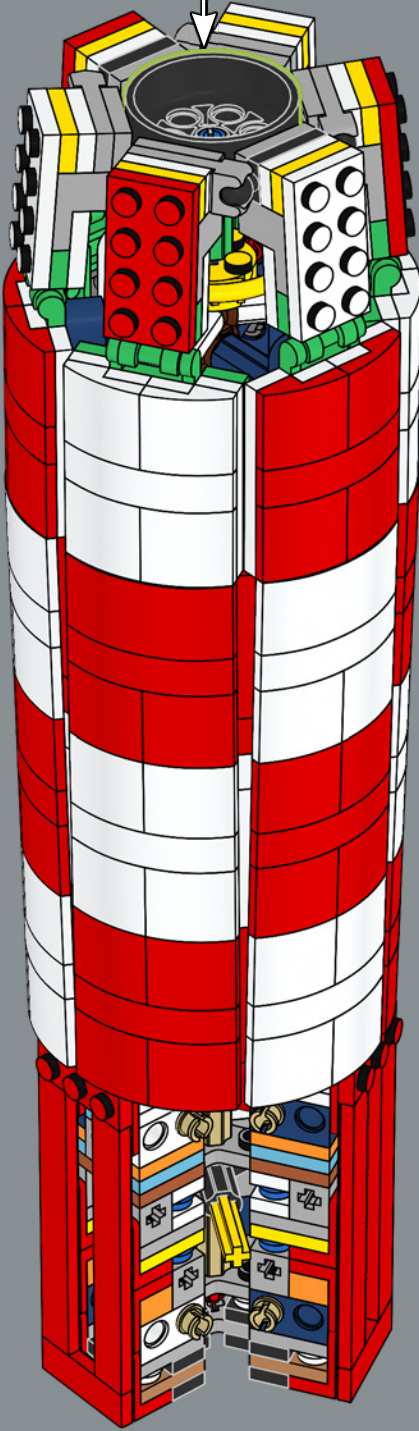

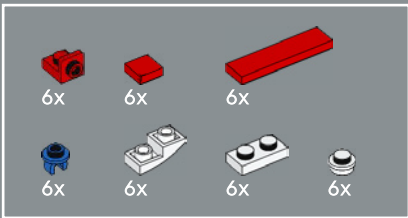

118

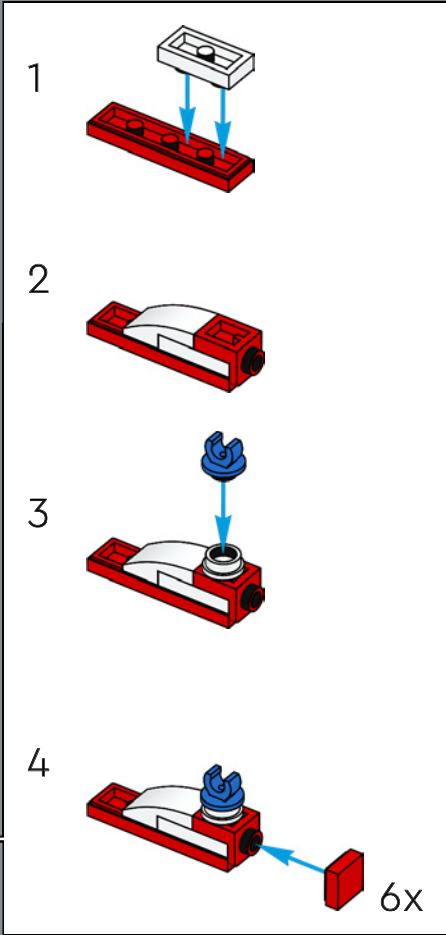
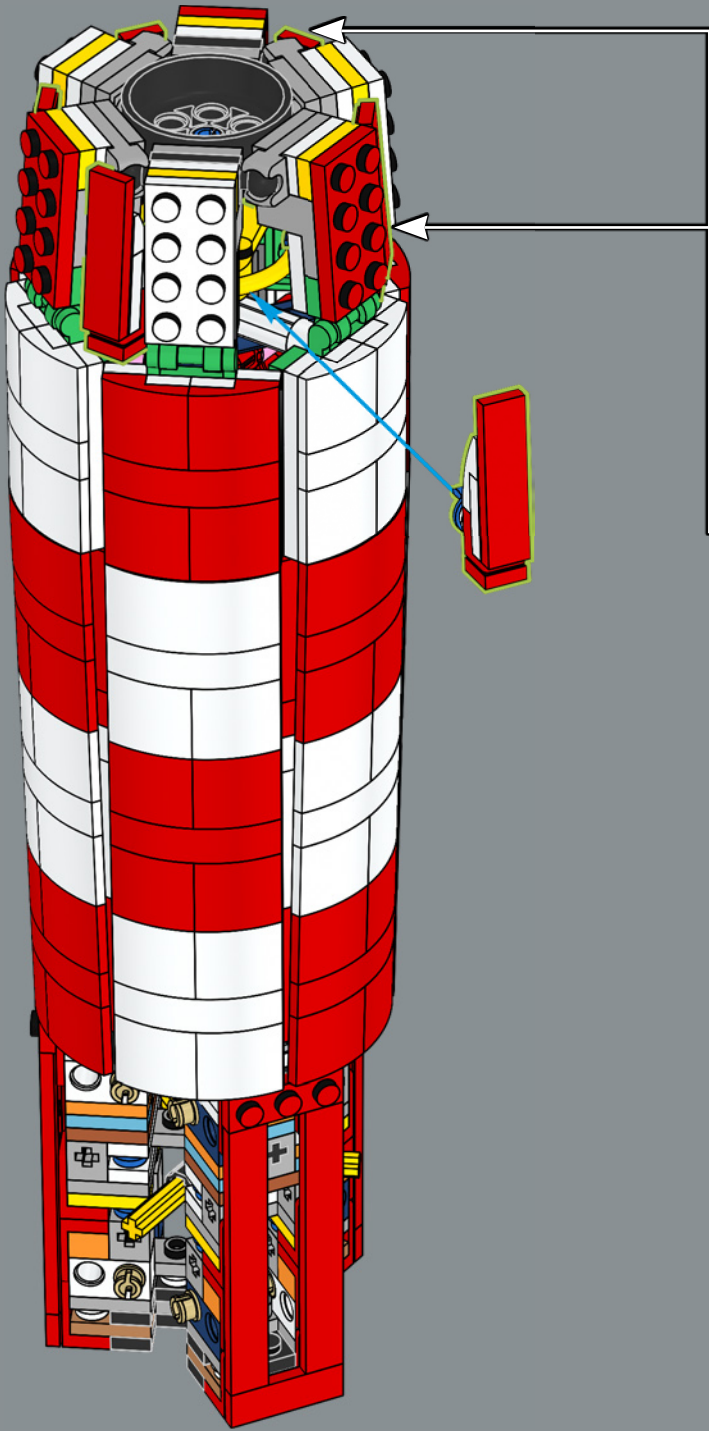

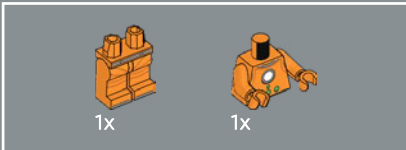
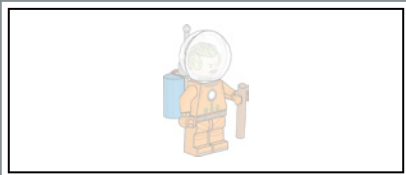

1

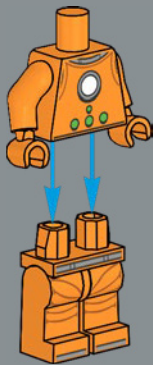

2

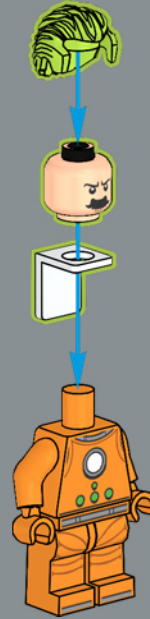

3

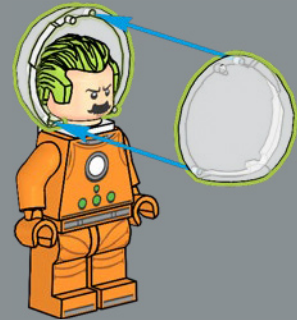



4

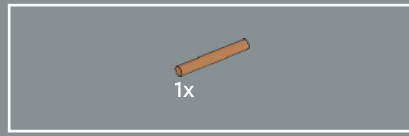
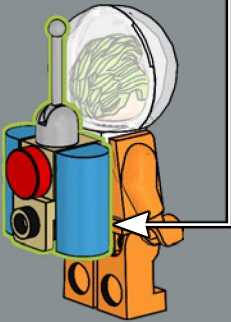
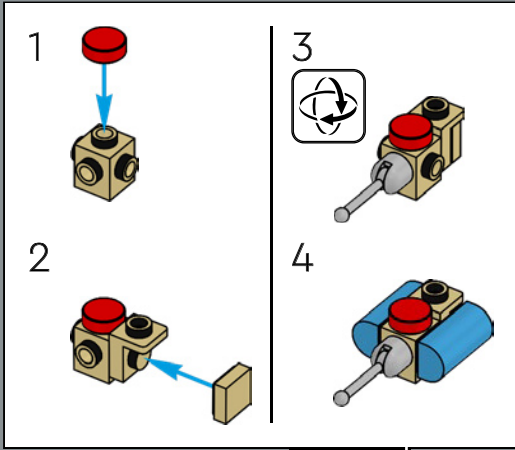

5

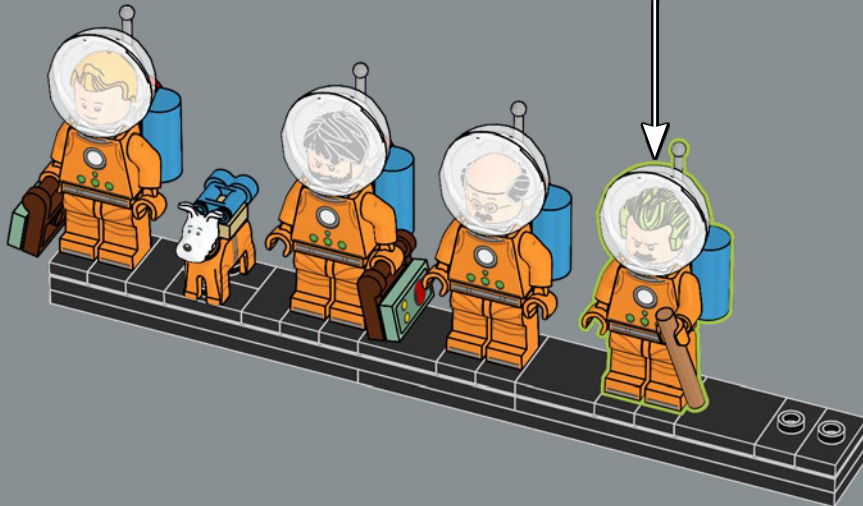

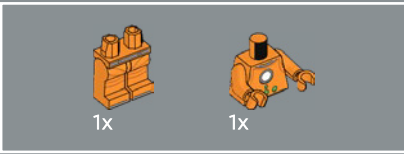
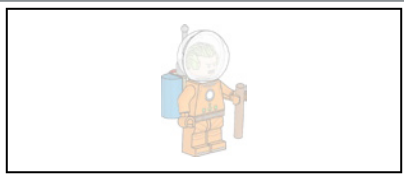

1

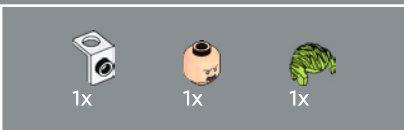
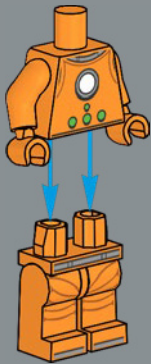

2

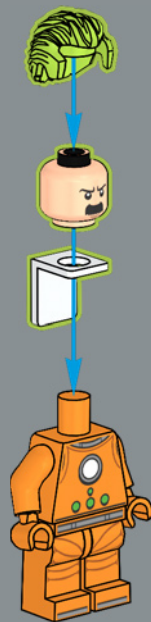

3

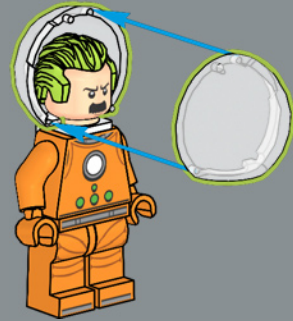

4

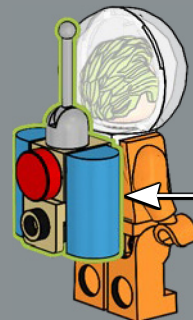
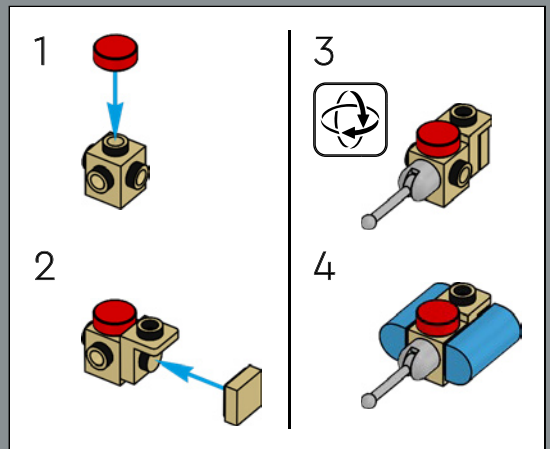

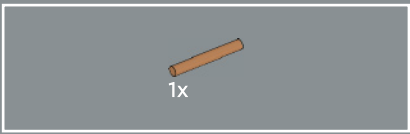

5

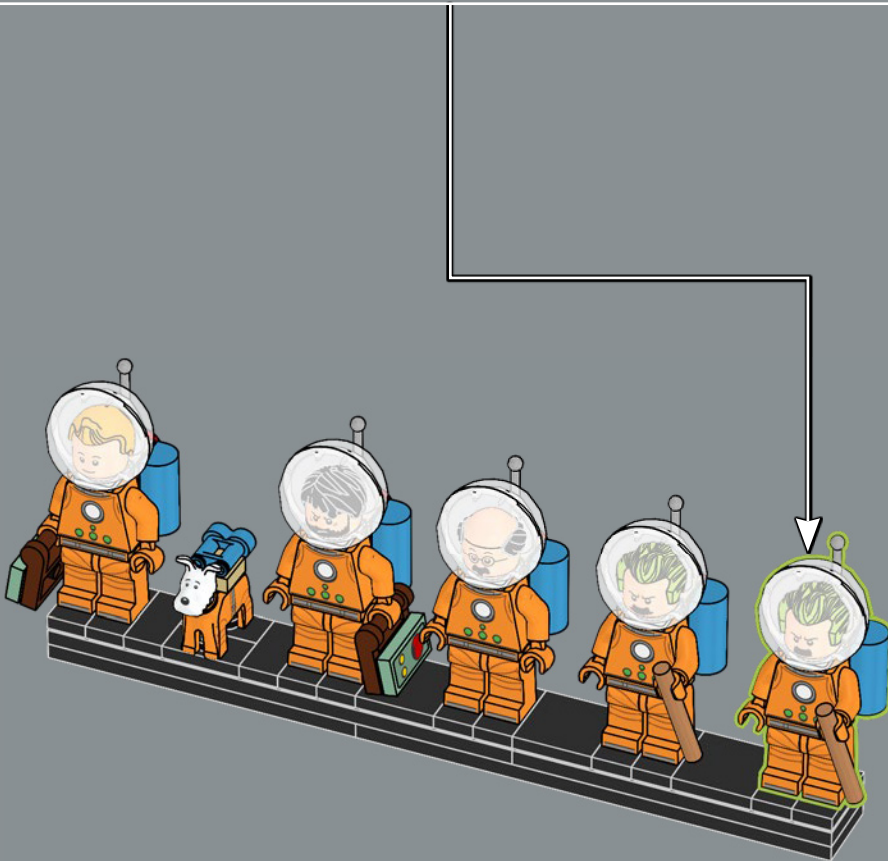
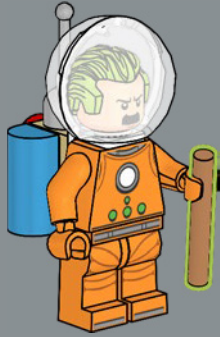

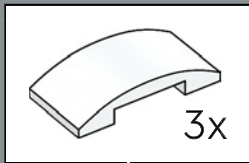
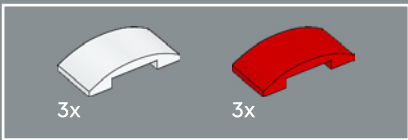

119

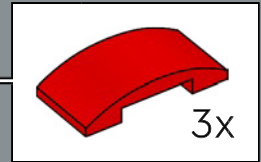
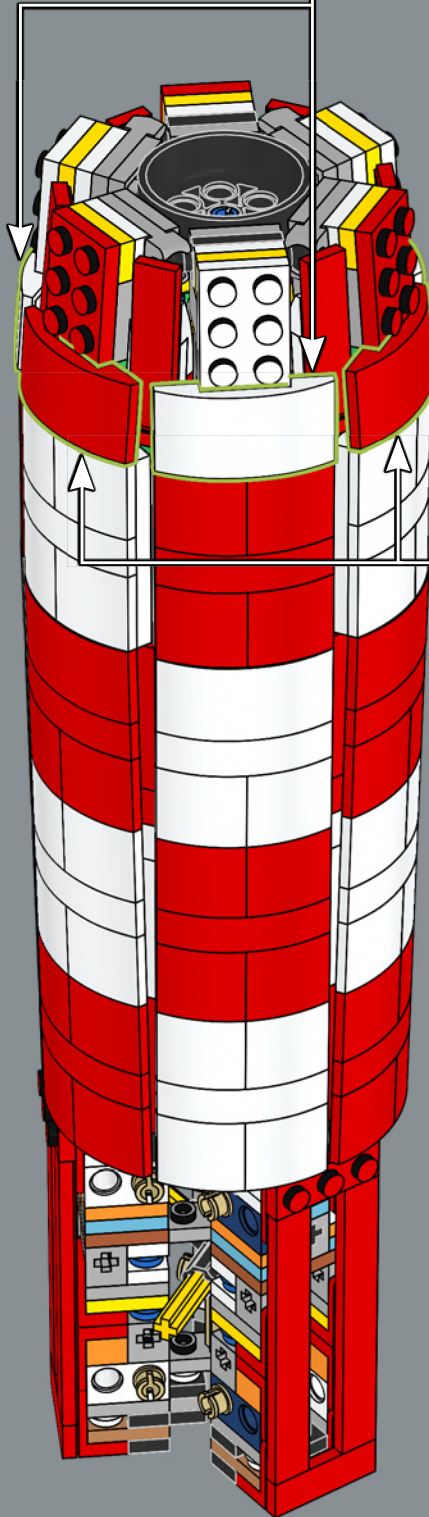

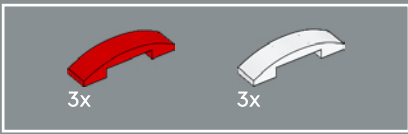

120

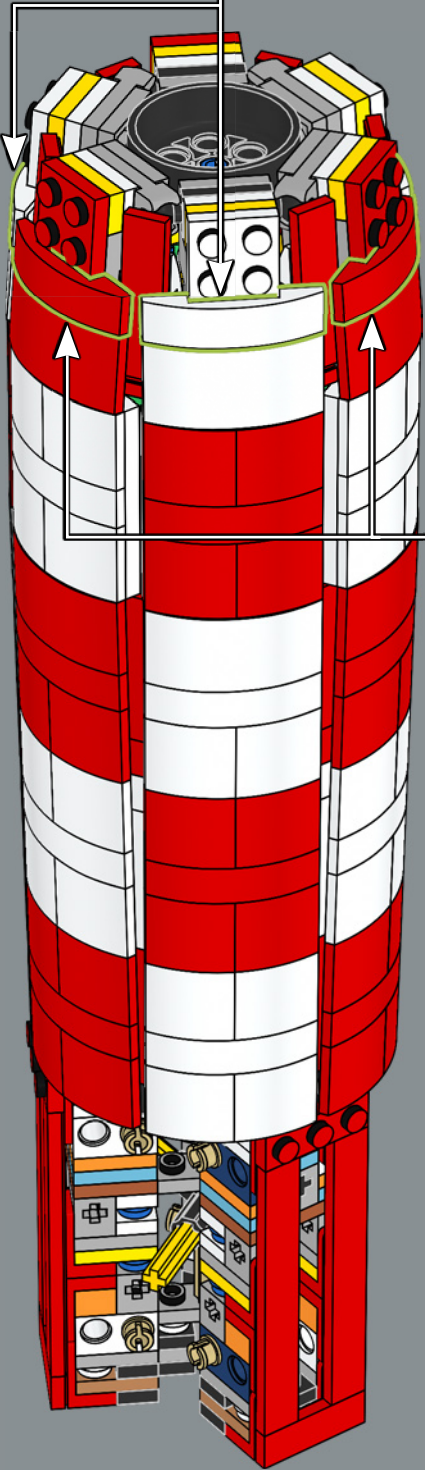
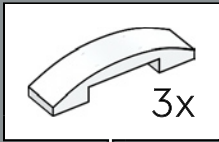

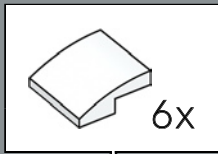
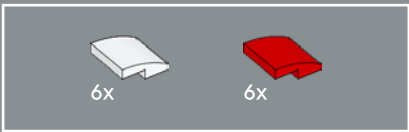

121

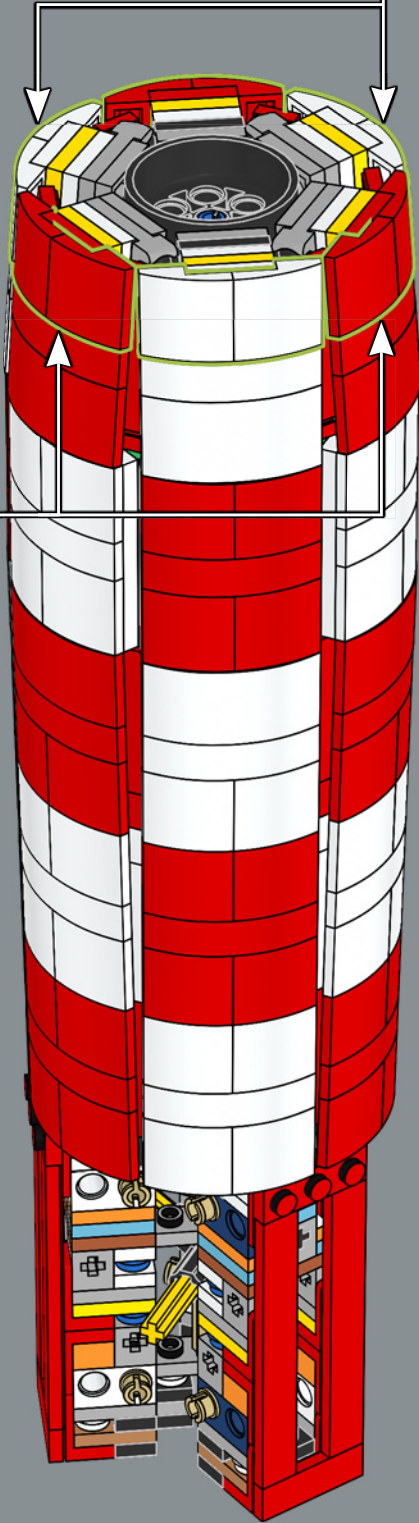
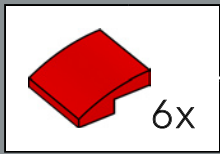

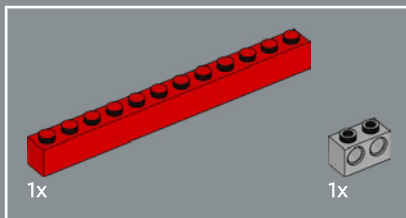
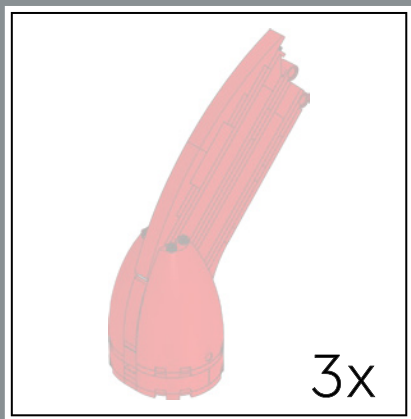

122

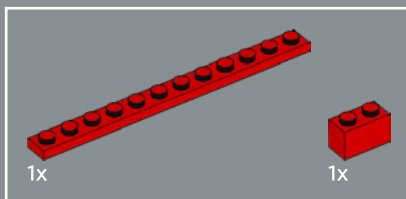
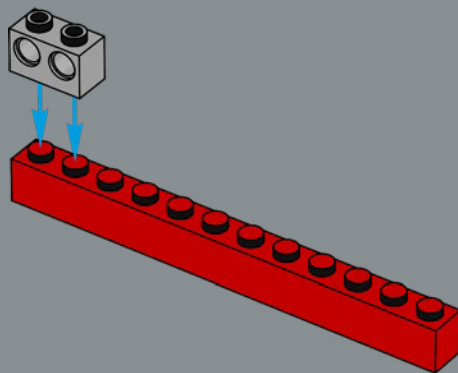

123

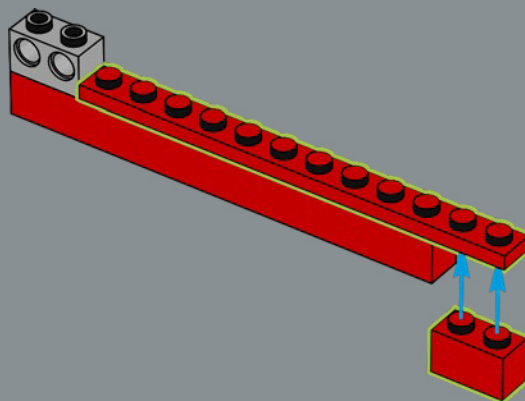

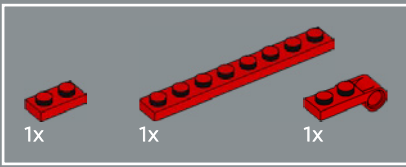

124

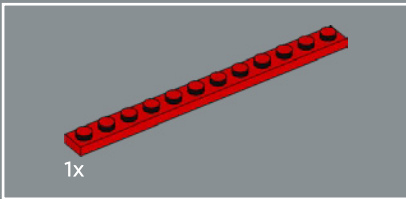
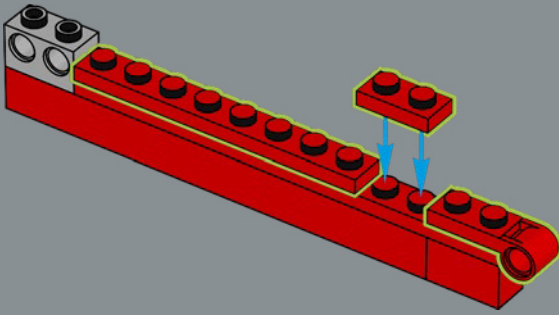

125

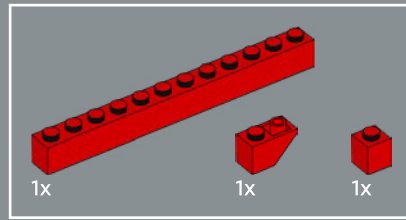
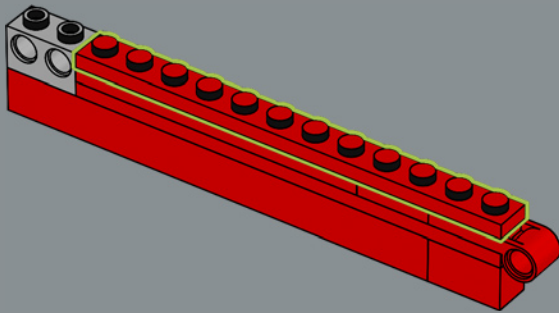

126

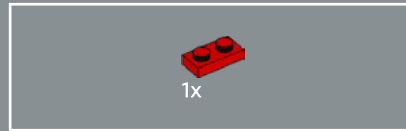
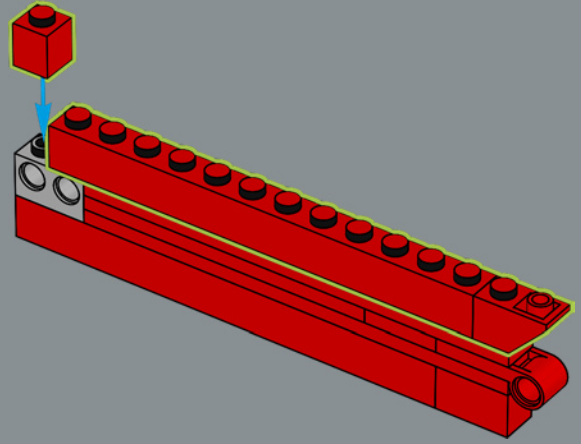

127

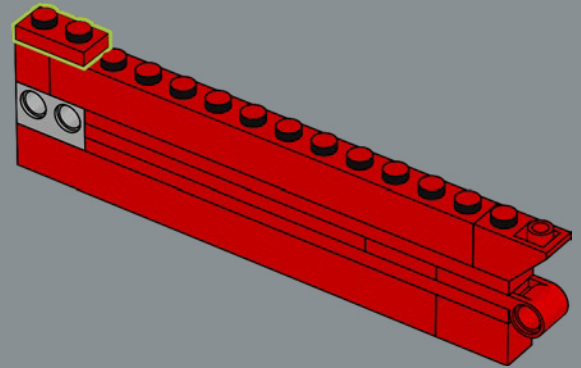

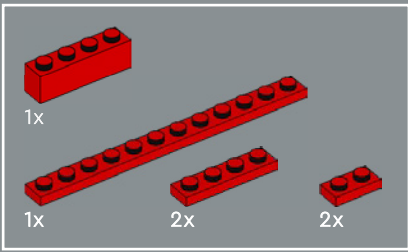

128

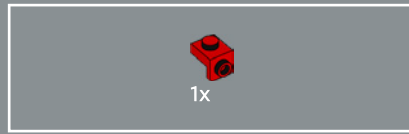
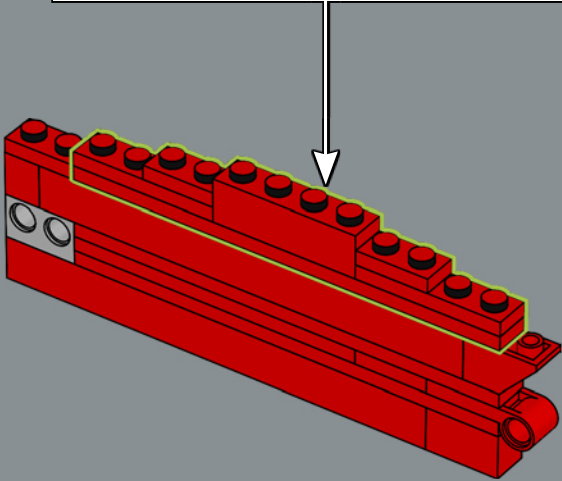
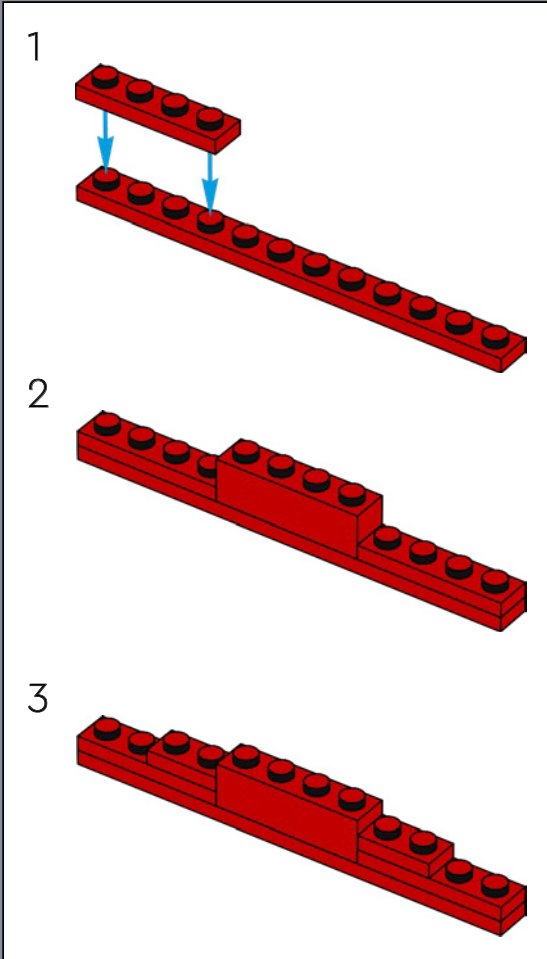

129

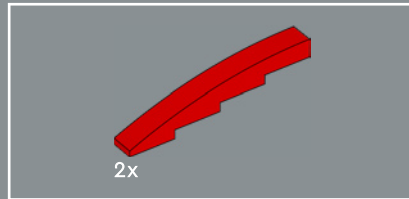
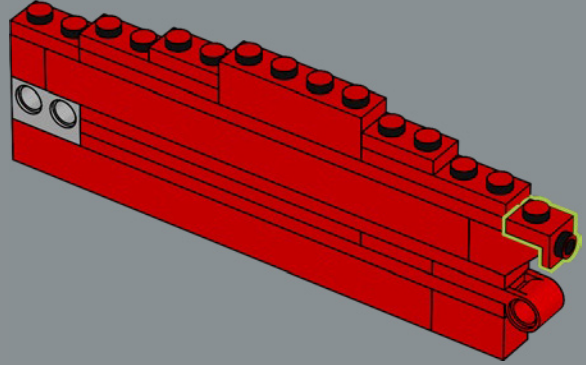

130

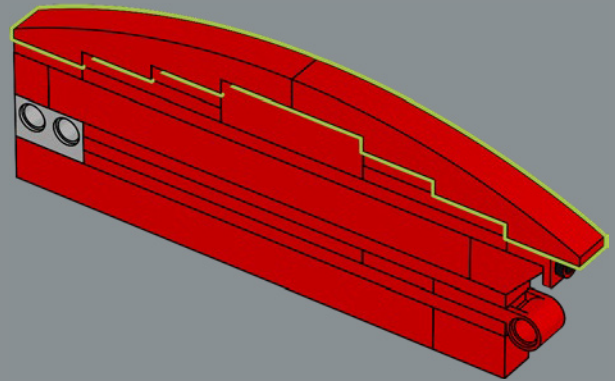

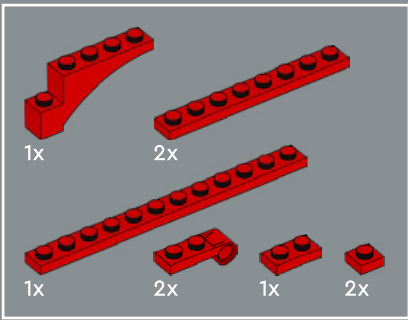

131

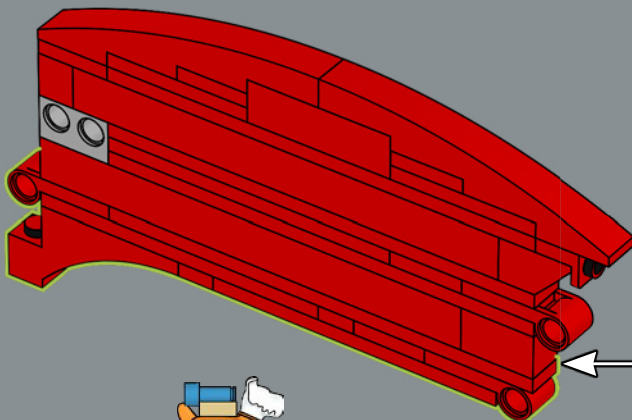
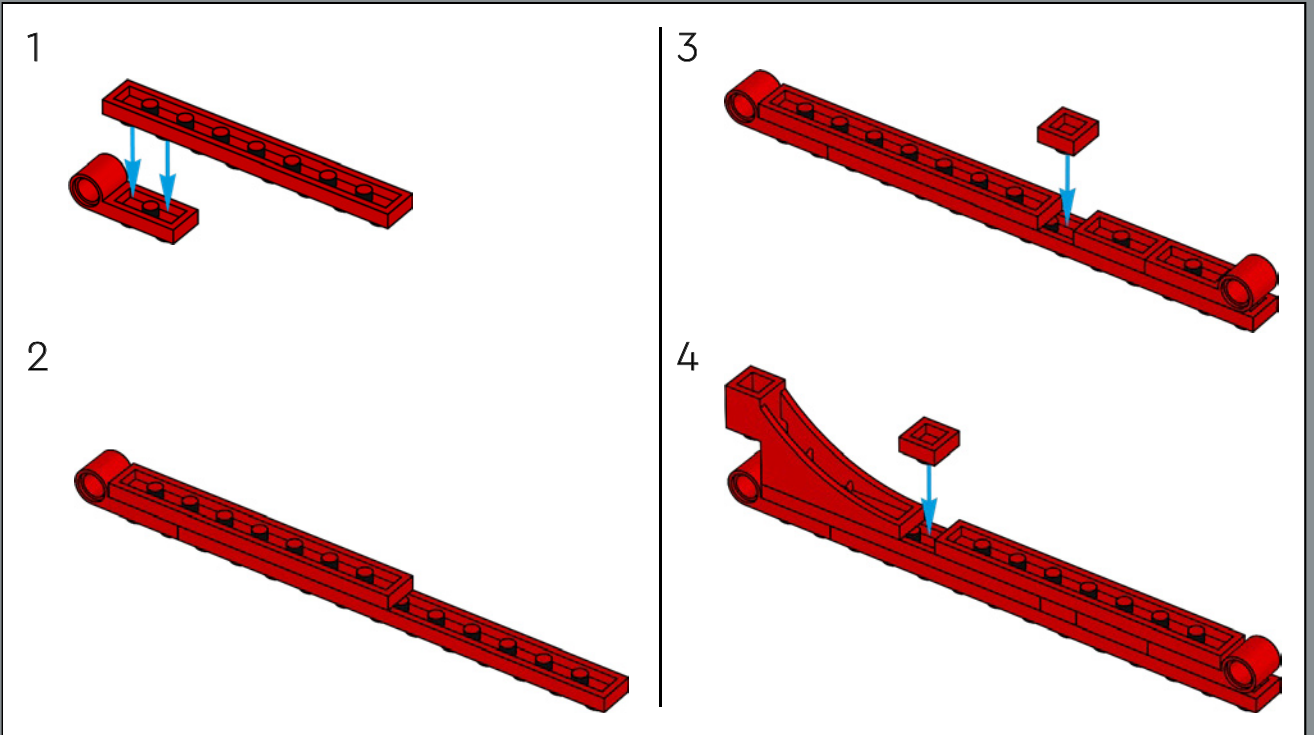

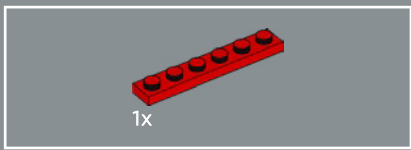

133

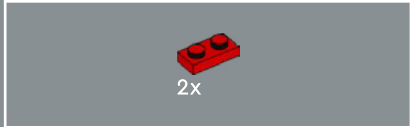
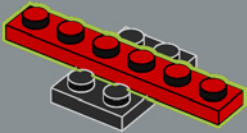

134

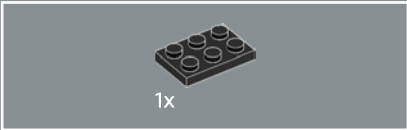
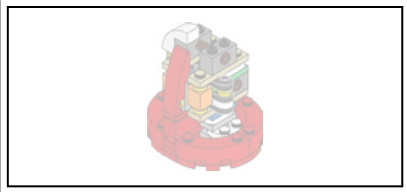
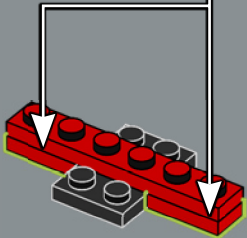
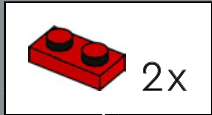

132

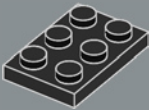



135

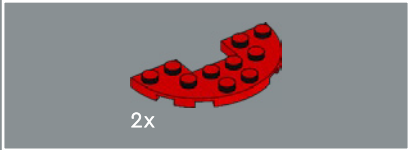
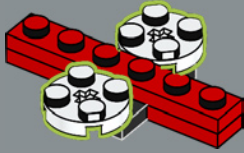

136

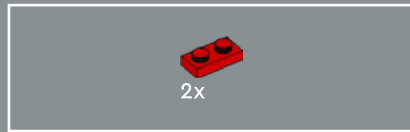
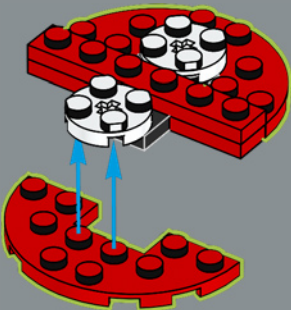

137

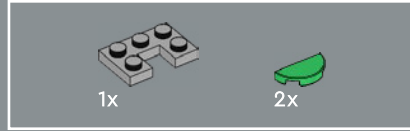
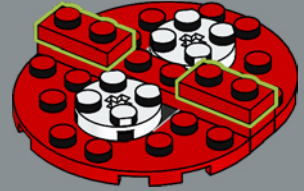

138

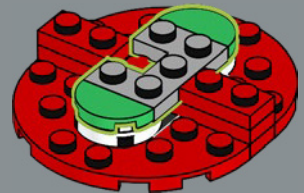

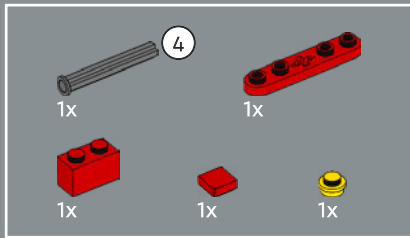

139

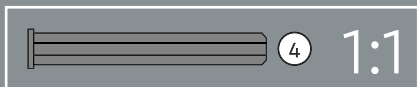
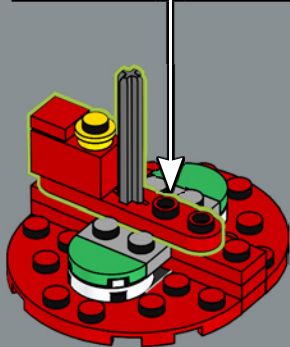
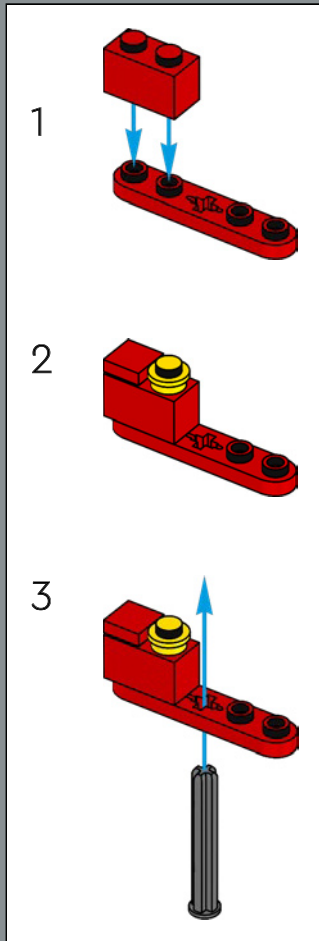

140

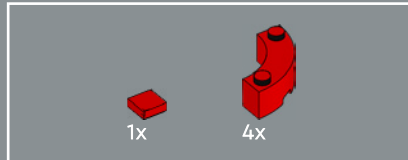
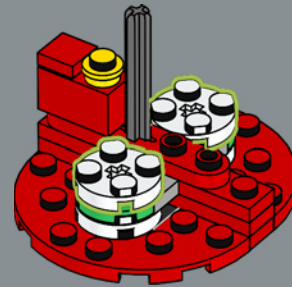

141

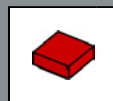
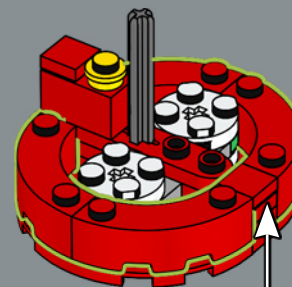

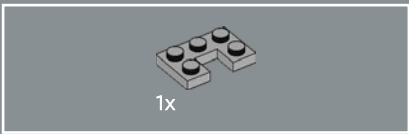

142

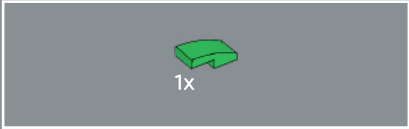
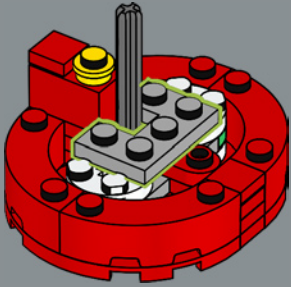

143

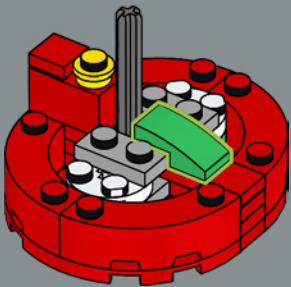

144

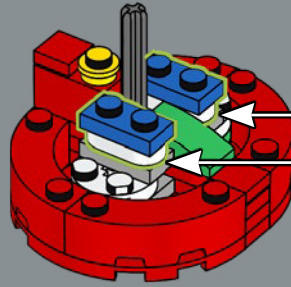
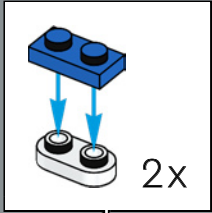

145

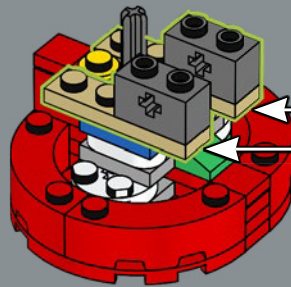
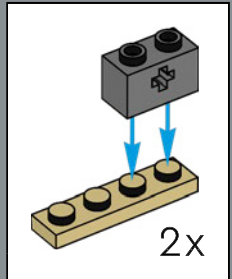

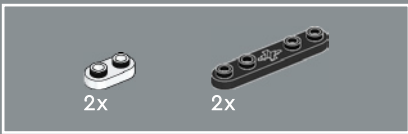

146

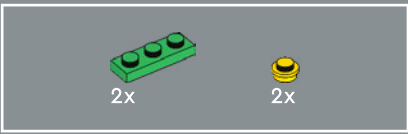
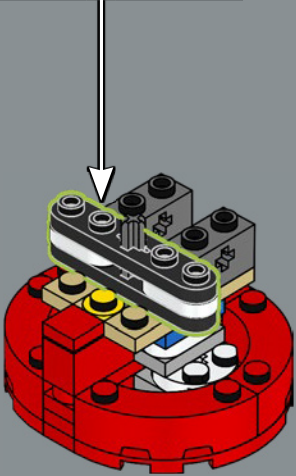
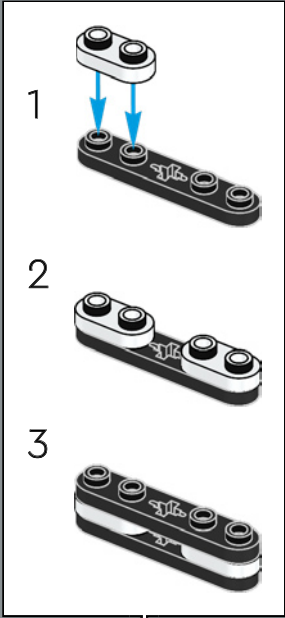

147

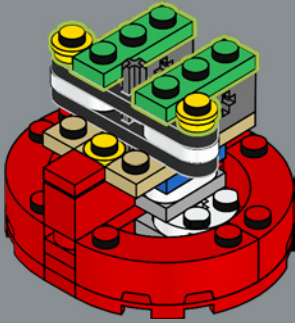

148

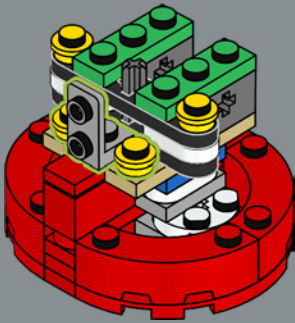

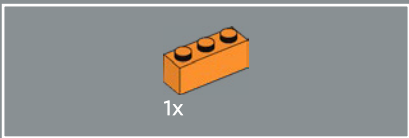

149

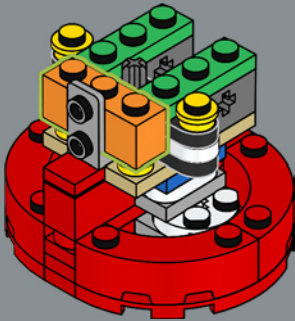

151

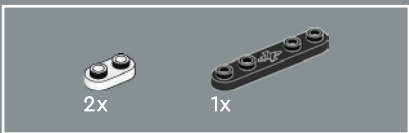
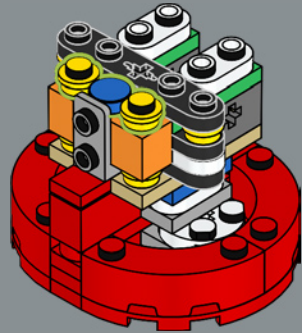

150

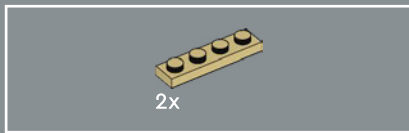
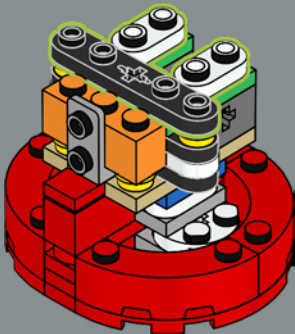

152

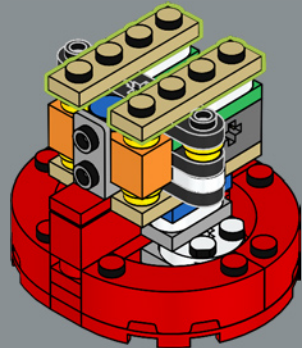

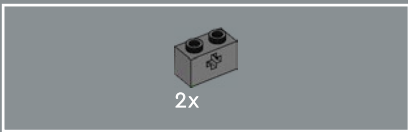

153

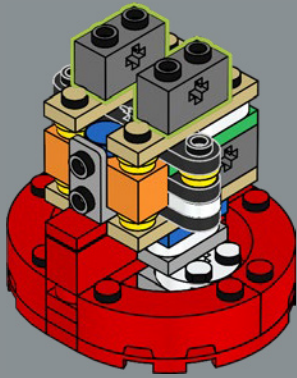

154

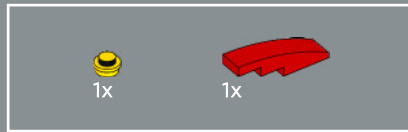
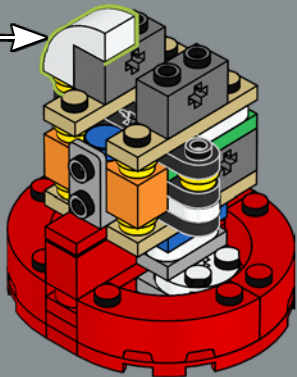
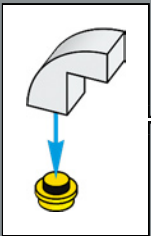

155

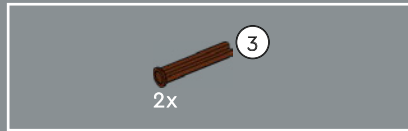
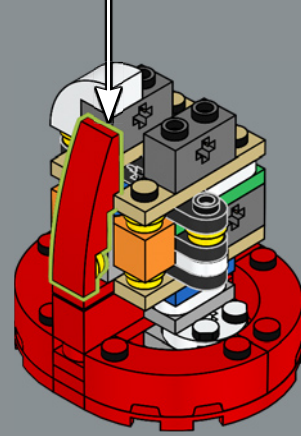
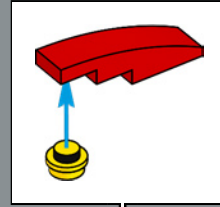

156

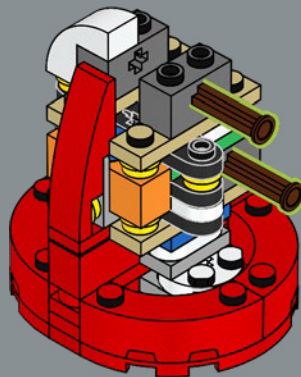

157

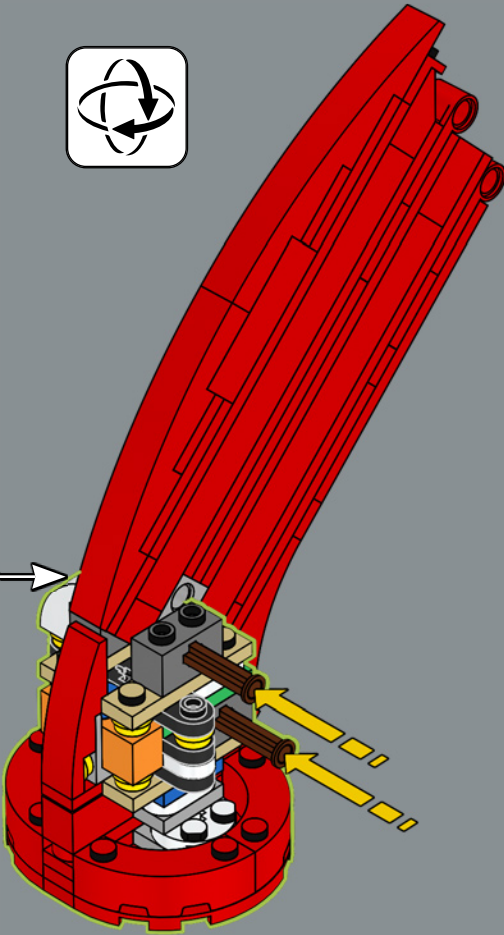

158

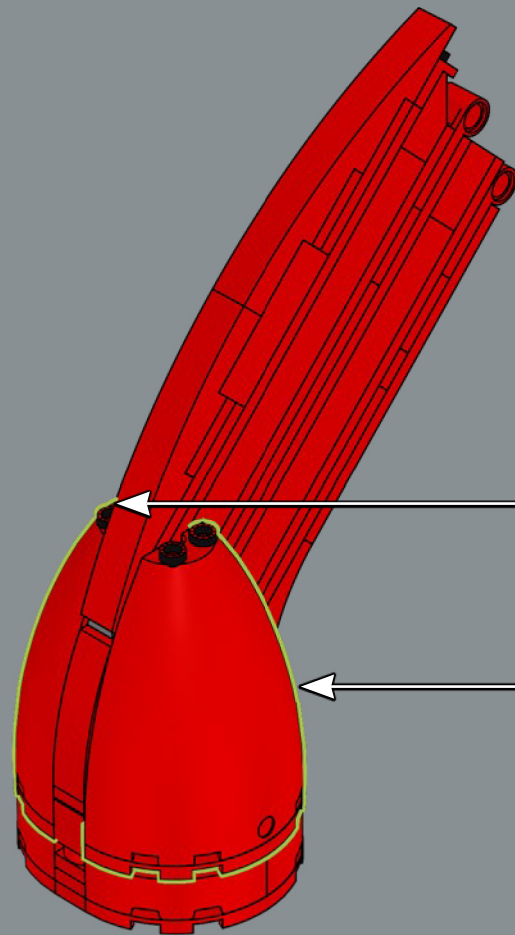
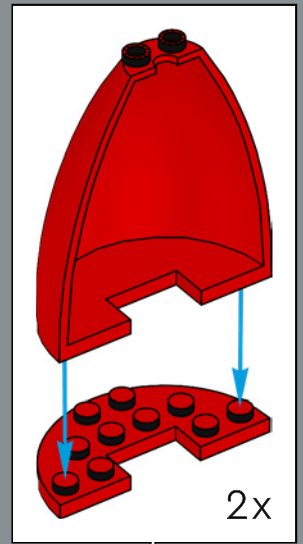
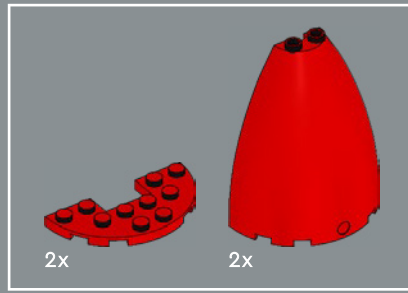

3x



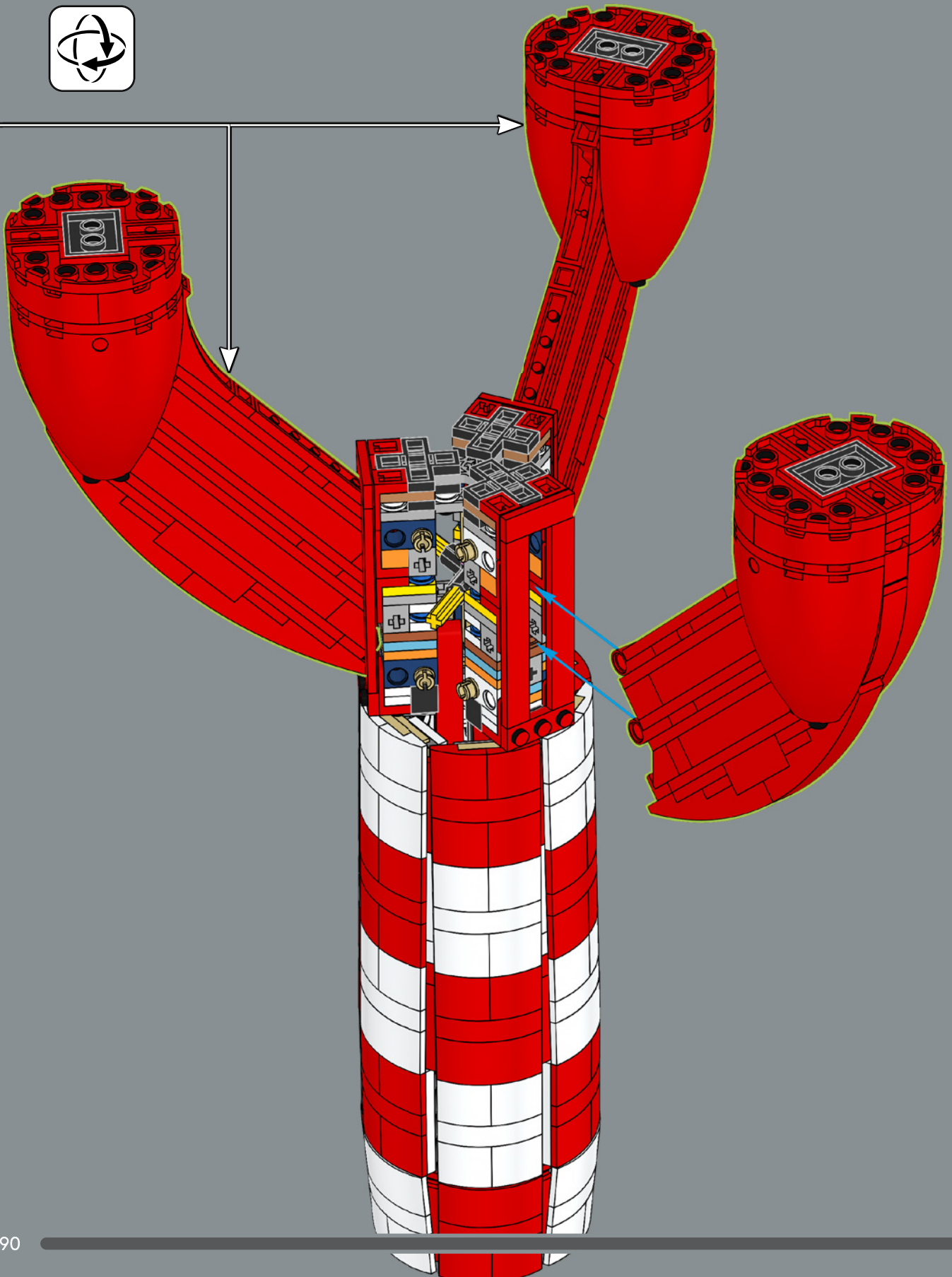

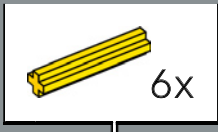
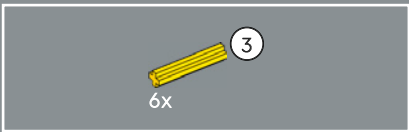

160

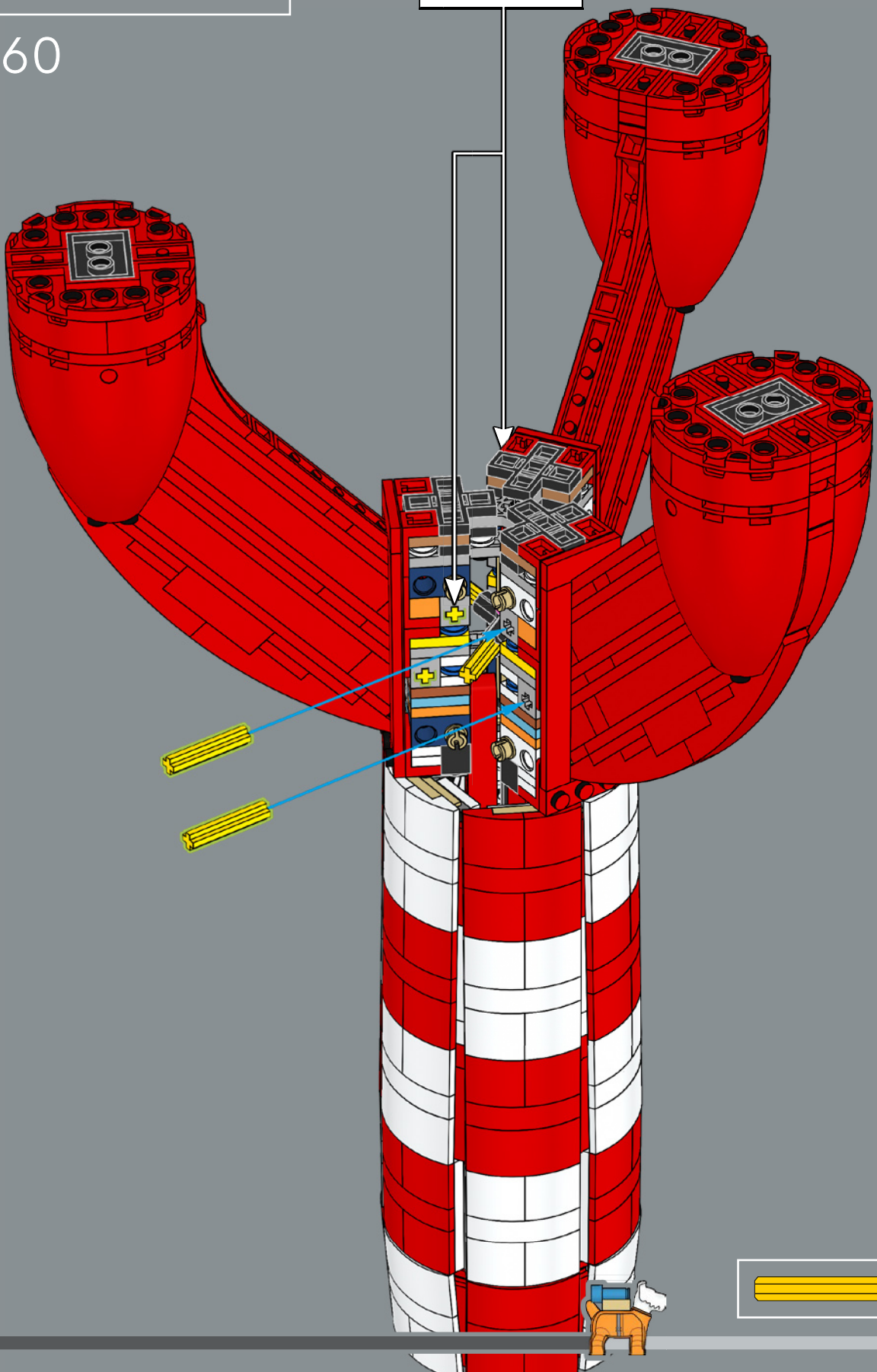

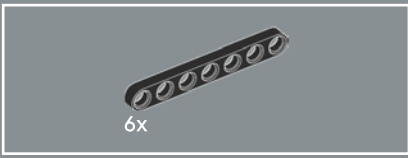

161

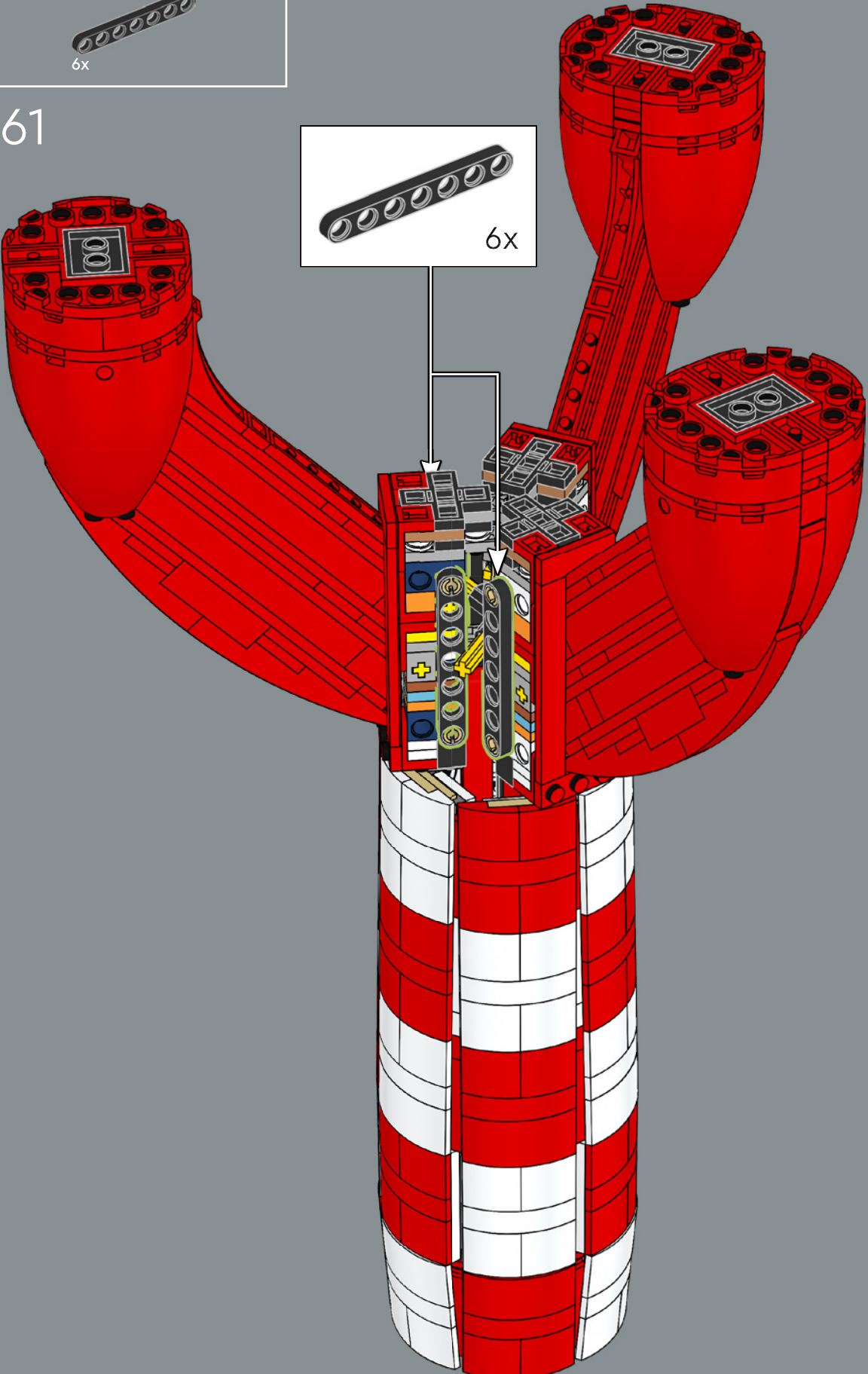
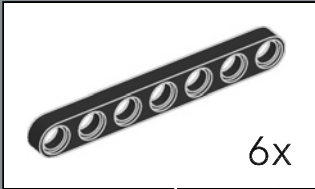

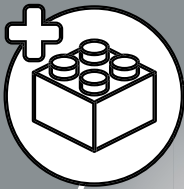

2x

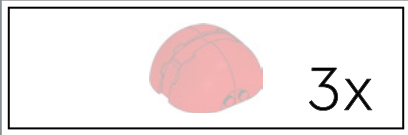

3x

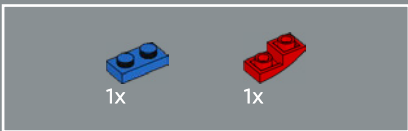

1x

1x

162

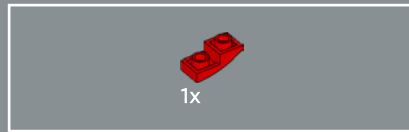
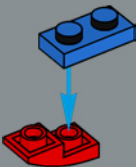

1x

163

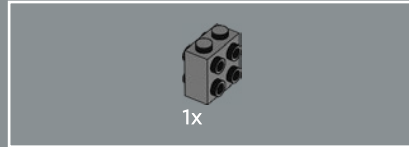

1x

164

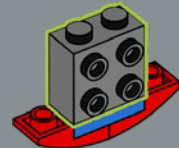



165

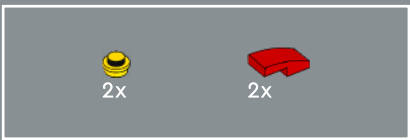
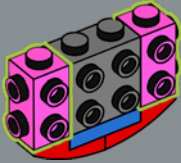

166

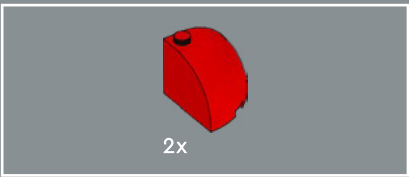
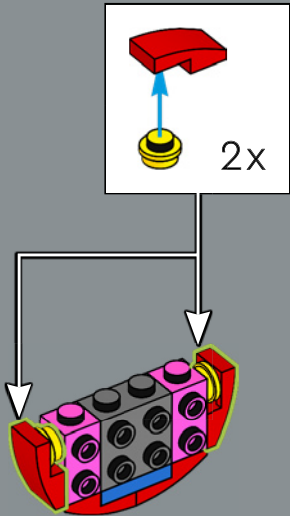

167

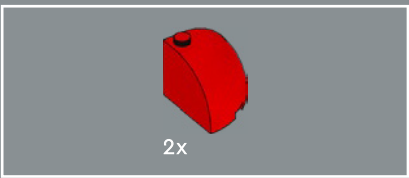
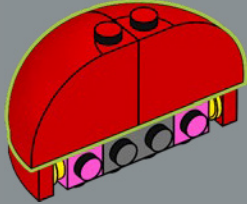

168

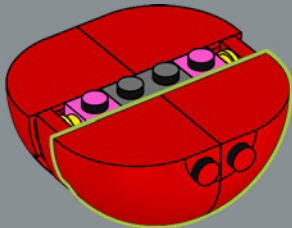

3x

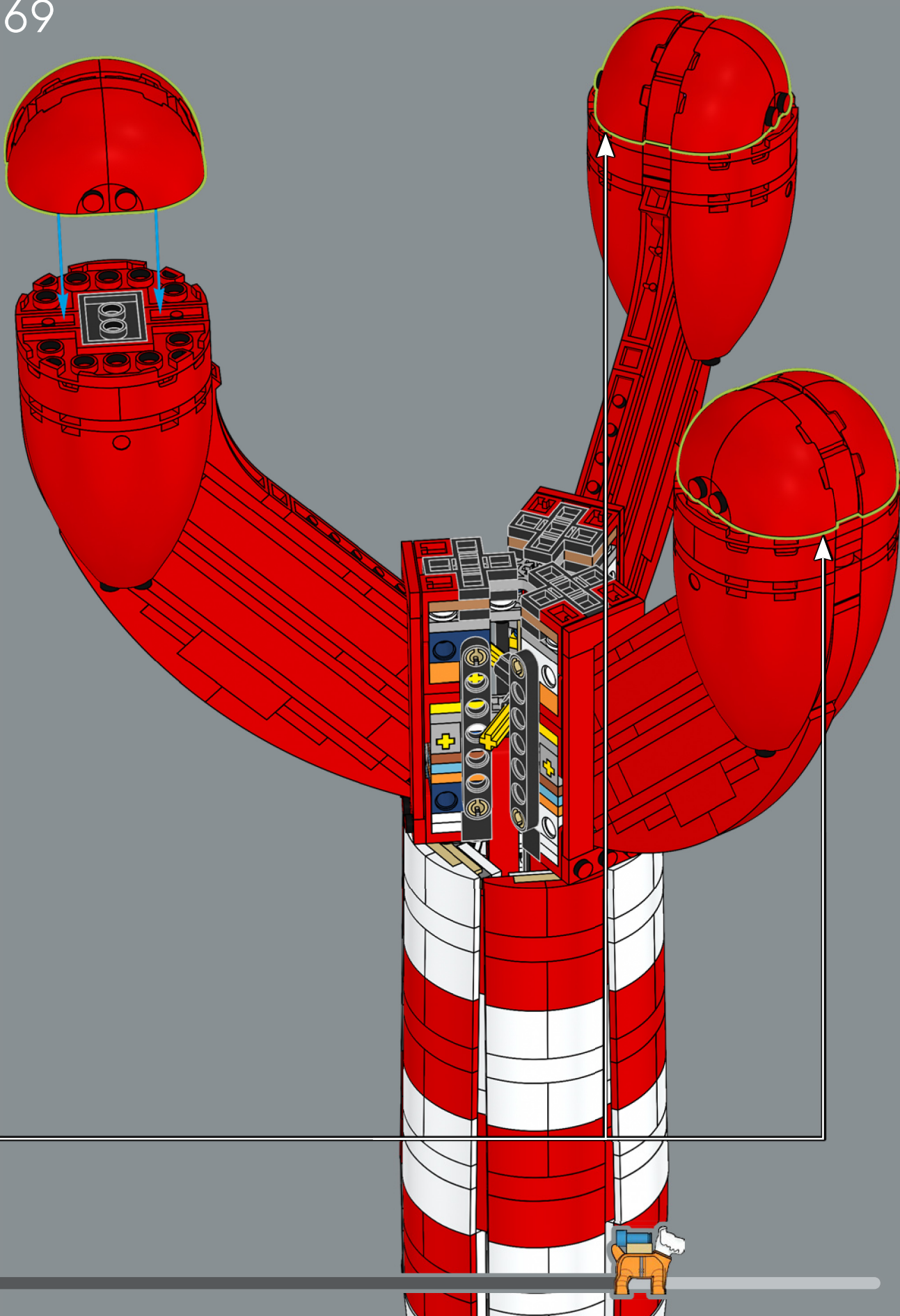



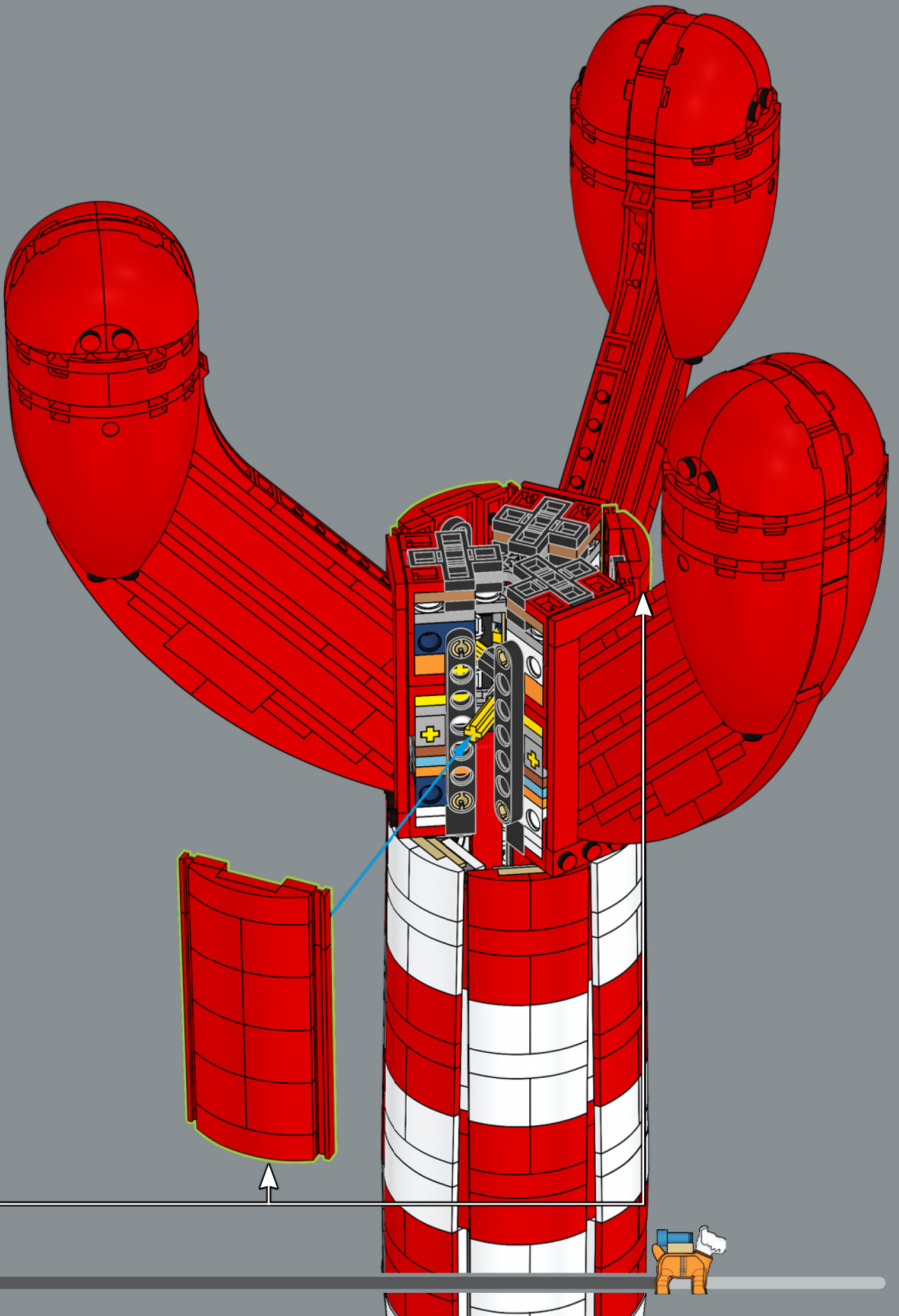

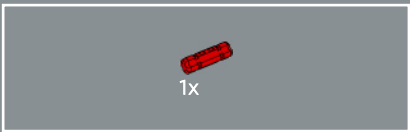

171

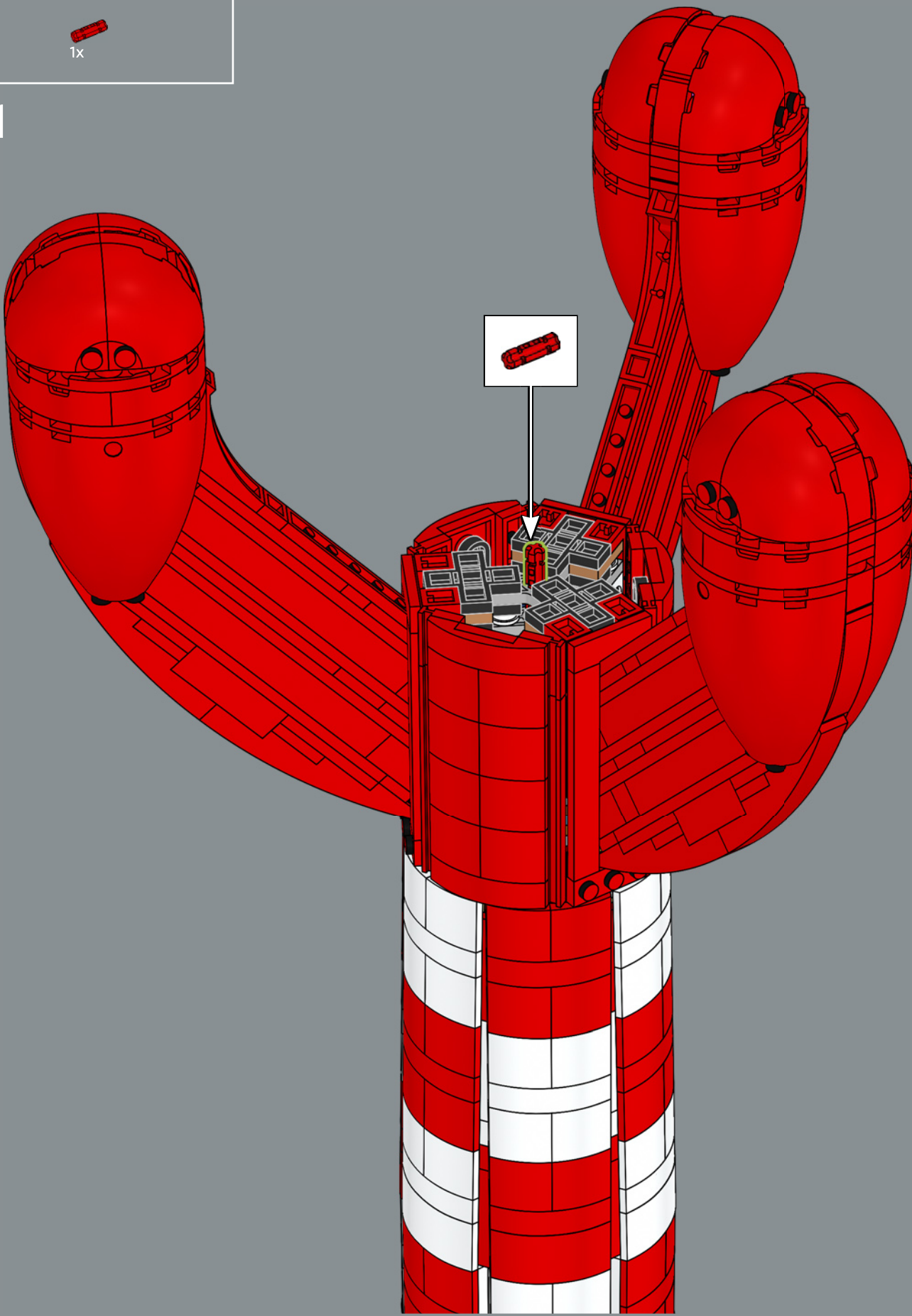

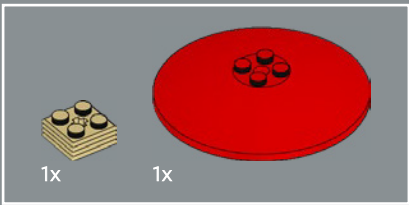

172

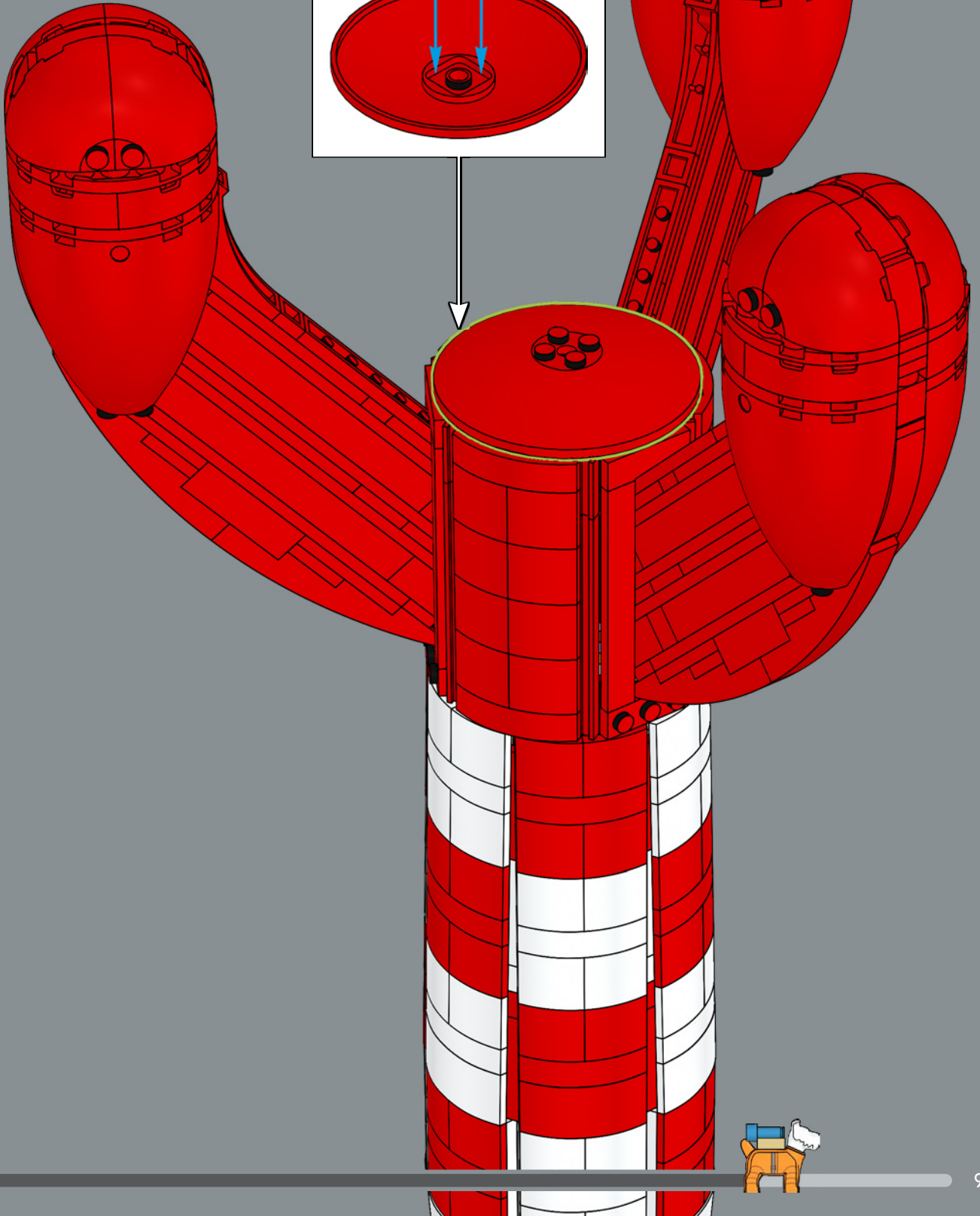
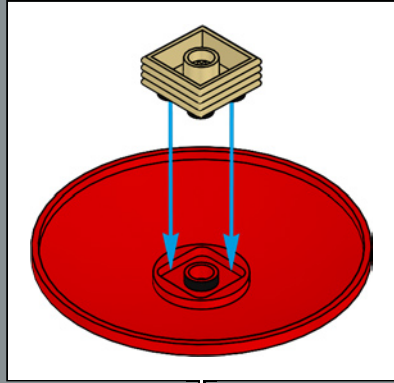

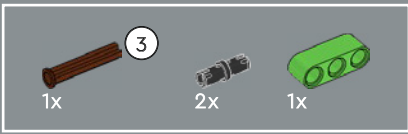

173

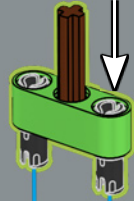
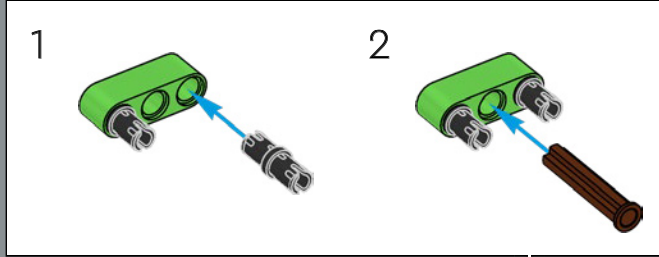

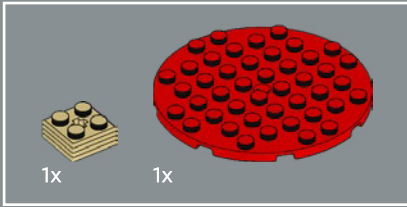

174

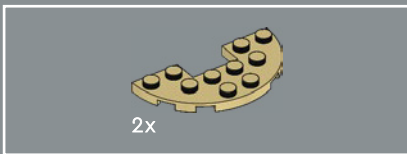
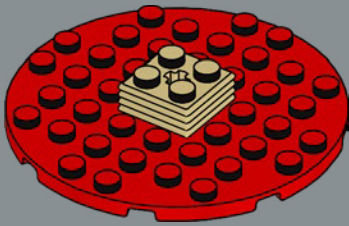

175

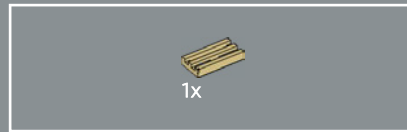
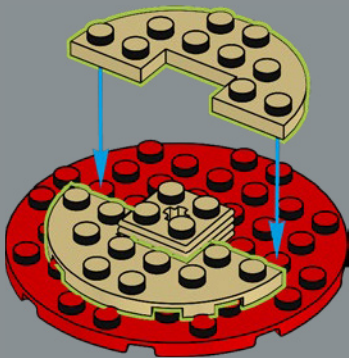

176

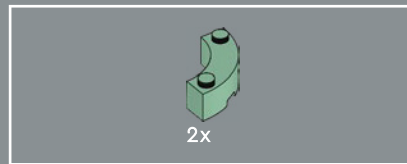
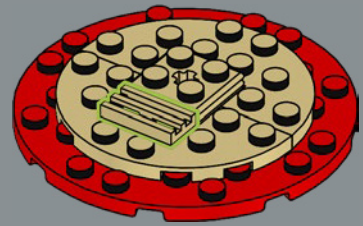

177

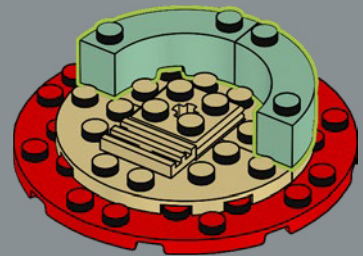



178

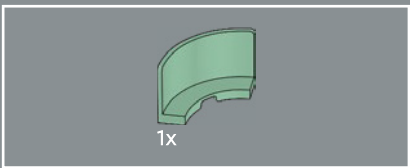
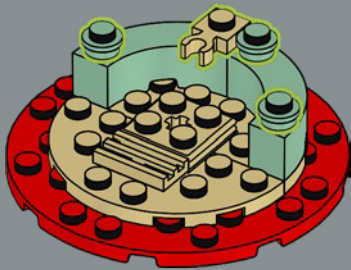

179

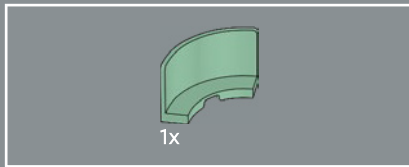
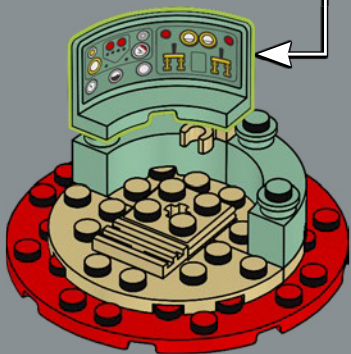
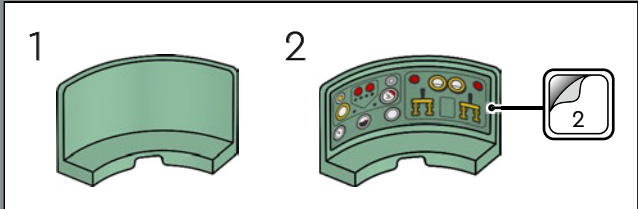

180

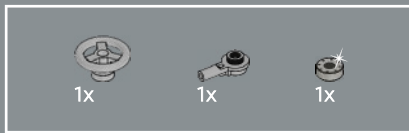
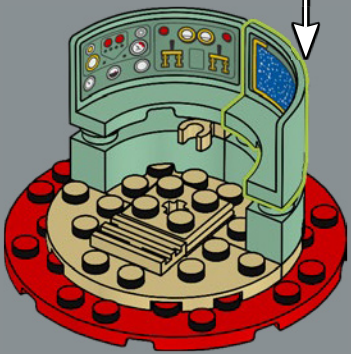
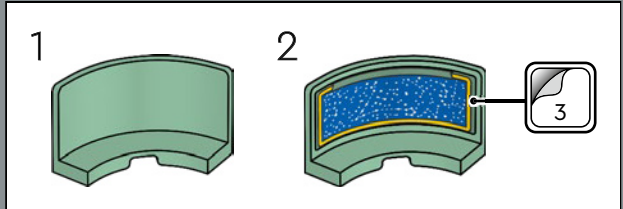

181

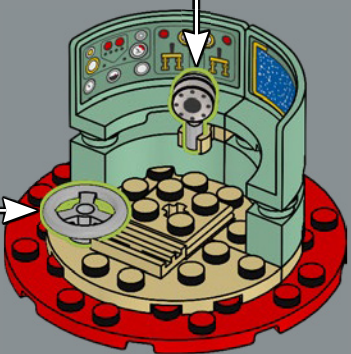

182

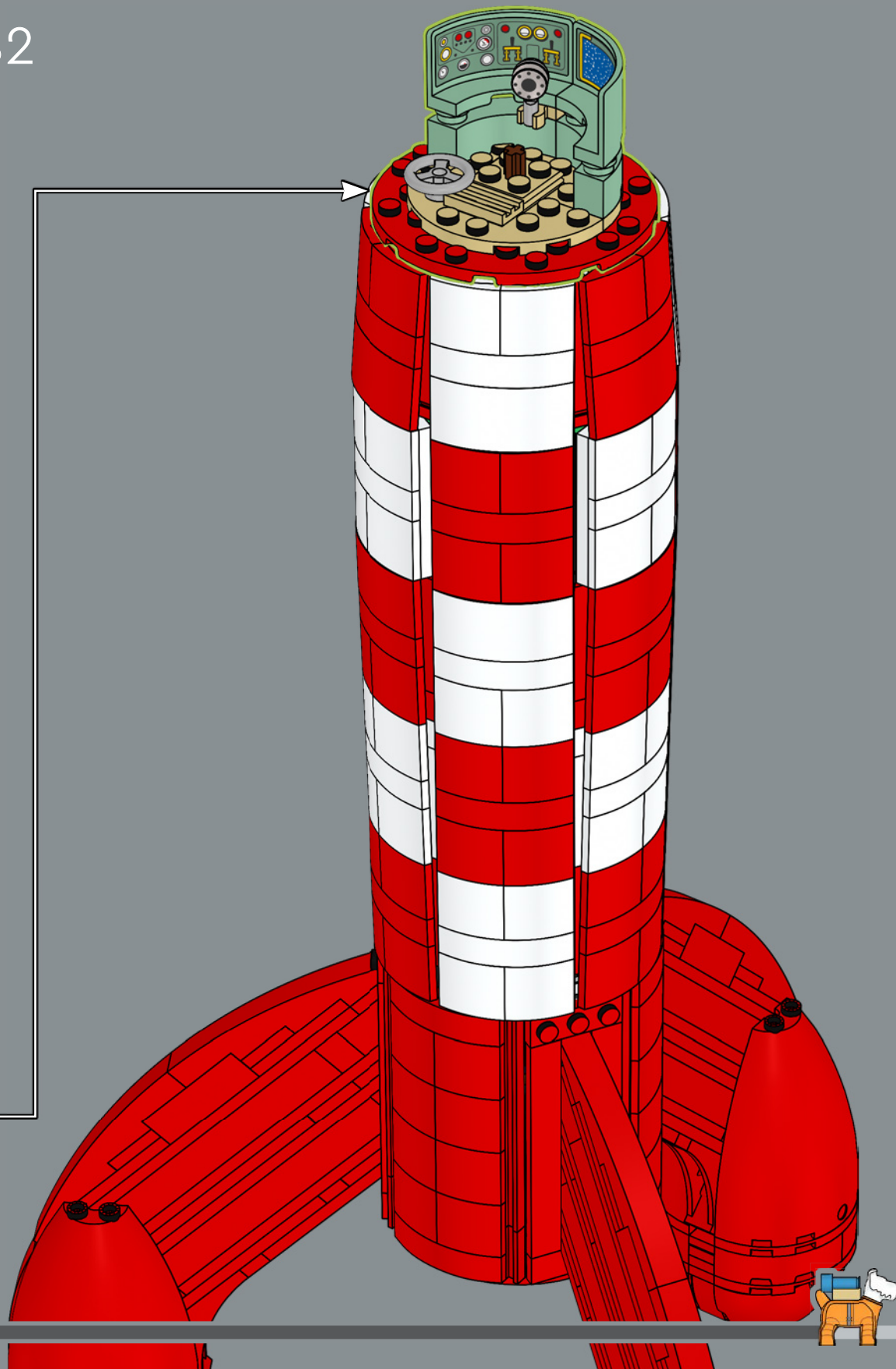

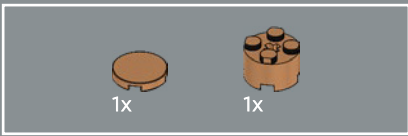

183

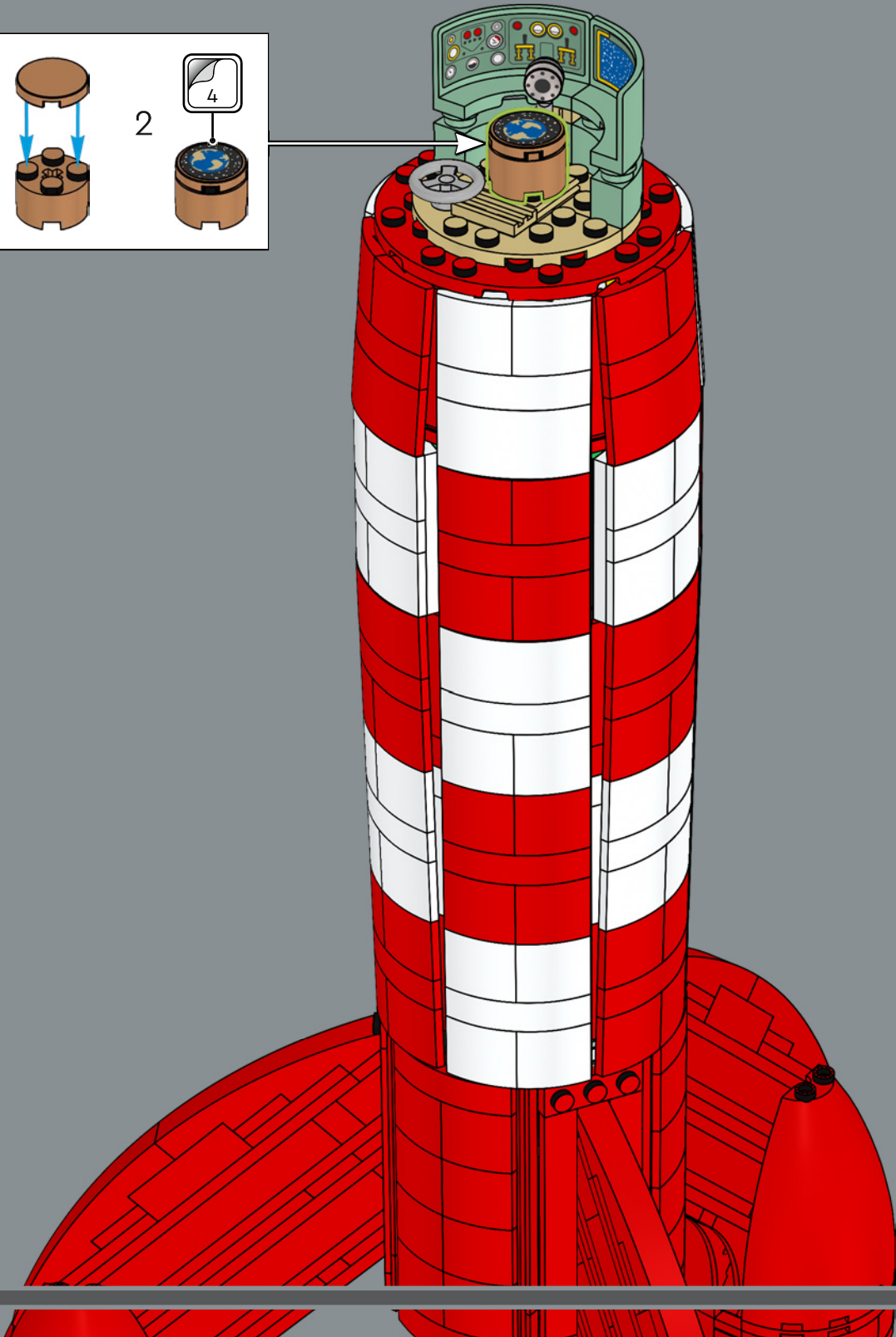
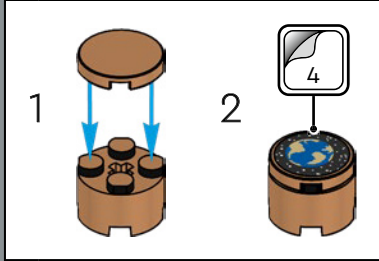



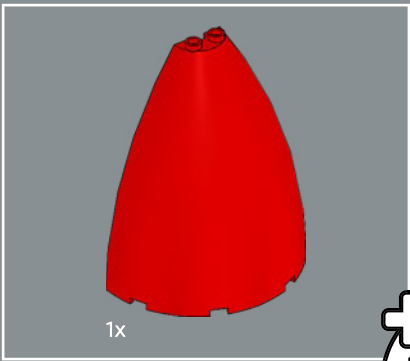

1x

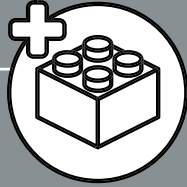

185

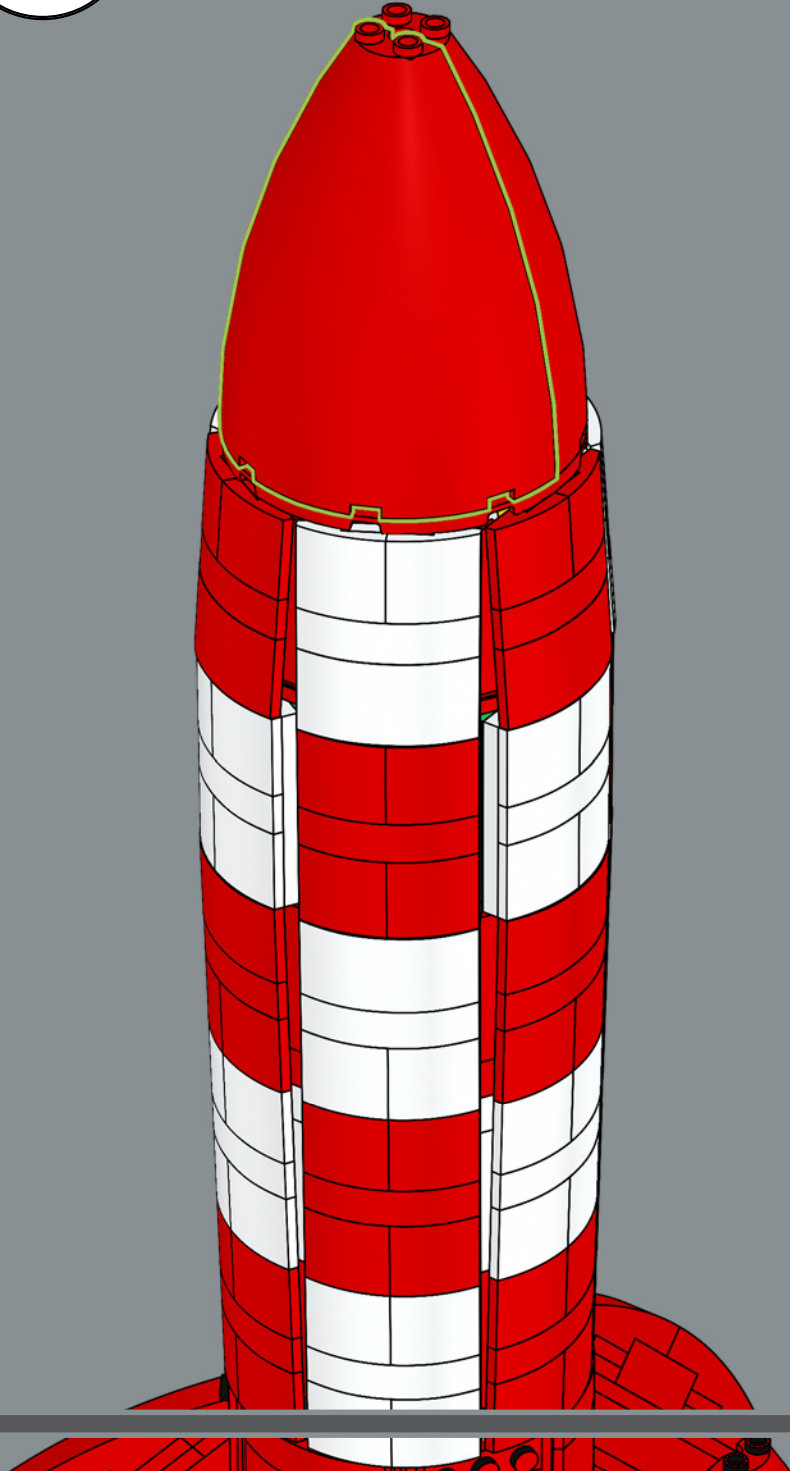

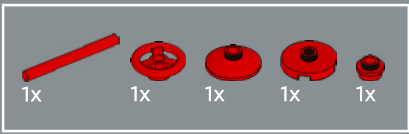

186

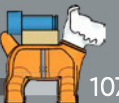
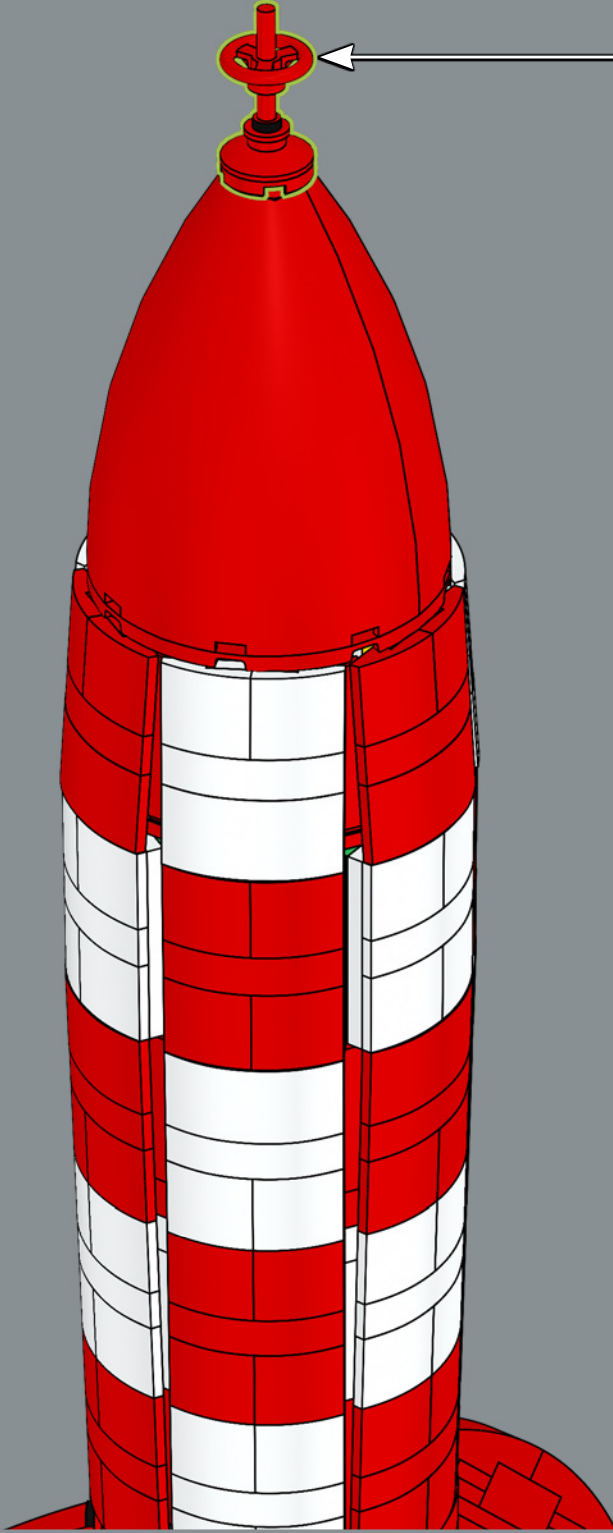
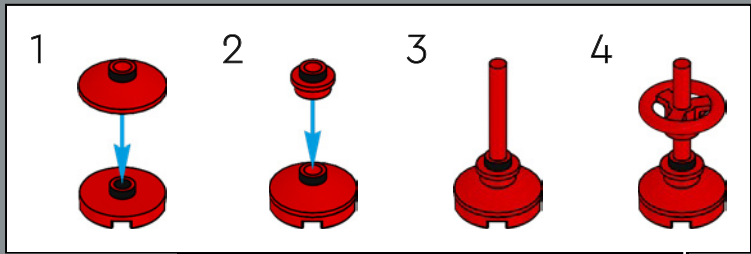

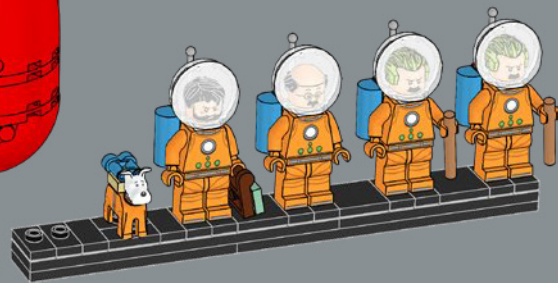
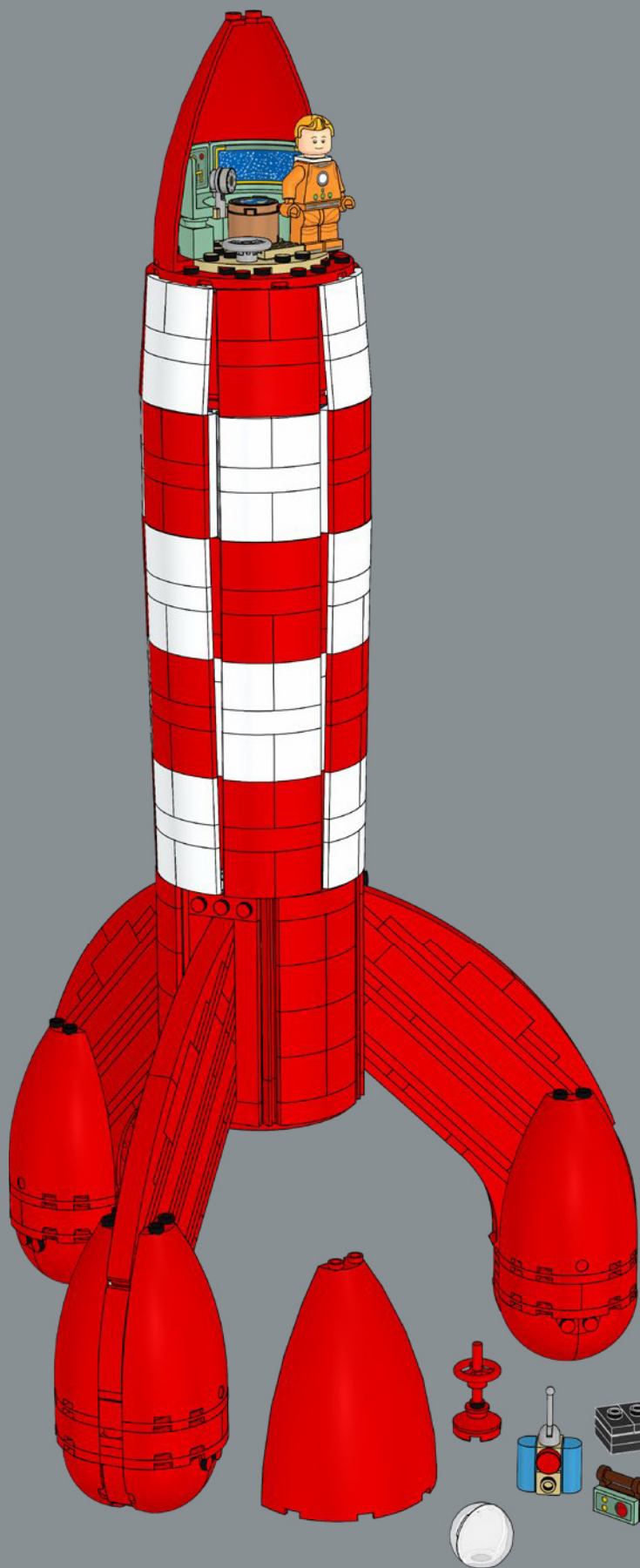

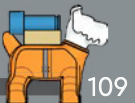
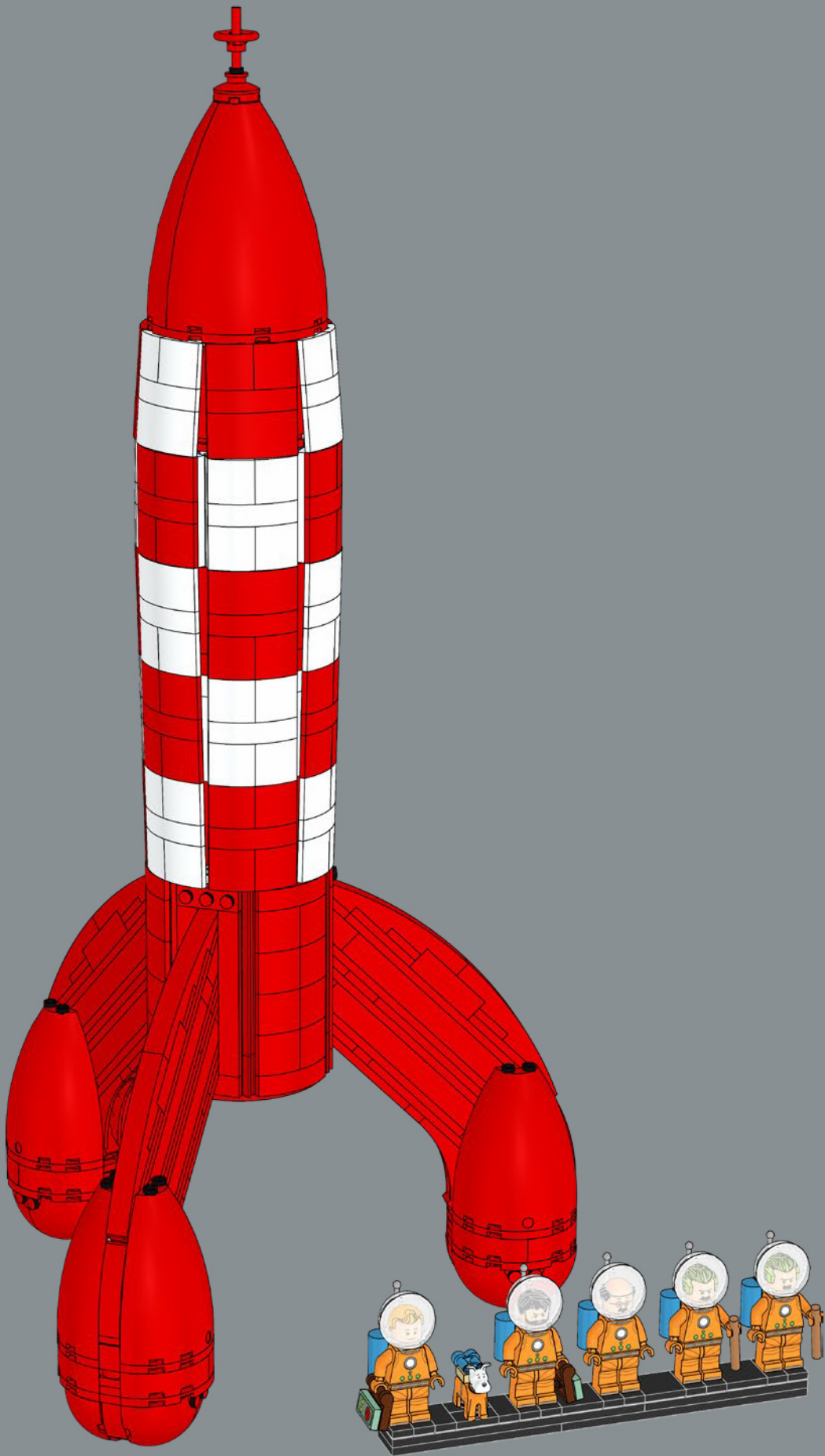



# IDEAS

GATHER SUPPORT  
HOL DIR UNTERSTÜTZUNG  
RECUEILLENZ DES VOTES  
CHIEDI DI ESSERE SUPPORTATO  
CONSIGUE APOYOS  
OBTÉM APOIO  
爭取支持  
ZDOBĄDŹ GŁOSY  
ZÍSKEJTE PODPORU  
ZÍSKAJTE PODPORU  
SZEREZZ TÁMOGATÁST!  
ЗБЕРІТЬ ПІДТРИМКУ  
CERE SPRIJIN  
ПОЛУЧЕТЕ ПОДКРЕПА  
IEGŪSTI ATBALSTU  
KOGU TOETUST  
RINK PALAIKYMĄ

SHARE YOUR IDEA  
TEILE DEINE IDEE  
PARTAGEZ VOTRE IDÉE  
CONDIVIDI LA TUA IDEA  
COMPARTÉ TU IDEA  
PARTILHA A TUA IDEIA  
分享创意  
PODZIEL SIĘ POMYSŁEM  
SDÍLEJTE SVÉ NÁPADY  
ZDIEĽAJTE SVOJE NÁPADY  
OSZD MEG AZ ÖTLETED!  
ПОДІЛІТЬСЯ СВОЮ ІДЕЮ  
İMPARTĂȘEȘTE IDEEA TA  
СПОДЕЛЕТЕ ИДЕИТЕ СИ  
PARÁDI SAVU IDEJU  
JAGA OMA IDEED  
PASIDALINK SAVO IDĒJA

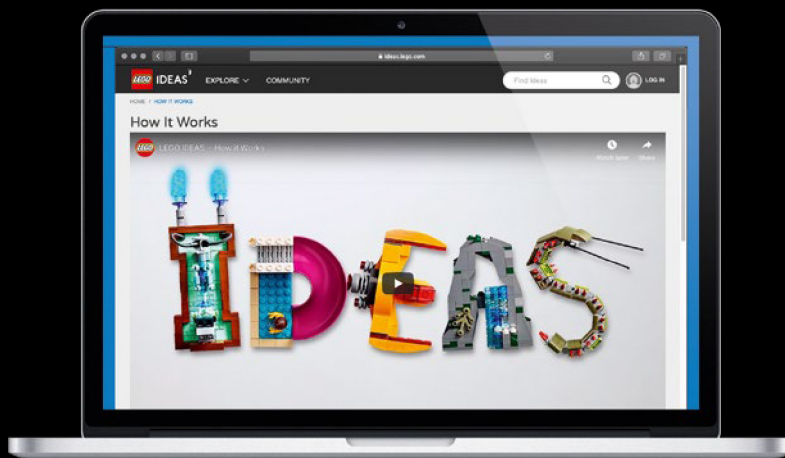
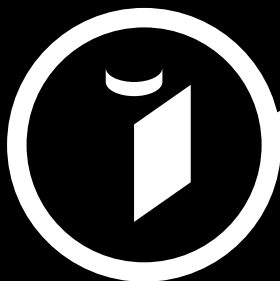
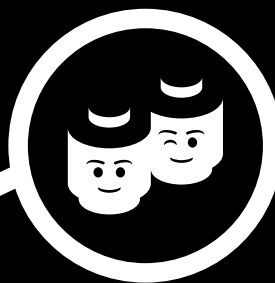

LEGO® REVIEW  
LEGO® PRÜFUNG  
EXAMEN PAR LEGO®  
REVIEW LEGO®  
REVISIÓN DE LEGO®  
AVALIAÇÃO LEGO®  
乐高®审核  
OCENA LEGO®  
POSOUZENÍ DESIGNÉRY LEGO®  
POSÚDENÉ DIZAJNÉRMÍ LEGO®  
LEGO® VÉLEMÉNYEZÉS  
ОГЛЯД LEGO®  
VERIFICARE LEGO®  
ΠΡΕΓΛΕΔ ΗΑ LEGO®  
LEGO® RECENZIJA  
LEGO® ARVUSTUS  
LEGO® APŽVALGA

NEW LEGO® PRODUCT  
NEUES LEGO® PRODUKT  
NOUVEAU PRODUIT LEGO®  
NUOVO PRODOTTO LEGO®  
NUEVO PRODUCTO LEGO®  
NOVO PRODUTO LEGO®  
全新乐高®产品  
NOWY PRODUKT LEGO®  
NOVÁ STAVEBNICE LEGO®  
NOVÁ STAVEBNICA LEGO®  
ÚJ LEGO® TERMÉK  
НОВИЙ ПРОДУКТ LEGO®  
PRODUS LEGO® NOU  
НОВ ПРОДУКТ LEGO®  
JAUNS LEGO® PRODUKTS  
UUS LEGO® TOODE  
NAUJAS LEGO® PRODUKTAS

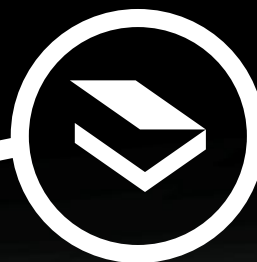

[ideas.LEGO.com](https://ideas.LEGO.com)

- 9x 6388018
- 15x 614101
- 6x 307001
- 5x 6277181
- 6x 6212049
- 18x 6210272
- 6x 393801
- 15x 302301
- 3x 6548968
- 6x 6172927
- 12x 403201
- 6x 3200001
- 12x 6361170
- 48x 6047220
- 6x 6223491
- 12x 362301
- 6x 302201
- 15x 6023806
- 6x 243101
- 6x 6554416
- 3x 302001
- 24x 6350399
- 3x 4249021
- 6x 6053026
- 5x 6365720
- 1x 4159553
- 5x 4125253
- 5x 6609636
- 1x 6352222
- 5x 6262188
- 12x 6013938
- 1x 4124456
- 2x 6330903
- 6x 4160483
- 12x 4113233
- 2x 6099893
- 6x 4114324
- 6x 6036487
- 5

- 5x 6284574
- 9x 6378120
- 6x 6249907
- 1x 6223427
- 18x 307021
- 6x 302421
- 3x 6372478
- 12x 6345637
- 3x 300521
- 12x 6435047
- 1x 6527648
- 1x 6132541
- 6x 6029946
- 1x 4585146
- 3x 4142865
- 27x 302321
- 6x 6186398
- 3x 366521
- 6x 300421
- 6x 6540808
- 72x 6105976
- 9x 6433069
- 6x 6347789
- 6x 4612575
- 3x 4533742
- 3x 362321
- 12x 6334053
- 1x 6296954
- 1x 6129995
- 3x 6583512
- 3x 6547141
- 21x 4633914
- 6x 371021
- 18x 243121
- 6x 6592314
- 3x 302021
- 3x 301021
- 3x 4142132
- 4
- 5

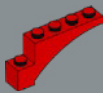

3x  
6594986



12x  
6295298



3x  
366621



6x  
6594751

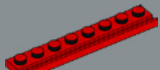

6x  
6078594



6x  
416221



9x  
346021



6x  
6594753



2x  
6595787



3x  
4645733



1x  
6603363



1x  
6594752

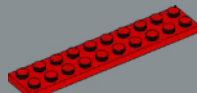

3x  
383221

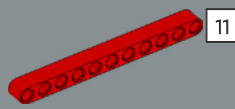

3x  
4562805



12x  
4514843

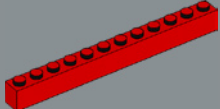

6x  
611221



3x  
6284575



3x  
6584954



6x  
6537695



12x  
614123



19x  
4206482



9x  
302323



6x  
6073890

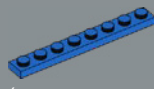

6x  
346023



33x  
614124



15x  
302324



9x  
6130007



6x  
4501232



1x  
6130008



6x  
371024



1x  
6389951



2x  
6332148



1x  
4526110



3x  
6299338



17x  
6279875



12x  
6210270



12x  
6092585



2x  
306926



3x  
6089119



6x  
6097283



3x  
306826



3x  
6572774



1x  
6460708



6x  
6428167



2x  
6416838



3x  
302126



9x  
6280168



1x  
6438426



6x  
6271573



6x  
379526

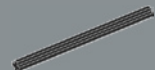

1x  
370726

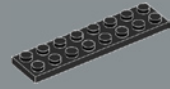

2x  
303426

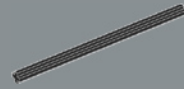

1x  
373726

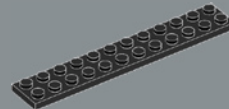

2x  
244526



6x  
4569058



6x  
6541878



6x  
6510079



1x  
6374076



3x  
6047426



21x  
302328



6x  
6347288



6x  
4521931



6x  
4107758



1x  
6573947



3x  
6359717



10x  
6414564



6x  
6442359

9

3

5

11

8

10



9x  
4177932



5x  
6593094



1x  
6593089



3x  
4118787



5x  
6607486

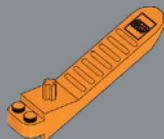

1x  
6240515



6x  
6539419



6x  
6574771

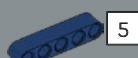

3x  
6420960



3x  
6403175



2x  
4616578



2x  
6599347



2x  
6599346

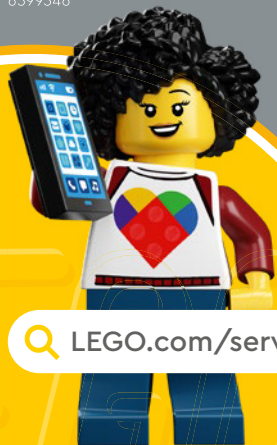

2x  
6607967



1x  
6595785



2x  
6236915



7x  
6135494



8x  
6441316



5x  
6267587



3x  
6345639



18x  
6336539



1x  
6227897



3x  
4211350



1x  
6092956



3x  
4211862



3x  
4211541



3x  
6540763



3x  
6321747



4x  
6043639



6x  
4211397



12x  
6421522



6x  
6347992



3x  
6549304



3x  
6307999



6x  
6372029



6x  
4211462



3x  
4611705



3x  
6395635



12x  
6178919



3x  
6514456



6x  
6284702



3x  
6083620



6x  
6039482



3x  
6083620



3x  
6083620



6x  
6039482



1x  
6443852



6x  
6574782



3x  
6573660



1x  
6593099



1x  
6593098



1x  
6593097



1x  
6593096



1x  
6593095



1x  
6593090



1x  
6368592



1x  
6454167



2x  
6600809



3x  
6336665



1x  
6551965



1x  
6603200



10x  
6601287



9x  
6097419

3

5

11

4



# YOU COULD WIN



## YOU COULD WIN

Your feedback will help shape the future development of this product series.

Visit:

## DU KÖNNTEST GEWINNEN

Dein Feedback trägt zur Weiterentwicklung dieser Produktreihe bei.

Geh auf:

## VOUS POURRIEZ GAGNER

Vos commentaires nous aideront à concevoir les futurs produits de cette gamme.

Visitez :

## POTRESTI VINCERE TU

La tua opinione ci aiuterà a migliorare la creazione futura di questa linea di prodotti.

Visita:

## PUEDES GANAR

Tu opinión contribuirá al futuro de esta serie de productos.

Visita:

## 轻松获奖

您的反馈将有助于我们在今后改进本产品系列。

请访问:

---

# LEGO.com/productfeedback

---

You also have the chance to win a LEGO® set.

Terms and conditions apply.\*

Außerdem hast du die Chance, ein LEGO® Set zu gewinnen.

Es gelten die Teilnahmebedingungen.\*

Vous pourriez également gagner un ensemble LEGO®.

Des conditions s'appliquent.\*

Hai anche la possibilità di vincere un set LEGO®.

Termini e condizioni sono applicabili.\*

También tienes la oportunidad de ganar un set LEGO®.

Aplican términos y condiciones.\*

您还有机会赢取乐高®套装。

条款和条件适用。\*

\*LEGO.com/productfeedback-terms



In partnership with the Hergé Museum  
In Partnerschaft mit dem Hergé-Museum  
En partenariat avec le Musée Hergé  
In collaborazione con l'Hergé Museum  
En colaboración con el Museo Hergé  
Em parceria com o Museu Hergé  
与埃尔热博物馆合作  
We współpracy z Muzeum Hergé  
Ve spolupráci s Muzeem Hergé  
V spolupráci s Múzeom Hergé  
A Hergé Museummal együttműködésben  
У партнерстві з музеєм Ерже  
În parteneriat cu Muzeul Hergé  
Съвместно с музей „Ерже”  
Sadarbībā ar Hergé muzeju  
Koostöös Hergé muuseumiga  
Sukurta bendradarbiaujant su Hergé muziejumi  
Hergé Müzesi ile iş birliği içinde

