



11378





LEGO.com/sustainable-packaging



FR
DONNEZ
OU
RECYCLEZ



ASSOCIATION

OU



MAGASIN

OU



DÉCHÈTERIE

Adresses sur quefairedemesdechets.fr



BUILDER



Apple and the Apple logo are trademarks of Apple Inc., registered in the U.S. and other countries and regions. App Store is a service mark of Apple Inc. Google Play and the Google Play logo are trademarks of Google LLC. Tencent and the Tencent logo are trademarks of Tencent Inc.

LEGO.com/devicecheck

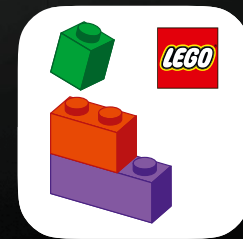

LEGO® Builder



Le plaisir de voyager depuis 1927™

Fondée en 1927 et active jusqu'en 1991, Pan American World Airways – Pan Am® – est entrée dans son âge d'or avec la mise en service du légendaire Douglas™ DC-3™ de la PAA® au milieu des années 1930. Première compagnie aérienne à opérer à l'échelle mondiale, Pan Am, tout comme le DC-3, est aujourd'hui encore considérée comme une icône ayant transformé le transport aérien et contribué à faire du voyage autour du monde un véritable art de vivre. Traverser des continents ne se résumait pas à se déplacer : c'était un symbole de prestige et de raffinement. Le PAA DC-3 offrait une fiabilité inégalée, aussi bien sur les lignes intérieures que transatlantiques. Le service Pan Am, célèbre pour les uniformes impeccables de ses équipages, ses cabines élégantes et son hospitalité sans équivalent, incarne encore l'âge d'or de l'aviation et a établi les standards mondiaux du luxe, de l'élégance et du raffinement dans les airs.







Le monde vous appartient

Le Douglas™ DC-3™ effectua son premier vol le 17 décembre 1935, avec une première livraison en juin 1936. Il domina ensuite les flottes aériennes des années 1940, avec 455 DC-3 construits pour un usage commercial jusqu'en 1946. Monoplan à ailes basses et à deux moteurs, il pouvait décoller de pistes courtes et se poser sans difficulté dans des espaces restreints, ce qui le rendait idéal pour presque toutes les destinations et tous les terrains. Les pilotes appréciaient le DC-3 pour sa fiabilité et sa maniabilité, tandis que les passagers profitaient de son confort soigné et, bien sûr, d'aventures exotiques aux quatre coins du globe ! Aujourd'hui encore, en sachant où regarder, il est parfois possible d'en apercevoir quelques-uns fendre le ciel.

Si le nom Douglas n'est plus utilisé, son histoire et ses designs perdurent au sein de la division Boeing Commercial Airplanes, qui continue de faire vivre avec fierté l'héritage du DC-3.



DOUGLAS DC-3



CARACTÉRISTIQUES

LONGUEUR:
19,7 M

ENVERGURE:
29 M

CAPACITÉ:
ÉQUIPAGE DE TROIS PERSONNES,
21 À 28 PASSAGERS EN CONFIGURATION JOUR
(14 EN COUCHETTES), OU 2 041 KG DE FRET

VITESSE DE CROISIÈRE:
333 KM/H ET JUSQU'À
3 420 KM D'AUTONOMIE





Par votre équipe de design LEGO® Icons

Le Douglas™ DC-3™ était un candidat idéal pour notre collection de véhicules LEGO® Icons dédiée au voyage. Nous voulions créer un modèle très détaillé, empreint de nostalgie pour une époque passionnante, tout en étant suffisamment robuste pour être retiré de son socle et observé sous tous les angles. Le dessus du cockpit et de la cabine passagers peut être retiré afin d'explorer l'intérieur. Grâce au soutien précieux de nos partenaires chez Pan Am® et Boeing, qui ont retrouvé dans leurs archives une rare illustration en couleur de la cabine, nous avons pu construire le modèle à une échelle proche de celle des minifigurines LEGO, avec un train d'atterrissage escamotable et une envergure impressionnante. Dès les premières phases de conception, nous avons choisi de reproduire l'une des livrées Pan Am de 1959 les plus emblématiques, appliquée à seulement quelques DC-3, en hommage à l'époque où cet avion constituait l'épine dorsale du transport aérien. (Il y a de fortes chances que vous l'ayez déjà aperçu dans des films sortis ou se déroulant à cette période.) Les décorations imprimées incluent un nouveau pare-brise et le célèbre logo Pan Am Globe® sur une nouvelle tuile LEGO 6x6. Pour compléter la scène, nous avons conçu un équipage de minifigurines LEGO en uniformes d'époque, avec notamment un nouvel élément de chapeau fidèle à l'histoire, ainsi que la bande bleue caractéristique sur le fuselage.



« Nous espérons que vous apprécierez votre voyage à bord et explorerez un monde de construction amusante ! »

– L'équipe de design LEGO® Icons



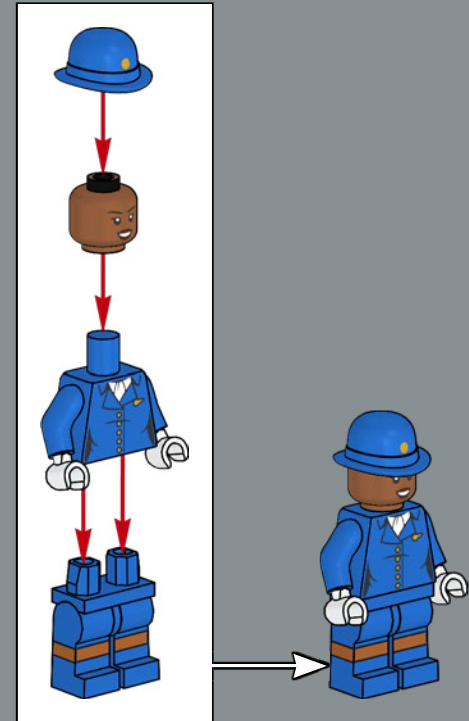
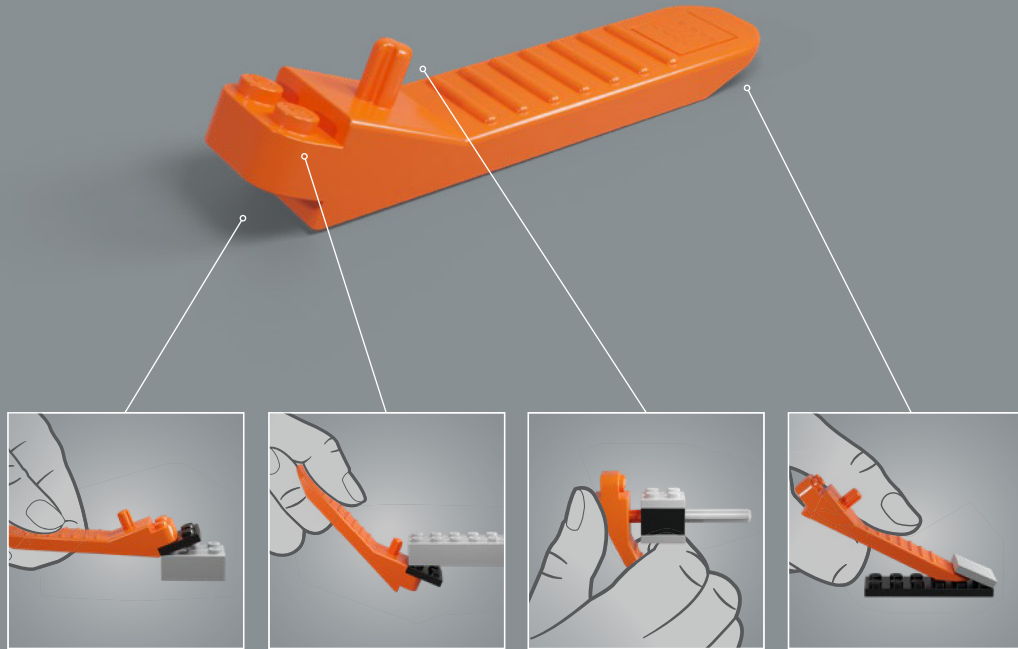

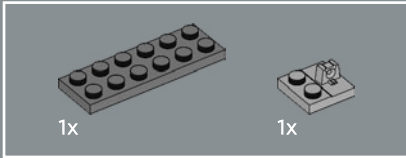
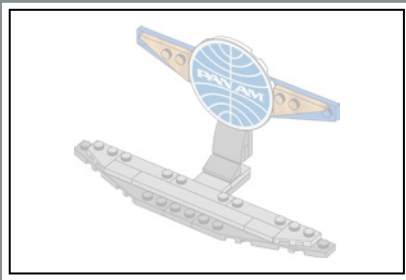

1

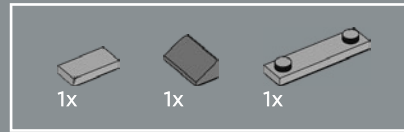
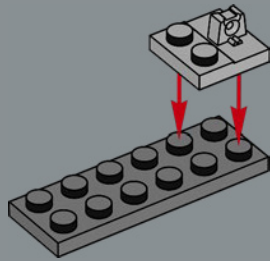

2

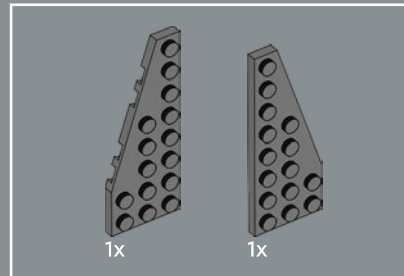
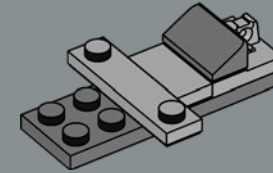

3

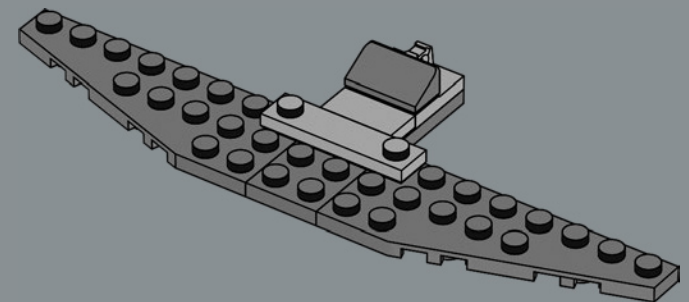

Le chapeau d'uniforme introduit en 1970 était parfois appelé derby, mais en interne, il était plus couramment désigné comme un chapeau melon.

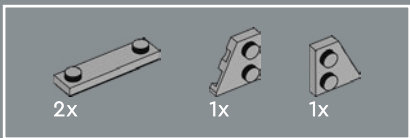

4

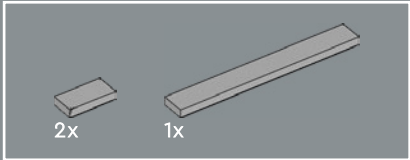
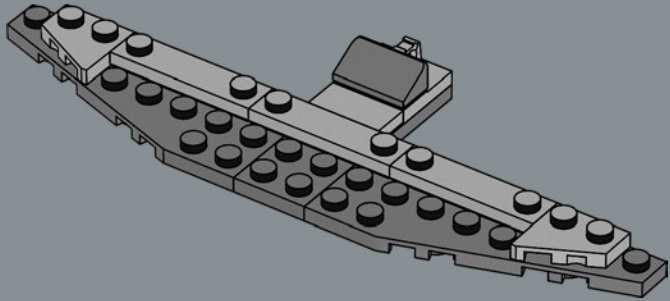

5

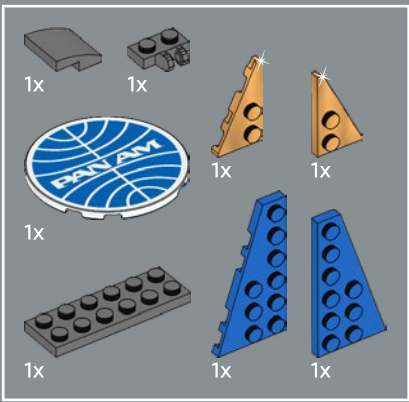
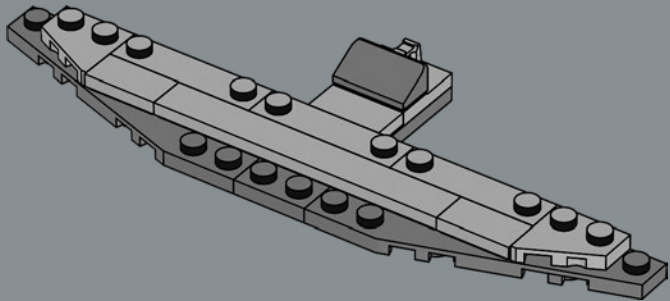

6

1

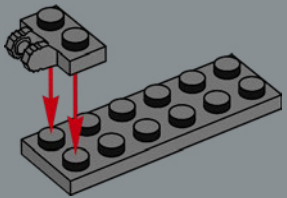

2

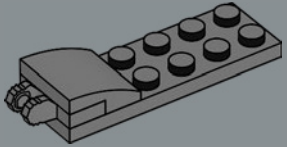

3



4



5

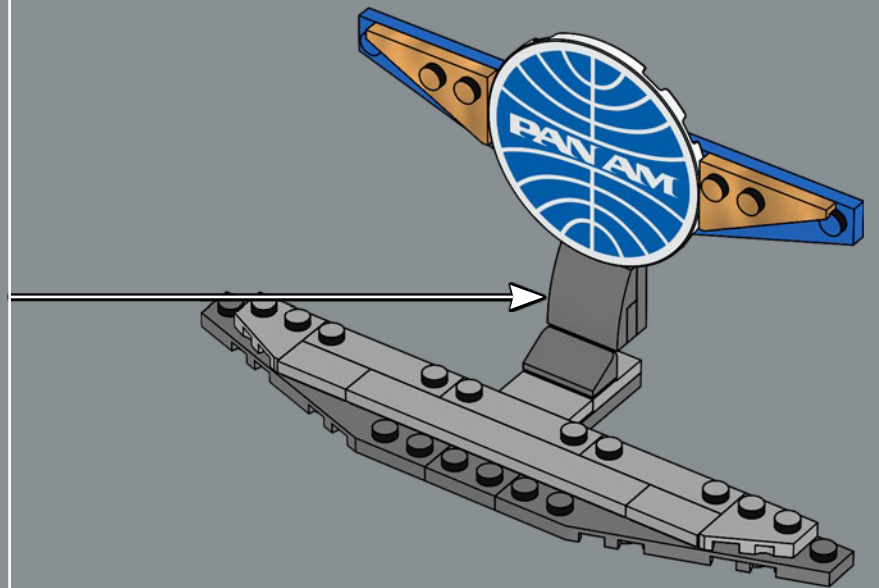

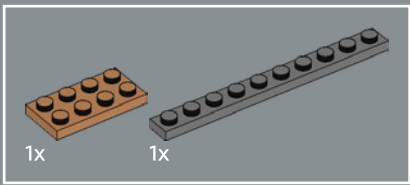

7

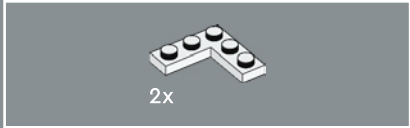
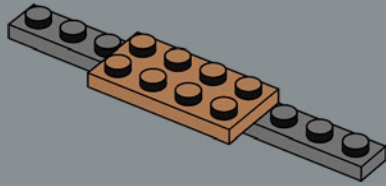

8

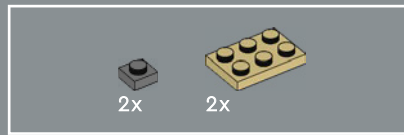
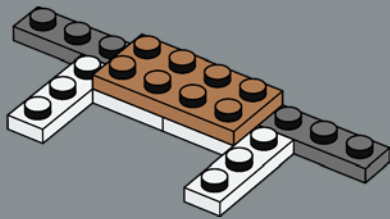

9

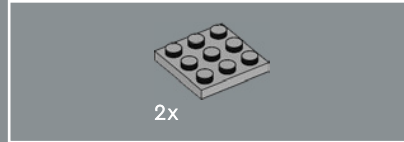
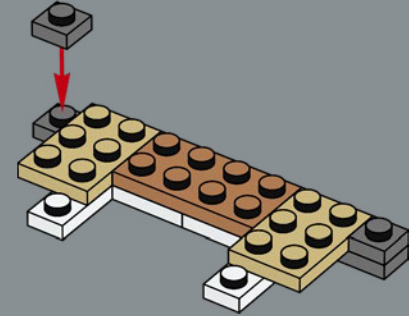

10

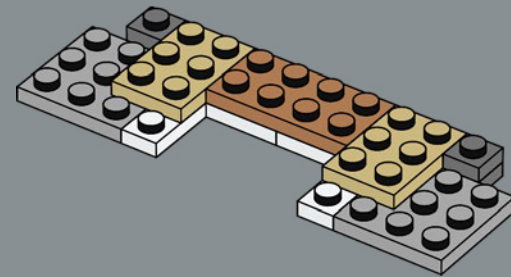

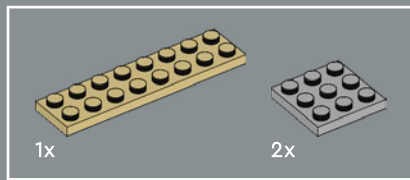

11

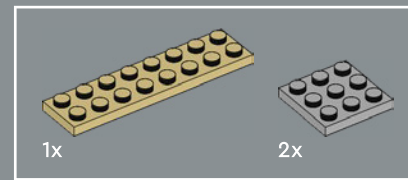
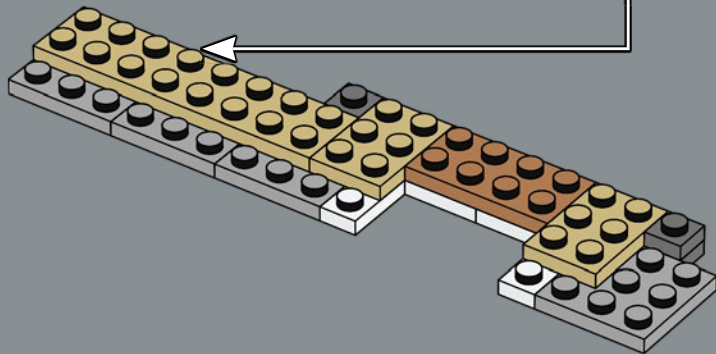
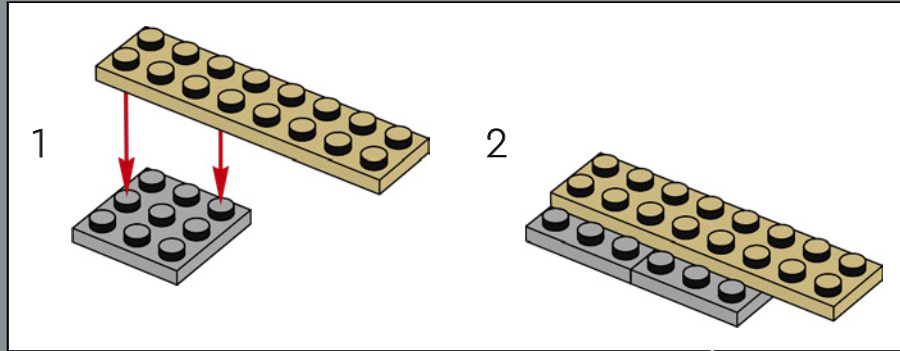

12

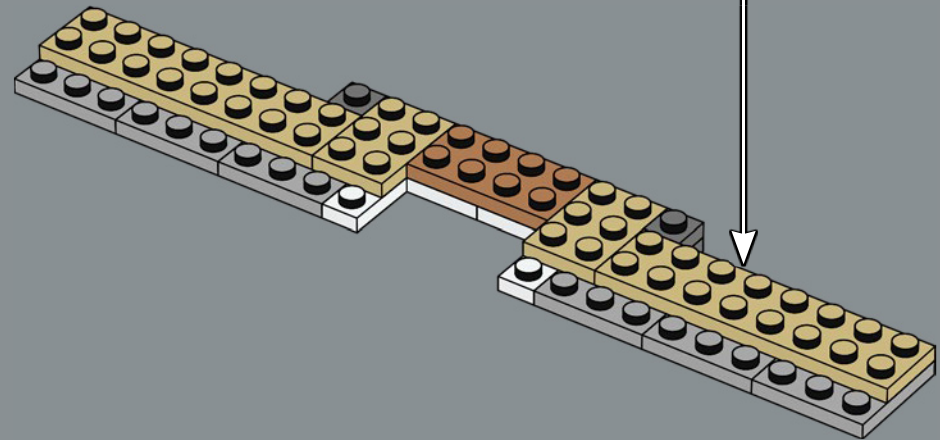
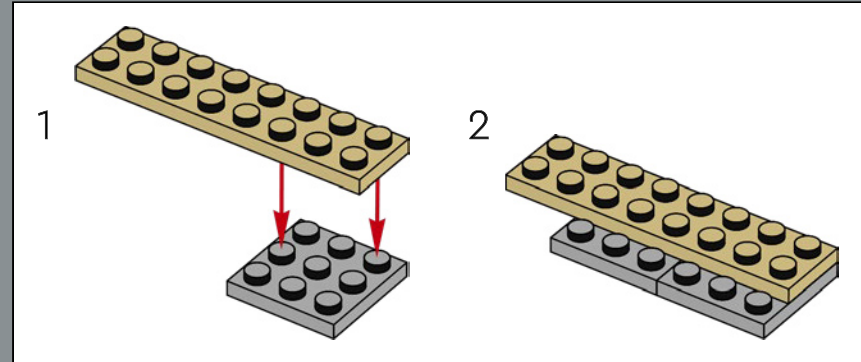

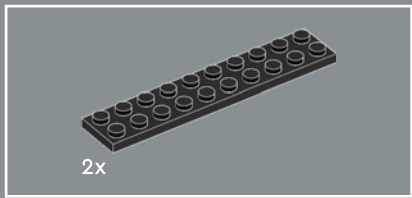

13

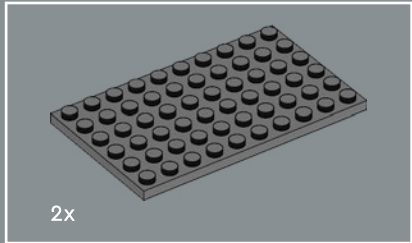
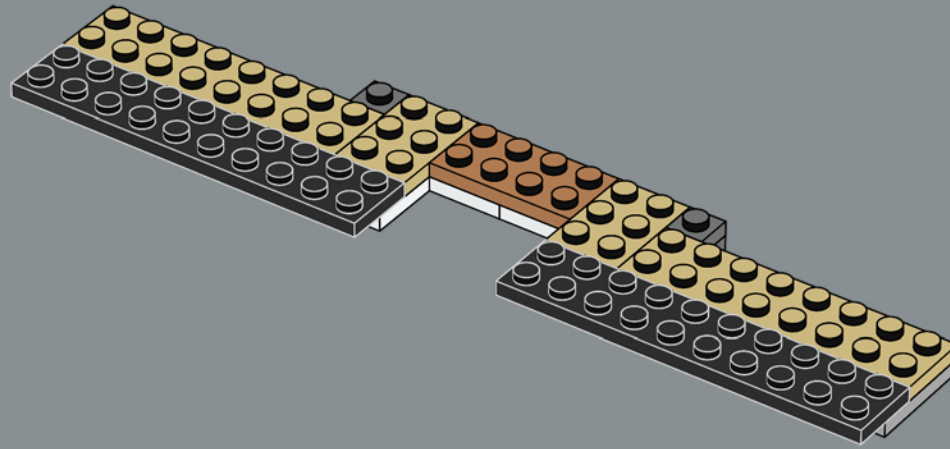

14

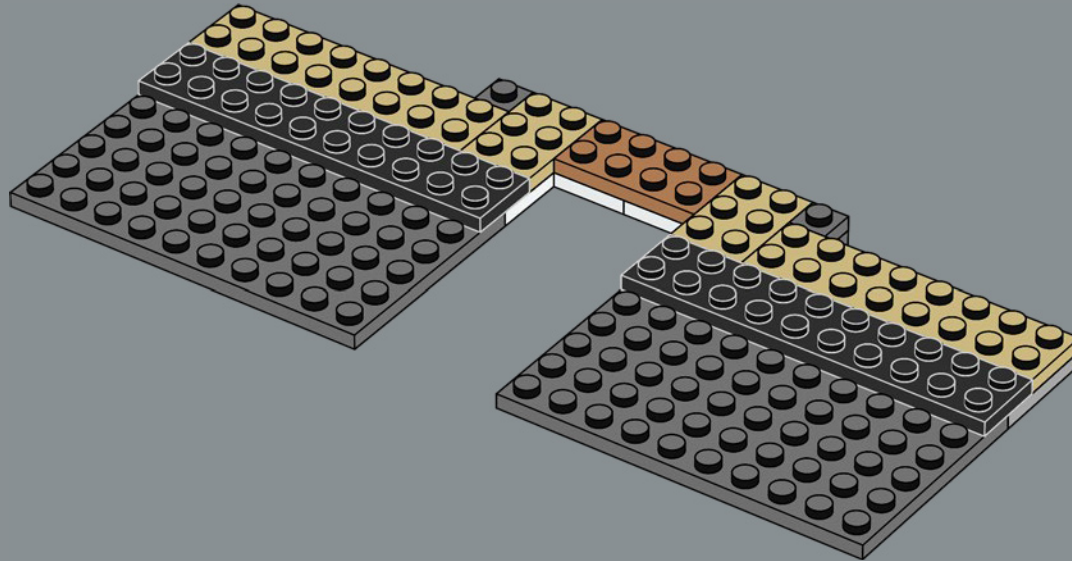

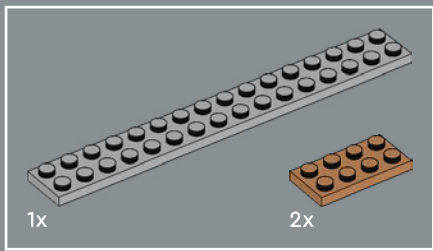

15

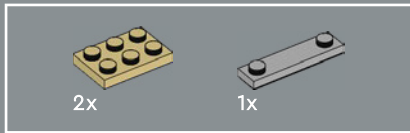
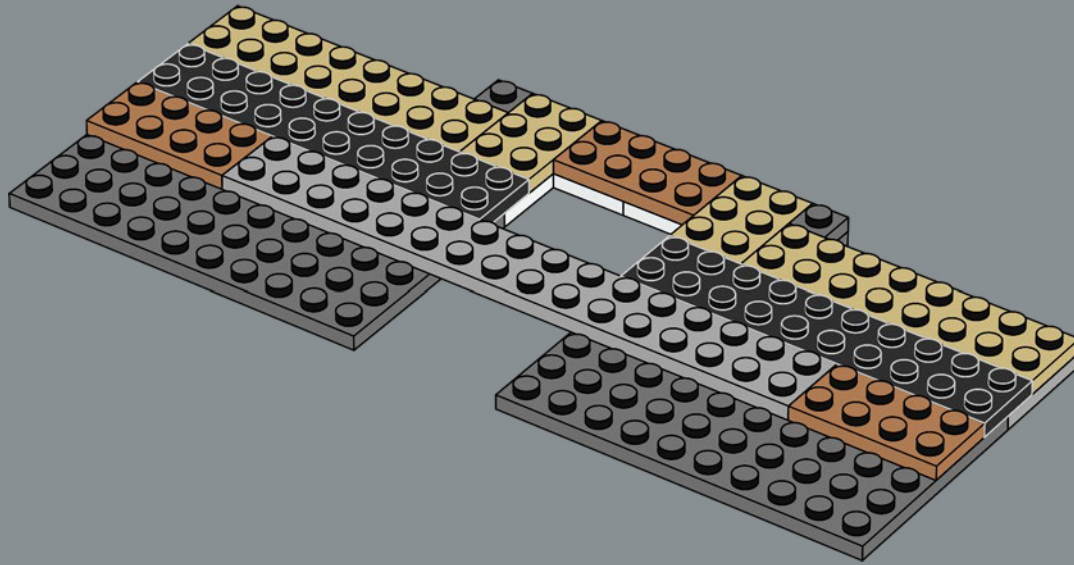

16

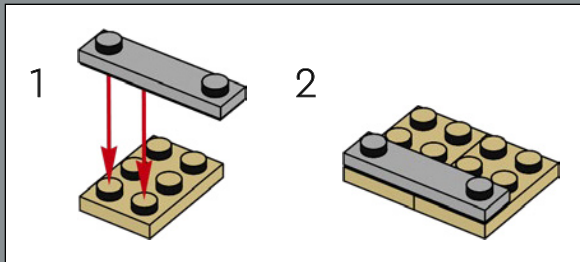
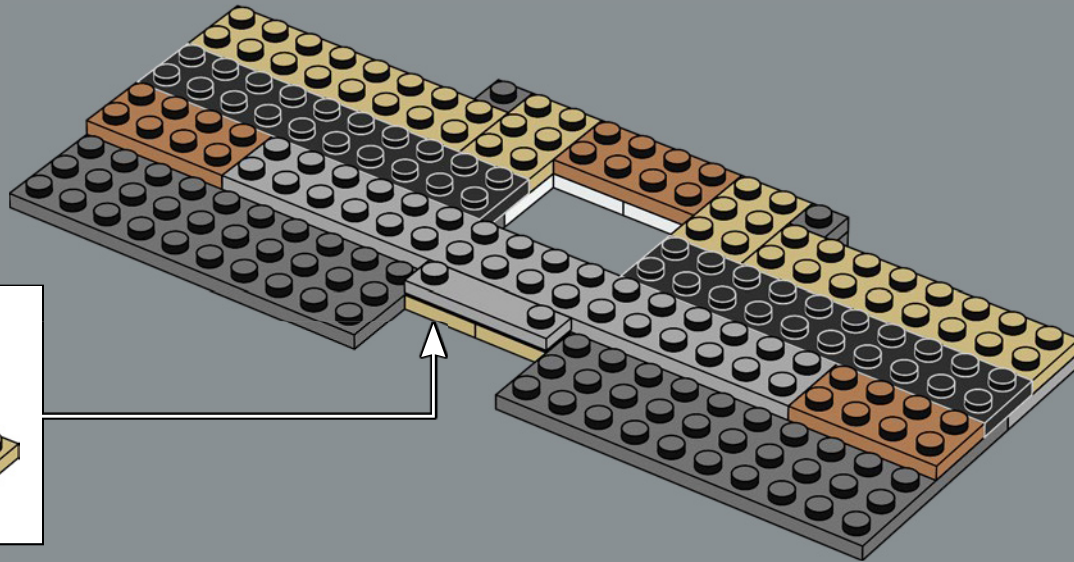

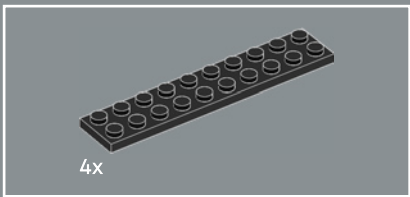

17

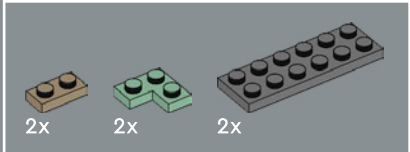
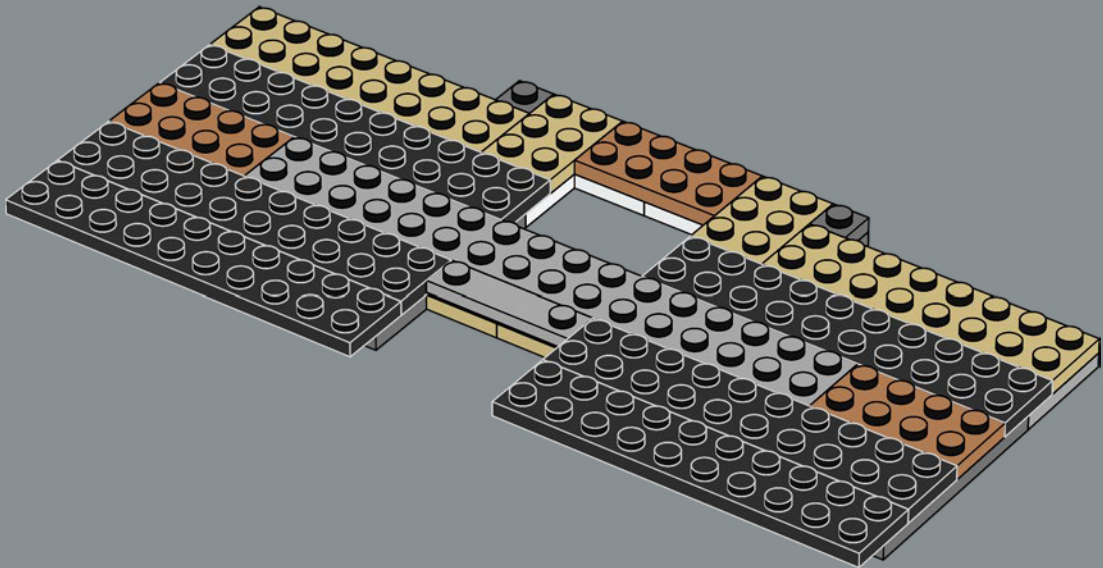

18

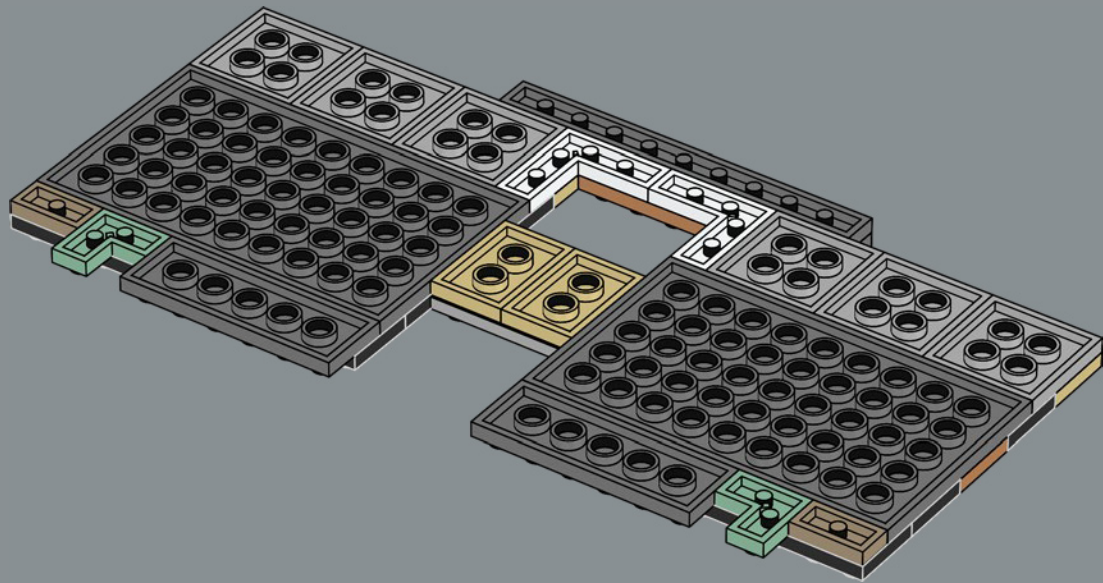

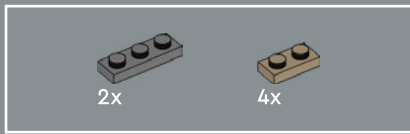

19

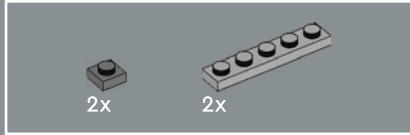
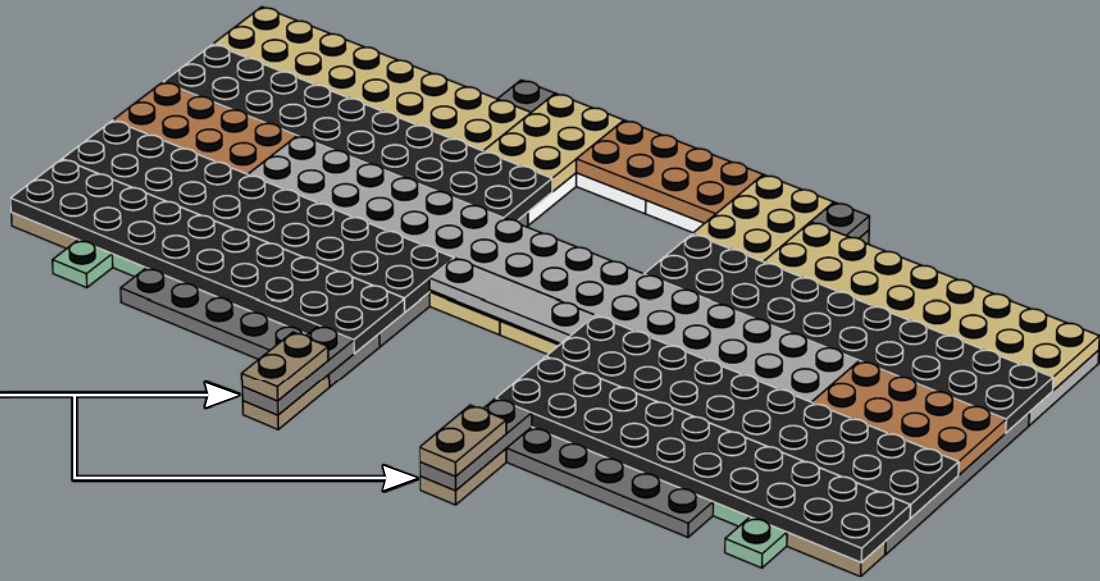
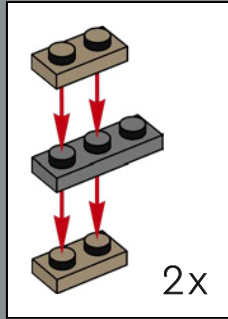

20



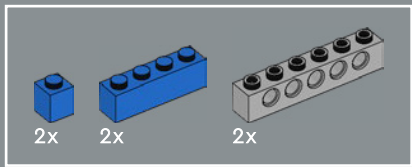

21

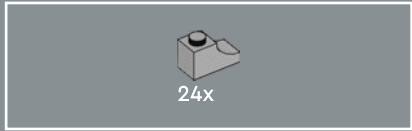
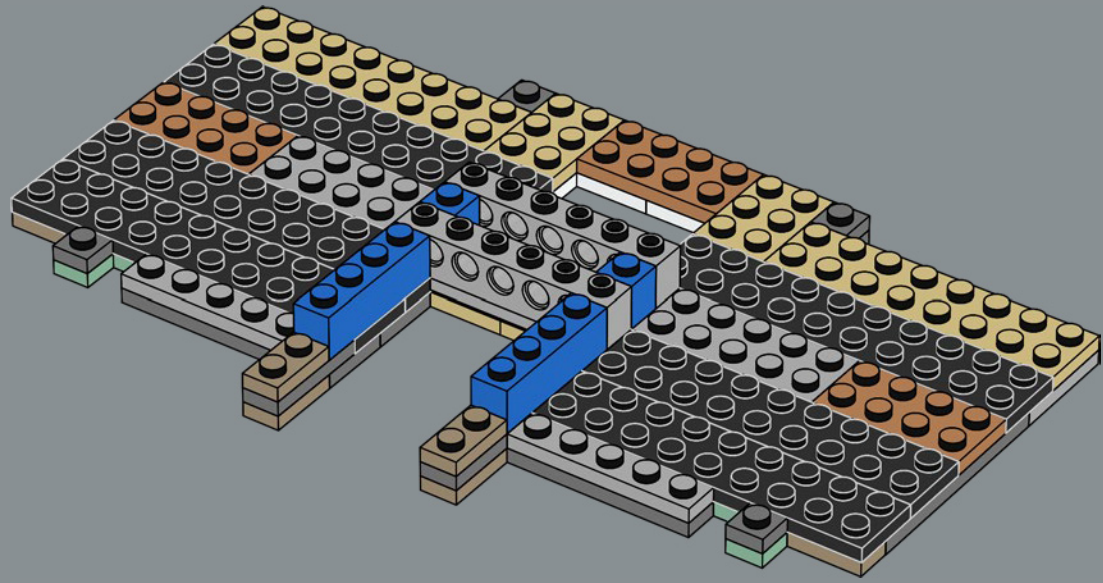

22

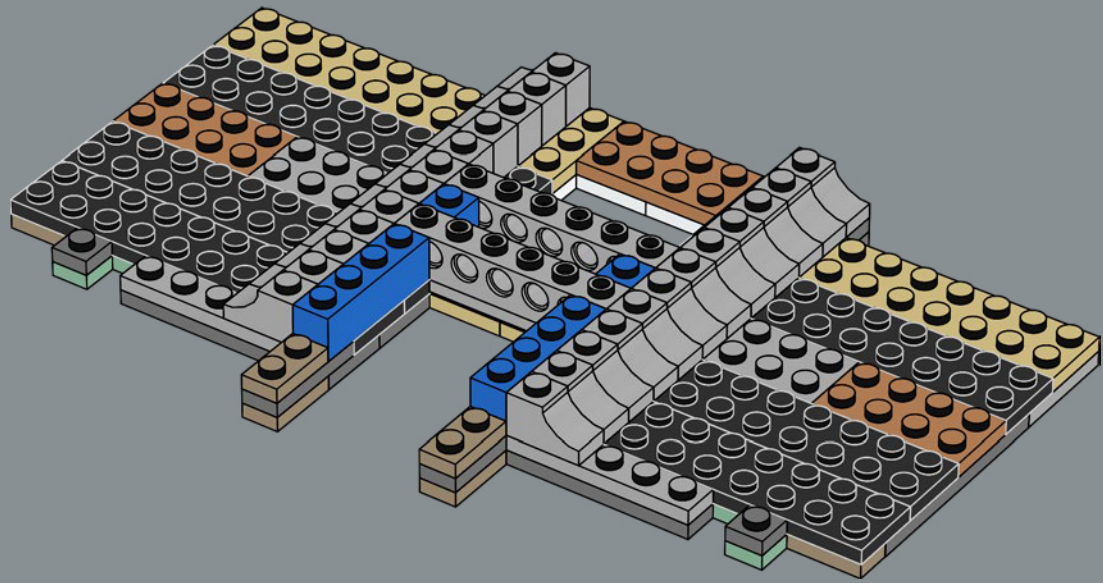

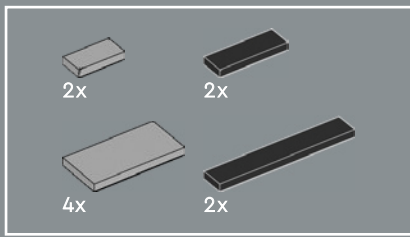

23

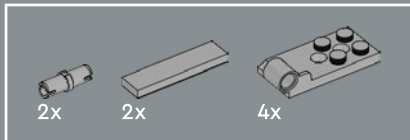
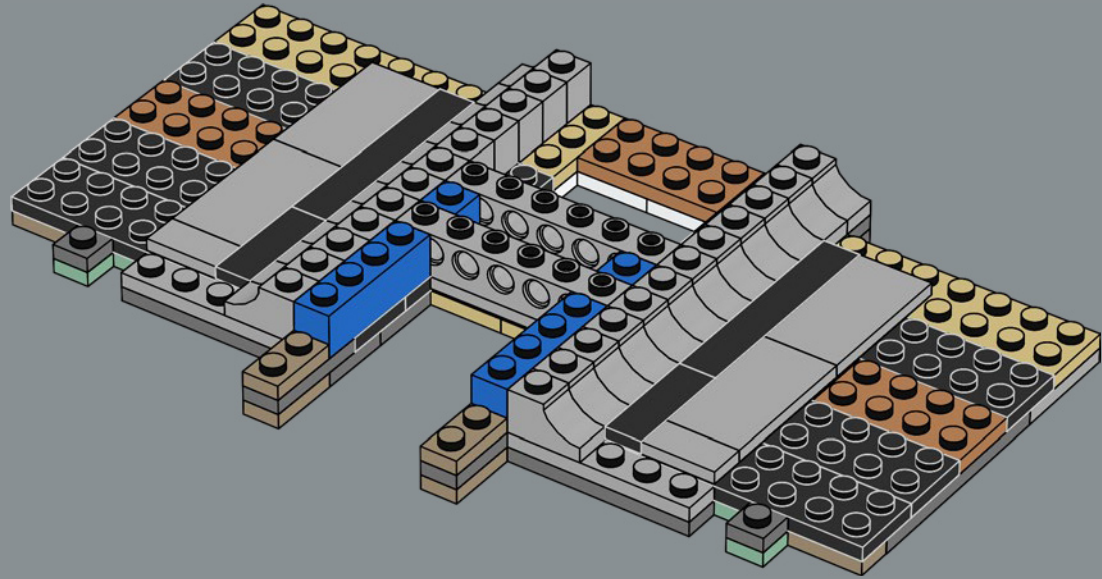

24

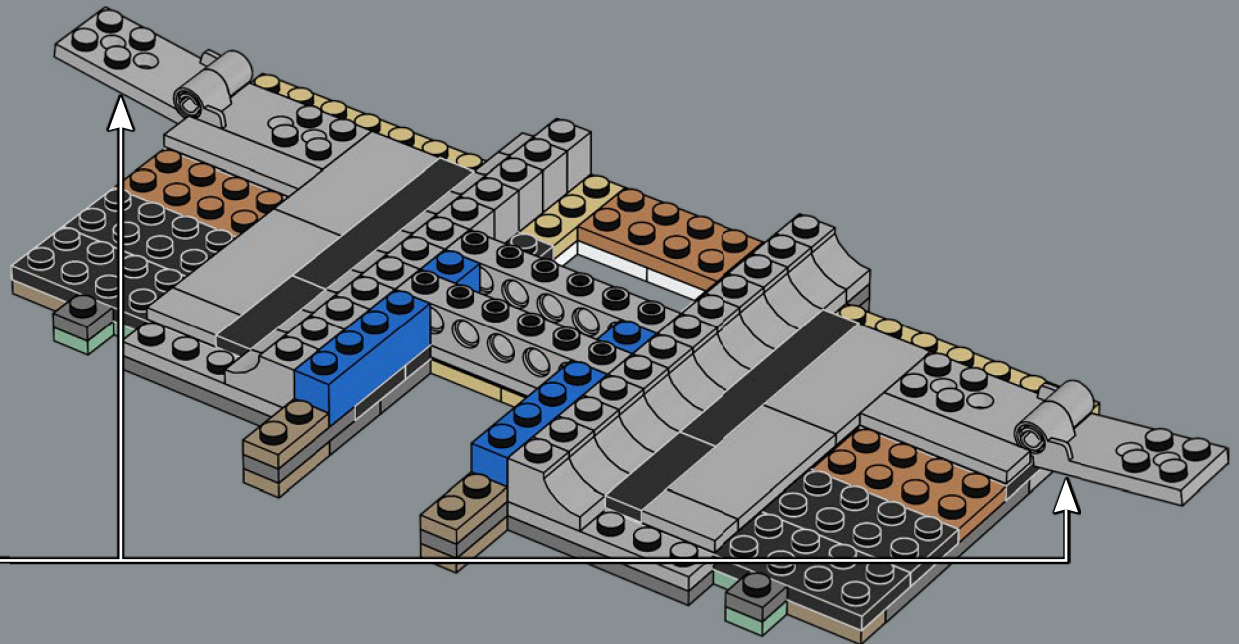
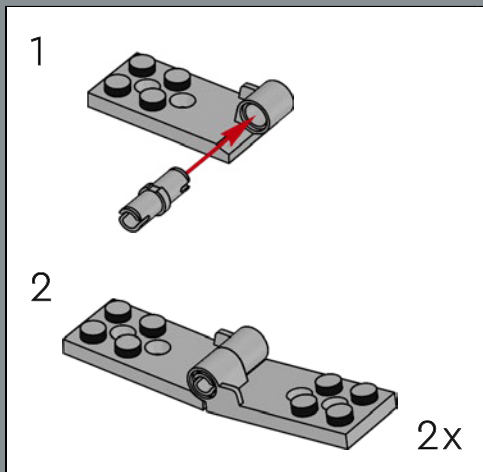

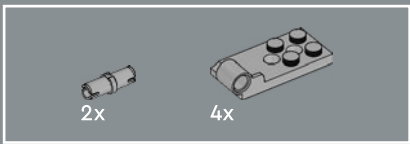

25

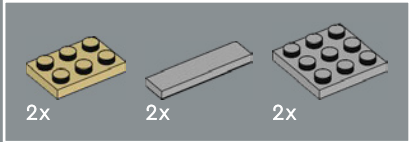
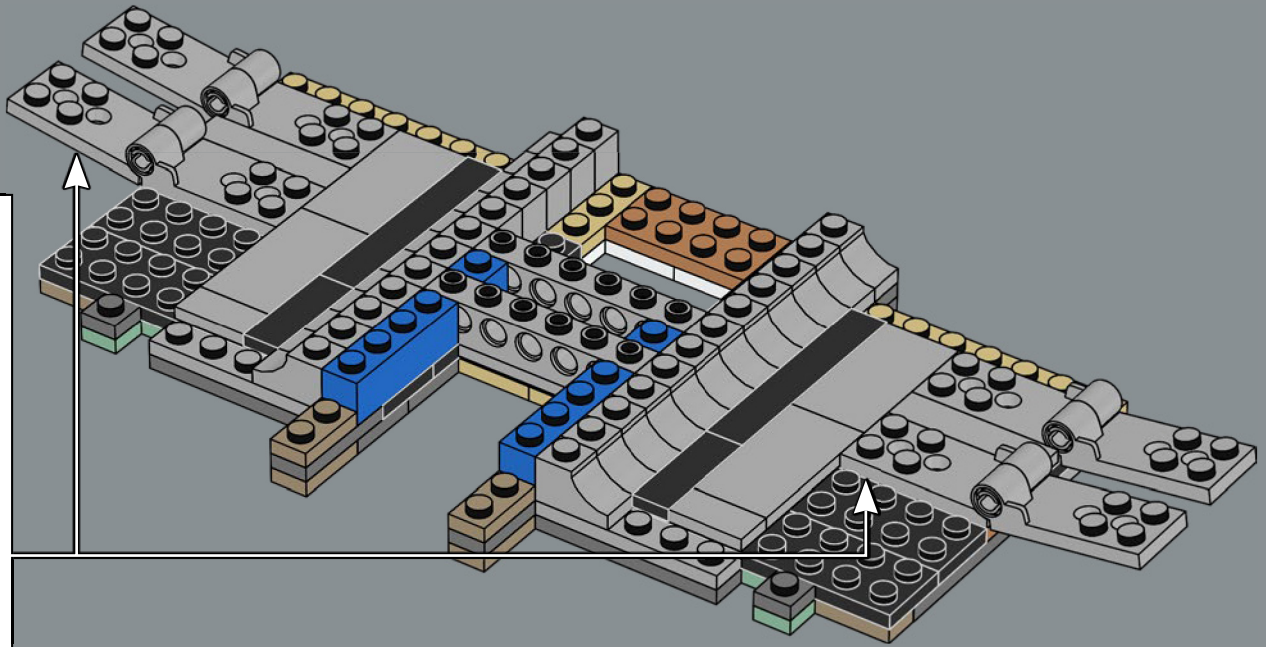
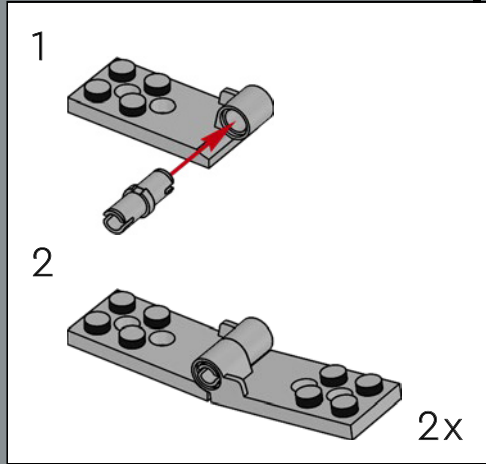

26

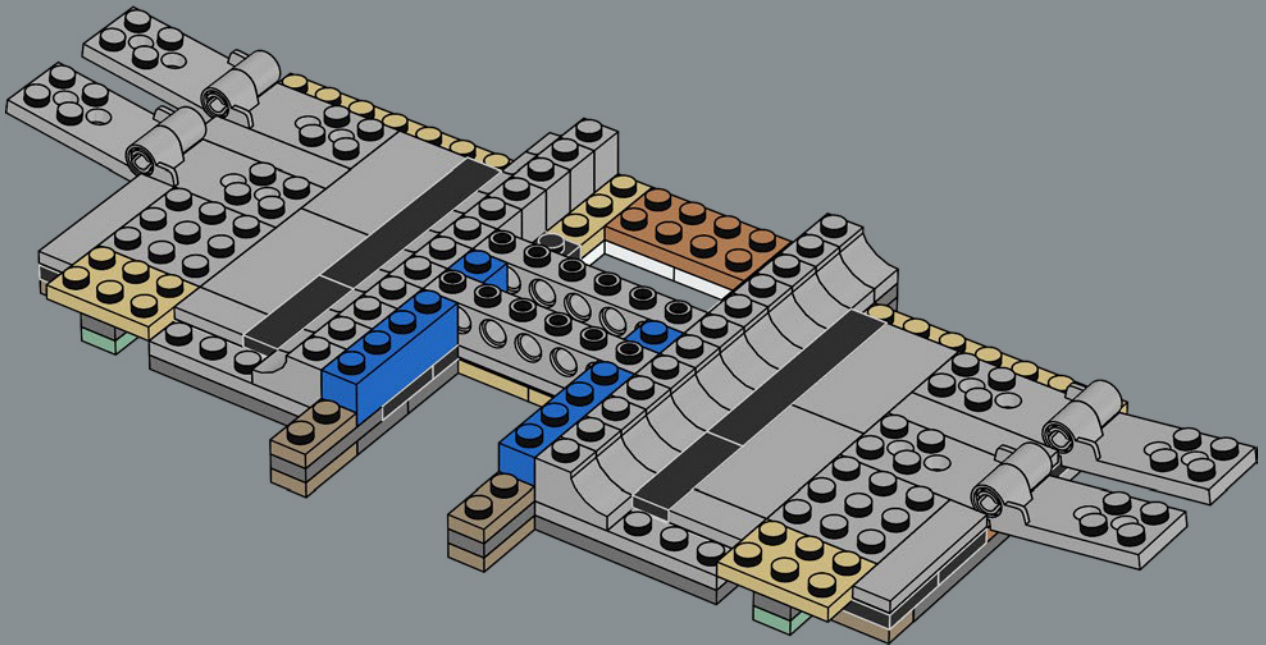

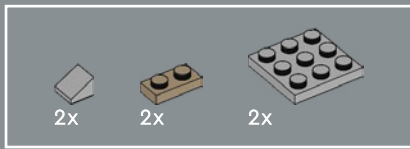

27

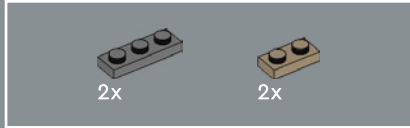
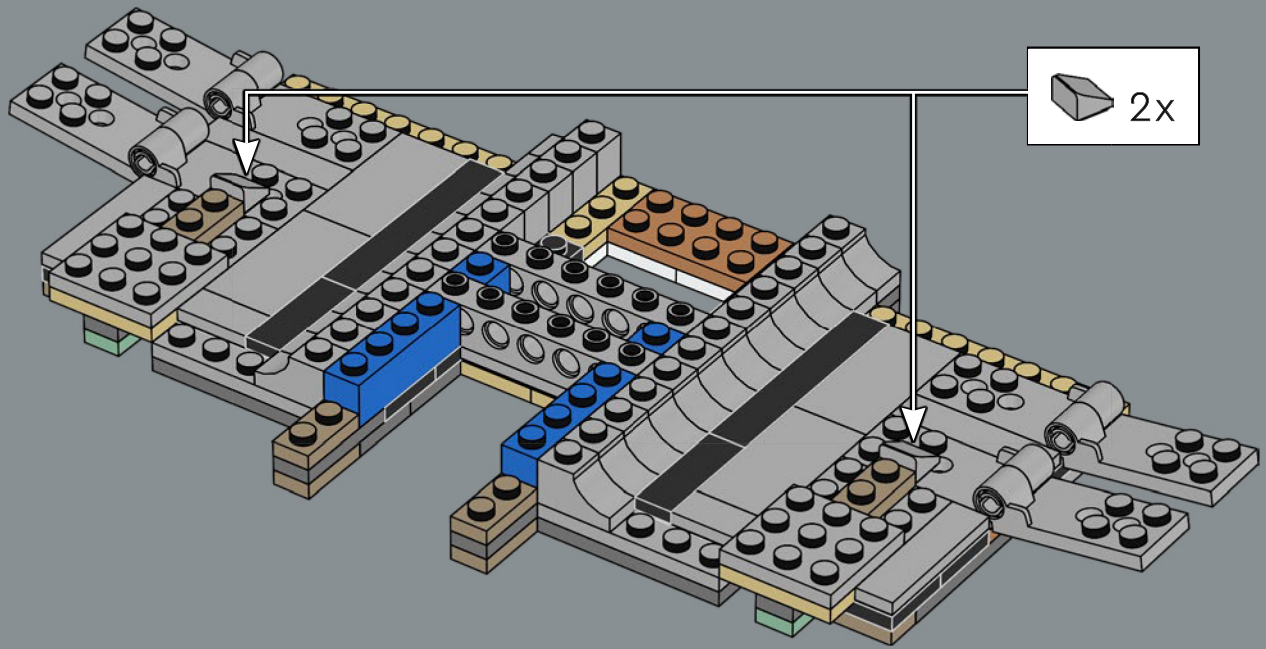

28

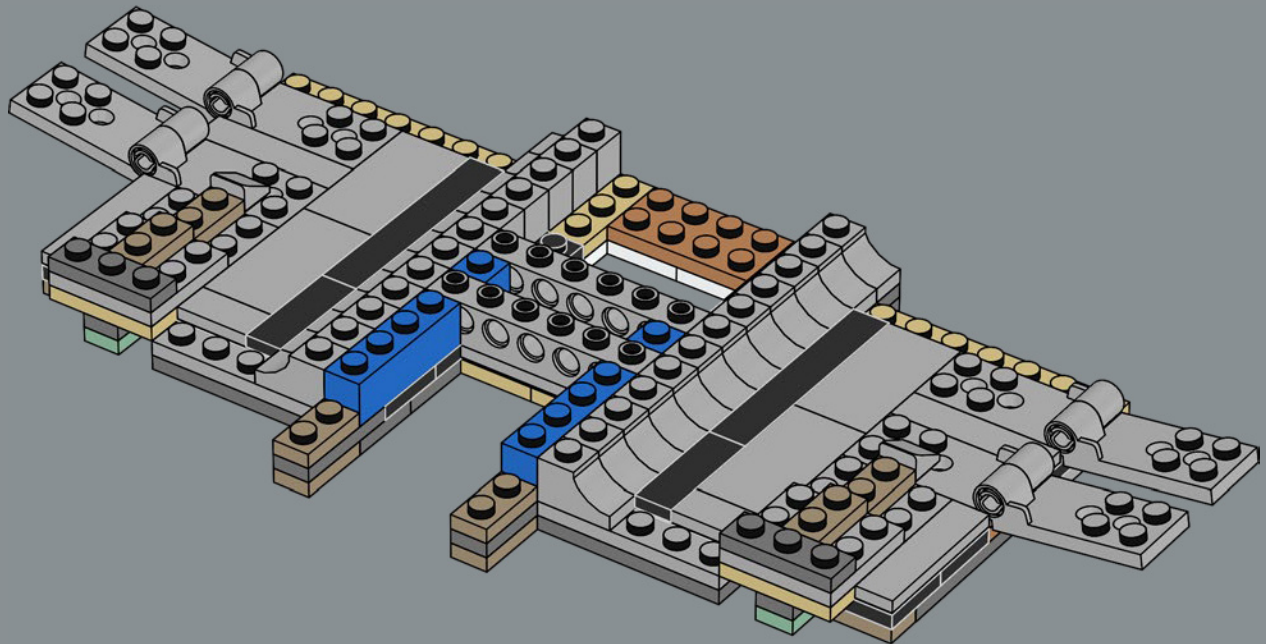

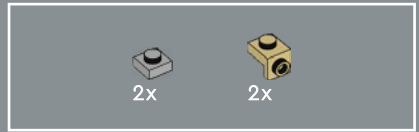

29

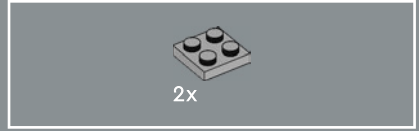
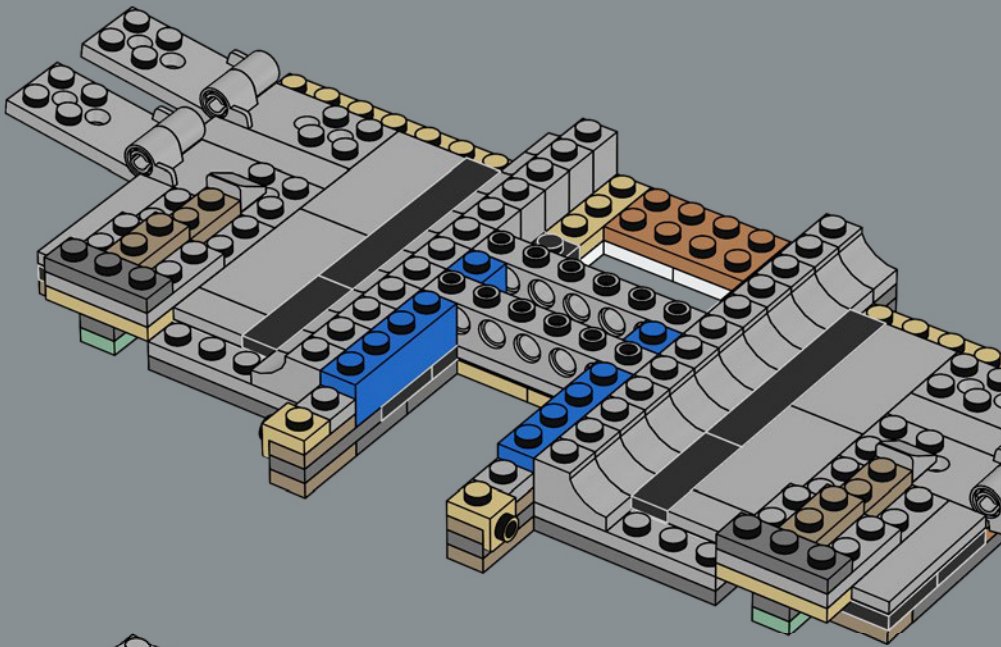

30

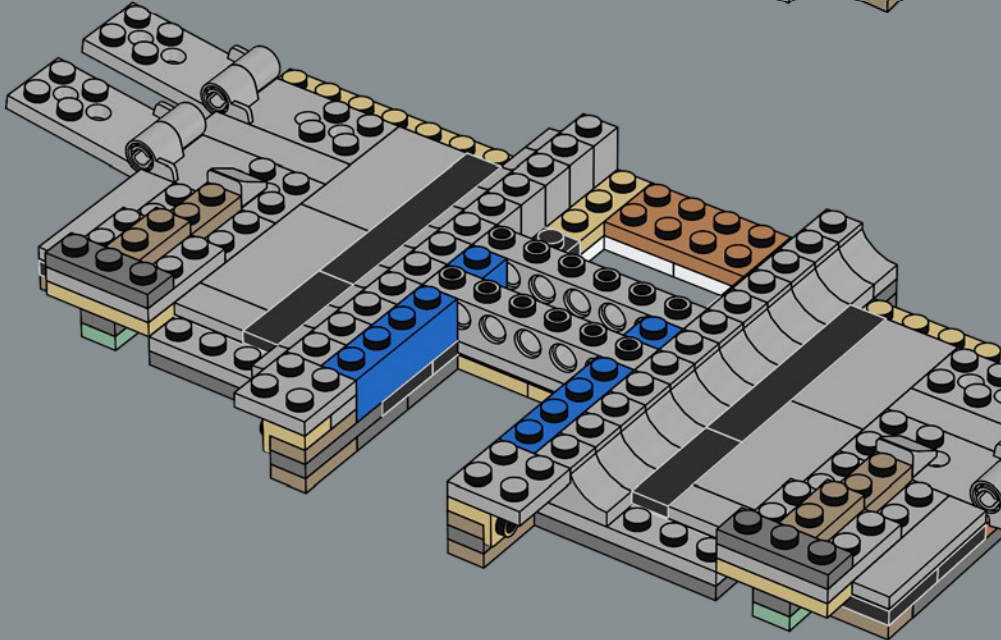

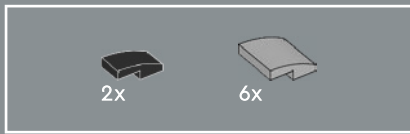

31

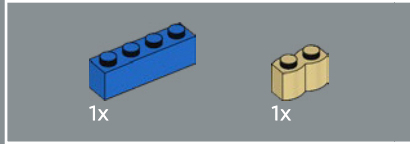
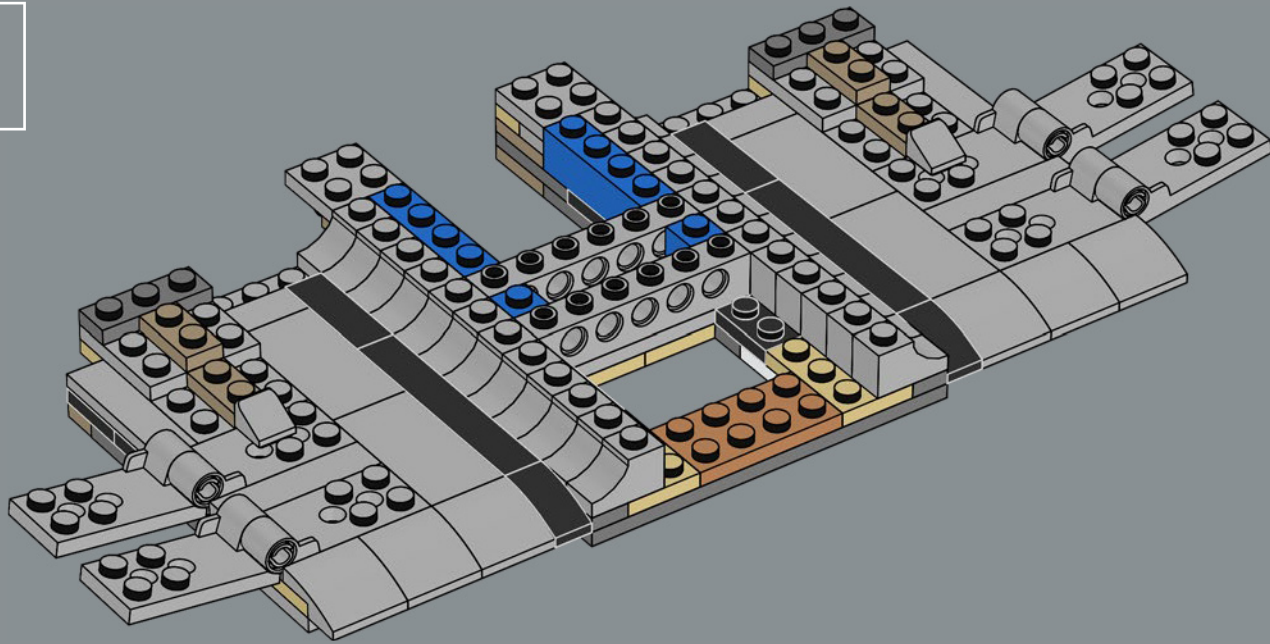

32

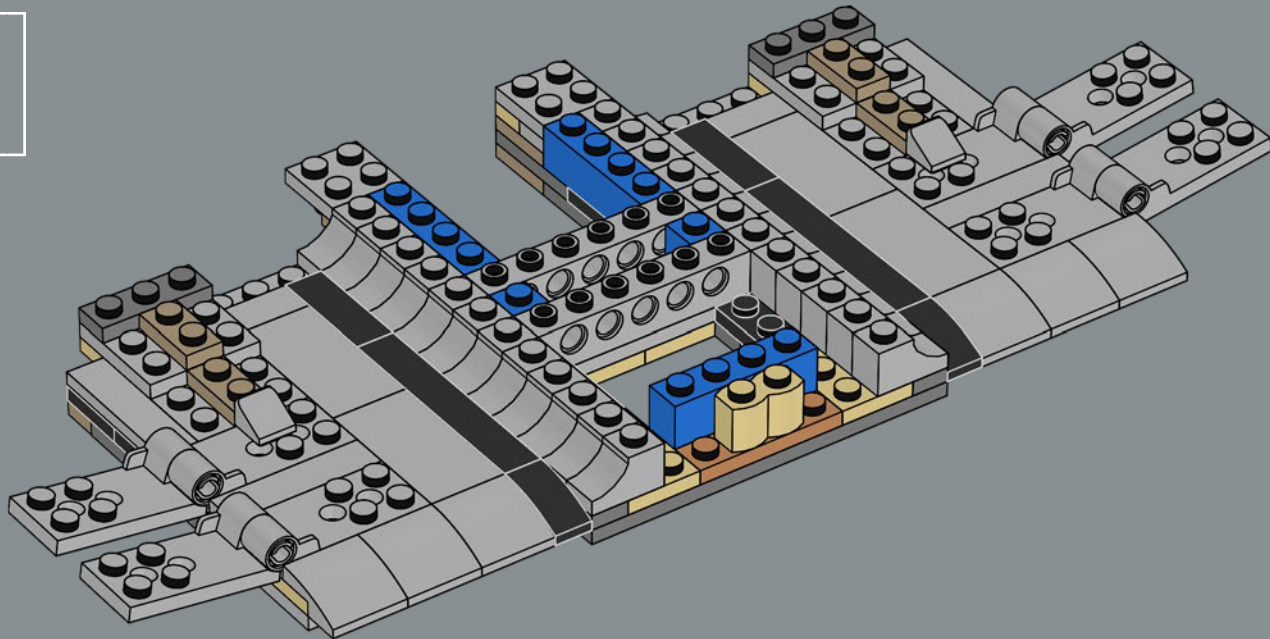

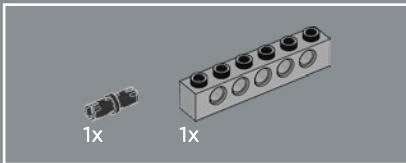
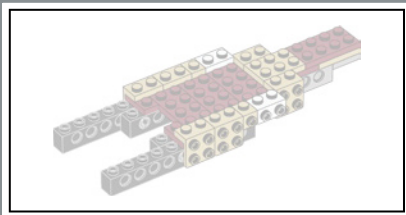

33

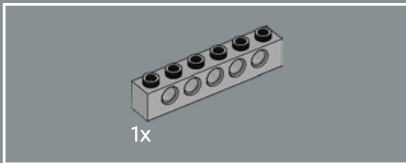
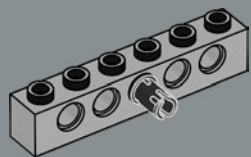

34

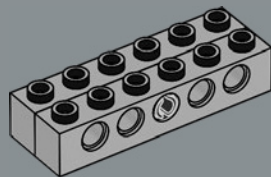

35

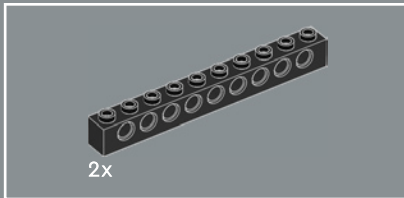
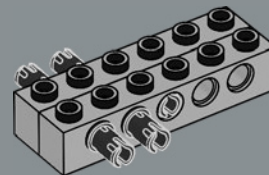

36

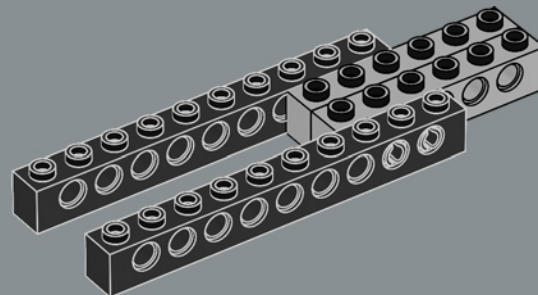

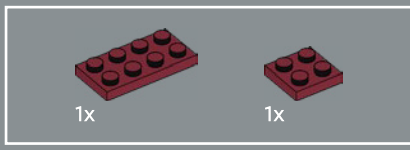

37

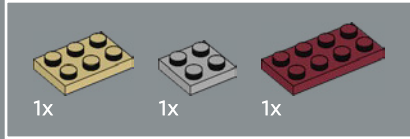
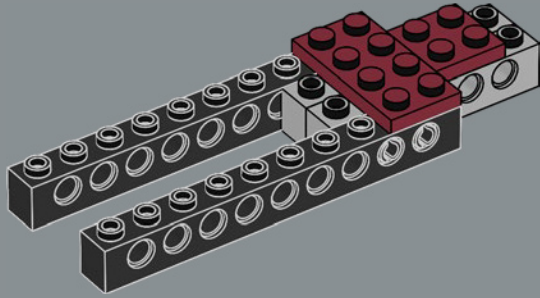

38

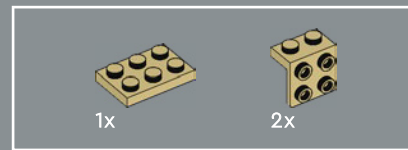
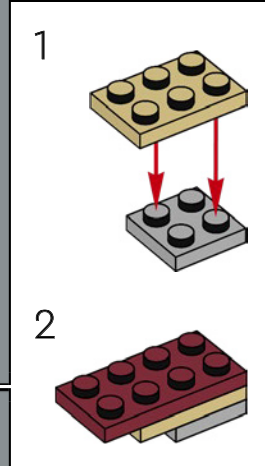
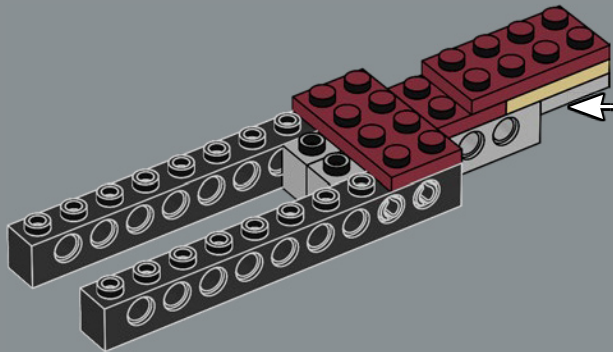

39

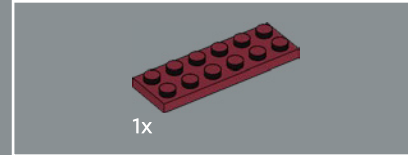
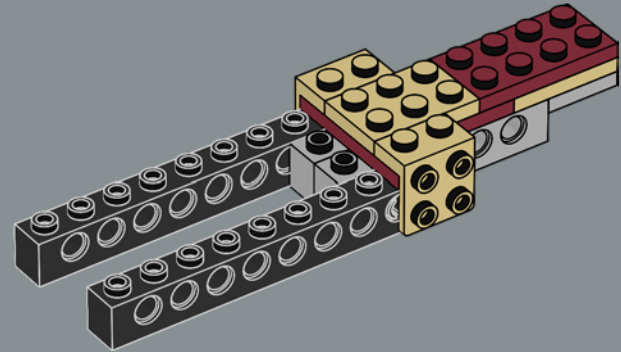

40

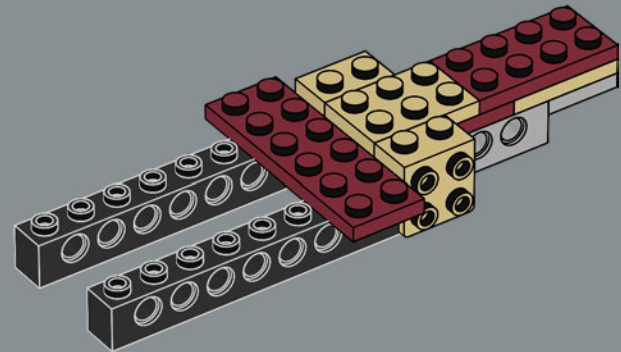

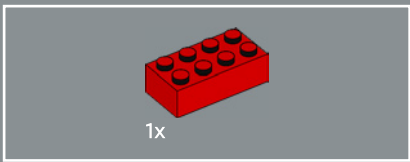

41

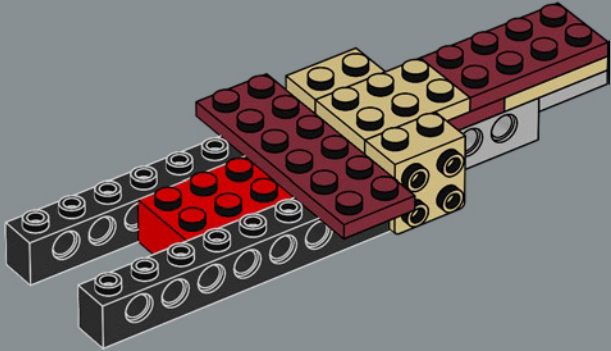

42

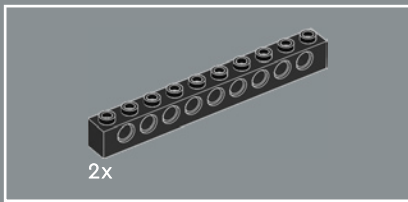
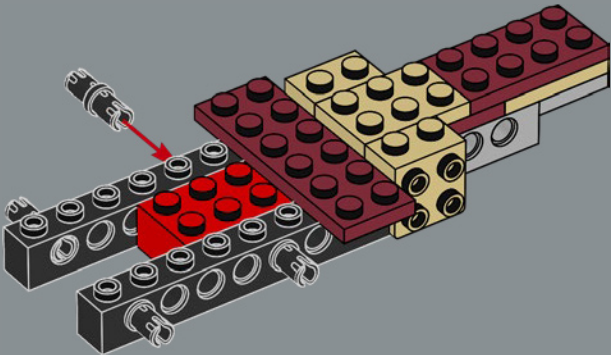

43

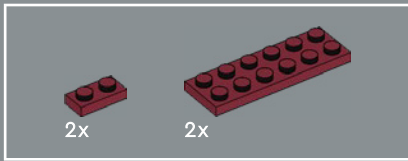
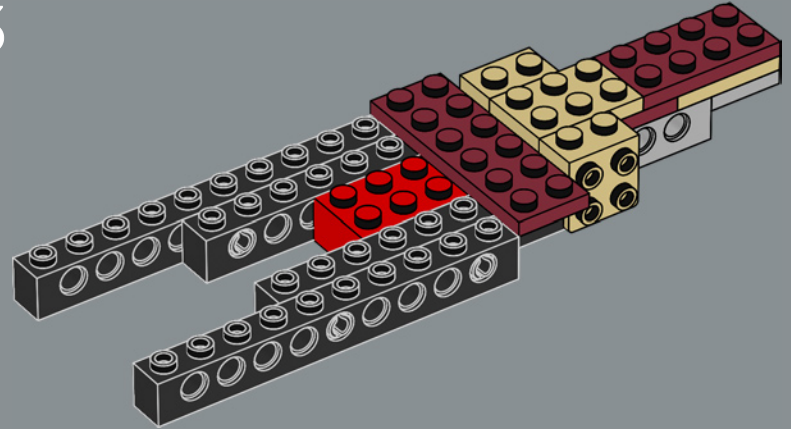

44

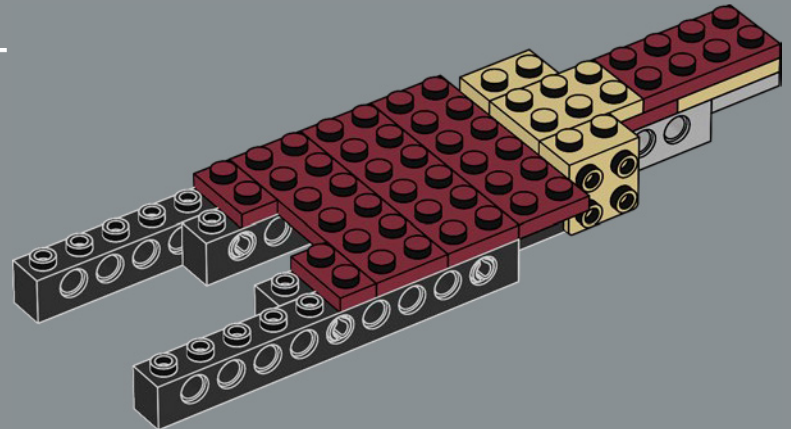



45

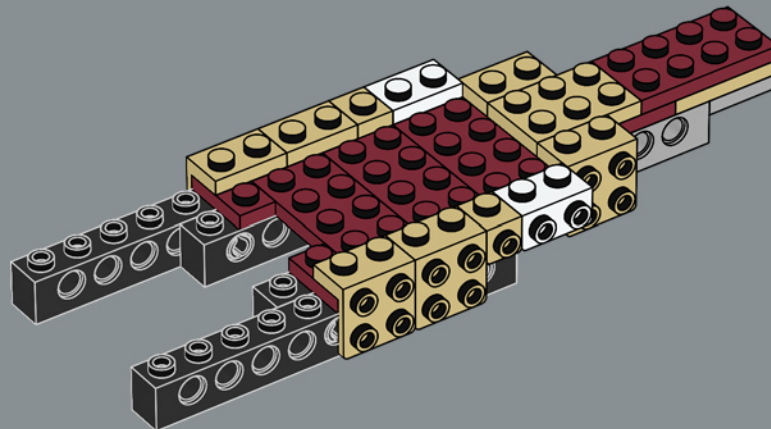

46

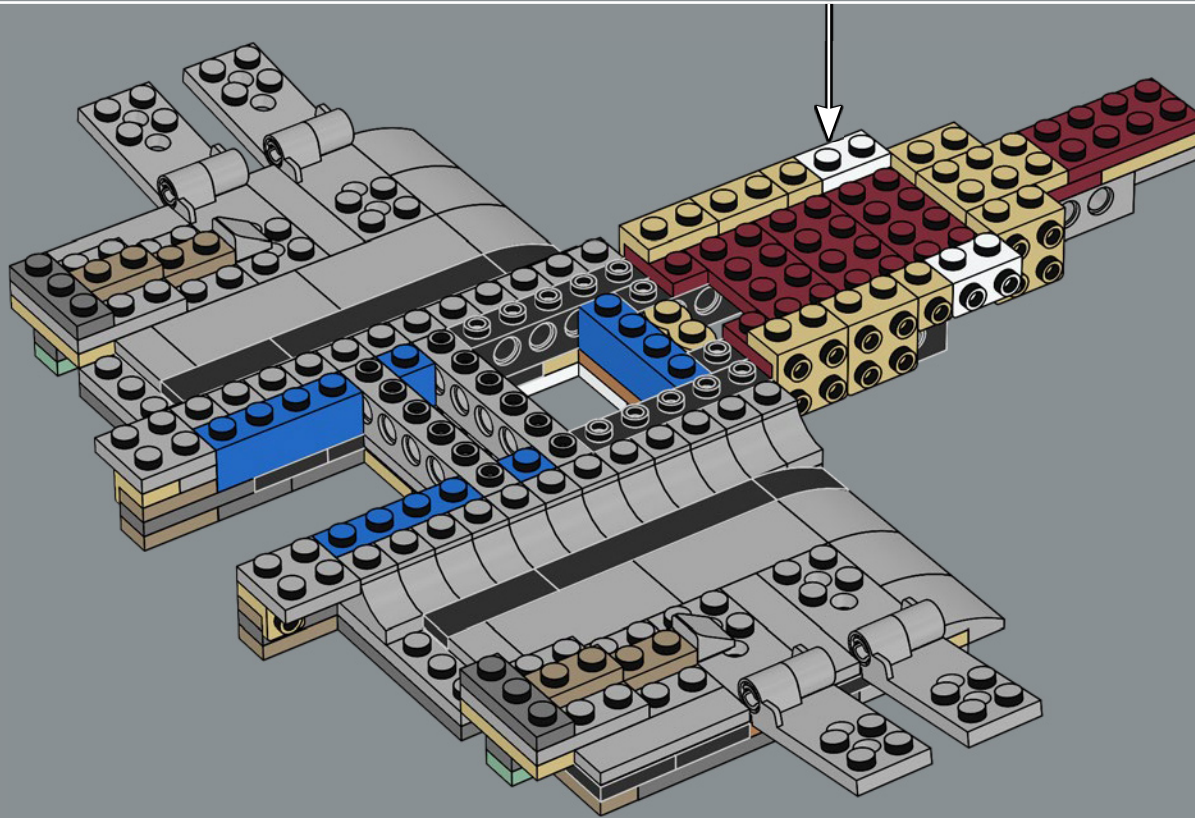

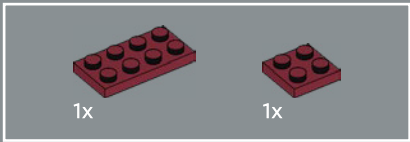

47

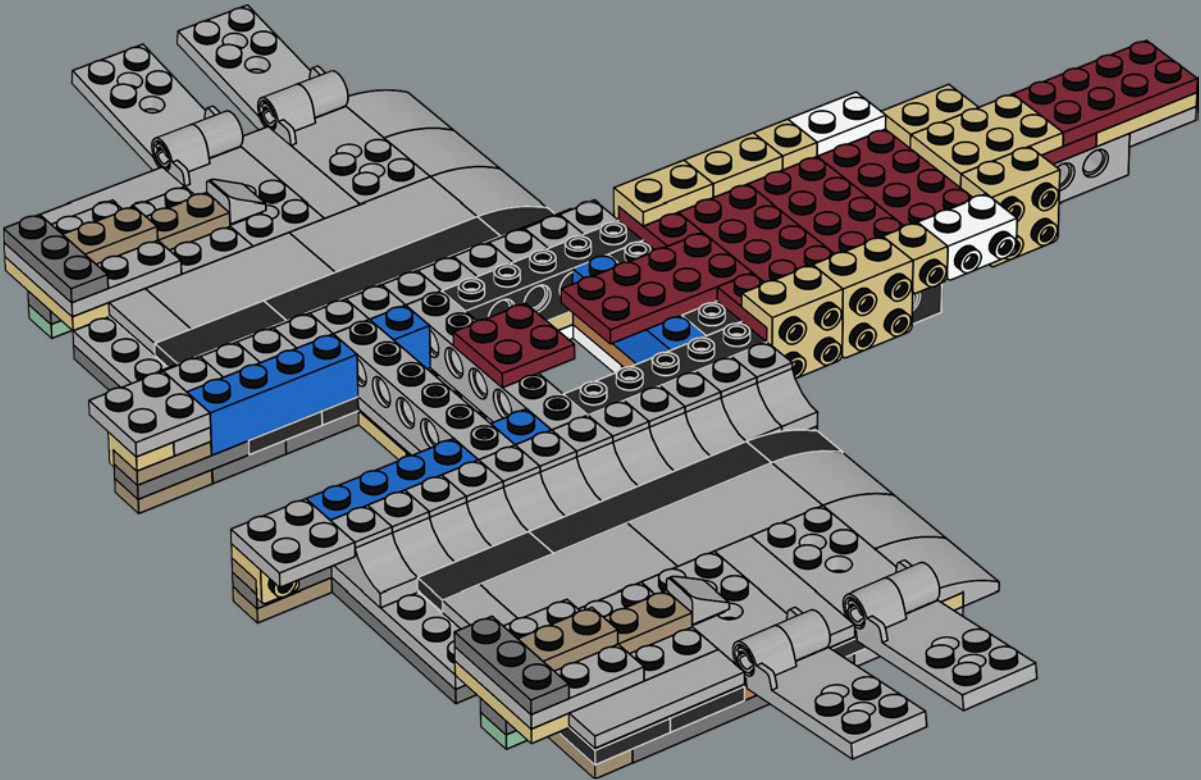

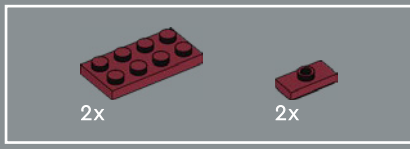

48

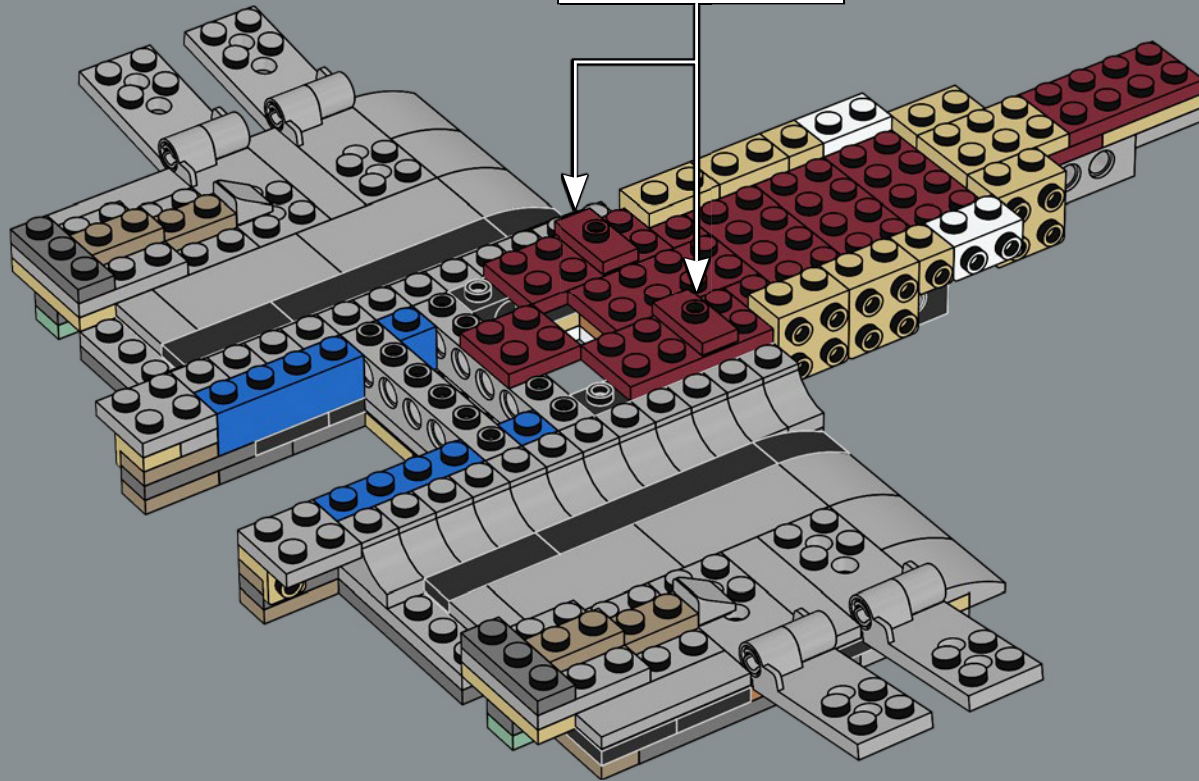
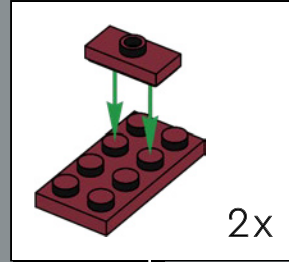

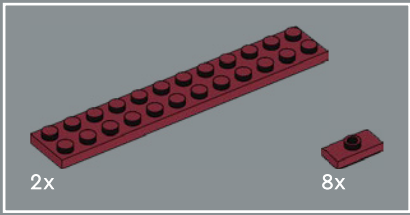

49

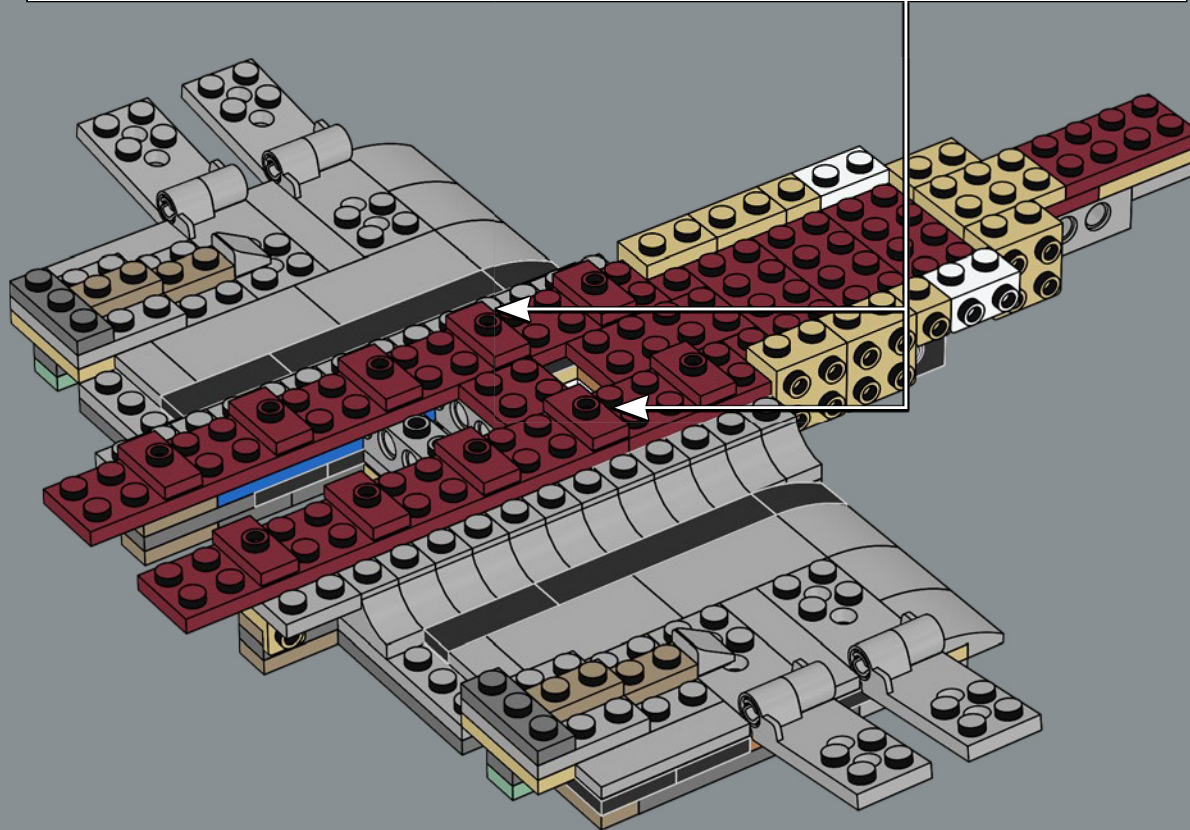
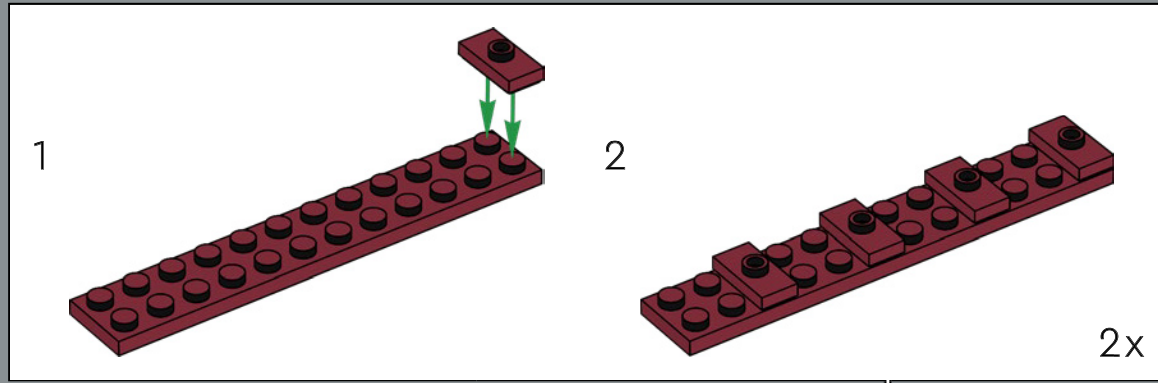

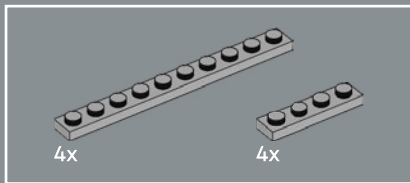

50

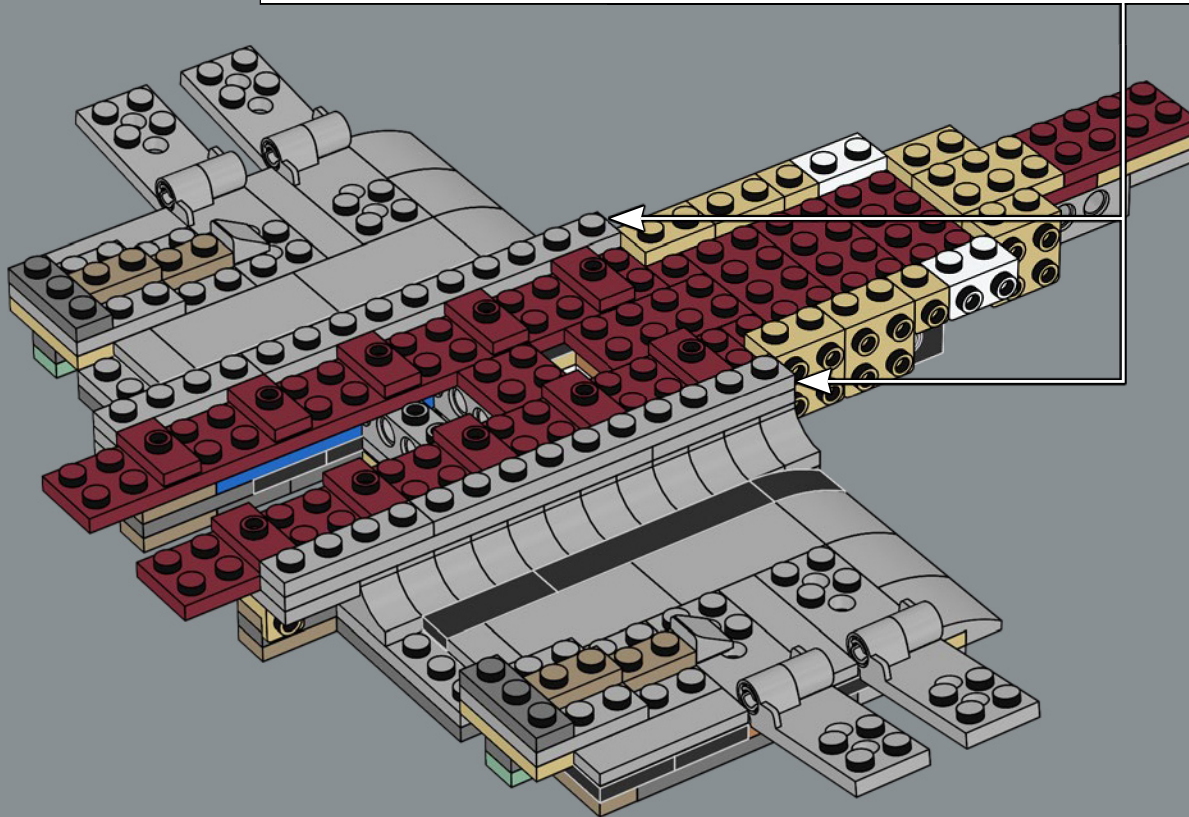
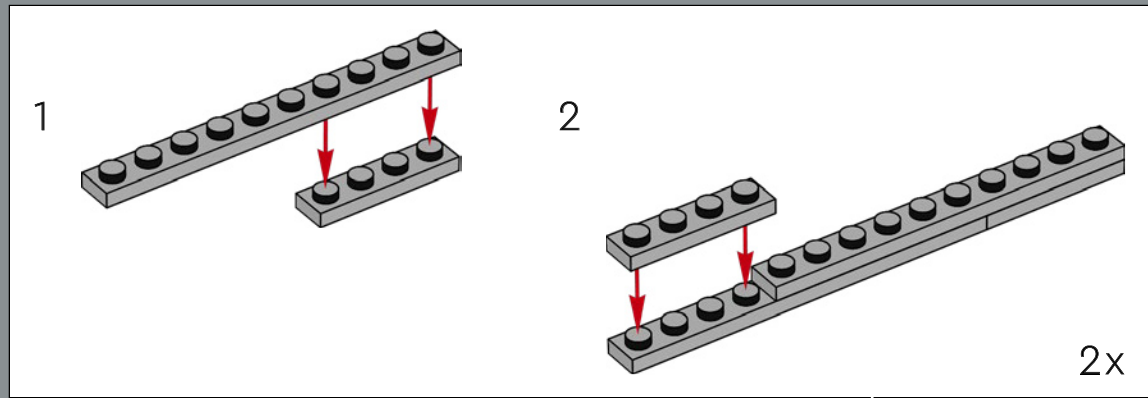



2x

51

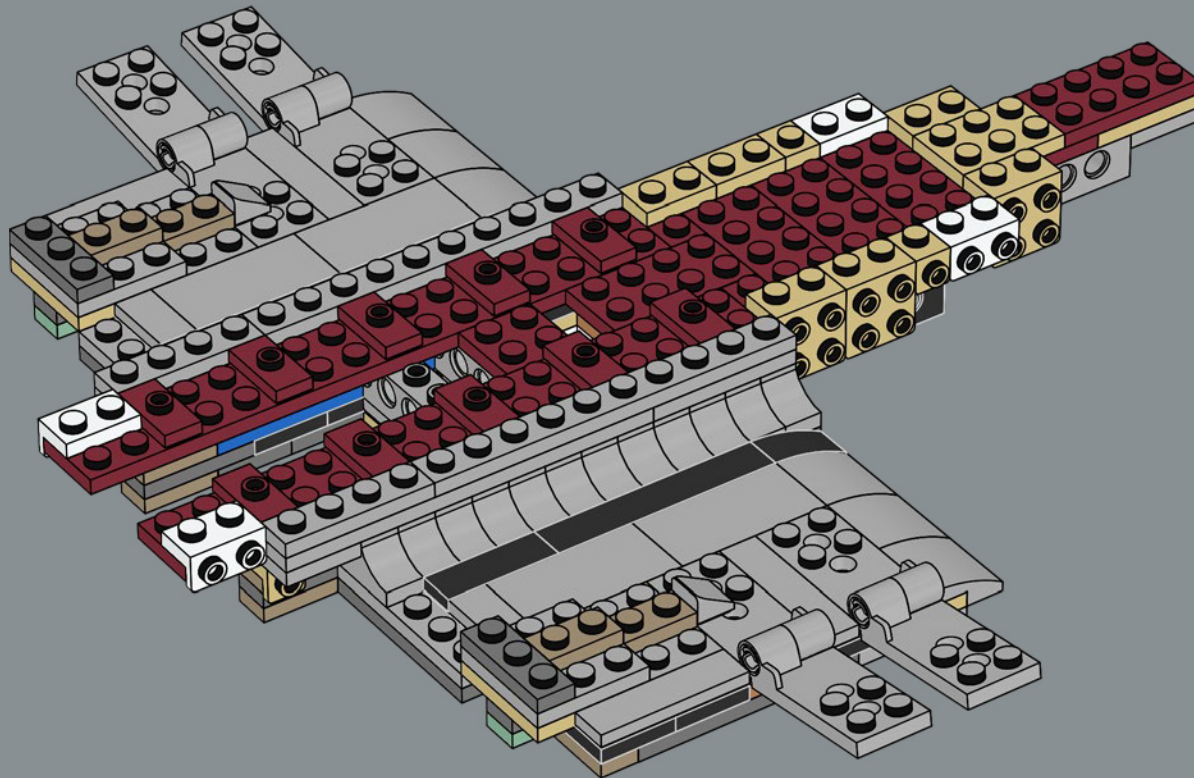

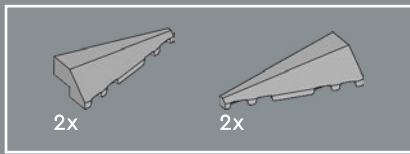

52

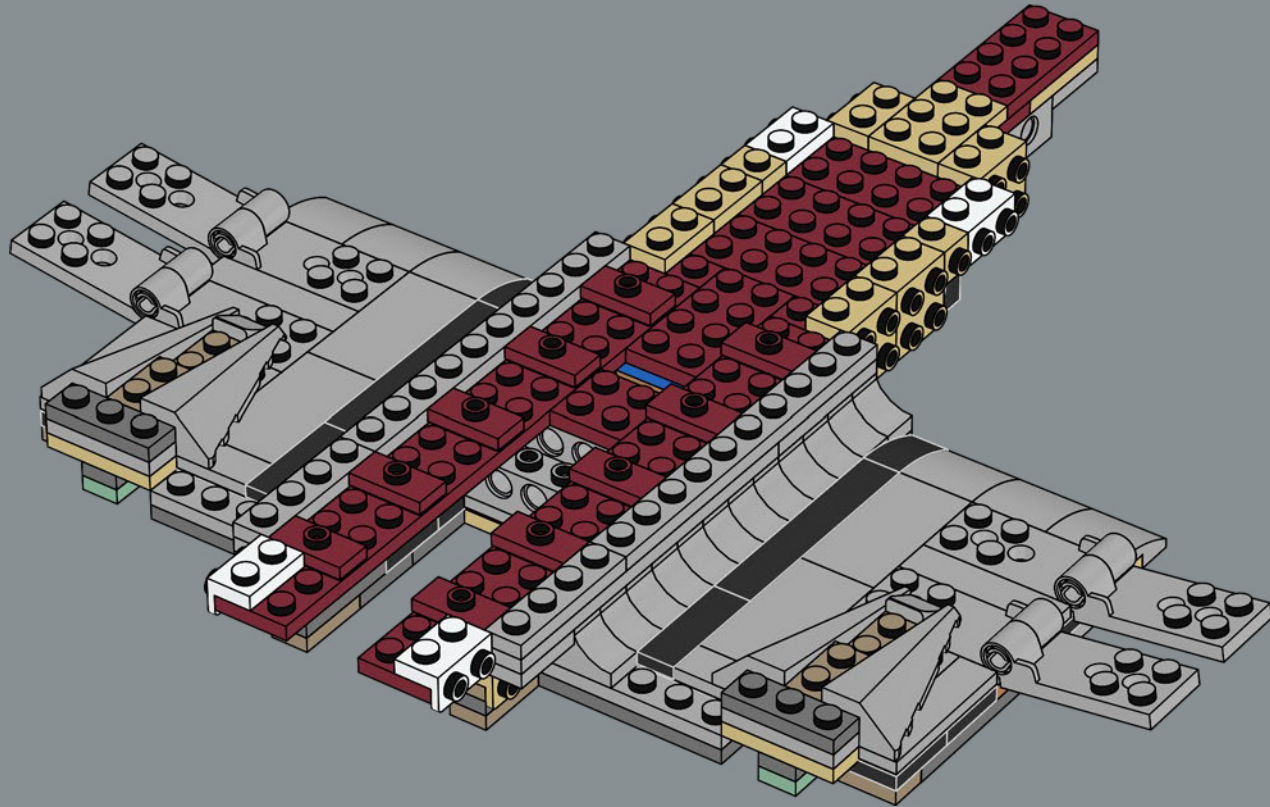

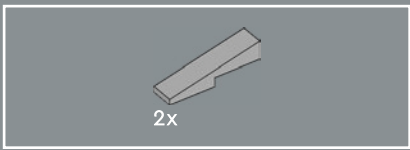

53

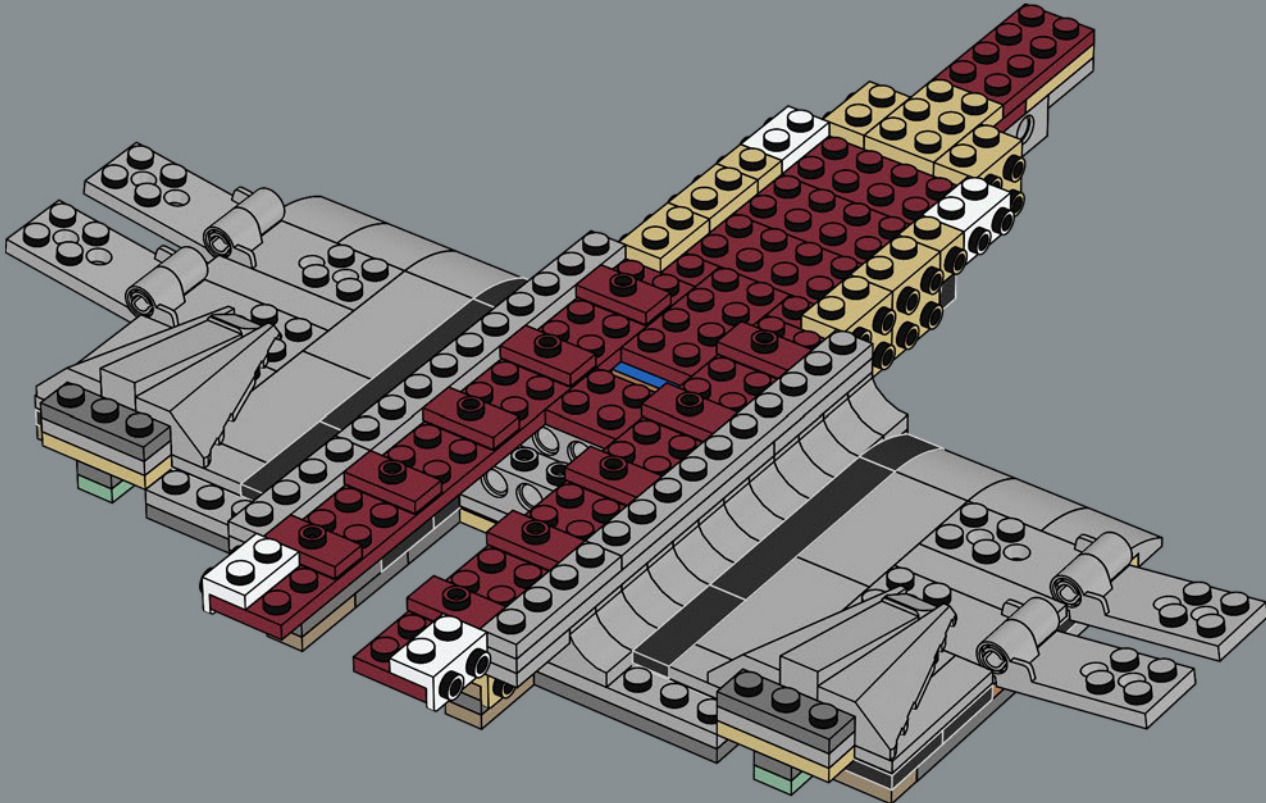

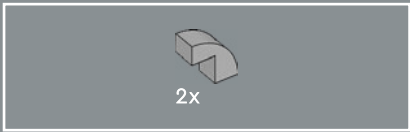

54

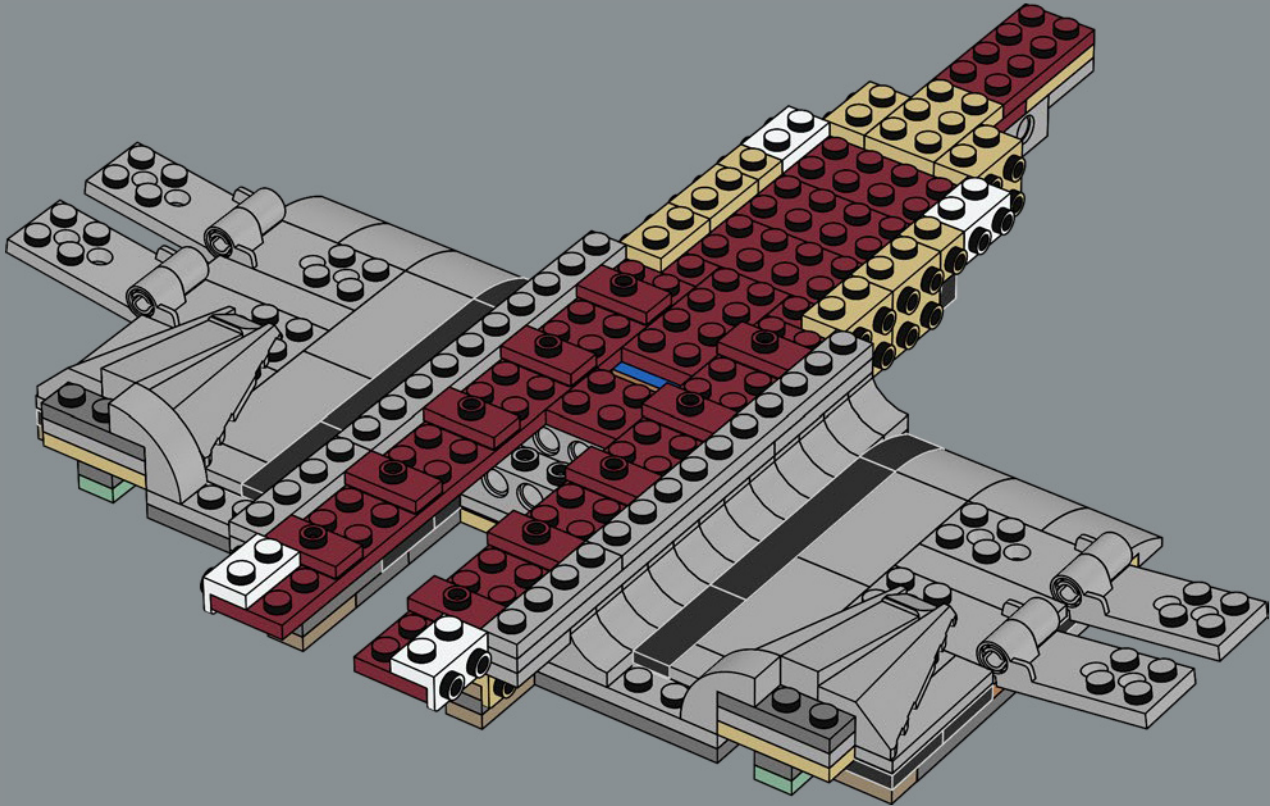



55

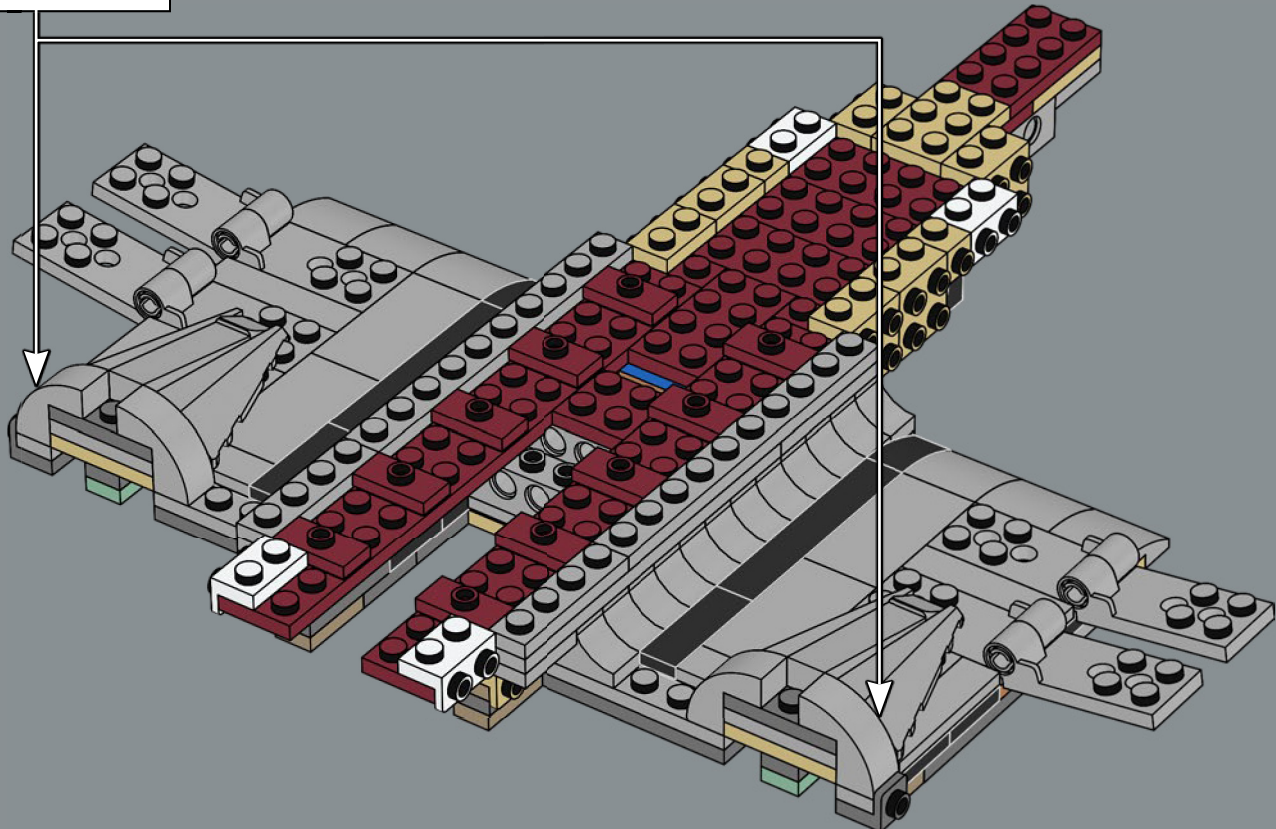
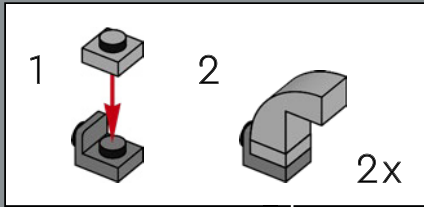

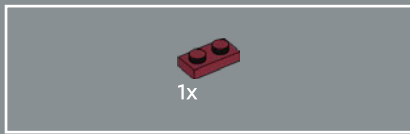

56

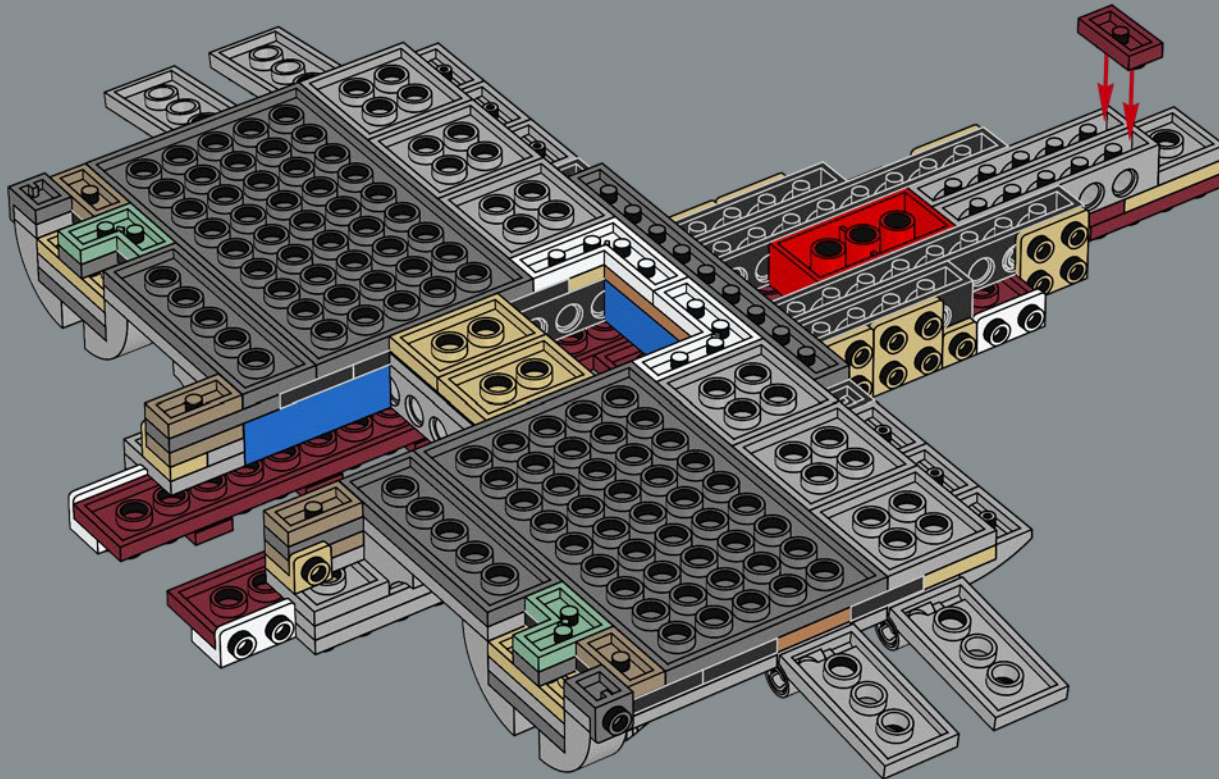

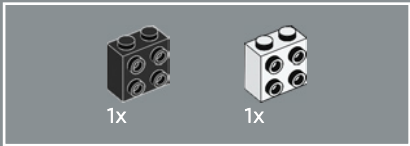
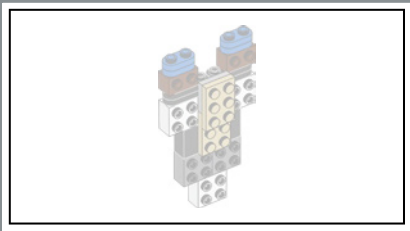

57

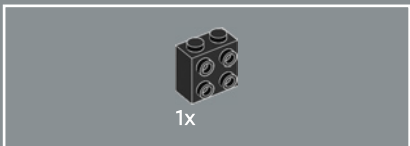
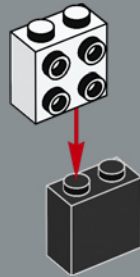

58

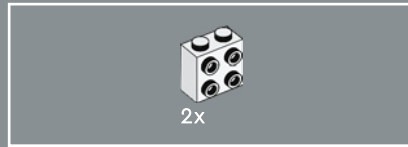
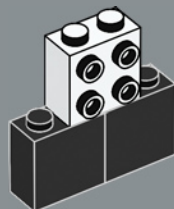

59

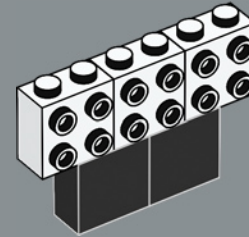

60

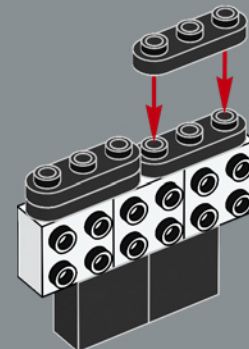

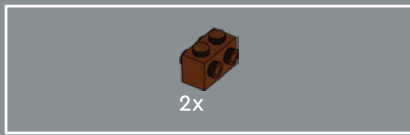

61

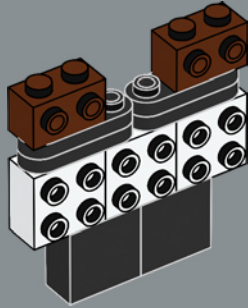

62

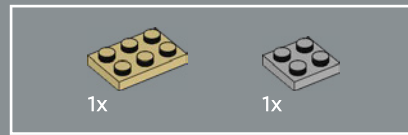
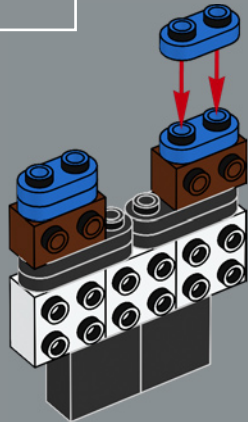

63

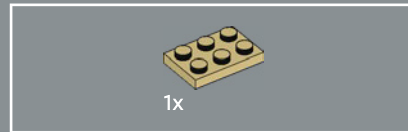
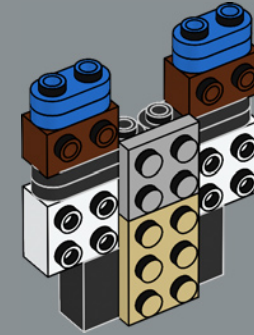

64

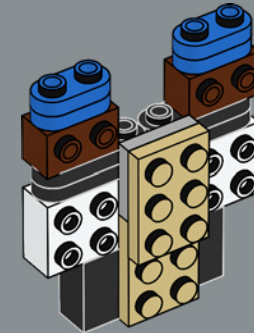



2x

65

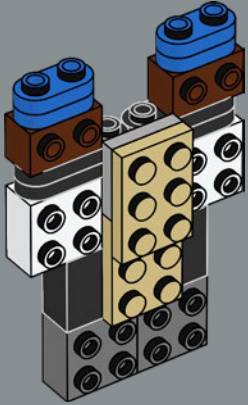

1x

66

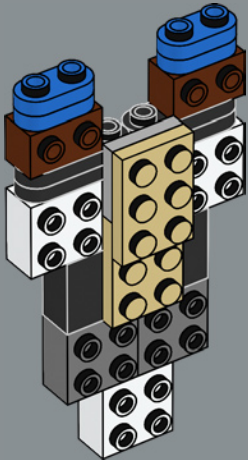

67

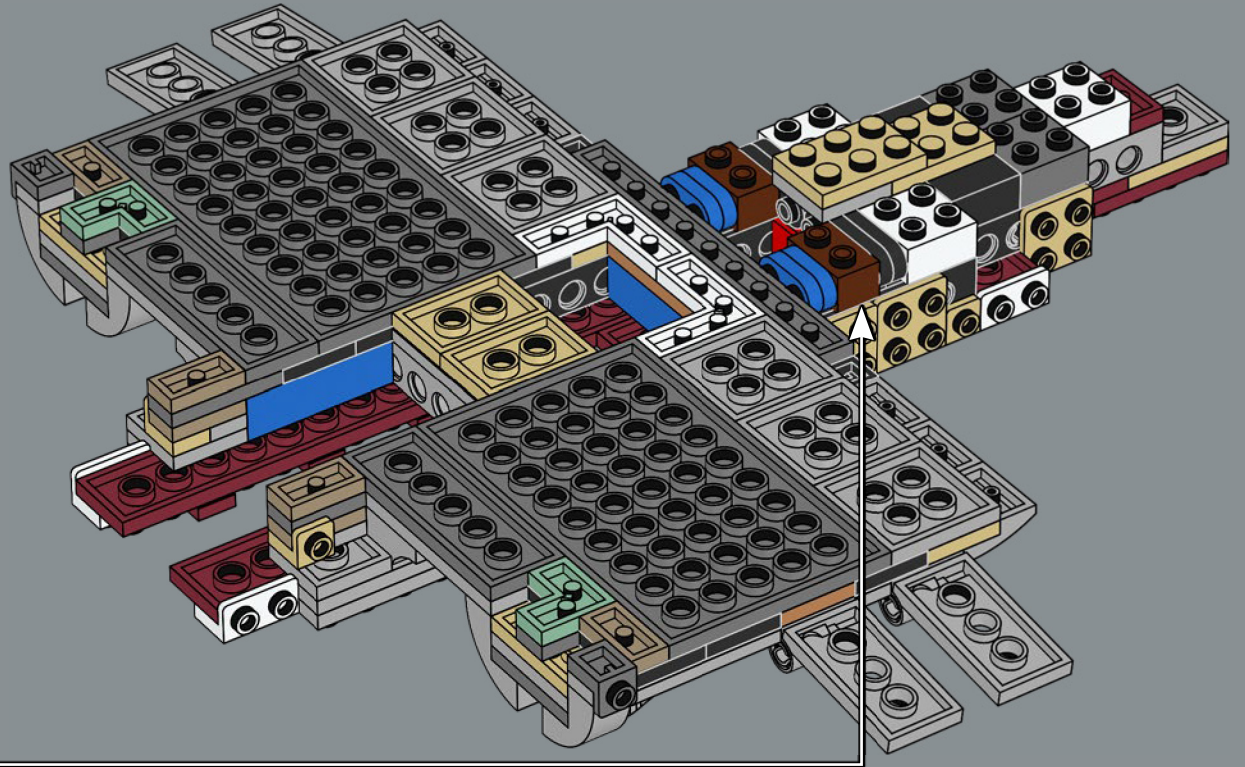

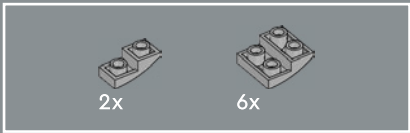

68

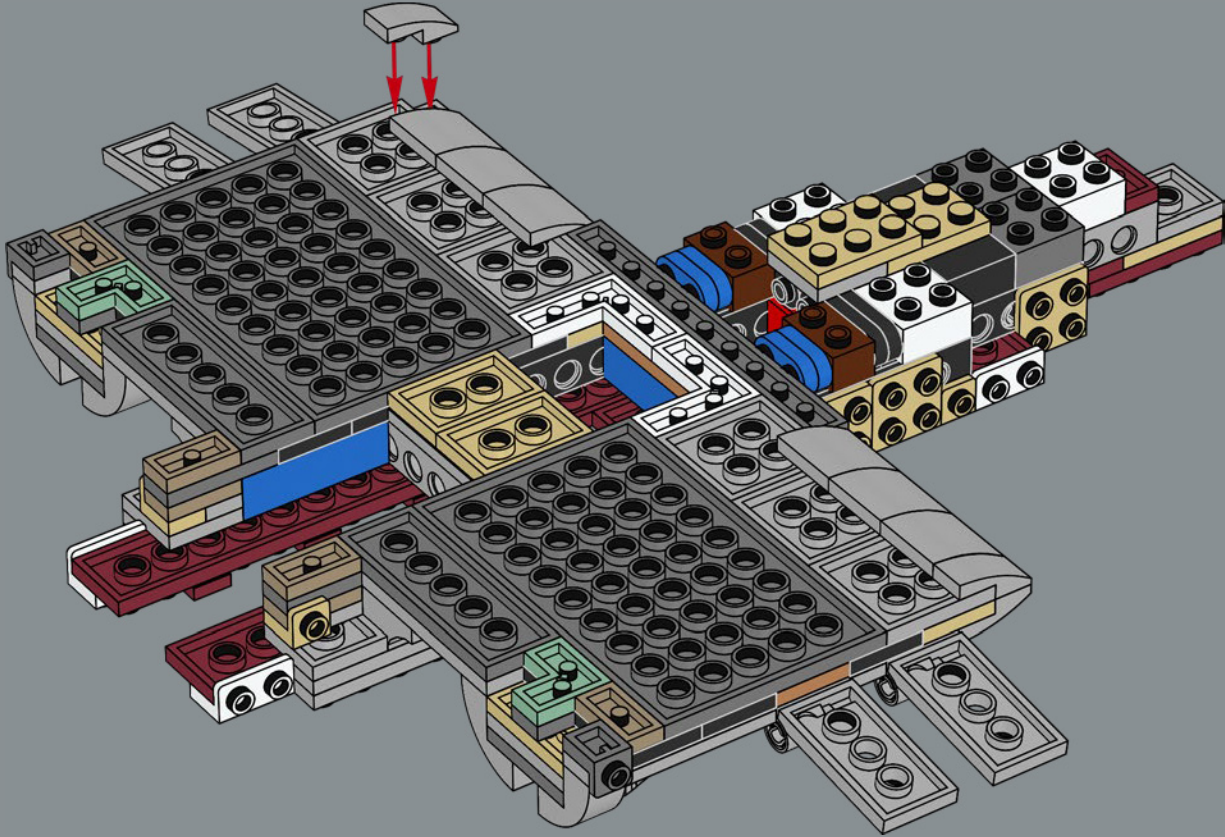

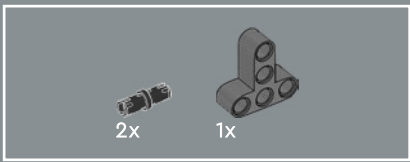

69

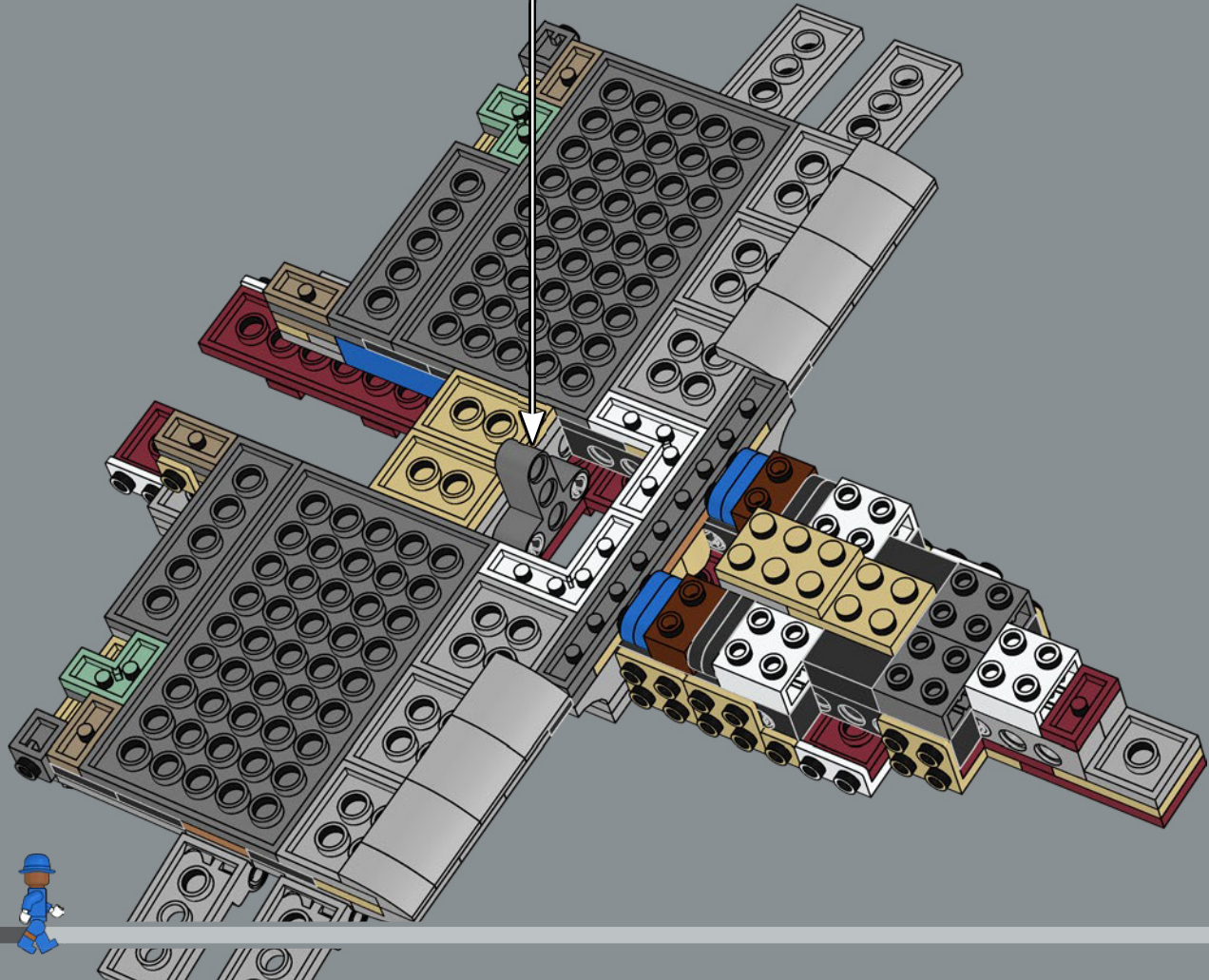
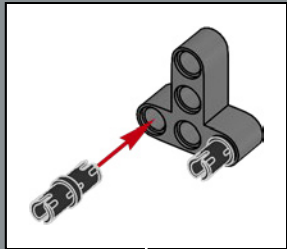

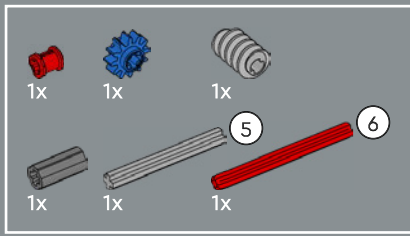

70

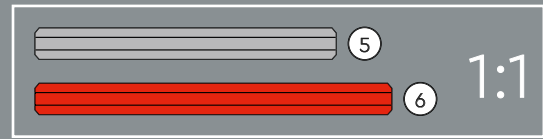
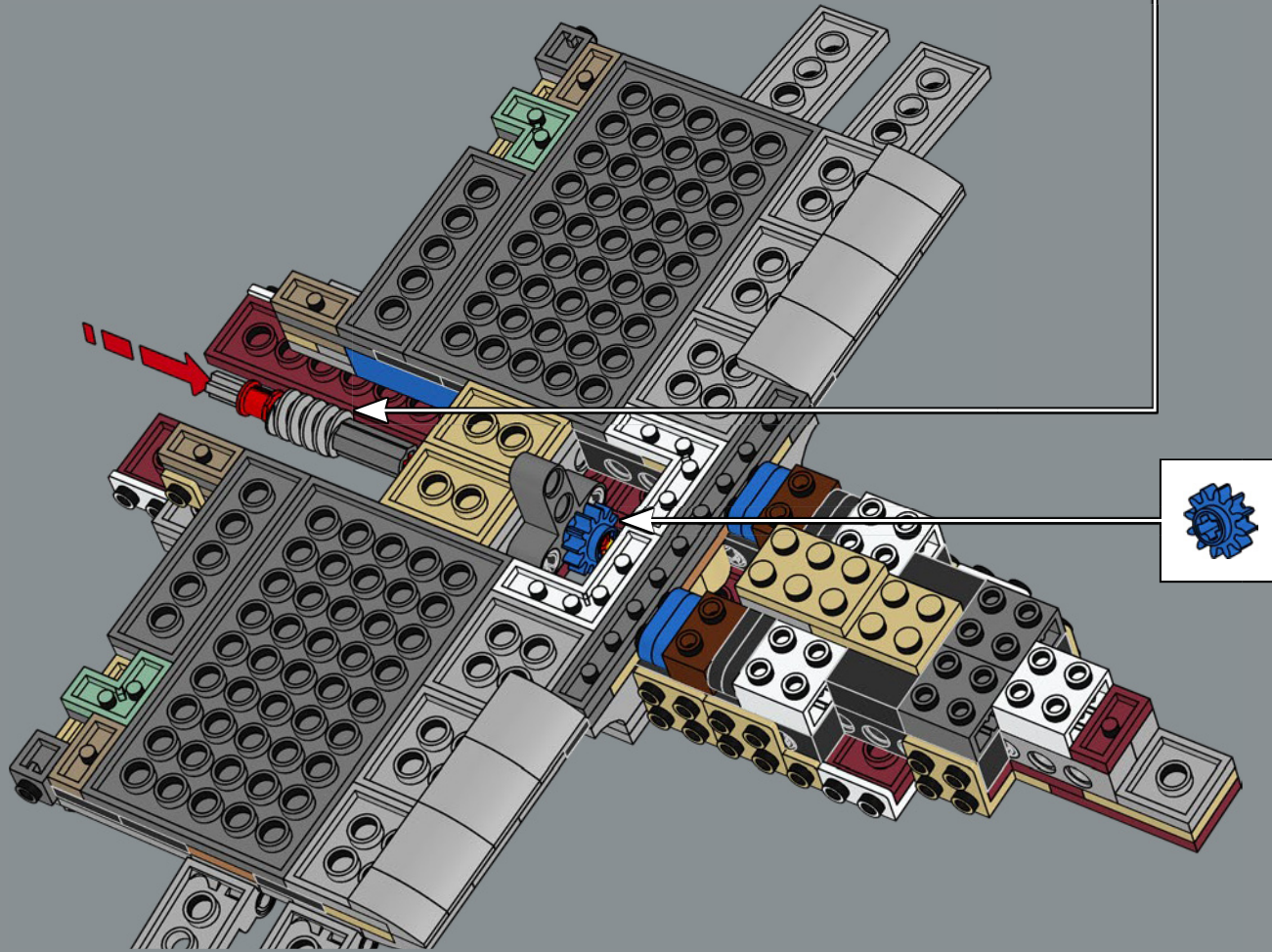
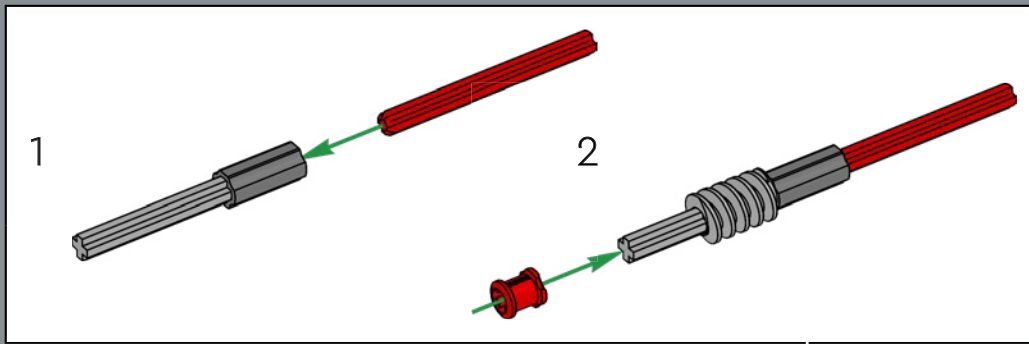

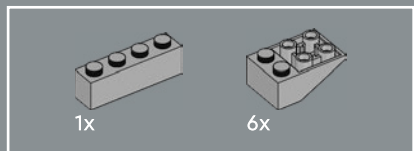

71

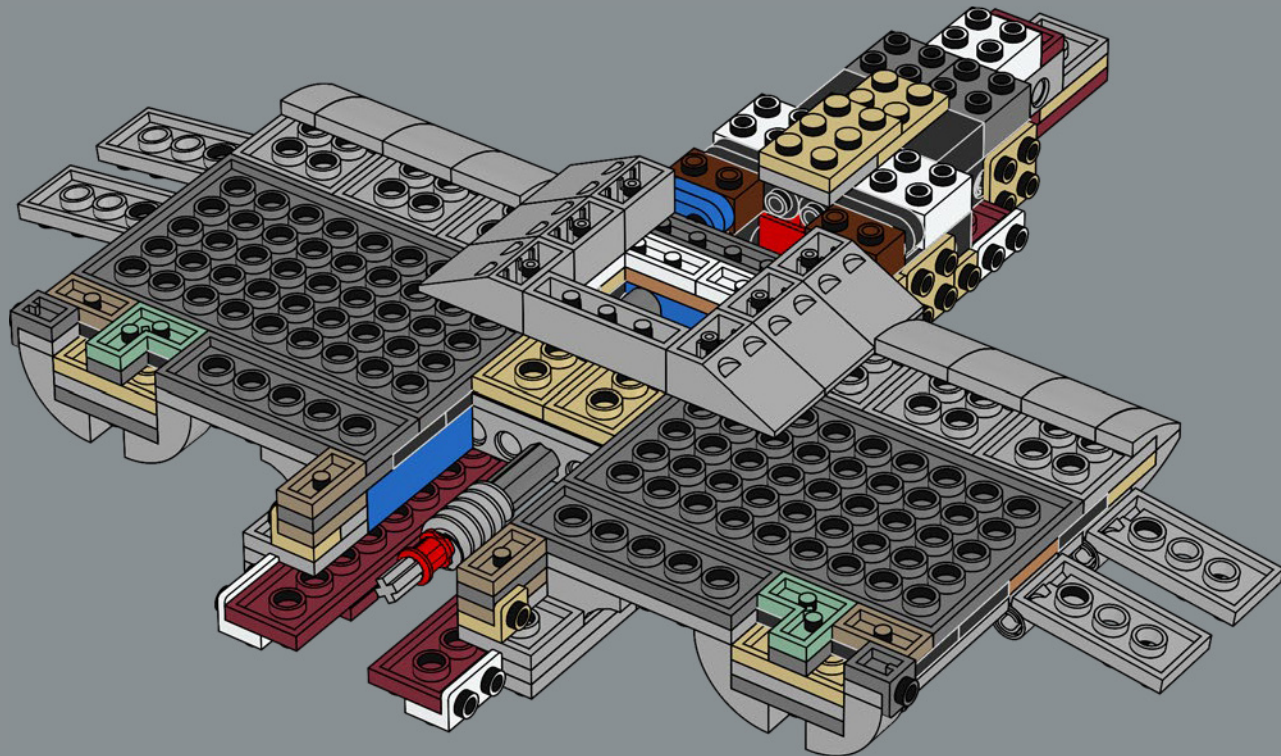

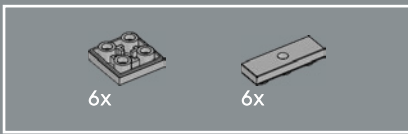

72

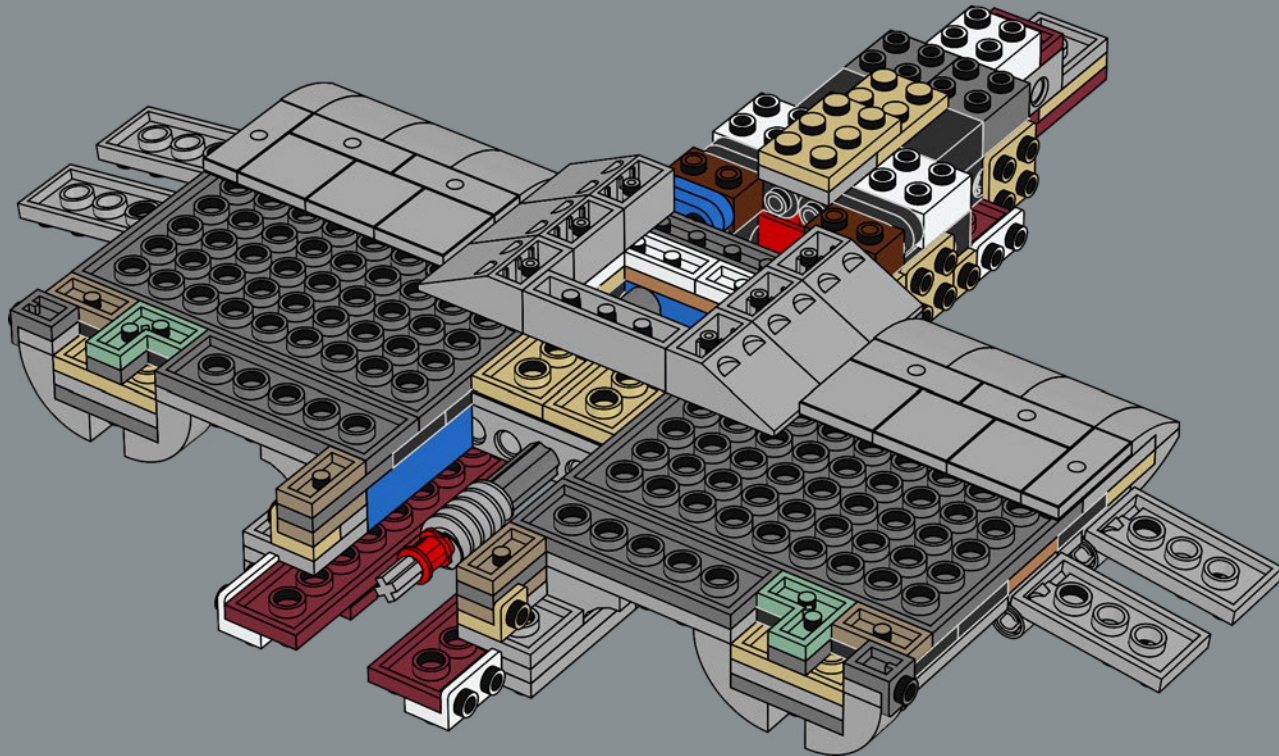

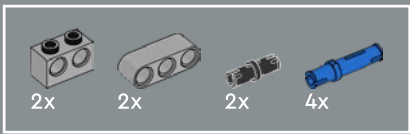

73

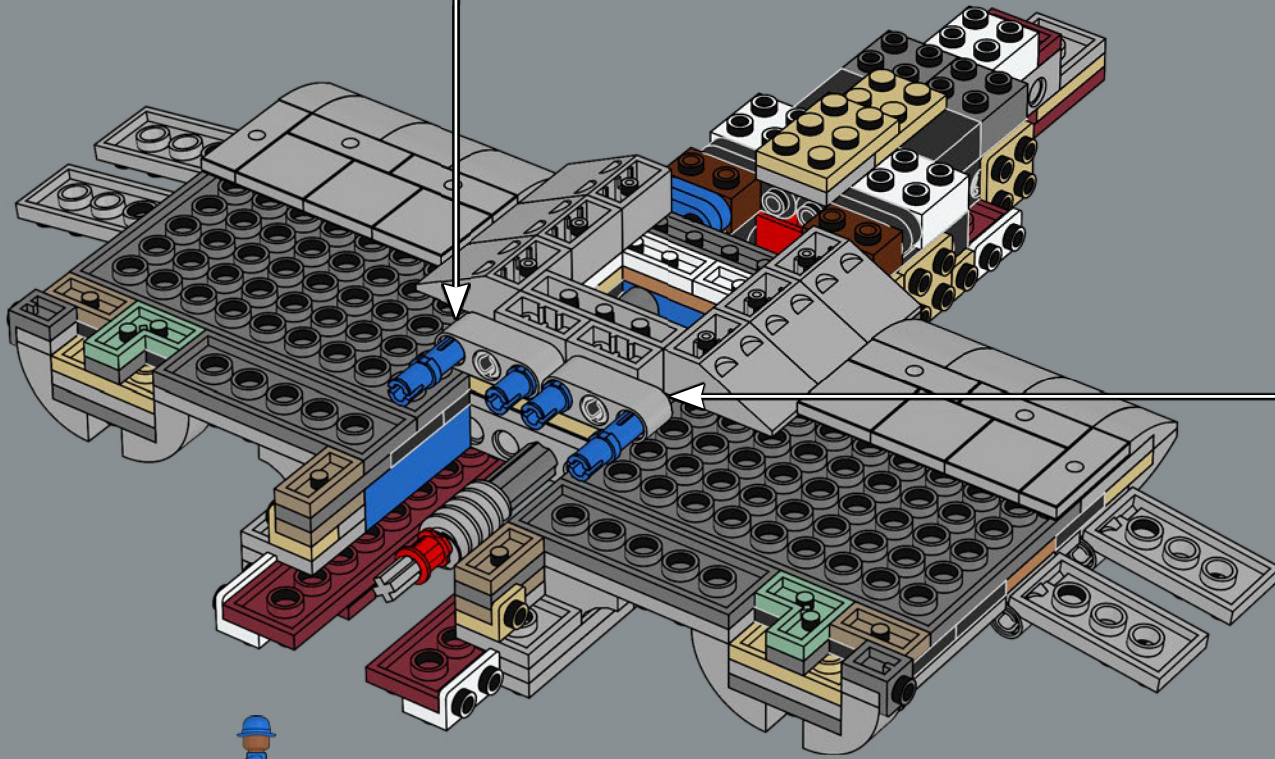
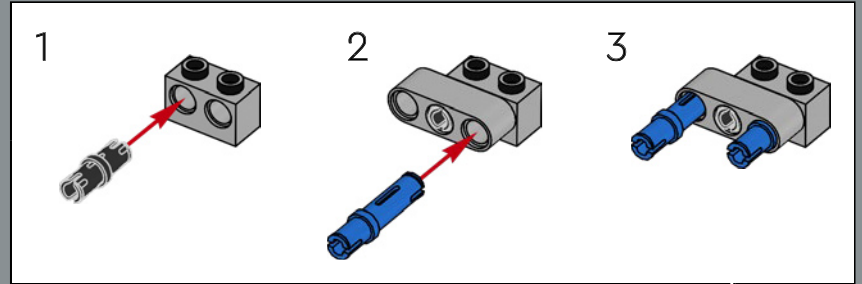
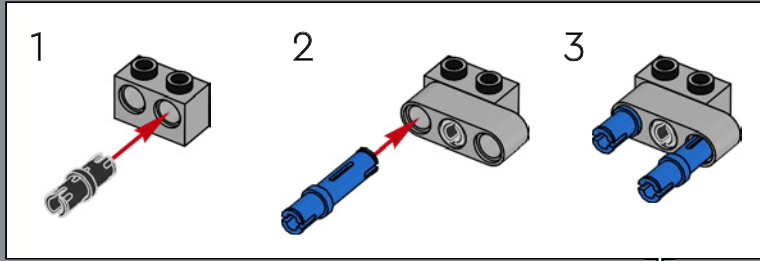

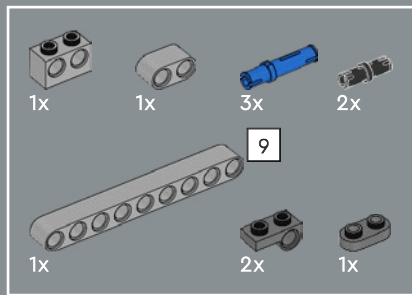

74

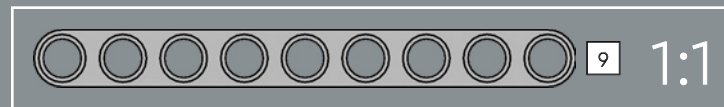
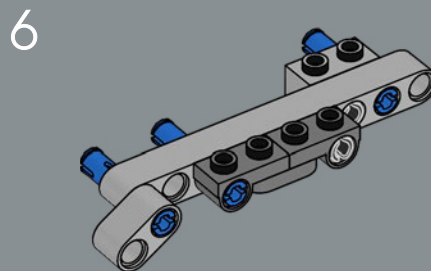
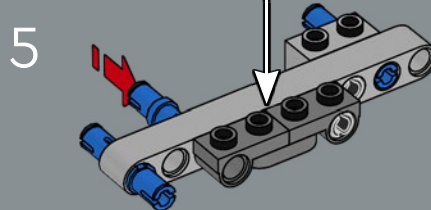
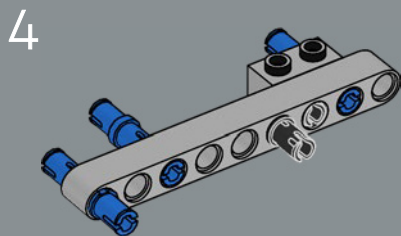
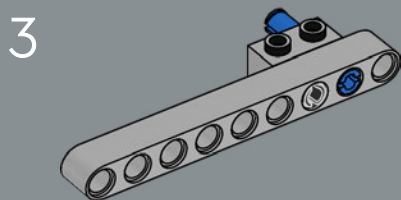
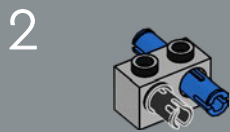
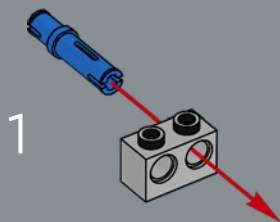
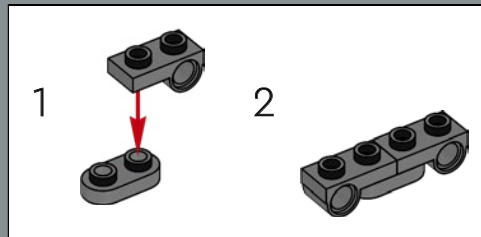

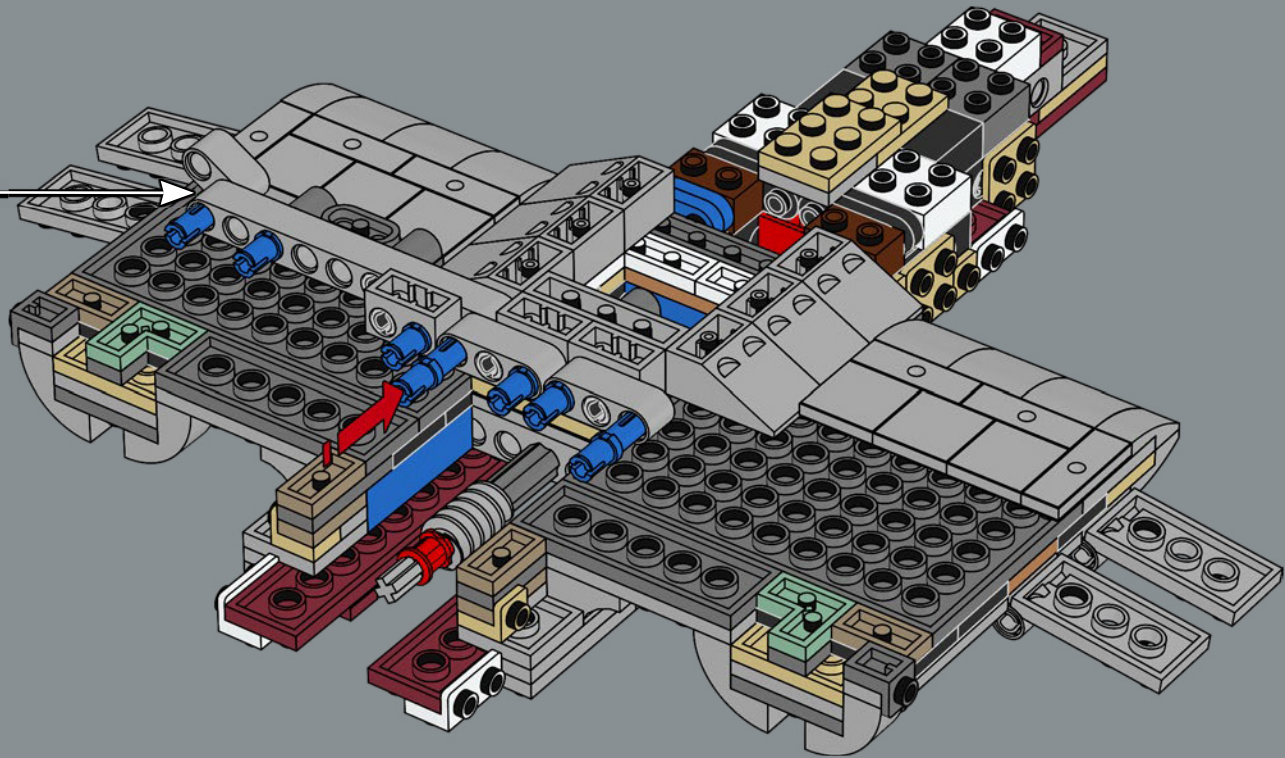

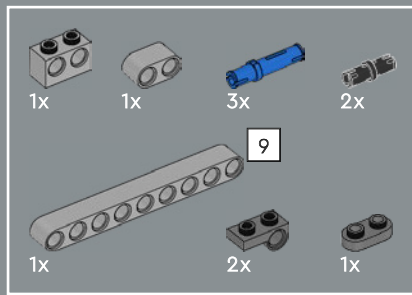

75

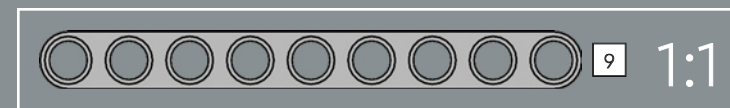
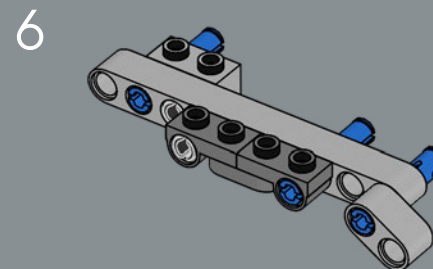
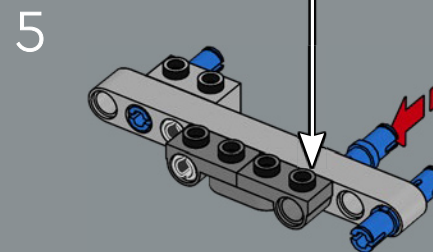
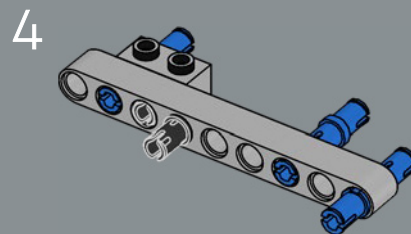
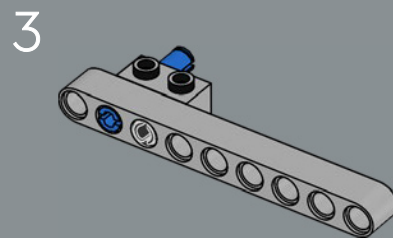
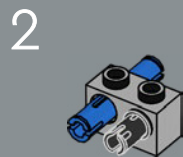
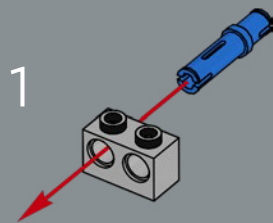
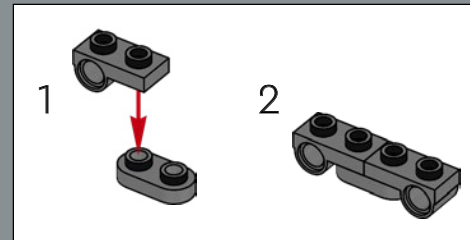

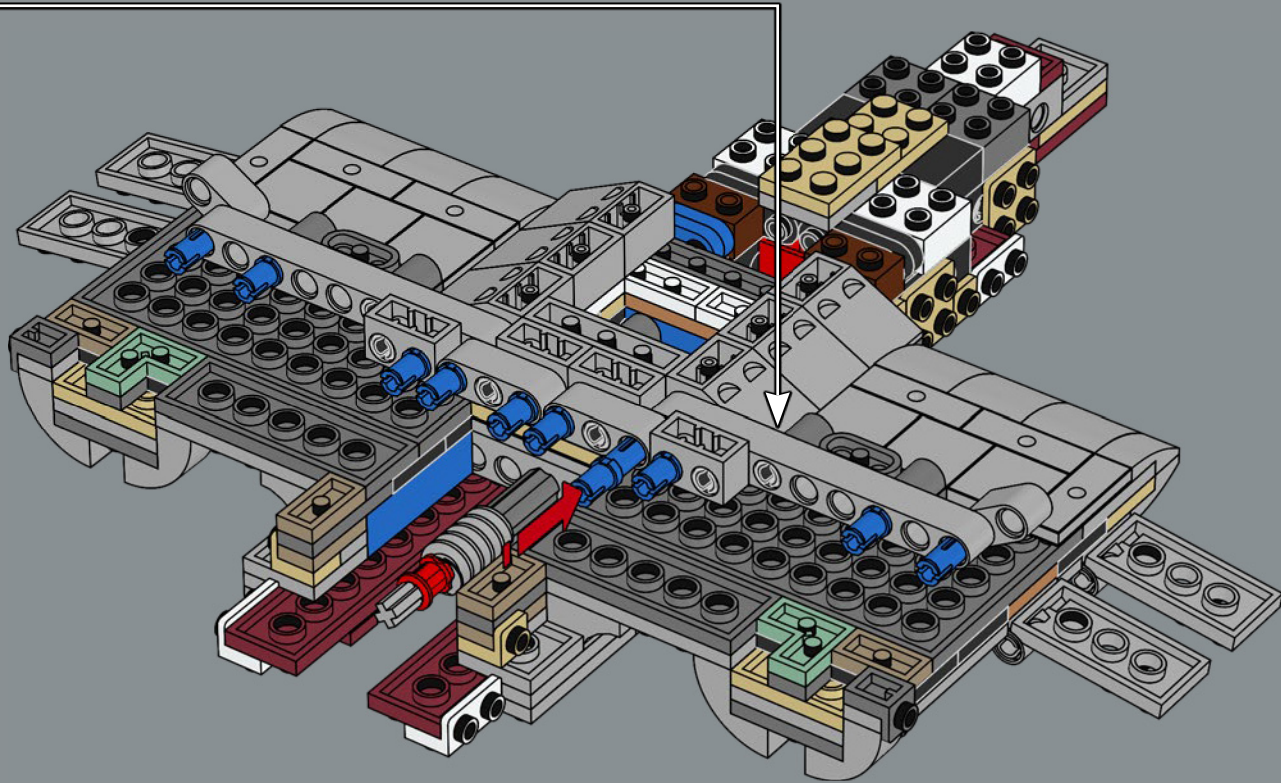

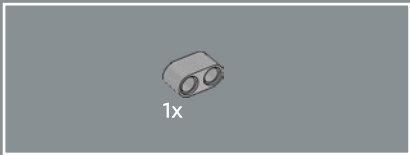

76

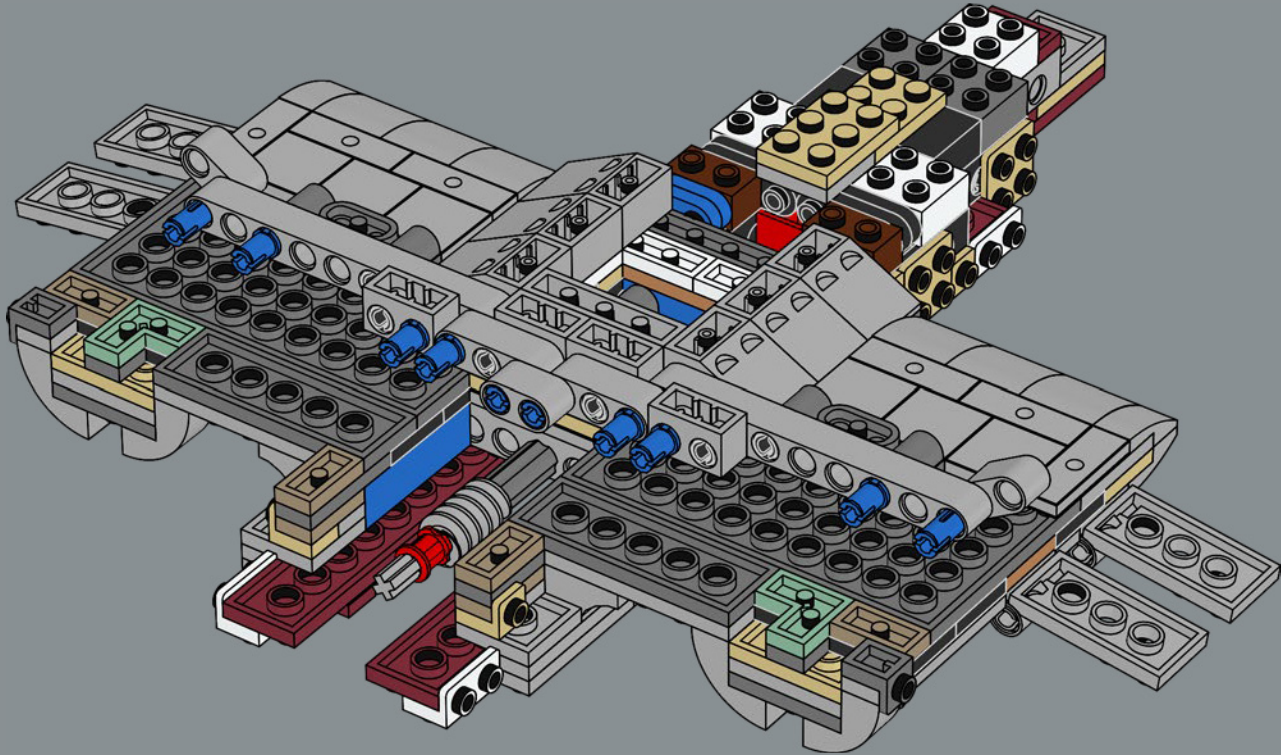

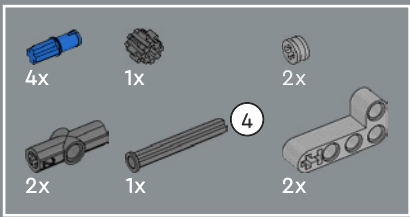

77

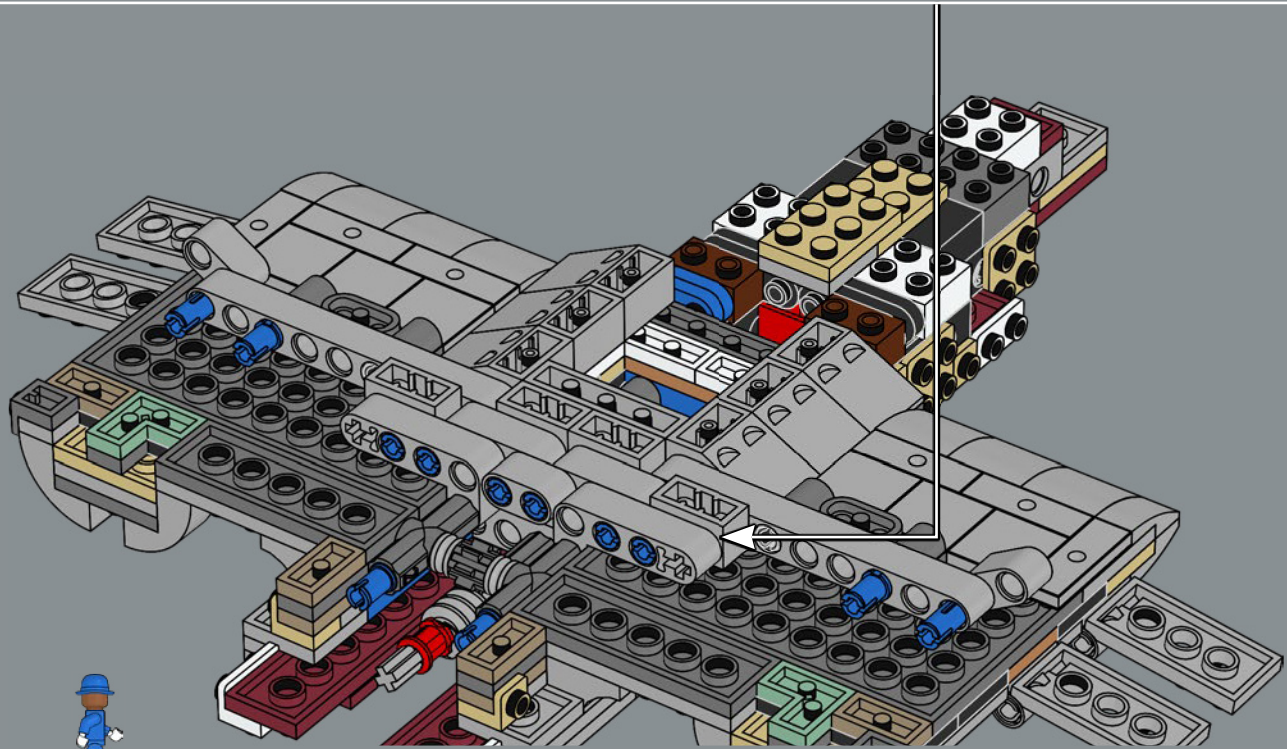
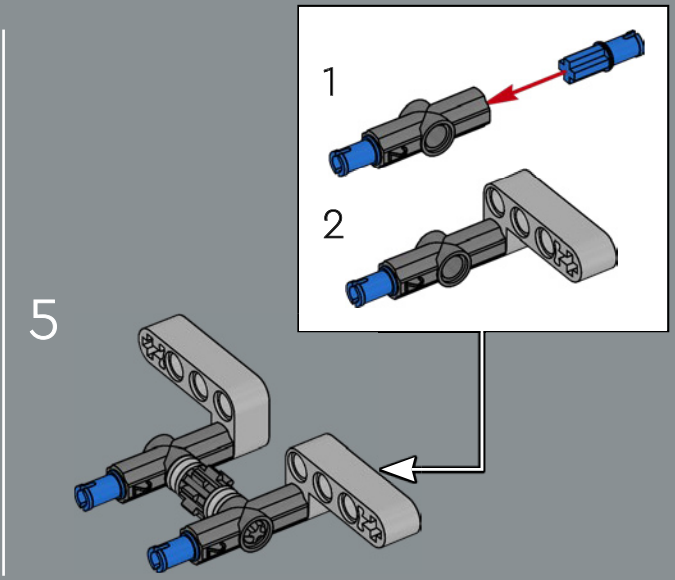
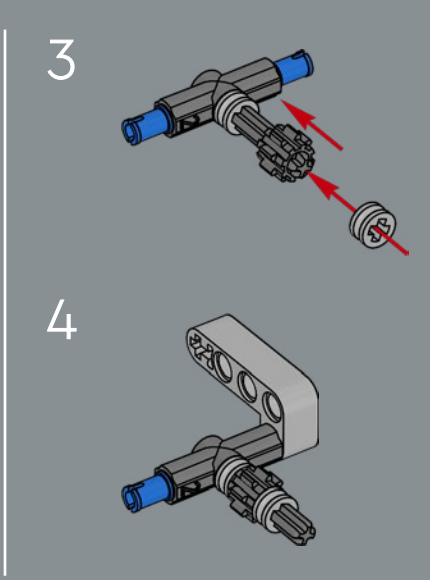
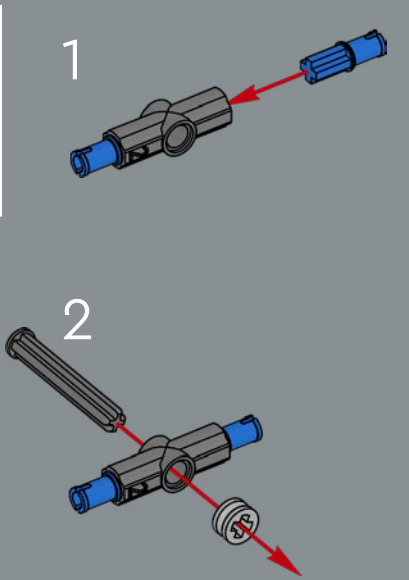

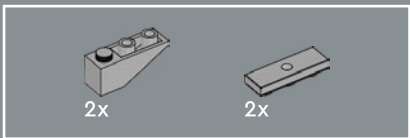

78

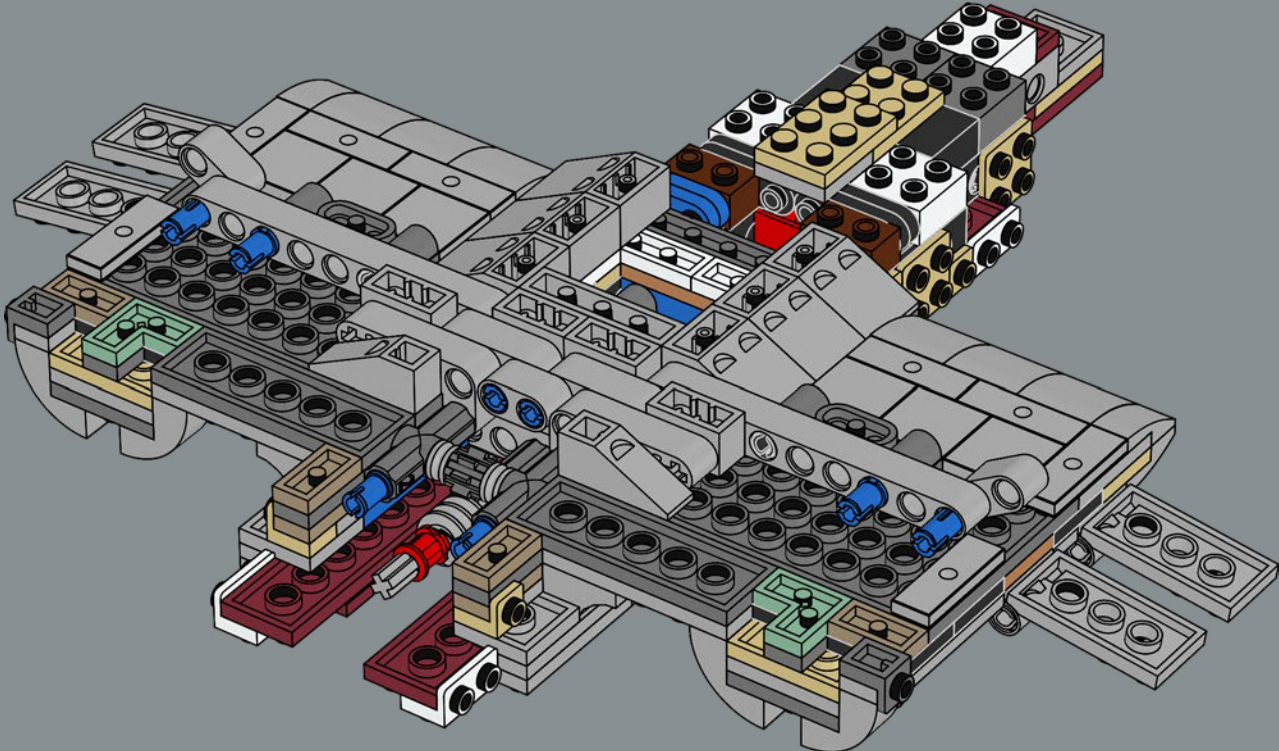

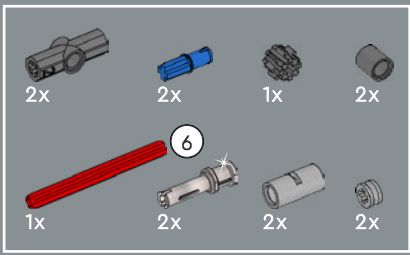

79

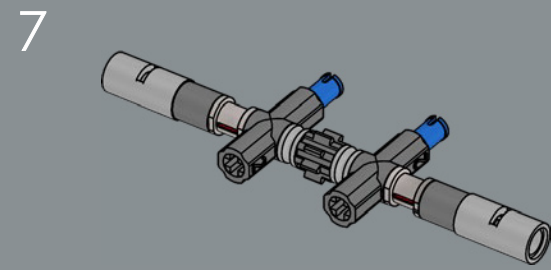
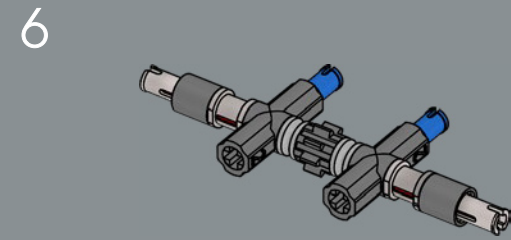
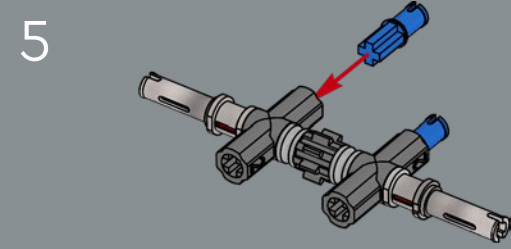
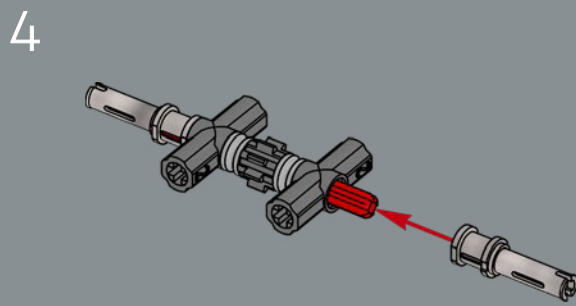
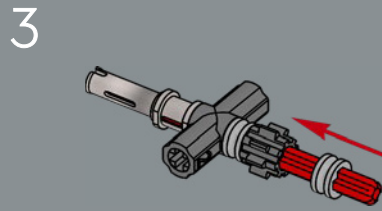
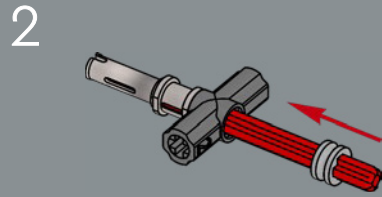
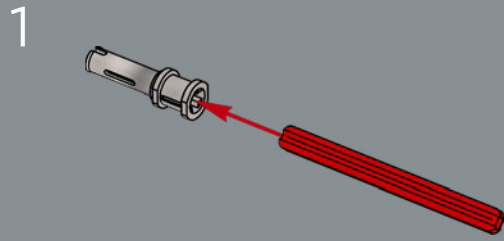

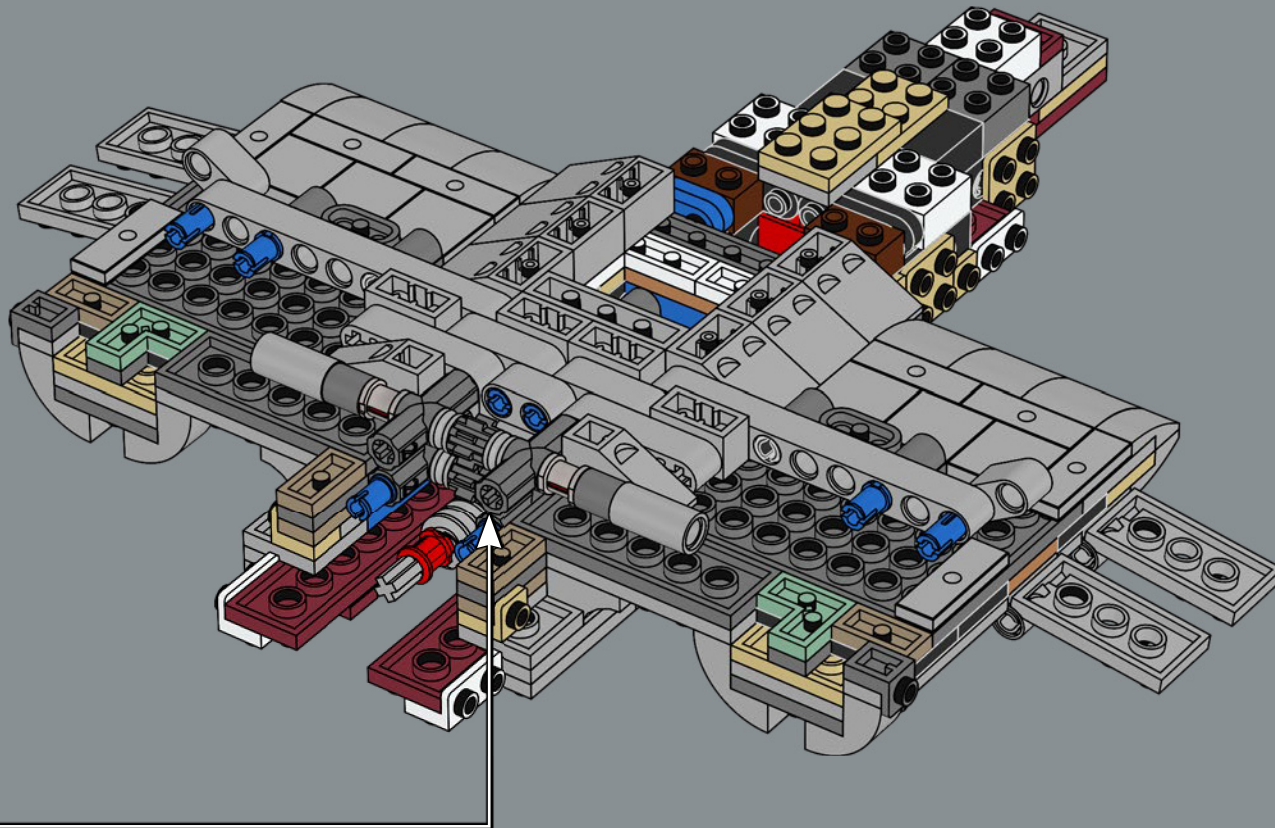



2x

80

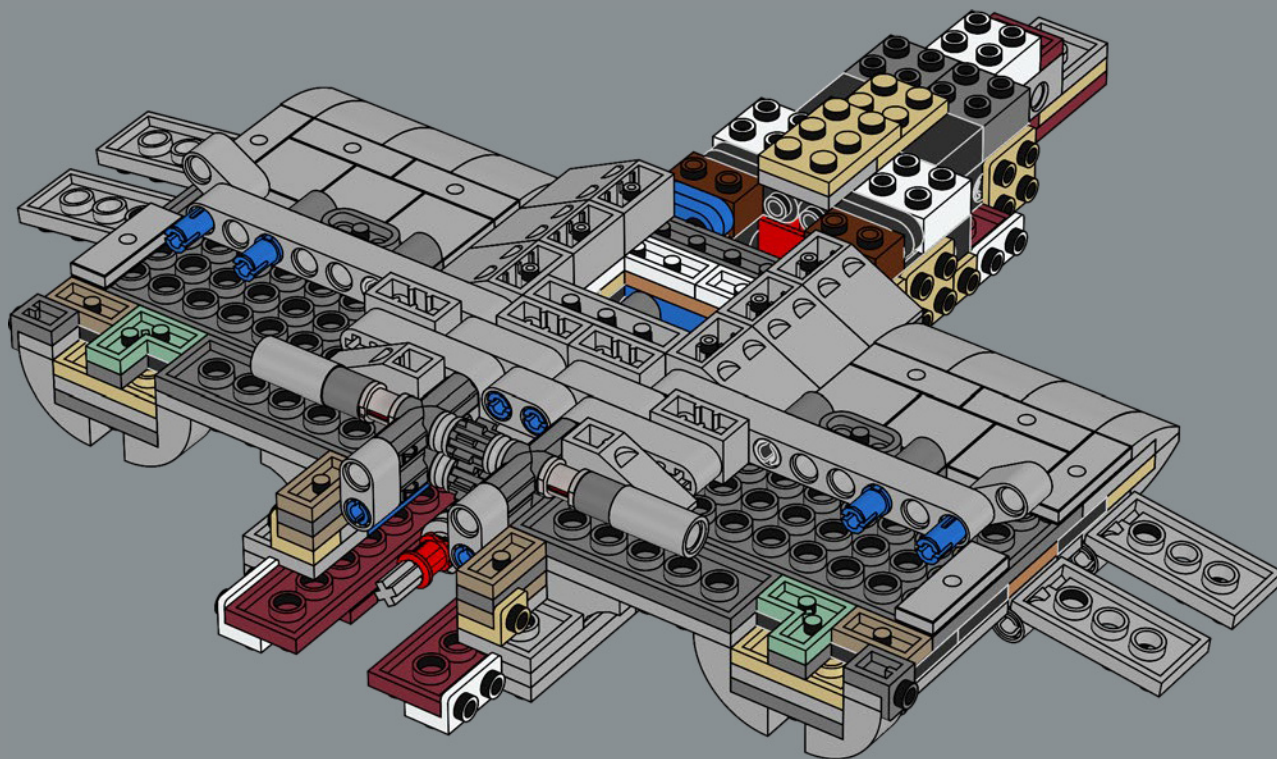

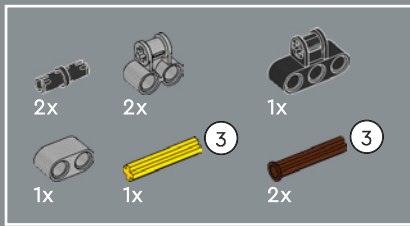

81

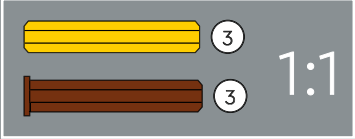
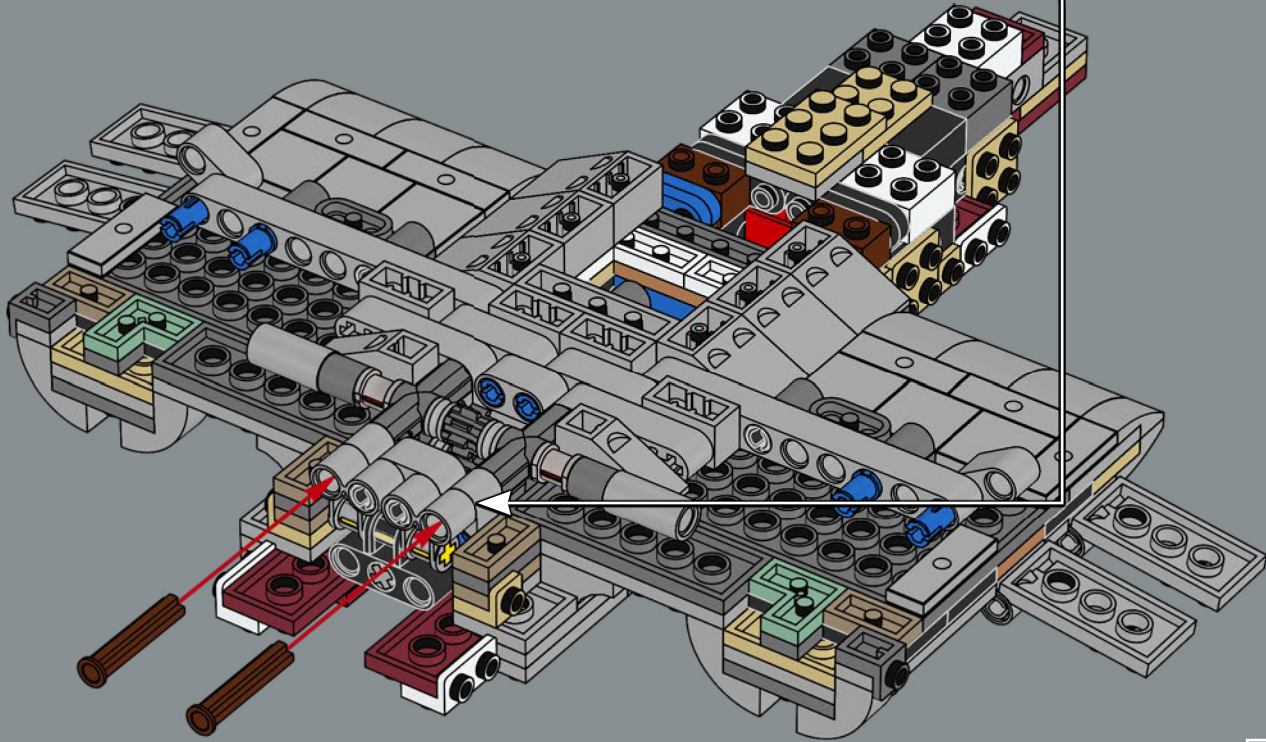
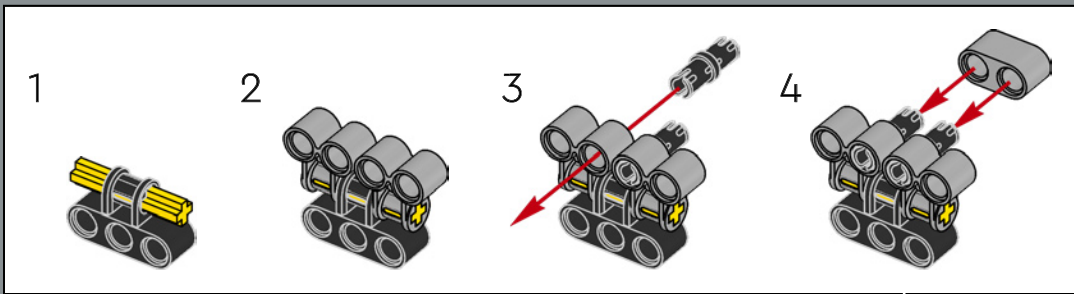

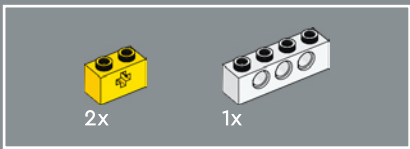

82

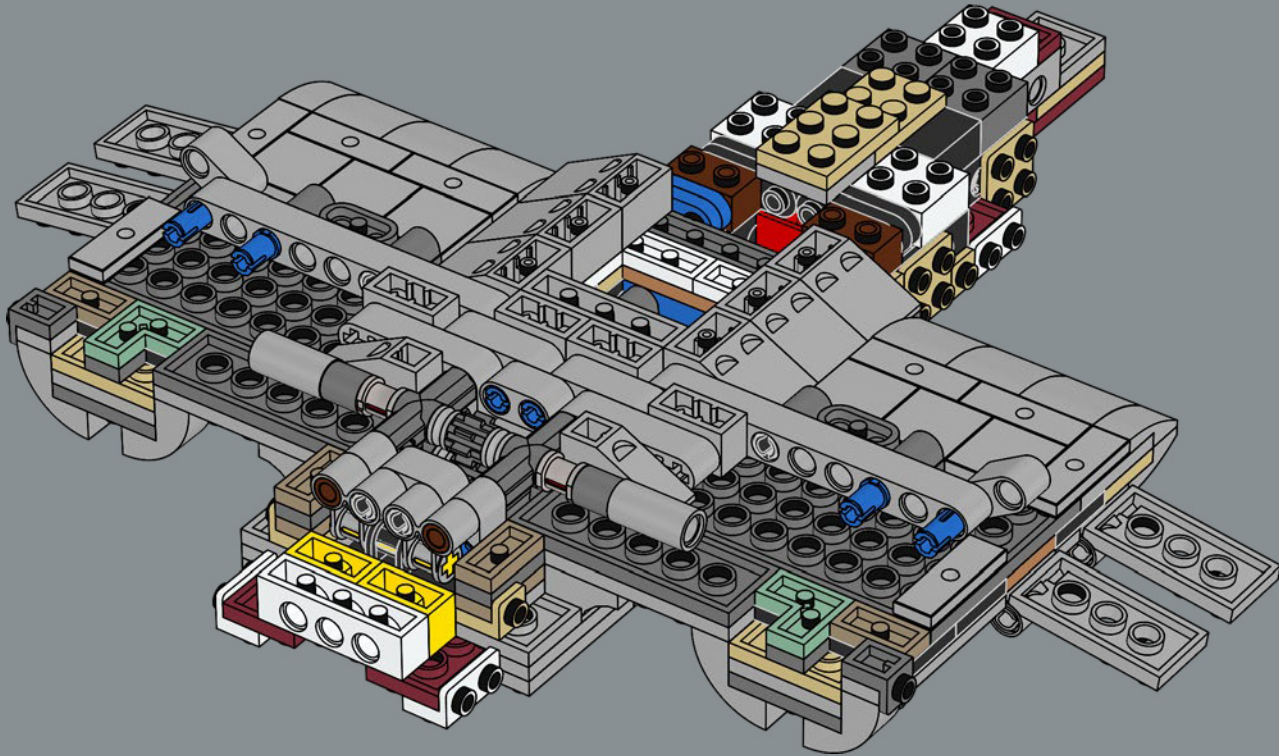

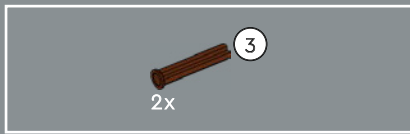

83

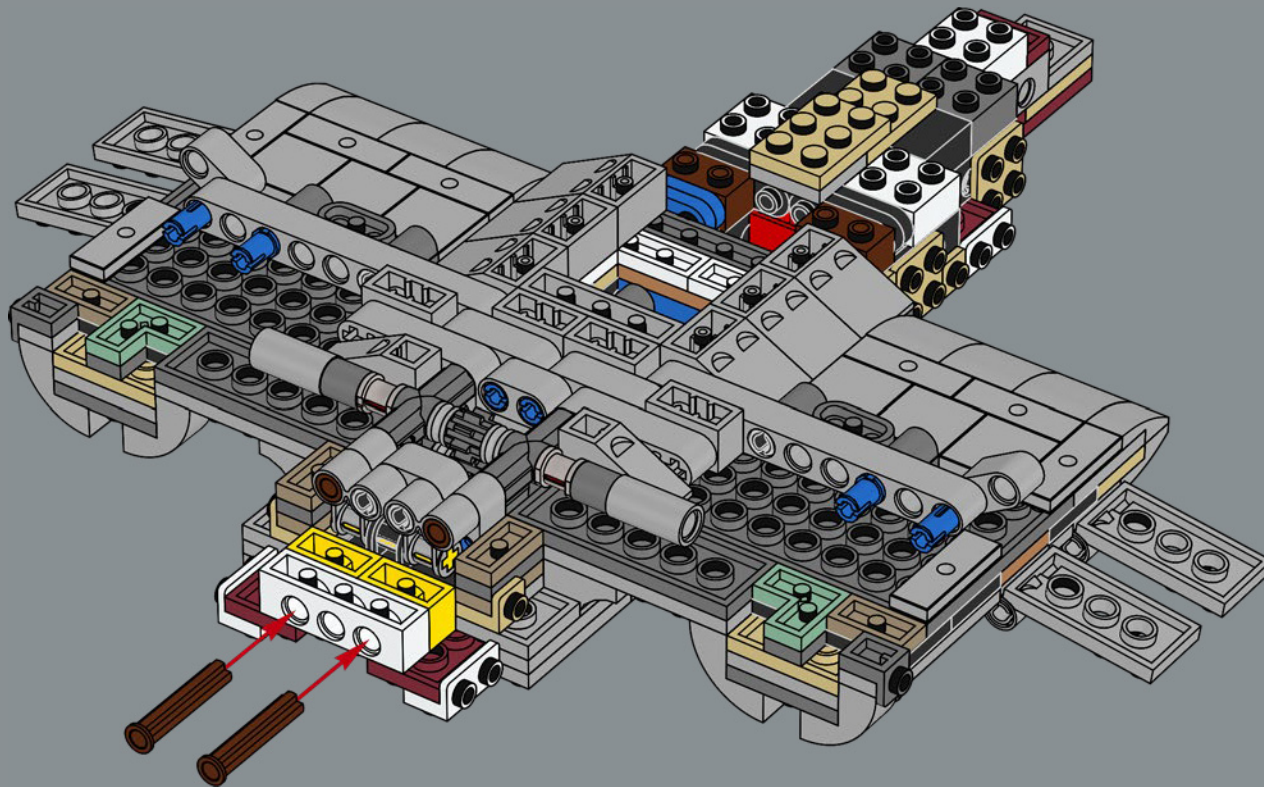

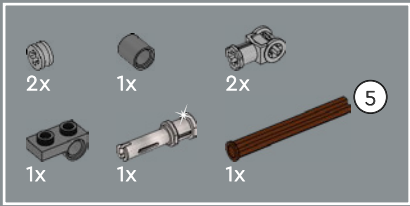

84

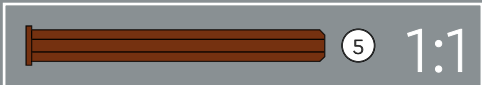
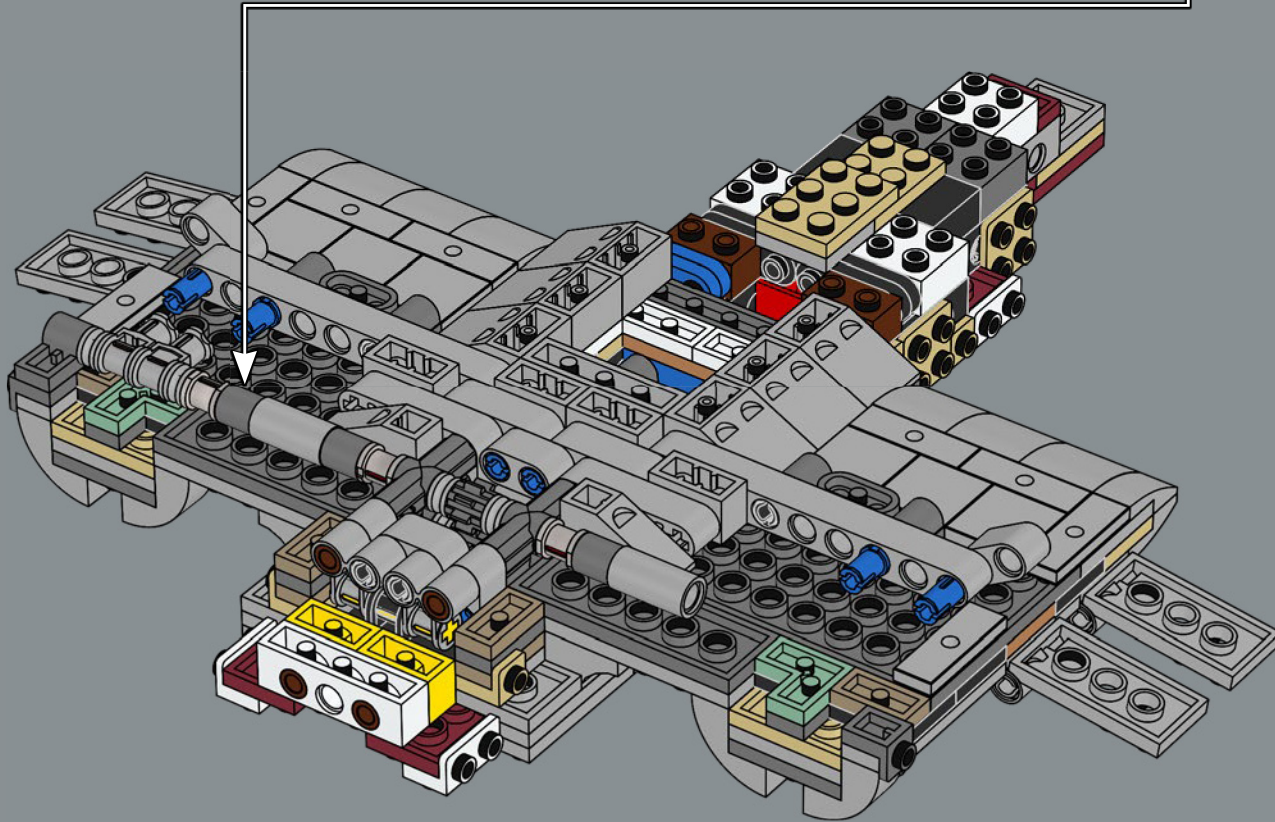
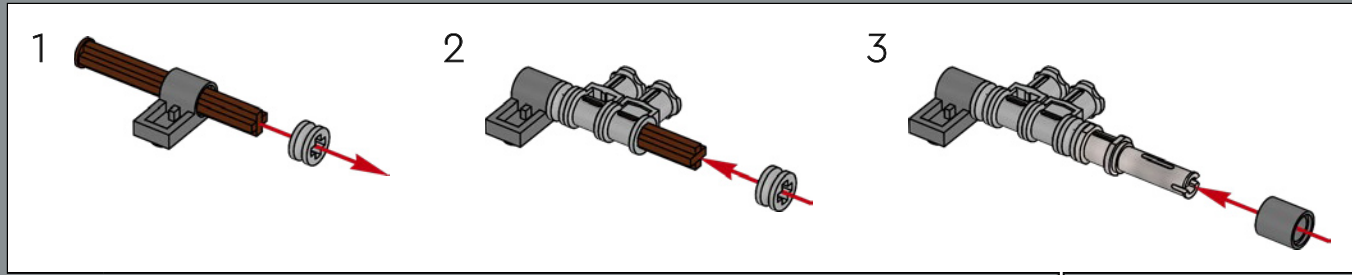

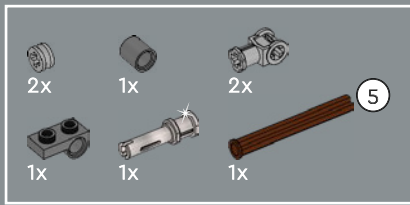

85

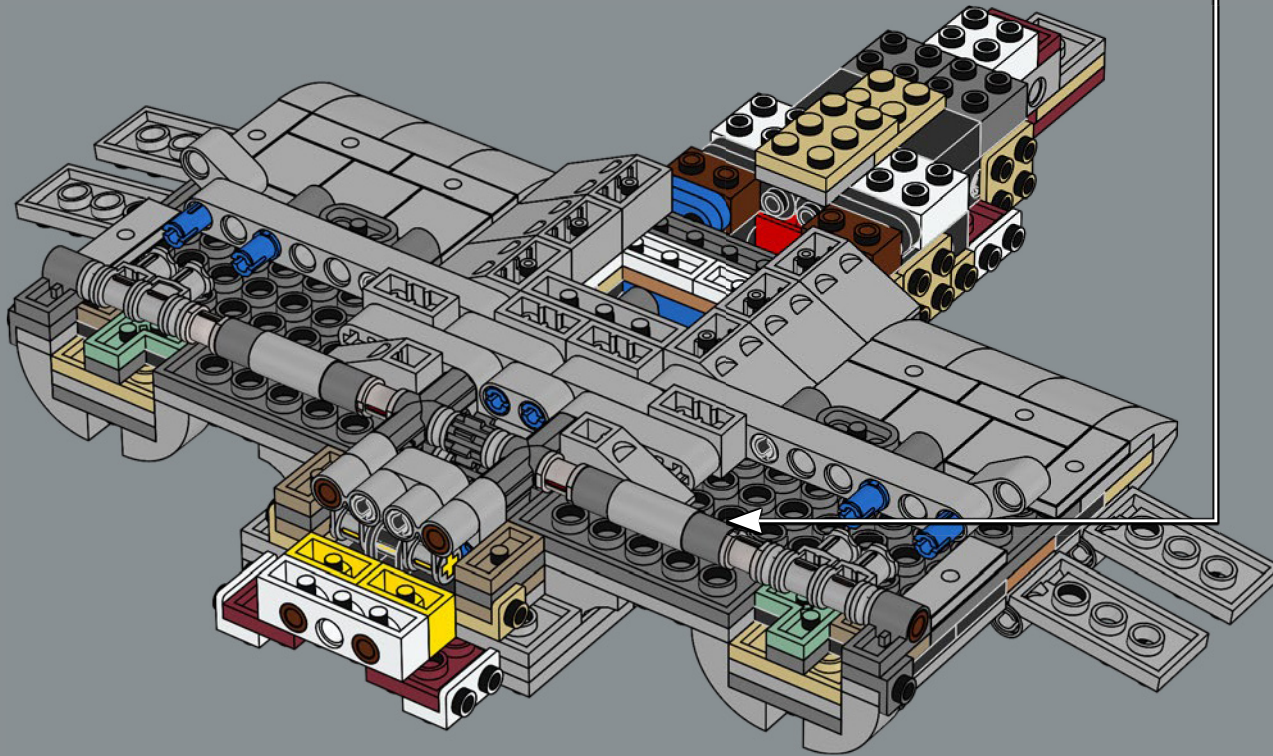
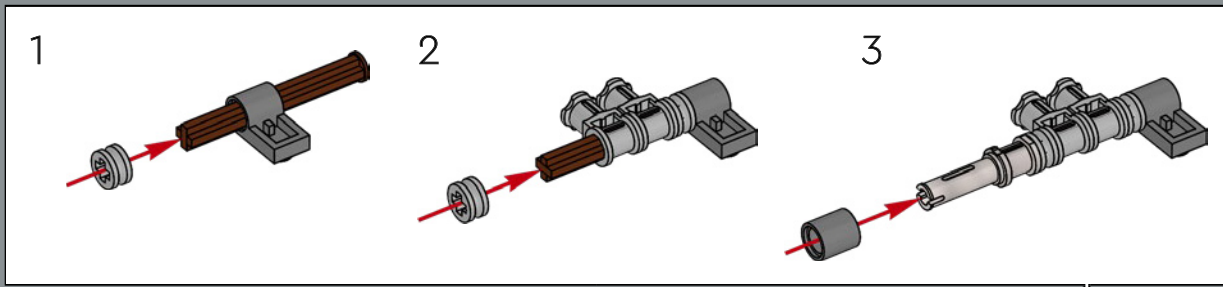

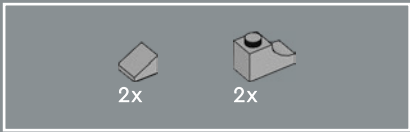

86

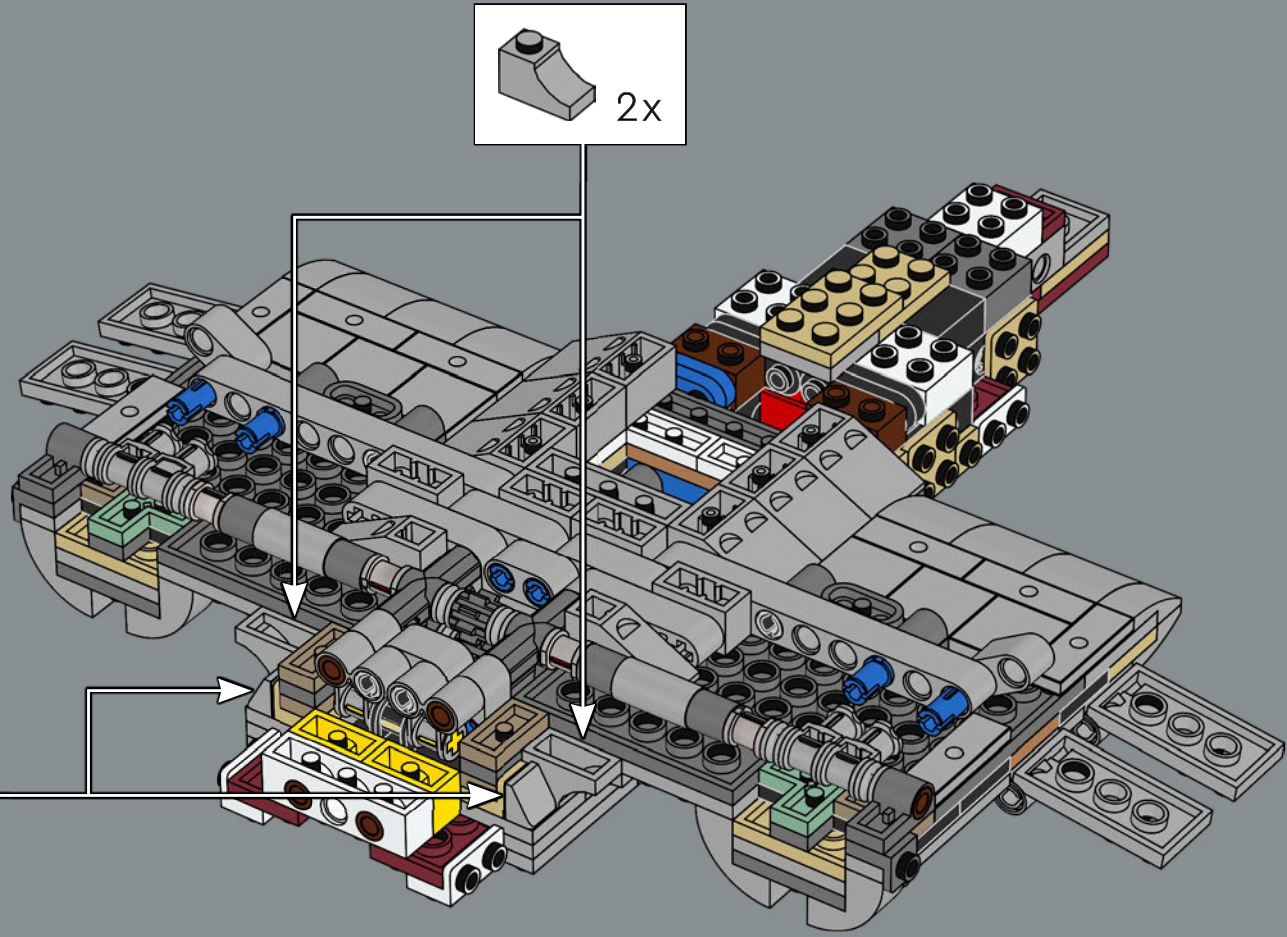
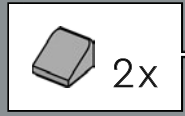
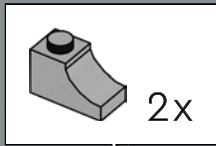



87

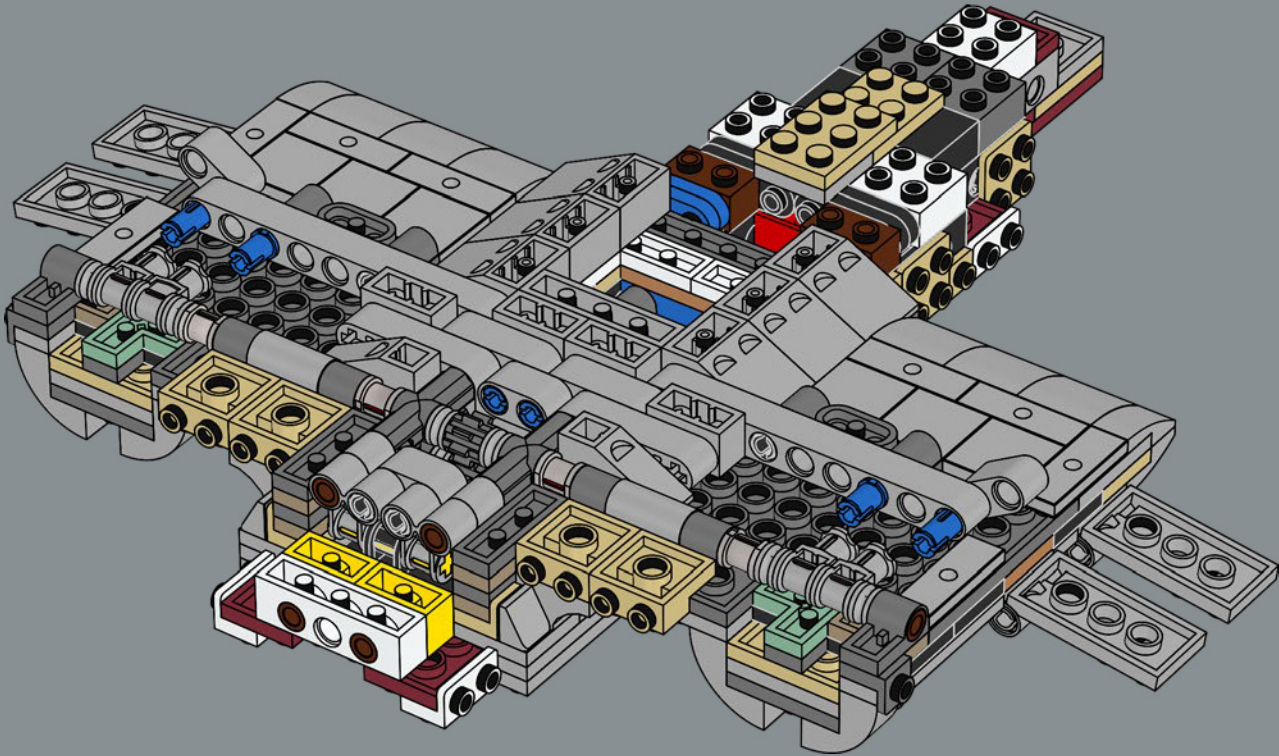



88

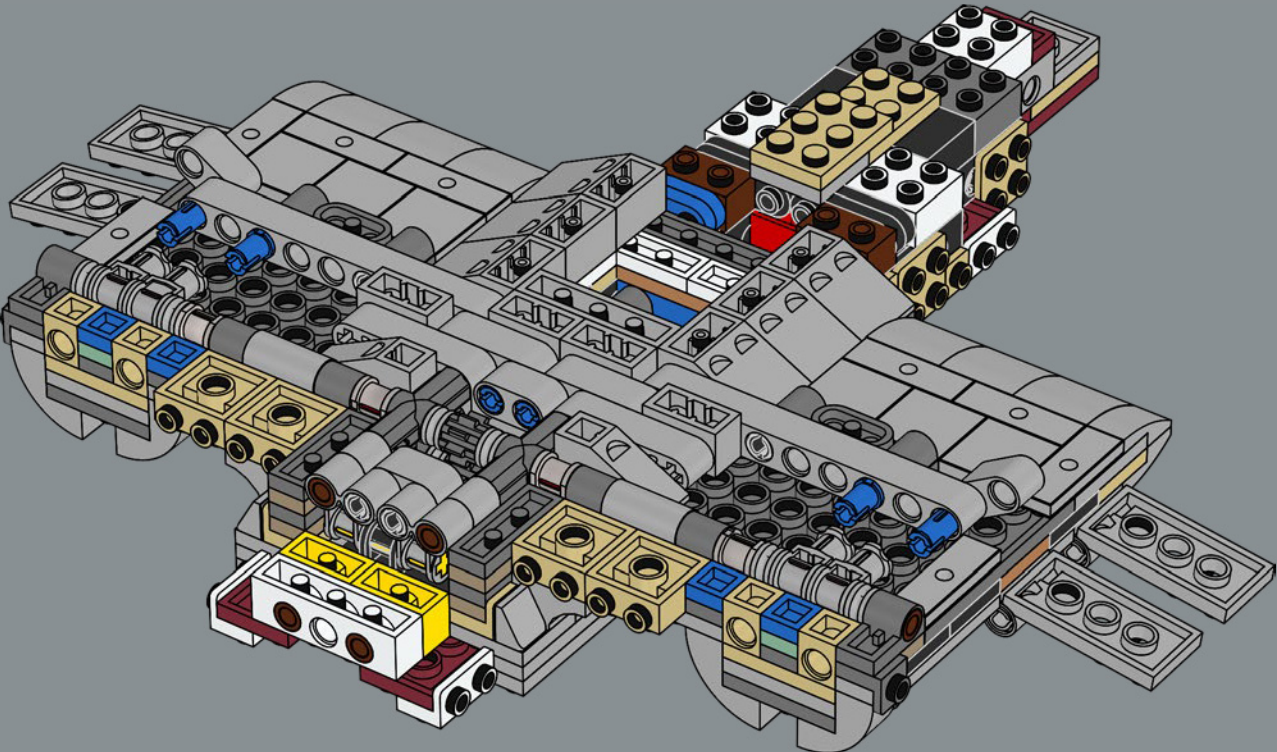

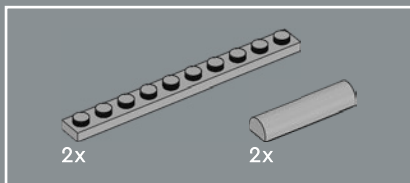

89

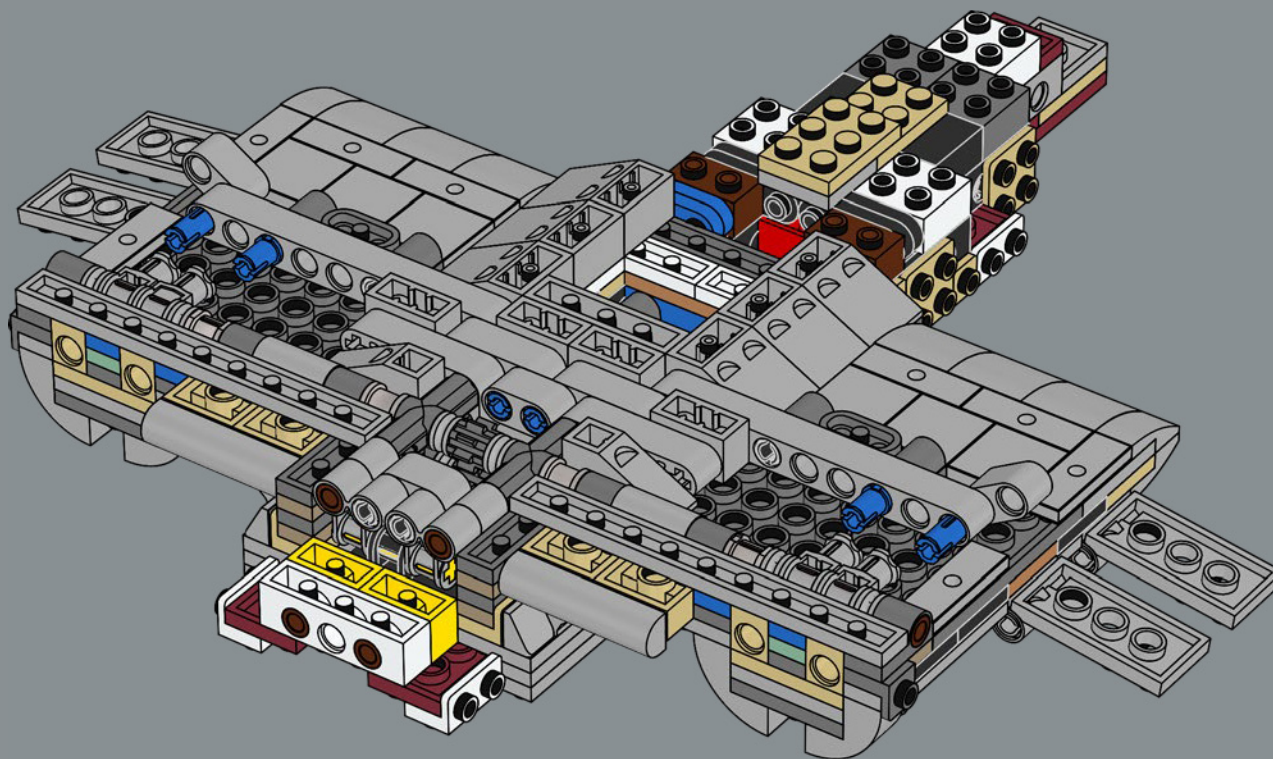

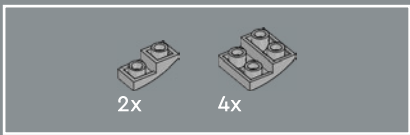

90

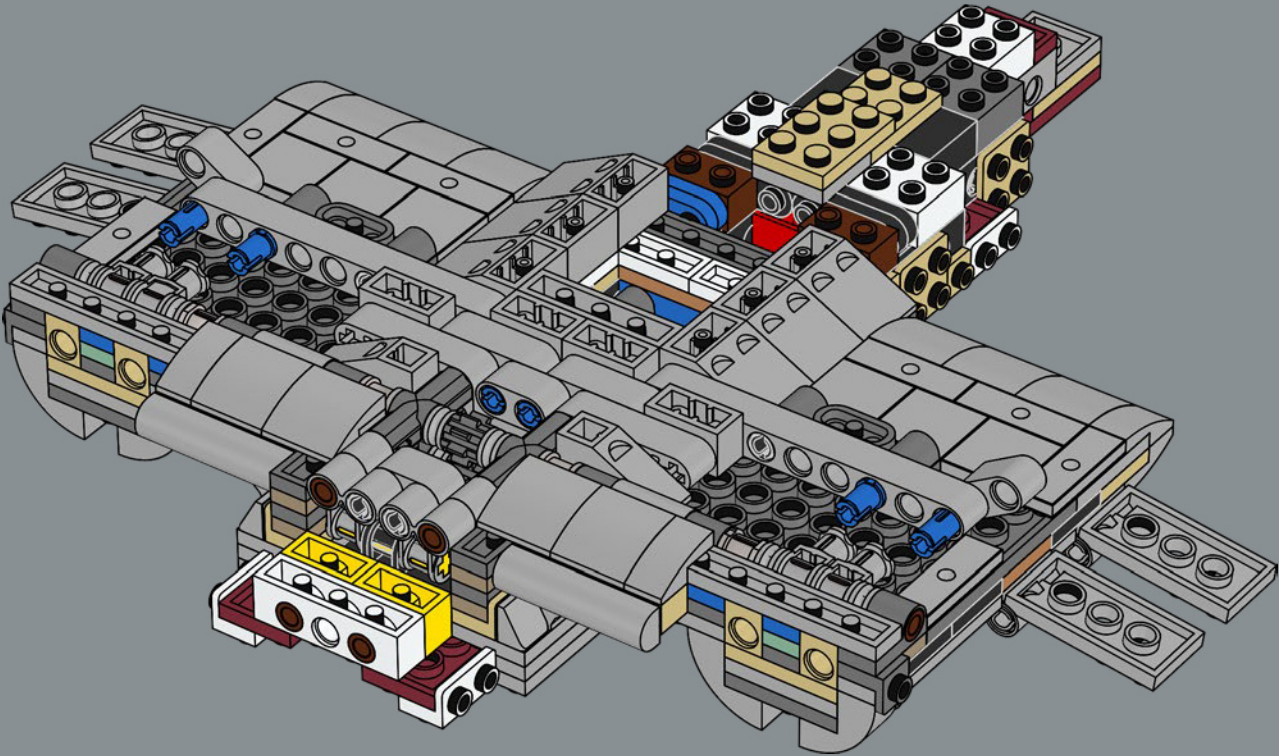

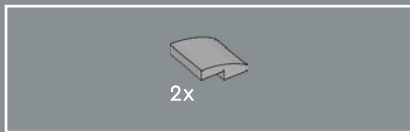

91

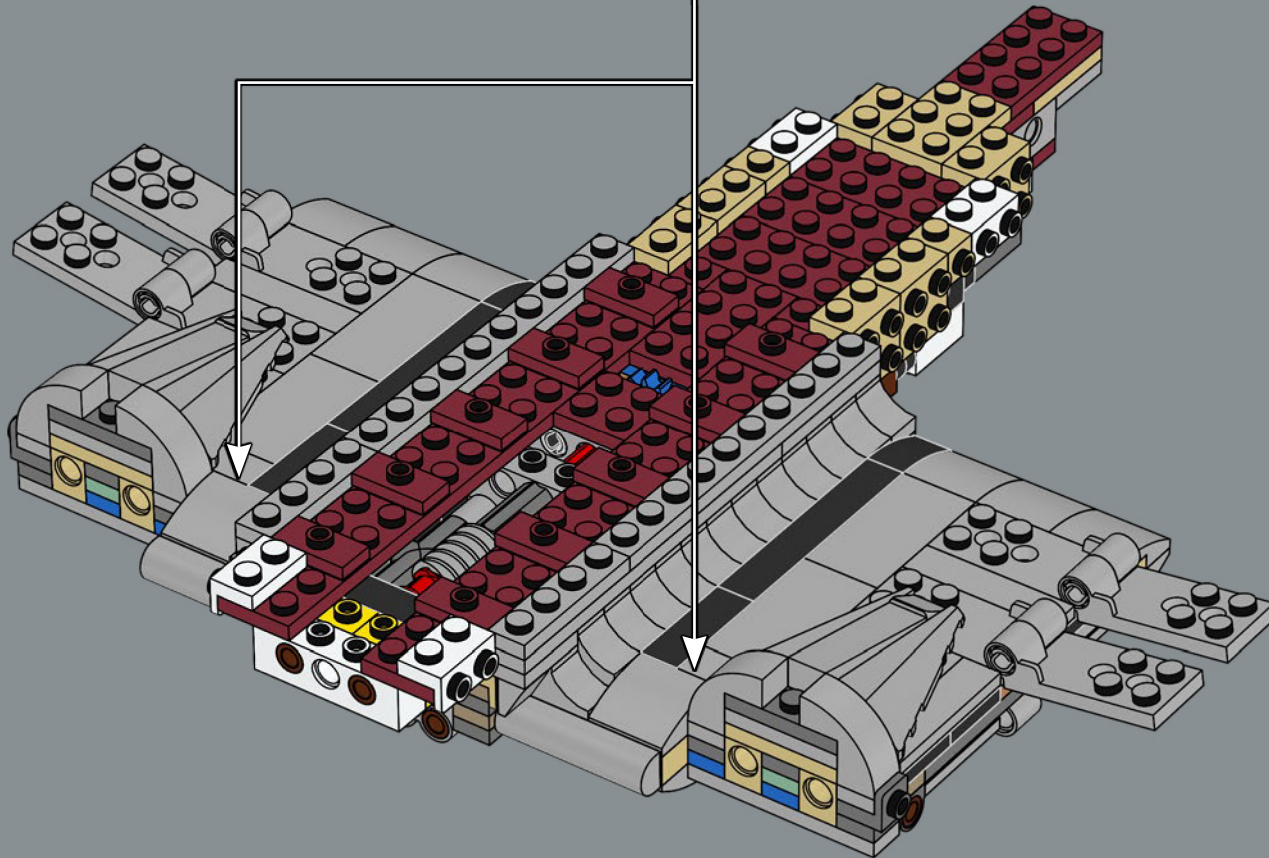
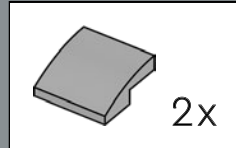



Les illustrations couleur du DC-3™ sont rares. Le partage par Boeing d'une illustration colorée de la cabine issue de ses archives a donc été un véritable privilège ! Elle révèle un intérieur avec une moquette rouge foncé et des sièges bleu sable.

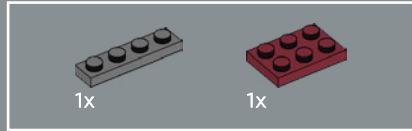

92

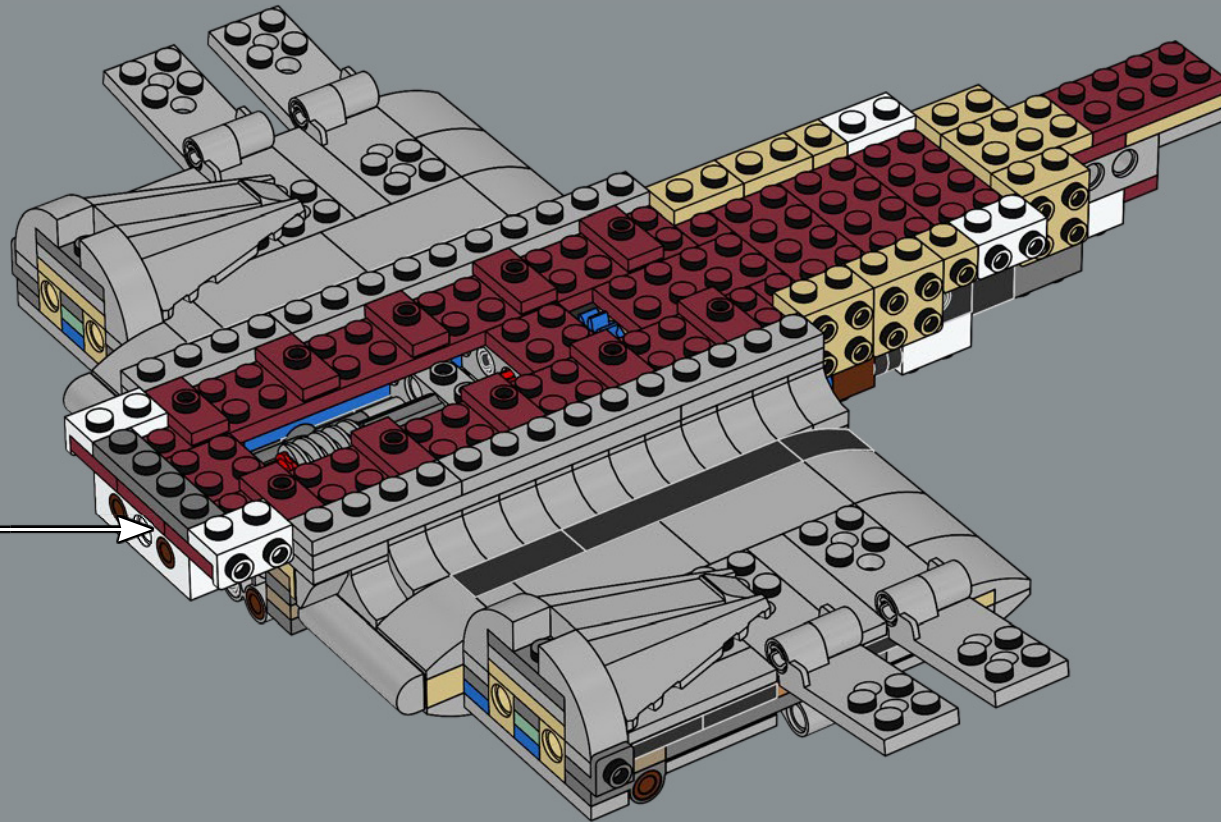
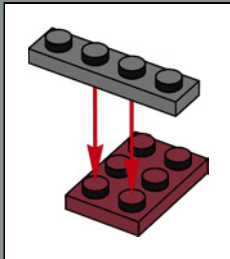

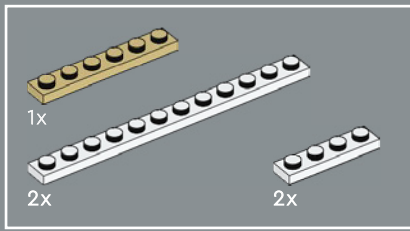

93

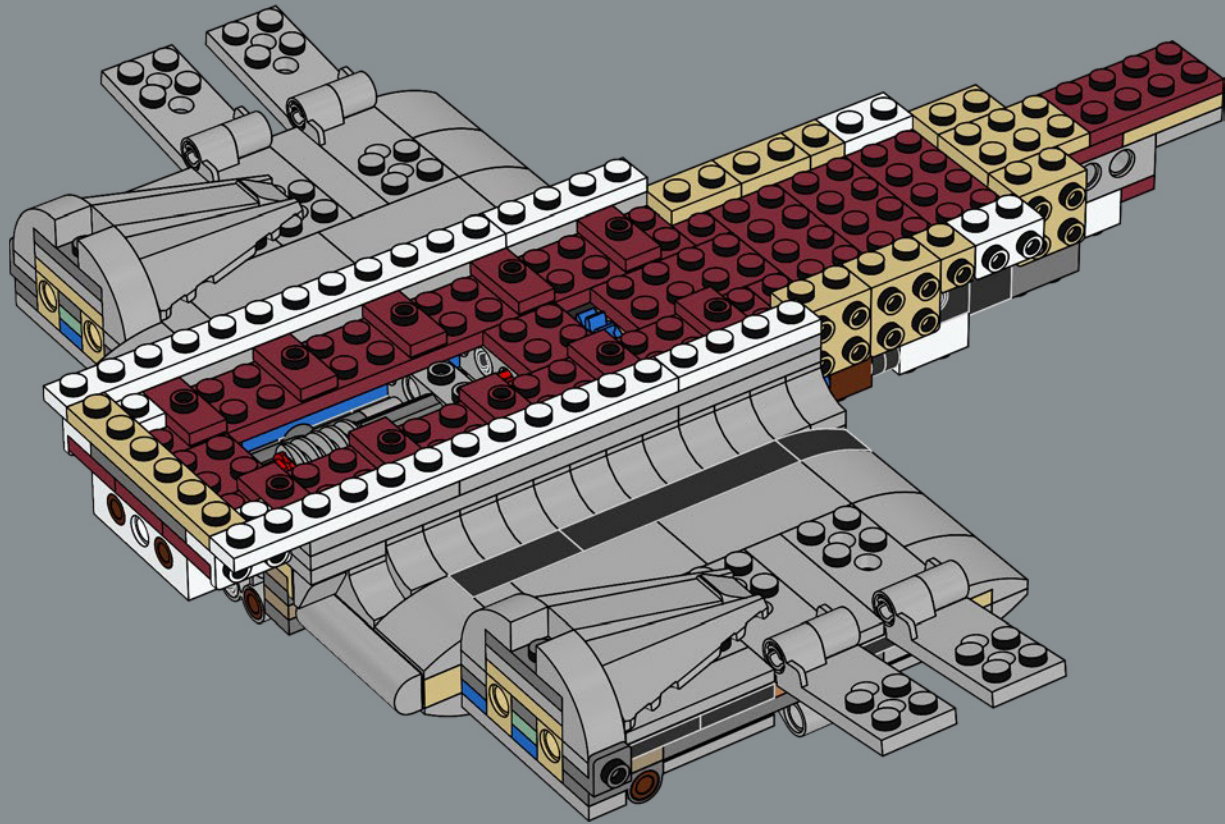

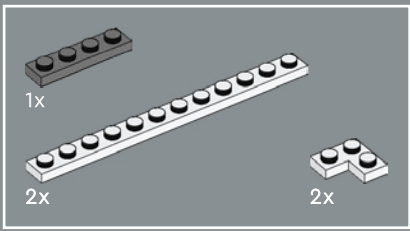

94

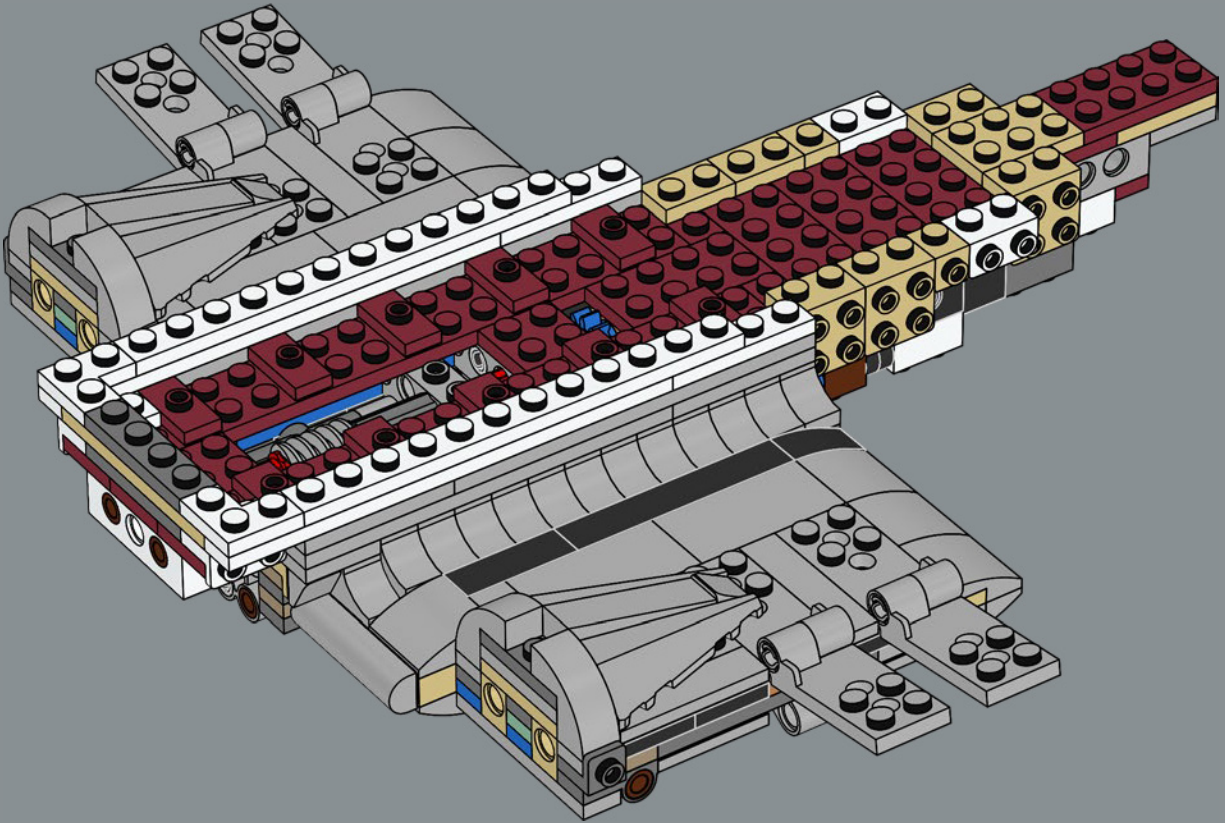

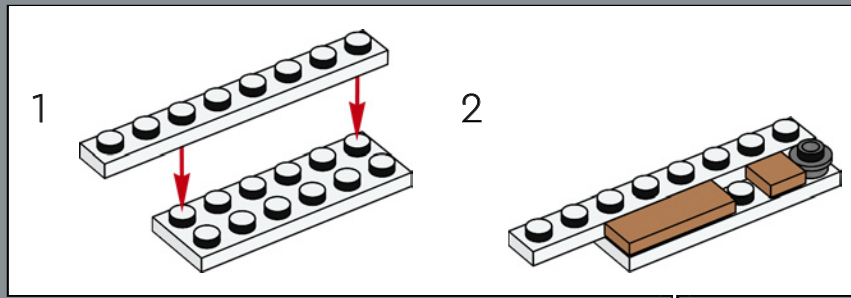
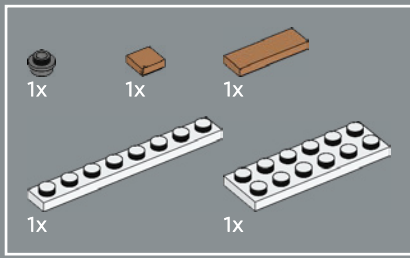

95

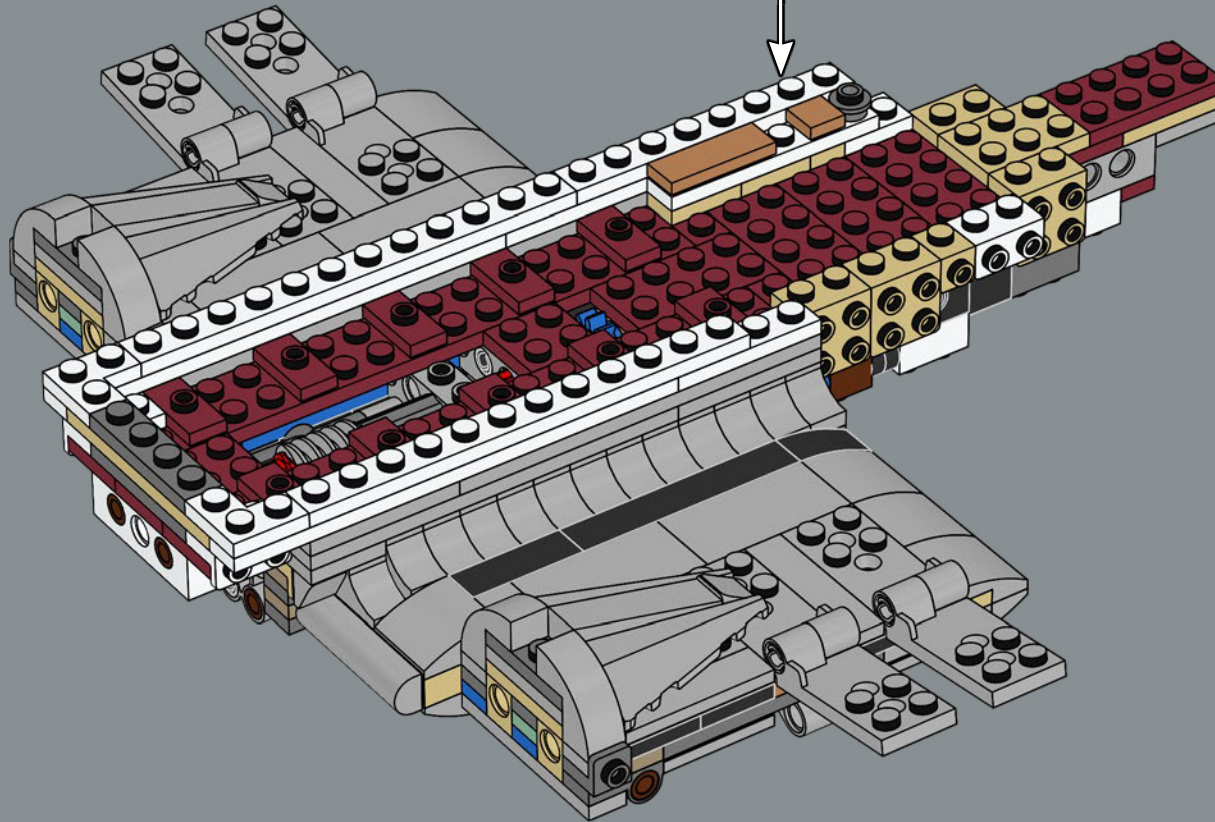

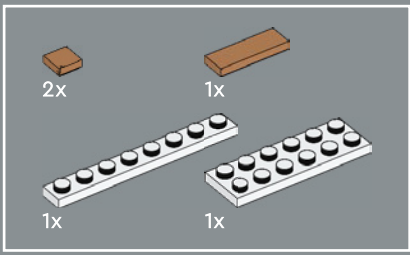

96

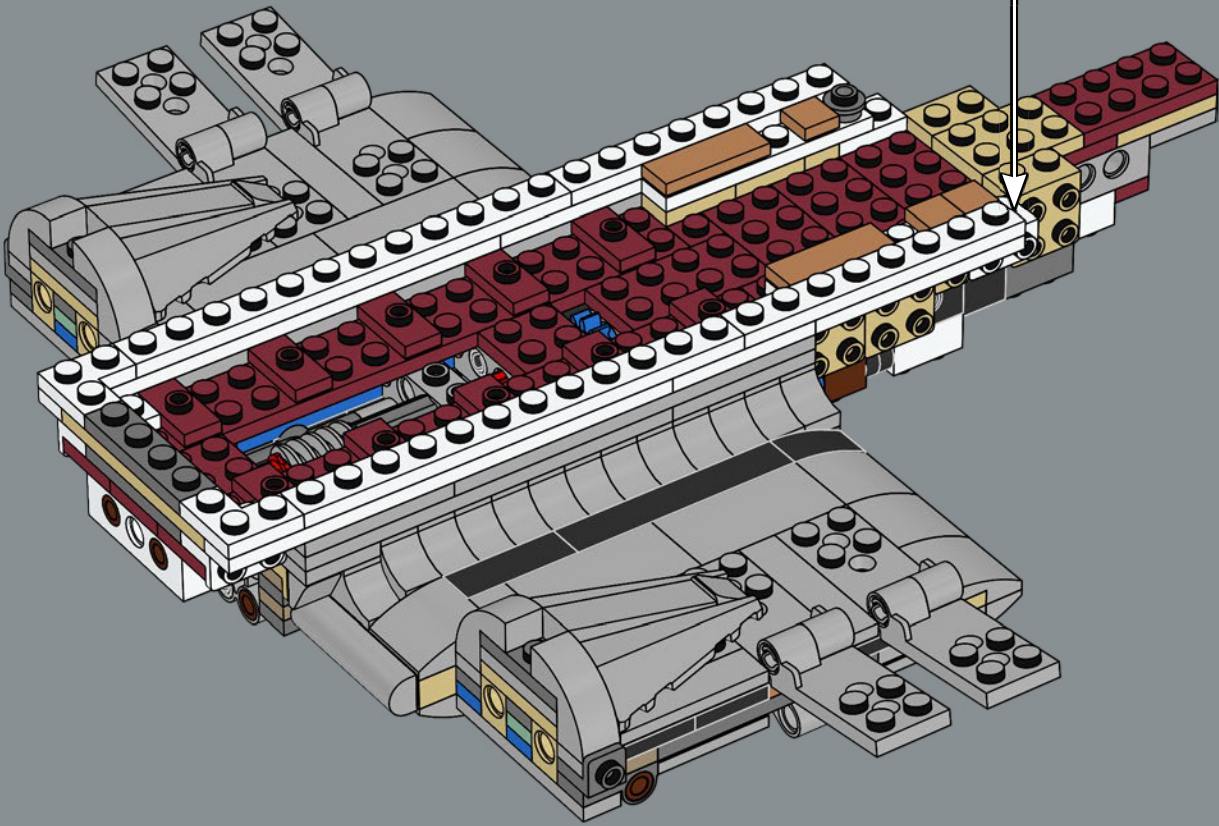
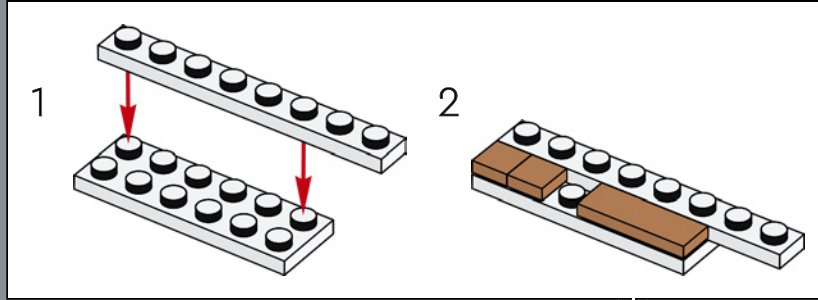

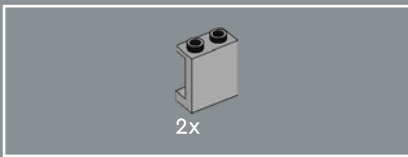

97

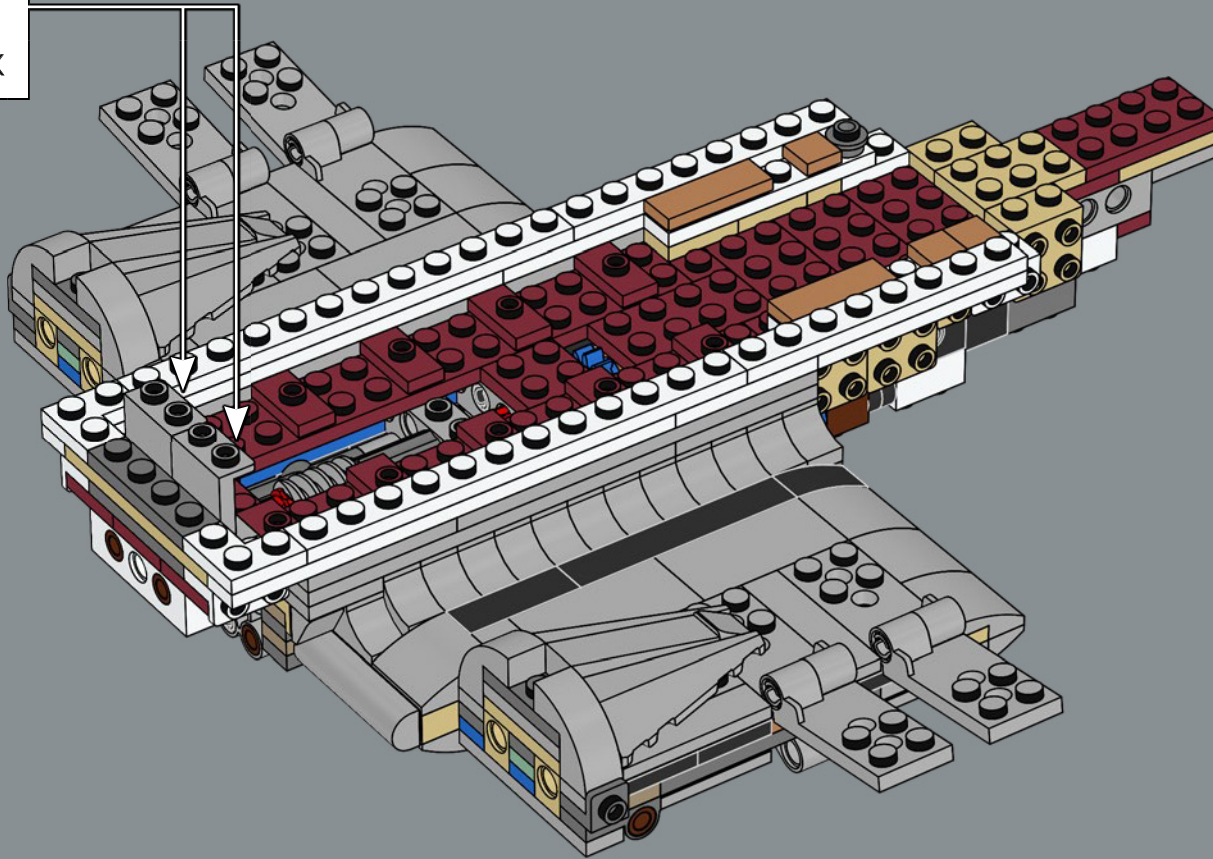
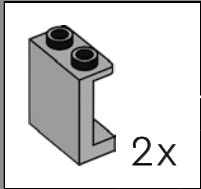

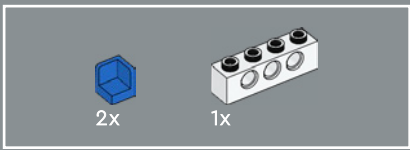



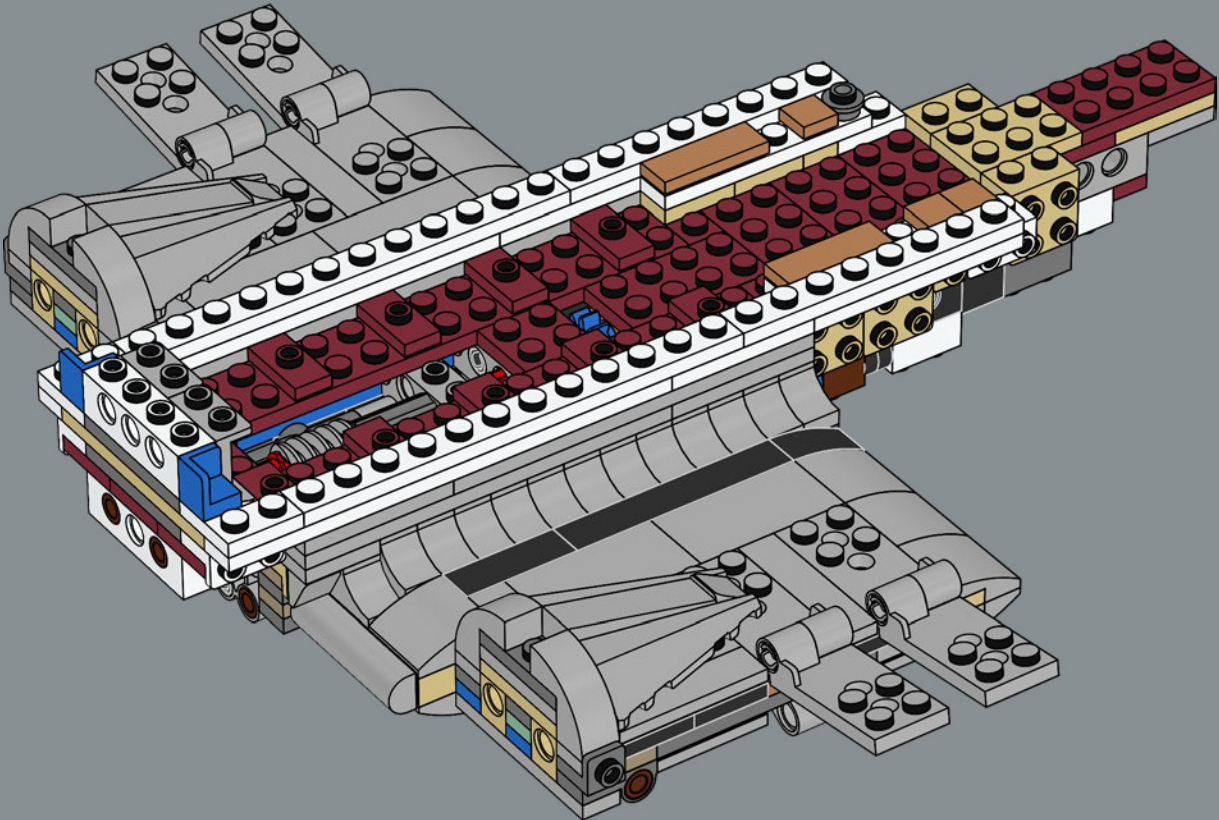

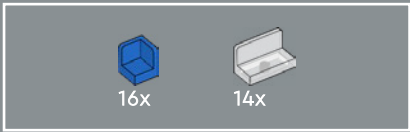
98



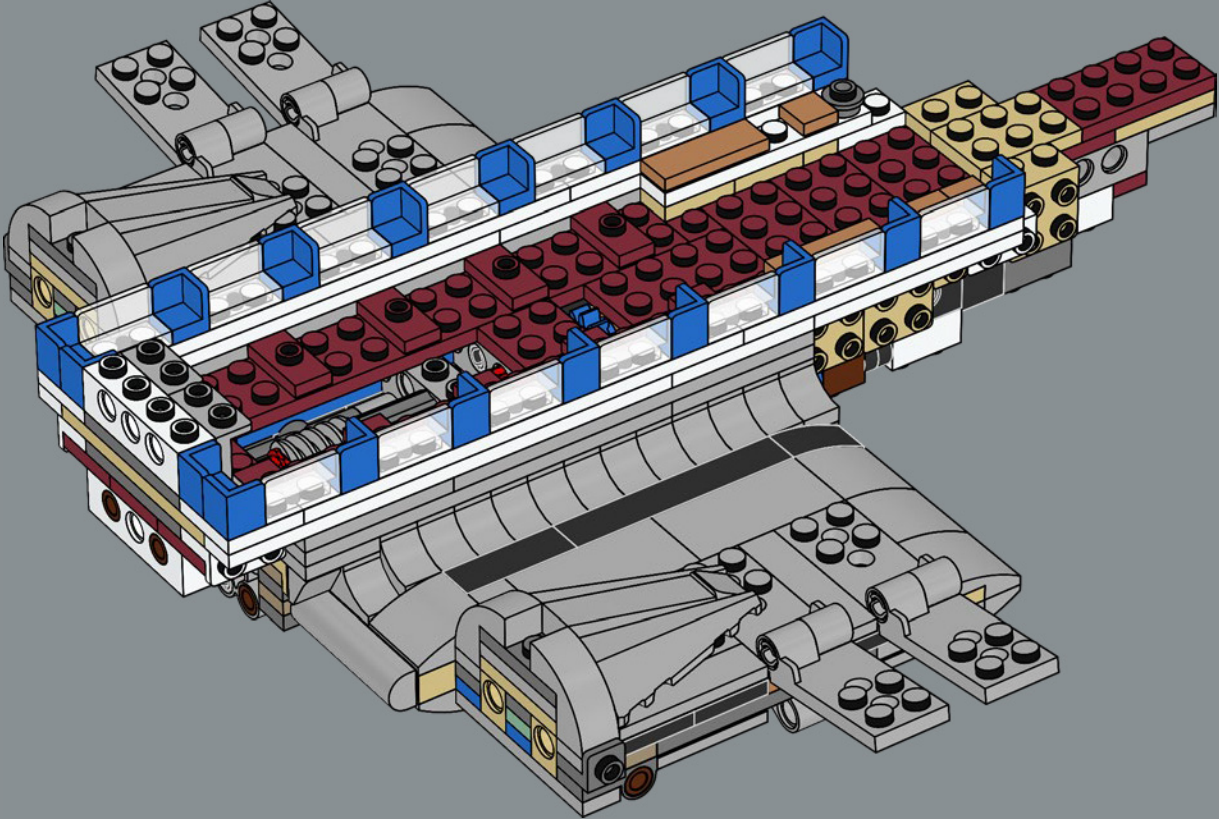

99



- 1x 
- 1x 
- 1x 
- 1x 

100

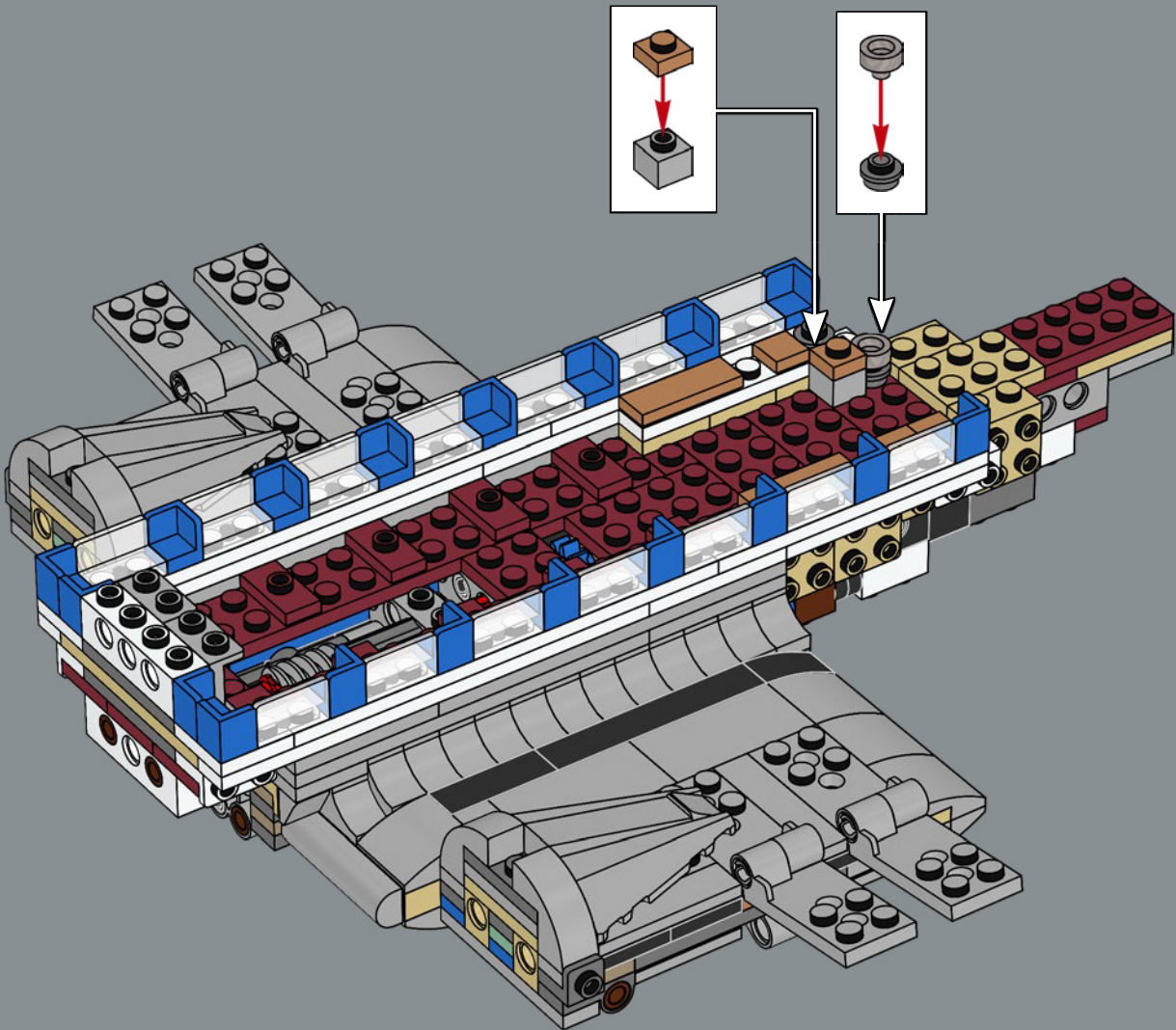

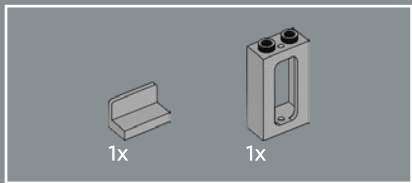

101

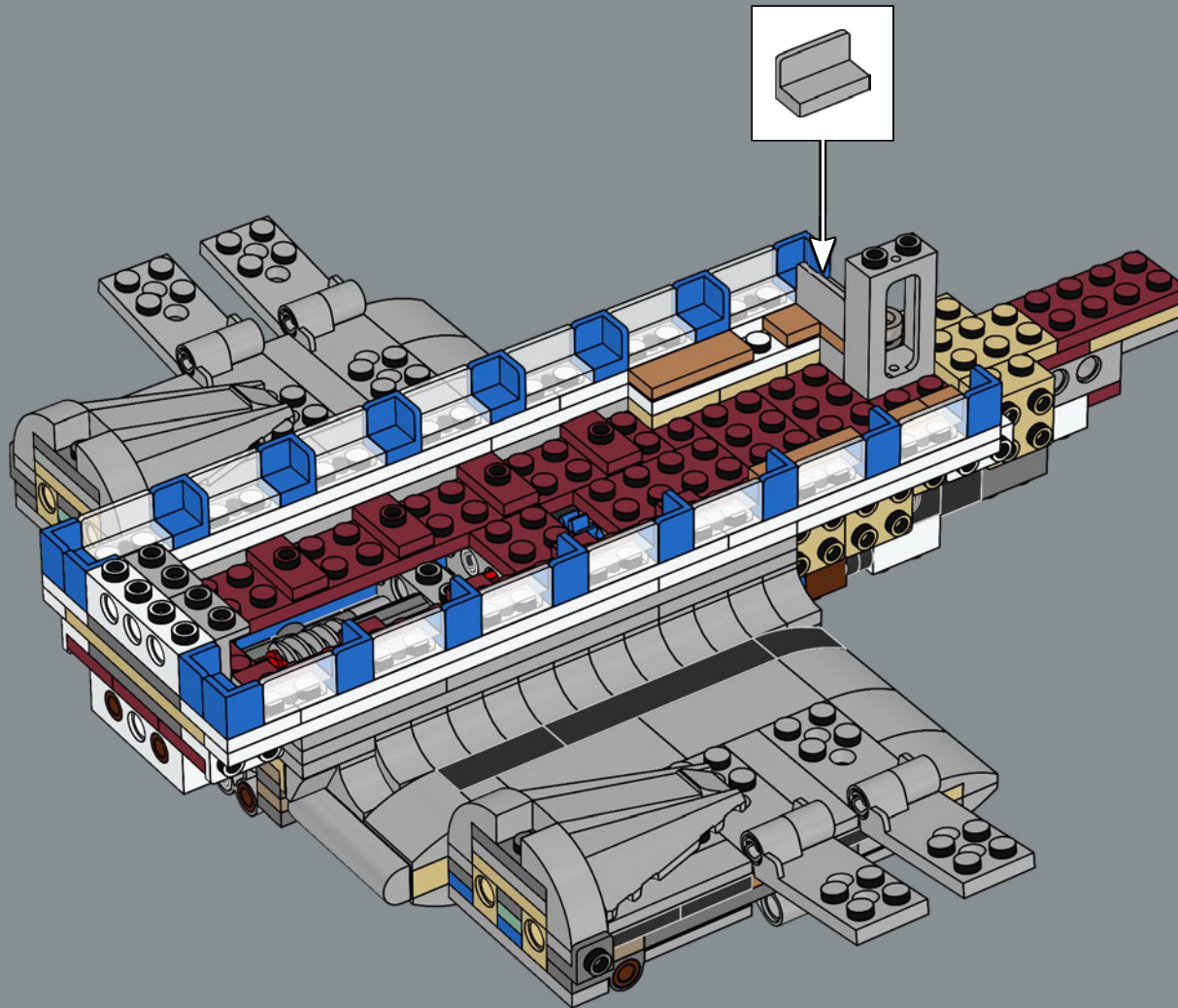

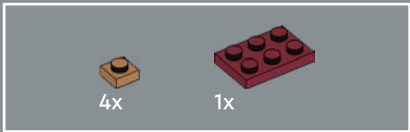

102

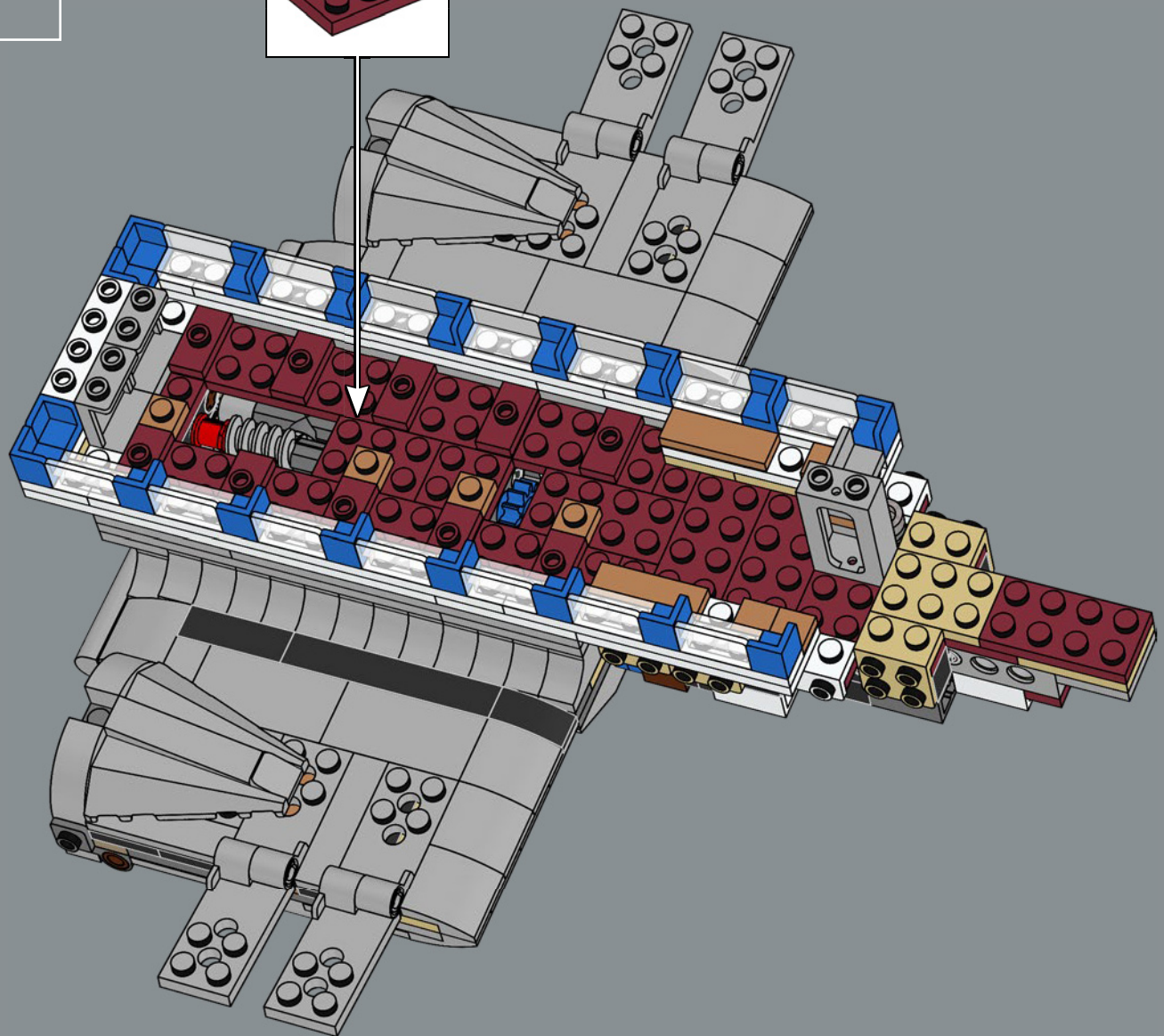
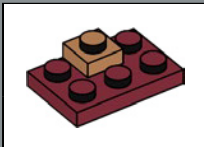

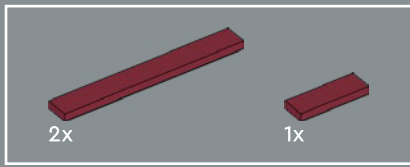

103

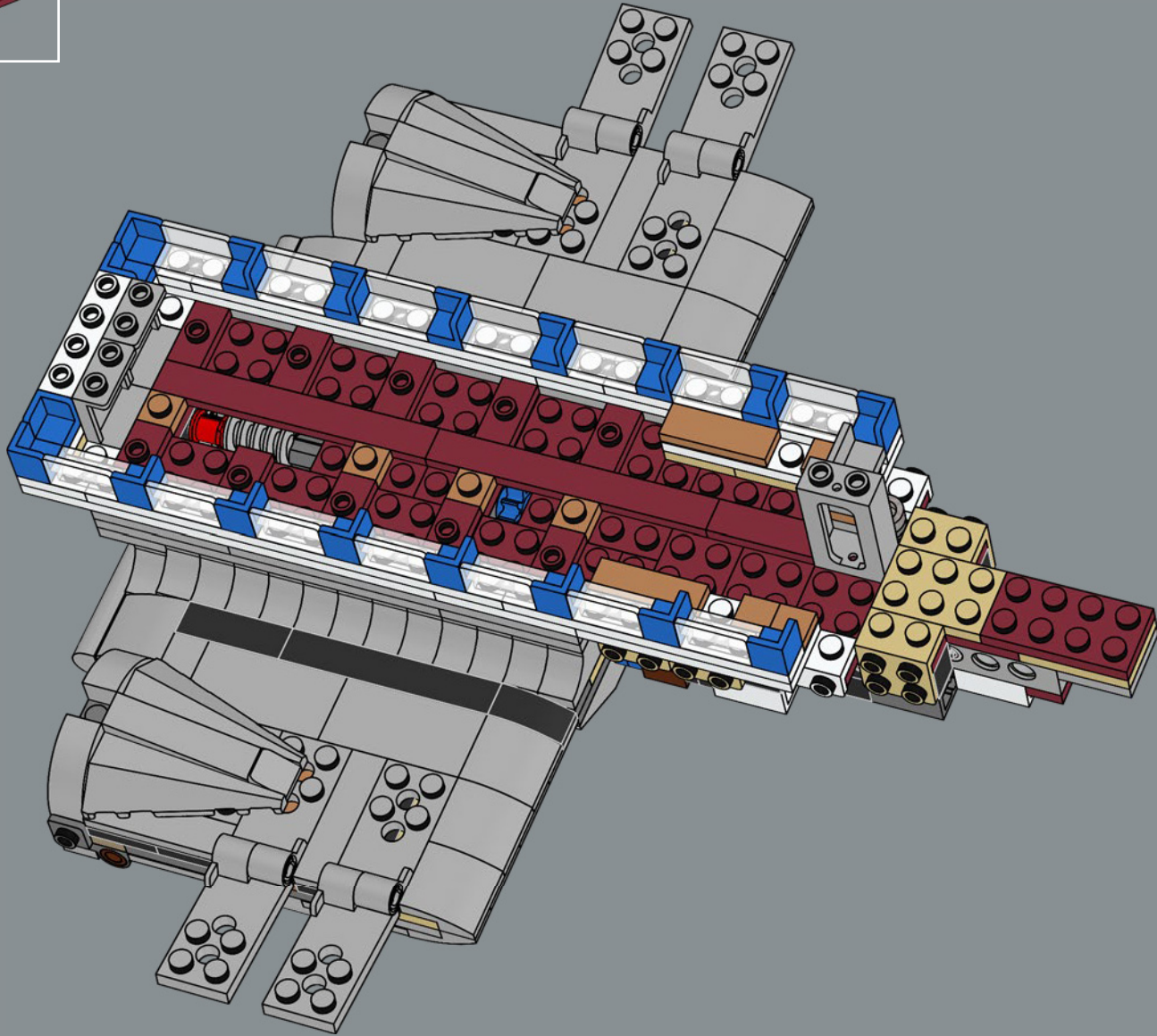



104

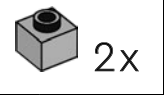
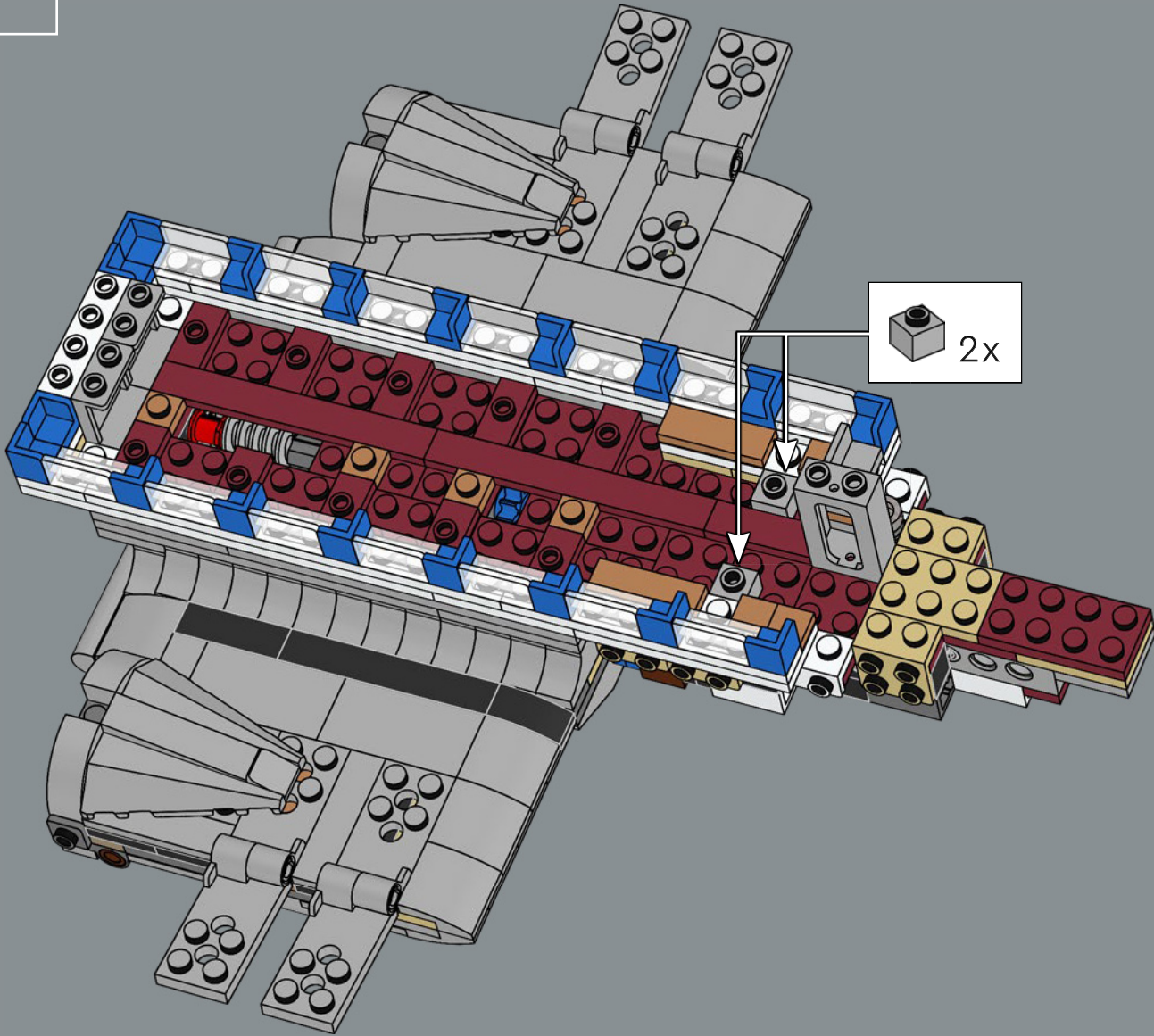

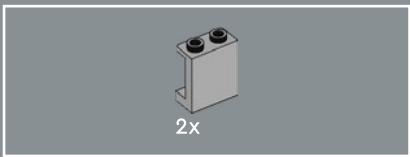

105

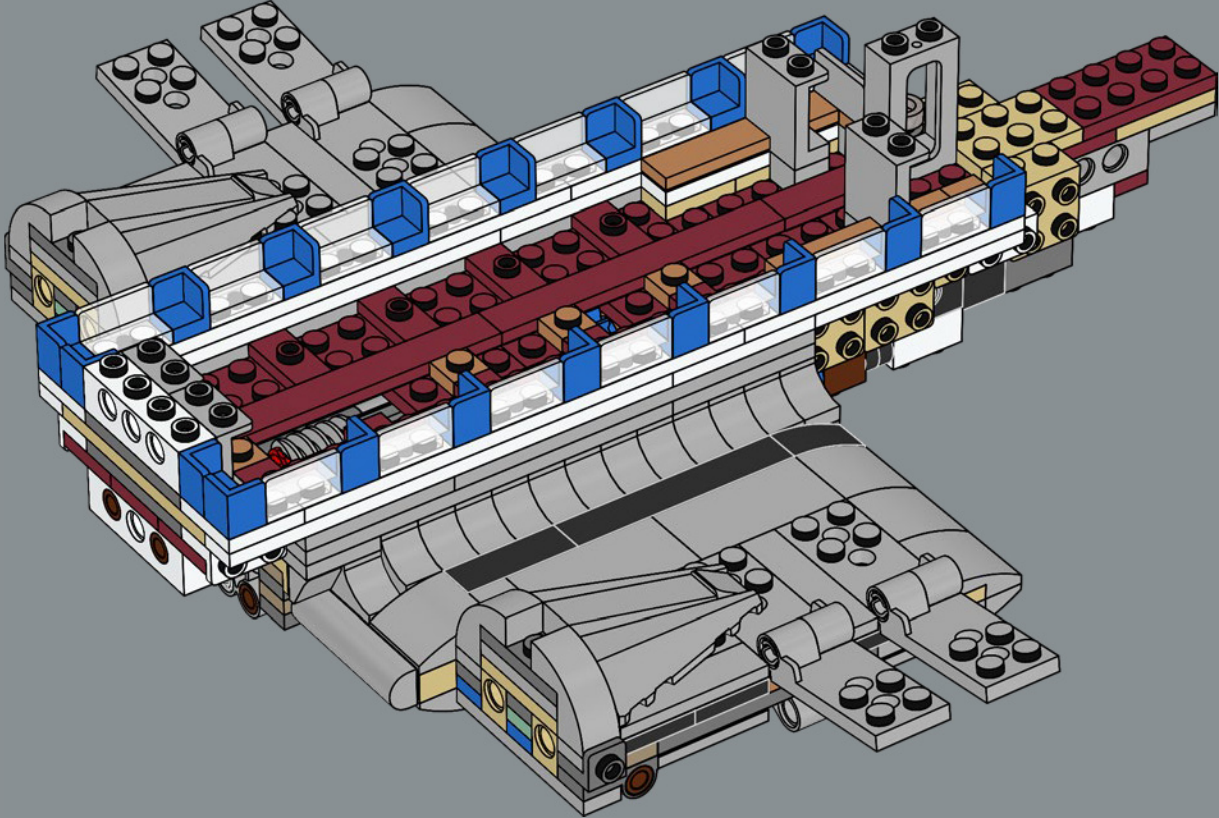

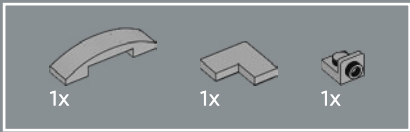

106

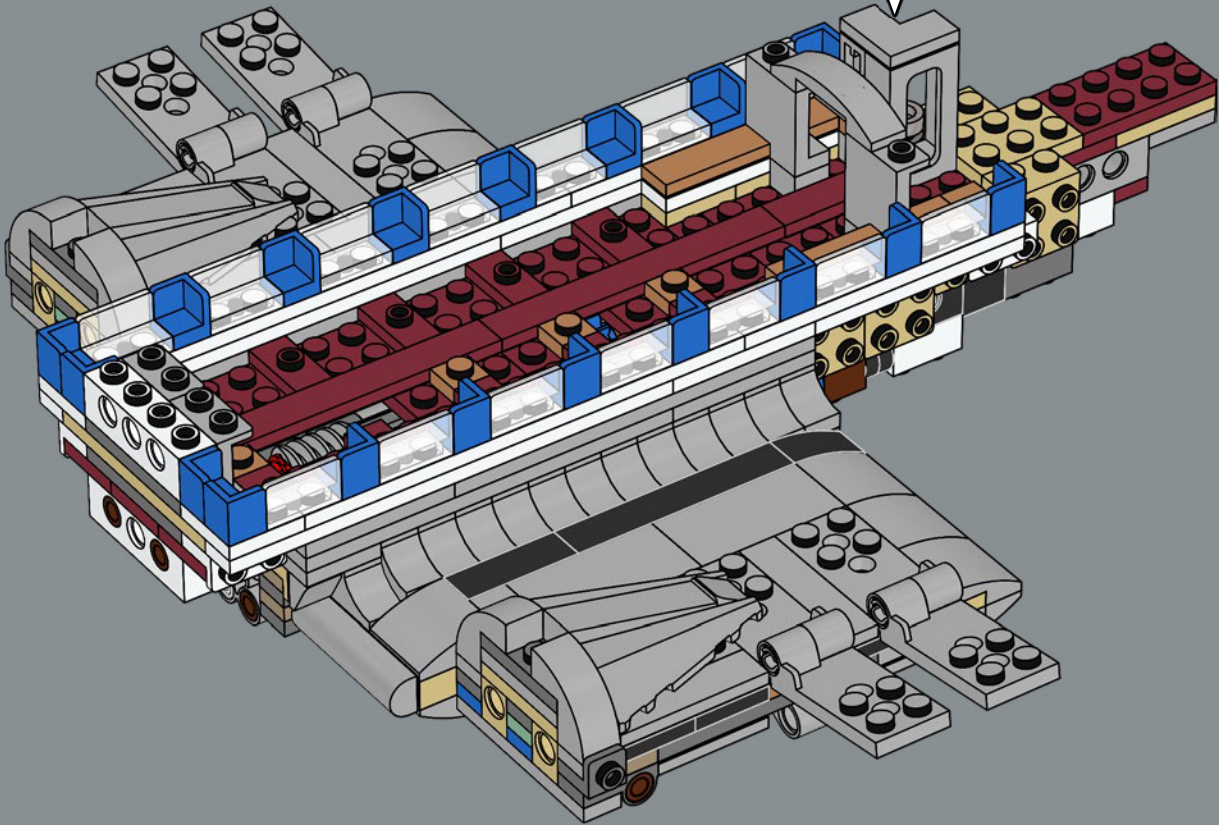
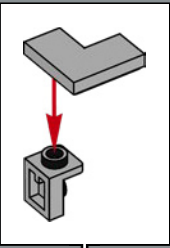

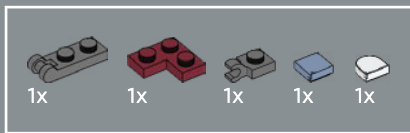

107

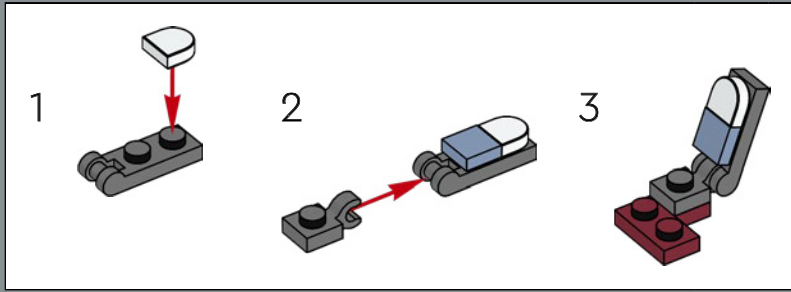
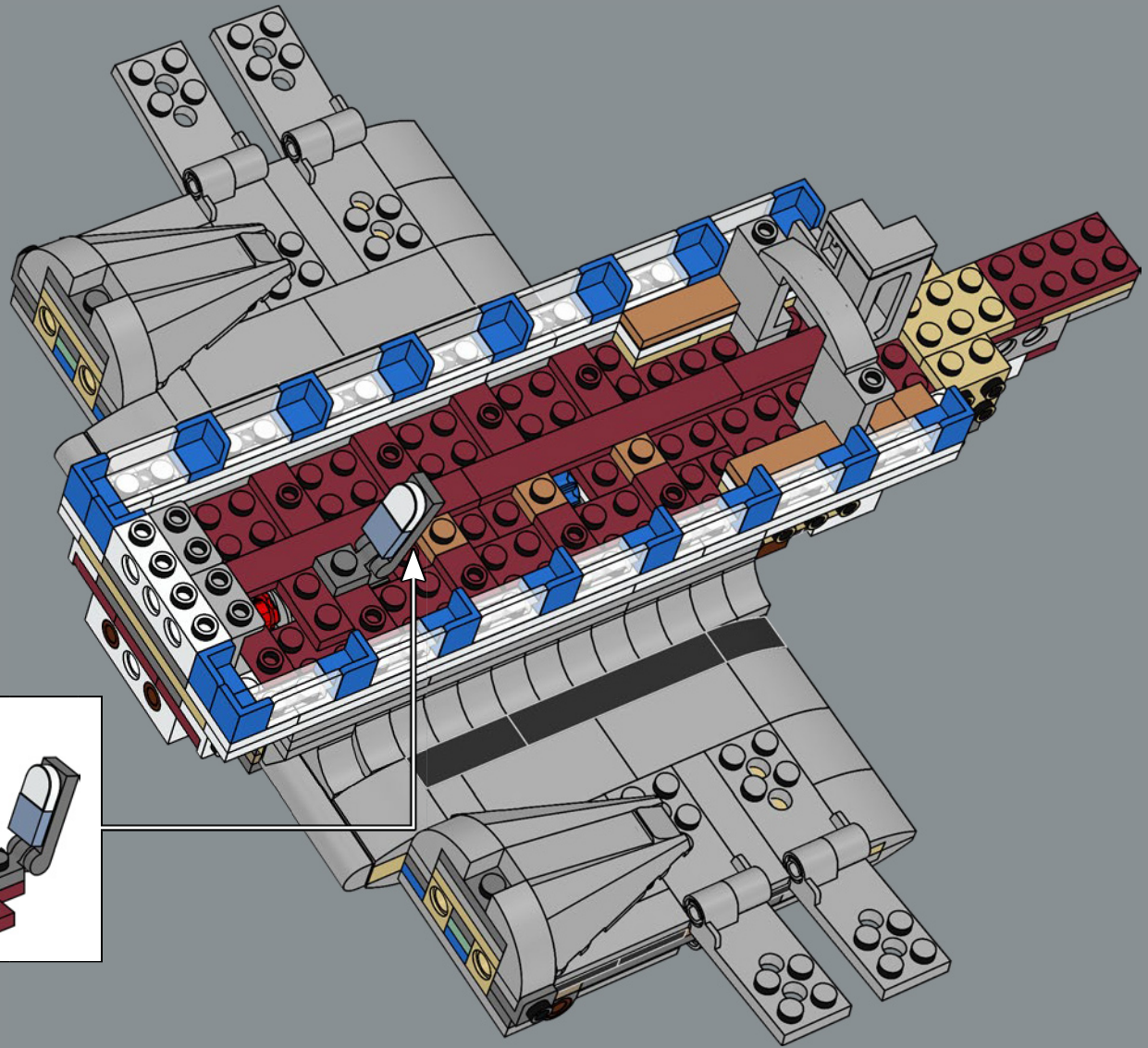

14x 14x 14x 14x

108

1 2

14x

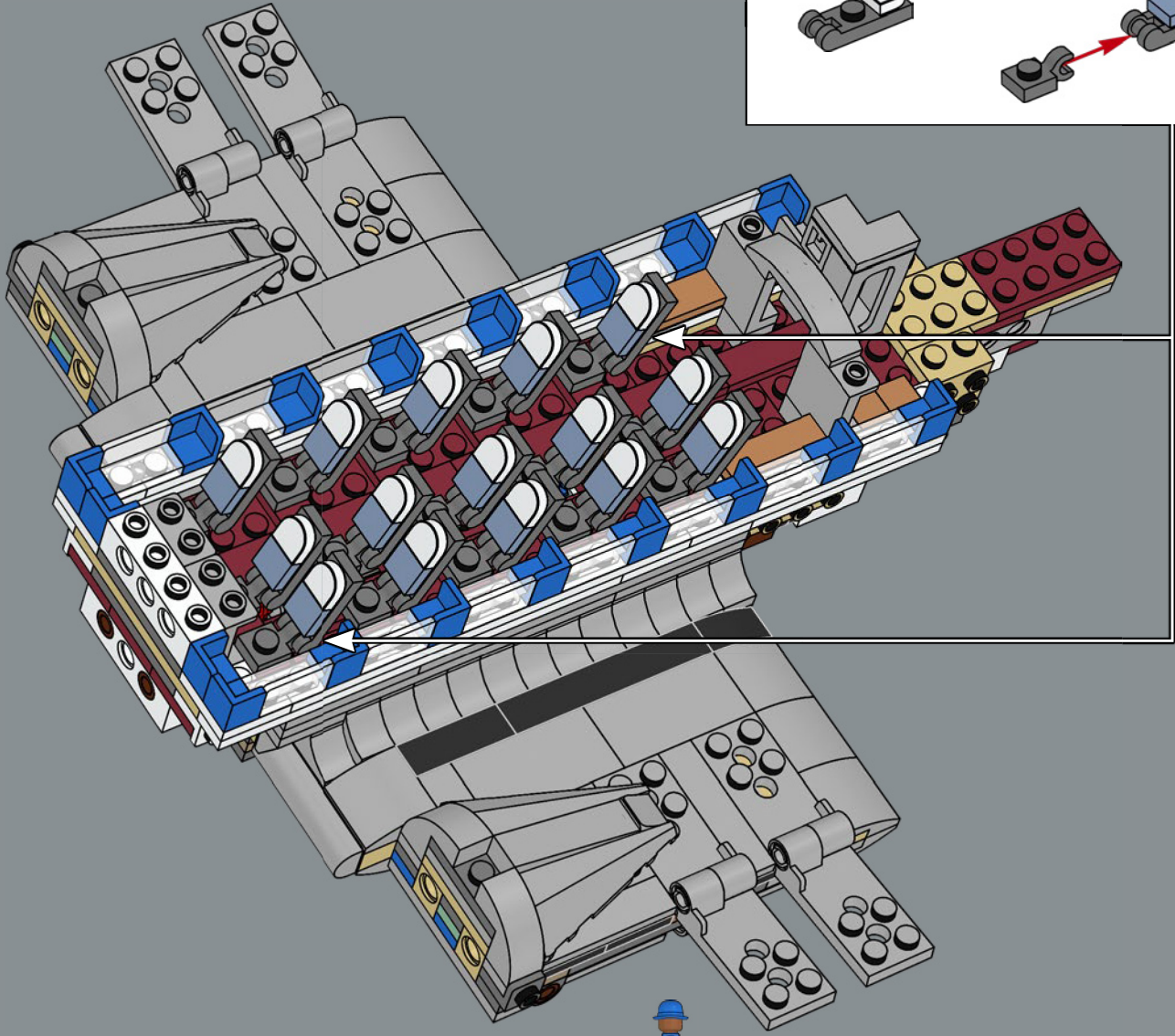

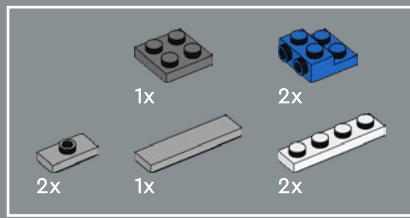

109

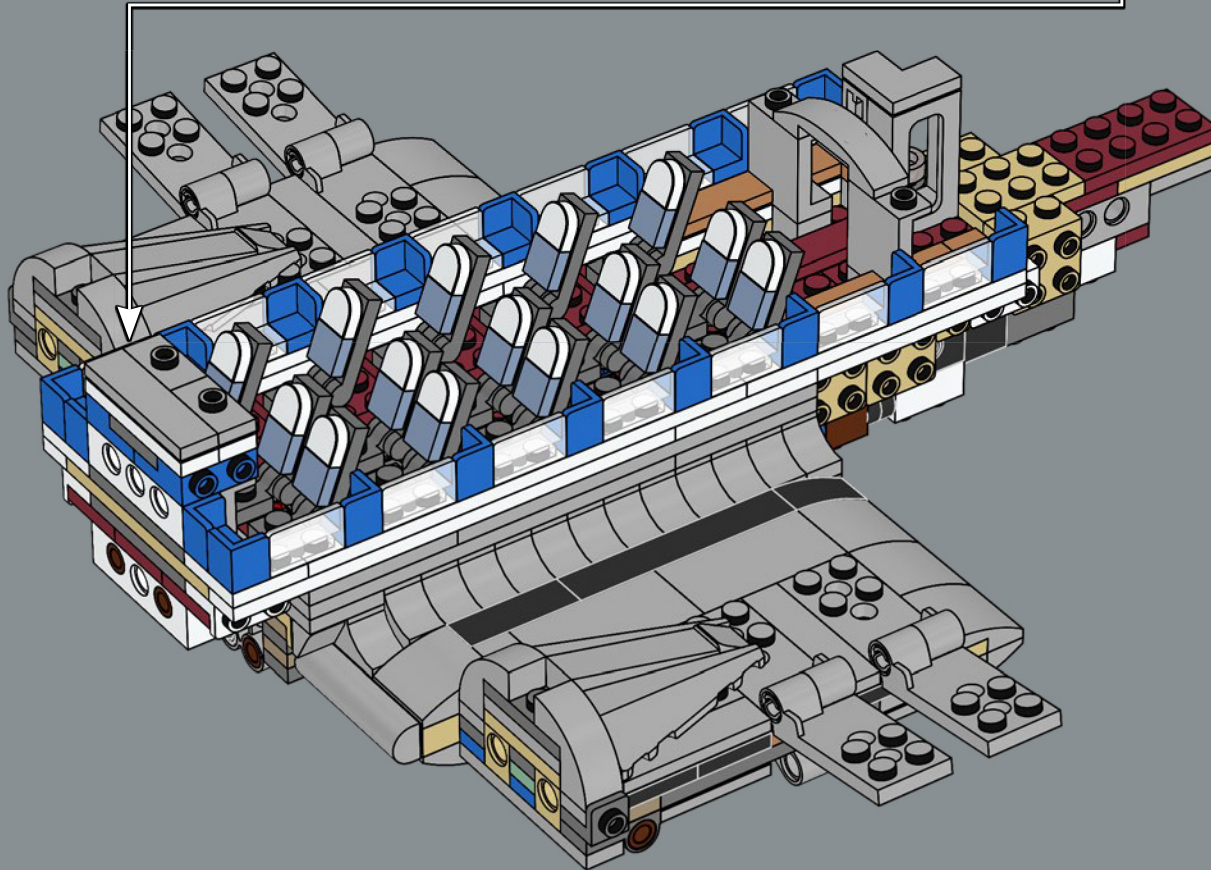
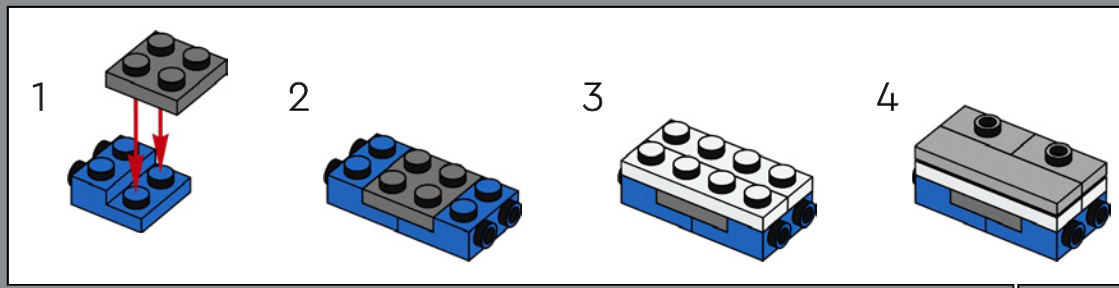

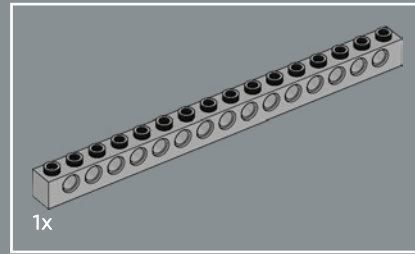
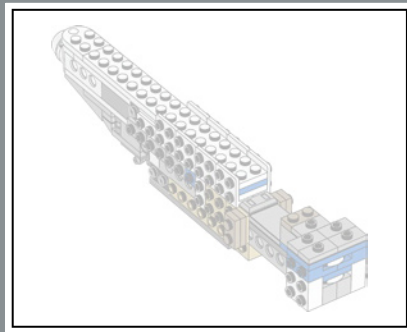

111

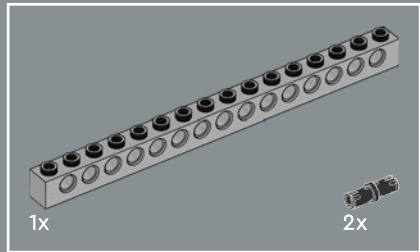
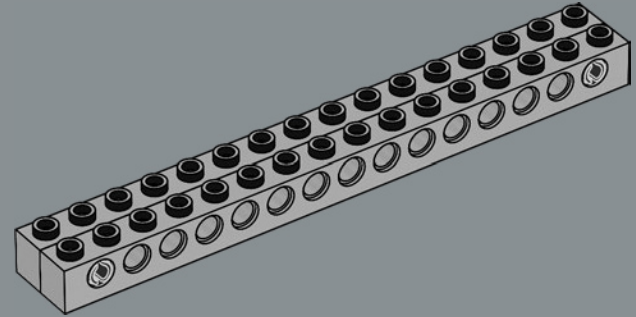

110

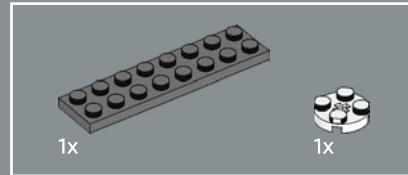
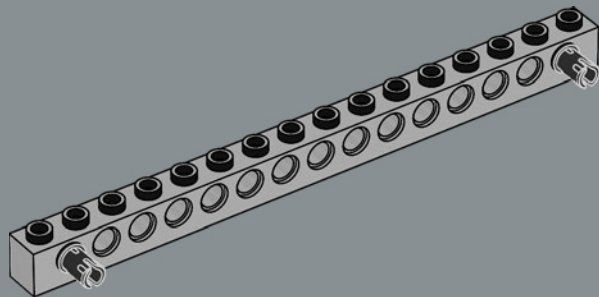

112

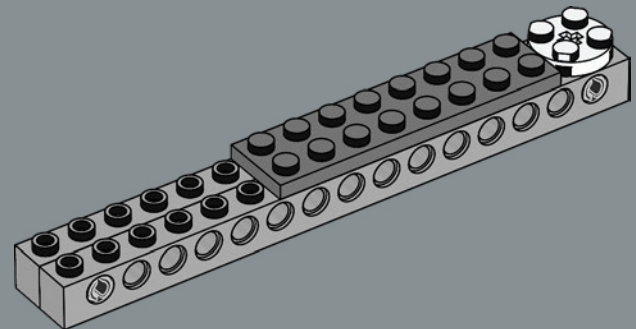

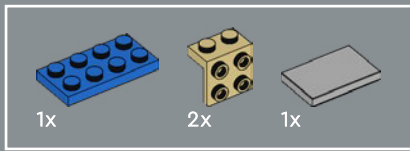

113

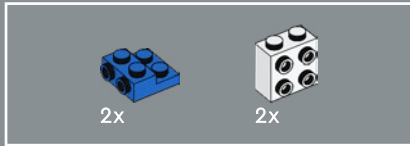
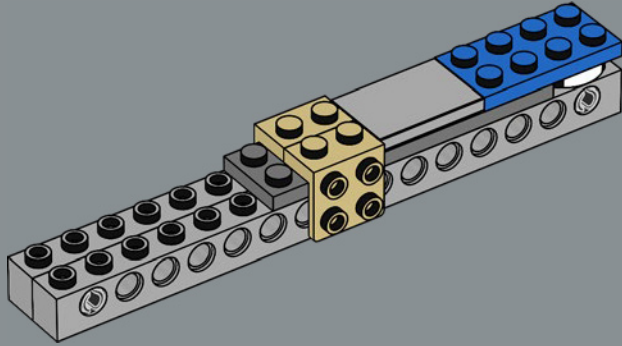

114

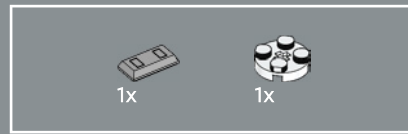
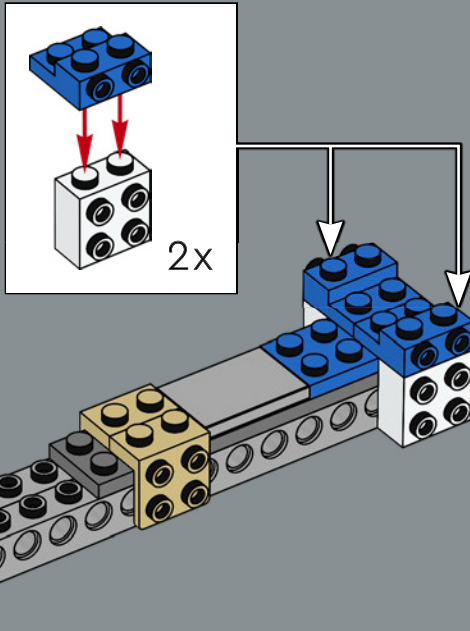

115

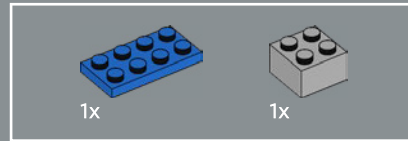
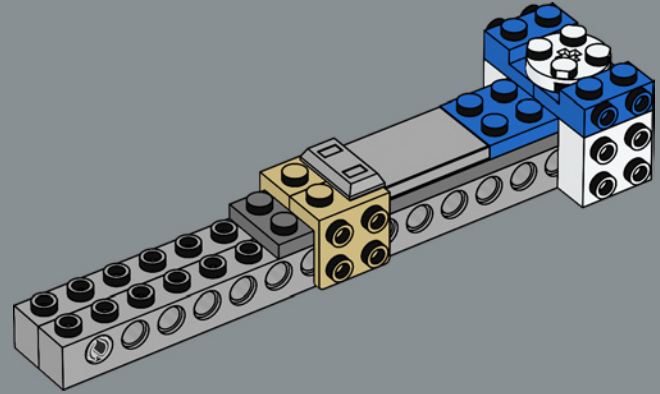

116

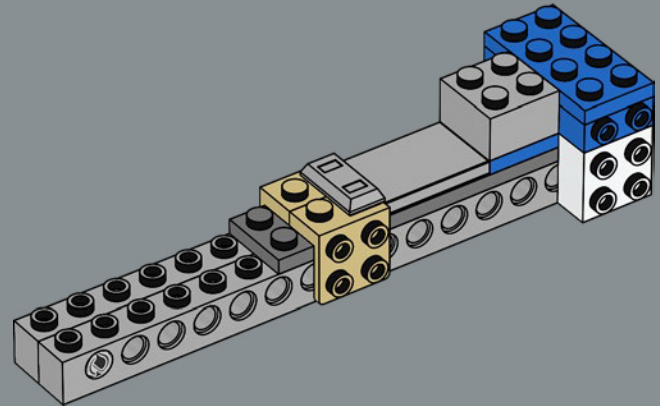

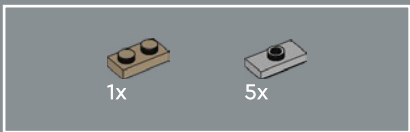

117

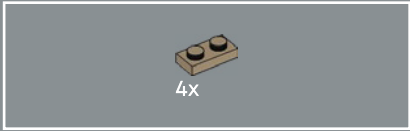
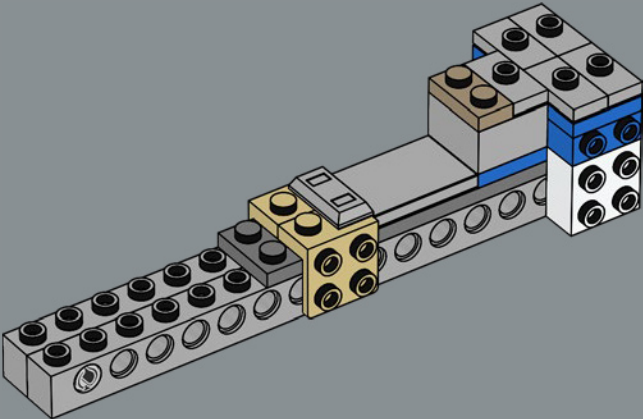

118

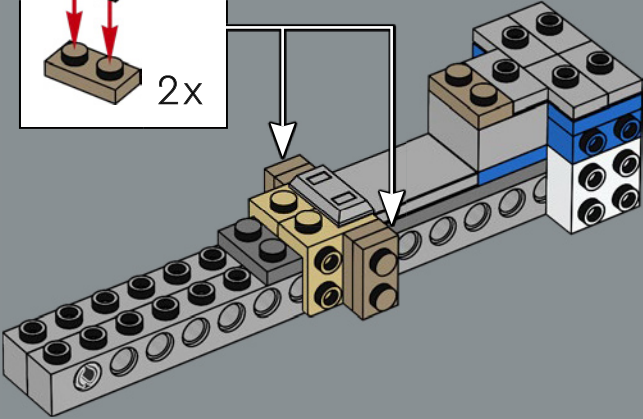
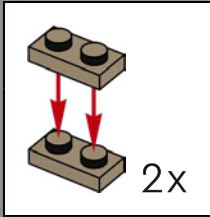

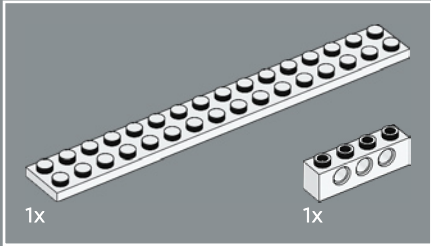
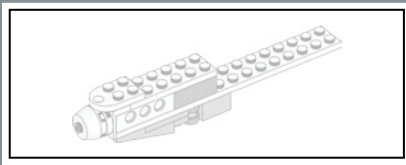

119

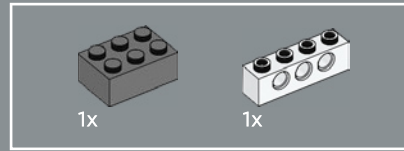
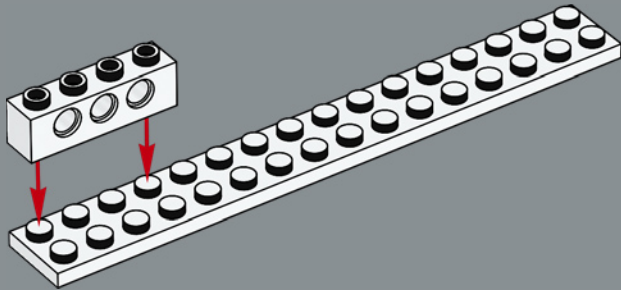

120

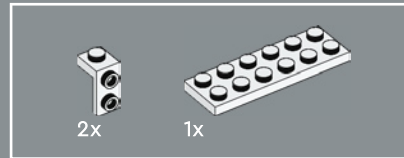
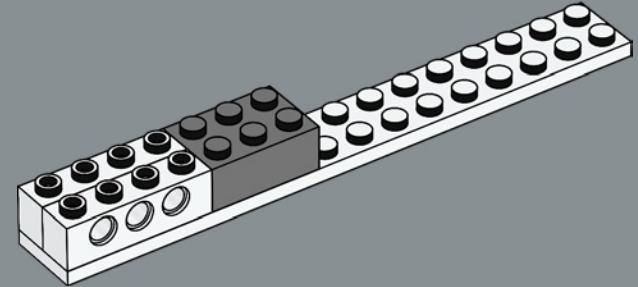

121

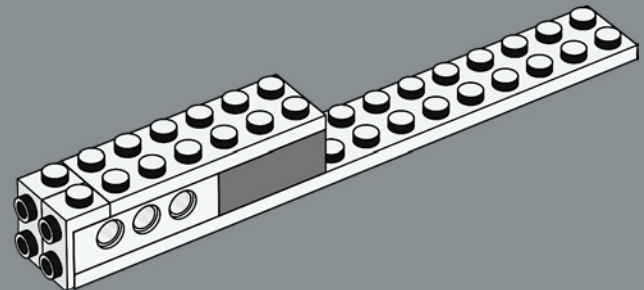

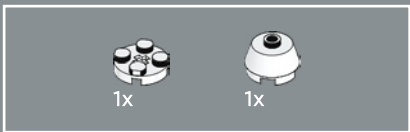

122

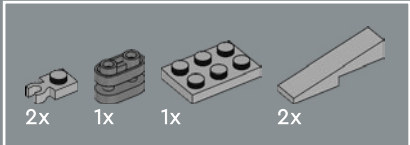
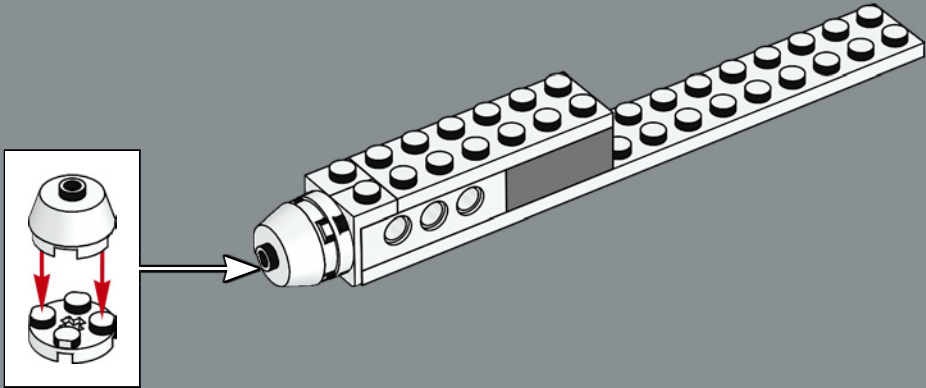

123

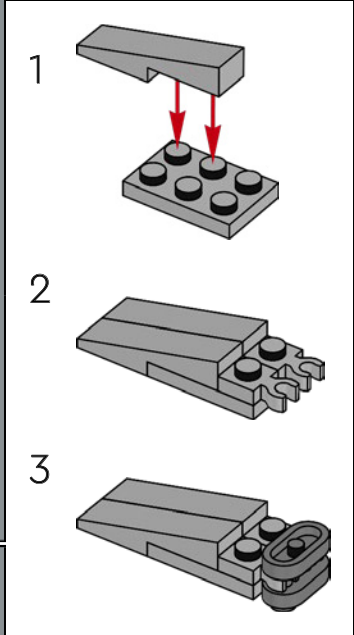
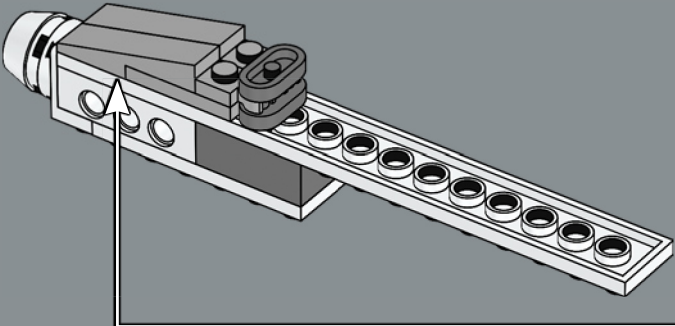
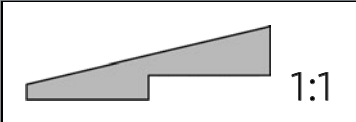

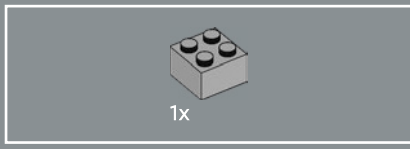

124

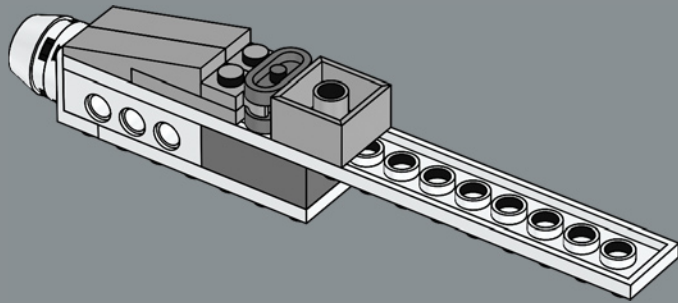

125

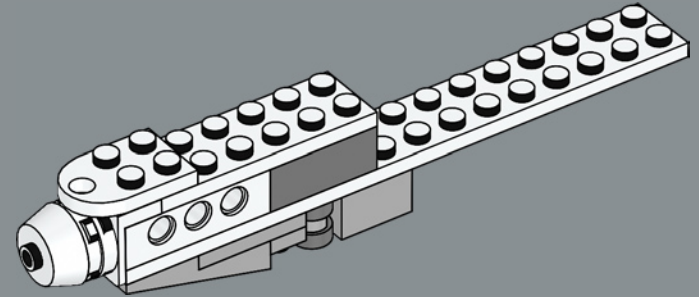

126

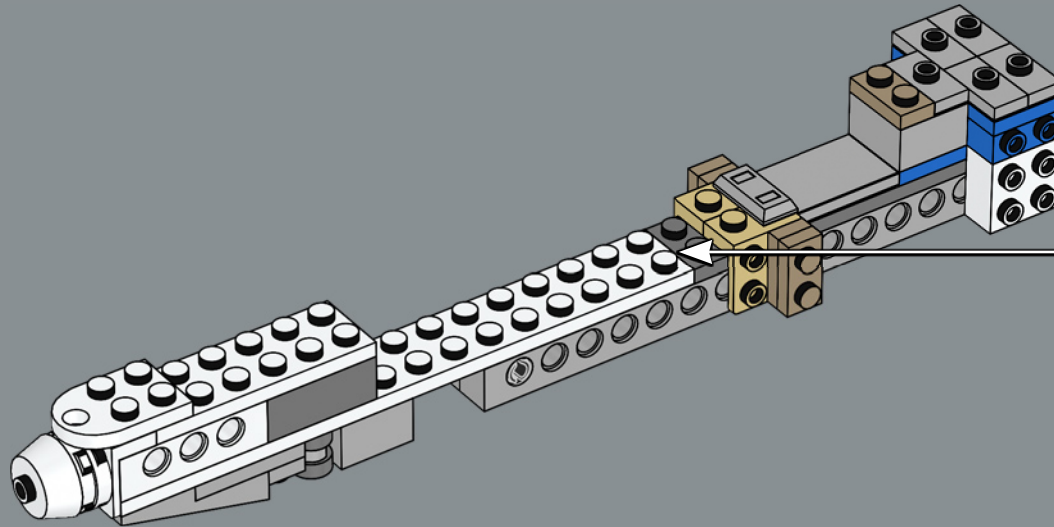

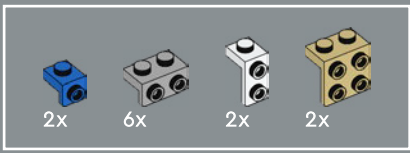

127

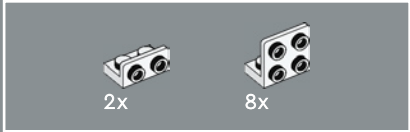
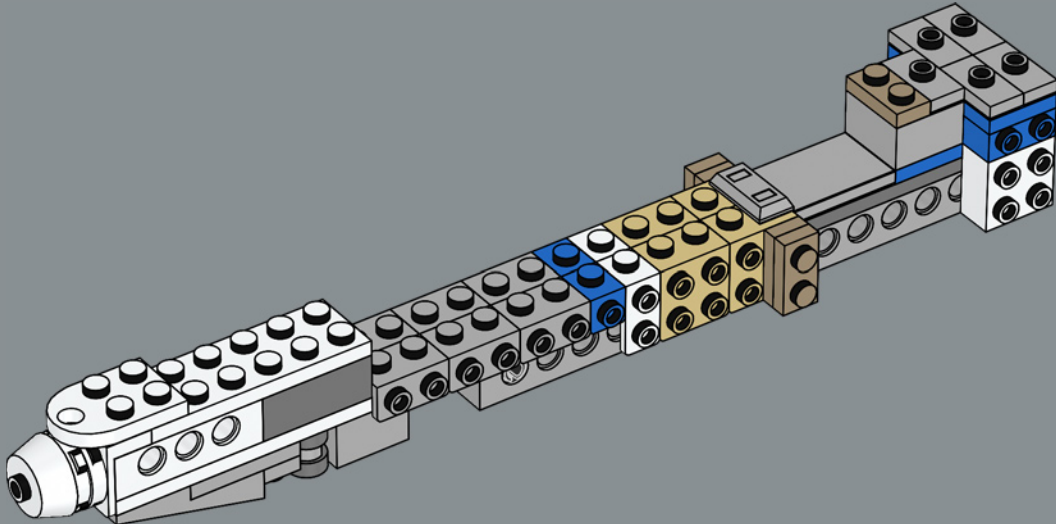

128

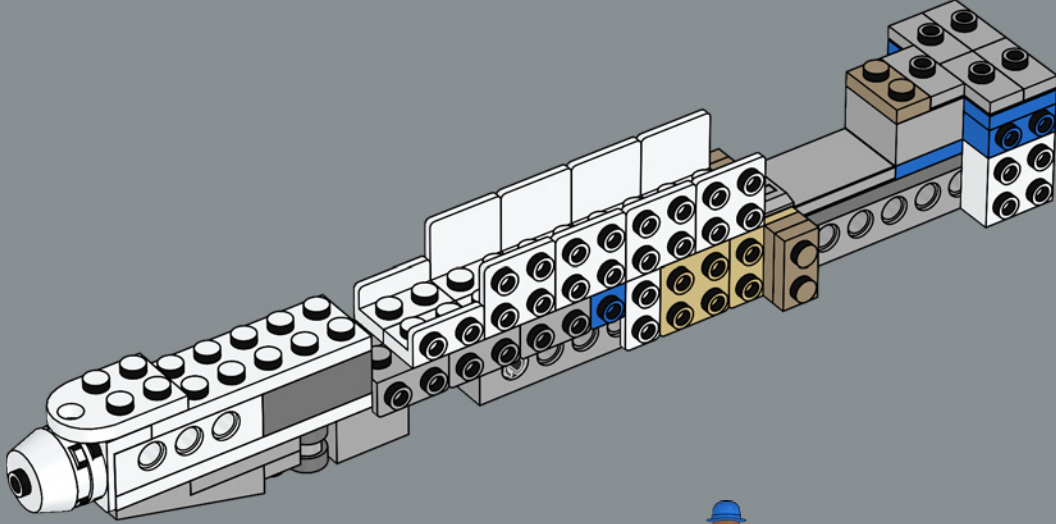

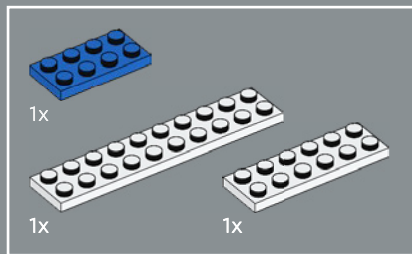

129

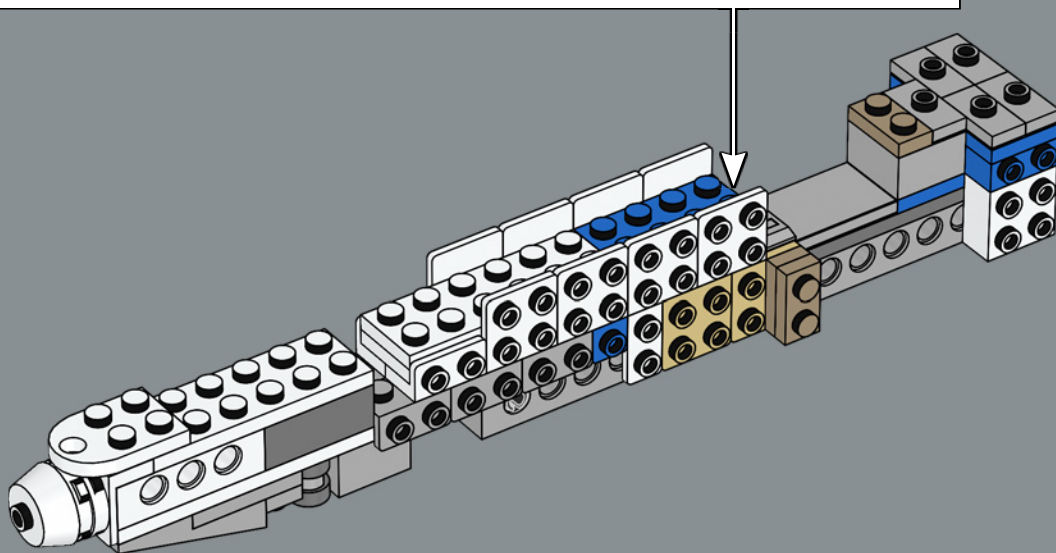
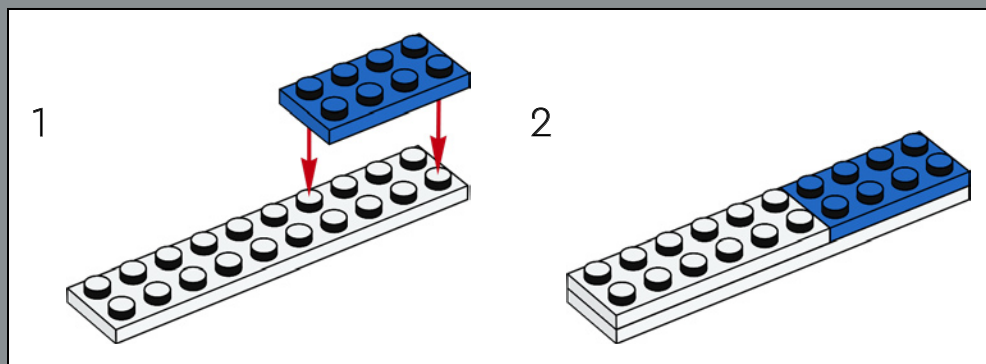



2x

130

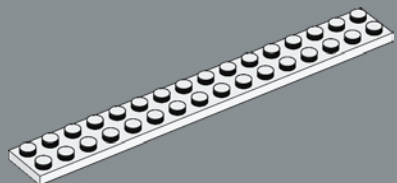
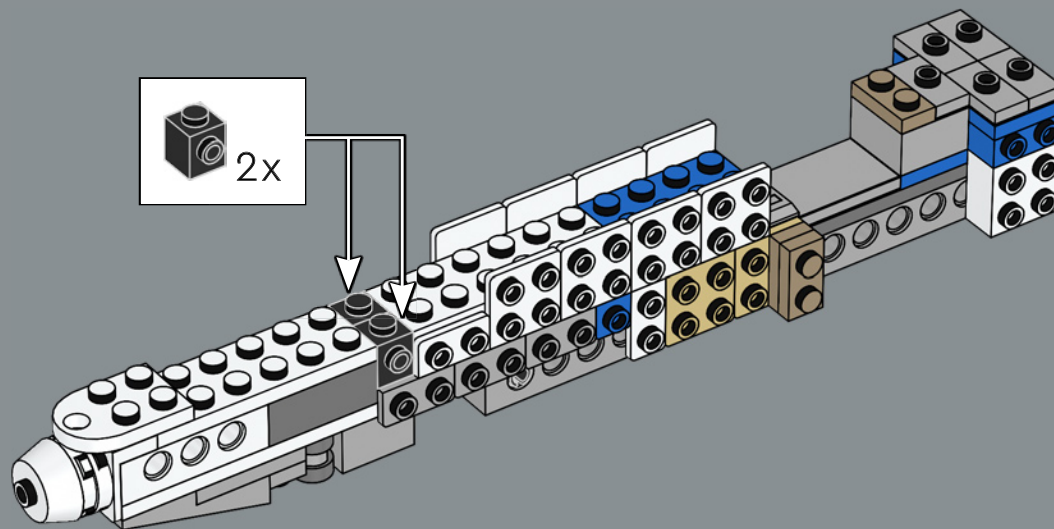

1x

131

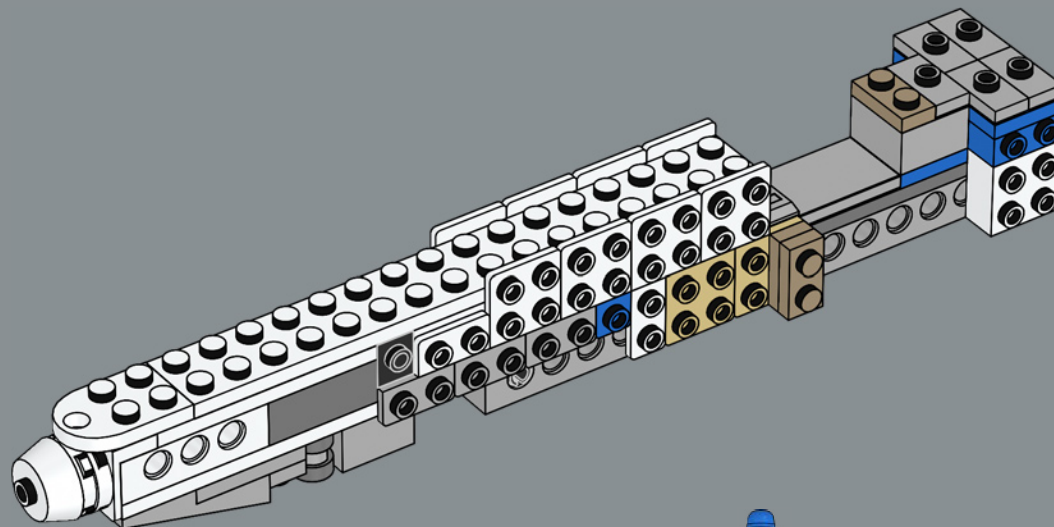

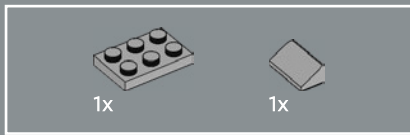

132

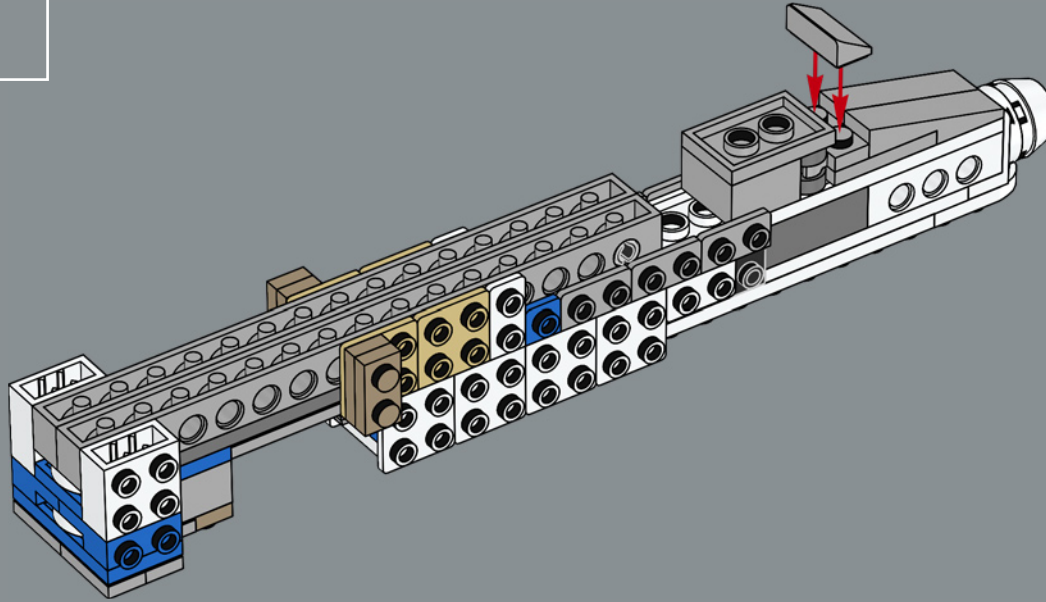

133

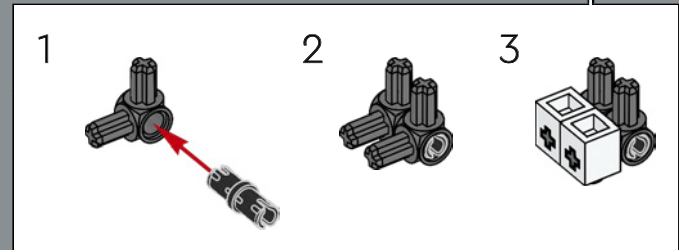
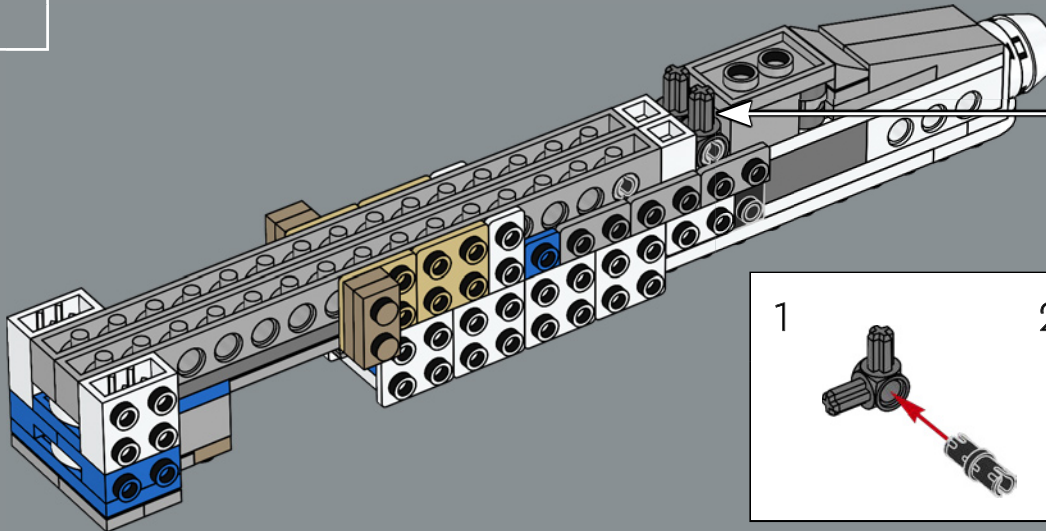

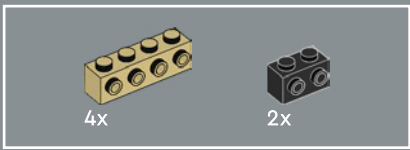

134

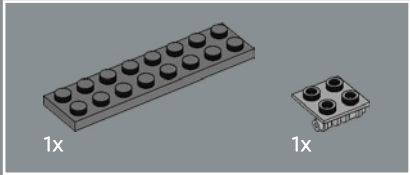
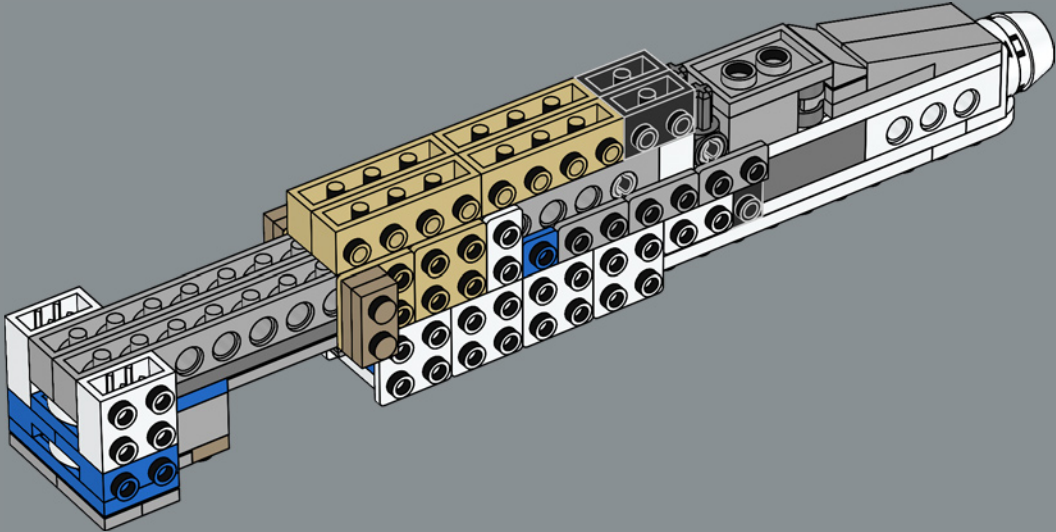

135

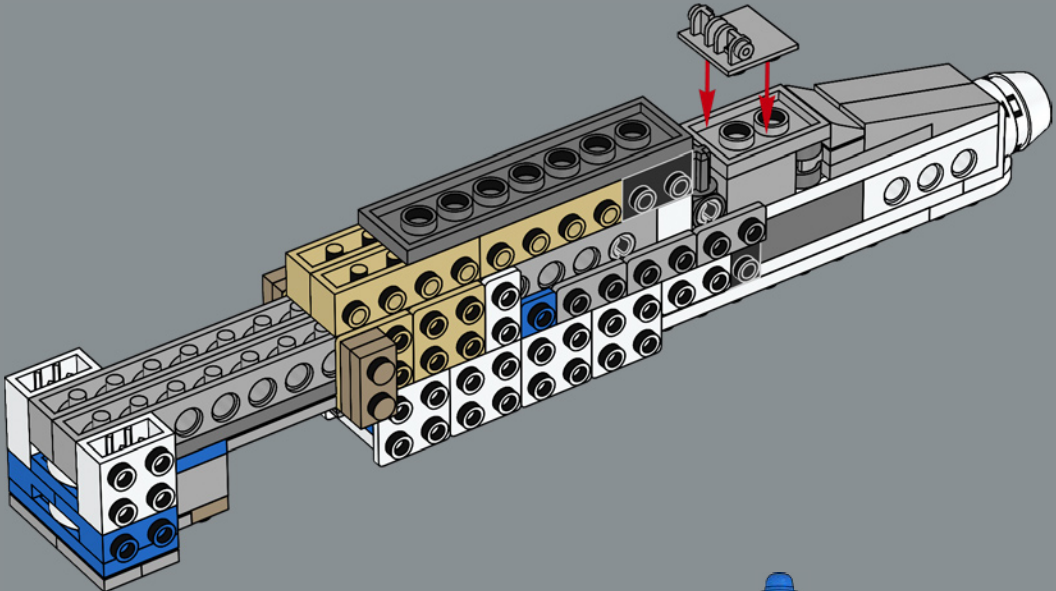

136

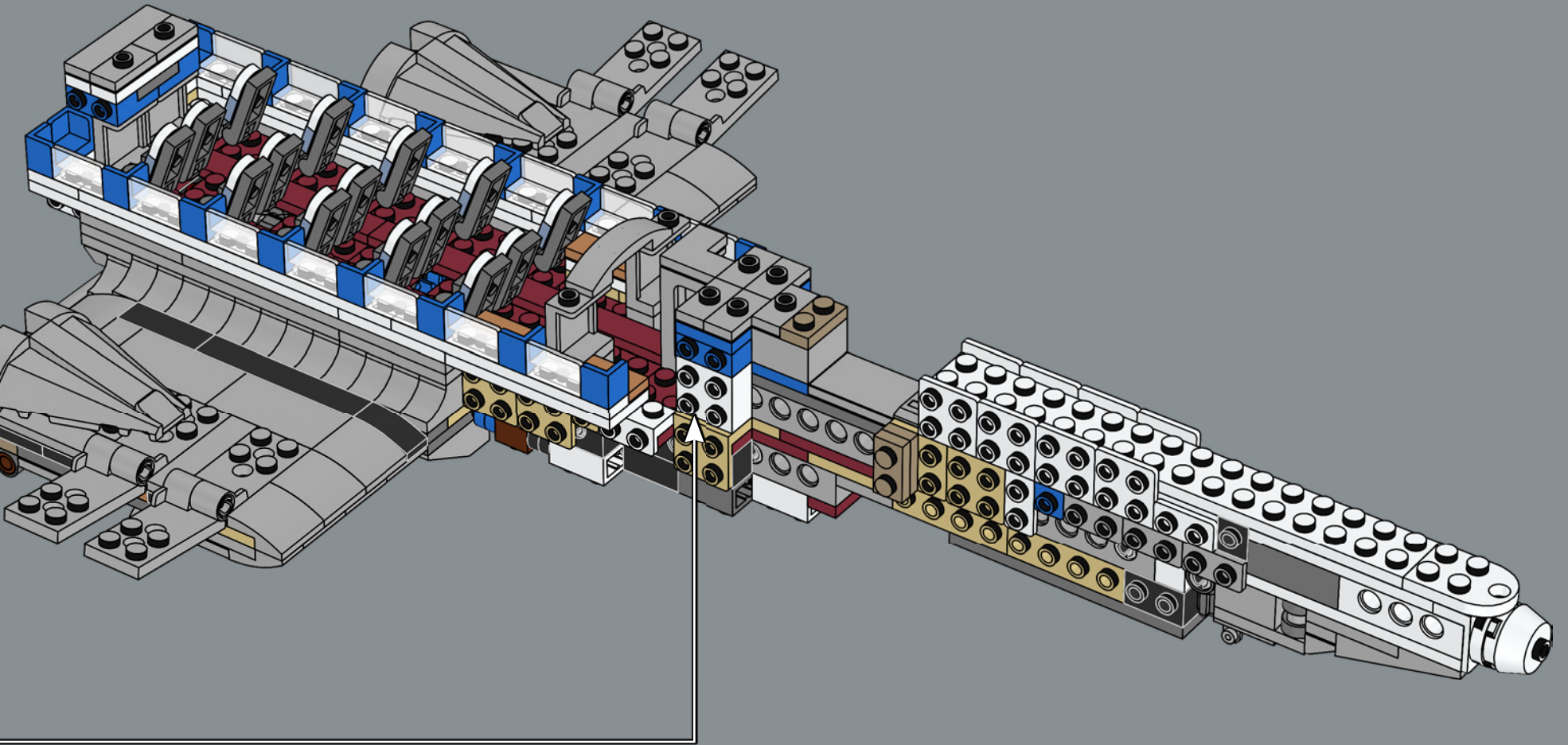



1x

137

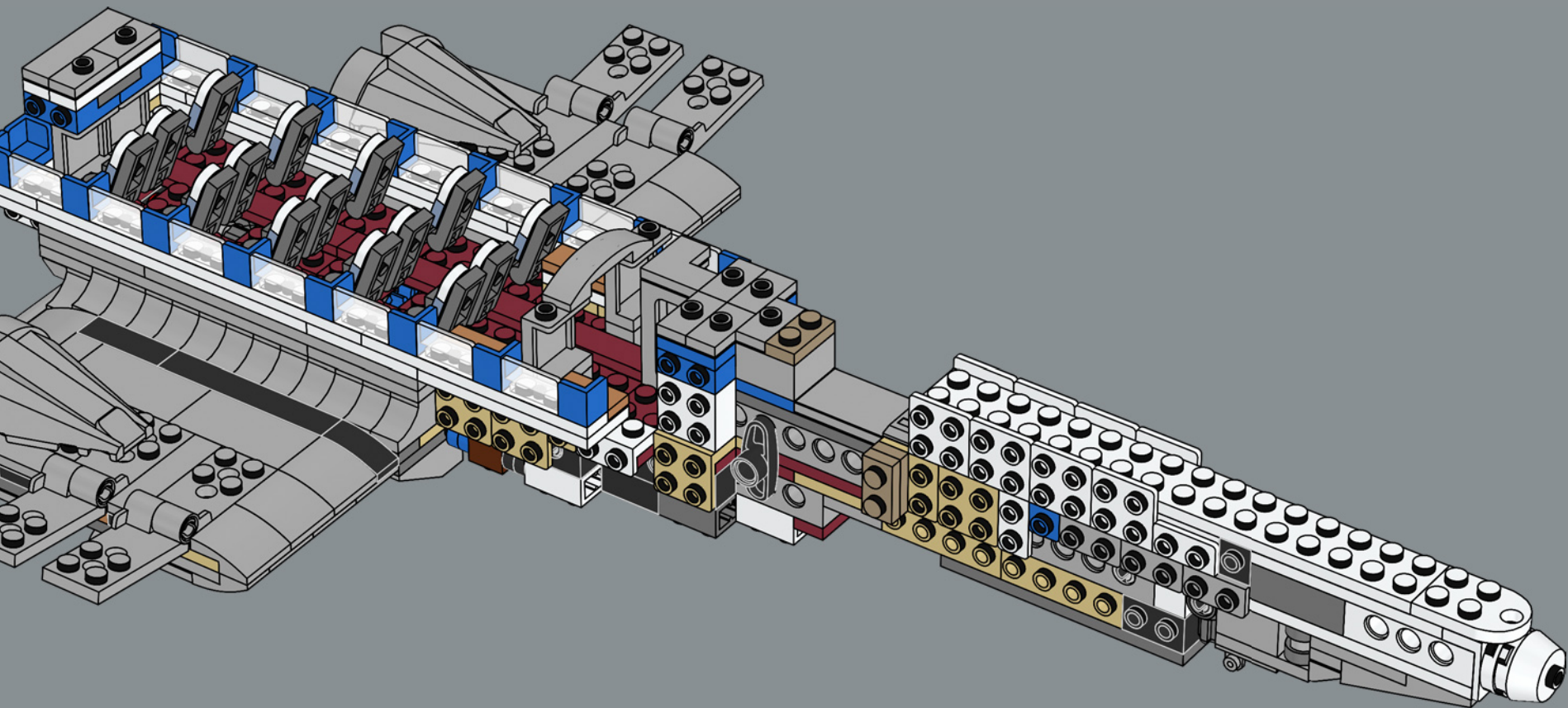

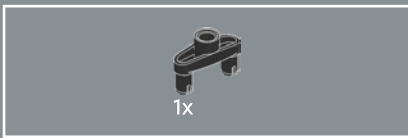

138

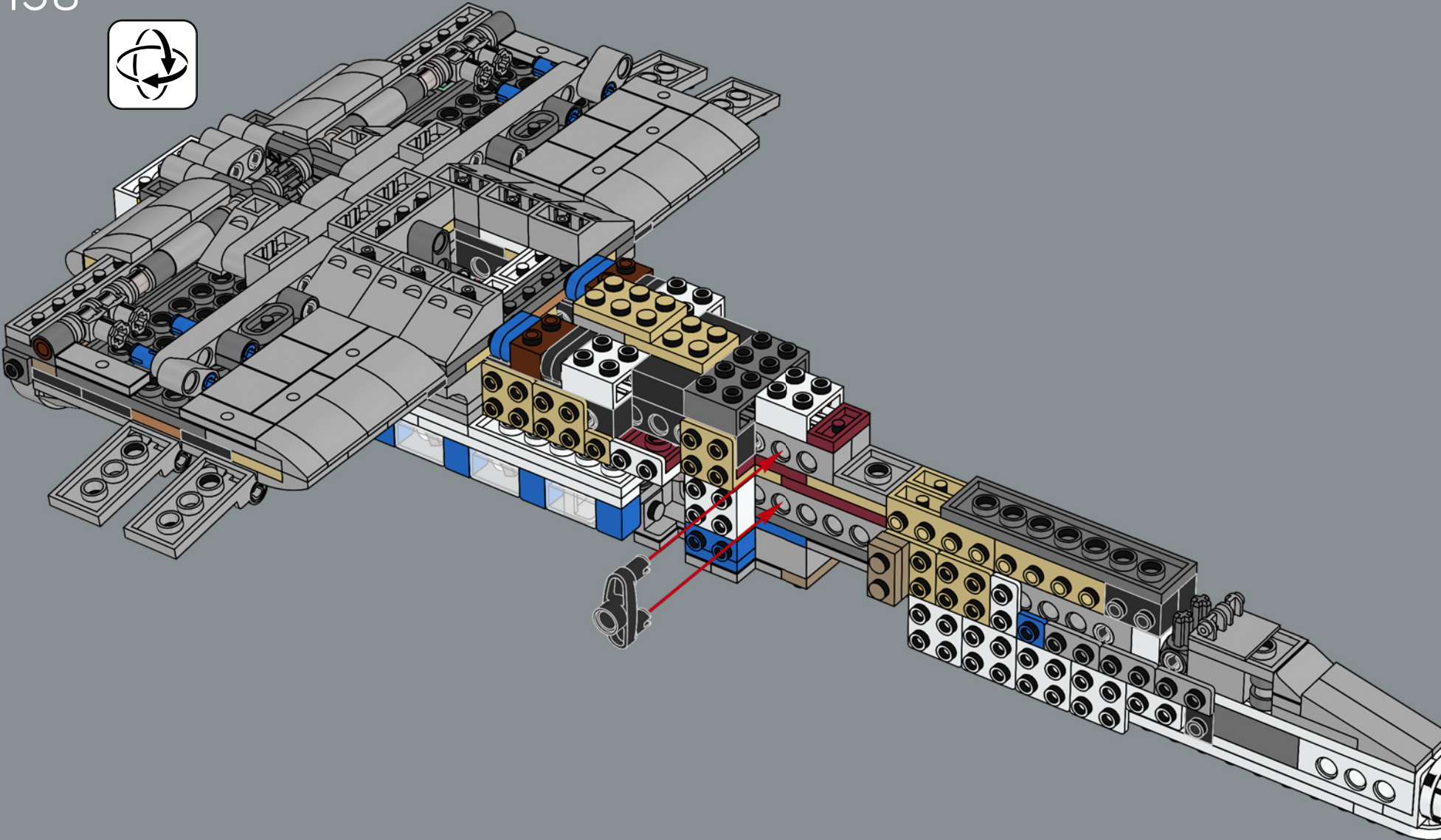

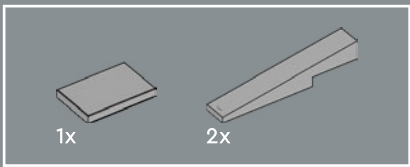

139

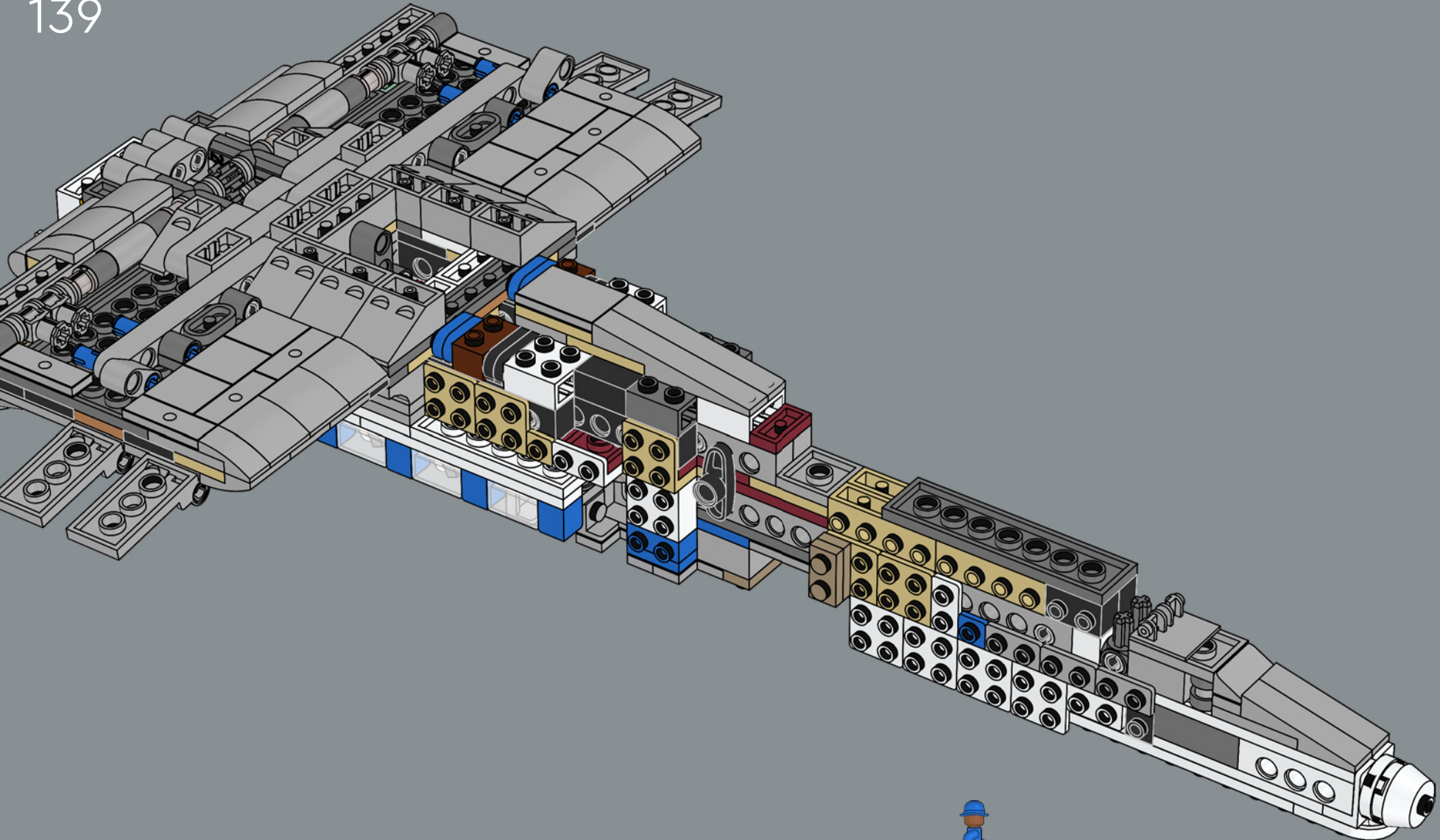

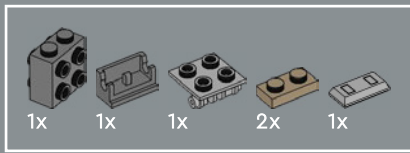

140

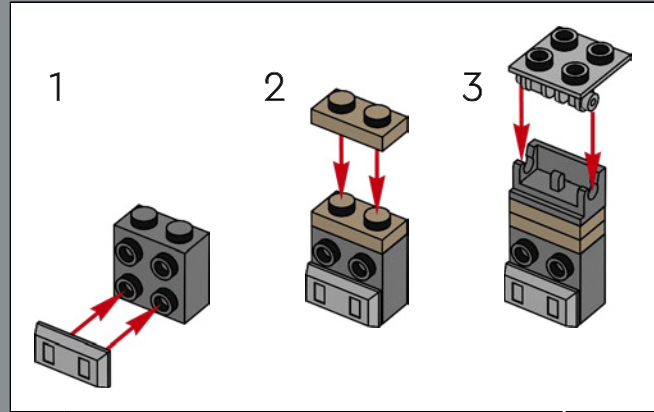
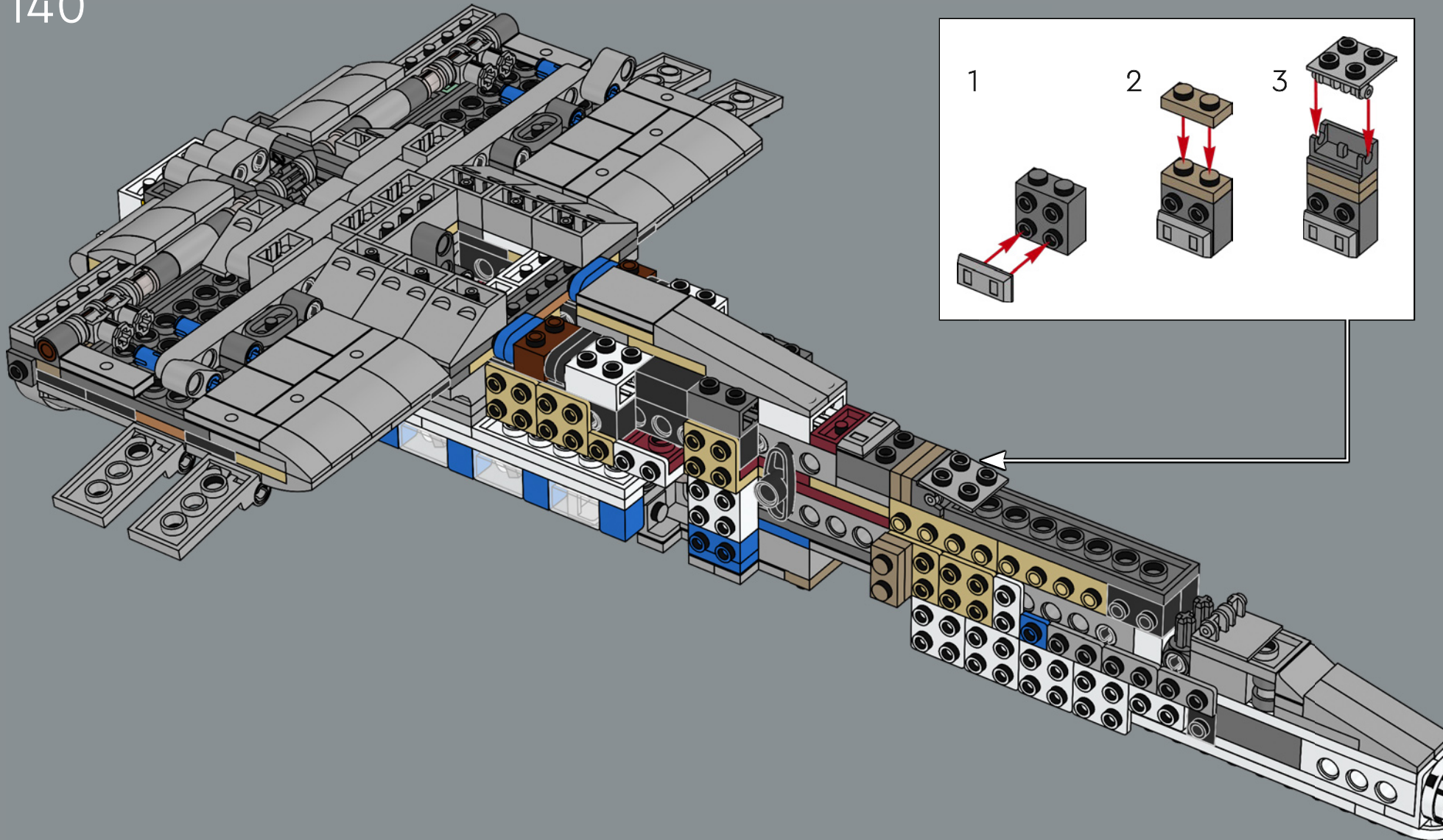

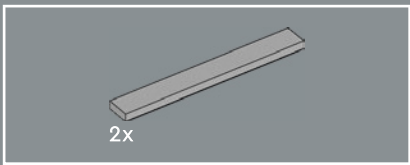

141

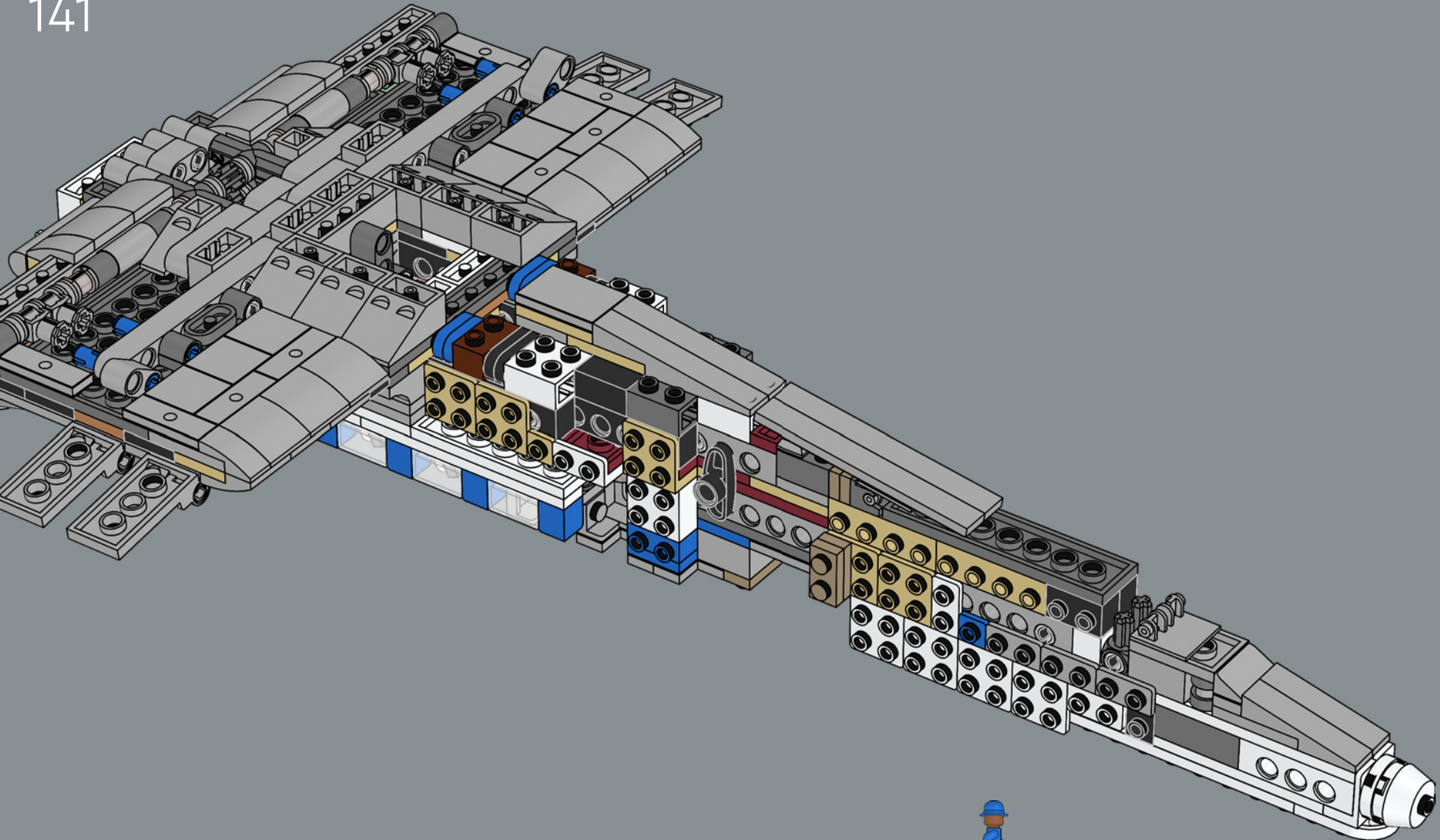

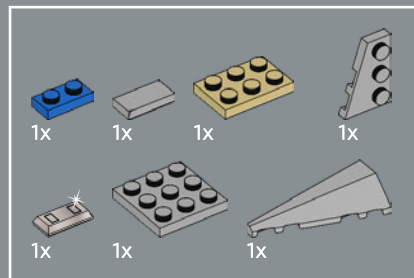
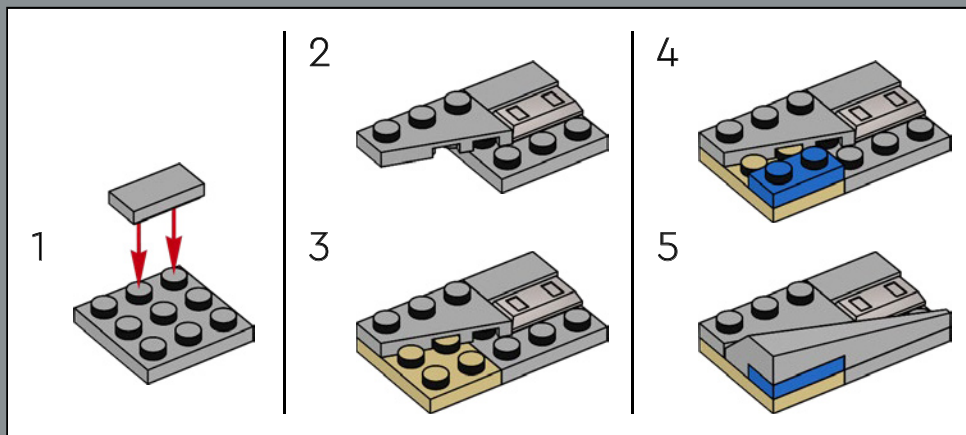

142

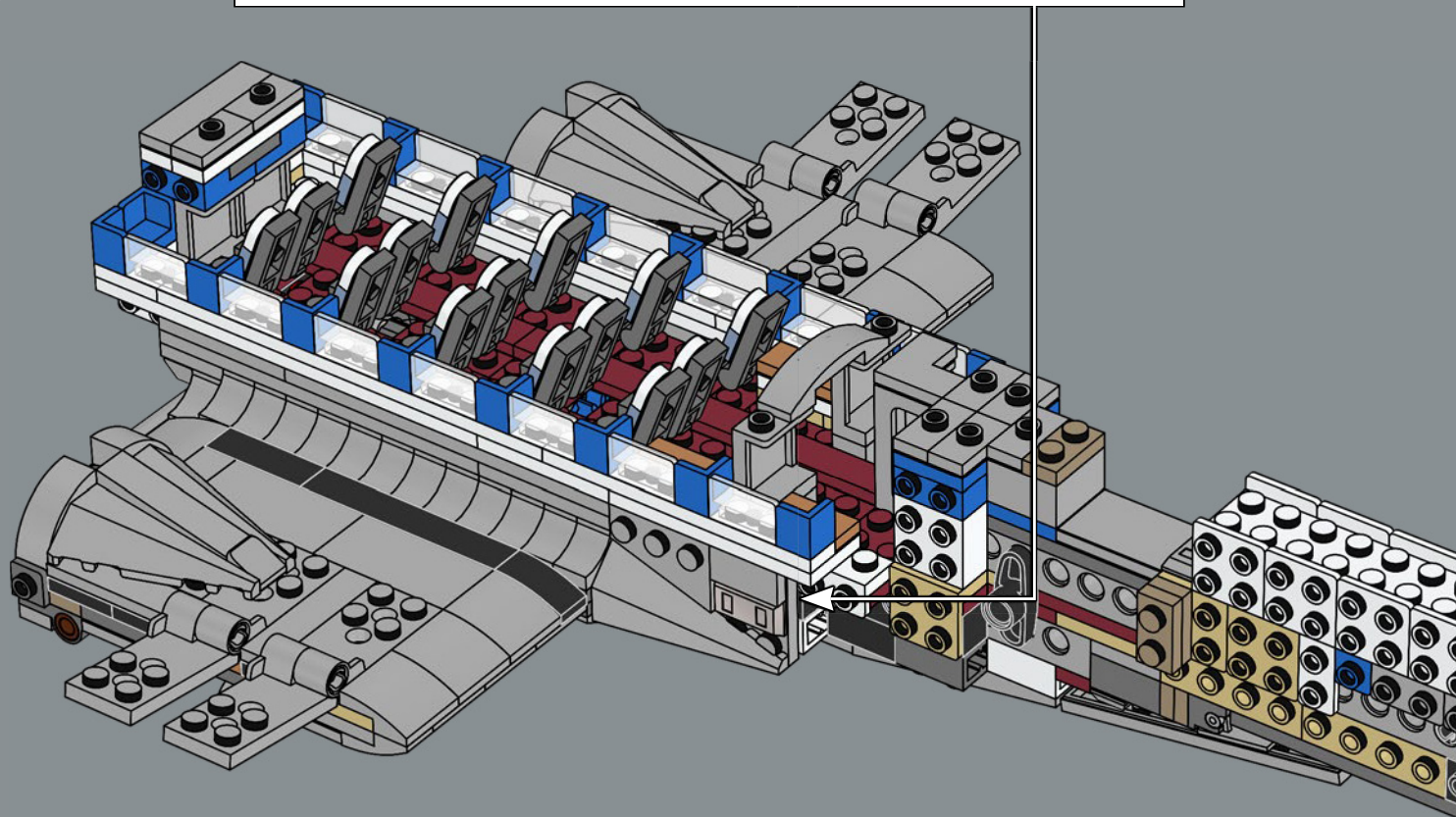

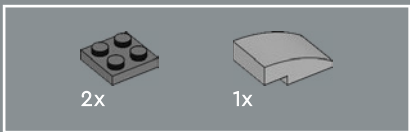

143

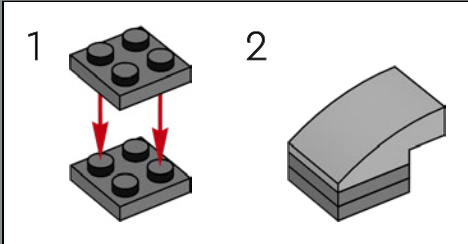
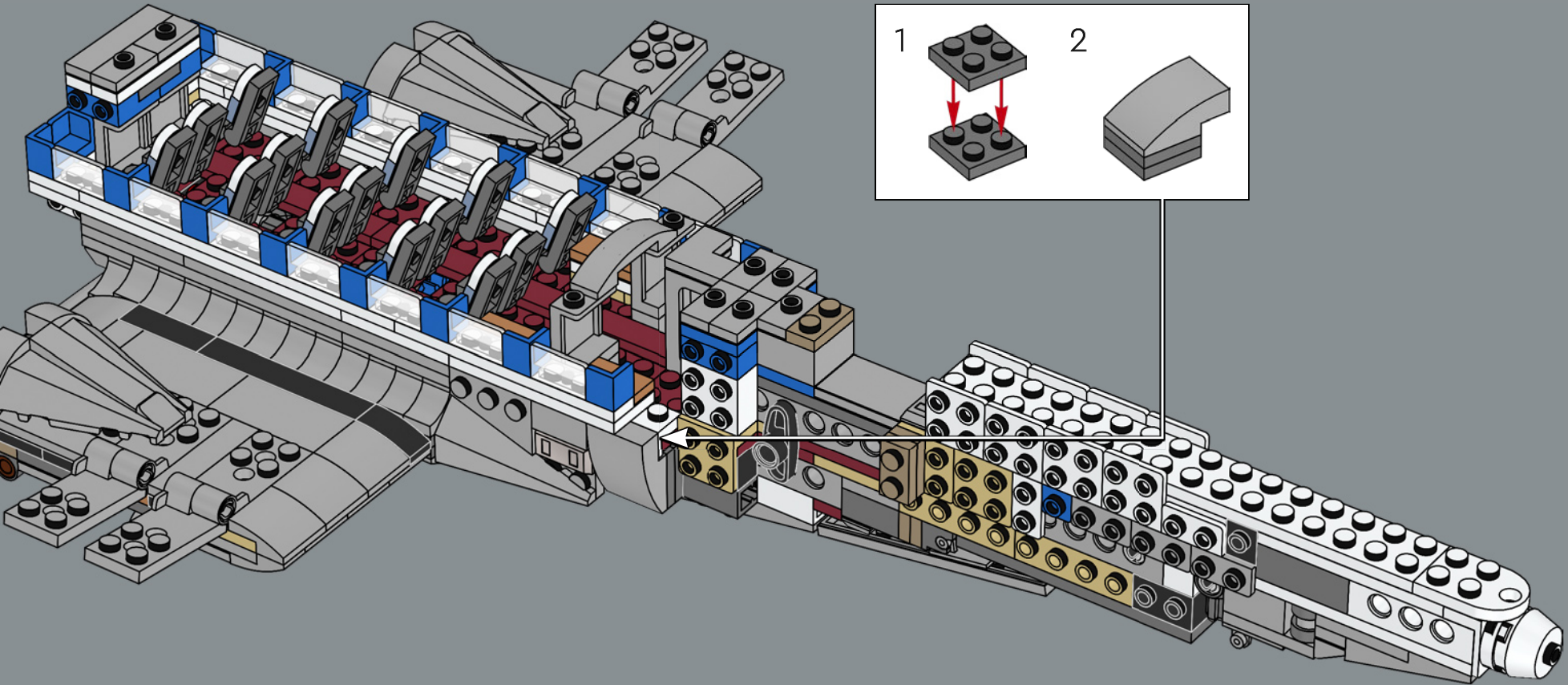

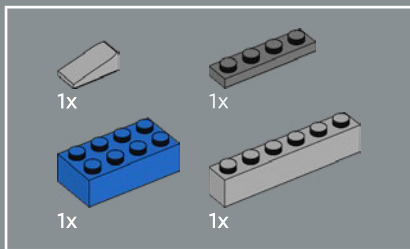

144

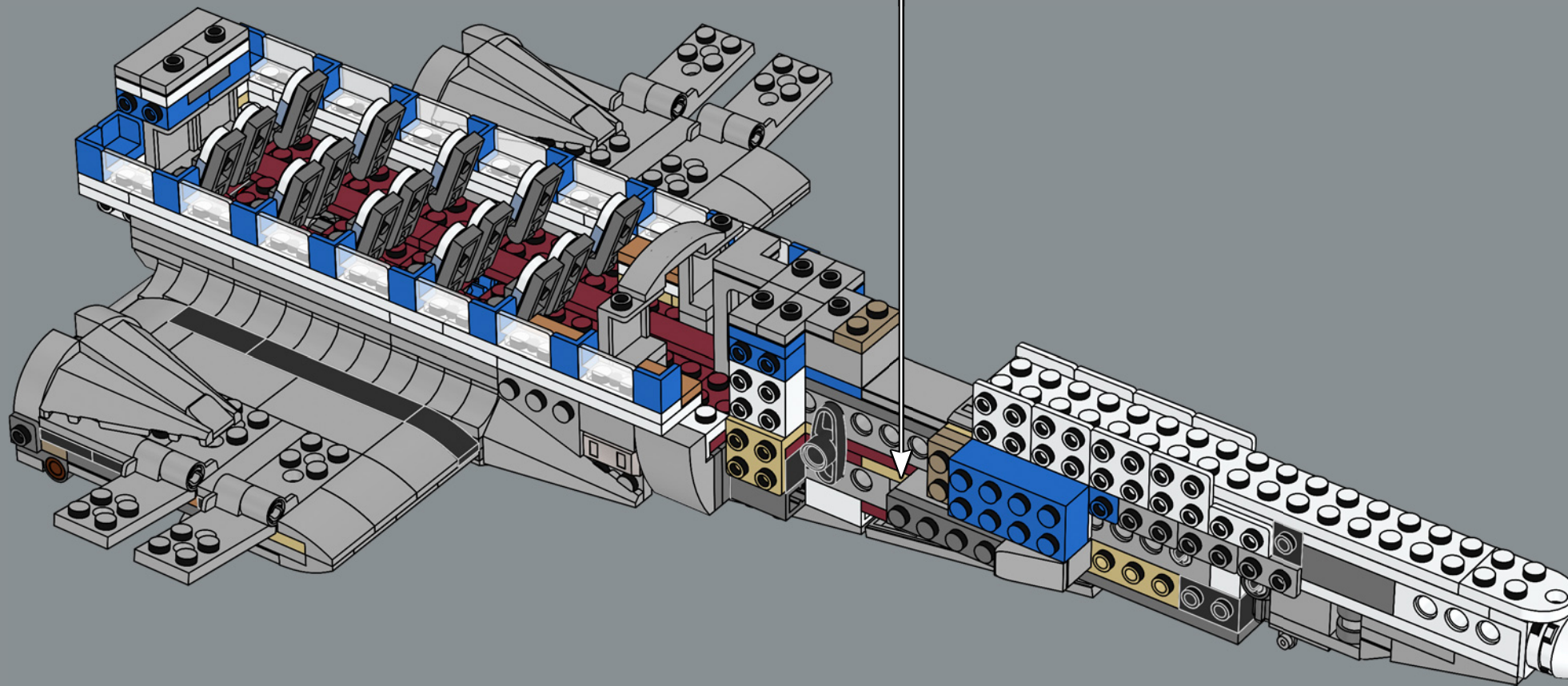
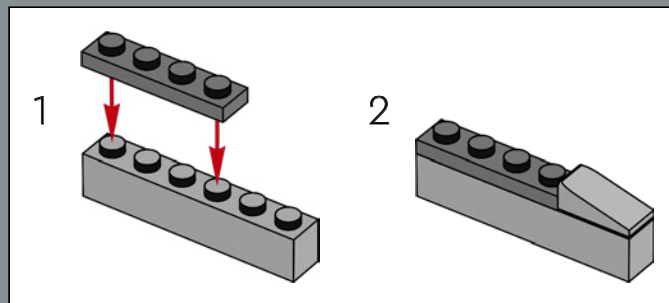

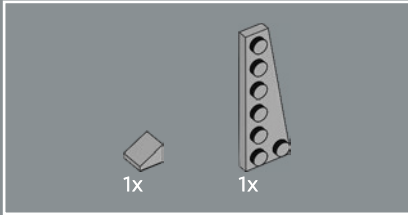
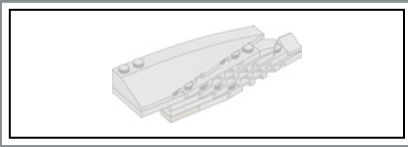

145

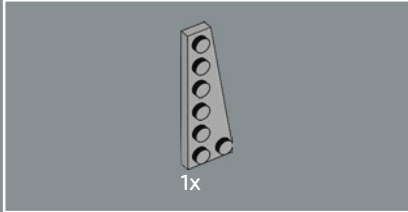
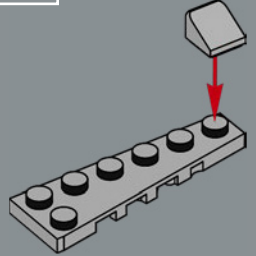

146

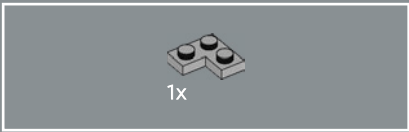
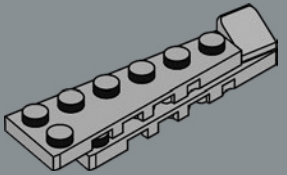

147

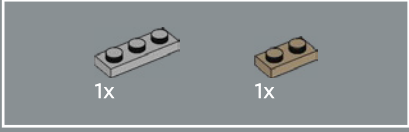
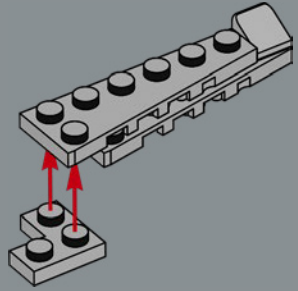

148

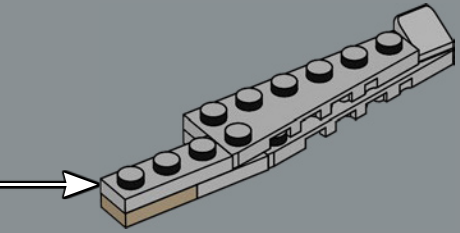
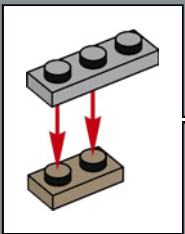

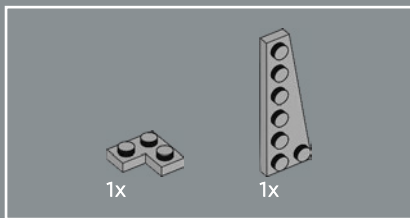

149

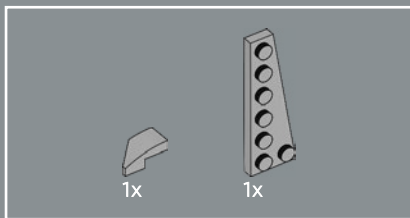
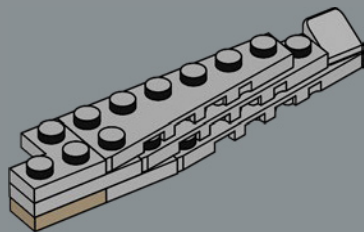

150

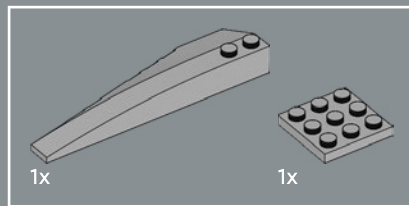
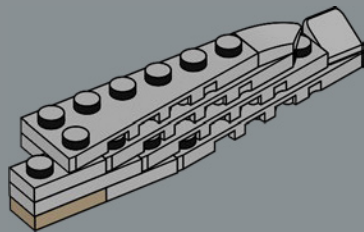

151

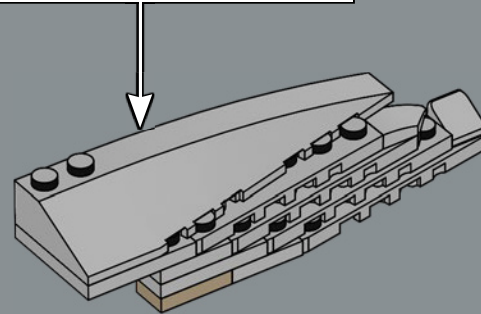
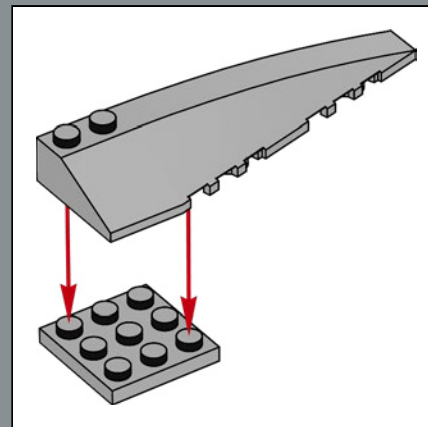

152

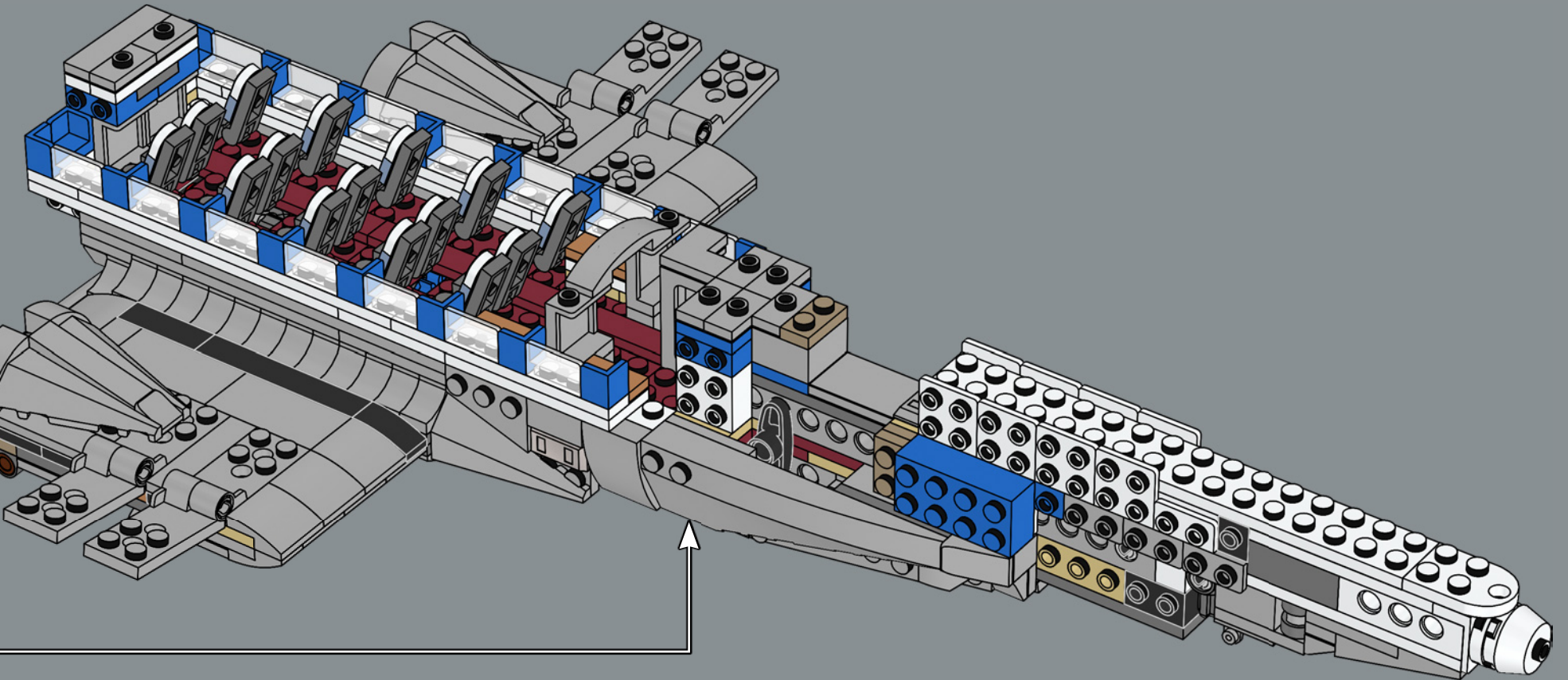

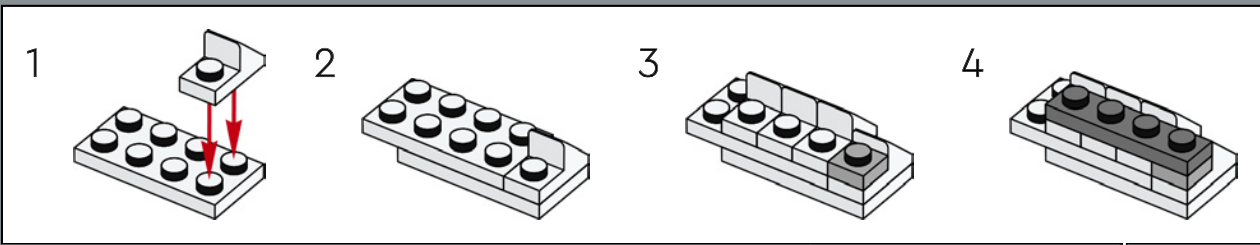
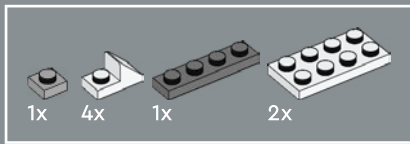

153

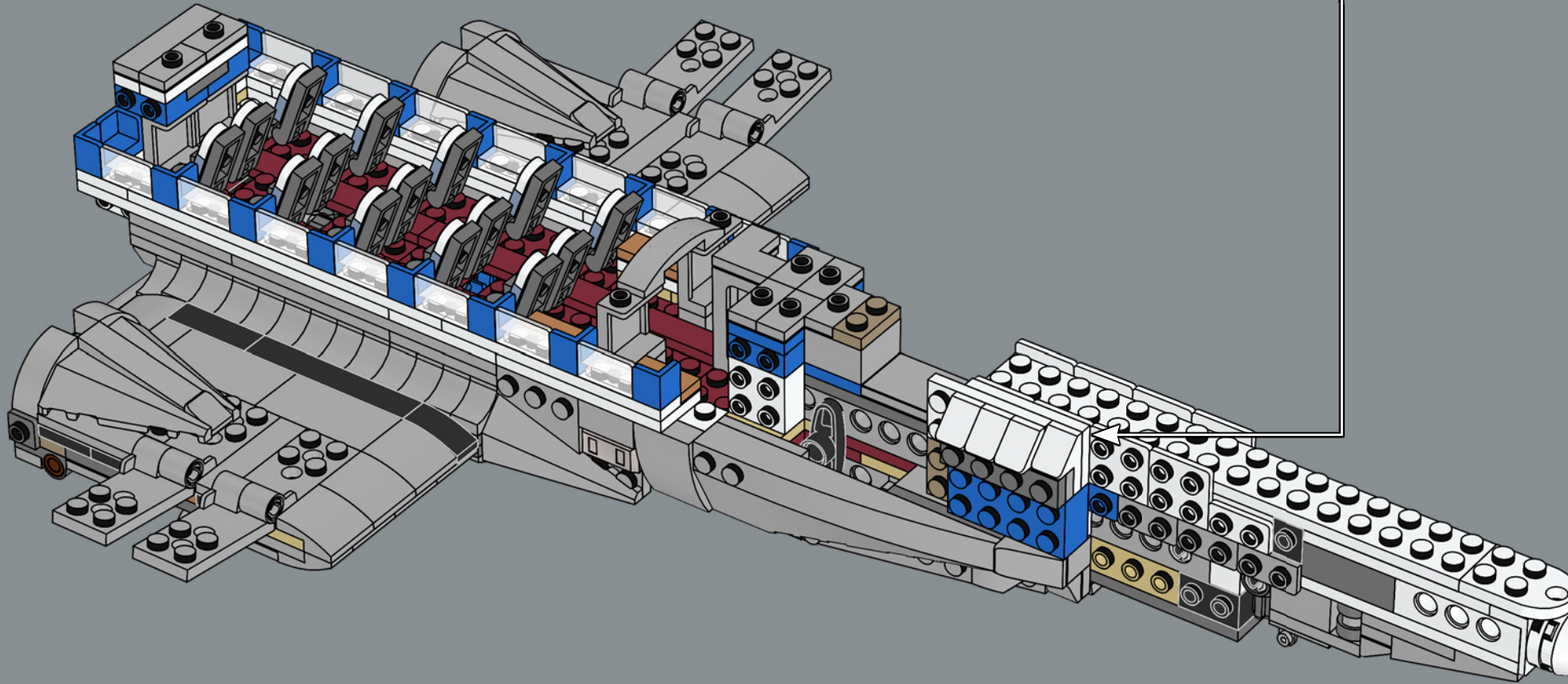

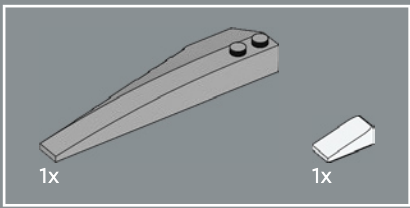

154

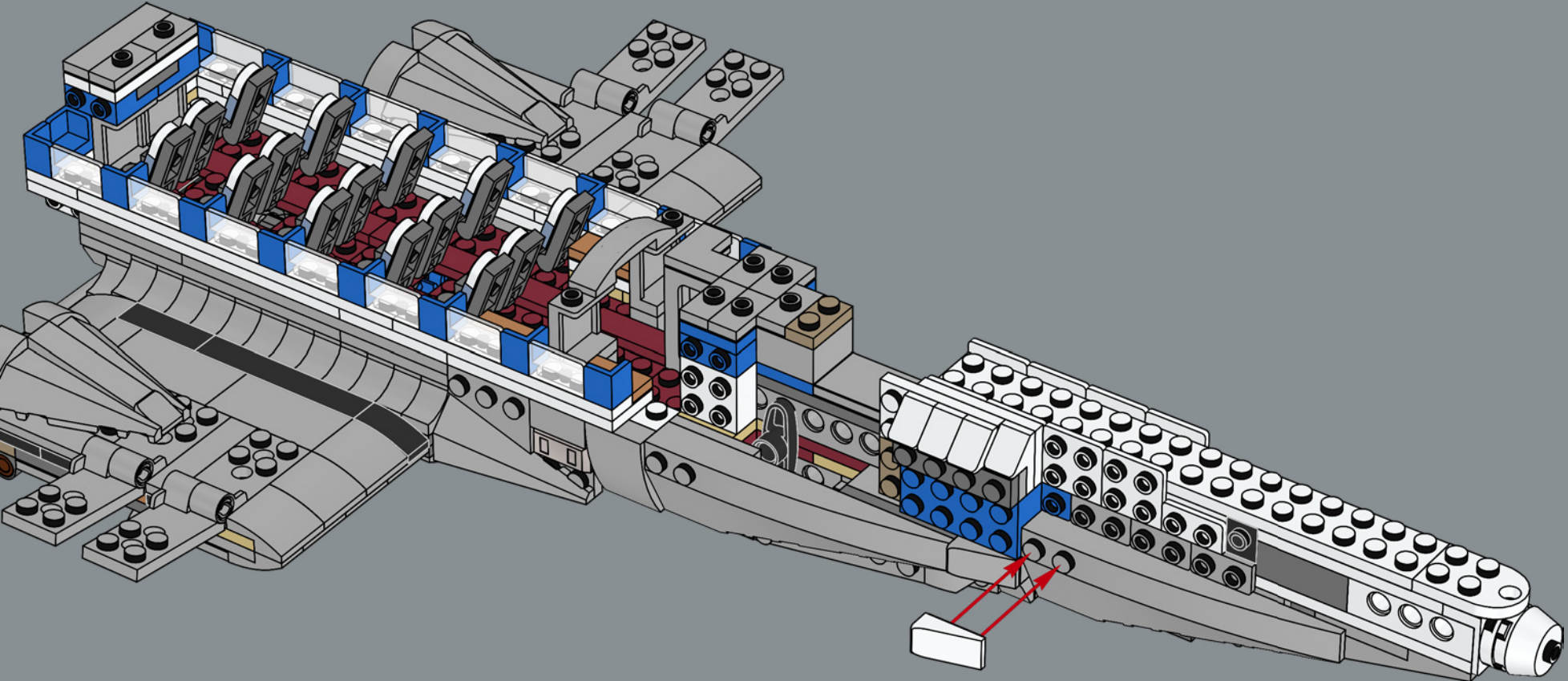

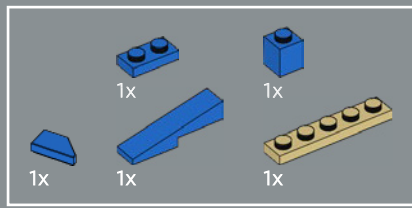

155

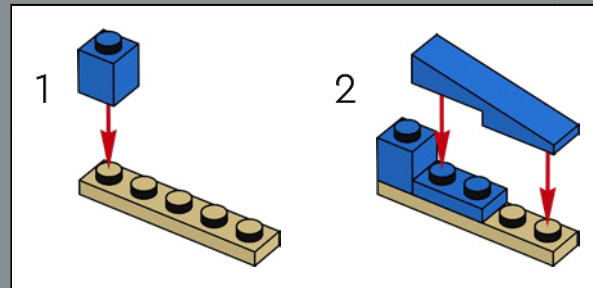
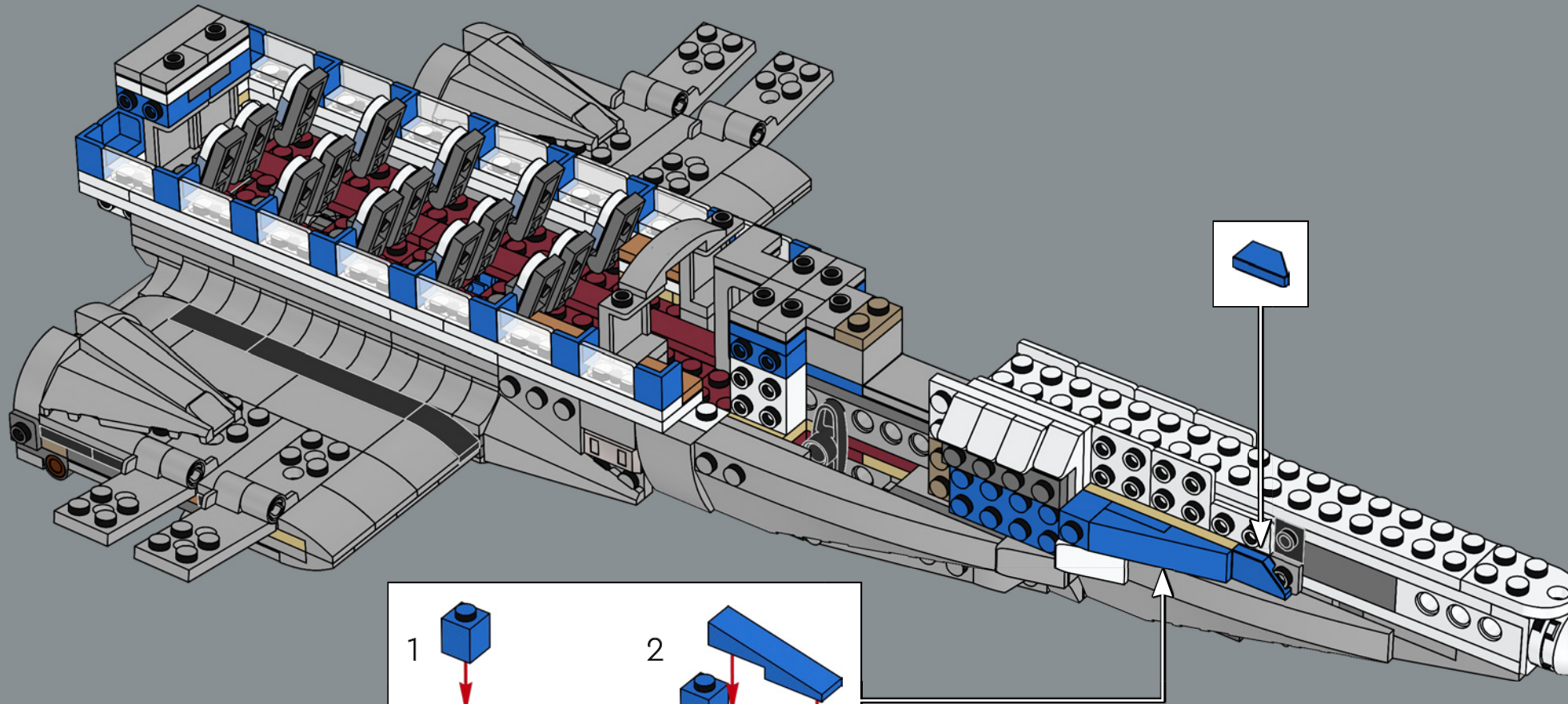

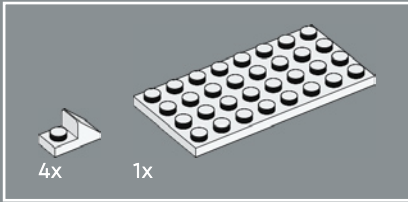
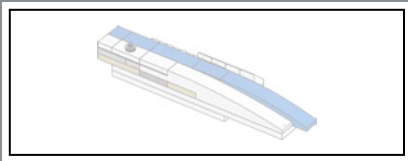

156

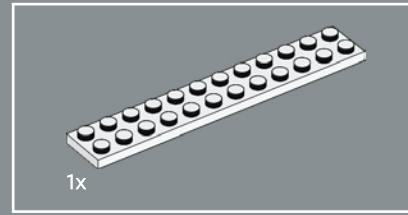
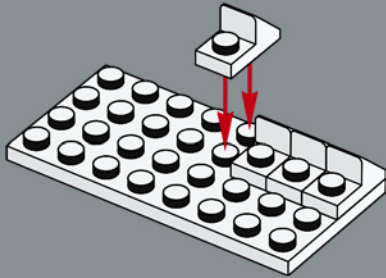

157

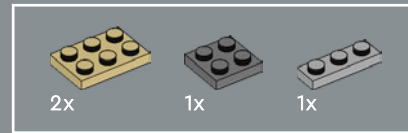
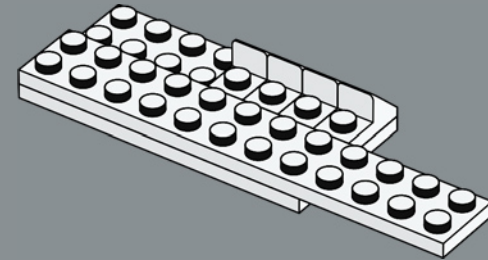

158

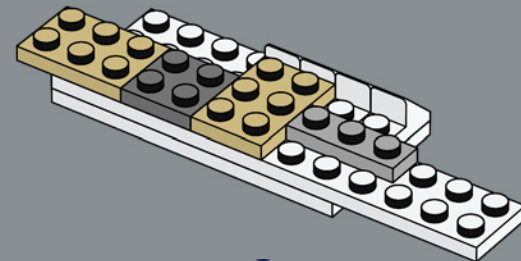

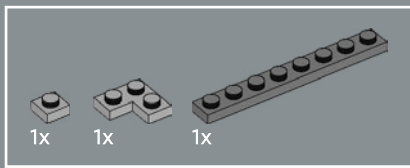

159

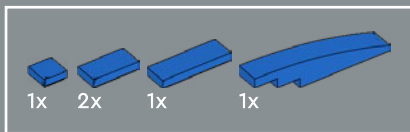
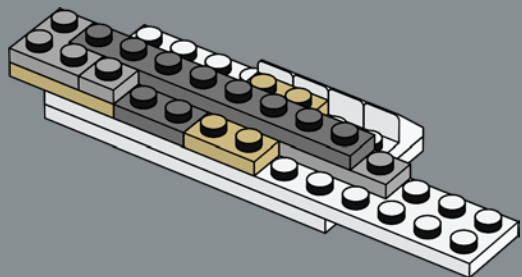

160

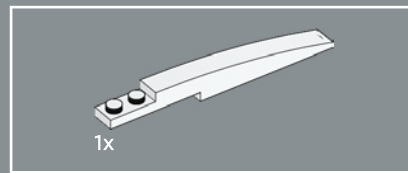
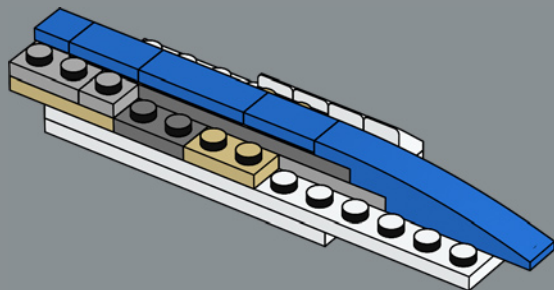

161

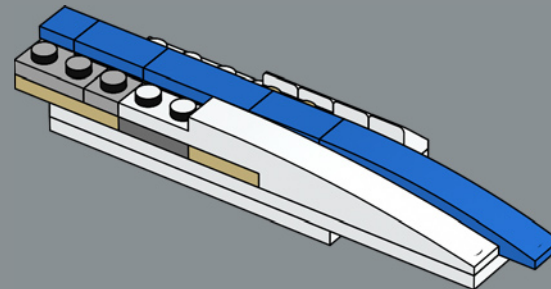

162

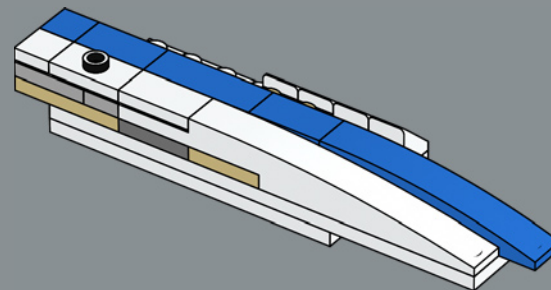

163

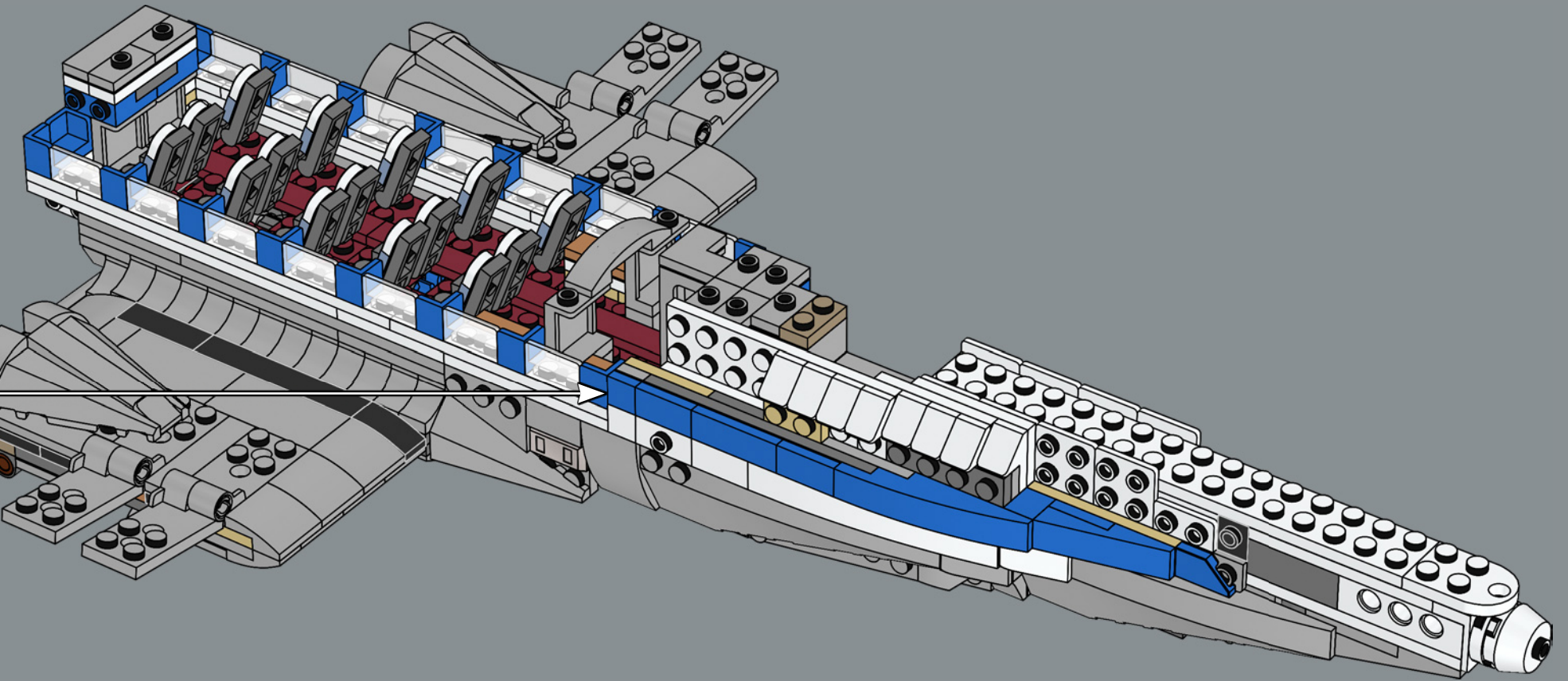

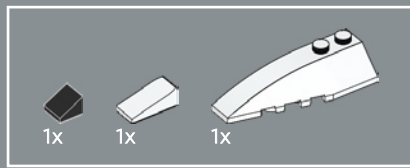

164

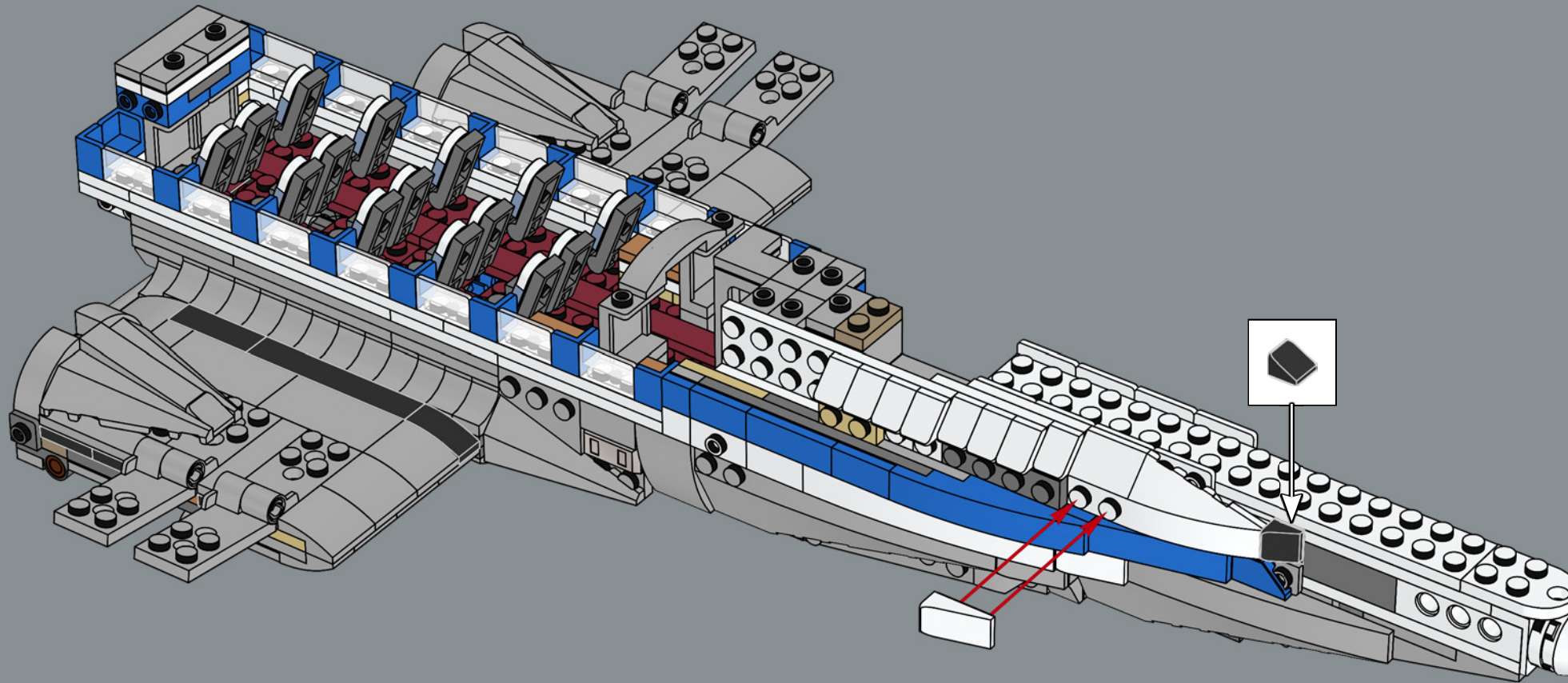

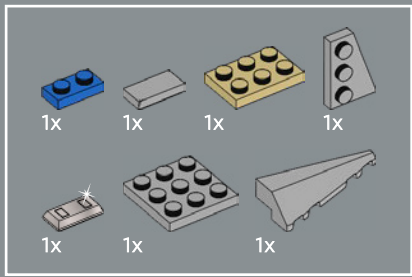

165

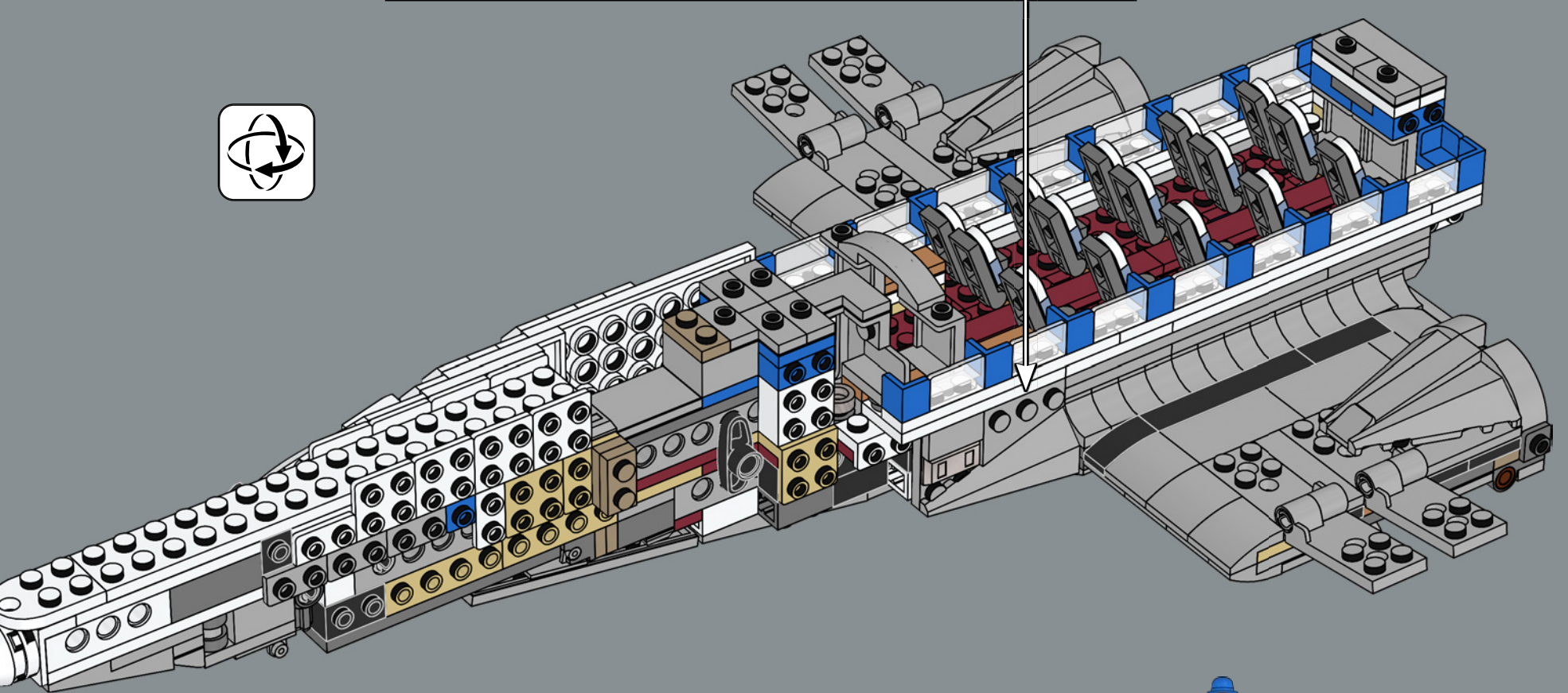
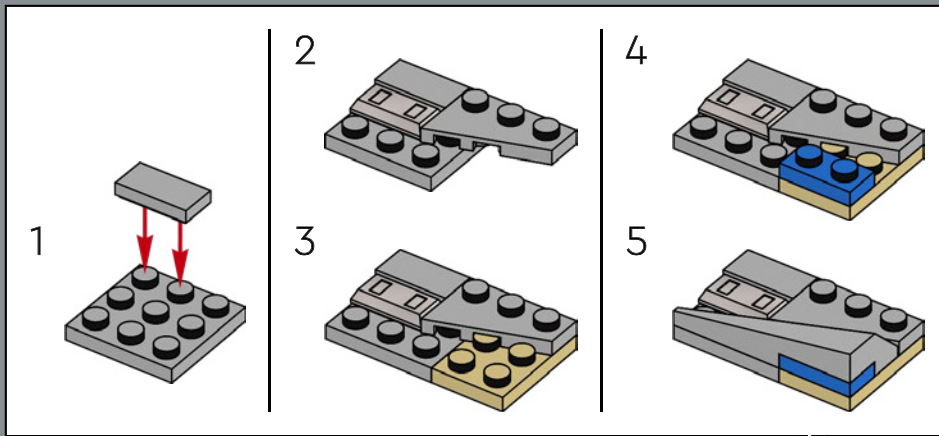

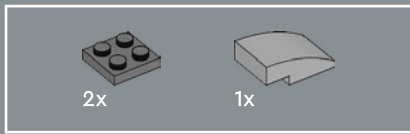

166

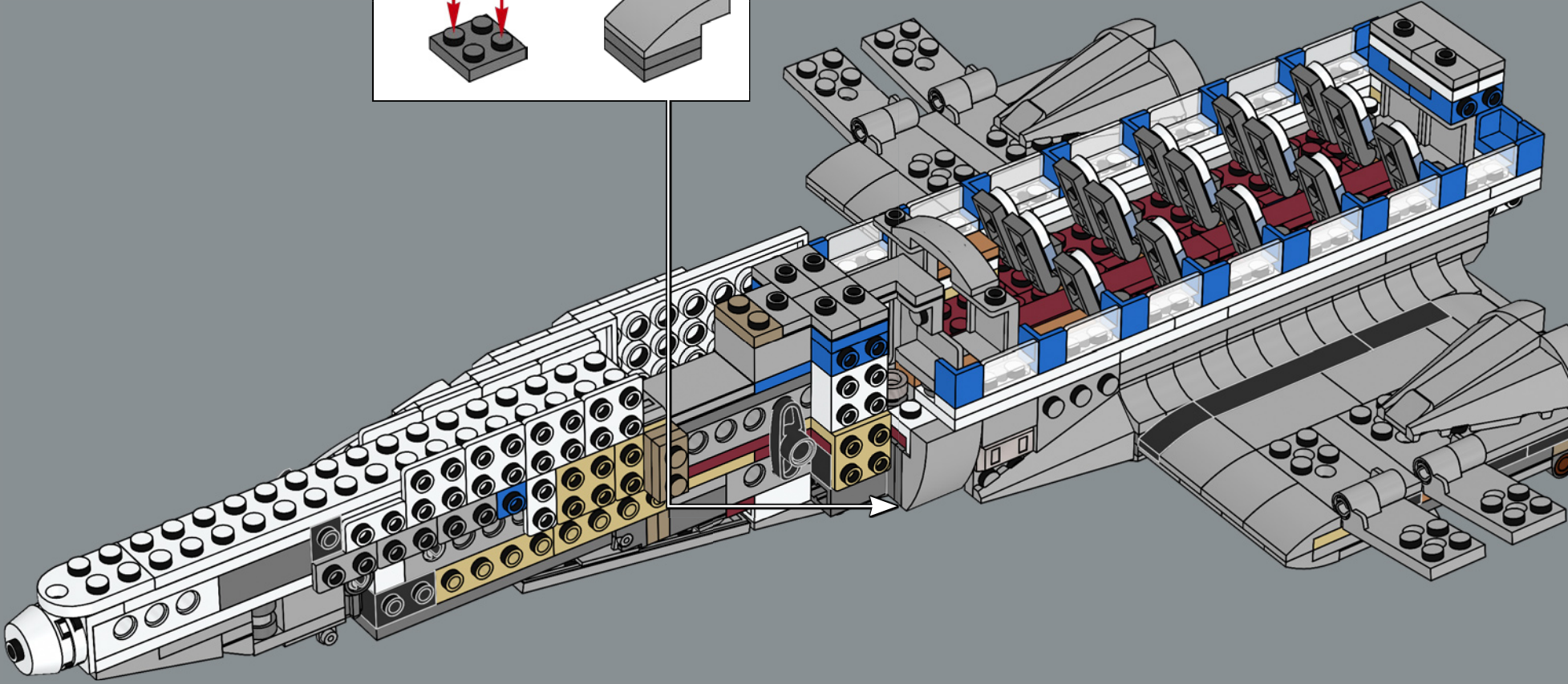
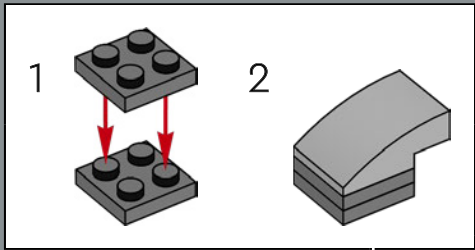

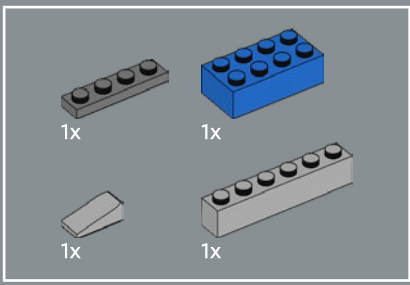

167

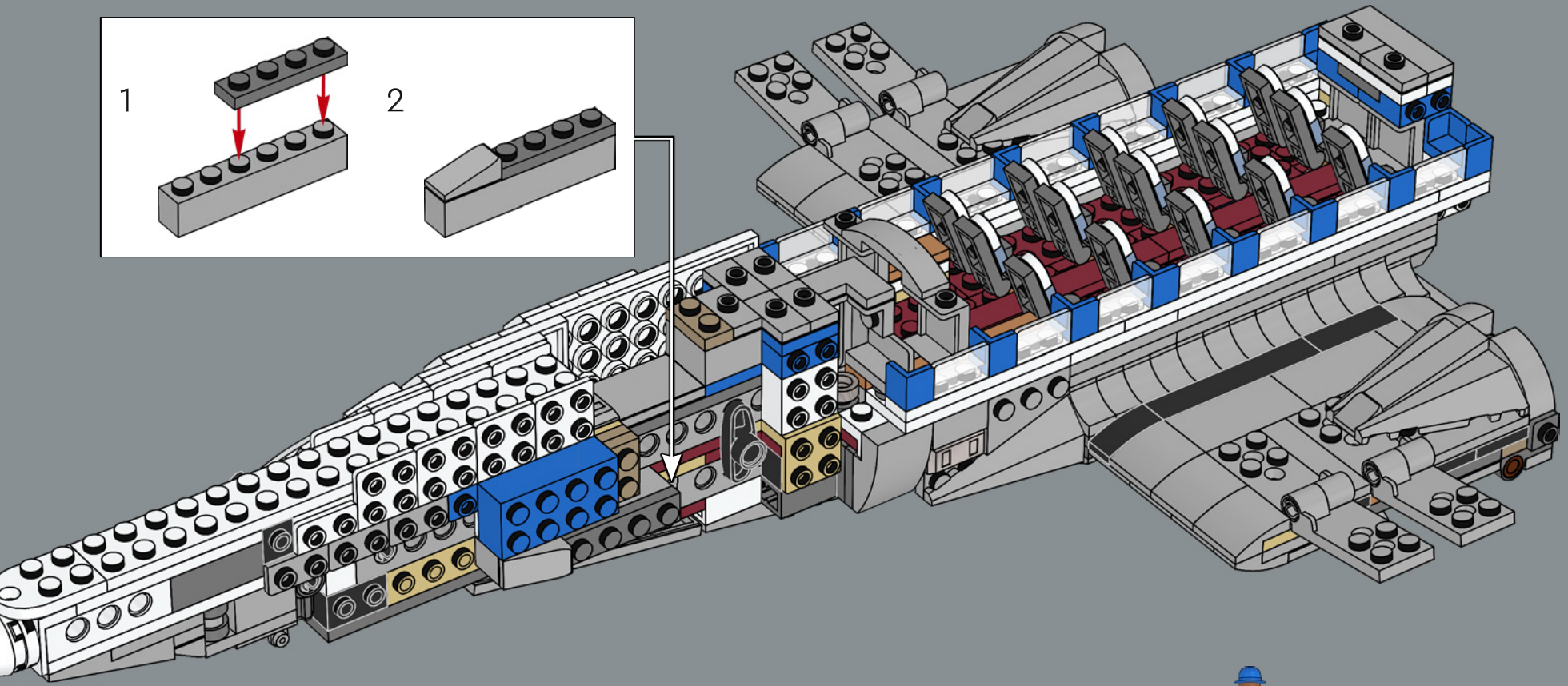
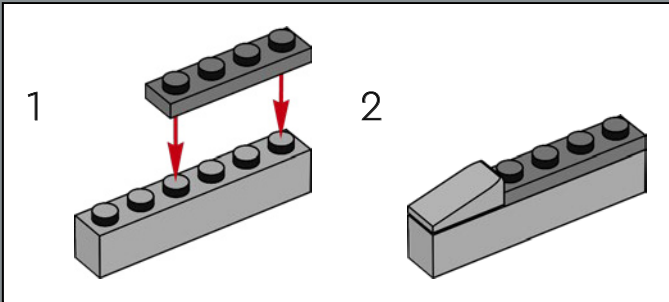

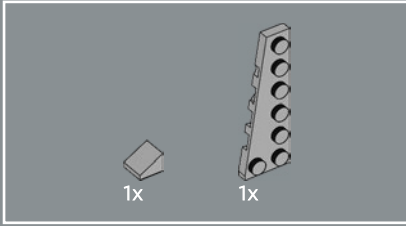
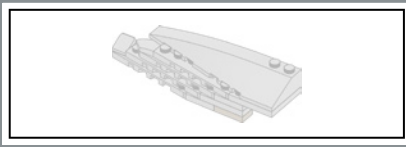

168

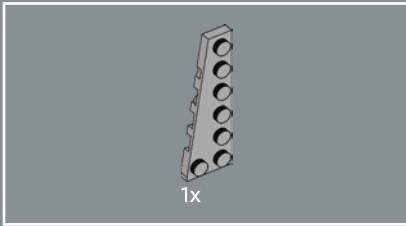
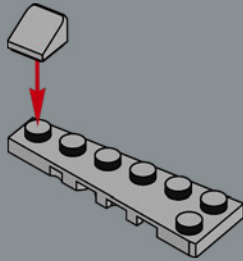

169

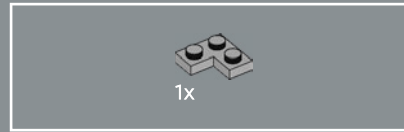
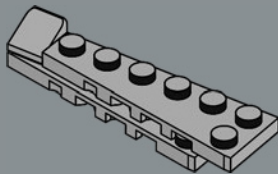

170

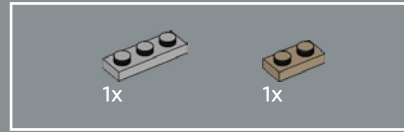
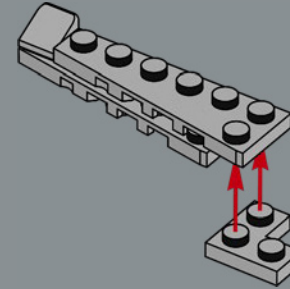

171

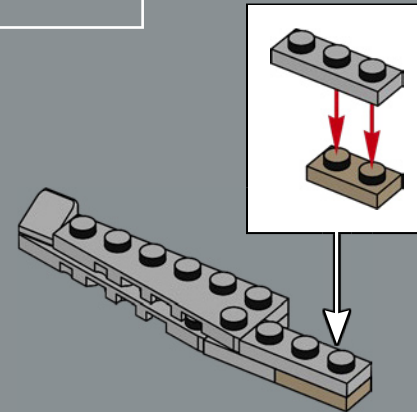

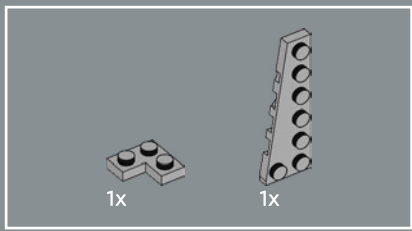

172

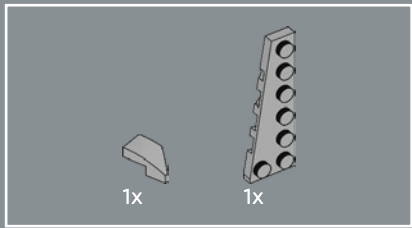
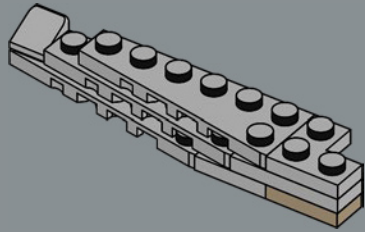

173

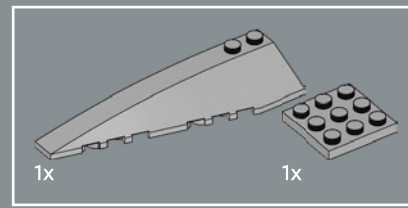
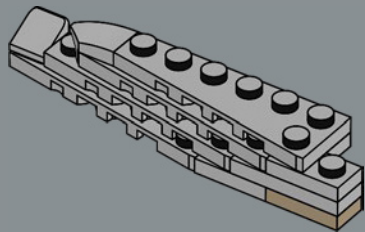

174

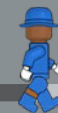
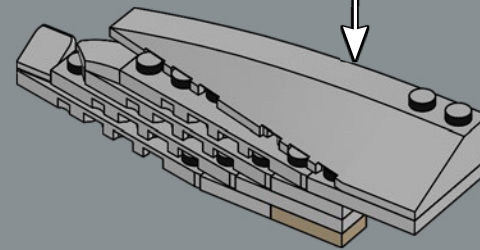
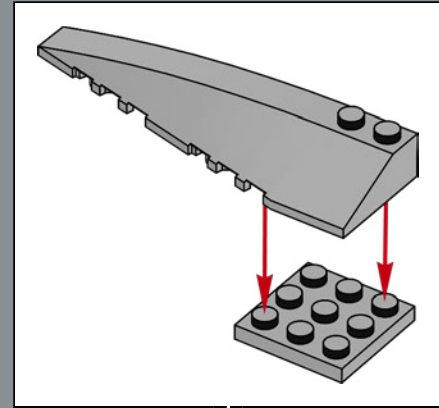

175

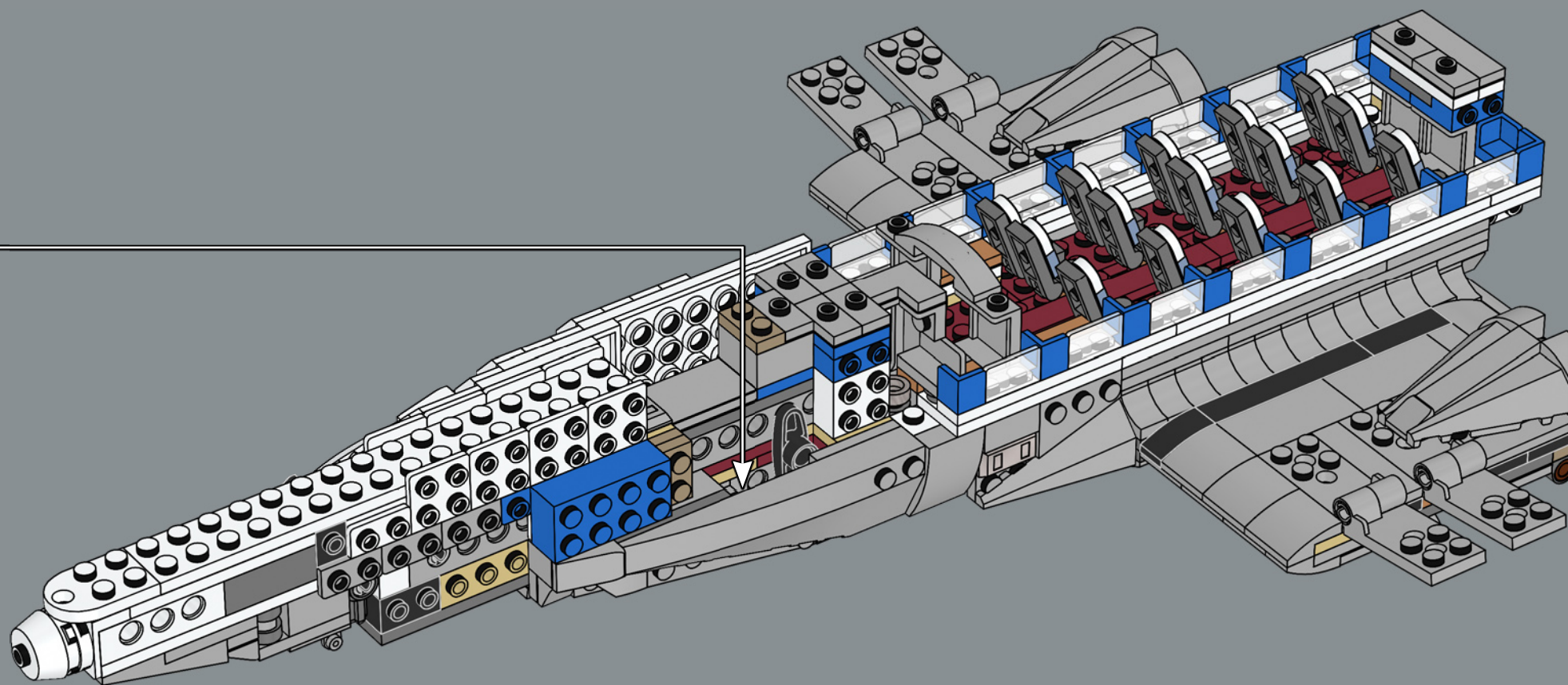

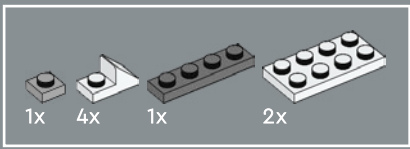

176

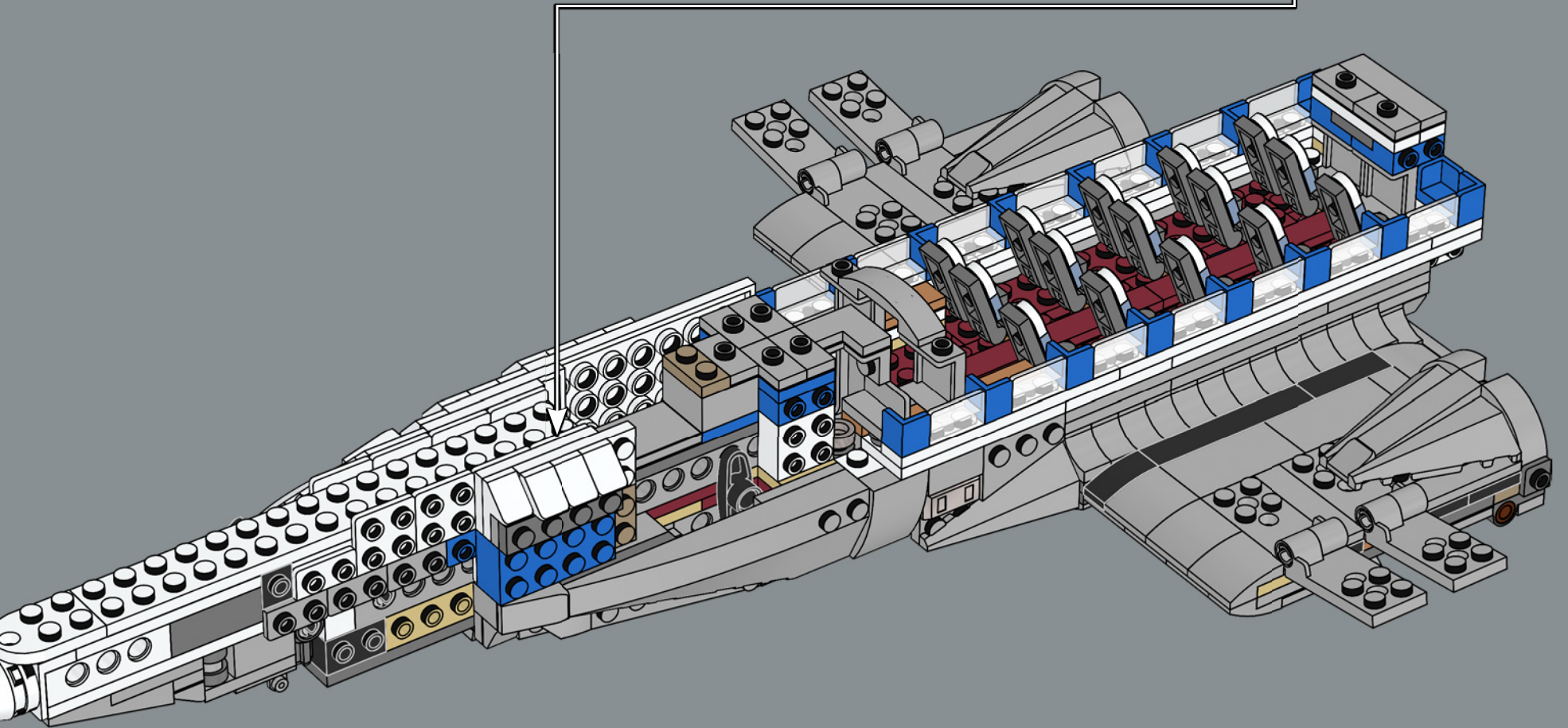
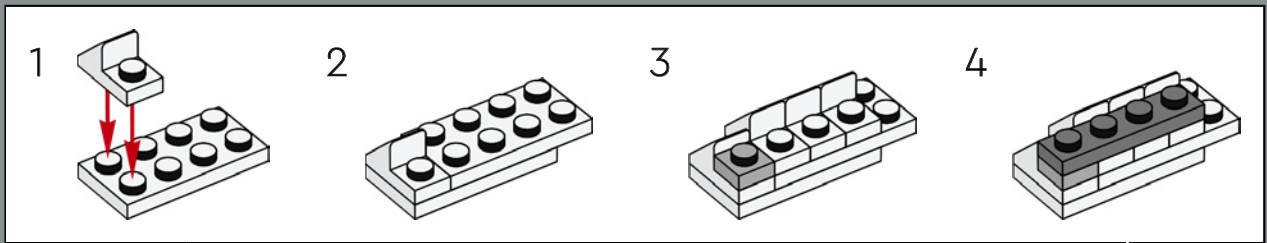

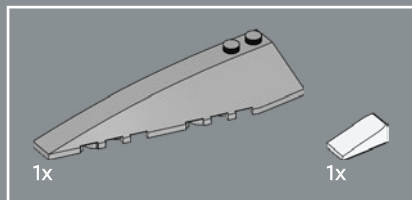

177

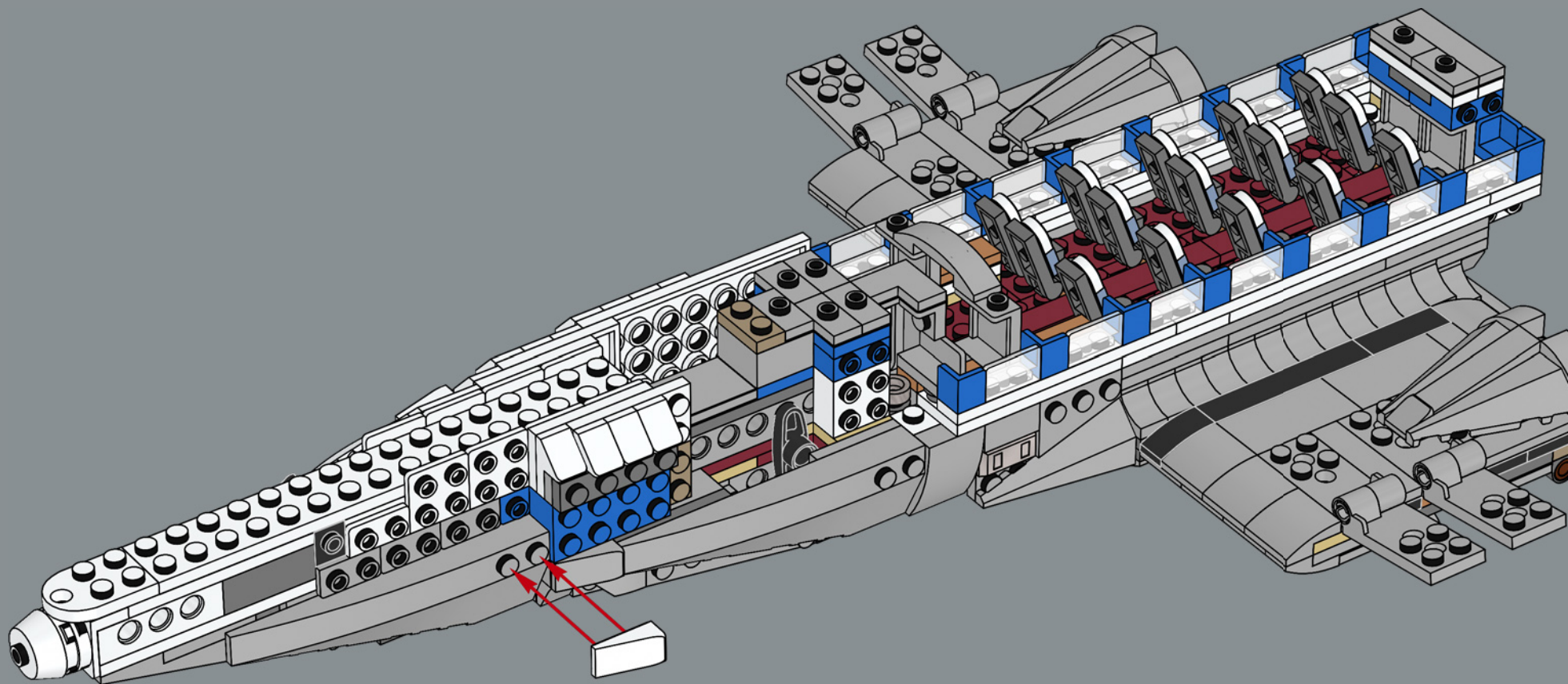

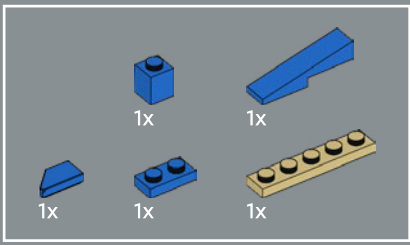

178

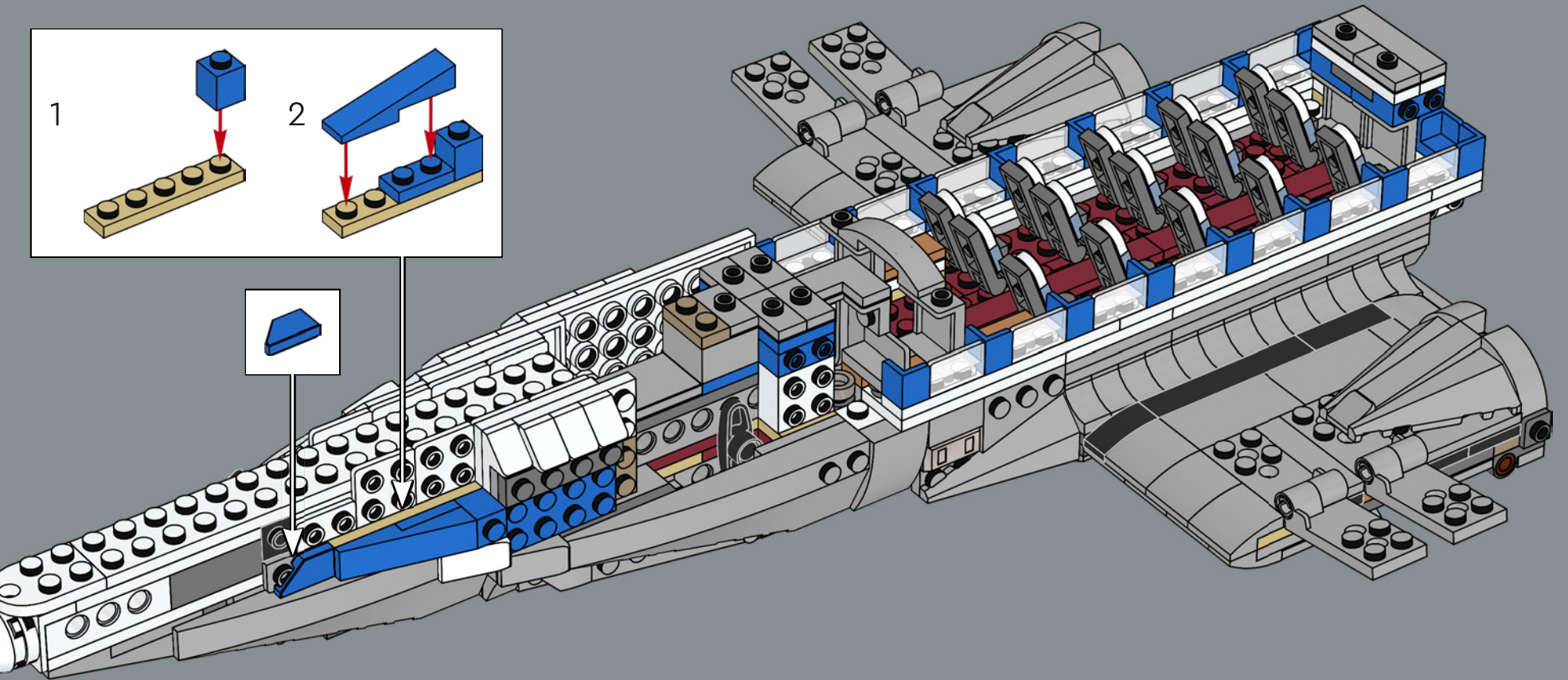
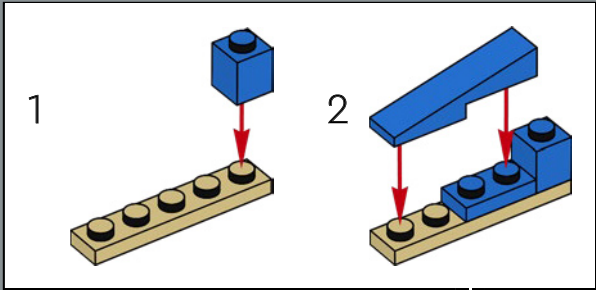

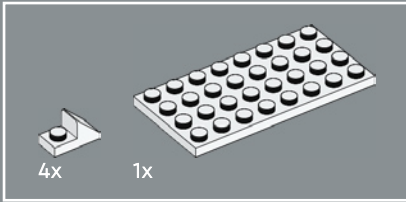
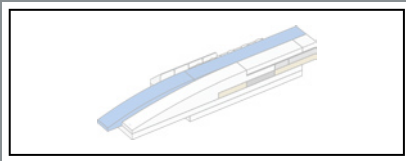

179

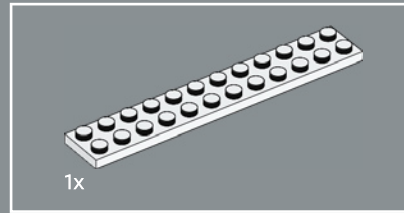
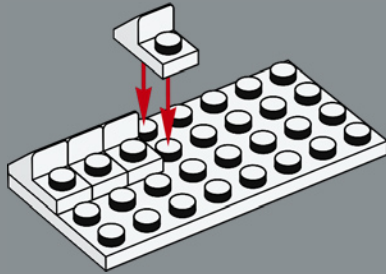

180

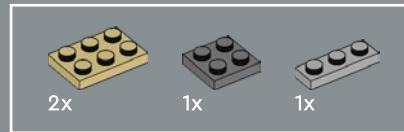
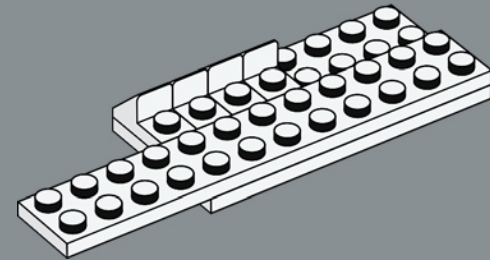

181

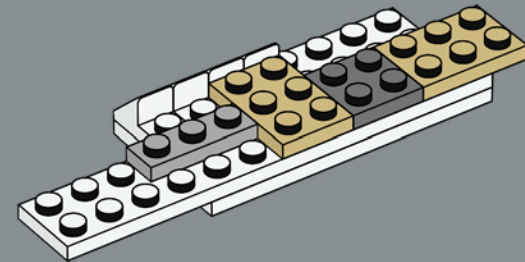

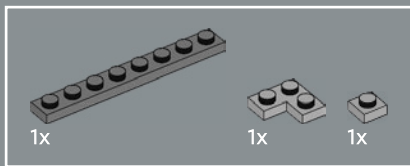

182

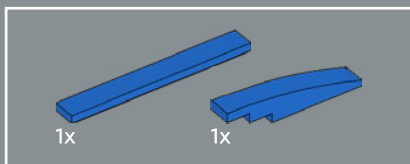
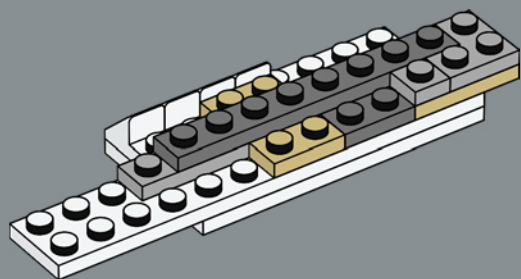

183

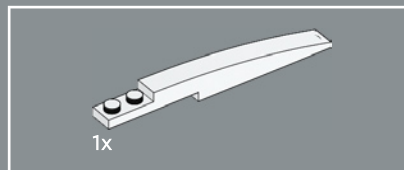
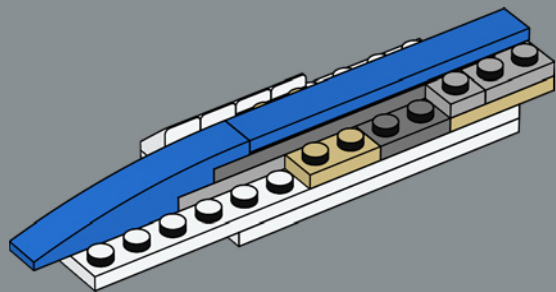

184

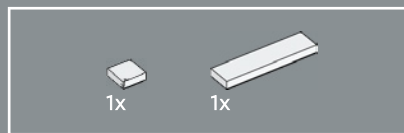
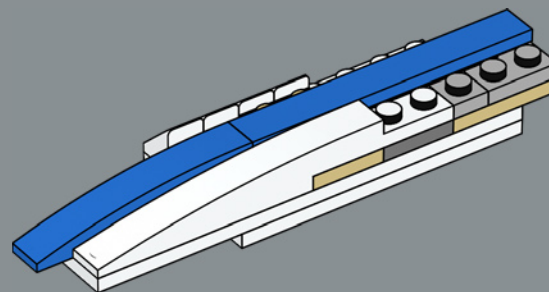

185

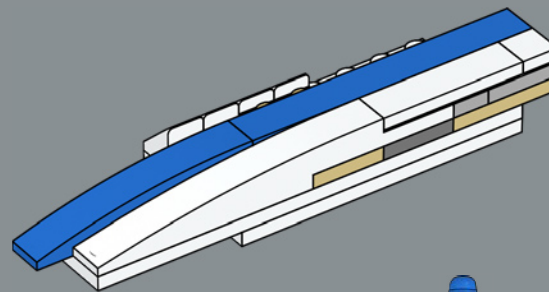

186

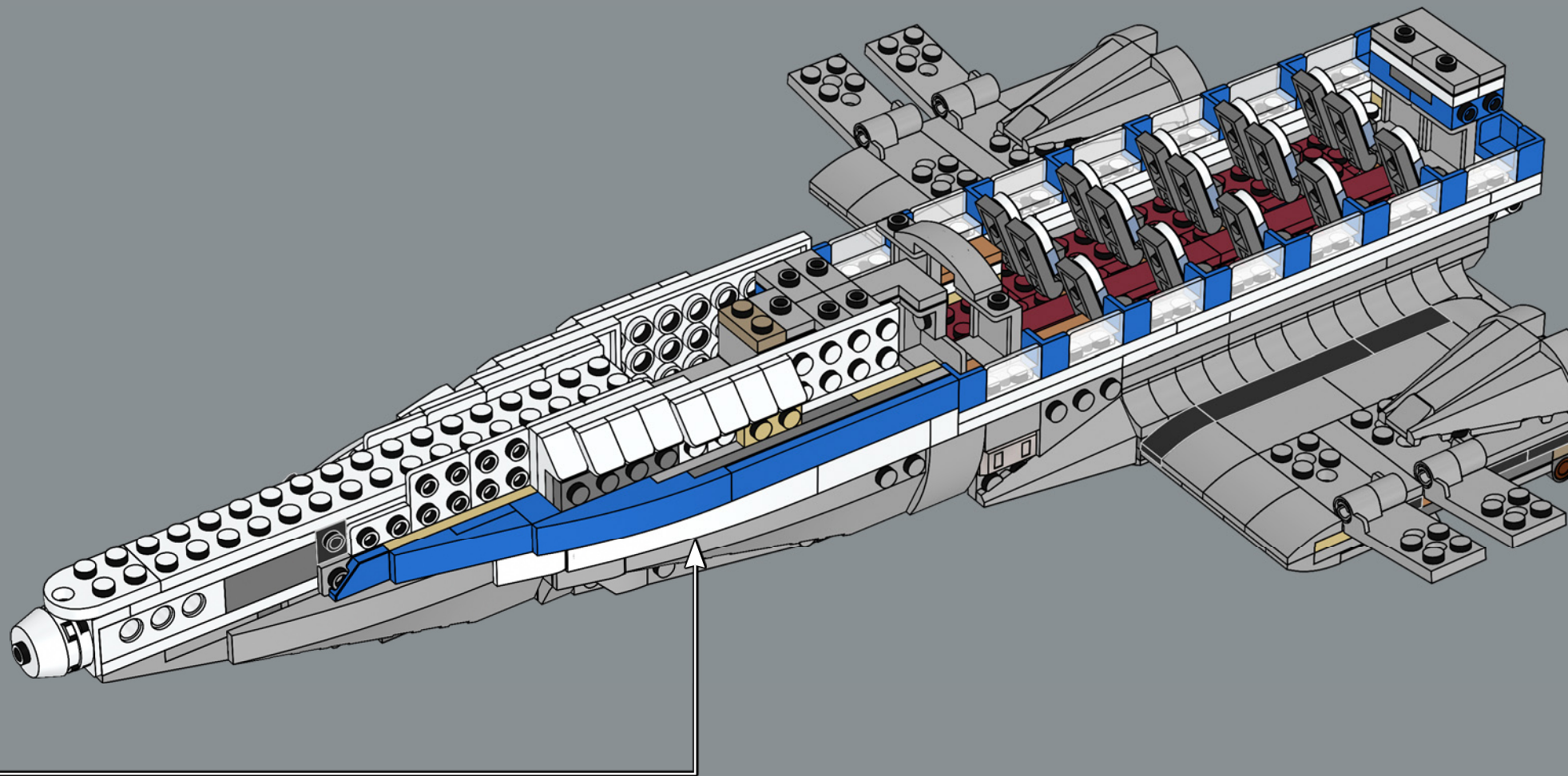

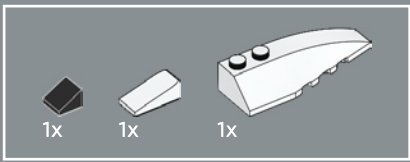

187

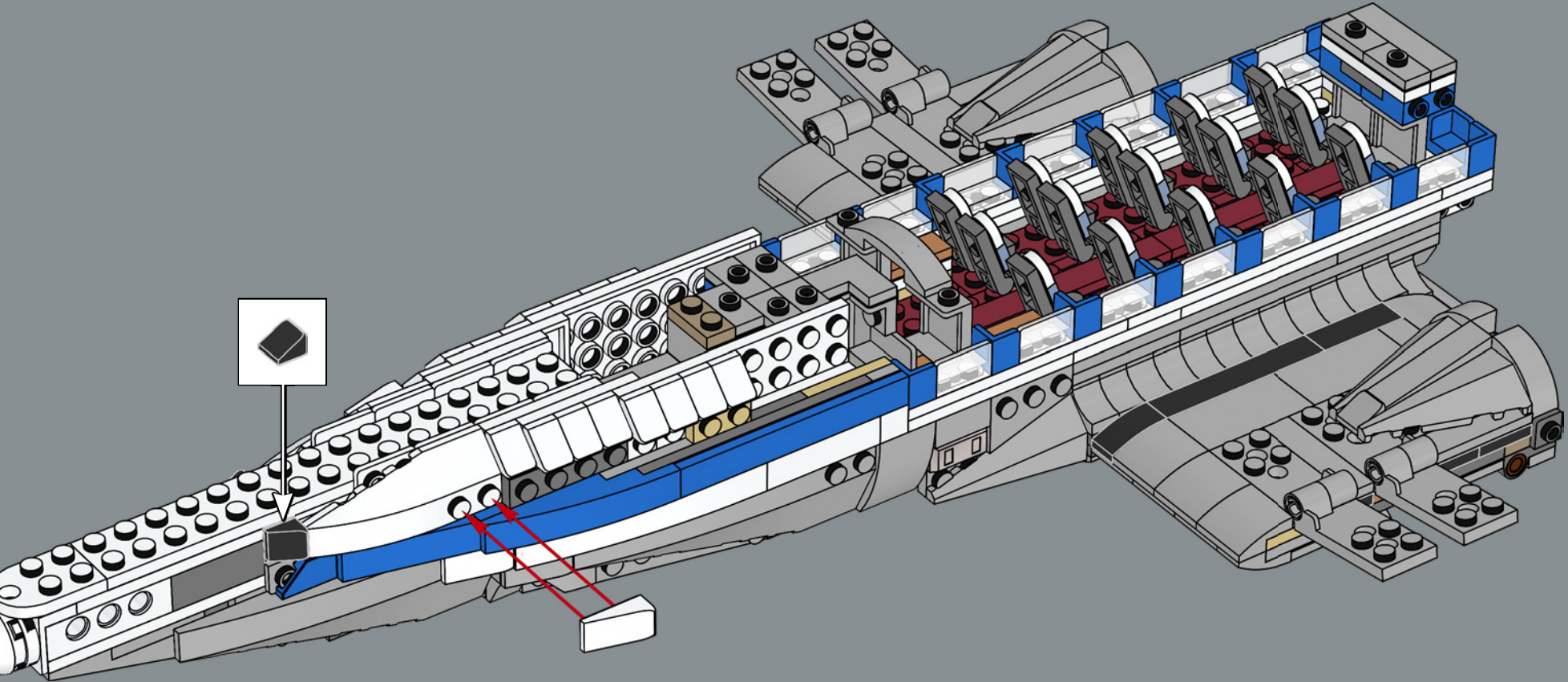



Pan Am® fut la première compagnie aérienne à introduire des uniformes standardisés pour les pilotes, inspirés de la marine.

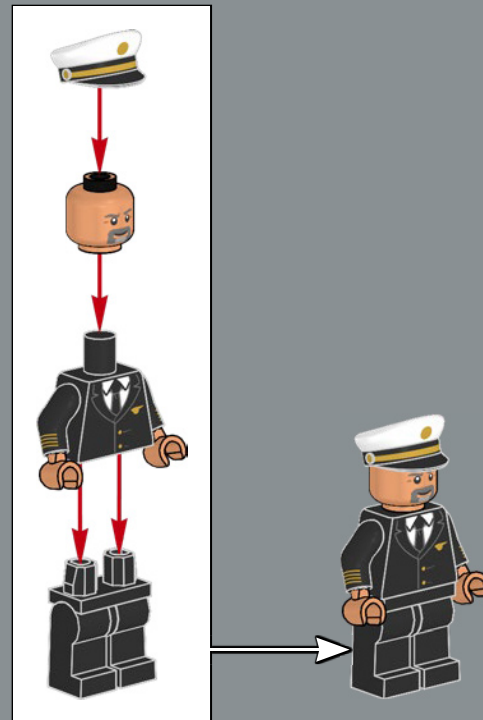

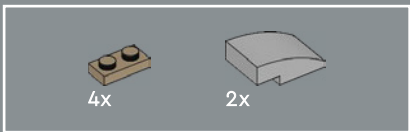

188

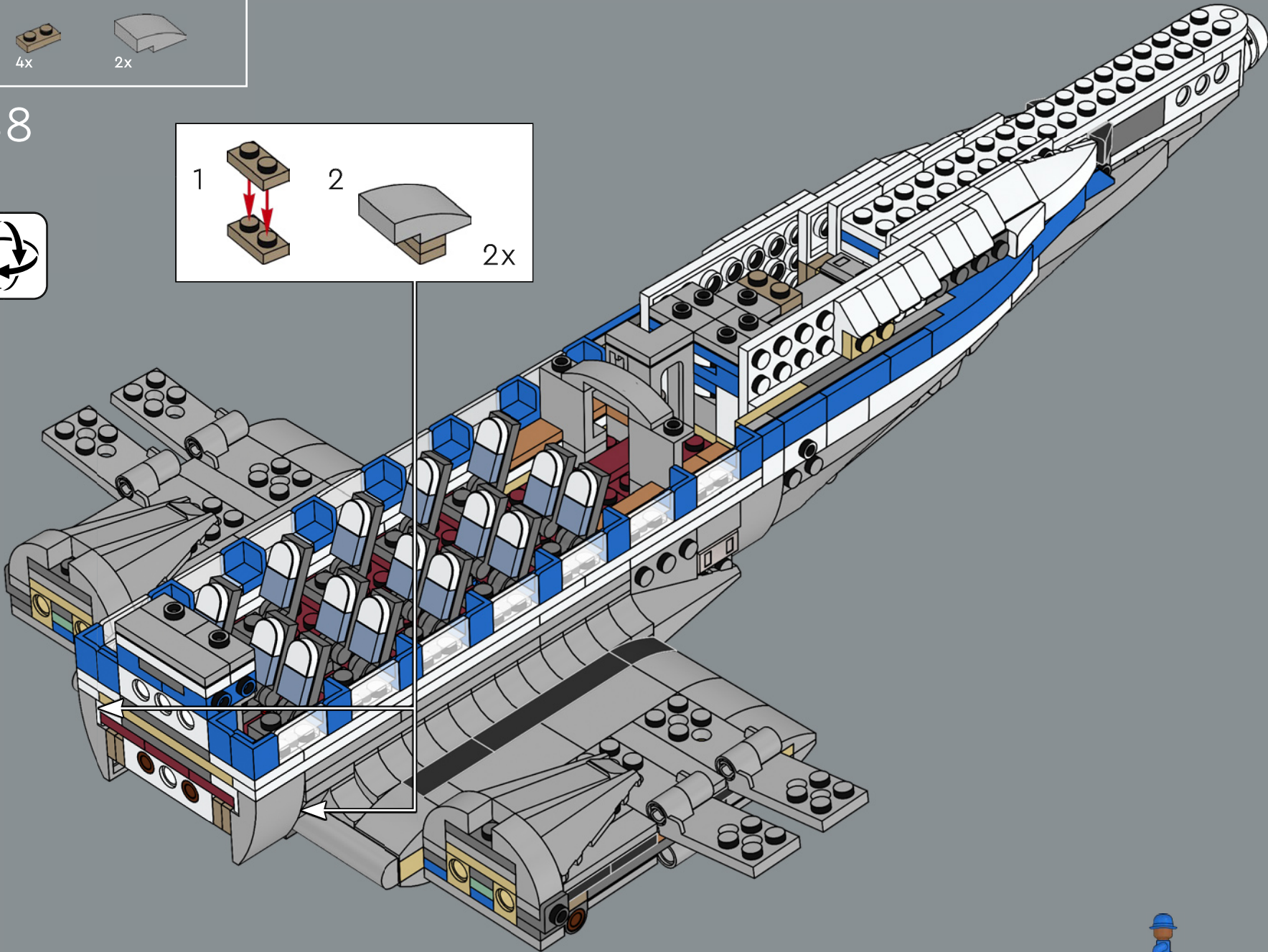
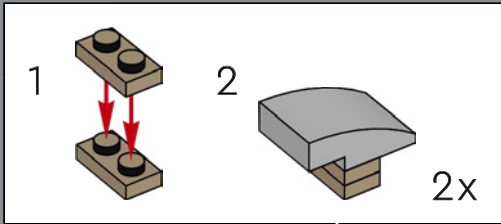

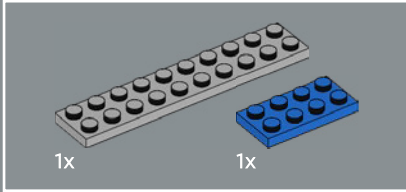
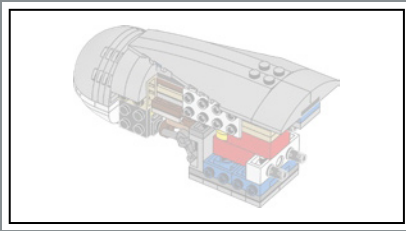

189

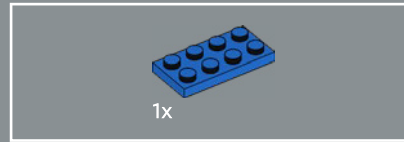
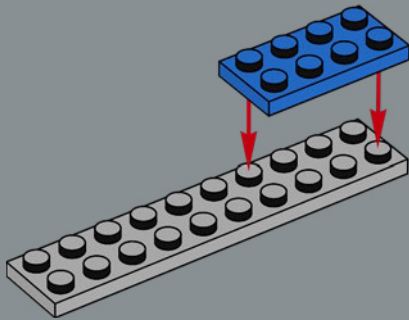

190

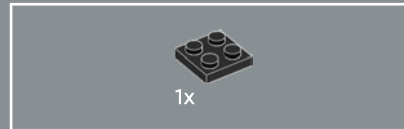
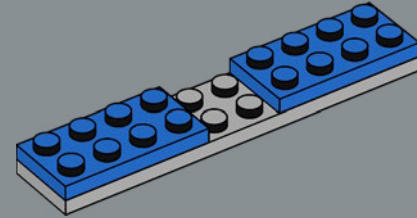

191

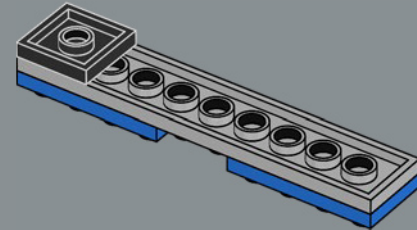



192

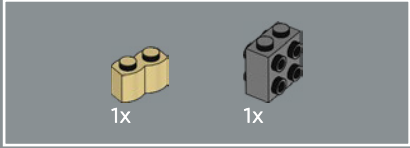
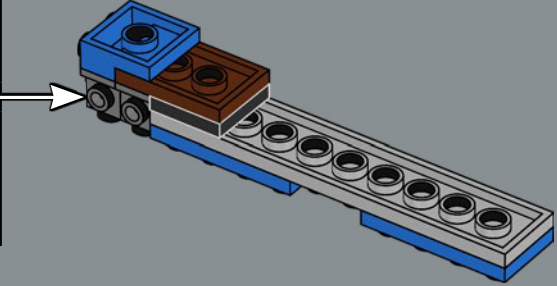
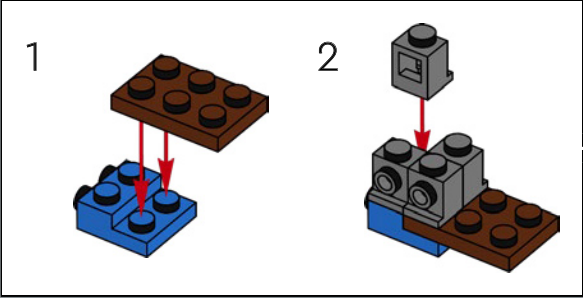

193

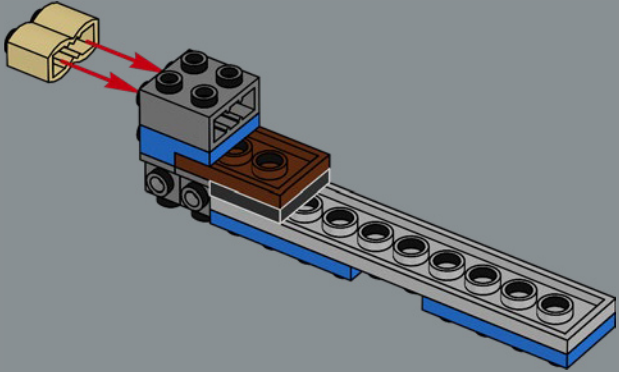

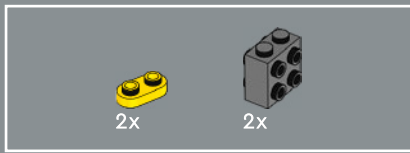

194

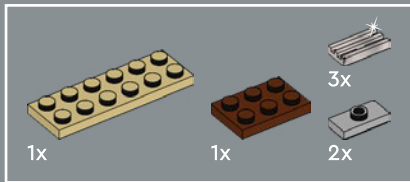
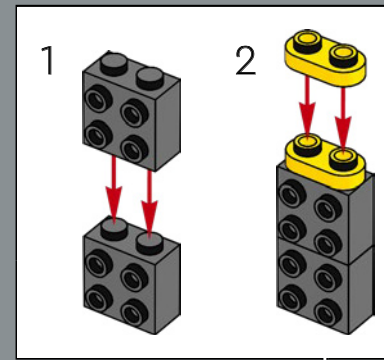
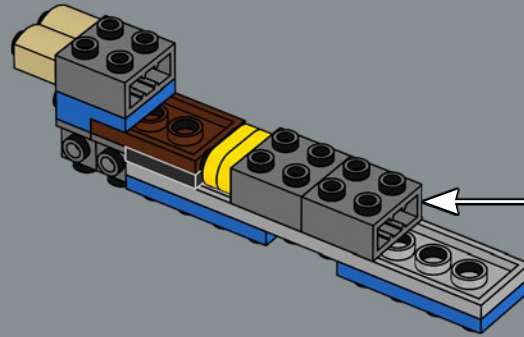

195

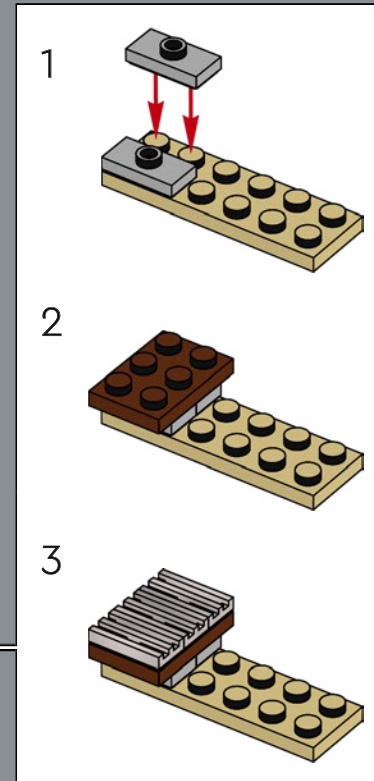
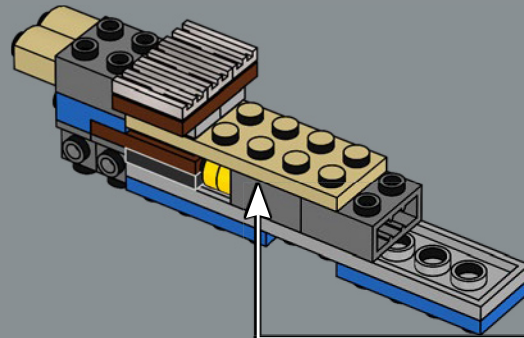



196

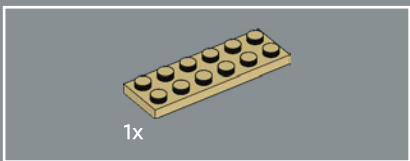
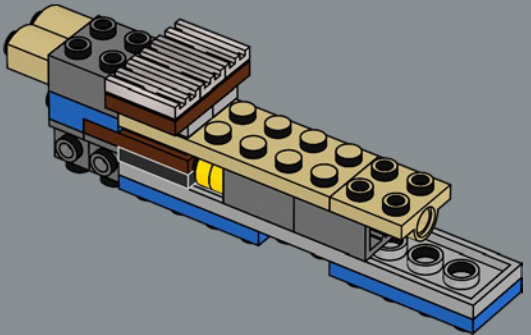

197

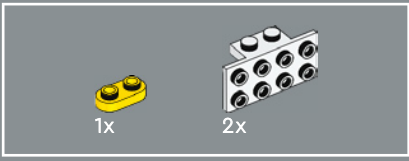
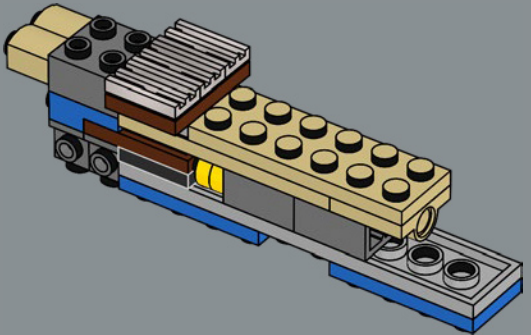

198

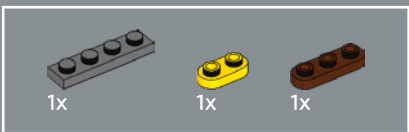
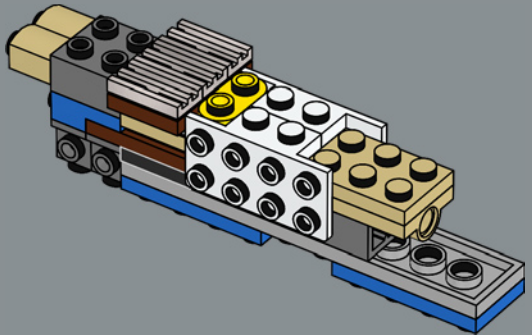

199

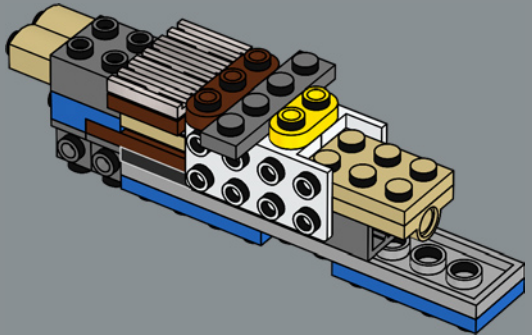

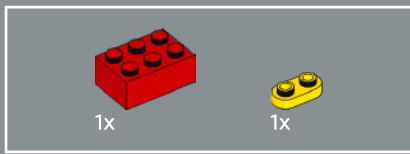

200

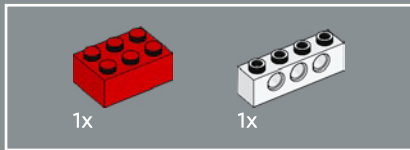
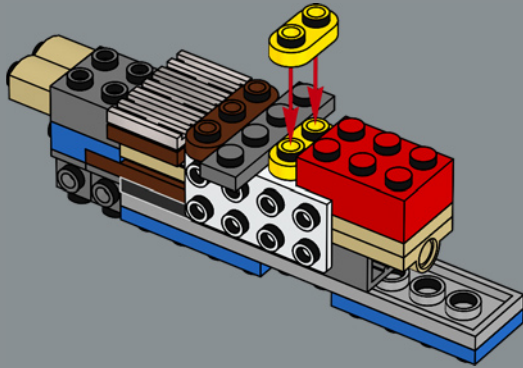

201

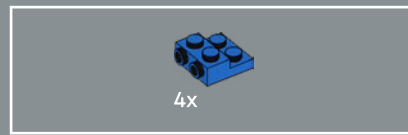
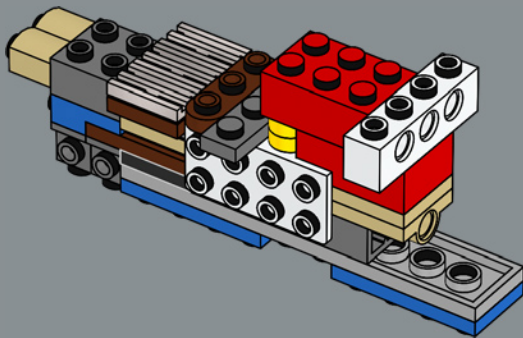

202

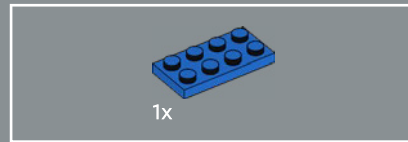
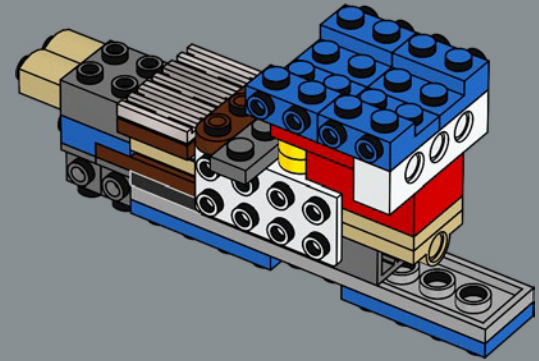

203

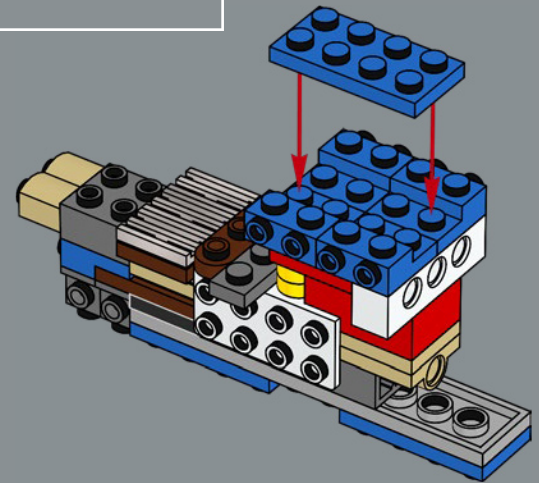

3x

204

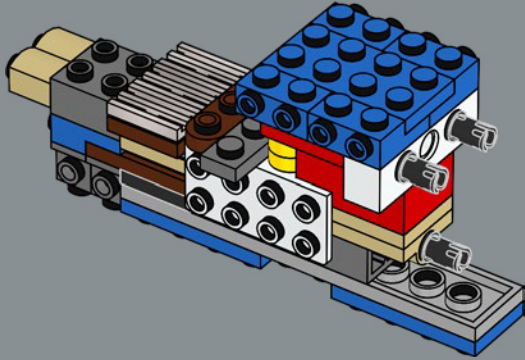

2x

205

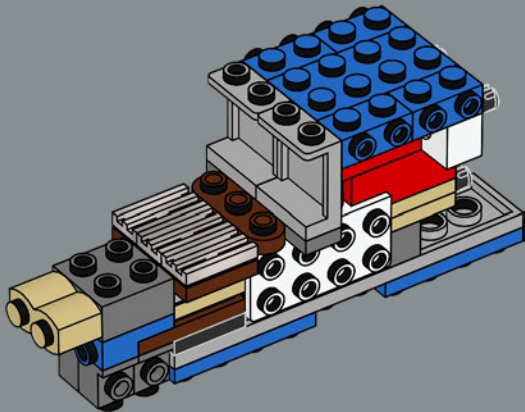

1x

206

1x

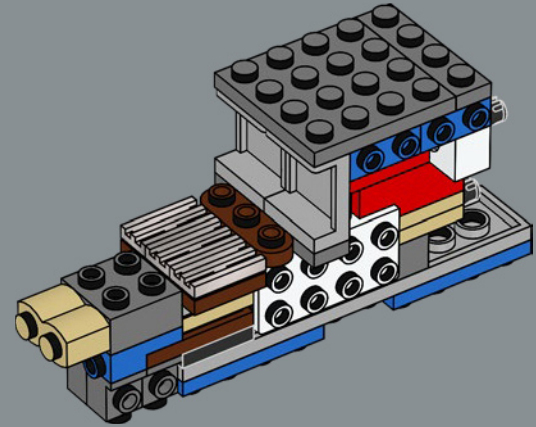

10x

207

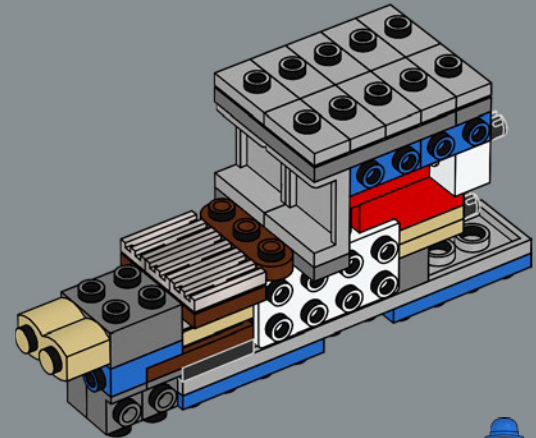

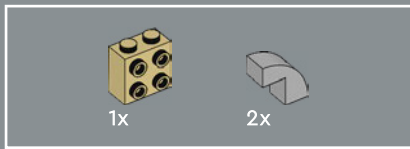

208

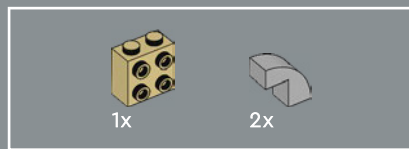
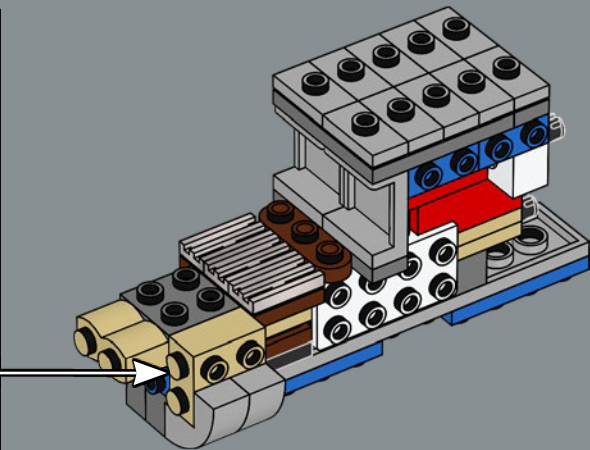
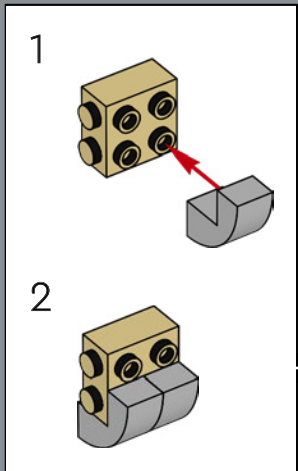

209

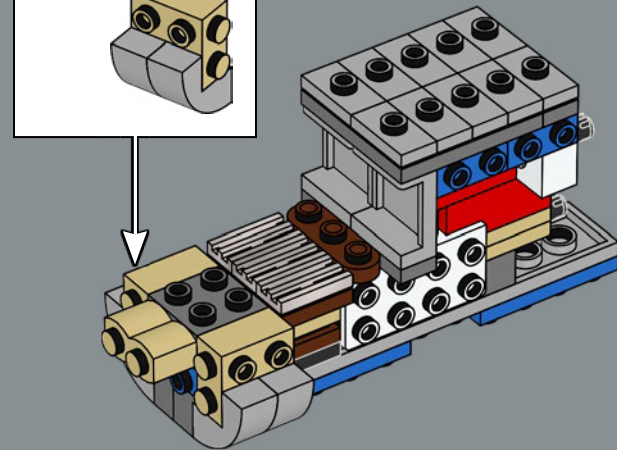
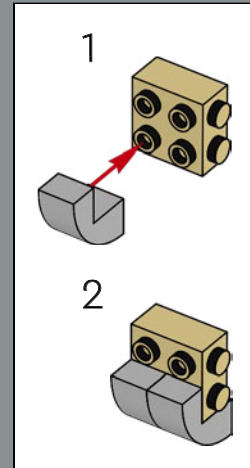



210

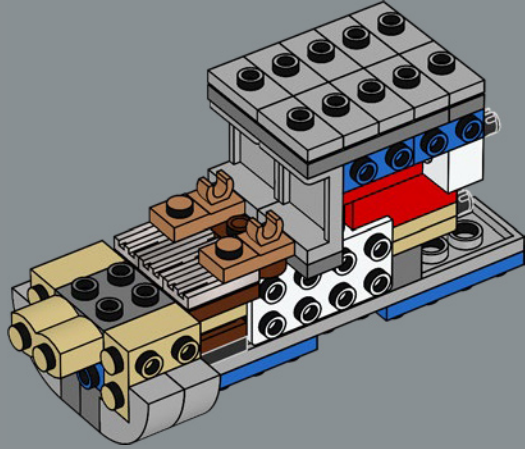

211

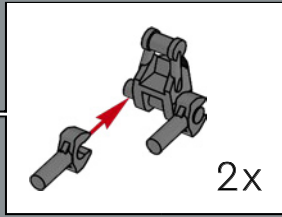
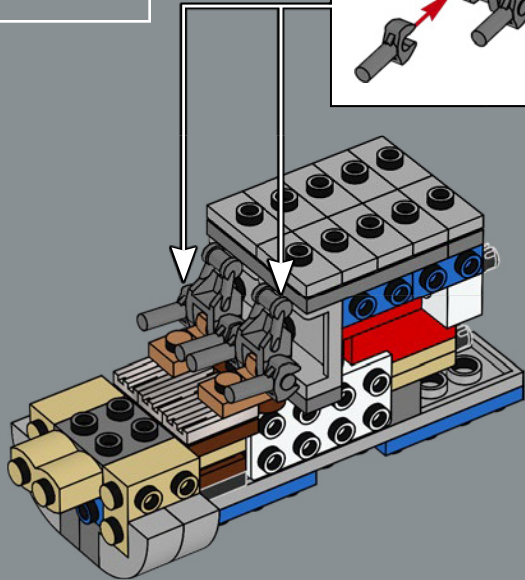

212

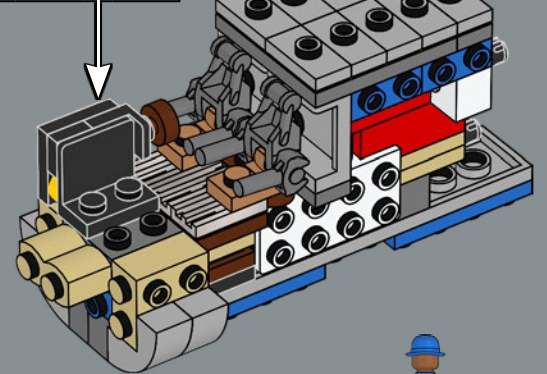
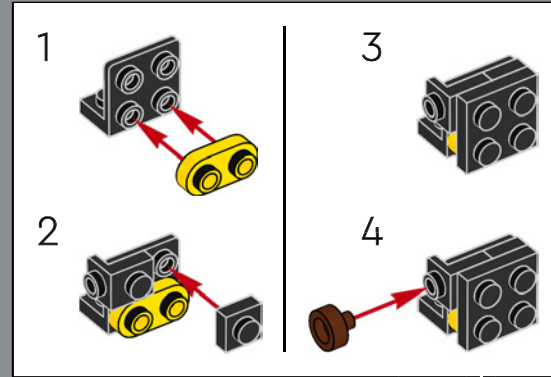

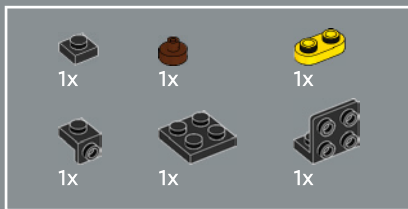

213

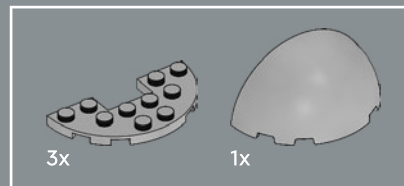
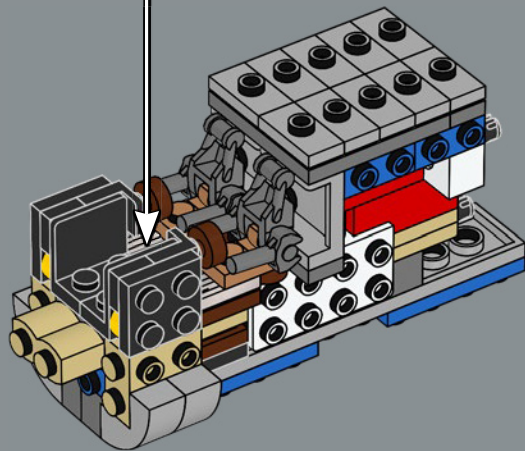
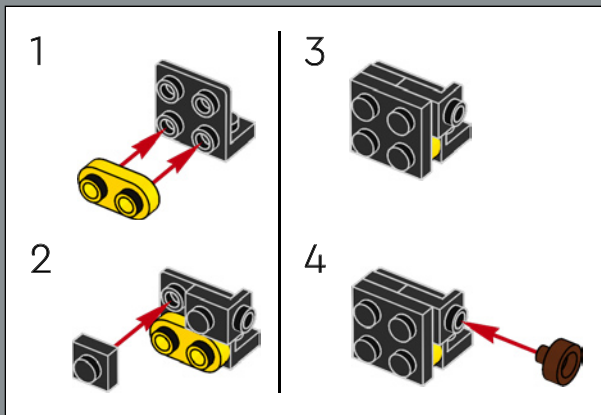

214

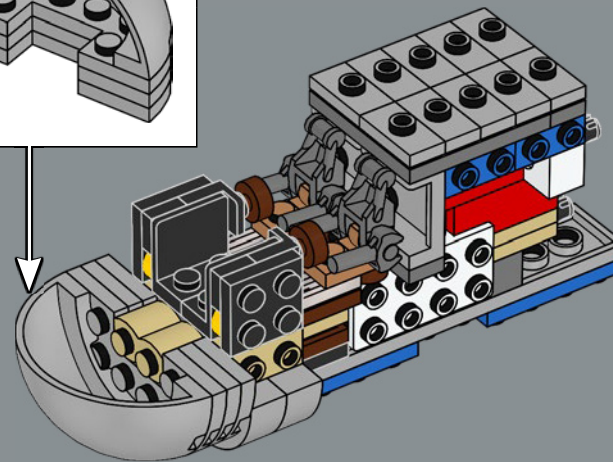
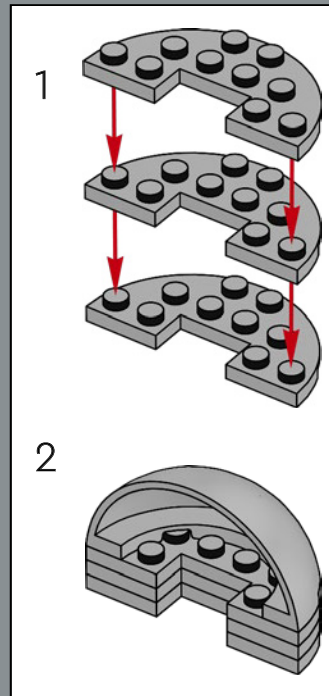

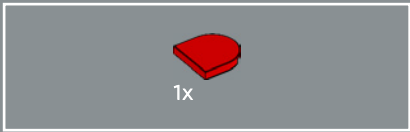

215

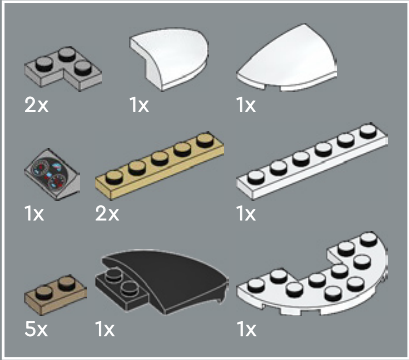
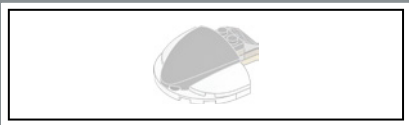
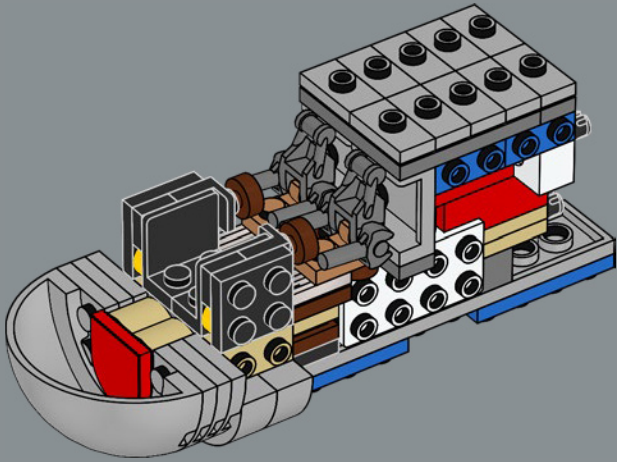

216

1



2

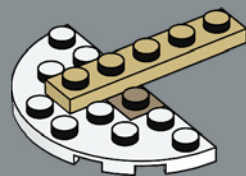

3

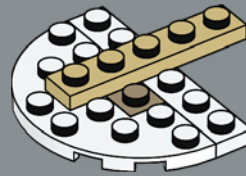



La pièce noire située à l'avant est un élément LEGO® initialement conçu comme pétale pour construire des tulipes.

4

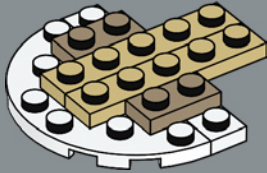

5

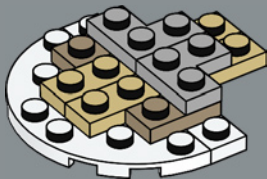

6

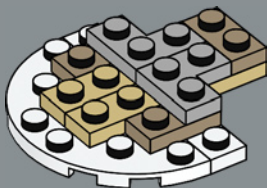

7

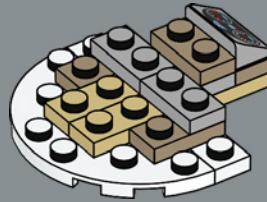

8

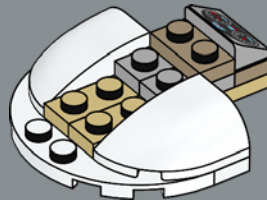

9

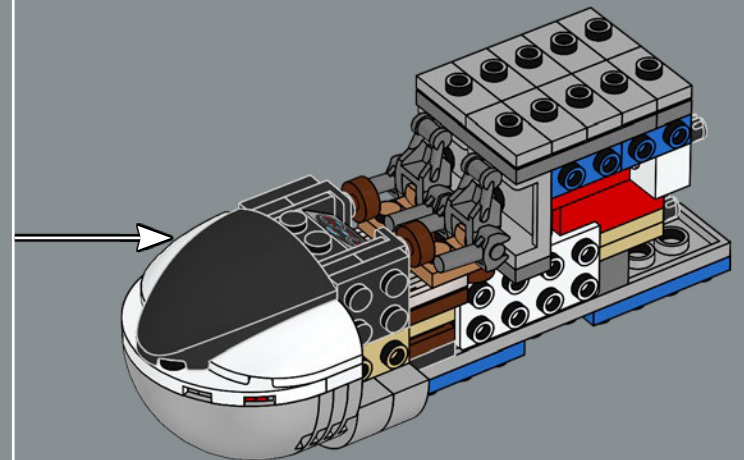
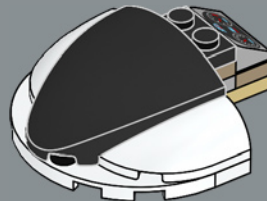

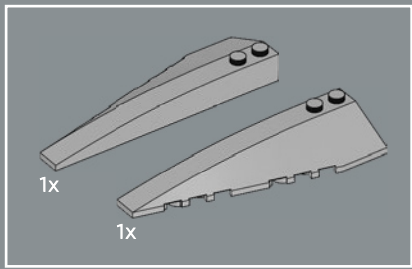

217

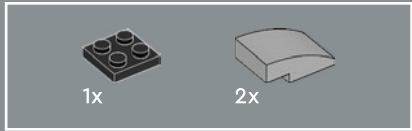
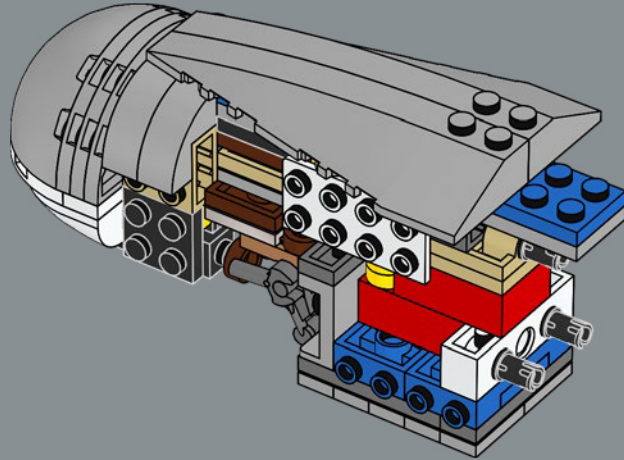

218

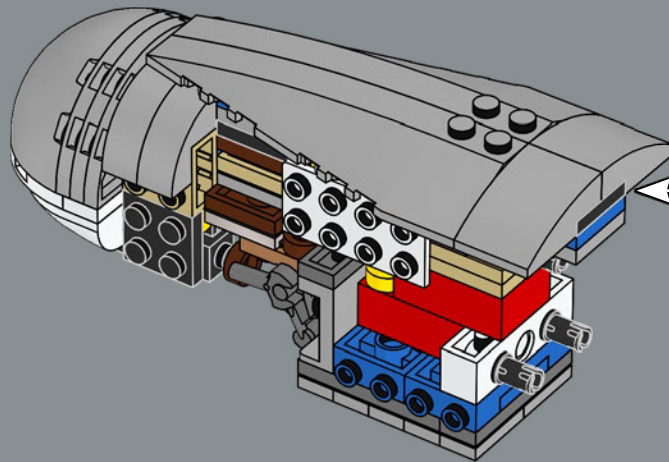
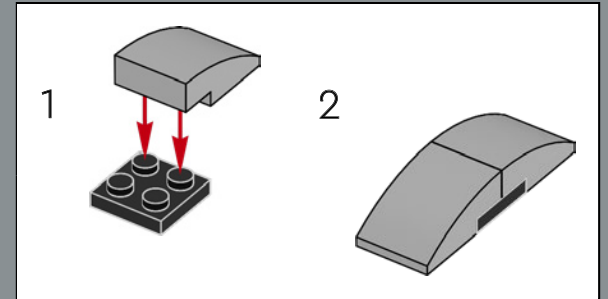

219

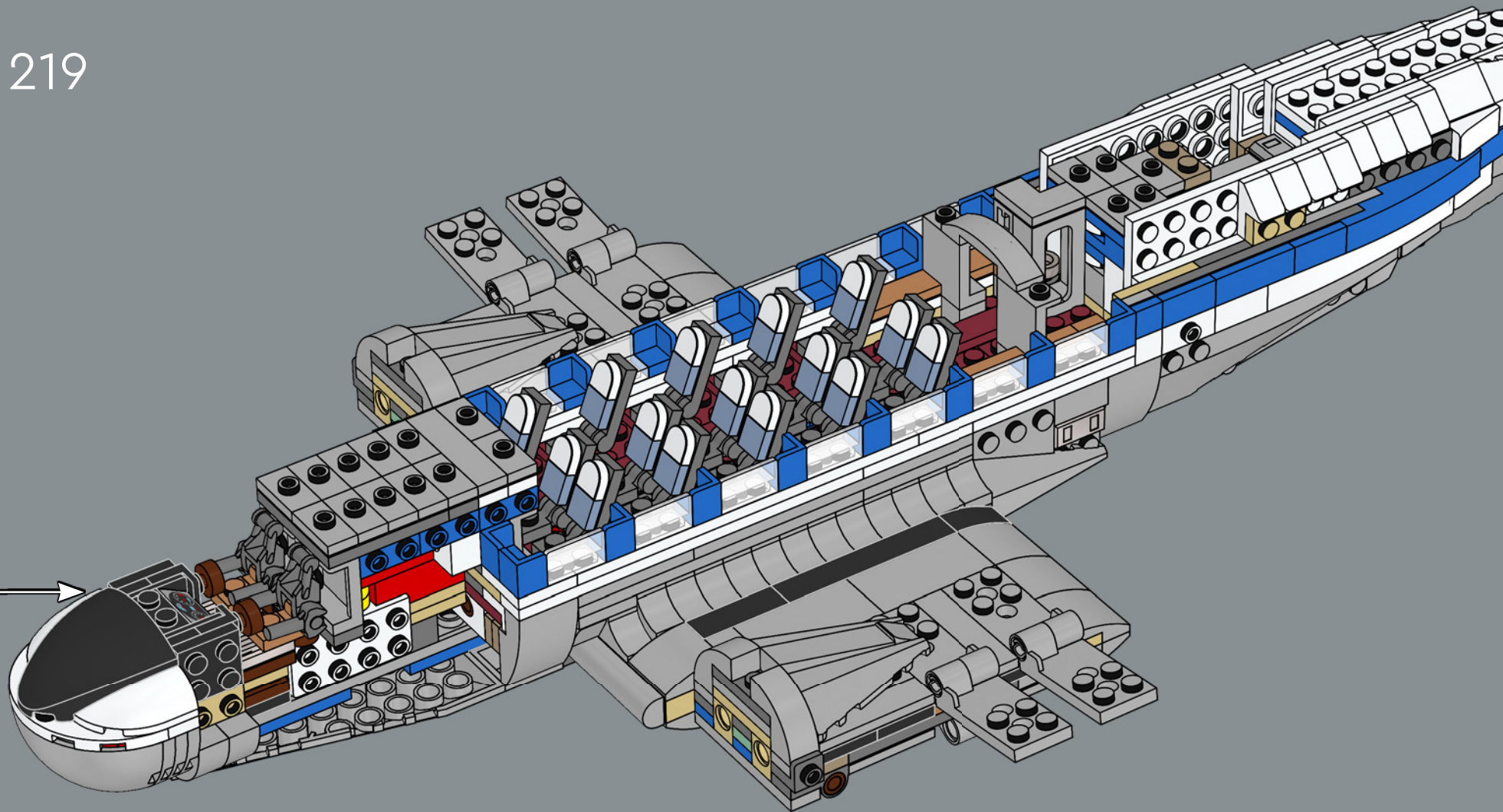

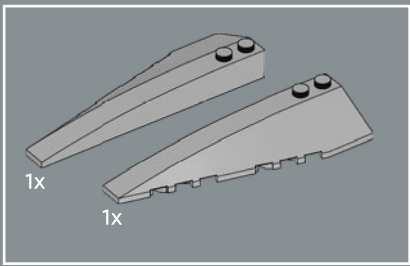

220

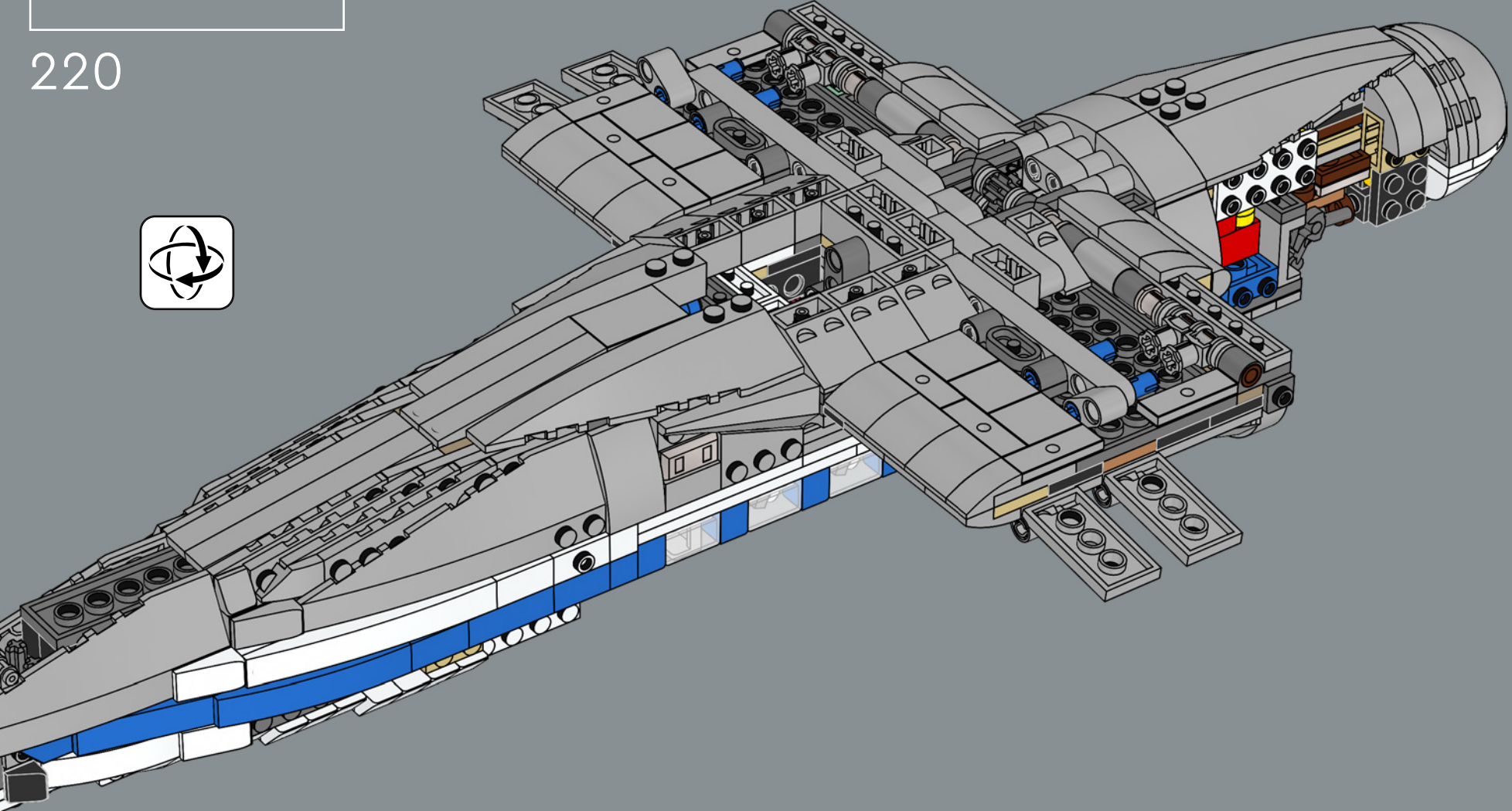

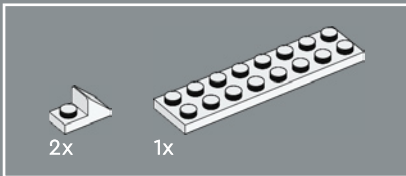
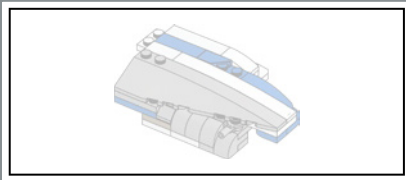

221

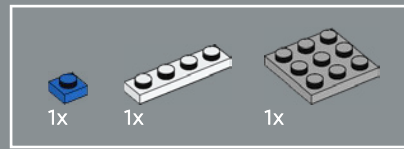
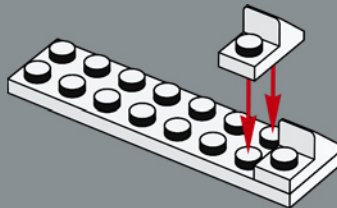

222

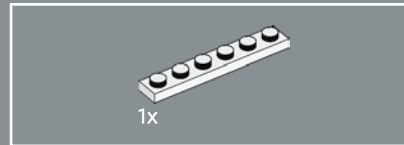
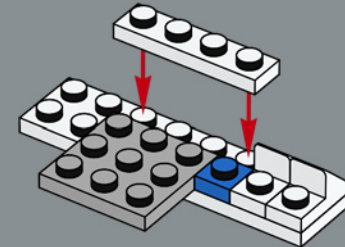

223

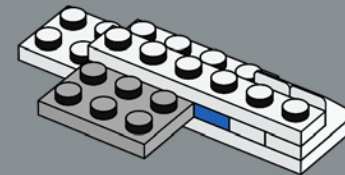

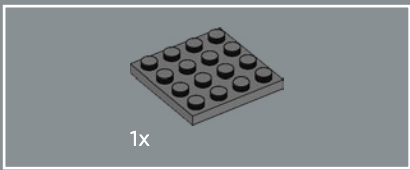

224

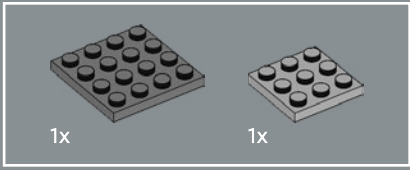
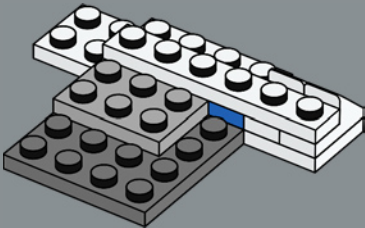

225

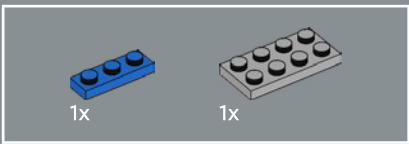
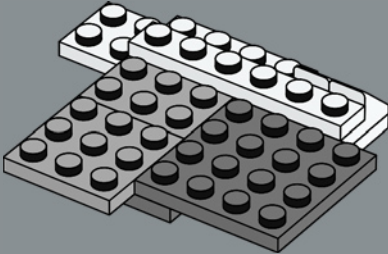

226

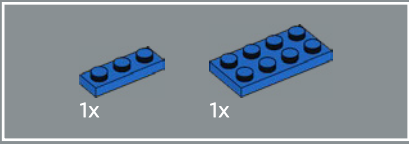
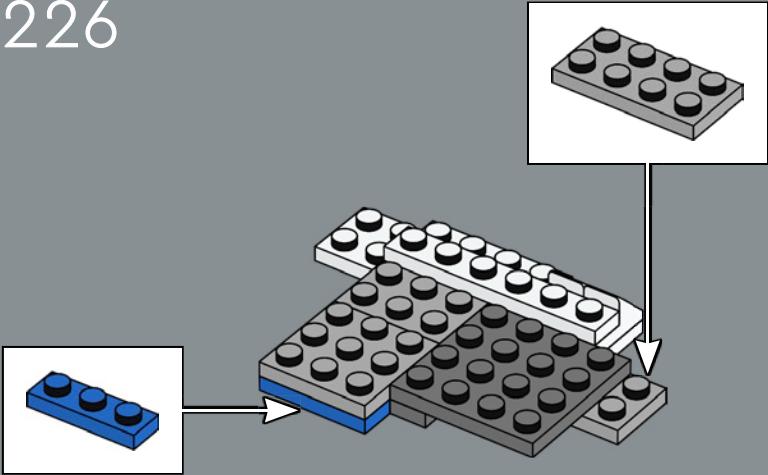

227

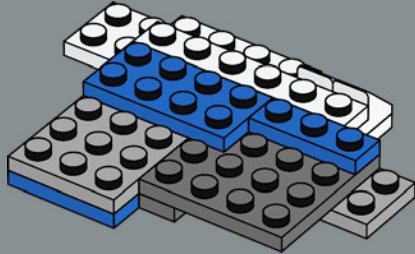

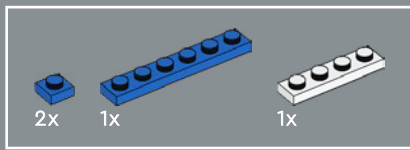

228

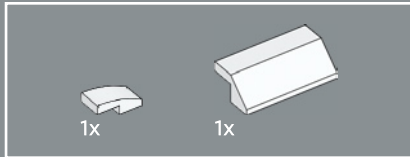
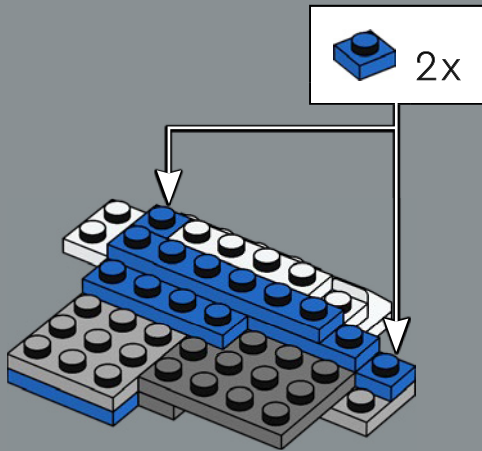

229

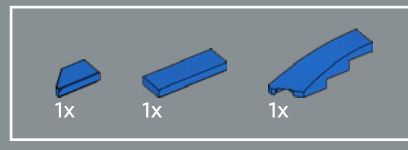
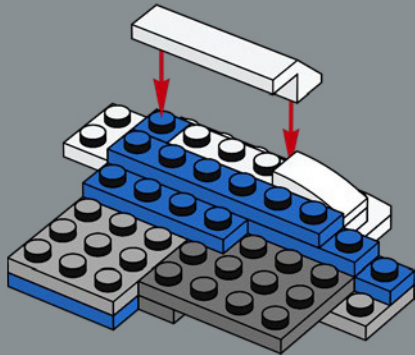

230

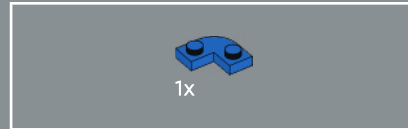
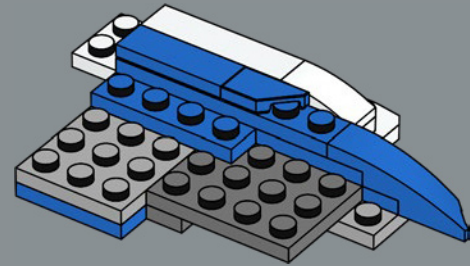

231

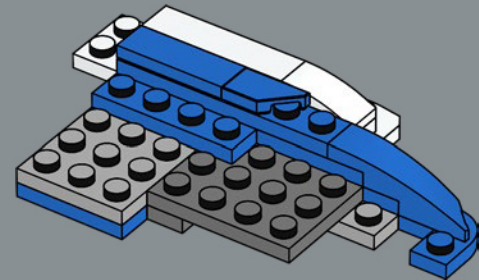

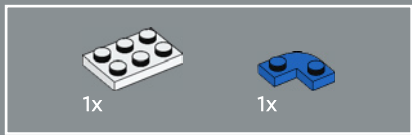

232

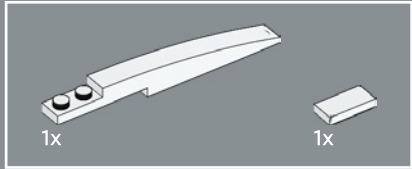
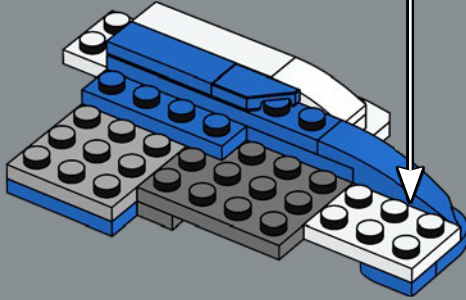
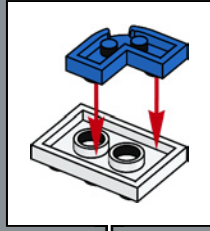

233

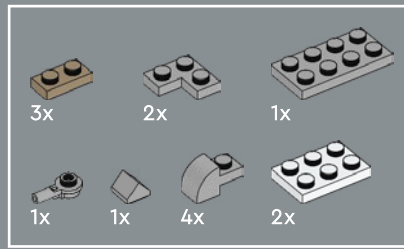
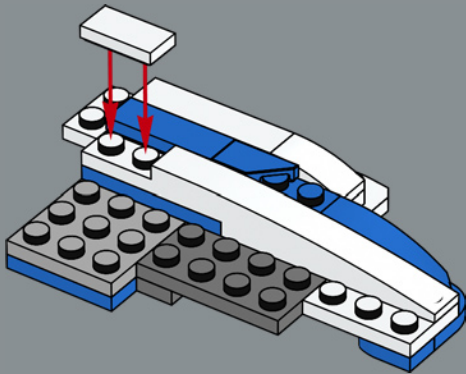

234

1

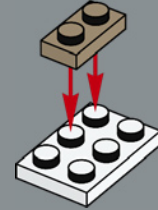

2

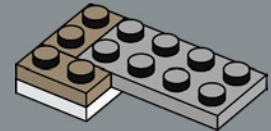

3

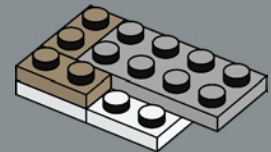

4

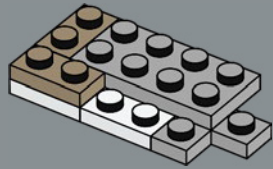

5

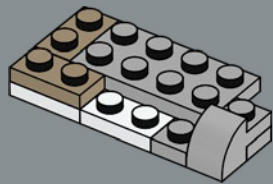

6

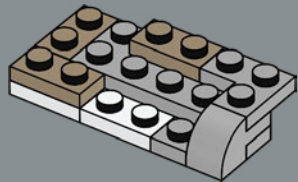

7

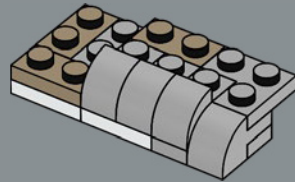

8

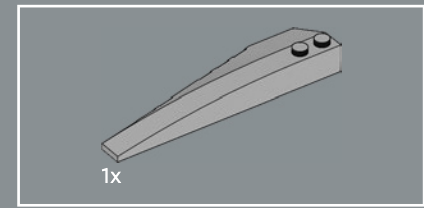
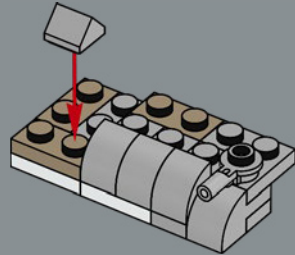

235

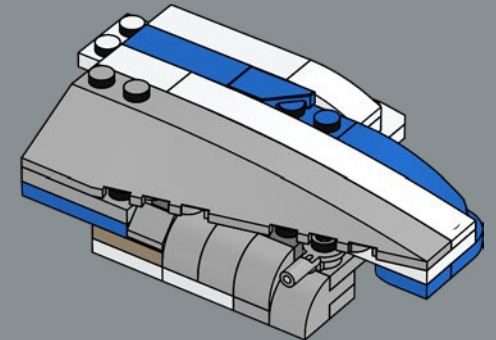
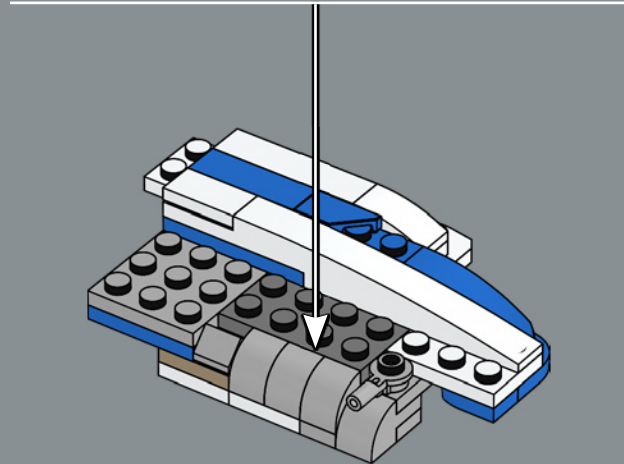

236

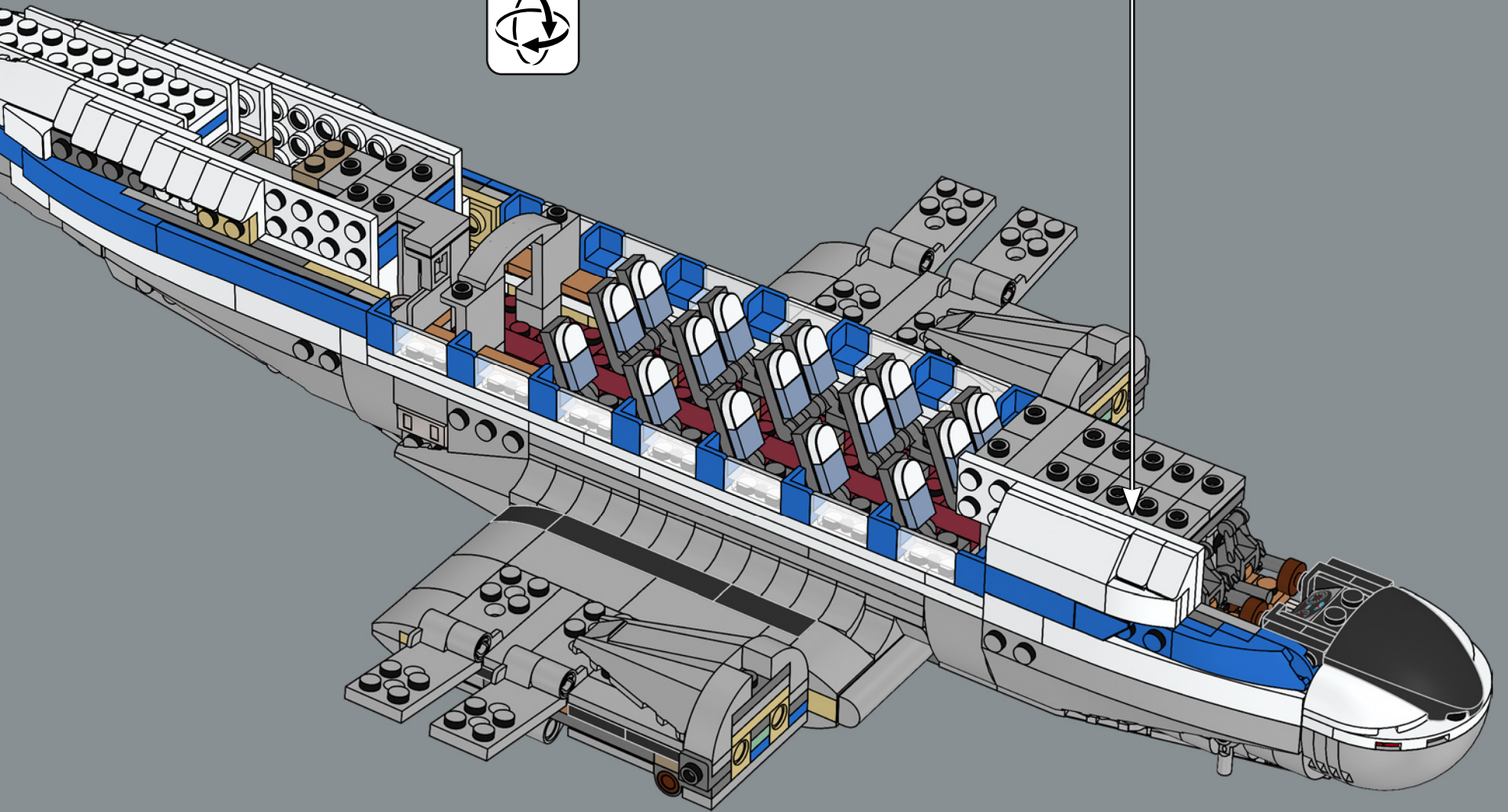

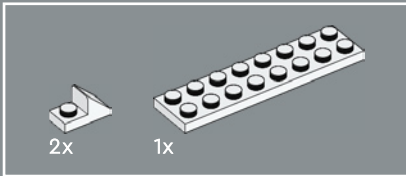
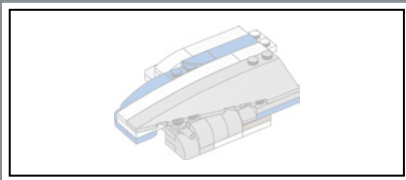

237

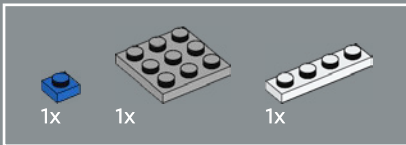
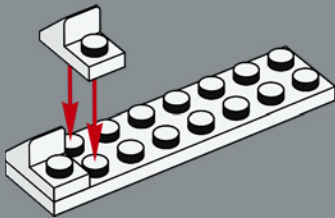

238

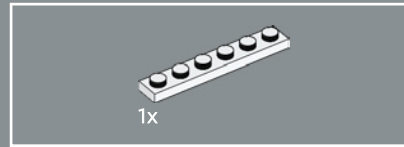
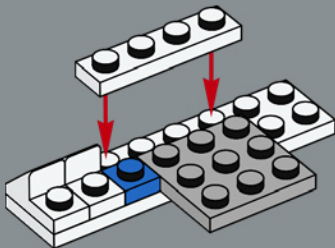

239

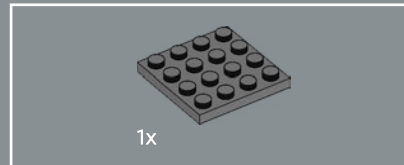
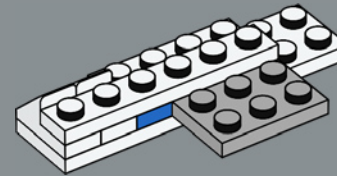

240

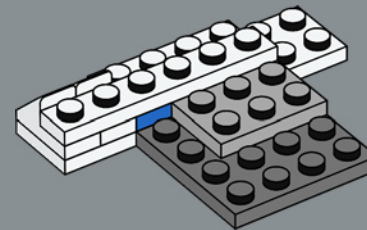

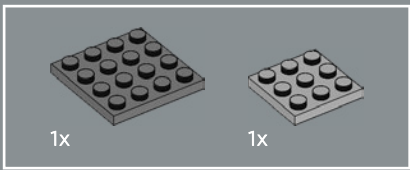

241

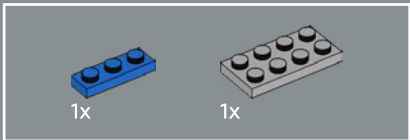
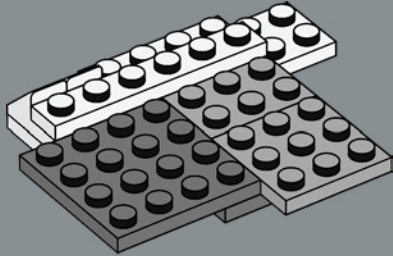

242

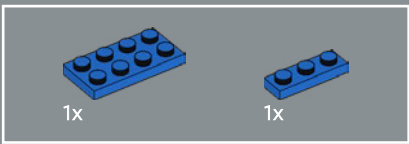
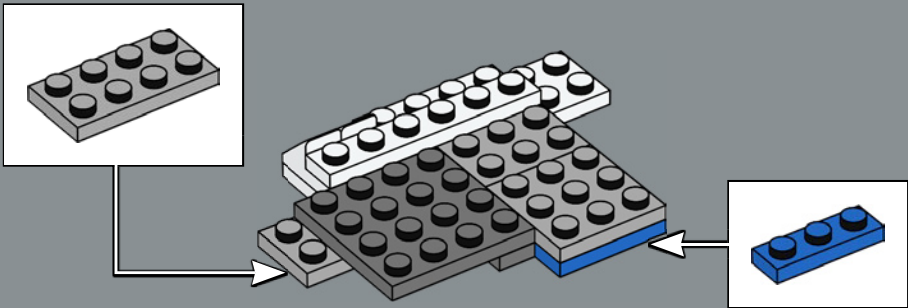

243

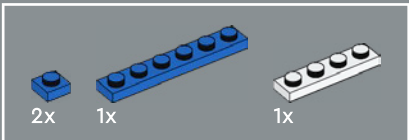
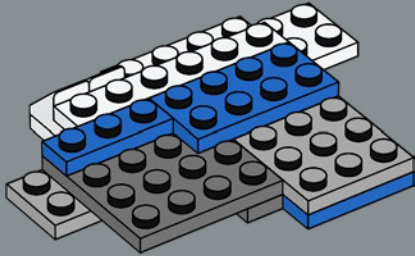

244

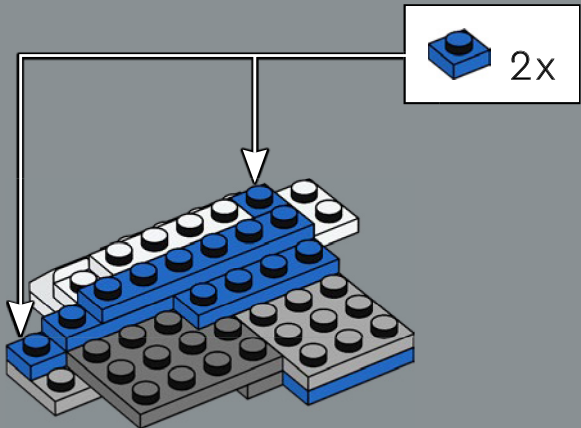

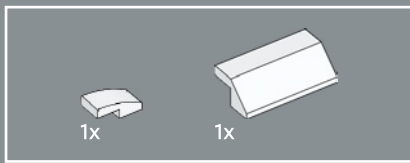

245

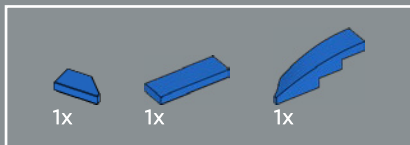
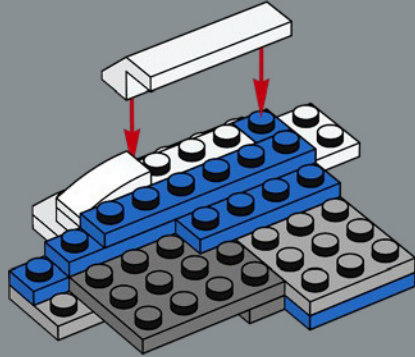

246

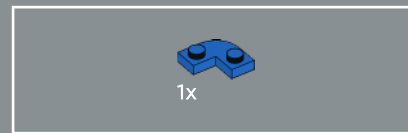
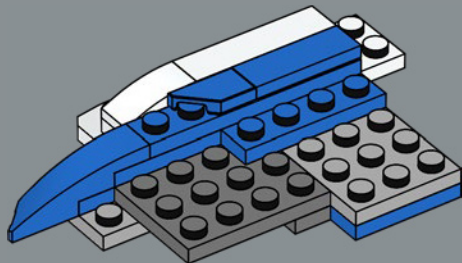

247

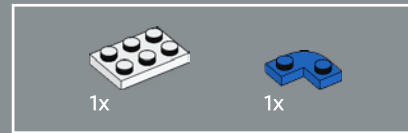
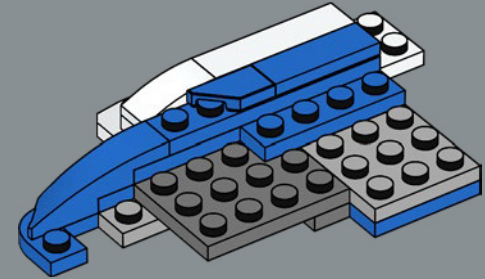

248

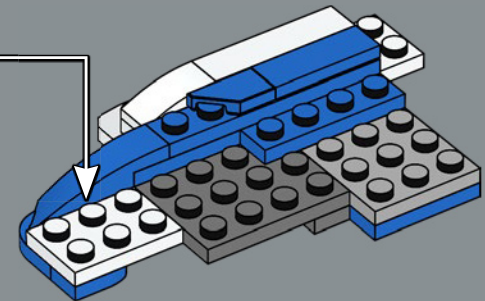
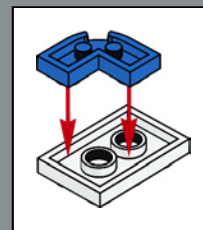

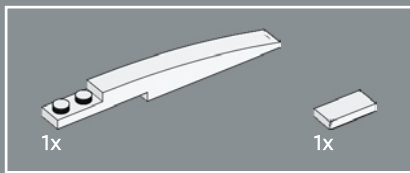

249

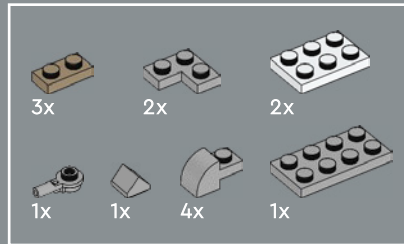
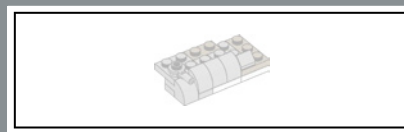
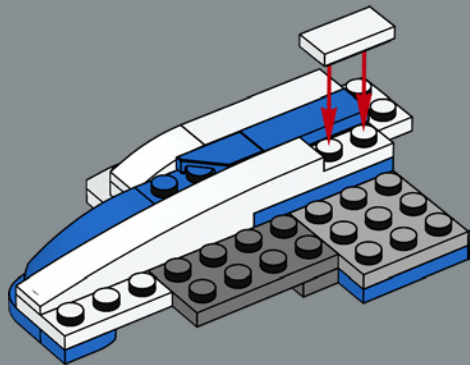

250

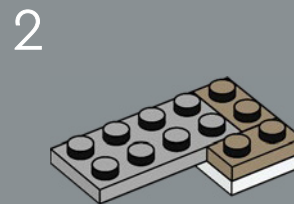
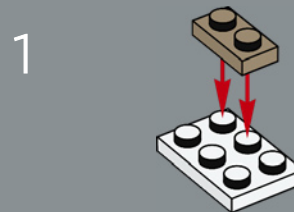

3

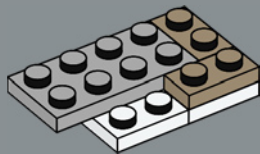

4

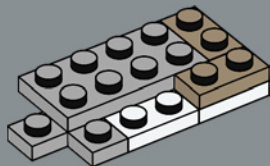

5

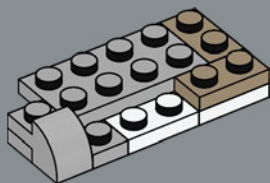

6

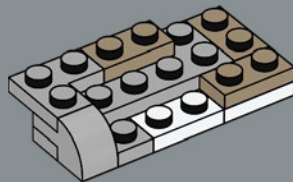

7

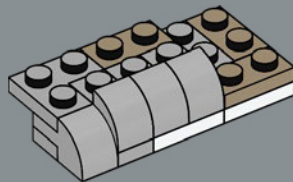

8

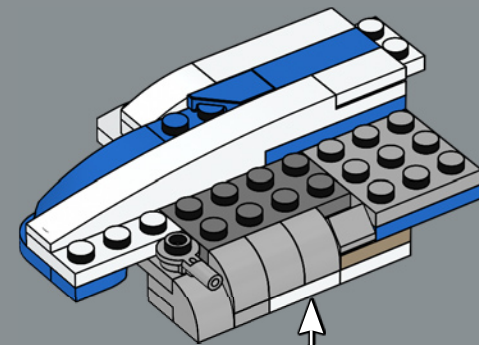
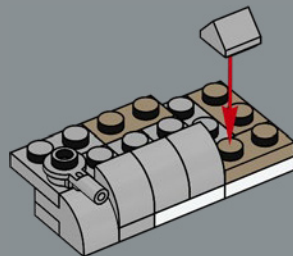

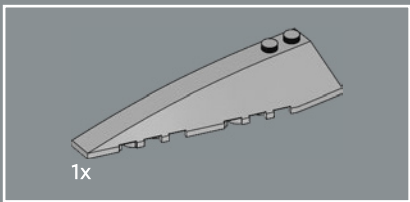

251

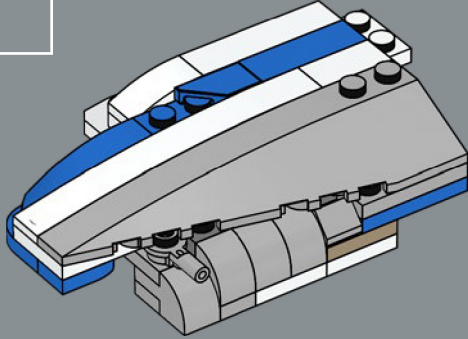

La livrée emblématique Pan Am® « Globe », avec une ligne bleue au niveau des hublots et un lettrage noir sur fond blanc, fut introduite en 1958 et utilisée jusqu'en 1984.

252

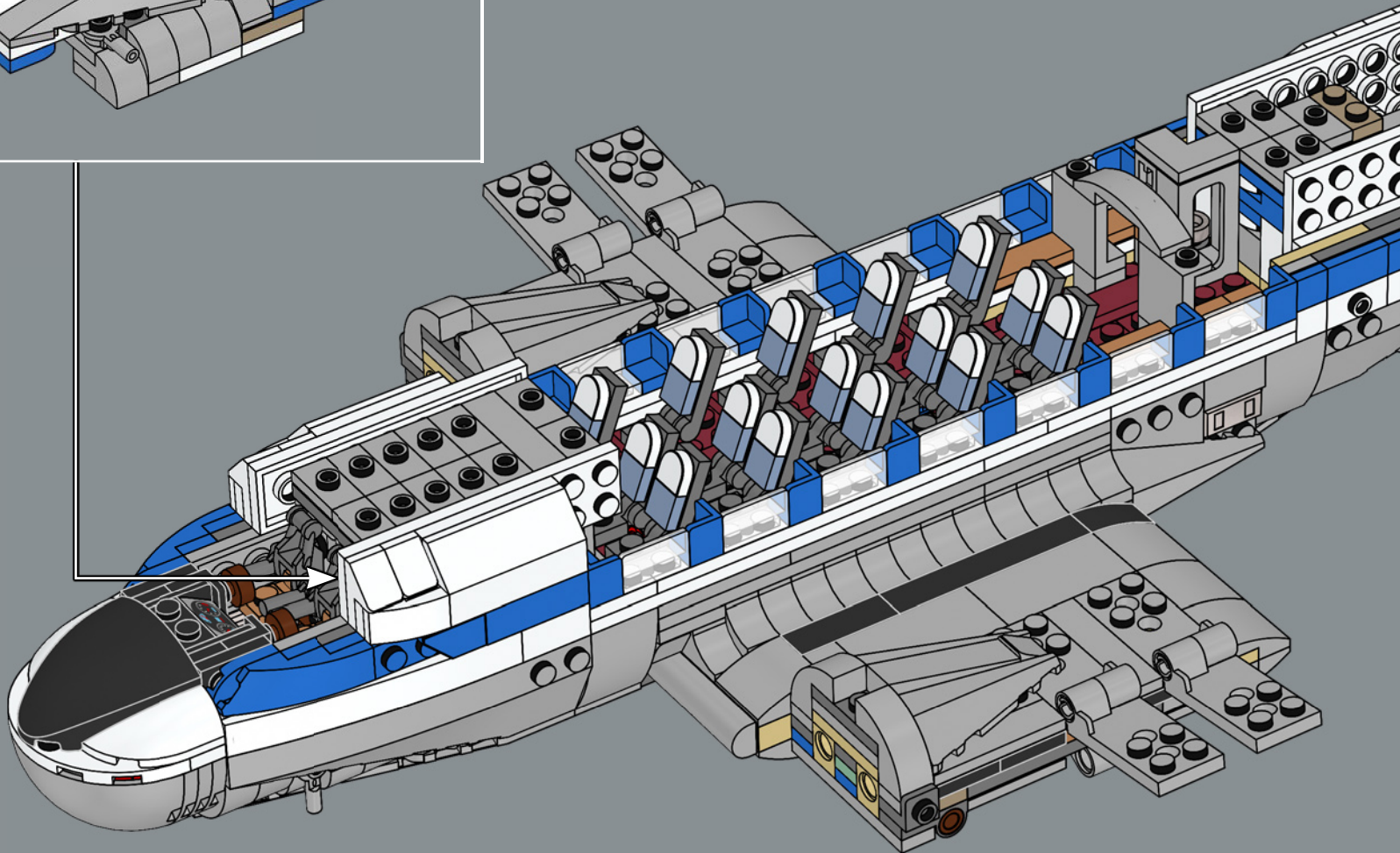

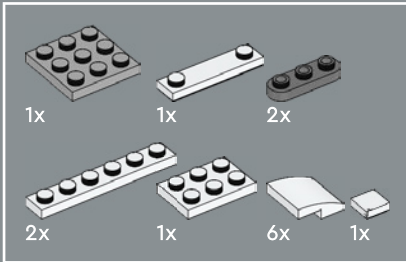
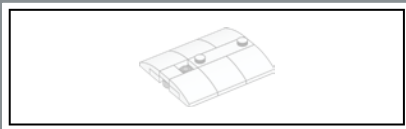

253

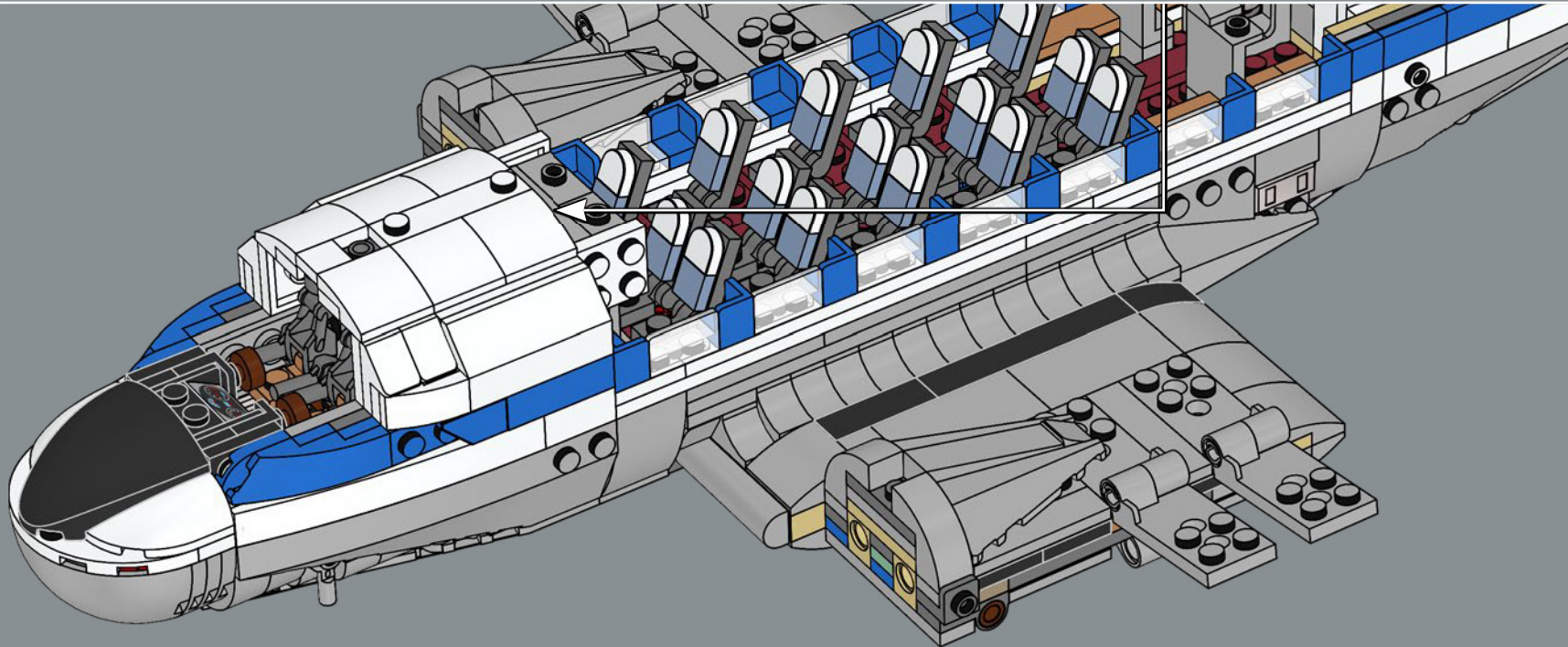
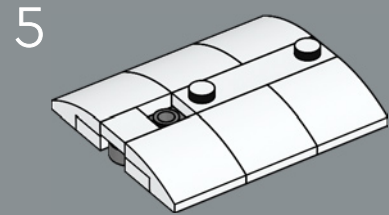
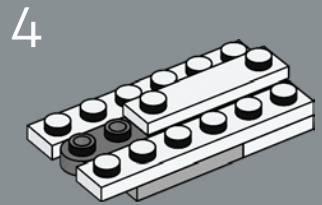
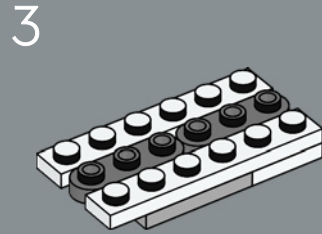
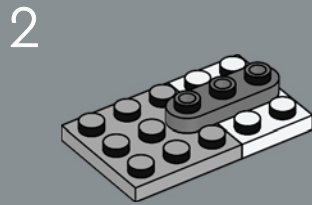
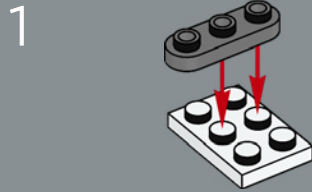

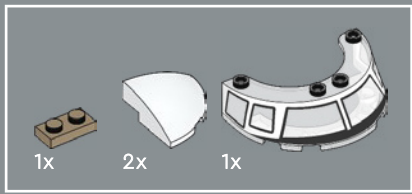

254

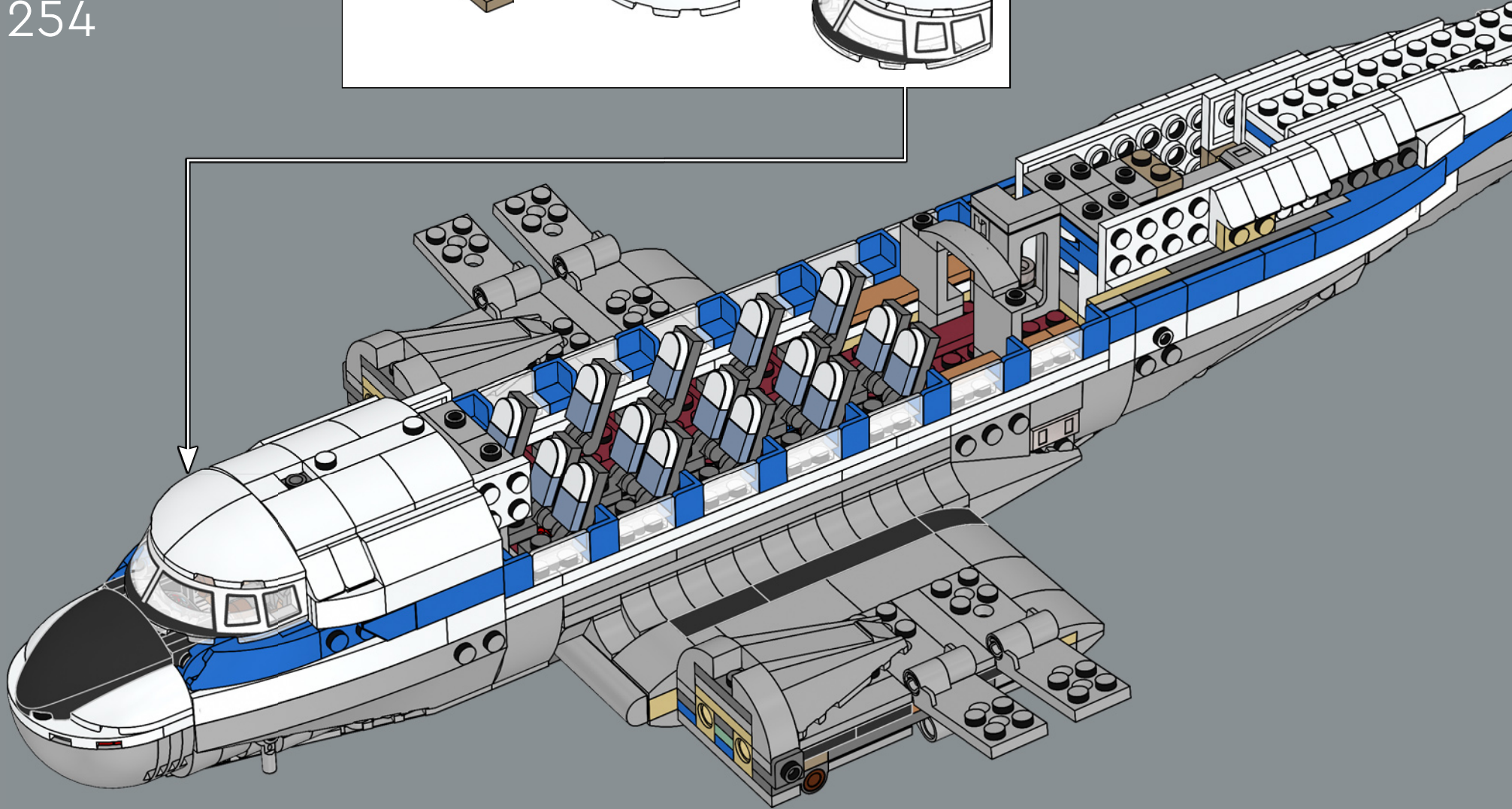
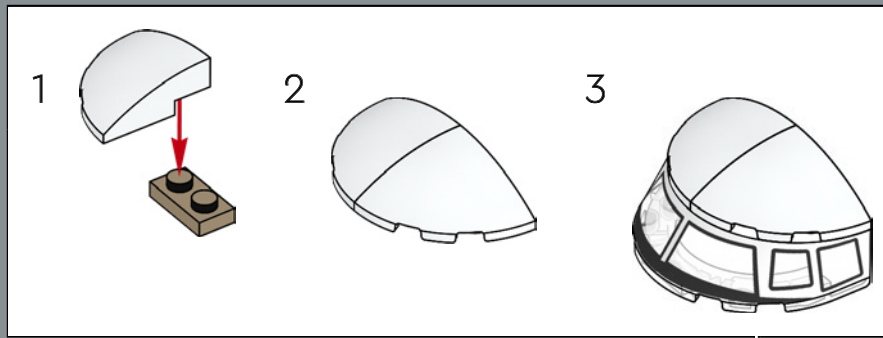

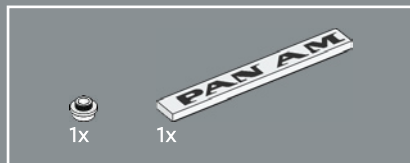
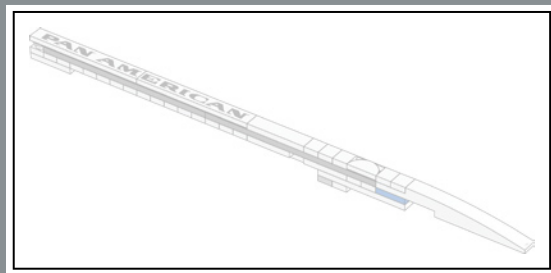

255

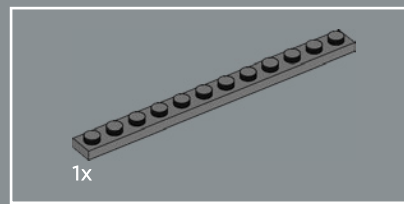

256

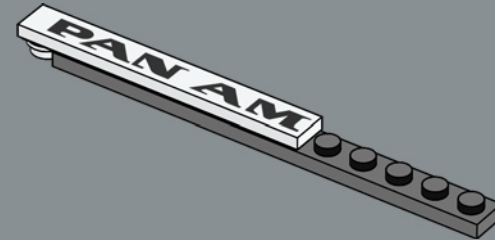

257

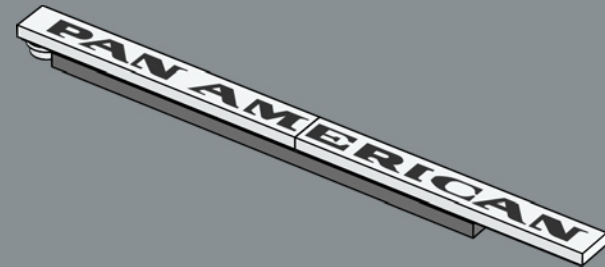

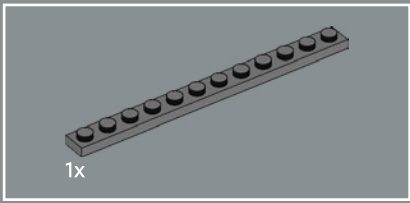

258

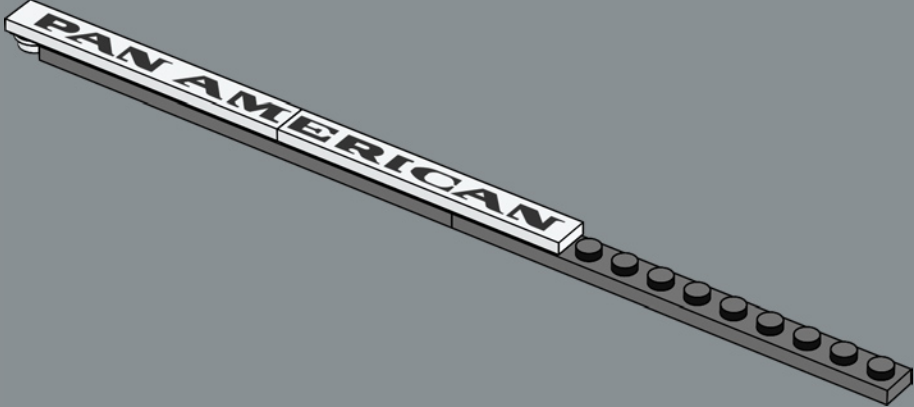

259

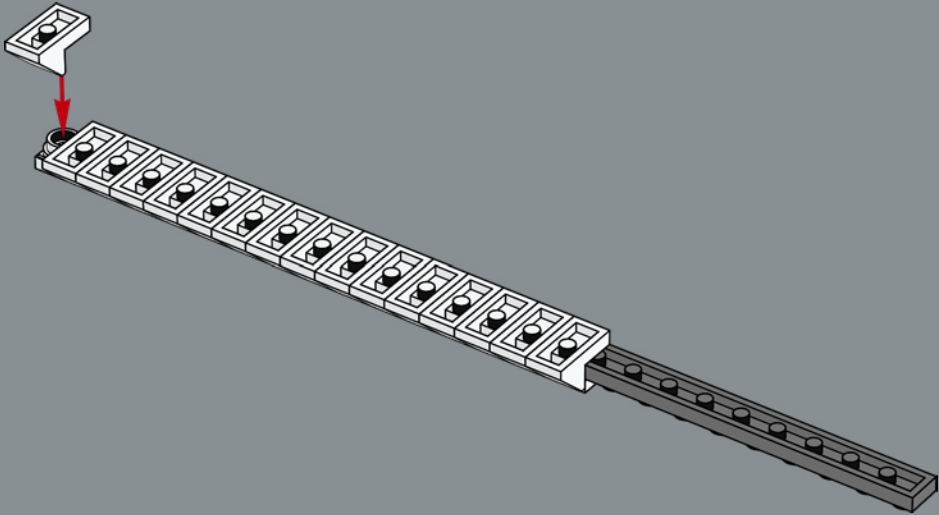

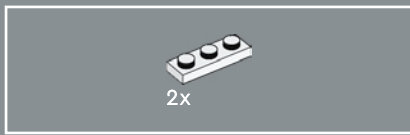

260

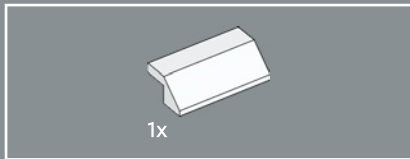
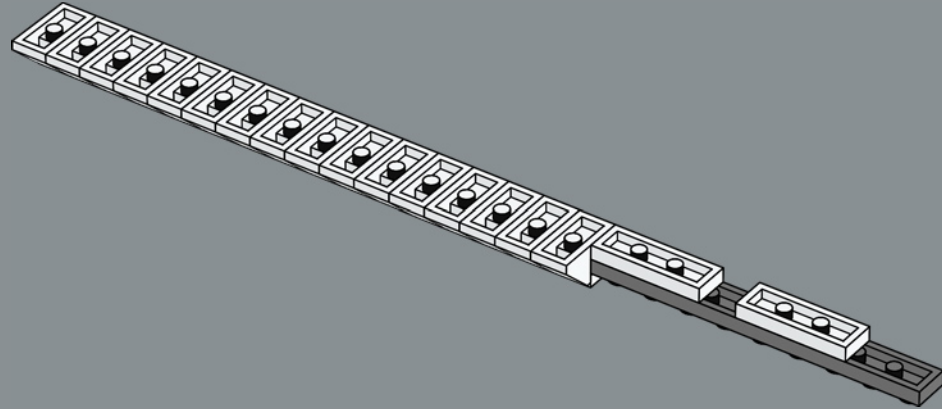

261

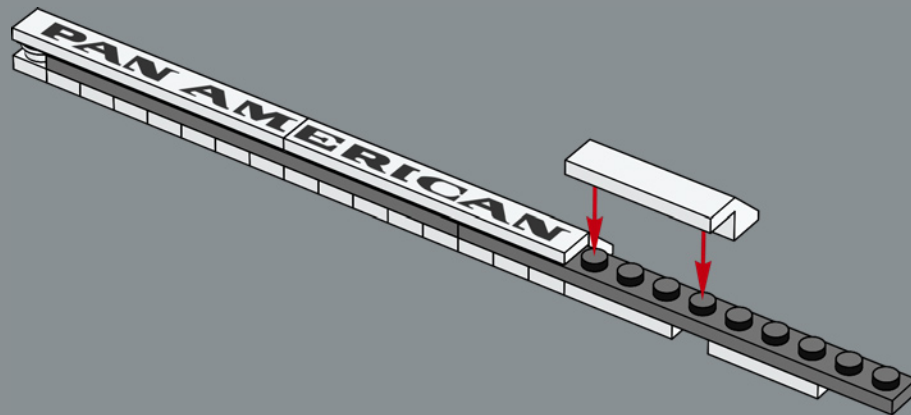

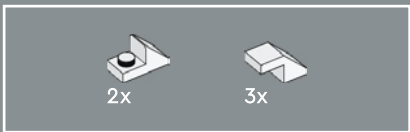

262

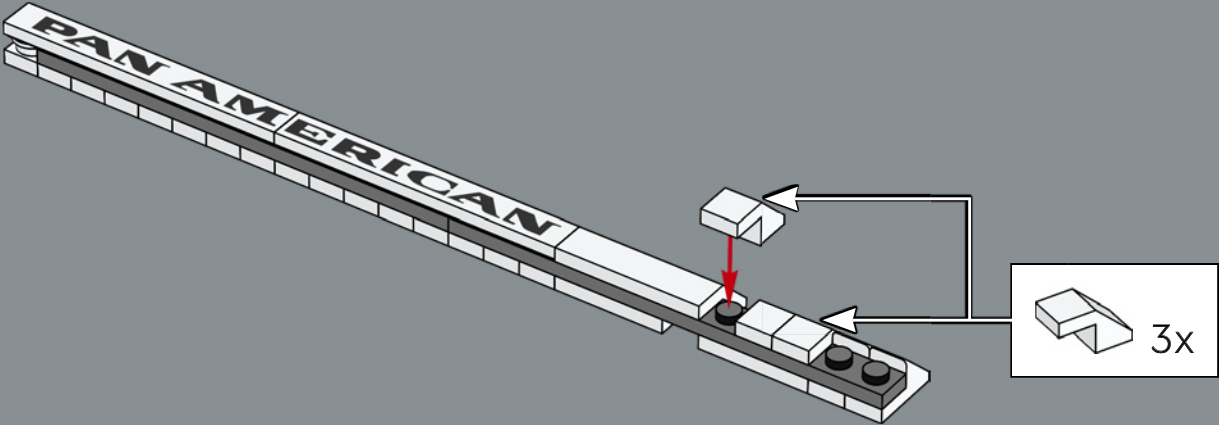

263

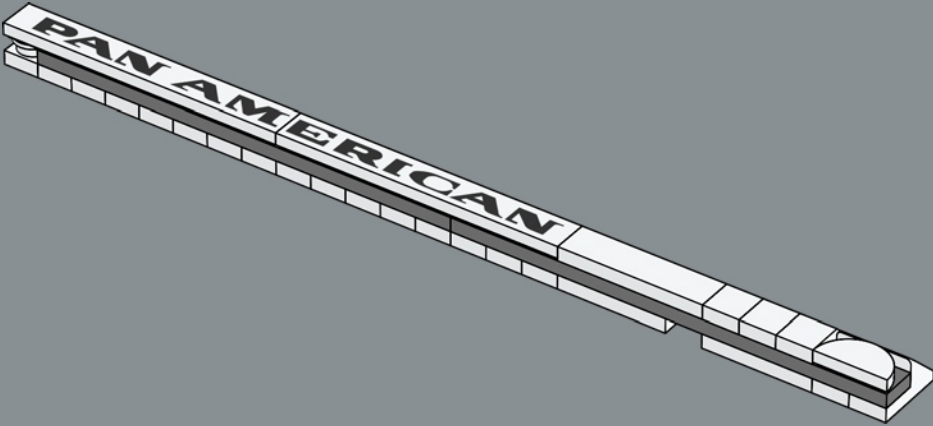

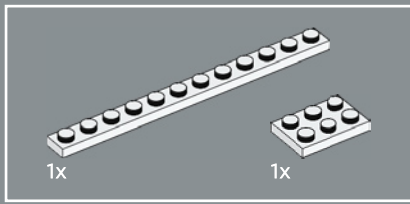

264

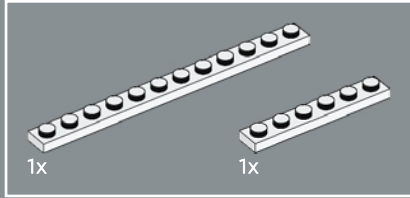
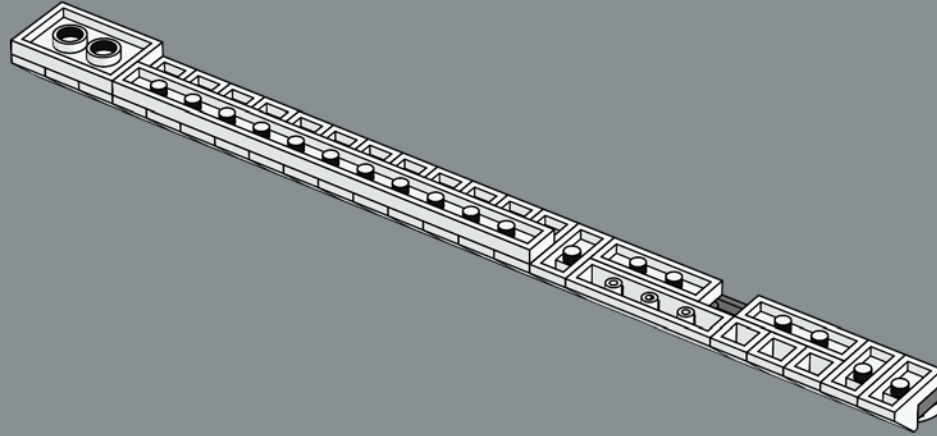

265

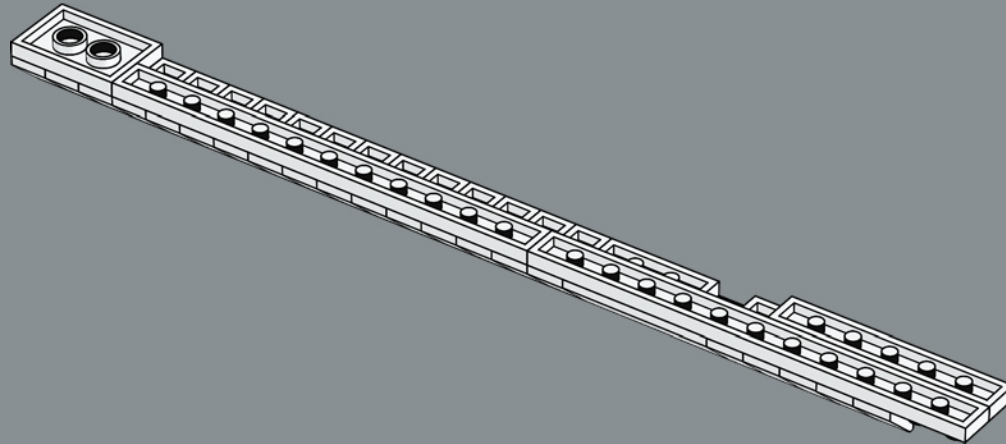

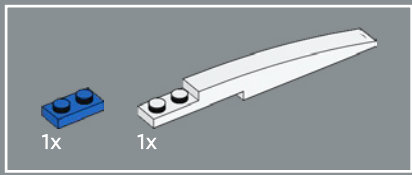

266

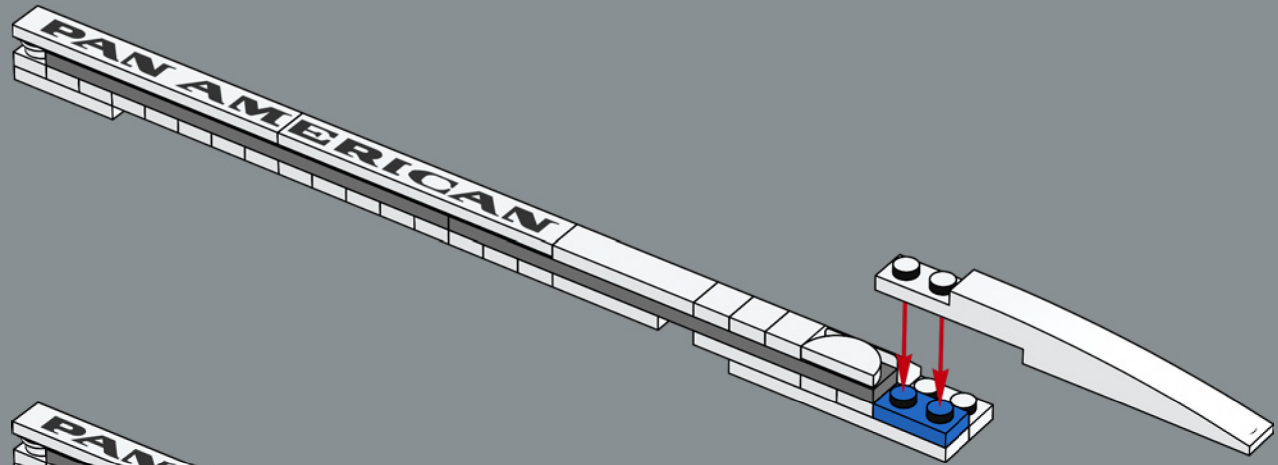

267

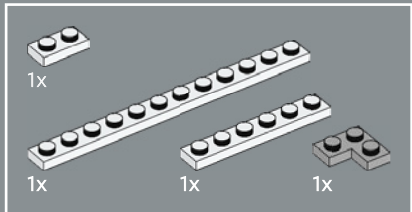
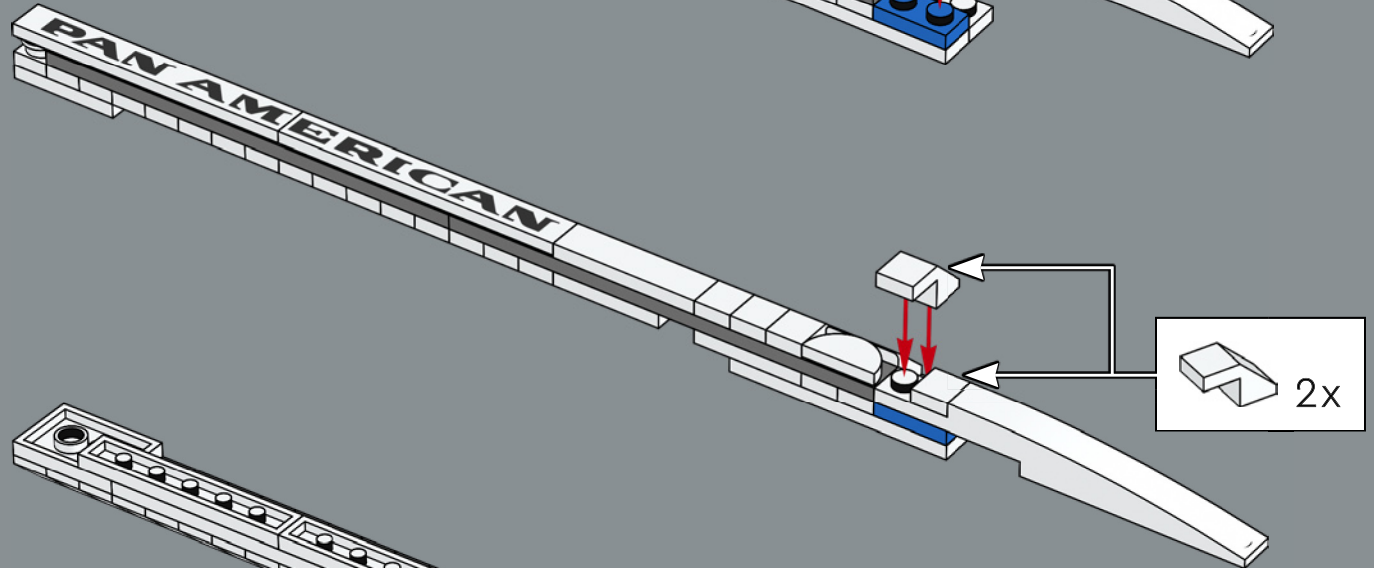

268

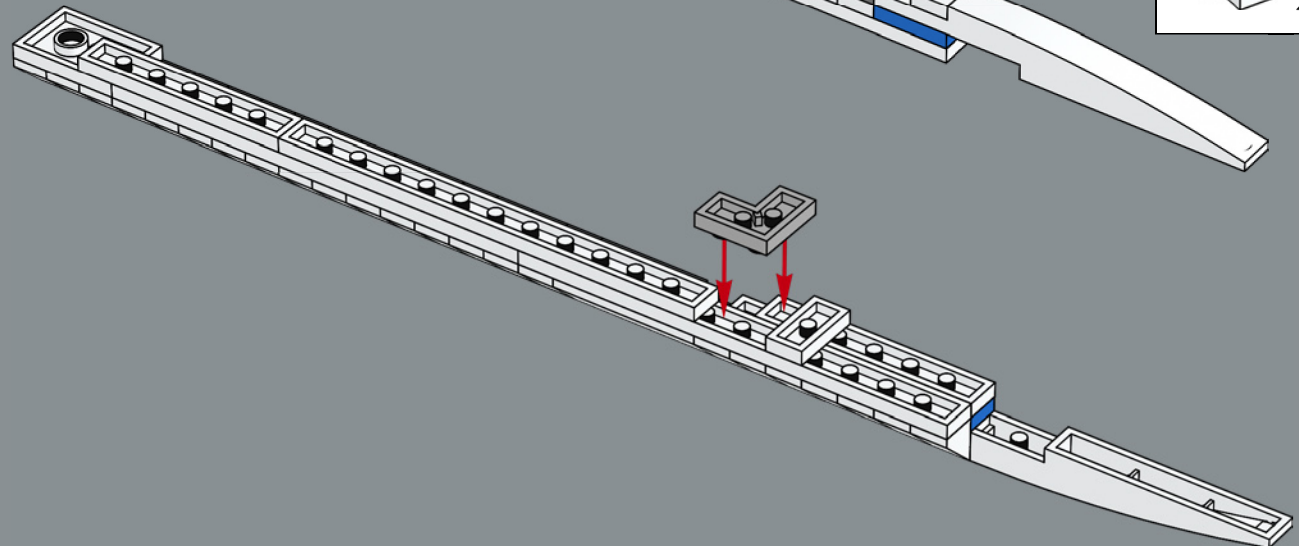

269

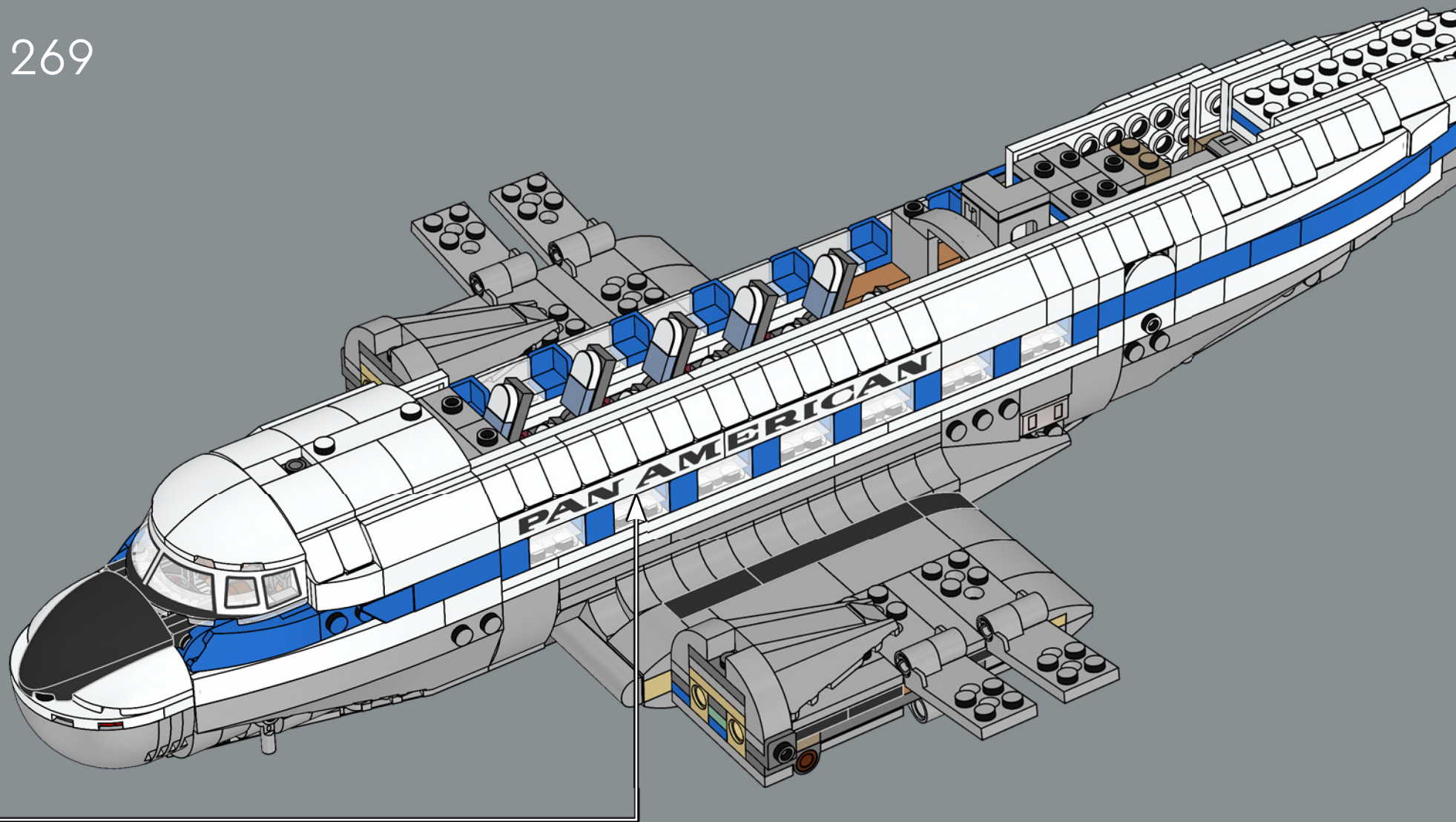

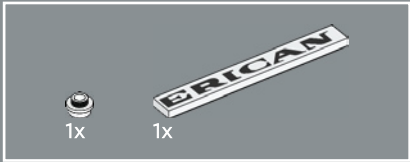
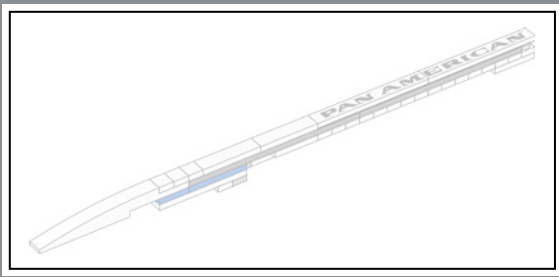

270

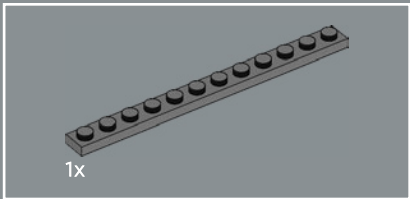

271

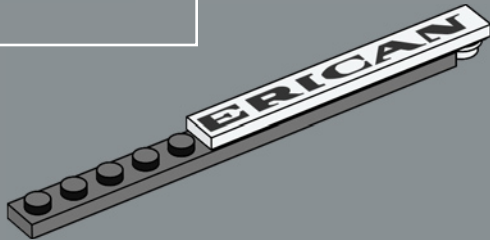

272

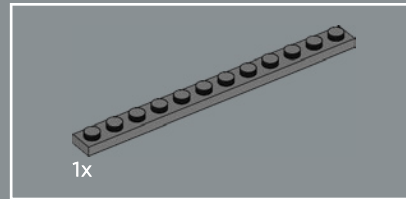
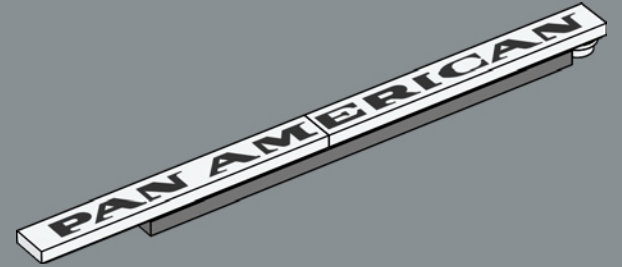

273

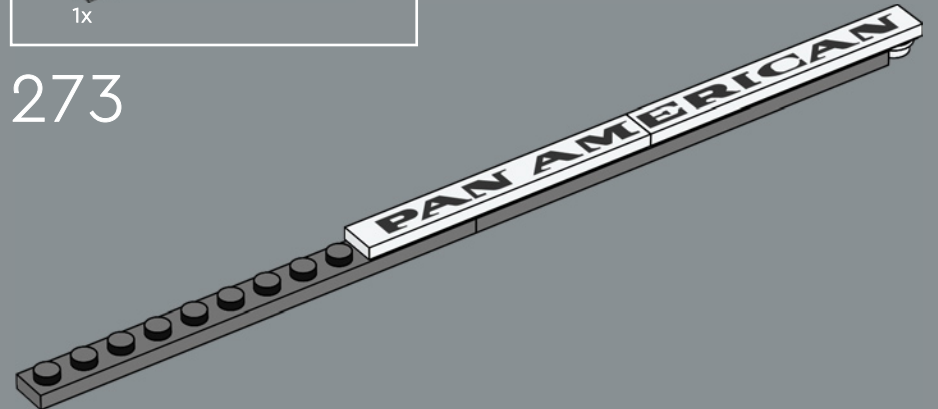



274

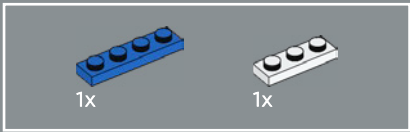
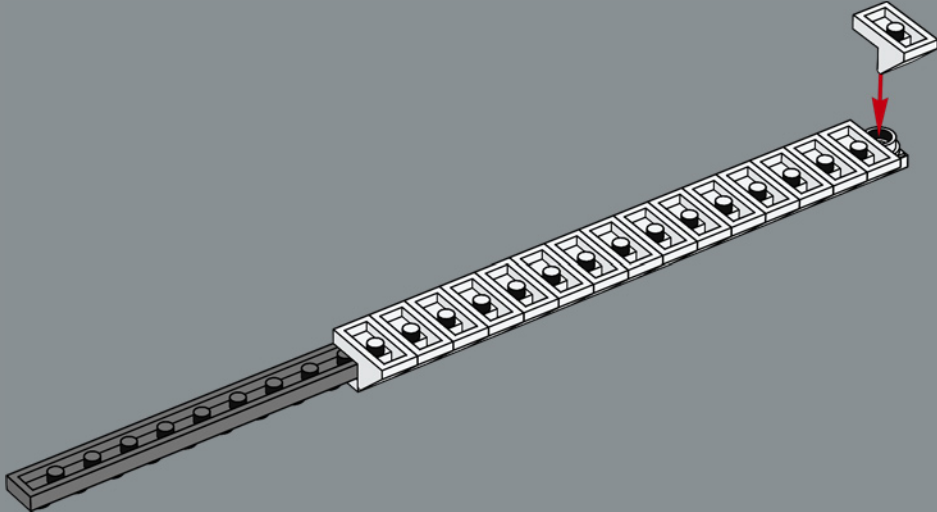

275

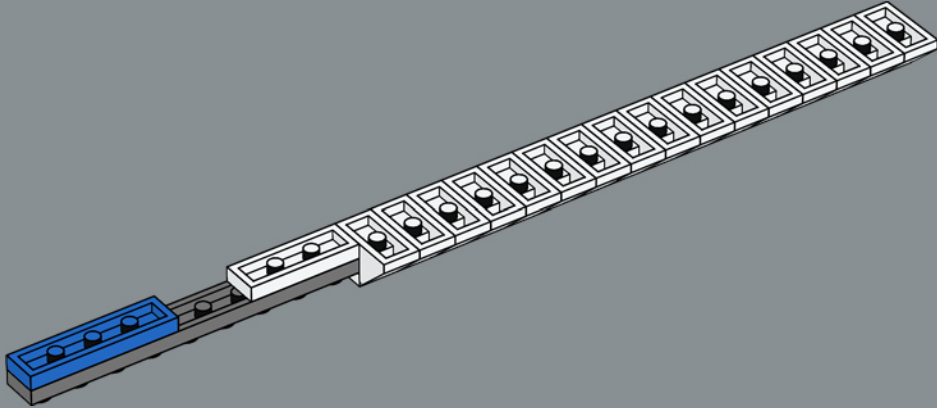

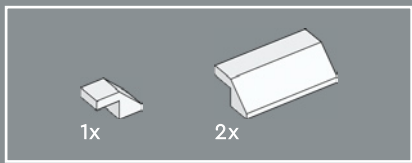

276

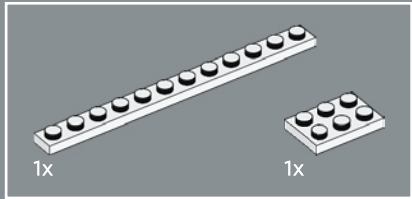
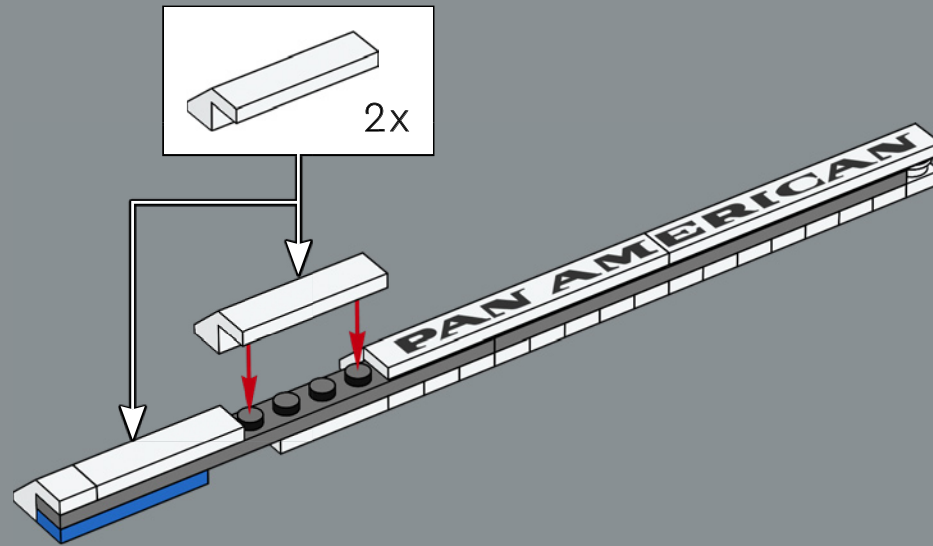

277

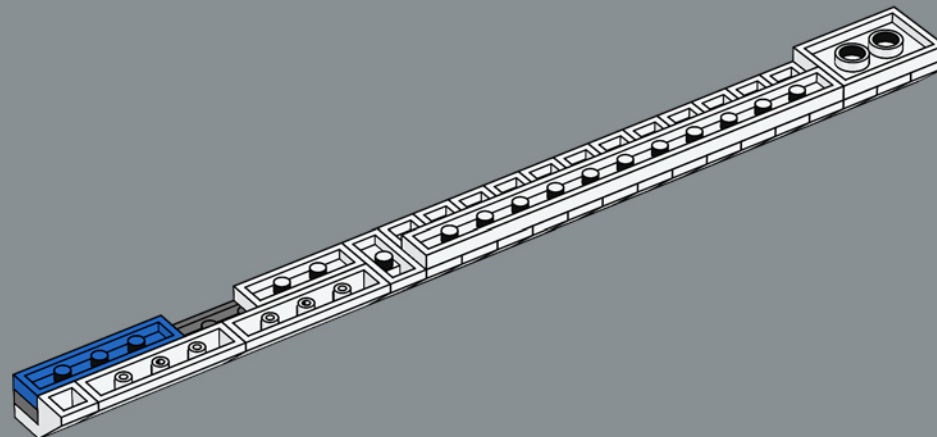

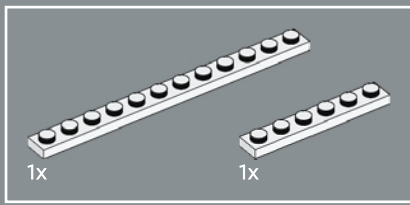

278

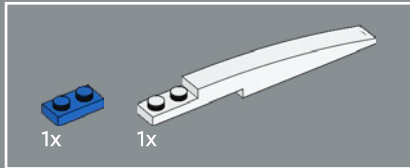
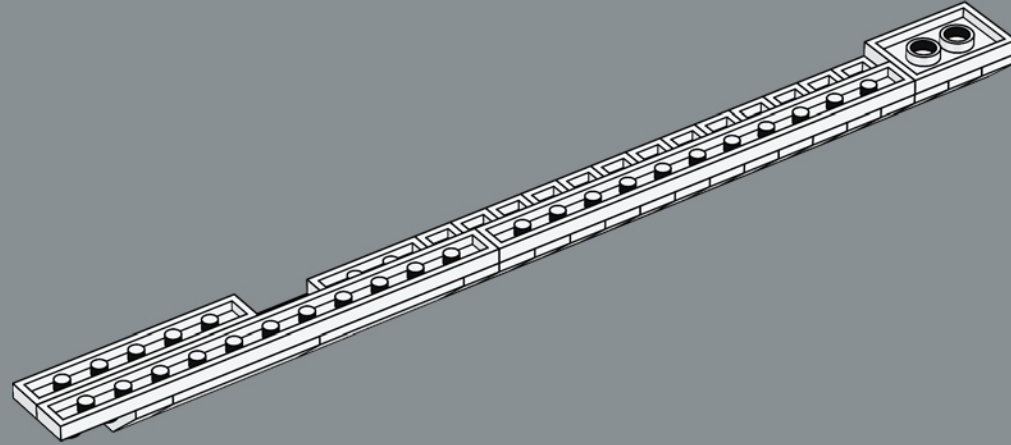

279

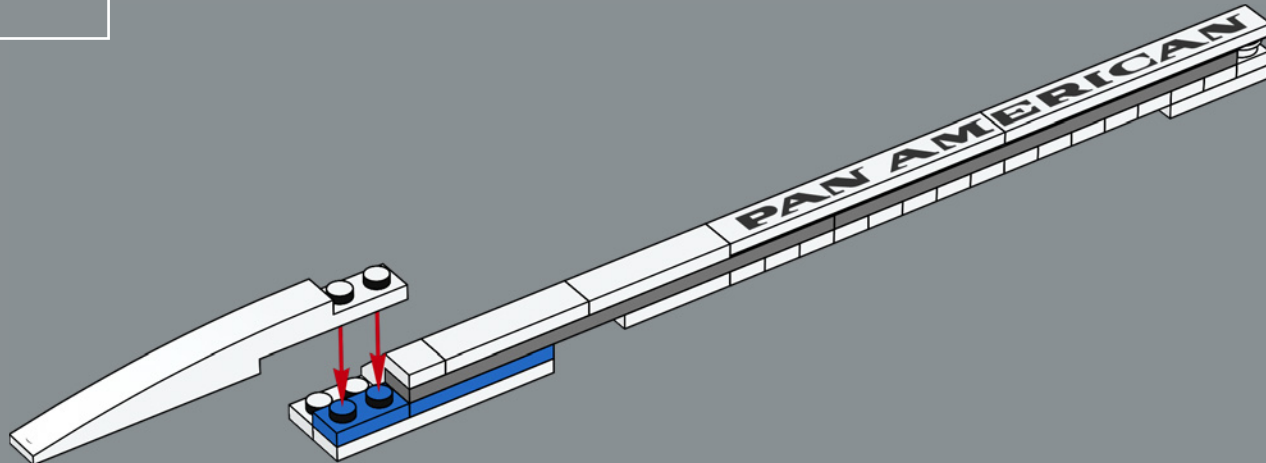



2x

280



2x

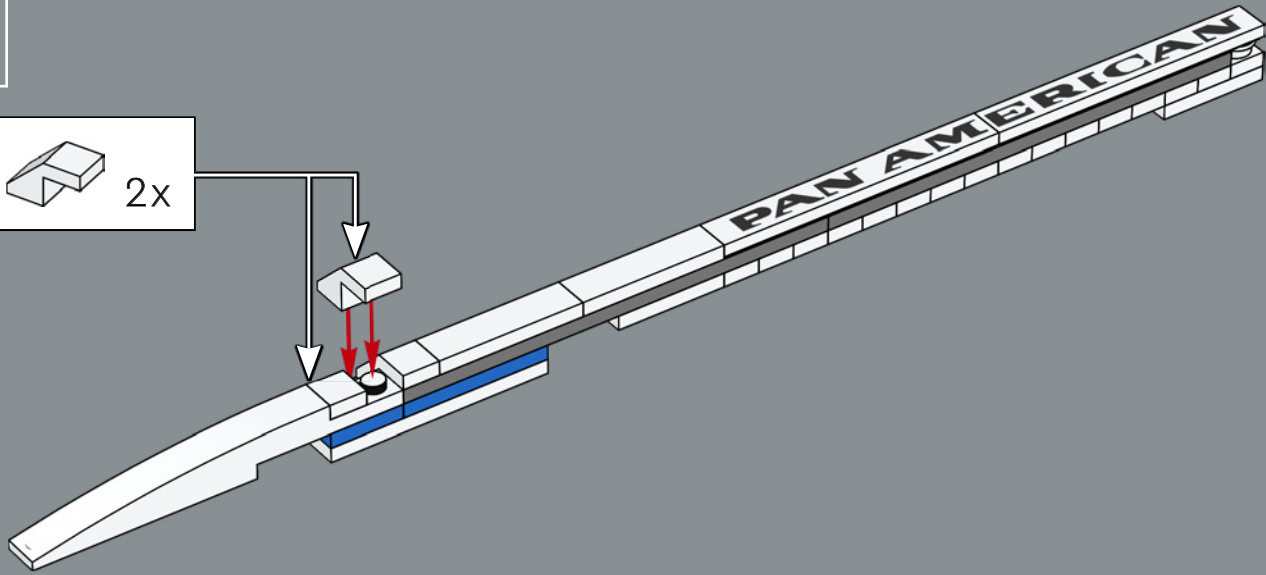

1x

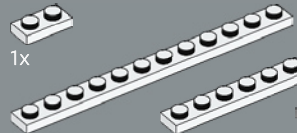

1x



1x



1x

281

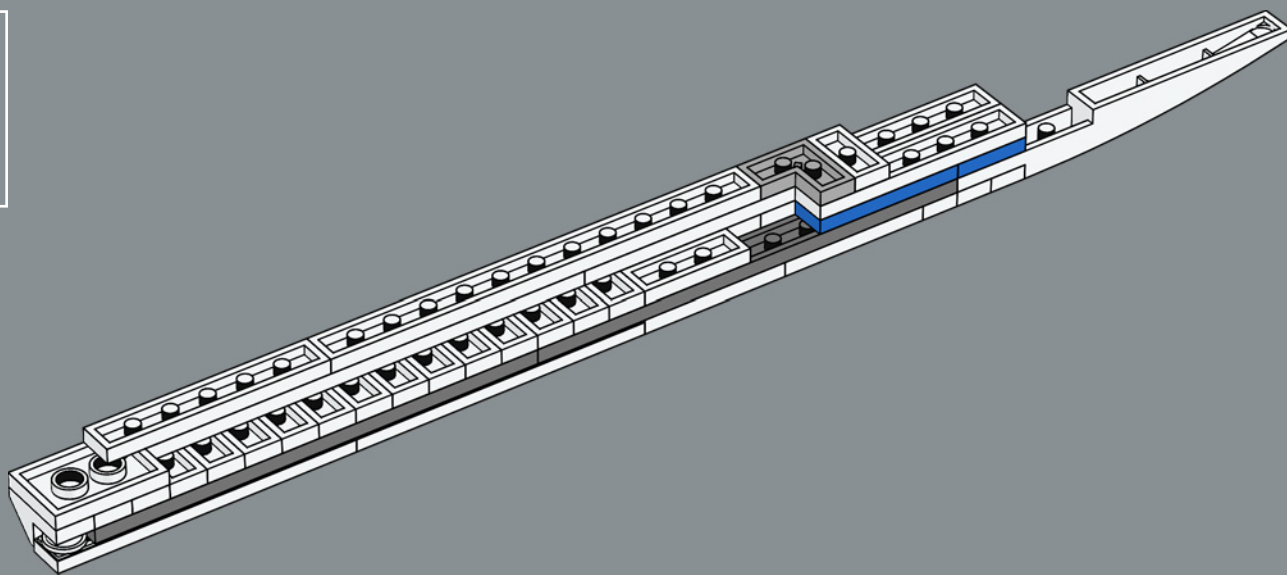

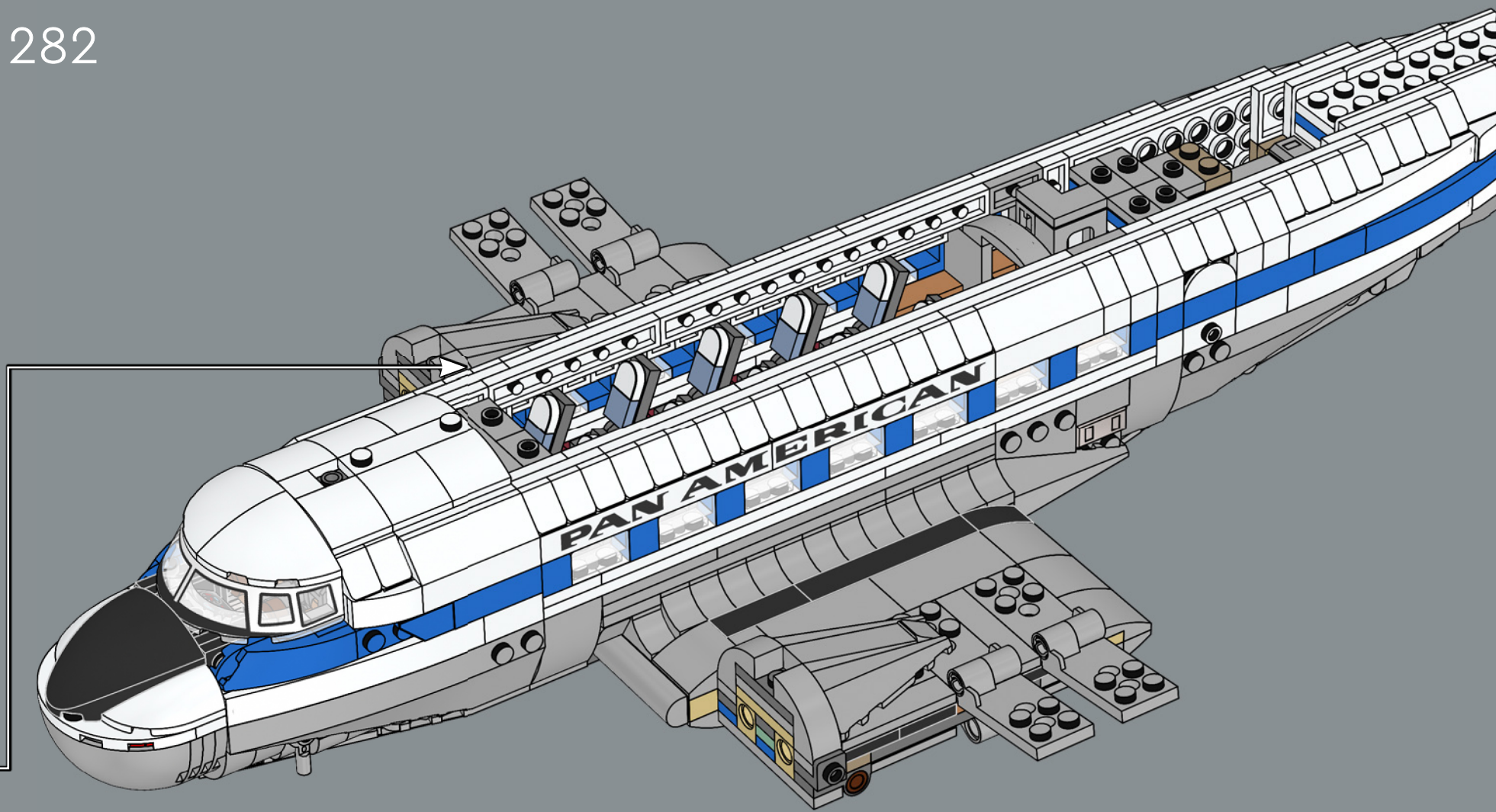

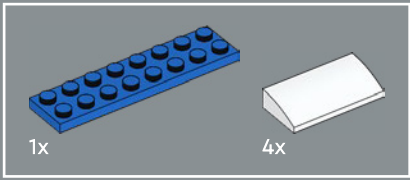

283

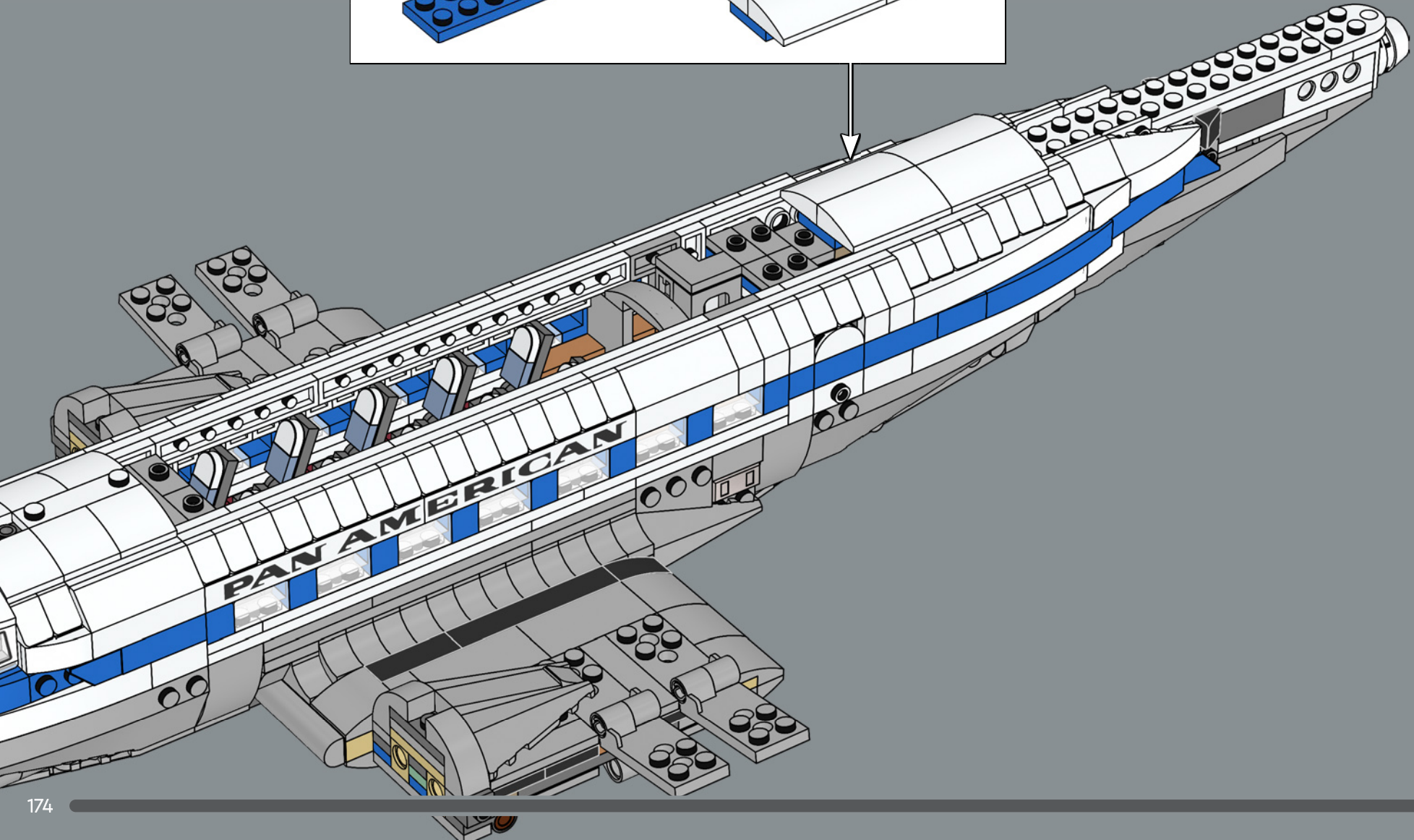
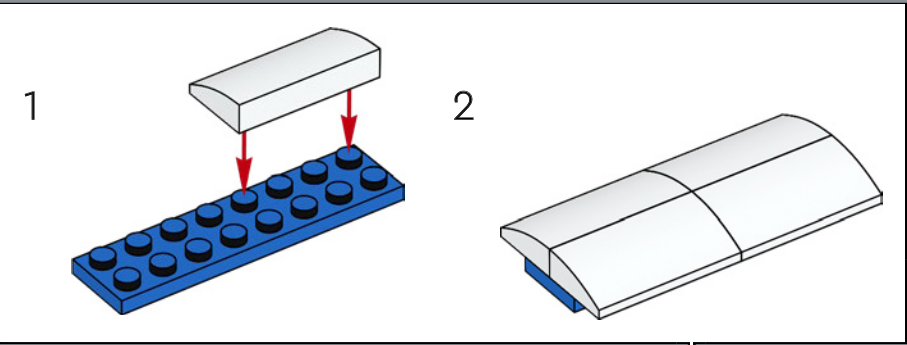

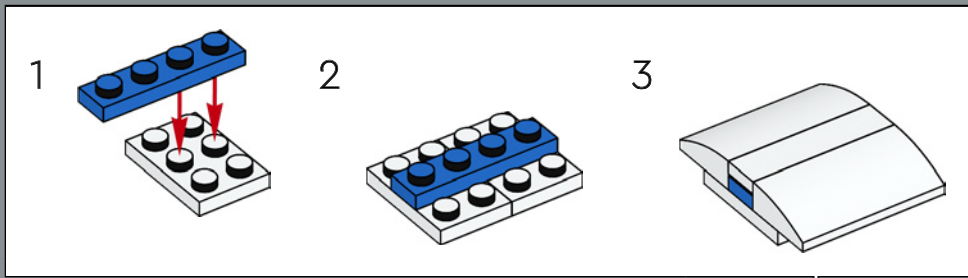
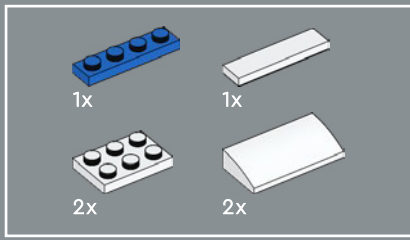

284

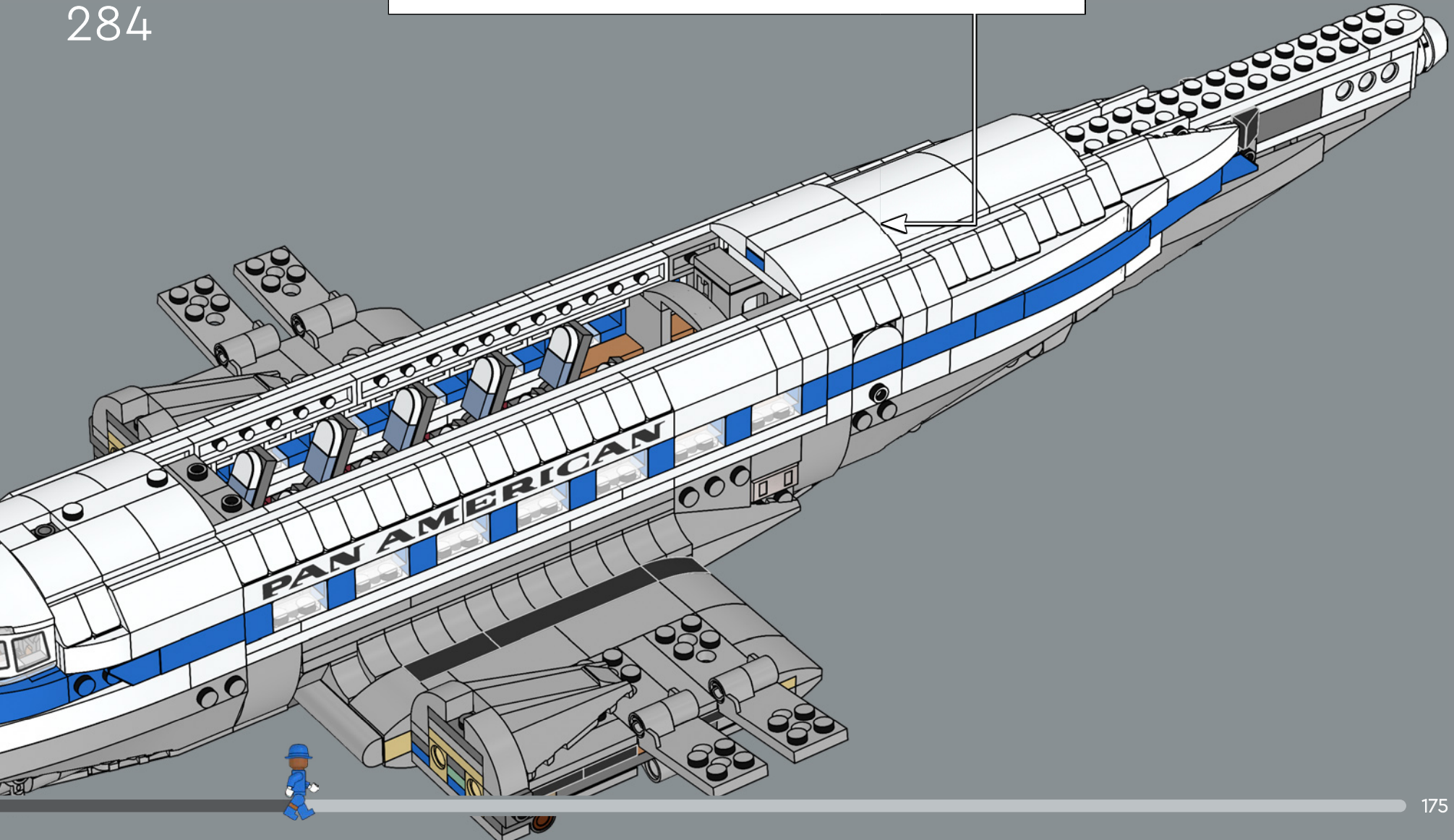

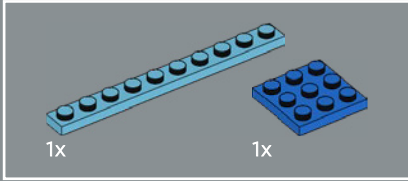
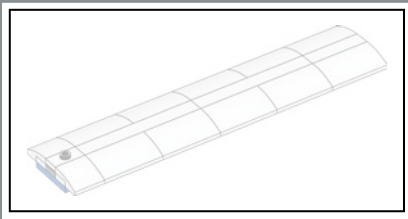

285

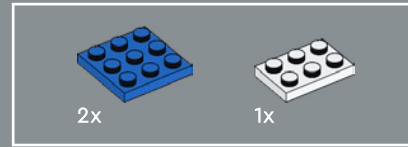
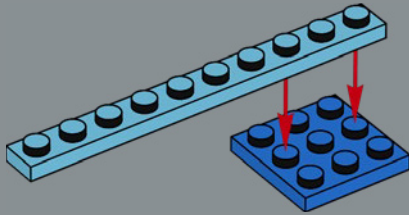

286

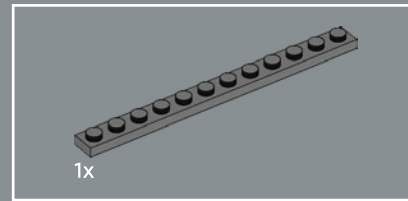
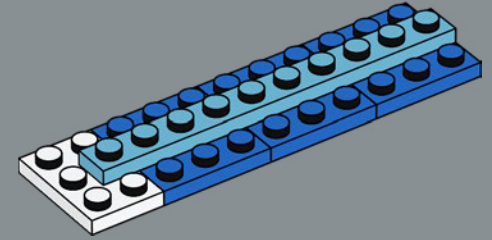

287

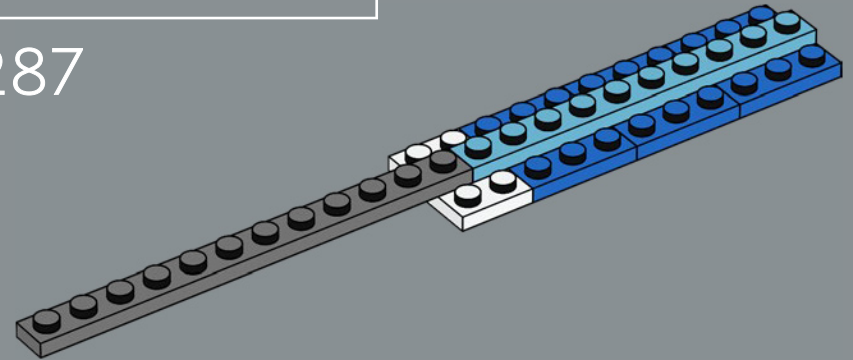

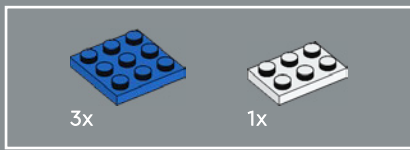

288

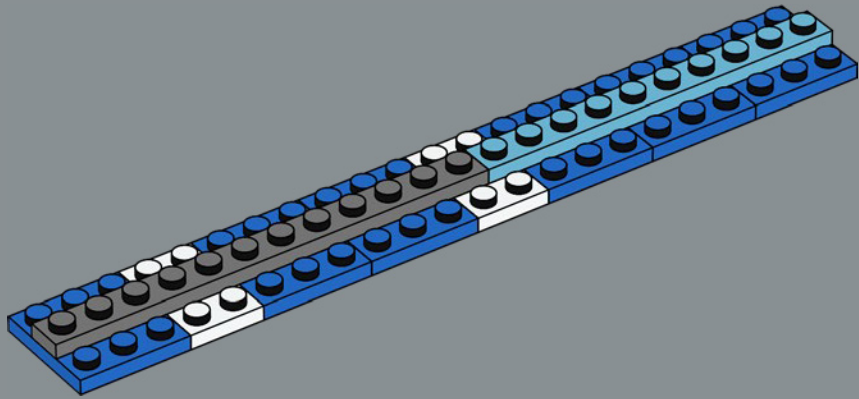

289

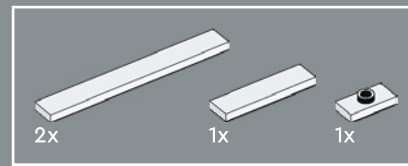
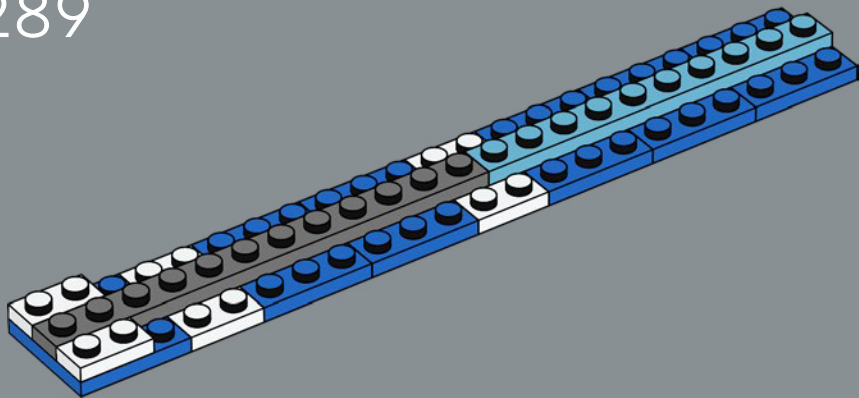

290

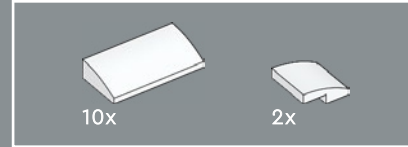
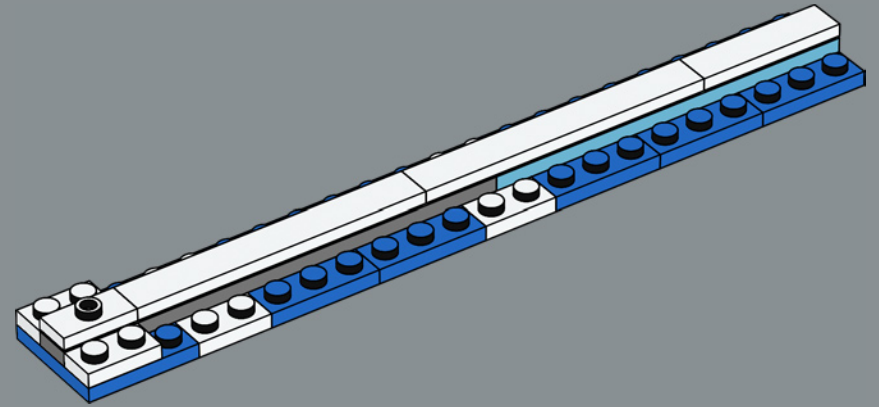

291

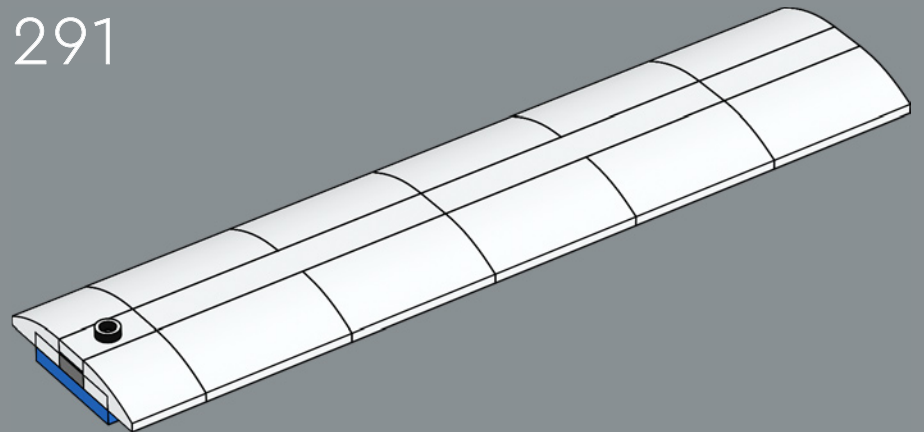

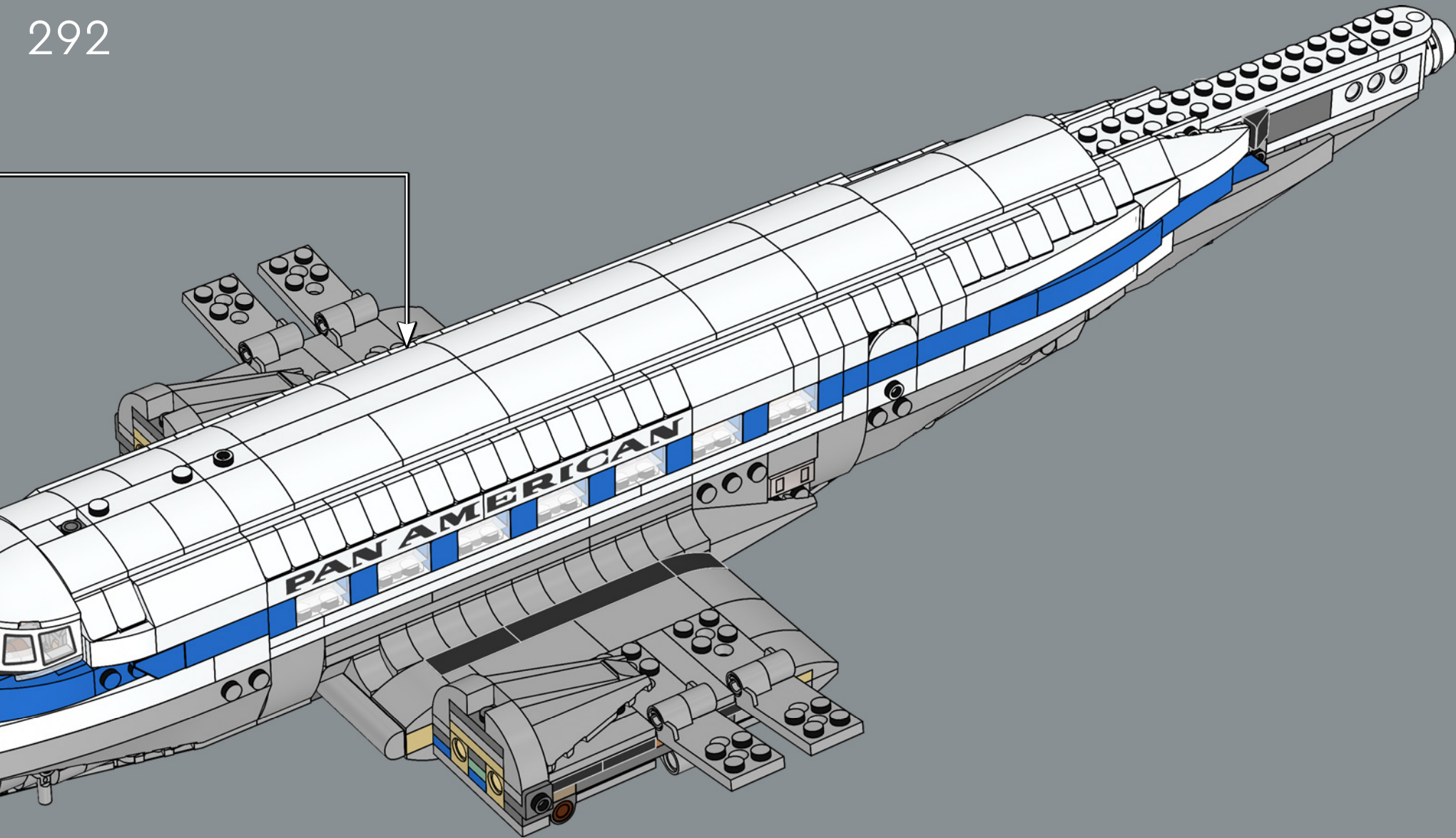

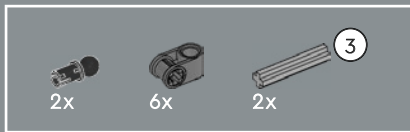

293

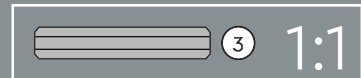
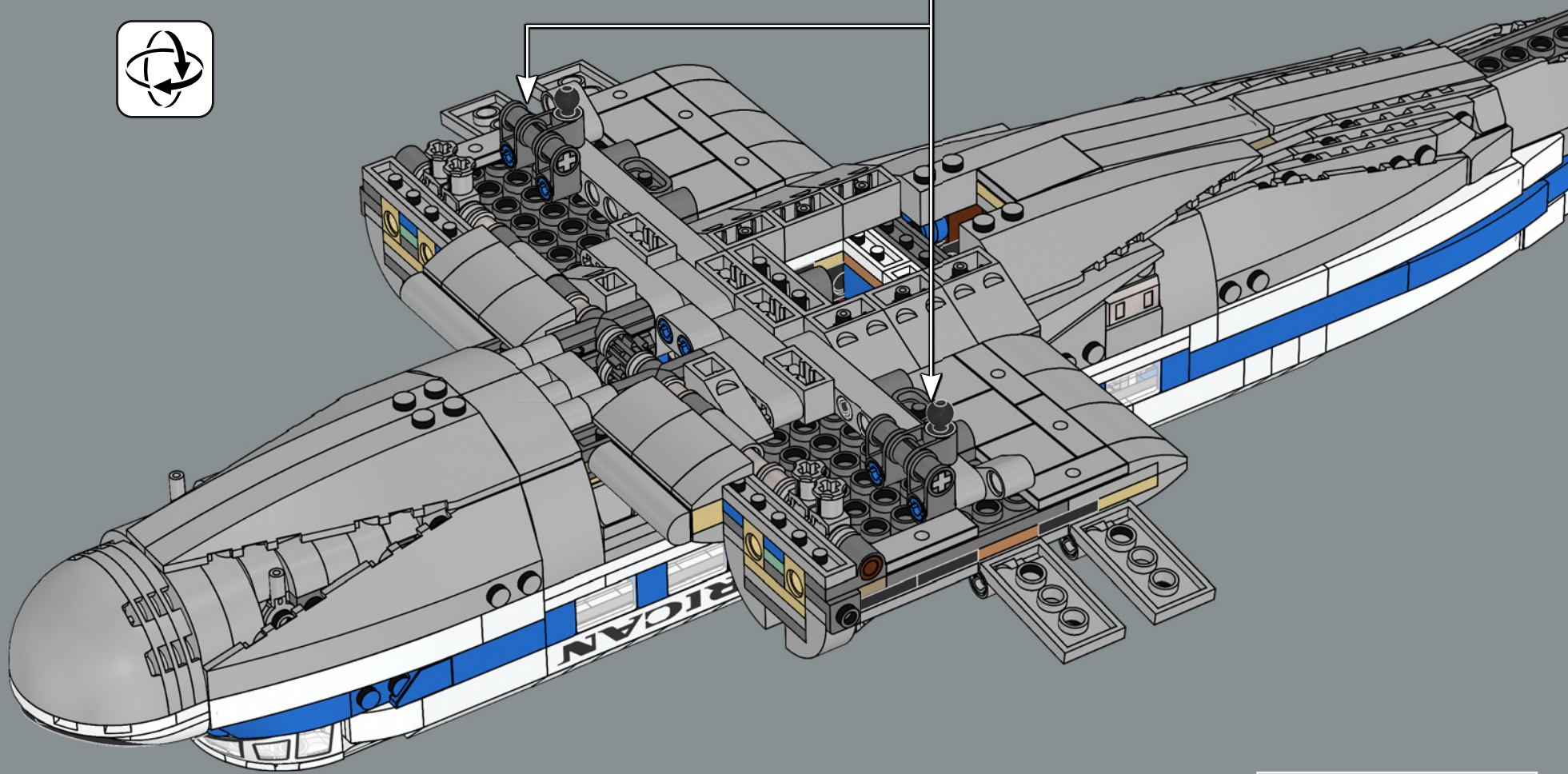
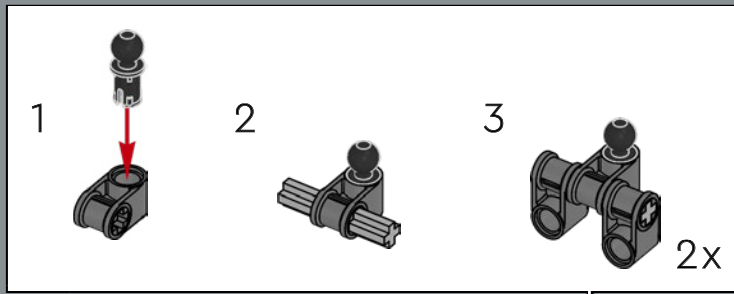

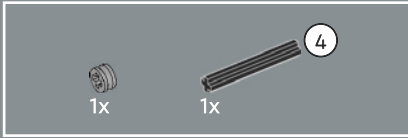
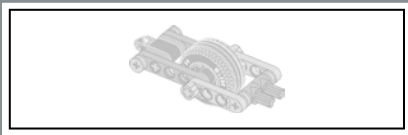

294

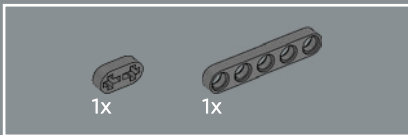

295

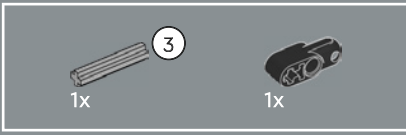
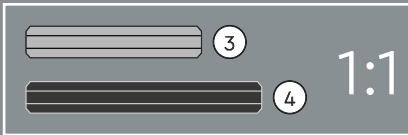
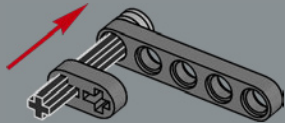

296

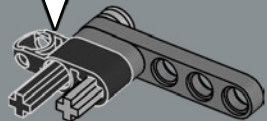
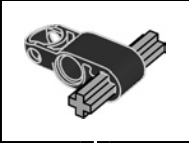

297

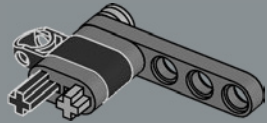

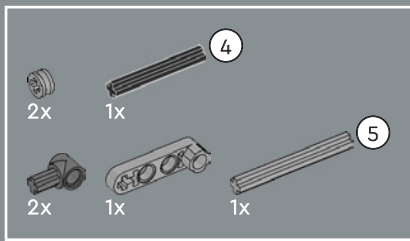

298

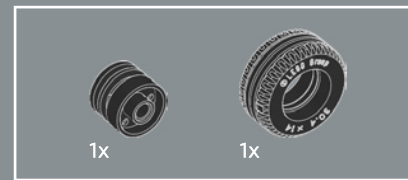
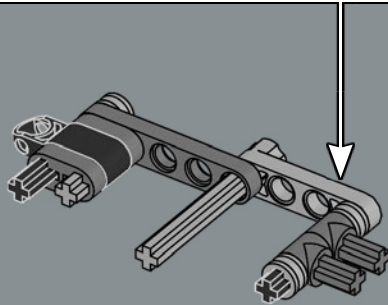
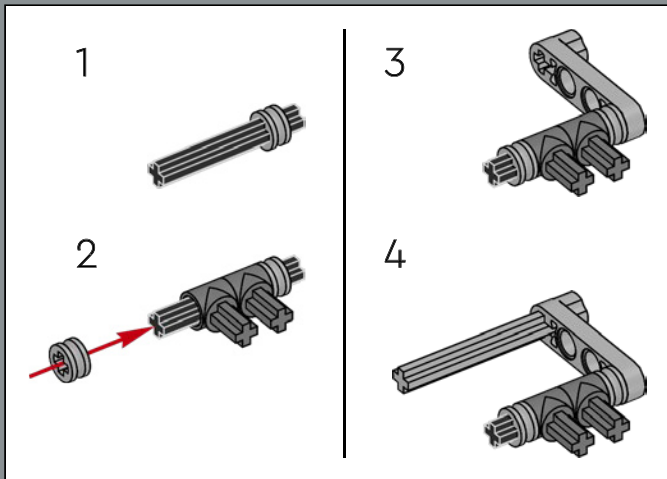

299

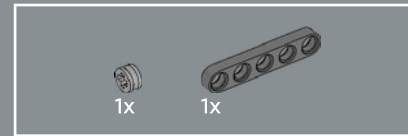
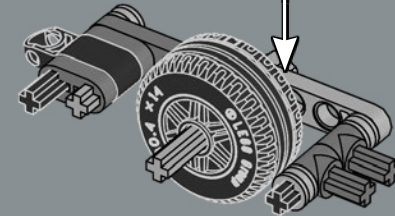
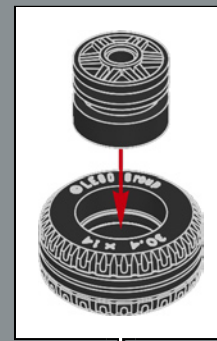

300

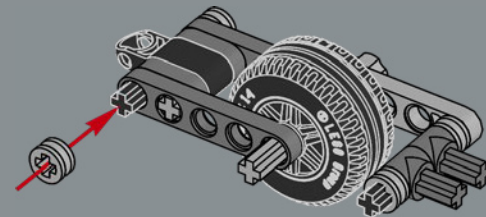



301

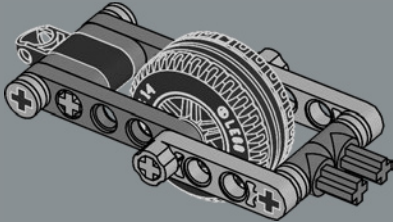

302

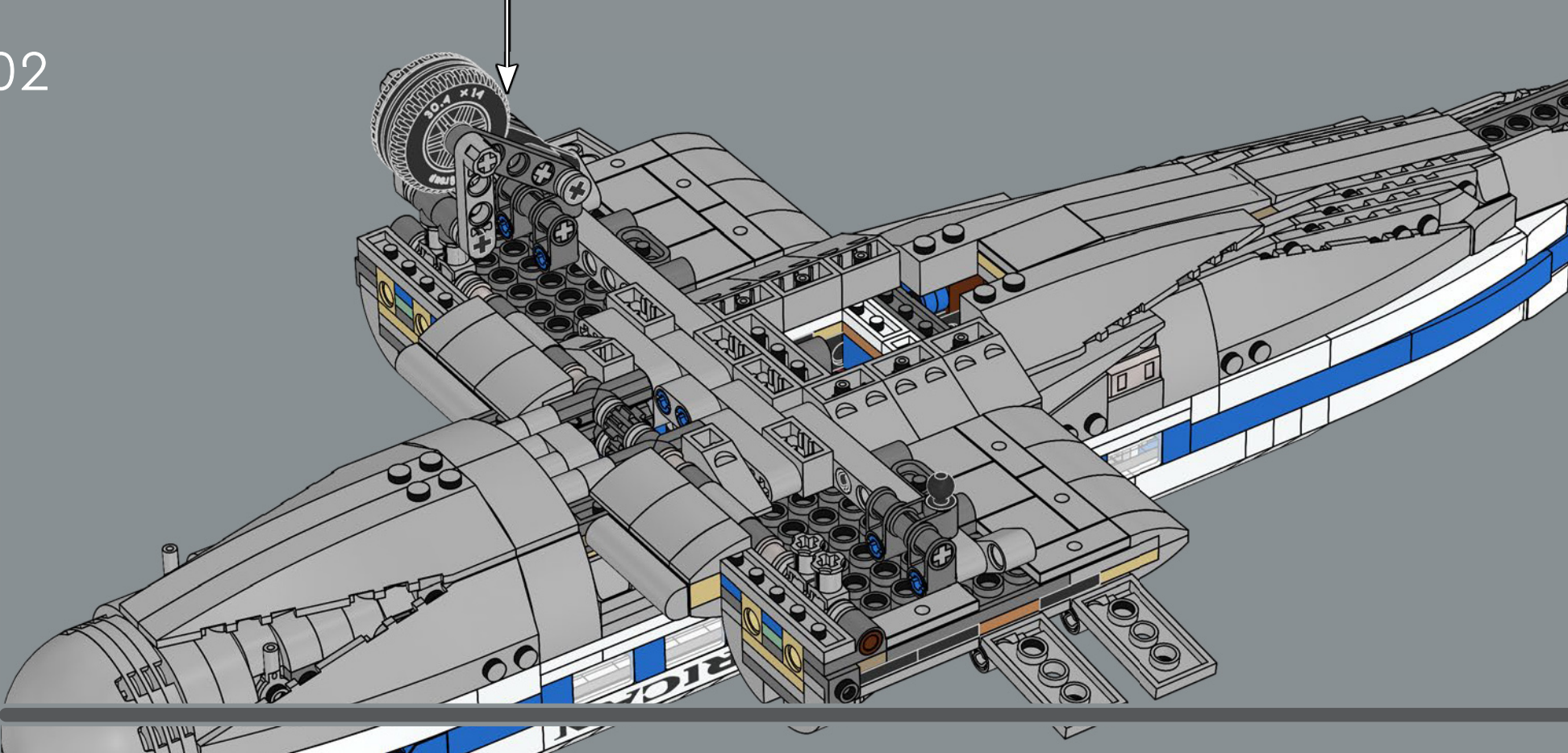

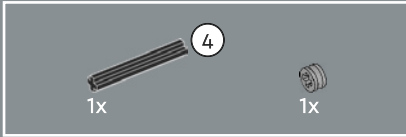
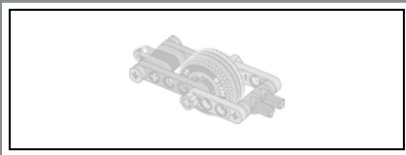

303

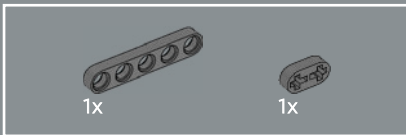

304

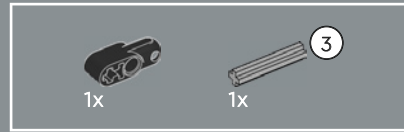
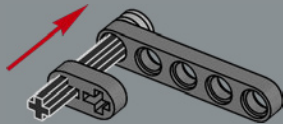

305

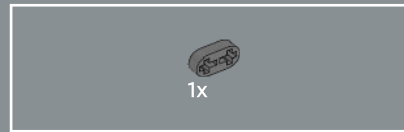
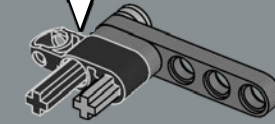
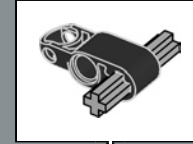

306

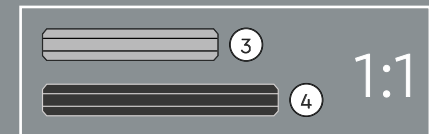
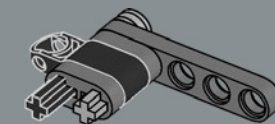

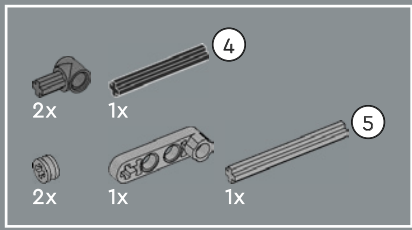

307

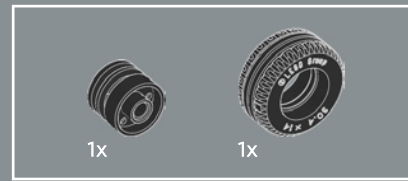
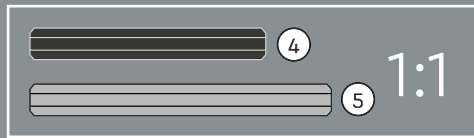
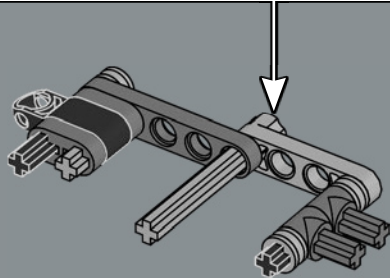
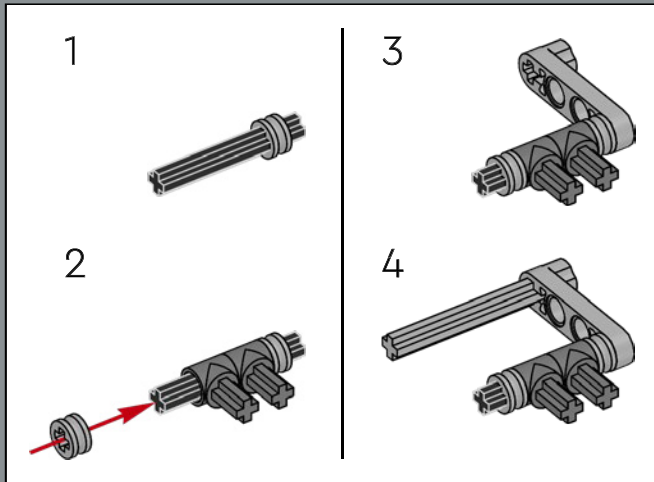

308

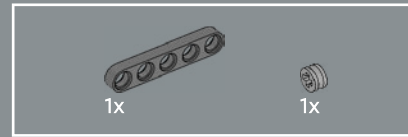
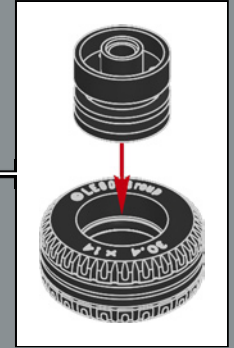
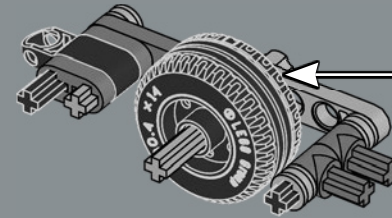

309

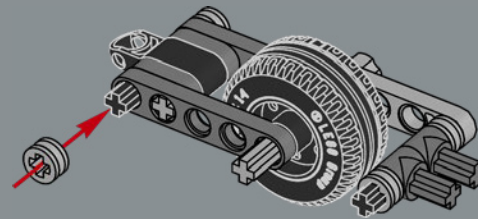



310

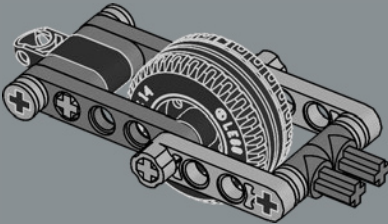

311

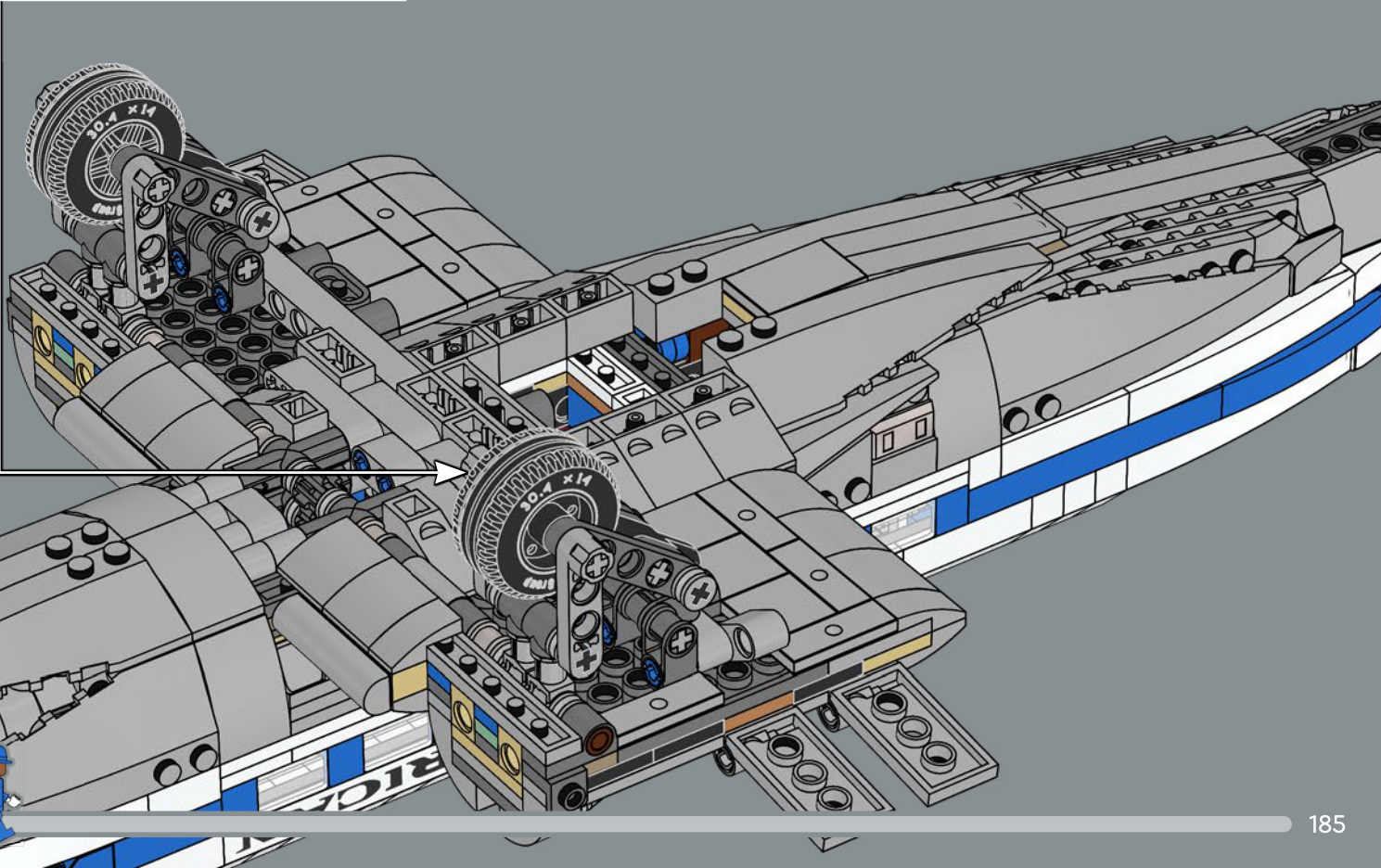

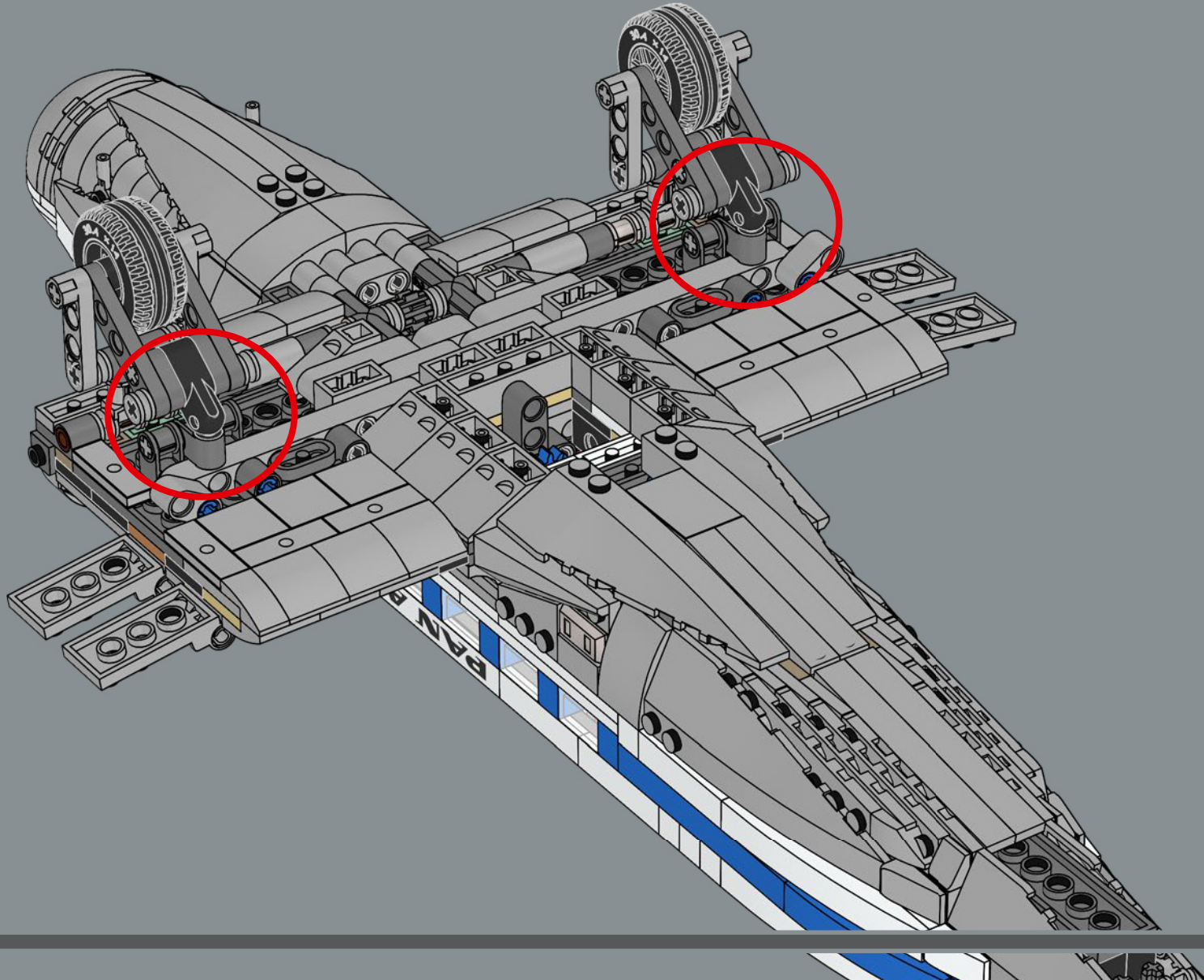

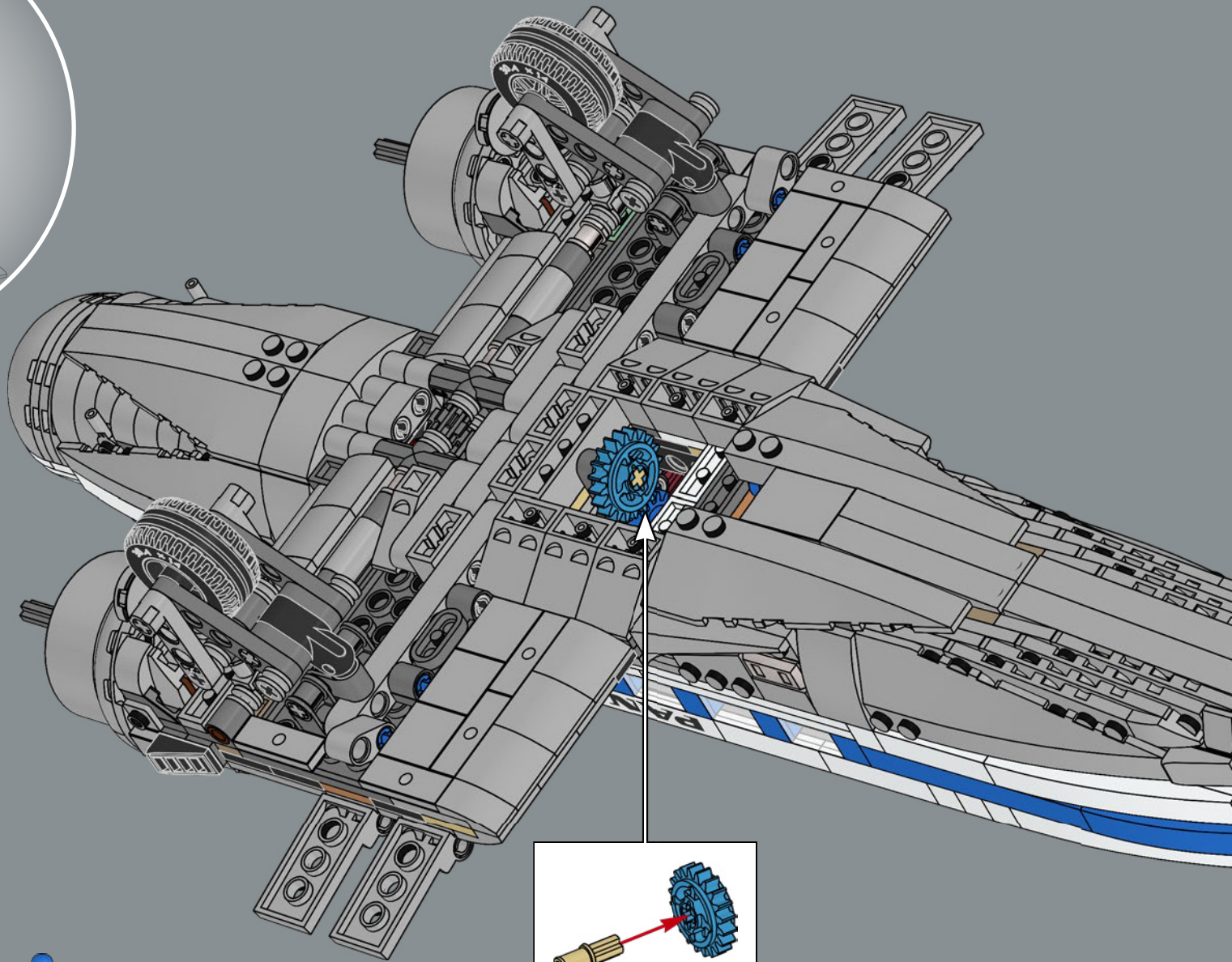

313

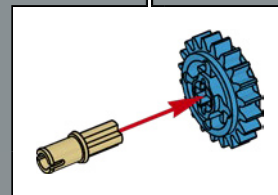

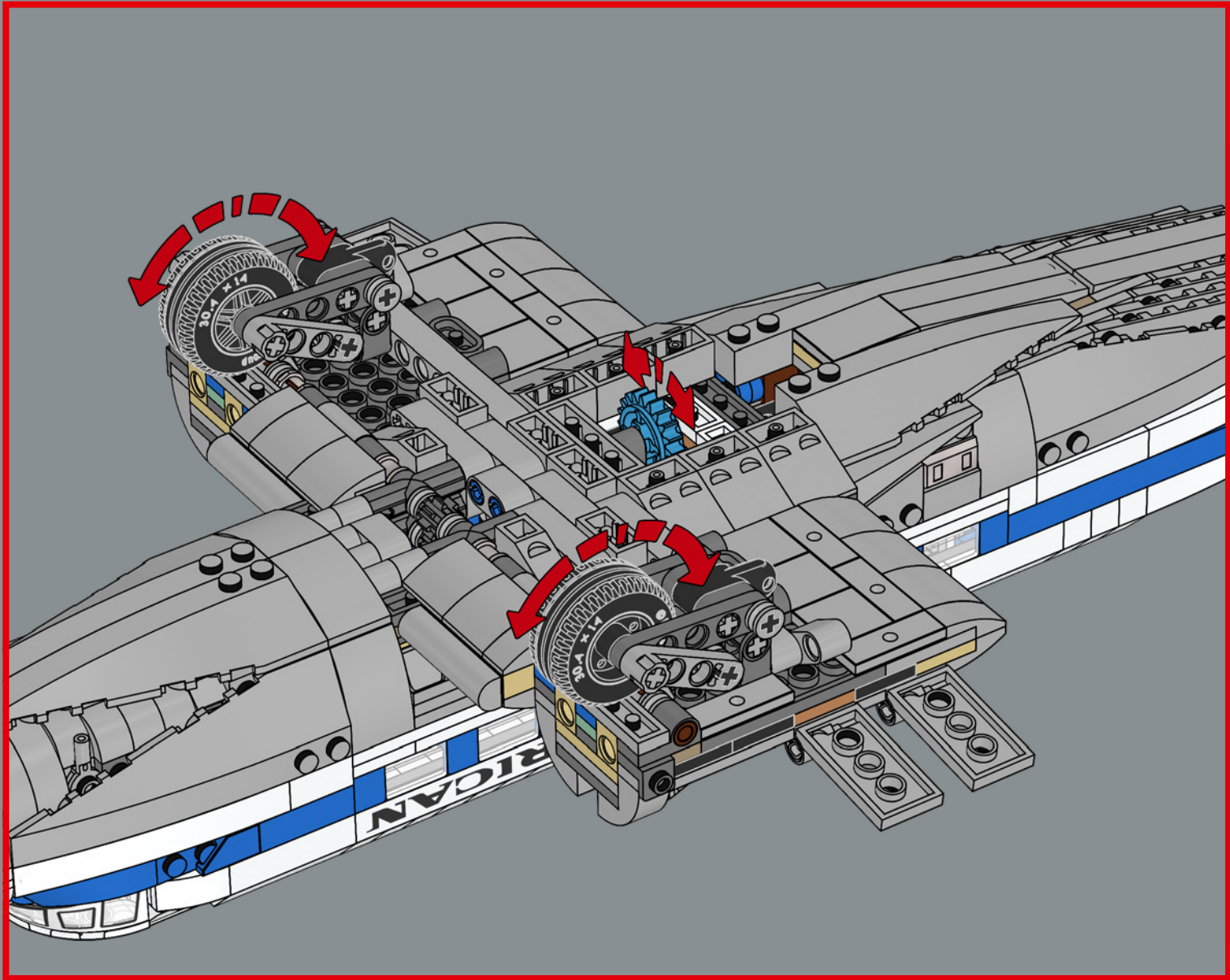

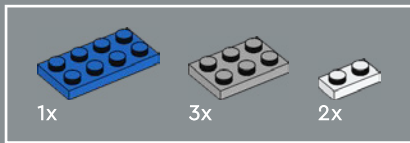

314

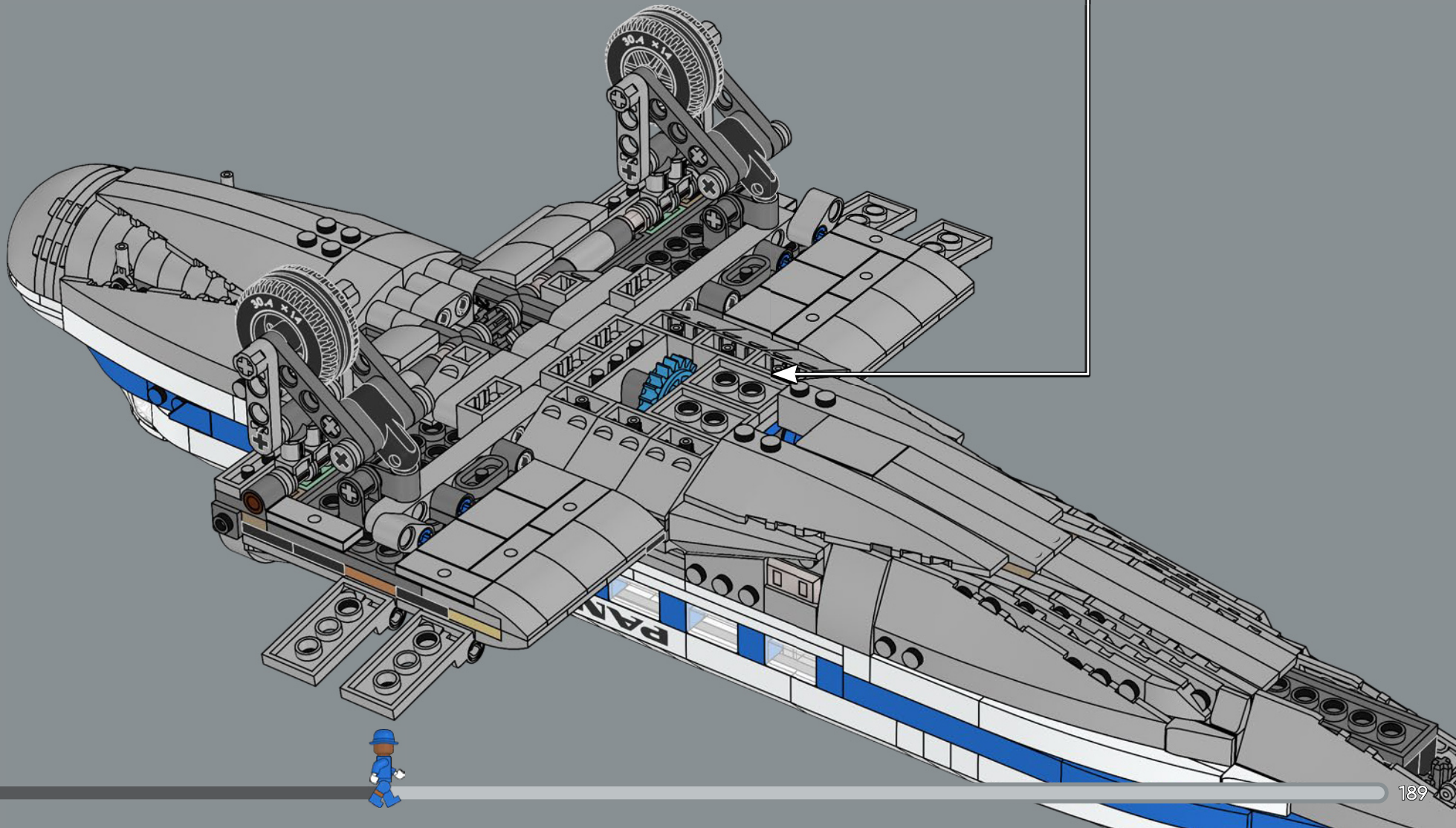
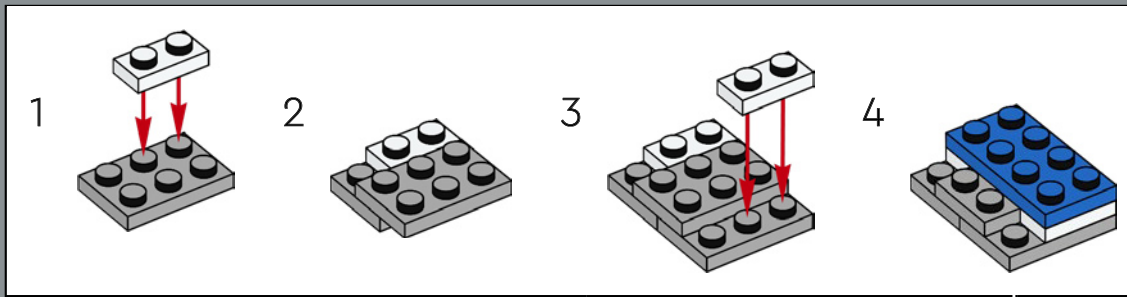



4x

315

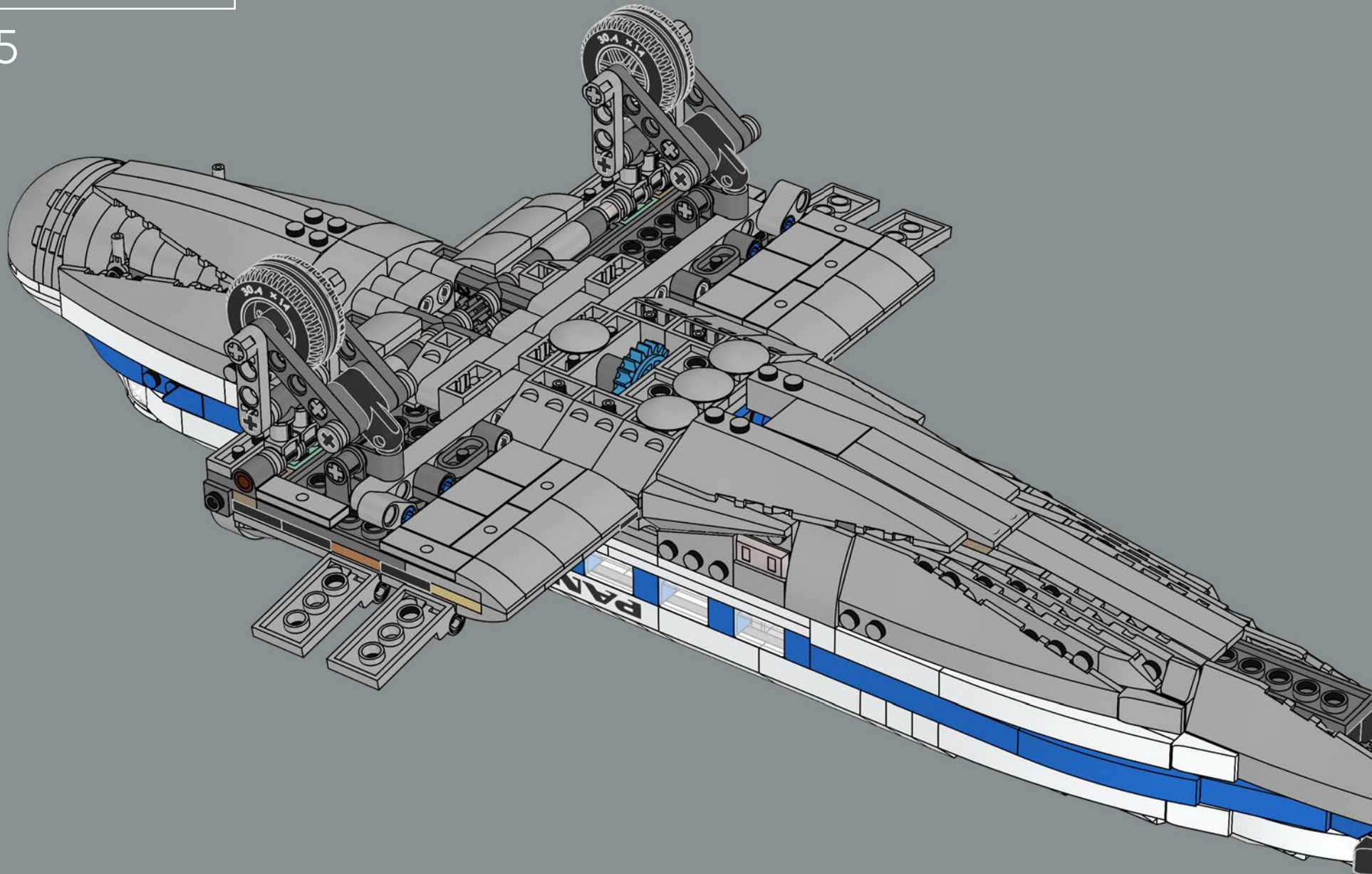

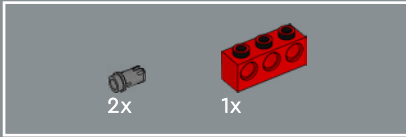
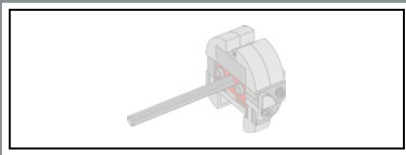

316

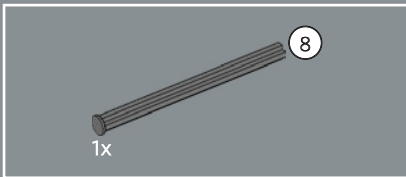
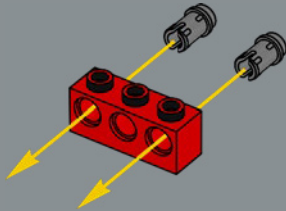

317

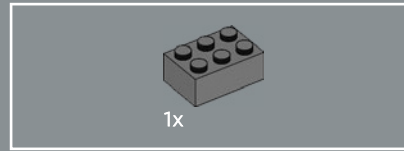
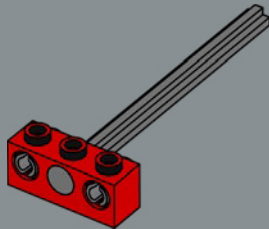

318

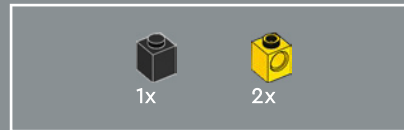
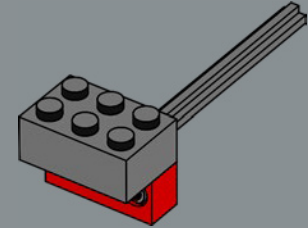

319

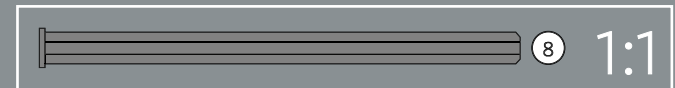
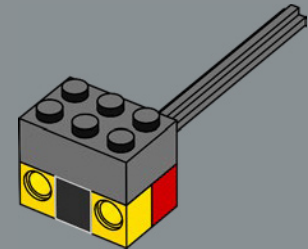

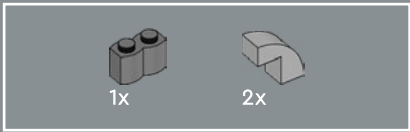

320

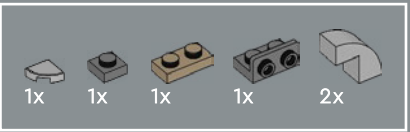
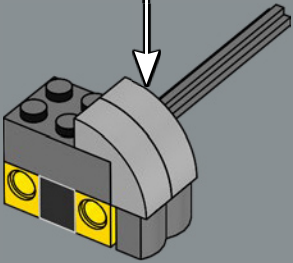
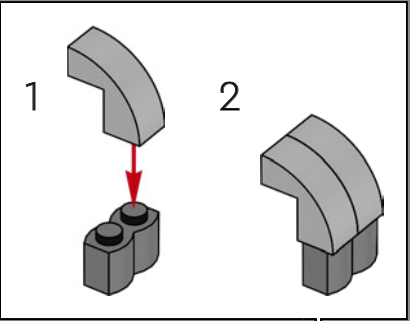

321

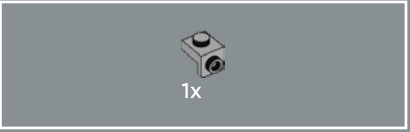
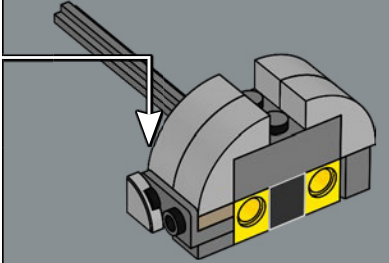
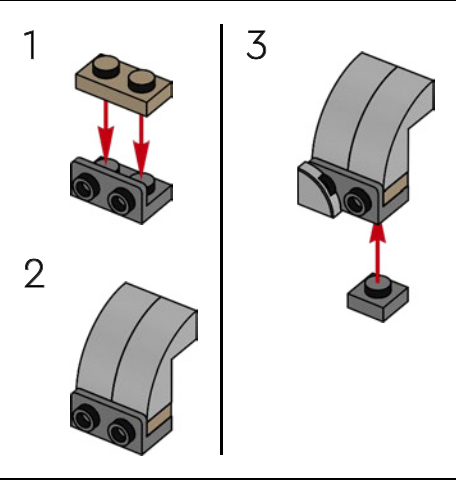

322

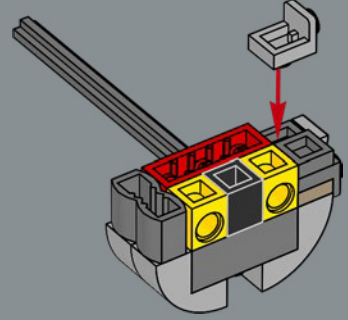



323

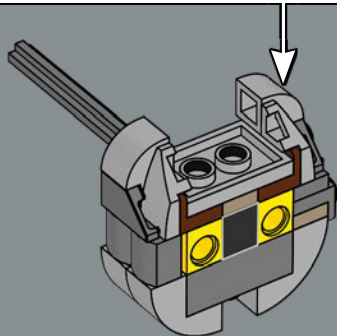
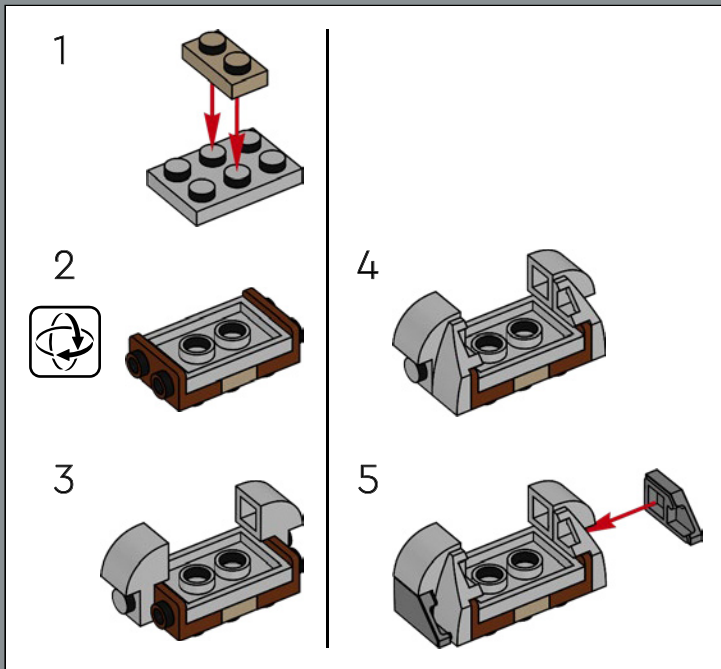

324

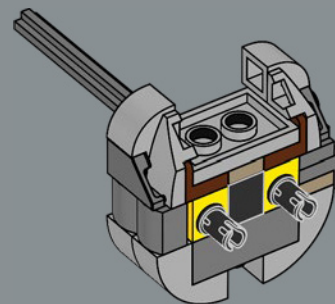



1x

325

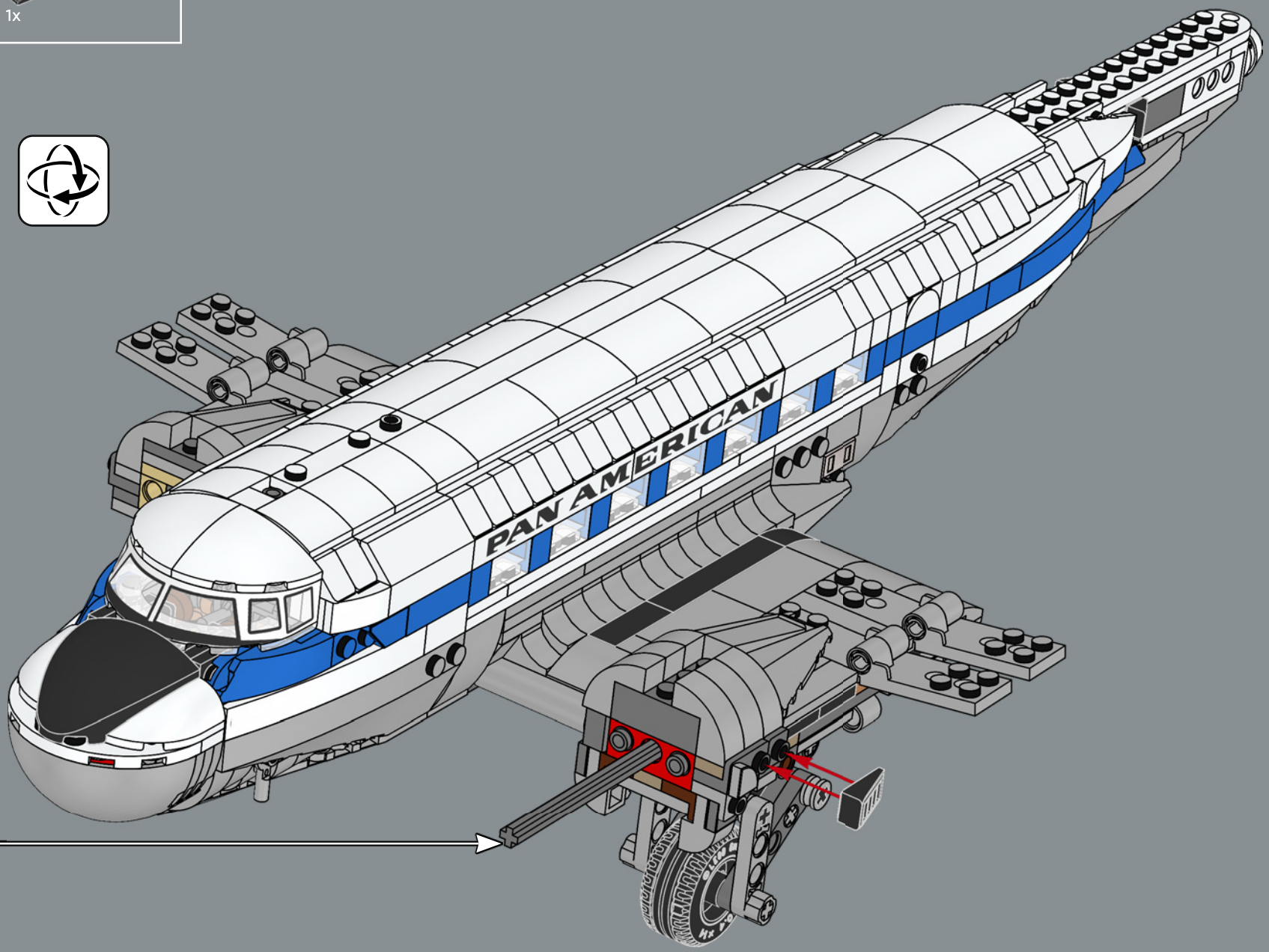

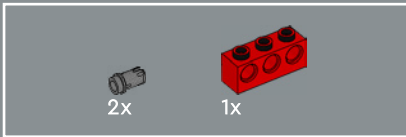
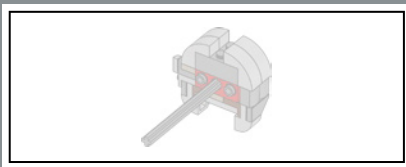

326

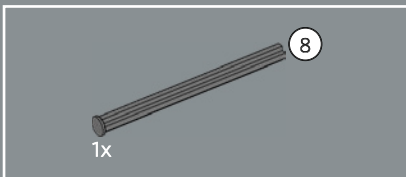
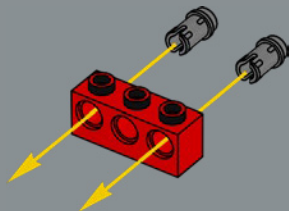

327

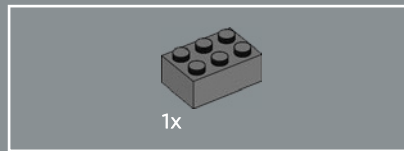
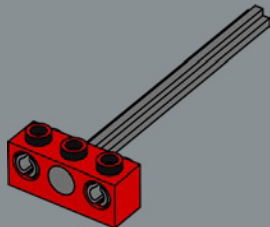

328

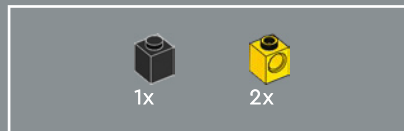
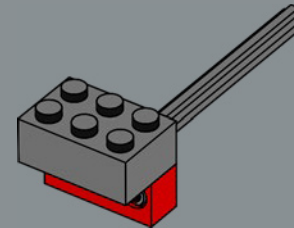

329

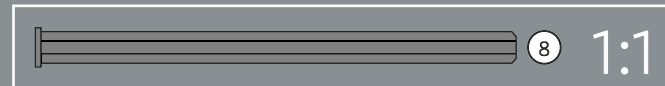
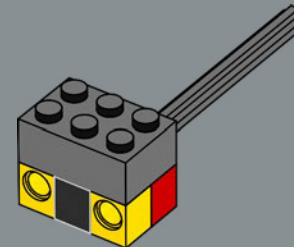

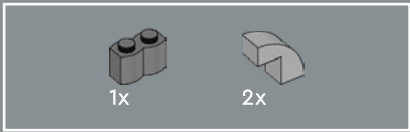

330

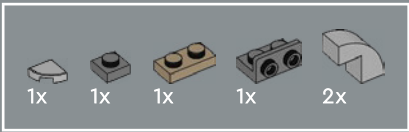
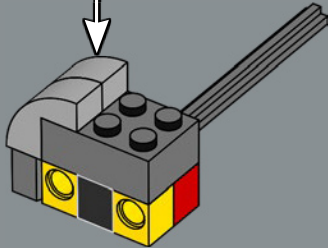
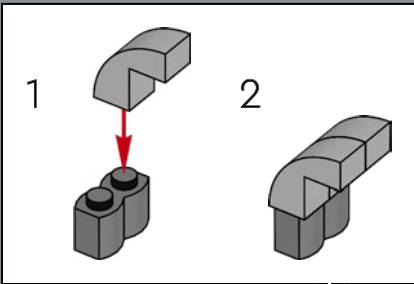

331

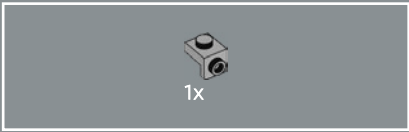
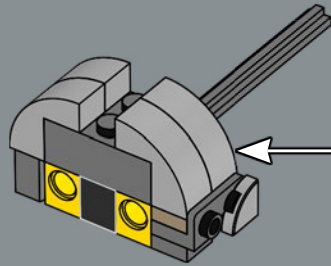
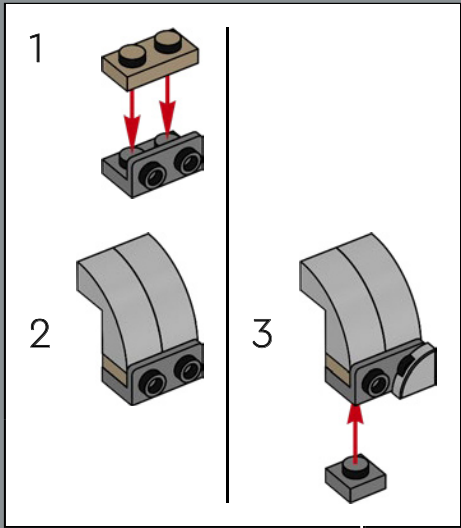

332

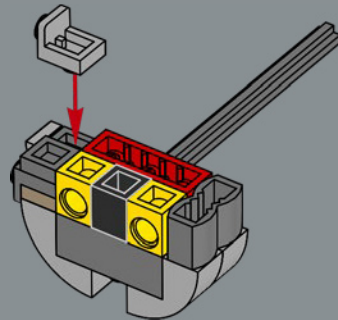

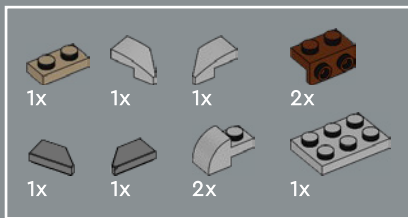

333

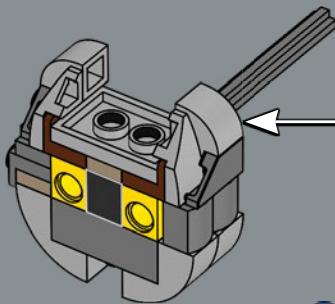
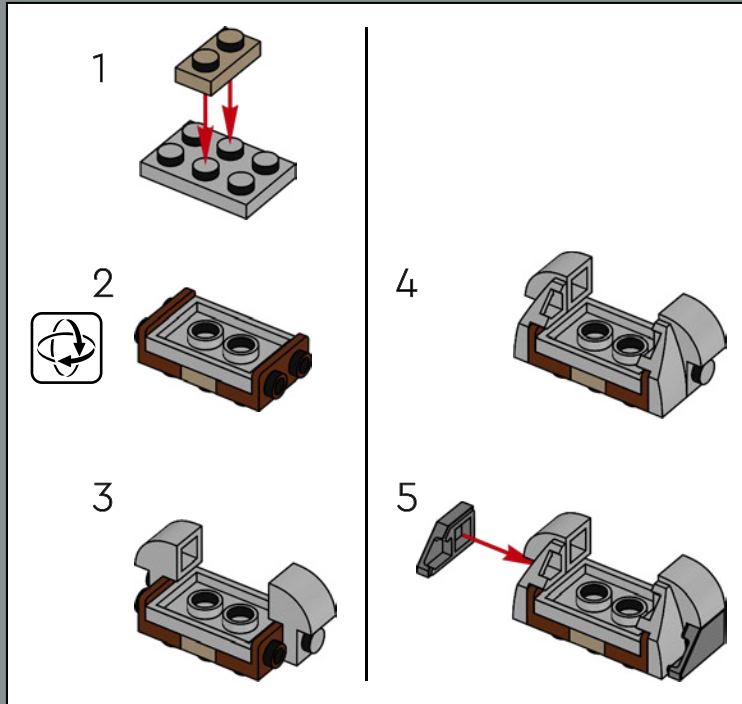

334

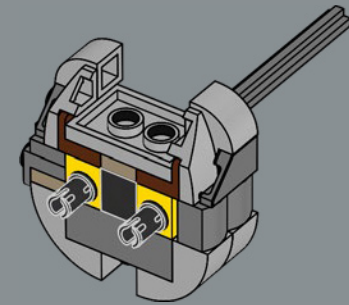



1x

335

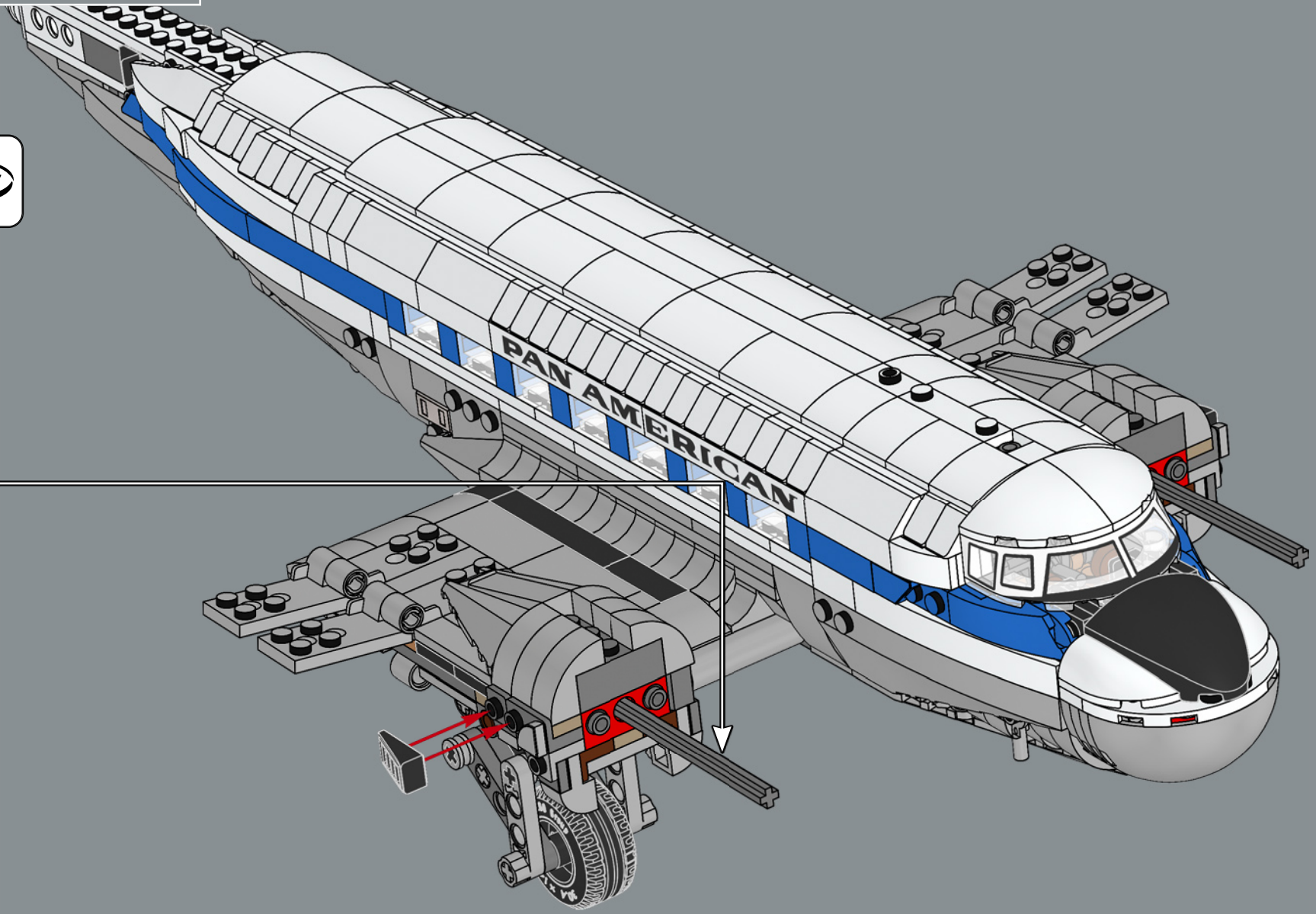

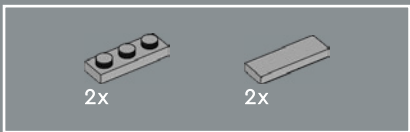

336

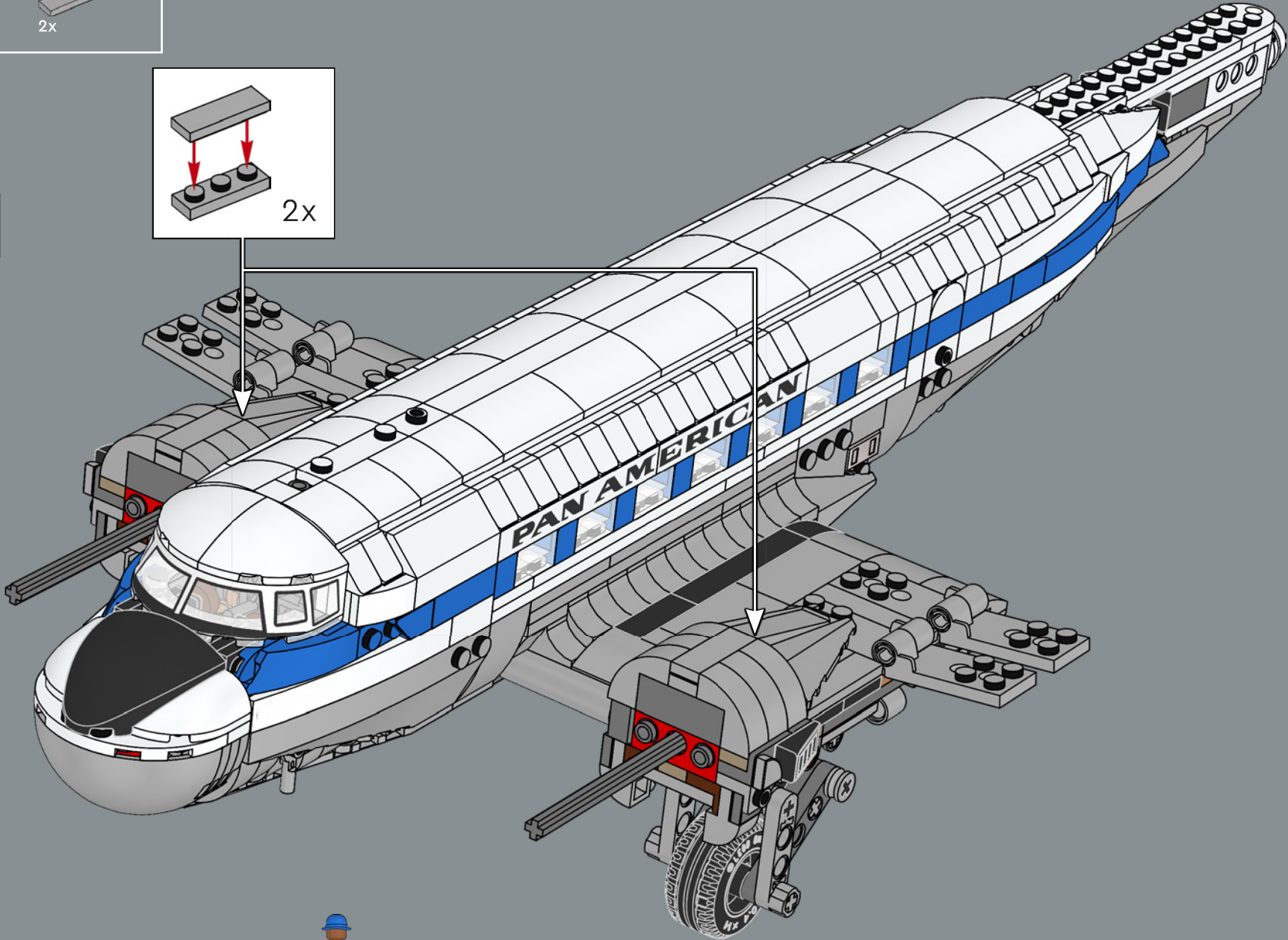
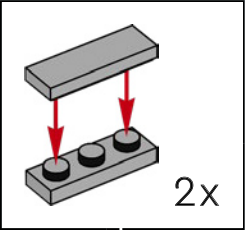

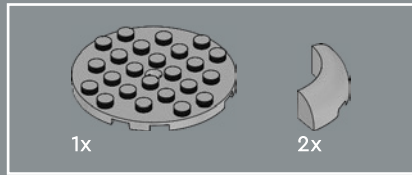

337

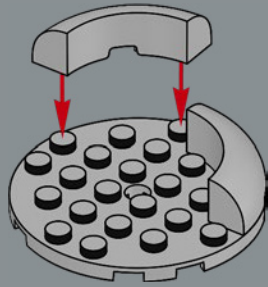

338

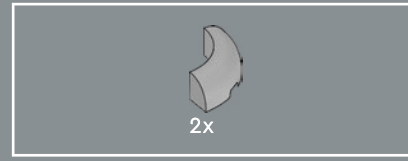
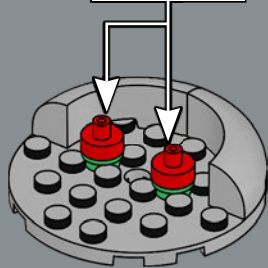
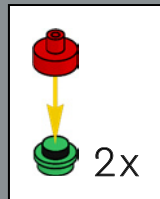

339

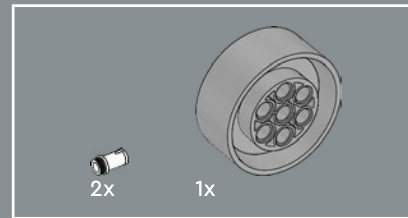
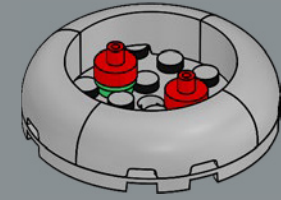

340

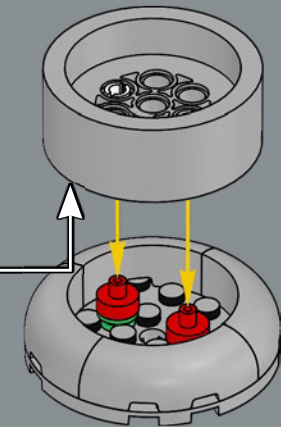
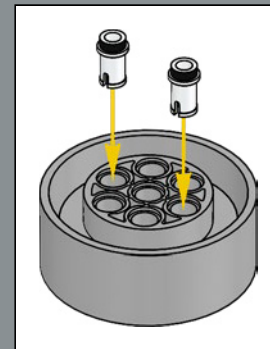

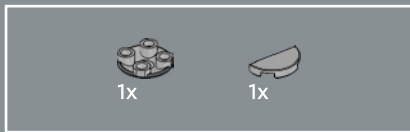

341

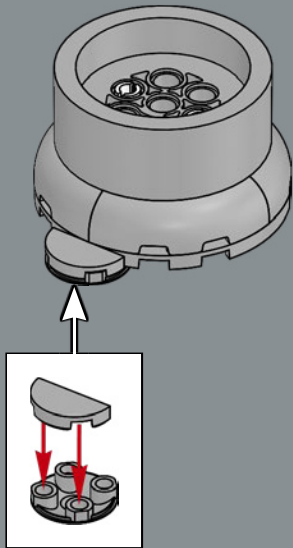

342

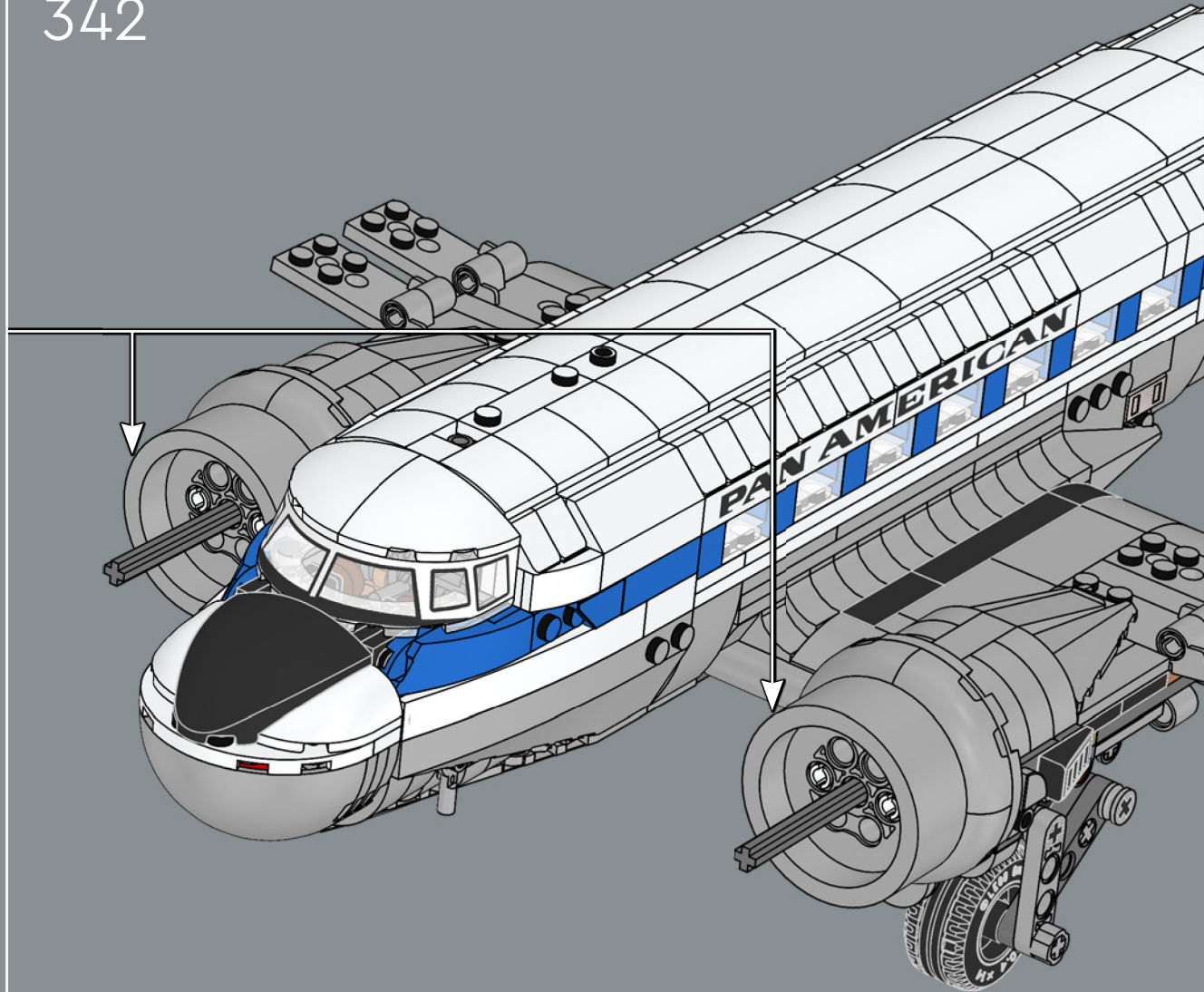

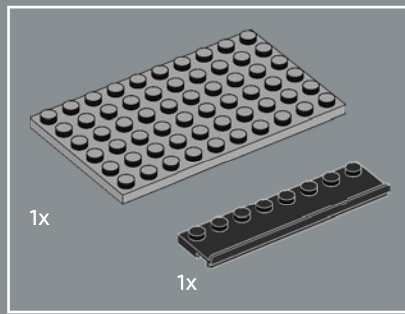
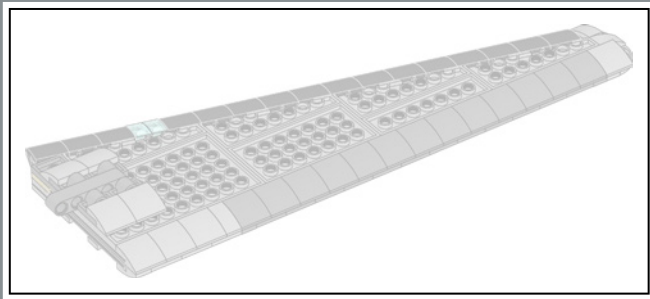

343

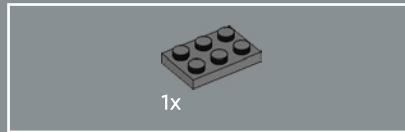
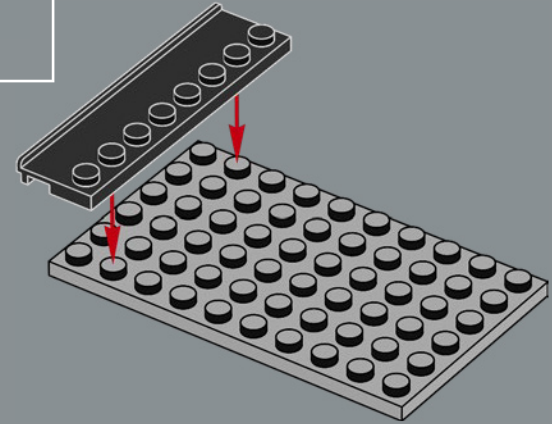

344

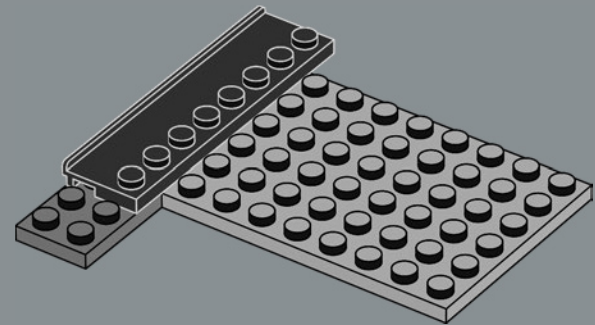

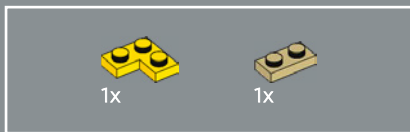

345

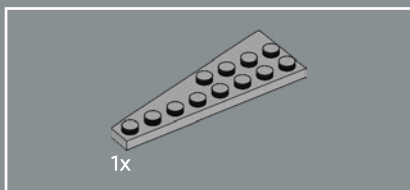
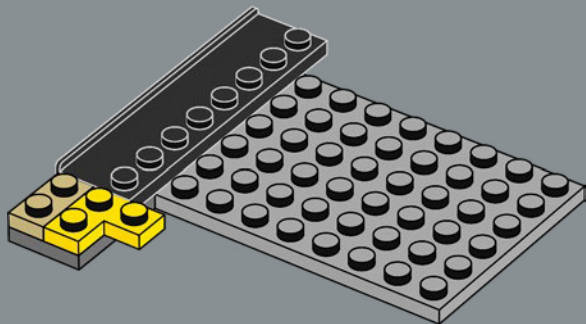

346

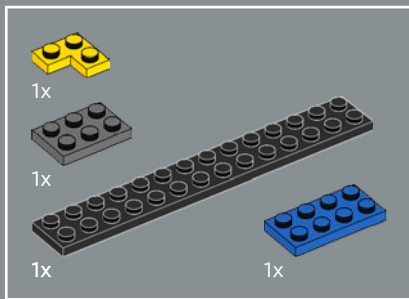
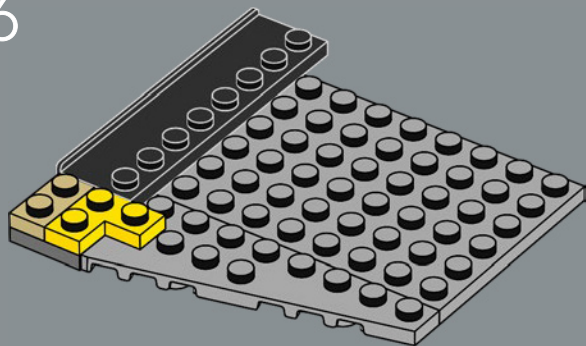

347

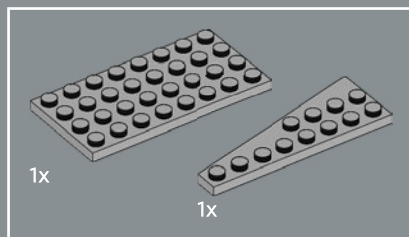
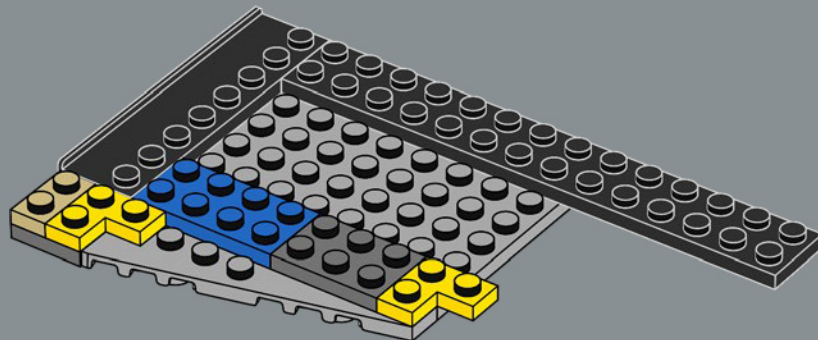

348

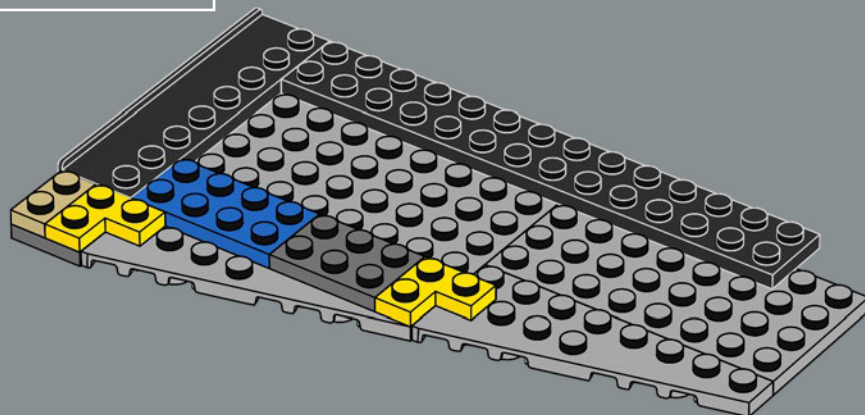

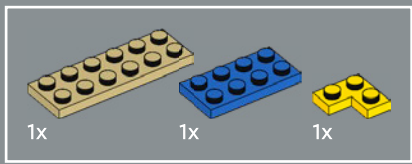

349

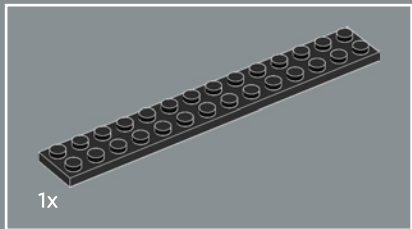
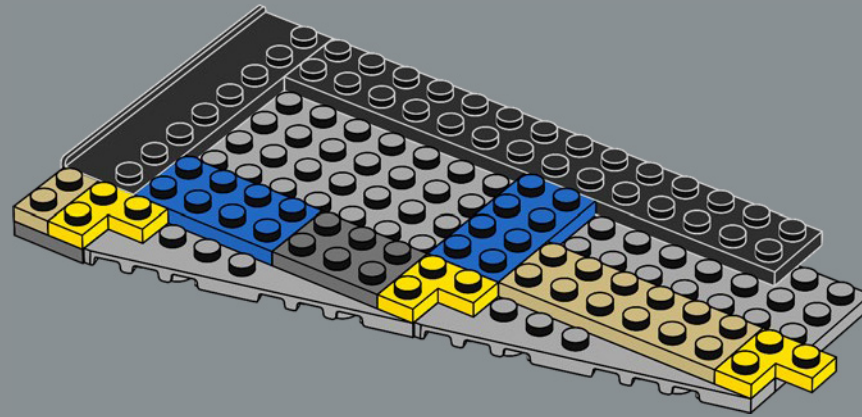

350

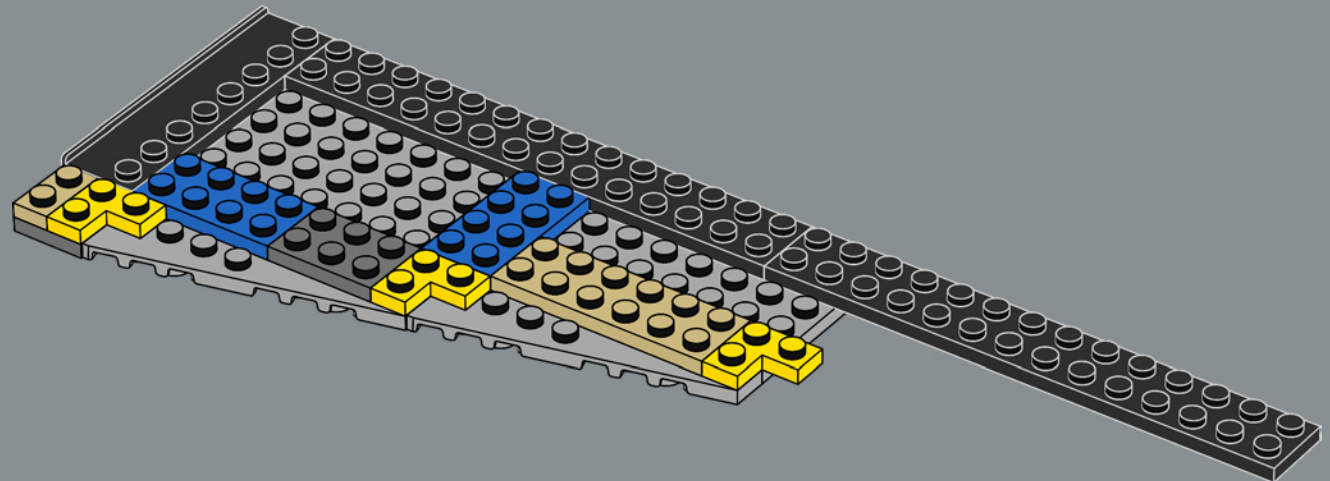

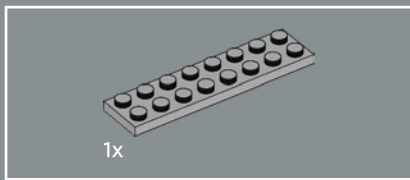

351

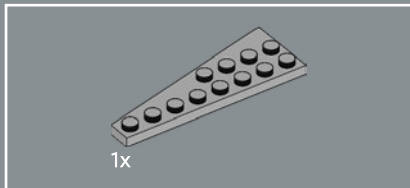
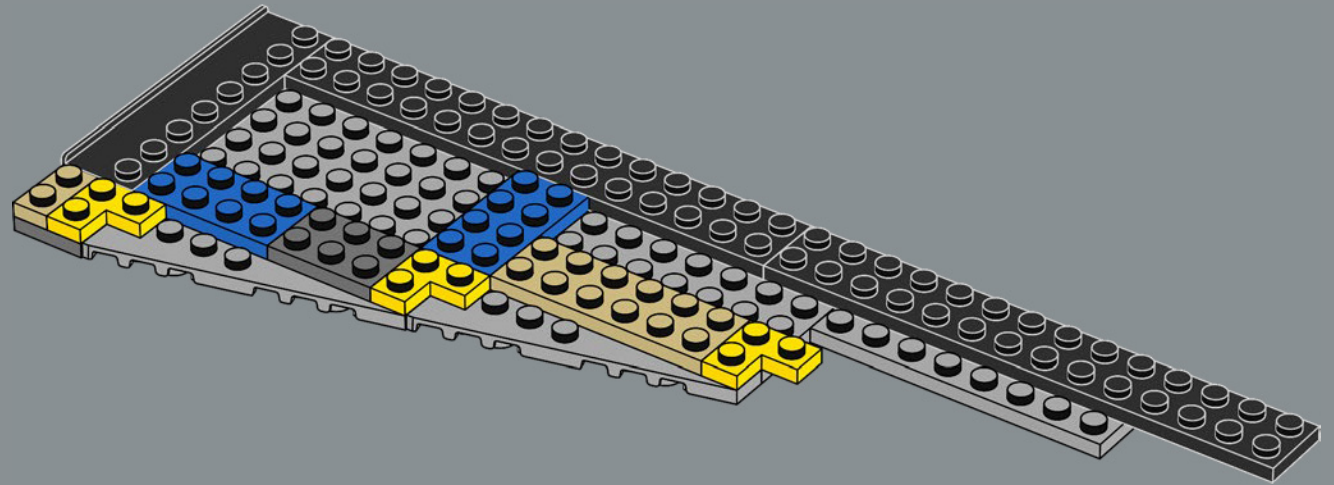

352

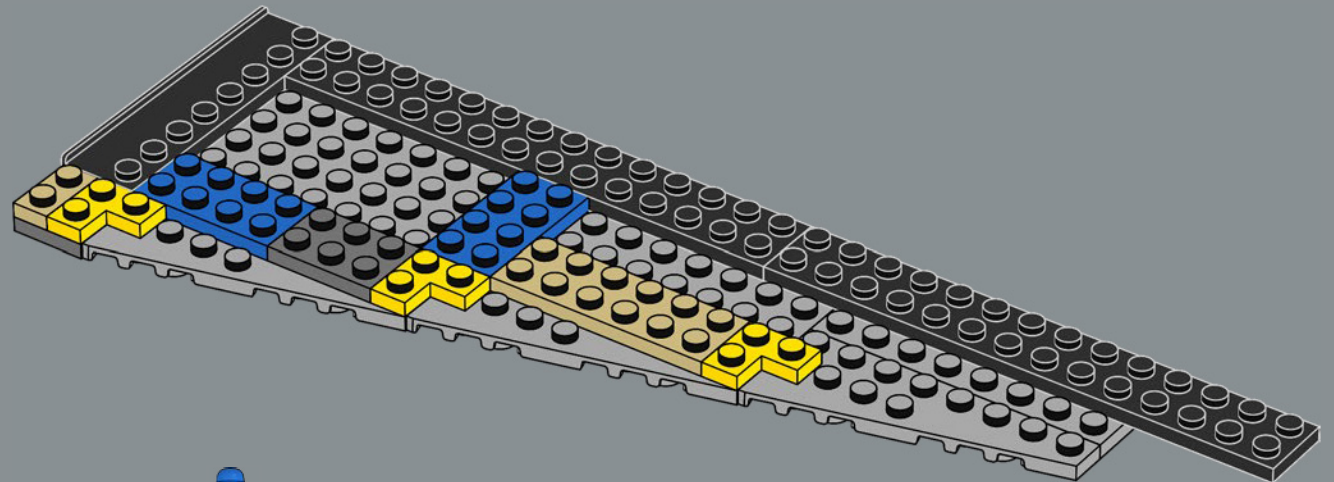

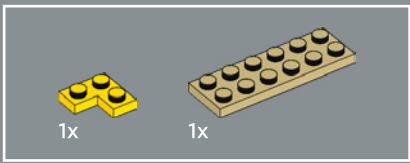

353

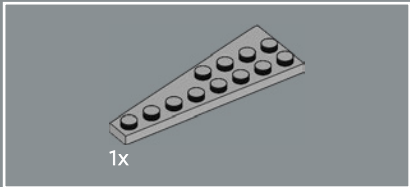
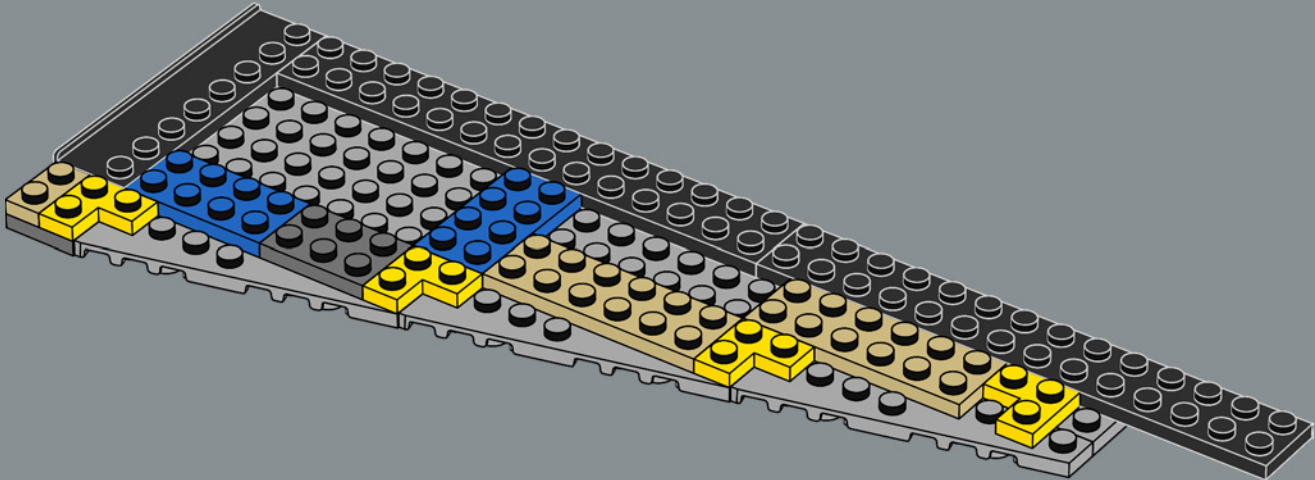

354

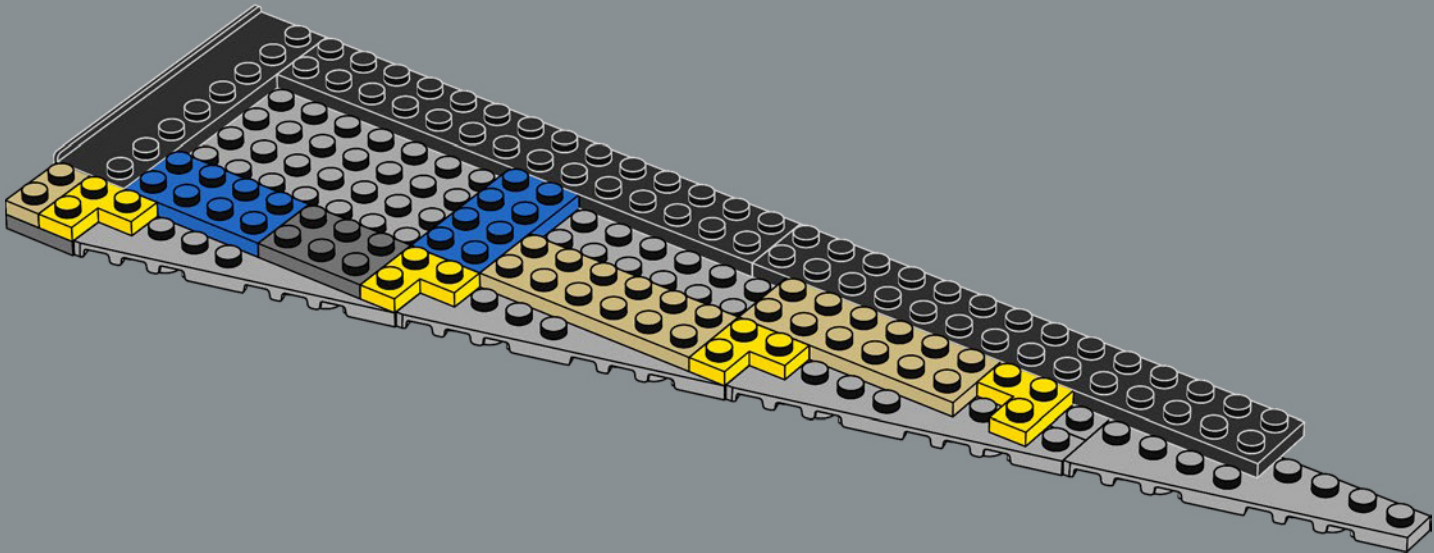

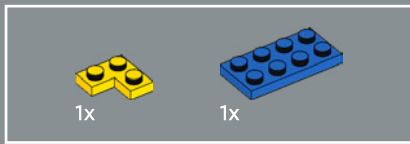

355

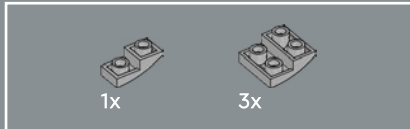
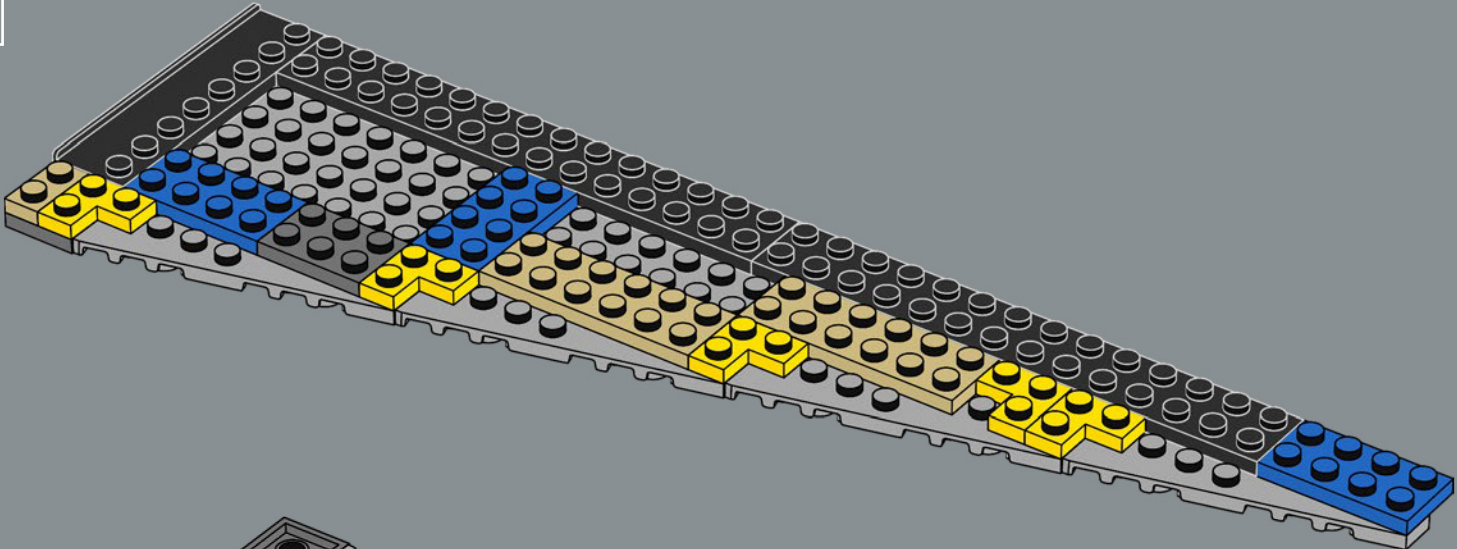

356

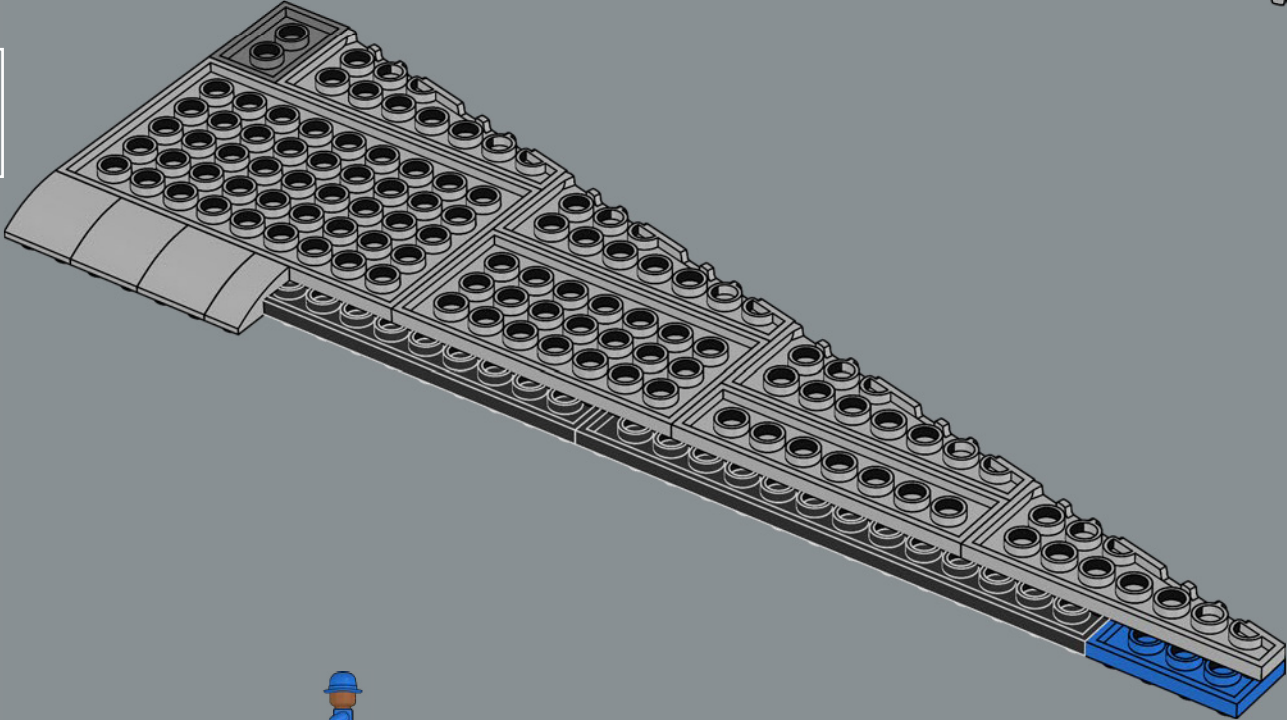

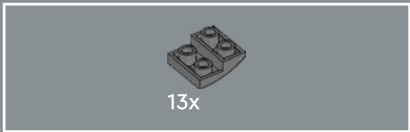

357

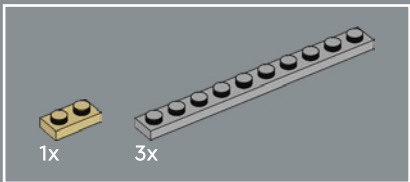
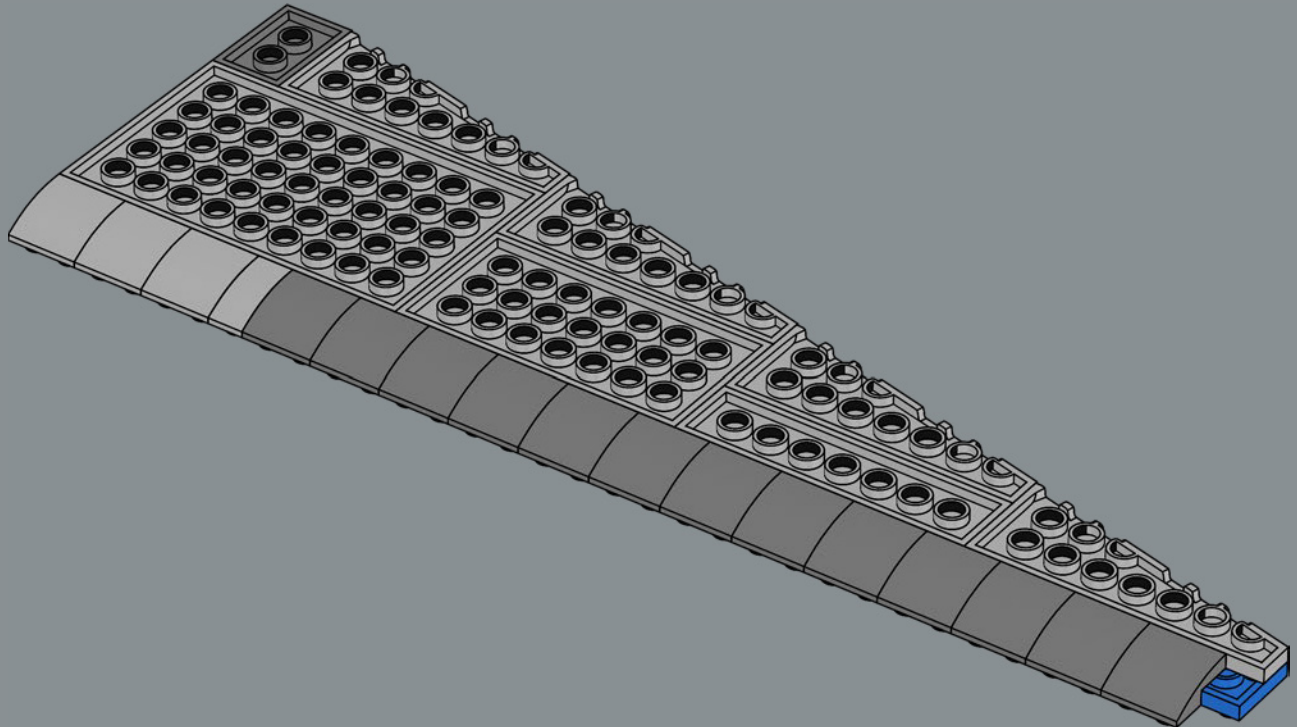

358

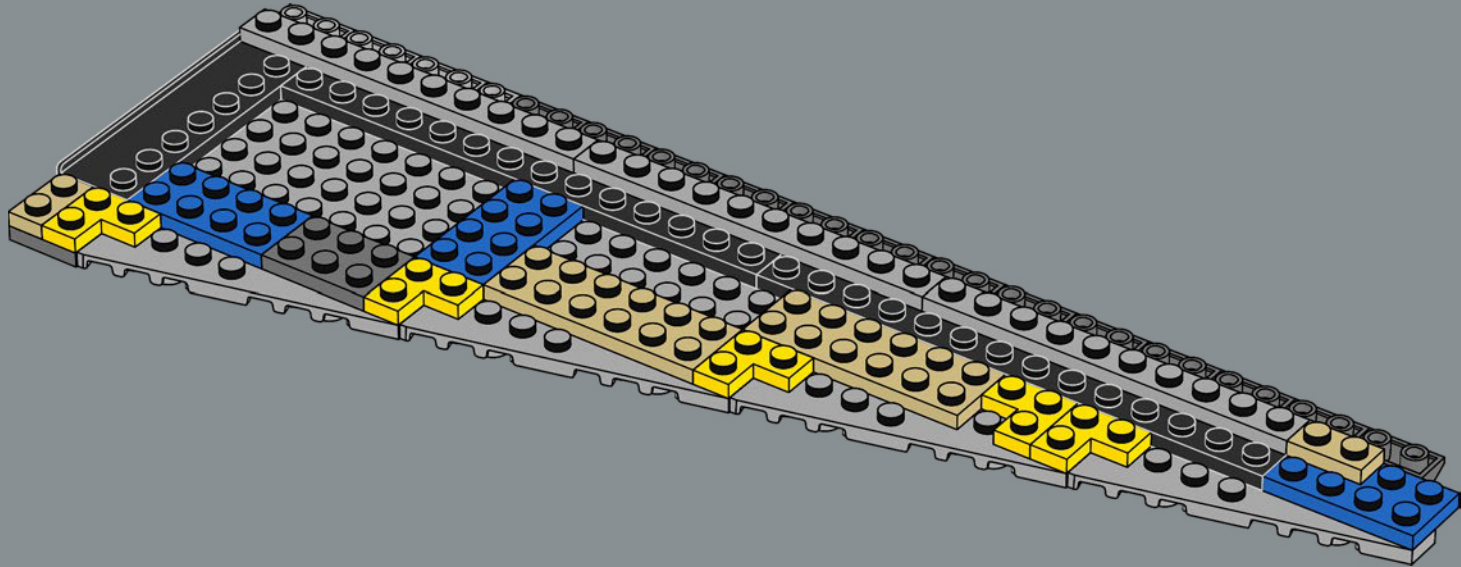

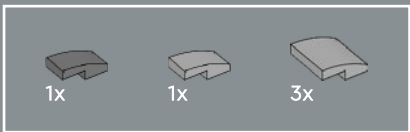

359

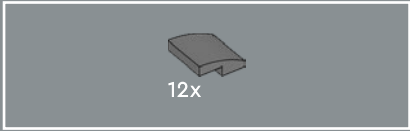
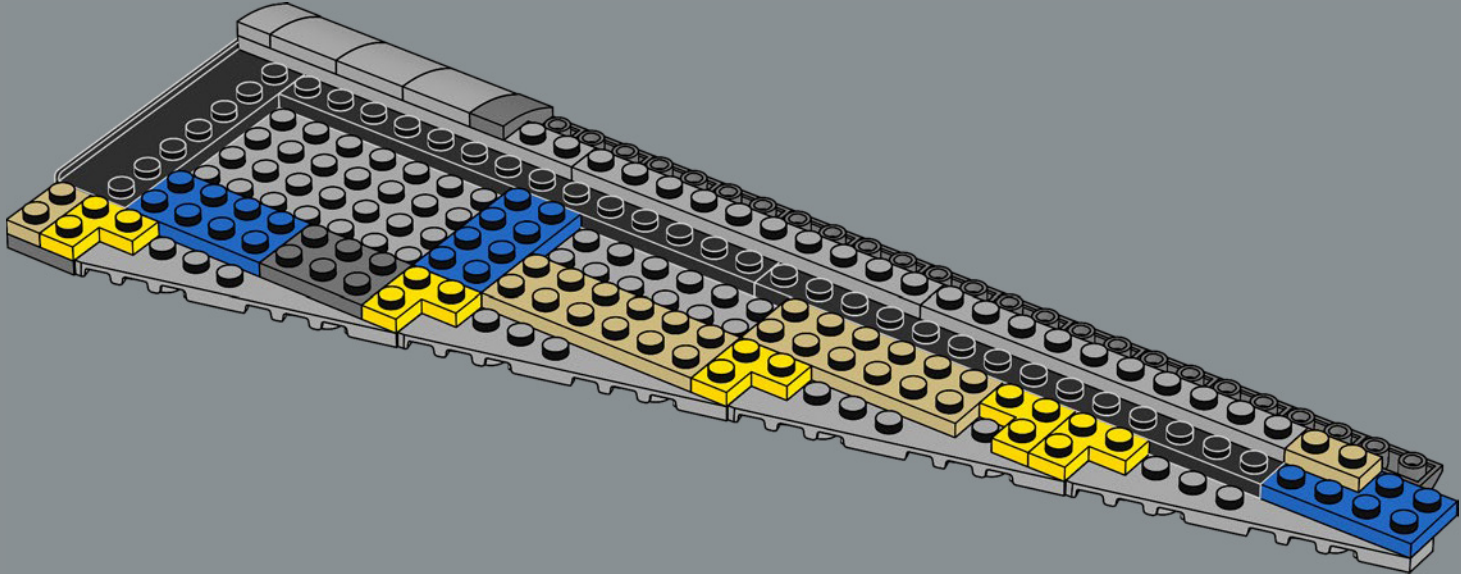

360

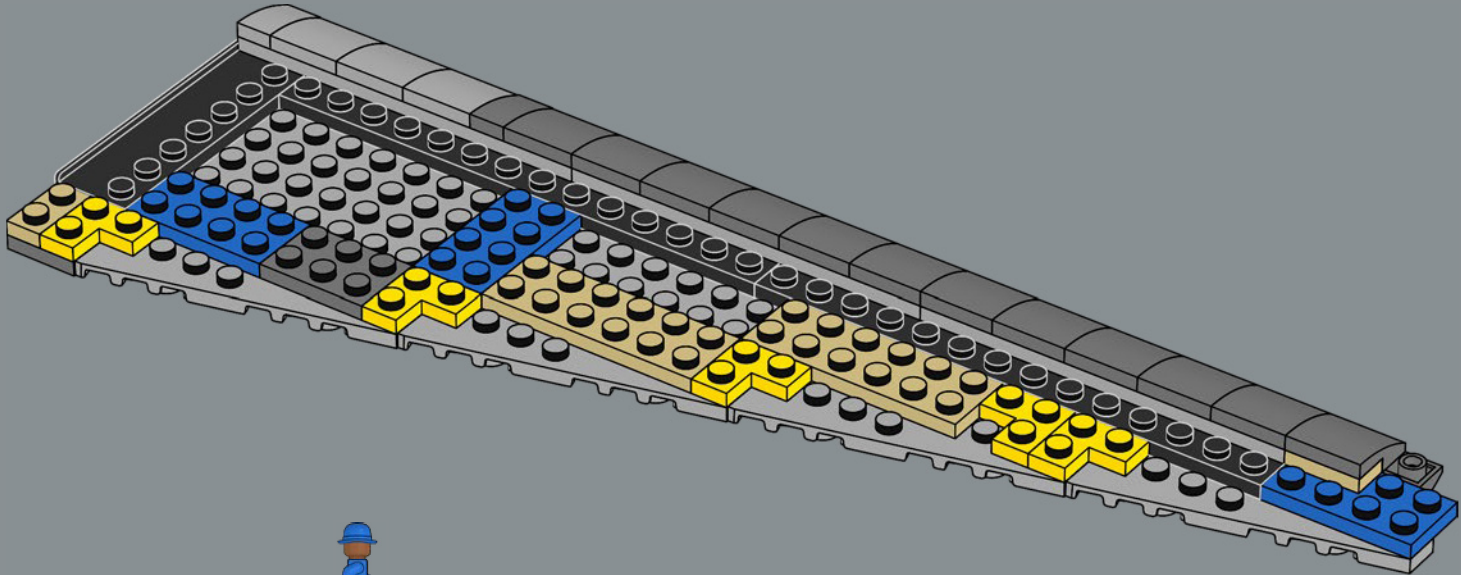

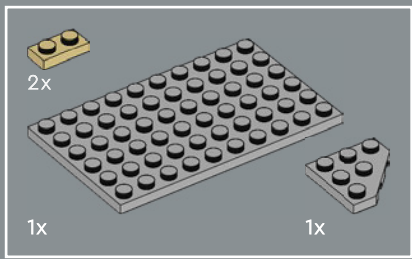

361

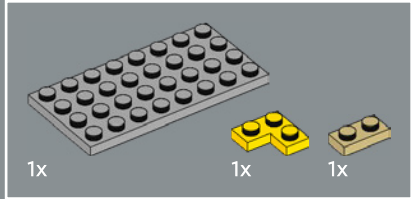
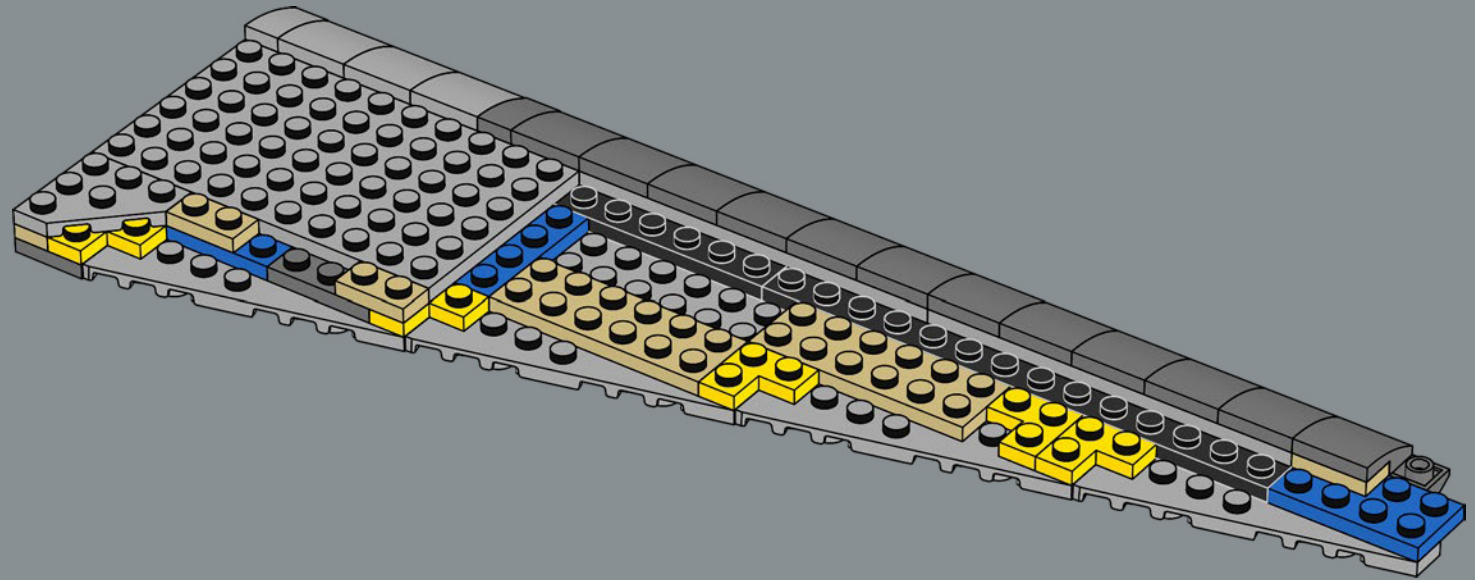

362

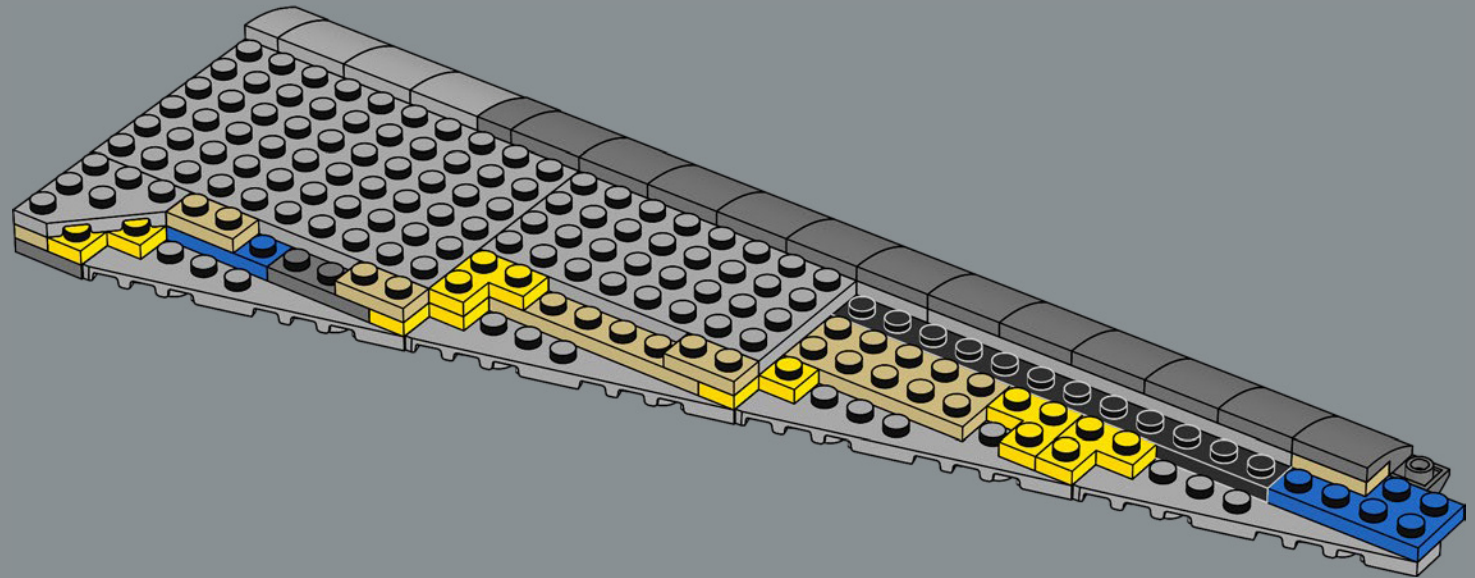

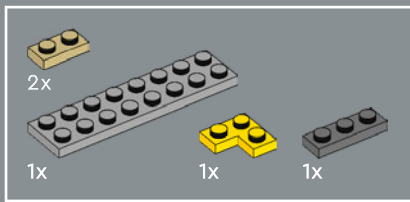

363

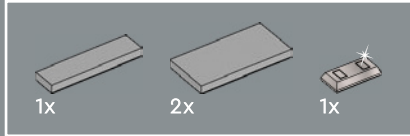
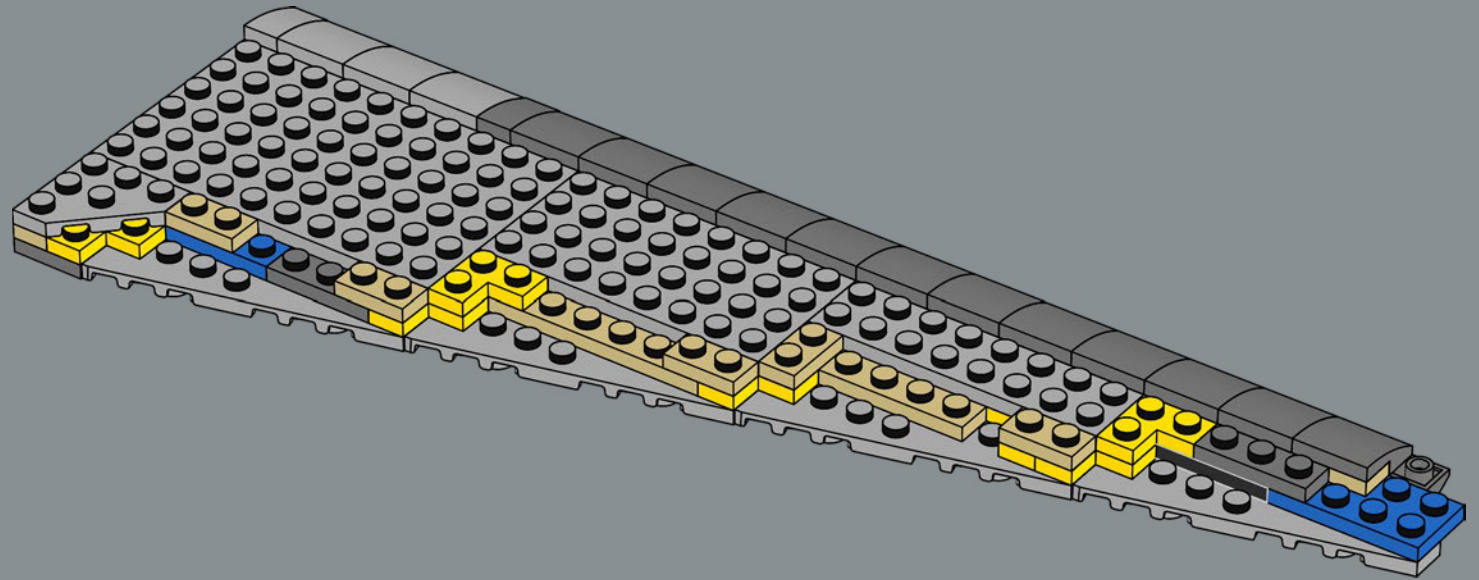

364

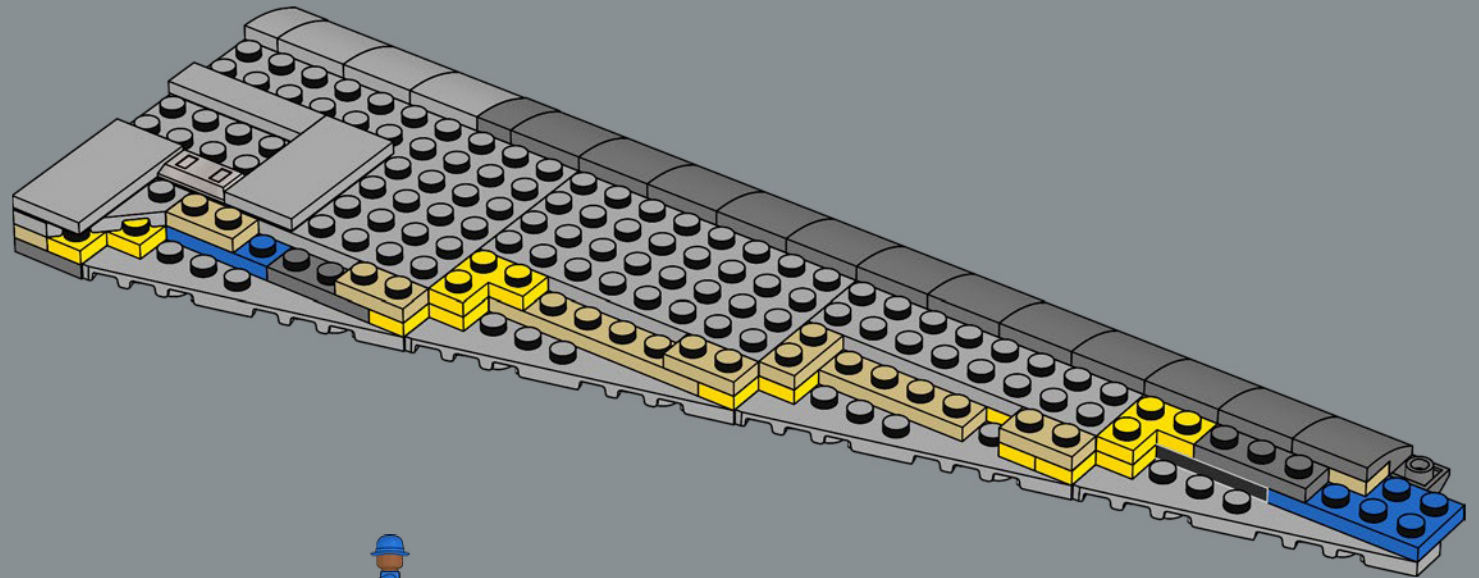

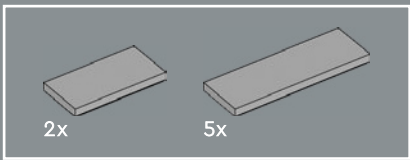

365

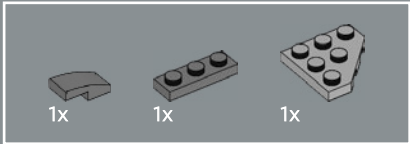
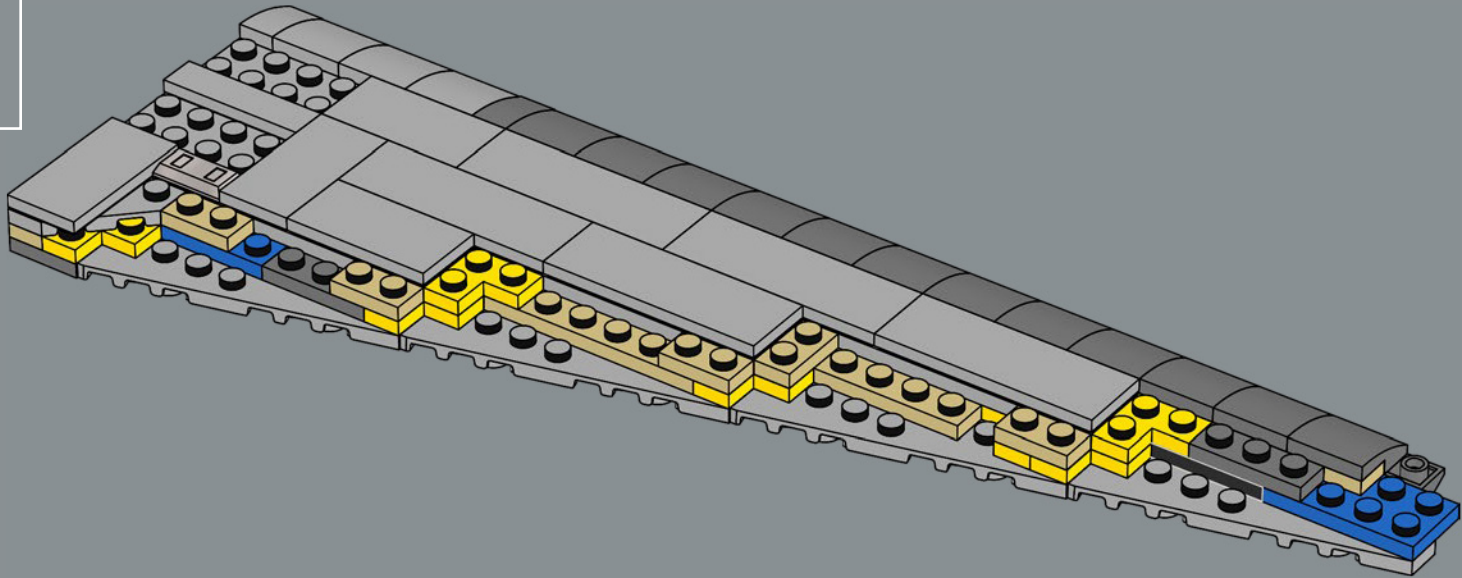

366

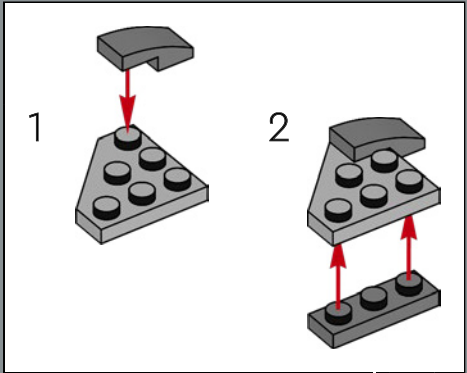
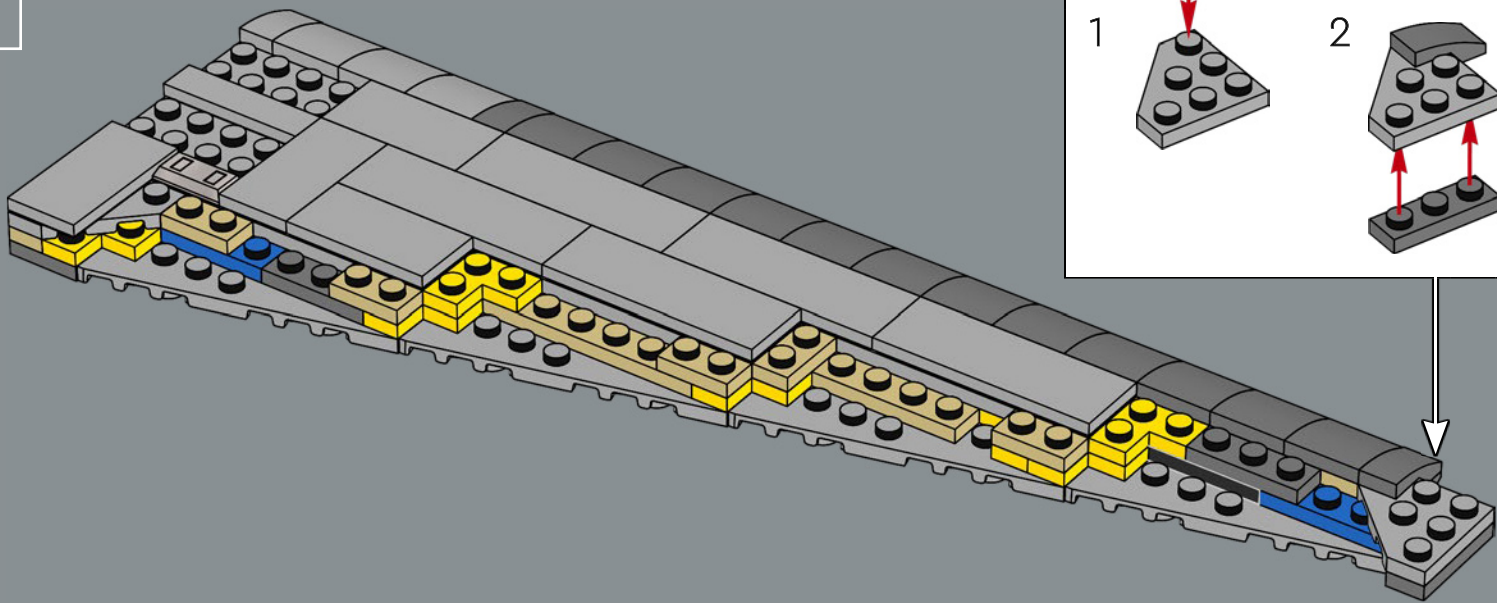

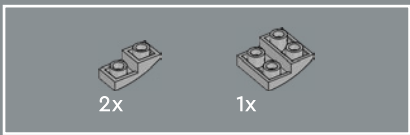

367

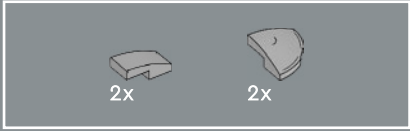
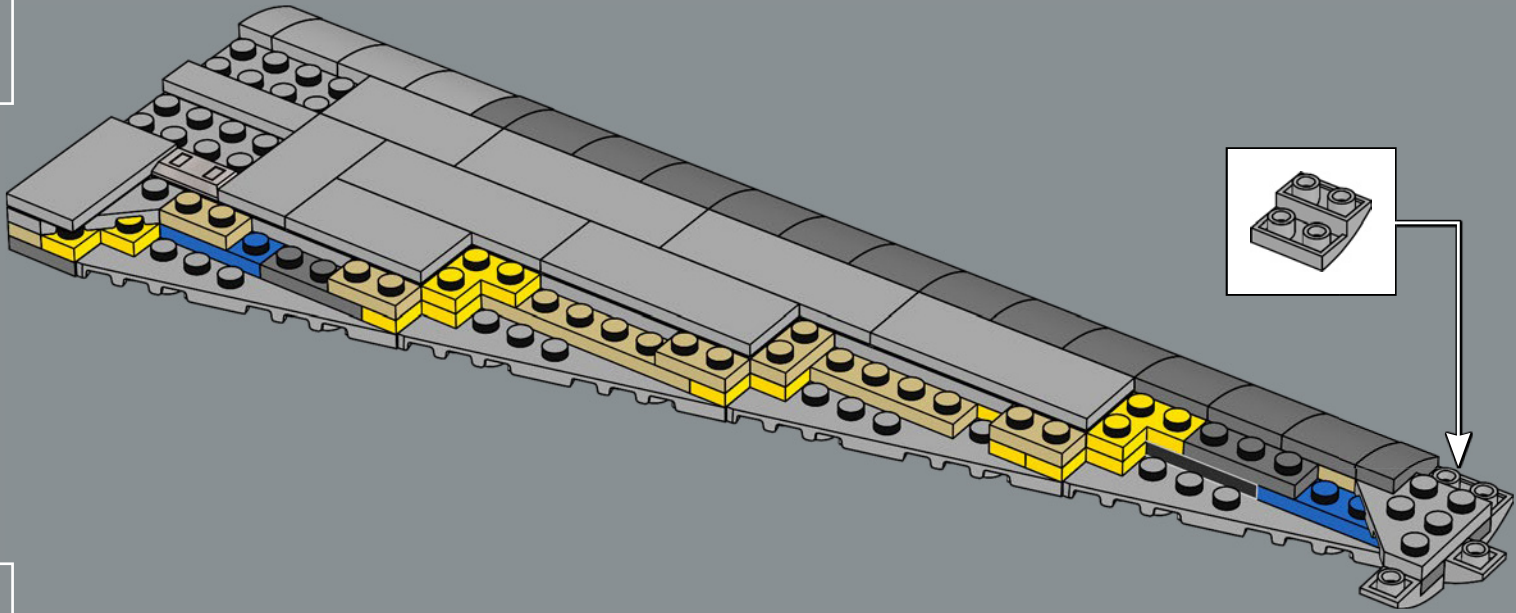

368

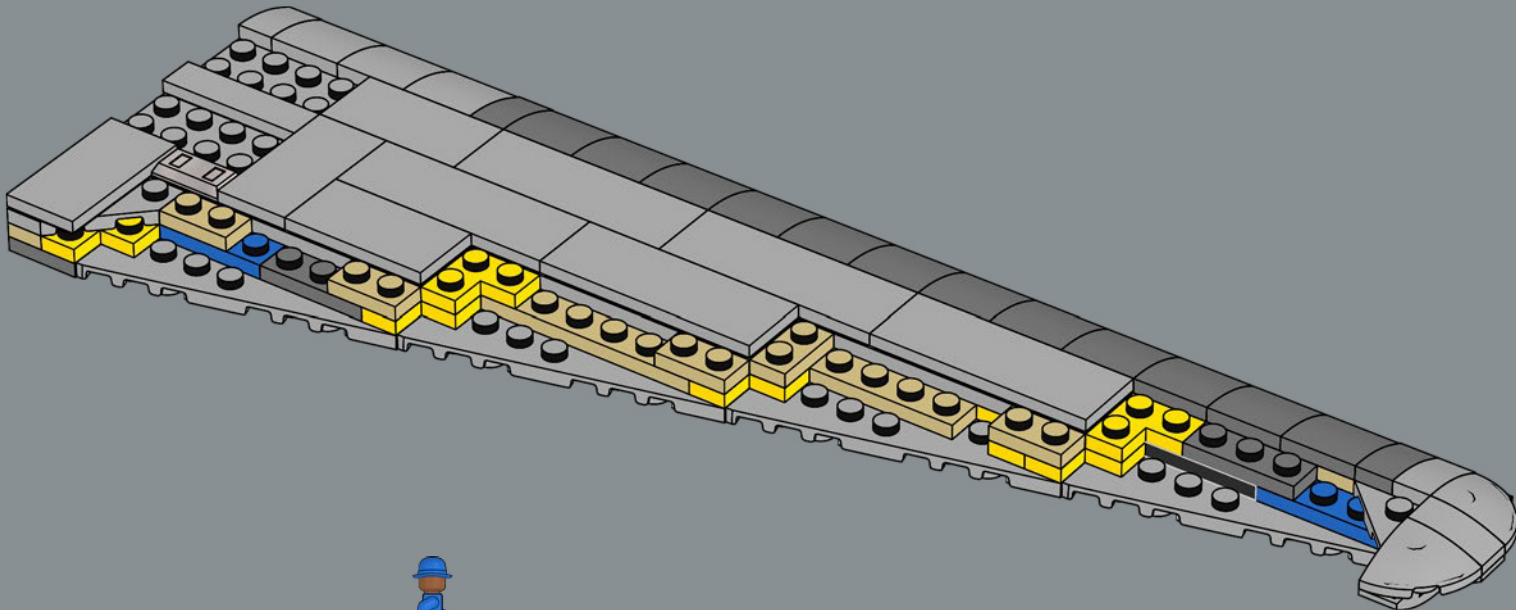

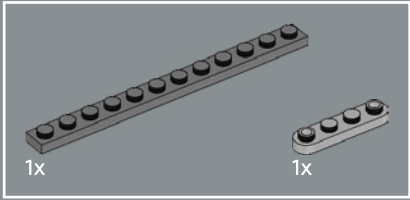
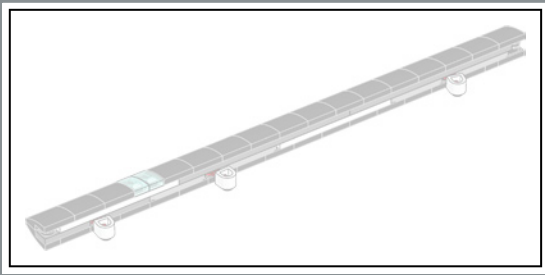

369

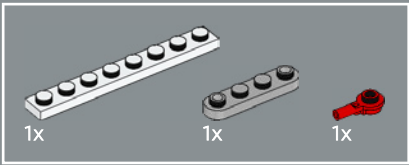
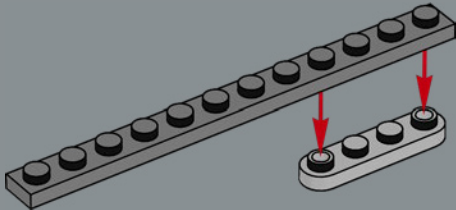

370

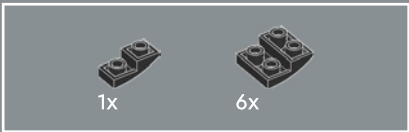
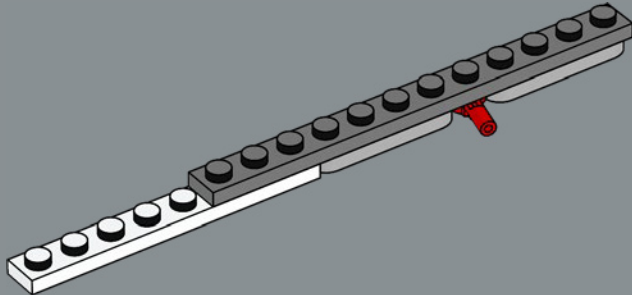

371

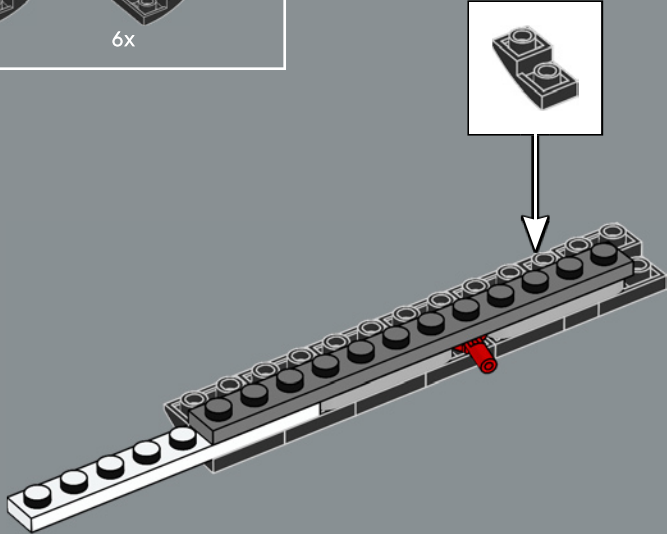



372

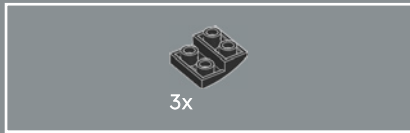
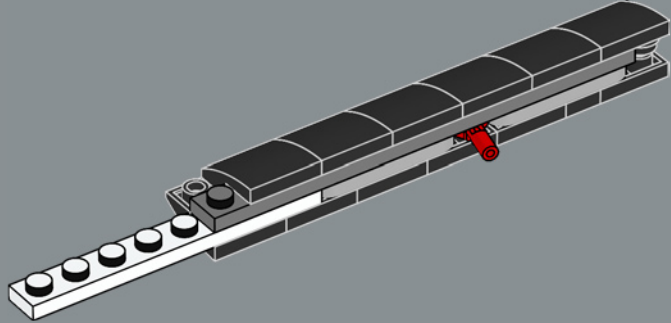
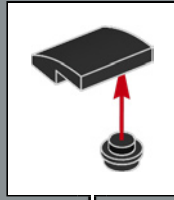

373

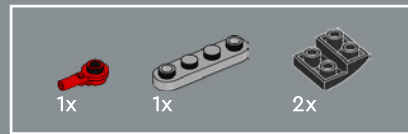
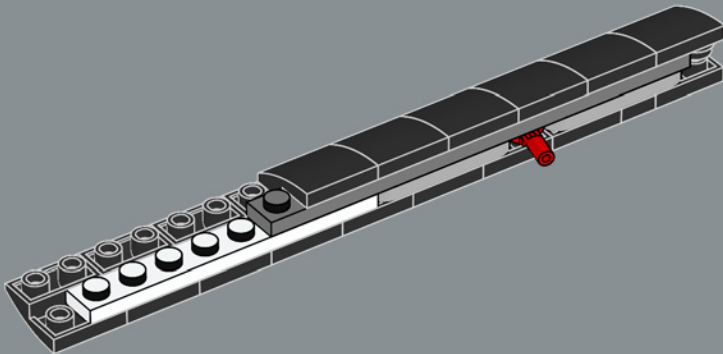

374

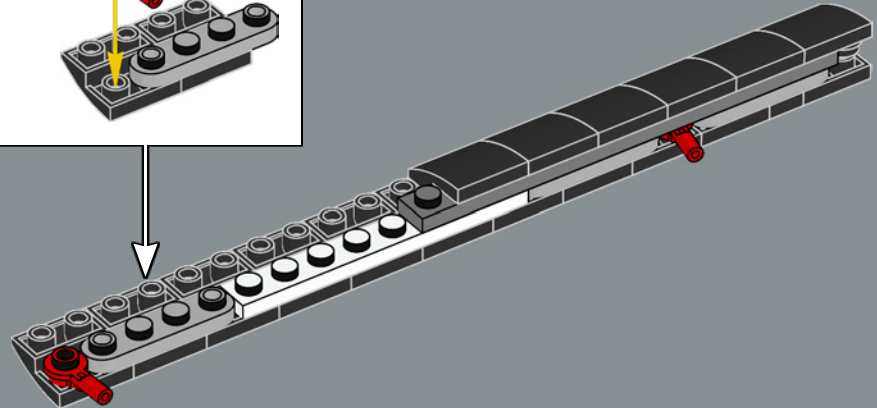
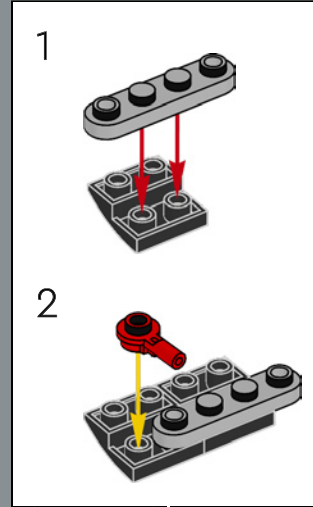

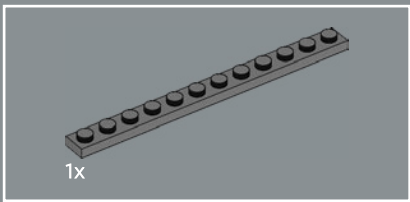

375

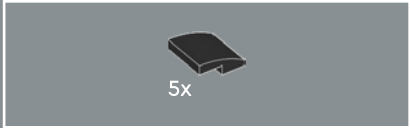
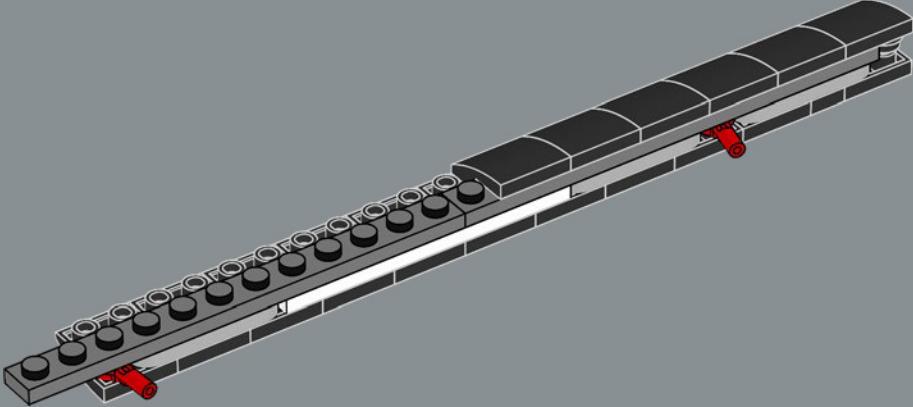

376

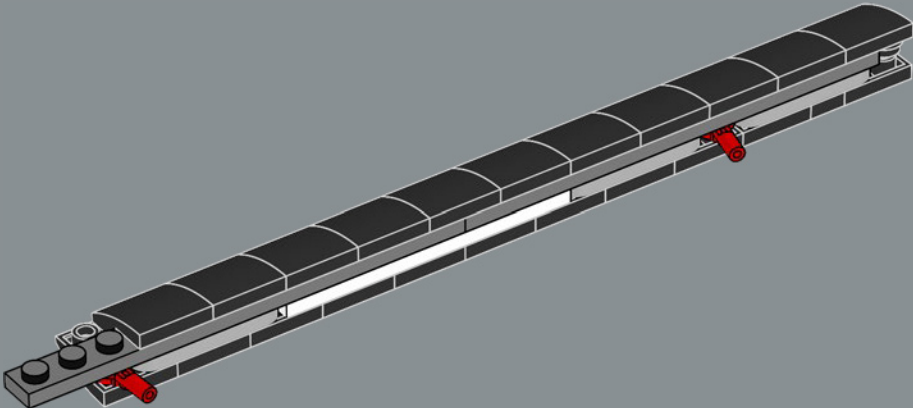

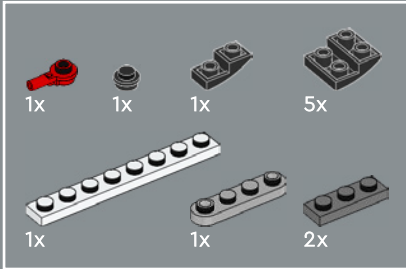
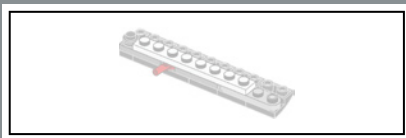

377

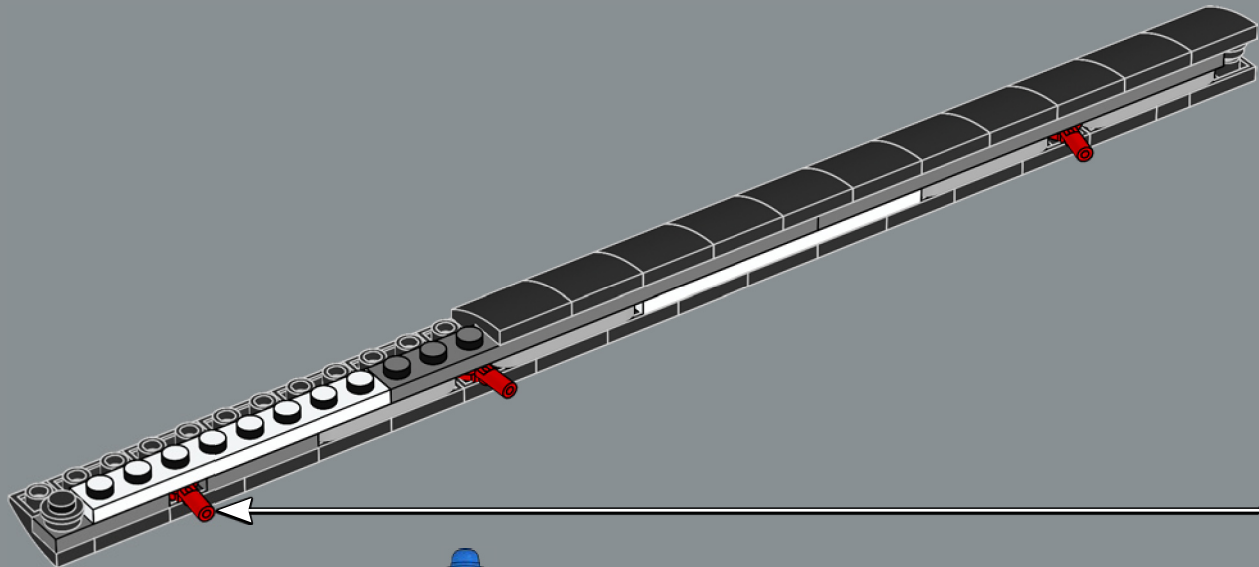
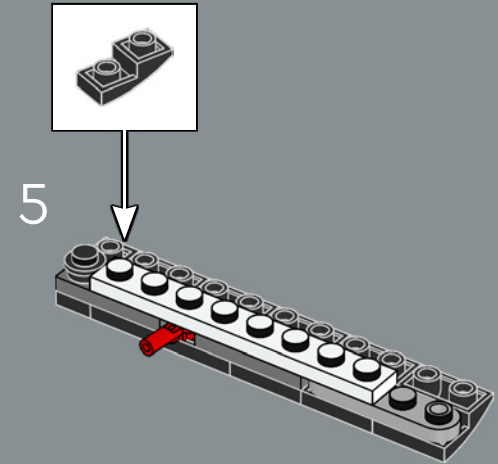
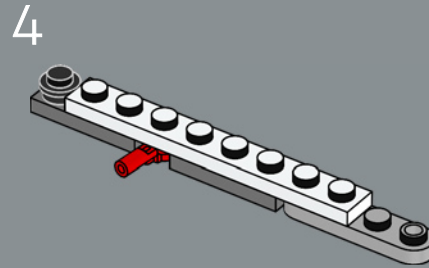
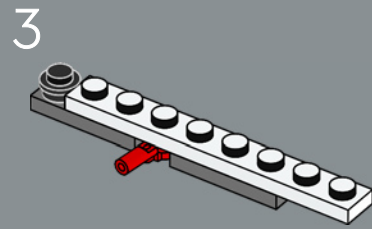
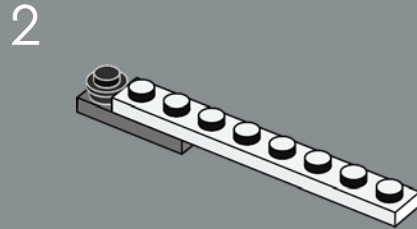
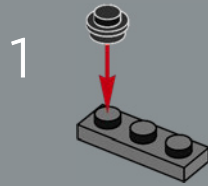



378

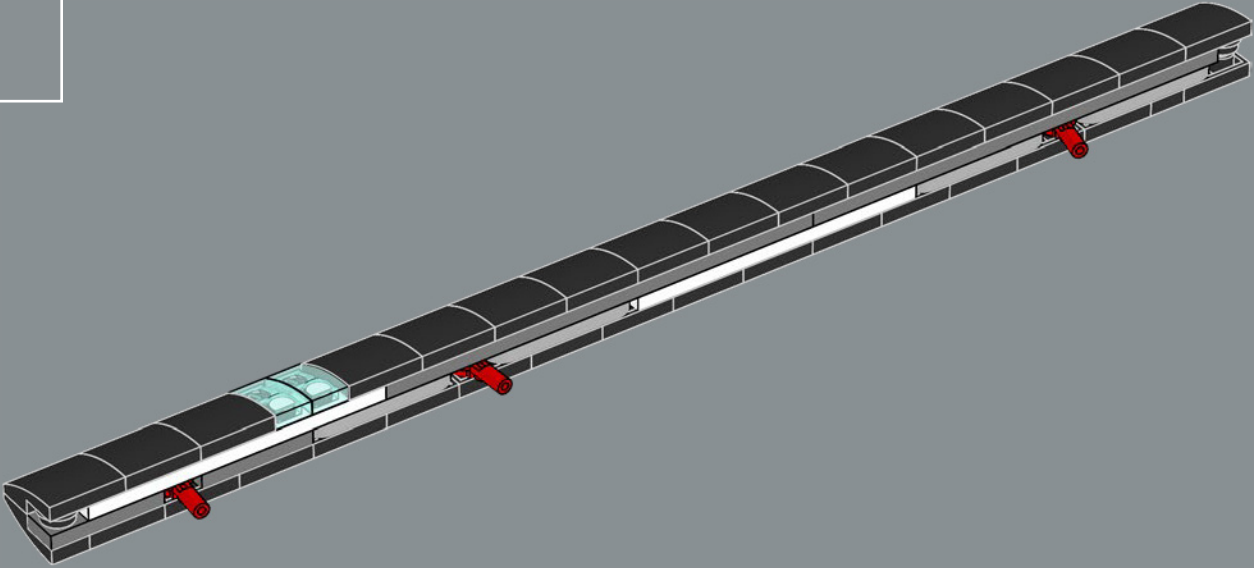

379

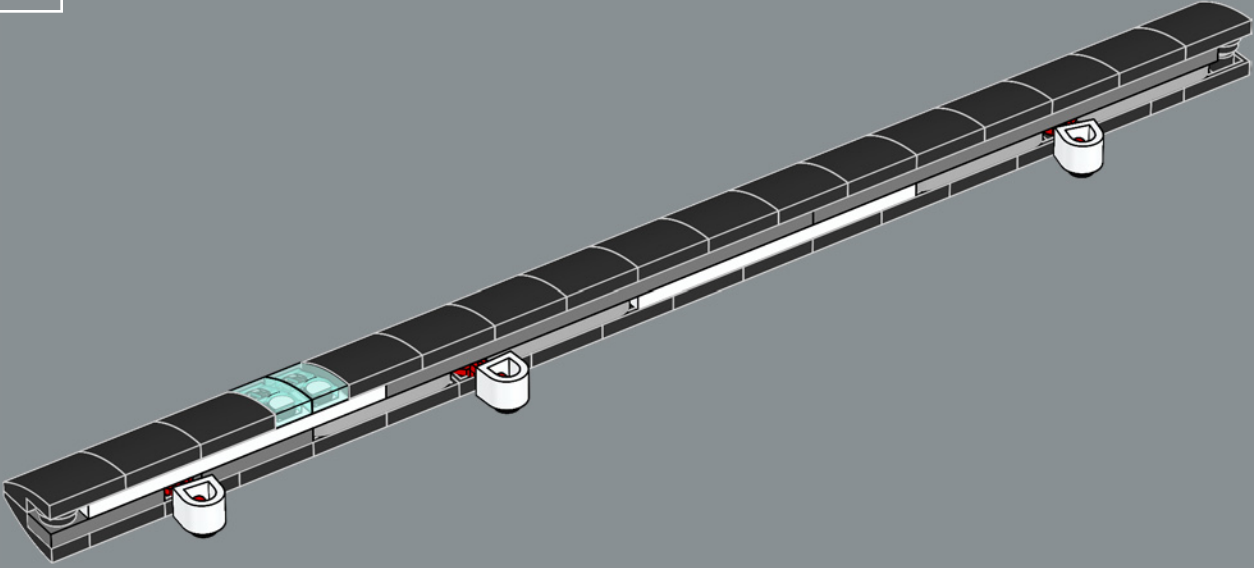

380

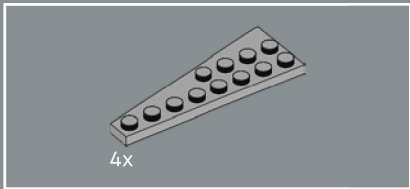
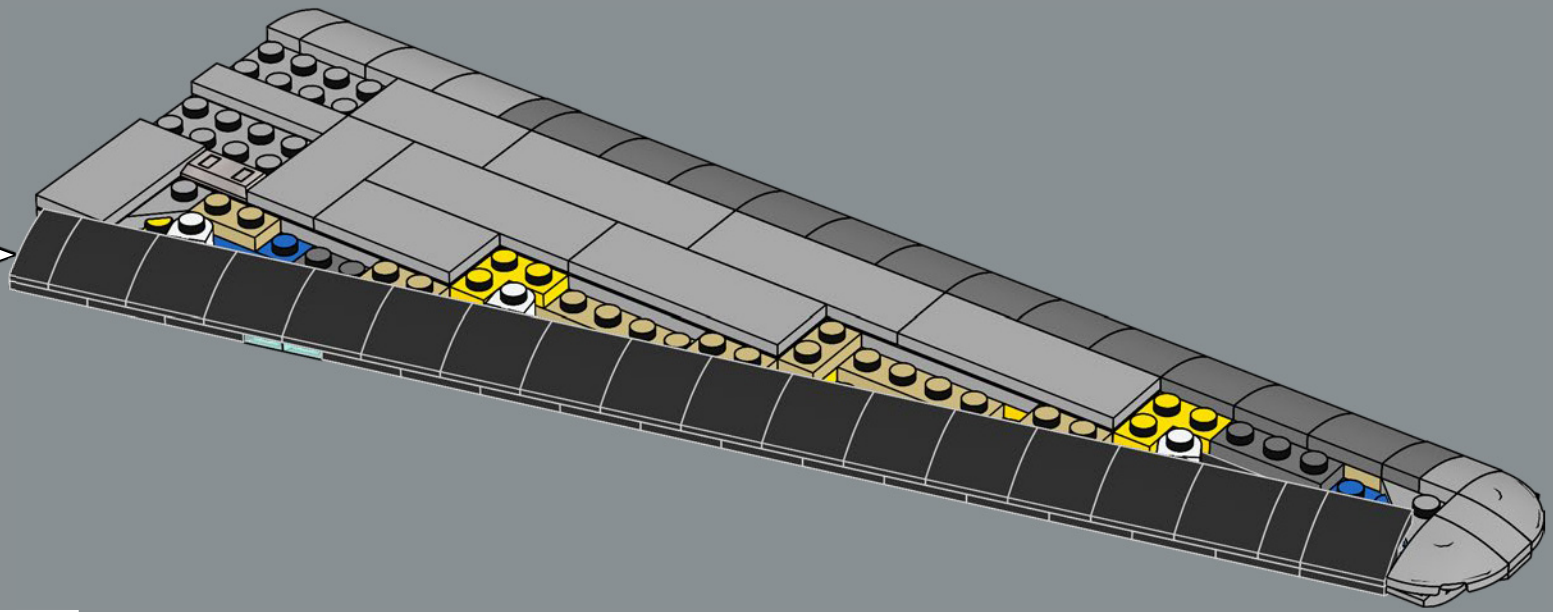

381

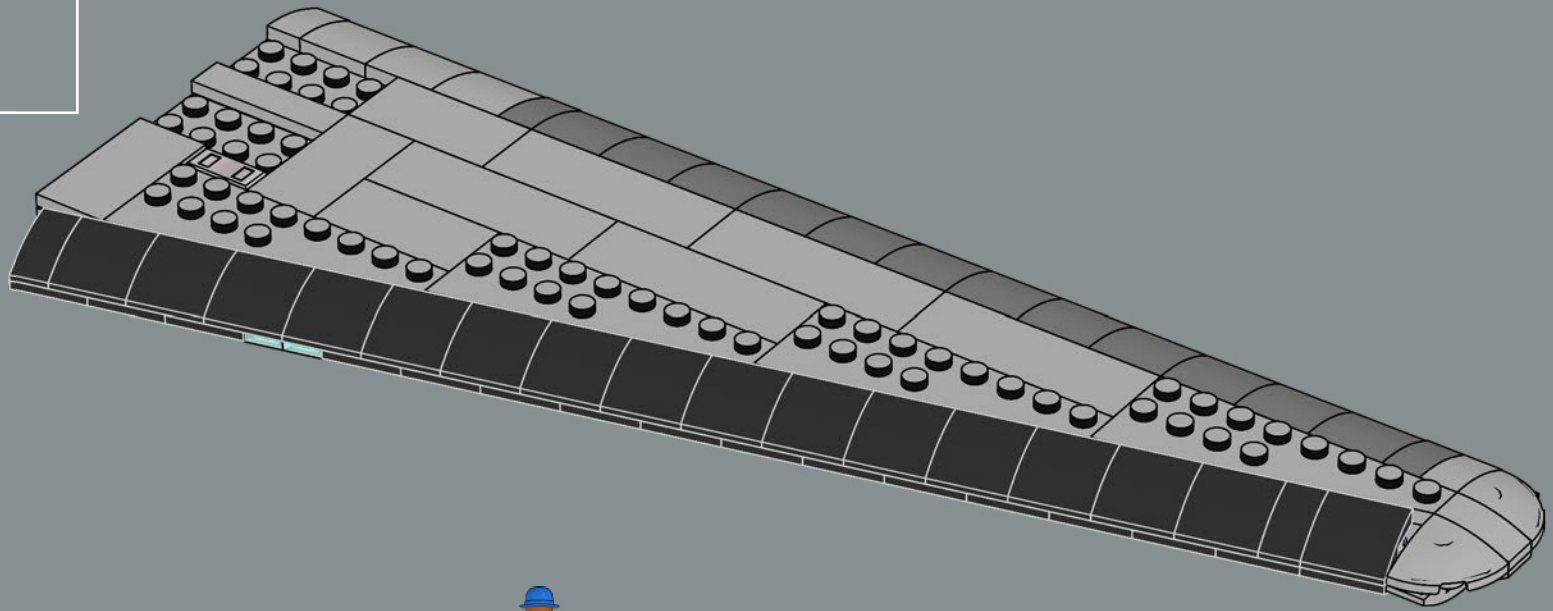

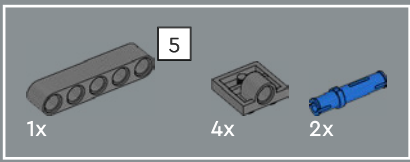

382

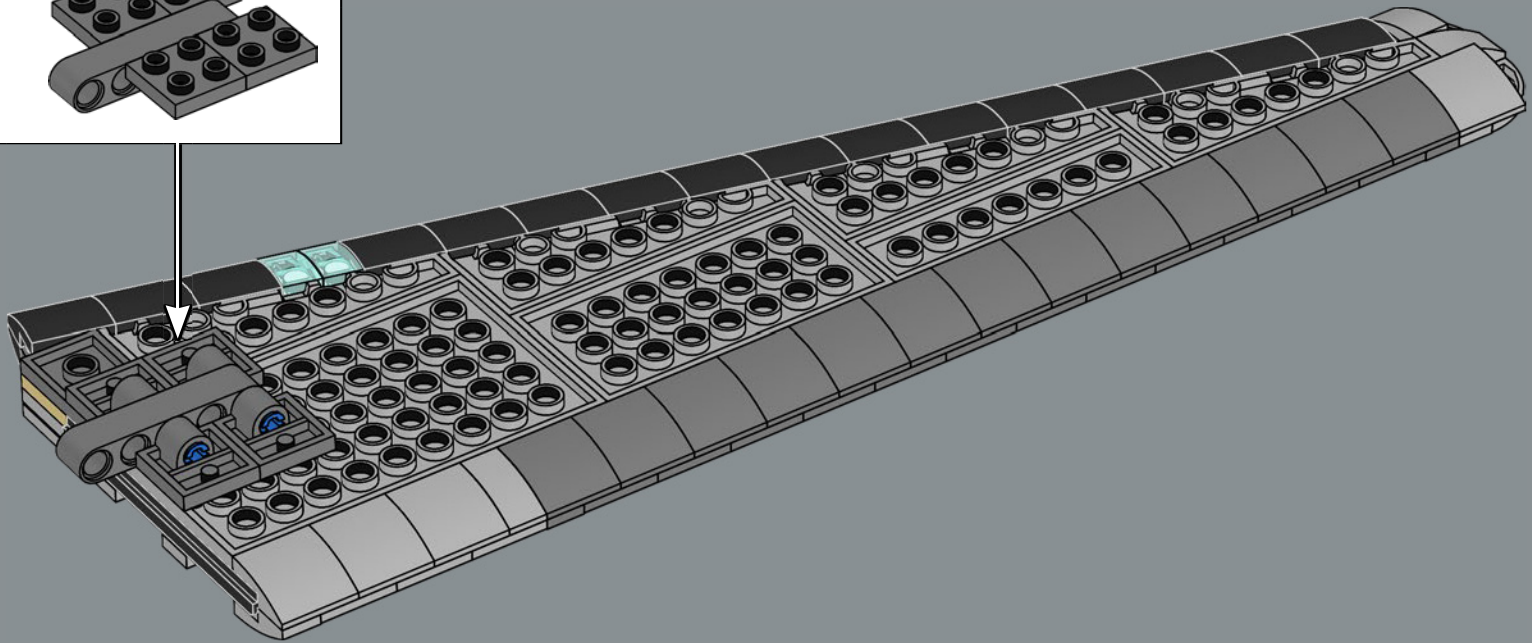
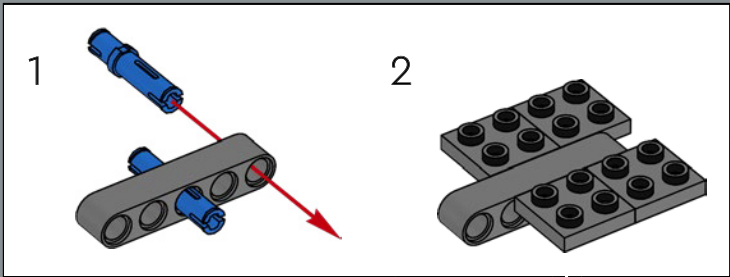



4x

383

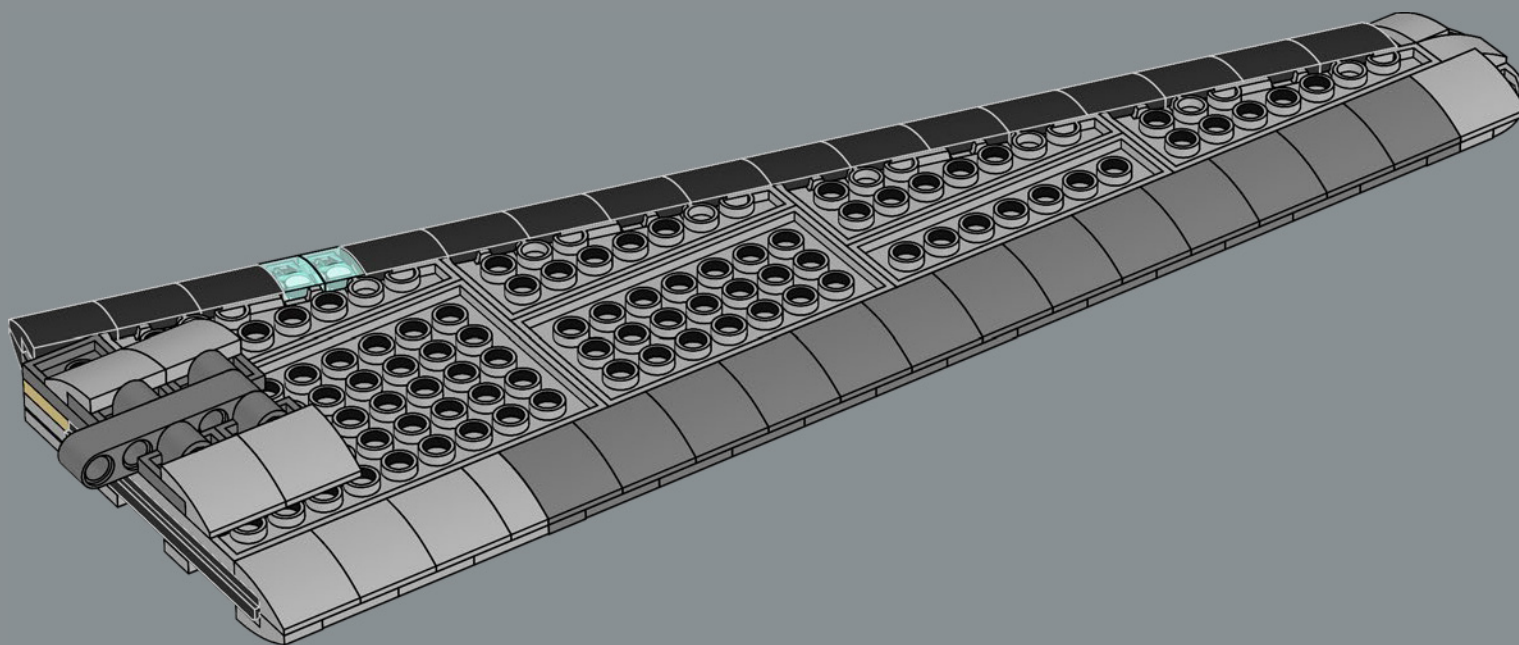

384

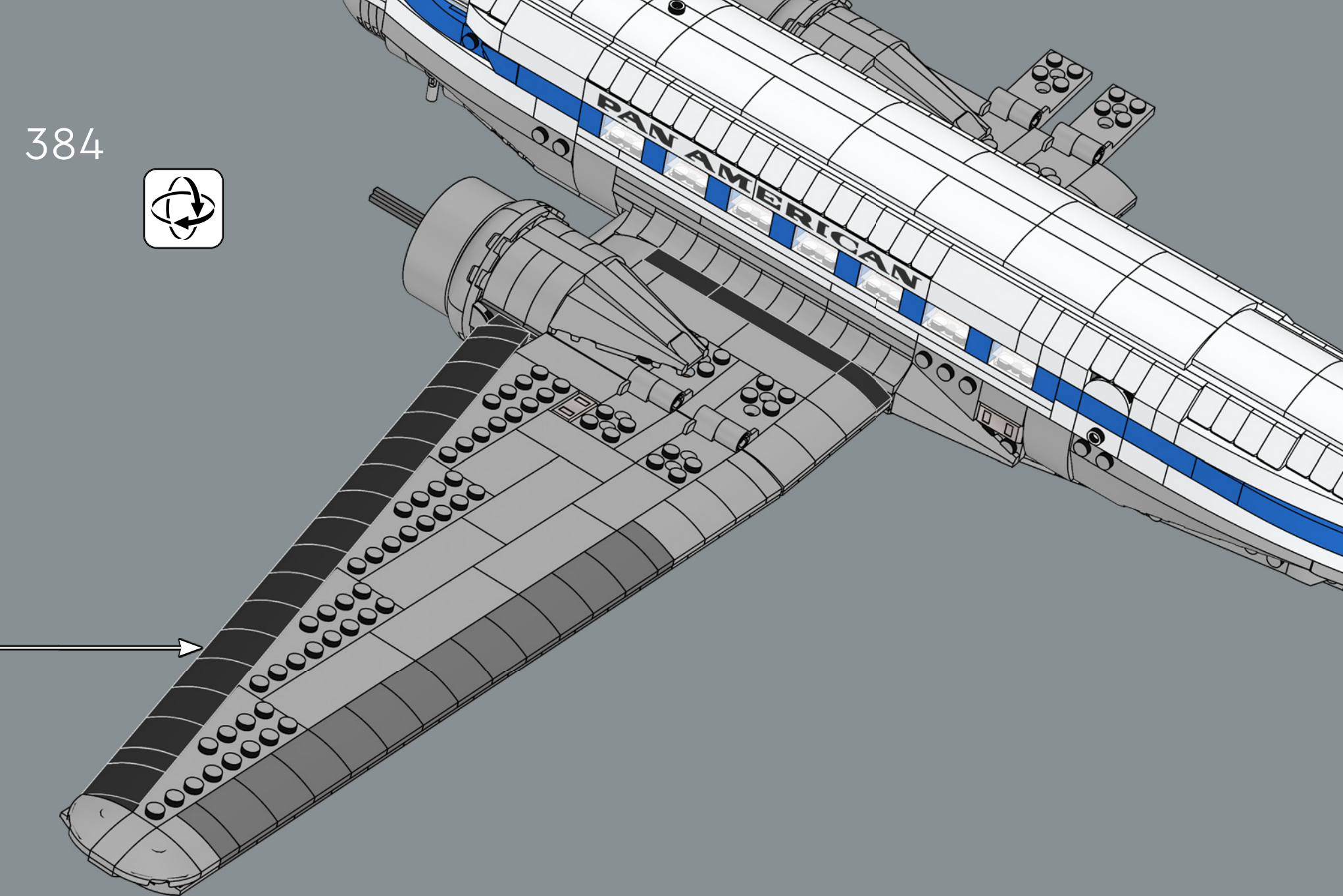



385



Un axe LEGO® Technic situé sous l'appareil permet de fixer l'aile. Les designers LEGO appellent cette pièce une « valve de vélo ».

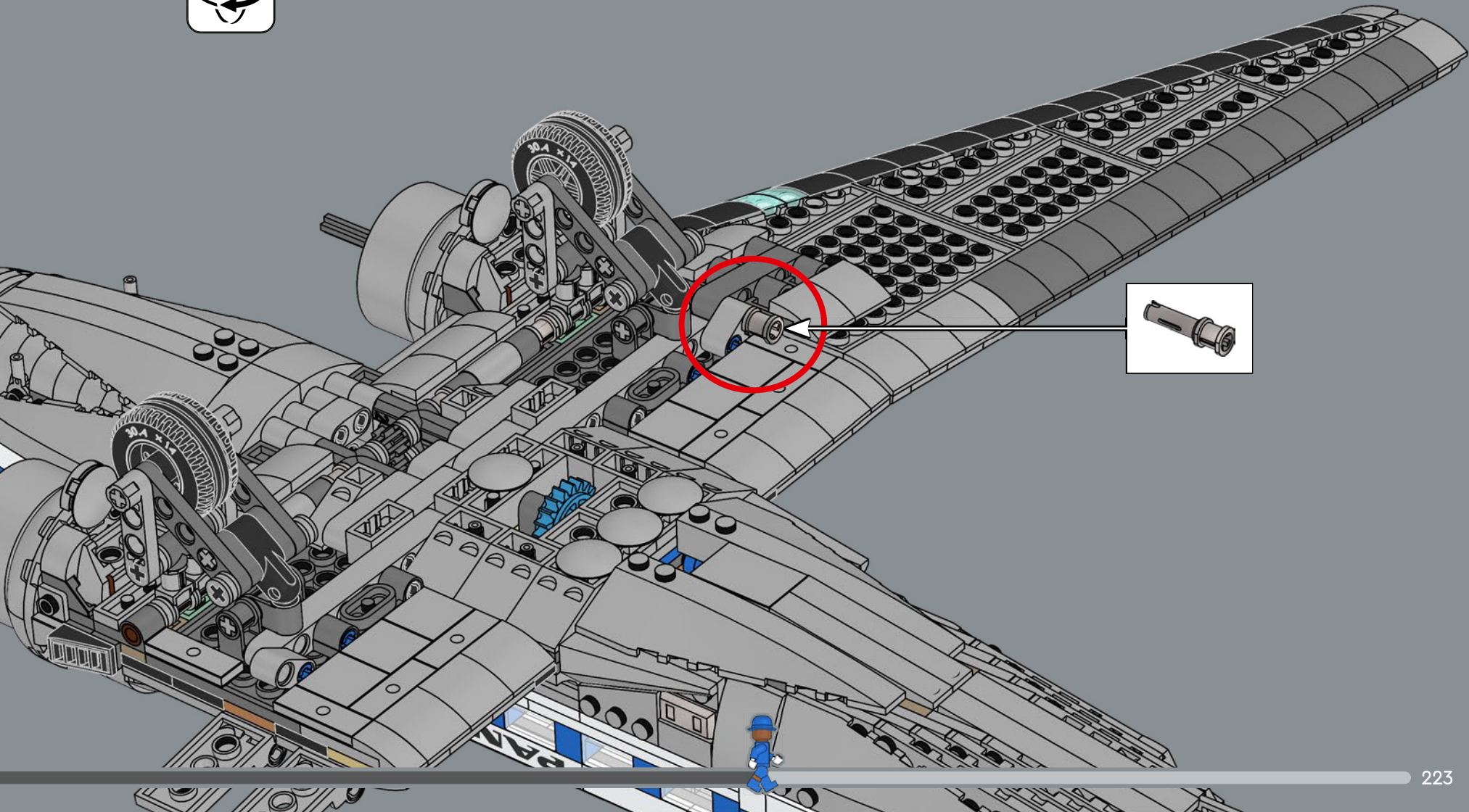

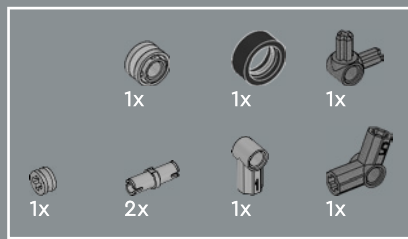

386



Les premiers uniformes conçus par des créateurs de mode célèbres apparurent en 1958 avec le lancement du B-707. Le styliste hollywoodien Don Loper conçut les uniformes des hôtesses Pan Am® lors de l'entrée dans l'ère du jet.

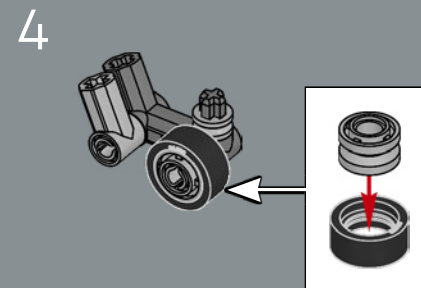
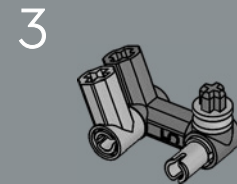
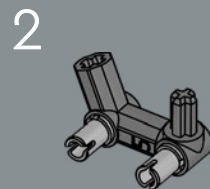
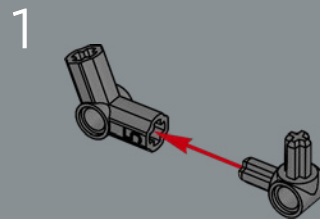
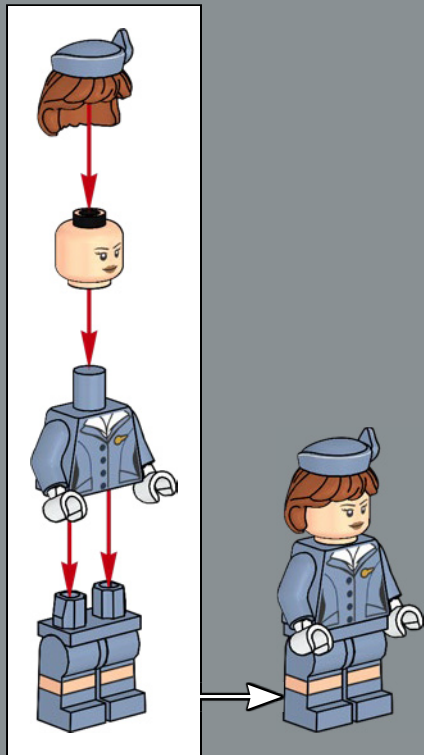



Les stewards et hôtesse pouvaient être promus au poste de chef de cabine à bord. À partir des années 1960, ce rôle fut de plus en plus souvent occupé par des femmes.

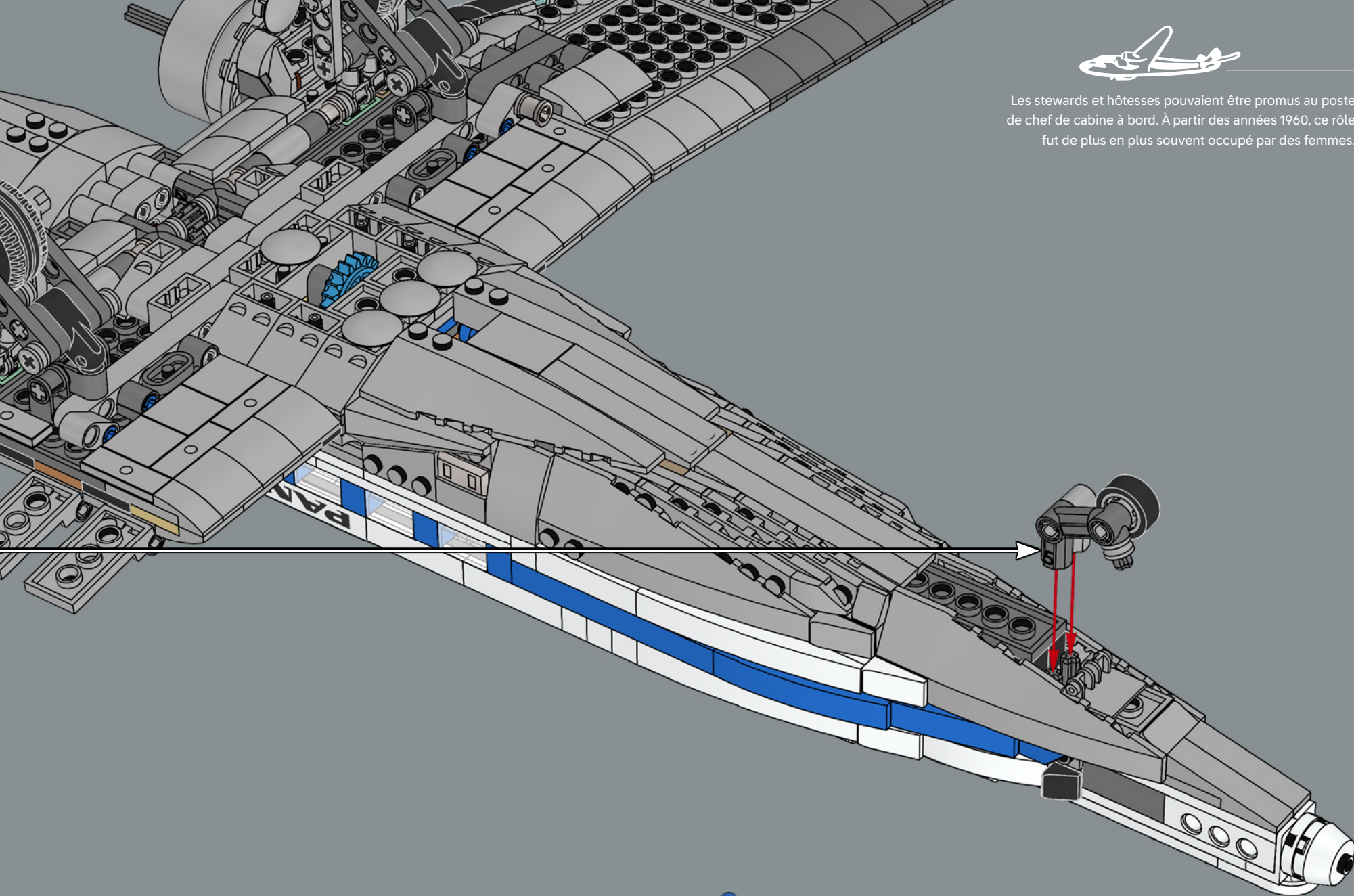

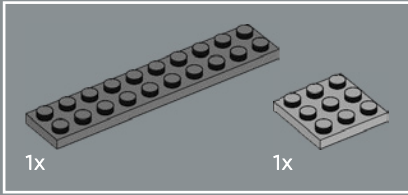
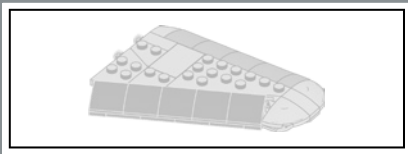

387

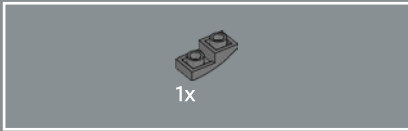
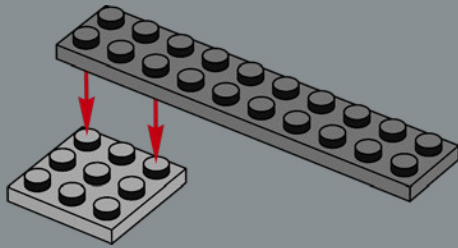

388

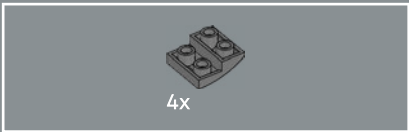
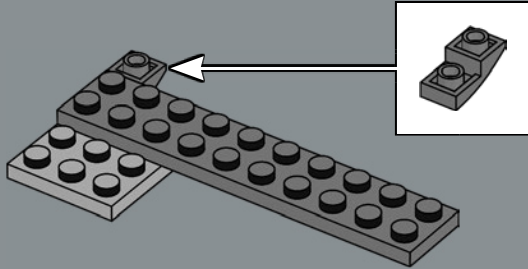

389

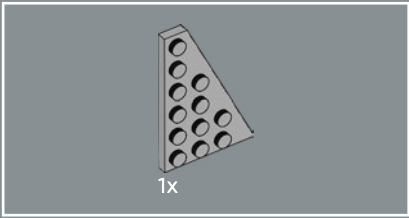
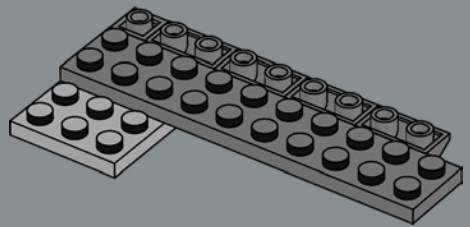

390

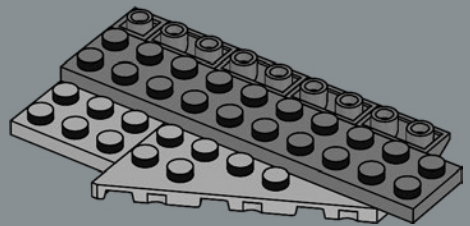

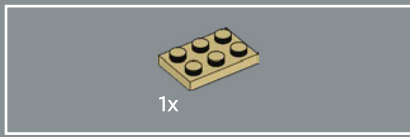

391

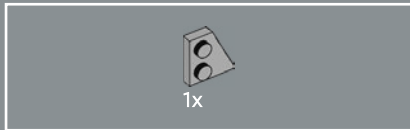
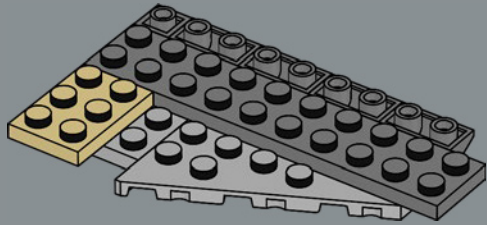

392

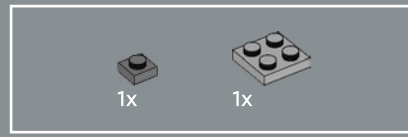
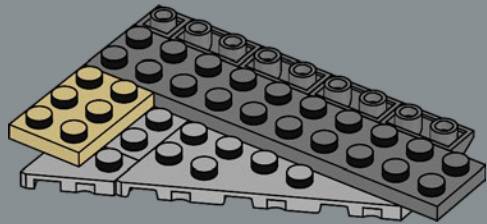

393

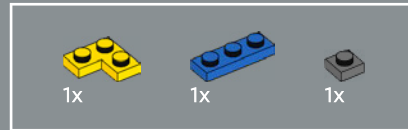
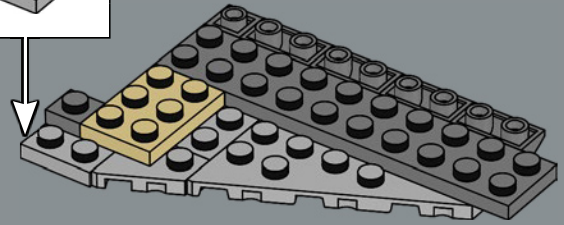
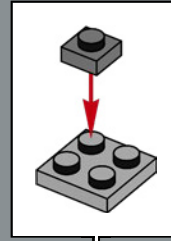

394

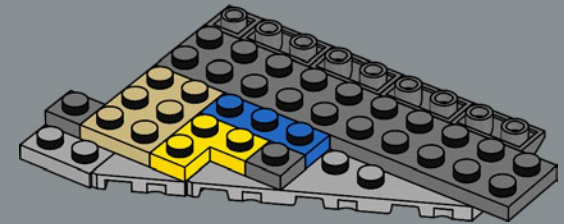

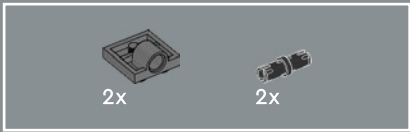

395

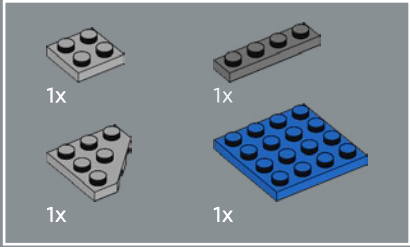
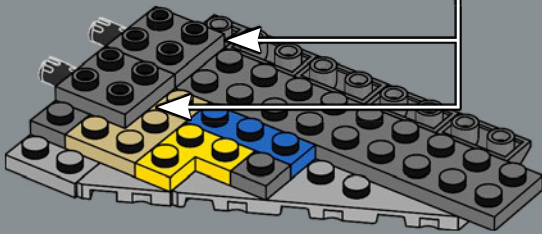
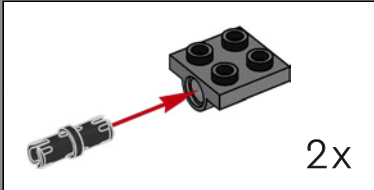

396

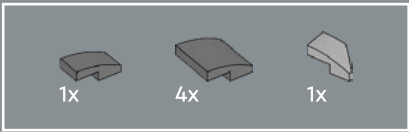
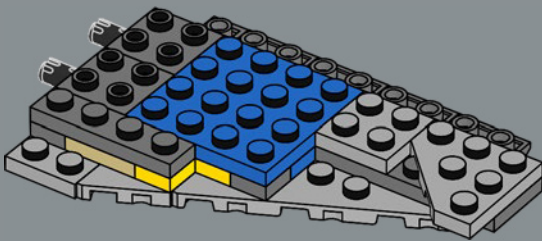

397

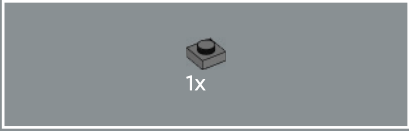
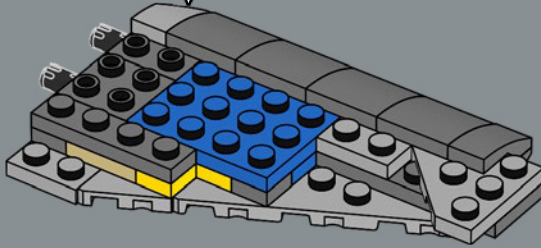
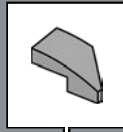

398

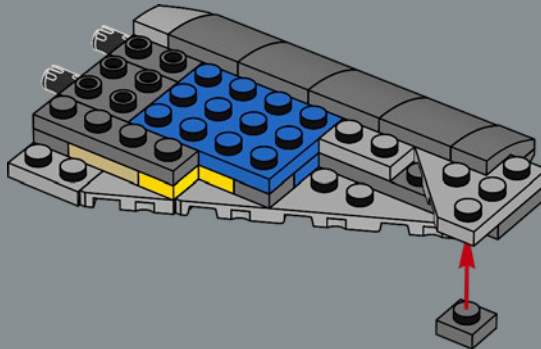



399

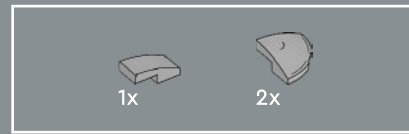
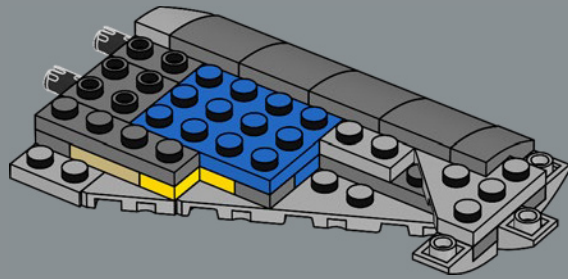

400

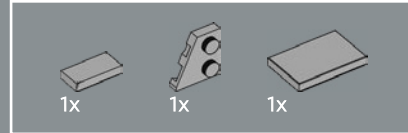
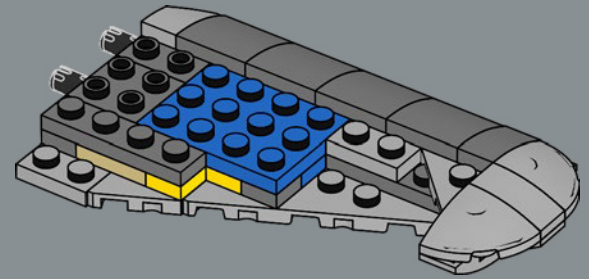

401

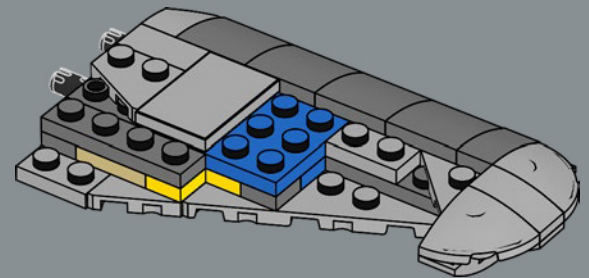

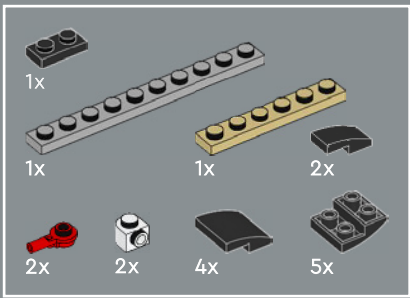

402

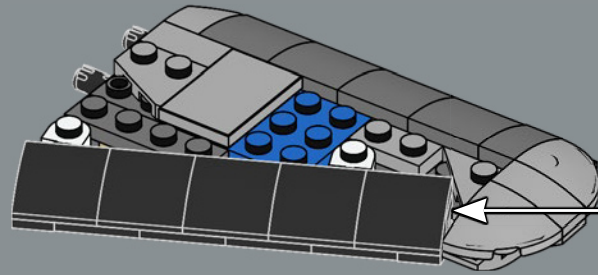
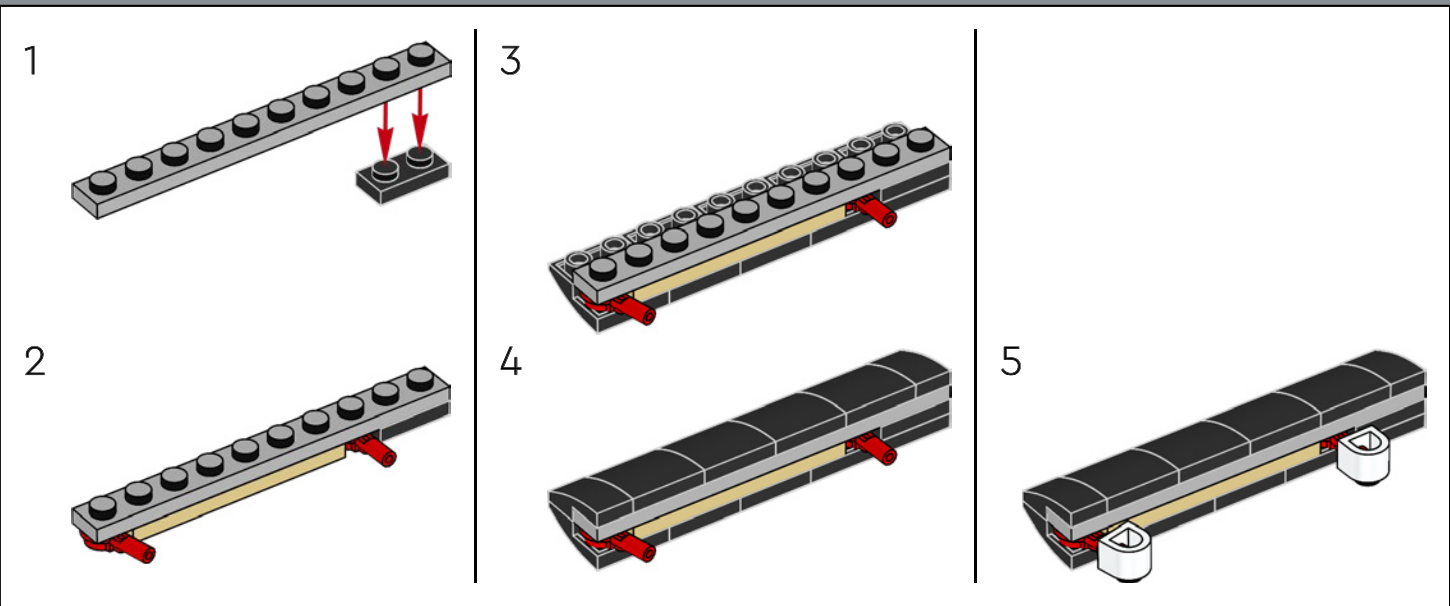

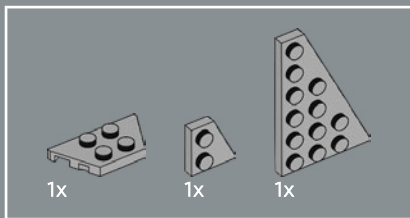

403

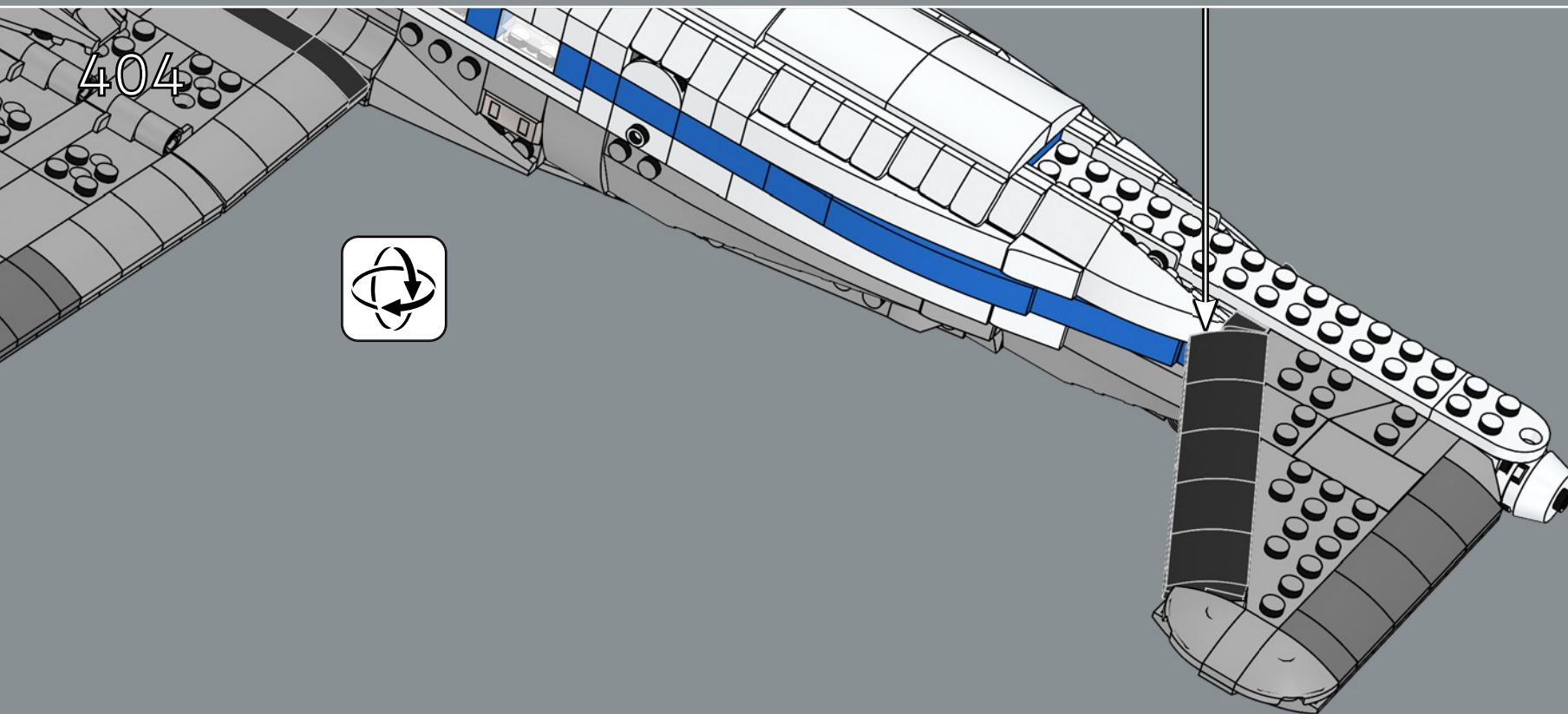
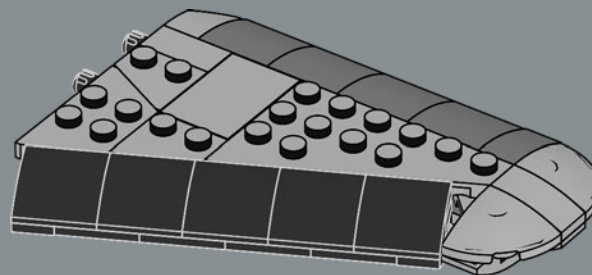

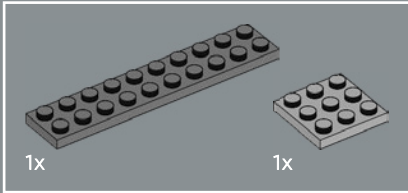
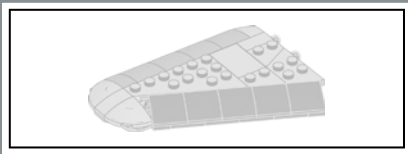

405

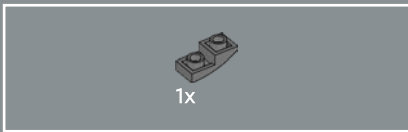
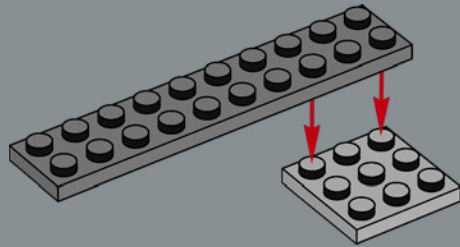

406

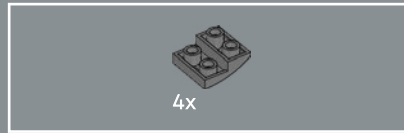
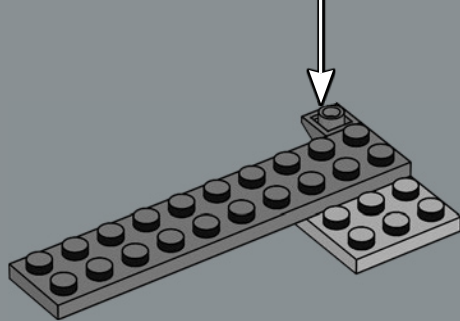
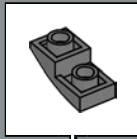

407

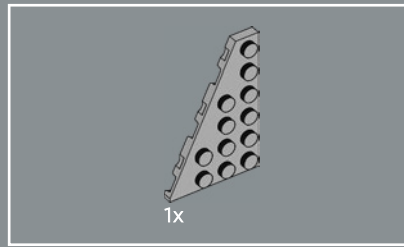
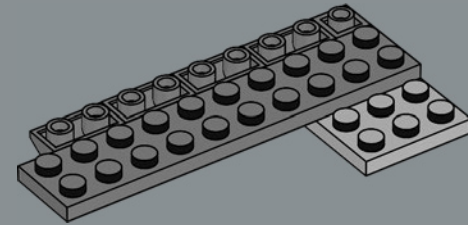

408

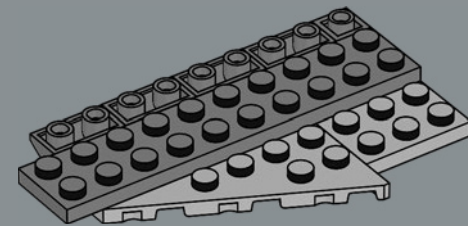

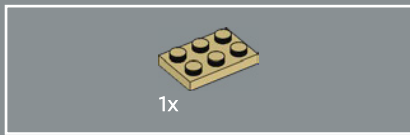

409

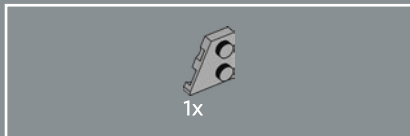
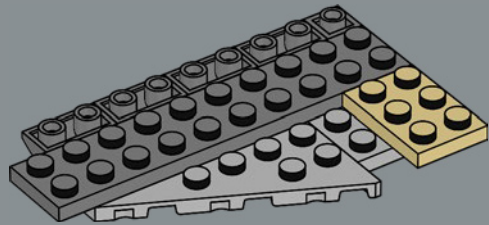

410

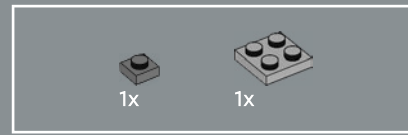
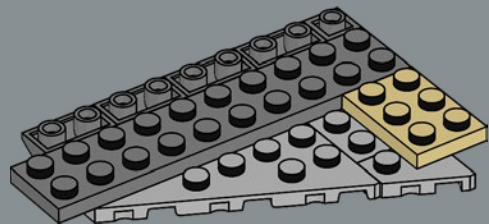

411

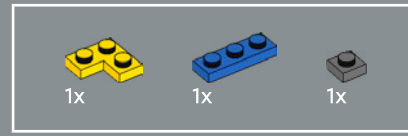
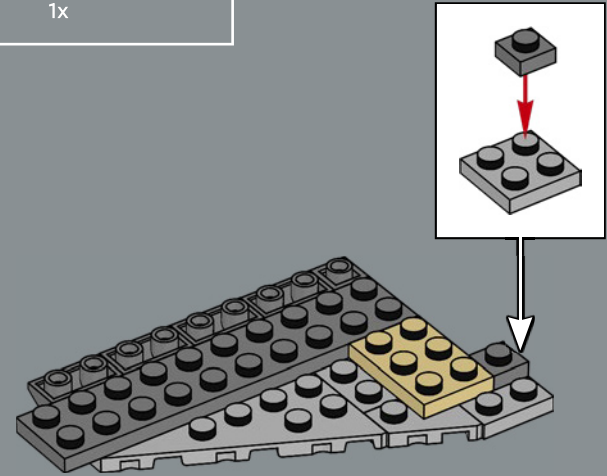

412

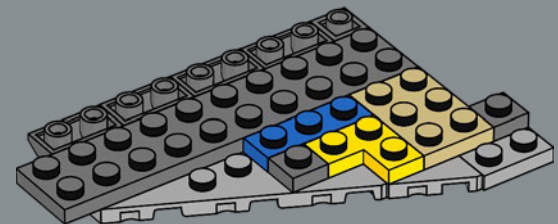



413

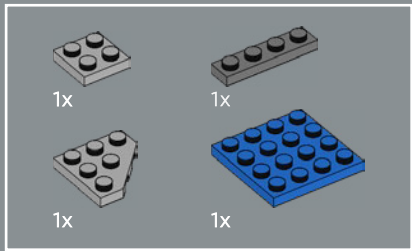
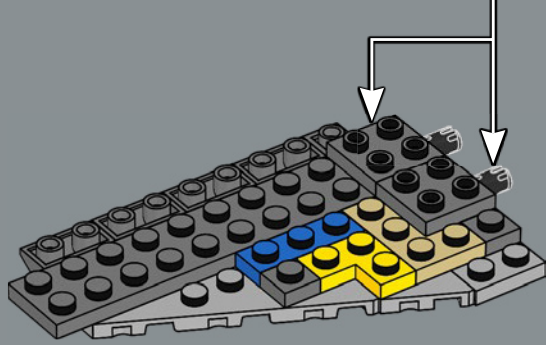
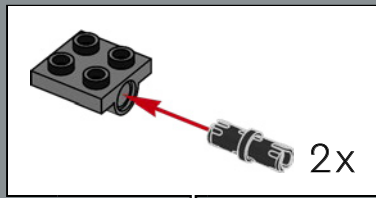

414

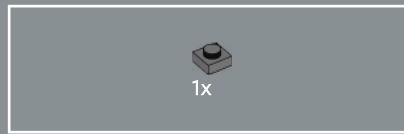
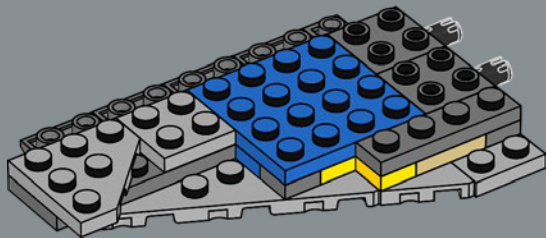

415

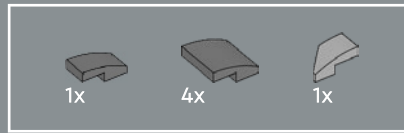
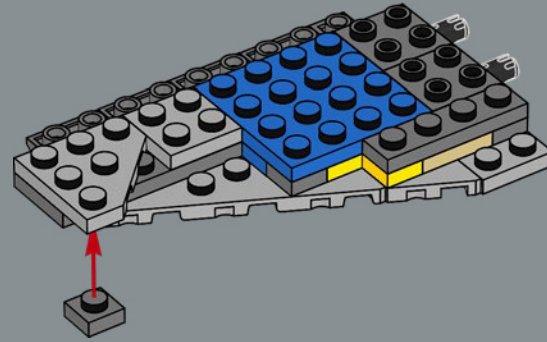

416

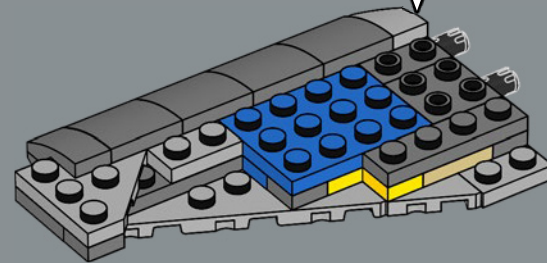
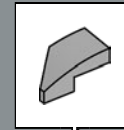

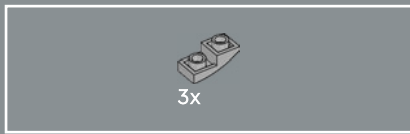

417

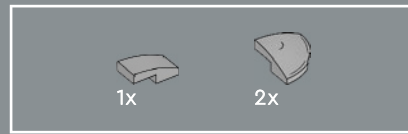
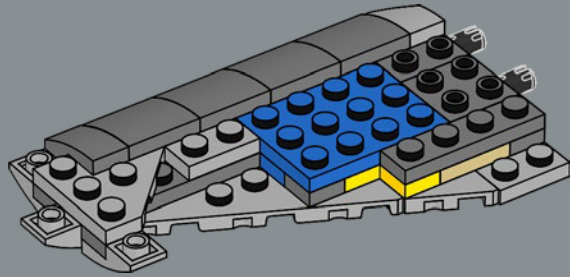

418

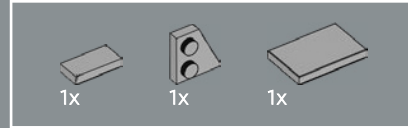
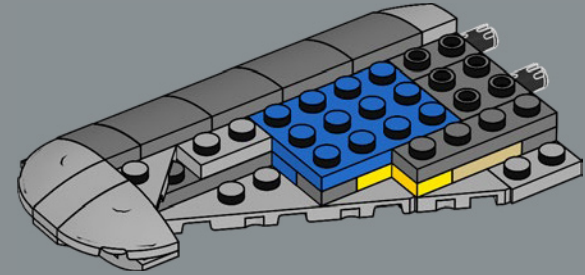

419

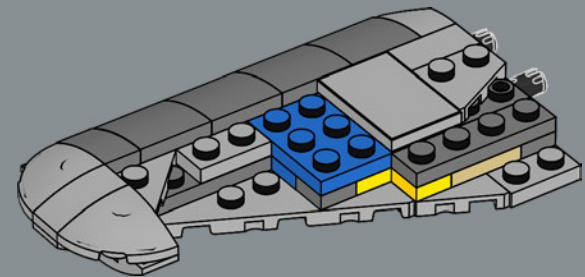

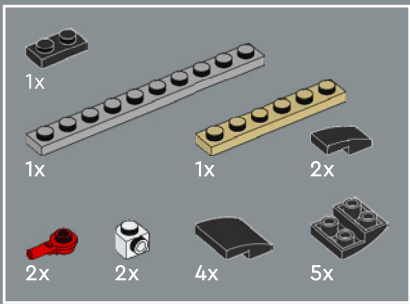

420

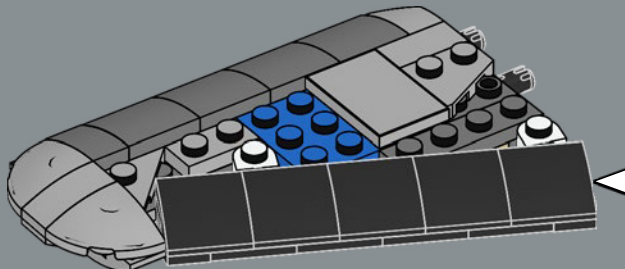
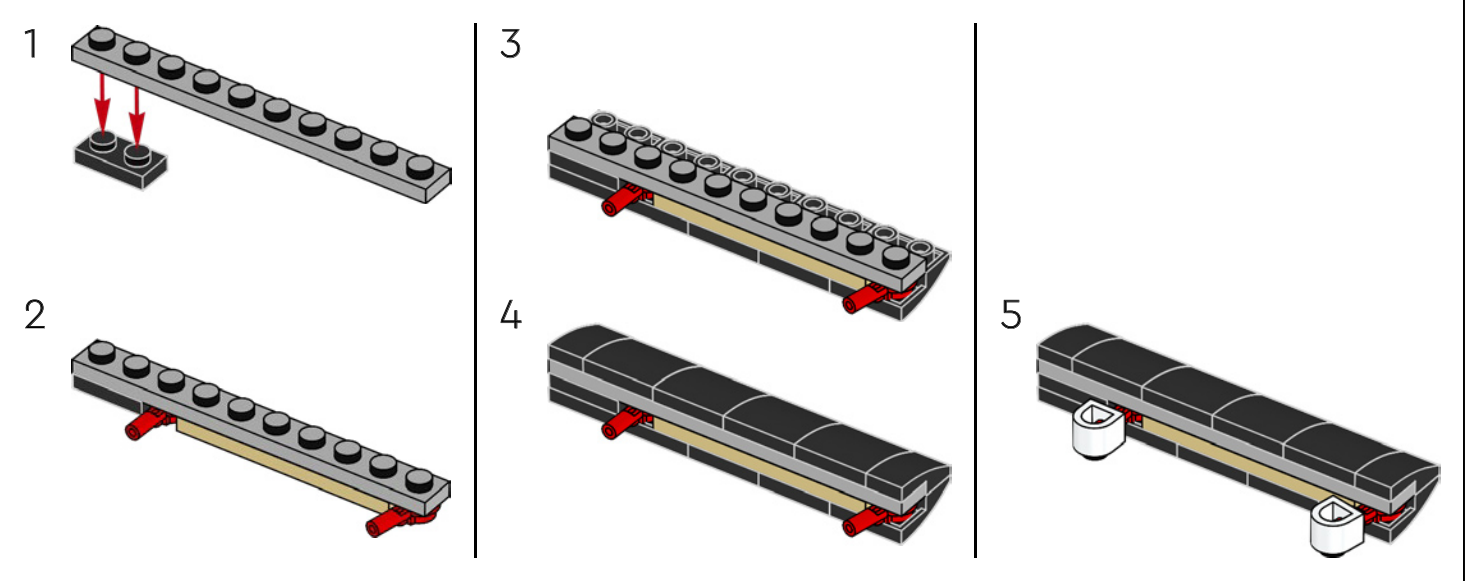

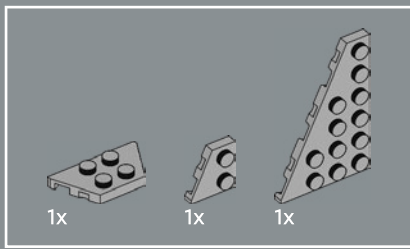

421

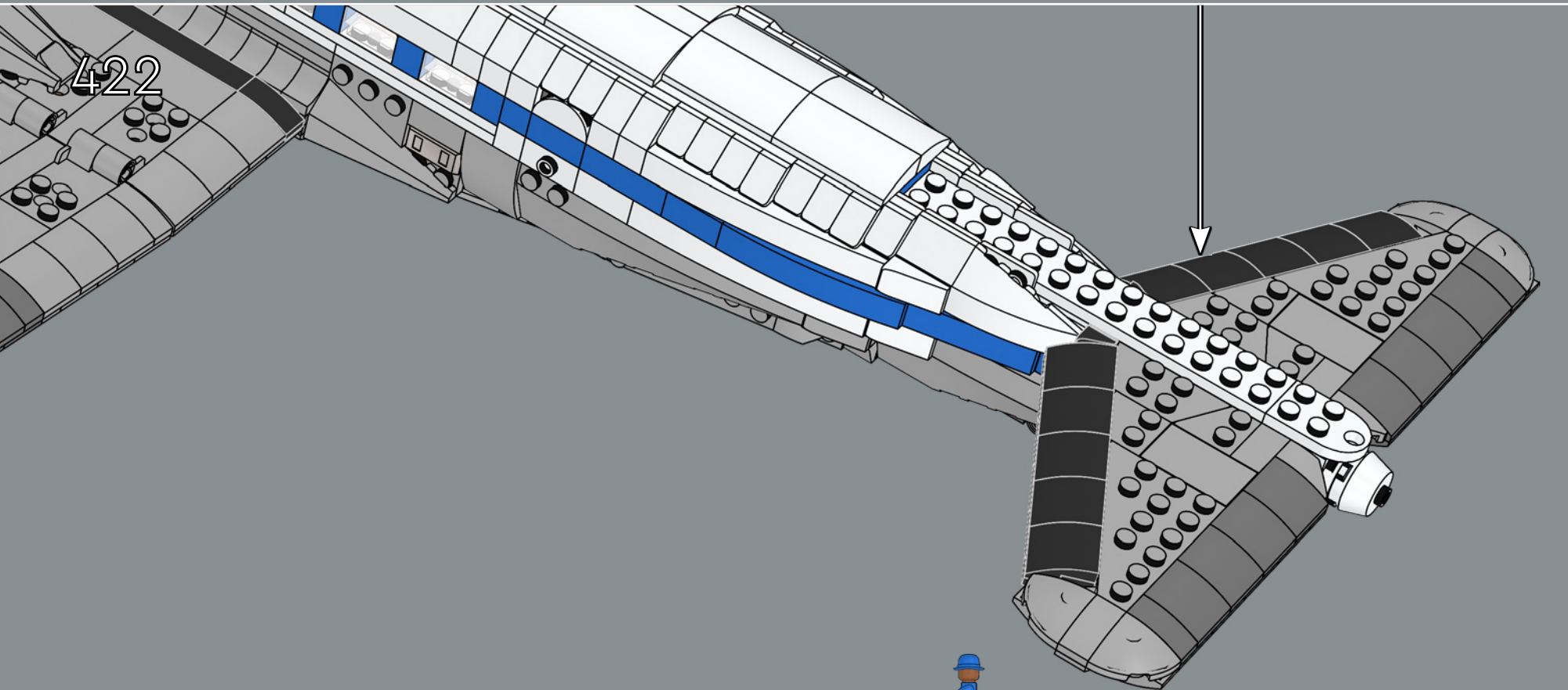
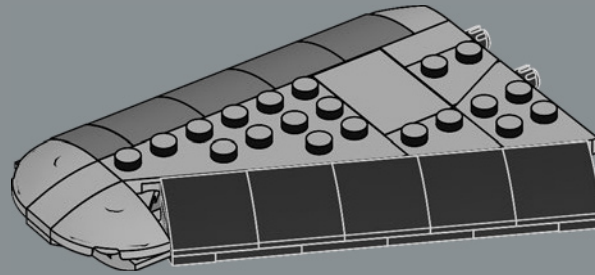

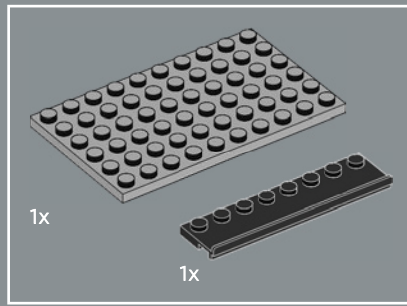
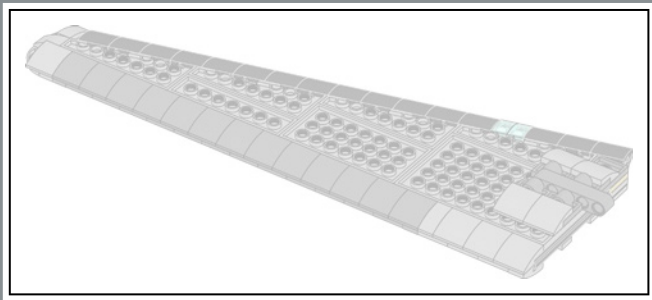

423

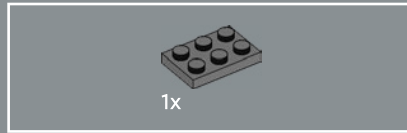
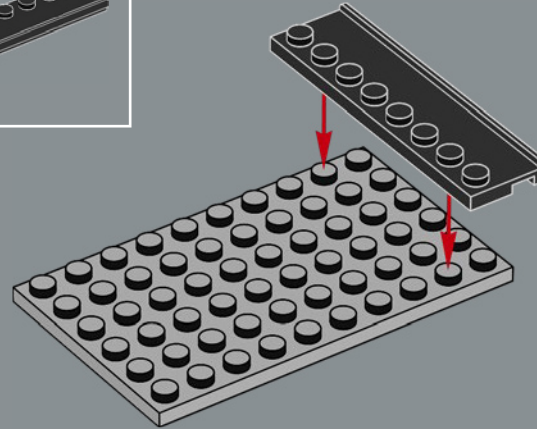

424

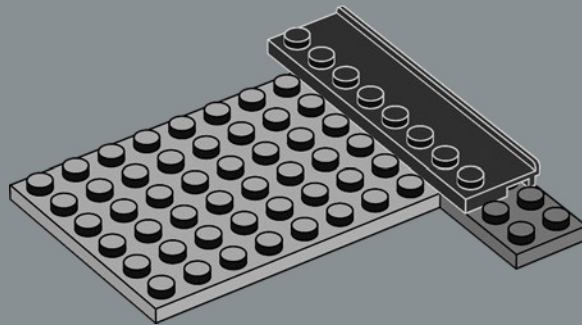



425

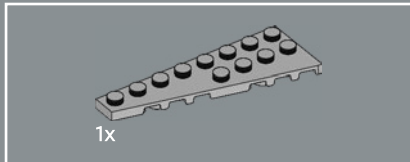
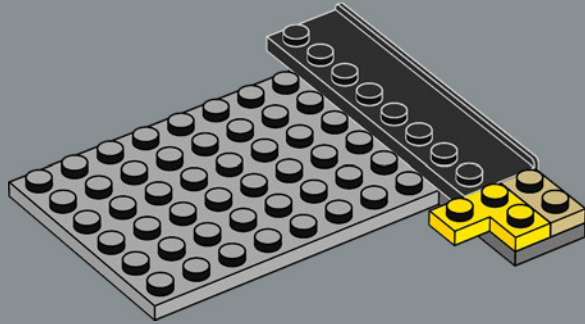

426

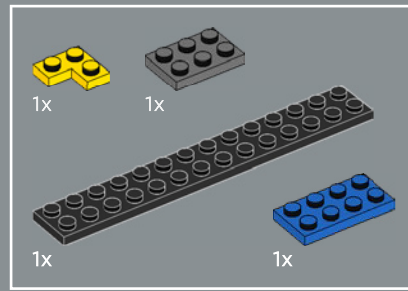
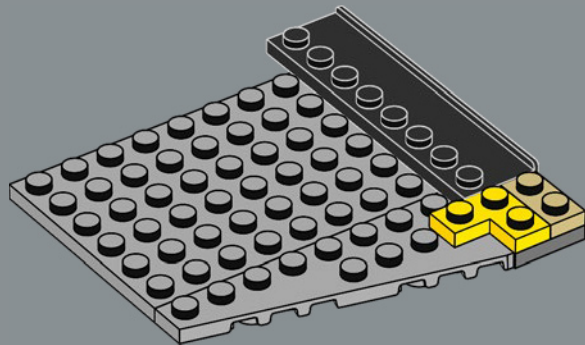

427

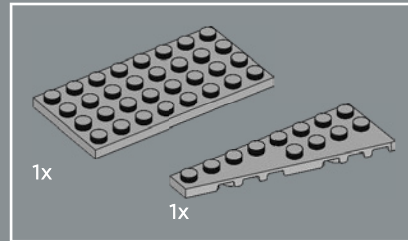
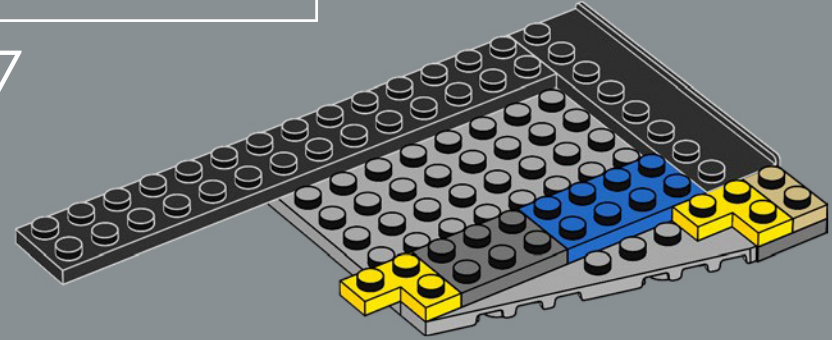

428

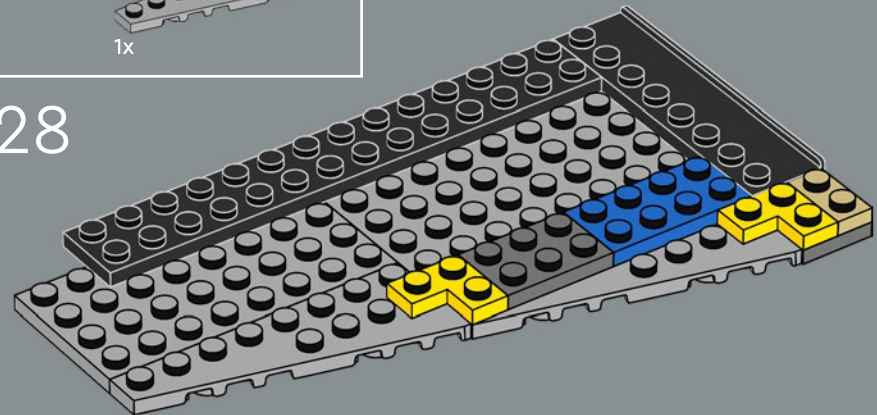

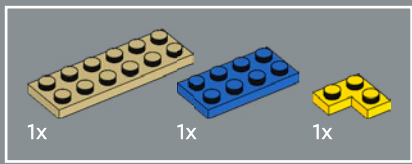

429

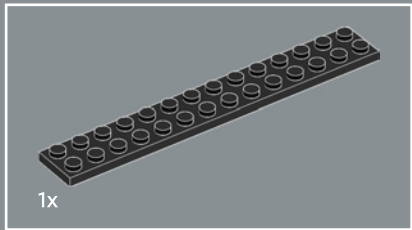
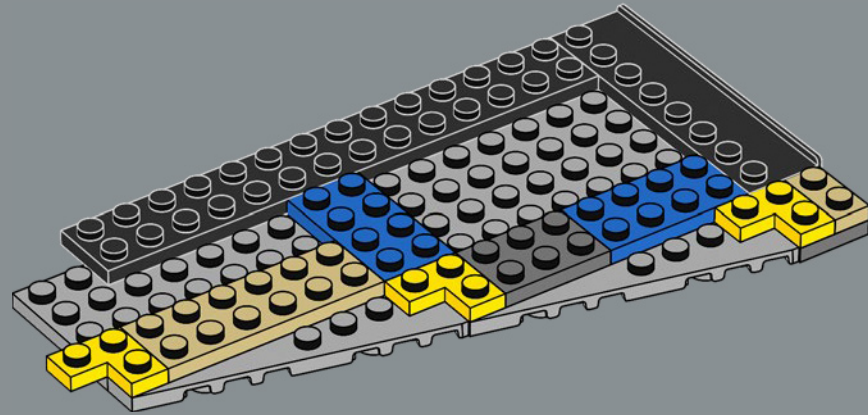

430

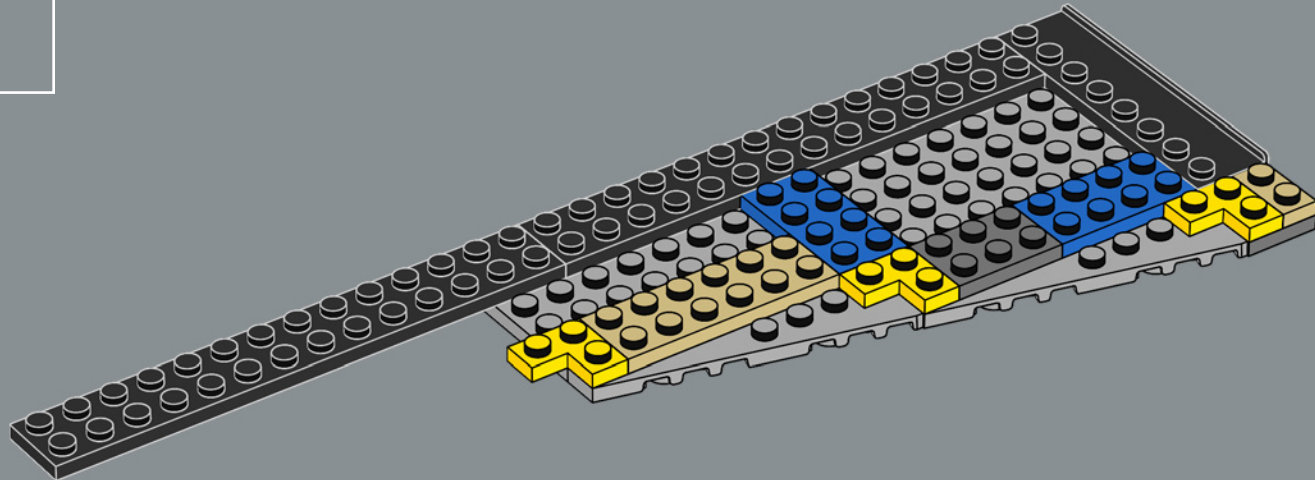

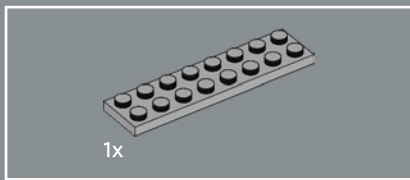

431

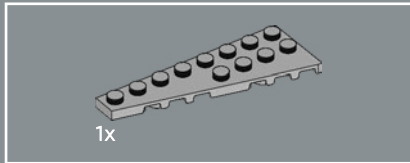
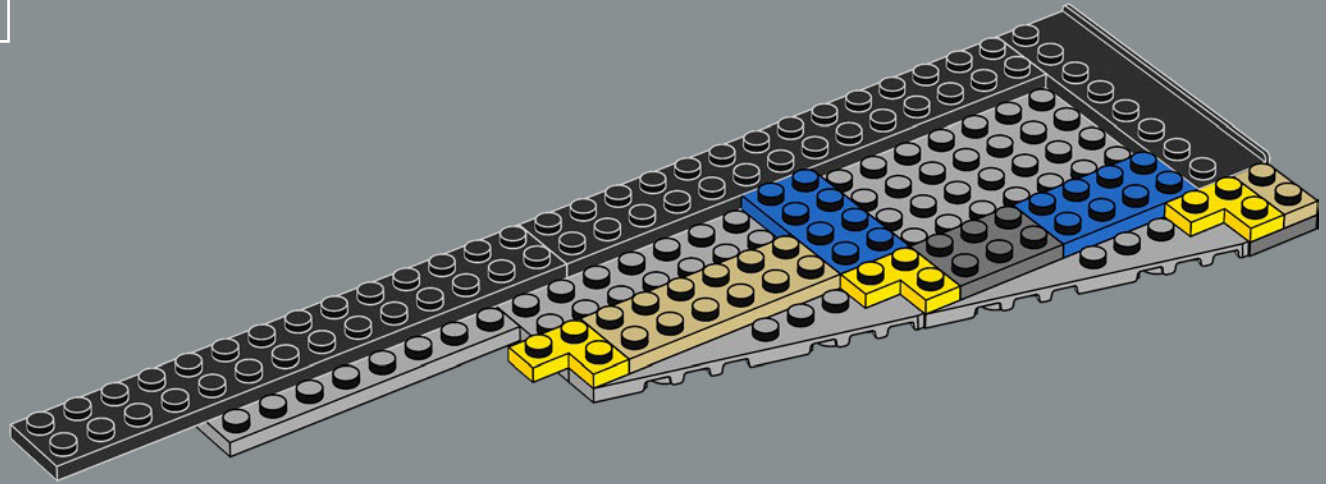

432

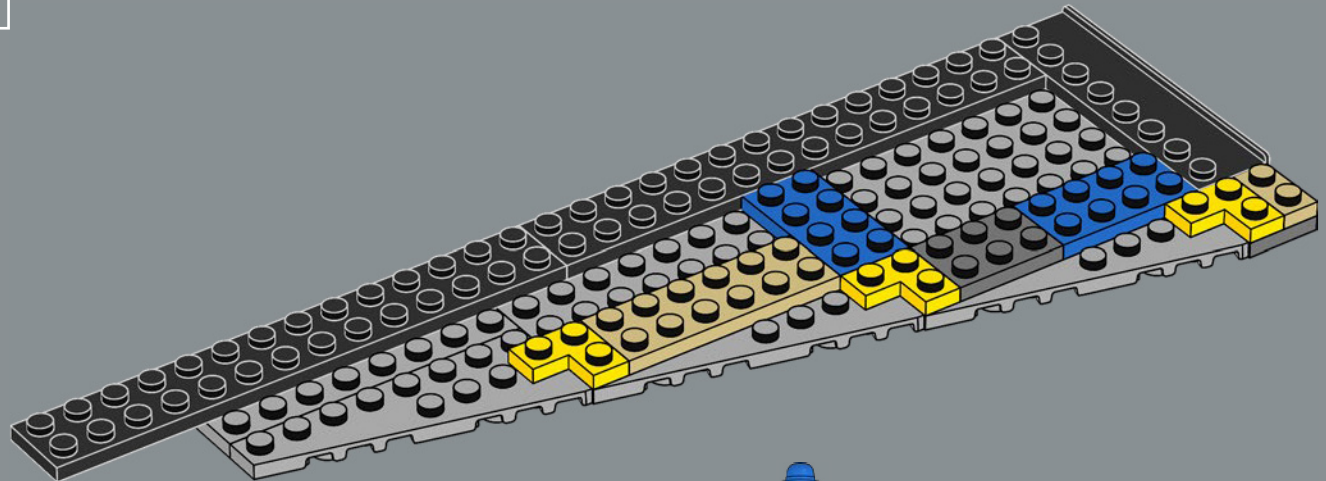

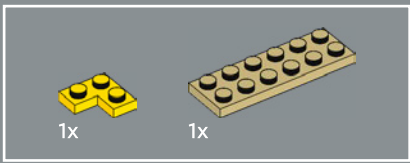

433

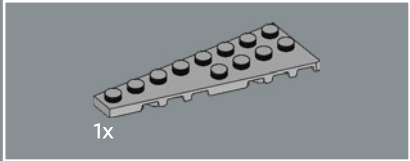
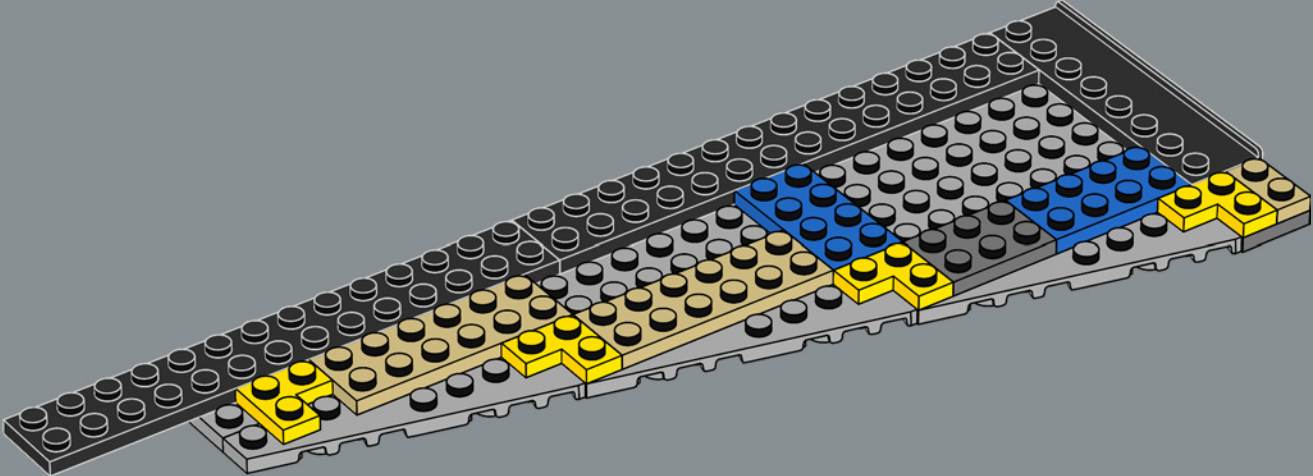

434

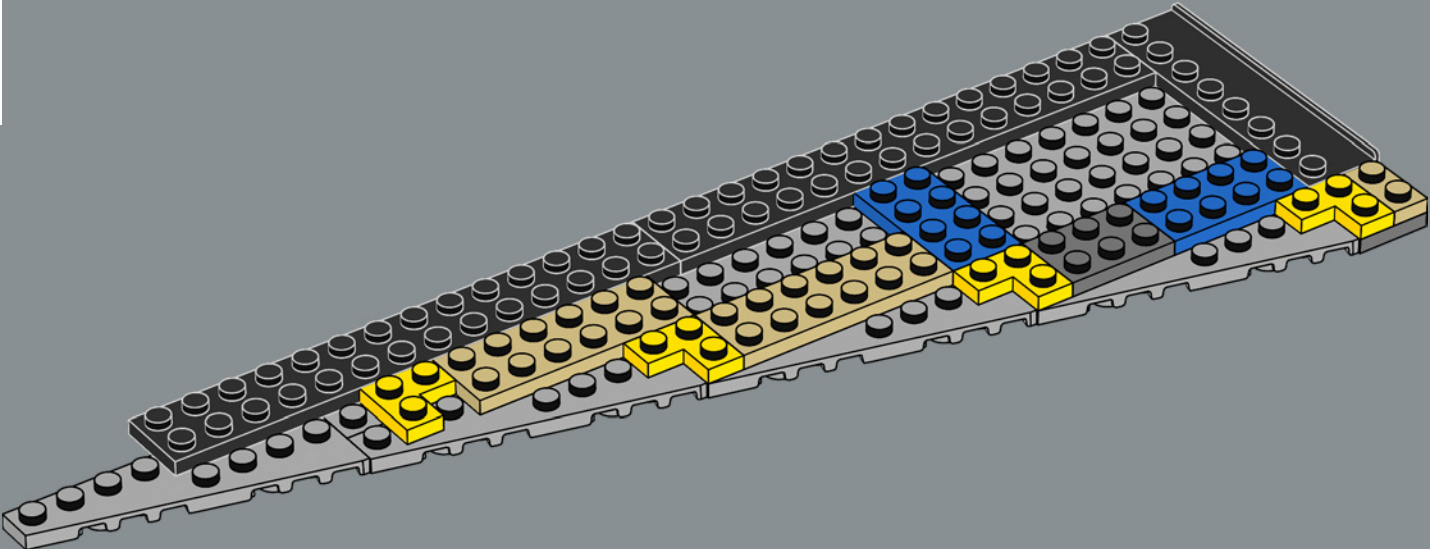

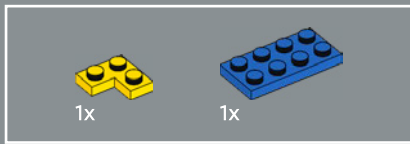

435

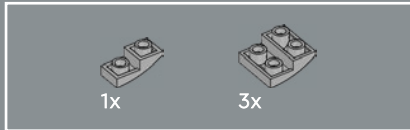
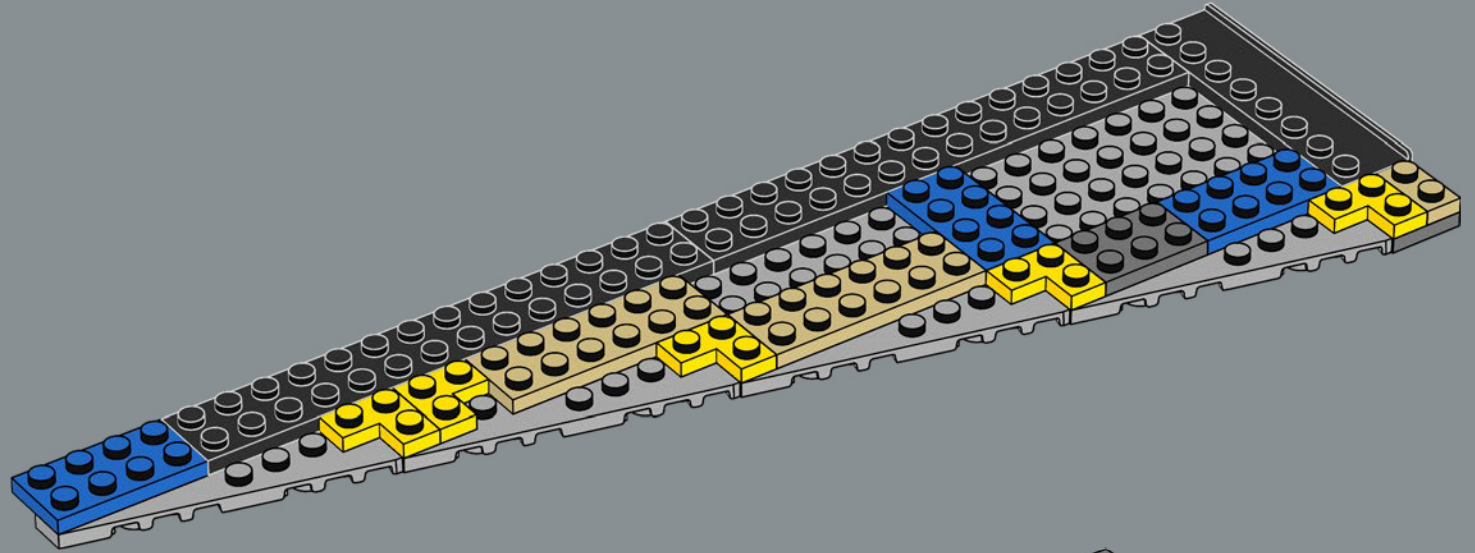

436

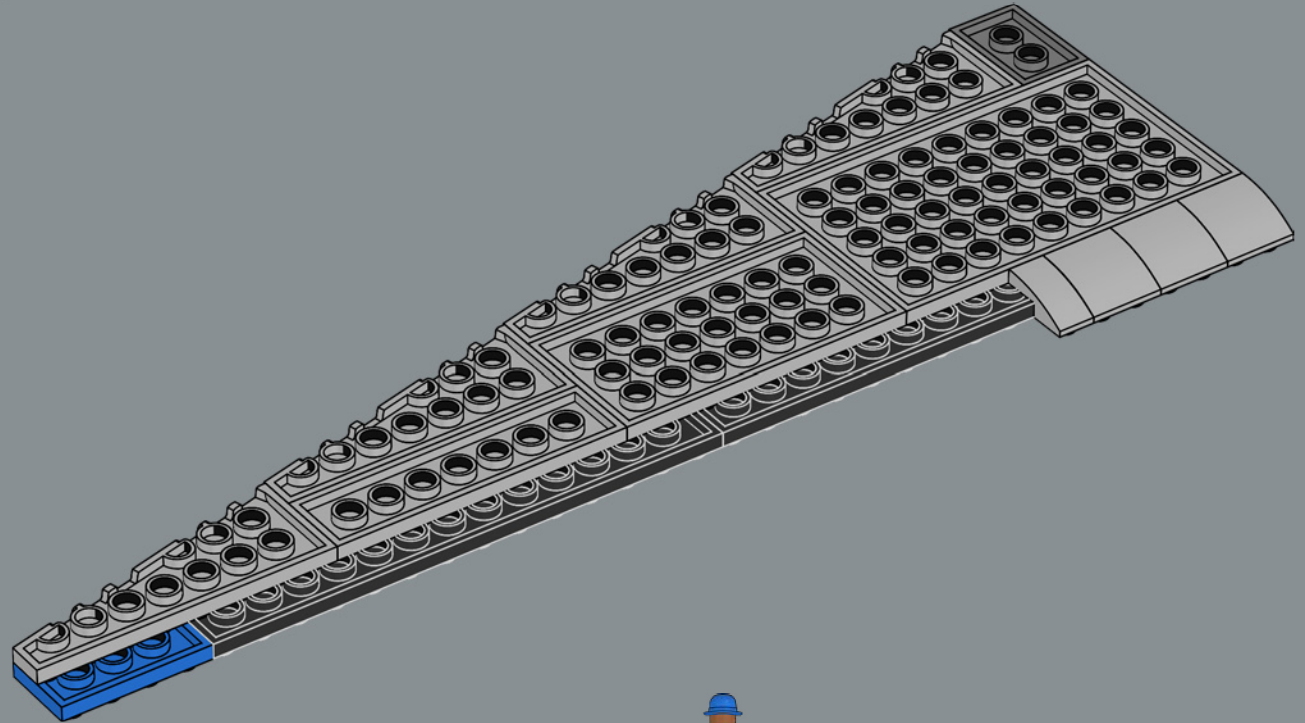

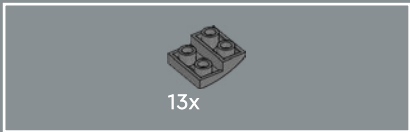

437

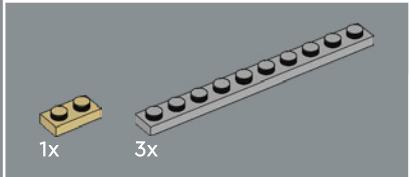
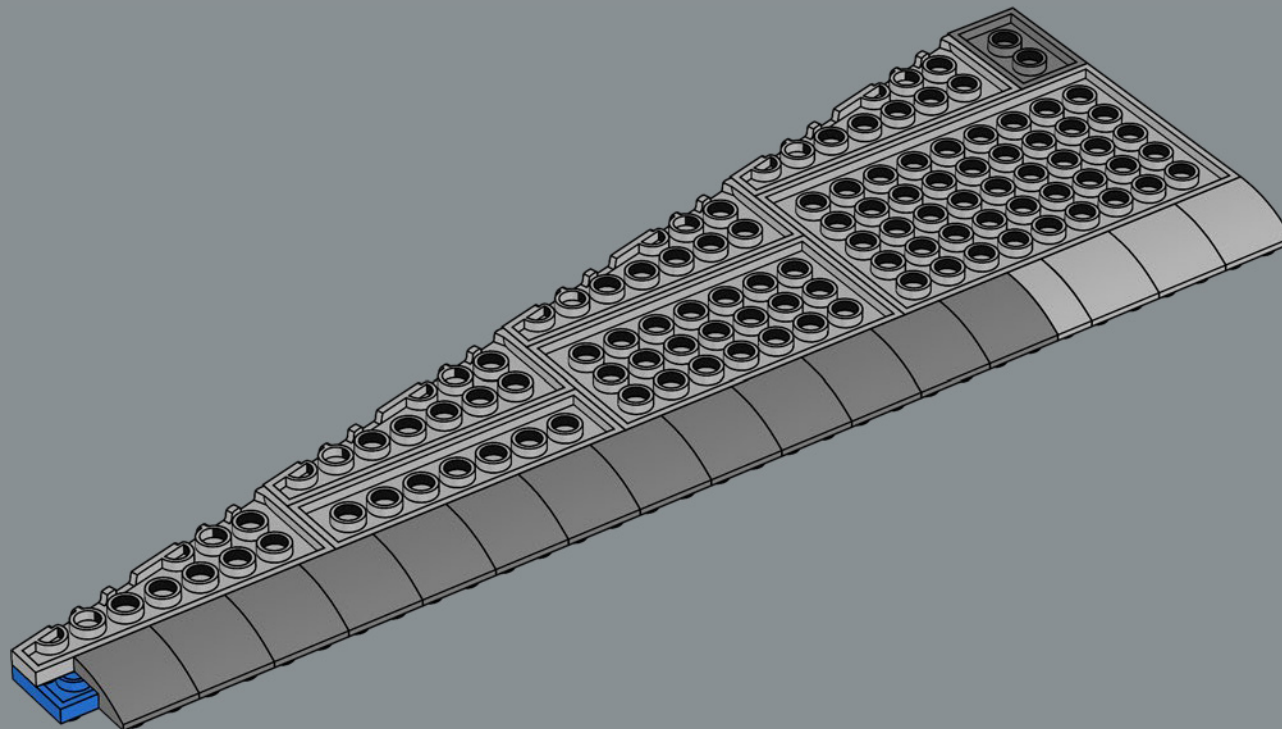

438

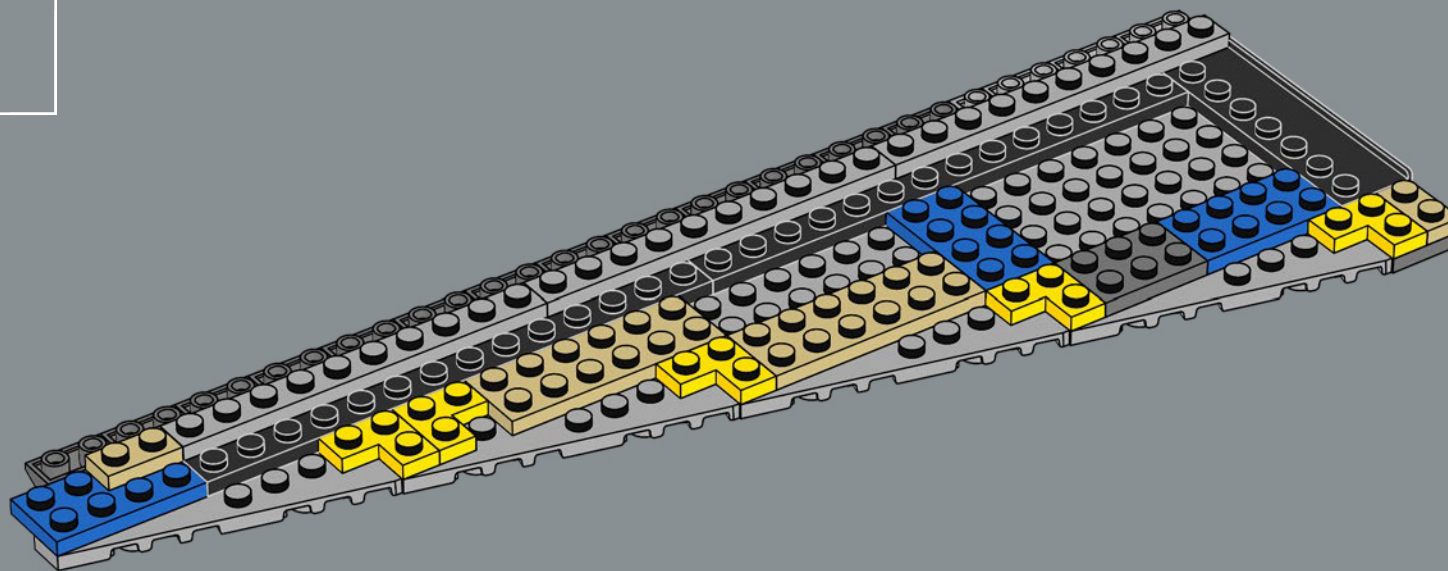

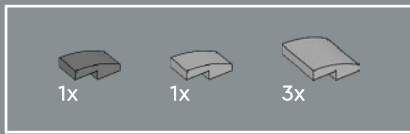

439

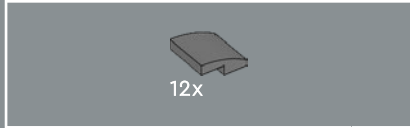
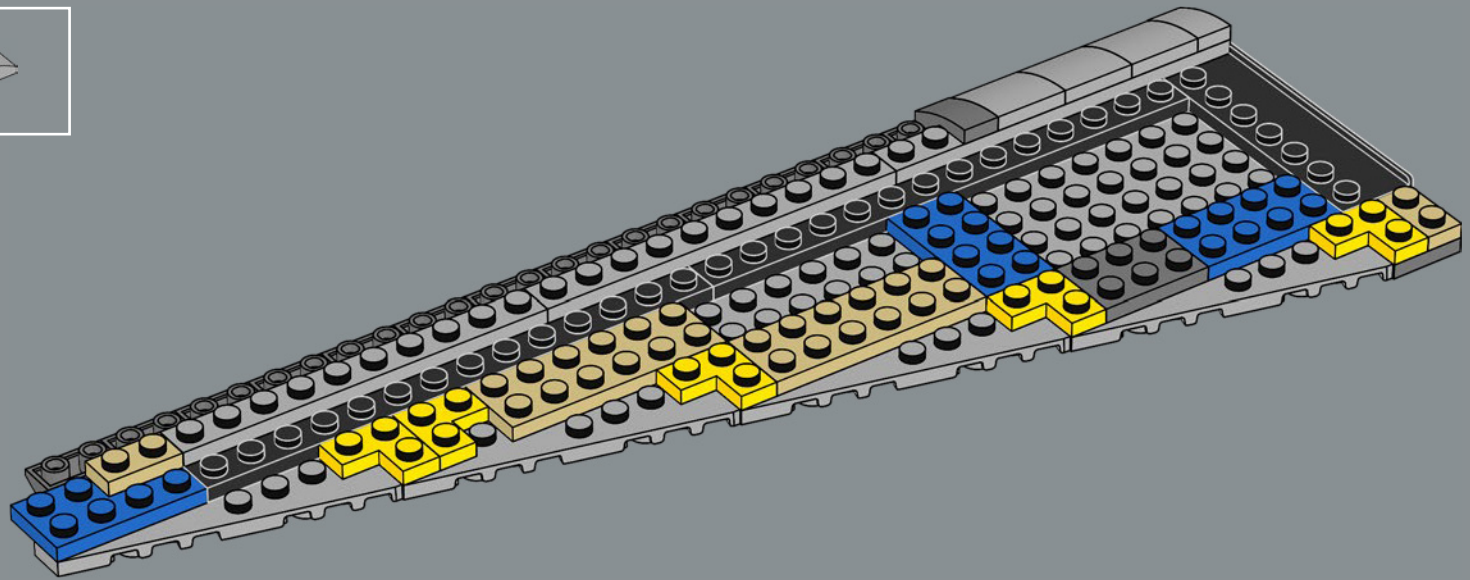

440

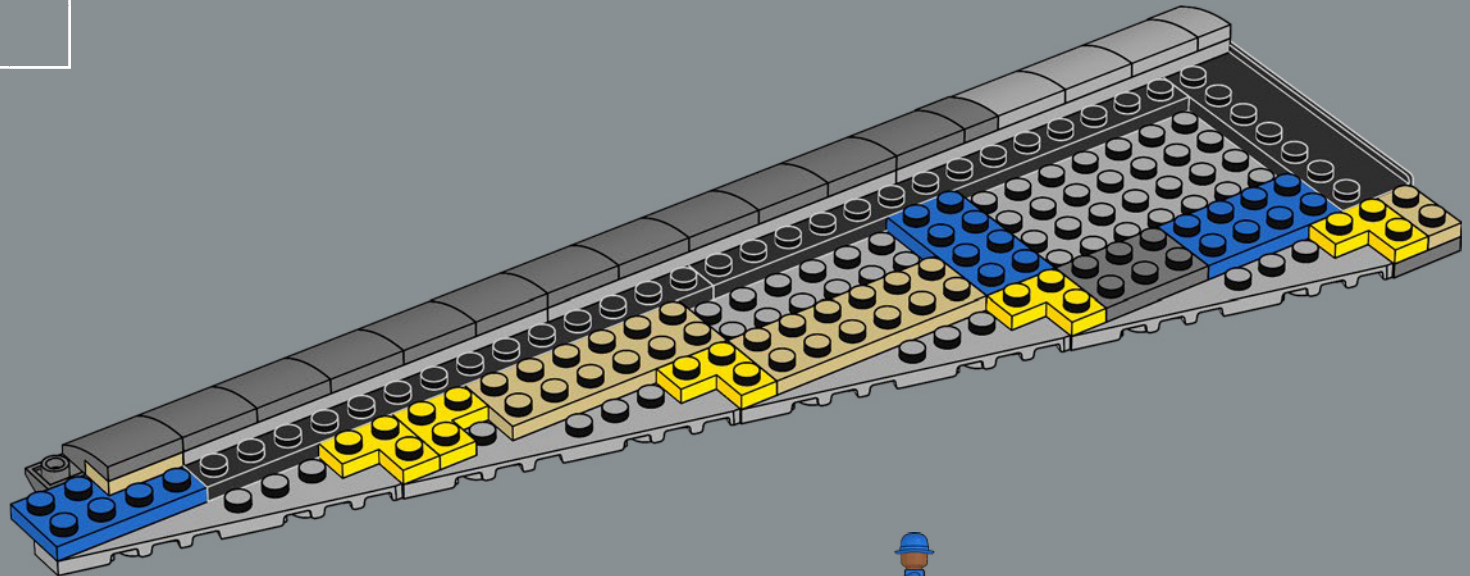

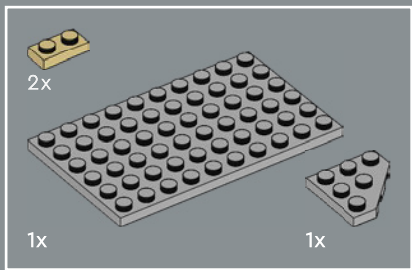

441

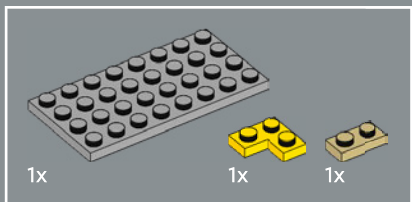
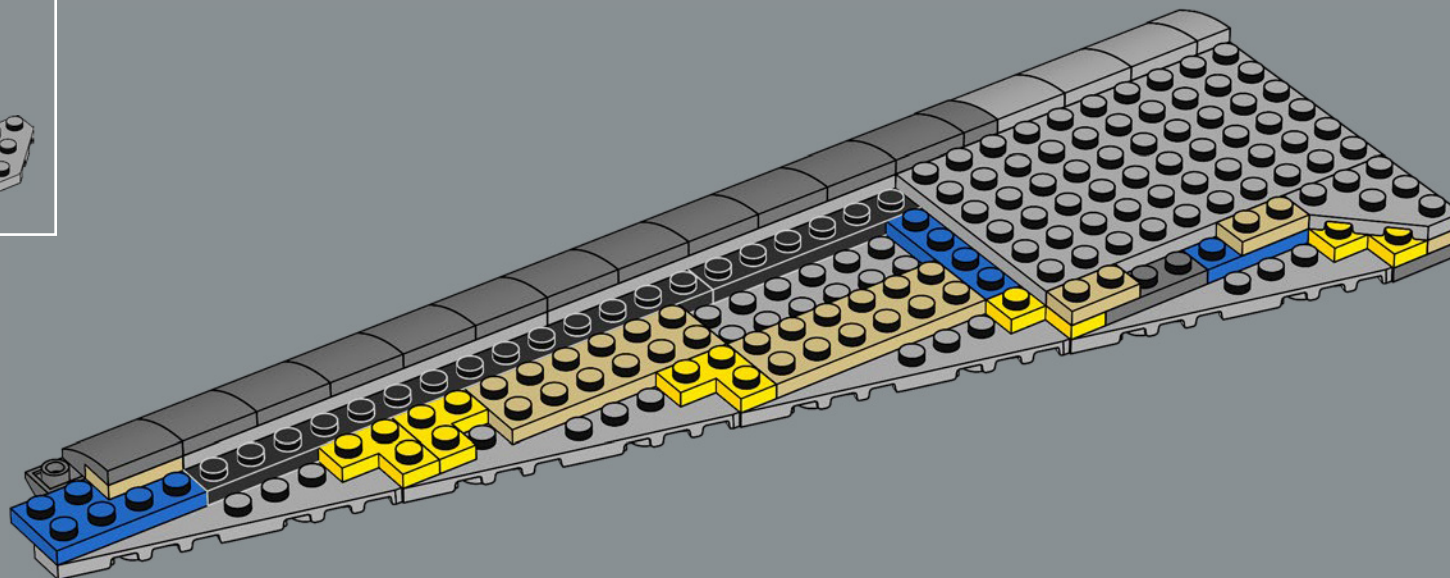

442

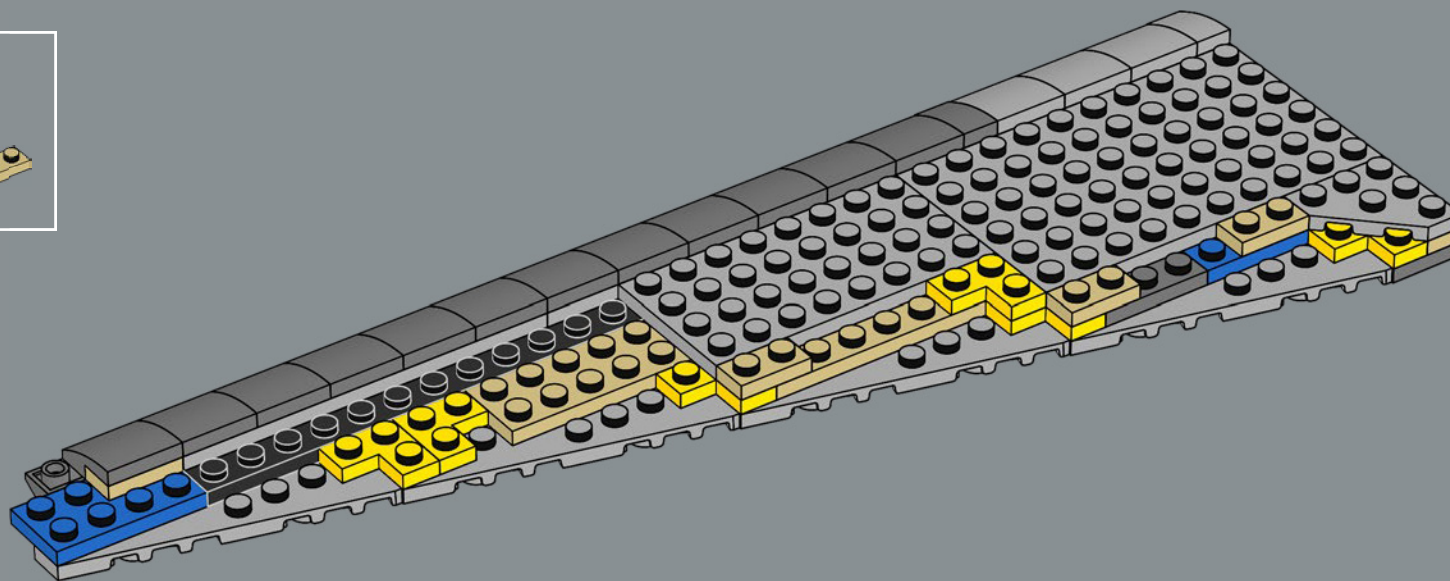

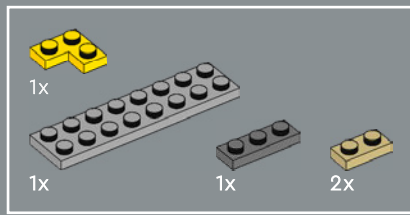

443

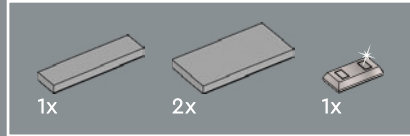
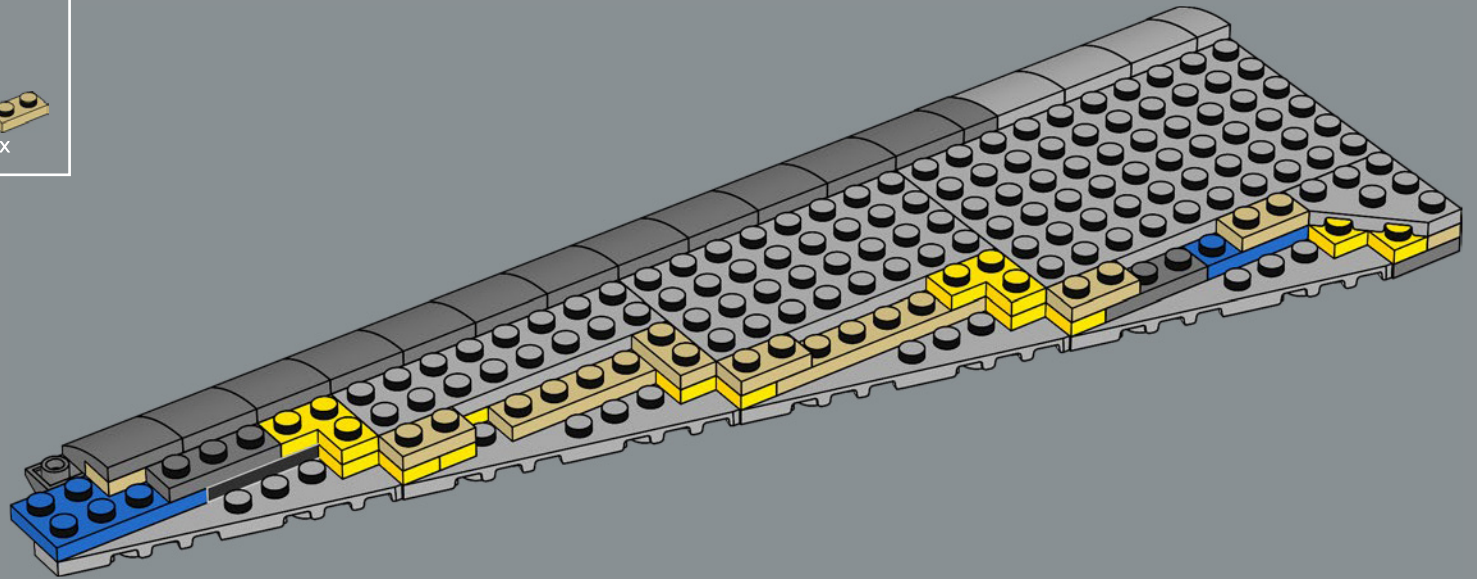

444

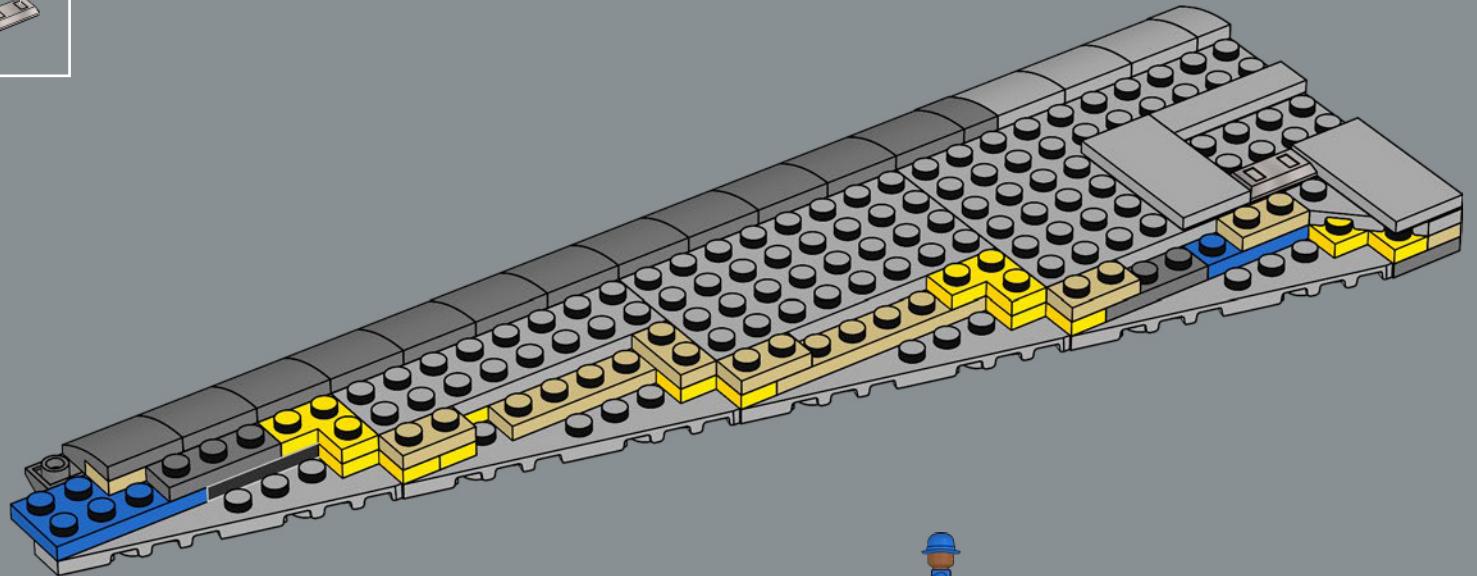

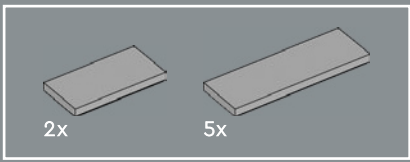

445

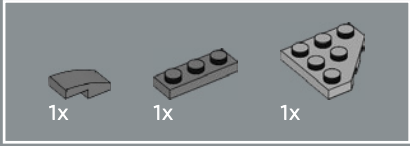
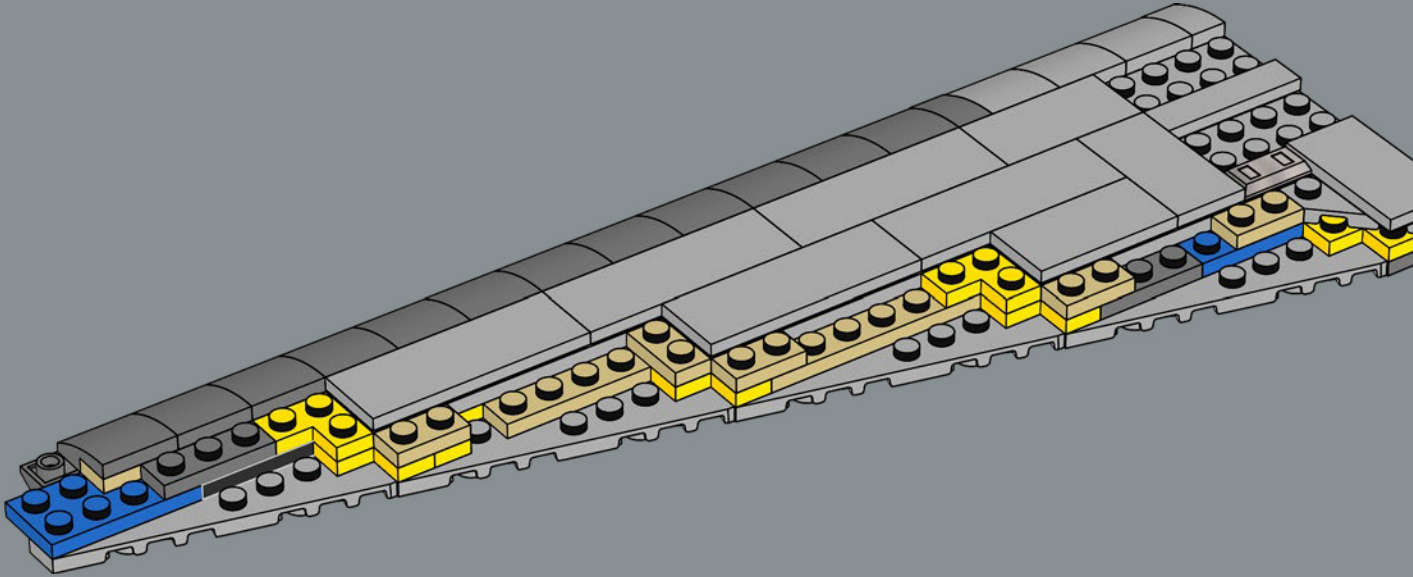

446

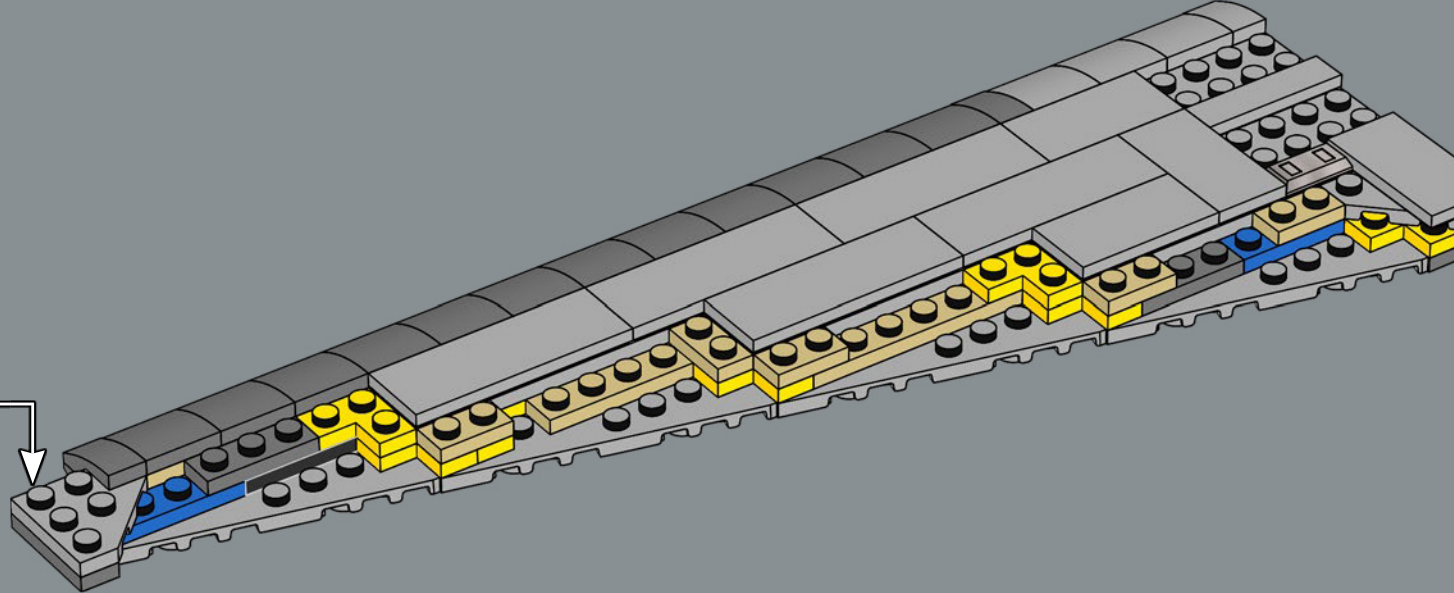
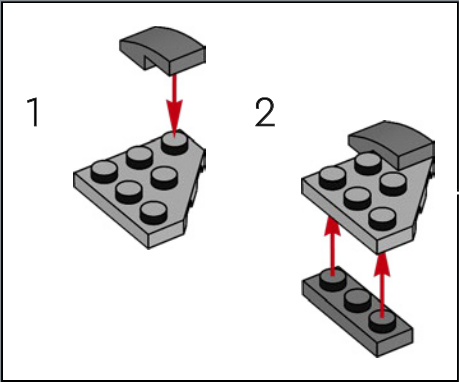

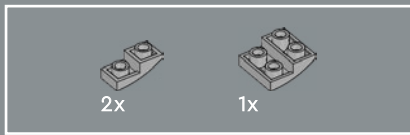

447

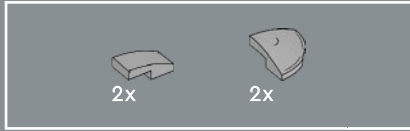
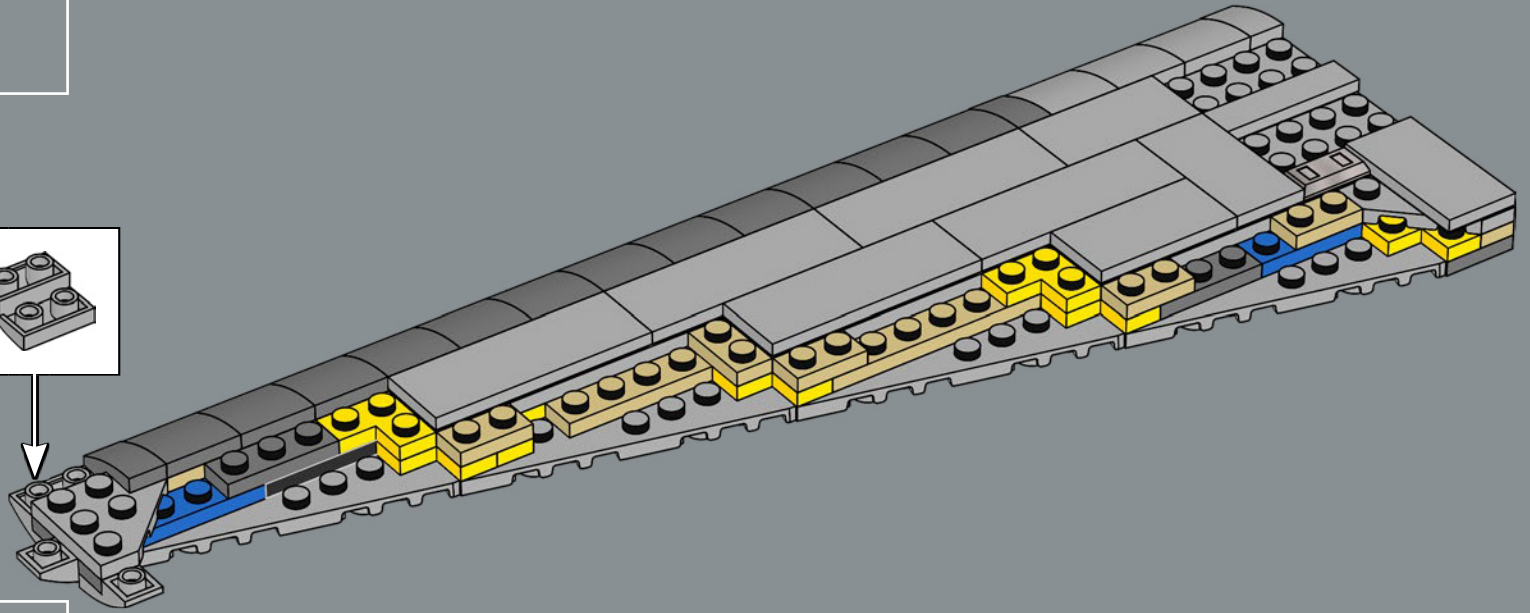
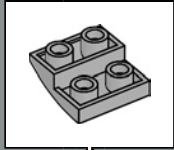

448

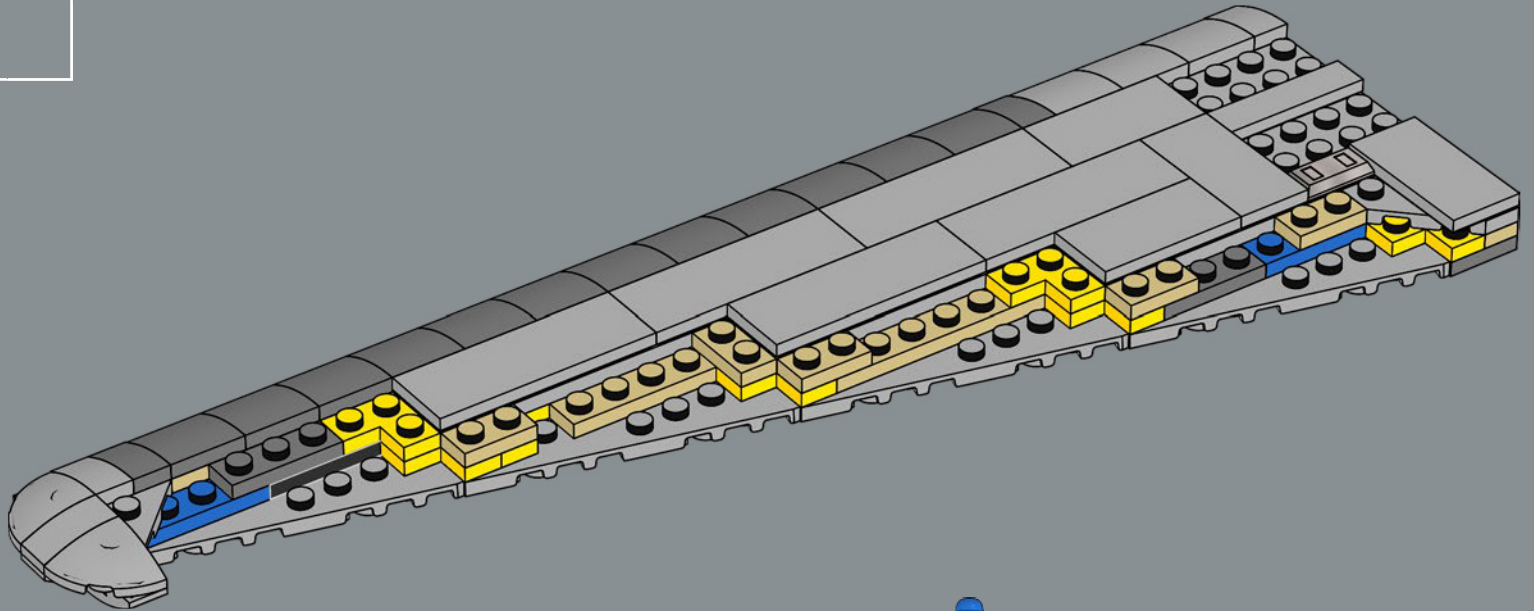

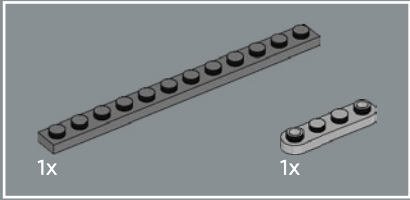
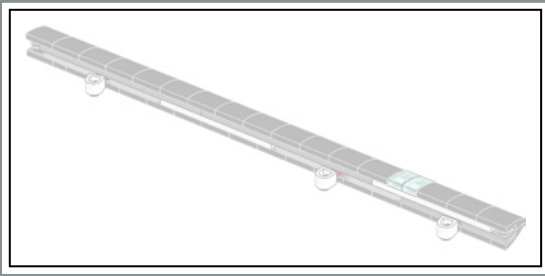

449

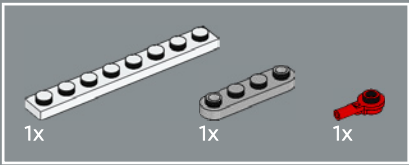
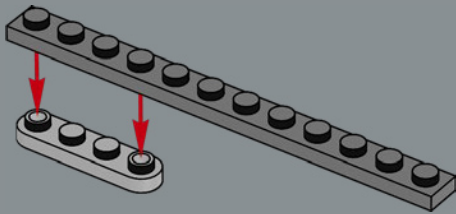

450

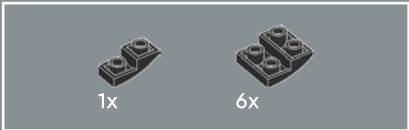
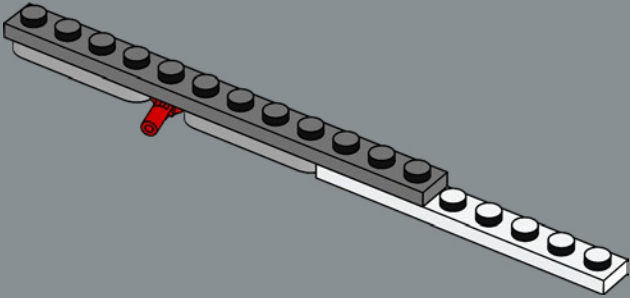

451

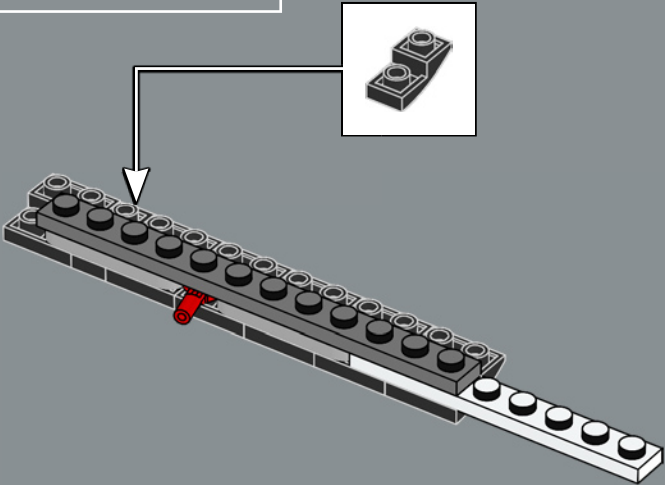



452

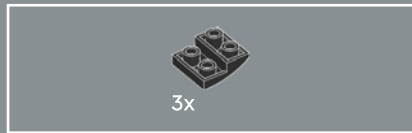
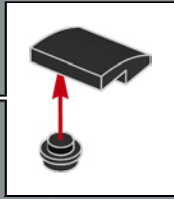
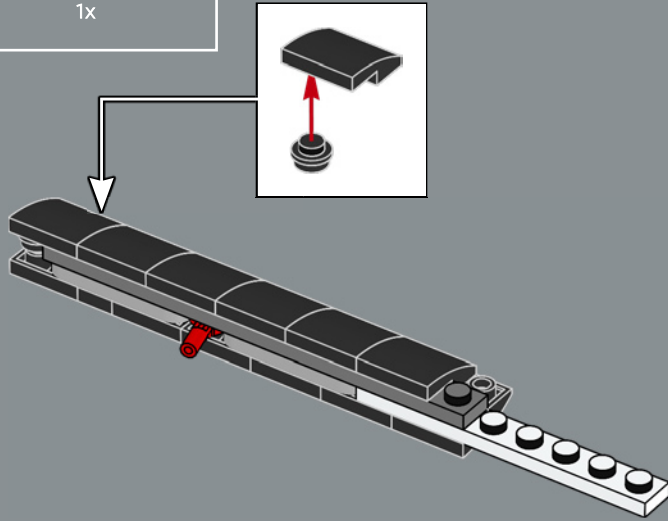

453

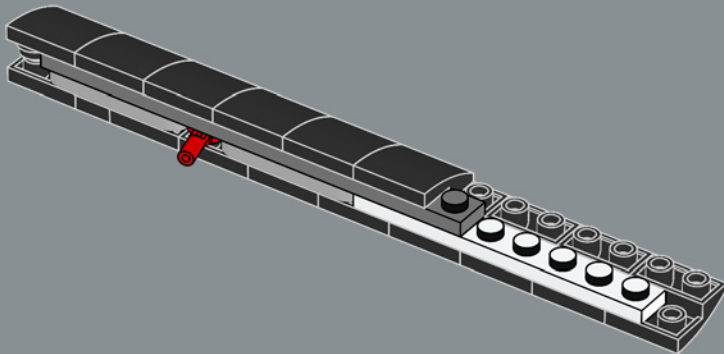

454

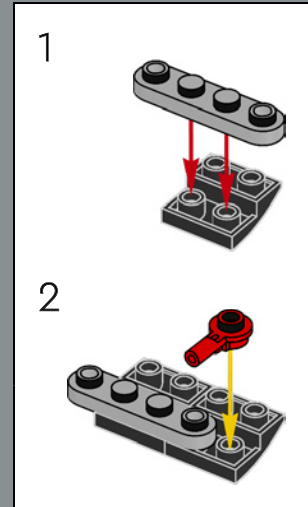
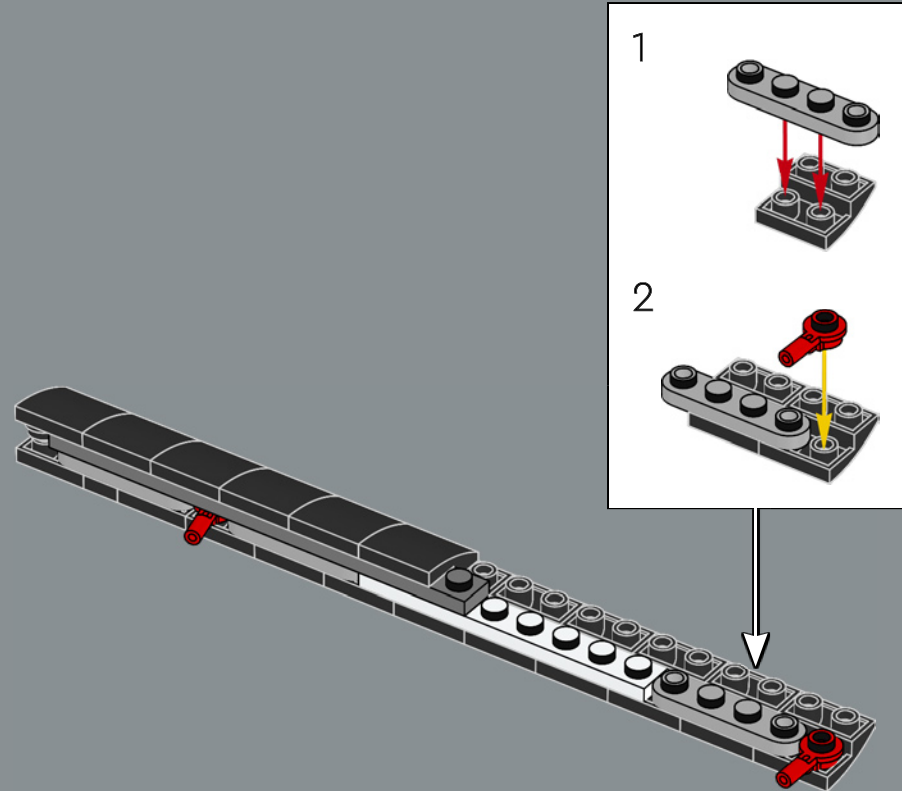

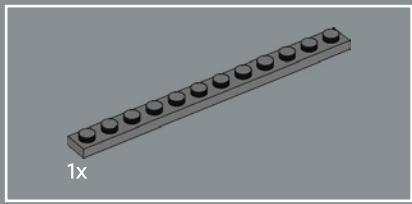

455

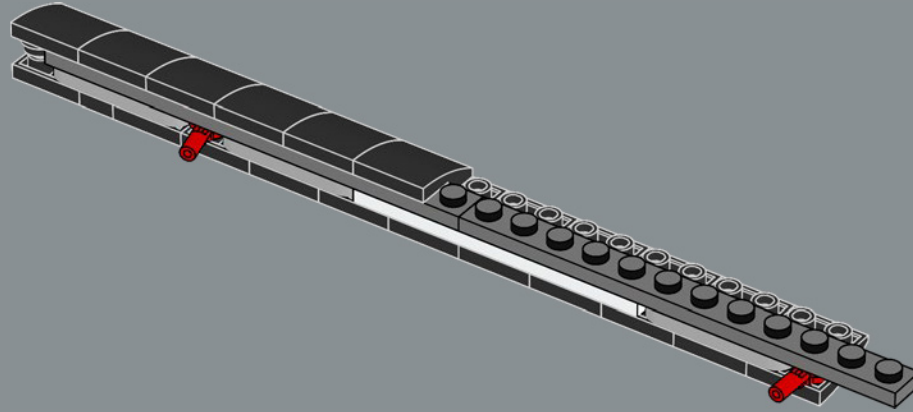

456

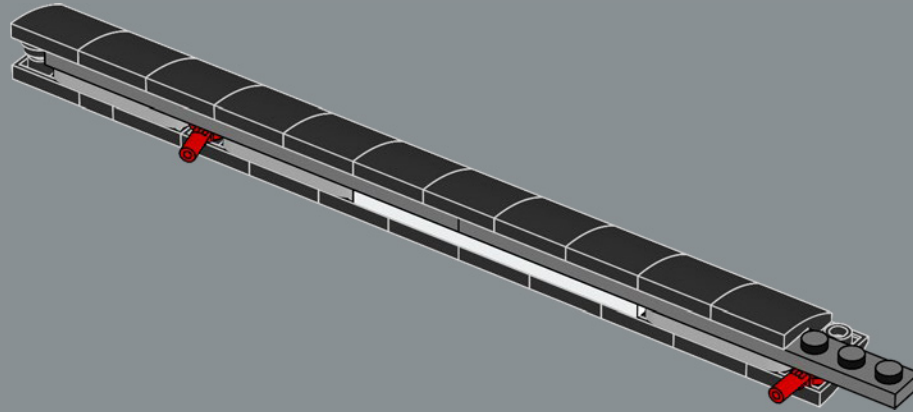

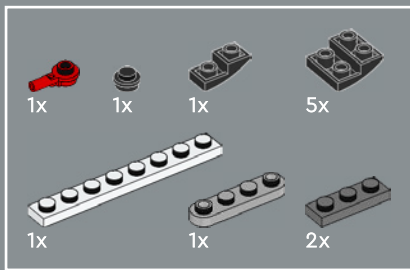

457

1

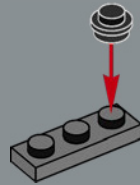

2

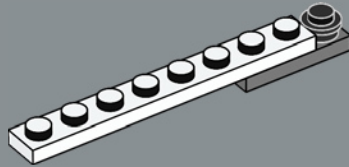

3

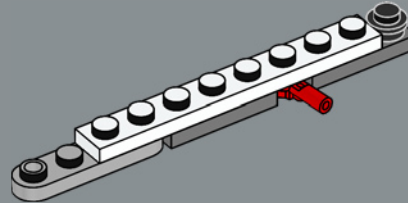

4

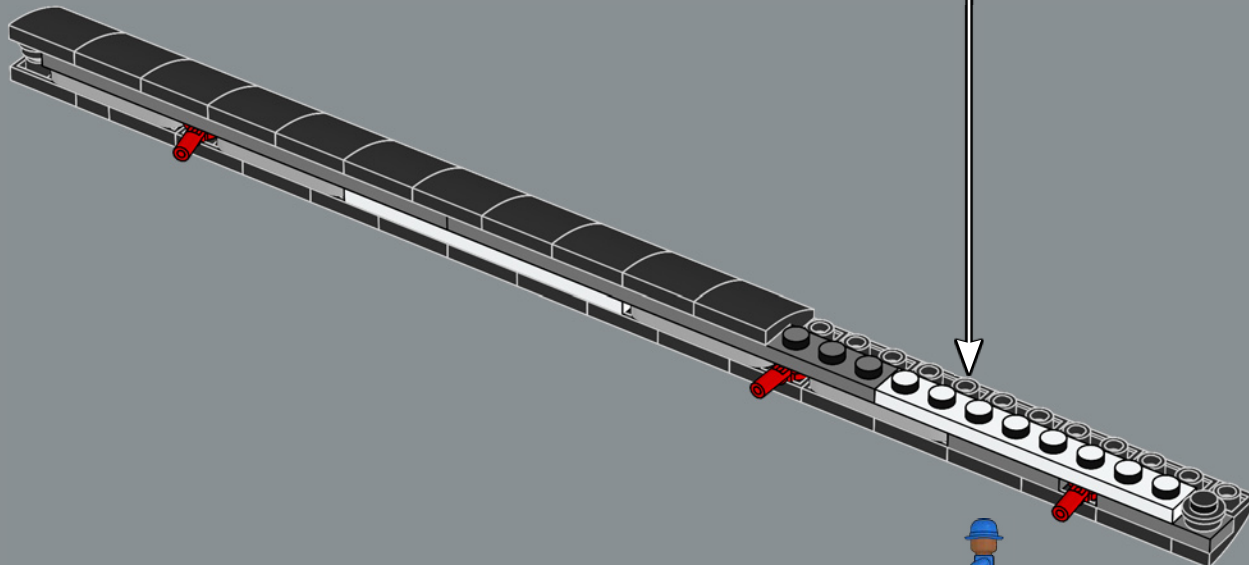
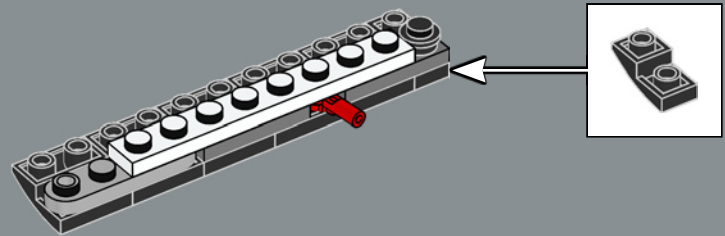



458

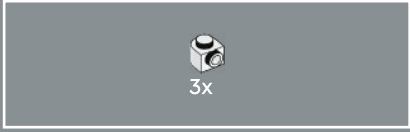
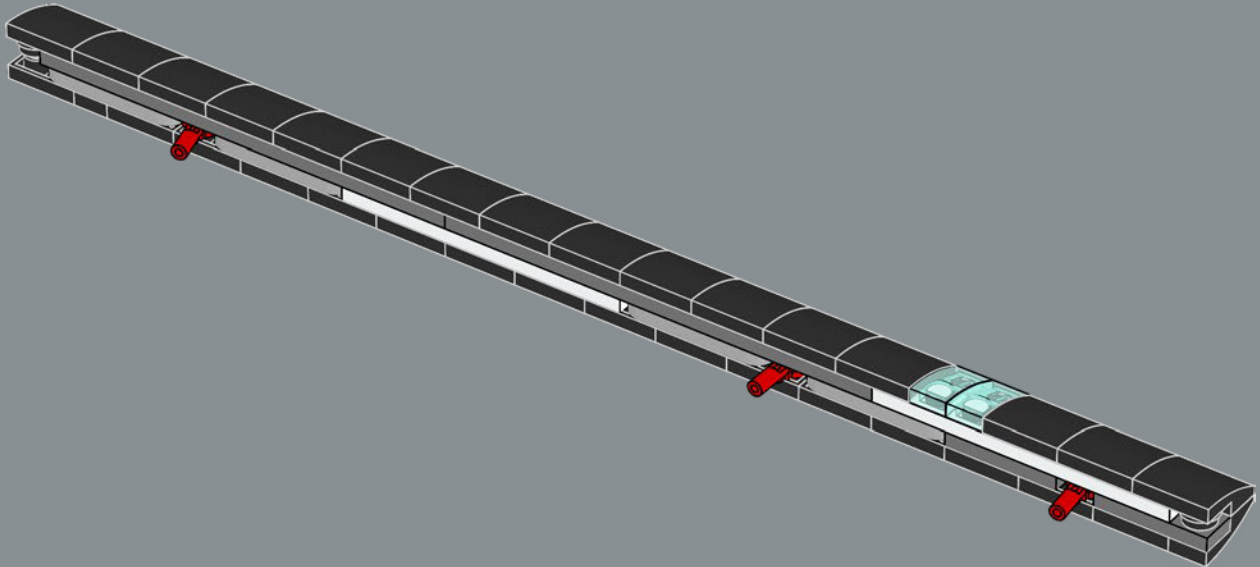

459

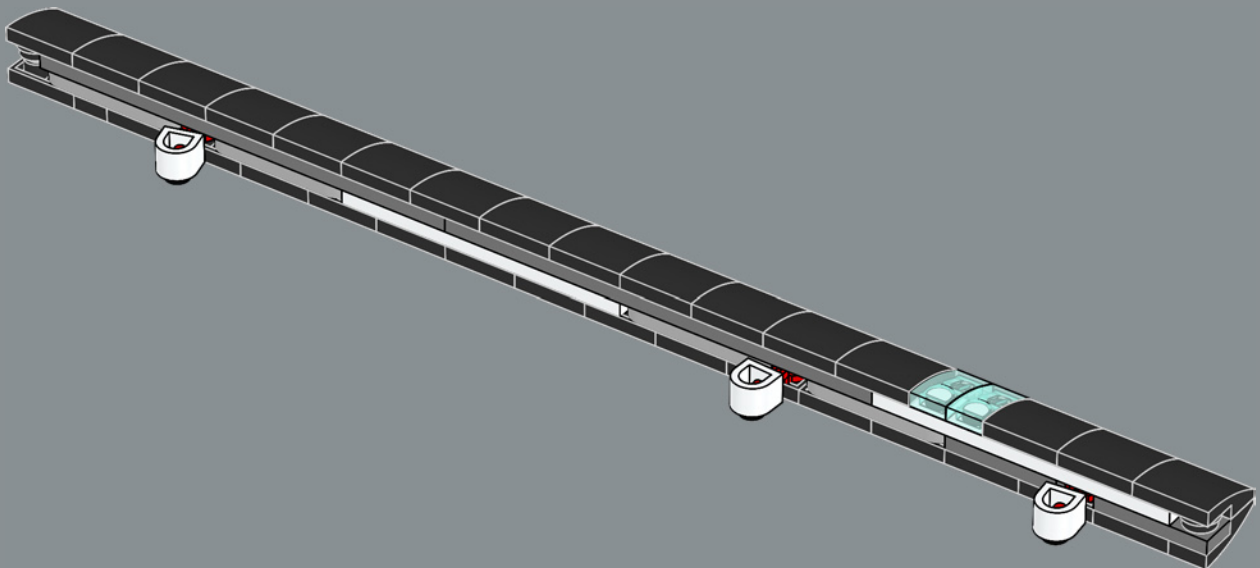

460

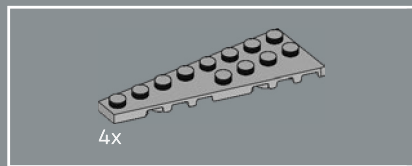
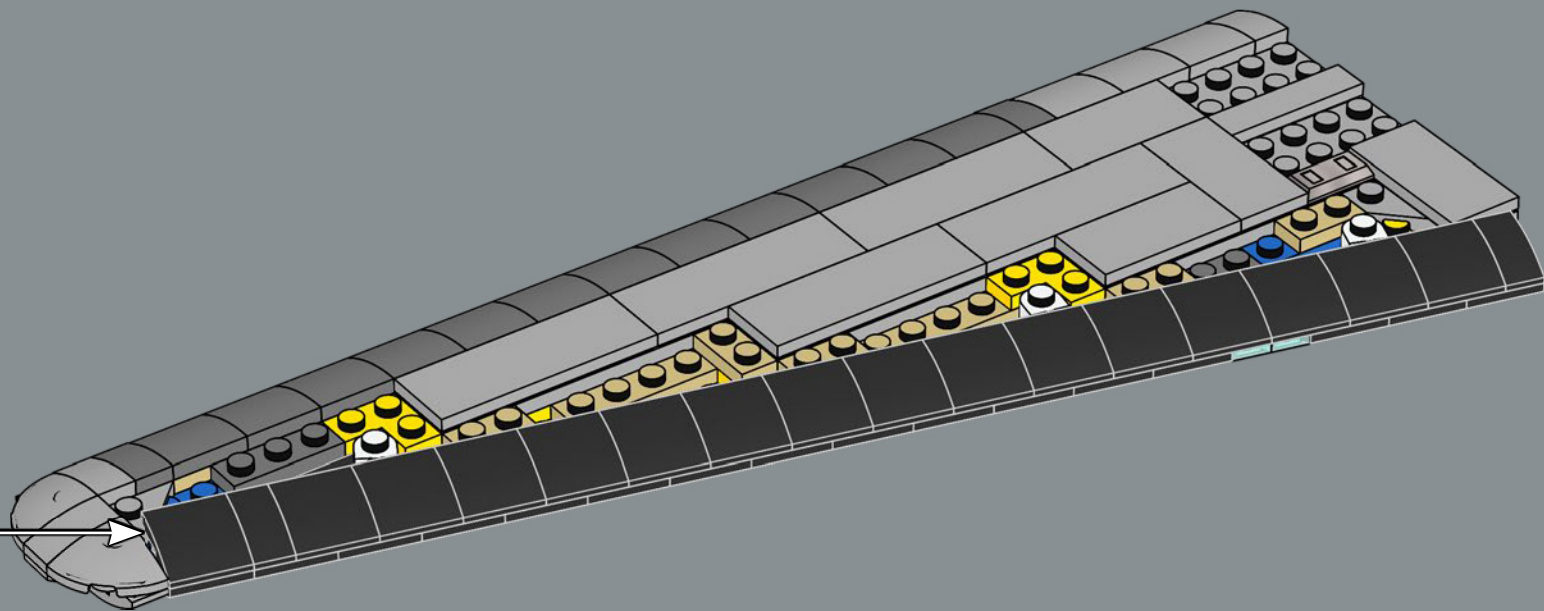

461

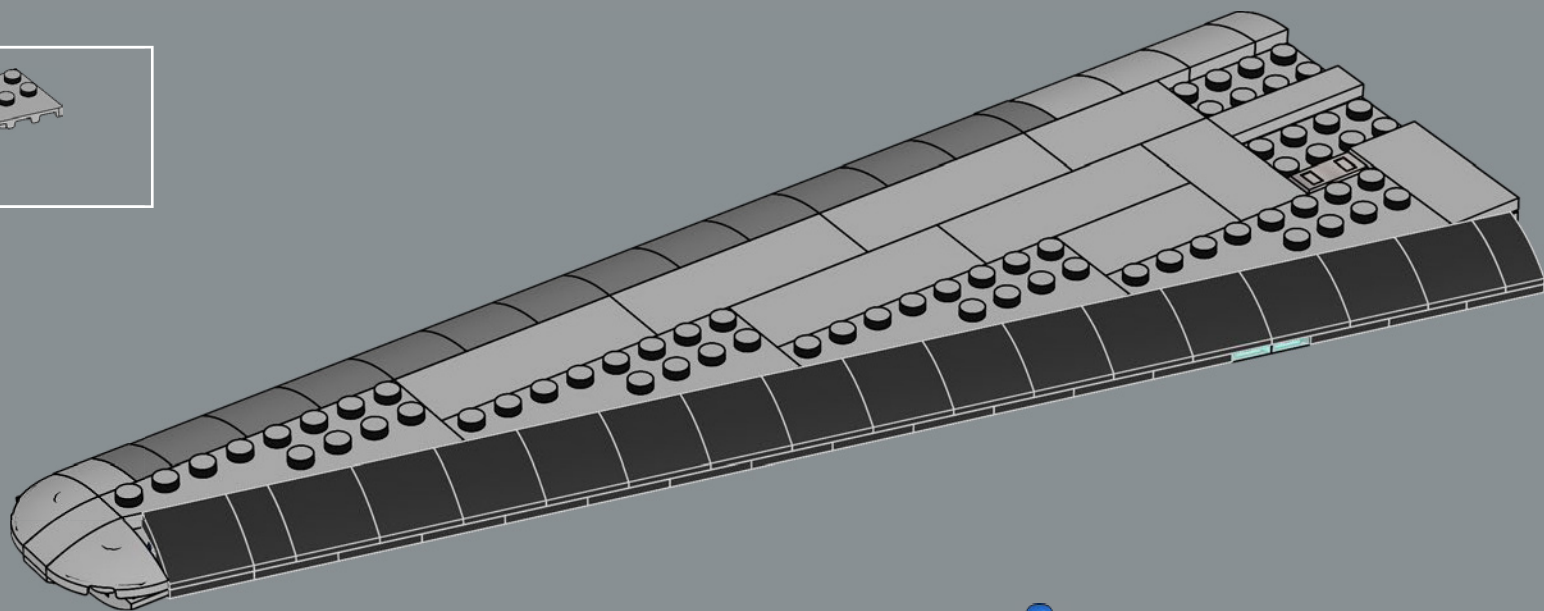

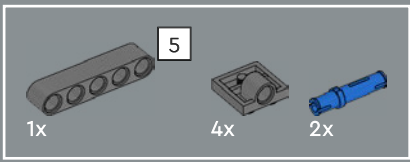

462

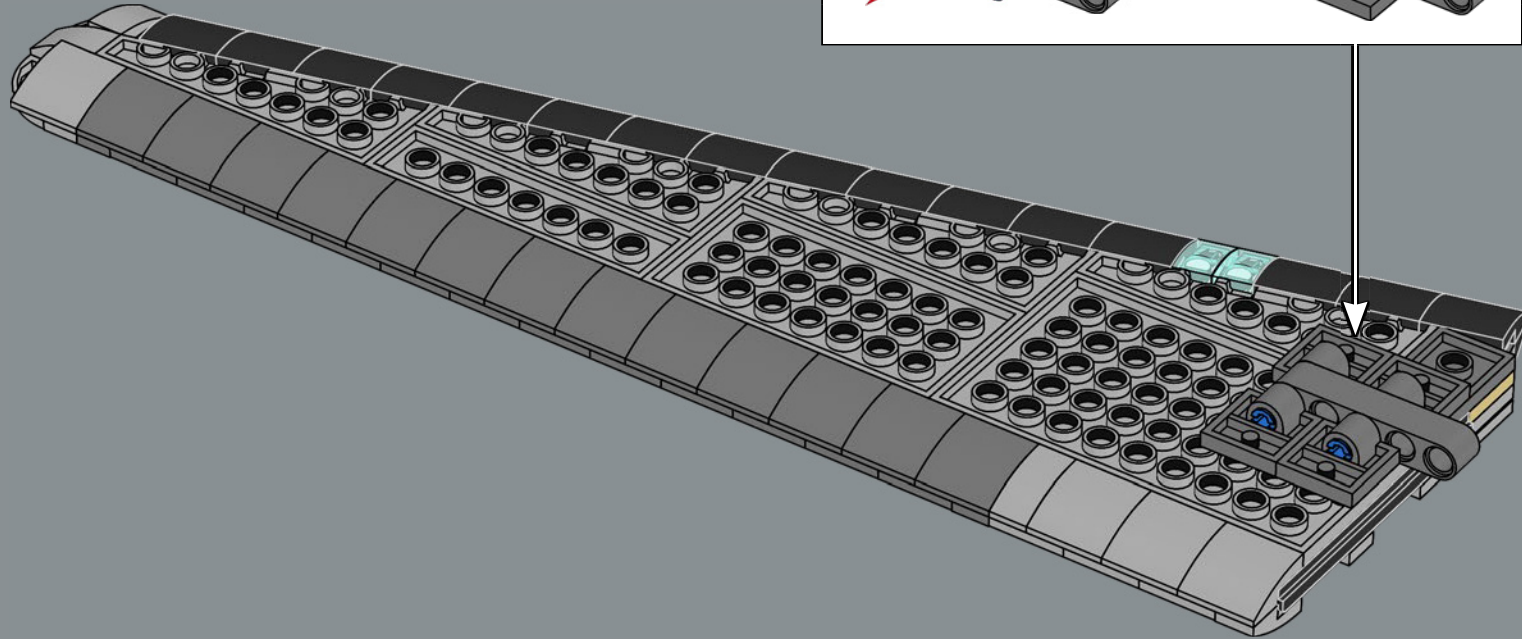
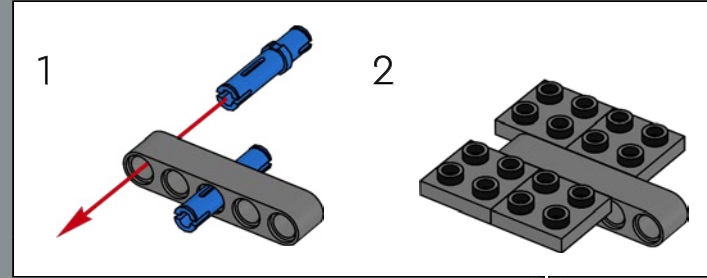



4x

463

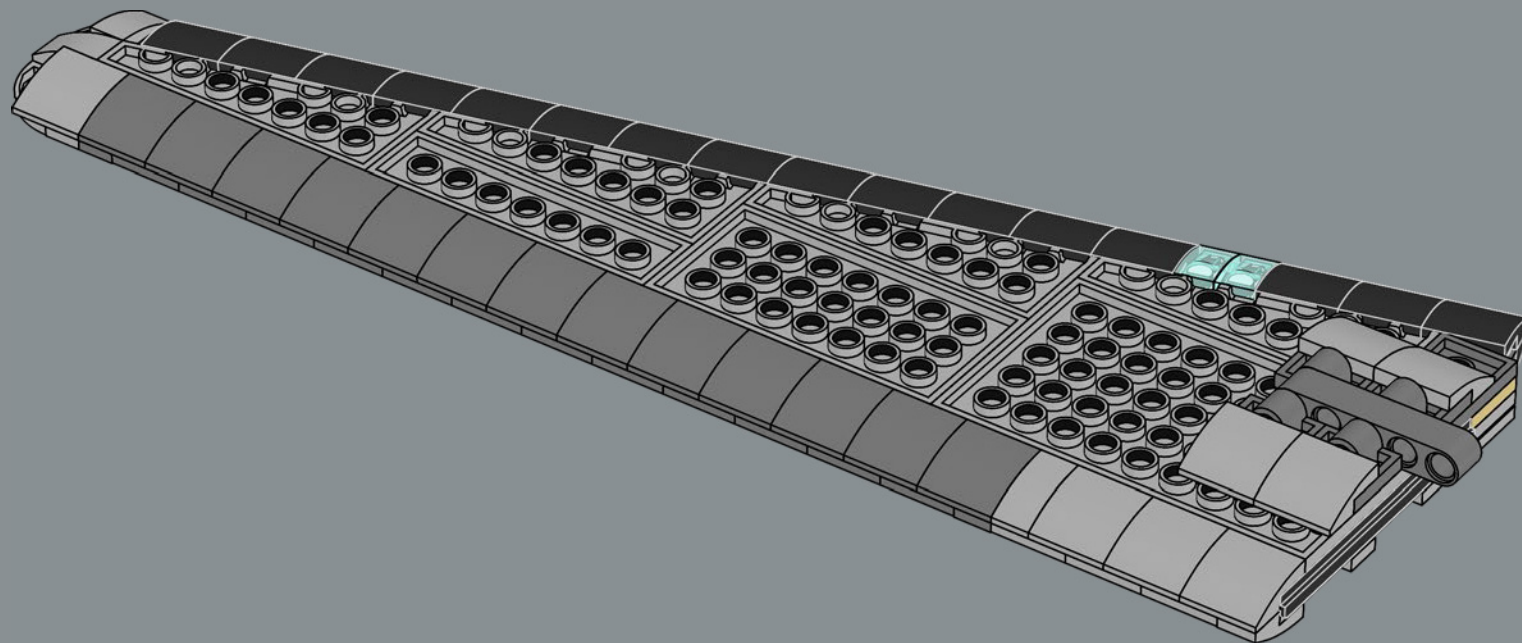

464

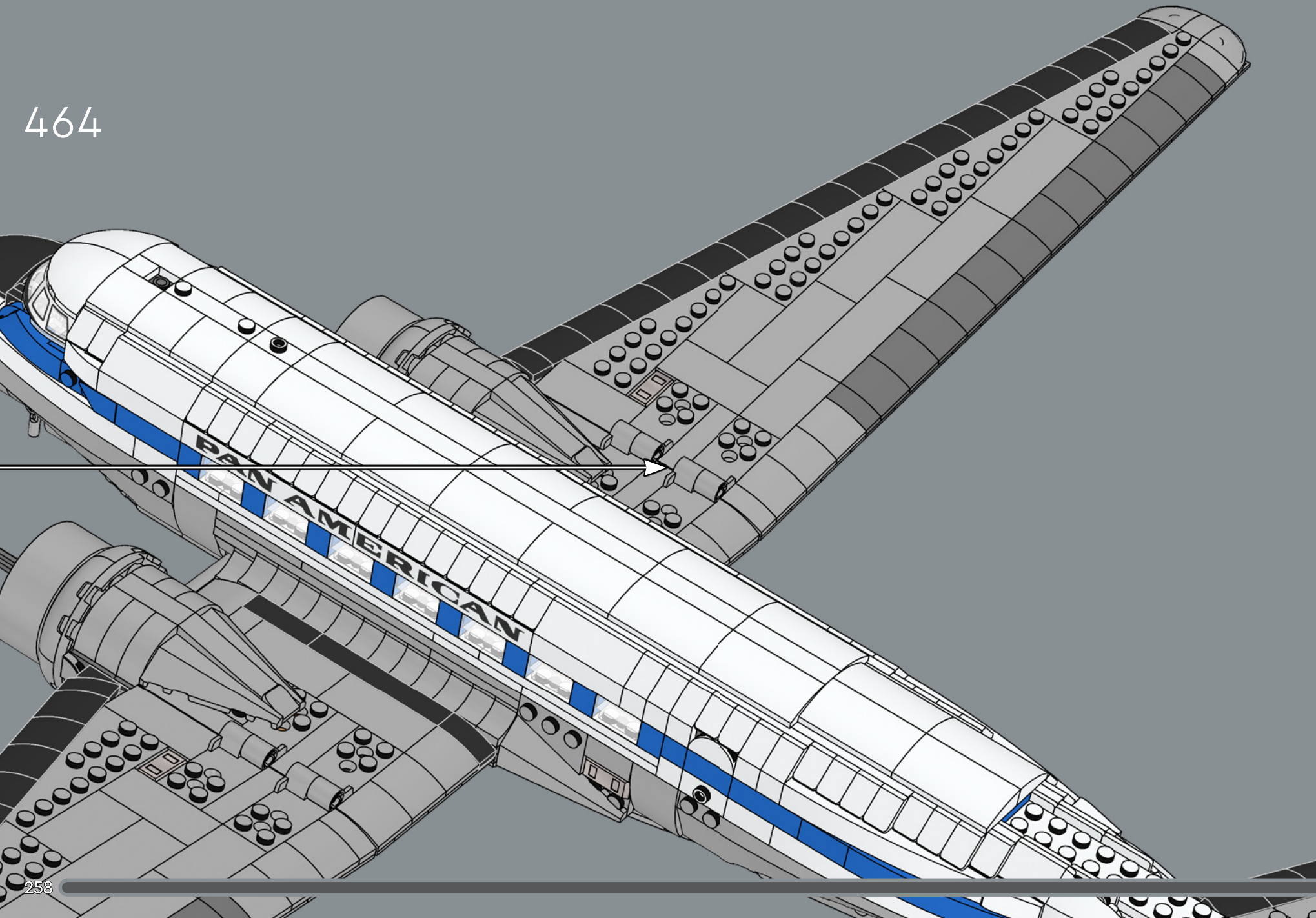



465

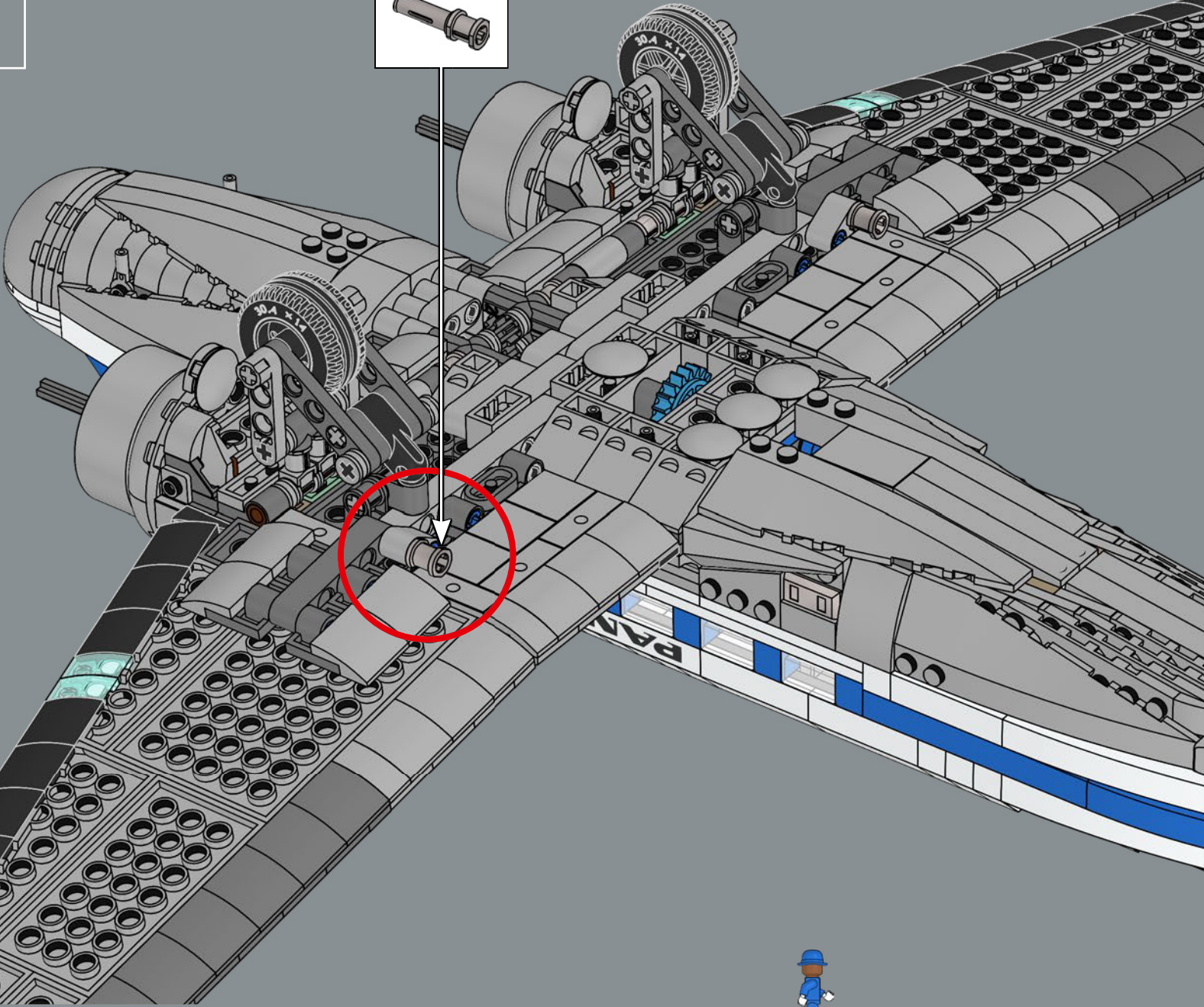



De nouveaux uniformes, dessinés par une maison de couture américaine, furent introduits en 1980. Les stewards étaient alors appelés pursers.

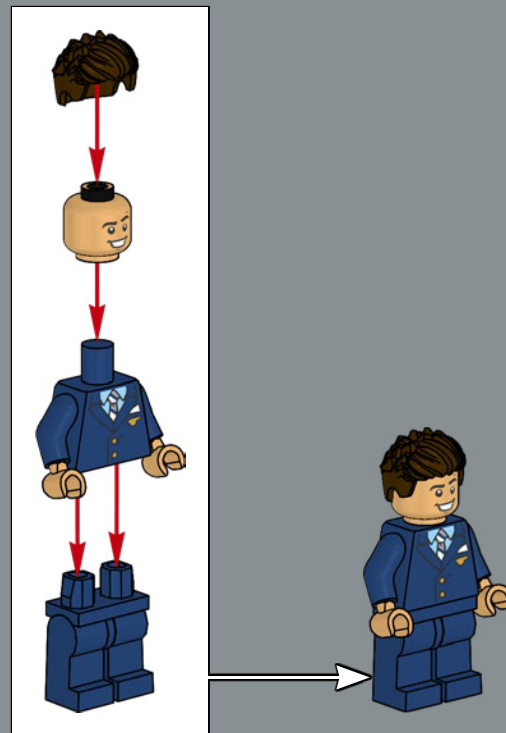

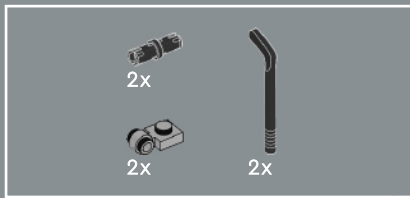

466

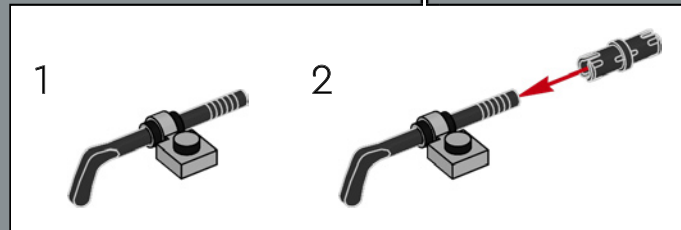
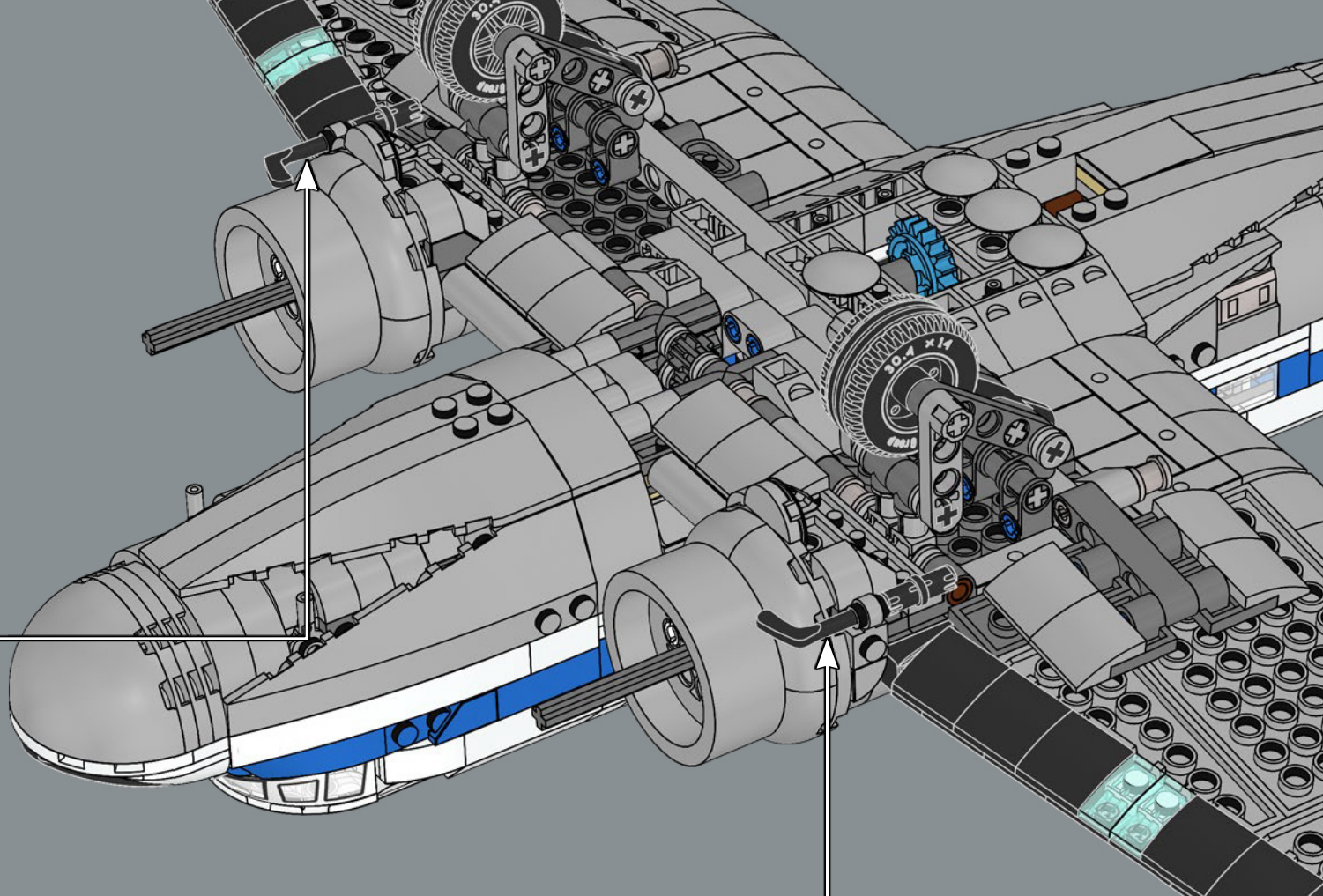
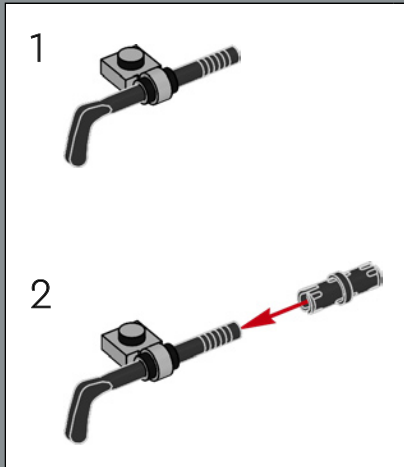



Les protubérances situées sous le cockpit
représentent des capteurs de vitesse de l'air.

467

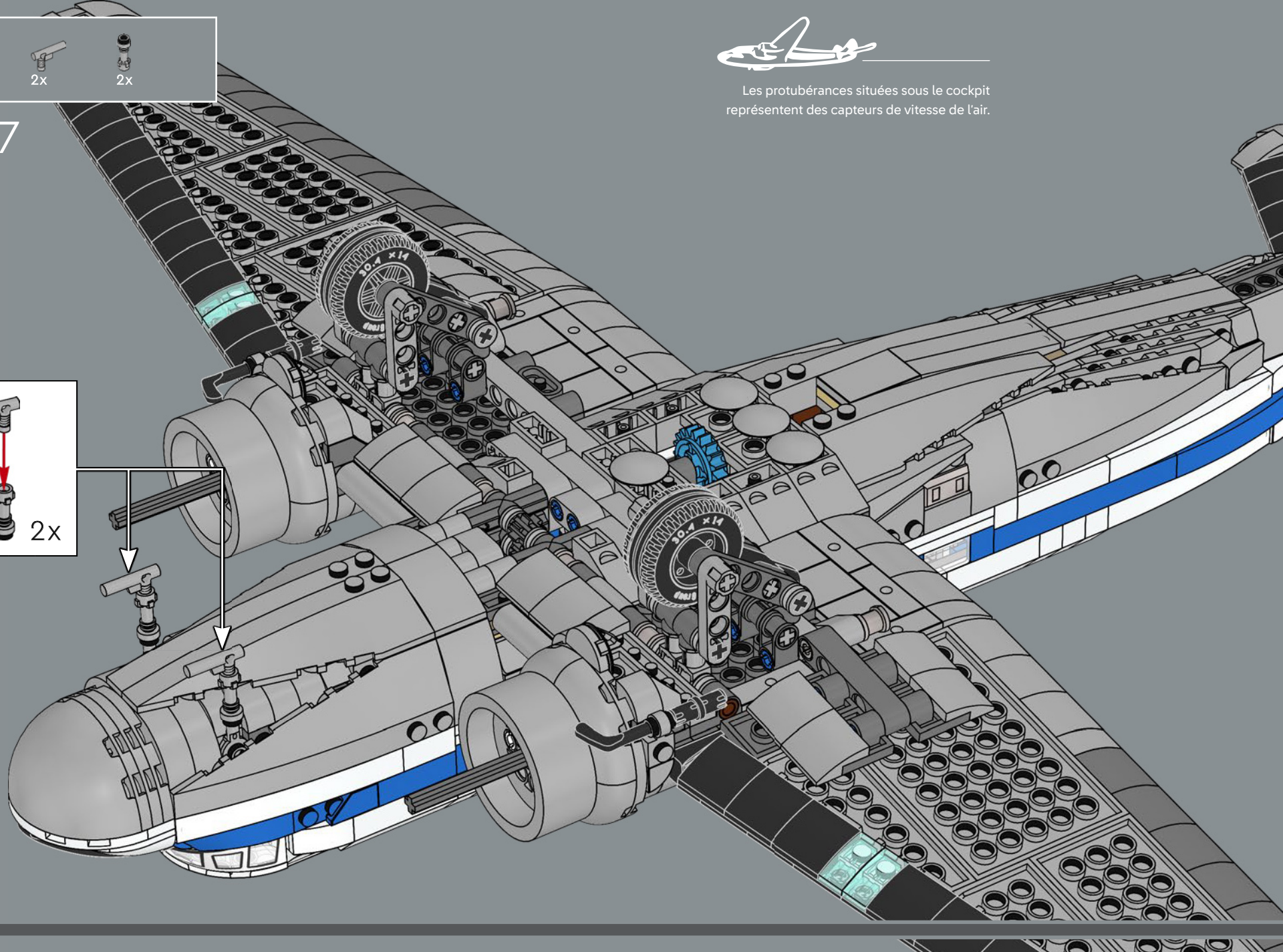
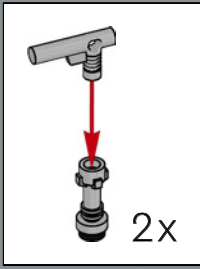

2x

468

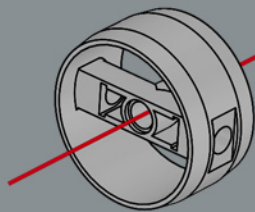

2x 2x



469

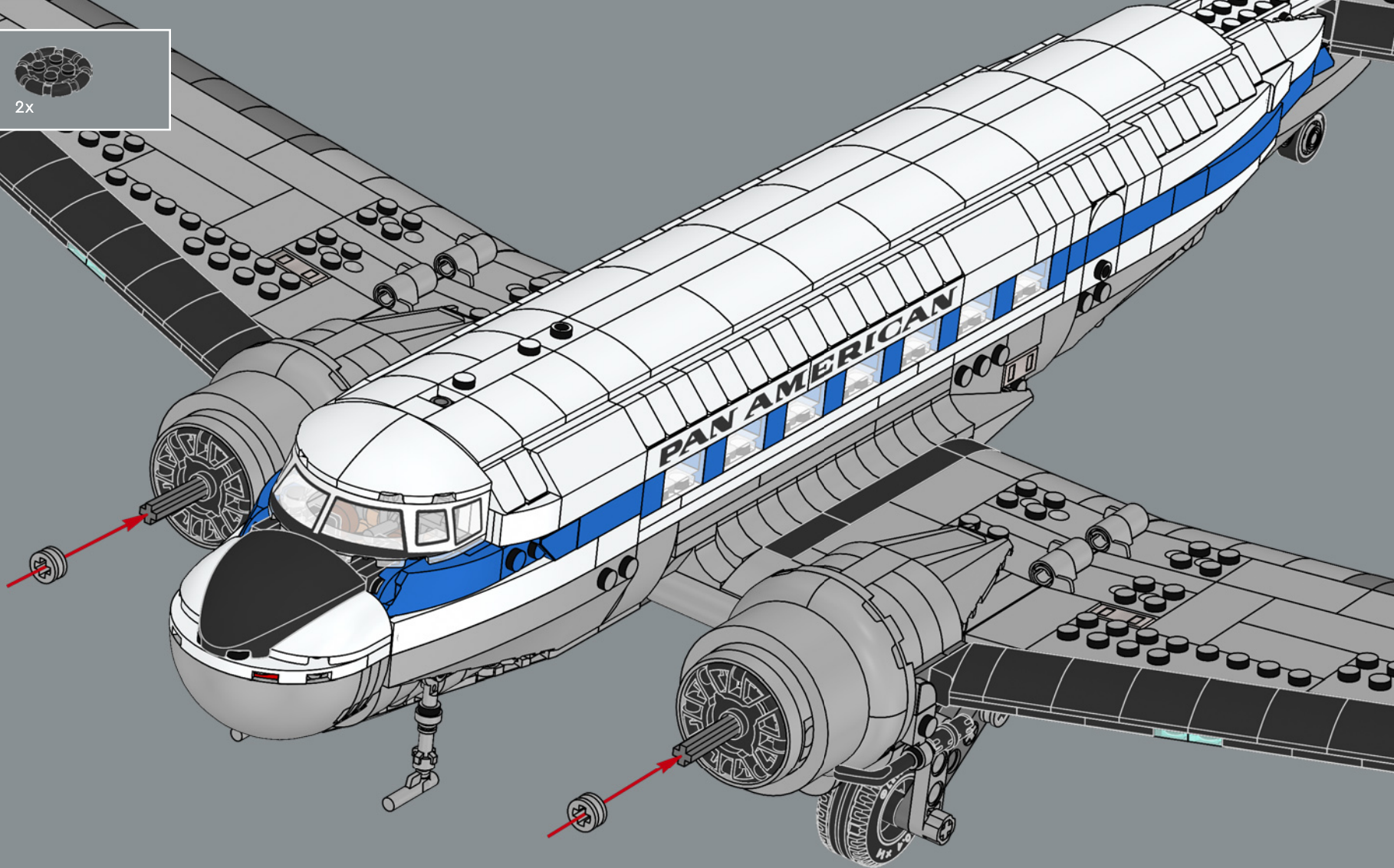

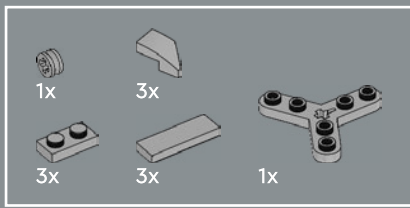

470

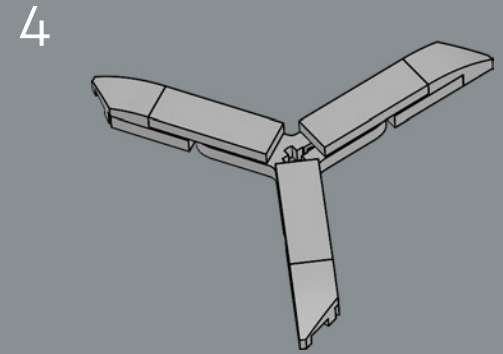
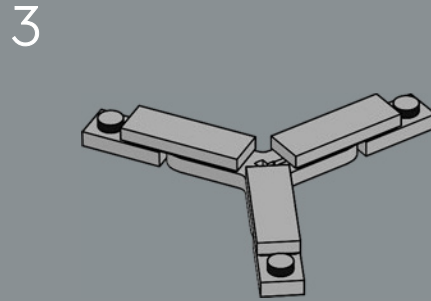
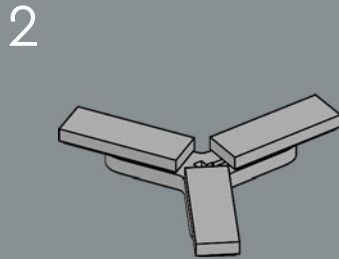
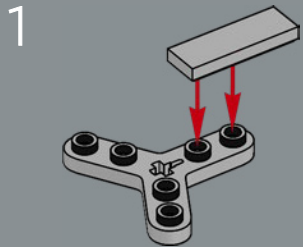

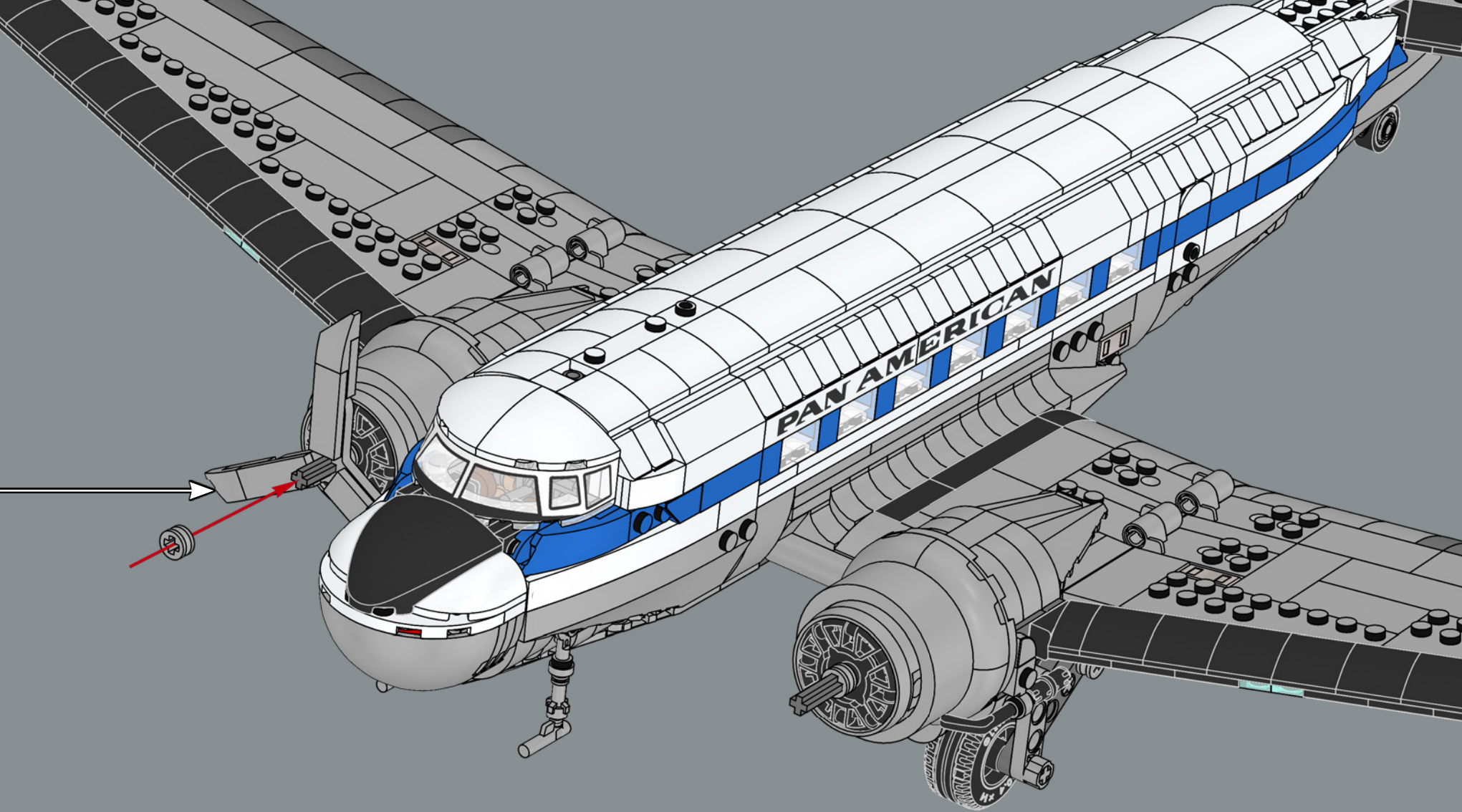

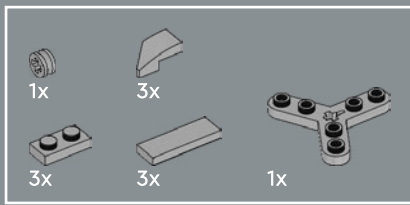

471

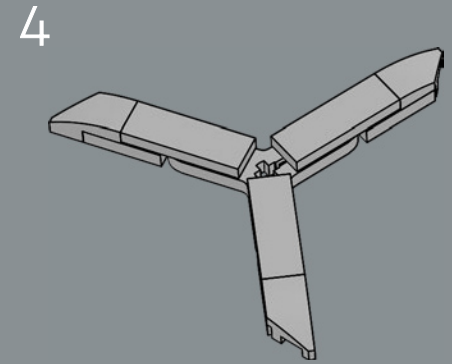
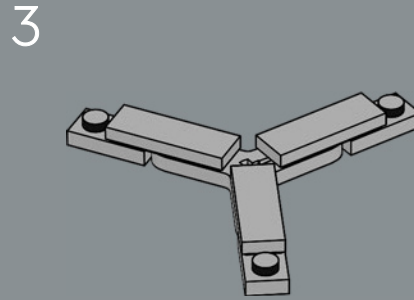
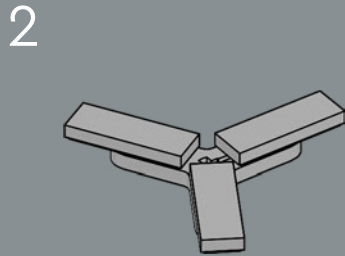
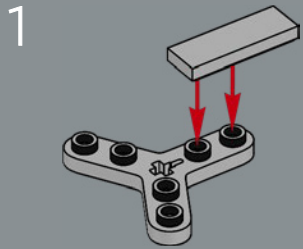

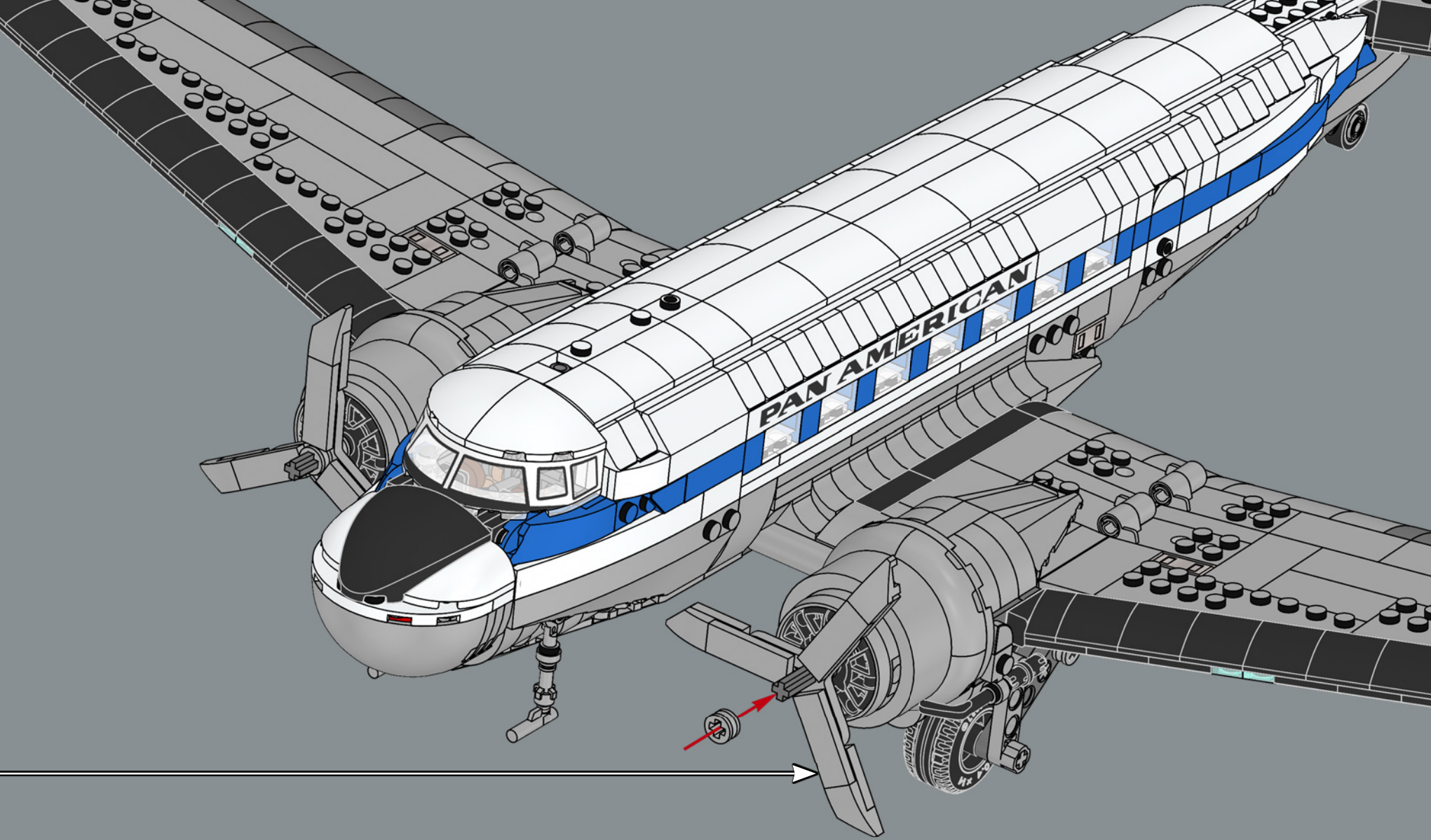



2x

472

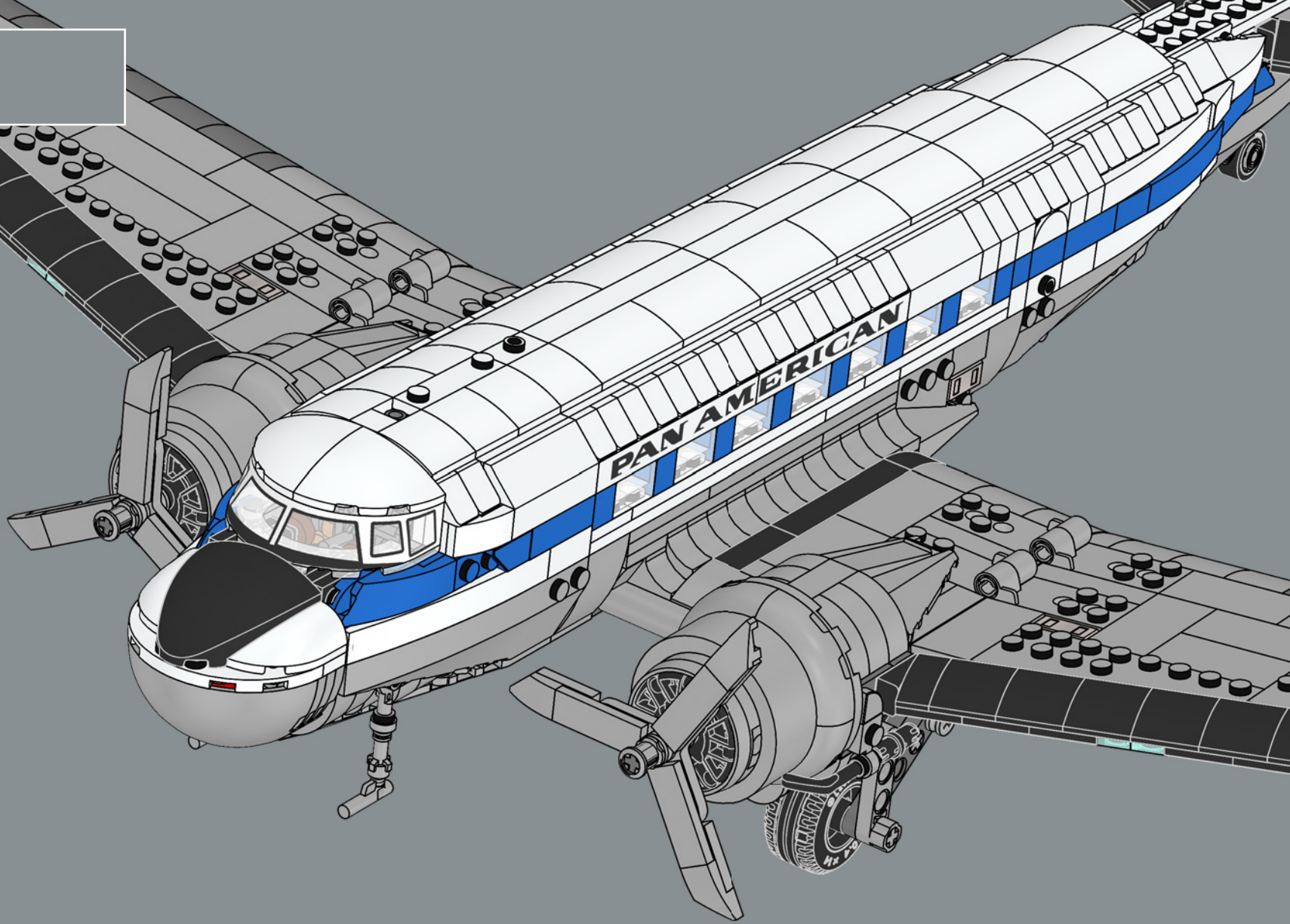

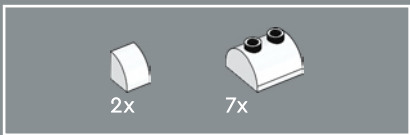

473

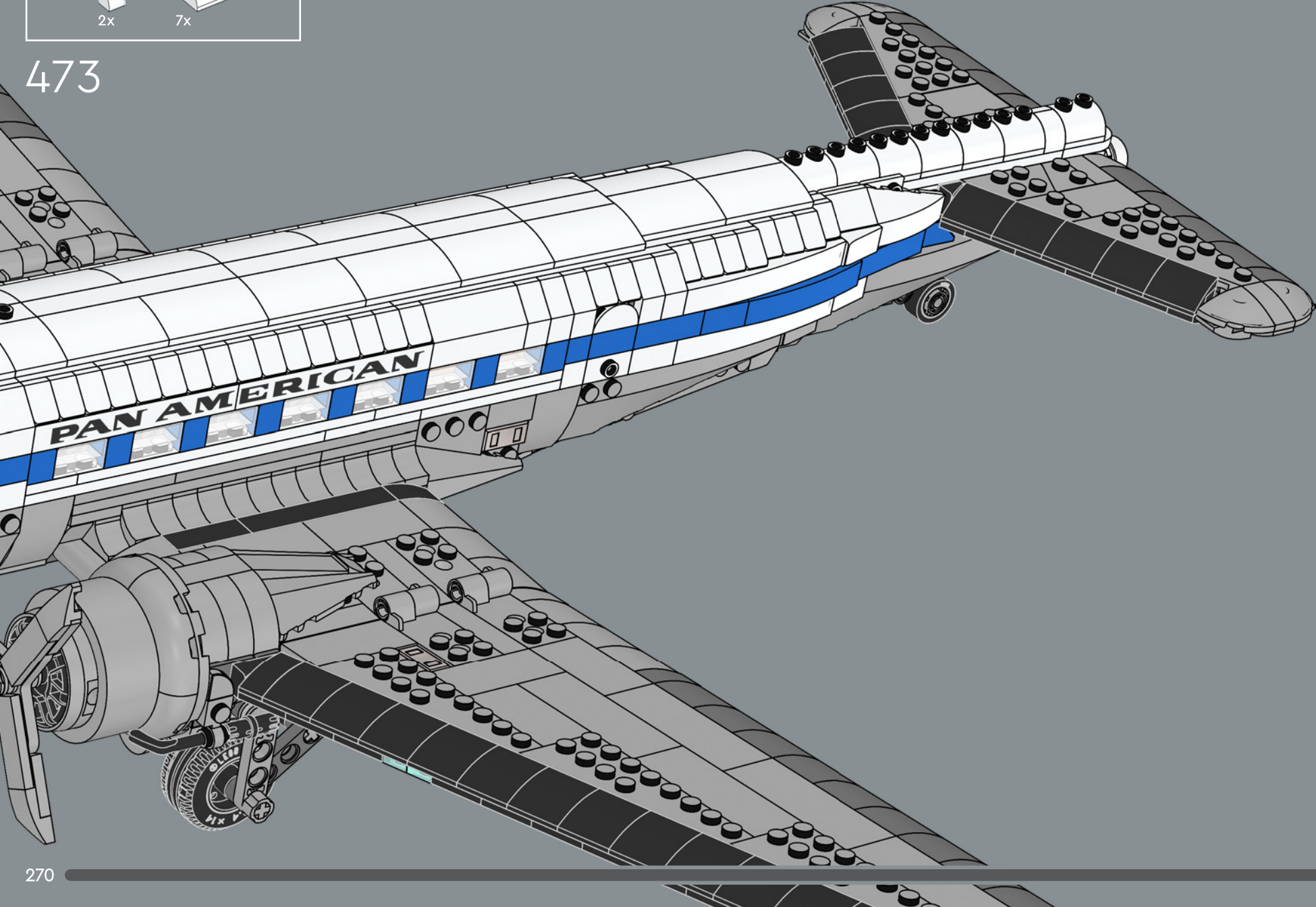

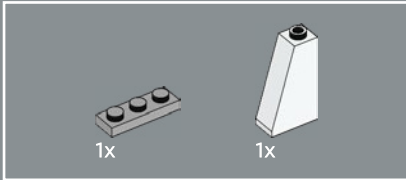
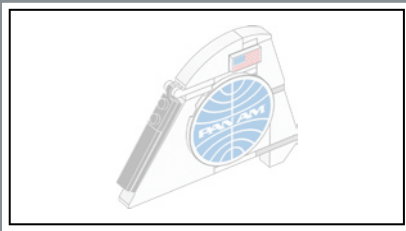

474

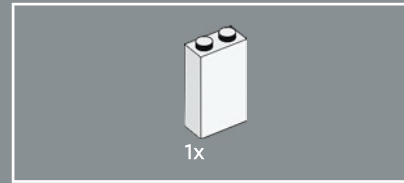
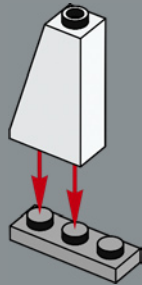

475

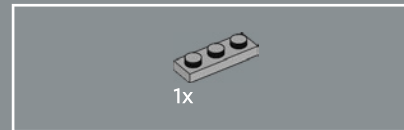
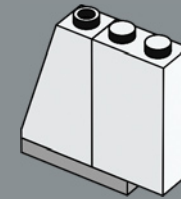

476

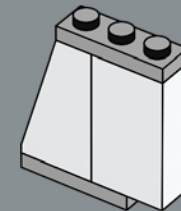

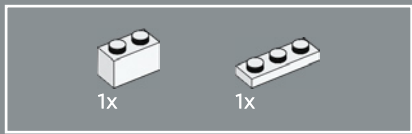

477

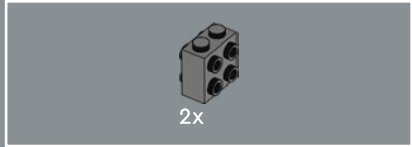
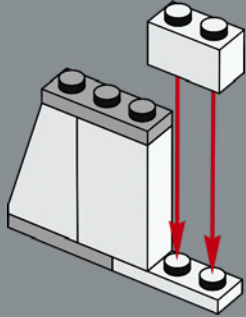

478

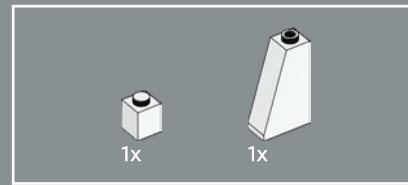
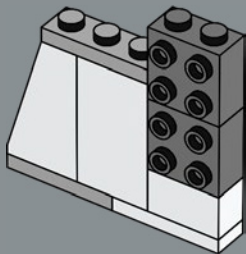

479

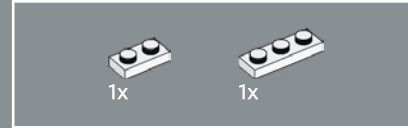
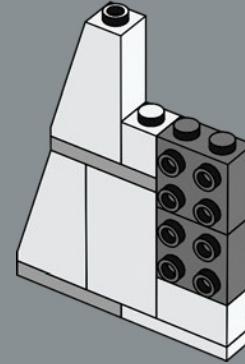

480

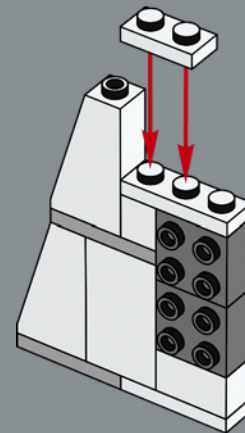

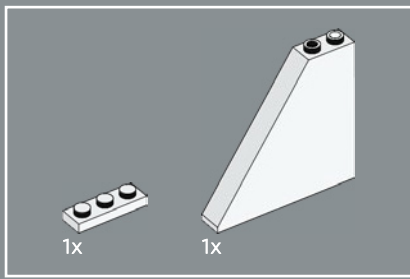

481

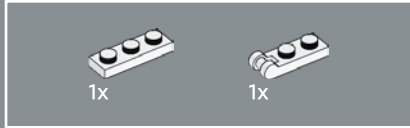
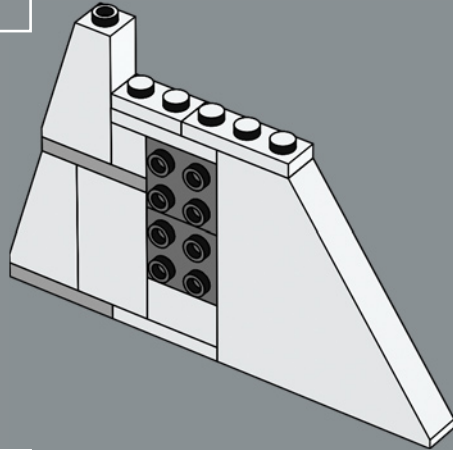

482

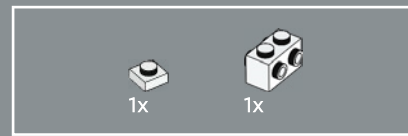
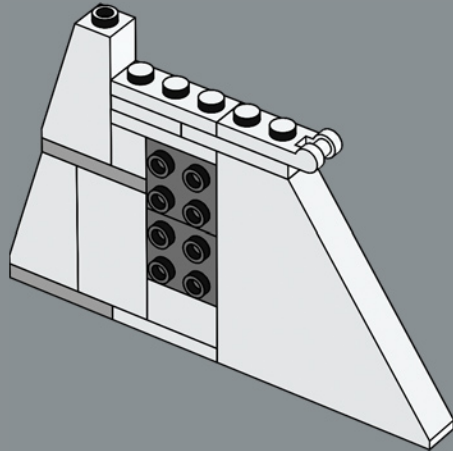

483

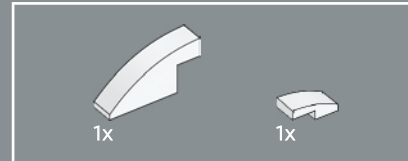
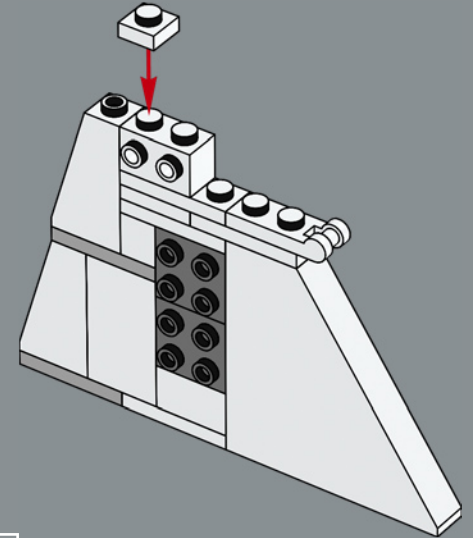

484

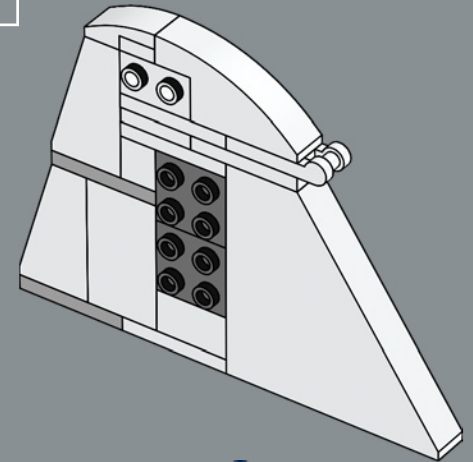

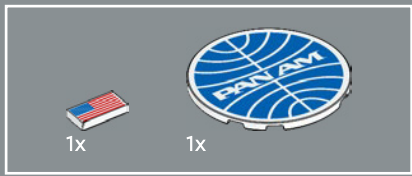

485

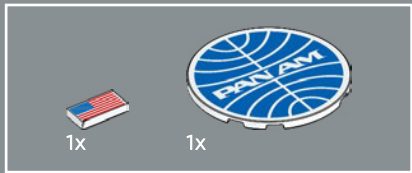
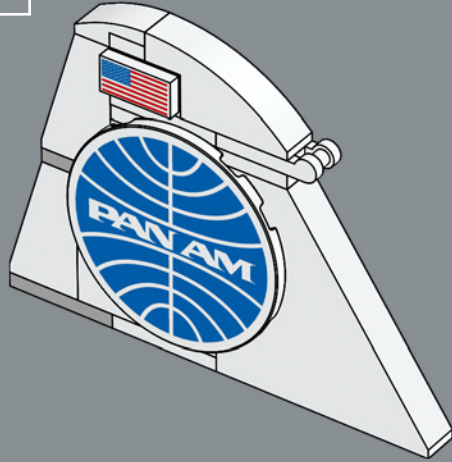

486

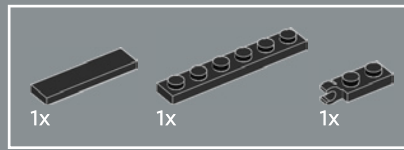
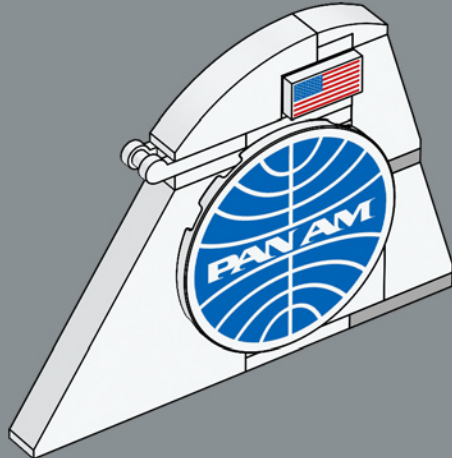

487

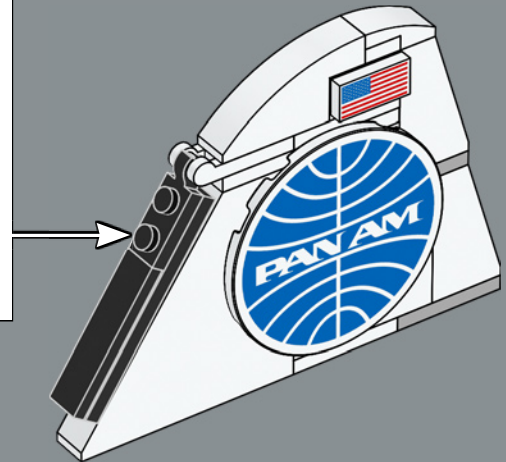
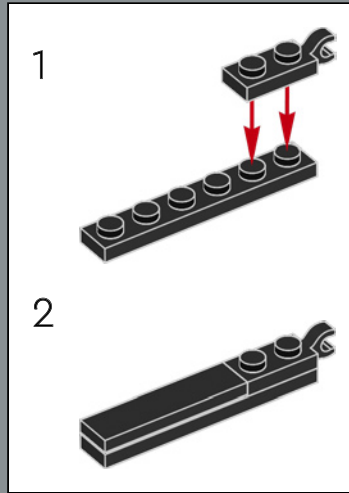



1x

488

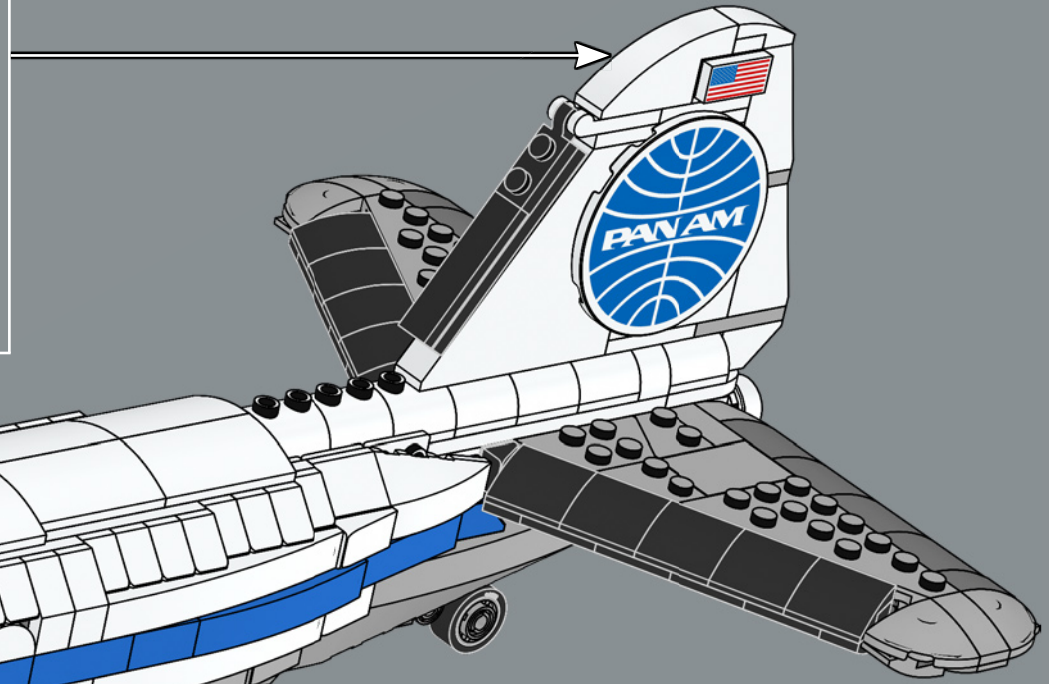
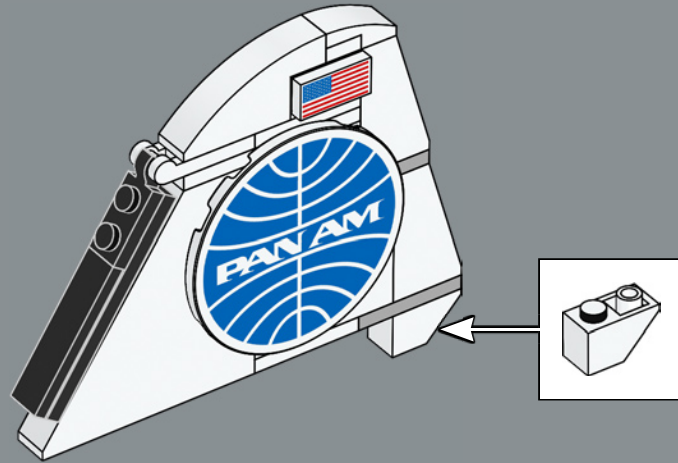

489

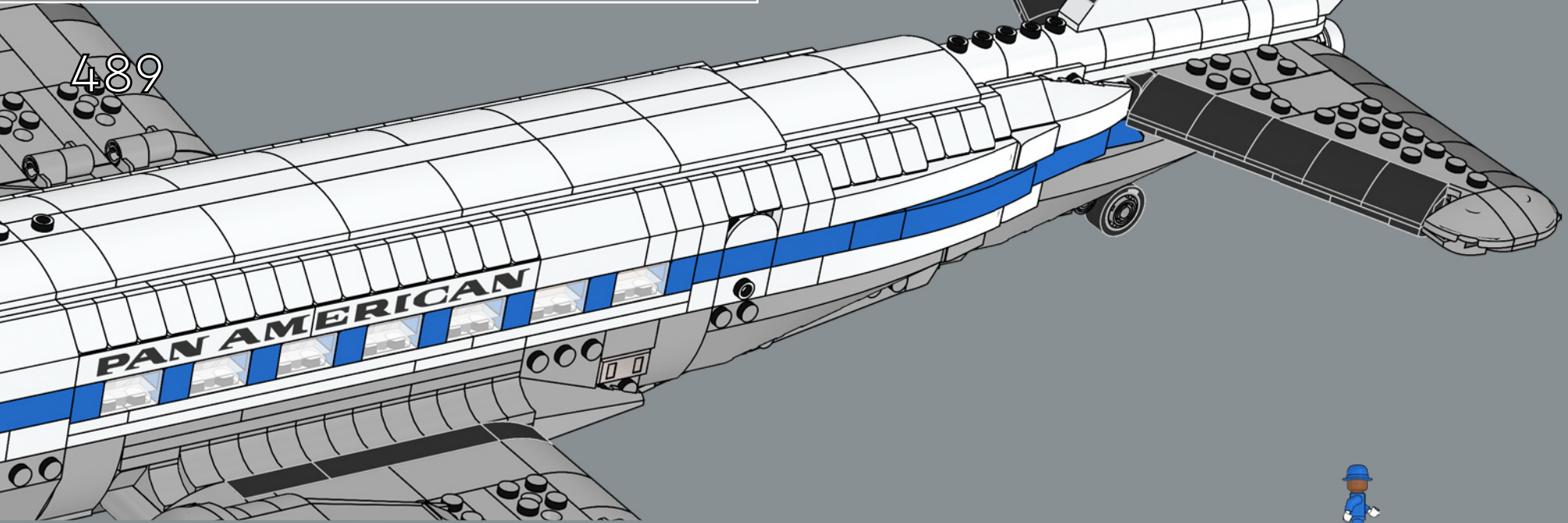

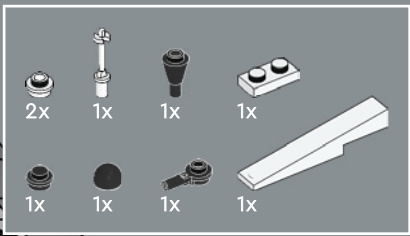

Le module noir correspond à l'Automatic Direction Finder (ADF), un instrument de radionavigation indiquant le relèvement relatif entre l'avion et une station radio appropriée.

490

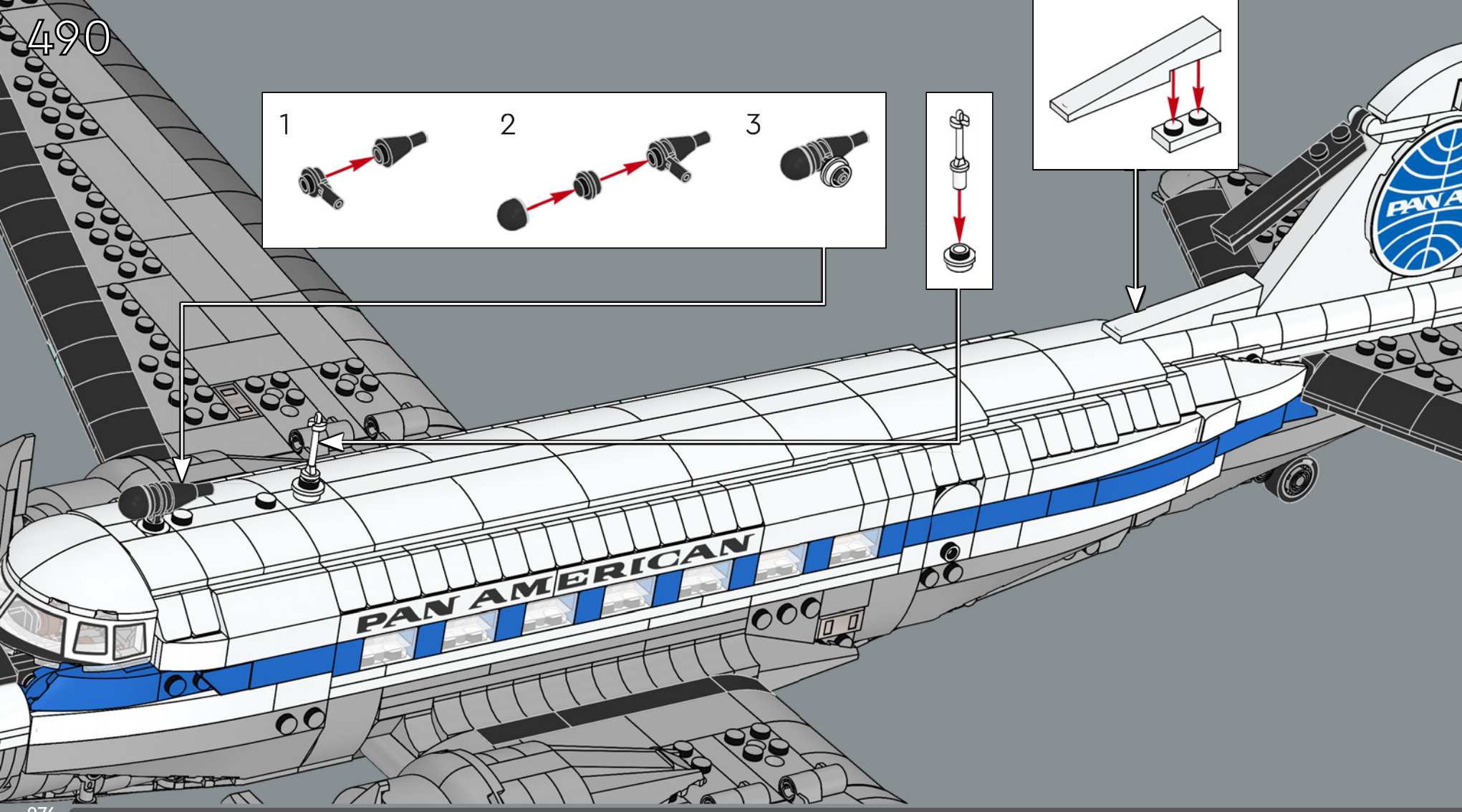
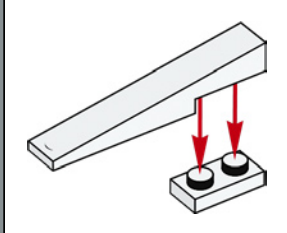
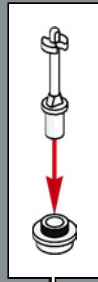
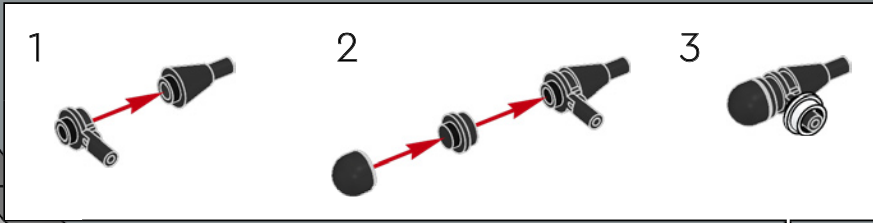

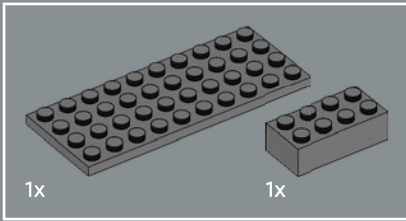
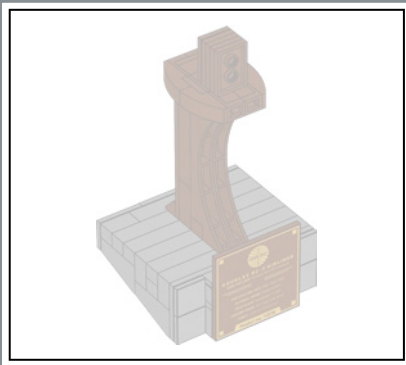

491

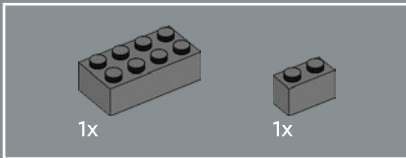
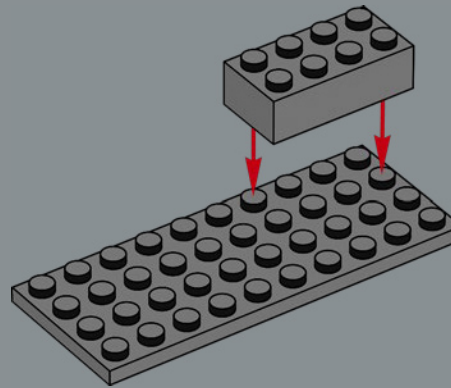

492

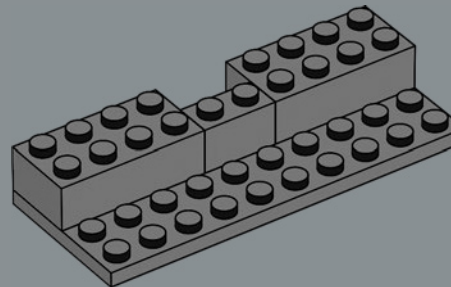

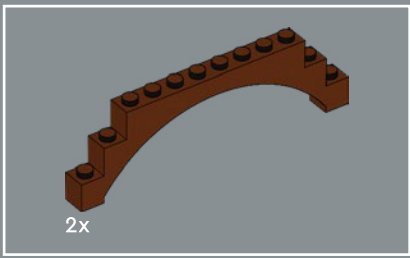

493

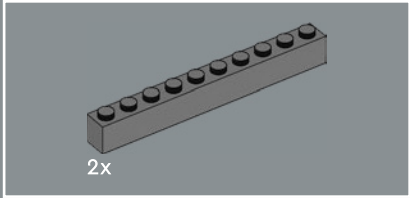
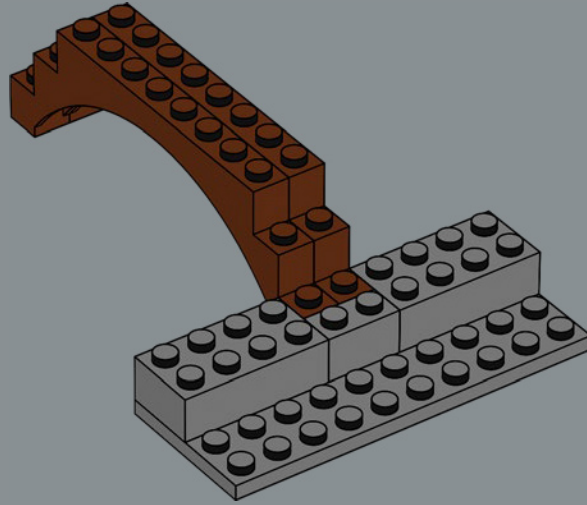

494

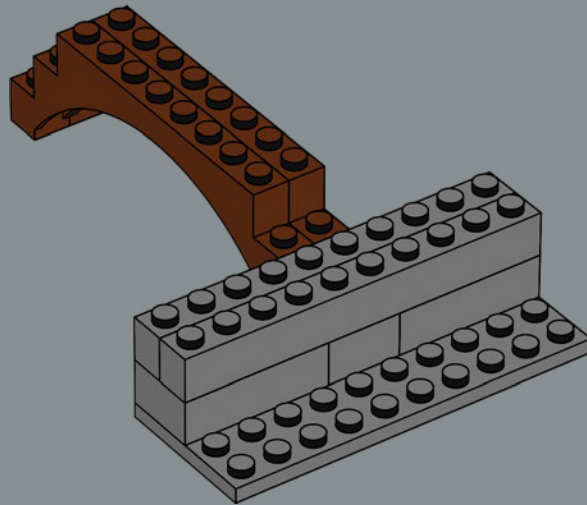

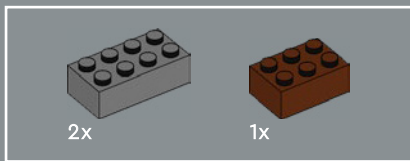

495

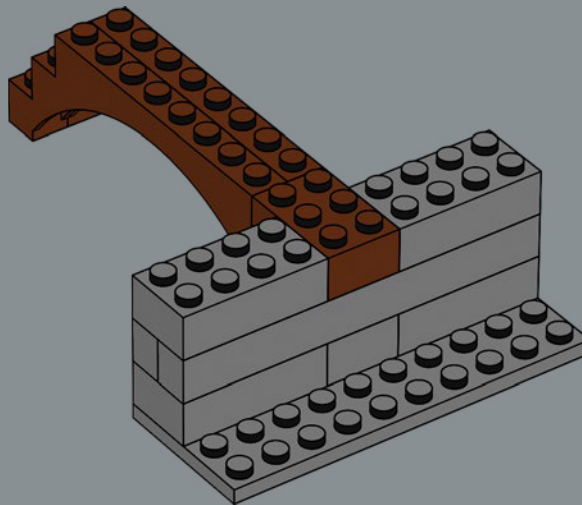

496

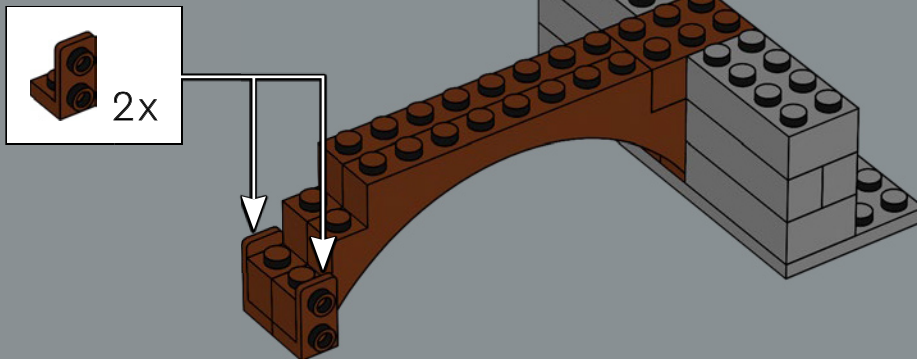

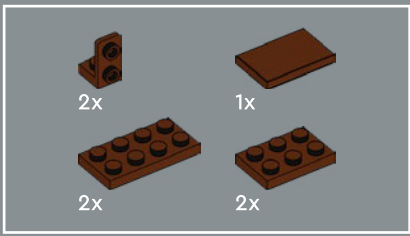

497

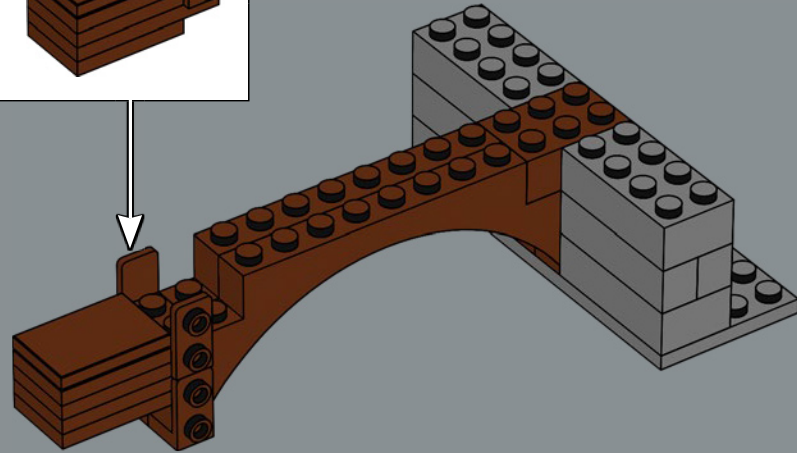
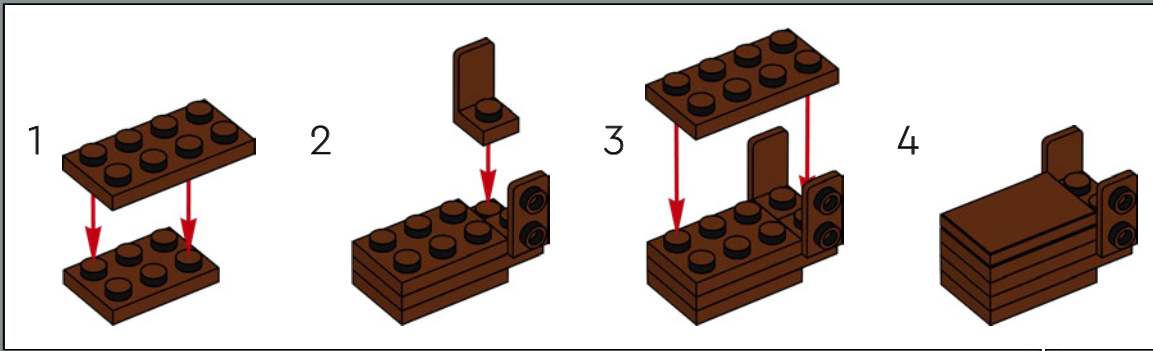

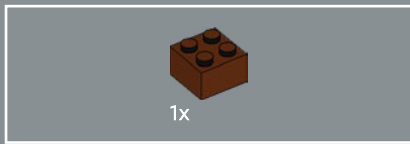

498

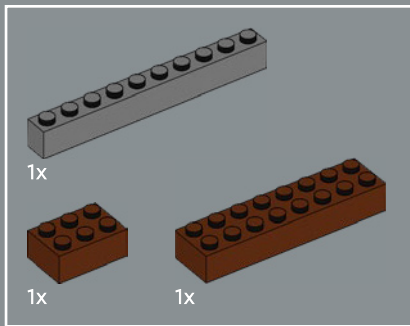
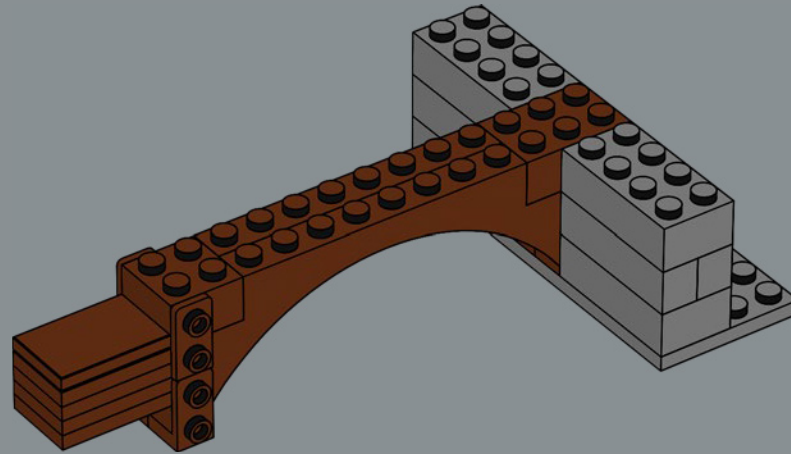

499

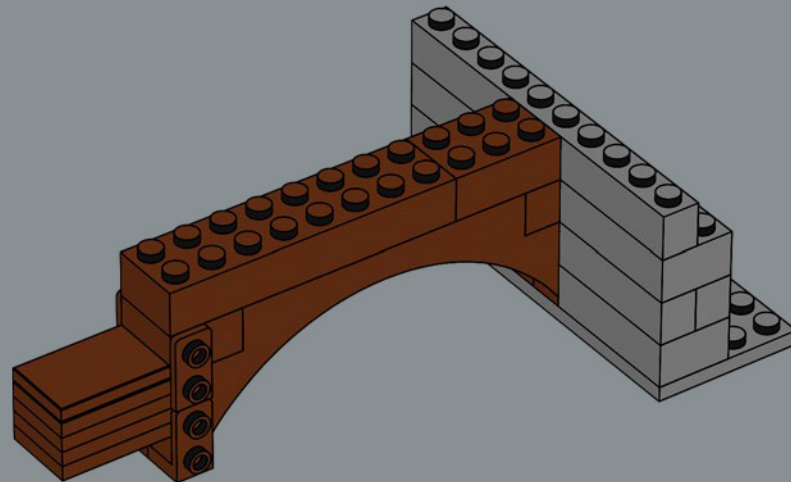

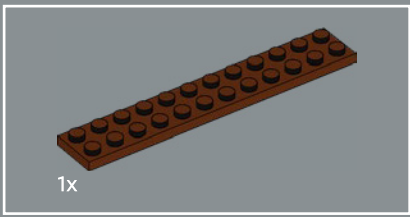

500

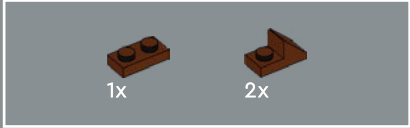
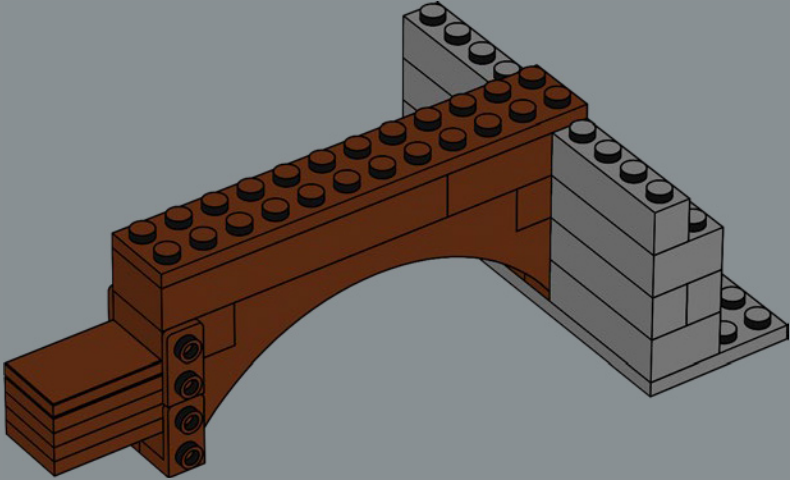

501

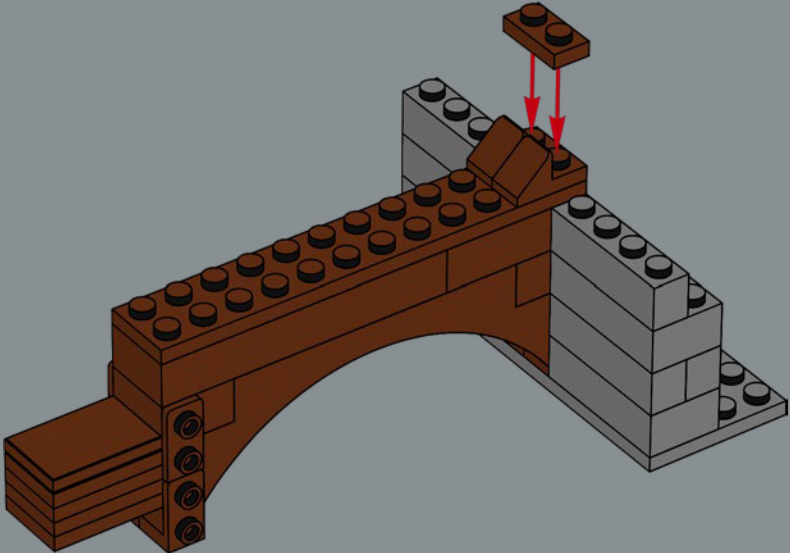



502

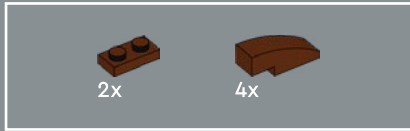
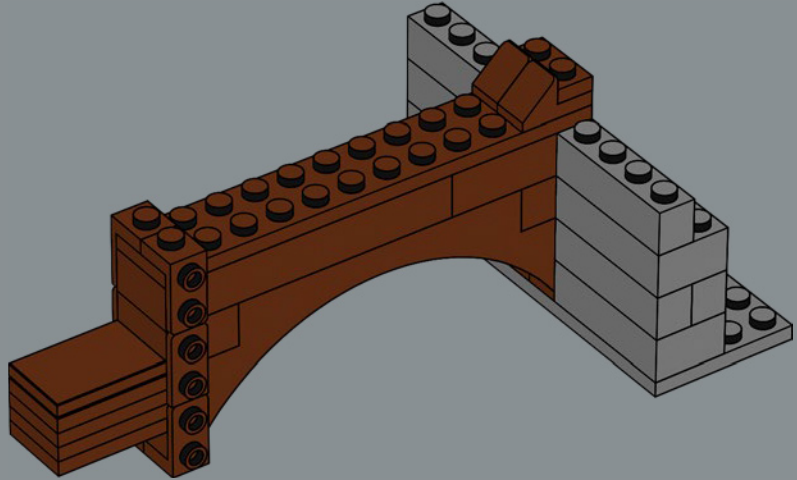

503

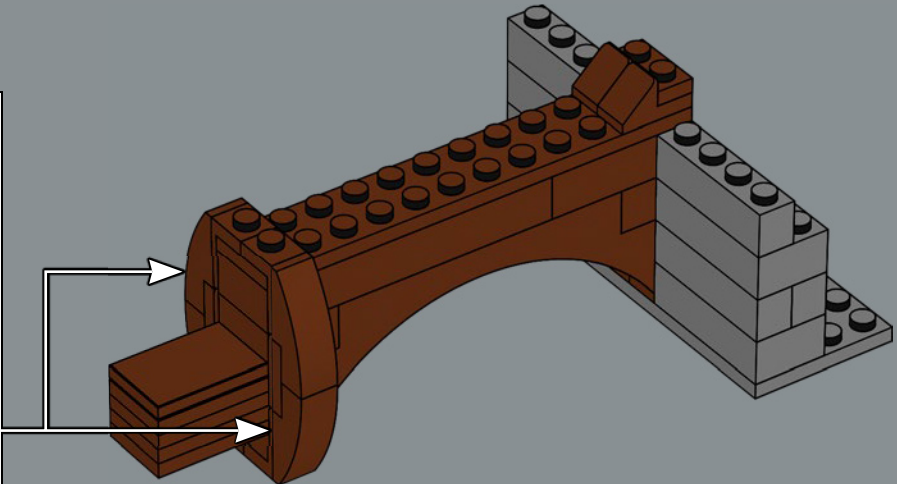
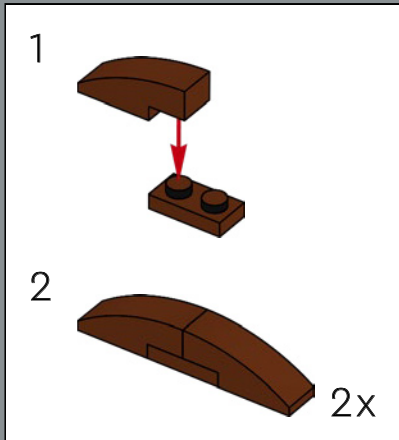



2x

504

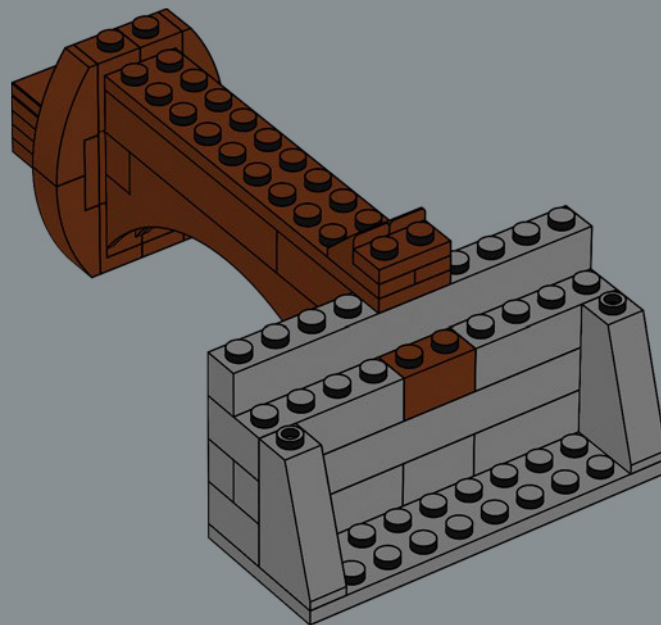

2x

505

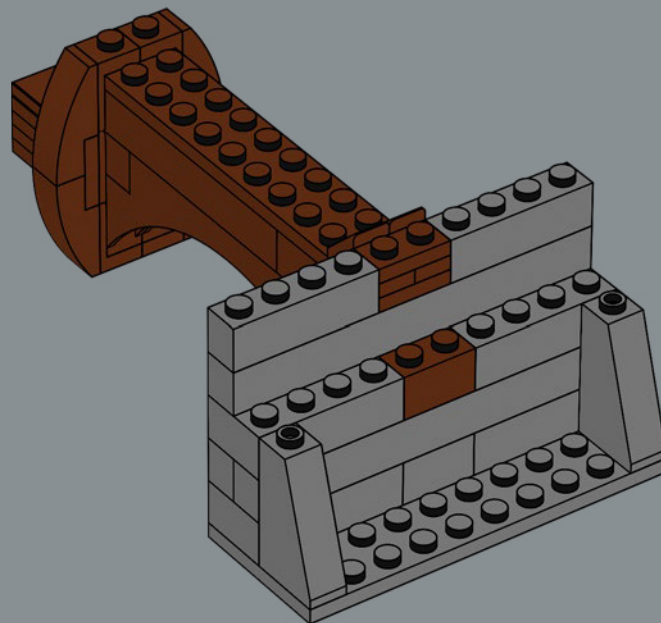

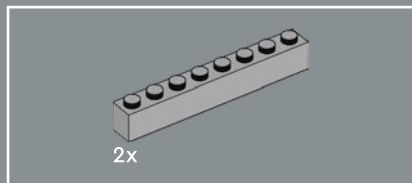

506

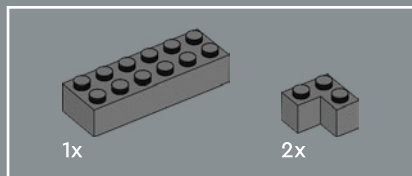
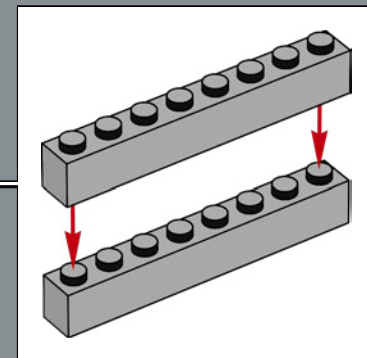
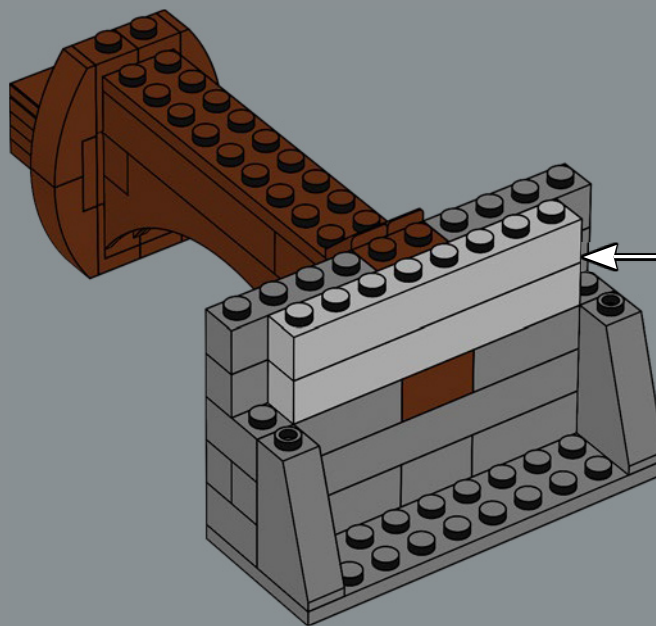

507

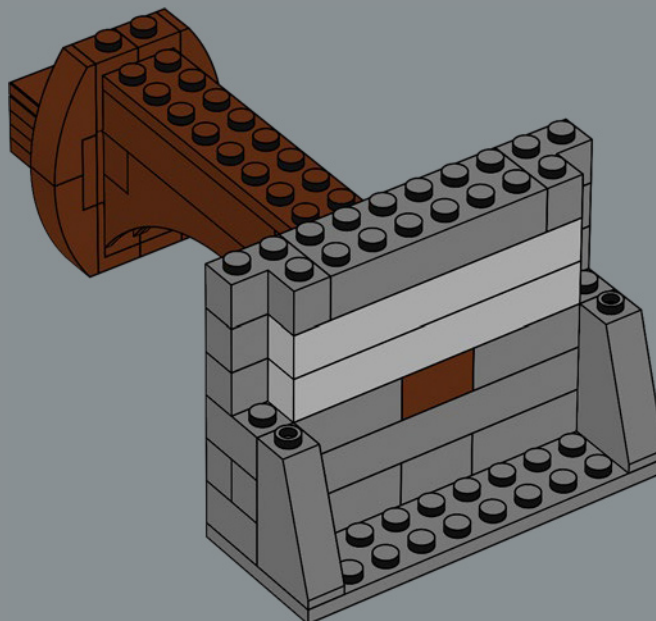

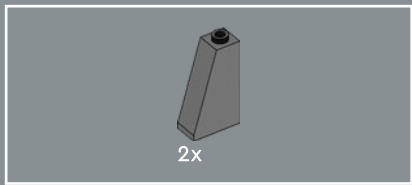

508

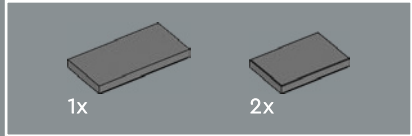
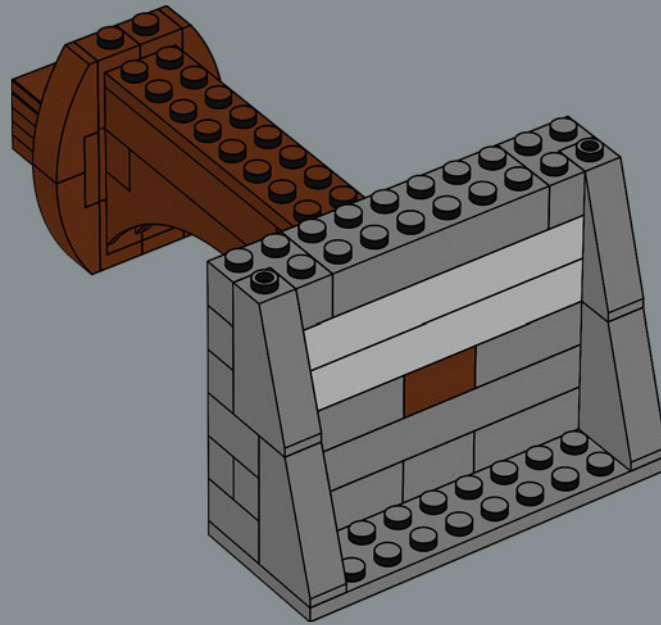

509

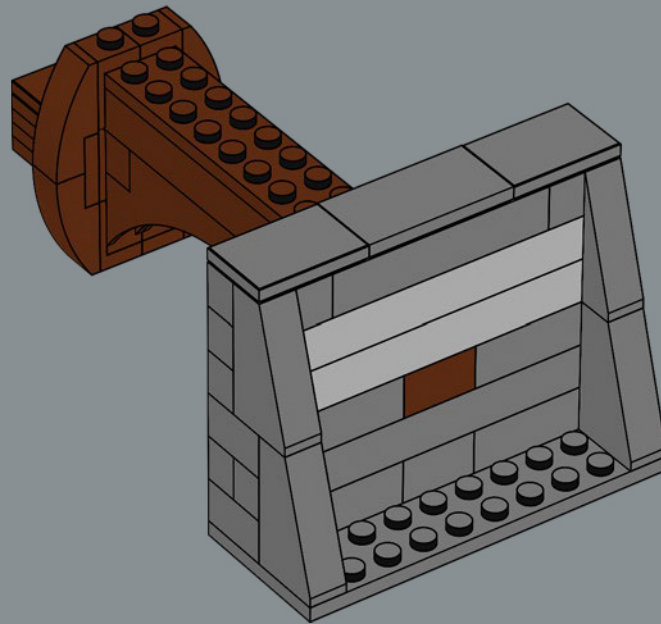



510

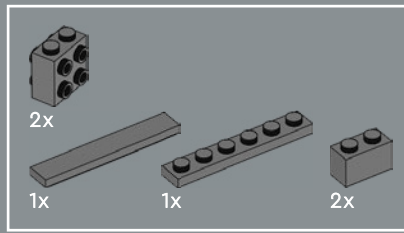
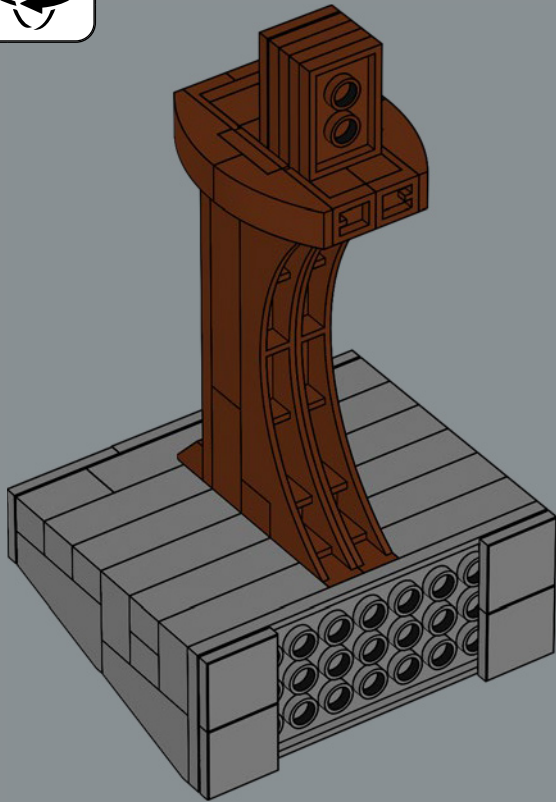

511

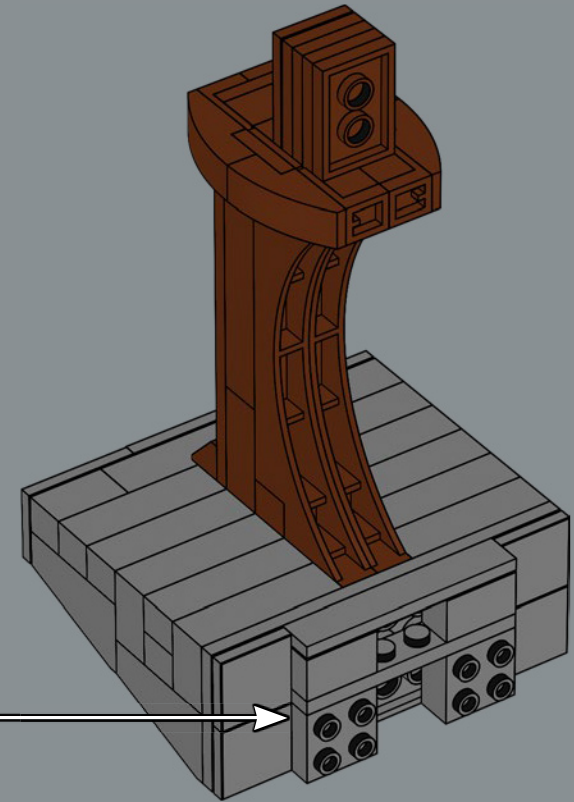
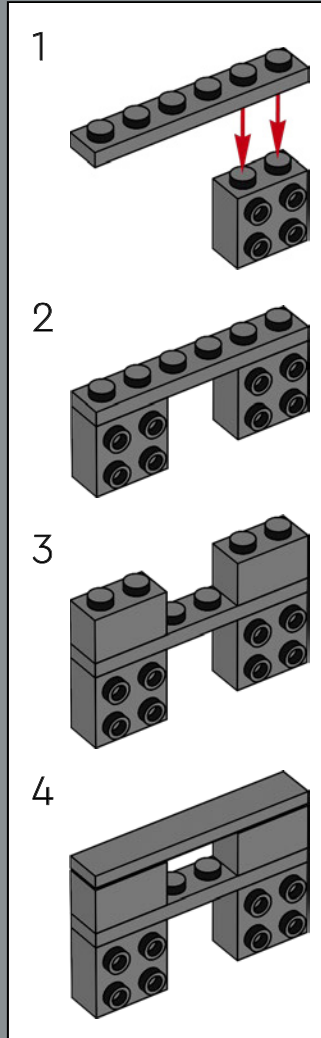



1x

512



513

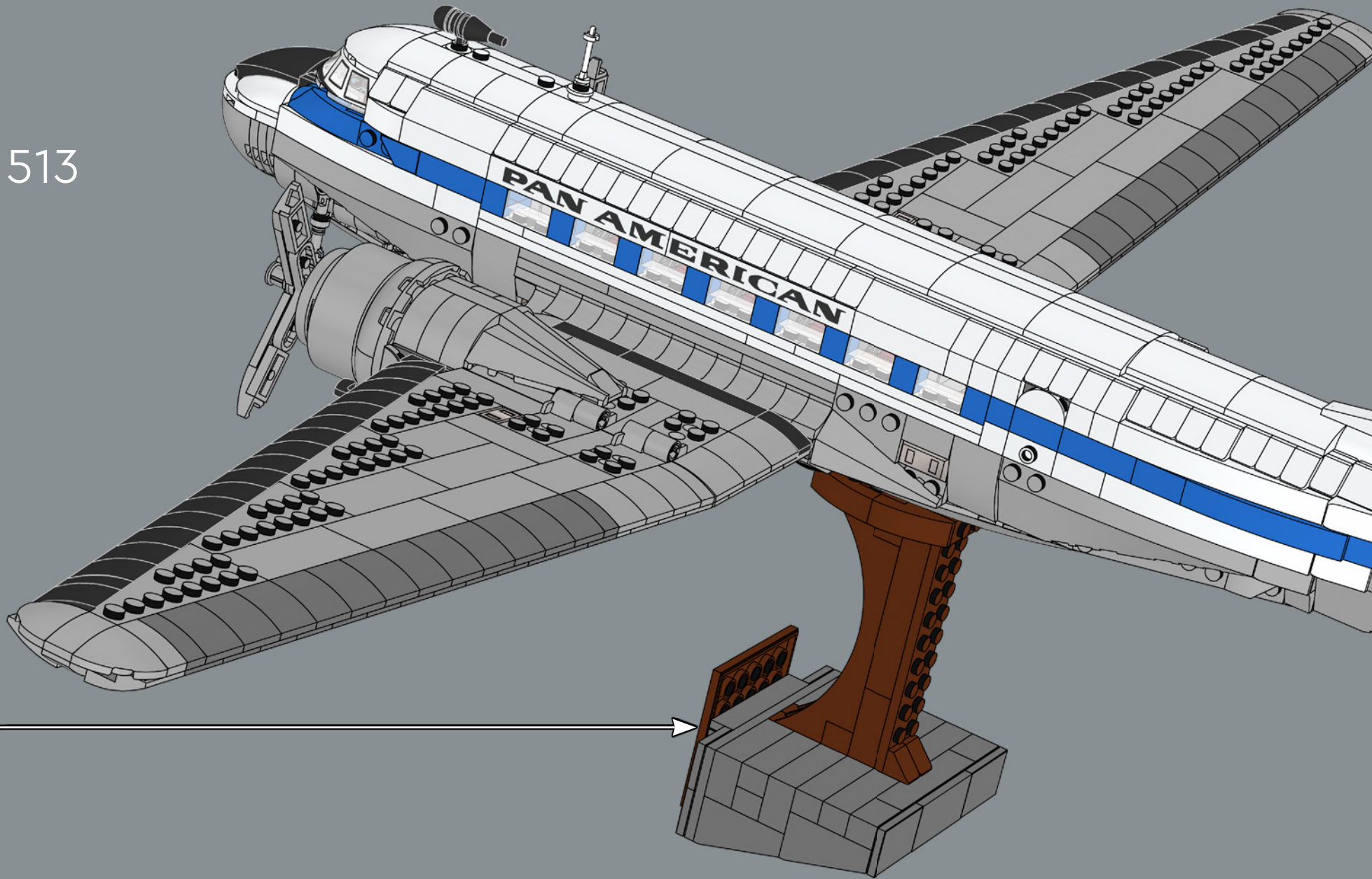

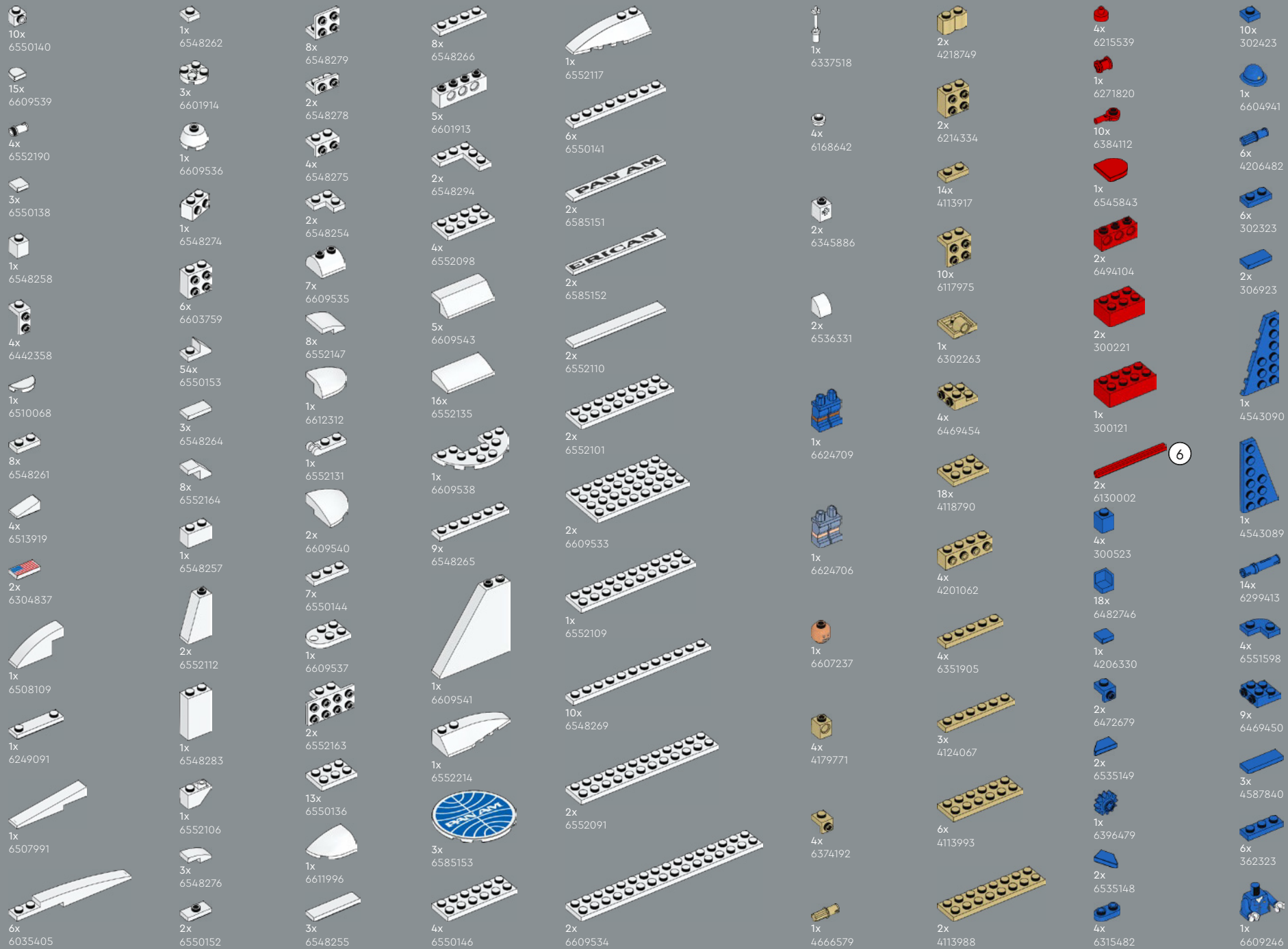

6

- 1x 6558857
- 1x 6558916
- 2x 371023
- 3x 301023
- 2x 6555137
- 6x 6307275
- 15x 302023
- 2x 300123
- 2x 6535145
- 2x 366623
- 2x 4243815
- 1x 416223
- 1x 303423
- 4x 654124
- 7x 6248971
- 2x 6206240
- 16x 242024
- 1x 6130007
- 5x 614126
- 1x 6538443
- 2x 6473449
- 2x 4558954
- 2x 4504382
- 2x 300526
- 2x 302426
- 2x 6299338
- 2x 6344752
- 1x 6585195
- 1x 6196548
- 1x 4246901
- 35x 6279875
- 1x 9339
- 4x 6147050
- 2x 6275806
- 2x 6138173
- 6x 6047276
- 2x 4541191
- 2x 302326
- 2x 6000650
- 2x 6325521
- 4x 6428168
- 1x 6336989
- 2x 6506201
- 40x 6053077
- 4x 302226
- 42x 6211476
- 2x 6109682
- 1x 6362991
- 2x 4558170
- 1x 6609279
- 2x 6537354
- 4x 370526
- 2x 6601610
- 1x 243126
- 1x 6597398
- 1x 366626
- 1x 6560654
- 2x 663626
- 2x 6161298
- 4x 273026
- 6x 383226
- 4x 6001494
- 4x 4569058
- 1x 6604940
- 14x 6514121
- 1x 6585145
- 4x 6508249
- 1x 6240515
- 1x 6486027
- 1x 6609230
- 39x 4528604
- 1x 4162916
- 1x 6609257
- 2x 6282619
- 10x 6092597
- 3x 4539097
- 2x 4585479
- 1x 4585751
- 1x 4583299
- 2x 6264030
- 5x 4539071
- 3x 4618986
- 1x 6604944
- 2x 6347304
- 2x 6365746
- 3x 6093494
- 4x 6208446
- 3x 4619636
- 6x 6287673
- 1x 6396480
- 1x 6423273
- 1x 6410056
- 1x 6404026
- 1x 6527824
- 1x 6508103
- 1x 6537328
- 3x 6177146
- 5x 6215606
- 2x 4539083
- 2x 6544174
- 15x 6138232
- 2x 6186673
- 4x 6341553
- 2x 6472546
- 2x 6223599
- 3x 4211150
- 2x 6075287
- 4x 6443654
- 1x 6551600
- 1x 4211210
- 4x 6135494
- 4x 6325975
- 4x 4211189

3

4

3



2x
4216668



1x
6311441



2x
4211186



2x
6159763

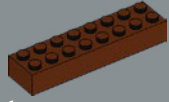

1x
6096701



1x
6609285

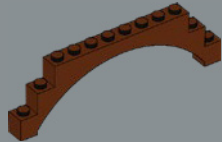

2x
6246843



1x
4225700



2x
4539481



21x
6271165



2x
6275844



1x
6296859



6x
4521921



2x
6253436



8x
4211399



2x
6176433



3x
6401023



1x
6335328



2x
6248078



7x
6225142



7x
6225139



1x
4211758



4x
6163478



4x
6163477



4x
6344702



2x
6510070



2x
6510070



4x
6344703



2x
6227897



1x
4211791



1x
4211794



8x
6294038



2x
6296894



2x
4514195



6x
6134378



26x
6396791



16x
6144138



16x
6548933



6x
4593679



12x
6539831



6x
6529502



1x
6185471



6x
4211862



8x
6028813



4x
6380605



2x
6280396



2x
6173127



9x
4211414



19x
6066097



2x
6493586



4x
4211541



26x
6396791



2x
6134378



16x
6144138



16x
6548933



6x
4593679



12x
6539831



6x
6529502



1x
6185471



6x
4211862



8x
6028813



4x
6380605



2x
6280396



6x
4654582



1x
6265742



14x
4211353



1x
6065824



8x
4211397



6x
632886



14x
6102357



2x
4211387



26x
6396791



2x
6185676



2x
4211881



4x
4211815



2x
4211655



8x
4211429



8x
6251044



2x
4211489



6x
4211361



8x
4558169



2x
6262083



2x
6262082



8x
6456718



2x
4507056



6x
6132207



7x
4211396



6x
6435930



4x
6171894



2x
6271831



4x
6331574



4x
6257593



4x
4211445



1x
4211394



7x
4211356



2x
6402876



4x
6558989



1x
4622803



21x
6015347



2x
4507052



3x
6493587



12x
4560183



8x
6258903



4x
4211395



2x
6307999



3x
4211639



2x
6372029



3x
6493589



2x
6303442



3x
6132983



1x
6597400



1x
6597400



1x
6597400



1x
6597400



1x
6597400



1x
6597400



1x
6597400



1x
6597400



1x
6597400



1x
6597400



1x
6597400

5

3

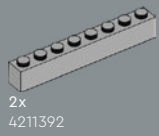

2x
4211392

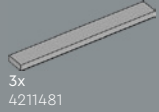

3x
4211481



8x
6448327



4x
4211406

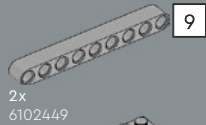

9



8x
6448326



5x
4505088

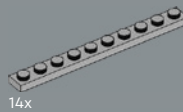

14x
4251149



LEGO.com/service

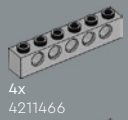

4x
4211466



2x
6508016



2x
6015349

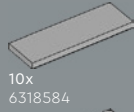

10x
6318584

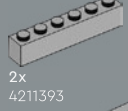

2x
4211393



5x
4505087

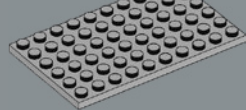

4x
4211405



2x
4211095



2x
4211443



1x
4211486



2x
6510131



1x
6510213



15x
6360111



2x
6221607



4x
6338422



2x
4521512



6x
6261374



1x
4567887



3x
6005331



4x
6135014



10x
6514456



1x
4516546



3x
4211088

4x
4221745



1x
6342558



6x
6396058



1x
4211066



2x
6215212



6x
6029948



2x
6000606



1x
6271356



2x
6543014



1x
4529728



1x
4529727



4x
6013082



2x
4211109



33x
6071261



7x
4211094



12x
6047417



34x
6344820



15x
4521187



1x
4552349



4x
6271876



14x
4211133



2x
6187008



3x
4211105



4x
4211043



1x
6083620



2x
4211103



10x
4211001

4x
6215176



4x
6395635



2x
6631413

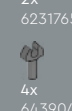

2x
6231765



4x
6439040



4x
6100030



4x
4211085



1x
4560184



2x
4210686



1x
4211056



1x
4210651



5x
4243831



1x
4210875



4x
4211002

2x
4499858



12x
4210719



2x
6225494



2x
6510145

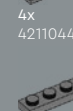

4x
4211044

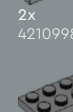

2x
4210998

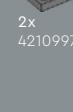

2x
4210997



1x
4257526



3x
4211107



2x
4210678



9x
6133611



1x
4211122



1x
4211114



2x
4211114

5

4

8



YOU COULD WIN



YOU COULD WIN

Your feedback will help shape the future development of this product series.

Visit:

DU KÖNNTEST GEWINNEN

Dein Feedback trägt zur Weiterentwicklung dieser Produktreihe bei.

Geh auf:

VOUS POURRIEZ GAGNER

Vos commentaires nous aideront à concevoir les futurs produits de cette gamme.

Visitez :

POTRESTI VINCERE TU

La tua opinione ci aiuterà a migliorare la creazione futura di questa linea di prodotti.

Visita:

PUEDES GANAR

Tu opinión contribuirá al futuro de esta serie de productos.

Visita:

轻松获奖

您的反馈将有助于我们在今后改进本产品系列。

请访问:

LEGO.com/productfeedback

You also have the chance to win a LEGO® set.

Terms and conditions apply.*

Außerdem hast du die Chance, ein LEGO® Set zu gewinnen.

Es gelten die Teilnahmebedingungen.*

Vous pourriez également gagner un ensemble LEGO®.

Des conditions s'appliquent.*

Hai anche la possibilità di vincere un set LEGO®.

Termini e condizioni sono applicabili.*

También tienes la oportunidad de ganar un set LEGO®.

Aplican términos y condiciones.*

您还有机会赢取乐高®套装。

条款和条件适用。*

*LEGO.com/productfeedback-terms



LEGO and the LEGO logo are trademarks of the LEGO Group. ©2026 The LEGO Group.

Produced under license from The Boeing Company. BOEING, DOUGLAS and DC-3 and the distinctive Boeing logos, product markings and trade dress are trademarks of The Boeing Company.
™ All related logos, characters, names, and distinctive likenesses thereof are the exclusive property of Pan American World Airways, LLC. Used under authorization.