

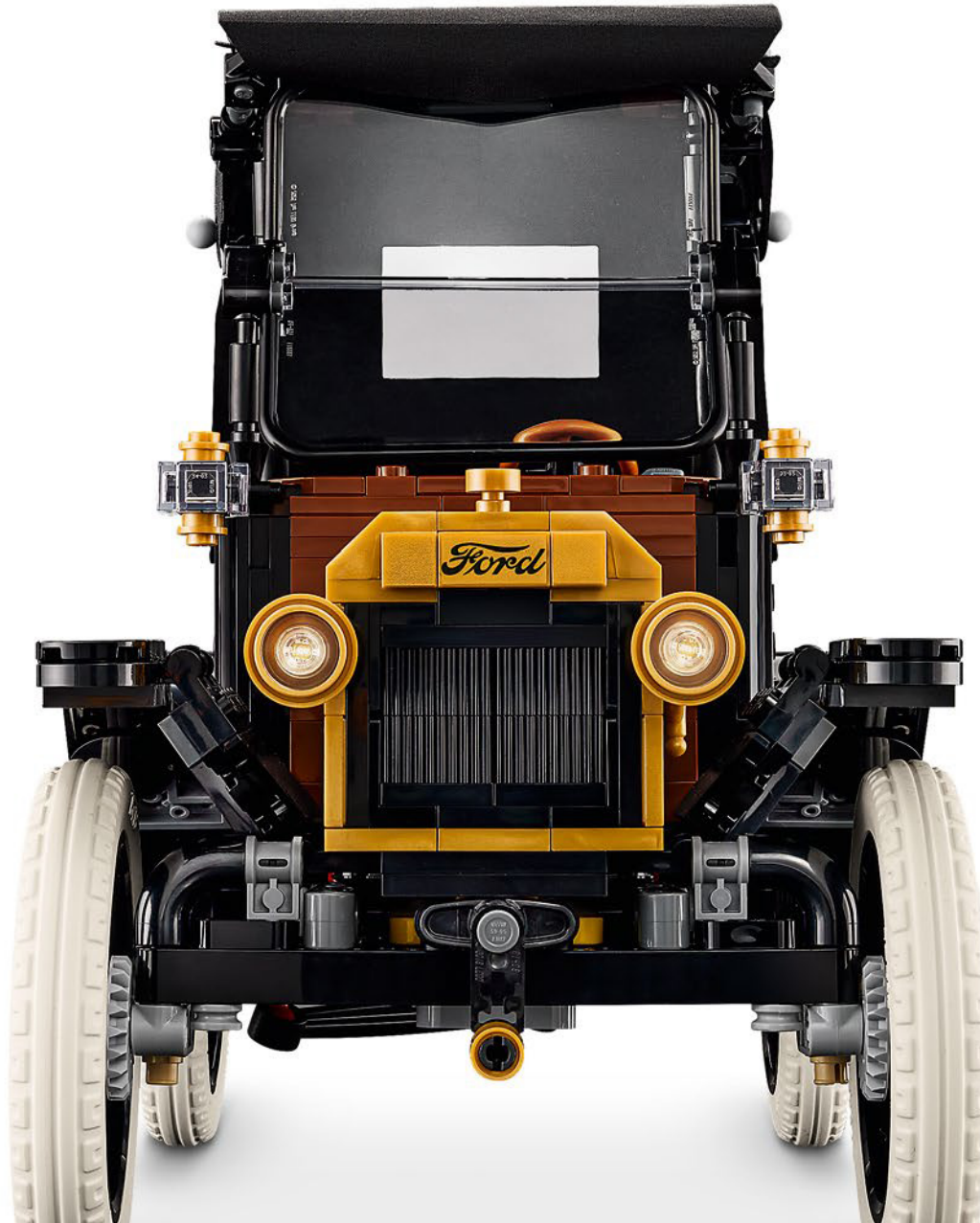

11376





LEGO.com/sustainable-packaging



FR
**DONNEZ
OU
RECYCLEZ**



ASSOCIATION

OU



MAGASIN

OU



DÉCHÈTERIE

Adresses sur quefairedemesdechets.fr



BUILDER



Apple and the Apple logo are trademarks of Apple Inc., registered in the U.S. and other countries and regions. App Store is a service mark of Apple Inc. Google Play and the Google Play logo are trademarks of Google LLC. Tencent and the Tencent logo are trademarks of Tencent Inc.

LEGO.com/devicecheck



LEGO® Builder

L'AUTO UNIVERSALE

Prima del 1° ottobre 1908, nonostante le automobili esistessero già da un paio di decenni, le carrozze trainate da cavalli dominavano ancora le strade. Le automobili erano un lusso riservato a pochi. Fino a quando non arrivò la Ford Motor Company. La sua visione: costruire un'auto per la gente. La Ford® Model T® non era solo robusta e confortevole (secondo gli standard dell'epoca), ma rappresentava anche un veicolo accessibile che rivoluzionò i trasporti e la produzione moderna. Per dimostrare le capacità e la versatilità dell'auto, questa fu sottoposta a test estenuanti che spaziavano da una battuta di caccia in montagna fino all'impresa di guidarla addirittura sulle scale del Campidoglio del Tennessee! Costruita presso lo stabilimento Ford di Highland Park, sulla prima linea di montaggio mobile, la Model T fu prodotta con grande efficienza; inizialmente venduta a \$850 nel 1908, grazie ai continui miglioramenti della catena di assemblaggio, il prezzo scese progressivamente fino a raggiungere i \$250. Innovativa per l'epoca, montava componenti in vanadio, aveva il volante sul lato sinistro, un cambio estremamente fluido, parabrezza, motore compatto e persino una cassetta degli attrezzi. Dai piccoli centri rurali ai sentieri più impervi, fino alle autostrade urbane, la Model T conquistò le strade americane e, poco dopo, quelle di tutto il mondo. Con oltre 15 milioni di esemplari venduti fino al 1927, la Model T non solo ha fatto la storia, ma l'ha accelerata, rendendo la mobilità accessibile a tutti.

* * * *



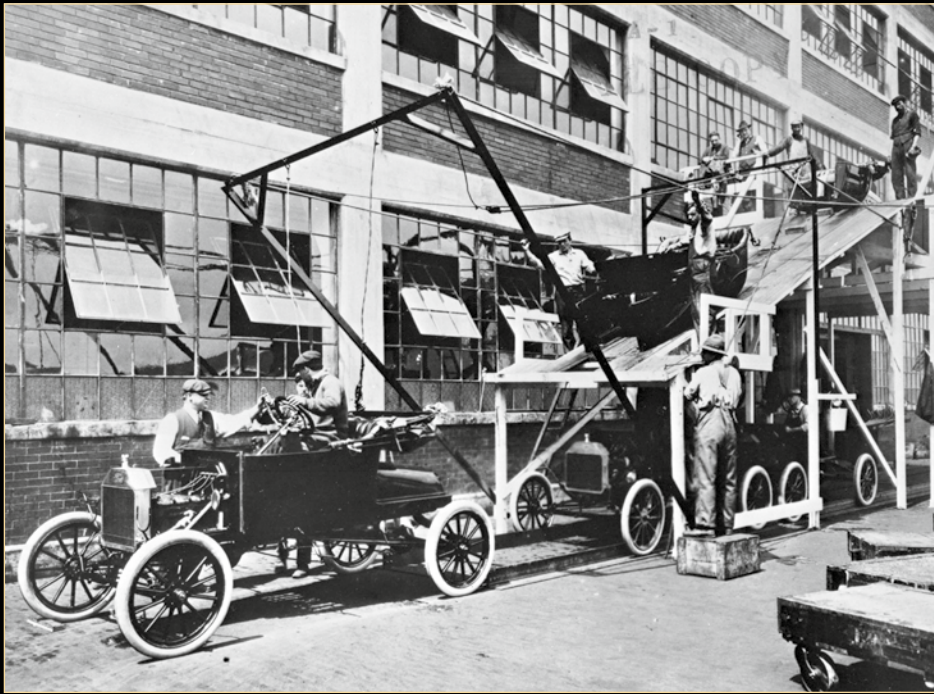

"Centinaia di queste auto furono utilizzate nel 1909 per viaggi turistici [...] non solo in America, ma in quasi tutti i paesi degli altri continenti".

- Libro Souvenir Ford Motor Cars (1910)

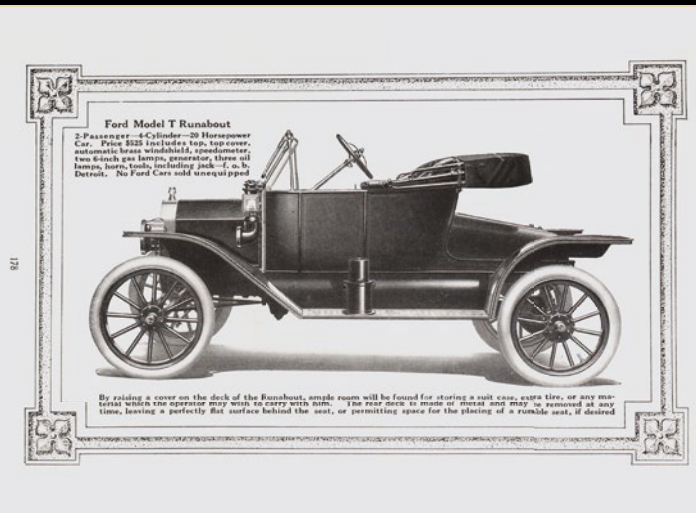
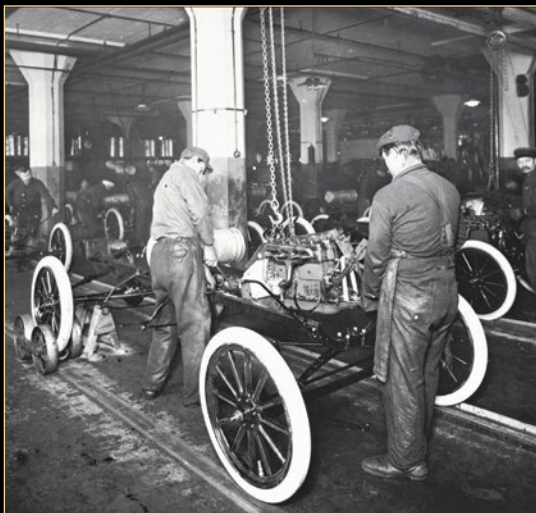

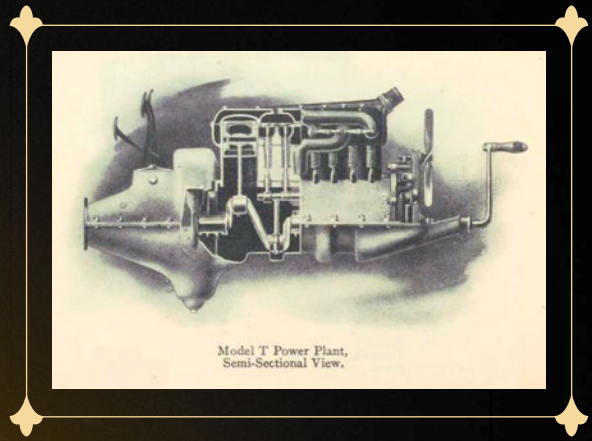

Model T Power Plant,
Semi-Sectional View.

IL COMMENTO DEL LEGO® ICONS DESIGN TEAM

Quando parliamo di auto d'epoca, l'estetica dei primi del '900, e in particolare la Ford® Model T®, racchiude tutta la magia e la nostalgia degli albori del design automobilistico. Questo omaggio dettagliato è ispirato alla versione Runabout del 1913, con il suo cofano angolare, il cruscotto piatto in legno e l'abitacolo a due posti. Un modello celebre per la sua livrea nera lucida, era disponibile anche in altri accattivanti colori! Il nostro modello si distingue per i preziosi dettagli in oro e ottone che catturano l'attenzione: dai fari color oro al clacson fino alla cornice della griglia. Abbiamo ricreato con precisione il design intelligente e iconico, riproponendo i dettagli ingegneristici originali: dal sistema di accensione a manovella all'acceleratore sul piantone dello sterzo, fino al serbatoio del carburante posizionato sotto il sedile. Ruote dotate di raggi e cerchi dal look autentico, un tetto pieghevole e un sistema di trasmissione funzionante completano l'autenticità di questo veicolo che ha rivoluzionato l'industria automobilistica.

* * * *

"Ci auguriamo che, durante la costruzione, scoprirete il funzionamento dell'auto: vedrete il motore girare, cambierete le marce e aprirete il sedile per raggiungere il serbatoio del carburante".

- Il LEGO® Icons Design Team



La diecimillesima Model T[®] esce dalla linea di assemblaggio

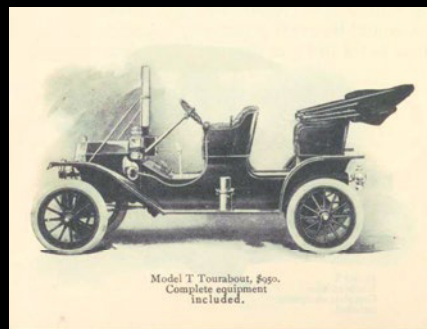
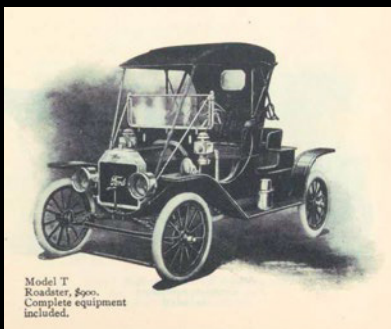
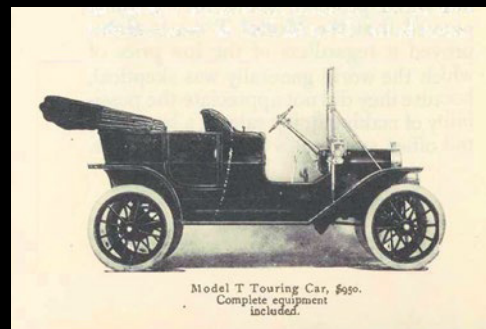

Gli storici della Ford Motor Company ci hanno aiutato a documentare tutte le caratteristiche distintive dell'auto. Hanno condiviso con noi incredibili foto d'archivio, diagrammi e riferimenti durante l'intero processo di progettazione. È così che abbiamo scoperto che questa versione della Model T aveva un solo sportello!

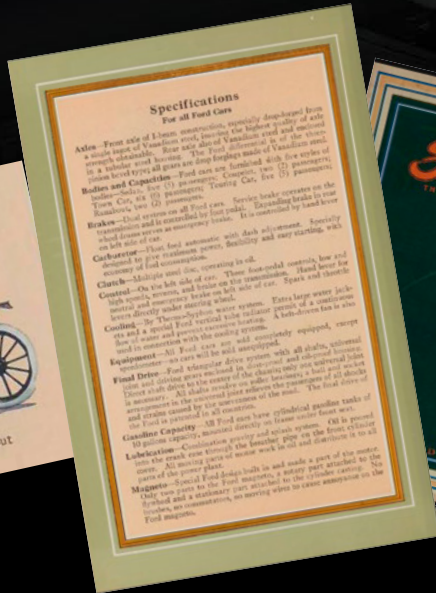

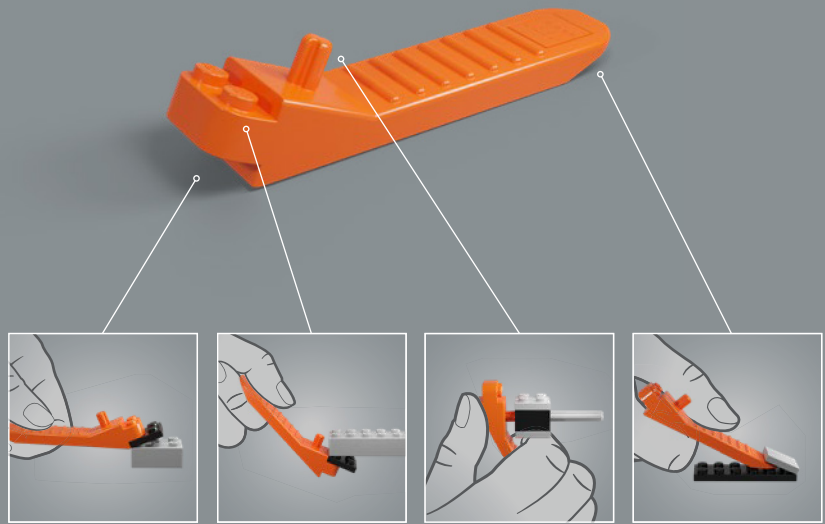



Introdotta nel 1908, la Ford® Model T®
rimase in produzione fino al 1927.

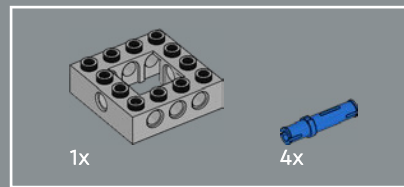

1

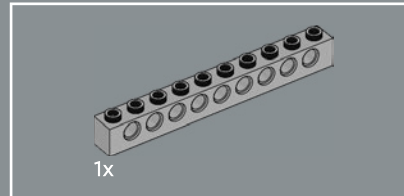
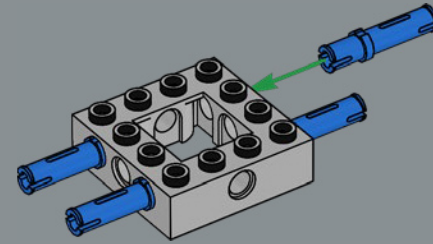

2

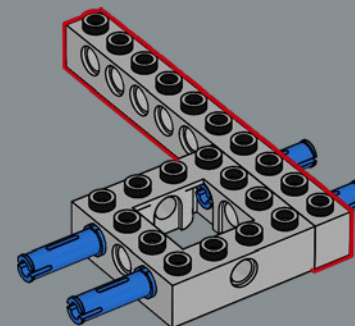

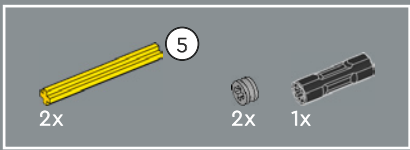

3

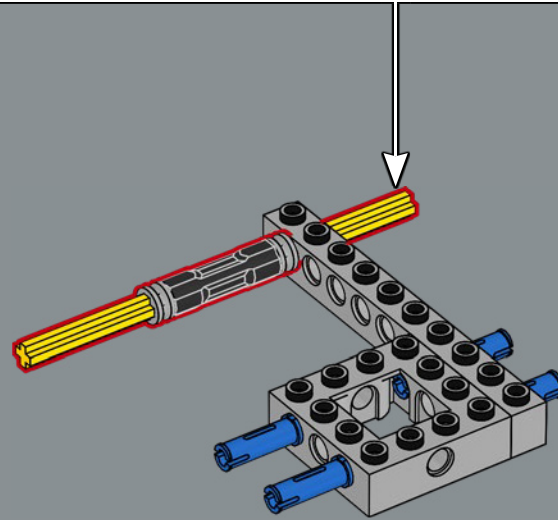
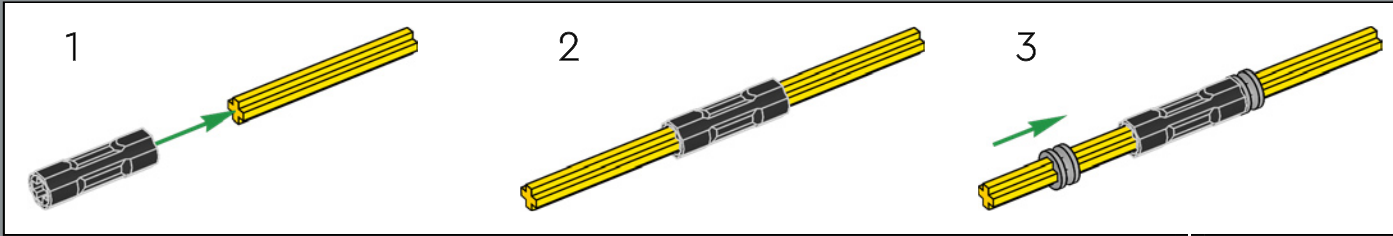

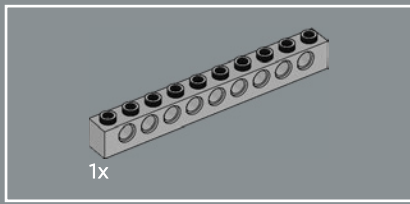

4

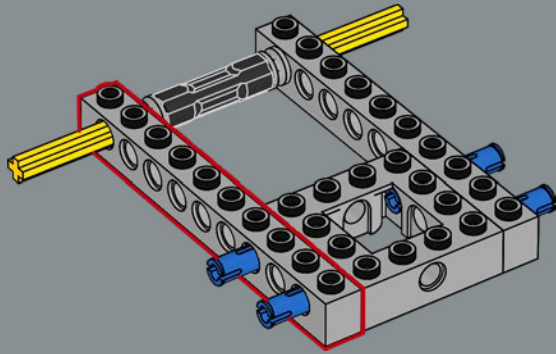

5

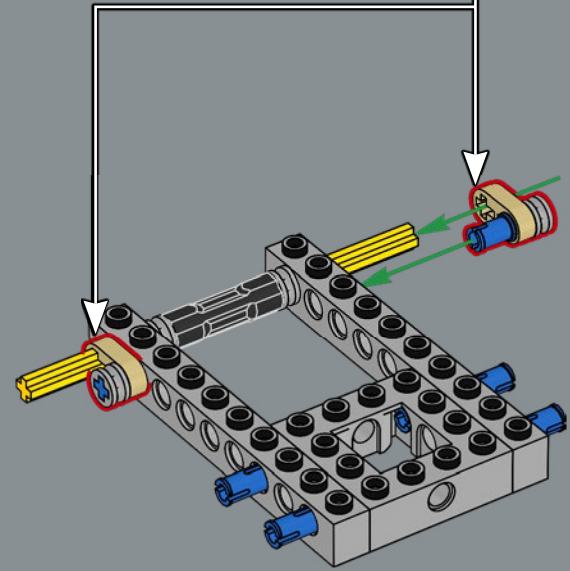
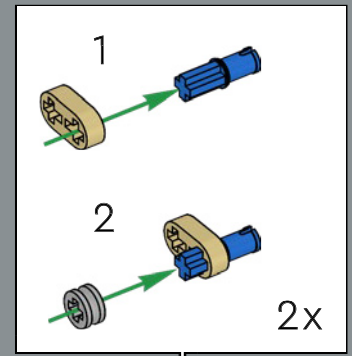

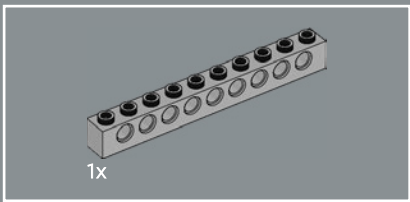

6

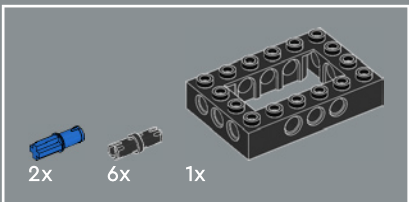
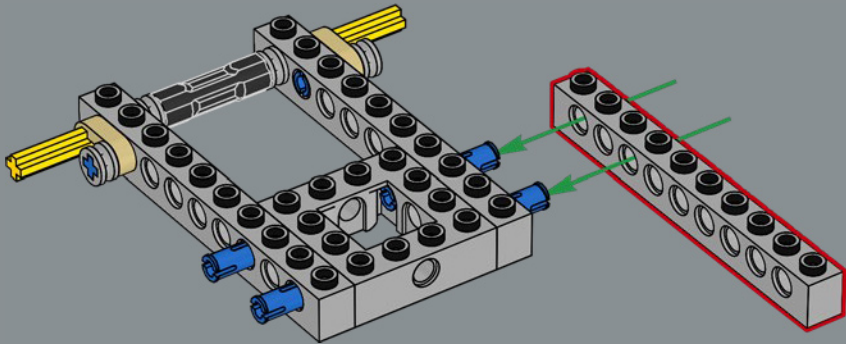

7

1

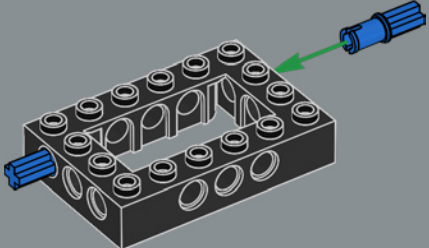

2

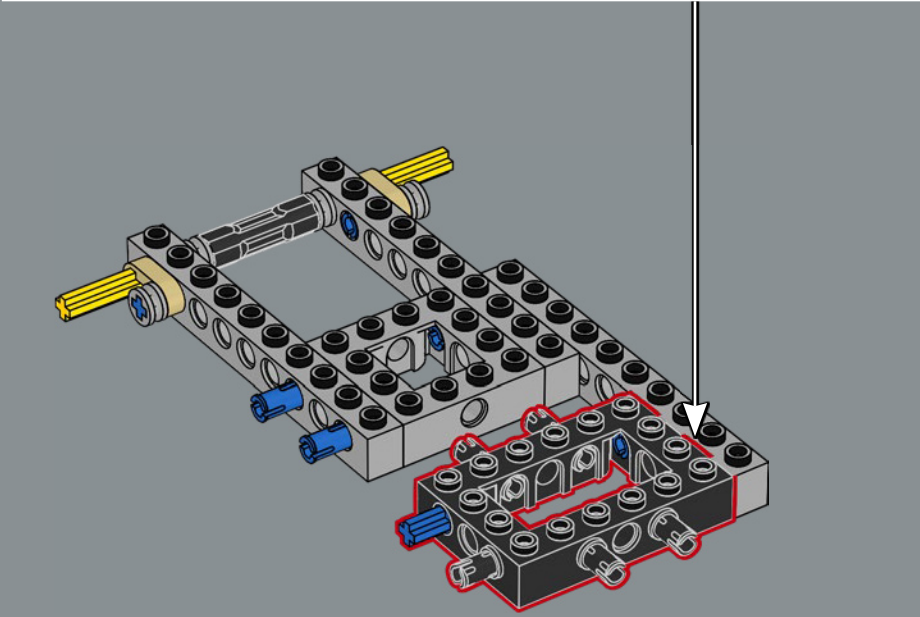
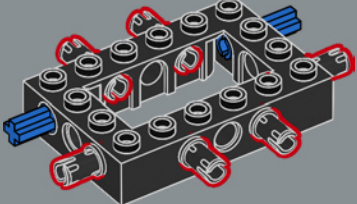

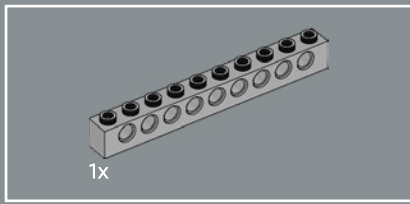

8

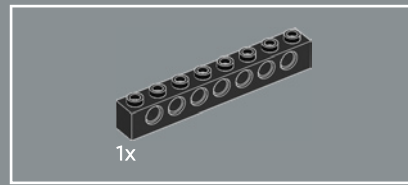
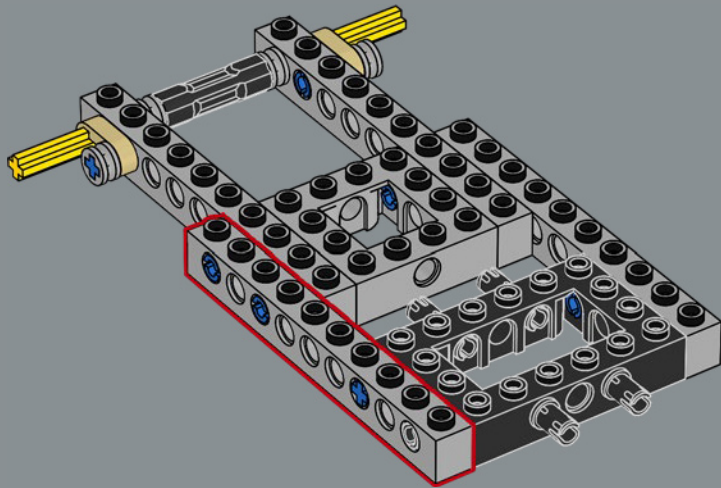

9

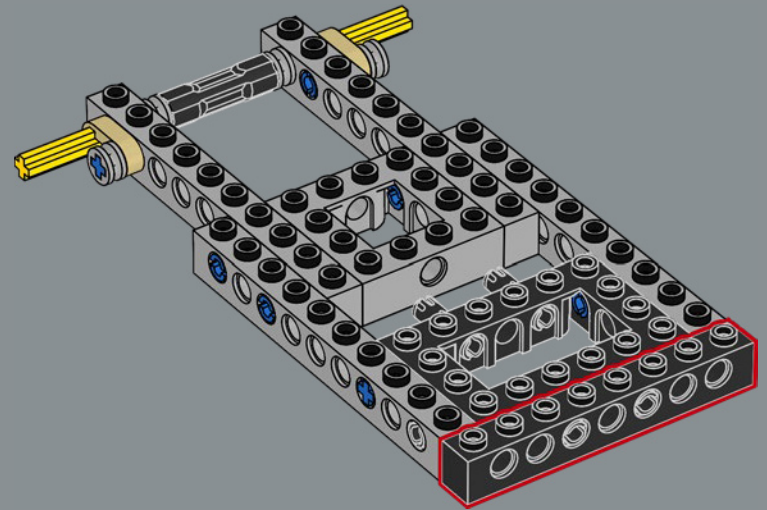

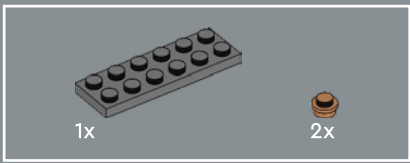

10

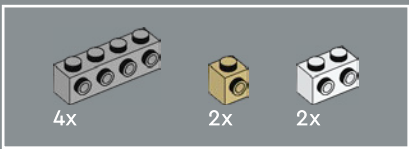
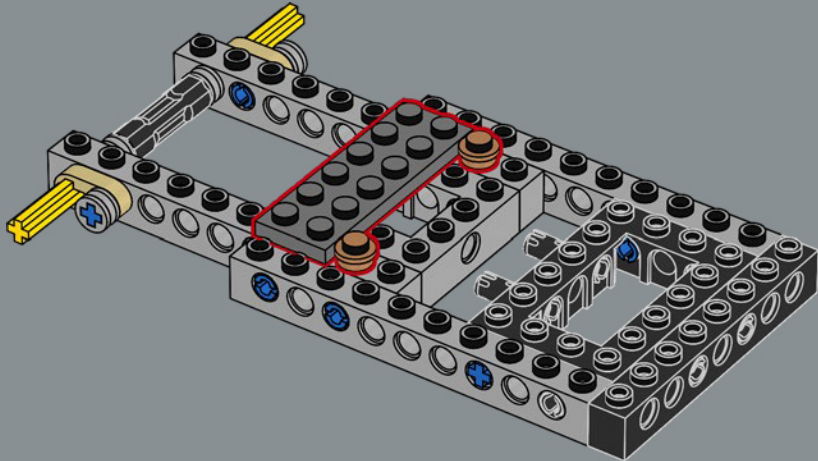

11

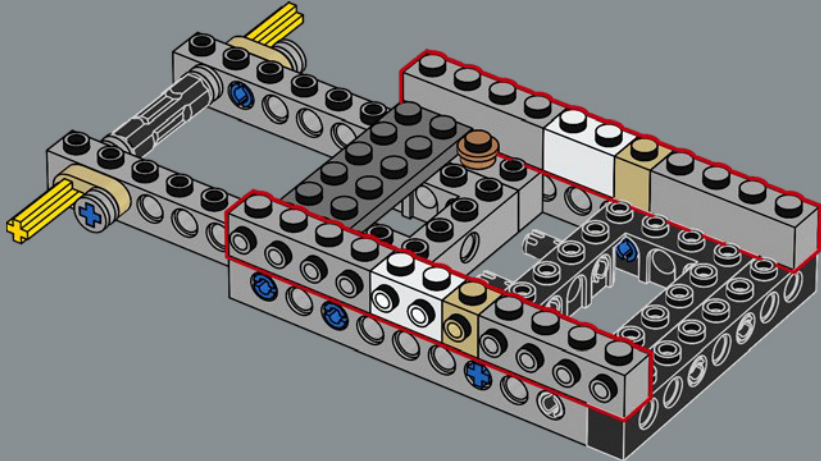

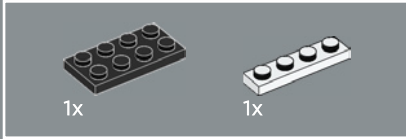
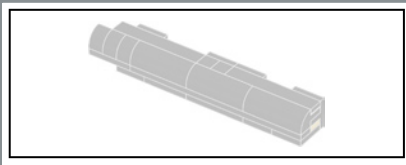

12

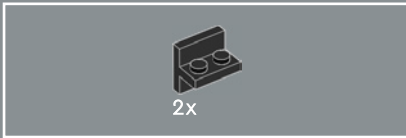
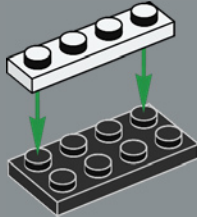

13

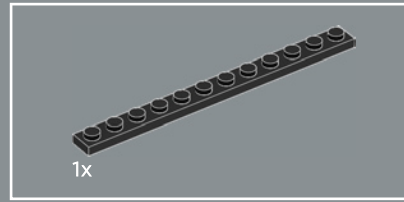
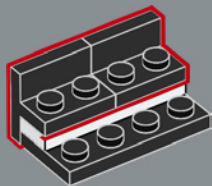

14

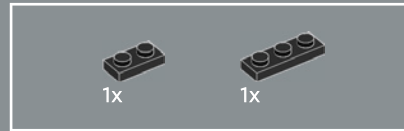
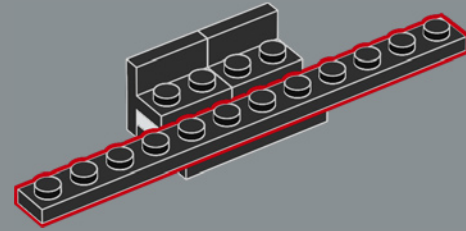

15

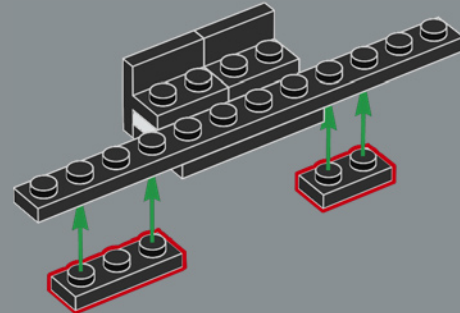

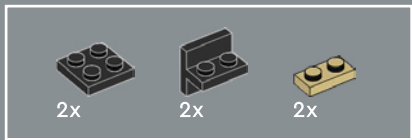

16

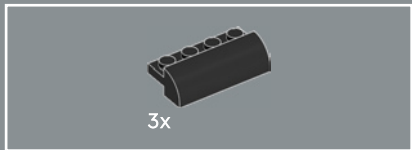
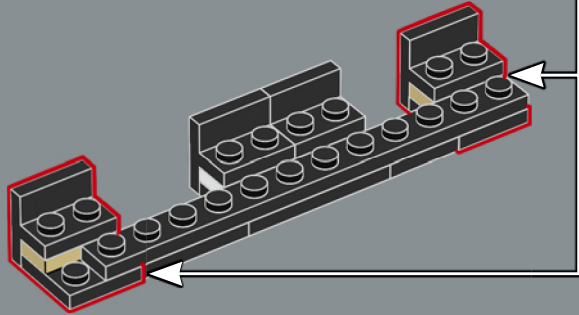
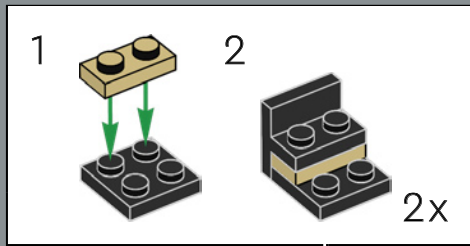

17

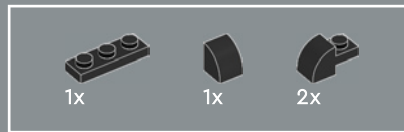
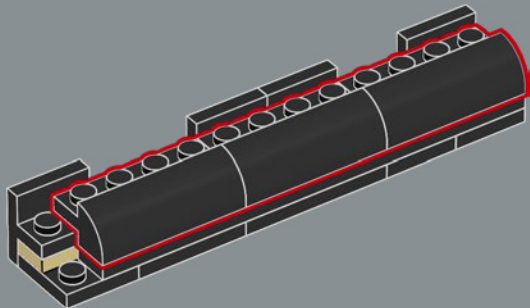

18

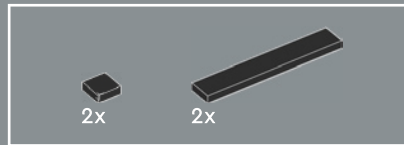
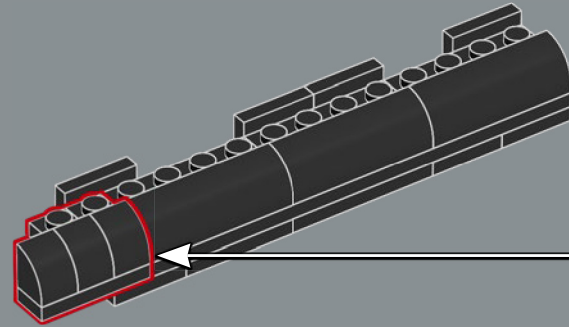
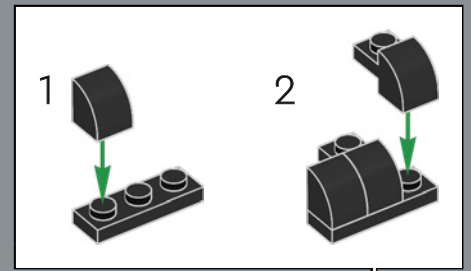

19

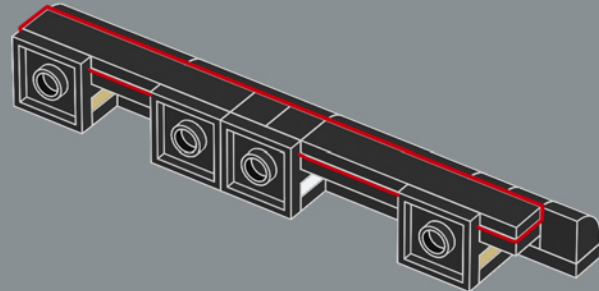

20

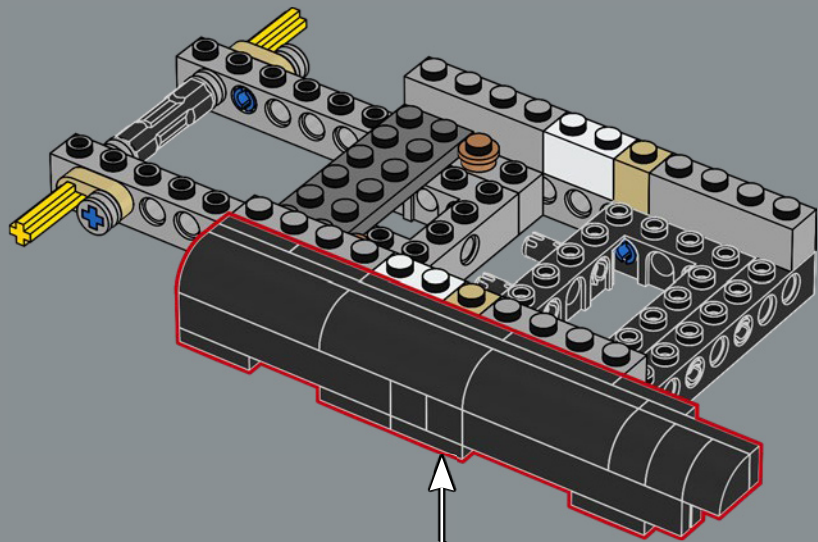

21

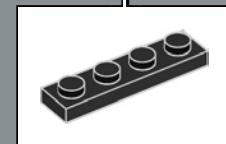
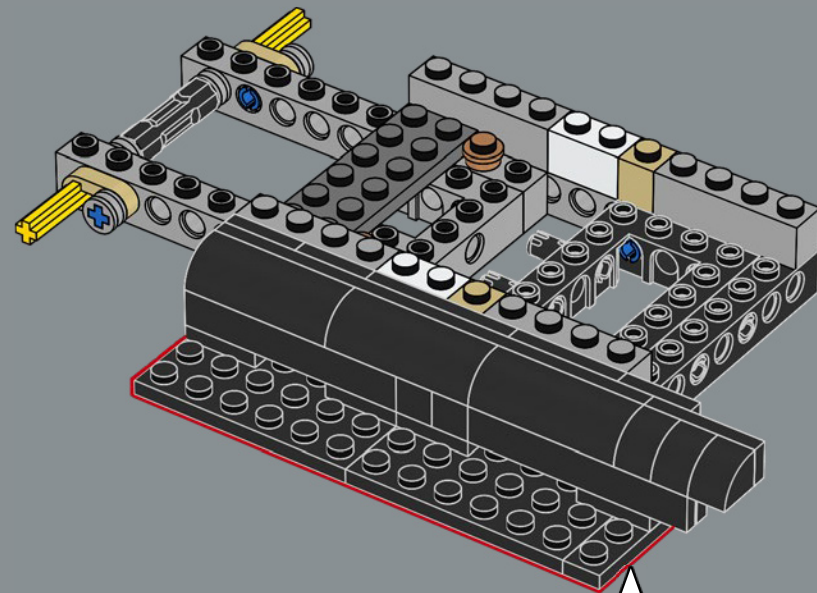
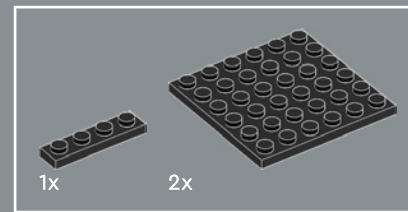

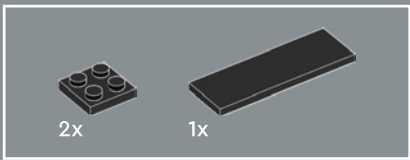

22

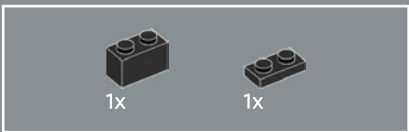
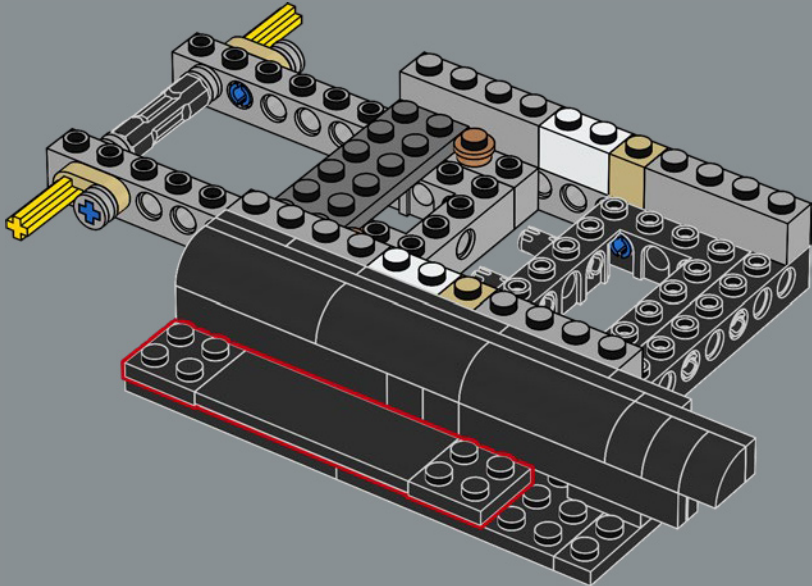

23

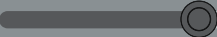
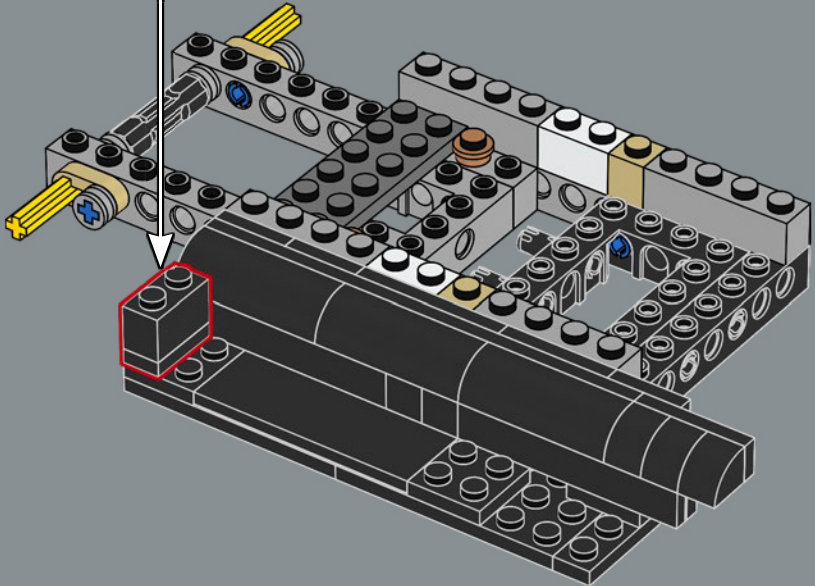
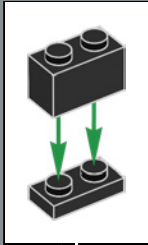

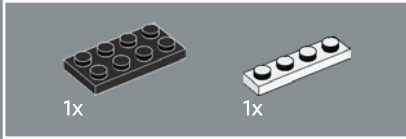
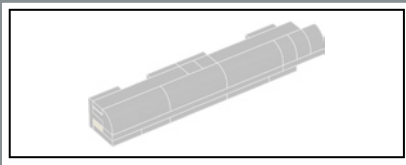

24

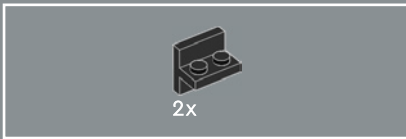
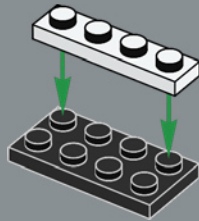

25

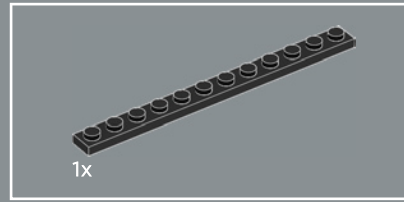

26

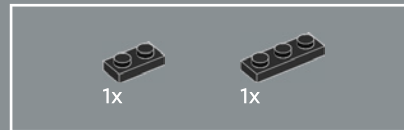
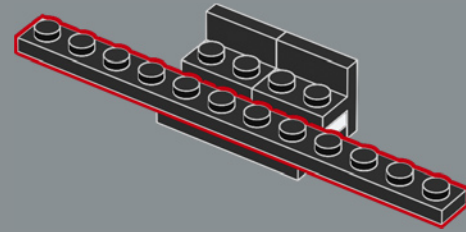

27

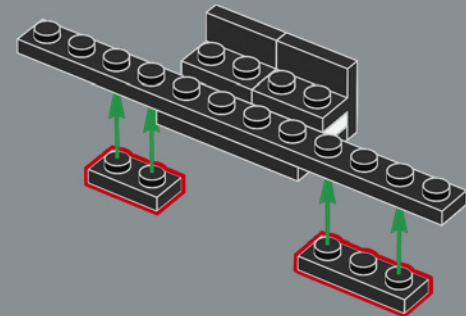

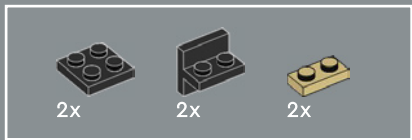

28

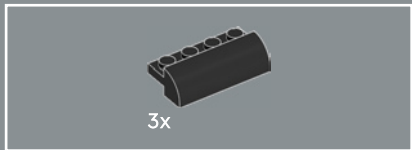
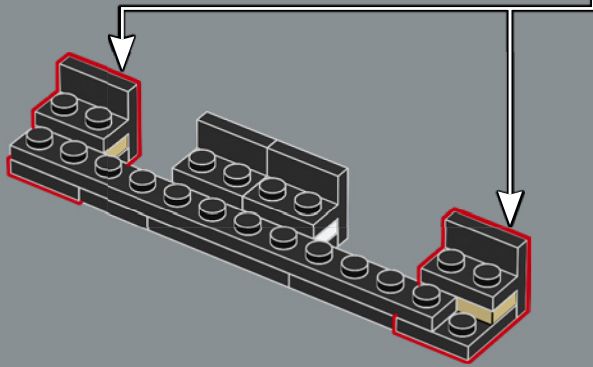
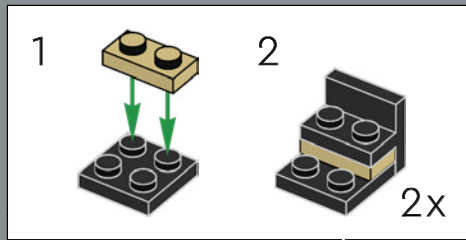

29

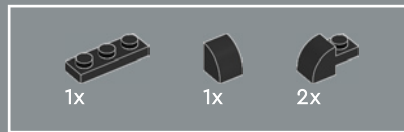
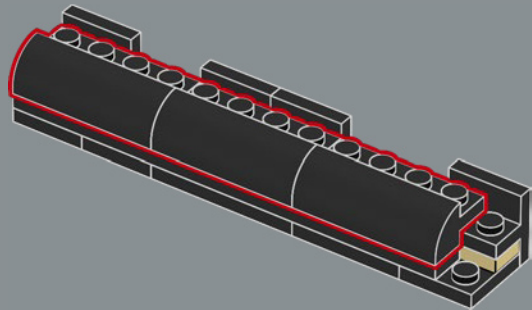

30

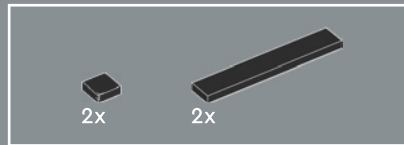
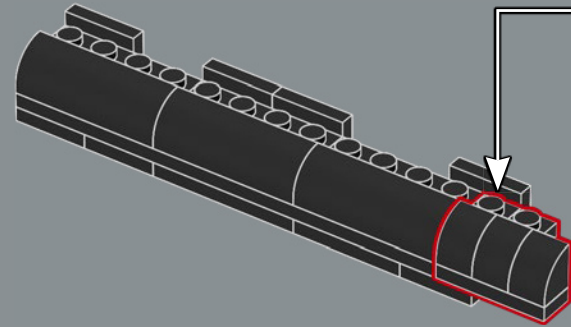
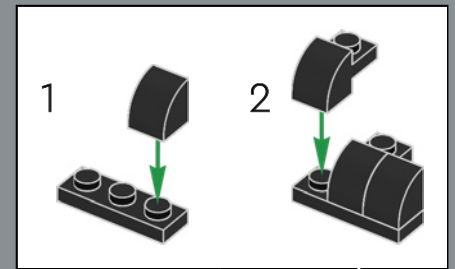

31

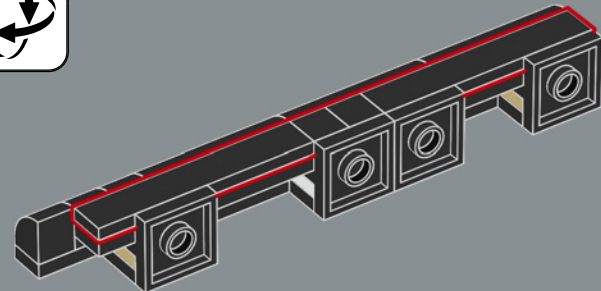



La Ford® Model T® fu progettata da Childe
Harold Wills insieme all'ingegnere capo
Joseph A. Galamb ed Eugene Farkas.

32

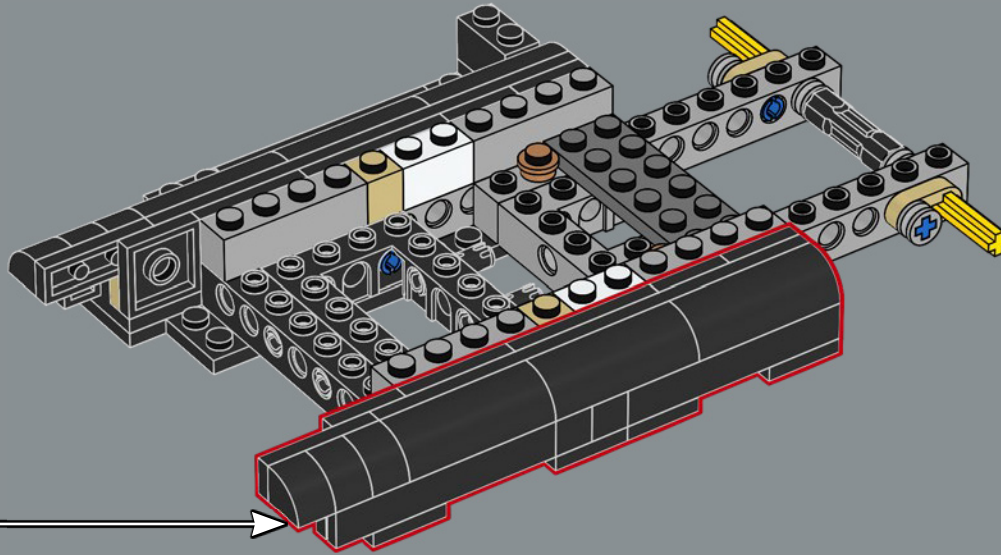

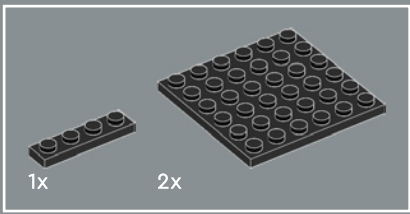

33

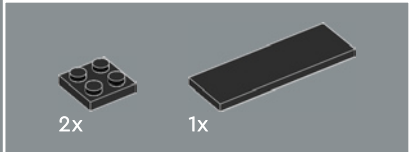
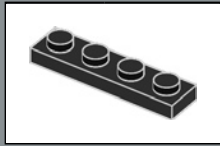
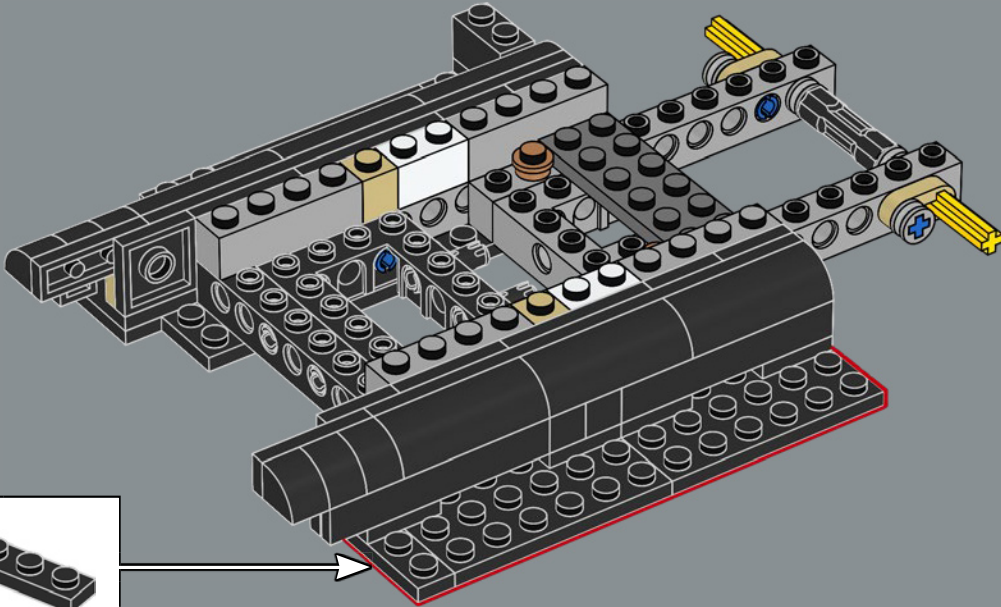

34

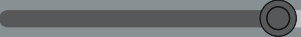
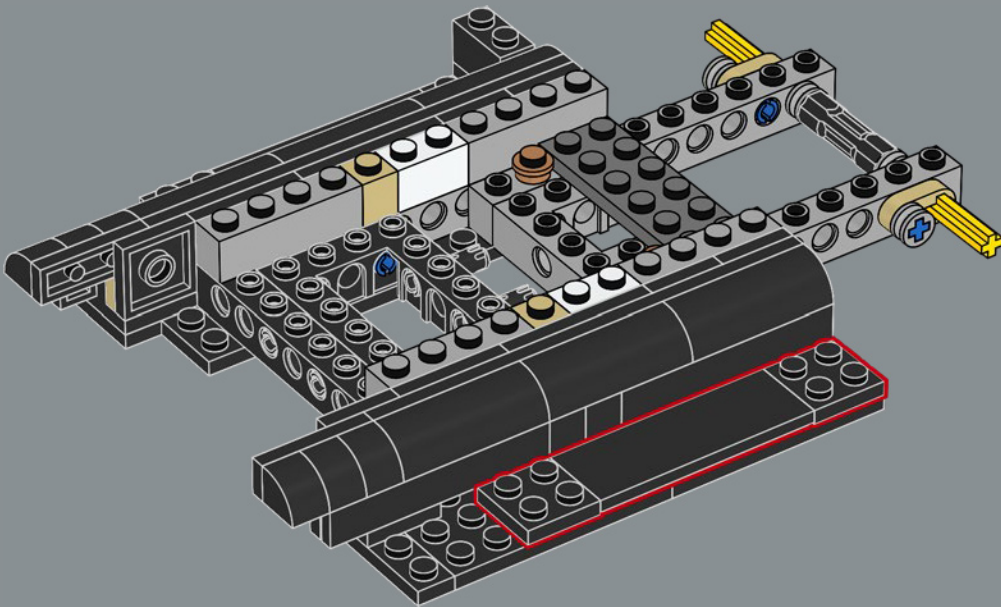

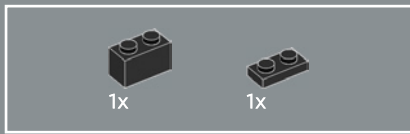

35

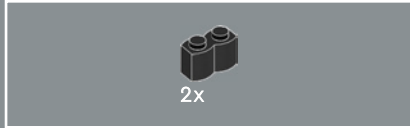
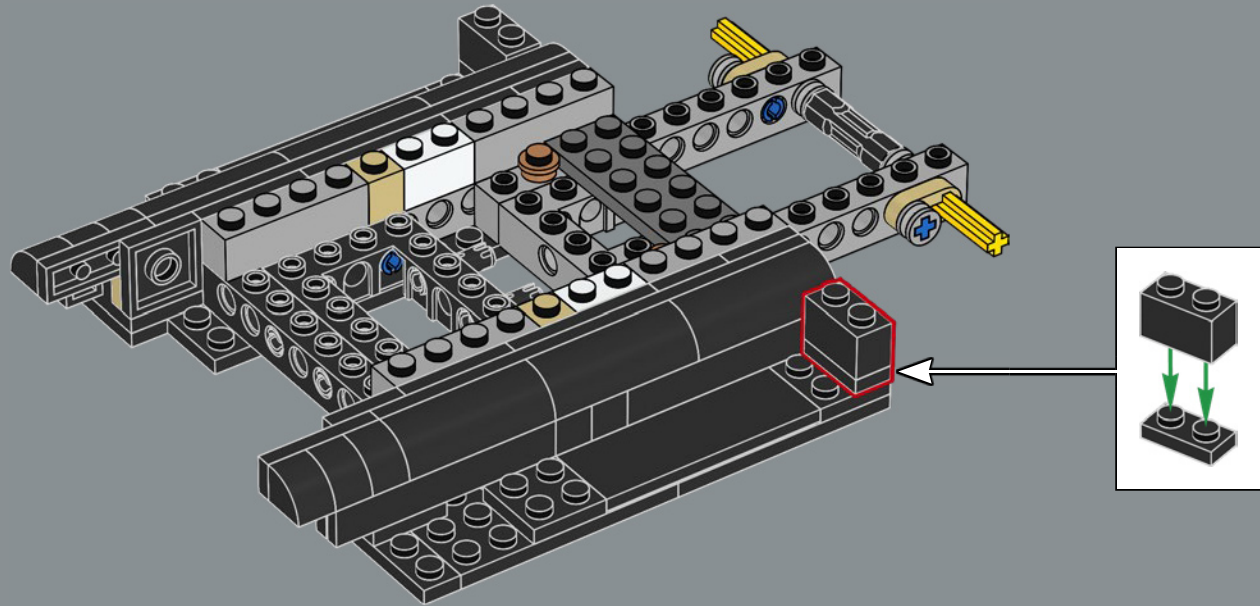

36

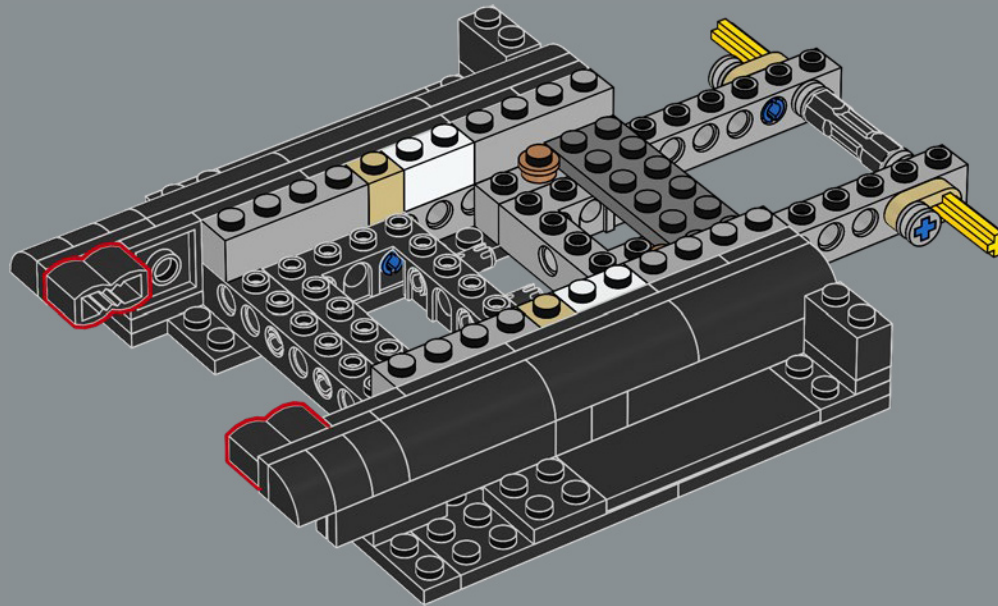

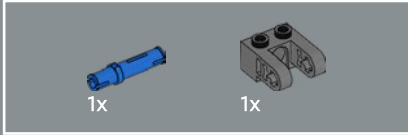
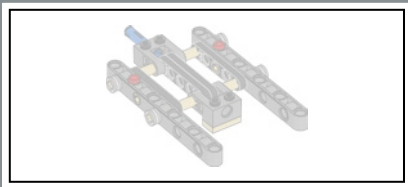

37

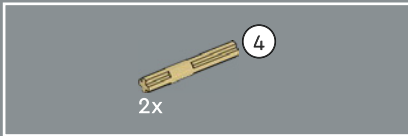
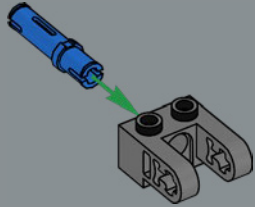

38

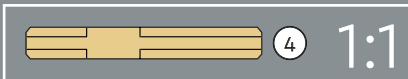
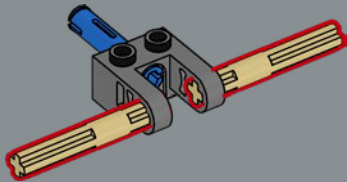

39

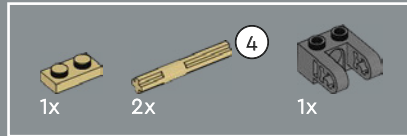
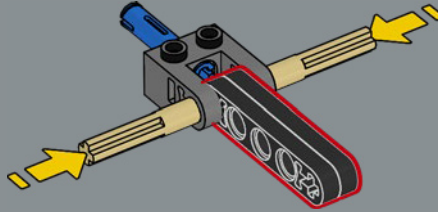

40

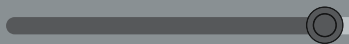
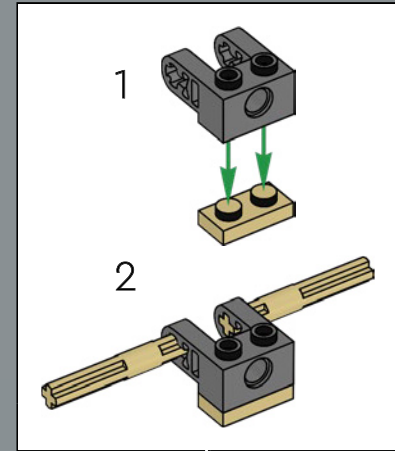
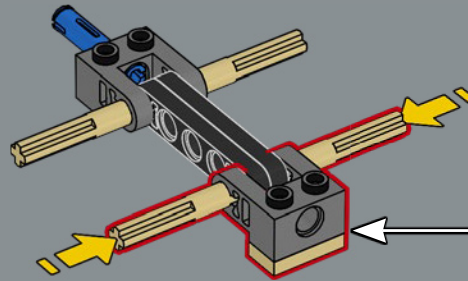



41

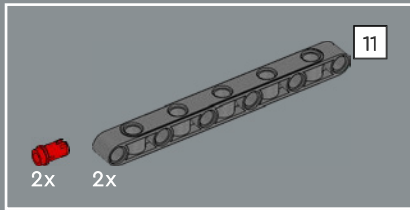
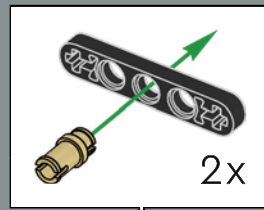
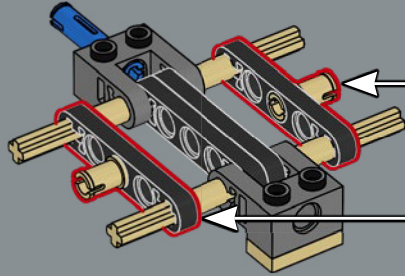

42

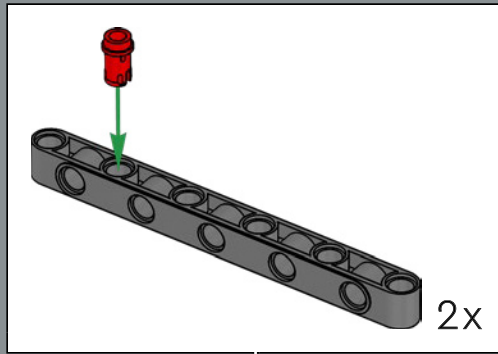
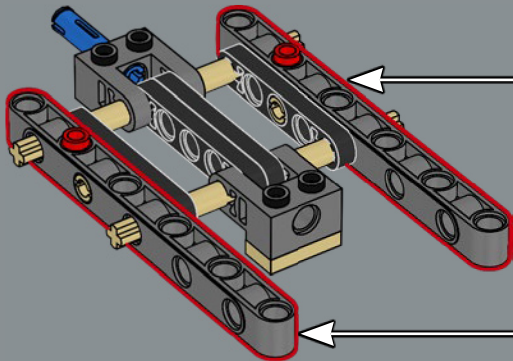

43

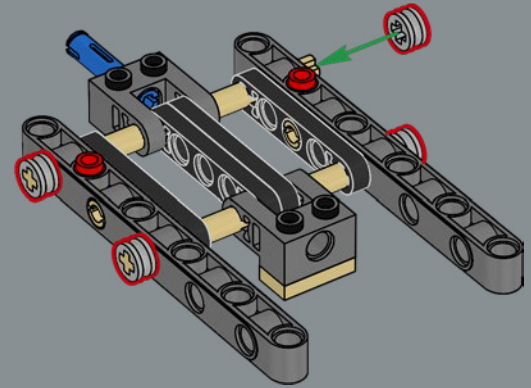

44

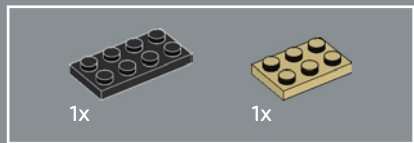
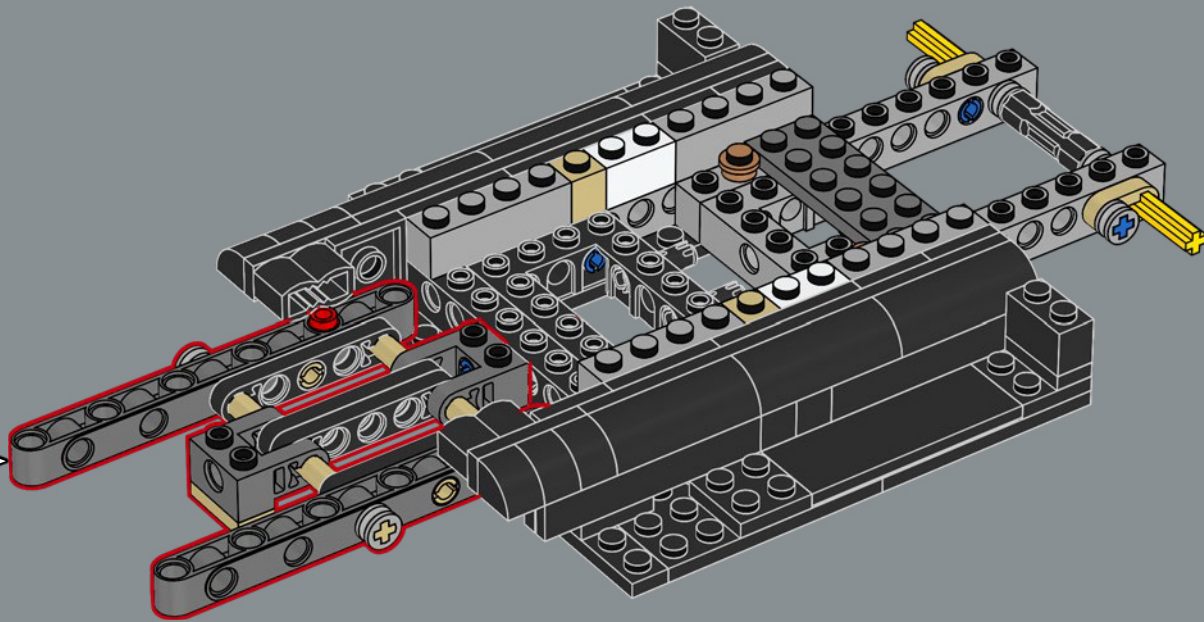

45

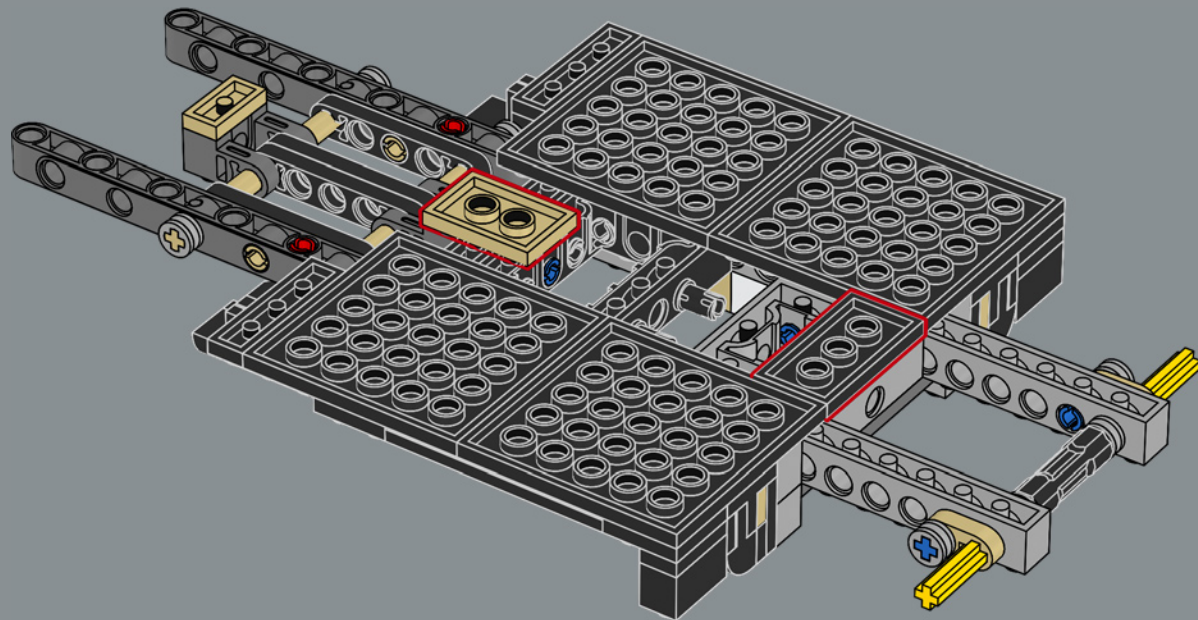

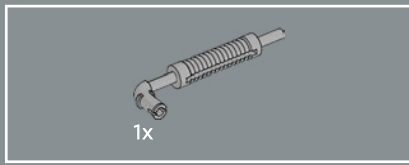

46

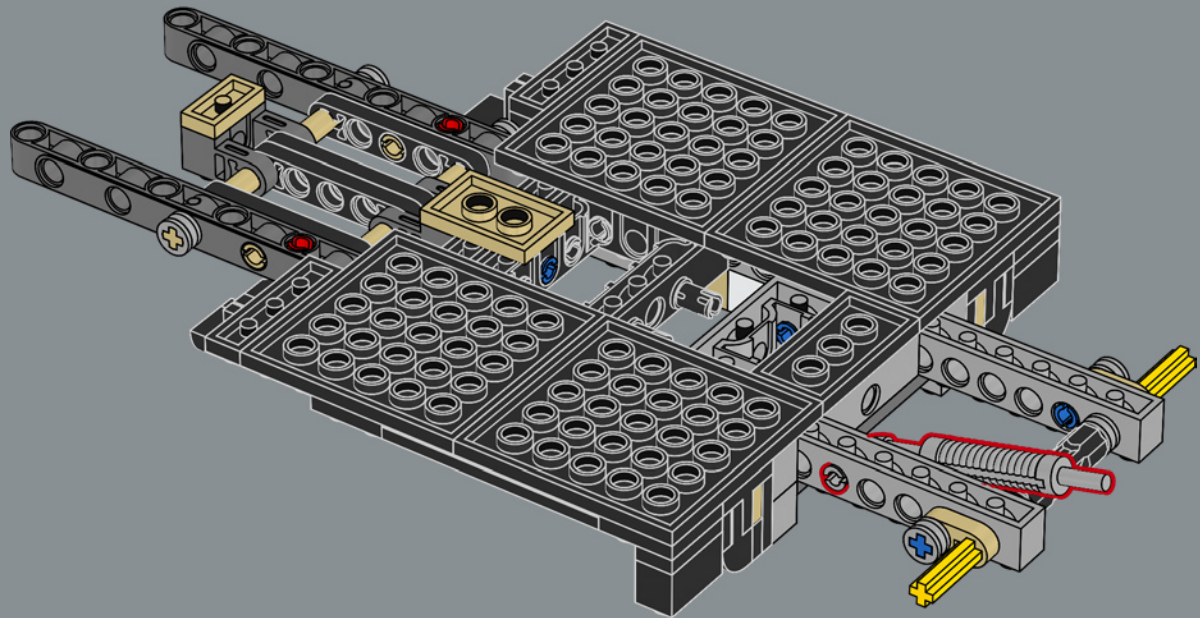

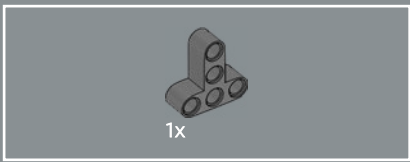

47

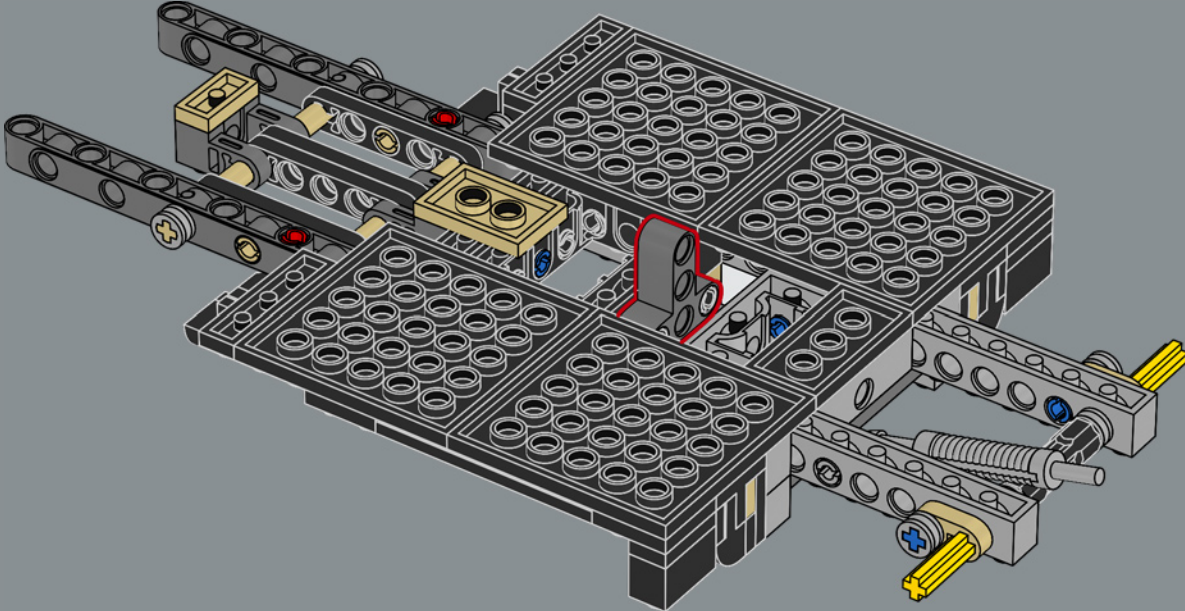

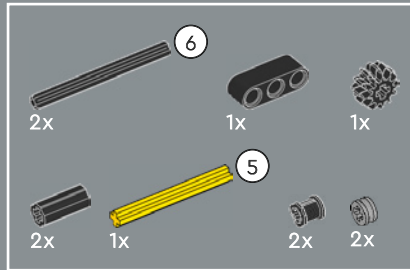
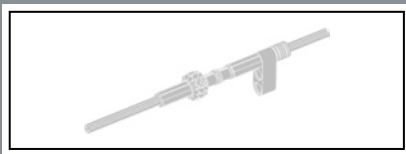

48

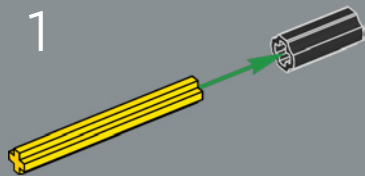

2

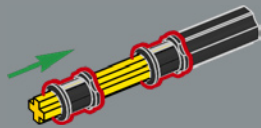

3

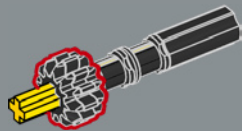

4

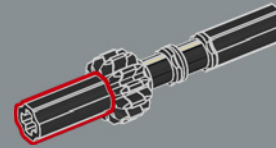

5

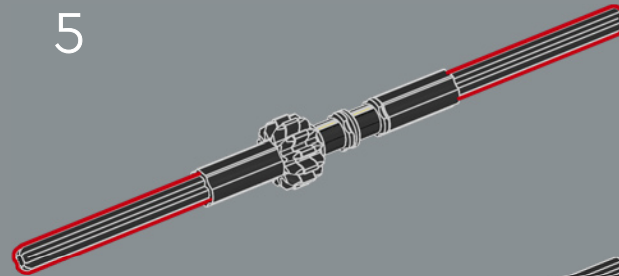

6

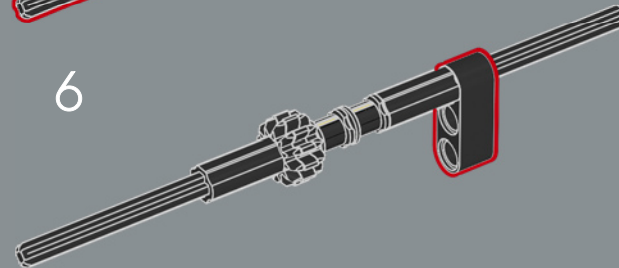

7

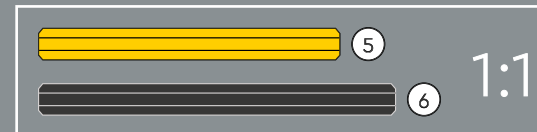
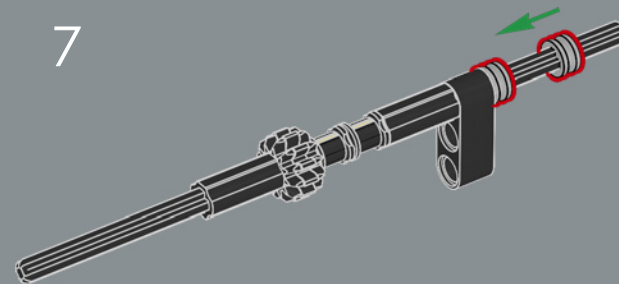

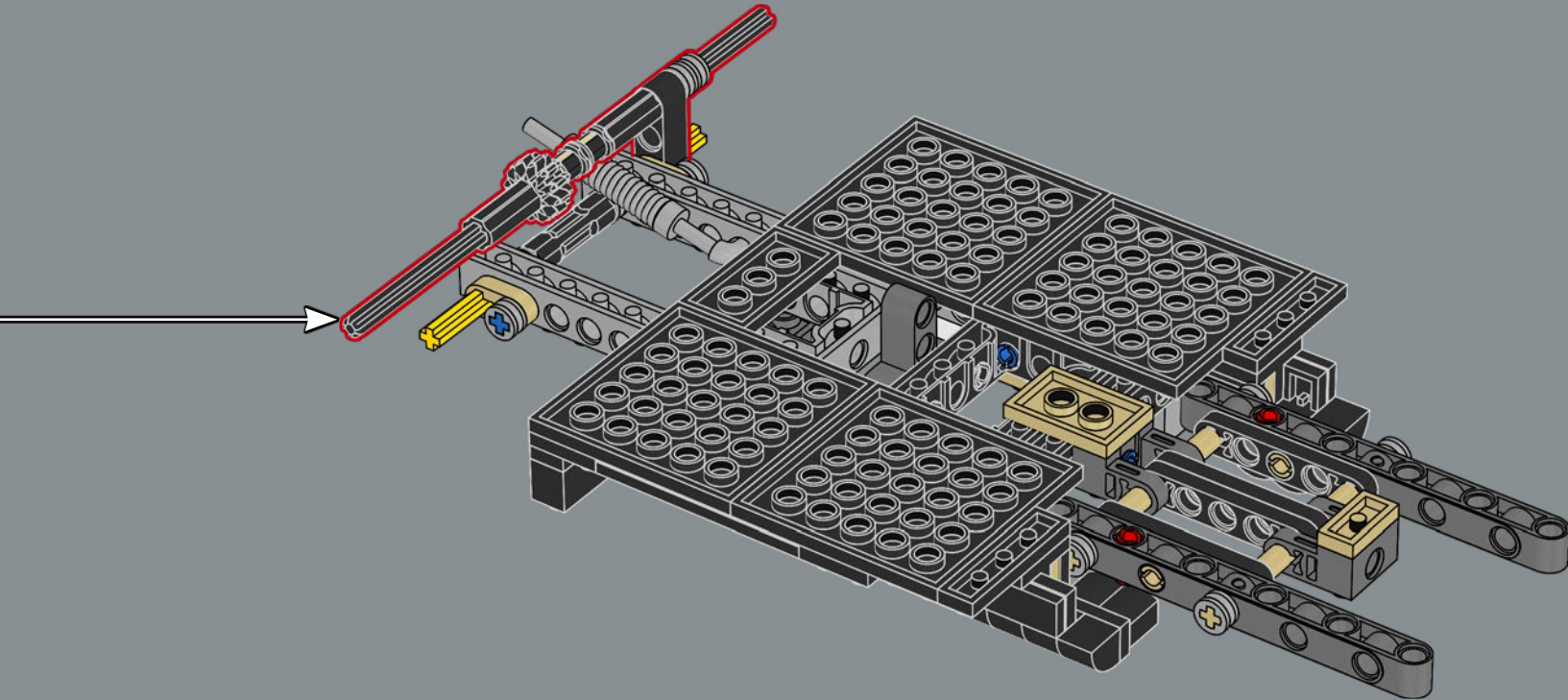

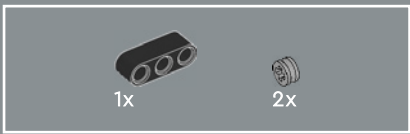

49

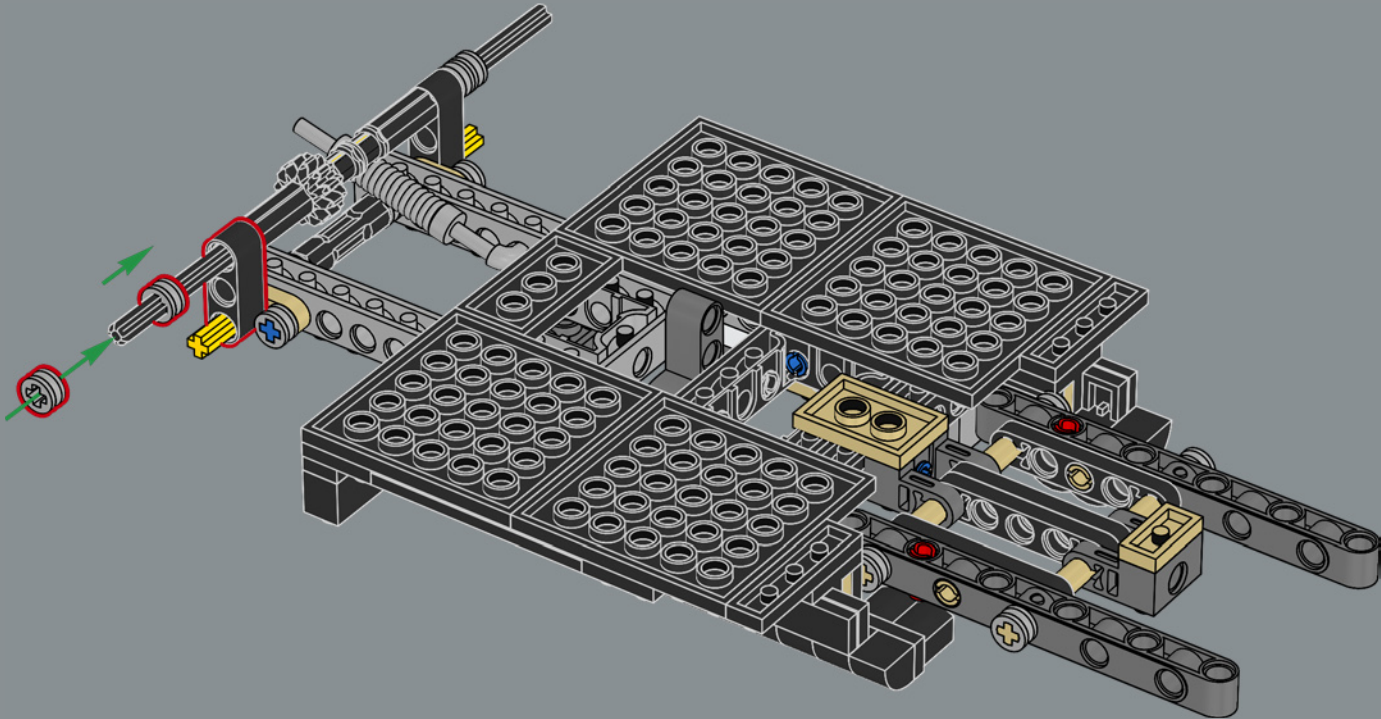



50

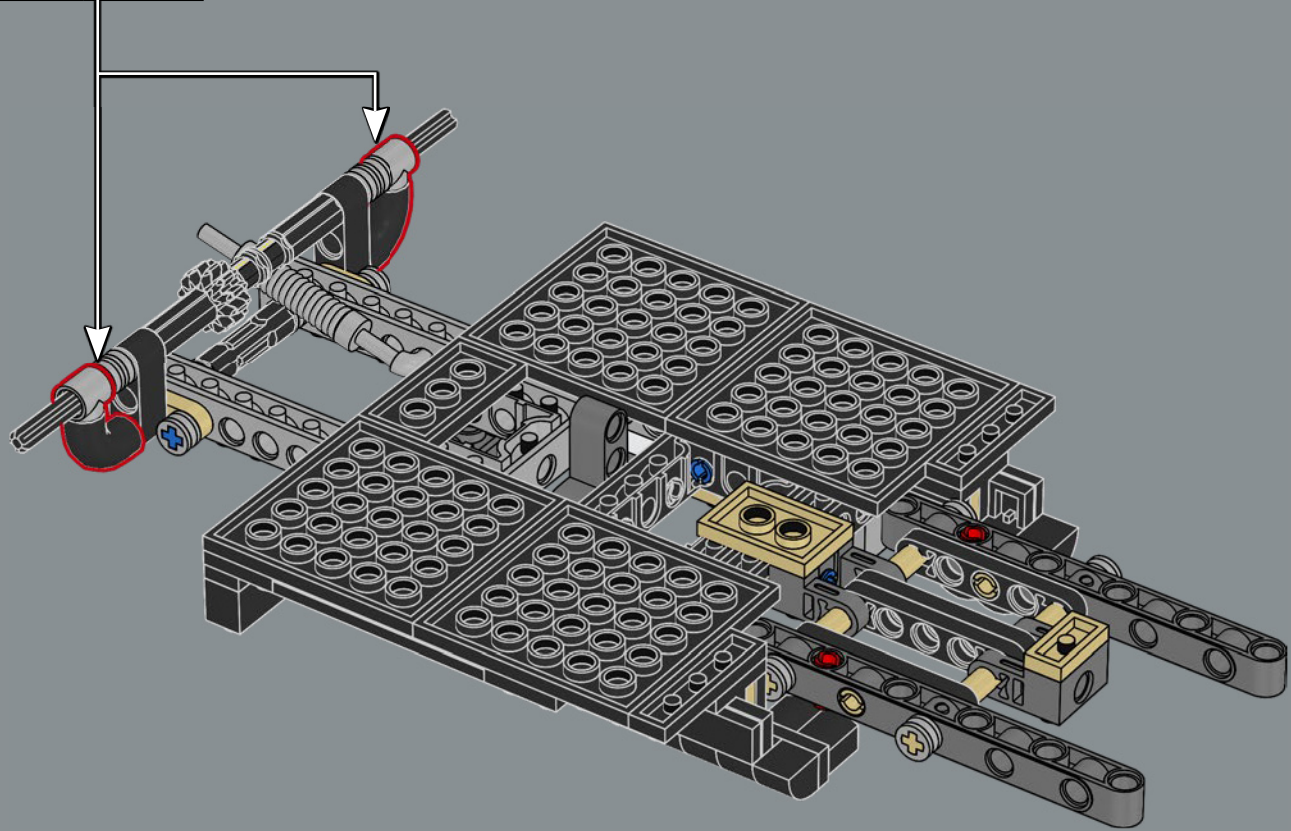
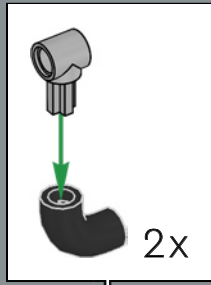

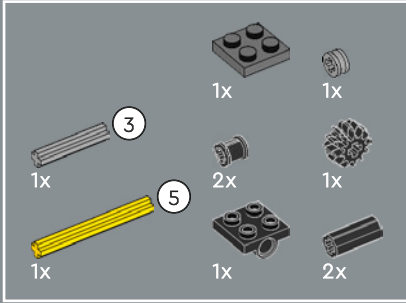
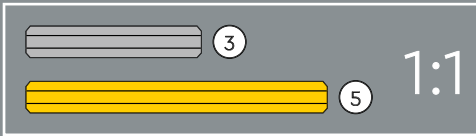
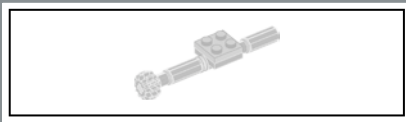

51

1

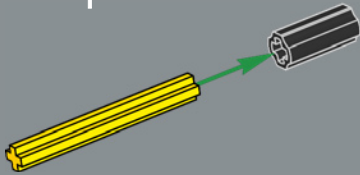

2

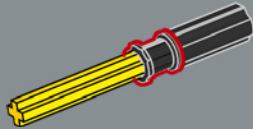

3

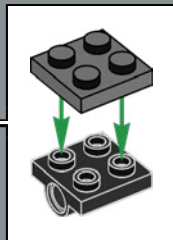
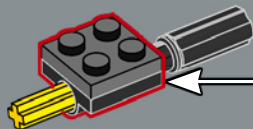

4

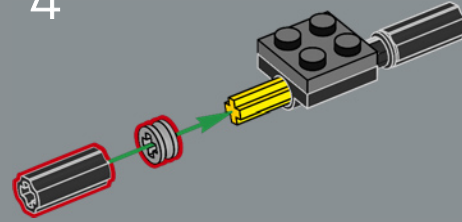

5

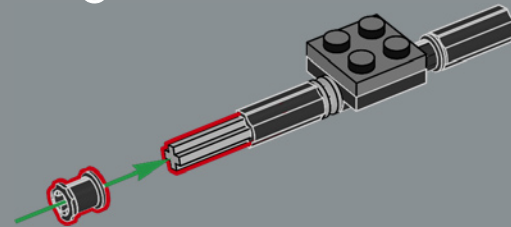

6

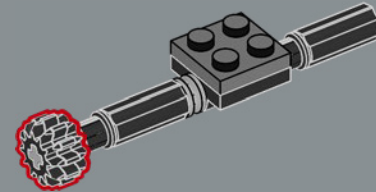



La Ford® Model T® è stata uno dei primi veicoli a essere dotata di trazione posteriore.

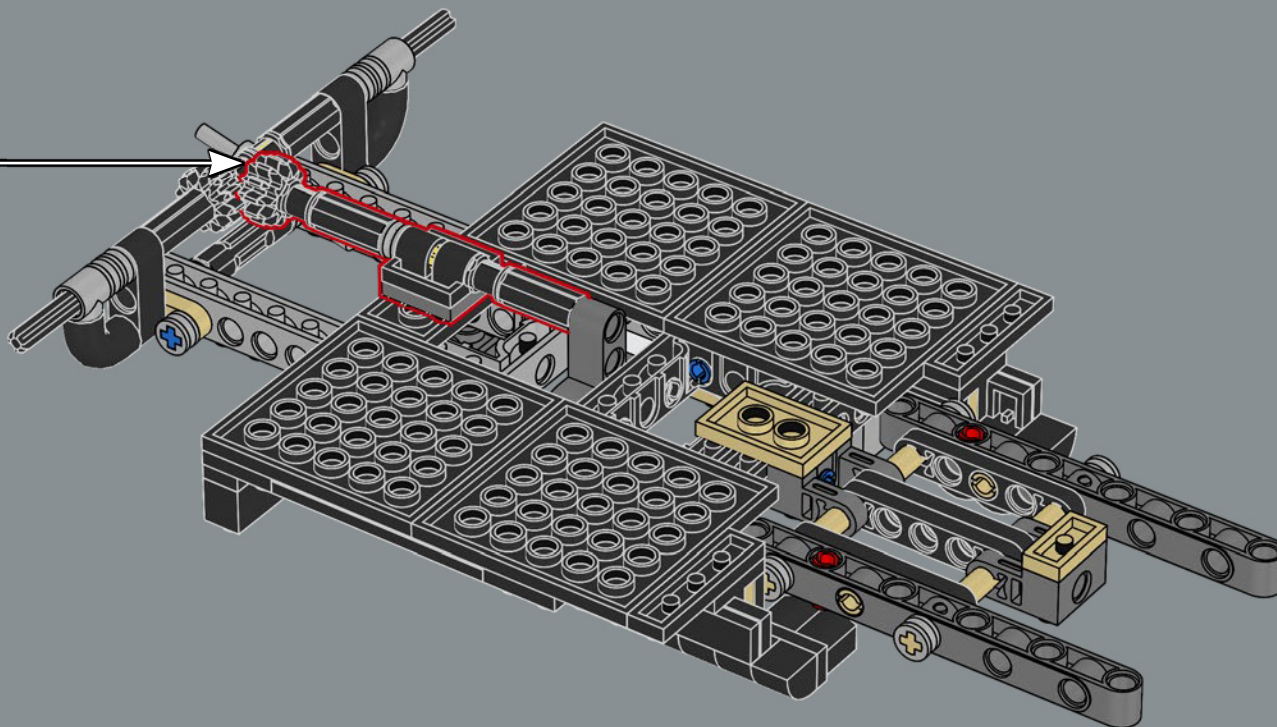

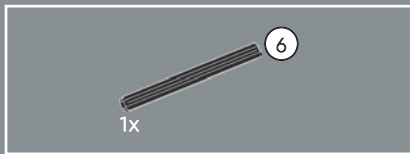

52

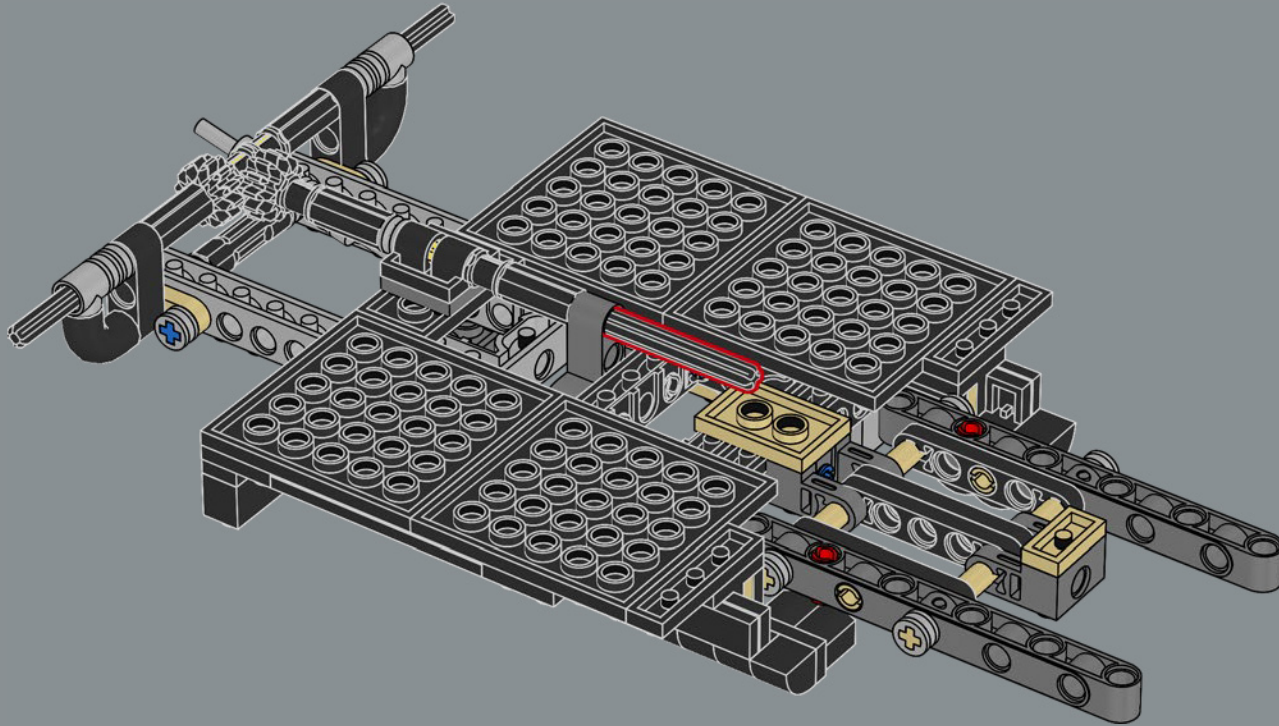

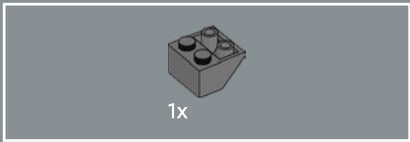

53

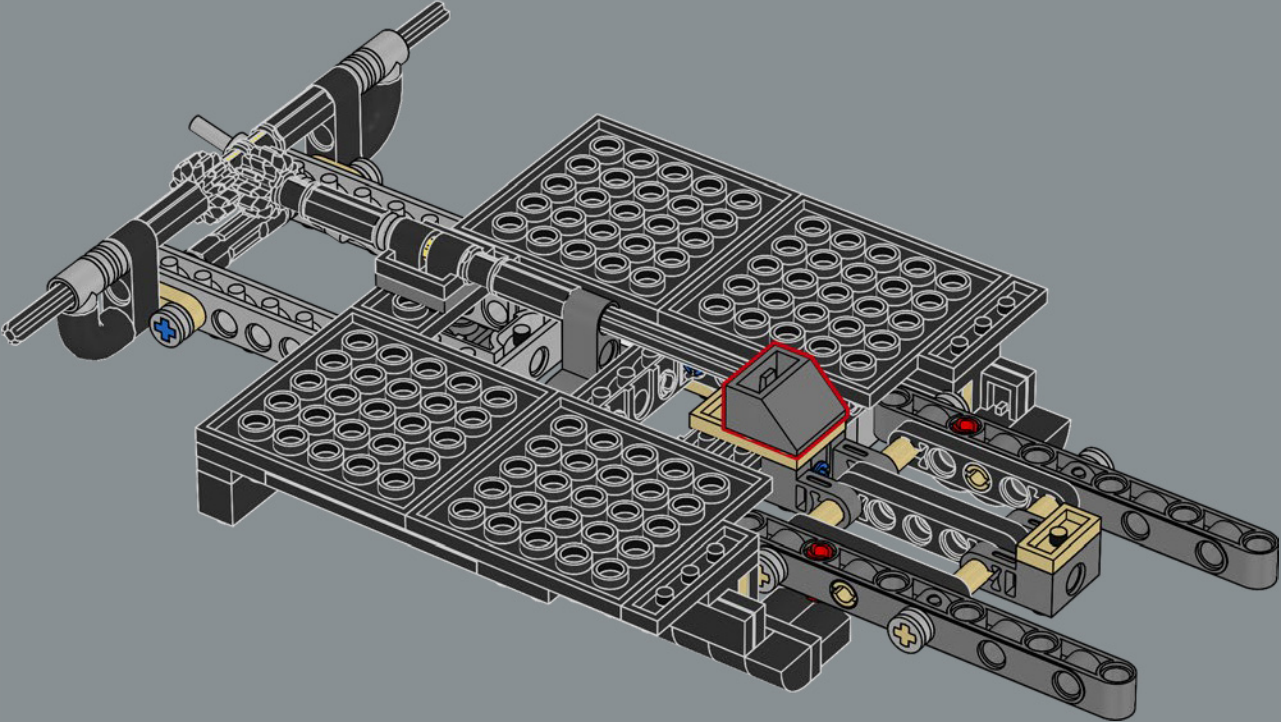



54

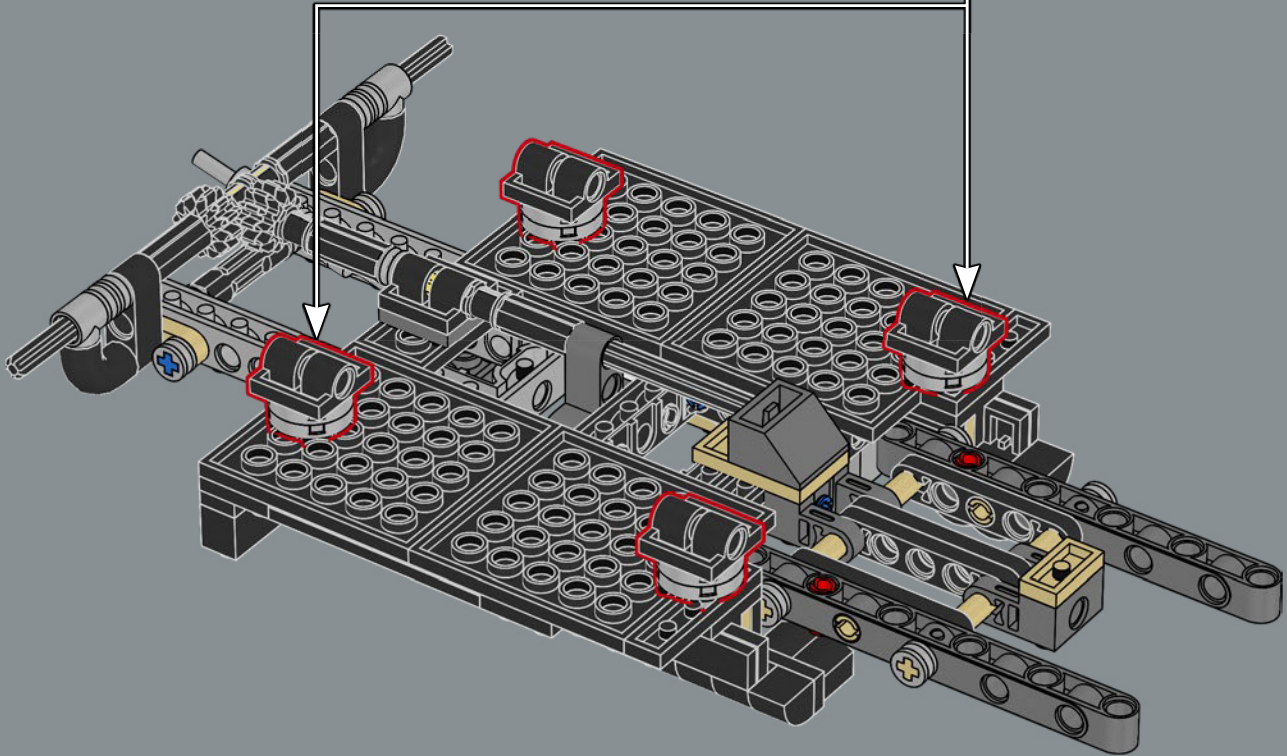
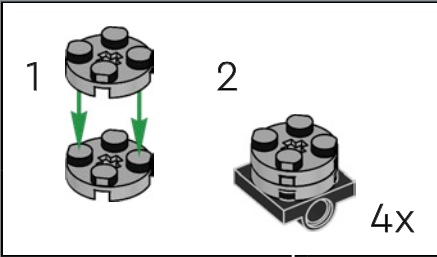

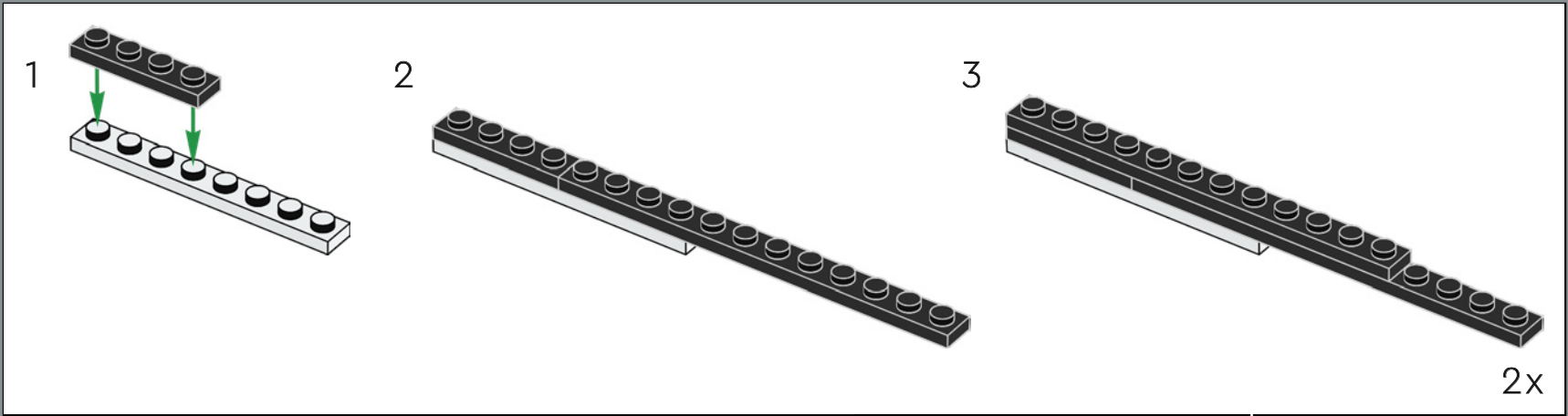

6

7

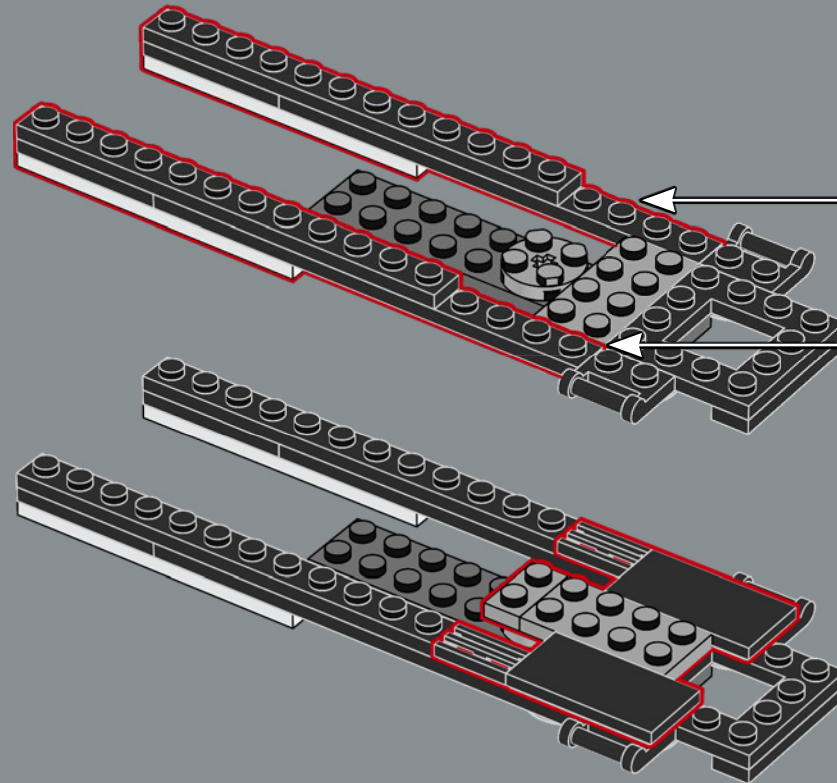

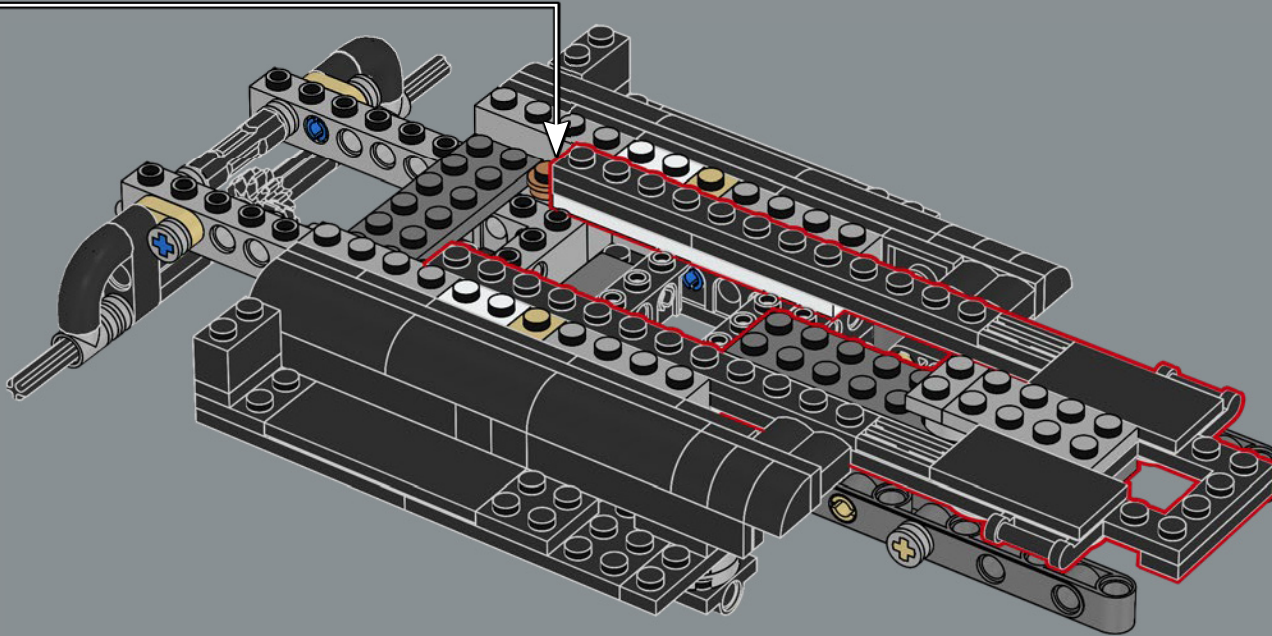

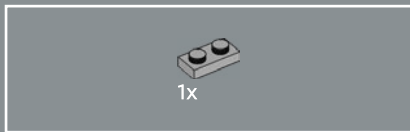

56

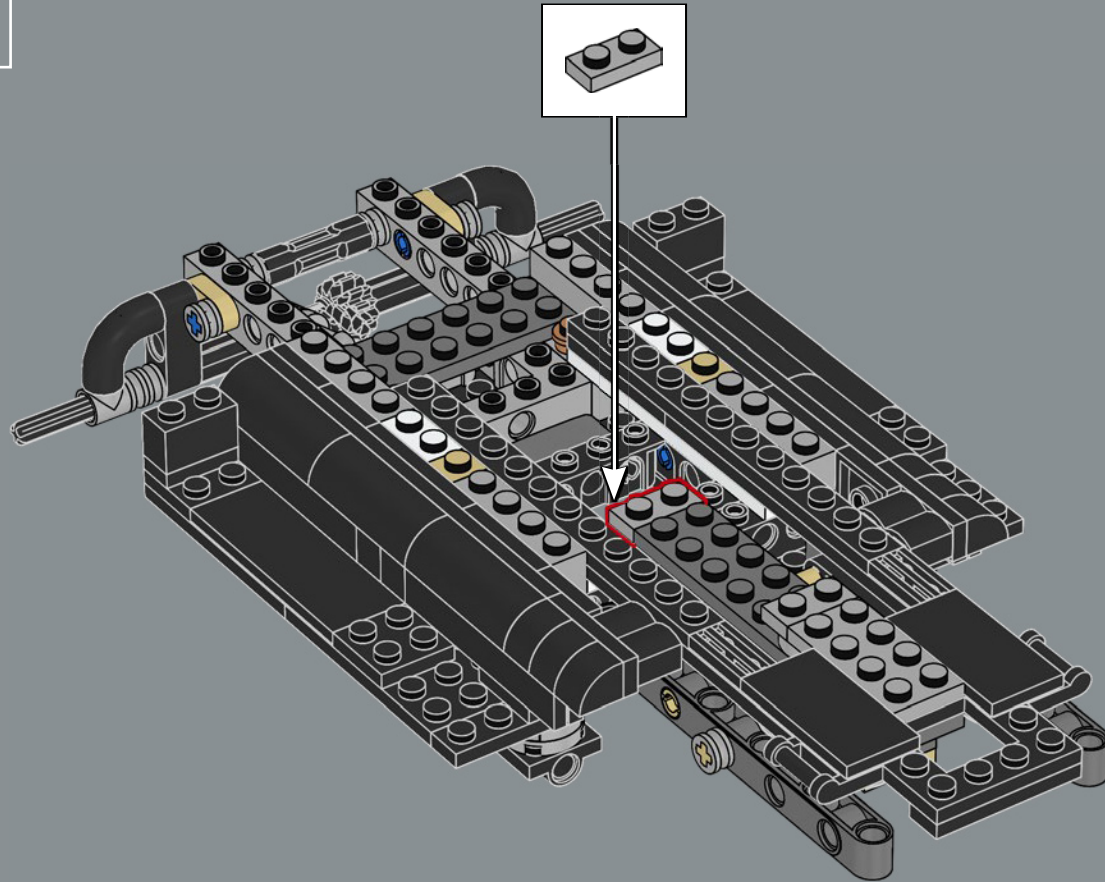

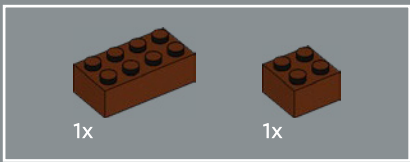

57

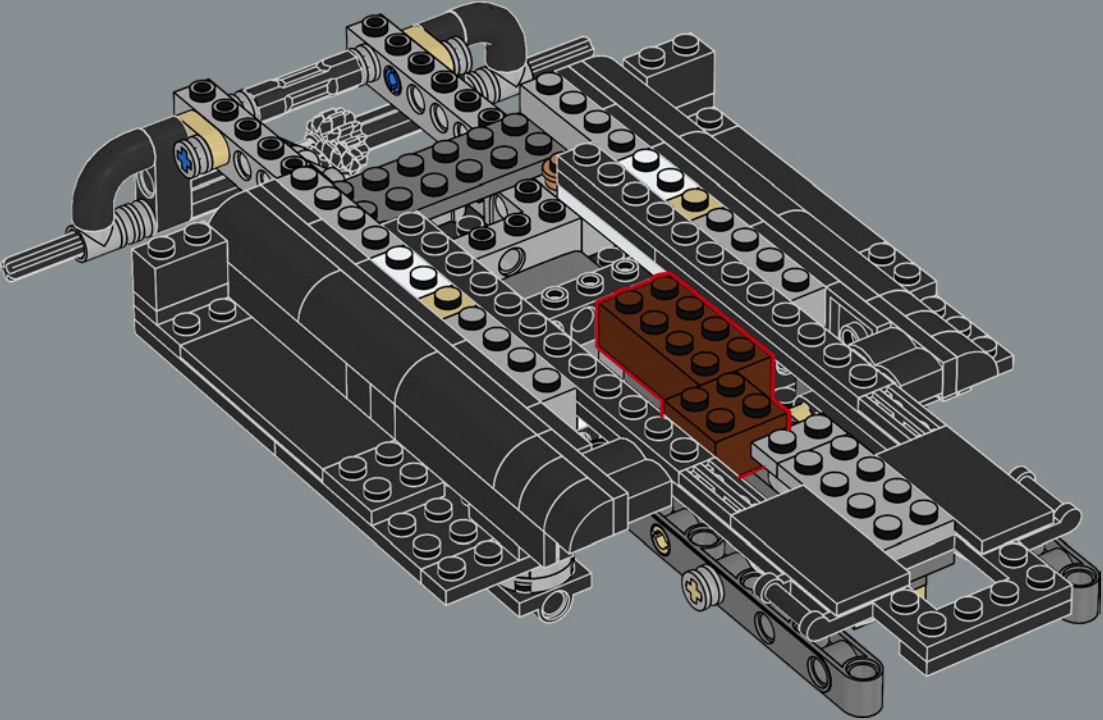

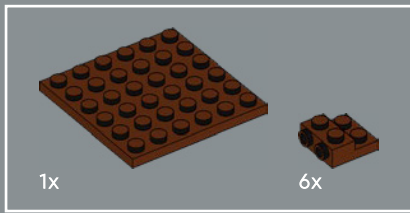

58

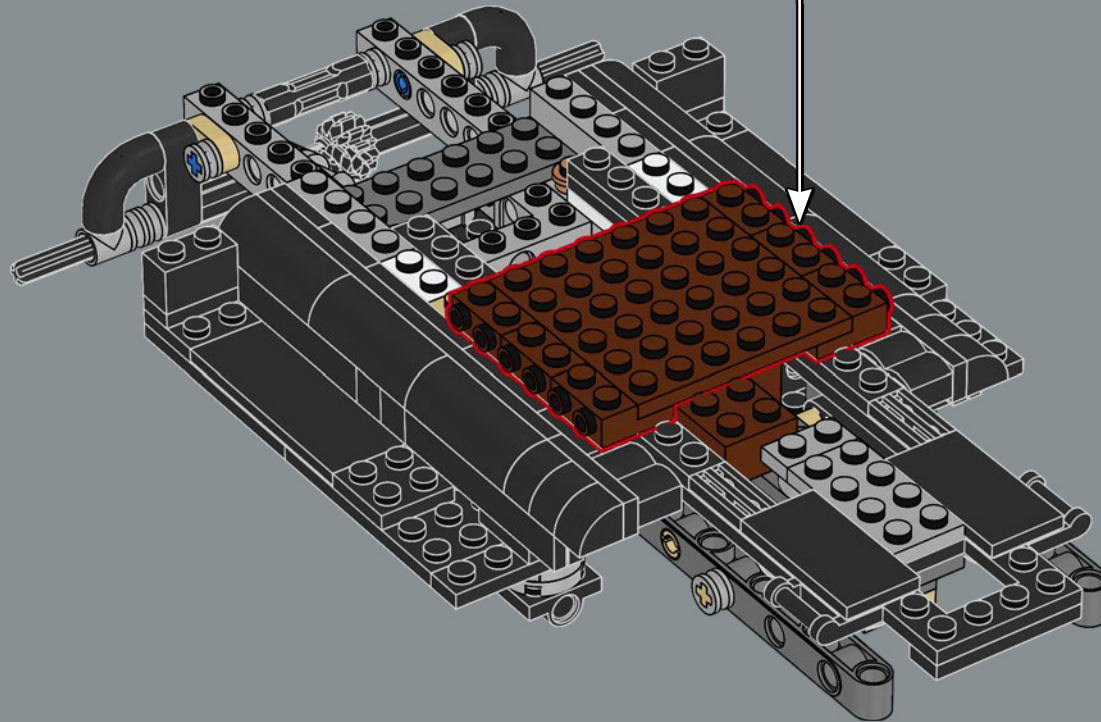
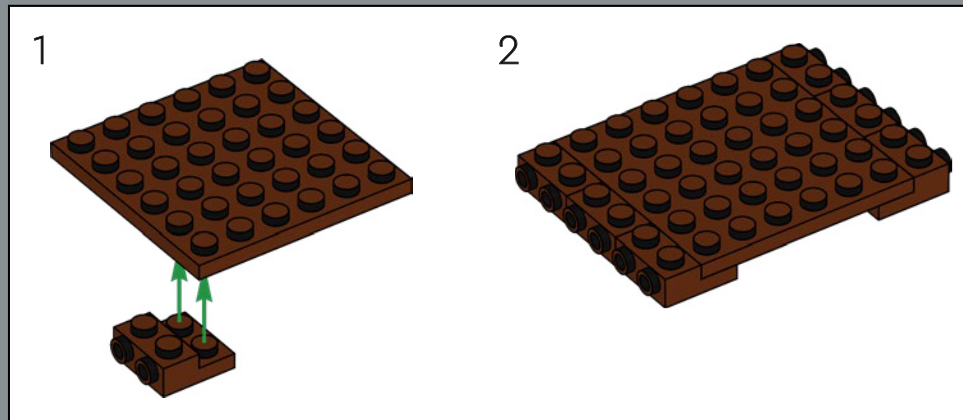



4x

59



La Ford® Model T® fu tra le prime auto prodotte su una linea di montaggio mobile, un progresso industriale che avrebbe abbassato i costi di produzione e reso l'acquisto di un'automobile accessibile.

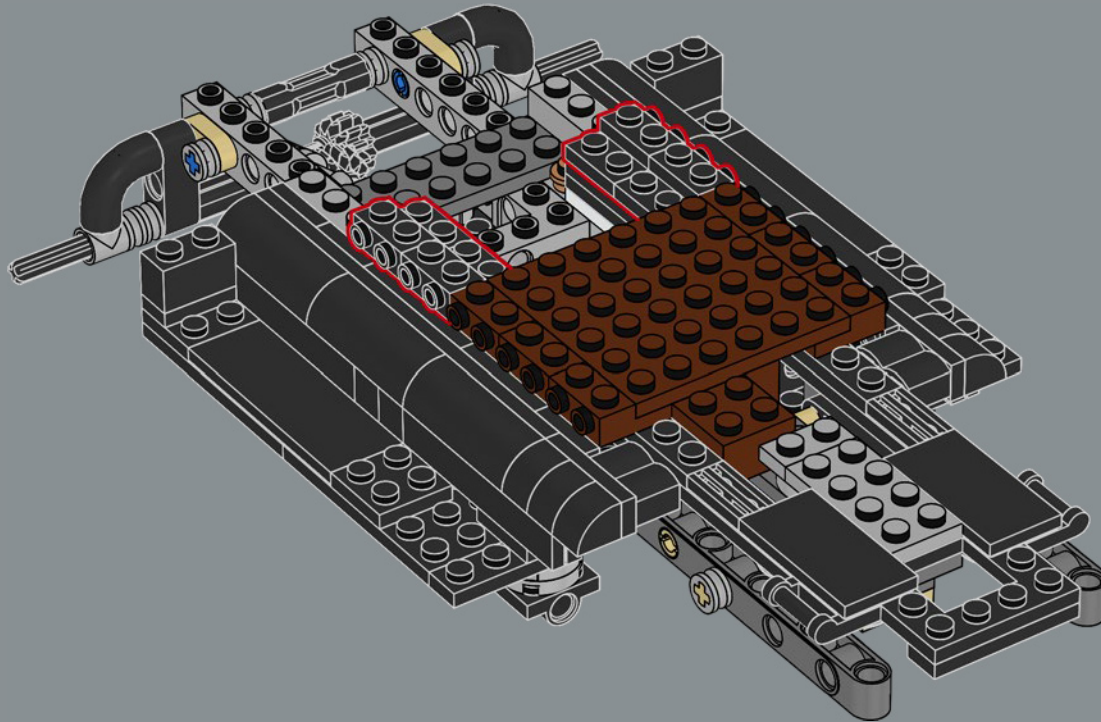

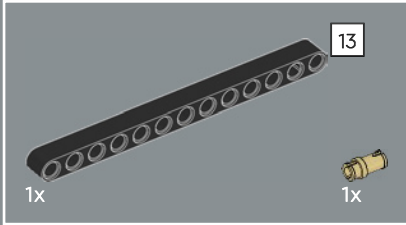
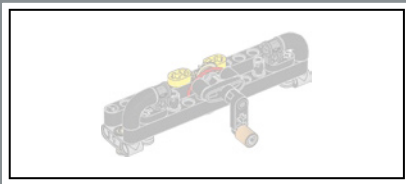

60

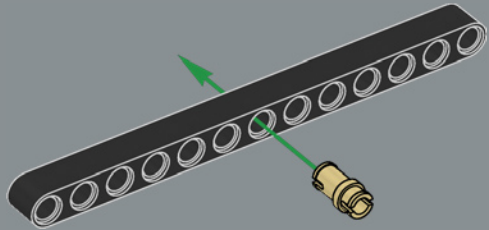

61

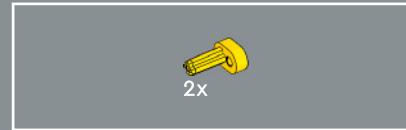
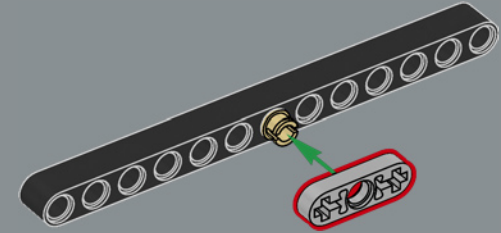

62

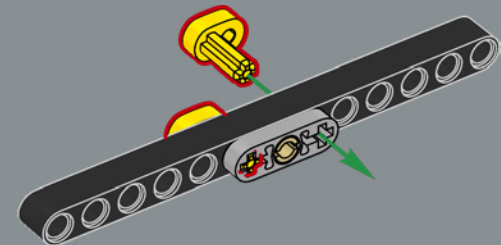



1x

63

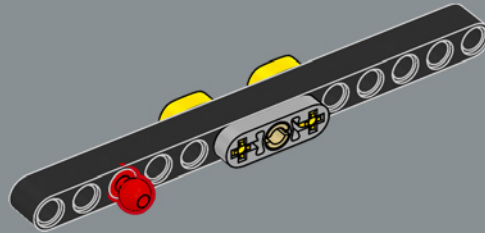

2x



2x

64

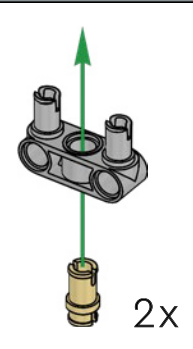
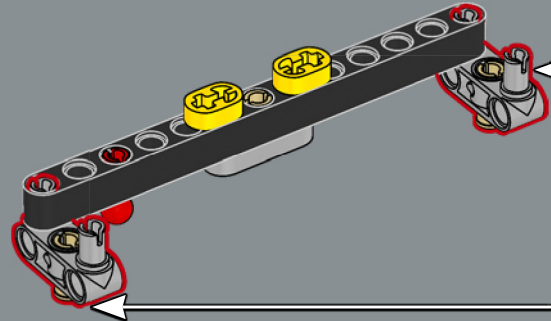

2x

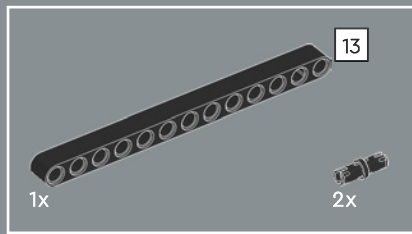

65

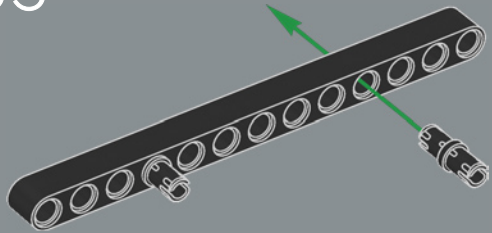

66

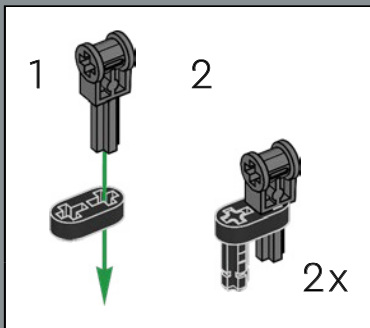
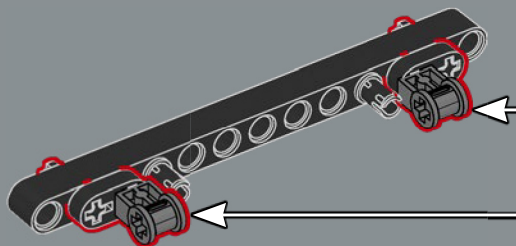

67

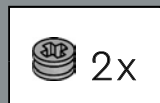
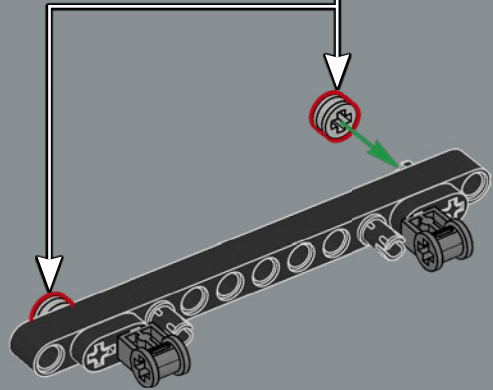

68

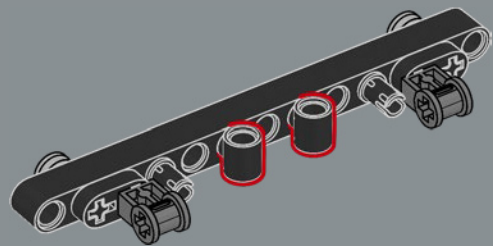

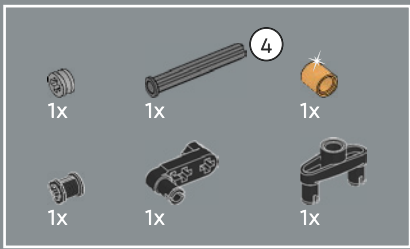

69

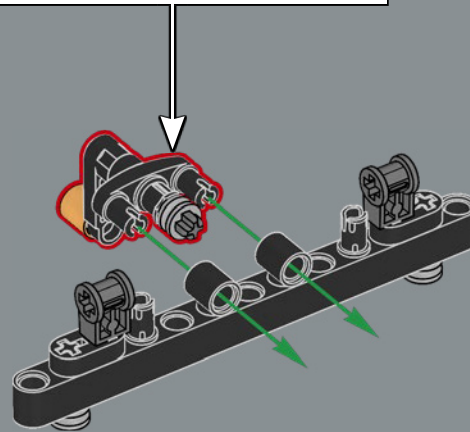
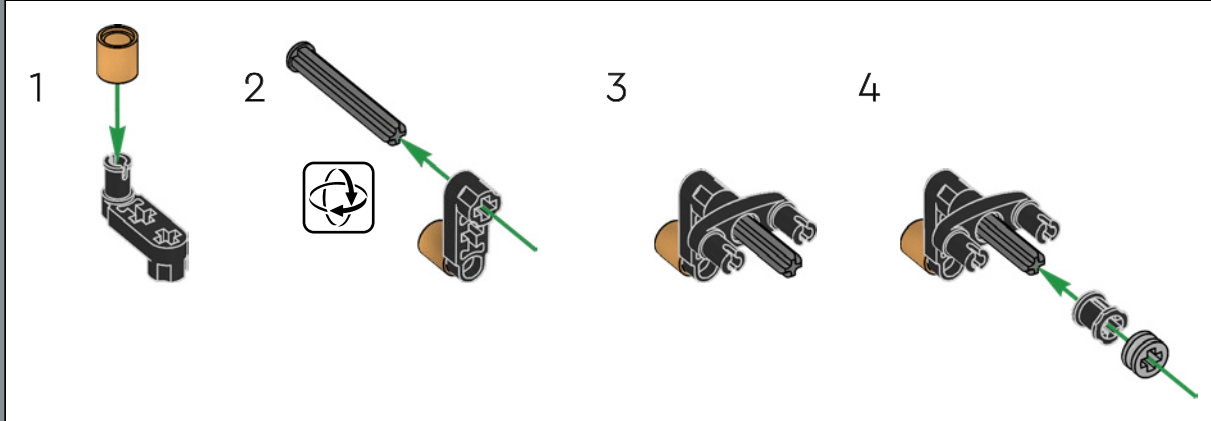



70

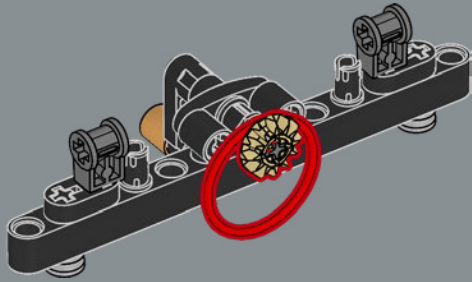

71

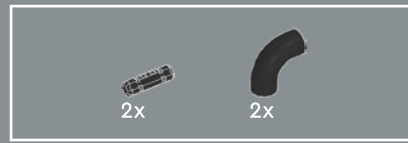
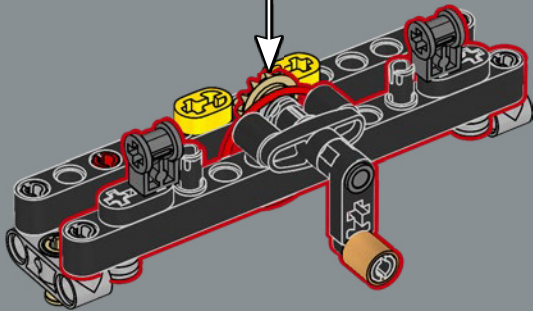

72

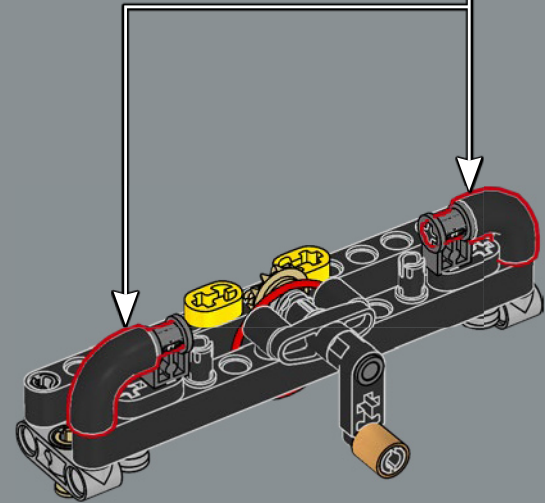
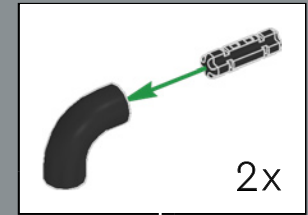



Per avviare il motore,
i conducenti utilizzavano una
manovella manuale.

73

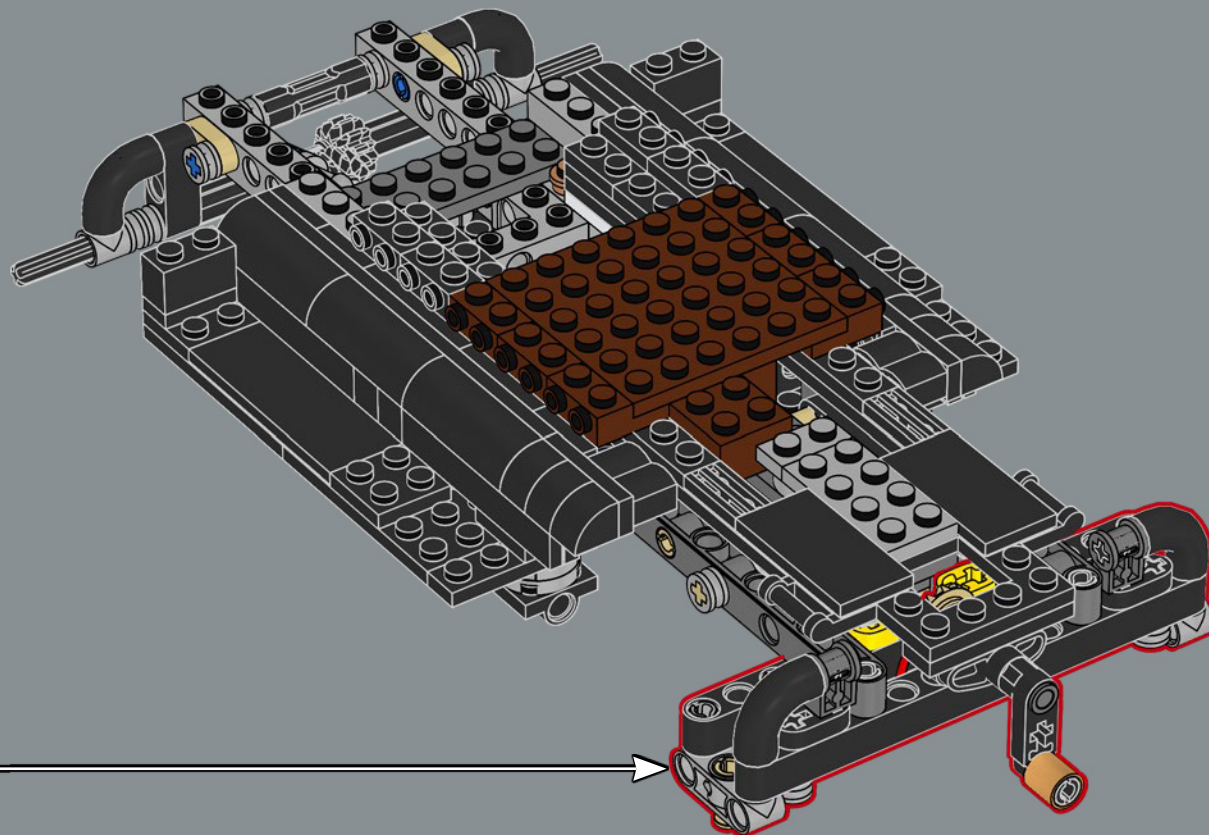

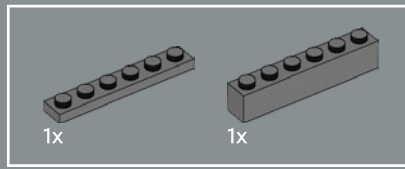

74

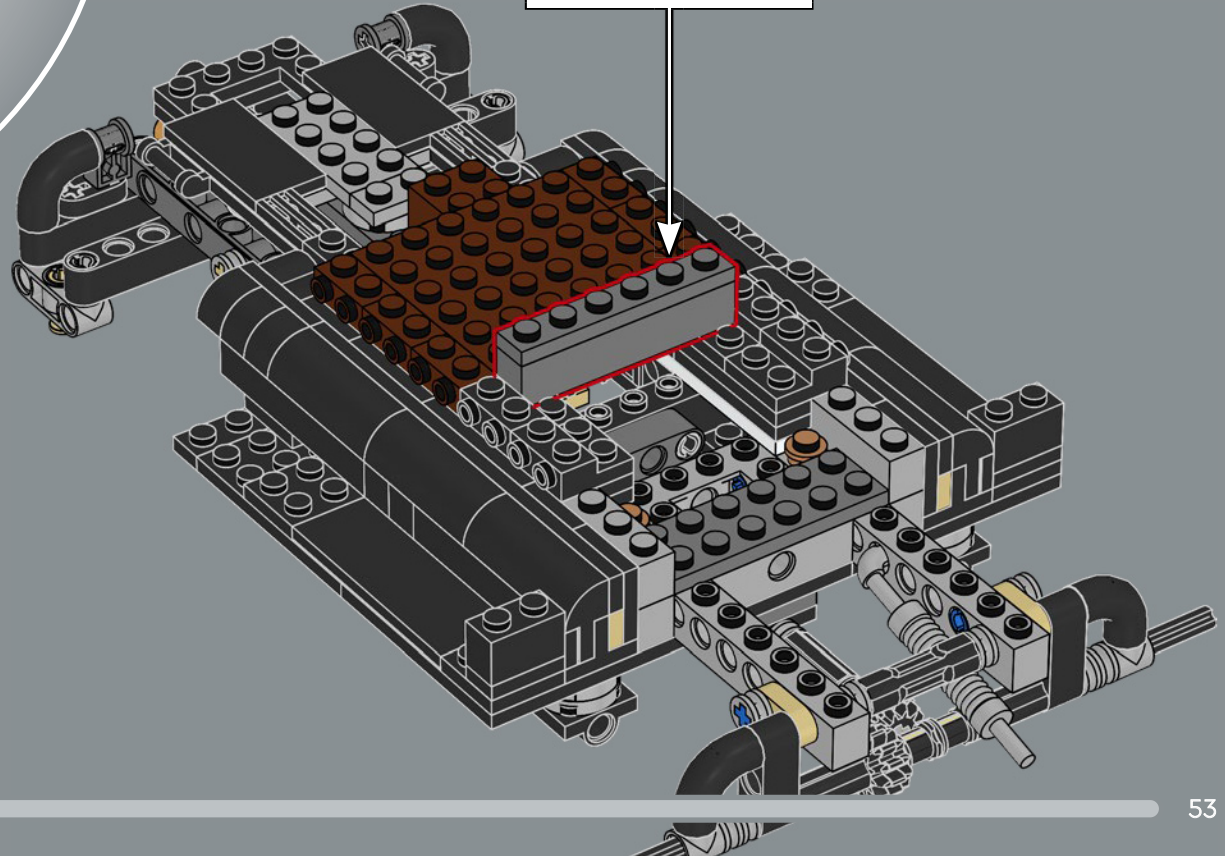
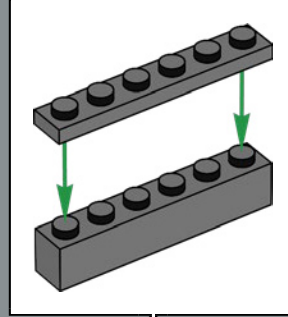

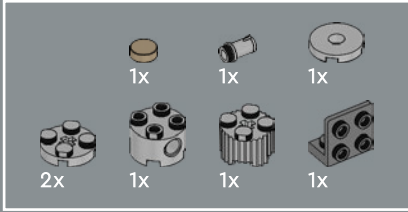
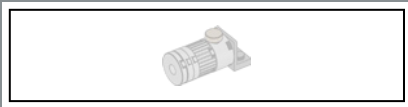

75

1

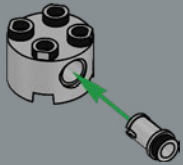

2



3

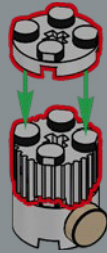

4

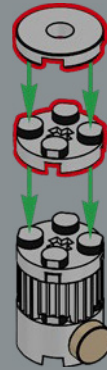

5

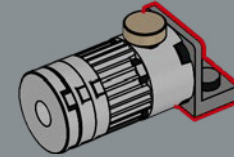



Come nuova caratteristica, il serbatoio del carburante era posizionato sotto il sedile del conducente e i guidatori dovevano sollevare il cuscino del sedile per riempire il serbatoio.

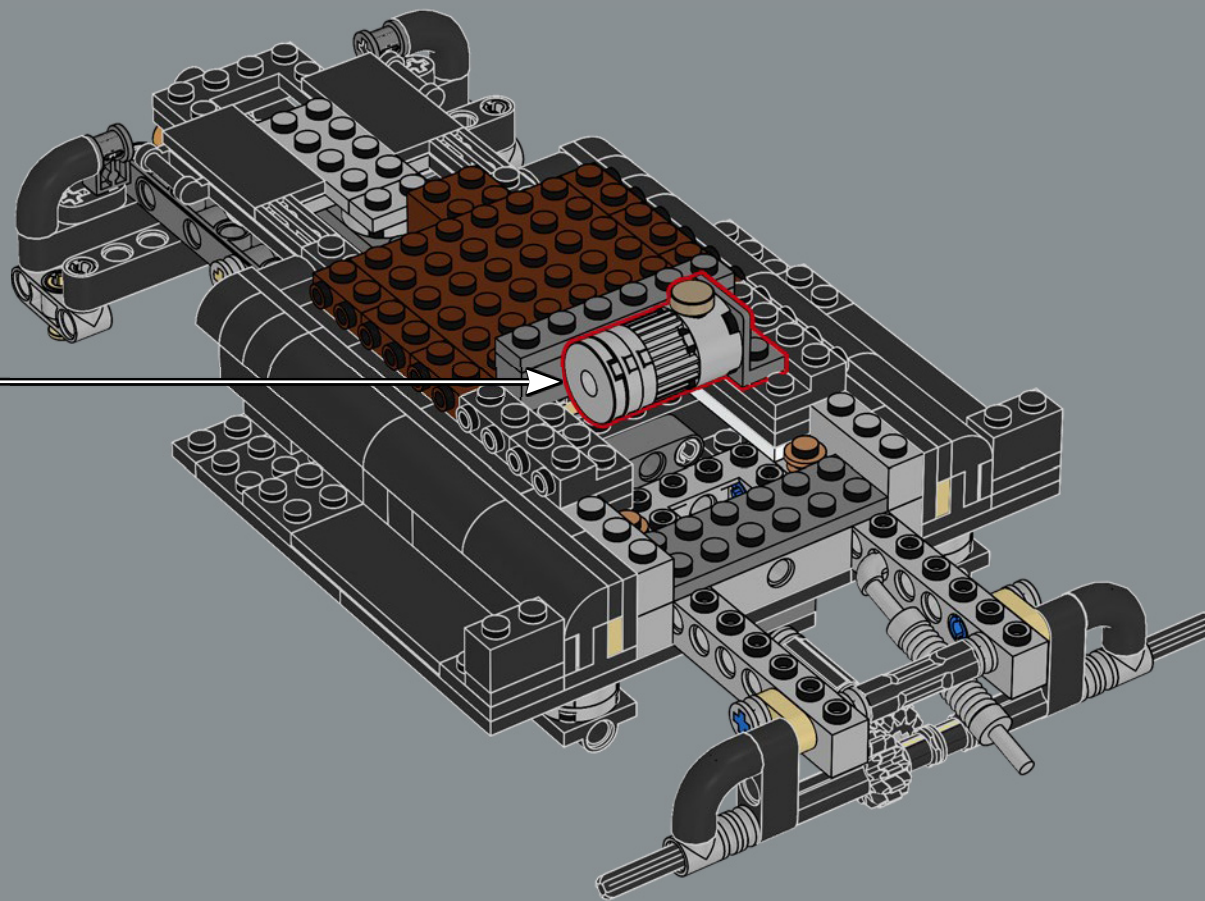

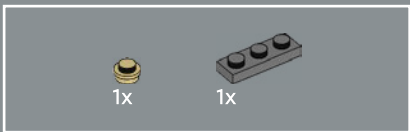

76

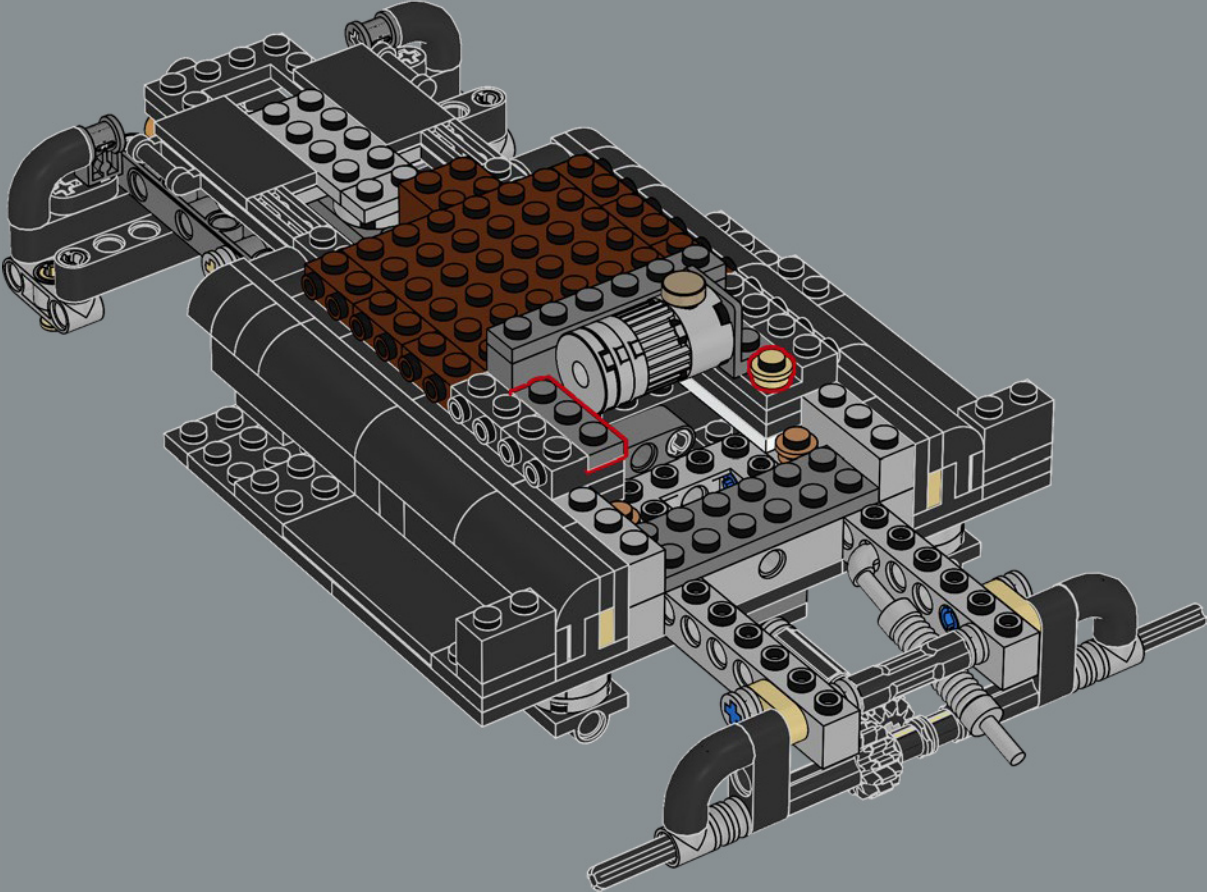

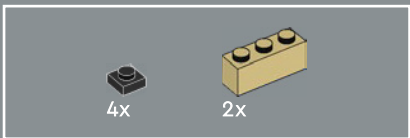

77

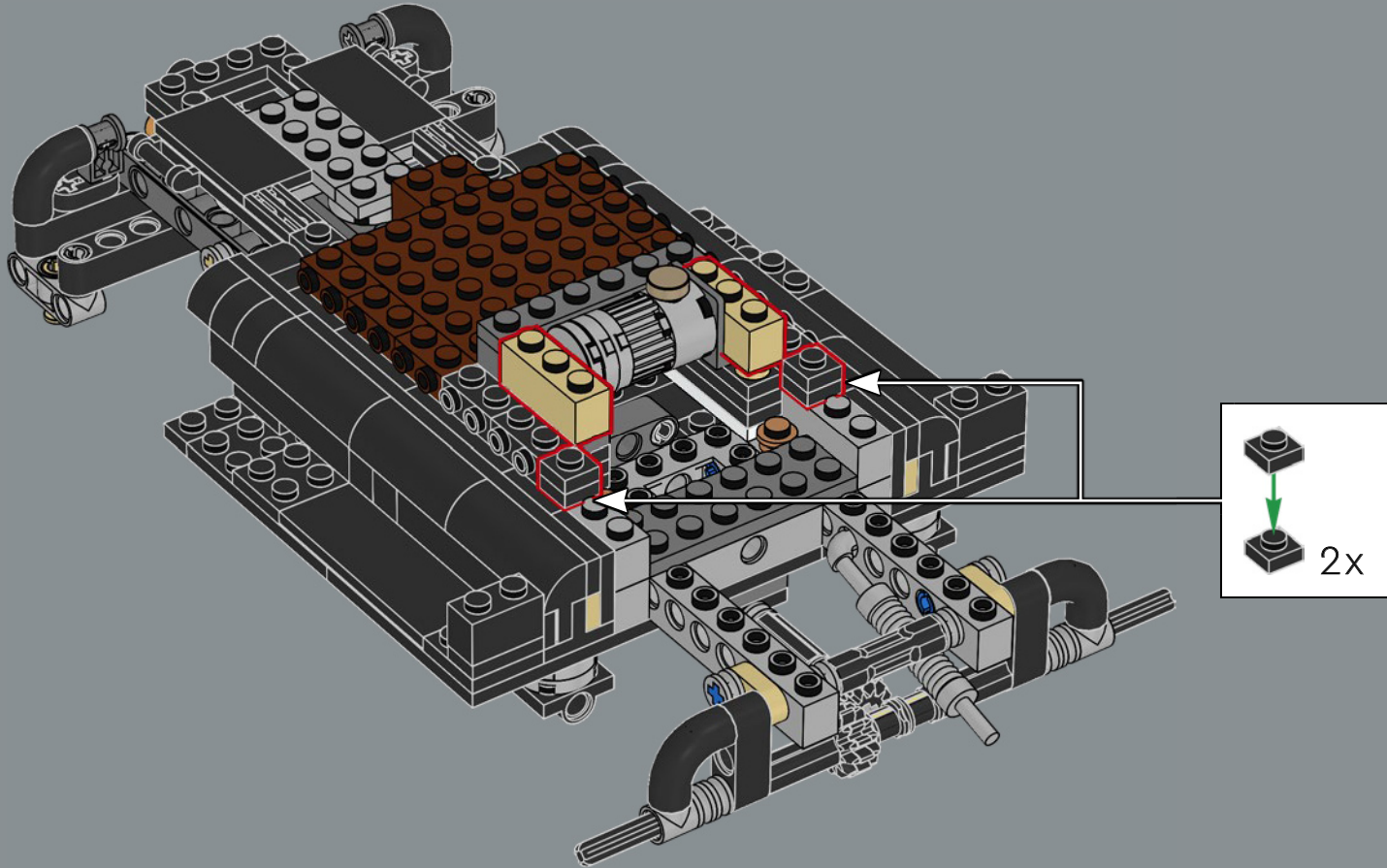



2x



4x

78

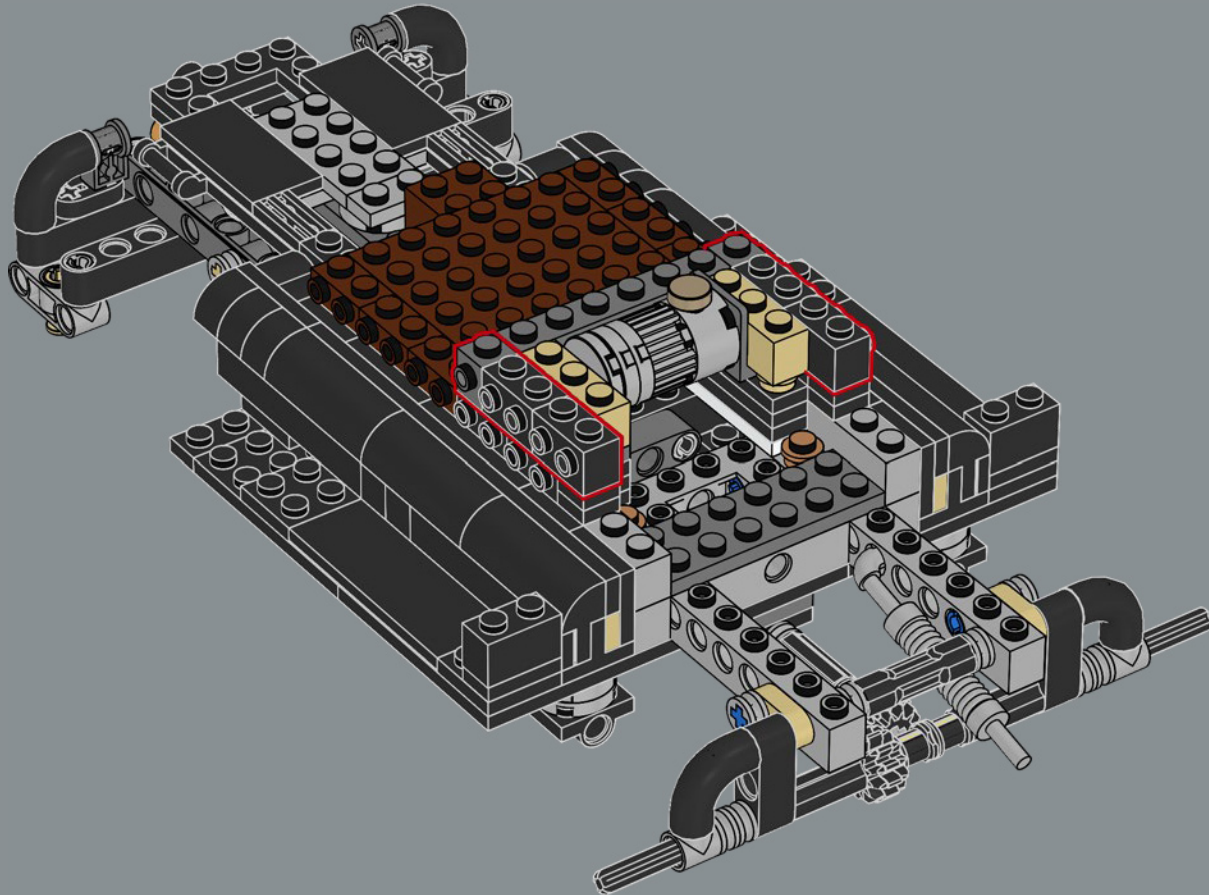

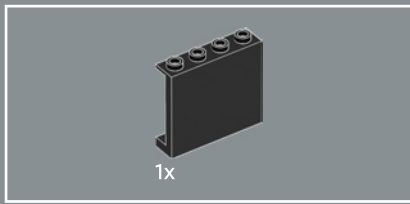

79

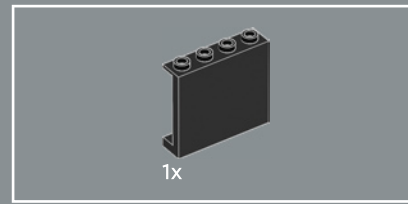
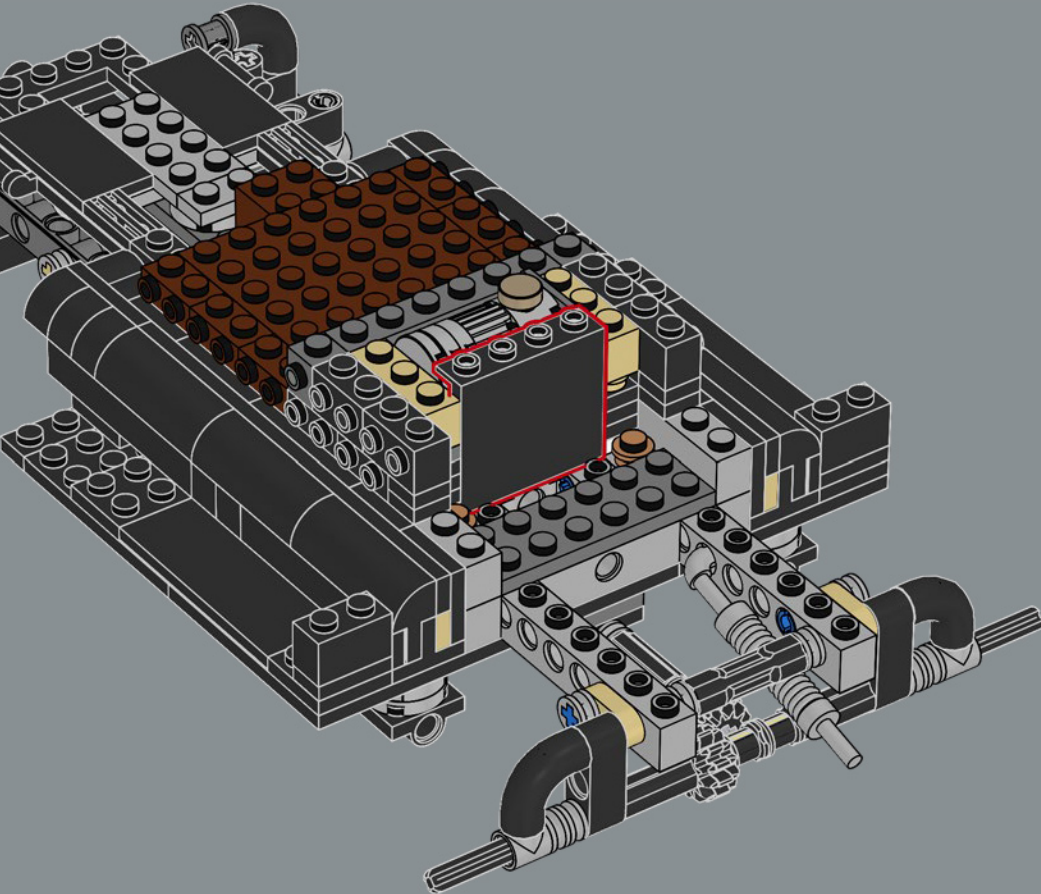

80

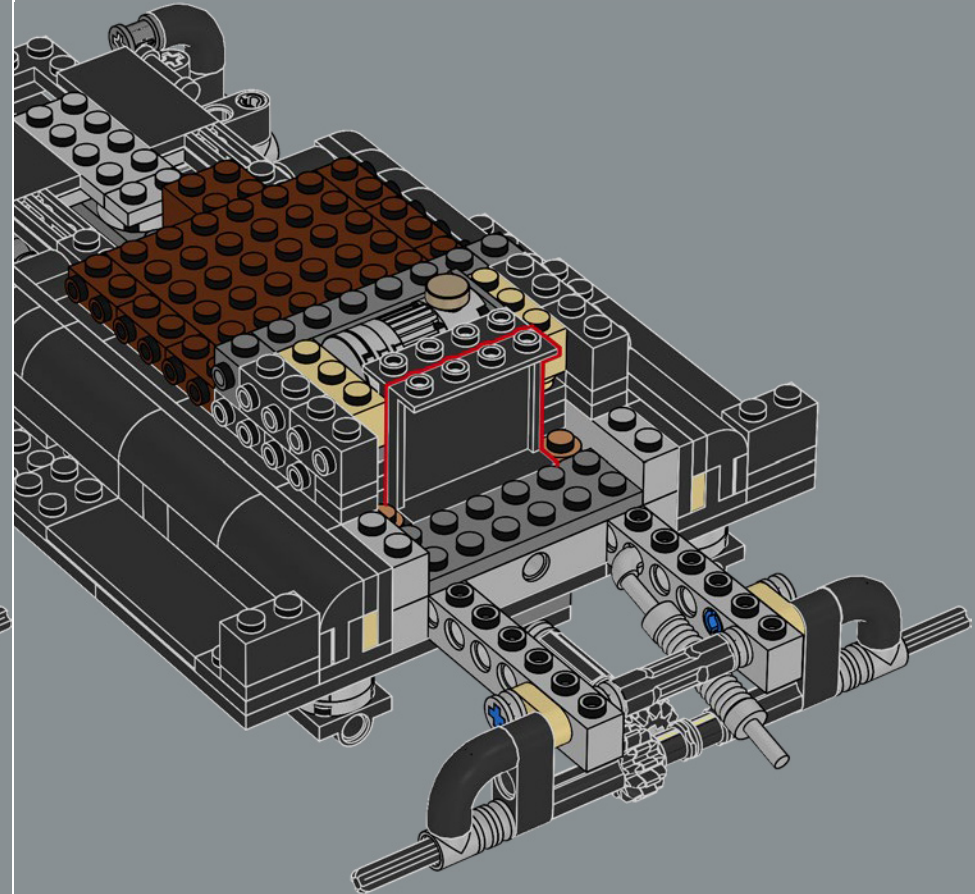

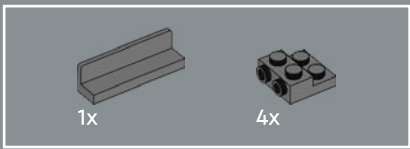

81

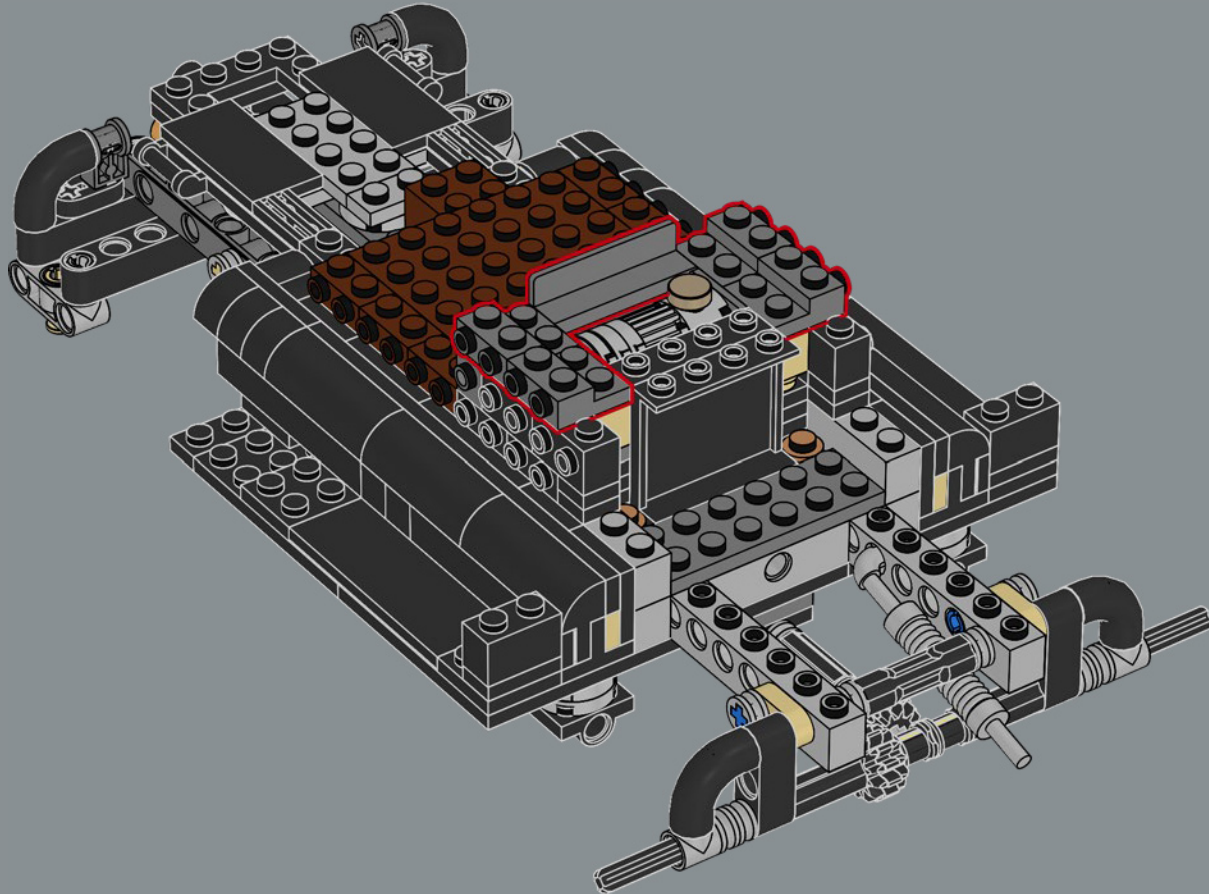

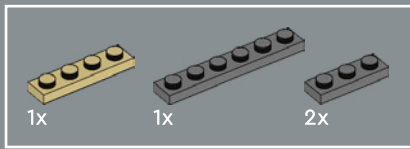

82

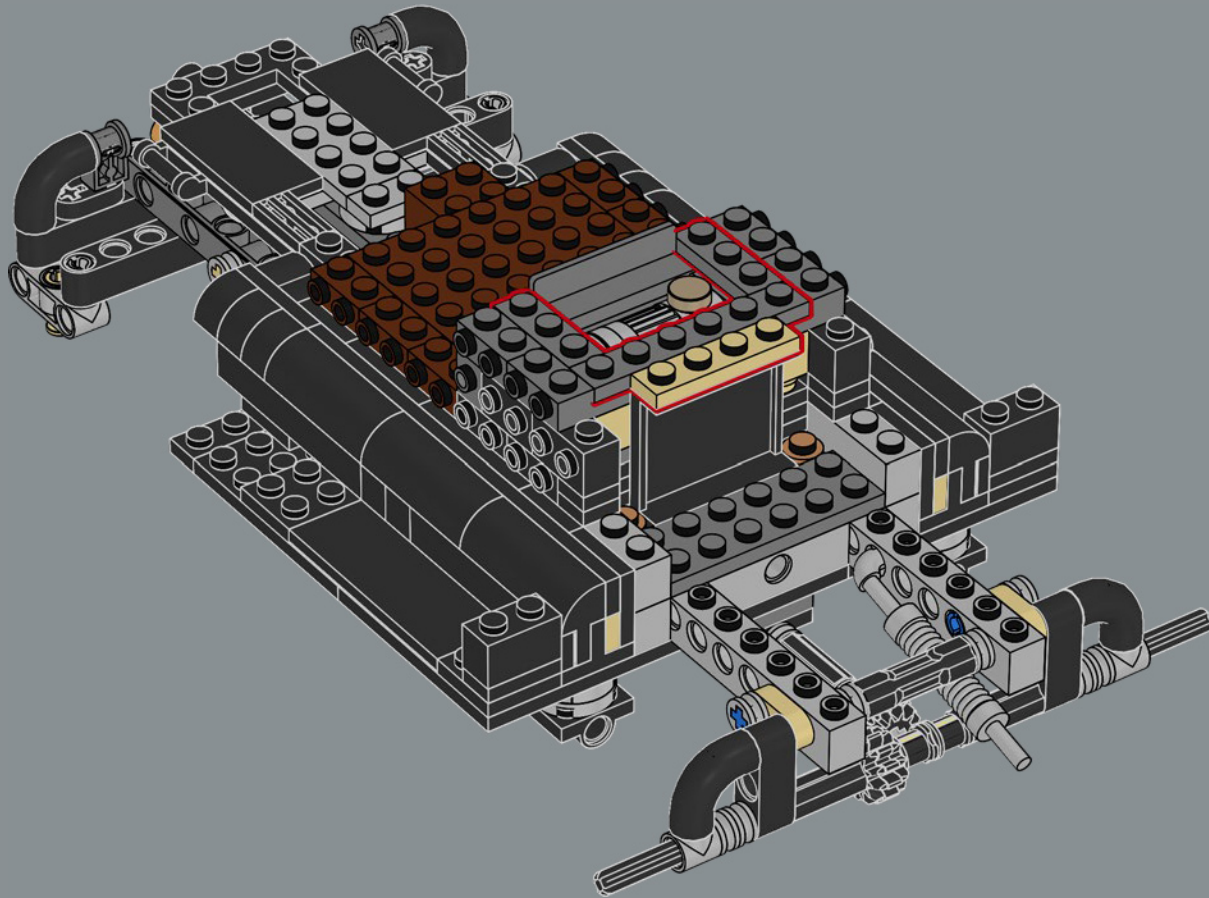

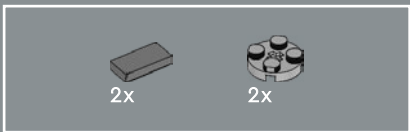

83

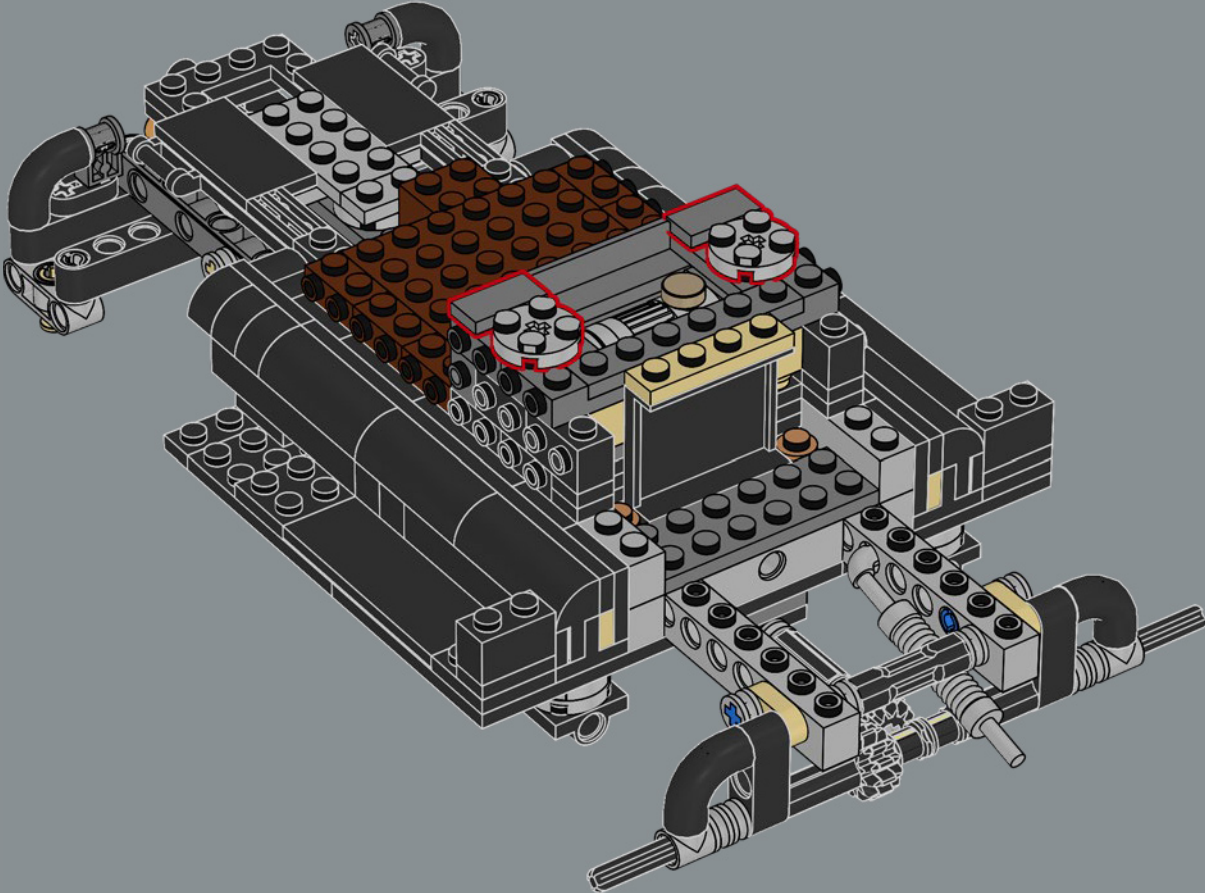

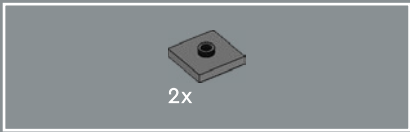

84

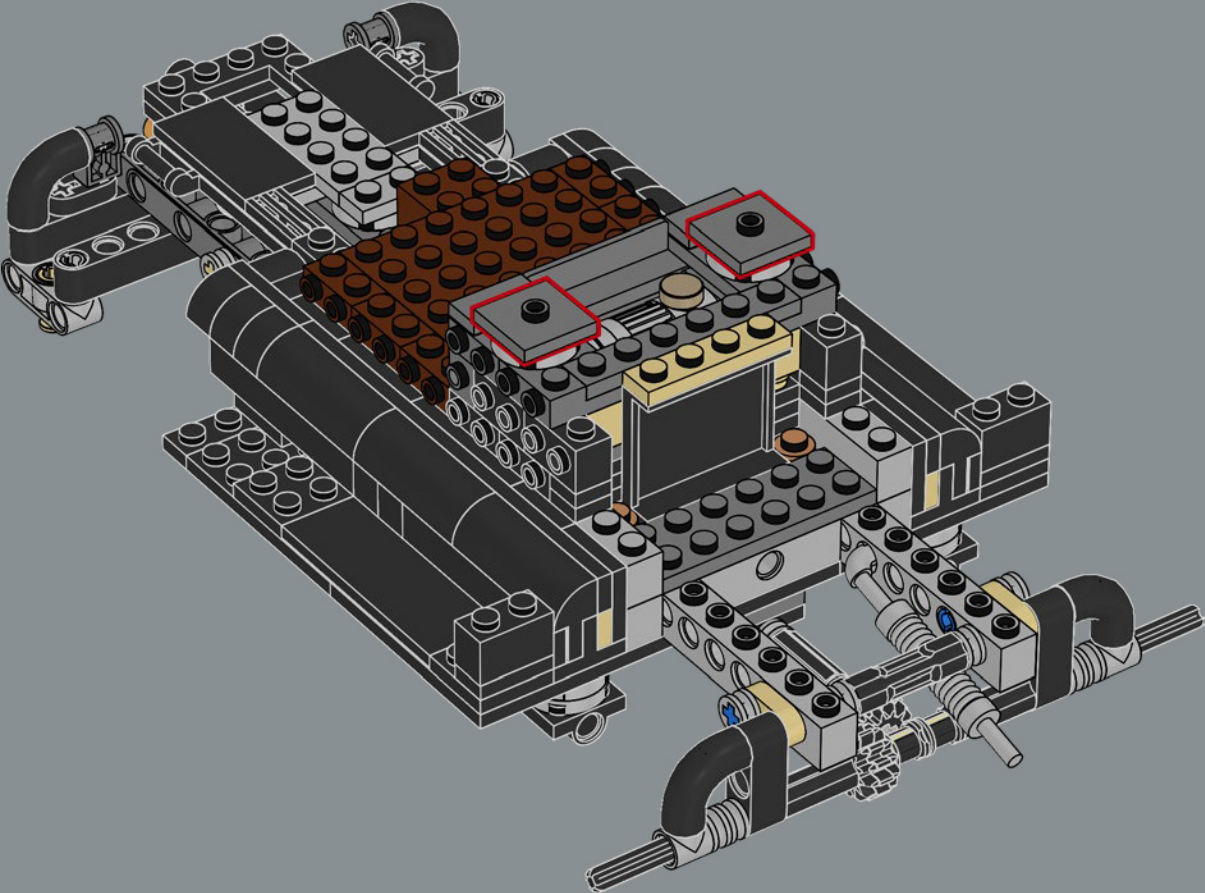



88

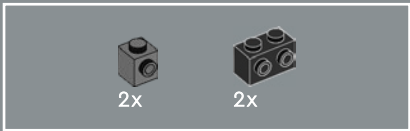
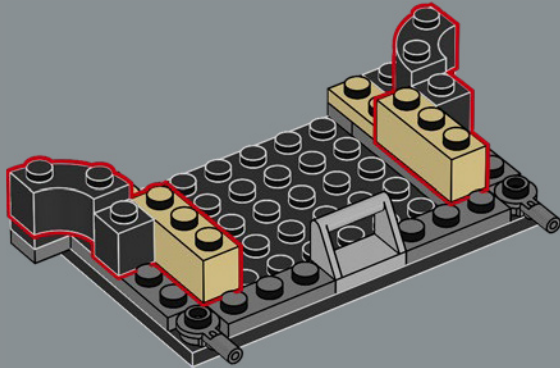

89

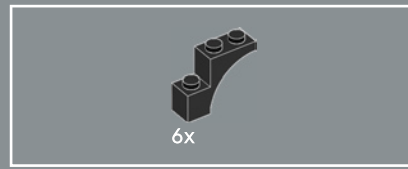
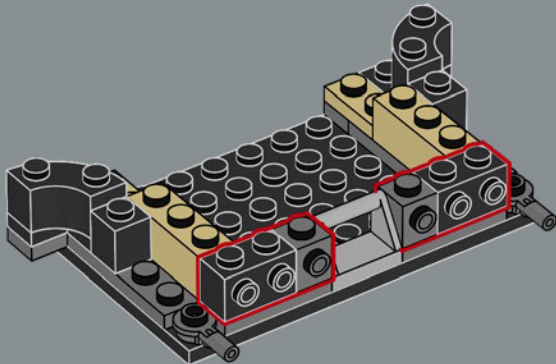

90

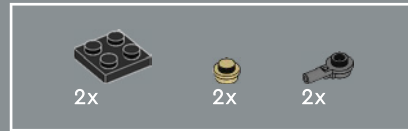
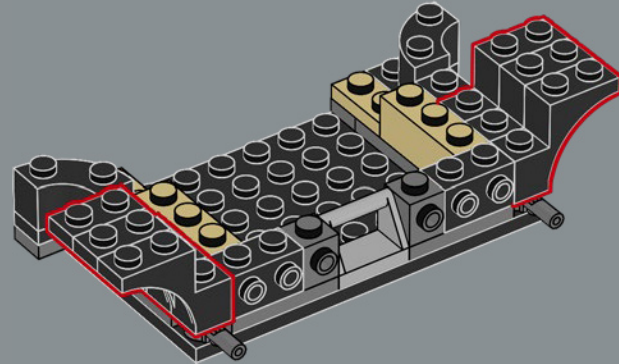

91

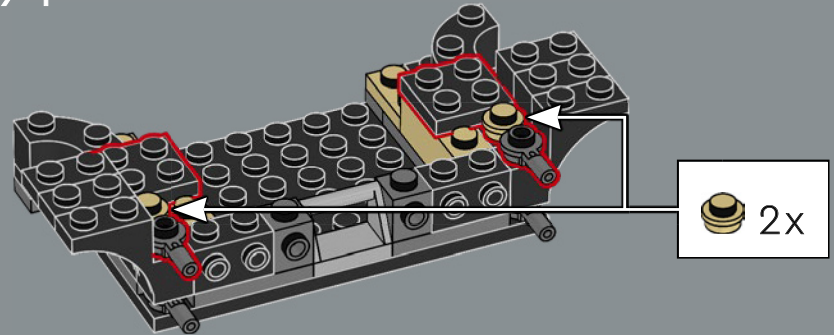

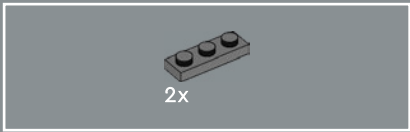

92

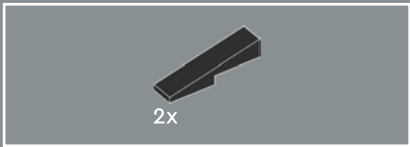
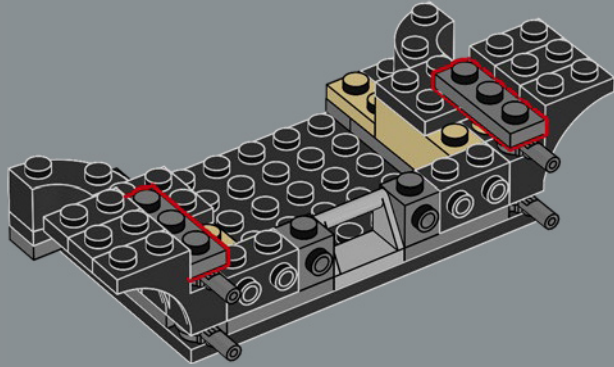

93

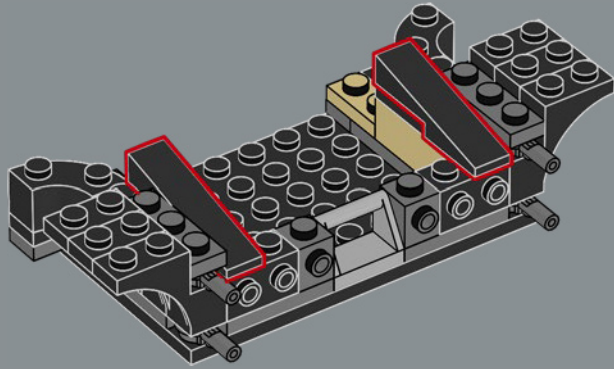

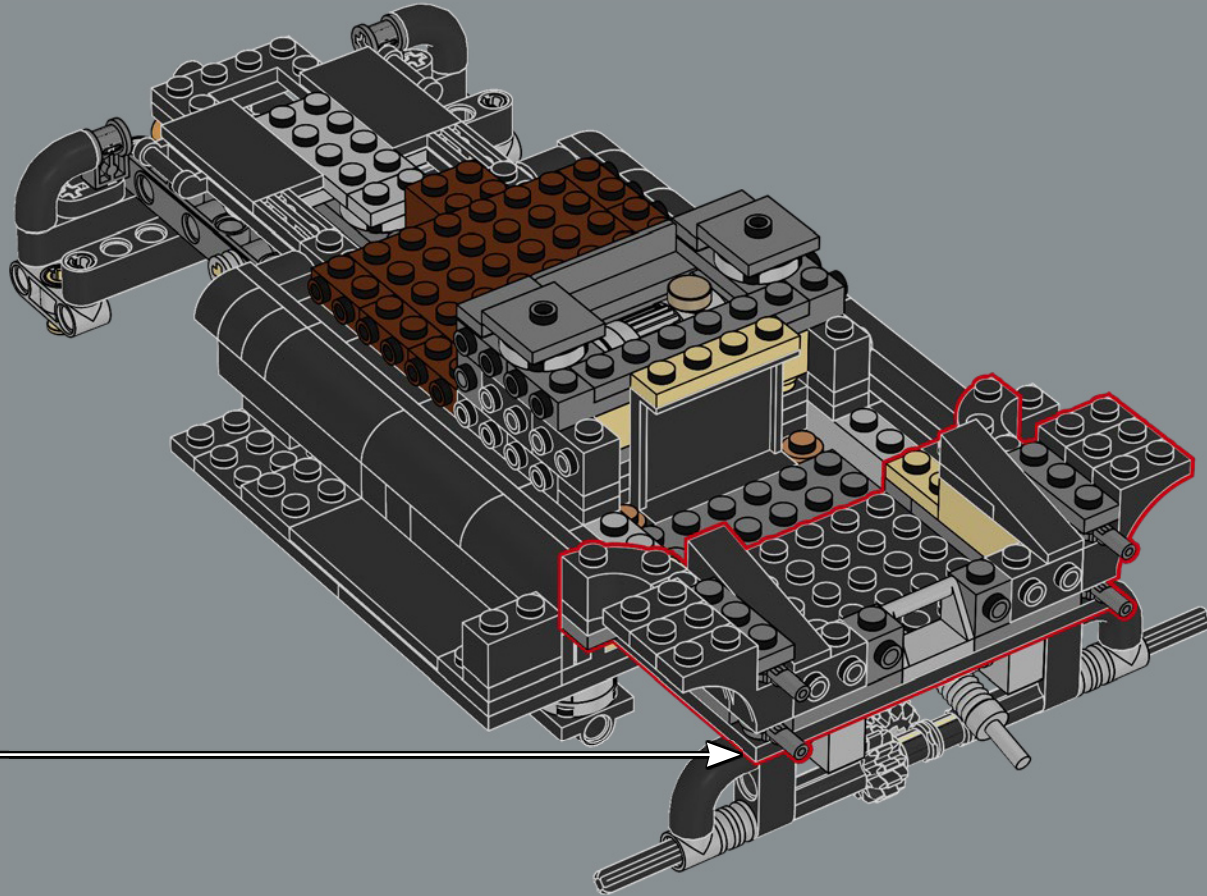

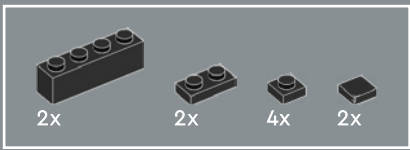

95

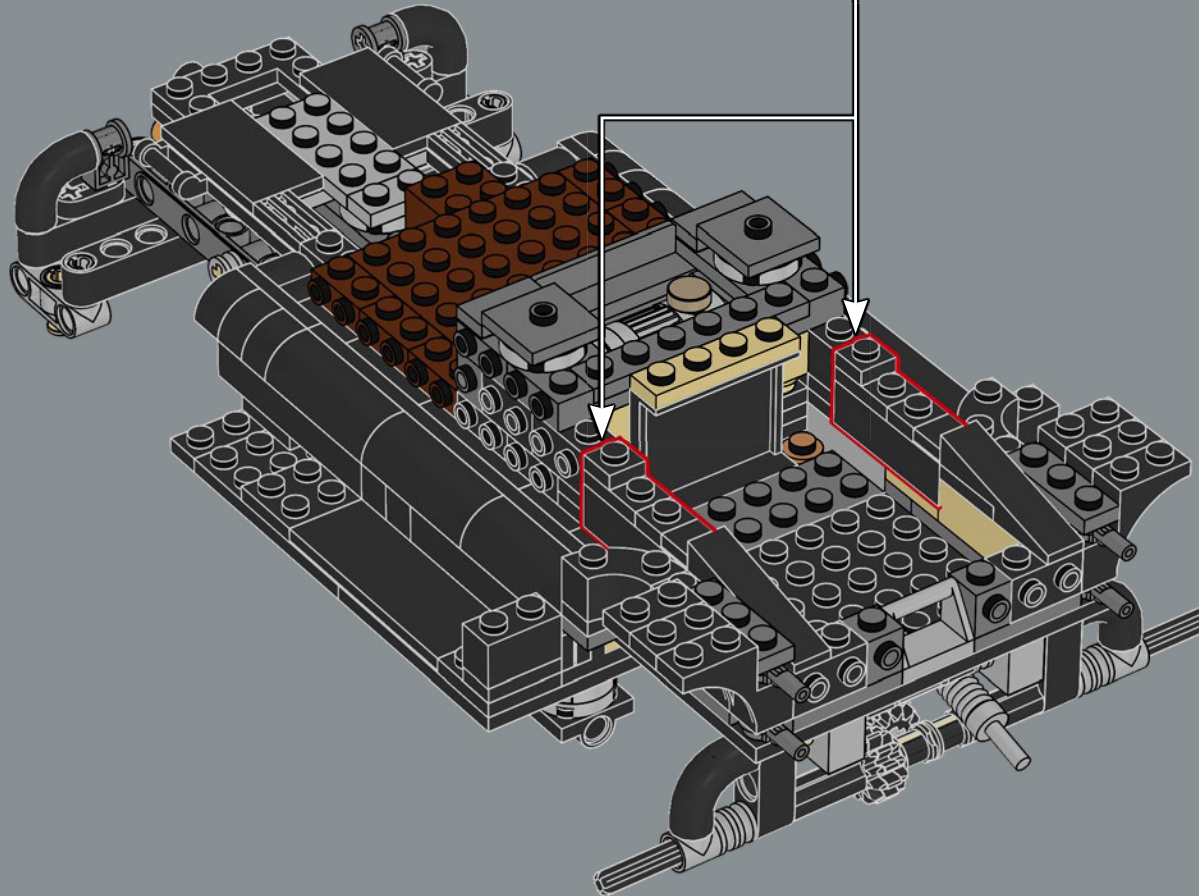
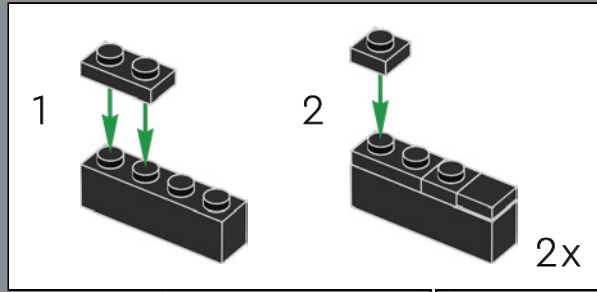

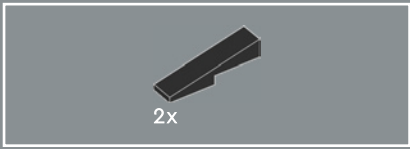

96

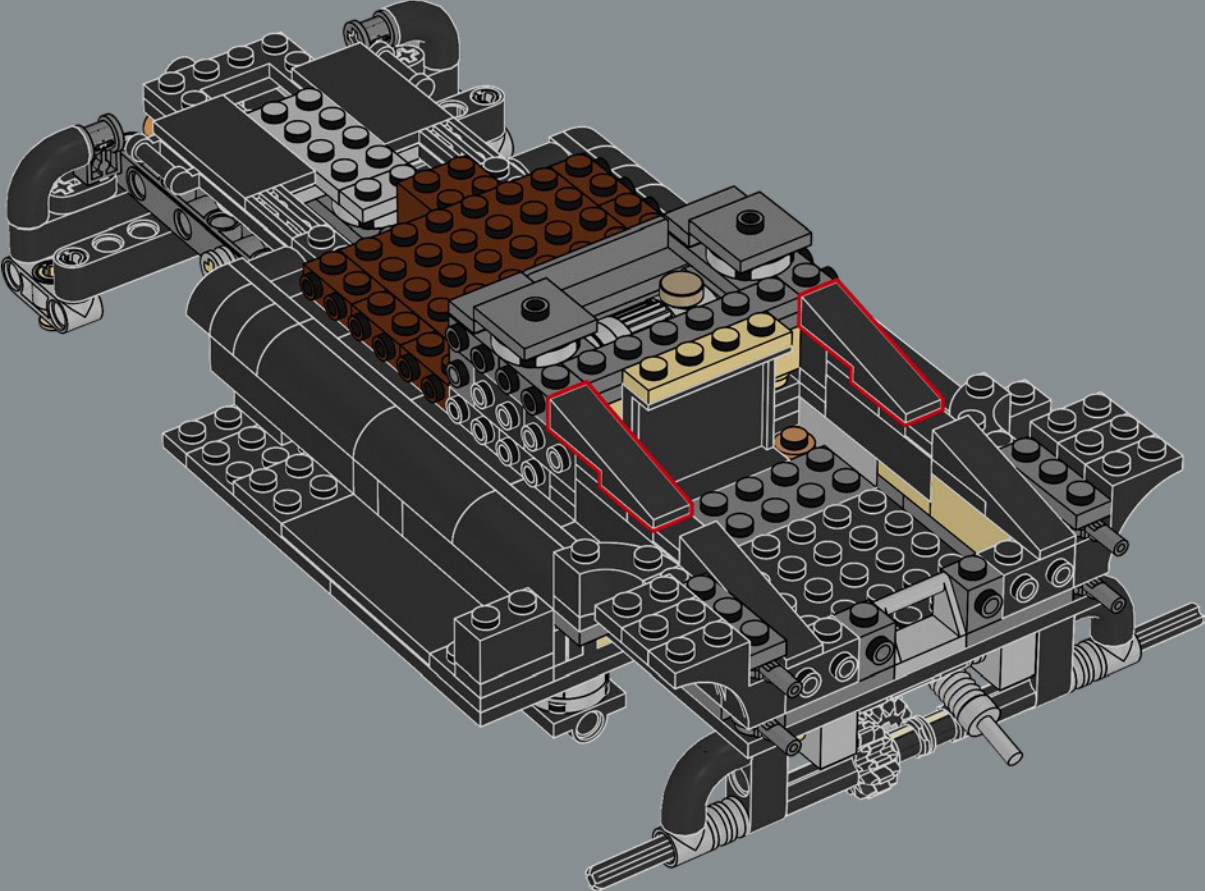

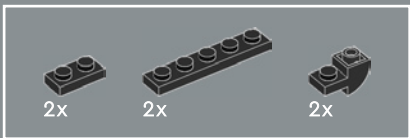

97

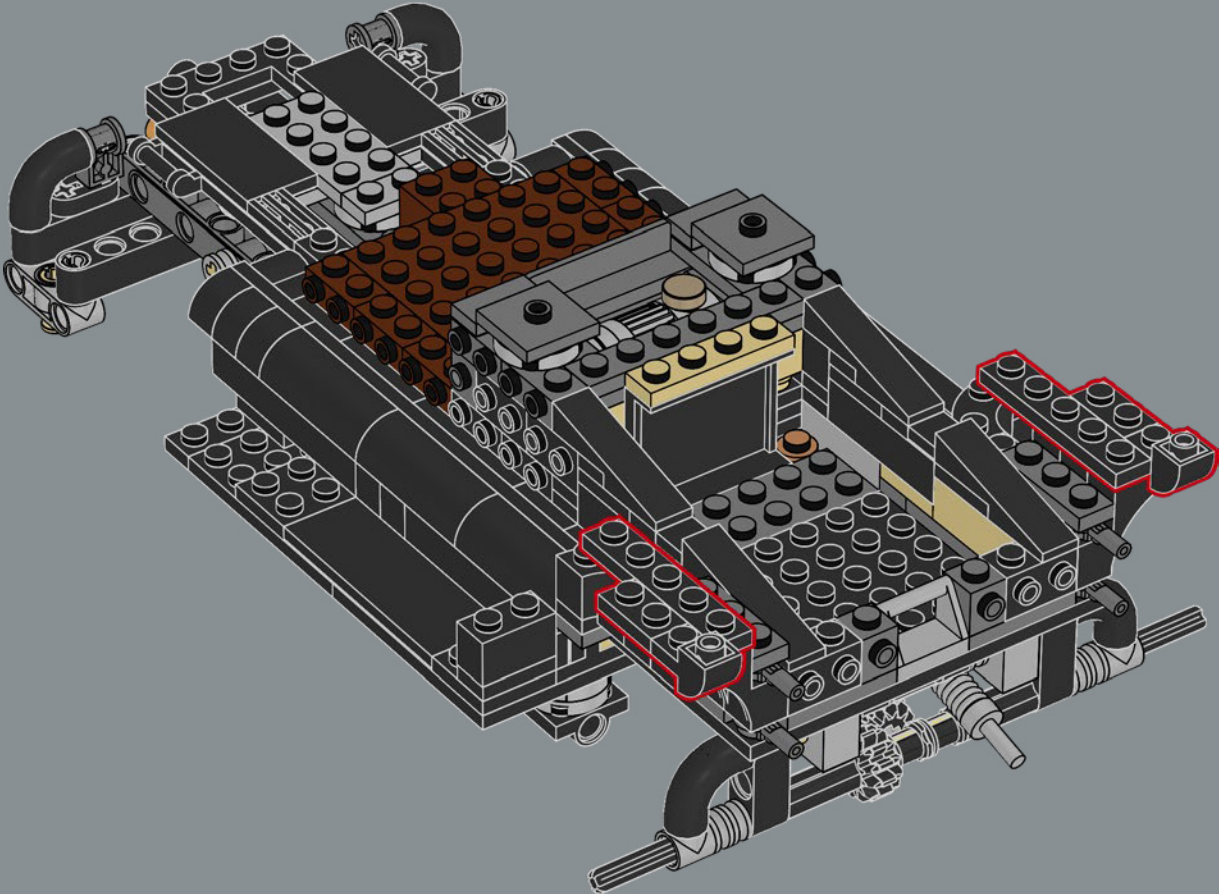

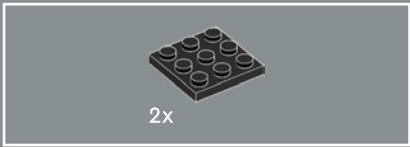

98

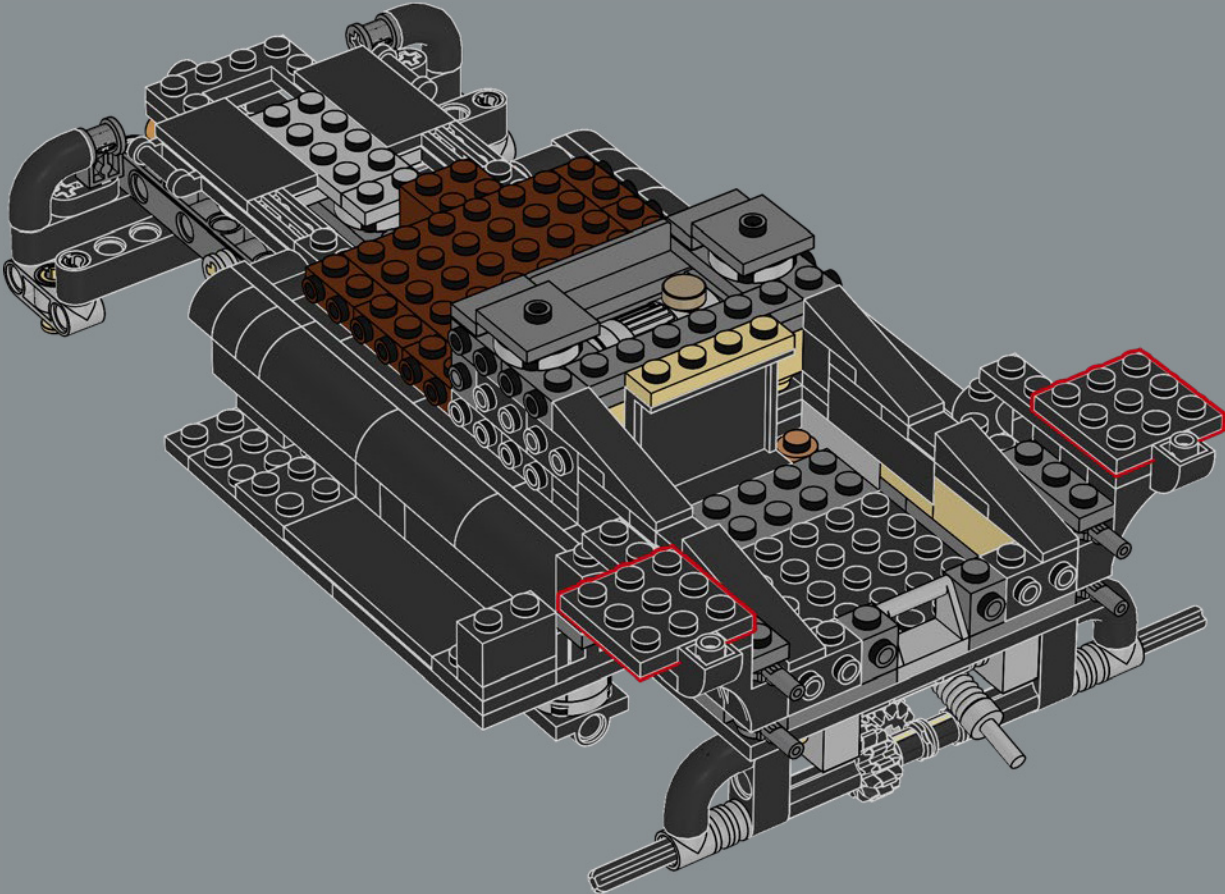



2x



2x

99

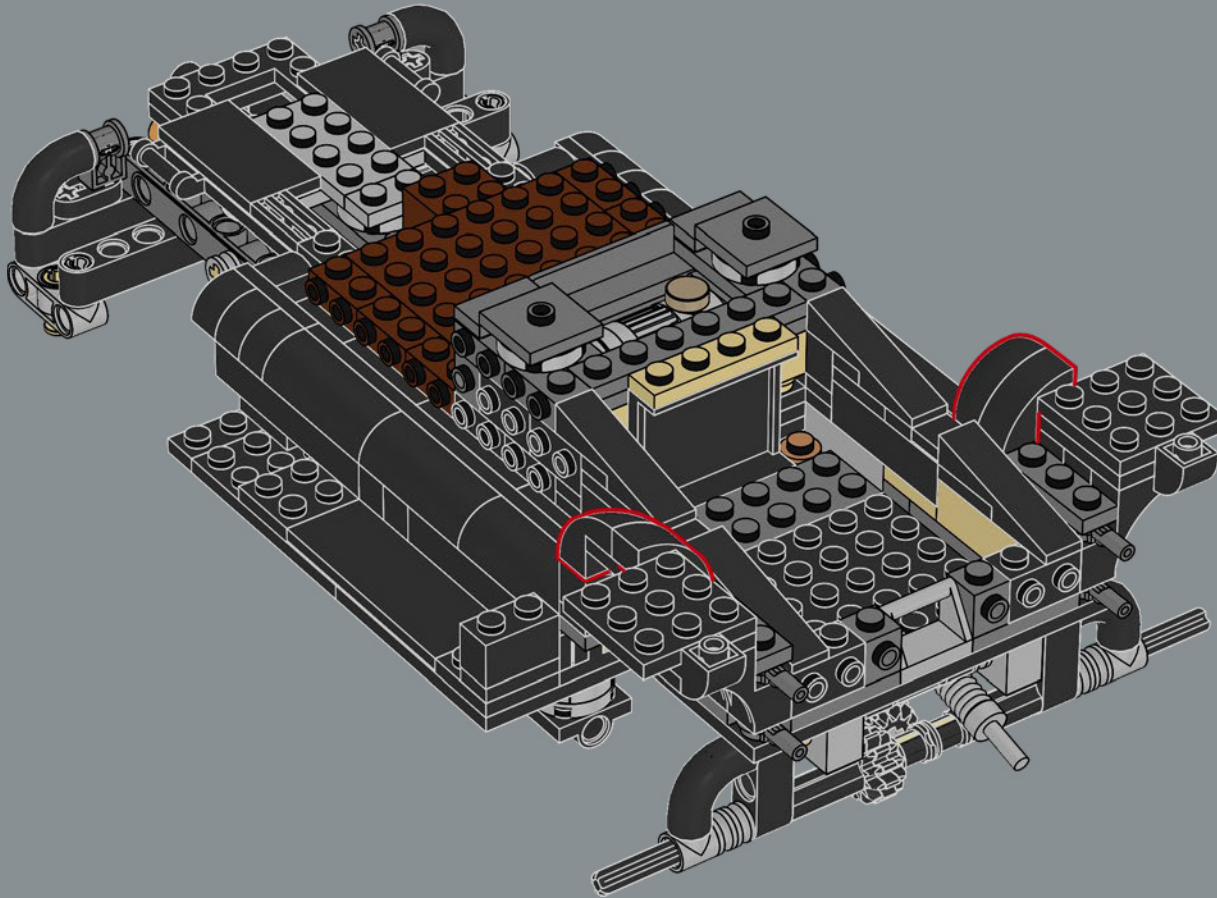



100

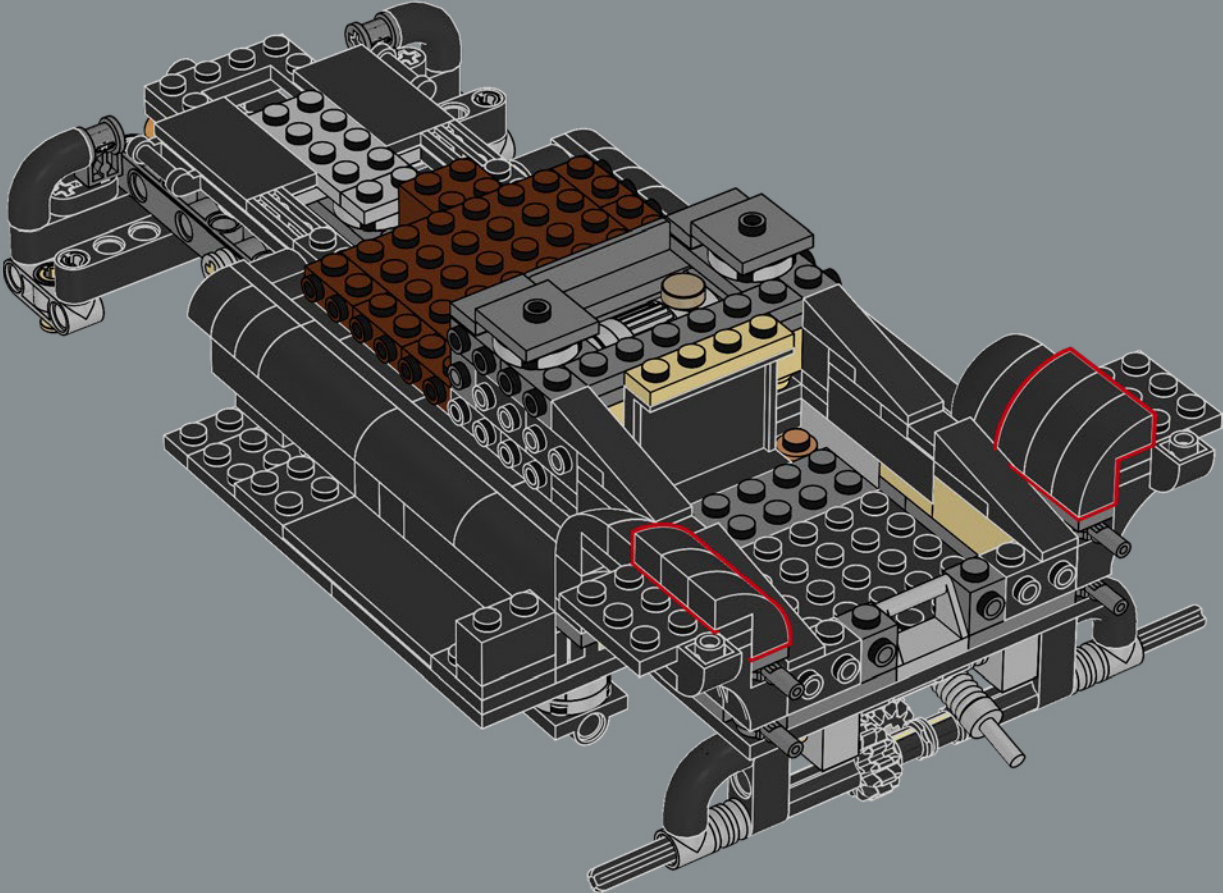

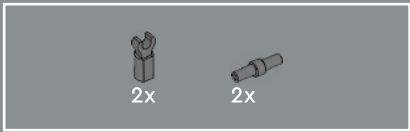

101

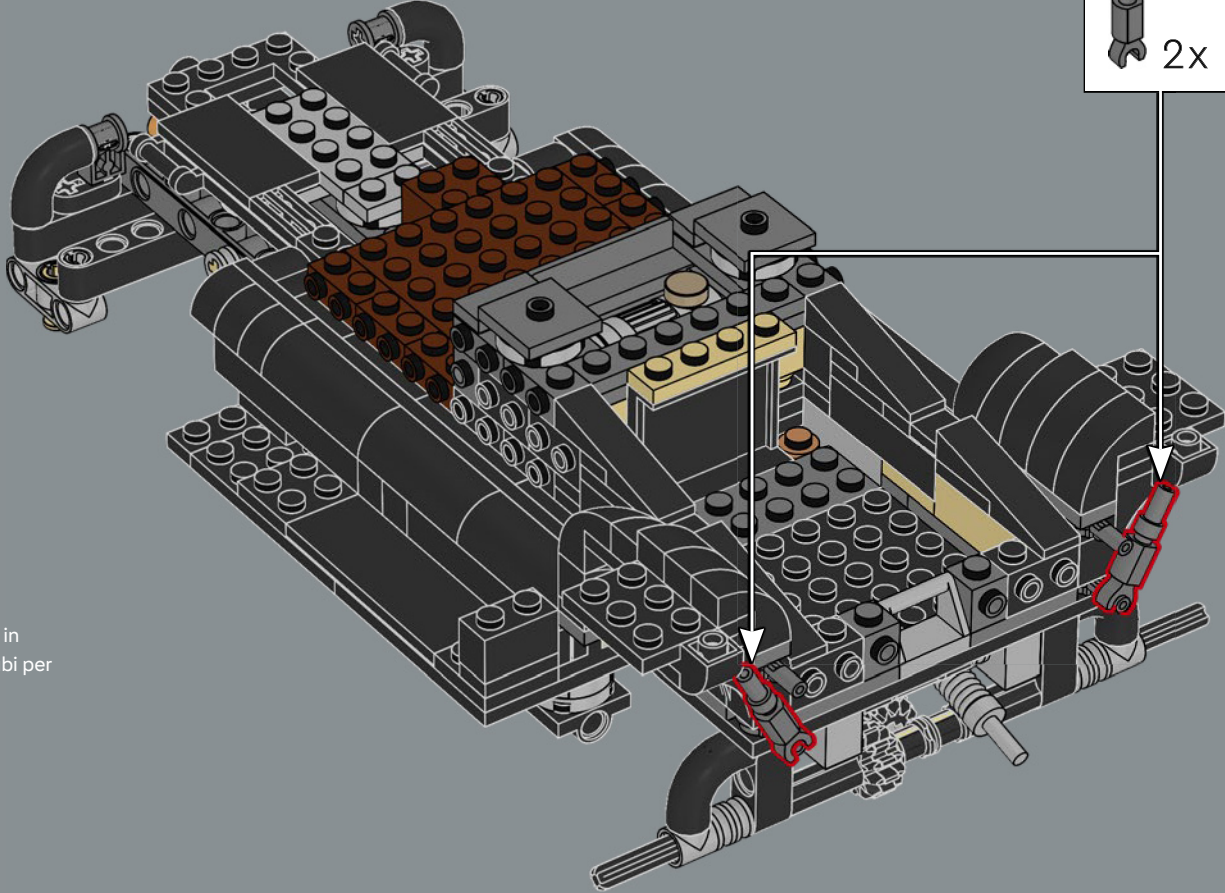
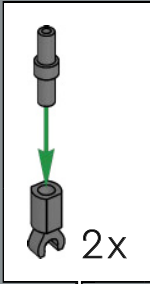

I paraurti dell'auto erano realizzati in metallo leggero e rinforzati con tubi per migliorarne la resistenza.





102

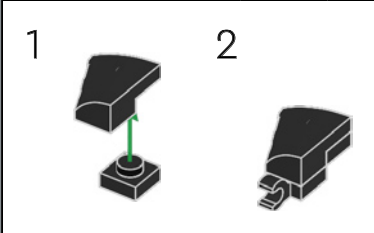
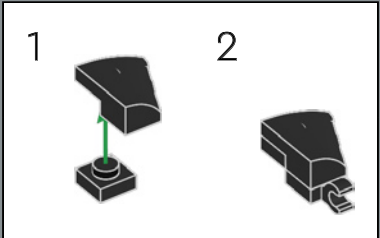
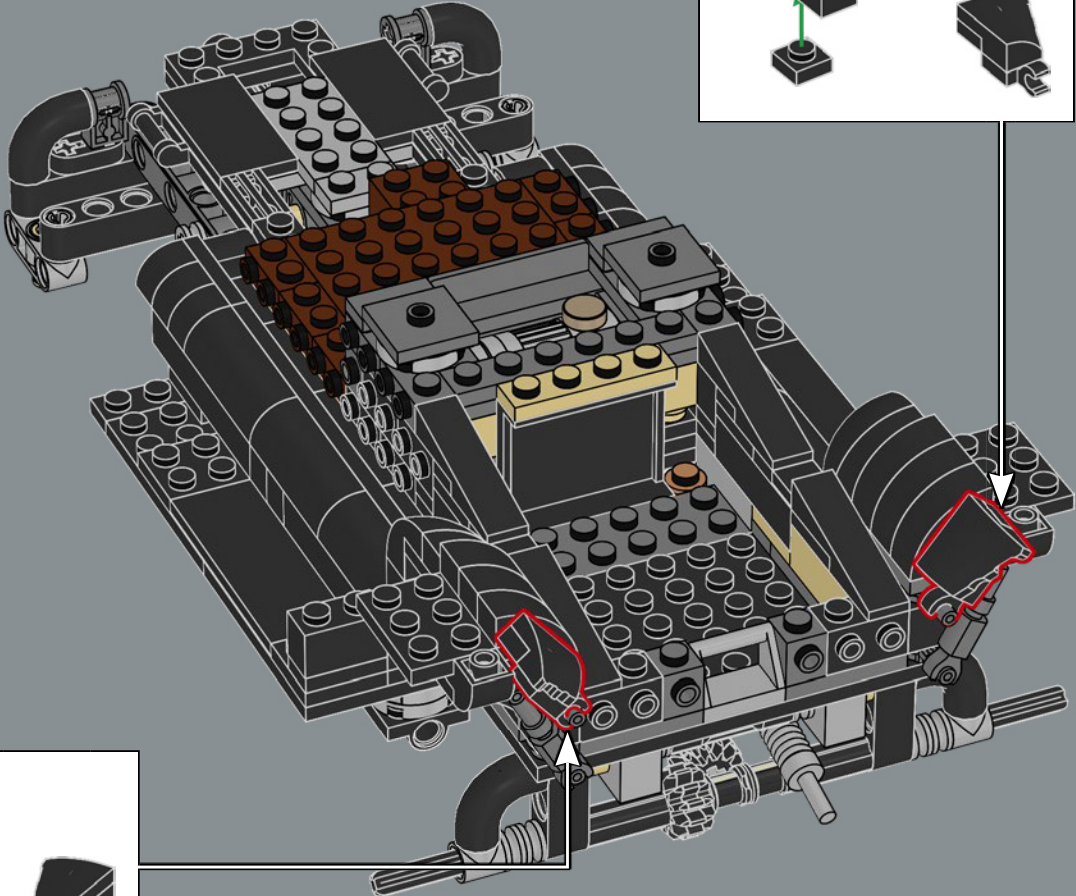

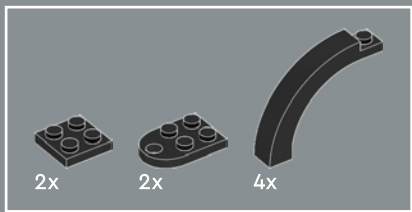

103

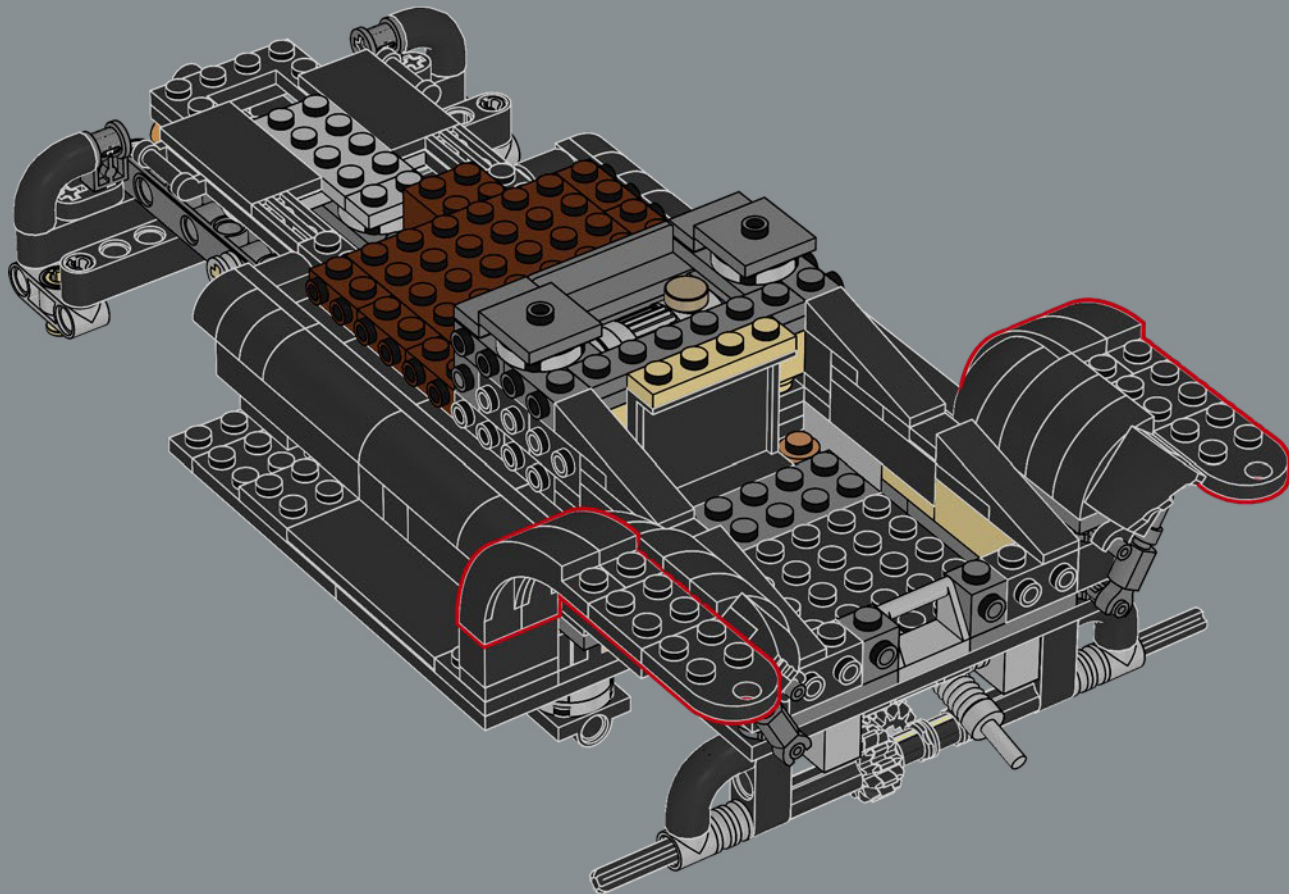

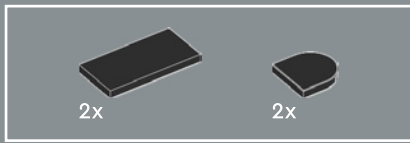

104

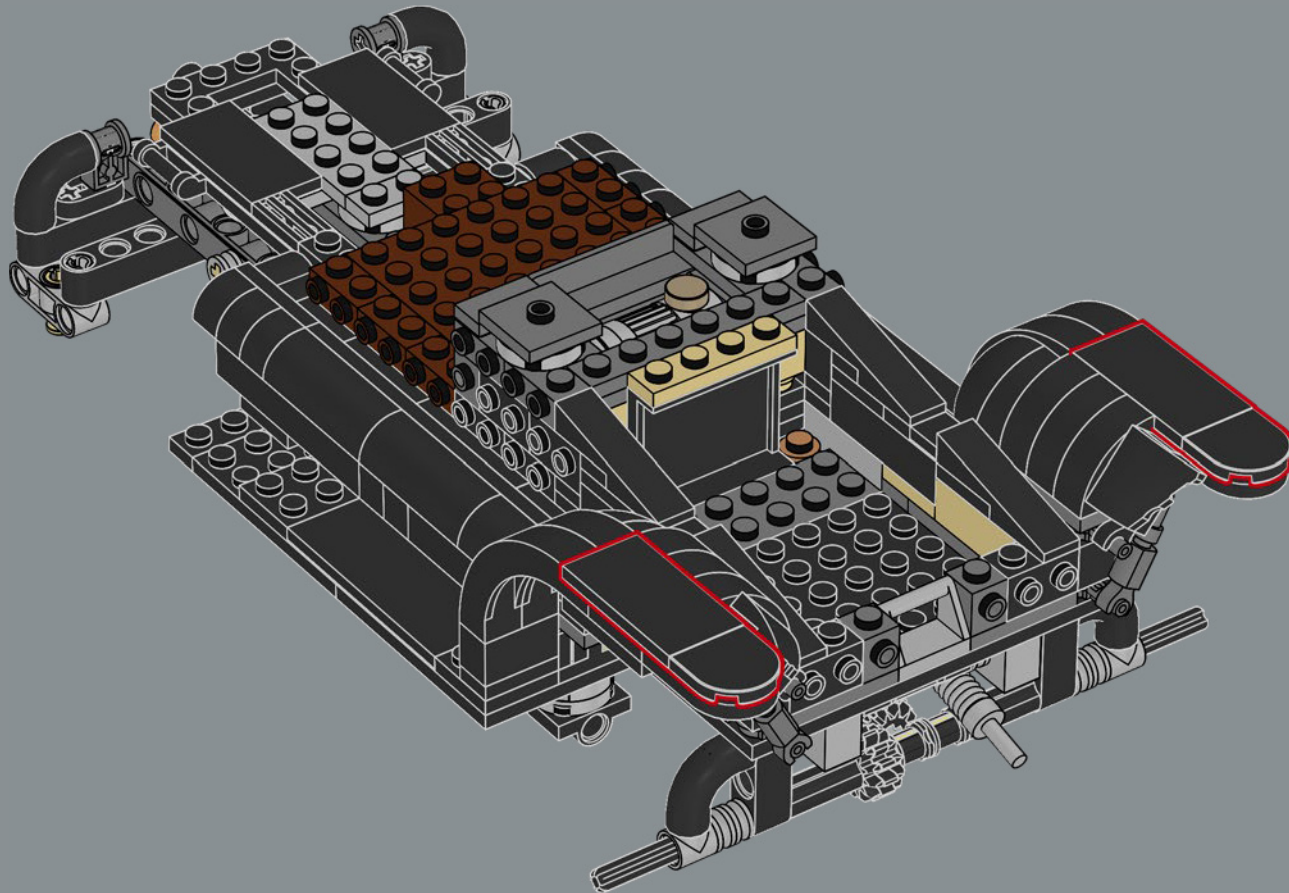



106

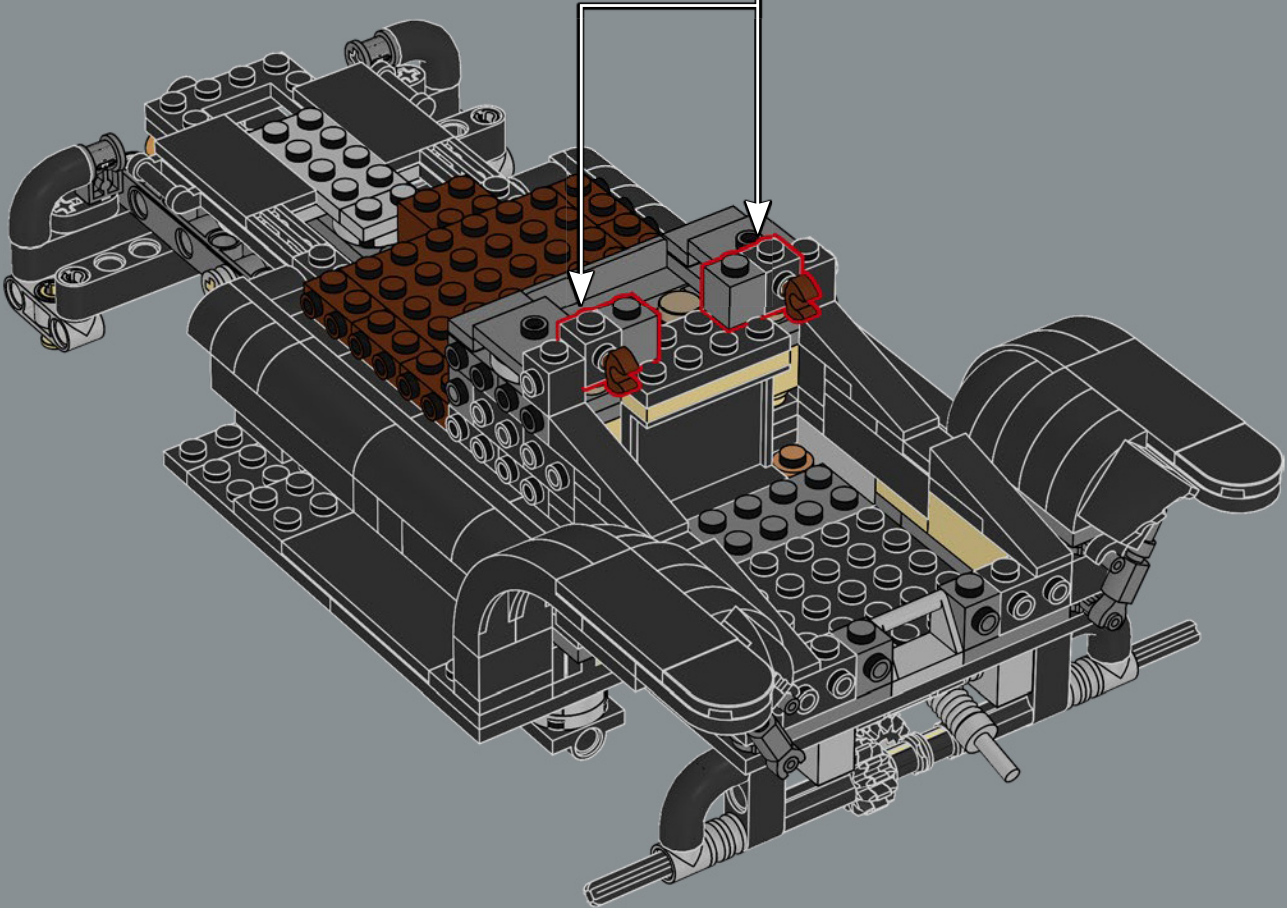
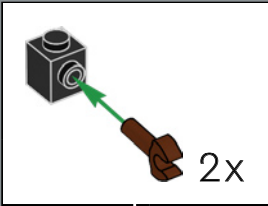



2x



2x



2x

107

1

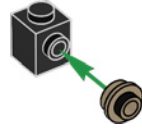

2



2x

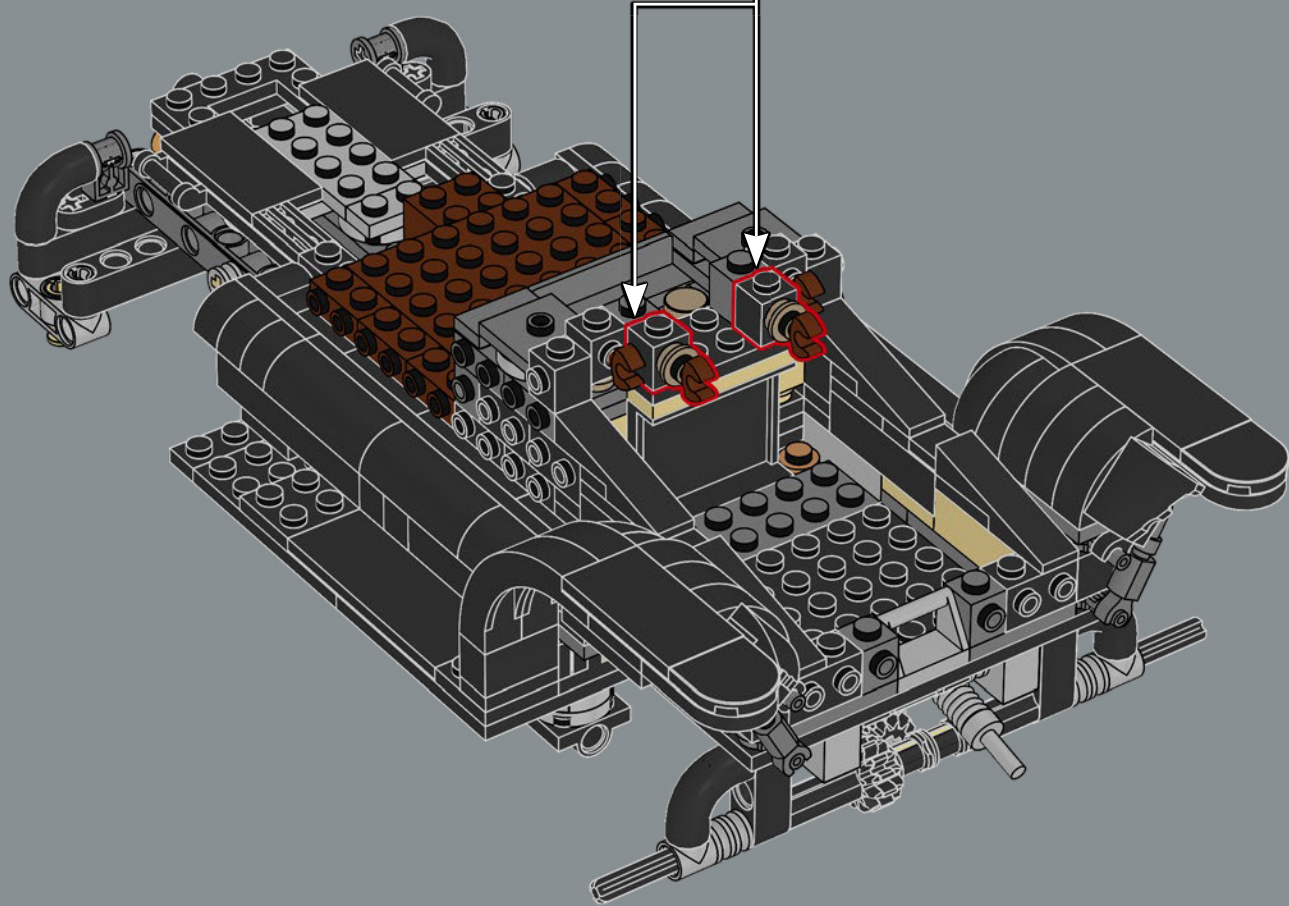

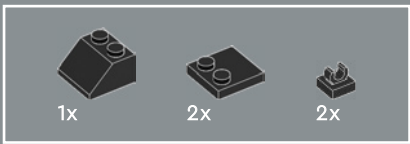

108

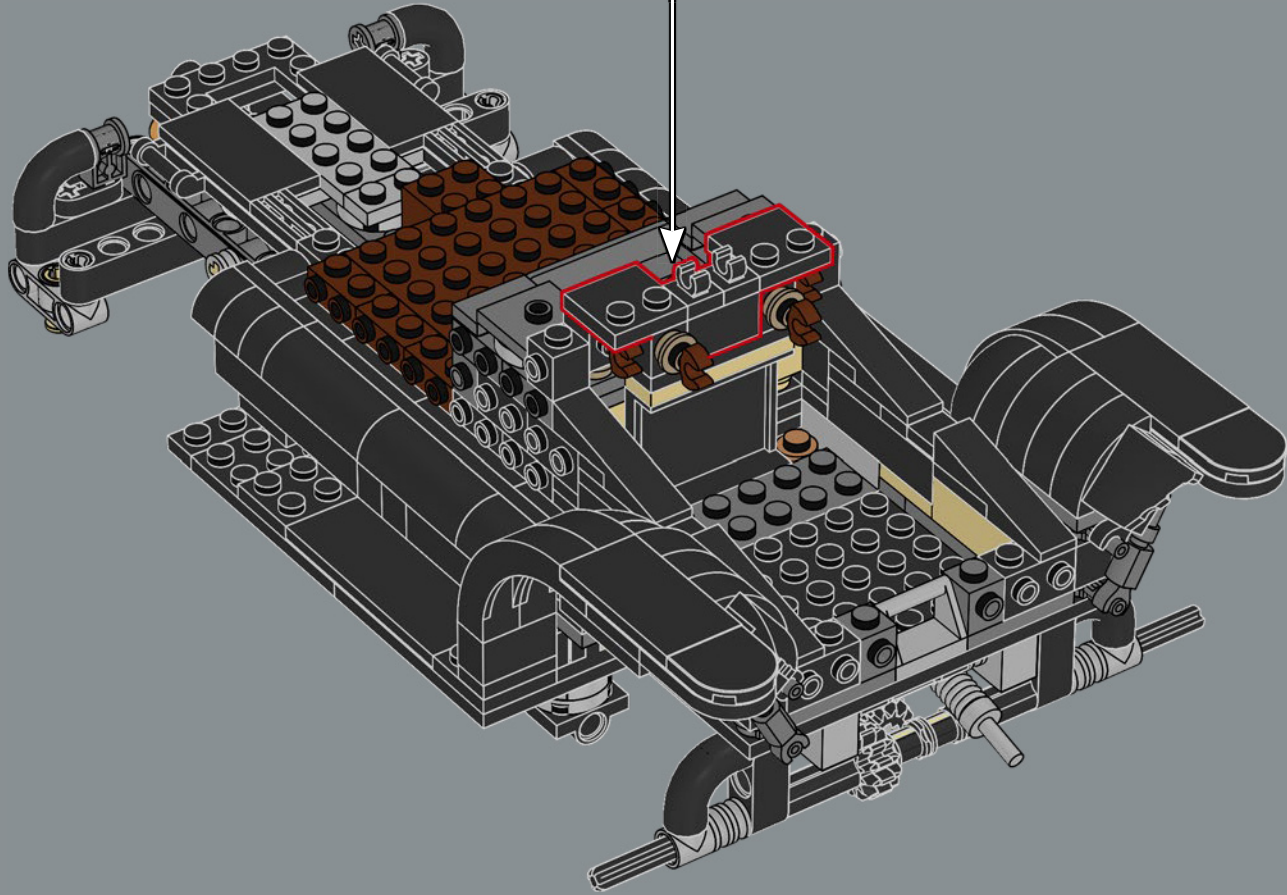
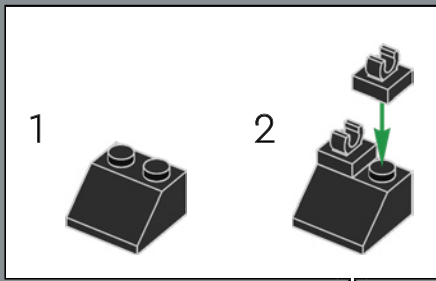



2x

109

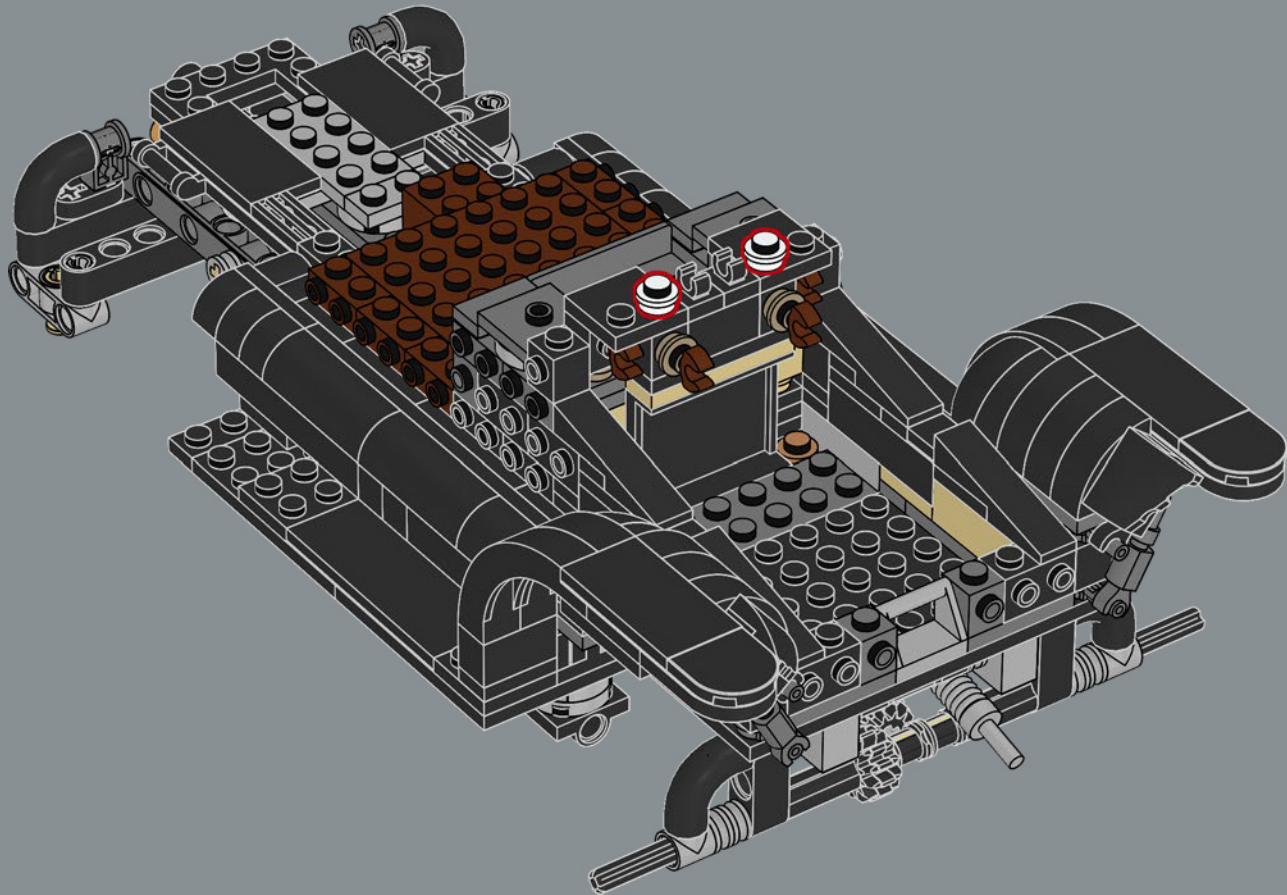

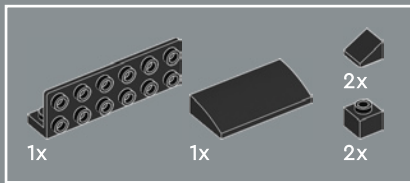

110

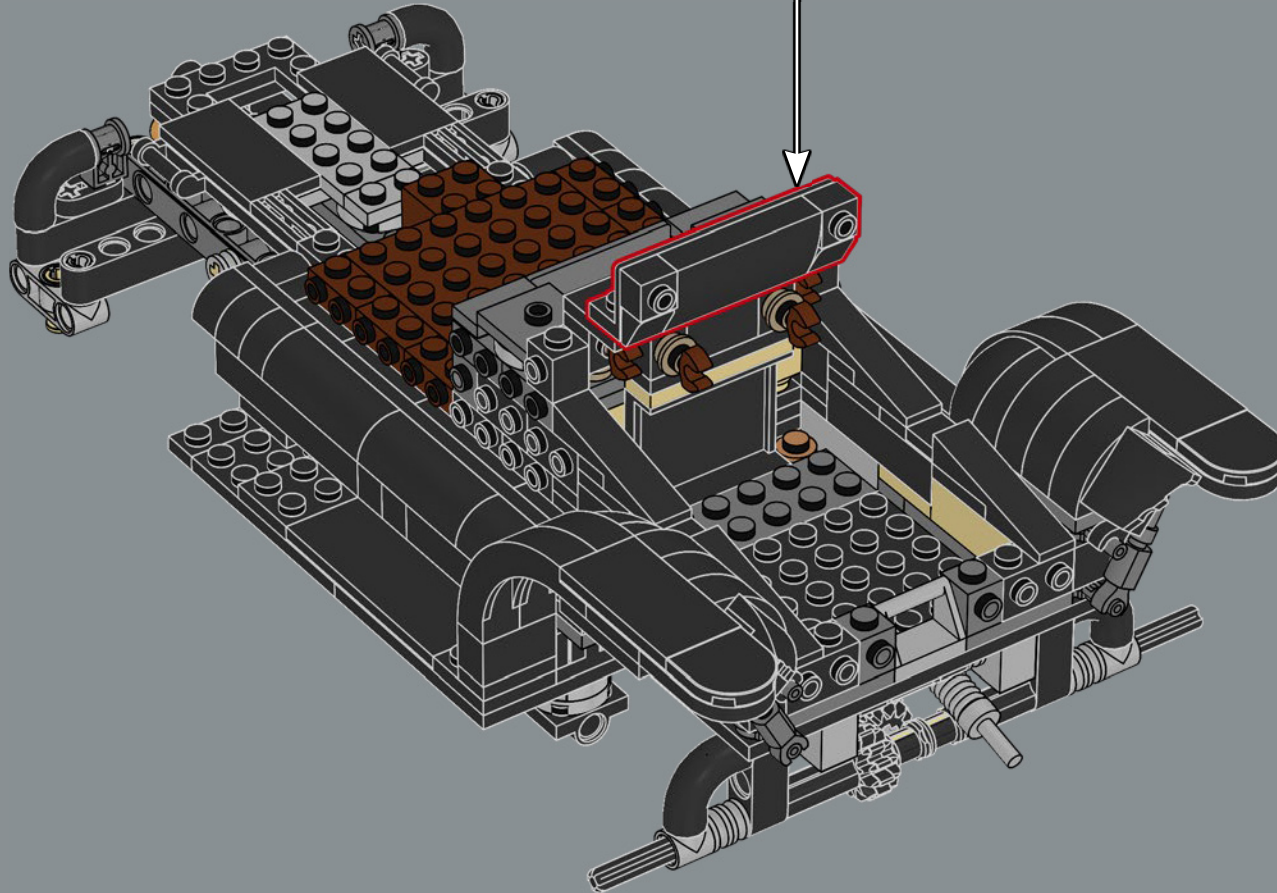
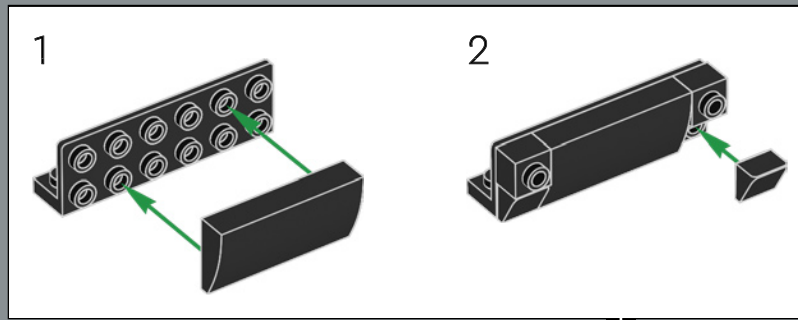

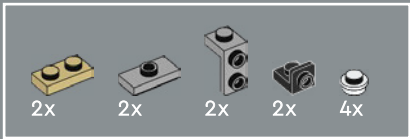

111

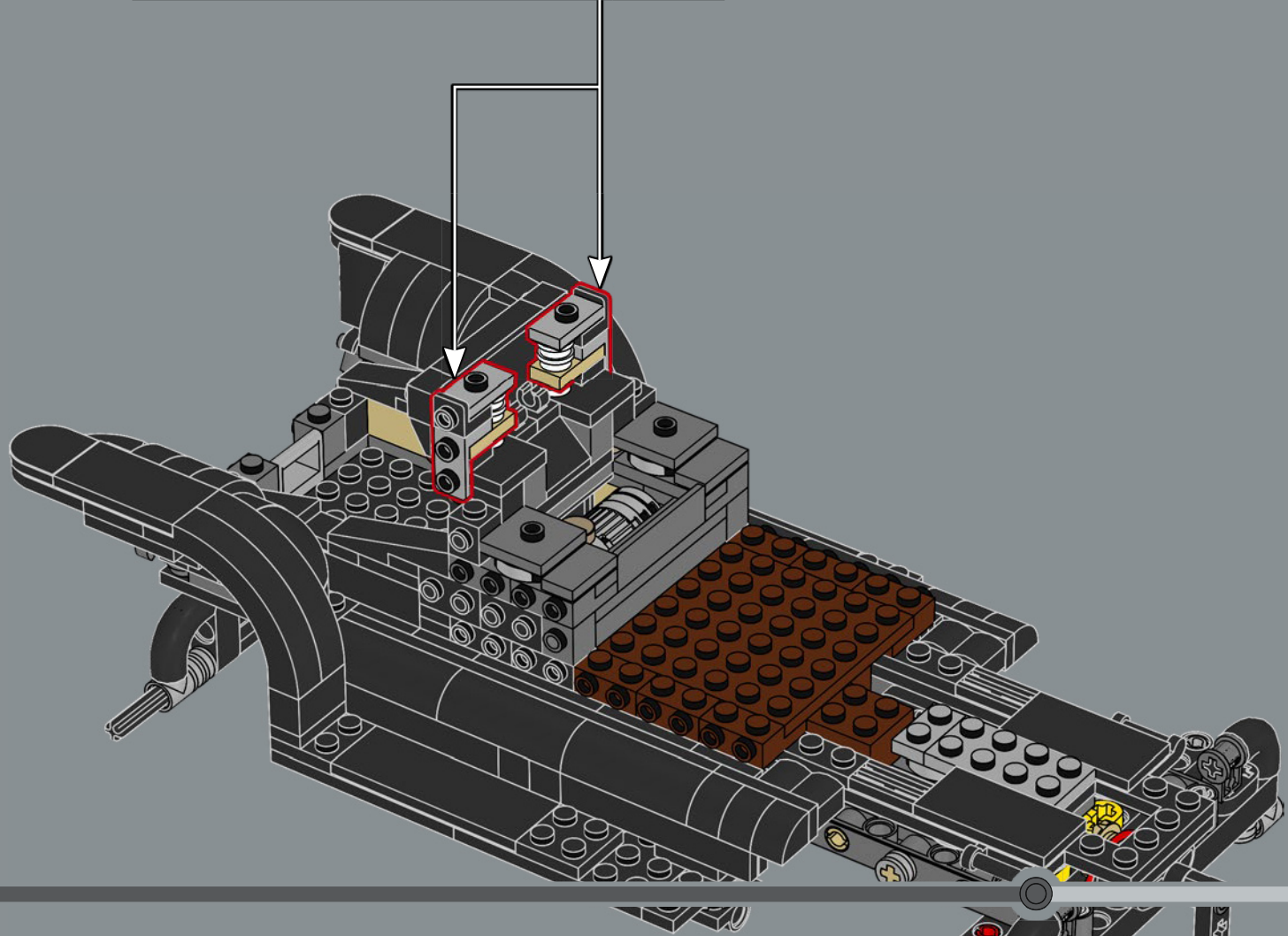
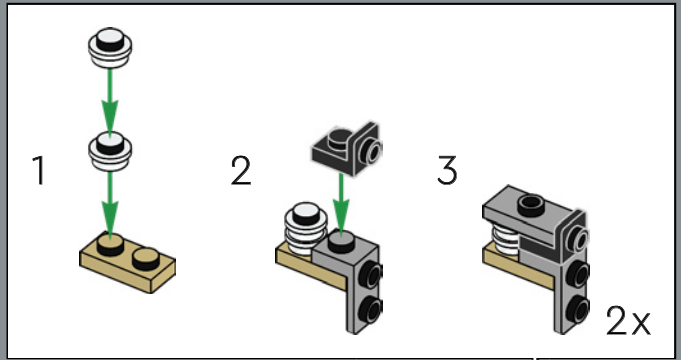

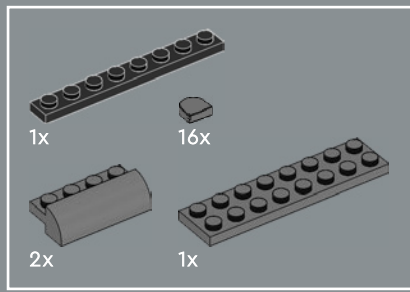

112

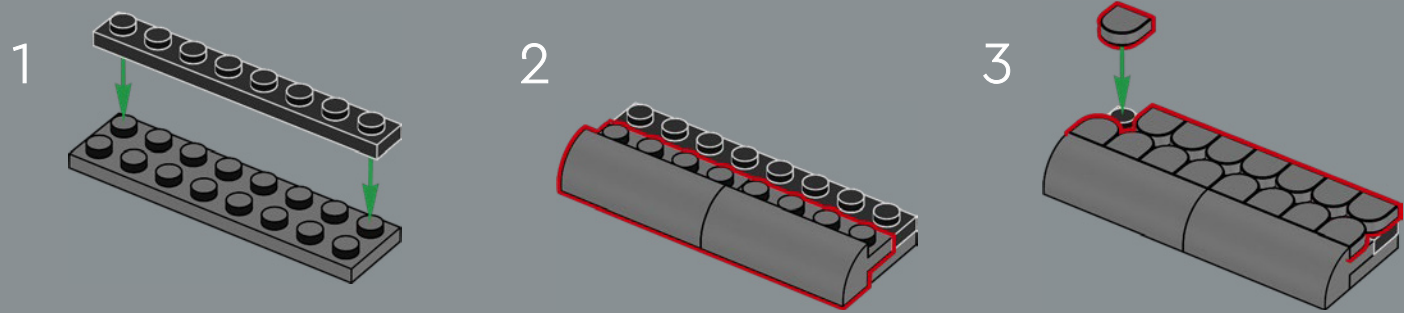

✦
All'interno, i sedili erano rivestiti in pelle e imbottiti con un mix di cotone grezzo e crine di cavallo per garantire un comfort straordinario.

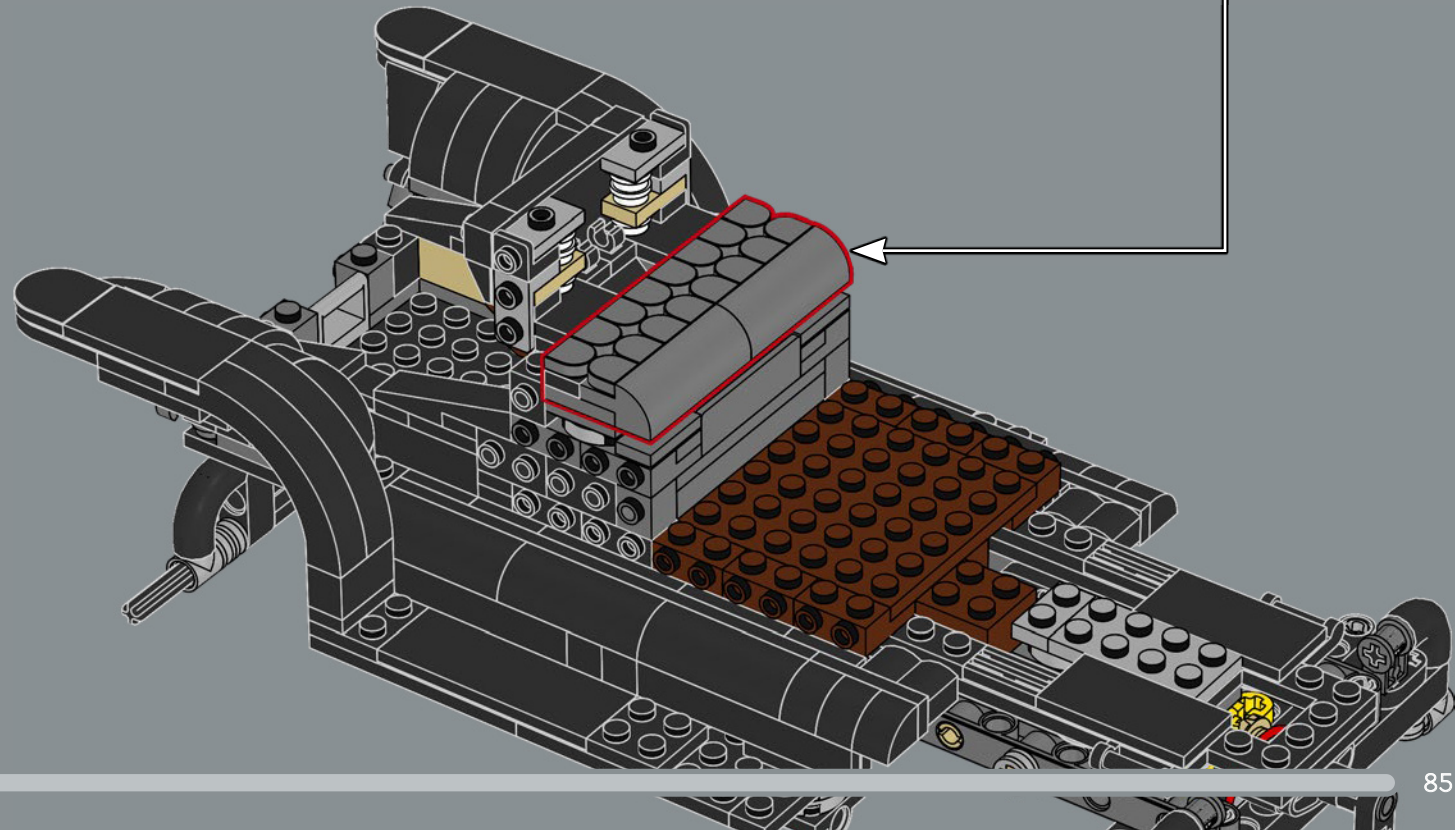

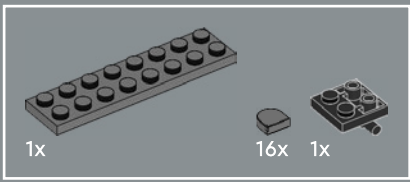

113

1

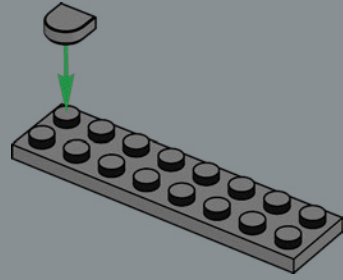

2

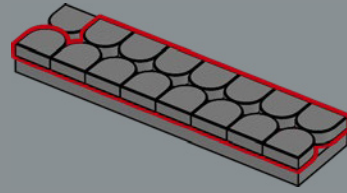

3

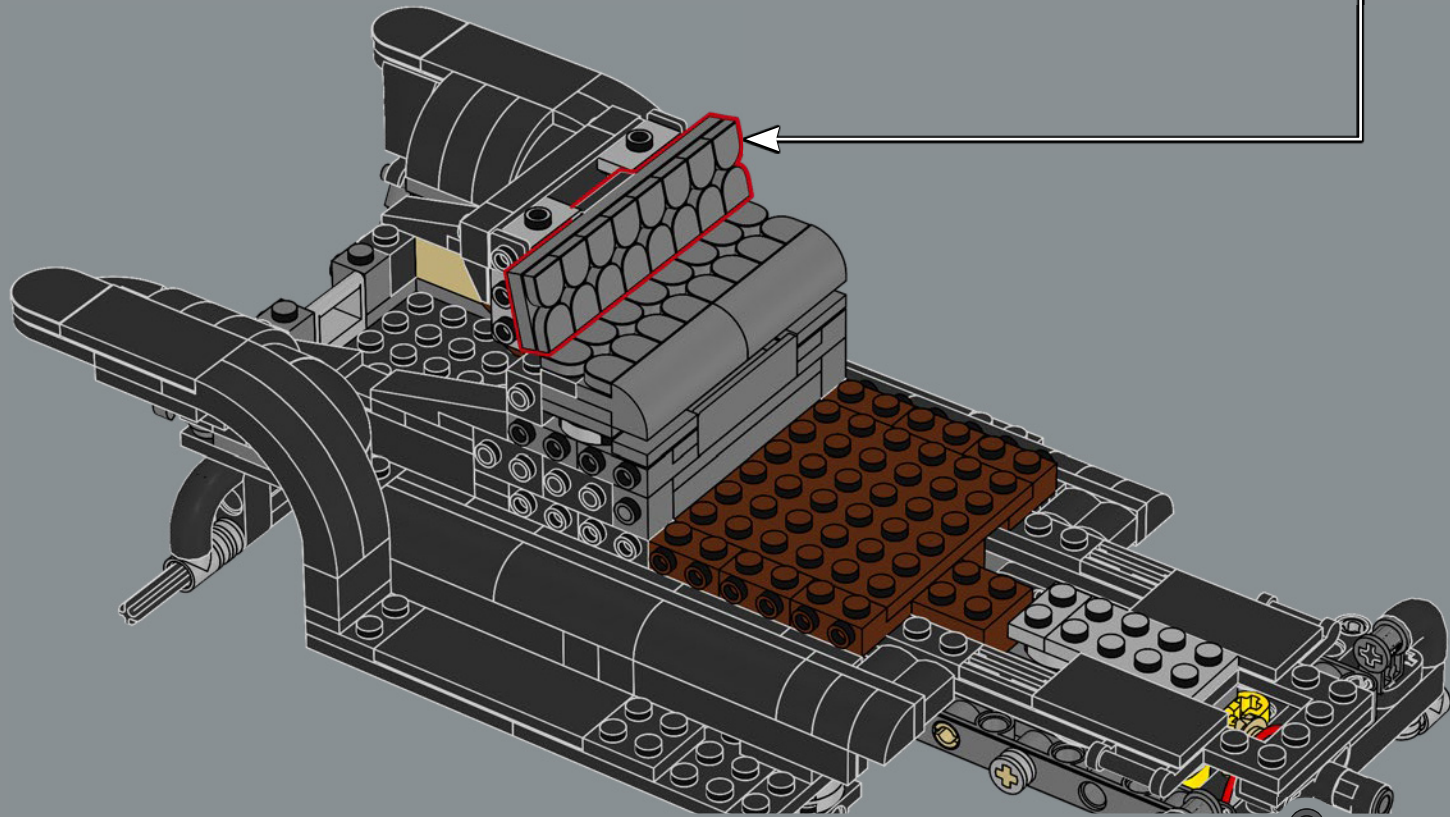
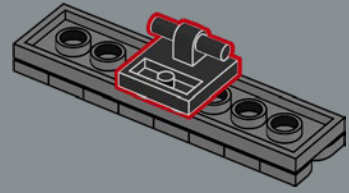

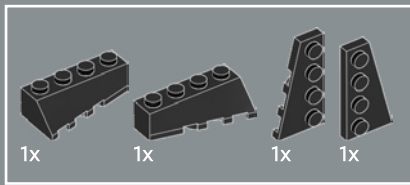

114

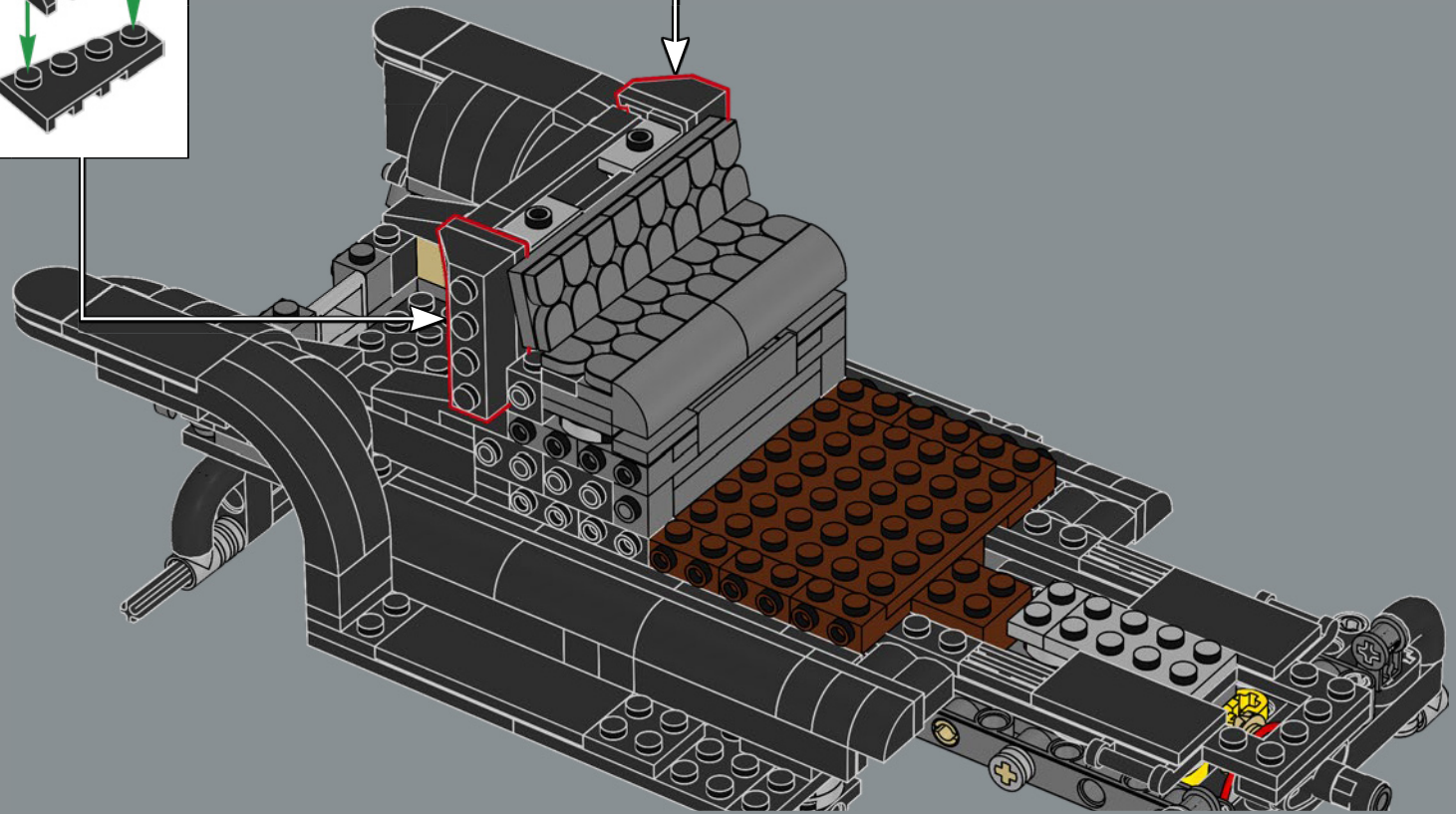
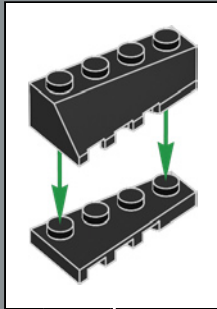
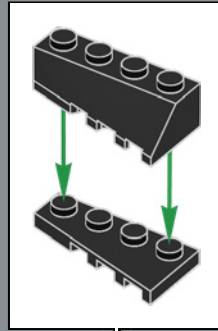

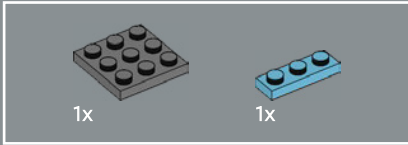
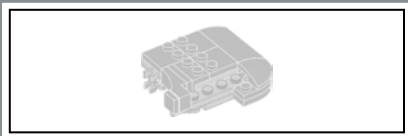

115

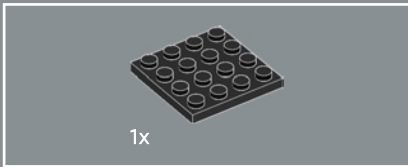
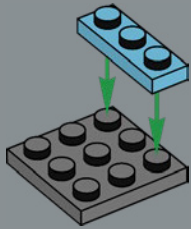

116

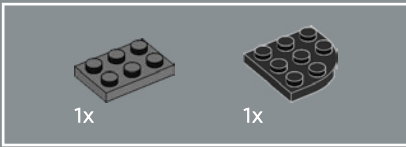
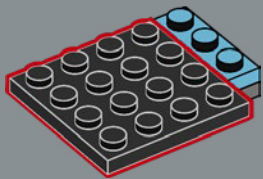

117

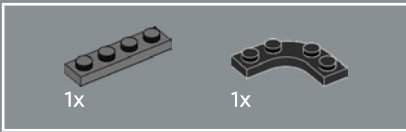
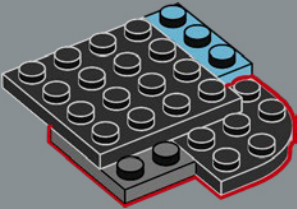

118

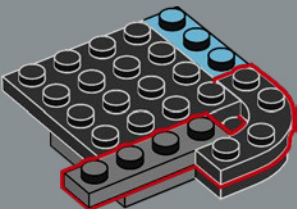

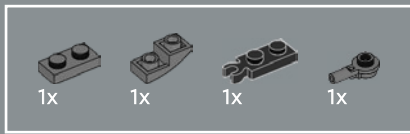

119

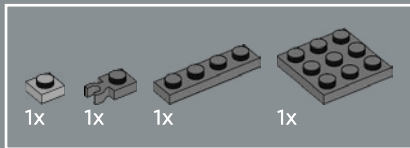
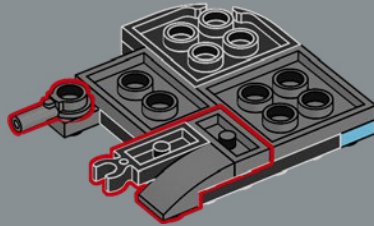

120

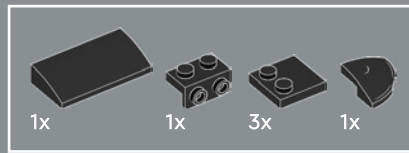
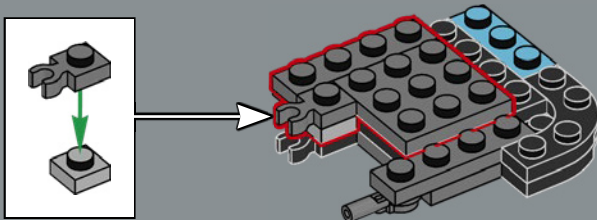

121

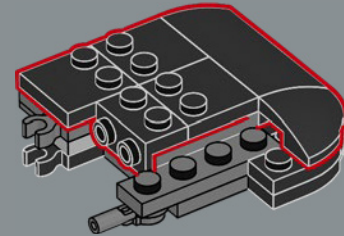

122

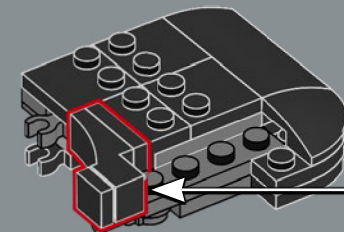
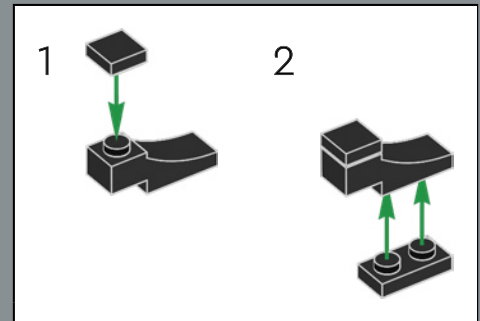

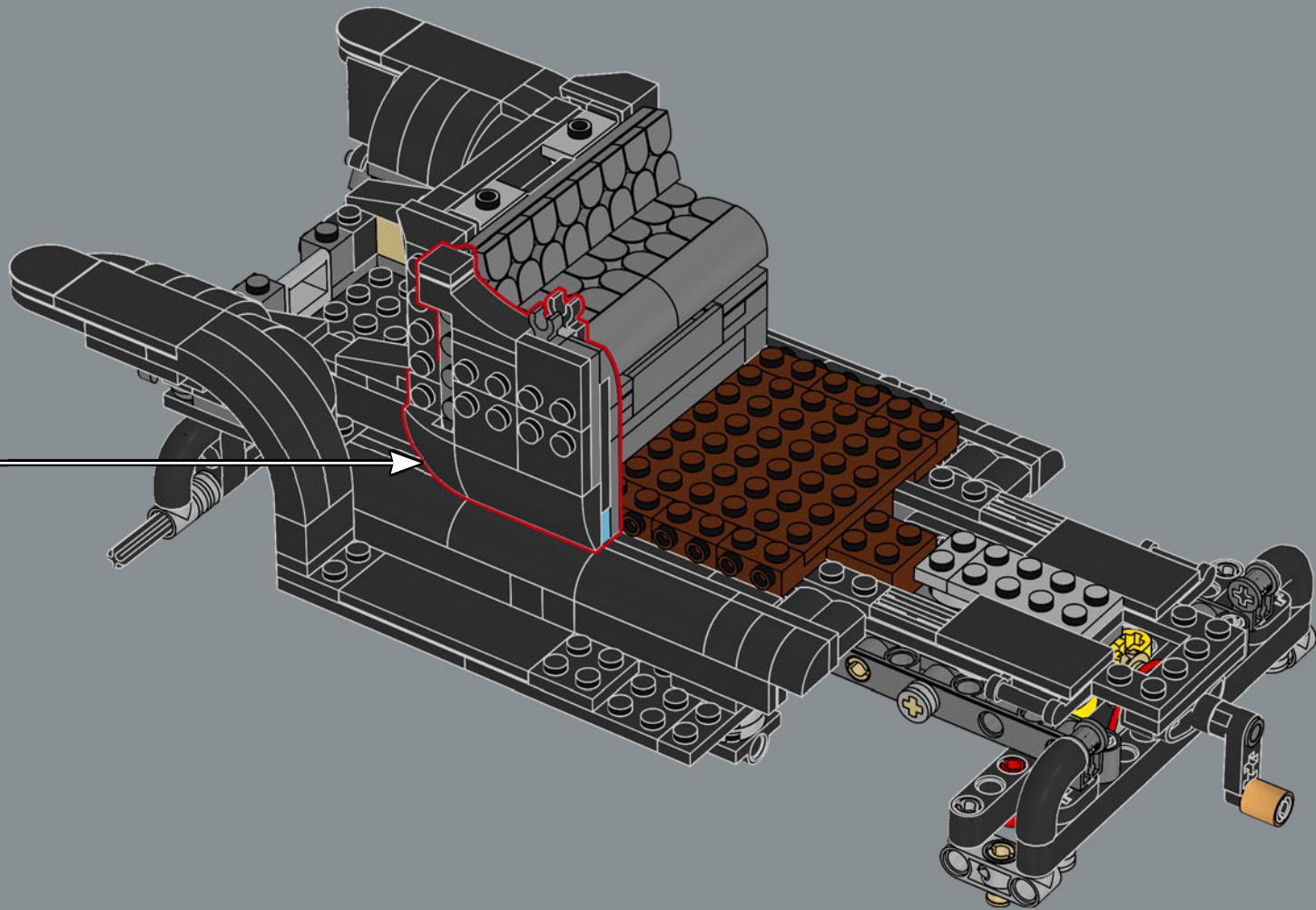



124

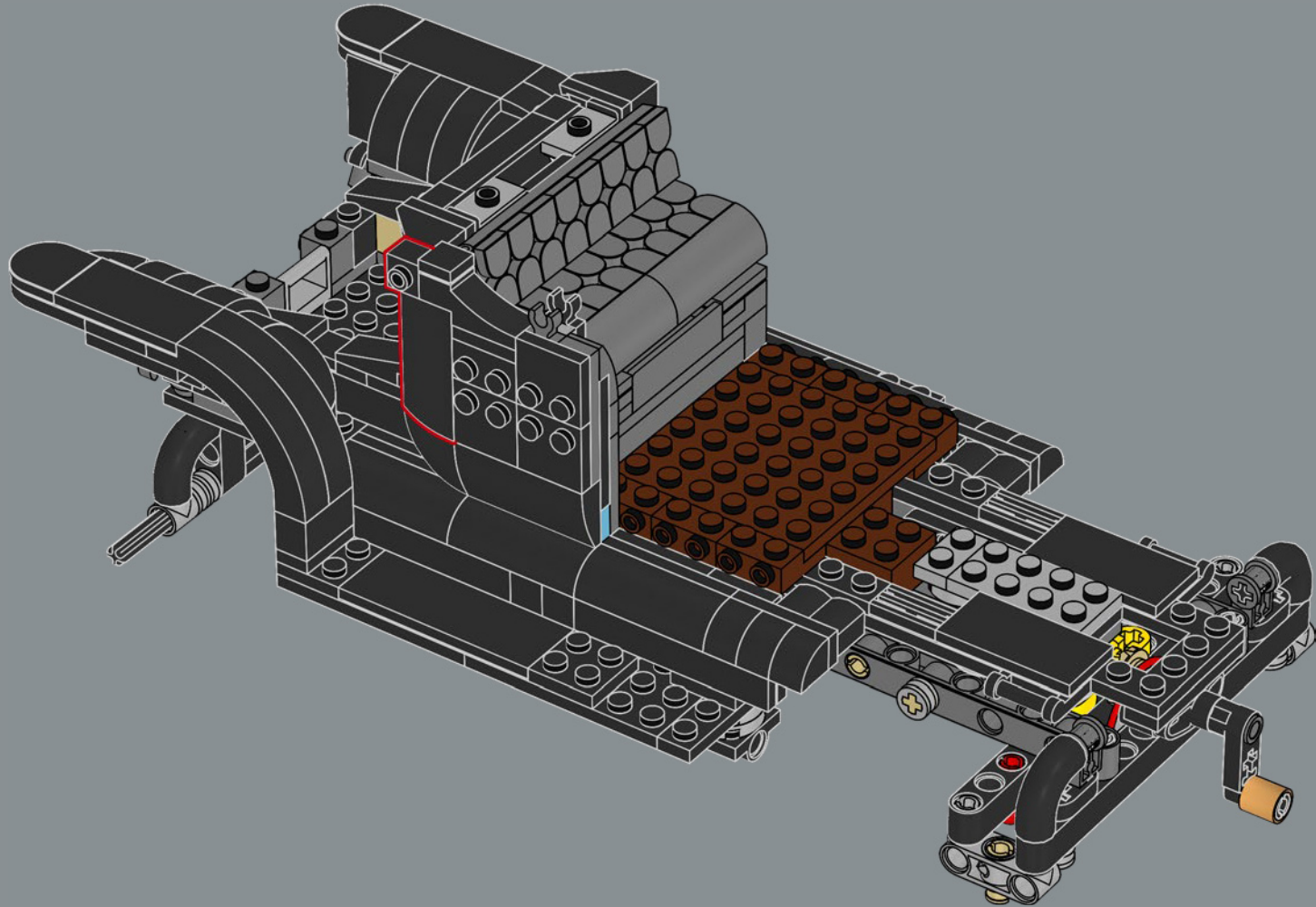

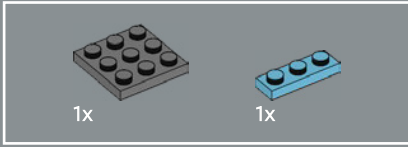
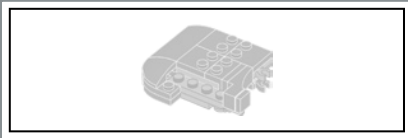

125

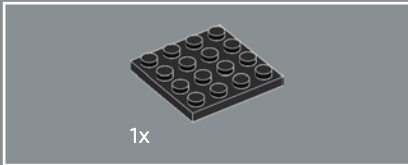
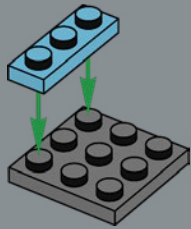

126

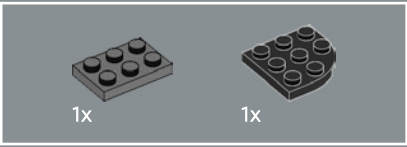
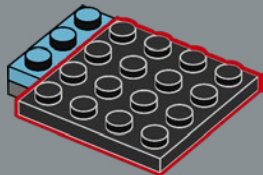

127

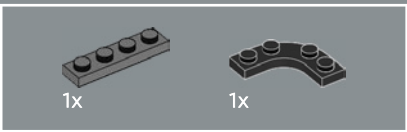
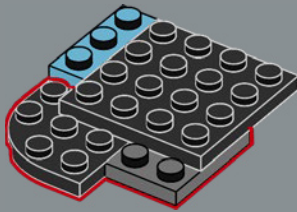

128

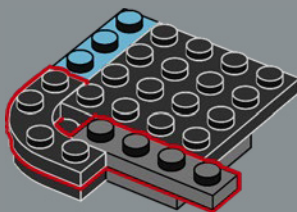

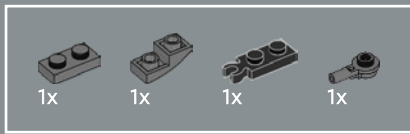

129

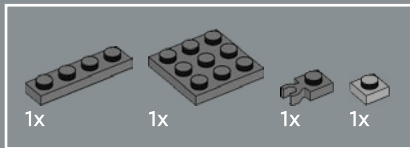
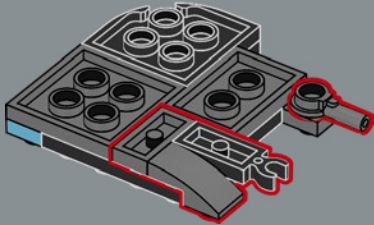

130

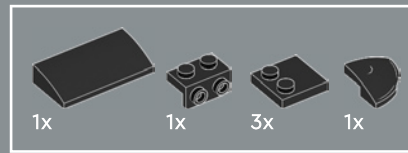
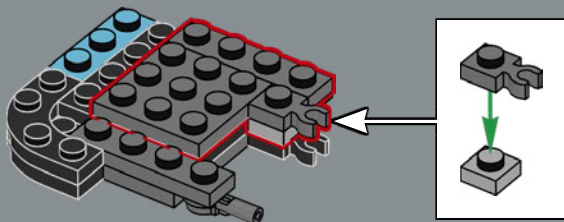

131

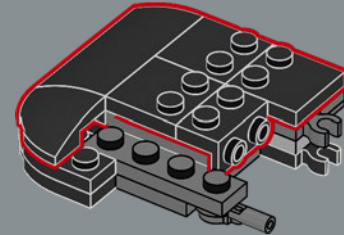

132

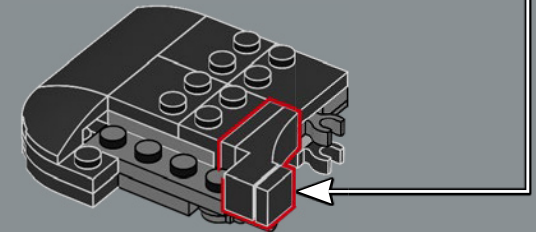
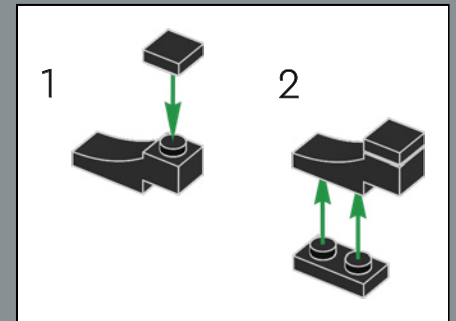

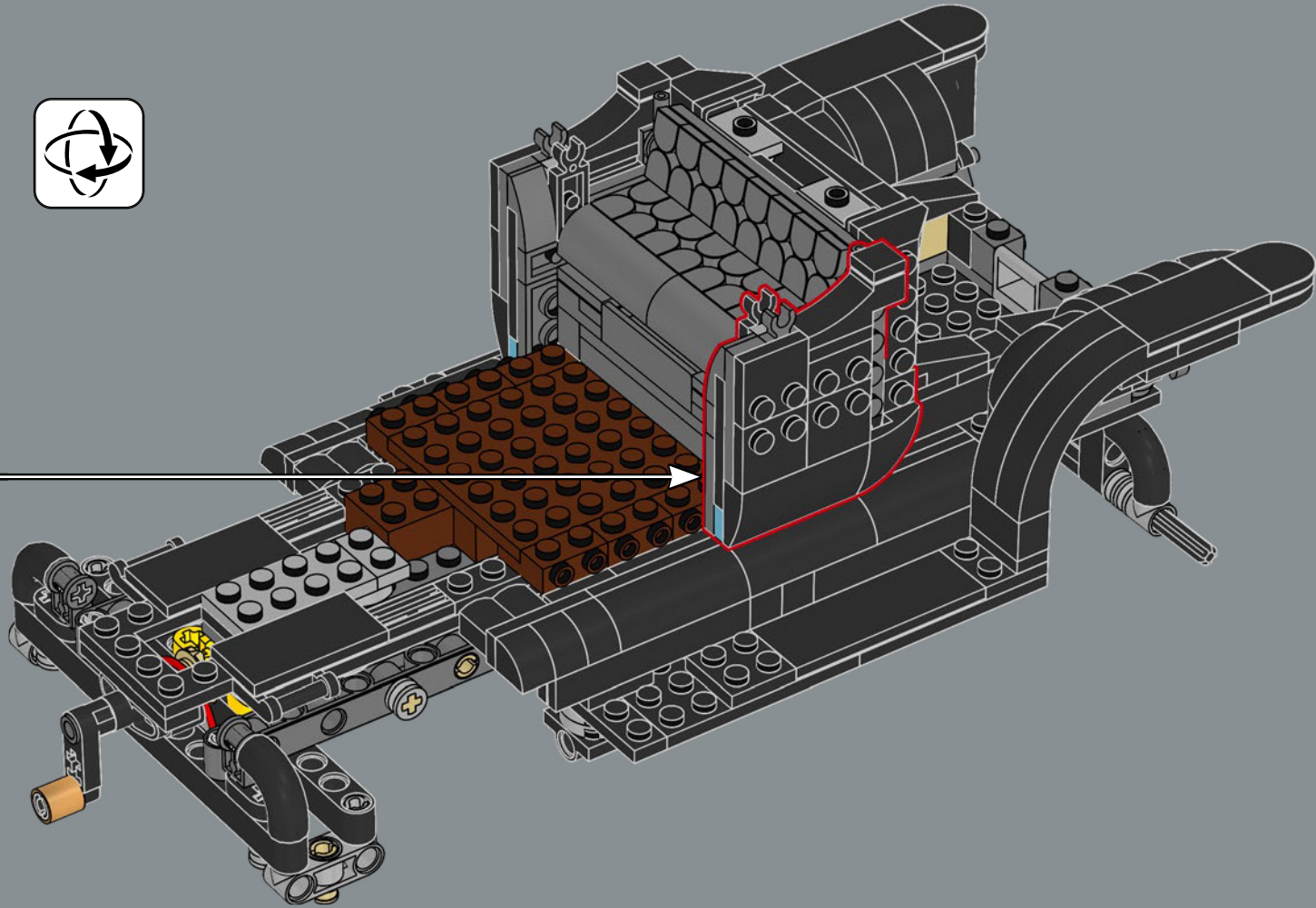



Gli acquirenti potevano scegliere tra versioni a due, tre o quattro posti, e alcune varianti presentavano addirittura un piccolo sedile esterno.

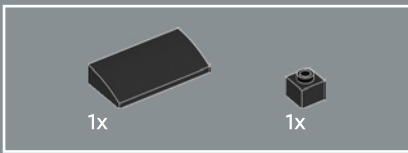

134

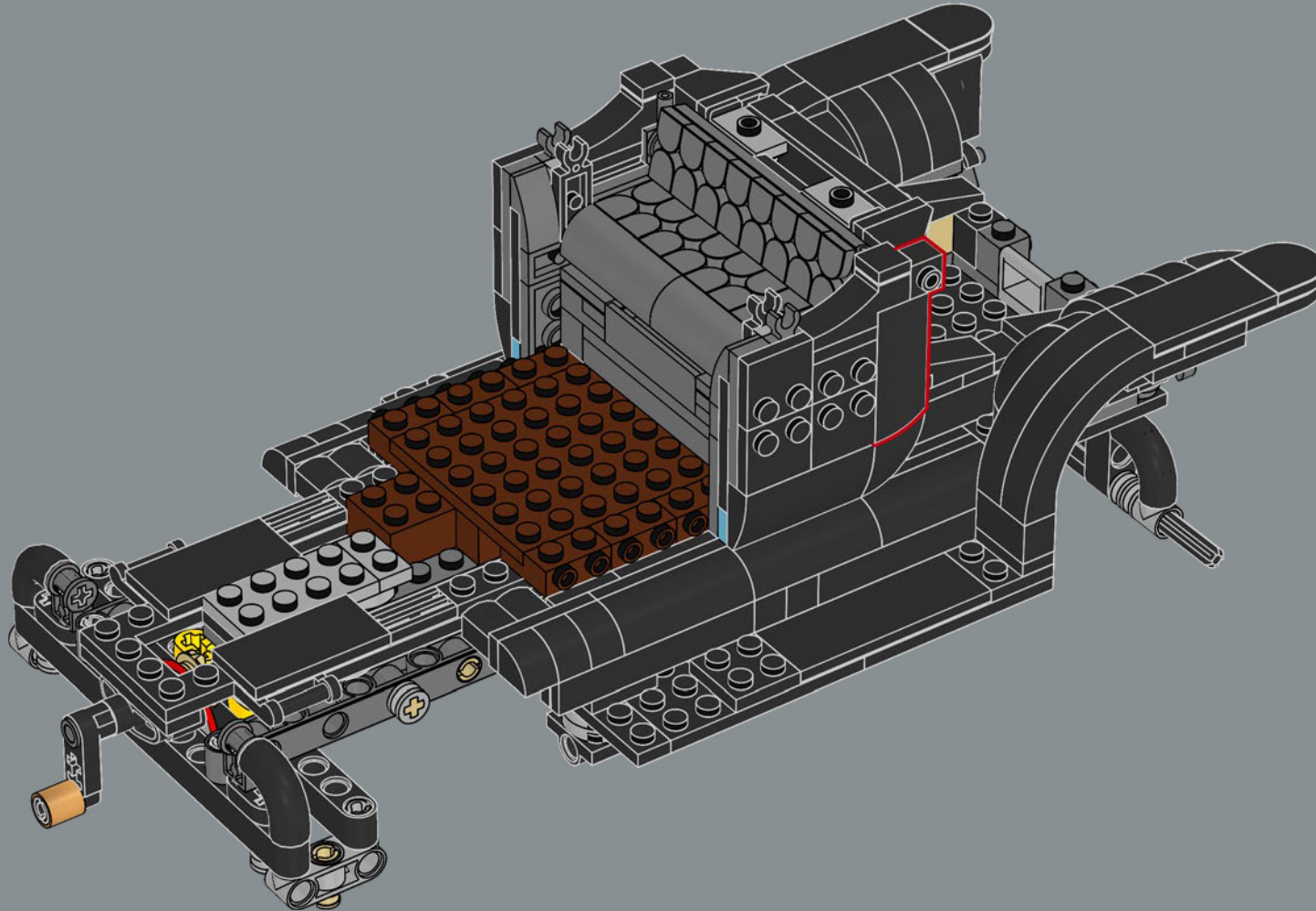

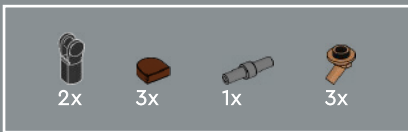

136

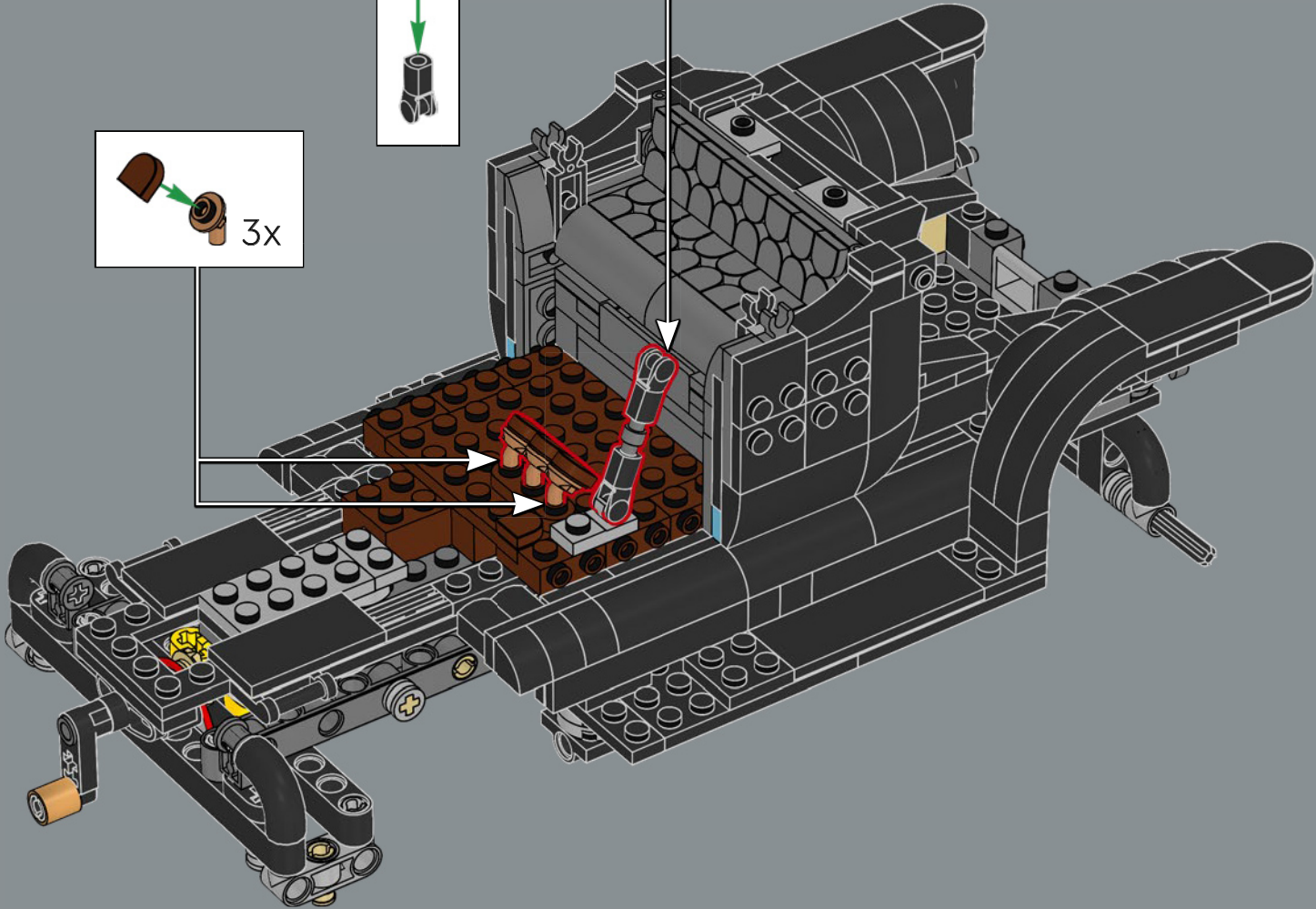
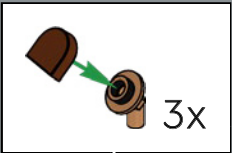
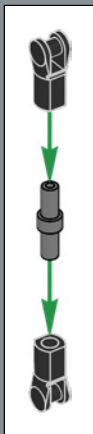

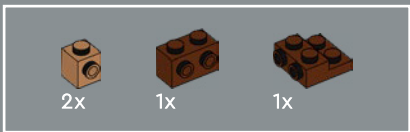

137

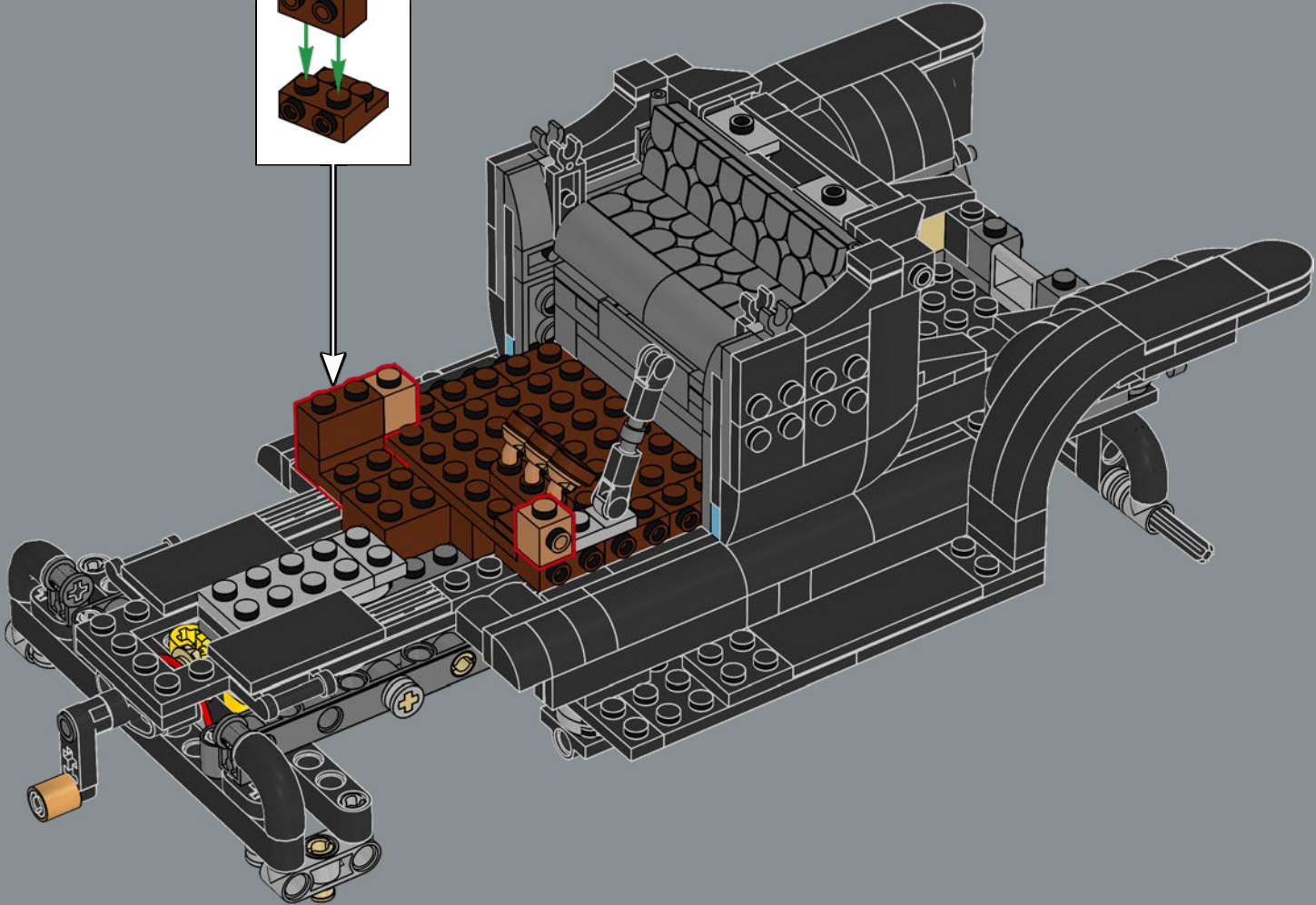
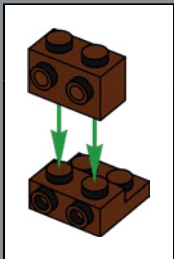

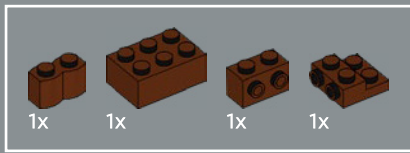

138

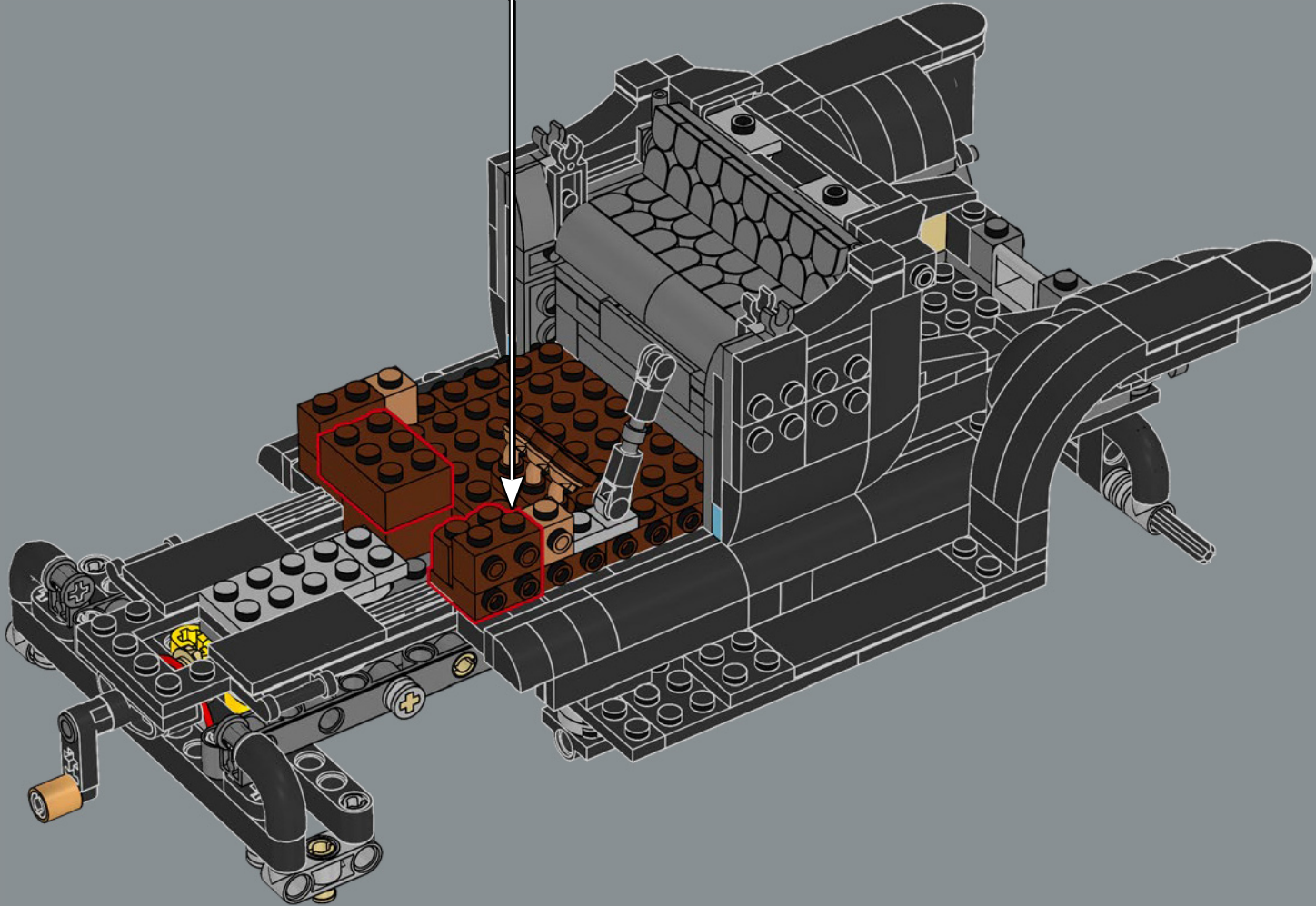
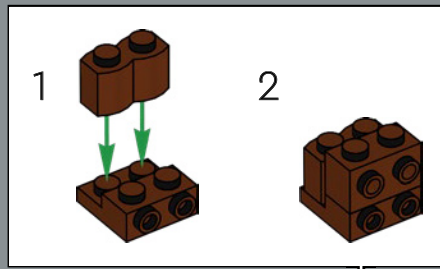

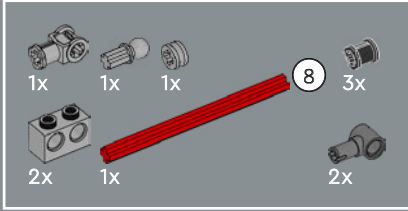
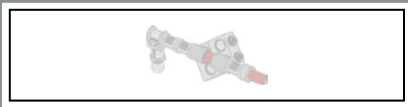

139

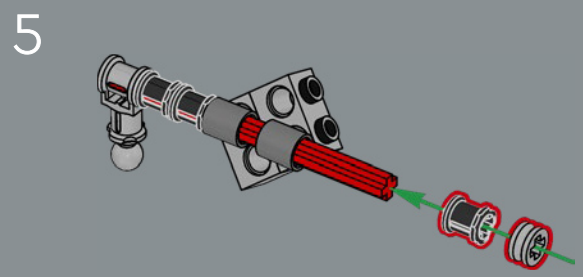
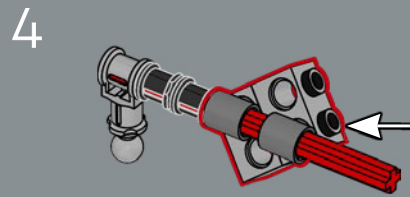
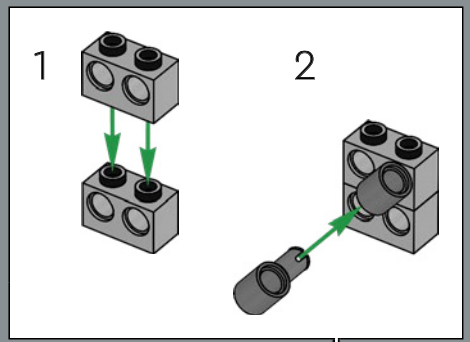
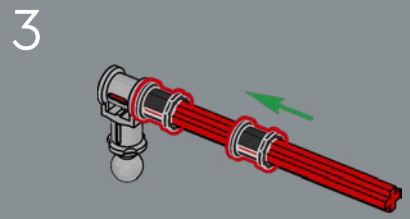
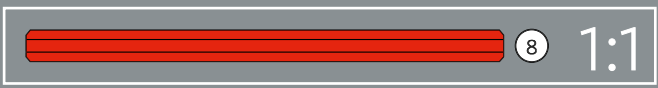
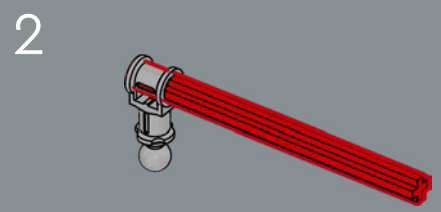
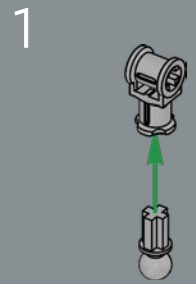

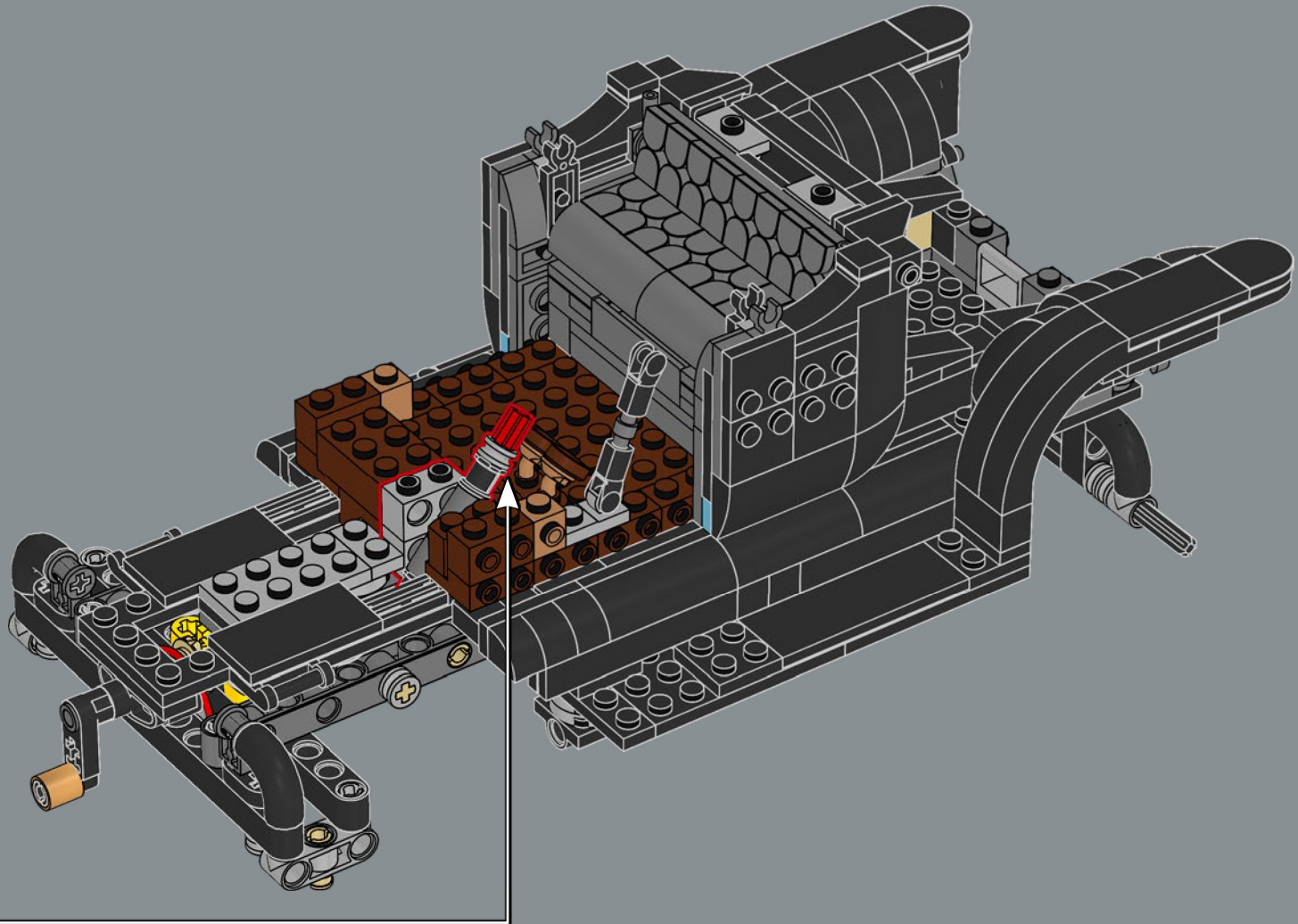

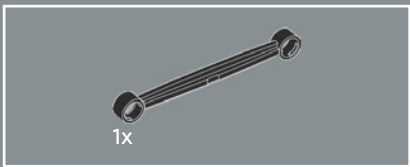

140

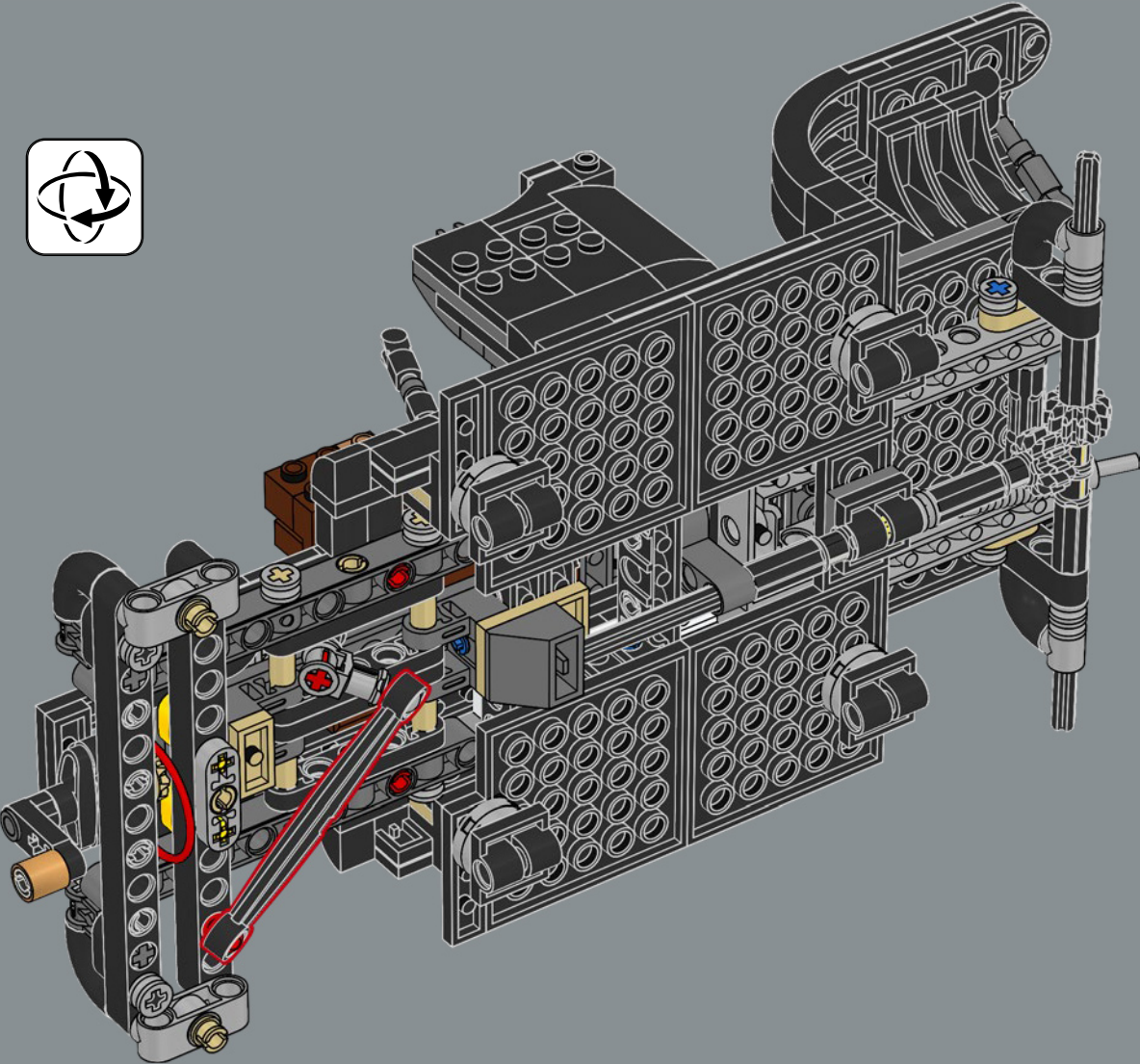

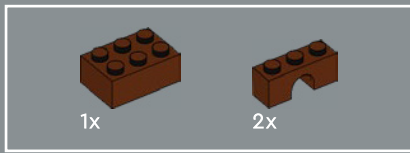

141

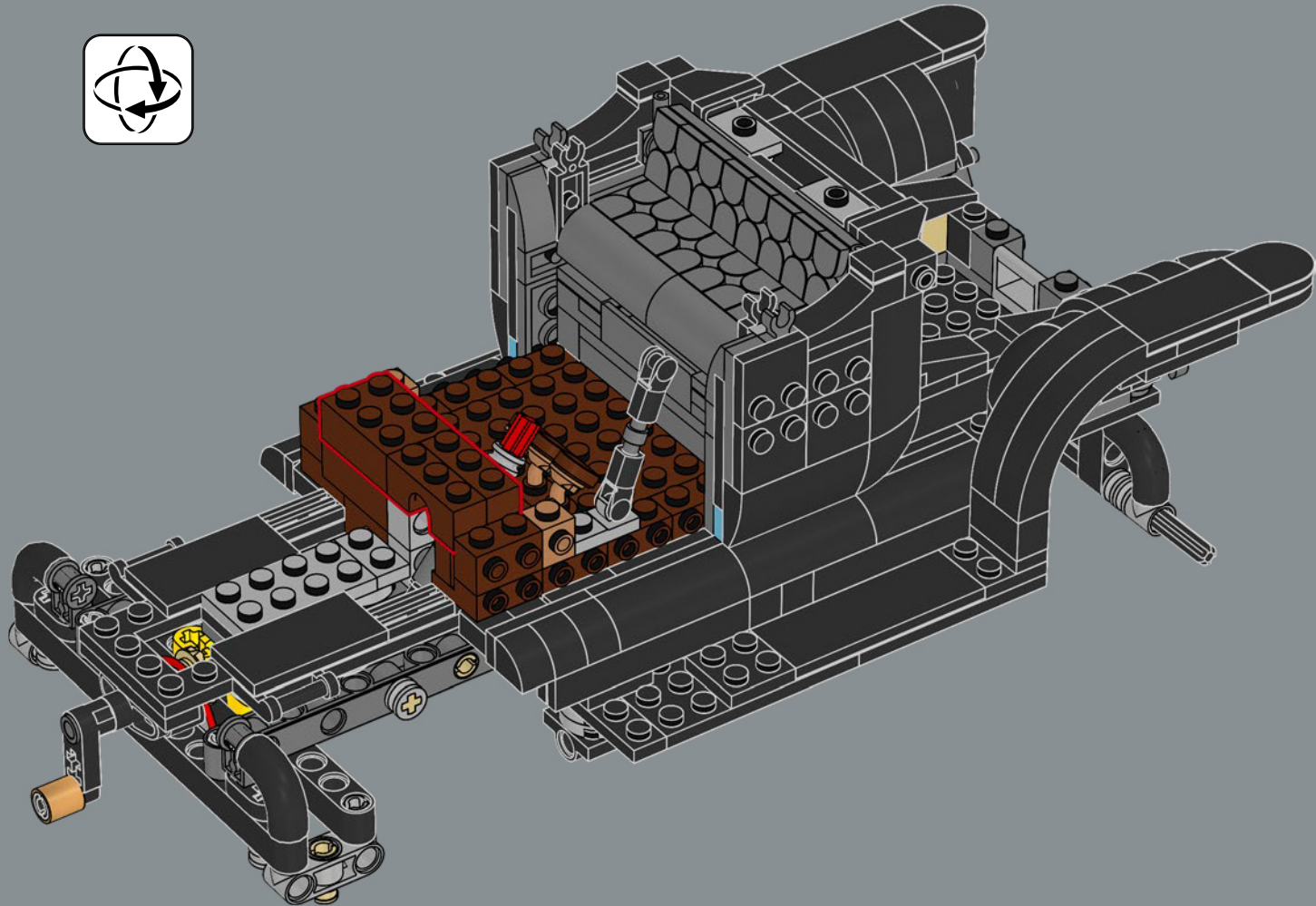

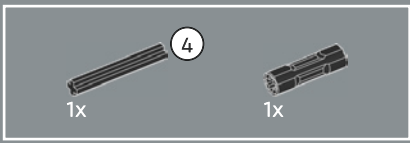

142

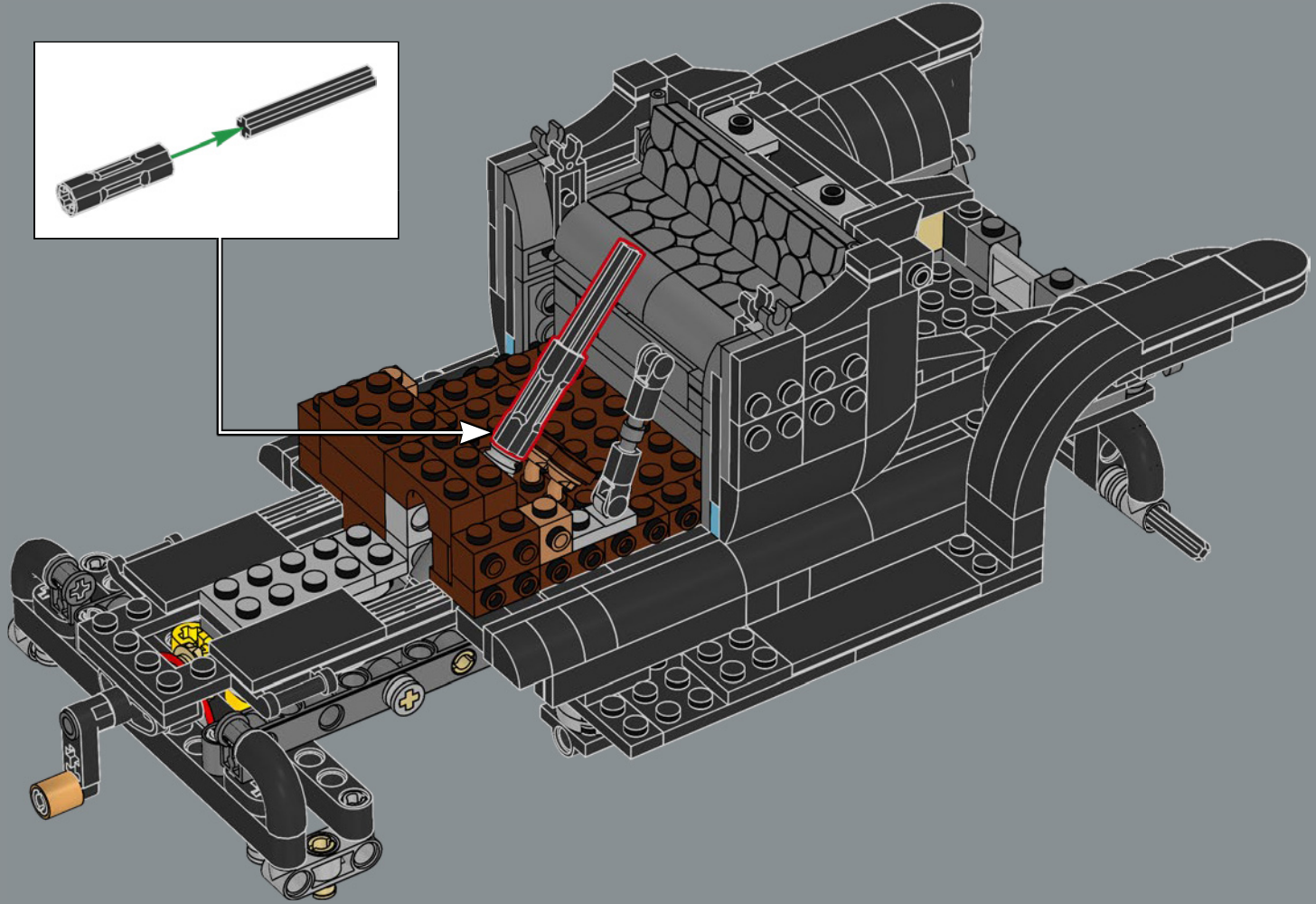
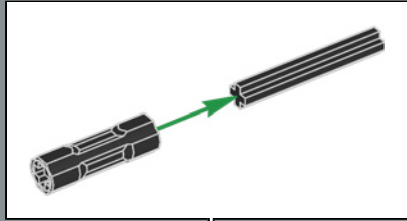

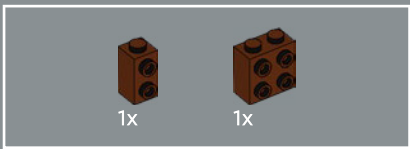

143

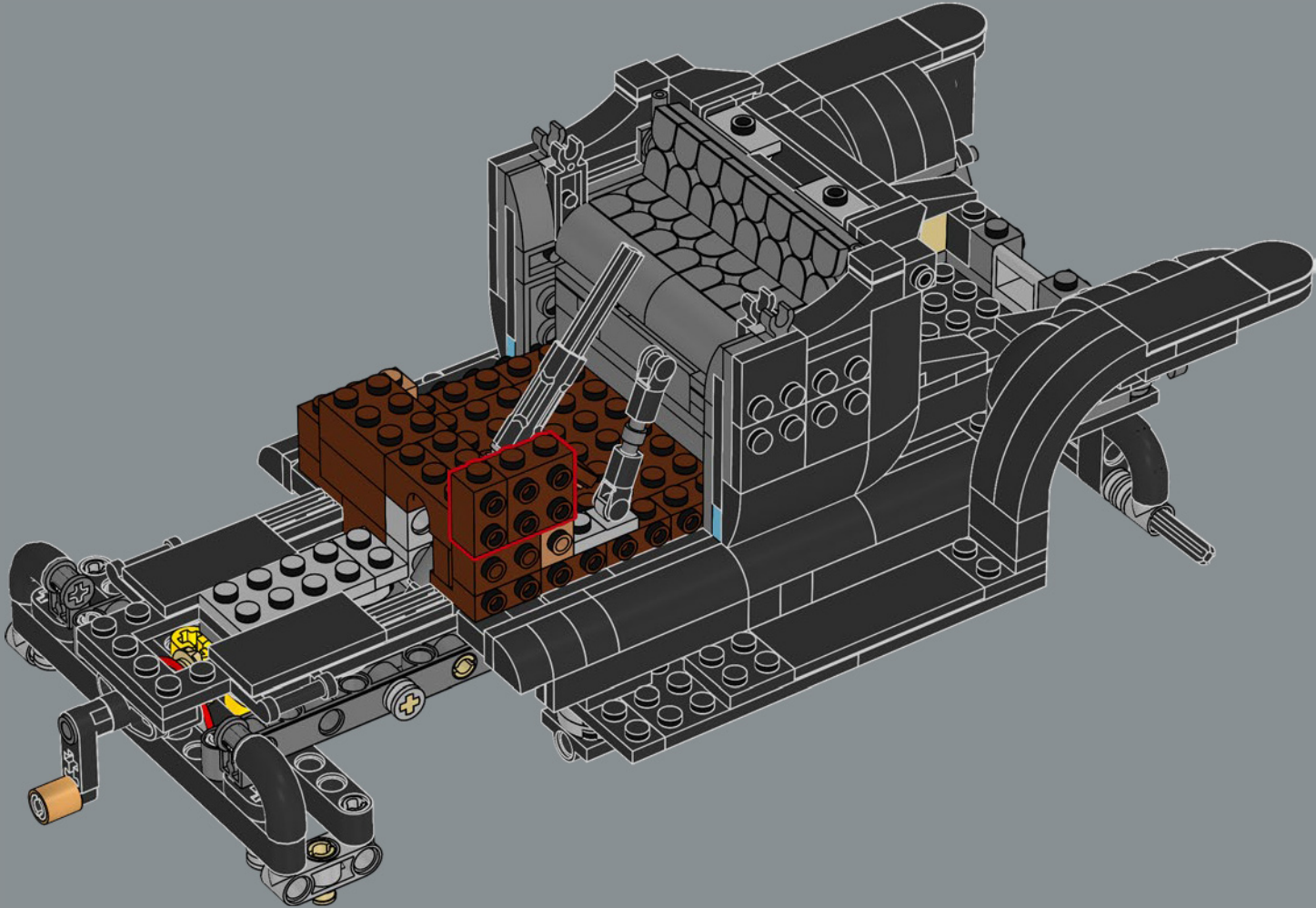



144

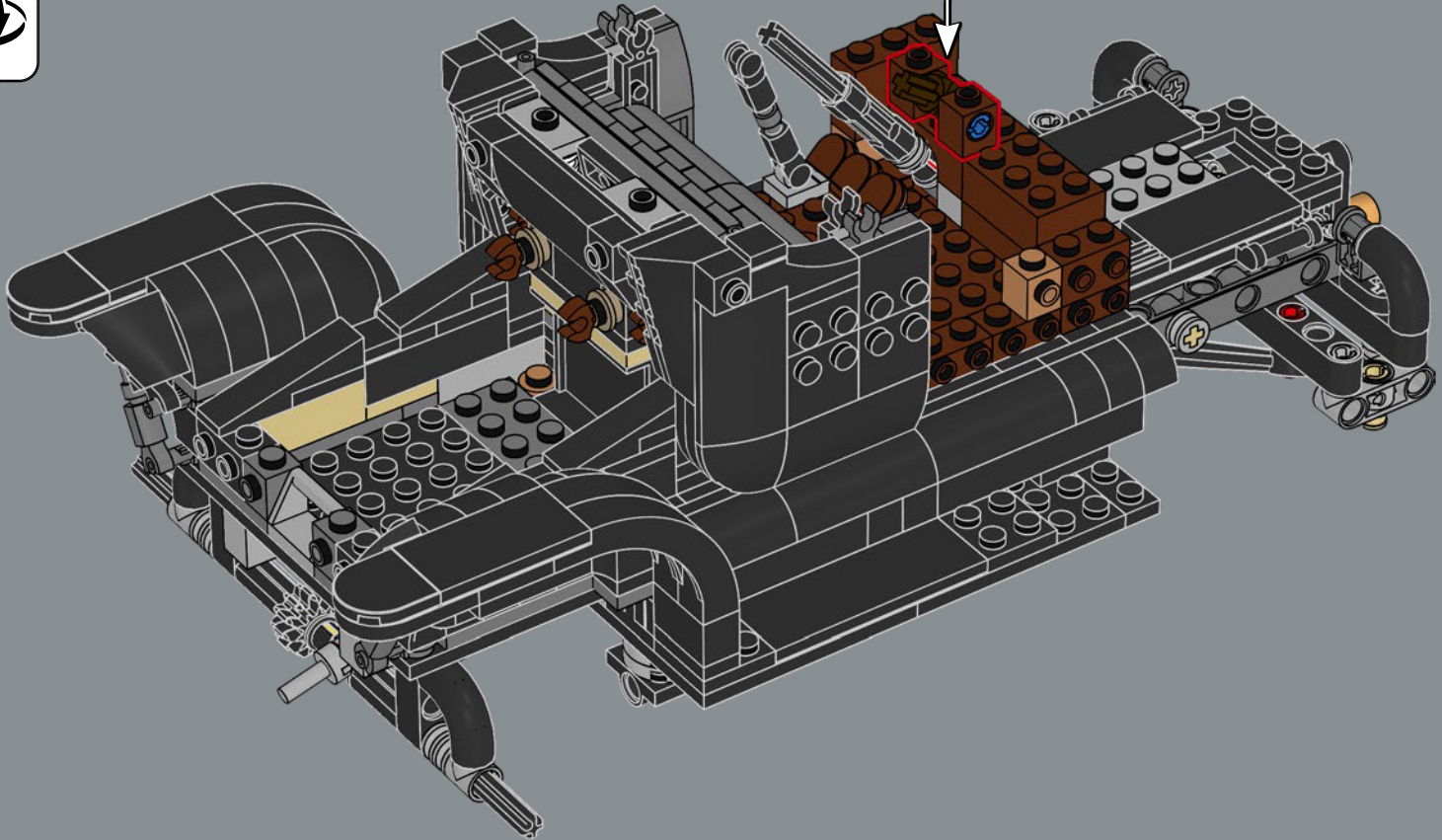
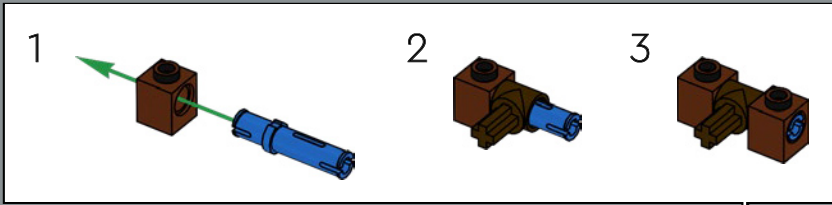

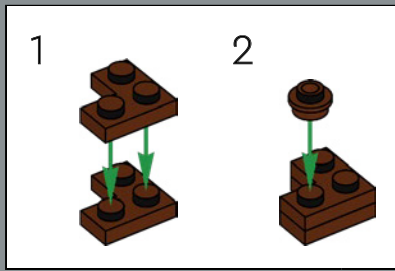

145

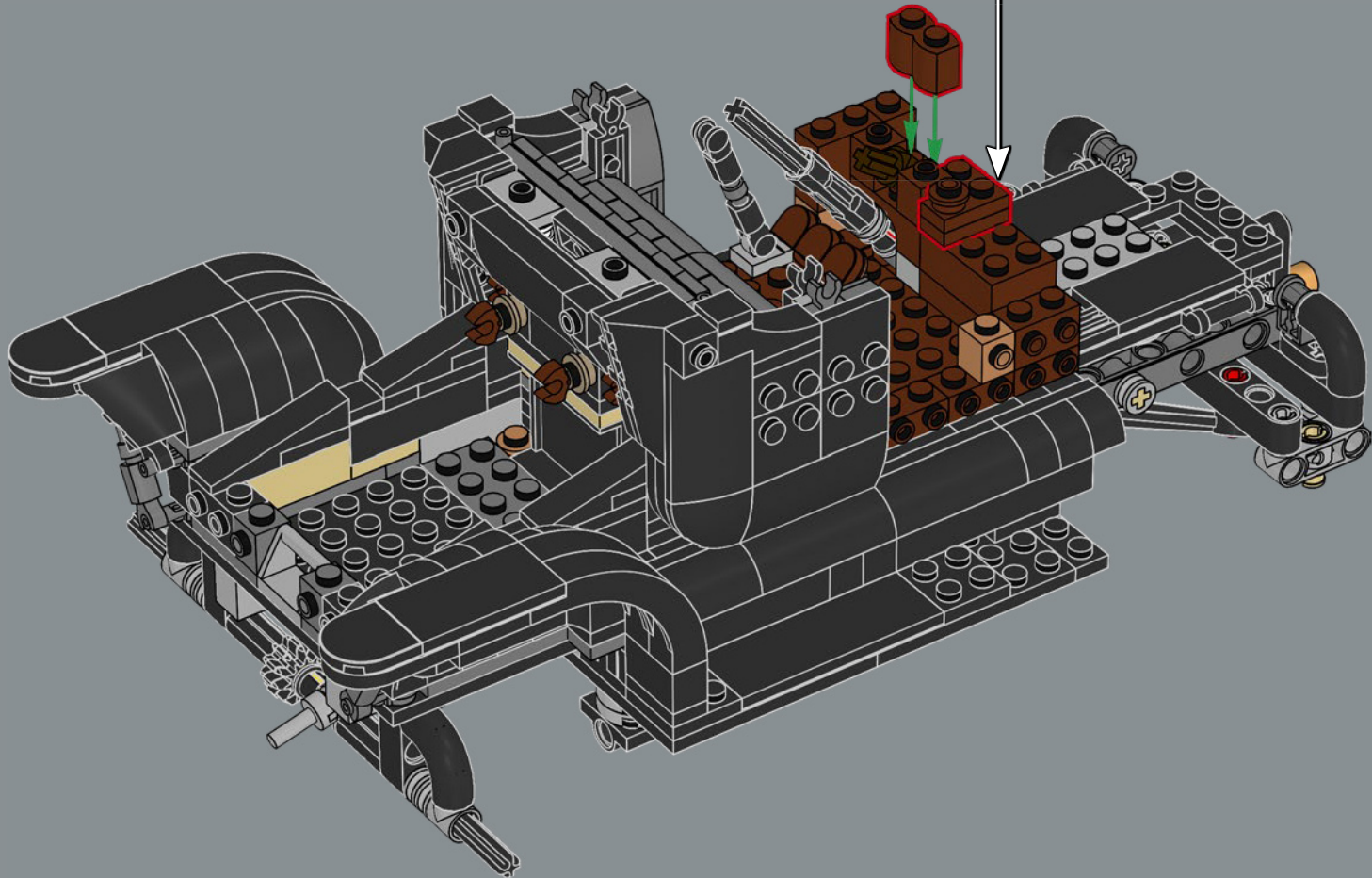

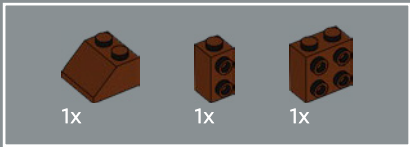

146

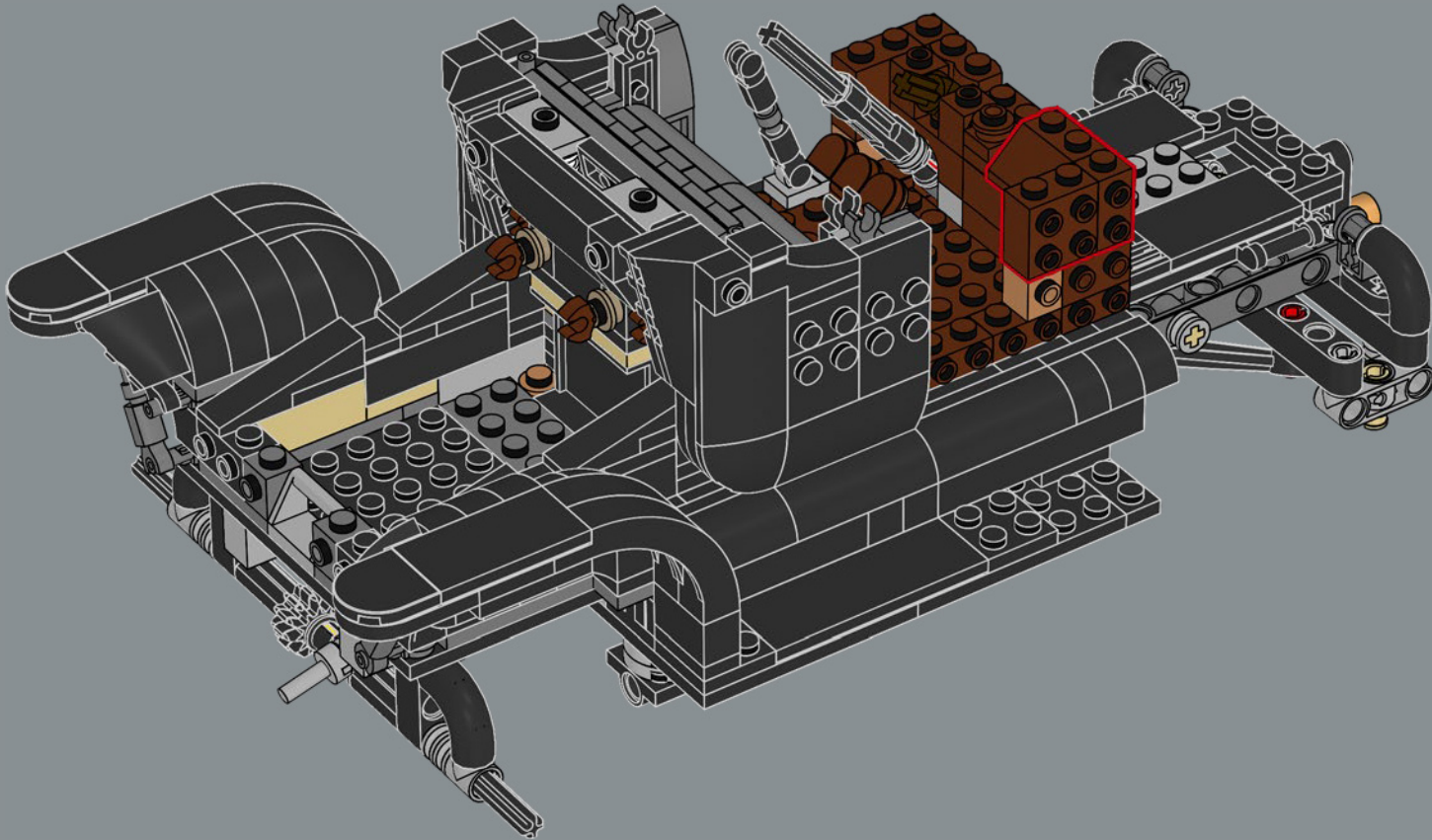



147

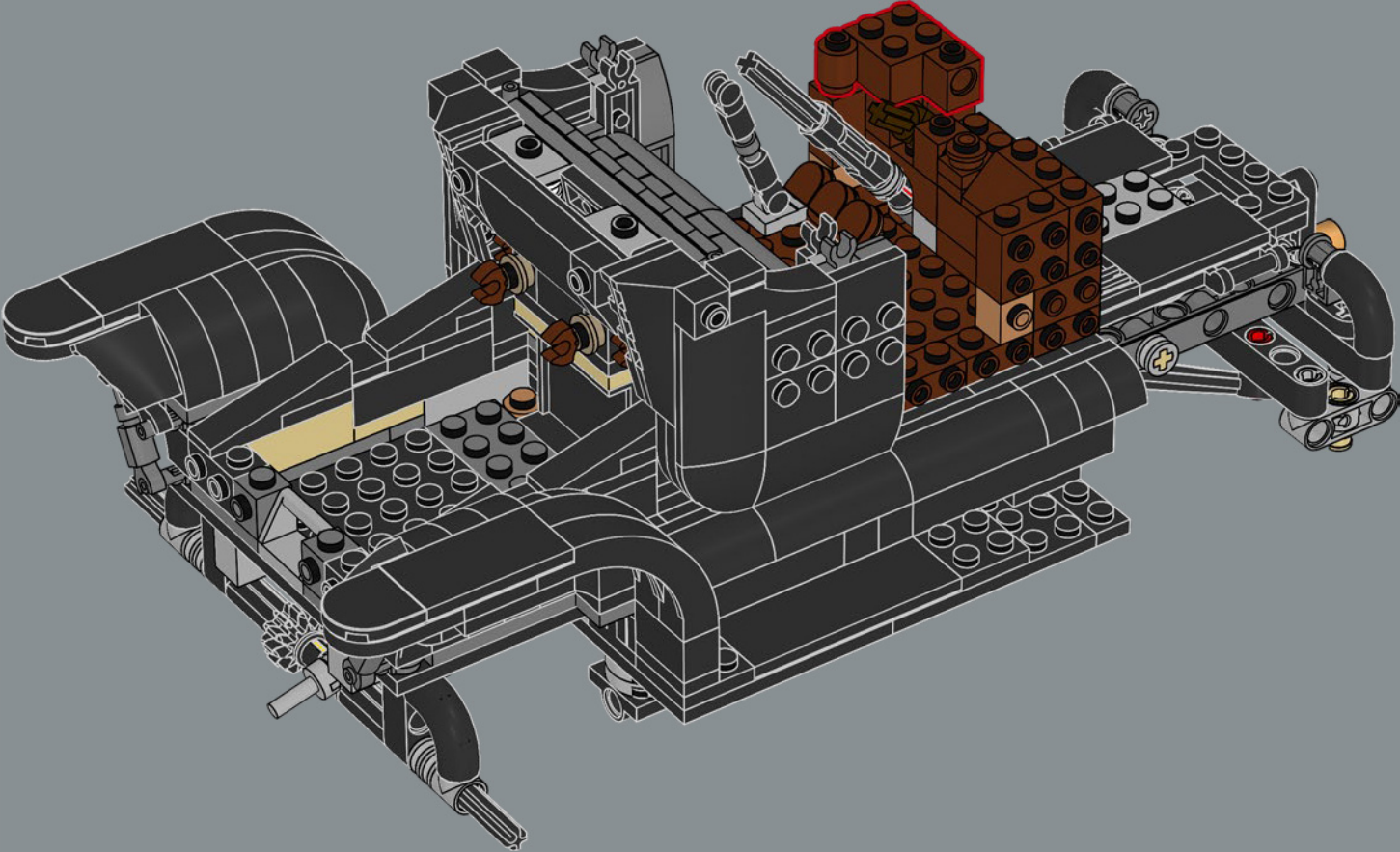

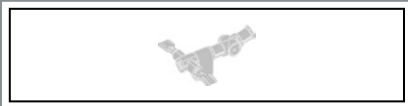

I comandi dei veicoli differivano da quelli delle auto moderne: il controllo dell'acceleratore era integrato nel volante, mentre i pedali venivano utilizzati per passare dalla prima marcia alla seconda, e viceversa.

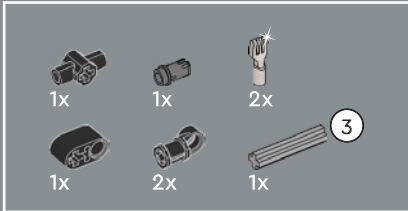

148

1

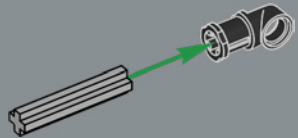

2

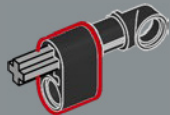

3



4

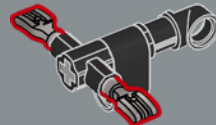

5

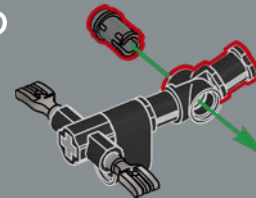

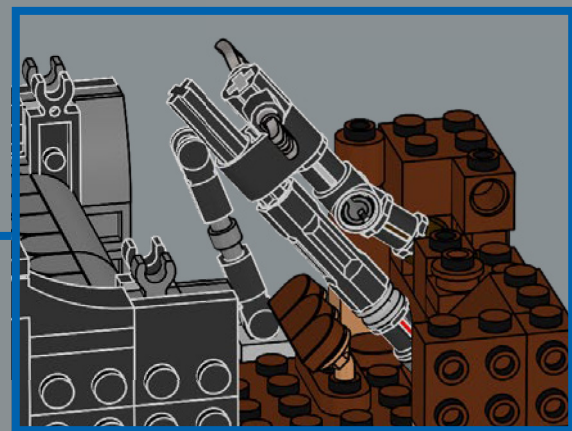
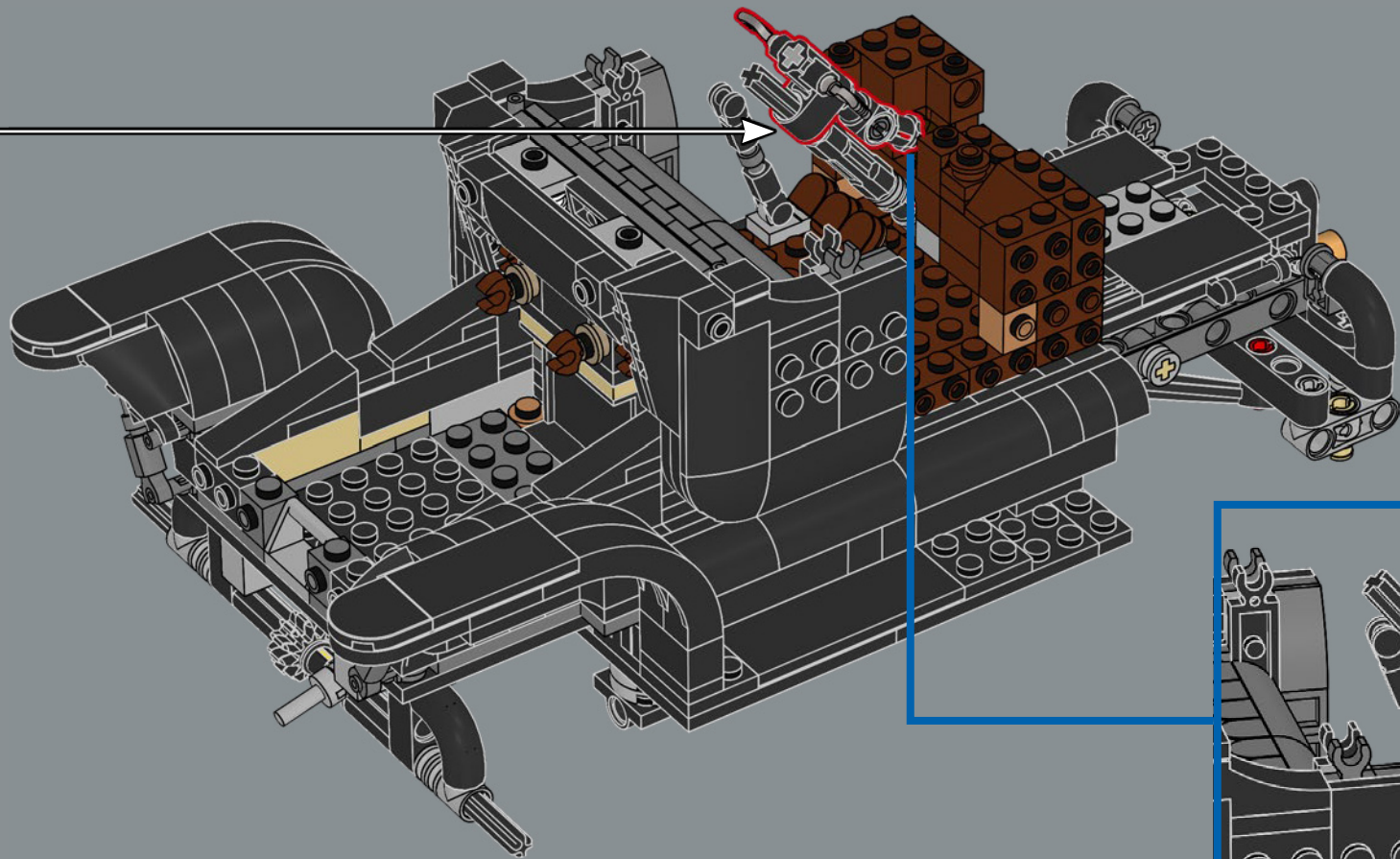

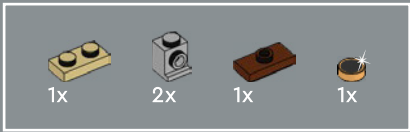

149

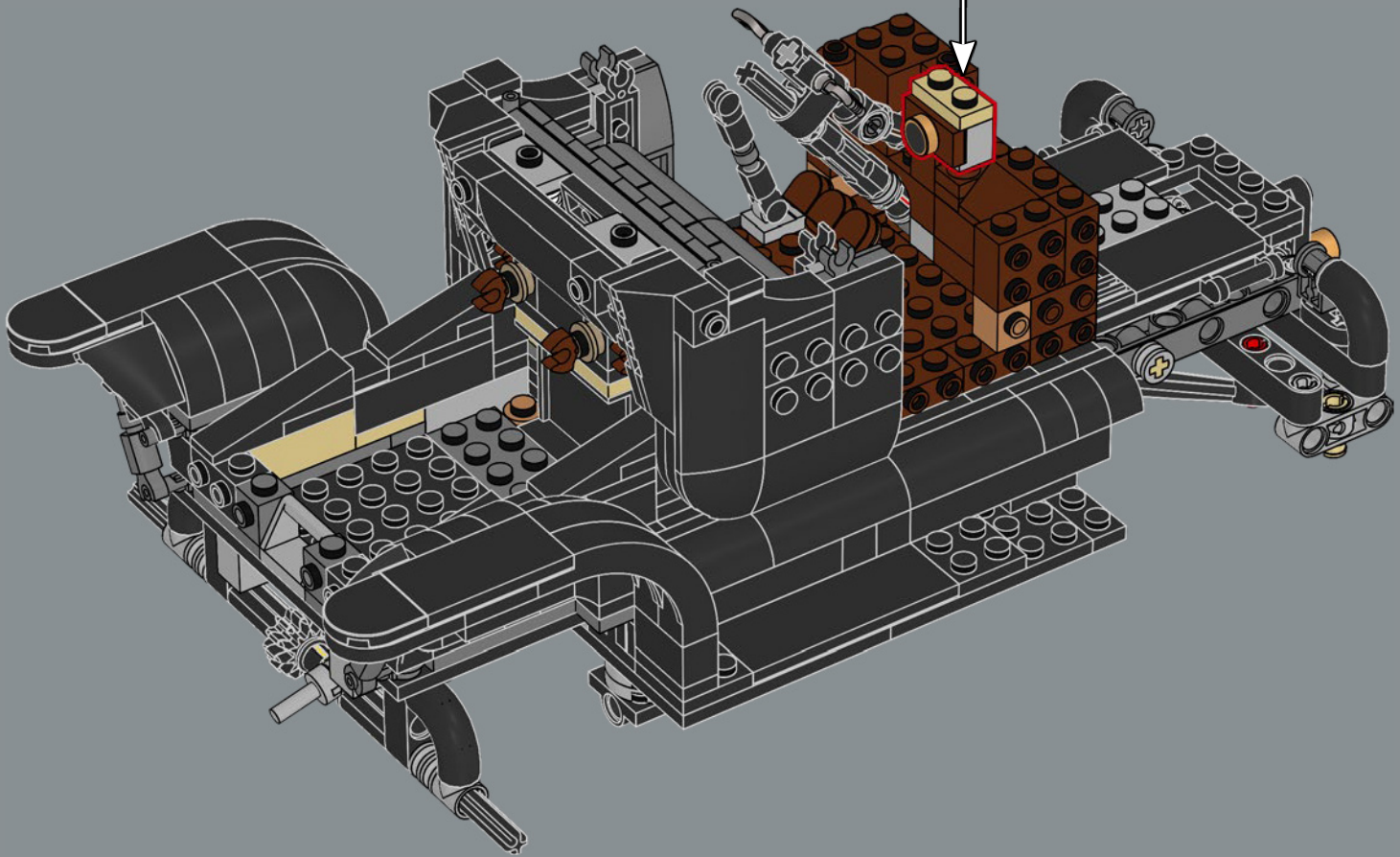
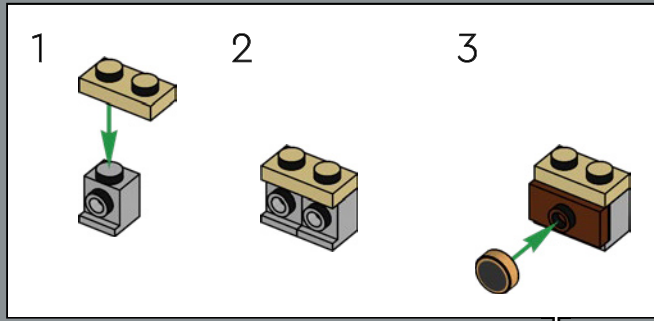

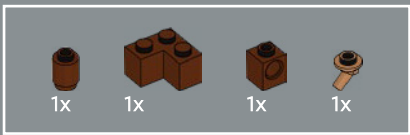

150

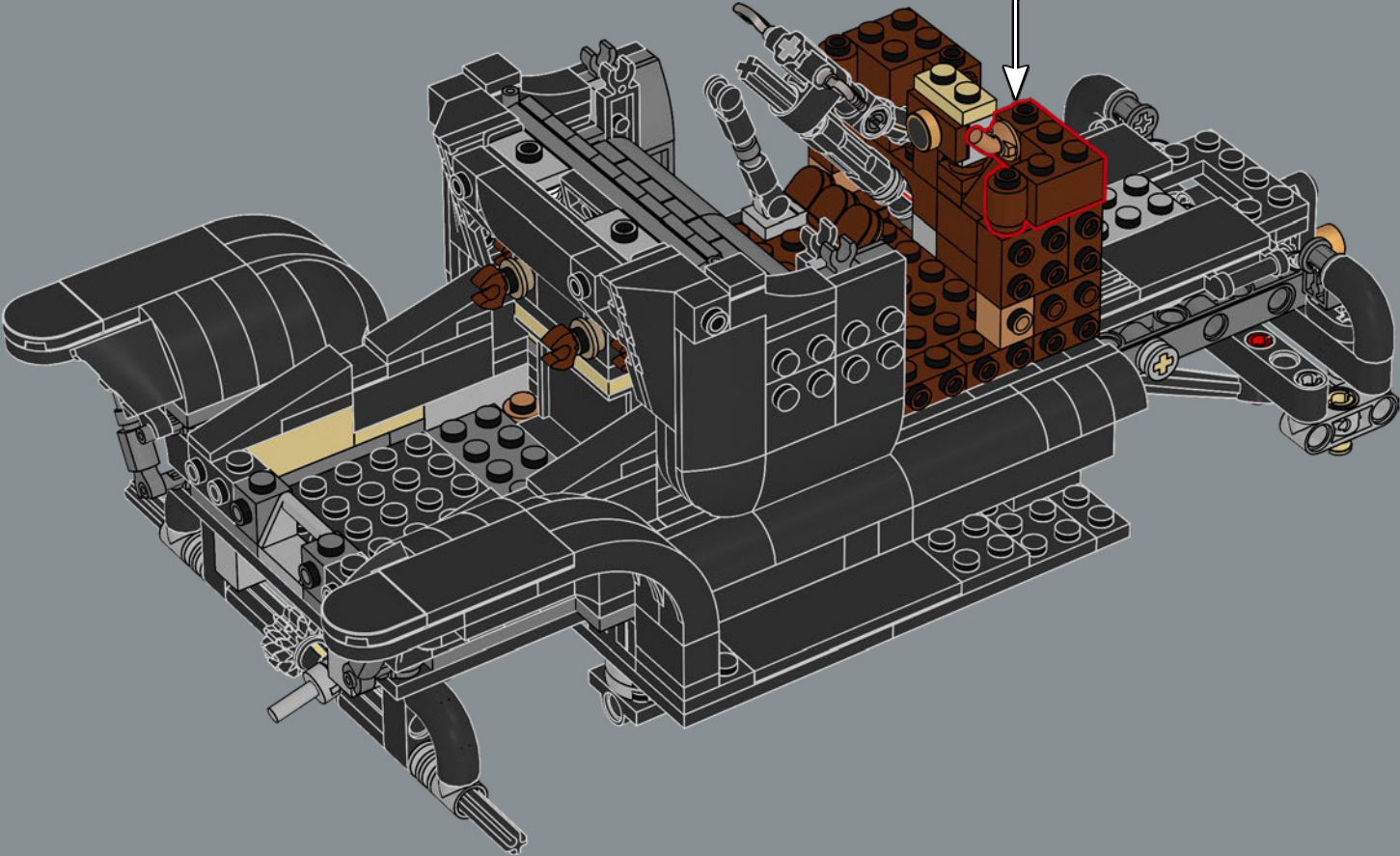
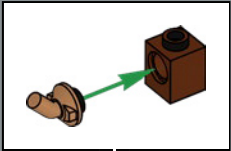



151

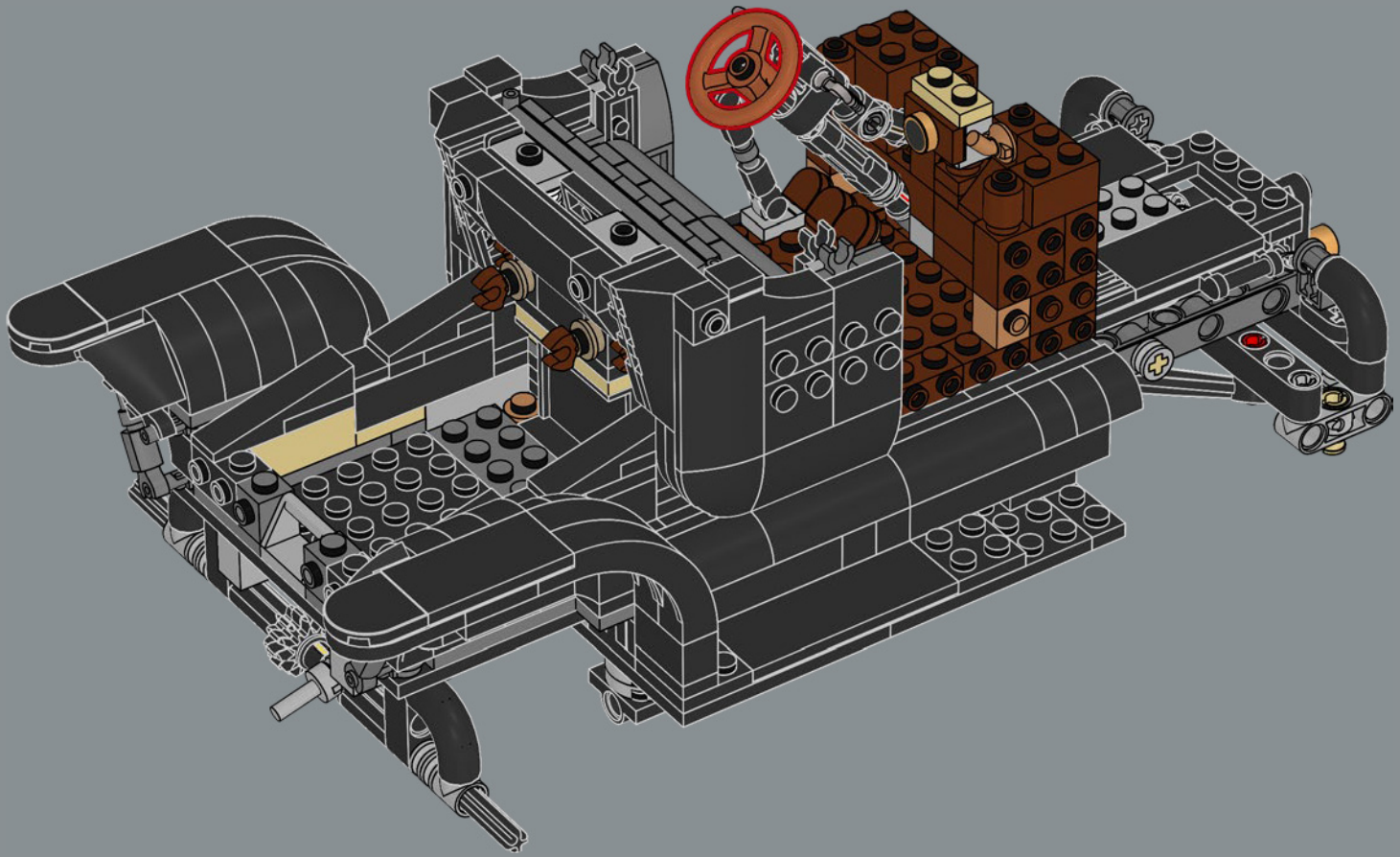

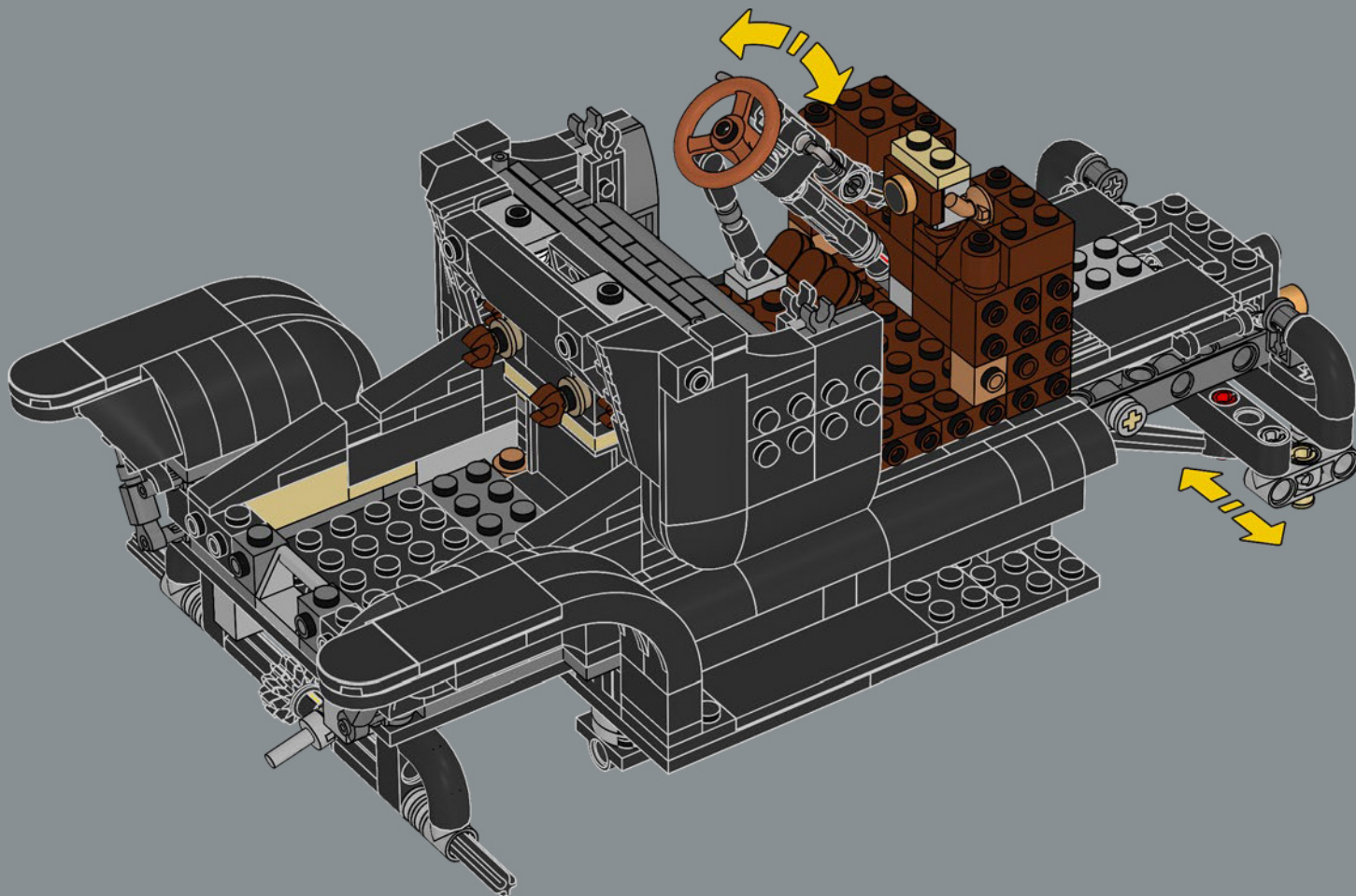

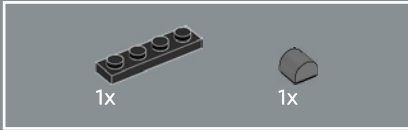
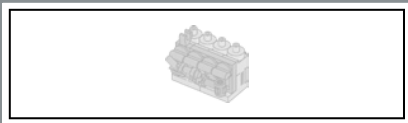

152

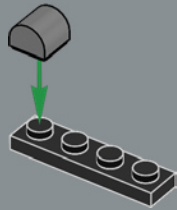

153

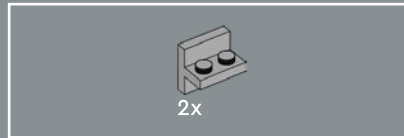
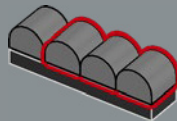

154

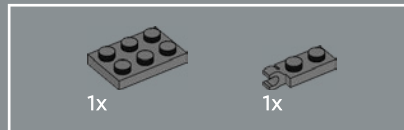
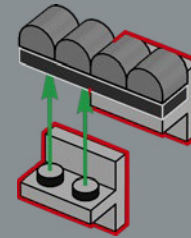

155

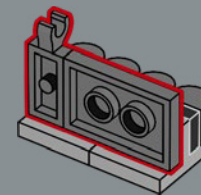

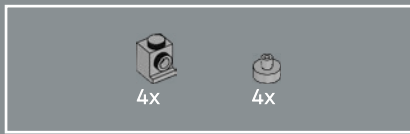

156

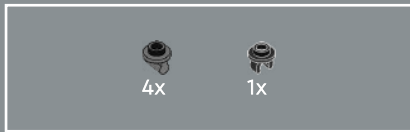
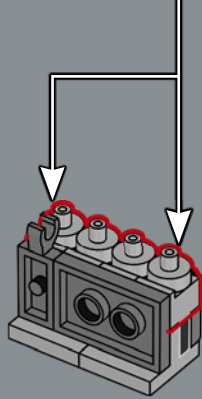
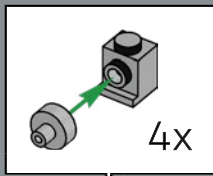

157

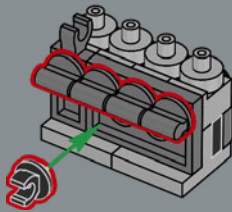

158

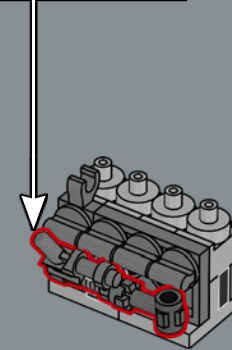
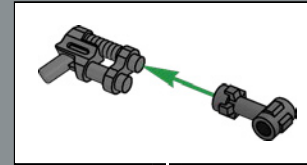

159

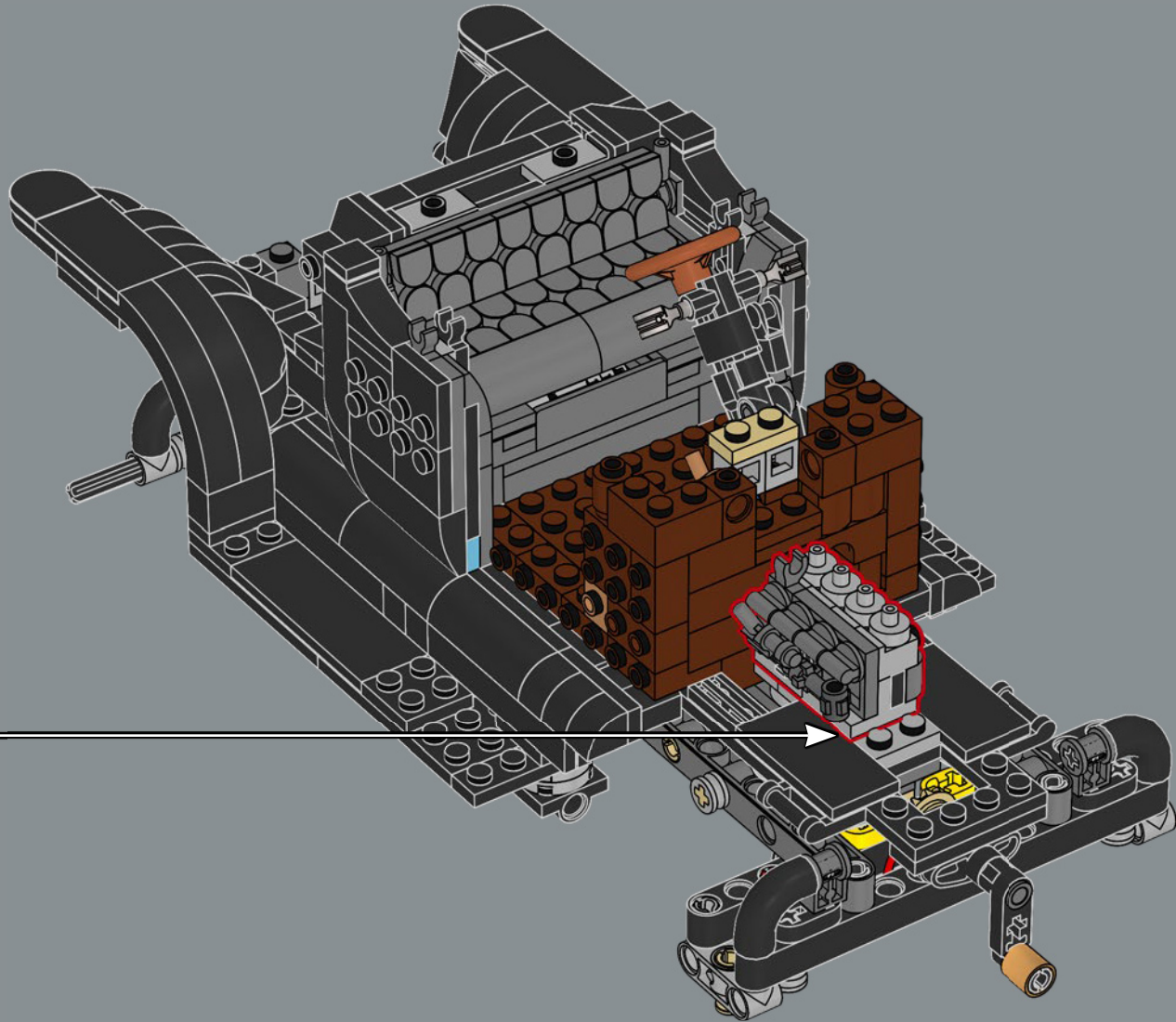

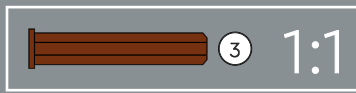
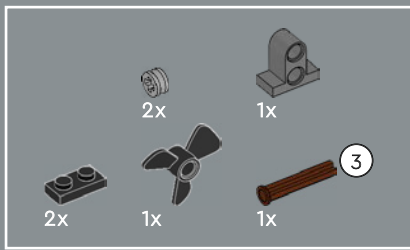

160

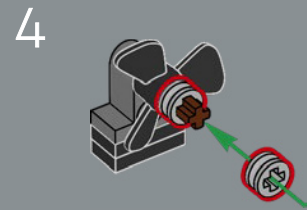
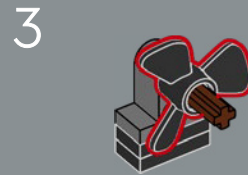
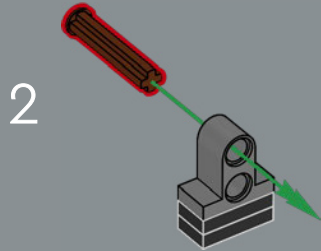
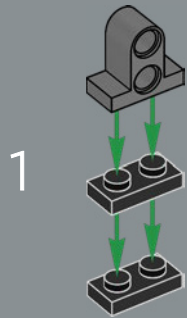

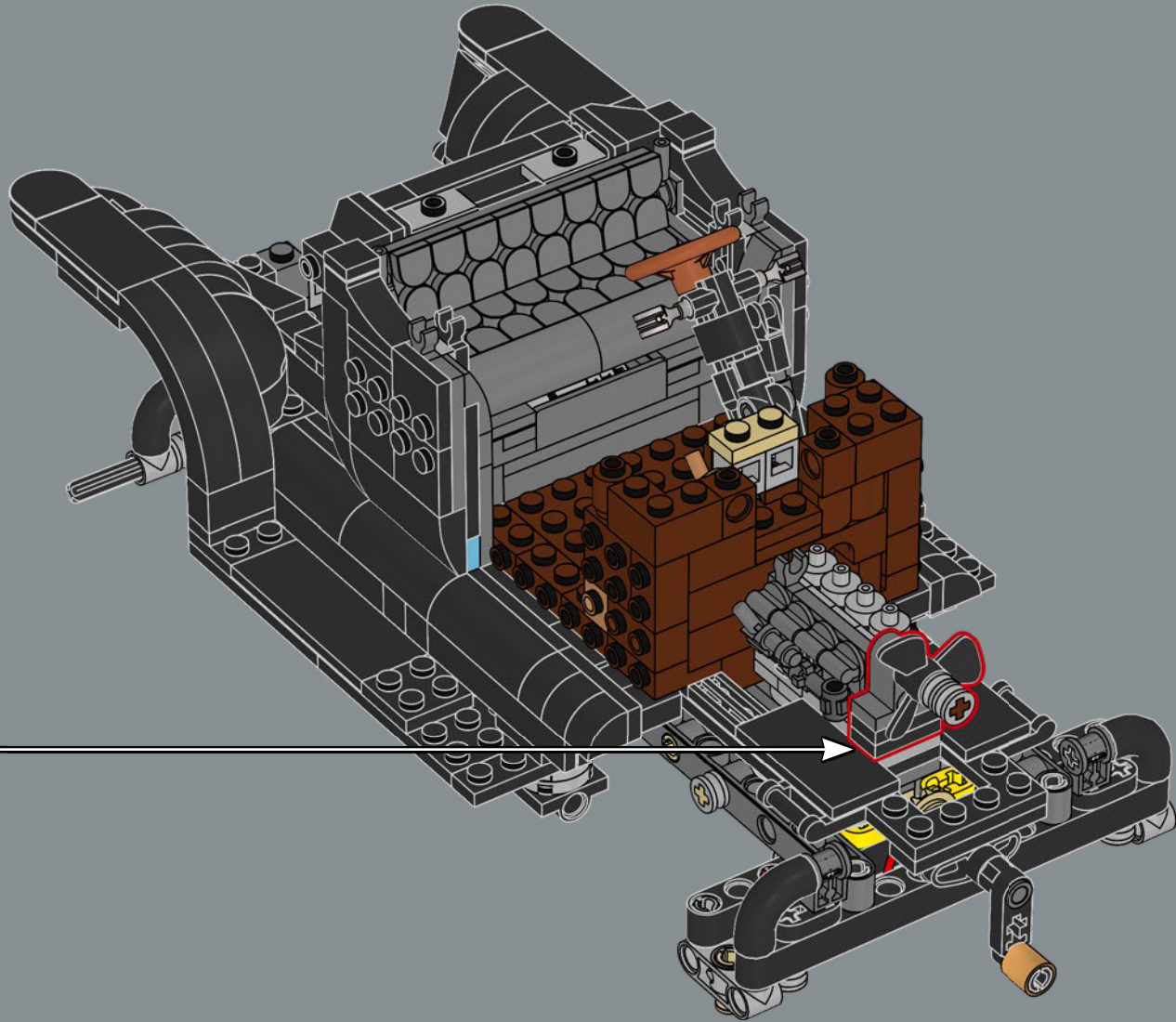

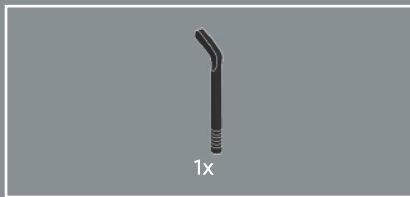

161

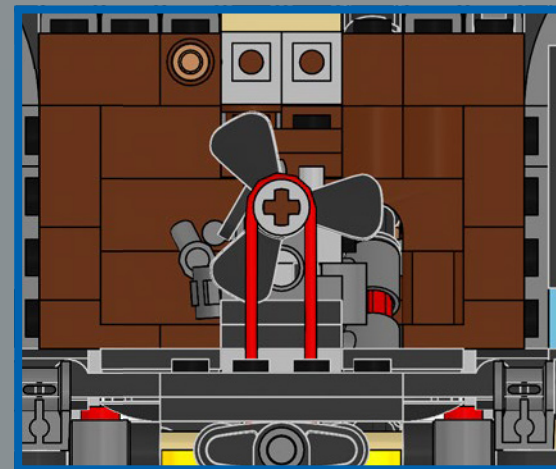
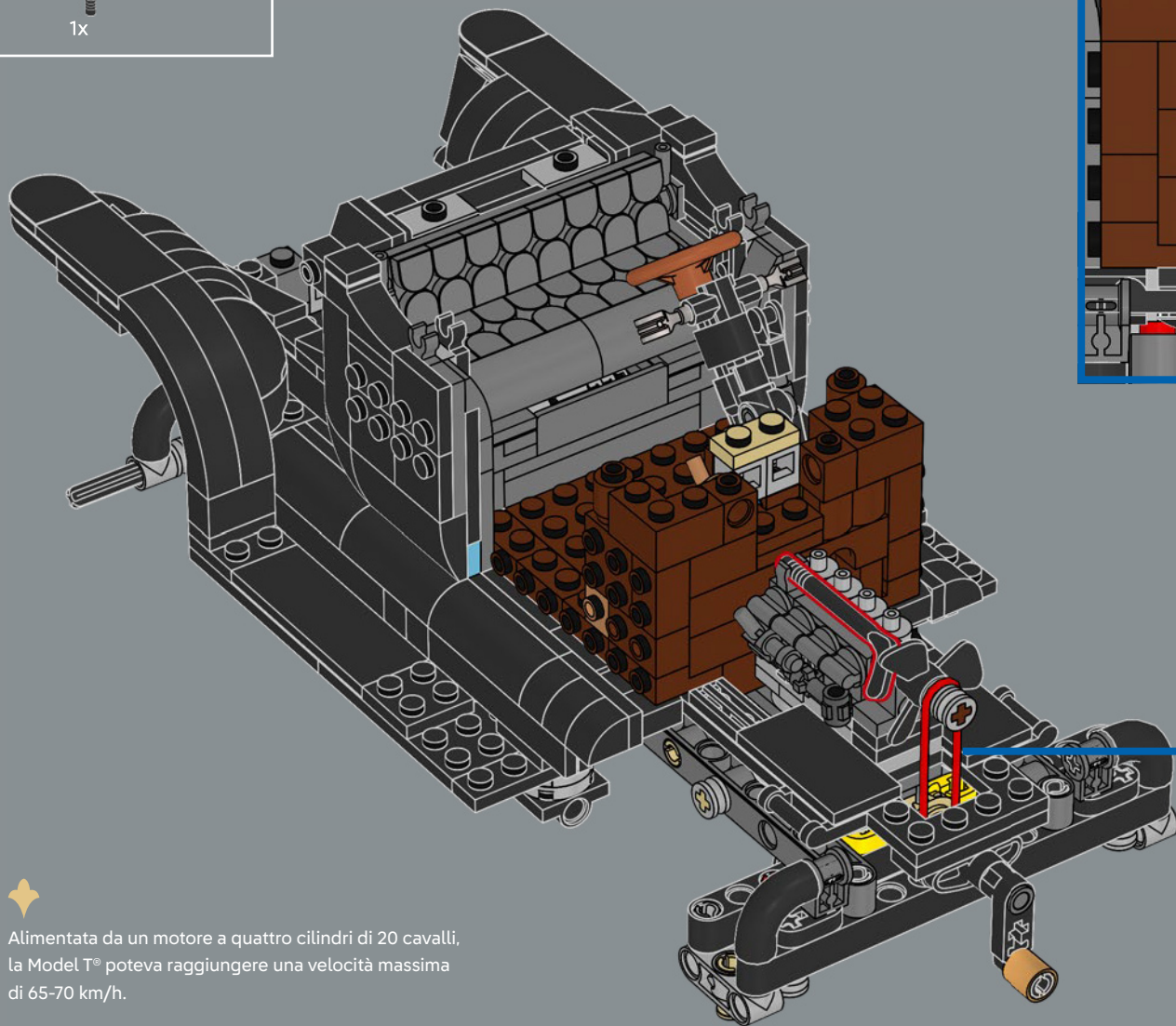

Alimentata da un motore a quattro cilindri di 20 cavalli, la Model T[®] poteva raggiungere una velocità massima di 65-70 km/h.

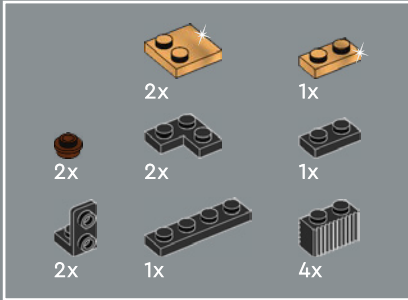
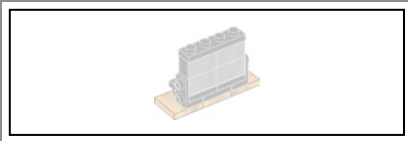

162

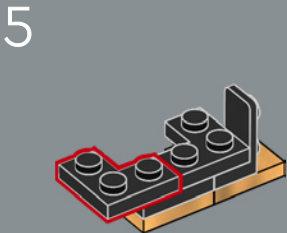
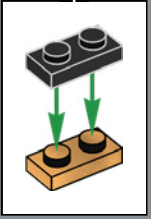
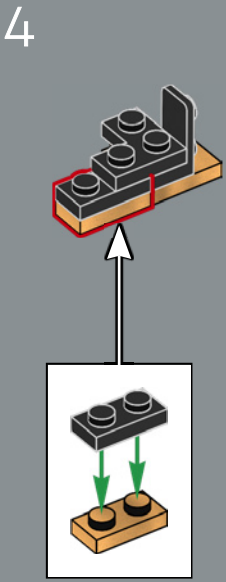
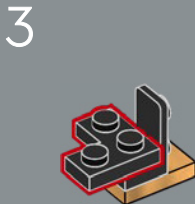
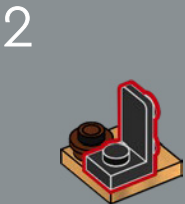
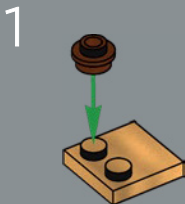

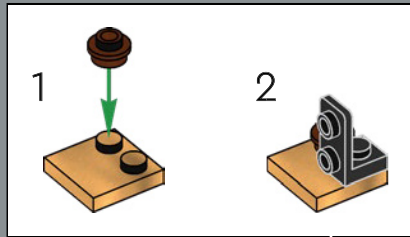

6

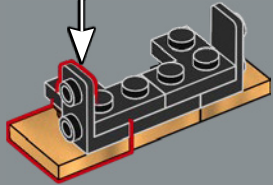

7

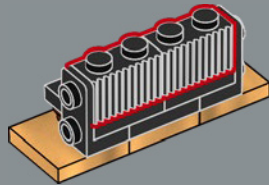

8

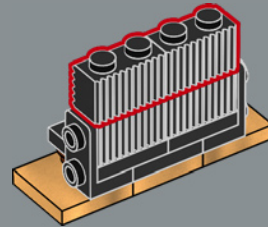

9

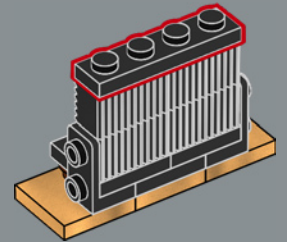

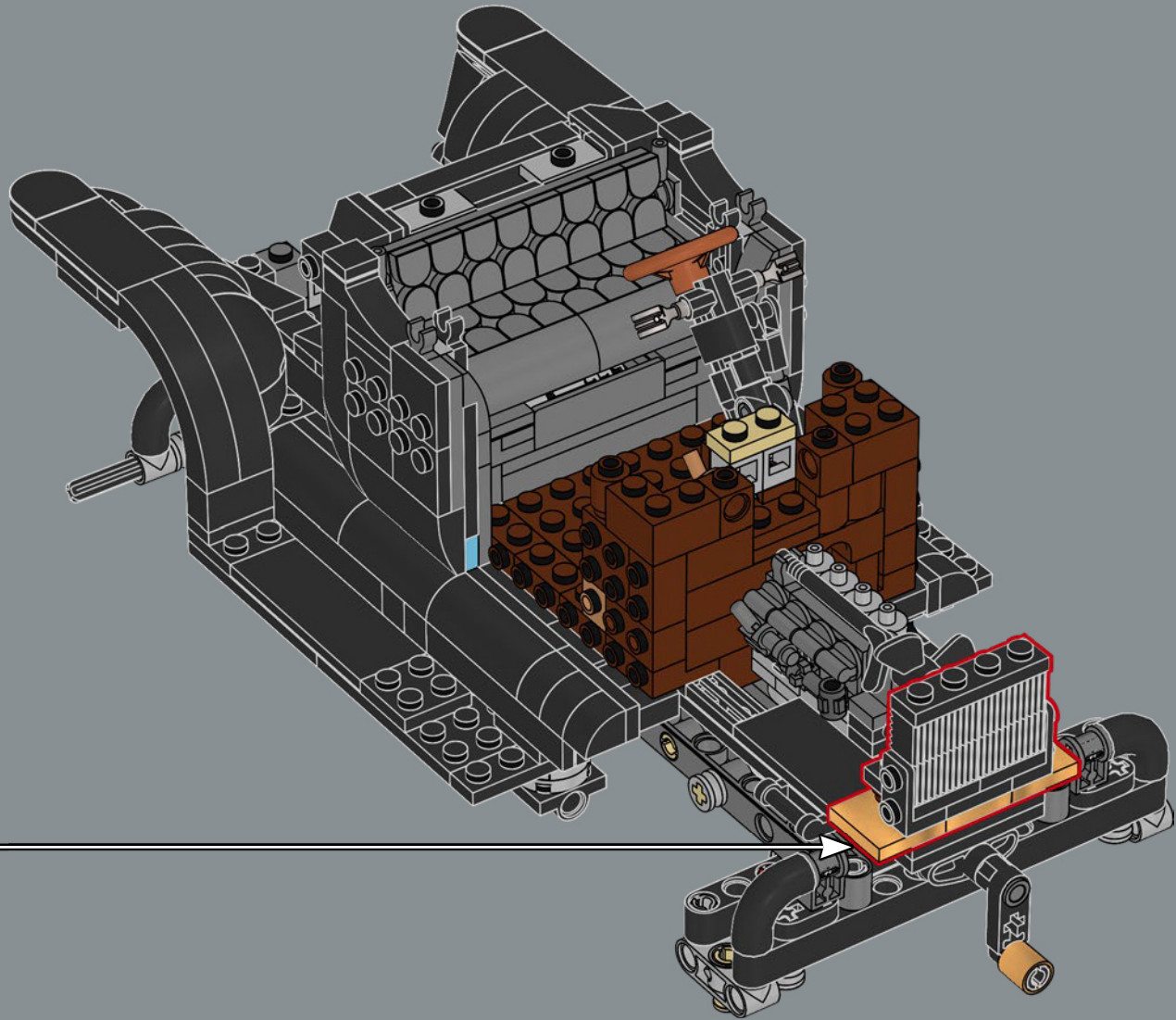

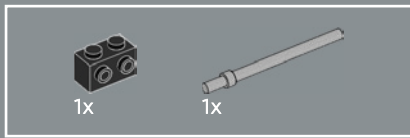

163

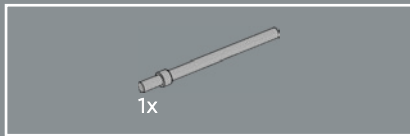
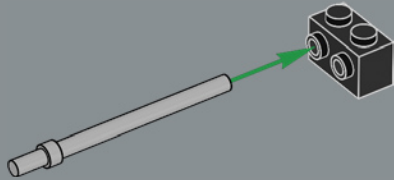

164

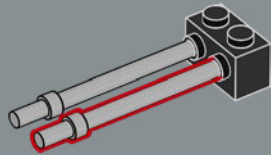

165

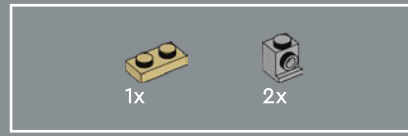
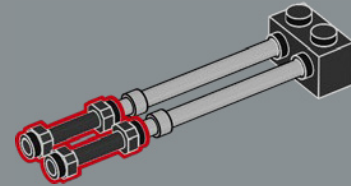

166

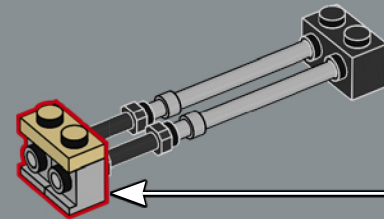
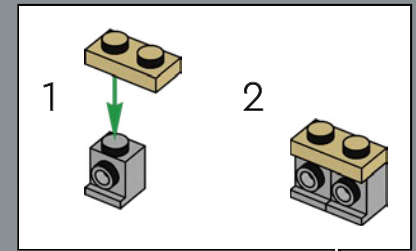

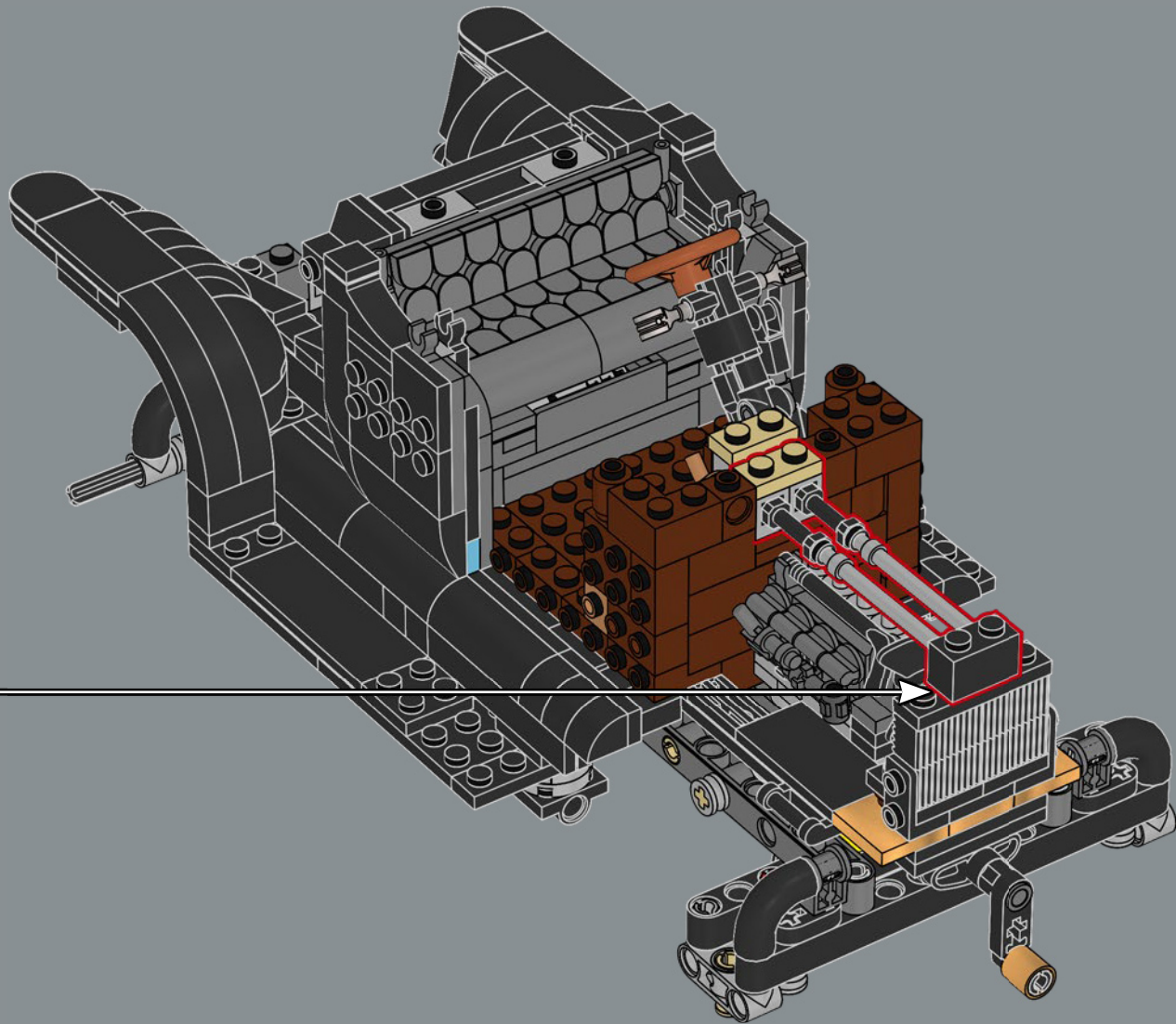

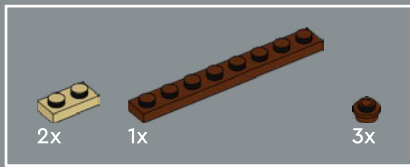

168

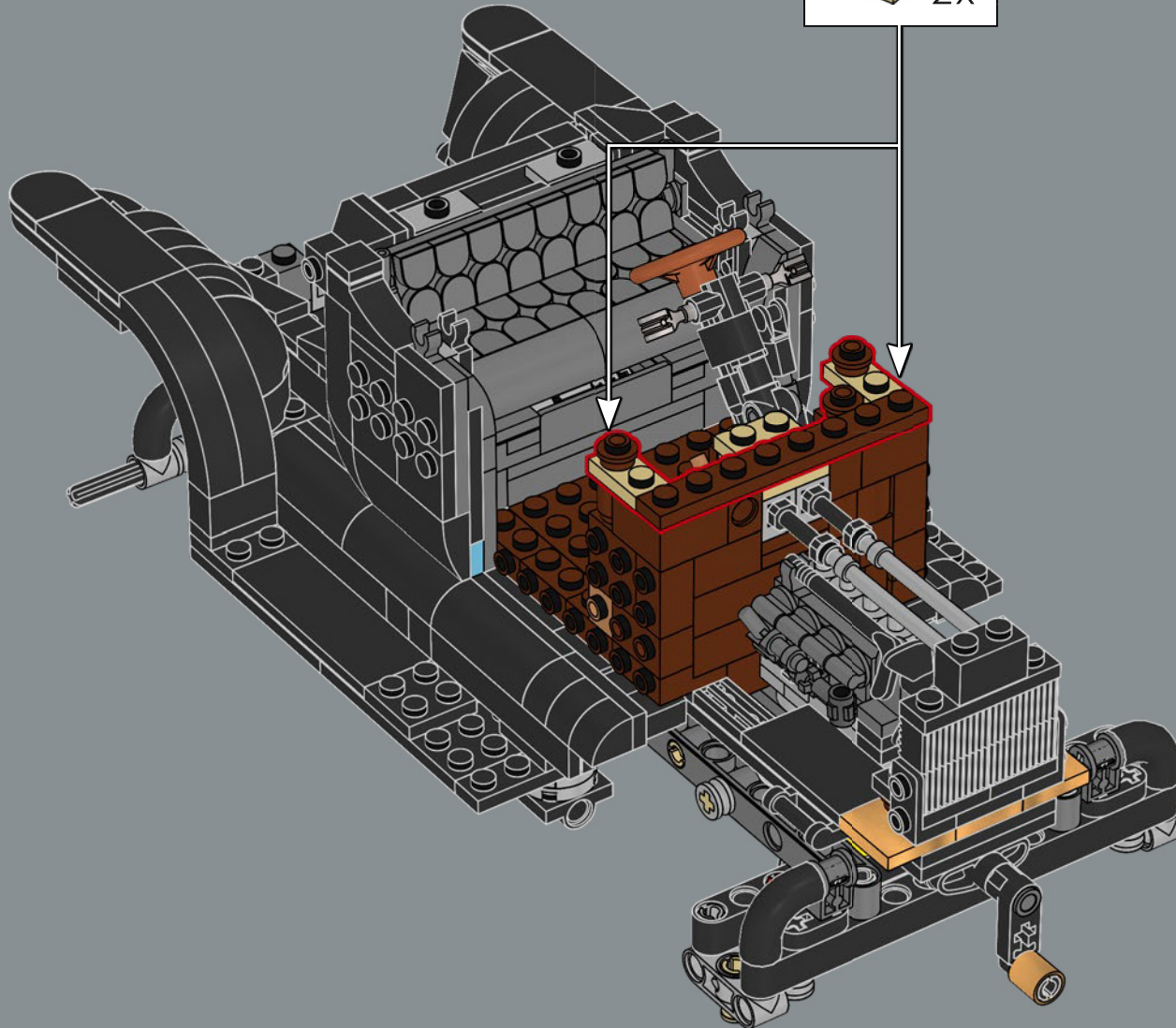
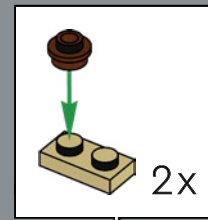

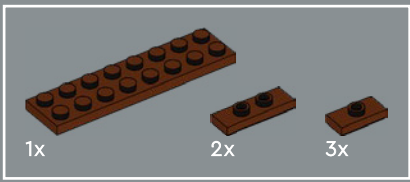

169

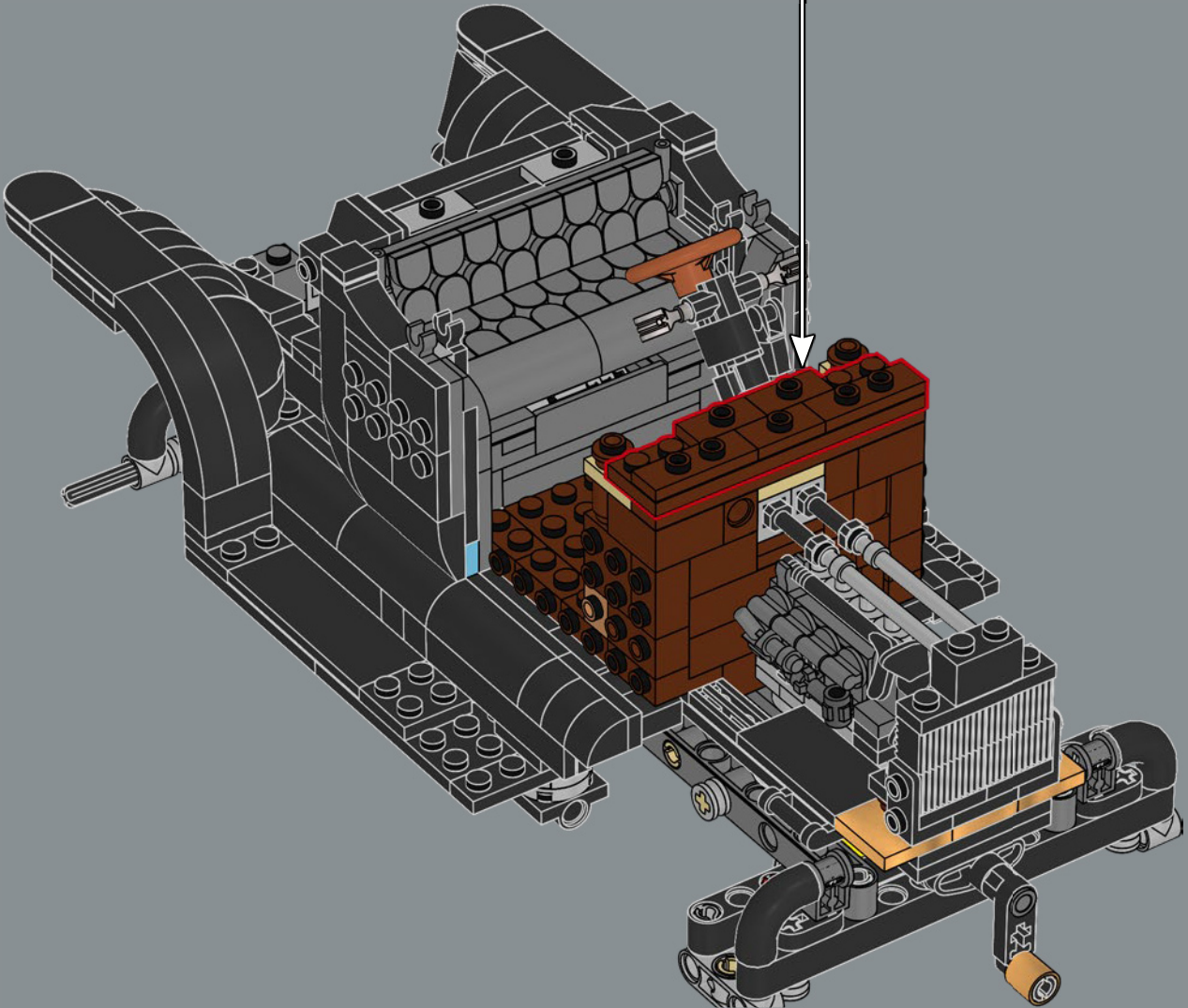
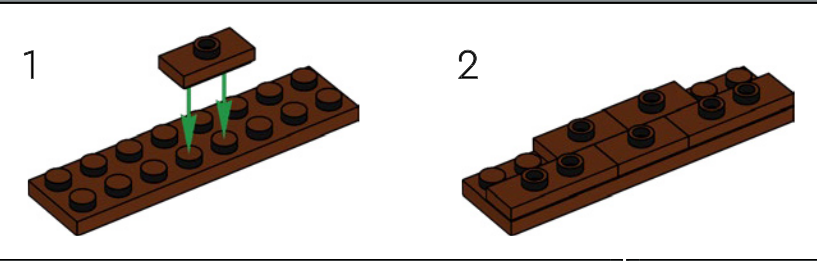

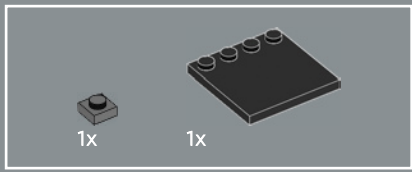

172

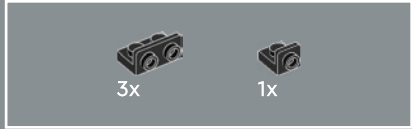
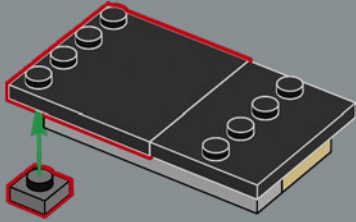

173

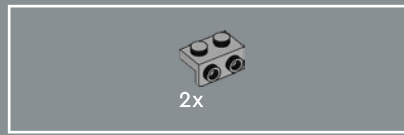
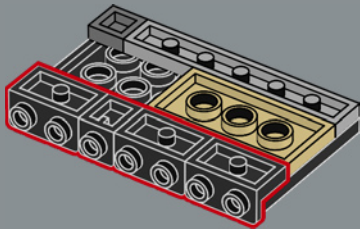

174

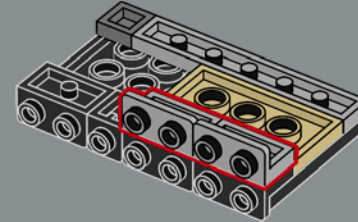

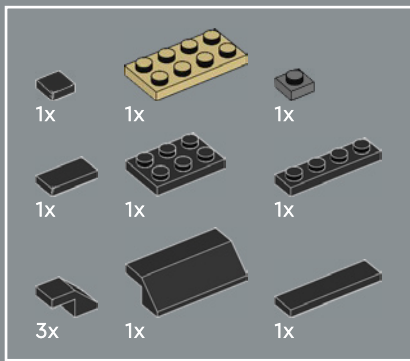

175

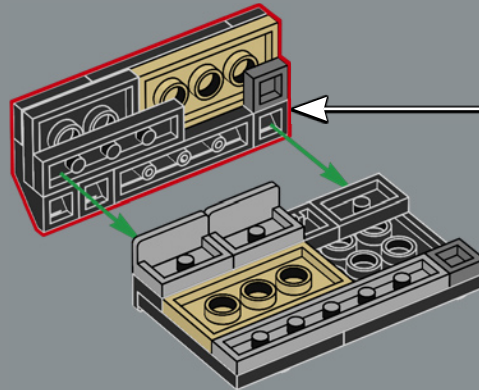
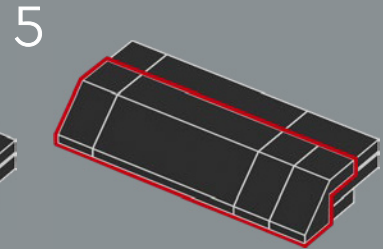
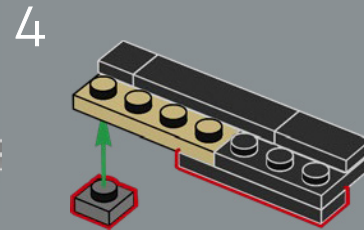
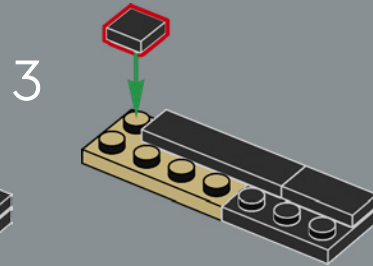
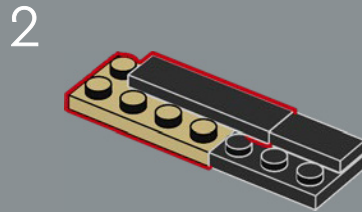
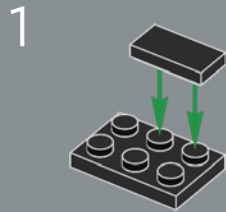

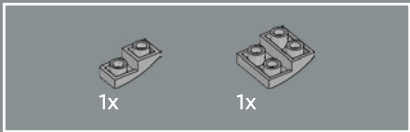

176

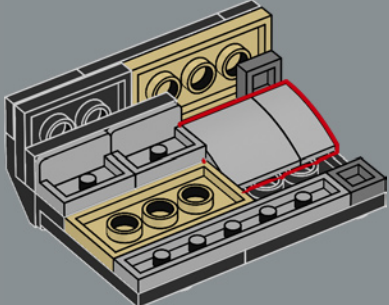

177

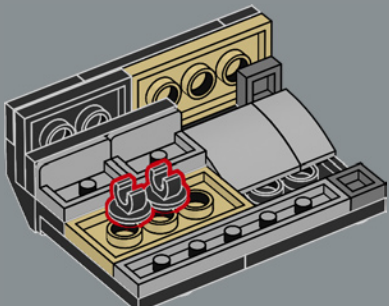

178

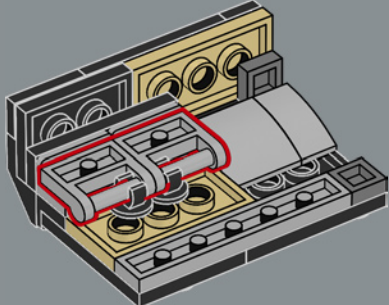

179

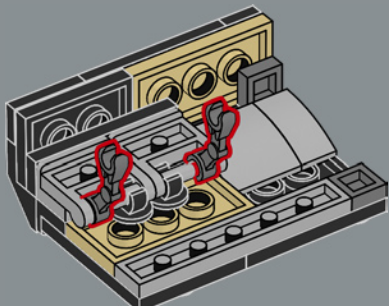

180

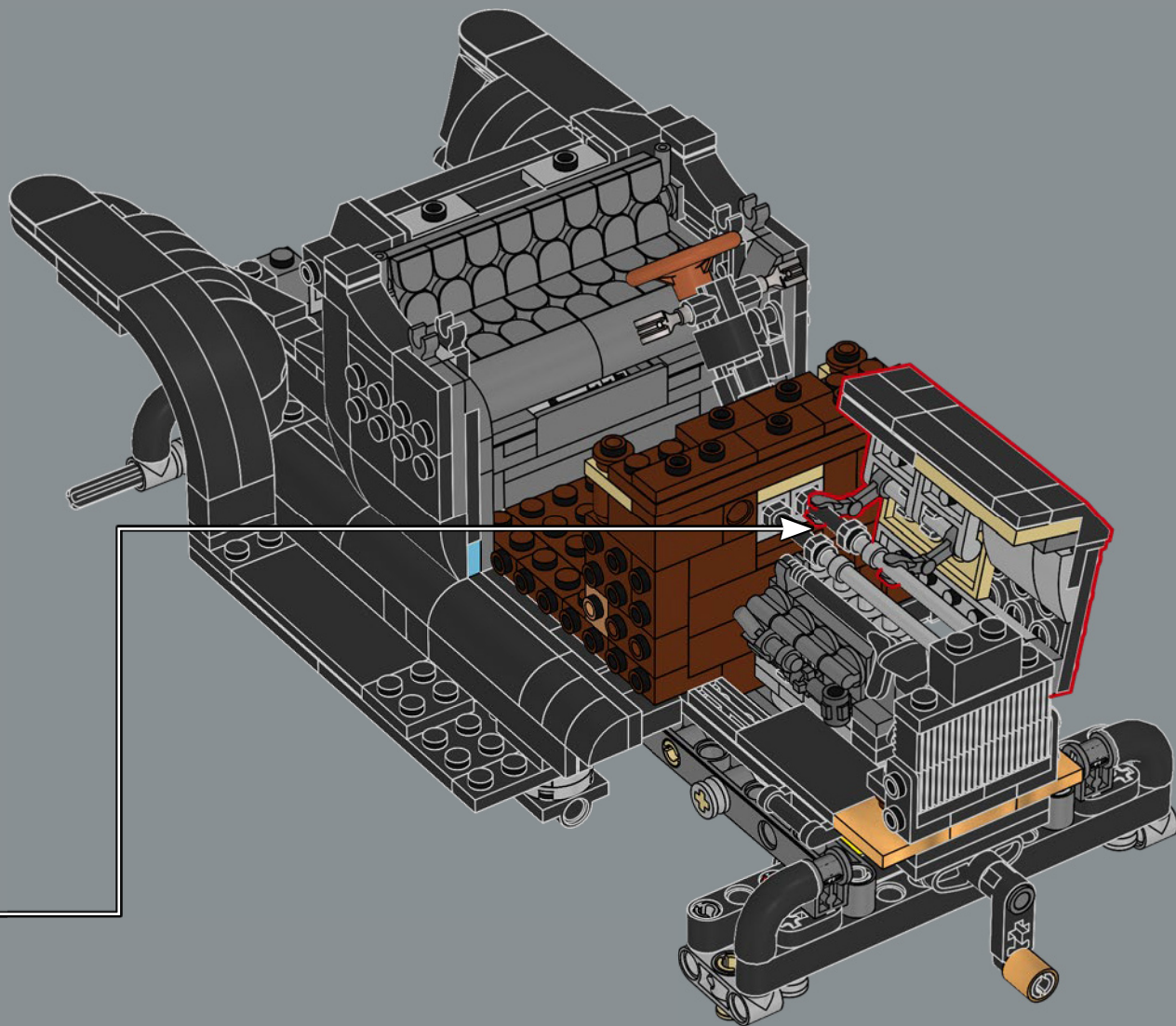

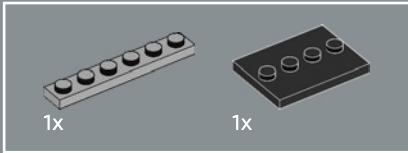
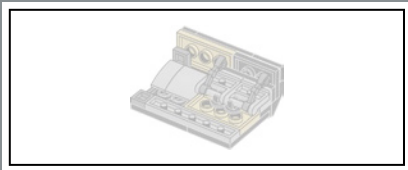

181

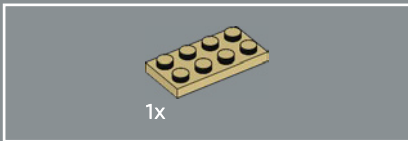
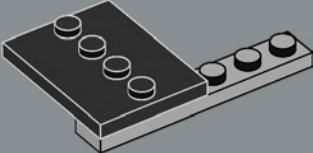

182

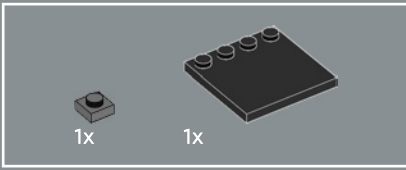
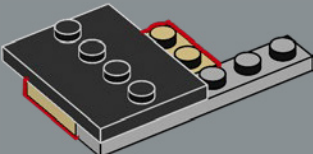

183

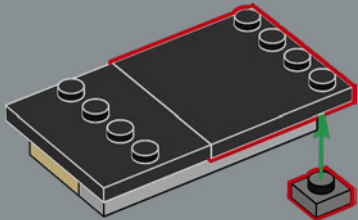

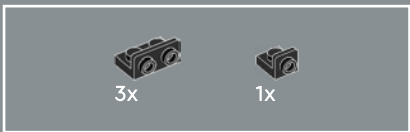

184

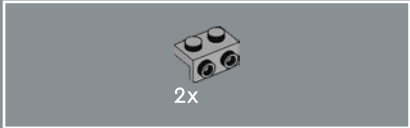
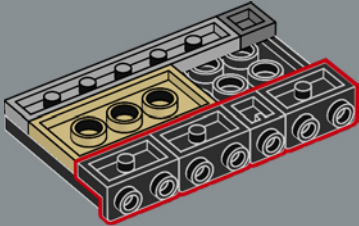

185

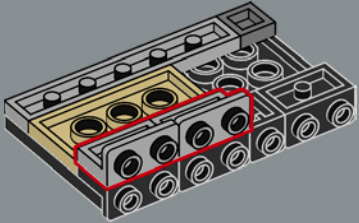

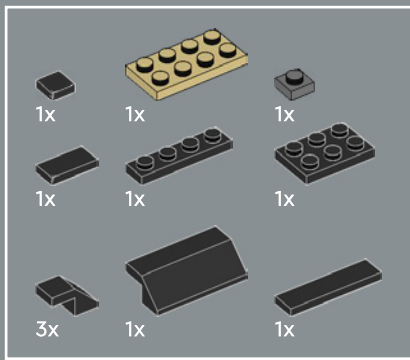

186

1

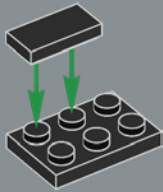

2

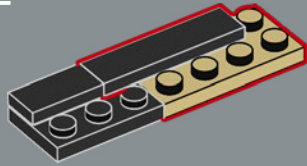

3

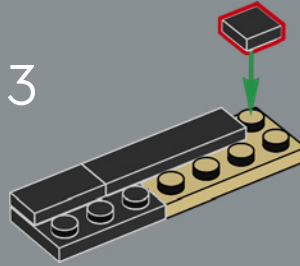

4

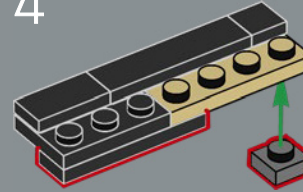

5

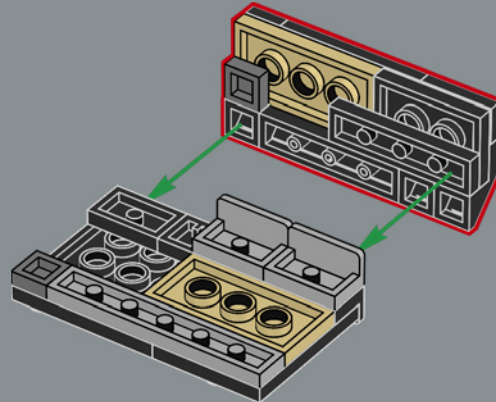
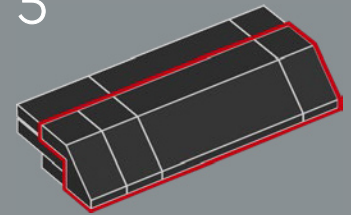

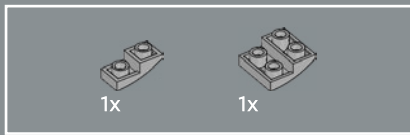

187

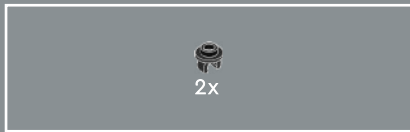
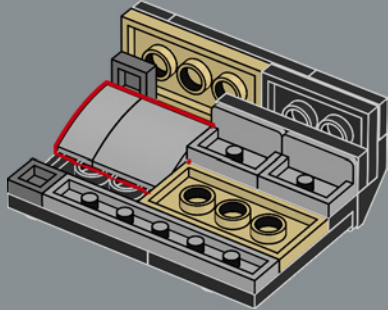

188

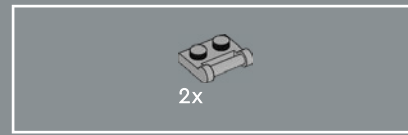
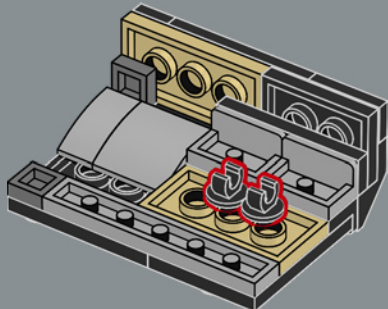

189

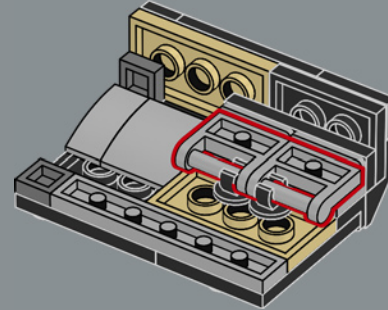

190

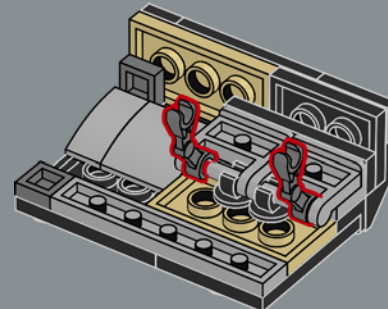

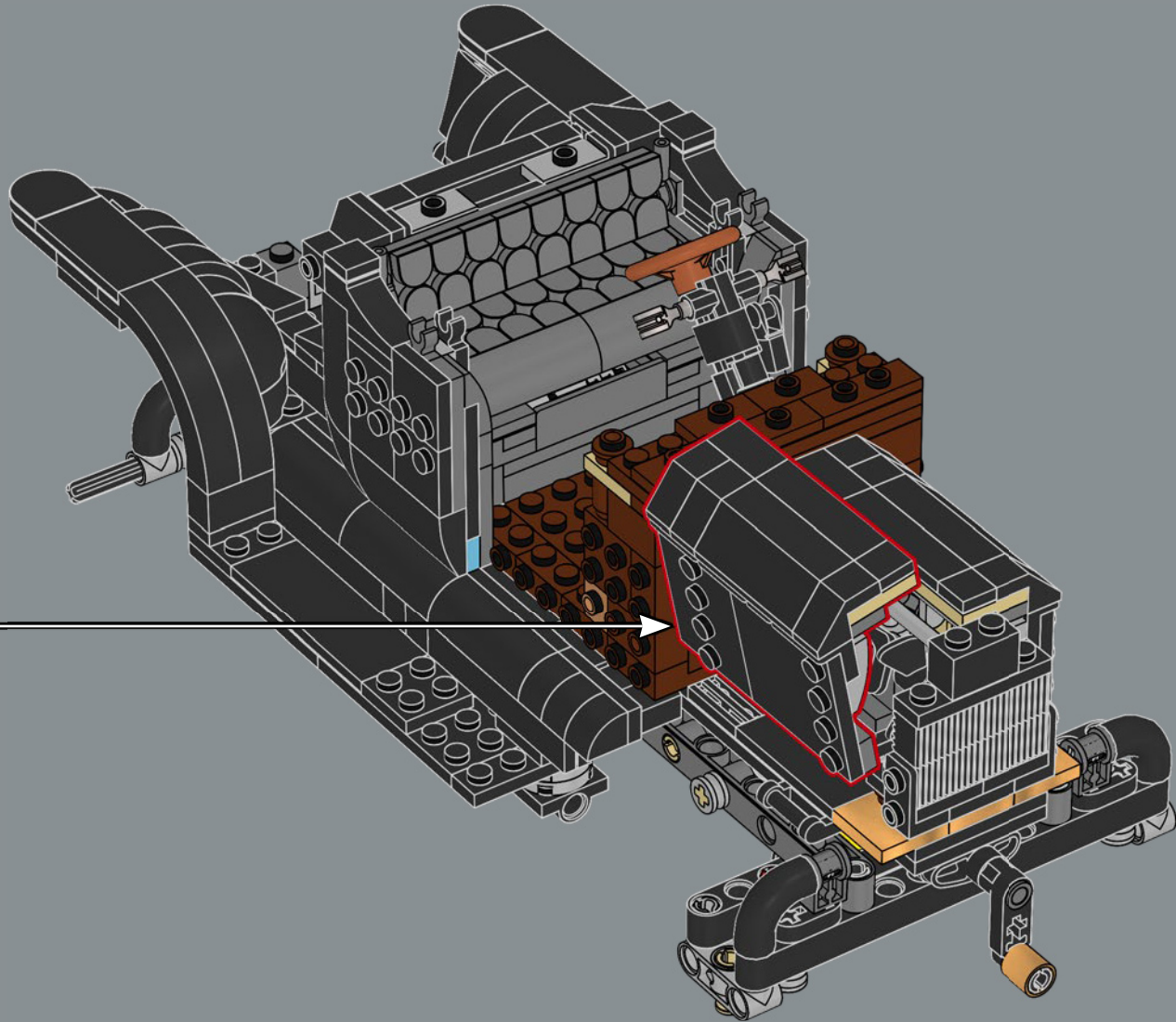

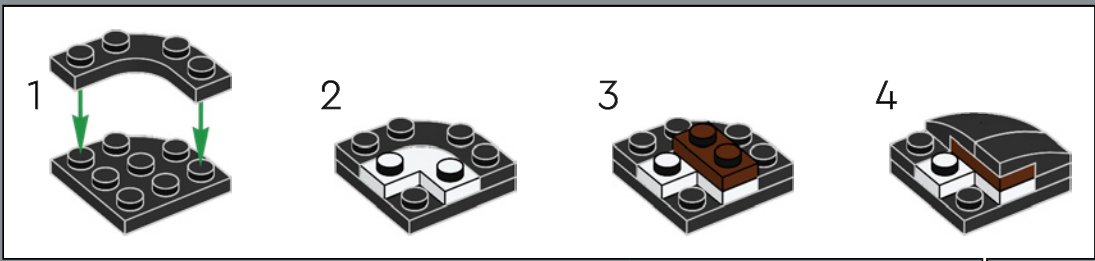
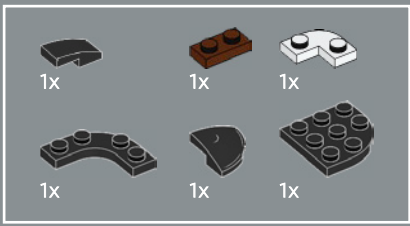

193

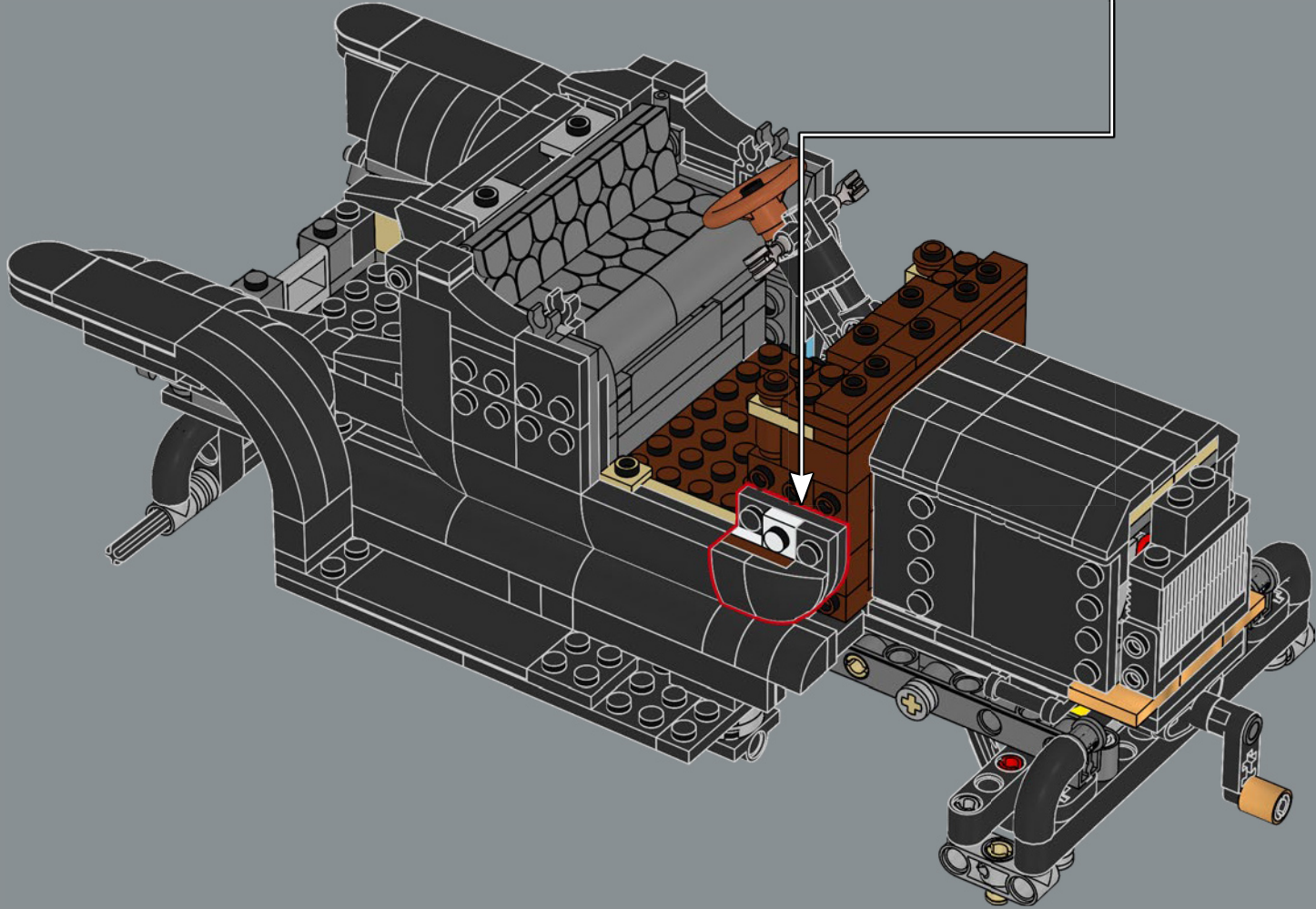

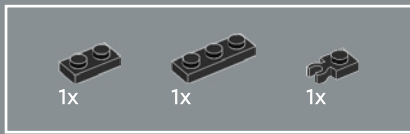

194

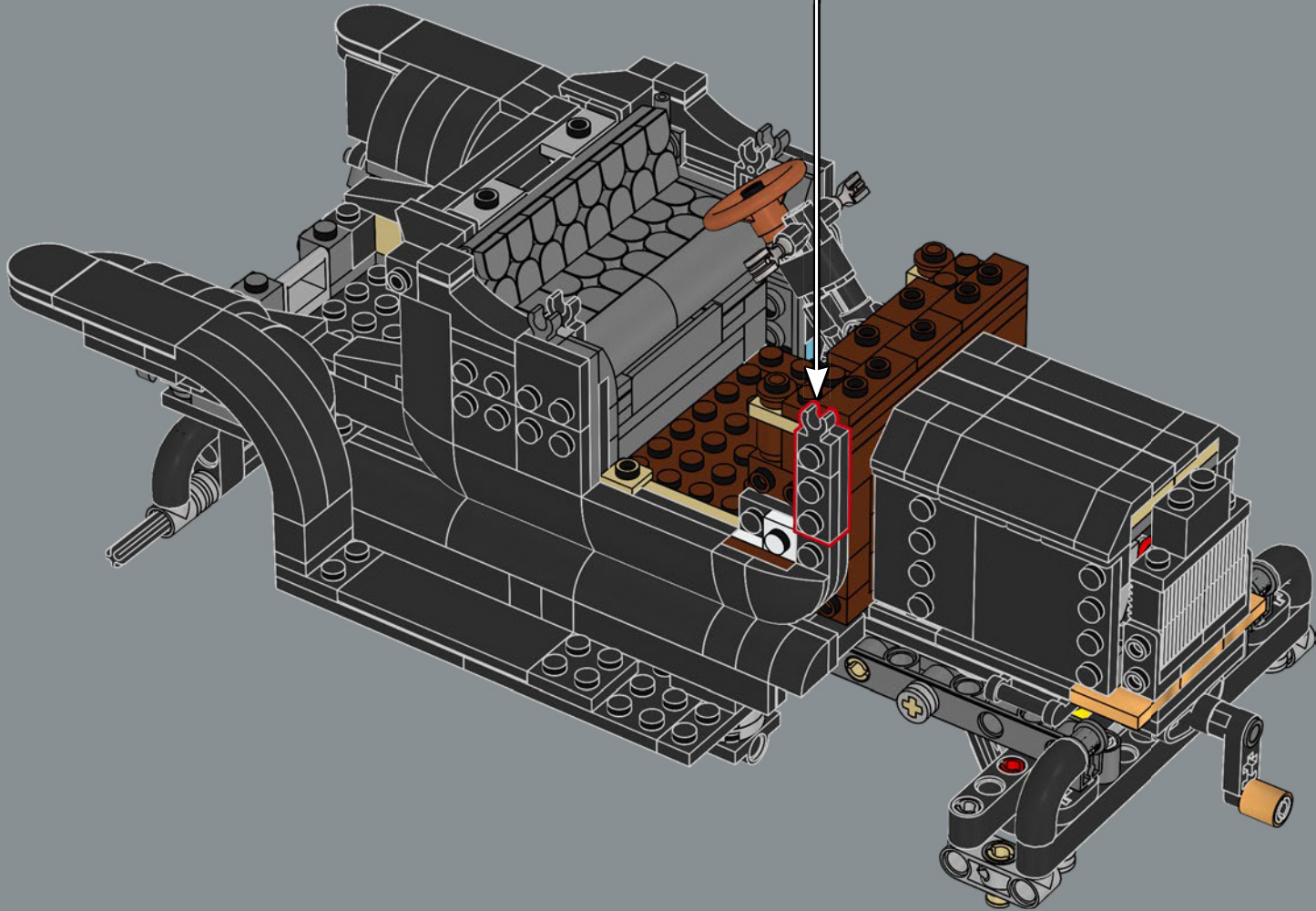
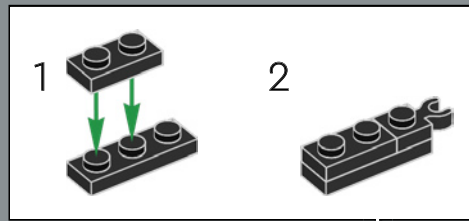

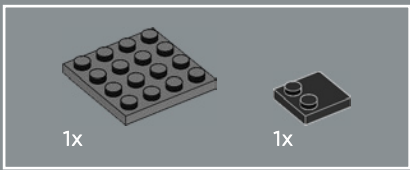

195

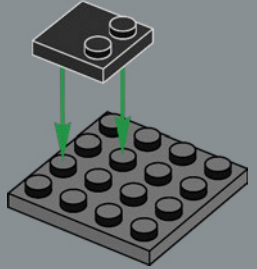

196

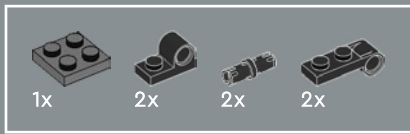
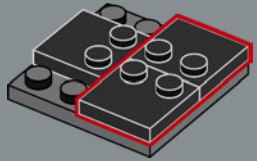

197

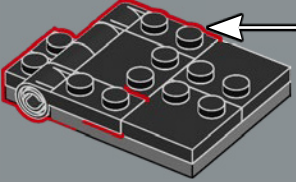
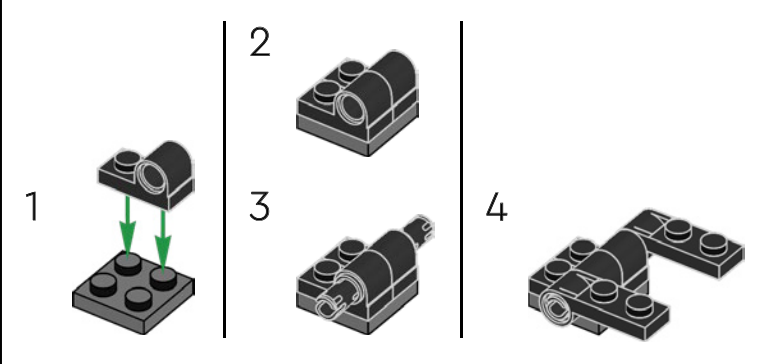

198

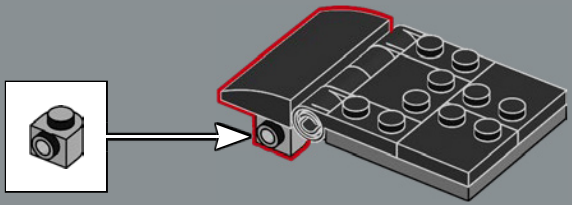



La Model T® 'Runabout' del 1913 aveva un solo sportello, situato sul lato passeggero.

199

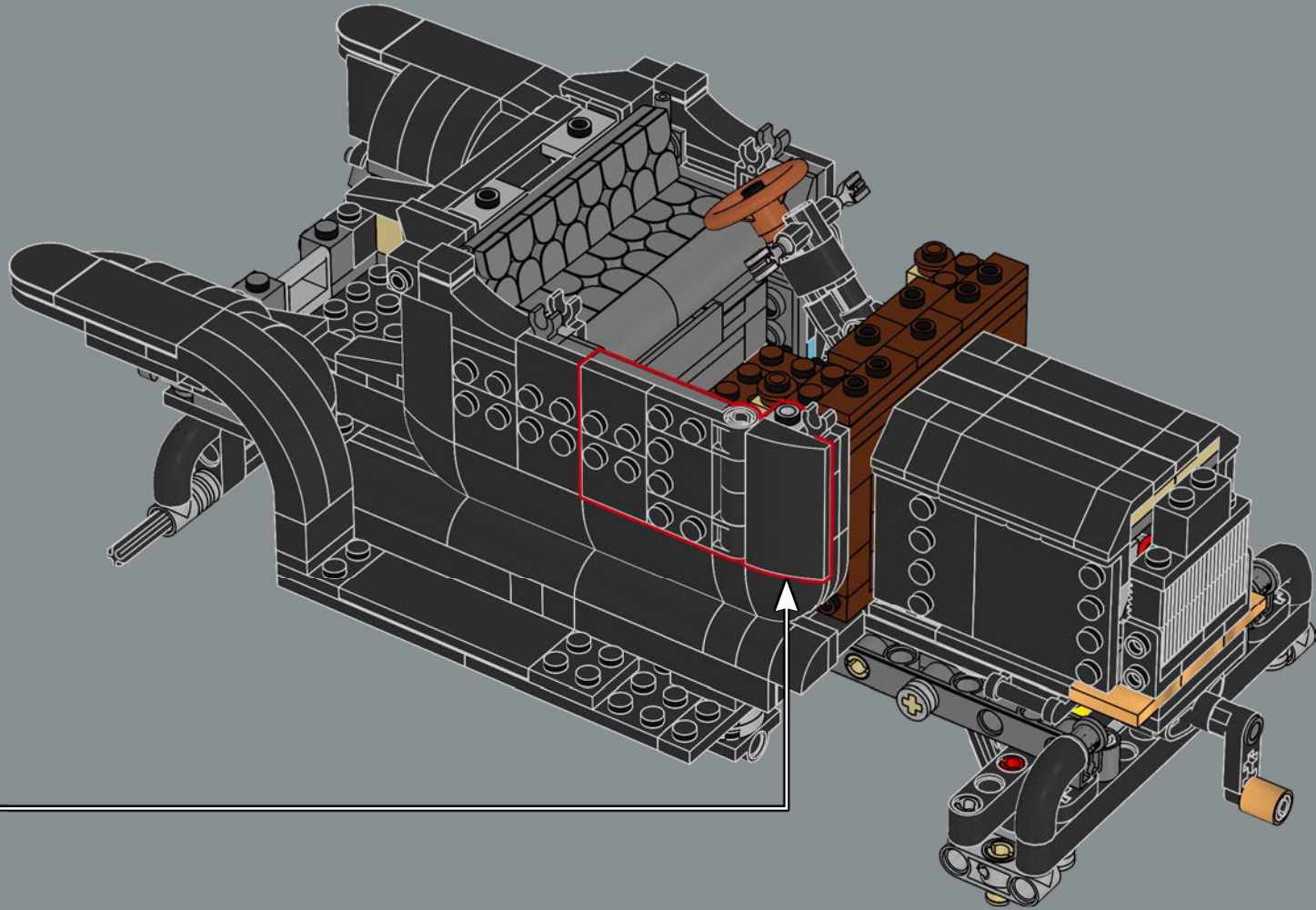

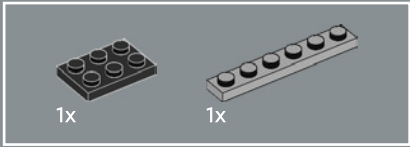
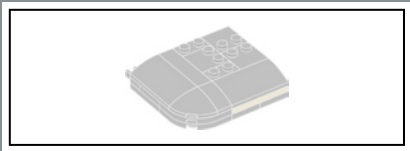

200

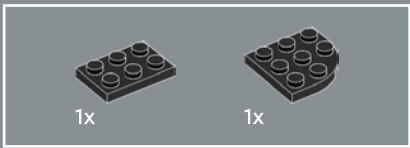
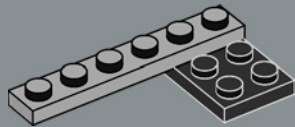

201

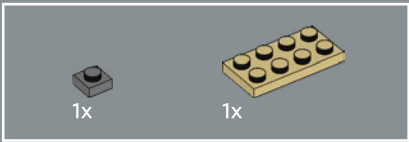
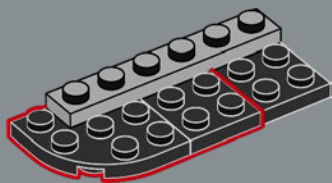

202

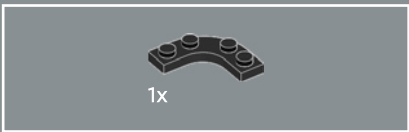
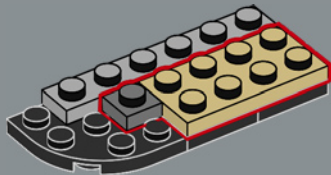

203

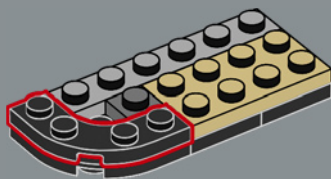

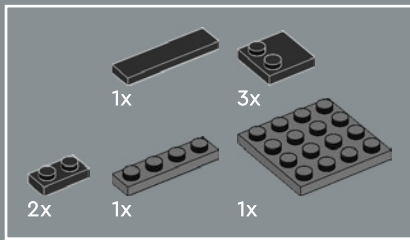

204

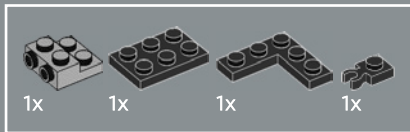
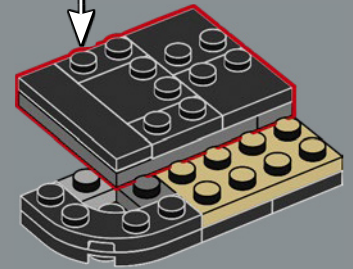
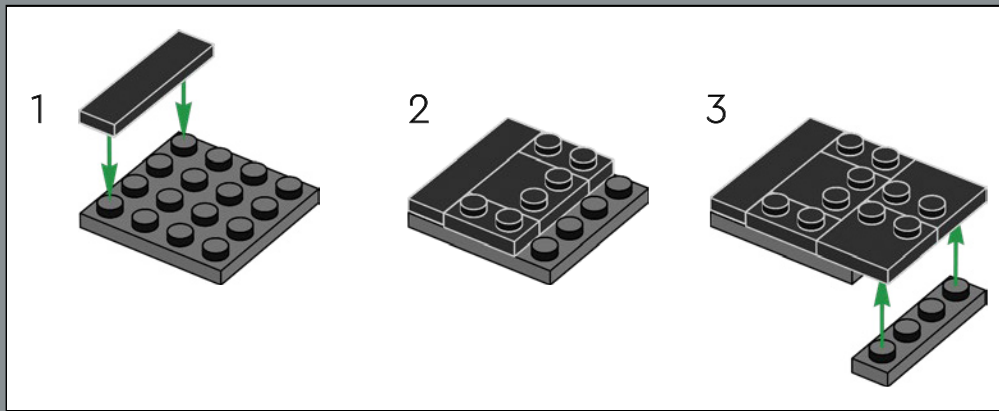

205

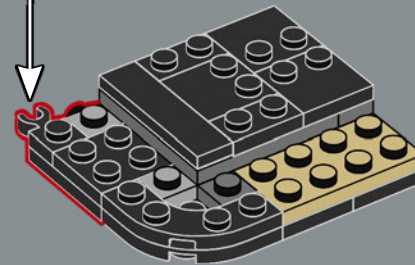
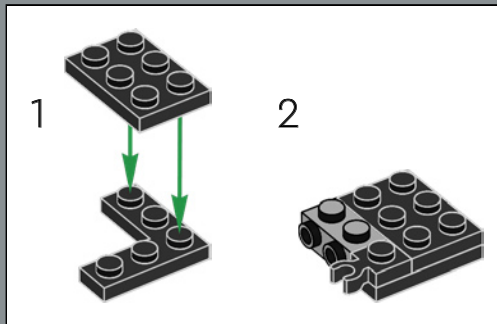



1x

206

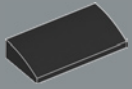
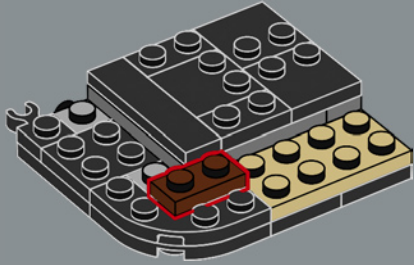

2x



1x



1x

207

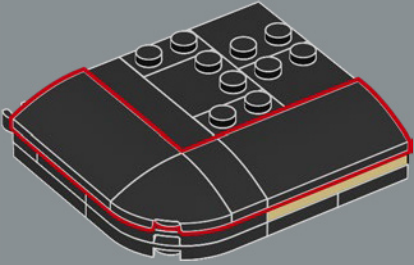

208

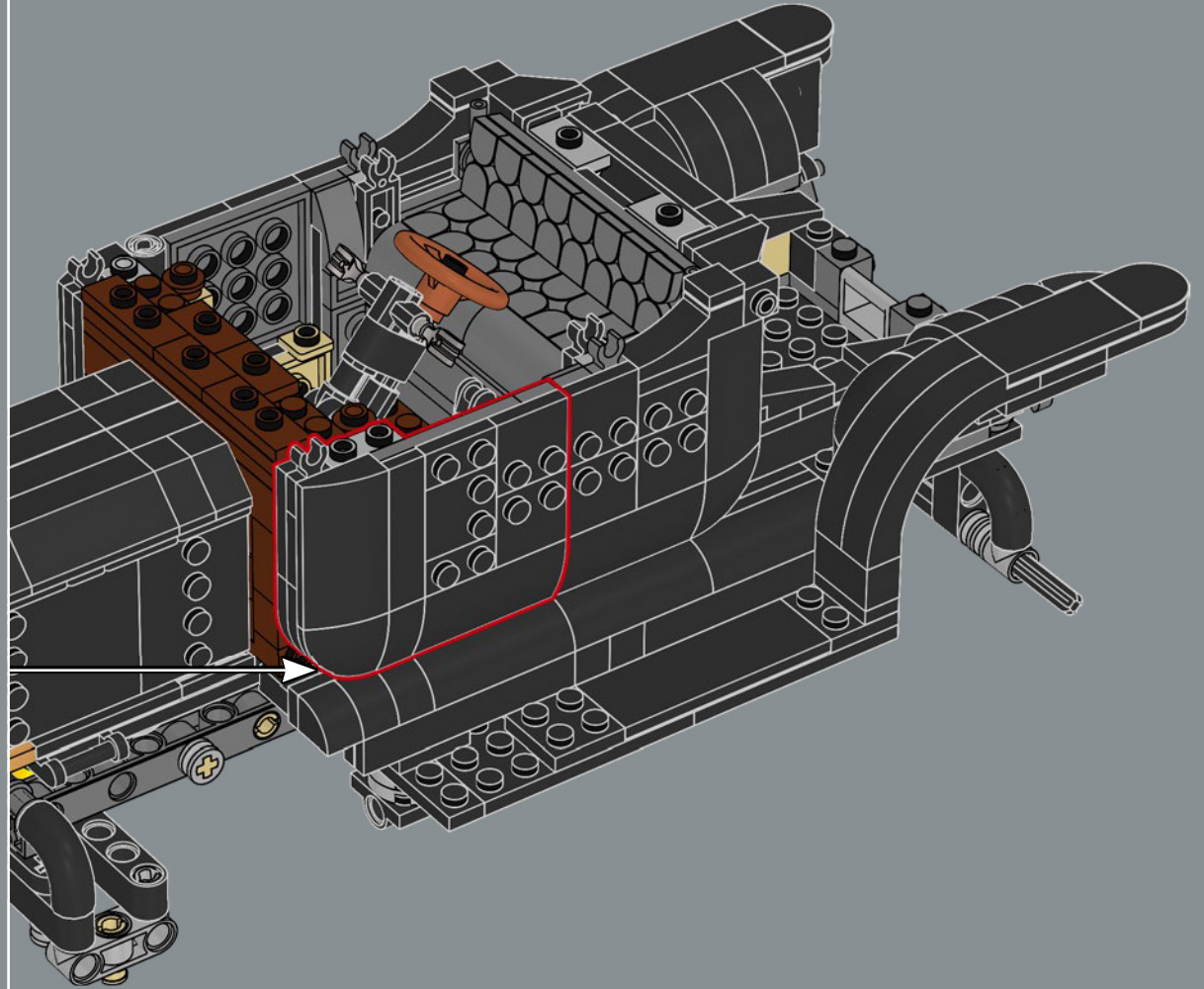



209

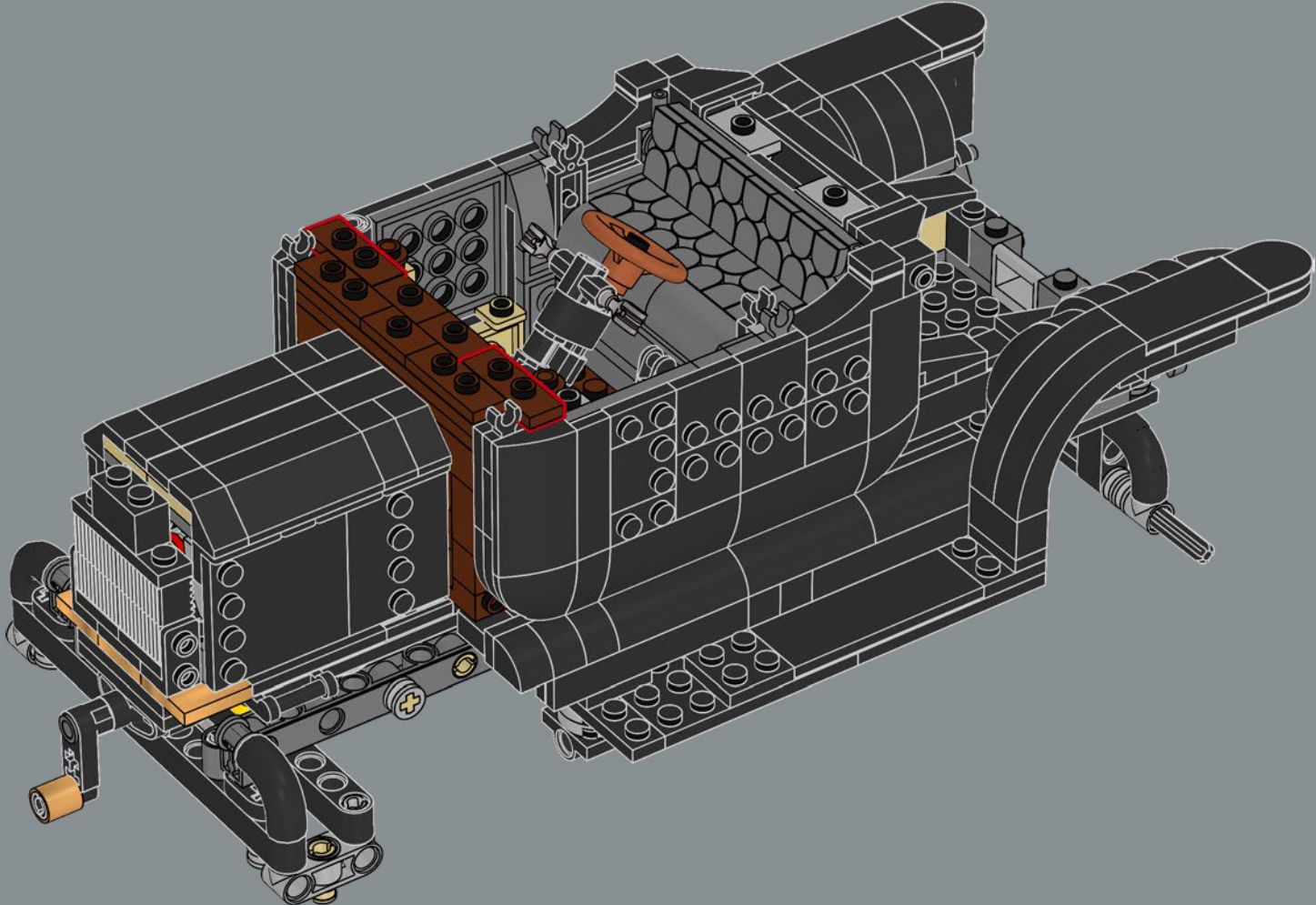



210

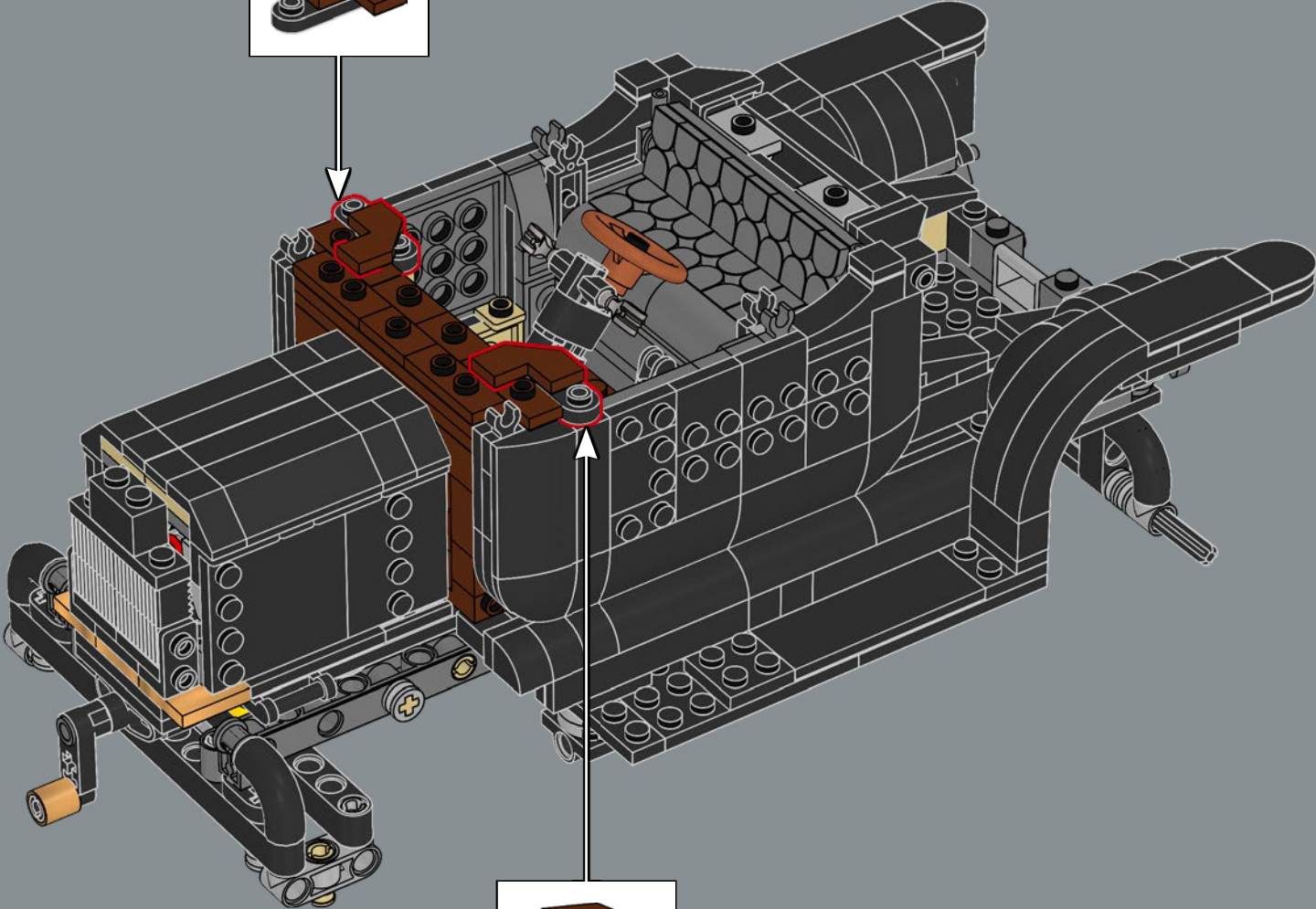

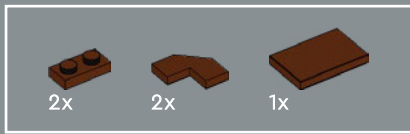

211

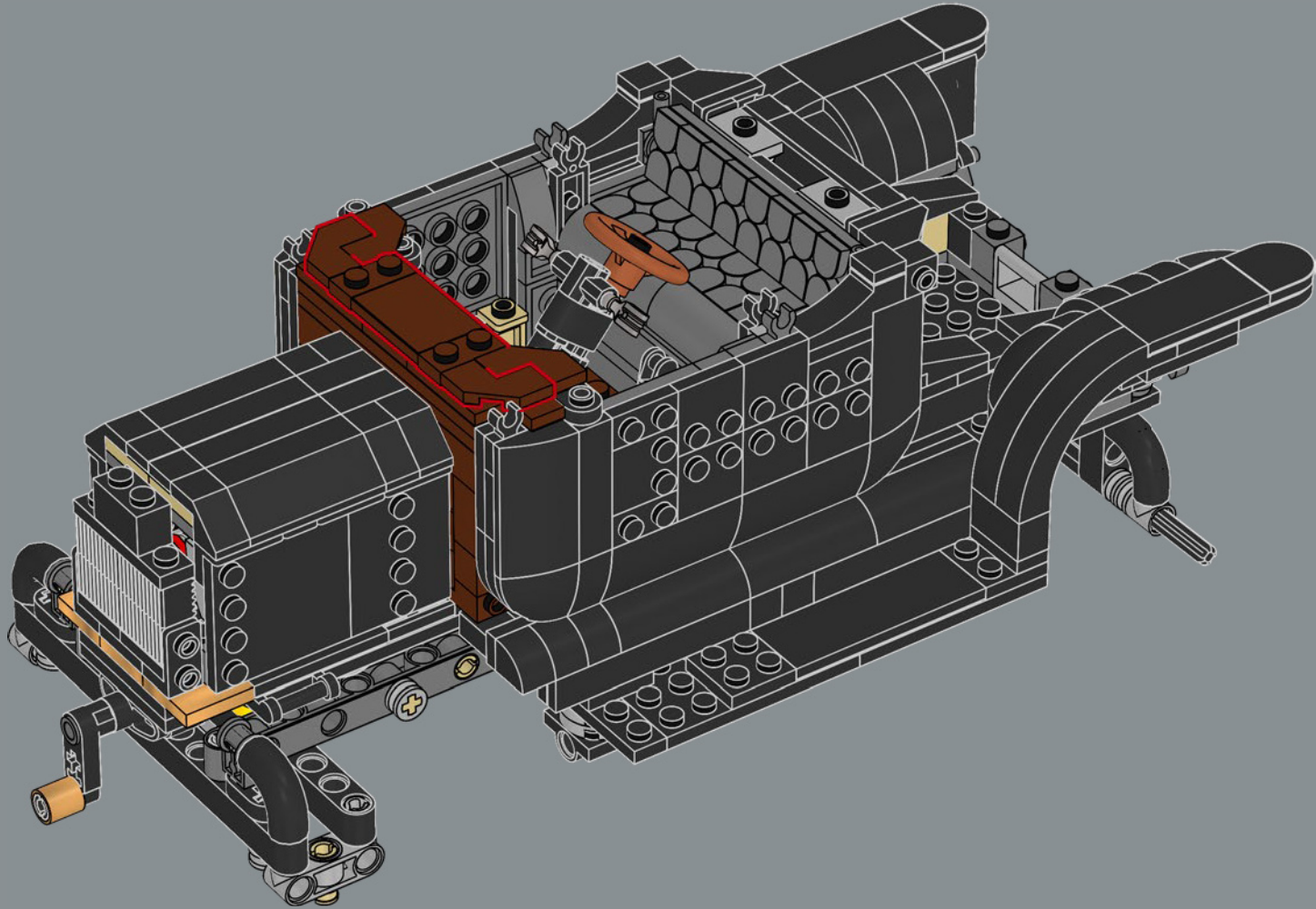



212

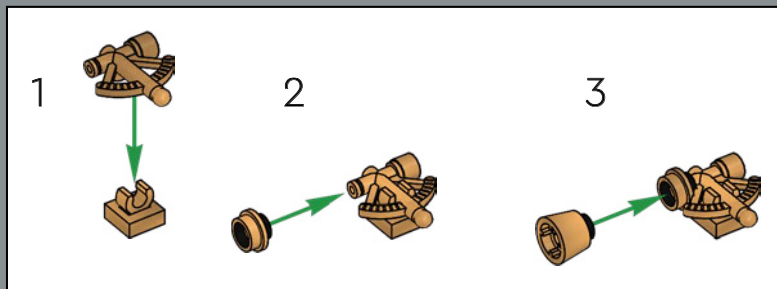

Un serbatoio separato, noto come generatore di carburo, alimentava i fari dell'automobile.

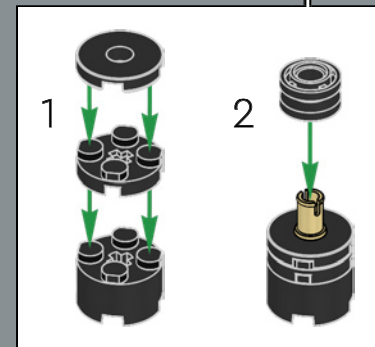
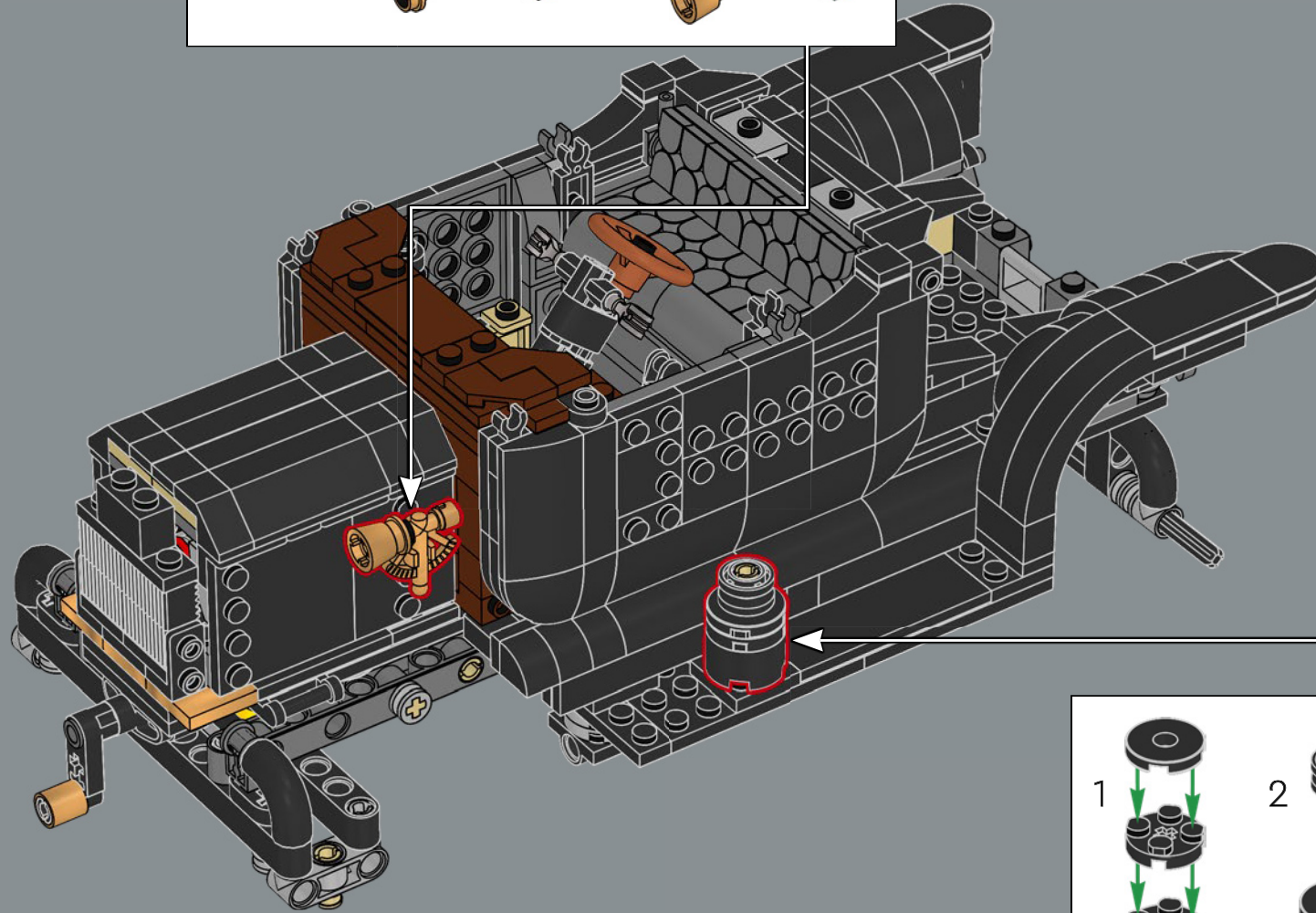



213

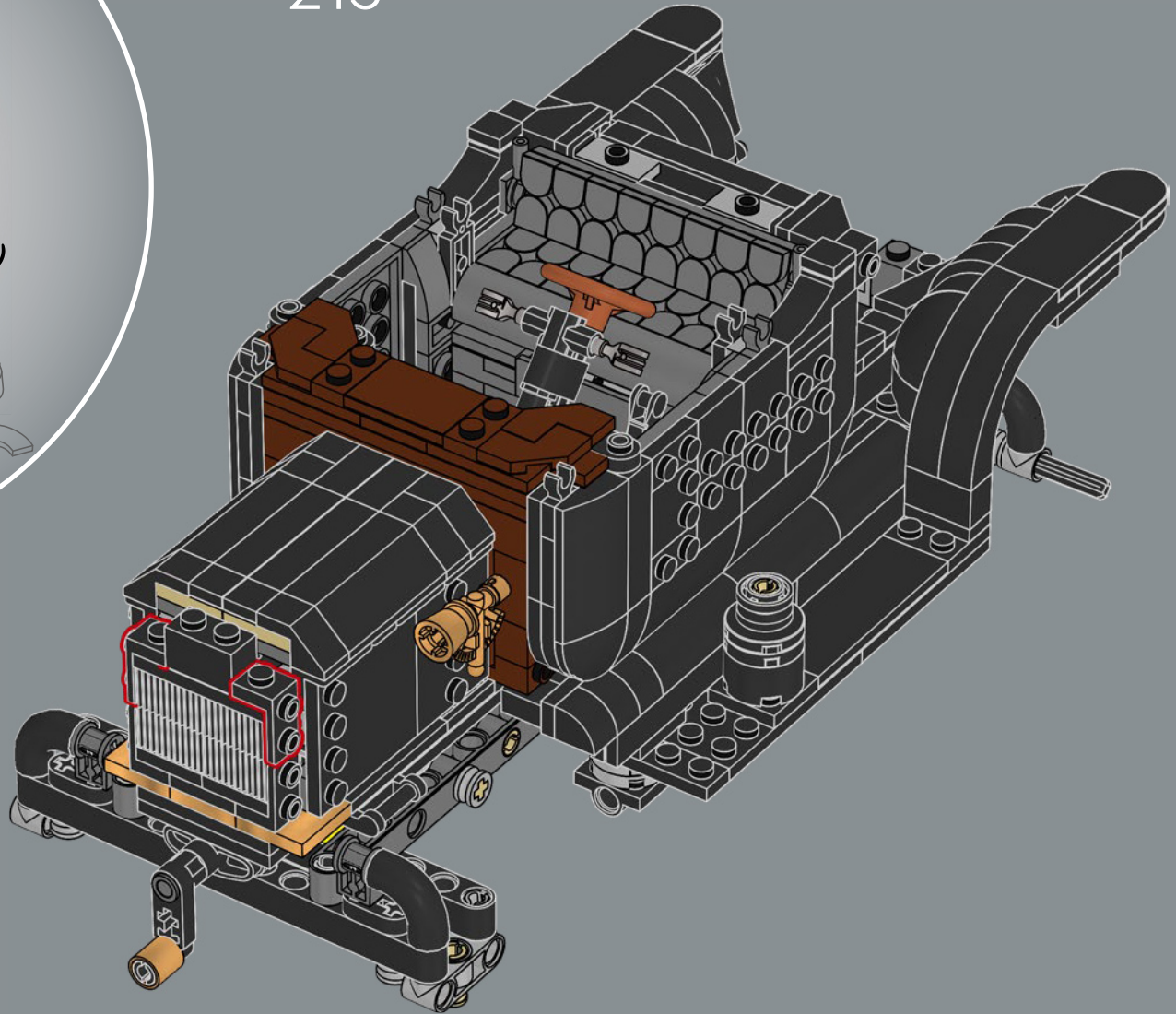

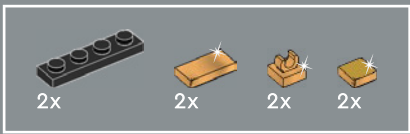

214

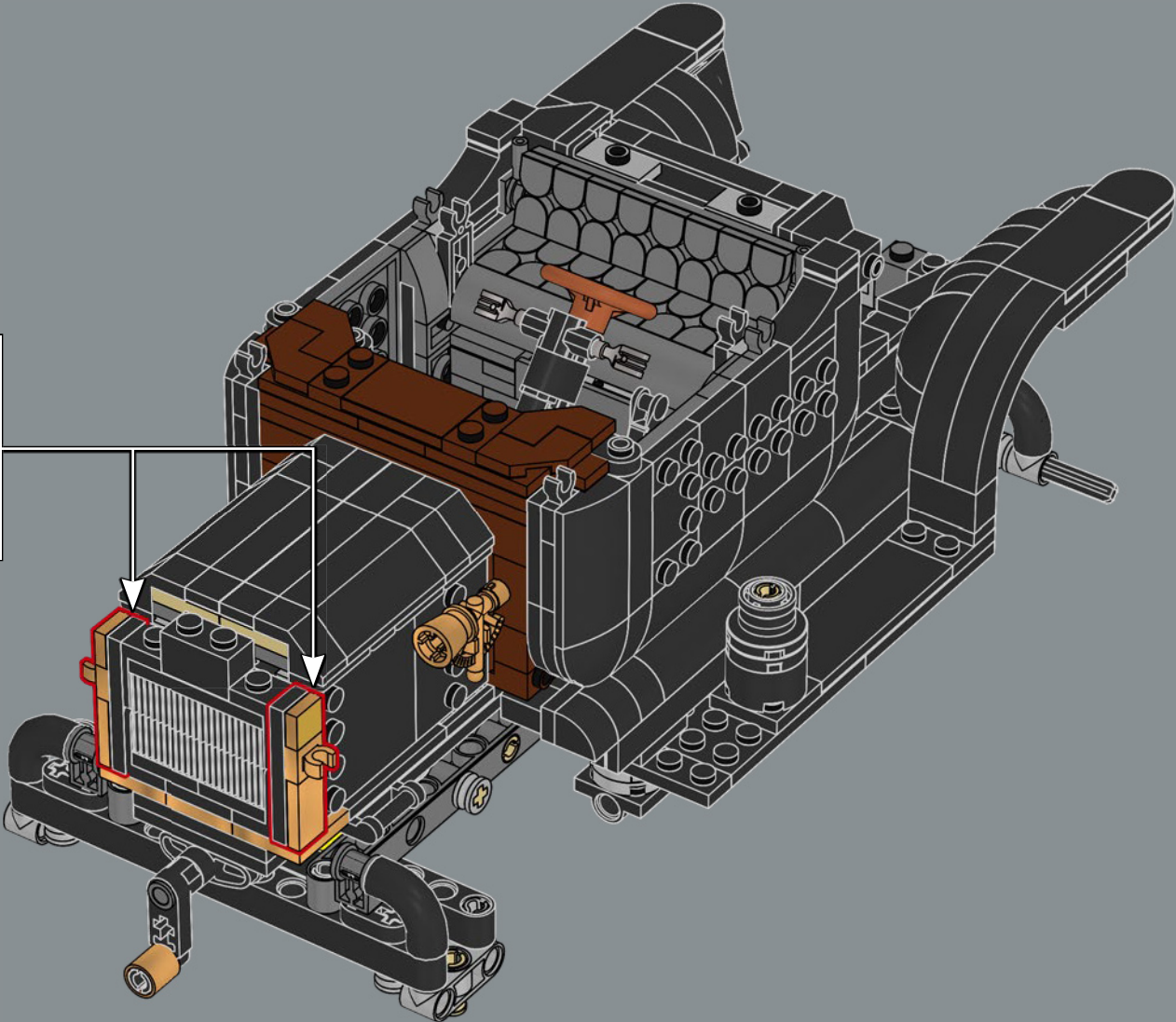
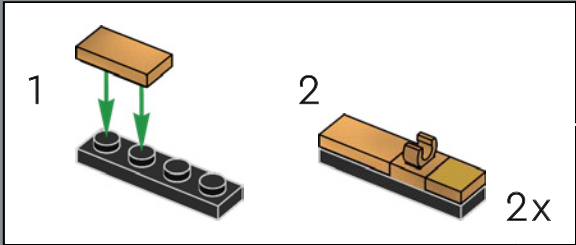

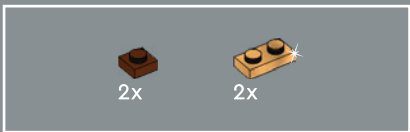

215

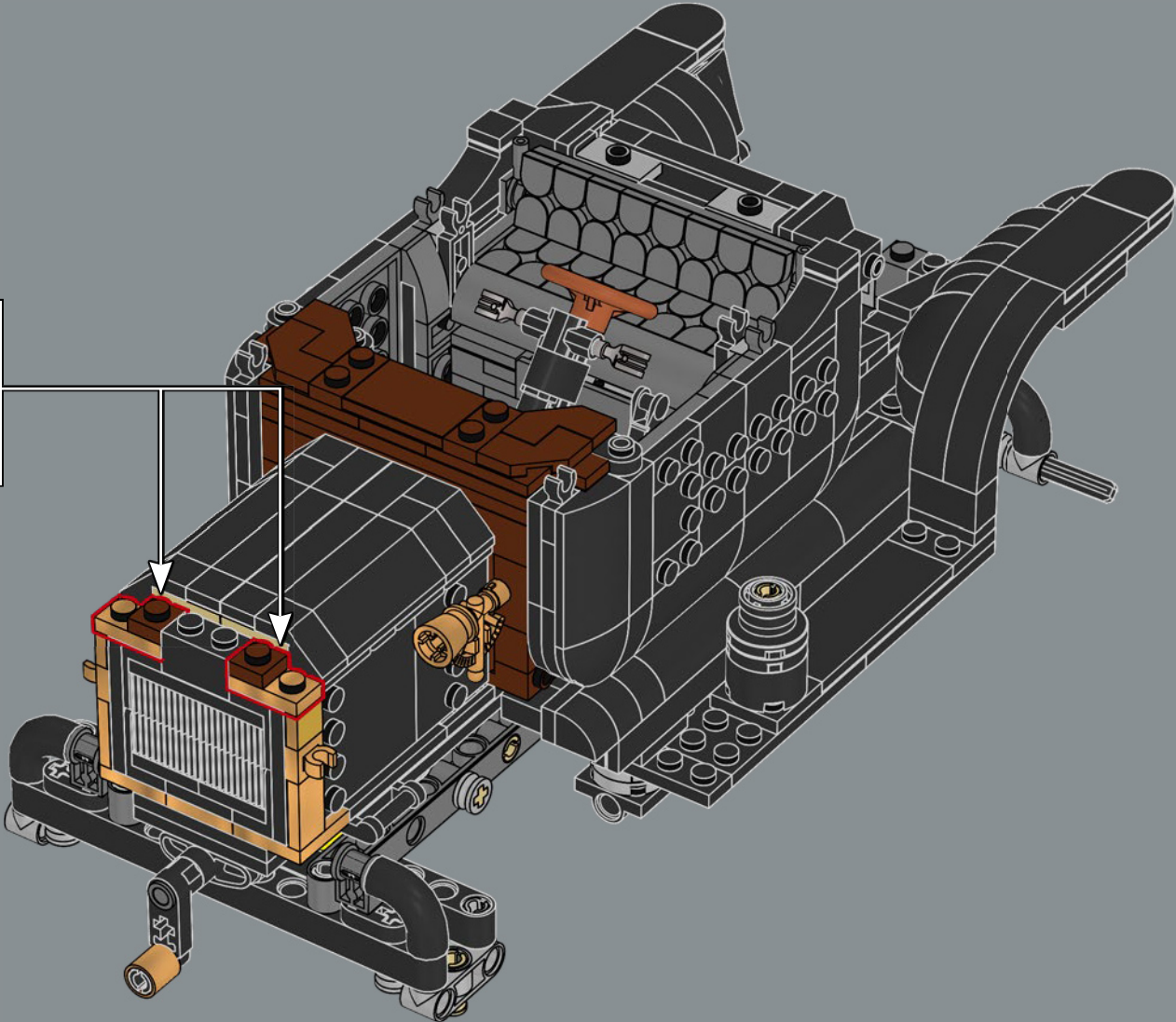
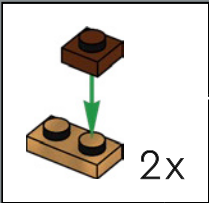



2x

216

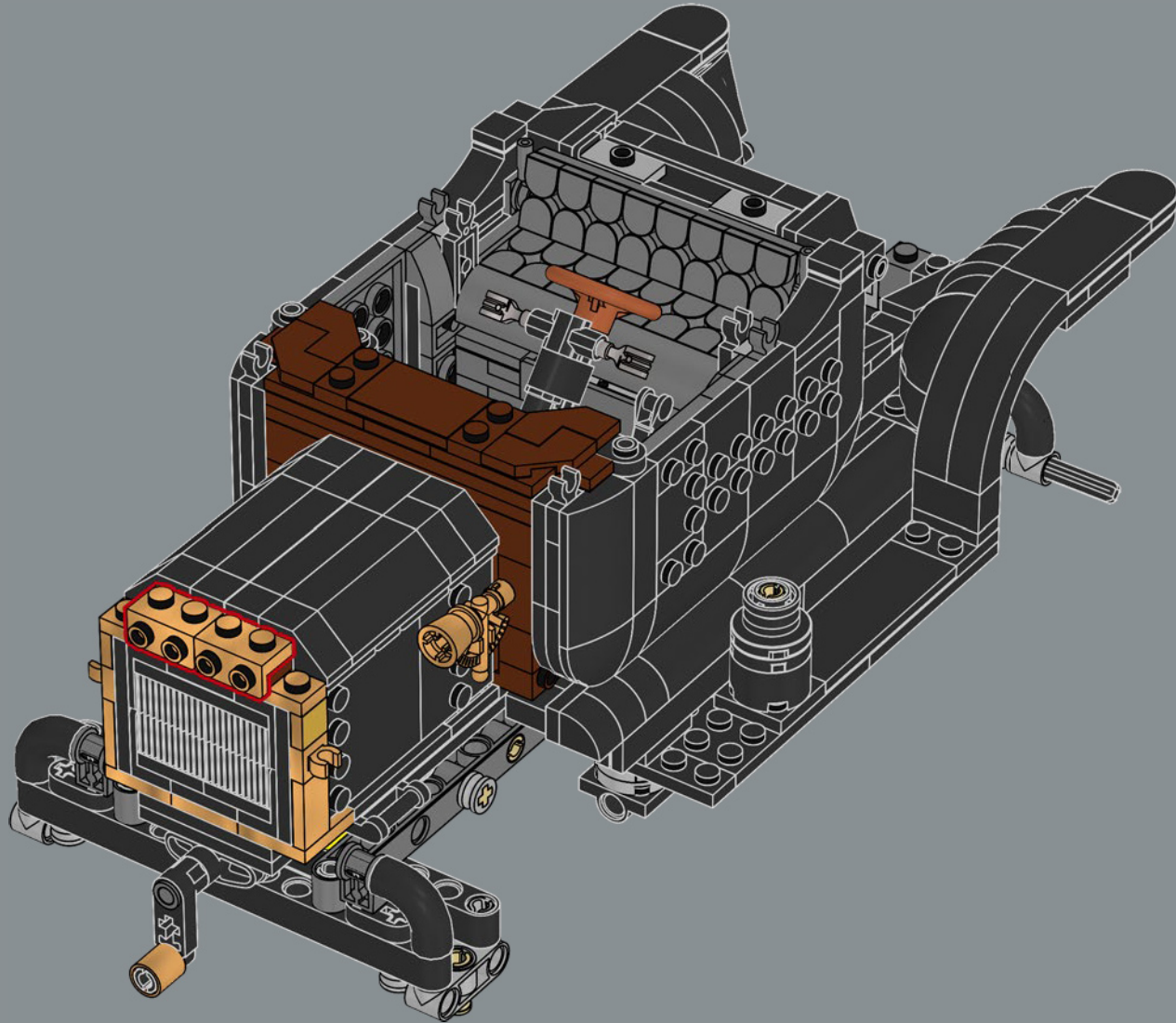

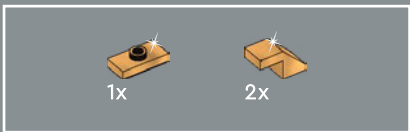

217

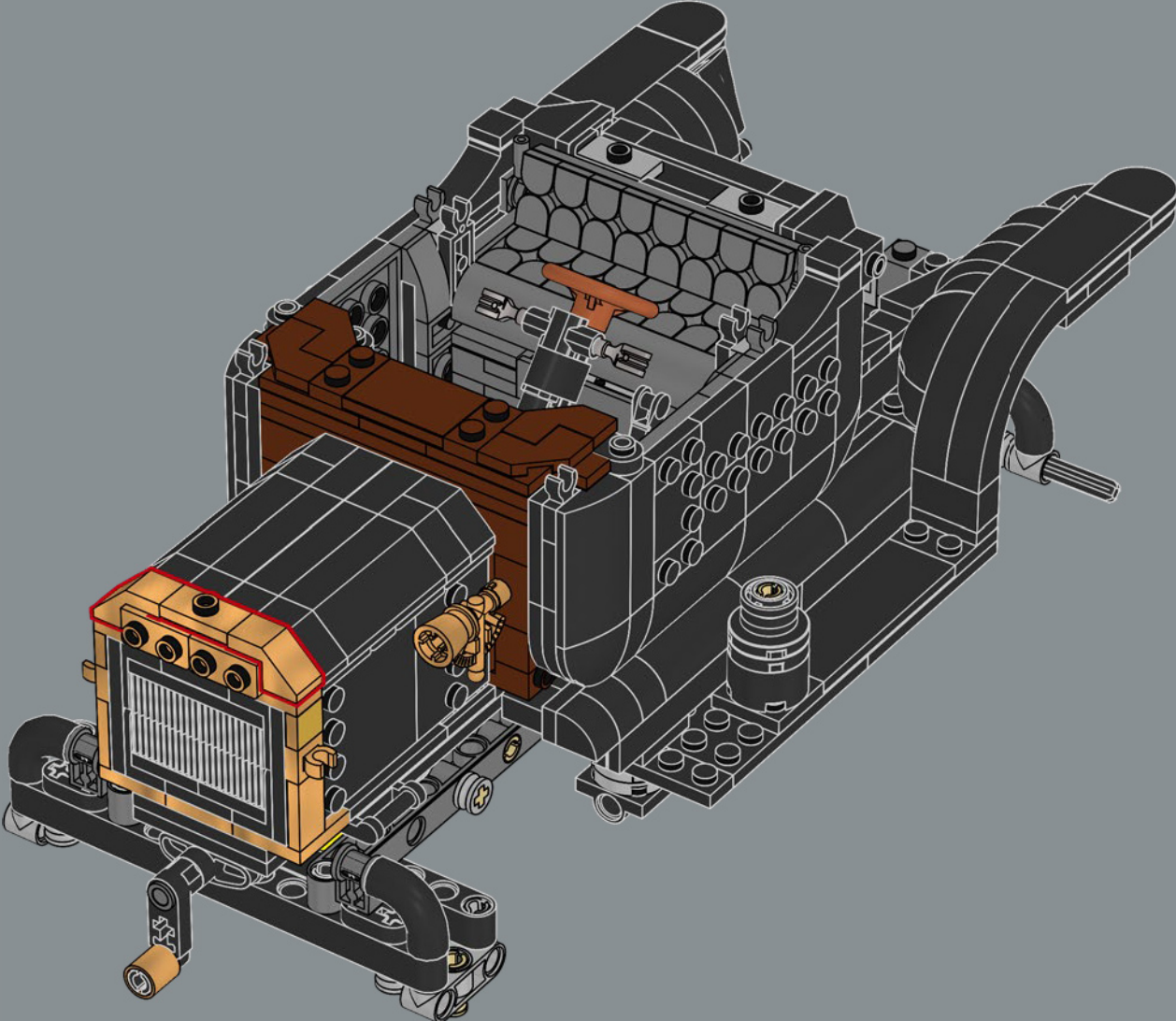



1x



1x



2x

218

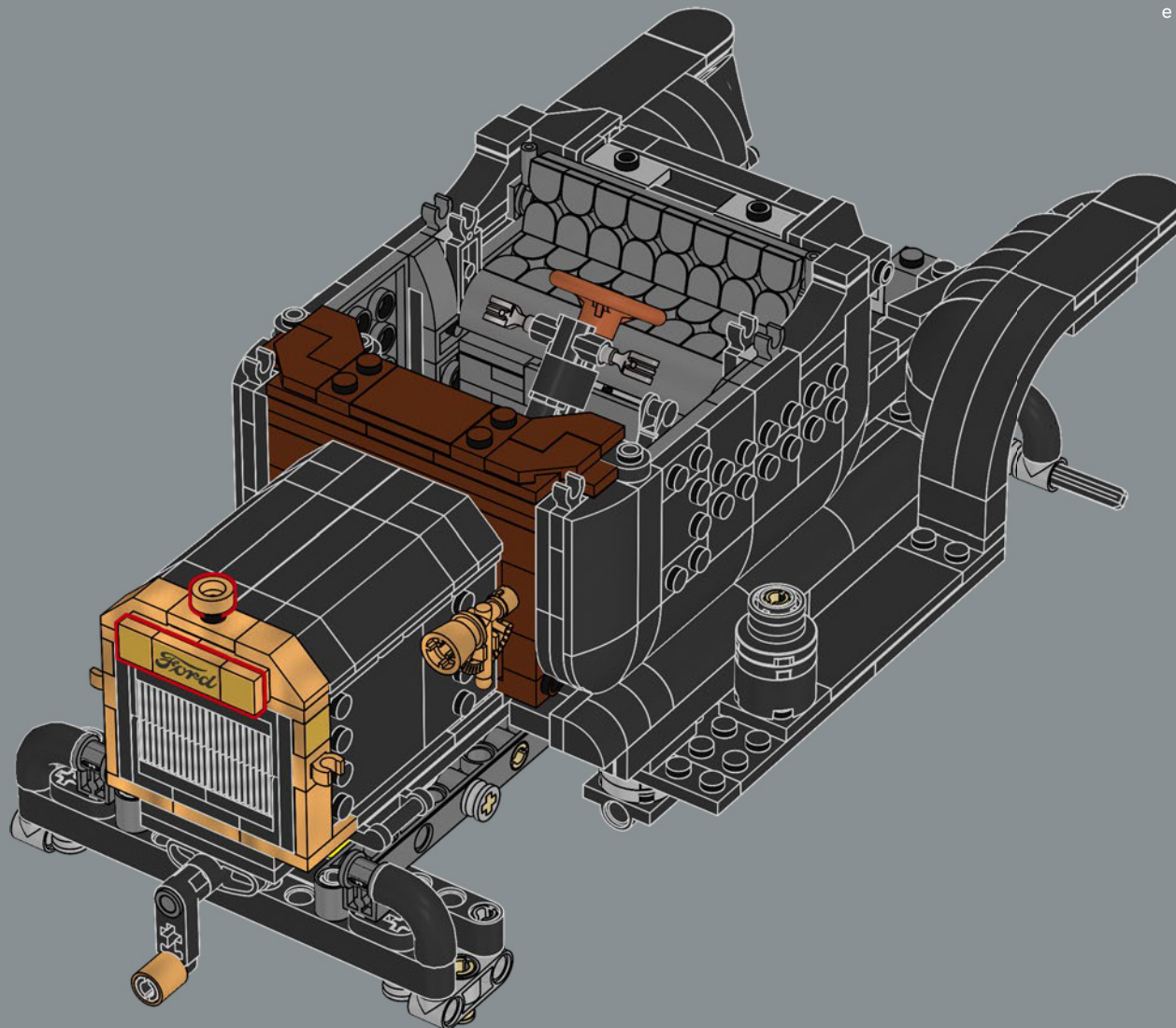

Famosa per la sua adattabilità, la Model T® poteva essere convertita per altri usi. Le riviste di settore avevano rubriche con consigli pratici per la personalizzazione, che includevano modifiche per l'uso come motoslitta, trattore e persino mulino per cereali!



219

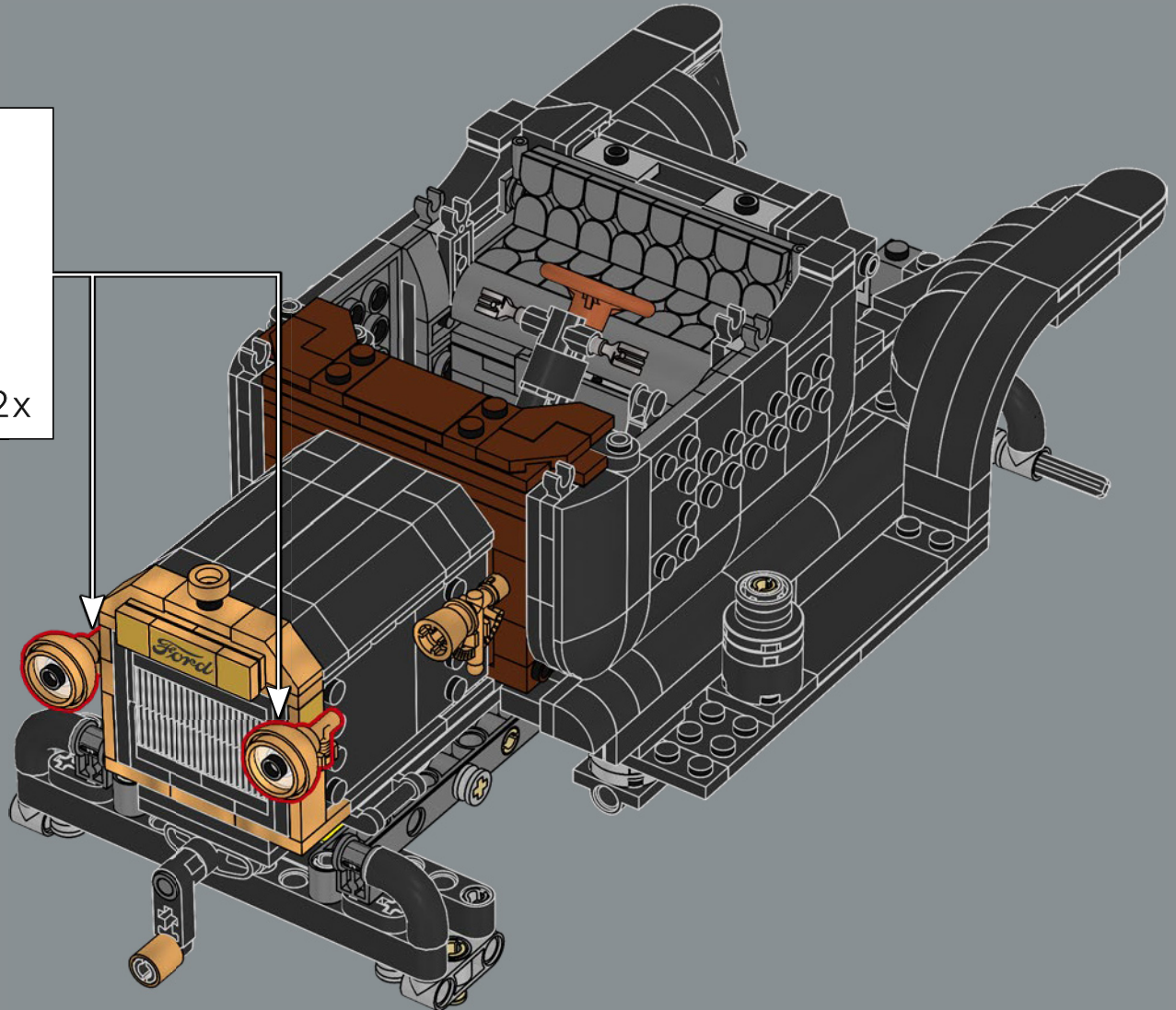
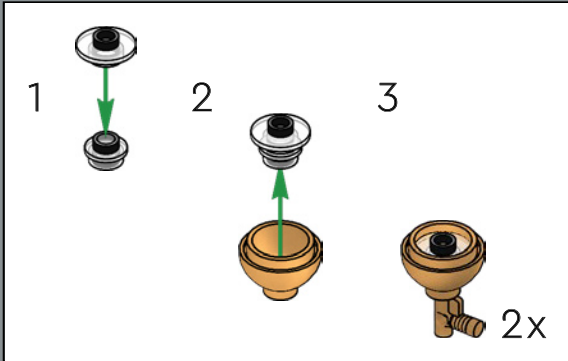

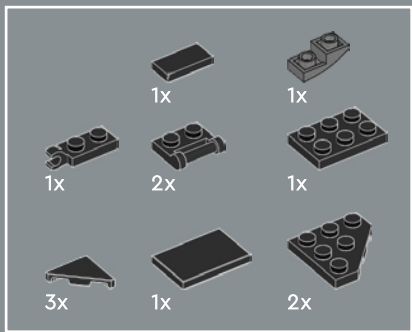

220

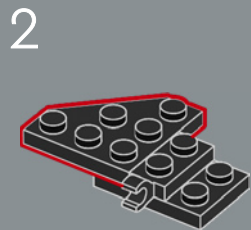
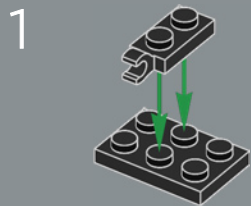

3

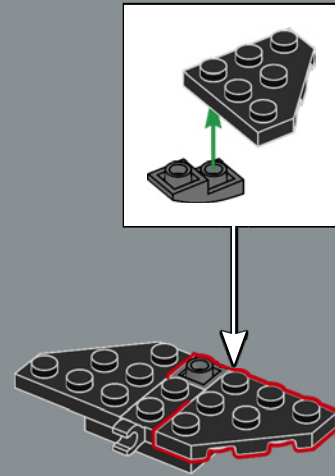

4

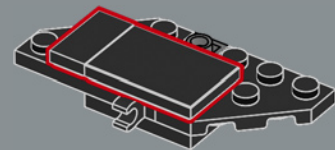

5

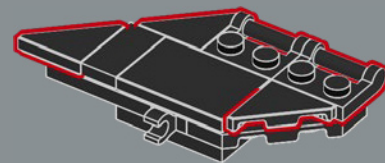

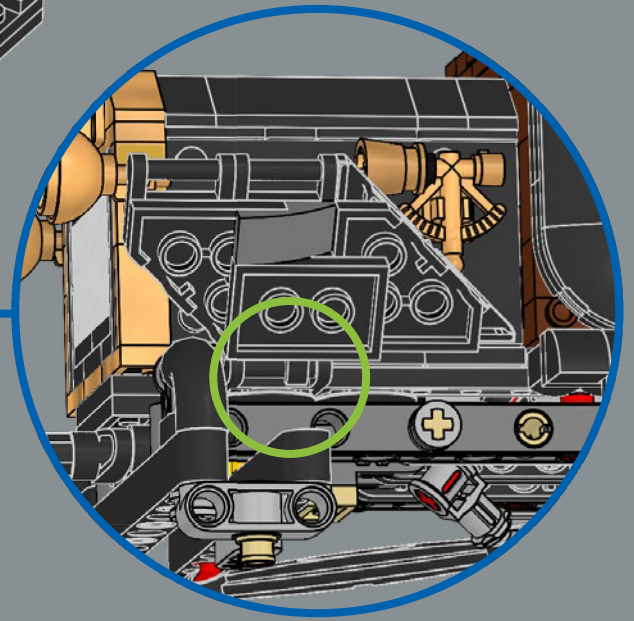
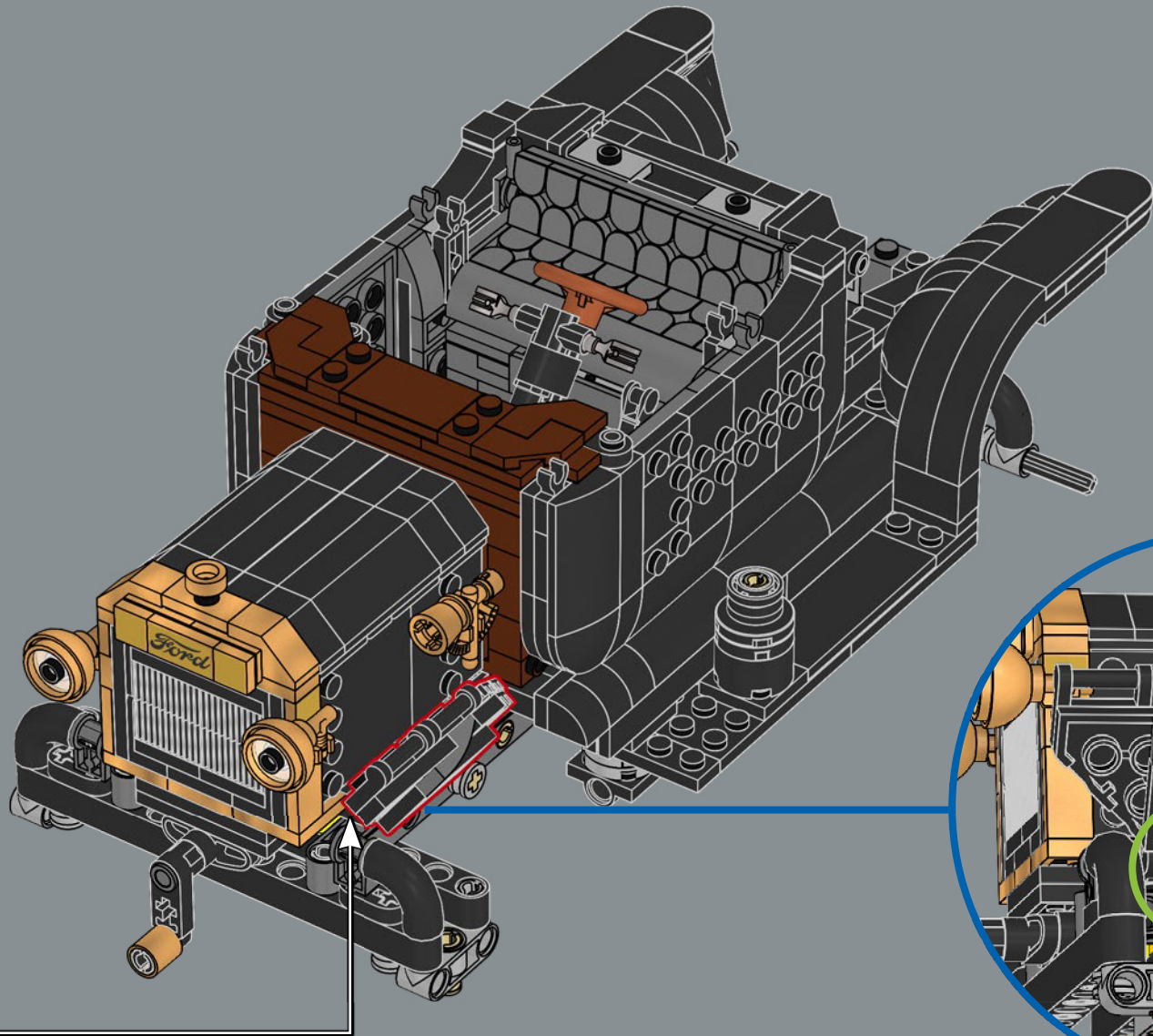

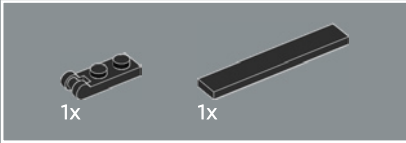
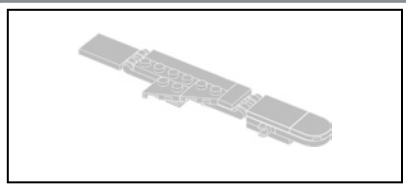

221

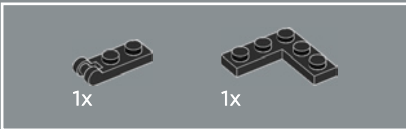
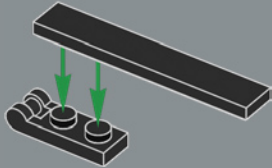

222

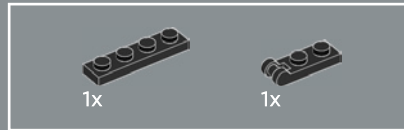
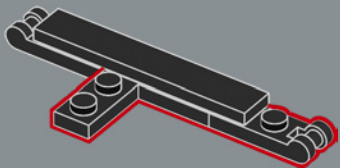

223

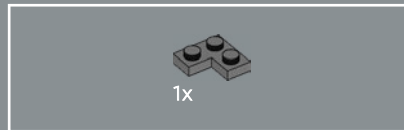
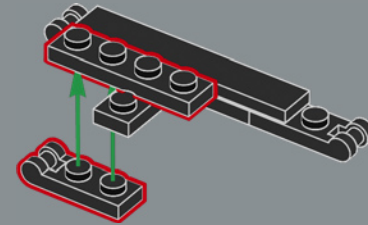

224

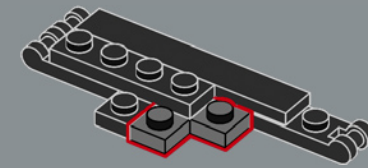

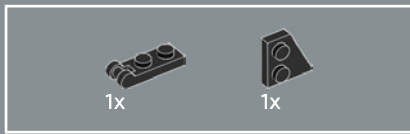

225

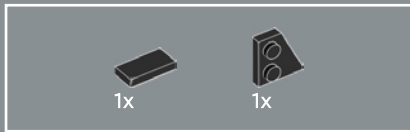
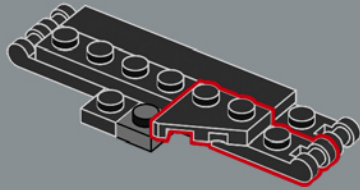

226

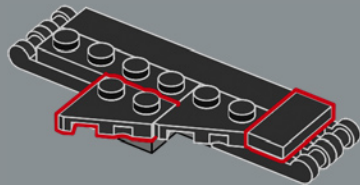

227

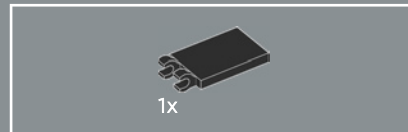
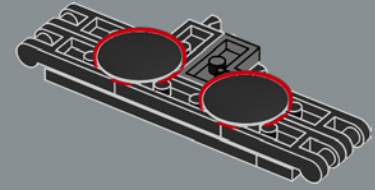

228

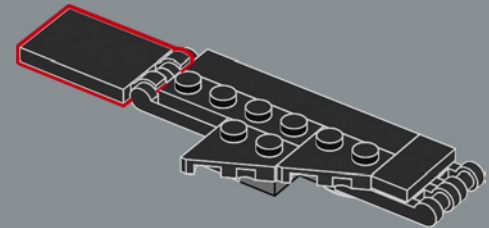

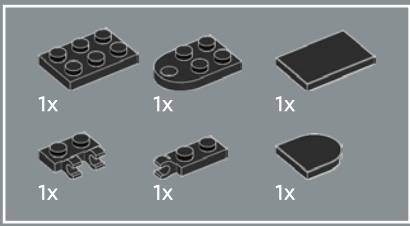

229

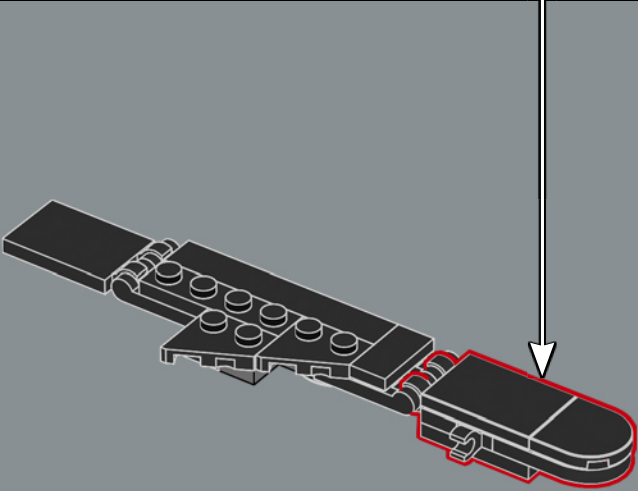
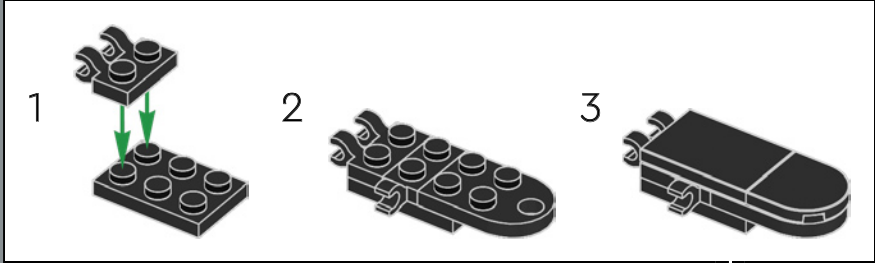

230

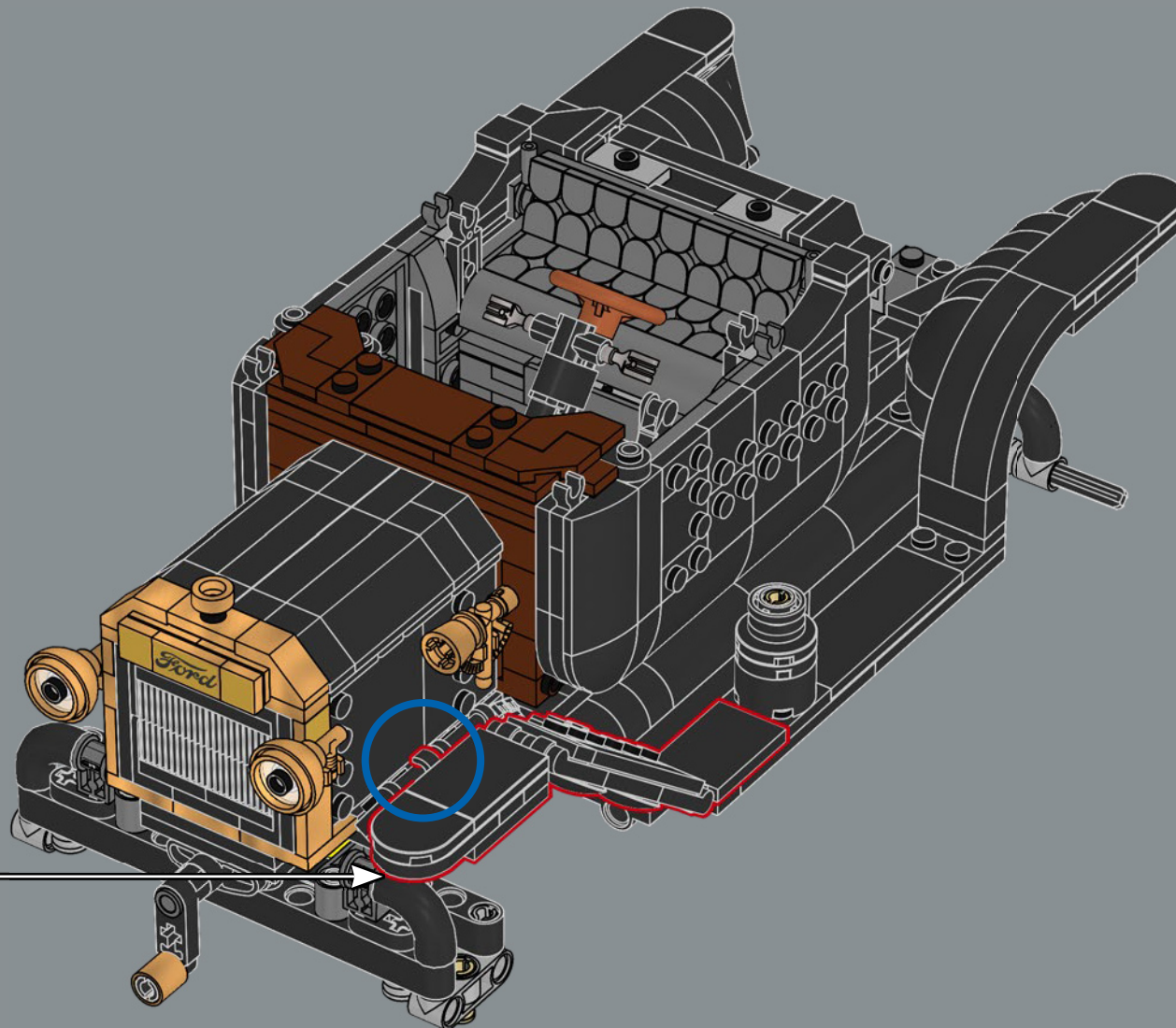

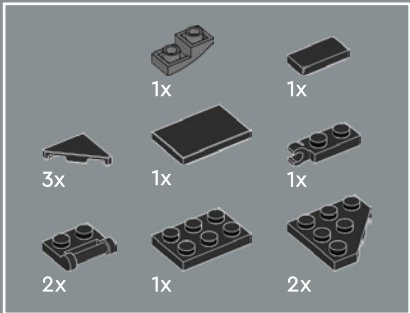
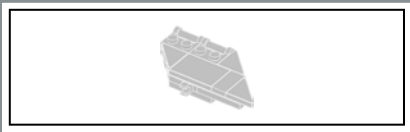

231

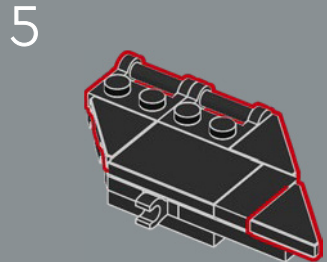
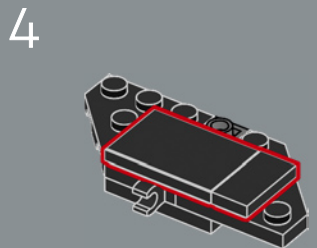
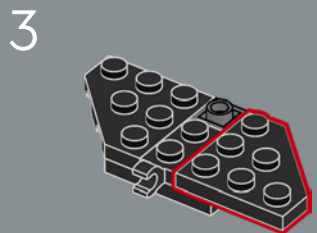
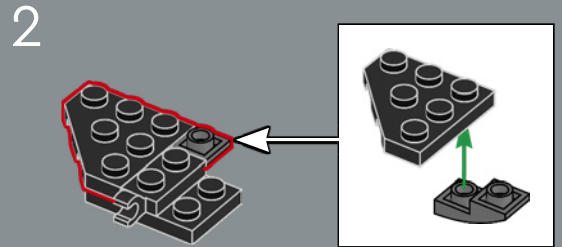
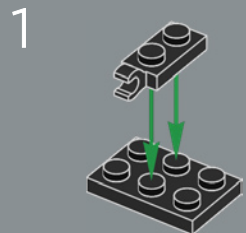

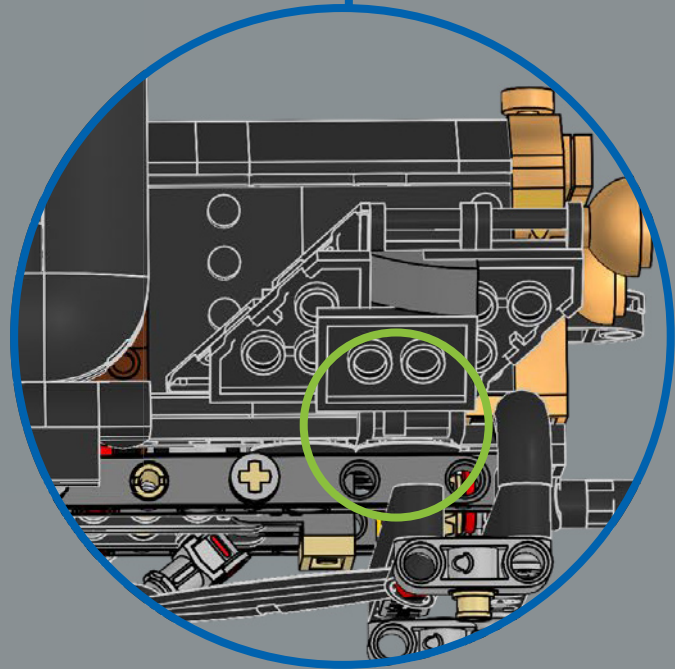
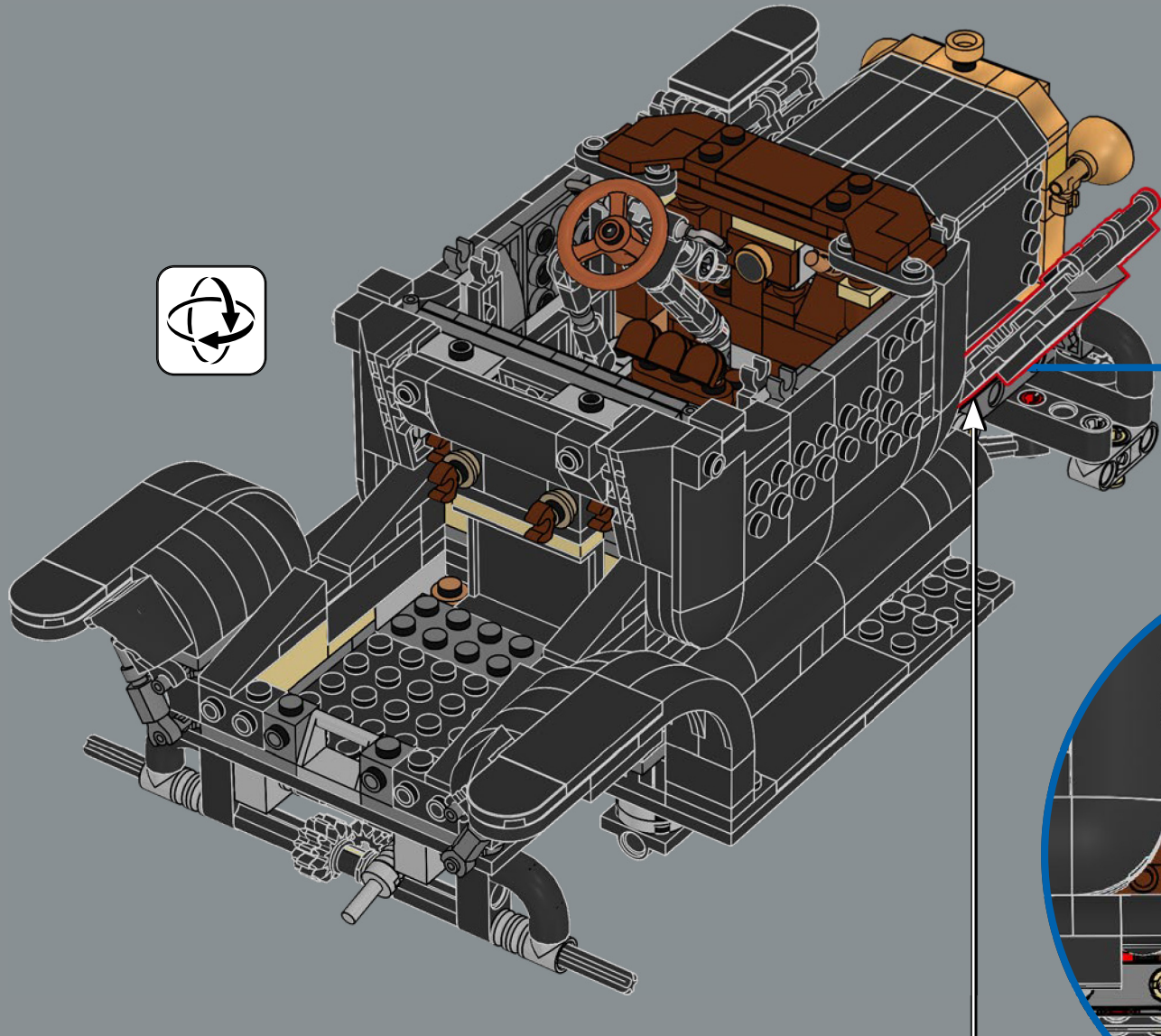

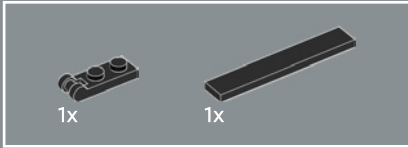
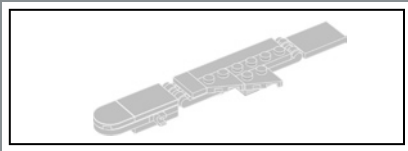

232

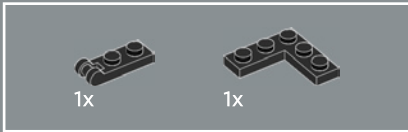
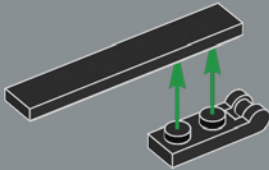

233

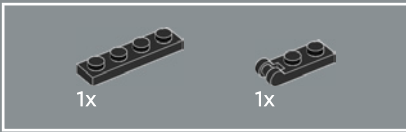
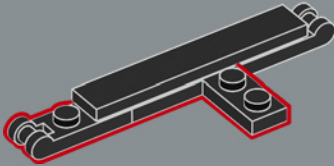

234

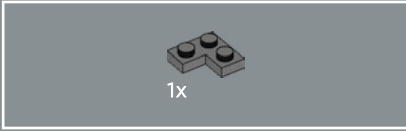
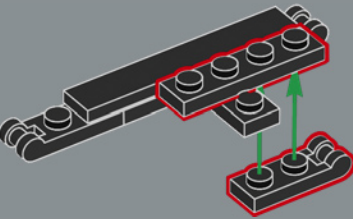

235

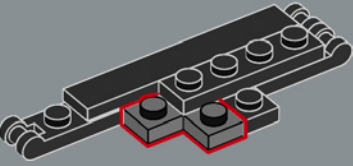

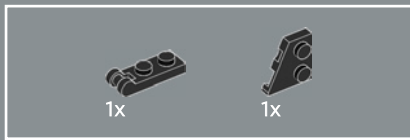

236

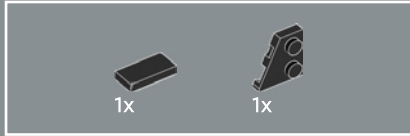
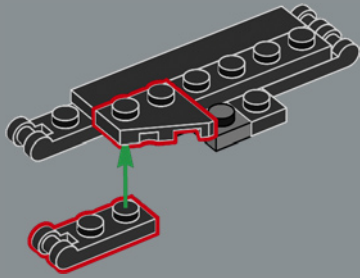

237

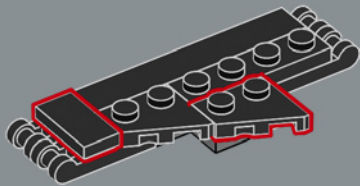

238

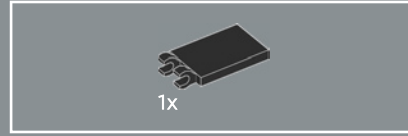
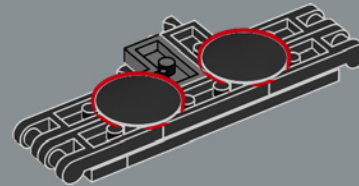

239

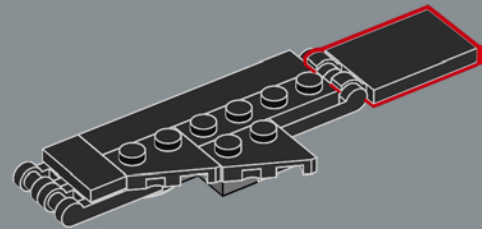

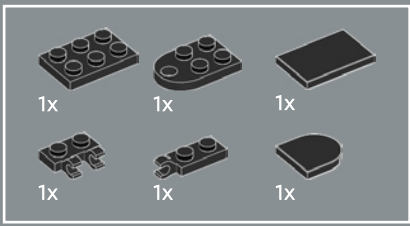

240

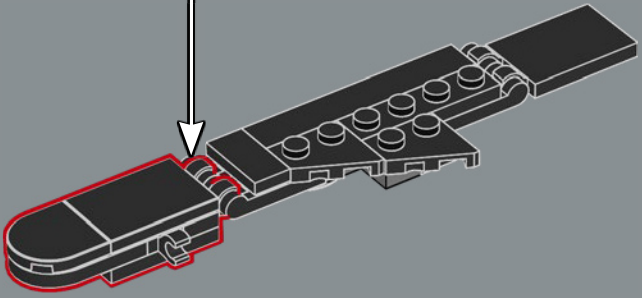
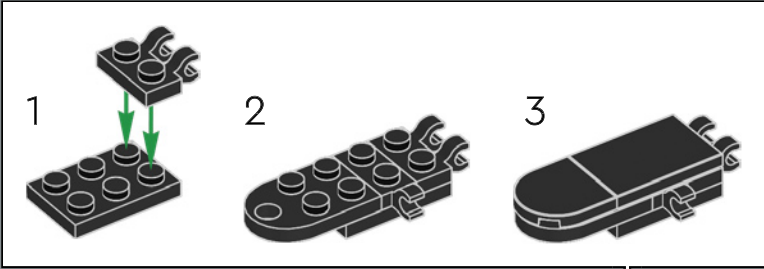

241

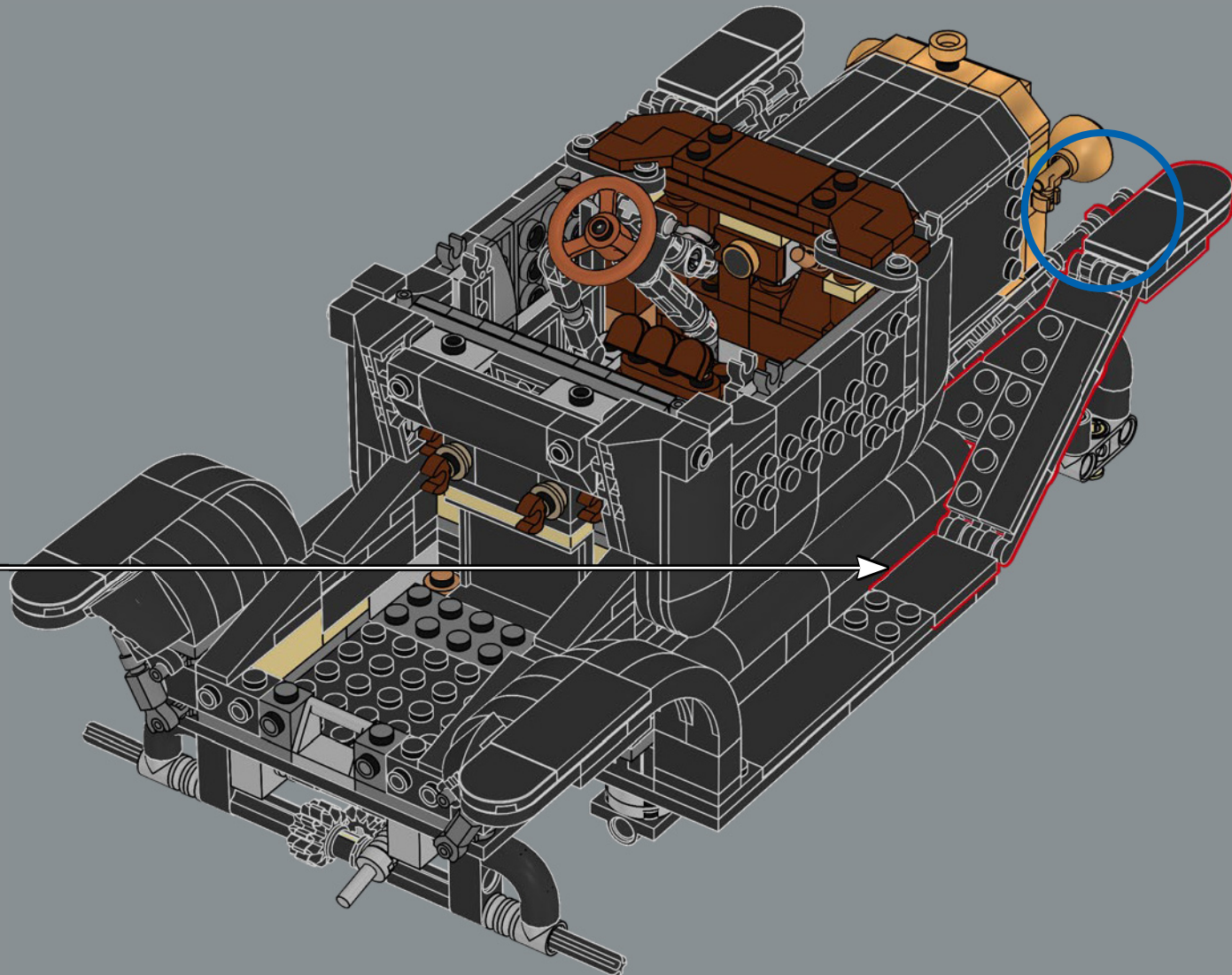

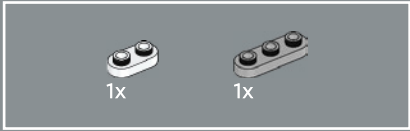
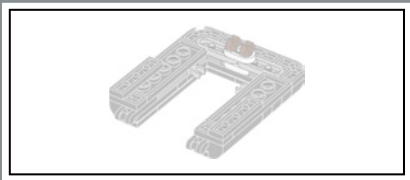

242

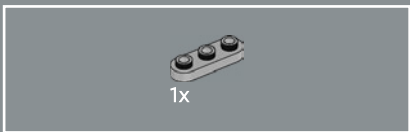
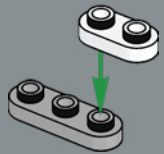

243

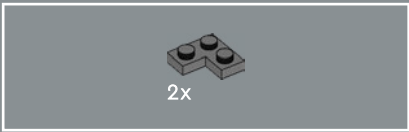
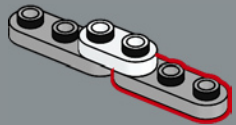

244

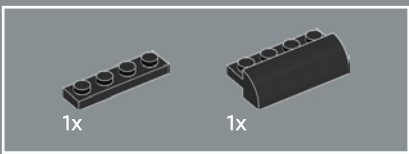
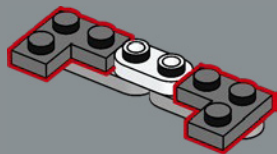

245

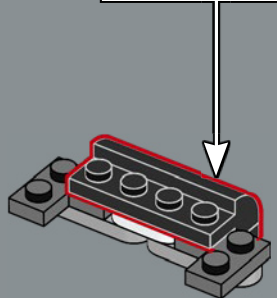
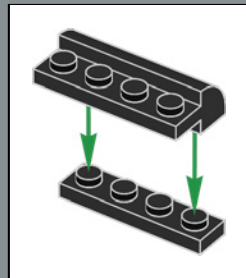

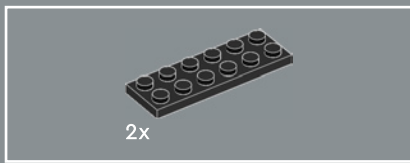

246

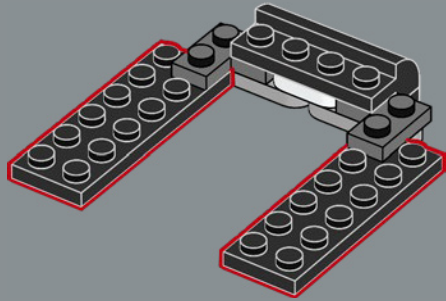

247

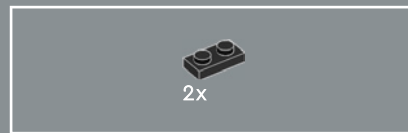
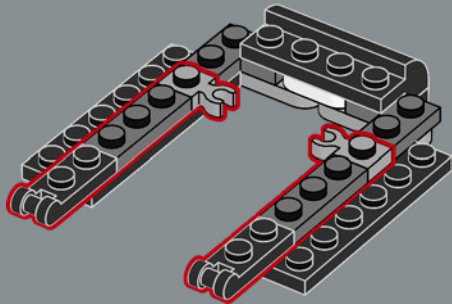

248

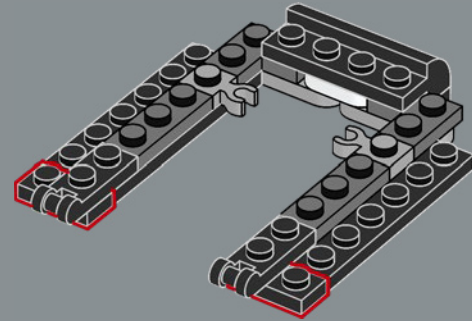

249

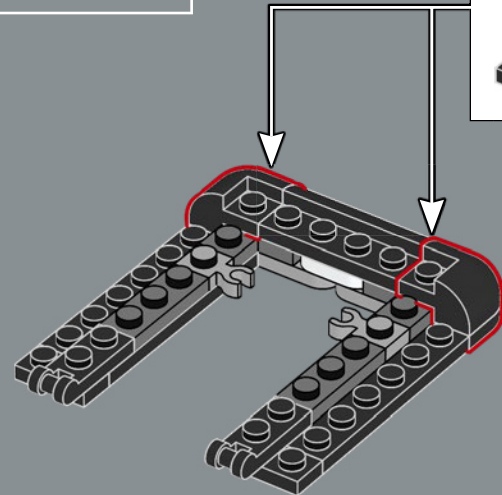
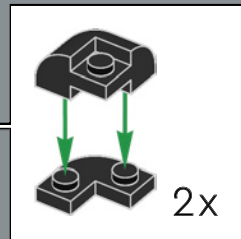

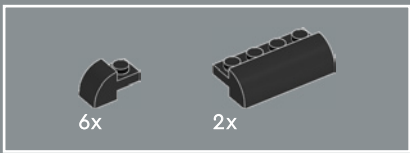

250

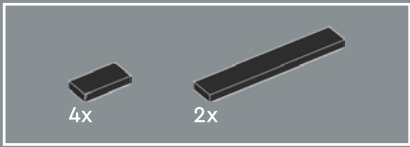
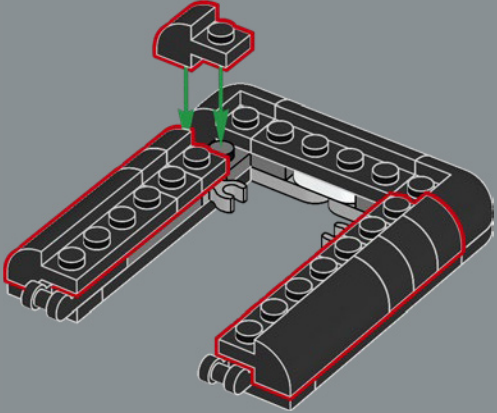

251

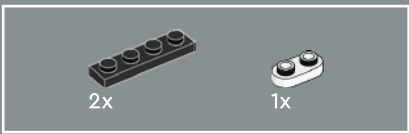
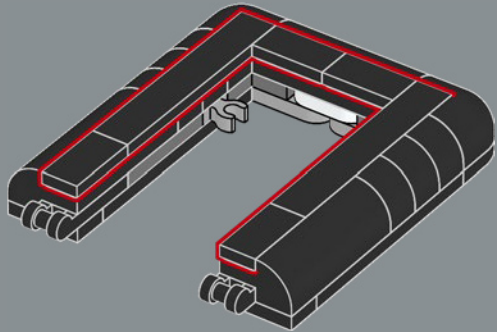

252

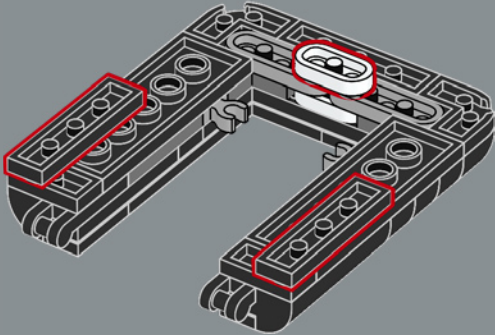

253

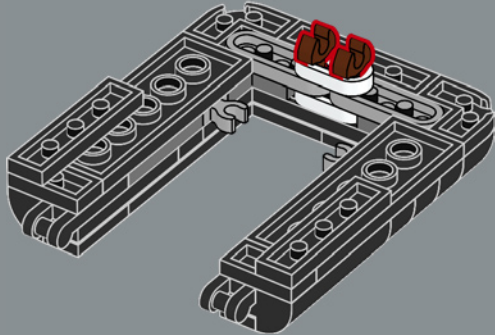

254

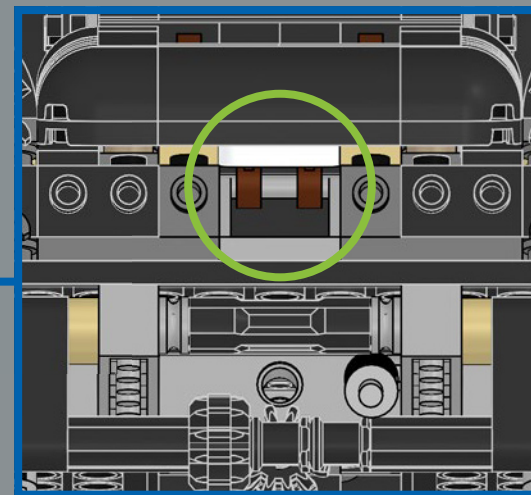
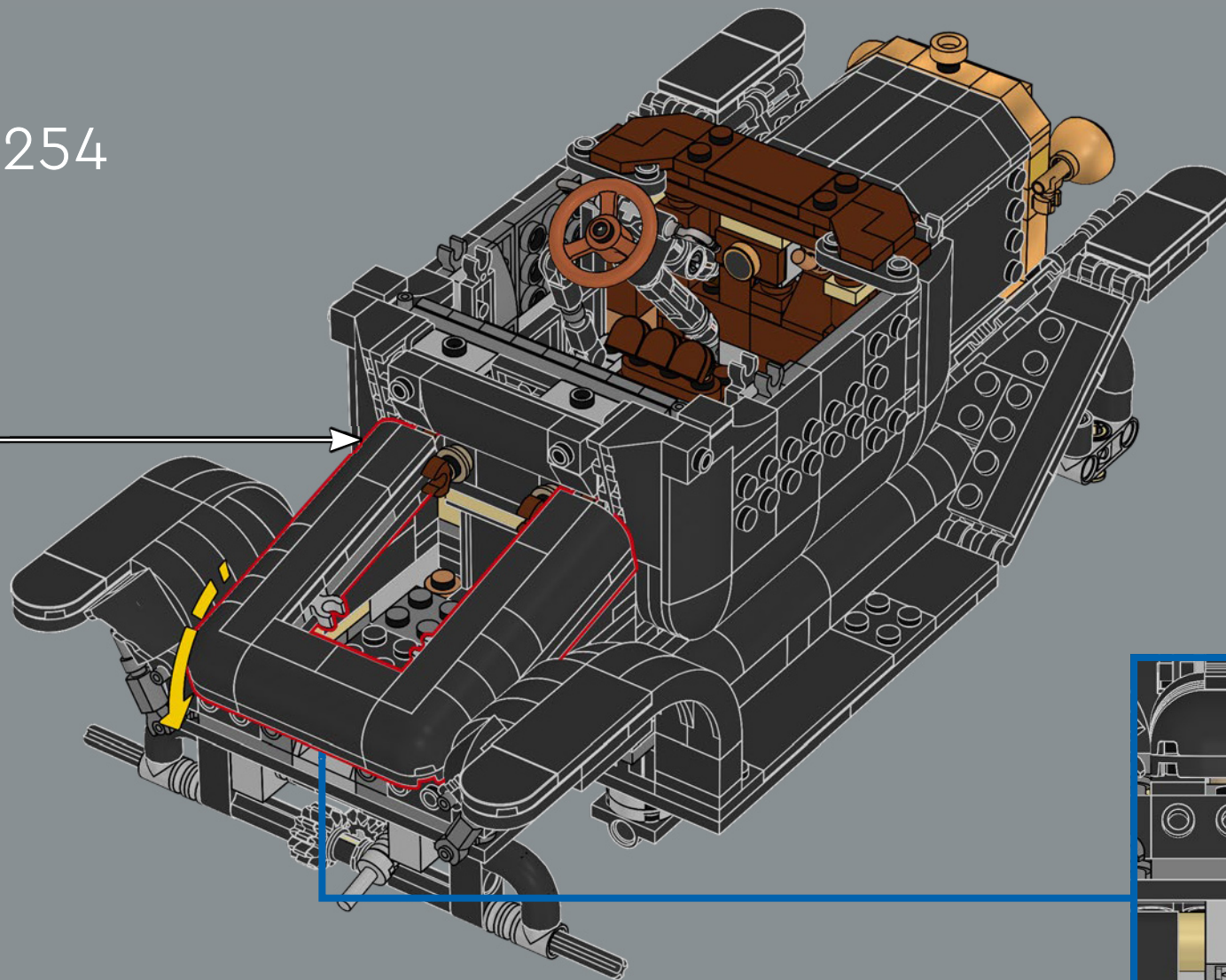

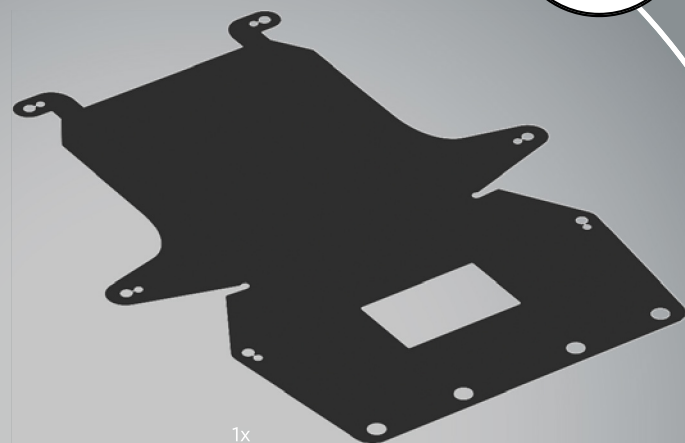
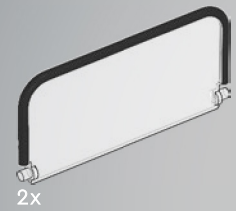
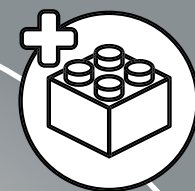

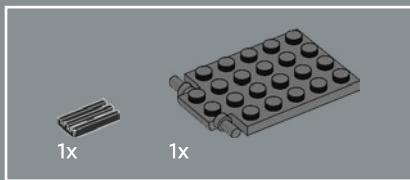

255

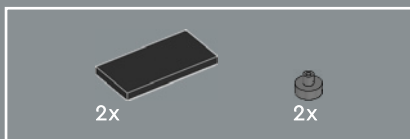
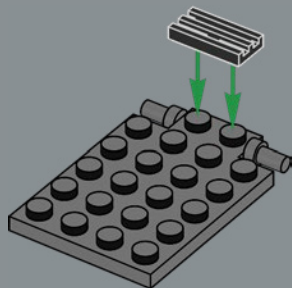

256

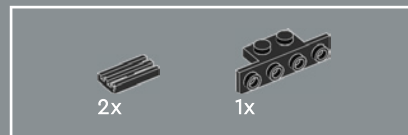
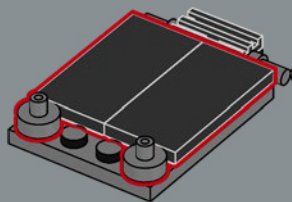

257

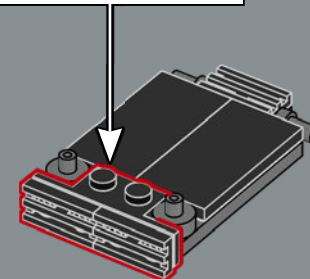
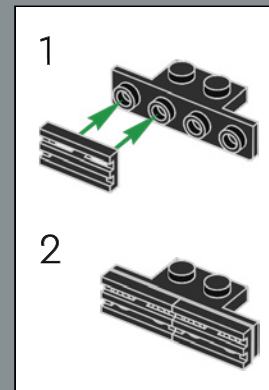

258

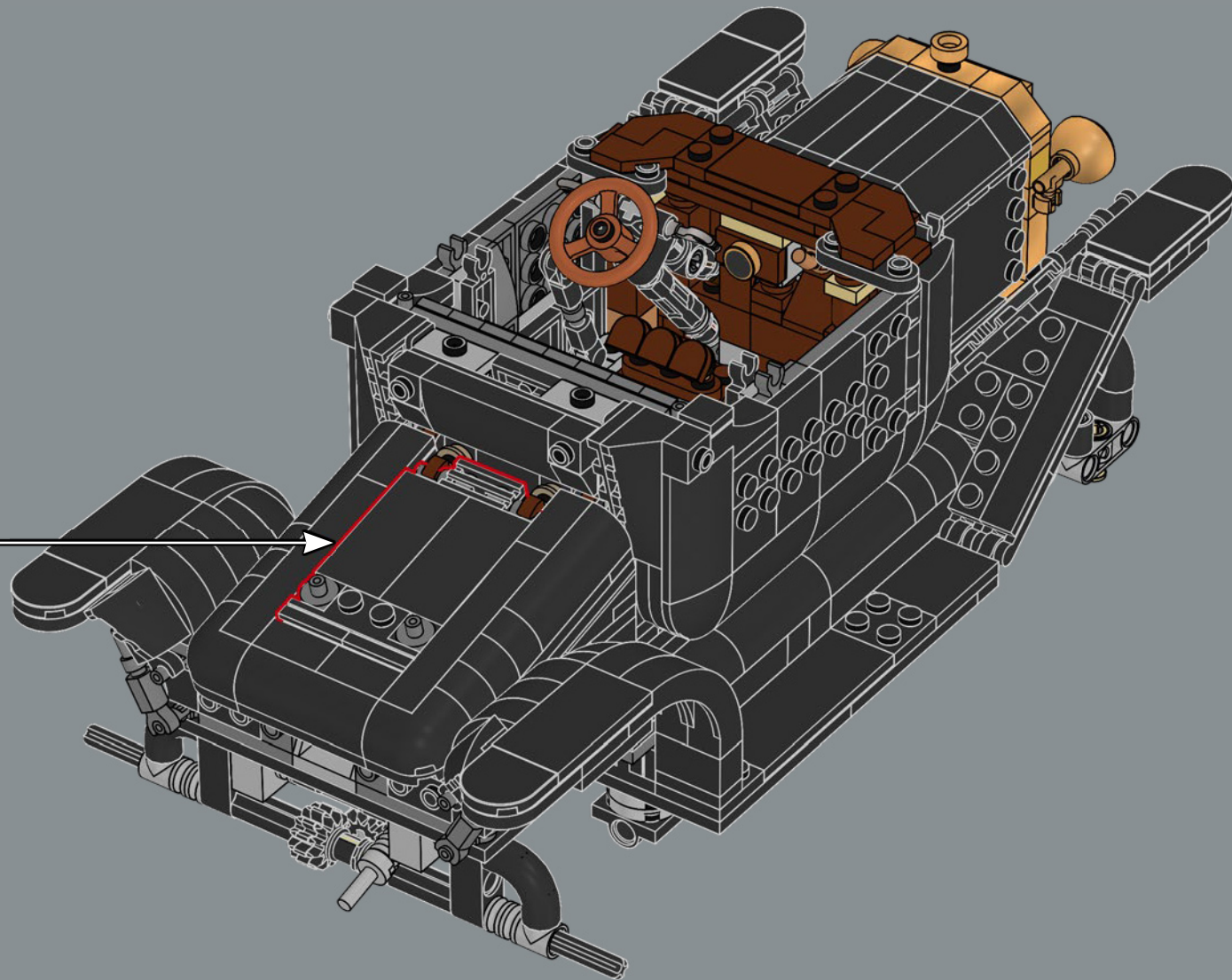

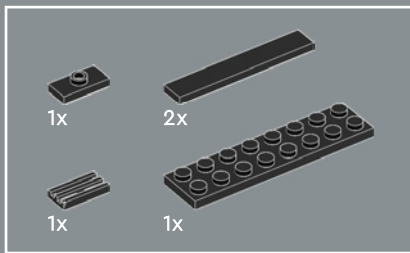

259

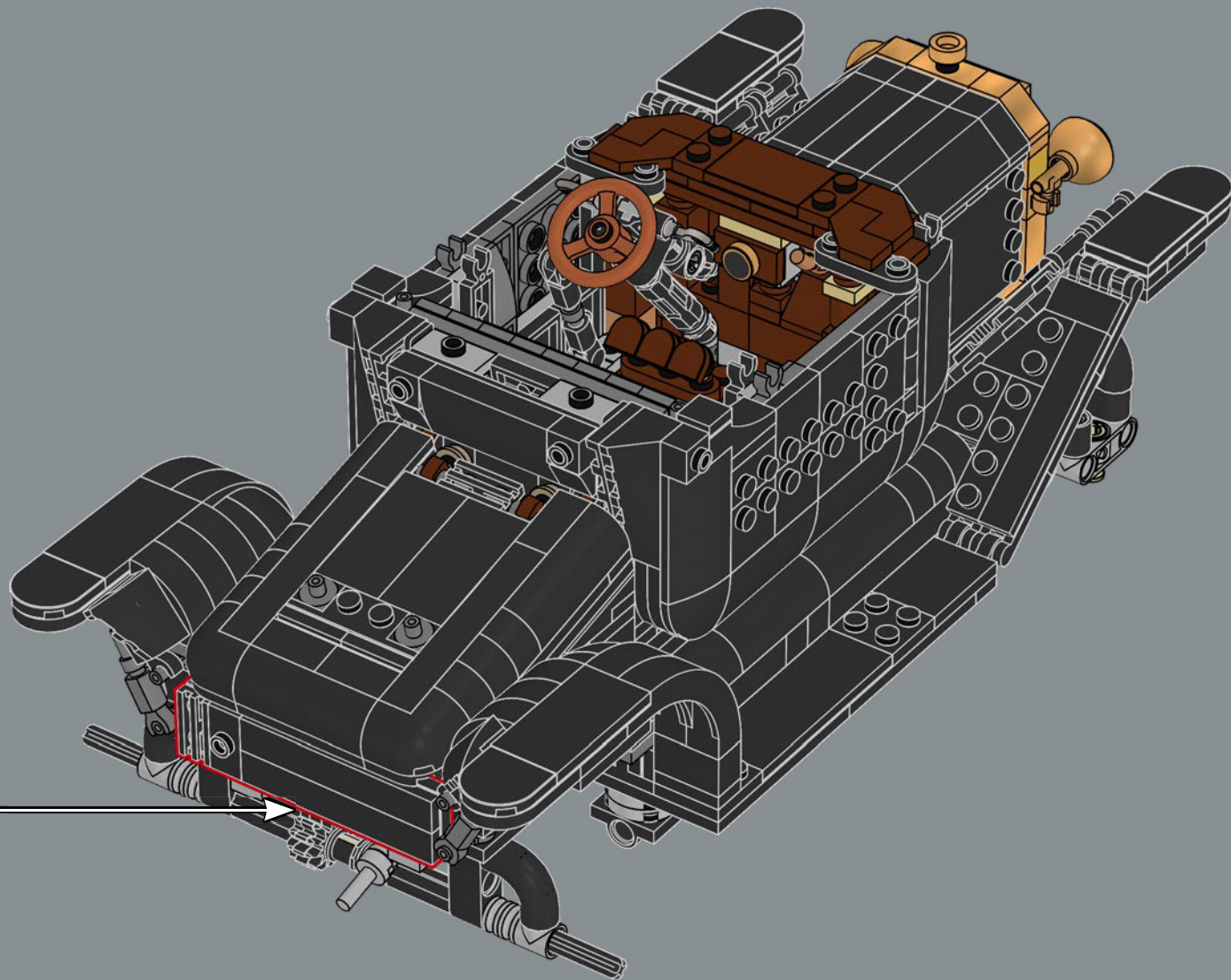
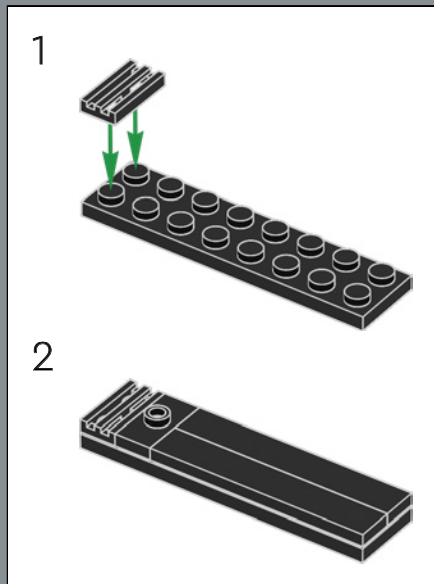

2x

1x

3x

260

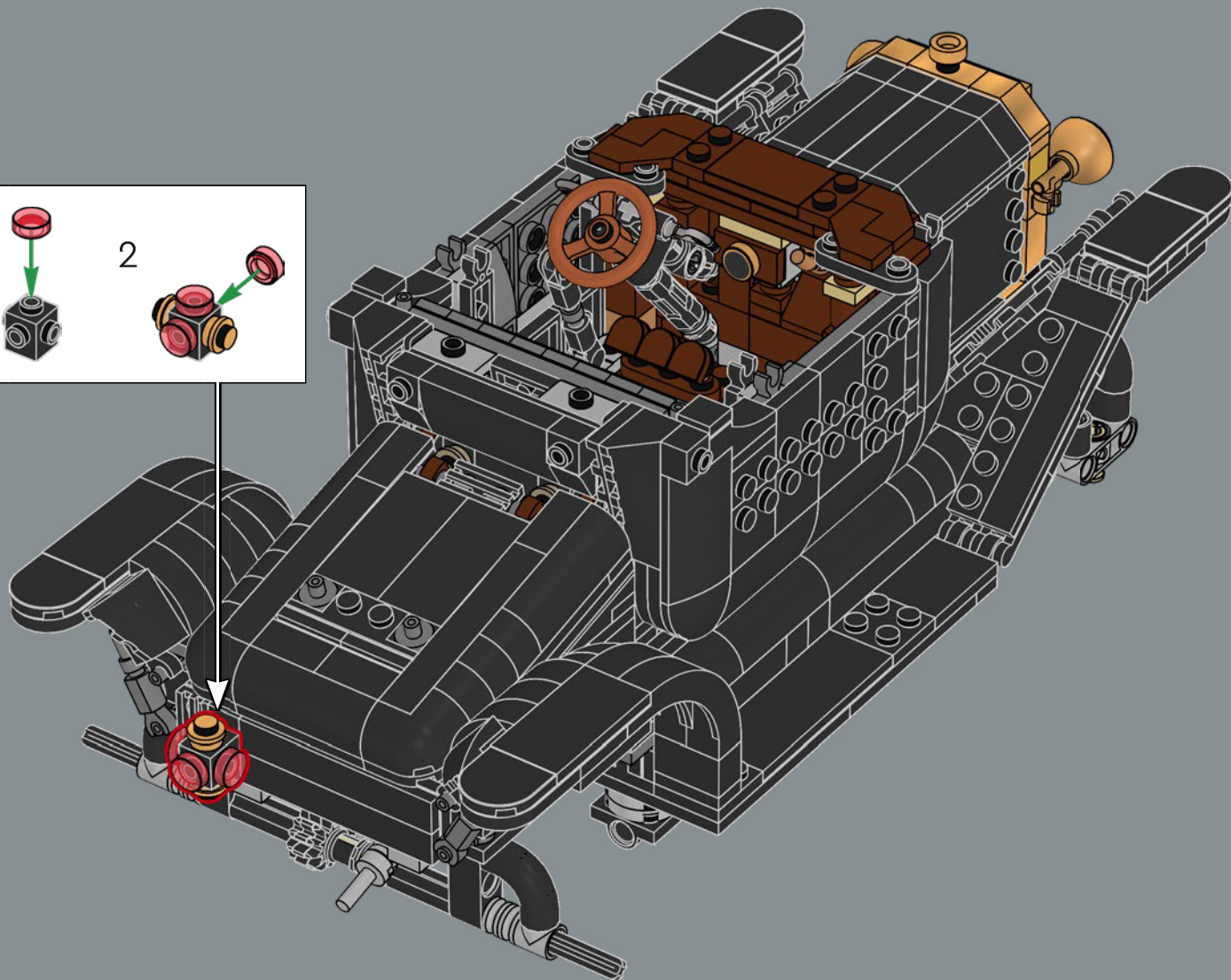
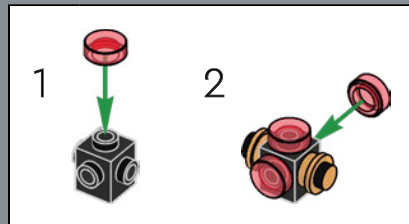

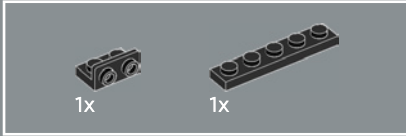
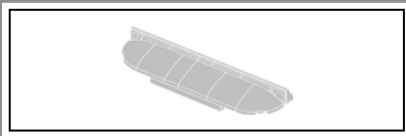

261

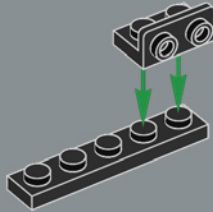

262

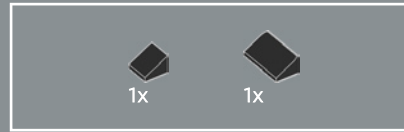
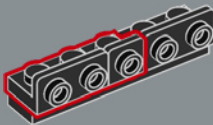

263

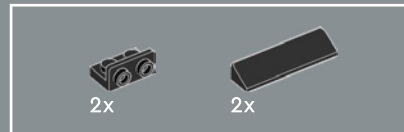
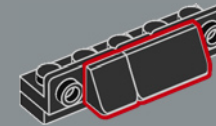

264

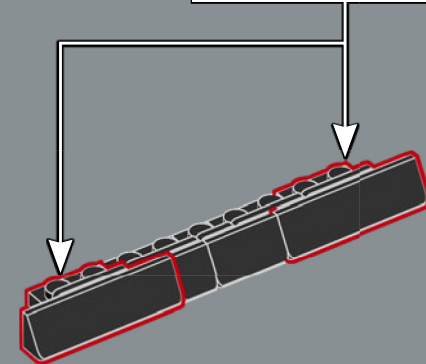
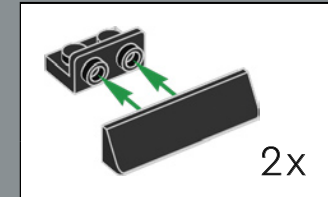

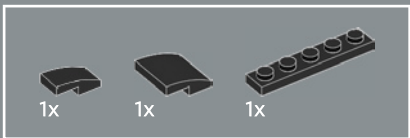

265

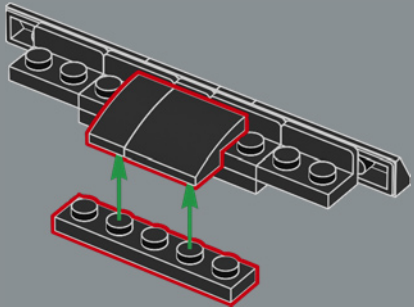

266

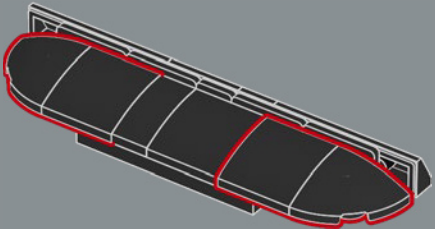

267

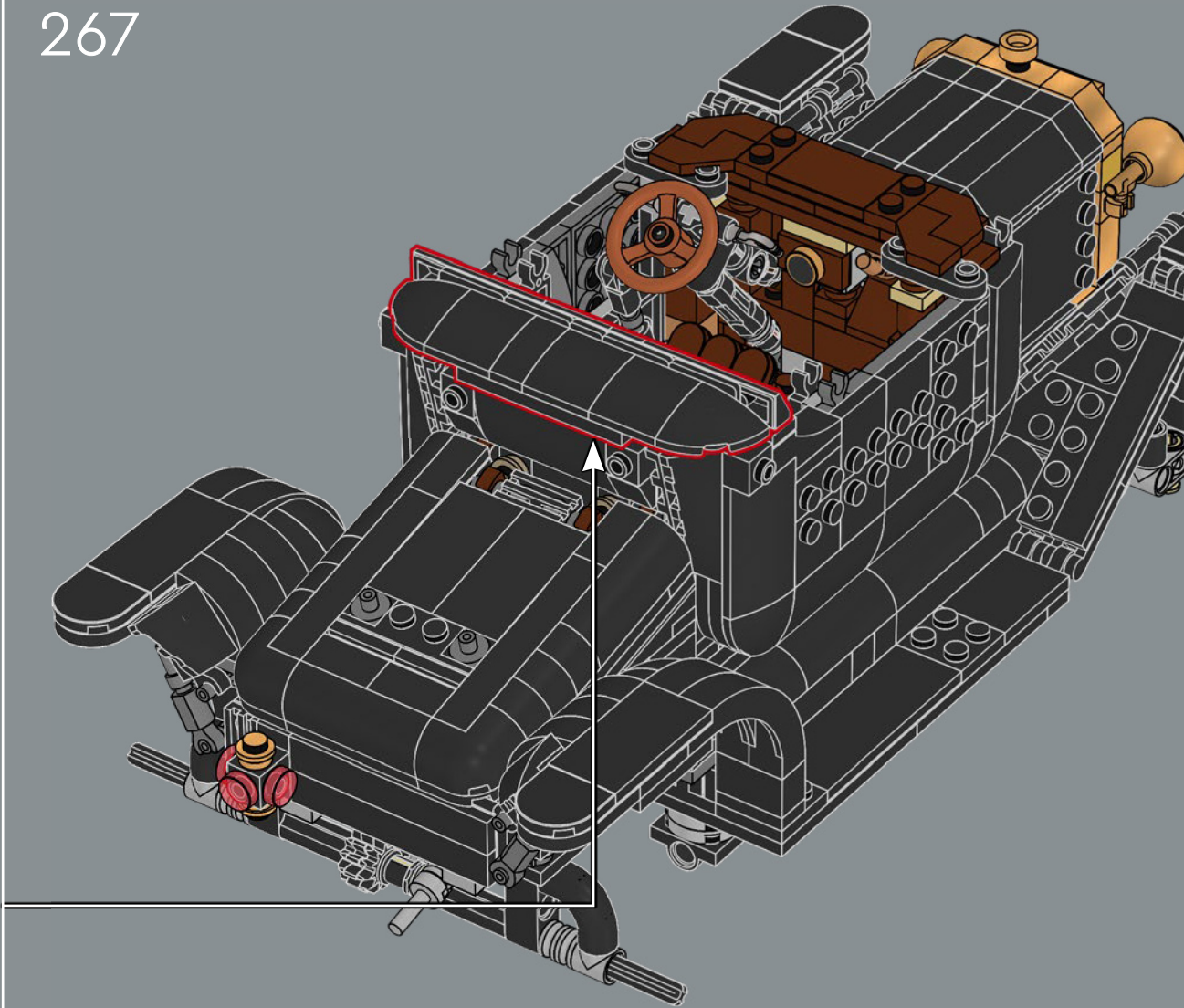

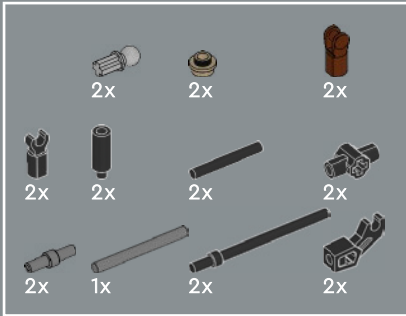
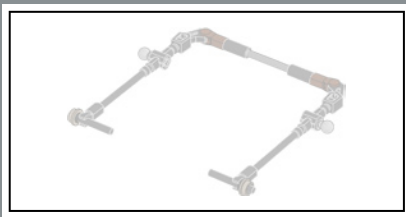

268

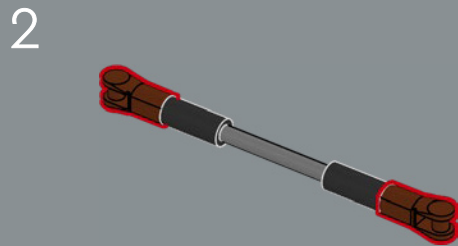
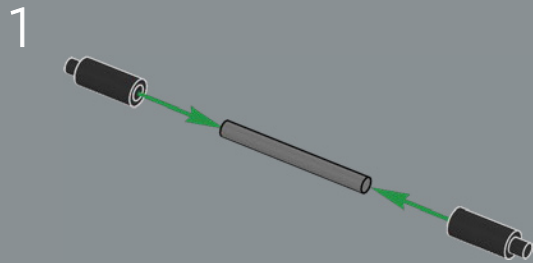

3

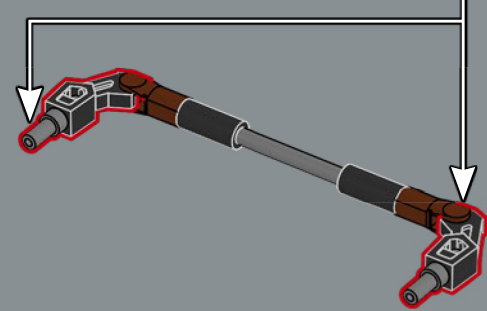
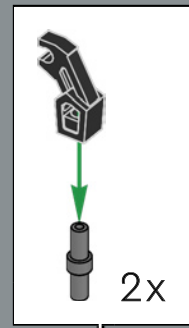

4

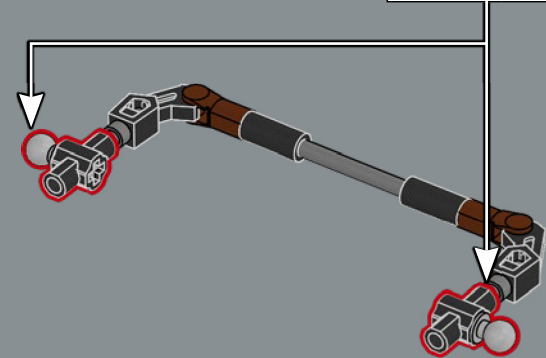
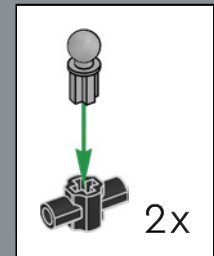

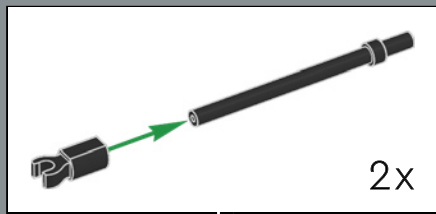

5

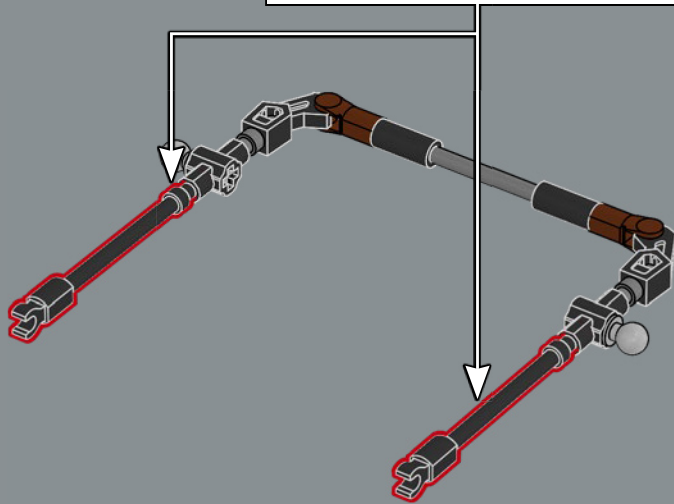

6

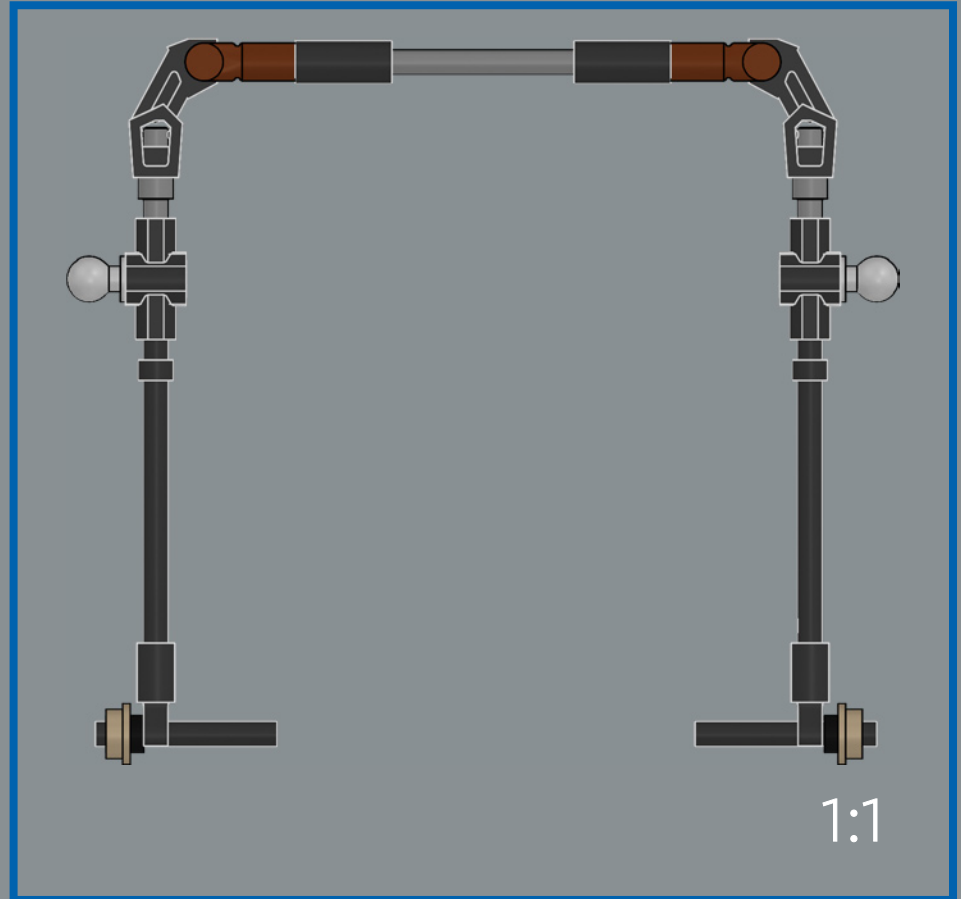
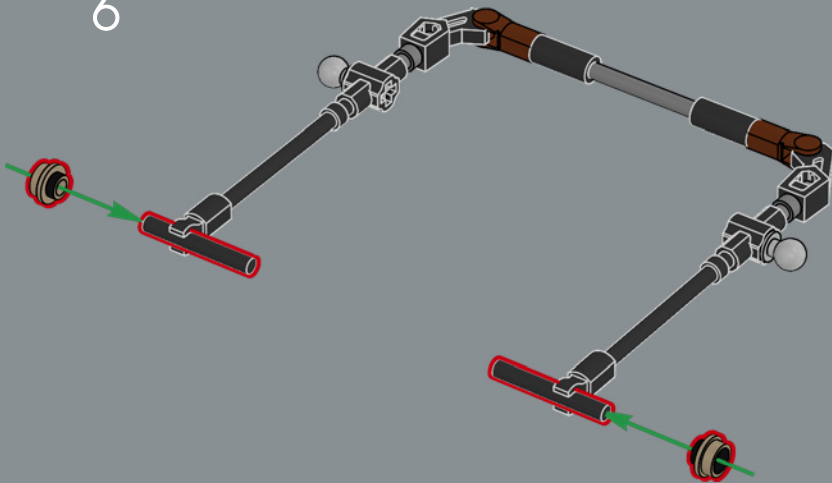



"Tin Lizzie" divenne un popolare soprannome per il veicolo.

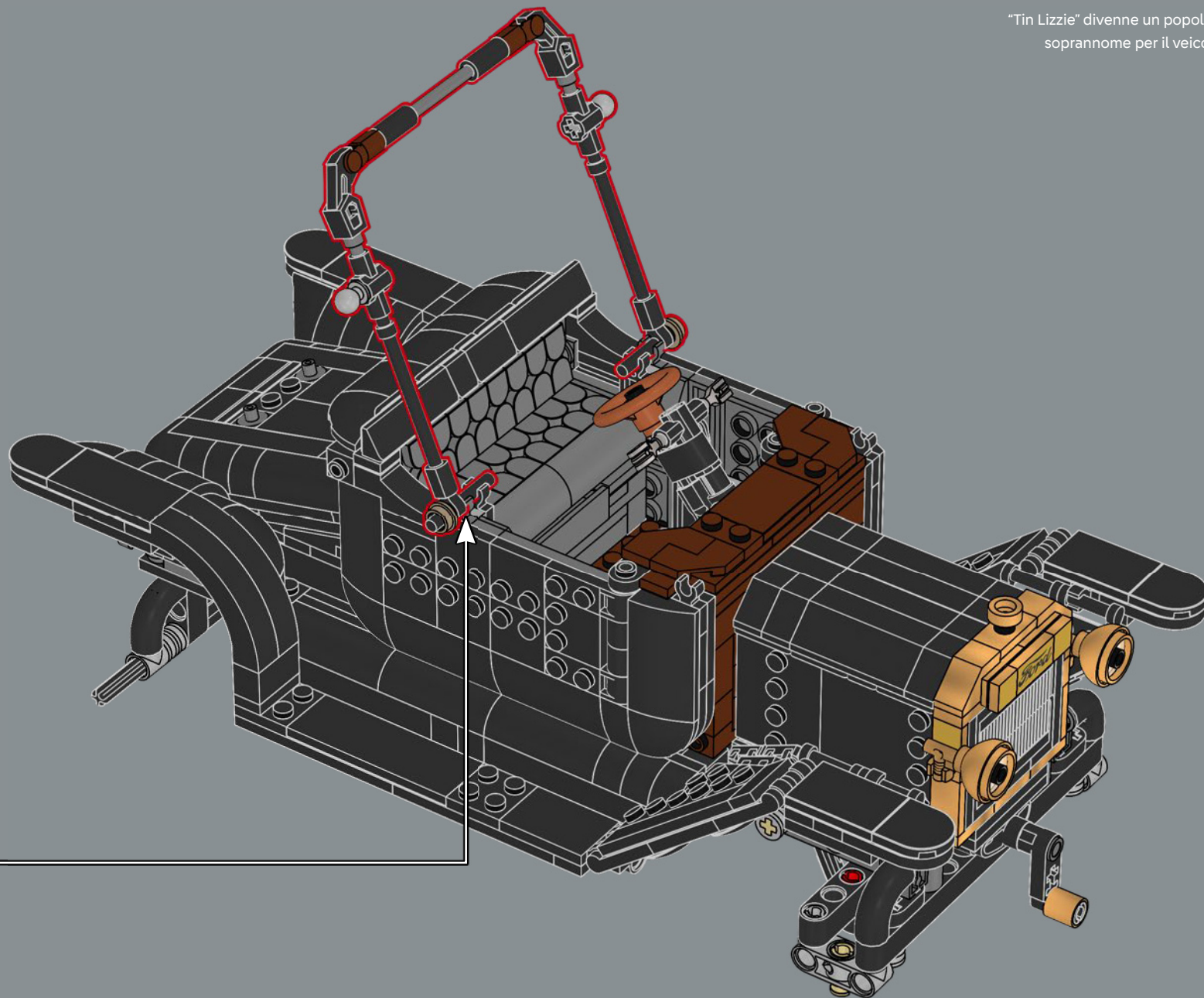

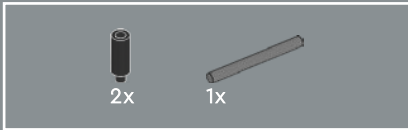
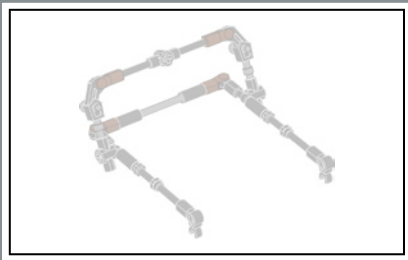

269

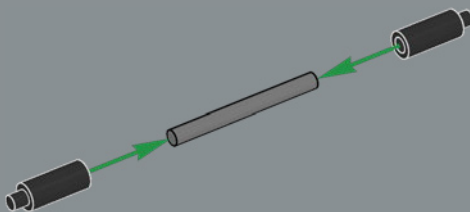

270

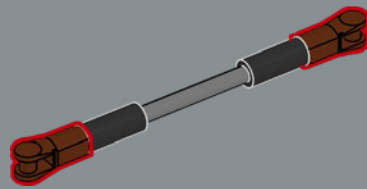

271

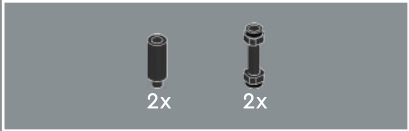
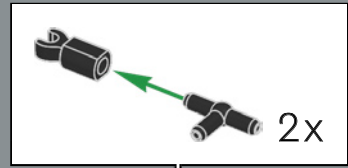
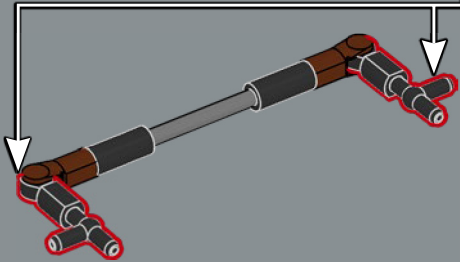

272

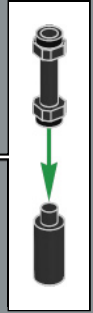
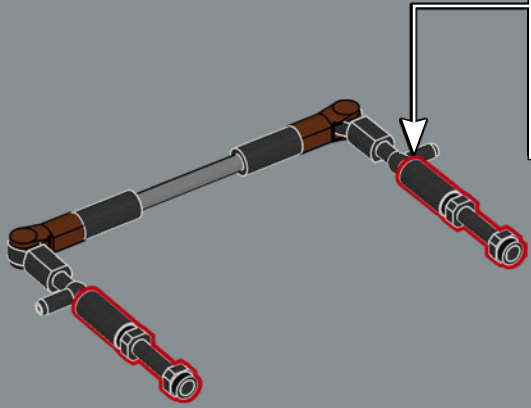



273

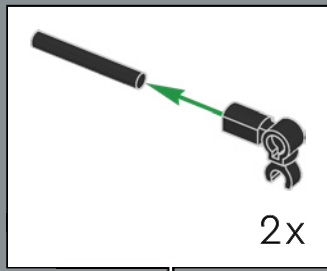
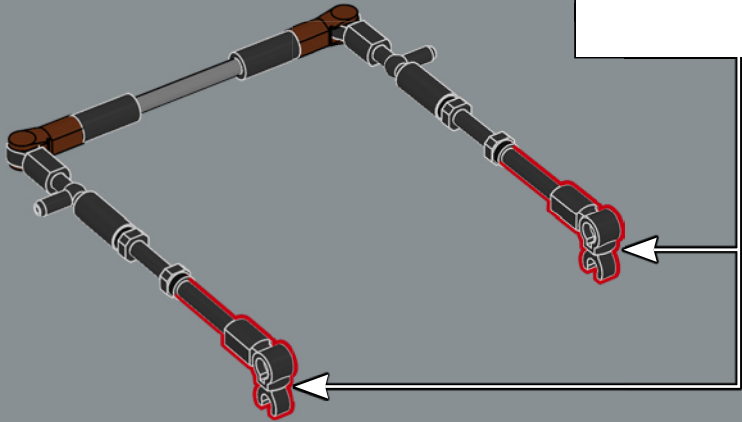

274

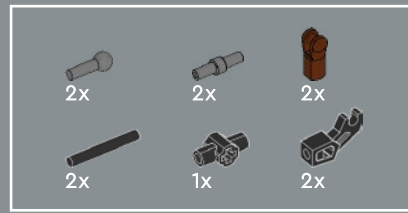
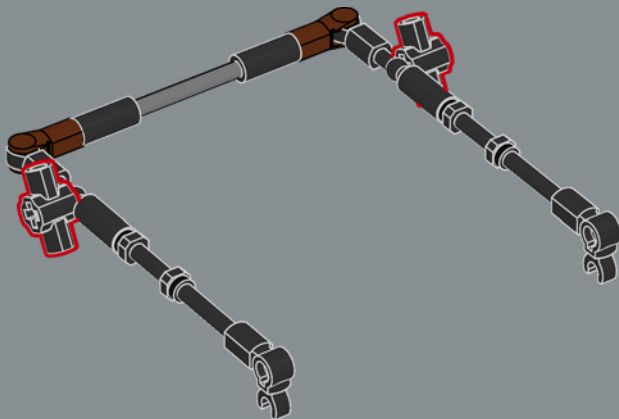

275

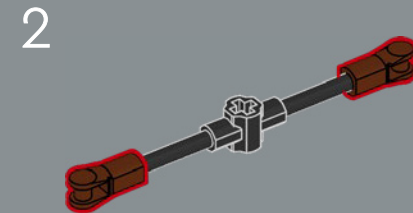
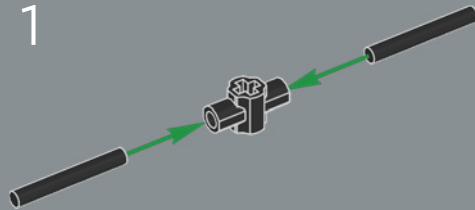

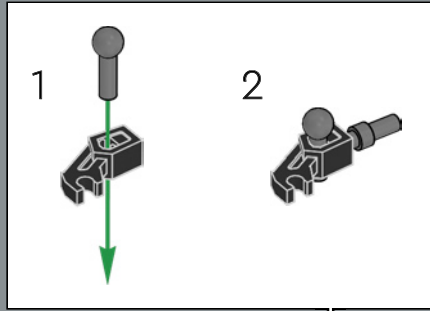



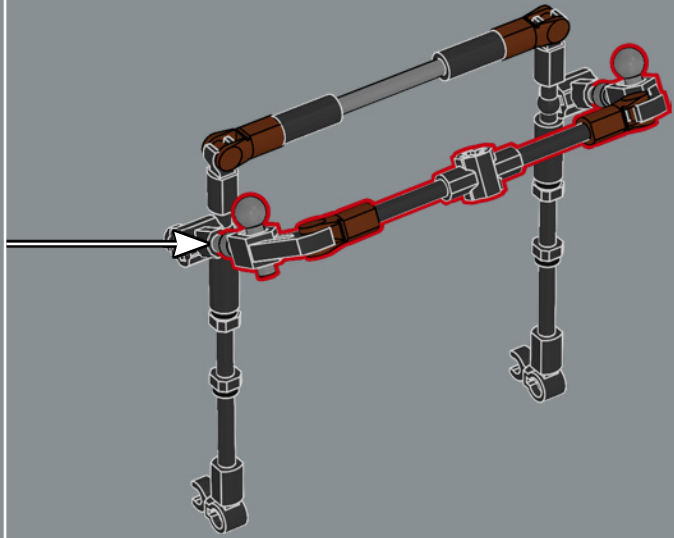
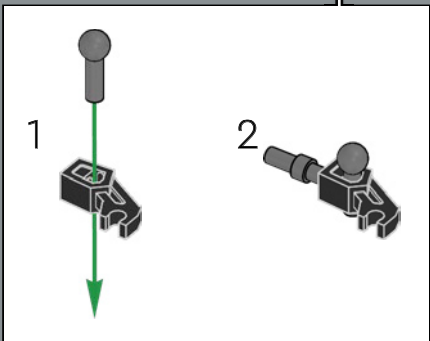
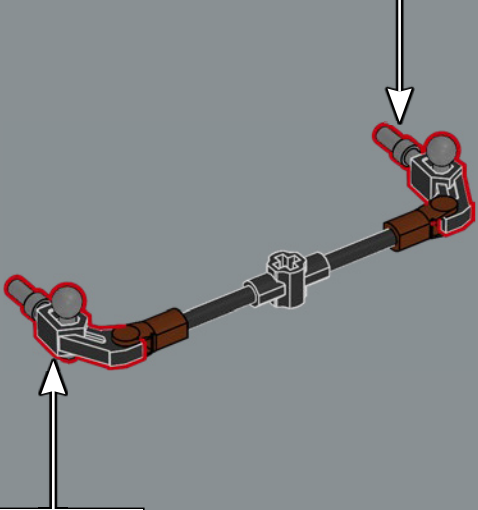

3

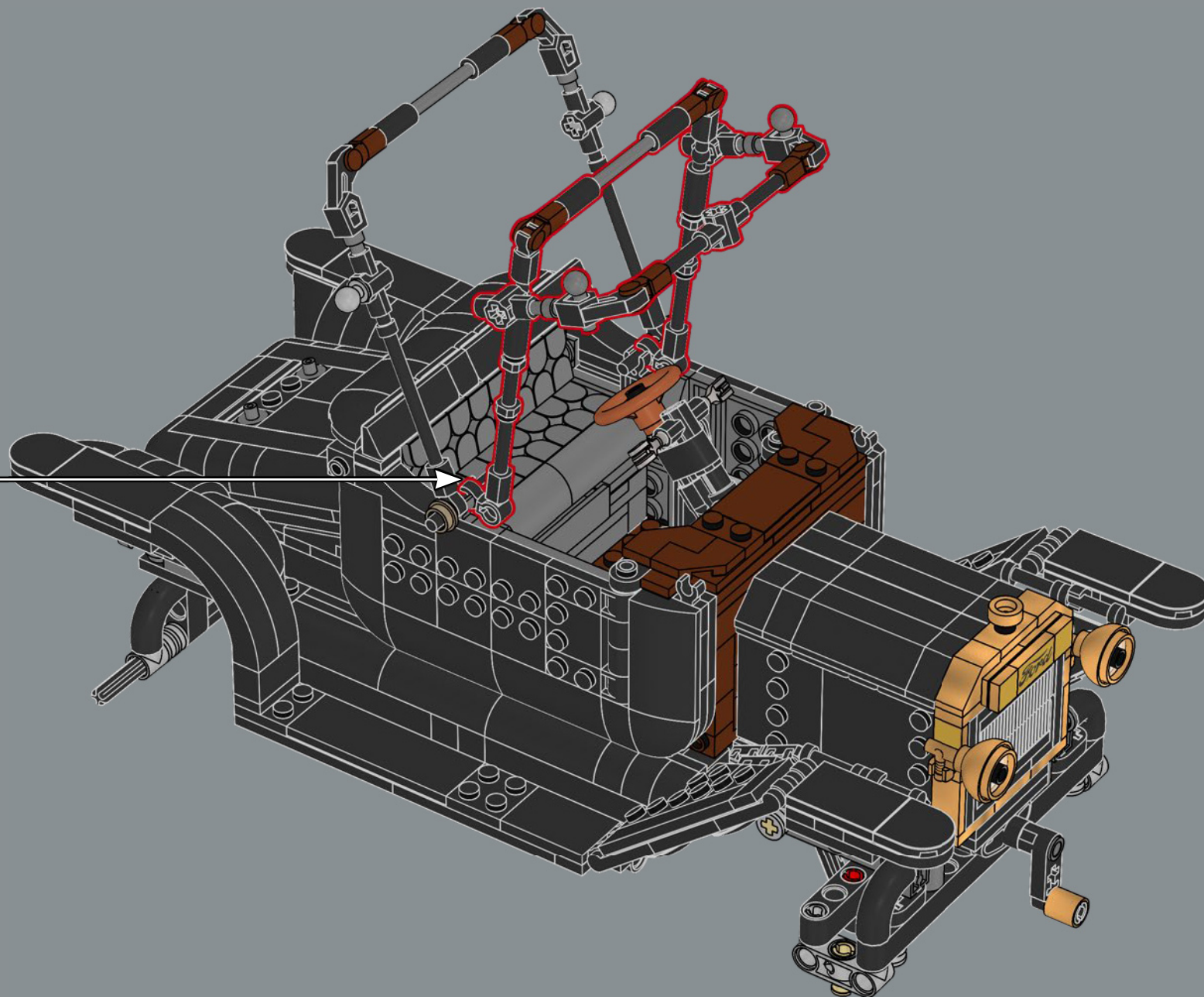

276



-  4x
-  2x
-  2x
-  6x

277

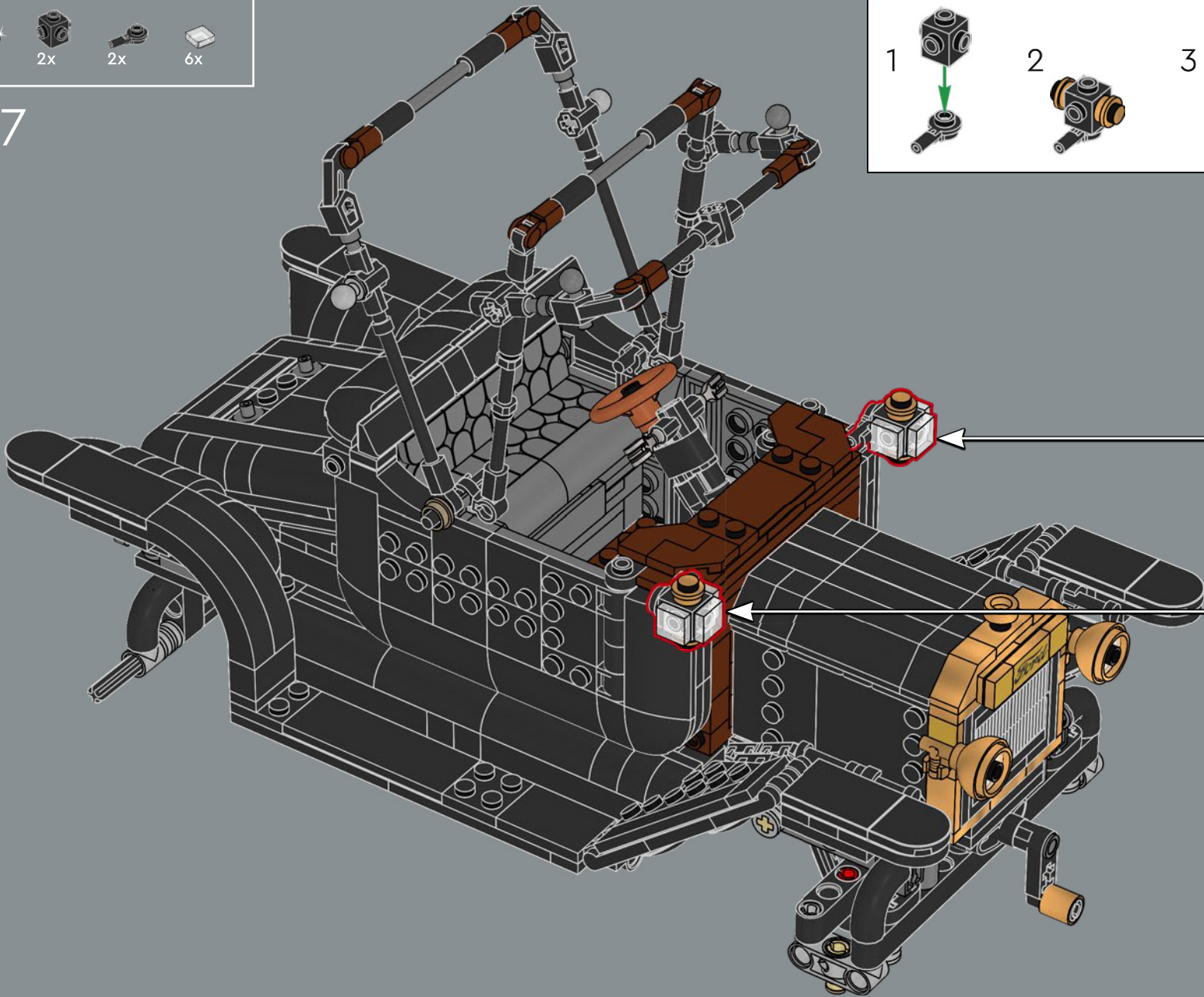

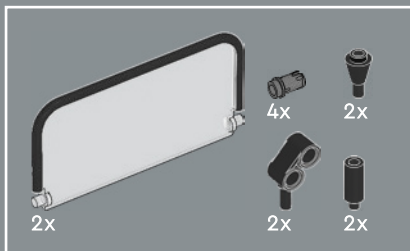

278

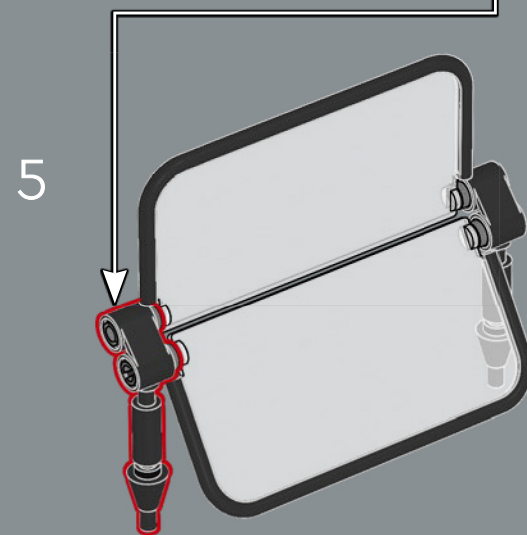
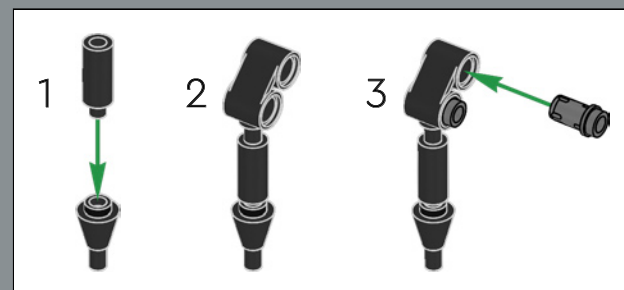
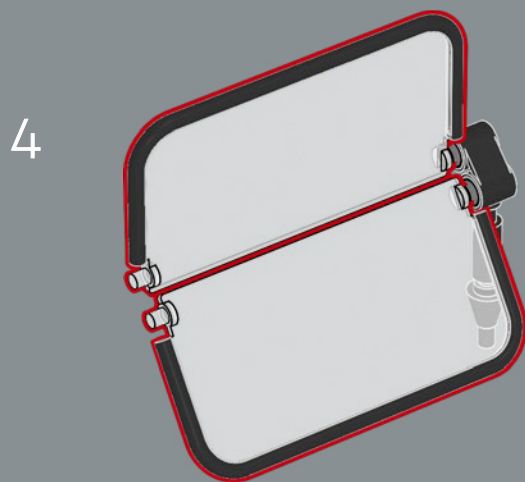
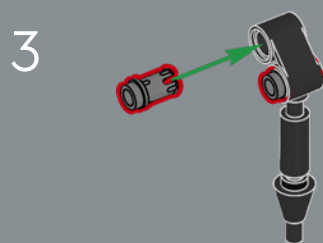
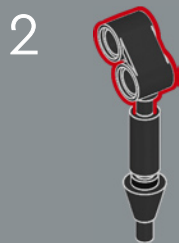
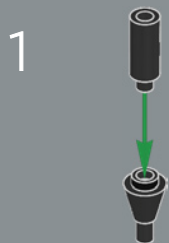

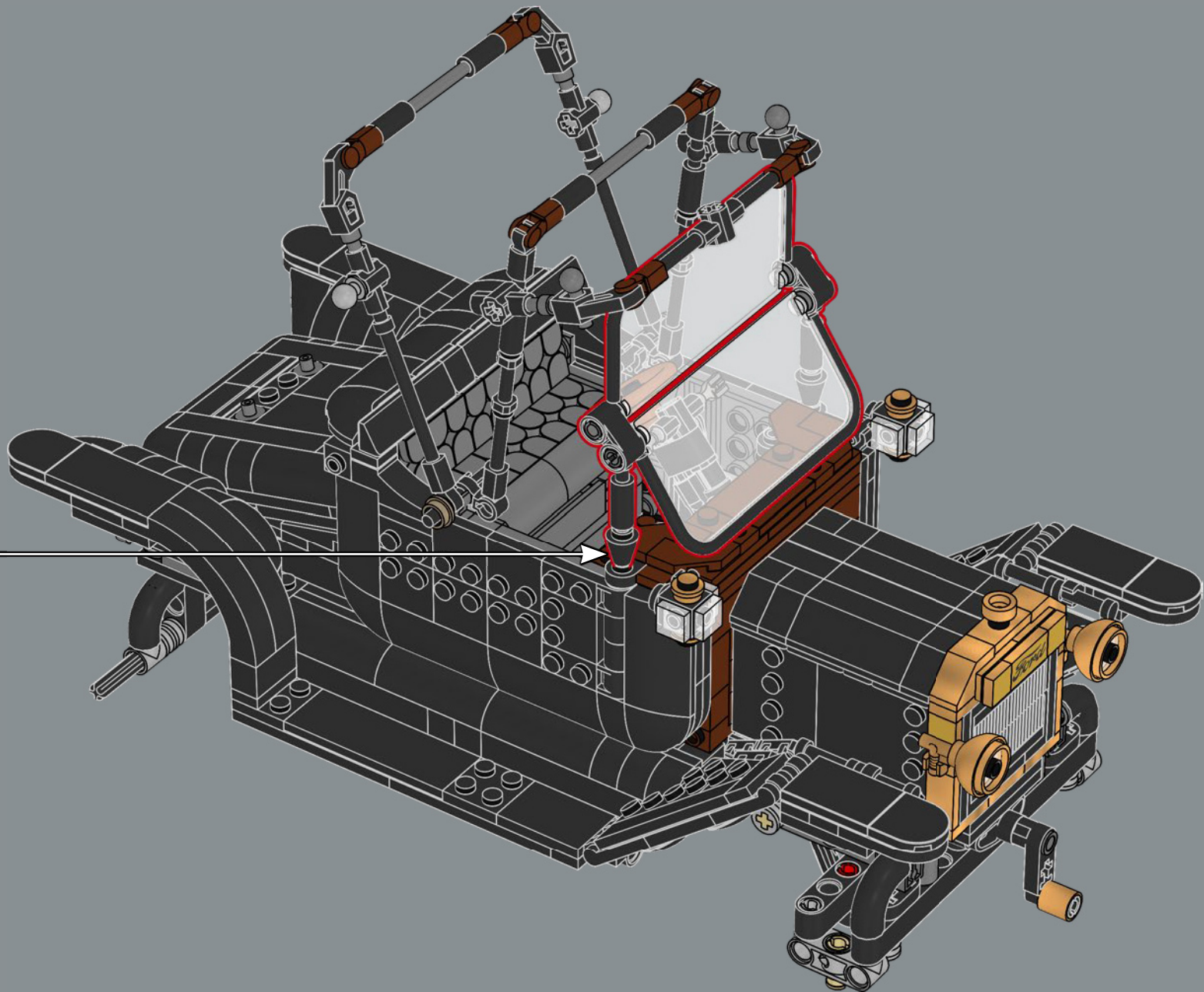

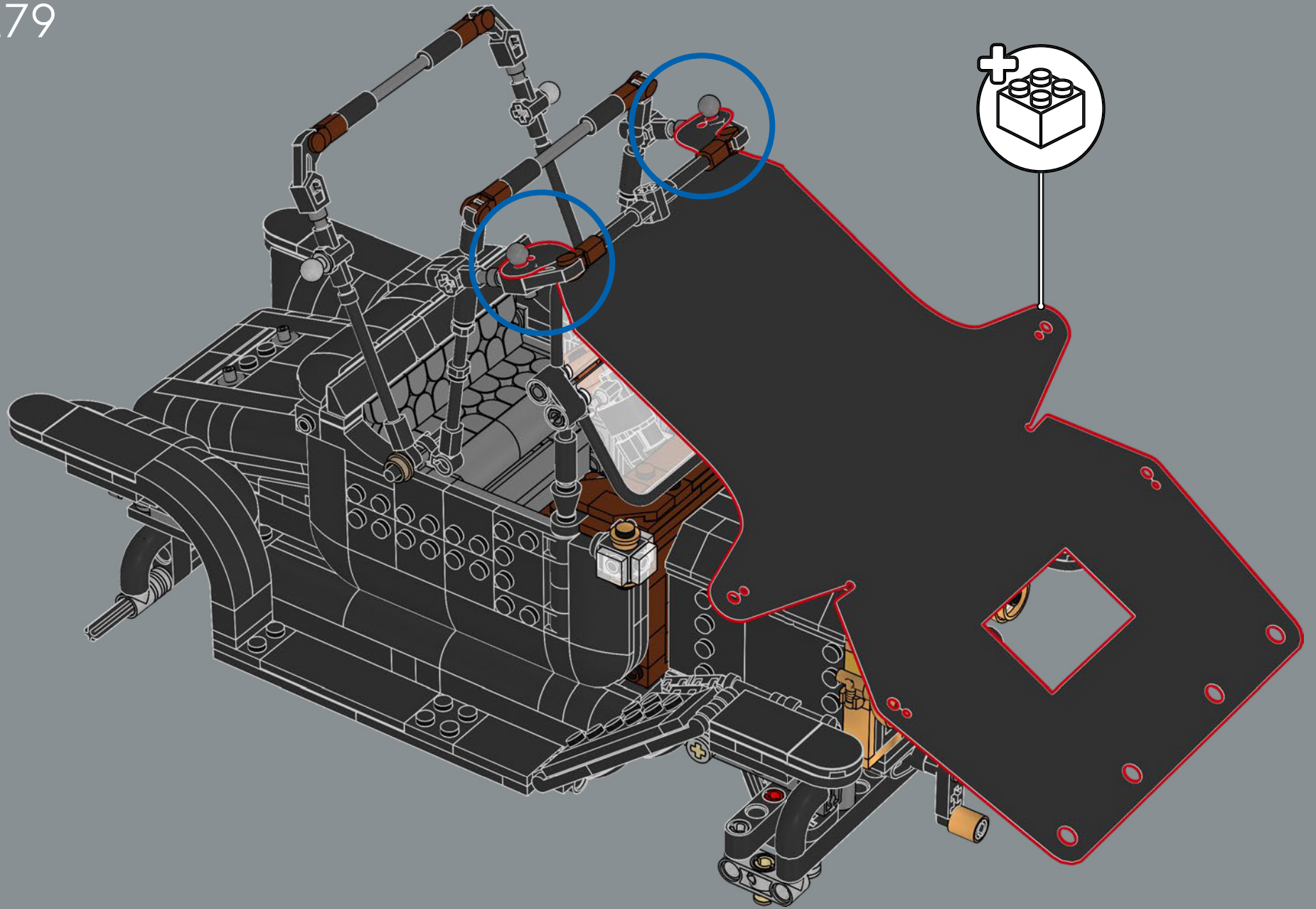



4x

280

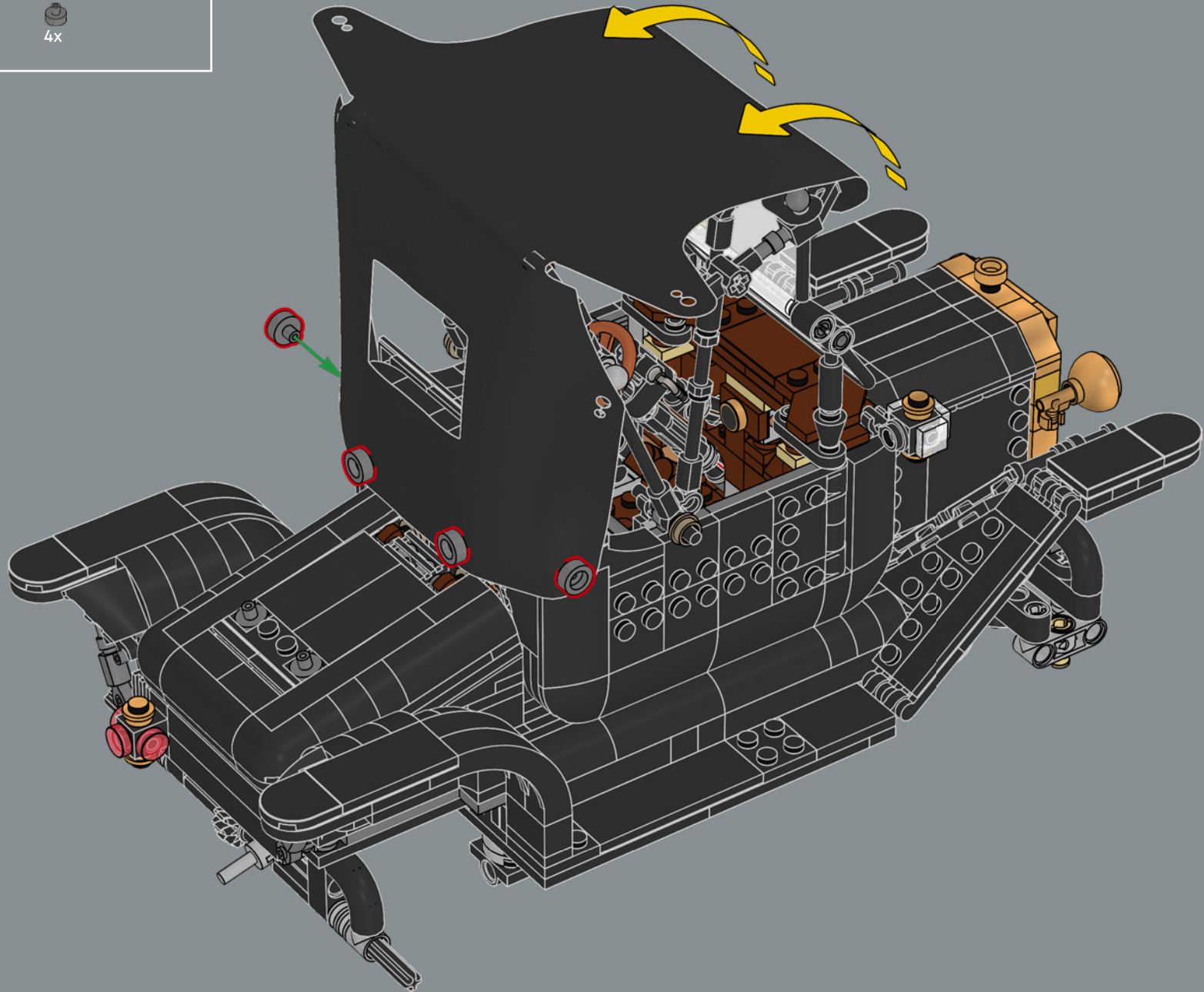

281

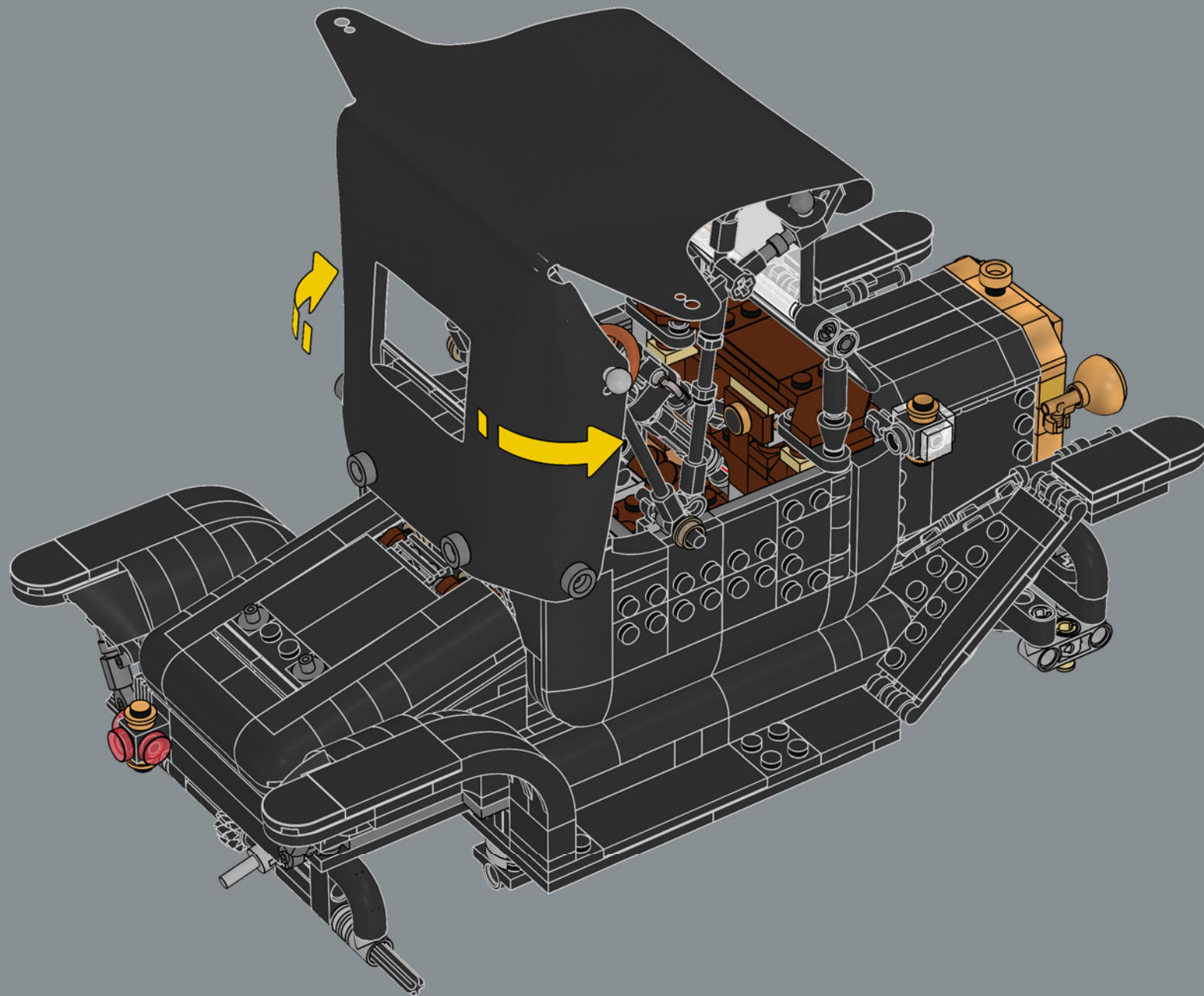

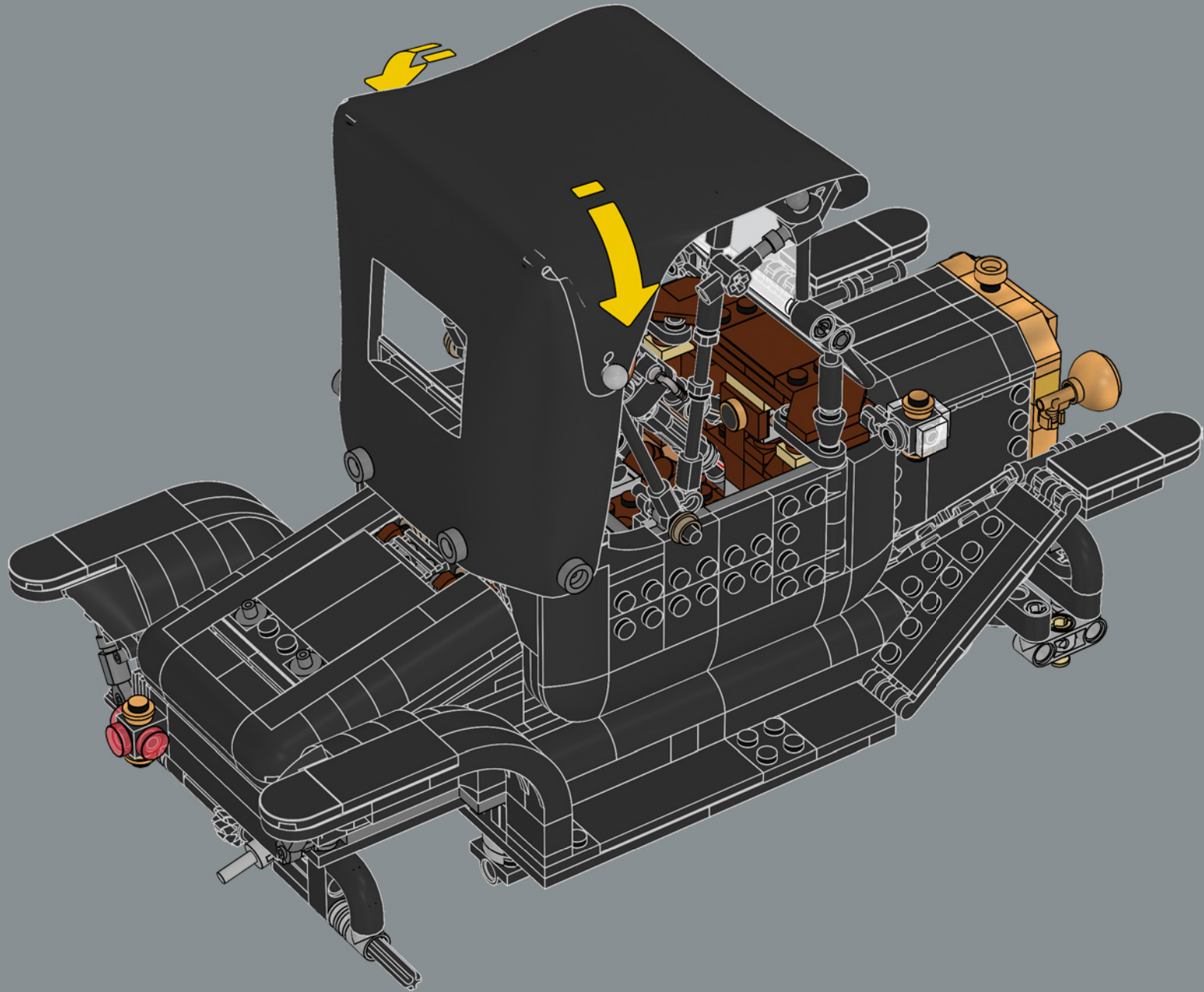

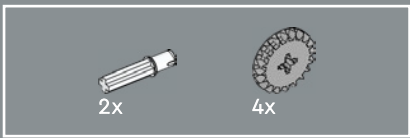

283

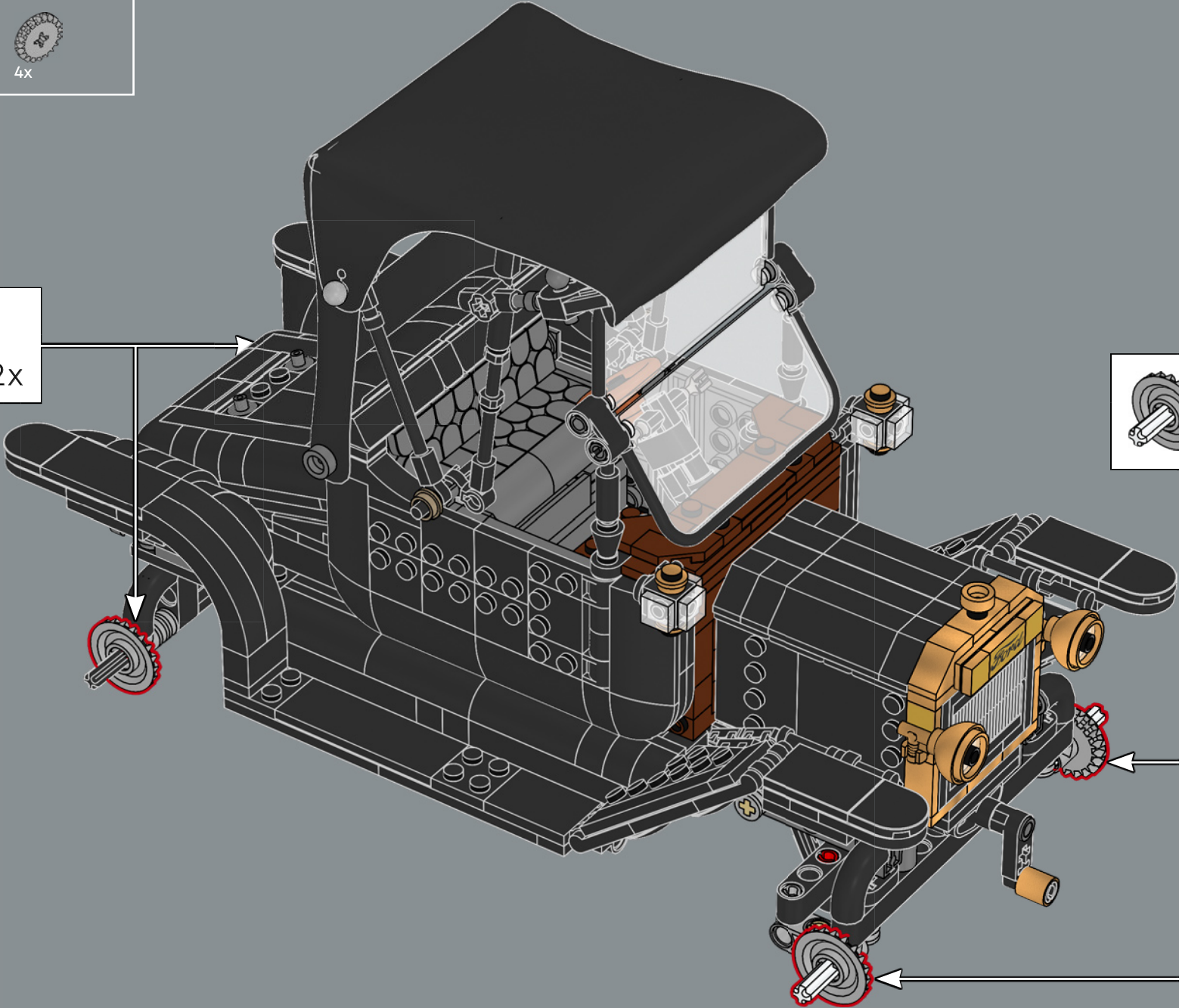
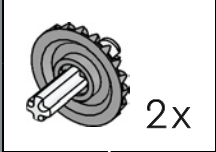
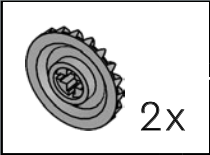

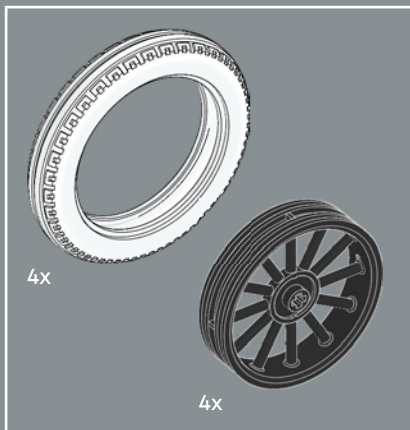

284

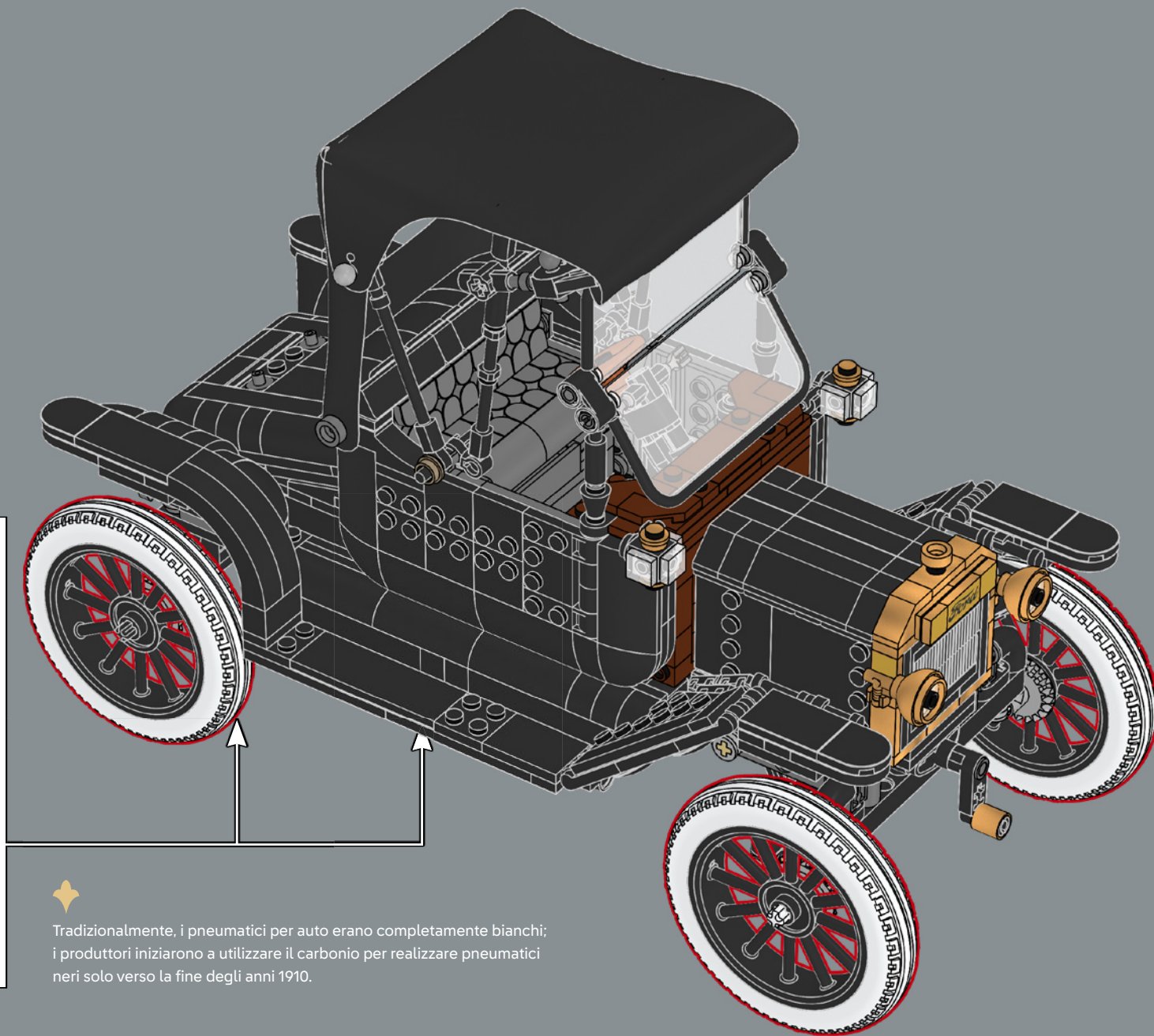
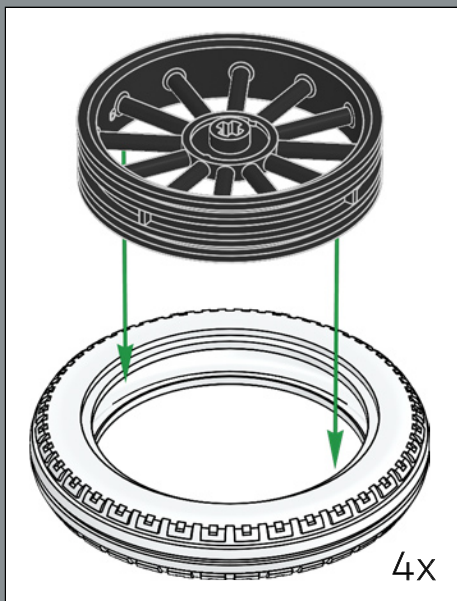

Tradizionalmente, i pneumatici per auto erano completamente bianchi; i produttori iniziarono a utilizzare il carbonio per realizzare pneumatici neri solo verso la fine degli anni 1910.



285

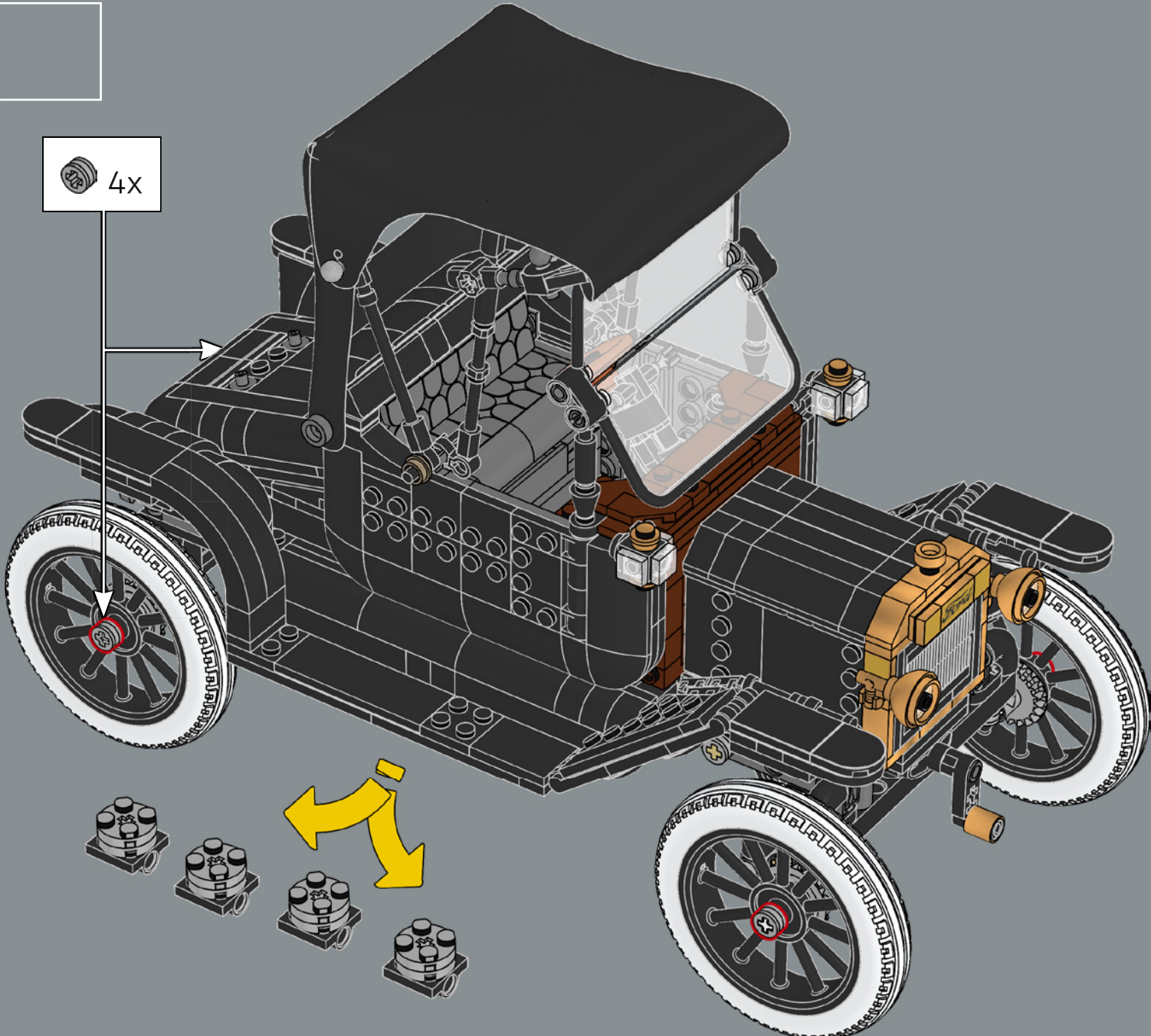
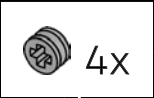

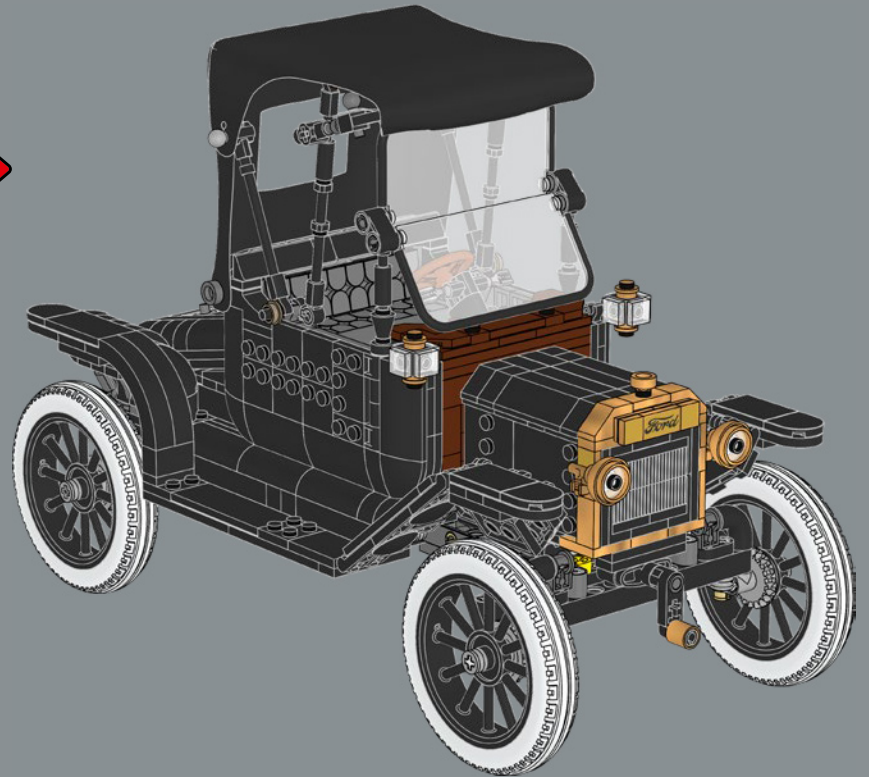
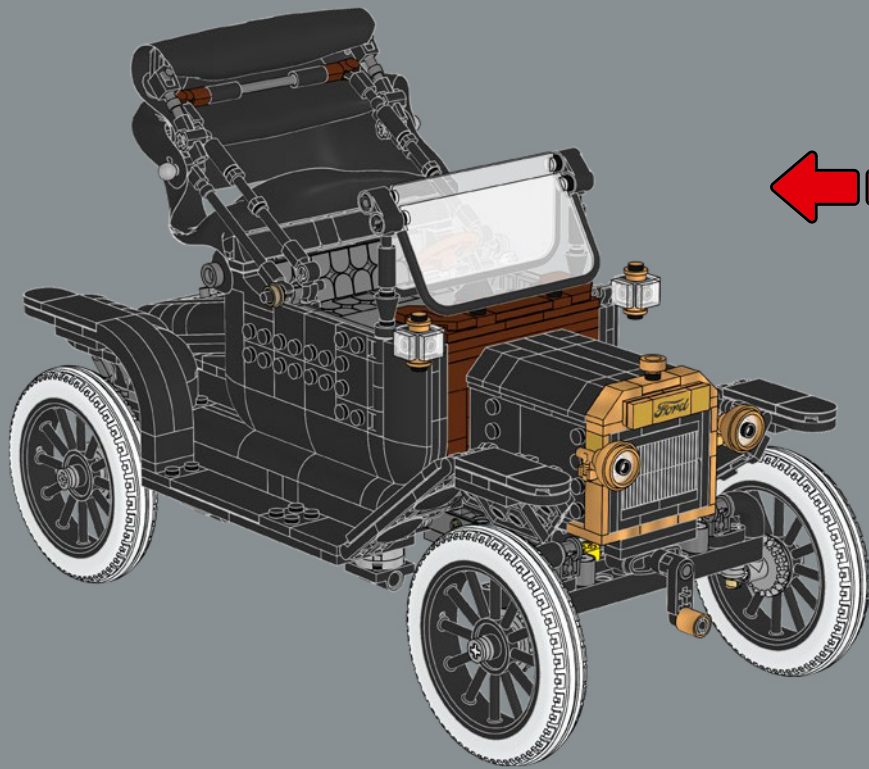

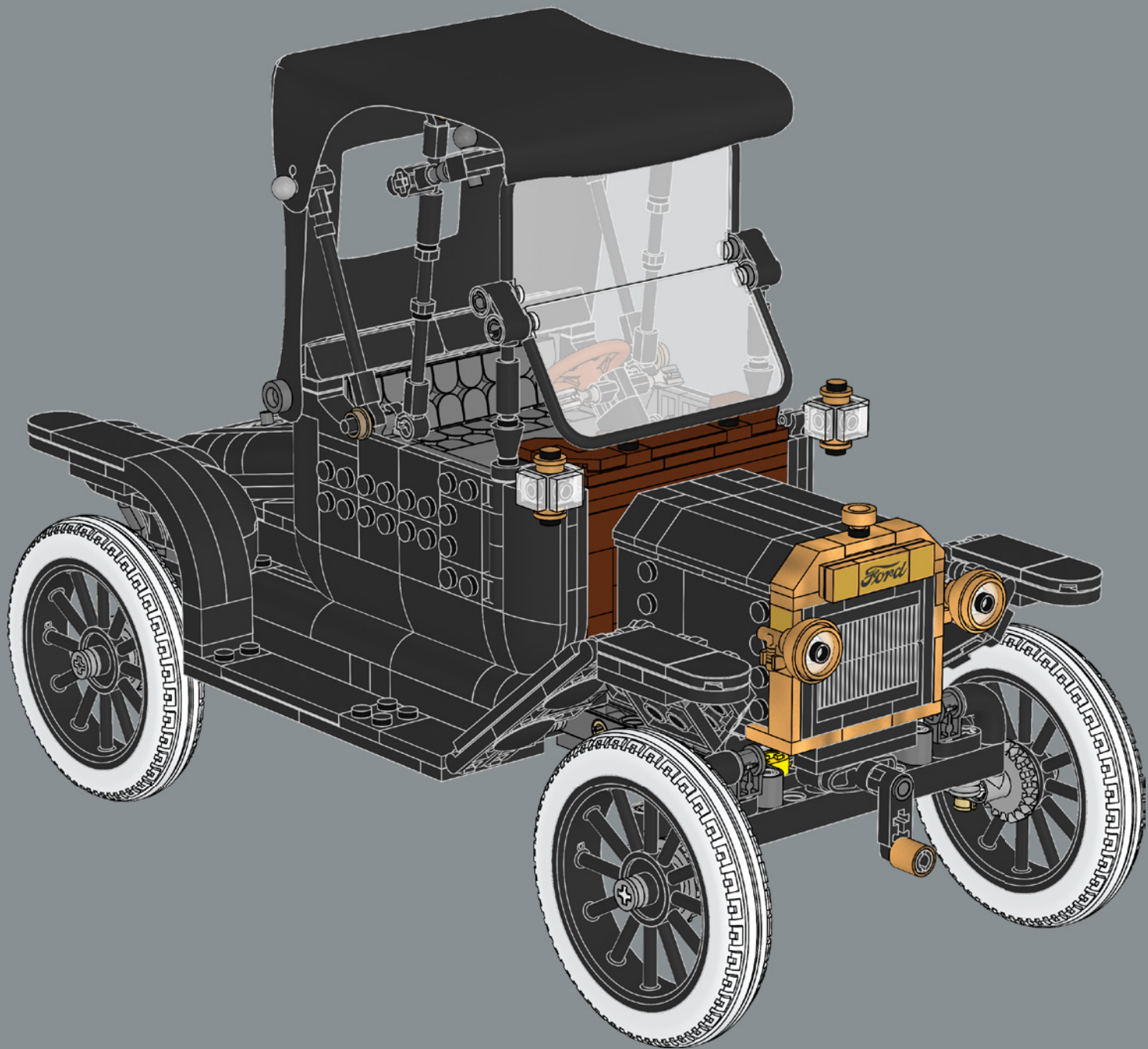

- 6x 614101
- 2x 6210272
- 2x 6058177
- 1x 6499714
- 2x 6289797
- 2x 371001
- 2x 346001
- 2x 346001
- 4x 6575457
- 1x 4565452
- 3x 4161734
- 1x 6374192
- 2x 4579260
- 2x 6376461
- 5x 6013938
- 1x 4666579
- 13x 4113917
- 4x 4162465
- 4x 4666999
- 1x 4118790
- 1x 4113233
- 6x 4114309
- 2x 6378120
- 1x 6360104
- 1x 4544143
- 1x 6130004
- 4x 4206482
- 2x 6376461
- 6x 6299413
- 2x 4119474
- 4x 6130008
- 4x 6331084
- 4x 6315887
- 8x 6290456
- 5x 6534180
- 4x 6388352
- 2x 6335388
- 8x 6332148
- 5x 6234695
- 3x 4504382
- 10x 307026
- 10x 302426
- 2x 6539387
- 2x 6538443
- 2x 6338384
- 2x 6335317
- 2x 6321194
- 3x 473326
- 6x 4558954
- 2x 300526
- 2x 6380236
- 1x 6473449
- 2x 6457112
- 2x 6338428
- 2x 6330189
- 2x 6308000
- 2x 6336214
- 6x 6280097
- 10x 6279875
- 6x 6267487
- 1x 6265091
- 2x 6196548
- 1x 6143850
- 2x 6104209
- 1x 6092585
- 1x 6047276
- 10x 6020193
- 4x 4512363
- 8x 4278359
- 4x 4109810
- 10x 306926
- 18x 302326
- 6x 241226
- 2x 6600029
- 6x 6562635
- 10x 6542614
- 8x 6534031
- 1x 6513908
- 1x 6507846
- 1x 6291068
- 4x 6276867
- 1x 614326
- 2x 6141556
- 7x 6138173
- 2x 6114987
- 2x 6016172
- 2x 6016172
- 2x 4644456
- 1x 4548180
- 2x 4177431
- 1x 403226
- 2x 300426
- 4x 287726
- 4x 6179182
- 2x 6173124
- 2x 6141554
- 1x 4160869
- 1x 4161332
- 2x 6430580
- 4x 6336989
- 2x 6328095
- 6x 6214807
- 6x 6093525
- 3x 6053077
- 2x 6592550
- 2x 6552467
- 4x 6517779
- 2x 6506033
- 1x 6488003
- 4x 6469445
- 2x 6428168
- 2x 6350725
- 1x 6313520
- 2x 6310268
- 2x 6286381
- 14x 6192346
- 2x 4567436
- 10x 4515368
- 6x 4225201
- 2x 4142822
- 5x 362326
- 12x 302226
- 5x 281726
- 4x 242026
- 1x 6371743
- 1x 6325521
- 8x 6250020
- 4x 4227684
- 1x 303926
- 6x 6585237
- 1x 6168620
- 4x 6162892
- 1x 370526
- 4x 317626
- 10x 302126
- 4x 4227392
- 2x 6601521
- 3x 6439175
- 4x 6325190
- 16x 371026
- 3x 243126
- 9x 6587076
- 4x 6577238
- 2x 6360129
- 4x 6327028
- 1x 6277462
- 2x 6174917
- 9x 4587844
- 6x 4560182
- 4x 302026
- 2x 301026
- 2x 6567221
- 1x 6279754
- 2x 4558209
- 4x 6350415
- 2x 6170421
- 2x 6076678
- 3x 370626
- 4x 6544447
- 10x 663626
- 1x 6458186
- 2x 617926
- 1x 6058118

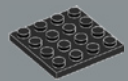

2x
4243819



2x
6318582

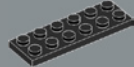

2x
379526



4x
6575789

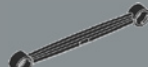

1x
6506200



1x
346026



1x
370226



1x
6456527

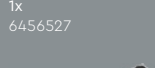

1x
303426

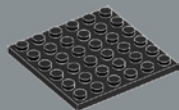

4x
395826



6x
4514845



2x
4522933



1x
303326

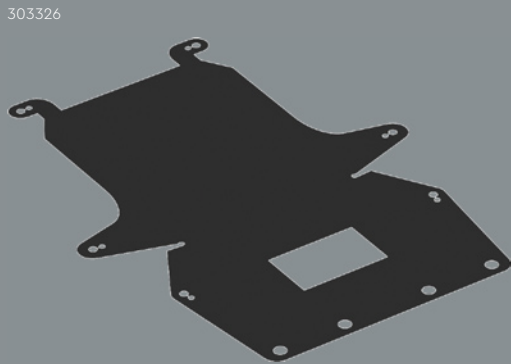

1x
6586353



1x
6539382



6x
6581822



2x
6510164



2x
6508150

13



2x
6584086



3x
6514189

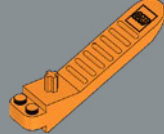

1x
6240515



1x
6322841



6x
6300322



4x
6328180



6x
6215659



2x
4221744



2x
4211183



6x
6476174



6x
6439053



4x
4620075



2x
6201911



4x
6092590



4x
4211150



2x
6397820



2x
4211180



2x
6500421



4x
6295302



1x
6551600



8x
6470170



4x
6251470



1x
6135494



2x
4211257



1x
4211200



2x
6600113



2x
4211210



1x
4211202



1x
6311441



2x
4216668



1x
4211201



1x
4216945



1x
4211211



1x
4217848



1x
6448793



23x
6271165



4x
6258831



1x
4211483



2x
4211399



2x
4211399



2x
4211399



8x
4211476



2x
6362975



3x
6443149



1x
6380605



2x
6296894



1x
6179186



2x
6123815



2x
6066097



2x
4211398



1x
6372076



1x
6326078



2x
6144138



4x
4654582



1x
4650645



2x
4211541



13x
4211475



4x
6359714



1x
4211357



2x
4211815



1x
6469440



2x
6446028



1x
6360043



2x
6185676



4x
4244627



2x
6408168



2x
6258820



4x
4211636



4x
4211636

3

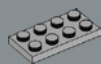

2x
4211395



2x
6170418



3x
4211438



1x
6313096



1x
4211640

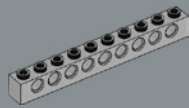

4x
4211374



2x
6336970



4x
6510220



5x
6395635



32x
6362252



4x
6333129



6x
6271752



6x
4210719



4x
4558955



2x
4211098



6x
6388118



2x
6364352



7x
6350724



4x
6319332



2x
6296892



2x
6282144



2x
4211063



2x
4211052



1x
6534688



4x
6215212



1x
6308045



1x
4210763



1x
6336990



4x
6469463



2x
6126083



11x
4211133



2x
4211094



2x
4210665



4x
4210635



1x
6622623



2x
6324639



1x
4552349



2x
6378143



1x
6083620



3x
4211043



5x
4211001



2x
6600112



1x
6092649



4x
6039176



2x
4211065



2x
4211056



2x
4243831



1x
4211100



1x
4211002



1x
4595710



2x
4210997



1x
6107197



1x
4210678



2x
6432384



1x
6511448



4x
6576385



3x
6262138



1x
6256803



1x
6190252



1x
6186672



1x
6173139



6x
4523159



1x
6615520



3x
6218047



2x
6287530



3x
6218047



2x
6107197



1x
6092594



2x
6493687



1x
6323378



2x
6317208



2x
6167585



2x
6508090



1x
6134197



4x
6510192



2x
6167641



2x
6314190



2x
6361354



1x
6158415



2x
6119107



LEGO.com/service

4

11



YOU COULD
WIN



**YOU COULD
WIN**

Your feedback will help shape the future development of this product series.

Visit:

**DU KÖNNTEST
GEWINNEN**

Dein Feedback trägt zur Weiterentwicklung dieser Produktreihe bei.

Geh auf:

**VOUS POURRIEZ
GAGNER**

Vos commentaires nous aideront à concevoir les futurs produits de cette gamme.

Visitez :

**POTRESTI
VINCERE TU**

La tua opinione ci aiuterà a migliorare la creazione futura di questa linea di prodotti.

Visita:

**PUEDES
GANAR**

Tu opinión contribuirá al futuro de esta serie de productos.

Visita:

轻松获奖

您的反馈将有助于我们在今后改进本产品系列。

请访问:

LEGO.com/productfeedback

You also have the chance to win a LEGO® set.

Terms and conditions apply.*

Außerdem hast du die Chance, ein LEGO® Set zu gewinnen.

Es gelten die Teilnahmebedingungen.*

Vous pourriez également gagner un ensemble LEGO®.

Des conditions s'appliquent.*

Hai anche la possibilità di vincere un set LEGO®.

Termini e condizioni sono applicabili.*

También tienes la oportunidad de ganar un set LEGO®.

Aplican términos y condiciones.*

您还有机会赢取乐高®套装。

条款和条件适用。*

*LEGO.com/productfeedback-terms

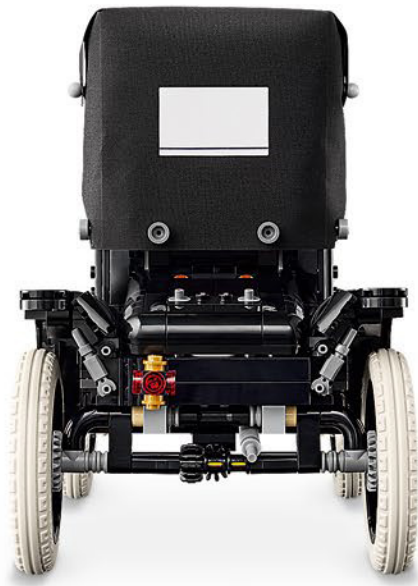

LEGO and the LEGO logo are trademarks of the LEGO Group. ©2026 The LEGO Group.
Ford Motor Company Trade Dress and Trademarks used under license to the LEGO Group.