

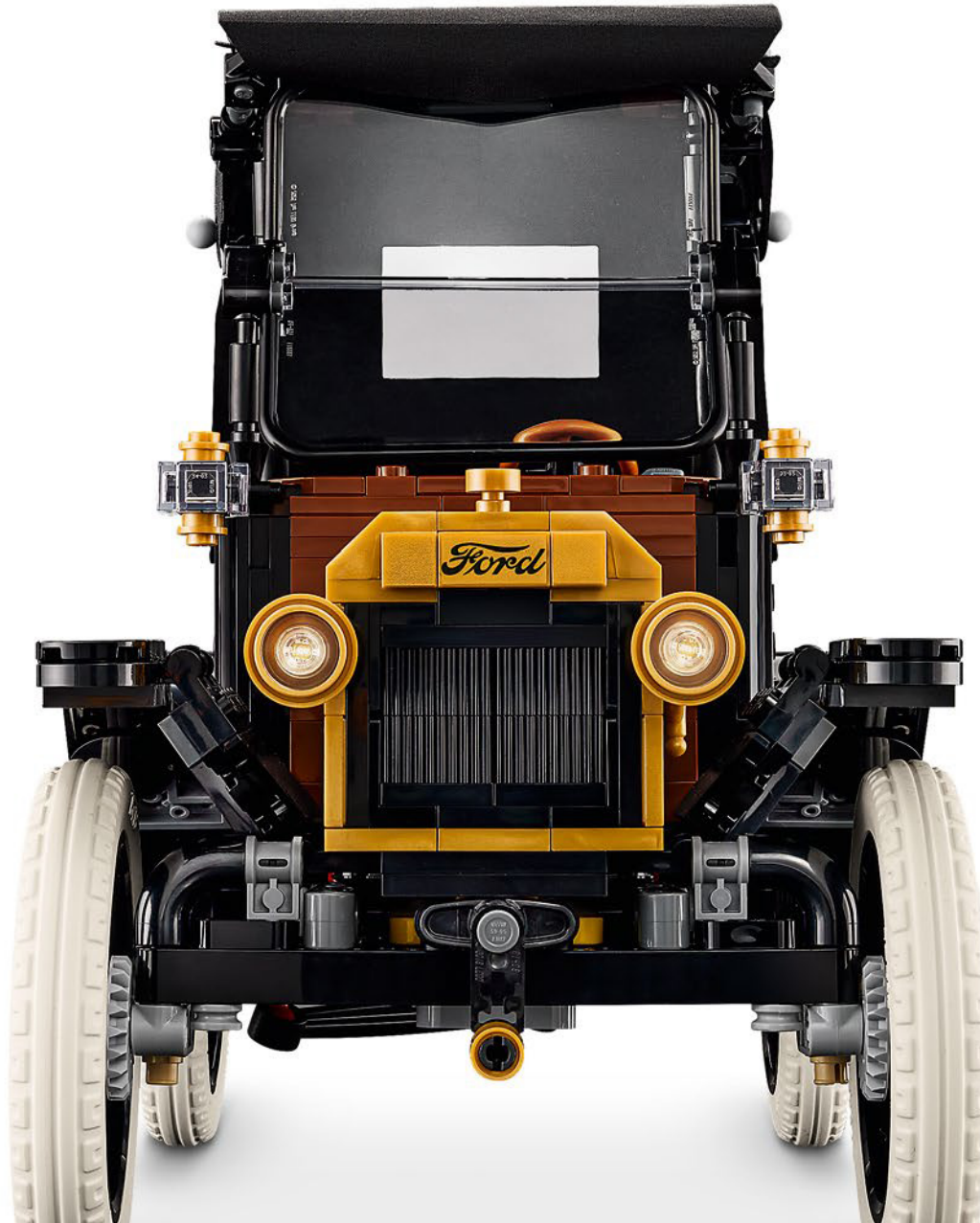

11376





LEGO.com/sustainable-packaging



FR
**DONNEZ
OU
RECYCLEZ**



ASSOCIATION

OU



MAGASIN

OU



DÉCHÈTERIE

Adresses sur quefairedemesdechets.fr



BUILDER



Apple and the Apple logo are trademarks of Apple Inc., registered in the U.S. and other countries and regions. App Store is a service mark of Apple Inc. Google Play and the Google Play logo are trademarks of Google LLC. Tencent and the Tencent logo are trademarks of Tencent Inc.

LEGO.com/devicecheck



LEGO® Builder

LA VOITURE UNIVERSELLE

Avant le 1^{er} octobre 1908, les routes étaient encore majoritairement peuplées de carrioles tirées par des chevaux. Les automobiles existaient, certes, mais restaient un luxe réservé à une élite. C'est là qu'intervient la Ford Motor Company avec une idée simple : fabriquer une voiture pour le peuple. La Ford® Model T® n'était pas seulement robuste et confortable (pour son époque) ; elle était aussi abordable, et a littéralement inspiré la naissance du transport moderne et de la production industrielle. Pour prouver sa fiabilité, la voiture fut soumise à toutes sortes d'épreuves : expéditions en montagne, montées d'escaliers – y compris ceux du Capitole de l'État du Tennessee ! Construite dans l'usine Ford de Highland Park sur la première ligne d'assemblage mobile, la Model T fut produite avec une efficacité révolutionnaire : vendue 850 dollars en 1908, son prix chuta progressivement jusqu'à atteindre 250 dollars grâce aux innovations de la chaîne de montage. Innovante pour l'époque, elle comportait des pièces en acier au vanadium, un volant à gauche, un levier de vitesses facile à manier, un pare-brise, un moteur compact et même une boîte à outils. Des routes de campagne aux grandes avenues, la Model T conquiert les États-Unis, puis le monde entier. Avec plus de 15 millions d'exemplaires vendus à l'horizon 1927, elle ne s'est pas contentée de marquer l'histoire : elle l'a accélérée, en démocratisant l'automobile.

* * * *



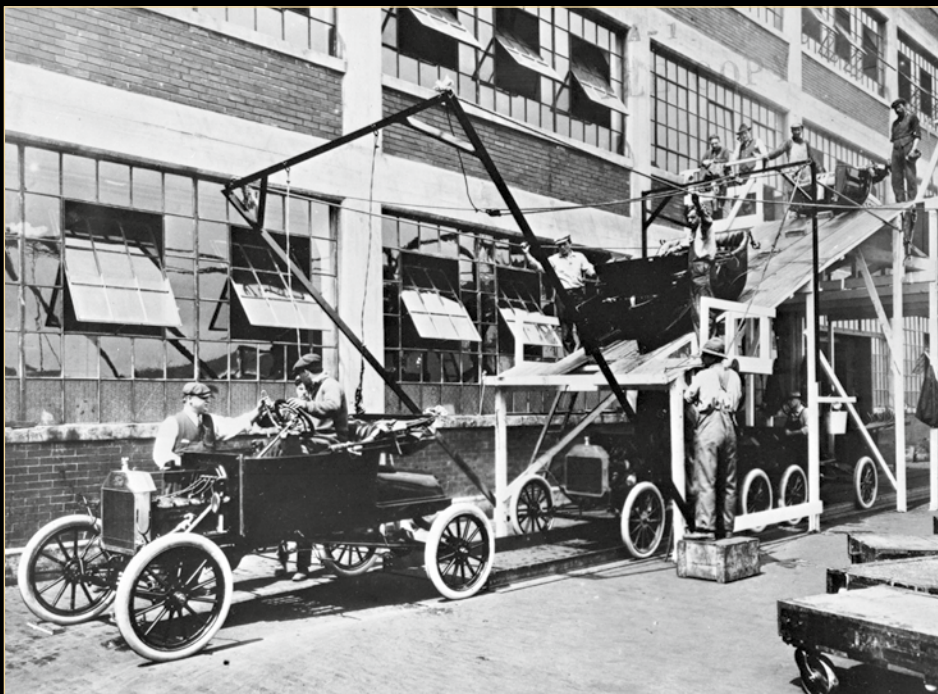

« Des centaines de ces voitures furent utilisées en 1909 pour des voyages touristiques [...], non seulement en Amérique, mais dans presque tous les pays des autres continents. »

- Livret souvenir de Ford Motor Cars (1910)

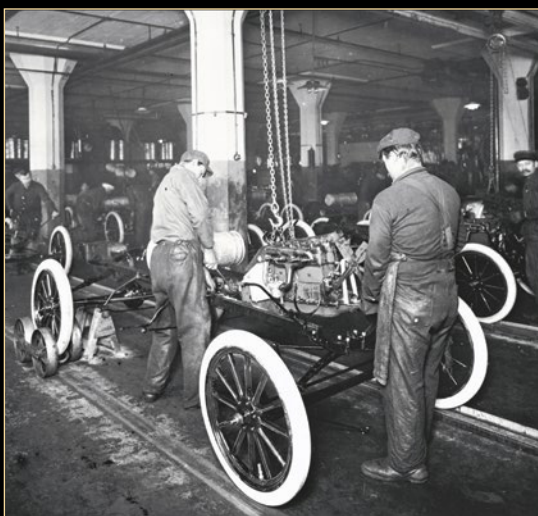

Ford Model T Runabout
 2-Passenger—4-Cylinder—20 Horsepower
 Car. Price \$225 includes top, top cover, automatic brake, windshield, speedometer, two 6-inch gas lamps, generator, three oil lamps, tools, including jack—i. e. in Detroit. No Ford Cars sold unequipped.

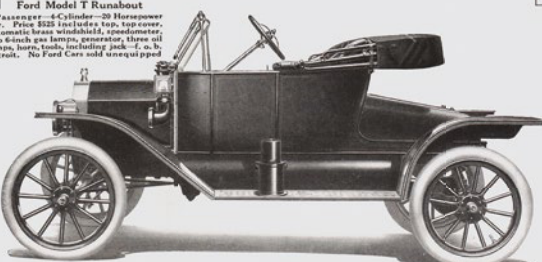

By raising a cover on the deck of the Runabout, ample room will be found for storing a suit case, extra tire, or any material which the operator may wish to carry with him. The rear deck is made of metal and may be removed at any time, leaving a perfectly flat surface behind the seat, or permitting space for the placing of a runside seat, if desired.



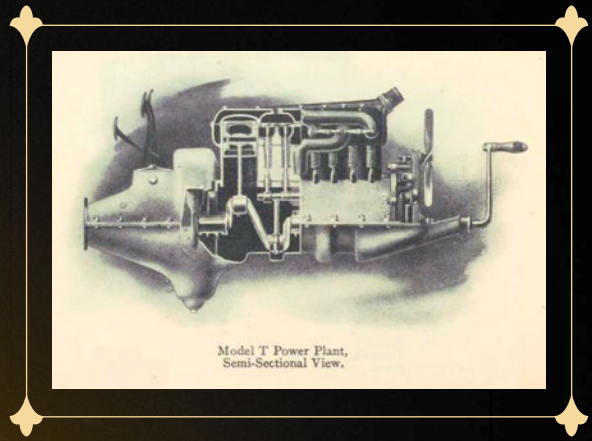

Model T Power Plant,
Semi-Sectional View.

LE MOT DE L'ÉQUIPE DE DESIGN LEGO® ICONS

Quand il s'agit de voitures anciennes, le charme des années 1900 et particulièrement celui de la Ford® Model T® évoque toute la magie et la nostalgie des débuts de la conception automobile. Ce modèle détaillé rend hommage à la version 1913 du « Runabout », avec son capot anguleux, son tableau de bord en bois plat et son habitacle deux places. Célèbre pour sa peinture noire, elle fut pourtant déclinée dans d'autres couleurs ! Notre version arbore des finitions dorées et cuivrées qui attirent le regard, comme les phares, le klaxon et la calandre. Nous avons reproduit avec soin le design emblématique et les détails d'ingénierie du modèle d'origine : allumage à manivelle, commande d'accélérateur sur la colonne de direction et réservoir de carburant sous le siège. Les roues à rayons, les jantes fidèles, la capote pliable et la transmission fonctionnelle renforcent le réalisme de cette voiture qui a révolutionné toute l'industrie automobile.

* * * *

« Nous espérons que vous prendrez plaisir à découvrir comment la voiture fonctionnait en la construisant : observez le moteur tourner, passez les vitesses et soulevez le siège pour accéder au réservoir. »

L'équipe de conception LEGO® Icons



Le dix-millionième Model T[®] sort de la chaîne de production

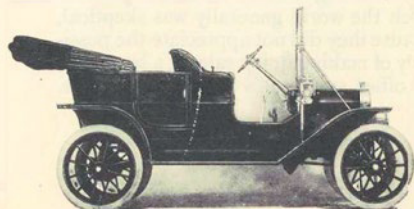

Model T Touring Car, \$950.
Complete equipment
included.

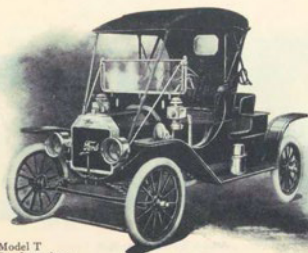

Model T
Roadster, \$900.
Complete equipment
included.

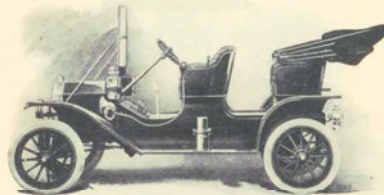

Model T Tourabout, \$900.
Complete equipment
included.

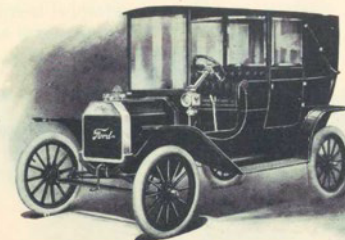

Model T
Town Car
\$1200.

Les historiens d'entreprise de Ford Motor Company nous ont aidés à reproduire toutes les caractéristiques emblématiques de la voiture. Ils nous ont partagé des photos d'archives incroyables, des schémas et toutes sortes de références tout au long de notre processus de conception. C'est ainsi que nous avons découvert que cette version du Model T n'avait... qu'une seule porte !

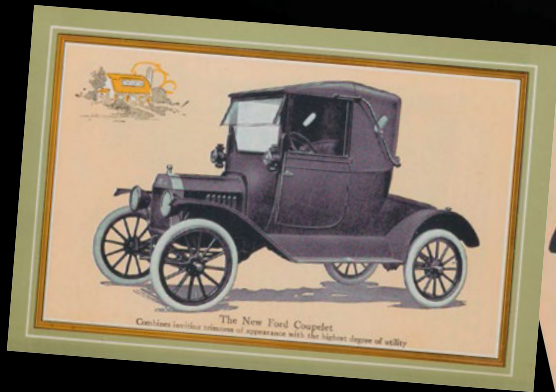

Specifications
For all Ford Cars

Axles—Front axle of 13mm construction, especially designed for a single layer of Vanadium steel, having the highest quality of axle strength obtainable. Rear axle of Vanadium steel and equipped in a tubular steel housing. The Ford differential is of the latest design and gives all gears an equal length made of Vanadium steel.

Bodies and Capacities—Ford cars are furnished with five series of bodies—Runabout, five (5) passenger; Touring Car, five (5) passenger; Truck Car, six (6) passenger; Service Car, five (5) passenger; Runabout, two (2) passenger.

Brakes—Dual system on all Ford cars. Service brake operates on the transmission and is controlled by foot pedal. Stopping brake in rear wheel frame serves as emergency brake. It is controlled by hand lever on left side of car.

Chassis—Ford cars are built completely equipped, except for the amount of fuel consumption.

Clutch—Multiple steel disc, operating in oil.

Control—On the left side of car. Three foot-pedal controls, low and high speed, and emergency brake on left side of car. Spark and throttle levers directly under steering wheel.

Cooling—By Thermostatic water system. Extra large water jackets directly under radiator and radiator parts of a maintenance-free and a special Ford vertical radiator fan in the front of car and a special Ford vertical radiator fan in the front of car.

Equipment—All Ford cars are well equipped, except for the amount of fuel consumption.

Ford Drive—Ford planetary drive system with all shafts, universal joints and sliding gears enclosed in oil-tight and oil-sprayed housing. Front shaft drive to the motor of the chassis and universal joint in necessary. All shafts made of steel. Bearings in ball and roller bearings in the motor and roller bearings in the planetary gear set.

Gasoline Capacity—All Ford cars have cylindrical gasoline tanks of 10 gallon capacity, mounted directly on frame under front seat and accessible in all positions.

Lubrication—Construction gravity and splash system. Oil is poured into the crank case through the filler pipe on the front of the motor. All motor parts are built in and made a part of the motor. Only the parts on the Ford motor are a ready part attached to the motor and a standard, no moving when in case operation on the Ford motor.



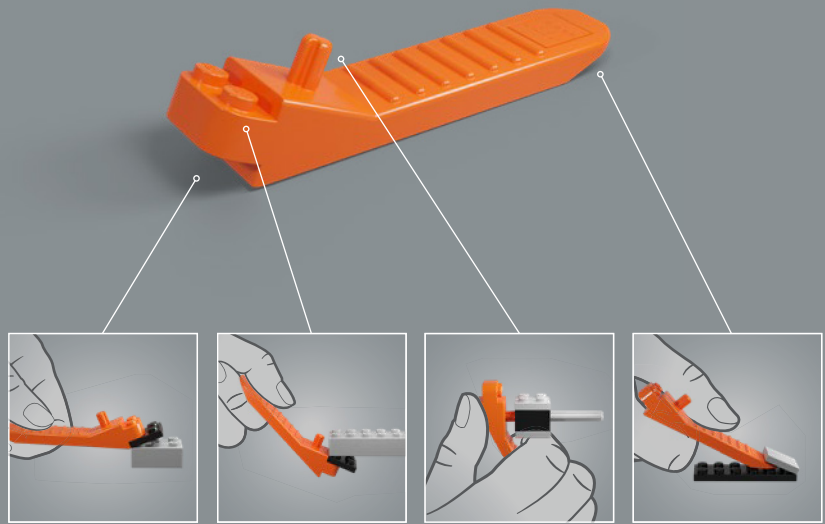



Introduite en 1908, la Ford® Model T® est restée en production jusqu'en 1927.

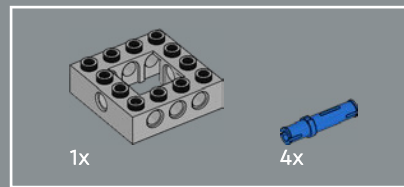

1

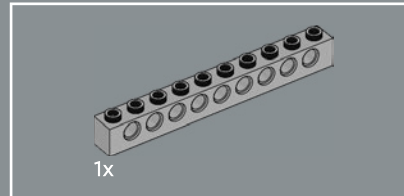
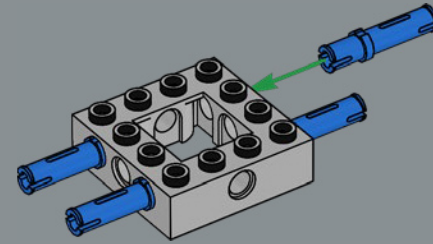

2

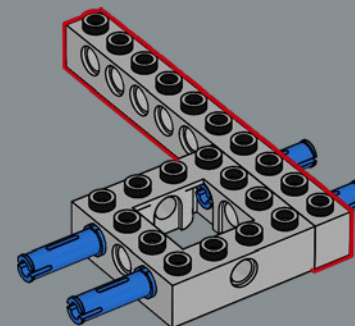

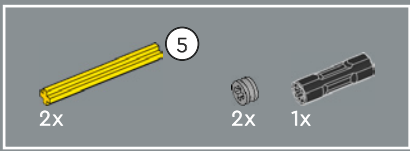

3

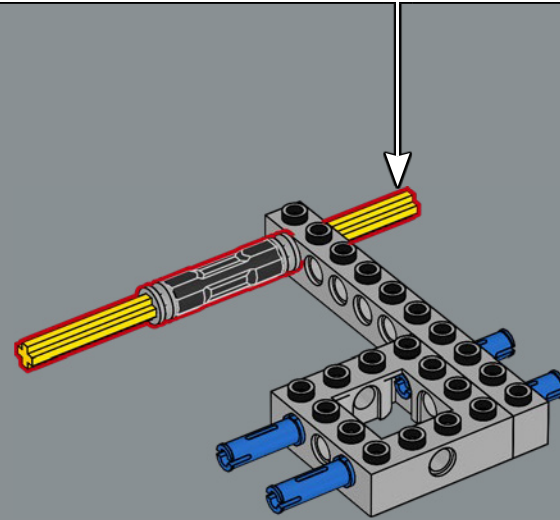
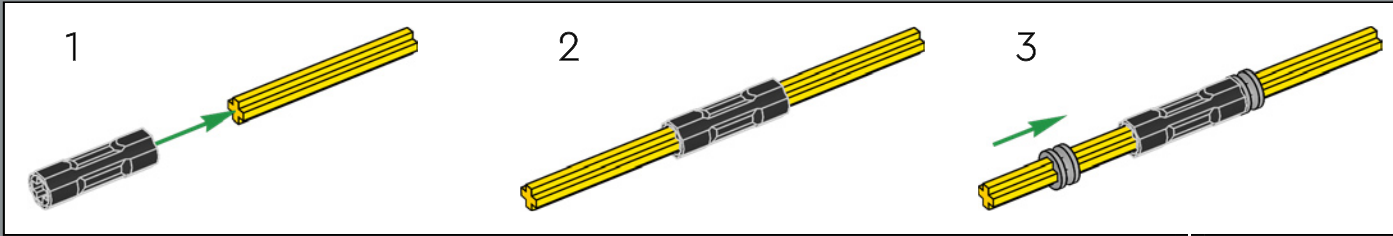

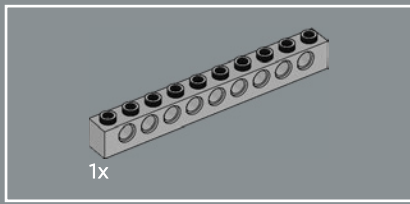

4

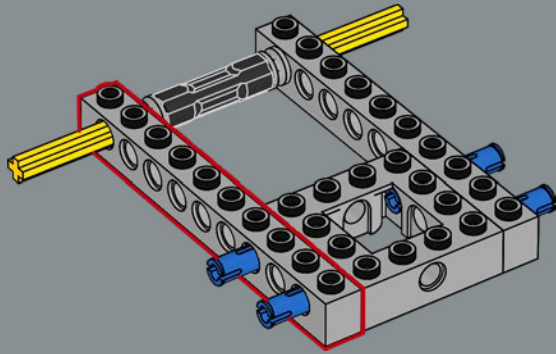

5

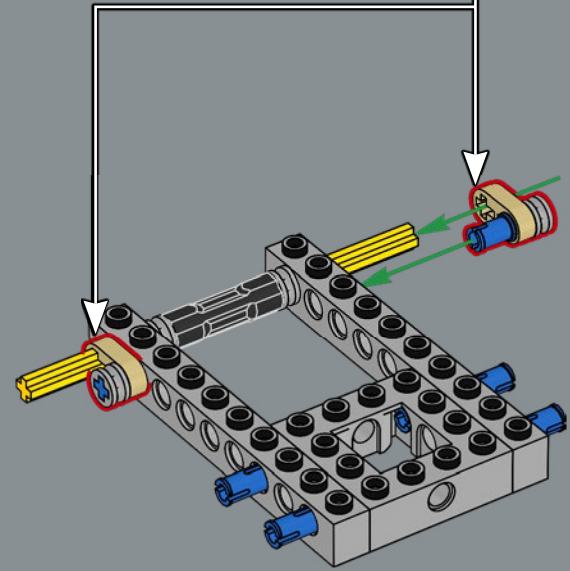
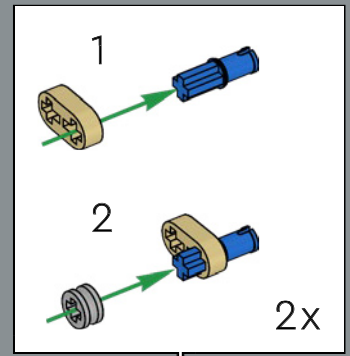

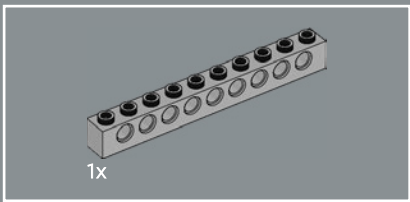

6

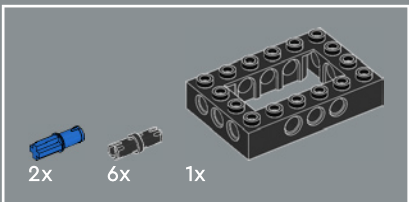
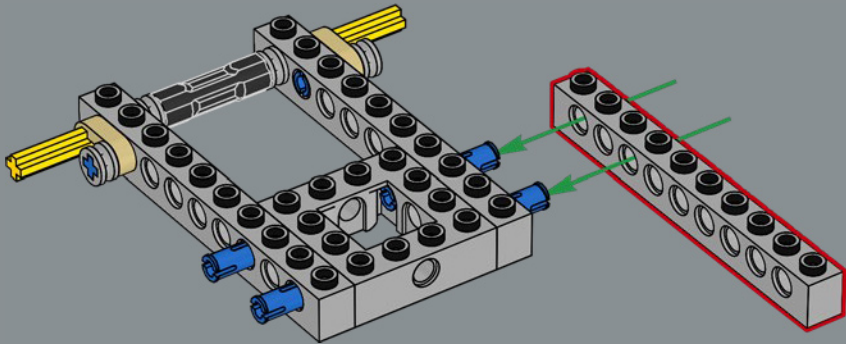

7

1

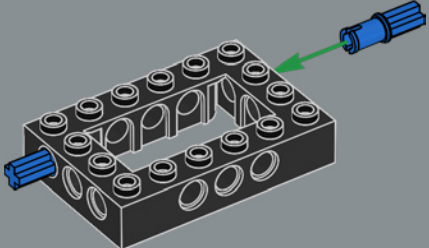

2

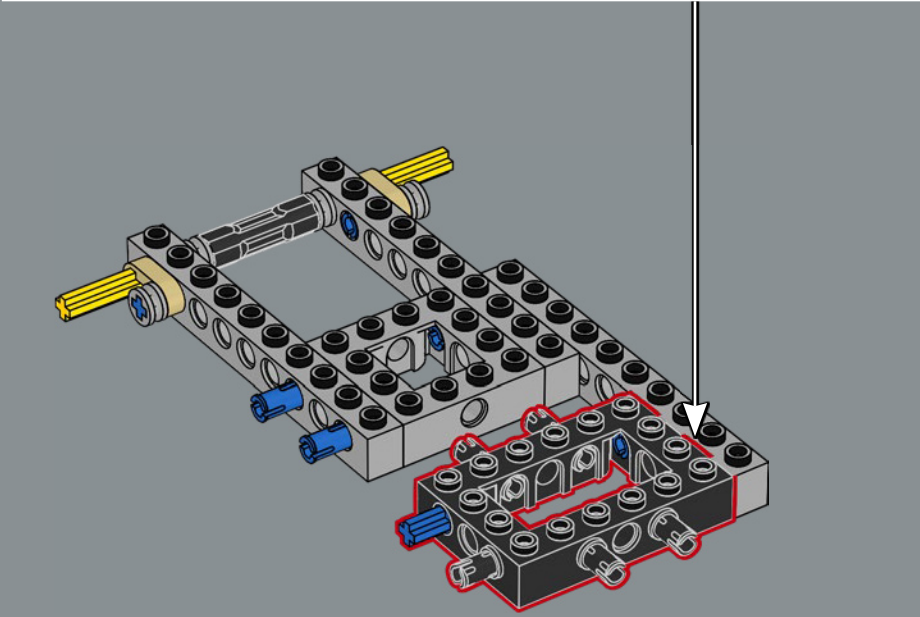
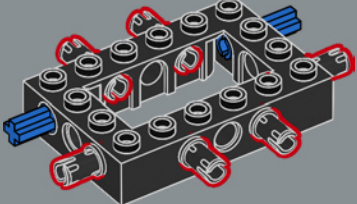

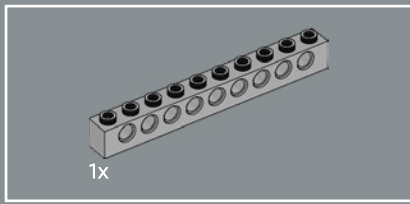

8

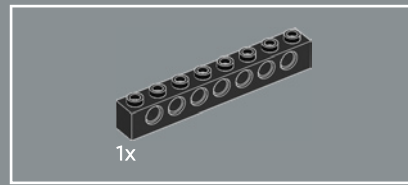
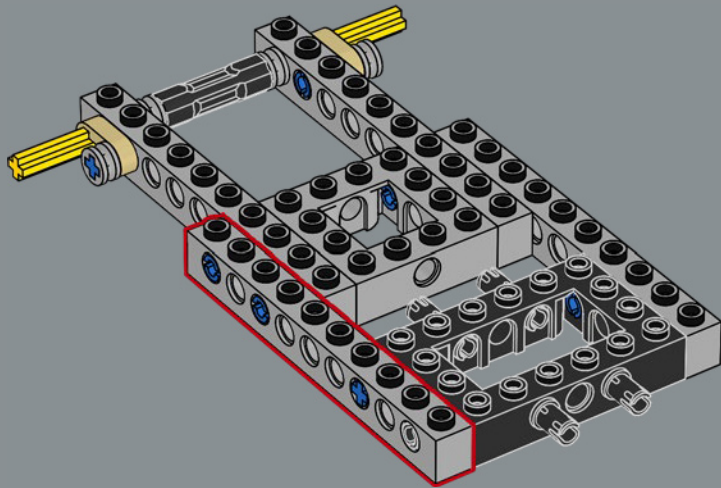

9

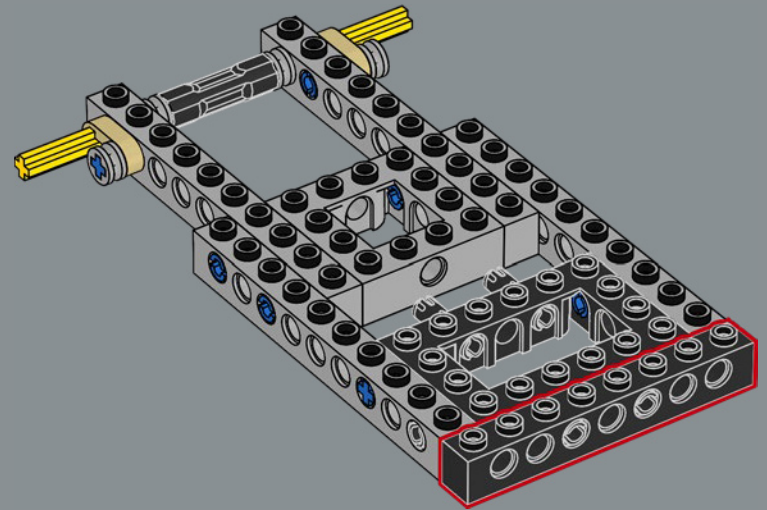

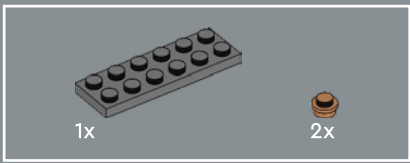

10

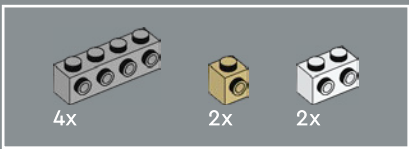
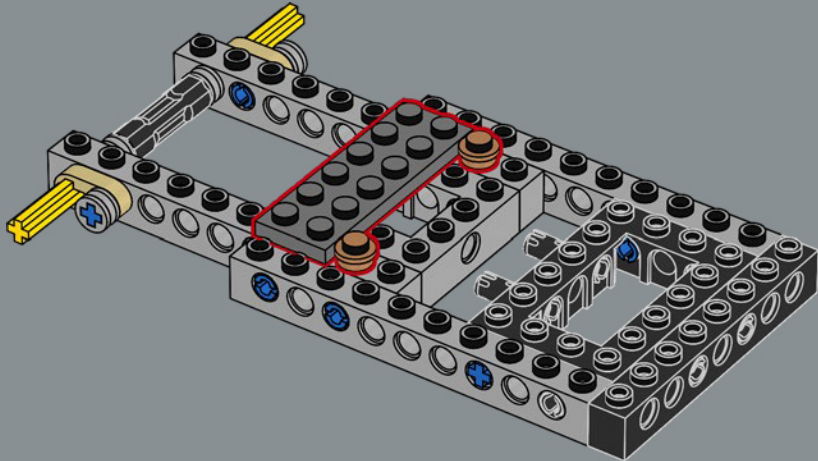

11

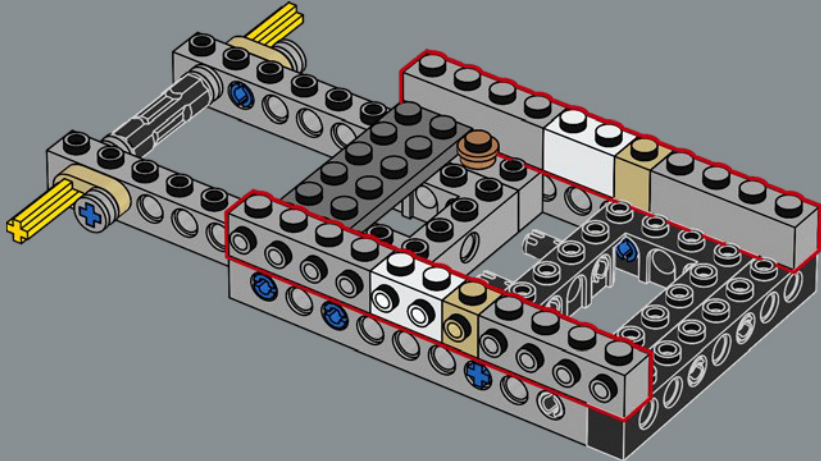

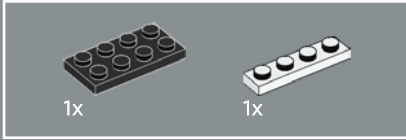
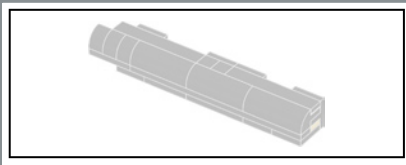

12

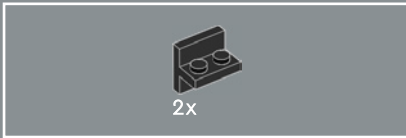
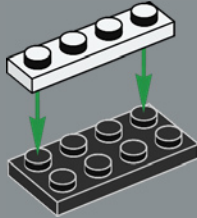

13

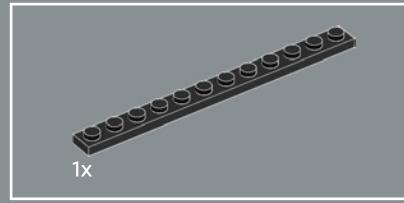
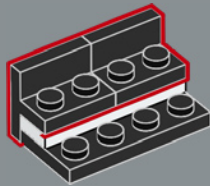

14

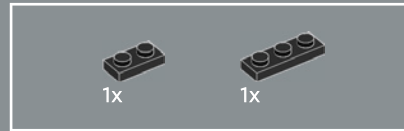
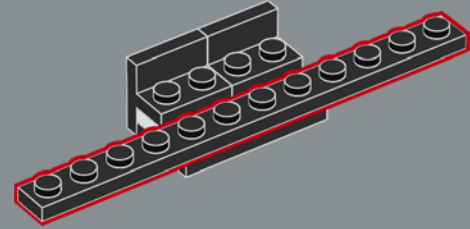

15

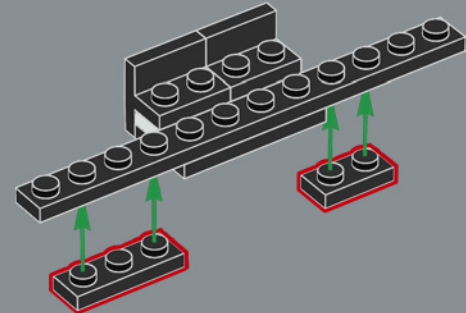



16

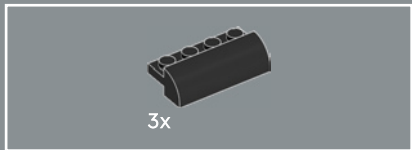
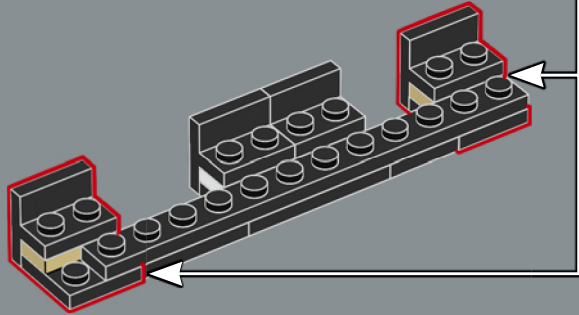
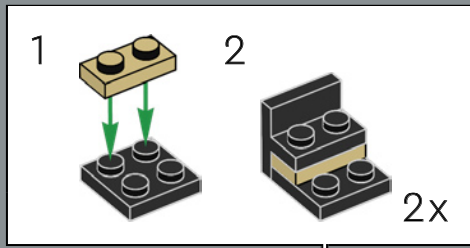

17

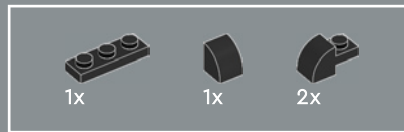
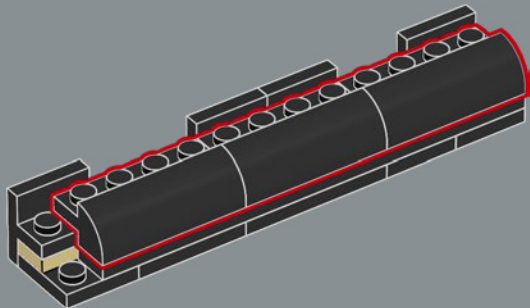

18

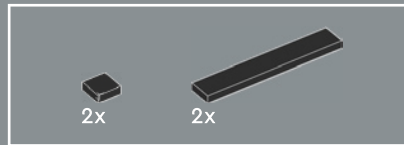
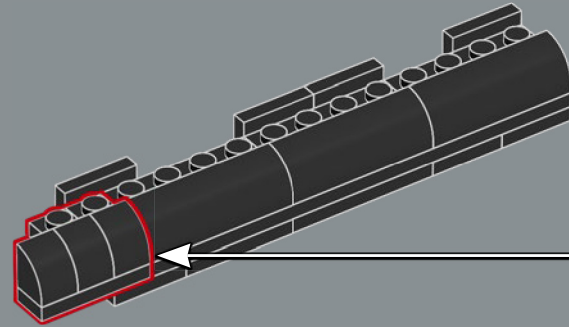
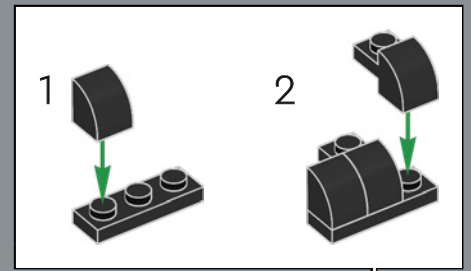

19

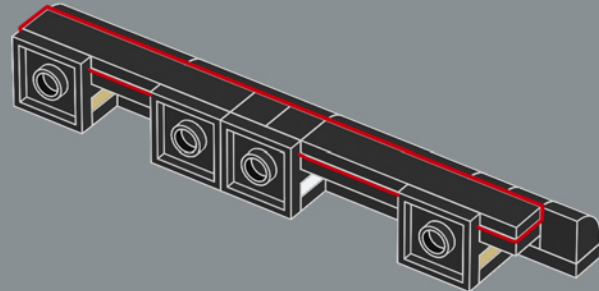

20

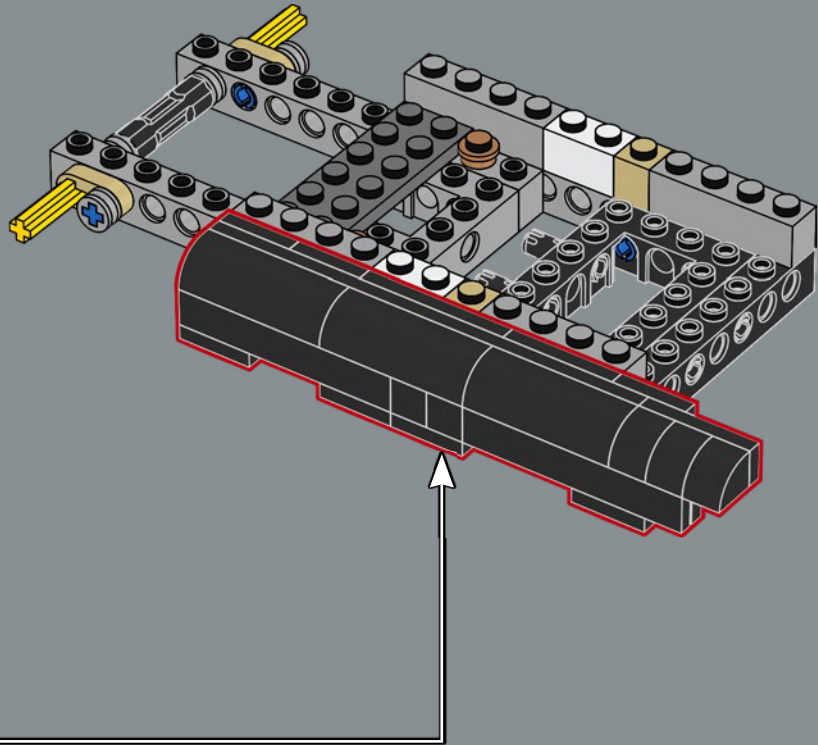

21

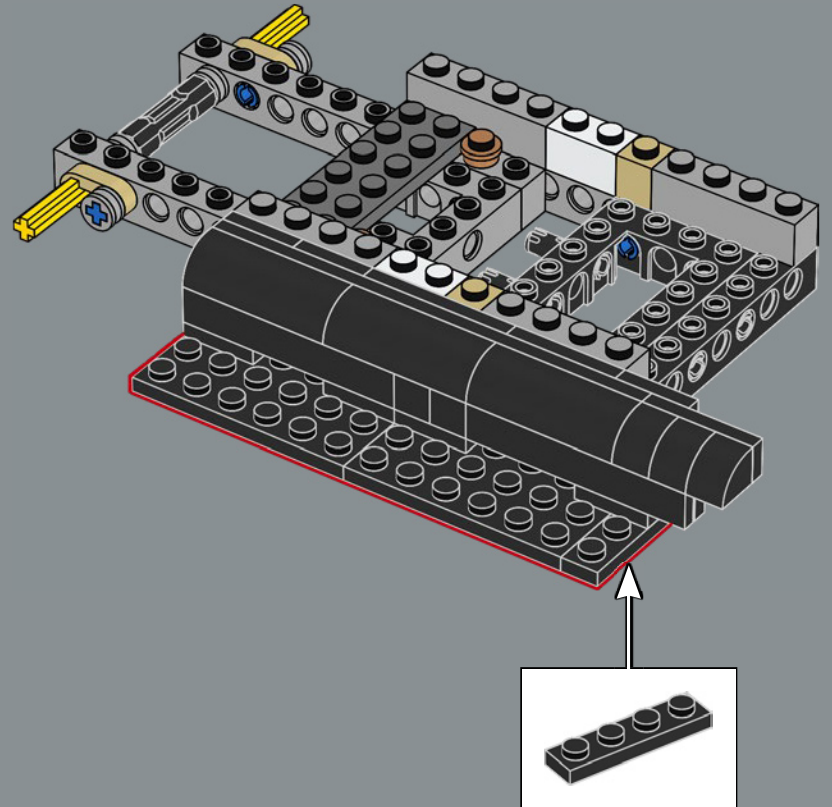
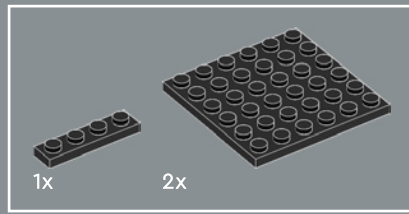

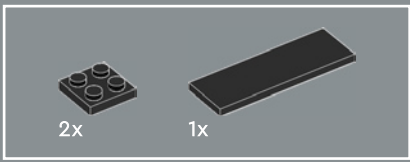

22

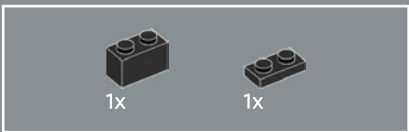
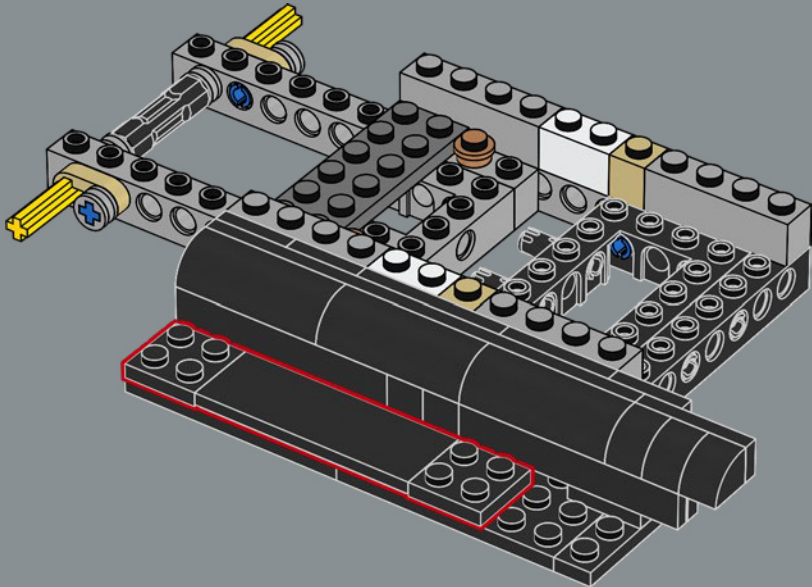

23

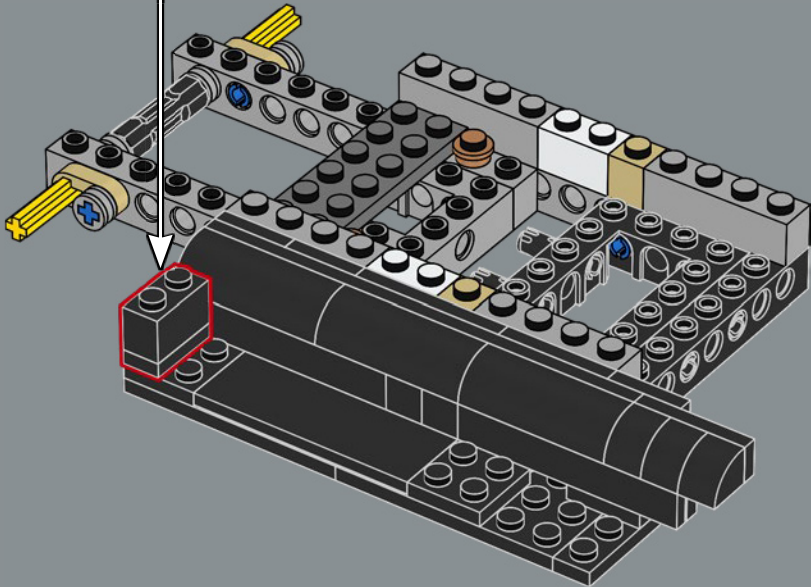
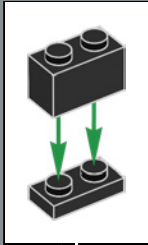

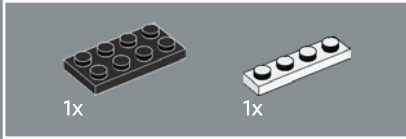
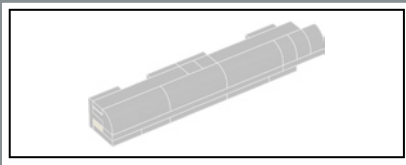

24

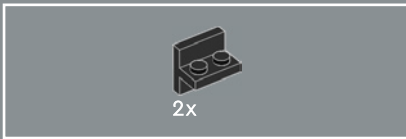
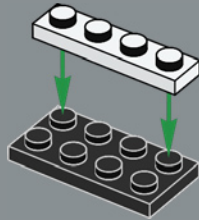

25

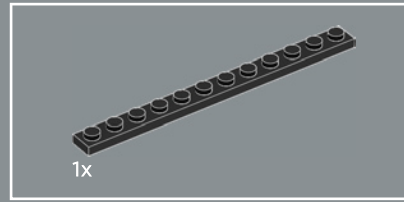

26

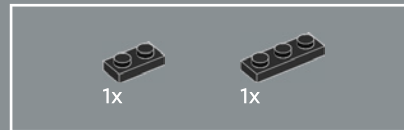
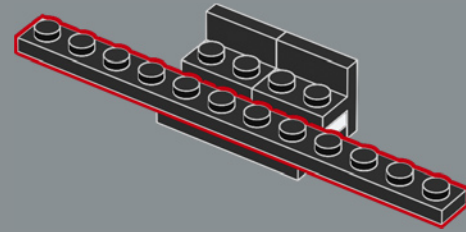

27

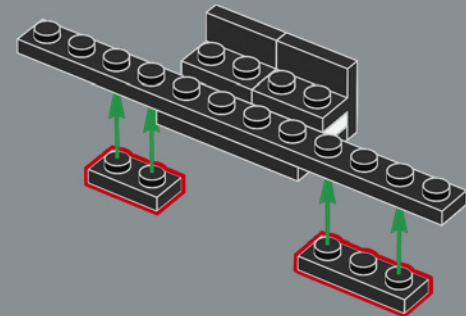

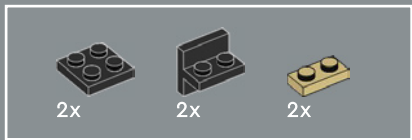

28

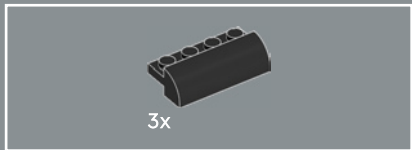
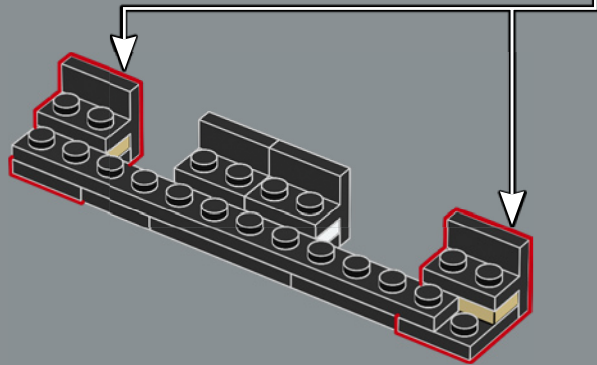
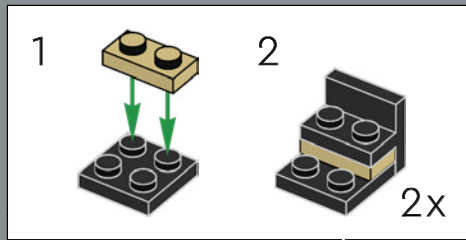

29

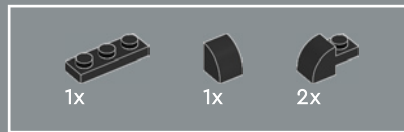
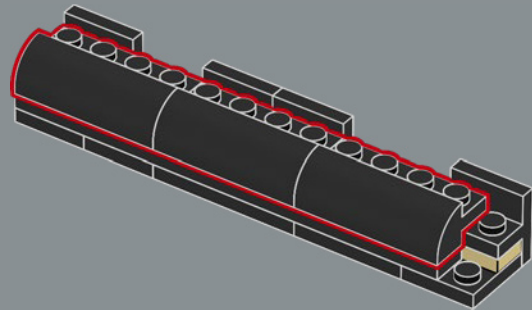

30

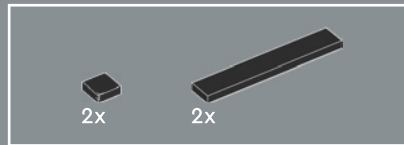
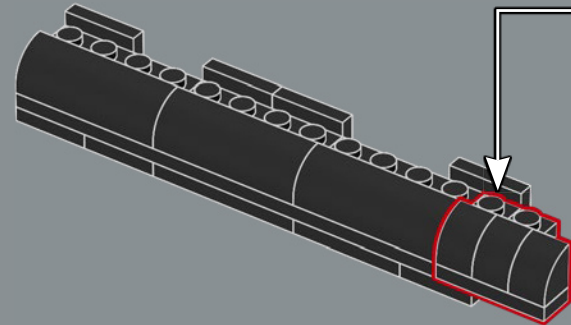
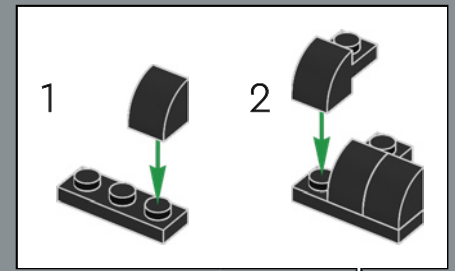

31

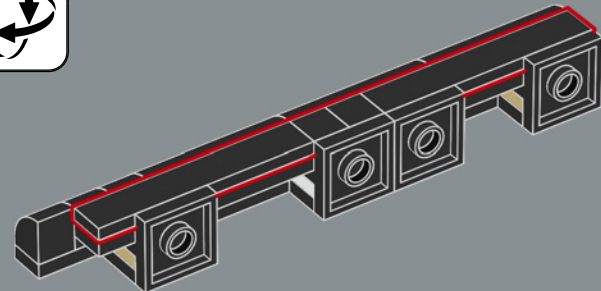



La Ford® Model T® a été conçue par Childe
Harold Wills, avec l'ingénieur en chef Joseph
A. Galamb et Eugene Farkas.

32

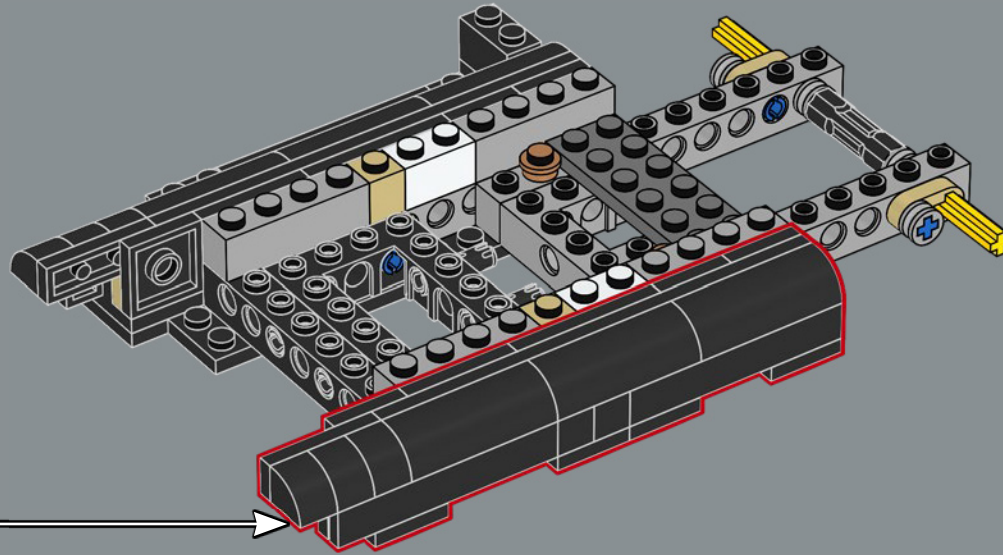

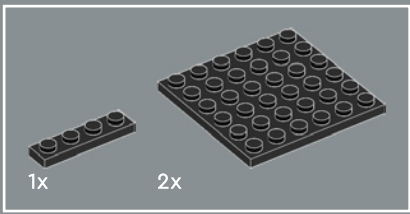

33

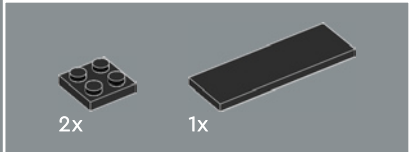
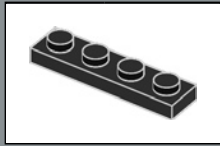
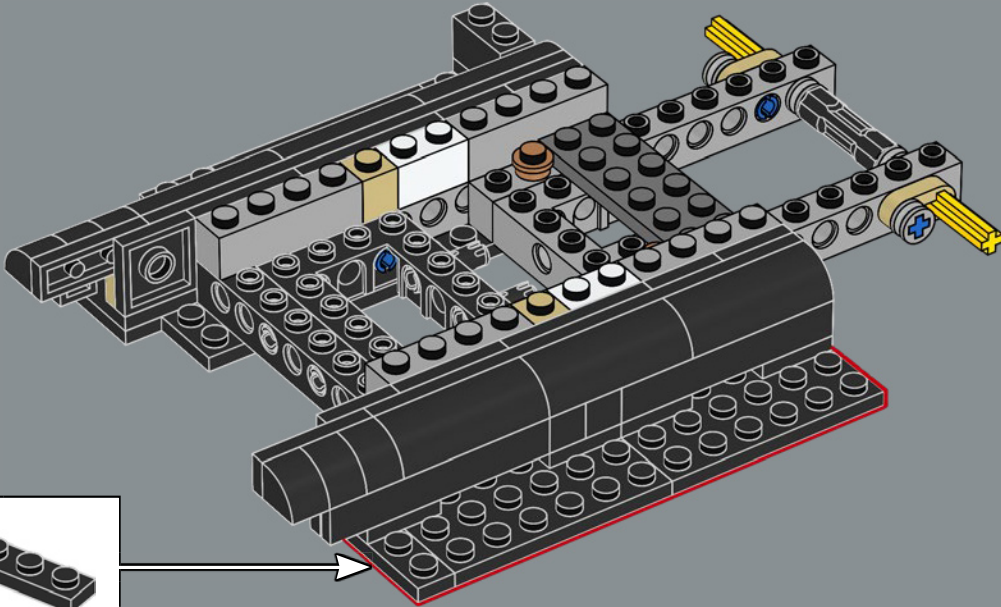

34

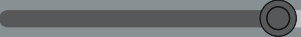
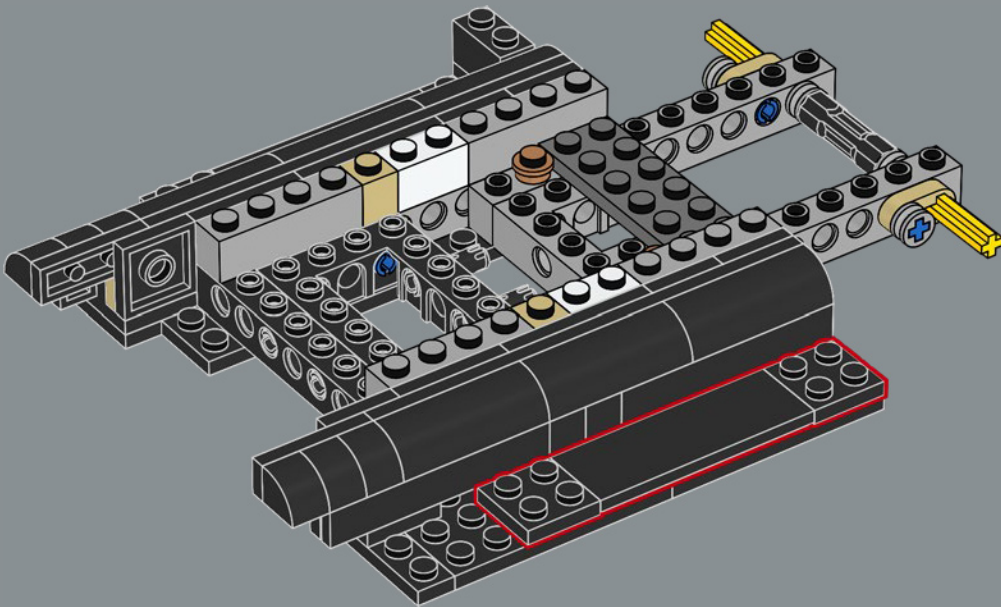

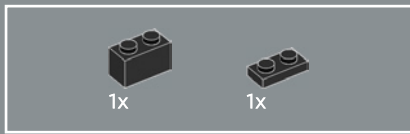

35

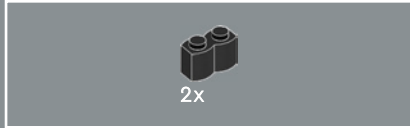
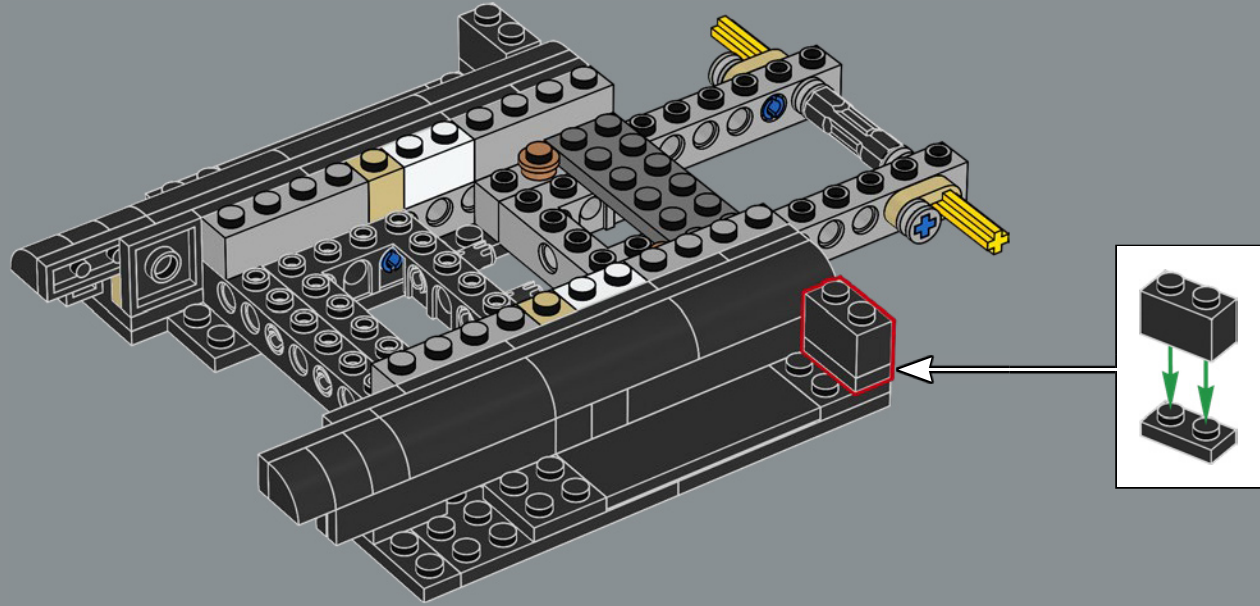

36

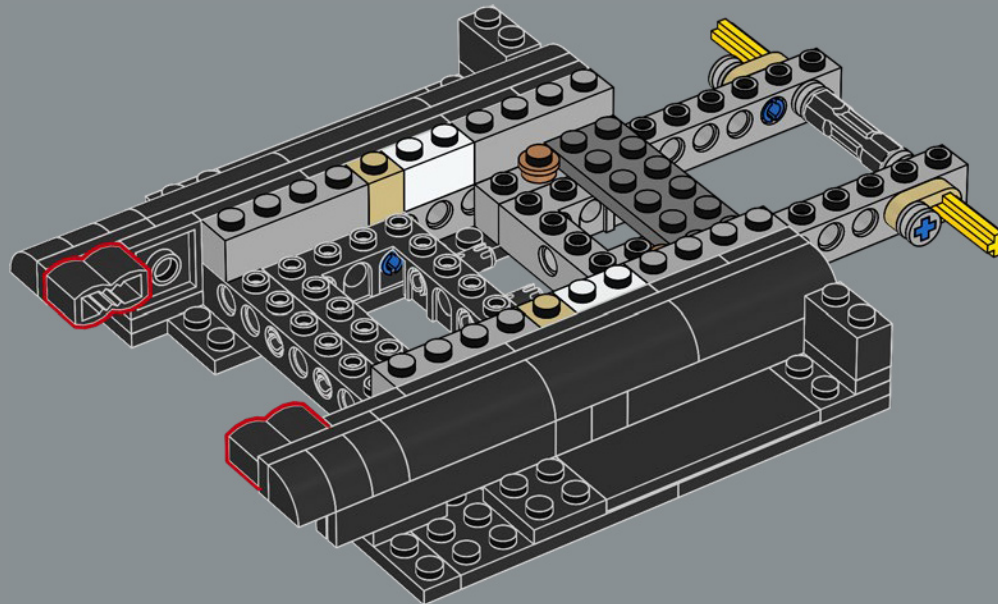

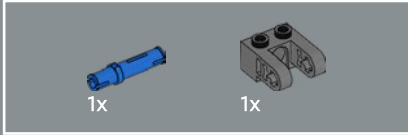
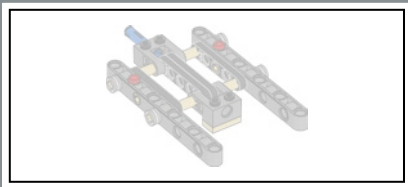

37

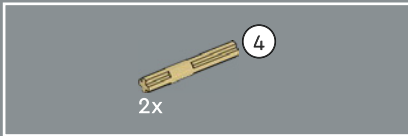
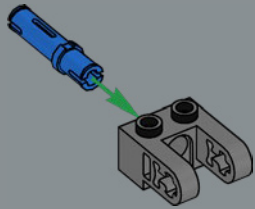

38

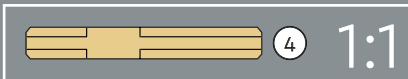
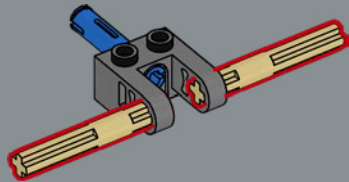

39

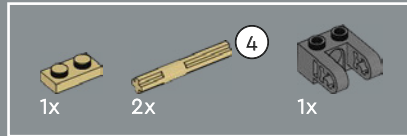
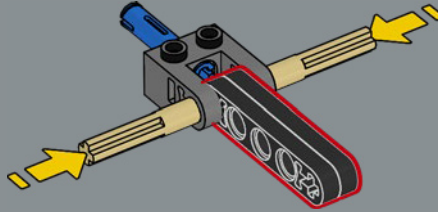

40

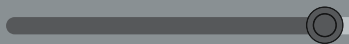
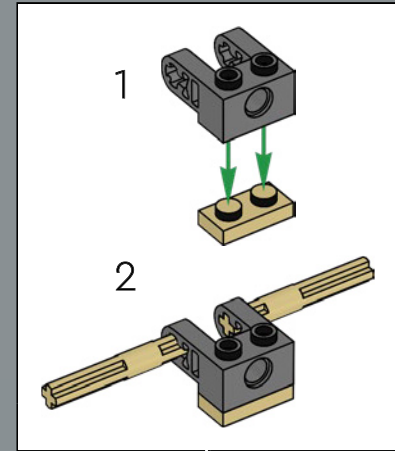
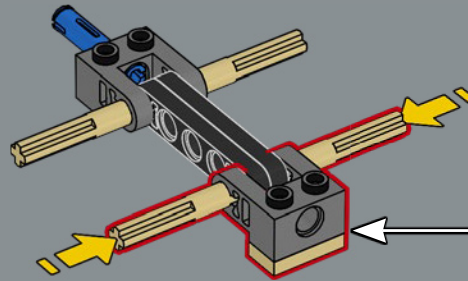



41

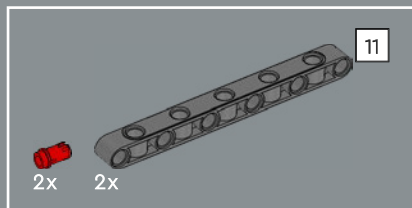
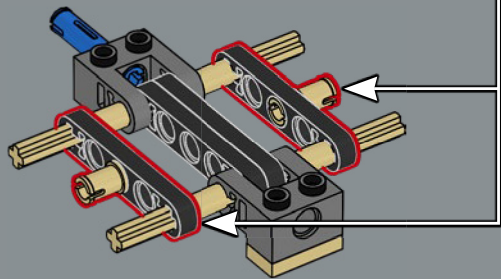
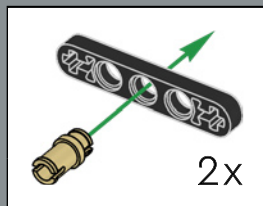

42

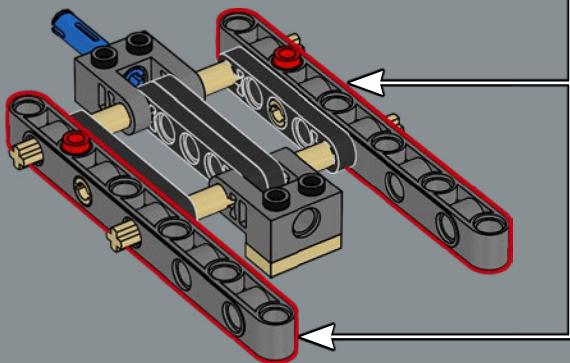
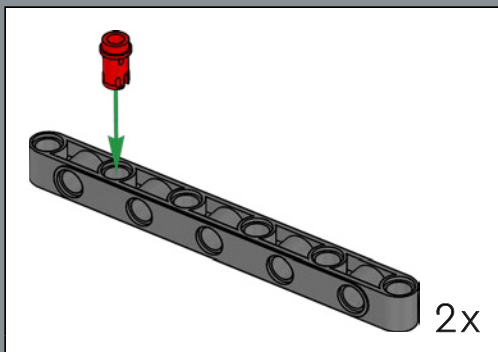

43

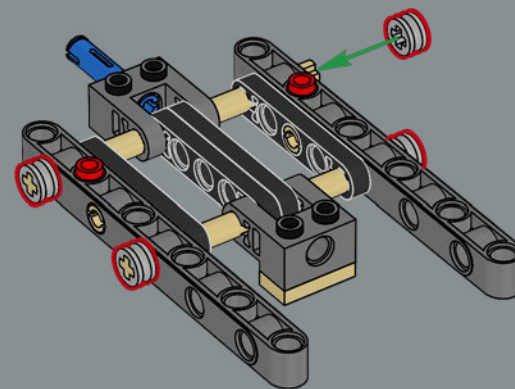

44

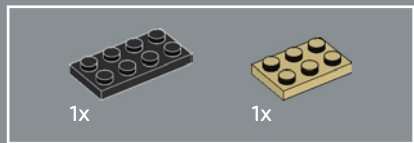
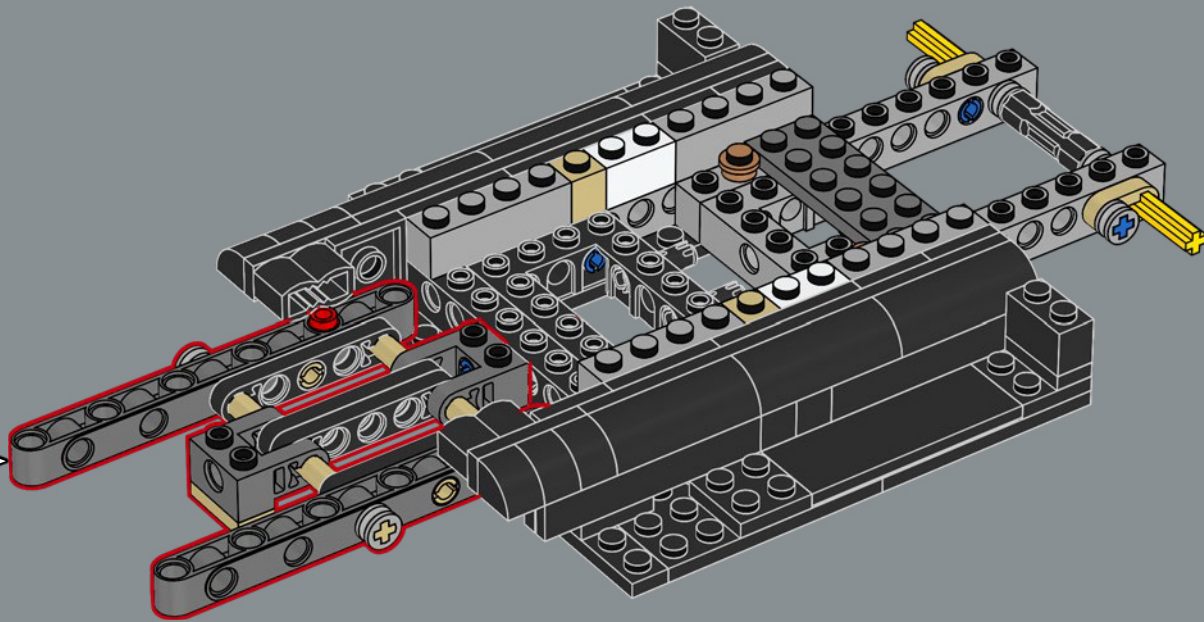

45

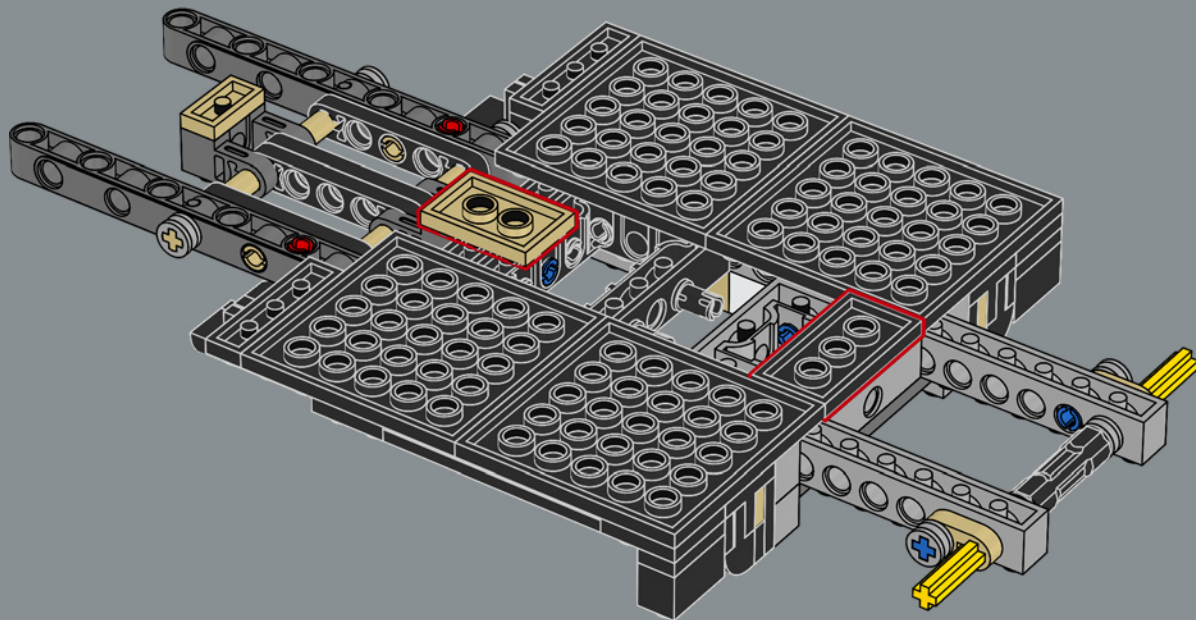

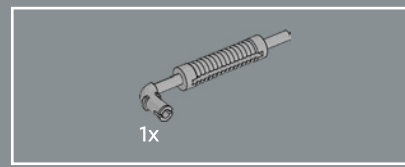

46

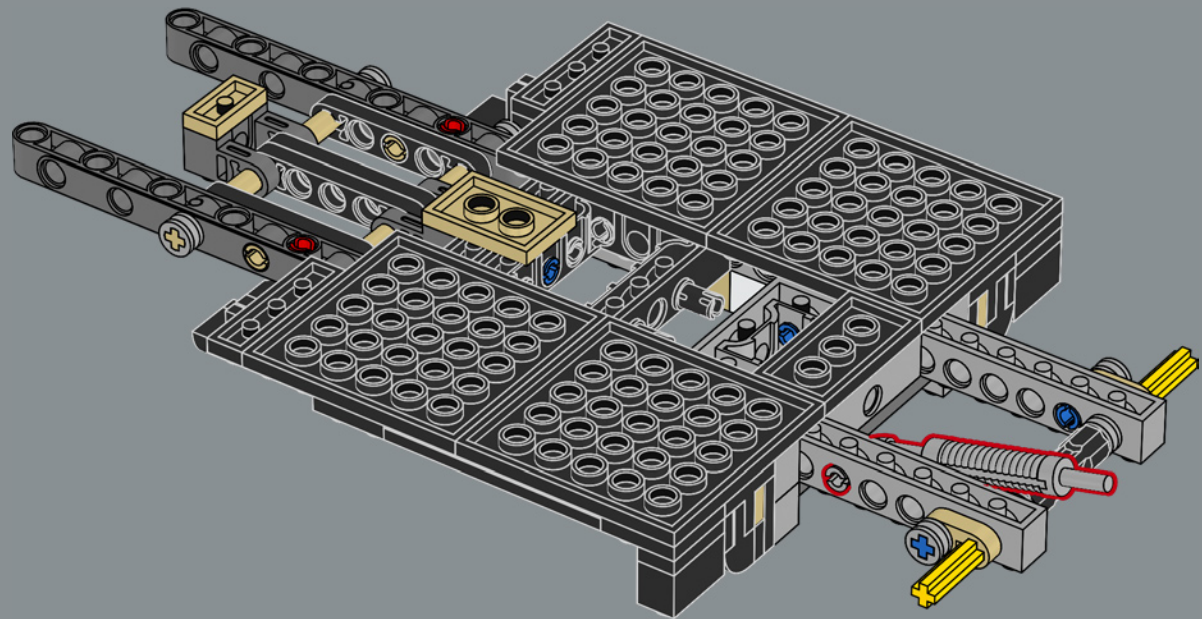

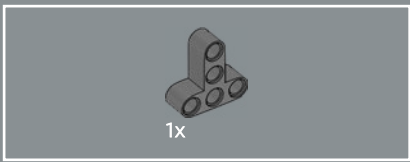

47

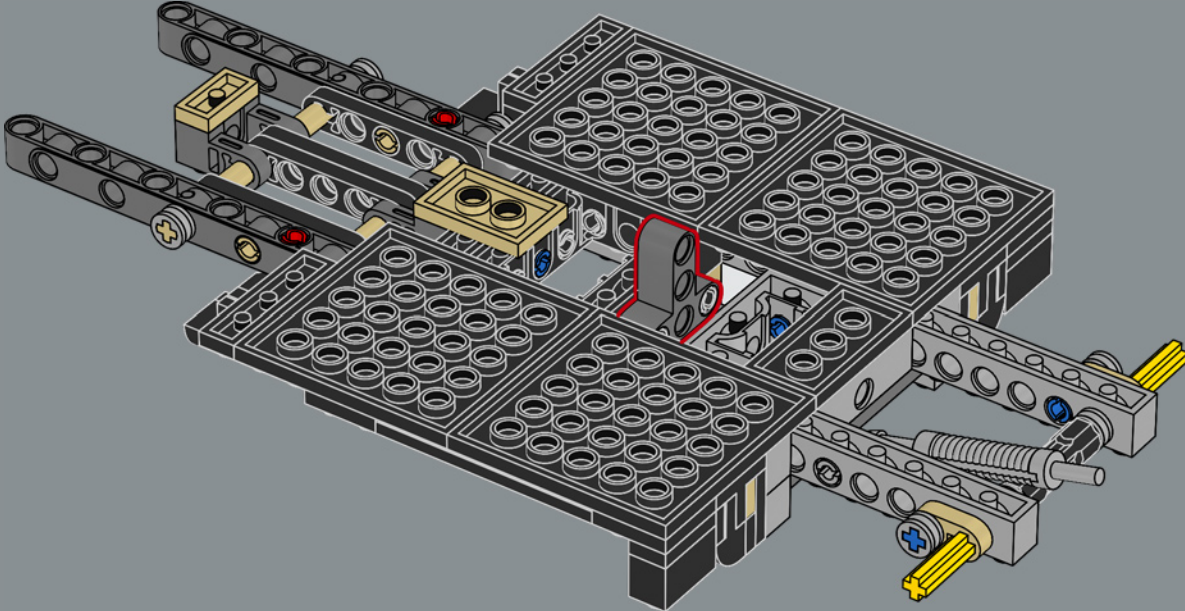

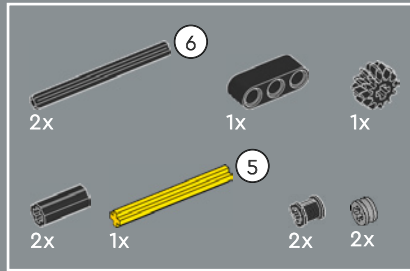
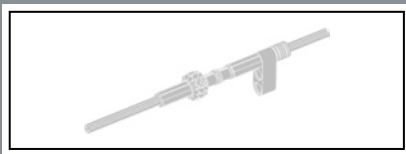

48

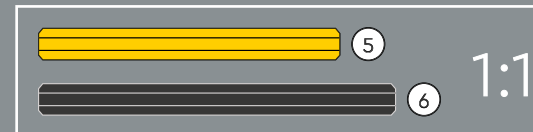
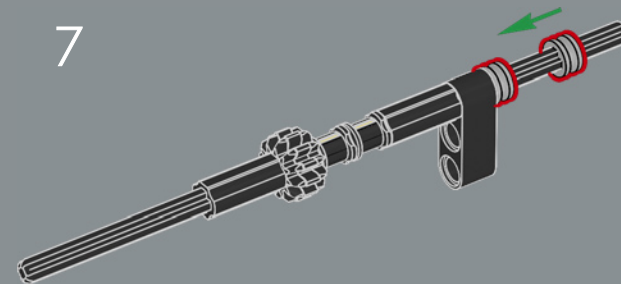
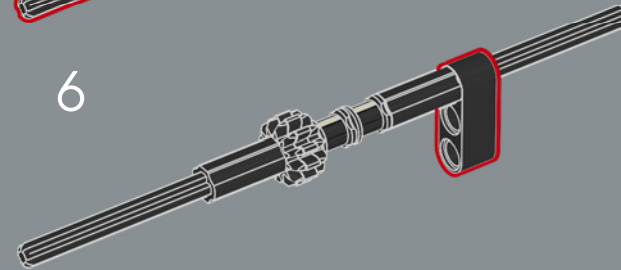
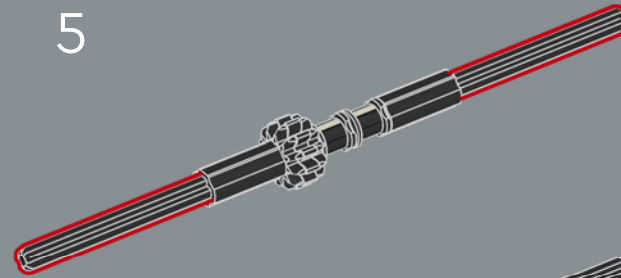
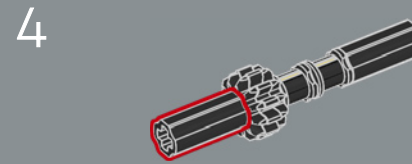
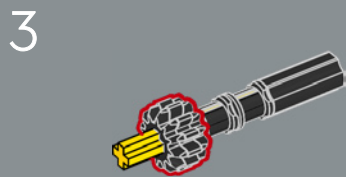
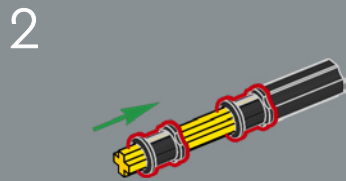
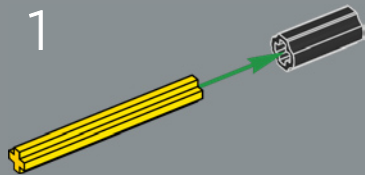

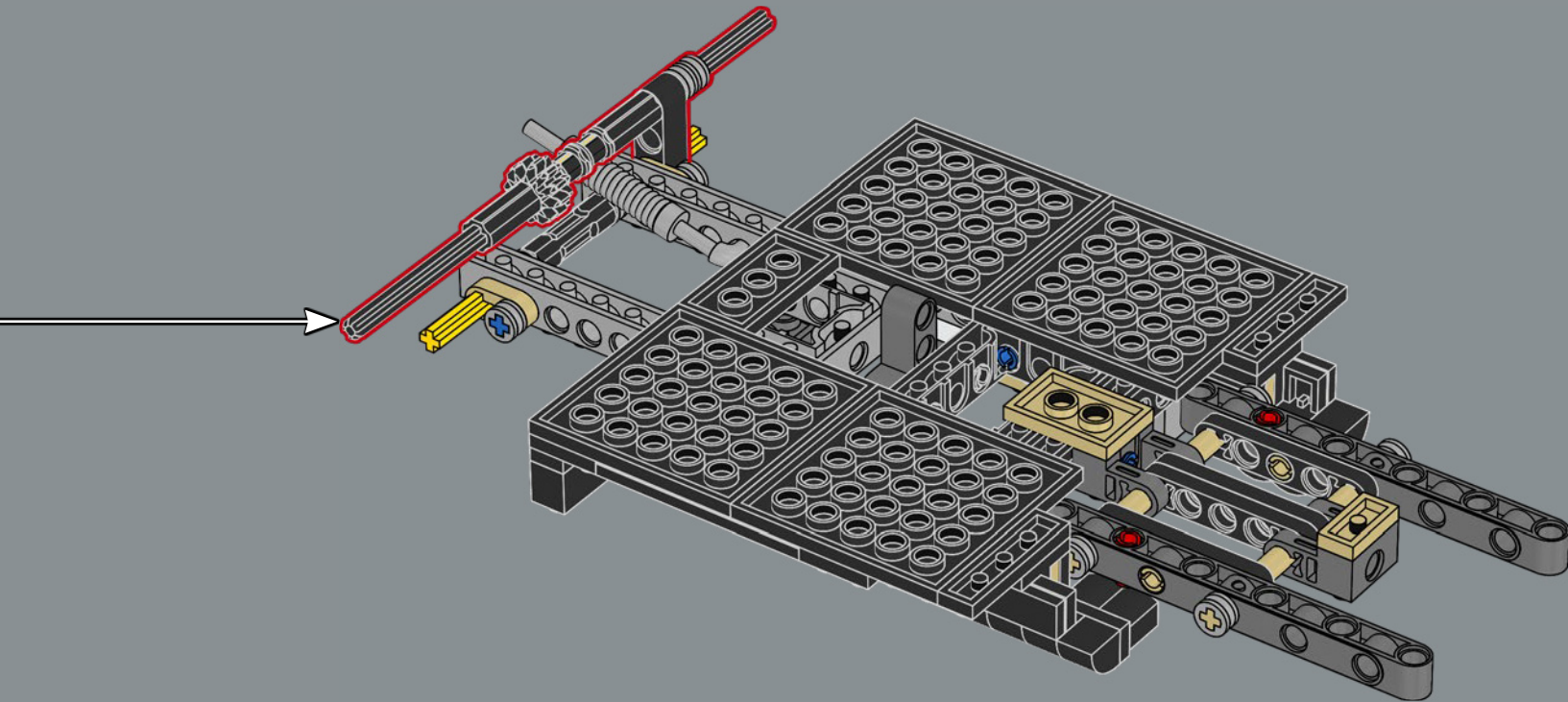



49

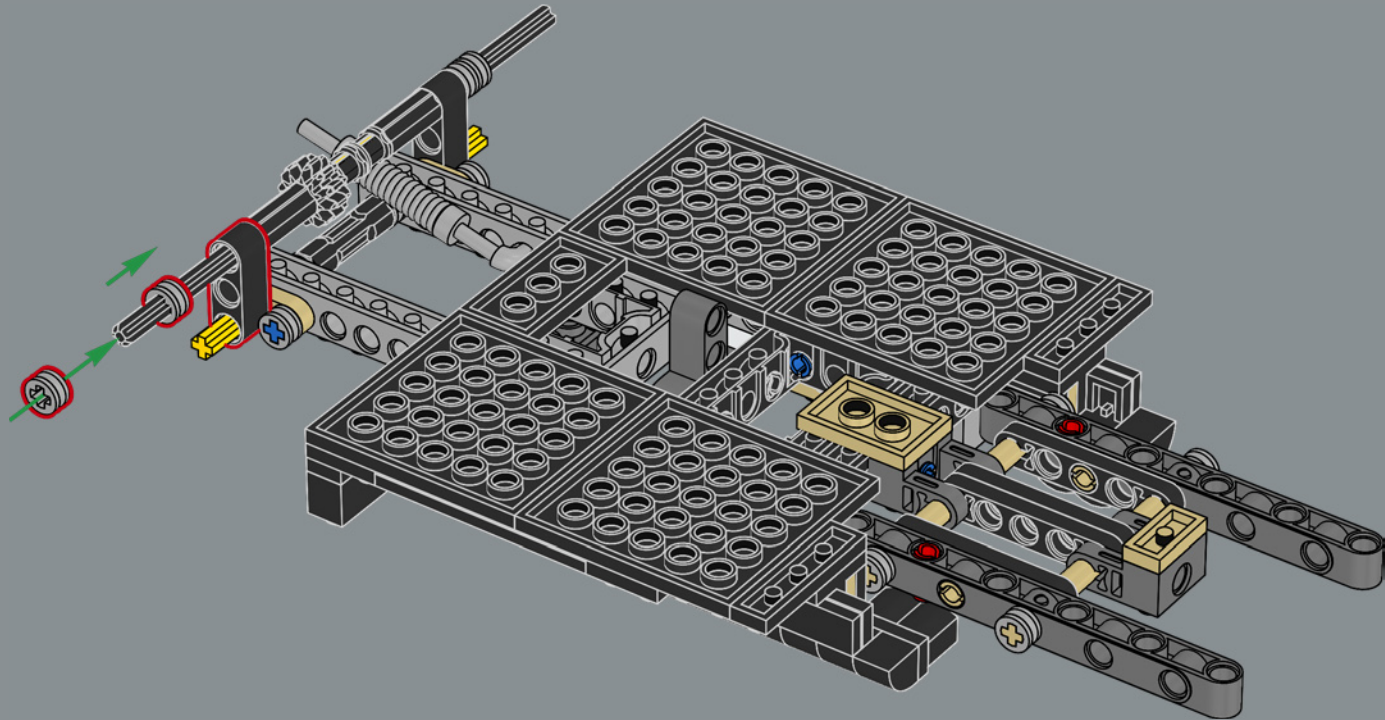



50

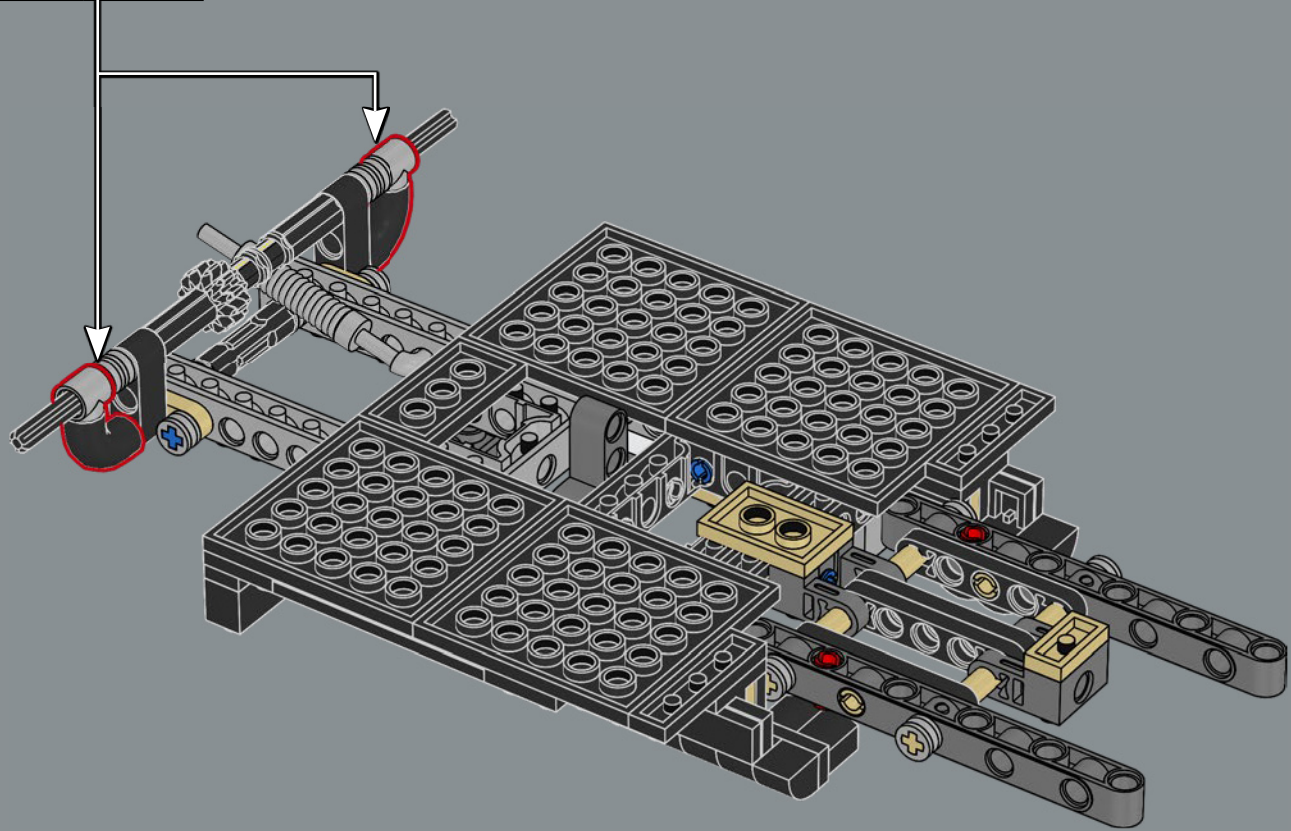
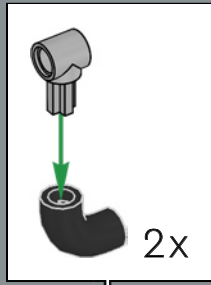

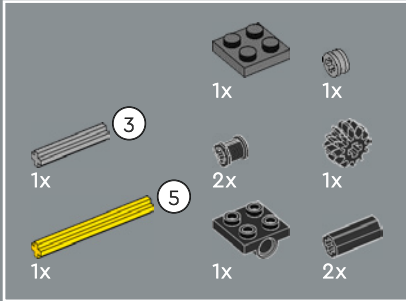
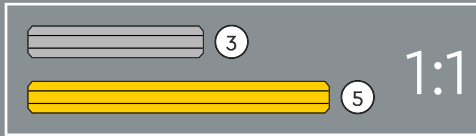
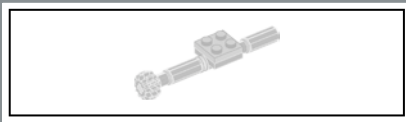

51

1

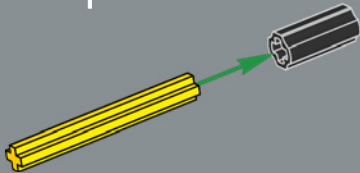

2

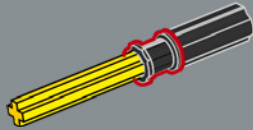

3

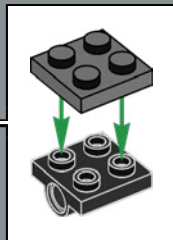
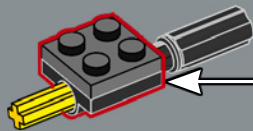

4

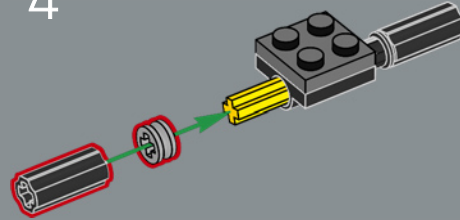

5

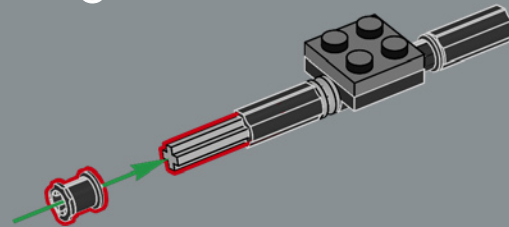

6

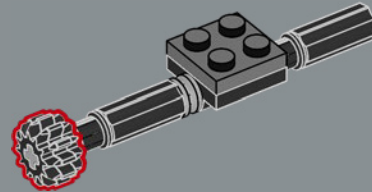



La Ford® Model T® a été l'un des premiers véhicules à être équipé de la propulsion arrière.

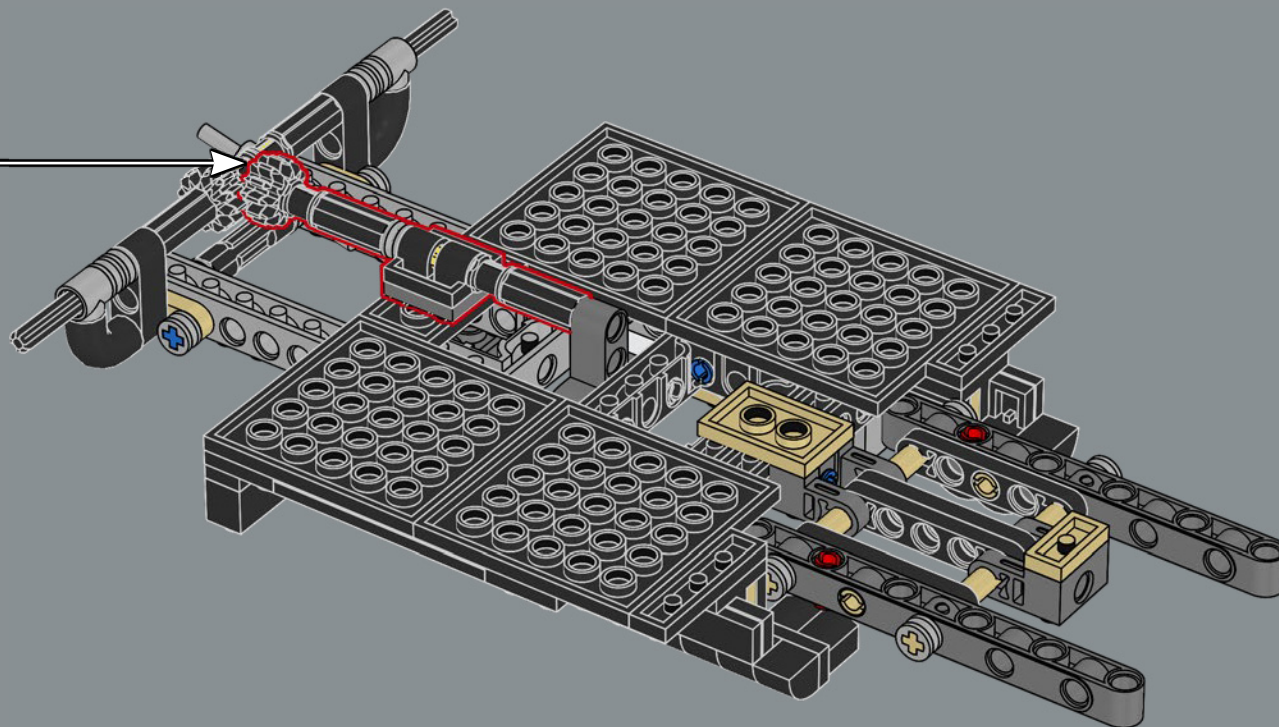

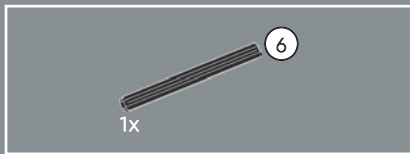

52

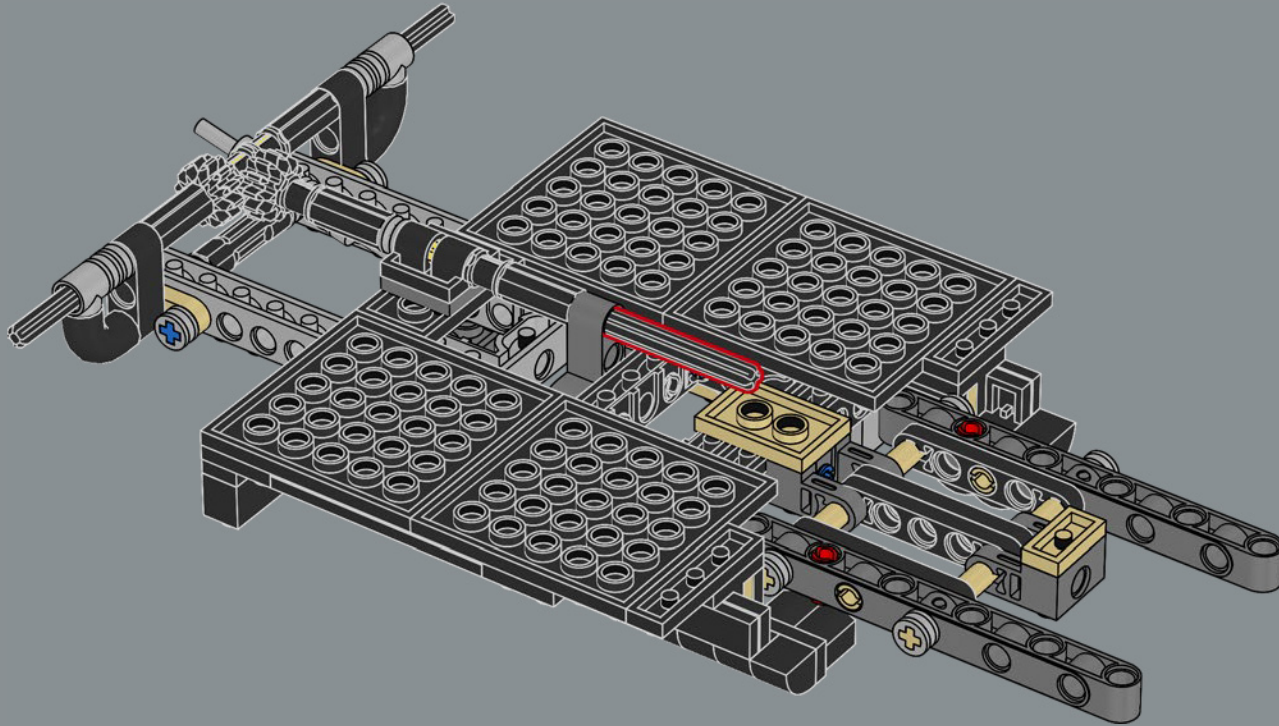

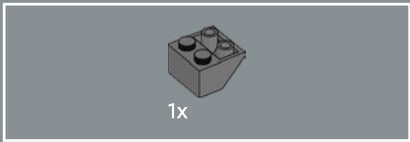

53

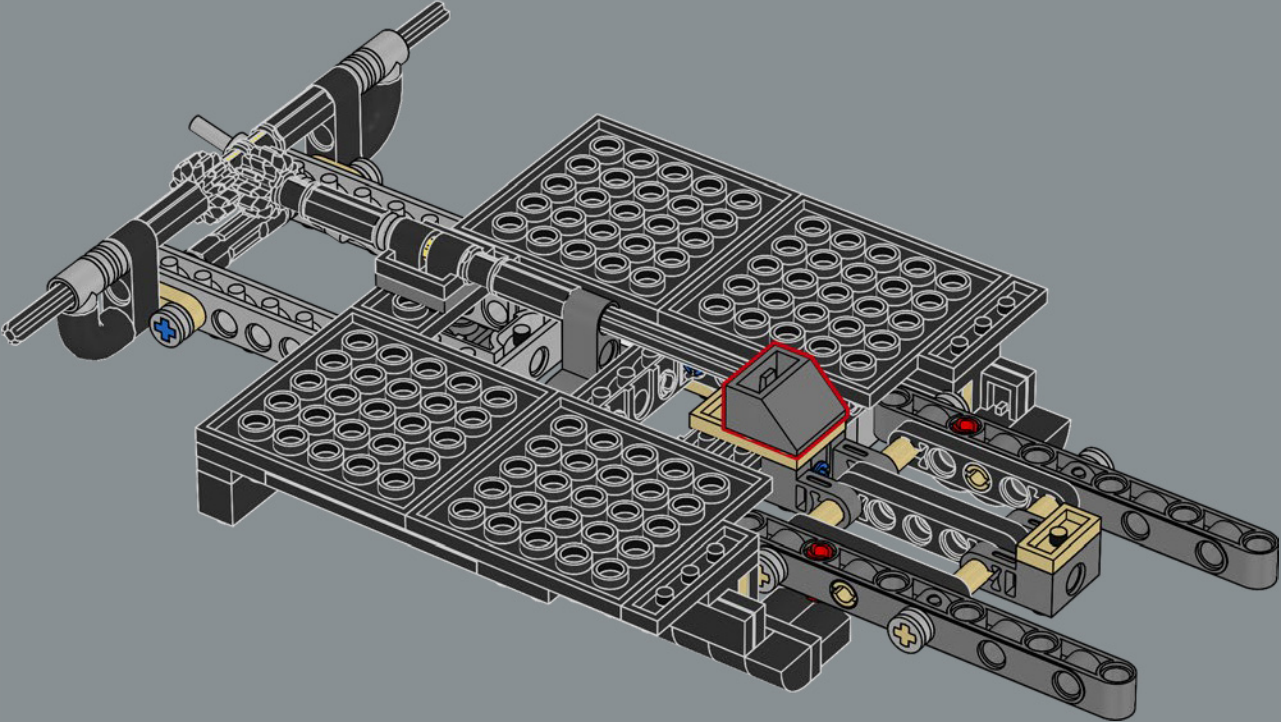



54

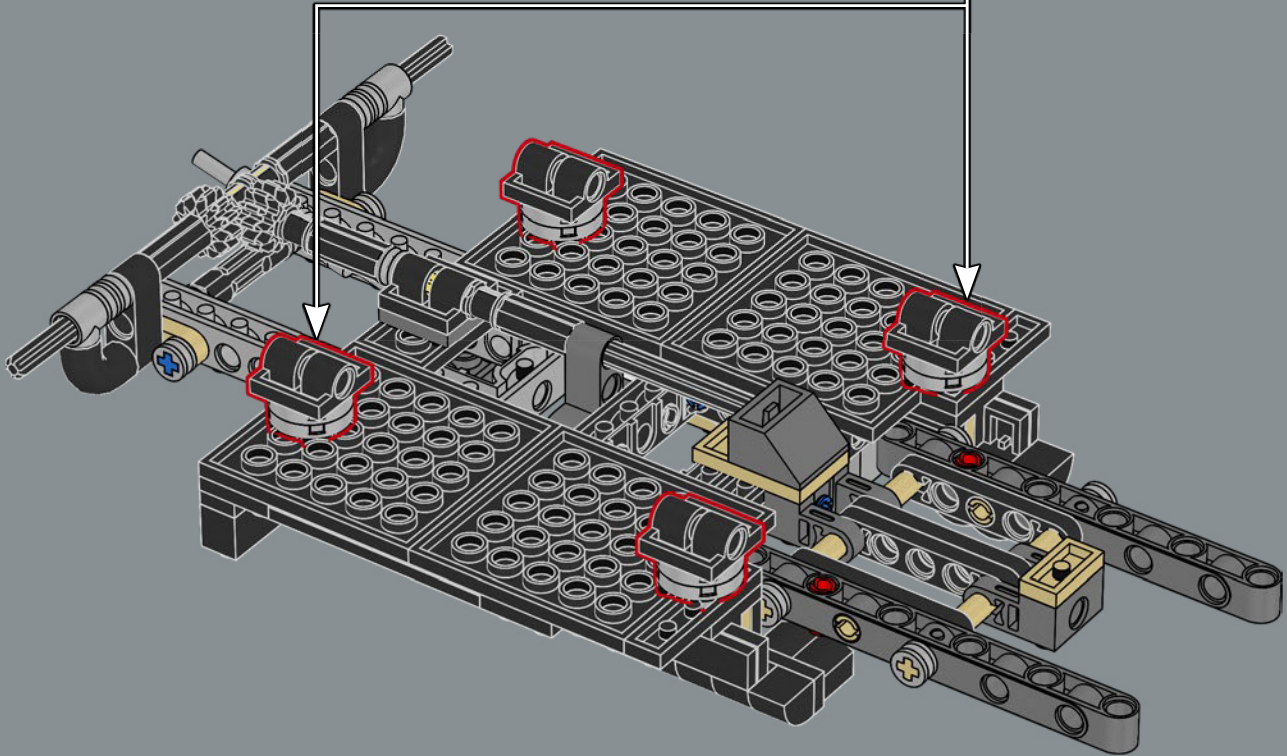
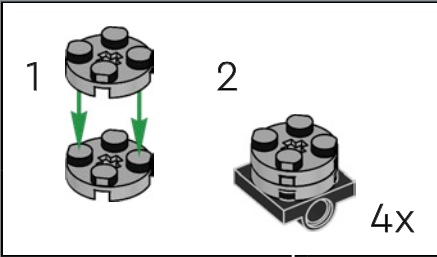

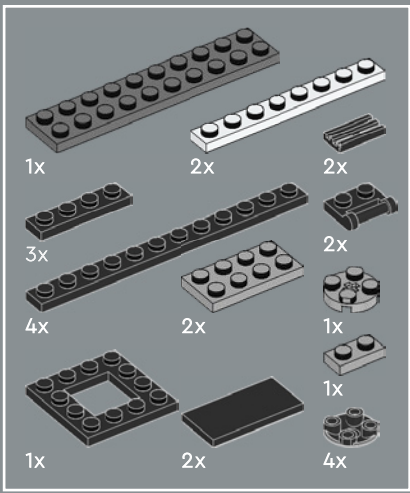

55

1

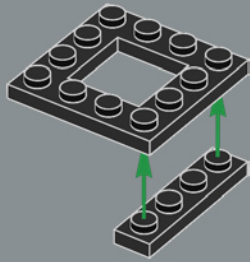

2

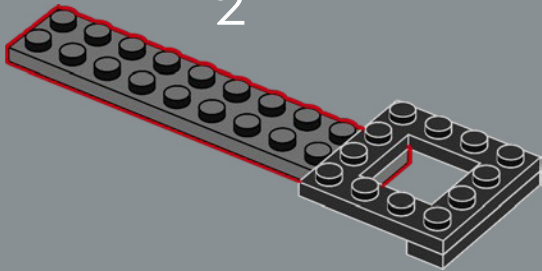

3

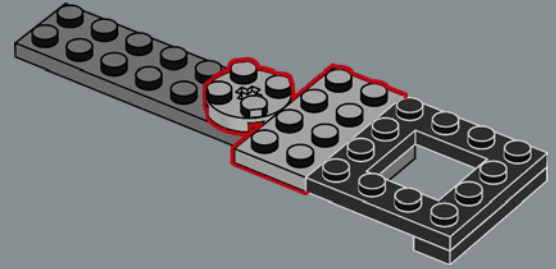

4

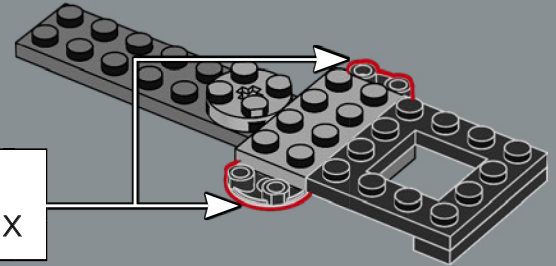

5

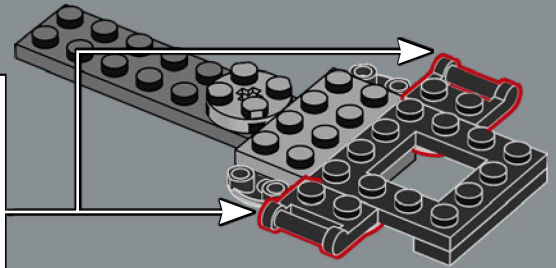
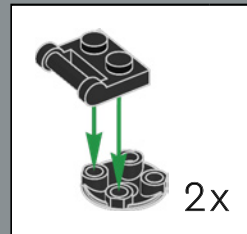

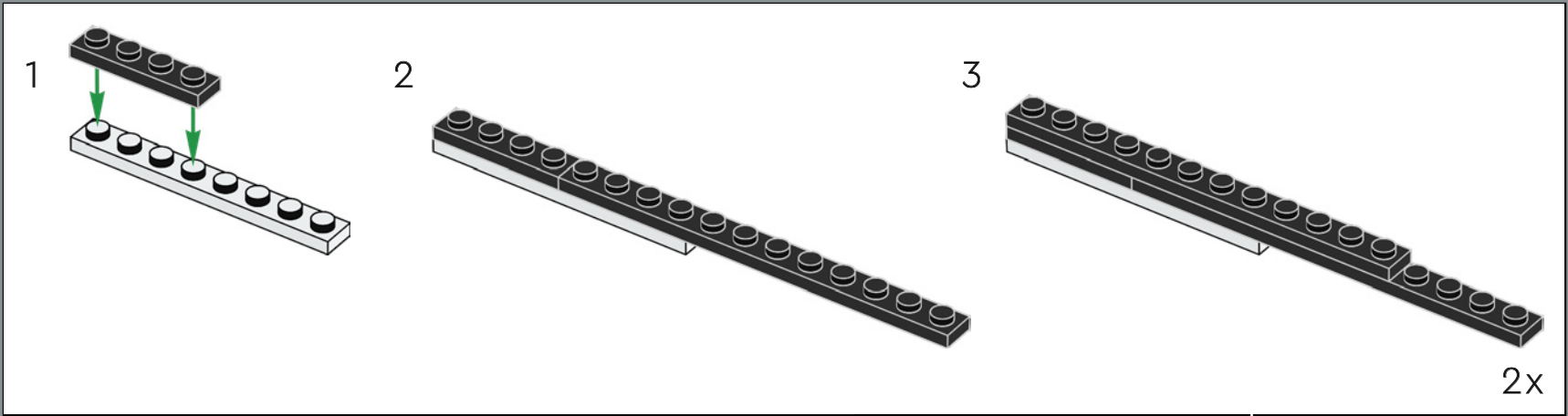

6

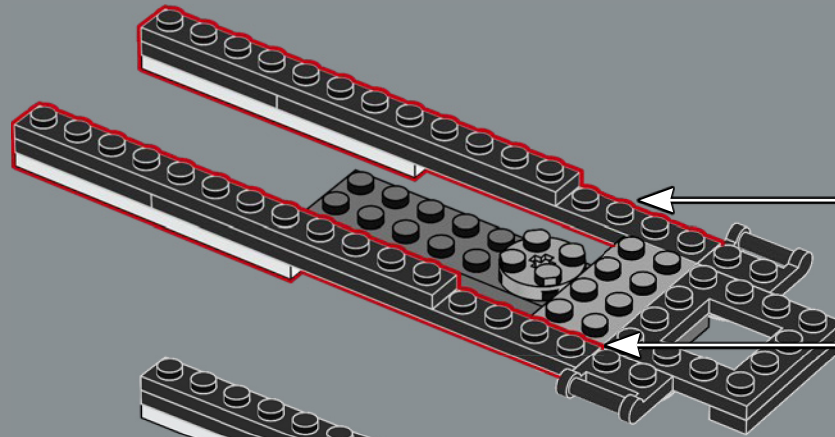

7

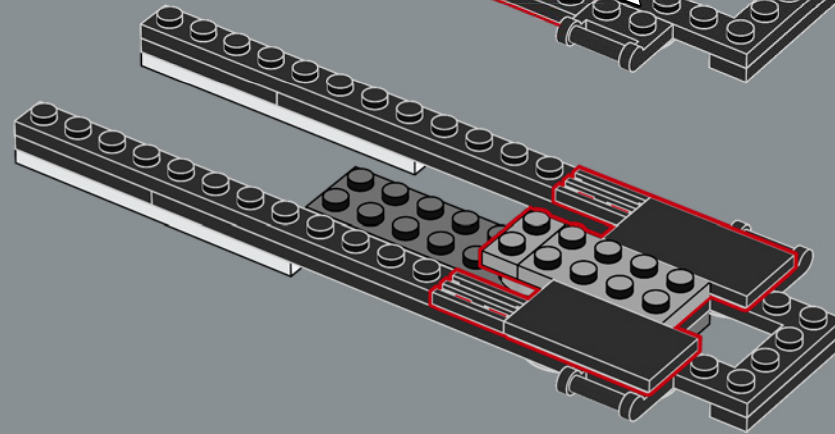

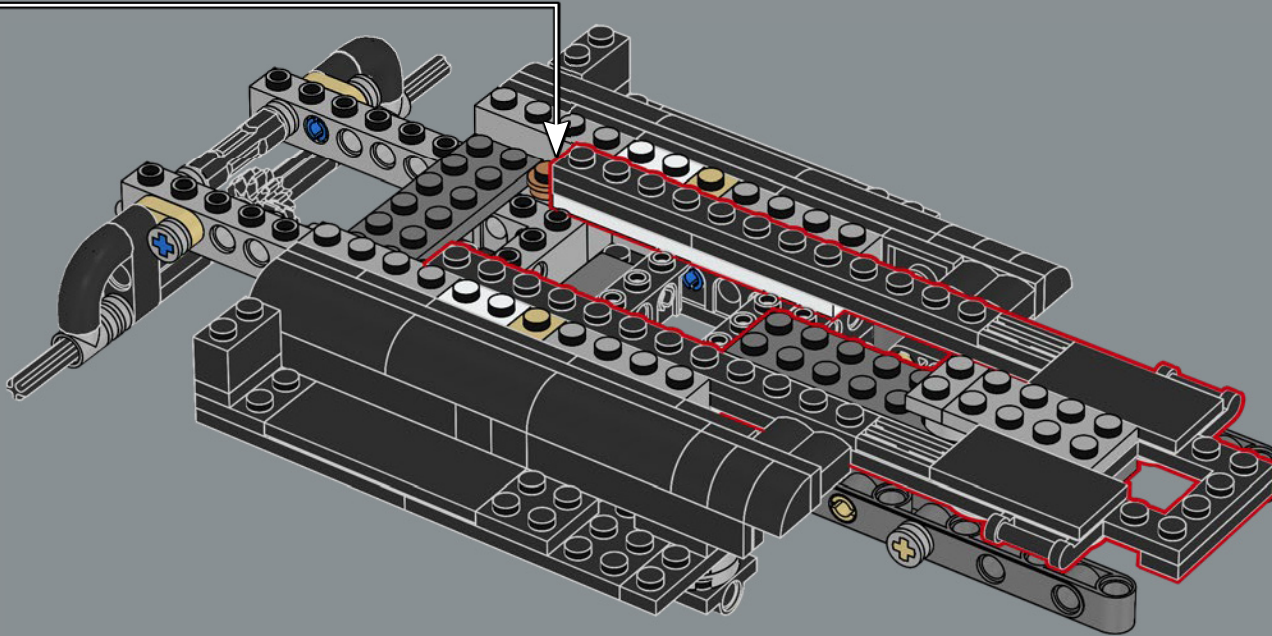

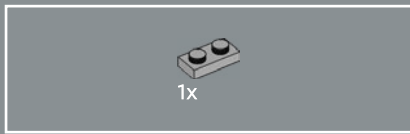

56

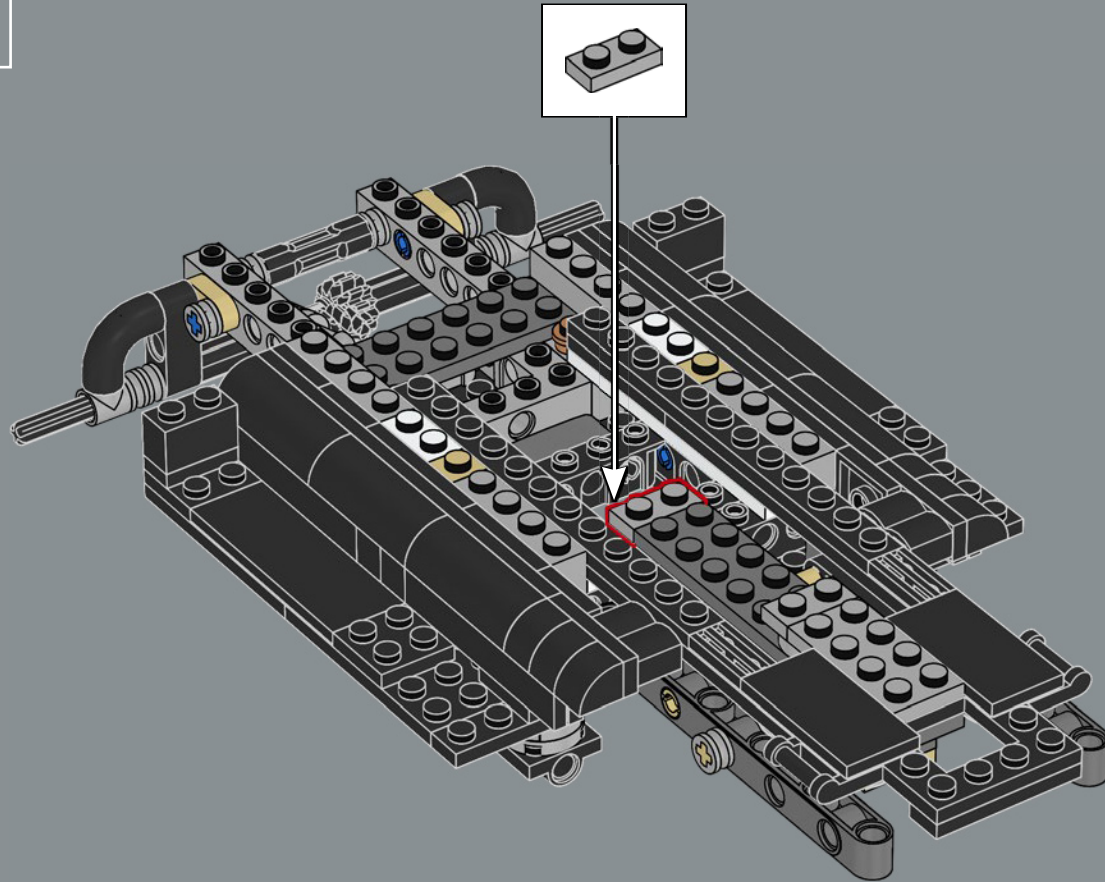

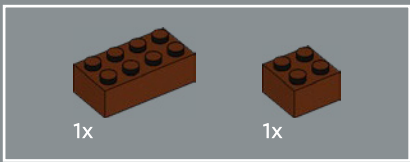

57

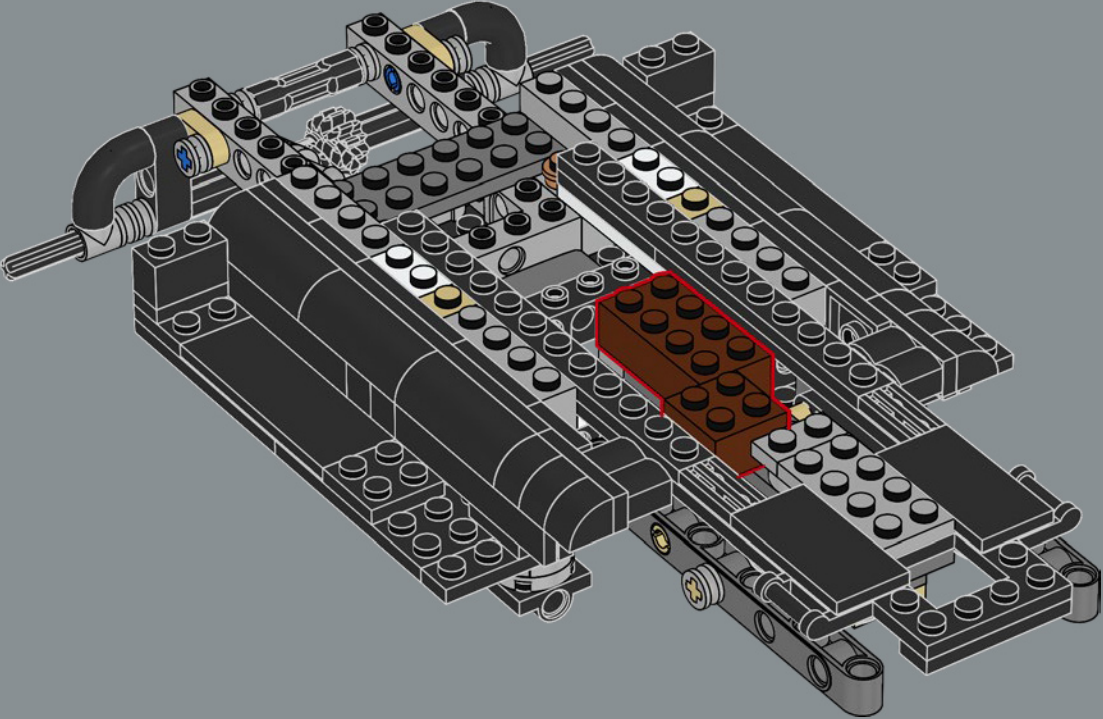

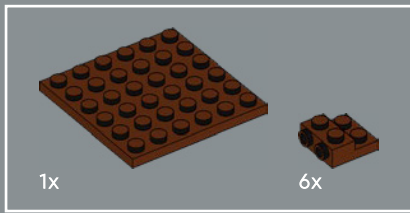

58

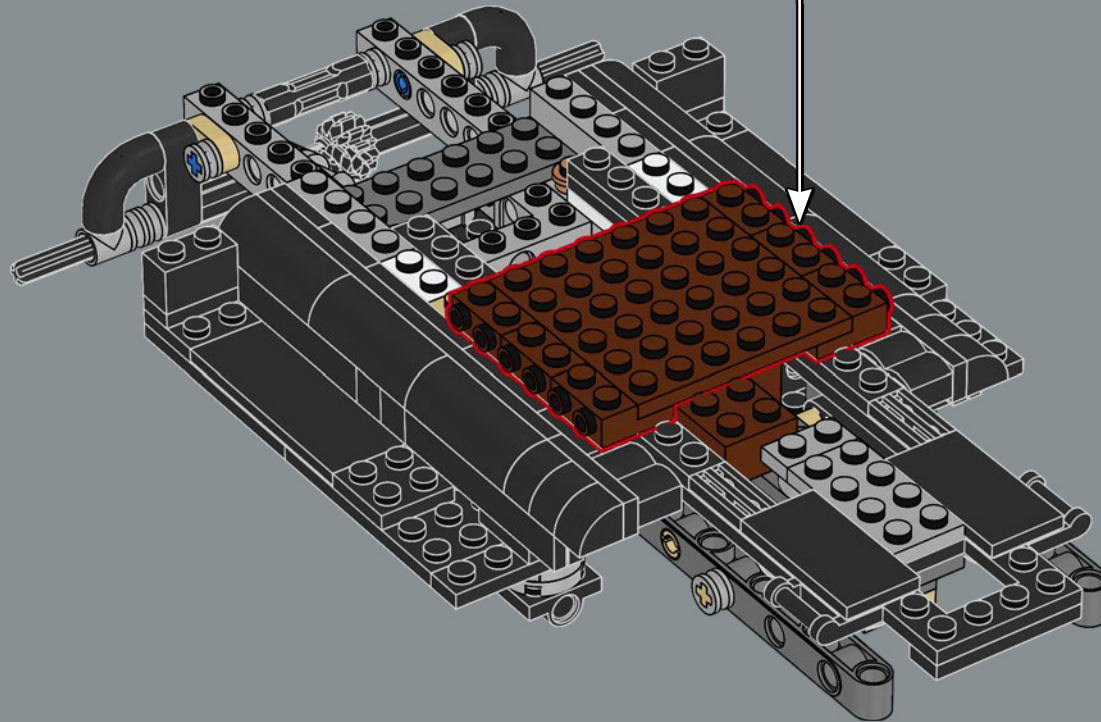
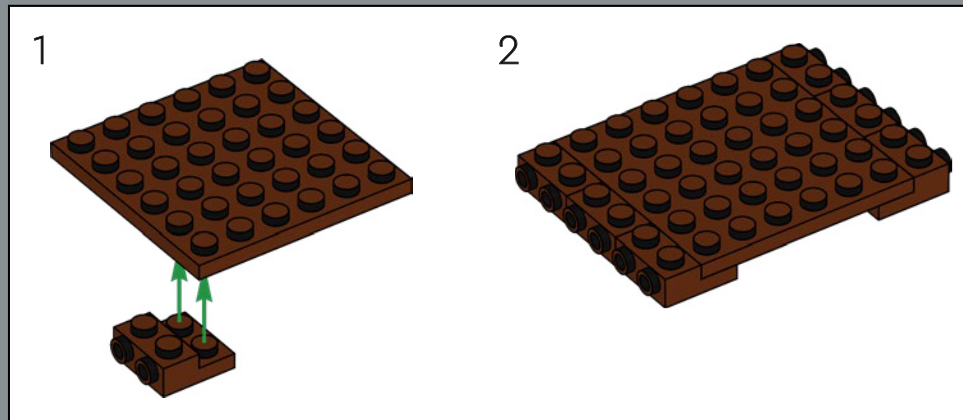



4x

59



La Ford® Model T® a également été parmi les premières voitures à être produites sur une chaîne d'assemblage mobile, une avancée industrielle qui permet de réduire les coûts de production et de rendre l'automobile accessible.

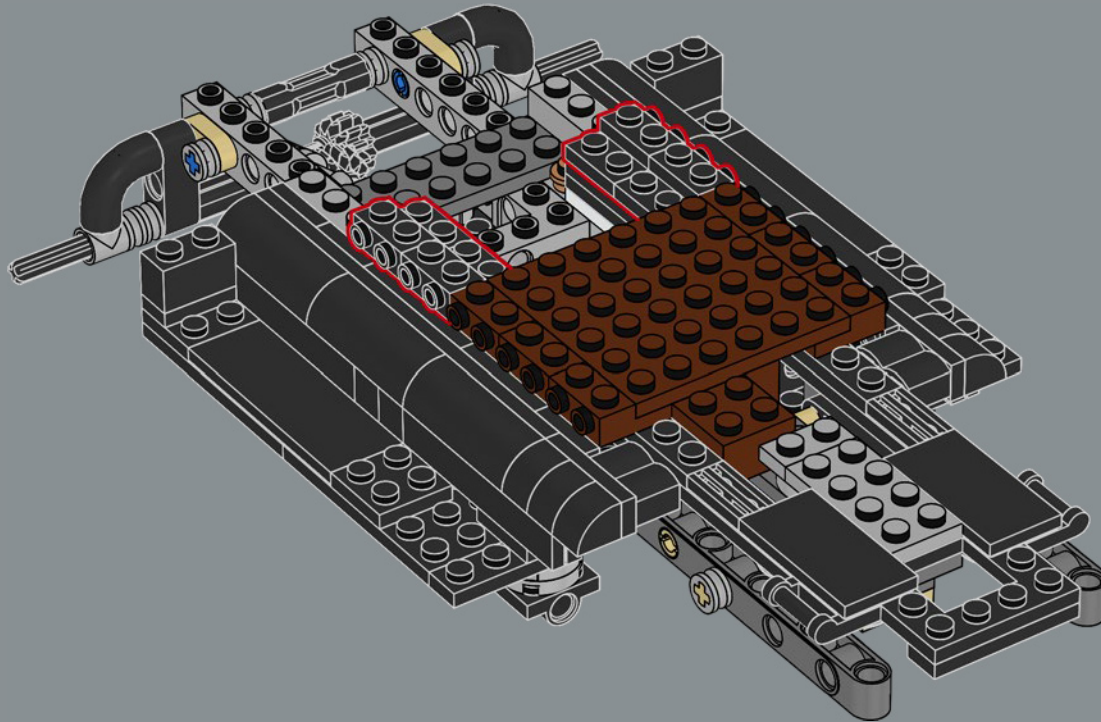

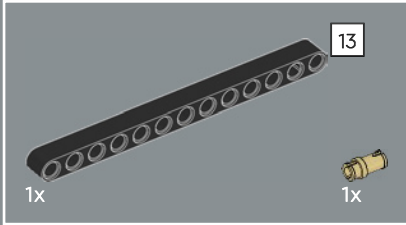
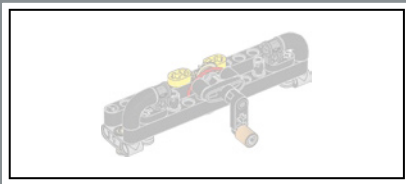

60

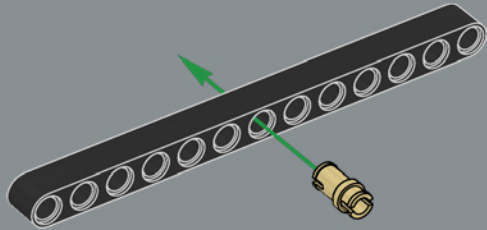

61

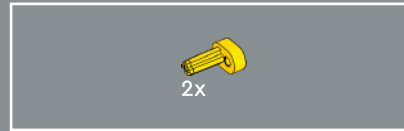
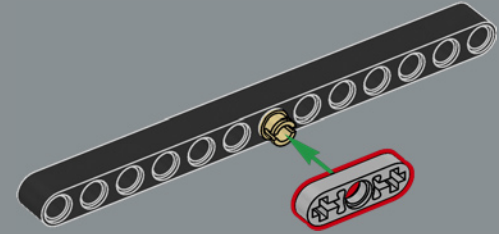

62

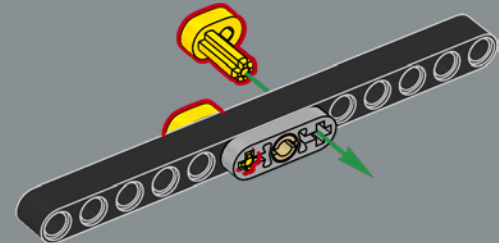



1x

63

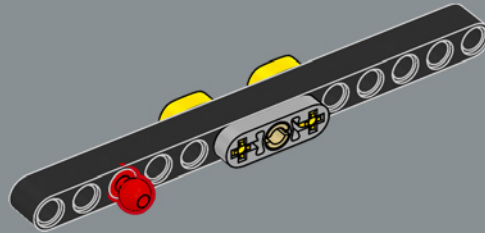

2x



2x

64

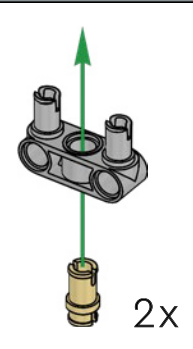
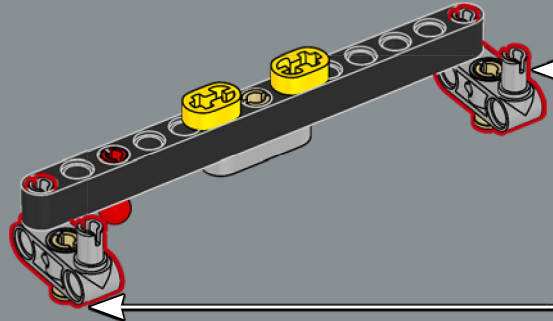

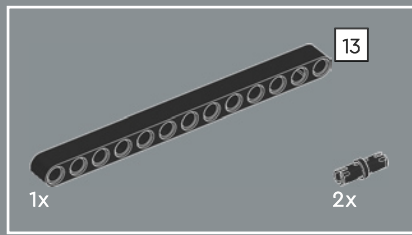

65

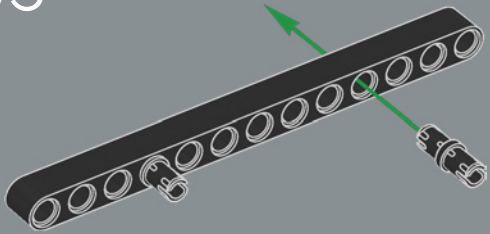

66

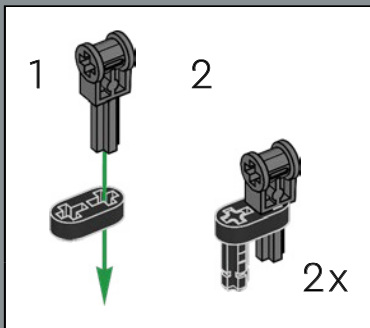
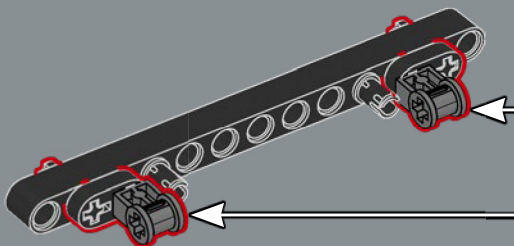

67

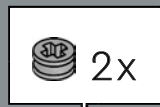
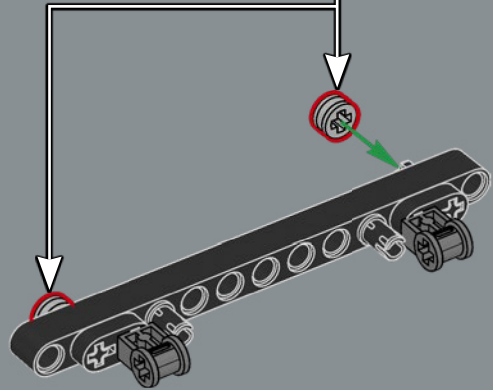

68

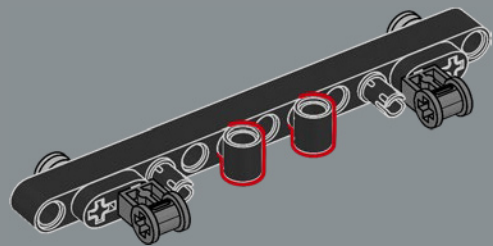

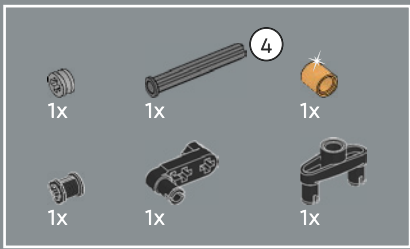

69

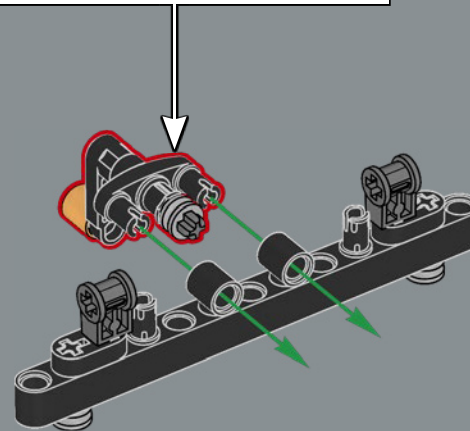
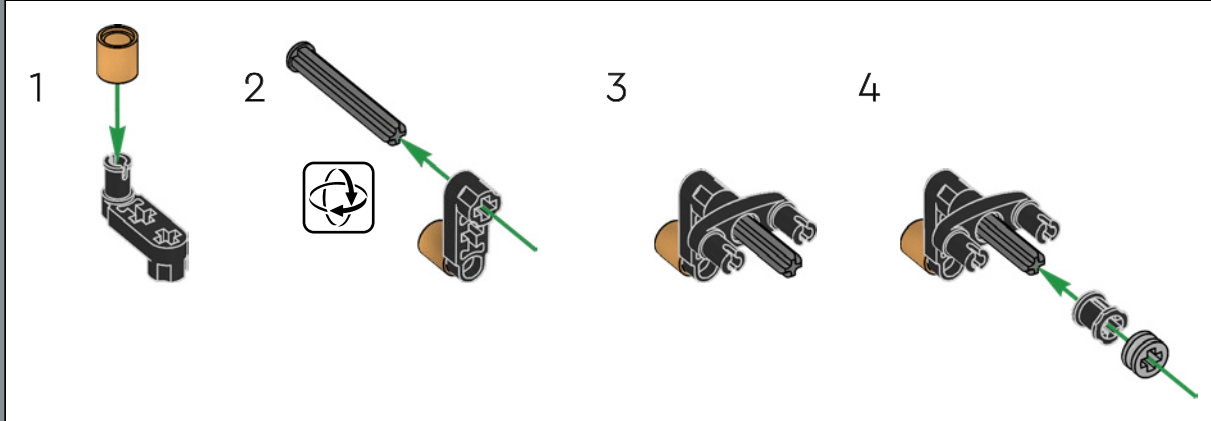



70

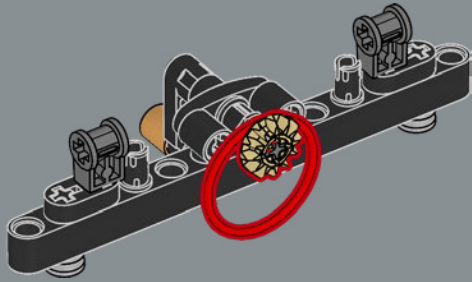

71

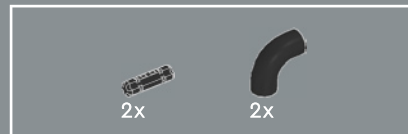
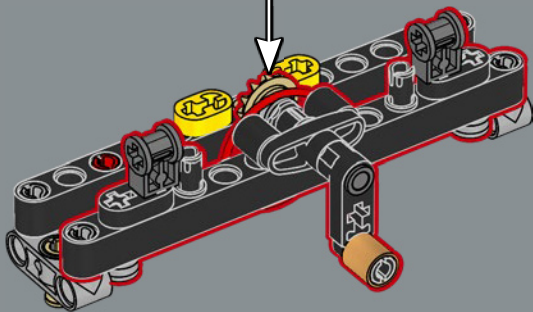

72

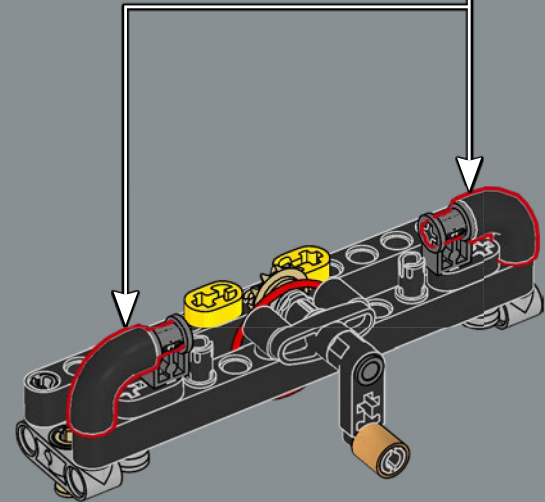
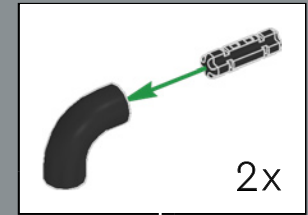



Pour démarrer le moteur, les conducteurs utilisaient une manivelle.

73

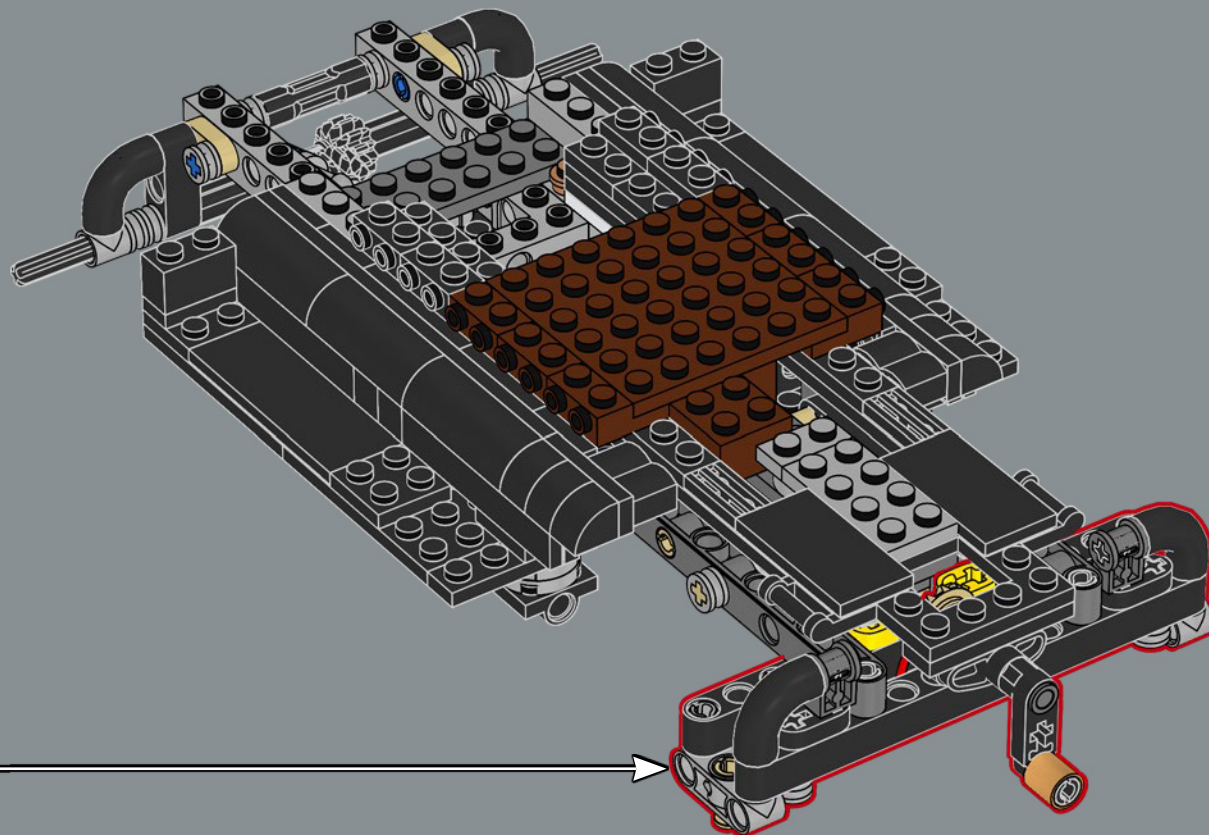

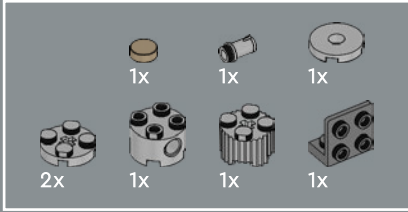
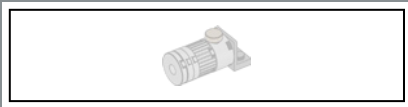

75

1

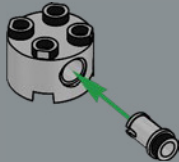

2



3

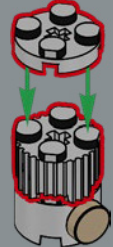

4

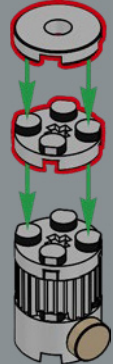

5

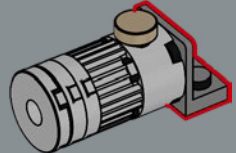



Parmi les nouvelles caractéristiques, le réservoir de carburant était placé sous le siège conducteur : il fallait soulever le coussin pour le remplir.

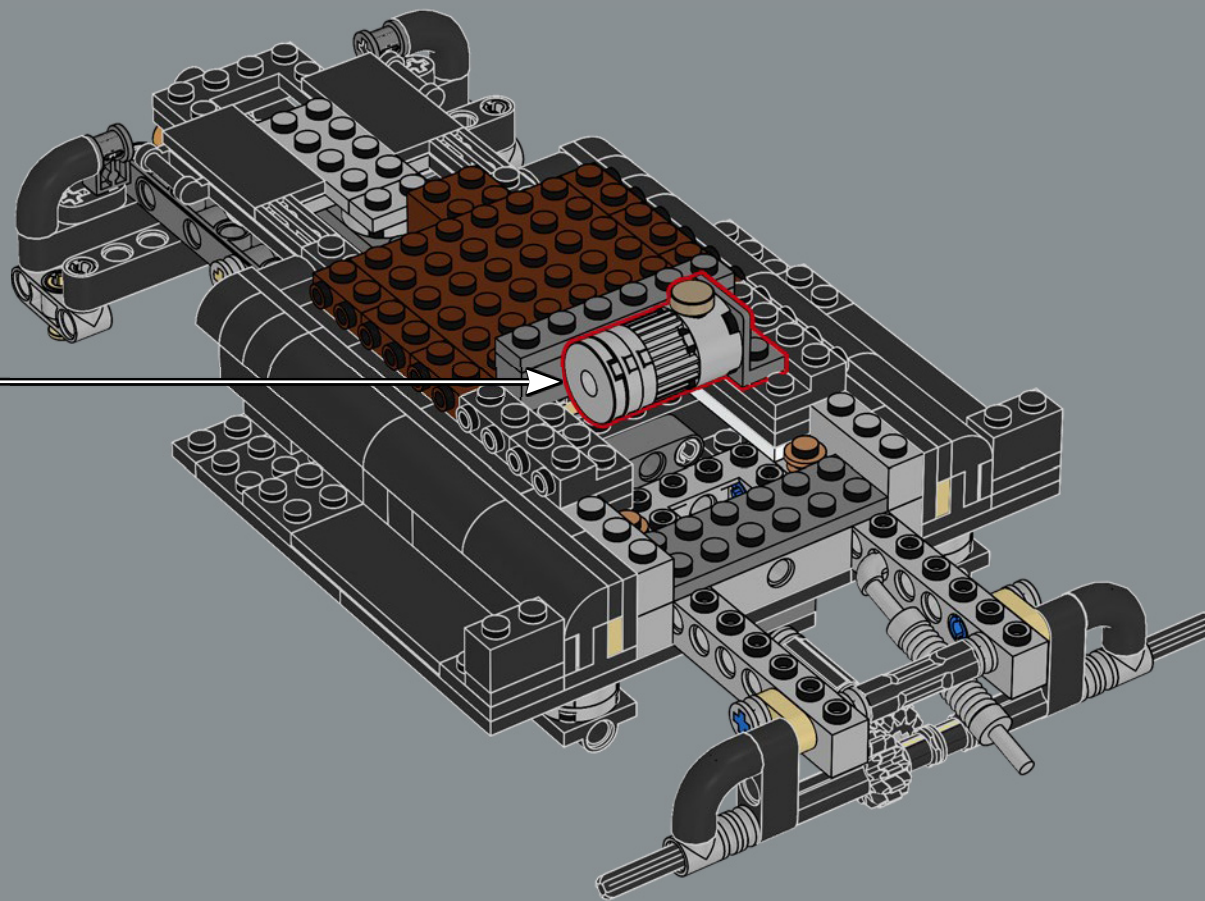

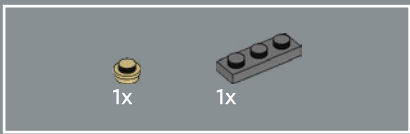

76

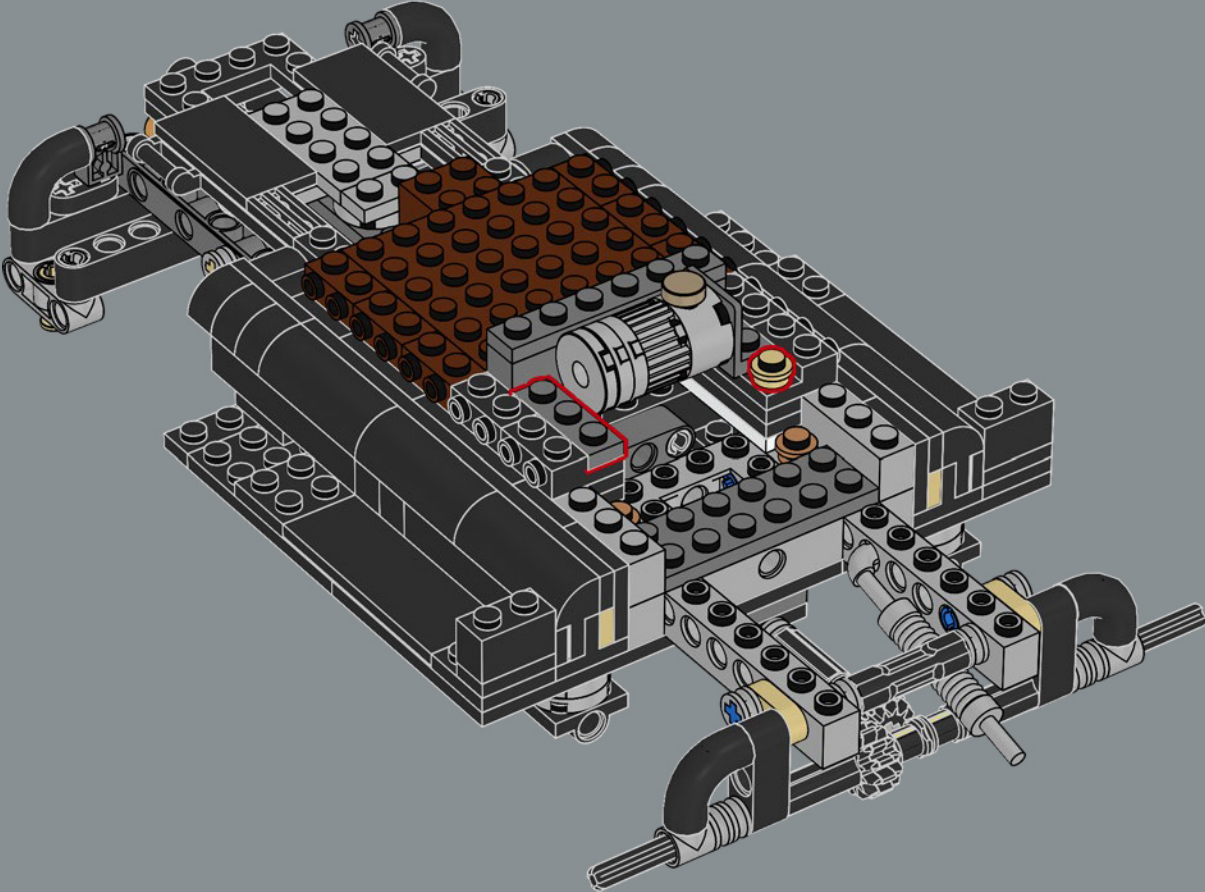

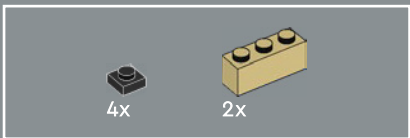

77

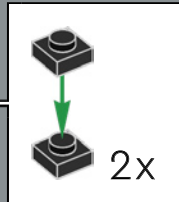
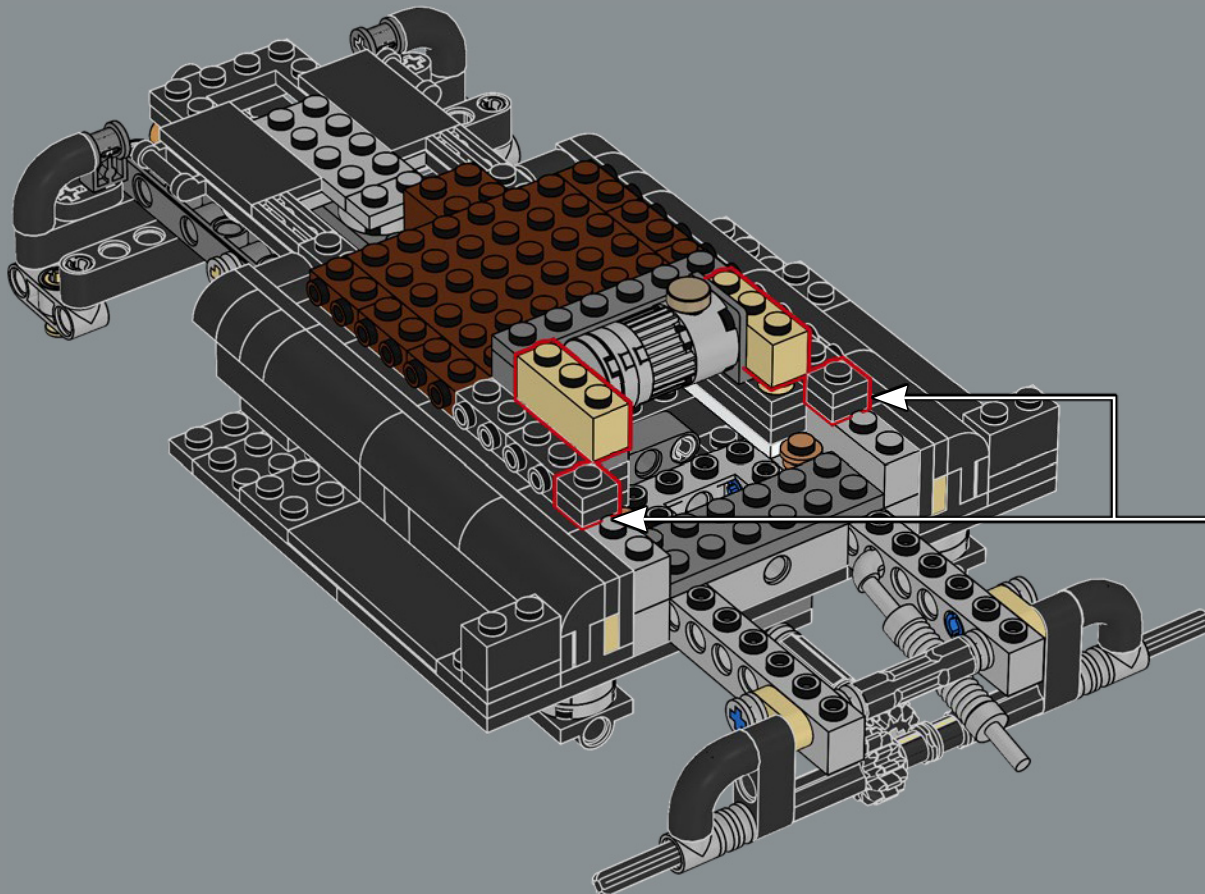



2x



4x

78

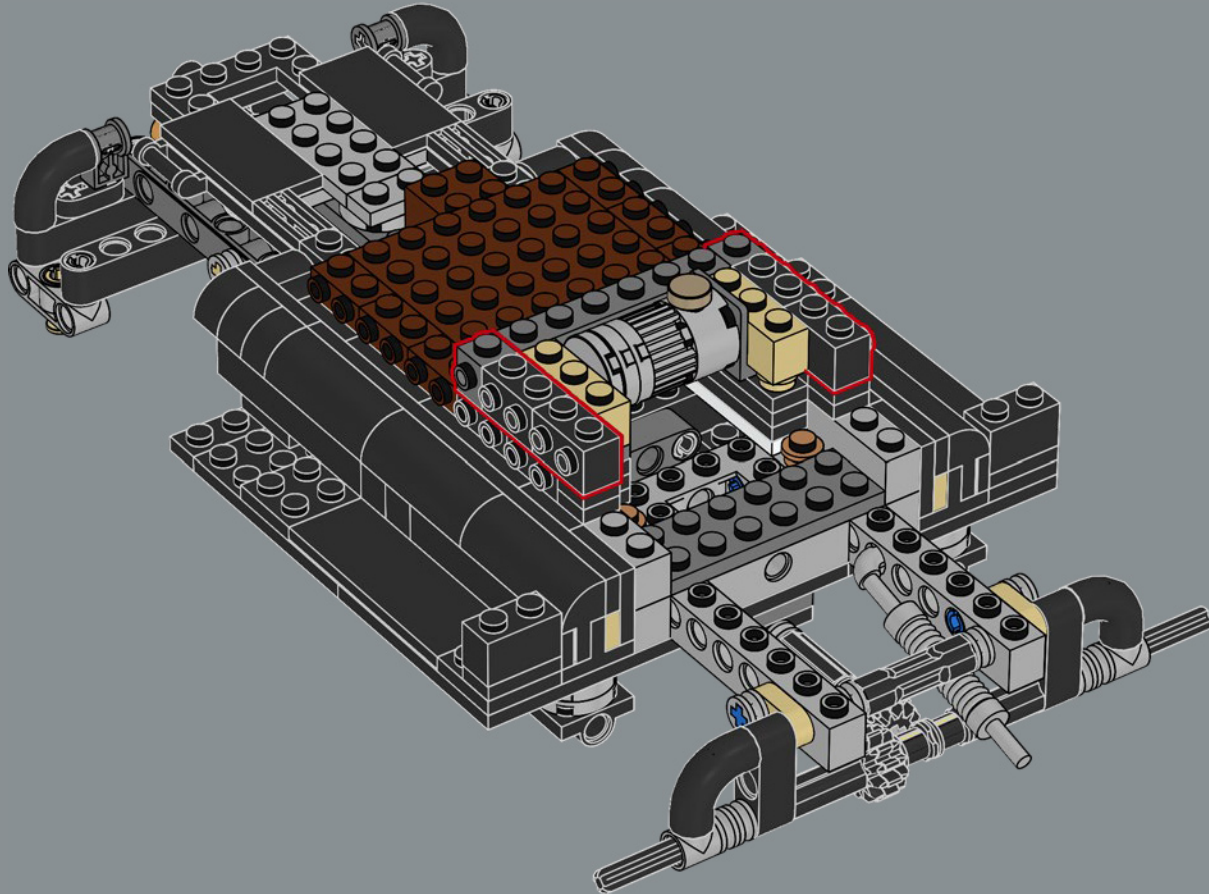

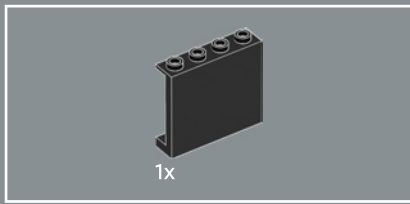

79

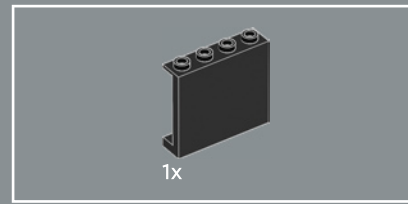
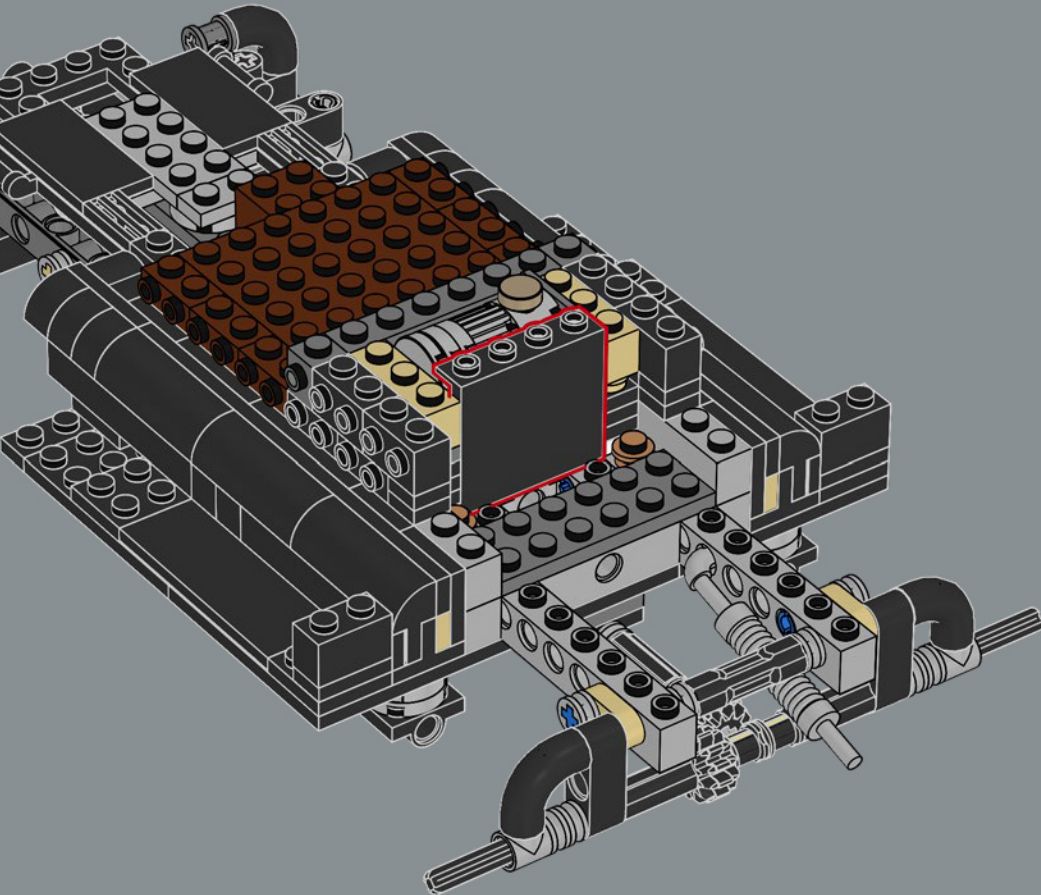

80

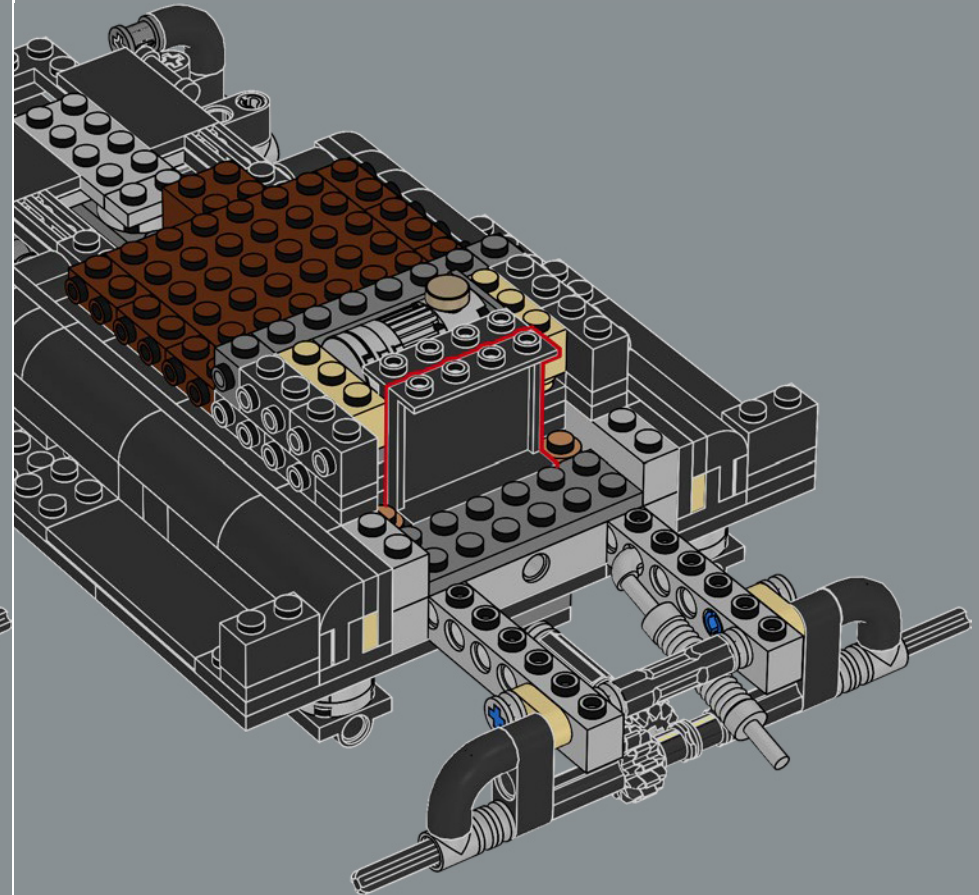

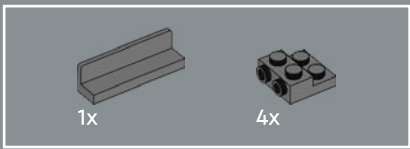

81

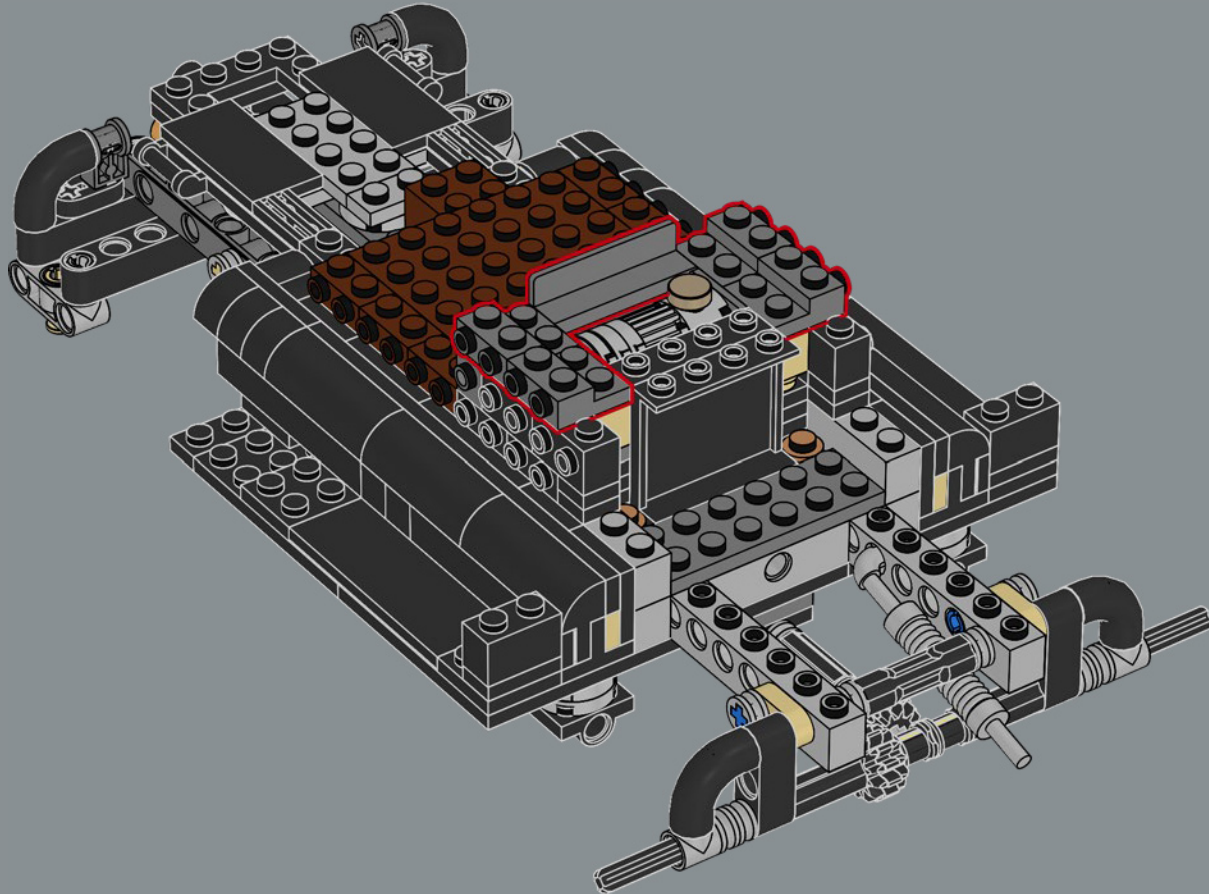

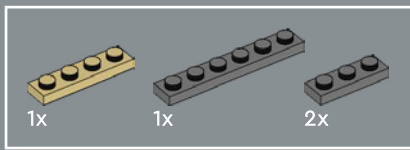

82

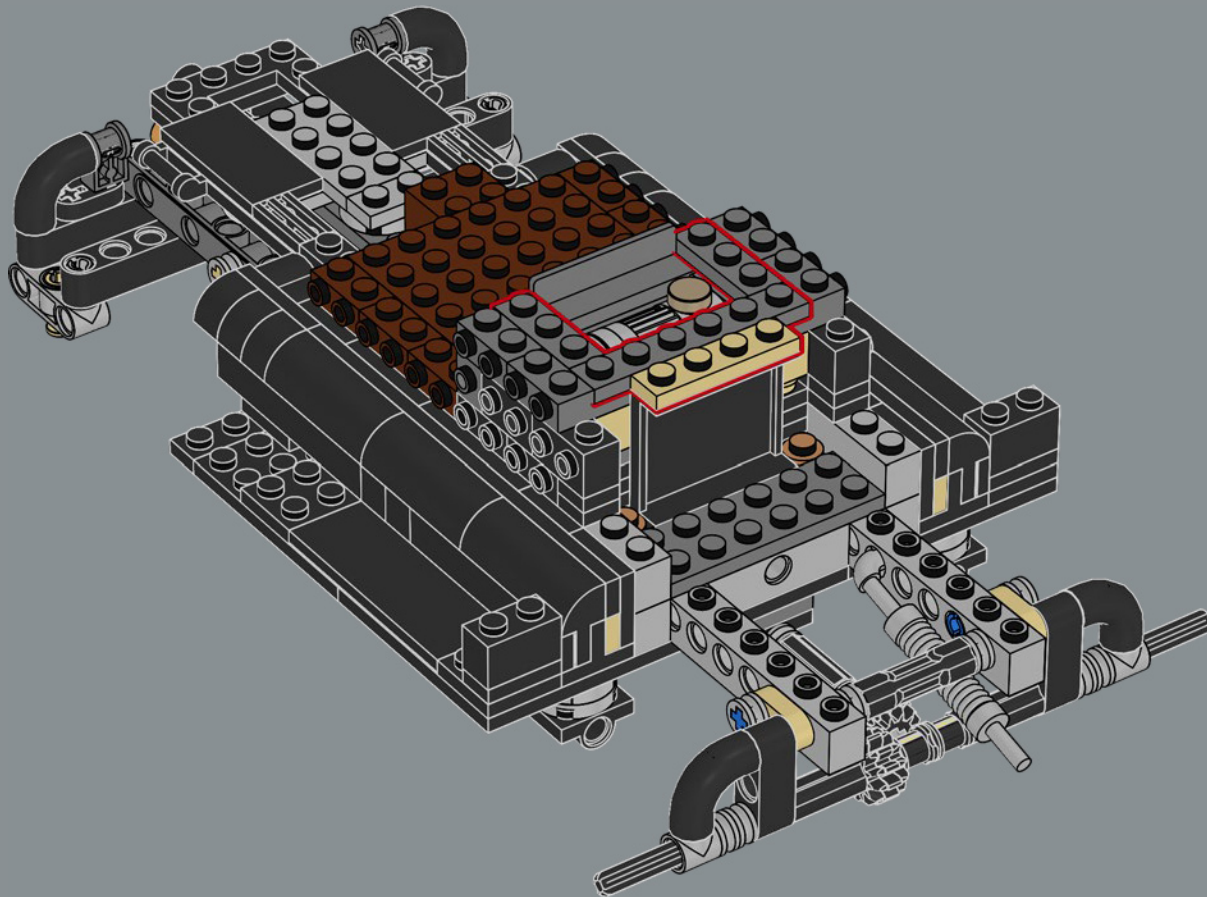

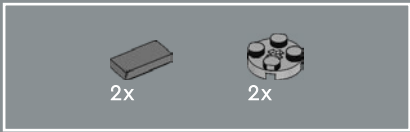

83

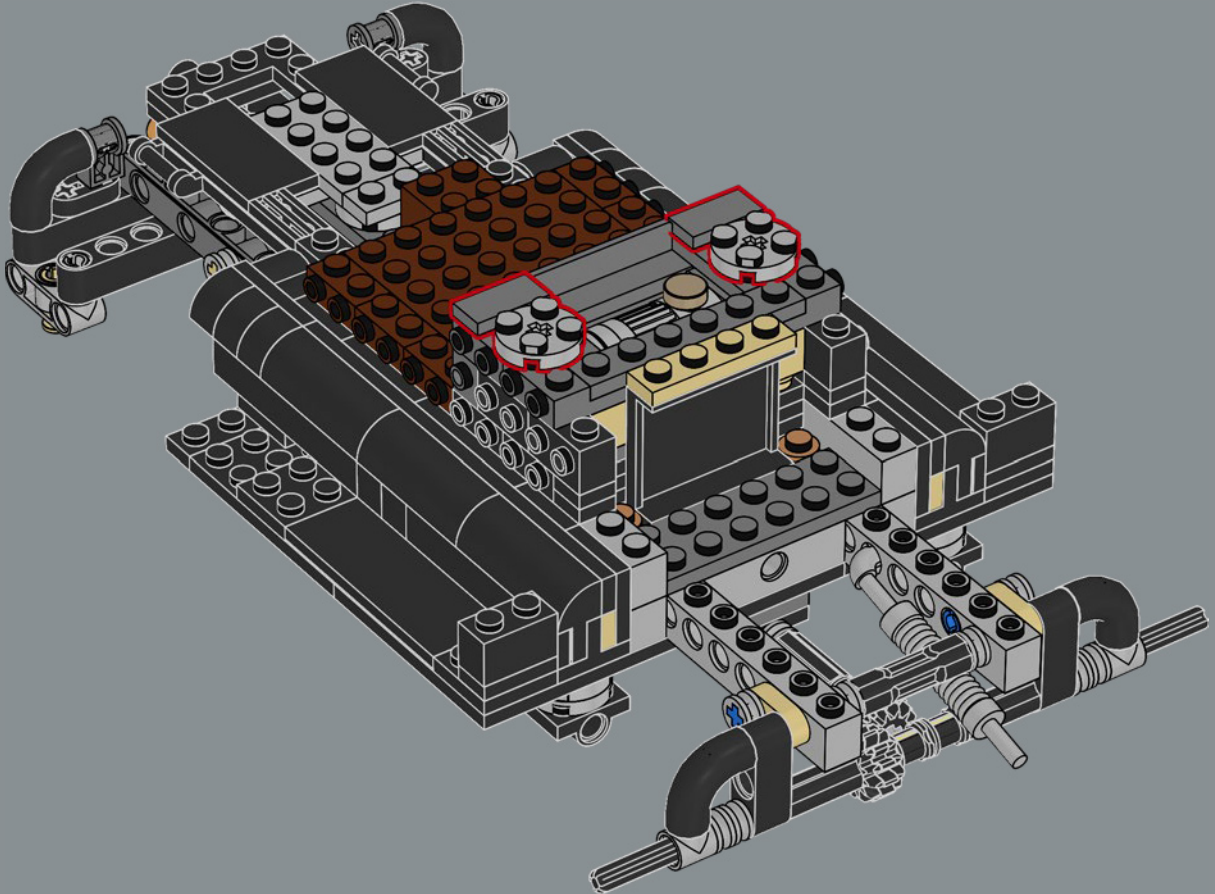

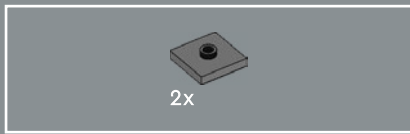

84

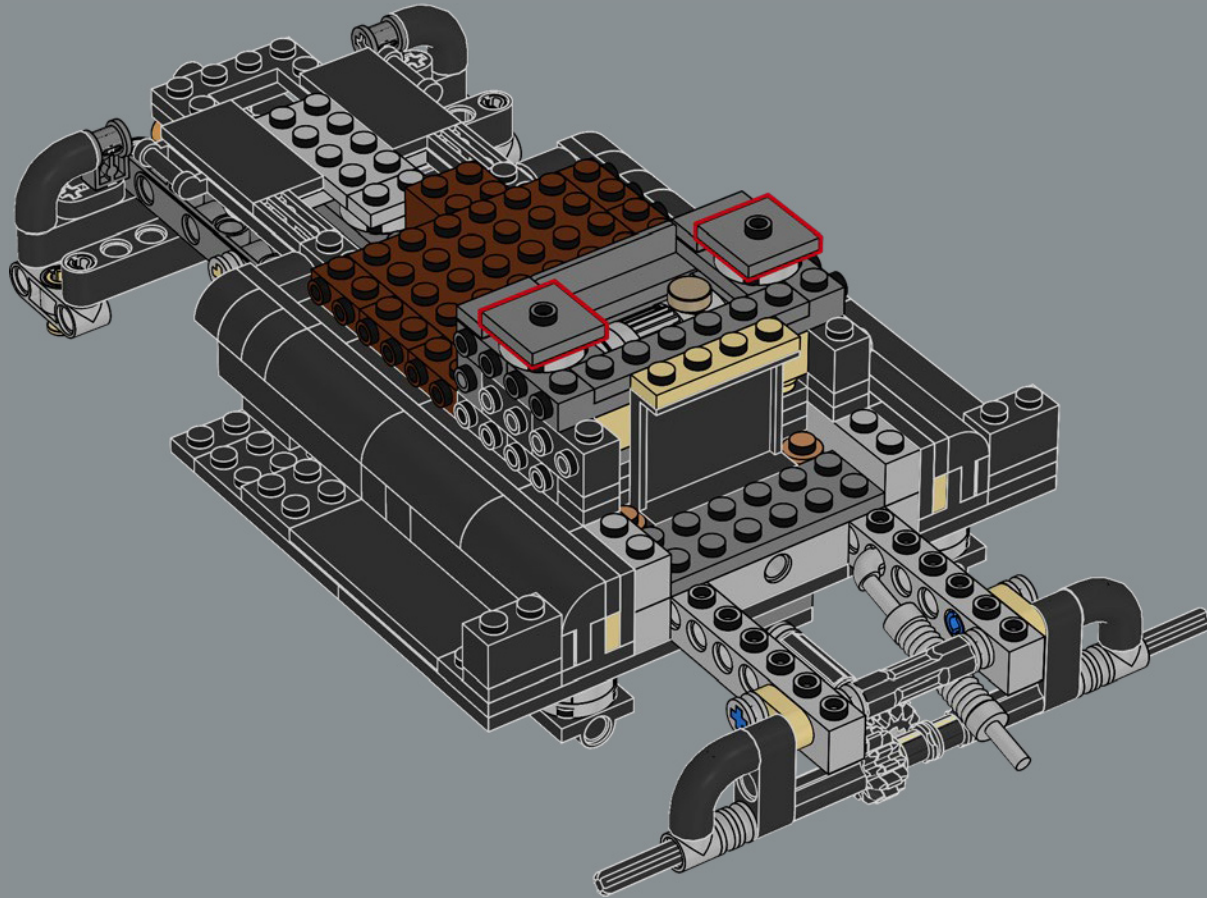

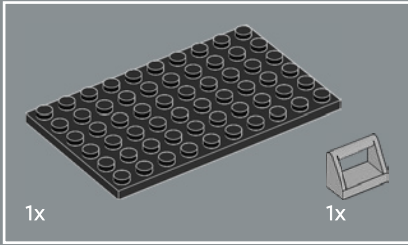
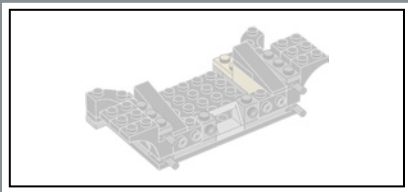

85

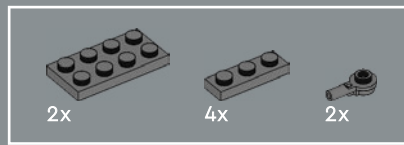
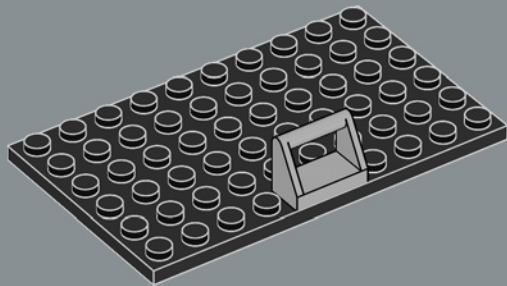

86

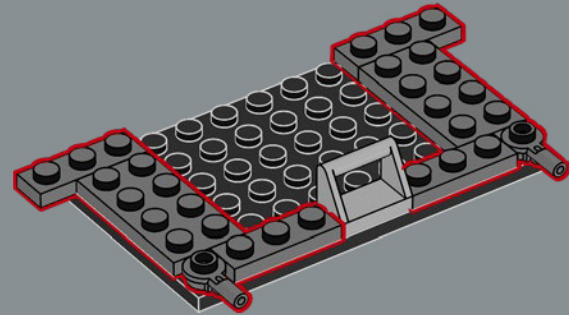

87

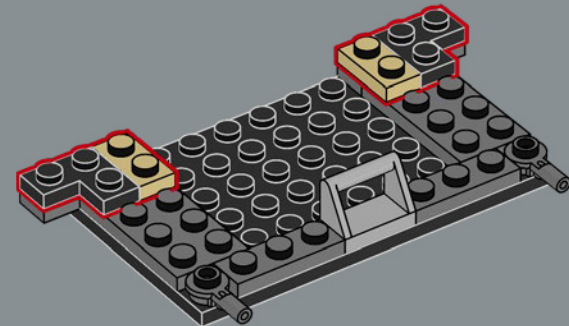



88

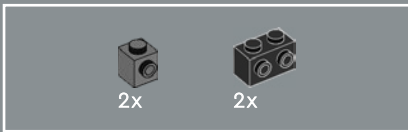
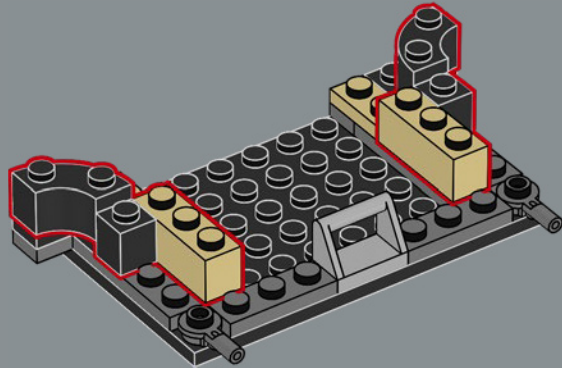

89

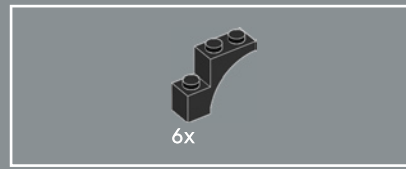
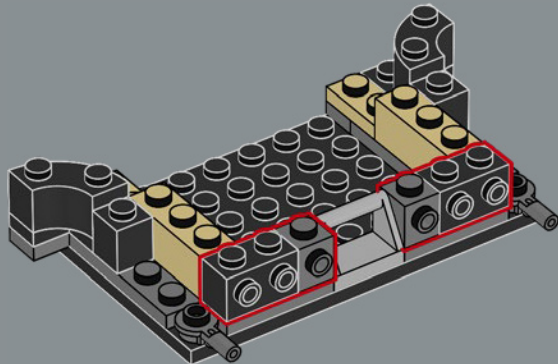

90

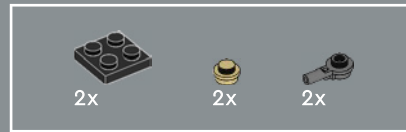
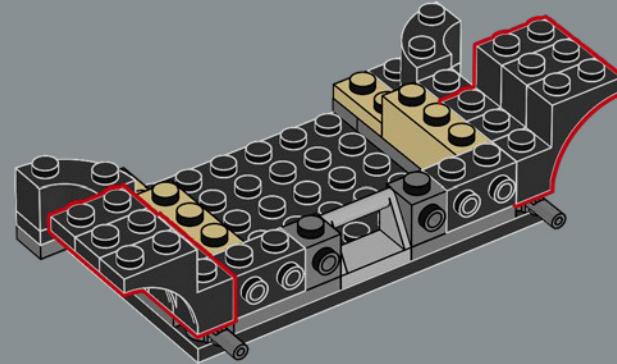

91

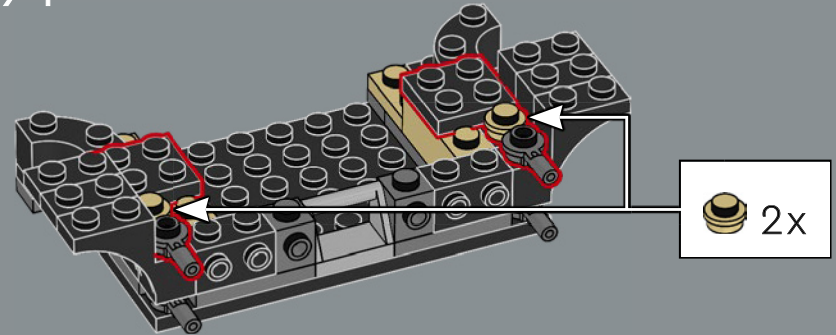

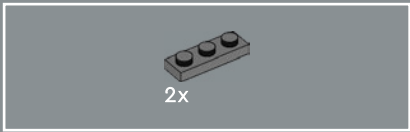

92

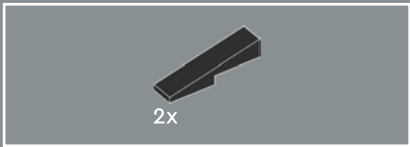
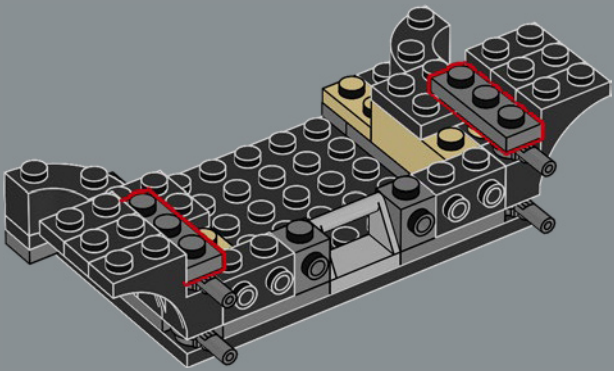

93

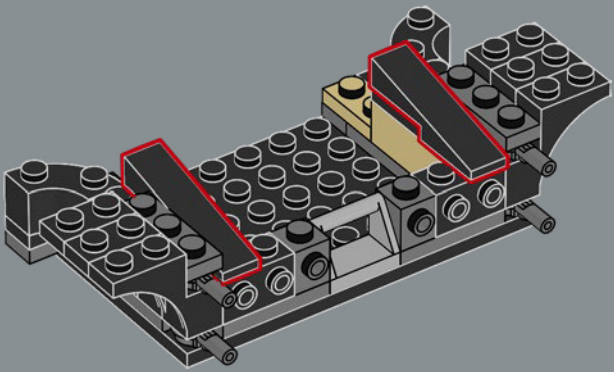

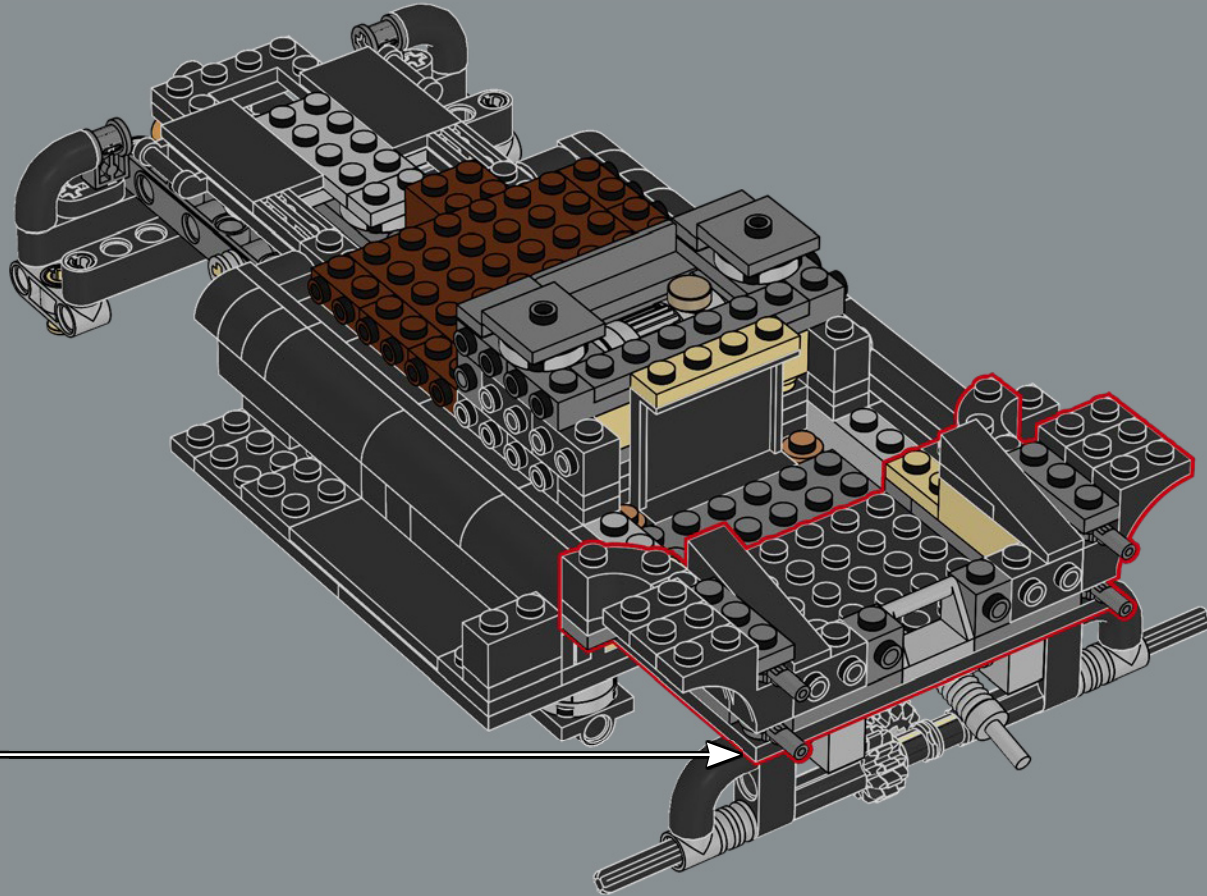

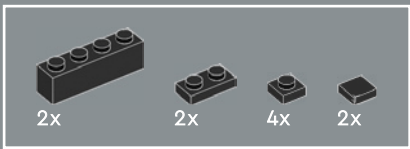

95

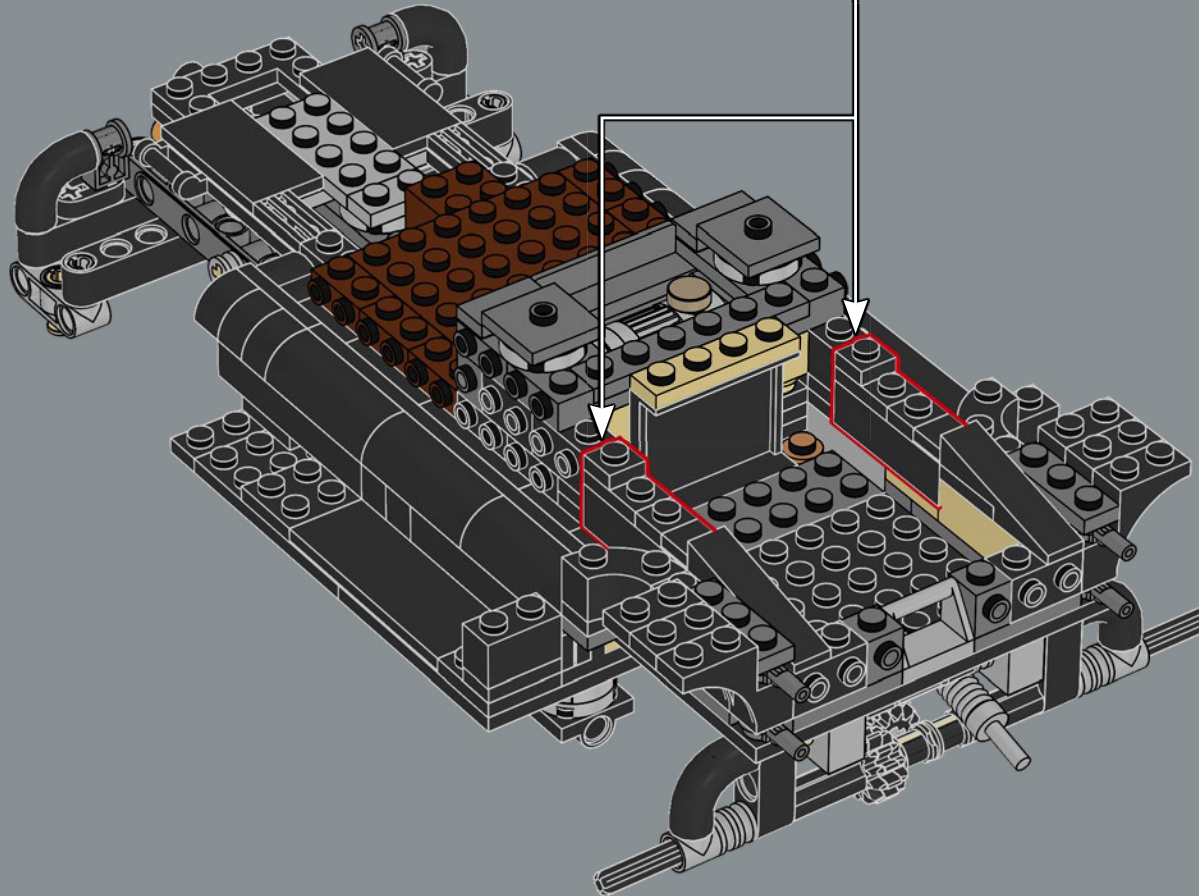
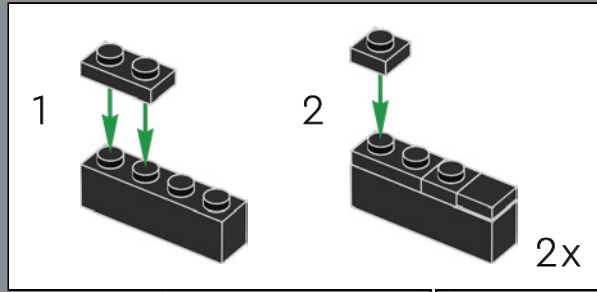

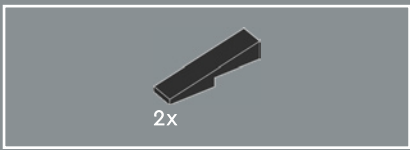

96

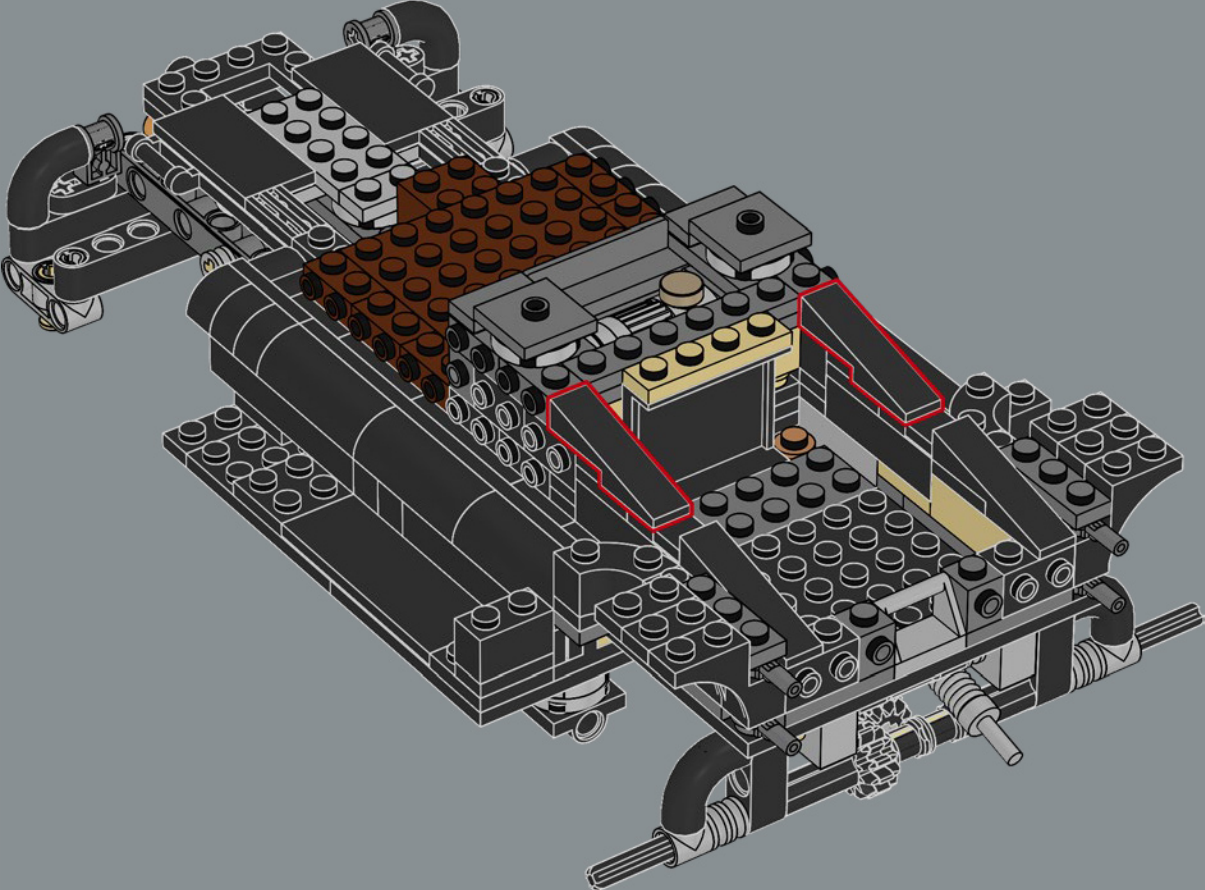

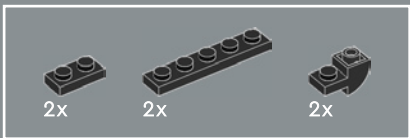

97

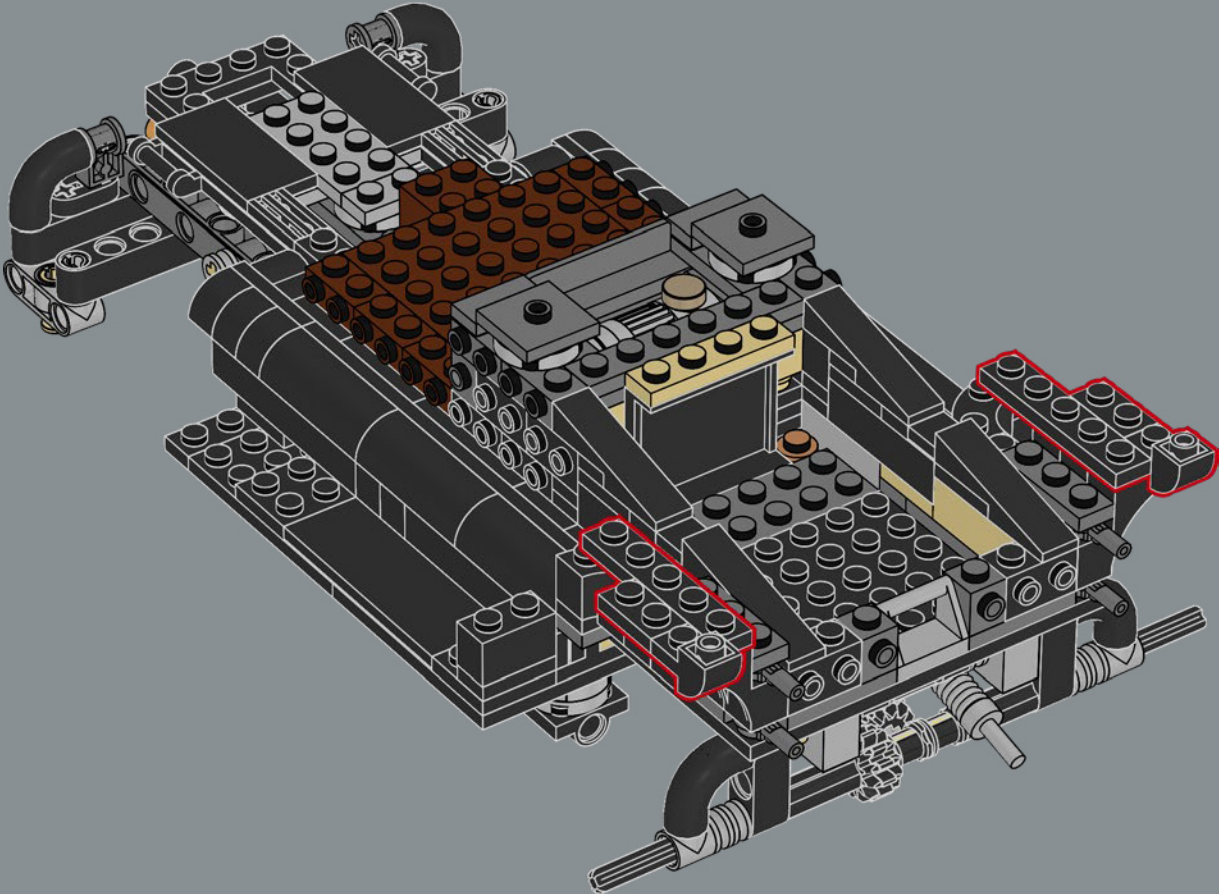

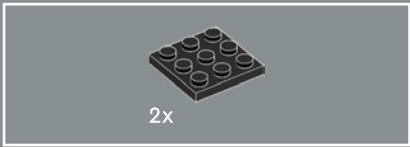

98

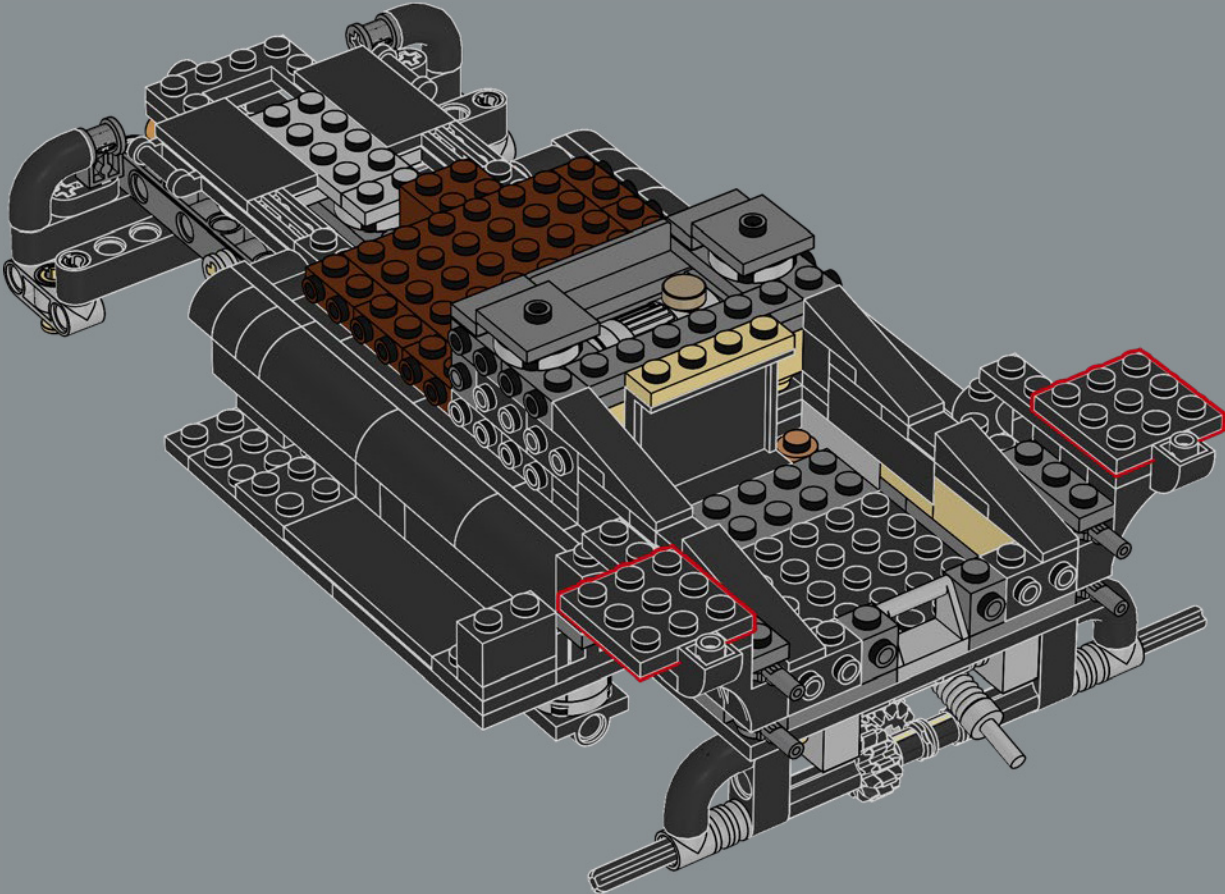



2x



2x

99

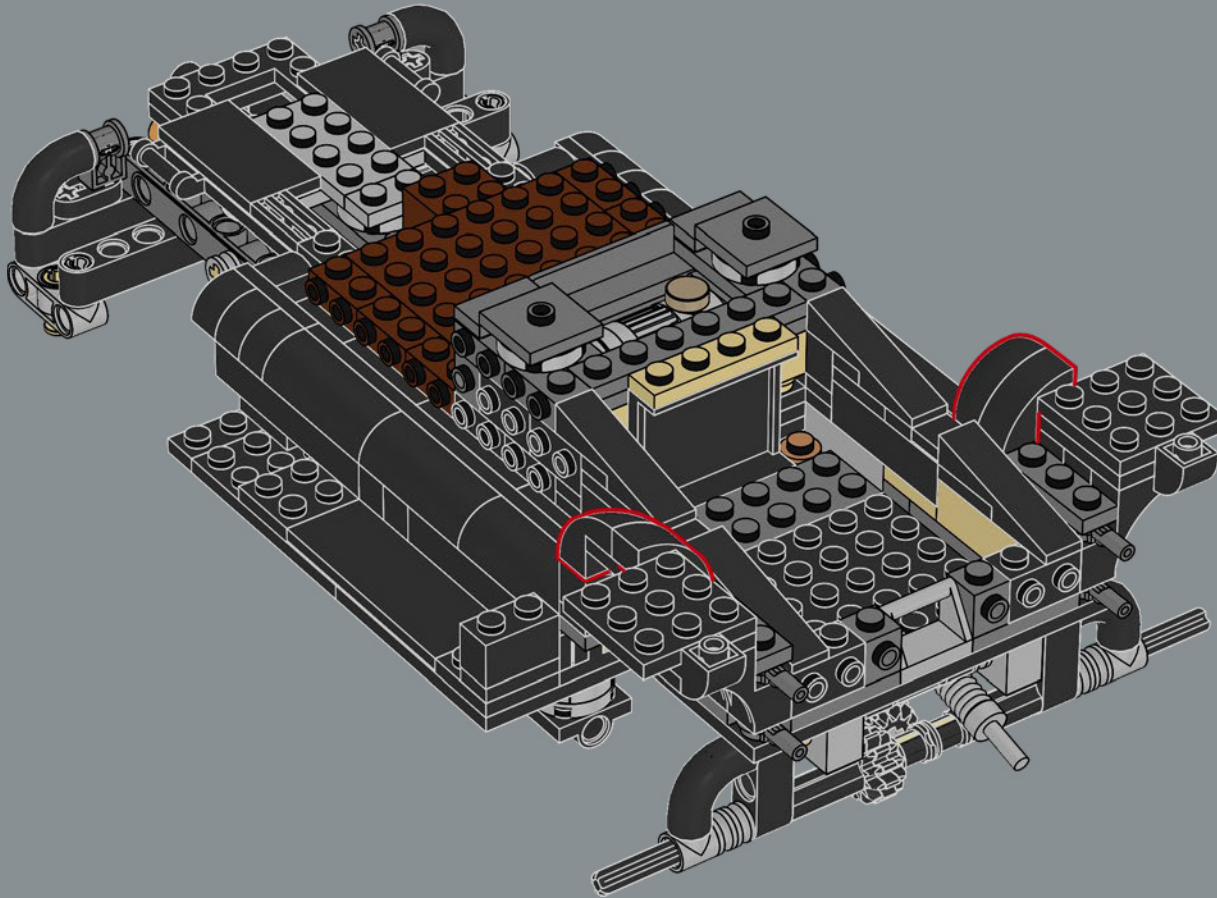



100

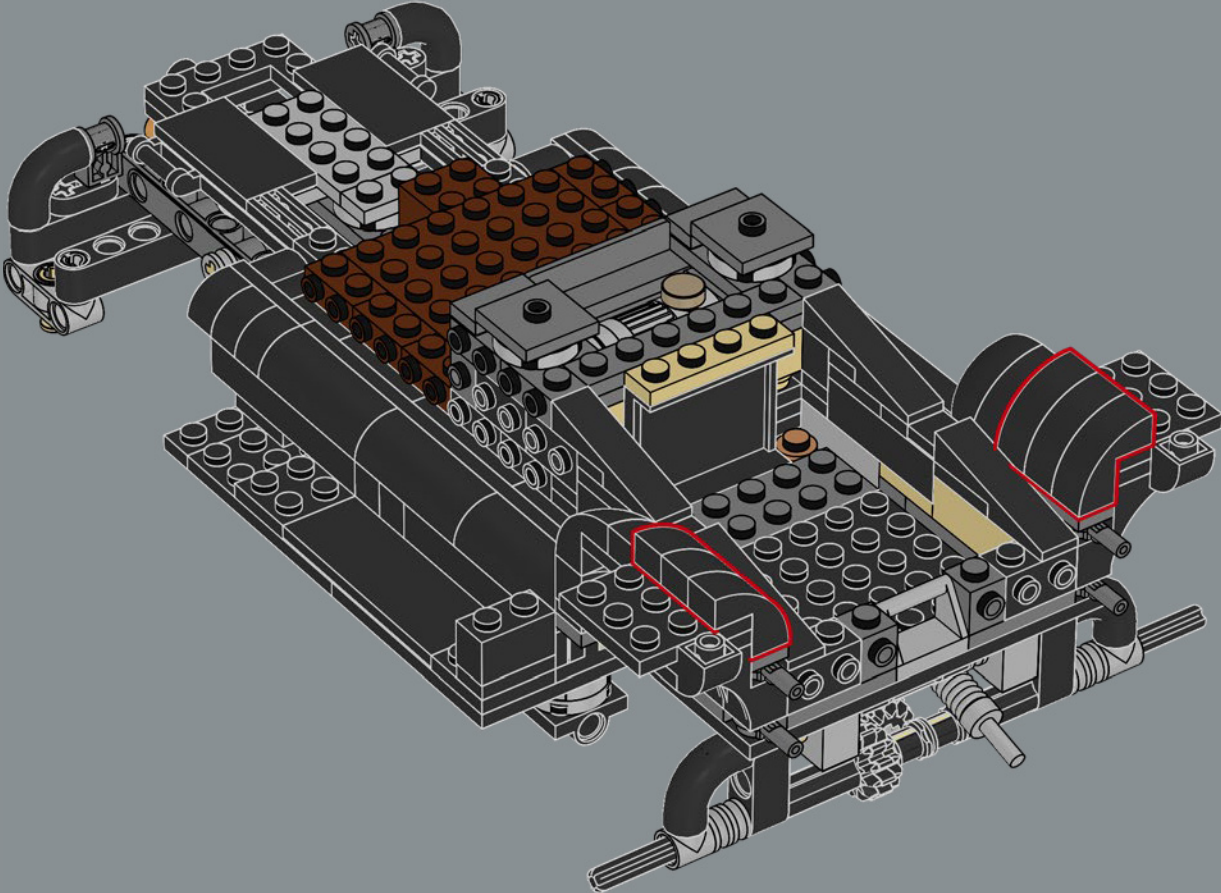

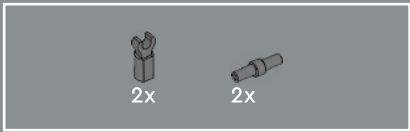

101

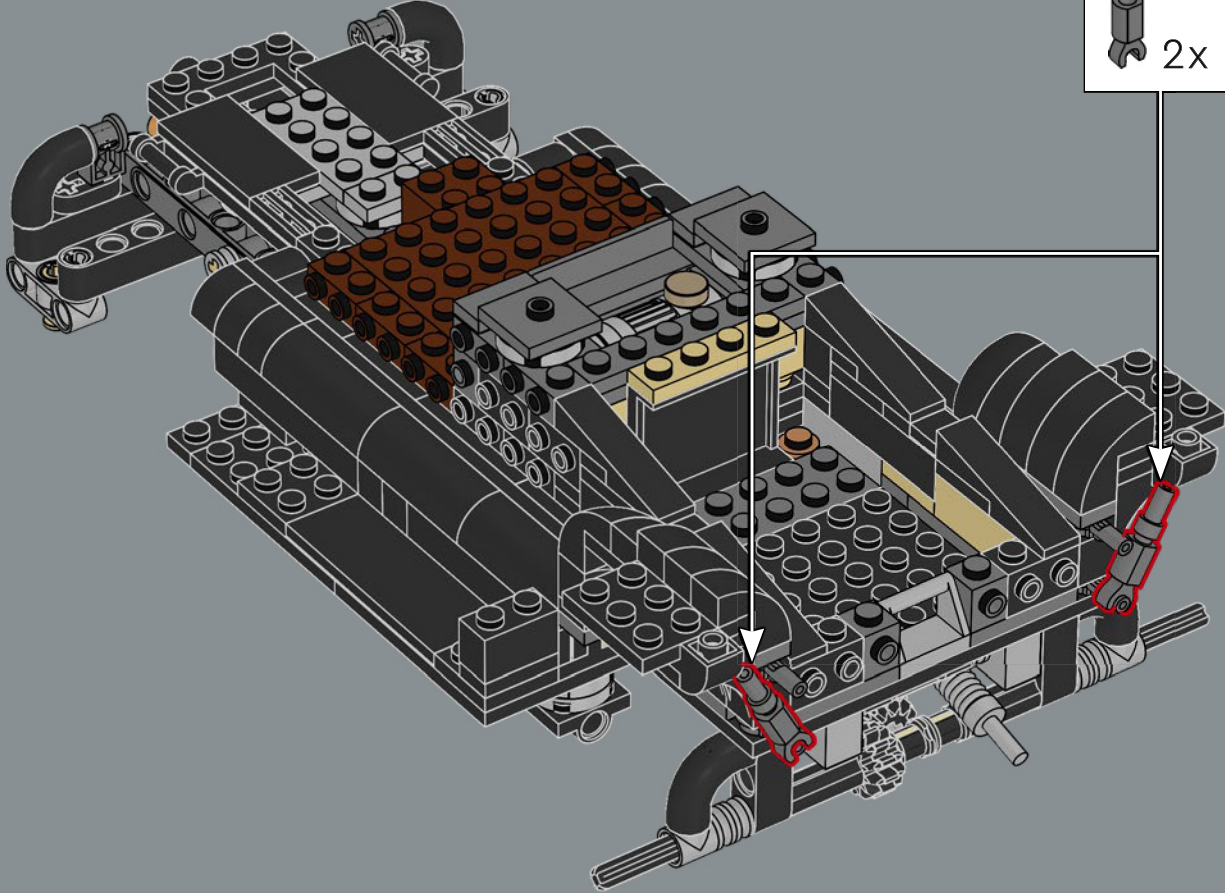
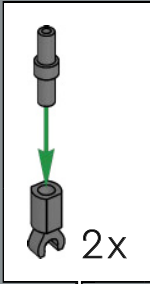

✦
Les ailes étaient en métal léger
et renforcées par des tubes pour
plus de solidité.





102

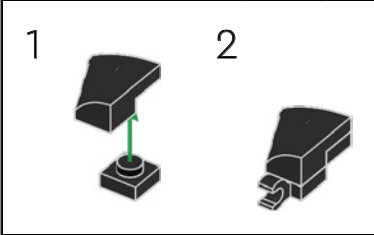
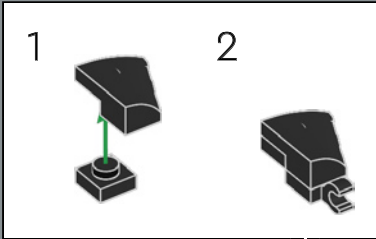
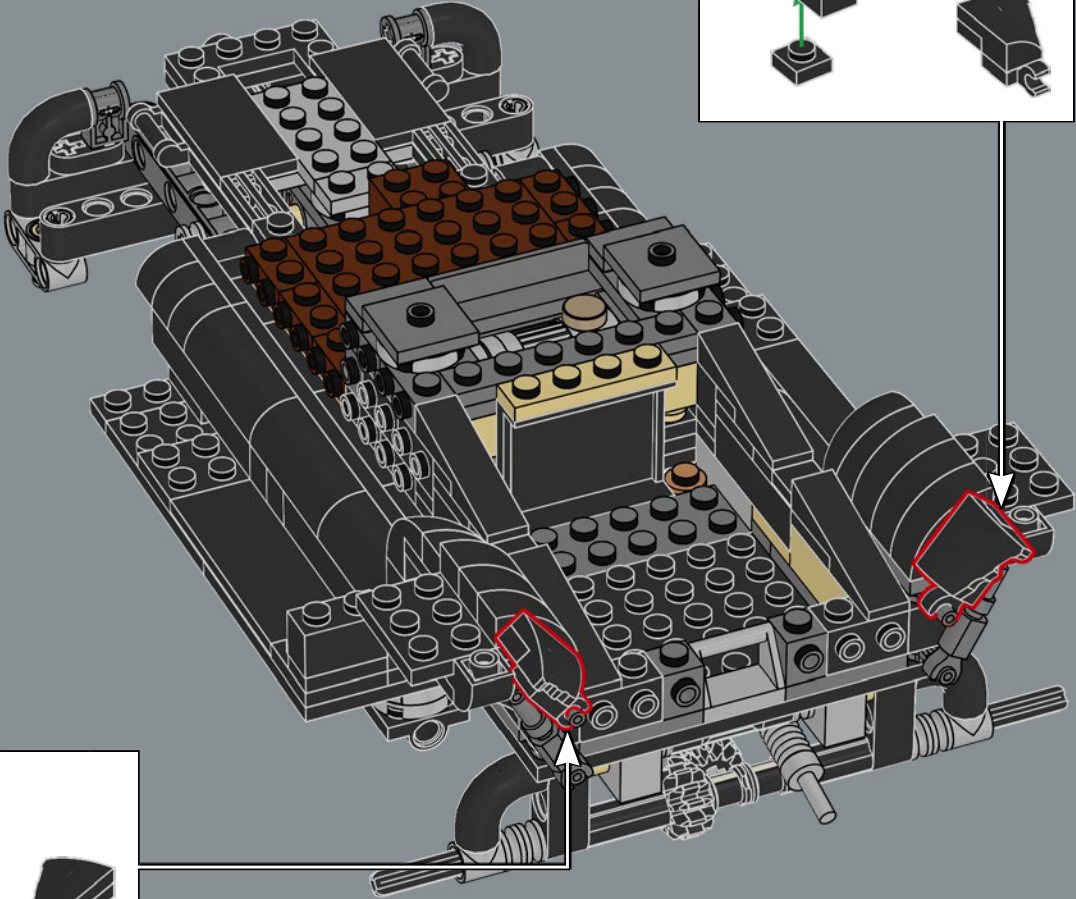

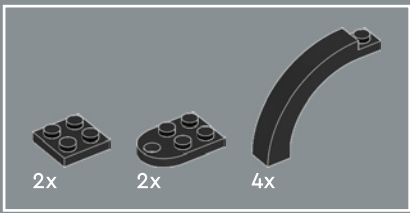

103

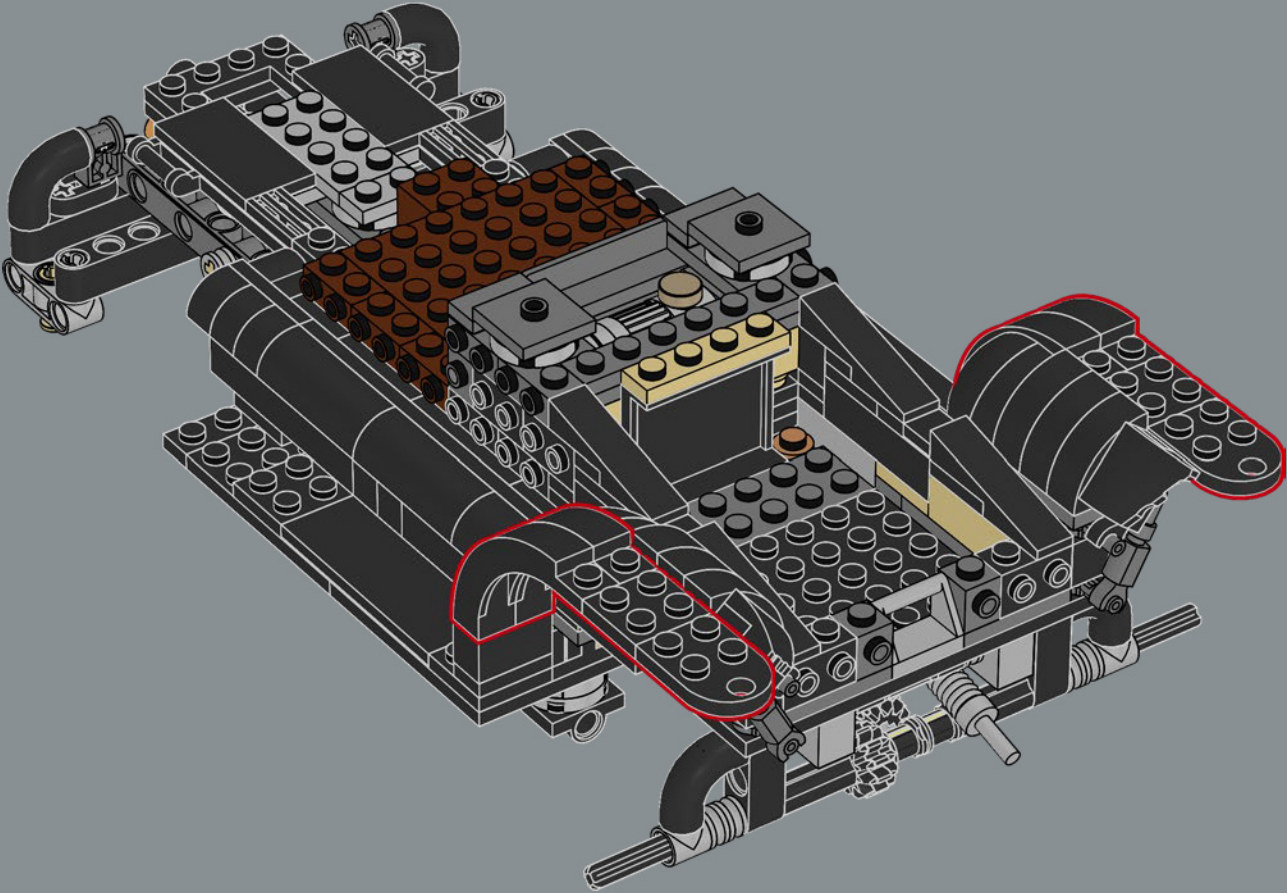

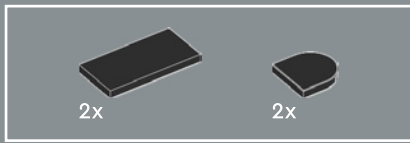

104

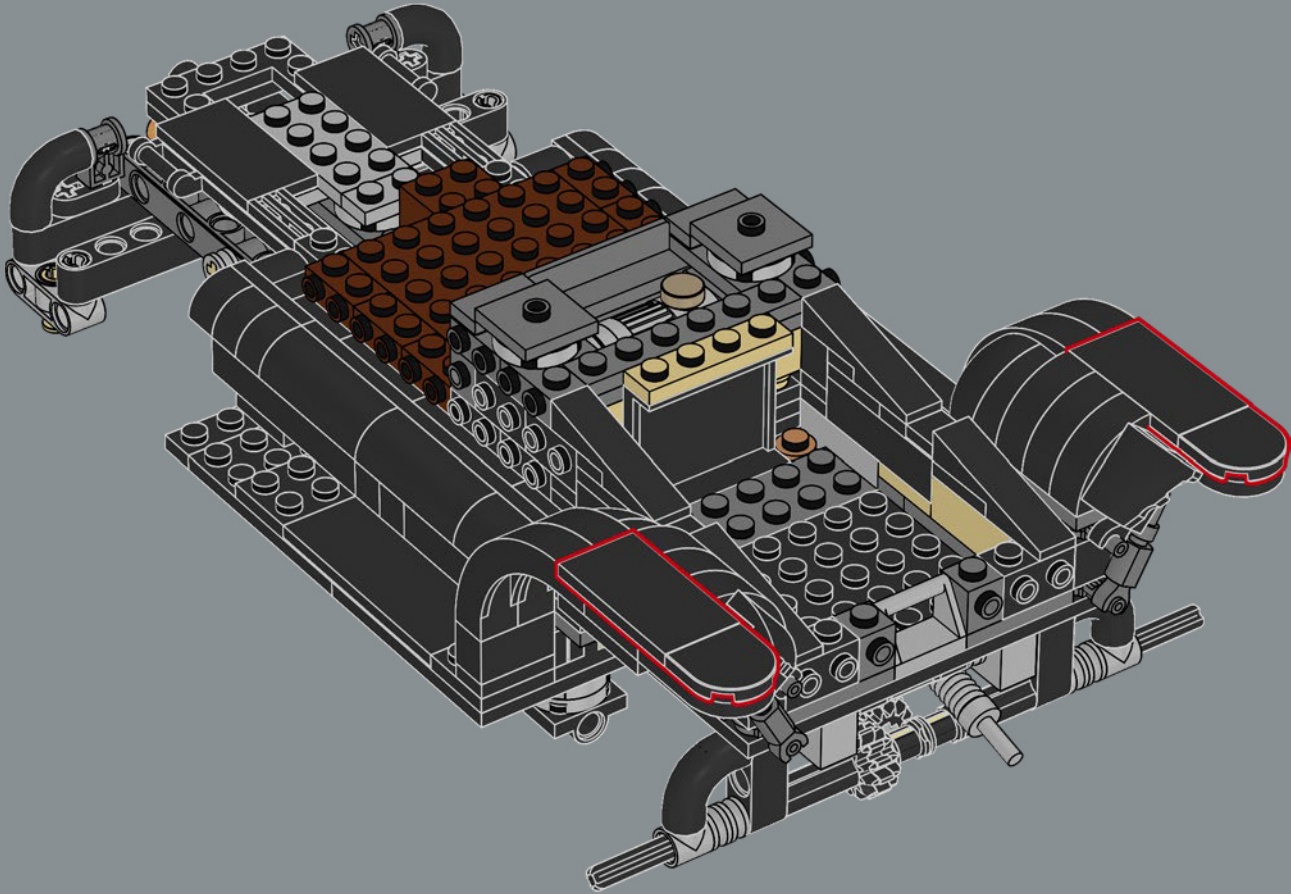



106

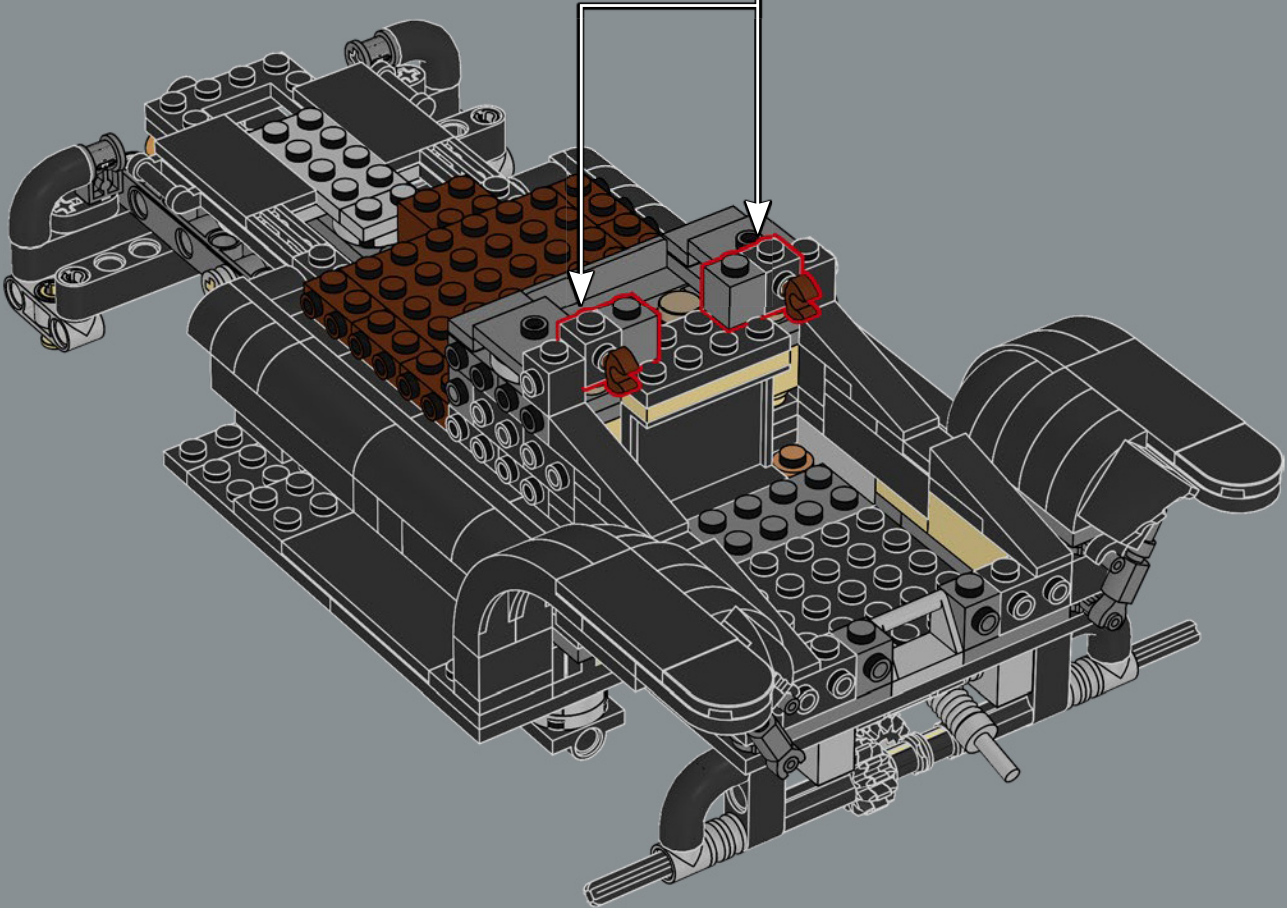
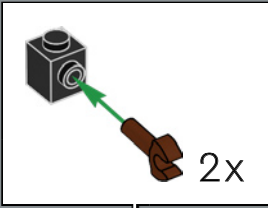

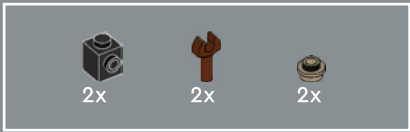

107

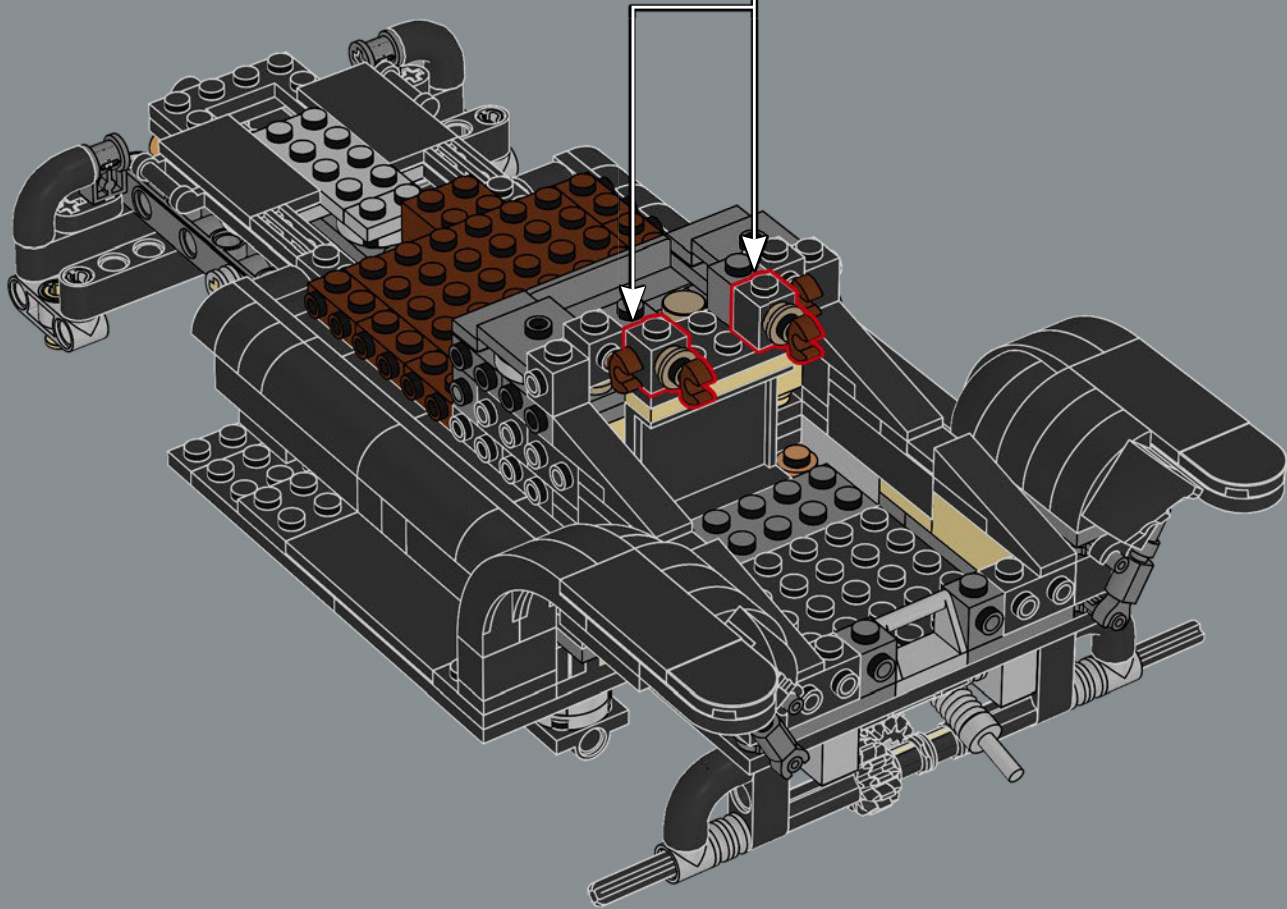
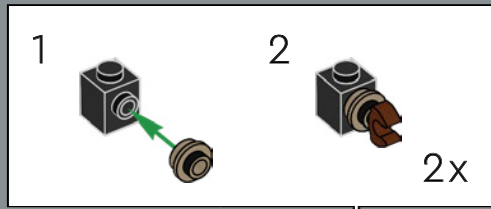

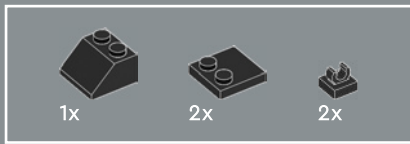

108

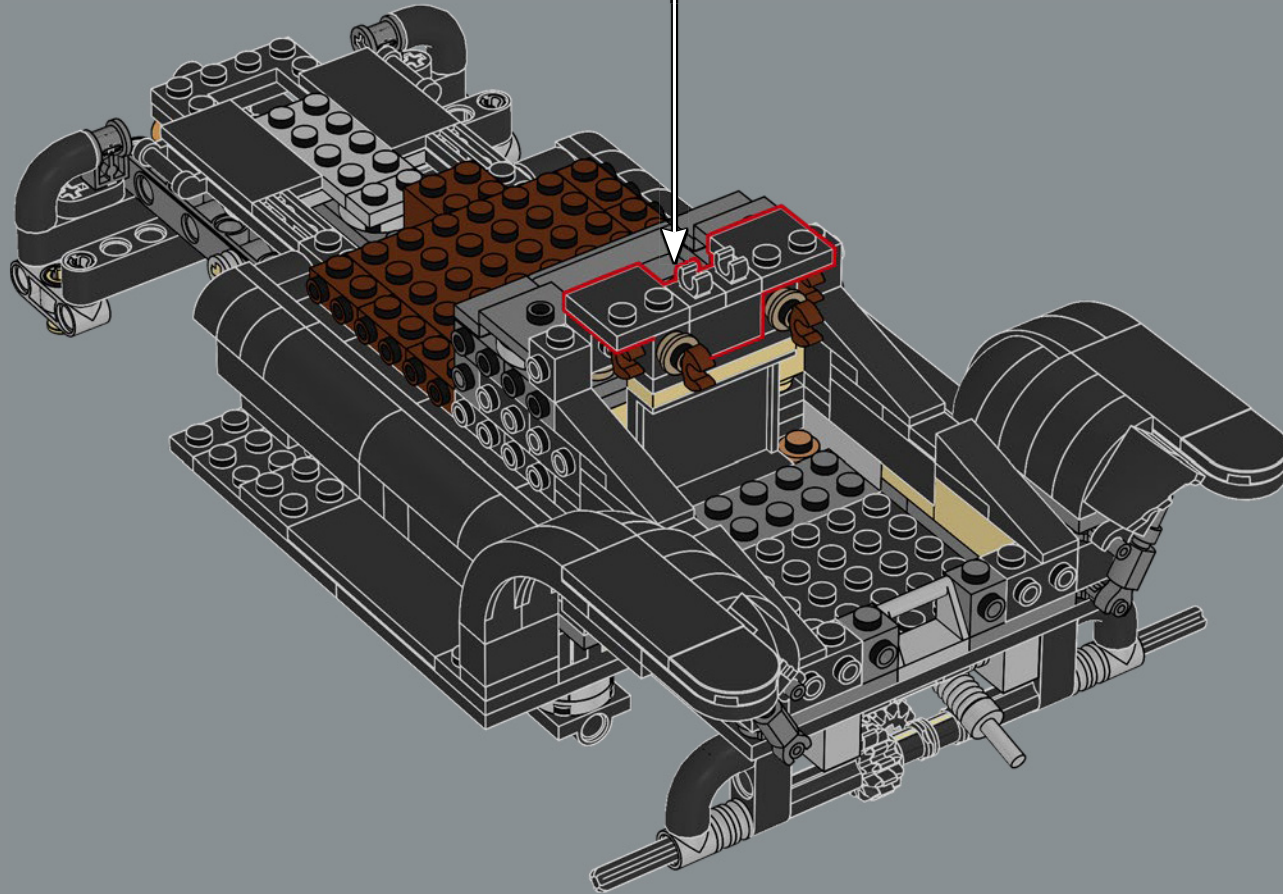
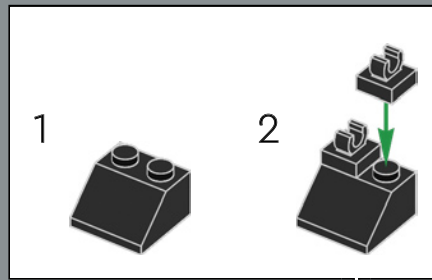



2x

109

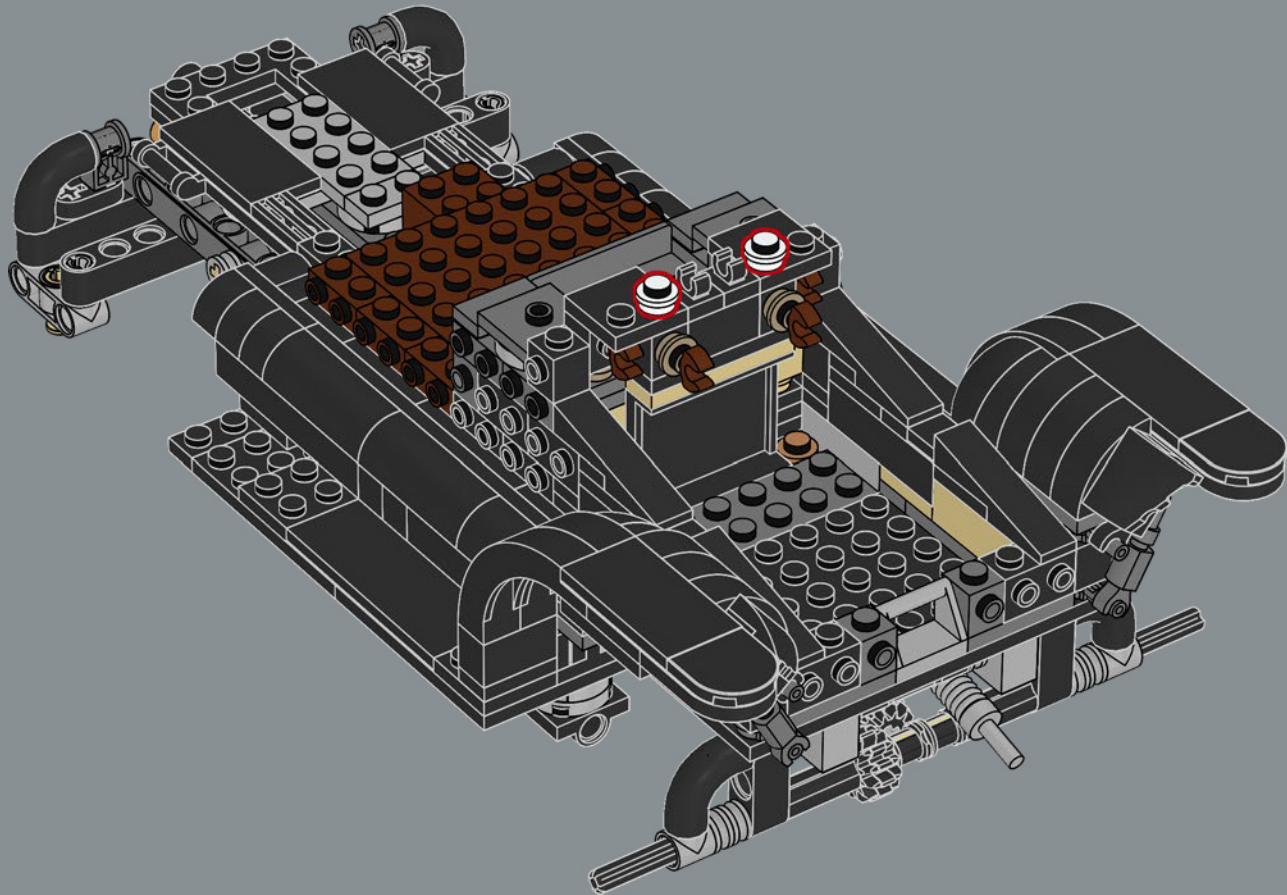

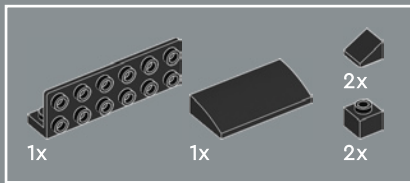

110

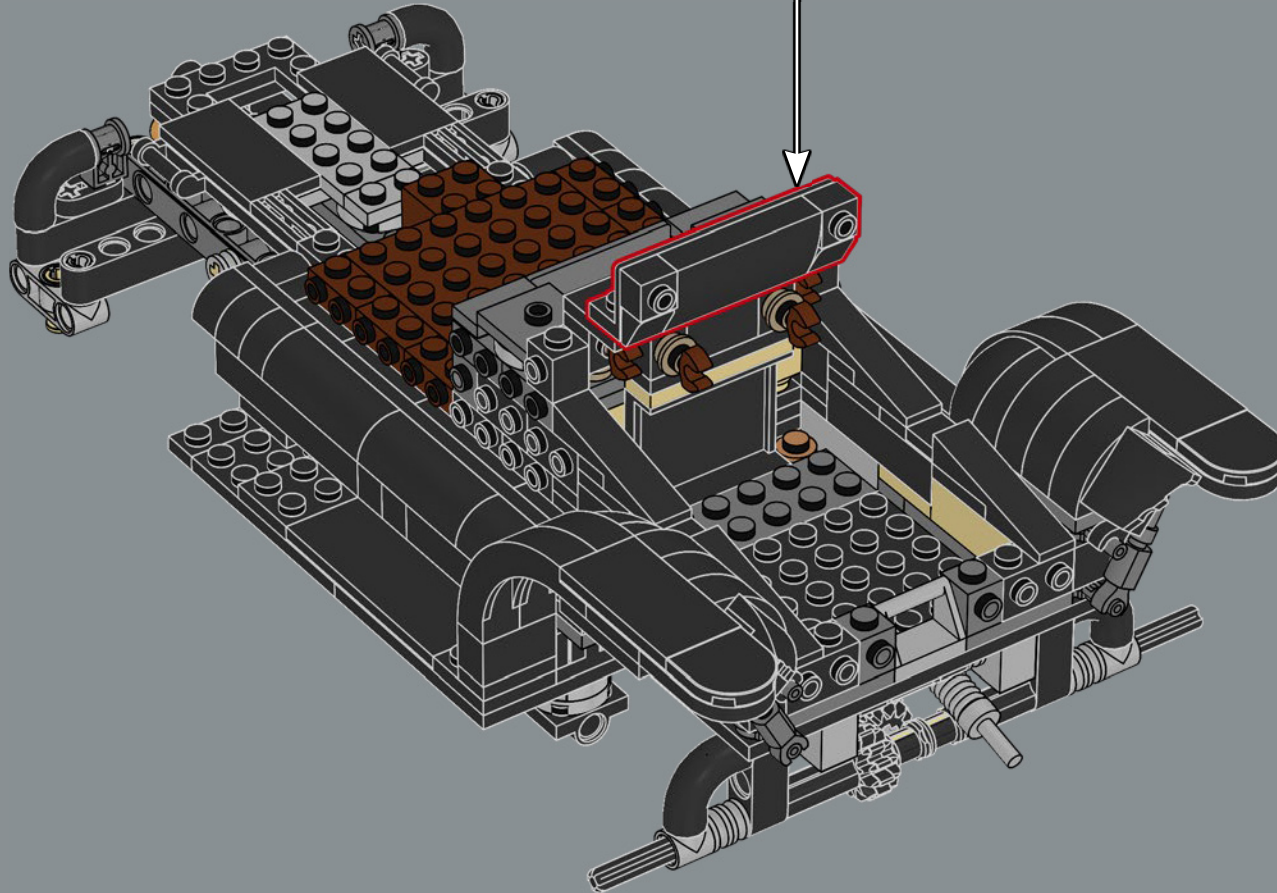
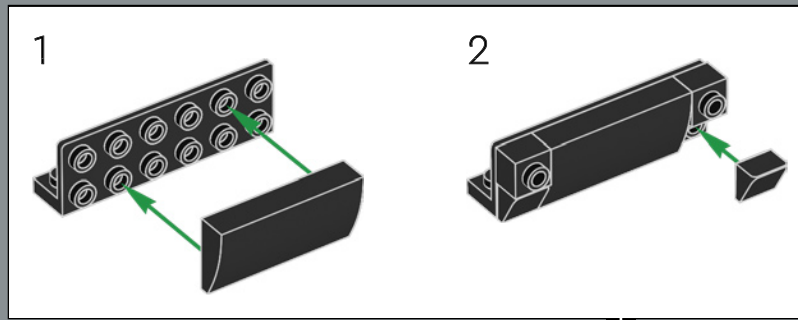

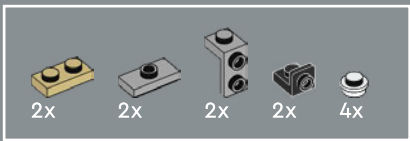

111

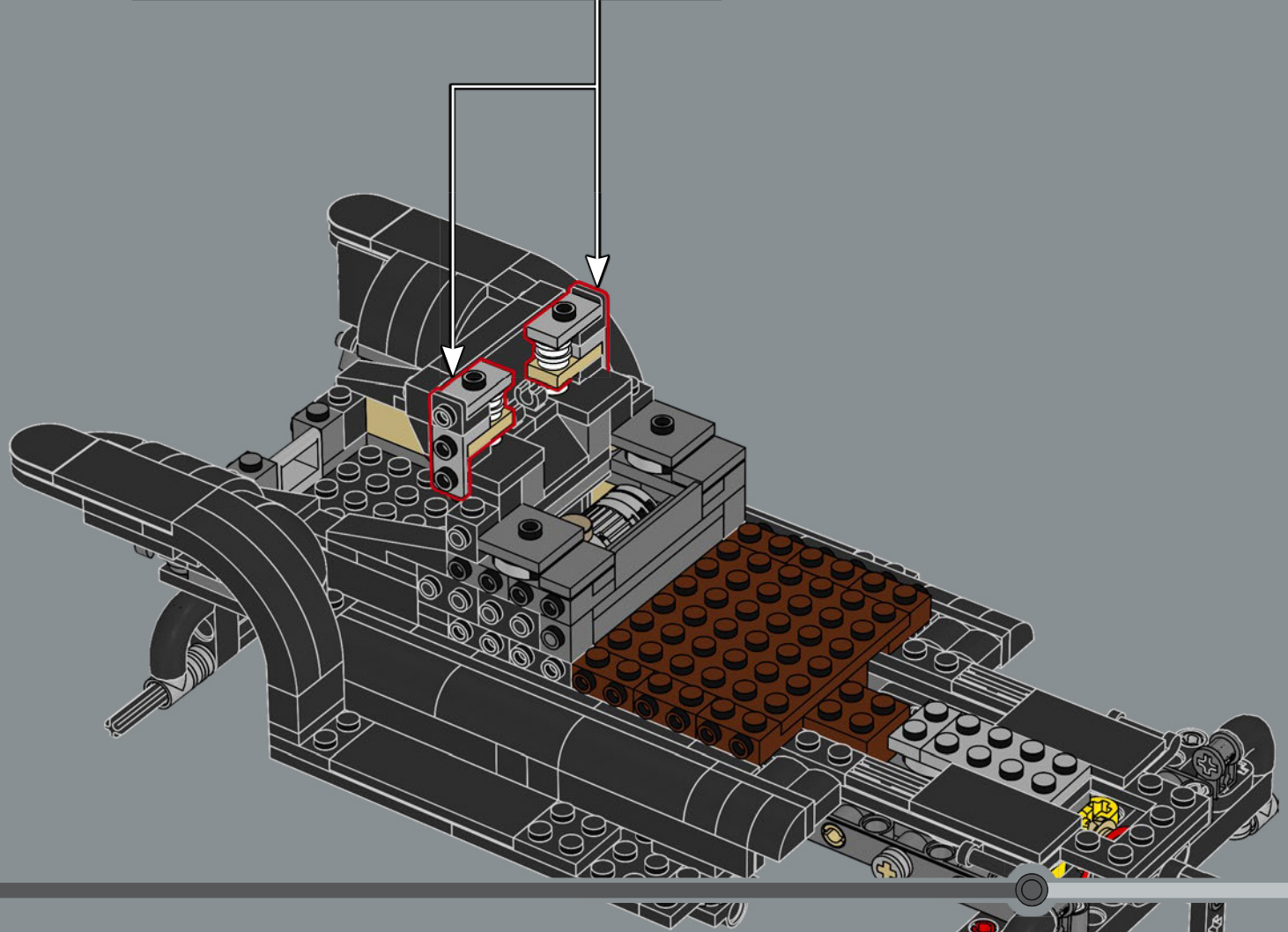
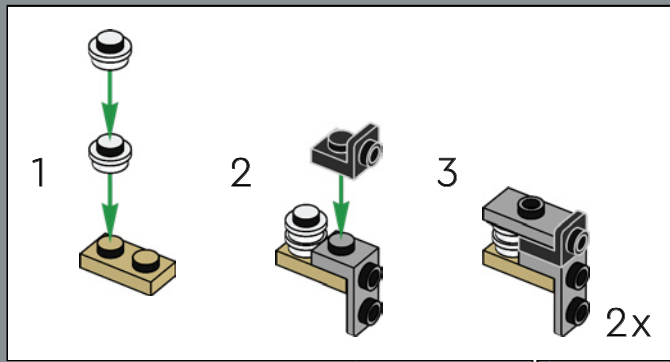

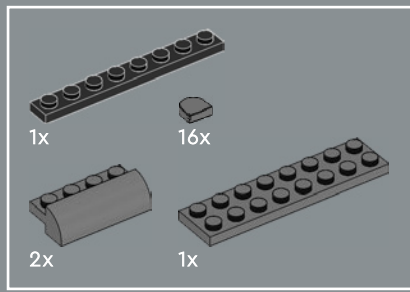

112

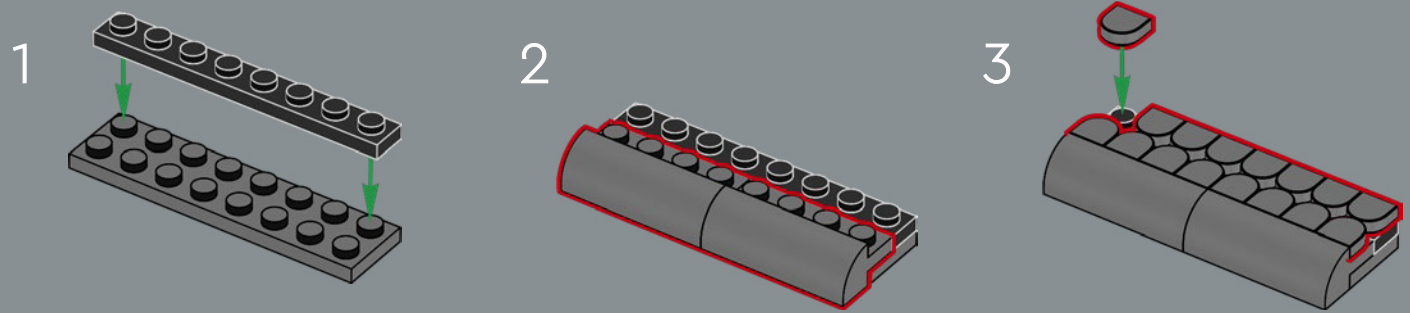

À l'intérieur, les sièges étaient recouverts de cuir et rembourrés d'un mélange de coton brut et de crin de cheval pour plus de confort.

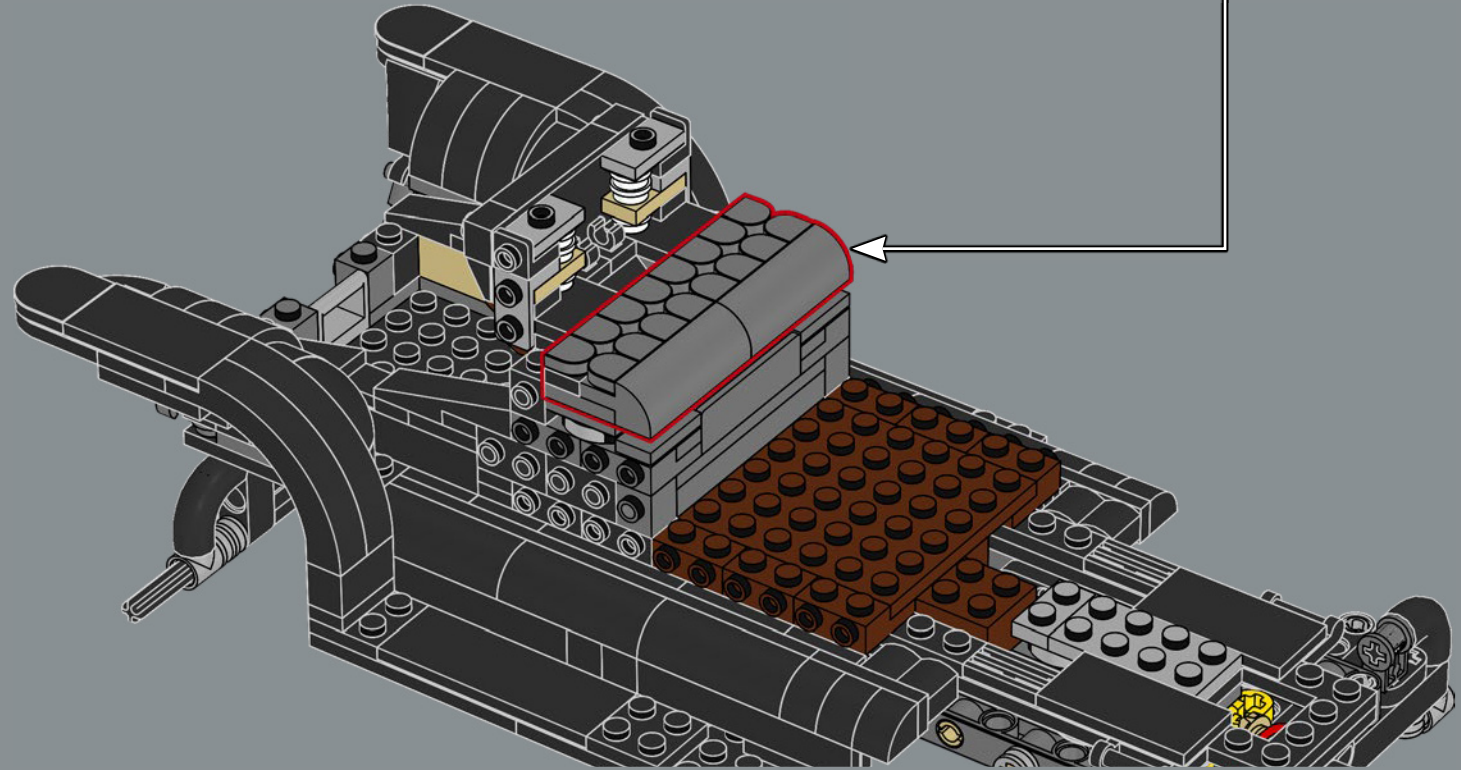

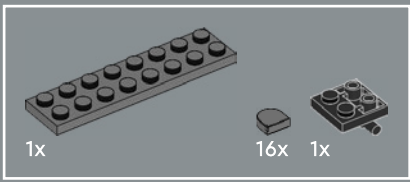

113

1

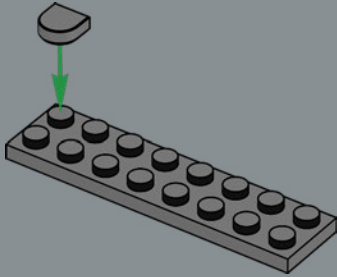

2

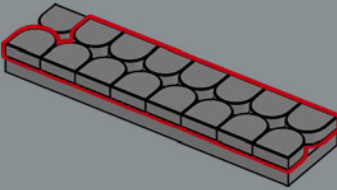

3

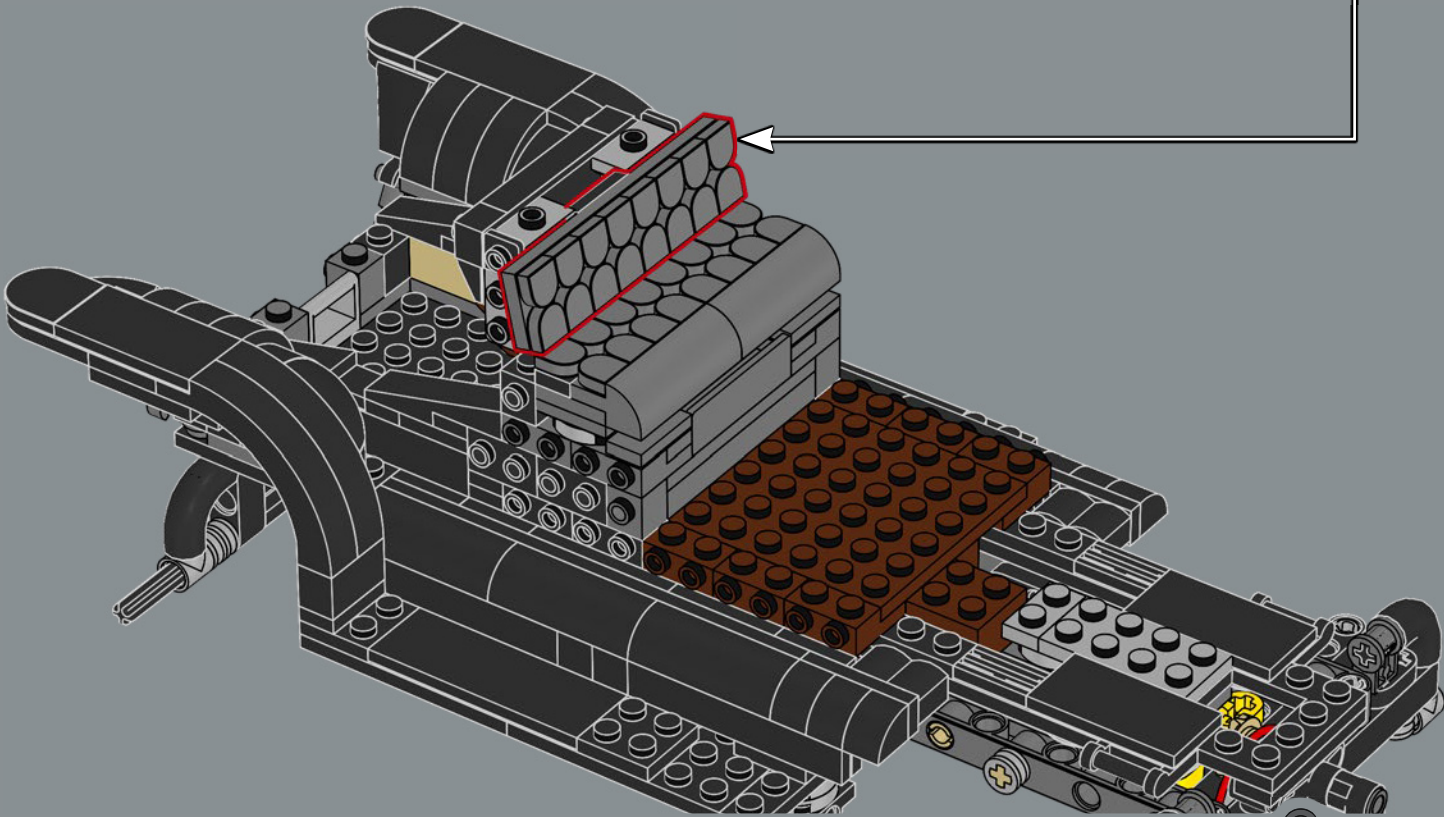
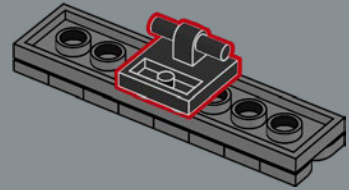

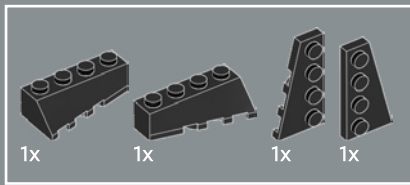

114

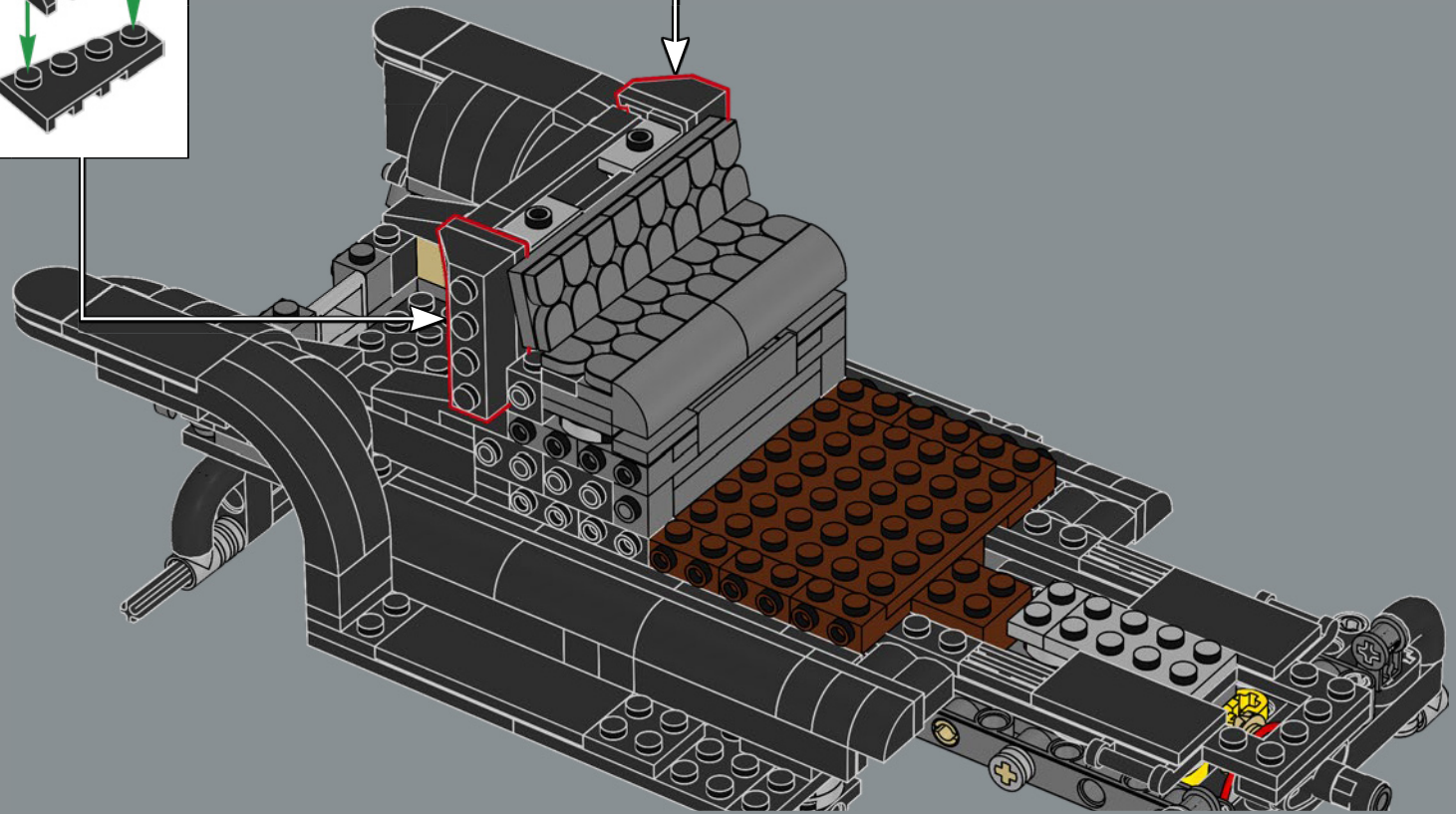
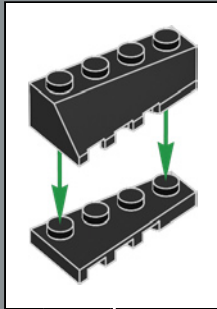
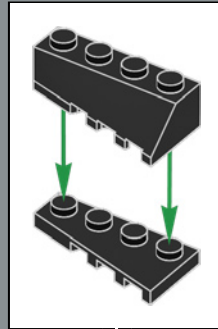

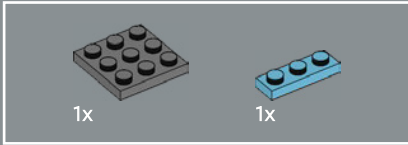
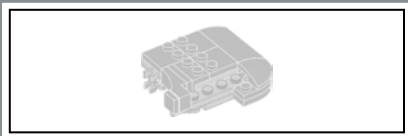

115

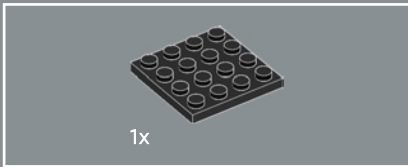
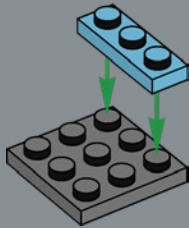

116

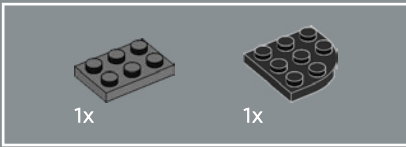
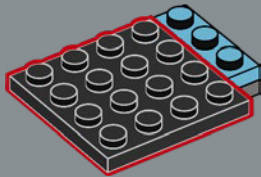

117

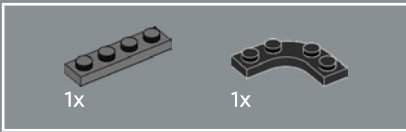
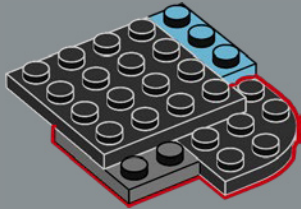

118

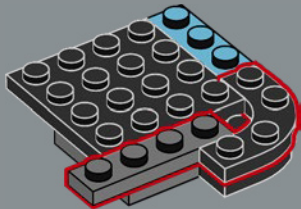

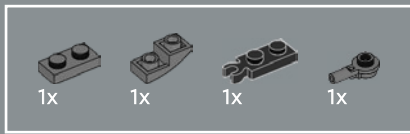

119

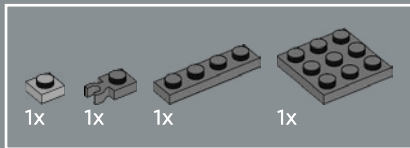
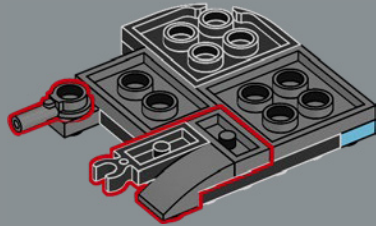

120

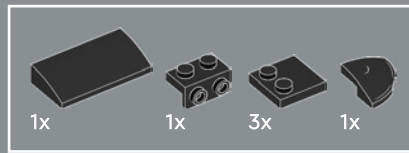
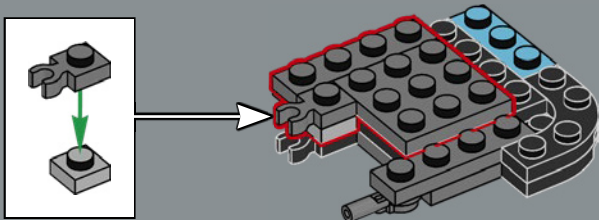

121

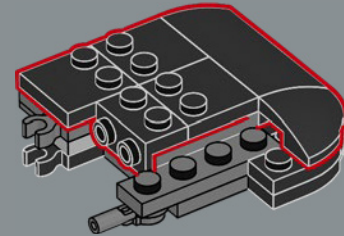

122

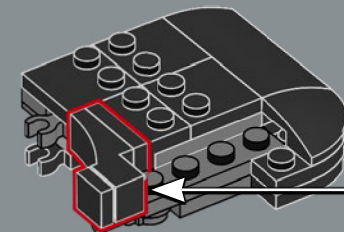
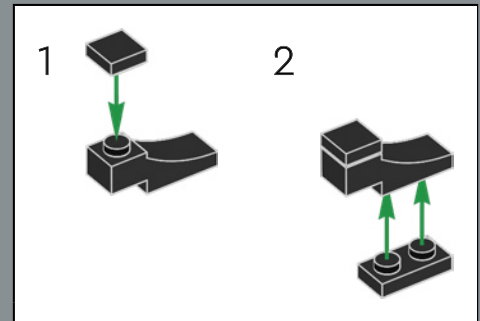

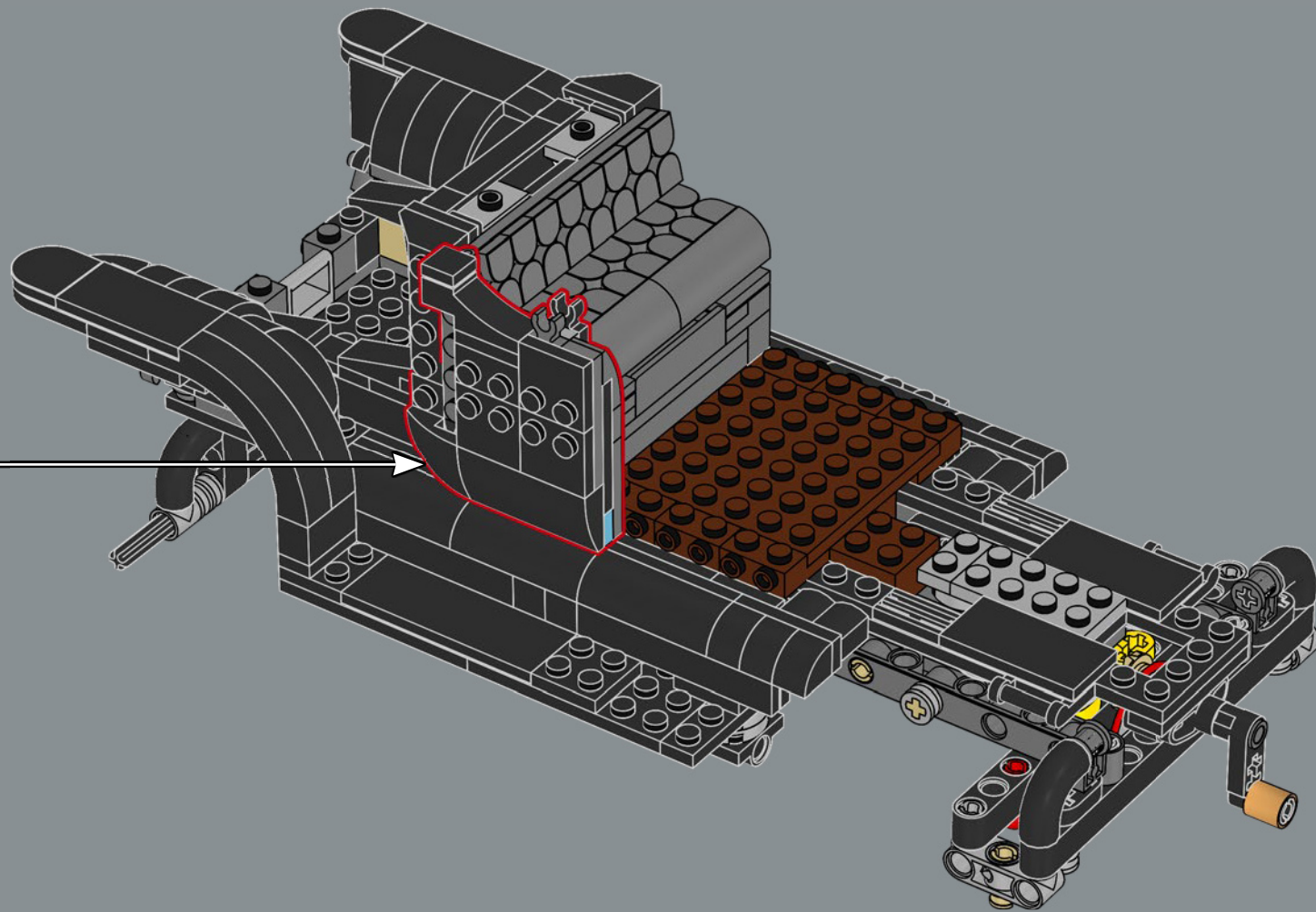



124

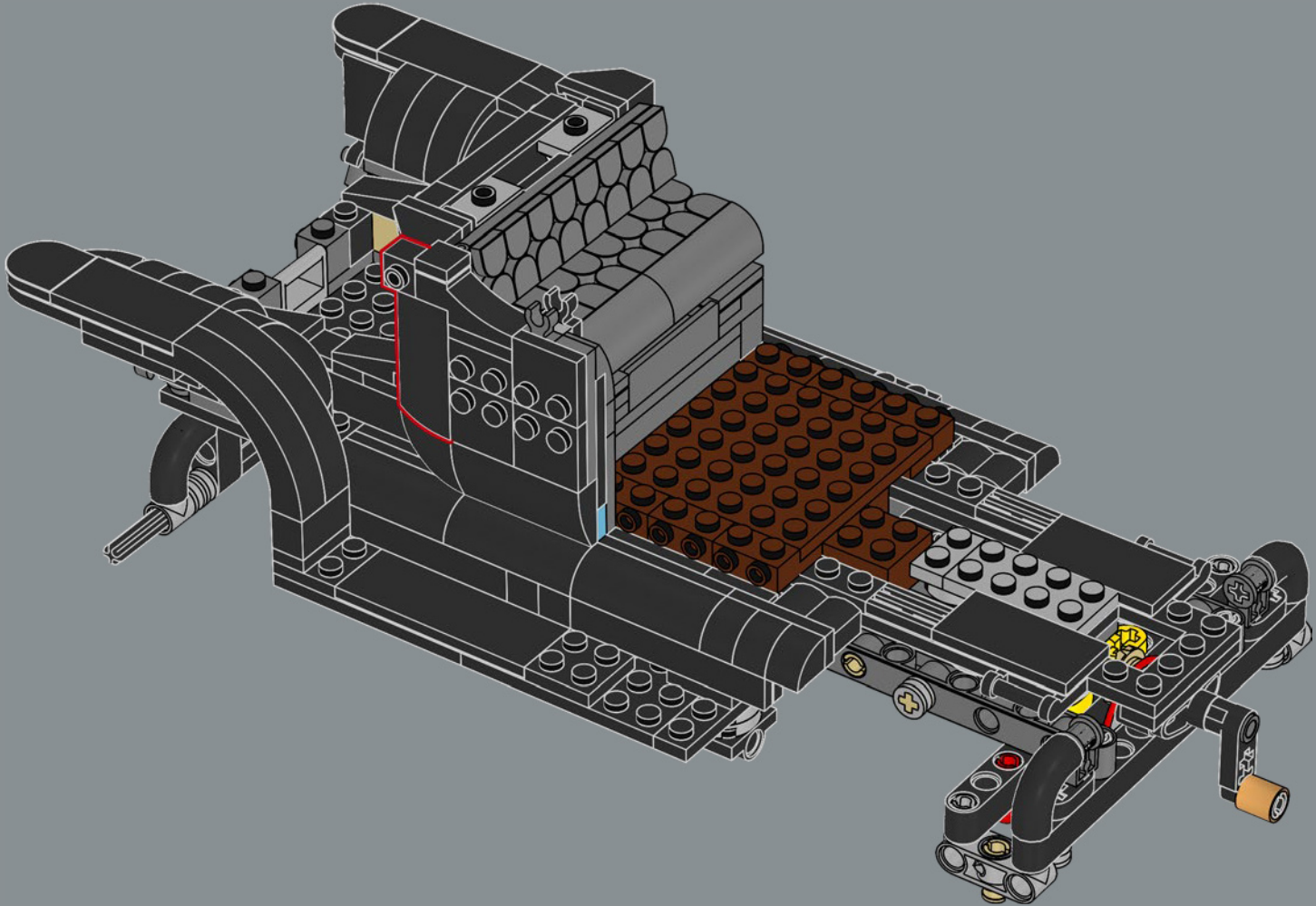

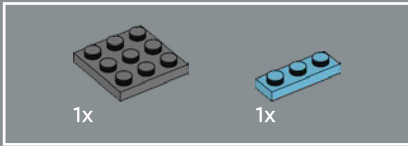
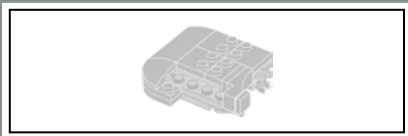

125

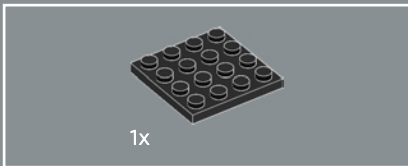
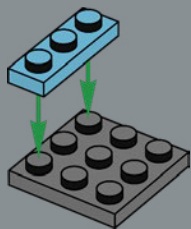

126

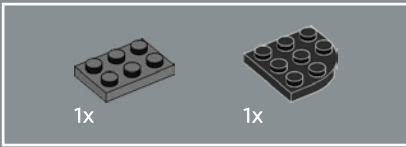
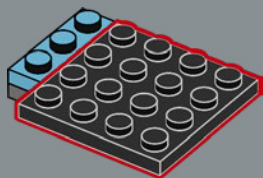

127

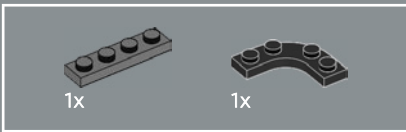
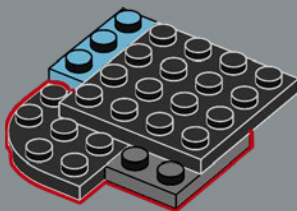

128

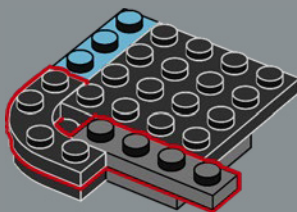

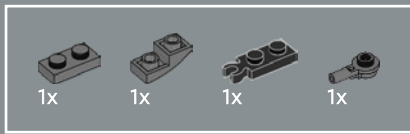

129

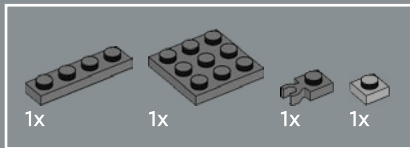
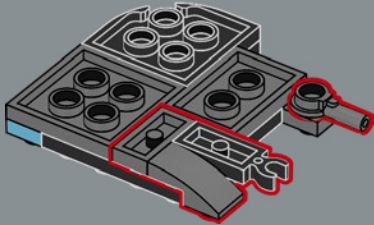

130

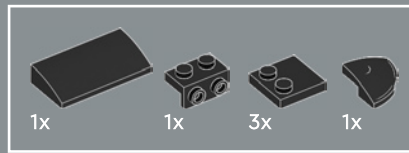
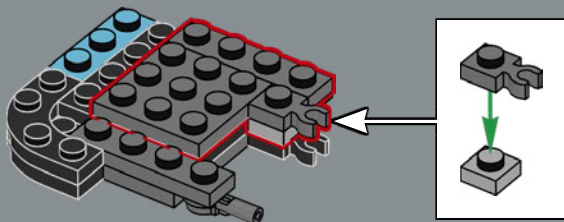

131

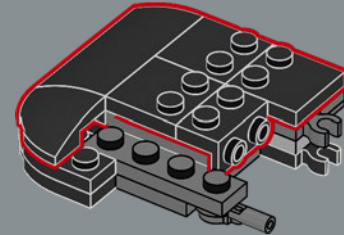

132

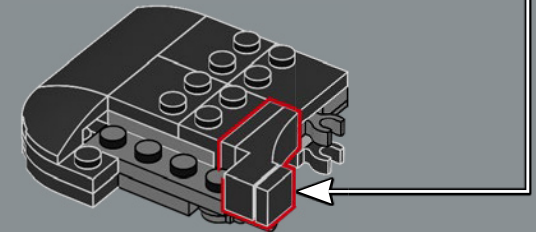
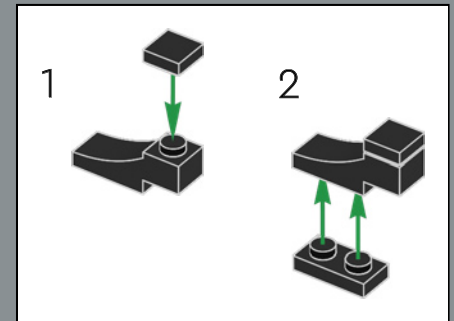

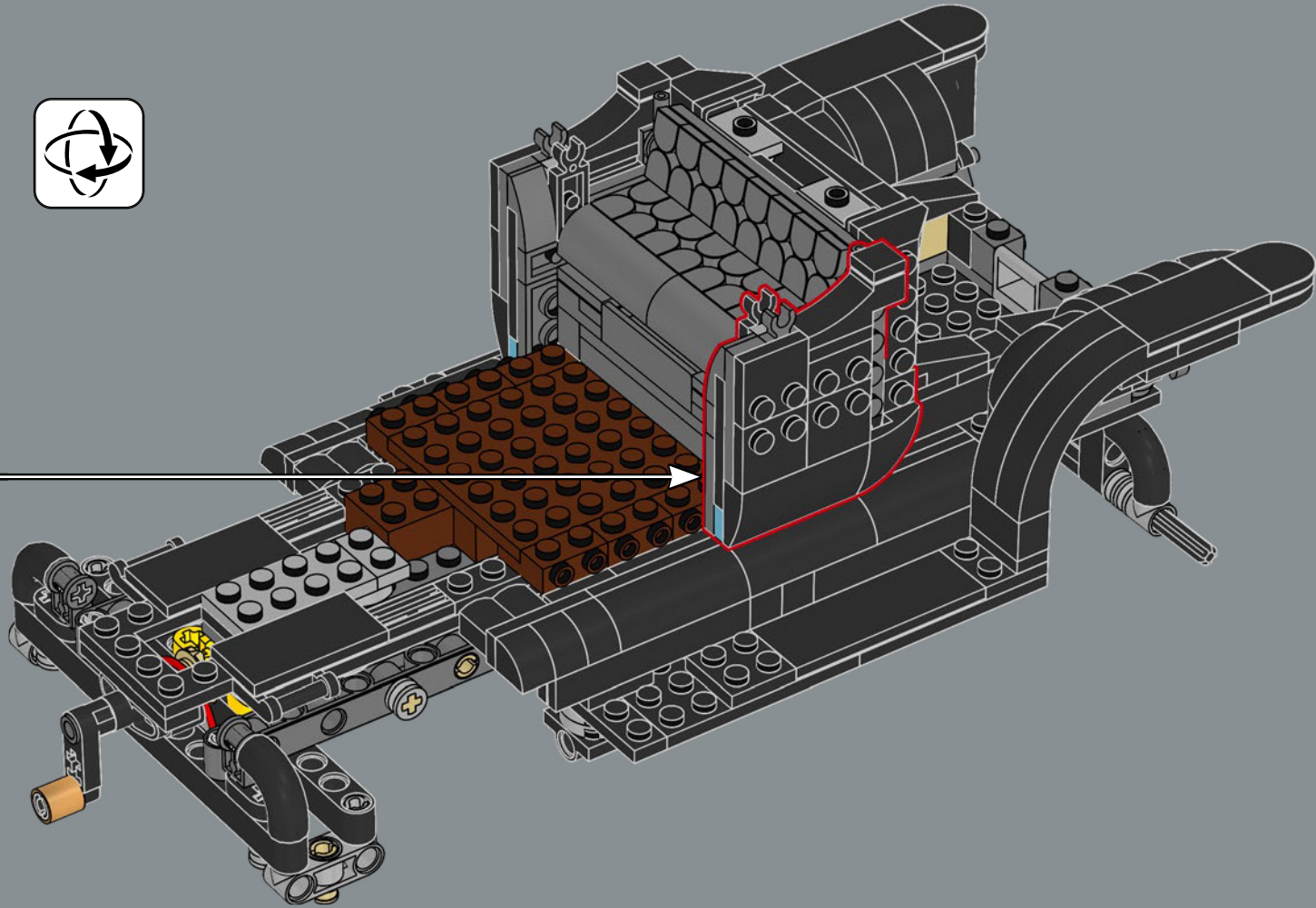



Les acheteurs pouvaient choisir entre des versions deux, trois ou quatre places, certaines variantes comportant même un petit siège extérieur.



134

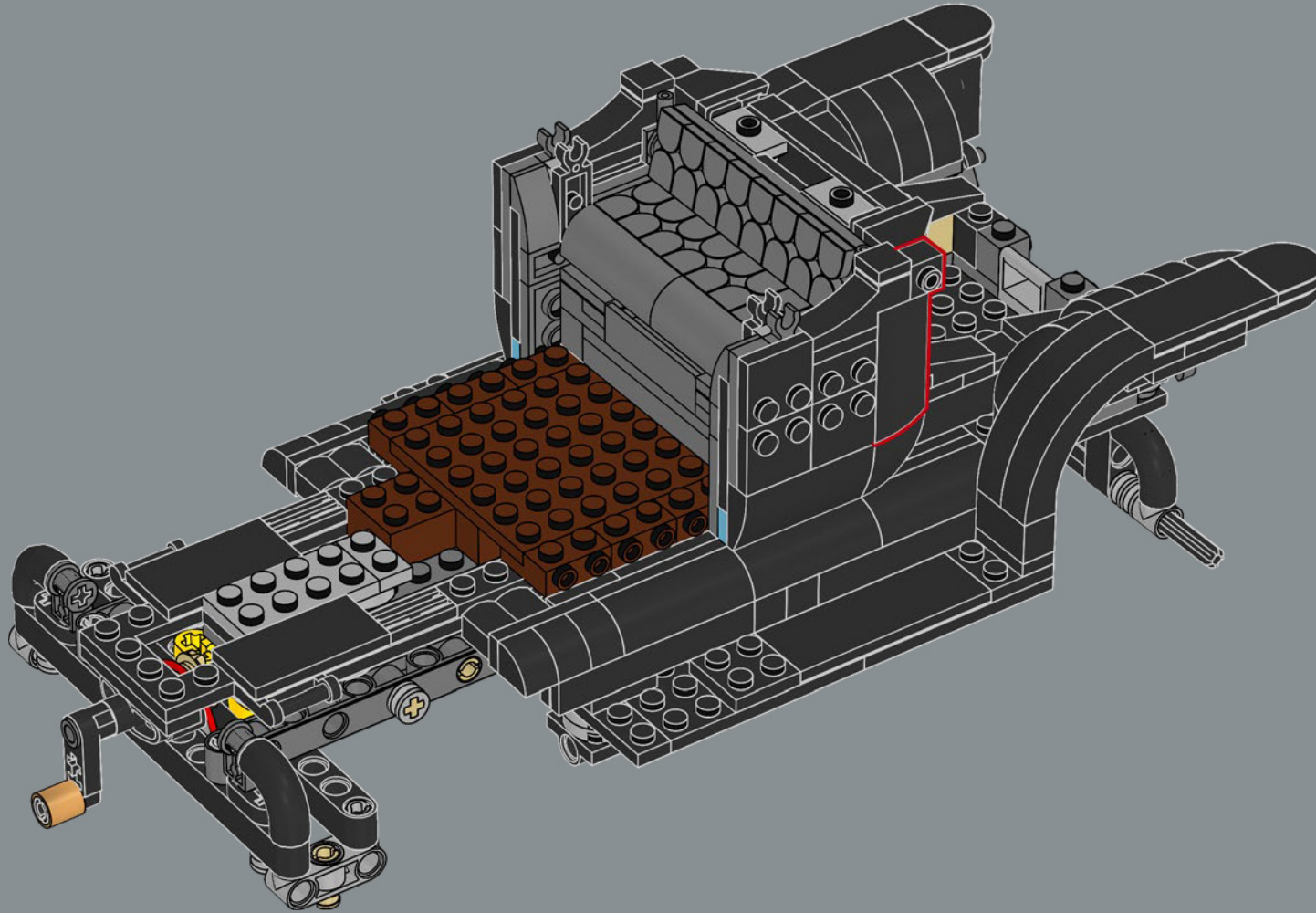

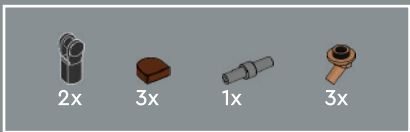

136

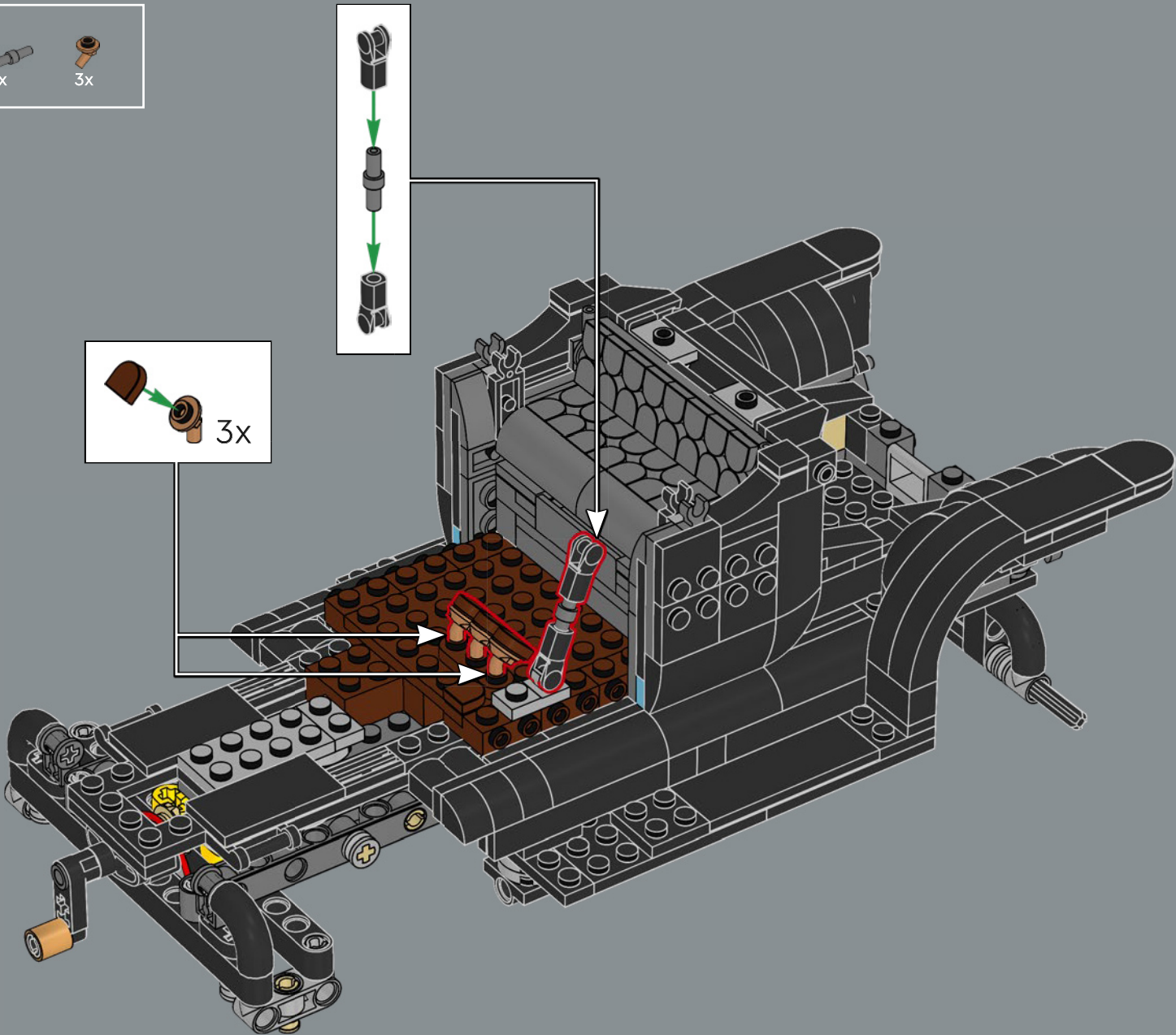

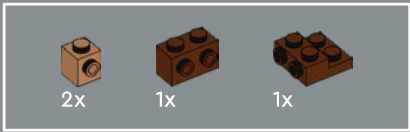

137

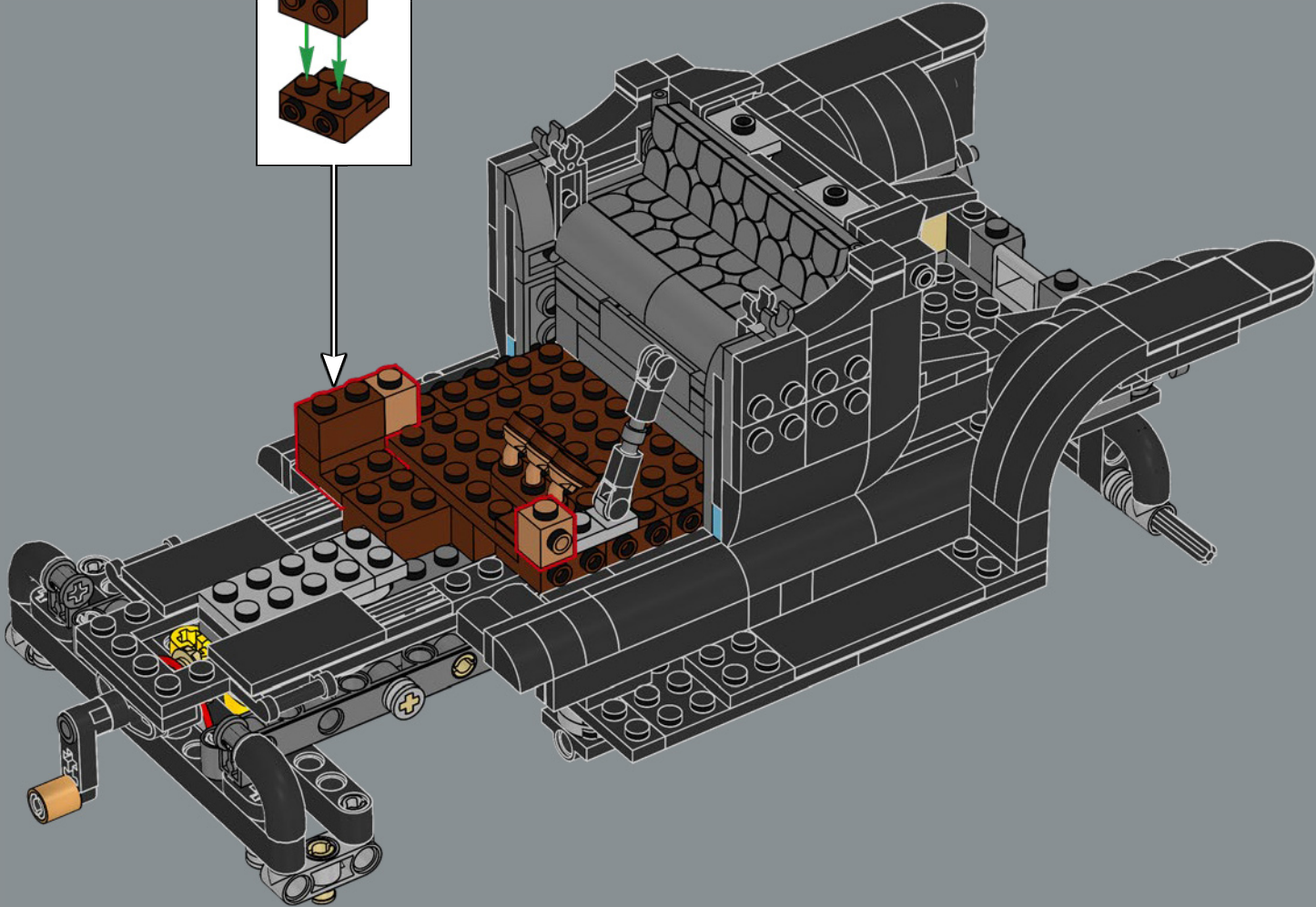
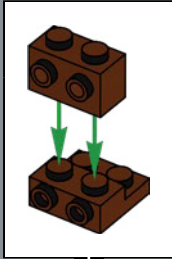

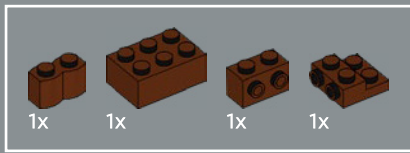

138

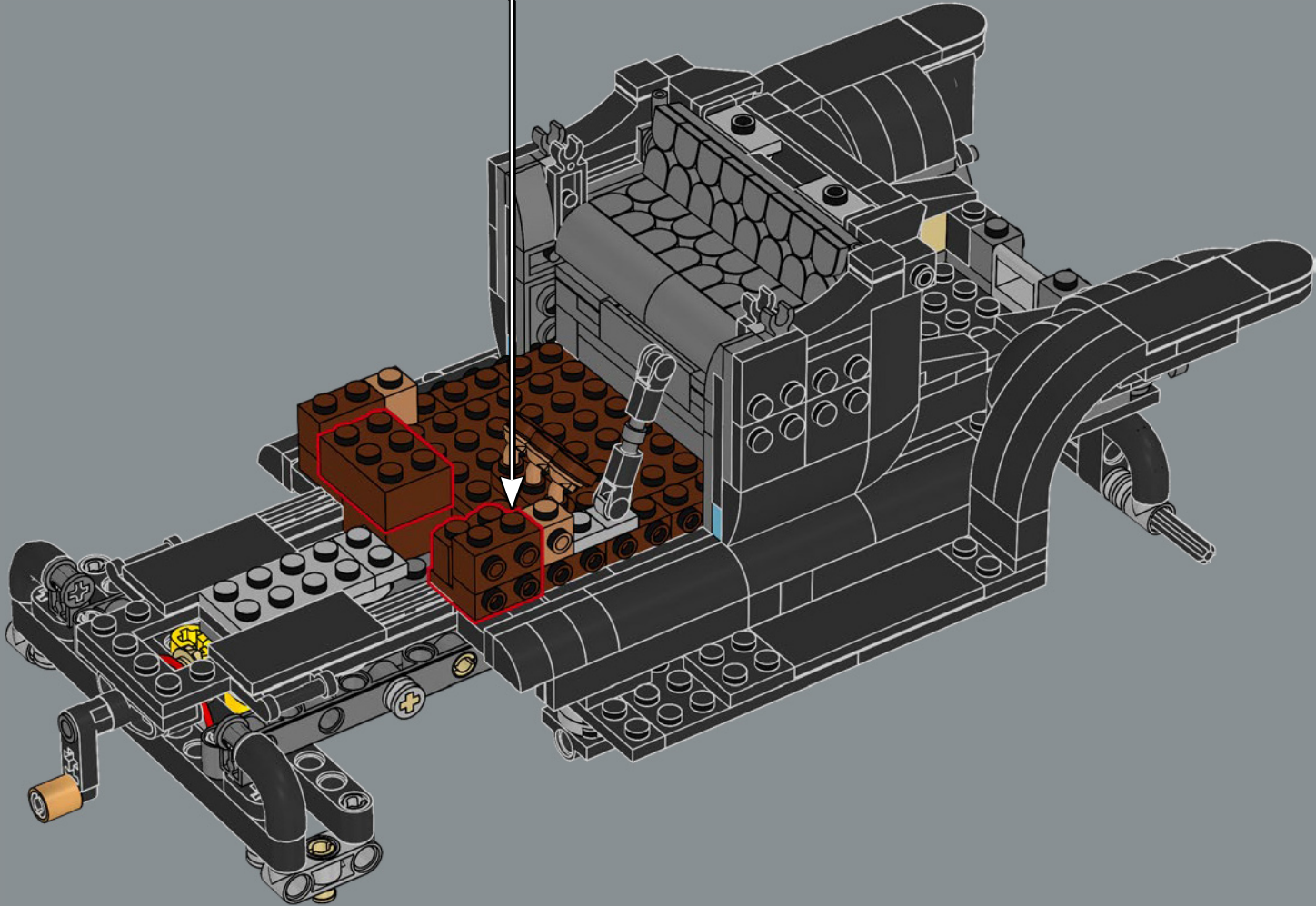
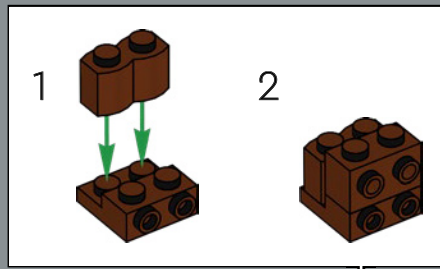

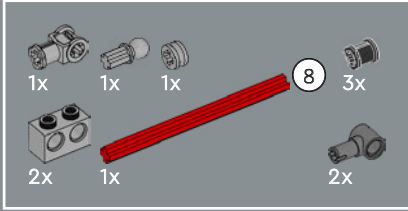
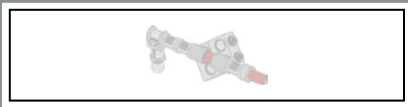

139

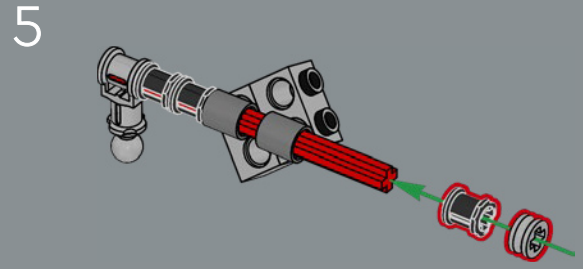
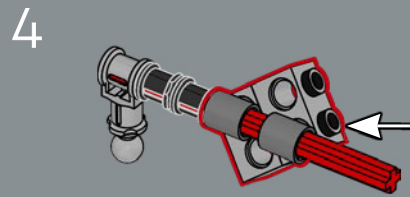
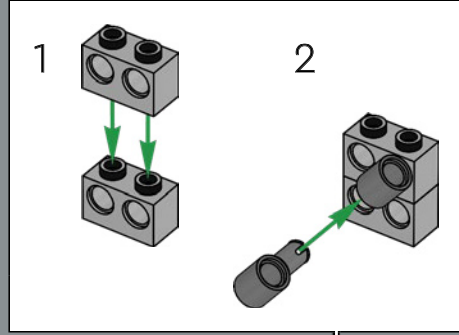
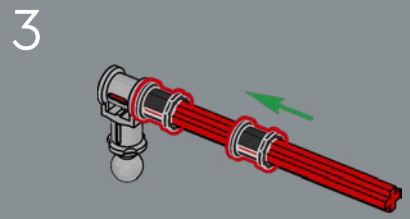
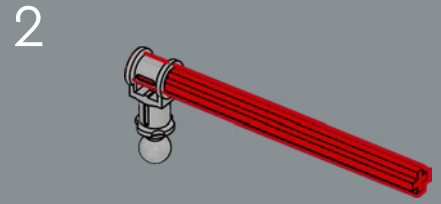
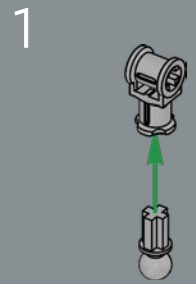

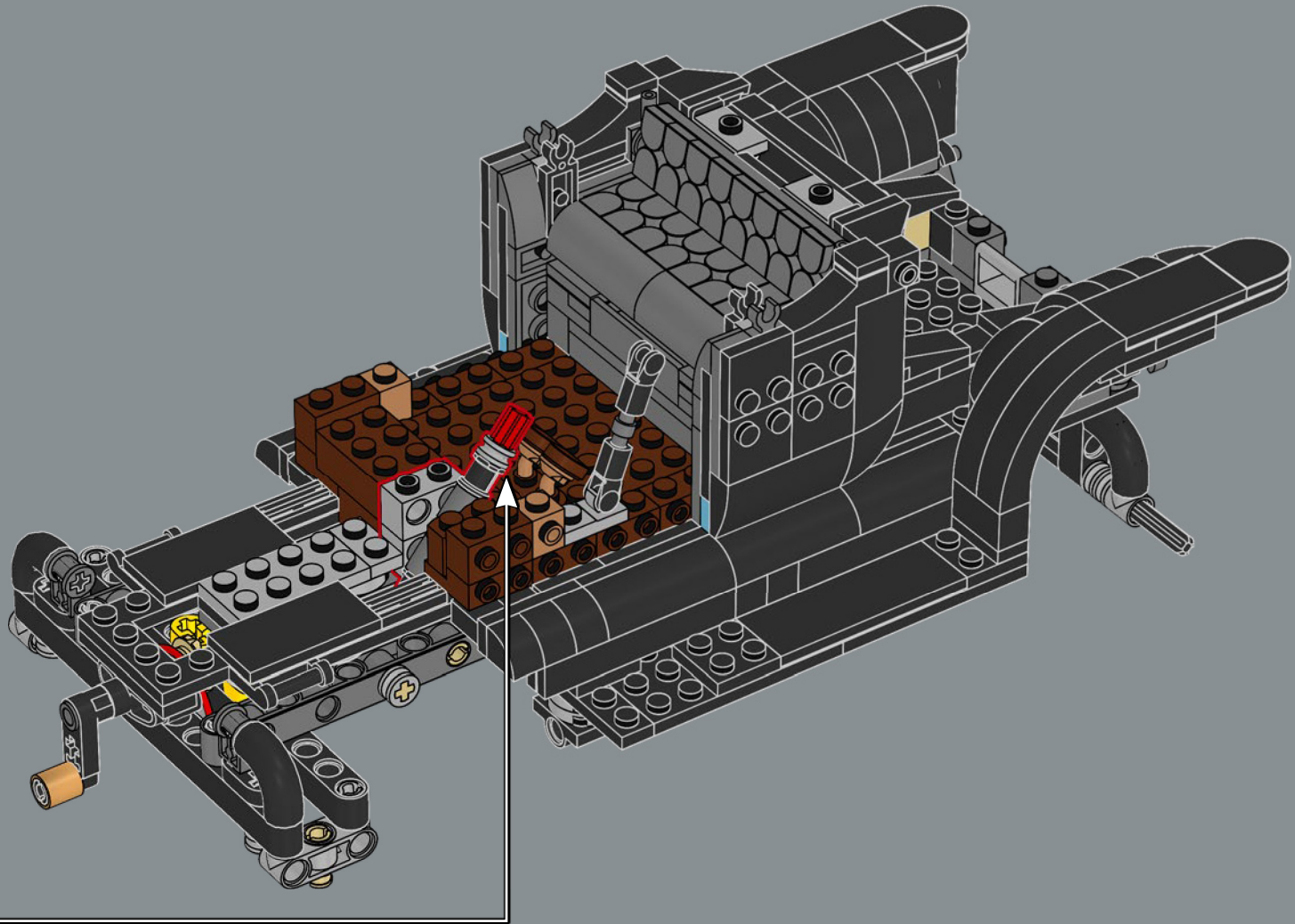

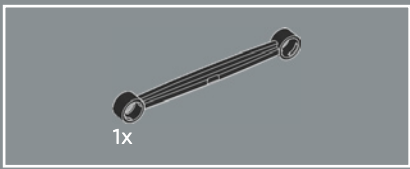

140

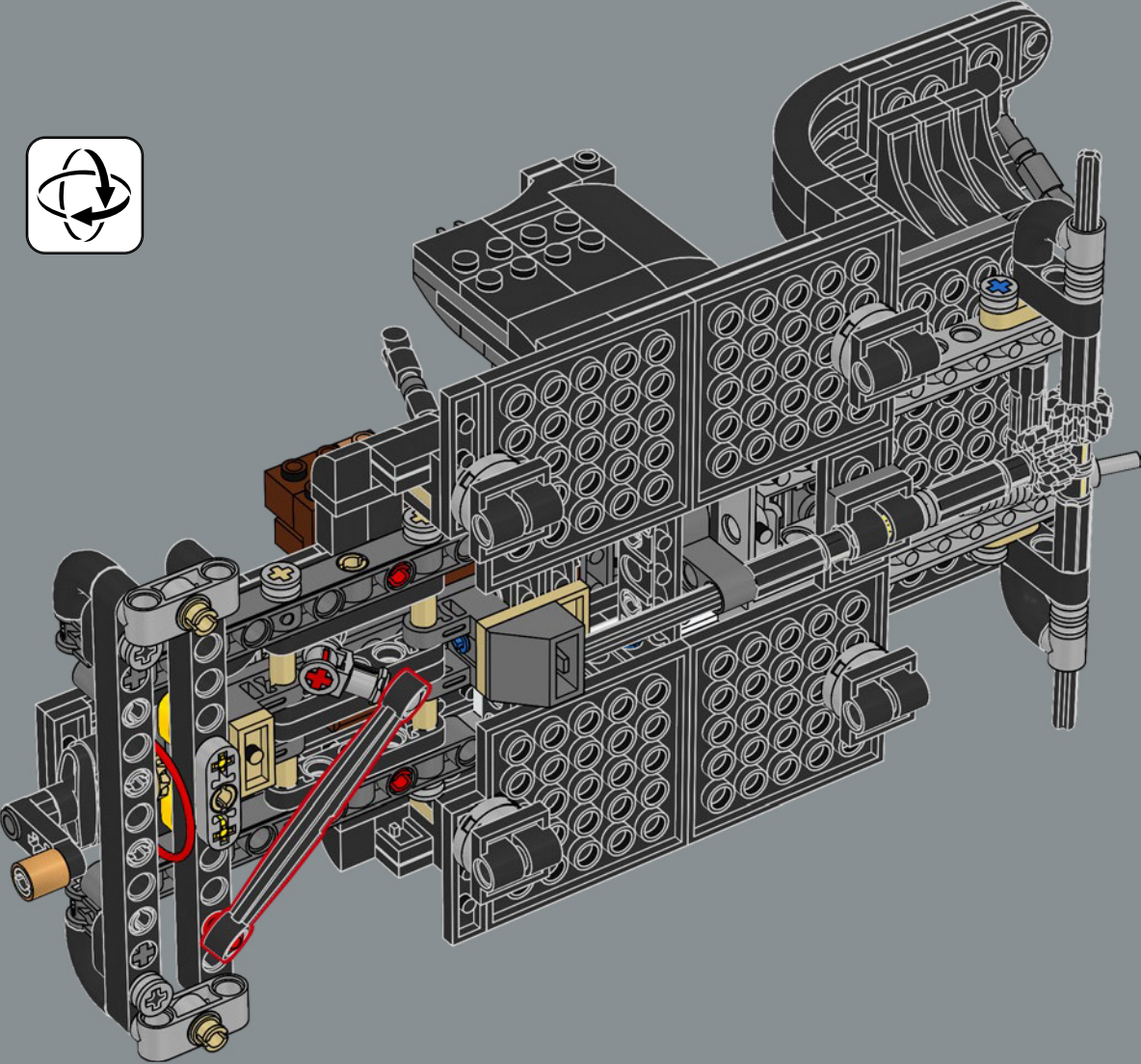

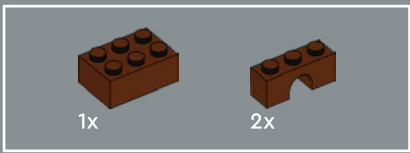

141

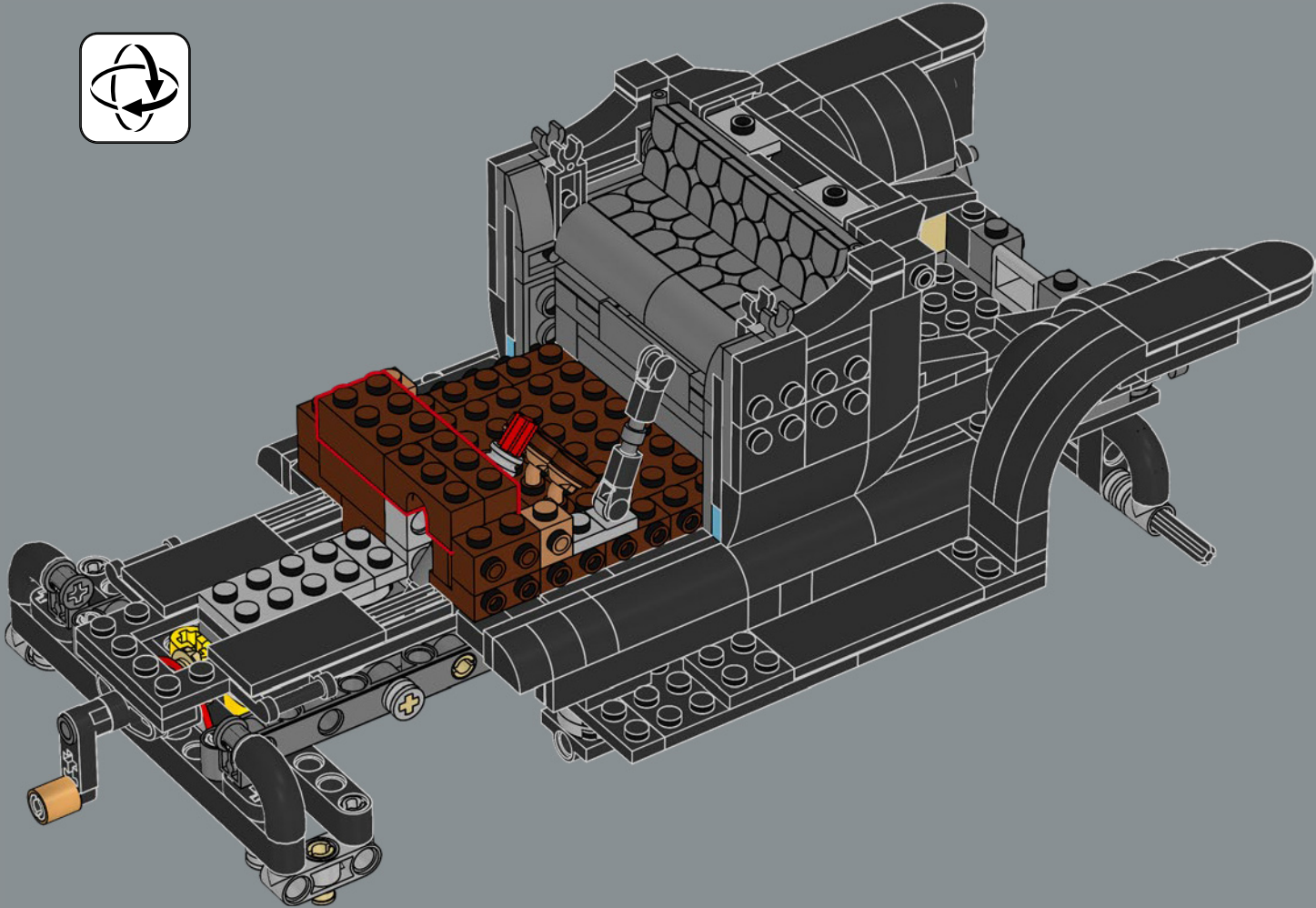

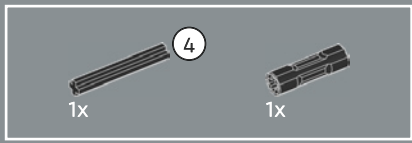

142

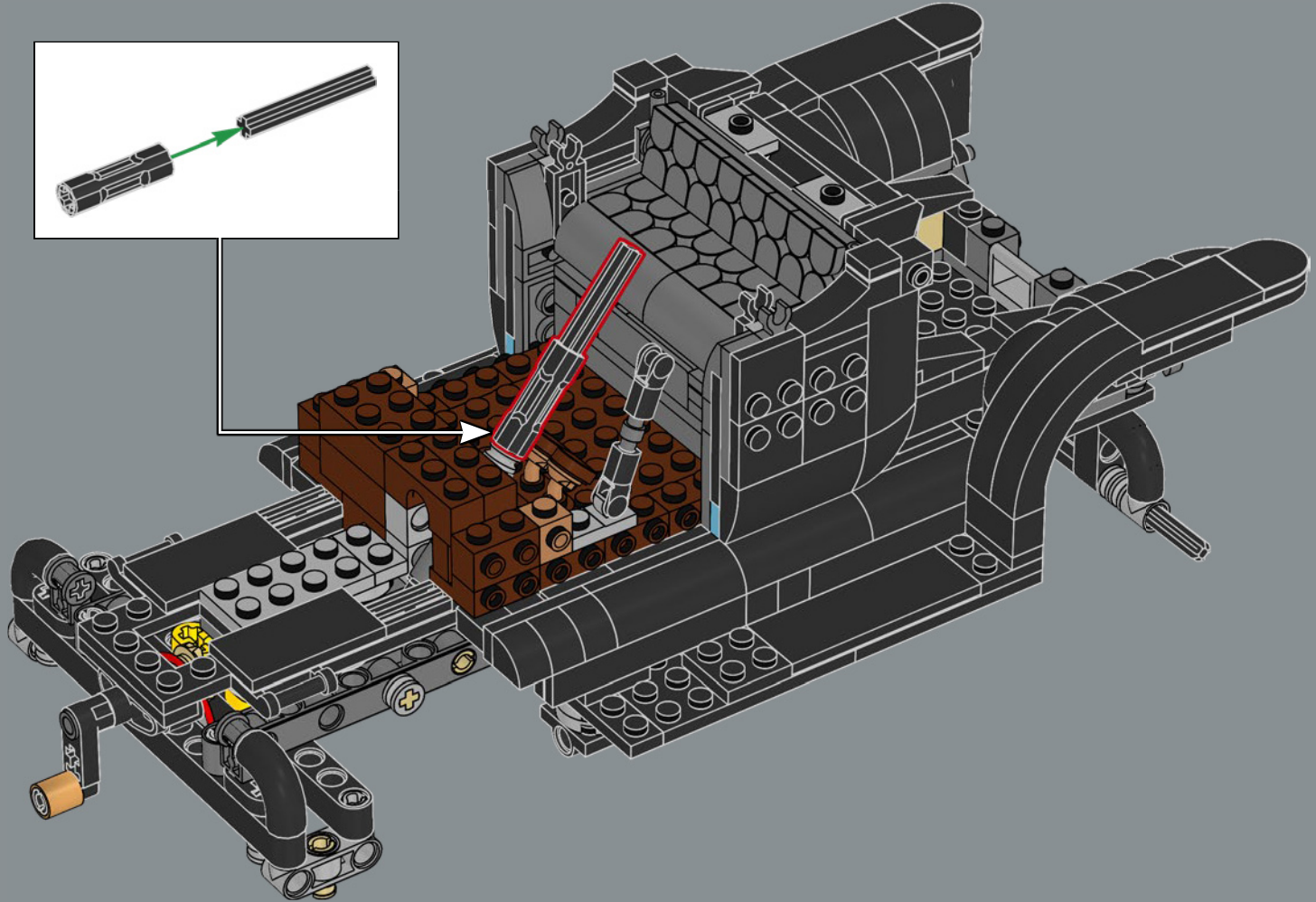

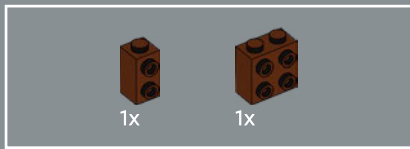

143

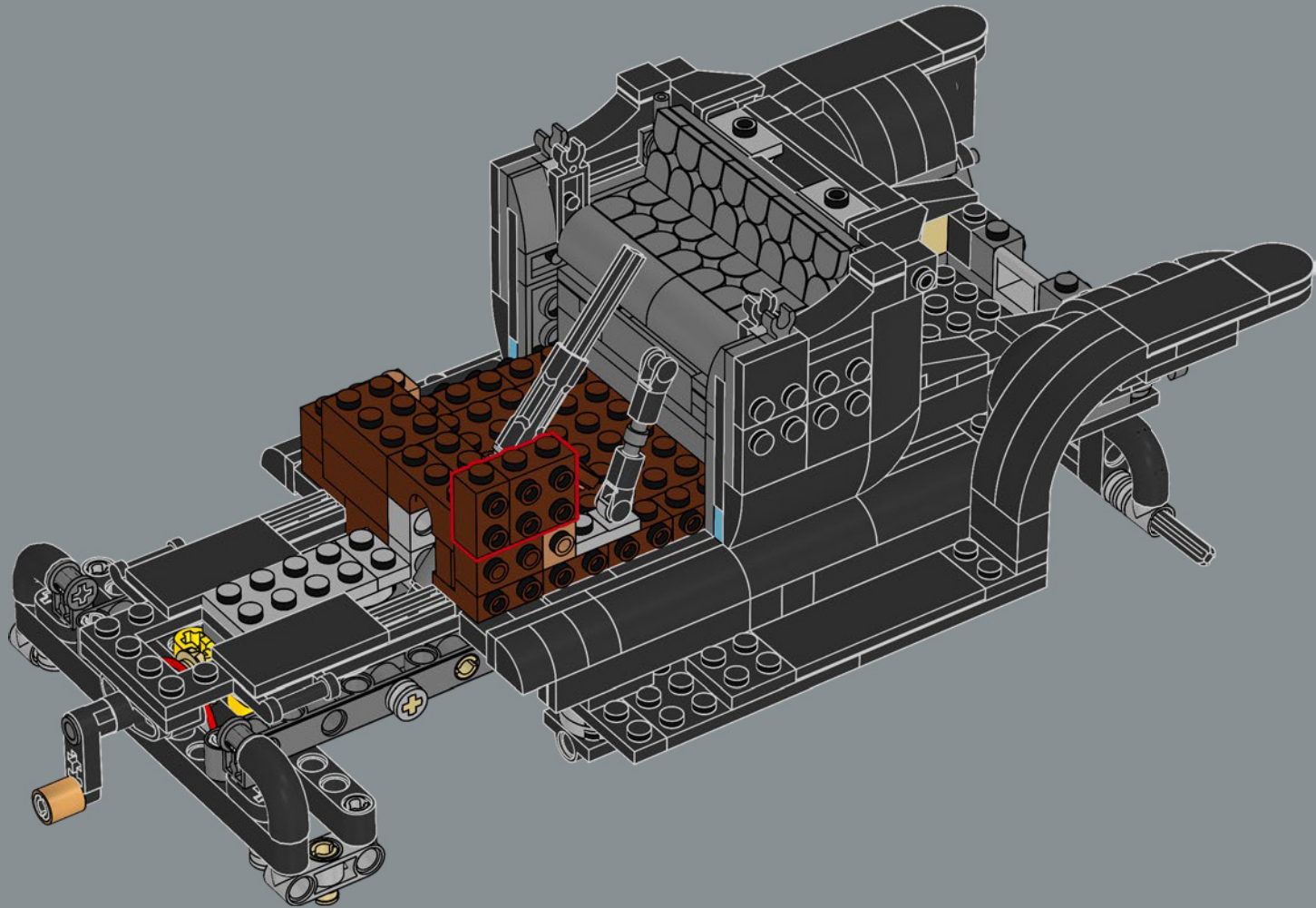



144

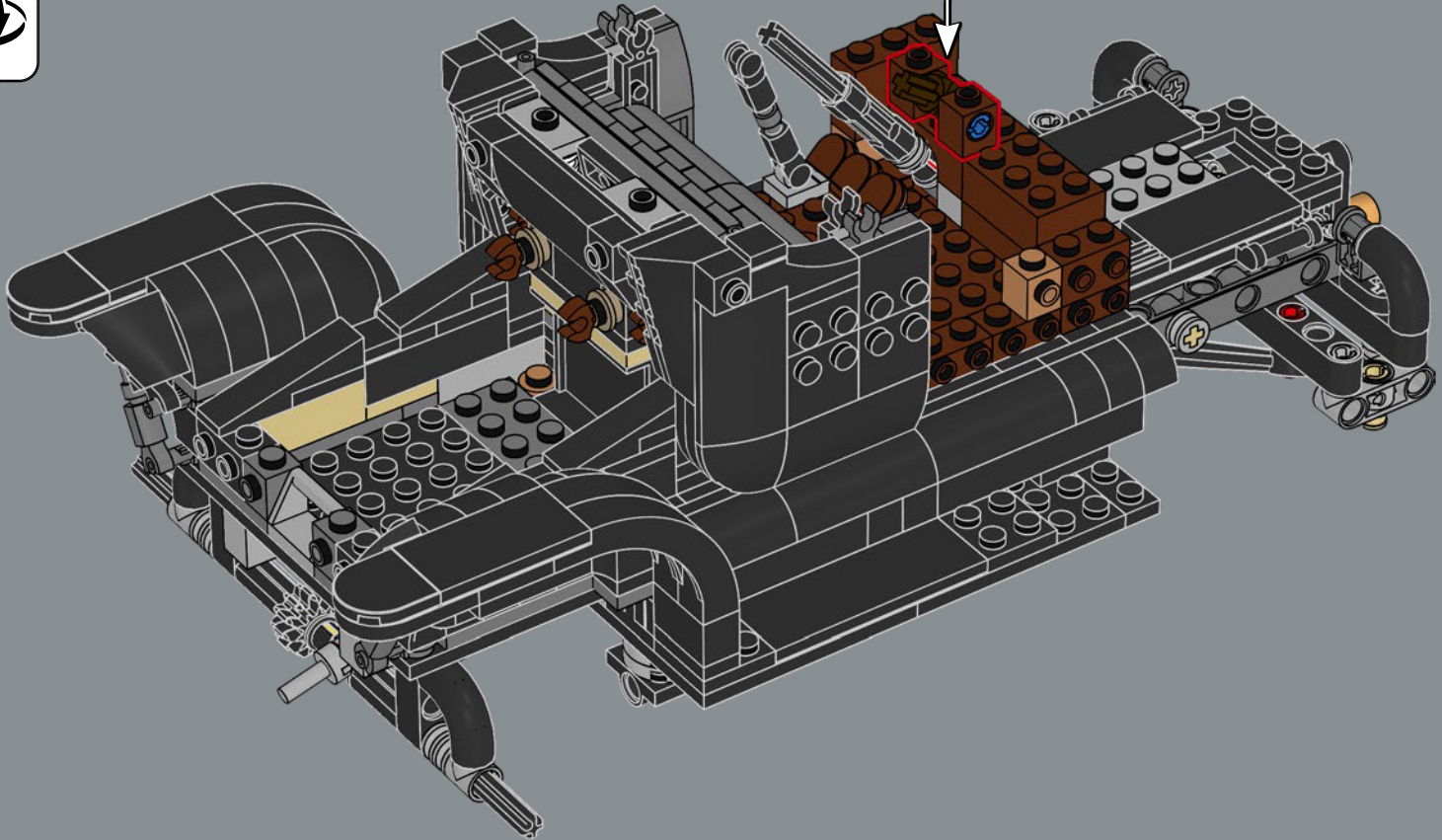
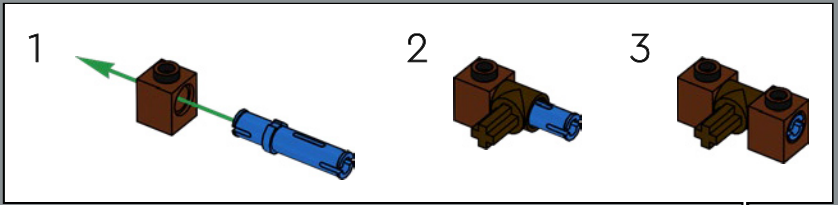

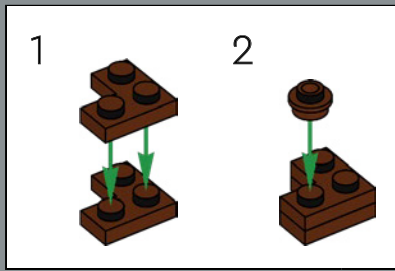

145

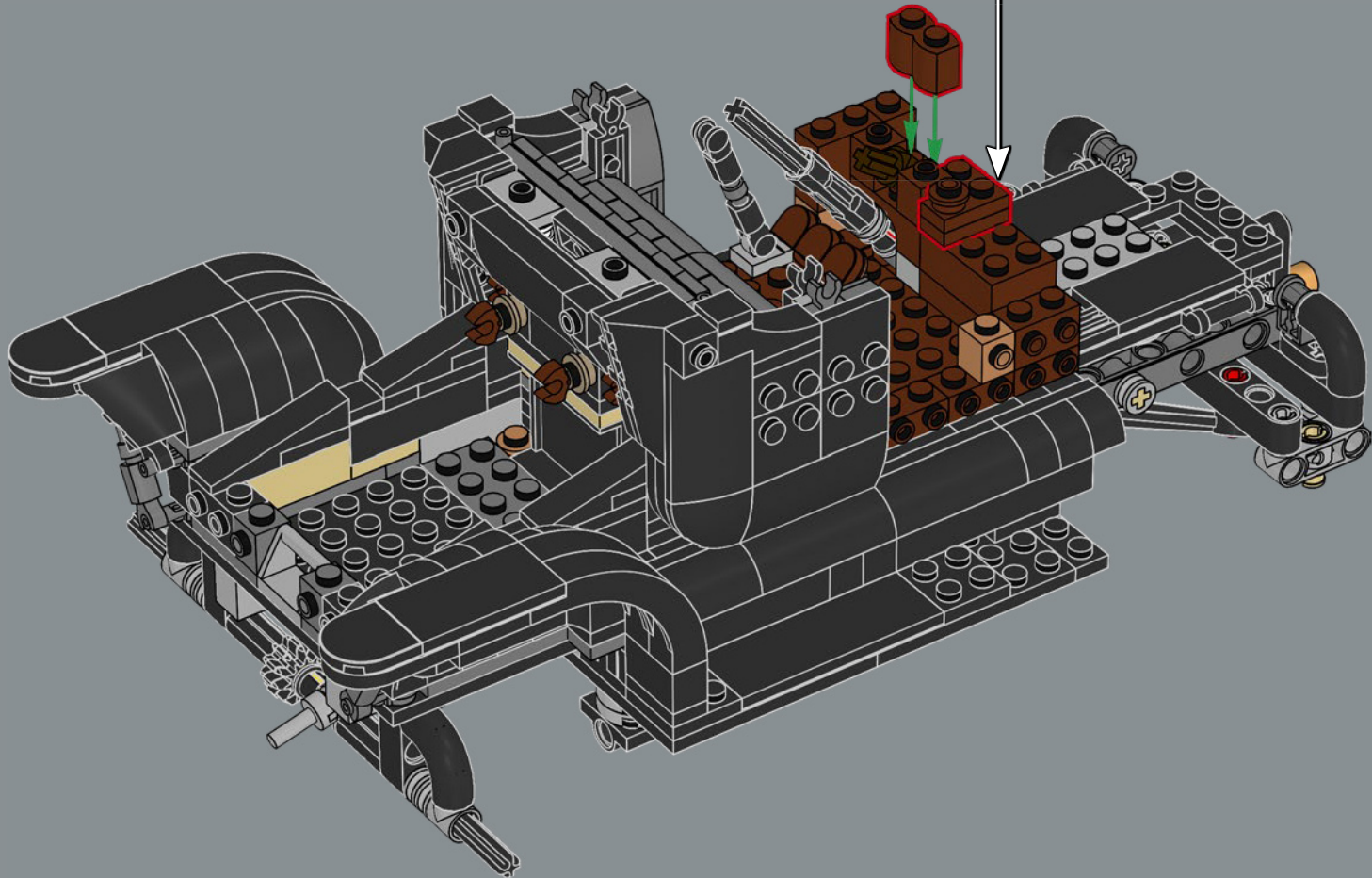

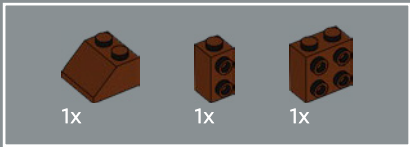

146

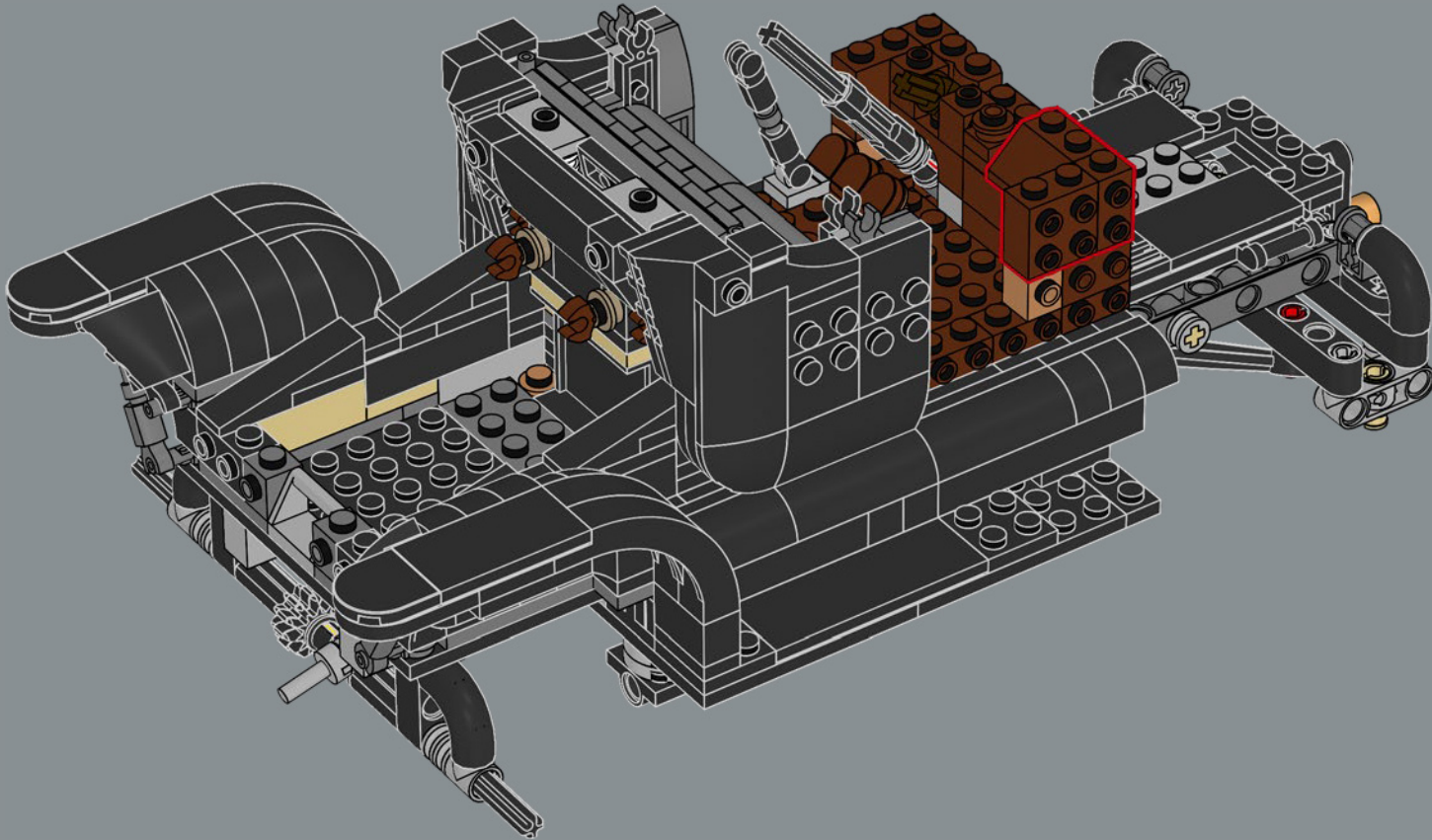



147

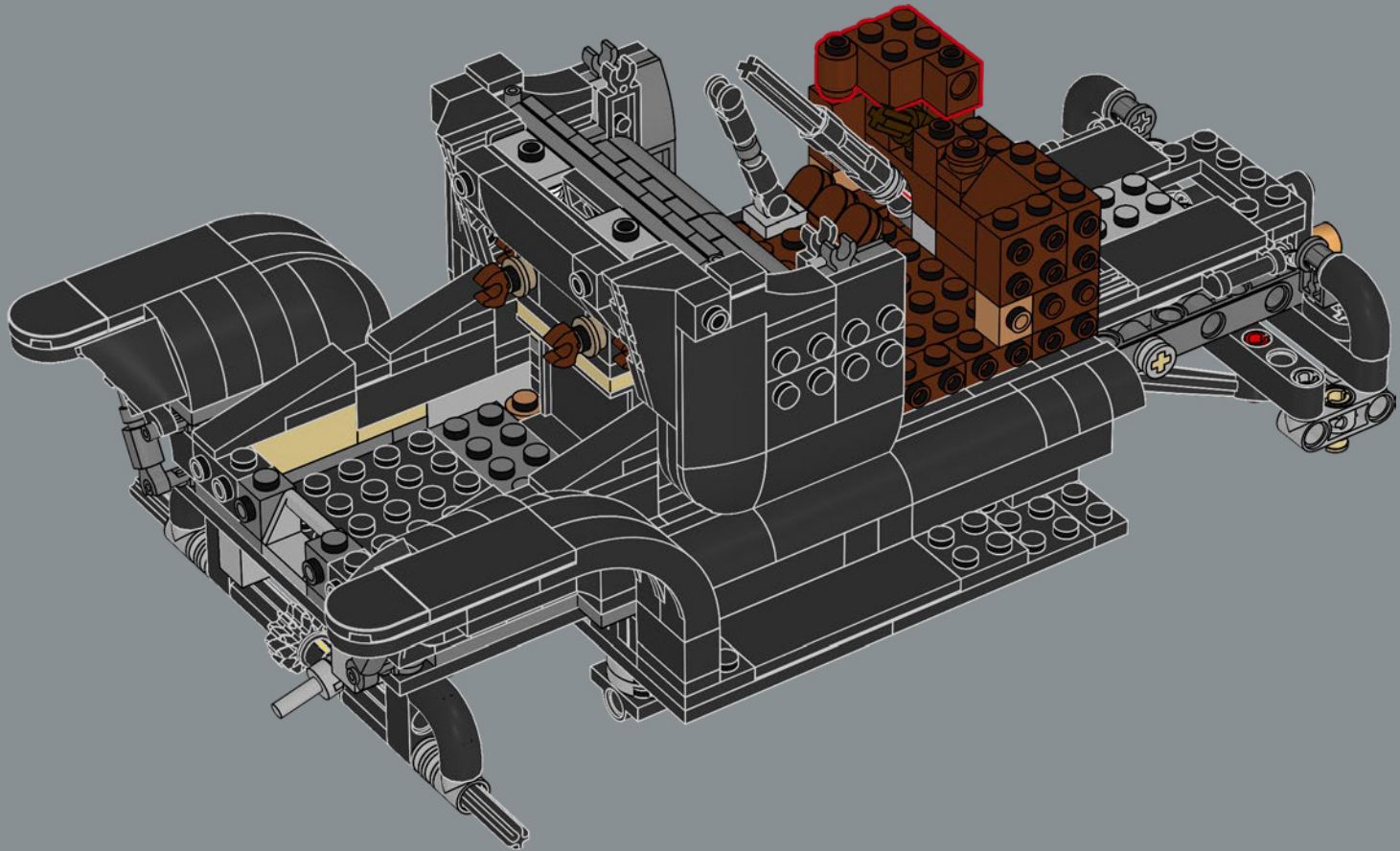

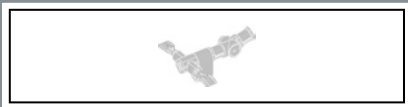

Les commandes différaient de celles des voitures modernes : l'accélérateur était intégré au volant et les pédales servaient à passer de la première à la deuxième vitesse.

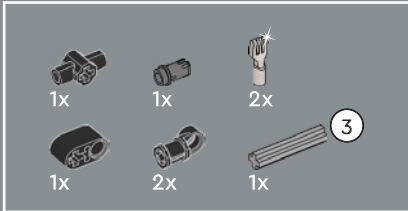

148

1

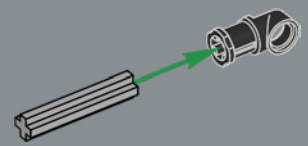

2

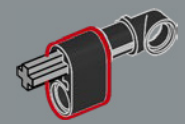

3

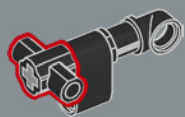

4

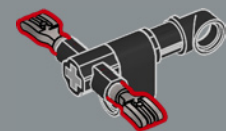

5

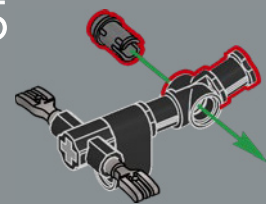

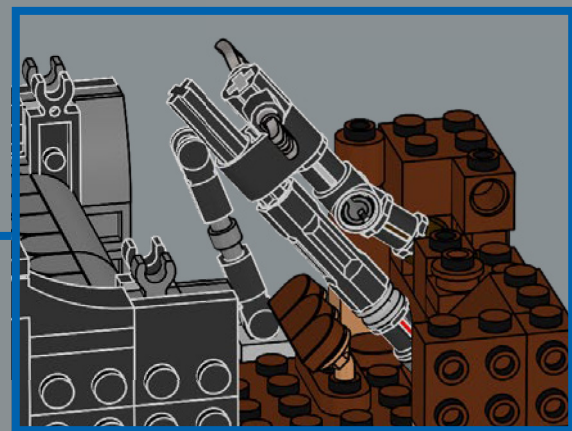
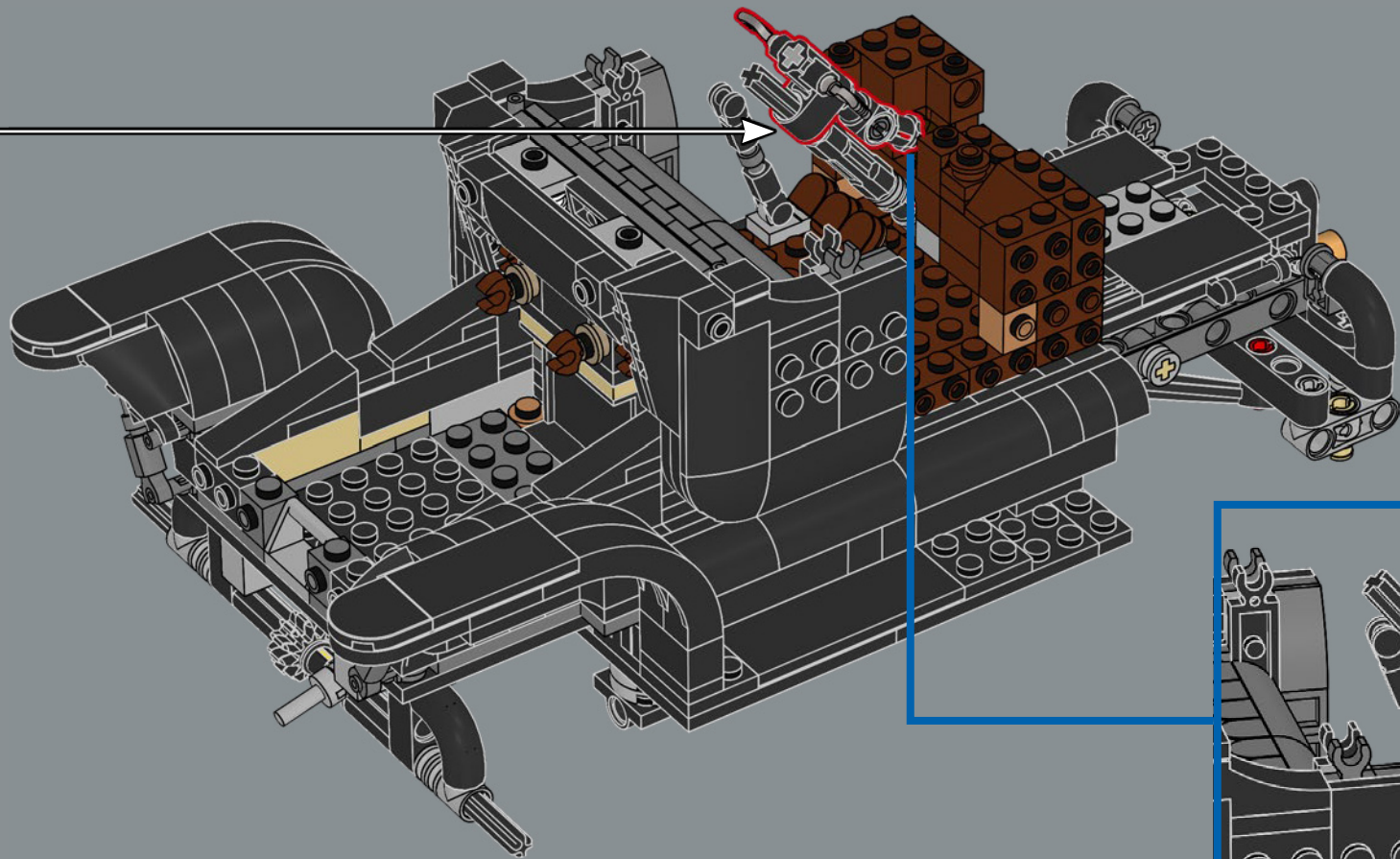

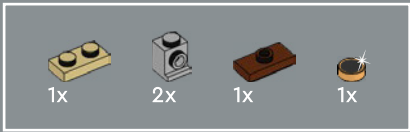

149

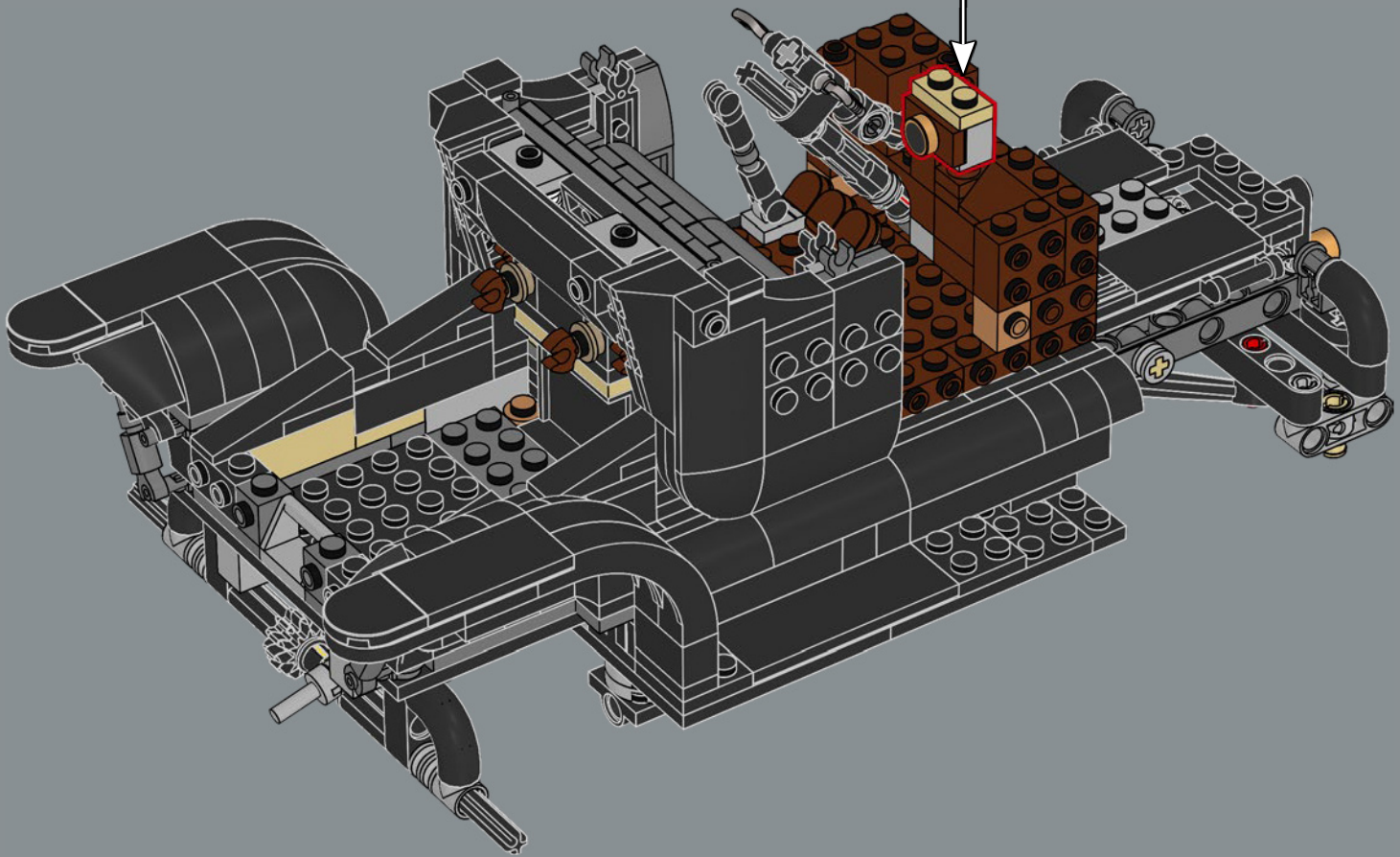
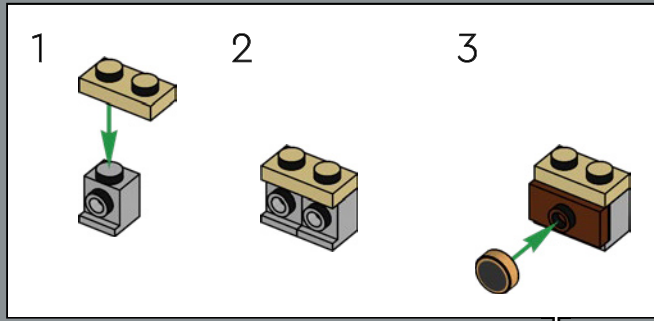

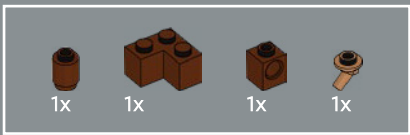

150

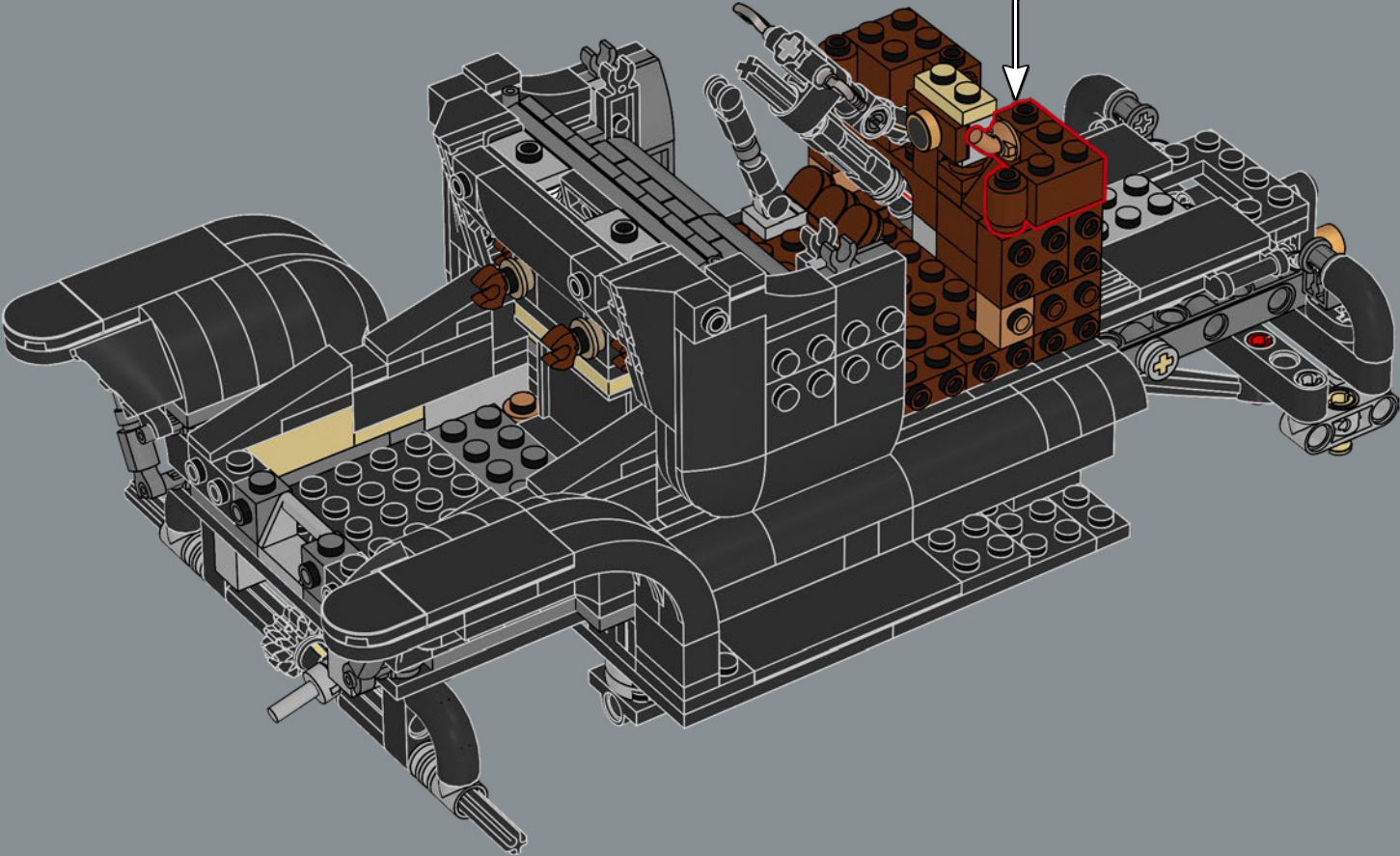
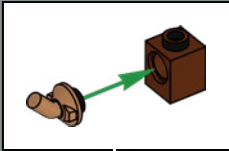



151

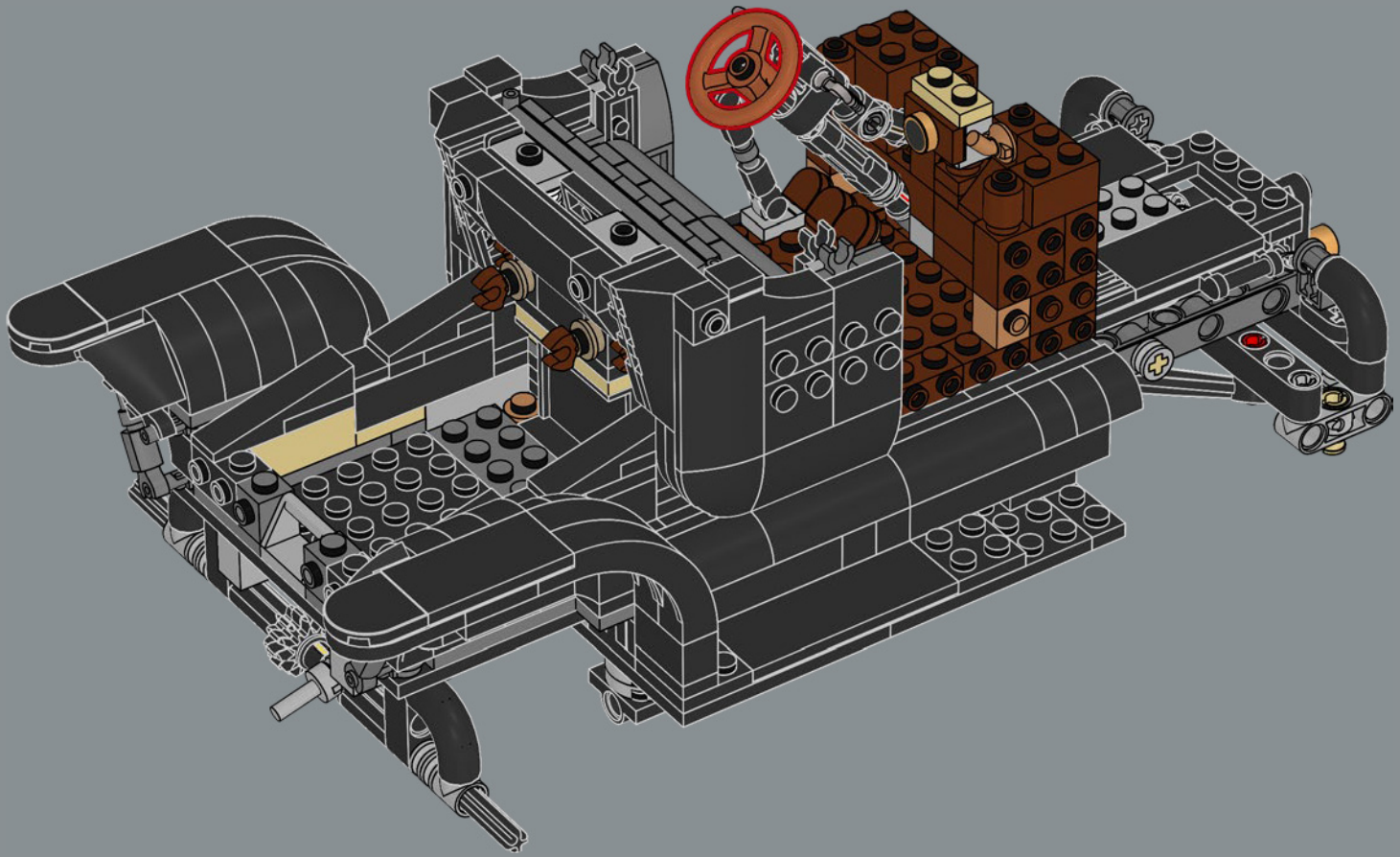

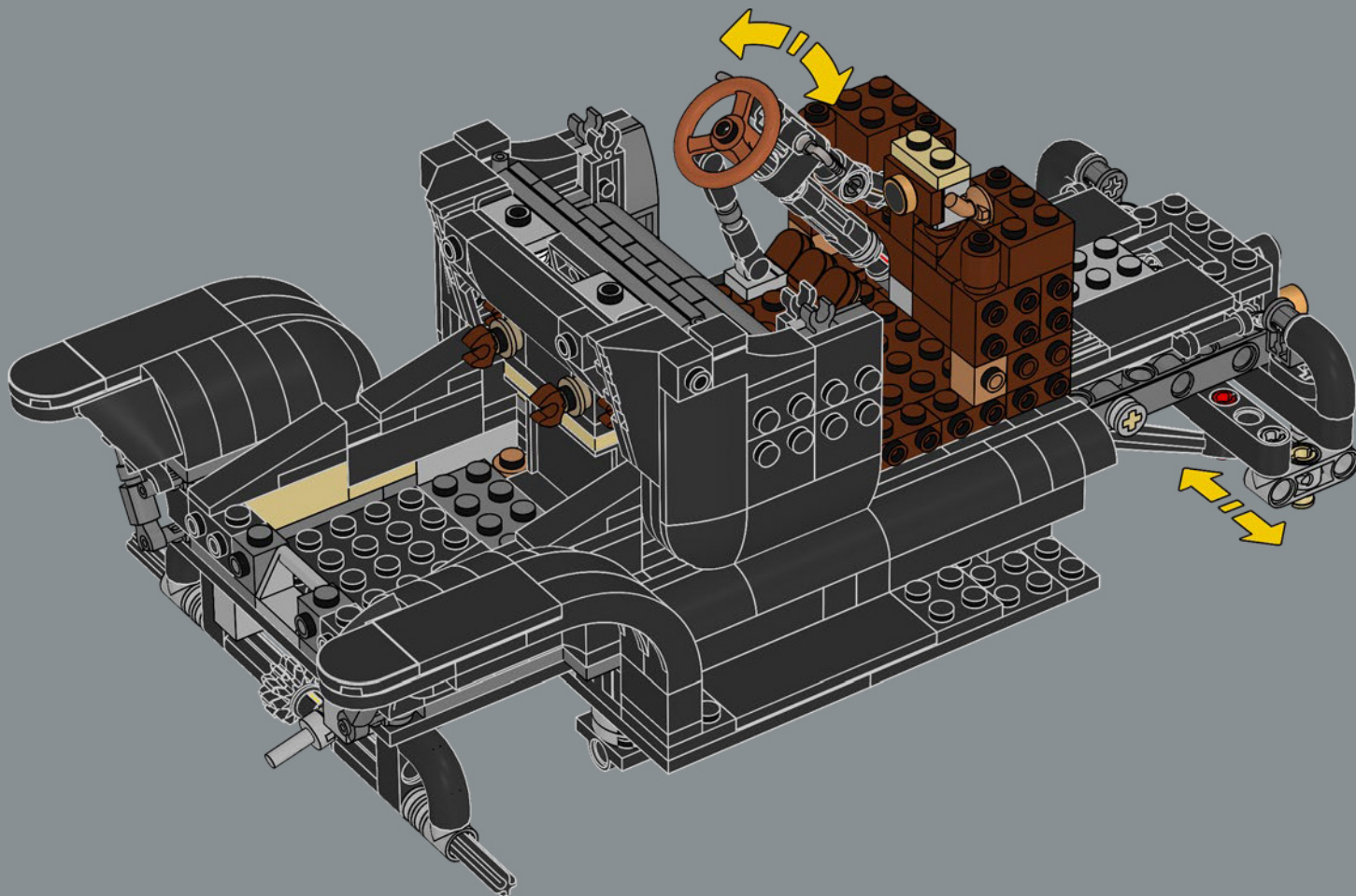

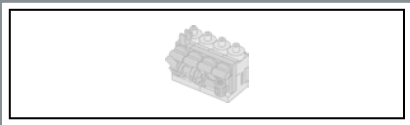

152

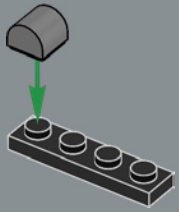

153

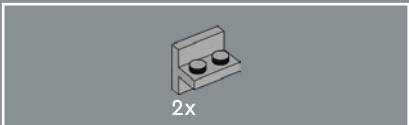
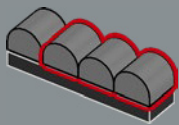

154

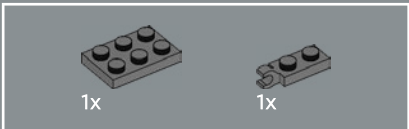
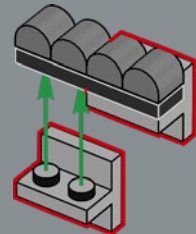

155

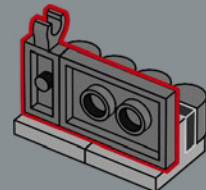

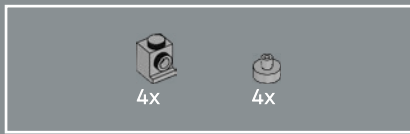

156

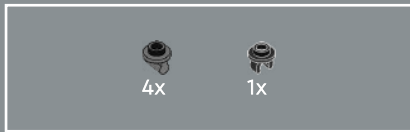
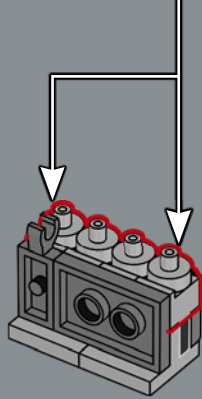
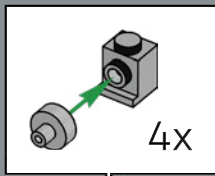

157

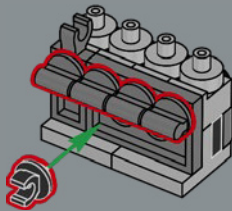

158

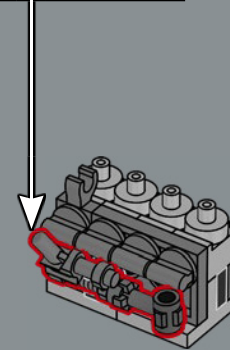
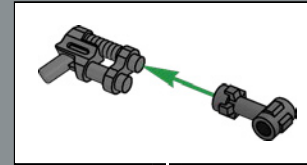

159

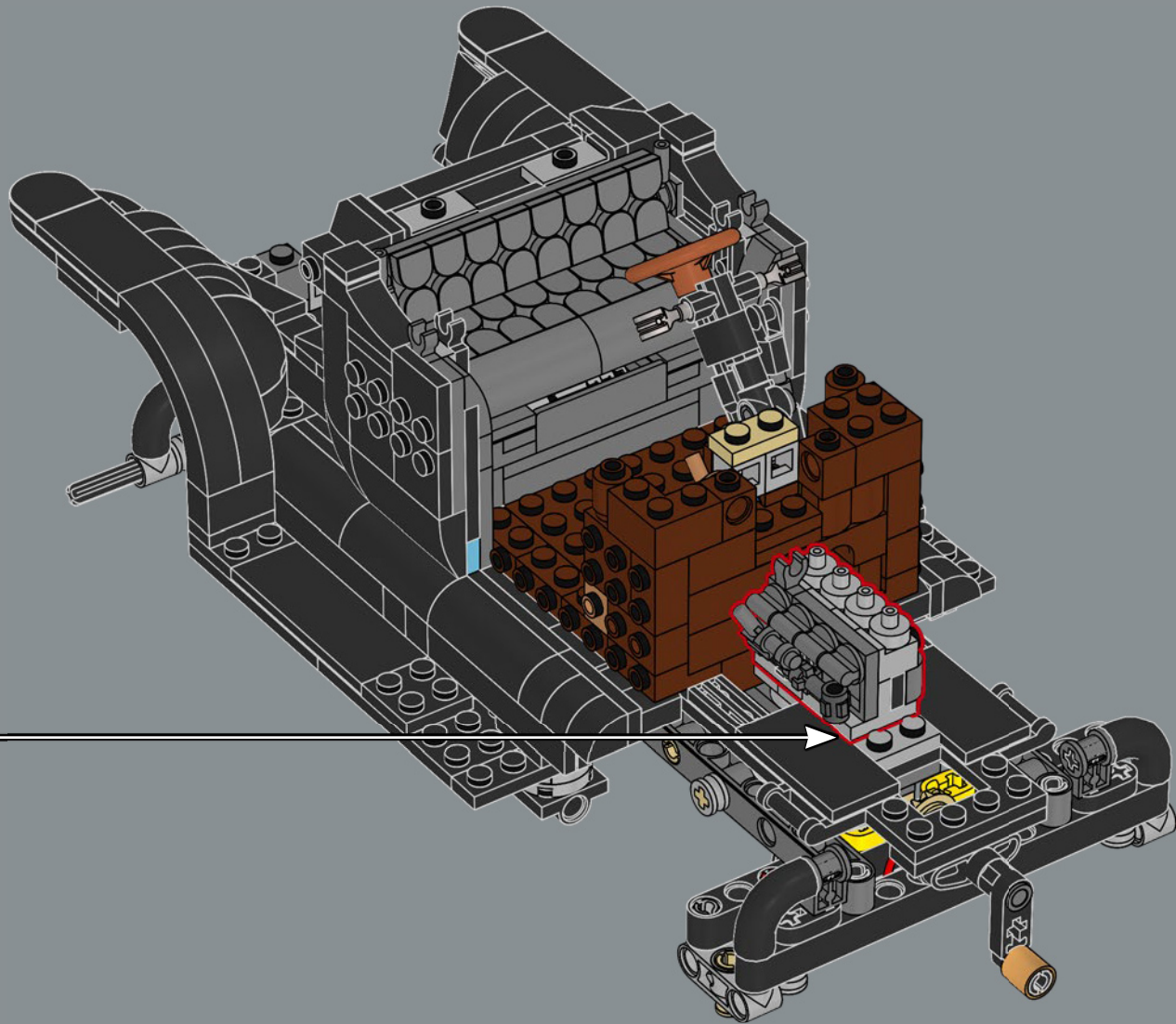

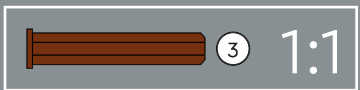
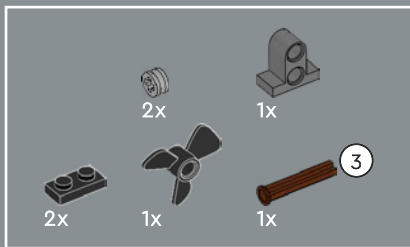

160

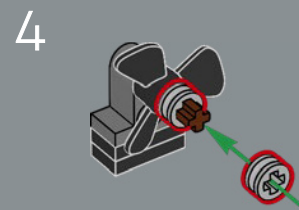
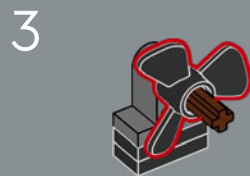
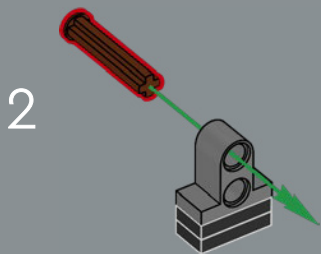
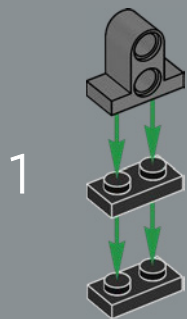

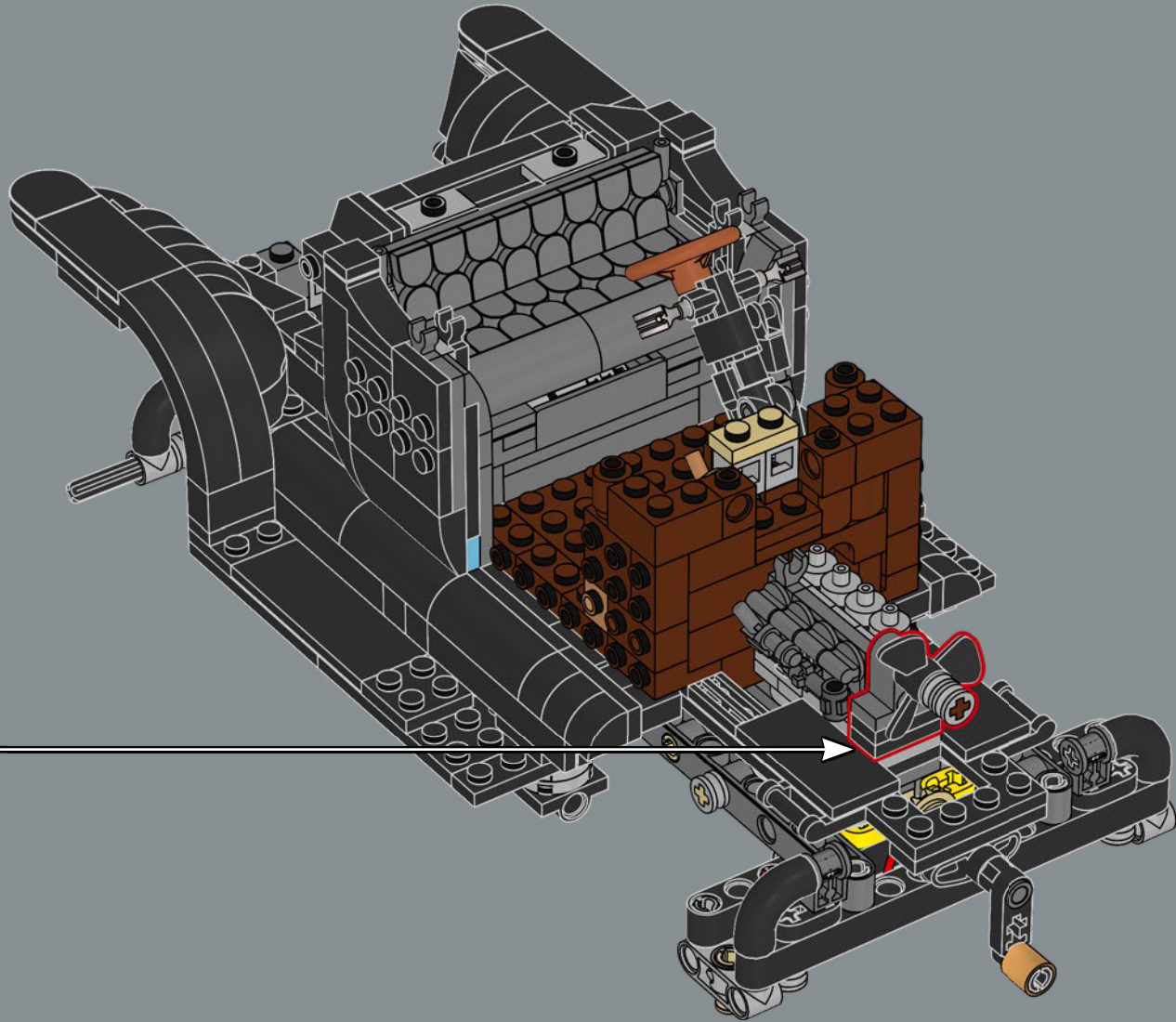

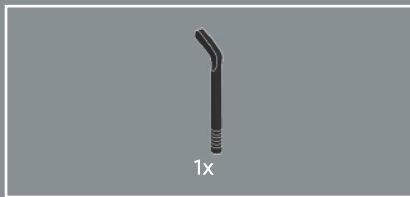

161

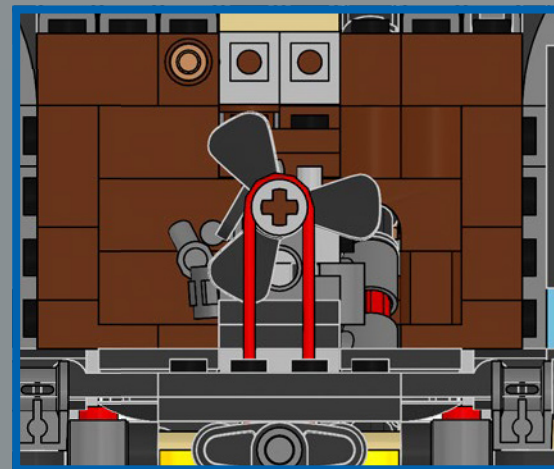
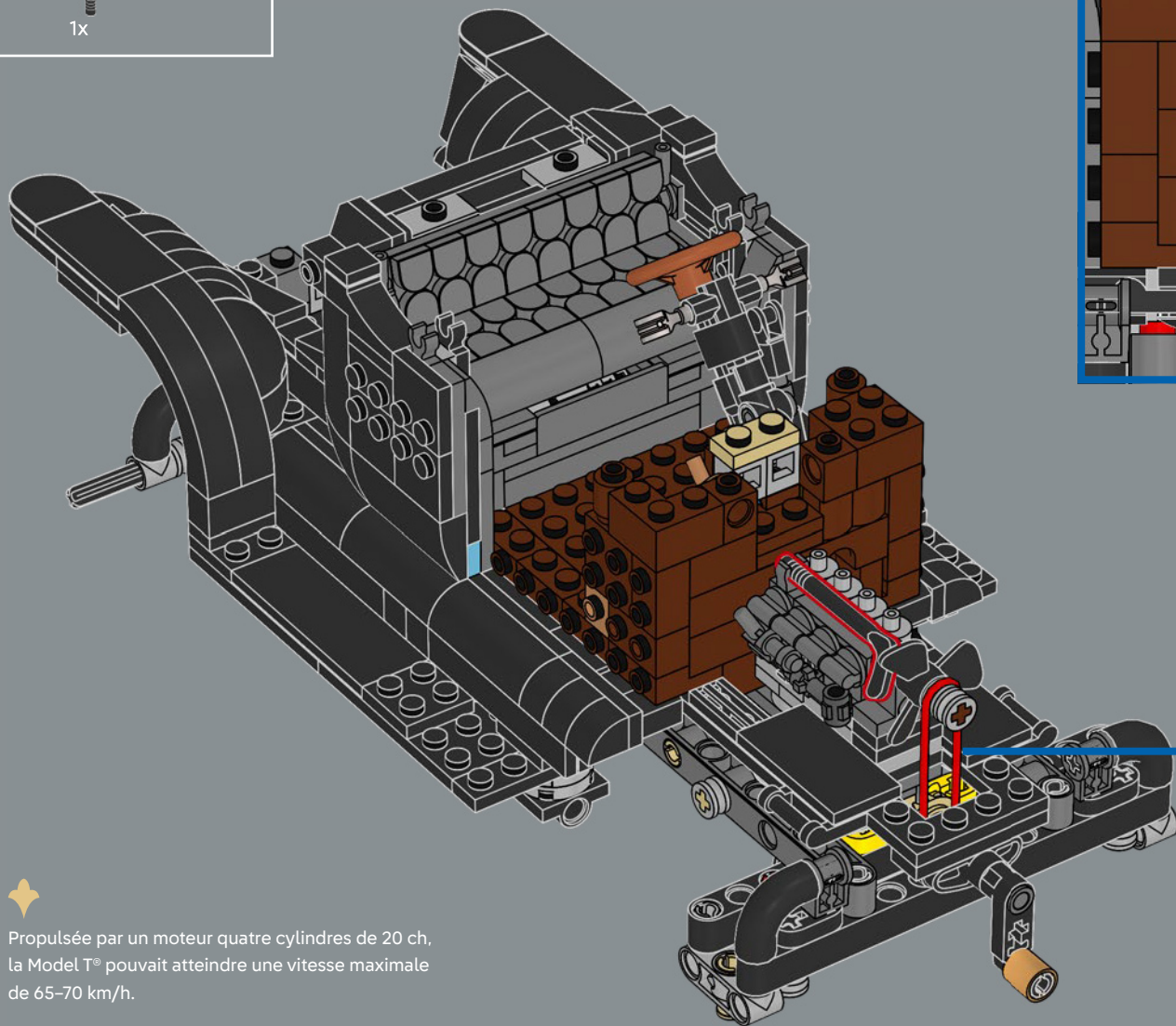

Propulsée par un moteur quatre cylindres de 20 ch, la Model T® pouvait atteindre une vitesse maximale de 65-70 km/h.



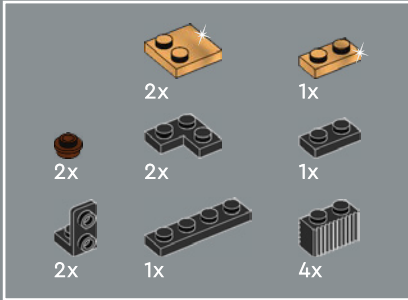
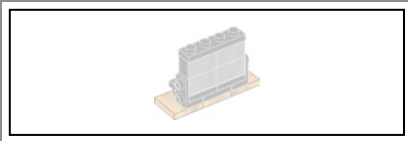

162

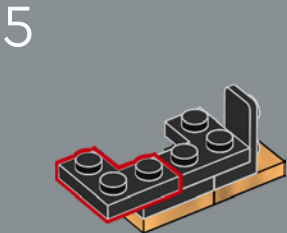
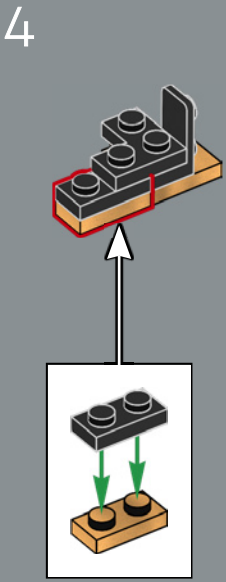
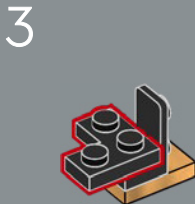
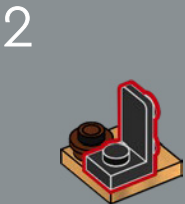
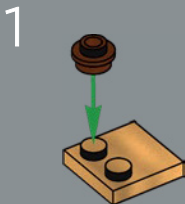

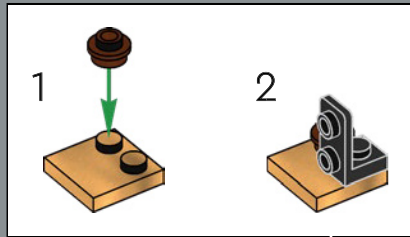

6

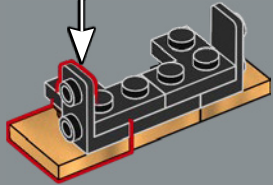

7

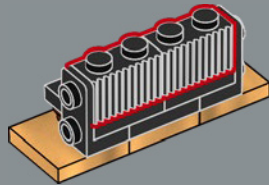

8

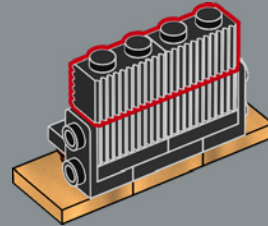

9

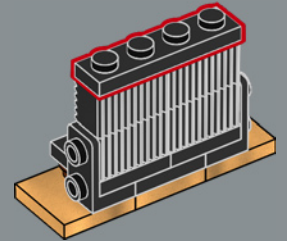

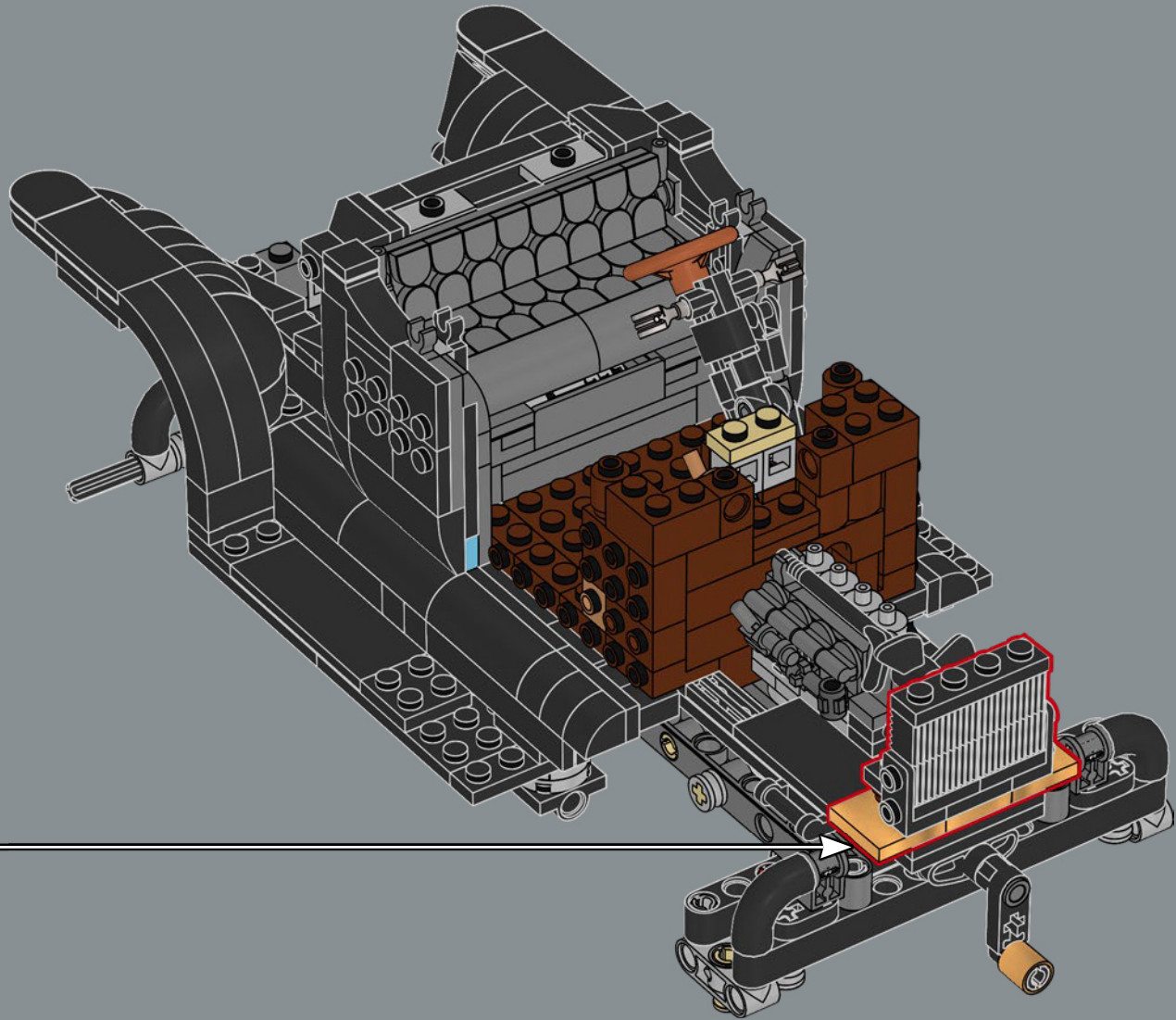

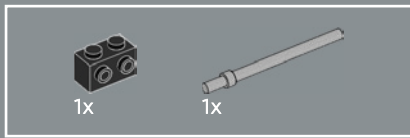

163

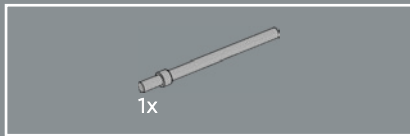
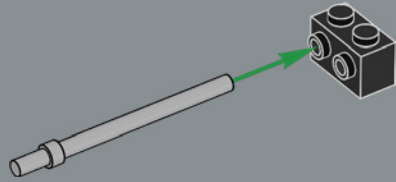

164

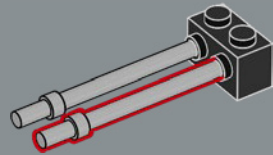

165

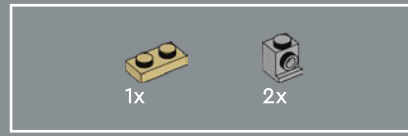
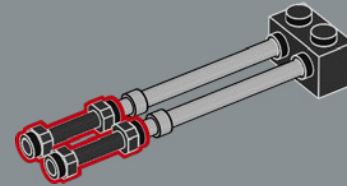

166

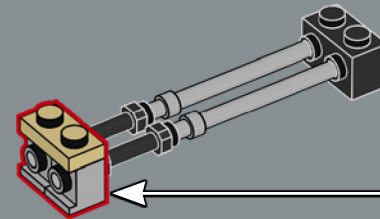
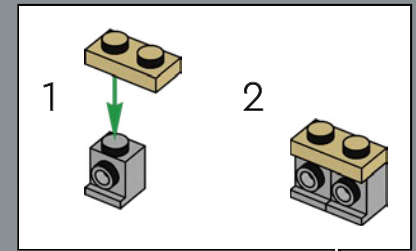

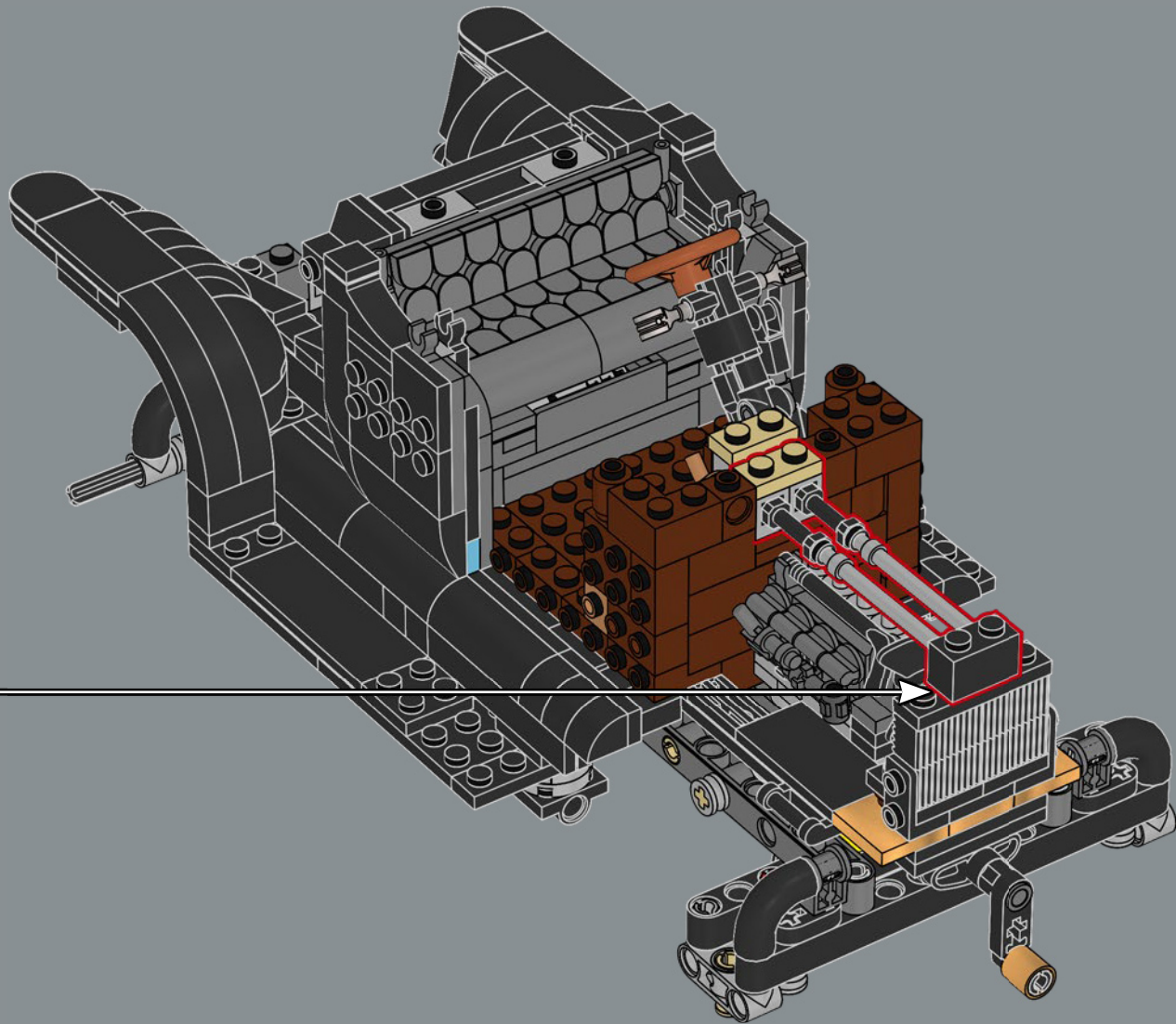

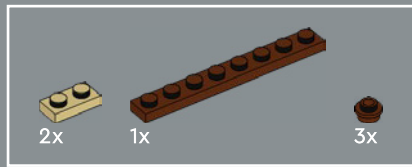

168

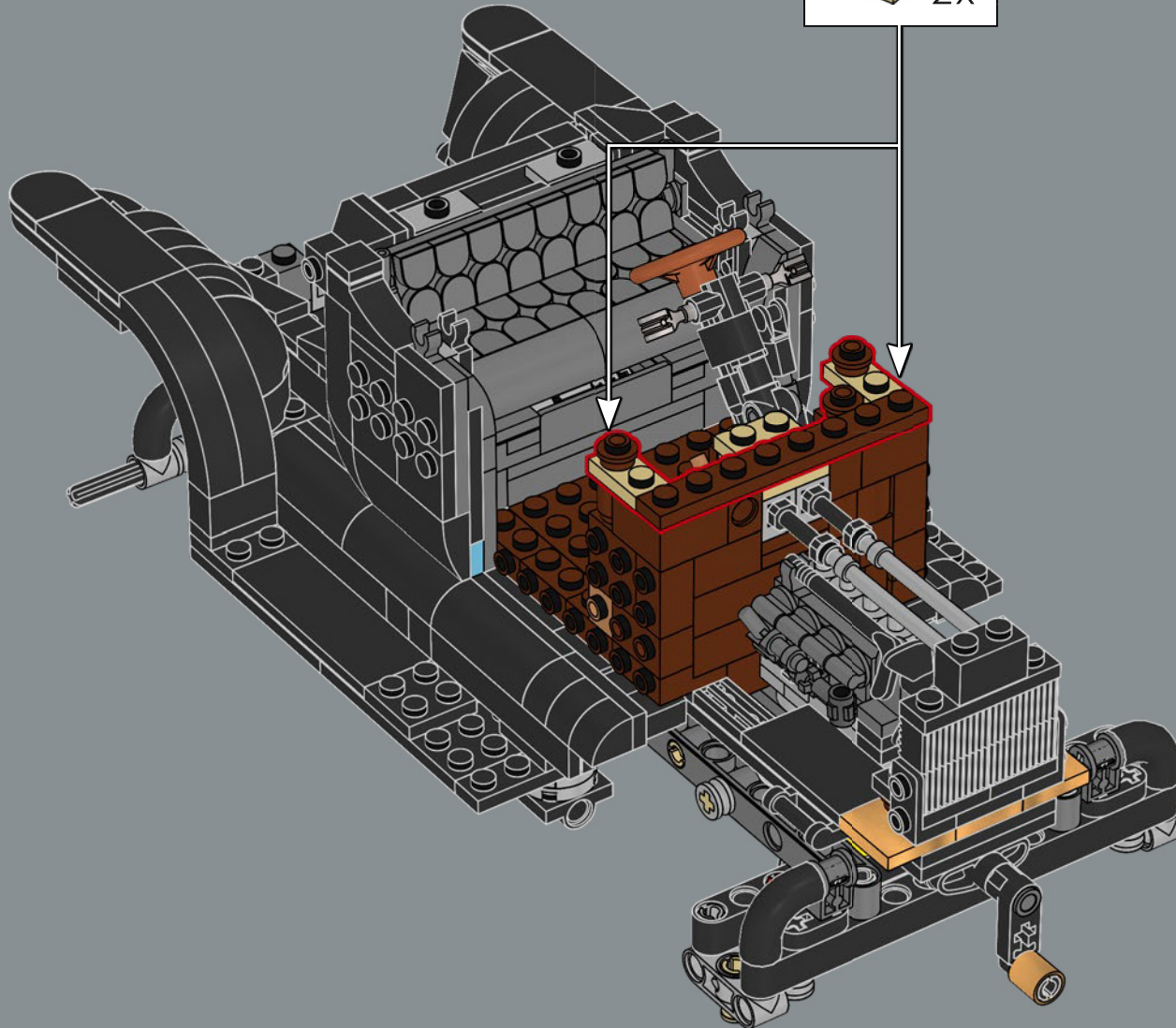
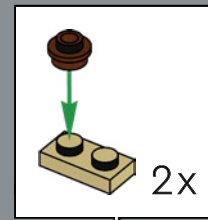

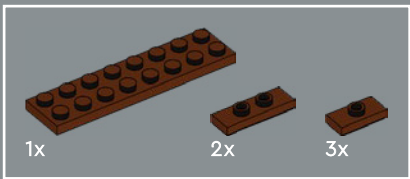

169

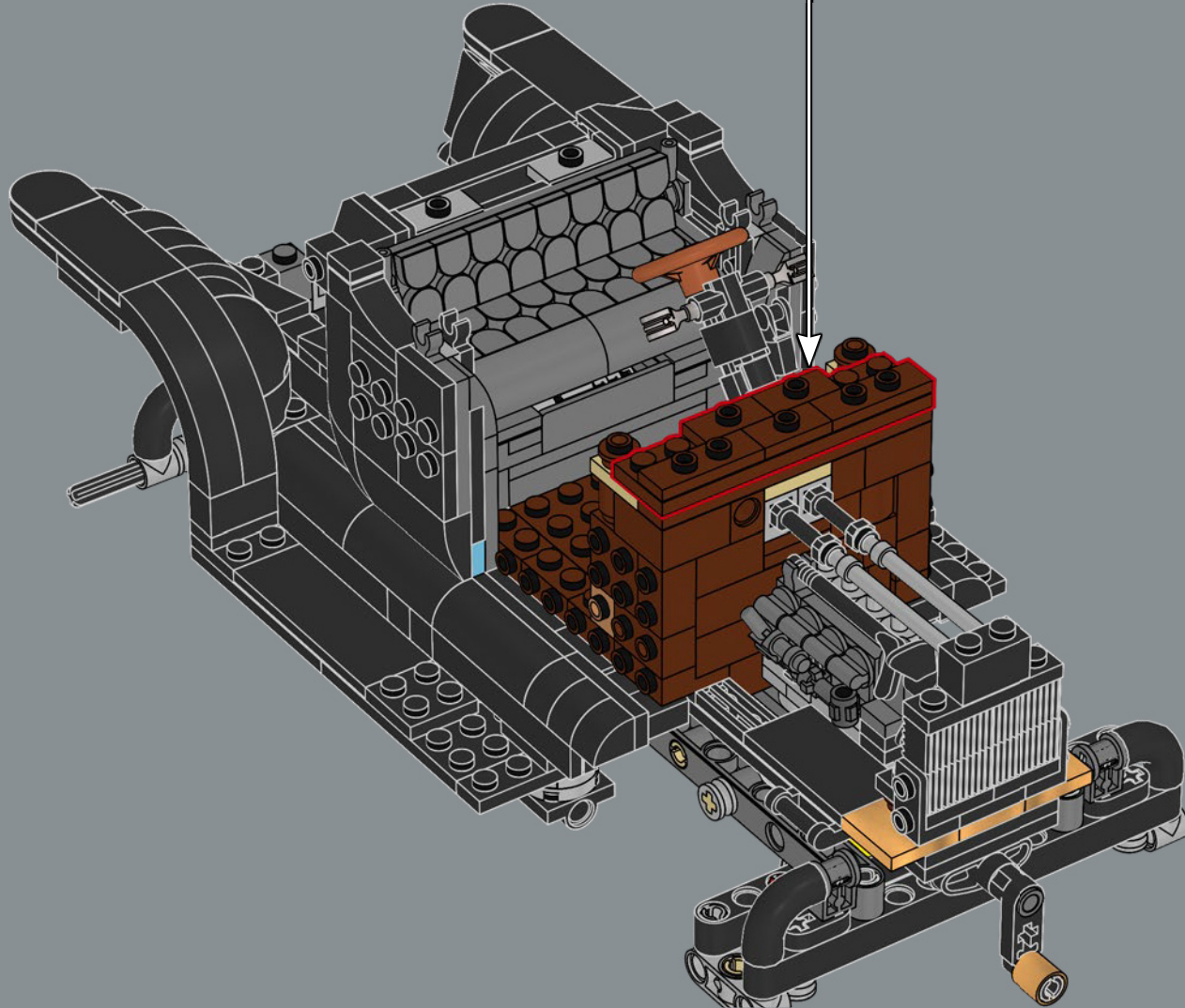
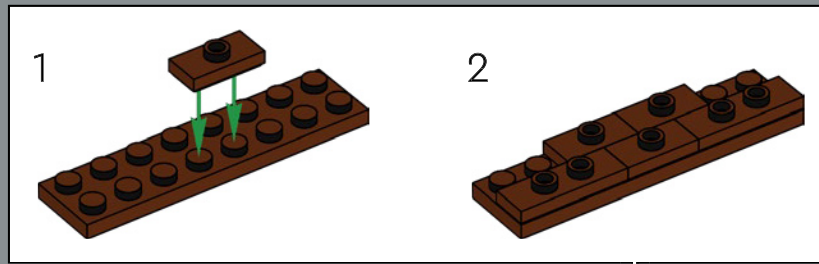

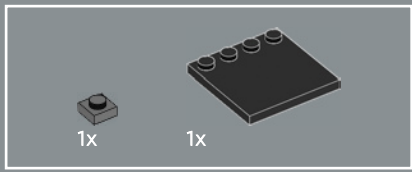

172

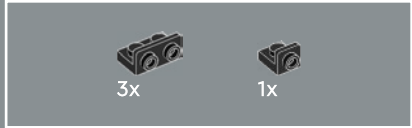
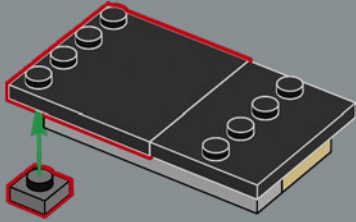

173

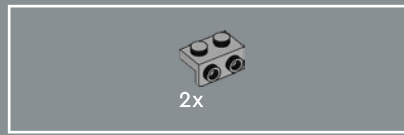
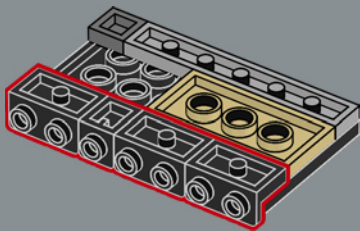

174

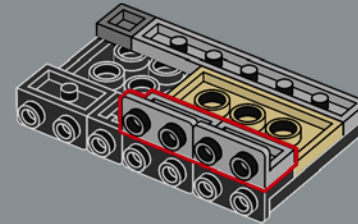

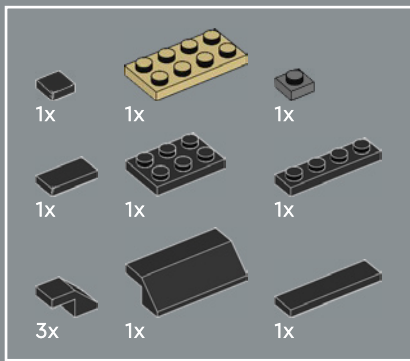

175

1

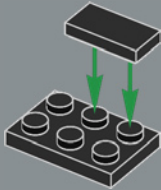

2

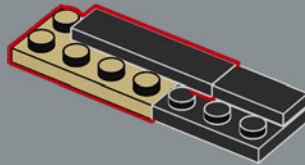

3

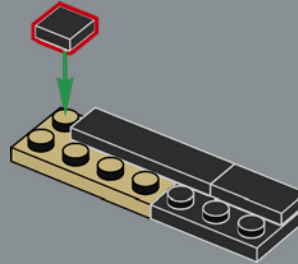

4

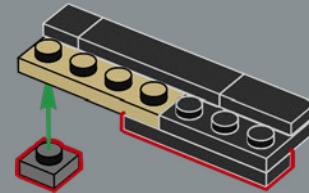

5

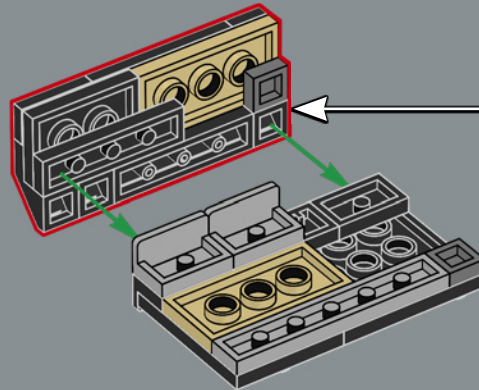
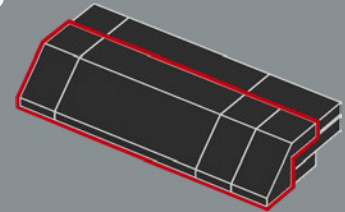

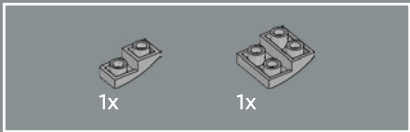

176

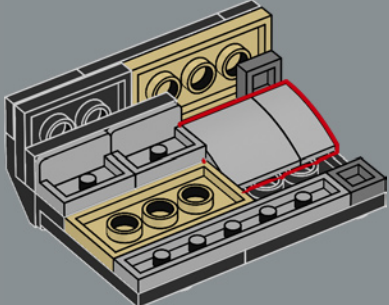

177

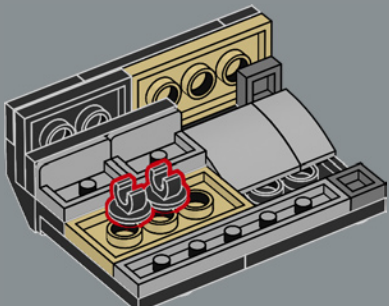

178

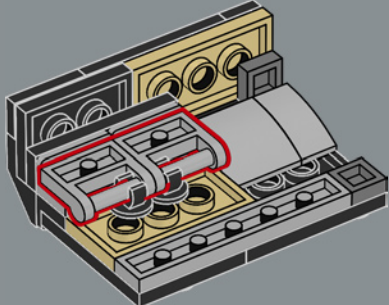

179

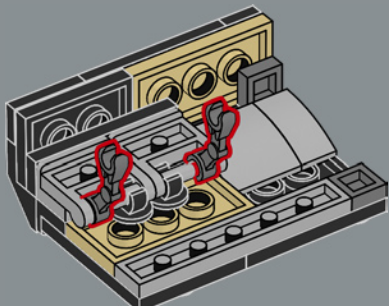

180

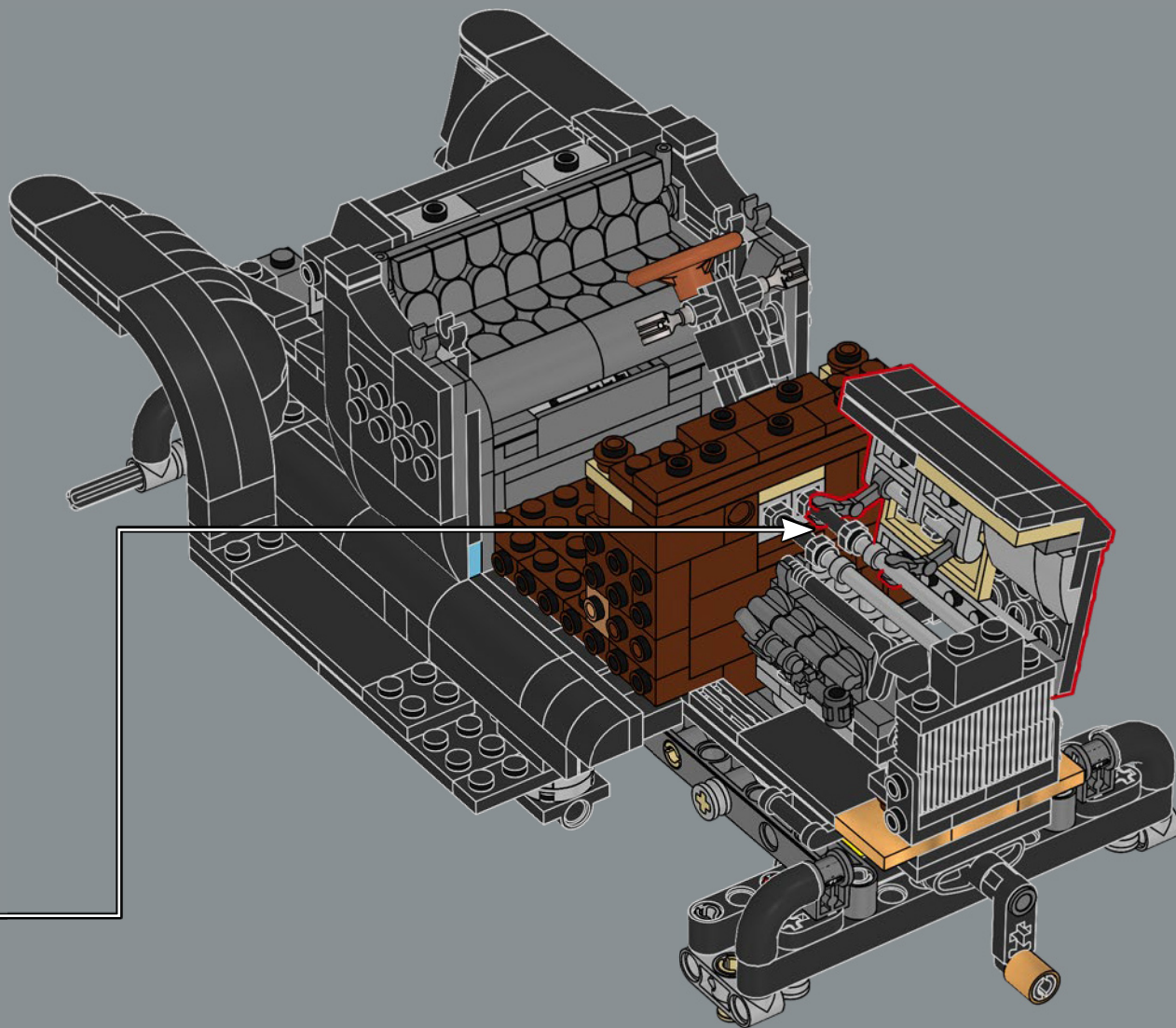

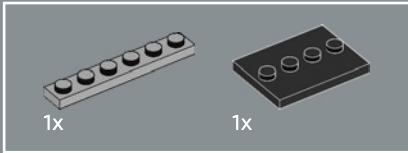
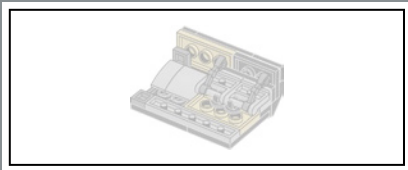

181

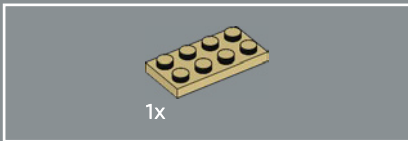
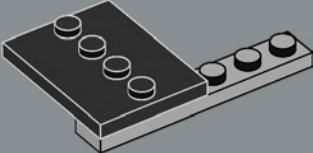

182

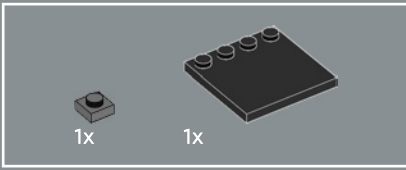
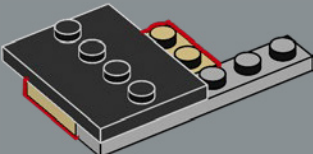

183

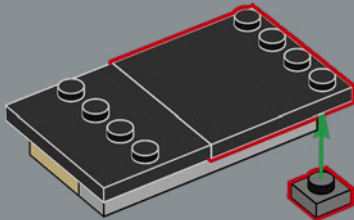

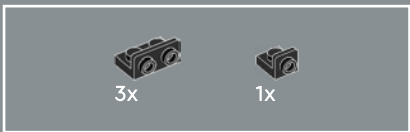

184

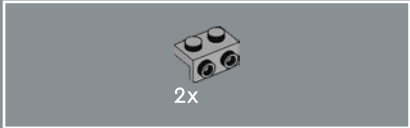
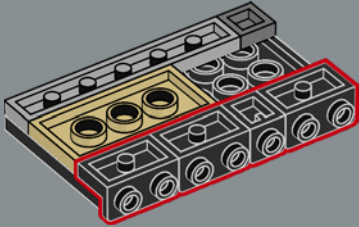

185

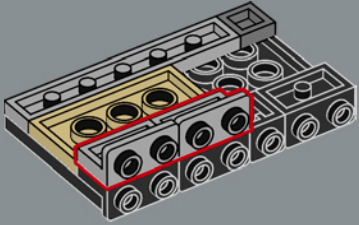

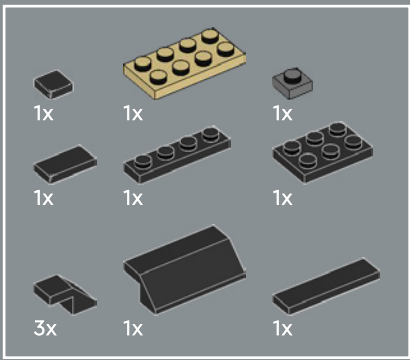

186

1

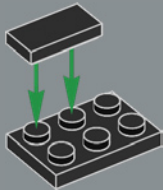

2

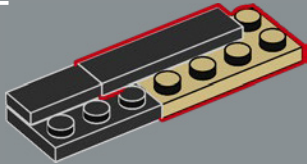

3

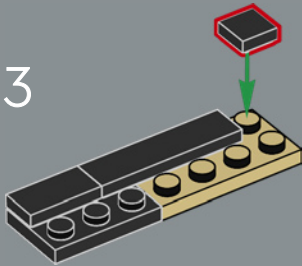

4

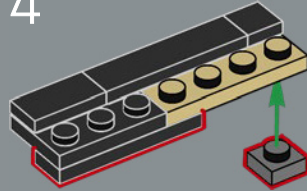

5

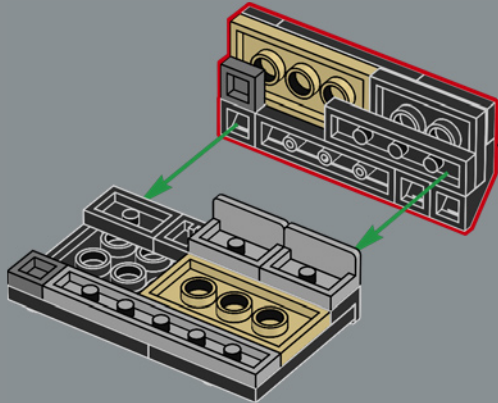
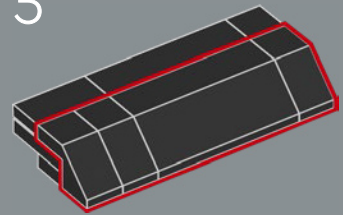

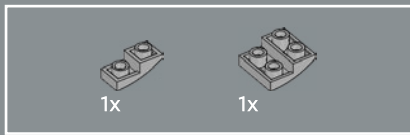

187

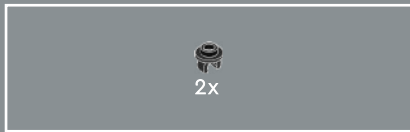
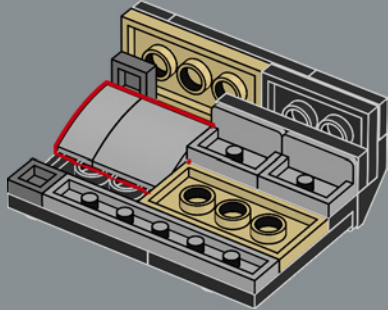

188

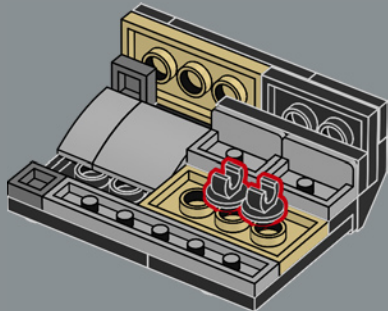

189

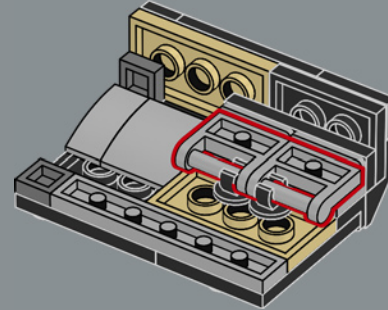

190

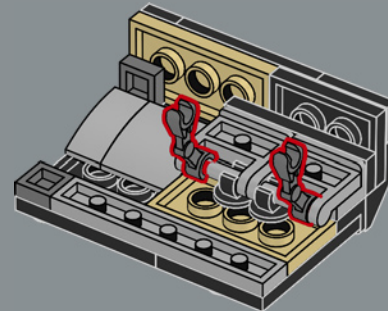

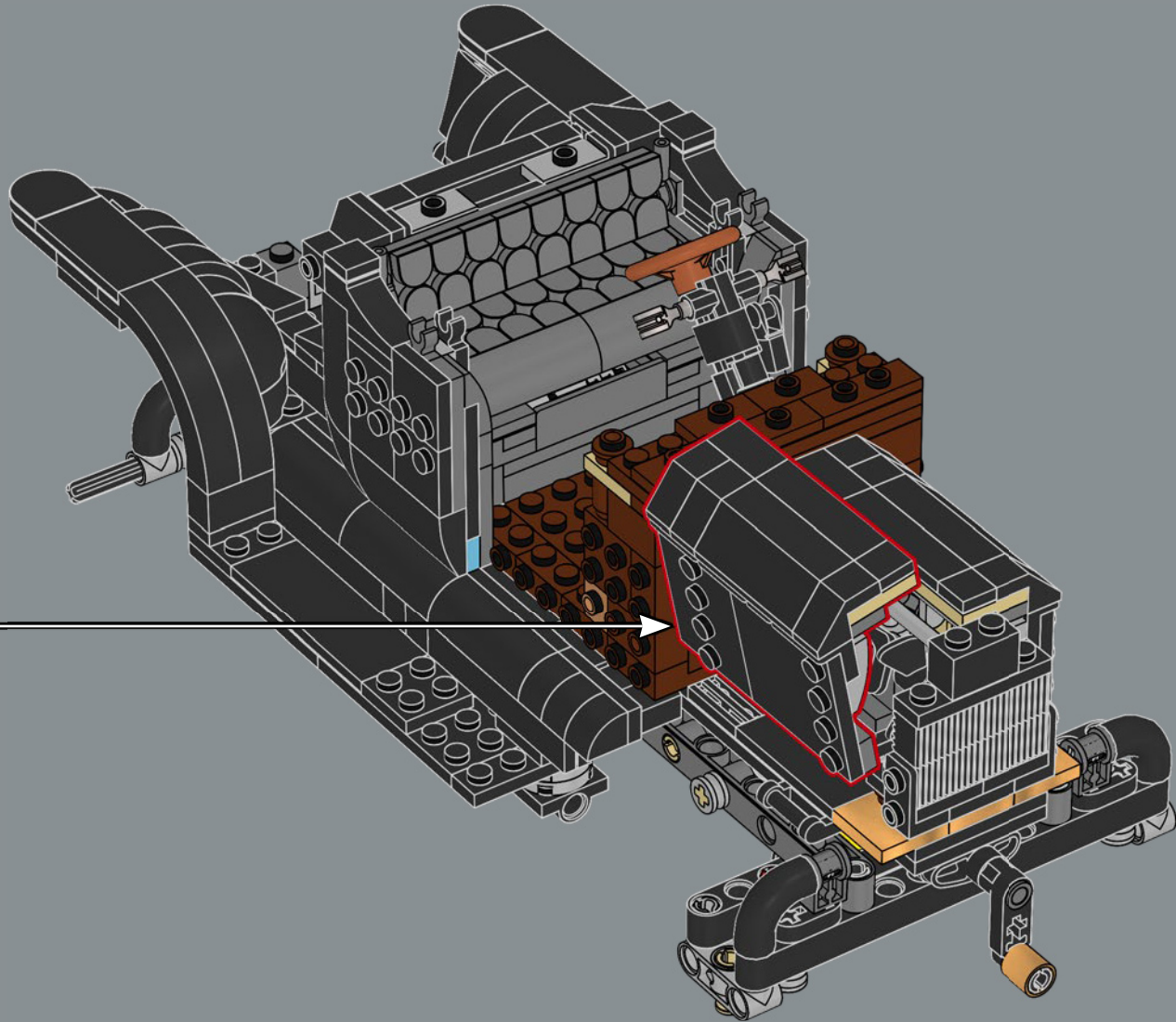

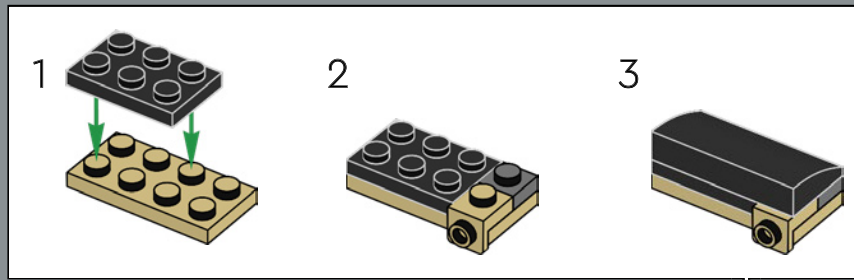
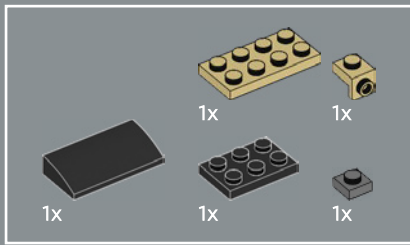

192

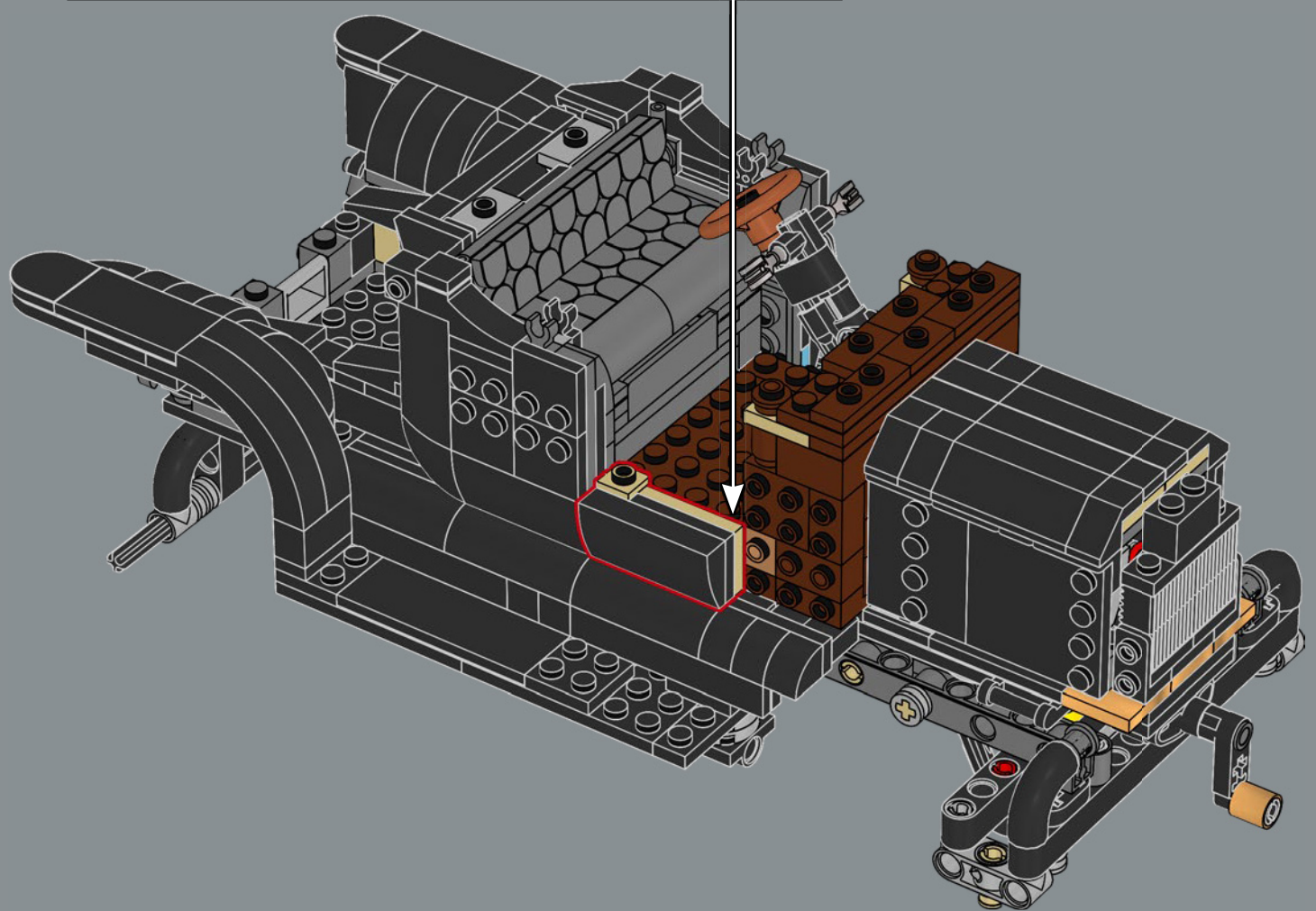

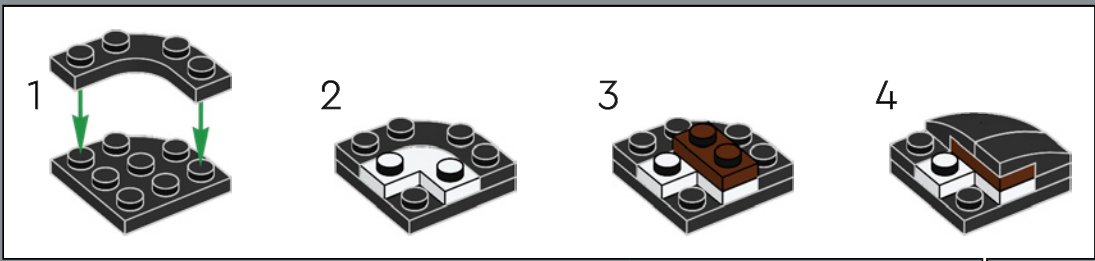
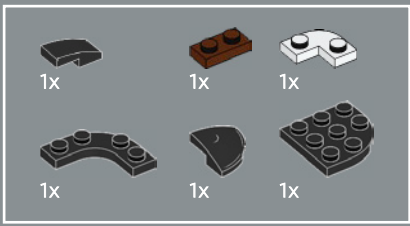

193

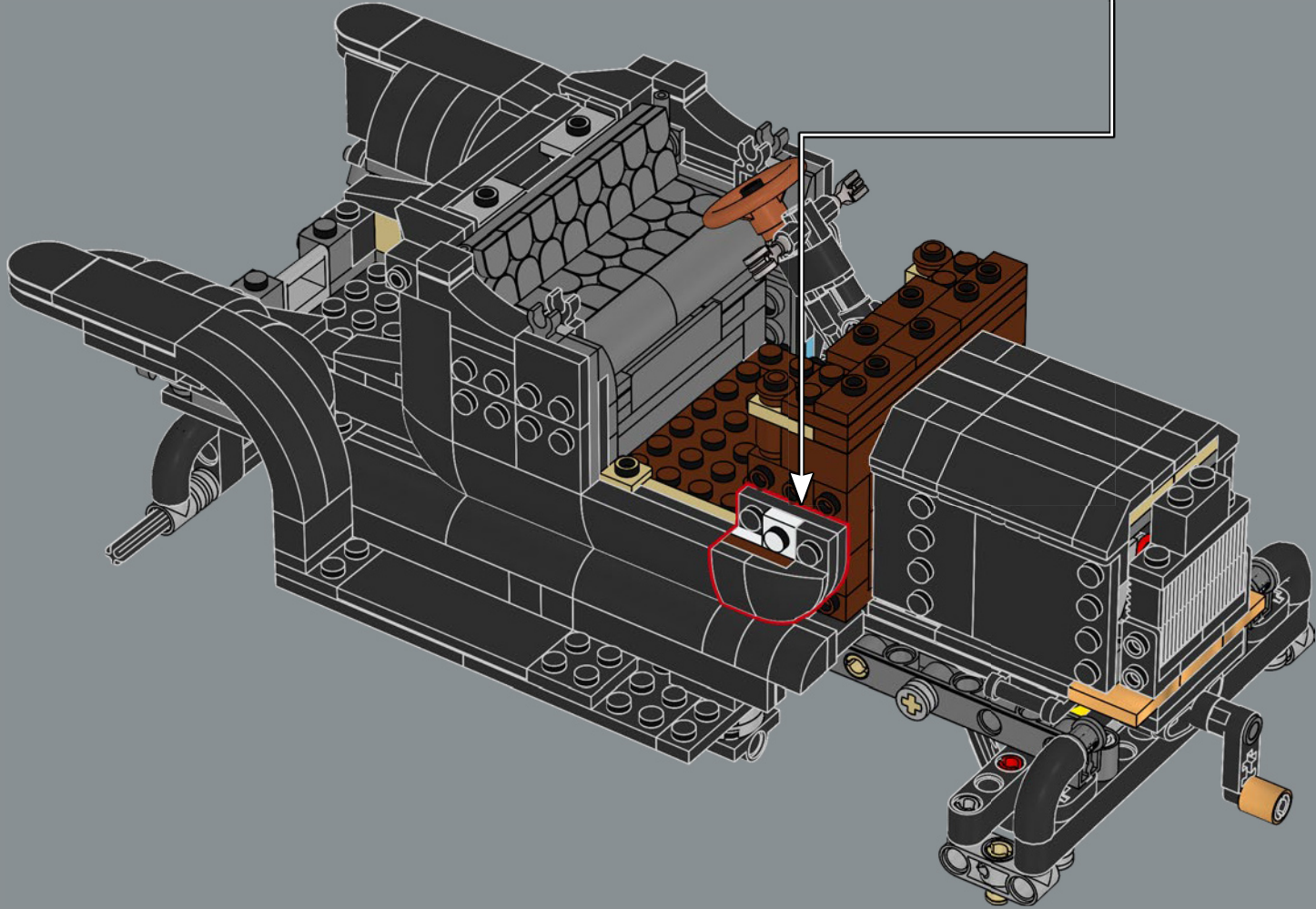

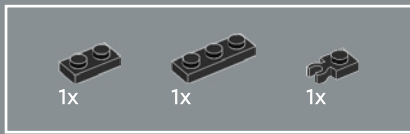

194

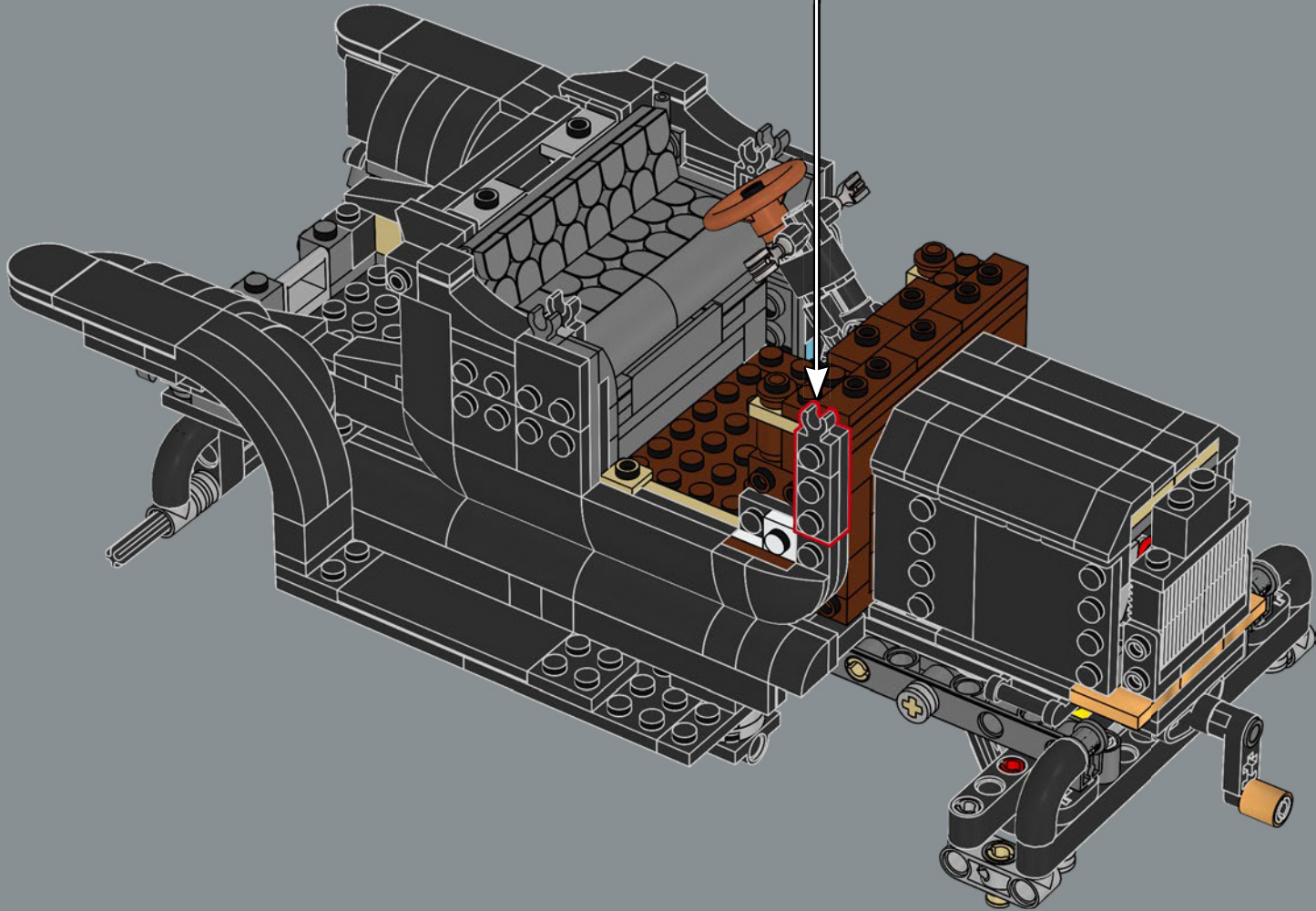
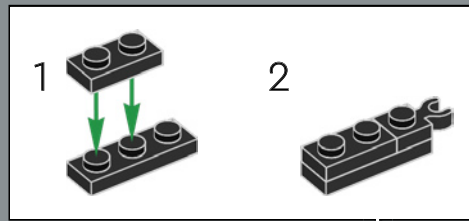

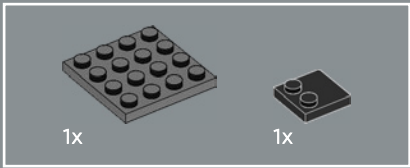

195

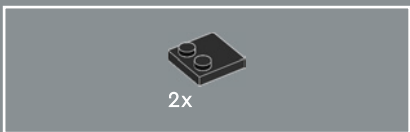
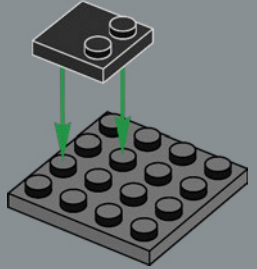

196

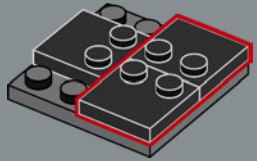

197

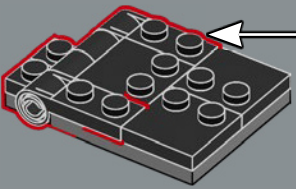
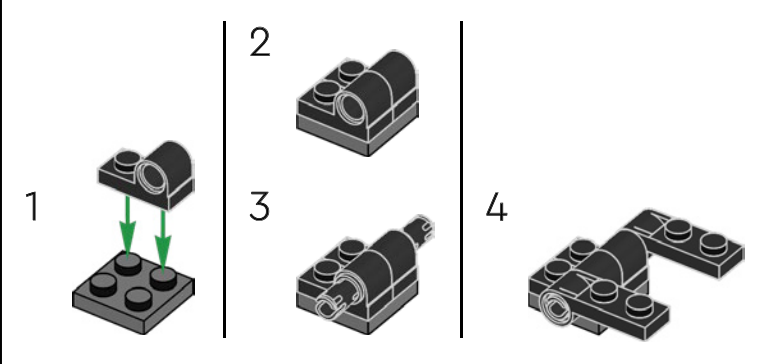

198

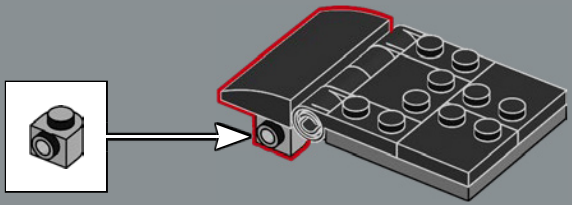



La version 1913 « Runabout » de la Model T®
n'avait qu'une seule porte, côté passager.

199

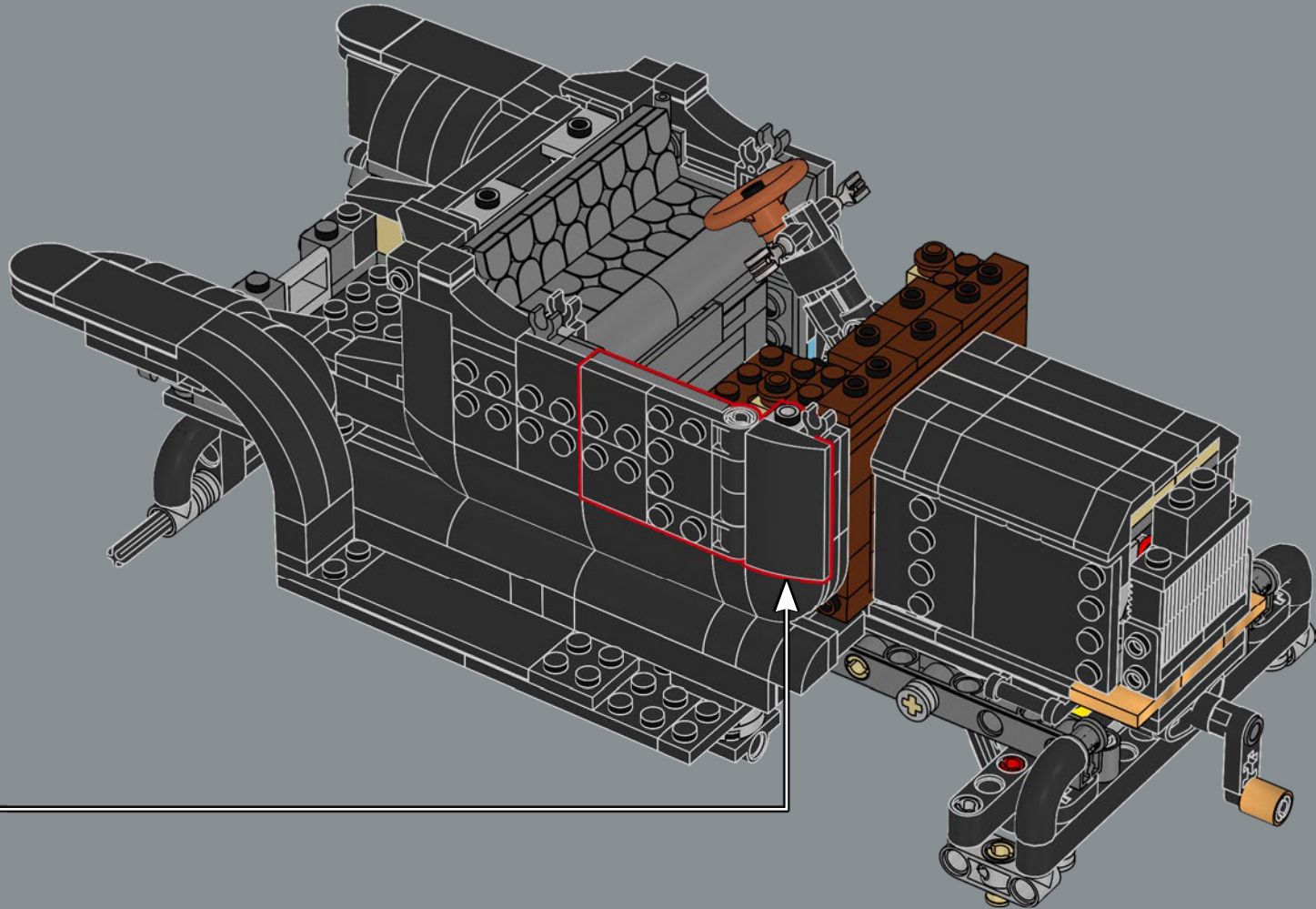

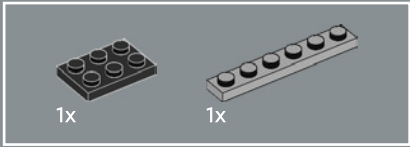
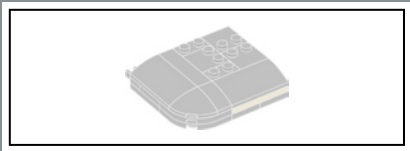

200

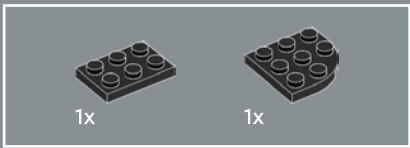
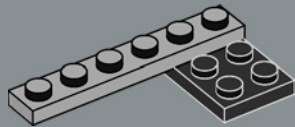

201

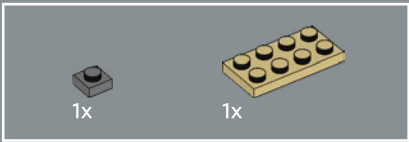
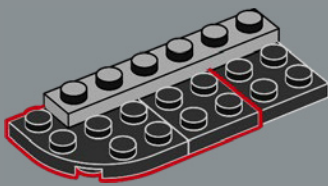

202

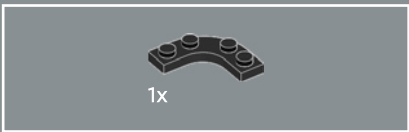
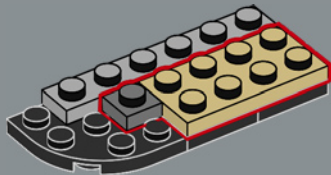

203

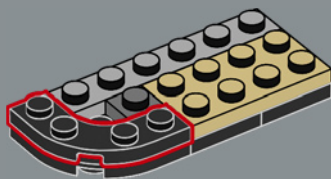

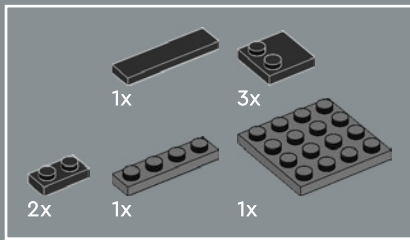

204

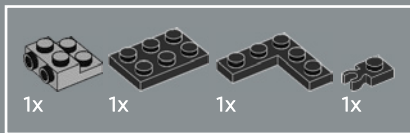
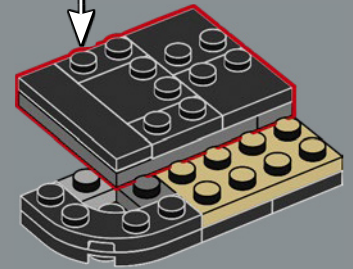
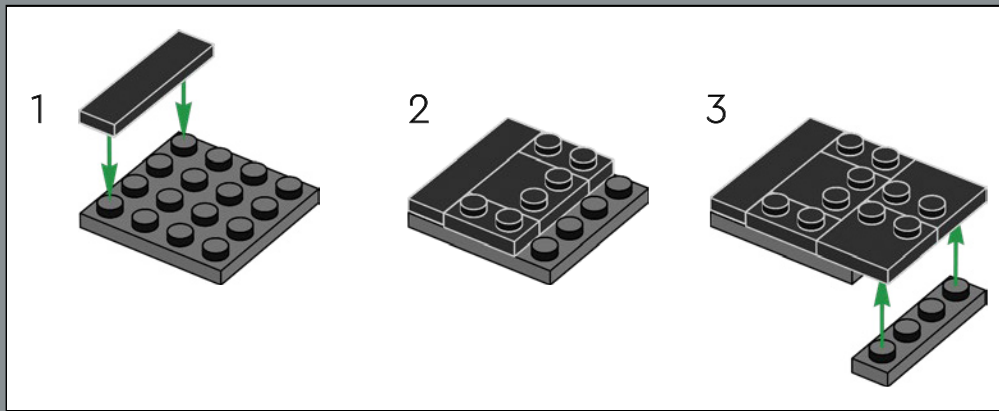

205

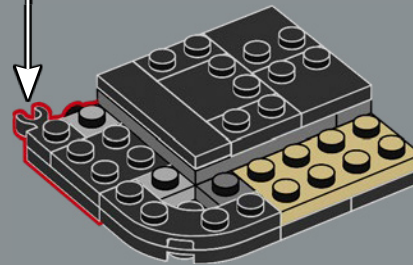
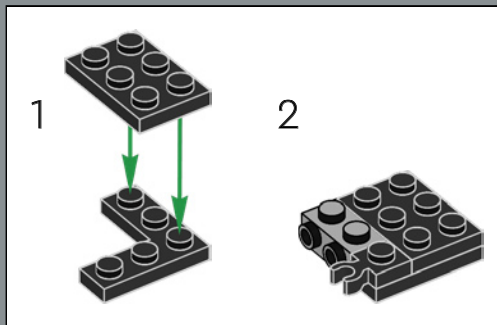



1x

206

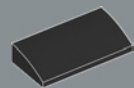
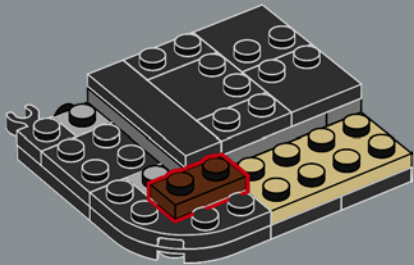

2x



1x



1x

207

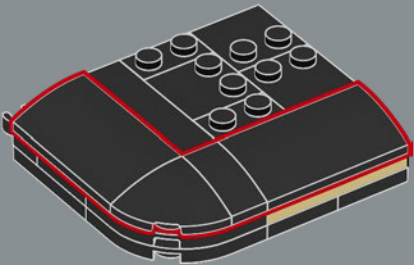

208

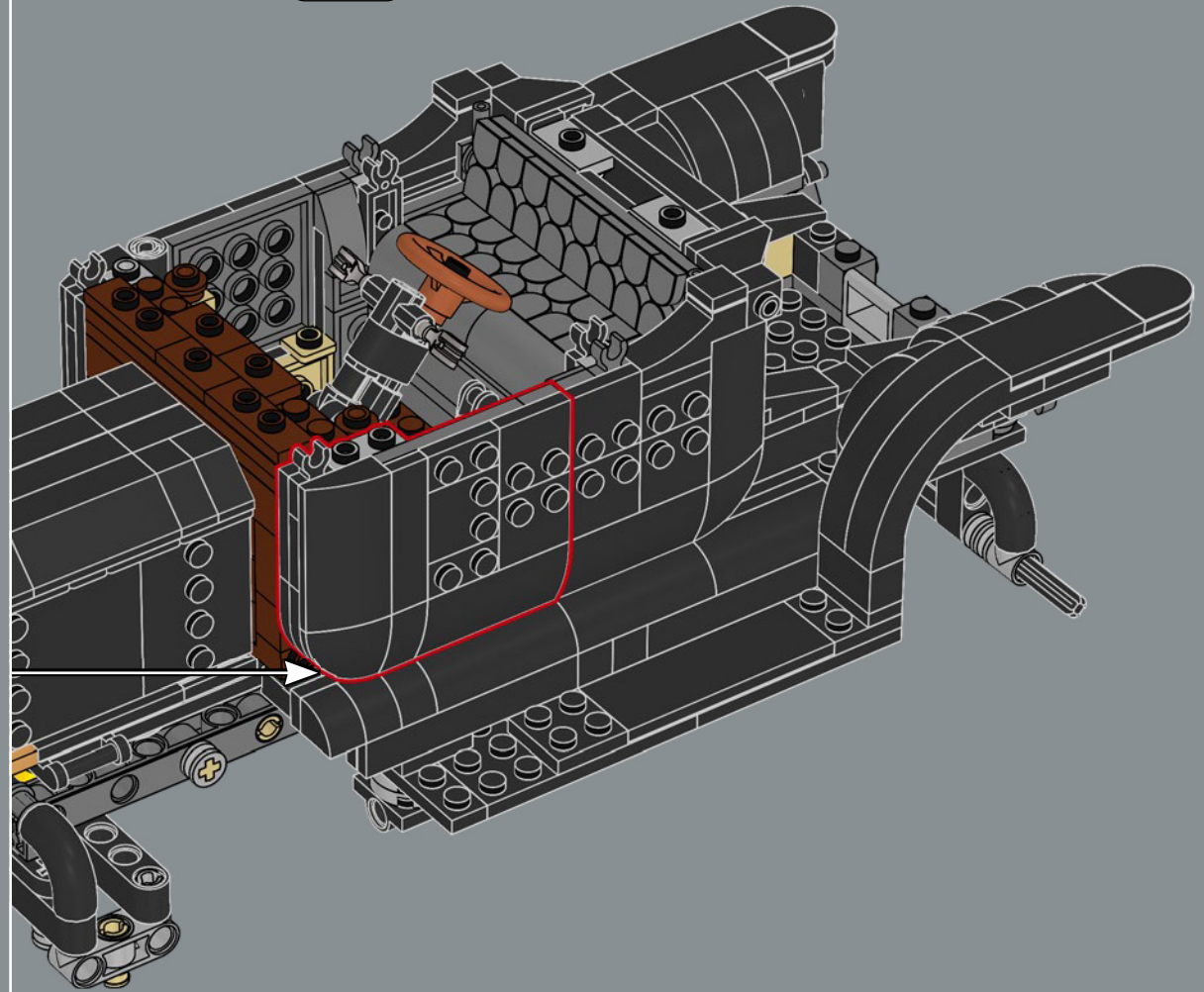



209

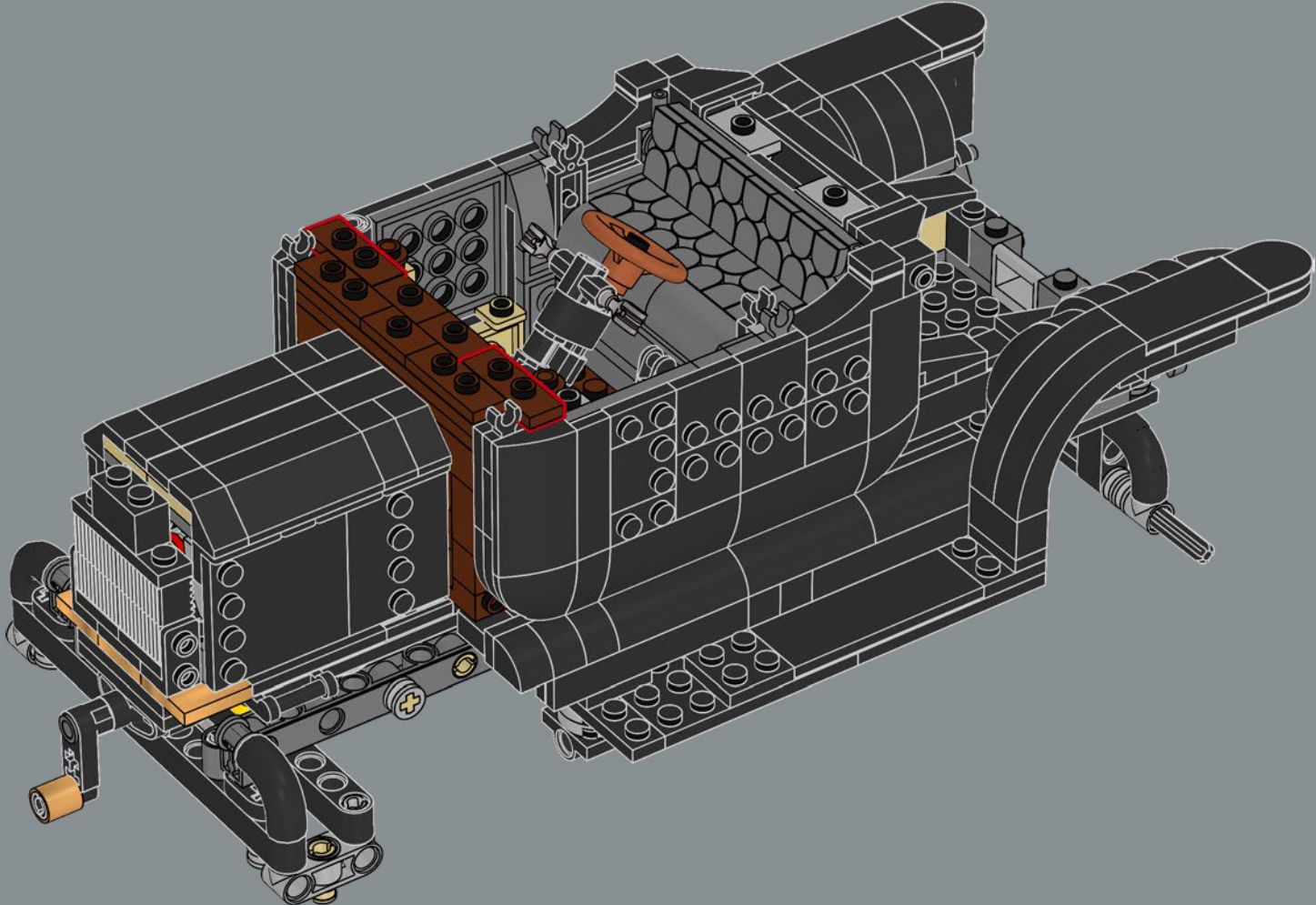



210

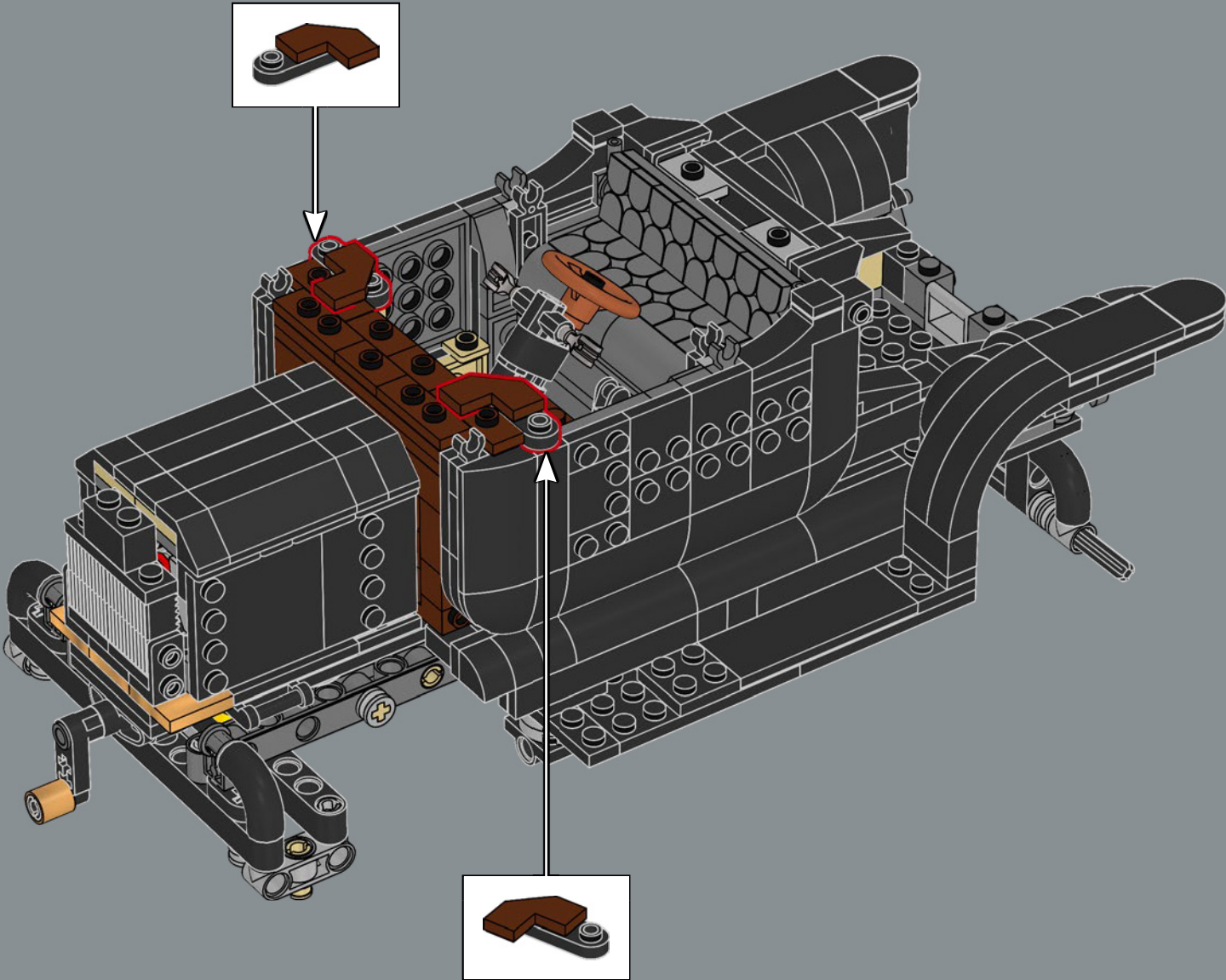

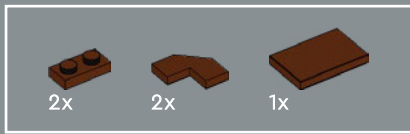

211

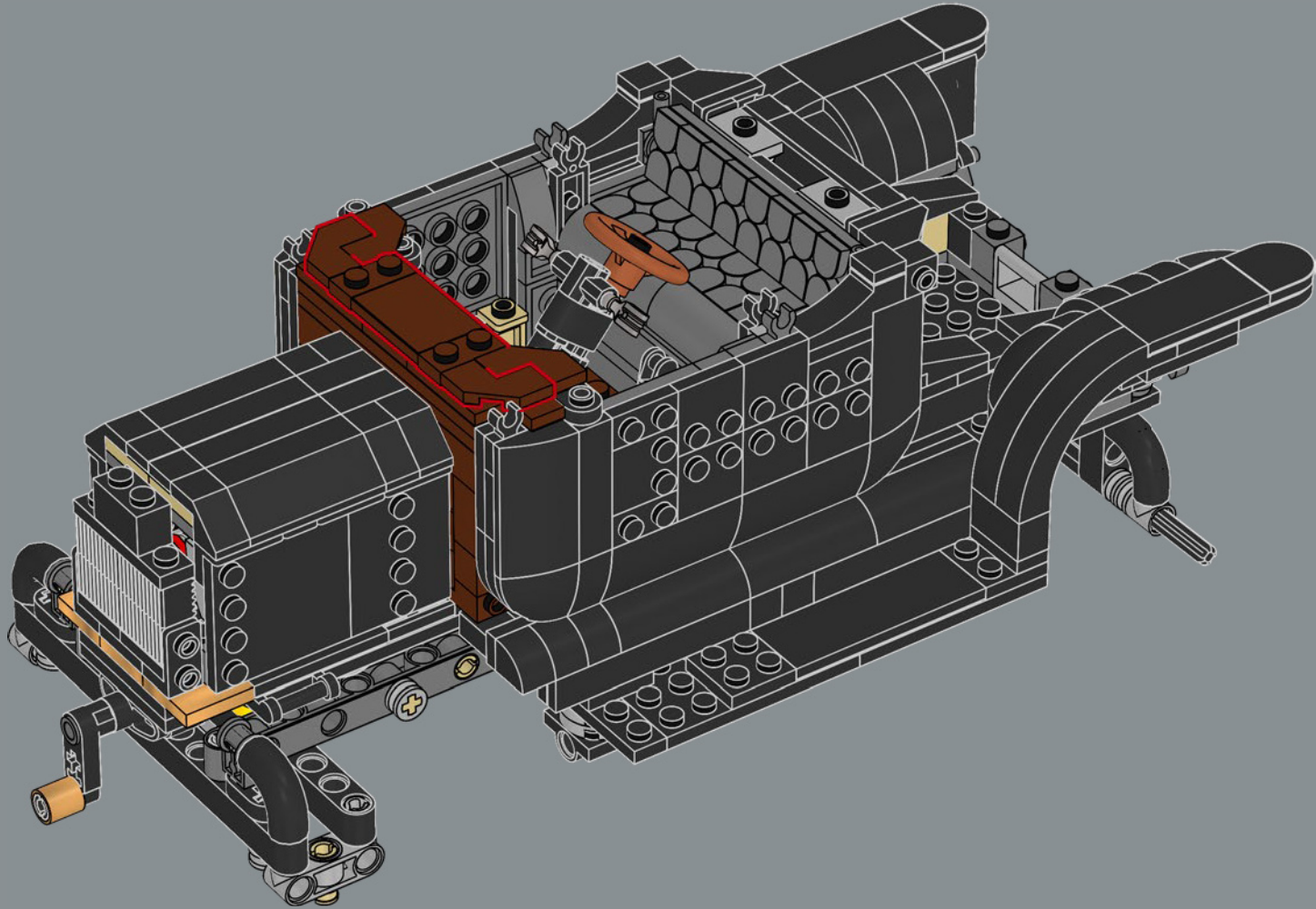



212

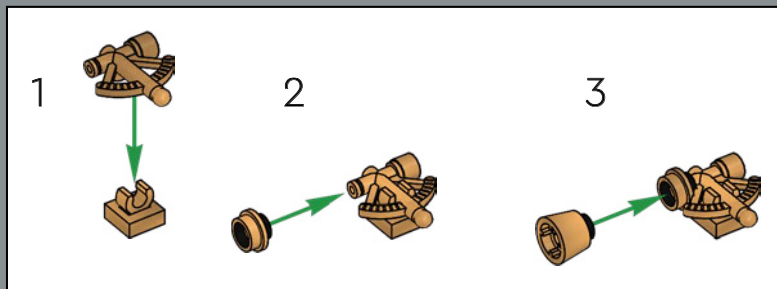

Un réservoir séparé, appelé générateur de carbone, alimentait les phares.

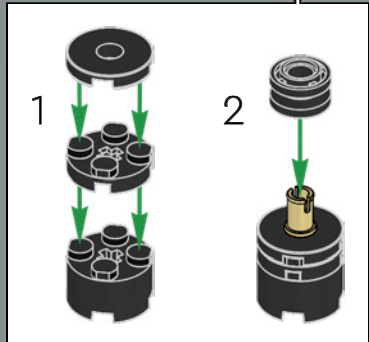
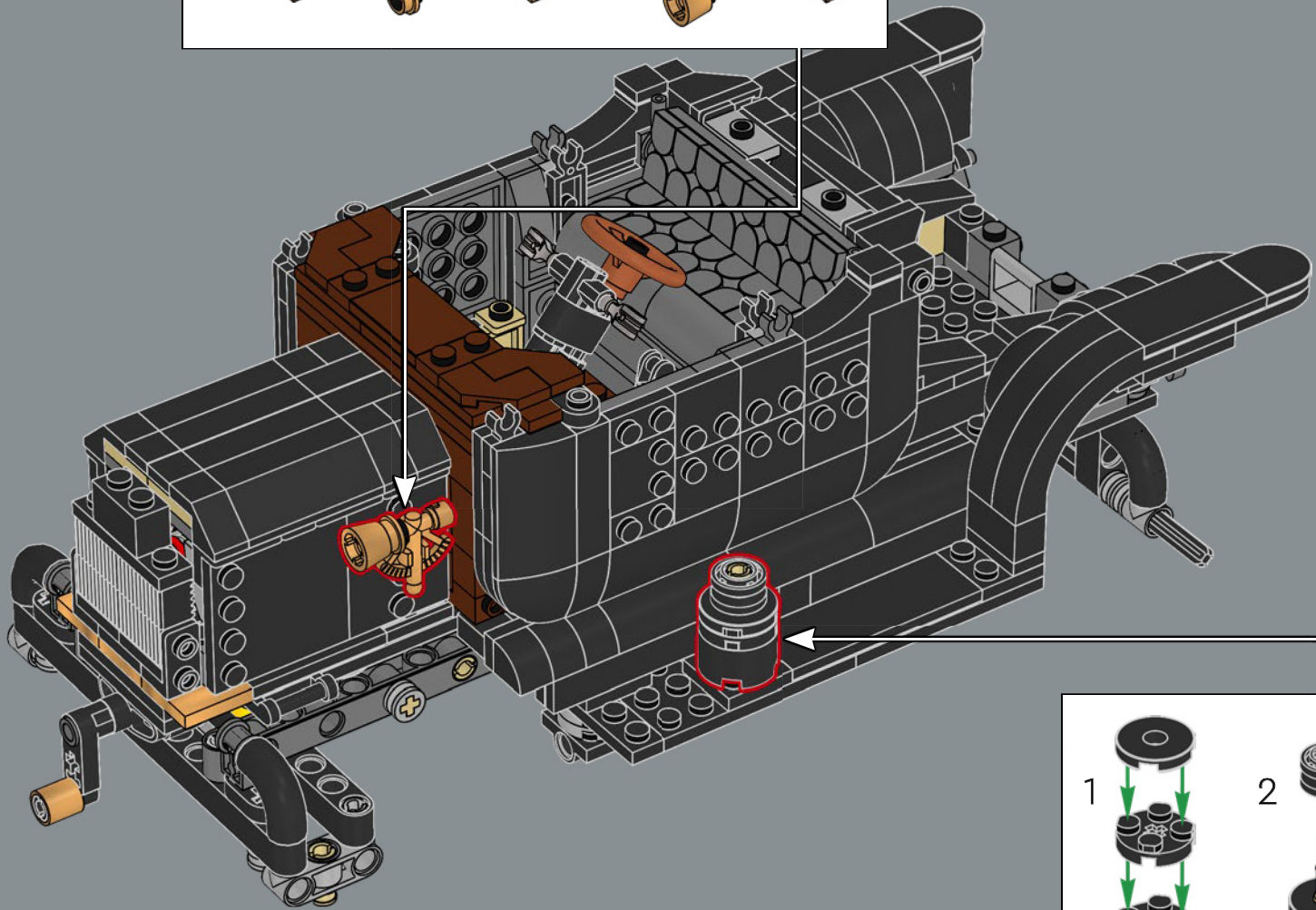



213

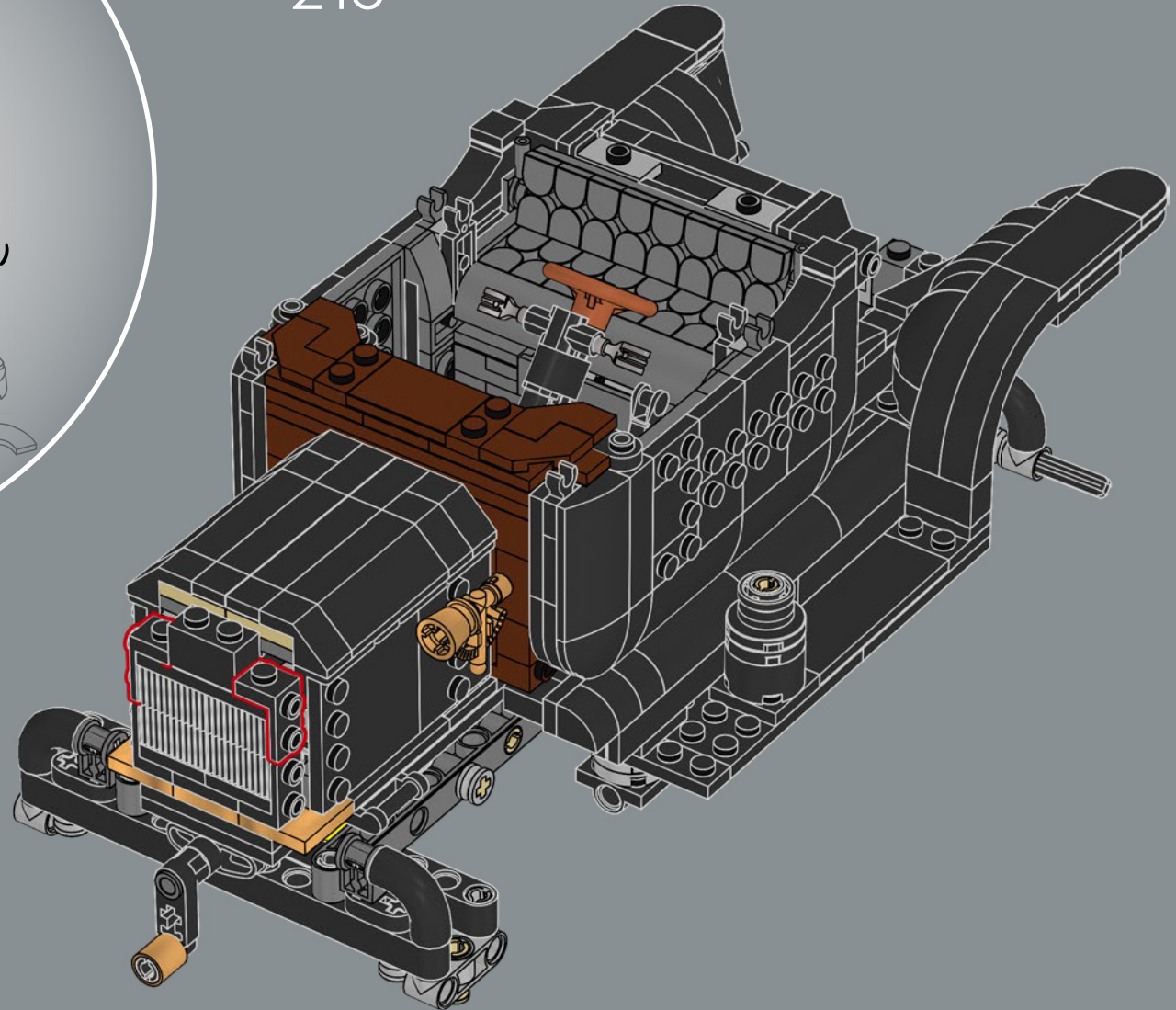

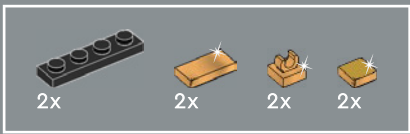

214

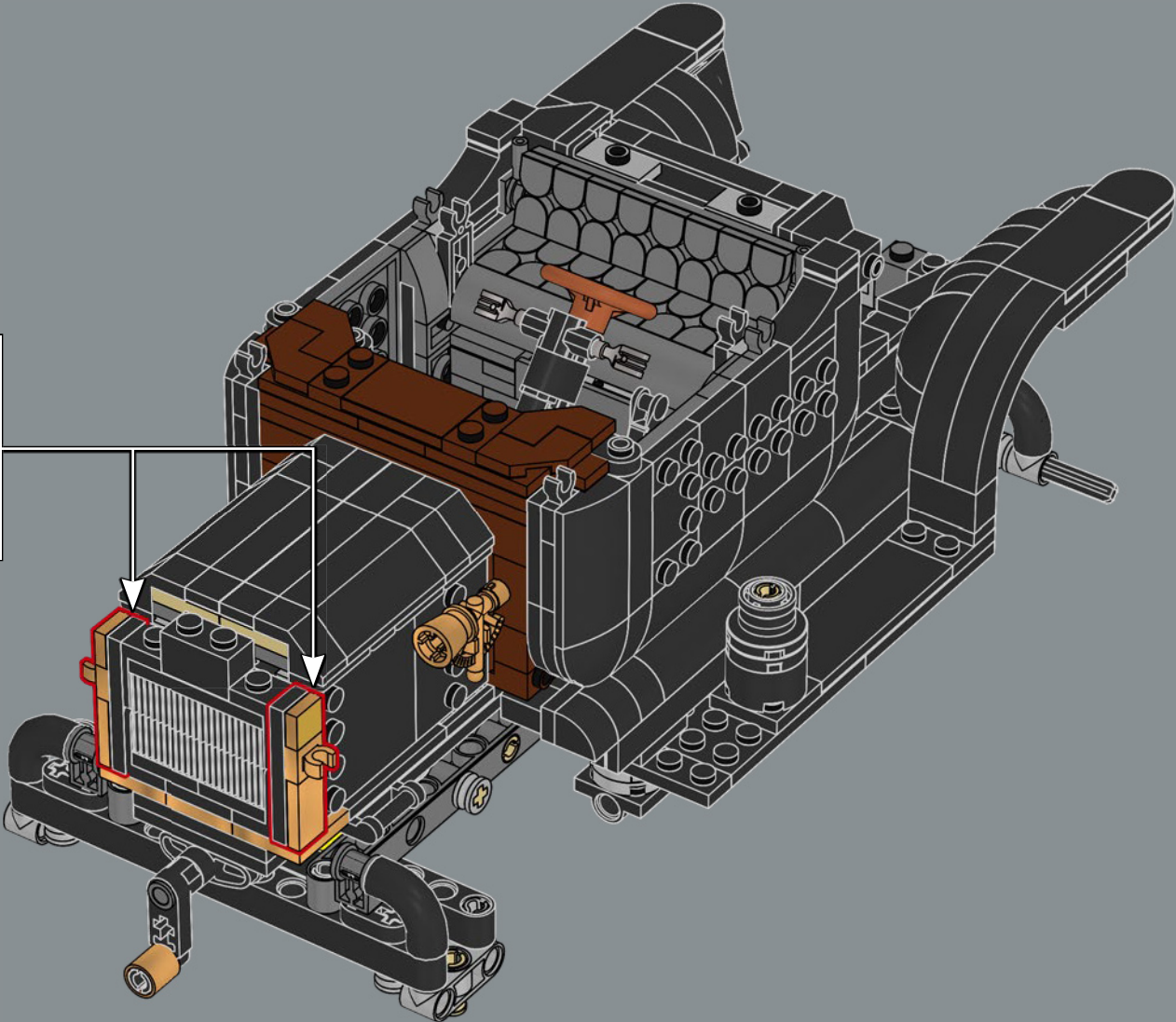
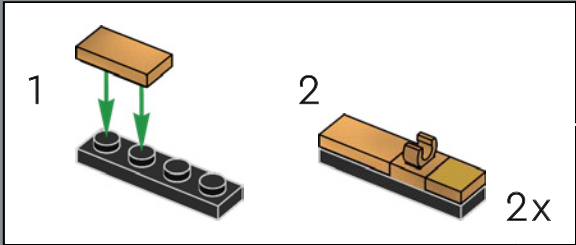



215

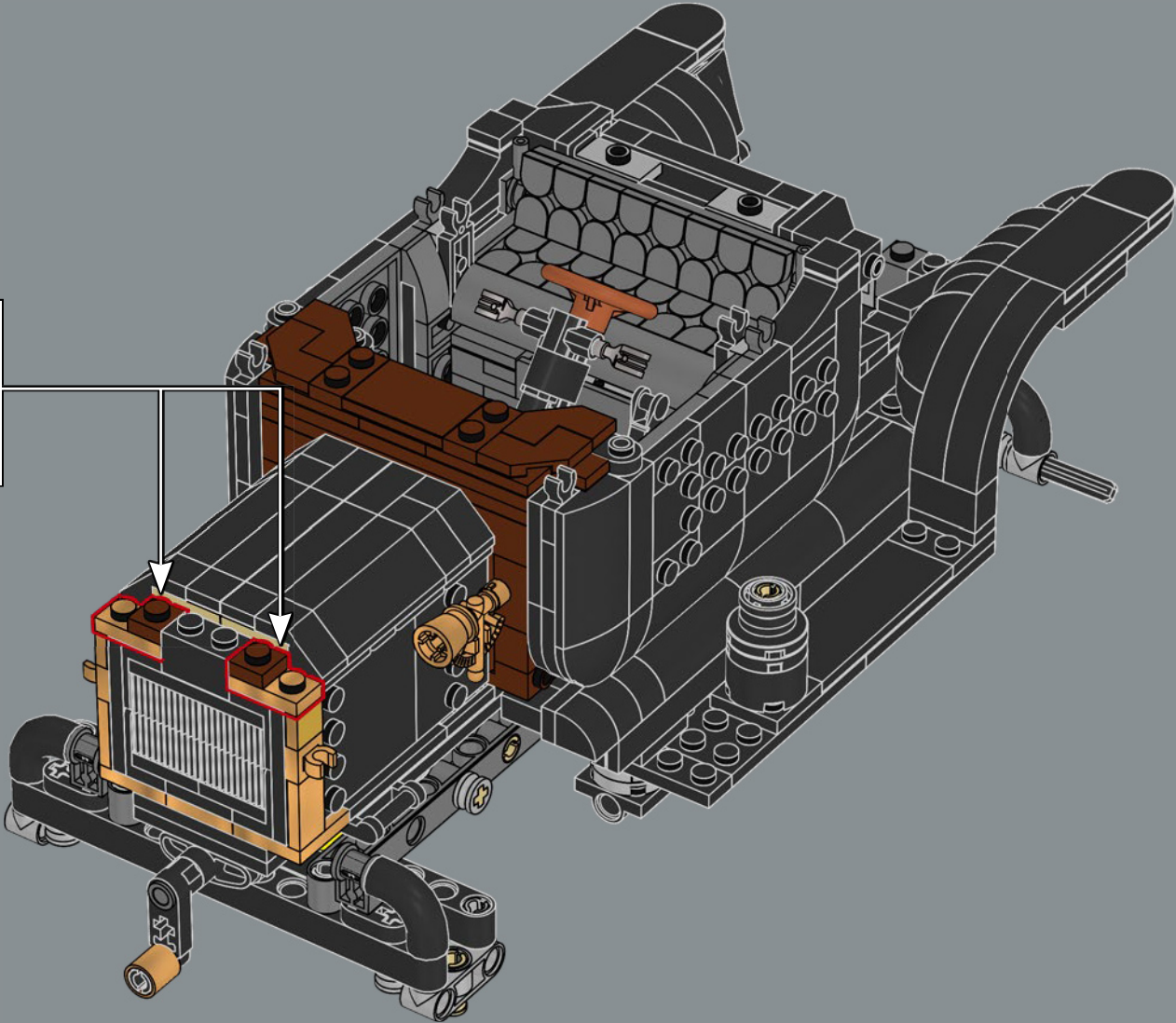
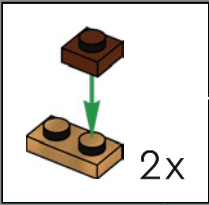



2x

216

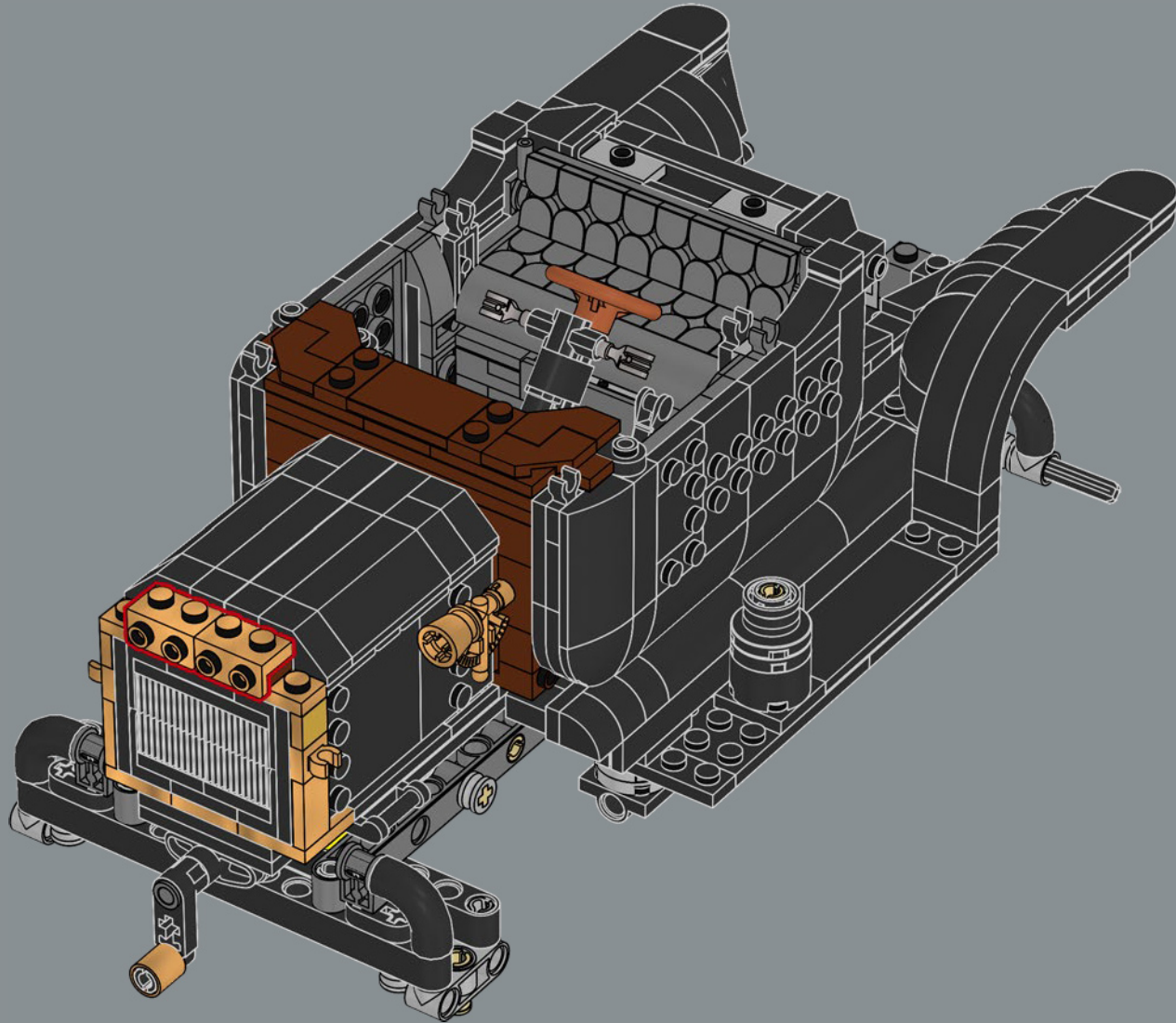

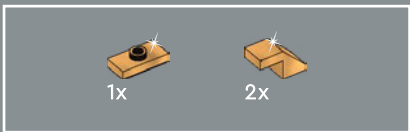

217

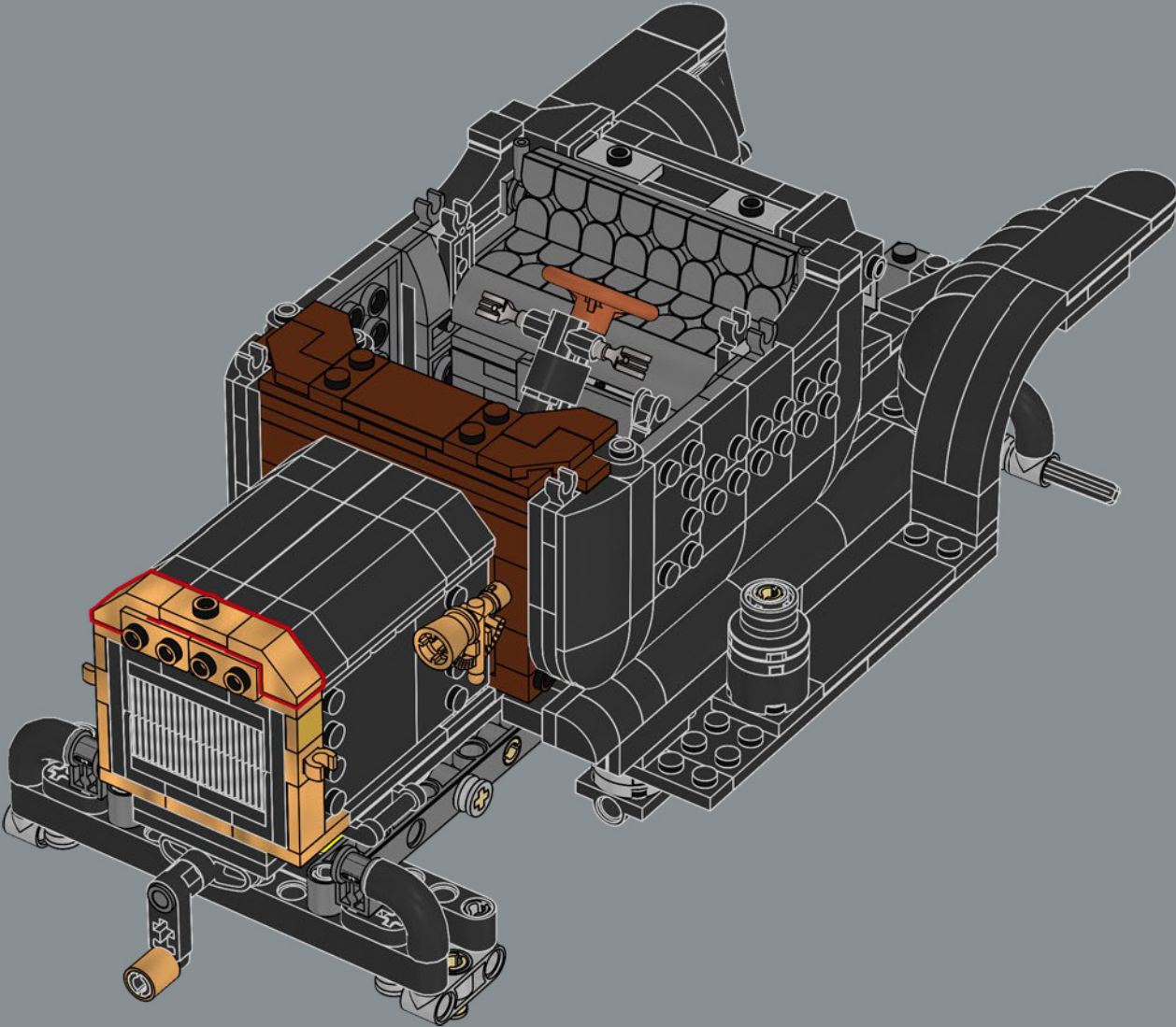



218

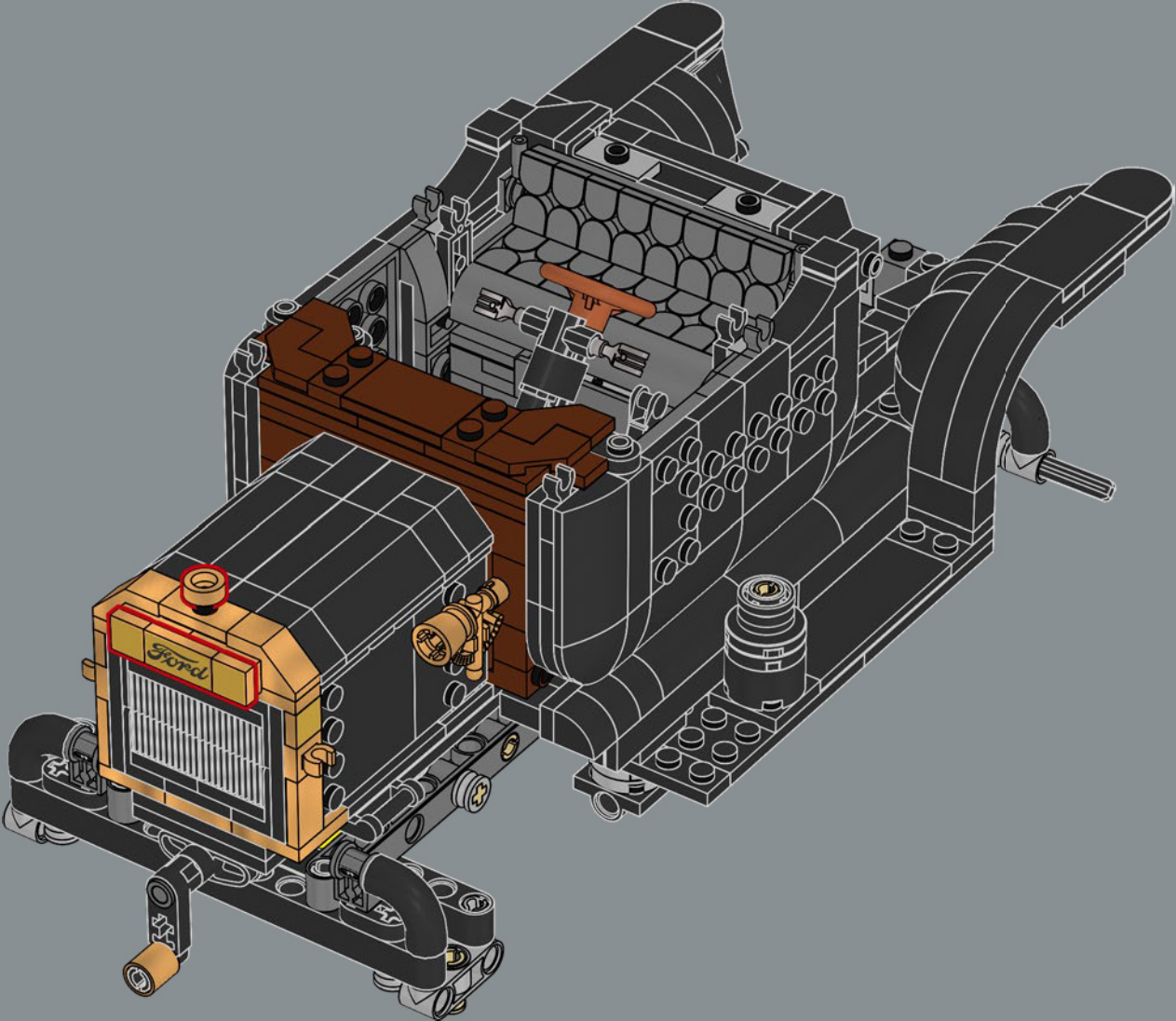

Reputée pour son adaptabilité, la Model T® pouvait être transformée pour d'autres usages. Des magazines publiaient des conseils pour la convertir en motoneige, en tracteur, voire en moulin à grain !





219

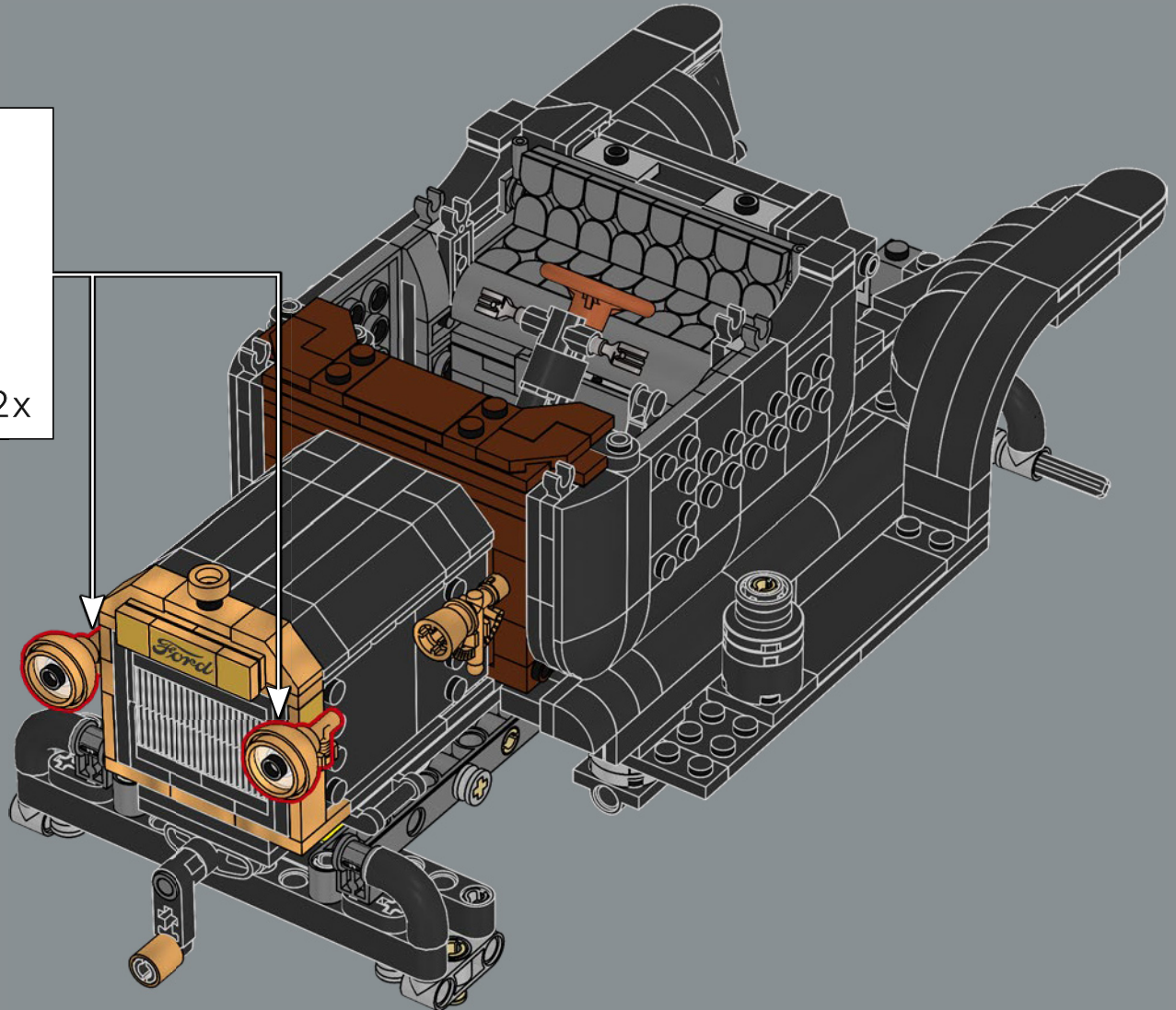
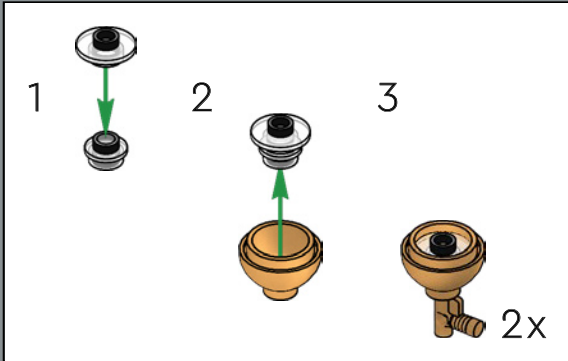

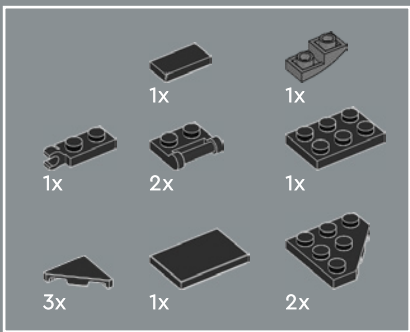

220

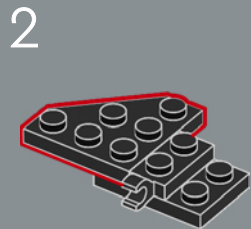
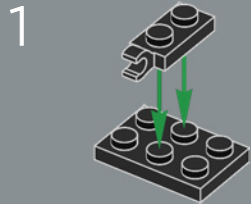

3

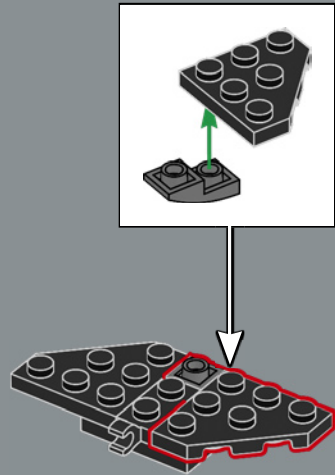

4

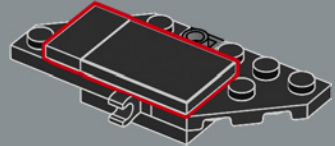

5

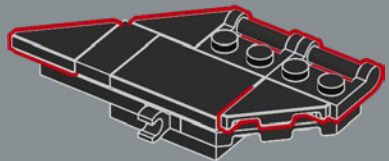

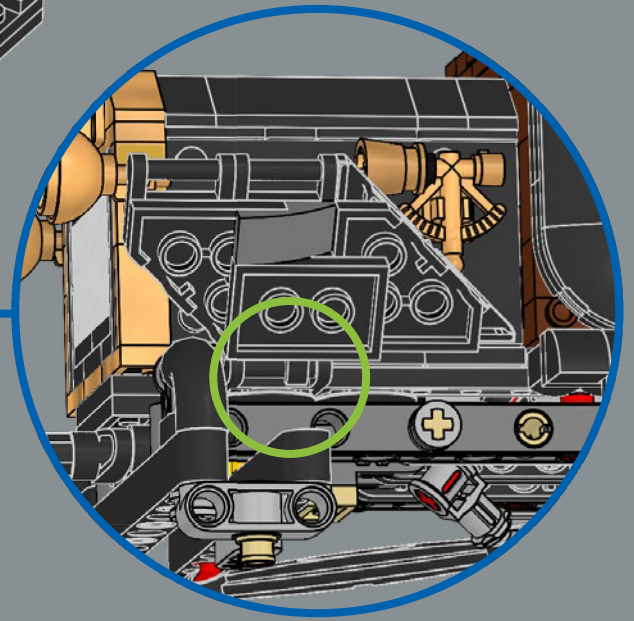
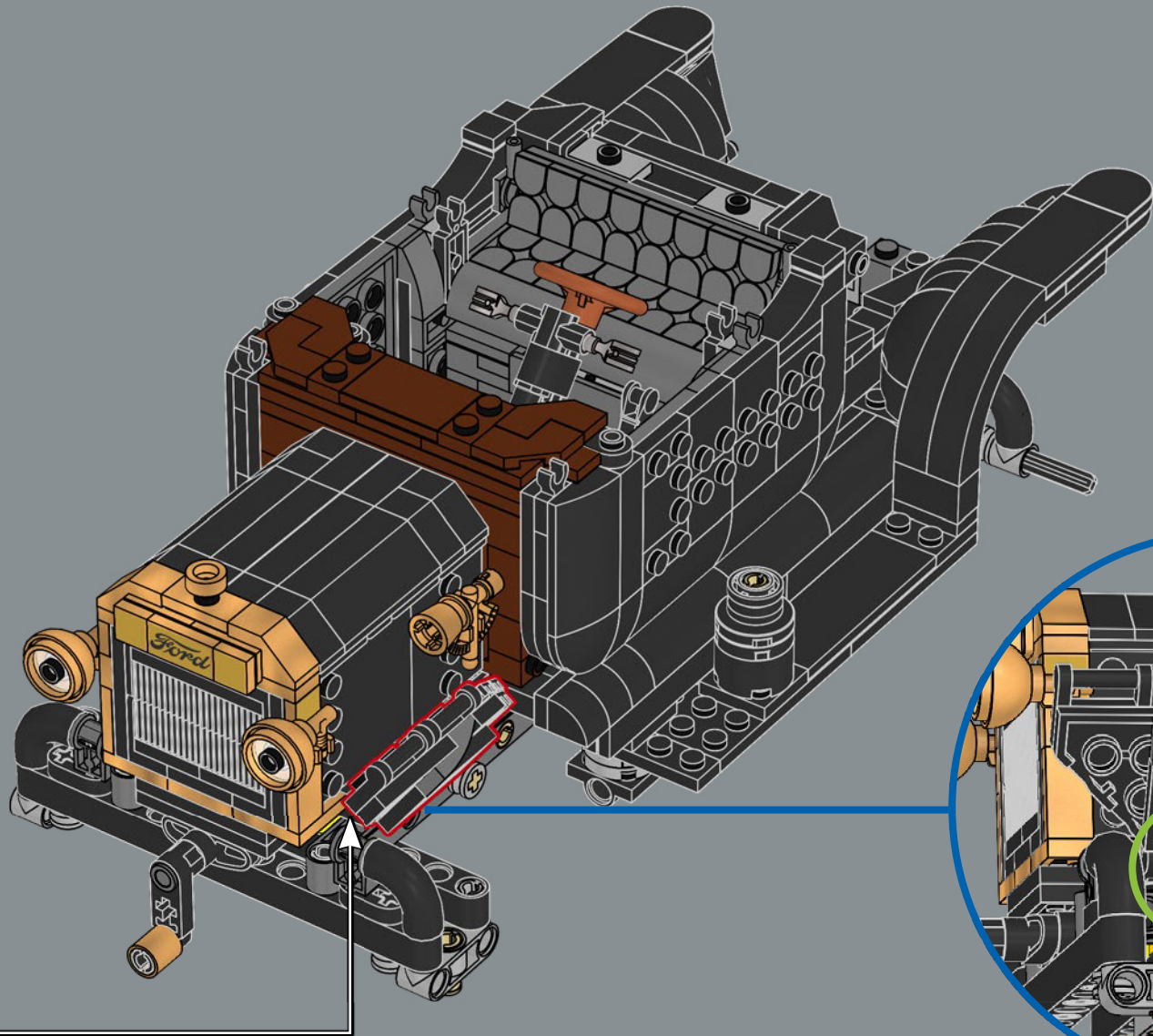

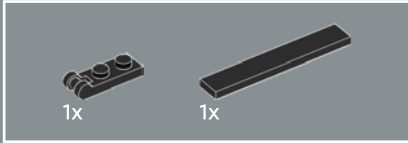
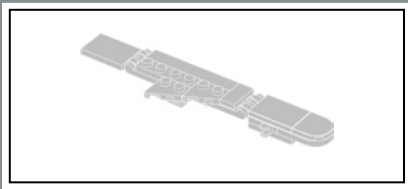

221

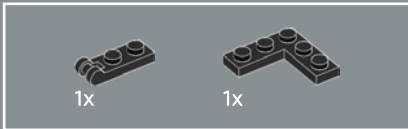
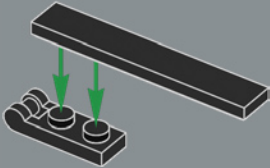

222

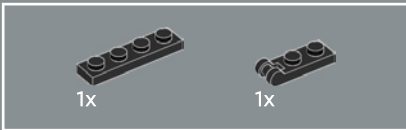
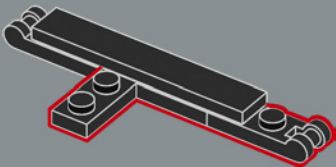

223

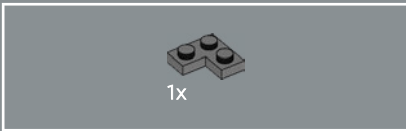
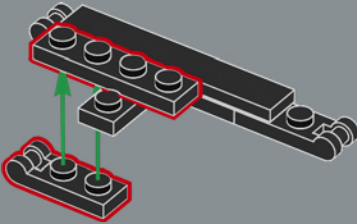

224

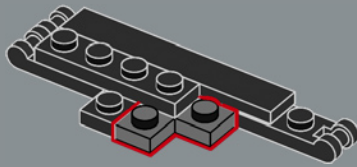

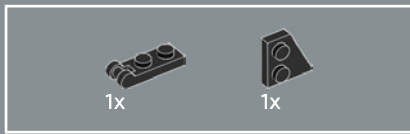

225

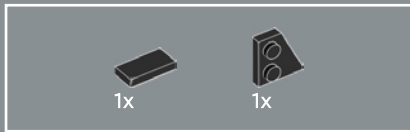
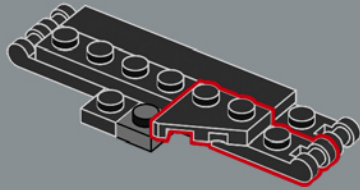

226

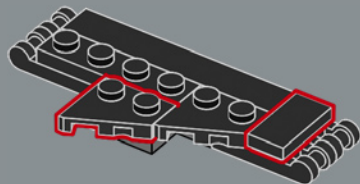

227

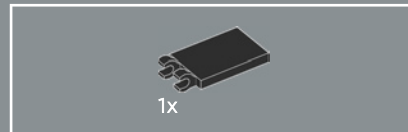
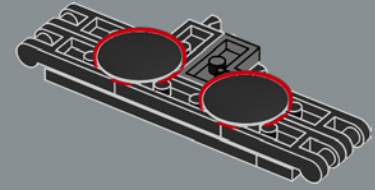

228

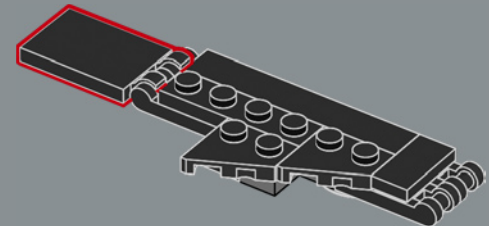

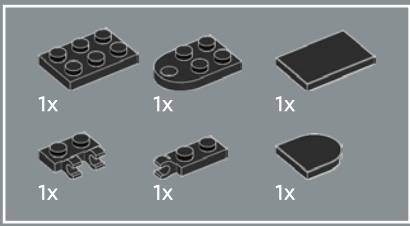

229

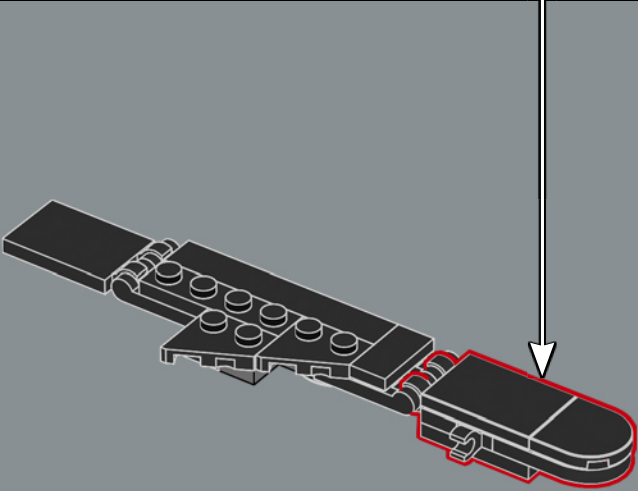
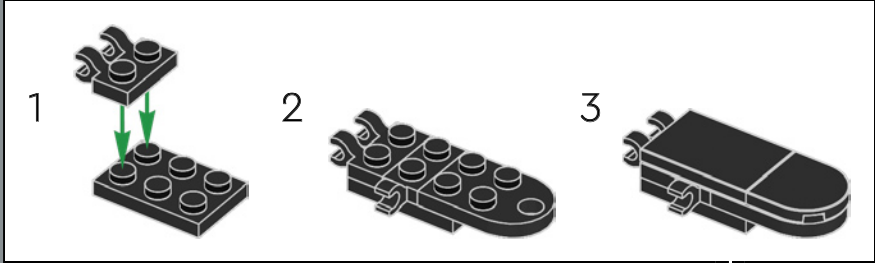

230

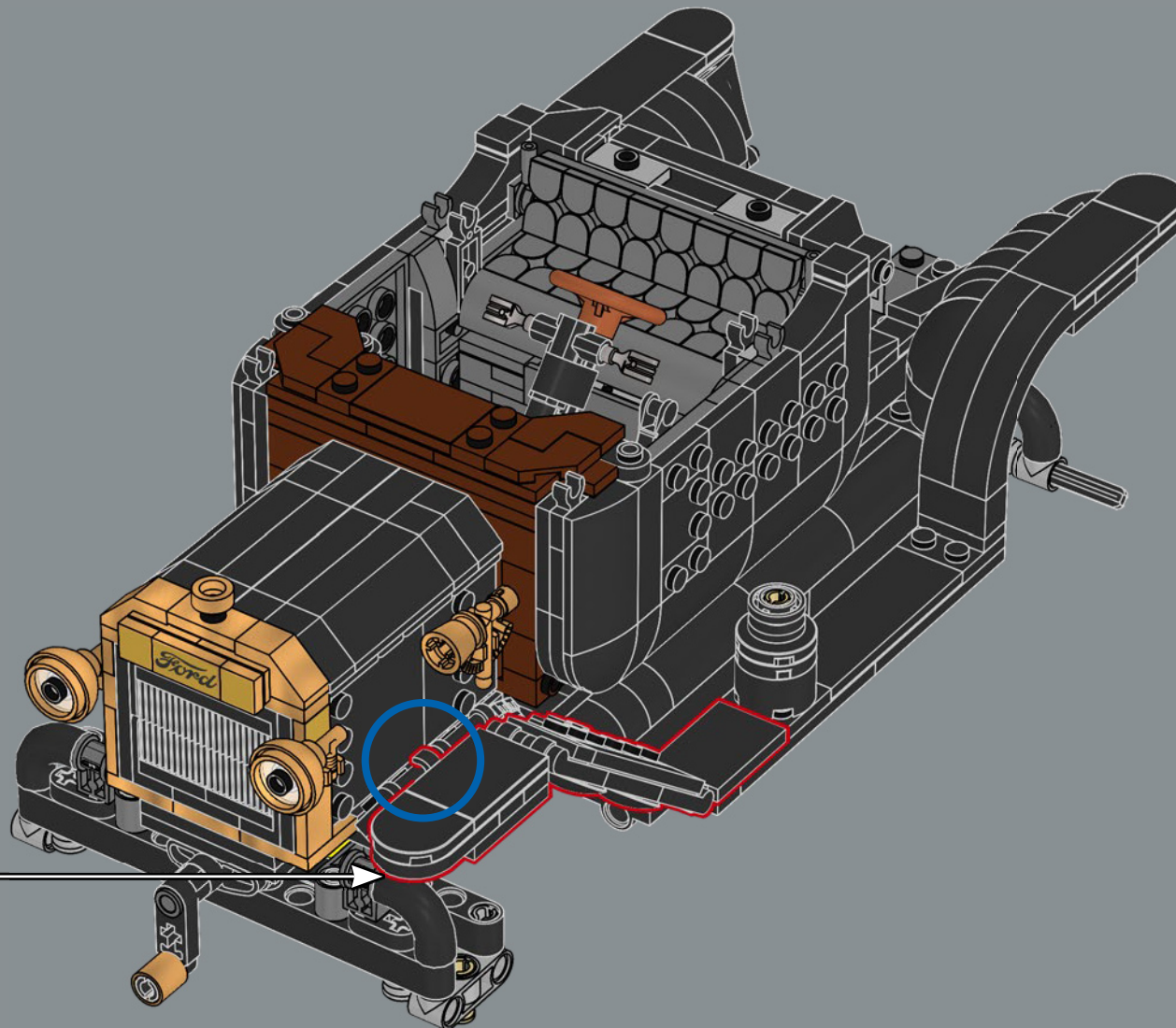

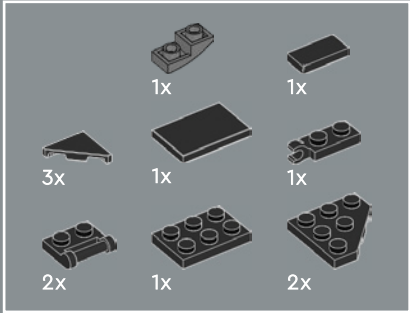
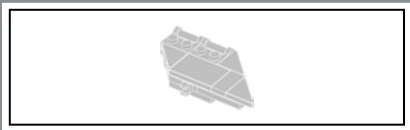

231

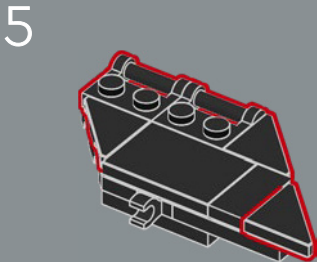
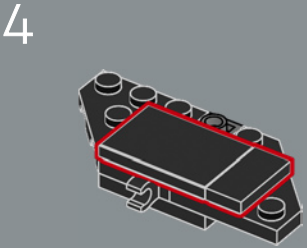
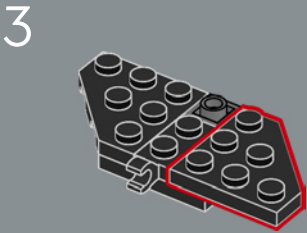
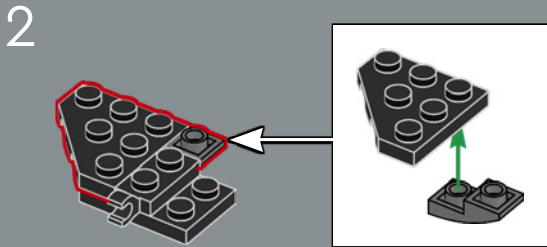
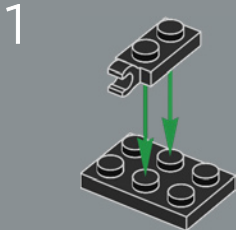

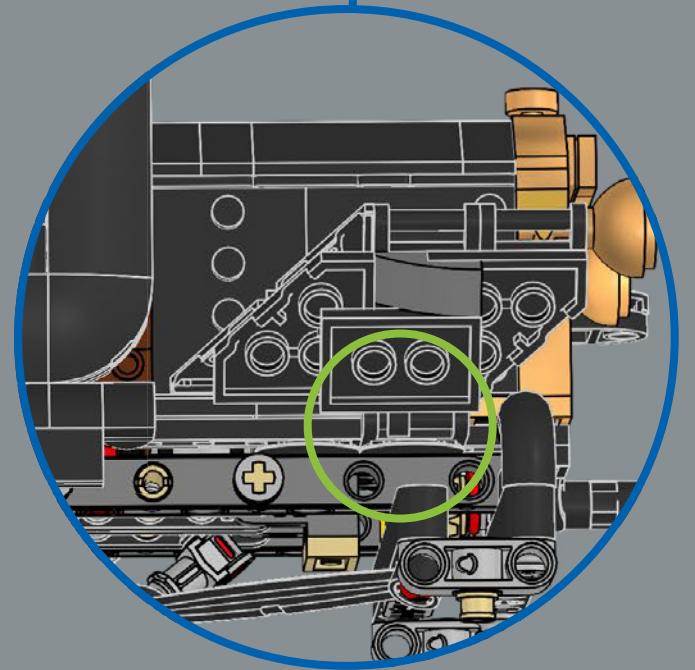
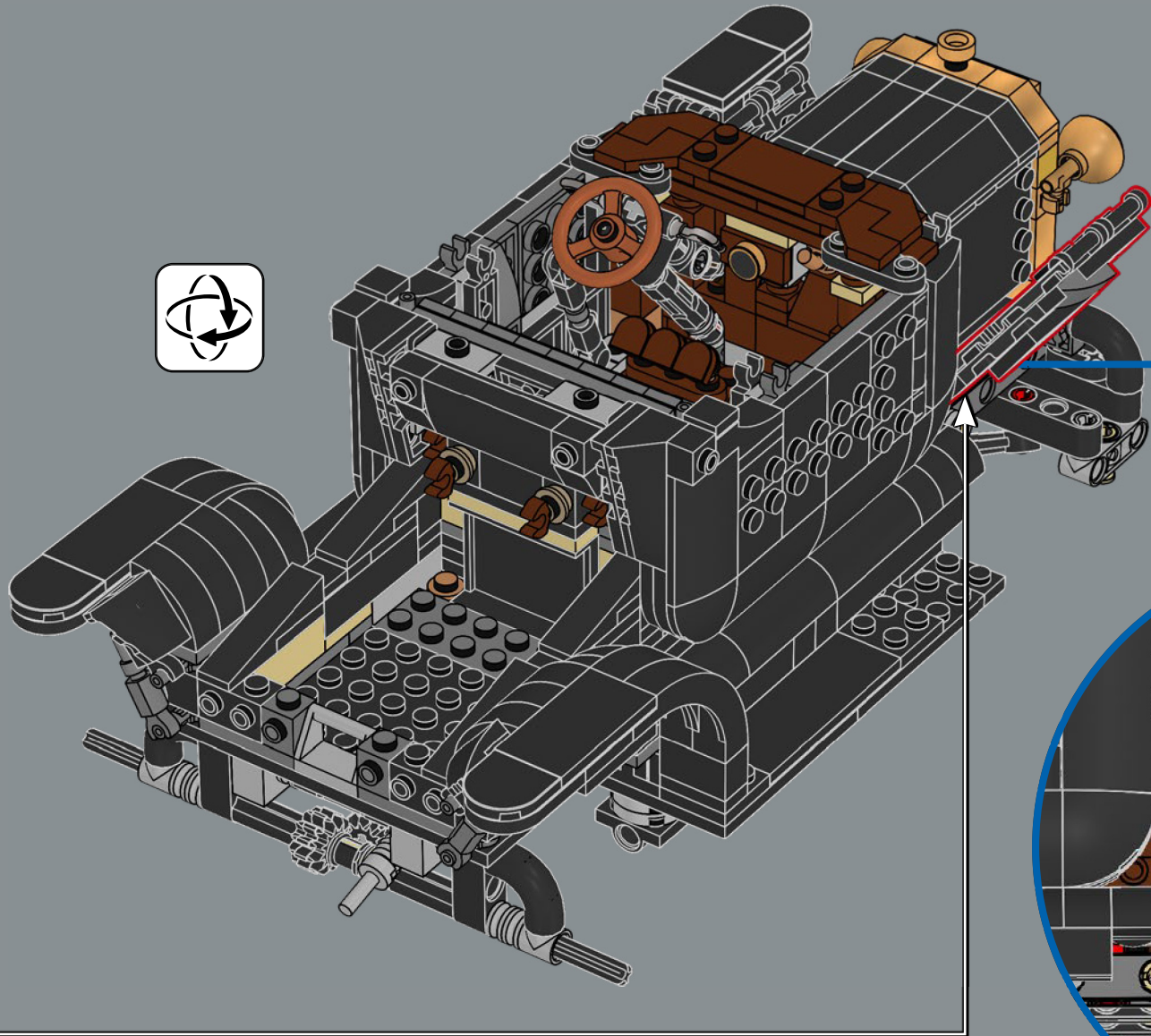

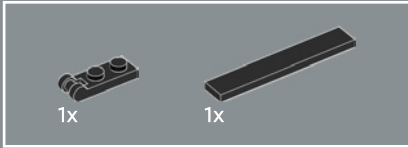
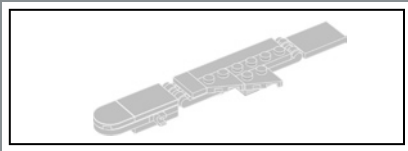

232

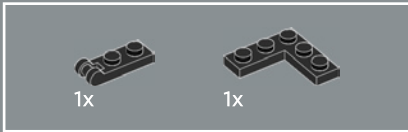
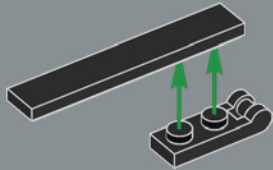

233

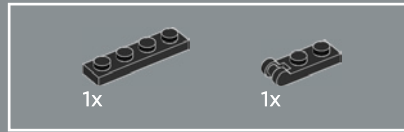
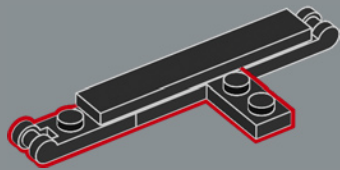

234

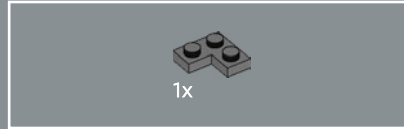
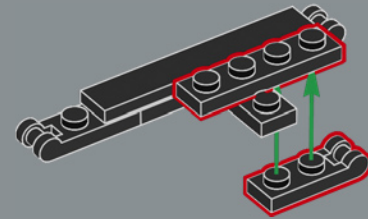

235

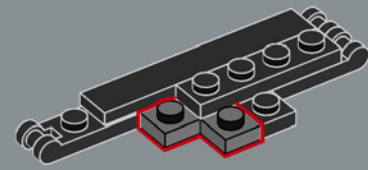

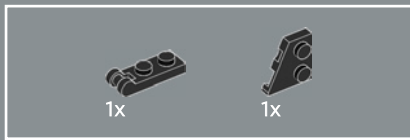

236

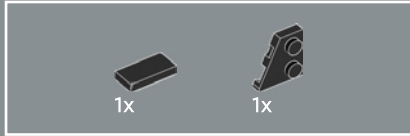
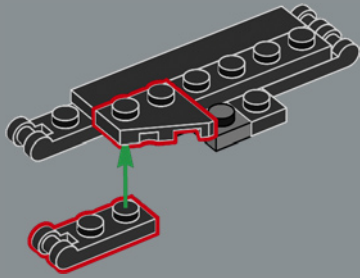

237

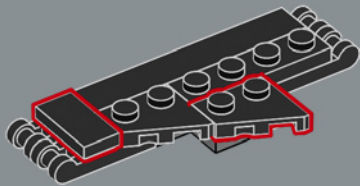

238

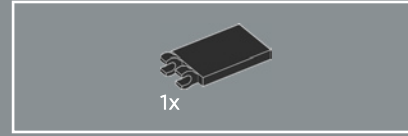
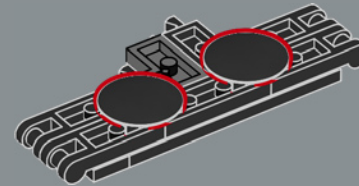

239

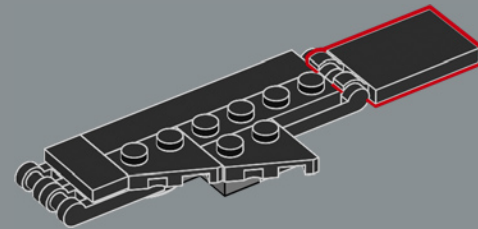

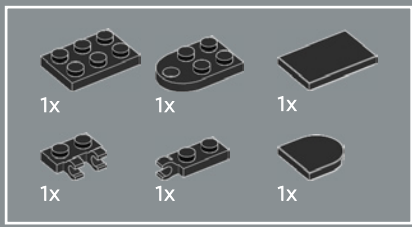

240

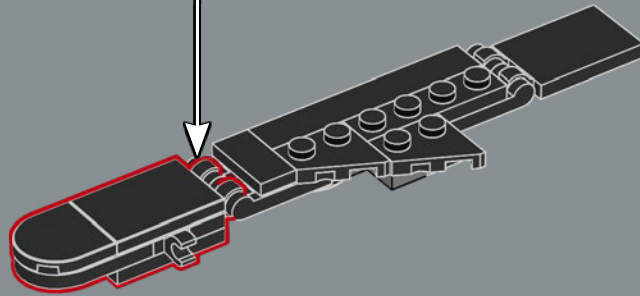
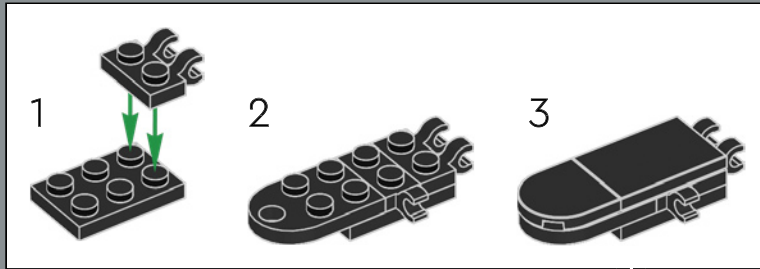

241

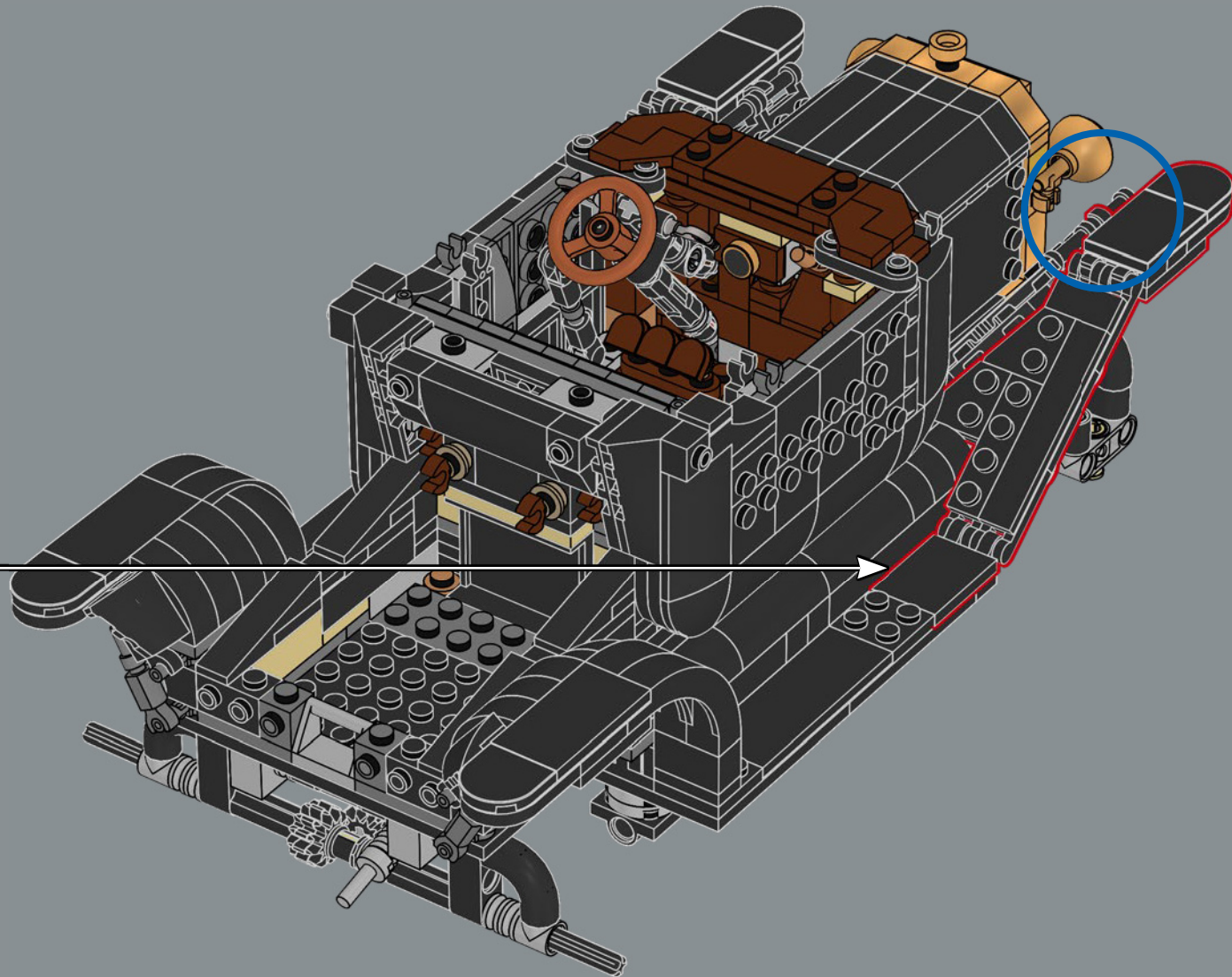

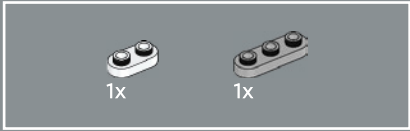
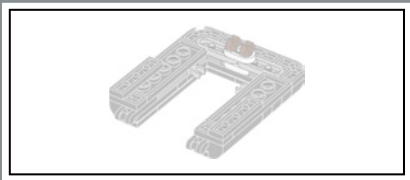

242

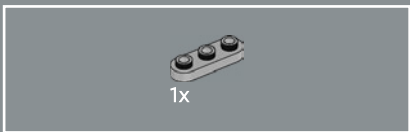
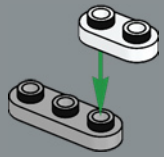

243

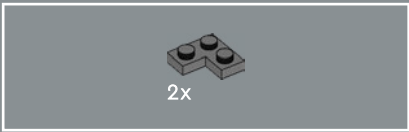
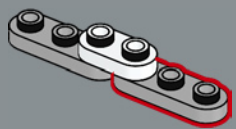

244

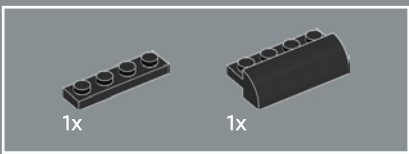
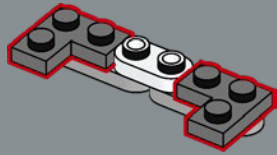

245

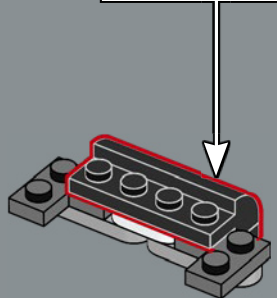
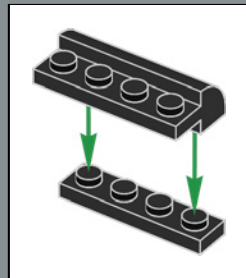

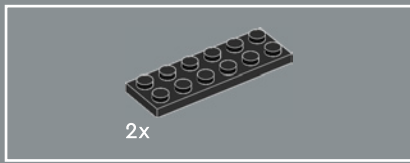

246

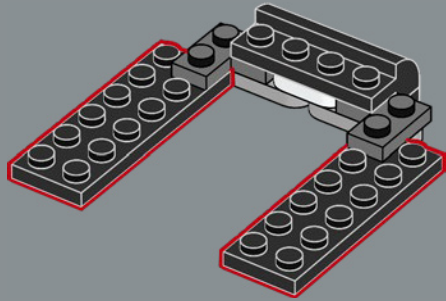

247

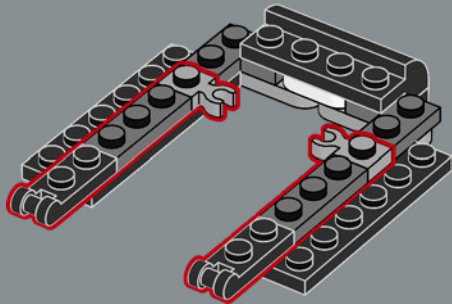

248

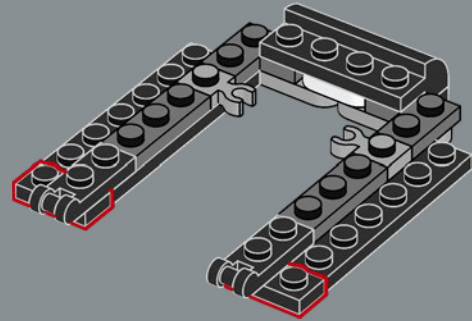

249

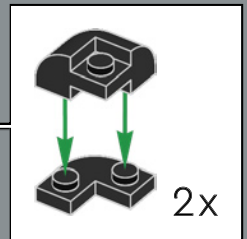
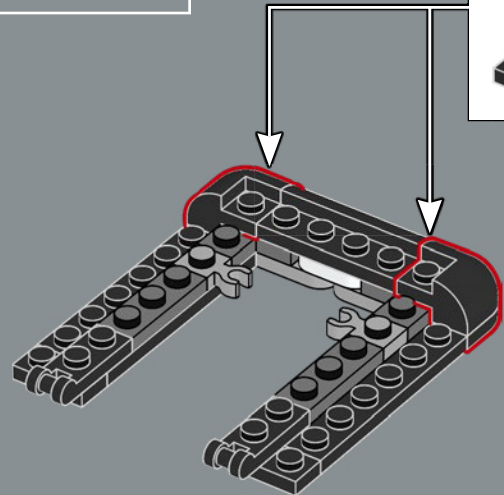

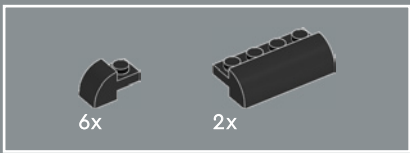

250

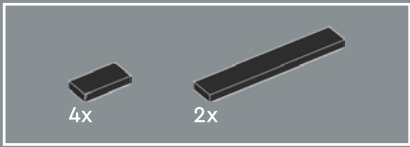
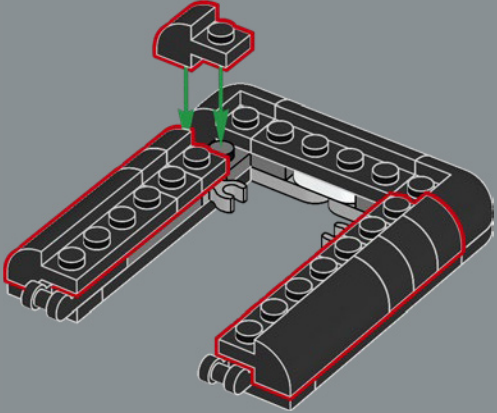

251

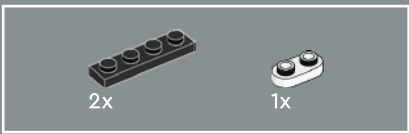
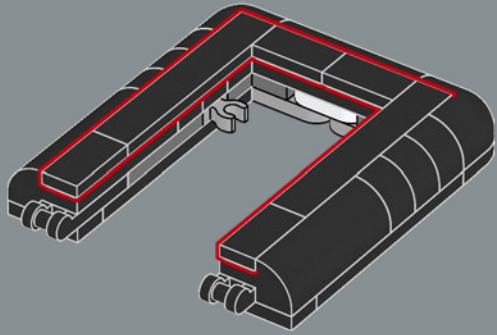

252

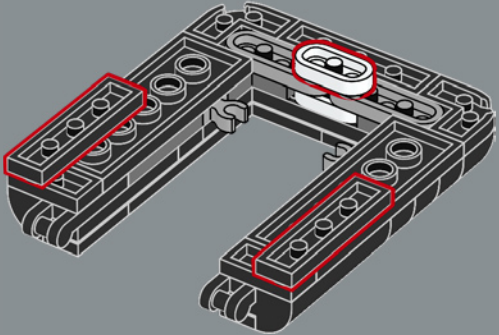

253

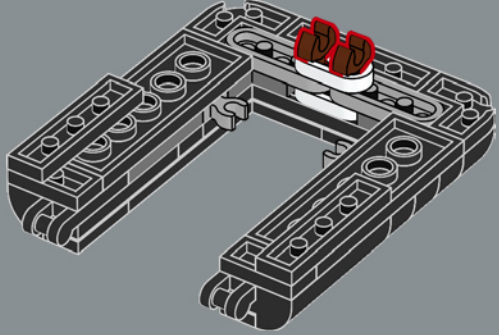

254

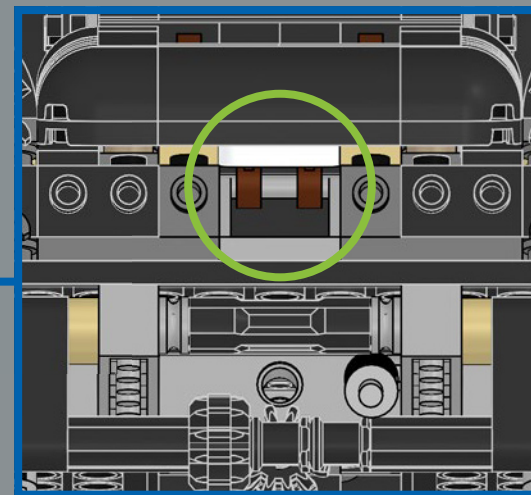
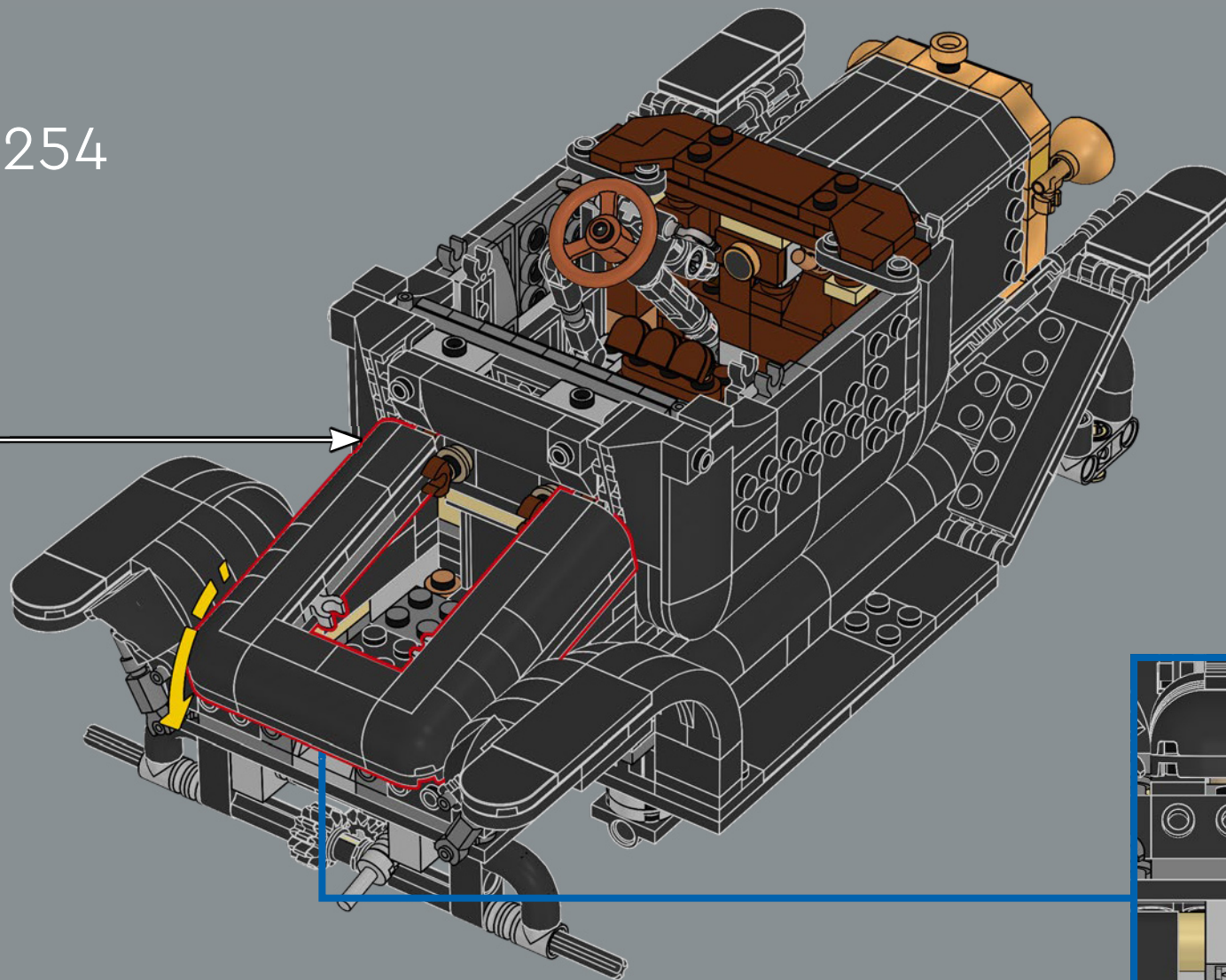

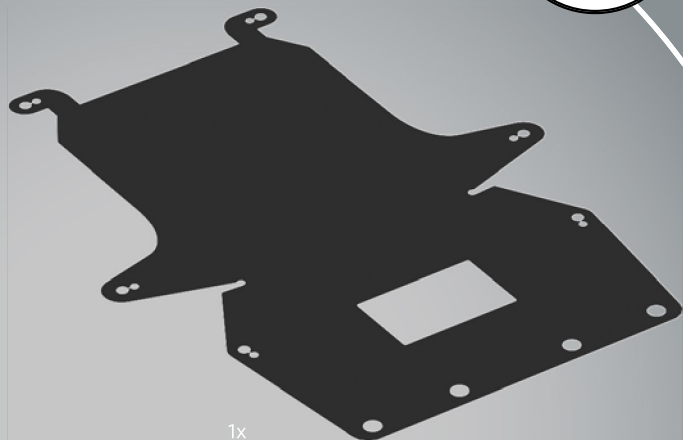
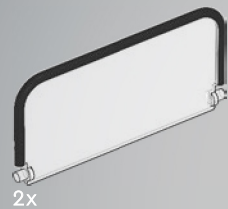
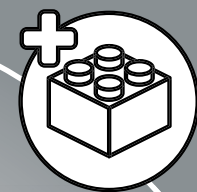

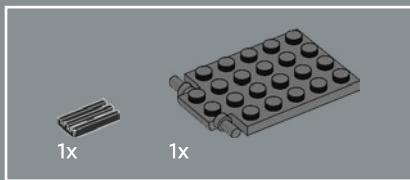

255

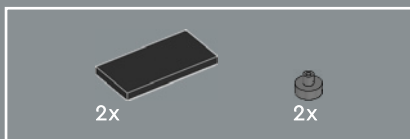
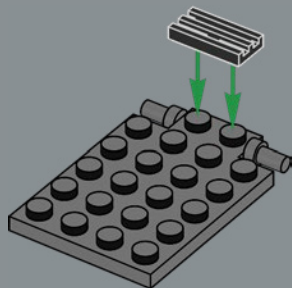

256

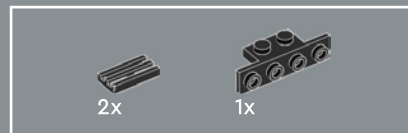
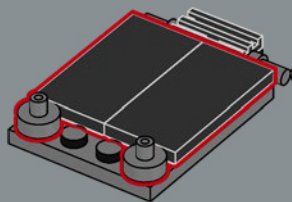

257

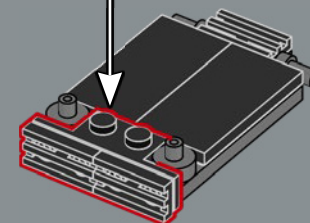
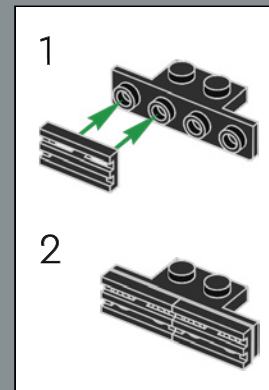

258

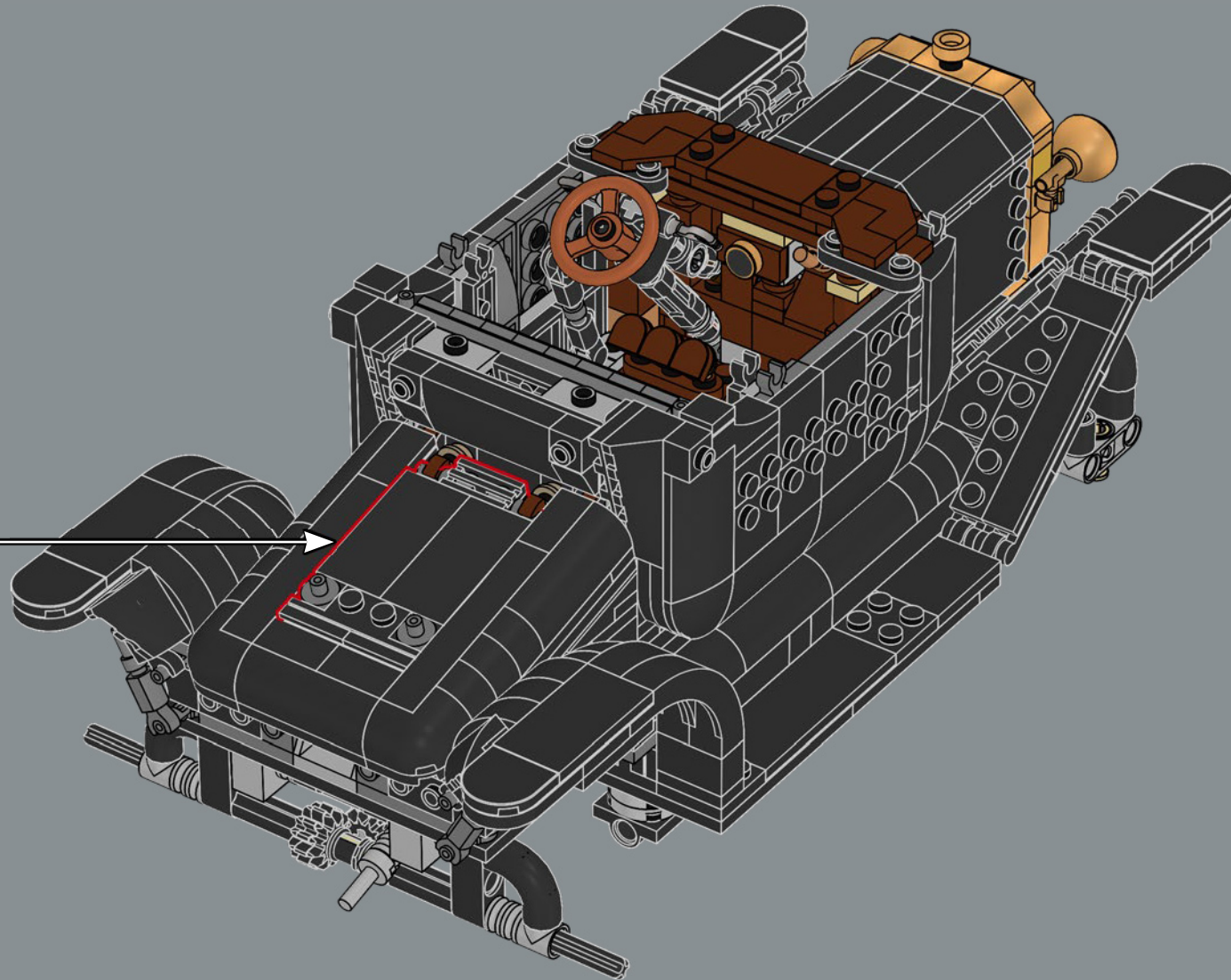

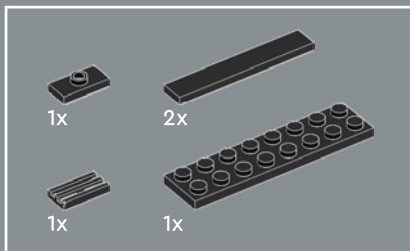

259

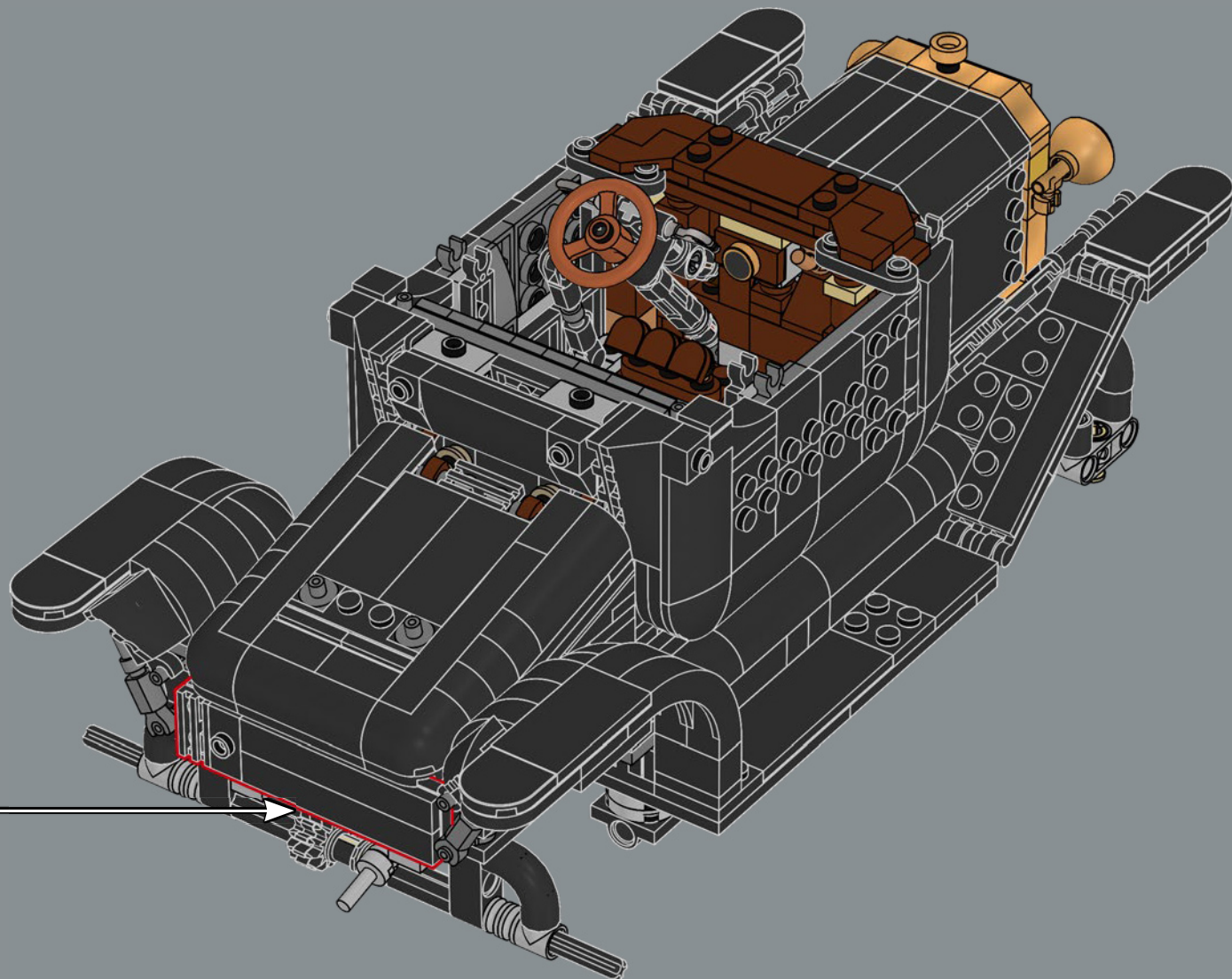
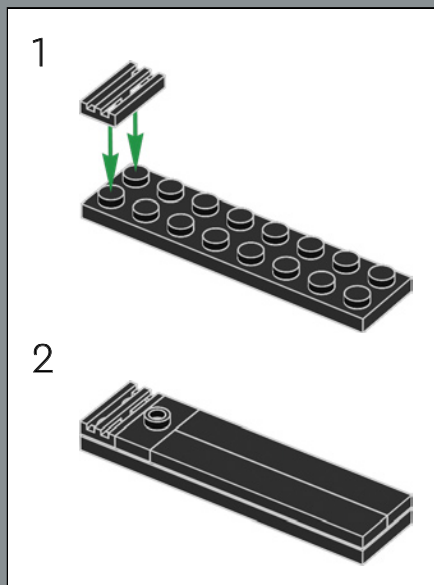

2x

1x

3x

260

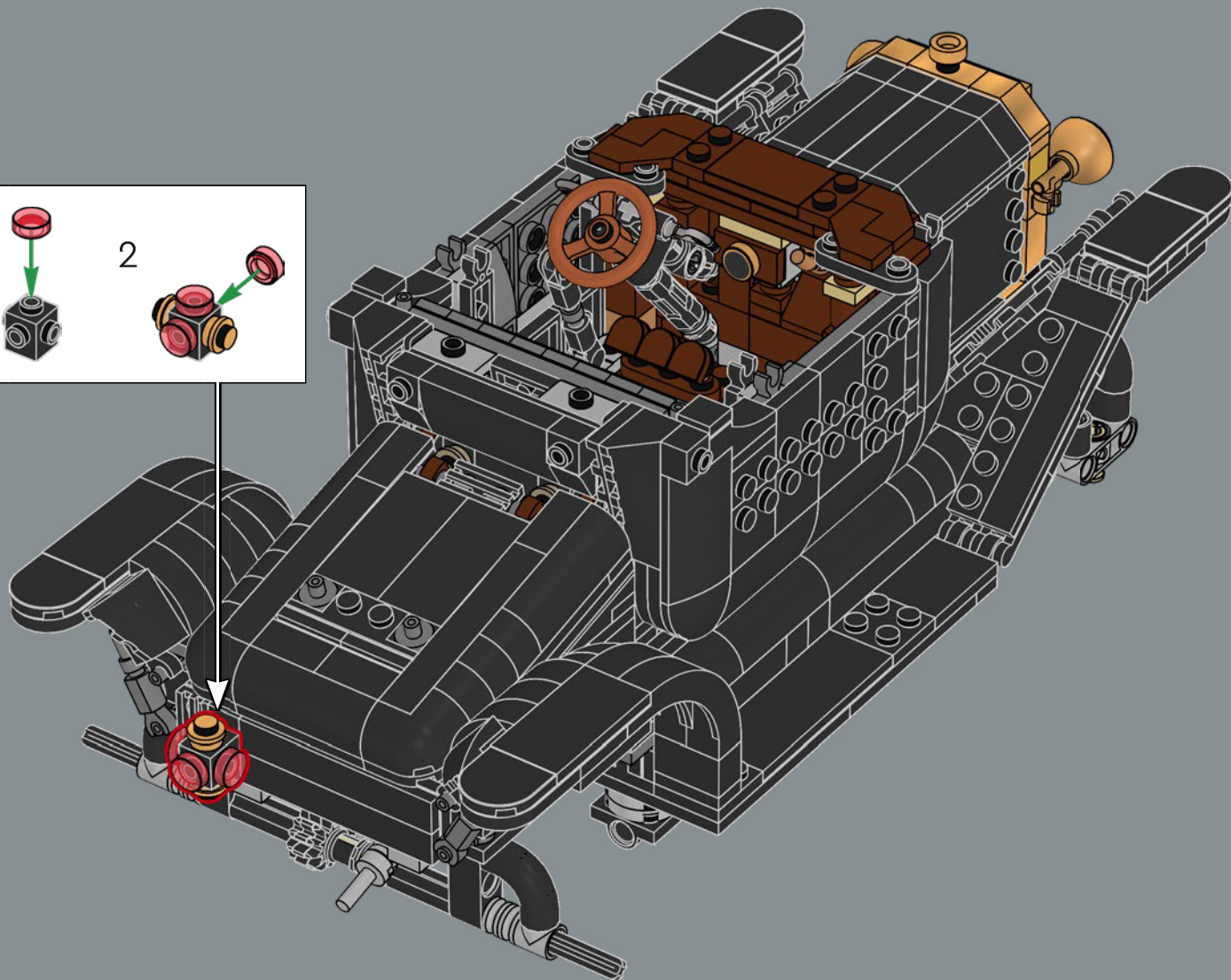
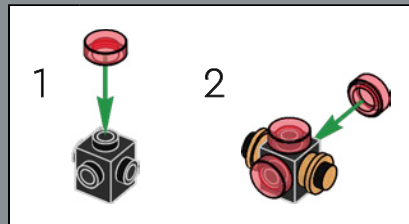

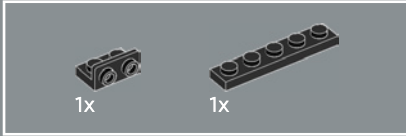
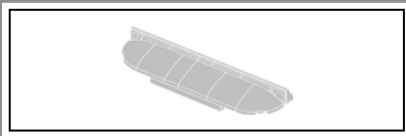

261

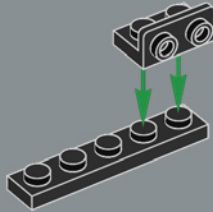

262

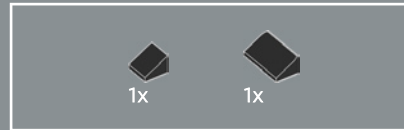
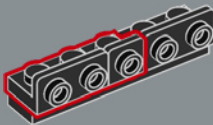

263

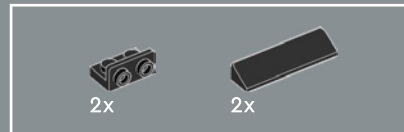
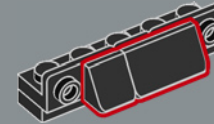

264

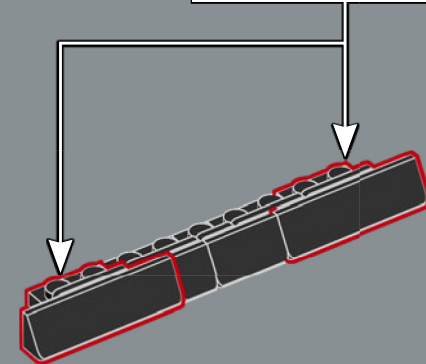
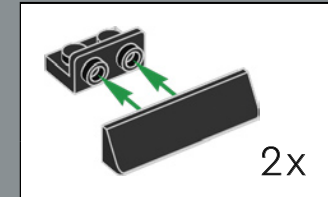

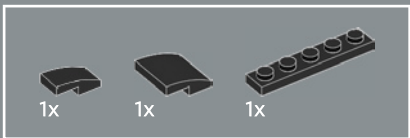

265

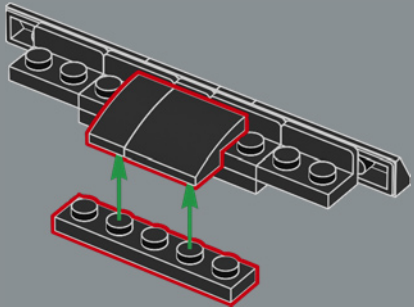

266

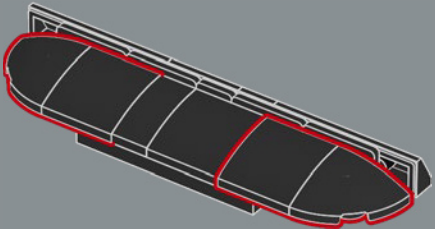

267

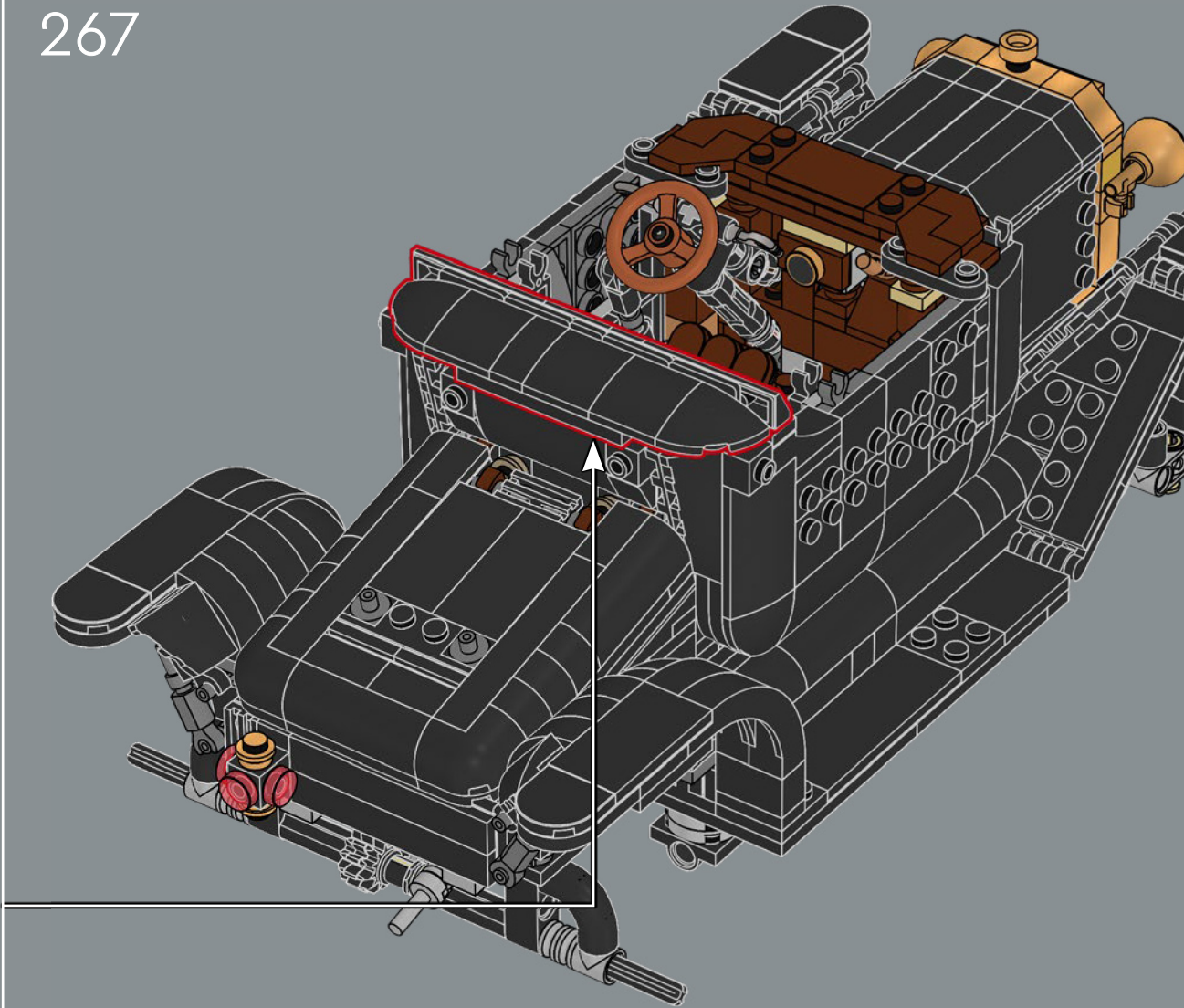

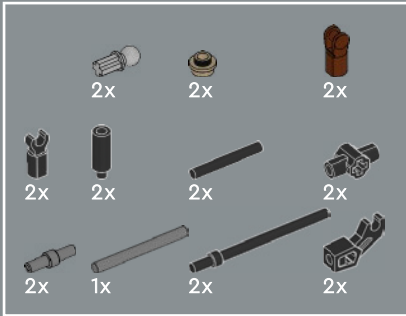
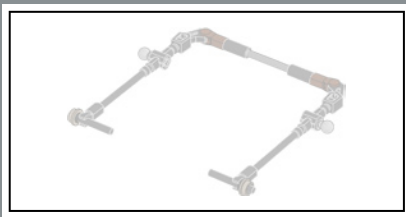

268

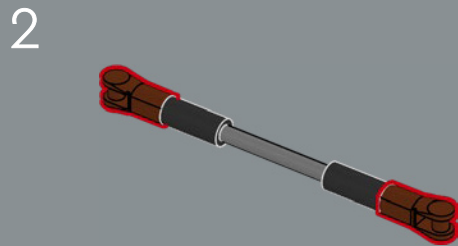
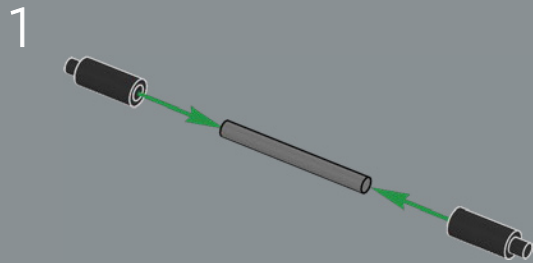

3

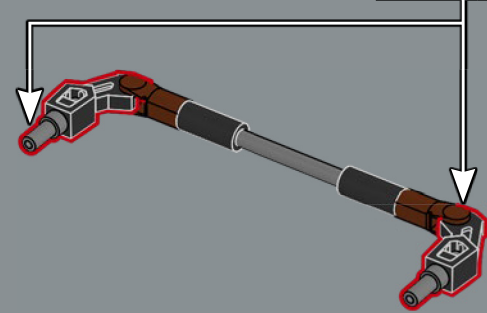
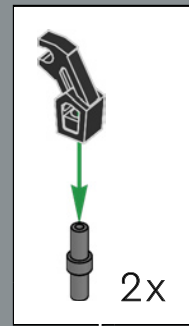

4

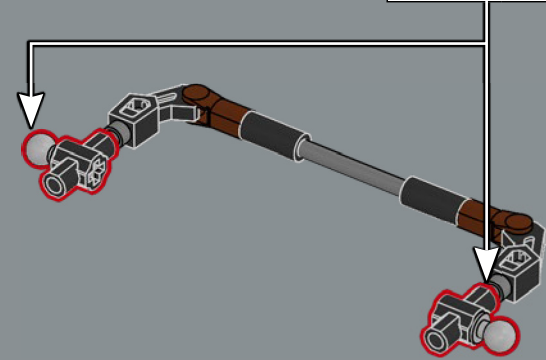
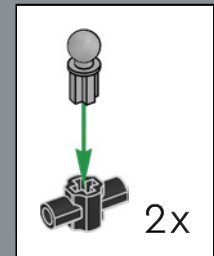

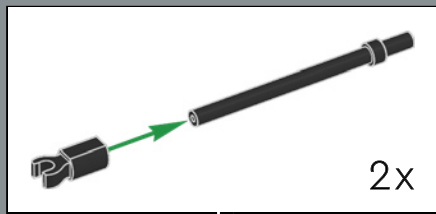

5

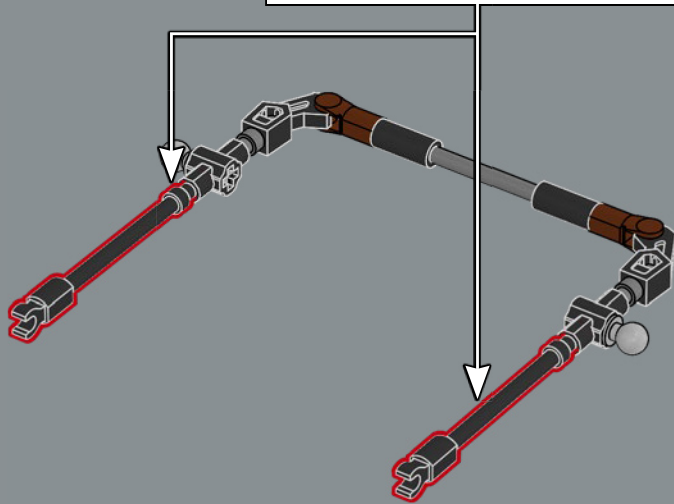

6

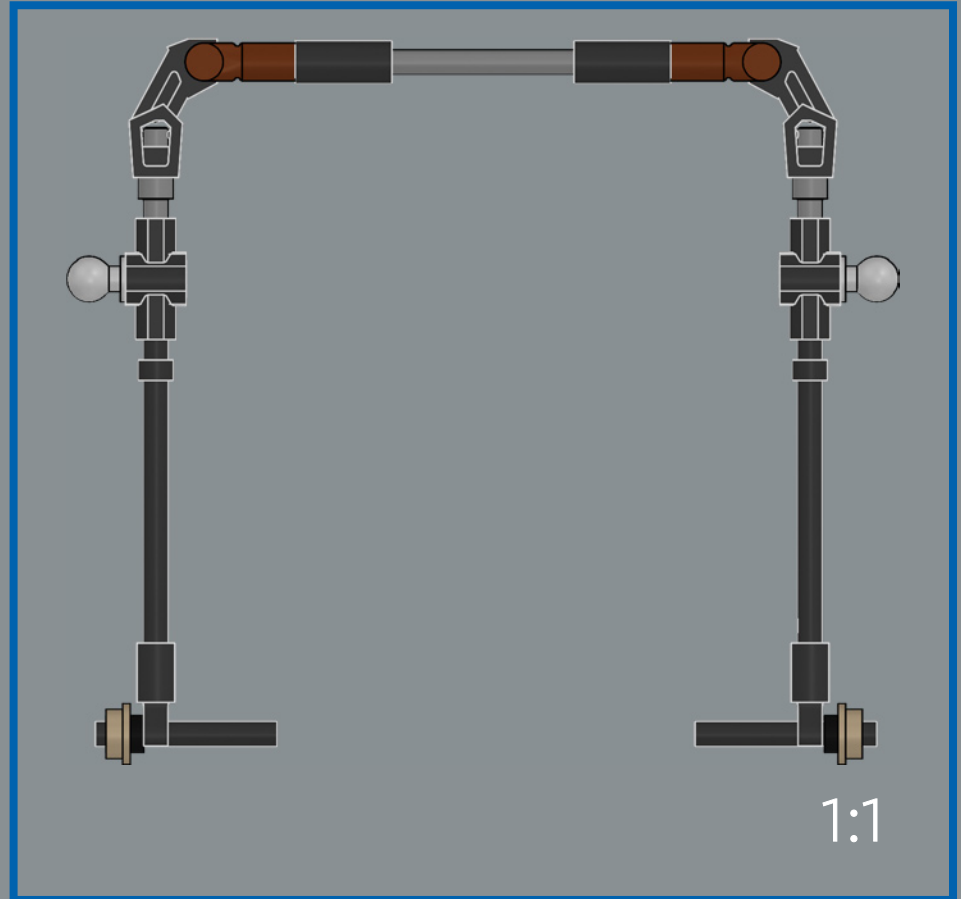
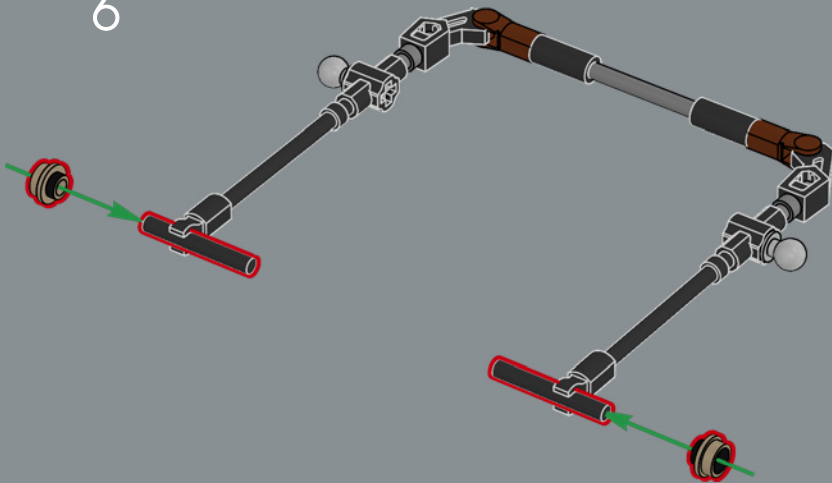



Surnommée « Tin Lizzie », elle devint rapidement un véhicule emblématique.

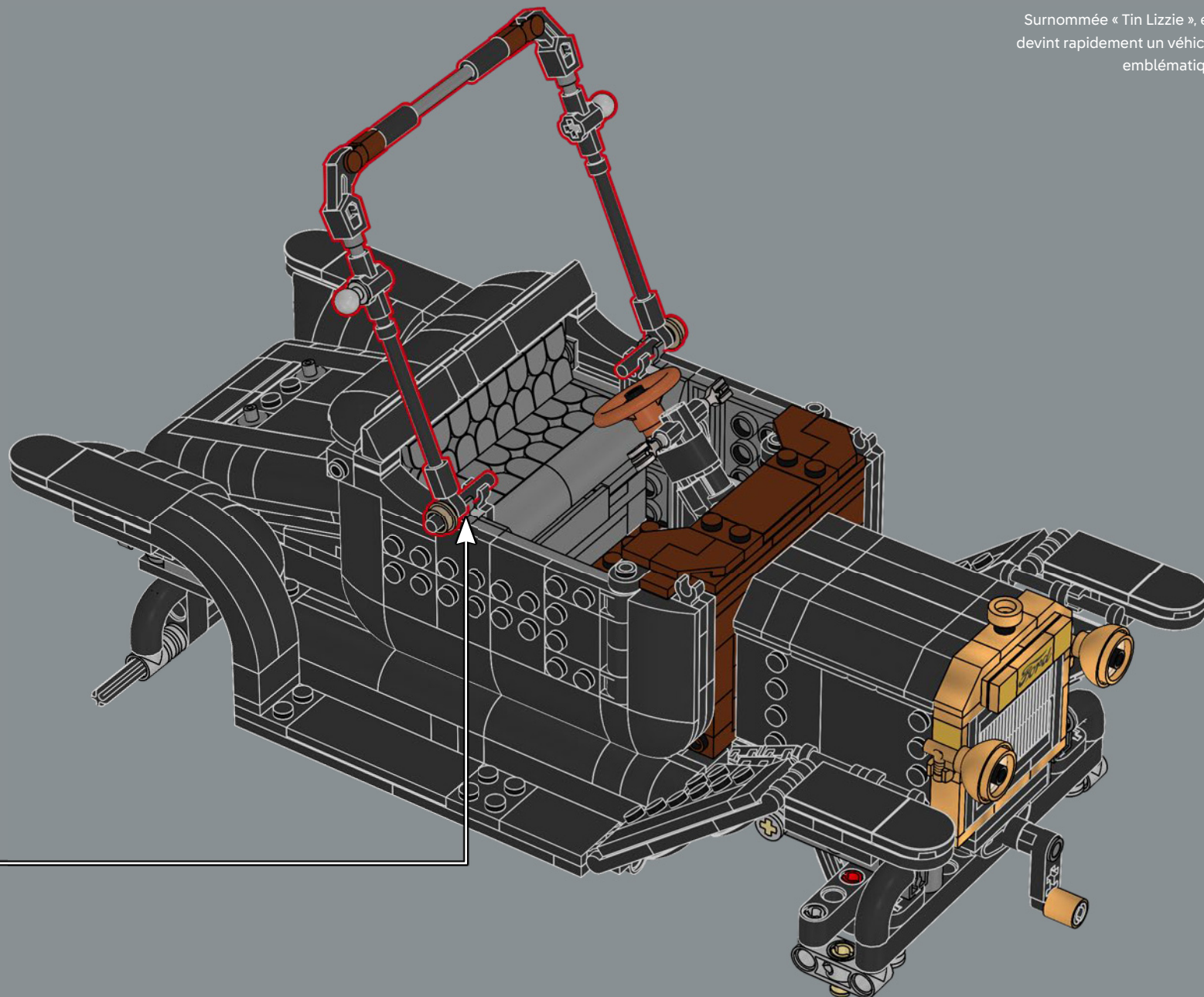

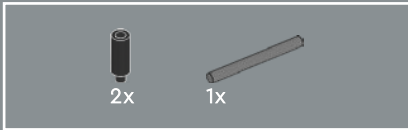
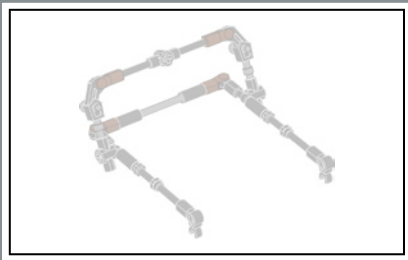

269

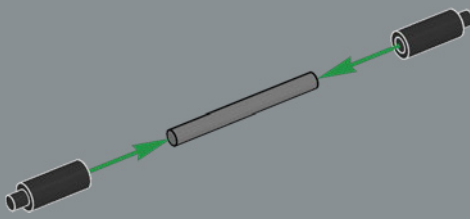

270

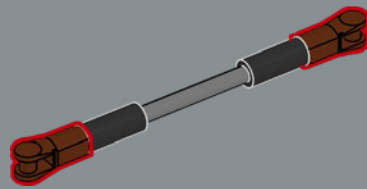

271

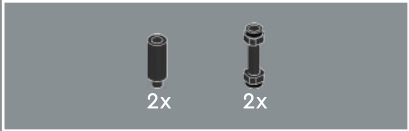
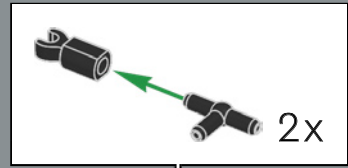
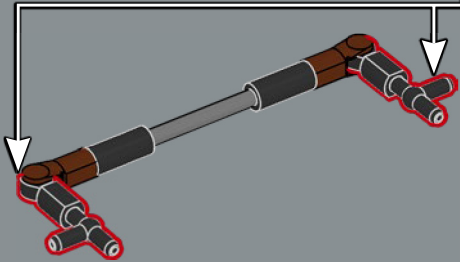

272

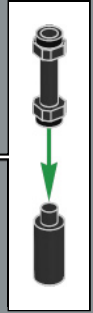
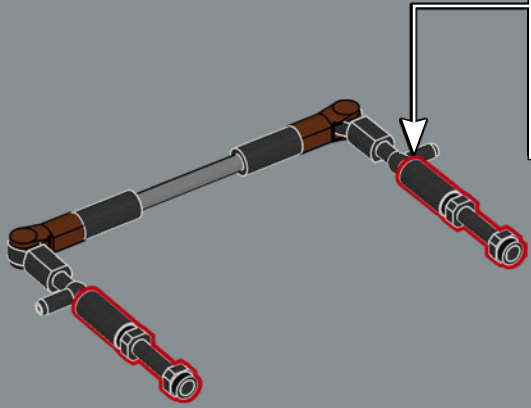



273

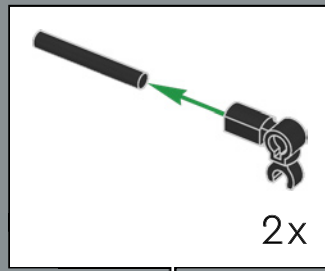
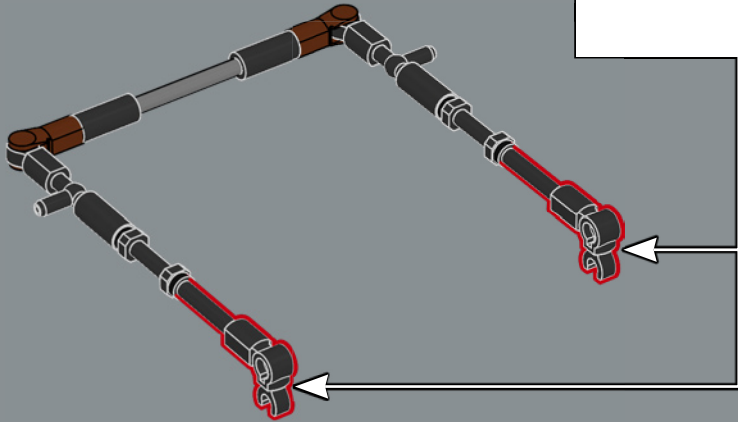

274

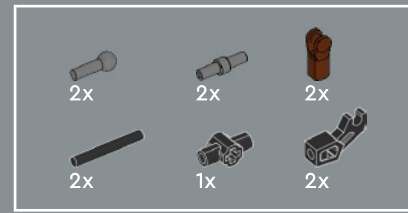
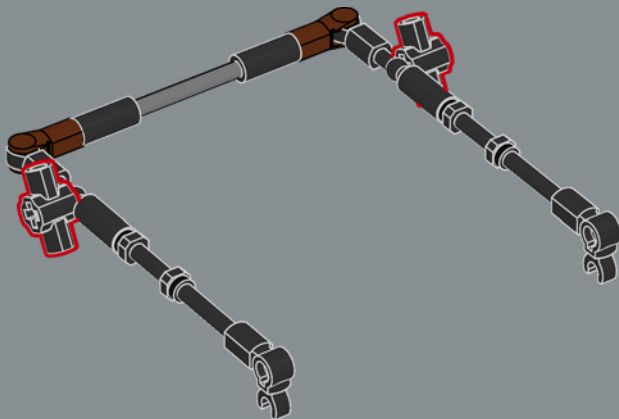

275

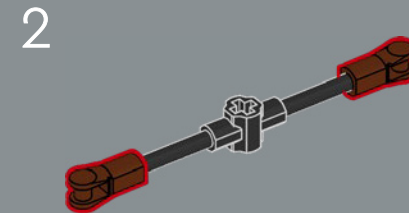
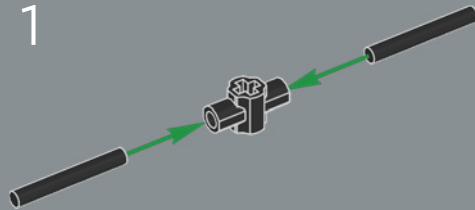

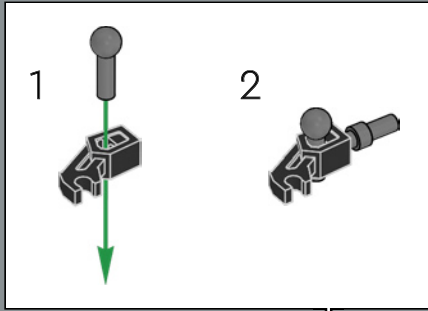



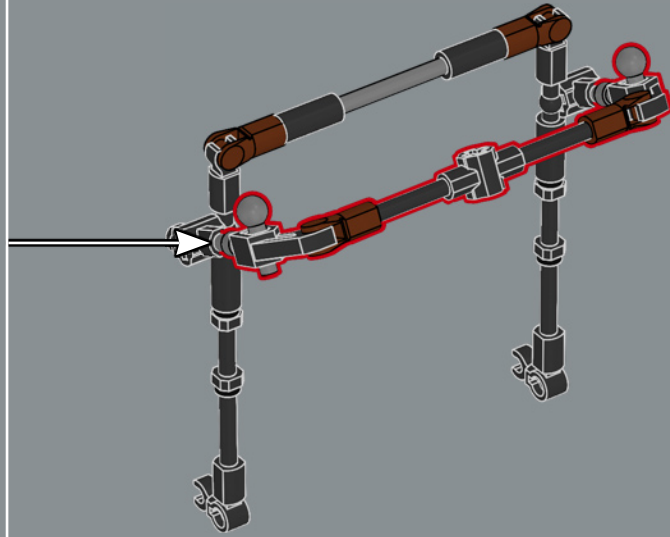
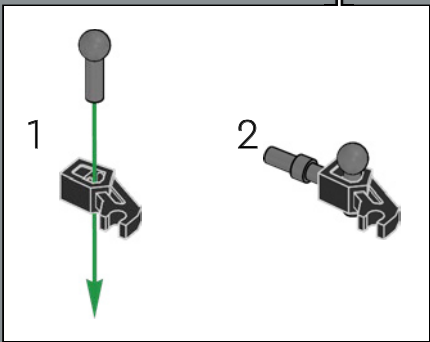
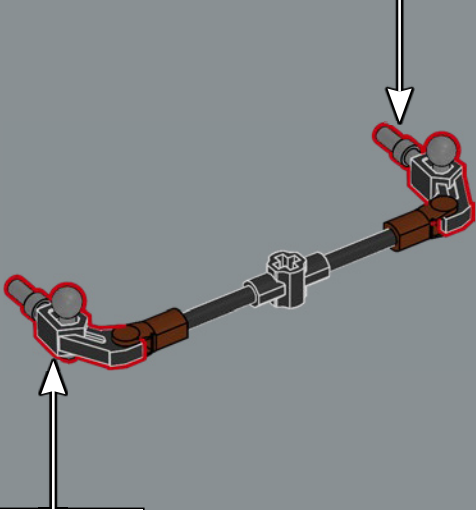

3

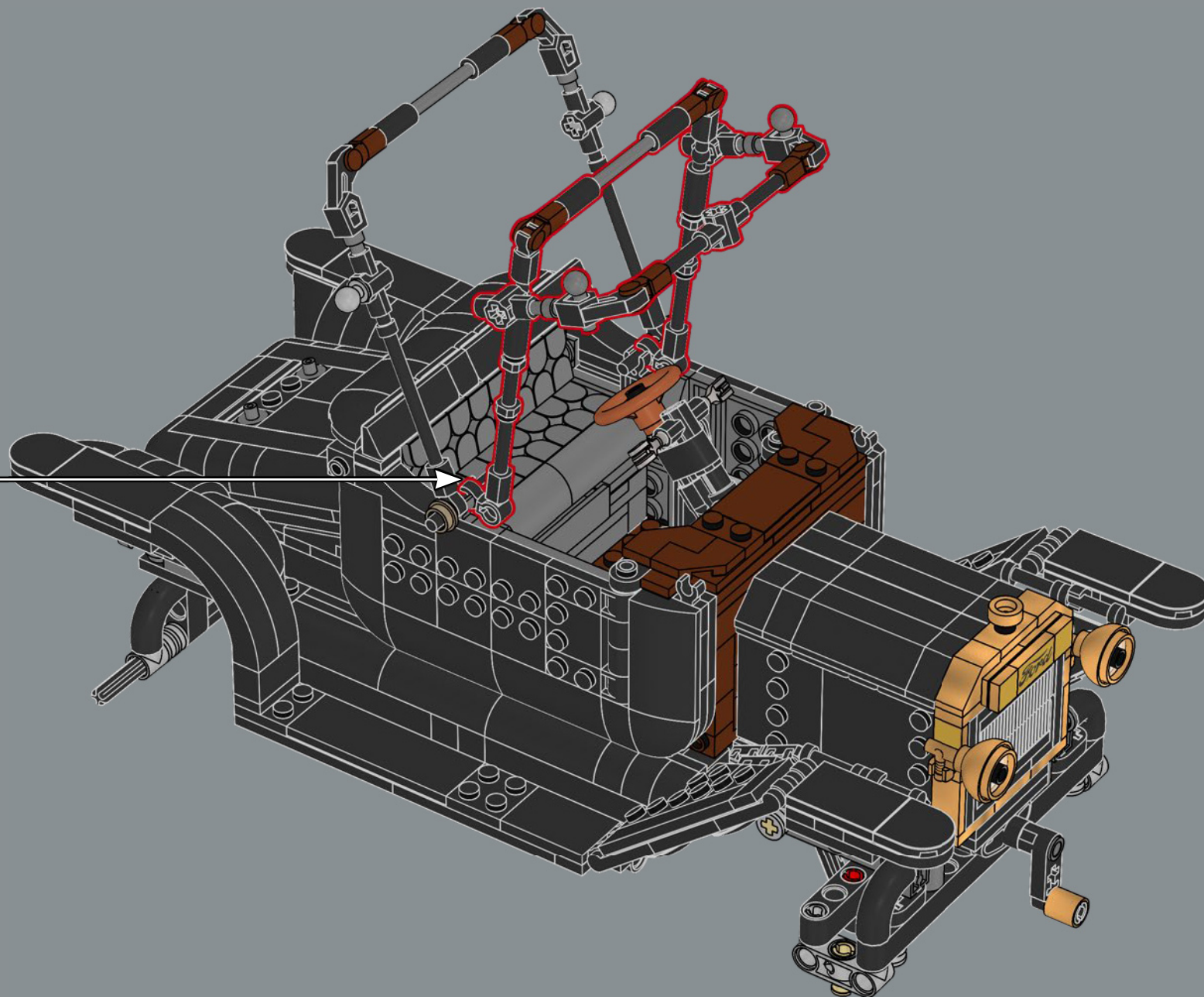

276



-  4x
-  2x
-  2x
-  6x

277

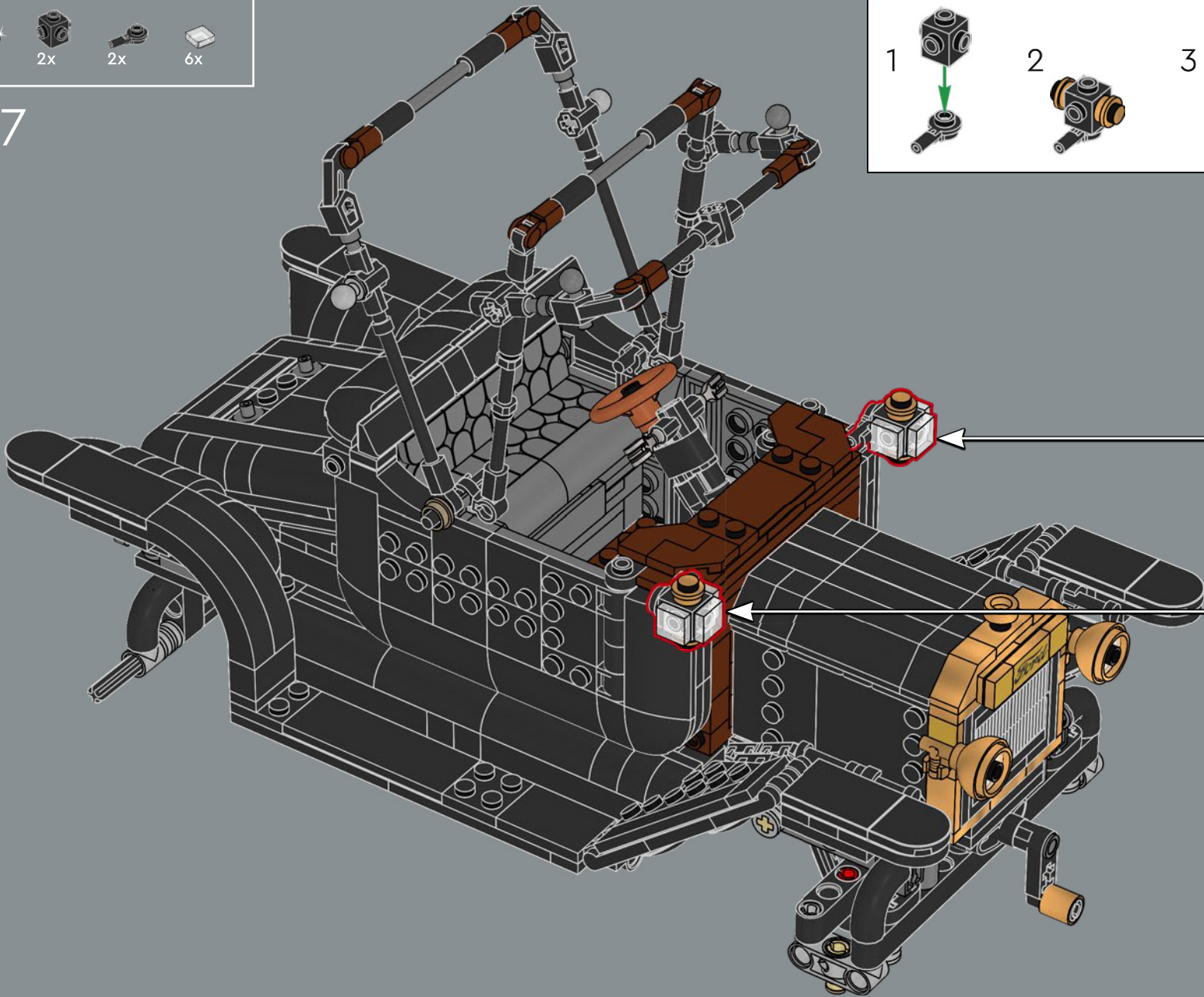

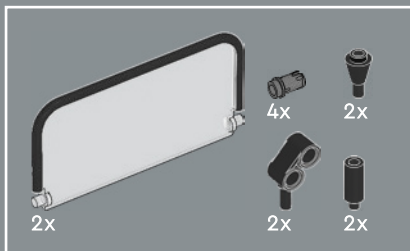

278

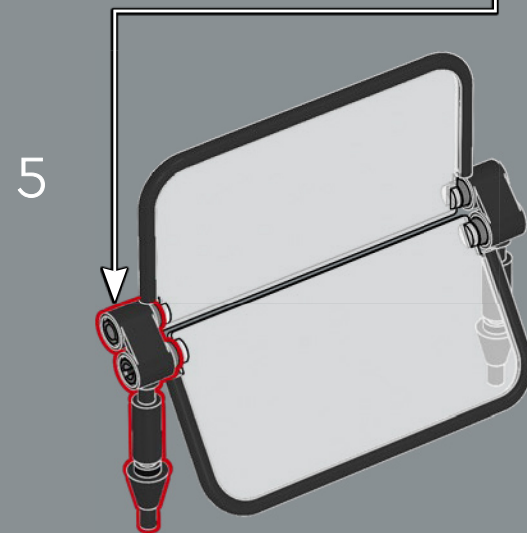
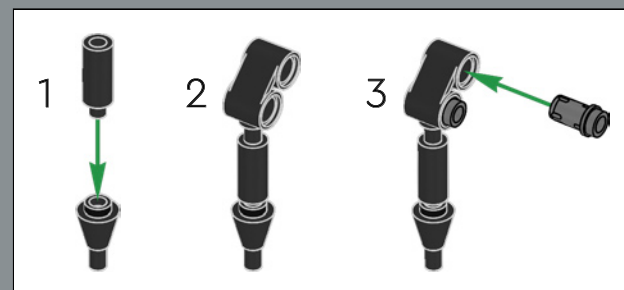
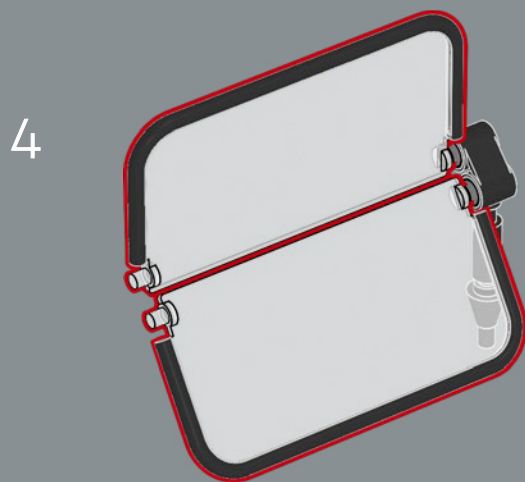
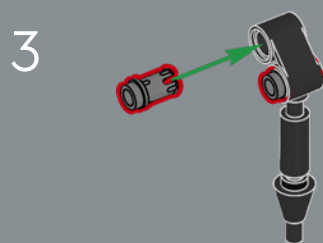
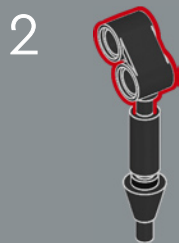
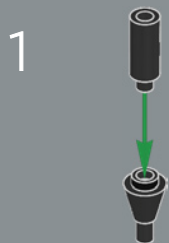

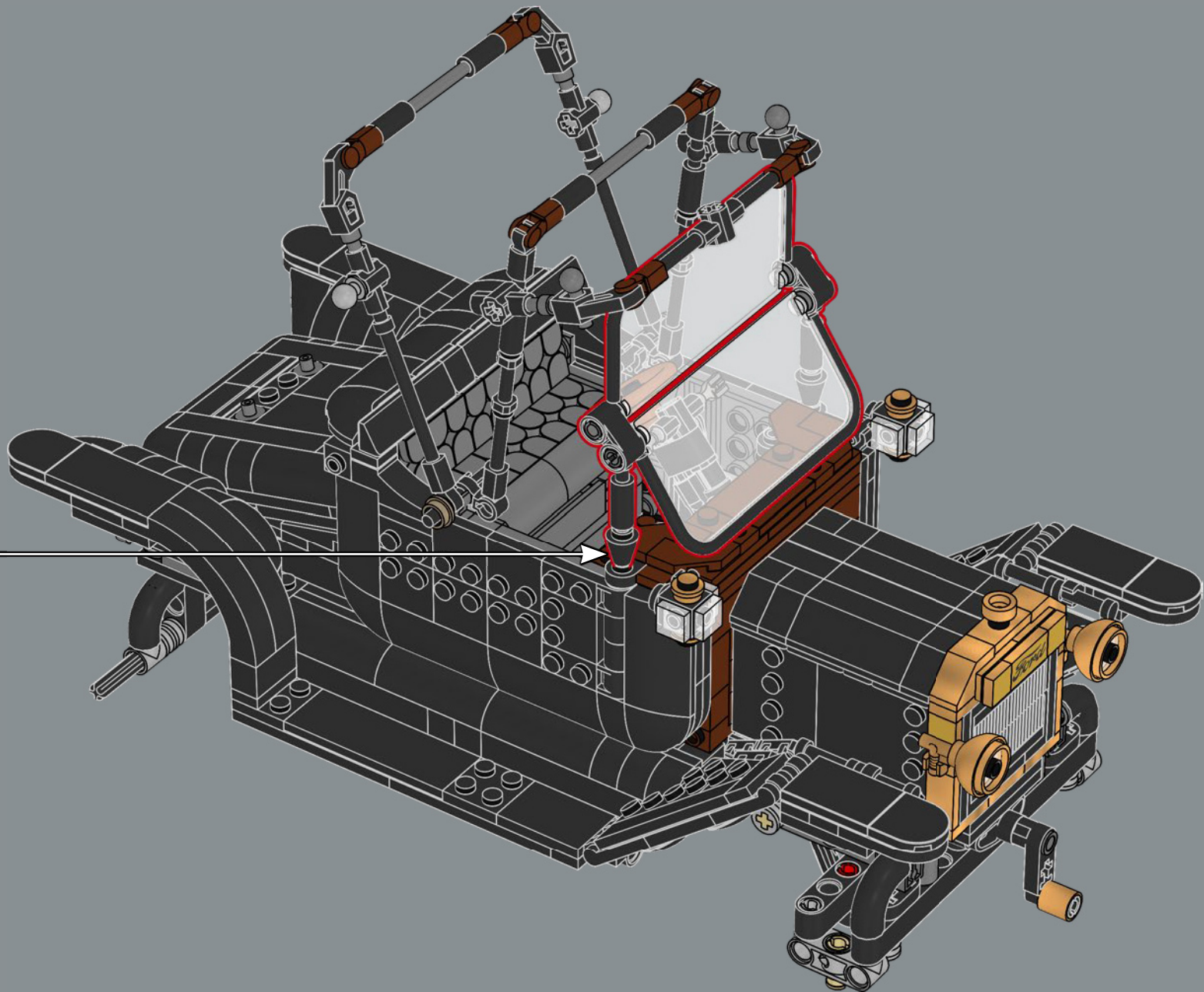

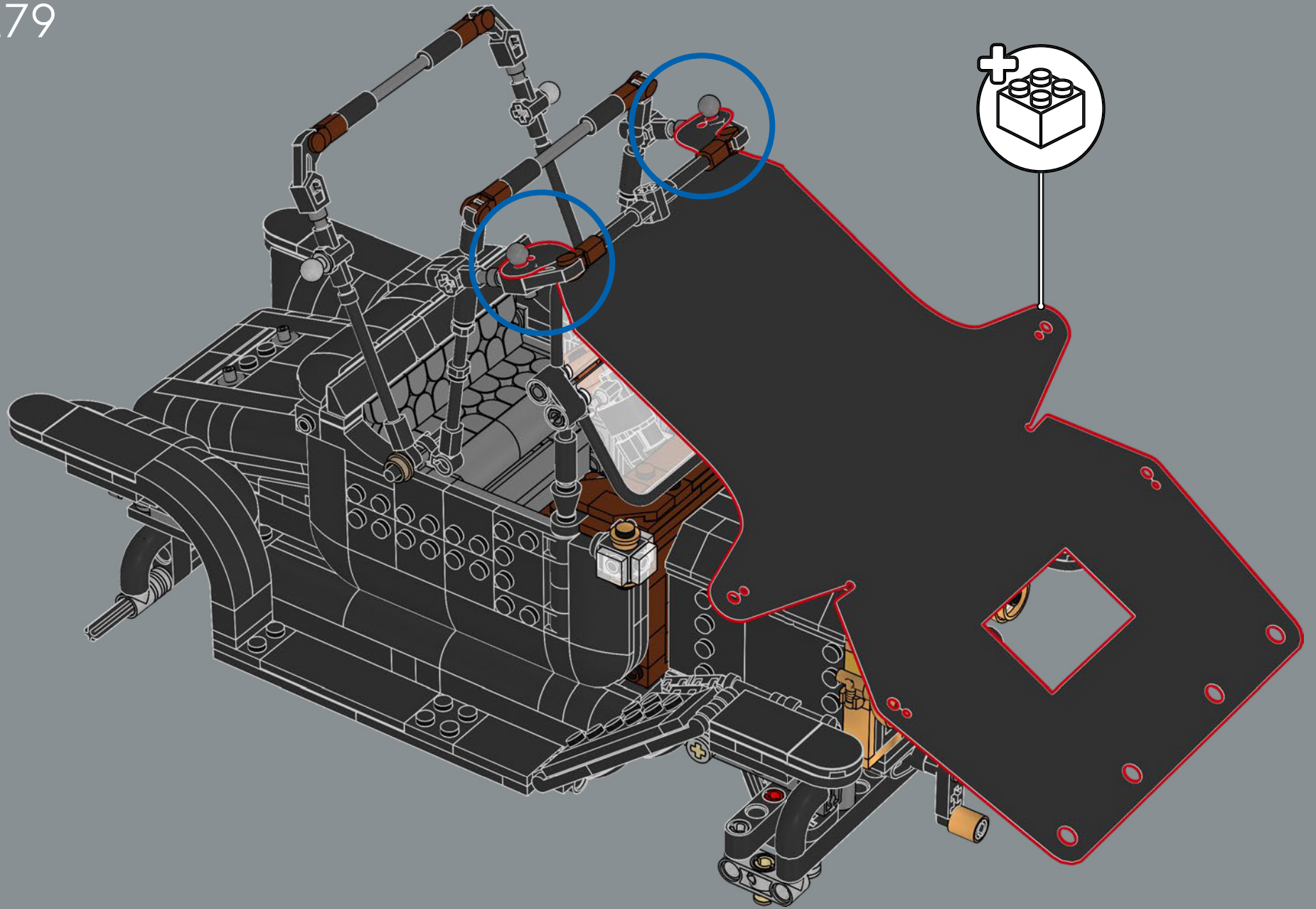



4x

280

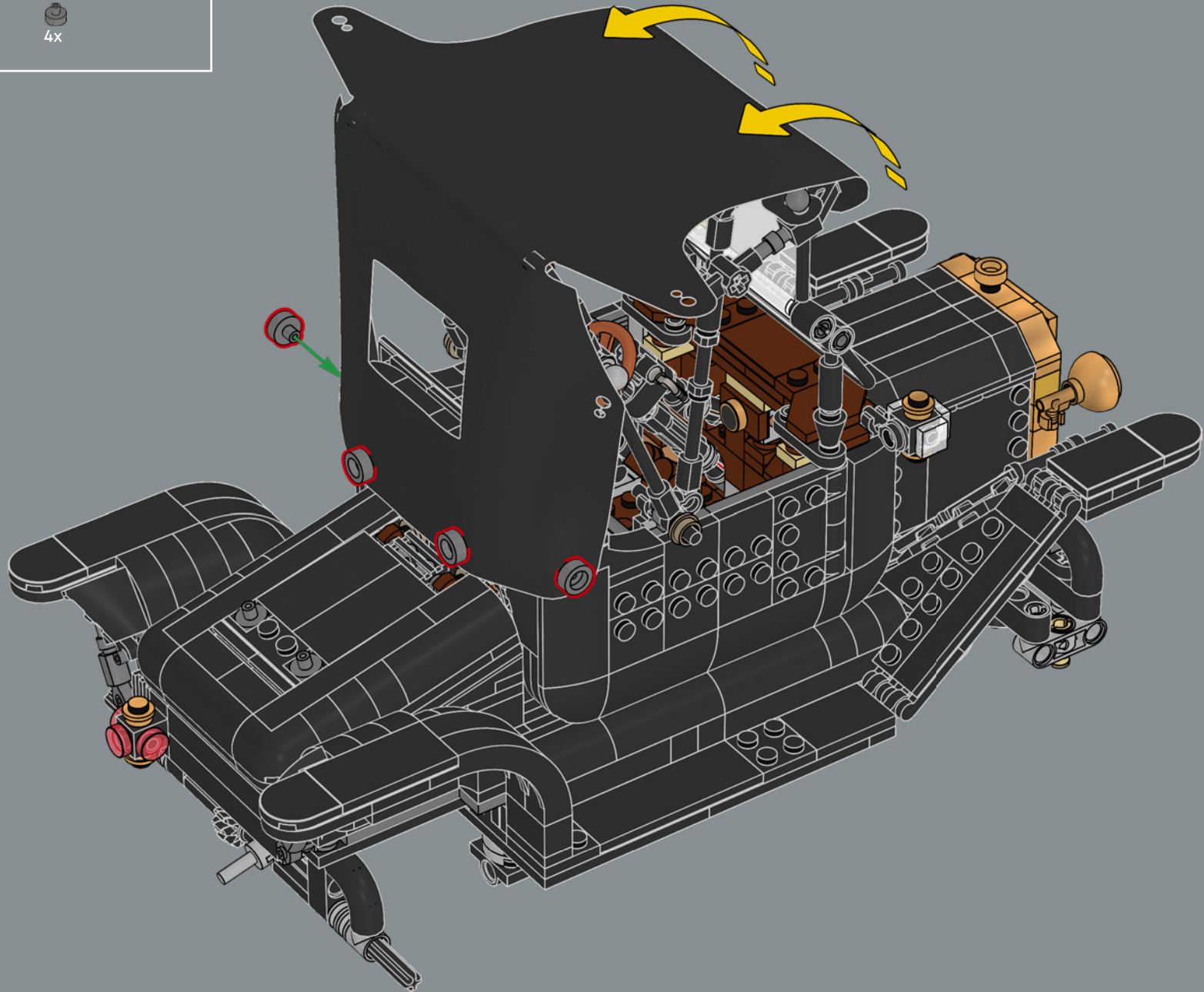

281

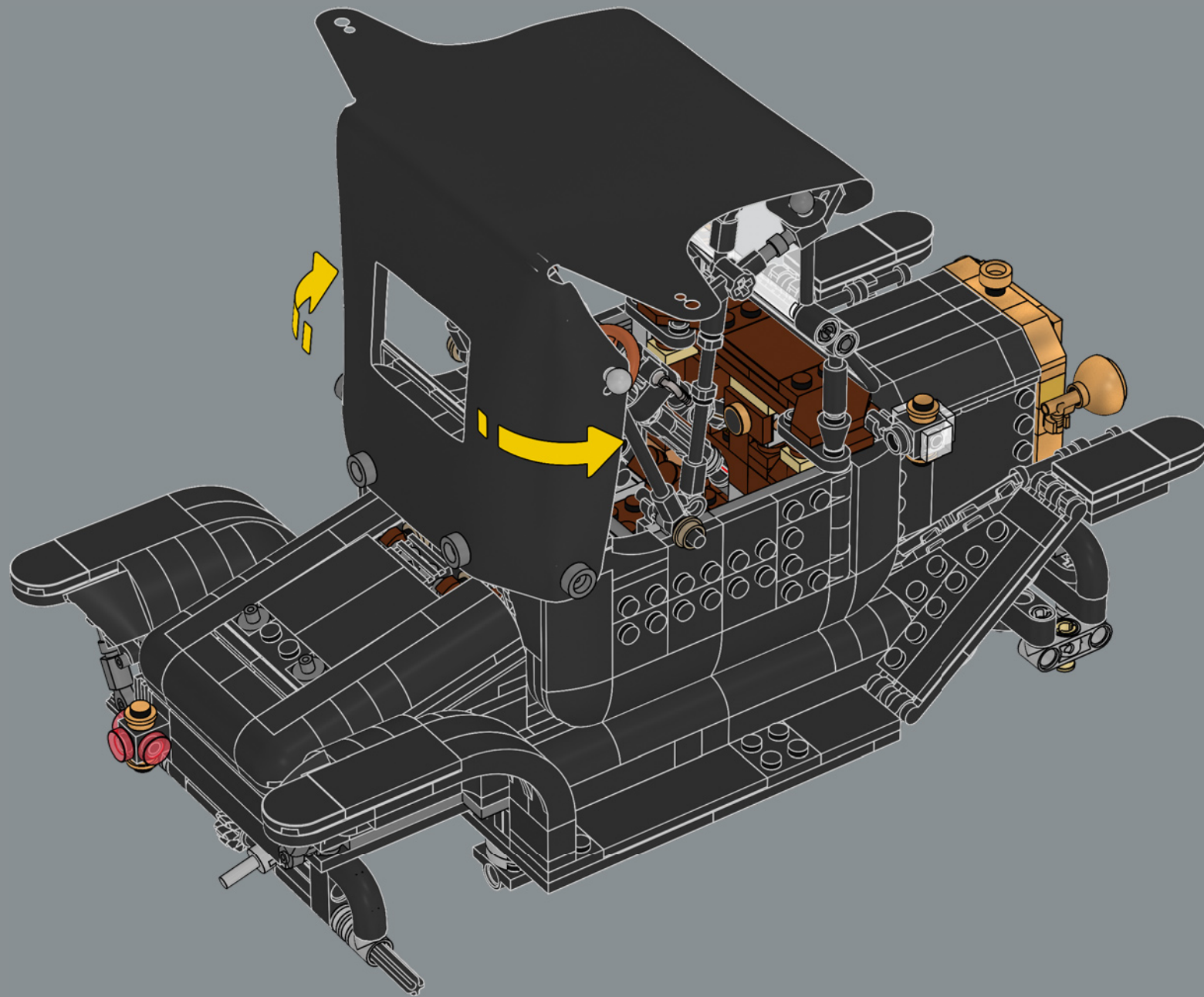

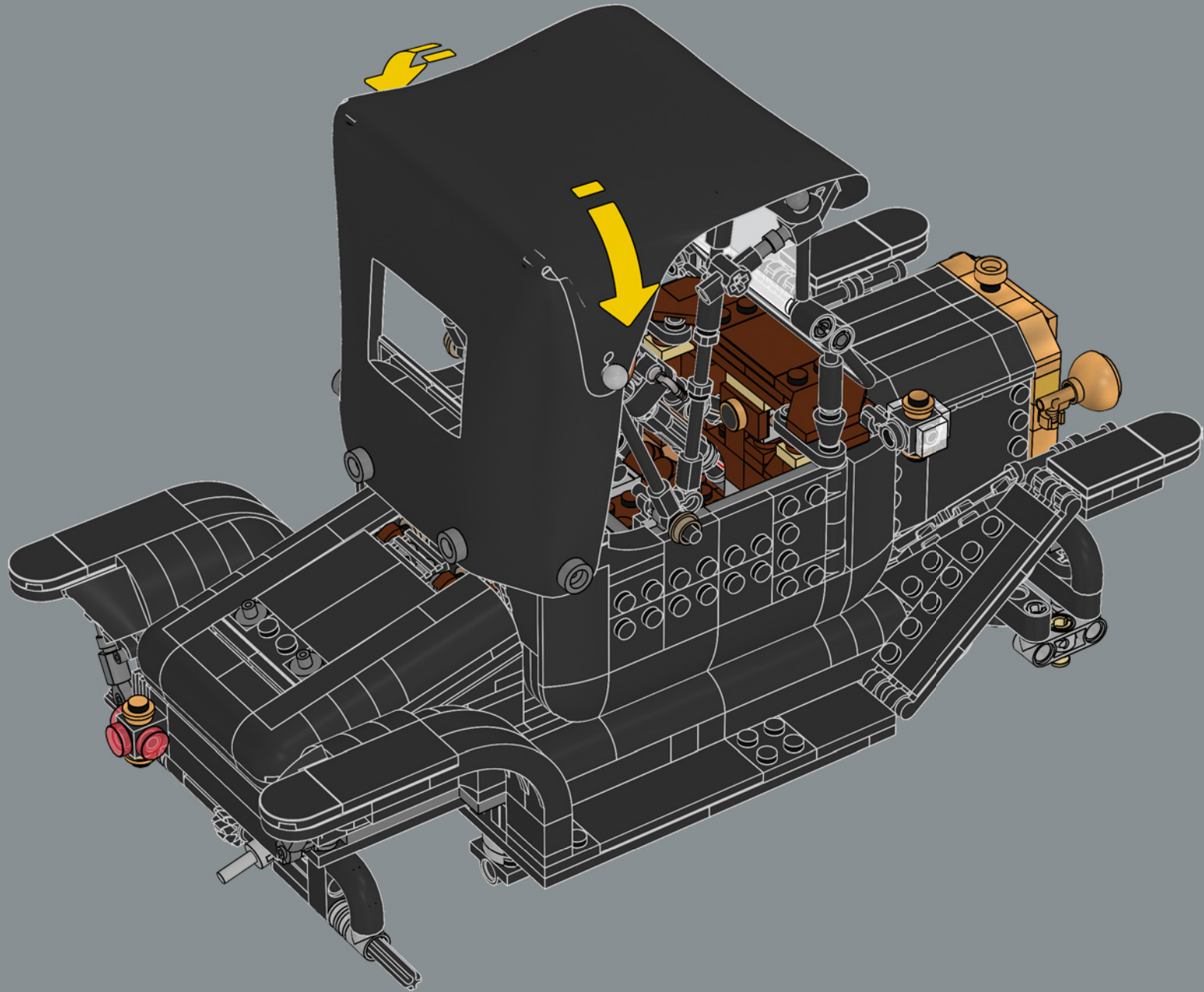

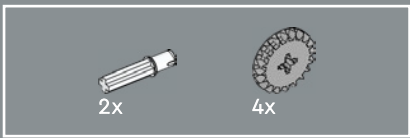

283

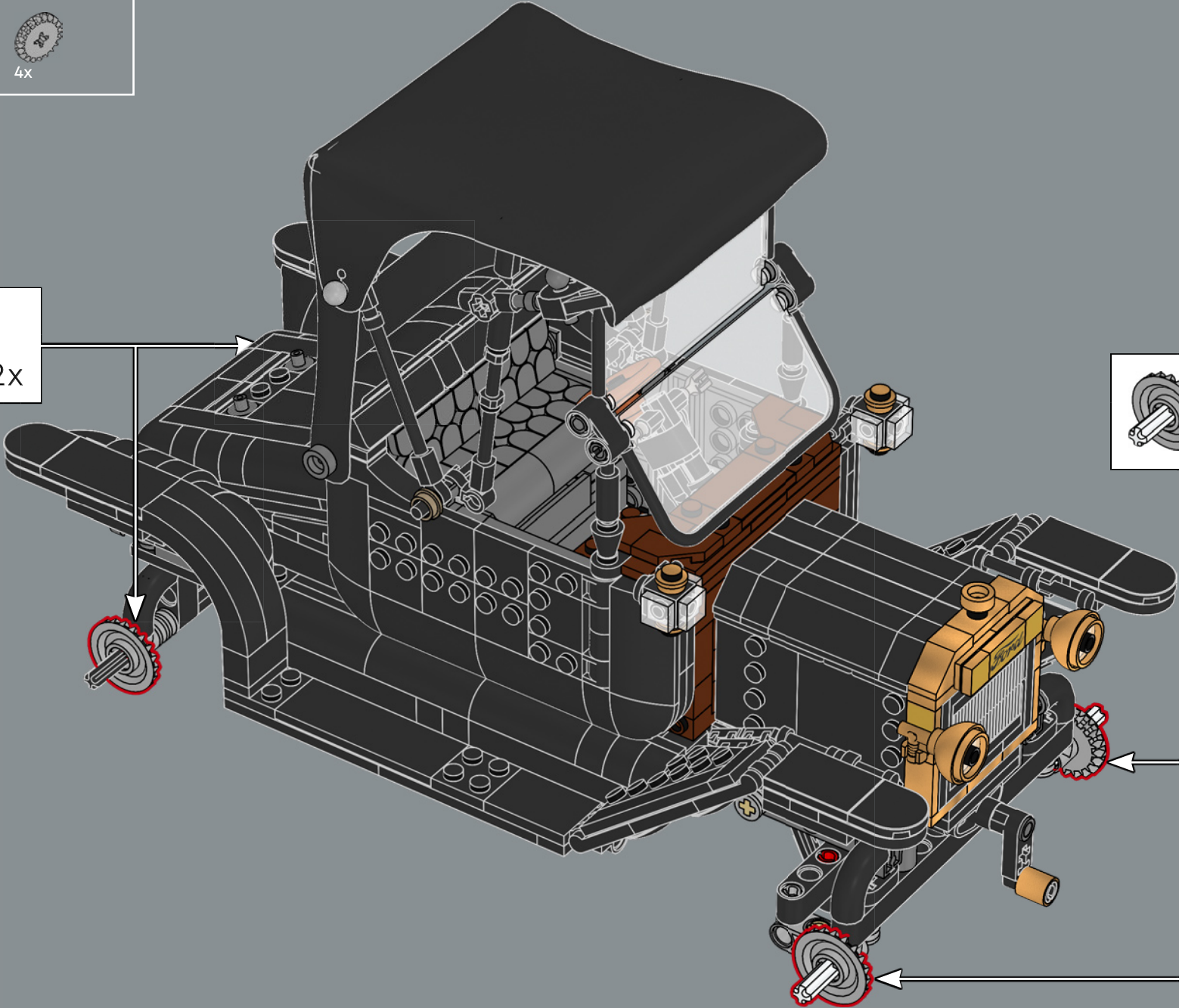
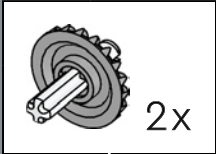
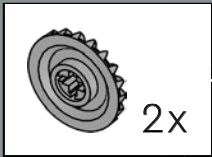

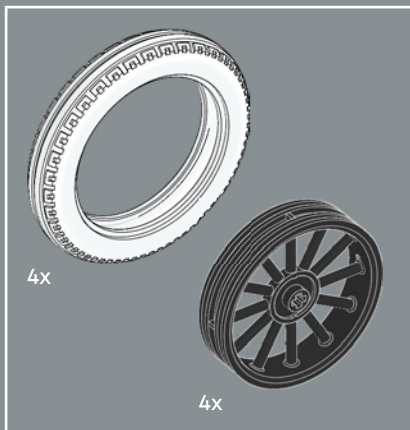

284

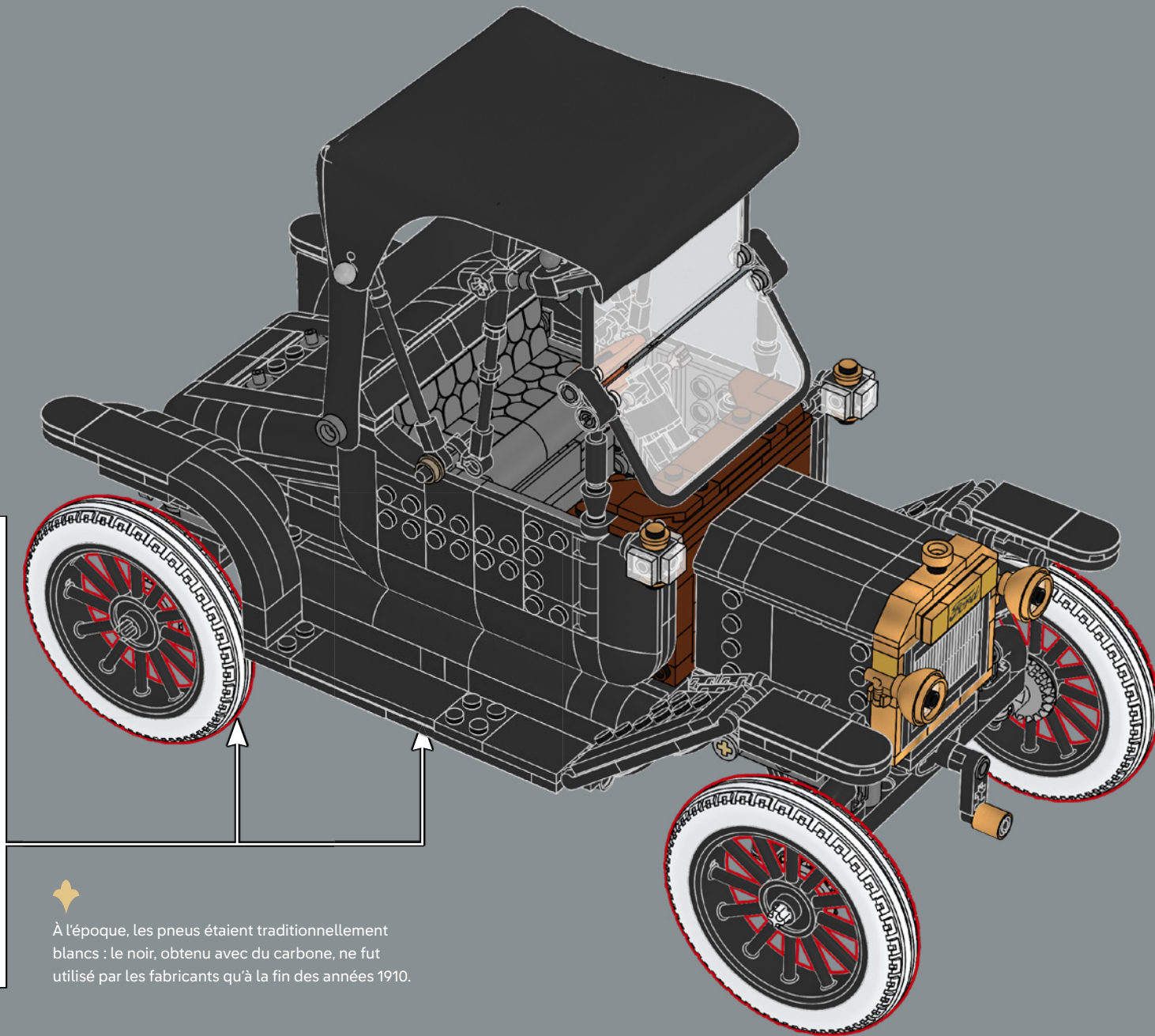
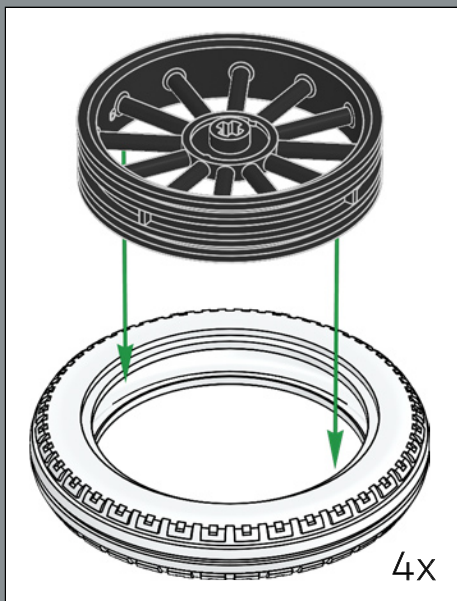

À l'époque, les pneus étaient traditionnellement blancs : le noir, obtenu avec du carbone, ne fut utilisé par les fabricants qu'à la fin des années 1910.



285

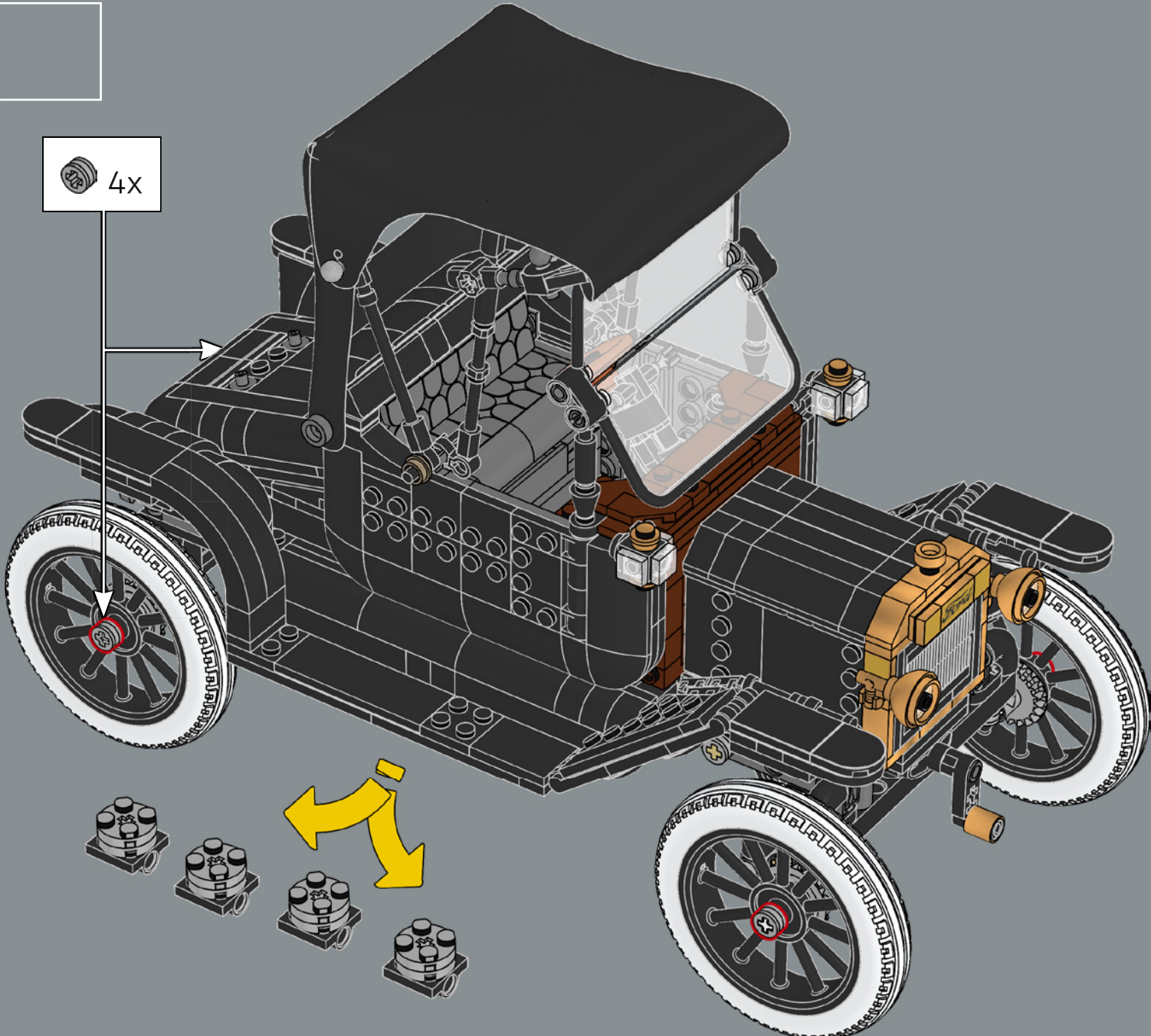
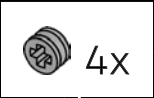

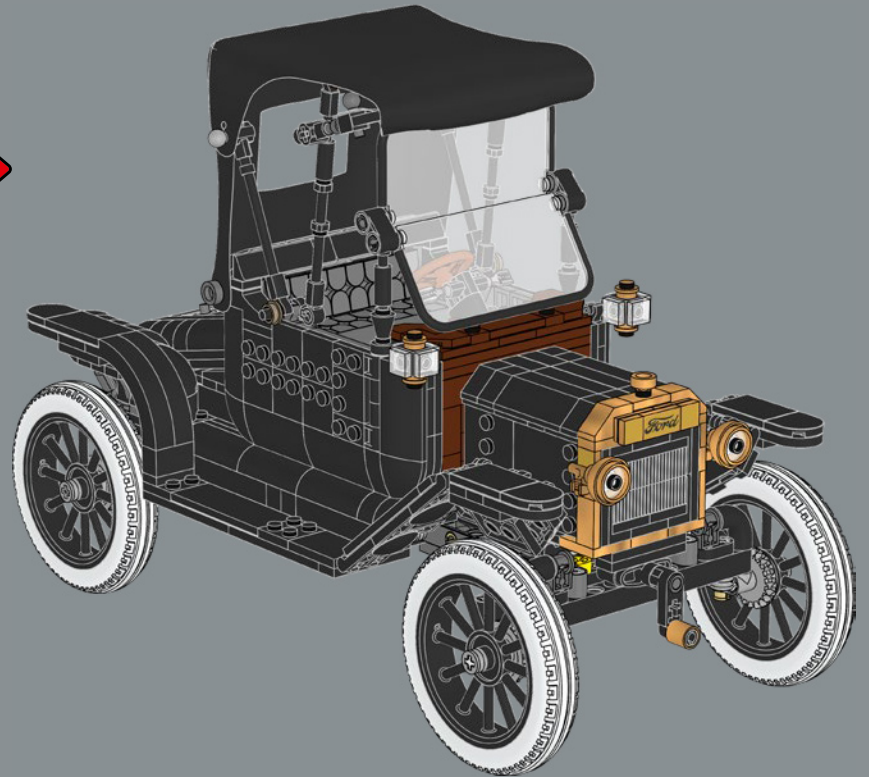
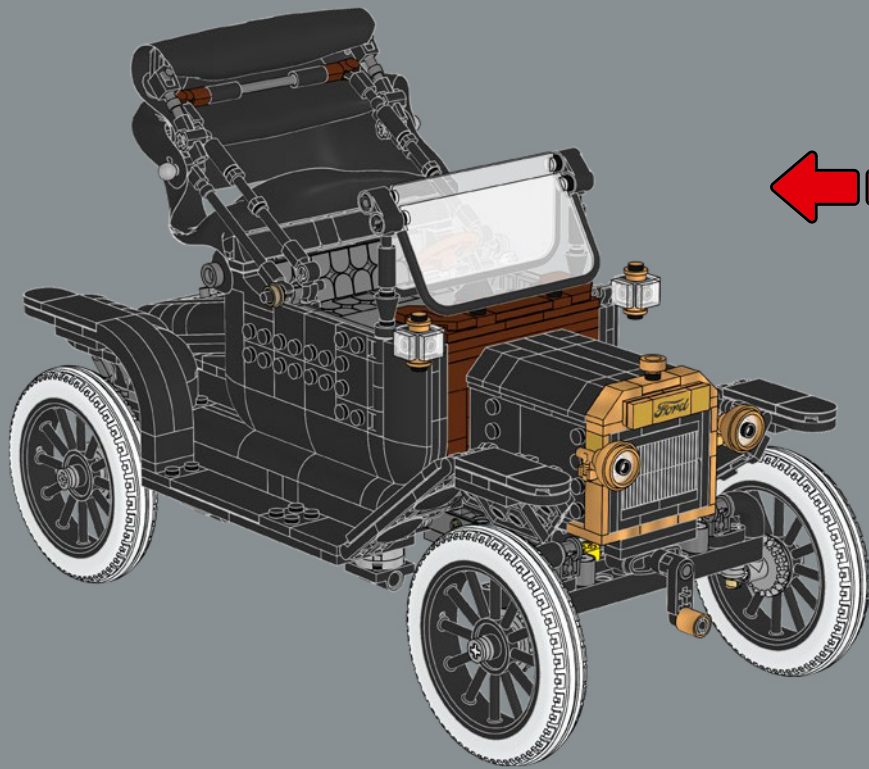

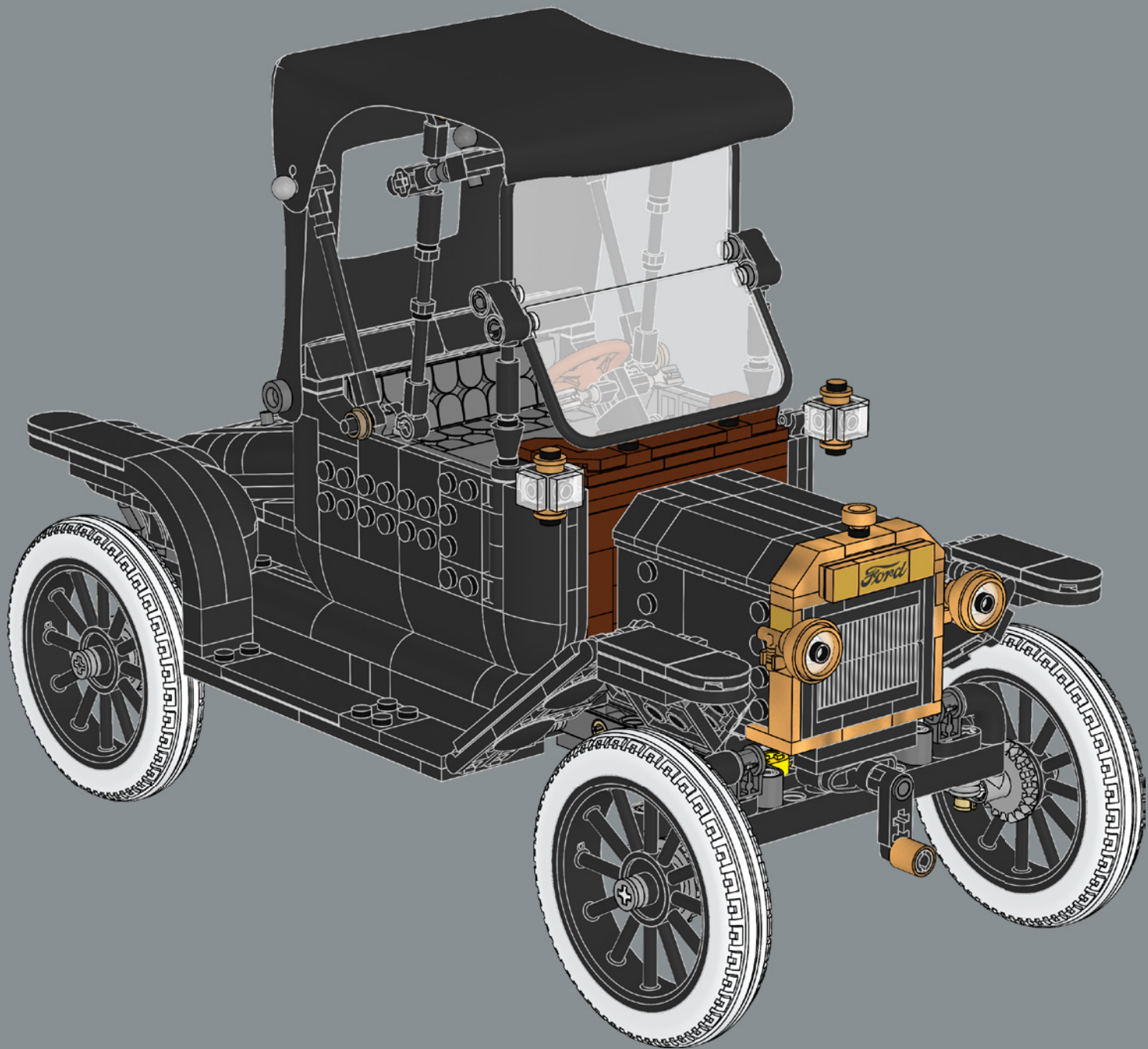

- 6x 614101
- 2x 6210272
- 2x 6058177
- 1x 6499714
- 2x 6289797
- 2x 371001
- 2x 346001
- 2x 346001
- 4x 6575457
- 1x 4565452
- 3x 4161734
- 1x 6374192
- 2x 4579260
- 2x 6376461
- 5x 6013938
- 1x 4666579
- 13x 4113917
- 4x 4162465
- 4x 4666999
- 1x 4118790
- 1x 4113233
- 6x 4114309
- 2x 6378120
- 1x 6360104
- 1x 4544143
- 1x 6130004
- 4x 4206482
- 2x 6376461
- 2x 6299413
- 2x 4119474
- 4x 6130008
- 4x 6331084
- 4x 6315887
- 8x 6290456
- 5x 6534180
- 4x 6388352
- 2x 6335388
- 8x 6332148
- 5x 6234695
- 3x 4504382
- 10x 307026
- 10x 302426
- 2x 6539387
- 2x 6538443
- 2x 6338384
- 2x 6335317
- 2x 6321194
- 3x 473326
- 6x 4558954
- 2x 300526
- 2x 6380236
- 1x 6473449
- 2x 6457112
- 2x 6338428
- 2x 6330189
- 2x 6308000
- 2x 63362140
- 6x 6280097
- 10x 6279875
- 6x 6267487
- 1x 6265091
- 2x 6196548
- 1x 6143850
- 2x 6104209
- 1x 6092585
- 1x 6047276
- 10x 6020193
- 4x 4512363
- 8x 4278359
- 4x 4109810
- 10x 306926
- 18x 302326
- 6x 241226
- 2x 6600029
- 6x 6562635
- 10x 6542614
- 8x 6534031
- 1x 6513908
- 1x 6507846
- 1x 6291068
- 4x 6276867
- 1x 614326
- 2x 6141556
- 7x 6138173
- 2x 6114987
- 2x 6016172
- 2x 6016172
- 2x 4644456
- 1x 4548180
- 2x 4177431
- 1x 403226
- 2x 300426
- 4x 287726
- 4x 6179182
- 2x 6173124
- 2x 6141554
- 1x 4160869
- 1x 4161332
- 2x 6430580
- 4x 6336989
- 2x 6328095
- 6x 6214807
- 6x 6093525
- 3x 6053077
- 2x 6592550
- 2x 6552467
- 4x 6517779
- 2x 6506033
- 1x 6488003
- 4x 6469445
- 2x 6428168
- 2x 6350725
- 1x 6313520
- 2x 6310268
- 2x 6286381
- 14x 6192346
- 2x 4567436
- 10x 4515368
- 6x 4225201
- 2x 4142822
- 5x 362326
- 12x 302226
- 5x 281726
- 4x 242026
- 1x 6371743
- 1x 6325521
- 8x 6250020
- 4x 4227684
- 1x 303926
- 6x 6585237
- 1x 6168620
- 4x 6162892
- 1x 370526
- 4x 317626
- 10x 302126
- 4x 4227392
- 2x 6601521
- 3x 6439175
- 4x 6325190
- 16x 371026
- 3x 243126
- 9x 6587076
- 4x 6577238
- 2x 6360129
- 4x 6327028
- 1x 6277462
- 2x 6174917
- 9x 4587844
- 6x 4560182
- 4x 302026
- 2x 301026
- 2x 6567221
- 1x 6279754
- 2x 4558209
- 4x 6350415
- 2x 6170421
- 2x 6076678
- 3x 370626
- 4x 6544447
- 10x 663626
- 4x 6458186
- 2x 617926
- 1x 6058118

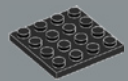

2x
4243819



2x
6318582

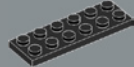

2x
379526



4x
6575789

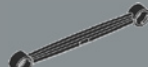

1x
6506200



1x
346026



1x
370226



1x
6456527

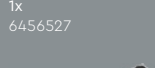

1x
303426



4x
395826



6x
4514845

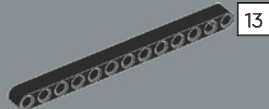

2x
4522933

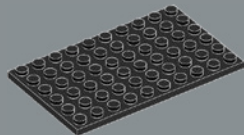

1x
303326

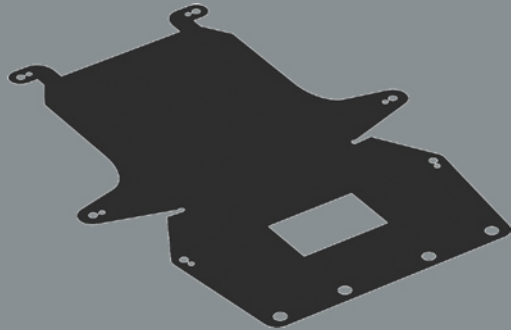

1x
6586353



1x
6539382



6x
6581822



2x
6510164



2x
6508150

13

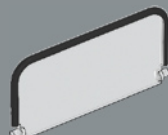

2x
6584086



3x
6514189

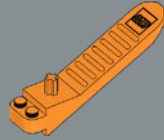

1x
6240515



1x
6322841



6x
6300322



4x
6328180



6x
6215659



2x
4221744



2x
4211183



6x
6476174



6x
6439053



4x
4620075

2x
4620191



4x
6092590



4x
4211150



2x
6397820



2x
4211180



2x
6500421



4x
6295302



1x
6551600



8x
6470170



4x
6251470



1x
6135494



2x
4211257



1x
4211200

2x
6600113

2x
4211210



1x
4211202



1x
6311441



2x
4216668



1x
4211201



1x
4216945



1x
4211211



1x
4217848



1x
6448793



23x
6271165



4x
6258831



1x
4211483



2x
4211399



8x
4211476



2x
6362975



3x
6443149



1x
6380605



2x
6296894



2x
6123815



2x
6066097



2x
4211398



1x
6372076



1x
6326078



2x
6144138



4x
4654582

1x
4650645



2x
4211541



13x
4211475



4x
6359714



1x
4211357



2x
4211815



1x
6469440



2x
6446028



1x
6360043



2x
6185676



4x
4244627



2x
6408168



2x
4211399

4x
4211636

3

201

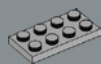

2x
4211395



2x
6170418

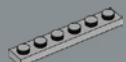

3x
4211438

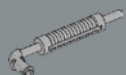

1x
6313096



1x
4211640



4x
4211374



2x
6336970



4x
6510220



5x
6395635



32x
6362252



4x
6333129



6x
6271752



6x
4210719



4x
4558955



2x
4211098



6x
6388118



2x
6364352



7x
6350724



4x
6319332



2x
6296892



2x
6282144



2x
4211063



2x
4211052



1x
6534688



4x
6215212



1x
6308045



1x
4210763



1x
638045



3x
4211043



1x
6336990



4x
6469463



2x
6126083



11x
4211133



2x
4211094



2x
4210665



4x
4210635



1x
6622623



2x
6324639



1x
4552349



2x
6378143



1x
6083620



5x
4211001



2x
6600112



1x
6092649



4x
6039176



2x
4211065

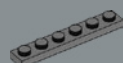

2x
4211056



2x
4243831



1x
4211100



1x
4211002



1x
4595710



2x
4210997



1x
4210678



2x
6432384



1x
6511448



4x
6576385



3x
6262138



1x
6256803



1x
6190252



1x
6186672



1x
6173139



6x
4523159



1x
6615520



3x
6218047



2x
6287530



3x
6218047



2x
6361354



1x
6092594



2x
6493687



1x
6323378



2x
6317208



2x
6167585



2x
6508090



1x
6134197



4x
6510192



2x
6167641



2x
6314190



2x
6361354



1x
6158415



2x
6119107



LEGO.com/service

4

11



YOU COULD
WIN



**YOU COULD
WIN**

Your feedback will help shape the future development of this product series.

Visit:

**DU KÖNNTEST
GEWINNEN**

Dein Feedback trägt zur Weiterentwicklung dieser Produktreihe bei.

Geh auf:

**VOUS POURRIEZ
GAGNER**

Vos commentaires nous aideront à concevoir les futurs produits de cette gamme.

Visitez :

**POTRESTI
VINCERE TU**

La tua opinione ci aiuterà a migliorare la creazione futura di questa linea di prodotti.

Visita:

**PUEDES
GANAR**

Tu opinión contribuirá al futuro de esta serie de productos.

Visita:

轻松获奖

您的反馈将有助于我们在今后改进本产品系列。

请访问:

LEGO.com/productfeedback

You also have the chance to win a LEGO® set.

Terms and conditions apply.*

Außerdem hast du die Chance, ein LEGO® Set zu gewinnen.

Es gelten die Teilnahmebedingungen.*

Vous pourriez également gagner un ensemble LEGO®.

Des conditions s'appliquent.*

Hai anche la possibilità di vincere un set LEGO®.

Termini e condizioni sono applicabili.*

También tienes la oportunidad de ganar un set LEGO®.

Aplican términos y condiciones.*

您还有机会赢取乐高®套装。

条款和条件适用。*

*LEGO.com/productfeedback-terms

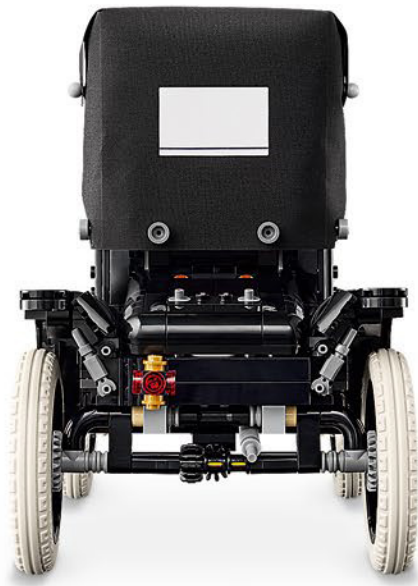

LEGO and the LEGO logo are trademarks of the LEGO Group. ©2026 The LEGO Group.
Ford Motor Company Trade Dress and Trademarks used under license to the LEGO Group.