



# Architecture

21042

## Statue of Liberty La statue de la Liberté Estatua de la Libertad

New York, USA  
New York, États-Unis  
Nueva York (EE. UU.)





[LEGO.com/architecture/booklet](https://www.lego.com/architecture/booklet)

## Liberty

The Statue of Liberty was a gift of friendship from the people of France to the United States, and has since become a universal symbol of freedom and democracy throughout the world. Dedicated on the 28th of October 1886, she was often the first thing people saw as they sailed into New York's harbor to start a new life in America.

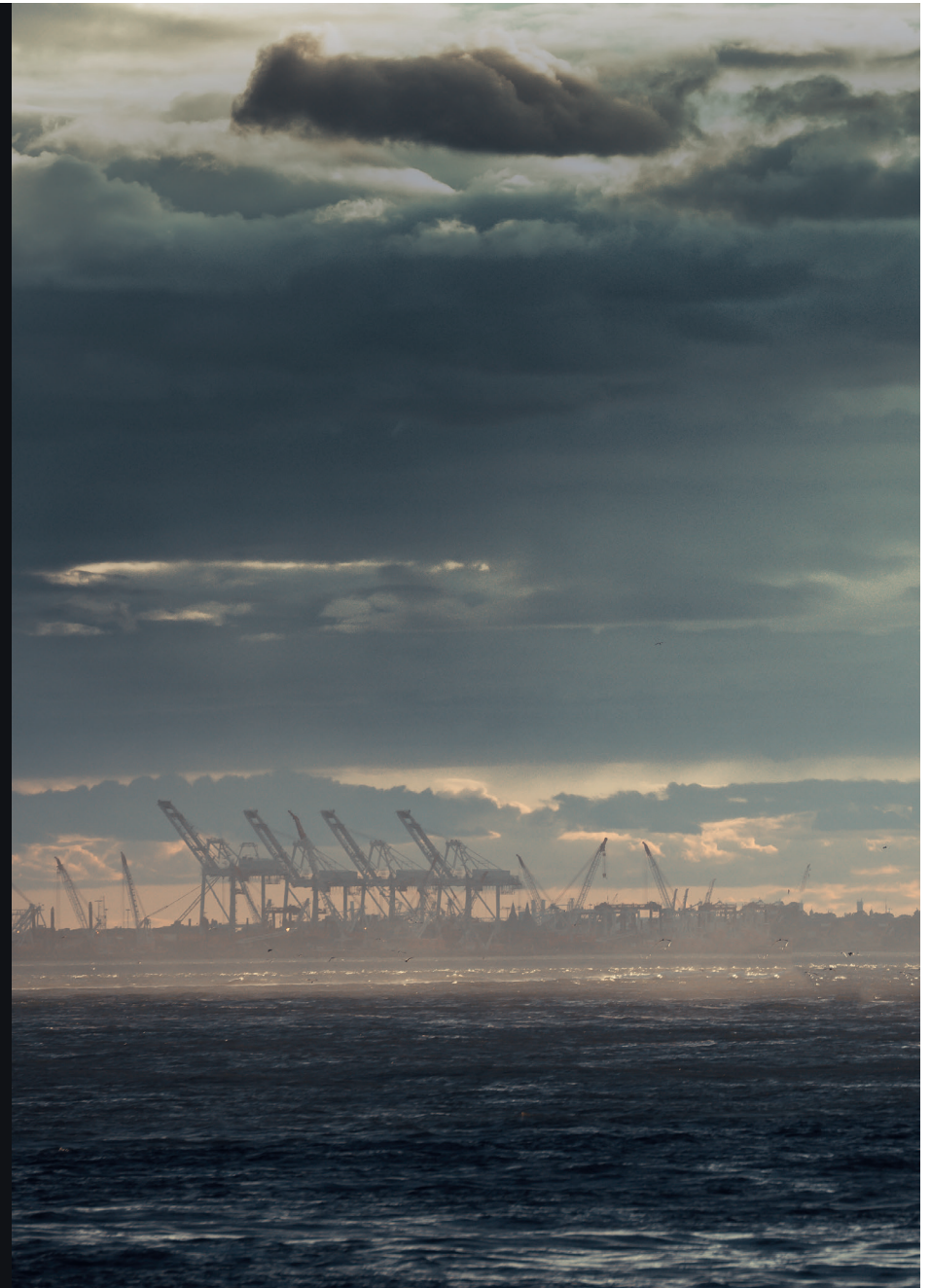
2



A photograph of the Statue of Liberty in New York Harbor, silhouetted against a dramatic, cloudy sky at sunset or sunrise. The water in the foreground is dark with some whitecaps. The sky is filled with large, dark clouds, with a bright glow on the horizon behind the statue.

*"Thou warden of the western gate, above Manhattan Bay,  
The fogs of doubt that hid thy face are driven clean away:  
Thine eyes at last look far and clear, thou liftest high thy hand  
To spread the light of liberty world-wide for every land."*

Henry van Dyke  
Liberty Enlightening the World  
1917

## The Gift

Édouard de Labouaye was a prominent French political thinker and a strong supporter of President Abraham Lincoln during the American Civil War. In 1865, he proposed creating a monument that would be gifted to the United States by the people of France in celebration of the recent Union victory in the Civil War and the abolition of slavery.

Ten years later, with the help of the sculptor Frédéric-Auguste Bartholdi, Labouaye turned his proposal into reality and founded the Franco-American Union to raise funds for the project. It was hoped that the French people would finance the proposed Statue, now entitled "Liberty Enlightening the World," while the American people would pay for its pedestal.

On one of his trips to the U.S. to help raise funds, the sculptor Bartholdi realized that New York was the gateway to America and spotted the perfect location for the Statue to stand.



Bedloe's Island was visible to every ship entering or leaving the city's harbor and Bartholdi envisioned his statue rising out of the star-shaped Fort Wood that already stood on the island.

The project soon caught the imagination of many on both sides of the Atlantic, and when the French had raised 400,000 francs the construction of the Statue finally began.

A photograph of the Statue of Liberty at sunset. The statue is illuminated from below, and its torch is lit. The sky is a mix of orange, red, and blue. The statue stands on a pedestal with a small building at its base. The water of the harbor is visible in the foreground.

*"...a stream of light shall pierce the darkness  
...until Liberty enlightens the world"*

President Grover Cleveland  
Dedication speech for the Statue of Liberty  
October 28, 1886



6



## From Dream to Reality

In 1876, French craftsmen began forging the individual elements of the Statue. While the outer design and materials were given, the real challenge lay in the Statue's internal construction.

Bartholdi turned to the French architect and structural engineer, Gustave Eiffel, and he proposed creating a 92 ft. (28 m) skeletal central pylon upon which asymmetrical girders could be attached. Flat metal bars were then bolted to the girders to hold the copper skin of the Statue in place. Eiffel would go on to use the same pylon construction method in his famous Eiffel Tower, which was completed in 1889.

The entire Statue was completed in Paris between 1881 and 1884. It arrived amid great fanfare in New York aboard the French Navy ship *Isère* on the 17th of June 1885. Once the pedestal was completed in 1886, the 151 ft. (46 m) tall statue was quickly assembled. The last section to be completed was the Statue of Liberty's face, which remained covered until the official dedication on the 28th of October 1886. Rain and foggy weather did not stop over one million New Yorkers from turning out to cheer the unveiling of the new Statue.

*"Keep, ancient lands, your storied pomp!" cries she  
With silent lips. "Give me your tired, your poor,  
Your huddled masses yearning to breathe free,  
The wretched refuse of your teeming shore.  
Send these, the homeless, tempest-tost to me,  
I lift my lamp beside the golden door!"*

Emma Lazarus  
The New Colossus  
1883

## A Universal Icon

The Statue of Liberty was intended to be seen as a universal symbol of enlightenment and freedom. The robed female figure itself represents Libertas, the Roman goddess of freedom, and although you cannot see her feet clearly she stands among a broken shackle and chains, with her right foot raised, depicting her moving away from oppression and slavery. The seven spikes on the crown represent the seven oceans and the seven continents of the world, reinforcing the universal concept of liberty.

Over time, the Statue would also emerge as a welcoming symbol of hope to different generations of immigrants to the U.S. Between 1886 and 1924, almost 14 million immigrants

entered the United States through New York. The Statue of Liberty was often the first thing they saw as they arrived by ship in their new homeland.

The American National Park Service took over responsibility for the island in 1937, and set about transforming the area around the Statue into a park. Bedloe's Island was renamed Liberty Island in 1957 to commemorate the completion of this work. The Statue was designated a UNESCO World Heritage Site in 1984 and continues to attract around 4 million visitors each year.











## Facts & Figures

<b>Style</b>	Neoclassical Sculpture
<b>Materials</b>	Statue: Copper & Iron Pedestal: Stone
<b>Height</b>	Statue: 151 ft. (46 m) Including Pedestal: 305 ft. (93 m)
<b>Weight</b>	224.9 short tons (204 metric tons)
<b>Dedicated</b>	October 28, 1886

## Liberté

La statue de la Liberté a été offerte aux États-Unis par le peuple français, en signe d'amitié. Elle est depuis devenue un symbole de liberté et de démocratie dans le monde entier. Inaugurée le 28 octobre 1886, elle a longtemps été la première chose que les gens apercevaient à leur arrivée dans le port de New York, alors qu'ils s'apprêtaient à refaire leur vie aux États-Unis.

12

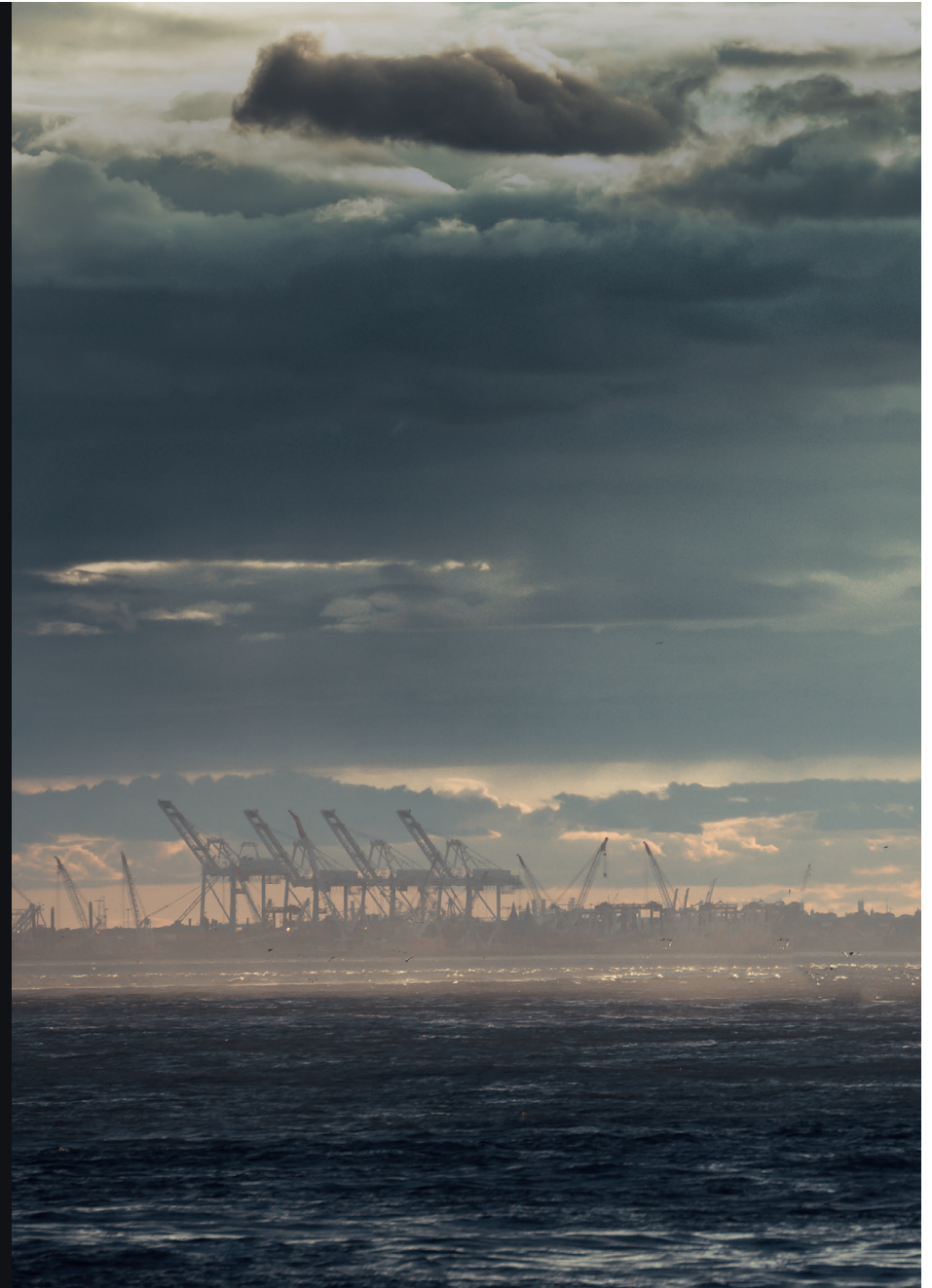

A photograph of the Statue of Liberty in New York Harbor, silhouetted against a dramatic, cloudy sky at sunset or sunrise. The water in the foreground is dark and textured. The overall mood is contemplative and historical.

*« Toi, gardienne de l'Occident,  
surplombant Manhattan et sa baie, Les brumes du doute  
qui cachait ton visage sont maintenant dissipées :  
Ton regard se porte au loin, ta main est fièrement dressée  
Pour éclairer de liberté les pays du monde entier. »*

Henry van Dyke  
La Liberté éclairant le monde  
1917

## Le cadeau

Édouard de Laboulaye était un célèbre homme politique français et un grand admirateur du président américain Abraham Lincoln au cours de la guerre de Sécession. En 1865, il propose la création d'un monument qui serait offert aux États-Unis par le peuple français pour célébrer la récente victoire de l'Union et l'abolition de l'esclavage.

Dix ans plus tard, avec l'aide du sculpteur Frédéric Auguste Bartholdi, Laboulaye concrétise sa vision et fonde l'Union franco-américaine afin de recueillir des fonds pour la réalisation du projet. On espère alors que le peuple français assumera les coûts de la statue, nommée « La Liberté éclairant le monde », et que le peuple américain paiera pour son piédestal.

Lors d'un voyage aux États-Unis visant à amasser des fonds, Bartholdi réalise que New York est la porte de l'Amérique. Il repère alors l'endroit idéal pour ériger sa statue. Bedloe's



Island était visible de tous les navires entrant ou sortant du port de la ville. Bartholdi imagine sa statue s'élevant au-dessus de Fort Wood, un fort en forme d'étoile construit sur l'île.

Le projet frappe rapidement l'imagination des deux côtés de l'Atlantique. Les Français ayant amassé 400 000 francs, on commence enfin à bâtir la statue.

A photograph of the Statue of Liberty in New York City, taken at sunset. The statue is illuminated from below, and the sky is a mix of orange, red, and blue. The statue is the central focus, standing on its pedestal. The background shows the city skyline and some trees.

*« [...] un rai de lumière percera les ténèbres  
[...] jusqu'à ce que la Liberté éclaire le monde »*

Grover Cleveland, président américain  
Discours lors de l'inauguration de la statue de la Liberté  
28 octobre 1886







## Du rêve à la réalité

En 1876, des artisans français commencent à fabriquer les pièces de la statue. L'aspect extérieur et les matériaux ayant été choisis, le véritable défi réside dans la structure interne.

Bartholdi fait appel à l'architecte et ingénieur en structures français Gustave Eiffel et lui propose de bâtir un pylône central de 28 m sur lequel seraient fixées des poutres asymétriques. Des bandes métalliques plates seraient ensuite vissées aux poutres pour retenir les plaques de cuivre formant la surface. Eiffel a par la suite utilisé la même méthode de construction pour sa célèbre tour Eiffel, achevée en 1889.

Les différentes pièces sont assemblées à Paris de 1881 à 1884. Le 17 juin 1885, la statue fait son arrivée à New York en grande pompe à bord de l'Isère, un navire de la marine française. Une fois la construction du piédestal terminée en 1886, la statue, qui s'élève à 46 m, est rapidement réassemblée. La dernière section achevée est le visage, qui reste caché jusqu'à l'inauguration officielle, le 28 octobre 1886. Malgré la pluie et le brouillard, plus d'un million de New-Yorkais se rassemblent pour assister au dévoilement sous les cris et les applaudissements.

*« Garde, Vieux Monde, tes fastes d'un autre âge », proclame-t-elle  
De ses lèvres closes. « Donne-moi tes pauvres, tes exténués,  
Qui en rangs pressés aspirent à vivre libres,  
Le rebut de tes rivages surpeuplés,  
Envoie-les-moi, les déshérités, que la tempête me les rapporte  
De ma lumière, j'éclaire la Porte d'Or ! »*

Emma Lazarus  
Le Nouveau Colosse  
1883

## Une icône universelle

La statue de la Liberté devait être un symbole universel de sagesse et de liberté. La figure féminine vêtue d'une toge représente Libertas, déesse romaine de la liberté. Ses pieds ne sont pas nettement visibles, mais elle se dresse parmi des chaînes et des fers brisés, son pied droit levé pour indiquer qu'elle laisse derrière elle l'oppression et l'esclavage. Les sept pointes de sa couronne représentent les sept océans et les sept continents du monde, renforçant l'idée de liberté pour tous.

Avec le temps, la statue est aussi devenue une figure d'accueil et d'espoir pour les nombreuses générations d'immigrants aux États-Unis. Entre 1886 et 1924, près de

14 millions d'immigrants sont entrés aux États-Unis en passant par New York. La statue de la Liberté était souvent leur première vision de leur nouvelle patrie, alors que le bateau arrivait au port.

L'American National Park Service prend à sa charge l'administration de l'île en 1937 et entreprend de transformer en parc l'espace entourant la statue. Bedloe's Island est renommée Liberty Island en 1957 pour commémorer la fin des travaux. La statue est inscrite au patrimoine mondial de l'UNESCO en 1984 et attire quelque 4 millions de visiteurs chaque année.

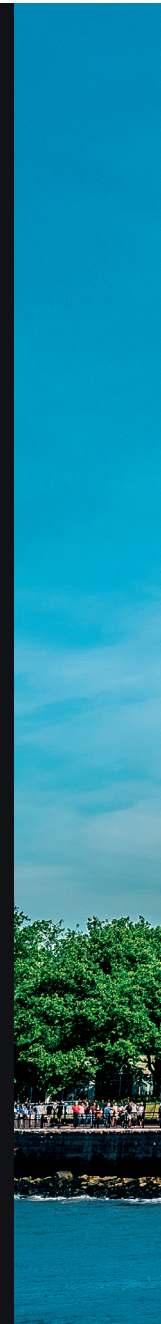







## Faits et chiffres

<b>Style</b>	Sculpture néoclassique
<b>Matériaux</b>	Statue : cuivre et fer Piédestal : pierre
<b>Hauteur</b>	Statue : 46 m Avec le piédestal : 93 m
<b>Poids</b>	204 t
<b>Inauguration</b>	28 octobre 1886

## Libertad

La Estatua de la Libertad fue un regalo del pueblo de Francia a los Estados Unidos en señal de amistad y se ha convertido en un símbolo universal de la libertad y la democracia en todo el mundo. Inaugurada el 28 de octubre de 1886, a menudo era la primera cosa que veía la gente a su llegada en barco al puerto de Nueva York para iniciar una nueva vida en América.



A photograph of the Statue of Liberty in New York Harbor, silhouetted against a dramatic, cloudy sky at sunset or sunrise. The water in the foreground is dark and textured. The overall mood is contemplative and historical.

*“Guardas la puerta occidental, sobre la bahía de Manhattan. Las nieblas de duda que ocultaron tu cara se han despejado. Tus ojos por fin miran con claridad a lo lejos y alzas la mano hacia el cielo para difundir la luz de la libertad por todo el mundo y toda la tierra”.*

Henry van Dyke  
La libertad iluminando al mundo  
1917

## El regalo

Édouard de Labouaye fue un destacado pensador político francés y un sólido partidario del presidente Abraham Lincoln durante la Guerra Civil Americana. En 1865, propuso crear un monumento para que el pueblo de Francia se lo regalara a los Estados Unidos con motivo de la reciente victoria de la Unión en la Guerra Civil y la abolición de la esclavitud.

Diez años más tarde, con ayuda del escultor Frédéric-Auguste Bartholdi, Labouaye hizo realidad su propuesta y fundó la Unión Francoamericana para recaudar los fondos necesarios para el proyecto. Se esperaba que el pueblo francés financiara la estatua propuesta, hoy llamada "La libertad iluminando al mundo", y que el pueblo americano pagara el pedestal.

En uno de sus viajes a los Estados Unidos para contribuir a la recaudación de fondos, el escultor Bartholdi se



dio cuenta de que Nueva York era la puerta de entrada a América y divisó un lugar perfecto para la estatua. La isla de Bedloe se podía ver desde todos los buques que llegaban al puerto de la ciudad o partían de él, y Bartholdi imaginó su estatua sobre el fuerte Wood, que ya estaba construido en la isla.

El proyecto pronto capturó la imaginación de muchos a ambos lados del Atlántico y, cuando los franceses recaudaron sus 400,000 francos, comenzó por fin la construcción de la estatua.



A photograph of the Statue of Liberty in New York City, taken at sunset. The statue is illuminated from below, and its torch is lit. The sky is a mix of orange, red, and blue. The statue stands on a pedestal with a base that is also illuminated. The water of the harbor is visible in the foreground.

*"[...] un manantial de luz perforará la oscuridad  
[...] hasta que Libertad ilumine al mundo".*

Presidente Grover Cleveland  
Discurso de inauguración de la Estatua de la Libertad  
28 de octubre de 1886





## Del sueño a la realidad

En 1876, artesanos franceses comenzaron a forjar los diferentes elementos de la estatua. Aunque el diseño exterior y los materiales estaban decididos, el verdadero desafío residía en la estructura interna.

Bartholdi recurrió al arquitecto e ingeniero estructural francés Gustave Eiffel, quien propuso la creación de un pilón central de 28 m al que podrían conectarse vigas asimétricas. Después podrían atornillarse barras planas de metal a las vigas para sostener la piel de cobre de la estatua. Eiffel se decidiría por el mismo método de construcción alrededor de un pilón que usó para su famosa Torre Eiffel, completada en 1889.

La estatua entera se fabricó en París entre 1881 y 1884. Llegó a Nueva York con bombos y platillos a bordo del barco francés Isère el 17 de junio de 1885. Una vez completado el pedestal en 1886, ensamblar la estatua, de 46 m de altura, fue bastante rápido. La última sección fue el rostro de la Estatua de la Libertad, que permaneció cubierto hasta la inauguración oficial, el 28 de octubre de 1886. Ni la lluvia ni la niebla impidieron que más de un millón de neoyorquinos presenciaran con júbilo la presentación de la nueva estatua.

*“¡Guárdense, antiguas tierras, su ilustre pompa!”*, grita  
con sus silenciosos labios. *“Denme a sus rendidos, a sus pobres,  
a sus masas hacinadas anhelando respirar en libertad.  
El miserable rechazo de sus orillas repletas.  
Envíenme a los que no tienen techo y a los que arrojó la tempestad.  
¡Levanto mi lámpara junto a la puerta dorada!”*

Emma Lazarus  
El nuevo coloso  
1883

## Un icono universal

La Estatua de la Libertad estaba destinada a convertirse en un símbolo universal de iluminación y libertad. La figura femenina de la túnica representa a Libertas, la diosa romana de la libertad, y aunque no se le ven claramente los pies, se encuentra entre un grillete roto y una cadena, con el pie derecho levantado, como alejándose de la opresión y la esclavitud. Las siete puntas de la corona representan los siete océanos y los siete continentes del mundo, respaldando con ello el concepto universal de libertad.

Con el tiempo, la estatua se convertiría también en un cálido símbolo de esperanza para las diferentes generaciones de inmigrantes que llegaron a los Estados Unidos. Entre 1886

y 1924, casi 14 millones de inmigrantes entraron en los Estados Unidos por Nueva York. A menudo, la Estatua de la Libertad era la primera cosa que veían al llegar en barco a su nuevo hogar.

El Servicio de Parques Nacionales de América se hizo cargo de la isla en 1937 y decidió transformar el área que rodea la estatua en un parque. La isla de Bedloe cambió su nombre por el de isla Libertad en 1957 para conmemorar la finalización de la obra. La estatua fue declarada Patrimonio de la Humanidad por la UNESCO en 1984 y sigue atrayendo unos 4 millones de visitantes al año.

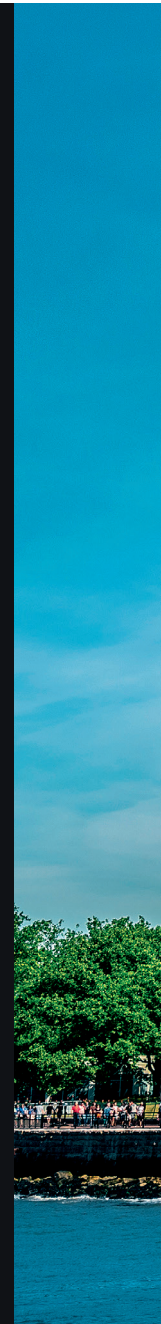







## Datos y cifras

<b>Estilo</b>	Escultura neoclásica
<b>Materiales</b>	Estatua: cobre y hierro Pedestal: piedra
<b>Altura</b>	Estatua: 46 m Con pedestal: 93 m
<b>Peso</b>	204 toneladas métricas
<b>Inauguración</b>	28 de octubre de 1886

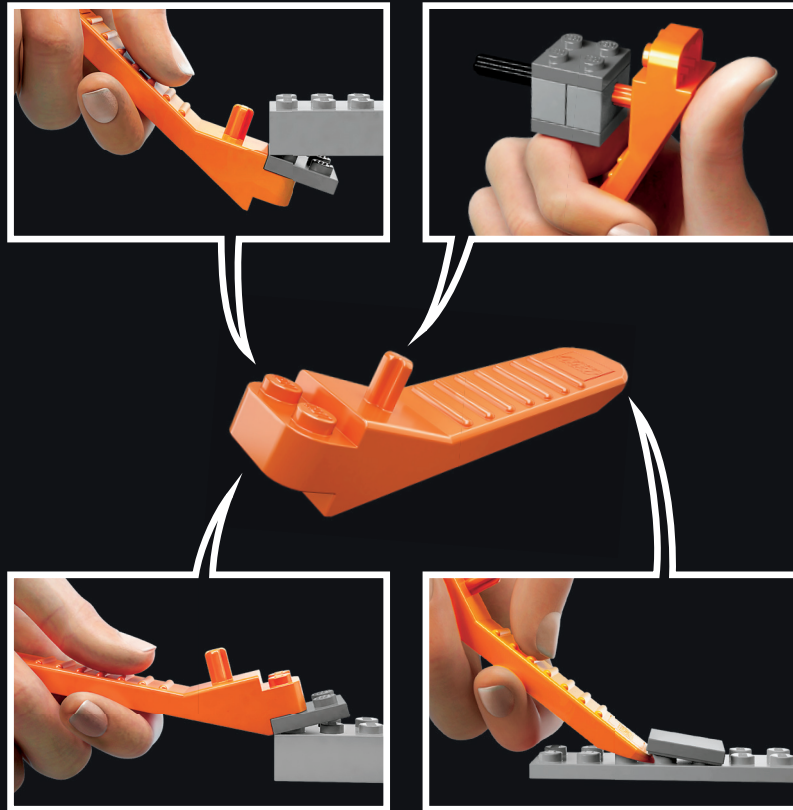

[LEGO.com/brickseparator](https://LEGO.com/brickseparator)



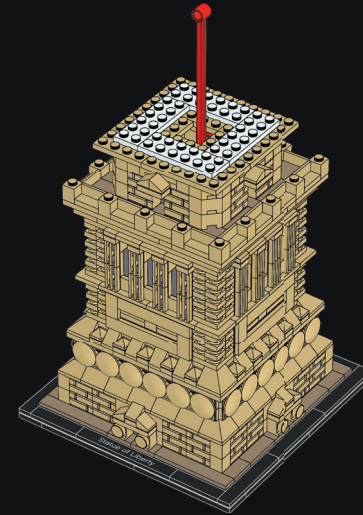
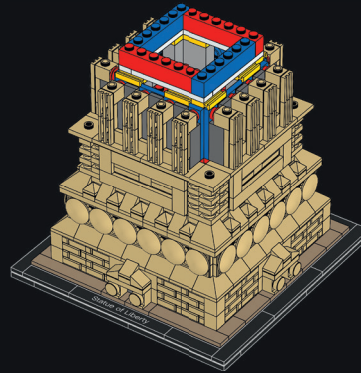
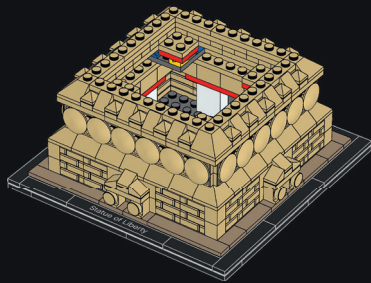
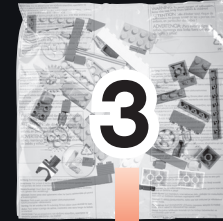
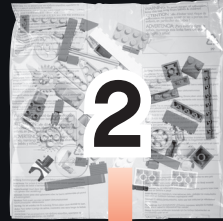

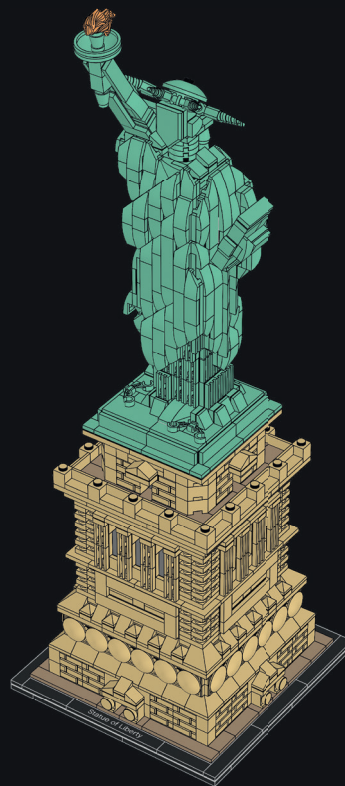
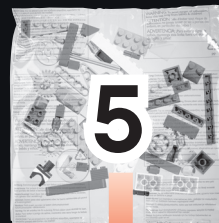
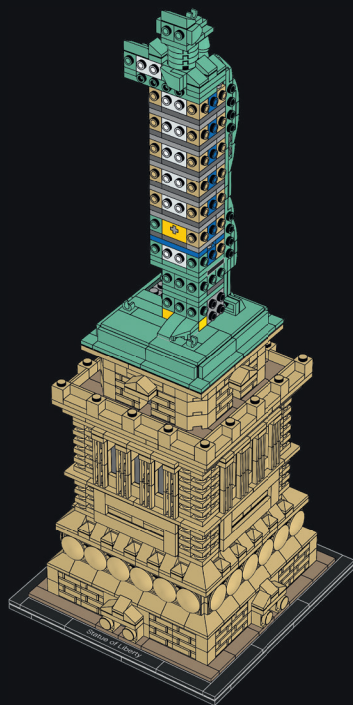
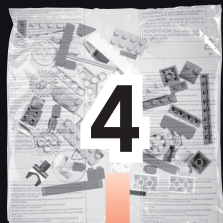

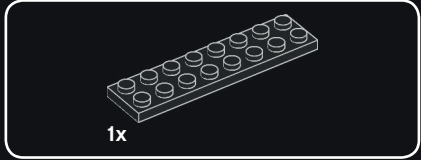

1

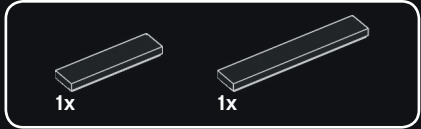
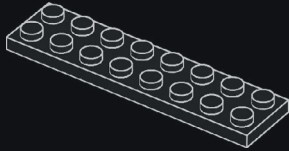

2

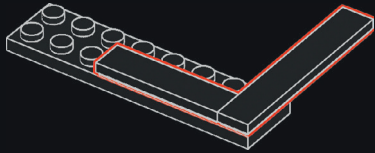

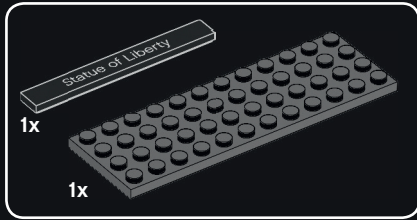

3

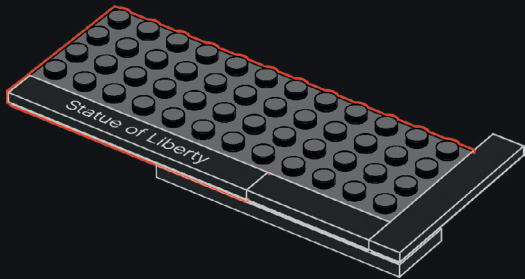

36

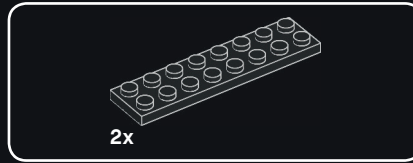

4

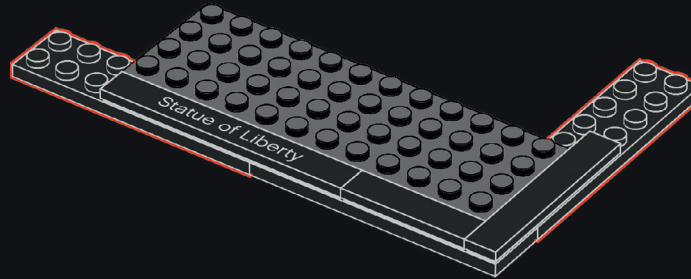

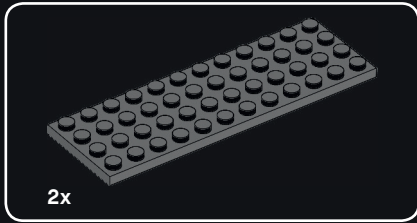

5

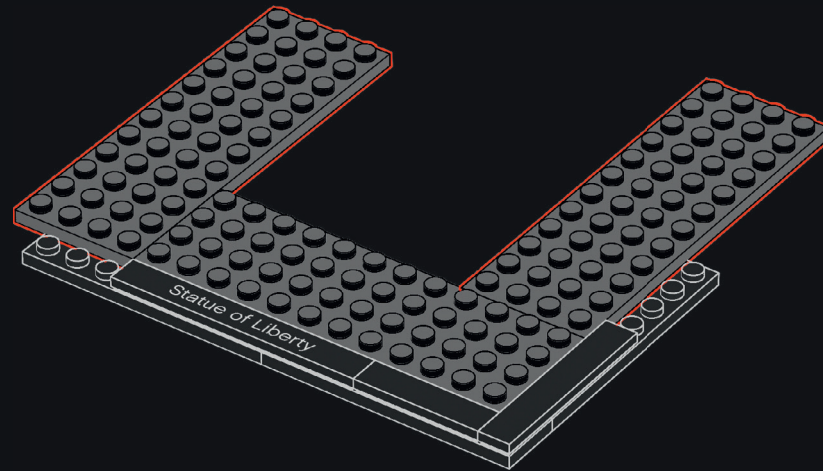

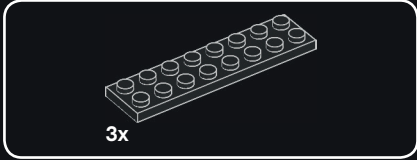

6

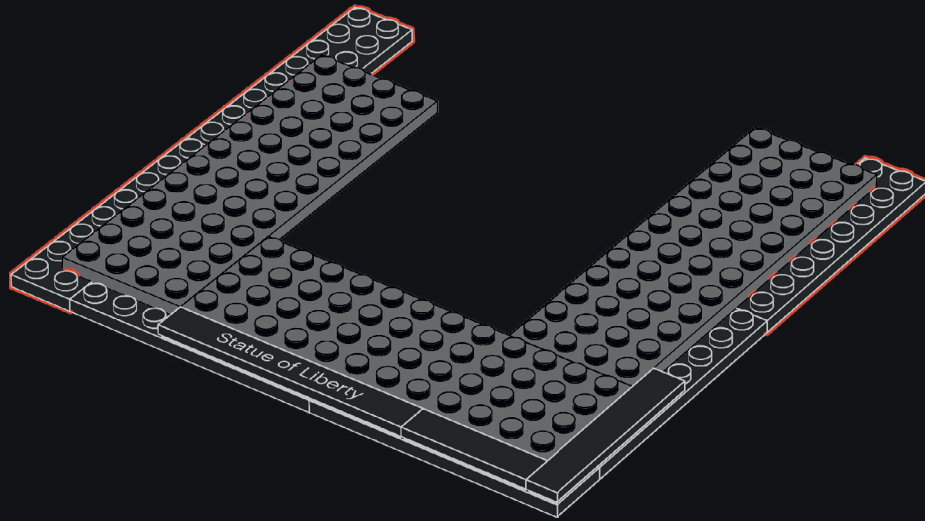

38

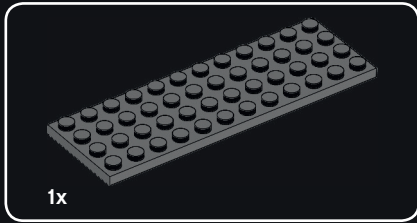

7

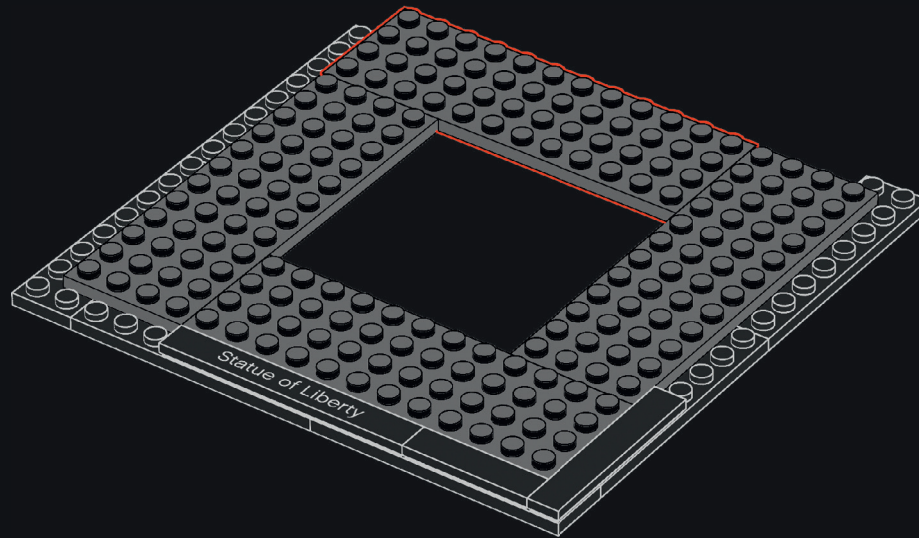

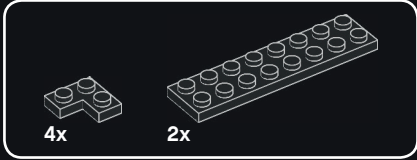

8

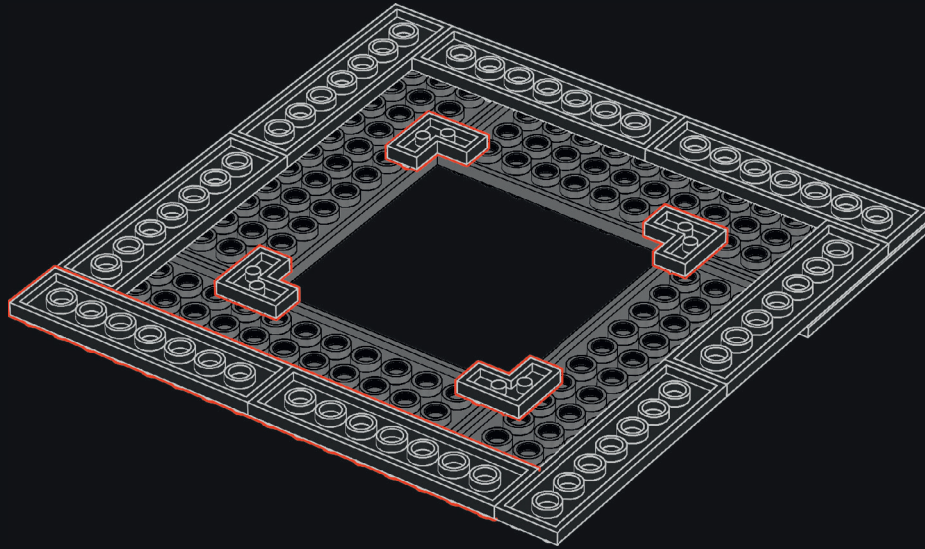

40



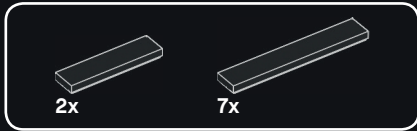

9

The Statue is thought to be hit by around 600 bolts of lightning every year.  
On estime que la statue de la Liberté est frappée par environ 600 éclairs chaque année.  
Se cree que la estatua es alcanzada por unos 600 rayos cada año.

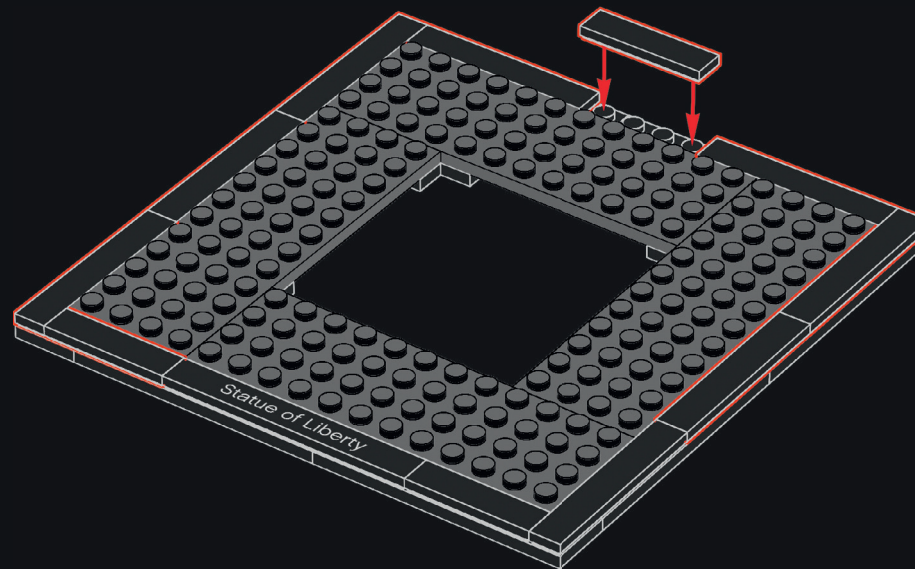
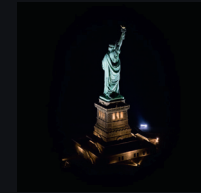

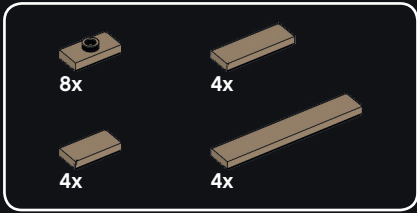

10

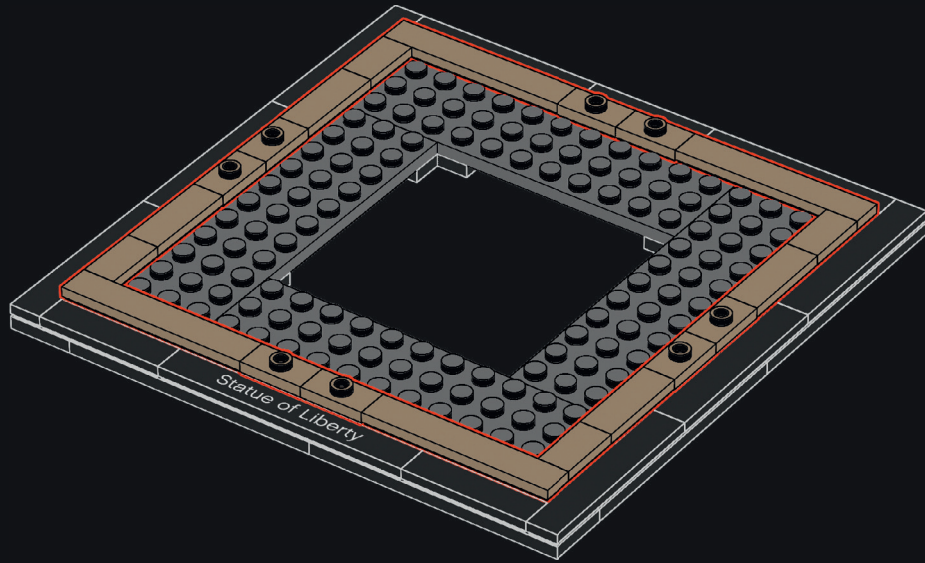

42

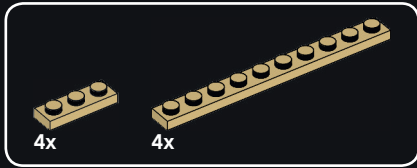

11

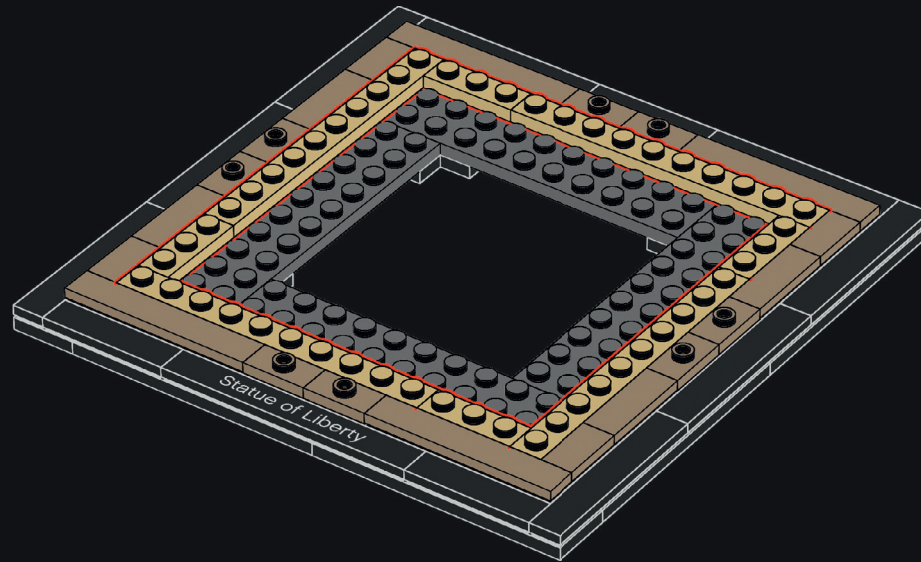



12x



16x

# 12

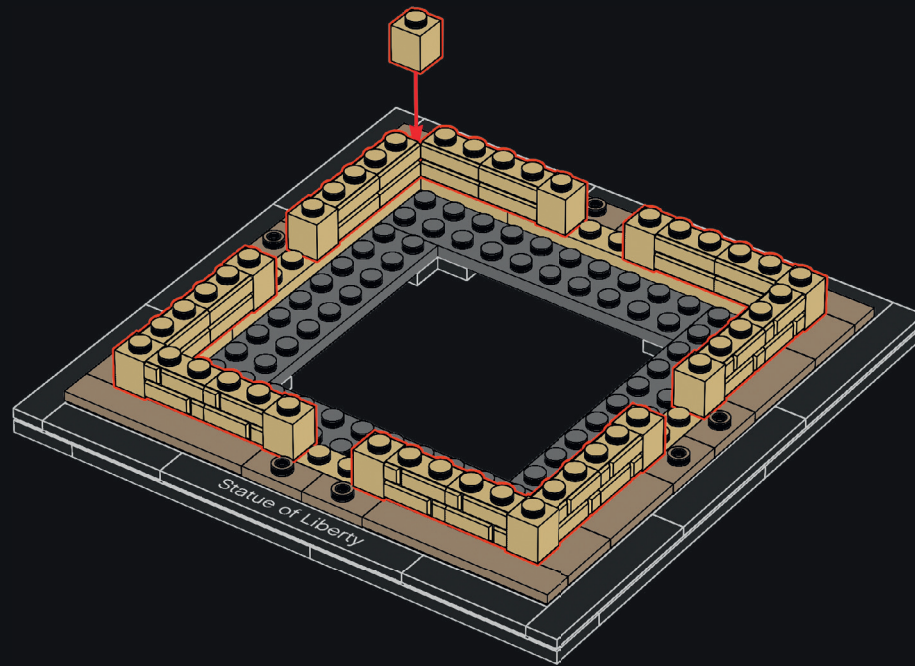

44

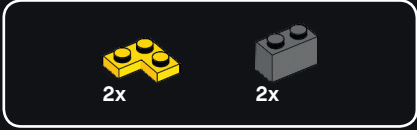

13

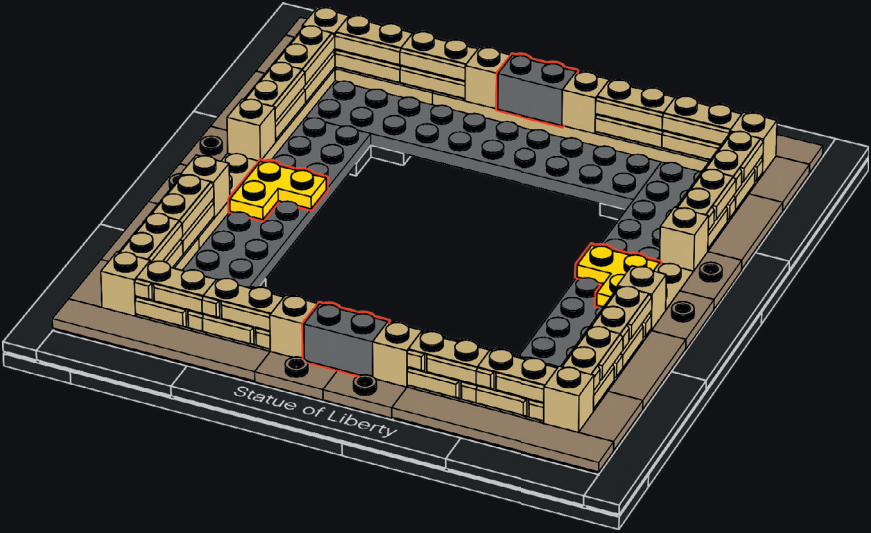

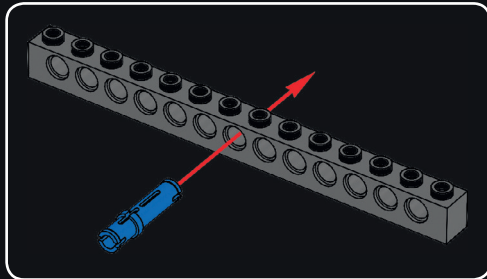
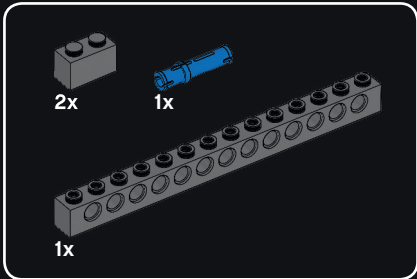

14

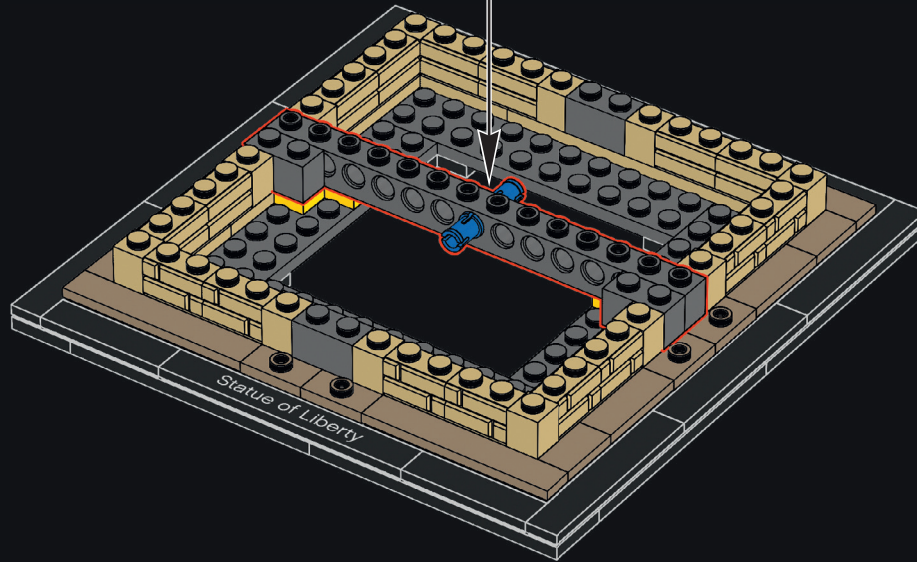

46



15

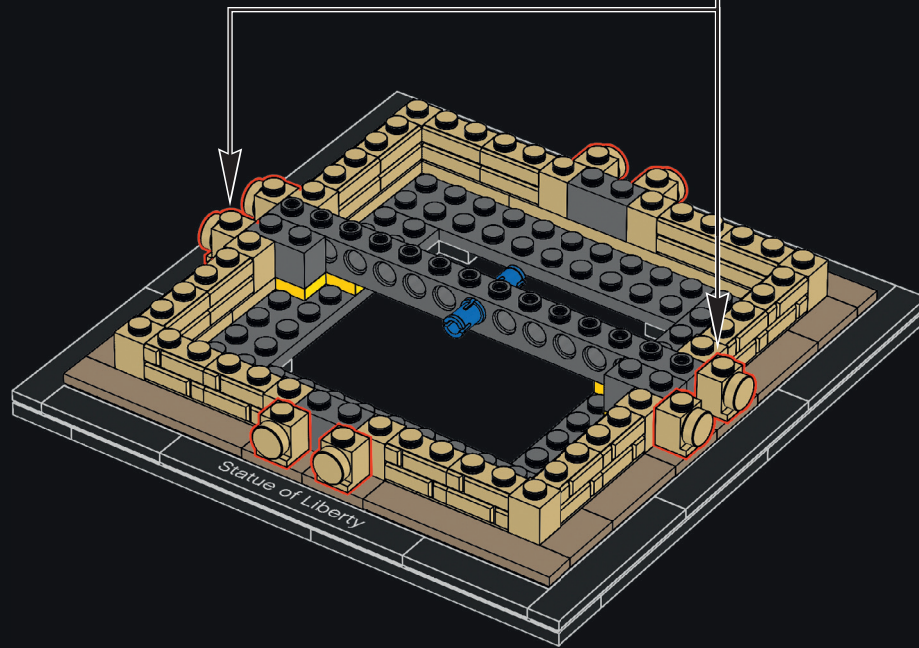
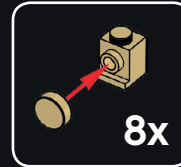



16

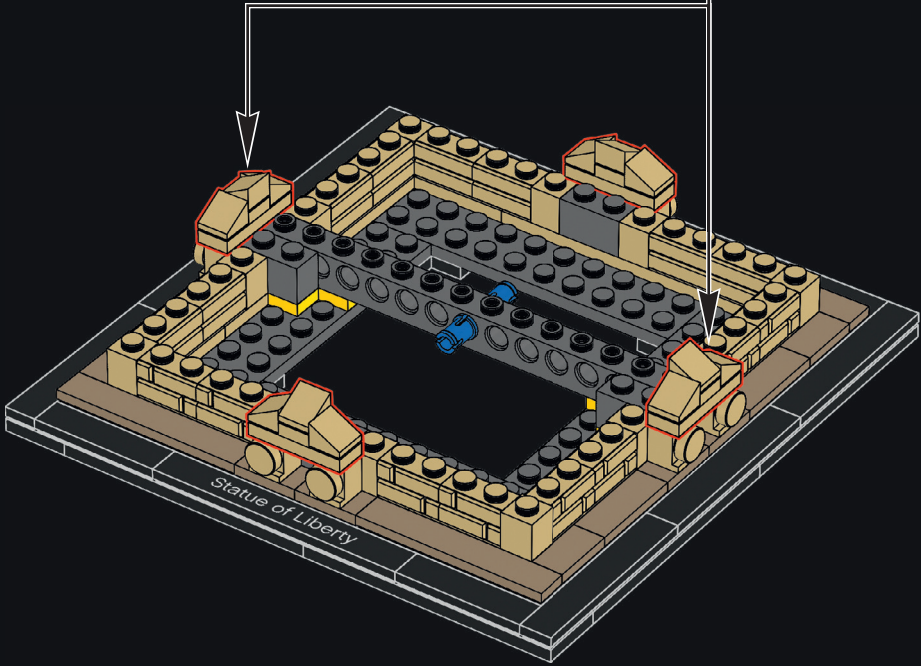
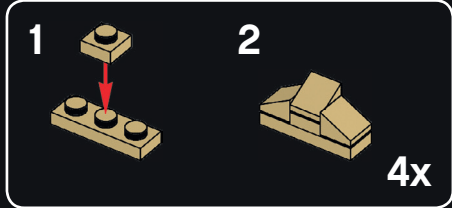

48





17

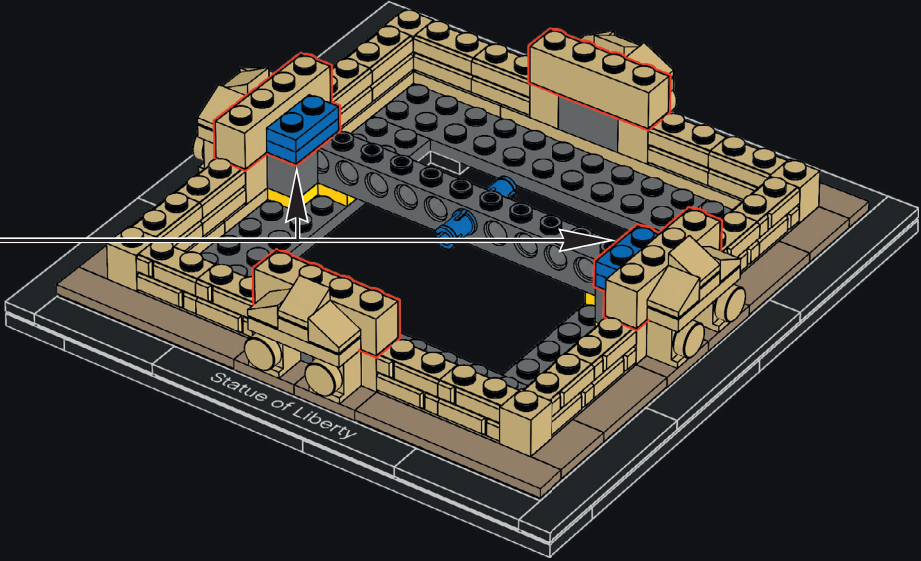
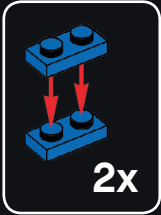



4x



16x

18

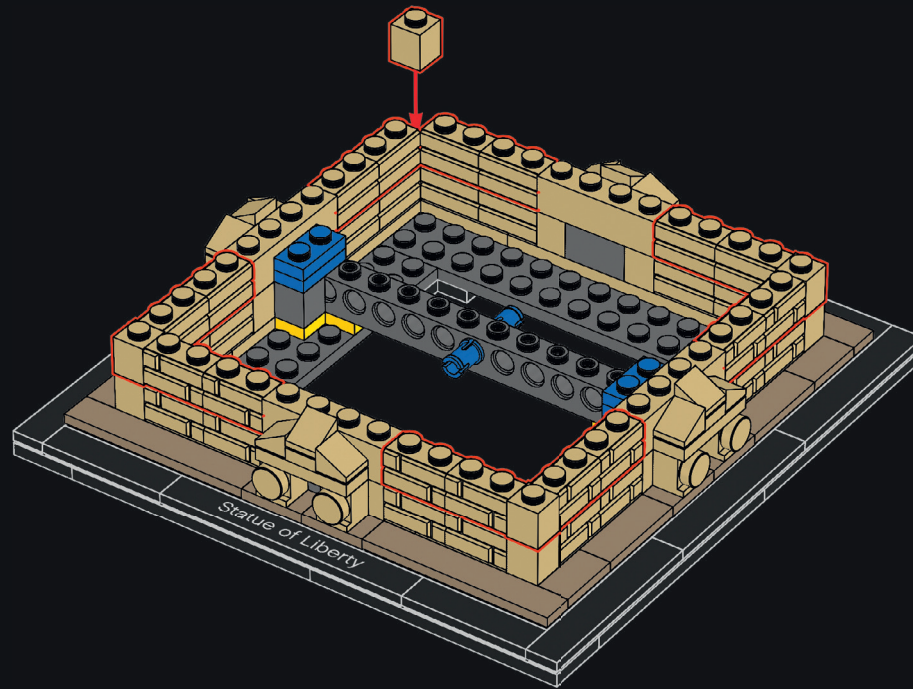

50

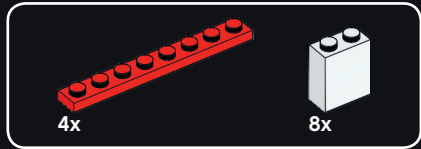

19

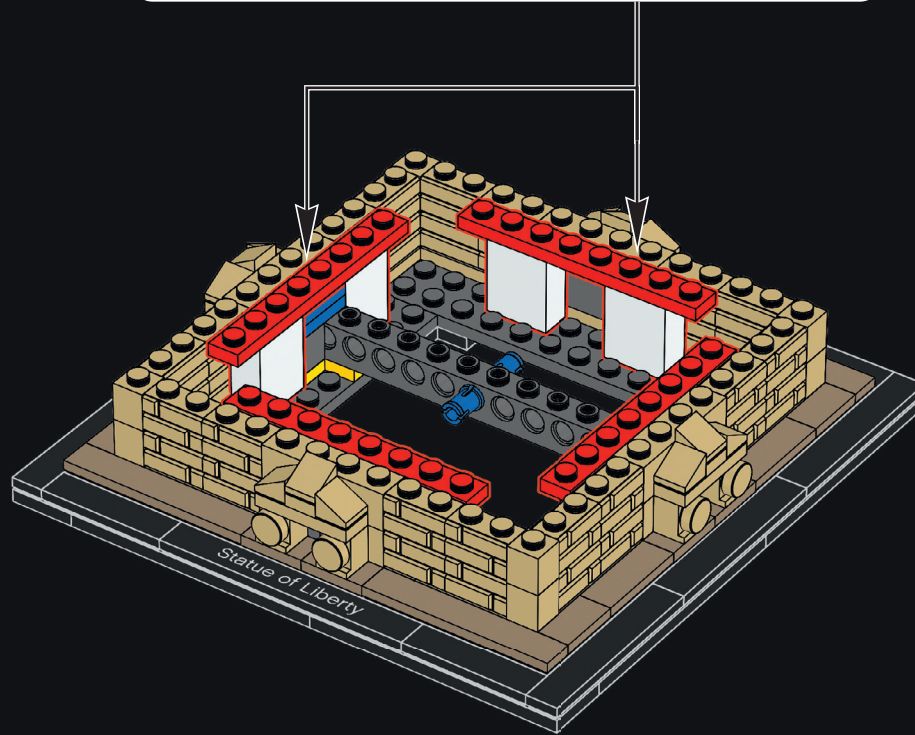
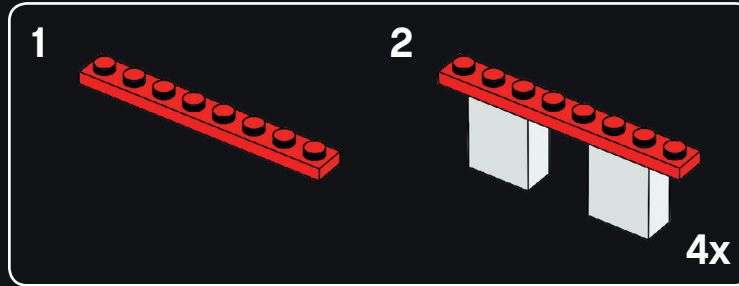



20

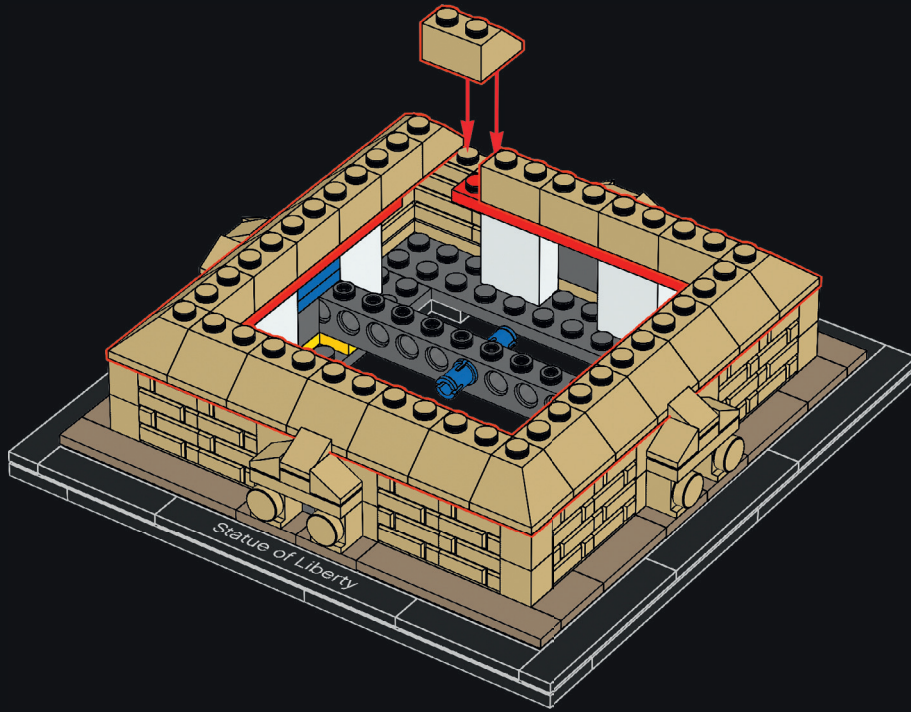

52

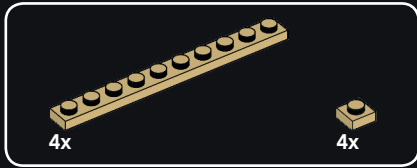

21

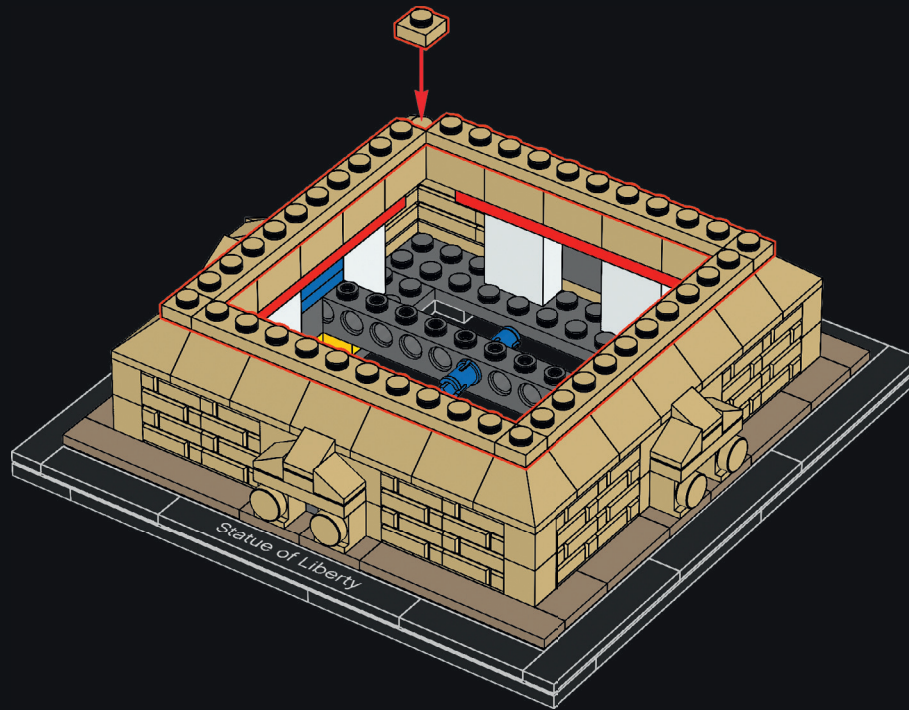

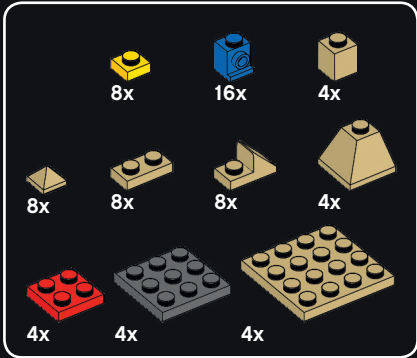
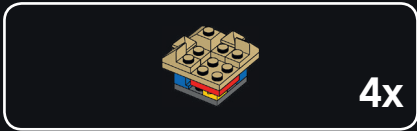

22

1

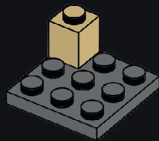

2

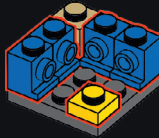

54

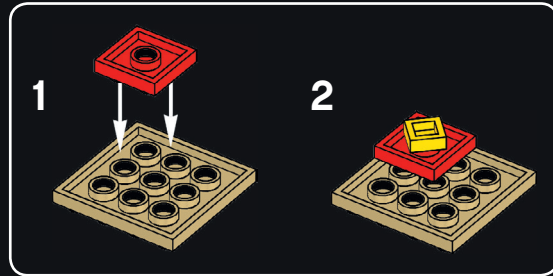

3

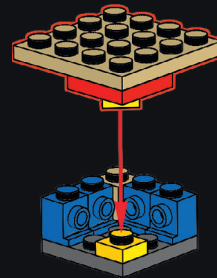

4

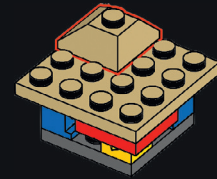

5

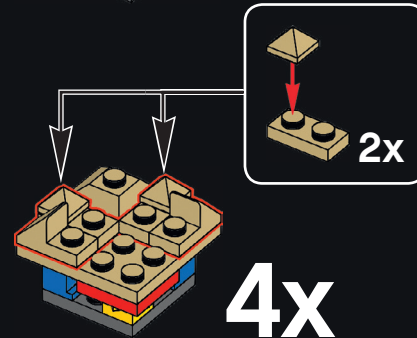

4x

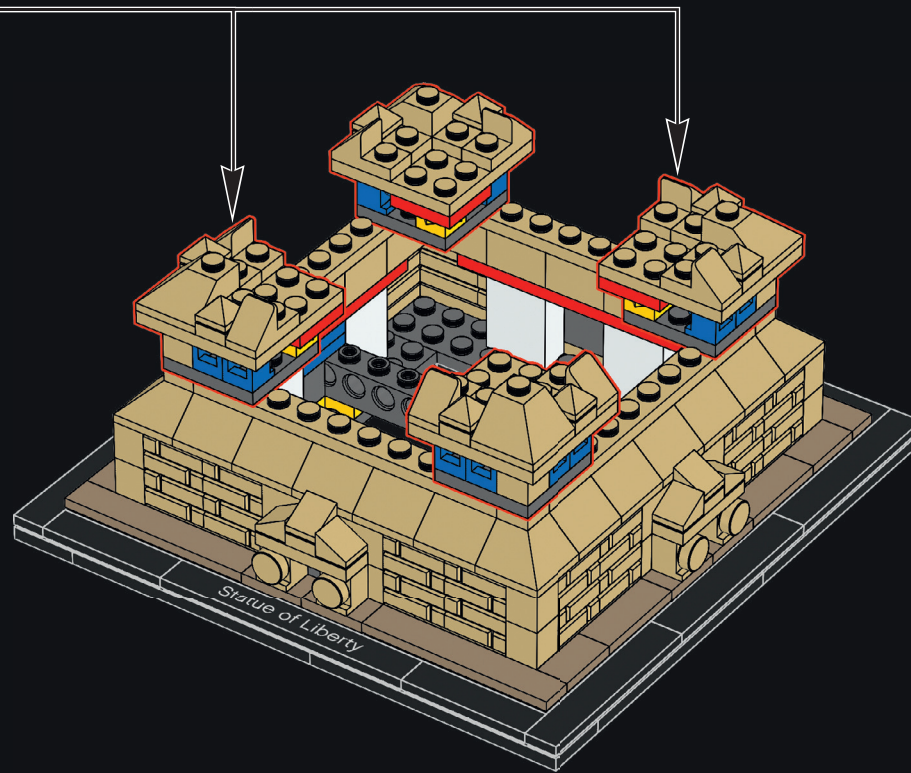

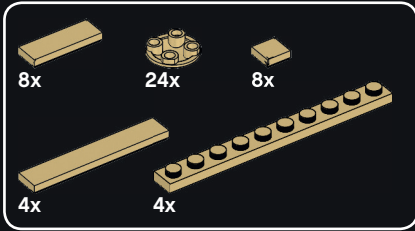
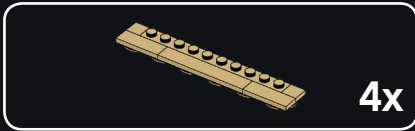

23

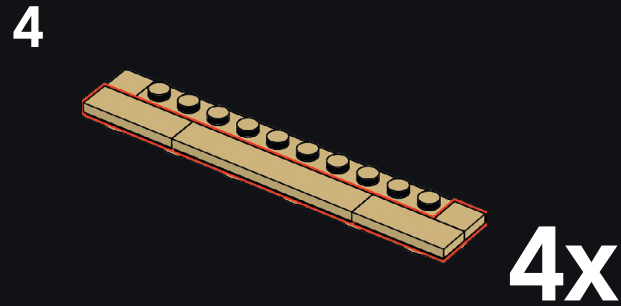
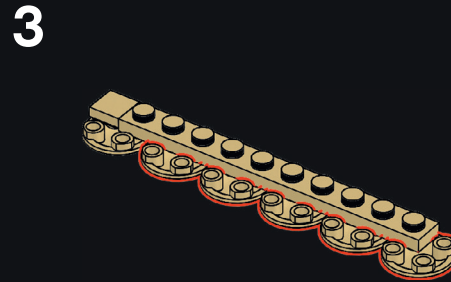
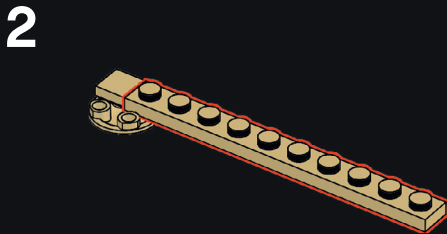
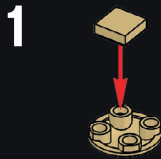



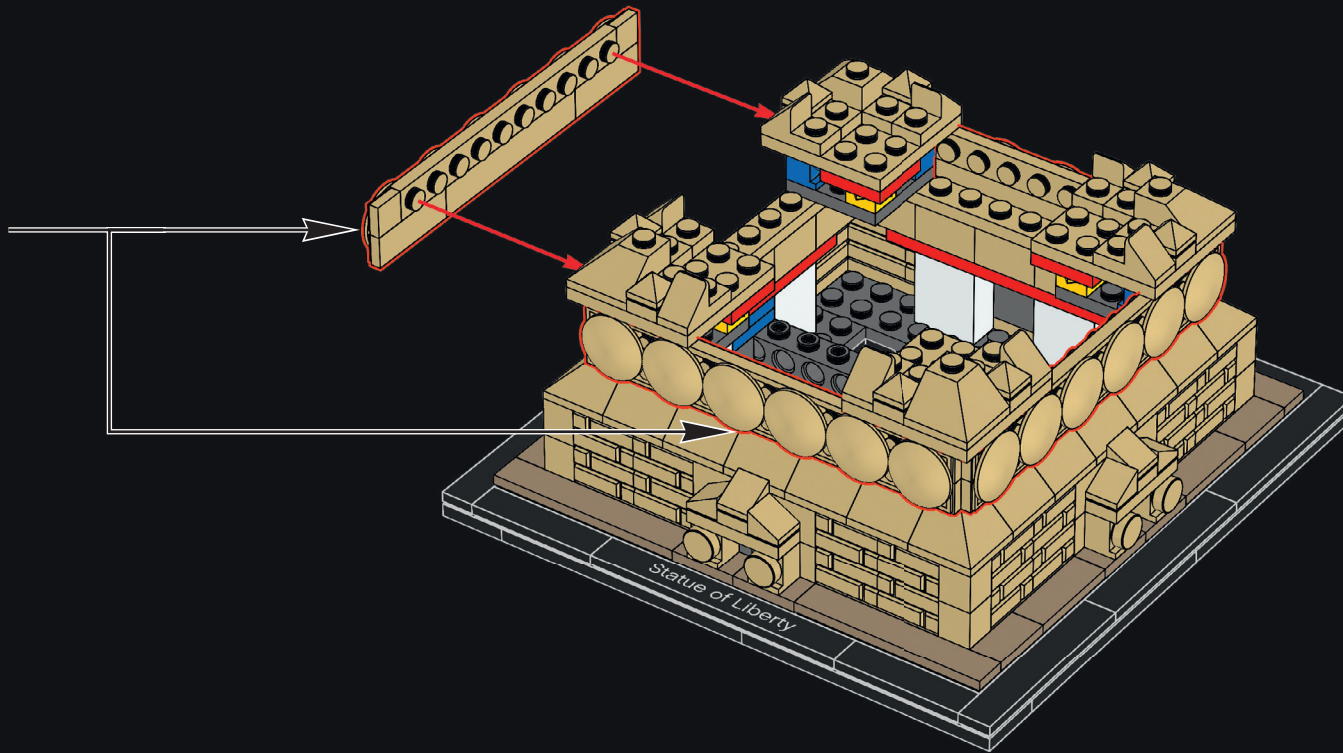

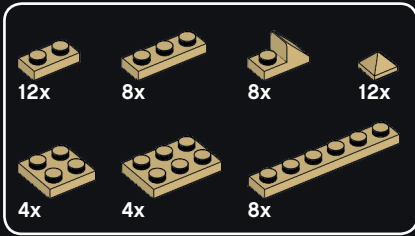
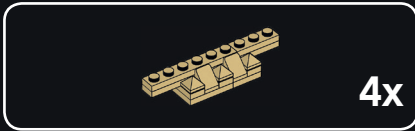

24

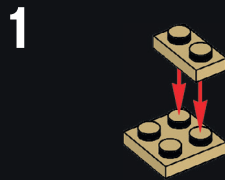

3

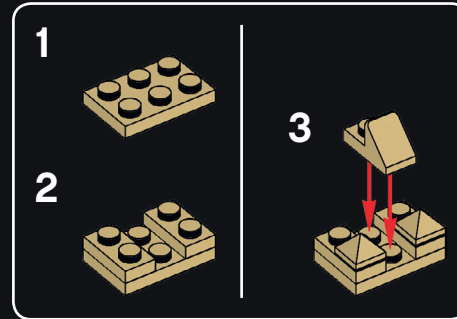
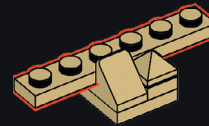

4

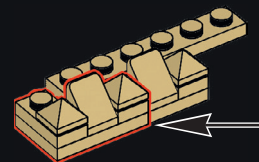

5

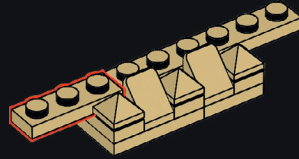

6

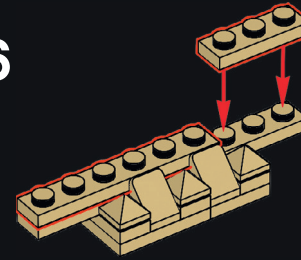

4x

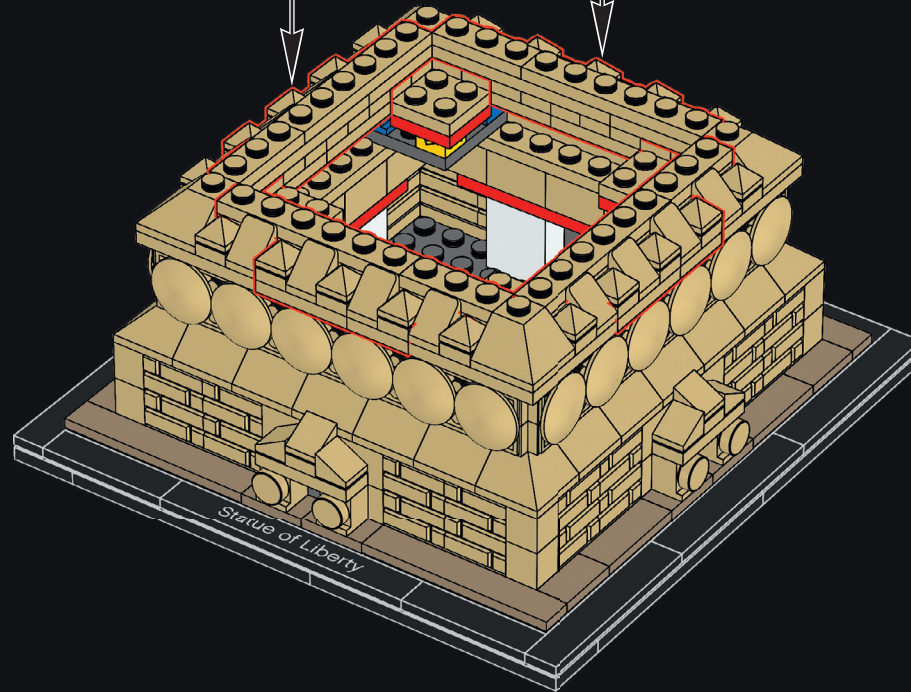

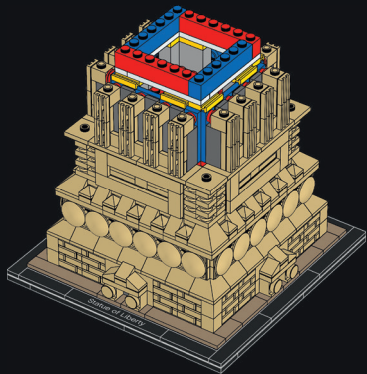
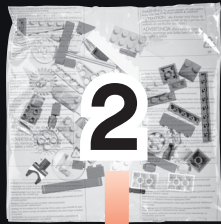

60

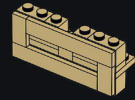

4x

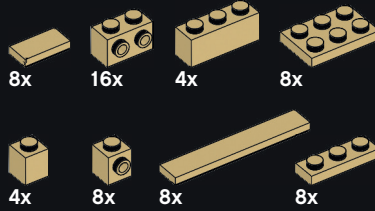

25

1

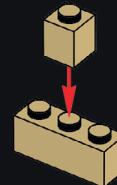

2

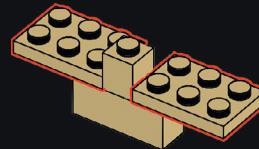

3

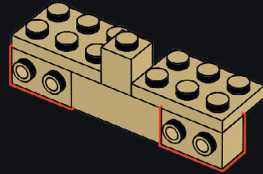

4

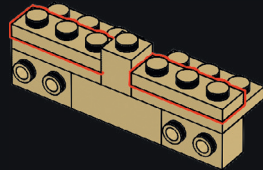

5

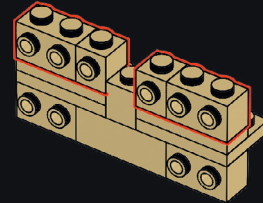

6

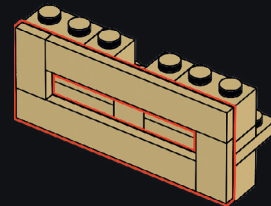

4x  
61

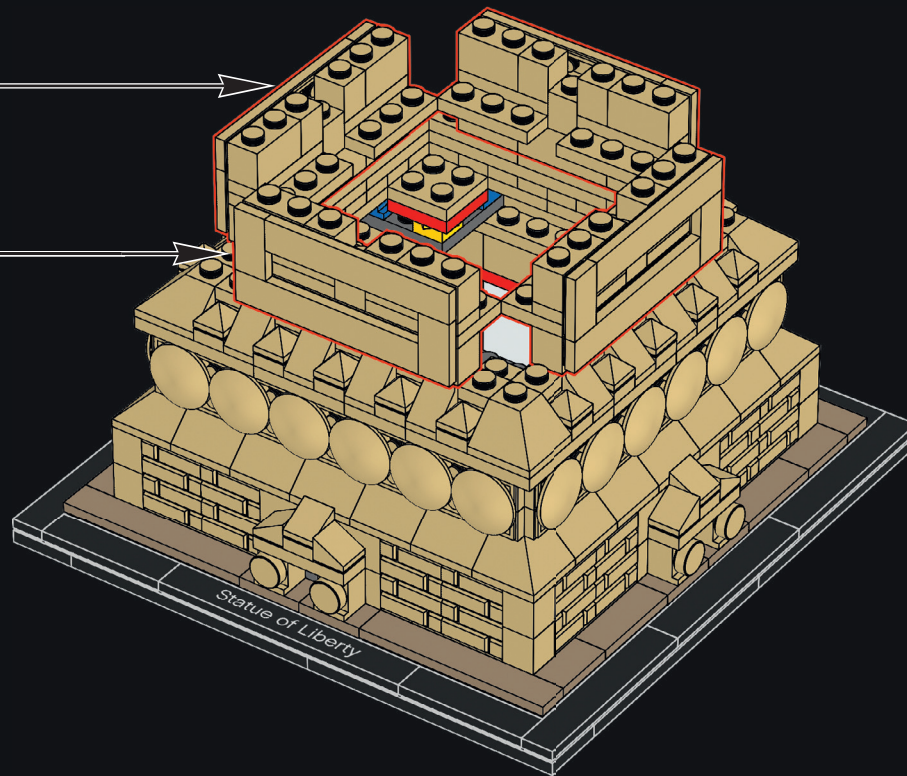



26

1



2



3



4

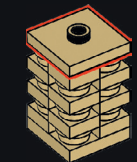

4x

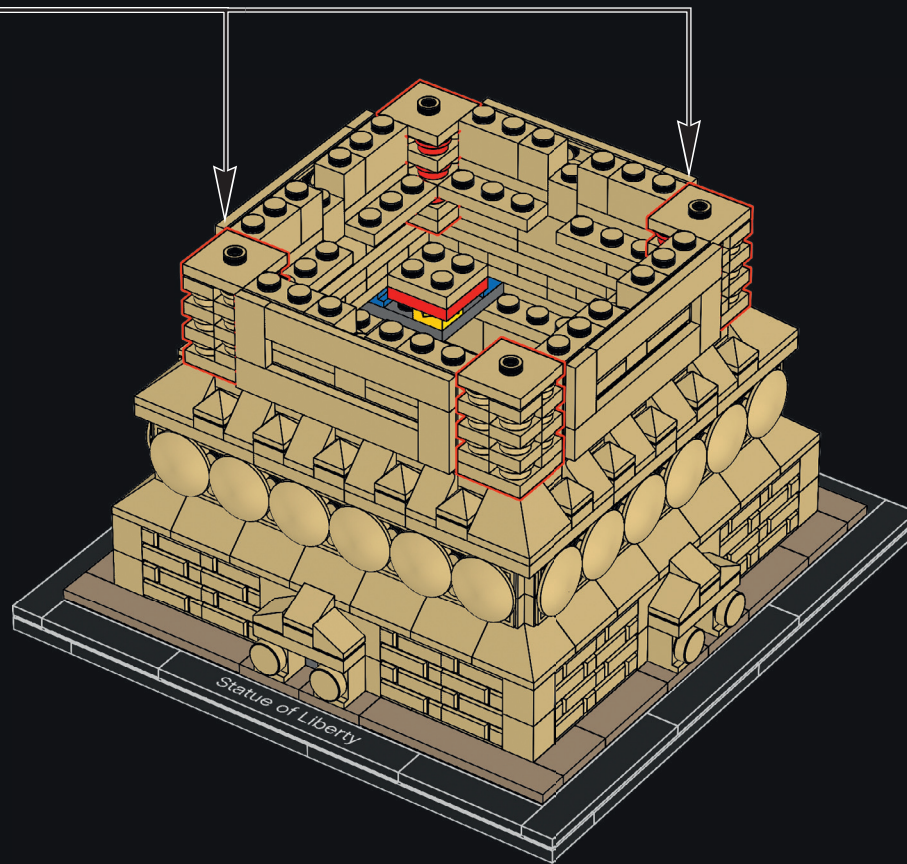





27

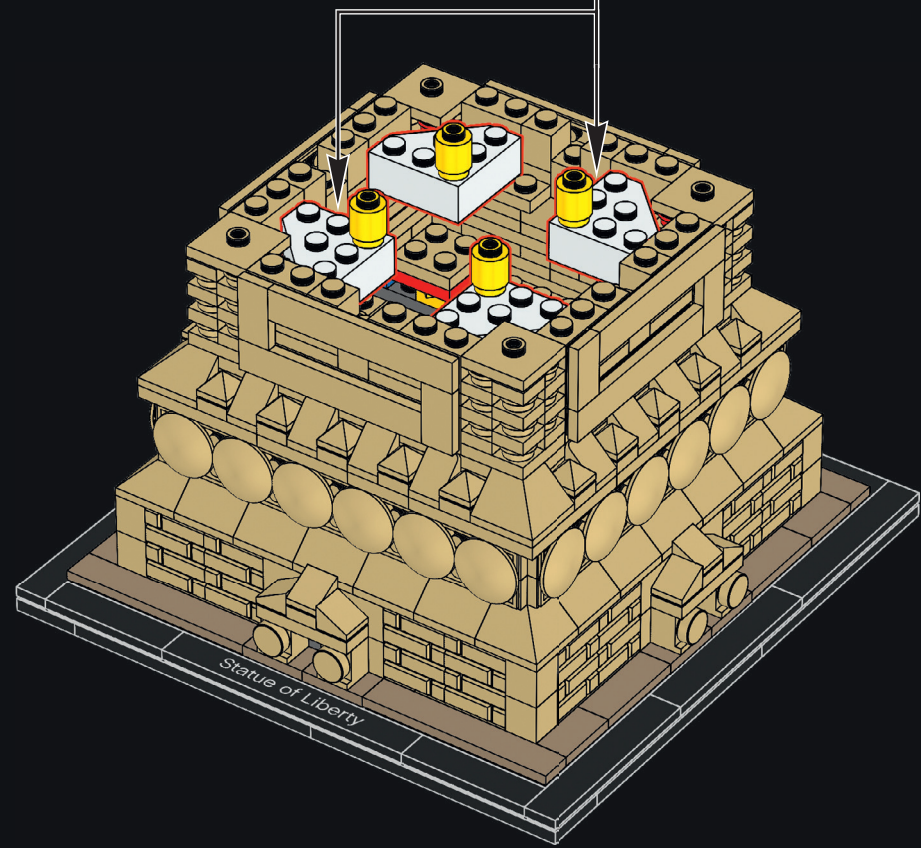
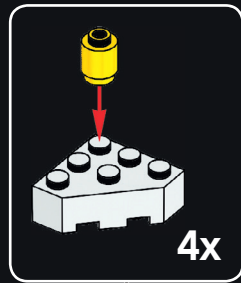

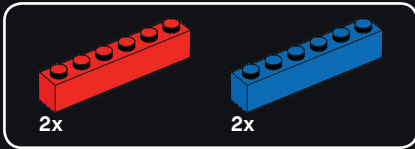

28

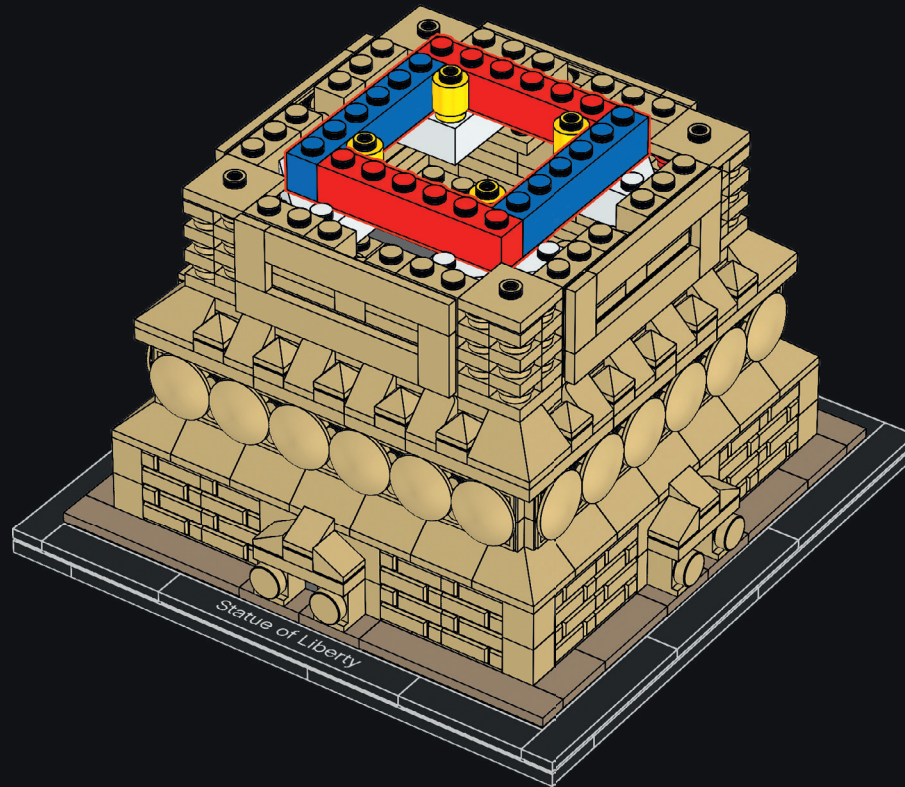

66



29

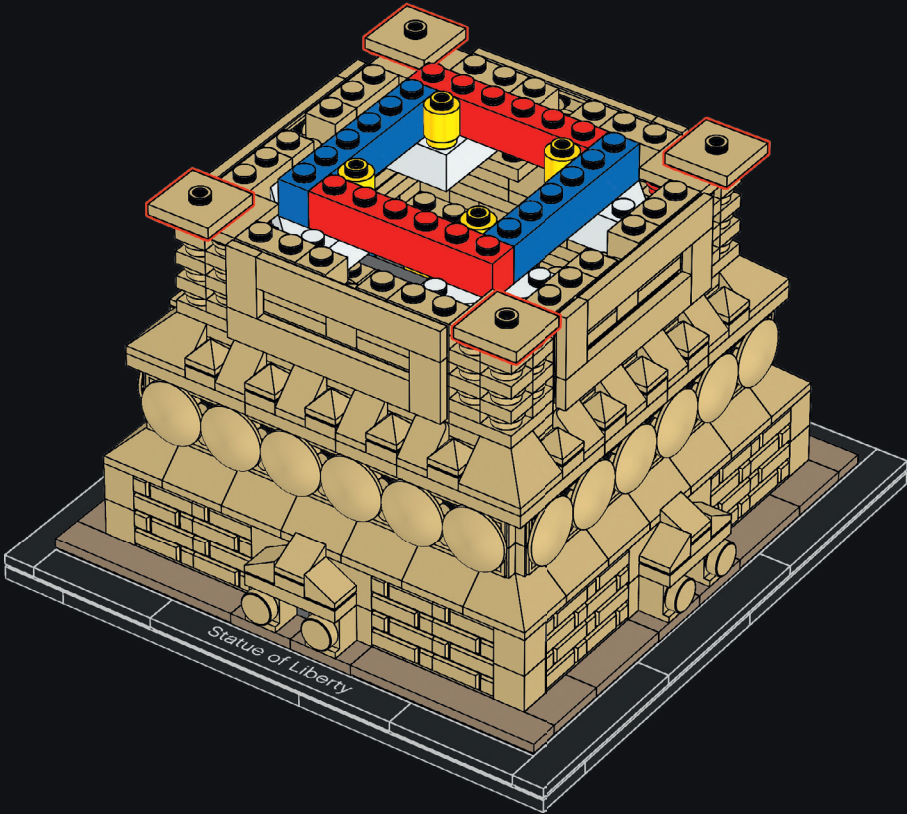



30

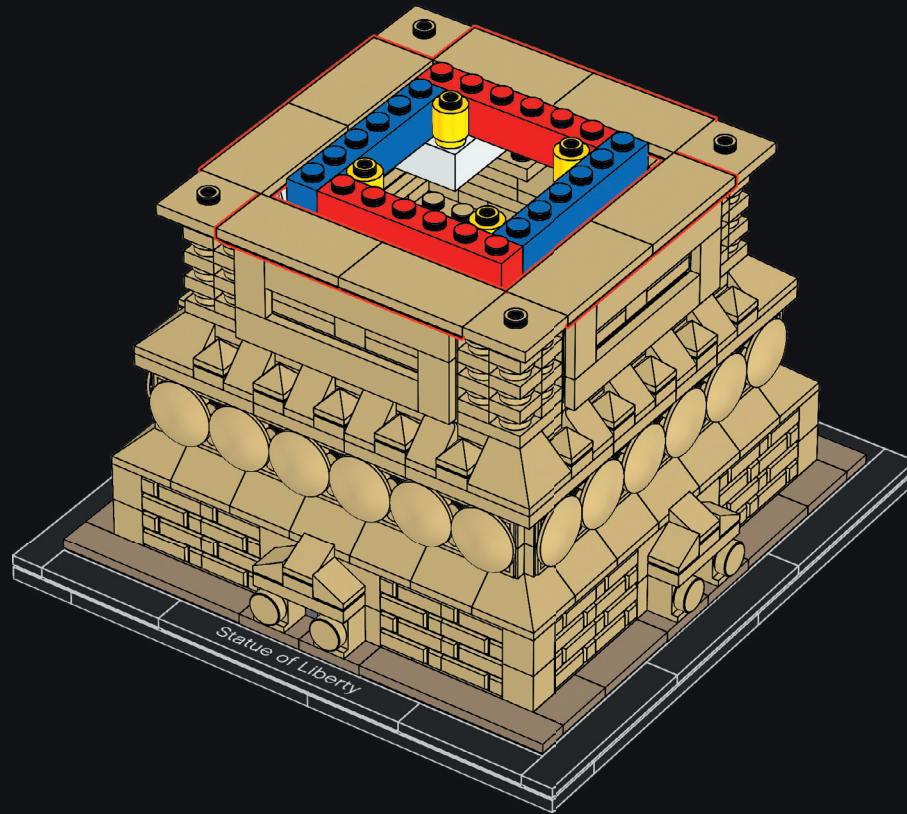

68

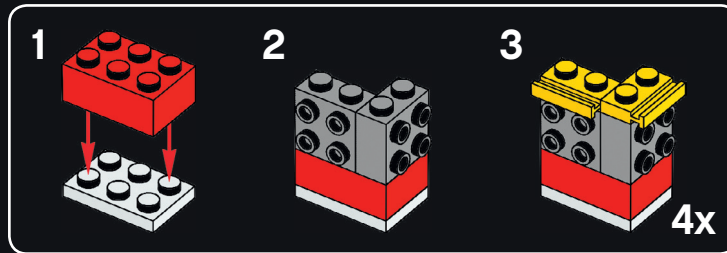
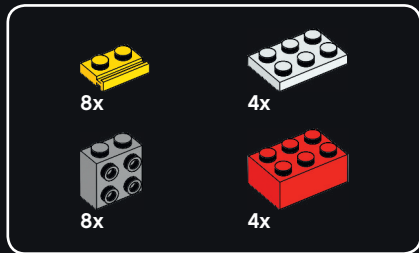

31

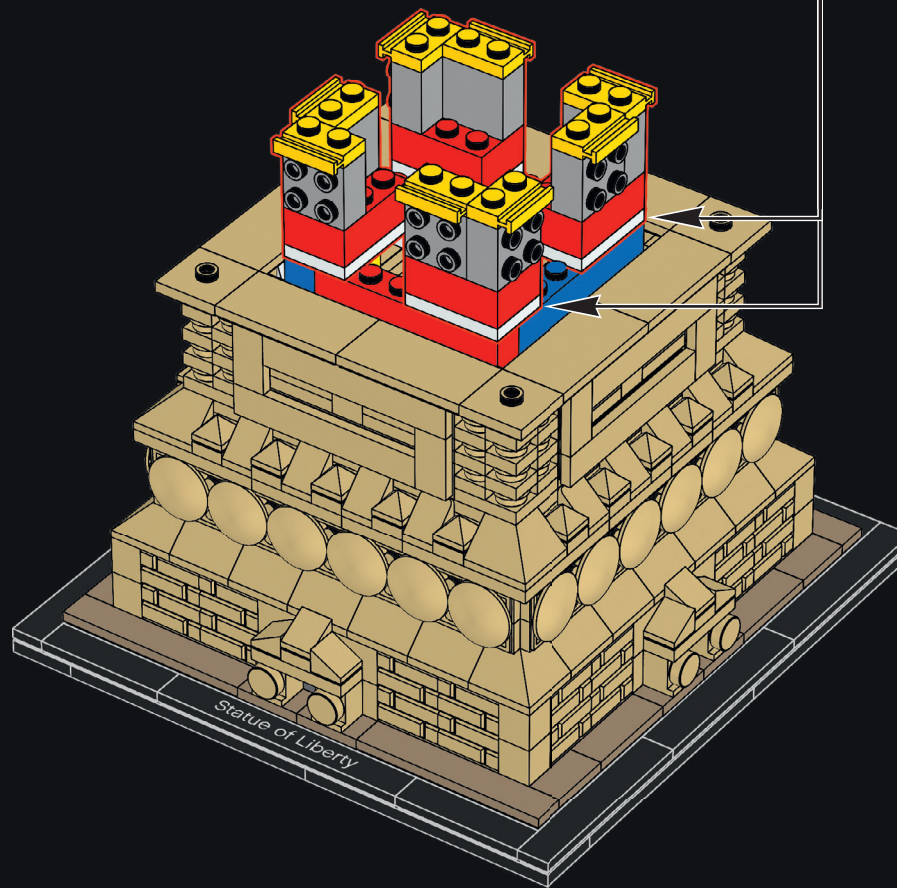

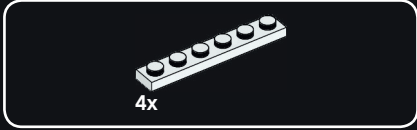

32

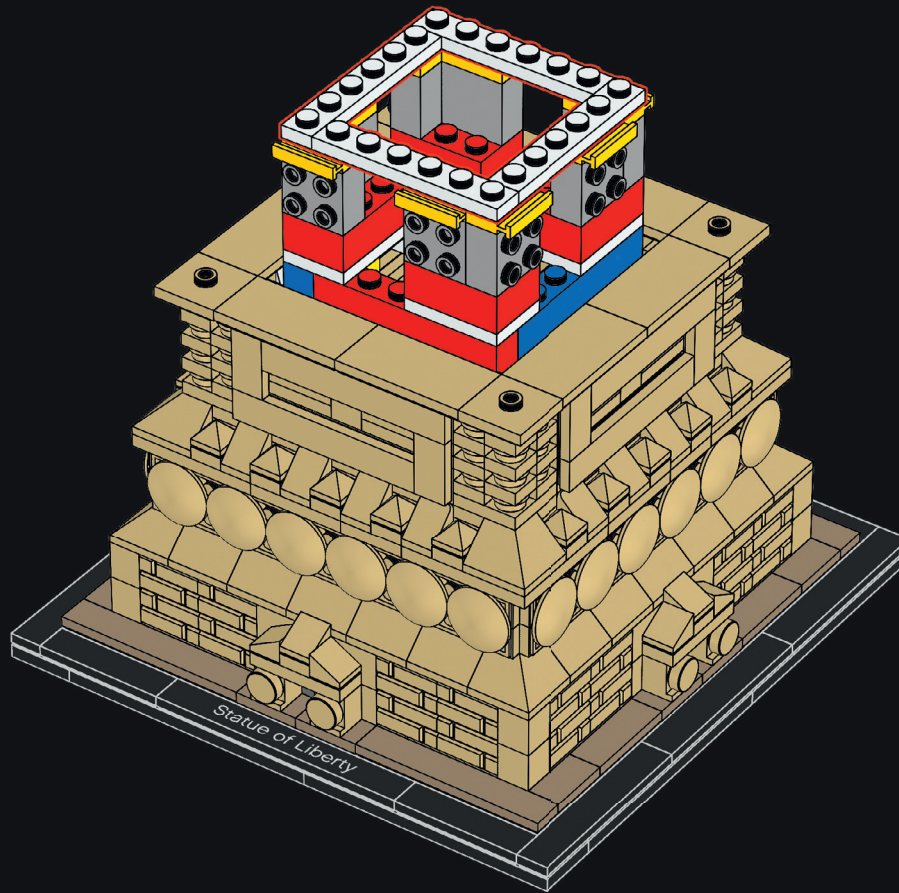

70

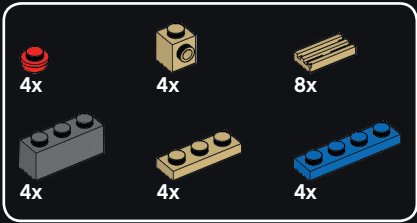

33

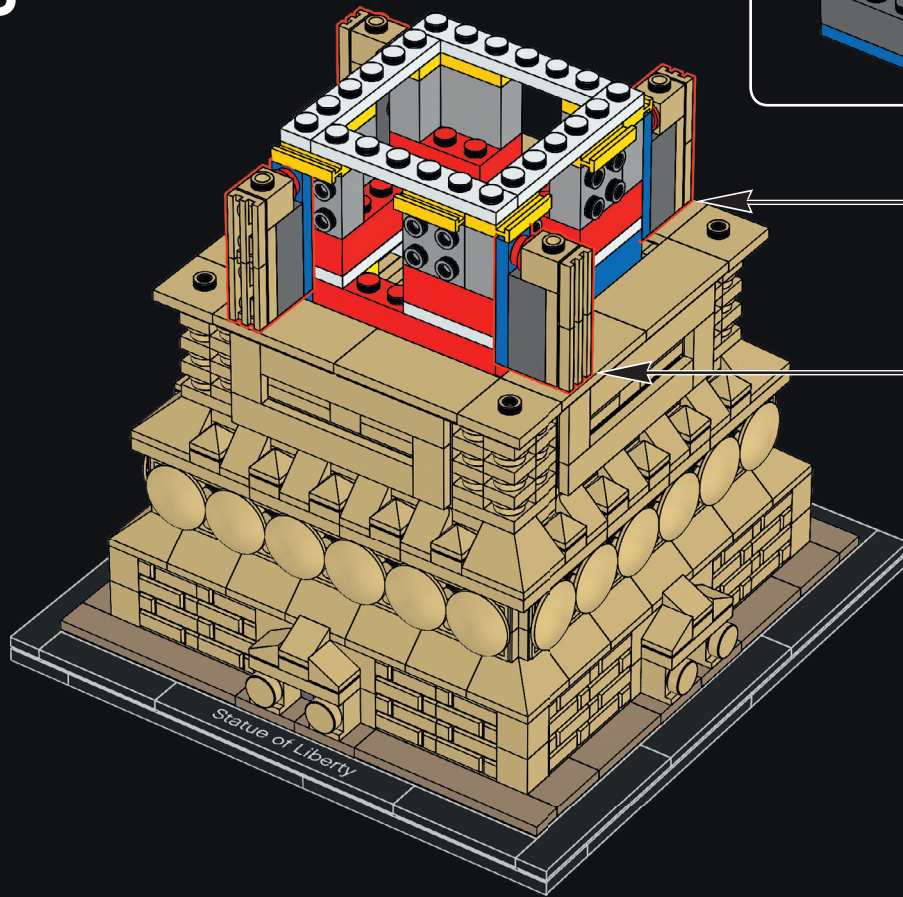
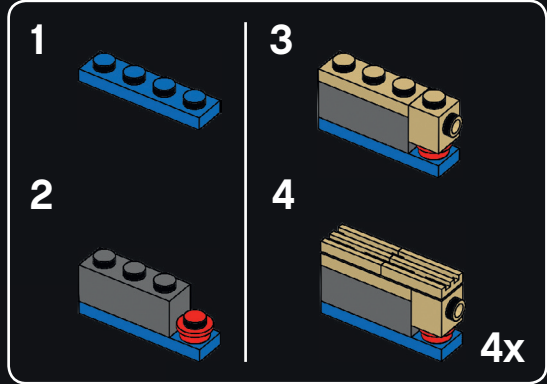

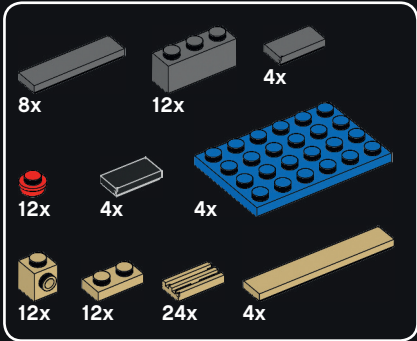
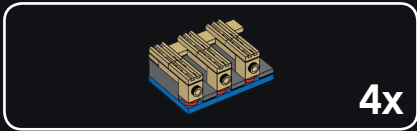

34

1

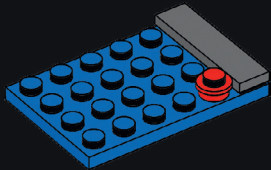

2

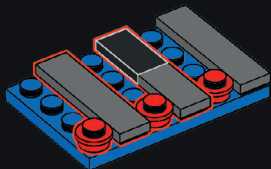

72

3

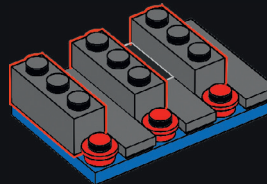

4

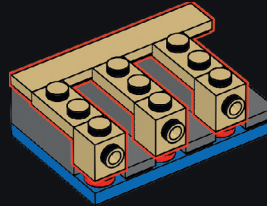

5

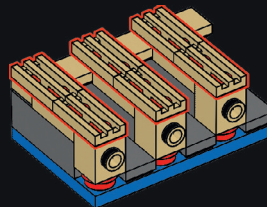

4x



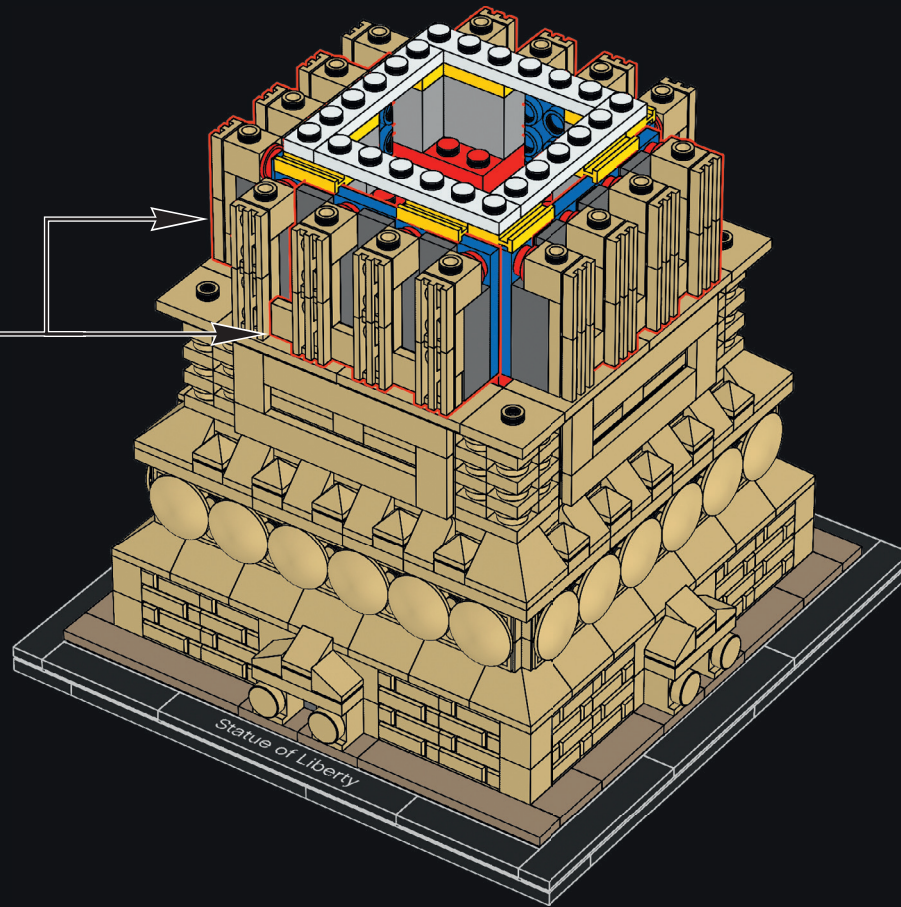

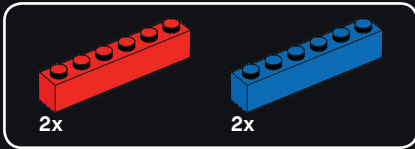

35

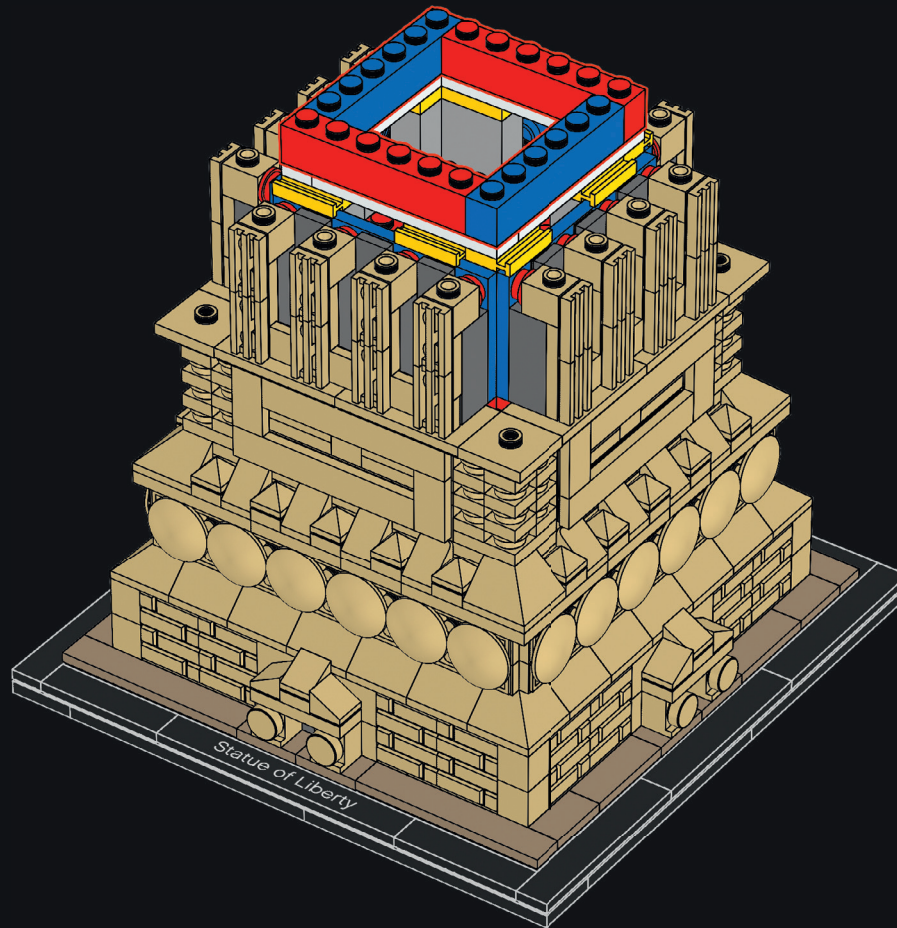

74

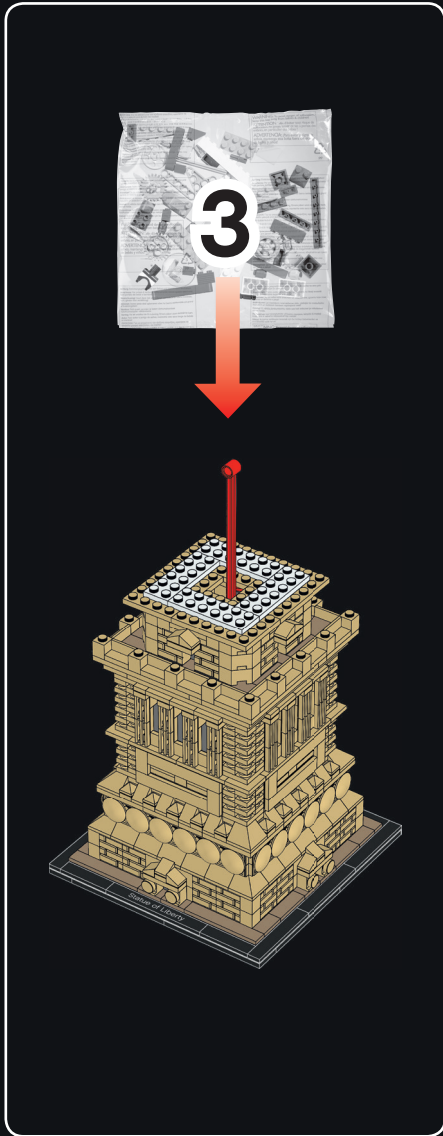

36

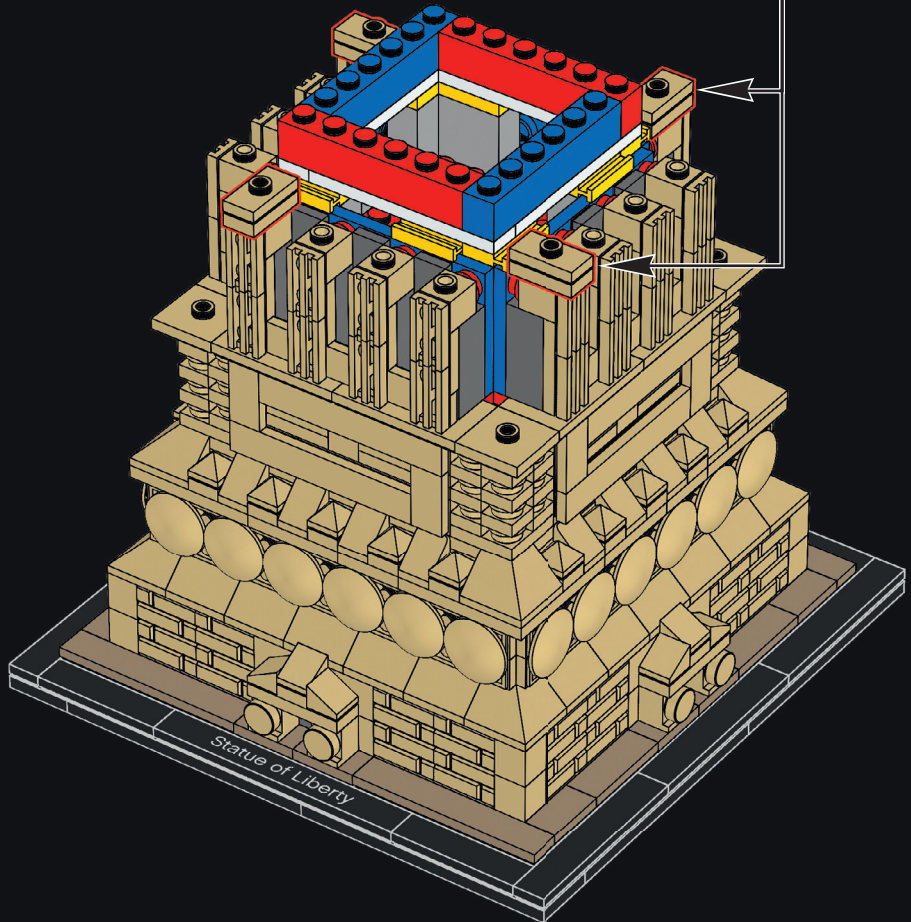
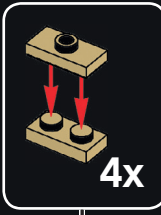

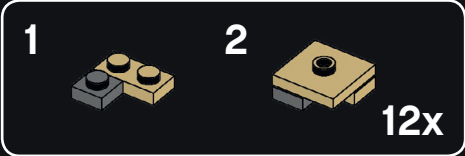
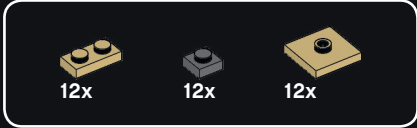

37

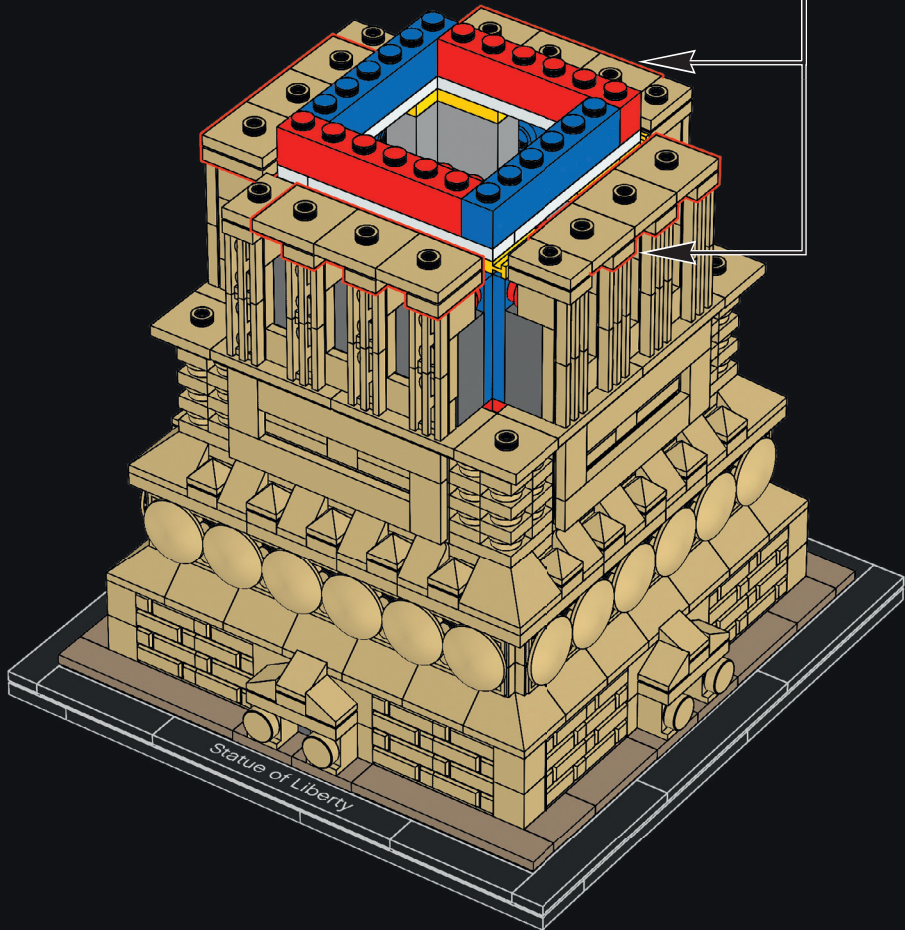

76



38

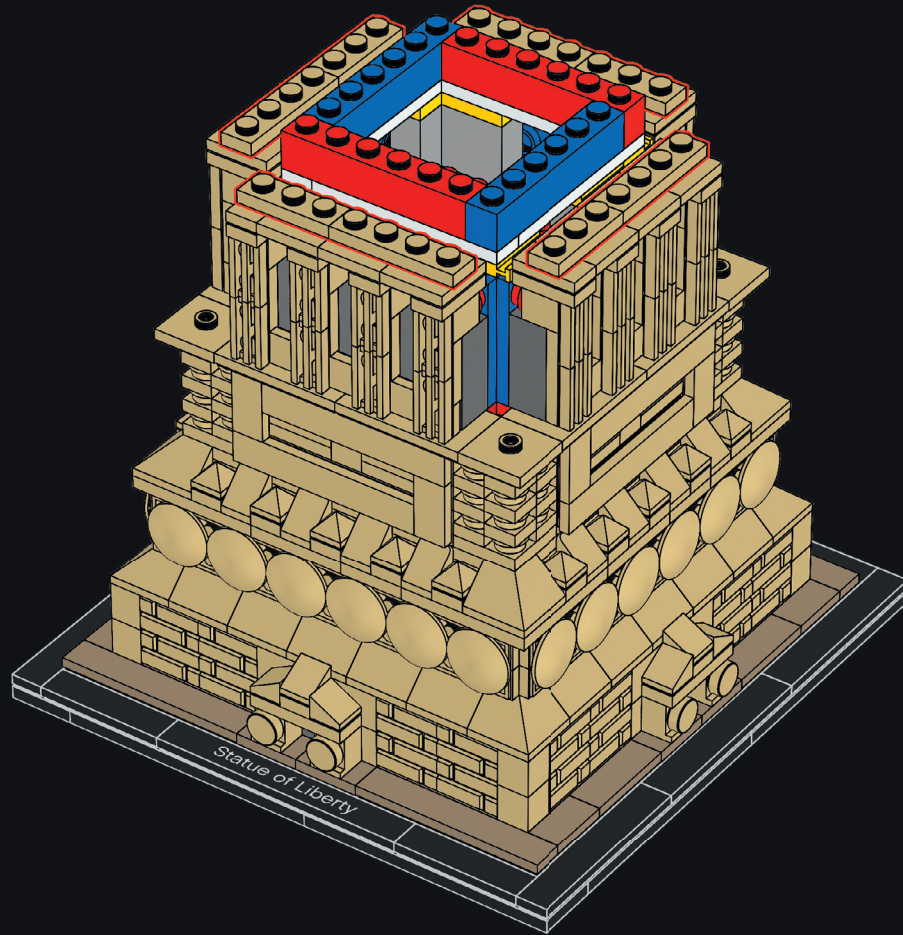

77

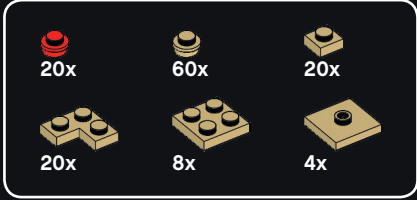

39

1



2



78

3



4

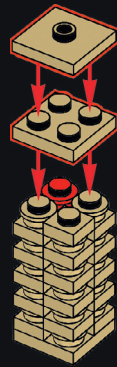

4x

In high winds of 50 mph (80 kph) or more, the Statue can sway  
by up to 3 in. (7.6 cm).  
Par vents forts de 80 km/h ou plus, la statue peut osciller  
jusqu'à 7,6 cm.  
Con vientos fuertes de 80 km/h o más, la estatua puede oscilar  
hasta 7,6 cm.

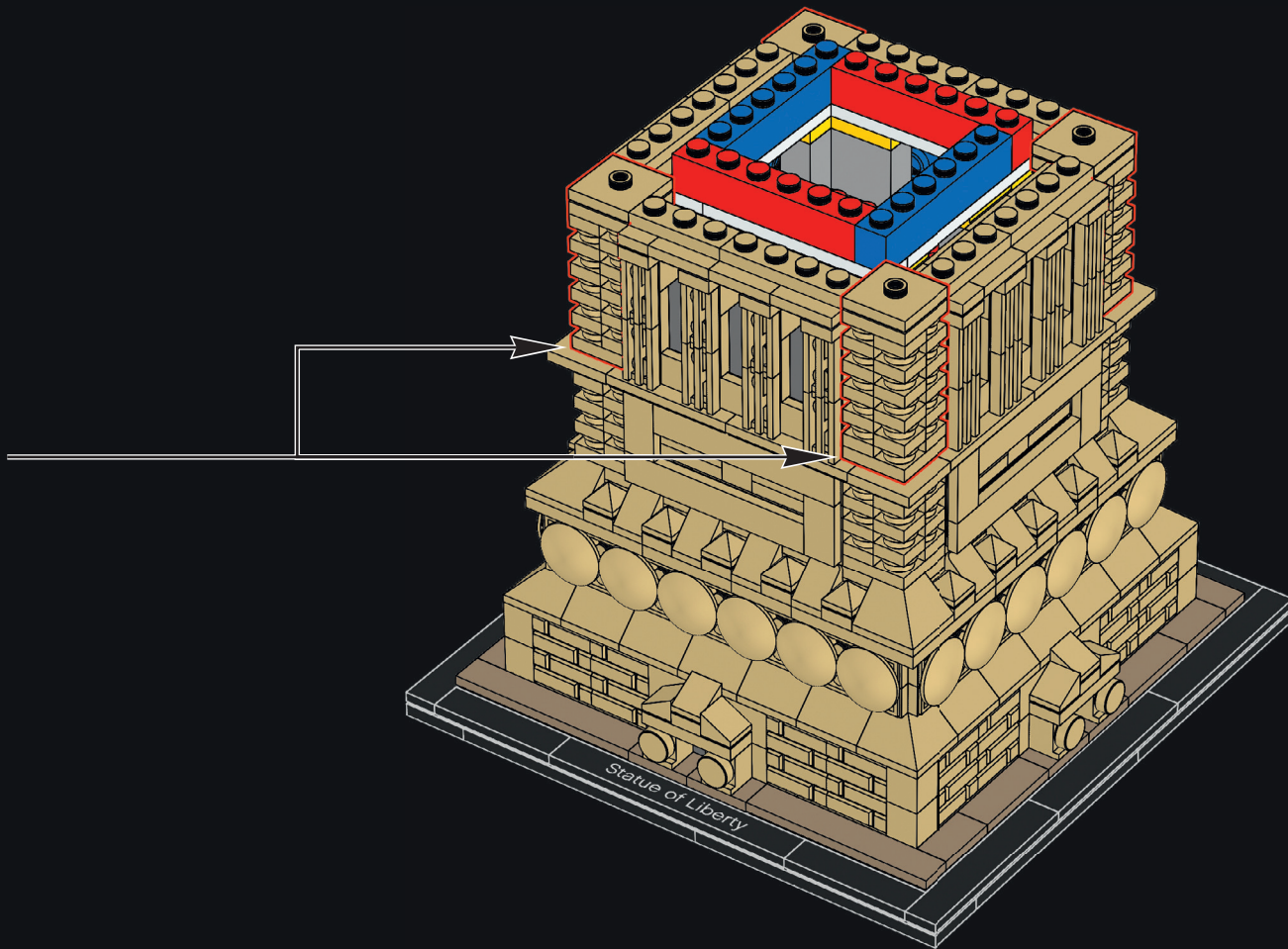

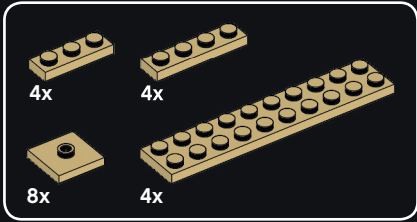
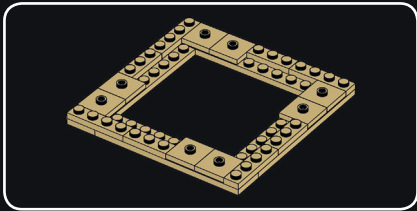

40

1

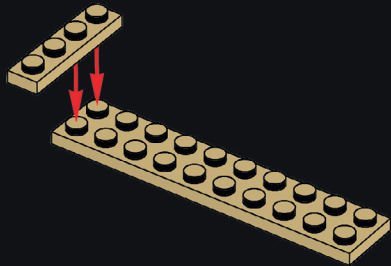

80

2

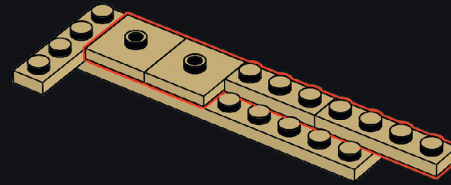

3

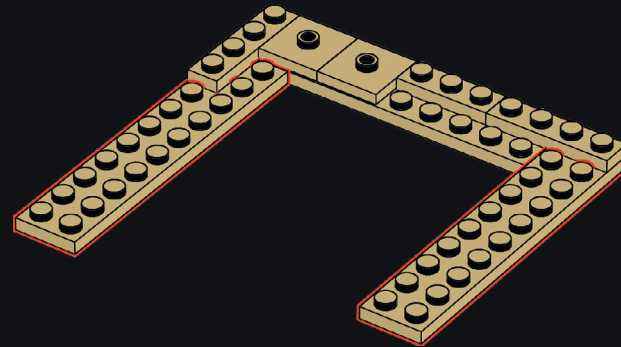



4

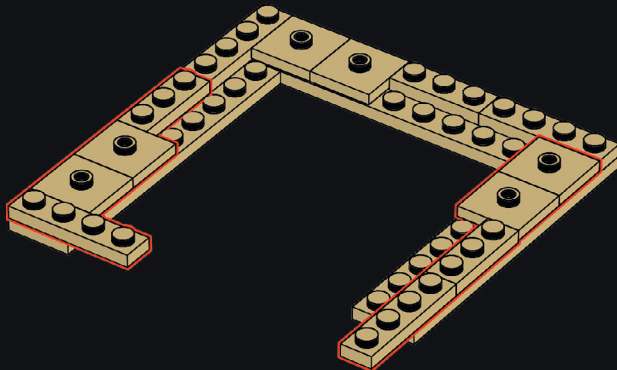

5

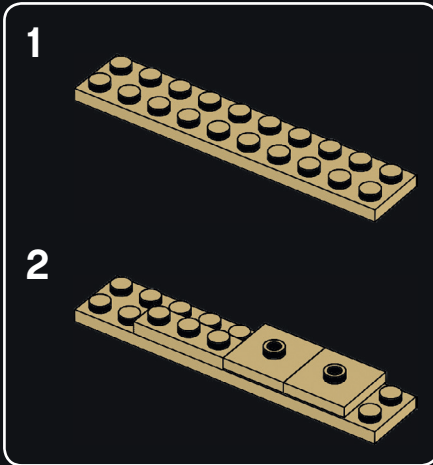
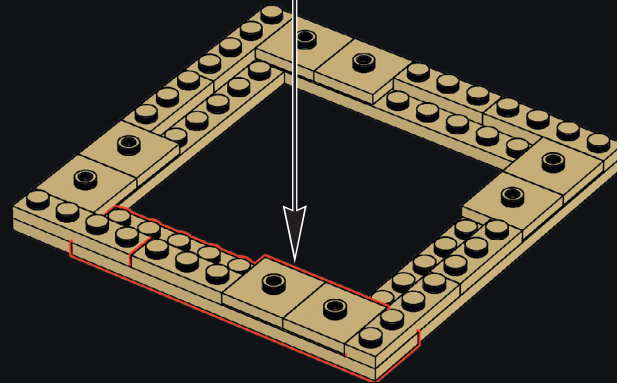

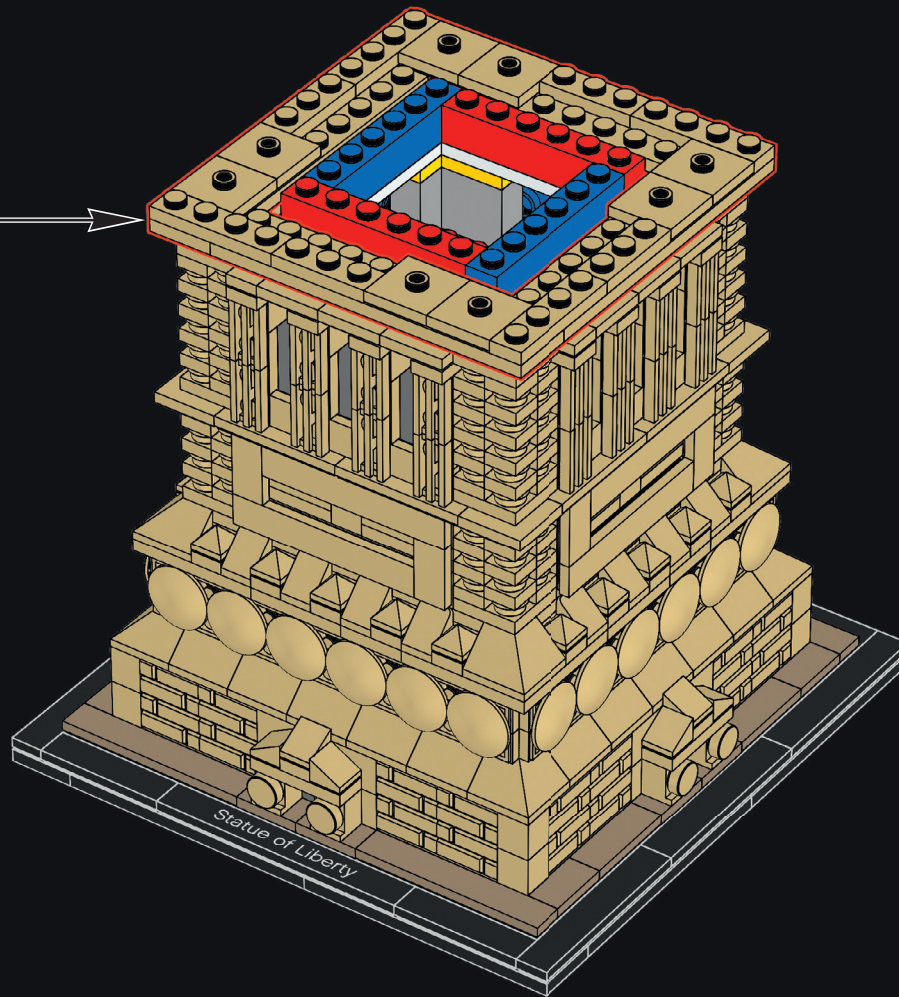

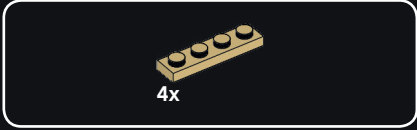

41

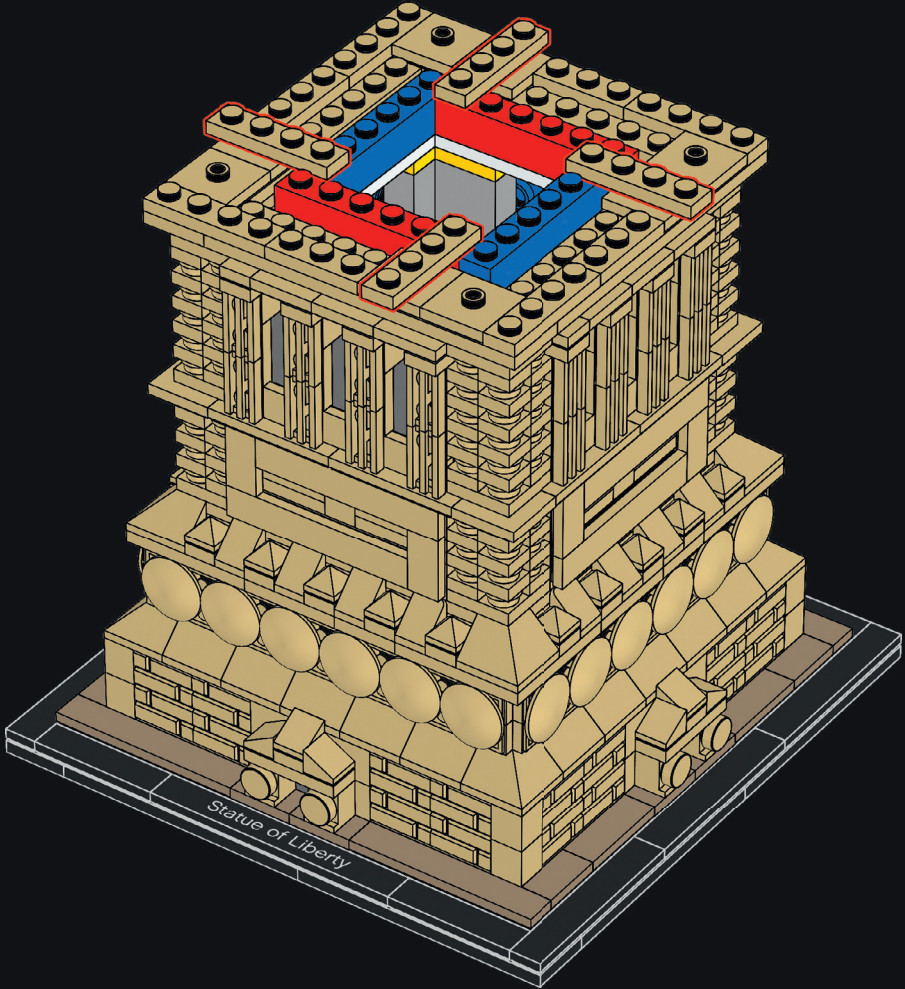

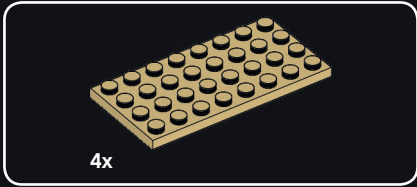

42

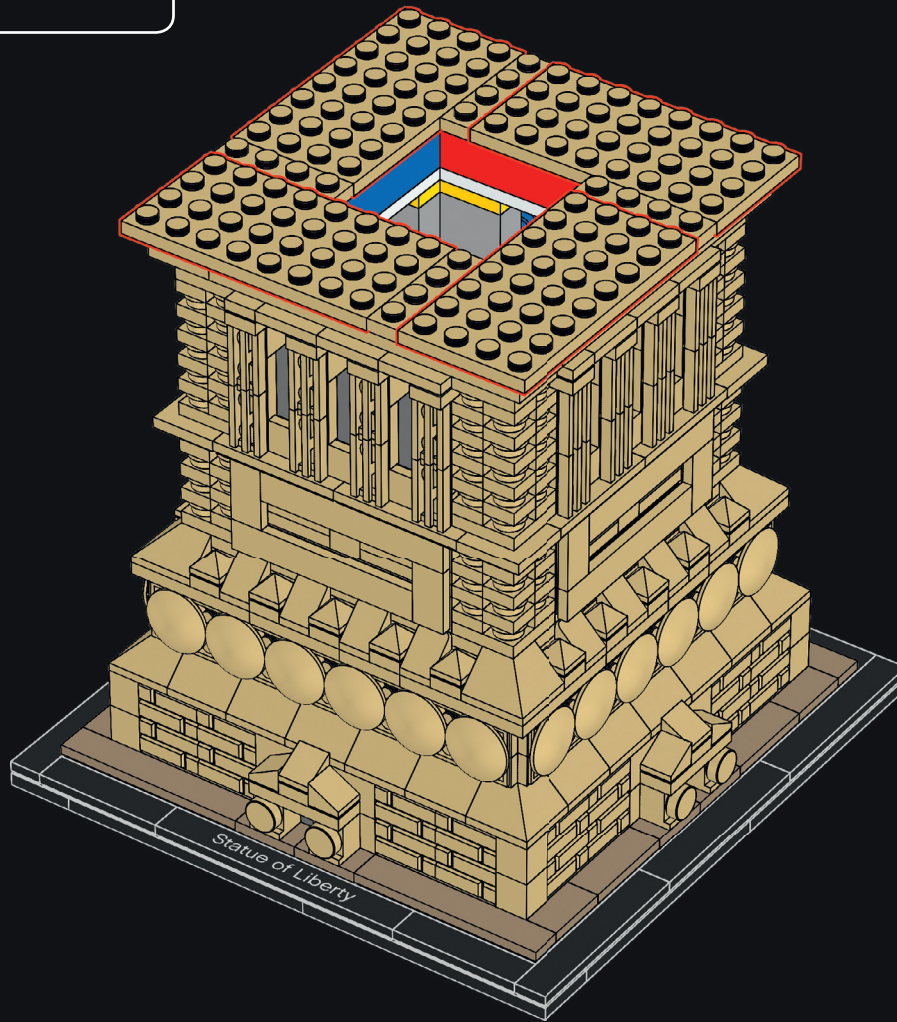

84



43





16x



16x

44

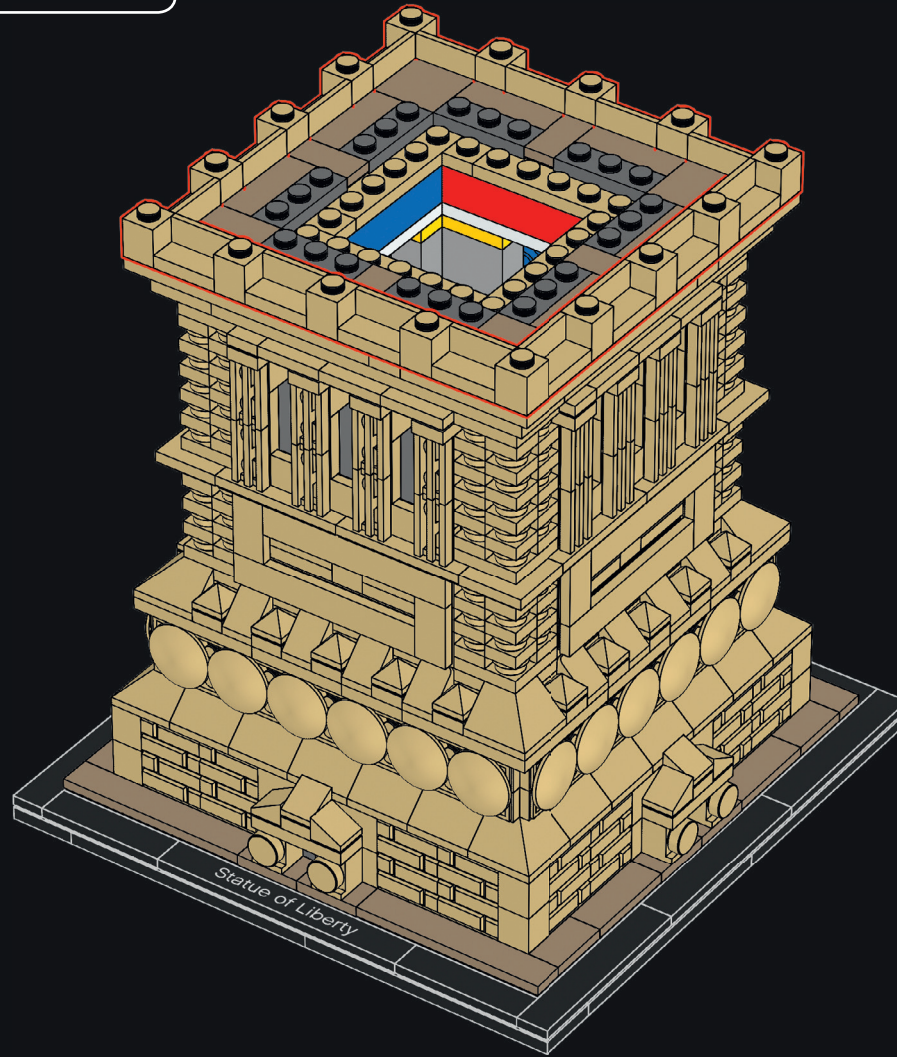

86

45

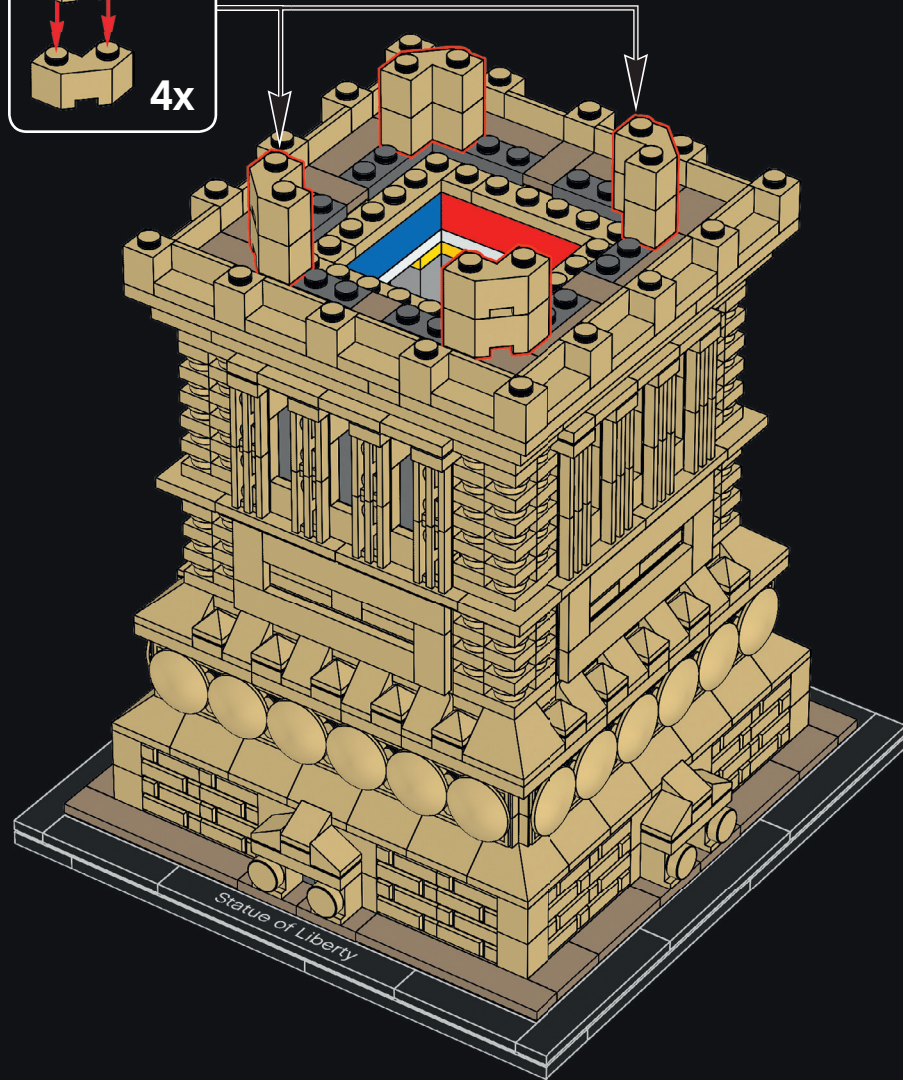
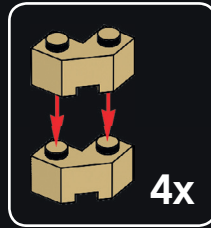



46

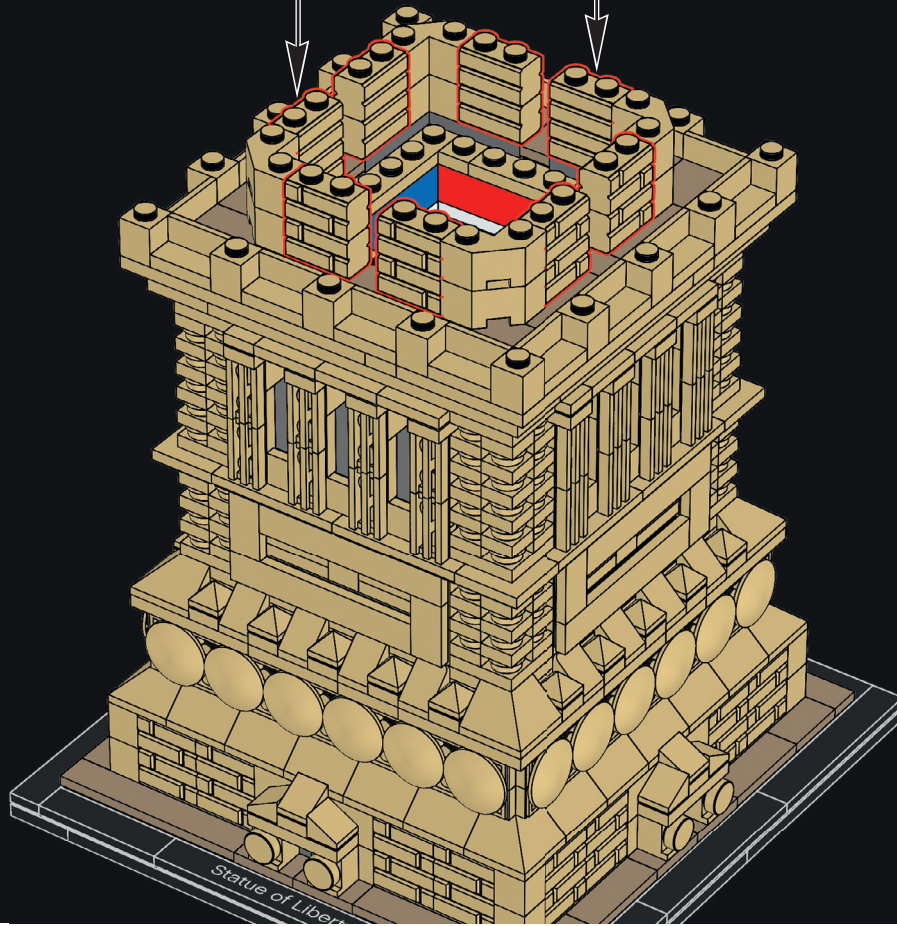
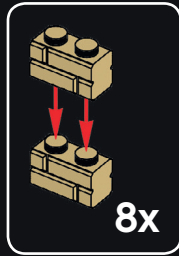

88

Statue of Liberty





47

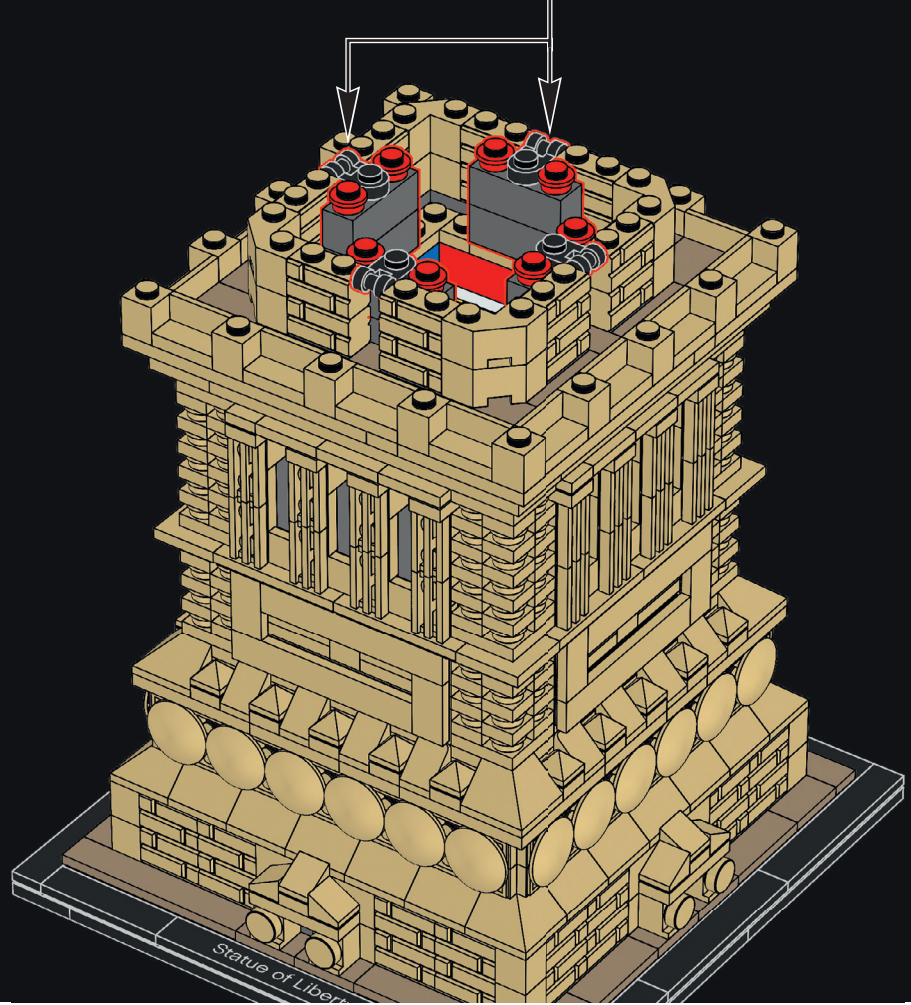
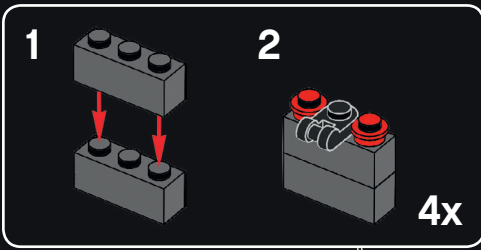

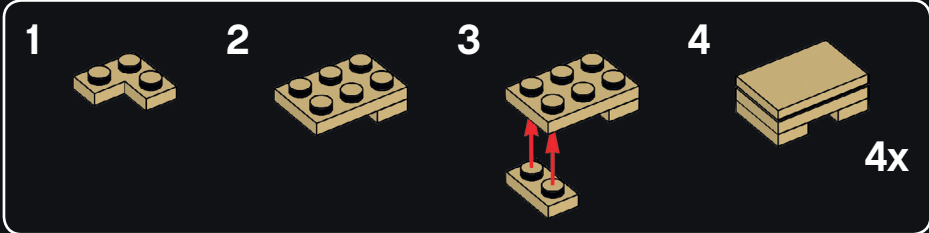
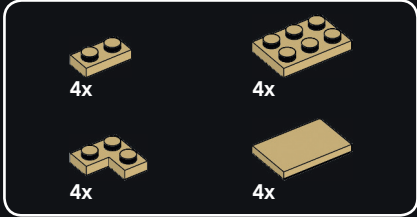

48

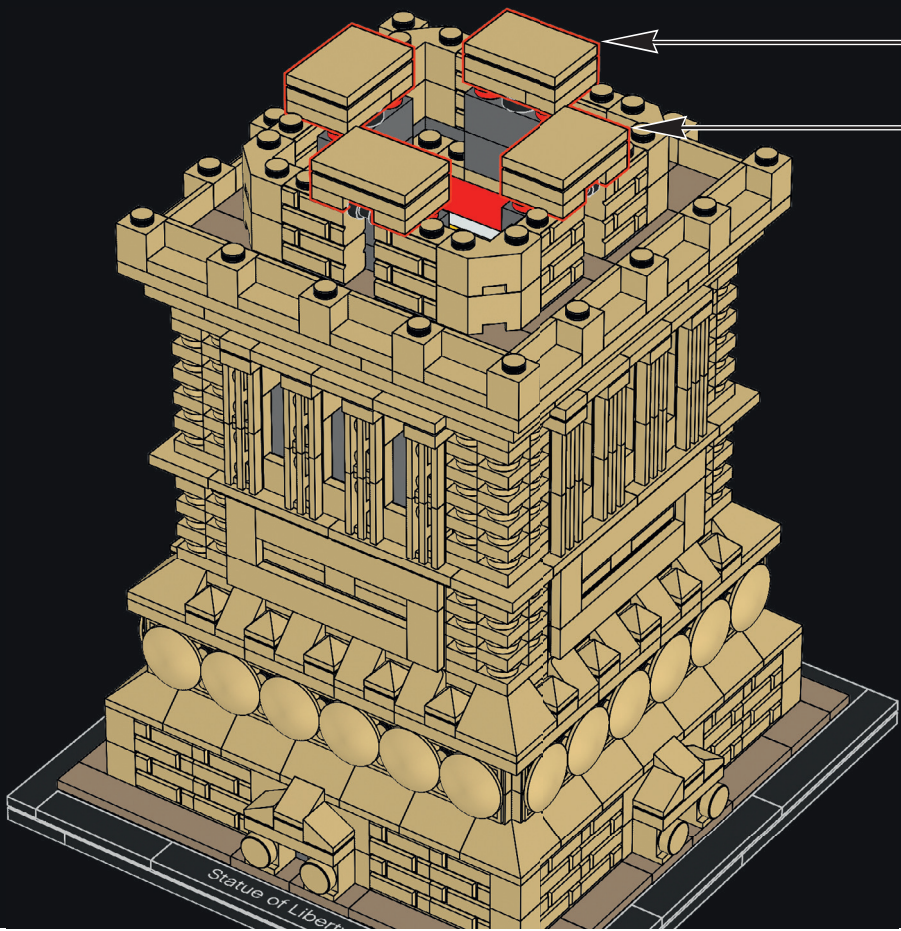

90

49

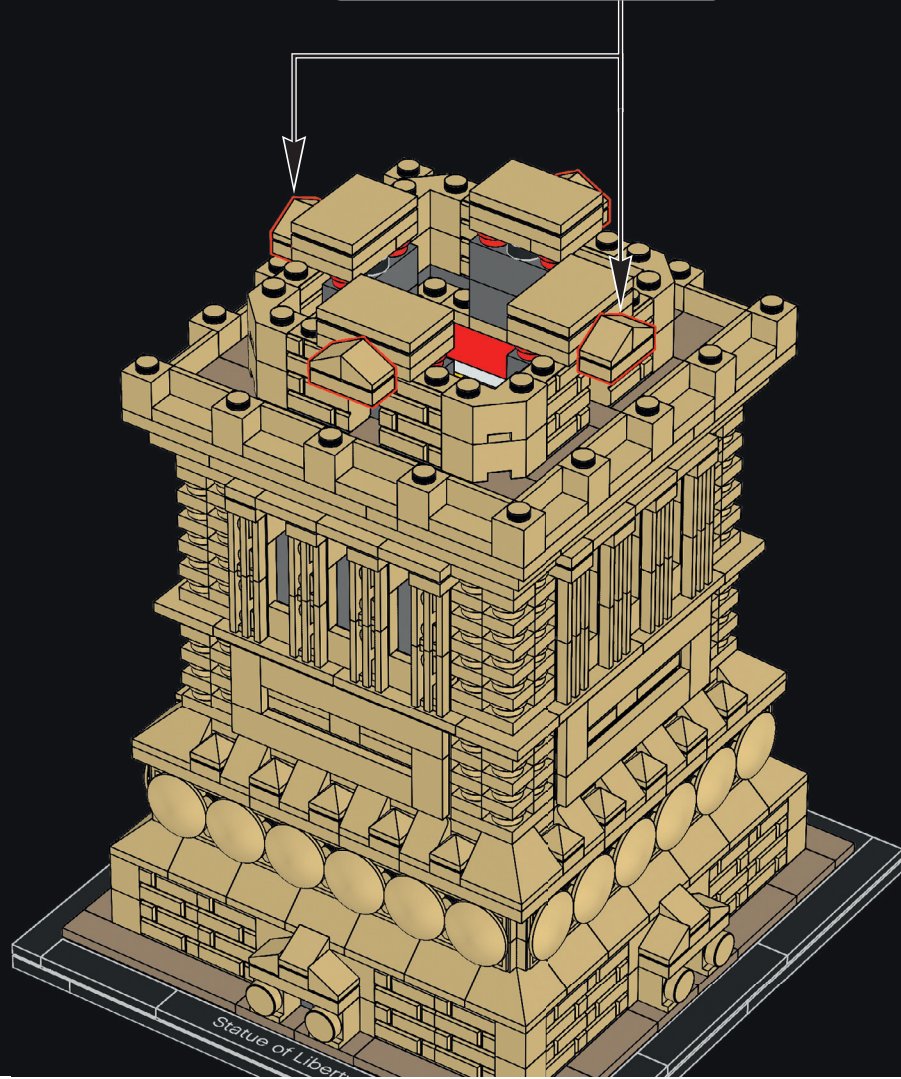



8x



4x

# 50

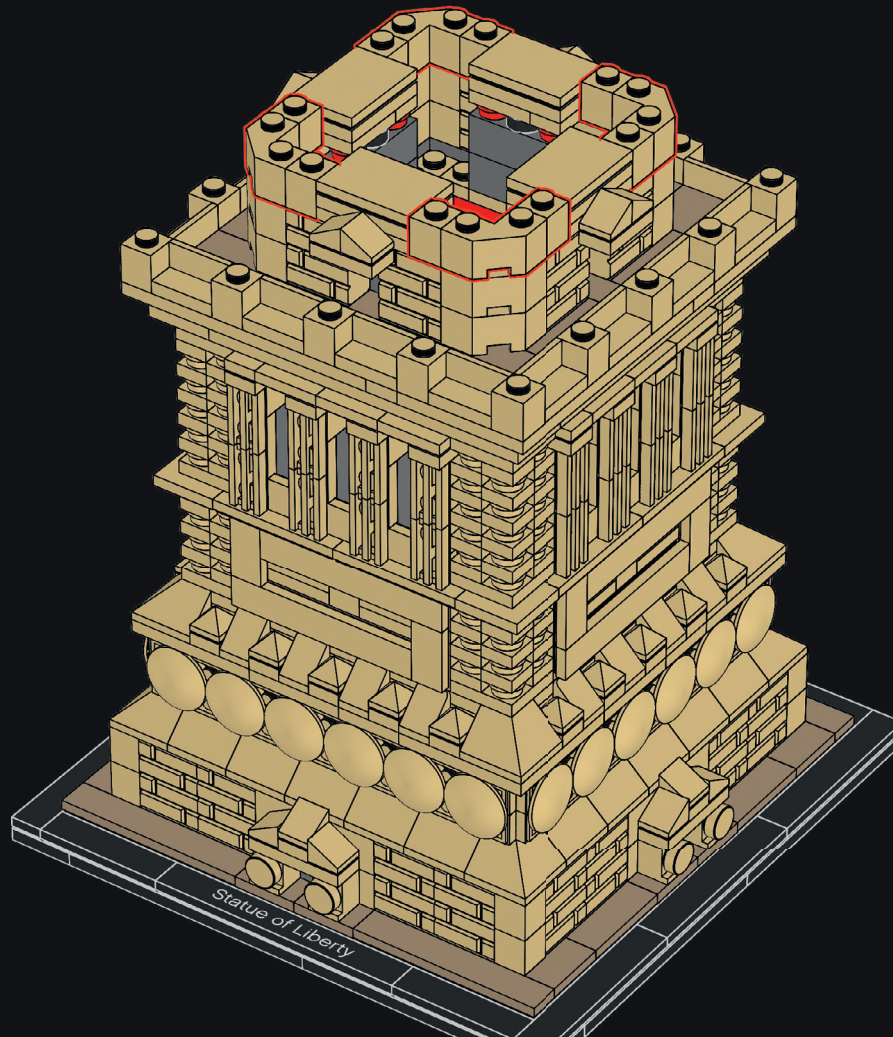

92

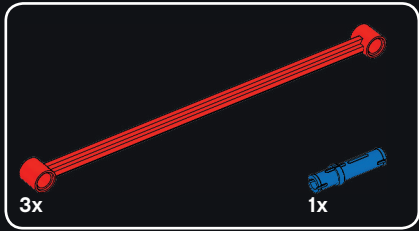

51

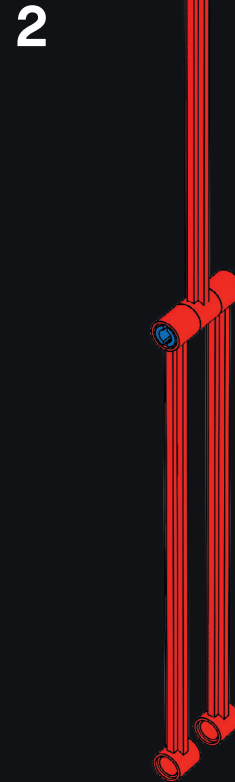
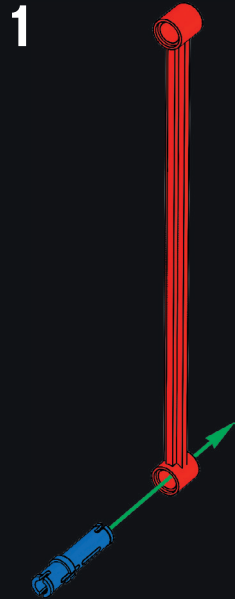

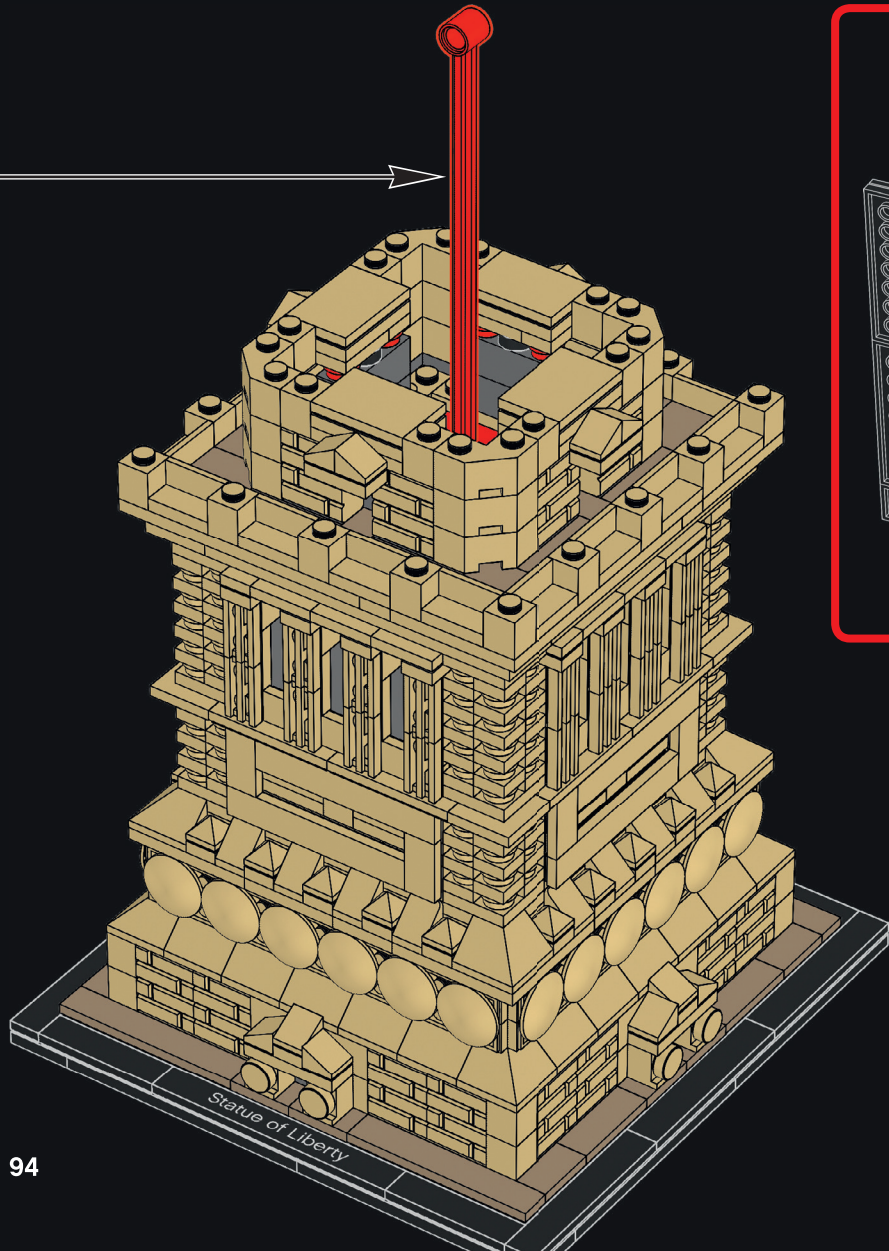

94

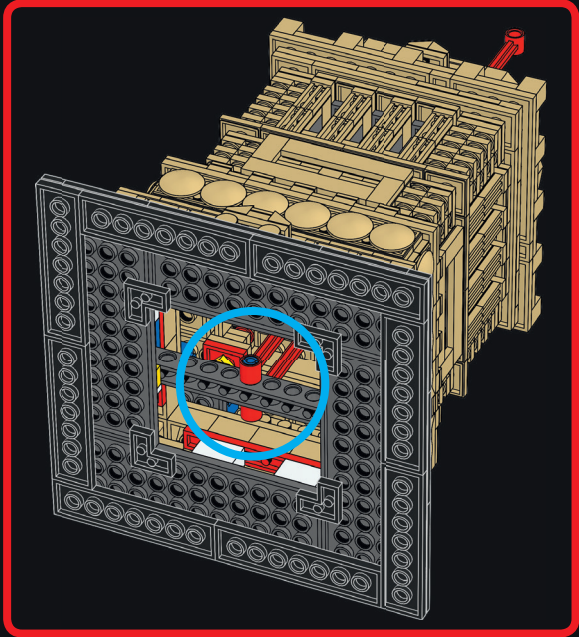

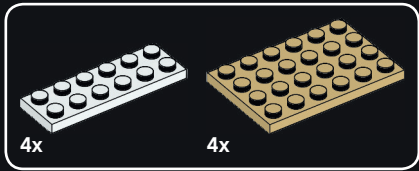
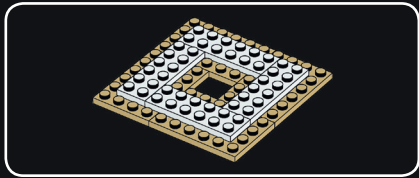

52

1

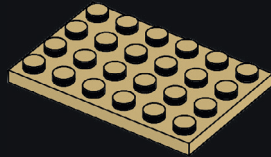

2

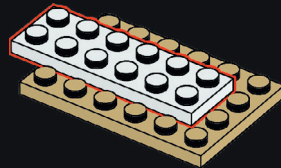

3

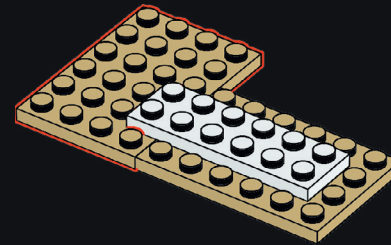

4

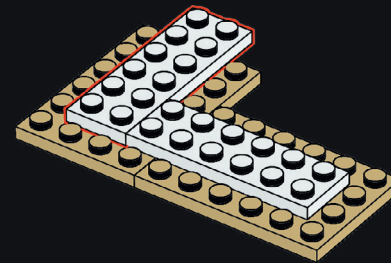

5

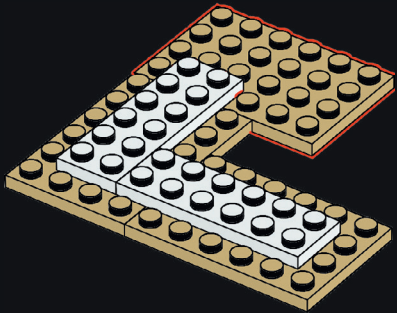

6

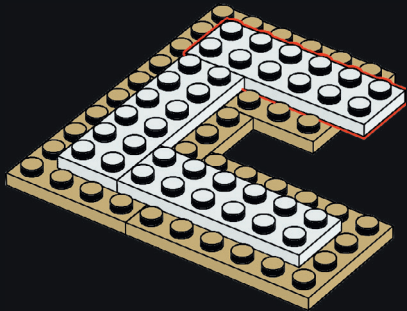

96

7

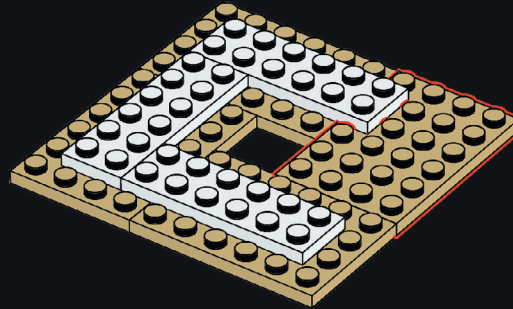

8

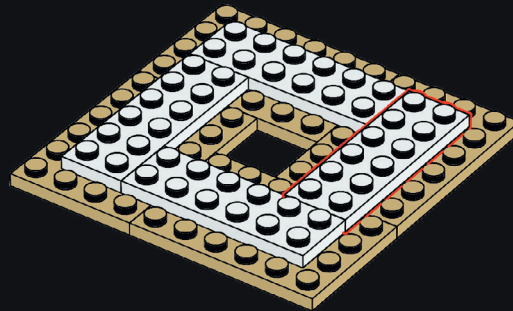



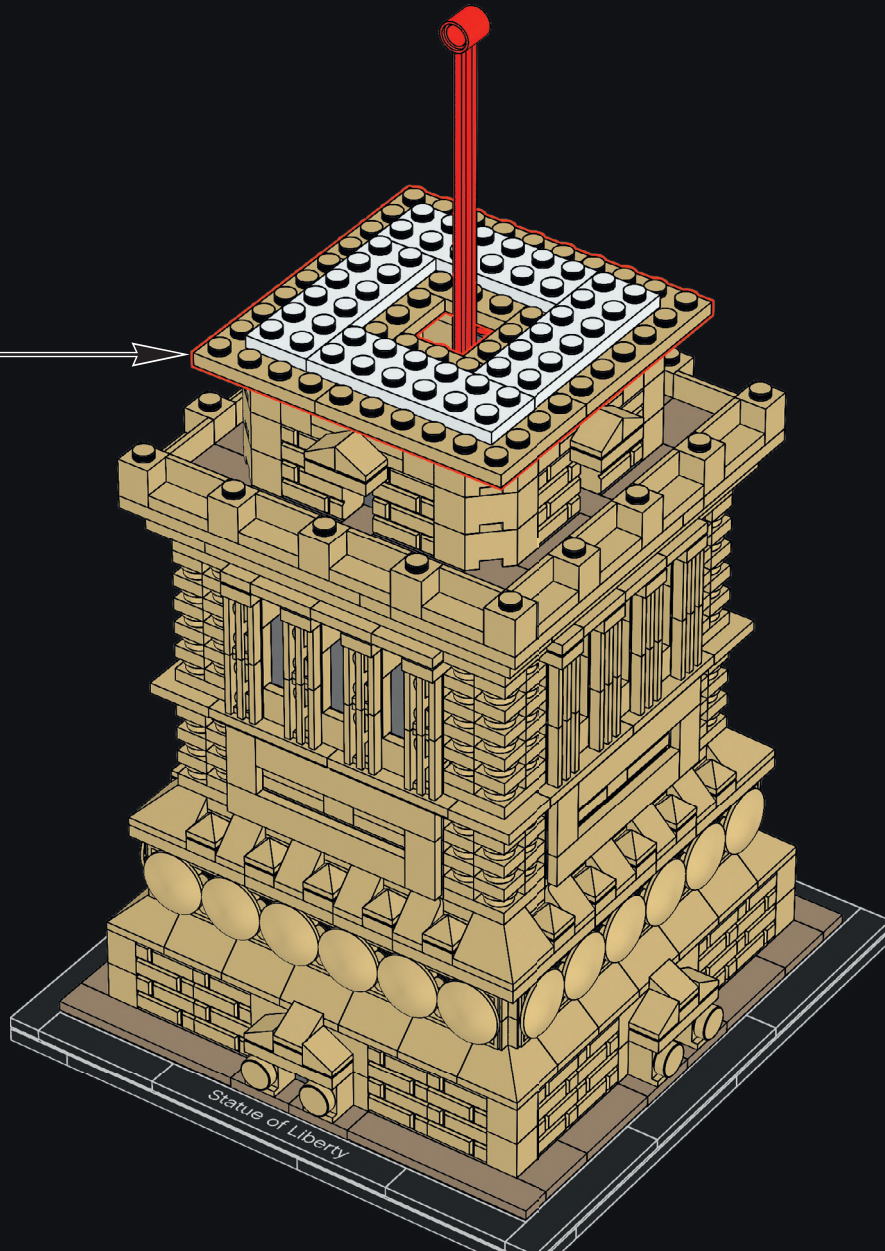



4

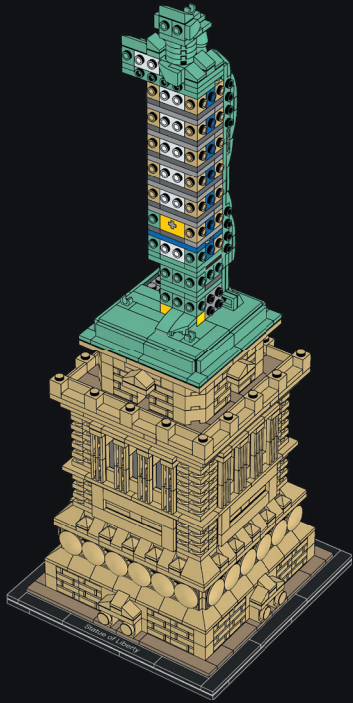

98



53

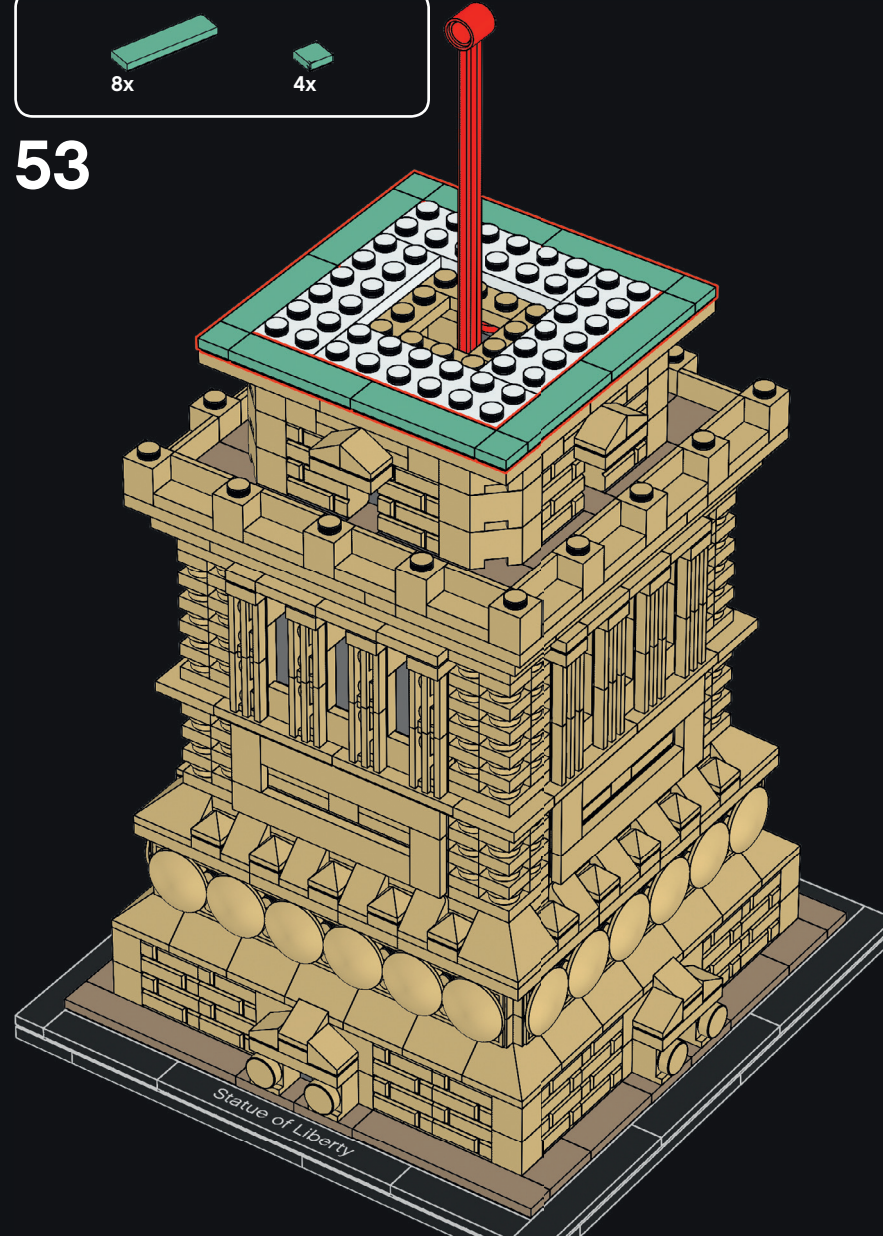



54

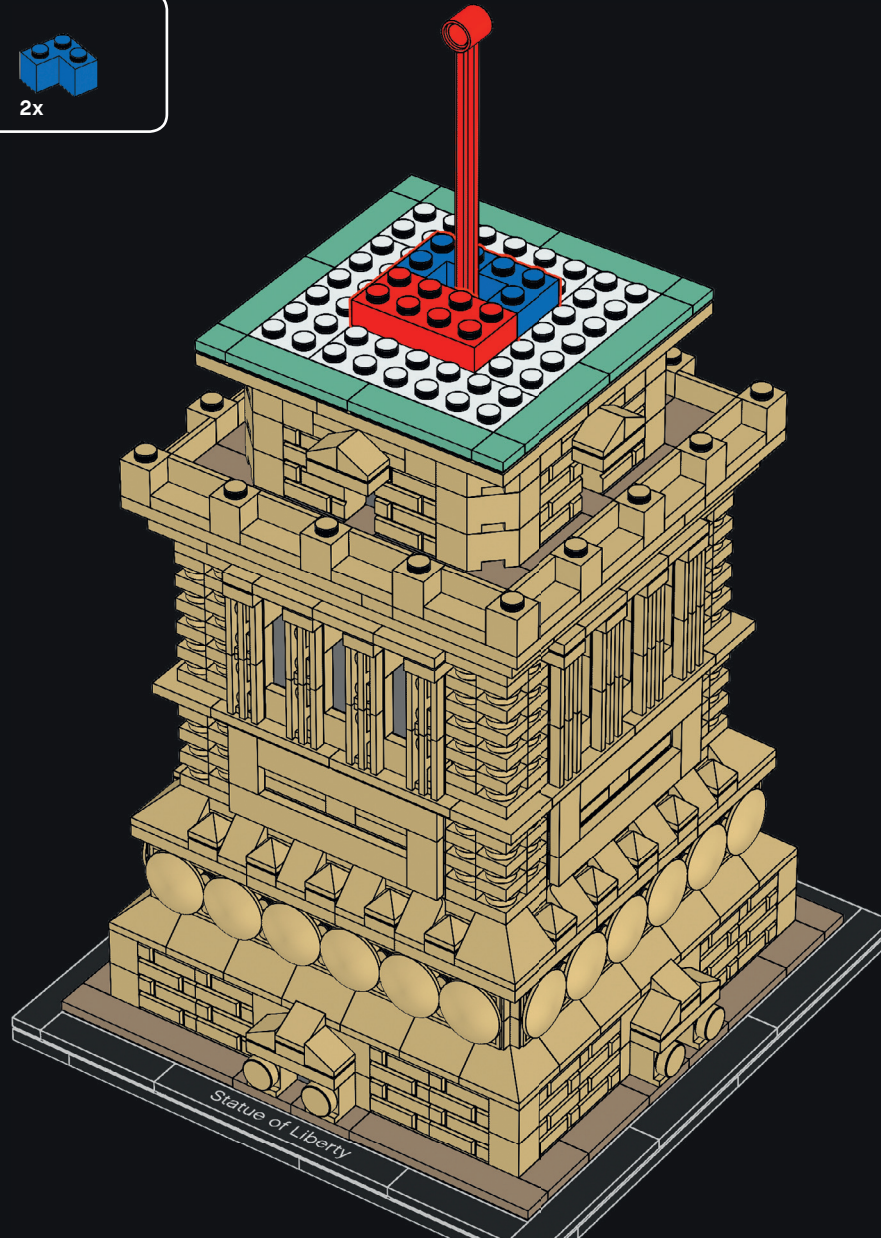



55

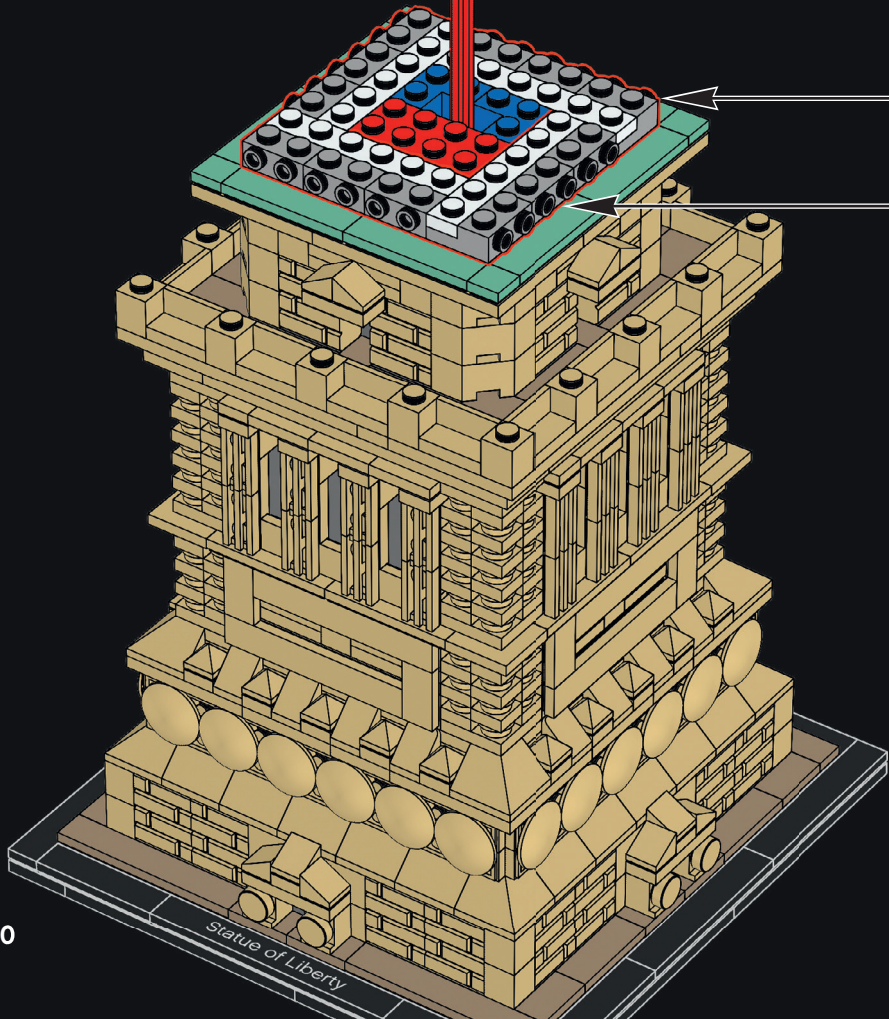
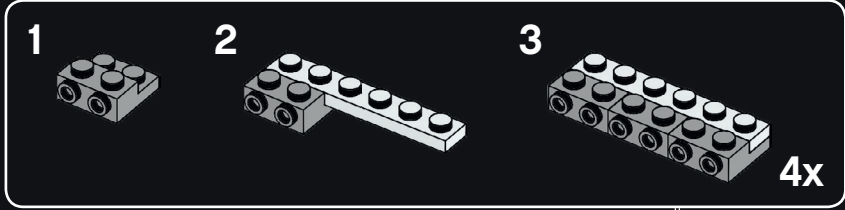



56

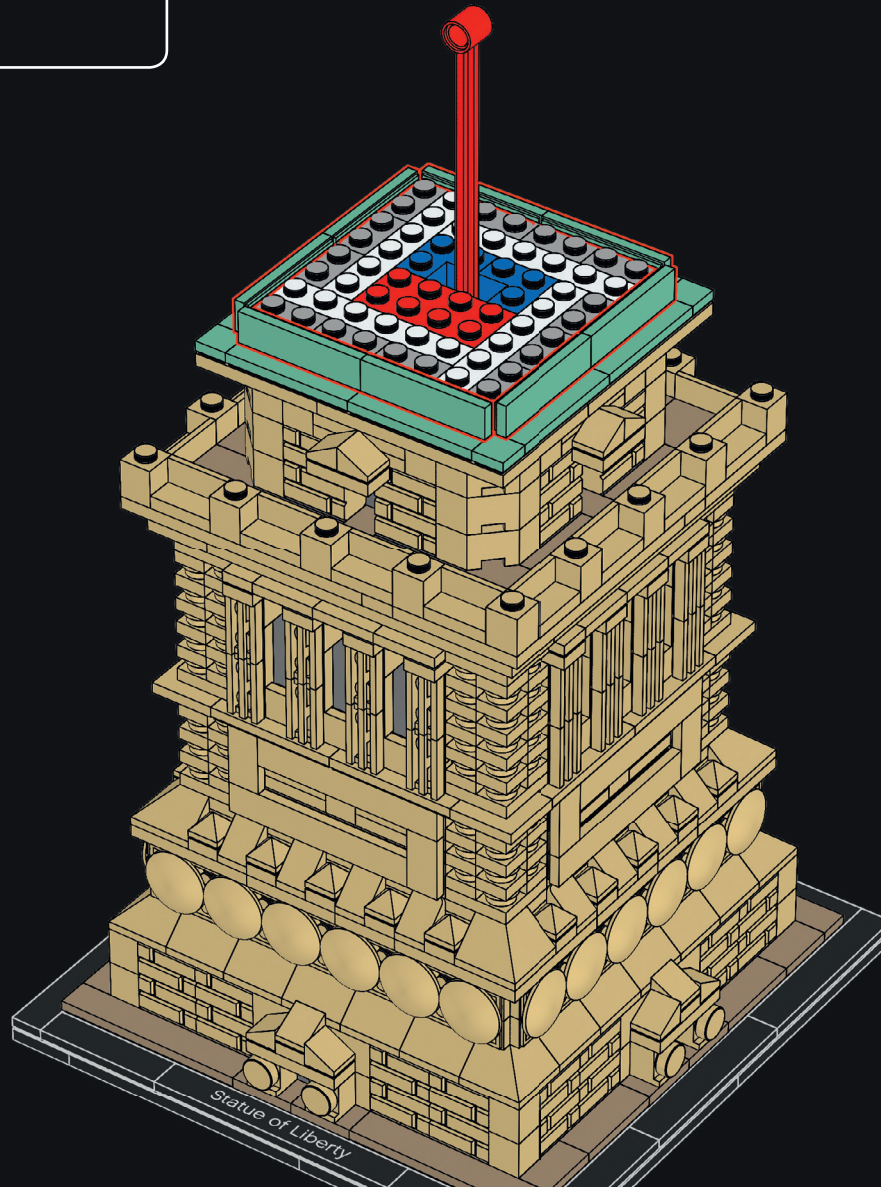



57

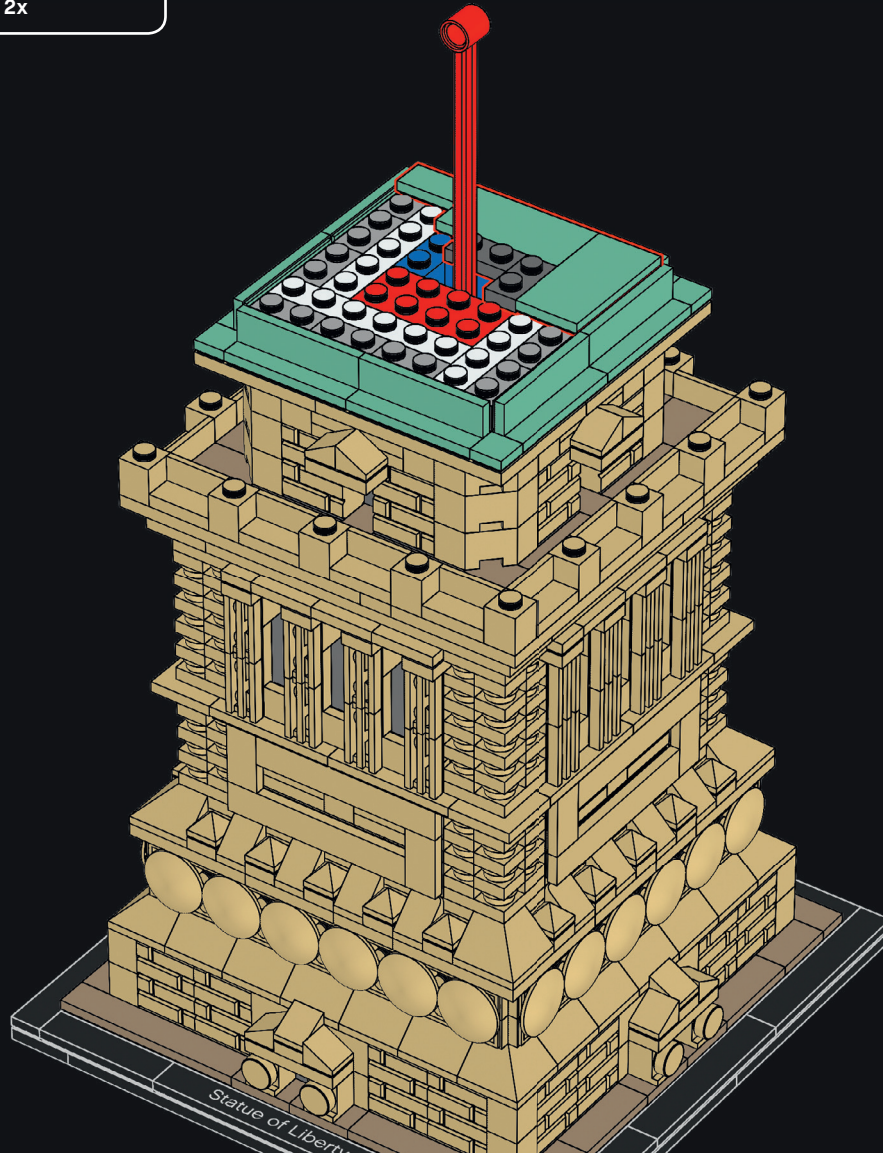

102

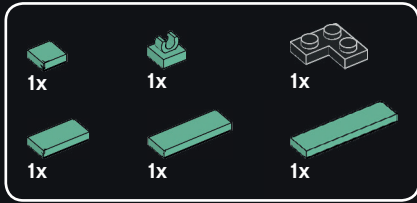

58

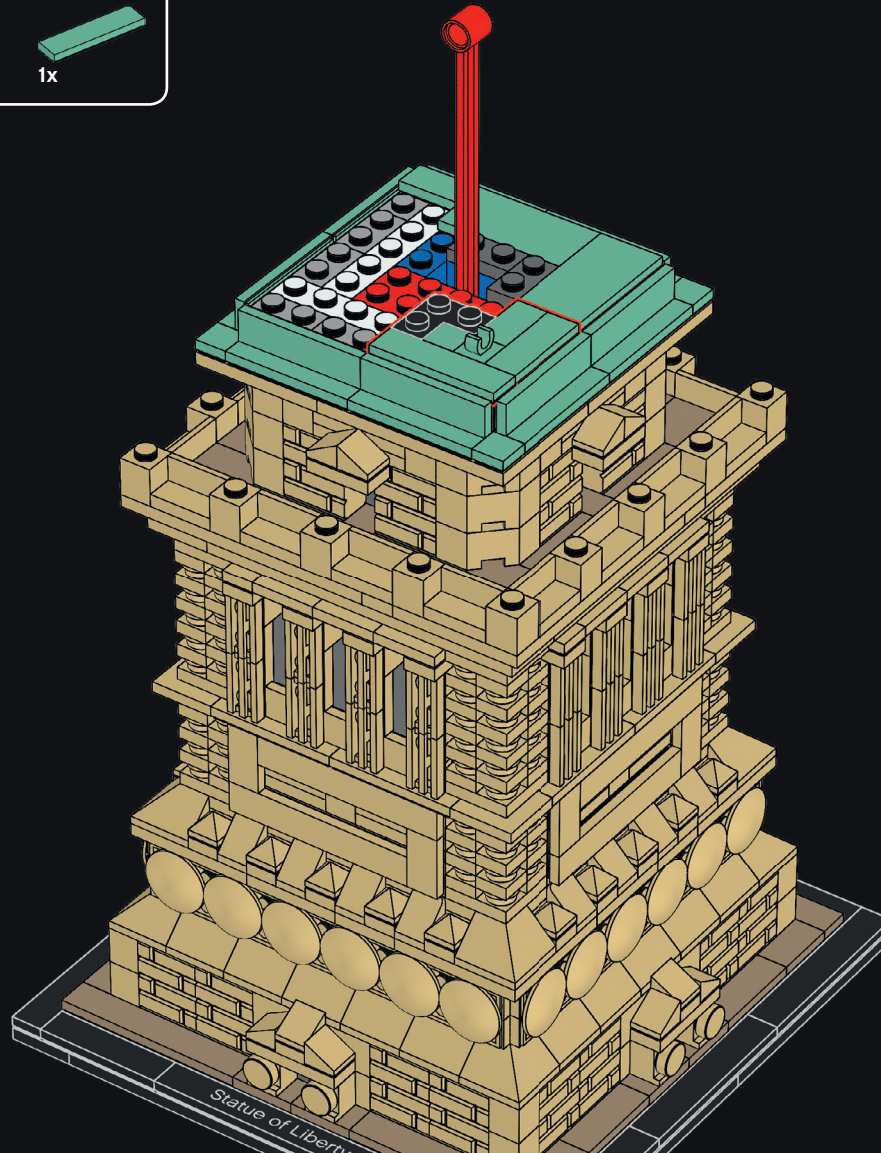

103



59



104





60

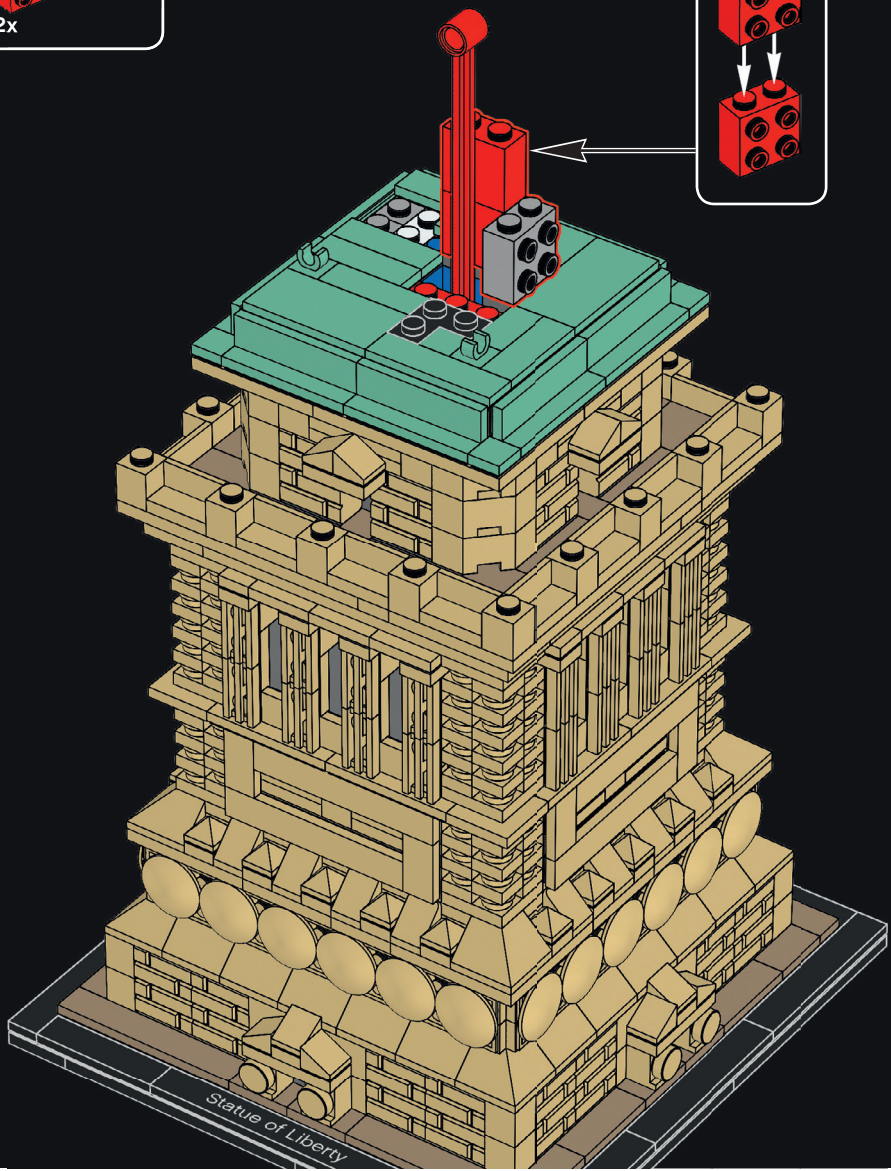
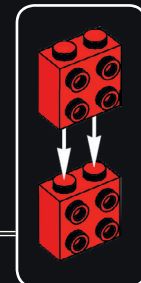

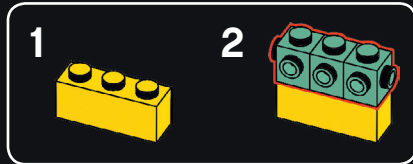
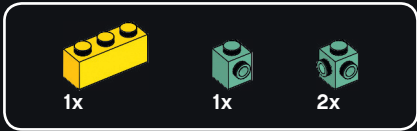

61

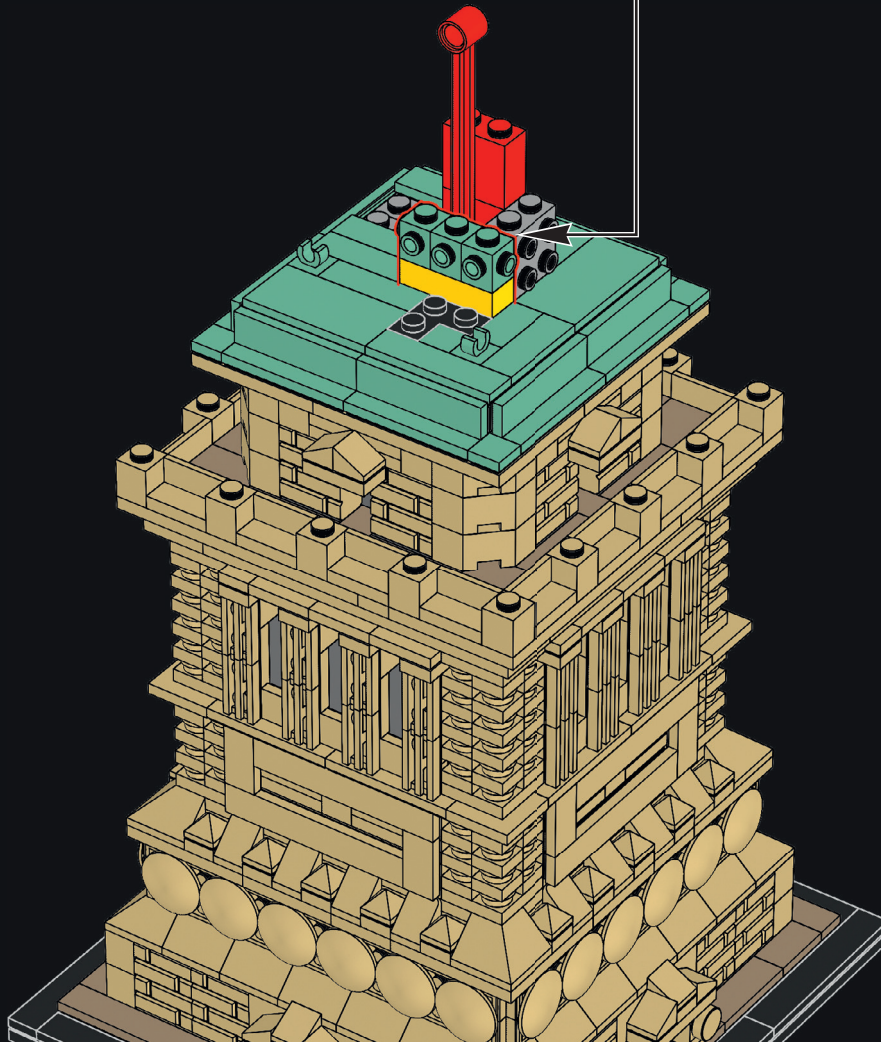

106



62

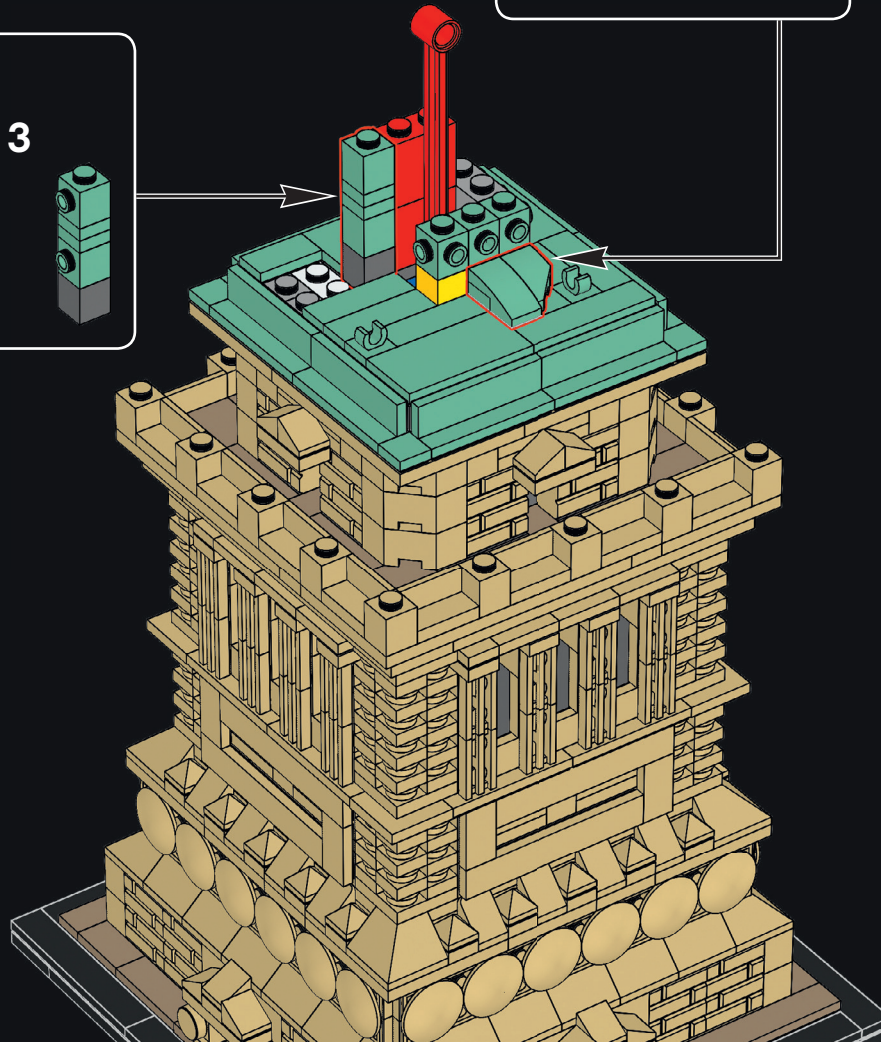
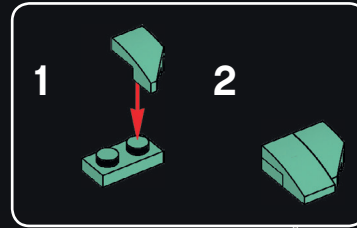
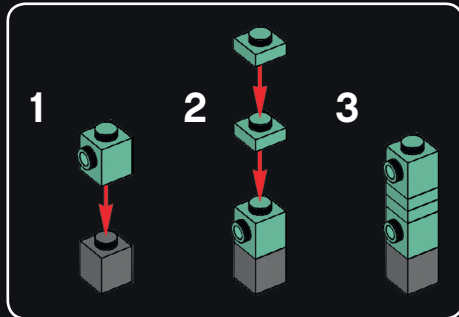

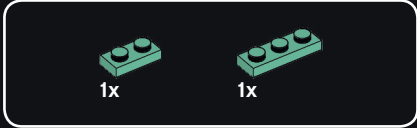

63

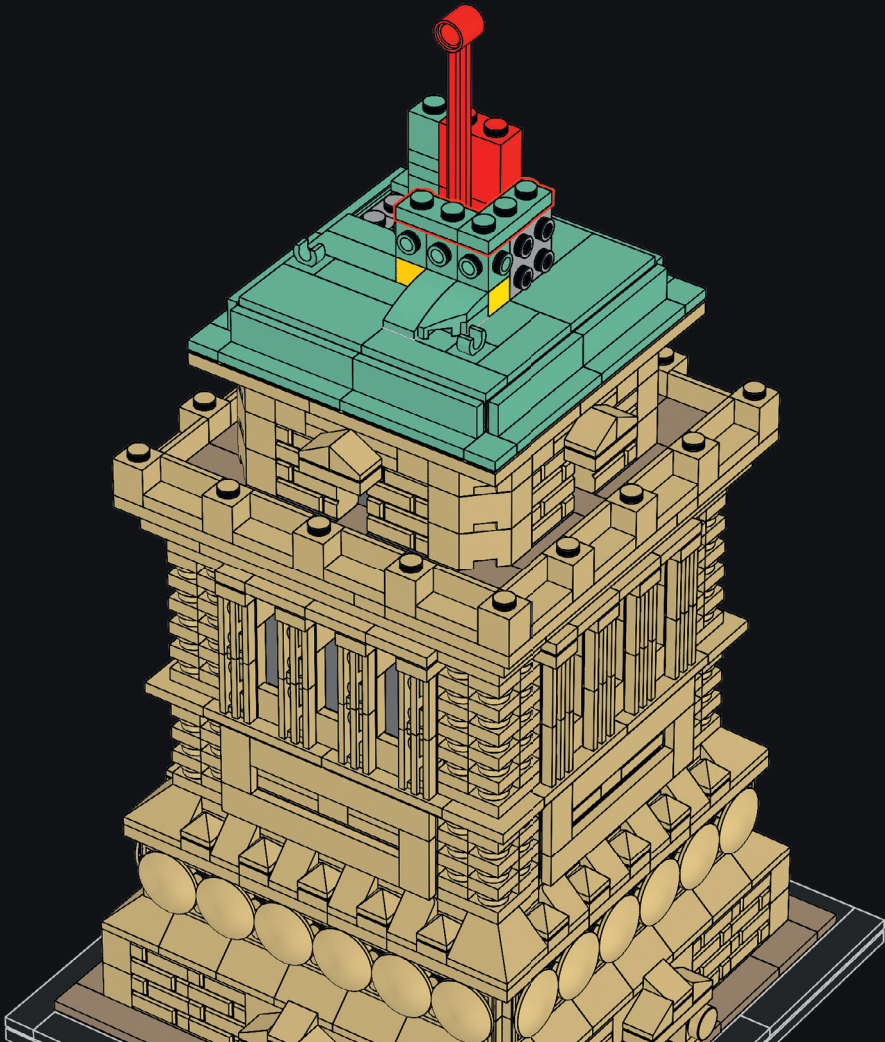

108



64

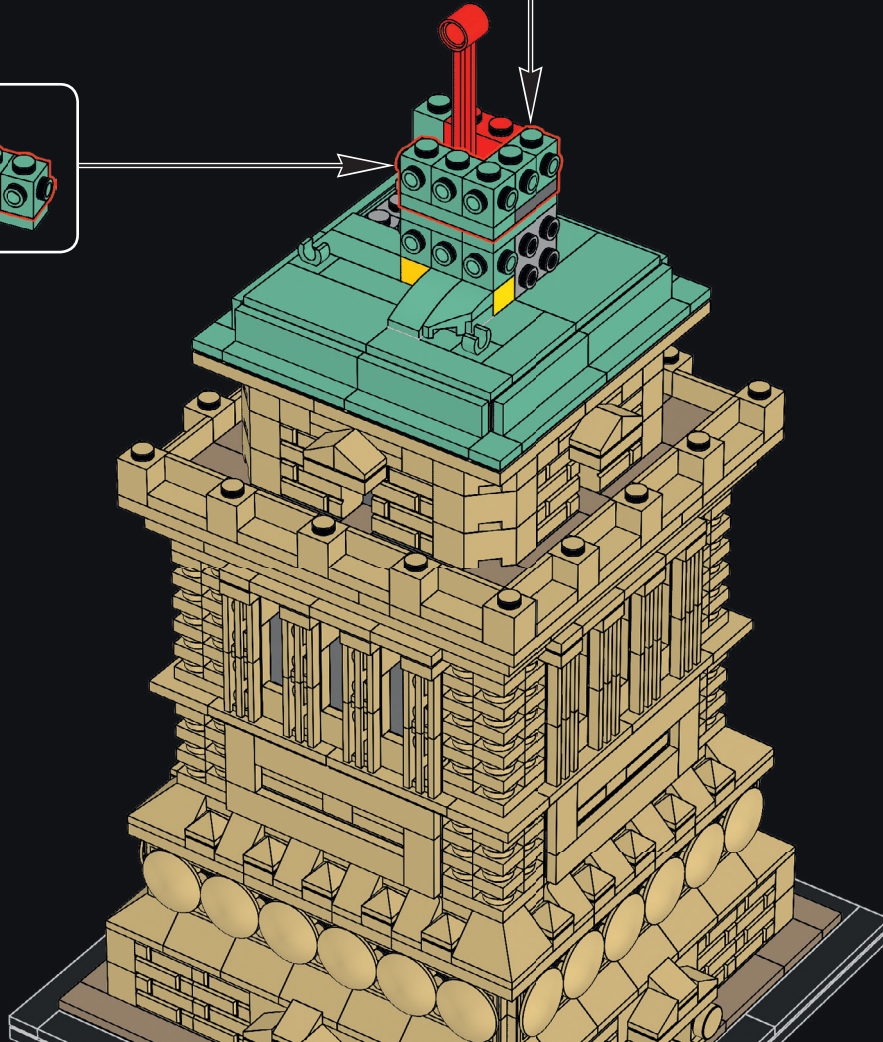
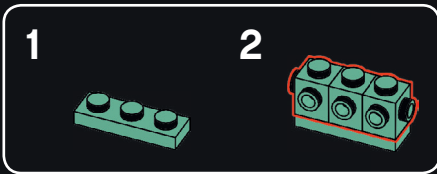
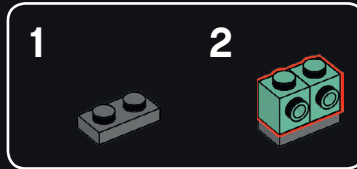



# 65

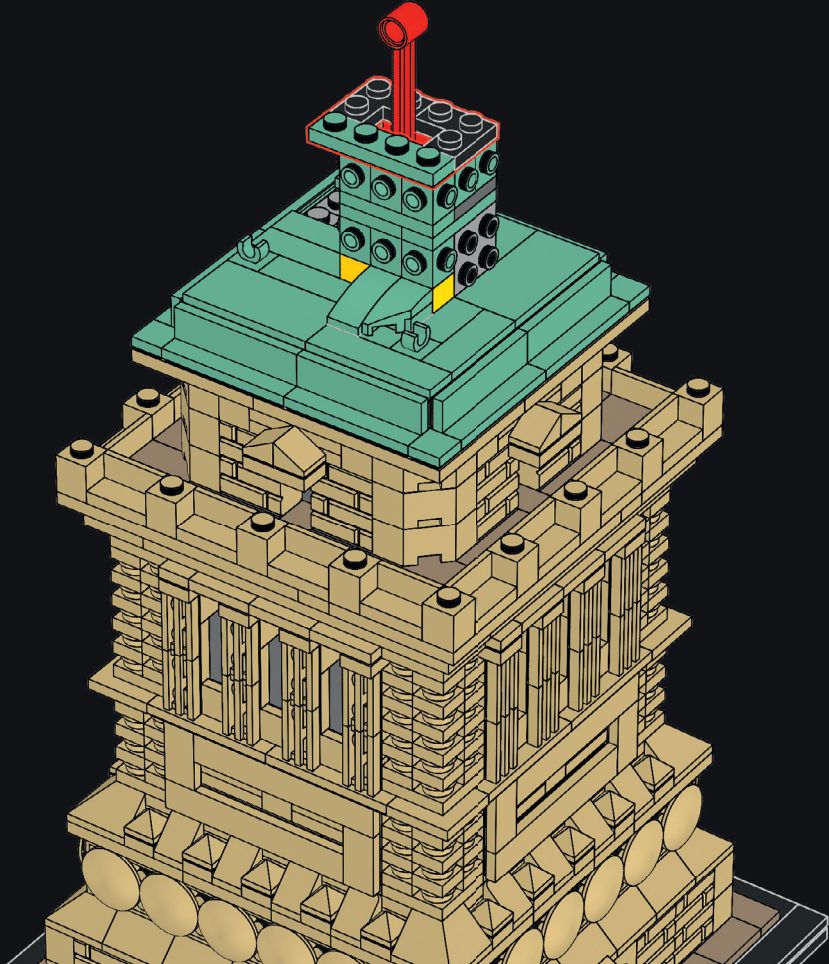

110



66

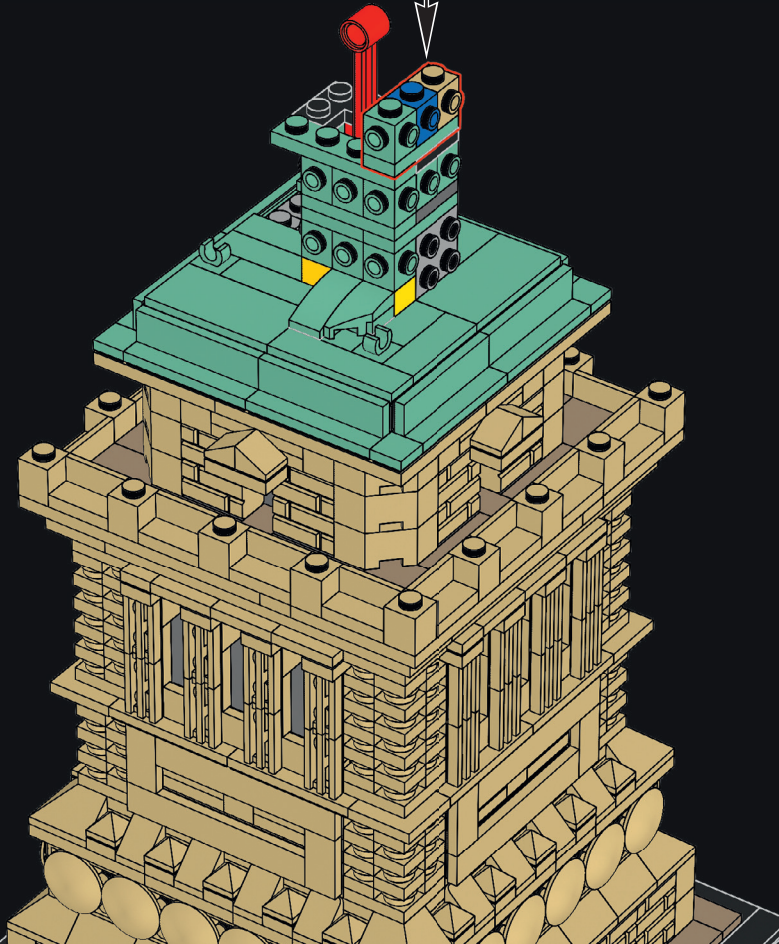
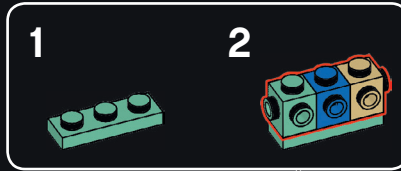

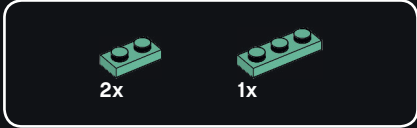

67

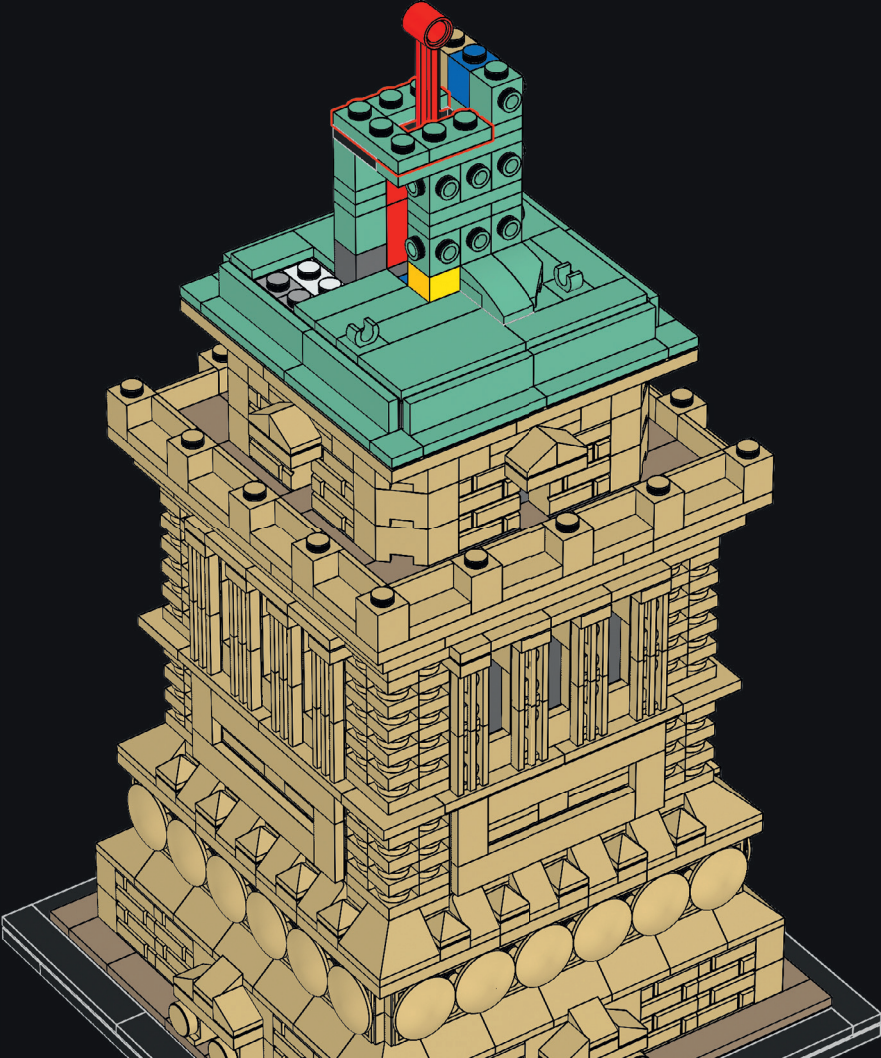

112





68

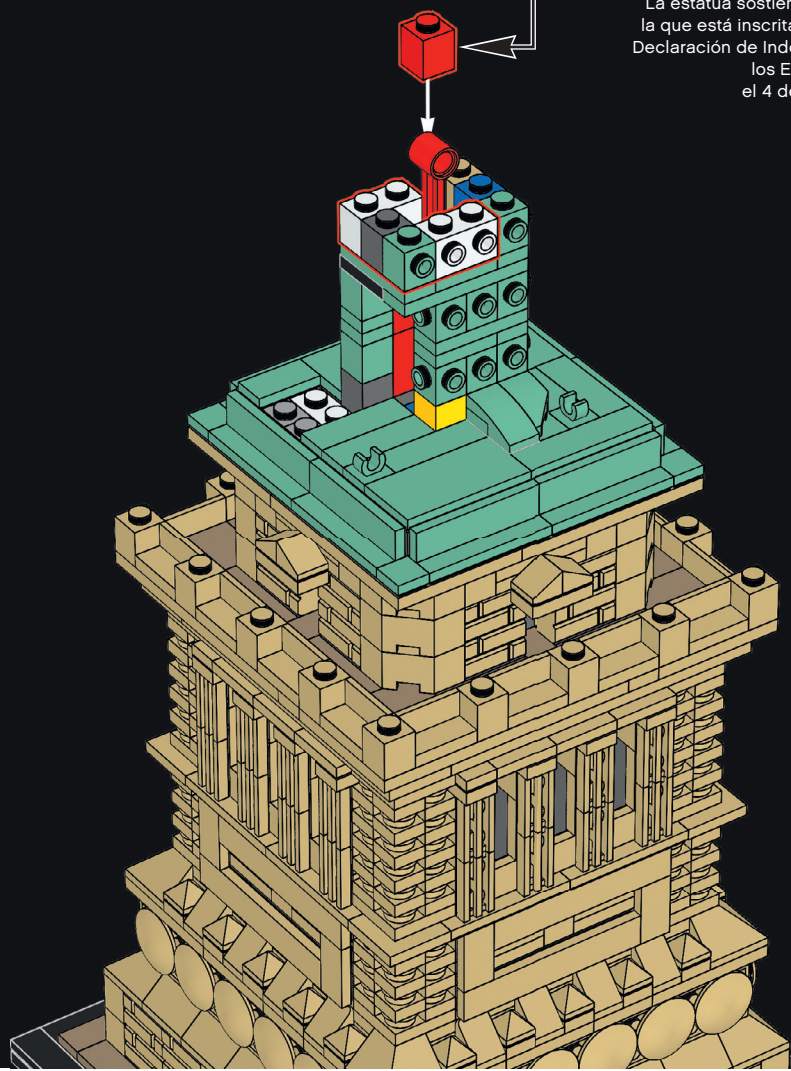

The Statue holds a tablet upon which is inscribed the date of the American Declaration of Independence (July 4, 1776).  
 La statue tient une tablette sur laquelle est inscrite la date de la Déclaration d'indépendance des États-Unis (le 4 juillet 1776).  
 La estatua sostiene una tabla en la que está inscrite la fecha de la Declaración de Independencia de los Estados Unidos: el 4 de julio de 1776.

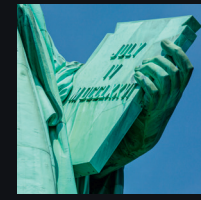



69

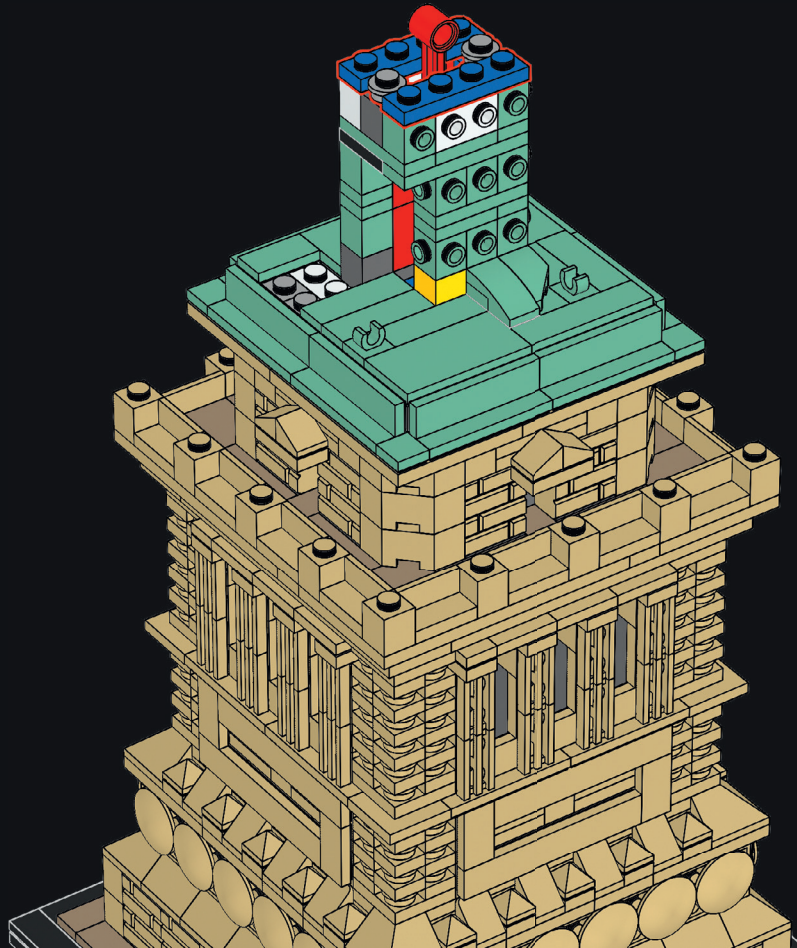

114



70

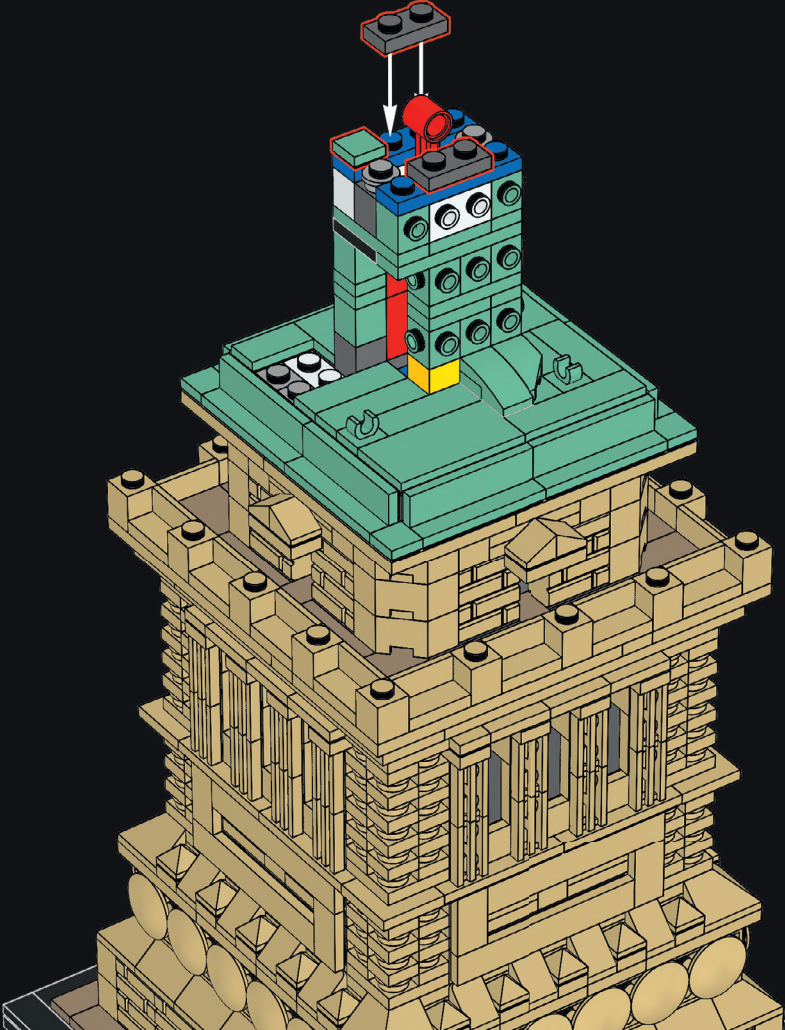

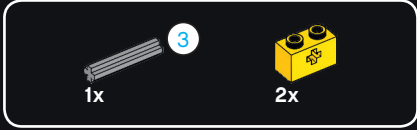

71

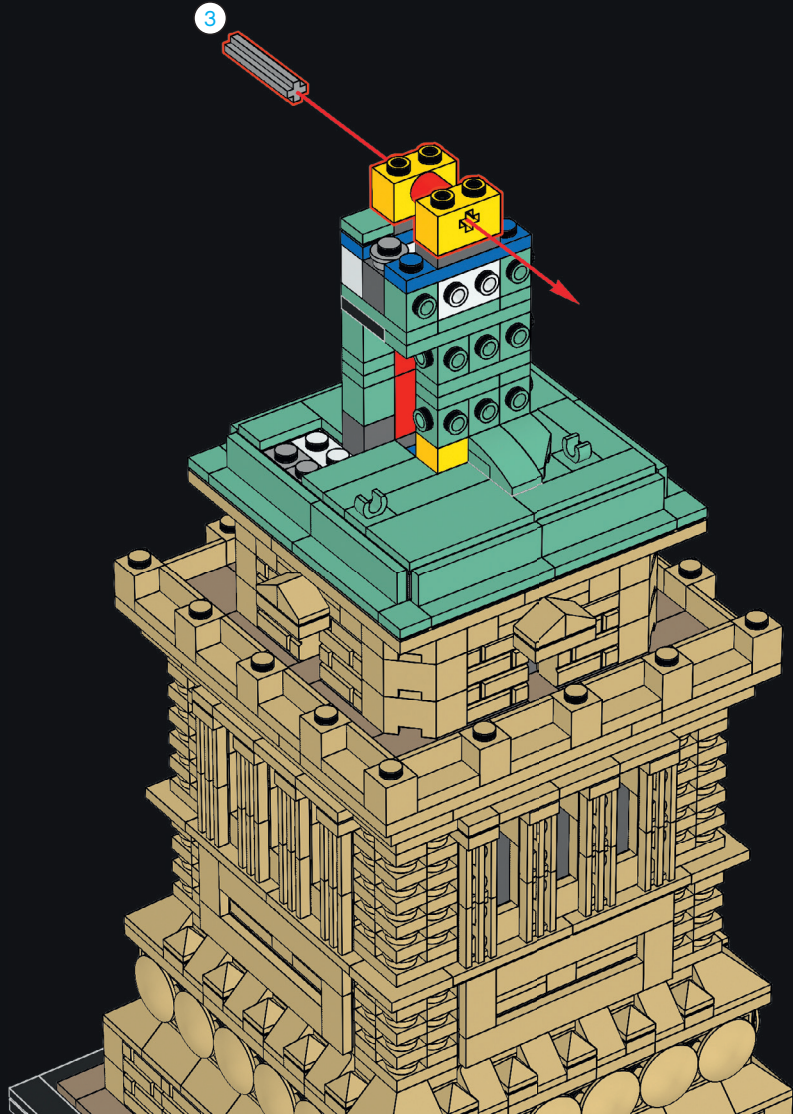

116



72

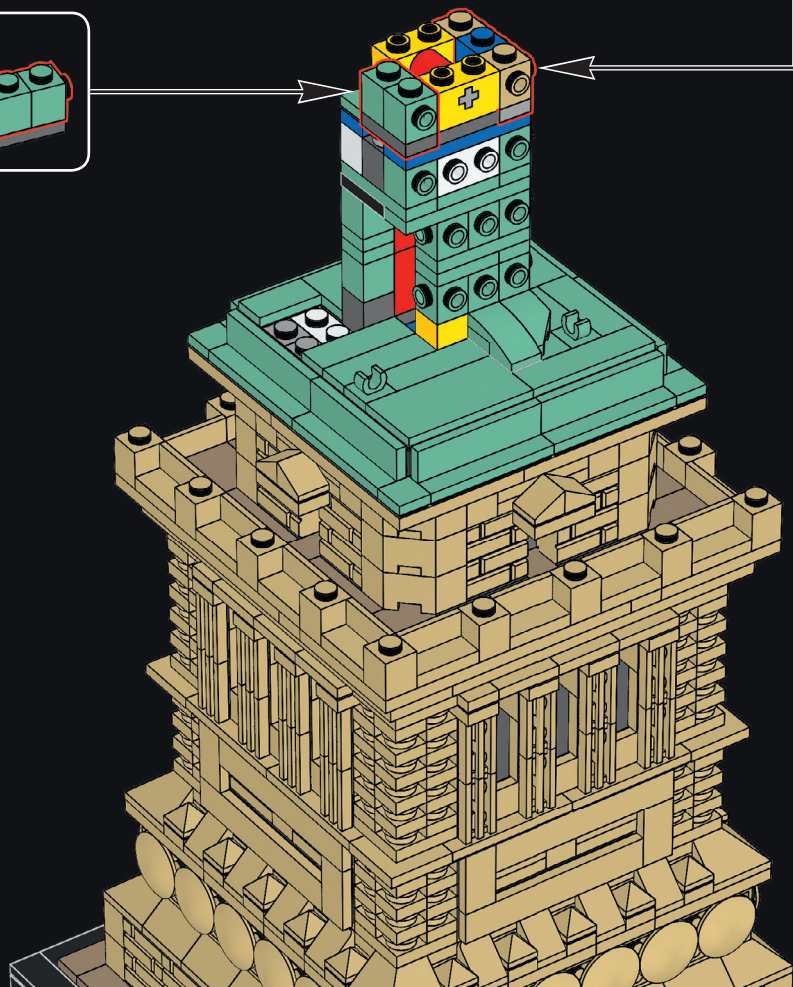

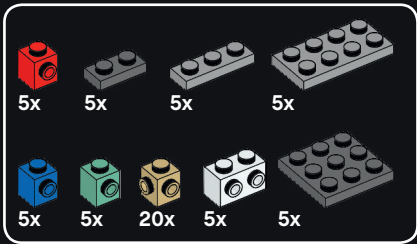

73

1



2

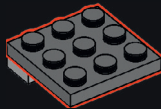

3

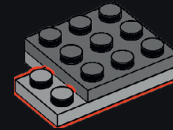

4

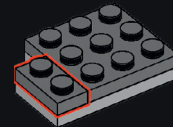

5

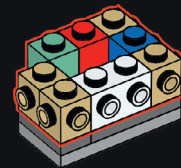

5x

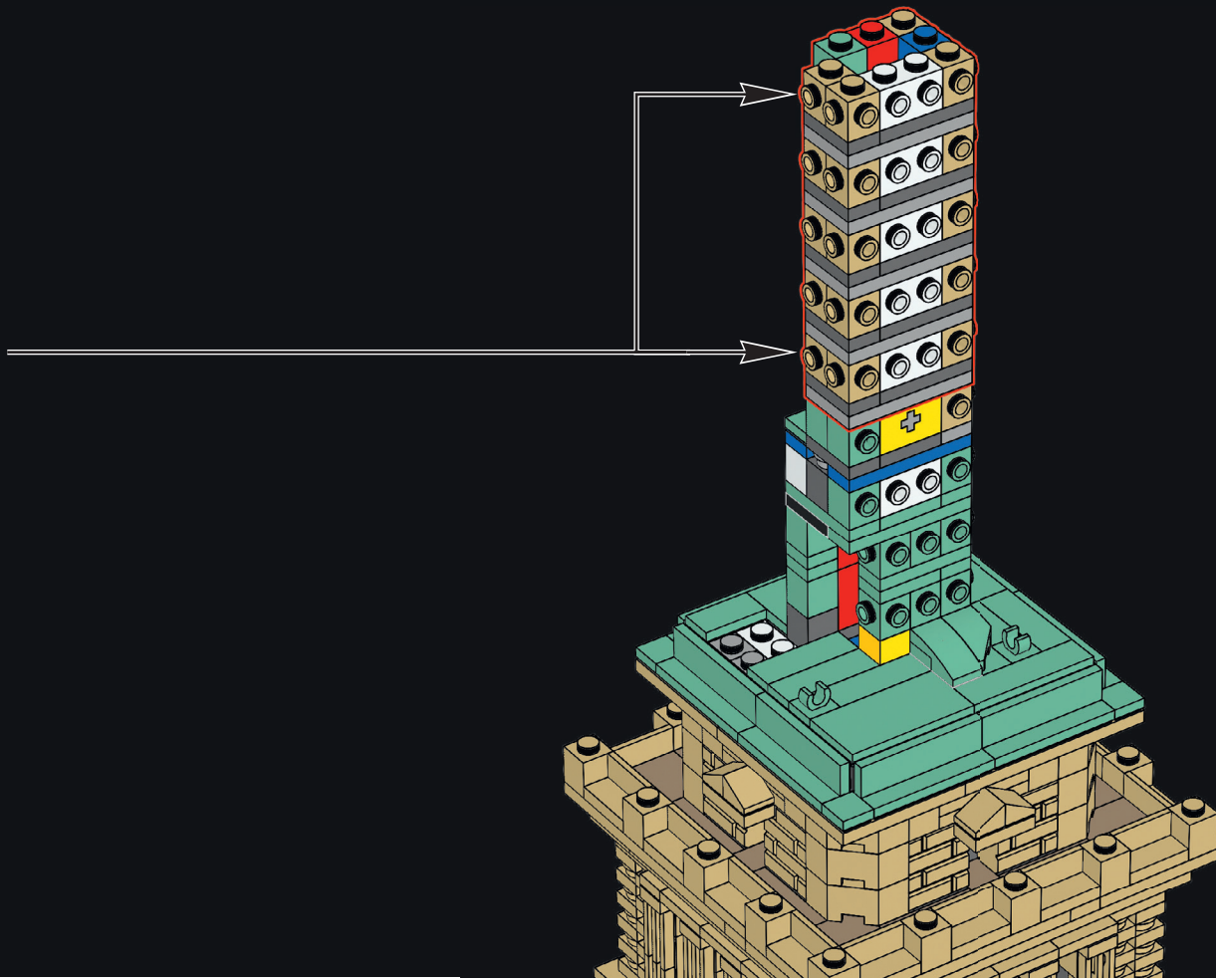



74

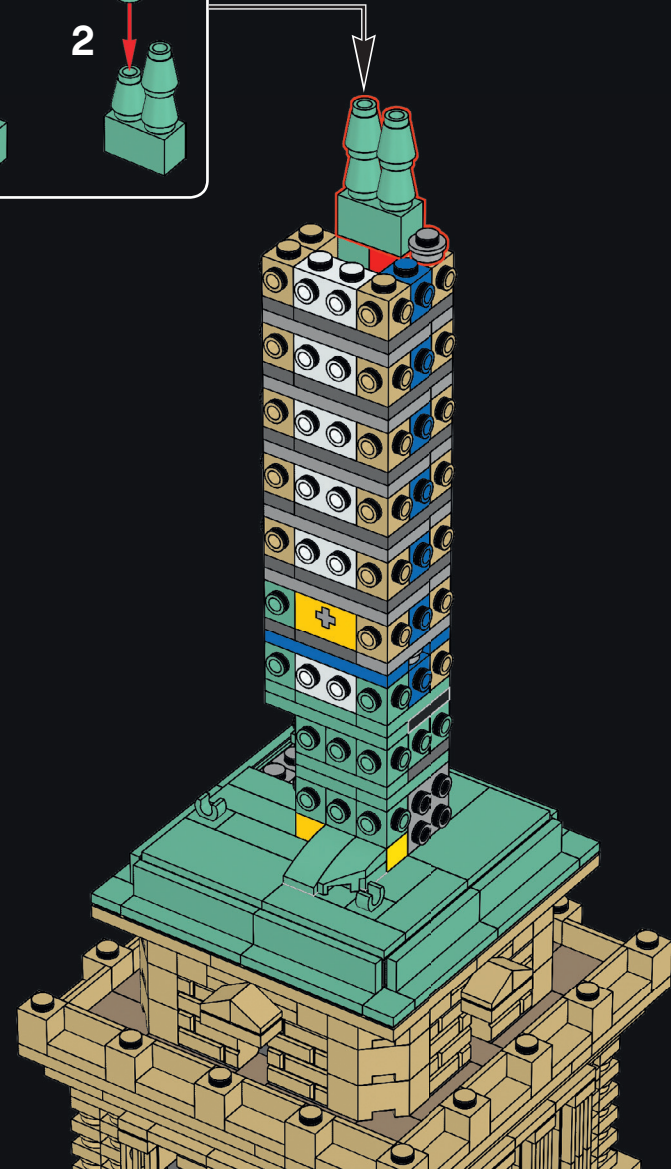
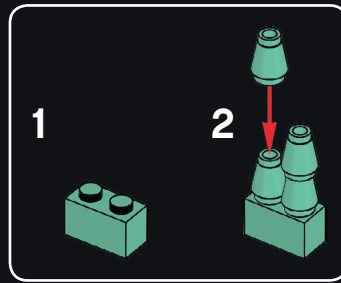

120





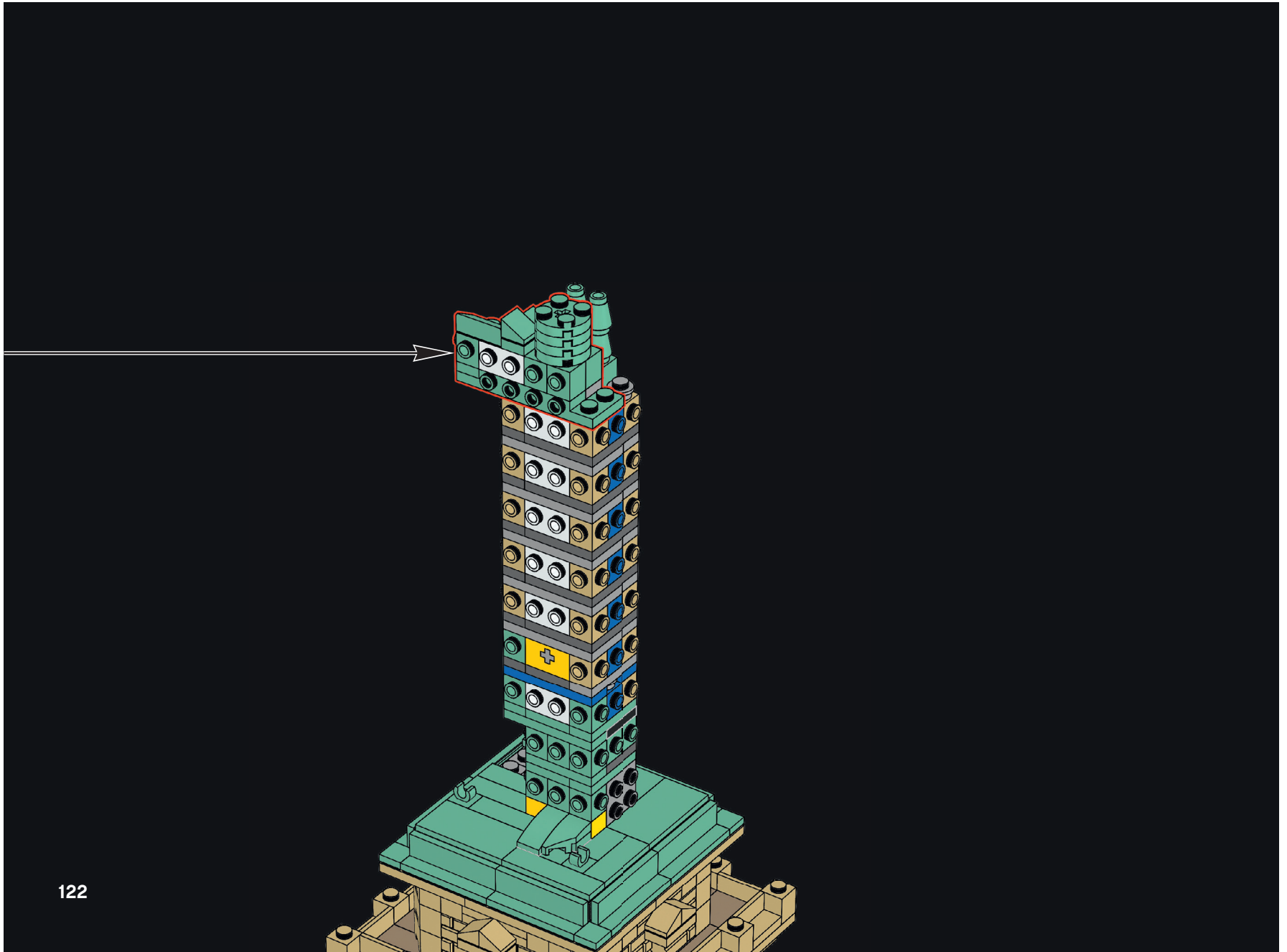



76

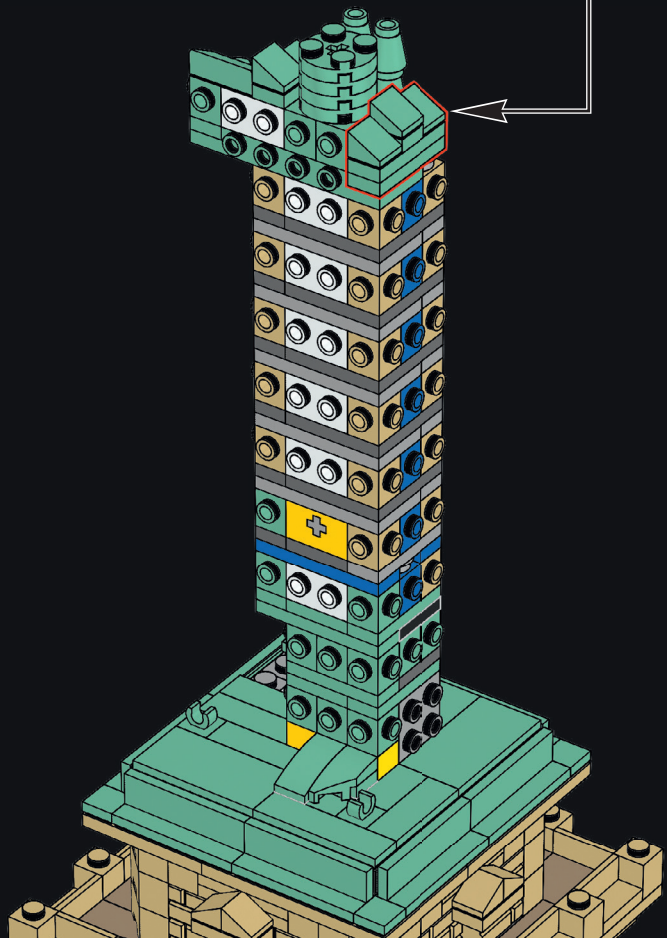
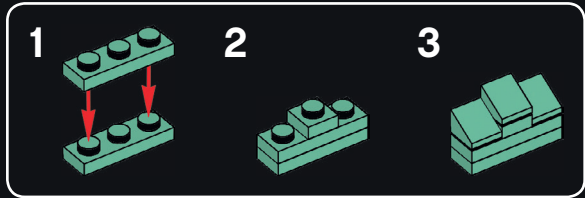



77

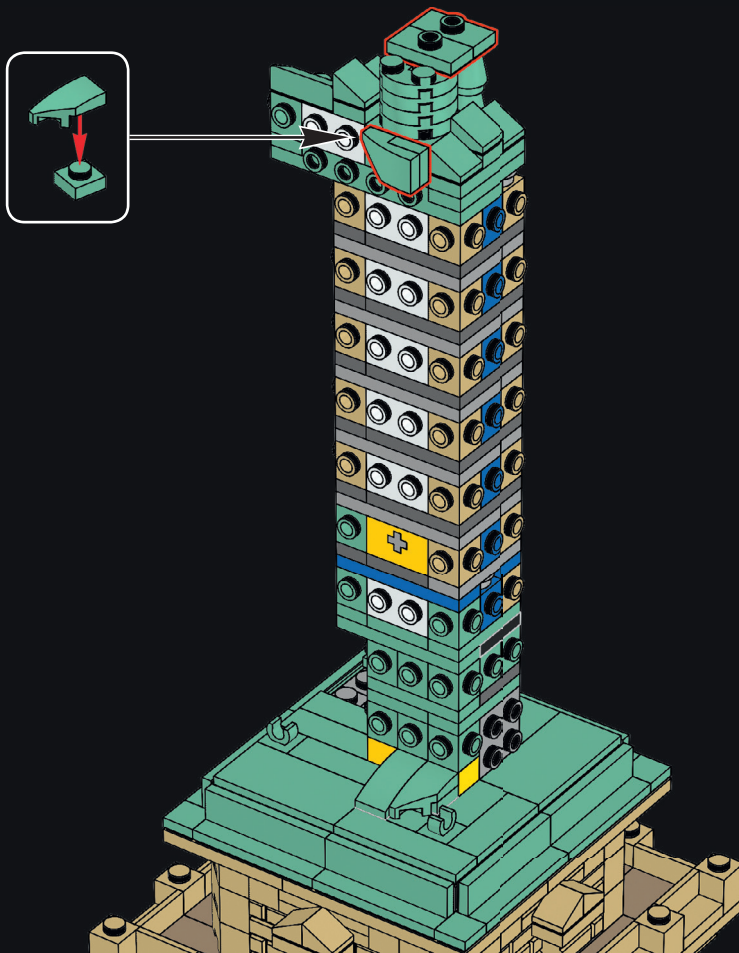

124



78

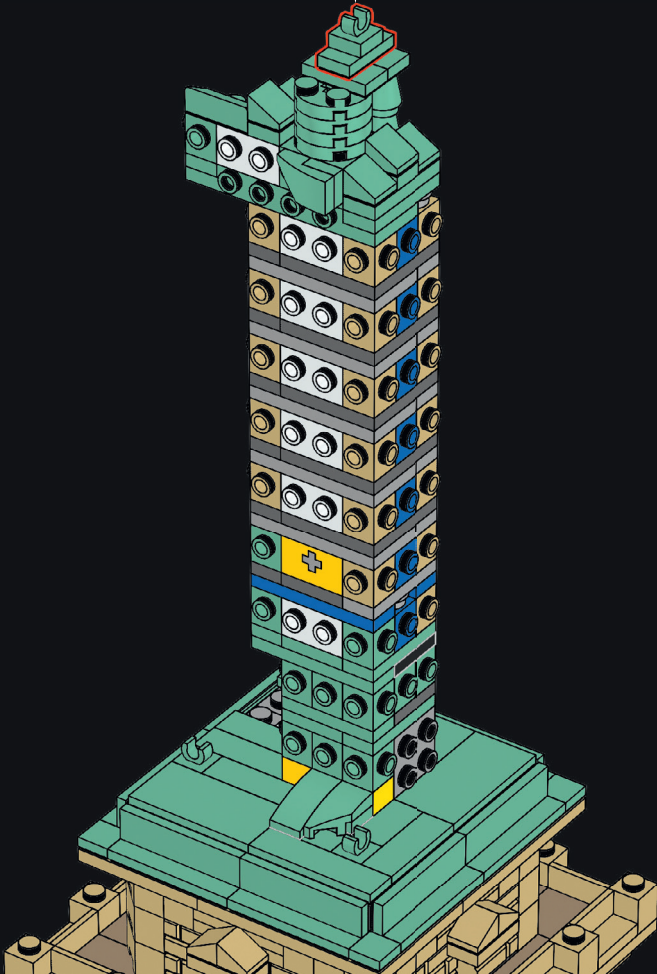
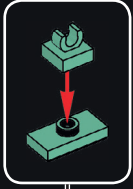



79

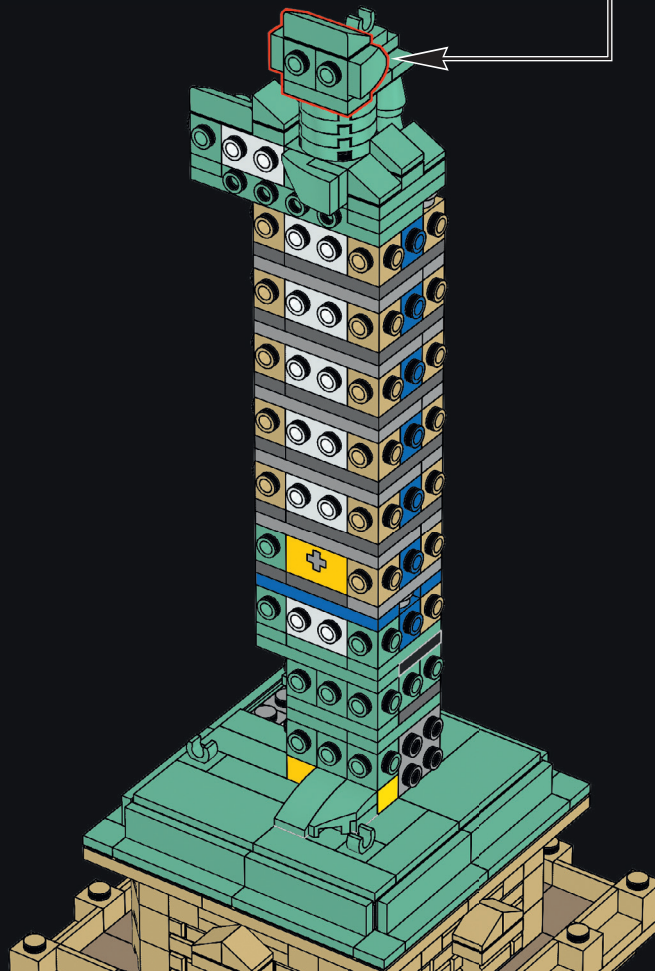
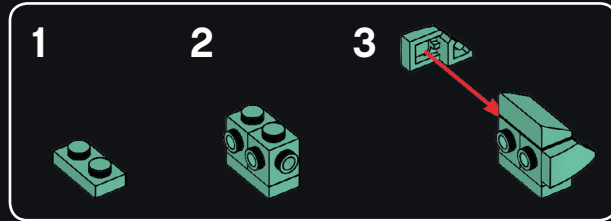

126

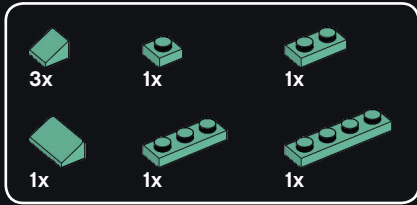

80

1



2



3

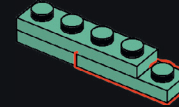

4

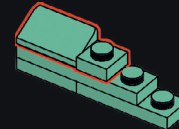

5

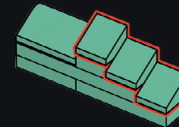

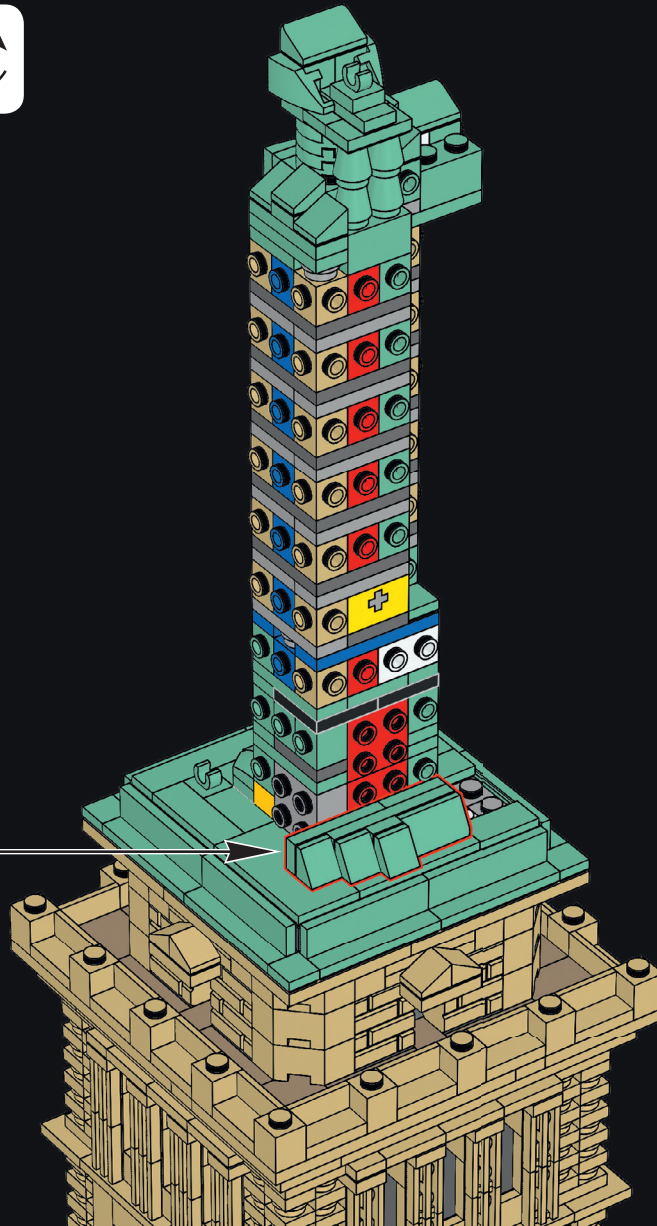





81

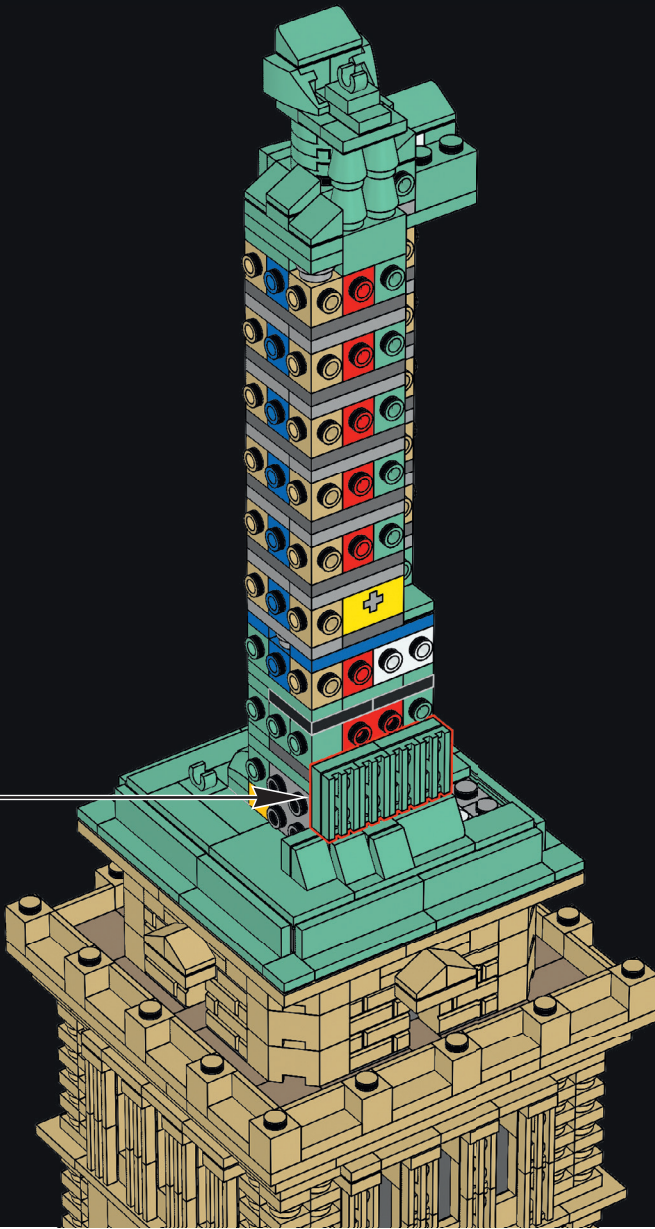
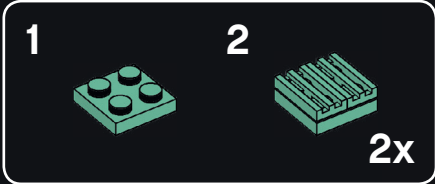

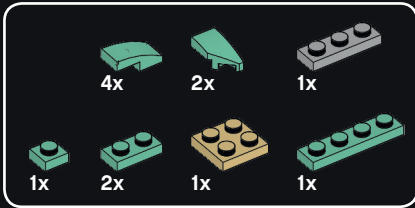

82

1



2



3

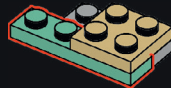

4

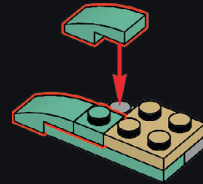

5

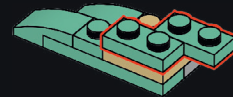

6

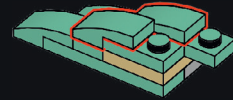

7

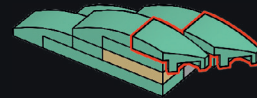

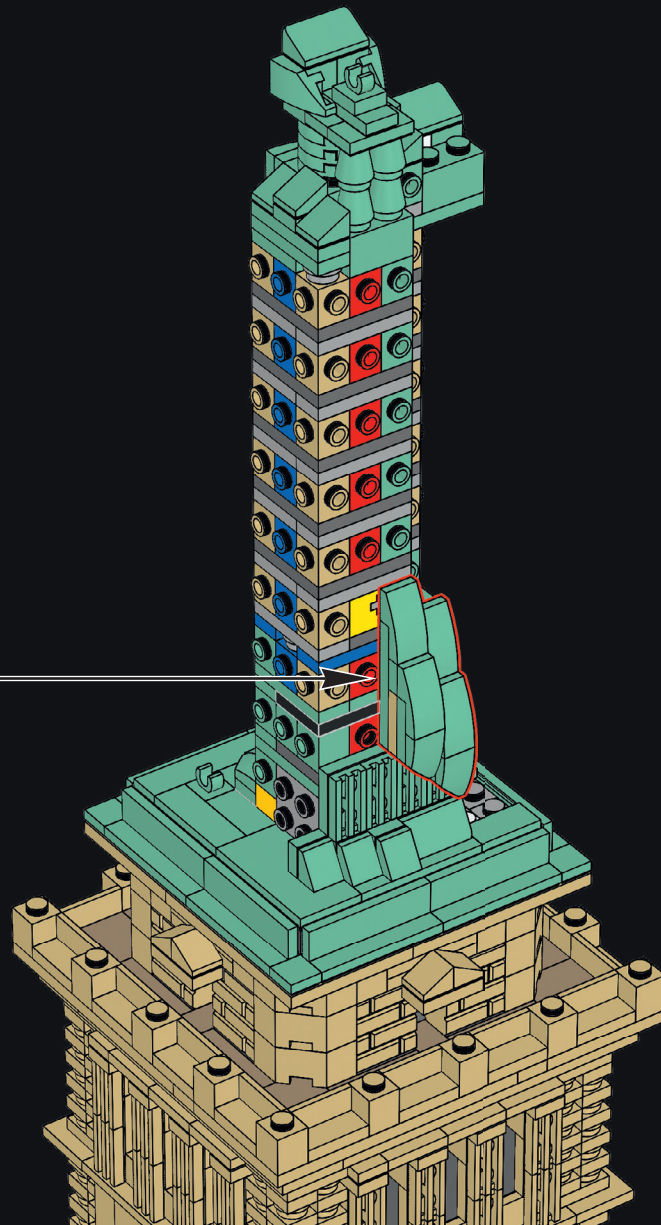

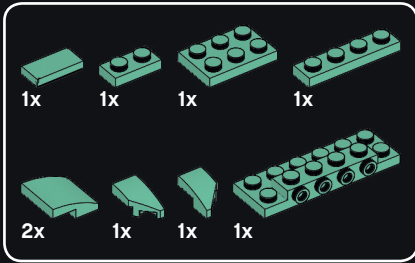

83

1

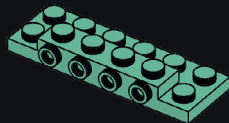

2

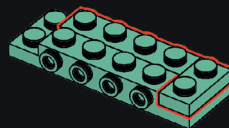

3

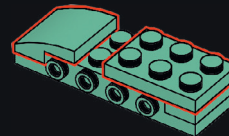

4

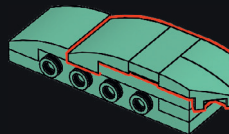

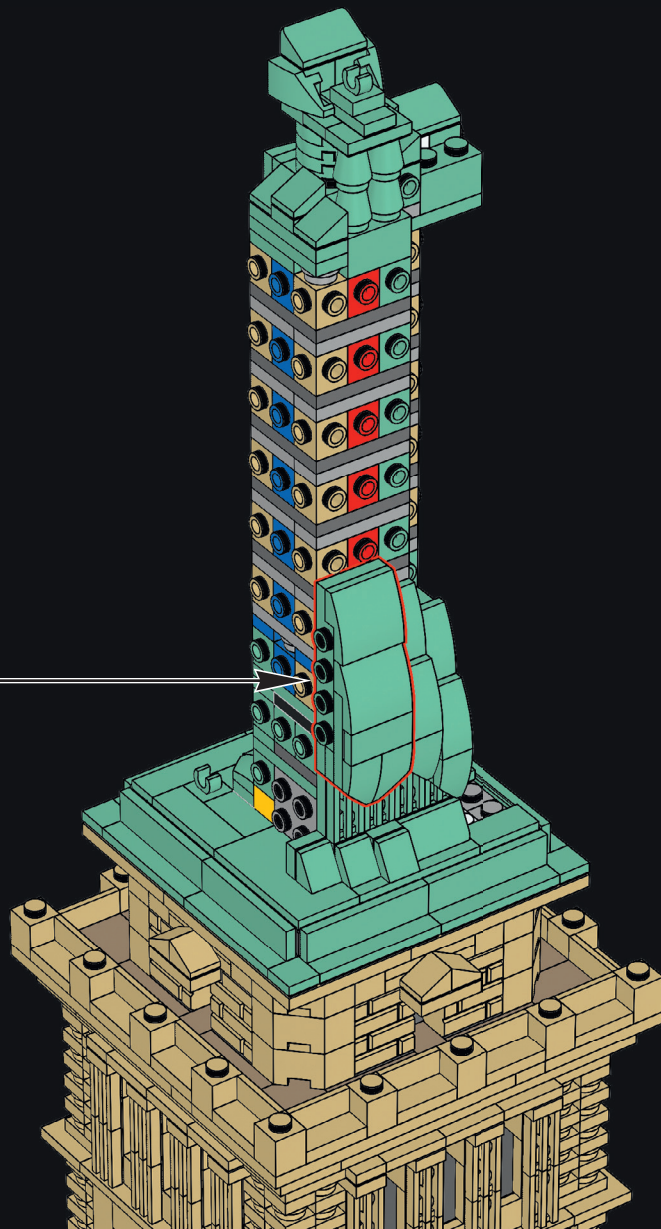



84

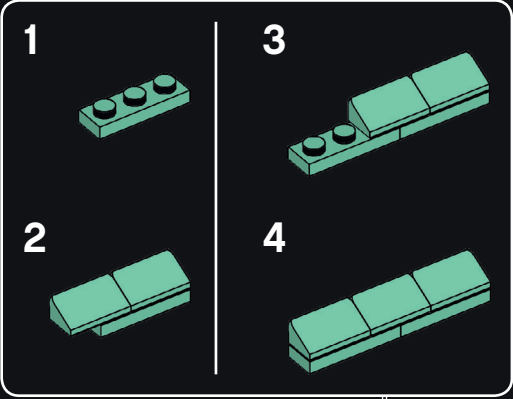
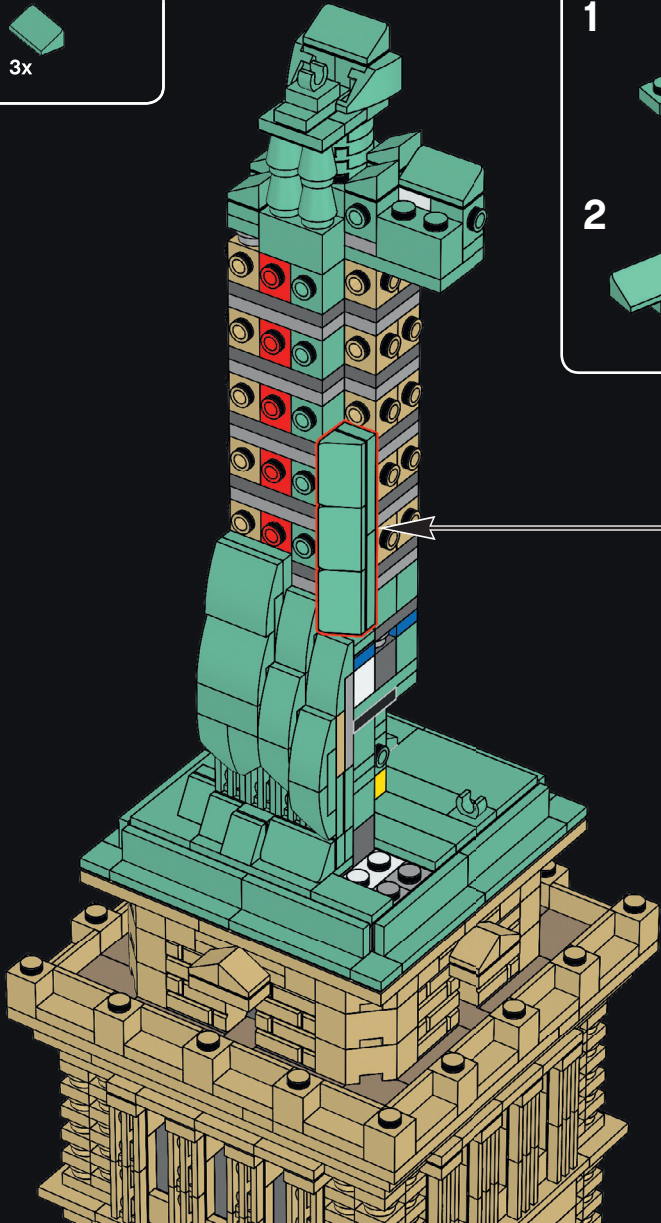

134

85



3x

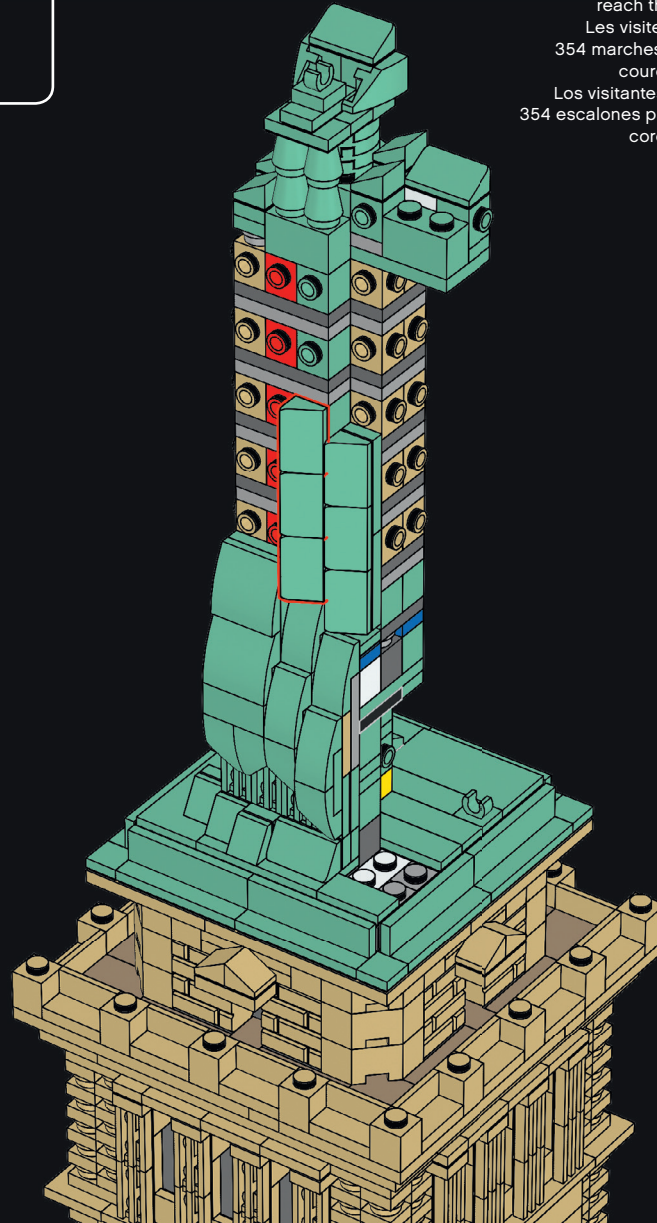

Visitors have to climb 354 stairs to reach the Statue's crown.  
Les visiteurs doivent gravir 354 marches pour atteindre la couronne de la statue.  
Los visitantes tienen que subir 354 escalones para llegar hasta la corona de la estatua.



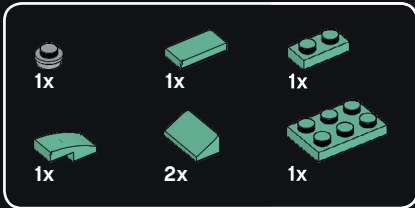

86

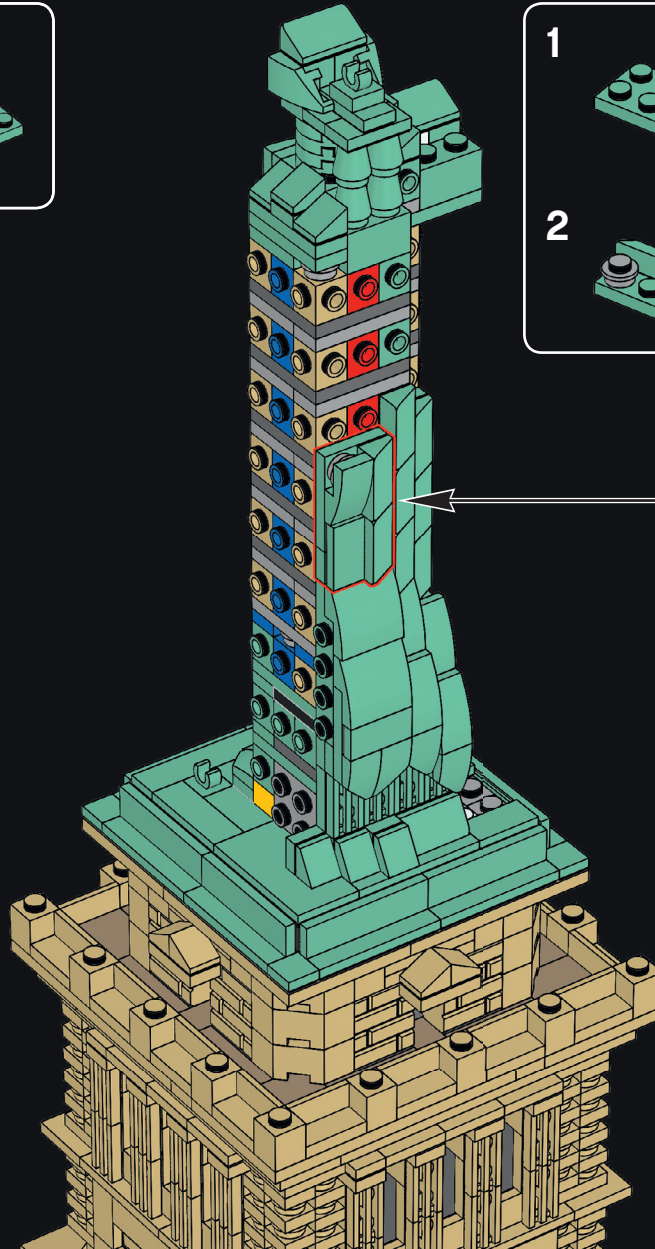
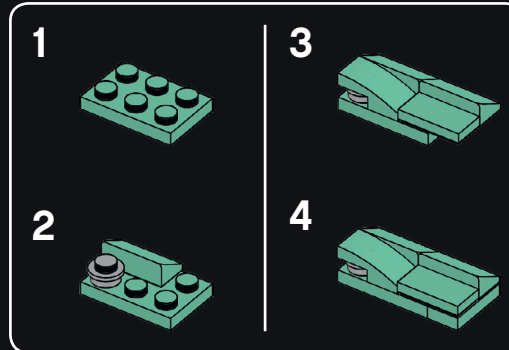

136





87

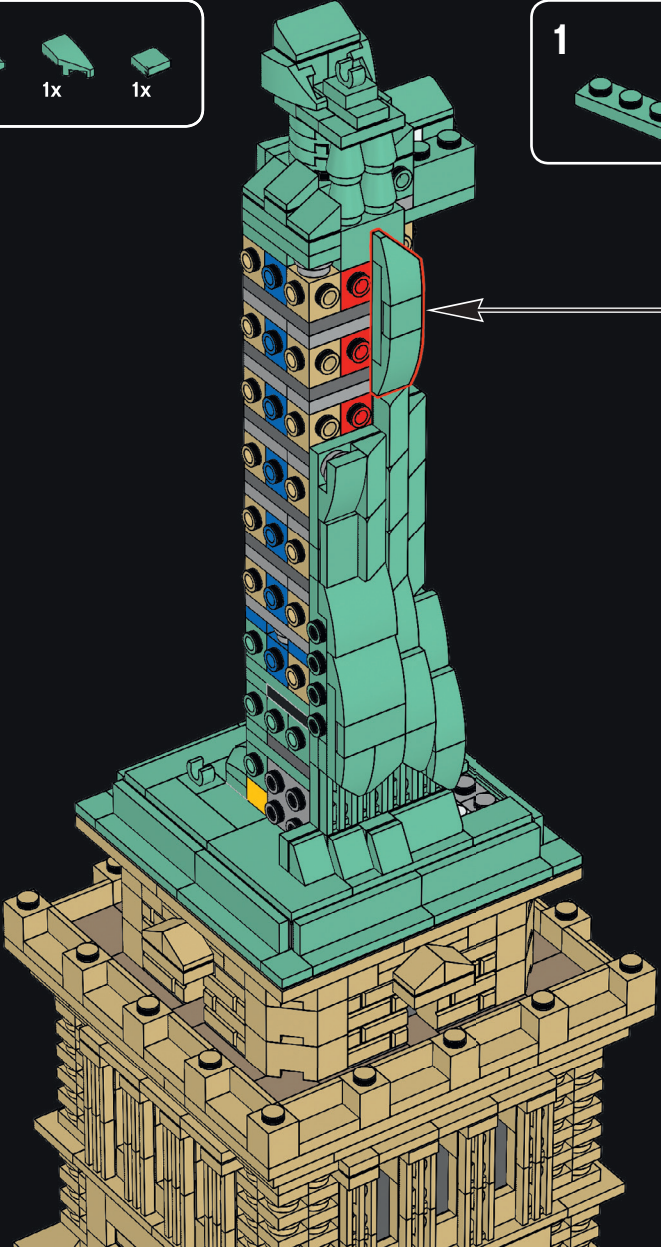
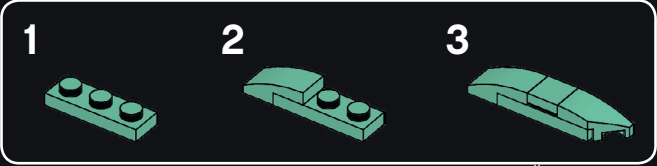

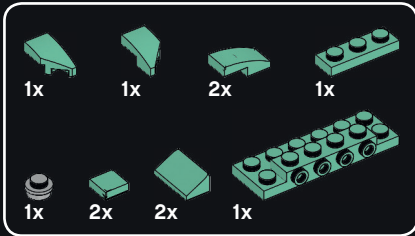

88

1

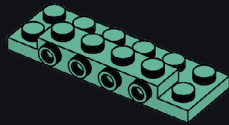

2

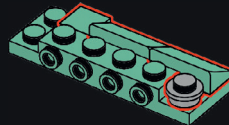

3

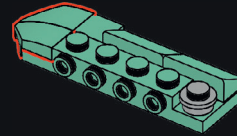

4

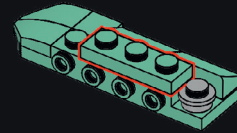

5

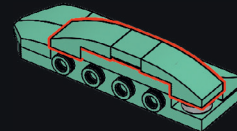

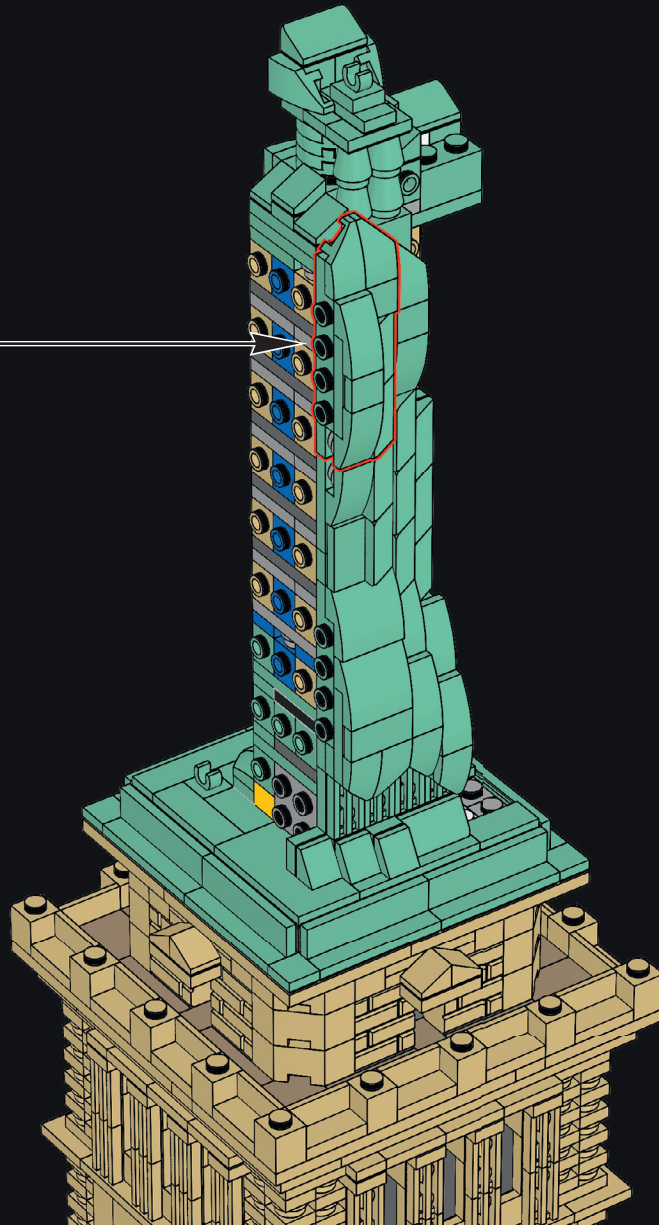

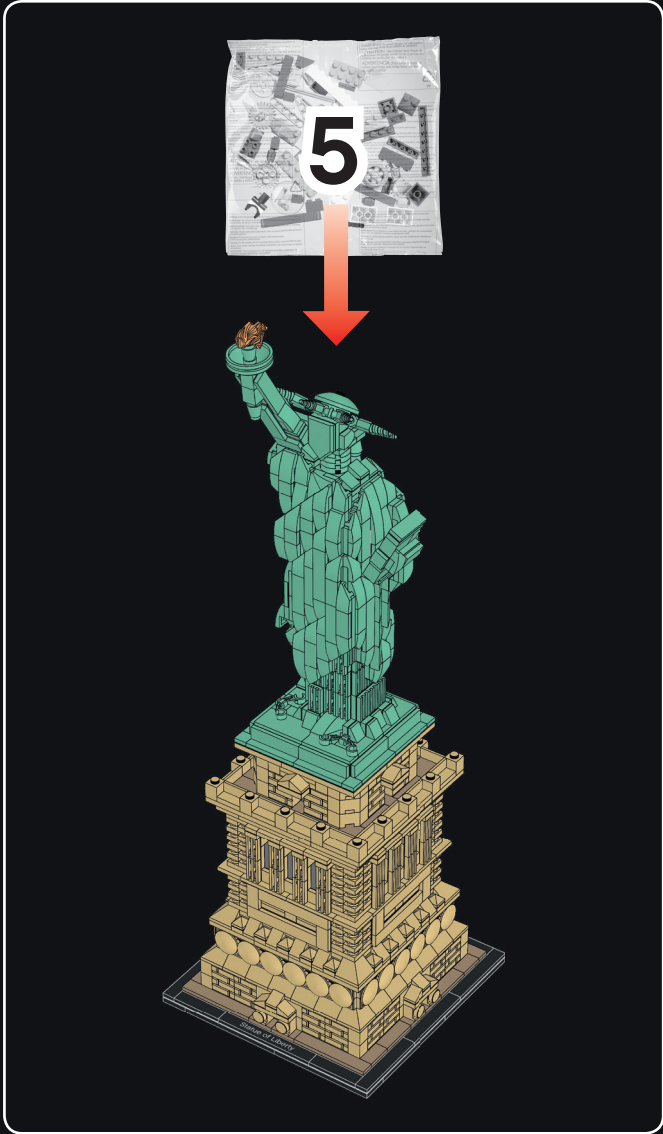

140

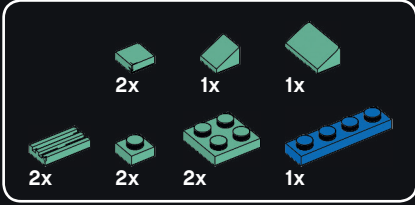

89

1



2

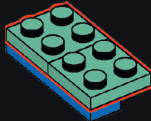

3

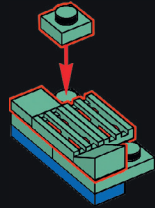

4

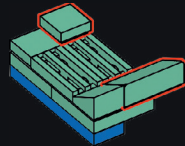

5

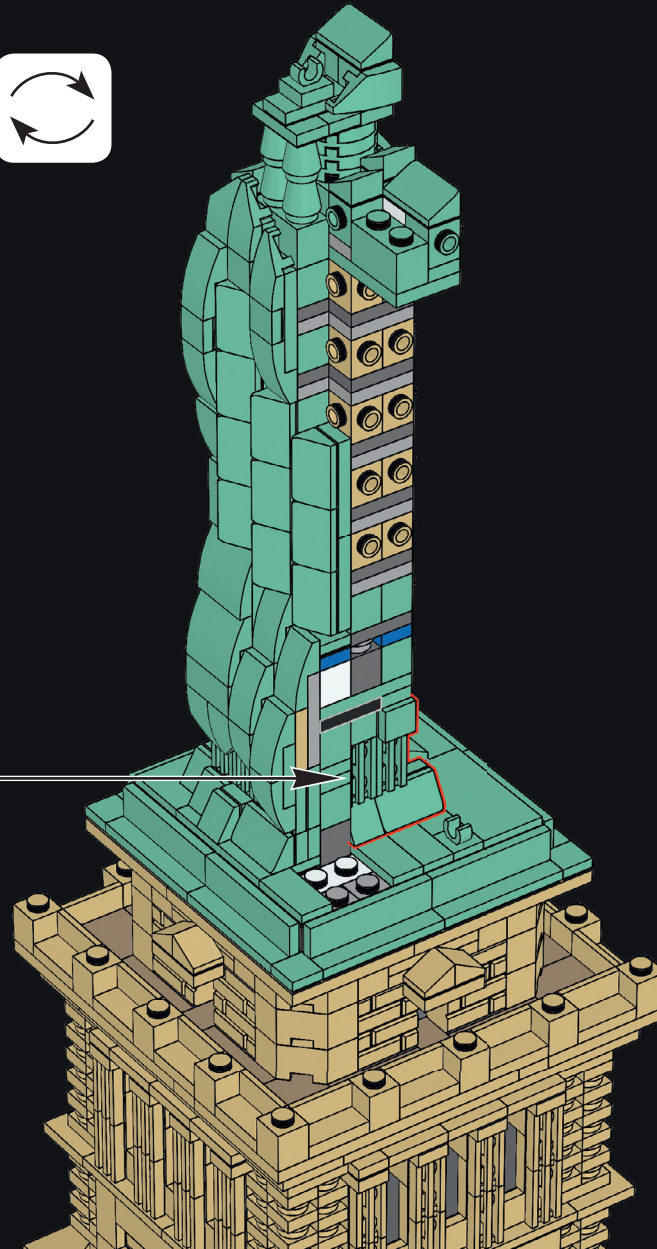
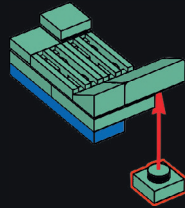

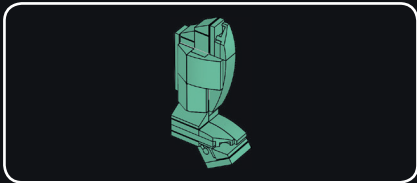

90

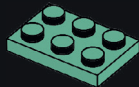

91

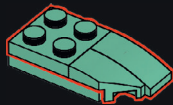

142



92

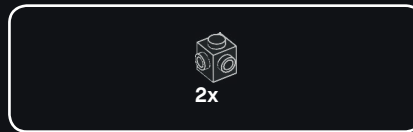
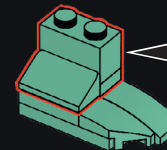
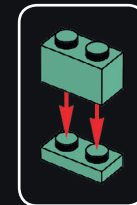

93

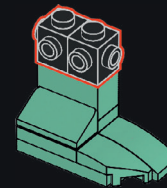



94

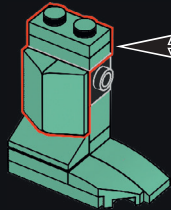
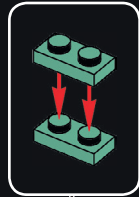

95

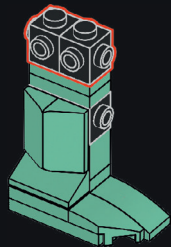

96

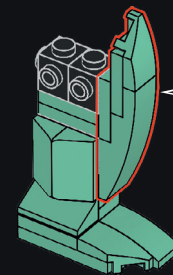
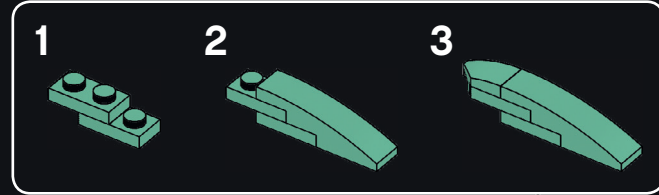



97

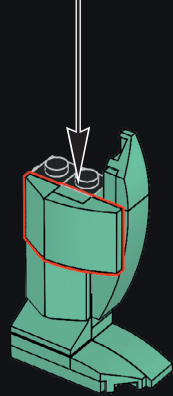
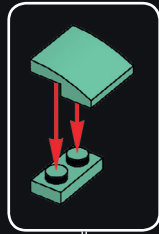

98

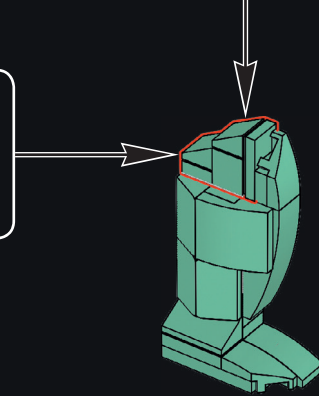
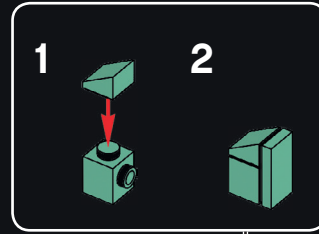





99

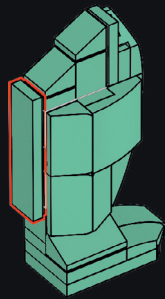

100

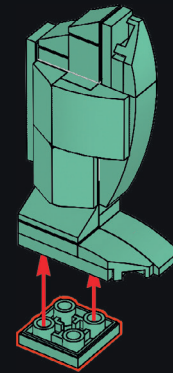



101

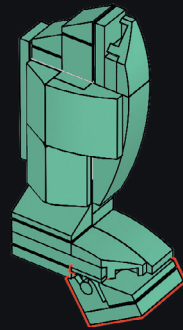
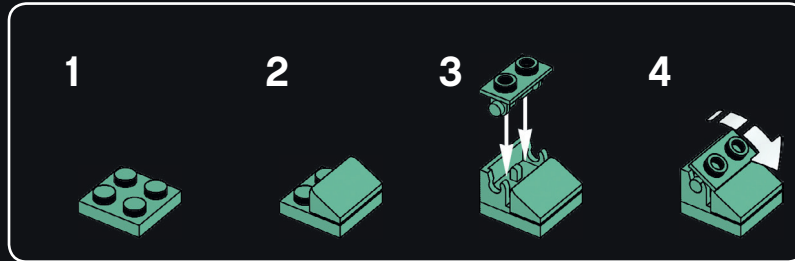



102

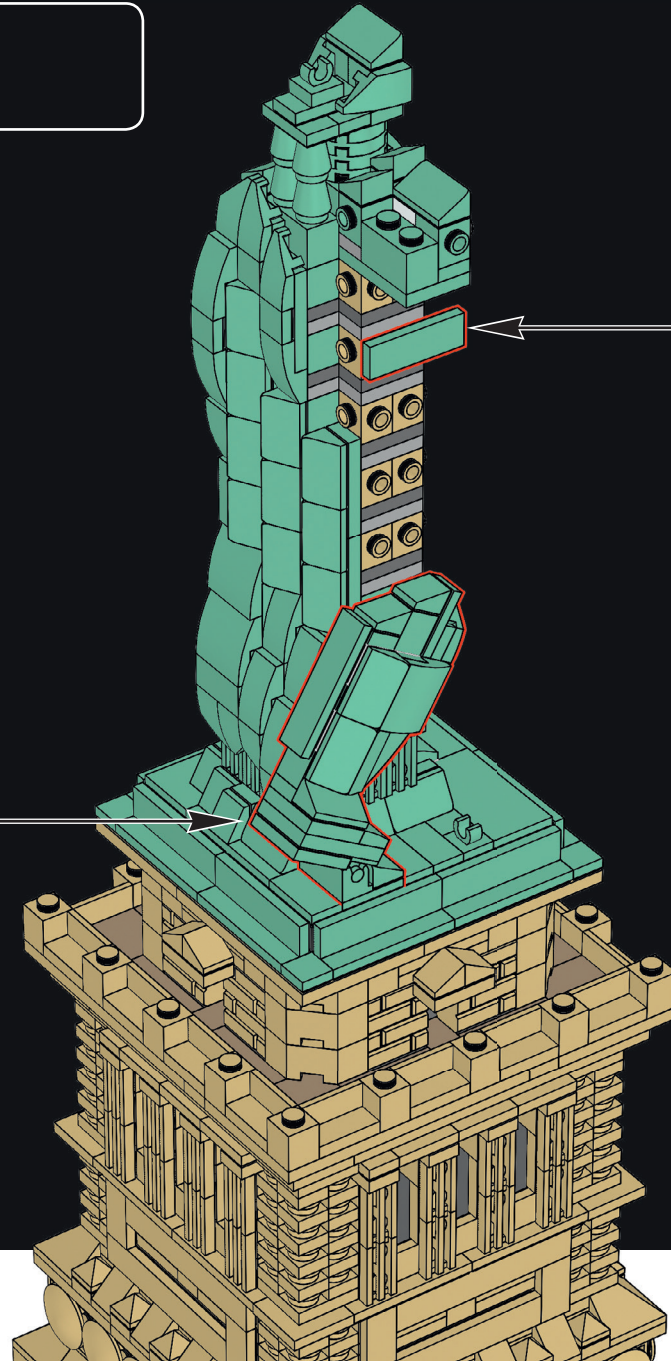

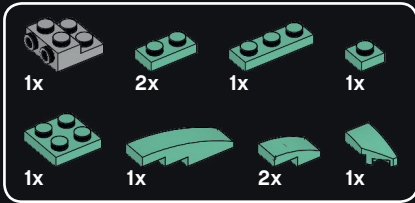

103

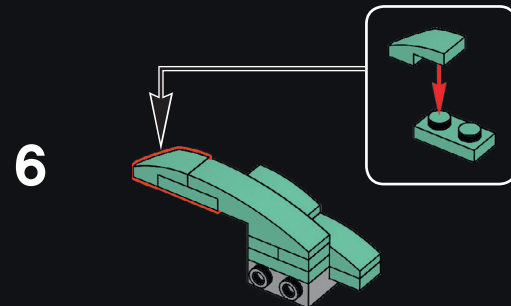
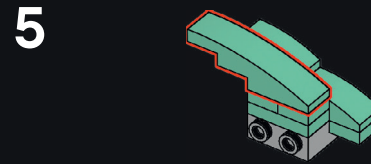
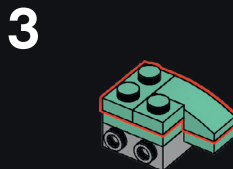
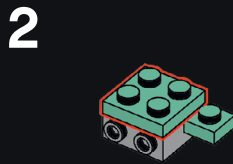
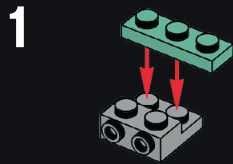

148

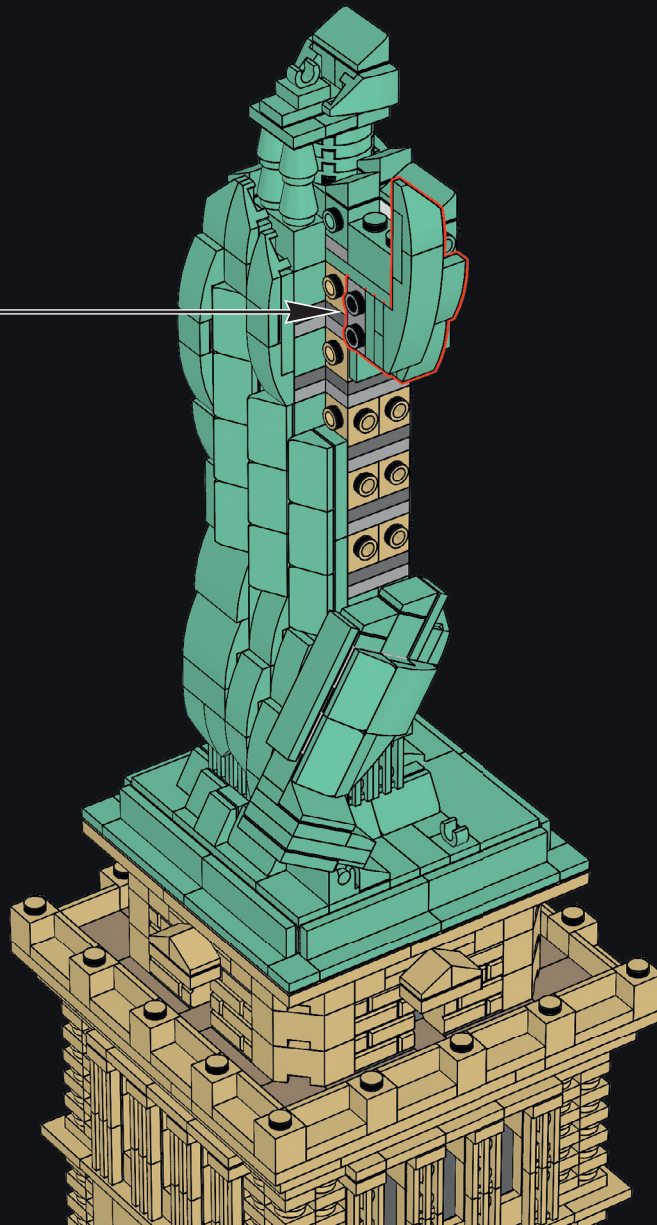

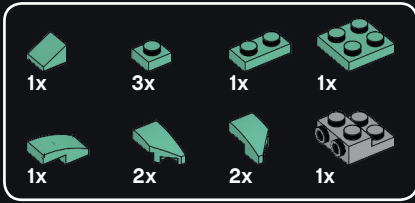

104

1



2

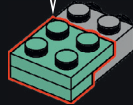
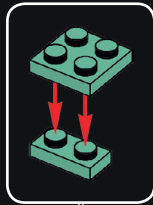

150

3

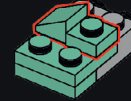

4



1

2



5

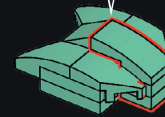

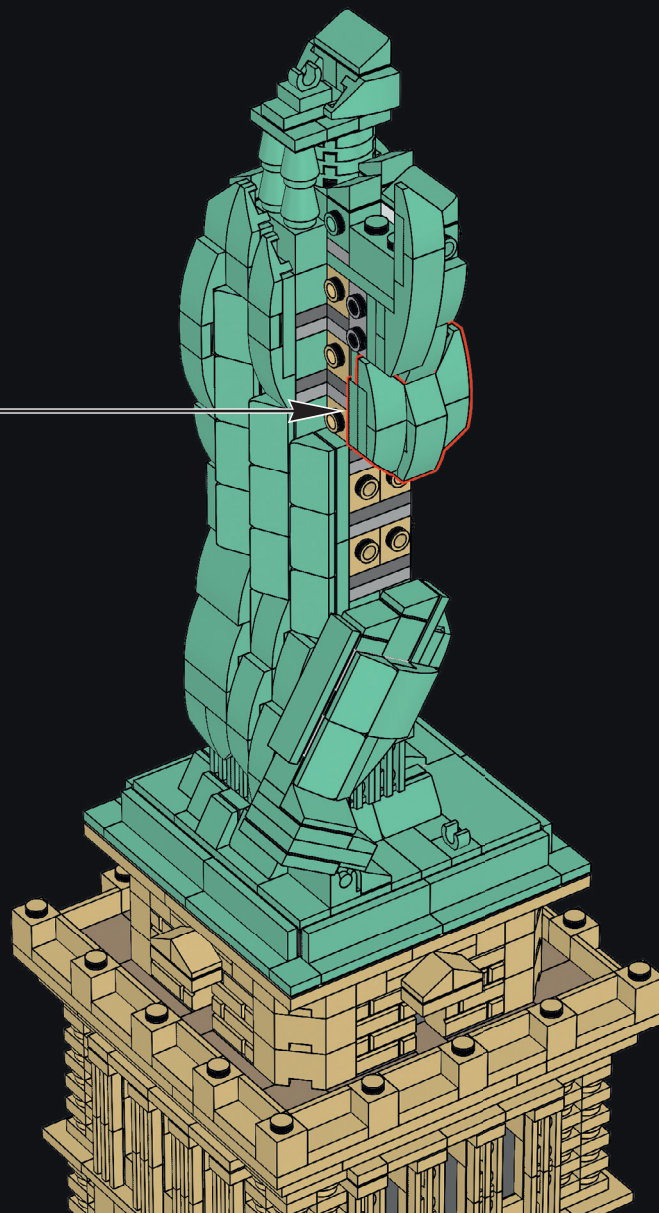

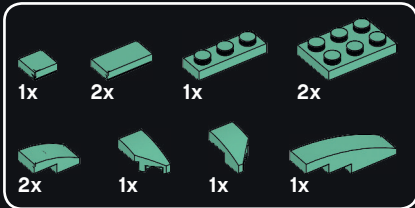

# 105

1

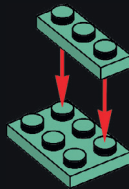

2



3

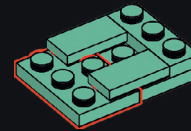

4

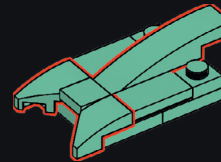

5

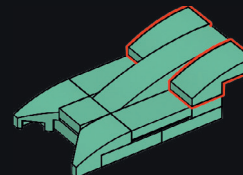



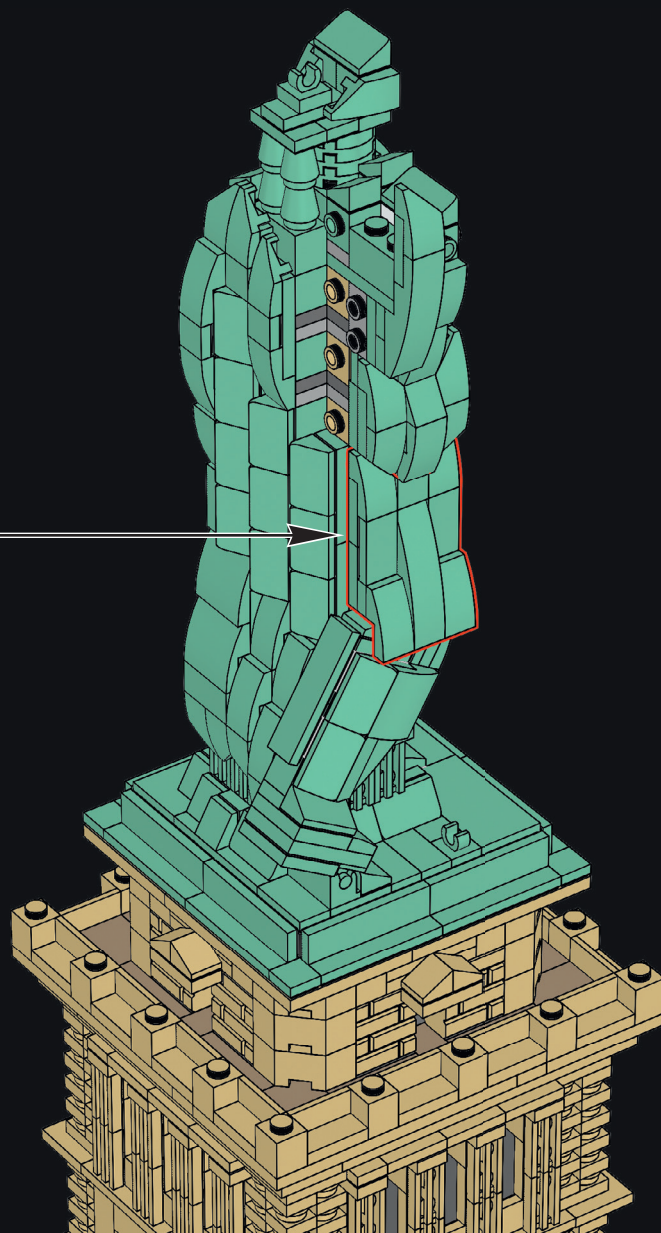

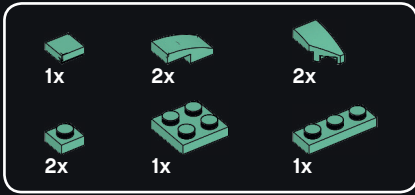

106

1

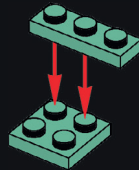

2

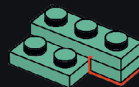

3

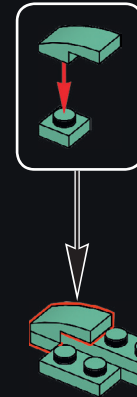

4



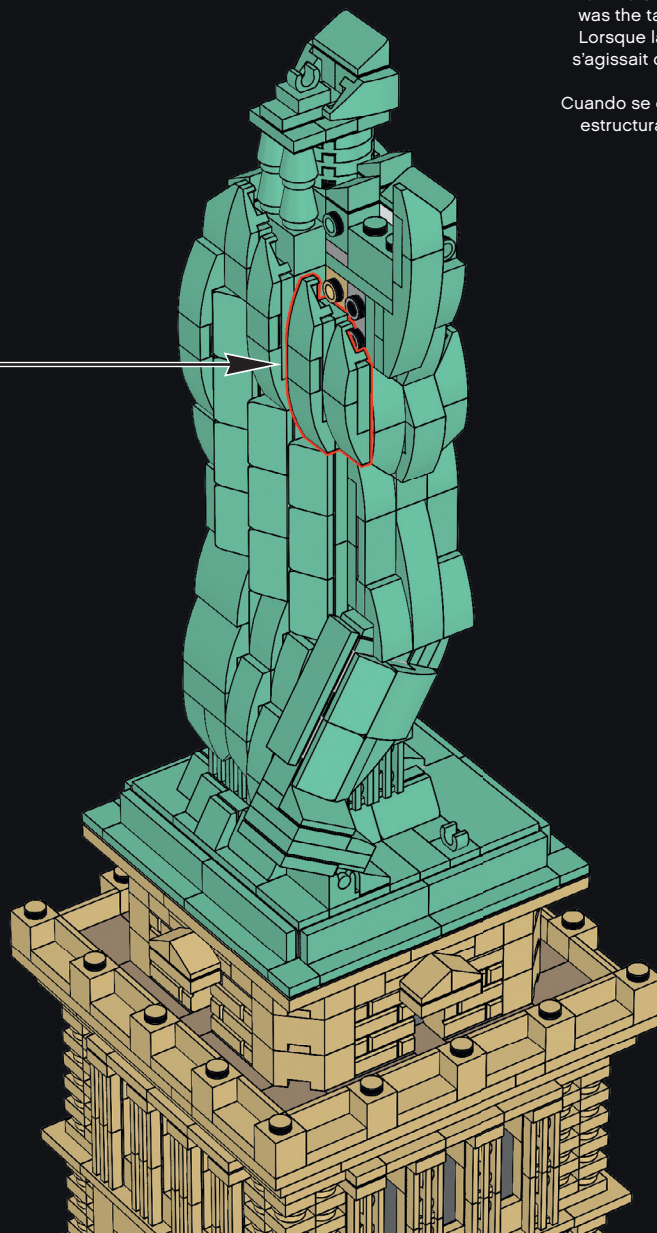

When the Statue was first erected in 1886 it was the tallest iron structure in the world.  
Lorsque la statue a été érigée en 1886, il s'agissait de la plus haute structure en fer dans le monde.  
Cuando se erigió en 1886, la estatua era la estructura de hierro más alta del mundo.

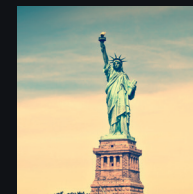



107

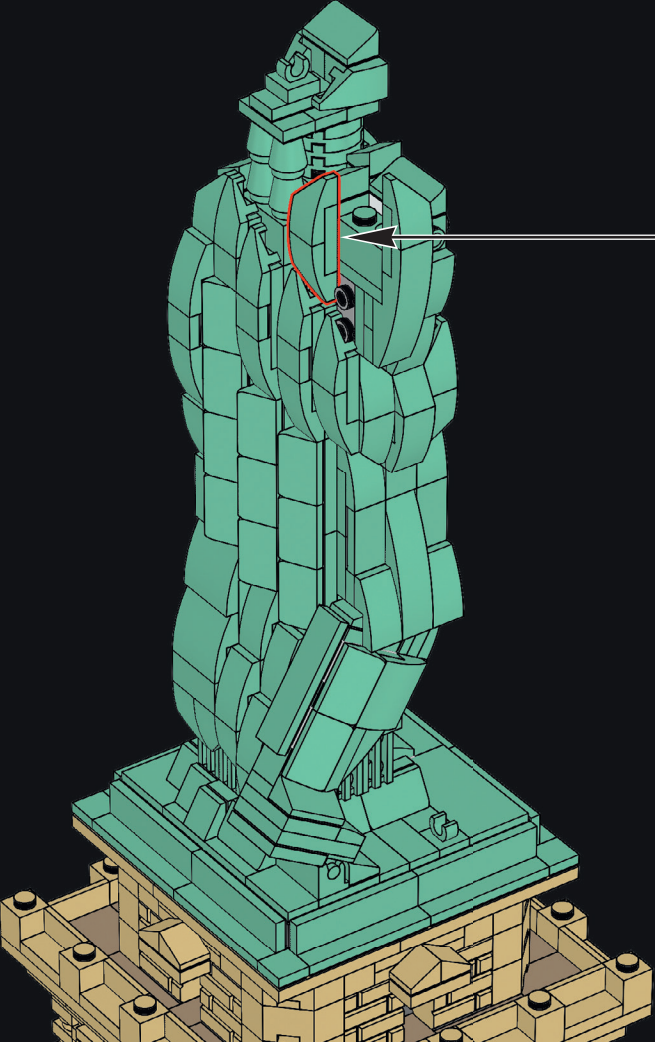

156



108

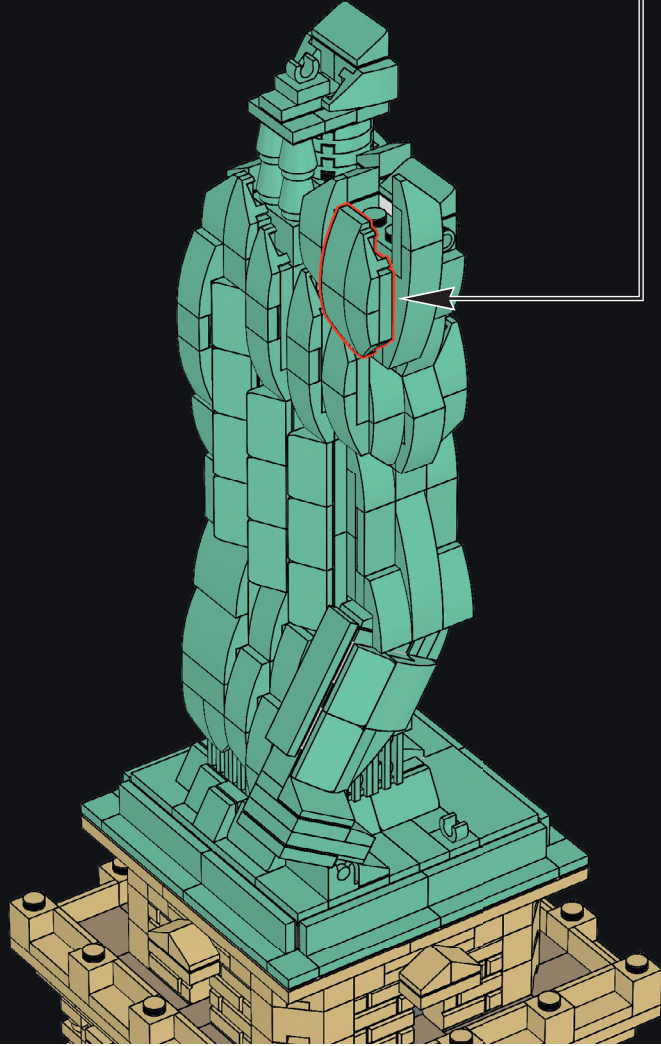



109

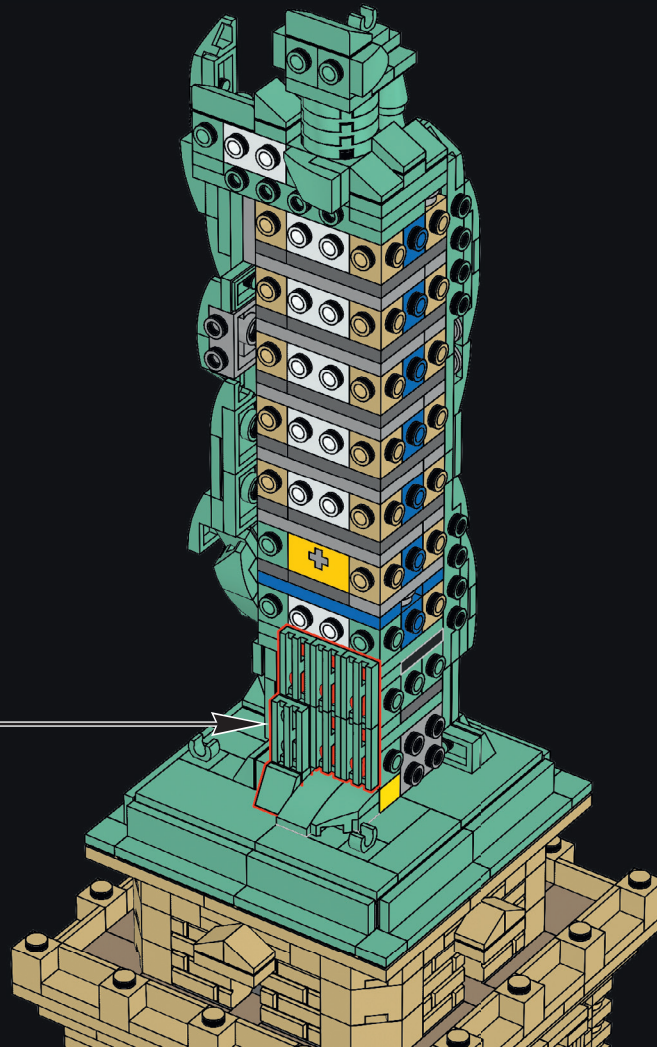

158

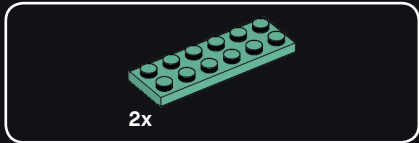
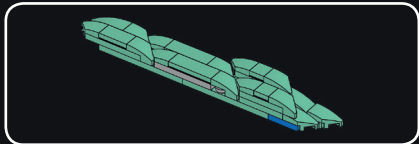

2x

110

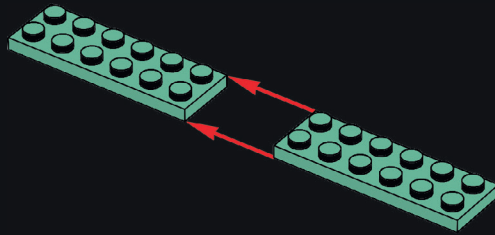

1x

2x

111

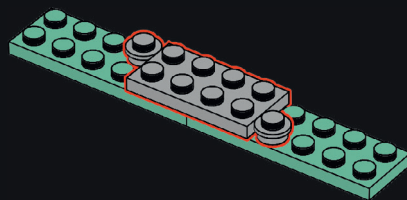

2x

4x

112

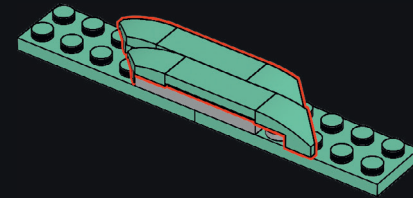

1x

1x

1x

113

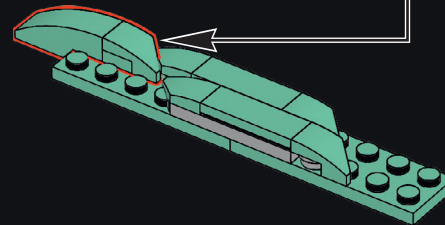
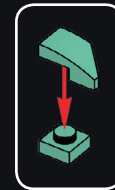

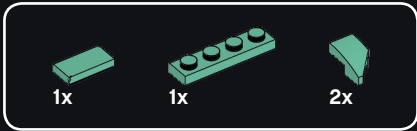

114

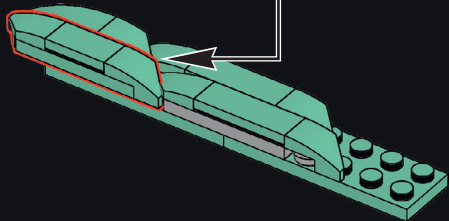
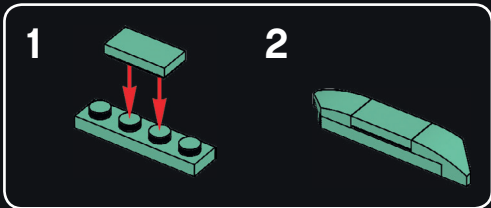

160



115

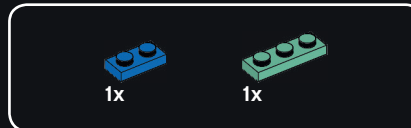
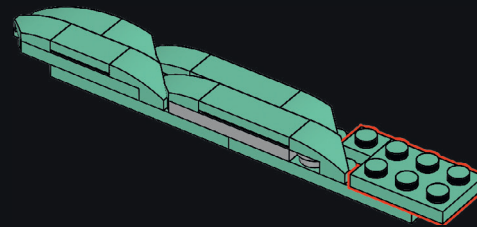

116

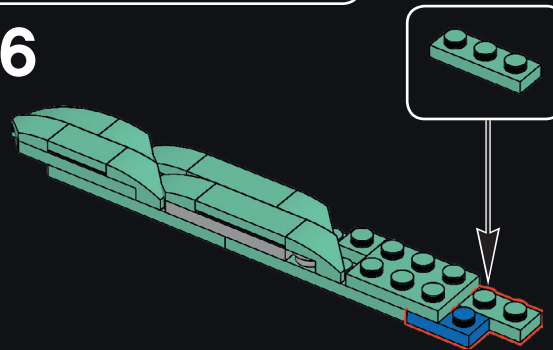





117

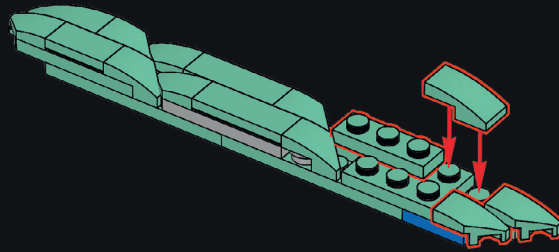

118

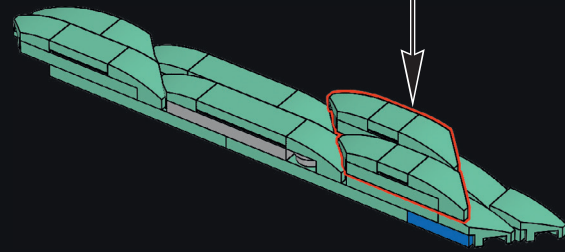
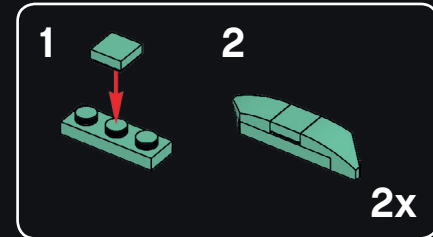

119

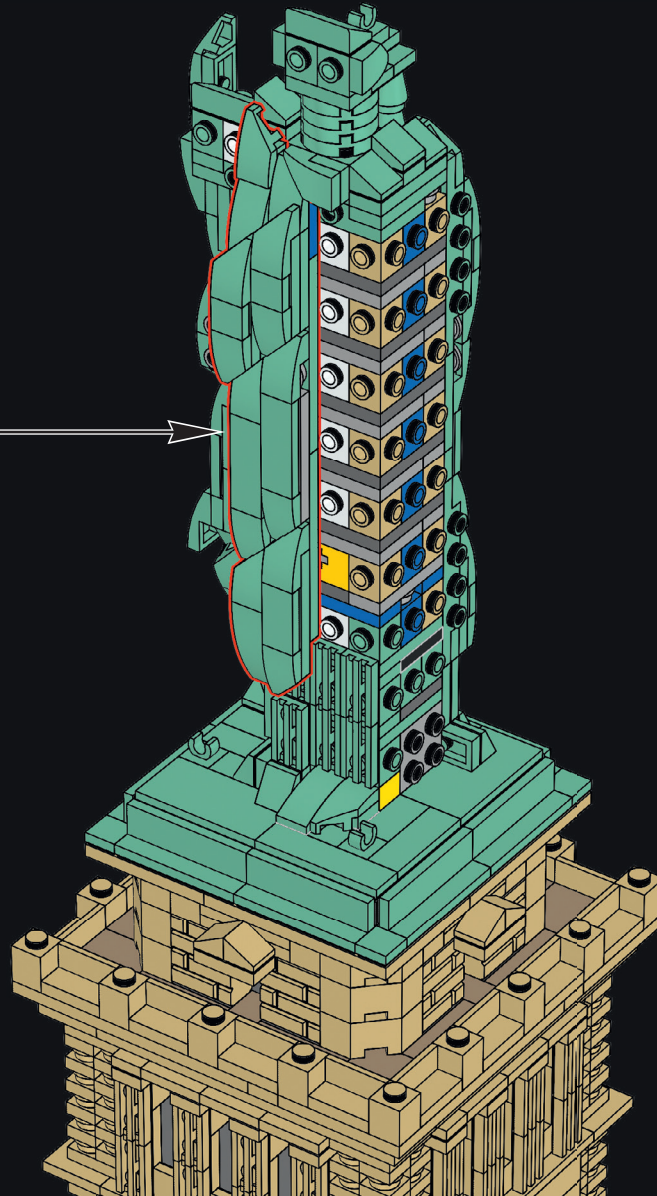

162



120

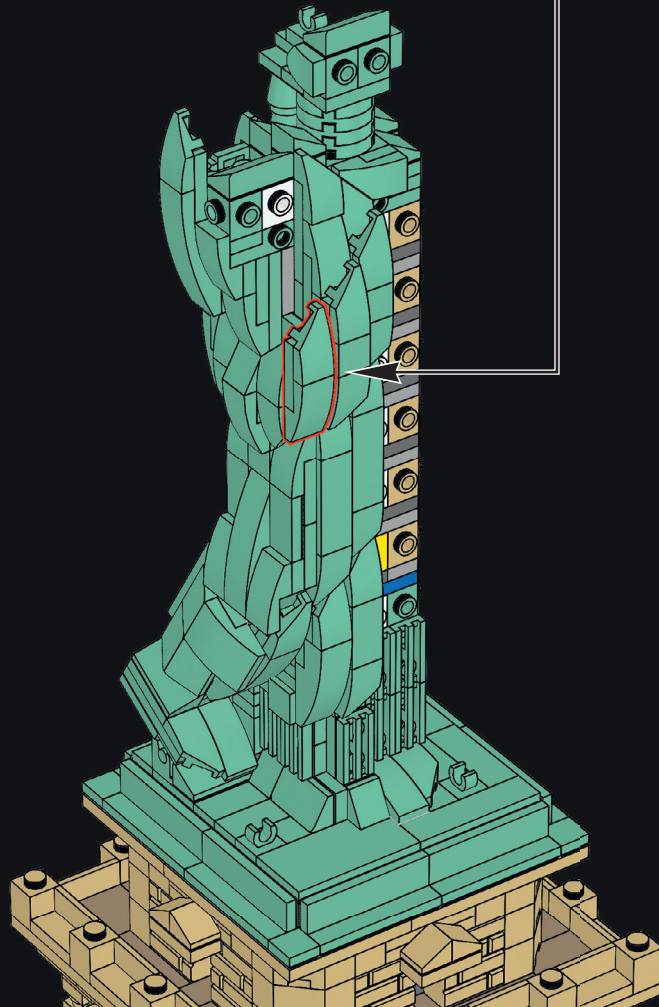

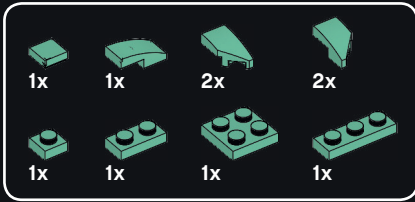

121

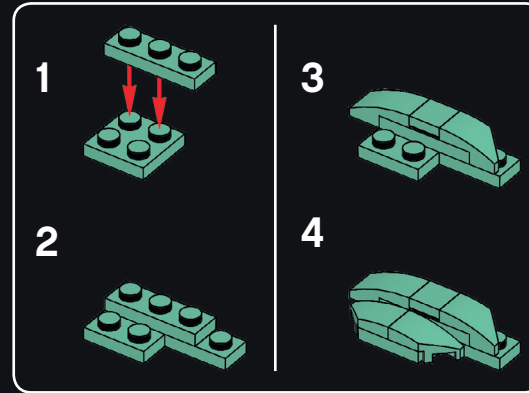
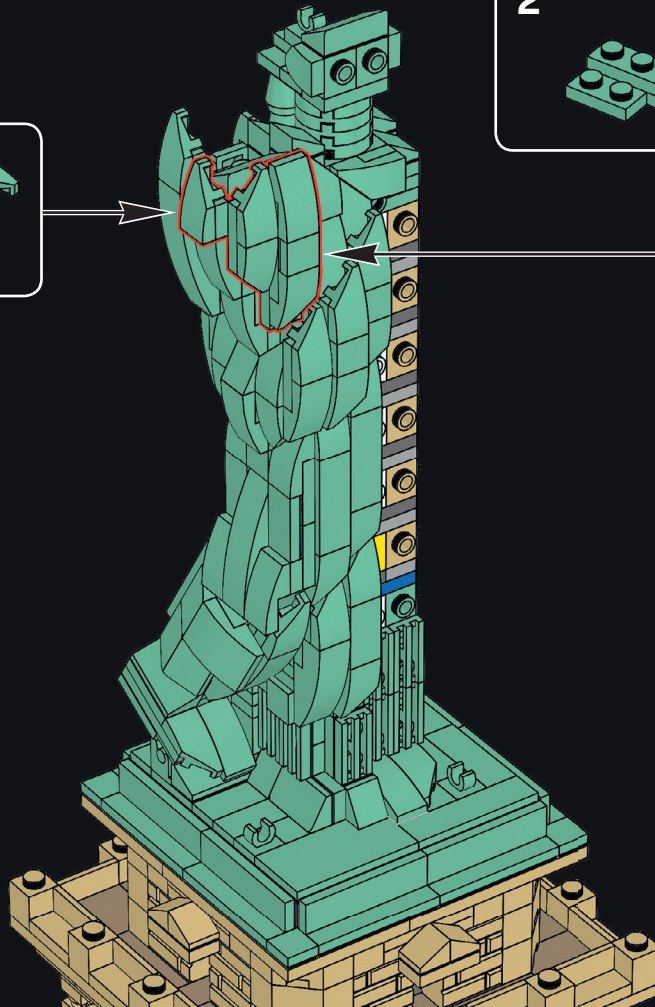

164

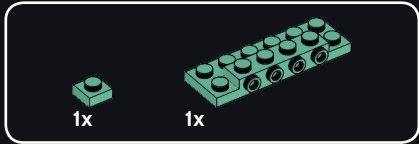
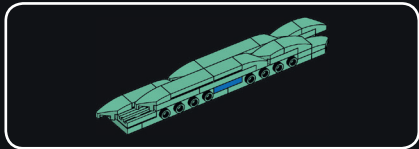

122

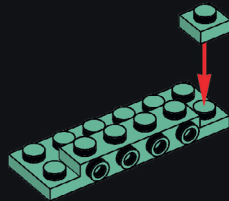

123

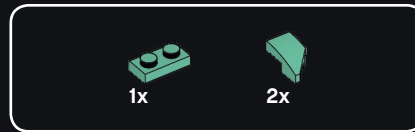
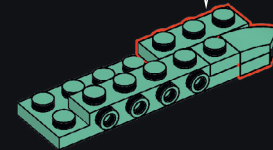
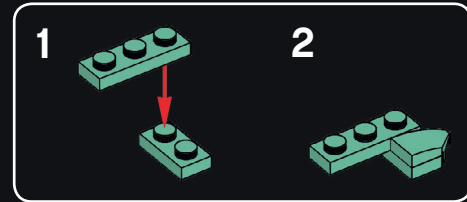

124

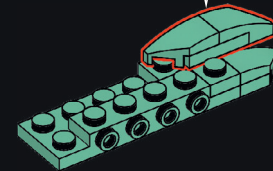

165

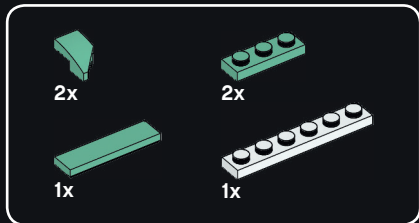

125

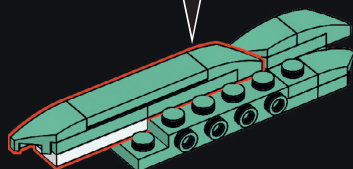
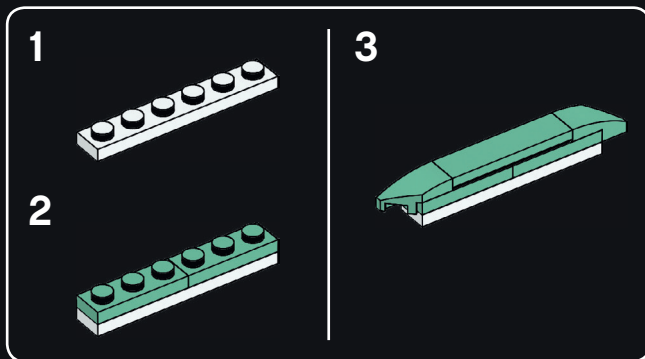

166

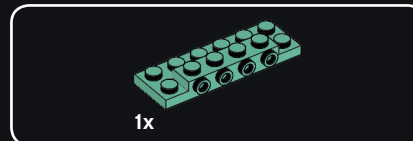

126

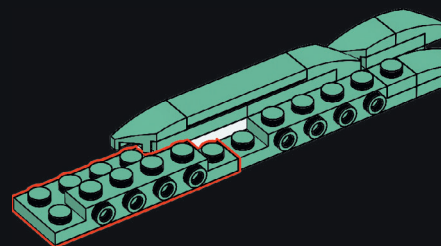

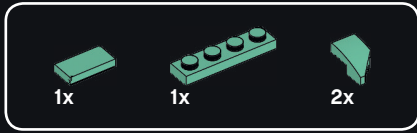

127

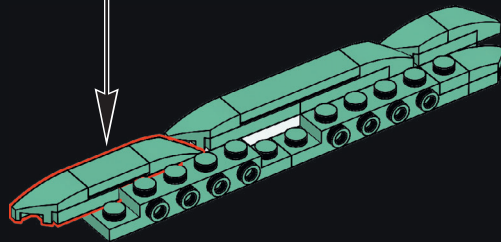
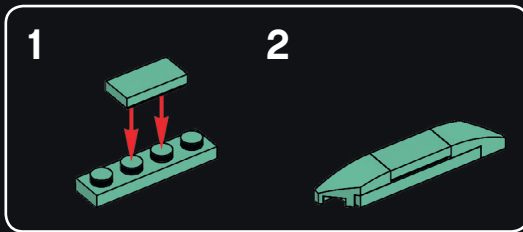

128

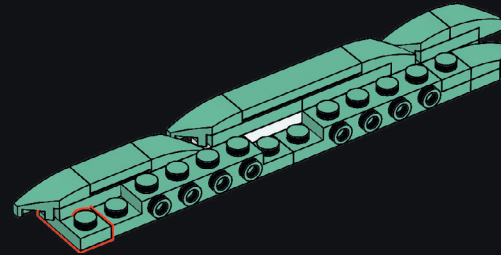

129

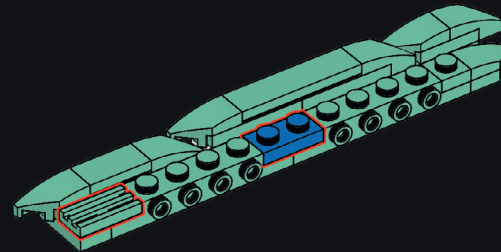

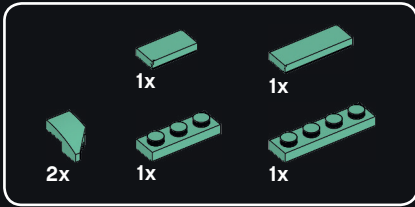

# 130

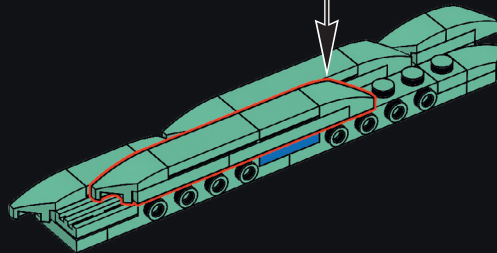
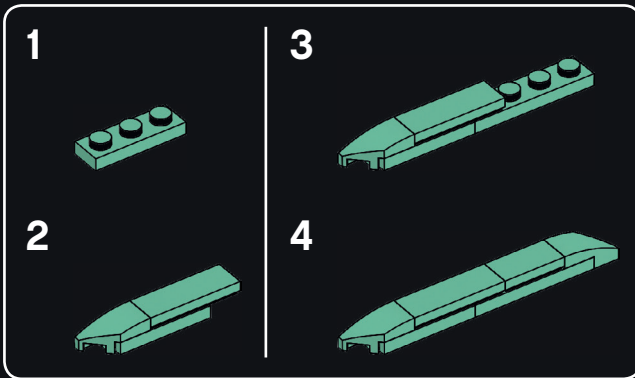

168



# 131

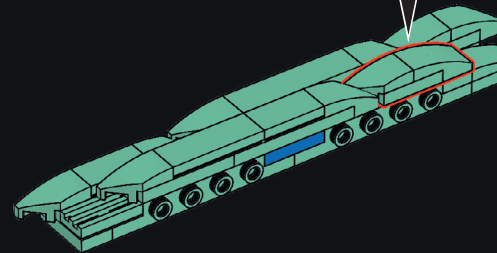



132

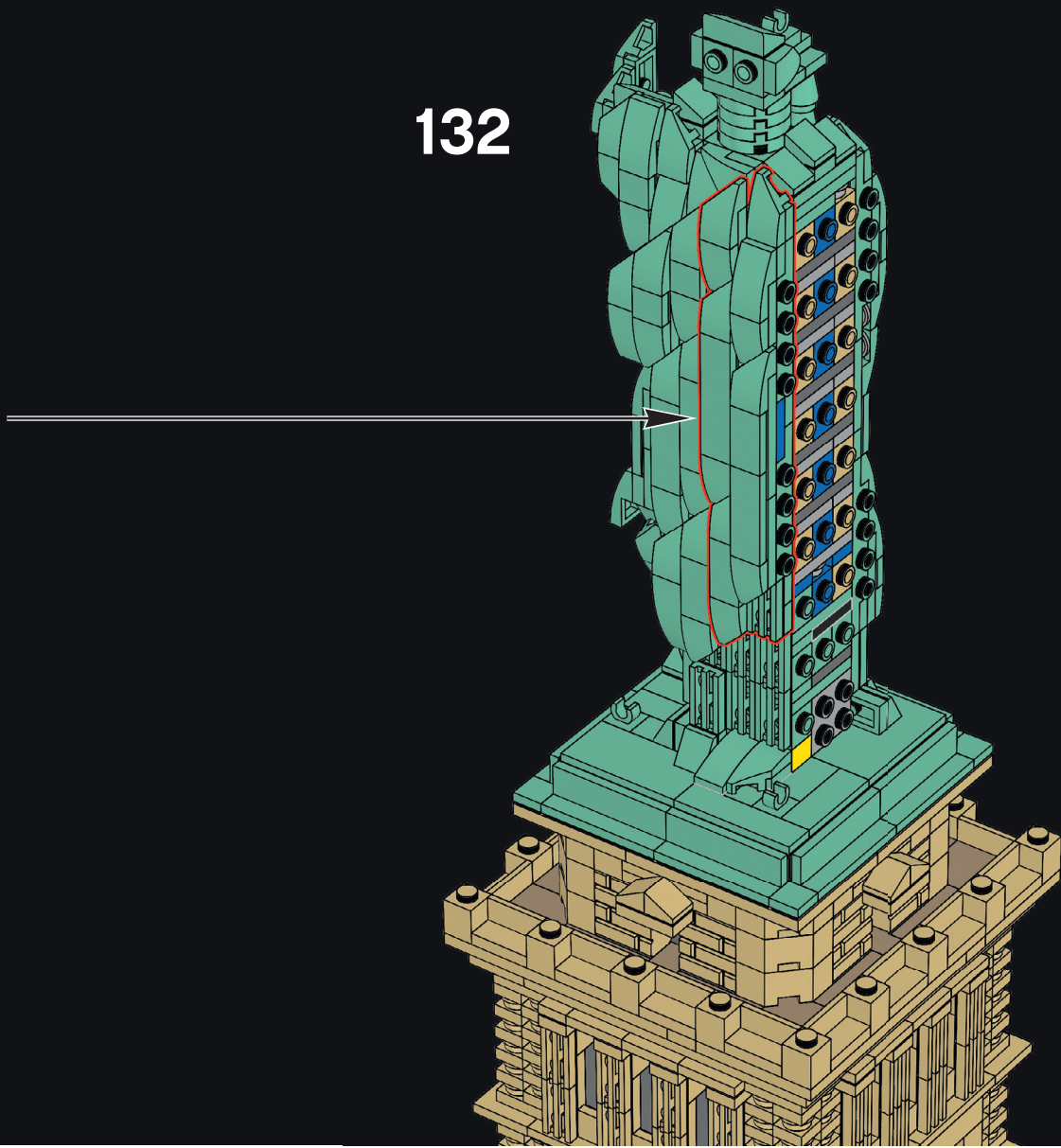

169

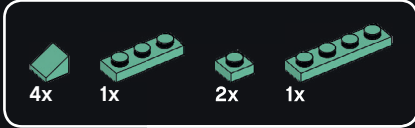

133

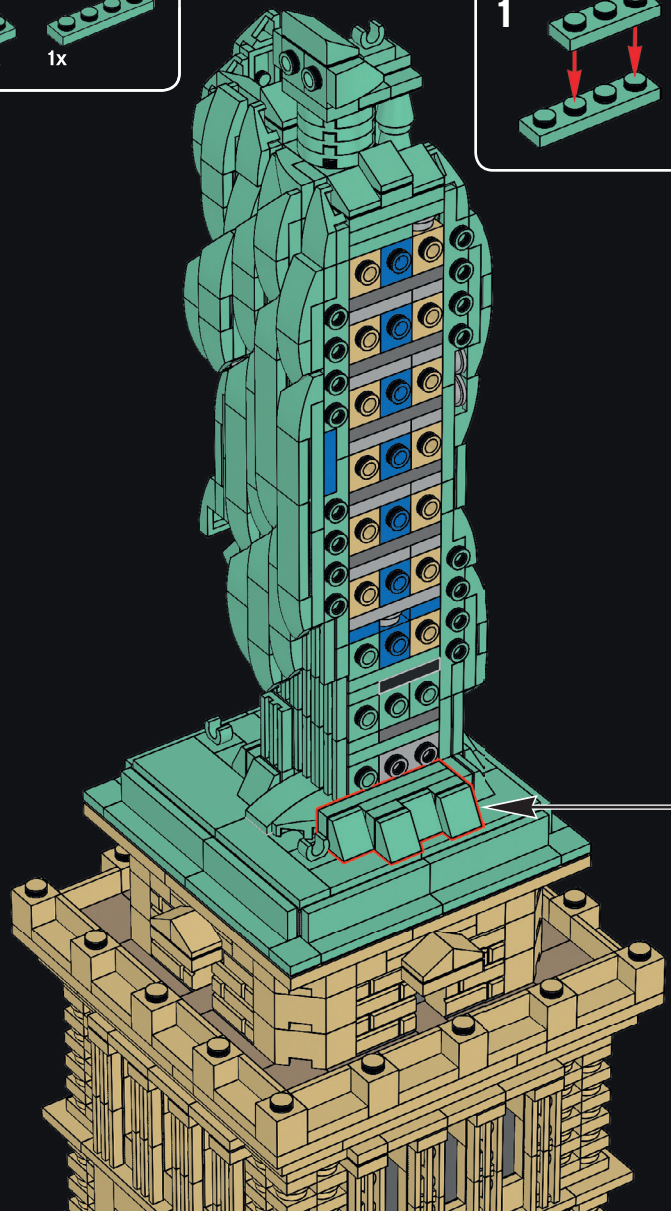
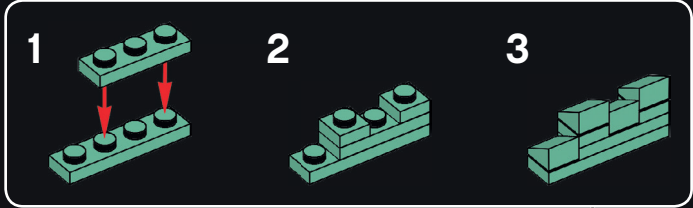

170

134

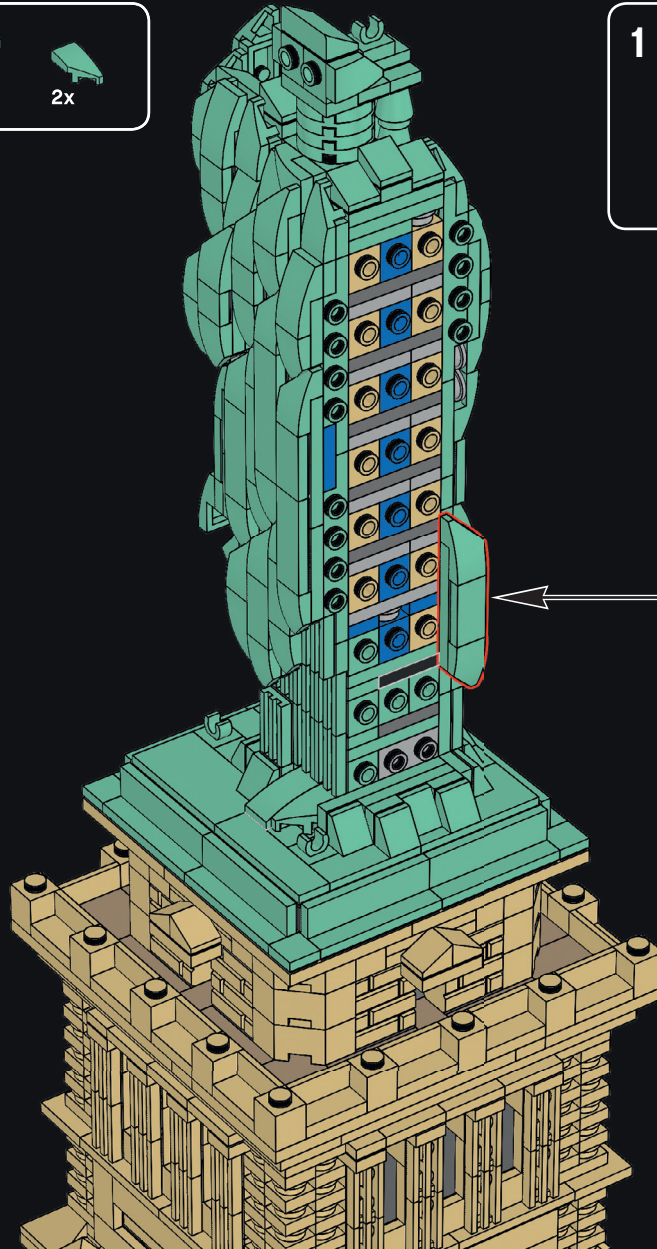
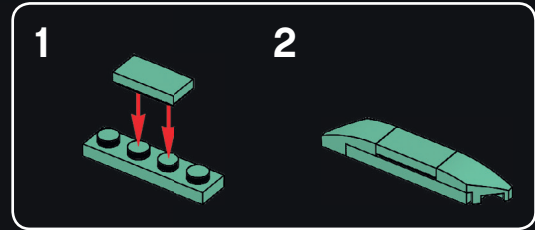
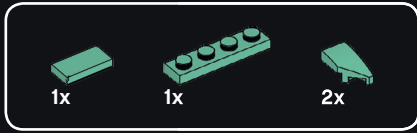



135

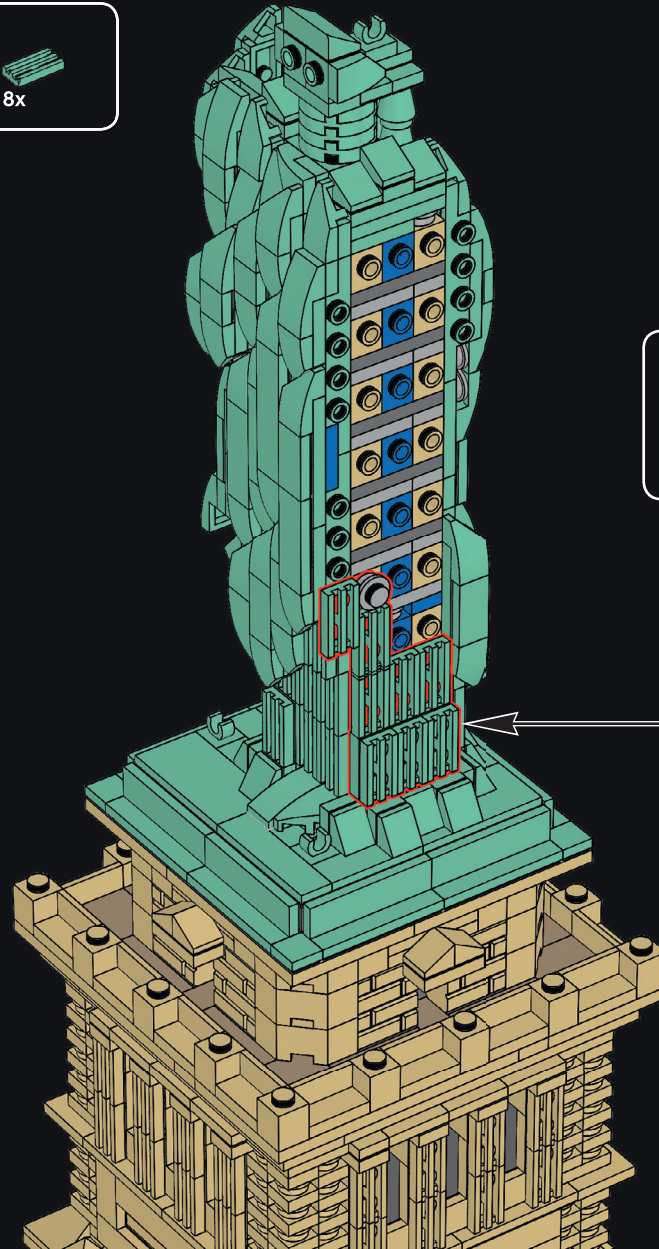

172

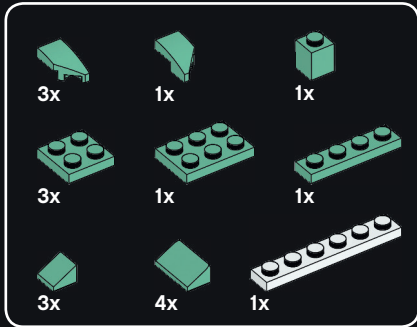

136

1



2

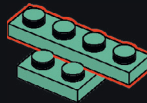

3

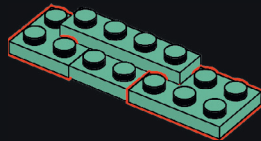

4

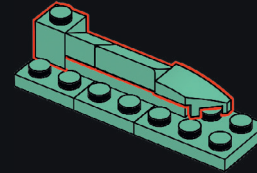

5

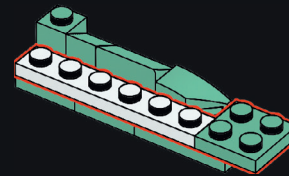

6

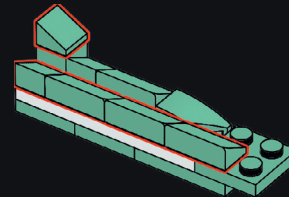

7

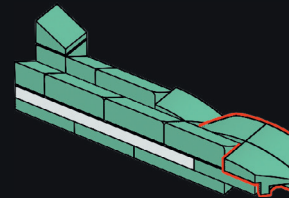

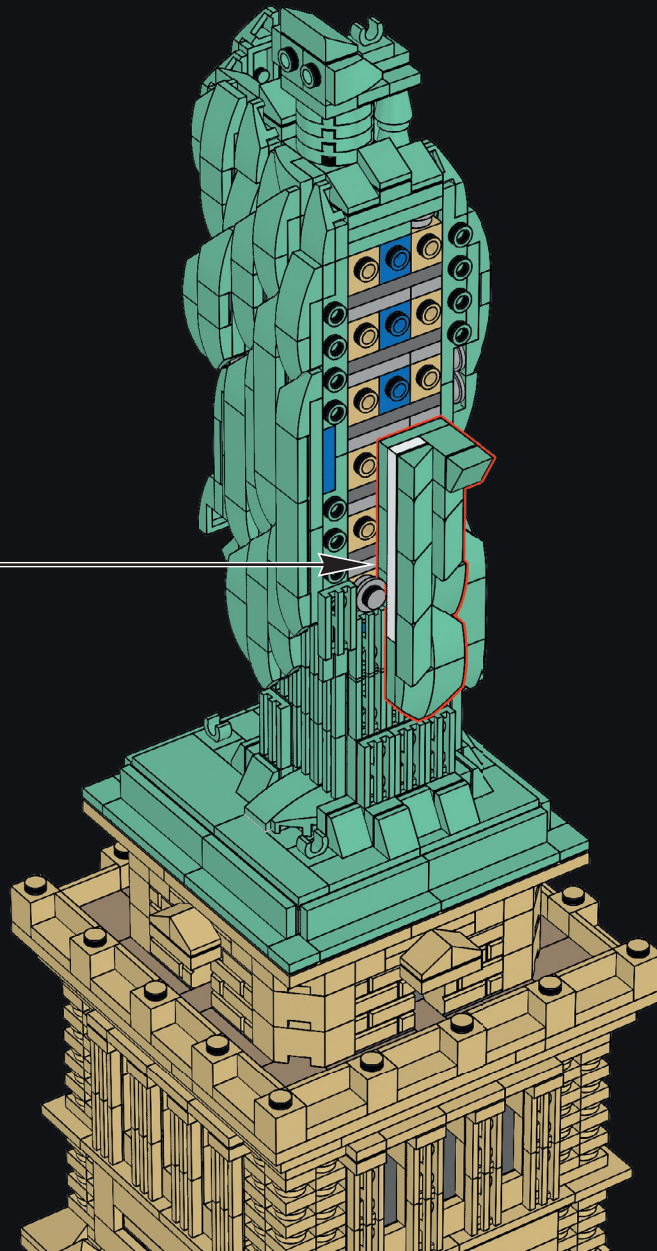

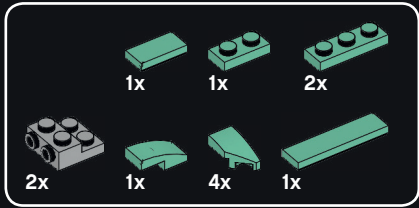

137

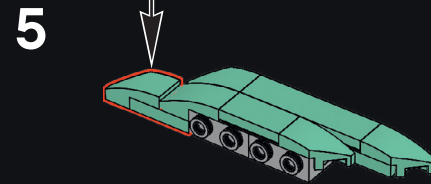
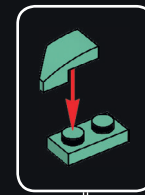
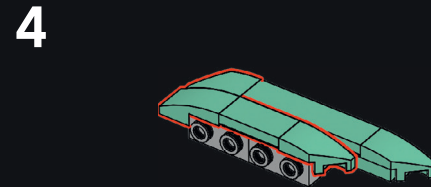
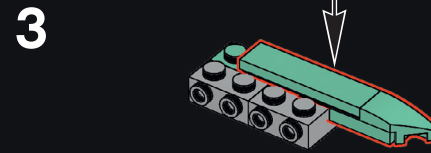
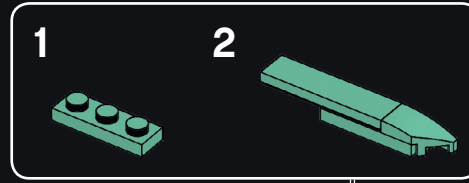
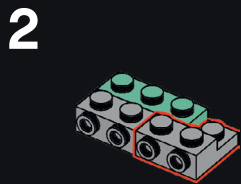
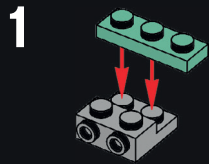

175

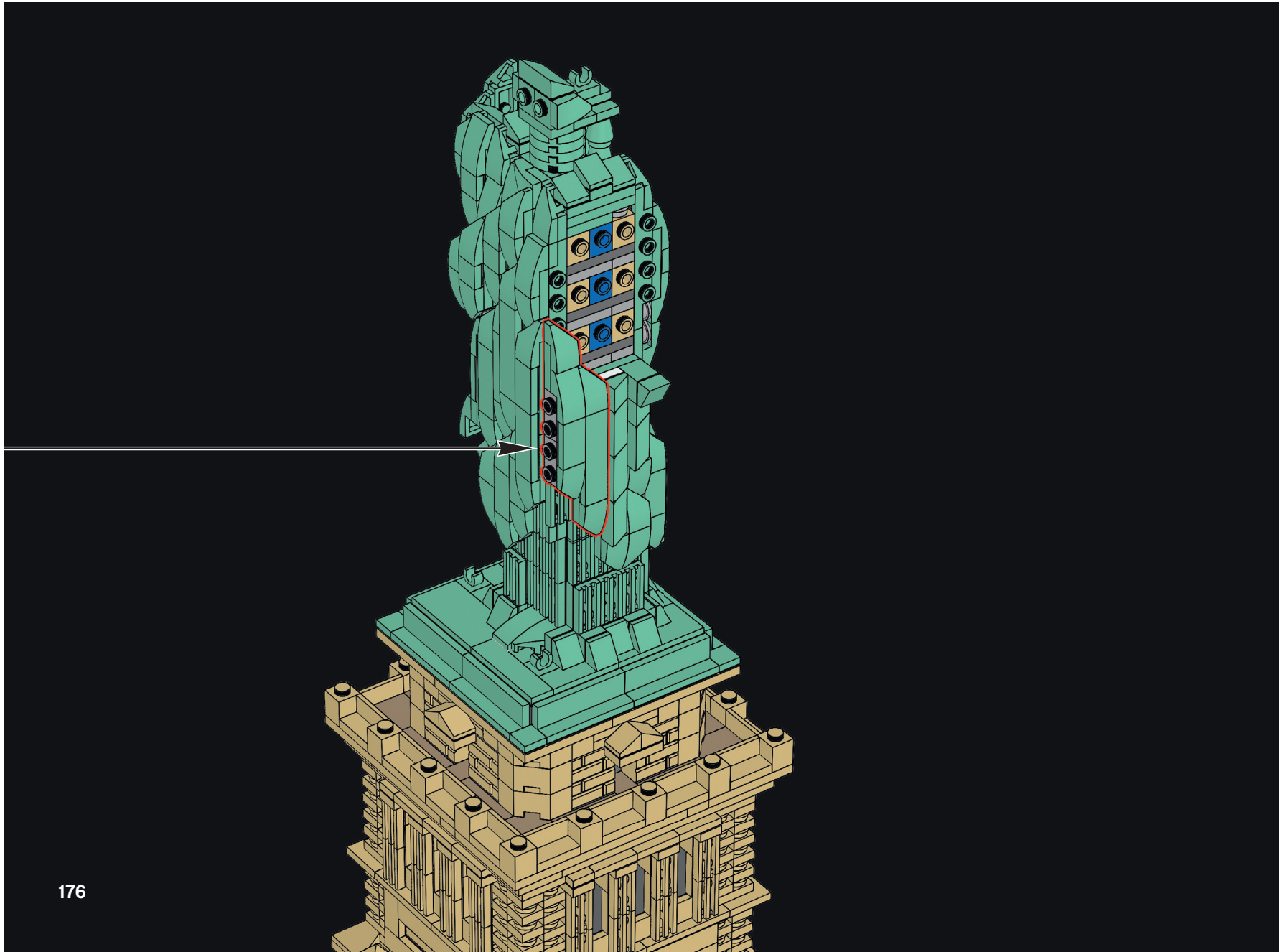

176



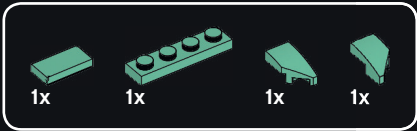

138

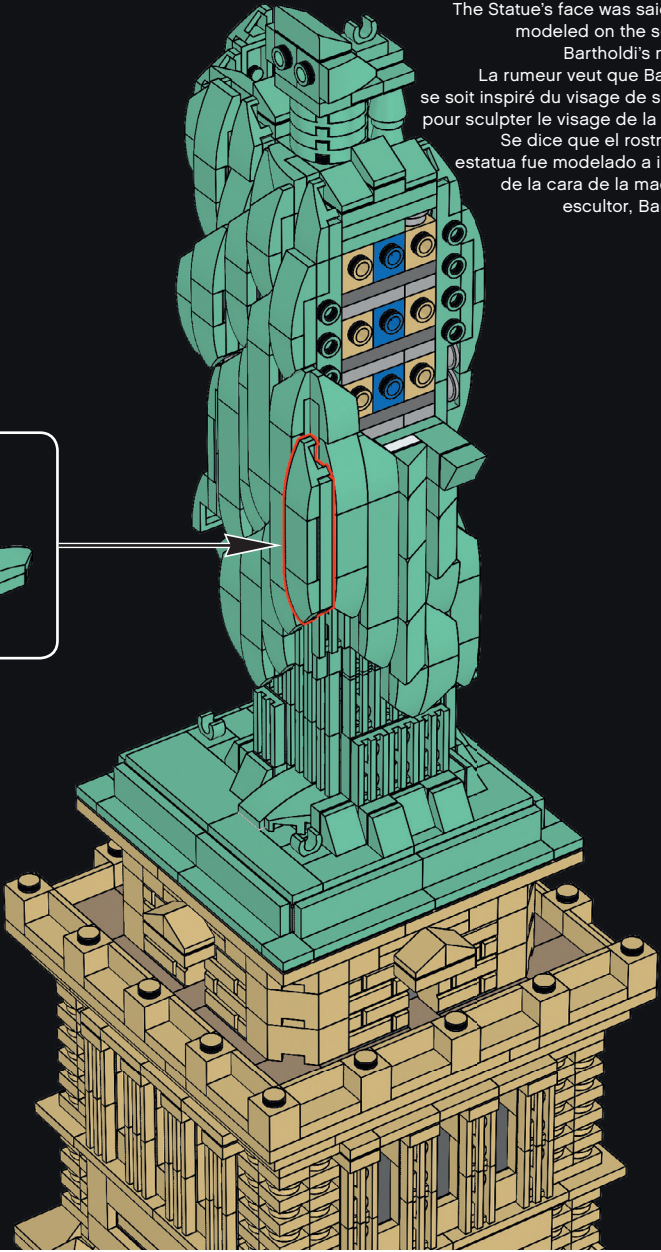
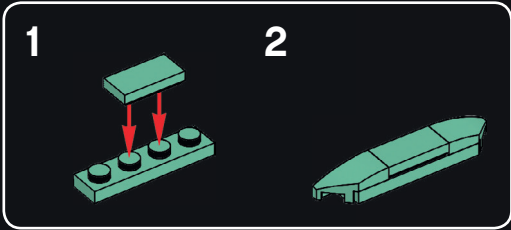

The Statue's face was said to be modeled on the sculptor Bartholdi's mother.  
 La rumeur veut que Bartholdi se soit inspiré du visage de sa mère pour sculpter le visage de la statue.  
 Se dice que el rostro de la estatua fue modelado a imagen de la cara de la madre del escultor, Bartholdi.



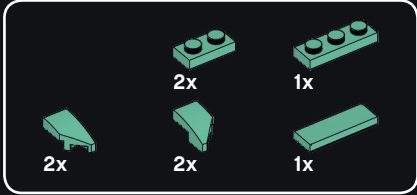

139

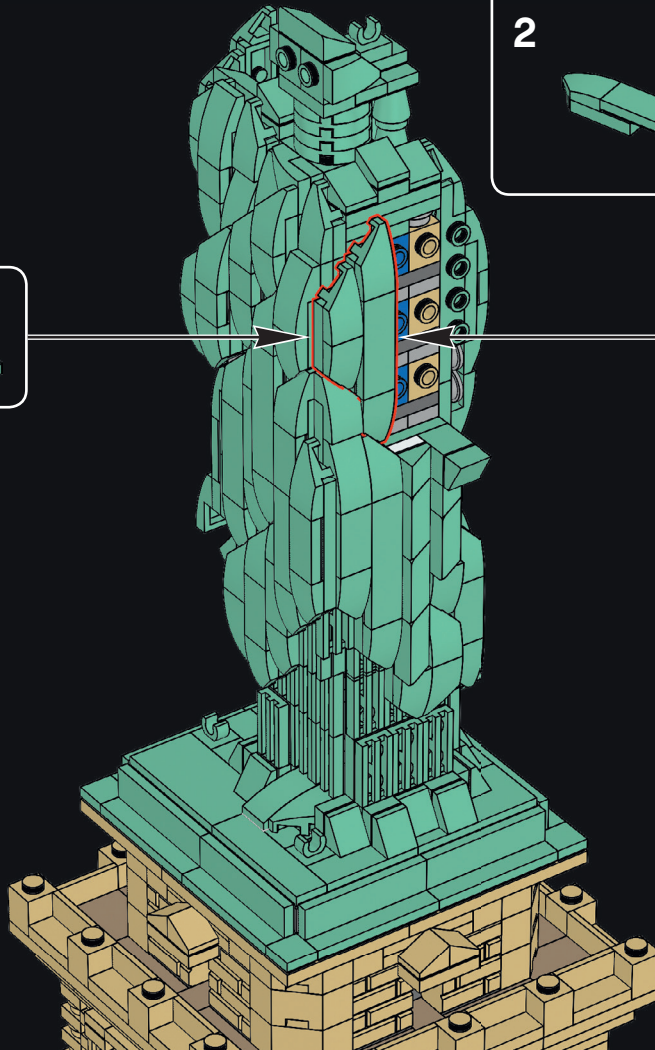
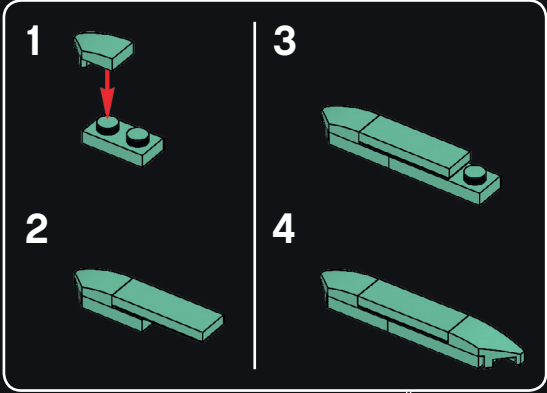

178

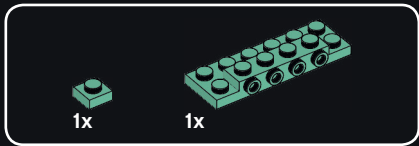

140

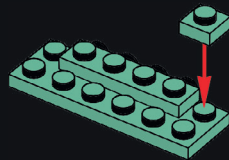

141

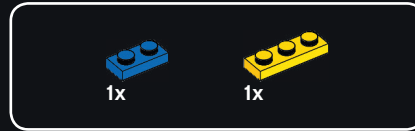
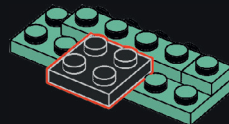

142

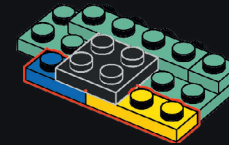

143

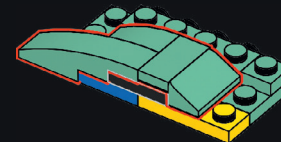



144

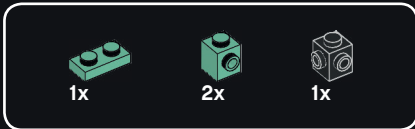
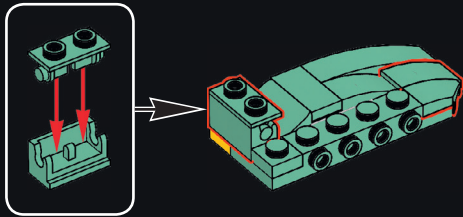

145

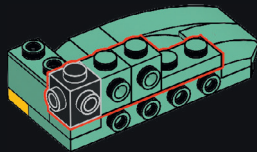

180



146

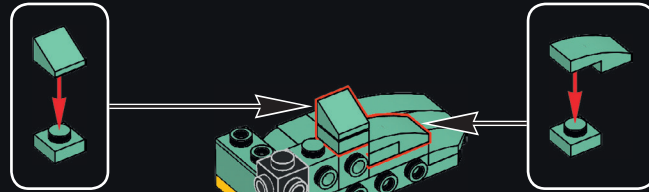

147

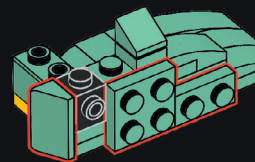



148

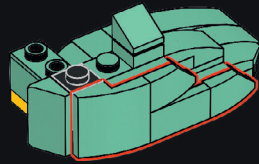

149

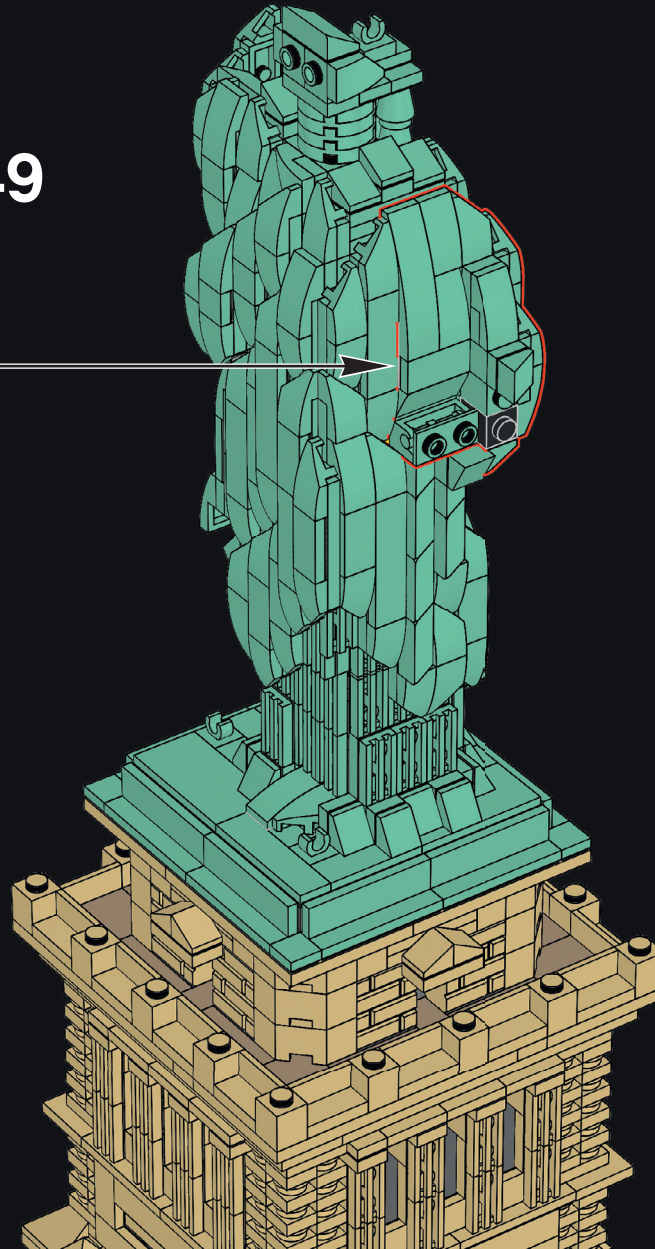

181

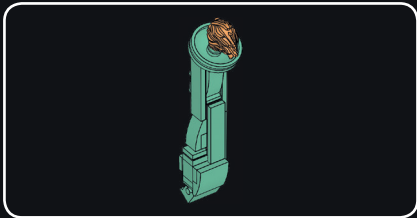

150

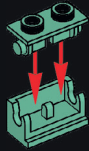

151

182



152



153





154



155



156

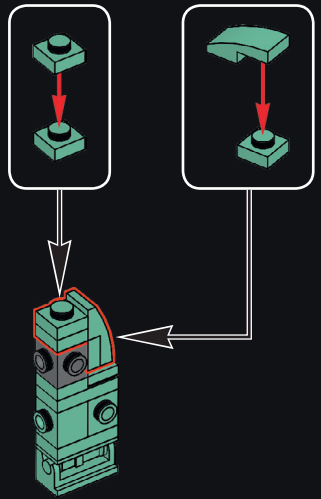



1x



1x

# 157

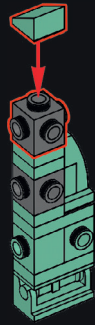

1x



1x

# 158

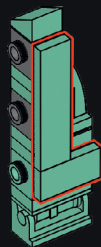

184



2x

# 159

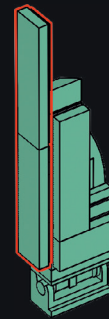



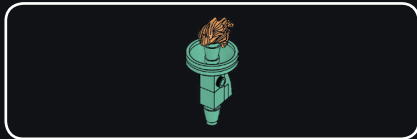

160

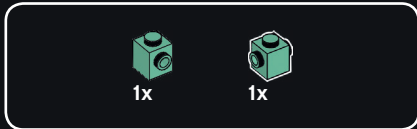
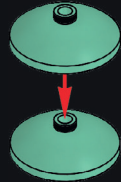

161

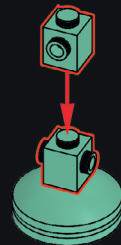

162

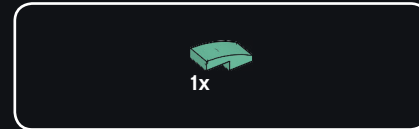
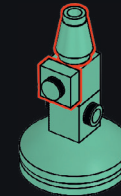

163

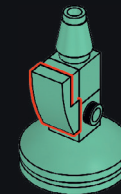

185



164

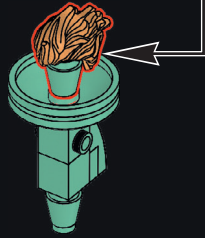

165

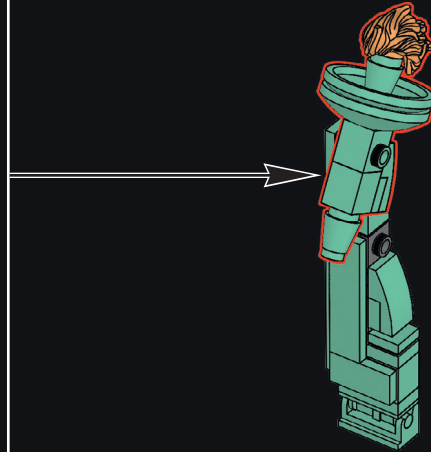

186



166

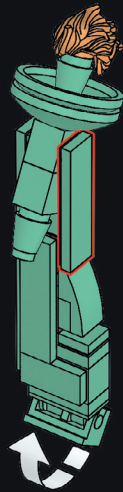

167

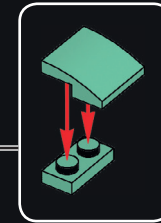
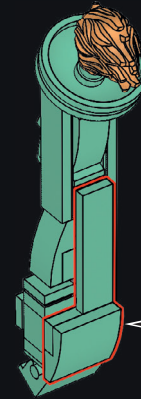

187

168

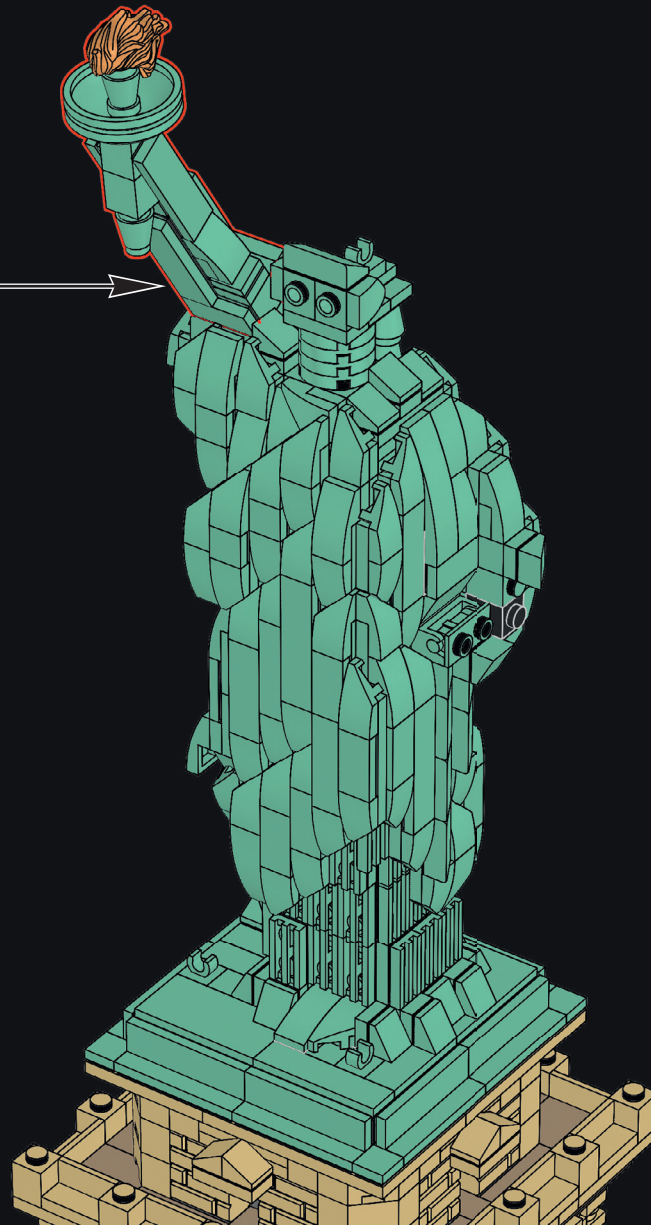

188

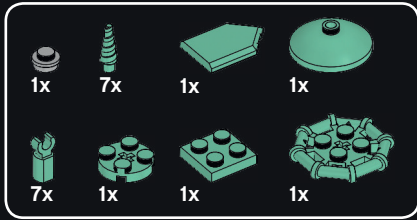

169

1



2



3

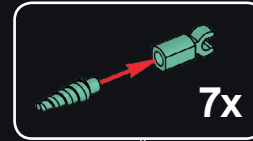
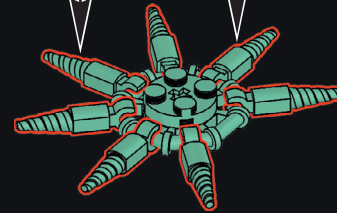

4

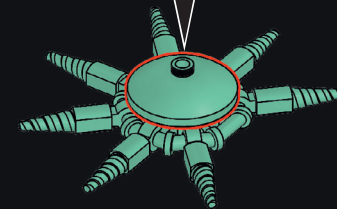



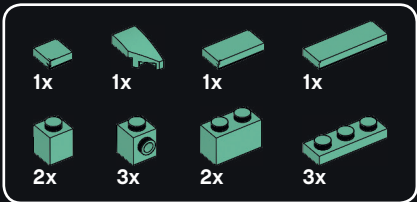

170

1

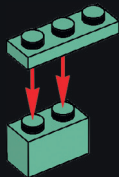

2

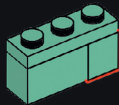

3

There are 25 windows  
in the crown.  
La couronne  
possède 25 fenêtres.  
Hay 25 ventanas  
en la corona.

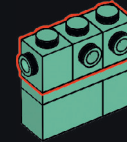

4

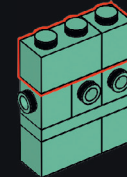

5

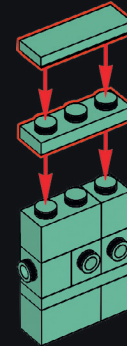

191

6

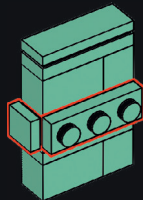

7

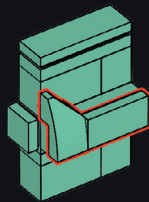

192

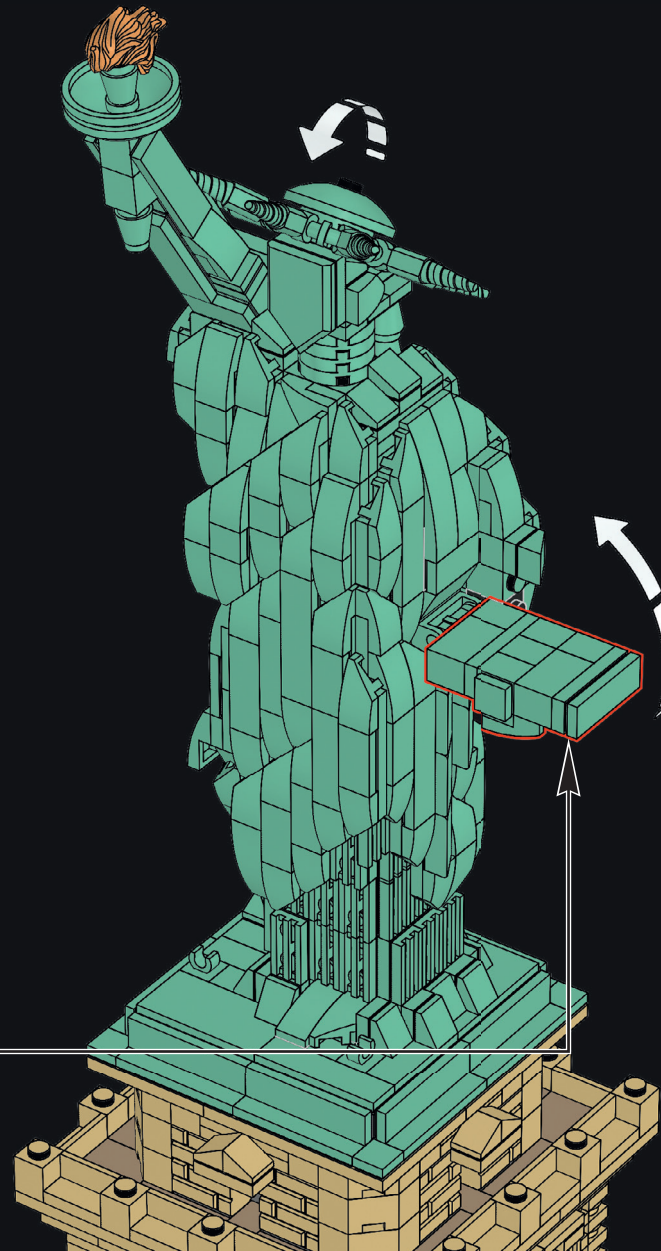





171

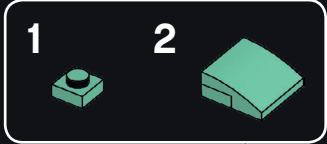
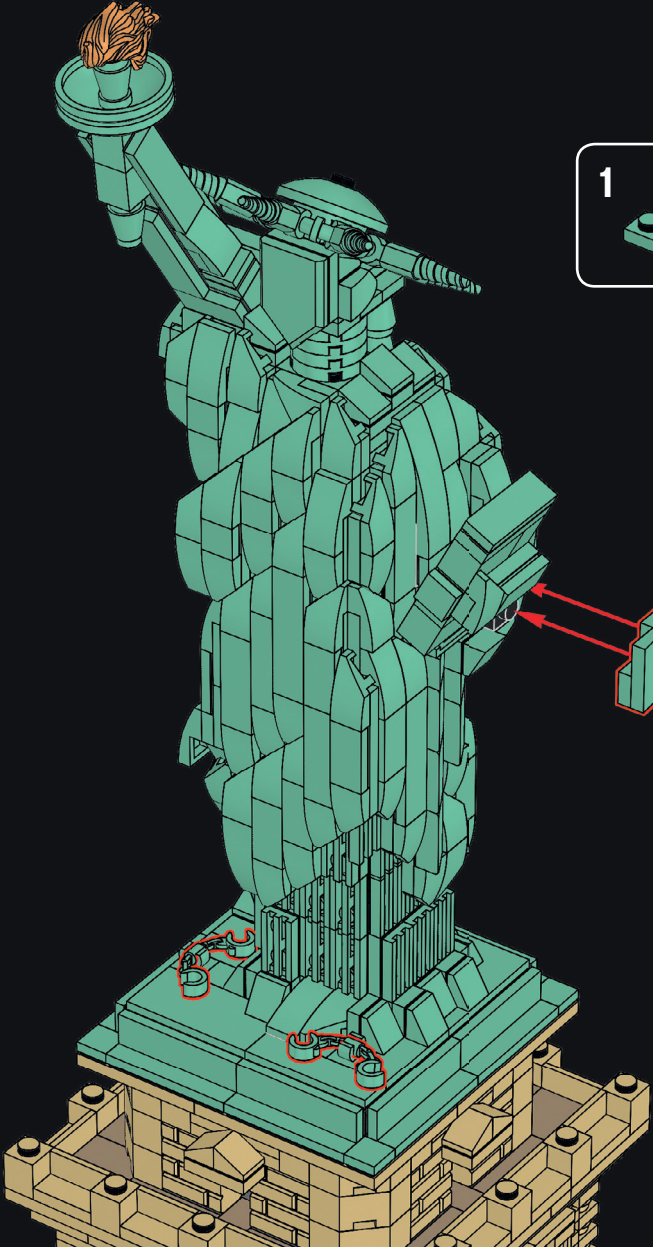

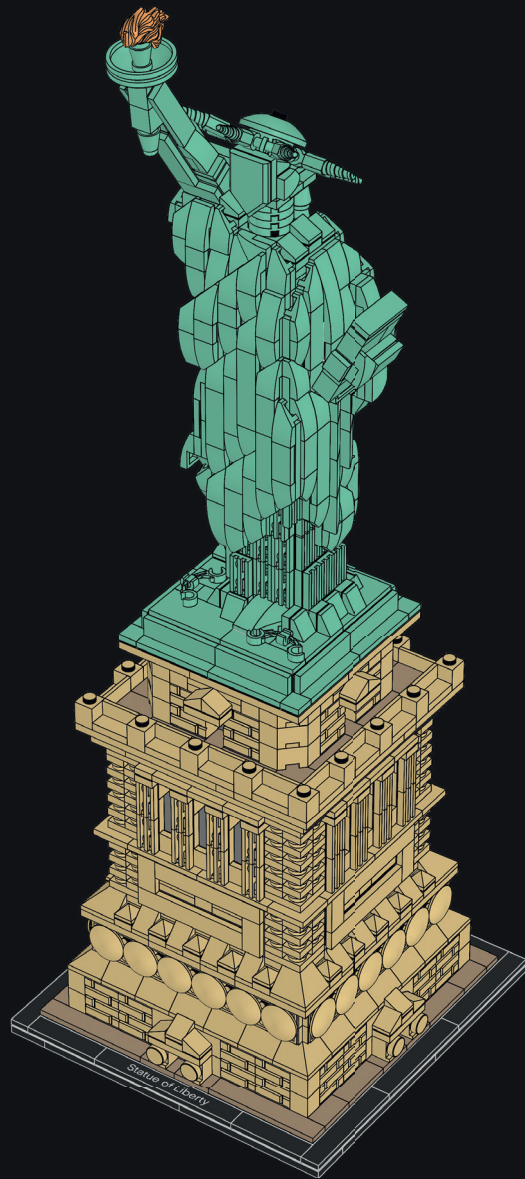

# References Références Referencias

*Pictures -  
Photos :  
Fotografías:*

© Shutterstock

© Offset

Customer Service  
Kundenservice  
Service Consommateurs  
Servicio Al Consumidor  
LEGO.com/service or dial



00800 5346 5555 : 

1-800-422-5346 : 



L

The  
you  
fut

LE

By  
yo  
to



# LEGO® Architecture – do you like it?

The LEGO Group would like your opinion on the new product you have just purchased. Your feedback will help shape the future development of this product series. Please visit:

**[LEGO.com/productfeedback](https://www.lego.com/productfeedback)**

By completing our short feedback survey, you will be automatically entered into a drawing to win a LEGO® prize.

Terms & Conditions apply.

197

# Aimez-vous LEGO® Architecture ?

Le Groupe LEGO aimerait connaître votre opinion sur le produit que vous venez d'acheter. Vos commentaires nous aideront à concevoir les futurs produits de cette gamme. Veuillez visiter :

**[LEGO.com/productfeedback](https://www.lego.com/productfeedback)**

En remplissant ce court sondage sur le produit, vous serez automatiquement inscrit à un tirage au sort pour gagner un prix LEGO®.



# LEGO® Architecture: ¿te gusta?

The LEGO Group quiere conocer tu opinión acerca del nuevo producto que acabas de comprar. Tus comentarios nos ayudarán a dar forma a los futuros productos de esta serie. Visita:

[LEGO.com/productfeedback](https://www.lego.com/productfeedback)

Al contestar este breve cuestionario de opinión, participarás automáticamente en el sorteo de un producto LEGO®.



Sujeto a términos y condiciones.



199

## LEGO® Architecture

The LEGO® Architecture series creatively captures the essence of many of the world's most iconic landmarks while giving you an enjoyable and engaging LEGO building experience.

Whether your interest is in travel, design, history or architecture, these sets are a physical memento of great trip abroad, a famous building you know well, or a city you still dream of visiting.

Every LEGO Architecture set is designed to be displayed. Much more than just a photo, building and displaying your model on your desk, in the bookcase or on the shelf, lets you be transported every time you admire the view.

Follow us on  

Adam Reed Tucker is the co-developer of the LEGO® Architecture product line.







## LEGO® Architecture

La série LEGO® Architecture capture l'essence de nombreux monuments parmi les plus célèbres du monde tout en vous offrant une expérience agréable et stimulante de construction LEGO.

Que votre intérêt porte sur les voyages, le design, l'histoire ou l'architecture, ces ensembles constituent un souvenir tangible d'un voyage mémorable, d'un célèbre bâtiment que vous connaissez bien ou d'une ville que vous rêvez de visiter.

Chaque ensemble LEGO Architecture est conçu pour être exposé. Construire votre modèle et l'exposer sur votre bureau, une bibliothèque ou une tablette vous fera voyager à chaque coup d'œil, bien plus qu'une simple photo ne pourrait le faire.

Suivez-nous sur  



Adam Reed Tucker est le codéveloppeur de la gamme de produits LEGO Architecture.

## LEGO® Architecture

La línea LEGO® Architecture captura con creatividad la esencia de muchos de los monumentos más populares del mundo y pone a tu alcance una experiencia de construcción gratificante y cautivadora con el sello característico de LEGO.

Ya sea que te guste viajar o sientas atracción por el diseño, la historia o la arquitectura, estos sets expresan físicamente tus recuerdos de aquel fantástico viaje al extranjero, ese famoso edificio que conoces tan bien o la ciudad que sueñas con visitar algún día.

Todos los sets LEGO Architecture están diseñados para exhibirse. Mucho más que una simple fotografía, construir y exponer un modelo en tu escritorio, un librero o una repisa te traslada a otro lugar al admirar las vistas.

Síguenos en  

Adam Reed Tucker es el codesarrollador de la línea de productos LEGO Architecture.



Celebrate the world of architecture and collect all the models  
Célébrez le monde de l'architecture et collectionnez tous les modèles  
Celebra el mundo de la arquitectura y colecciona todos los modelos

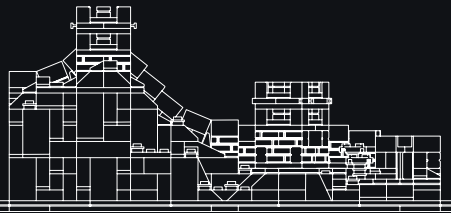

21041  
Great Wall of China  
La Grande Muraille de Chine  
Gran Muralla China



21030  
United States Capitol Building  
Le Capitole des États-Unis  
Edificio del Capitolio de Estados Unidos

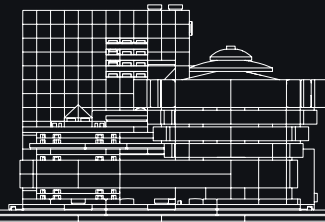

21035  
Solomon R. Guggenheim Museum®  
Musée Solomon R. Guggenheim®  
Museo Solomon R. Guggenheim®



21042  
Statue of Liberty  
La statue de la Liberté  
Estatua de la Libertad

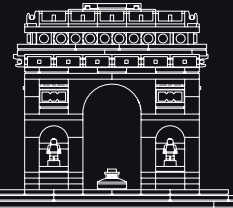

21036  
Arc de Triomphe  
L'Arc de Triomphe  
Arco del Triunfo

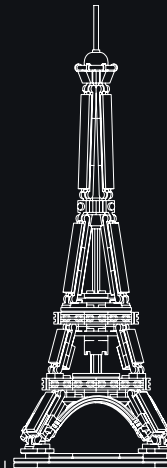

21019  
The Eiffel Tower  
La tour Eiffel  
La Torre Eiffel

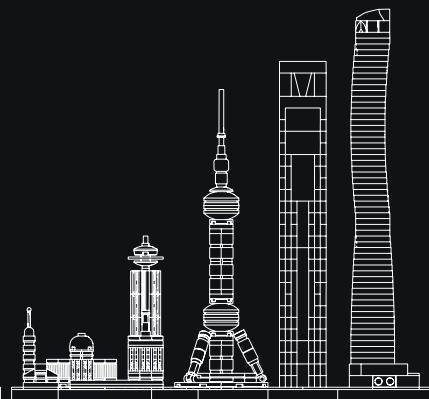

21039  
Shanghai  
Shanghai



21033  
Chicago

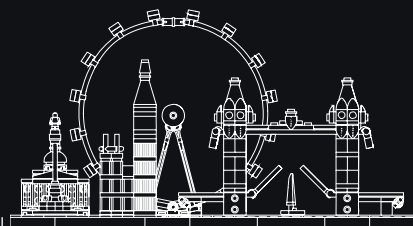

21034  
London  
Londres



21028  
New York City  
New York  
Nueva York



21032  
Sydney  
Sidney

- 8x 4496699
- 8x 6092591
- 4x 4507045
- 12x 6015452
- 4x 4507047
- 96x 4161734
- 8x 6139649
- 8x 4118793
- 20x 6177165
- 24x 4579260
- 8x 4125253
- 20x 4516055
- 40x 4159553
- 48x 4113915
- 23x 6175968
- 24x 4278422
- 16x 6069165
- 4x 6177314
- 48x 6148262
- 32x 4124456
- 4x 6092587
- 16x 6146221
- 16x 6024495
- 8x 4114026
- 52x 4113917
- 12x 6148265
- 32x 4565387
- 17x 4114084
- 20x 4114322
- 36x 4114077
- 8x 6222431
- 4x 4162465
- 8x 6131896
- 36x 4121921
- 16x 4118790
- 4x 6175367
- 12x 4113233
- 4x 4113916
- 8x 6122047
- 8x 4124067
- 16x 4157277
- 4x 4243824
- 4x 4114001
- 12x 4143409
- 4x 4509897
- 4x 4249019
- 1x 6190252
- 1x 6234261
- 4x 306224
- 8x 302424
- 2x 6206240
- 8x 4141630
- 2x 242024
- 1x 362224
- 1x 362324
- 1x 6240515
- 5x 6187572
- 4x 6157554
- 4x 306926
- 1x 302226
- 7x 242026
- 3x 243126
- 8x 663626
- 1x 6223269
- 8x 303426
- 56x 614121
- 6x 4558886
- 2x 6135130
- 4x 302221
- 4x 300221
- 1x 300121
- 4x 300921
- 4x 346021
- 3x 6212053

7x  
6223215

7x  
6226411

6x  
6134280

40x  
6221730

18x  
6223913

22x  
4652205

25x  
6009656

8x  
6223225

2x  
6125672

3x  
6184432

3x  
6125669

33x  
6099189

3x  
4521948

35x  
6221729

25x  
6210479

5x  
6223237

34x  
4655080

21x  
6223126

6x  
4616581

2x  
6225000

3x  
6223168

17x  
4616578

3x  
6223234

28x  
6196591

6x  
6080431

16x  
6186823

1x  
6186828

3x  
6223166

10x  
6202626

31x  
6069257

1x  
6100237

1x  
6245273

8x  
6184348

1x  
6223219

11x  
6100234

25x  
6192923

4x  
6187611

3x  
4633693

2x  
6194726

6x  
6227190

9x  
4211525

9x  
6123809

1x  
4211815

7x  
4583862

16x  
407023

7x  
302323

2x  
4558606

2x  
4514553

7x  
371023

4x  
300923

4x  
303223

16x  
4654577

8x  
4211429

6x  
4211395

8x  
6058177

8x  
4113261

1x  
6093526

4x  
302101

4x  
6210105

10x  
366601

4x  
379501

2x  
4211098

12x  
4210719

2x  
4210700

4x  
4211052

4x  
4211088

11x  
4211063

24x  
4211104

8x  
4211133

8x  
4211053

9x  
6039176

1x  
4211137

4x  
4210706

**LEGO** Architecture

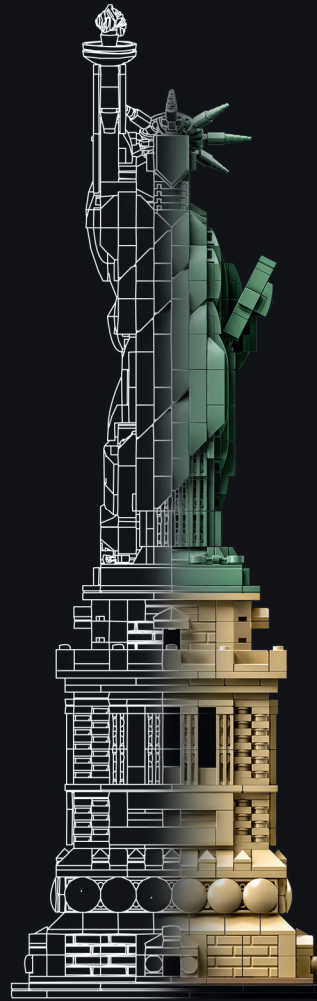

LEGO and the LEGO logo are trademarks of the/son des marques de commerce de/son marcas registradas de LEGO Group. ©2018 The LEGO Group. 6262201

Follow LEGO® Architecture on  
Suivez LEGO® Architecture sur  
Sigue a LEGO® Architecture en

