



# TECHNIC

42070





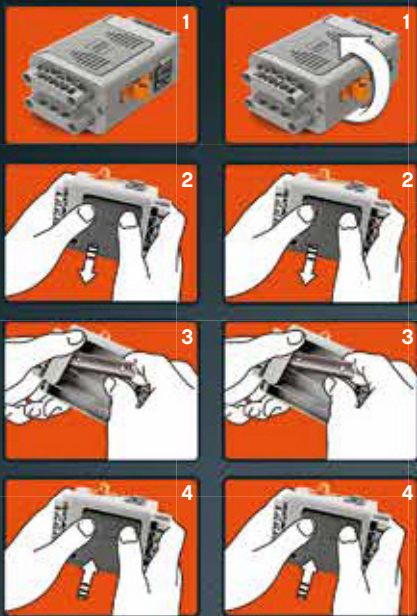

**1.5V** LR 6 (AA) **6x**

**1.5V** LR 03 (AAA) **3x**

**EN**  
Save this leaflet because it contains important information.

**Important information about batteries**

Never use different types of batteries together, or a combination of old and new batteries. Always remove the batteries if the product is not to be used for a long time or if the batteries have run down. Never use damaged batteries. Only use batteries of the type recommended, or a corresponding type. Insert the batteries so that the poles are correctly positioned. Rechargeable batteries must be recharged using the correct battery charger under the supervision of an adult. You cannot recharge batteries while they are still in the product, and you must never try to do so. Never attempt to recharge non-rechargeable batteries. Never short-circuit the battery holder.

**DE**

**Wichtige Informationen zu Batterien**

Benutzen Sie niemals unterschiedlich Arten von Batterien oder alte und neue gleichzeitig. Nehmen Sie stets die Batterien heraus, wenn mit dem Modell längere Zeit nicht gespielt wird oder wenn die Batterien leer sind. Verwenden Sie niemals beschädigte Batterien. Verwenden Sie ausschließlich empfohlene bzw. geeignete Batterien. Achten Sie beim Einsetzen der Batterien auf die richtige Polung. Wiederaufladbare Batterien sollten mit einem geeigneten Ladegerät aufgeladen werden - unter der Aufsicht eines Erwachsenen. Wiederaufladbare Batterien können und sollten niemals aufgeladen werden, während sie sich im Modell befinden. Versuchen Sie unter keinen Umständen, „normale“ Batterien wieder aufzuladen. Schließen Sie das Batteriefach niemals kurz.

**FR**

**Informations importantes concernant les piles**

Ne jamais utiliser un mélange de différents types de piles, ou de piles neuves et de piles anciennes ou déjà utilisées. Toujours retirer les piles si le produit n'est pas utilisé durant une période prolongée ou si les piles sont vides. Ne jamais utiliser de piles endommagées. Utiliser uniquement des piles du type recommandé ou d'un type équivalent. En insérant les piles, respecter scrupuleusement le sens d'orientation des pôles (+/-). Les piles rechargeables doivent être rechargées en utilisant un chargeur de piles adéquat et sous la surveillance d'un adulte. Il est impossible de recharger les piles quand elles sont installées dans le produit. Ne jamais tenter de le faire. Ne jamais essayer de recharger des piles non-rechargeables. Ne jamais court-circuiter le compartiment des piles.

**IT**

**Salvare questo foglio perché contiene importanti informazioni.**

**Importanti informazioni sulle batterie**

Non usare mai contemporaneamente le batterie di tipo diverso o batterie nuove e usate insieme. Rimuovere sempre le batterie qualora il prodotto non venga utilizzato per periodi prolungati, oppure se le batterie sono esauste. Non utilizzare mai batterie danneggiate. Usare esclusivamente batterie del tipo raccomandato o un equivalente. Inserire le batterie avendo cura che la loro polarità sia corretta. Le batterie ricaricabili vanno ricaricate in un caricabatterie di tipo idoneo e con la supervisione di un adulto. Non è possibile e non bisogna mai tentare di ricaricare le batterie mentre queste sono inserite nel prodotto. Non tentare mai di ricaricare batterie non ricaricabili. Non cortocircuitare mai il portabatterie.

**NL**

**Belangrijke informatie over batterijen**

Gebruik nooit verschillende soorten of een combinatie van oude en nieuwe batterijen tegelijkertijd. Verwijder de batterijen altijd als je het product lange tijd niet wilt gebruiken of als batterijen leeg zijn. Gebruik nooit beschadigde batterijen. Gebruik uitsluitend batterijen van het aanbevolen type of een overeenkomstig type. Plaats de batterijen met de polen in de juiste richting. Oplaadbare batterijen moeten in een voor dit doel bestemde oplader en onder toezicht van een volwassene opnieuw worden opgeladen. Oplaadbare batterijen kunnen niet worden opgeladen terwijl ze zich nog in het product bevinden en dit mag ook nooit worden geprobeerd. Probeer nooit niet-oplaadbare batterijen opnieuw op te laden. Laat de batterijhouder nooit kortsluiten.

**ES**

**Información importante acerca de las pilas**

No use pilas de diferentes tipos ni pilas nuevas y antiguas para alimentar el producto. Extraiga las pilas del producto si este va a permanecer sin uso durante un período prolongado de tiempo o aquellas se han agotado. No use pilas dañadas. Use sólo pilas del tipo recomendado u otro equivalente. Inserte las pilas de modo que los polos queden situados en las posiciones correctas. La carga de pilas recargables debe tener lugar empleando un cargador apropiado y bajo la supervisión de un adulto. Las pilas recargables no se pueden cargar mientras permanecen insertadas en el producto; no intente hacerlo. No trate de cargar pilas no recargables. No cortocircuite el compartimento de las pilas.

**DA**

**Vigtige oplysninger om batterier**

Brug aldrig forskellige batterityper sammen eller en kombination af gamle og nye batterier. Fjern altid batterierne, hvis produktet ikke skal bruges i lang tid, eller hvis batterierne er flade. Brug aldrig beskadigede batterier. Brug kun den anbefalede type batterier eller en tilsvarende type. Sæt batterierne i, så polerne vender den rigtige vej. Genopladelige batterier skal oplades i den rigtige batterioplader. Batterierne skal sættes i opladeren under opsyn af en voksen. Batterierne kan ikke oplades, mens de stadig sidder i produktet, og man må aldrig forsøge at gøre det. Forsøg aldrig at oplade ikke-genopladelige batterier. Kortslut aldrig batteriholderen.

**IS**

**Mikilvægar upplýsingar um rafhlöður**

Aldrei skal nota mismunandi gerðir rafhlöðna samtímis, né nýjar og eldri rafhlöður samtímis. Ef ekki á að nota tækið í lengri tíma eða ef rafhlöðurnar eru orðnar tómar skal fjarlægja rafhlöðurnar. Aldrei skal nota rafhlöður sem hafa skemmt, Aðeins skal nota rafhlöður af þeirri gerð sem mælt er með, eða samsvarandi gerð. Setja skal rafhlöðurnar í þannig að ++ og -skaut þeirra snúi rétt. Endurhláðanlegar rafhlöður skal endurhláða með réttu hleðslutæki undir eftirliti fullorðinna. Rafhlöður er ekki hægt að endurhláða á meðan þær eru enn í vórunni og það má aldrei reyna að gera það. Aldrei skal reyna að endurhláða rafhlöður sem ekki eru endurhláðanlegar. Aldrei ætti að valda skammhlaupi í rafhlöðuhöfnu.

**FI**

**Tärkeää tietoa paristoista**

Älä koskaan käytä erityyppisiä paristoja yhdessä. Älä myöskään käytä samassa laitteessa sekä vanhoja että uusia paristoja. Poista paristot tuotteesta aina, kun se on pitemmän aikaa käyttämättä, tai kun paristot ovat tyhjentyneet. Älä koskaan käytä viallisia paristoja. Käytä vain tuotteesta suositeltuja tai vastaavaan tyyppiä paristoja. Aseta paristot siten, että navat osoittavat oikeaan suuntaan. Ladattavat paristot on ladattava oikeanlaisella laiturilla aikuisen valvonnassa. Ne on poistettava tuotteesta lataamisen ajaksi. Älä koskaan yritä ladata paristoja, joita ei ole tarkoitettu ladattaviksi. Älä koskaan aiheuta oikosulkua pariston kosketintien välillä.

**SV**

**Viktig information om batterier**

Använd aldrig olika sorters batterier samtidigt, och inte heller en kombination av gamla och nya batterier. Ta alltid ur batterierna om produkten inte ska användas under en längre tid eller om batterierna är slut. Använd aldrig skadade batterier. Använd bara batterier av den typ som rekommenderas, eller av en motsvarande typ. Sätt i batterierna så att polerna hamnar i rätt läge. Laddningsbara batterier måste laddas med rätt slags batteriladdare och under en vuxens överinseende. Du kan inte ladda batterierna medan de fortfarande sitter i produkten, och du får heller aldrig försöka göra det. Försök aldrig ladda icke laddningsbara batterier. Kortslut aldrig batteriutrymmets kontaktytor.

**NO**

**Viktig informasjon om batterier**

Bruk aldri ulike typer batterier sammen og heller aldri gamle og nye batterier sammen. Ta alltid ut batteriene hvis produktet ikke skal brukes på lang tid, eller hvis batteriene er brukt opp. Bruk aldri skadde batterier. Bruk kun anbefalt type batterier eller tilsvarende type. Sett inn batteriene med polene vendt riktig vei. Oppladbare batterier skal lades opp med riktig batterilader, under overoppsyn av en voksen. Det er ikke mulig å lade opp batteriene mens de fremdeles er i produktet, og du må aldri forsøke å gjøre det. Forsøk aldri å lade opp ikke-oppladbare batterier. Kortslut aldri batteriholderen.

**PT**

**Guardar este folheto por conter informações importantes.**

**Informação importante sobre as pilhas**

Nunca use diferentes tipos de pilhas em simultâneo, ou uma combinação de pilhas usadas e novas. Retire sempre as pilhas se o produto não for usado durante muito tempo ou se as pilhas já não tiverem carga. Nunca use pilhas danificadas. Use apenas pilhas do tipo recomendado ou de um tipo correspondente. Insira as pilhas de forma a que os polos fiquem corretamente posicionados. As pilhas recarregáveis devem ser recarregadas com o carregador de pilhas correto e sob a supervisão de um adulto. Não pode recarregar as pilhas enquanto as mesmas se encontram colocadas no produto e nunca deve tentar fazê-lo. Nunca tente recarregar pilhas não recarregáveis. Nunca deixe o compartimento das pilhas entrar em curto-circuito.

**EL**

**Σημαντικές πληροφορίες για τις μπαταρίες**

Μην χρησιμοποιείτε ποτέ διαφορετικούς τύπους μπαταριών μαζί και μην συνδυάζετε παλιές και καινούργιες μπαταρίες. Αφαιρείτε πάντα τις μπαταρίες αν δεν σκοπεύετε να χρησιμοποιήσετε το προϊόν για αρκετό καιρό ή αν οι μπαταρίες έχουν αδειάσει. Ποτέ μην χρησιμοποιείτε μπαταρίες που έχουν φθορές. Χρησιμοποιείτε μόνο μπαταρίες του συνιστούμενου τύπου ή κάποιο αντίστοιχο τύπου. Τοποθετήστε τις μπαταρίες με τους πόλους στη σωστή θέση. Οι επαναφορτιζόμενες μπαταρίες πρέπει να επαναφορτίζονται χρησιμοποιώντας το σωστό φορτιστή μπαταριών υπό την επίβλεψη ενήλικου. Δεν μπορείτε να επαναφορτίσετε τις μπαταρίες όταν αυτές βρίσκονται μέσα στο προϊόν και δεν πρέπει ποτέ να δοκιμάσετε κάτι τέτοιο. Μην επιχειρήσετε ποτέ να επαναφορτίσετε μη επαναφορτιζόμενες μπαταρίες. Ποτέ μην βραχυκυκλώσετε τη θήκη των μπαταριών.

**JA**

**電池取扱いに関する重要事項**

異なるタイプの電池や古い電池を混ぜて使用しないでください。商品を長時間使用しないときや電池が切れたときは、電池を必ず取り外してください。不具合のある電池は絶対に使用しないでください。推奨されているタイプまたは対応しているタイプの電池を必ず使用してください。電極を確認して電池を正しい向きに入れてください。充電式電池は、保護者に見てもらった上で適切な充電器を使って充電してください。電池の商品の中に入れてそのまま充電することは絶対に避けてください。充電式ではない電池は絶対に充電しないでください。電池ホルダーをショートさせないでください。

**ZH**

**该包装含重要信息应保留。**

**关于电池的重要信息**

请勿同时使用不同类型的电池，或把新旧程度不同的电池混合使用。如果产品将有很长时间不会使用，或者电池已经没电，请注意取出电池。切勿使用已破损的电池。务必仅使用推荐类型或兼容类型的电池。装入电池时请注意正负极。如果使用充电电池，务必在成人监护下使用正确的电池充电器进行充电。电池仍在产品中时不可进行充电，请勿强行尝试充电。请勿尝试给非充电电池充电。切勿对电池仓进行短路连接。

**KO**

**배터리 사용 시 주의사항**

다른 종류의 배터리를 함께 사용하지 마세요. 새 전지와 오래된 전지를 혼용하지 마세요. 배터리가 방전되었거나 장기간 제품을 작동하지 않을 때에는 반드시 배터리를 분리하세요. 파손된 배터리는 사용하지 마세요. 레고에서 권장하는 유형의 배터리만 사용하세요. 양극과 음극의 위치를 잘 맞춰서 넣으세요. 어른의 감독에 따라 지정된 충전기에 충전지를 충전해야 합니다. 충전지를 제품에 넣은 상태로 충전하면 안 됩니다. 일반 배터리는 충전해서 사용할 수 없습니다. 배터리 홀더의 접촉부에 배터리를 정확히 끼워서 사용하세요.



**RU**  
**Необходимая информация об элементах питания**  
 Ни в коем случае не используйте одновременно элементы питания различных типов, а также элементы питания с разным сроком годности. В обязательном порядке внимайайте элементы питания из терминалов в случае, если вы не пользуетесь прибором в течение долгого времени, либо в случае, если в элементах питания закончился заряд. Ни в коем случае не используйте поврежденные элементы питания. Используйте только рекомендуемые элементы питания либо элементы питания соответствующего типа. Установите элементы питания, соблюдая указанную полярность. Аккумуляторные элементы питания должны подзаряжаться в соответствующем зарядном устройстве под наблюдением взрослого. Ни в коем случае не пытайтесь подзаряжать элементы питания, находящиеся в приборе. Ни в коем случае не пытайтесь подзаряжать перезаряжаемые элементы питания. Ни в коем случае не пытайтесь замкнуть полюса в устройстве для элементов питания.

**PL**  
**Ważne informacje dotyczące baterii**  
 Nigdy nie należy stosować razem różnych rodzajów baterii ani stosować równocześnie starych i nowych baterii. Jeżeli produkt nie jest używany przez dłuższy czas lub jeżeli baterie się wyczerpały, należy wyjąć z baterie. Nigdy nie należy stosować uszkodzonych baterii. Należy stosować wyłącznie zalecany rodzaj baterii lub rodzaj mu odpowiadający. Przy wkładaniu baterii należy zwrócić uwagę na właściwe położenie biegunów. Baterie akumulatrowe należy ładować w odpowiedniej ładowarce pod nadzorem osoby dorosłej. Nie można naładować baterii bez wyjęcia ich z produktu i nigdy nie należy tego próbować. Nigdy nie należy próbować ładowania baterii jednorazowych. Nigdy nie należy doprowadzać do zwarcia w gnieździe baterii.

**CZ**  
**Důležitá informace o bateriích**  
 Nikdy nepoužívejte najednou různé typy baterií nebo kombinaci starych a nových baterií. Nebude-li se výrobek delší dobu používat nebo jsou-li baterie vybité, vždy je vyjměte z výrobku. Nikdy nepoužívejte poškozené baterie. Používejte pouze doporučené nebo odpovídající typy baterií. Baterie instalujte se správnou orientací pólů. Nabíjecíné baterie musí být nabity ve vhodné nabíječce pod dohledem dospělé osoby. Nabíjecíné baterie nelze nabíjet, jsou-li umístěny ve výrobku, a nesmíte se o to ani pokoušet. Nikdy se nesnažte nabíjet baterie, které nejsou nabíjecíné. Nikdy neskratujte kontakty v prostoru pro baterie.

**SK**  
**Dôležitá informácia o batériách**  
 Nikdy nepoužívajte naraz odlišné typy batérií ani nekombinujte staré batérie s novými. Batérie vždy vyberte, ak sa výrobok nebude dlhšie používať, alebo ak sa batérie vybili. Nikdy nepoužívajte poškodené batérie. Používajte len odporúčané alebo zodpovedajúce typy batérií. Batérie vkladajte so správnou orientáciou pólou. Nabíjateľné batérie sa musia nabíjať vo vhodnej nabíjačke pod dozorom dospeljej osoby. Nabíjateľné batérie sa nesmú nabíjať, ak sú umiestnené vo výrobku, a nesmiete sa o to ani pokúšať. Nikdy sa nesnažte nabíjať batérie, ktoré nie sú nabíjateľné. Nikdy neskratujte kontakty v priestore pre batérie.

**HU**  
**Fontos tudnivalók az elemekről**  
 Soha ne használjon különböző típusú elemeket, illetve ne használjon vegyesen új és használt elemeket. Mindig távolítsa el az elemeket, ha a készüléket előre láthatóan hosszabb ideig nem fogják használni, vagy ha az elemek lemerültek. Soha ne használjon megrongálódott elemeket. Csak az ajánlott típusú, vagy annak megfelelő elemet használjon. Az elemeket helyesen helyezze be, a polaritásuknak megfelelően. Az akkumulátorokat csak a megfelelő akkumulátor-töltővel szabad feltölteni, felnőtt felügyelete mellett. Az akkumulá- torokat nem lehet feltölteni, ha azok a készülékben vannak. Ezt meg sem szabad próbálni. Soha ne próbálja meg feltölteni a nem tölthető elemeket. Soha ne hozzon létre rövidzárlatot az elemtartó kivezetésein.

**UA**  
**Необхідна інформація про батареїки**  
 Ніколи не використовуйте одночасно батареїки різних типів або батареїки з різним терміном придатності. Обов'язково вилучайте батареїки з приладу, якщо довго не користуєтесь ним, або якщо в батареїках вже скінчився заряд. Ніколи не використовуйте пошкоджені батареїки. Використовуйте батареїки лише рекомендованого або відповідного типу. Вставляйте батареїки, враховуючи задану полярність. Акумуляторні батареїки повинні заряджатись у відповідному зарядному приладі під наглядом дорослого. В будь-якому випадку не намагайтесь підзарядити батареїки, що знаходяться в приладі. В будь-якому випадку не намагайтесь підзарядити батареїки, що не підлягають підзарядці. В будь-якому випадку не намагайтесь зробити коротке замикання в приладі для батарей.

**HR**  
**Važne obavijesti o bateriji**  
 Nikada nemoj koristiti različite vrste baterija zajedno, isto tako ni kombinaciju starih i novih baterija. Uvijek izvadi baterije ako dugo nećeš koristiti proizvod ili ako su one potrošene. Nikada nemoj koristiti oštećene baterije. Koristi samo preporučenu vrstu ili odgovarajuću vrstu baterija. Umetni baterije pažeci da dobro okreneš polove. Akumulatorske se baterije moraju puniti uz pomoć propisanog punjača i uz nadzor odrasle osobe. Baterije se ne smiju puniti dok su još u proizvodu i to nikada nemoj pokušavati. Nikada ne pokušavaj puniti baterije koje nisu predviđene za punjenje. Nikada ne izlazivaj kratki spoj u držaču baterija.

**SR**  
**Важне информације о батеријама**  
 Никада не користите различите типове батерија заједно нити комбинацију старих и нових батерија. Увек извадите батерије уколико производ нећете дуже време користити или уколико су батерије празне. Никада не користите оштећене батерије. Употребљавајте само препоручени тип батерија или одговарајућу замену. Ставите батерије тако да су полови правилно позиционисани. Батерије на пуњење се морају пунити одговарајућим пуњачем под надзором одраслог лица. Није могуће пунити батерије док су у производу и никад не покушавајте да радите то. Никада не покушавајте да пуните батерије које не могу да се пуне. Никада не изазивајте кратак spoj у кулишту за батерије.

**MK**  
**Важни информации за батериите**  
 Никогаш не користете различни типови батери заедно или комбинација од стари и нови батери. Секогаш отстранувајте ги батериите доколку не го користите производот додолго време или доколку се потрошиле. Никогаш не користете оштетени батери. Користете ги само препорачаните батери или батери од соодветен тип. Вметнете ги батериите така што точно ќе ги наместите половите. Батериите на полнење мора да се полнат со соодветниот полнач под надзор на возрасно лице. Не може да ги полните батериите додека сè уште се наоѓаат во производот и никогаш не смеете да го правите тоа. Никогаш не обидувајте се да ги полните батериите за еднократна употреба. Никогаш не предизвикувате краток spoj на држачот за батери.

**SL**  
**Pomembne informacije o baterijah**  
 Nikoli ne uporabljajte skupaj različnih baterij ali kombinacije starih in novih baterij. Vedno odstranite baterije, če izdelka dlje časa ne boste uporabljali ali če so iztrošene. Nikoli ne uporabljajte poškodovanih baterij. Uporabljajte le baterije priporočenege ali ustreznega tipa. Baterije vstavite tako, da so njihovi poli pravilno obrnjeni. Akumulatorske baterije je treba polniti s pravim polnilnikom pod nadzorom odrasle osebe. Akumulatorskih baterij ni mogoče polniti, dokler so še v izdelku. Tega tudi ne smete poskušati. Nikoli ne poskušajte polniti baterij, ki niso akumulatorske. Pazite, da ležišč za baterije ne boste spravili v kratek stik.

**RO**  
**Informații importante despre baterii**  
 Nu folosiți niciodată împreună tipuri diferite de baterii, sau o combinație de baterii vechi și noi. Îndepărtați întotdeauna bateriile dacă produsul nu este folosit timp îndelungat sau dacă bateriile s-au epuizat. Nu folosiți niciodată baterii deteriorate. Folosiți numai baterii de tipul recomandat, sau un tip corespunzător. Introduceți bateriile astfel ca poli să fie poziționați corect. Bateriile reincărcabile trebuie reincărcate utilizând încărcătorul corect sub supravegherea unui adult. Nu puțeți reincărca bateriile în timp ce acestea sunt încă în produs, și niciodată nu trebuie să încercați să faceți acest lucru. Nu încercați niciodată să reincărcați baterii nereîncărcabile. Nu scurtcircuitați niciodată suportul bateriei.

**BG**  
**Важна информация за батериите**  
 Никога не използвайте едновременно различни типове батерии или комбинация от стари и нови батерии. Винаги изваждайте батериите, ако izdelieto няма да се използва продължително време или ако батериите са се изтозили. Никога не използвайте повредени батерии. Използвайте само батерии от препоръчвания тип или съответстващ на него тип. Поставете батериите така, че полюсите да са разположени правилно. Аккумуляторните батерии трябва да се зареждат с подходящо зареждащо устройство под надзора на възрастни. Батериите не могат да се зареждат, докато са поставени в izdelieto, затова никога не опитвайте да правите това. Никога не свързвайте да зареждате батерии, които не са акумулаторни. Никога не свързвайте на късо контактите на отделението за батериите.

**LV**  
**Svarīga informācija par baterijām**  
 Nekad vienlaikus nelietojiet dažādu tipu, kā arī vecas un jaunas baterijas. Vienmēr izņemiet baterijas, ja tās ir izlādējušas vai ja produkts ilgāku laiku netiek lietots. Nekad nelietojiet bojātas baterijas. Lietojiet tikai ieteicamā tipa vai atbilstoša tipa baterijas. Ievietojiet baterijas, ievērojiet pareizo polaritāti. Uzlādējumu bateriju lādēšanai izmantojiet atbilstošo bateriju lādētāju; uzlāde jāveic pieaugušo uzraudzībā. Baterijas nevar uzlādēt nekad nedrīkst mēģināt uzlādēt, kamēr tās ievietotas produktā. Nekad nemēģiniet uzlādēt baterijas, kas nav uzlādējamas. Nepielaujiet issavienojumu bateriju nodalījumā.

**ET**  
**Oluline teave patareide kohta**  
 Ära kunagi kasuta koos erinevat tüüpi patareisid, samuti vanu ja uusi patareisid. Kui märguasja ei kasutata pika aja jooksul, võta patarei sellest välja. Ära kunagi kasuta kahjustatud patareisid. Kasuta ainult ettenähtud tüüpi või nendega samaväärsed patareisid. Pane patareid märguasja sisse nii, et pluss- ja miinusklemmi asend oleks õige. Akusid tuleb laadida ainult neile ettenähtud akulaadijaga abil täiskasvanu järelevalve all. Akusid ei saa laadida sel ajal, kui need on märguasja sees. Ära kunagi püüa nii teha. Ära kunagi proovi akulaadijaga laadida tavalisi patareisid. Patareipesa klemmide vahel ei tohi tekkida lühist.

**LT**  
**Svarbi informacija apie elementus**  
 Vienu metu nenaudokite skirtingų elementų, taip pat su naujais elementais nenaudokite senų. Jei nenaudosite gaminio ilgesnį laiką arba jei elementai išsekę, visuomet išimkite juos iš gaminio. Niekada nenaudokite pažeistų elementų. Naudokite tik rekomenduojamo arba atitinkamo tipo elementus. Elementus dėkite atsižvelgdami į jų poliškumą. Elementus galima įkrauti tik tinkamu krovikliu ir prižiūrint suaugusiesiems. Jokiu būdu negalima, ir niekuomet nebandykite, įkrauti elementų neišėjus jų iš gaminio. Niekada nebandykite įkrauti vienkartinių elementų. Saugokitės, kad elementų įdėjkle nesukeltumėte trumpojo jungimo.

**TR**  
**Piller hakkında önemli bilgiler**  
 Hiçbir zaman farklı tipte pilleri ya da eski pilleri yeni pilleri bir arada kullanmayın. Ürün uzun süre kullanılmayacaksa ya da piller bitmişse, pilleri ürünün içinden çıkarın. Hiçbir zaman zedelemmiş piller kullanmayın. Sadece önerilen tipe piller ya da bunların dengi olan piller kullanın. Pilleri kutularını doğru konumda olacak şekilde yerleştirin. Şarj edilebilen pilleri doğru pil şarj aletini kullanarak, bir yetişkinin denetiminde şarj edin. Şarj edilebilen pilleri, pil ürünü içindeyken şarj edemezsiniz bunu hiçbir zaman yapmaya çalışmayın. Hiçbir zaman, şarj edilebilir olmayan pilleri şarj etmeye çalışmayın. Hiçbir zaman pil kutusuna kısa devre yaptırmayın.

**AR**  
**معلومات مهمة عن البطاريات**  
 يُحظَر استخدام أنواع مختلفة من البطاريات معًا أو مزيج من البطاريات القديمة والجديدة. احرص دائمًا على نزع البطاريات في حال عدم استخدام المنتج لفترة طويلة أو إذا نفذت طاقة البطاريات. تجنب استخدام البطاريات التالفة. لا تستخدم إلا نوع البطاريات الموصى به أو نوع متماثل. قم بتربط البطاريات بحيث تكون الأقطاب في موضعها الصحيح. يجب إعادة شحن البطاريات القابلة لإعادة الشحن باستخدام شاحن البطاريات المناسب وذلك تحت إشراف شخص بالغ. لا يمكن إعادة شحن البطاريات وهي لا تزال داخل المنتج. ويجب ألا تجرب فعل ذلك. يُحظَر إعادة شحن البطاريات غير القابلة لإعادة الشحن. تجنب إحداث دائرة قصر في حامل البطارية.

**ID**  
**Informasi penting tentang baterai**  
 Jangan gunakan baterai yang jenisnya berlainan, atau mencampur baterai lama dan baterai baru. Lepas baterai jika produk tidak akan digunakan untuk waktu lama atau jika baterai sudah lemah. Jangan gunakan baterai yang rusak. Gunakan jenis baterai yang dianjurkan atau yang sejenis. Masukkan baterai dengan posisi kutub yang tepat. Baterai isi ulang harus diisi ulang dengan charger baterai yang sesuai dan di bawah pengawasan orang dewasa. Anda tidak dapat mengisi ulang baterai saat masih terpasang di dalam produk, dan jangan pernah coba melakukannya. Jangan pernah coba mengisi ulang baterai biasa. Jangan pernah membuat arus pendek pada dudukan baterai.

**MS**  
**Maklumat penting tentang bateri**  
 Jangan guna jenis bateri yang berbeza bersama-sama, atau gabungan bateri baharu dan lama. Tanggalkan bateri jika produk tidak akan digunakan untuk tempoh masa yang lama atau jika bateri telah kehabisan kuasa. Jangan guna bateri yang rosak. Hanya guna jenis bateri yang disyorkan, atau jenis yang berkaitan. Selitkan bateri supaya supaya paksi berada pada kedudukan yang betul. Bateri yang boleh dicaskan semula perlu dicas semula menggunakan pengcas bateri yang betul bawah pengawasan orang dewasa. Anda tidak boleh mengcas bateri semasa bateri masih berada pada produk, dan anda jangan cuba berbuat demikian. Jangan cuba untuk mengcas semula bateri yang tidak boleh dicaskan semula. Jangan pintas litar pemegang bateri.





EN	Protect the environment by not disposing of this product with your household waste (2012/19/EU). Check with your local authority for recycling advice and facilities.
DE	Schützen Sie die Umwelt und entsorgen Sie dieses Produkt nicht mit Ihrem Hausmüll (2012/19/EU). Informationen zu Recycling-Möglichkeiten erhalten Sie bei den örtlichen Behörden.
FR	Protégez l'environnement : ne jetez pas ce produit avec vos autres déchets ménagers (Directive européenne 2012/19/UE). Contactez les autorités locales pour obtenir des informations sur le recyclage et connaître les points de collecte.
IT	Proteggi l'ambiente! Non smaltire questo prodotto con i rifiuti domestici (2012/19/UE). Per consulenza sul riciclaggio dei rifiuti e le strutture di riciclaggio, rivolgersi alle proprie autorità locali.
NL	Bescherm het milieu: gooi dit product niet samen met het andere huisvuil weg (2012/19/EU). Raadpleeg de plaatselijke instanties voor locaties van milieustations en advies over hergebruik.
ES	Proteja el medio ambiente no deshaciéndose de este producto junto con sus residuos domésticos (2012/19/UE). Solicite a su autoridad local consejos e información sobre instalaciones de reciclado.
DA	Beskyt miljøet! Smid ikke dette produkt ud sammen med husholdningsaffaldet (2012/19/EU). Få vejledning om genbrug og genbrugsstationer hos din kommune.
IS	Stuðlið að verndun umhverfis með því að farga þessari vöru ekki með heimilissorpi (2012/19/ESSB). Leiðið upplýsinga um endurvinnslu- og förgunarstaði hjá staðaryfirvöldum.
FI	Tämä tuote on hävitettävä ympäristönsuojelun vuoksi asianmukaisesti talousjätteistä erillään (2012/19/EU). Tietoja keräyspisteiden sijainnista saa kunnan tai kaupungin teknisestä virastosta.
SV	Skydda miljön genom att inte kasta denna produkt bland ditt hushållsavfall (2012/19/EU). Kontakta din kommun för frågor om återvinning och miljöstationer.
NO	Beskytt miljøet. Ikke kast dette produktet i husholdningsavfallet (2012/19/EU). Kontakt kommunen for veiledning om gjenbruk og miljøstasjoner.
PT	Proteja o ambiente não eliminando este produto com o seu lixo doméstico (2012/19/UE). Consulte as autoridades locais para informação sobre reciclagem e sistemas de recolha.
EL	Προστατέψτε το περιβάλλον. Μην πετάτε αυτό το προϊόν μαζί με τα συνηθισμένα οικιακά απόρριμματα (2012/19/ΕΕ). Επικοινωνήστε με τις τοπικές αρχές σχετικά με συμβουλές και εγκαταστάσεις ανακύκλωσης.
JA	環境保護のため、本製品は家庭ごみとは別に処分してください(2012/19/EU)。リサイクルに関する指示や施設については、お住まいの地方自治体にお問い合わせください。
ZH	注意保护环境，请勿将本产品与家庭垃圾一起丢弃处理(2012/19/EU)。请咨询您当地相关部门，了解回收设施与回收建议
KO	환경 보호를 위해 이 제품을 생활폐기물과 함께 버리지 마십시오(2012/19/EU)。 재활용 방법 및 시설에 관한 사항은 현지 관계 당국에 문의하십시오。
RU	Защитите окружающую среду, не утилизируйте этот продукт вместе с бытовым мусором (директива 2012/19/EU). Осведомитесь у местных органов власти о правилах вторичной переработки и утилизации таких отходов.
PL	Chroń środowisko — nie wyrzucaj tego produktu razem z odpadami z gospodarstwa domowego (2012/19/EU). W celu uzyskania informacji dotyczących recyklingu i miejsc składowania zużytego sprzętu należy się skontaktować z lokalnymi władzami.
CZ	Nevyhazujte tento produkt do domácího odpadu, chráňte životní prostředí (2012/19/EU). Zjistěte si prosím u místních úřadů možnosti recyklace a dostupná zařízení.
SK	Nevyhádzajte tento produkt do domáceho odpadu, chráňte životné prostredie (2012/19/EU). Zistite si prosím na miestnych úradoch možnosti recyklácie a dostupné zariadenia.
HU	Környezetét óvja, ha ettől a terméktől nem a háztartási hulladékkal együtt válik meg (2012/19/EU). Érdeklődjék a lakóhelyéhez közel eső hatóságnál az újrahasznosítás módjáról és lehetőségeiről.
UA	Допоможіть захистити довкілля: не утилізуйте цей виріб разом із побутовим сміттям (2012/19/EU). Вказівки з утилізації та відомості про пункти прийому з'ясуєте в місцевих компетентних органах.
HR	Zaštite okoliš tako da ovaj proizvod ne odložite u otpad zajedno s kućanskim otpadom (2012/19/EU). Od lokalnih vlasti zatražite savjet ili informacije o pogonima za recikliranje.
SR	Zaštite životnu sredinu tako što nećete odlagati ovaj proizvod sa kućnim otpadom (2012/19/EU). Obratite se lokalnoj ovlašćenoj službi da biste dobili savete o recikliranju i saznali o objektima za reciklažu.
MK	Zaštite je a oколinata така што нема да се ослободите од производа то са домаћиот отпад (2012/19/EU). Консултирајте се со локалните власти за да дознаете за советите и објектите за рециклирање.
SL	Zaščitite okolje! Okolje varujte tako, da tega izdelka ne zavrzete skupaj z gospodinjiskimi odpadki (2012/19/EU). Pri krajevni upravi preverite, kakšne možnosti in kateri obrati za recikliranje obstajajo v vaši okolici.
RO	Protejați mediul înconjurător și nu vă debarasați de acest produs împreună cu deșeurile menajere (2012/19/UE). Consultați autoritățile locale pentru îndrumări și facilități de reciclare.
BG	Защитете околната среда и не изхвърляйте този продукт заедно с битовите си отпадъци (2012/19/EC). Свържете се с местните власти относно съвети и съоръжения за рециклиране.
LV	Lai saudzētu vidi, neizmetiet šo produktu su būtinēm atliekām (2012/19/ES). Vērsieties vietējās varas iestādēs, lai noskaidrotu, kur un kā tas nododams pārstrādei.
ET	Keskonda saate kaitsta nii, et ei kõrvalda seda toodet koos olmejäätmetega (2012/19/EL). Nüüandeid toote taaskasutusse võtmise ja ümbertöötlemispunktide kohta saate asjaomaselt kohalikult asutuselt.
LT	Saugokite aplinką: neišmeskite šio produkto su būtinėmis atliekomis (2012/19/ES). Patarimų, kaip ir kur rūšiuoti šiukšles, teiraukitės vietos valdžios įstaigose.
TR	Bu ürünü, evsel atıklarla birlikte atmayarak çevreyi koruyun (2012/19/EU). Geri dönüşüm tavsiyeleri ve tesisler hakkında bilgi için yerel yönetimle iletişime kurun.
AR	استنشر السلطة المحلية للحصول على ساهم في حماية البيئة عن طريق عدم التخلص من هذا المنتج مع الخلفات المنزلية استنشر السلطة المحلية للحصول على (2012/19/EU)
ID	Jagalah lingkungan dengan tidak membuang produk ini bersama sampah rumah tangga Anda (2012/19/EU). Periksa peraturan pemerintah setempat tentang saran dan fasilitas daur ulang.
MS	Lindungi persekitaran dengan tidak melupuskan produk ini bersama dengan sisa isi rumah anda (2012/19/EU).Rujuk pihak berkuasa tempatan anda bagi nasihat dan kemudahan kitar semula



This device complies with part 15 of the FCC Rules. Operation is subject to the following conditions: (1) This device may not cause harmful interference, and (2) this device must accept any interference received, including interference that may cause undesired operation.

NOTE: This equipment has been tested and found to comply with the limits for a Class B digital device, pursuant to part 15 of the FCC Rules. These limits are designed to provide reasonable protection against harmful interference in a residential installation. This equipment generates, uses and can radiate radio frequency energy and, if not installed and used in accordance with the instructions, may cause harmful interference to radio communications. However, there is no guarantee that interference will not occur in a particular installation. If this equipment does cause harmful interference to radio or television reception, which can be determined by turning the equipment off and on, the user is encouraged to try to correct the interference by one or more of the following measures:

- Reorient or relocate the receiving antenna.
- Increase the separation between the equipment and receiver.
- Connect the equipment into an outlet on a circuit different from that to which the receiver is connected.
- Consult the dealer or an experienced radio/TV technician for help.

Caution: Changes or modifications not expressly approved by the party responsible for compliance could void the user's authority to operate the equipment.

This Class B digital apparatus complies with Canadian ICES-003.  
Cet appareil numérique de la classe B est conforme à la norme NMB-003 du Canada.

1



2

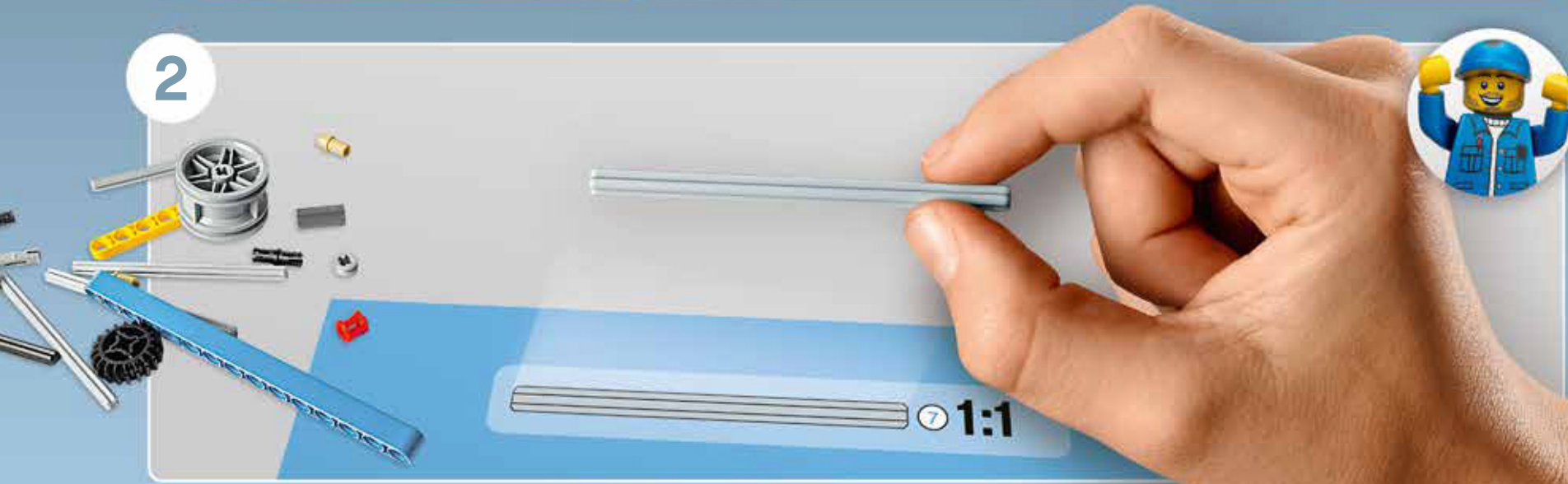



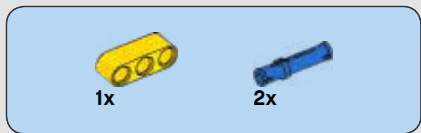

1

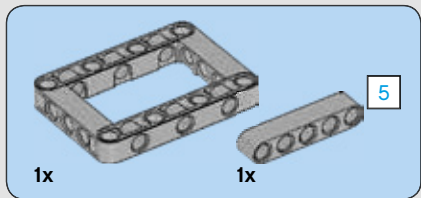
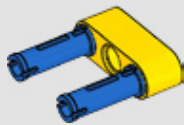

2

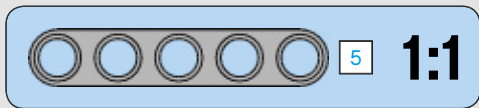
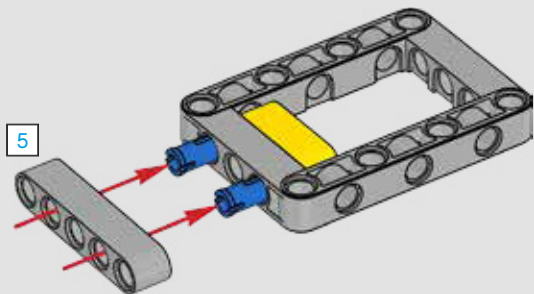

6

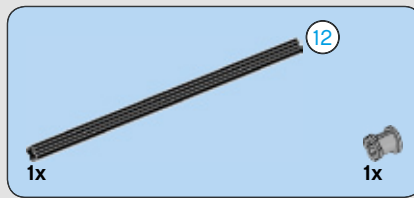

3

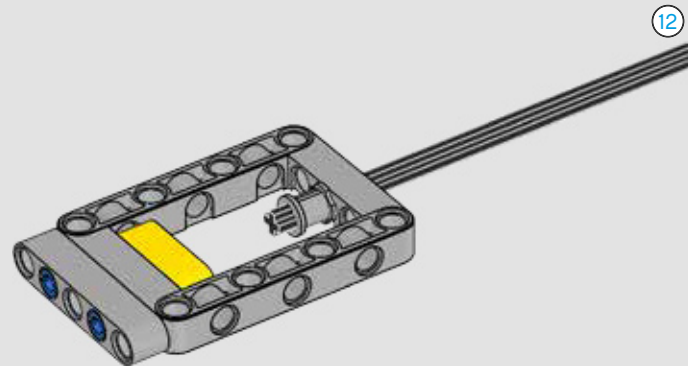

4

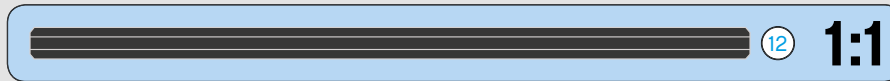
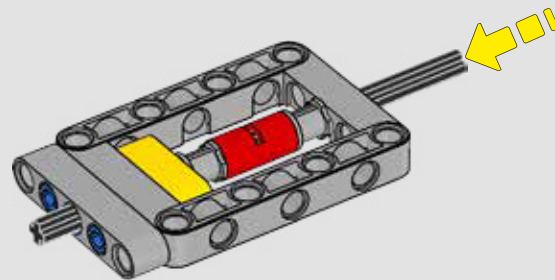



5

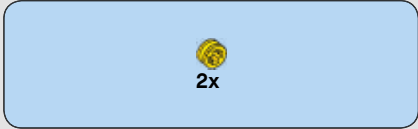
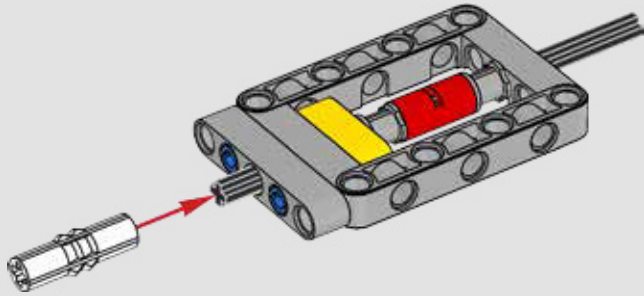

6

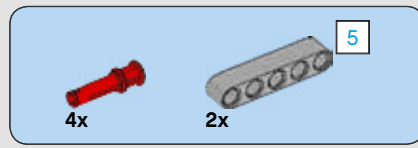
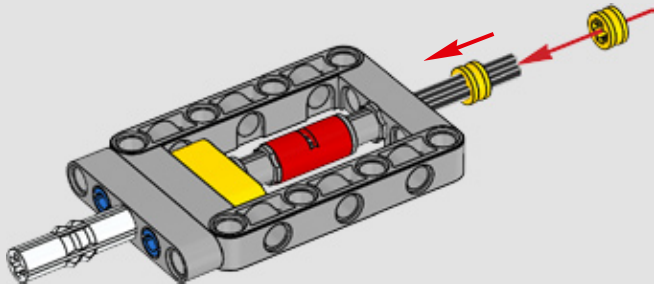

7

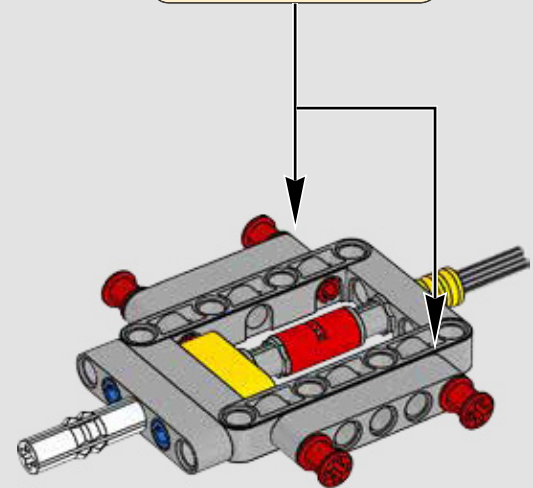
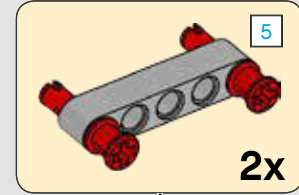
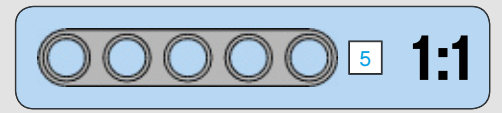





8

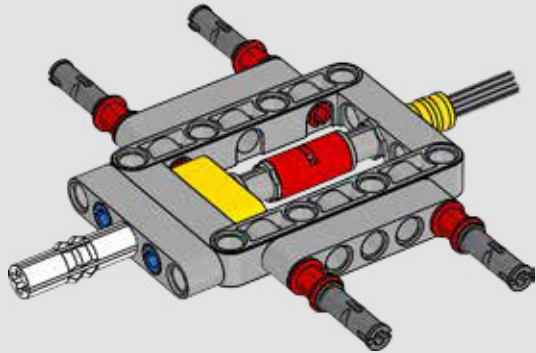

9

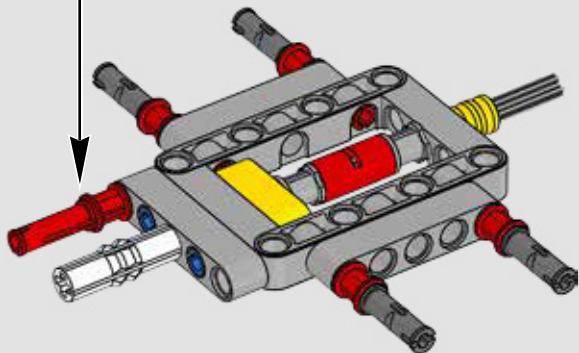
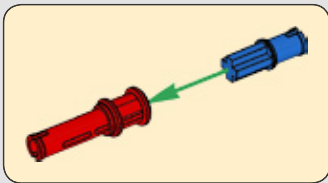

10

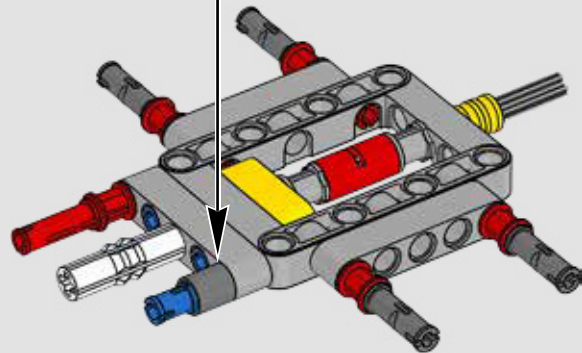
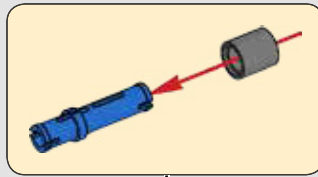

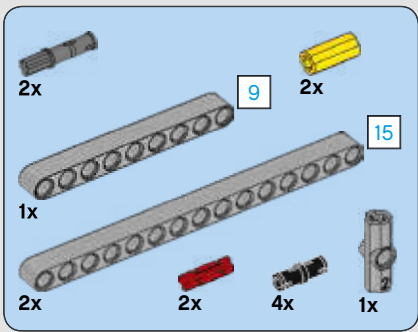

11

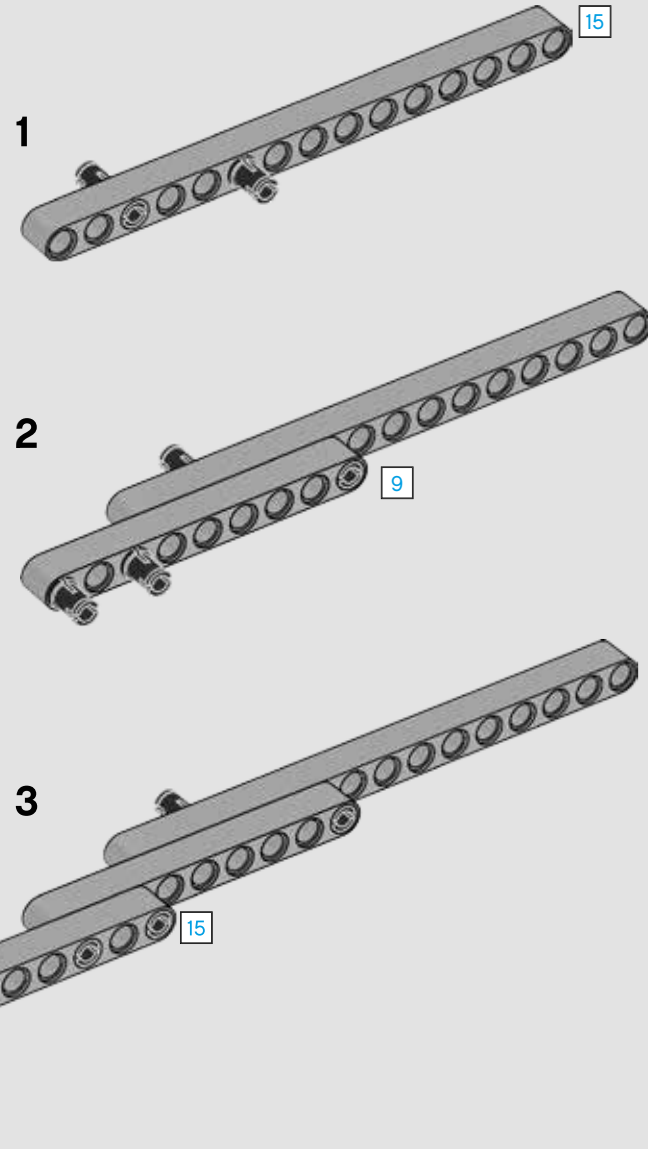
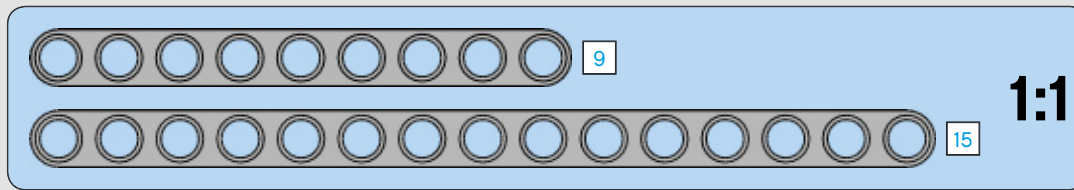



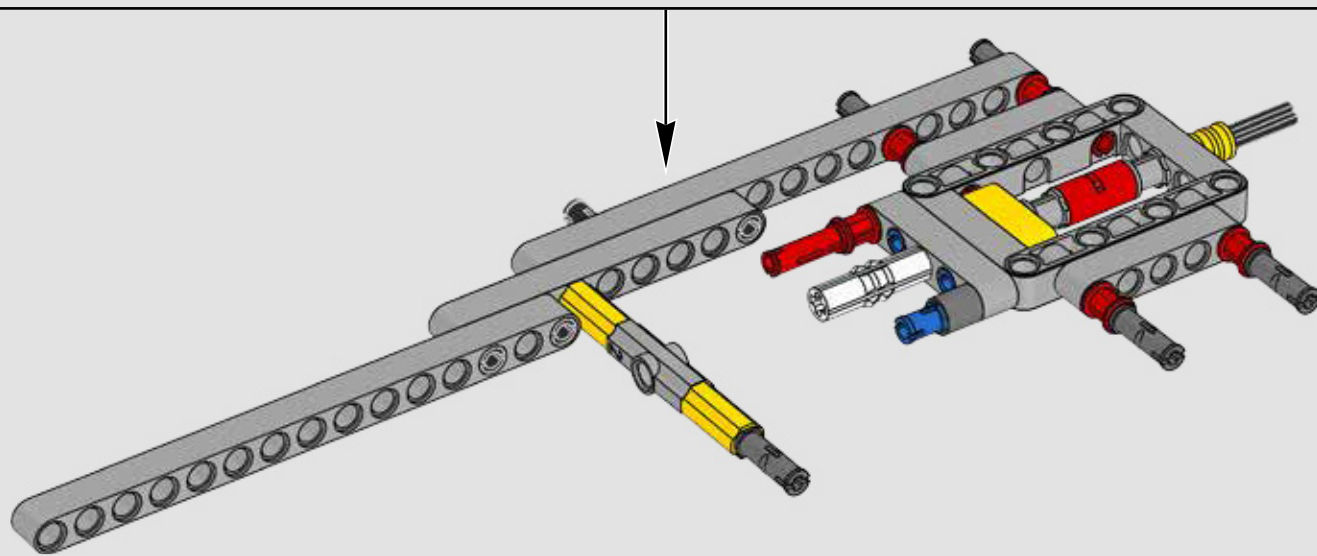
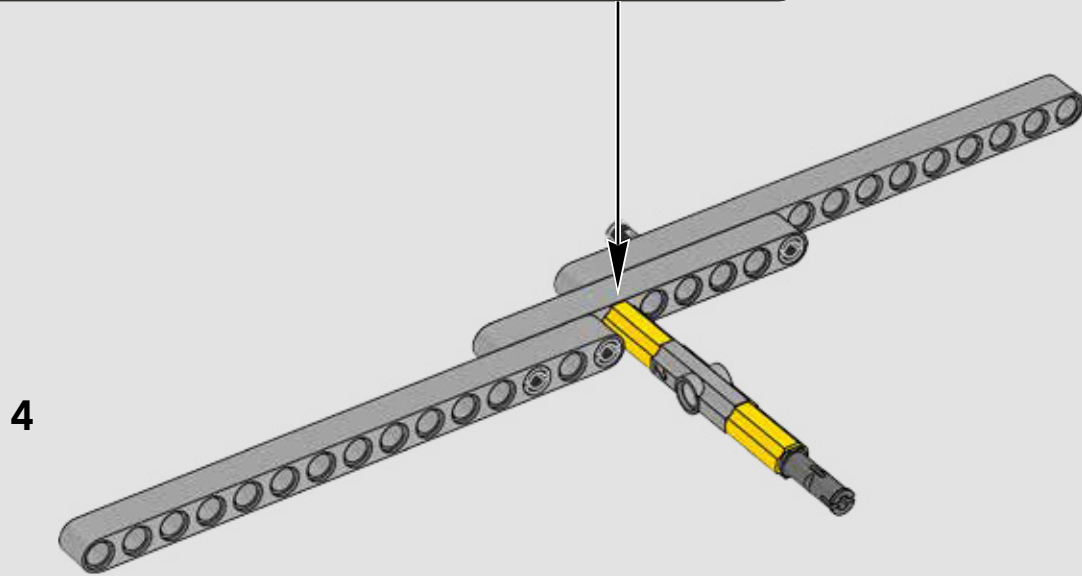
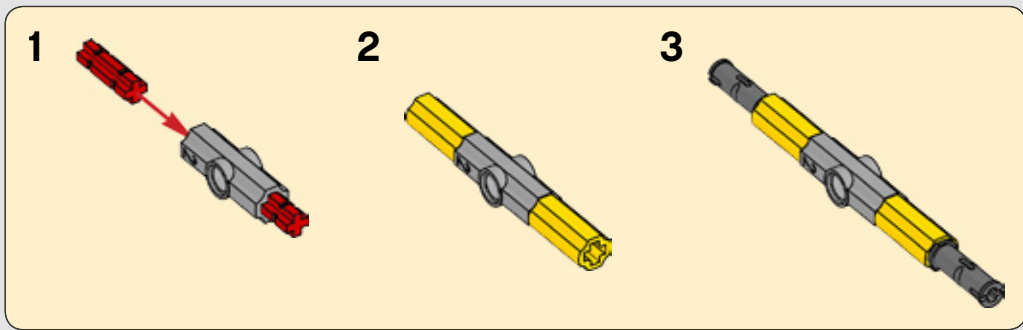

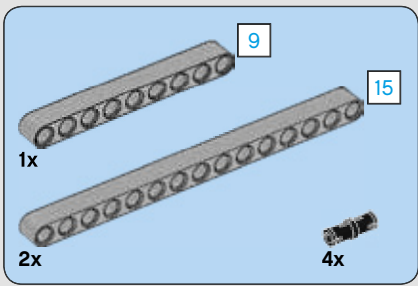

12

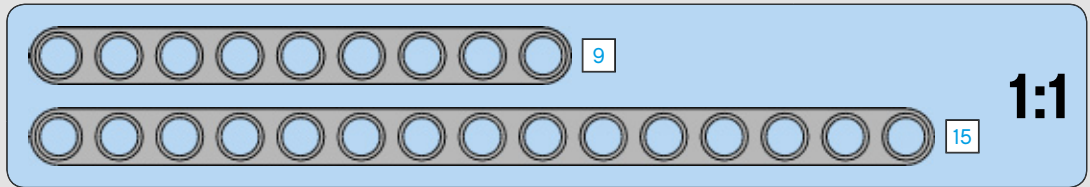
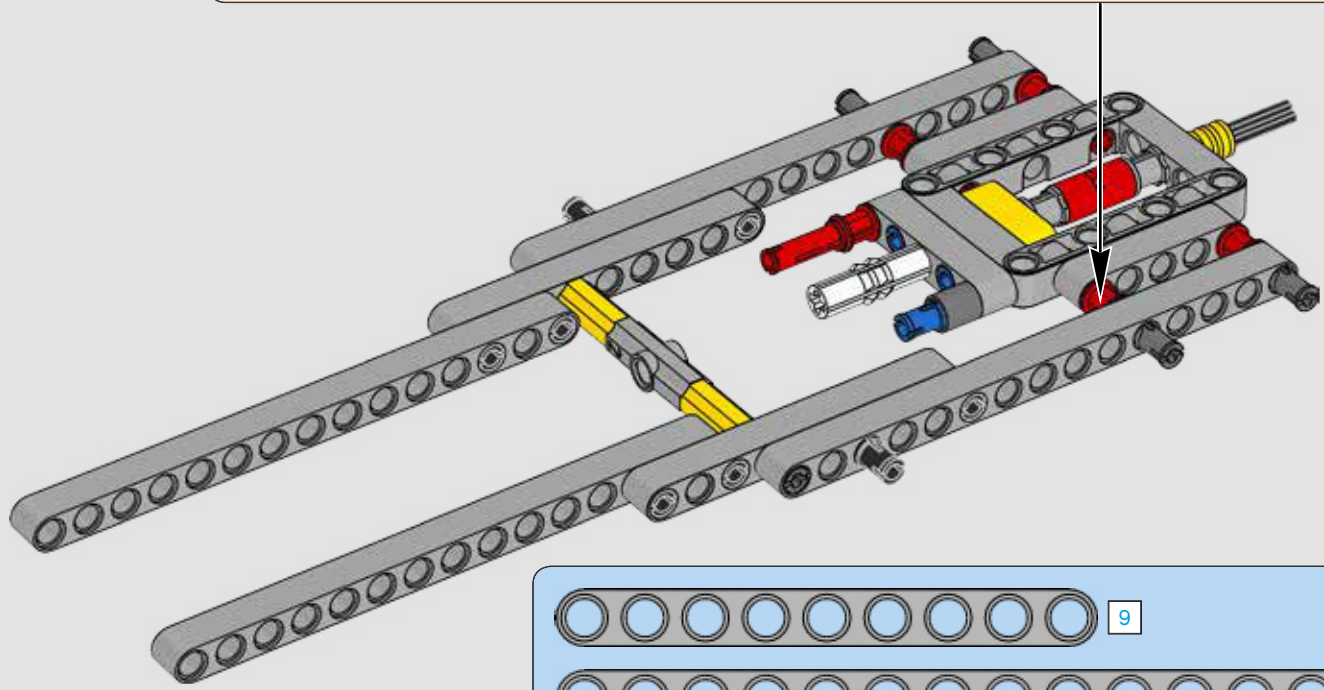
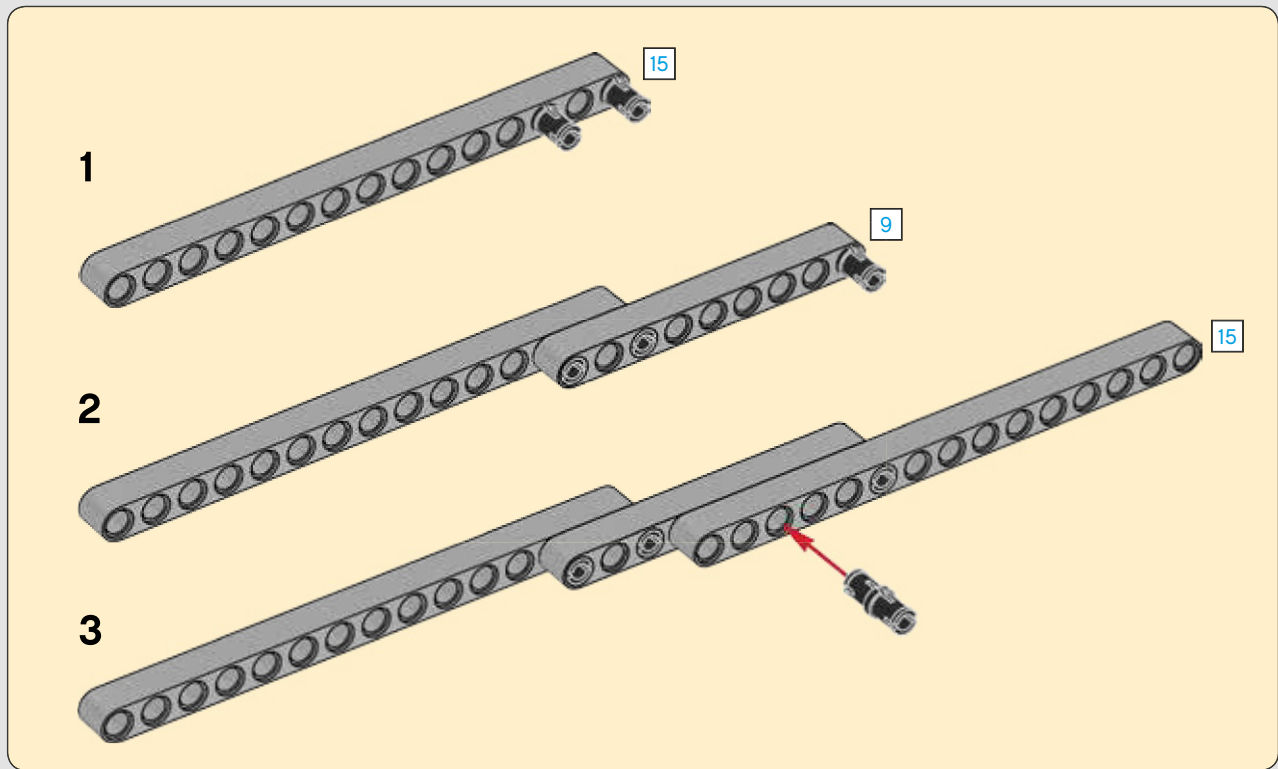





13

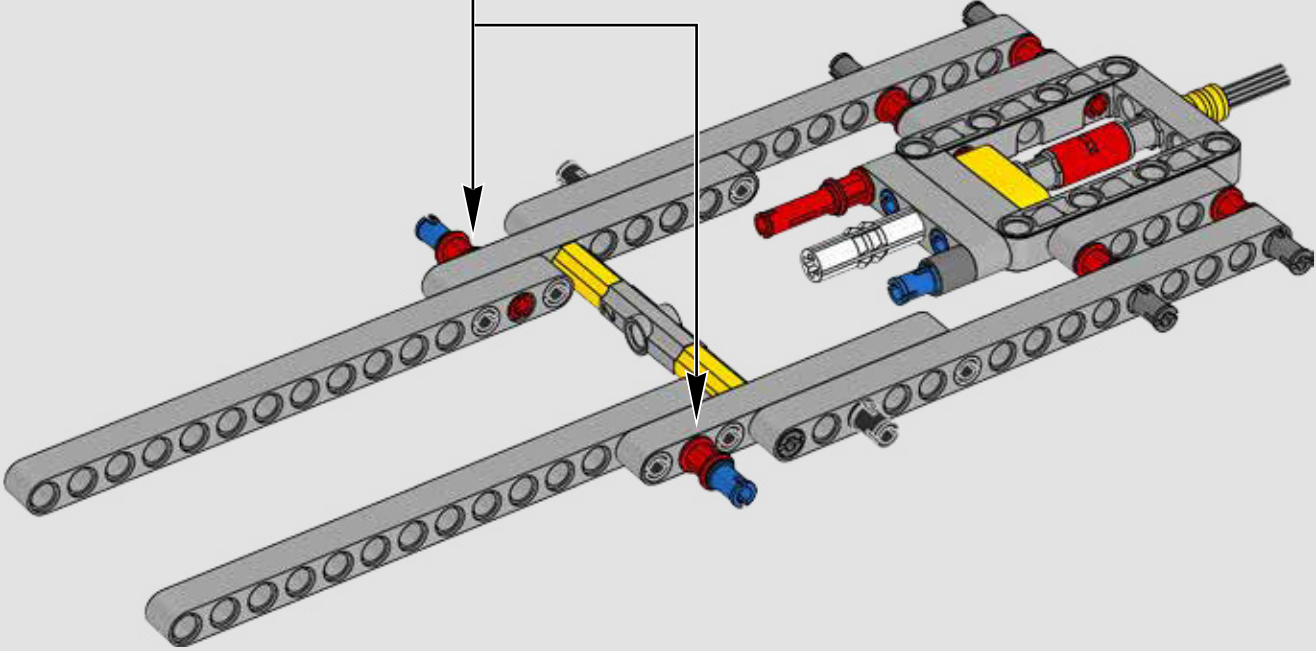
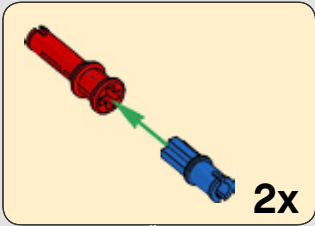

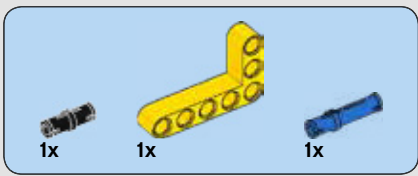

14

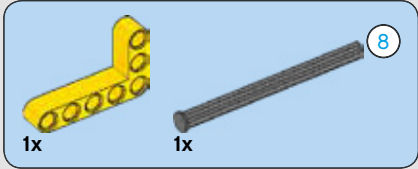
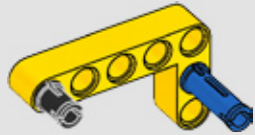

15

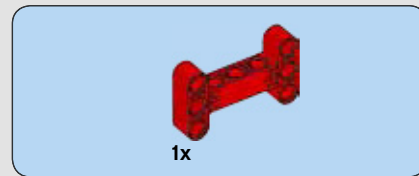
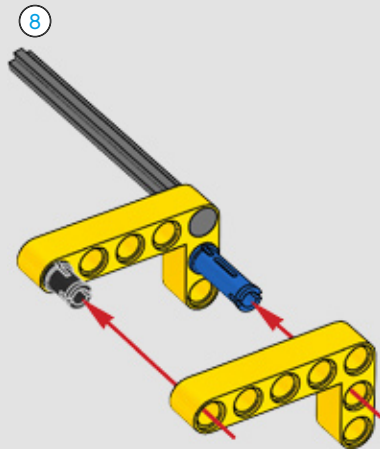

16

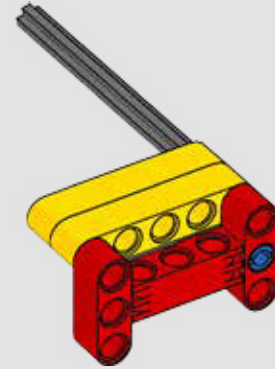

17

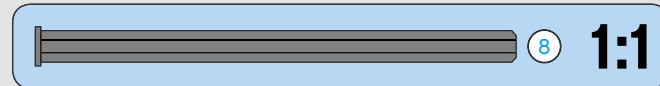
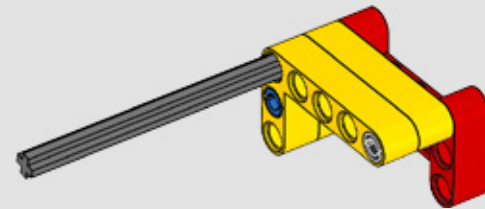
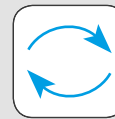

18

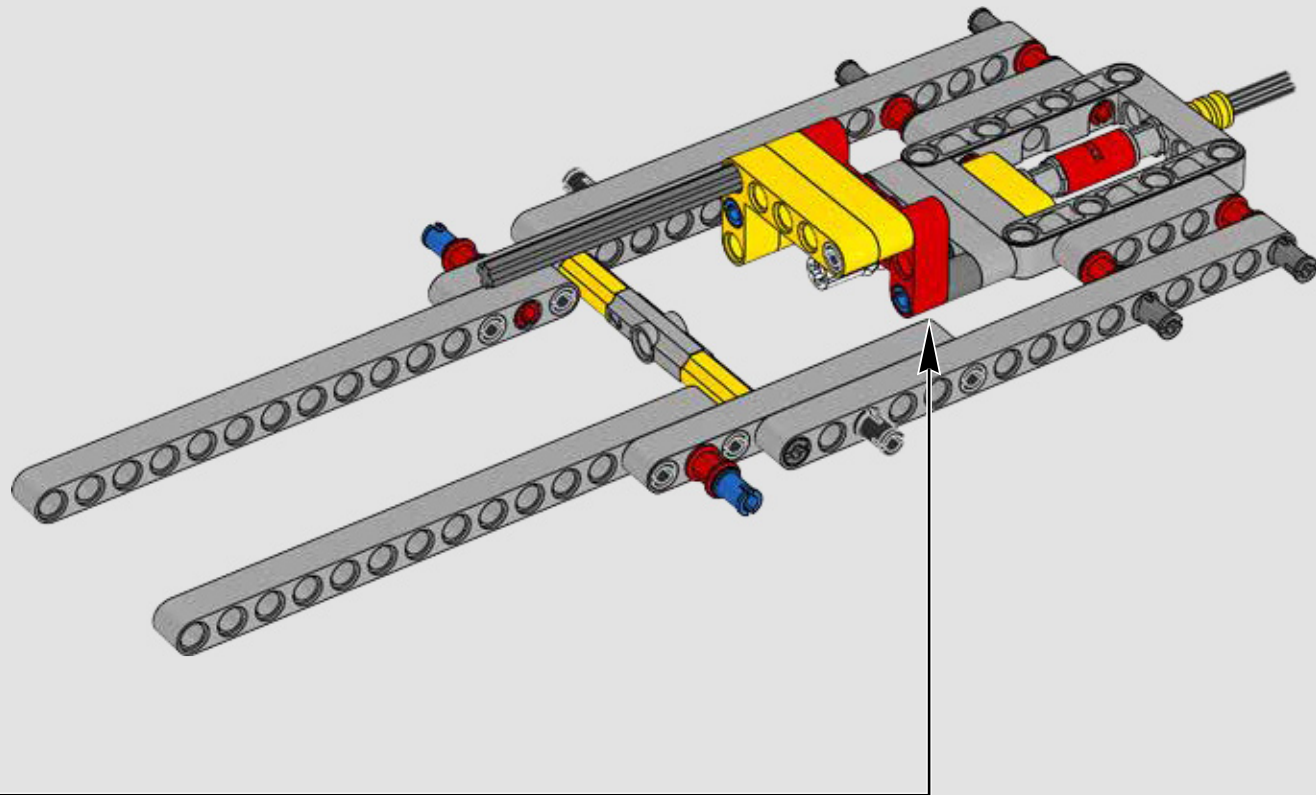



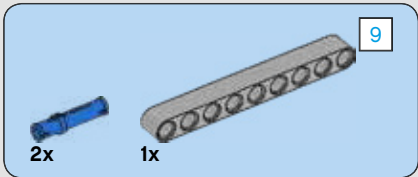
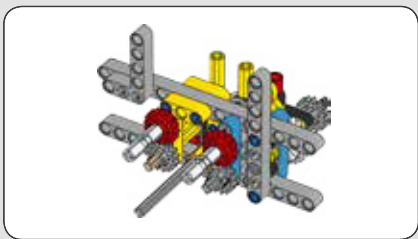

19

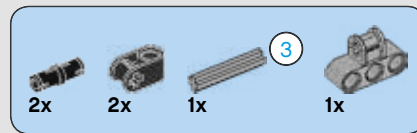
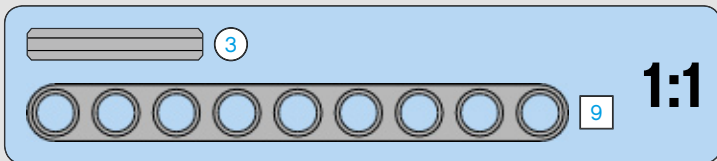
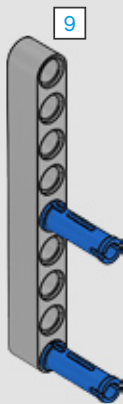

20

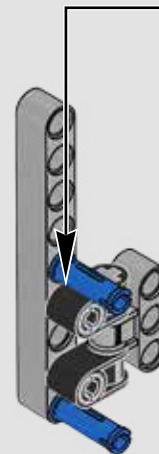
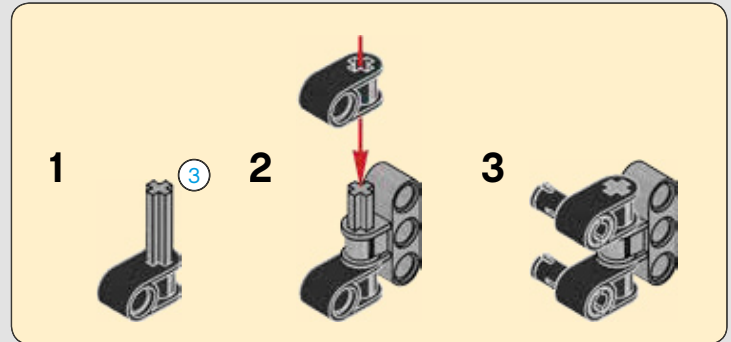

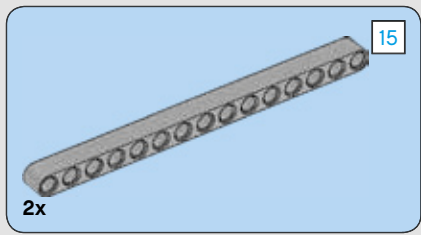

21

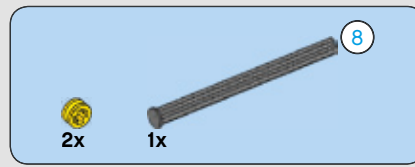
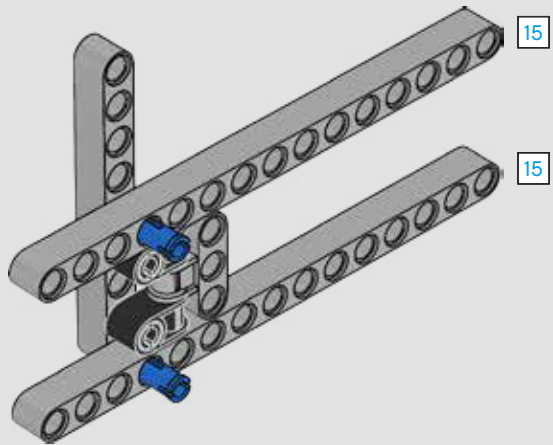

22

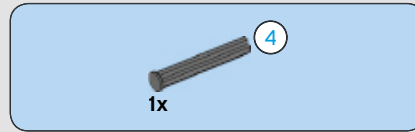
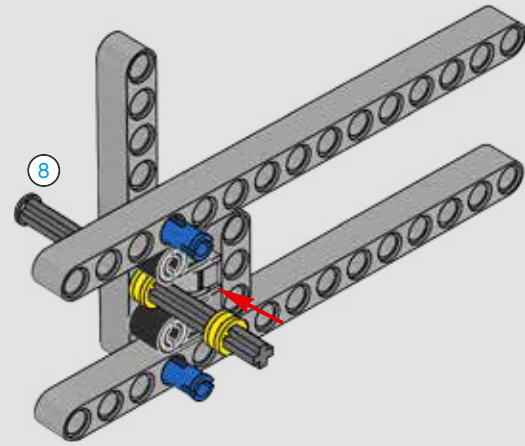

23

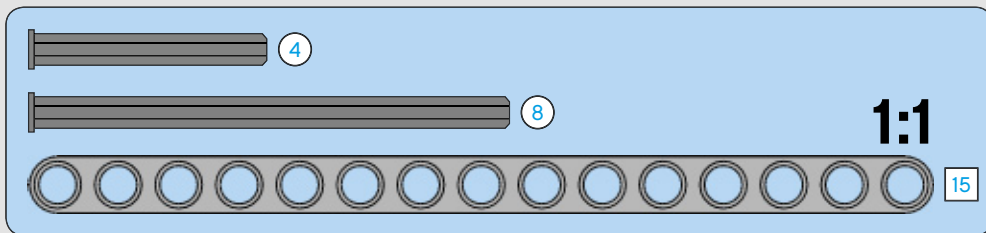
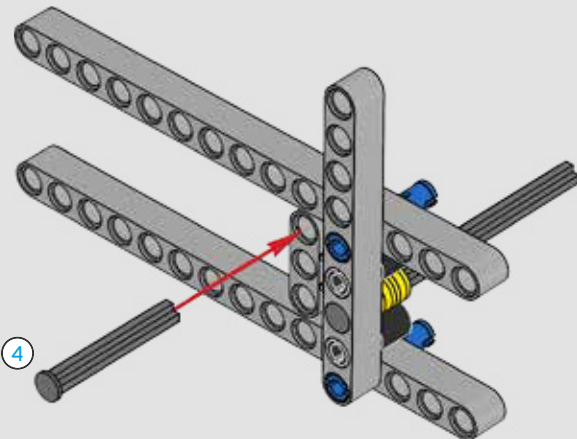
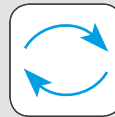

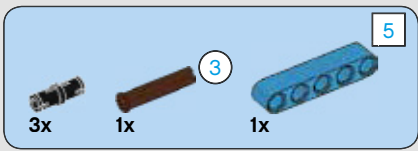

# 24

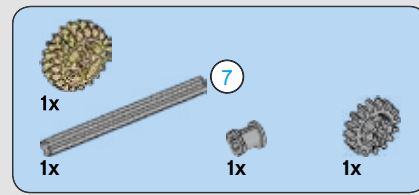
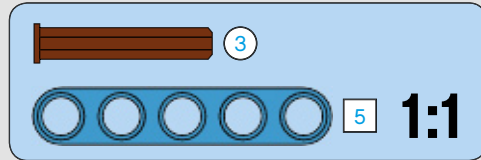
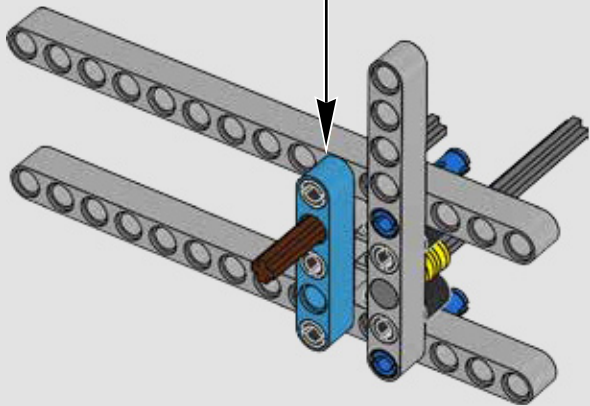
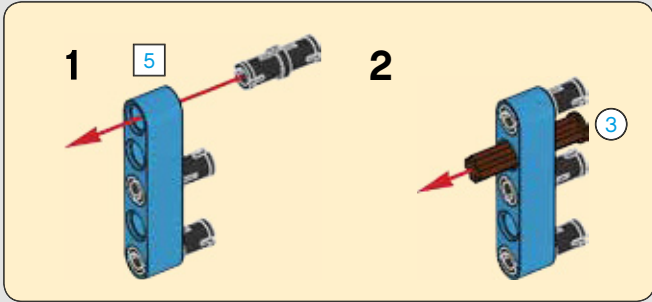

# 25

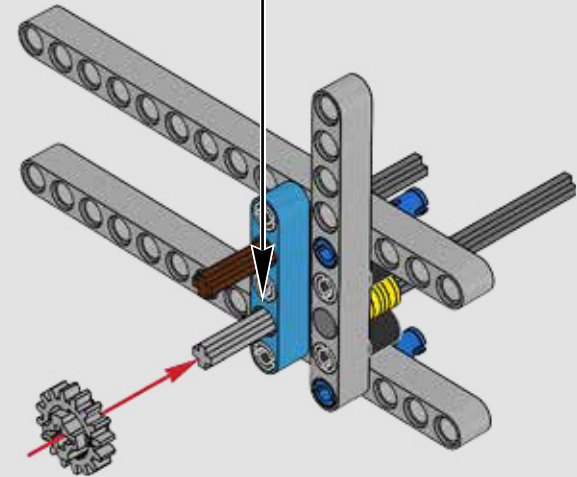
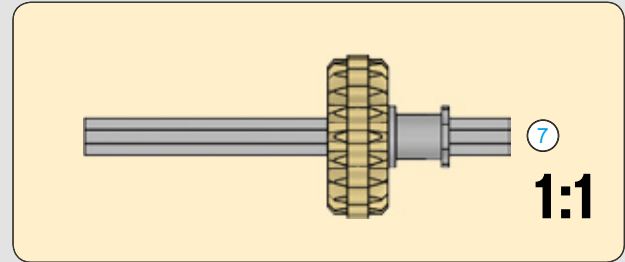



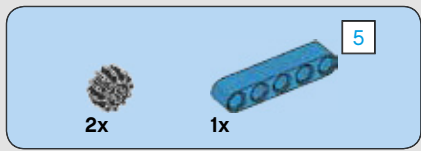

26

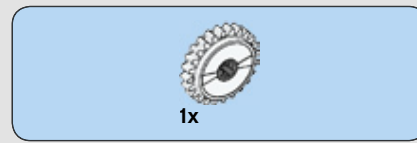
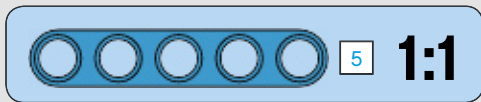
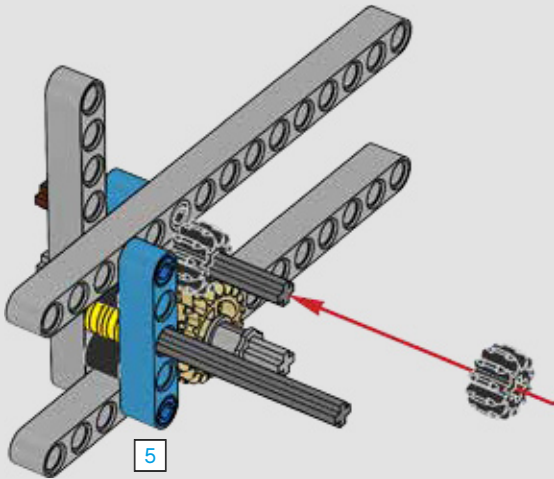
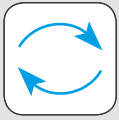

27

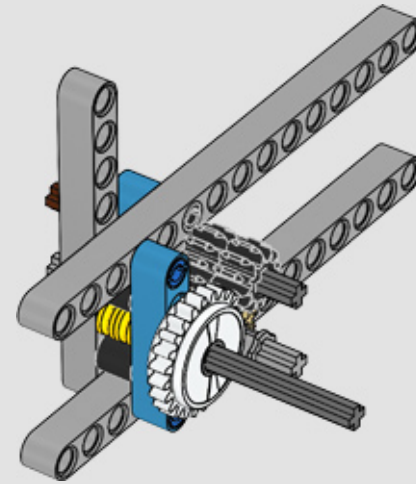

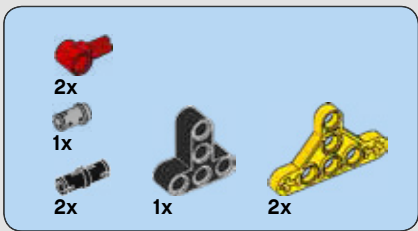

28

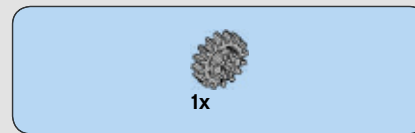
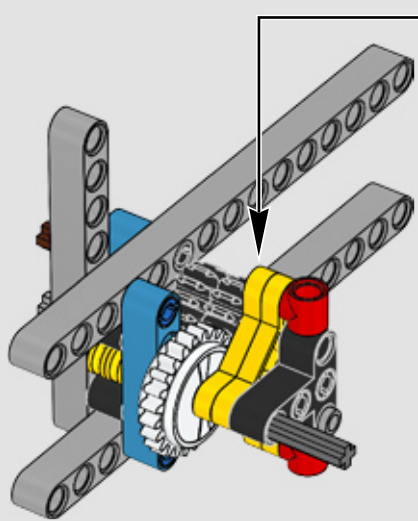
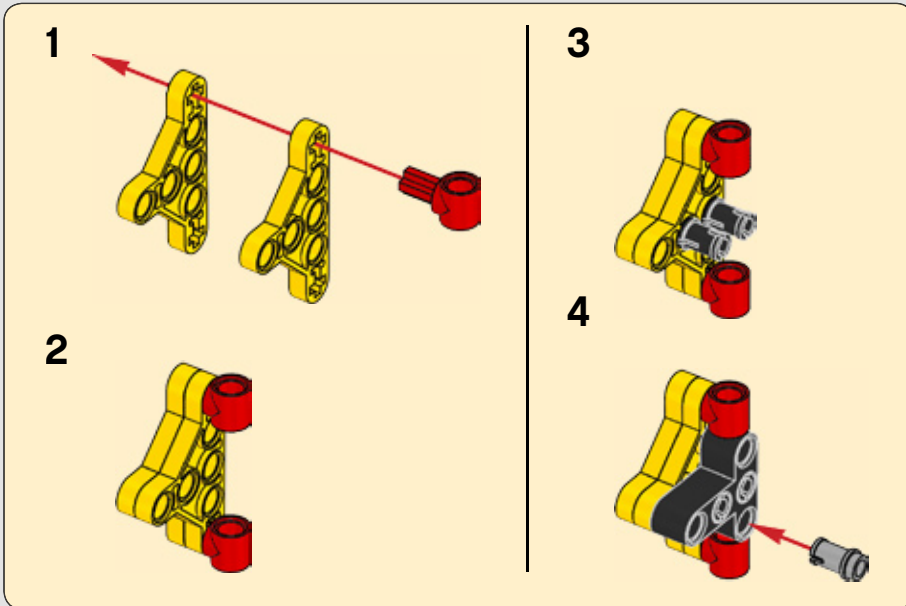

29

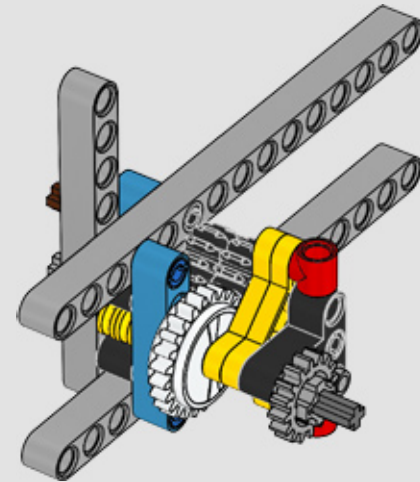

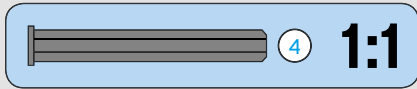
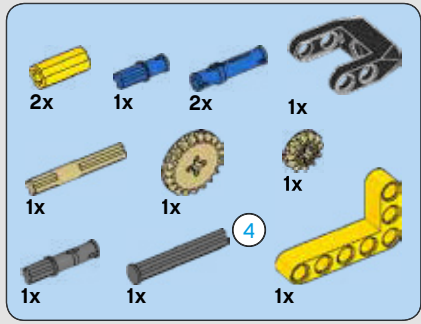

30

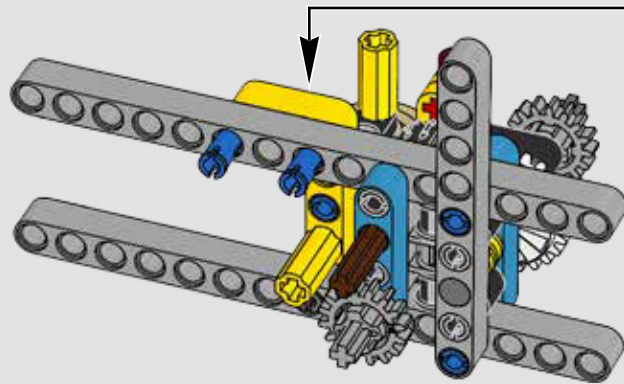
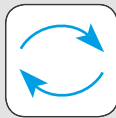
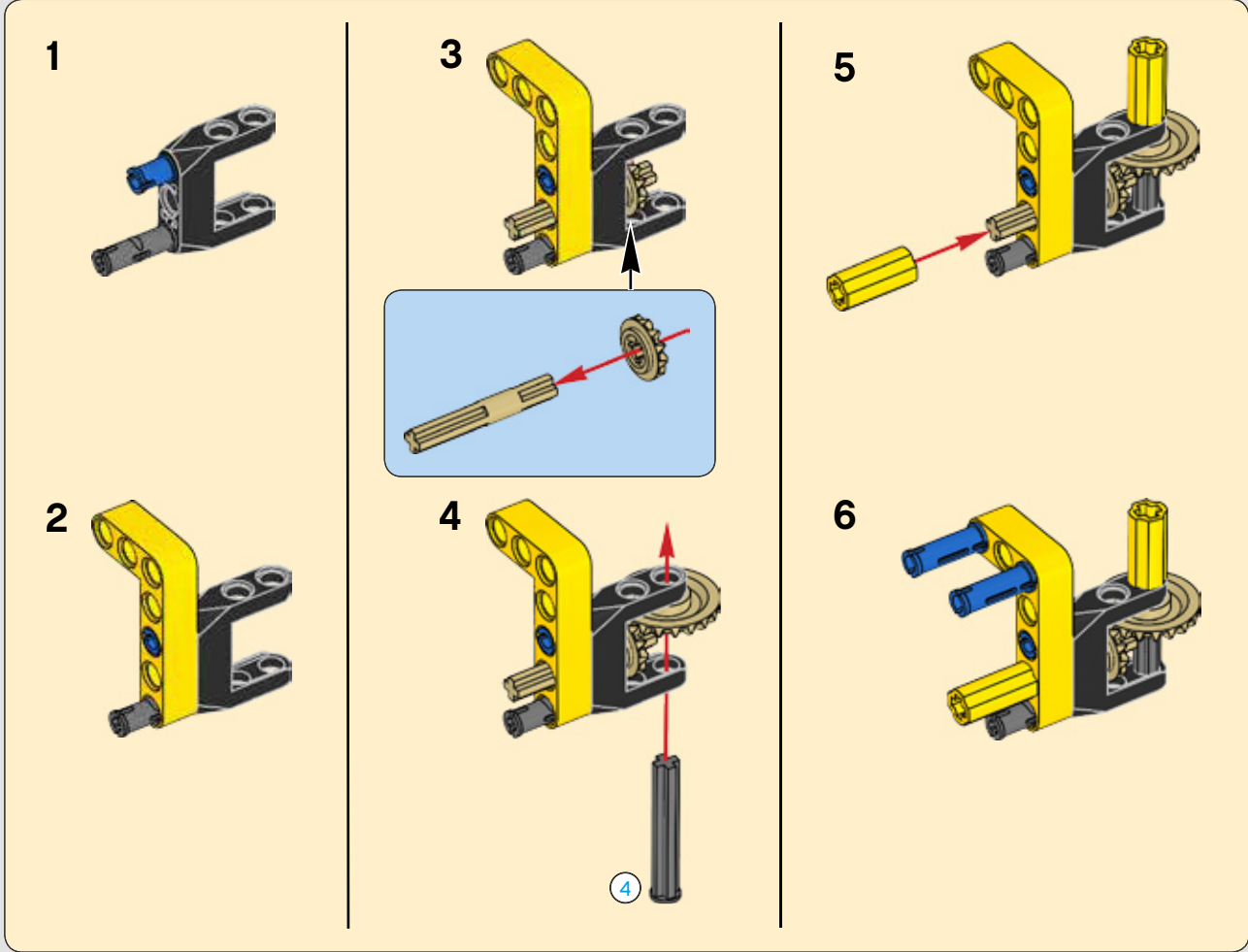



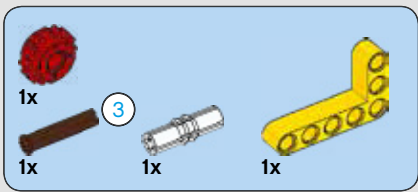

31

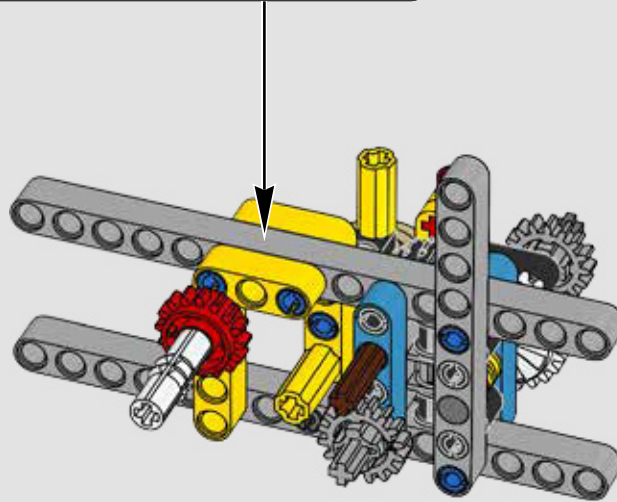
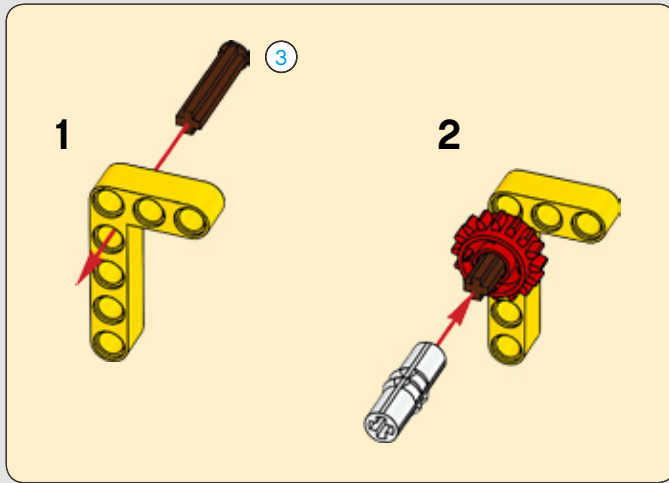



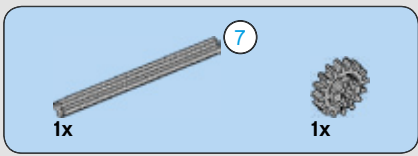

33

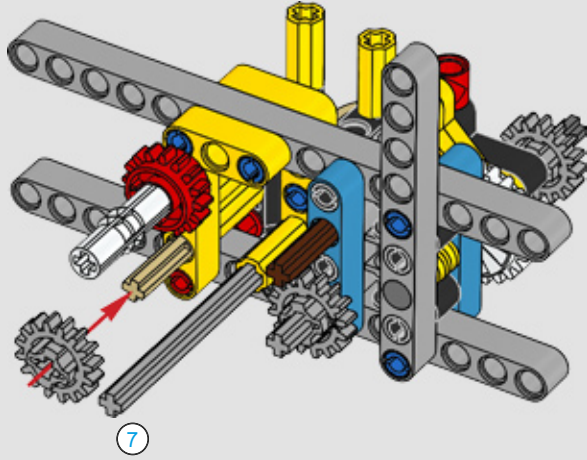

34

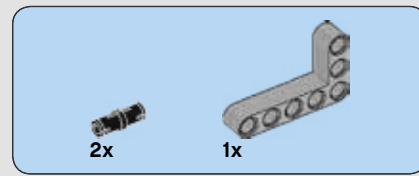
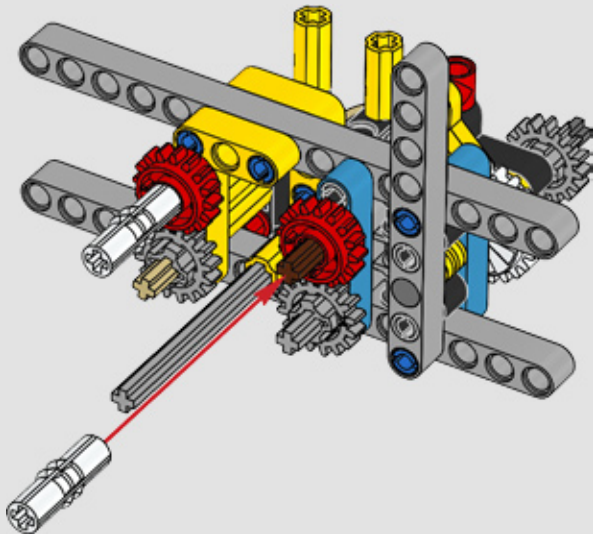

35

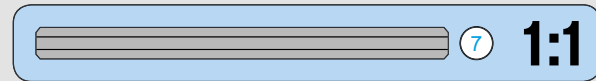
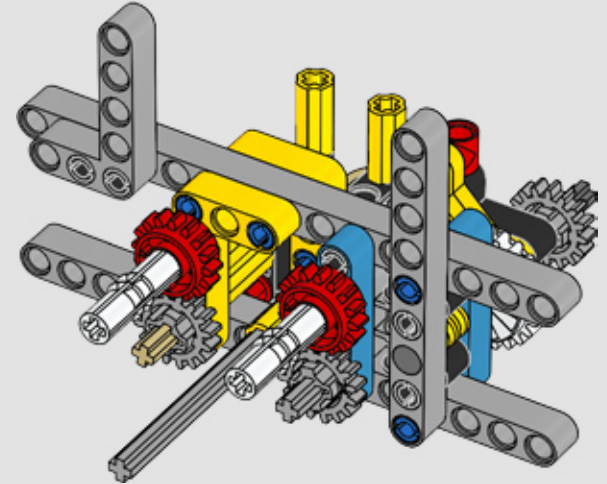
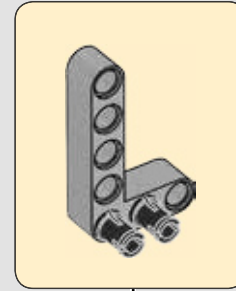

36

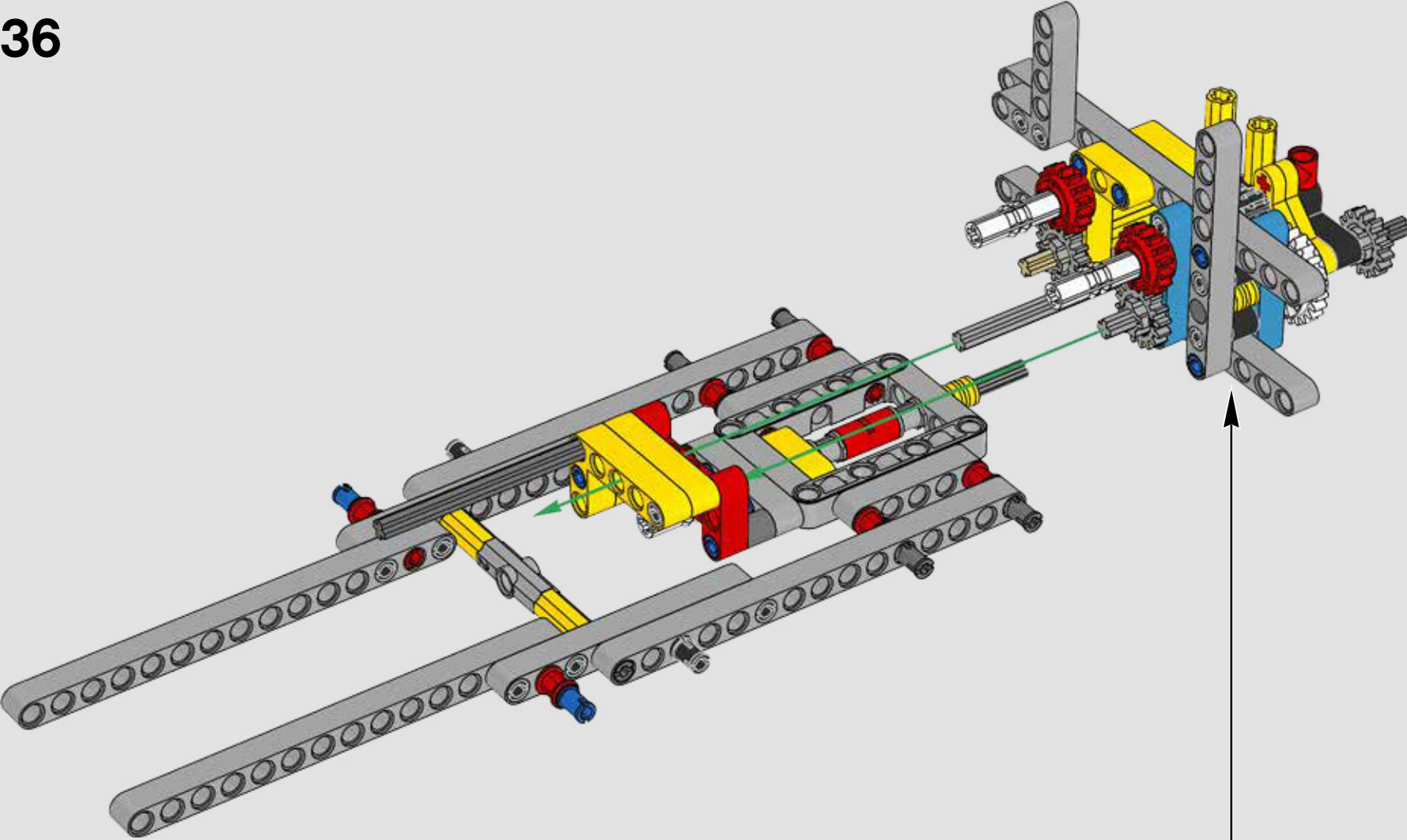





37

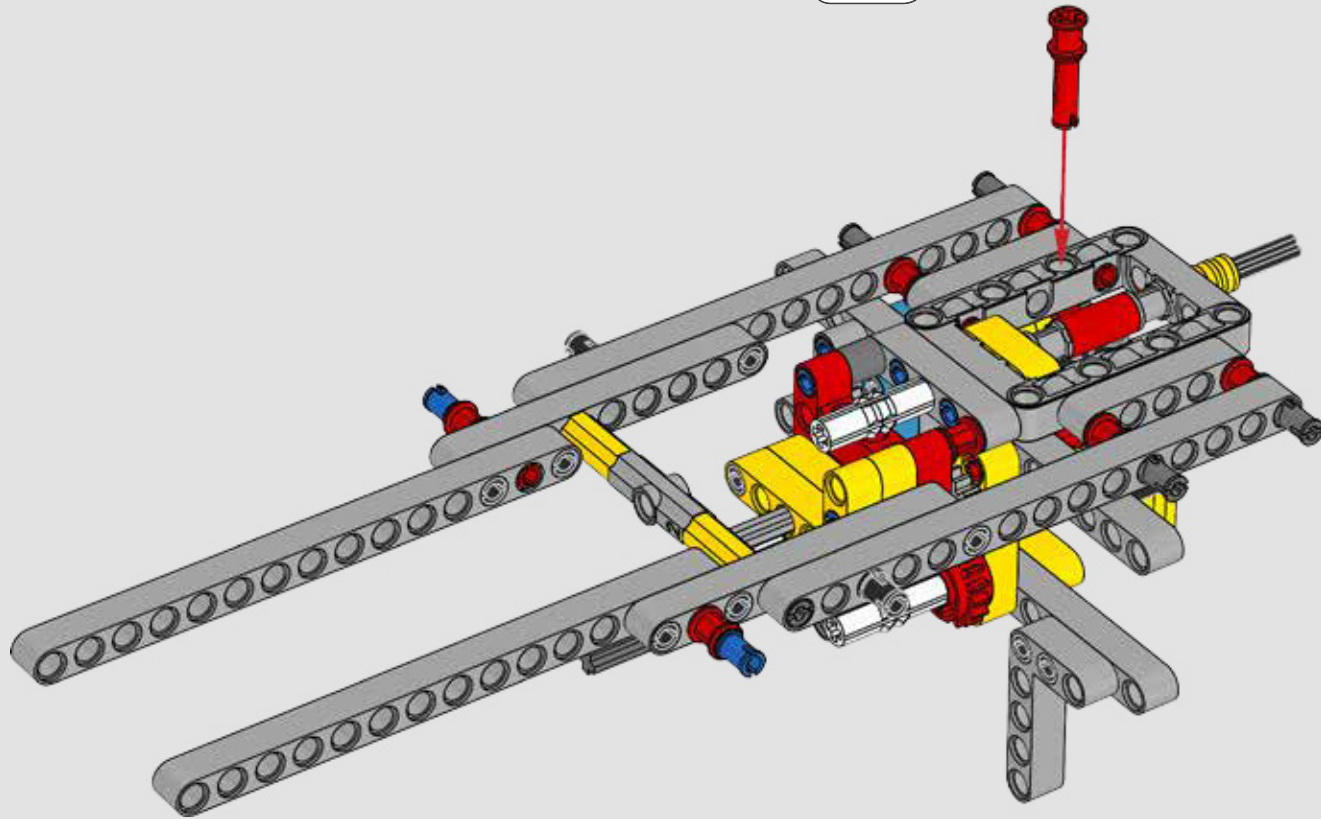
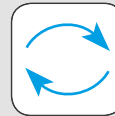



38

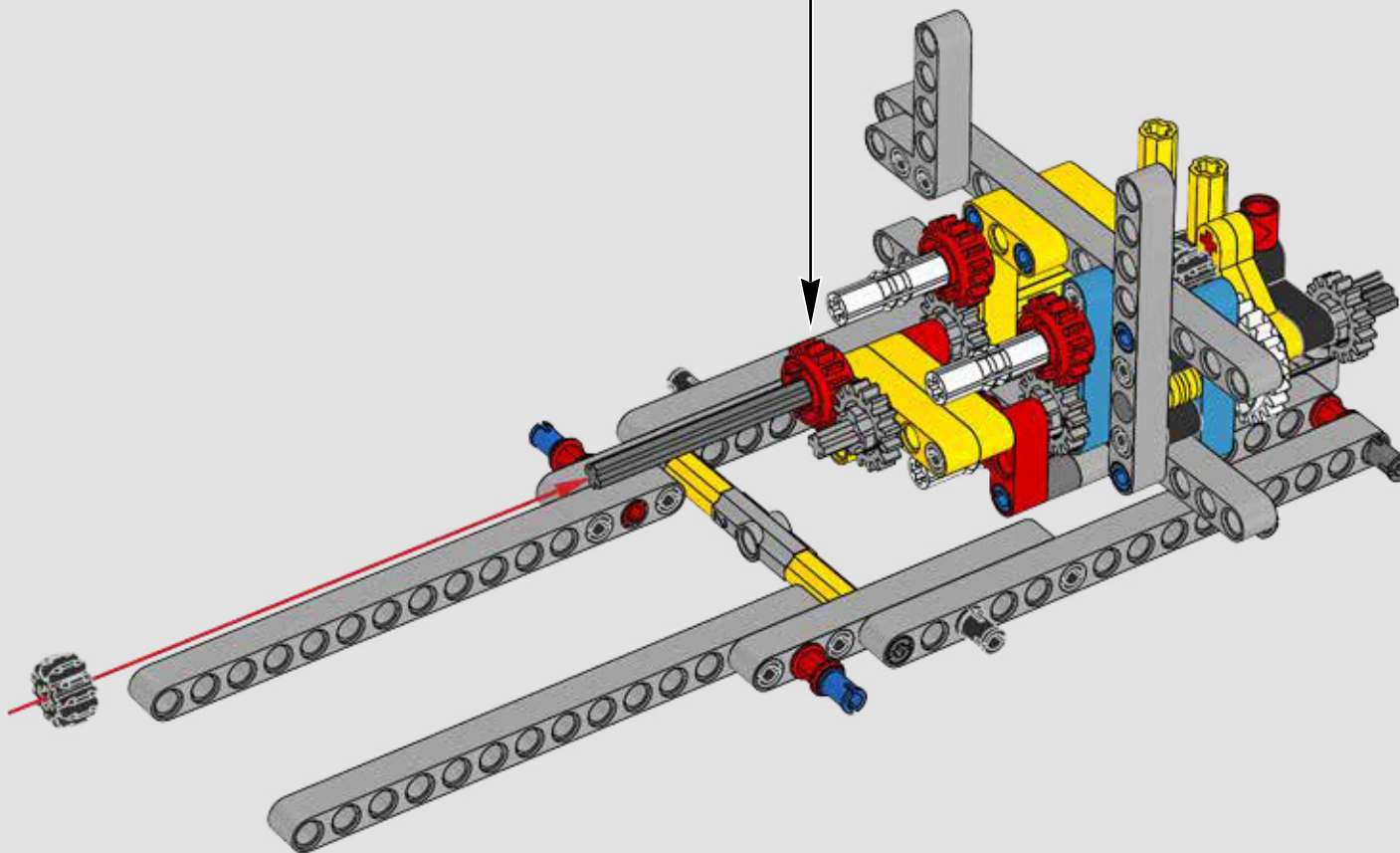
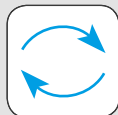

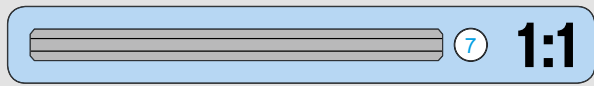
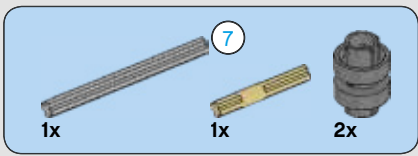

39

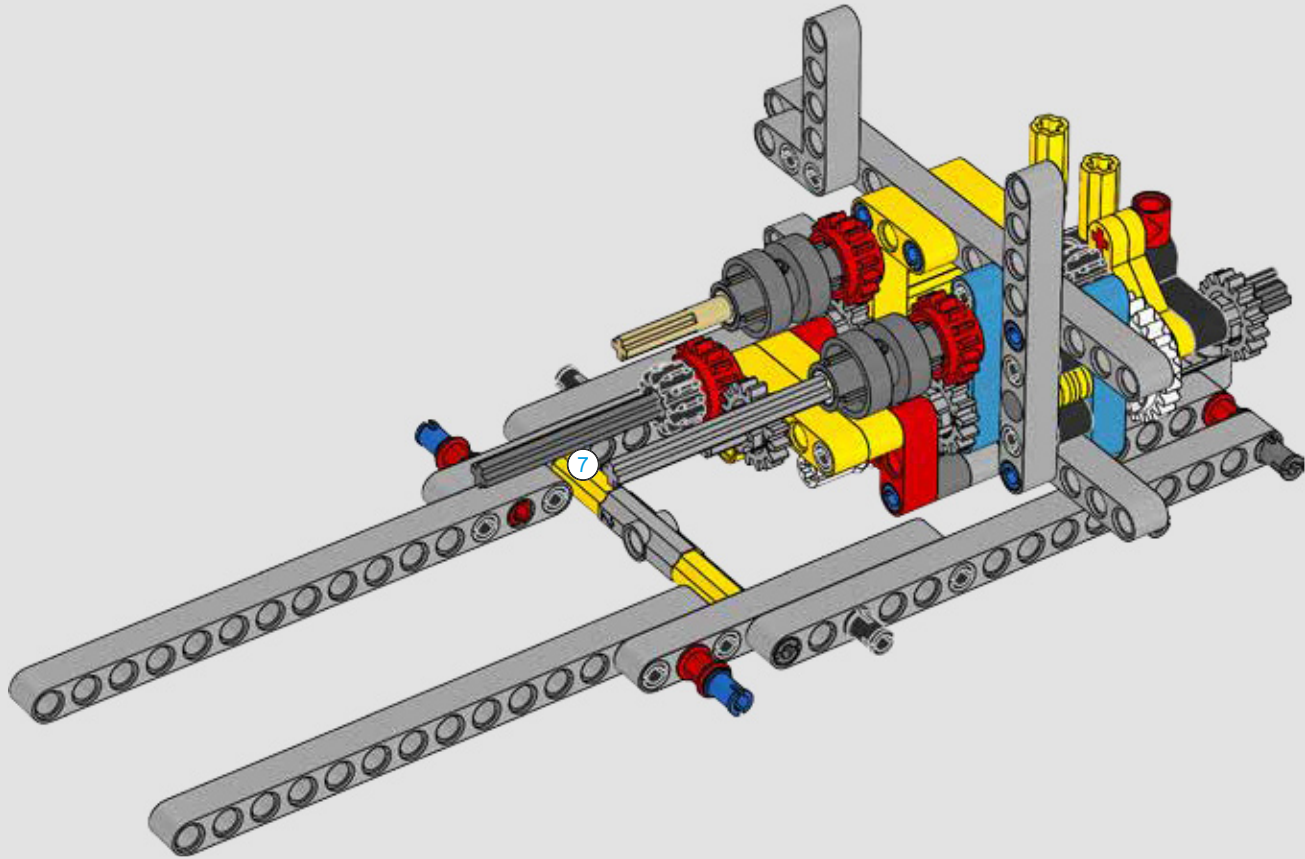

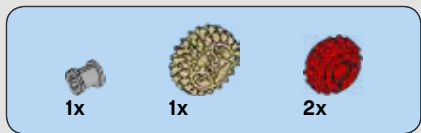

40

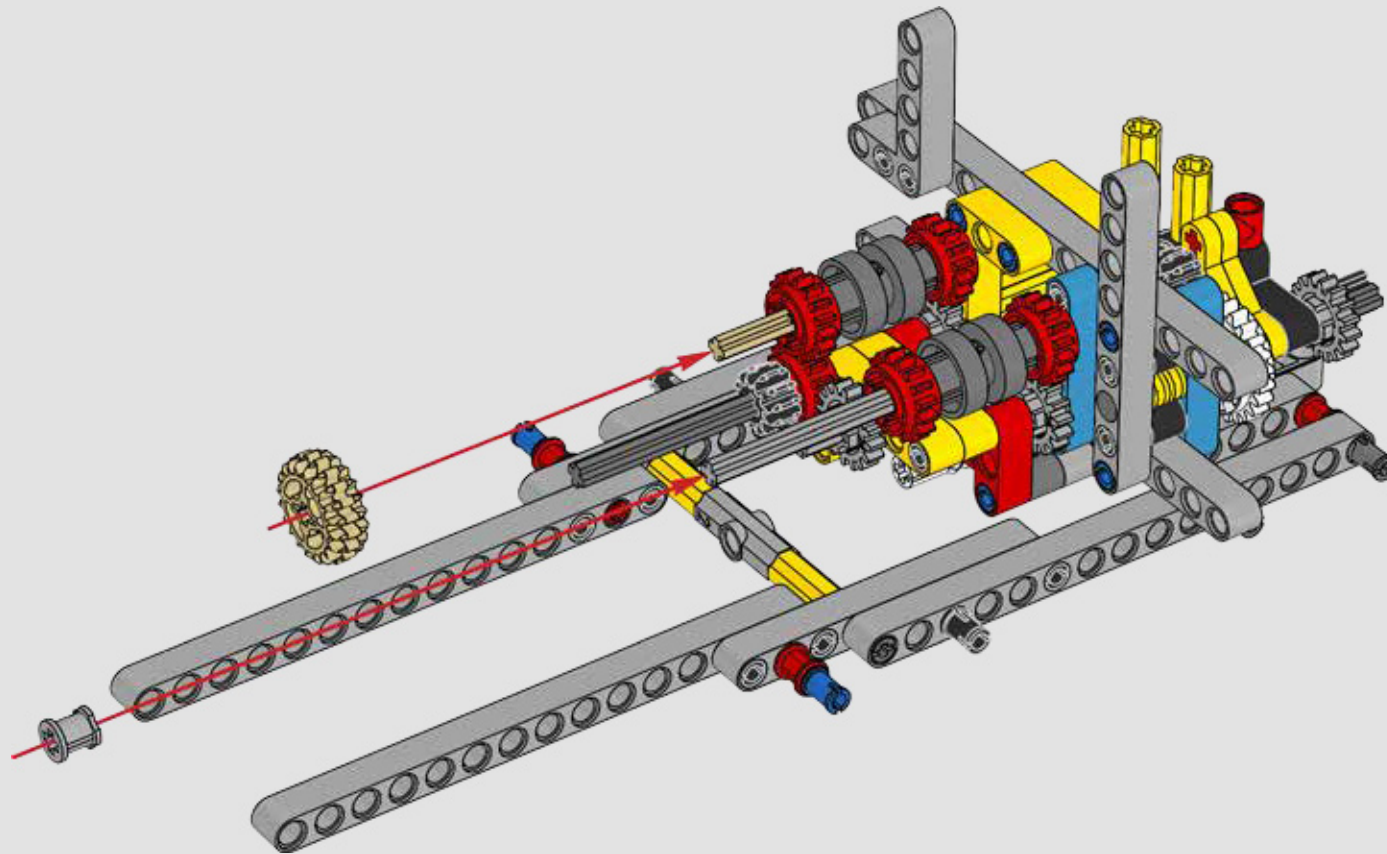



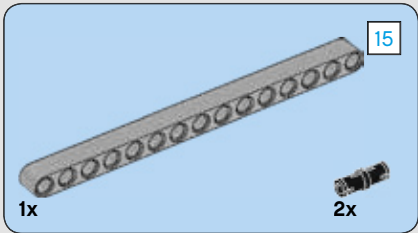
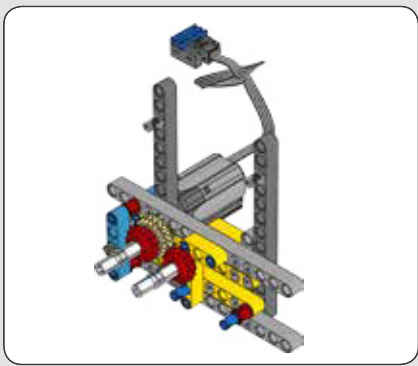

41

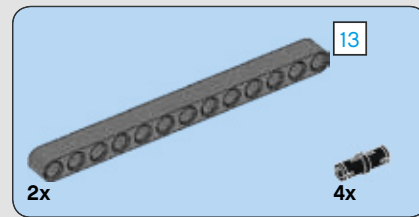
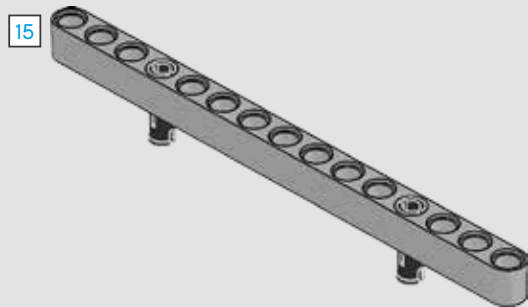

42

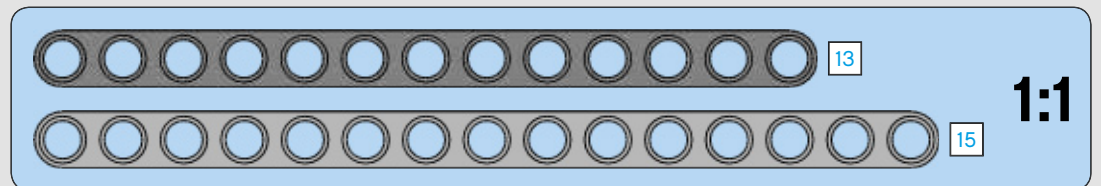
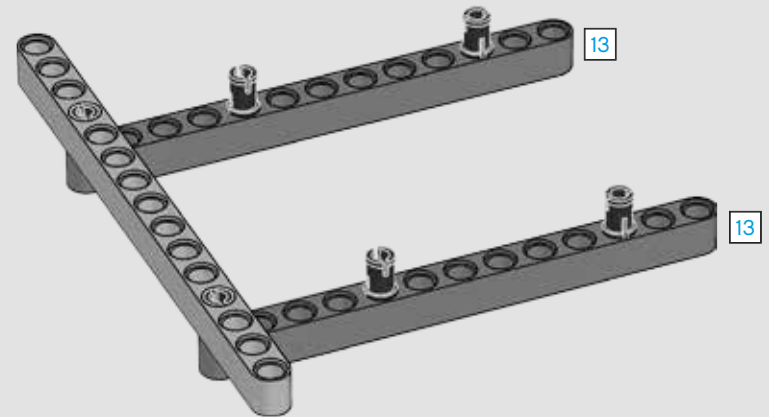

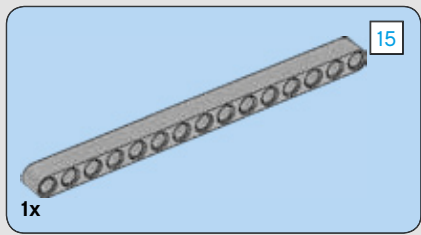

43

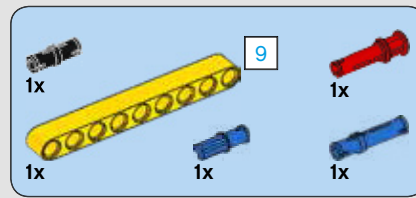
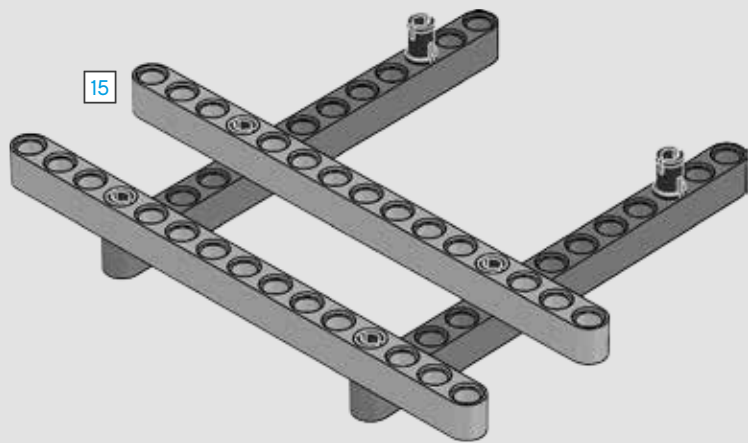

44

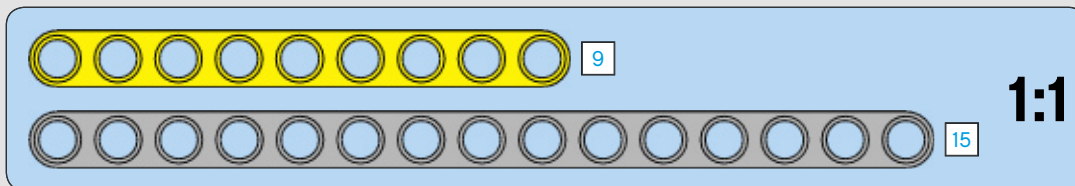
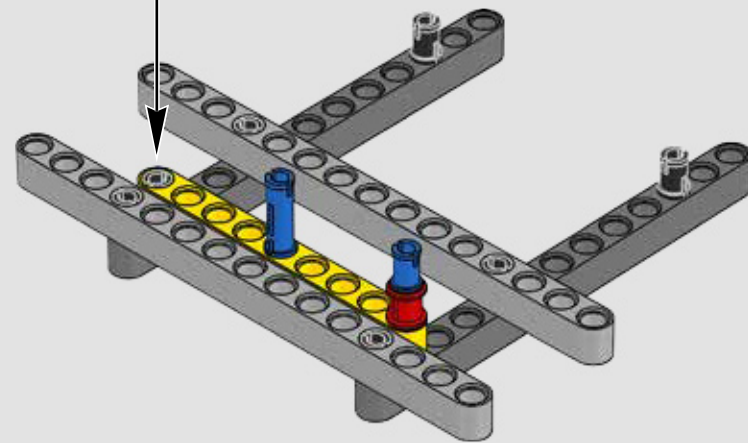
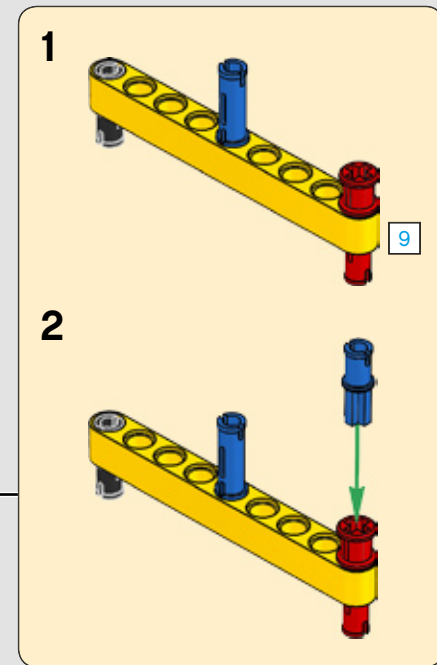

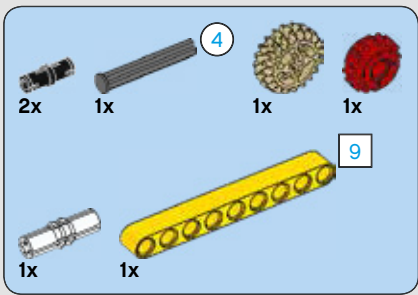

45

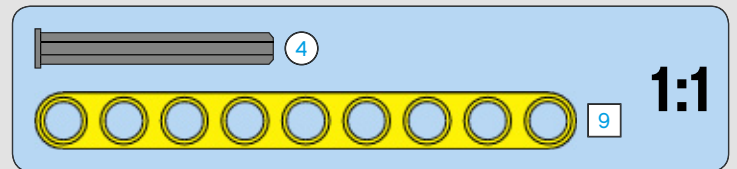
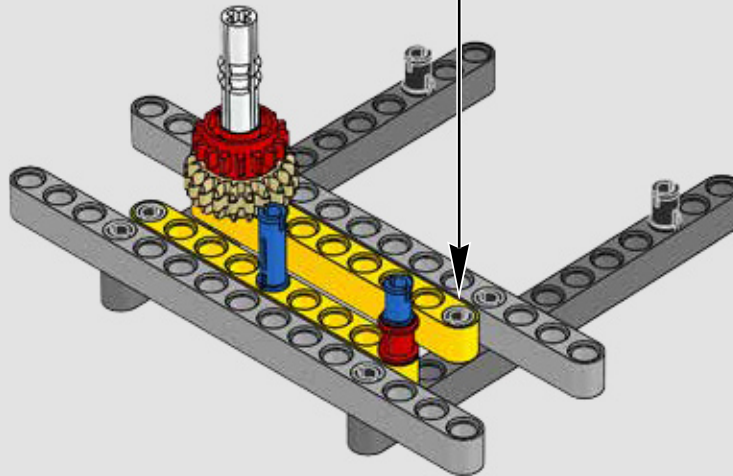
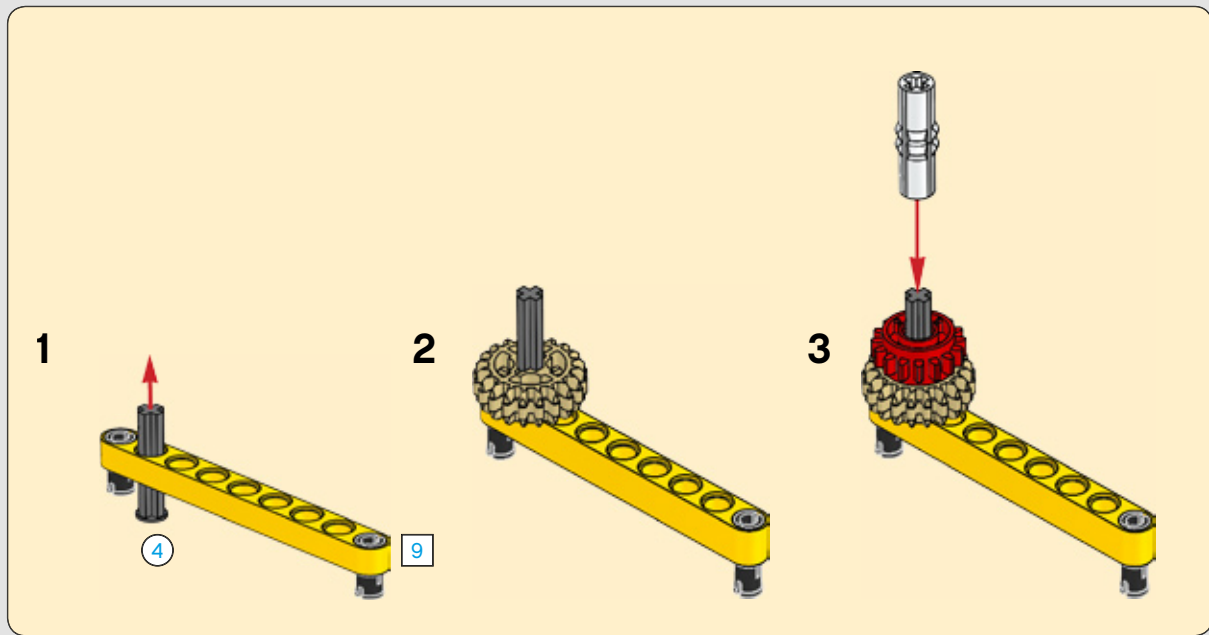

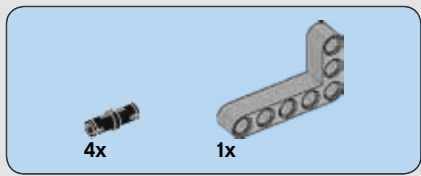

46

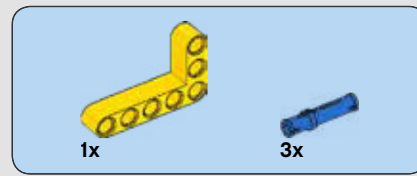
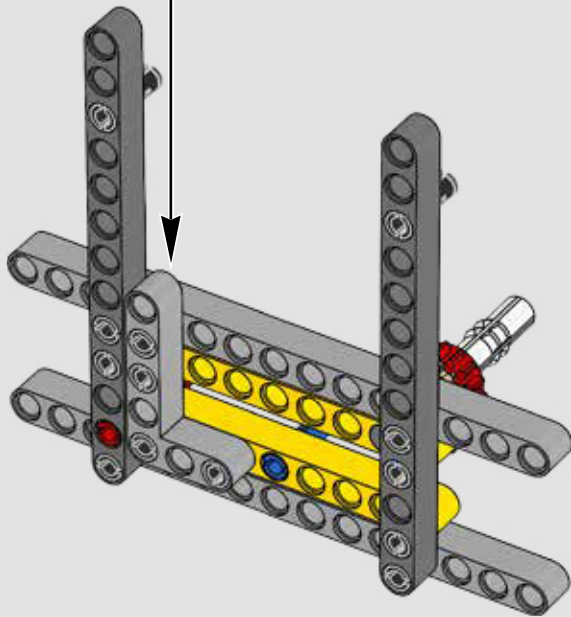
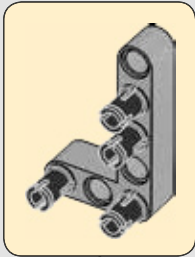

47

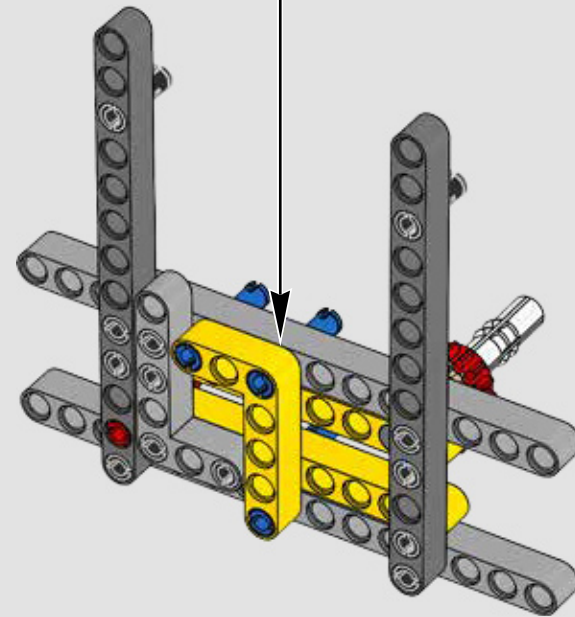
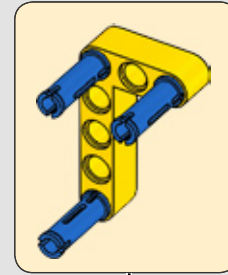



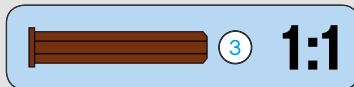
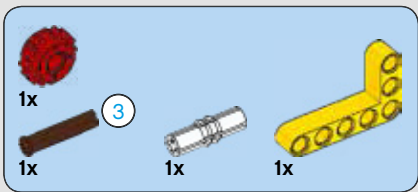

48

49

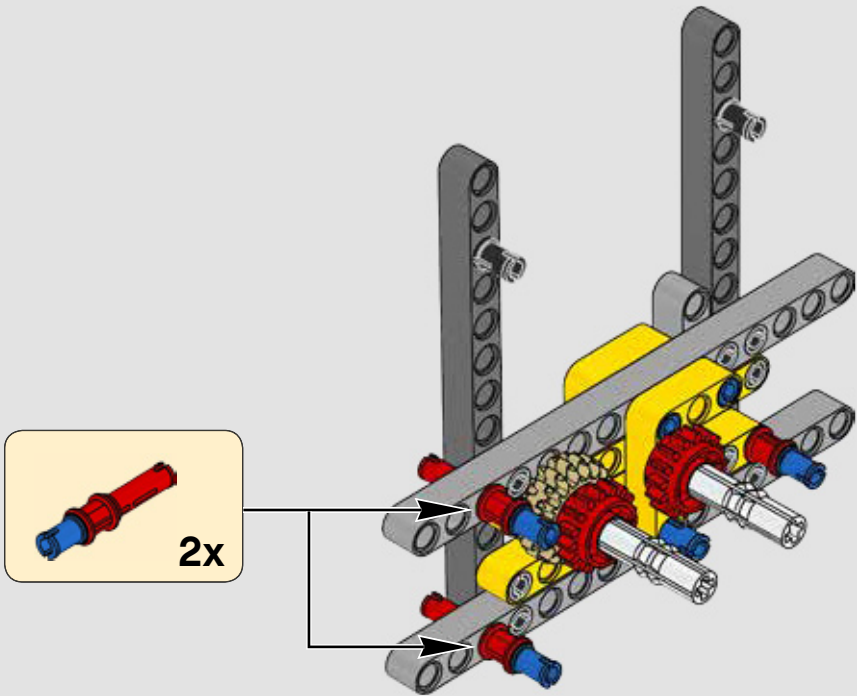
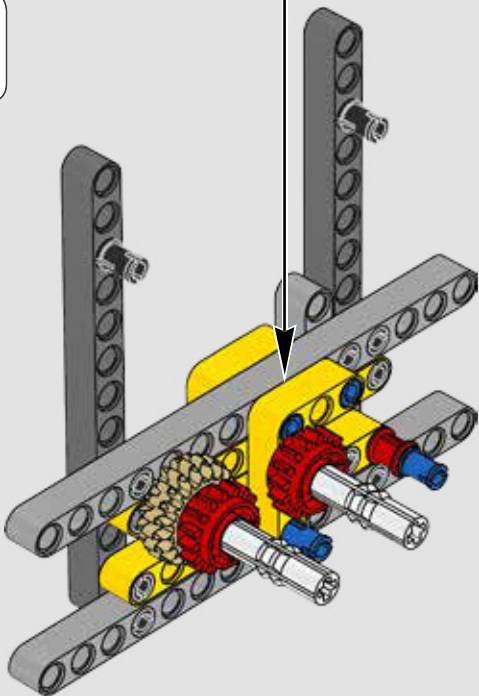
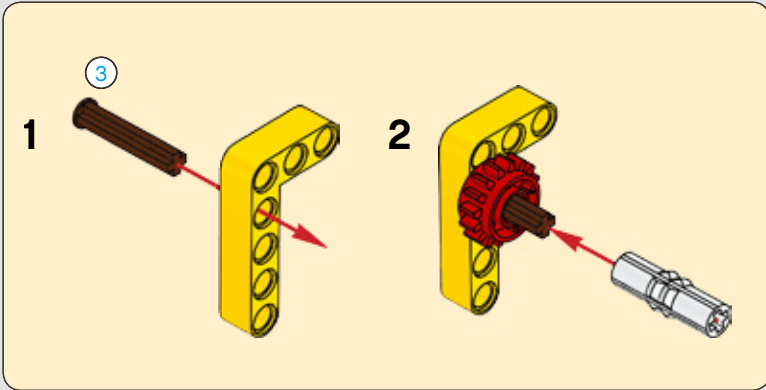

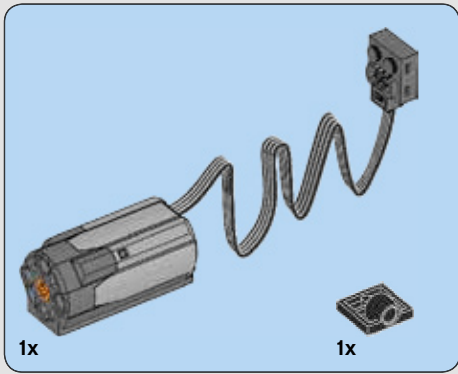
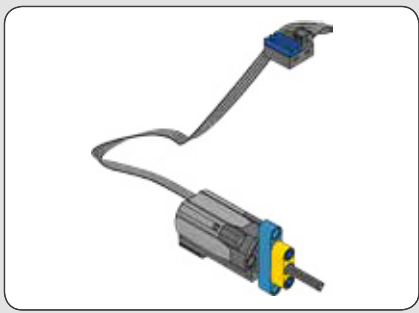

50

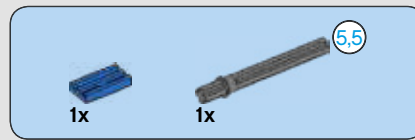
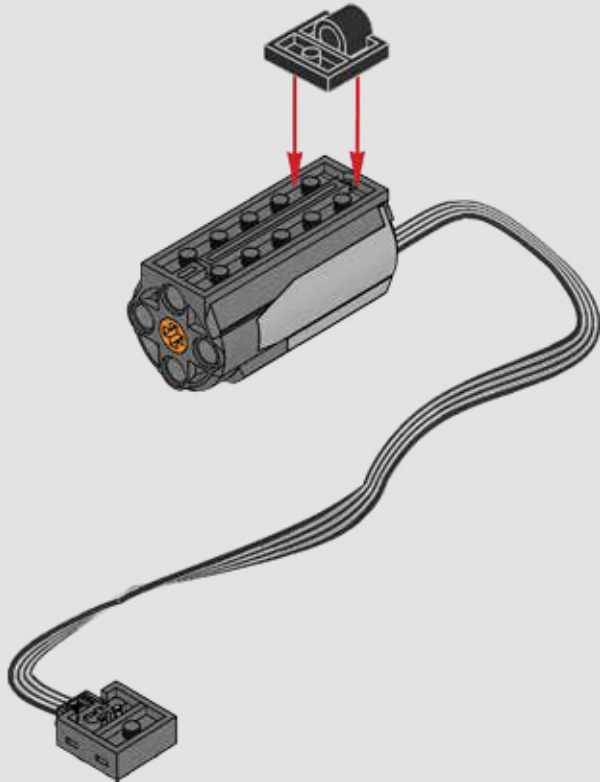

51

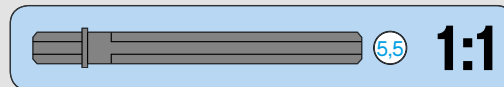
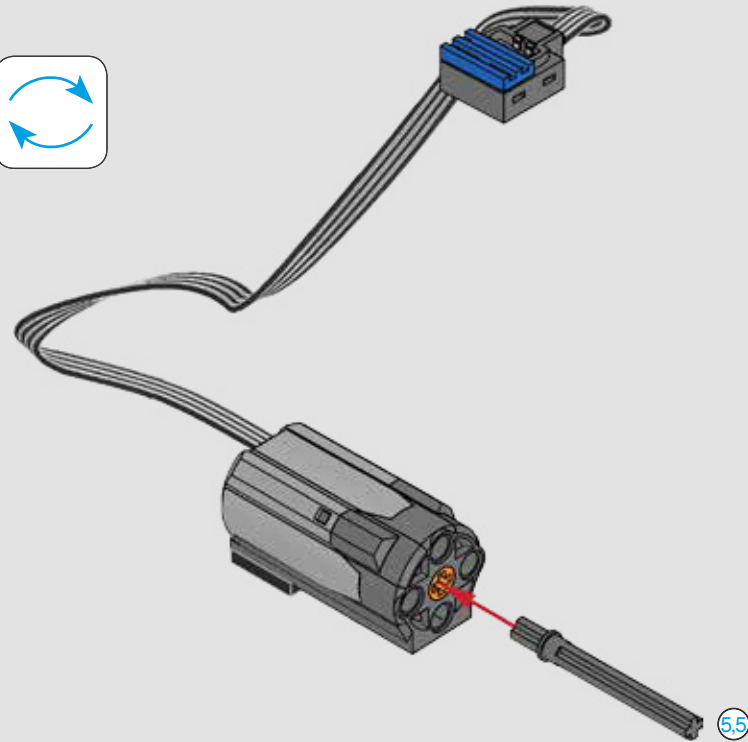
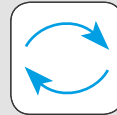

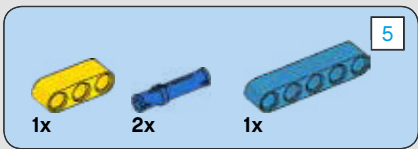

52

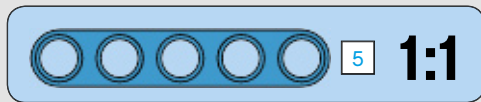
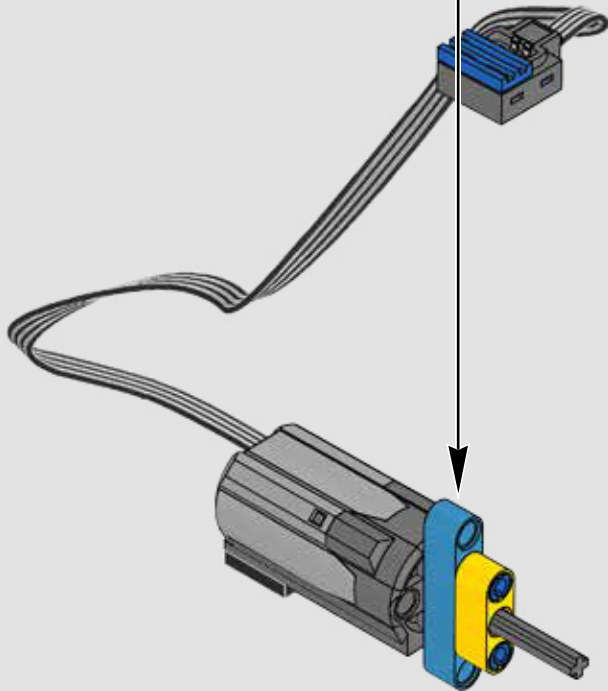
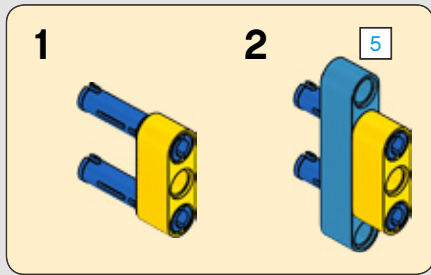

53

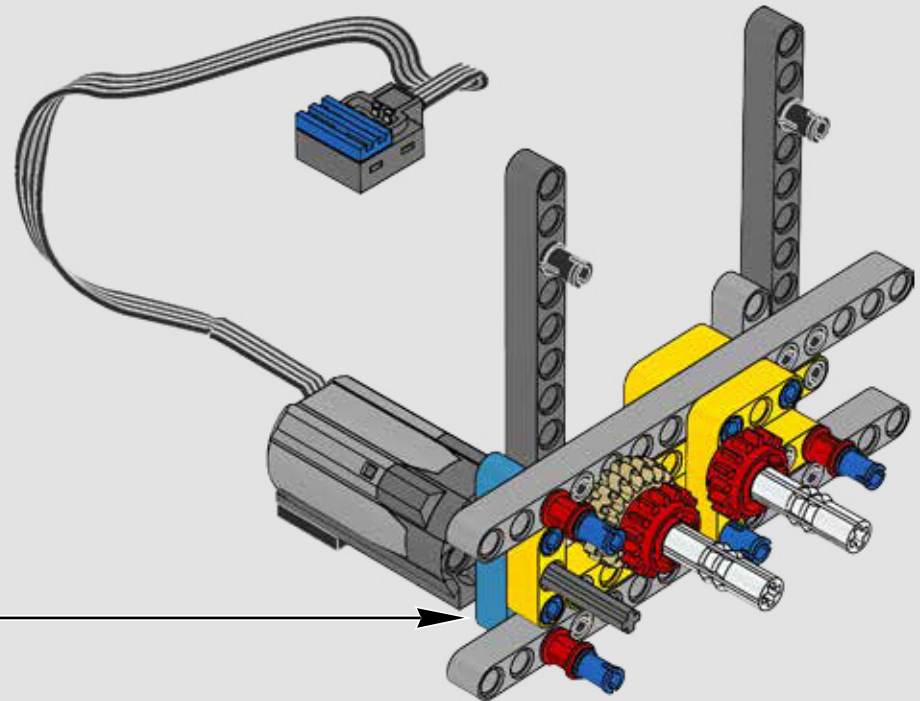

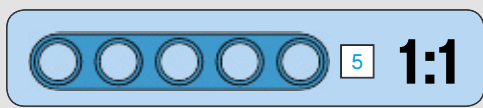
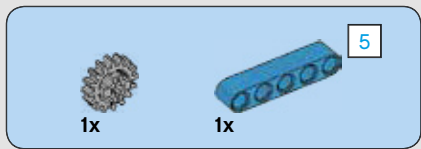

54

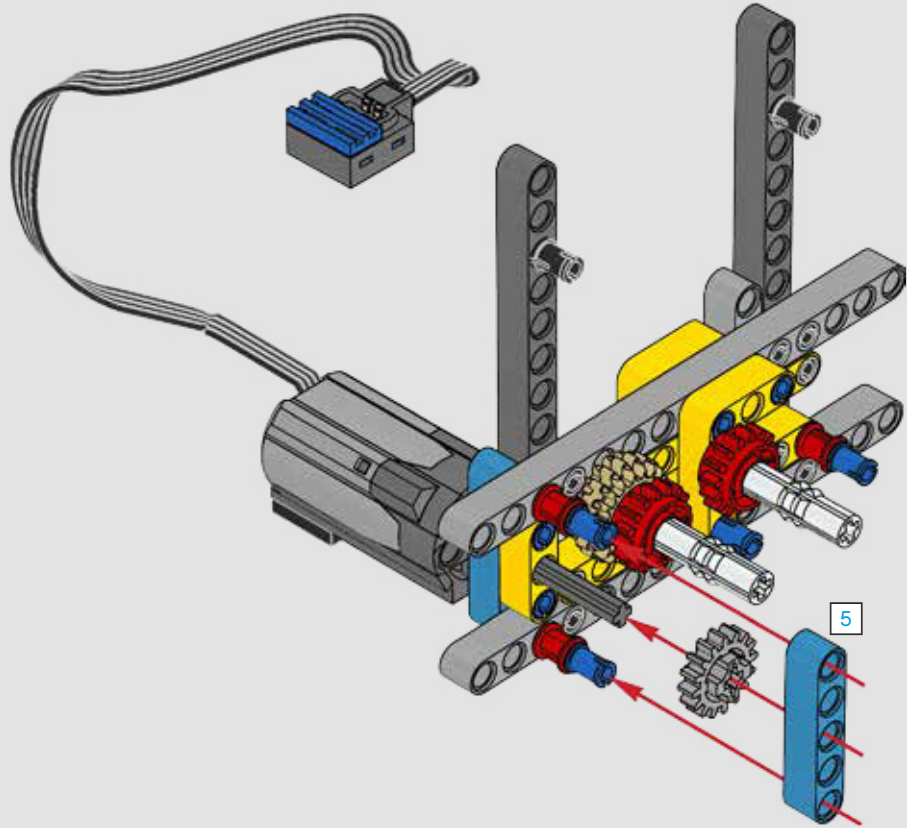

55

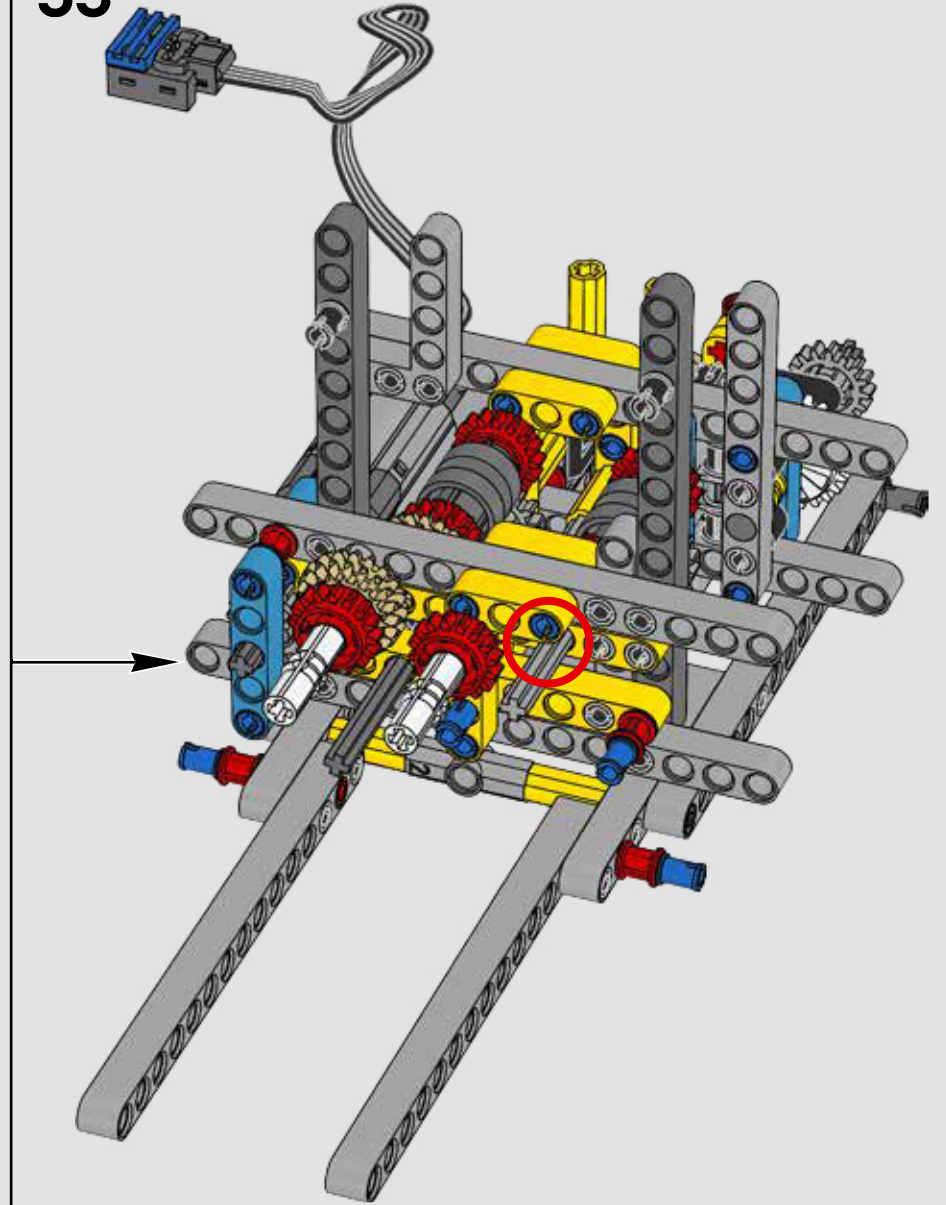





56

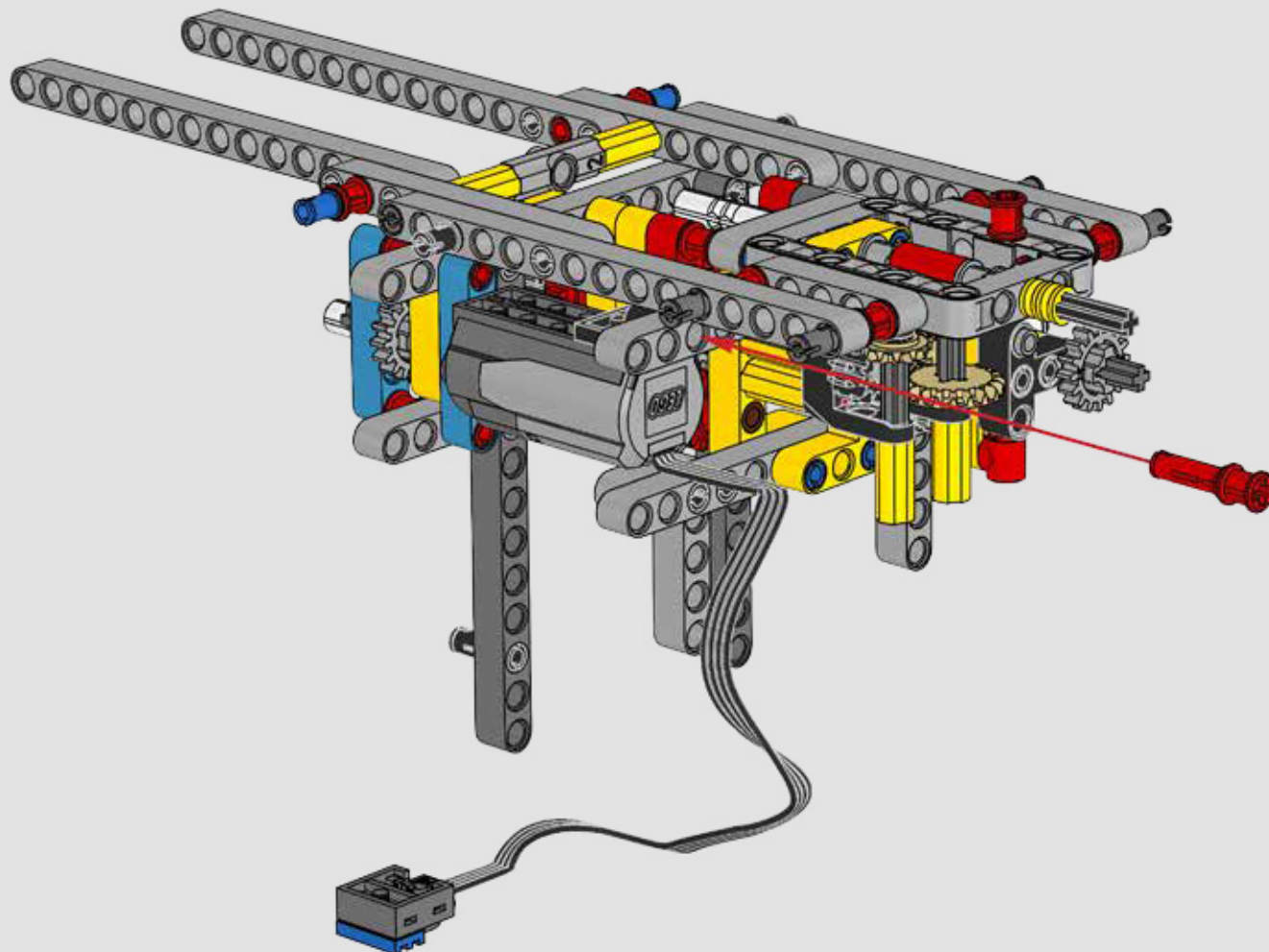

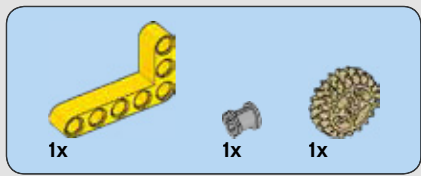

57

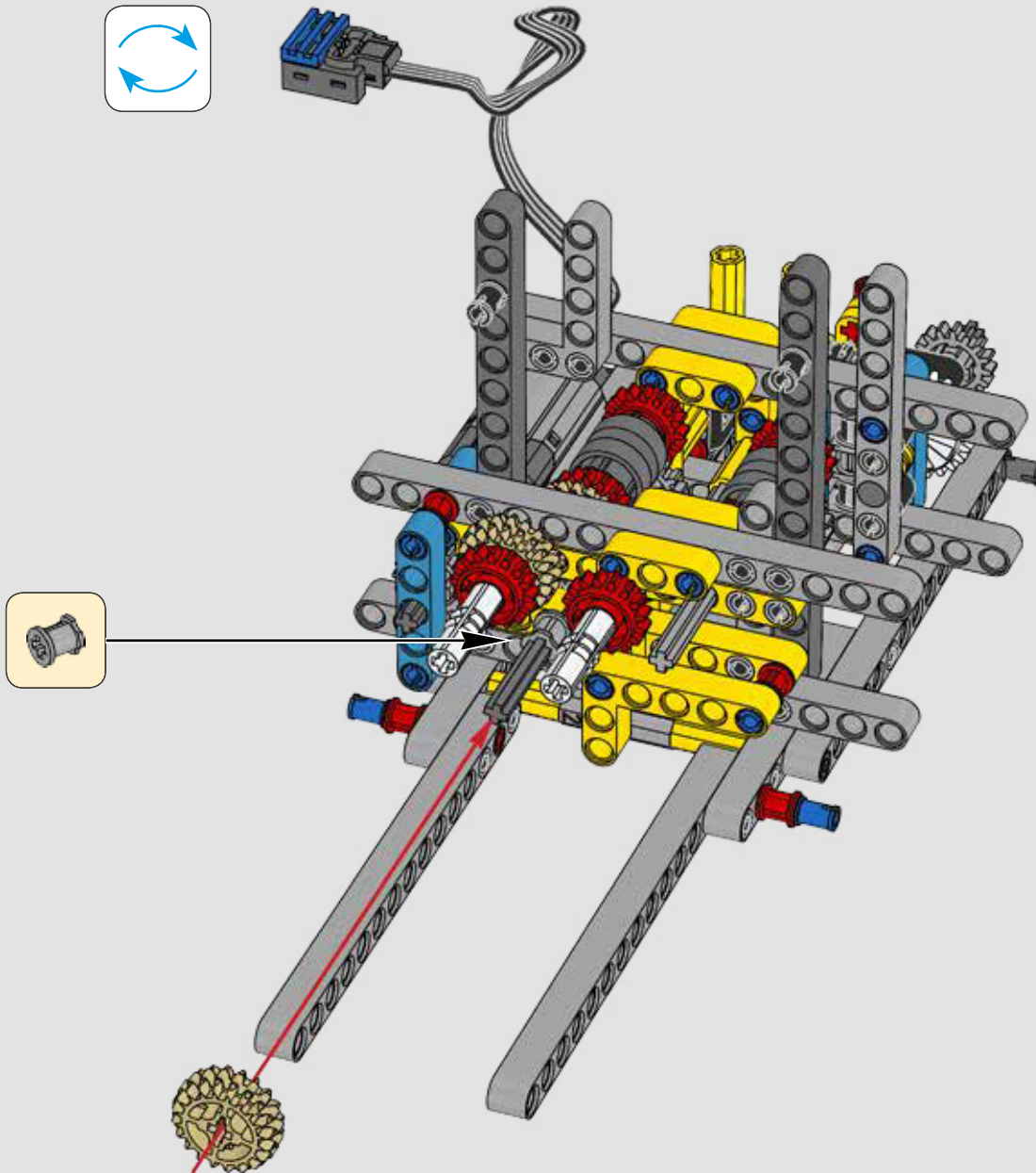

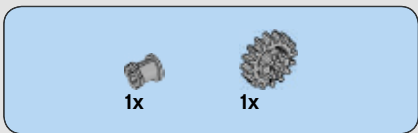

58

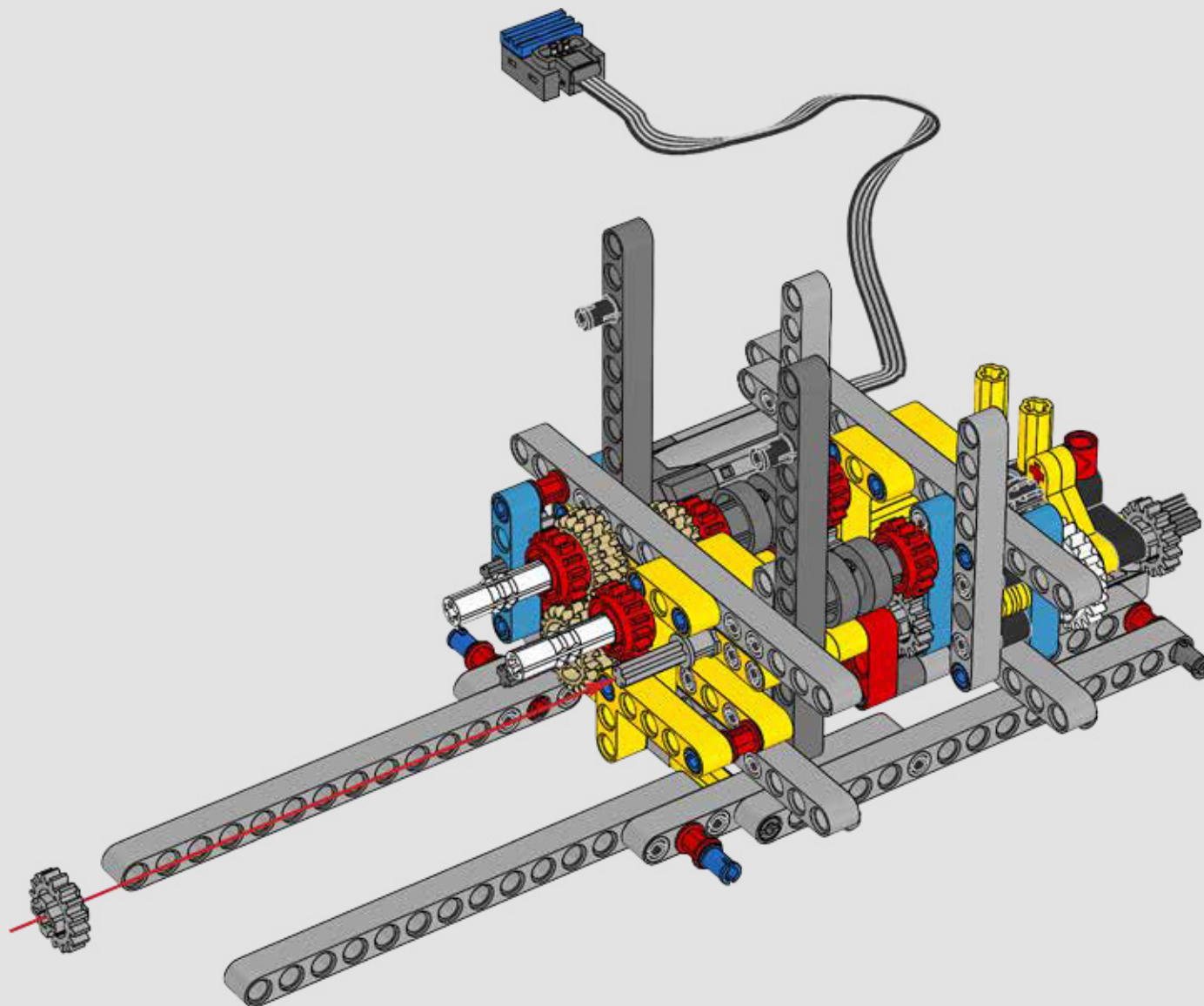

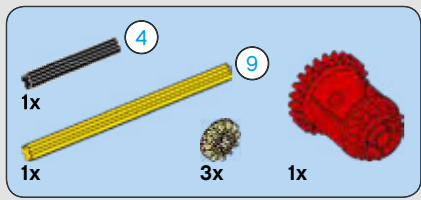

59

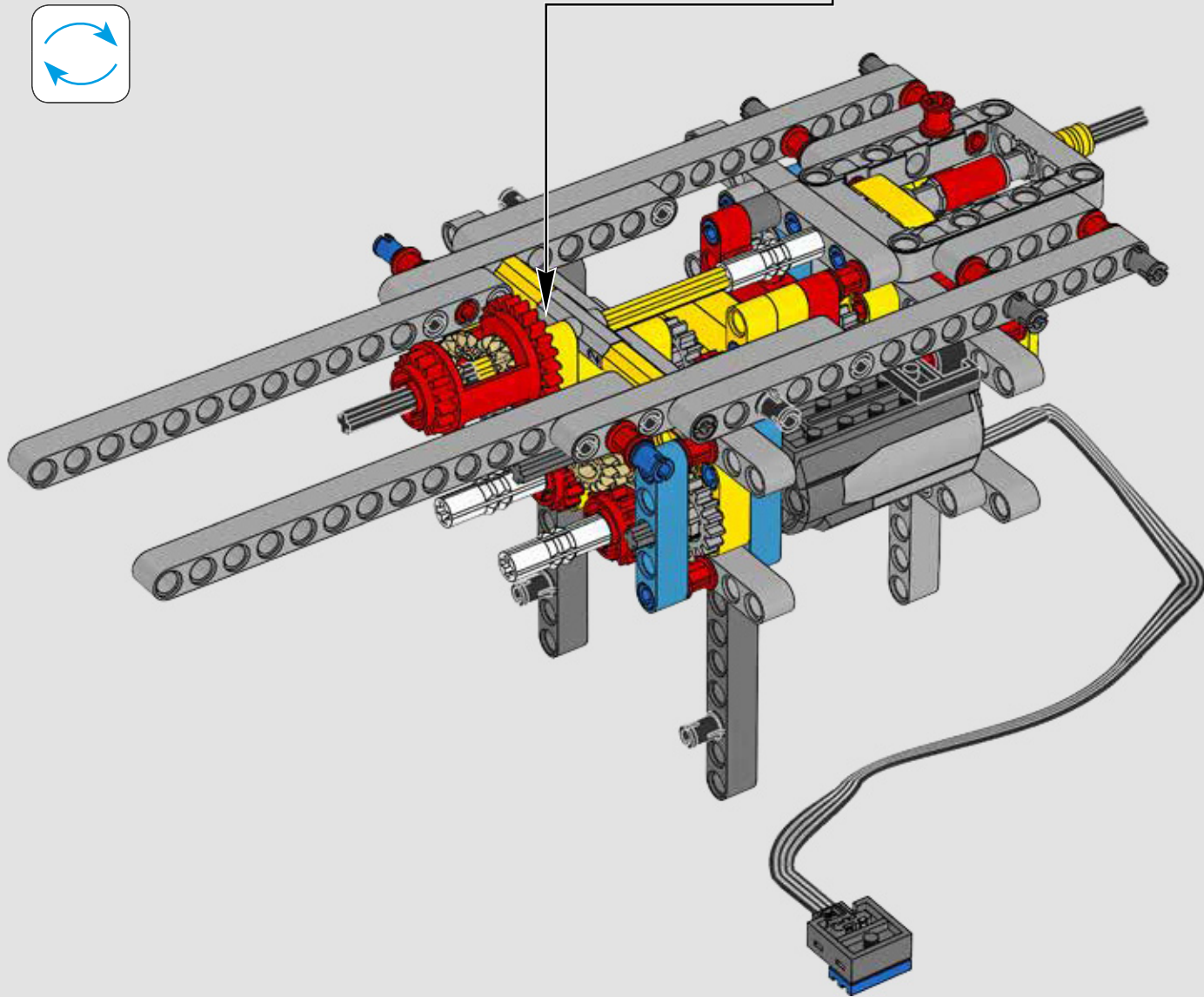
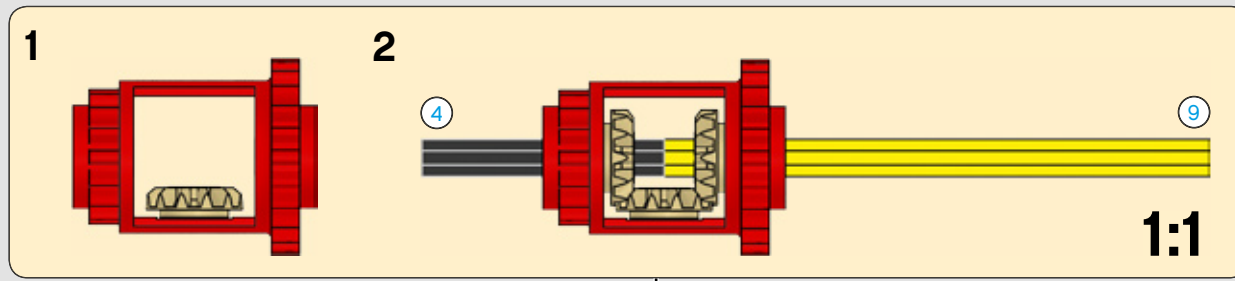



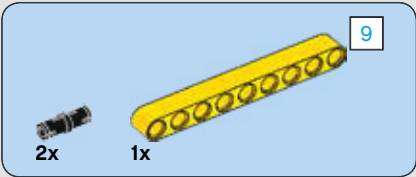

60

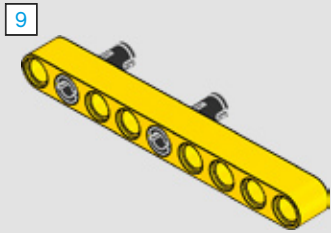

61

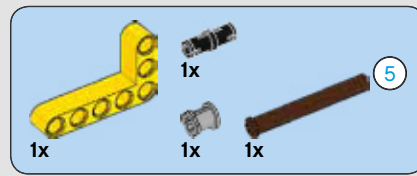
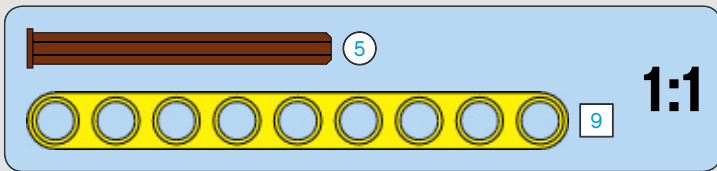
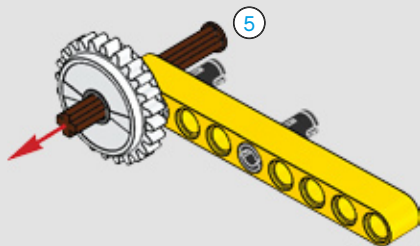

62

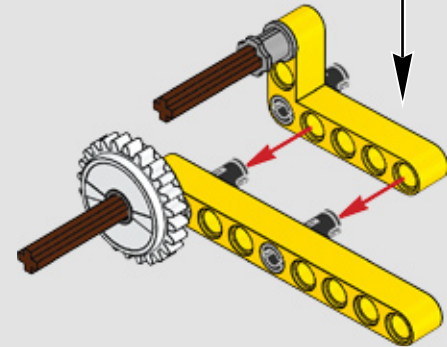
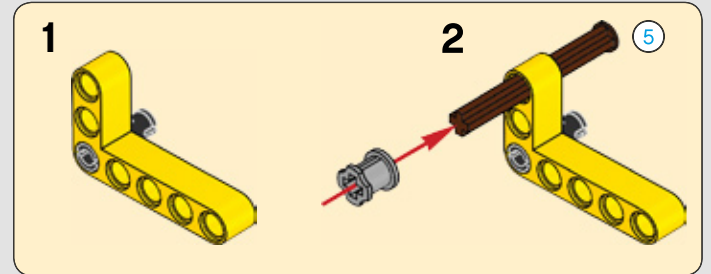

63

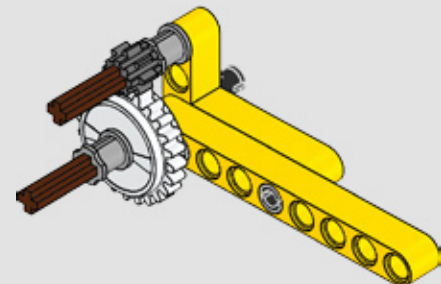



1:1

64

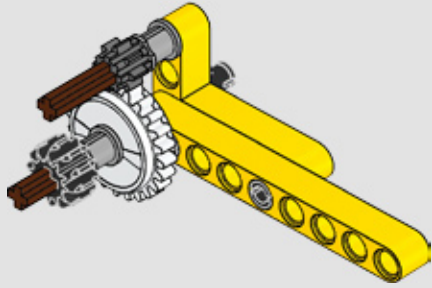

2x

1x

65

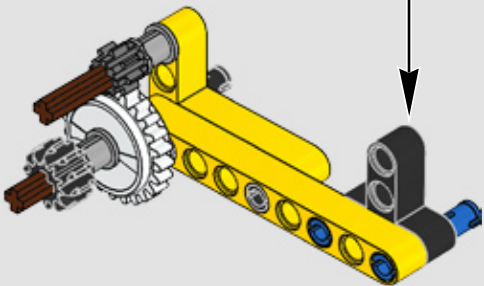
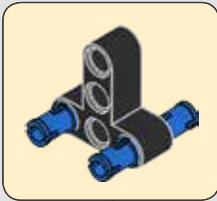

66

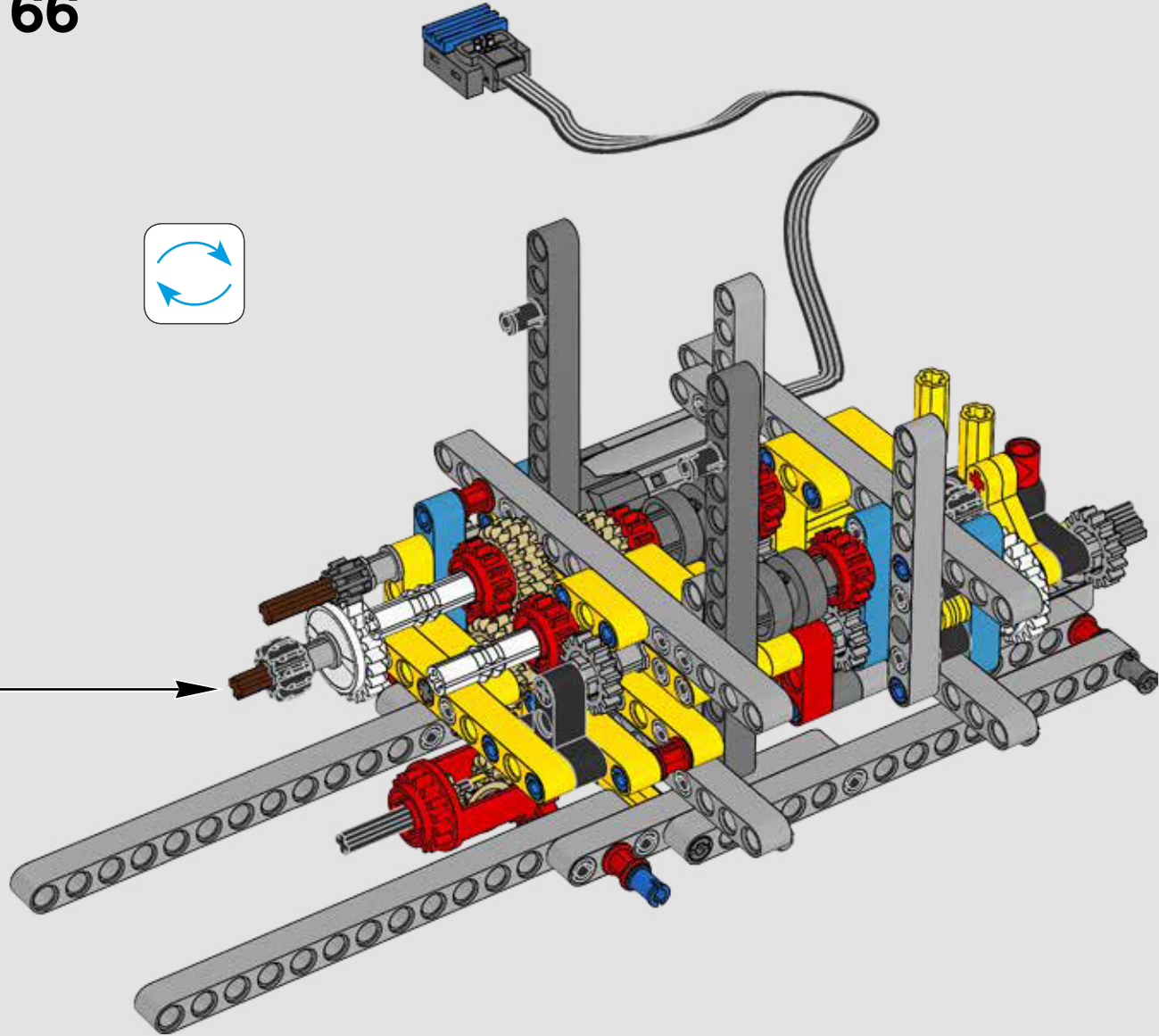

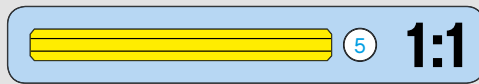
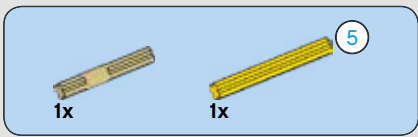

67

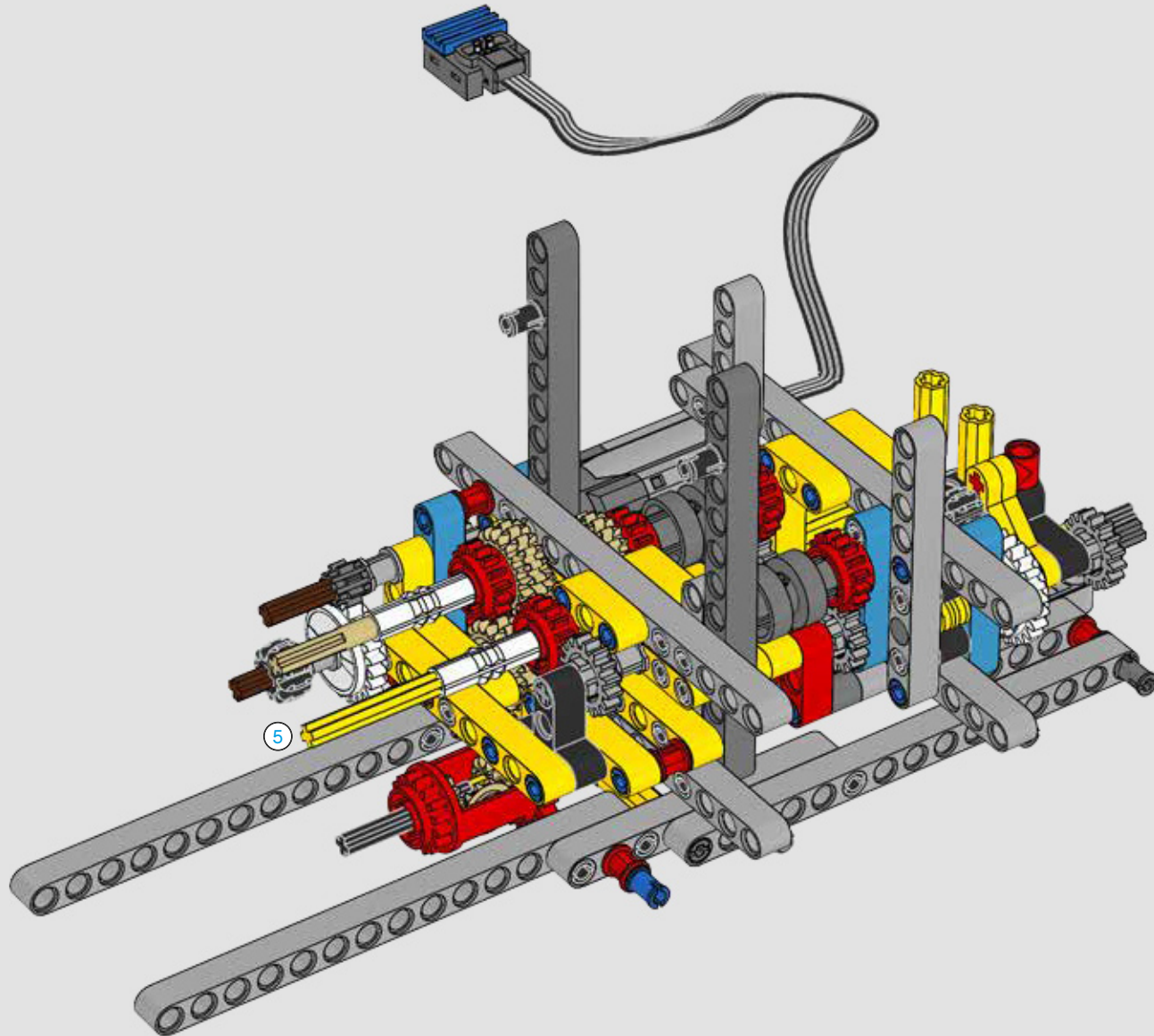

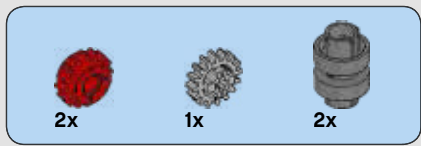

68

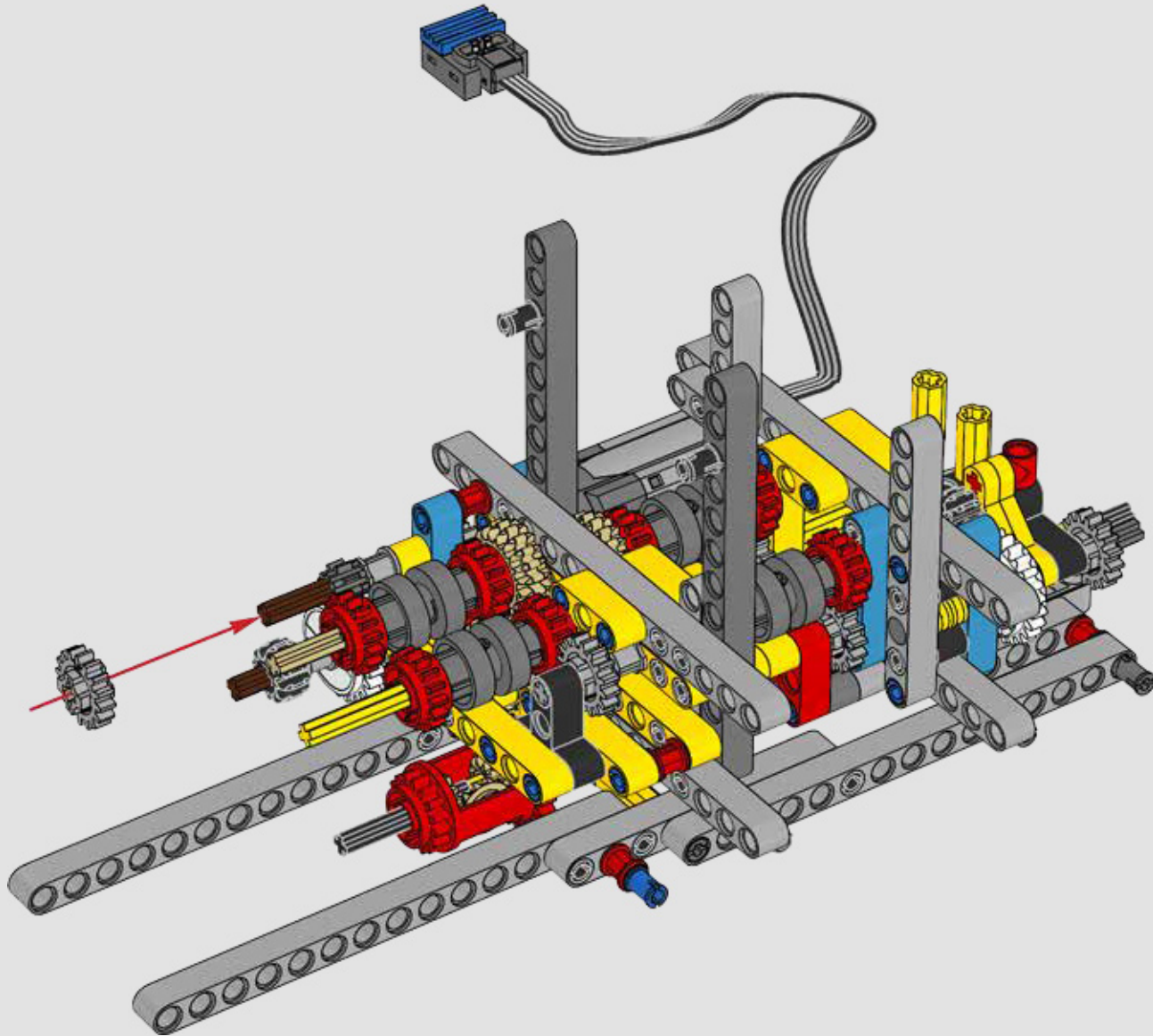



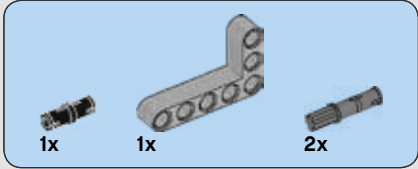
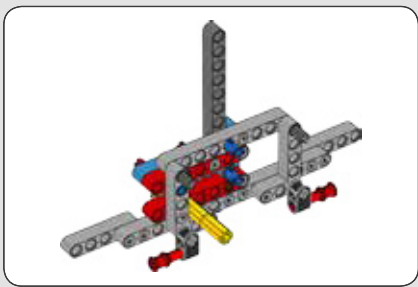

69

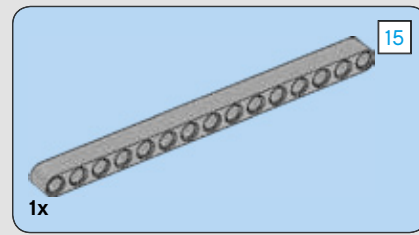
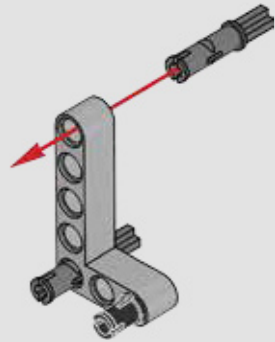

70

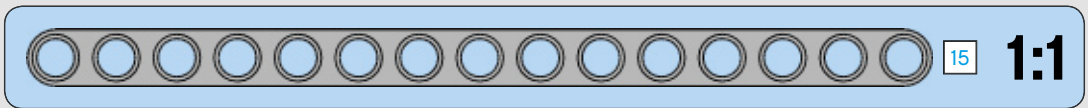
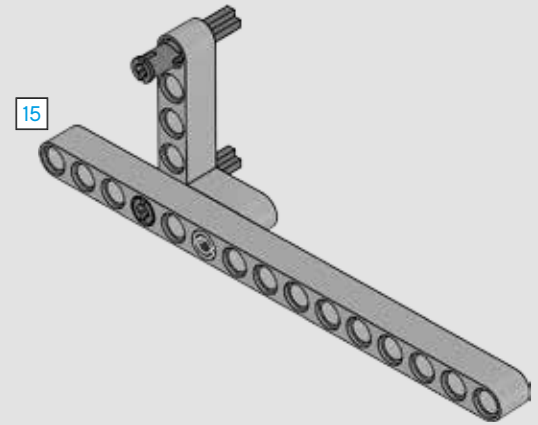

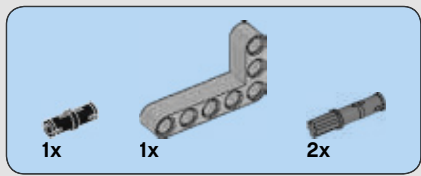

71

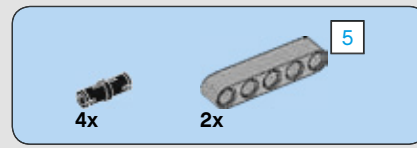
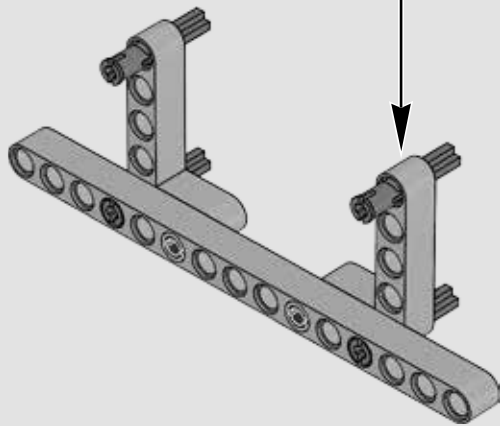
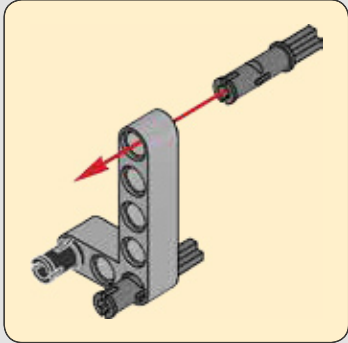

72

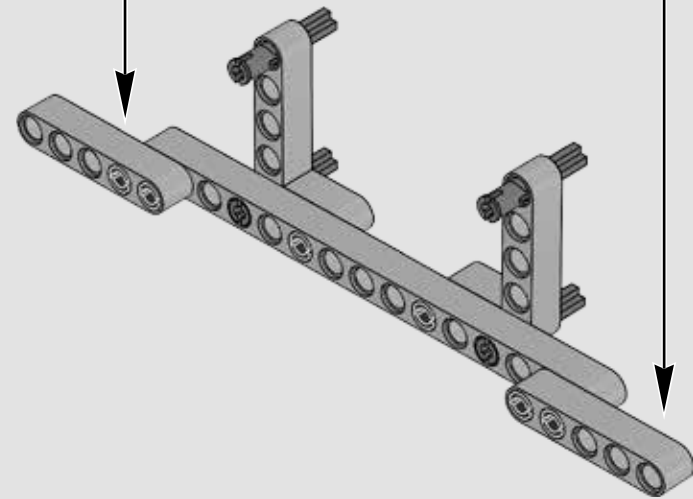
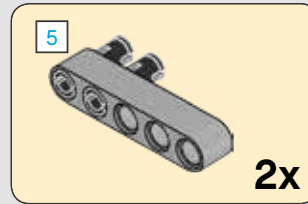

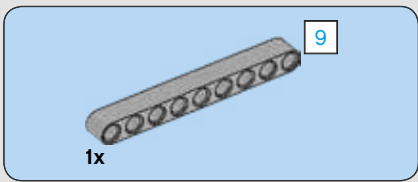

73

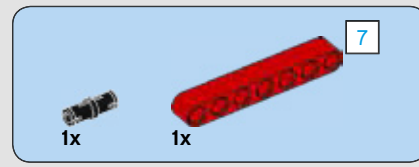
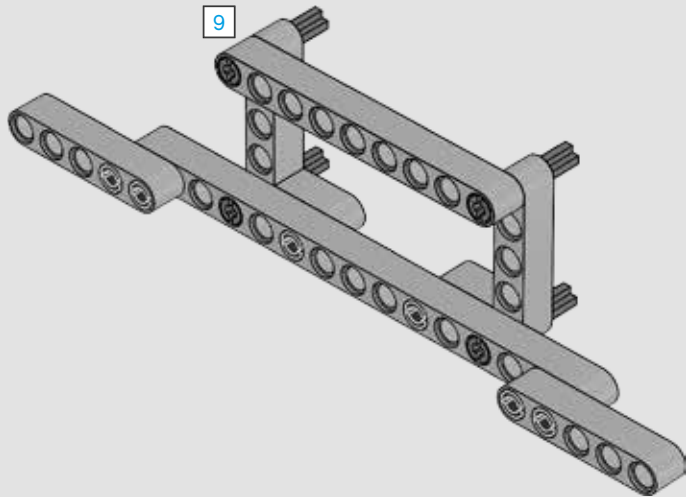

74

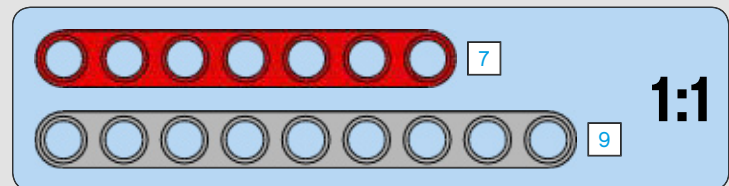
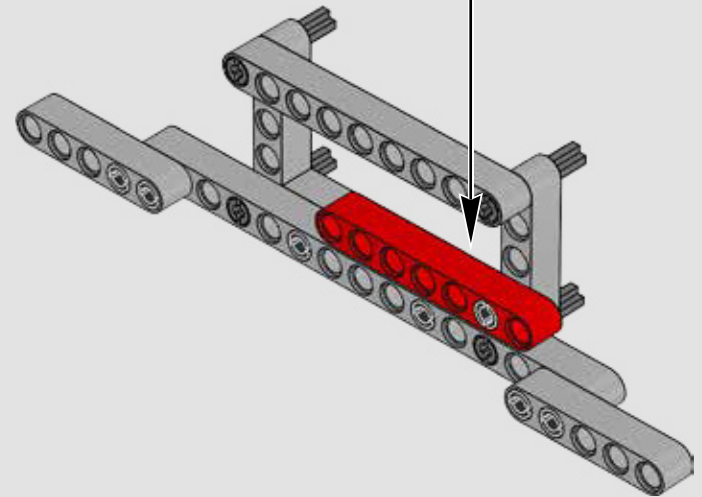
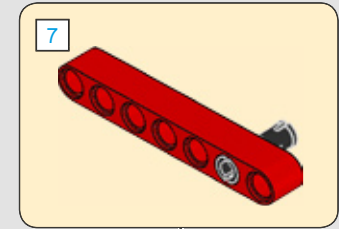

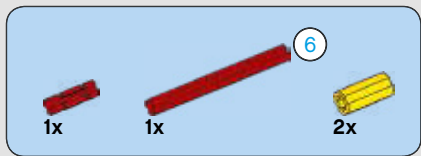

75

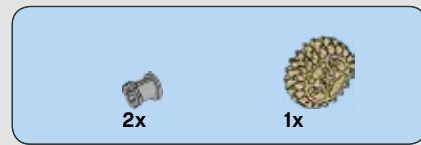
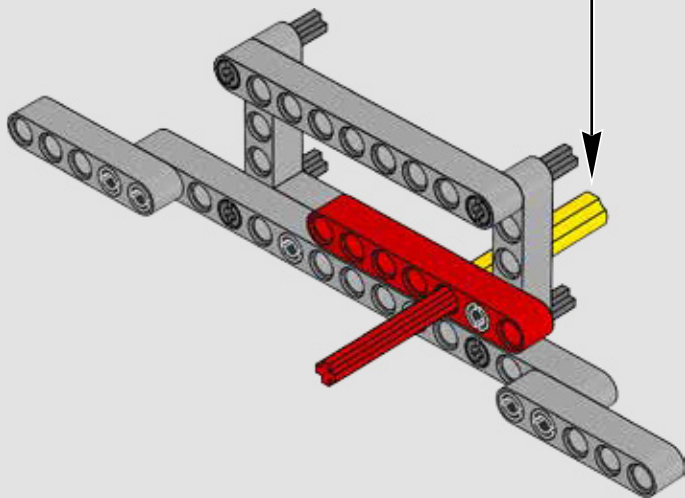
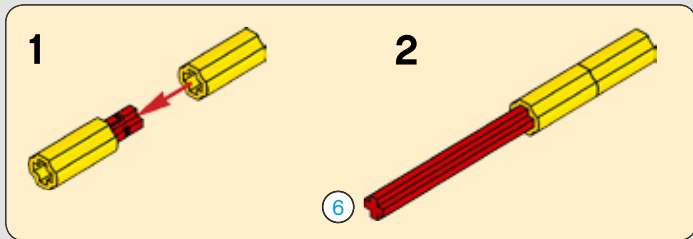

76

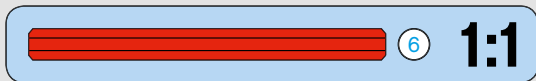
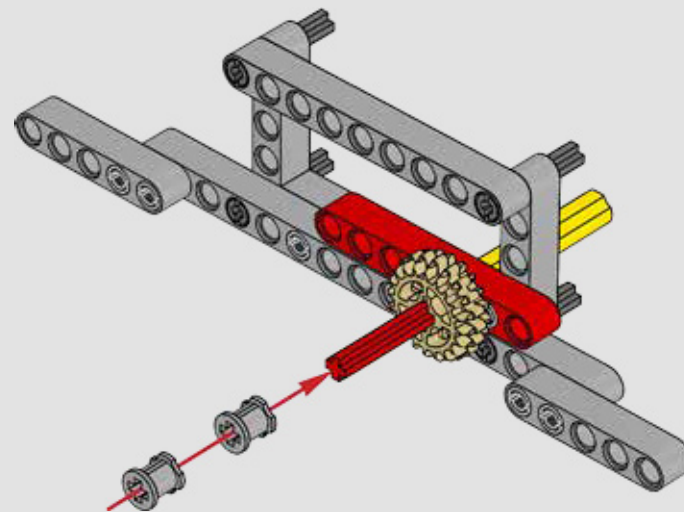



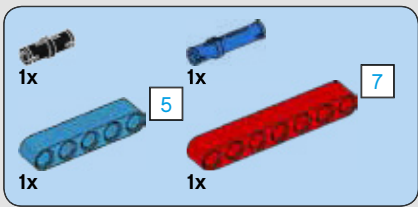

77

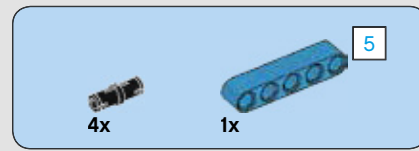
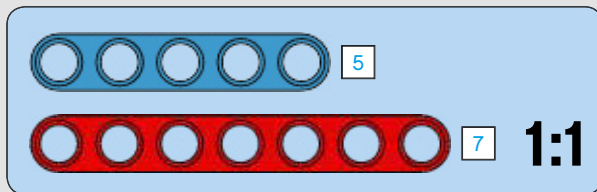
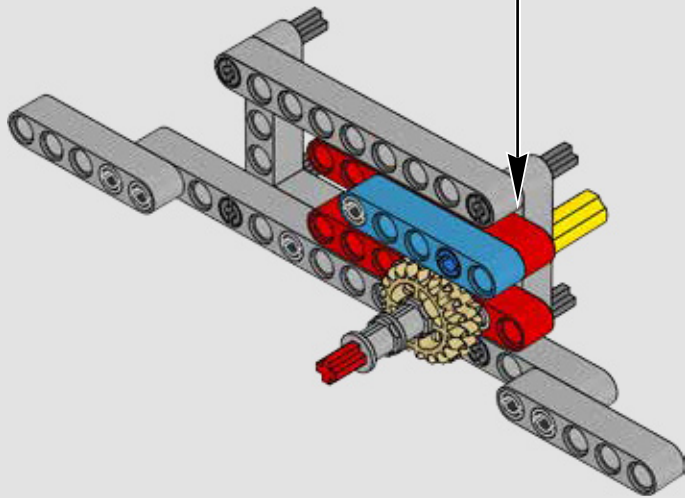
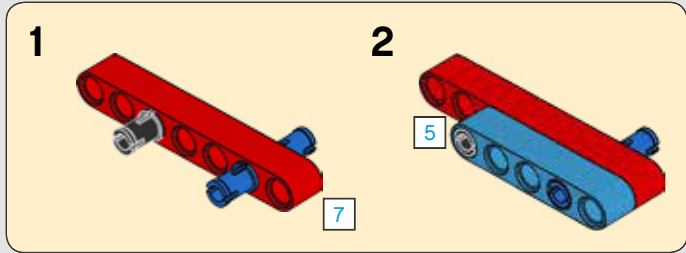

78

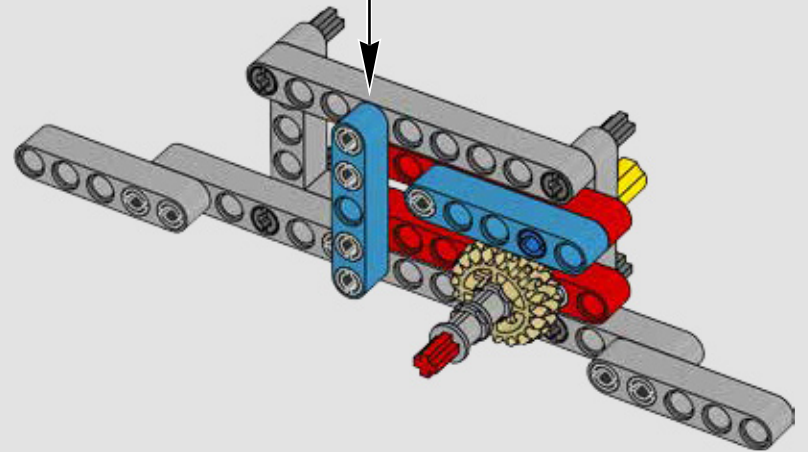
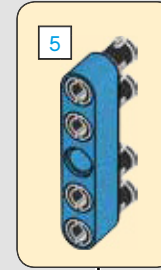

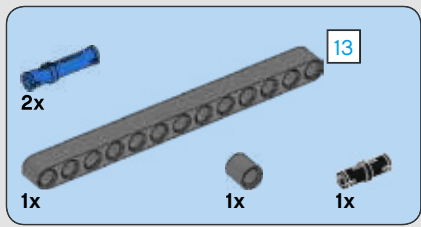

79

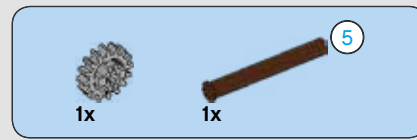
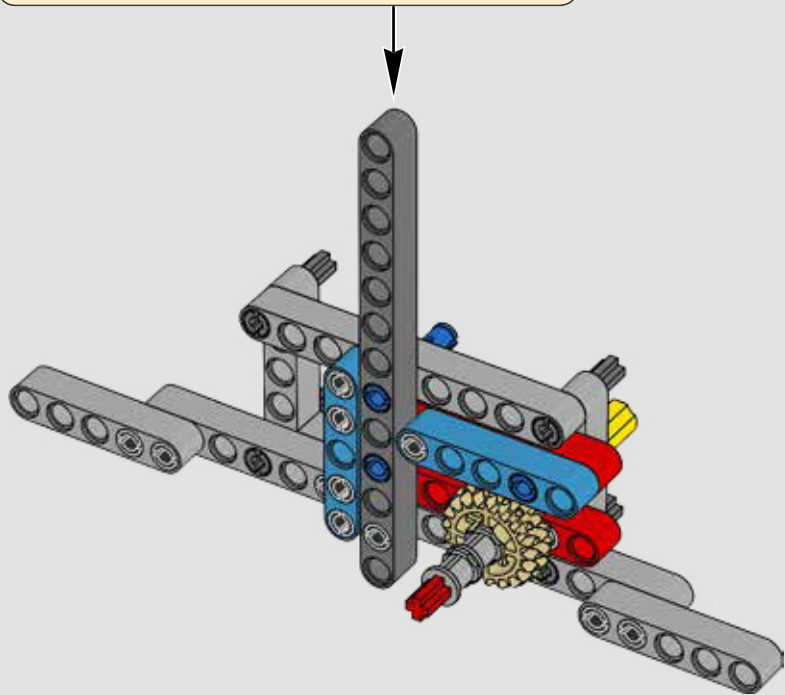
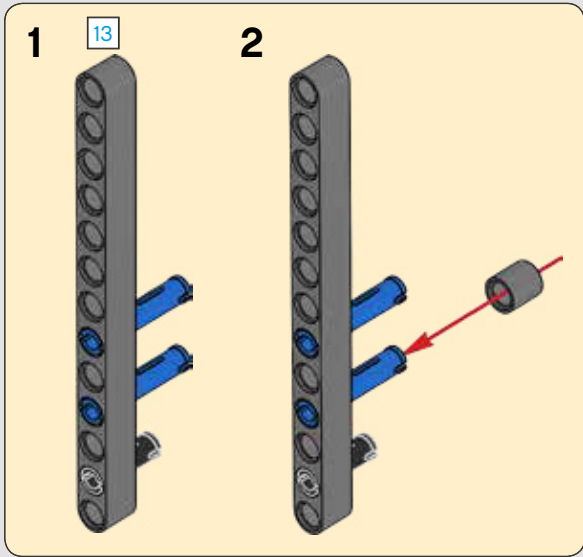

80

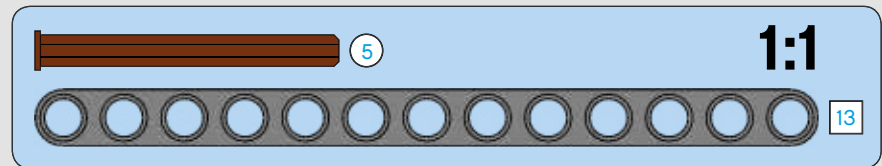
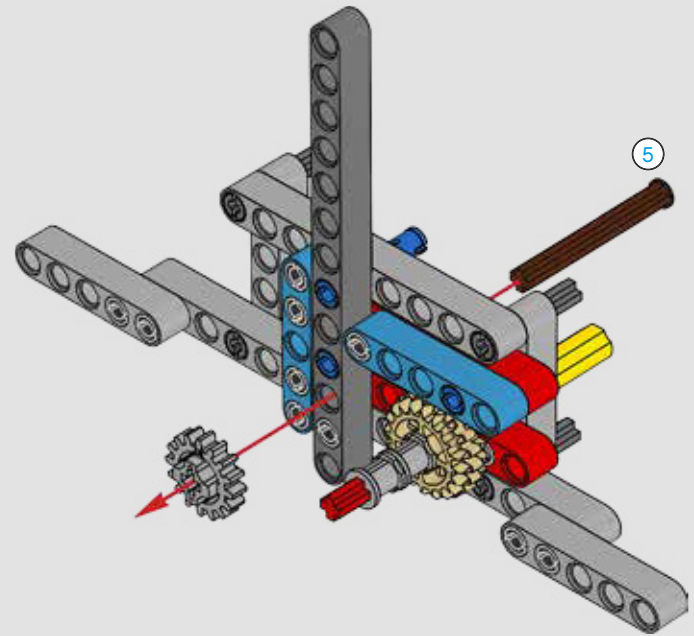

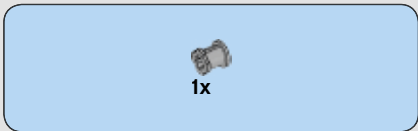

81

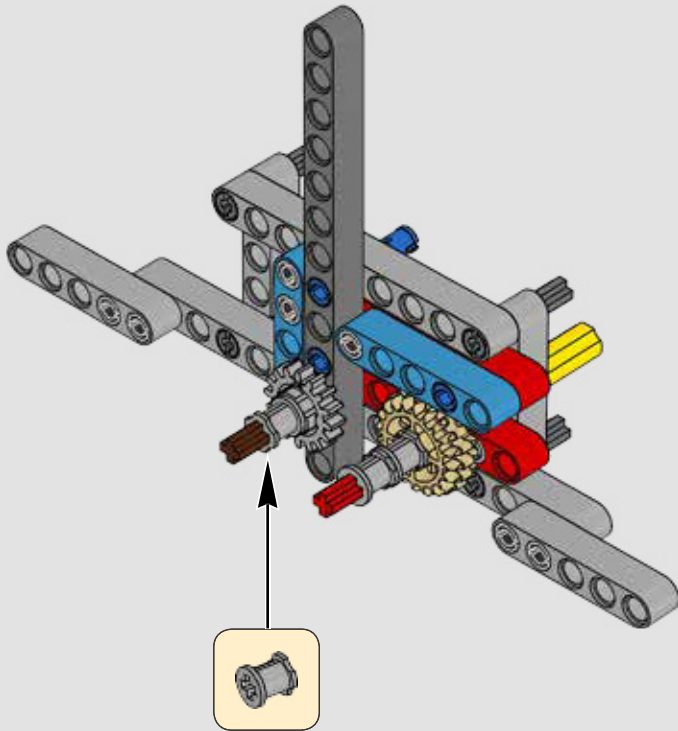

82

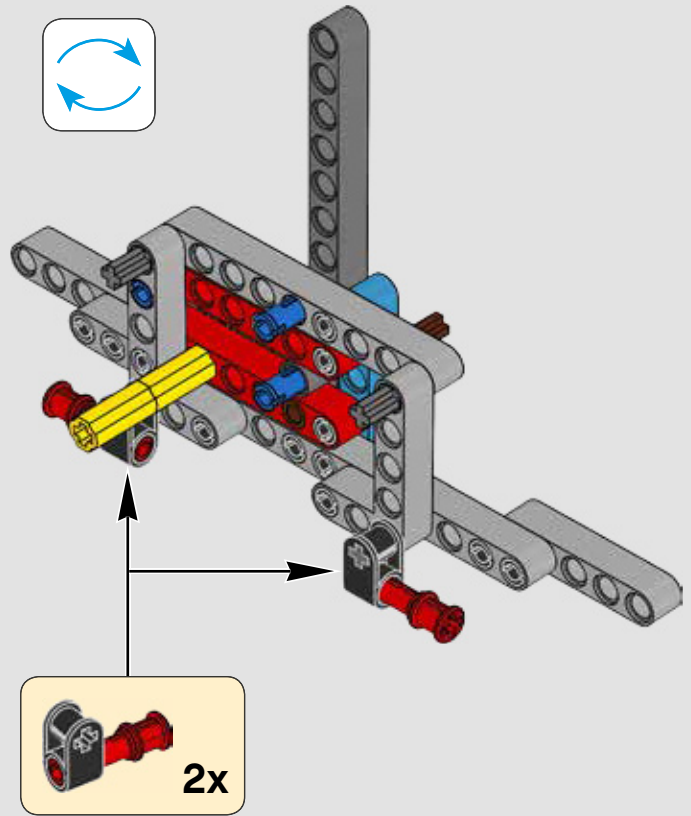



83

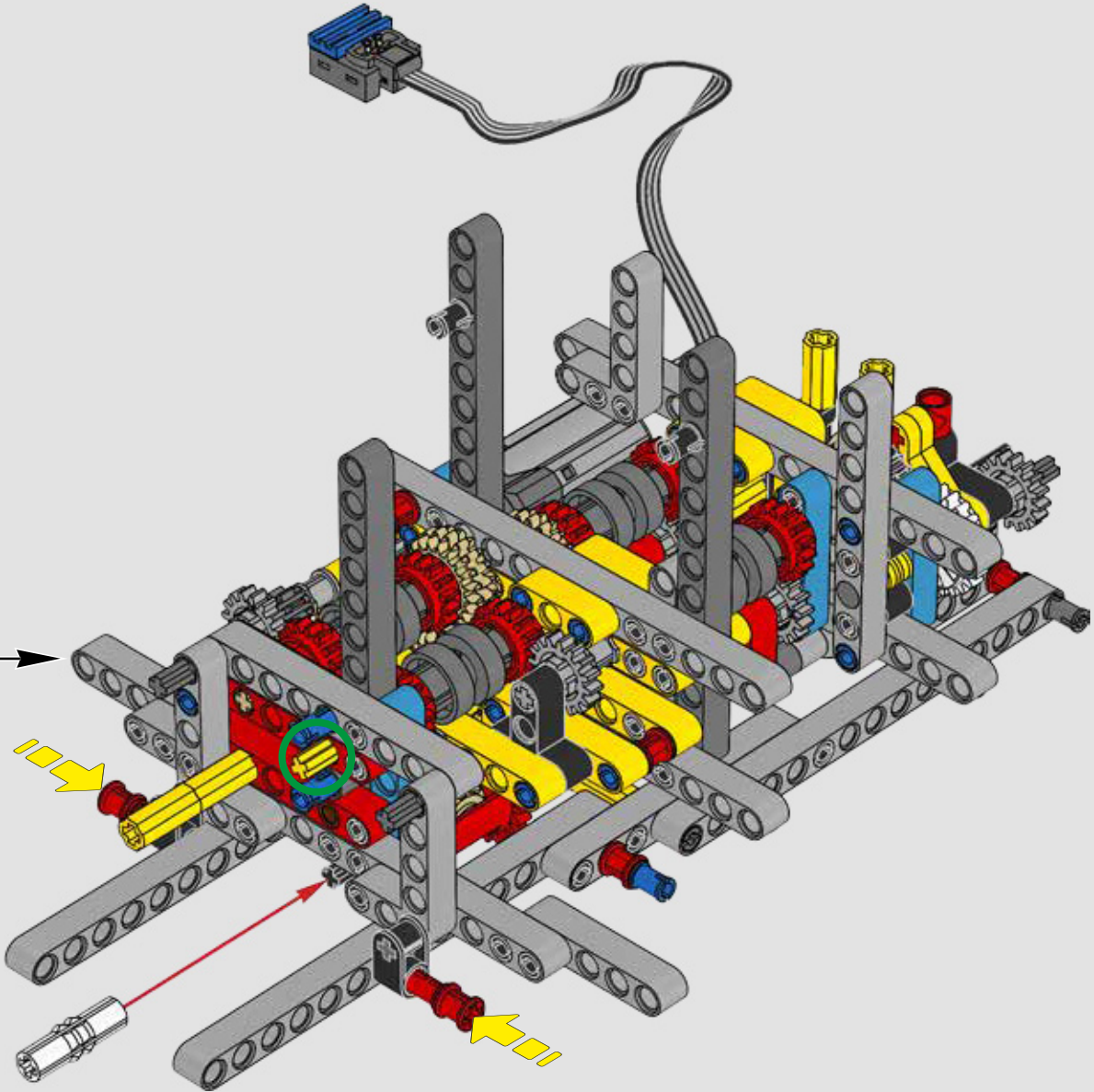





84

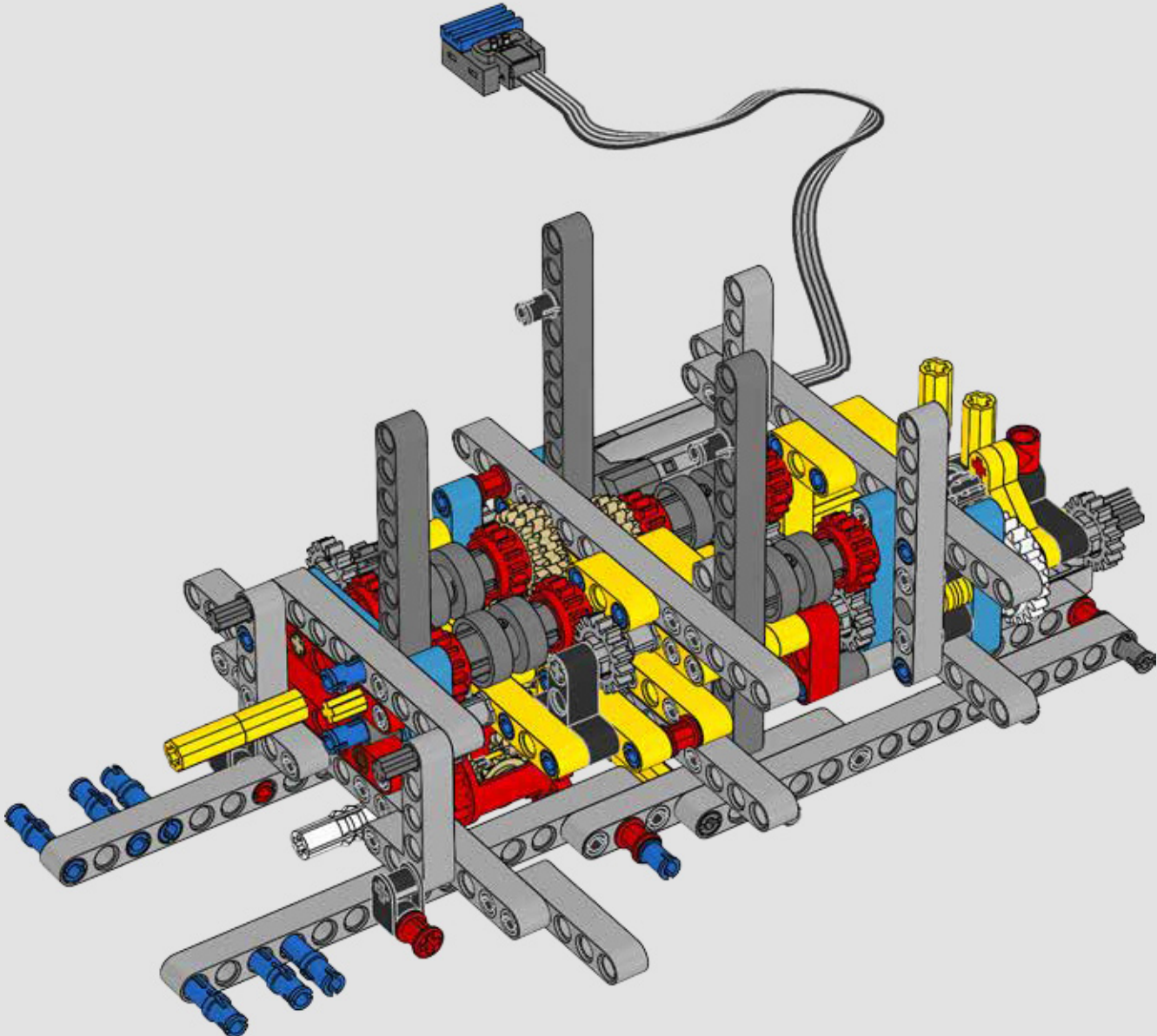

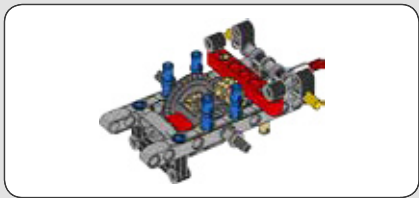

85

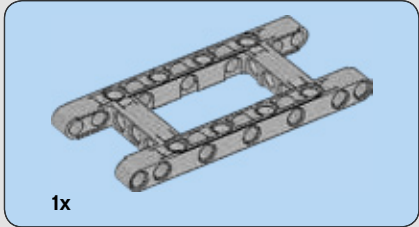
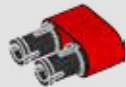

86

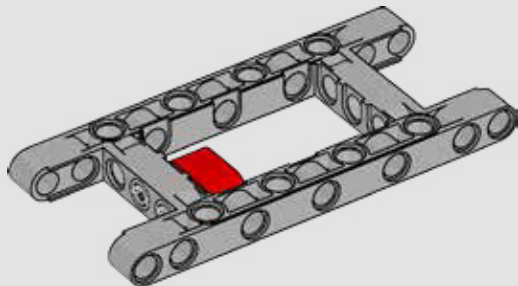

87

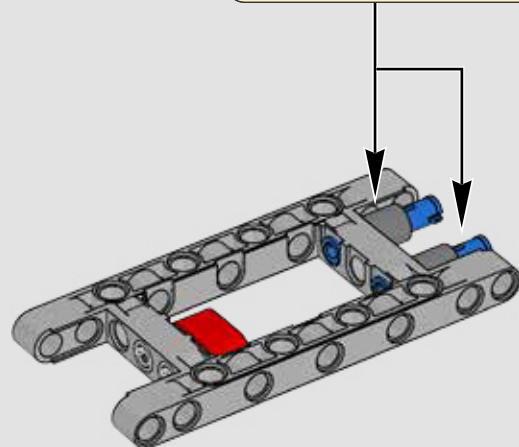
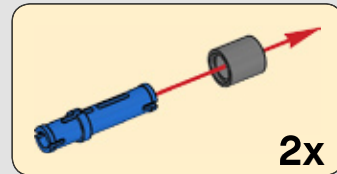

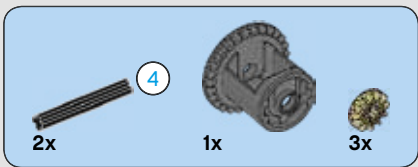

88

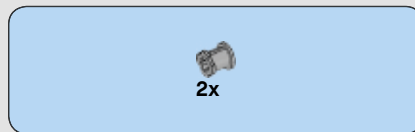
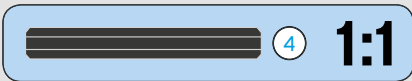
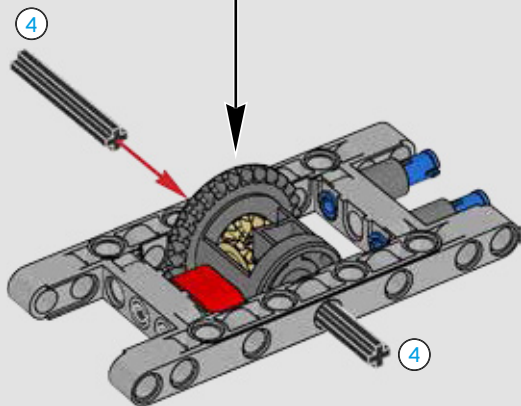
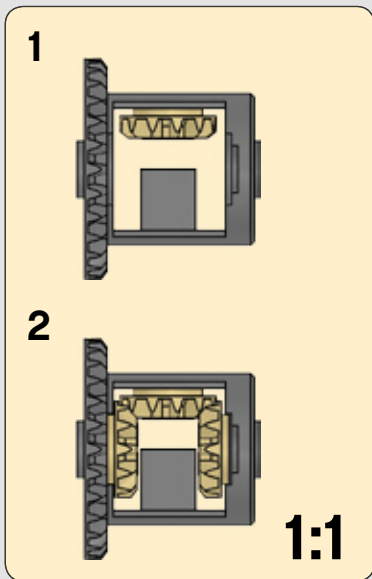

89

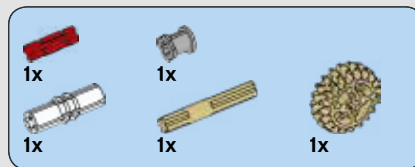
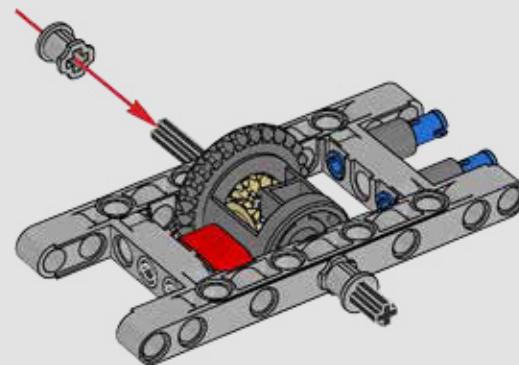

90

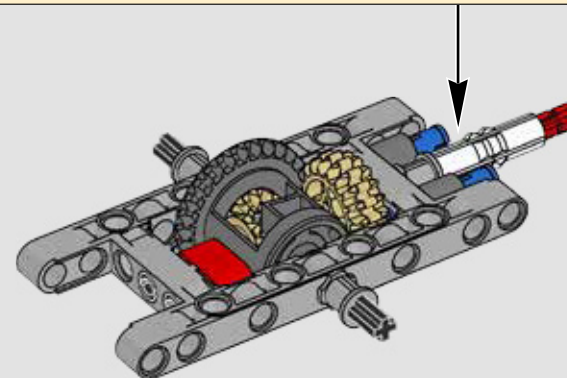
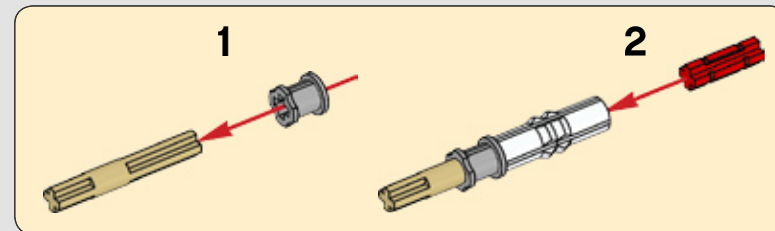

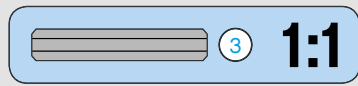
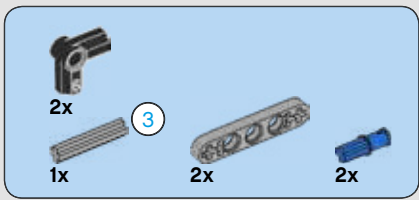

91

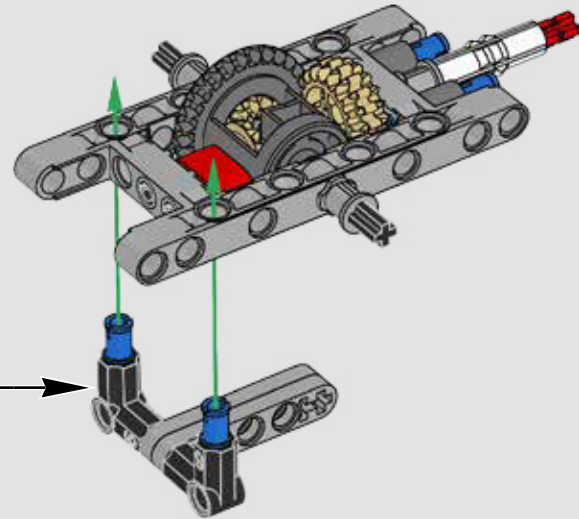
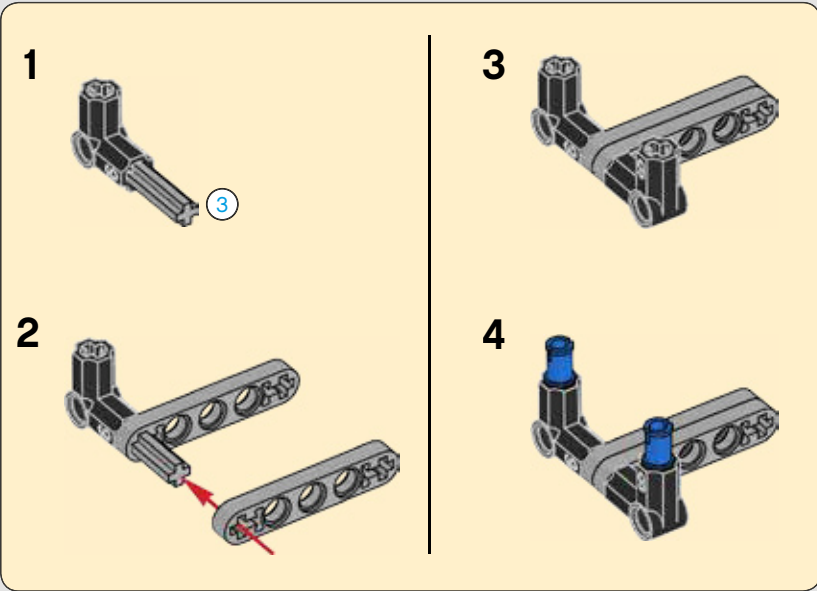



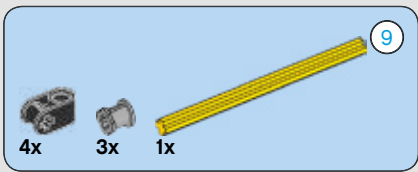

92

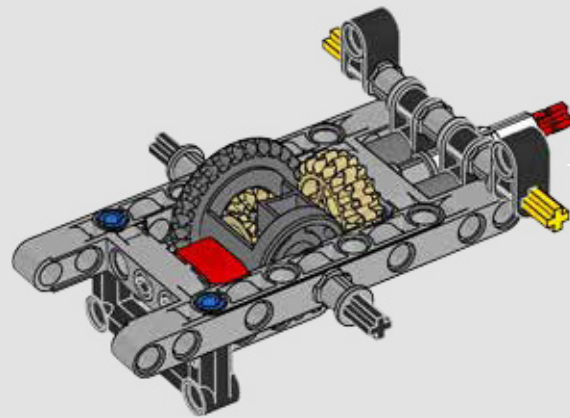
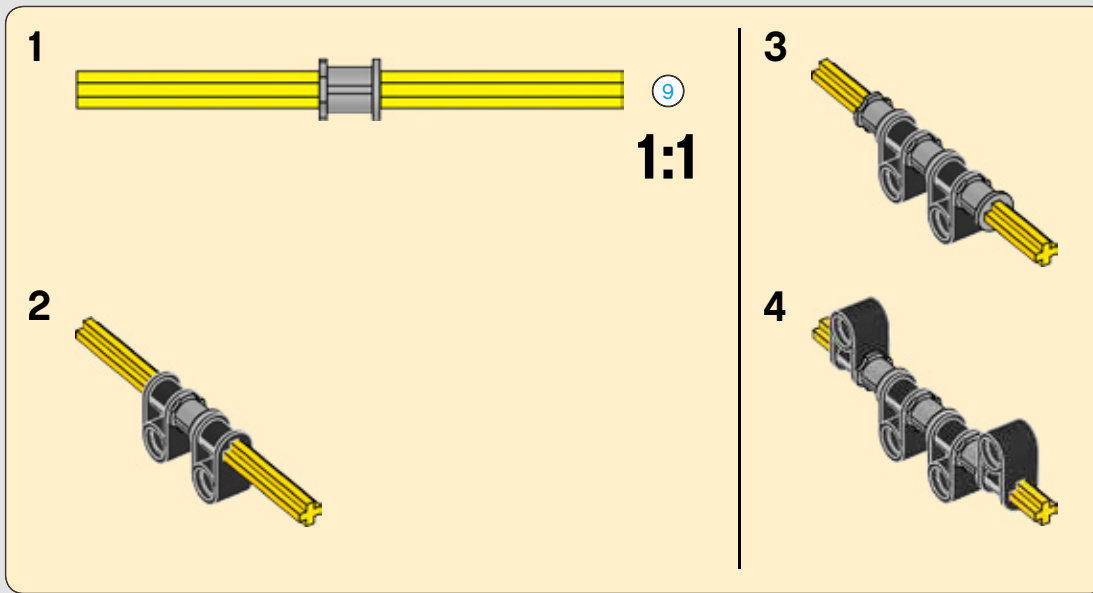

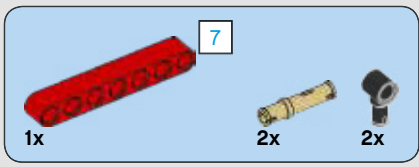

93

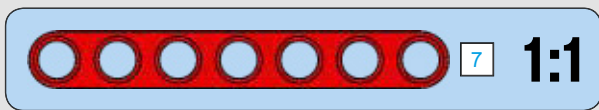
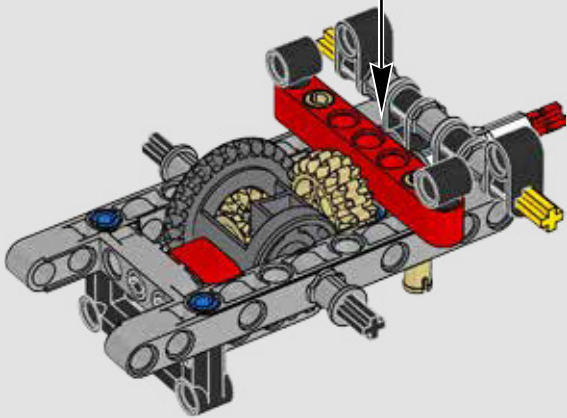
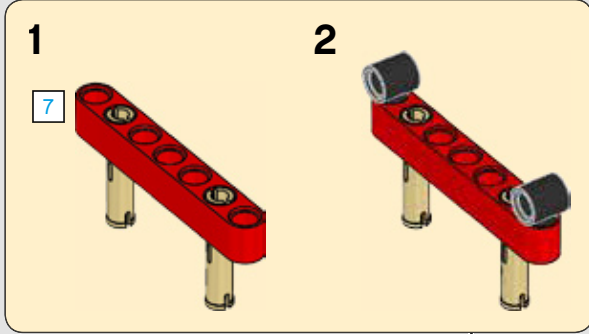

94

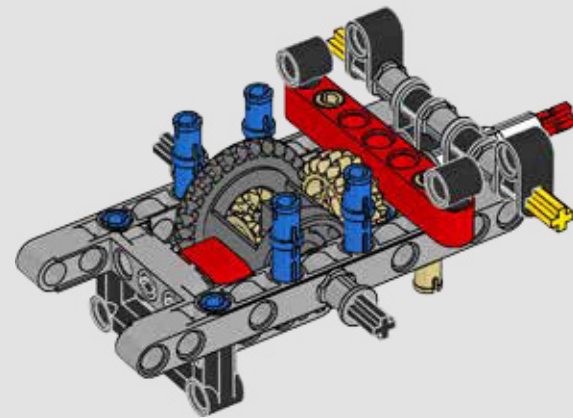

95

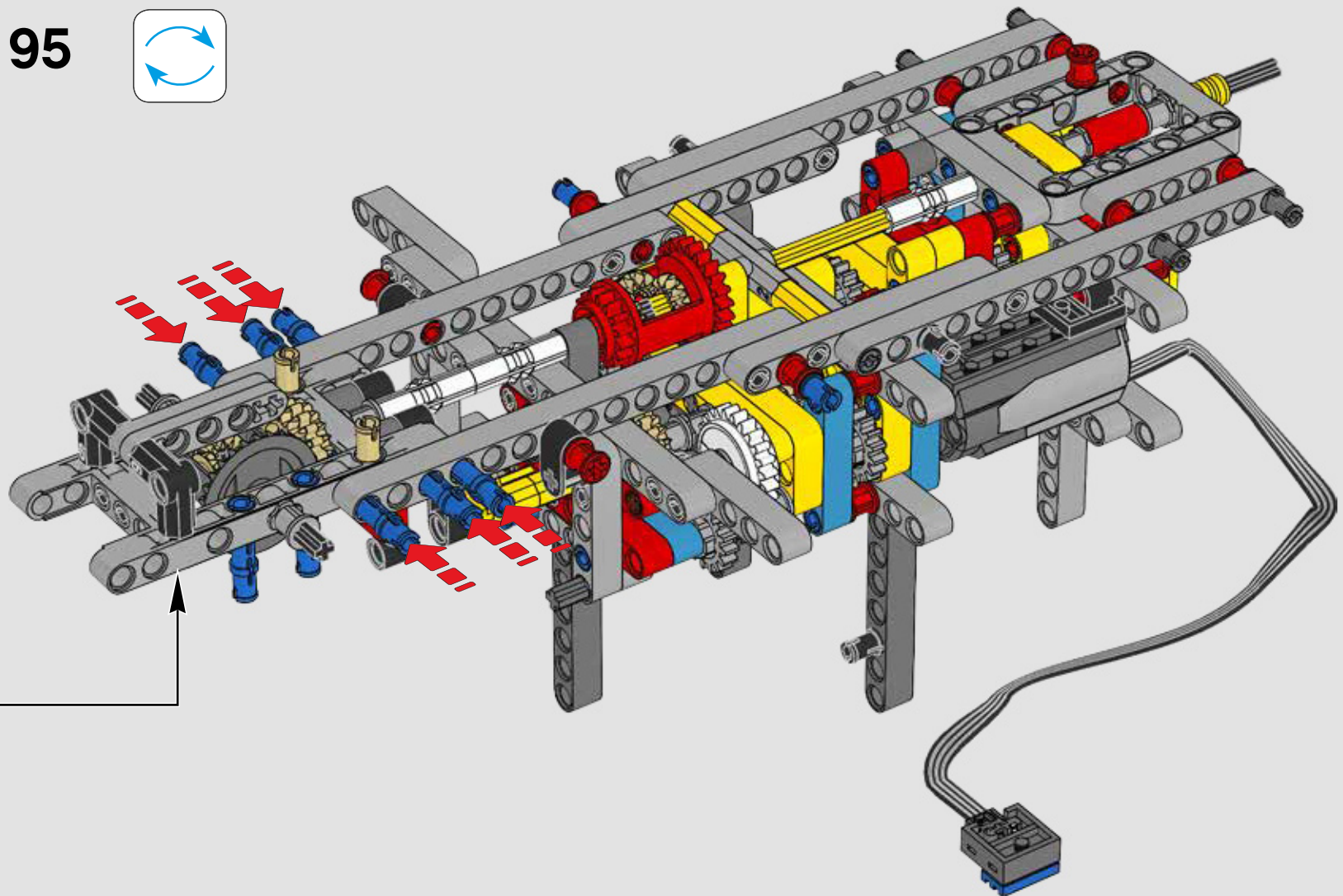
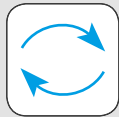



96

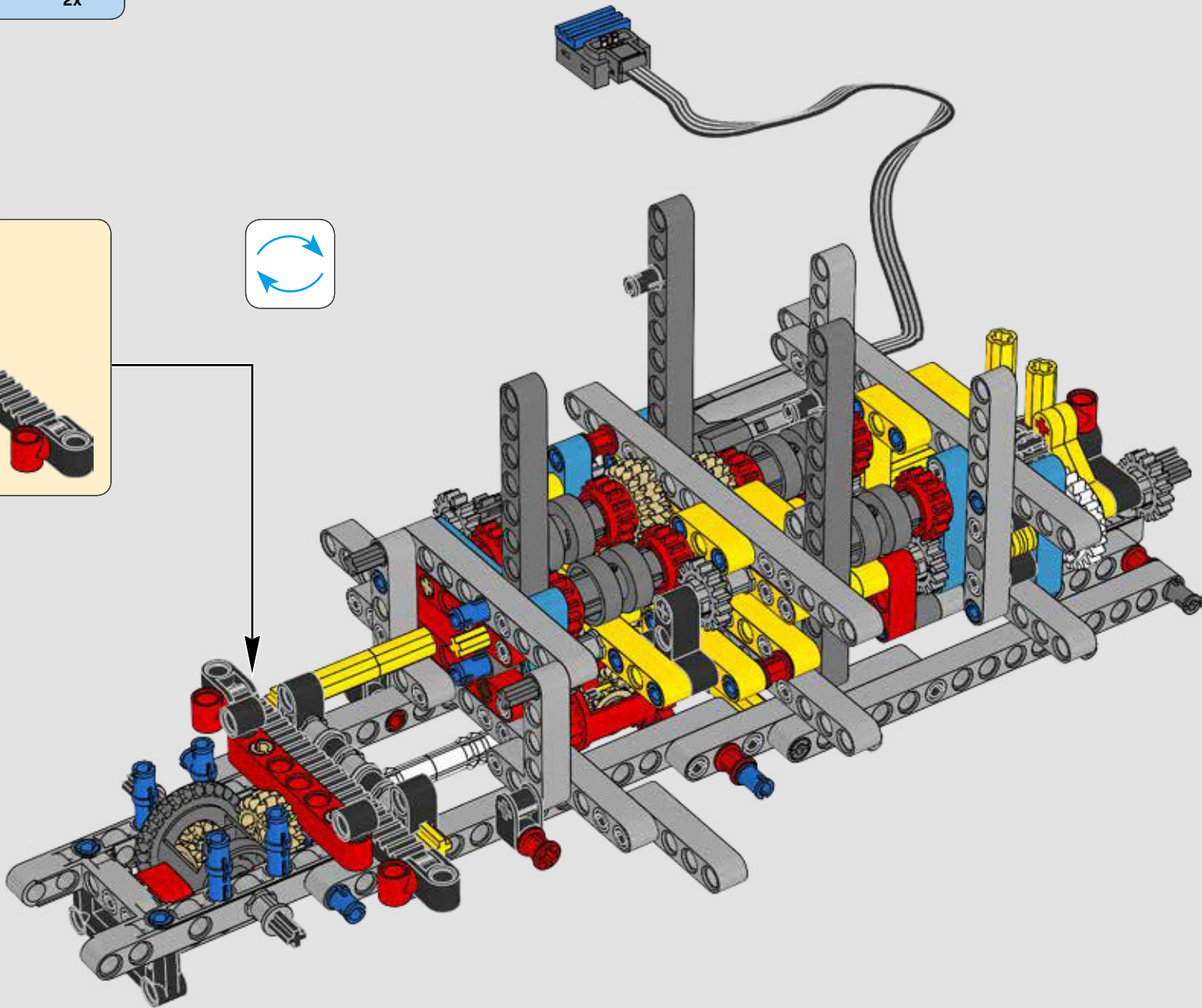
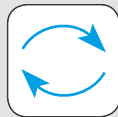
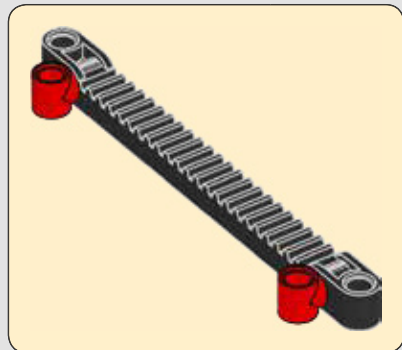



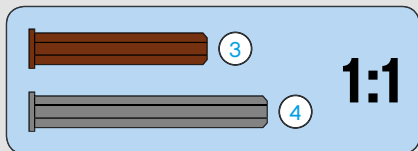
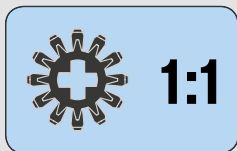
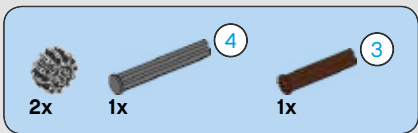

97

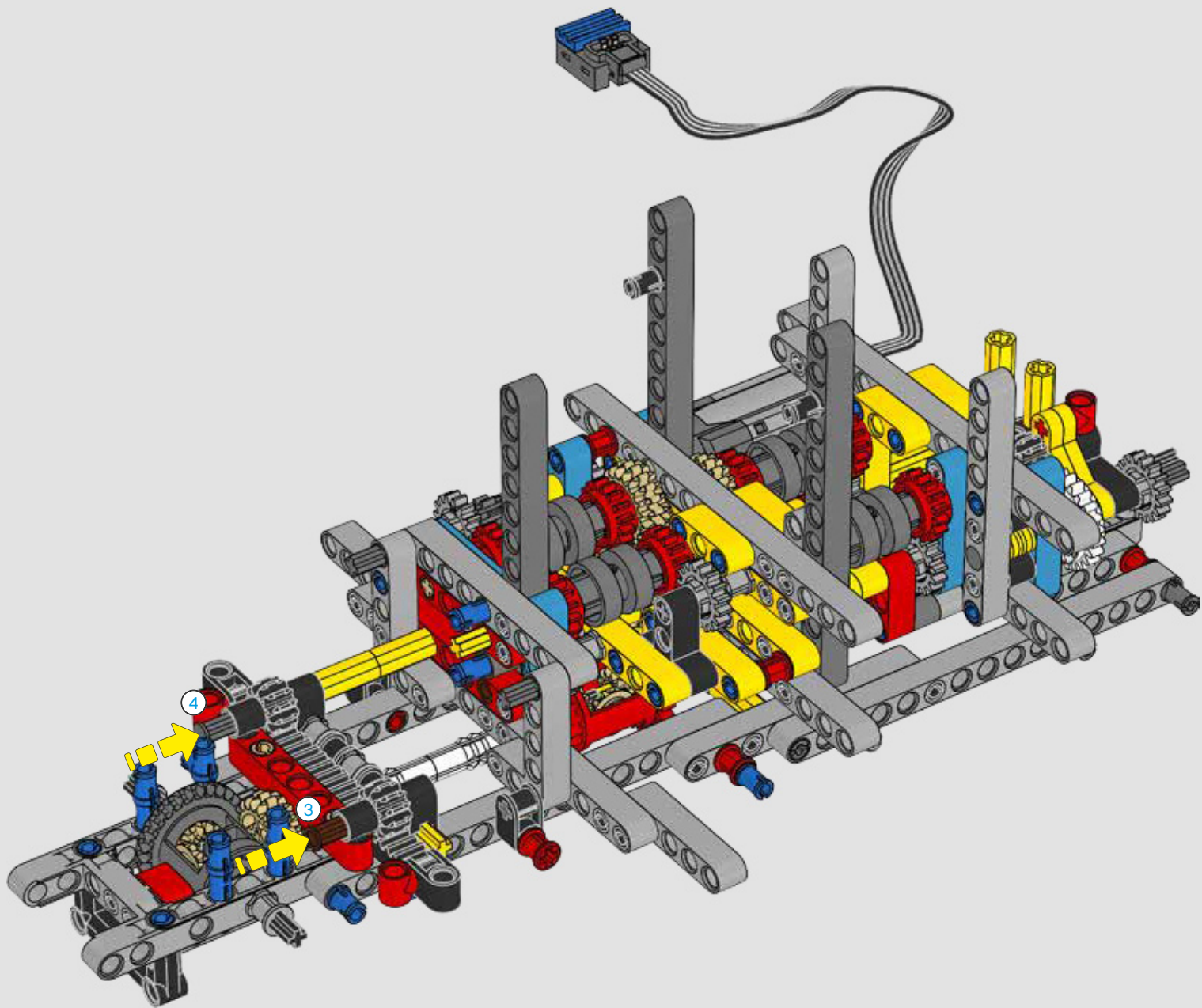

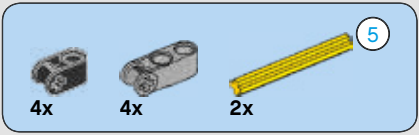

# 98

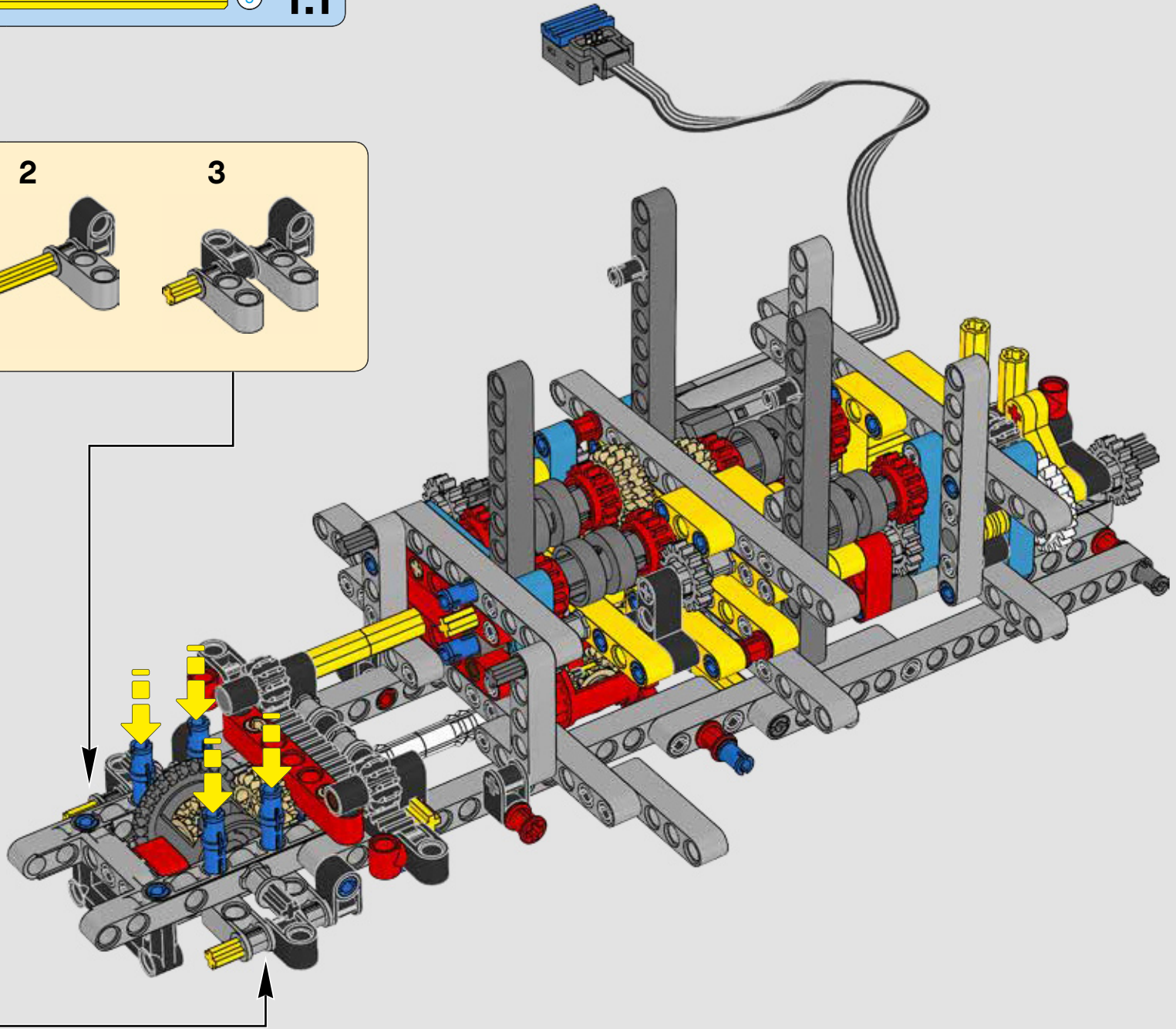
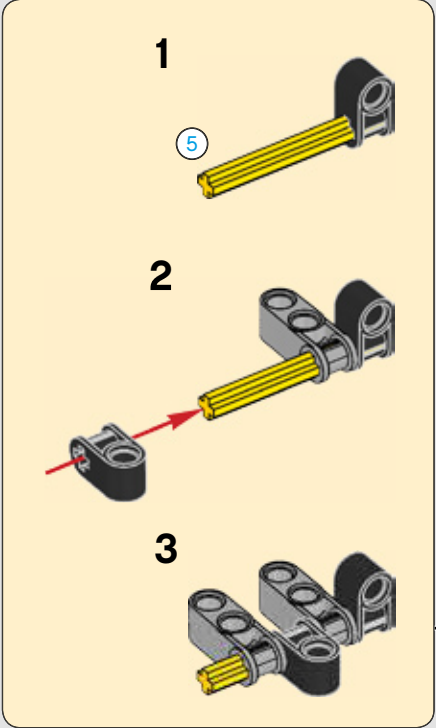
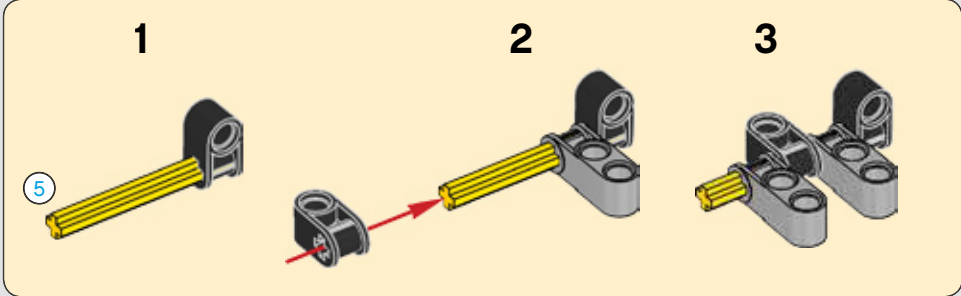

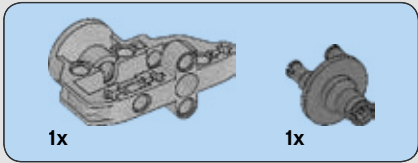

99

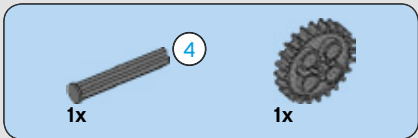
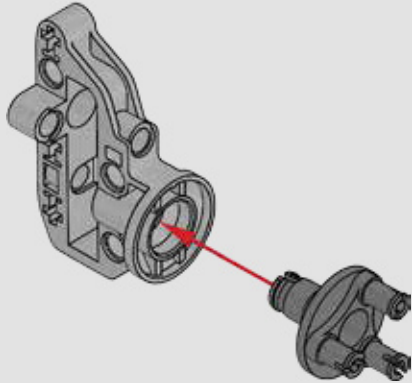

100

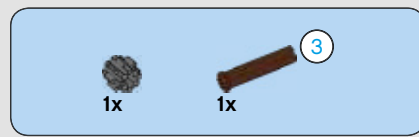
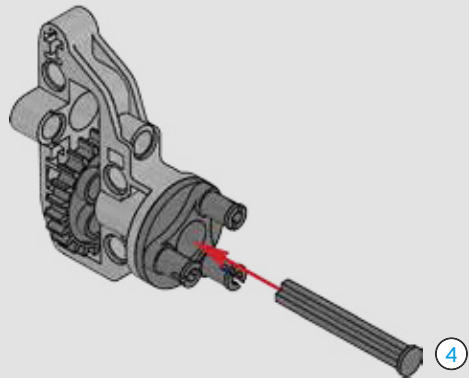

101

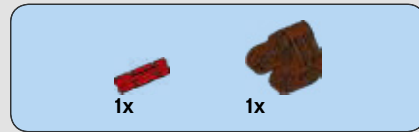
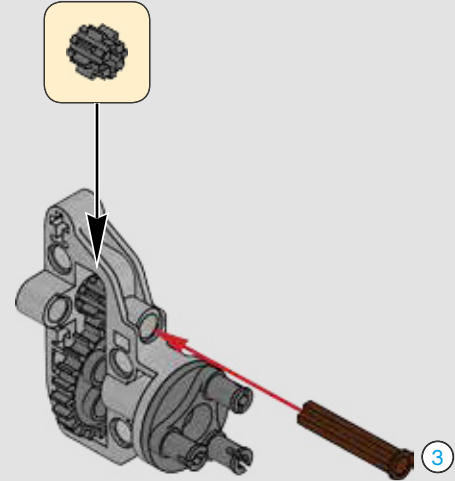

102

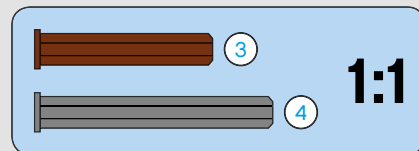
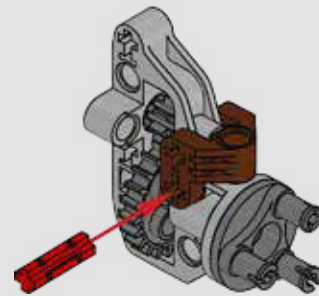

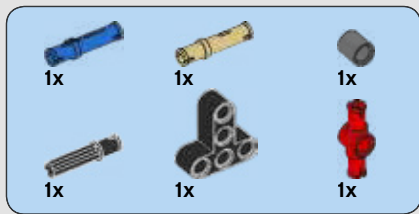

# 103

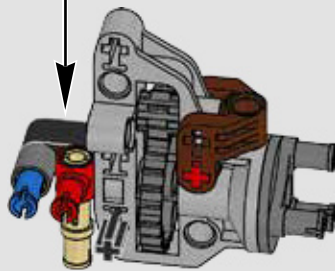
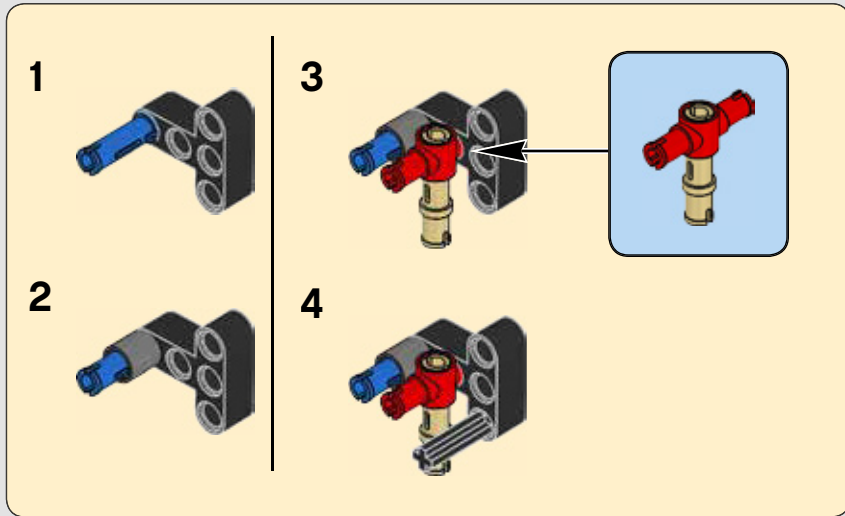

# 104

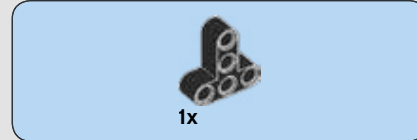
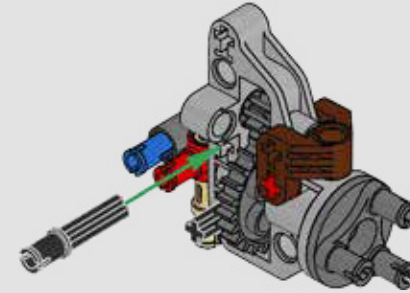

# 105

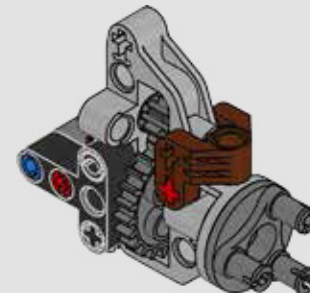



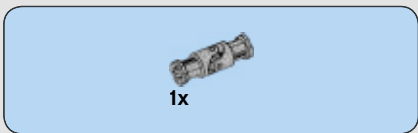

1x

106

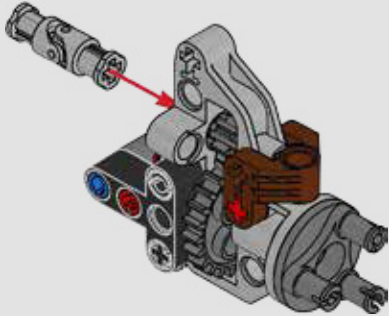

1x

107

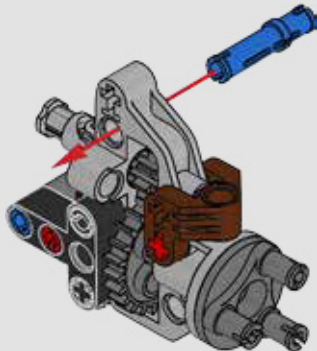

2x

108

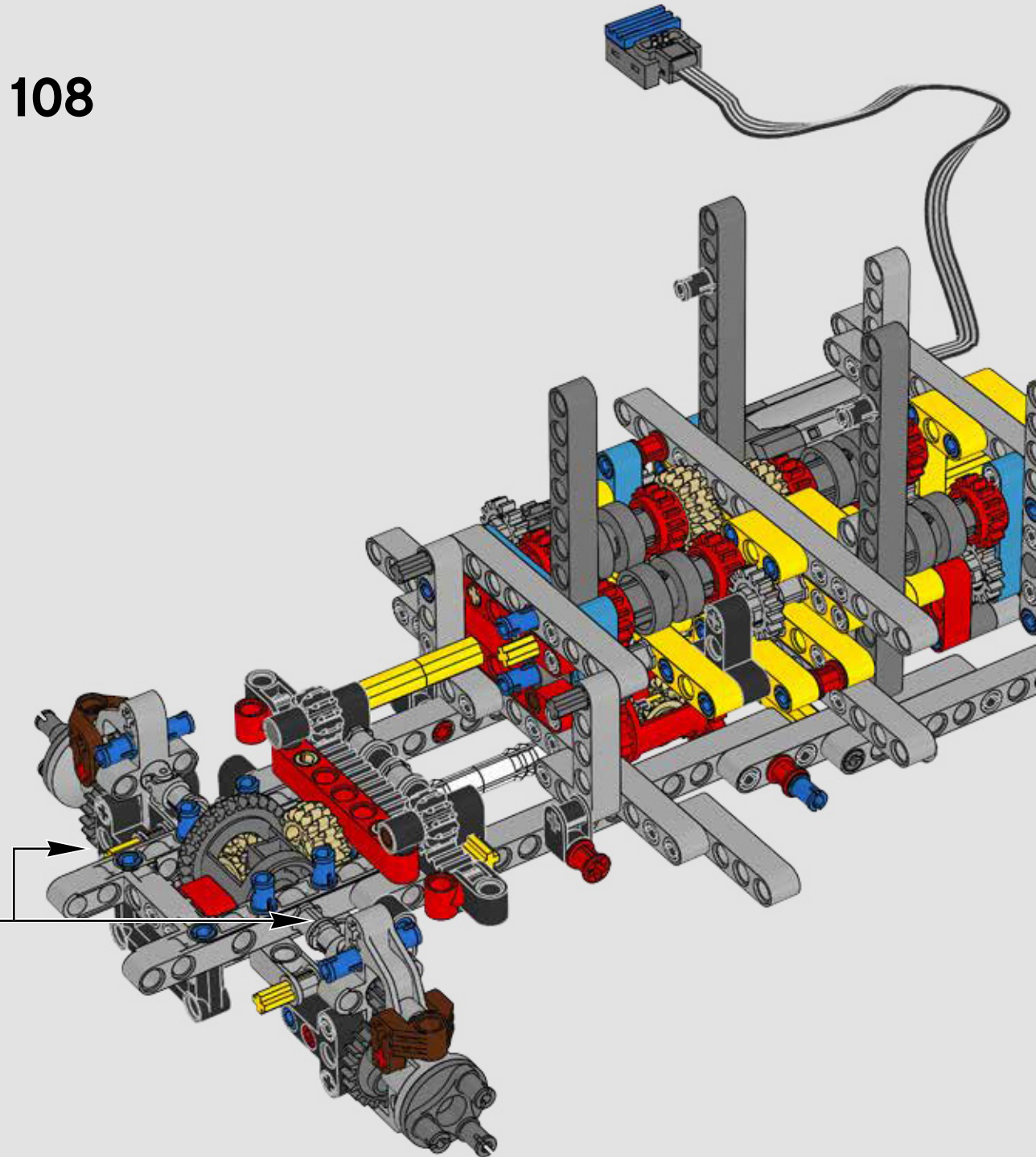

109

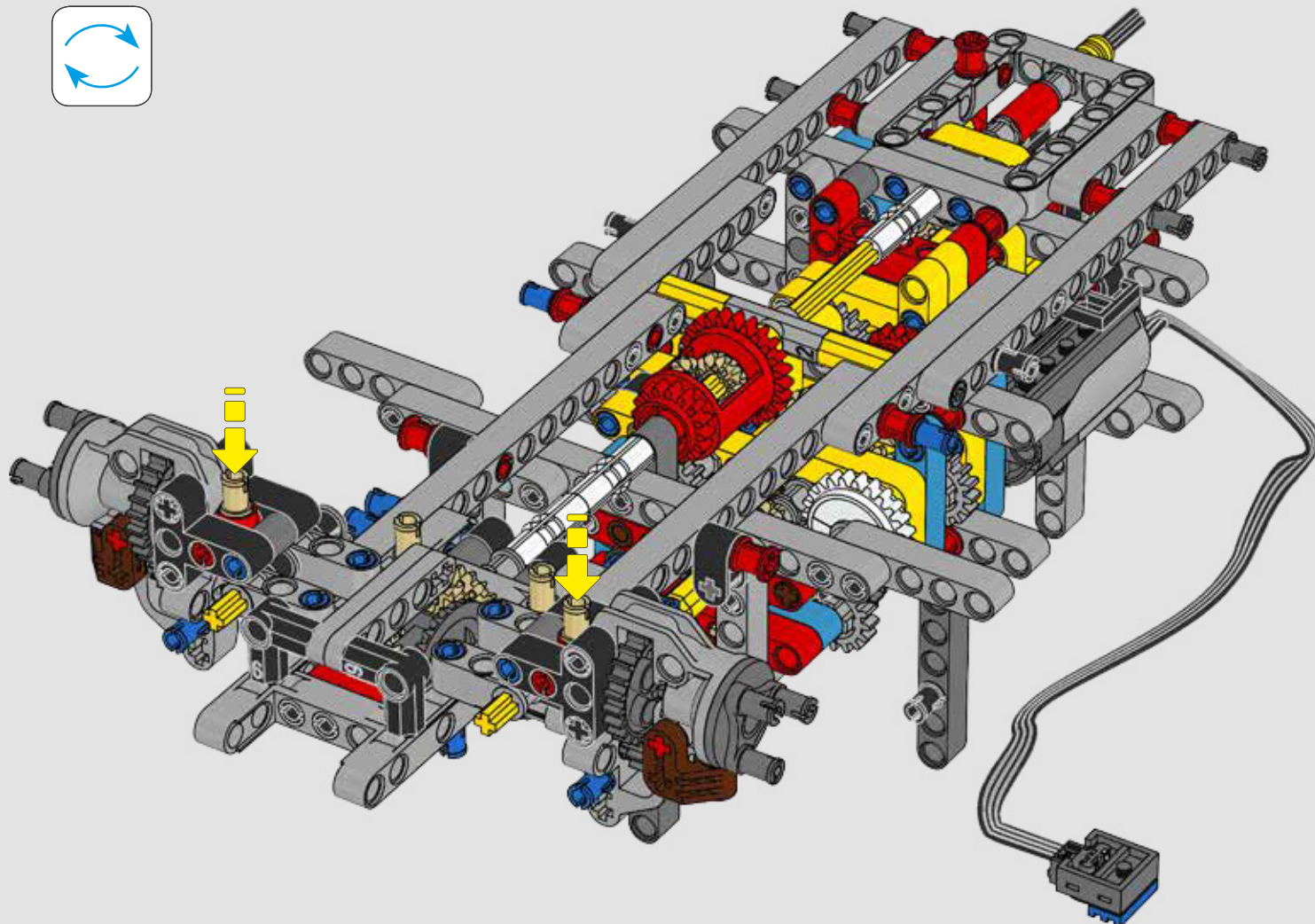
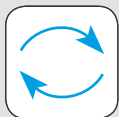



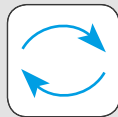
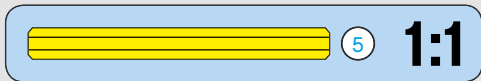
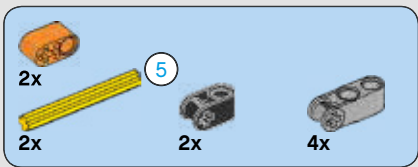

110

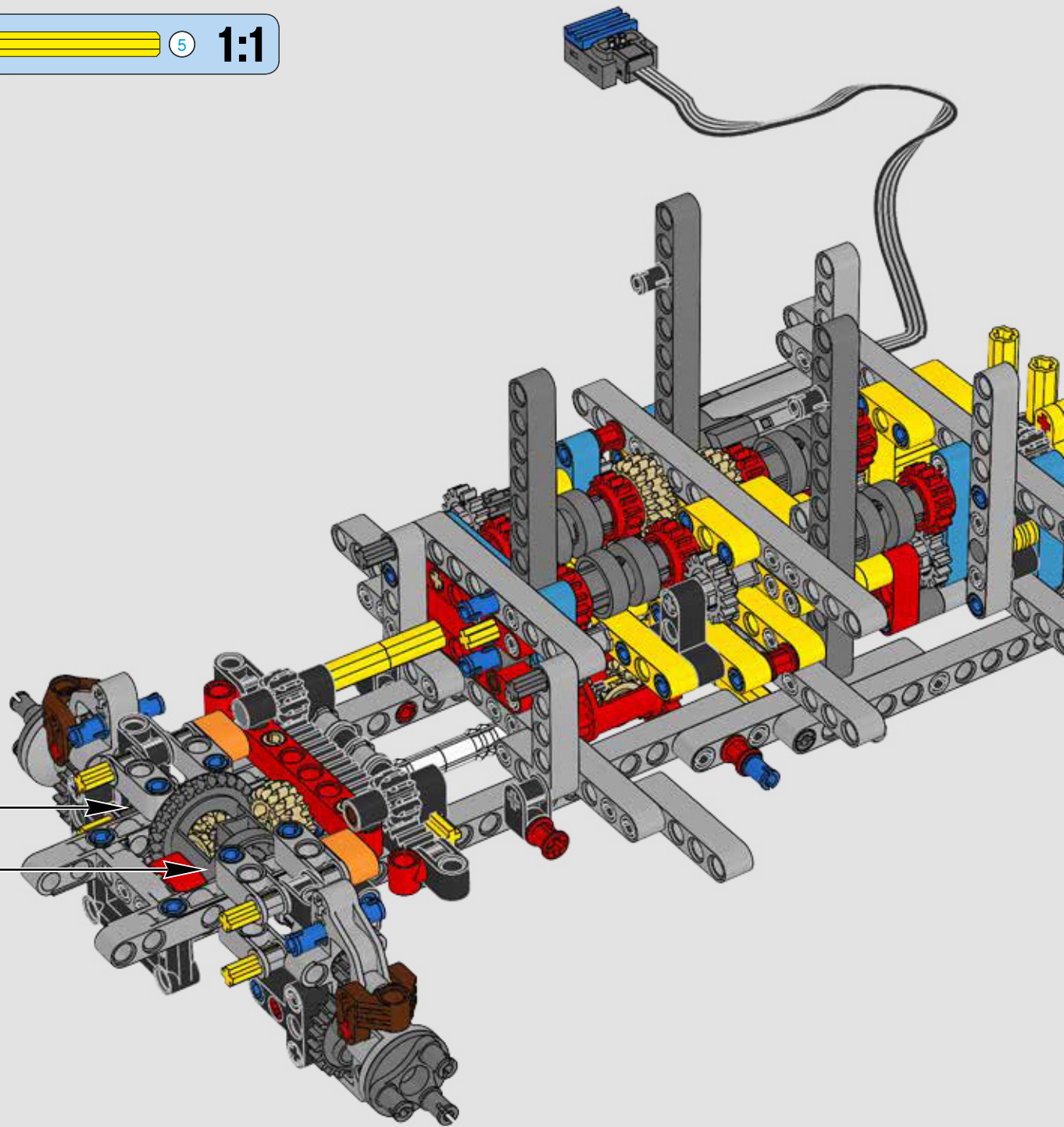
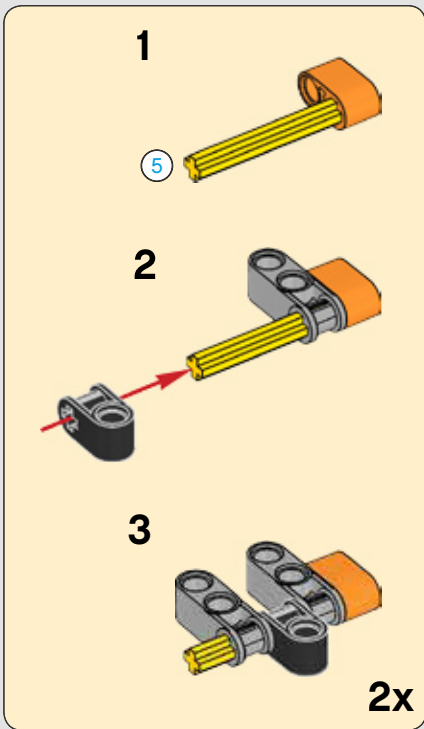

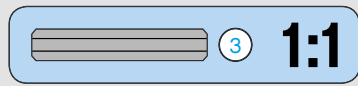
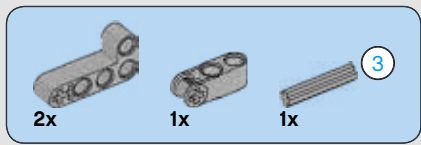

111

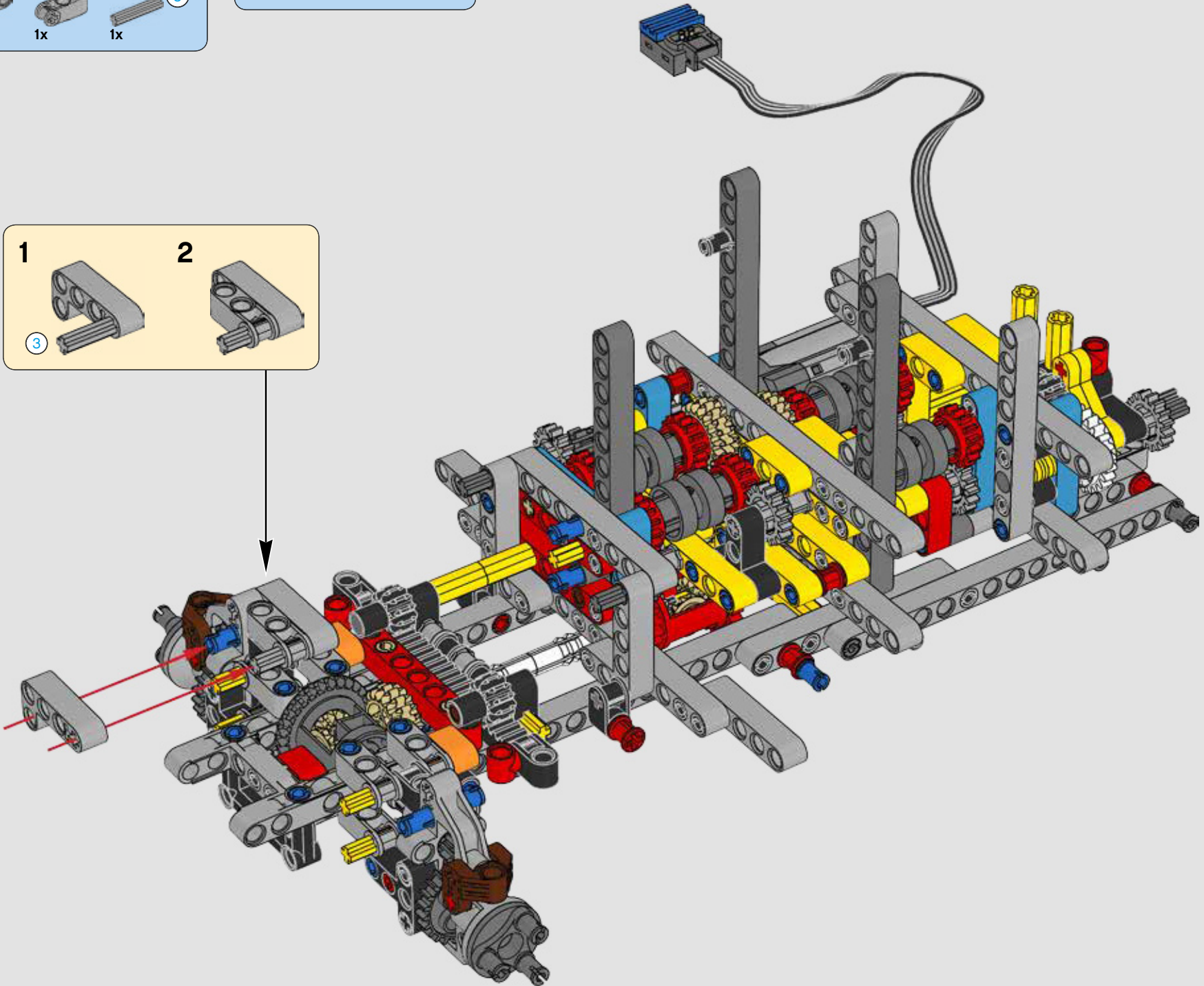
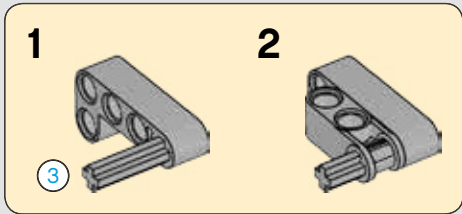



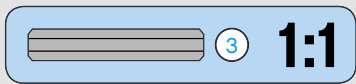
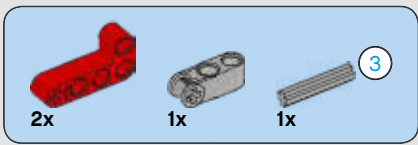

112

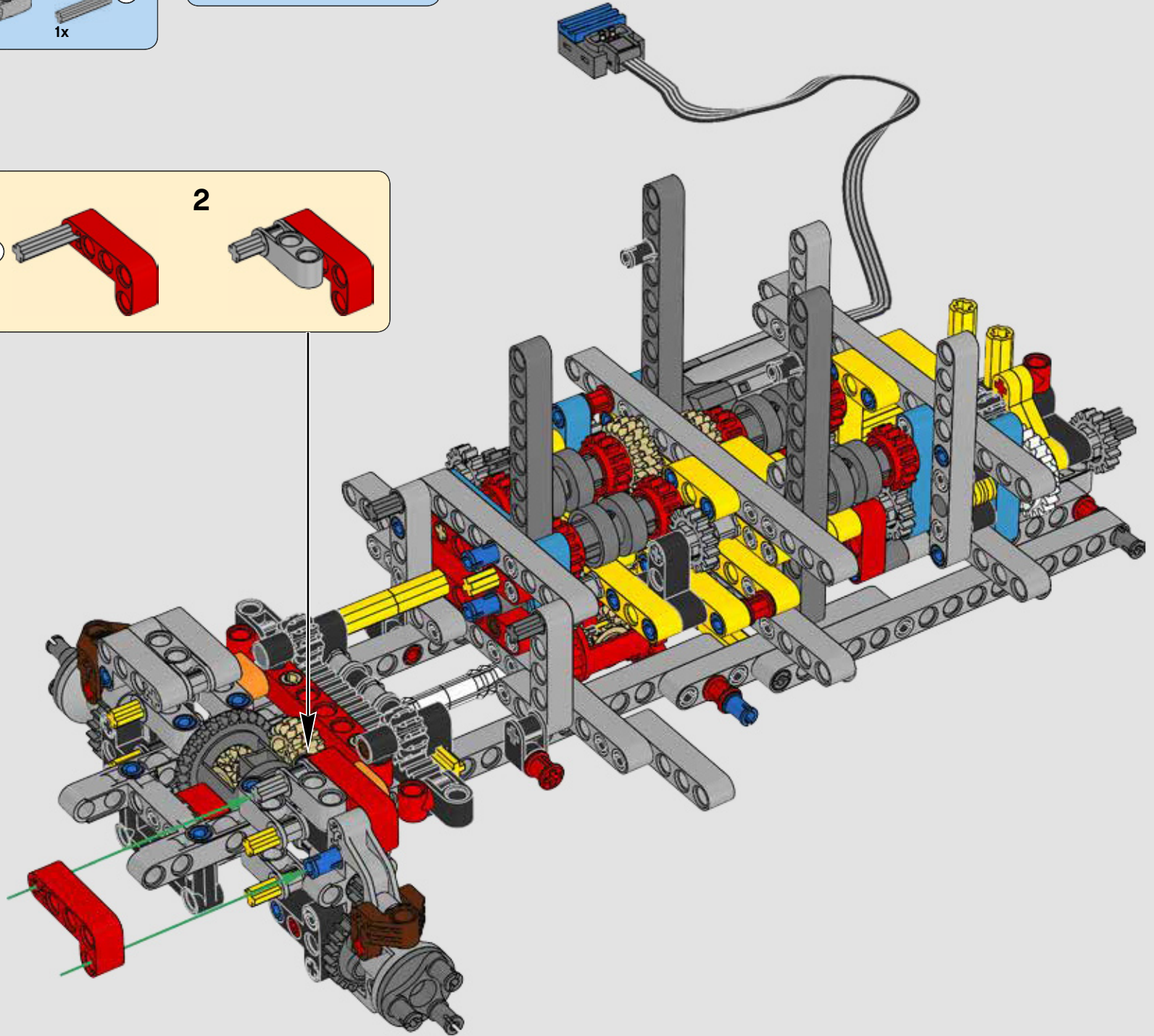
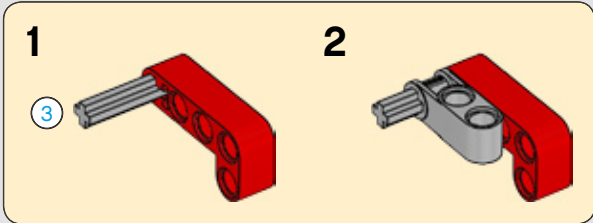

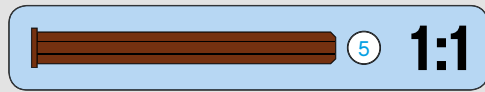
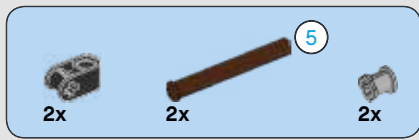

113

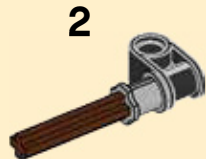
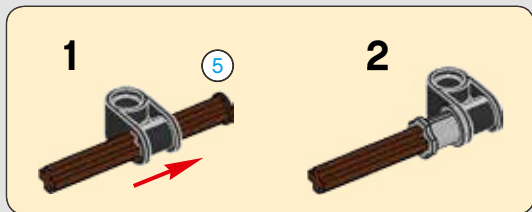
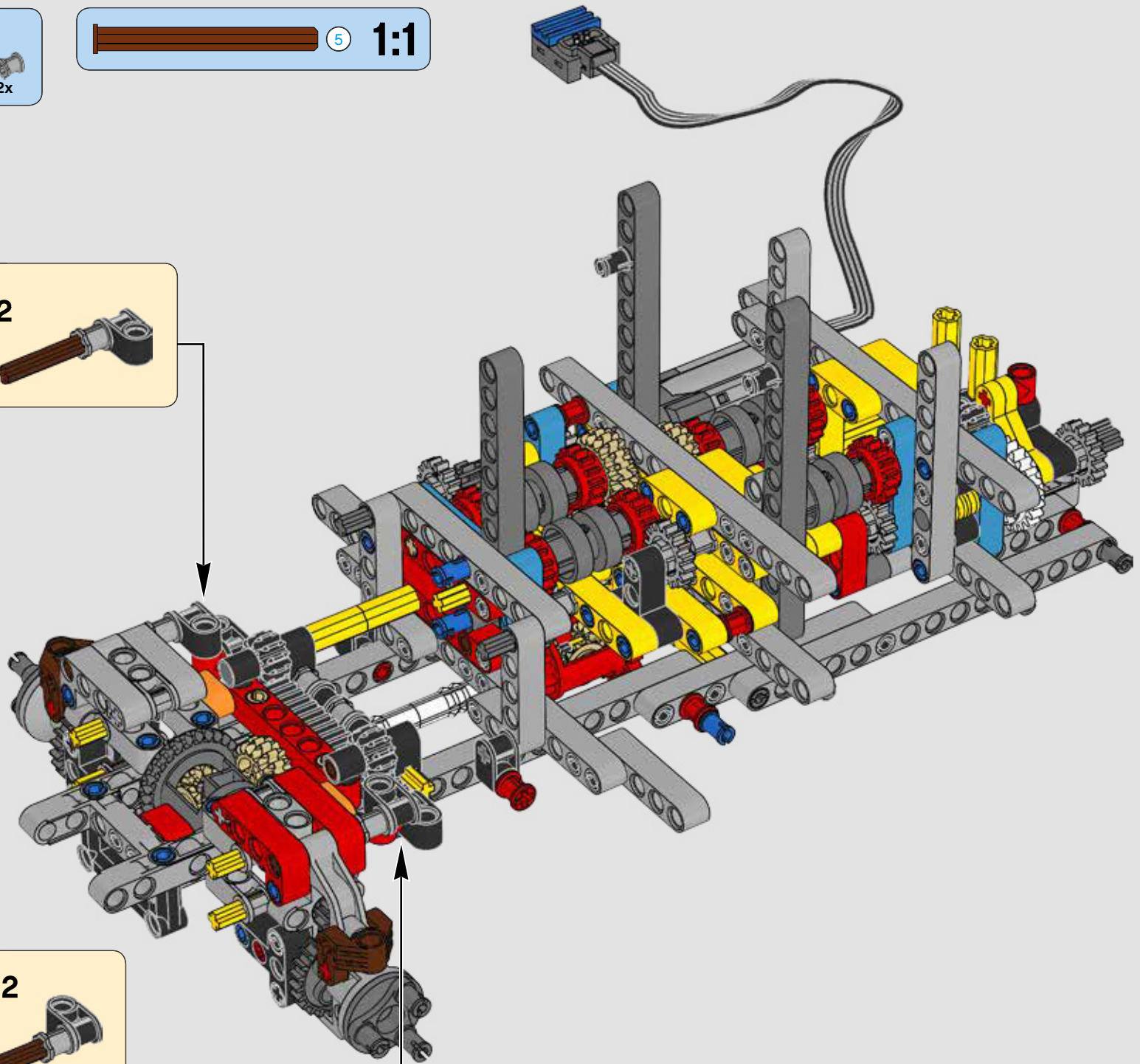
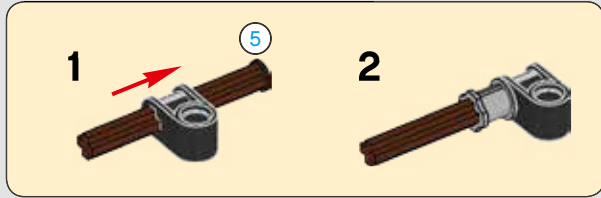



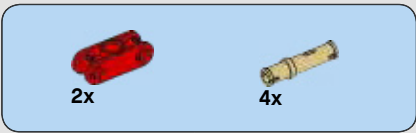

114

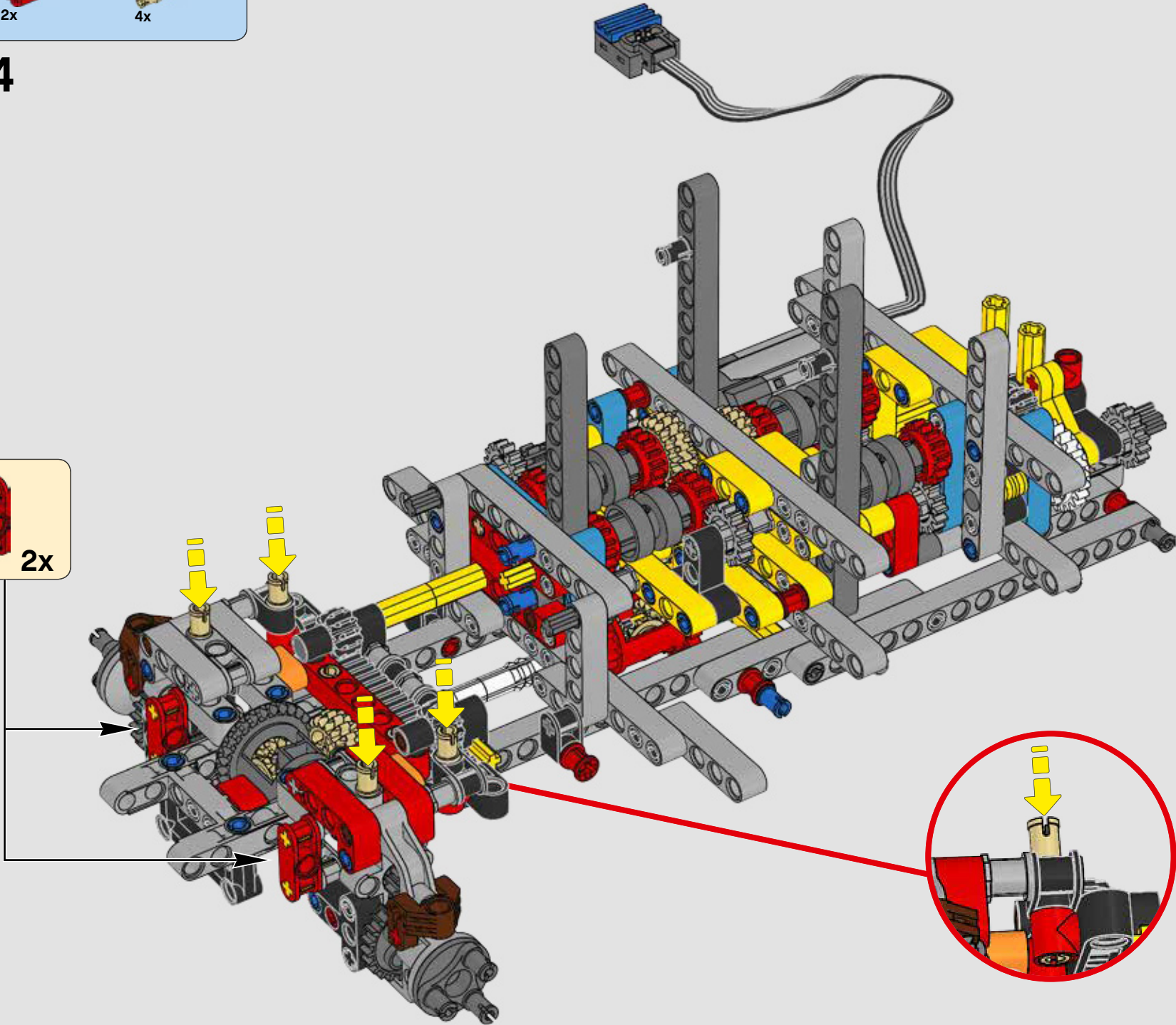
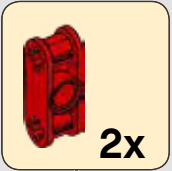



115

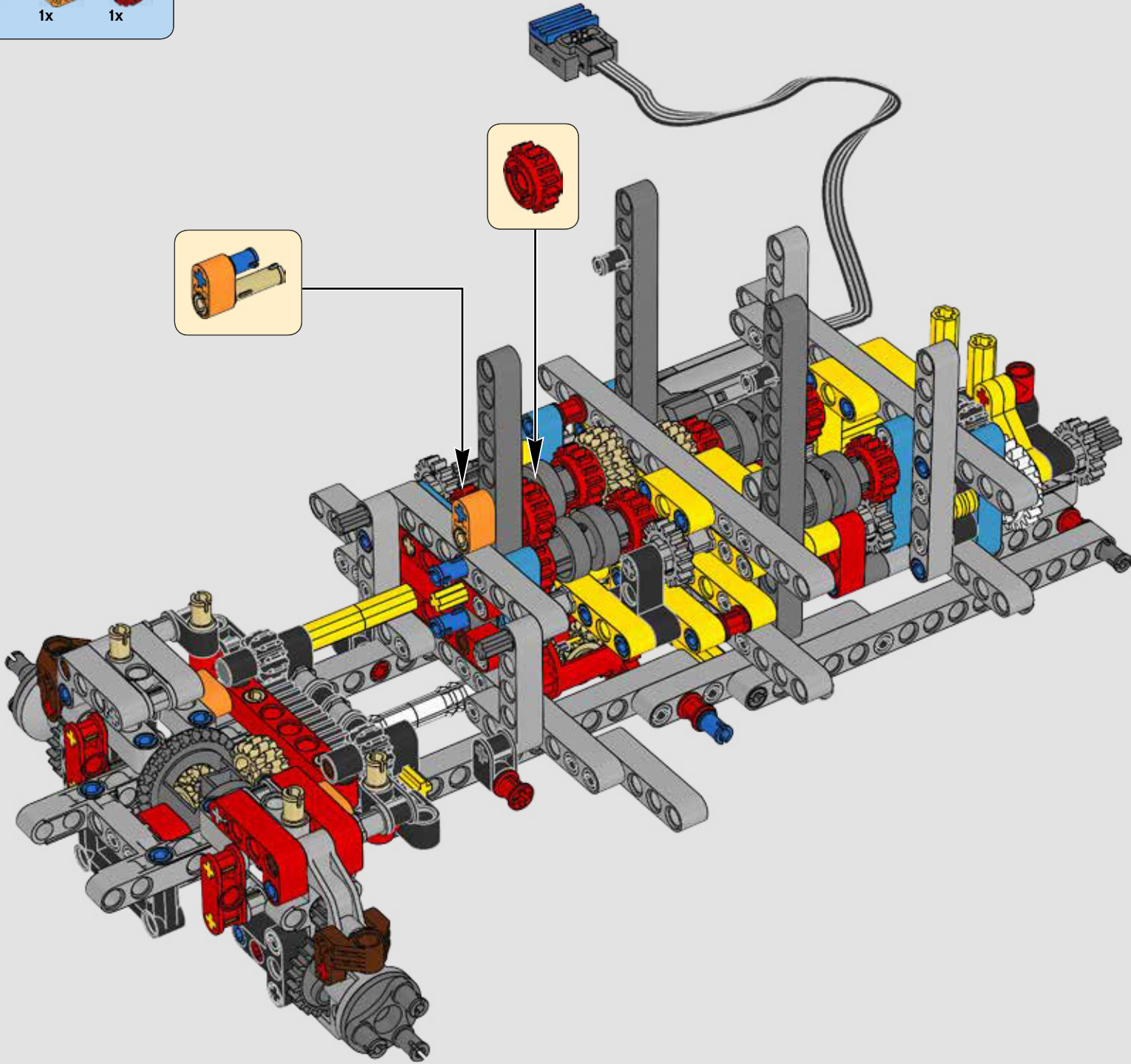



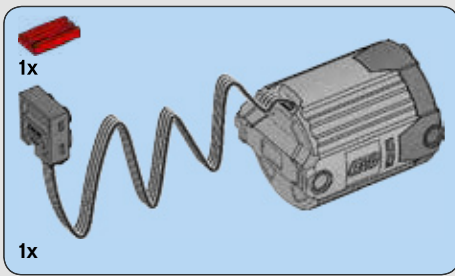

116

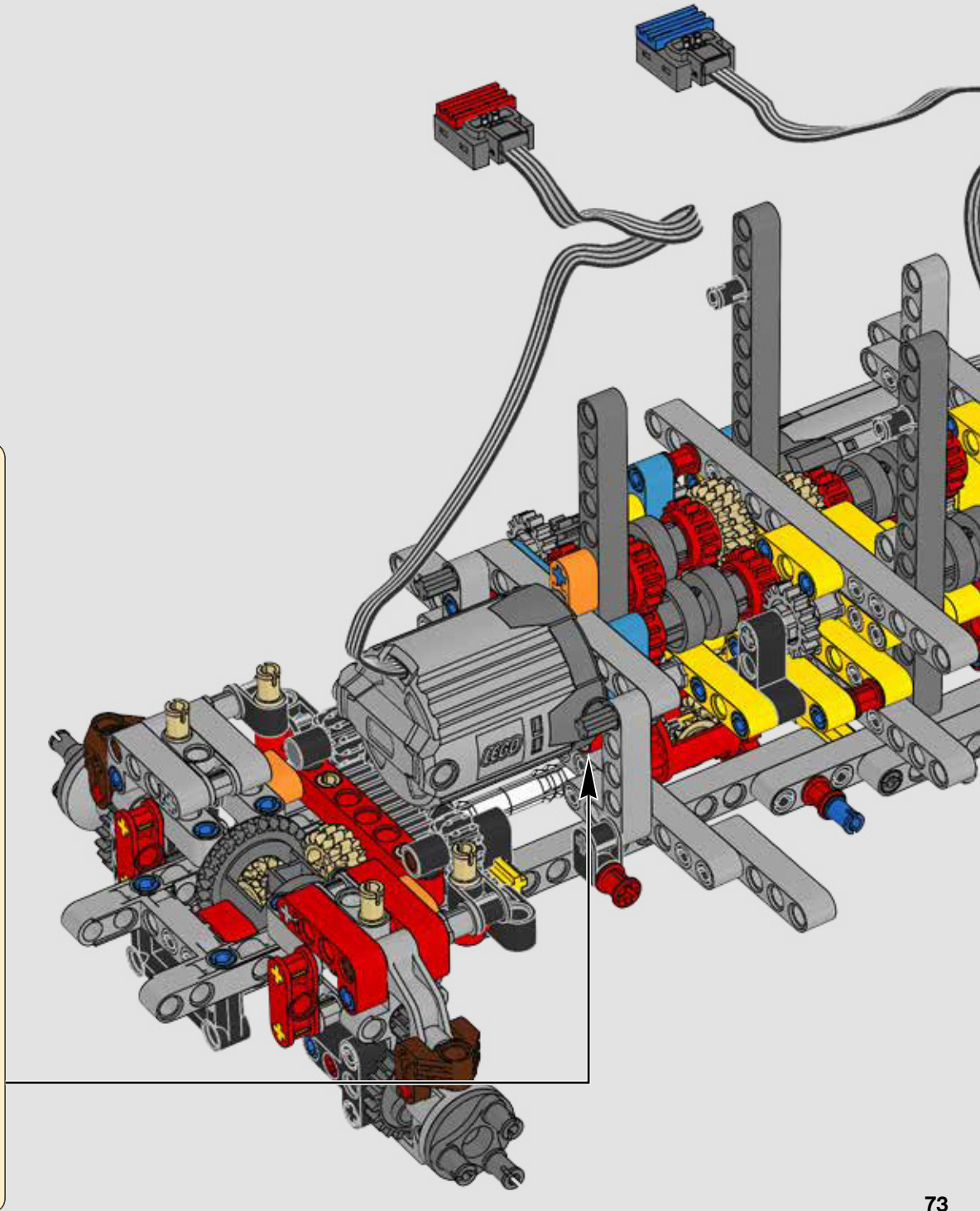
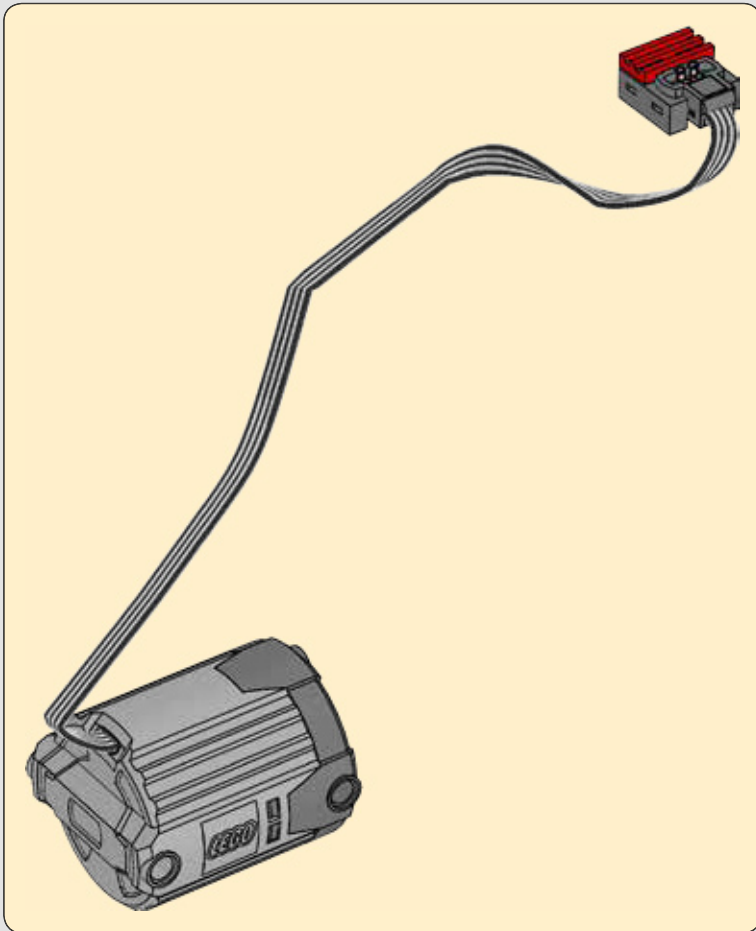

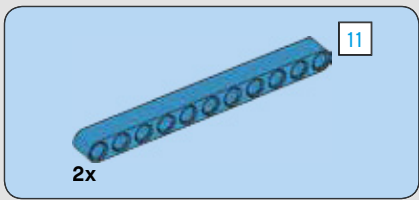

117

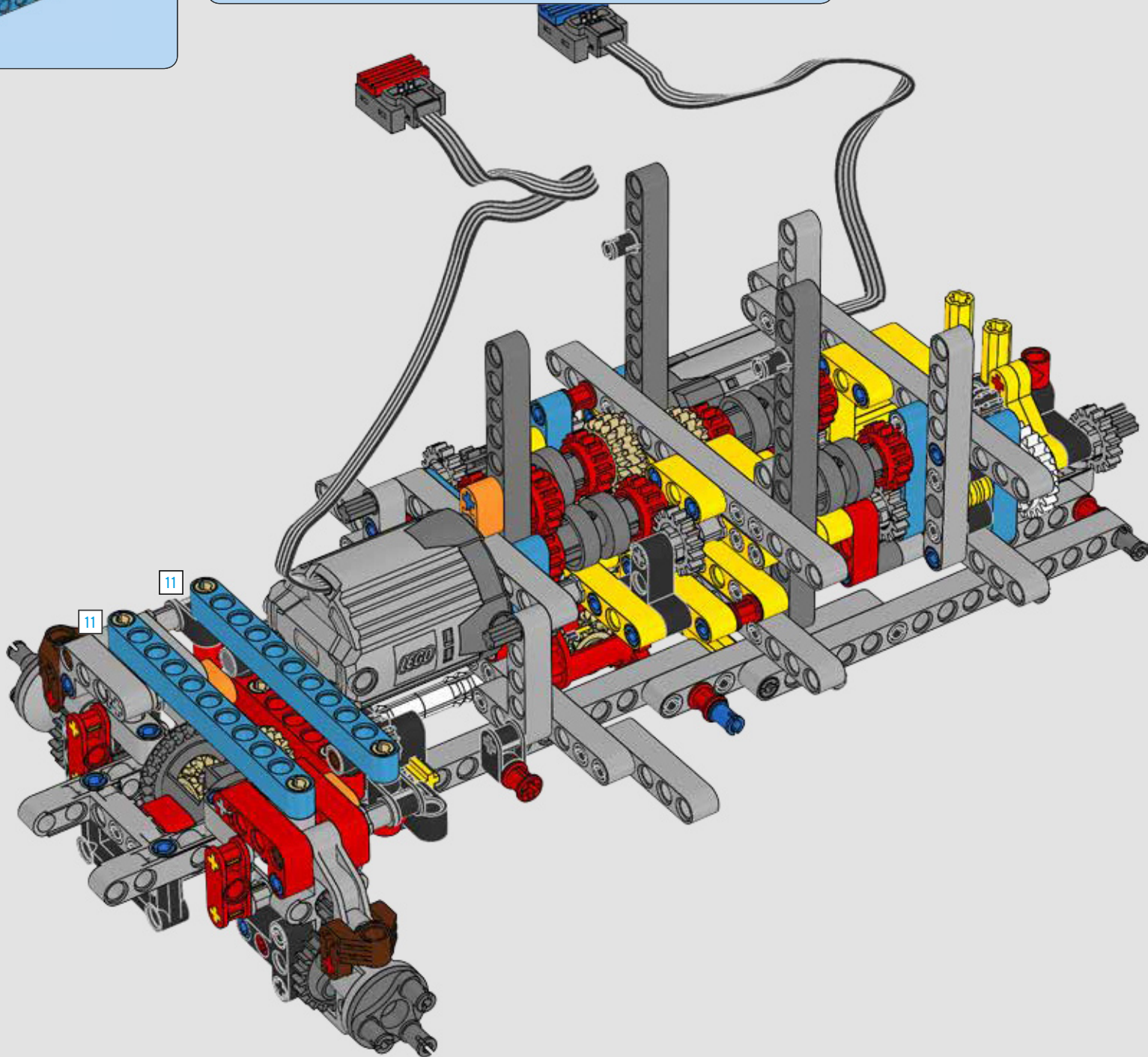





118

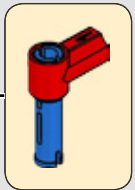
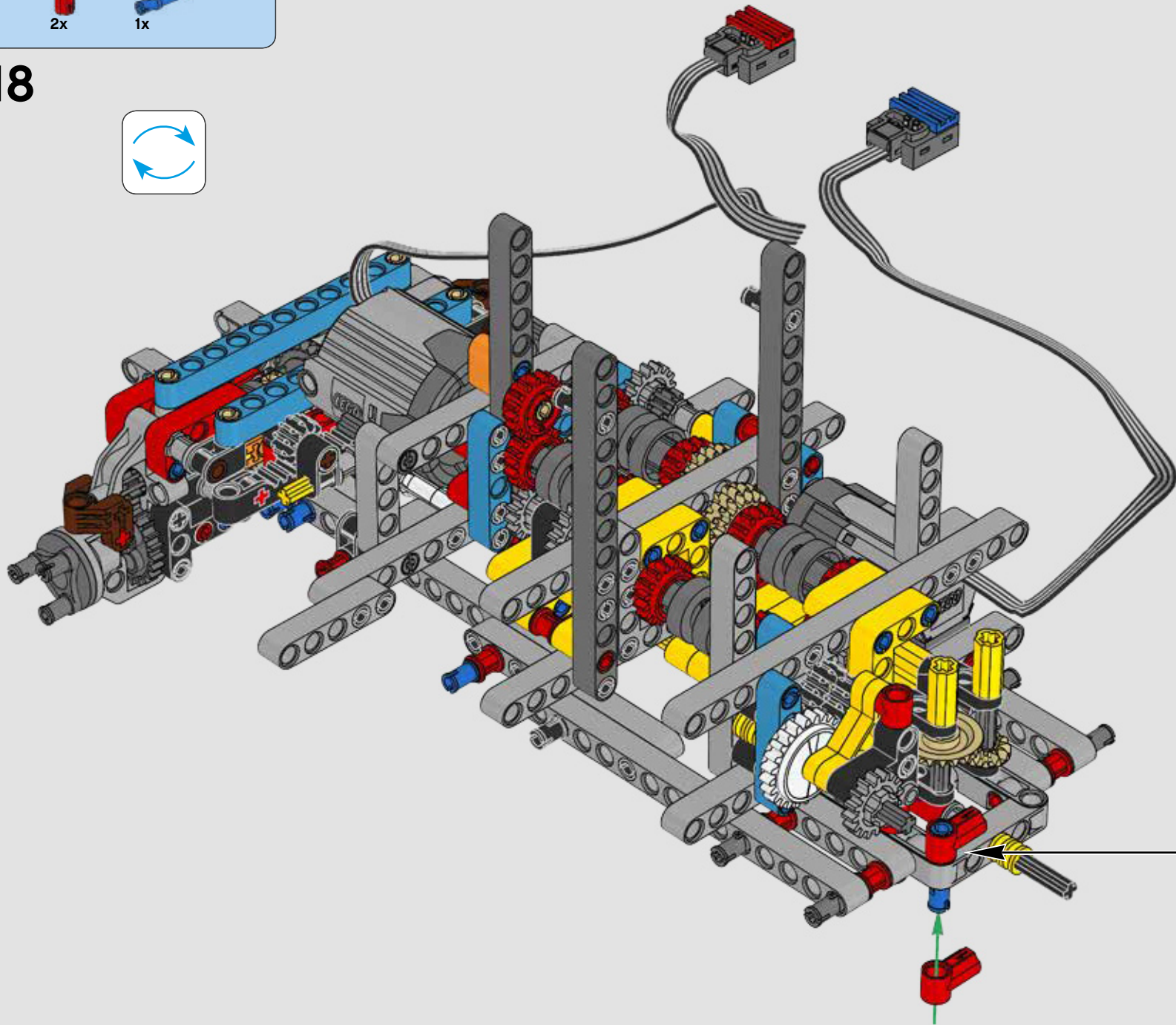
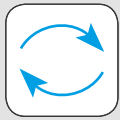

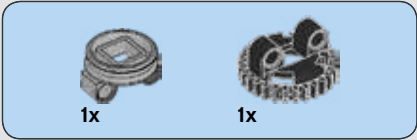

119

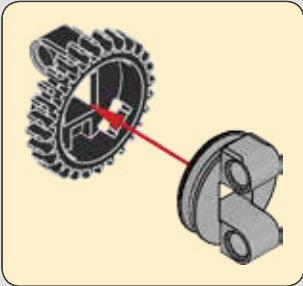
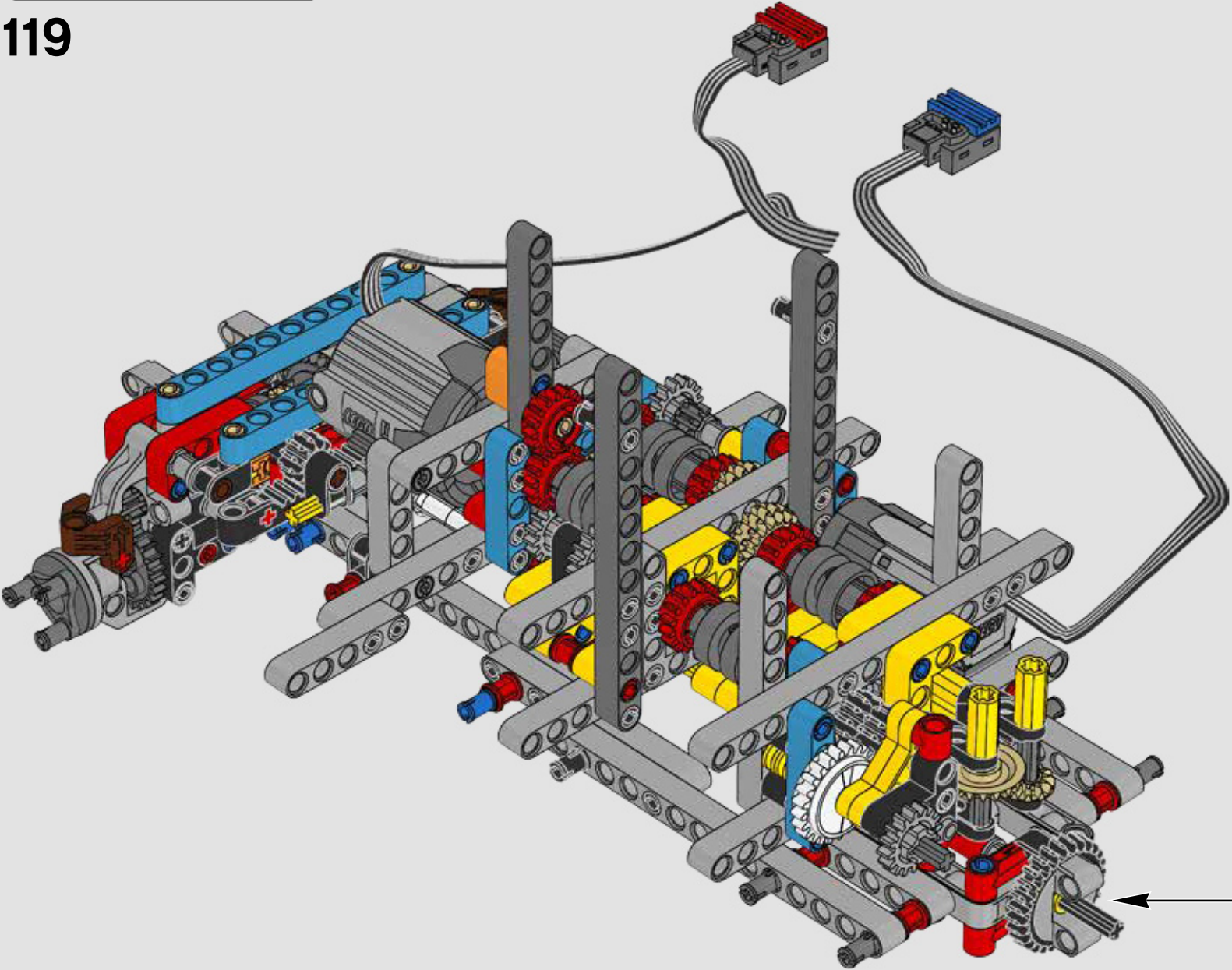



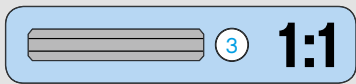
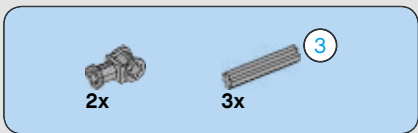

120

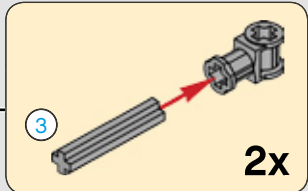
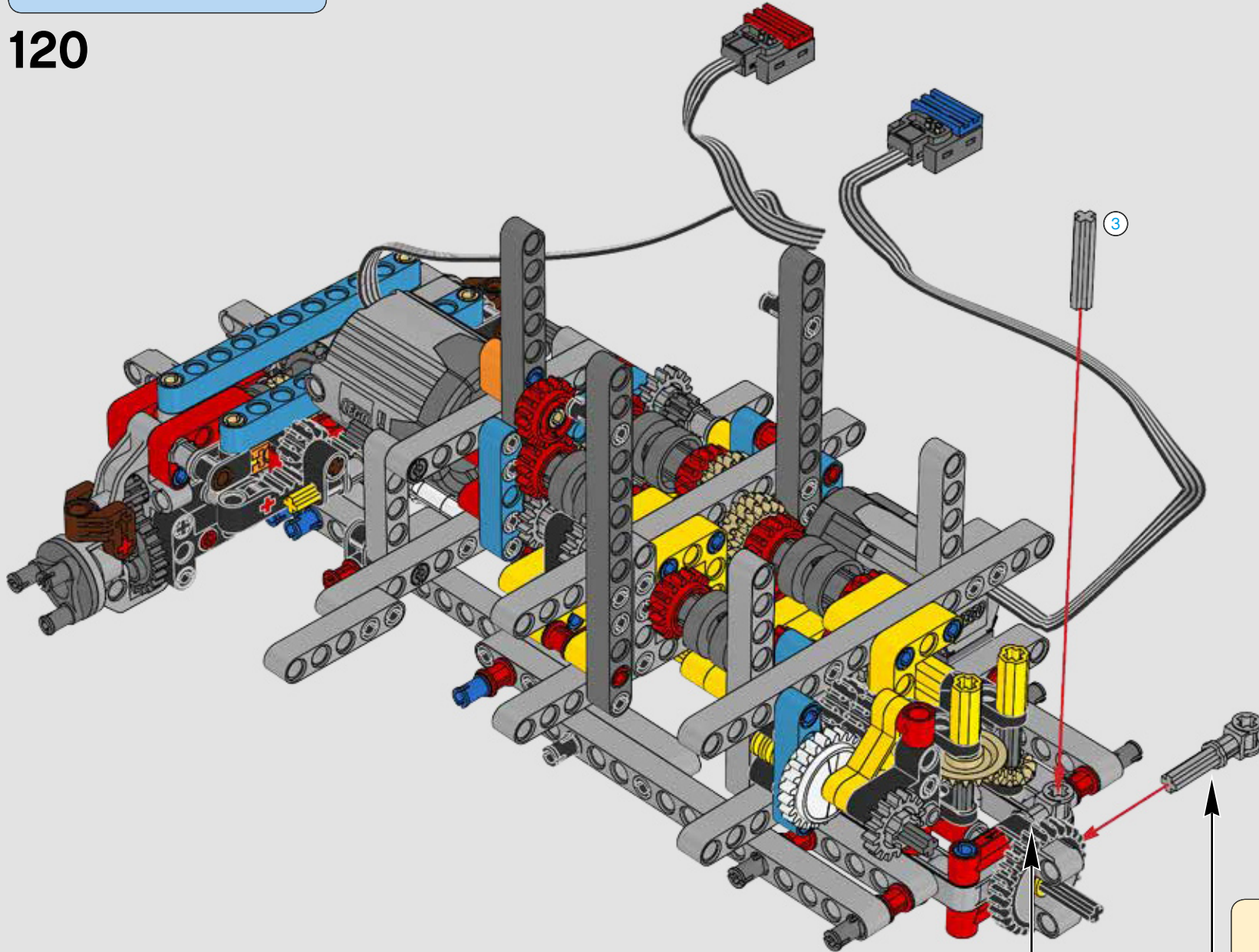

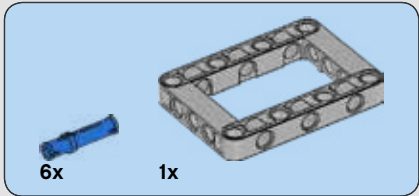
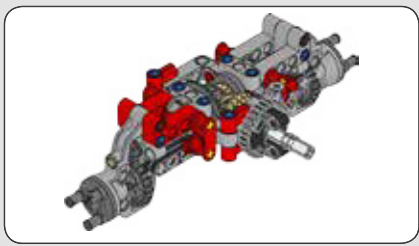

121

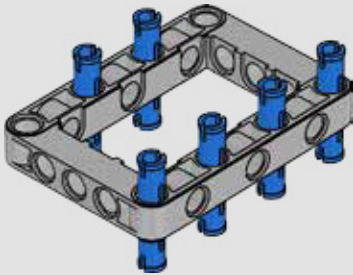

122

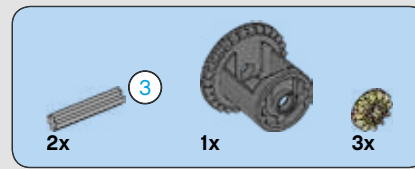
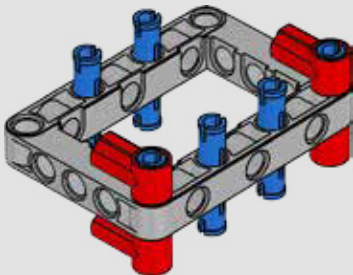

123

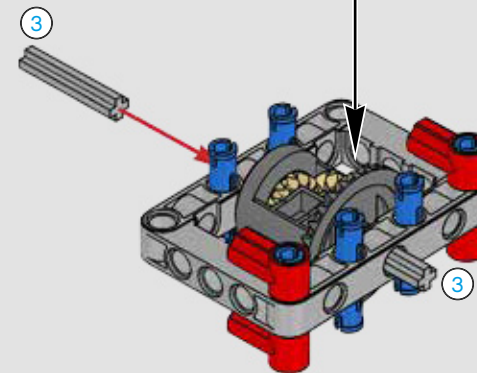
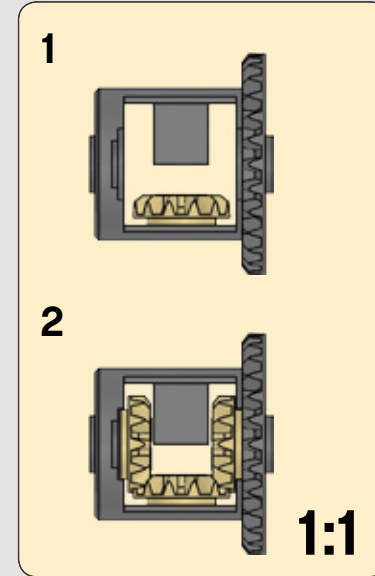
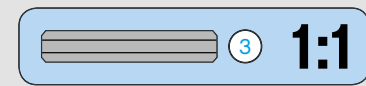



124

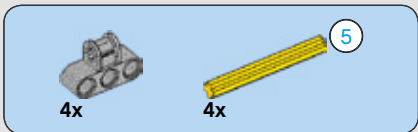
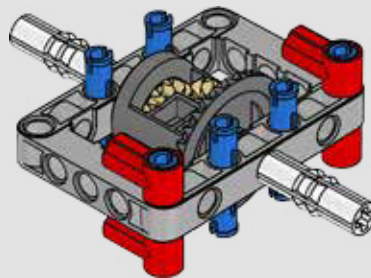

125

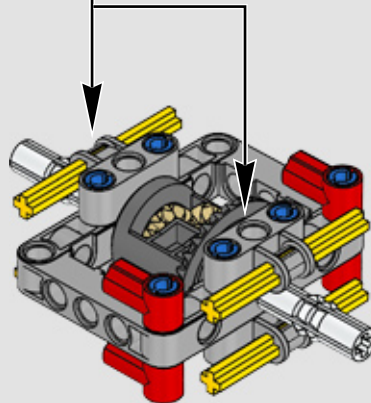
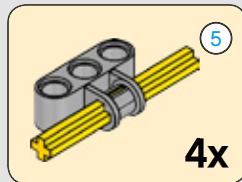
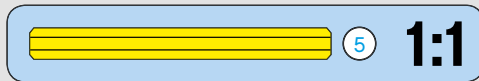

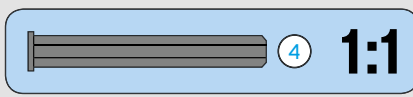
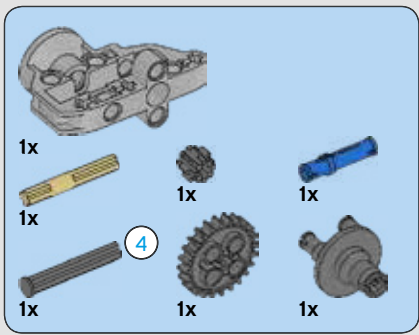

126

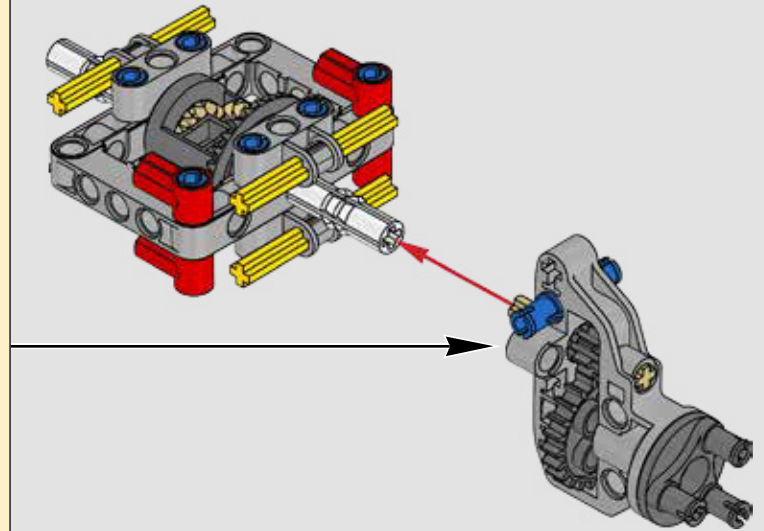
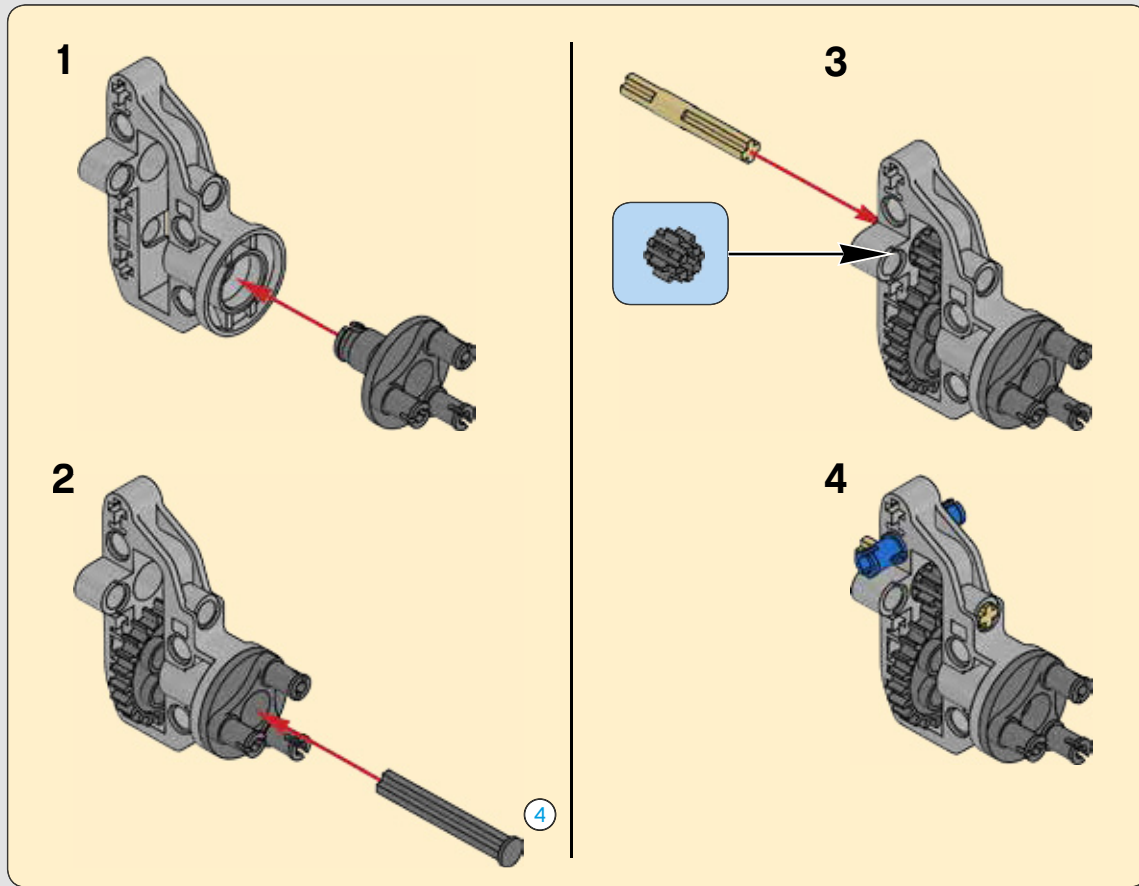



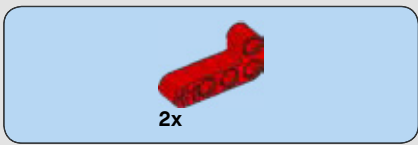

127

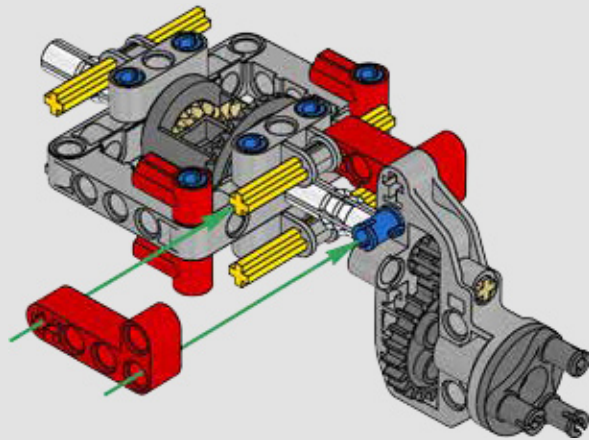

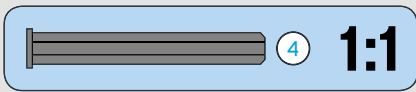
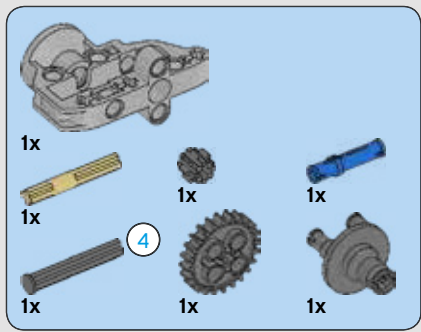

128

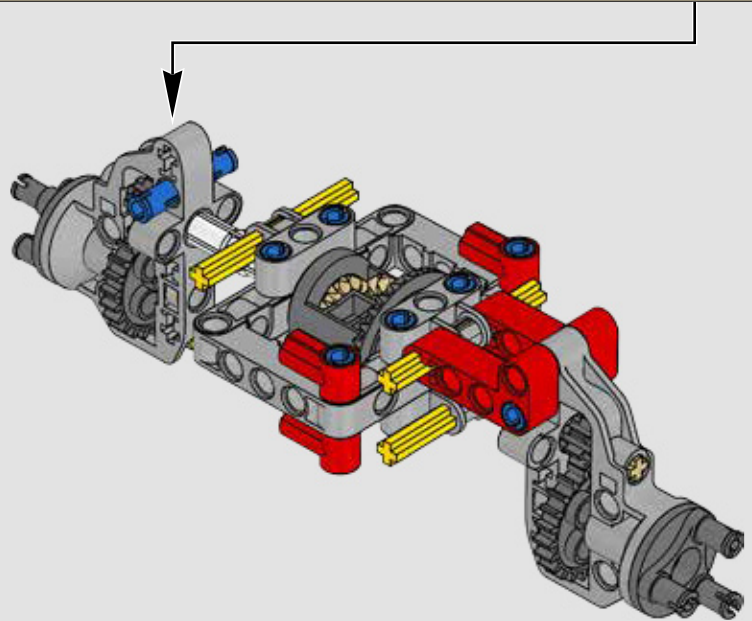
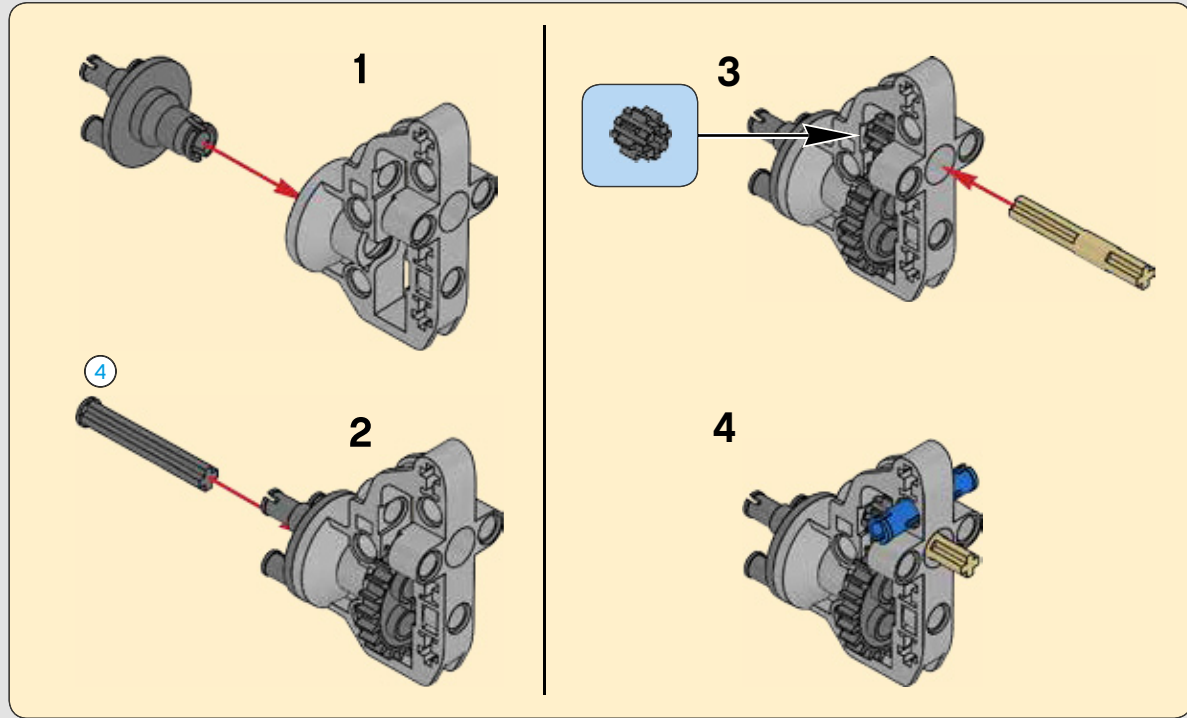

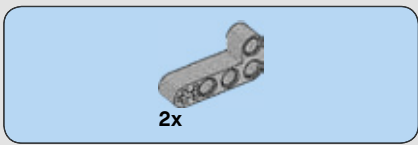

129

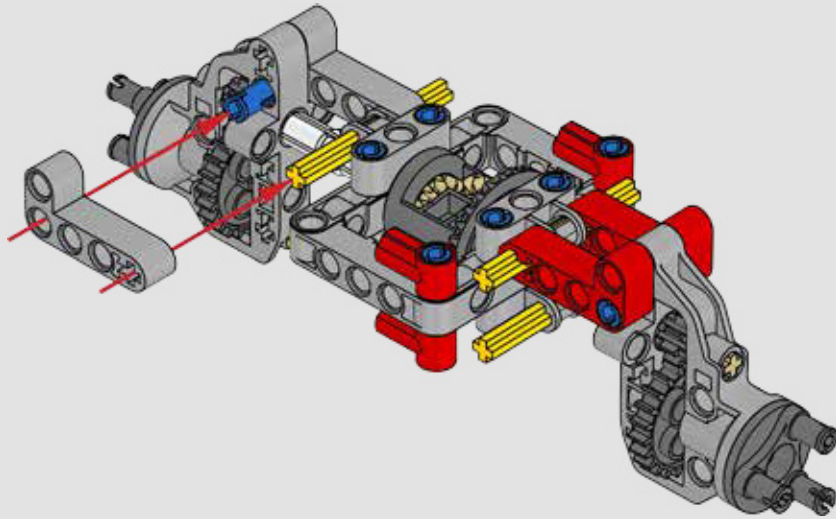

130

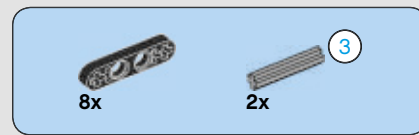
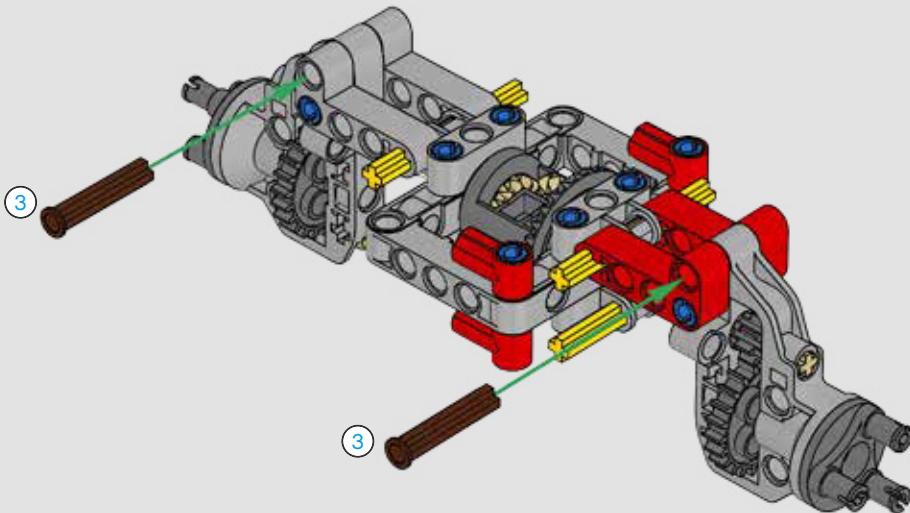

131

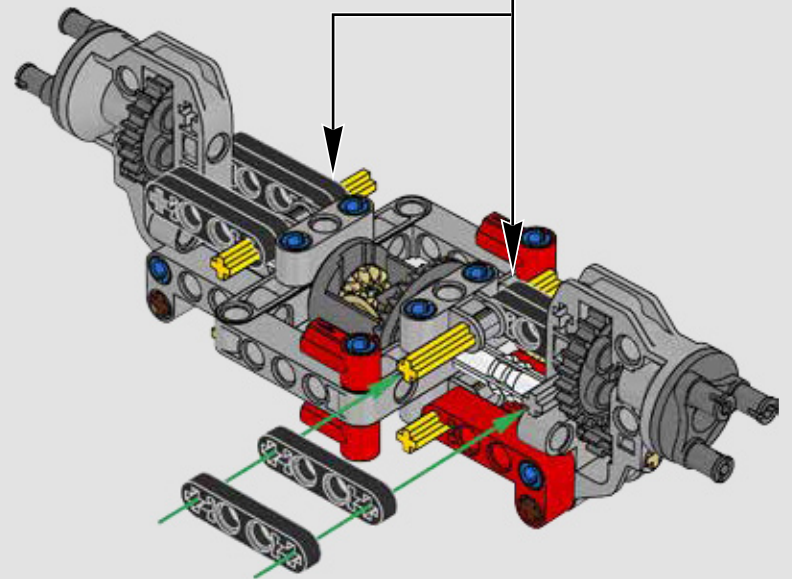
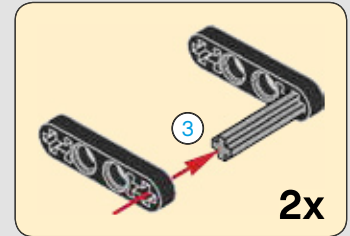
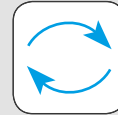
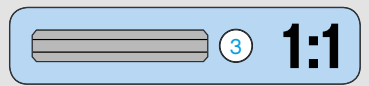



# 132

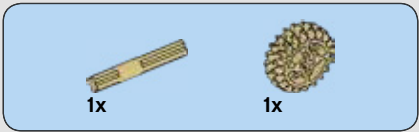
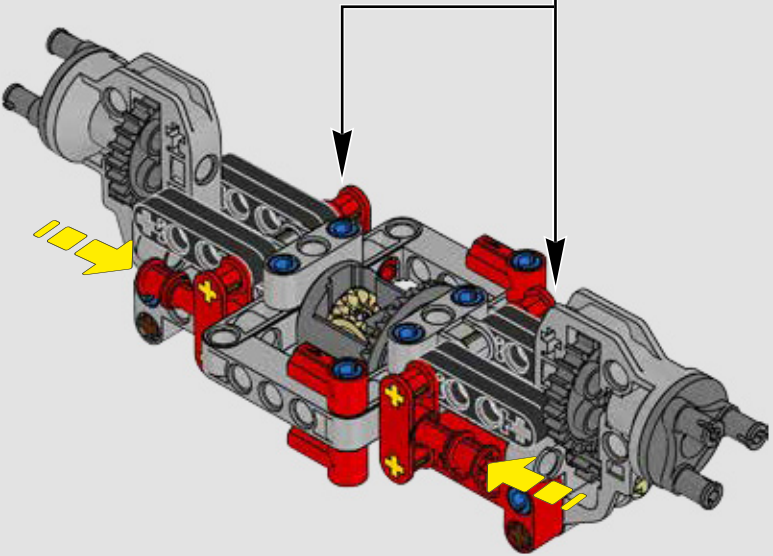

# 133

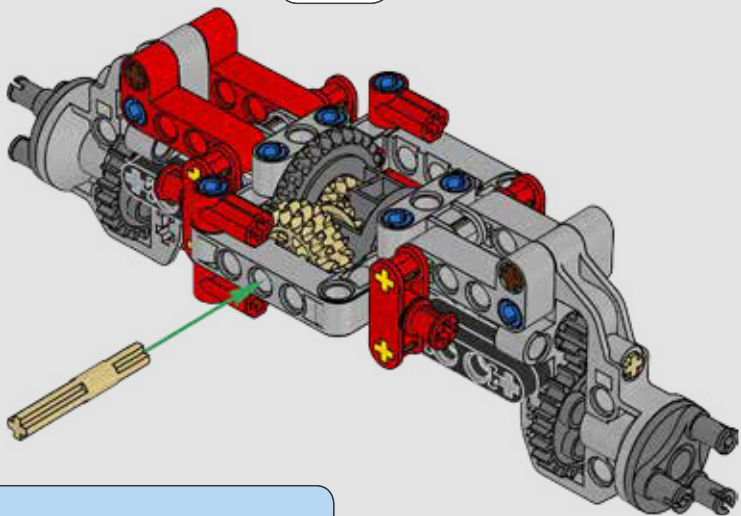
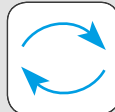

# 134

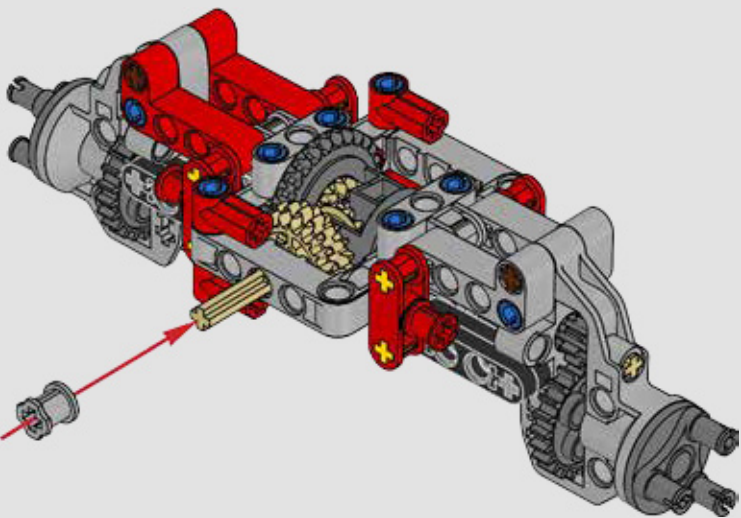





135

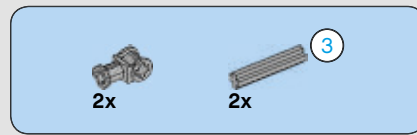
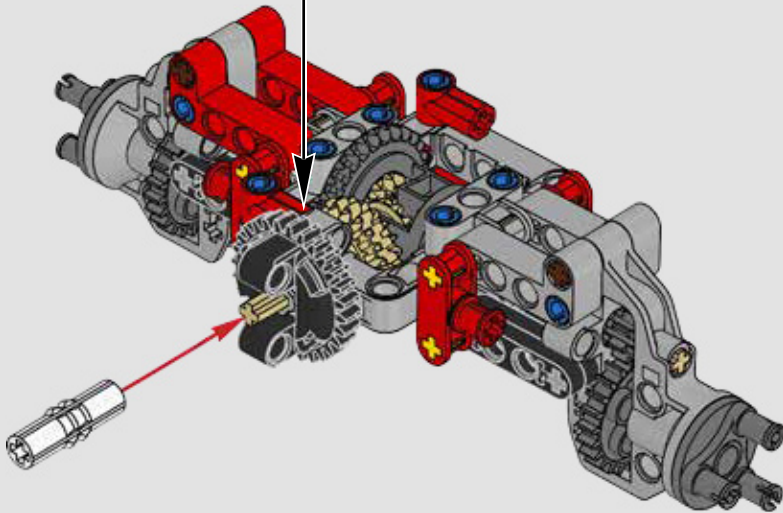
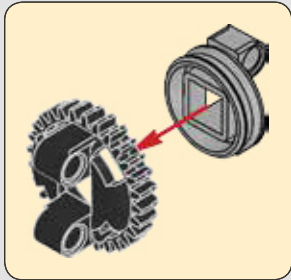

136

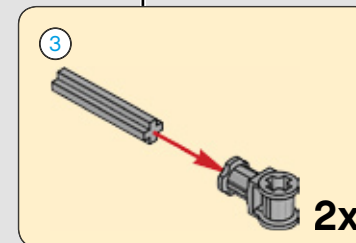
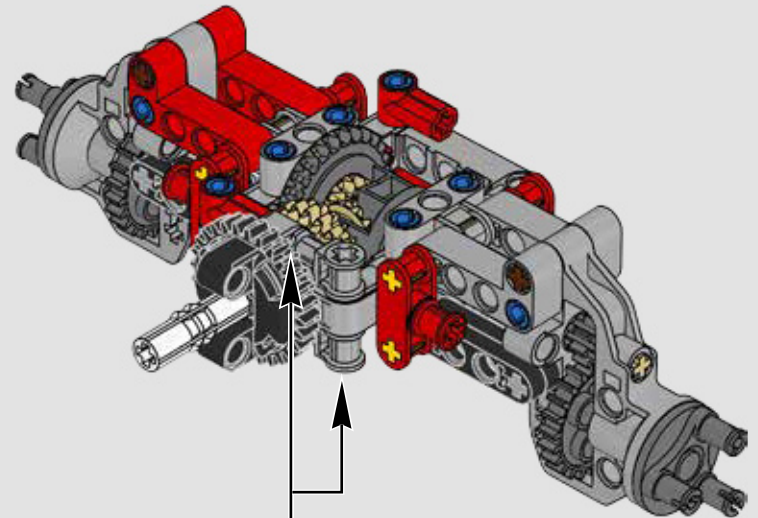
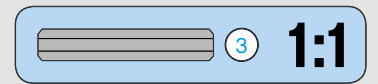

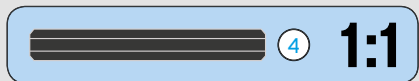
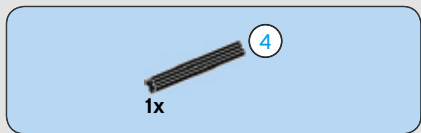

137

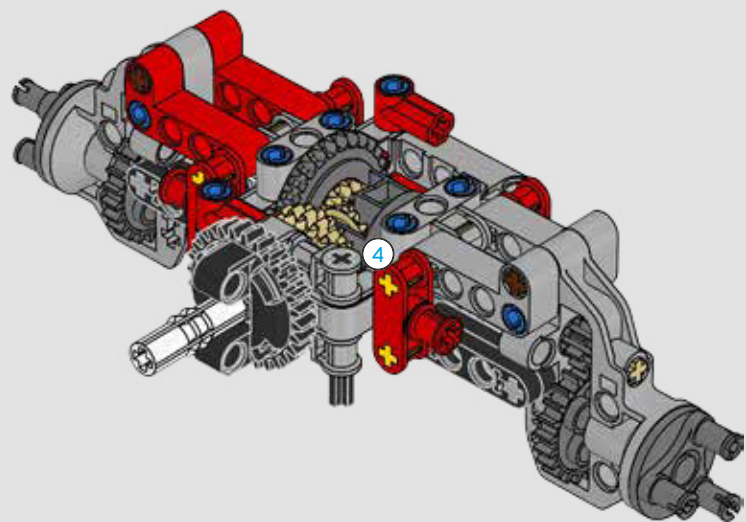

138

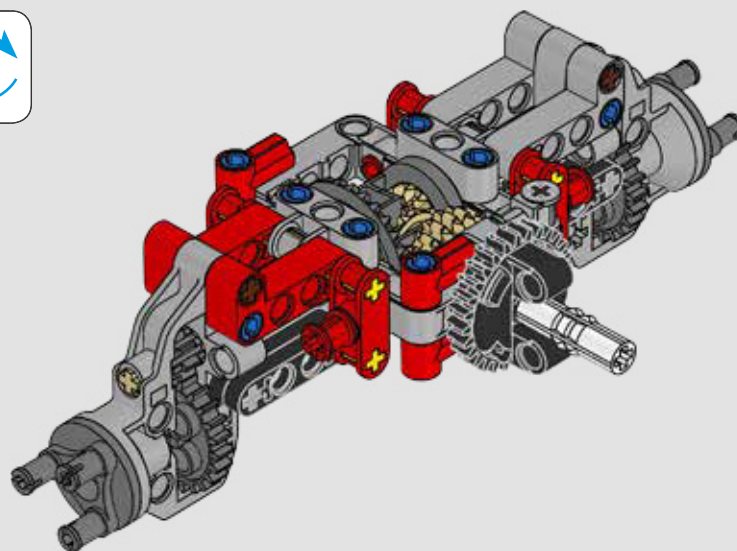
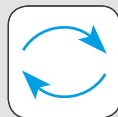

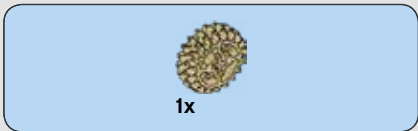

139

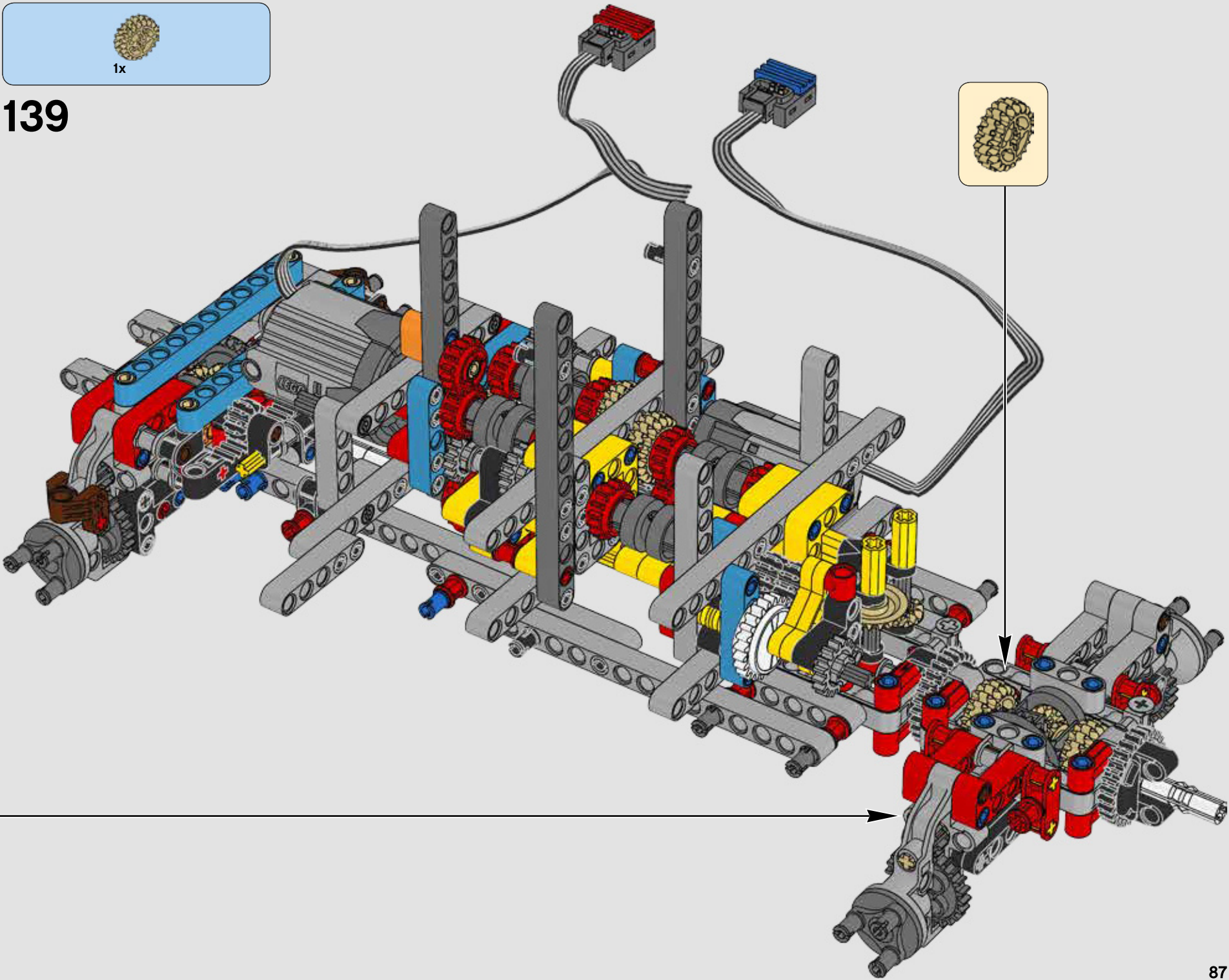



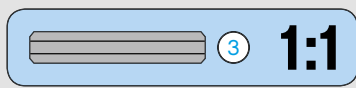
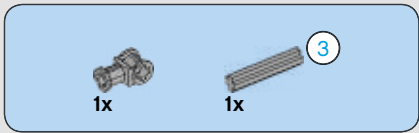

140

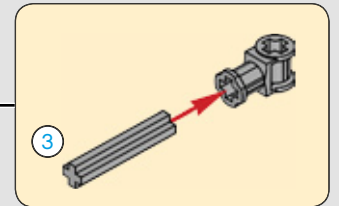
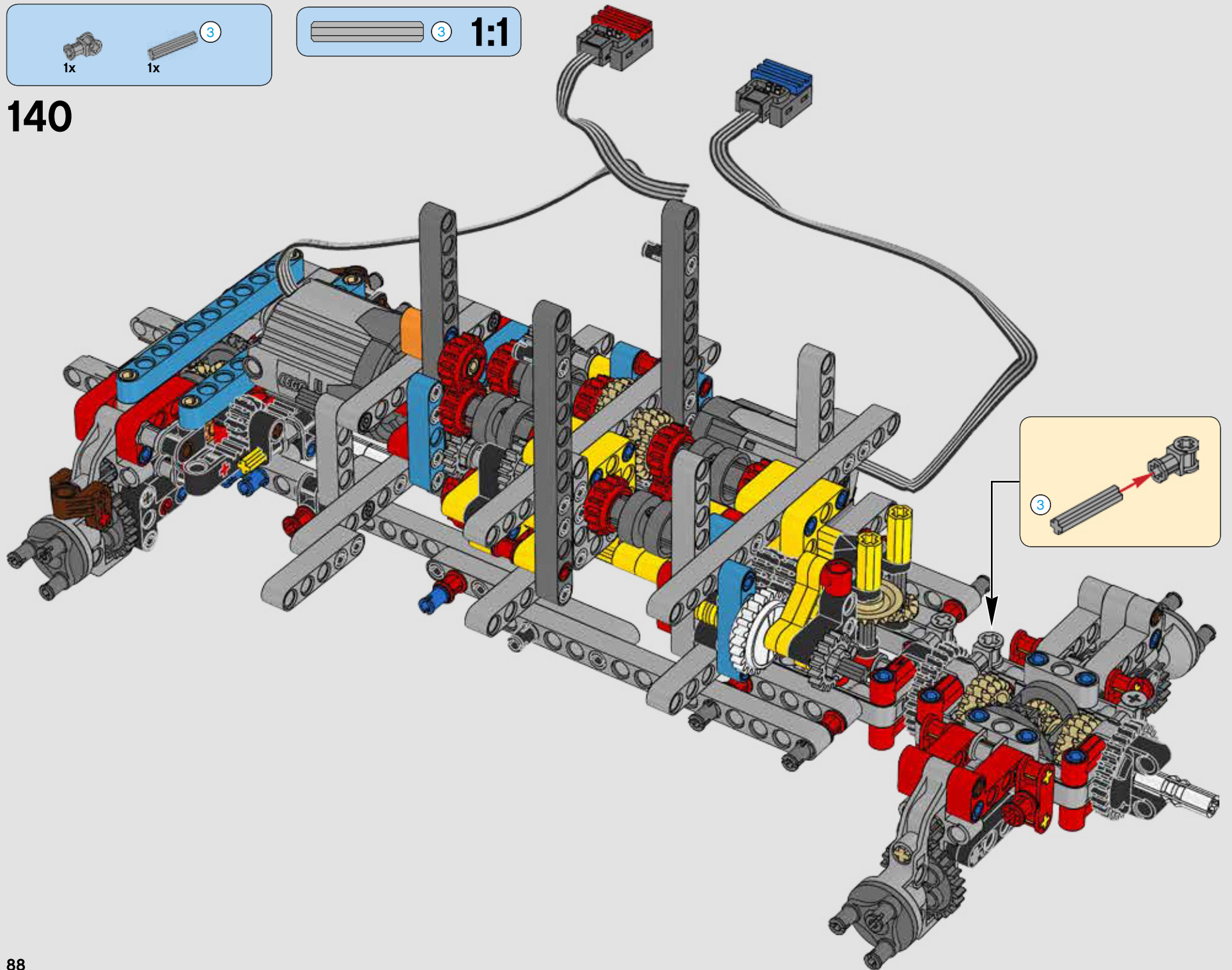



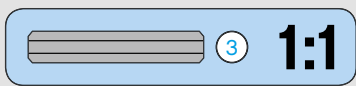
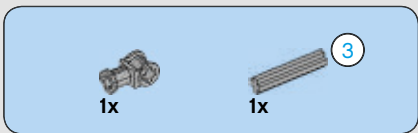

141

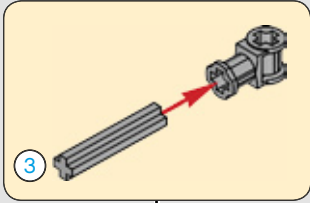
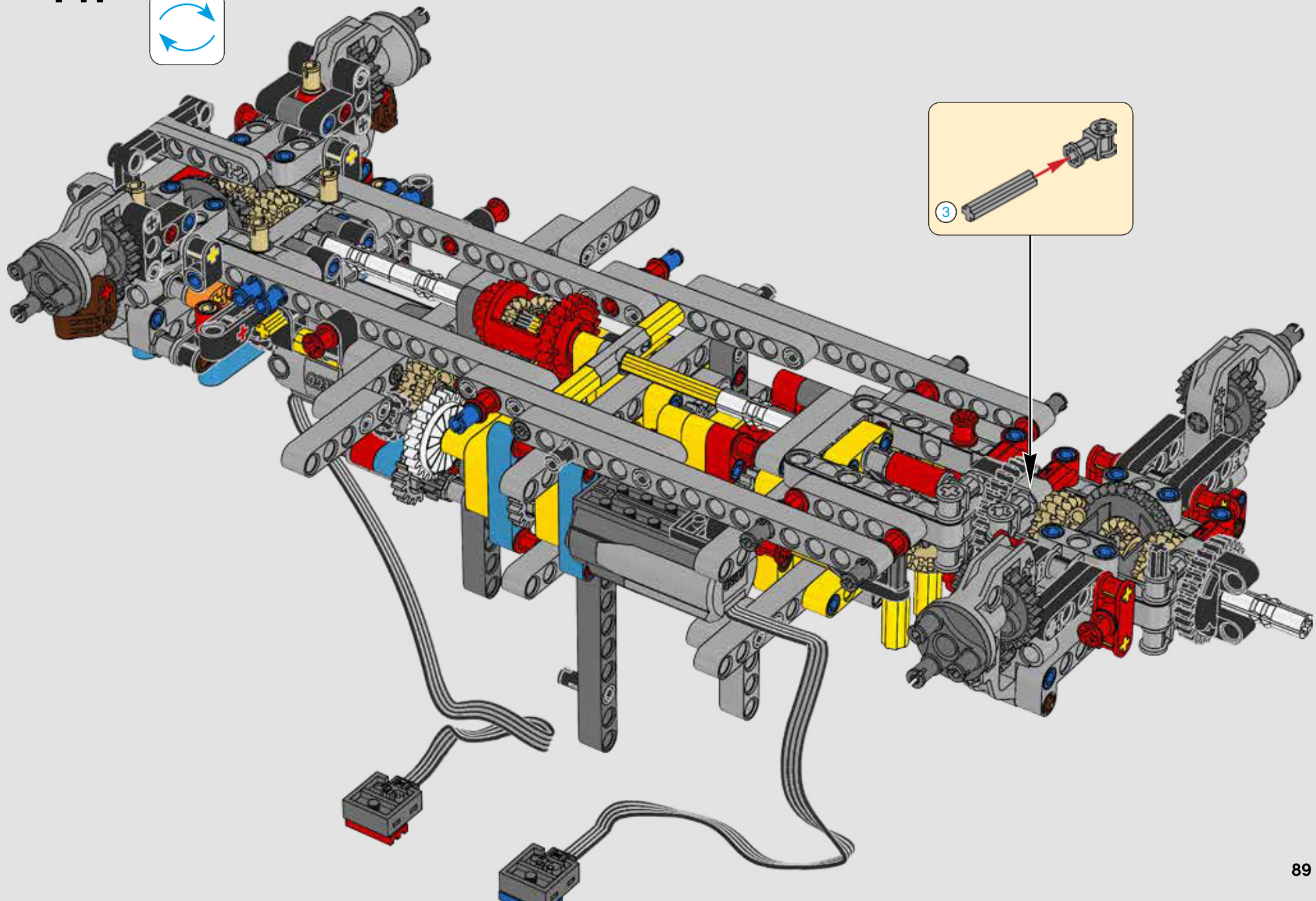

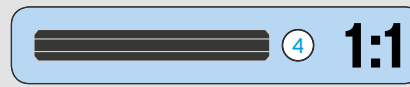
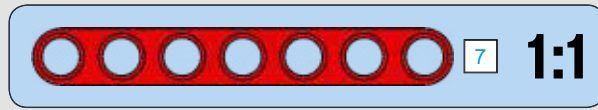
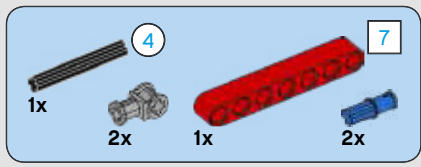

142

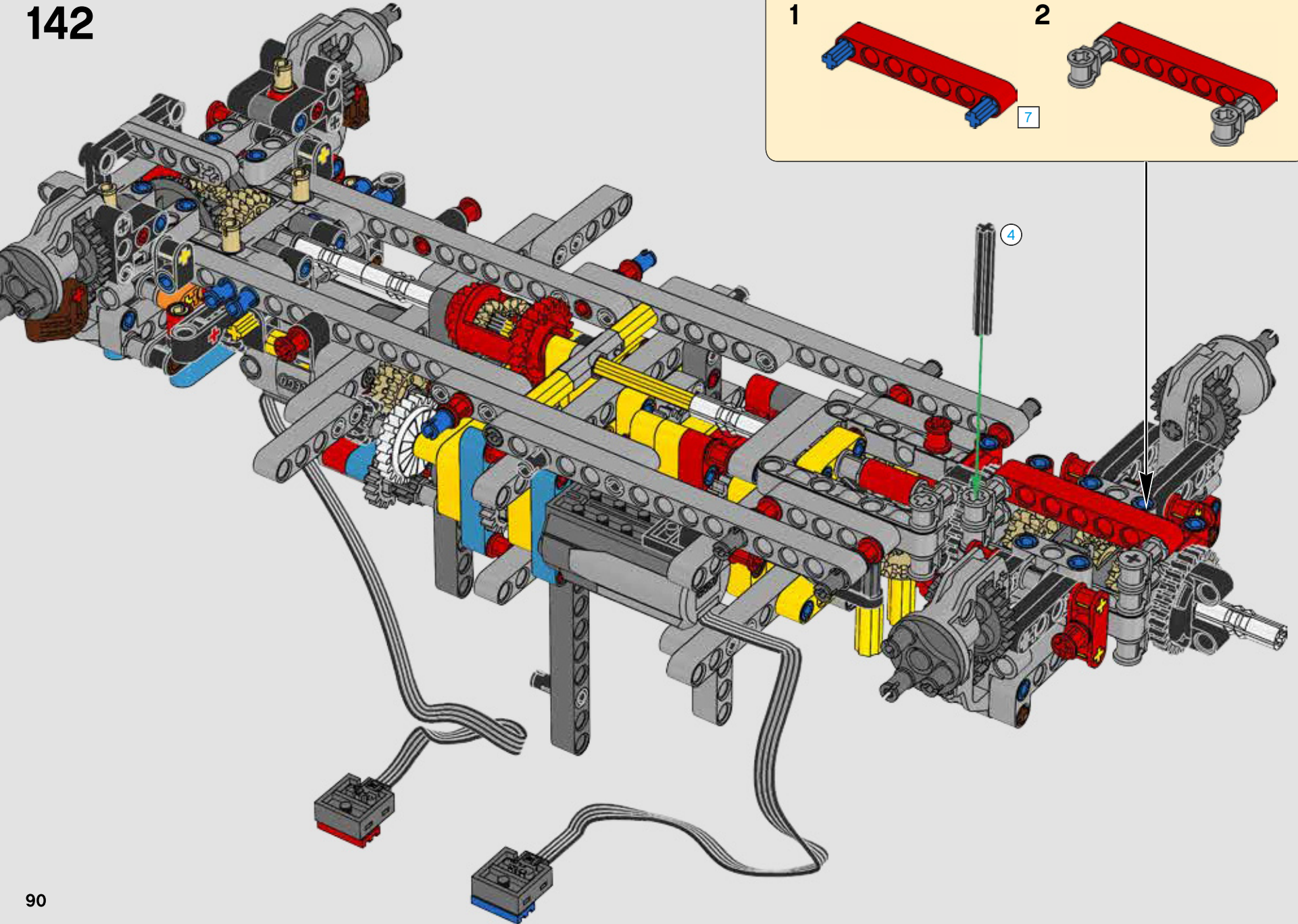
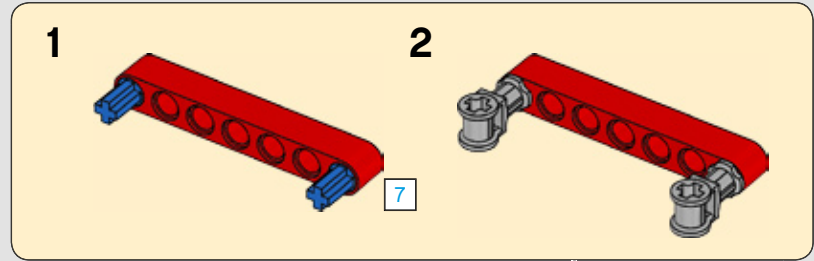



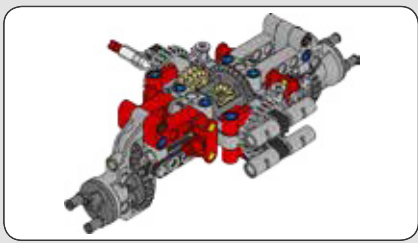

143

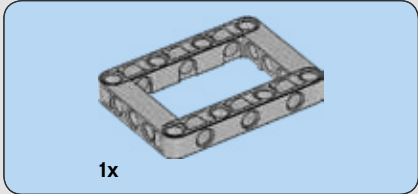

144

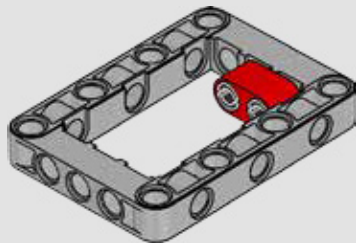

145

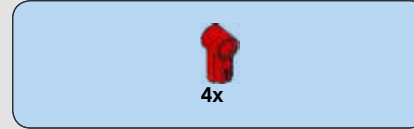
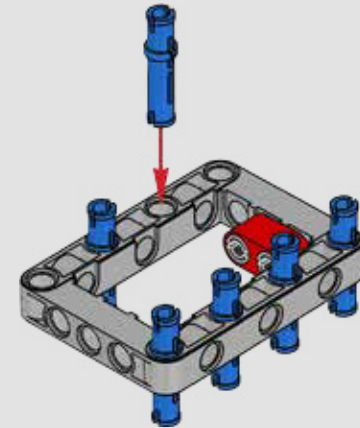

146

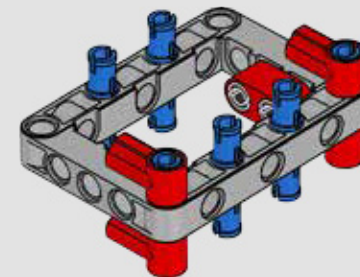

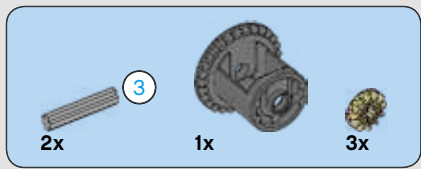

147

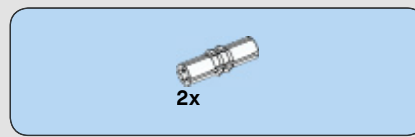
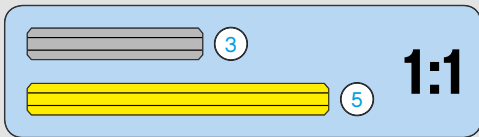
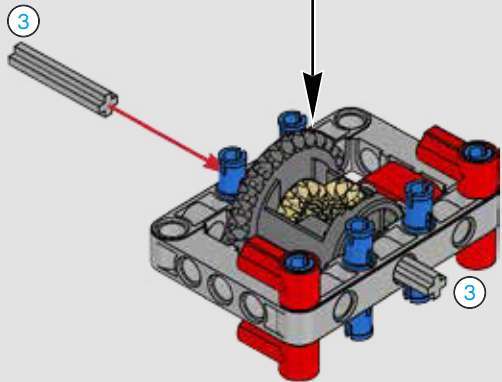
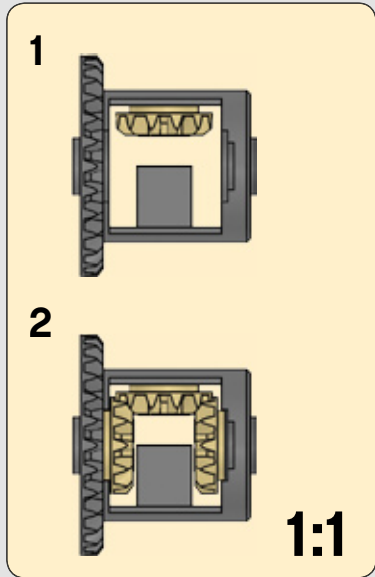

148

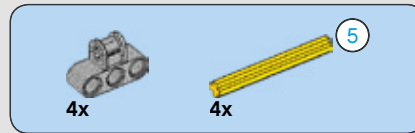
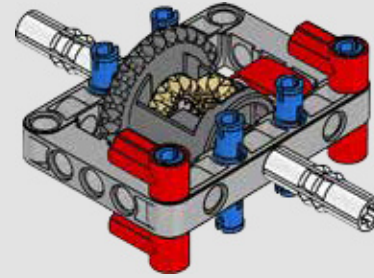

149

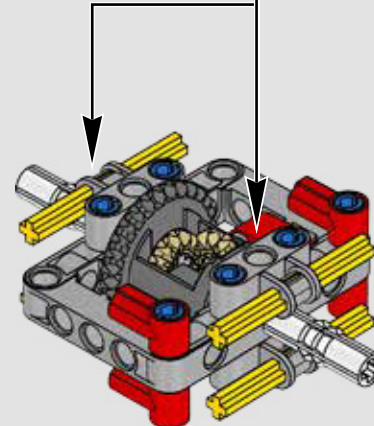
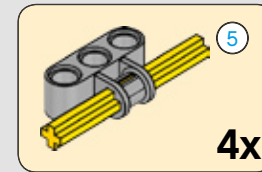



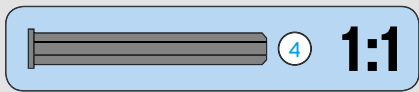
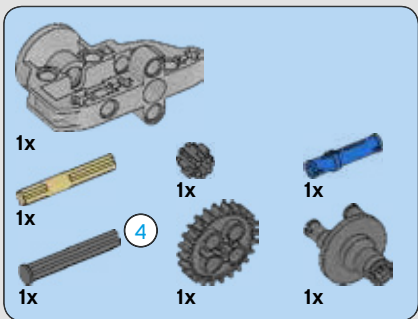

# 150

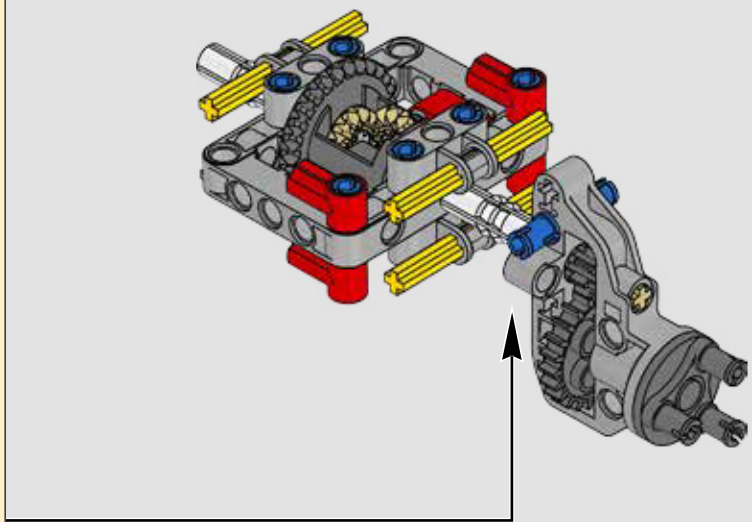
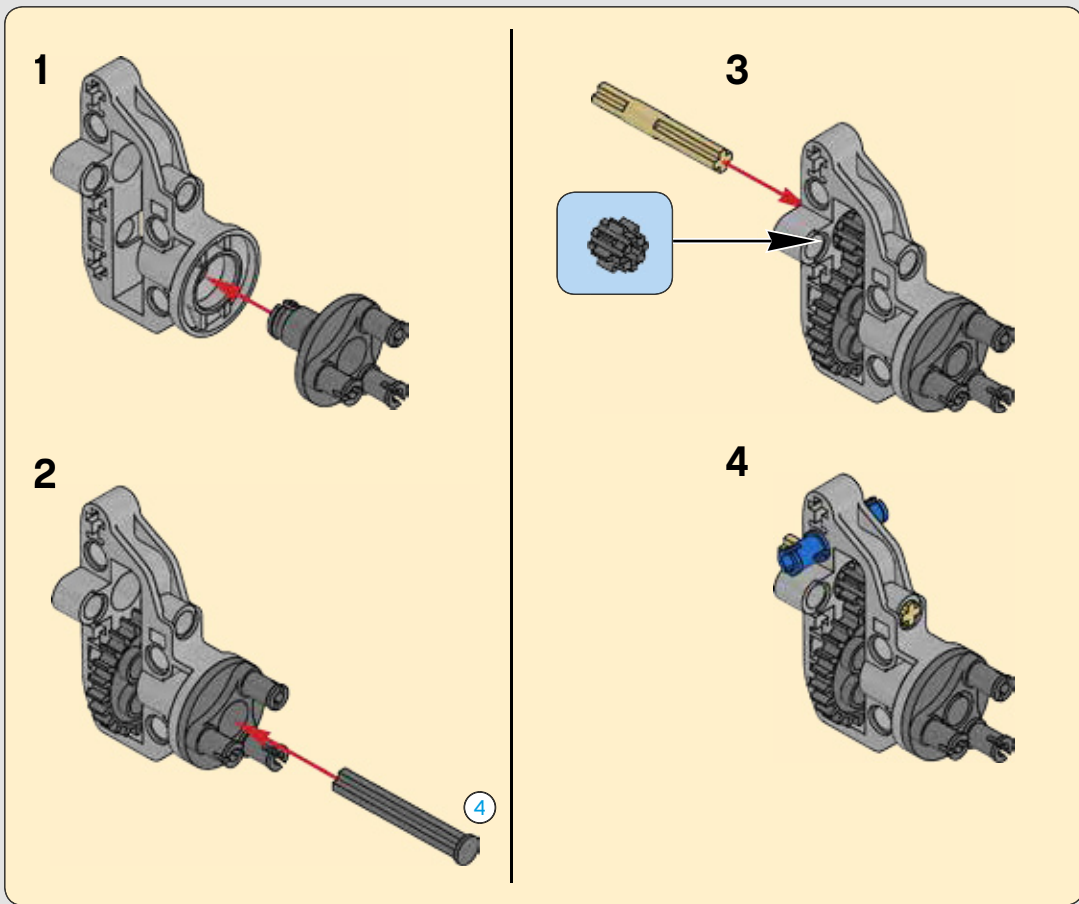

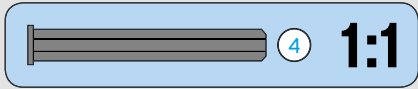
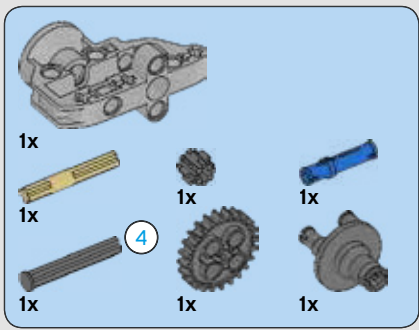

151

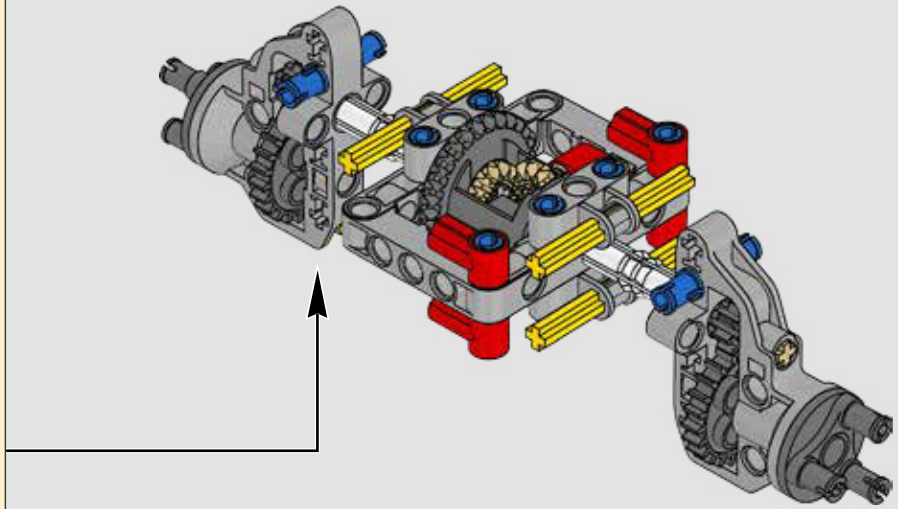
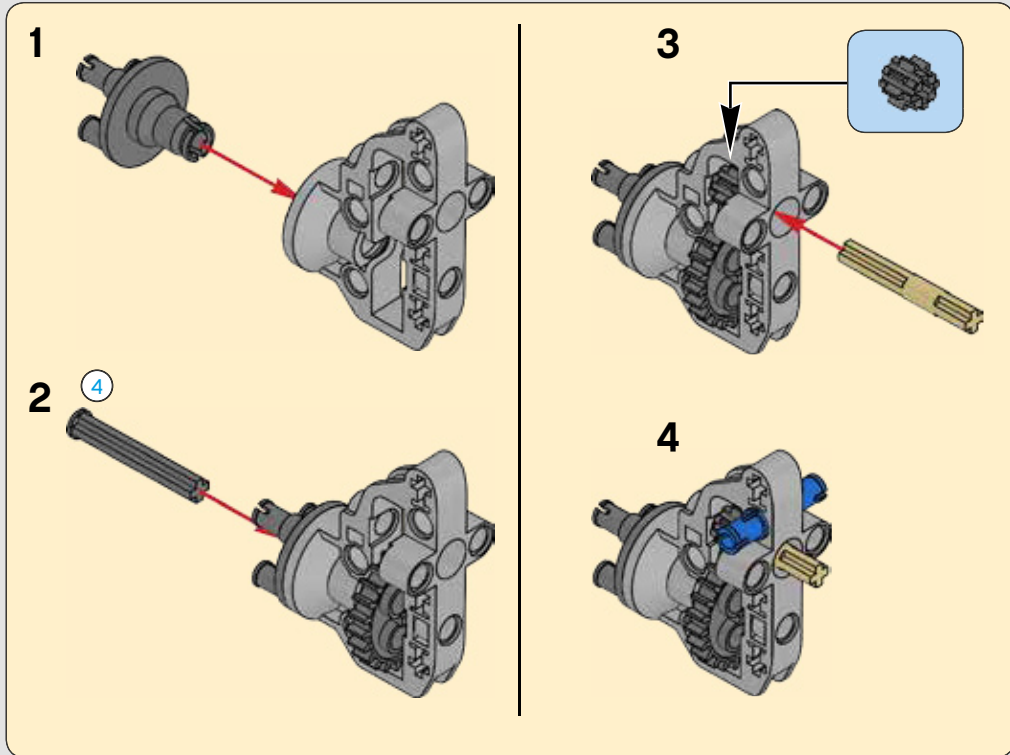

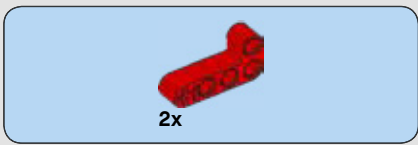

152

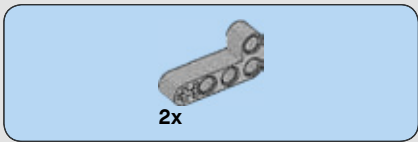
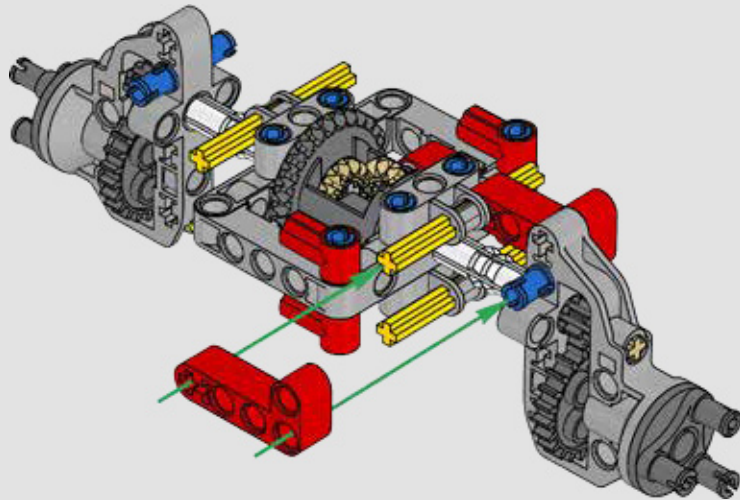

153

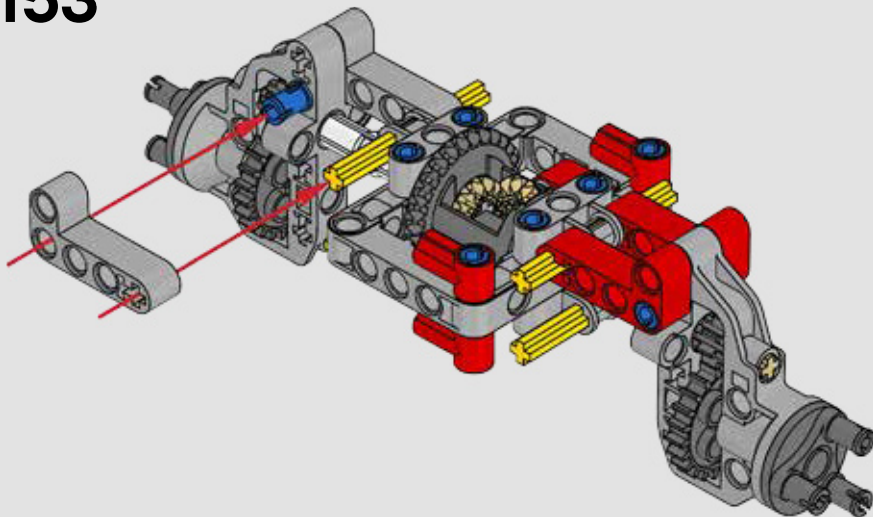

154

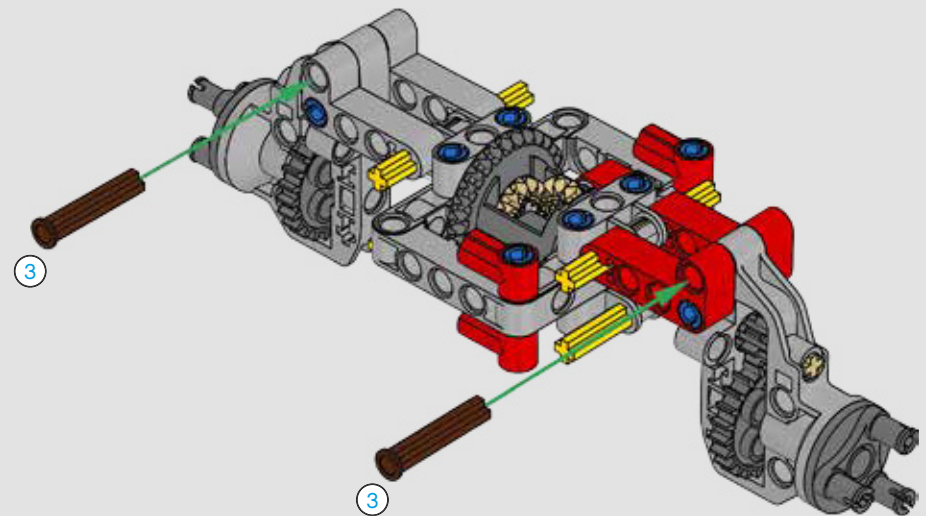
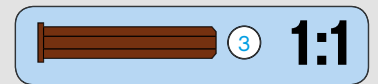

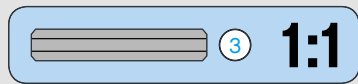
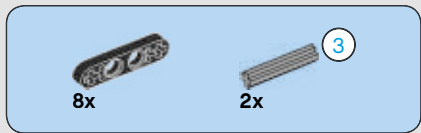

155

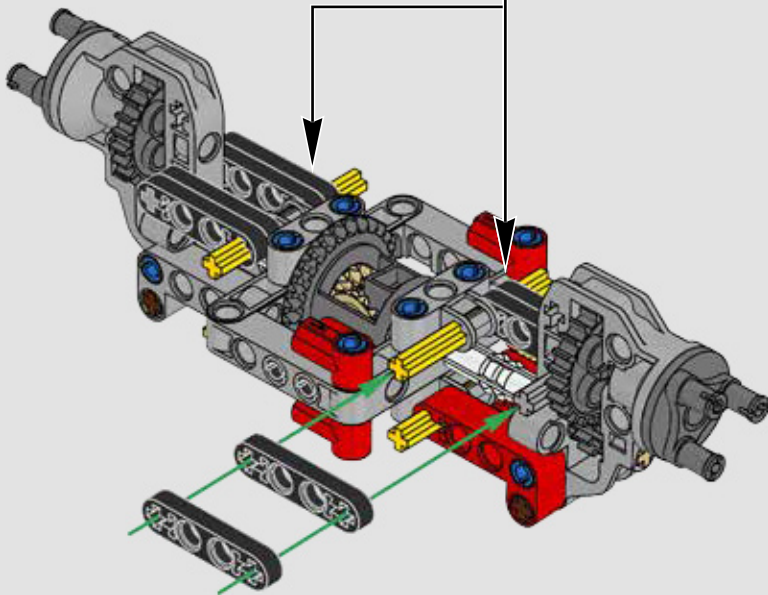
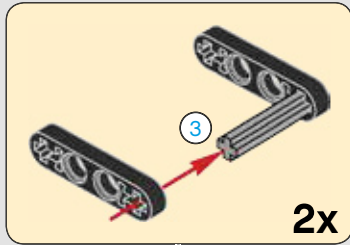

156

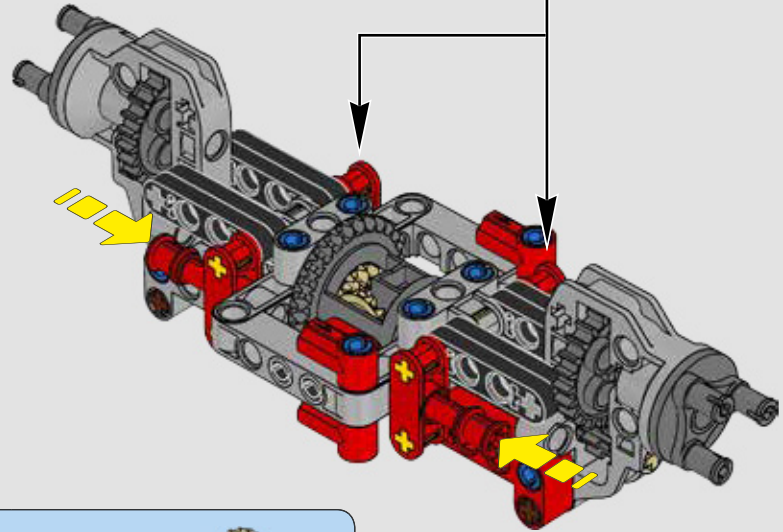

157

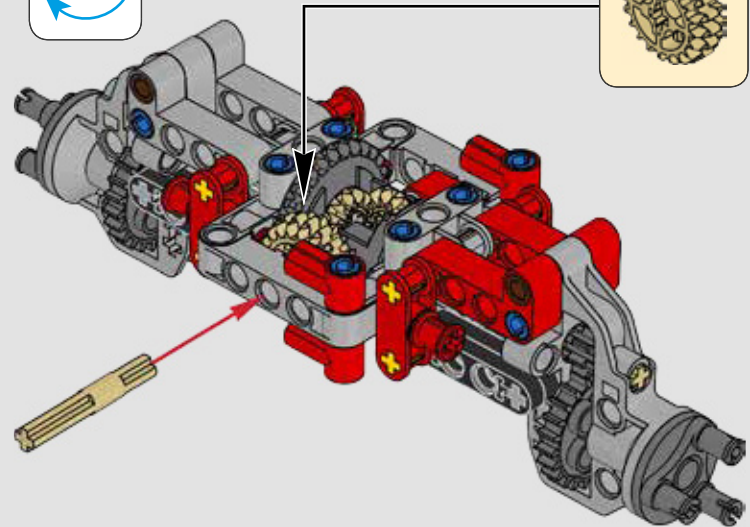



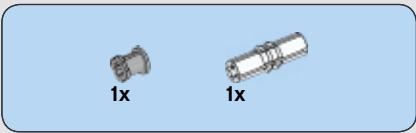

158

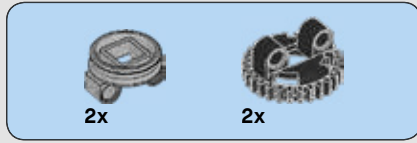
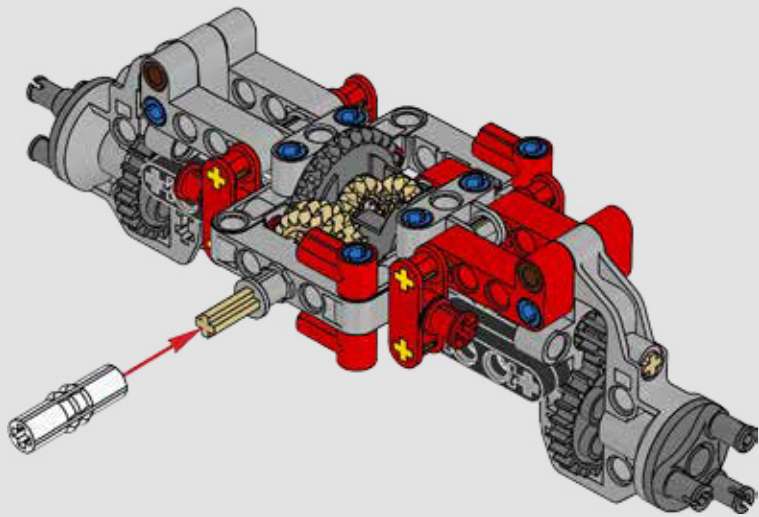

159

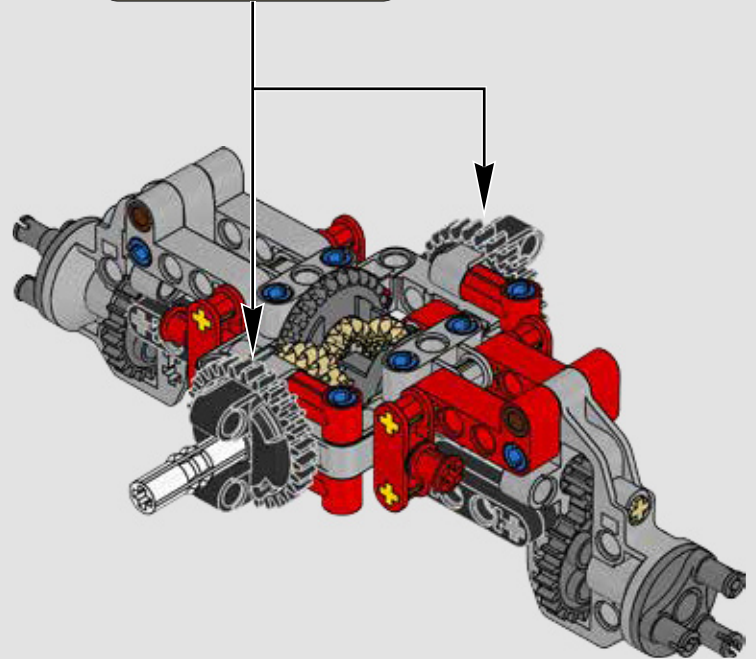
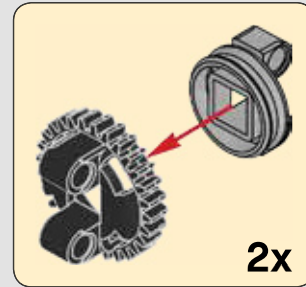

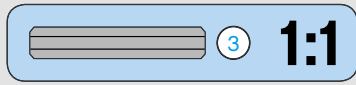
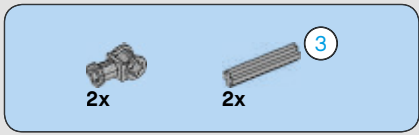

160

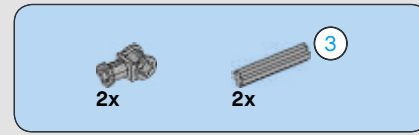
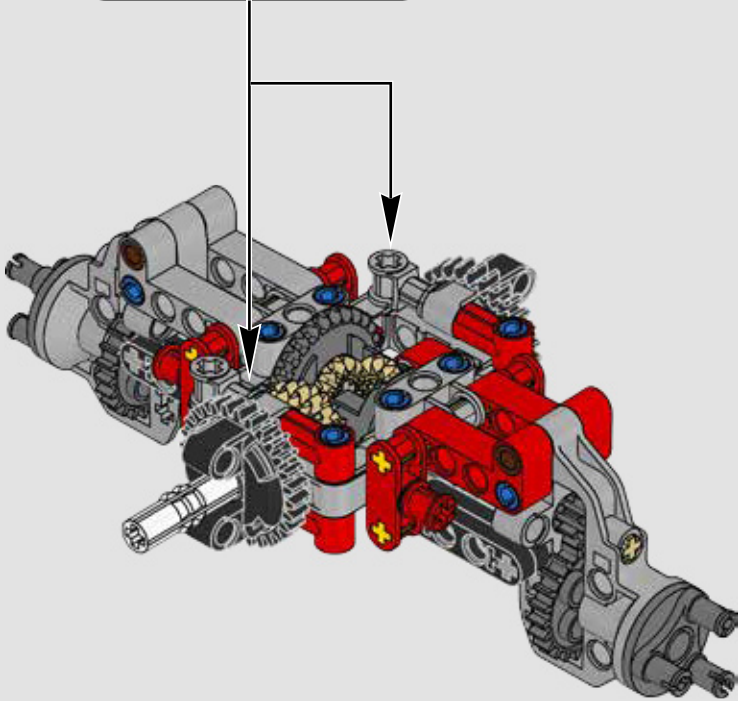
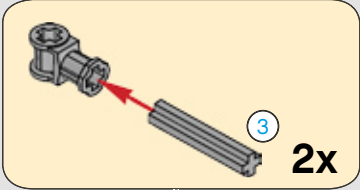

161

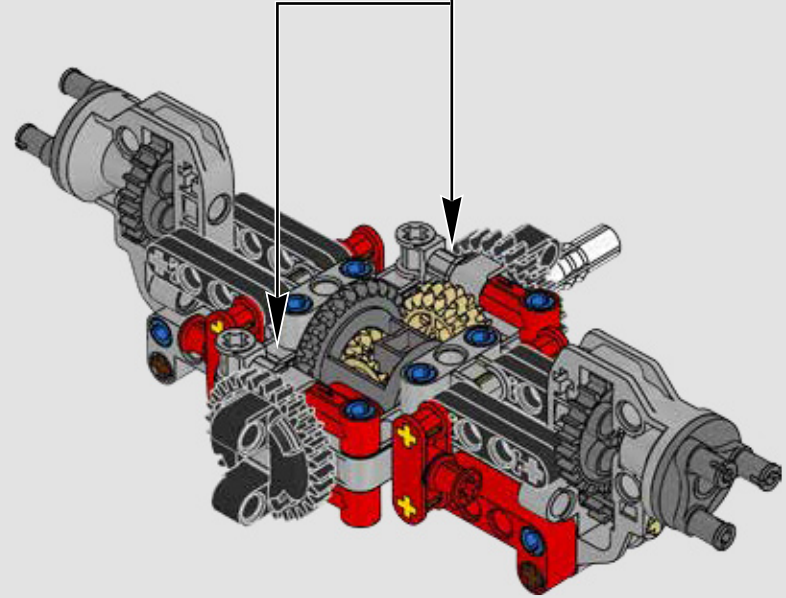
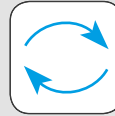
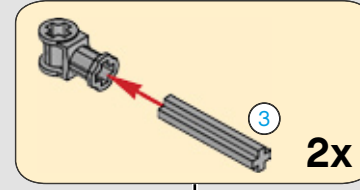

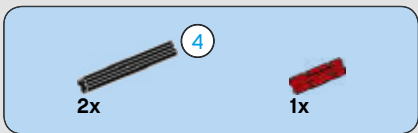

162

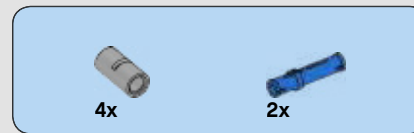
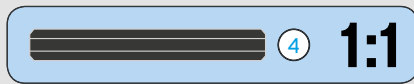
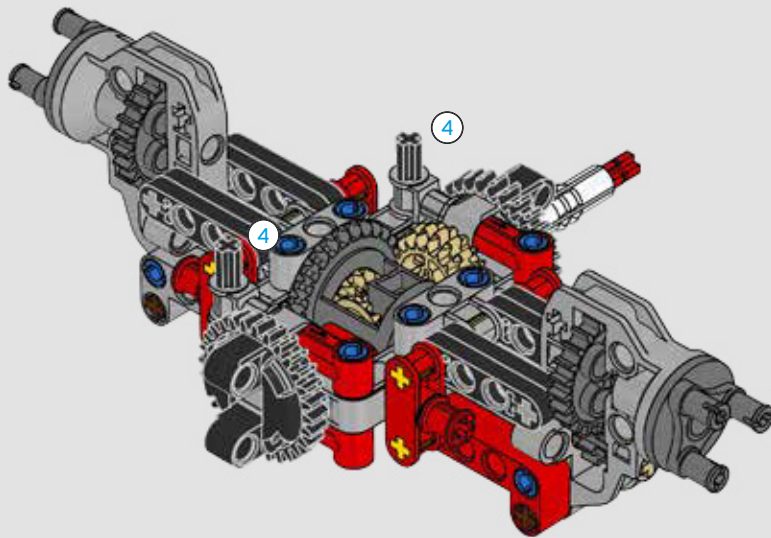

163

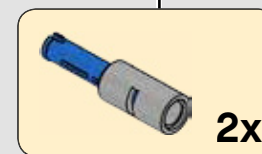
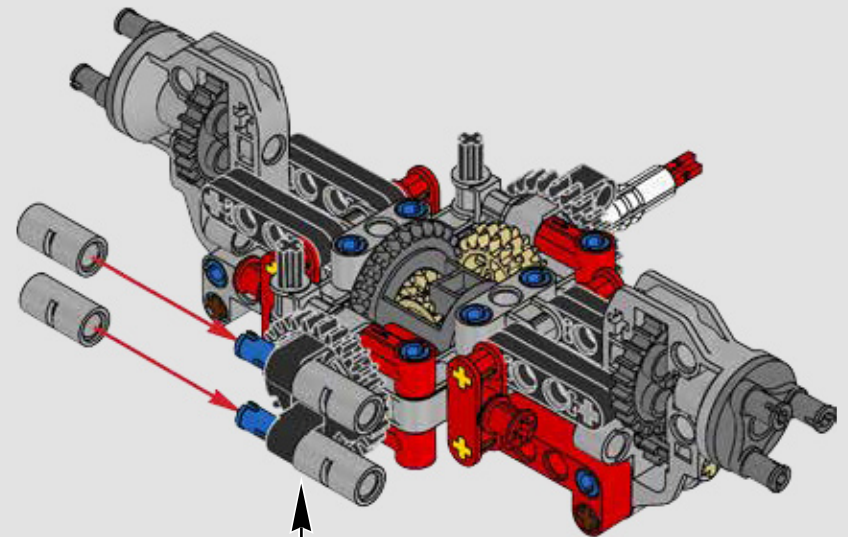

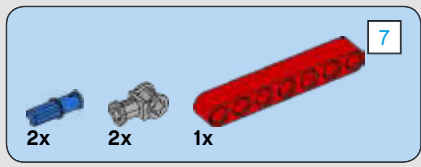

164

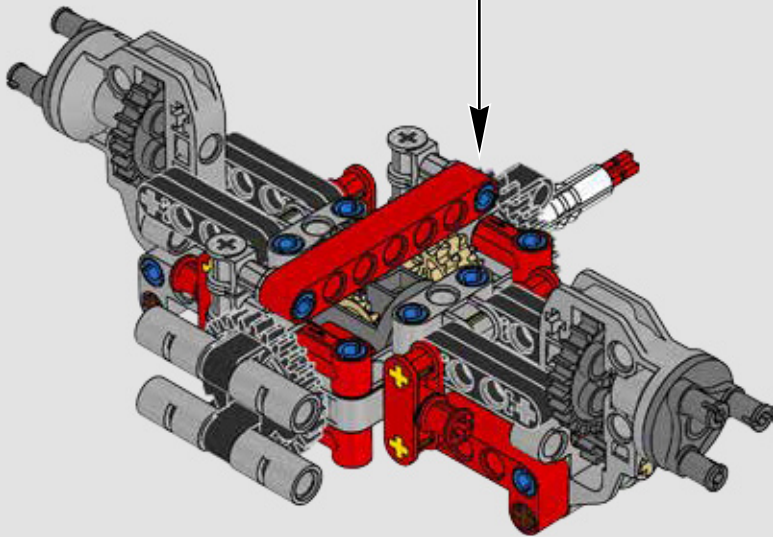
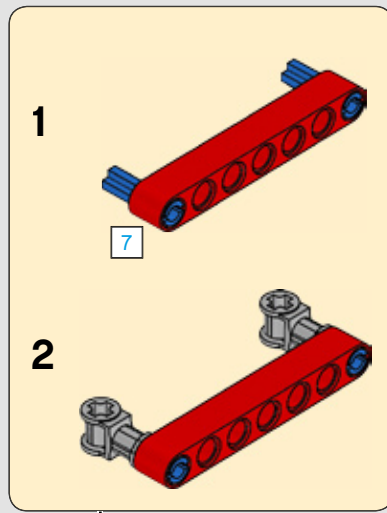

165

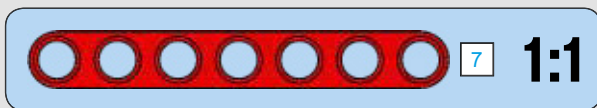
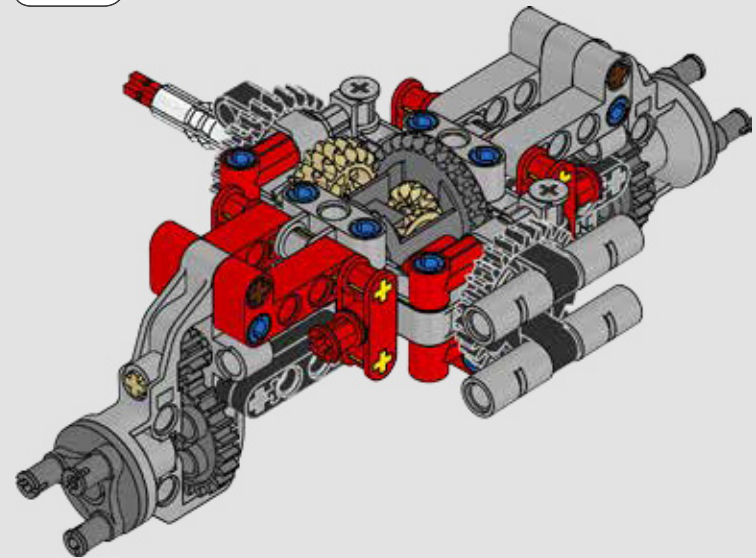
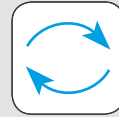



166

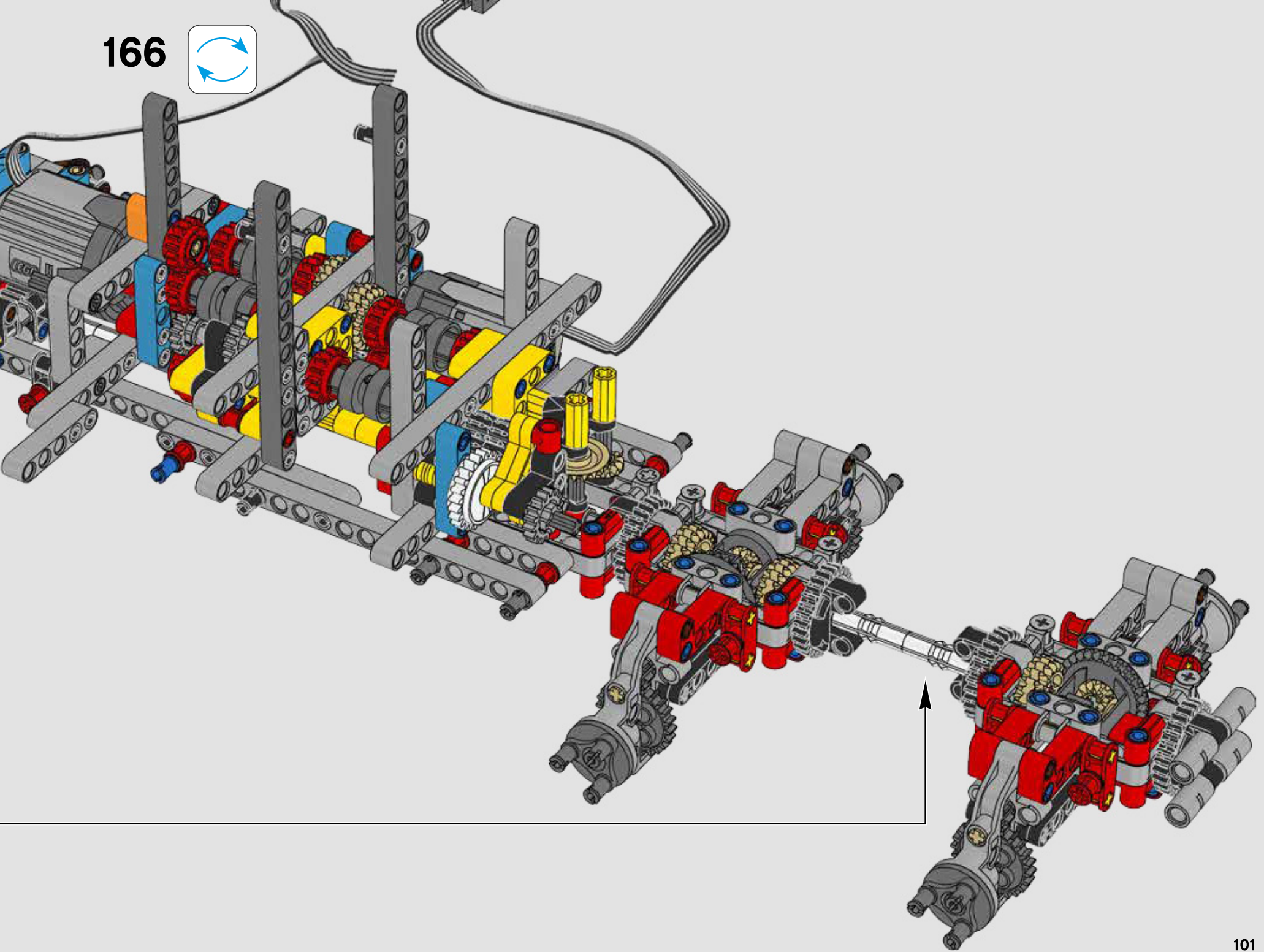

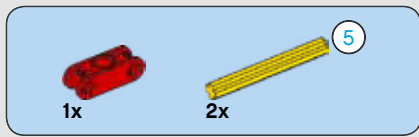

167

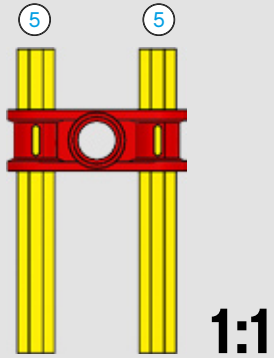

168

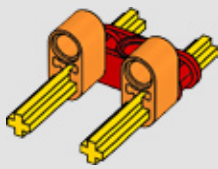

169

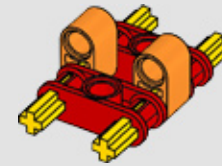

170

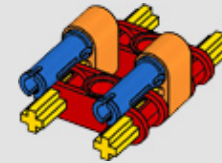

171

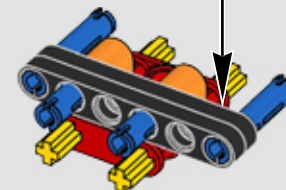
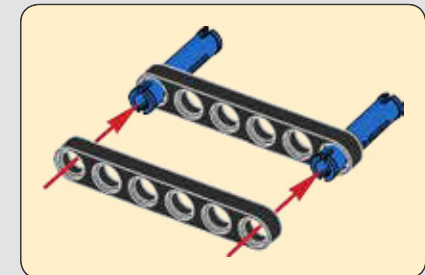

172

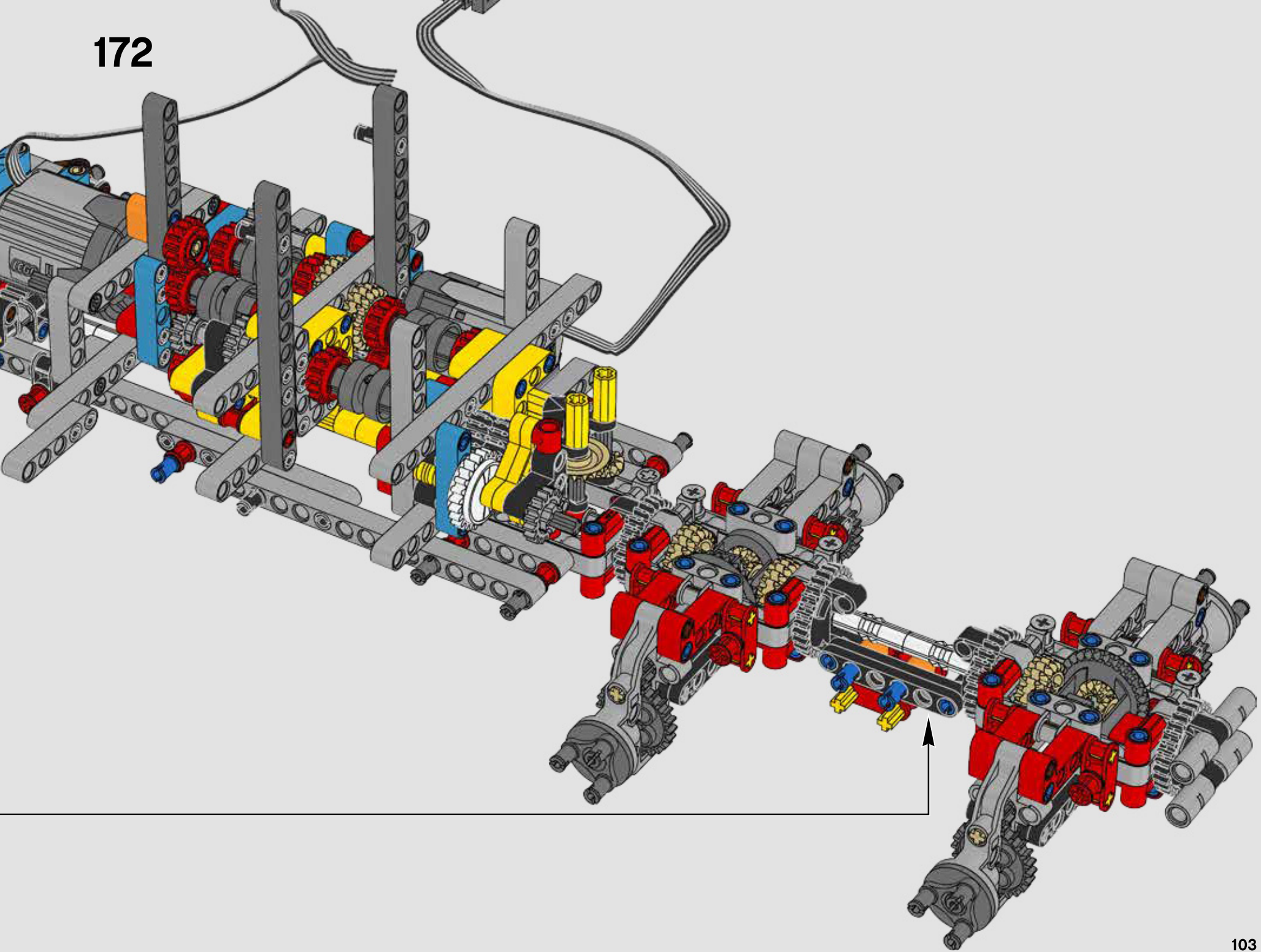





173

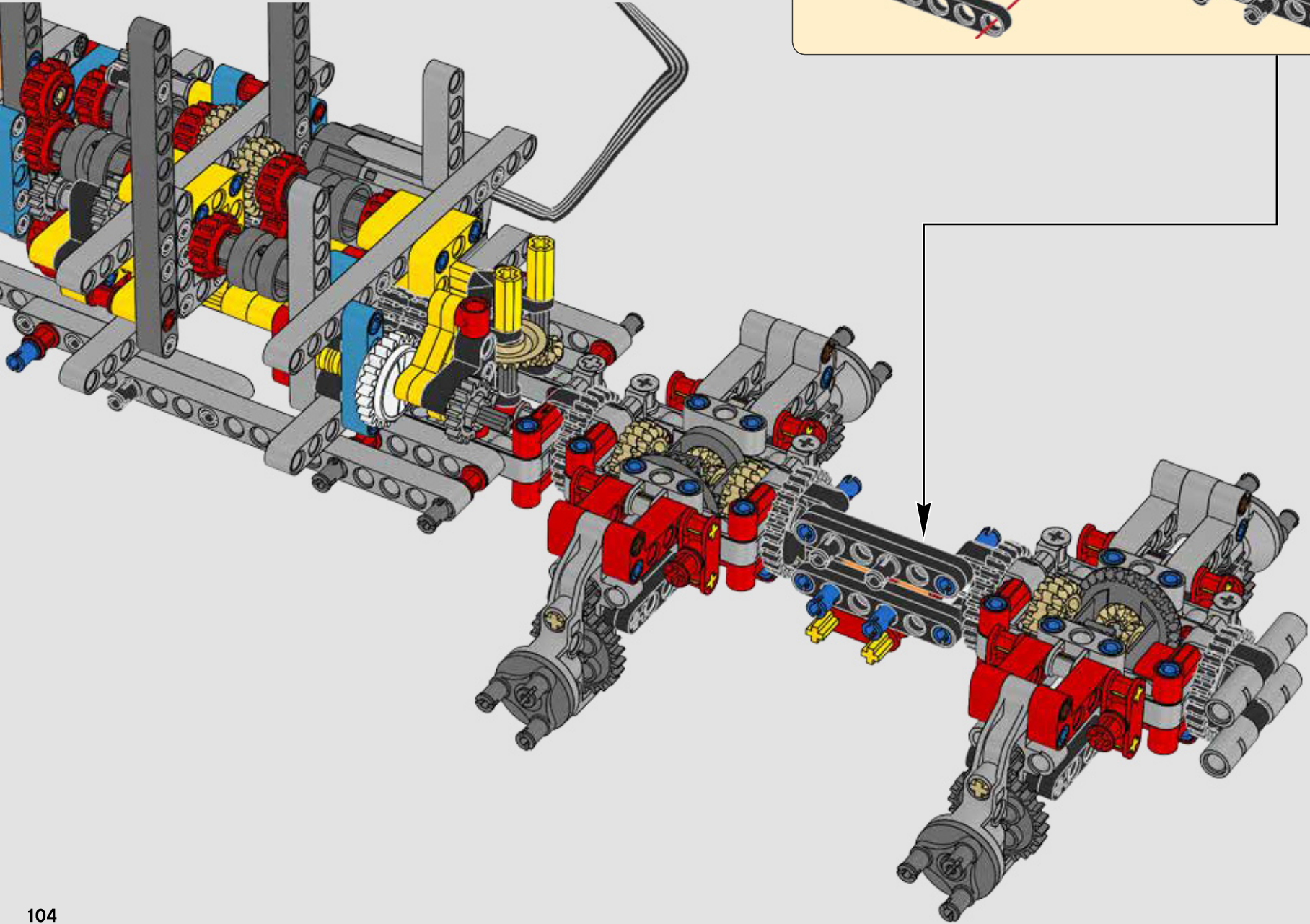
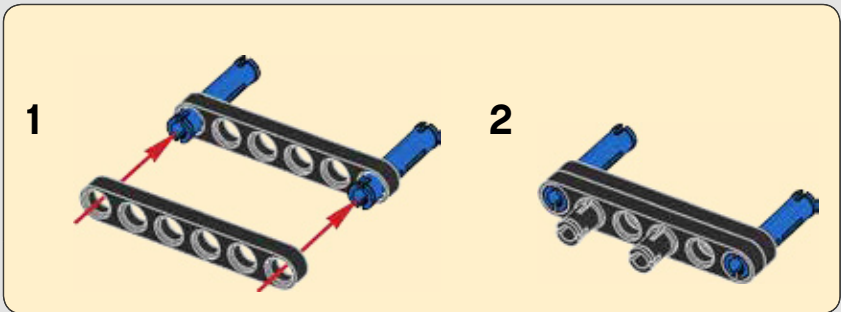





174

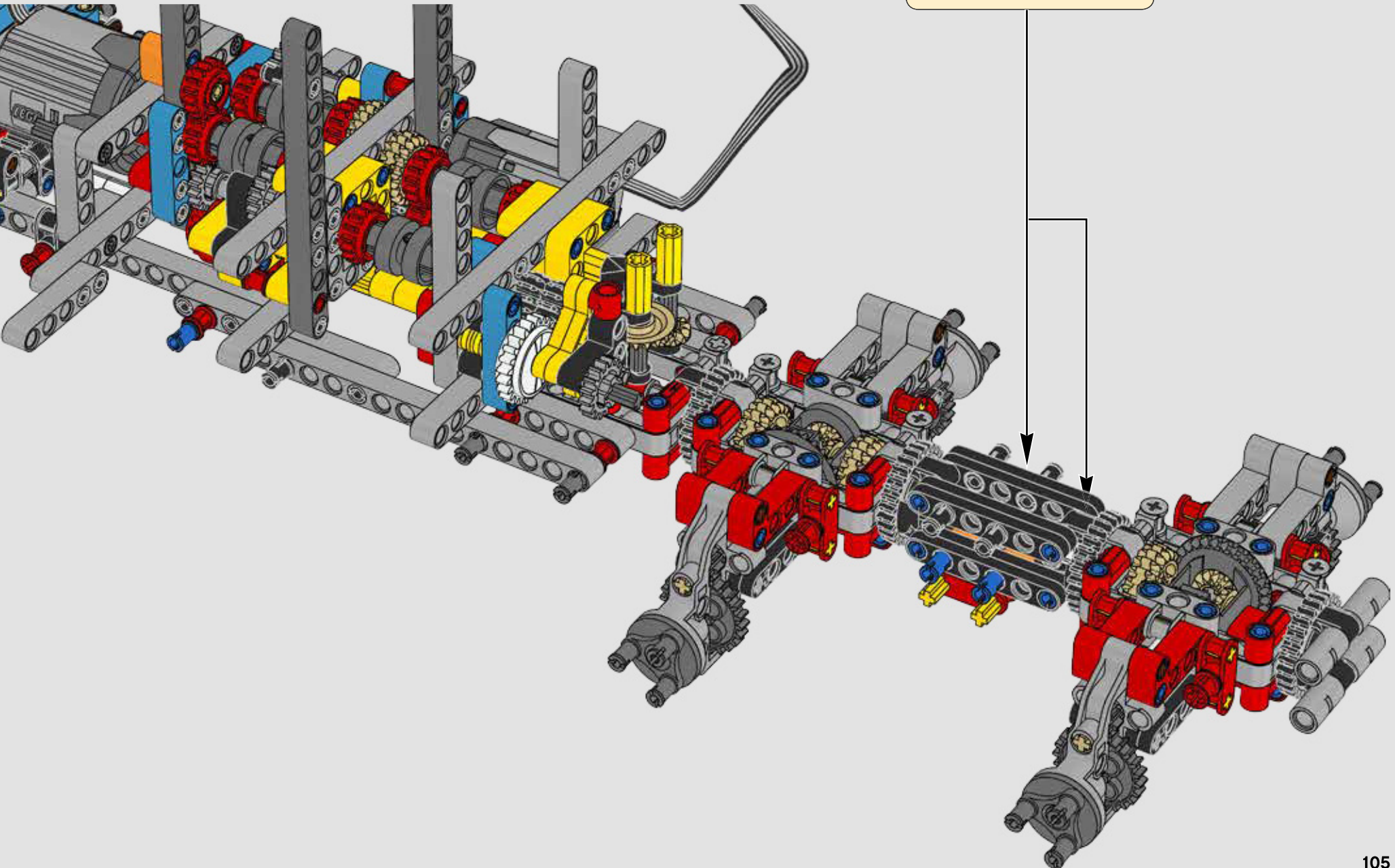
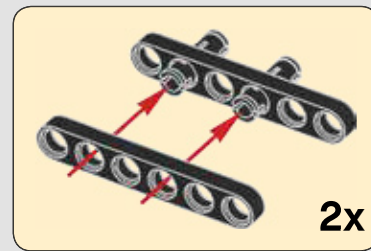

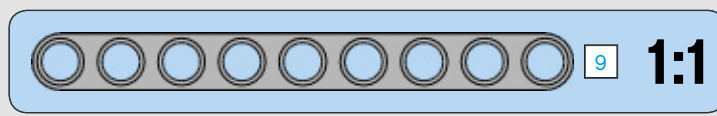
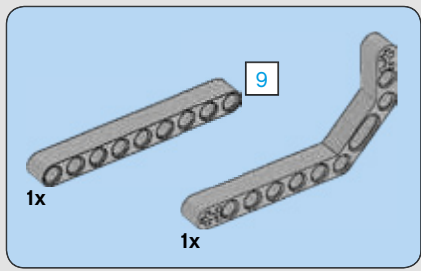

175

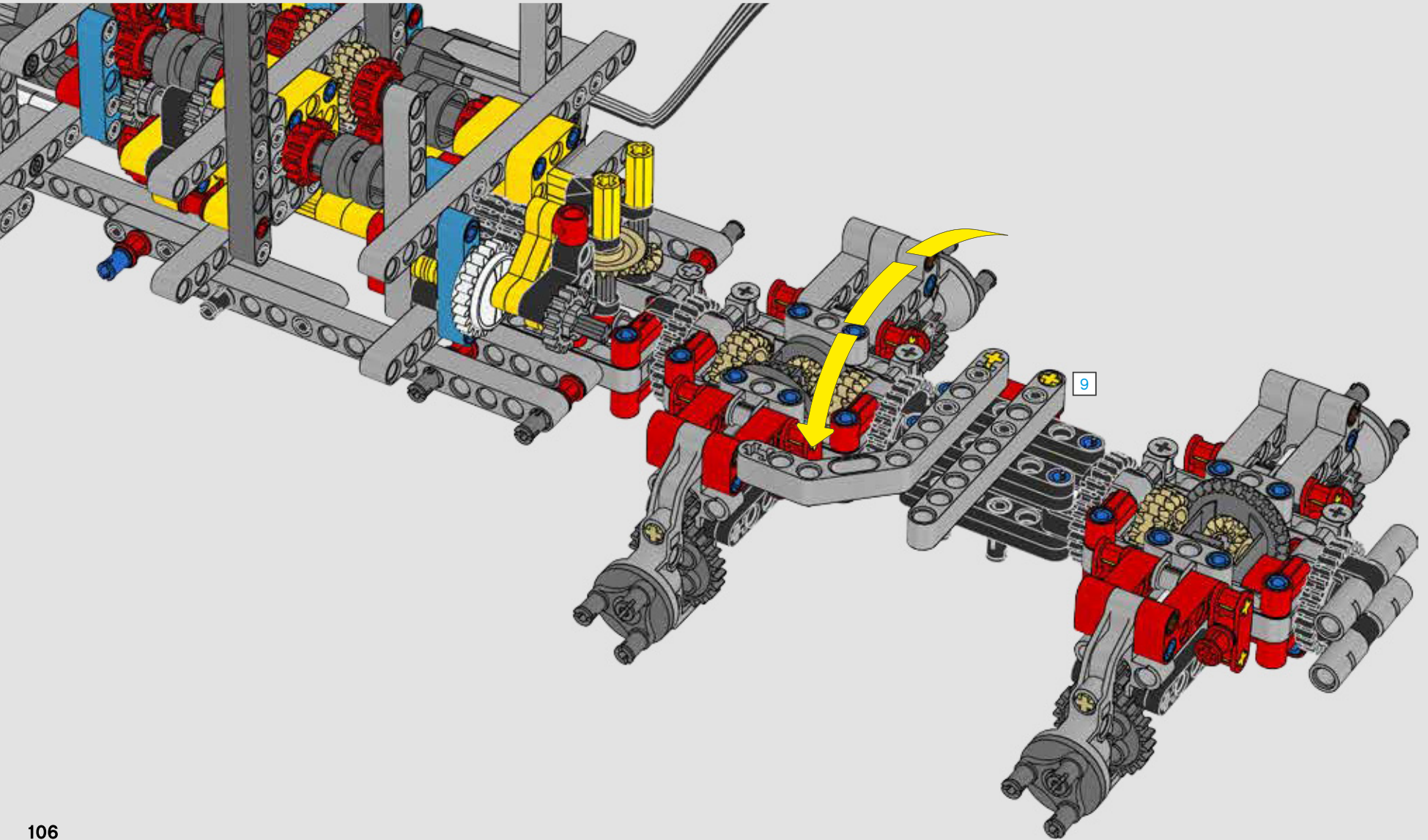



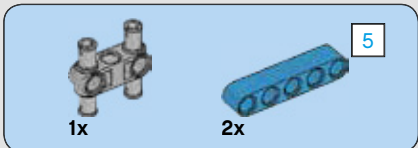
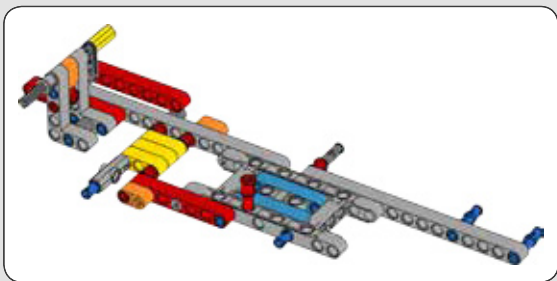

176

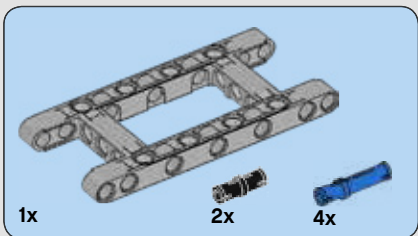
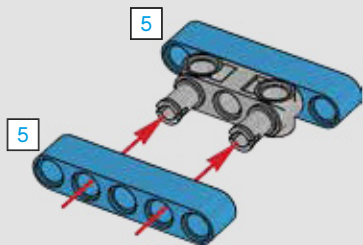

177

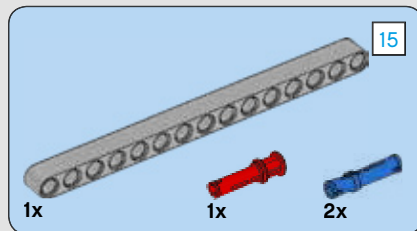
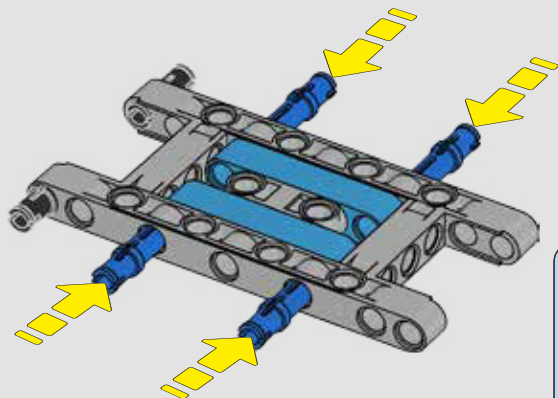

178

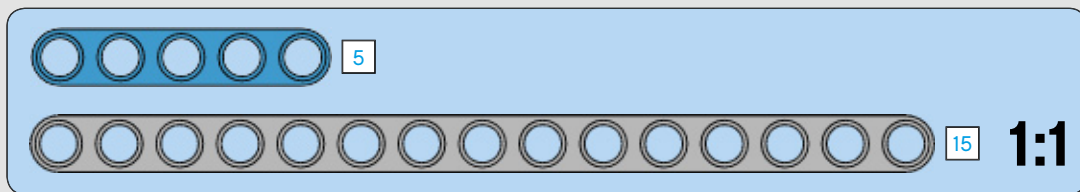
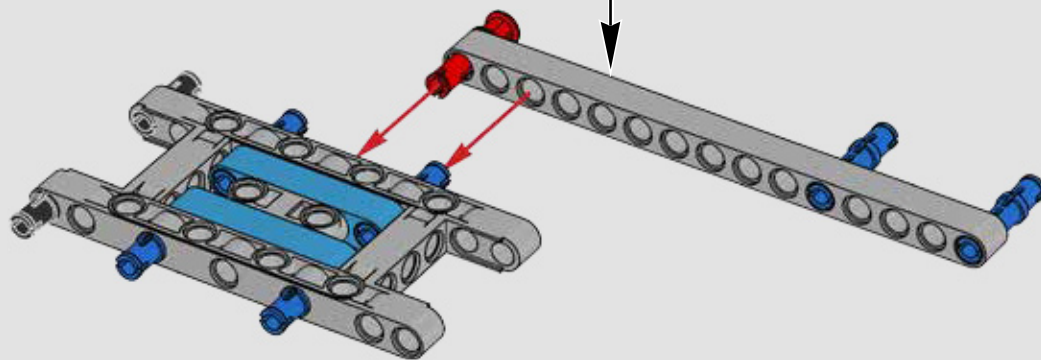
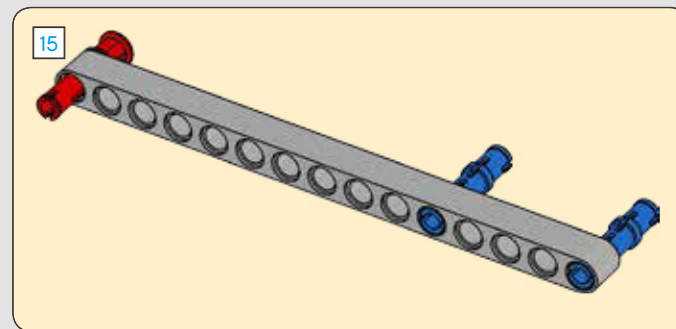

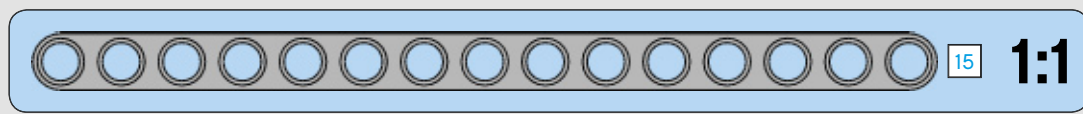
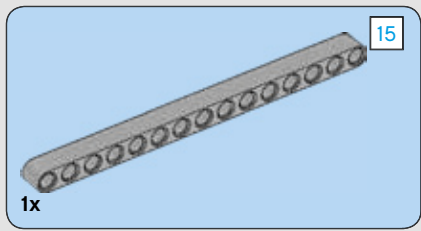

179

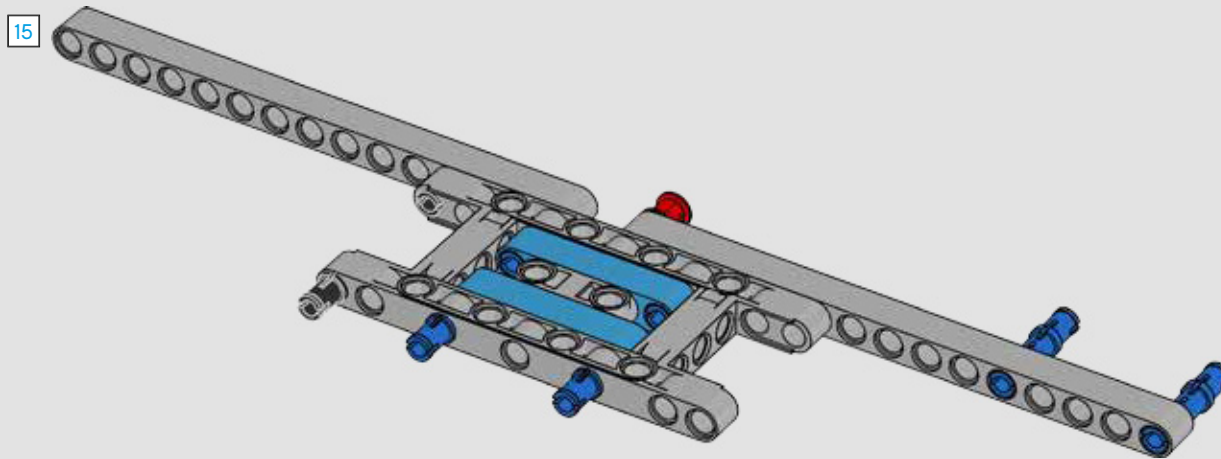



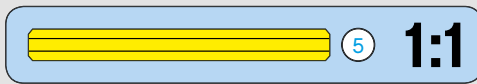
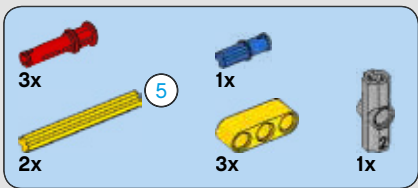

180

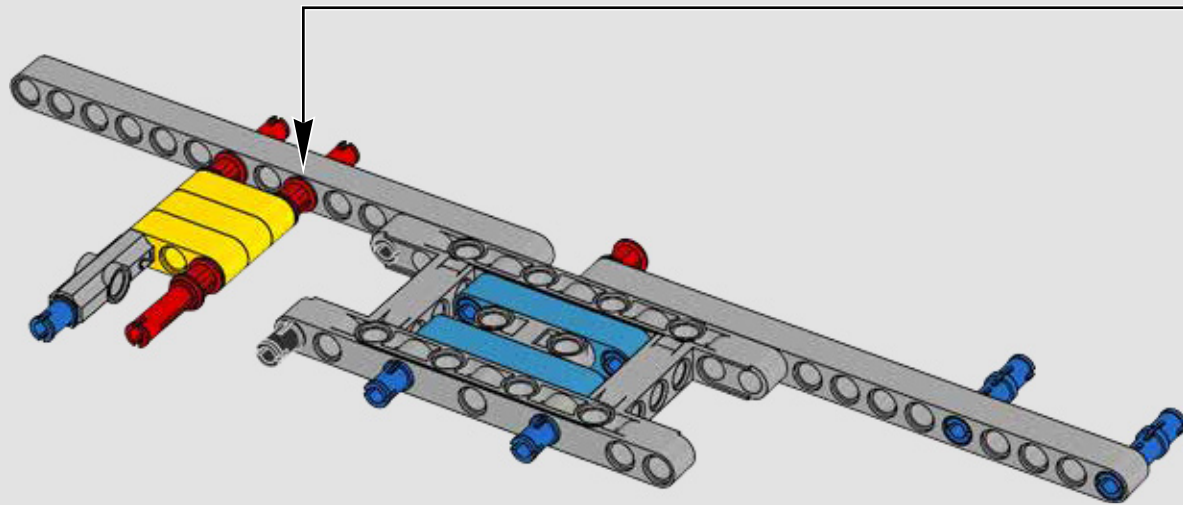
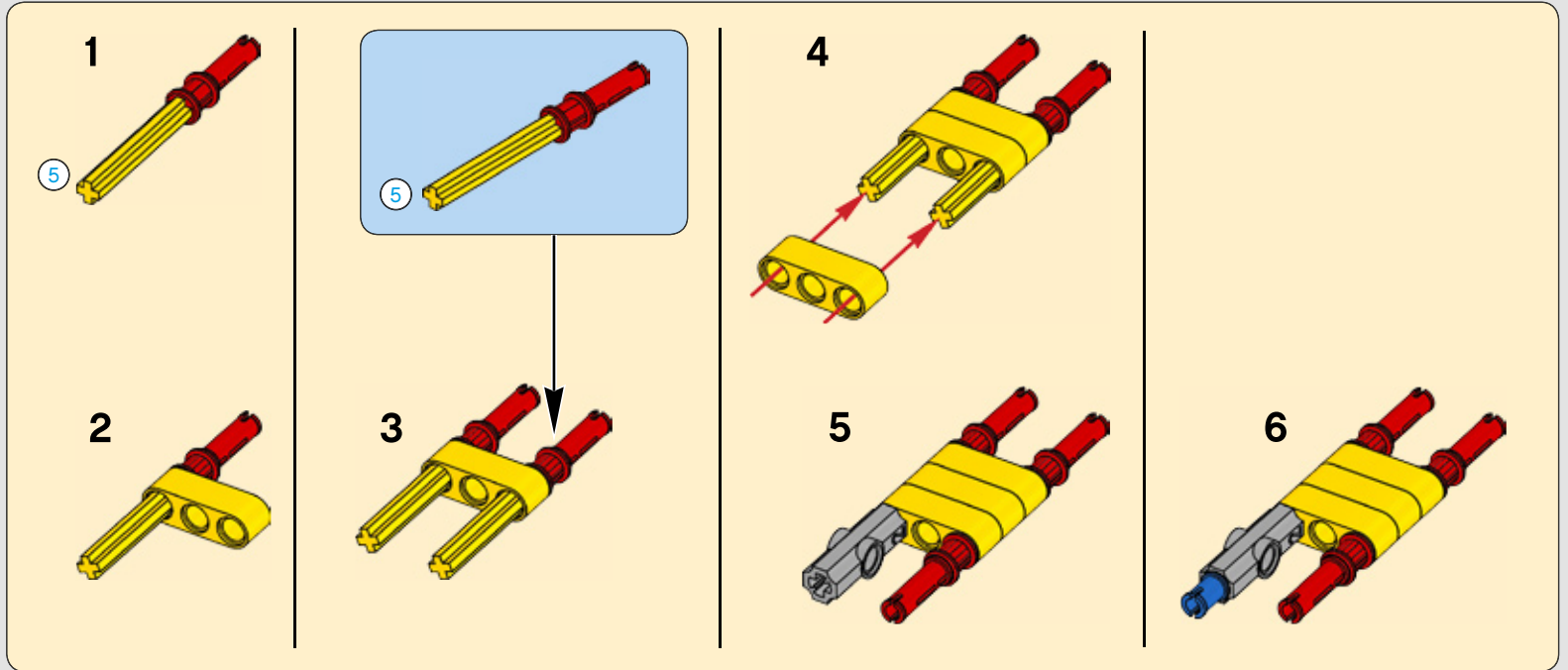

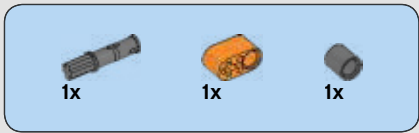

181

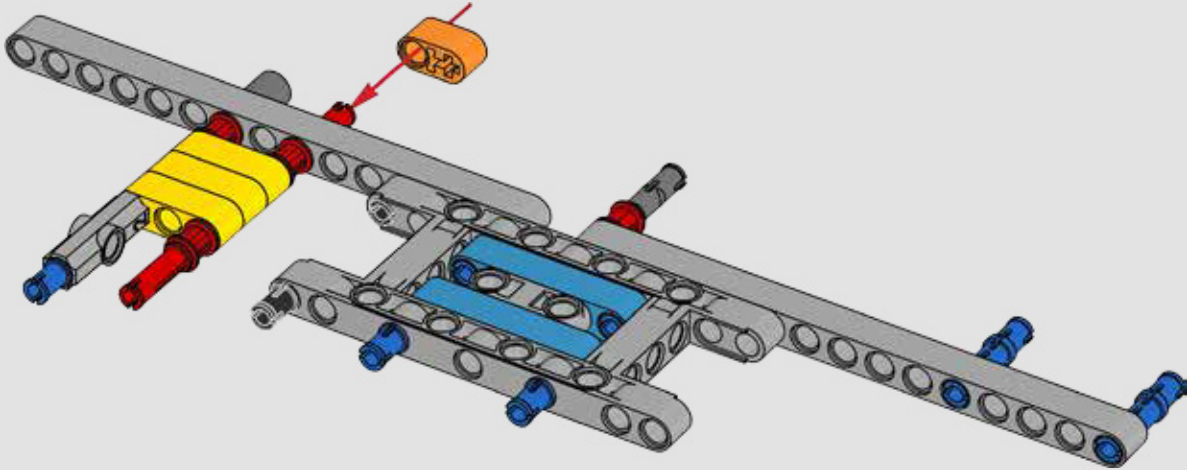

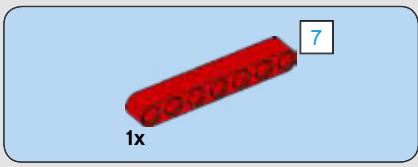

182

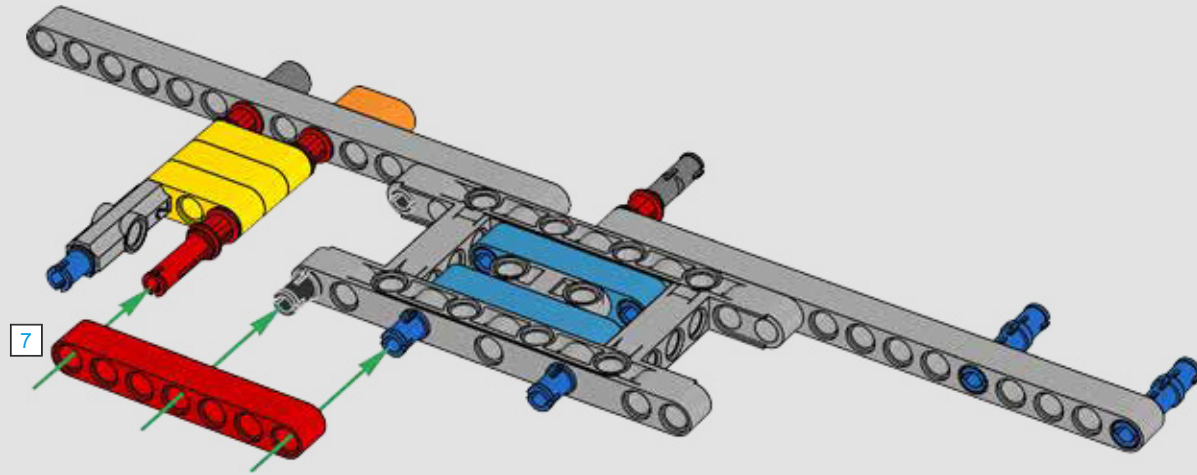
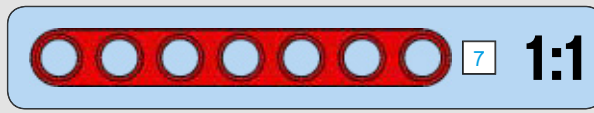

183

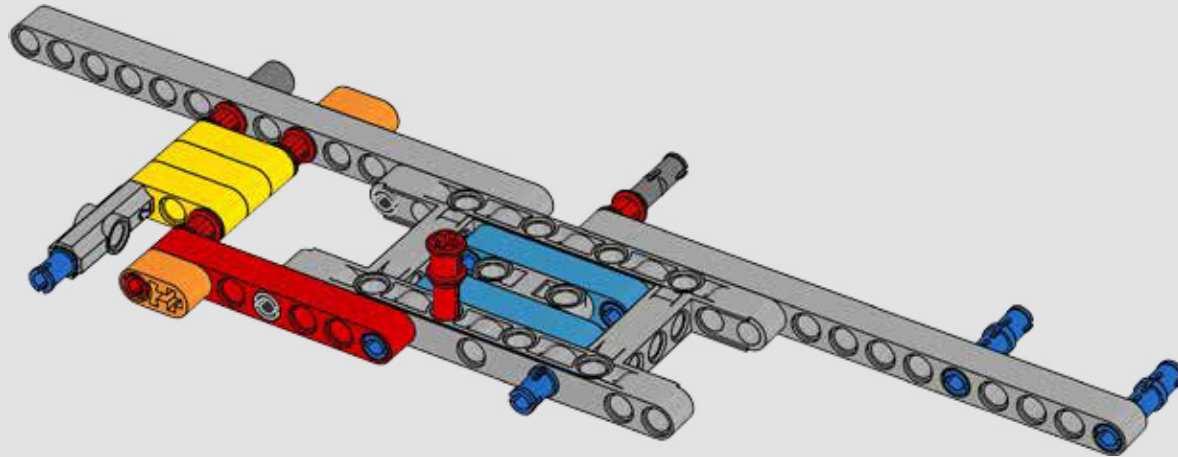

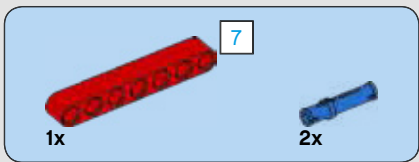
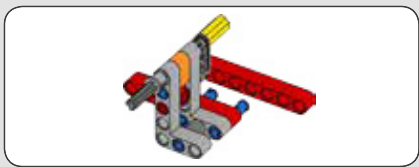

184

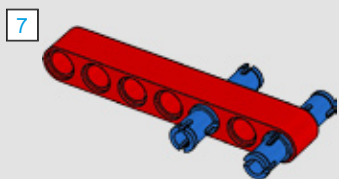

185

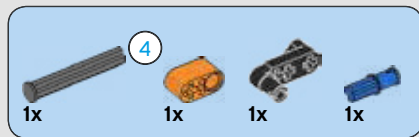
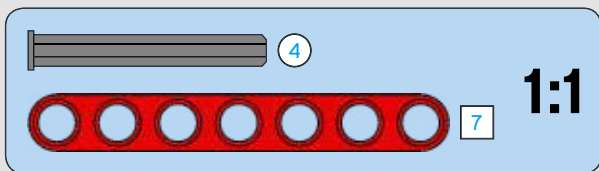
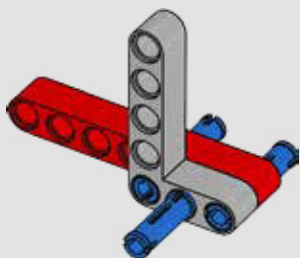

186

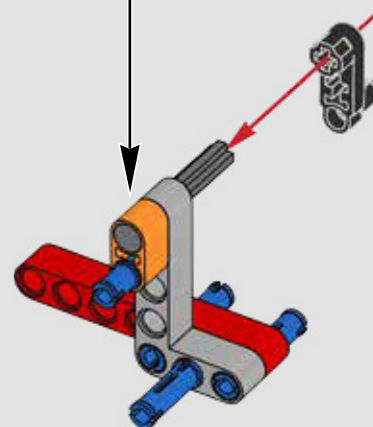
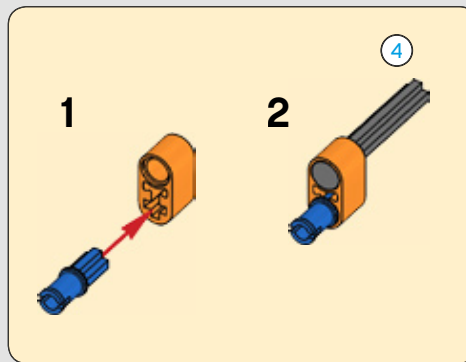





187

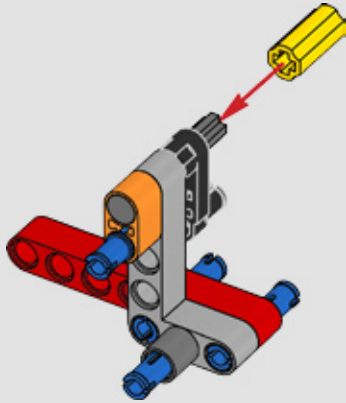

188

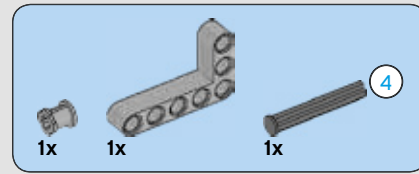
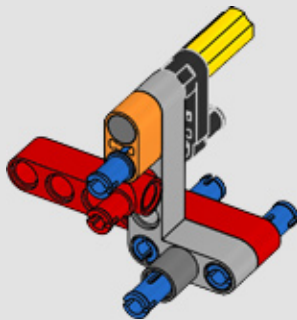

189

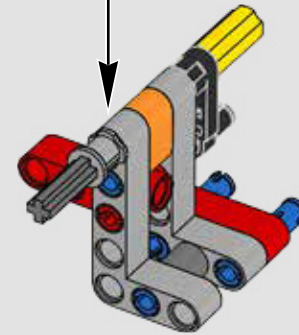
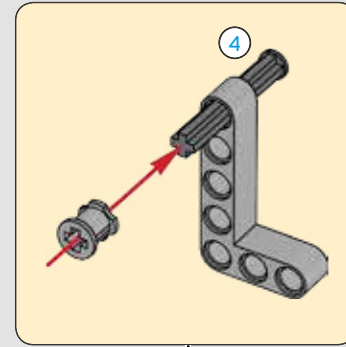
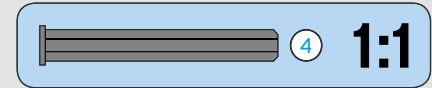

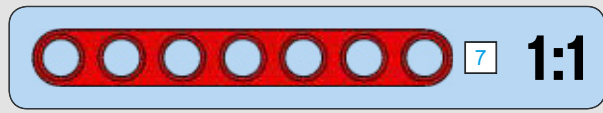
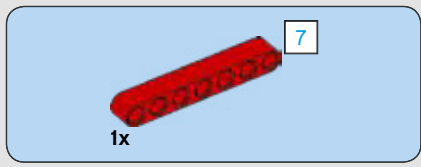

190

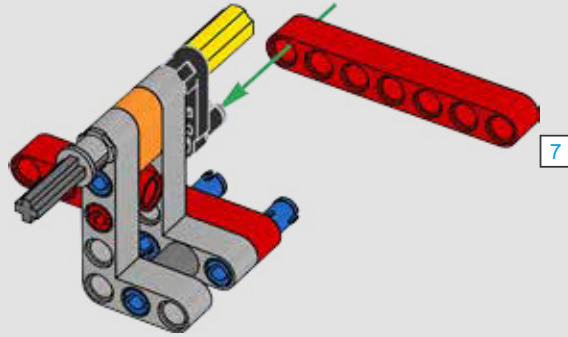

191

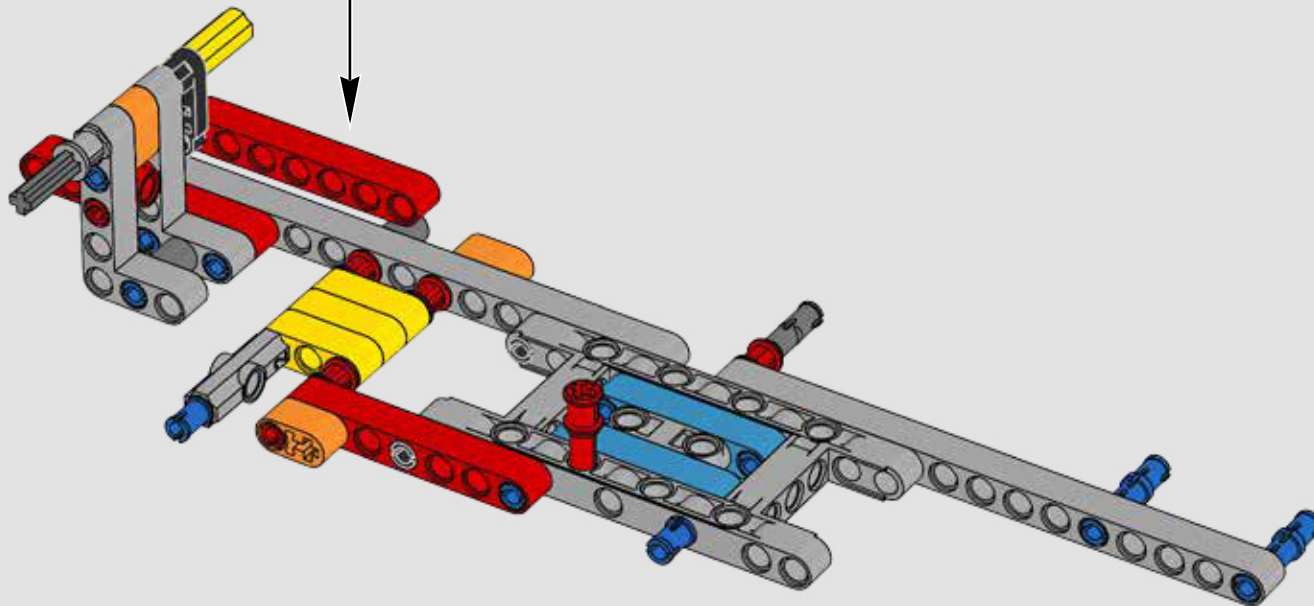

192

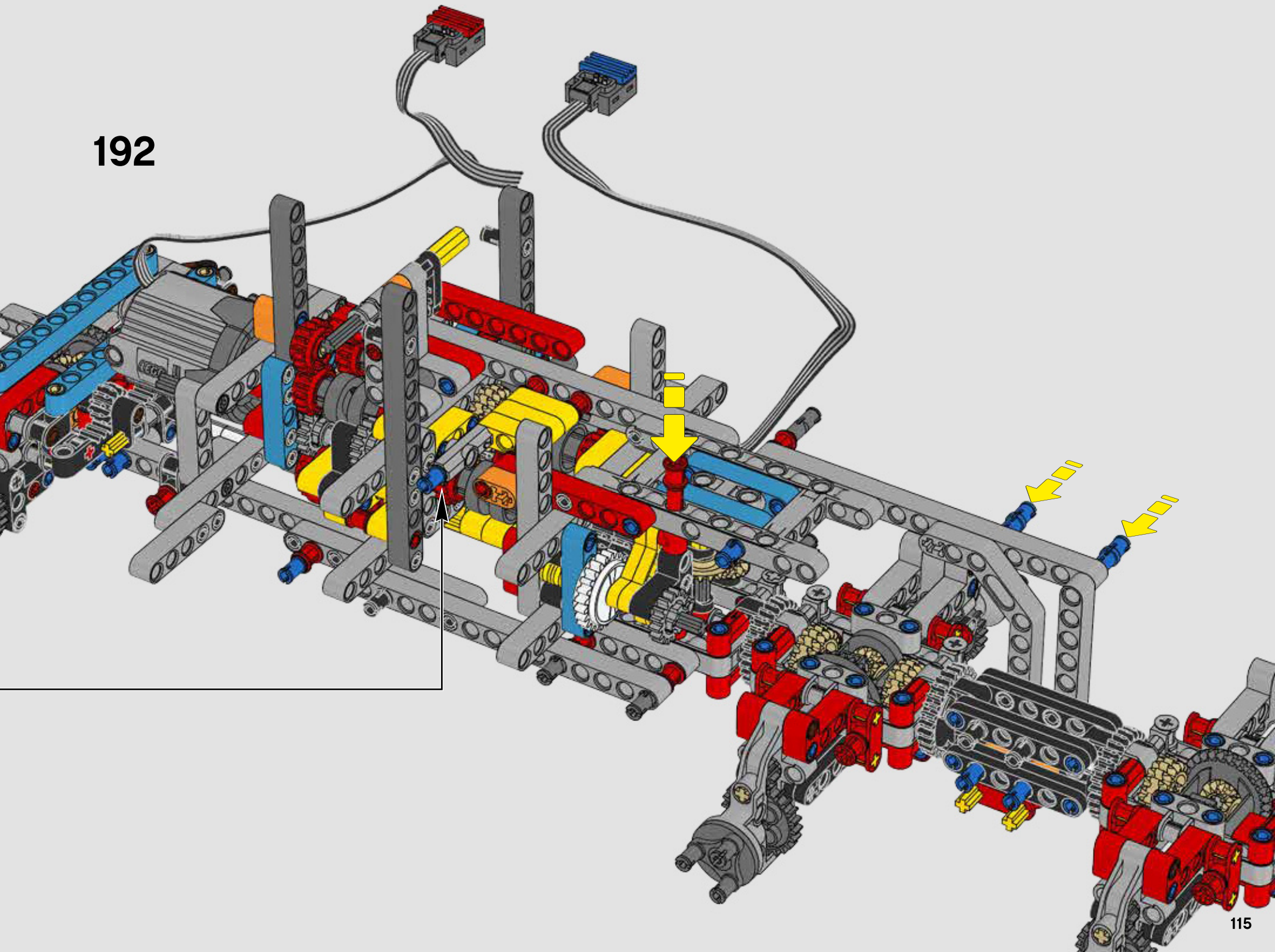



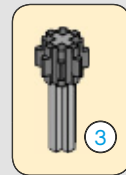
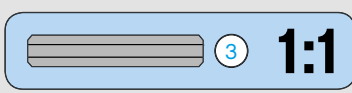
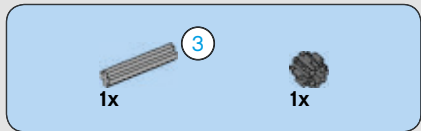

193

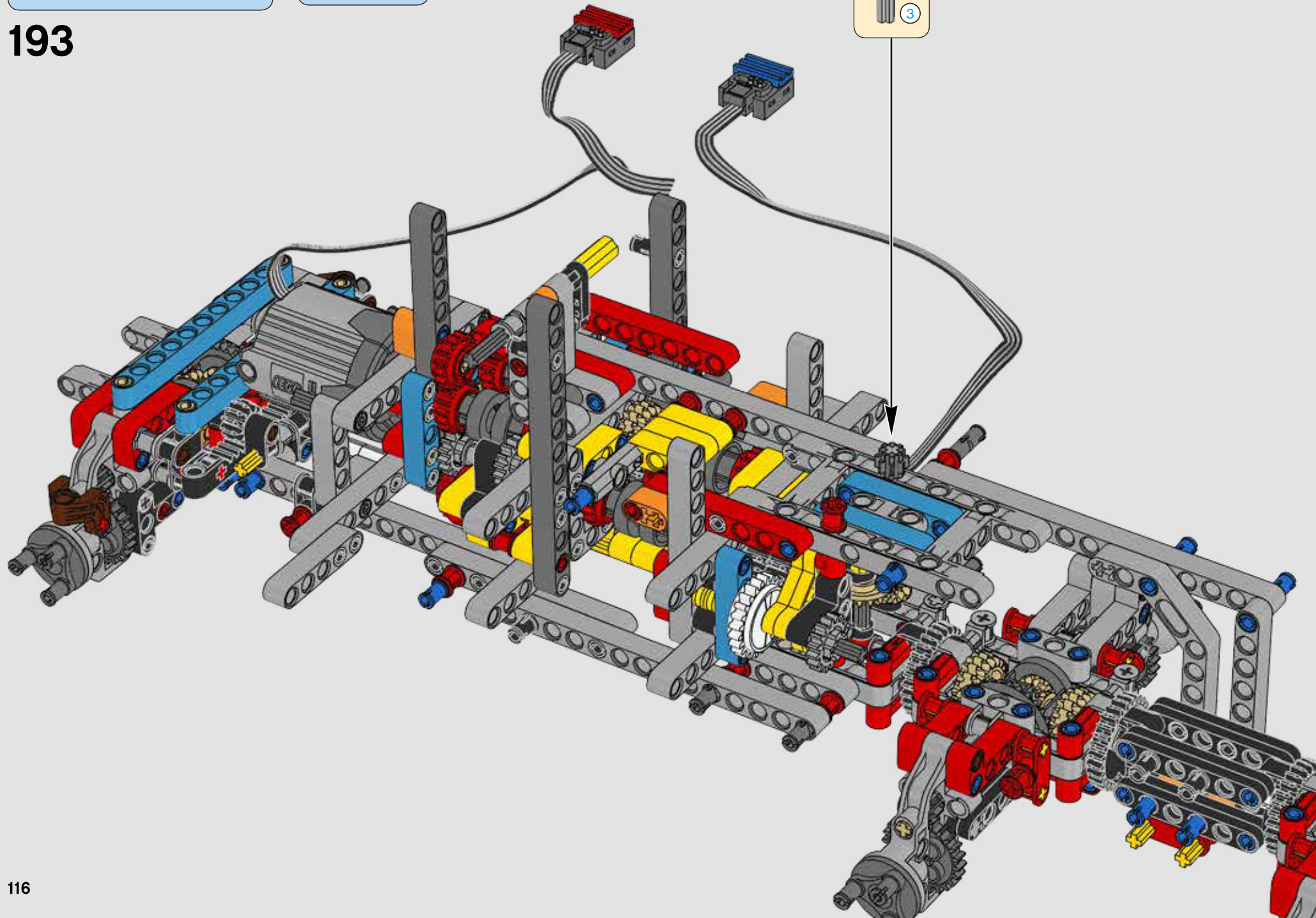



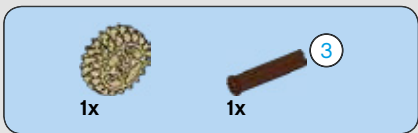

194

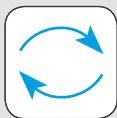

3

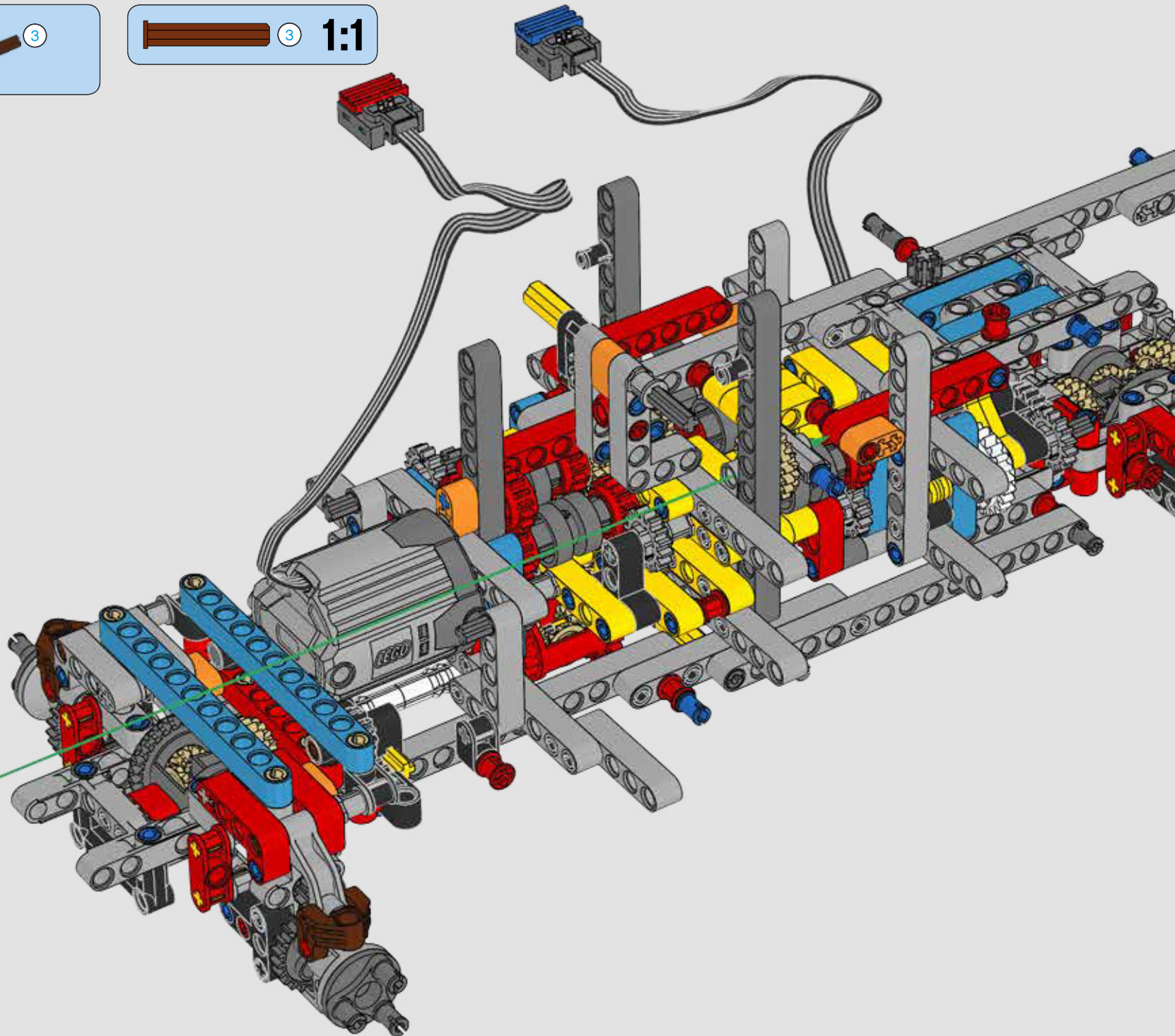

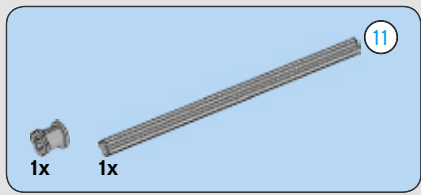

195

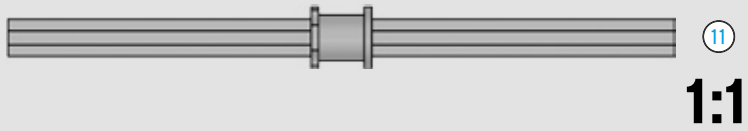

196

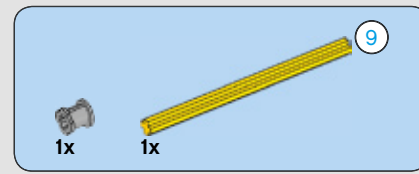
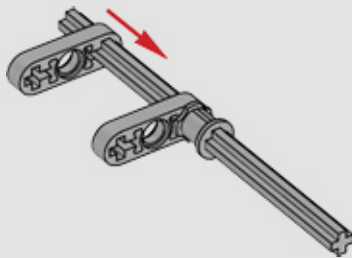

197

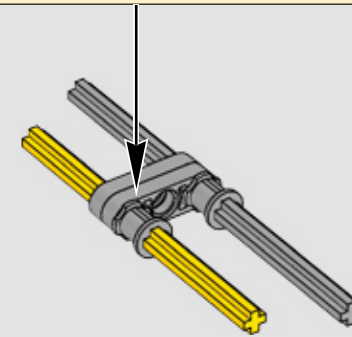
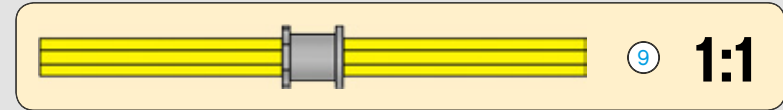

198

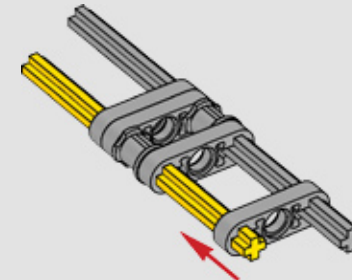



199

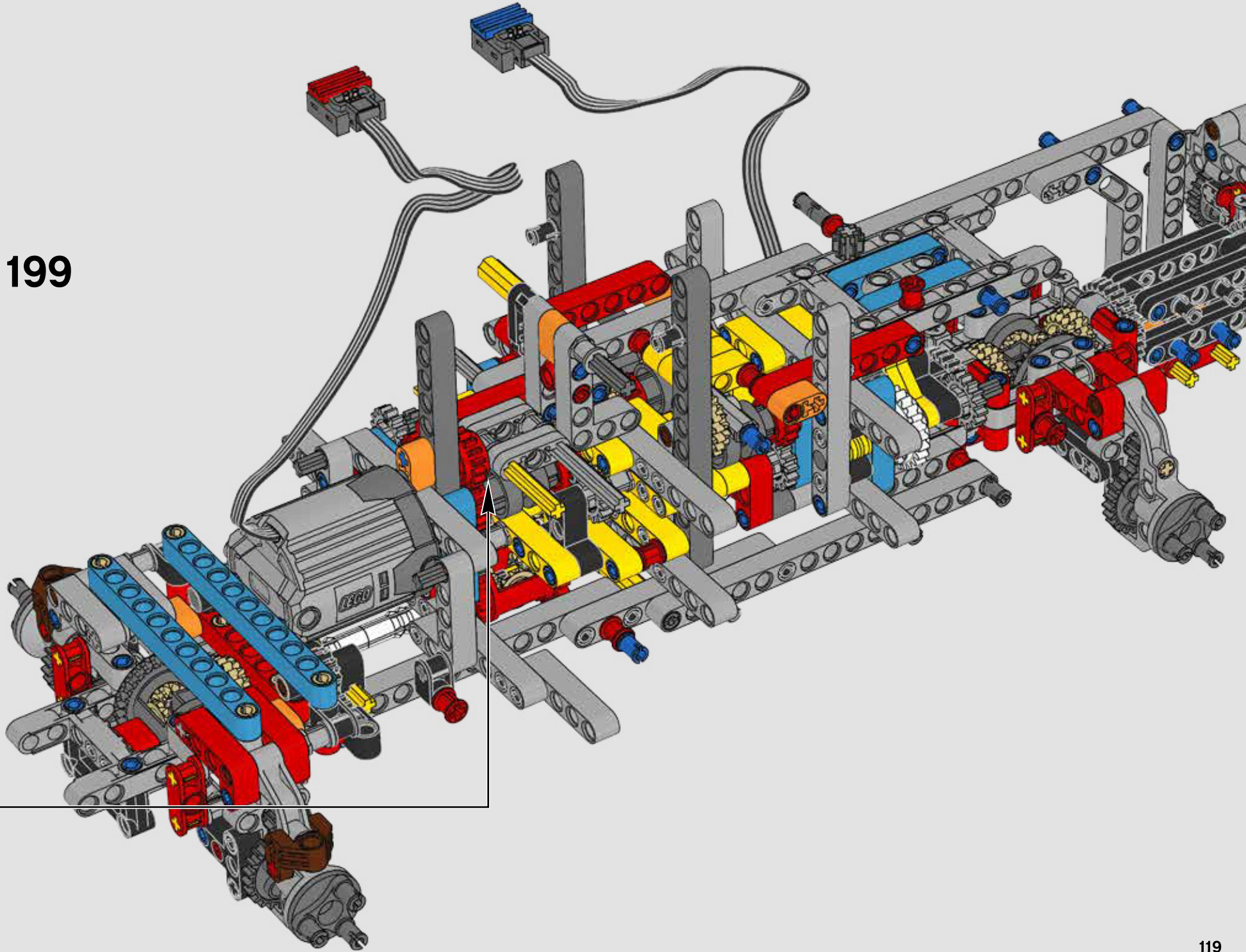



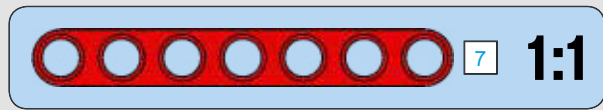
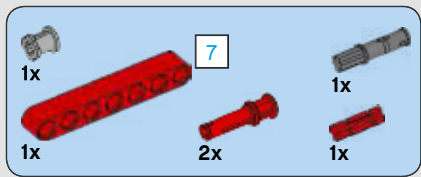

200

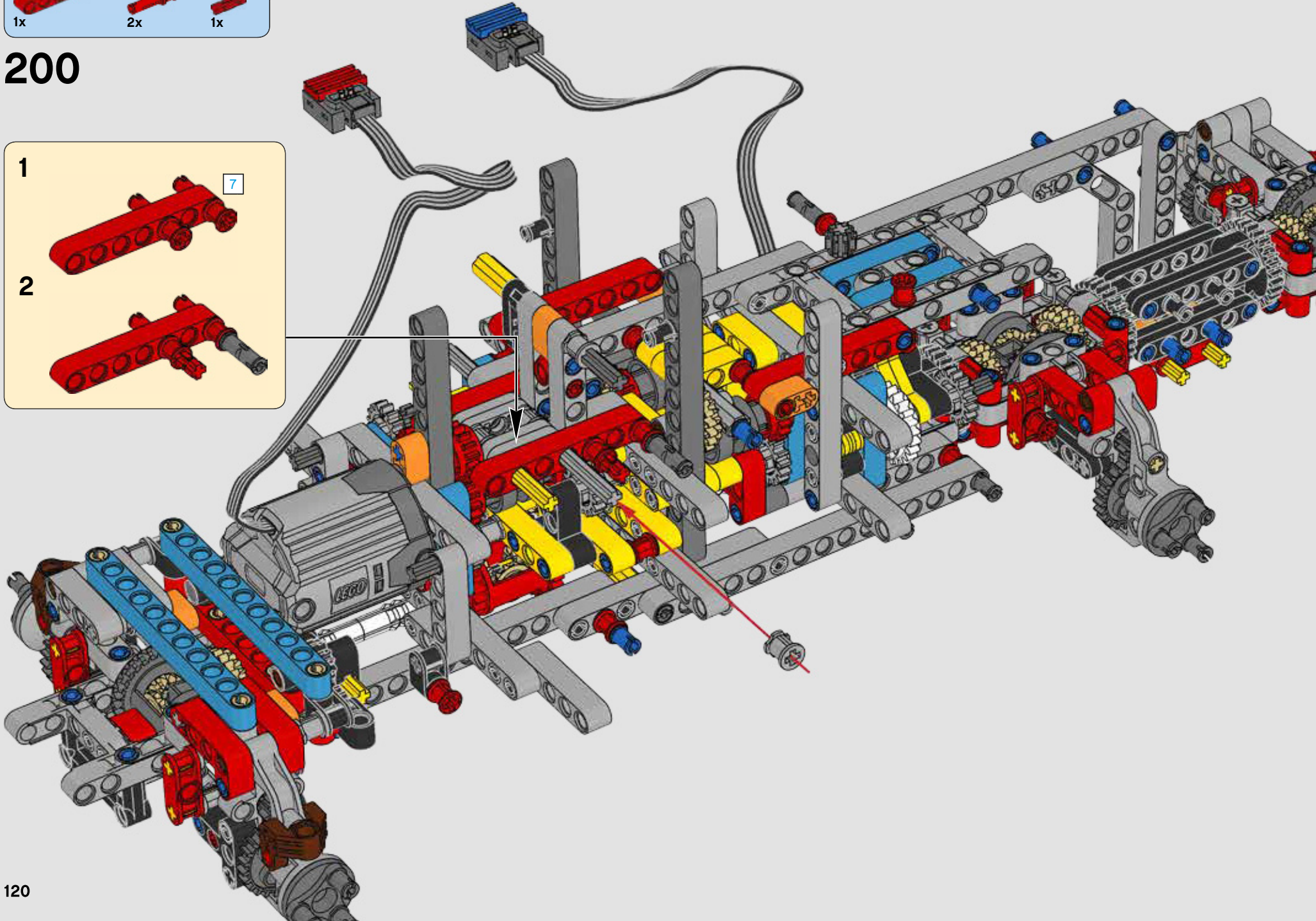
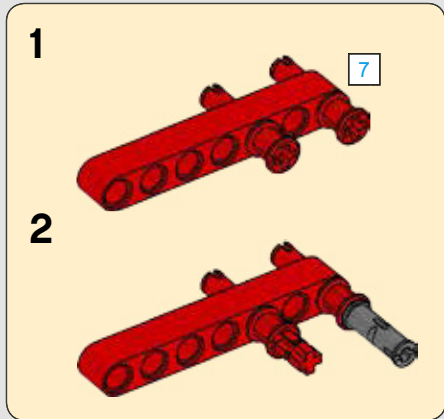



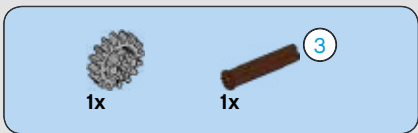

201

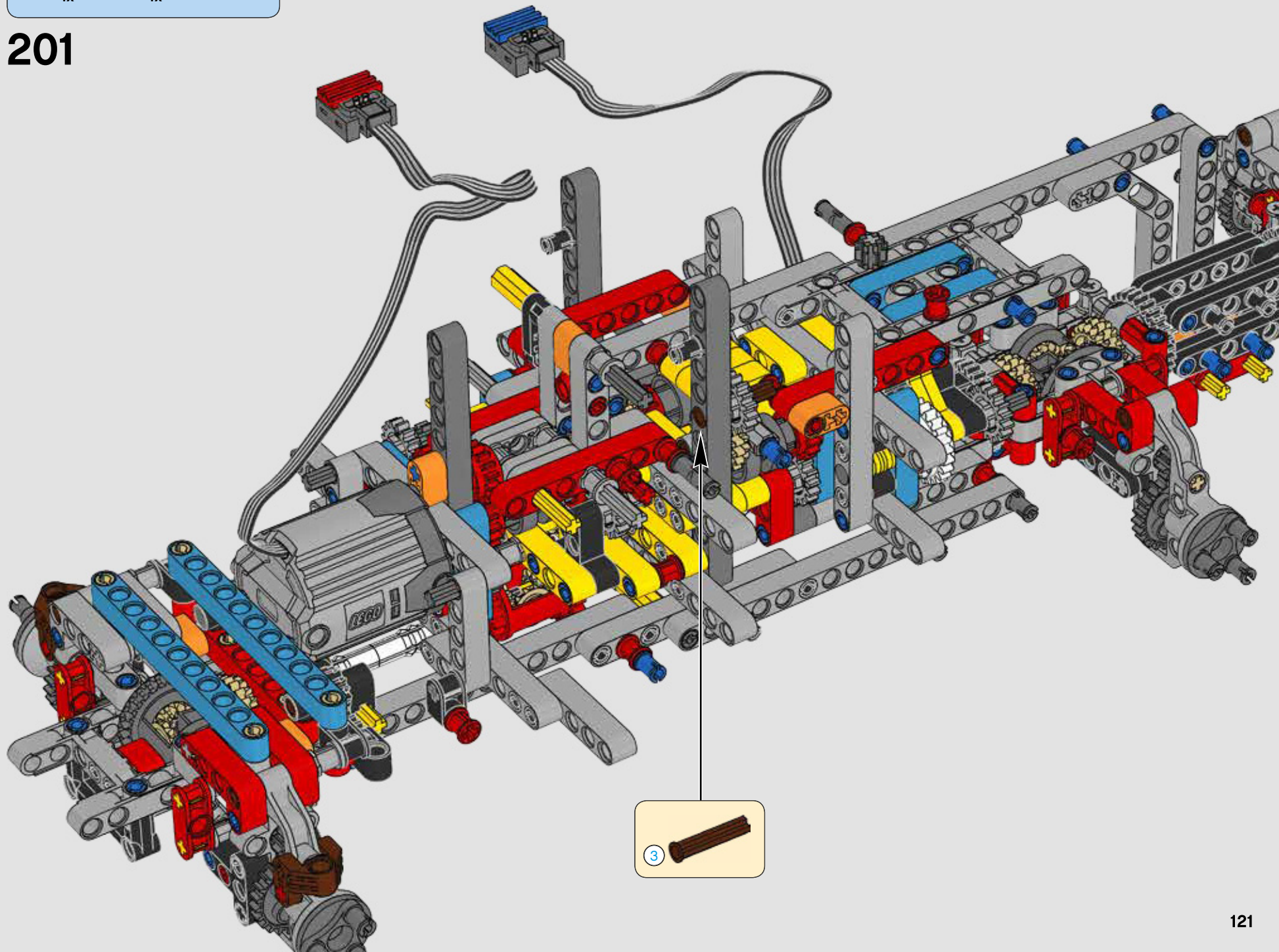



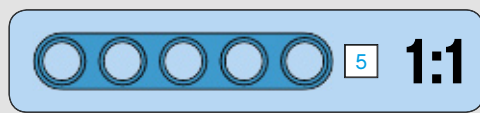
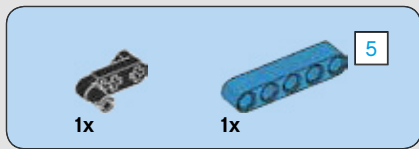

202

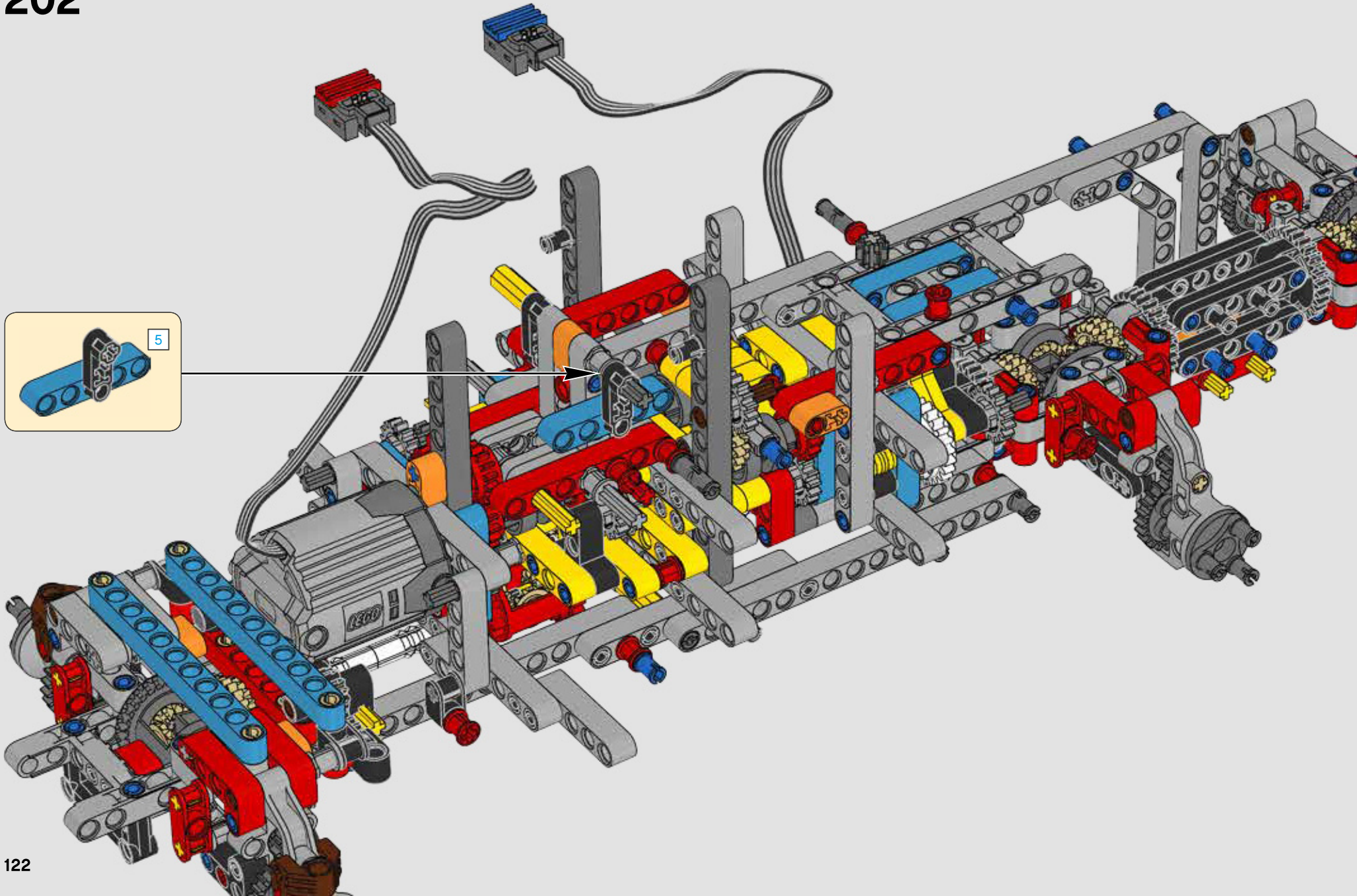
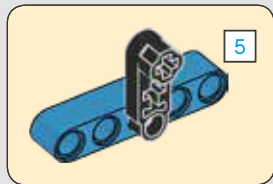



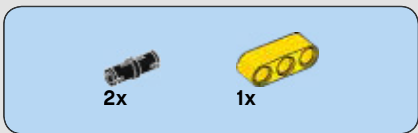

203

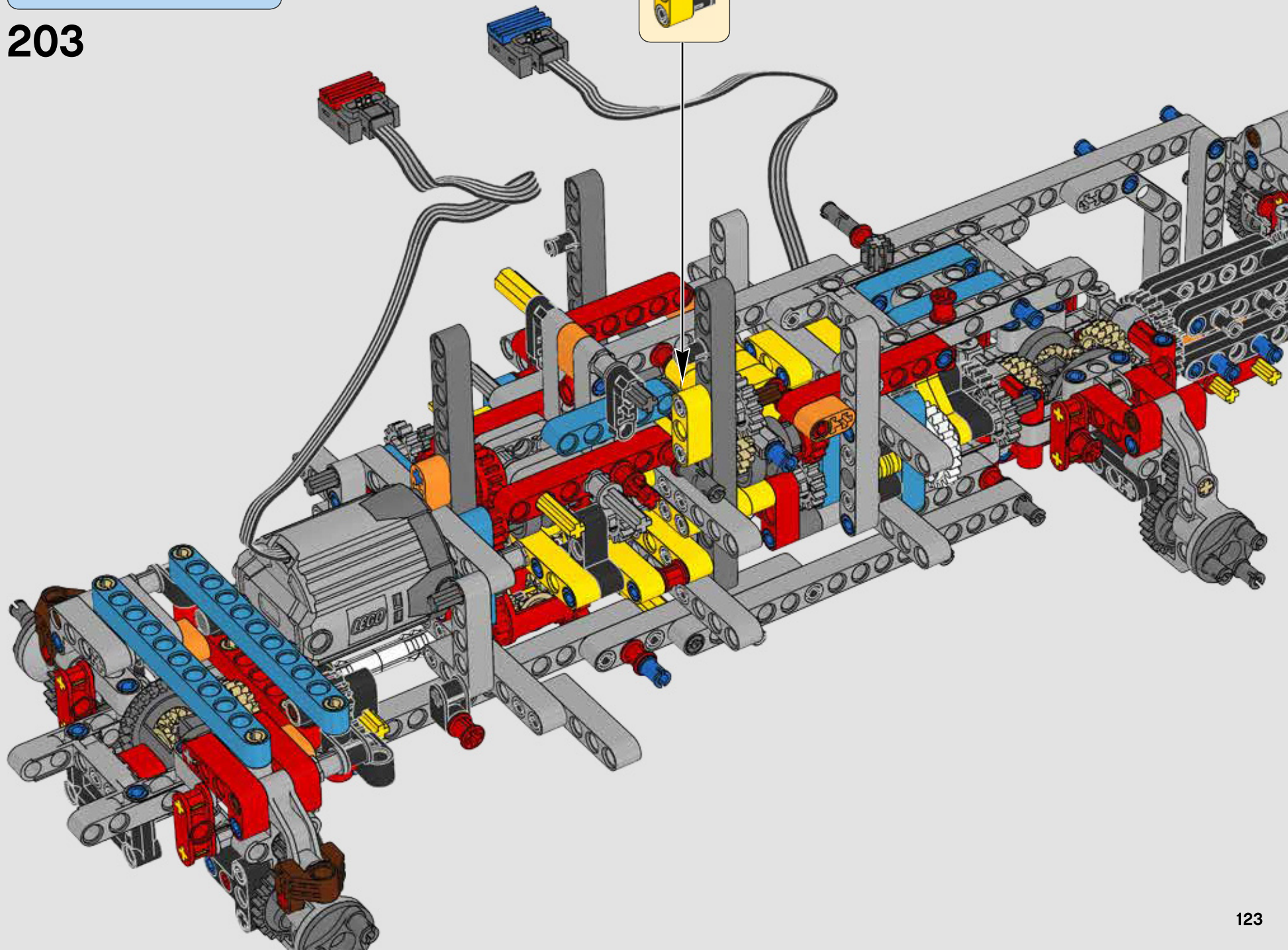
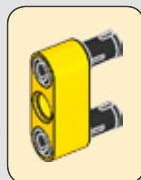





1x

204

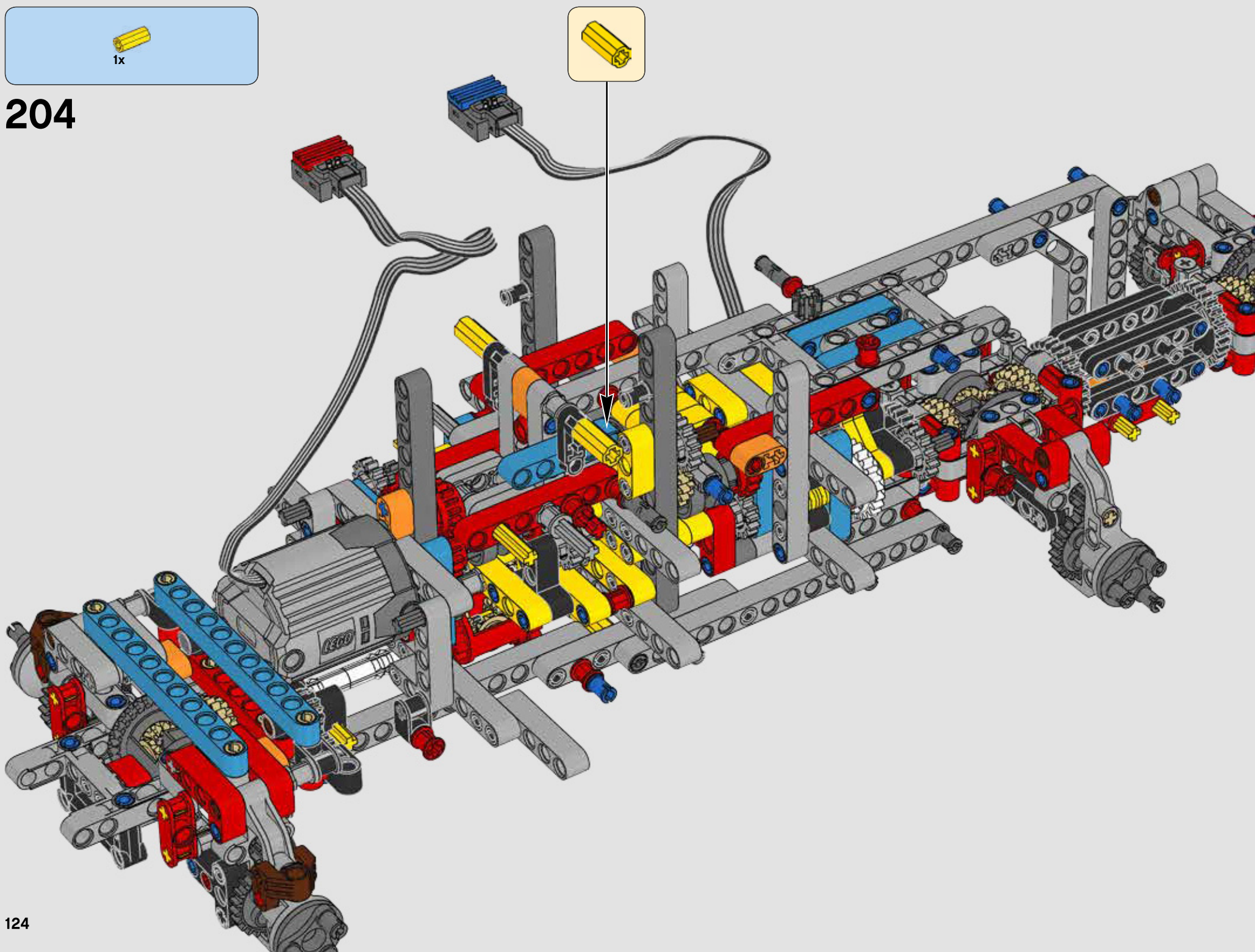
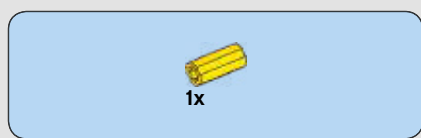



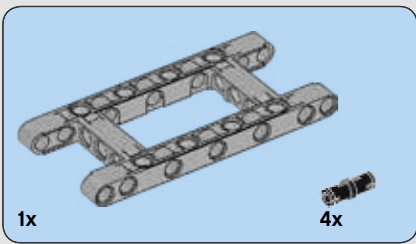

205

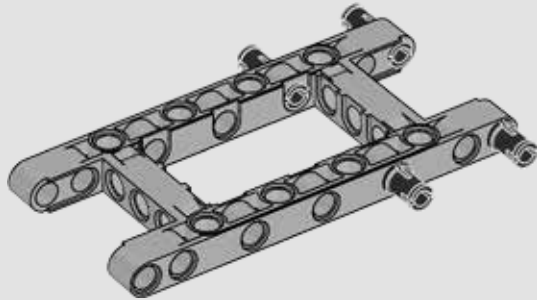

206

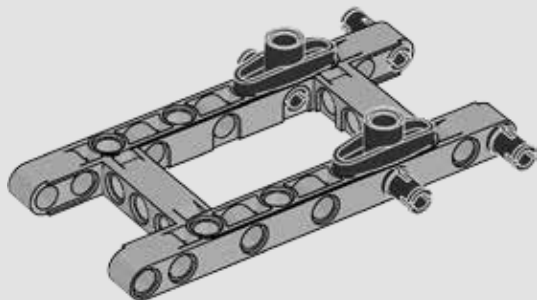

207

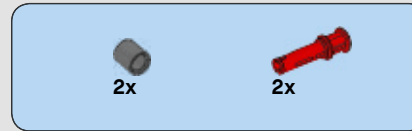
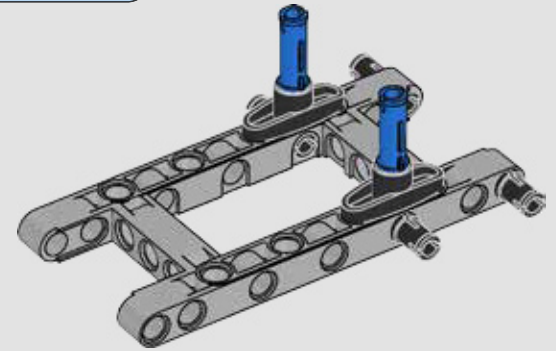

208

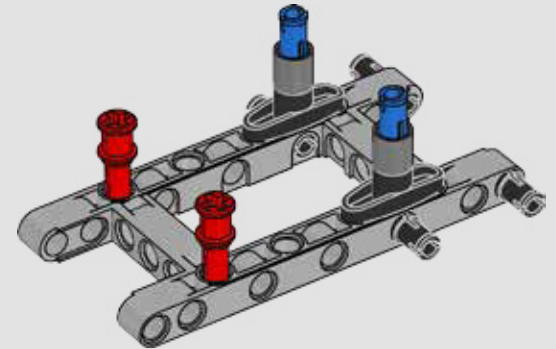

209

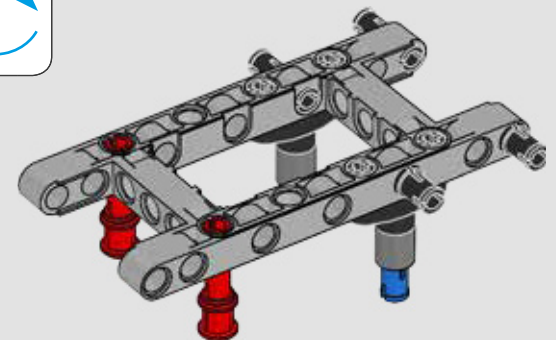
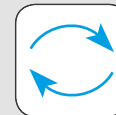

210

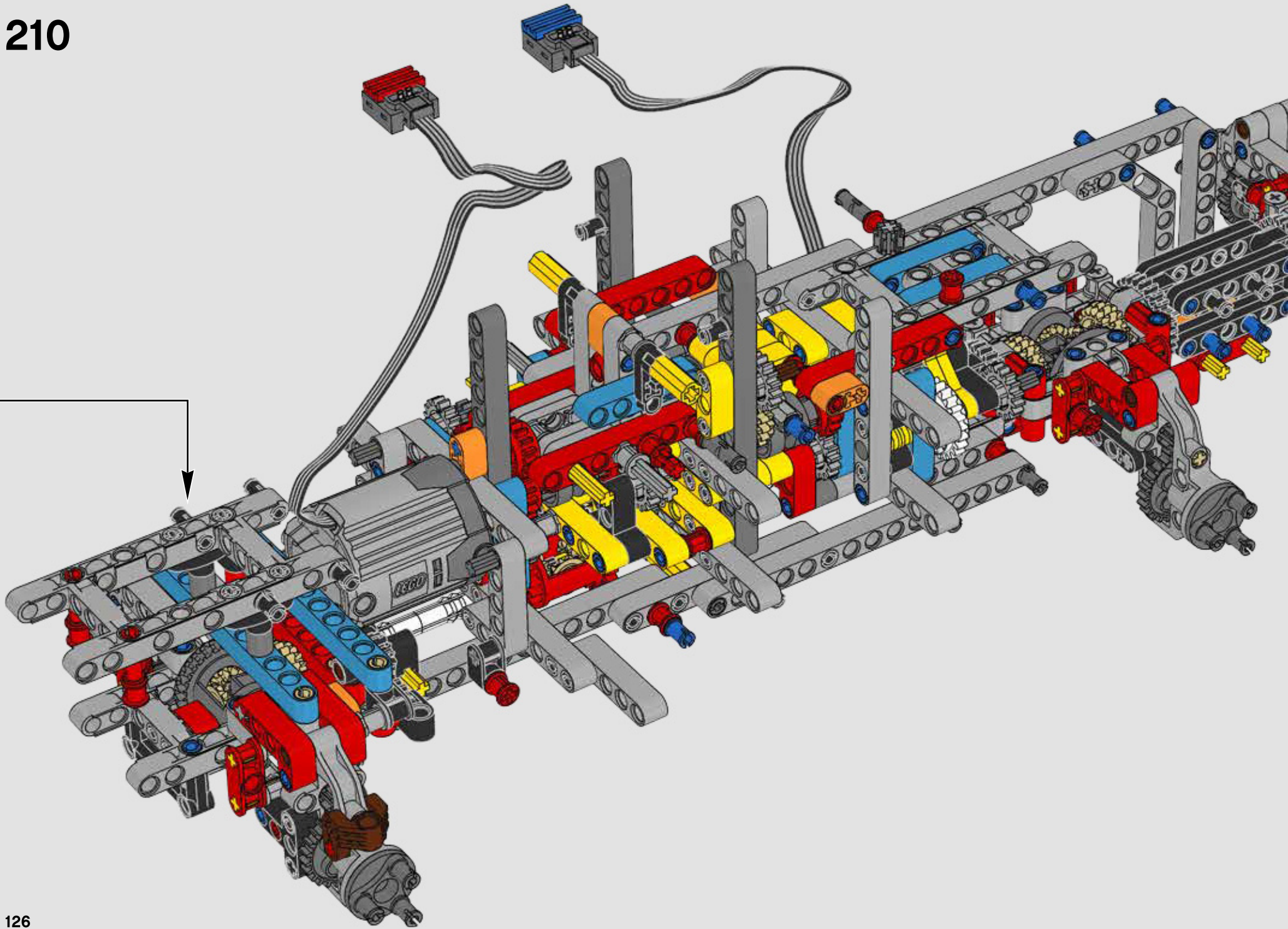

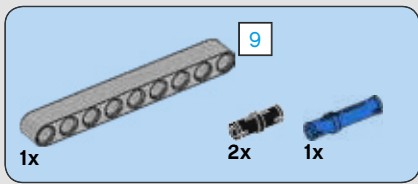

211

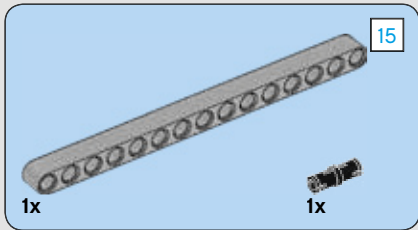
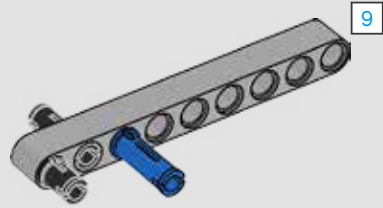

212

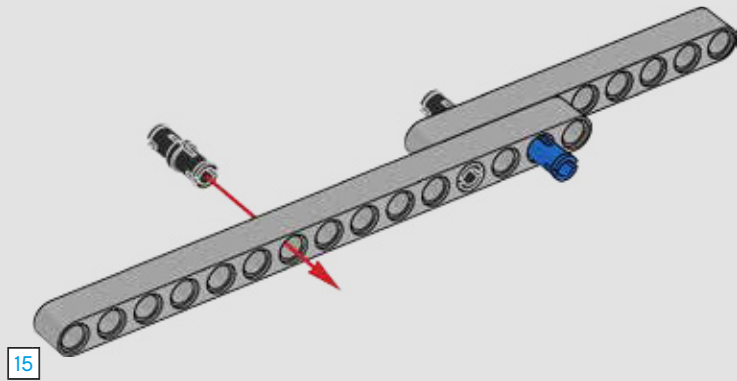

213

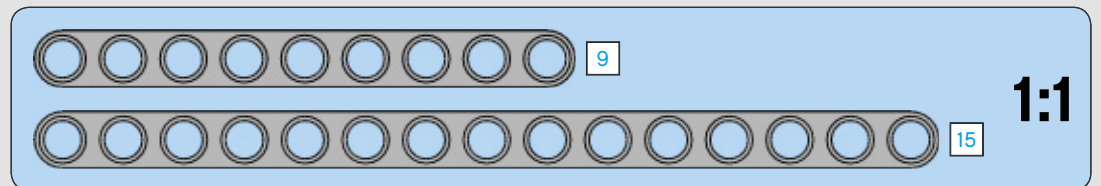
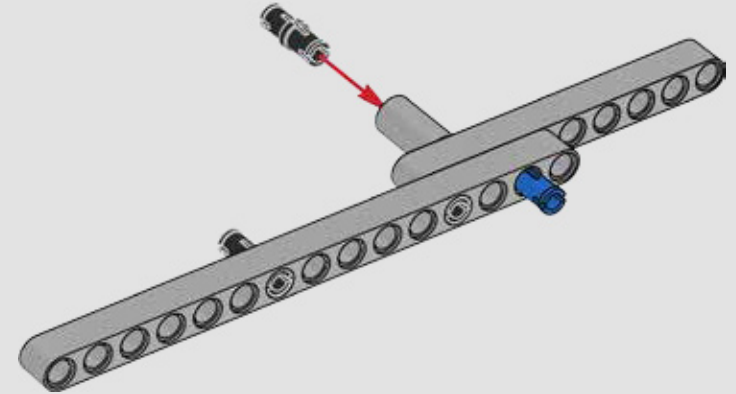



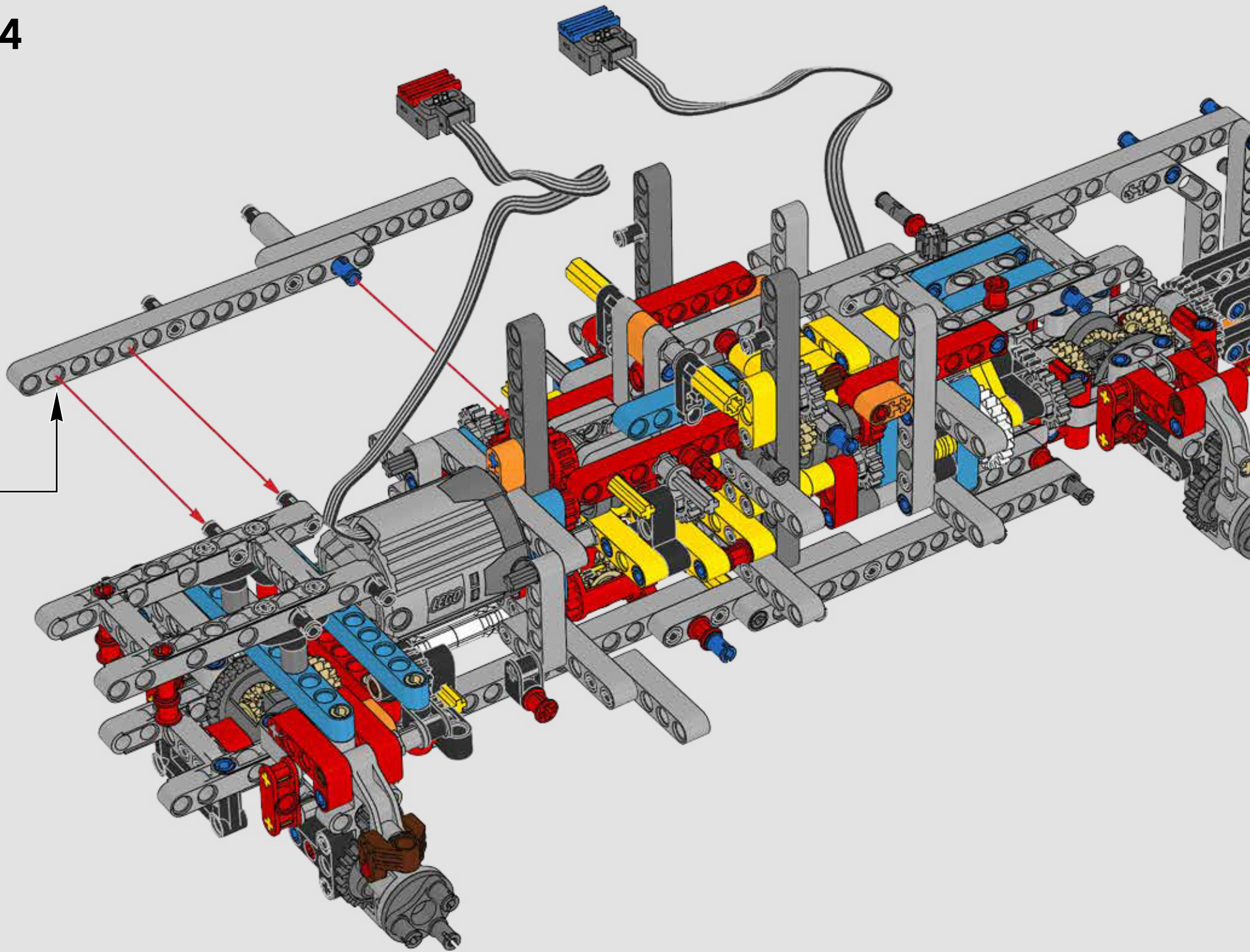



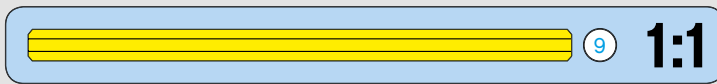
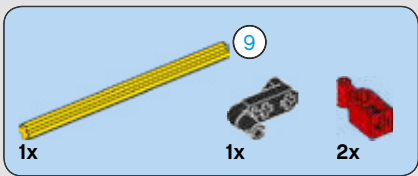

215

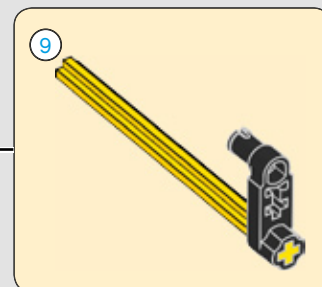
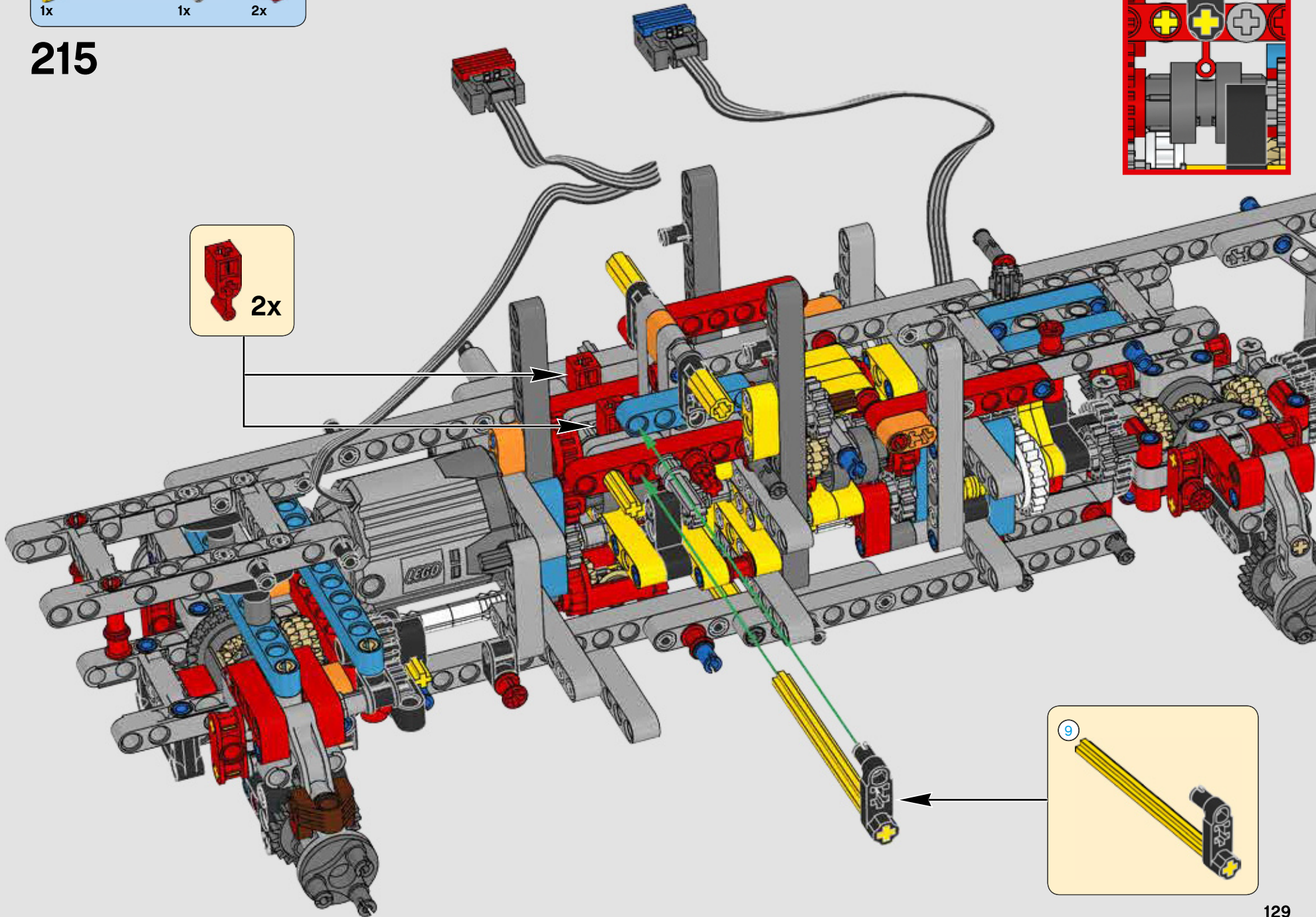
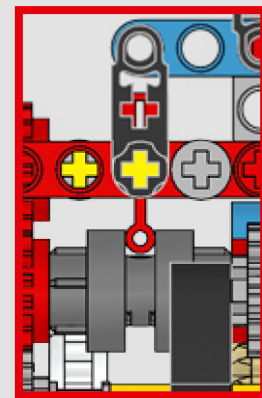



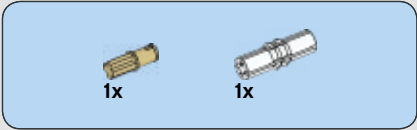

216

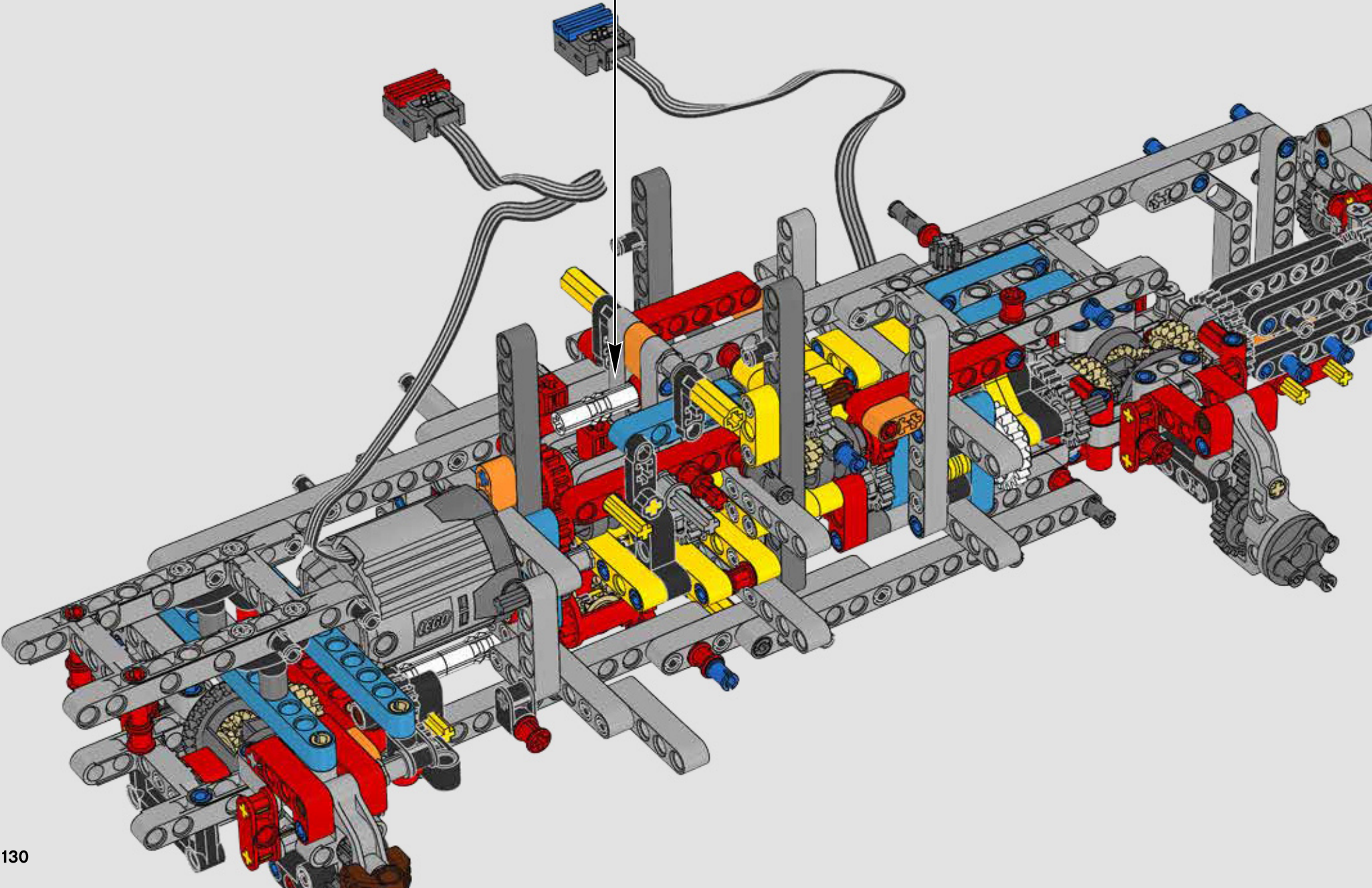
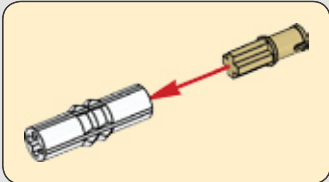



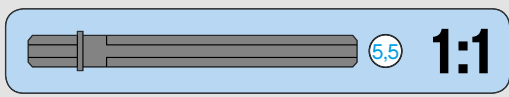
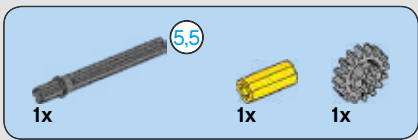

217

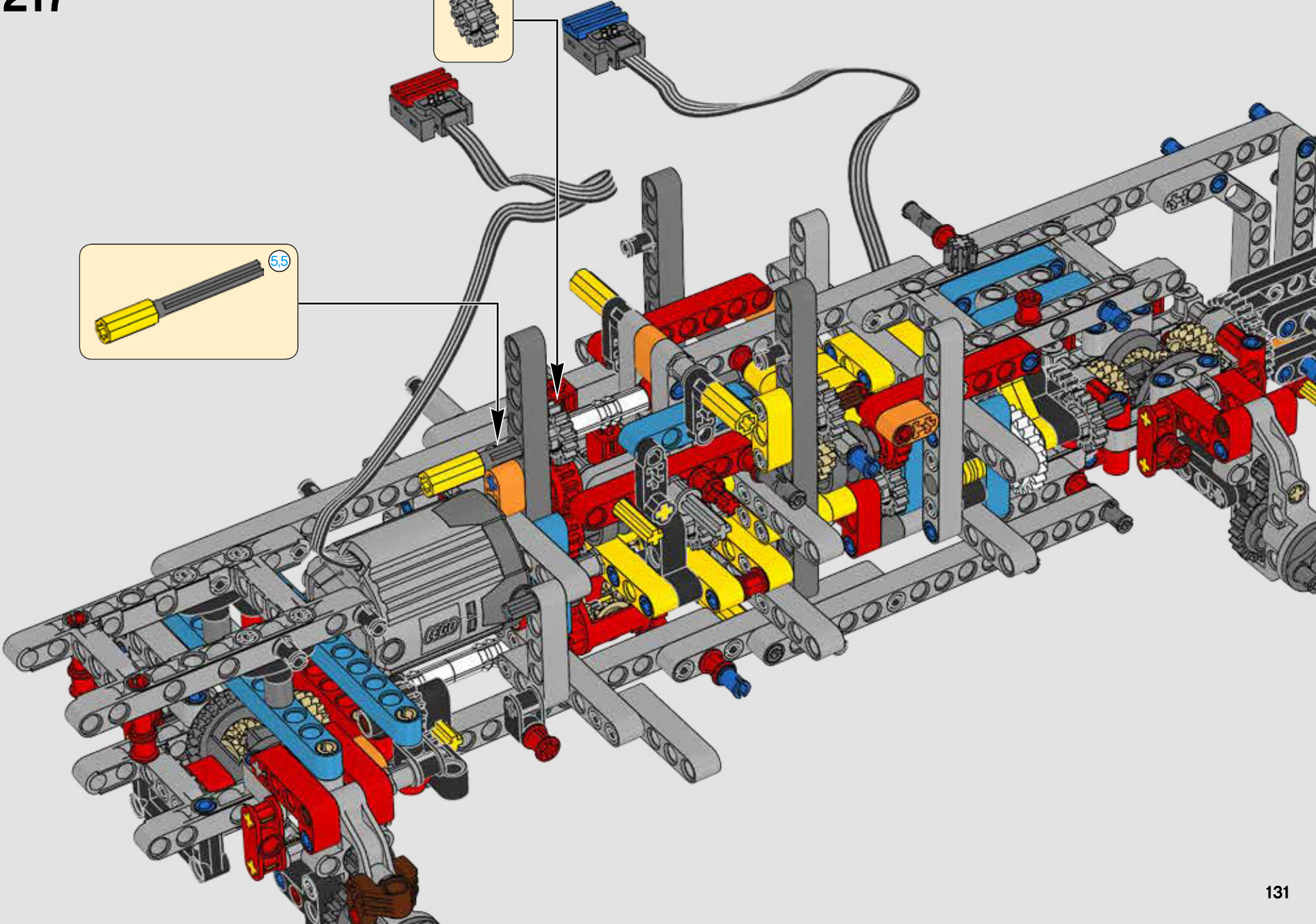
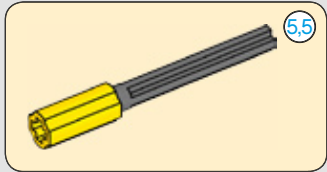



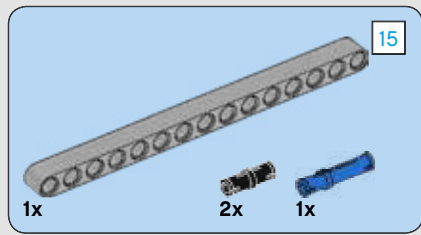

218

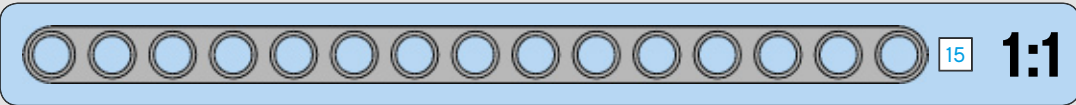
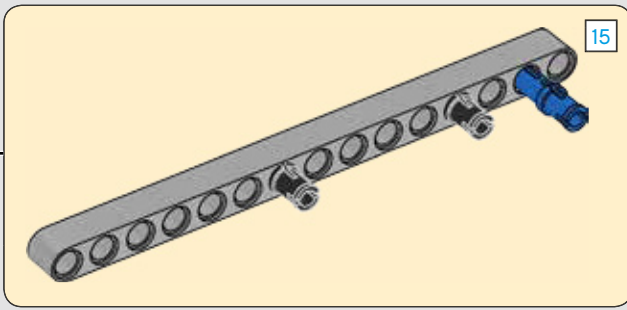
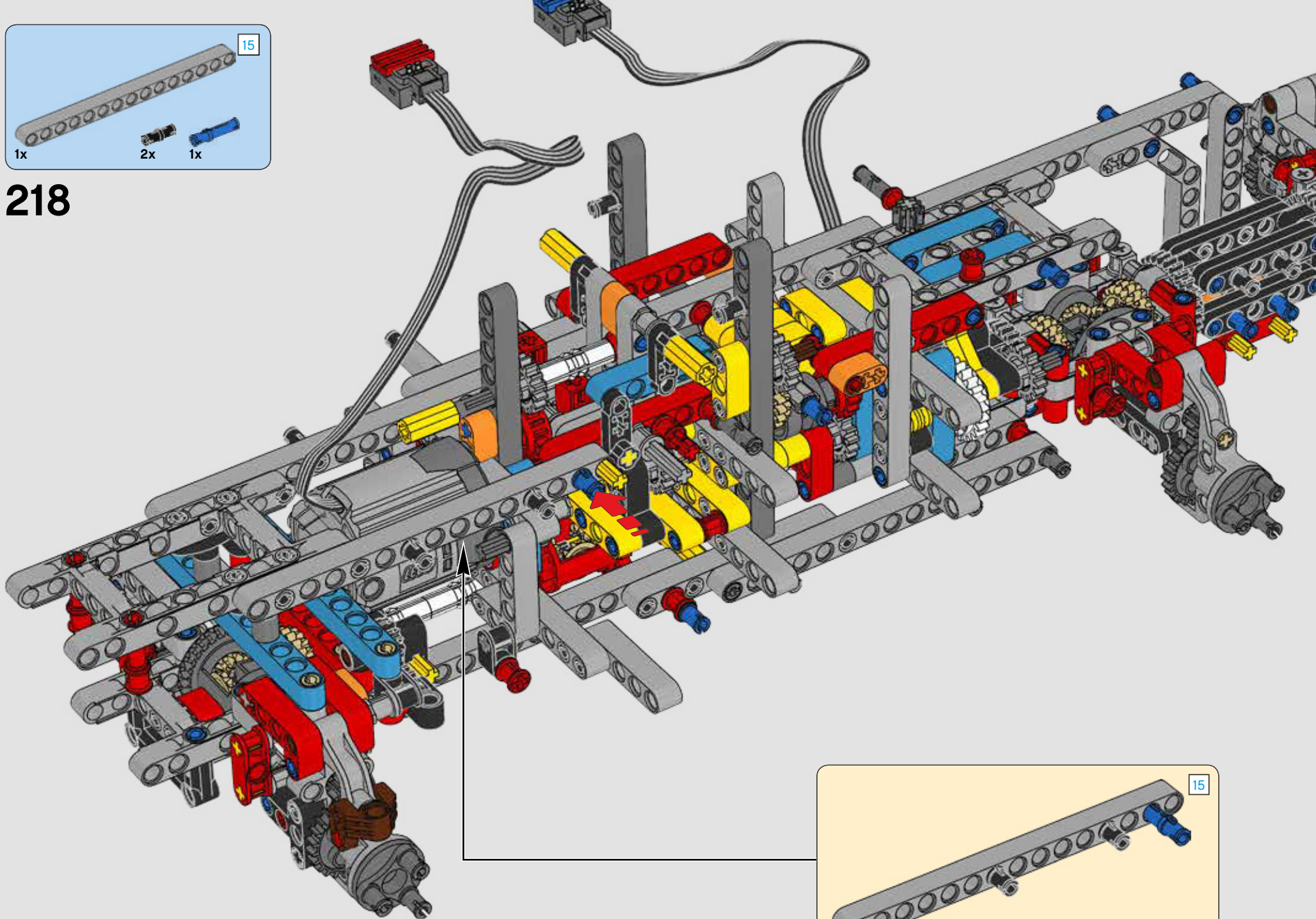





219

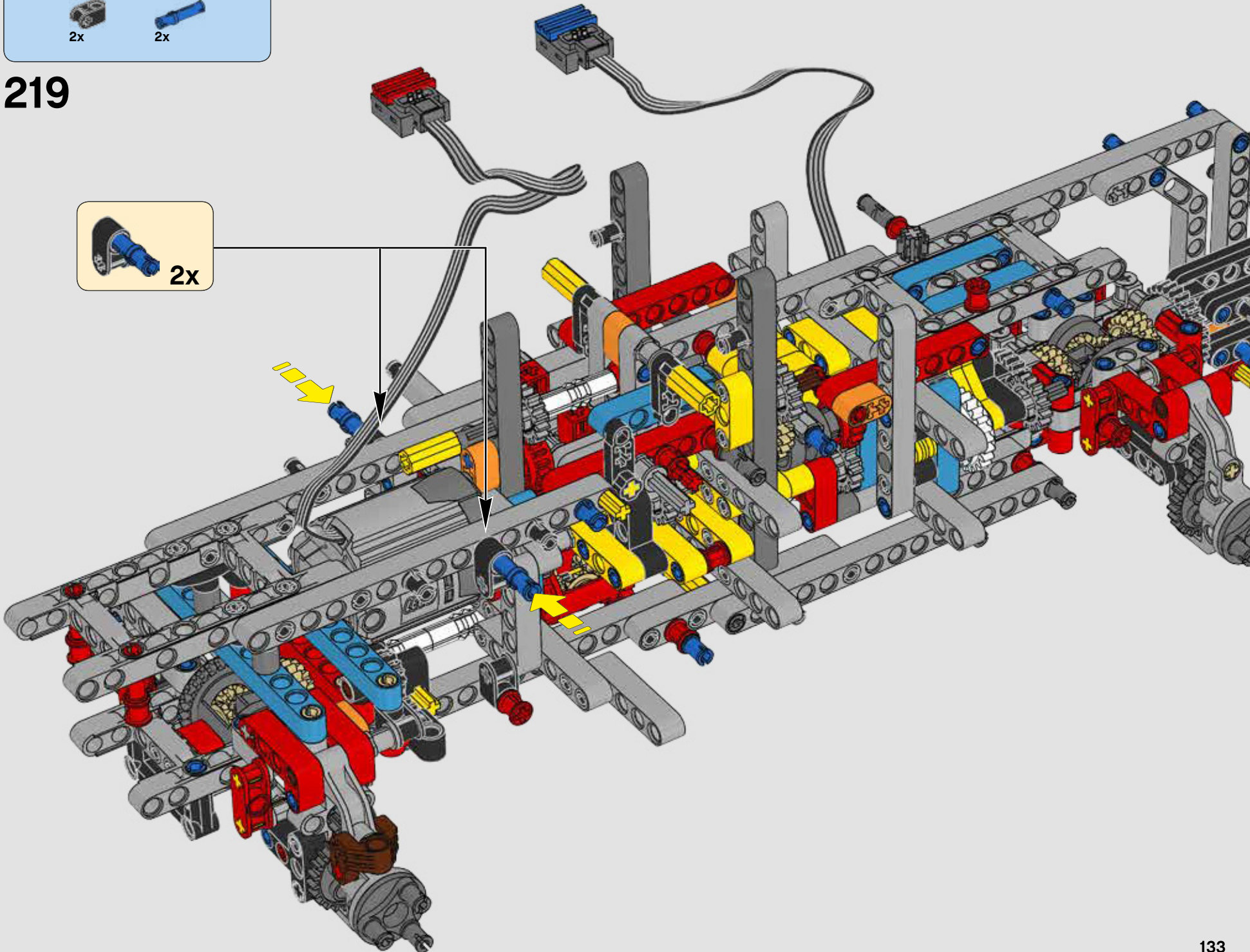



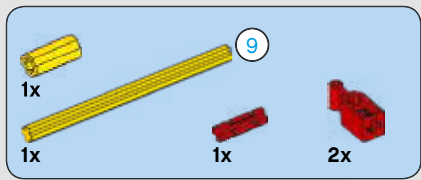

220

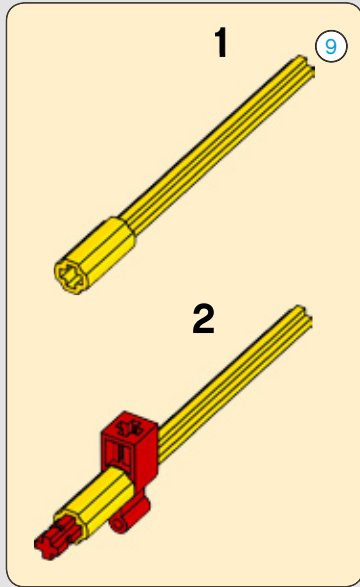
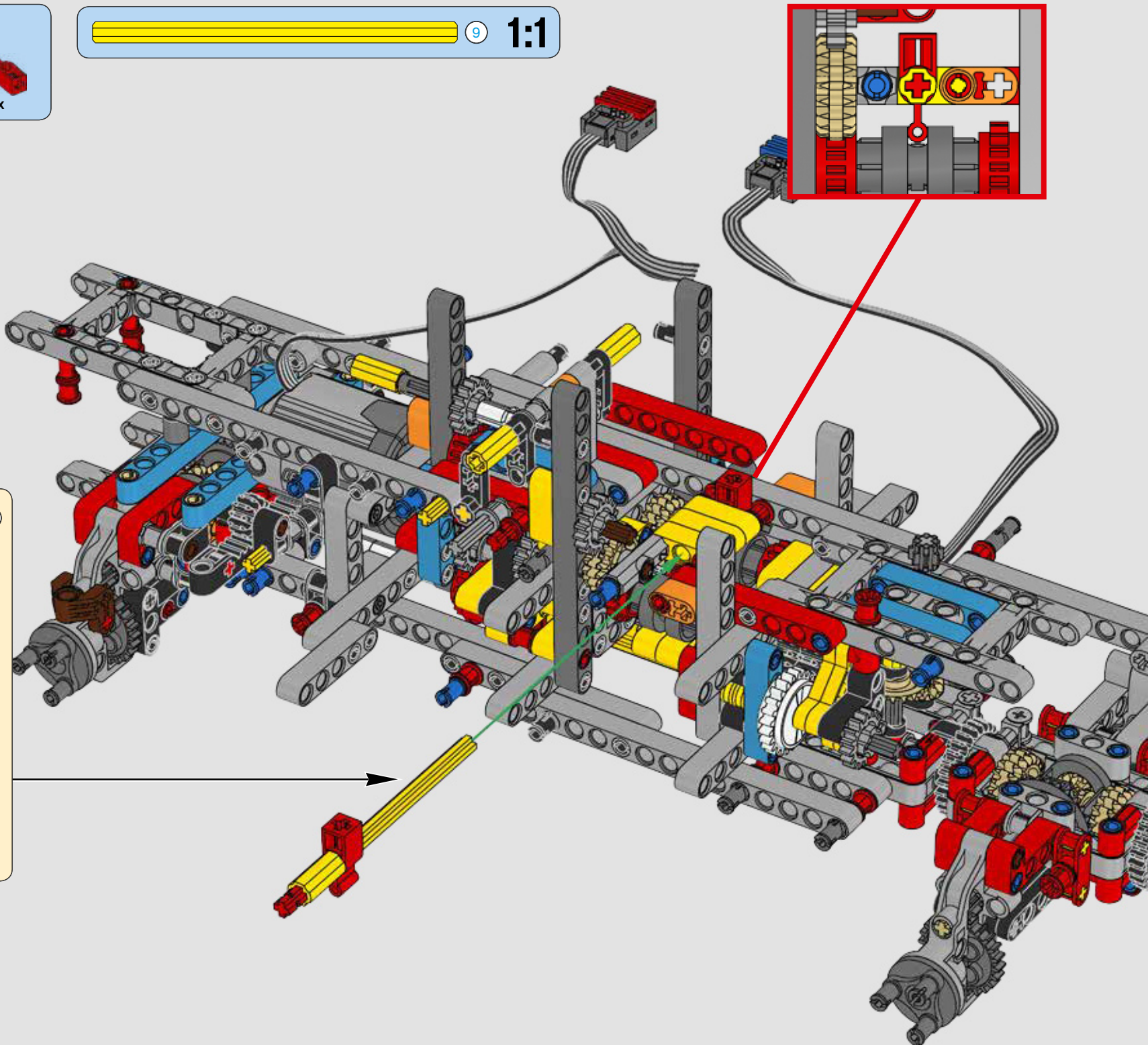





221

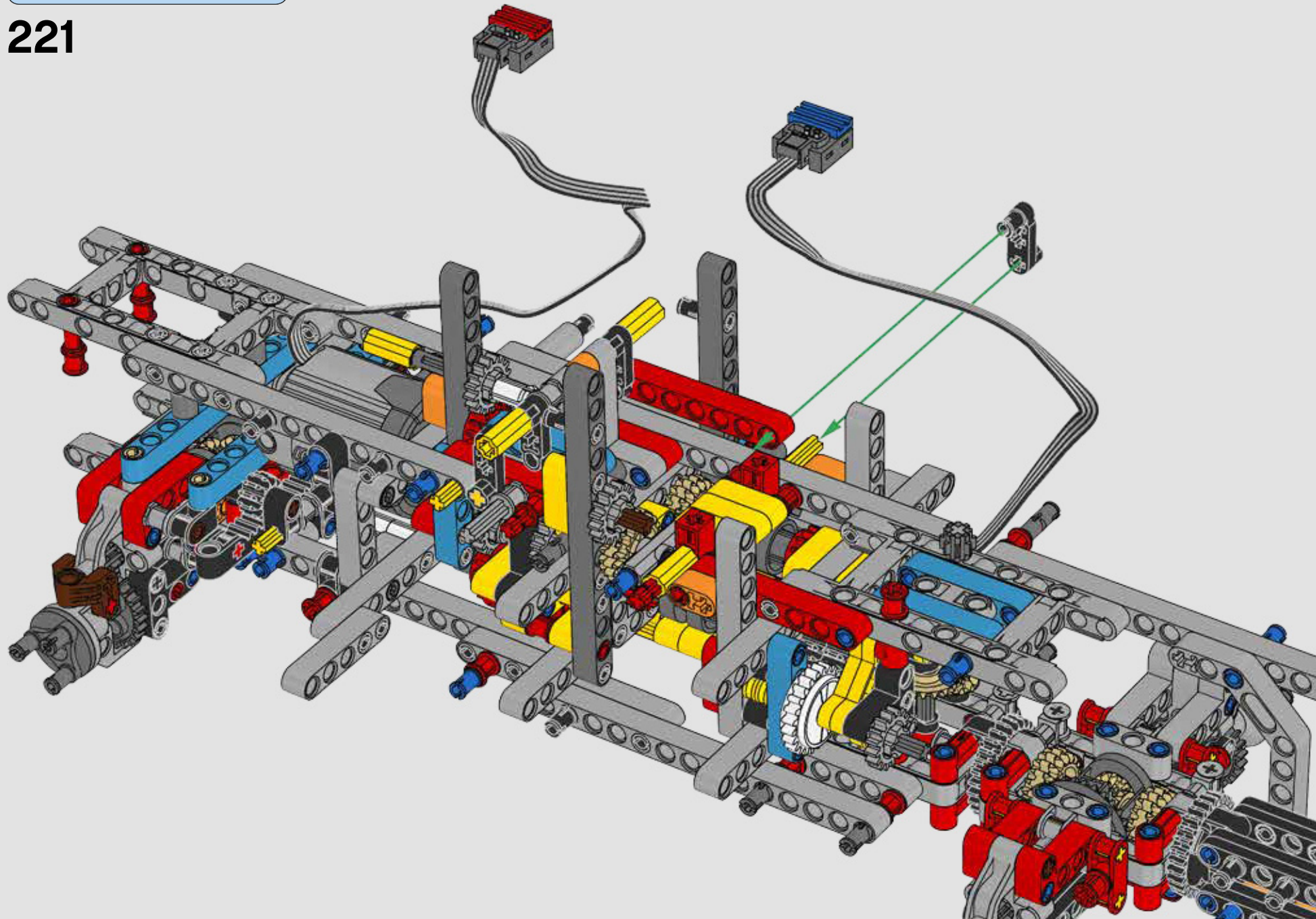



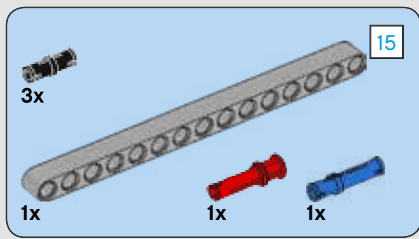

222

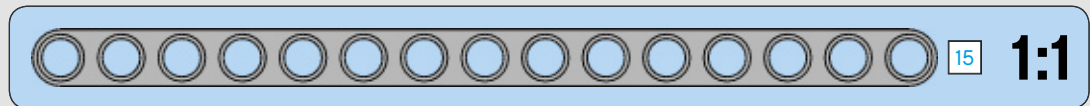
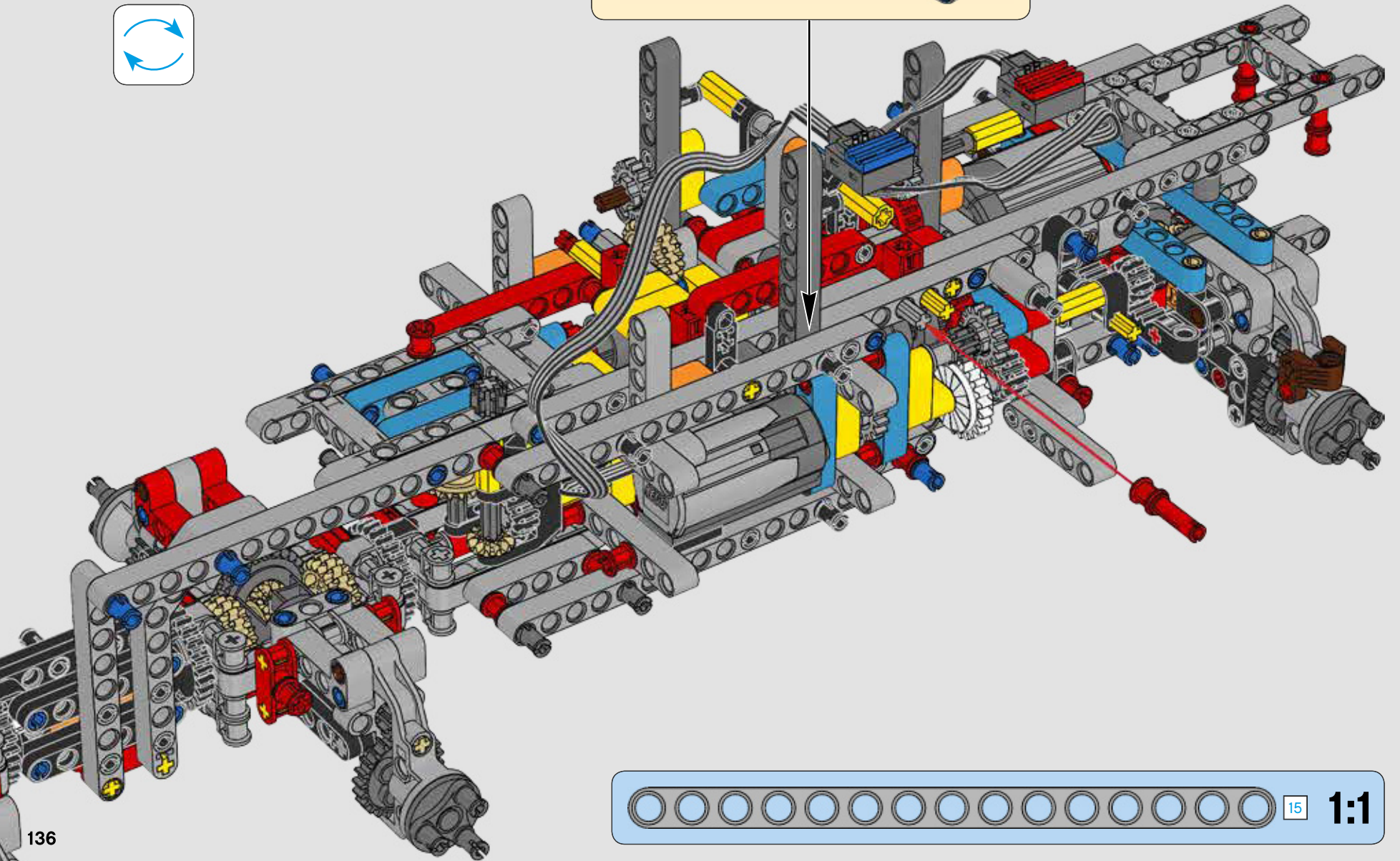
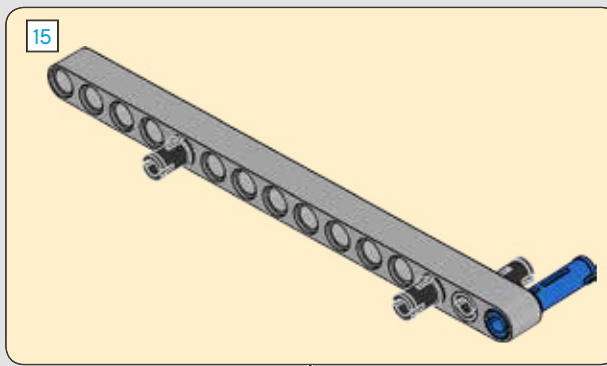



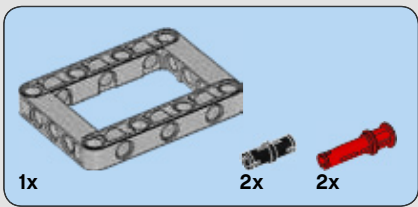

223

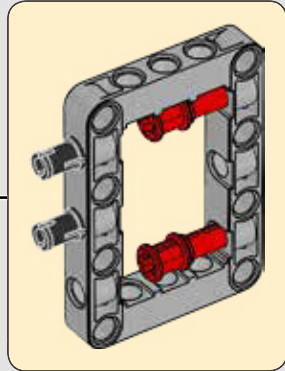
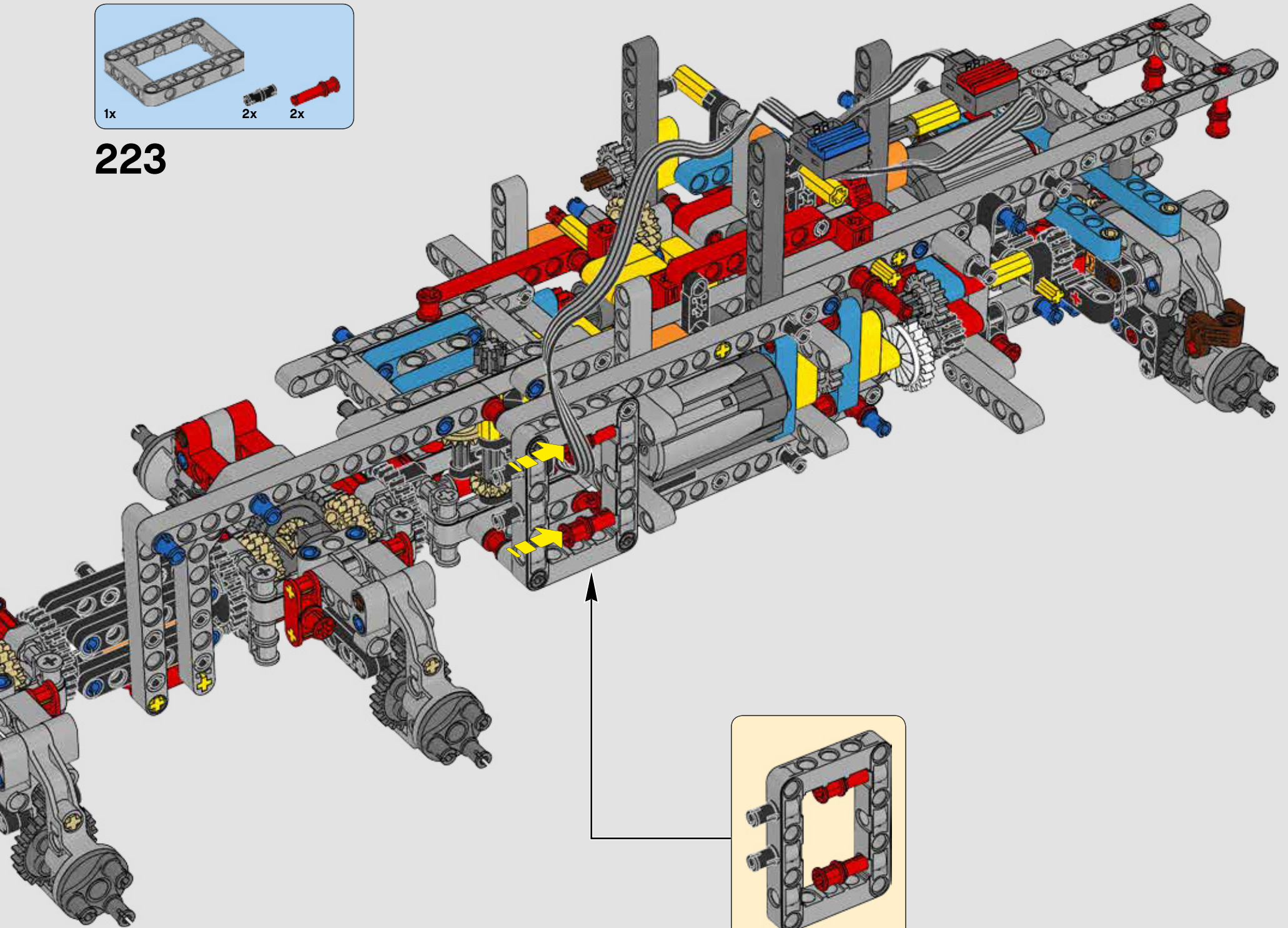

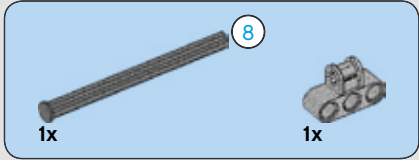
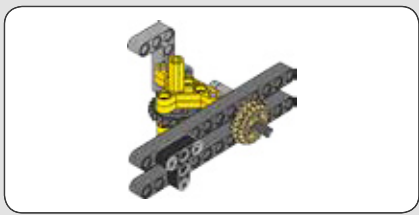

224

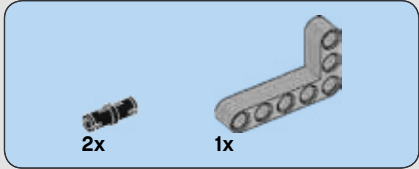
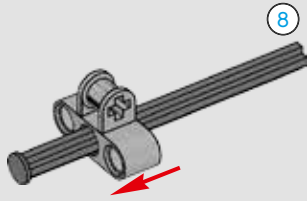

225

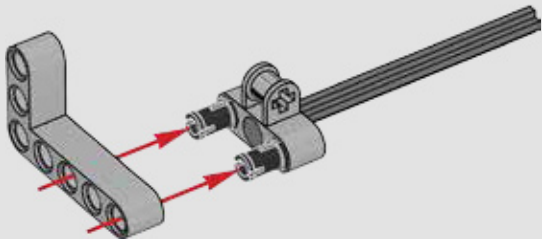

226

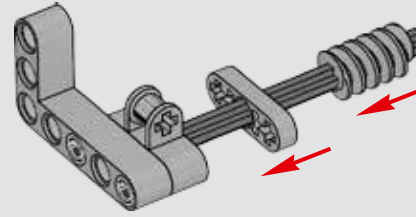

227

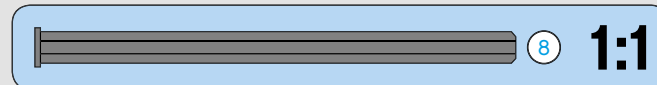
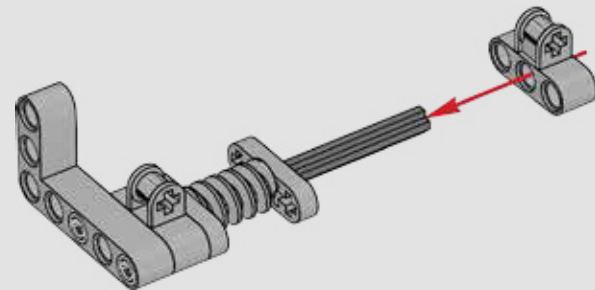

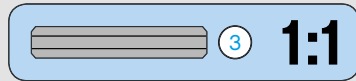
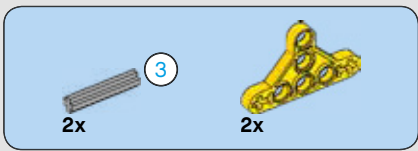

228

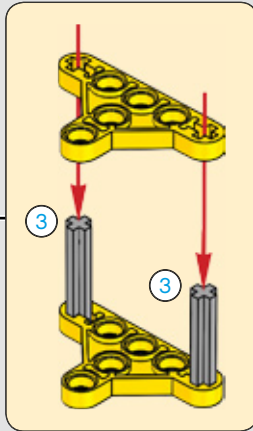
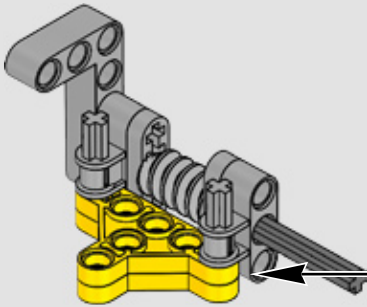

229

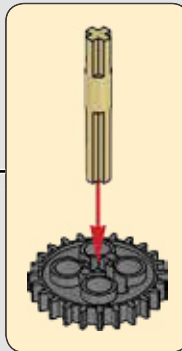
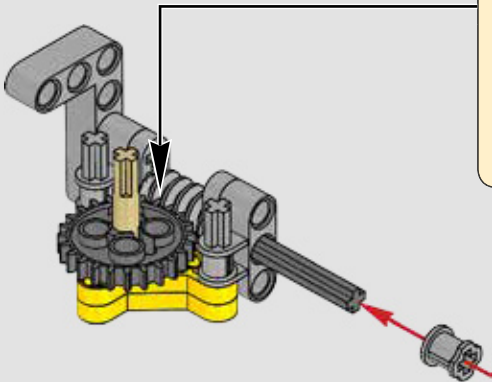

230

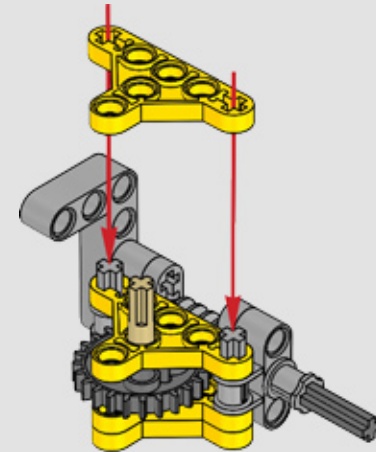

231

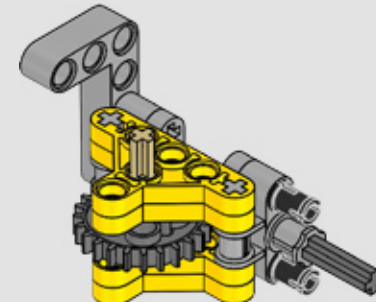



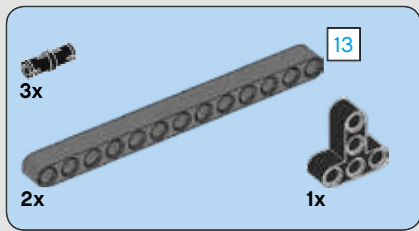

# 232

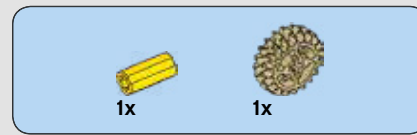
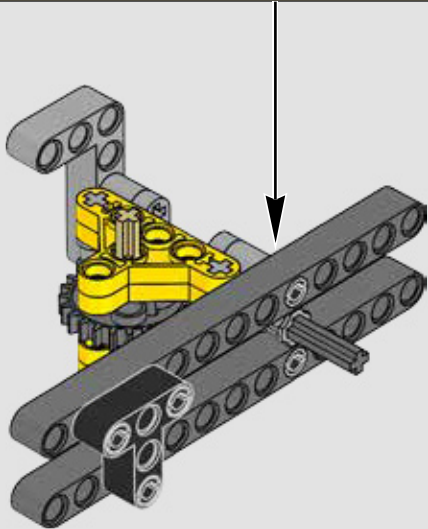
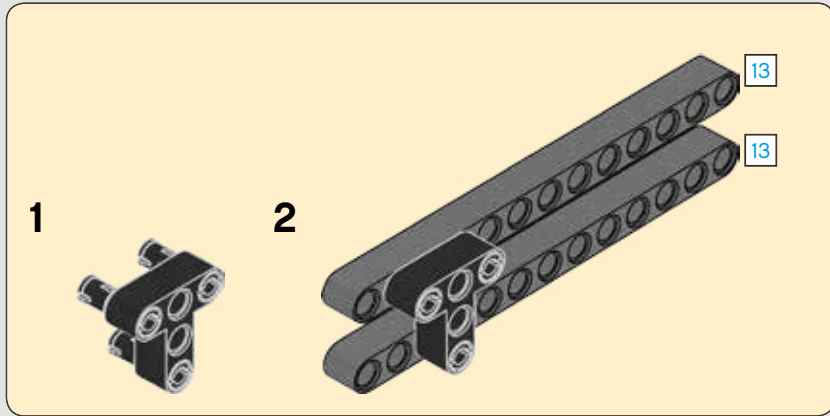

# 233

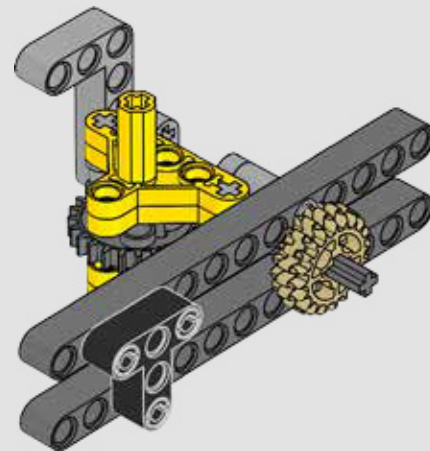

234

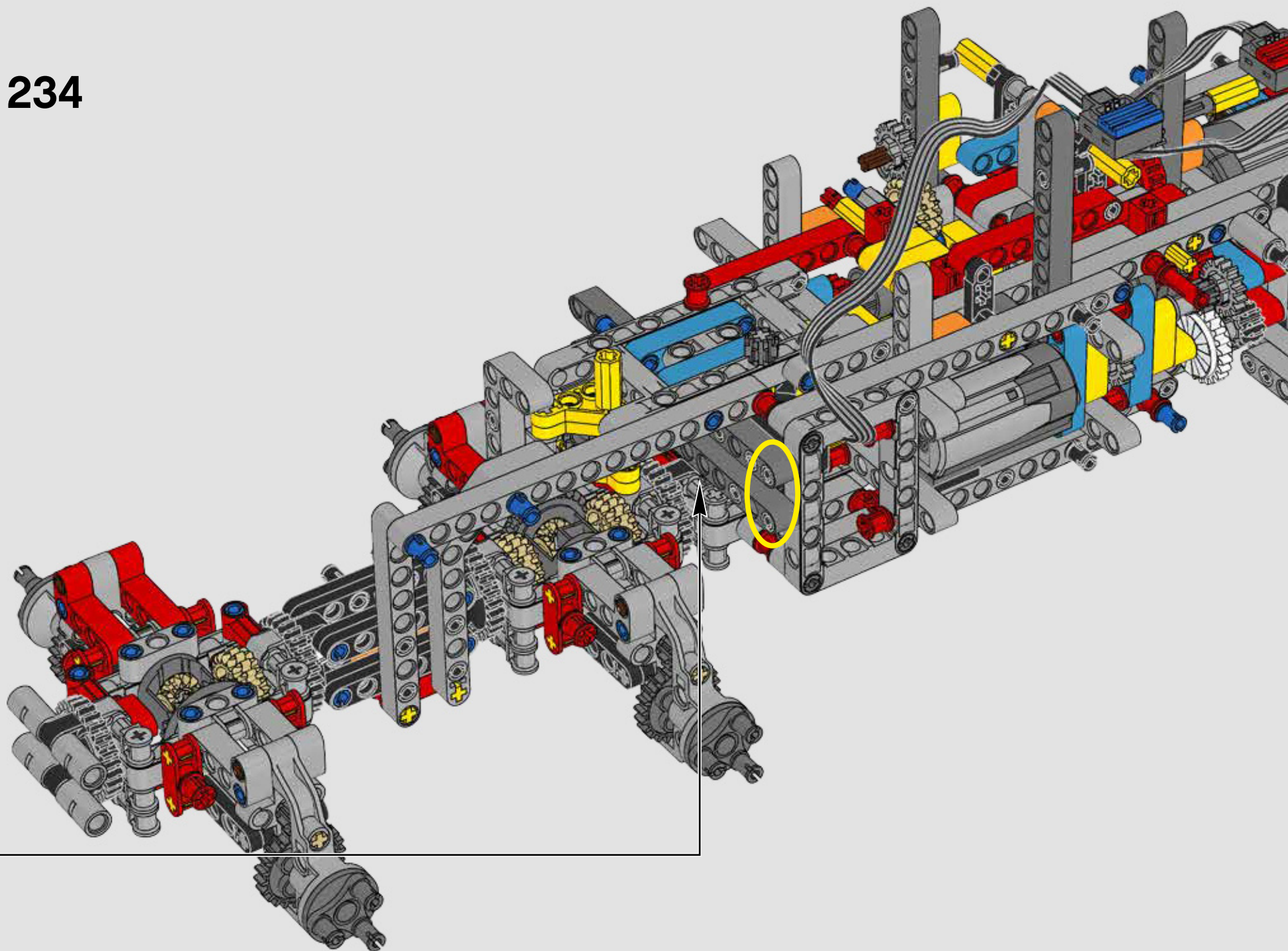



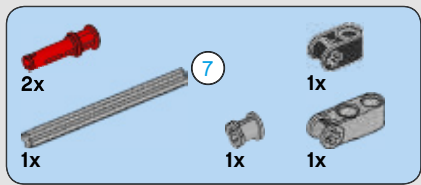

235

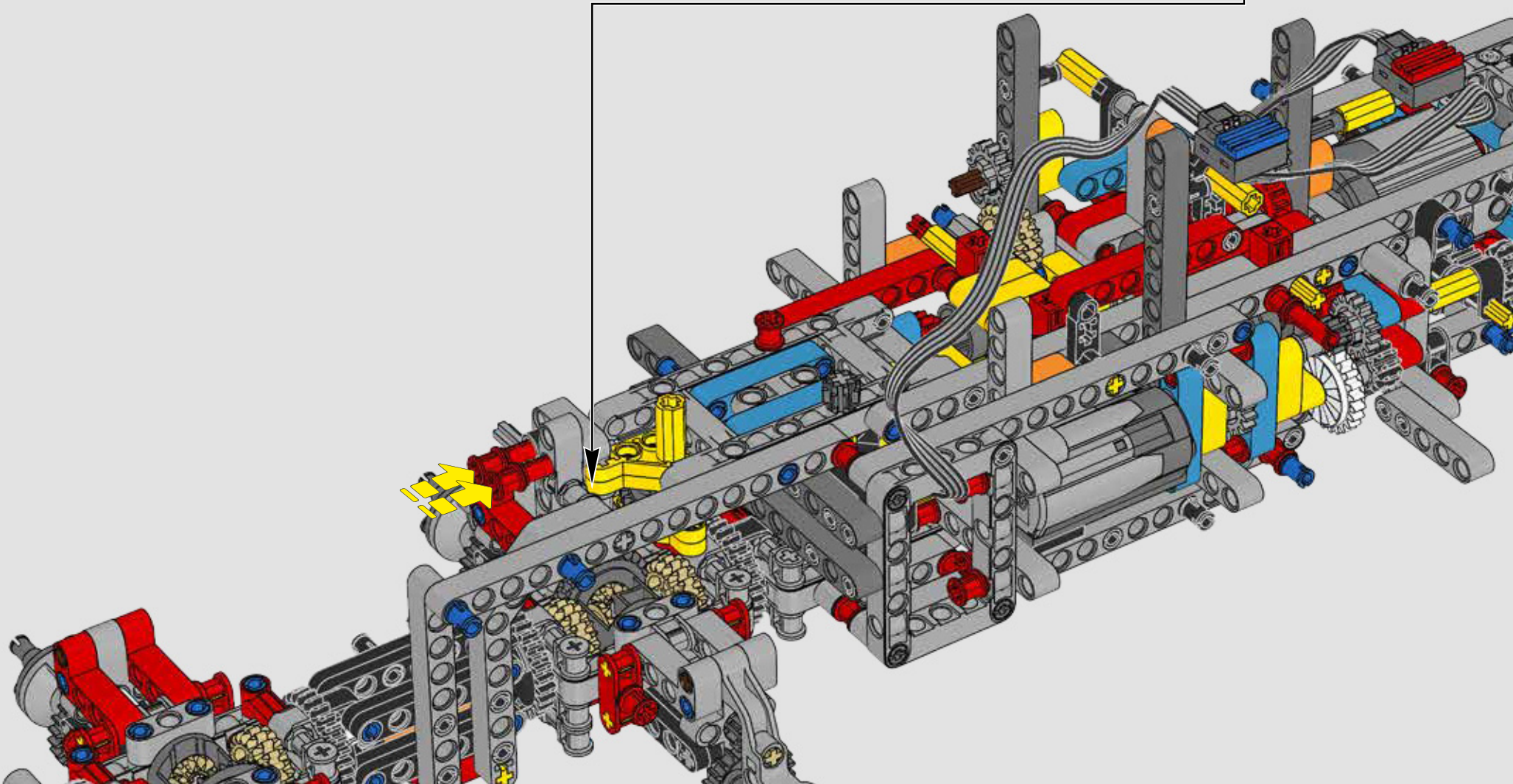
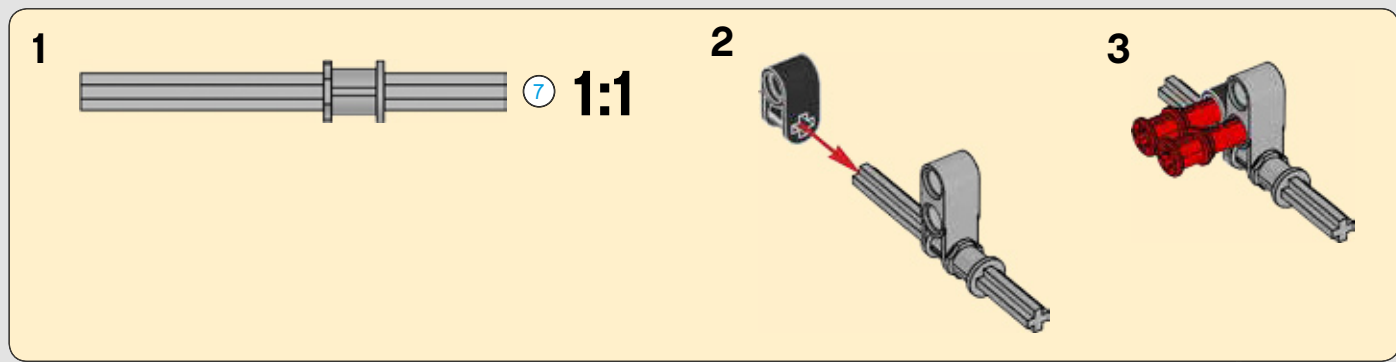



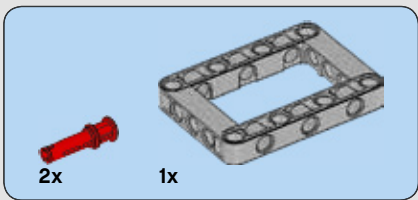

236

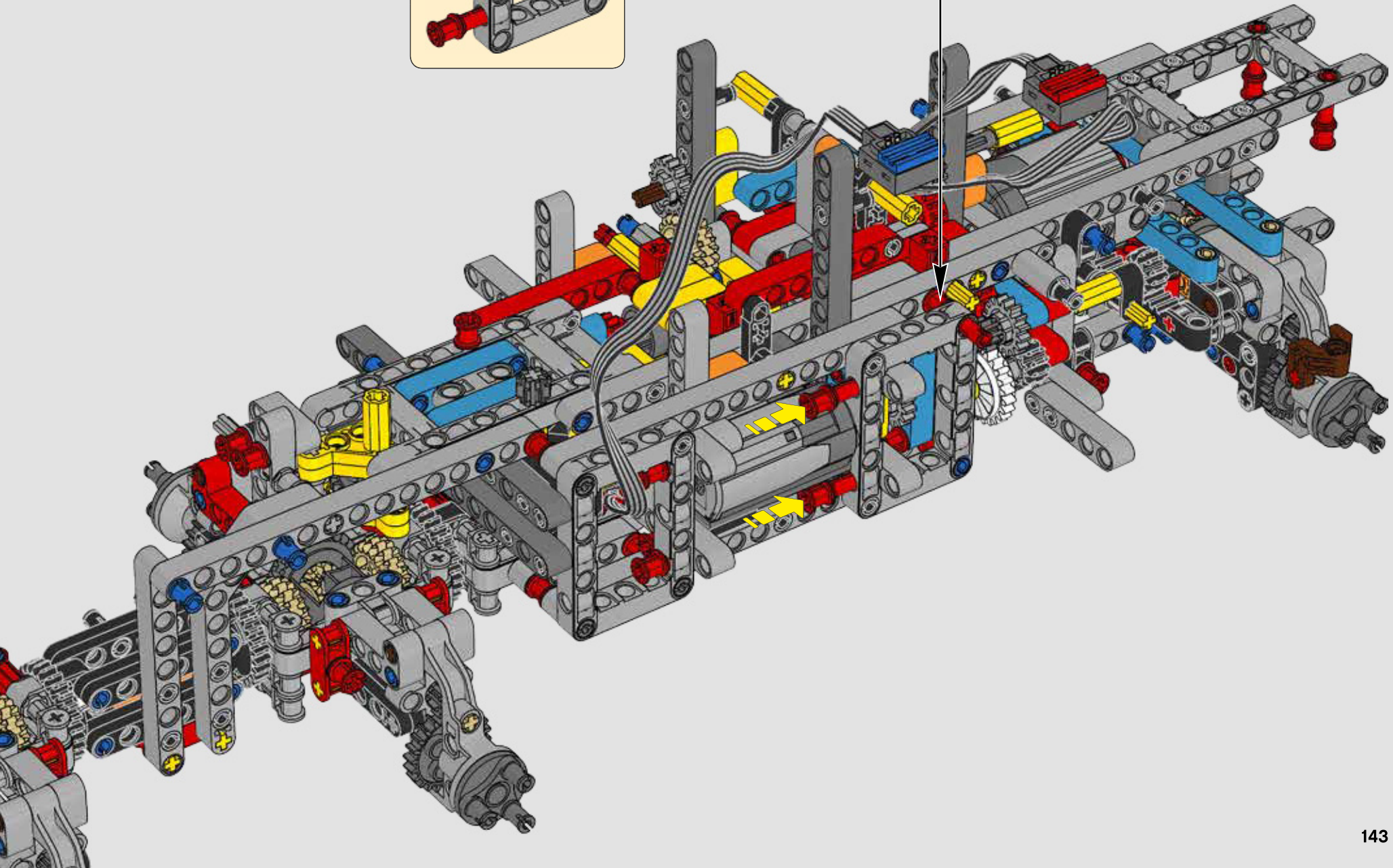
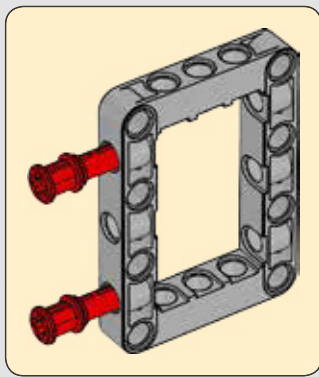

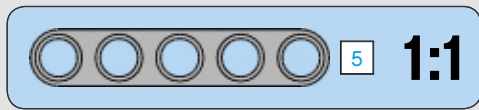
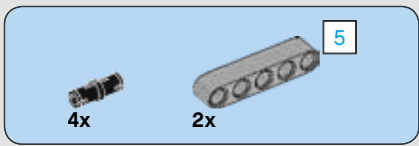

237

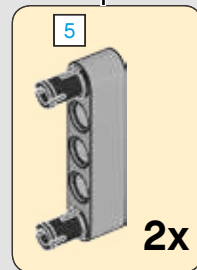
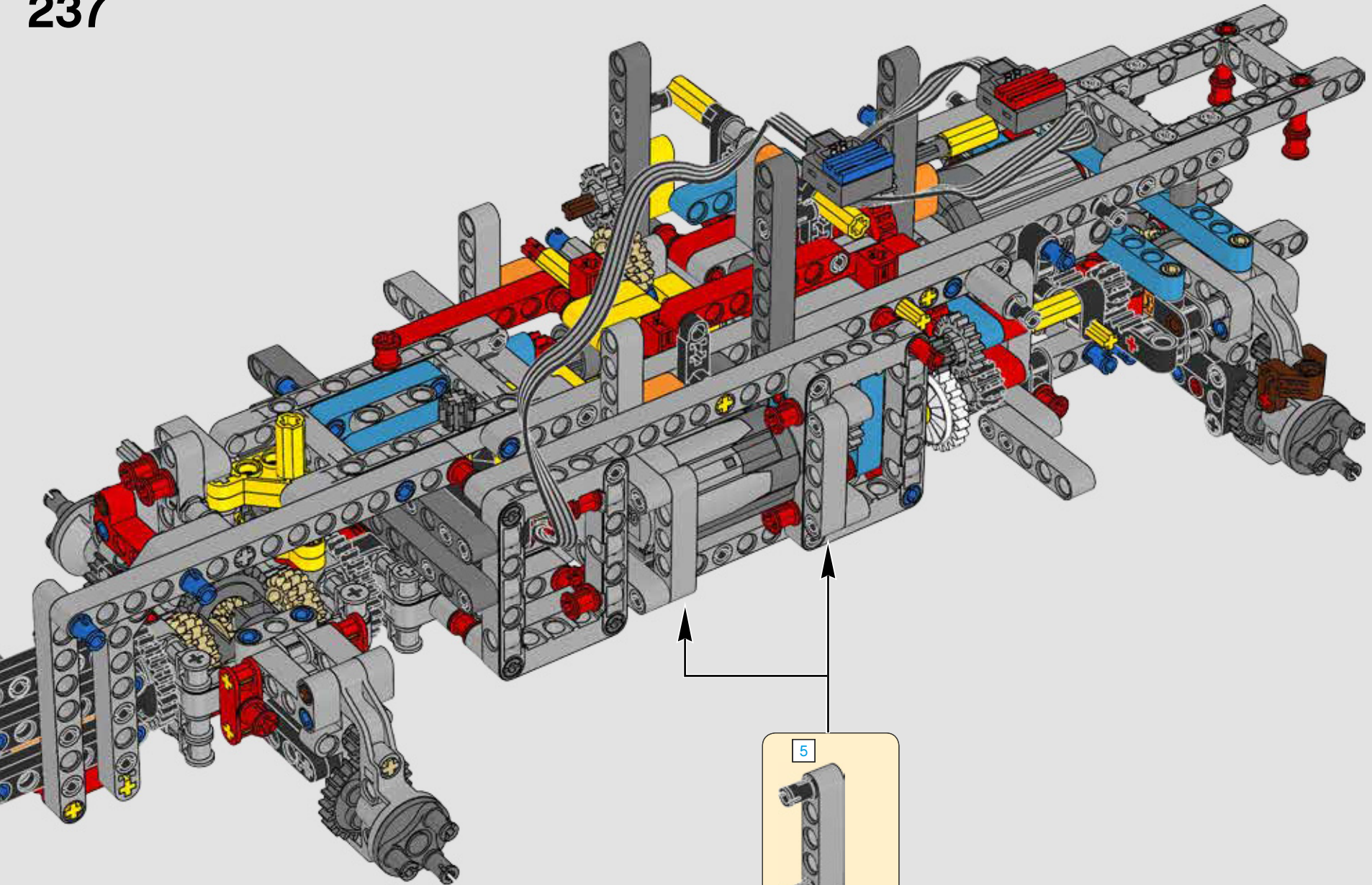



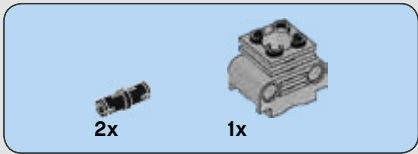

238

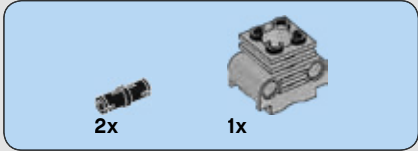
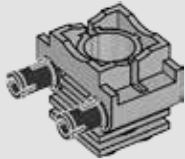

239

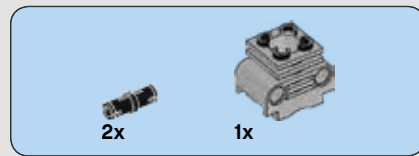
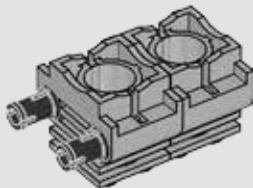

240

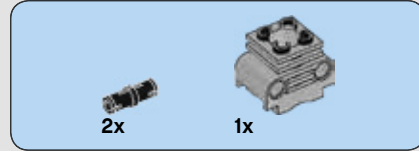
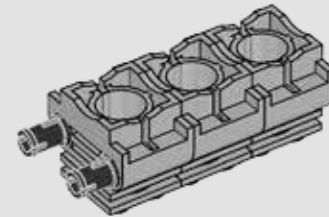

241

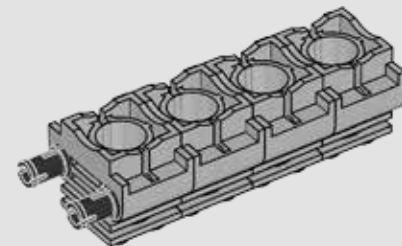





242

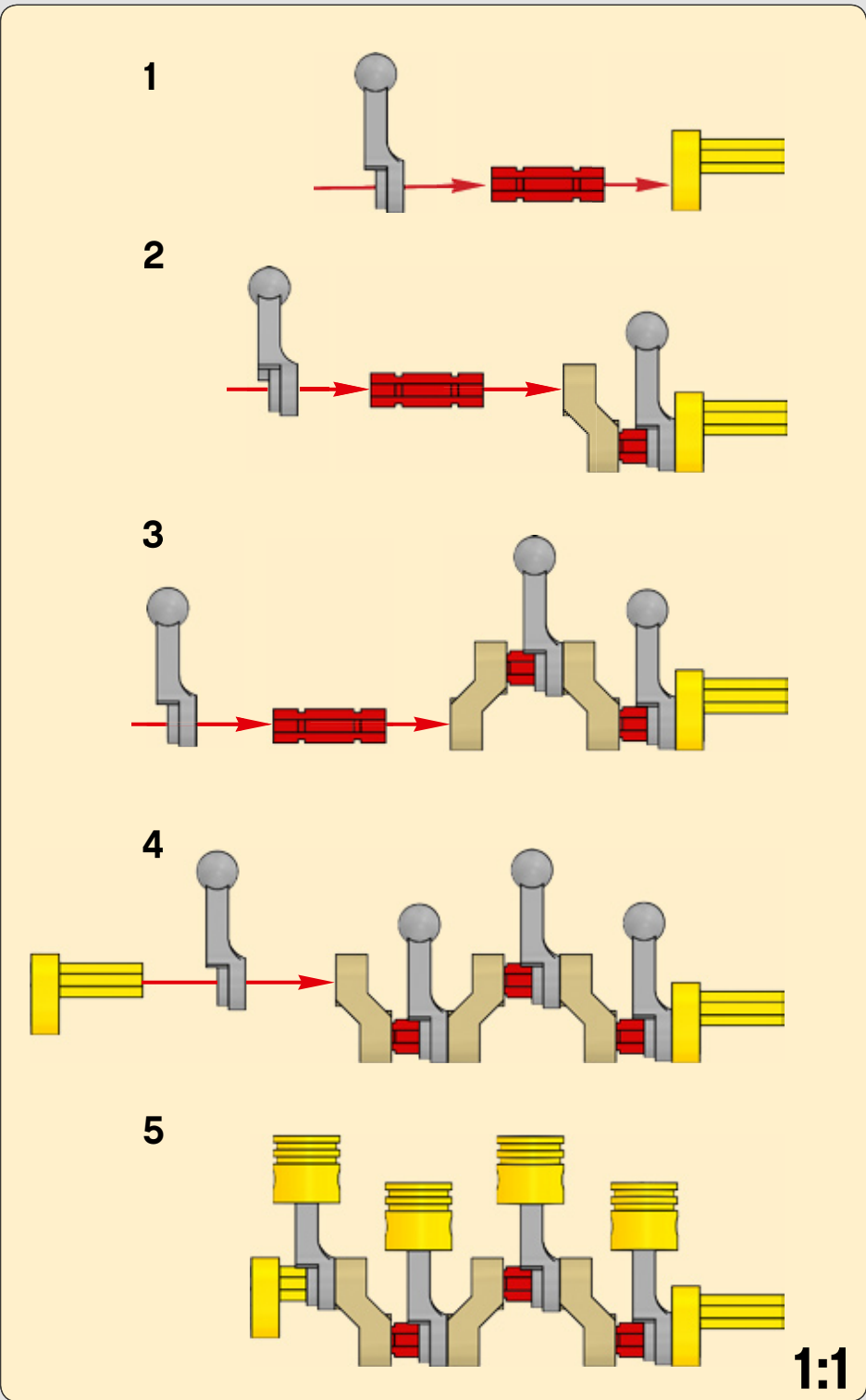
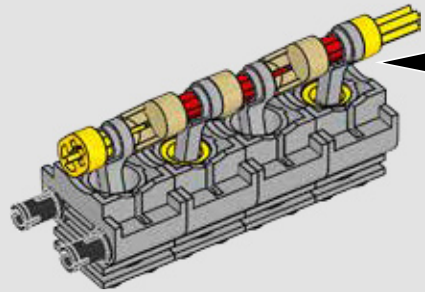

1:1

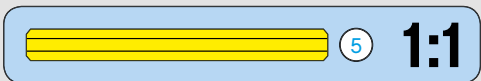

243

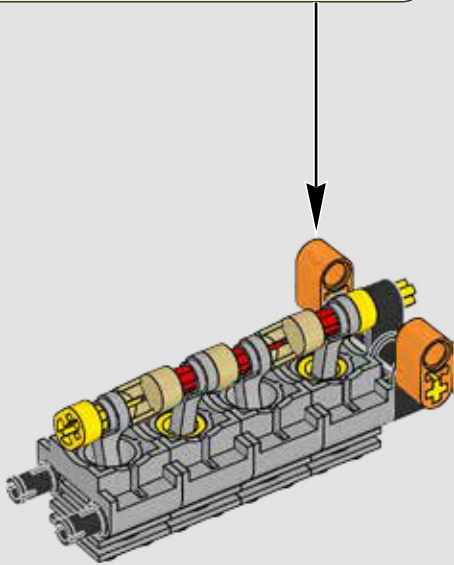
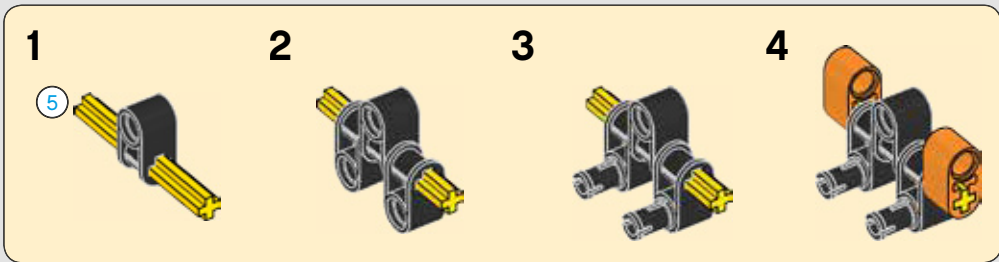

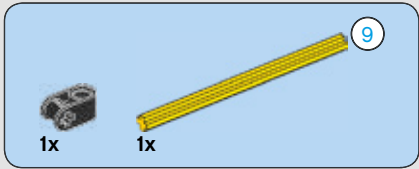
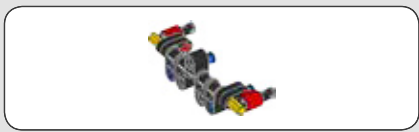

244

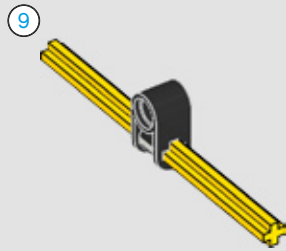

245

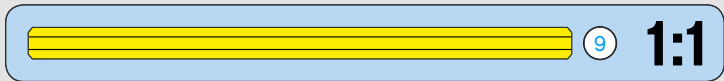
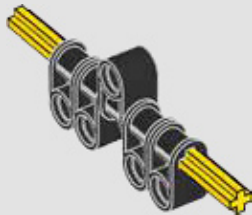

246

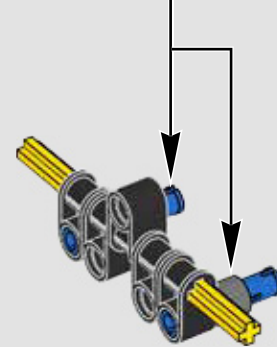
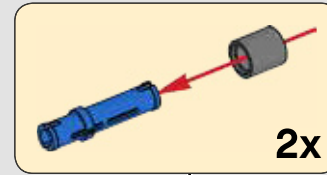

247

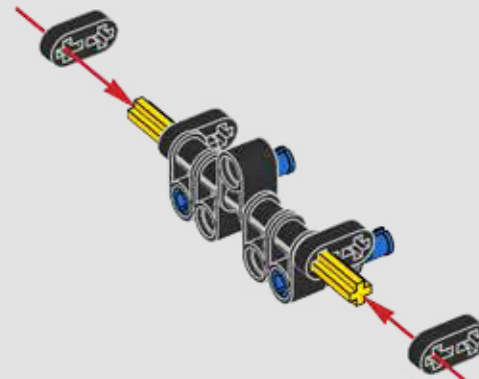



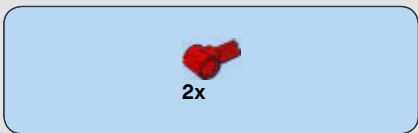

248

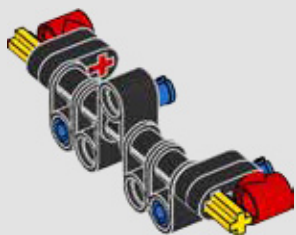

249

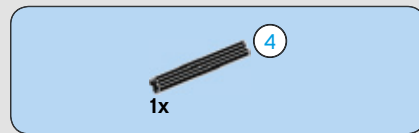
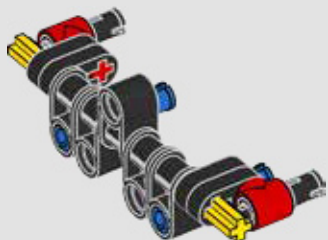

250

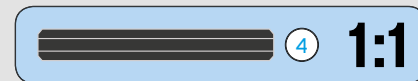
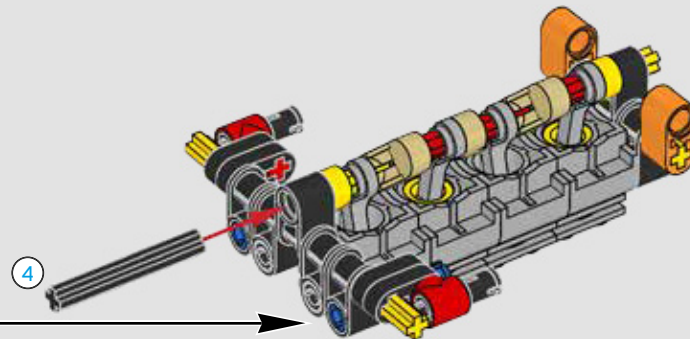

251

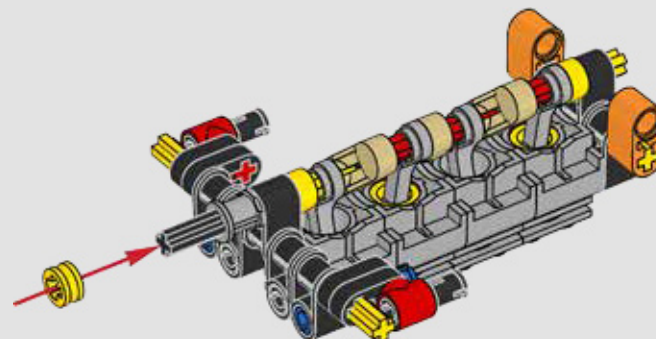

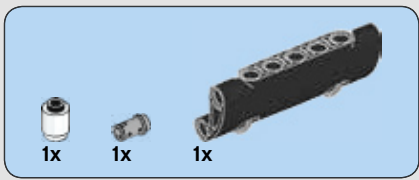

252

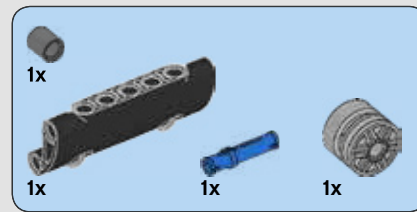
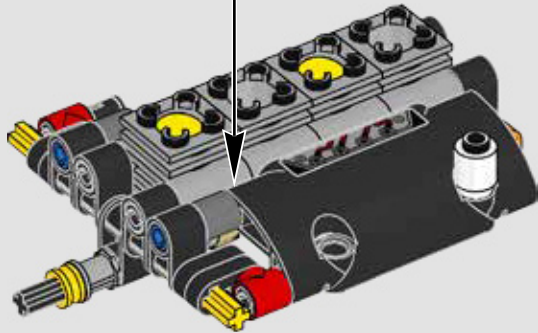
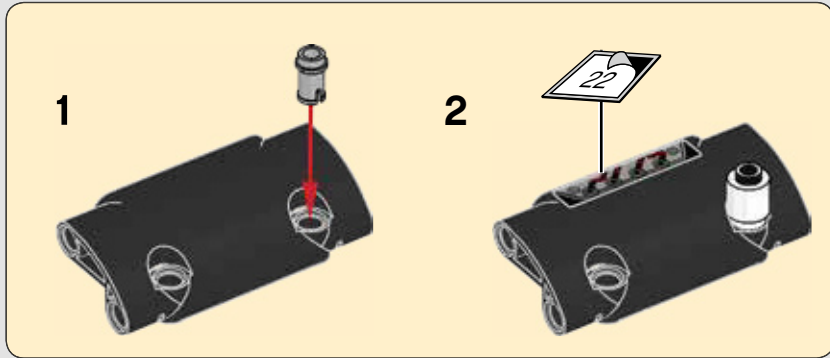

253

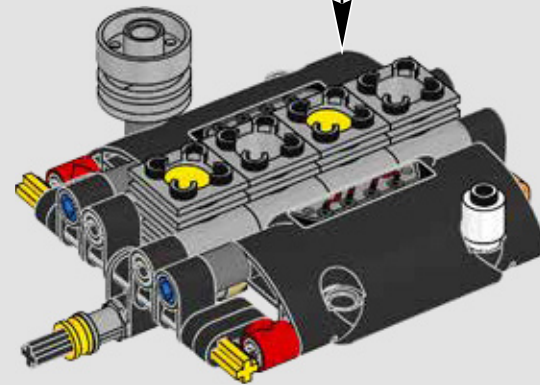
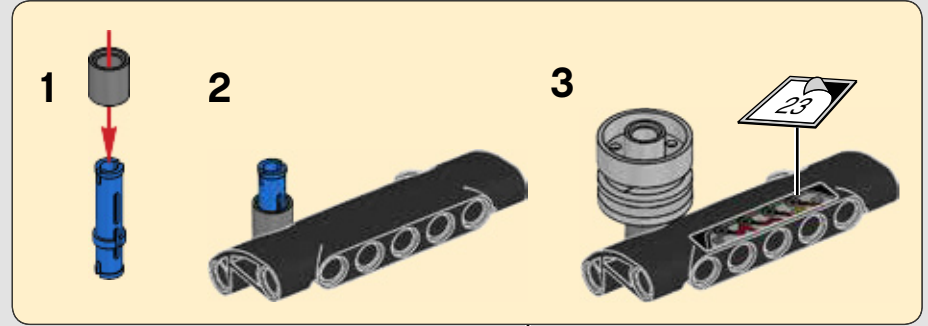

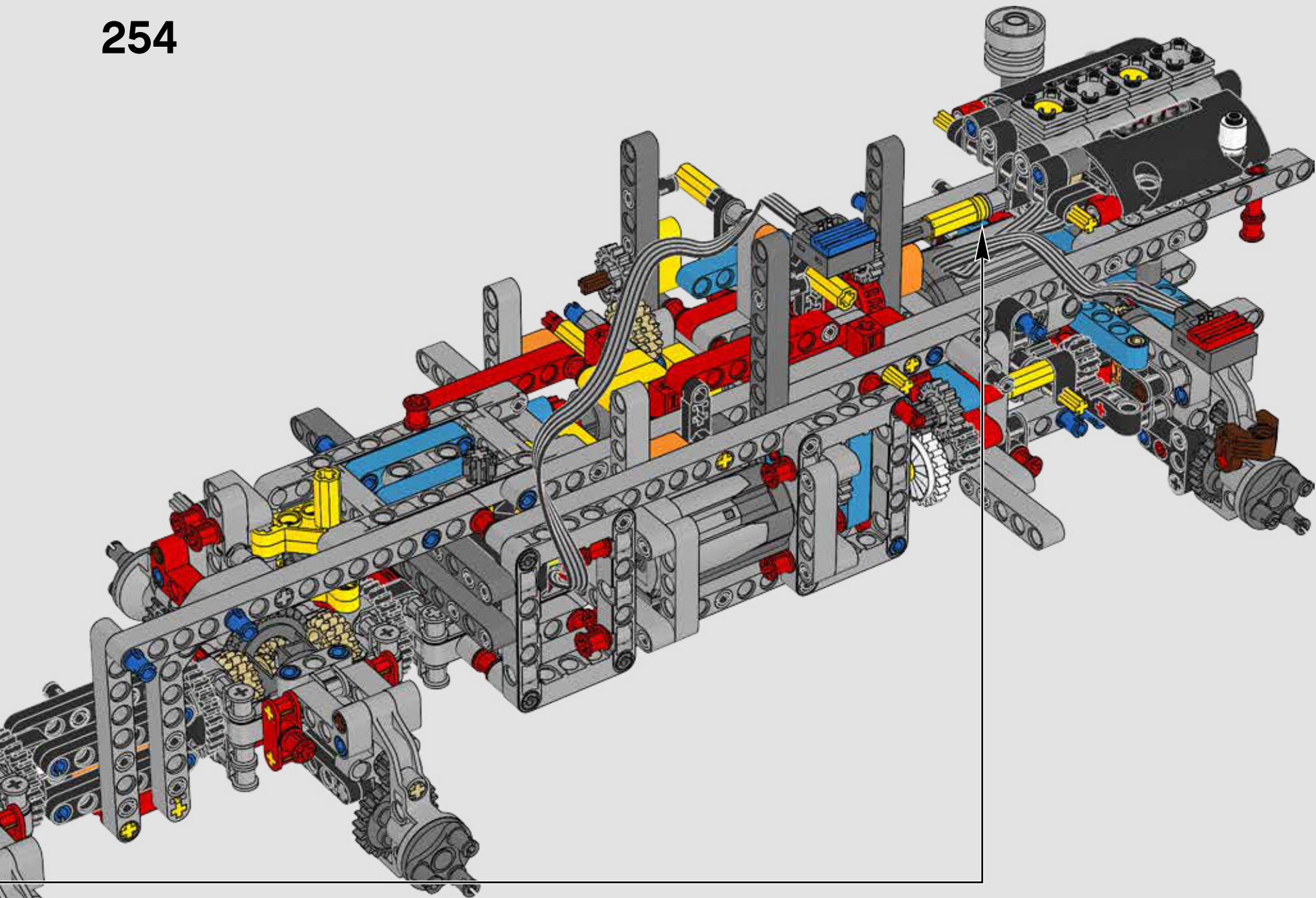



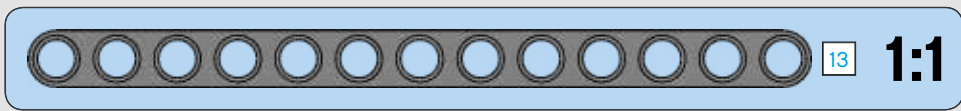
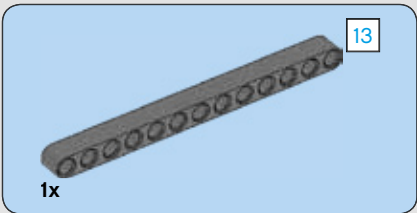

255

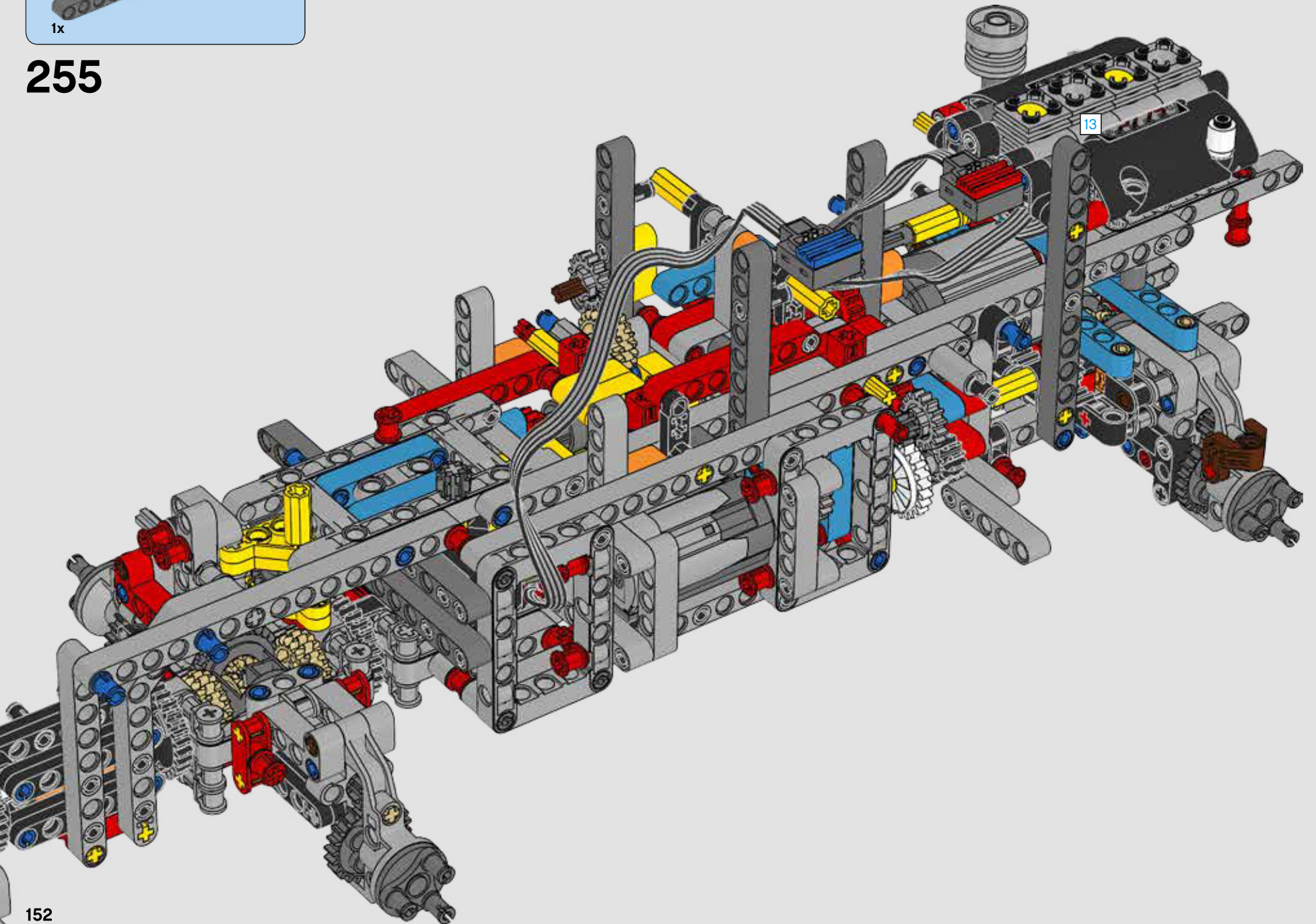

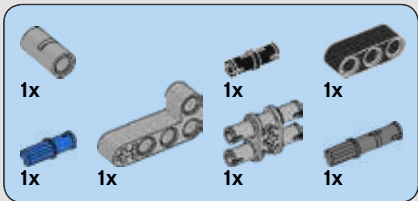

256

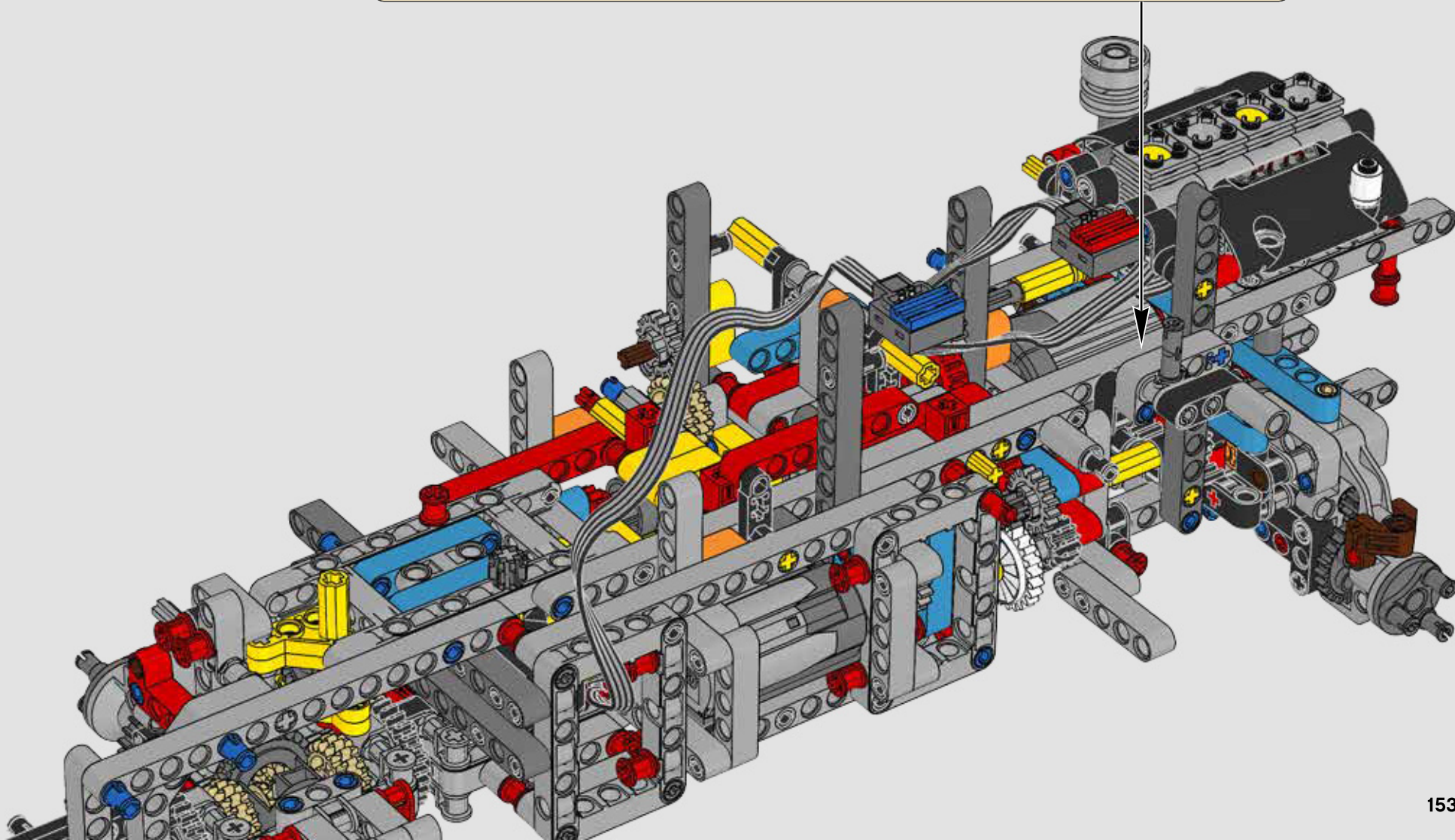
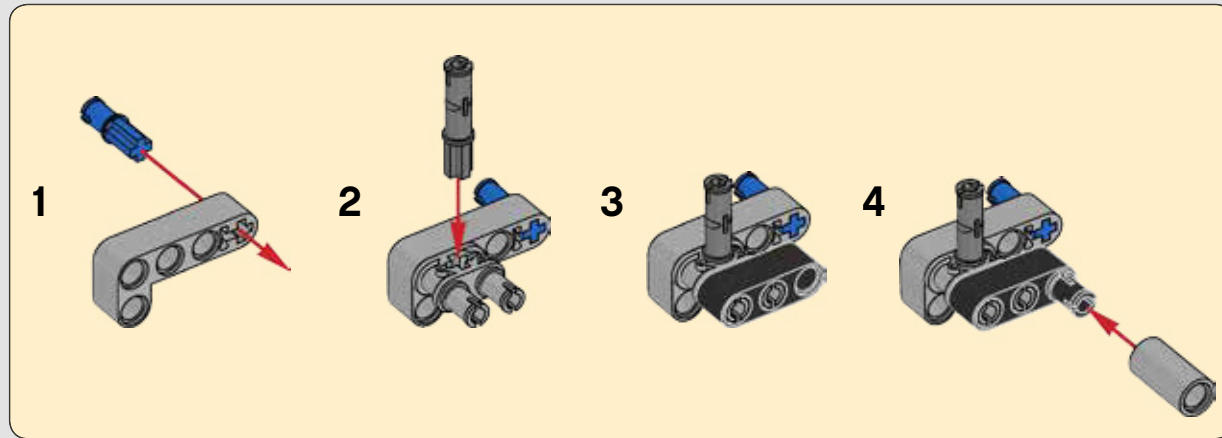



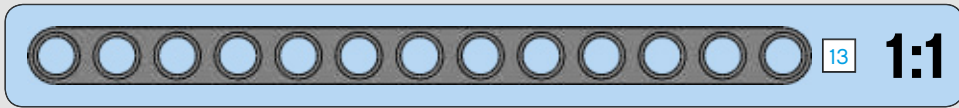
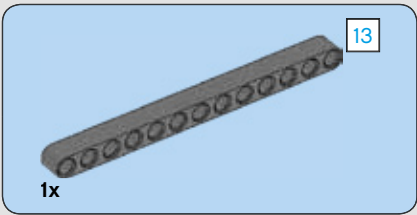

257

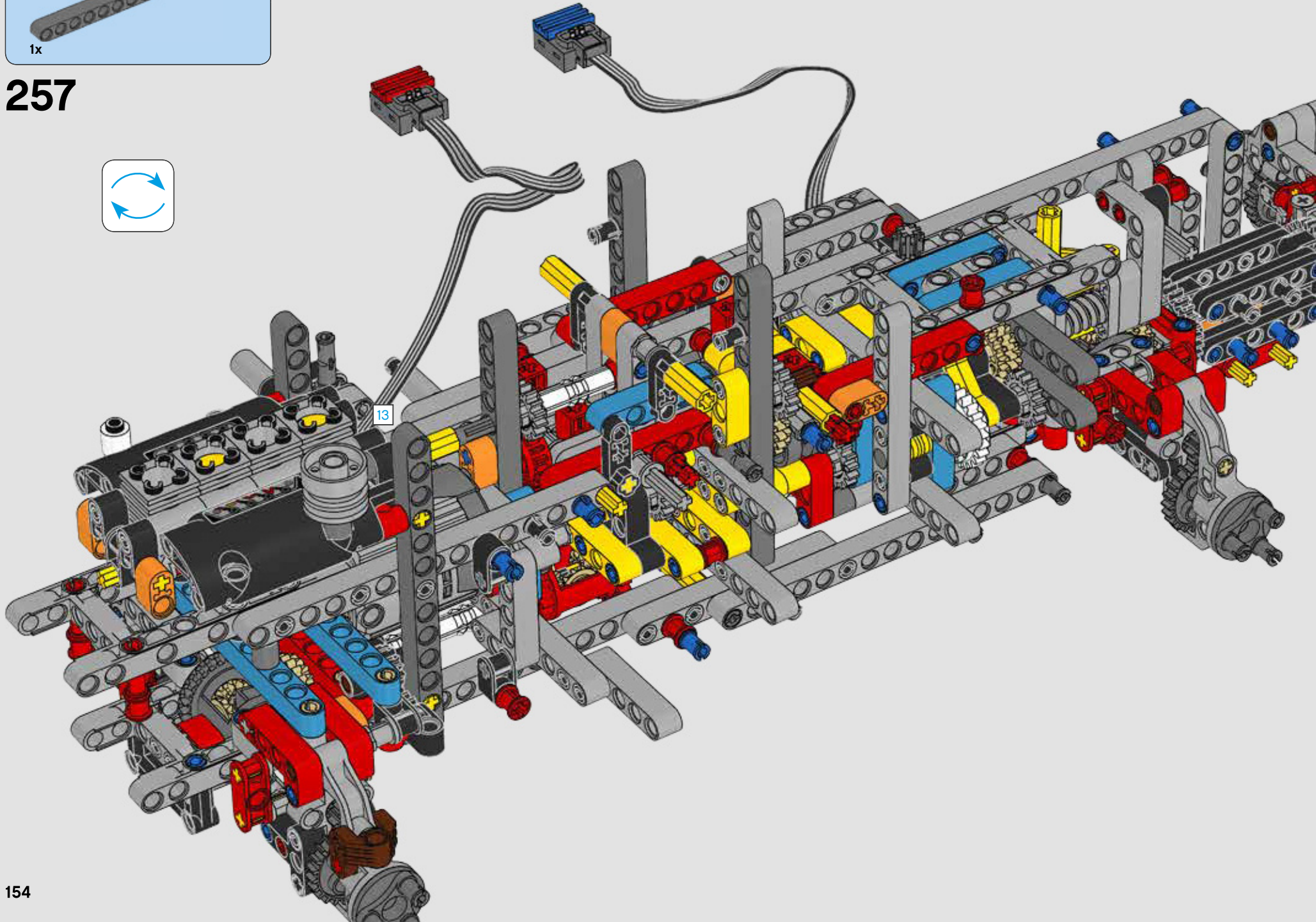



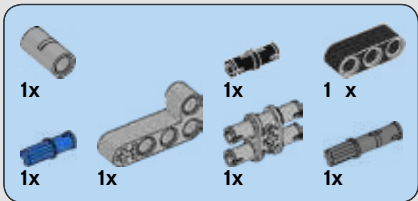

258

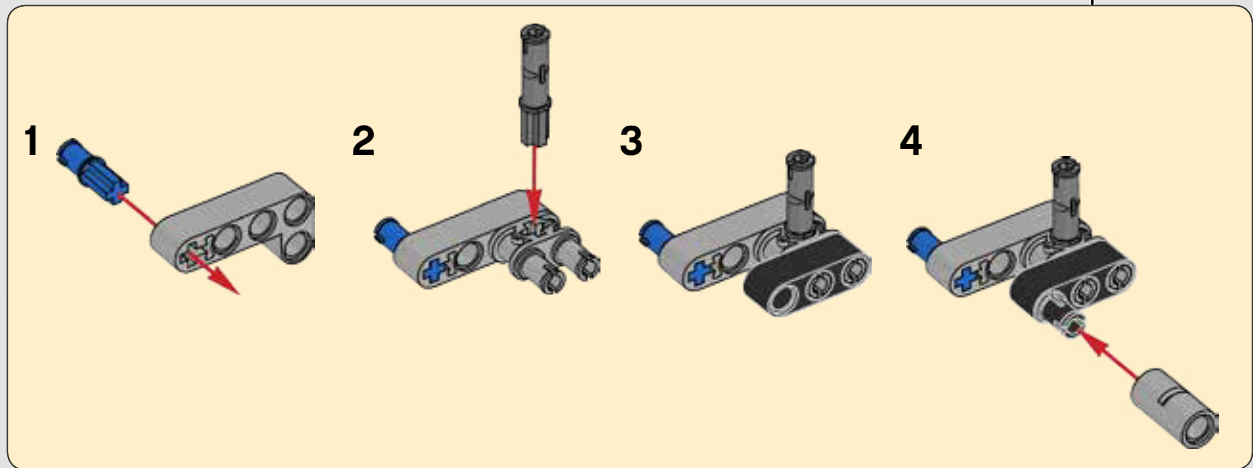
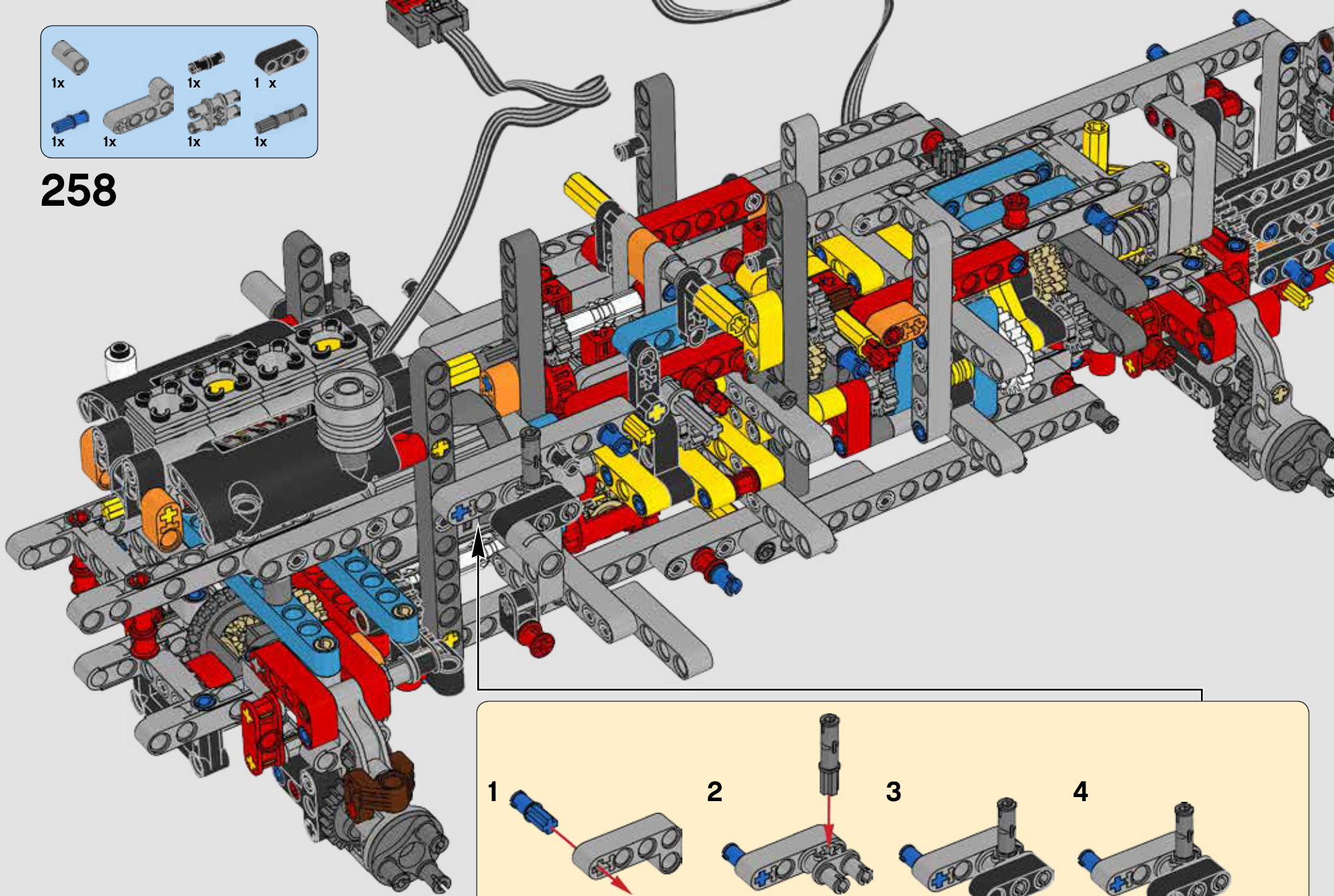



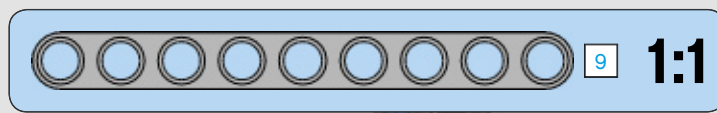
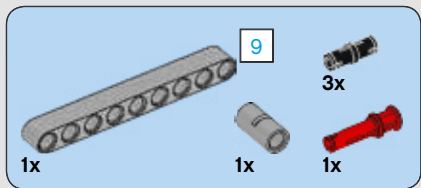

259

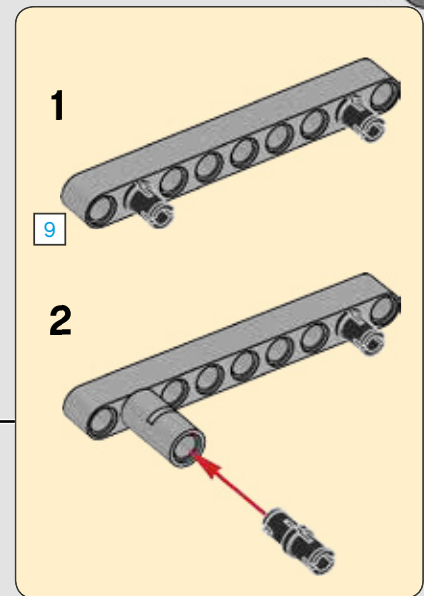
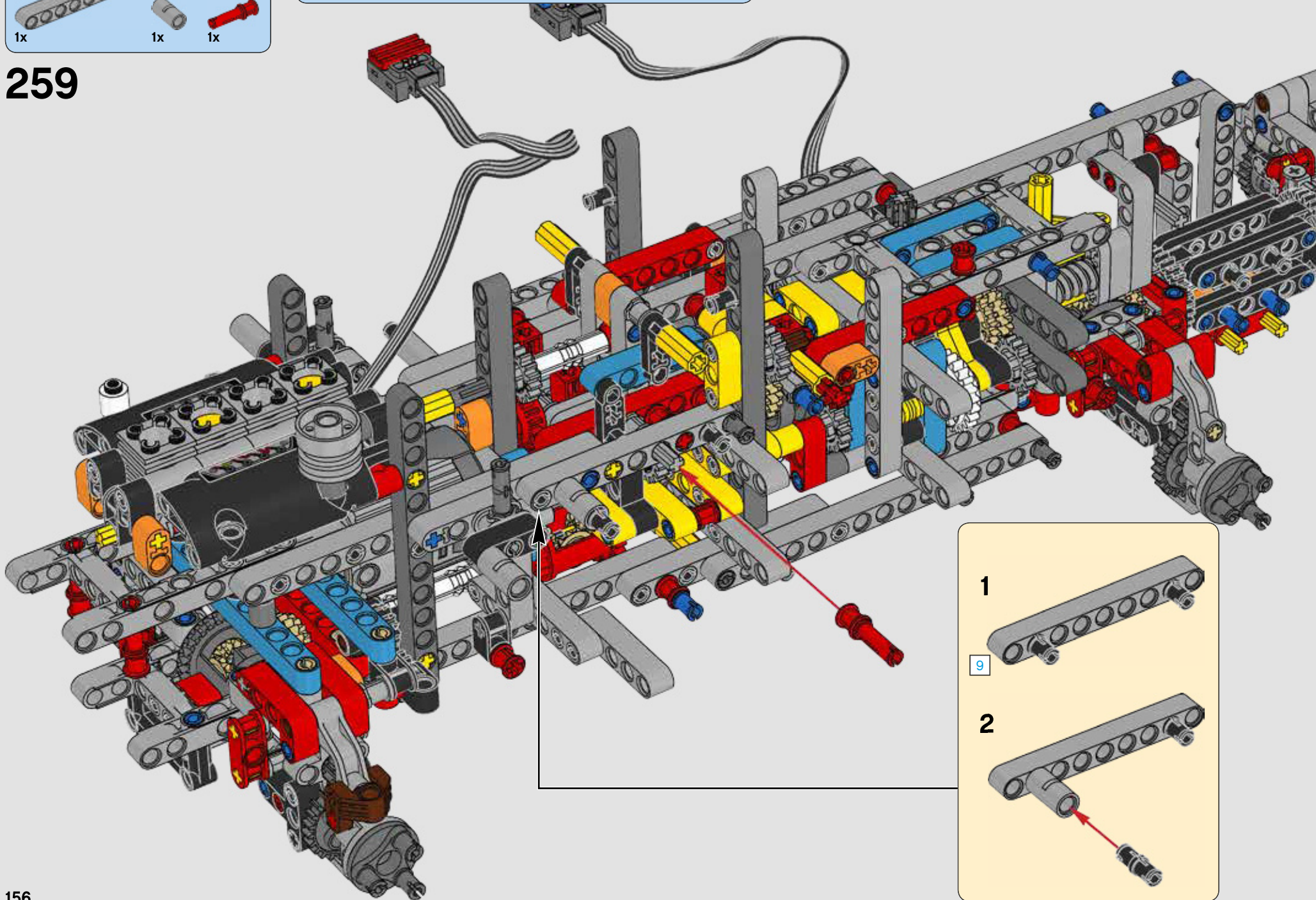





260

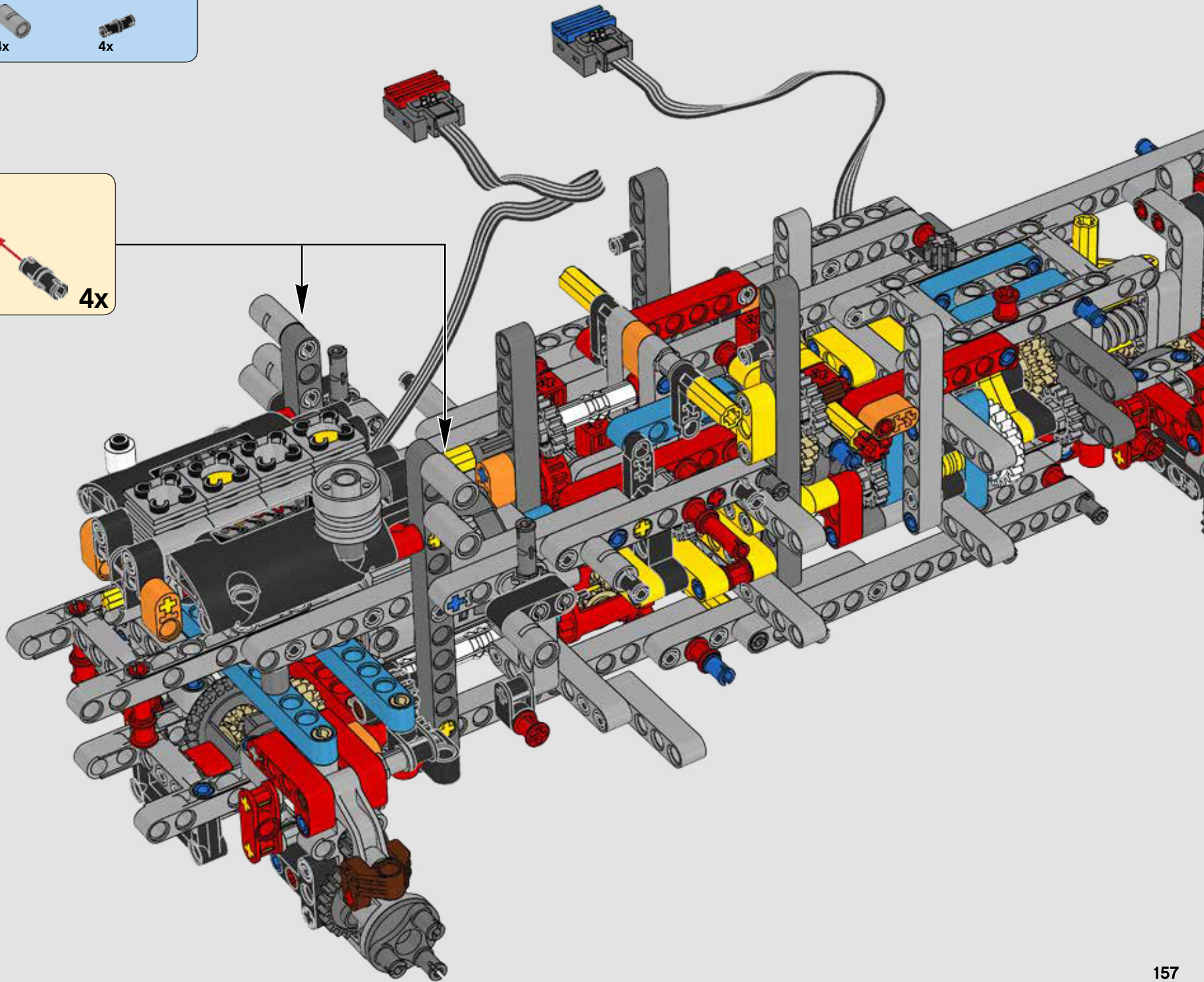
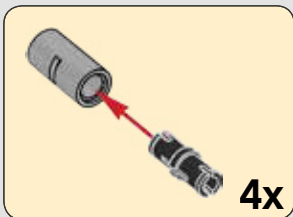



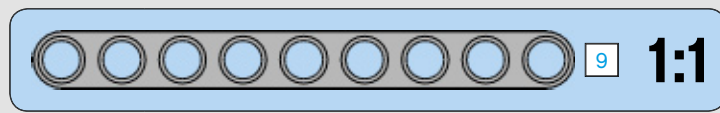
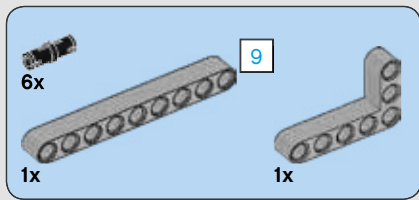

261

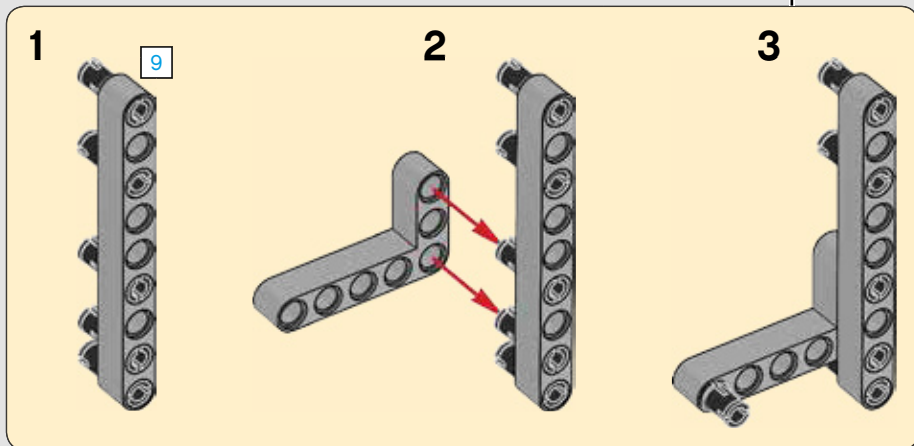
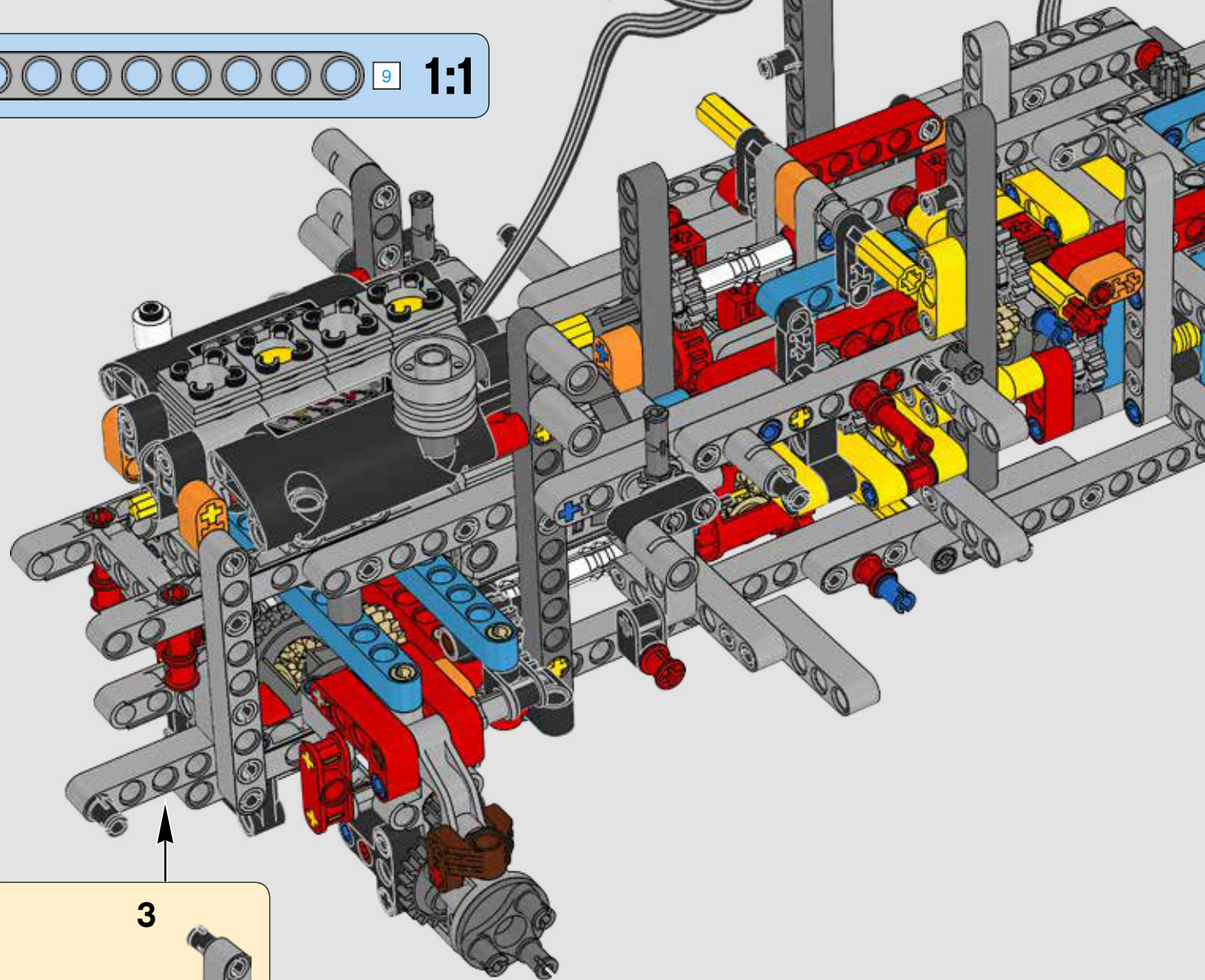

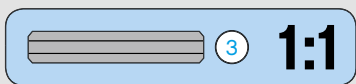
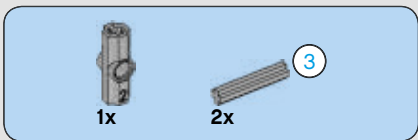

262

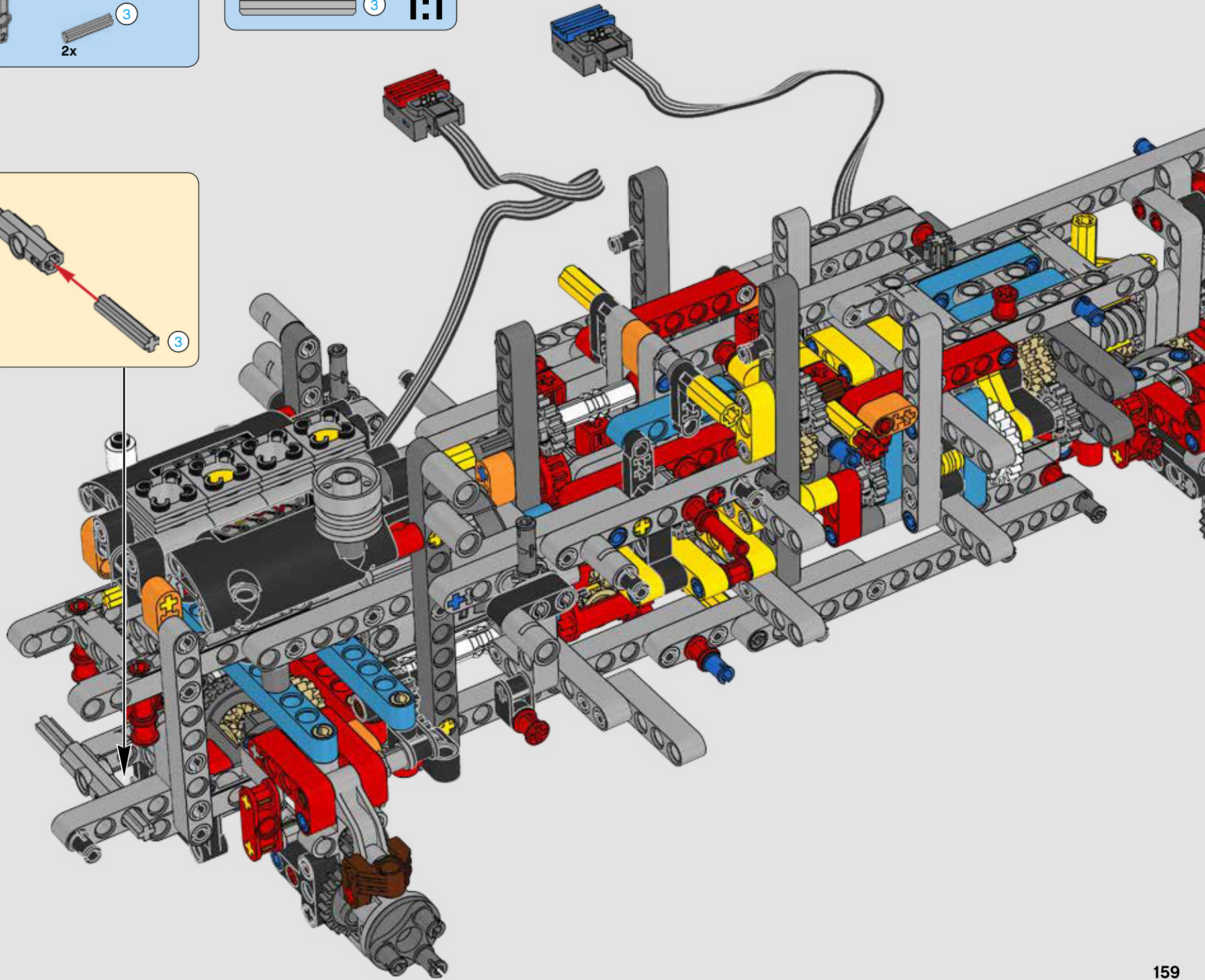
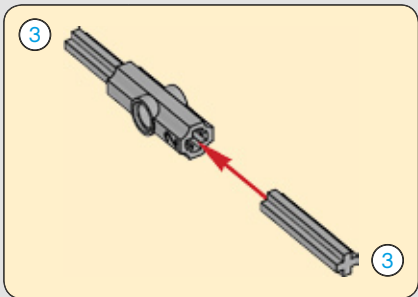



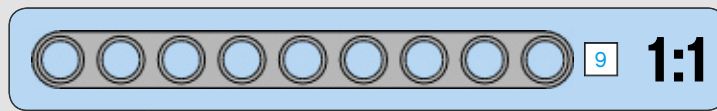
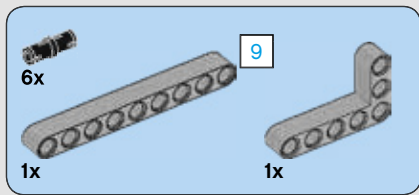

263

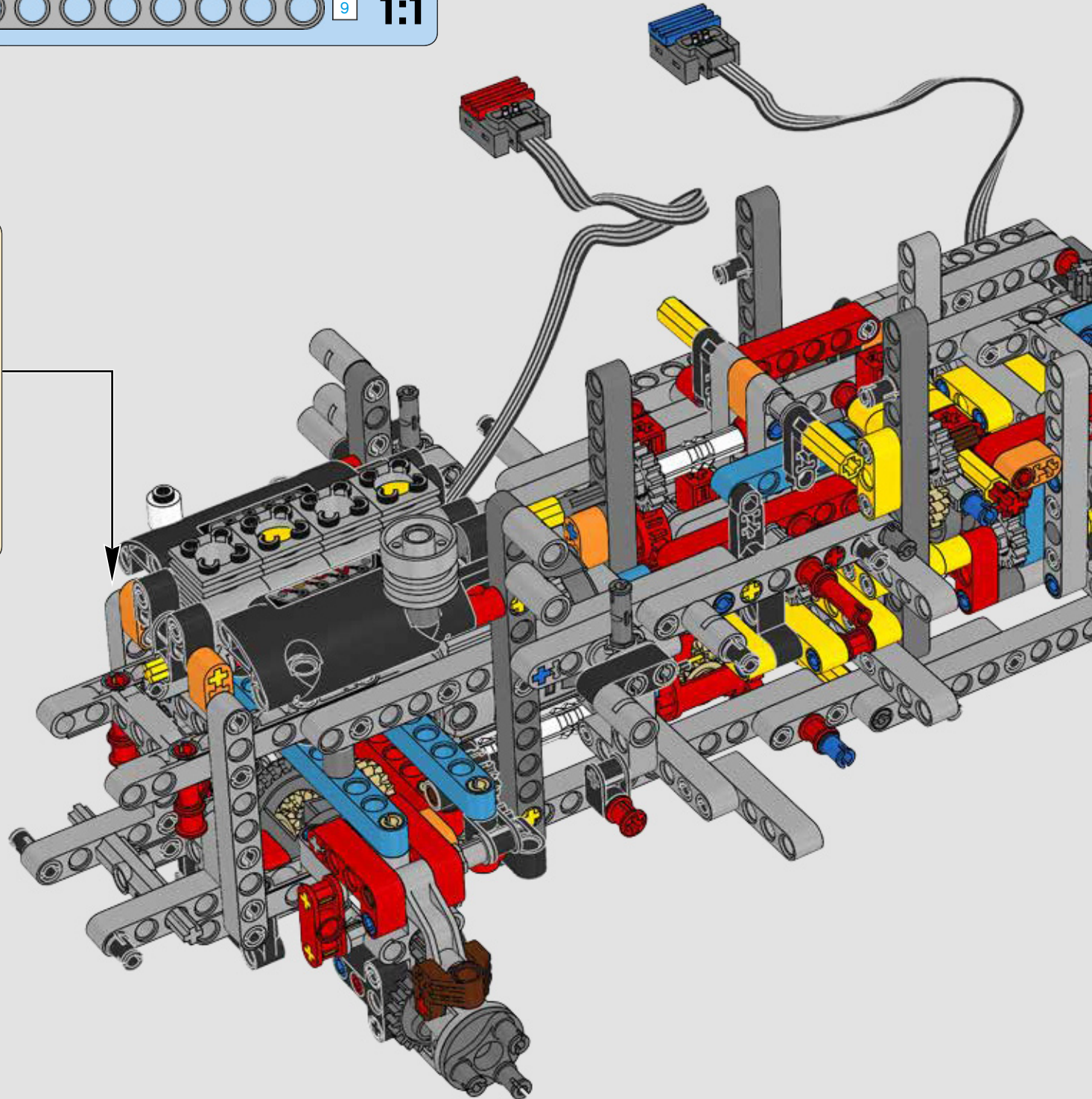
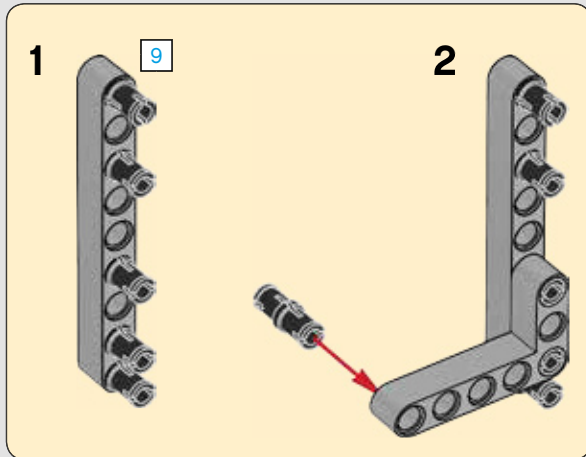



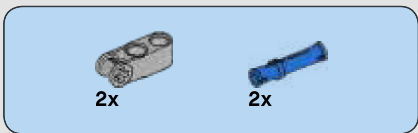

264

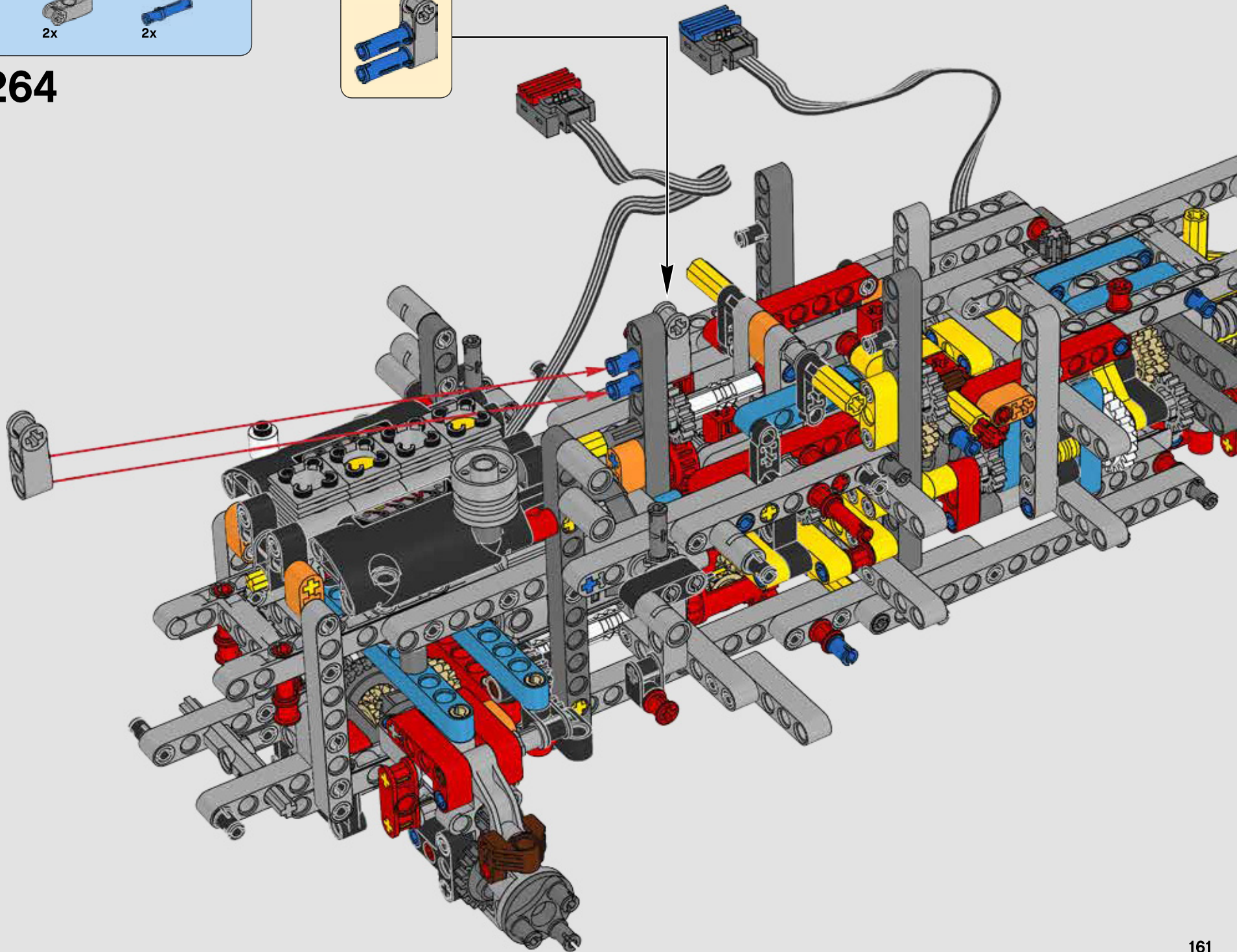
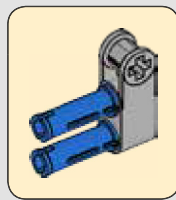

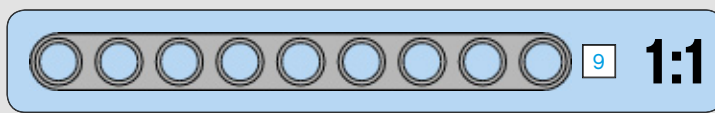
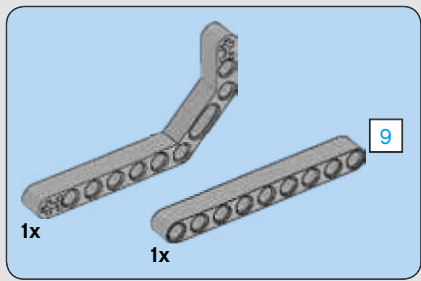

265

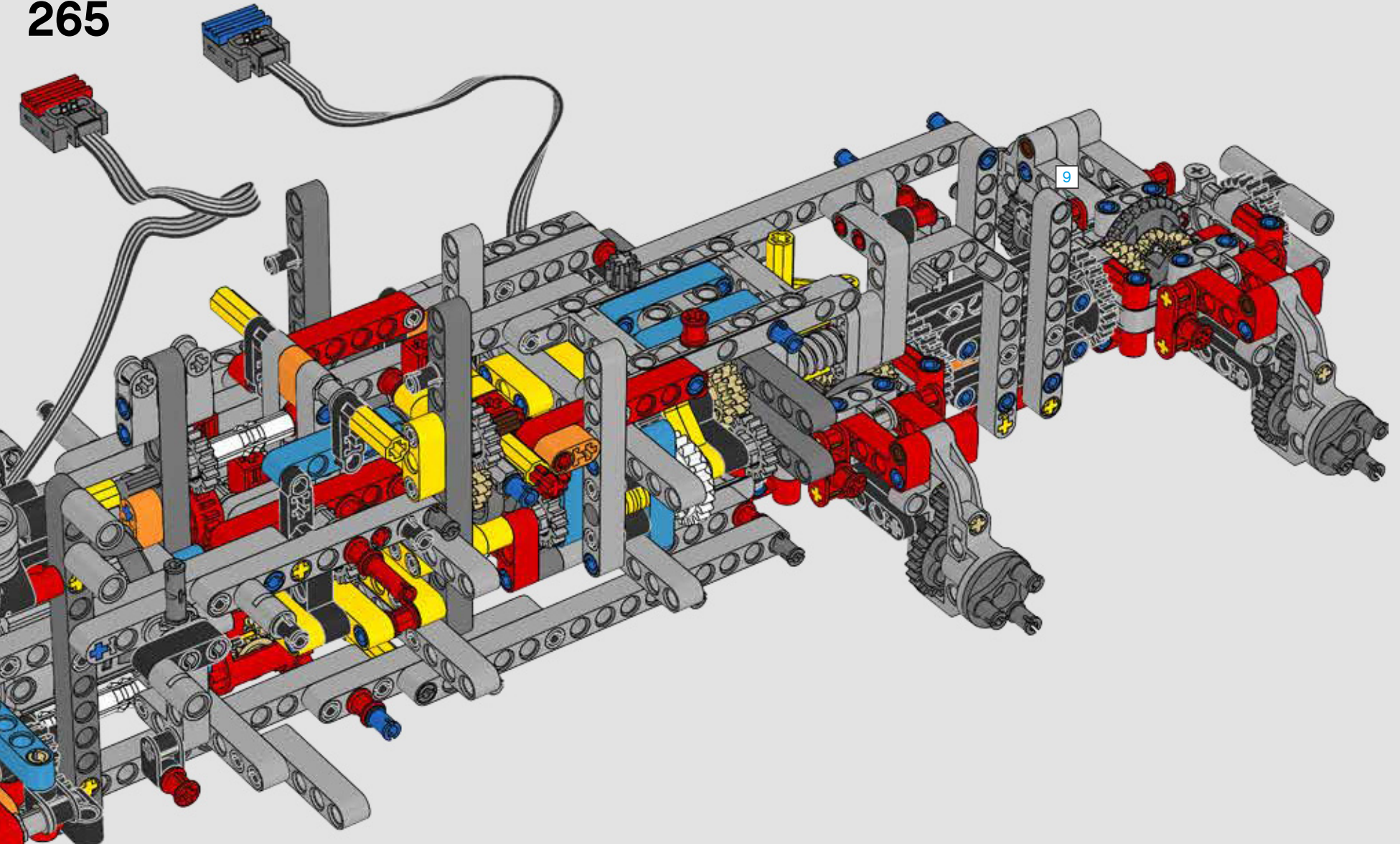



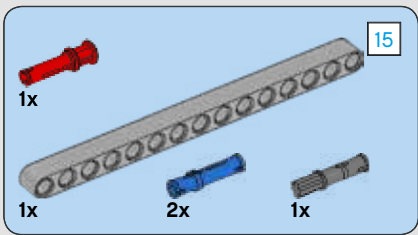

266

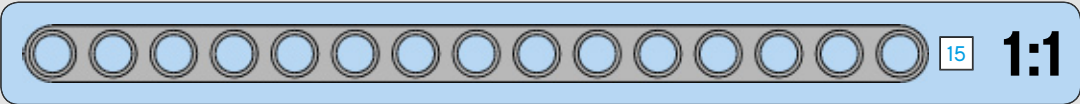
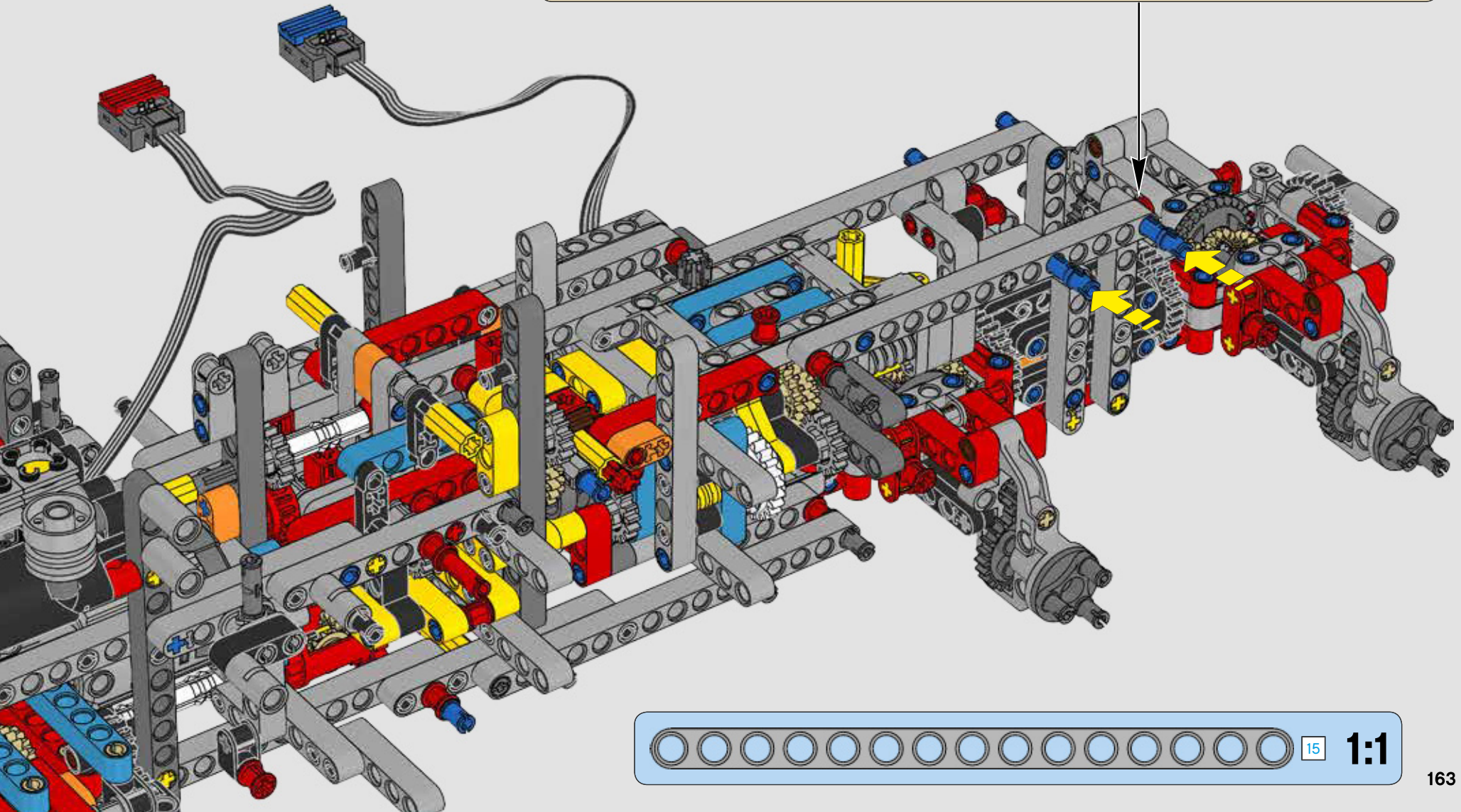
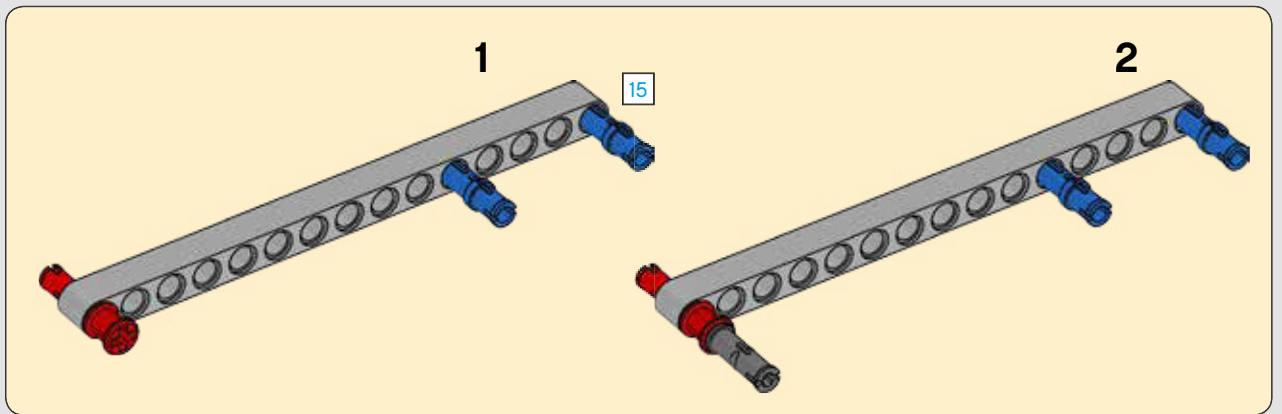



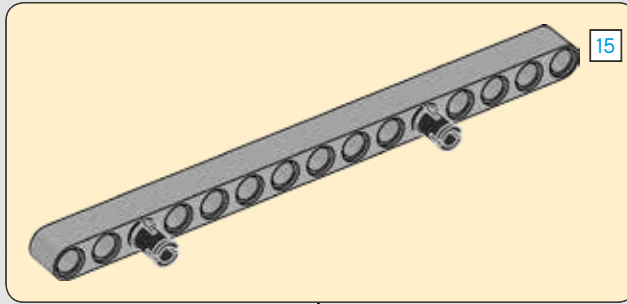
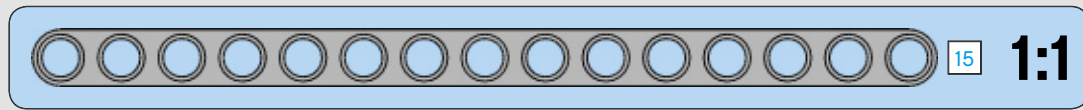
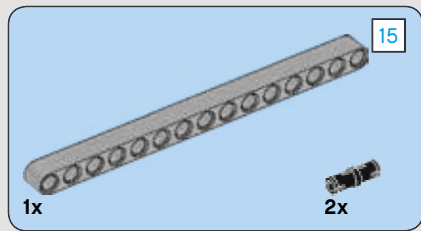

267

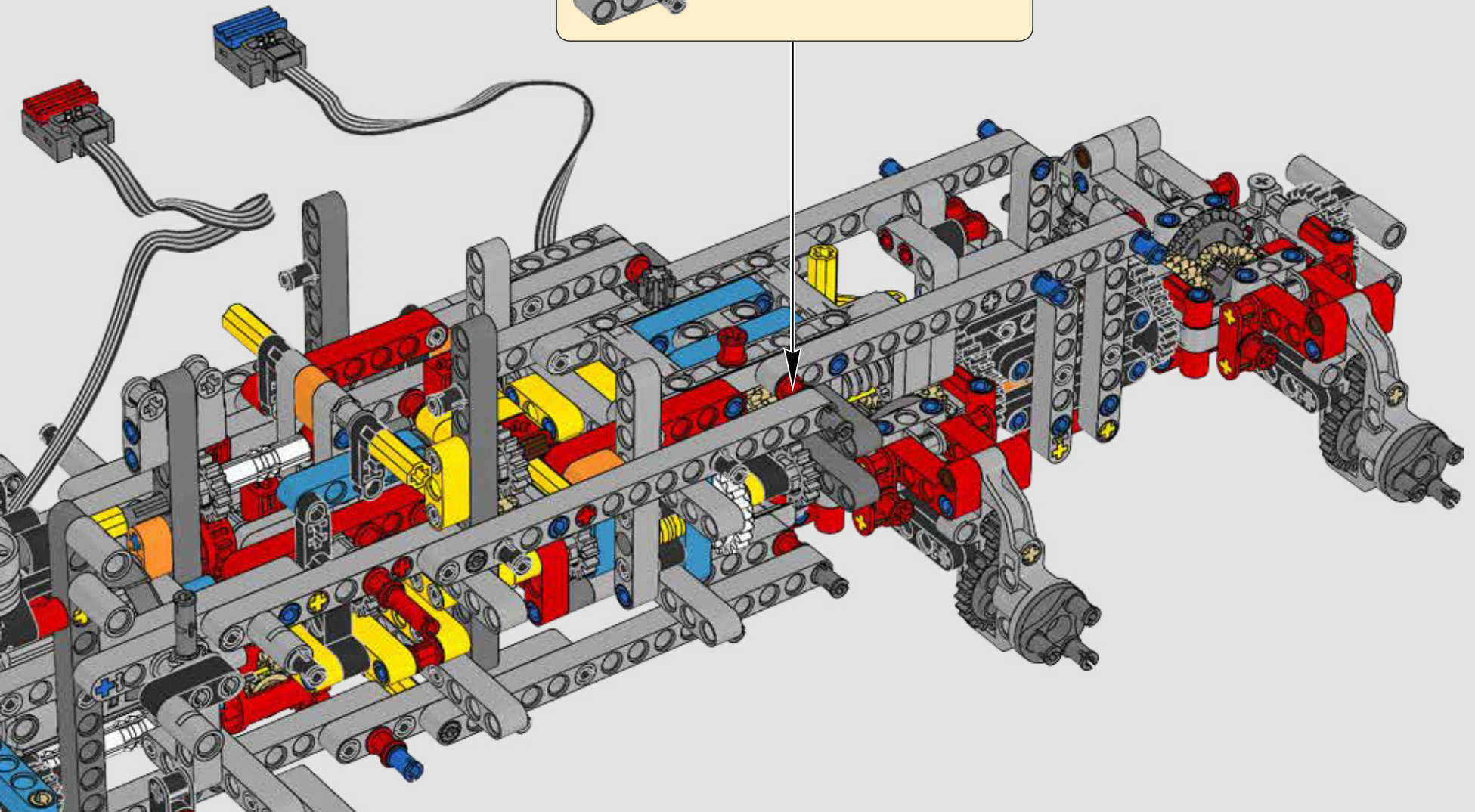



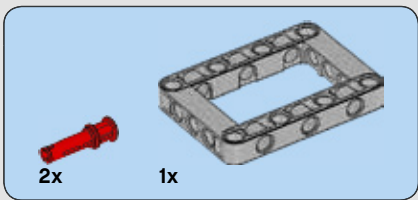

268

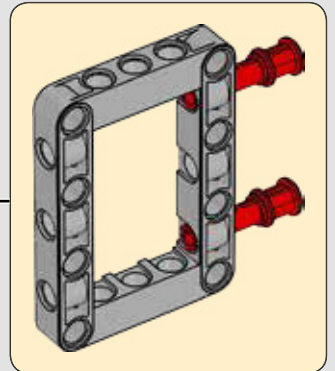
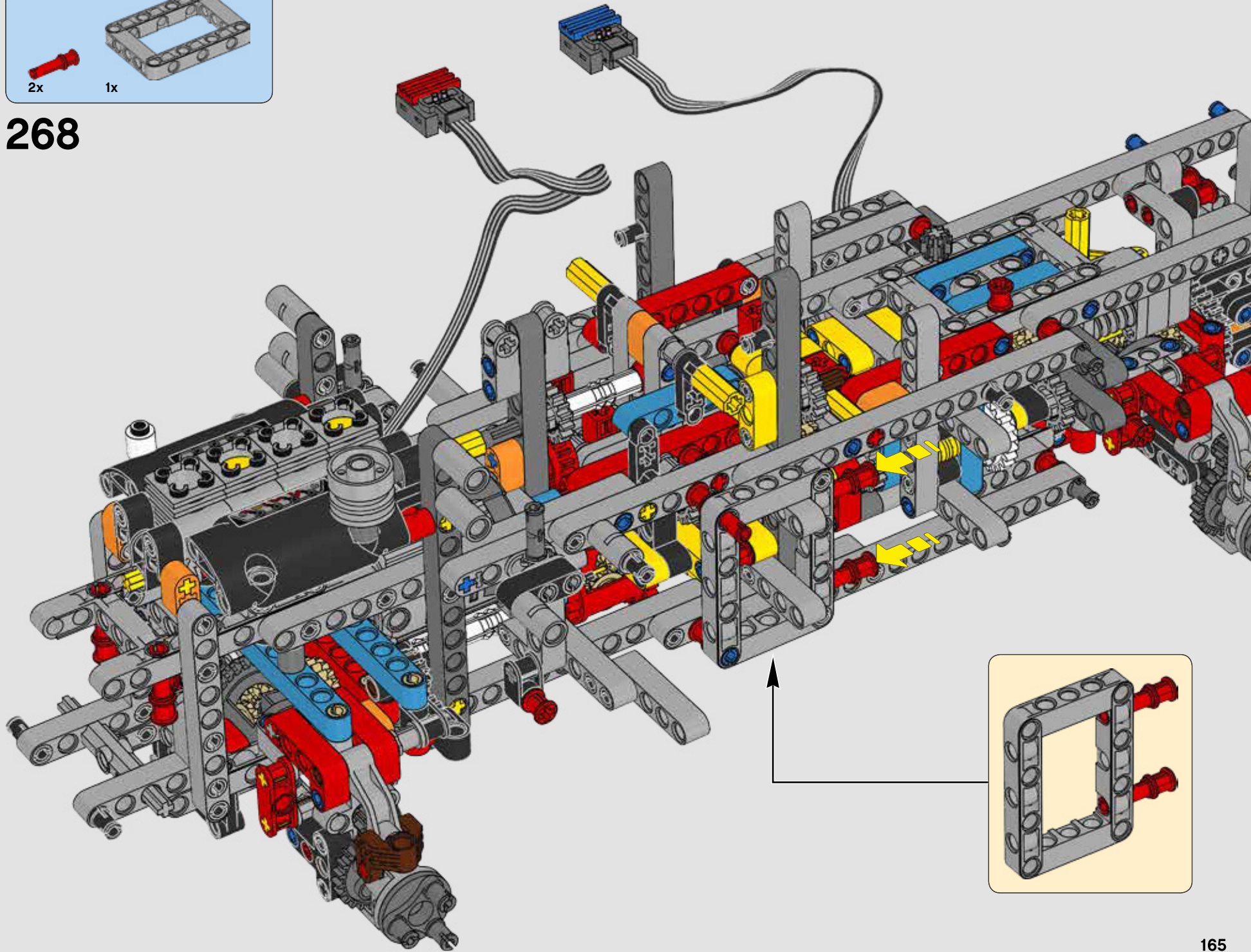



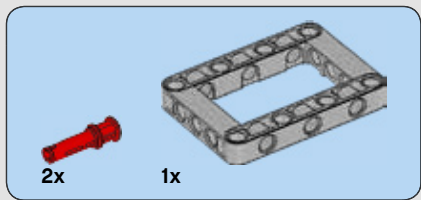

269

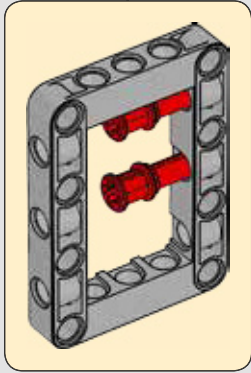
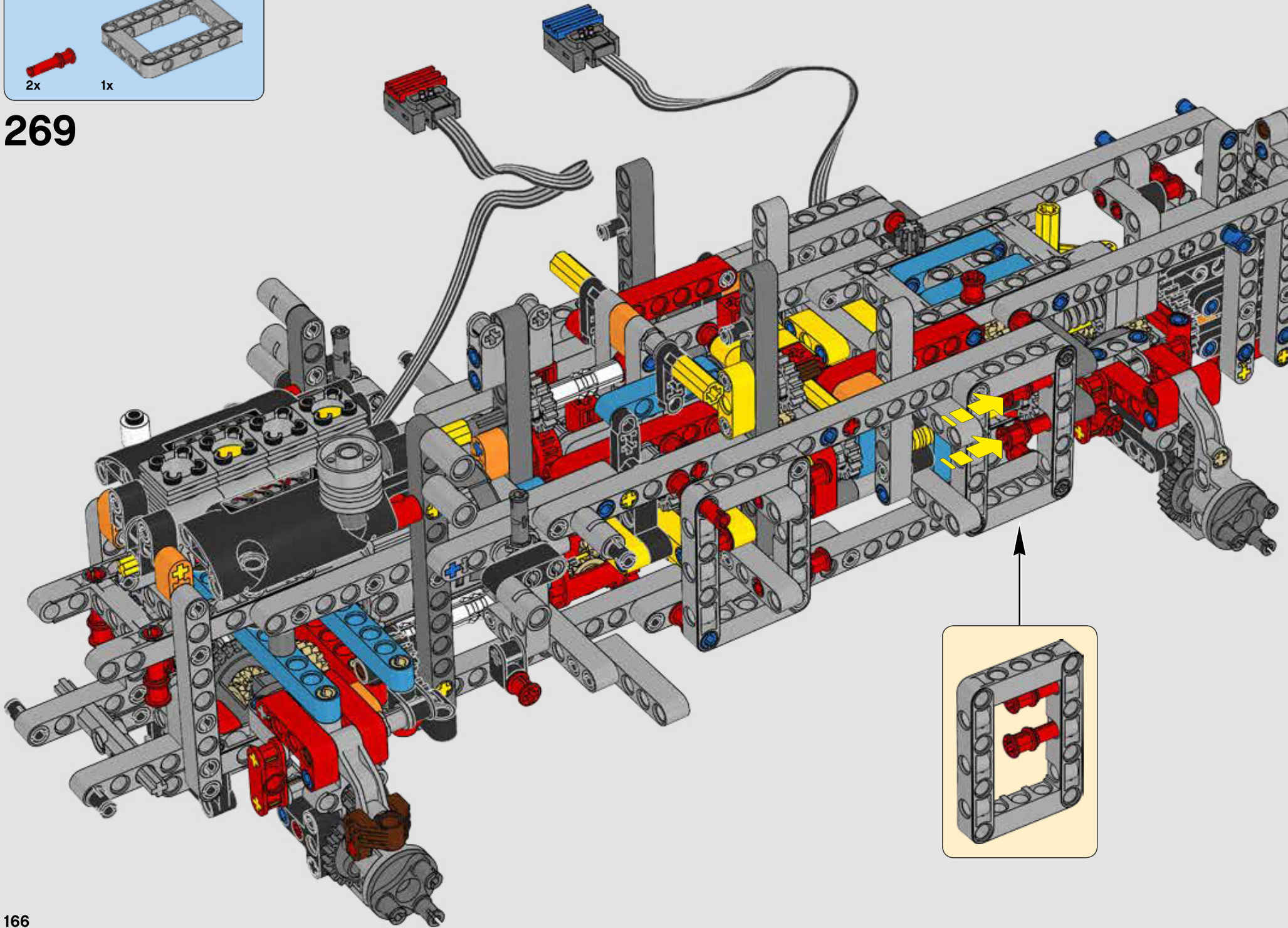





270

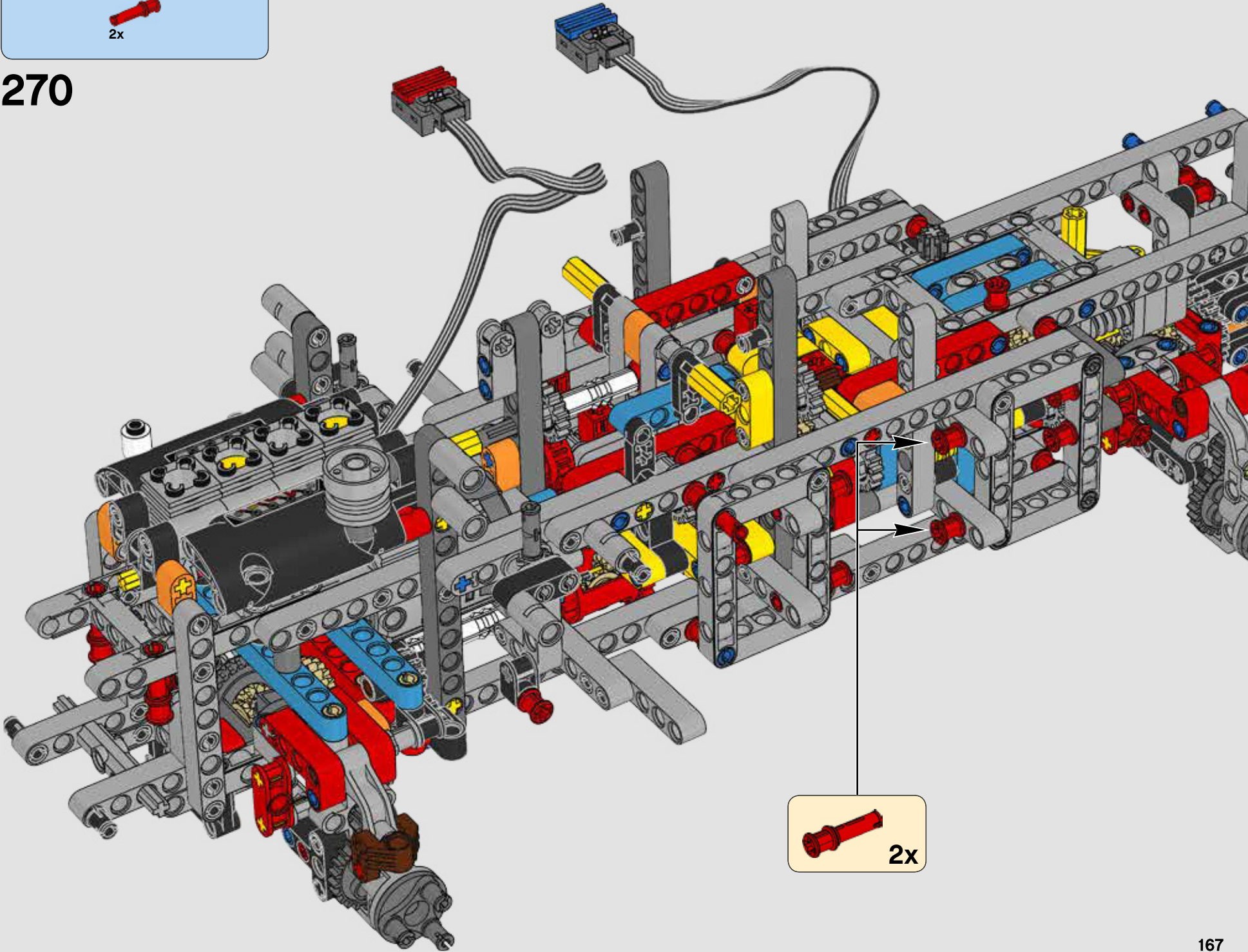



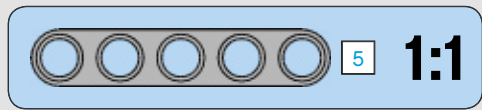
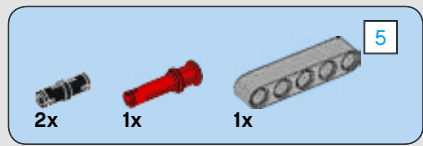

271

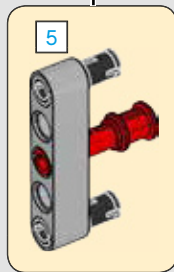
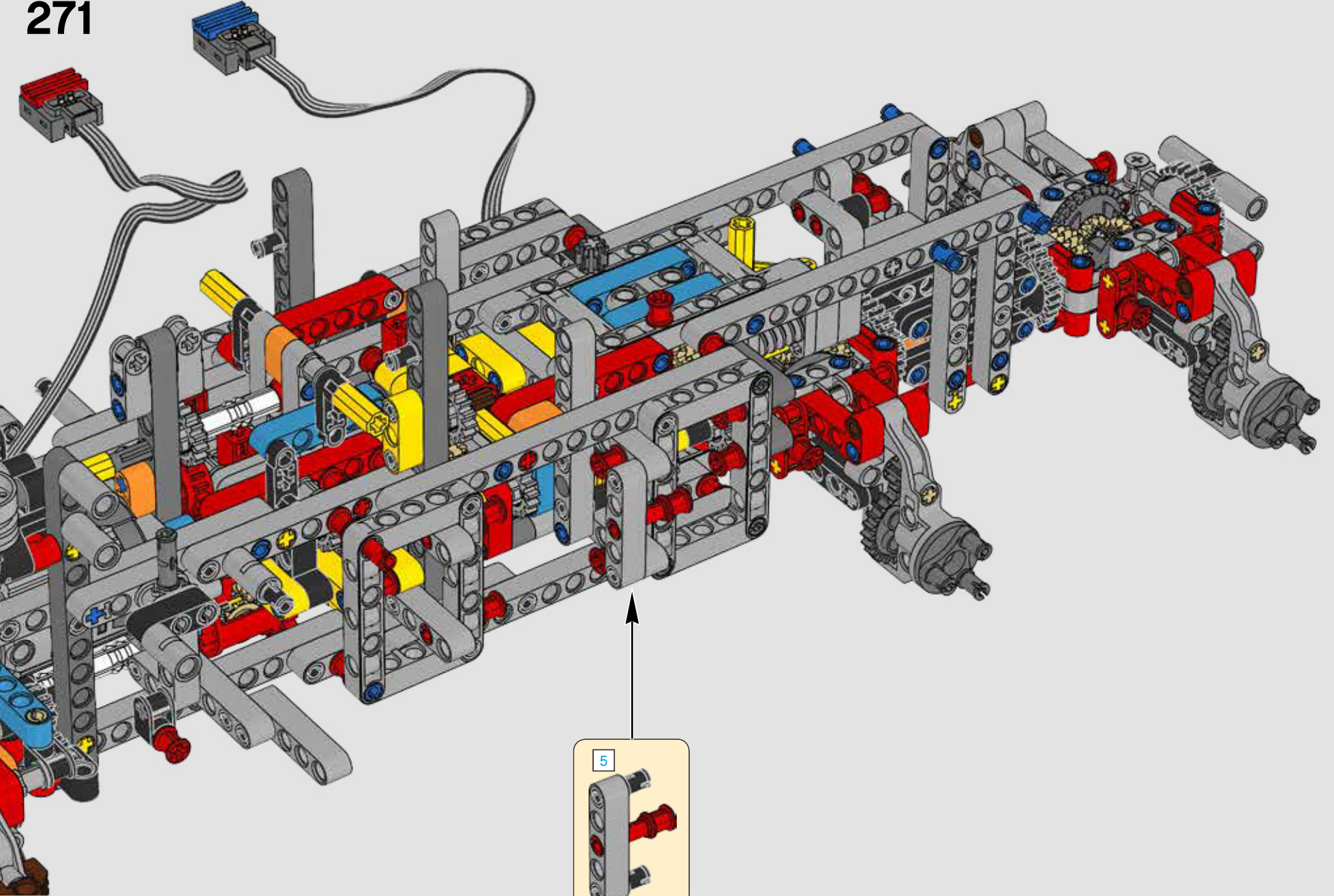



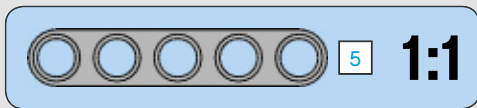
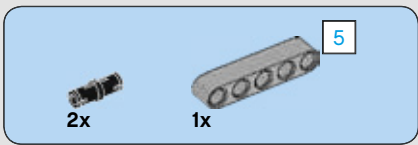

272

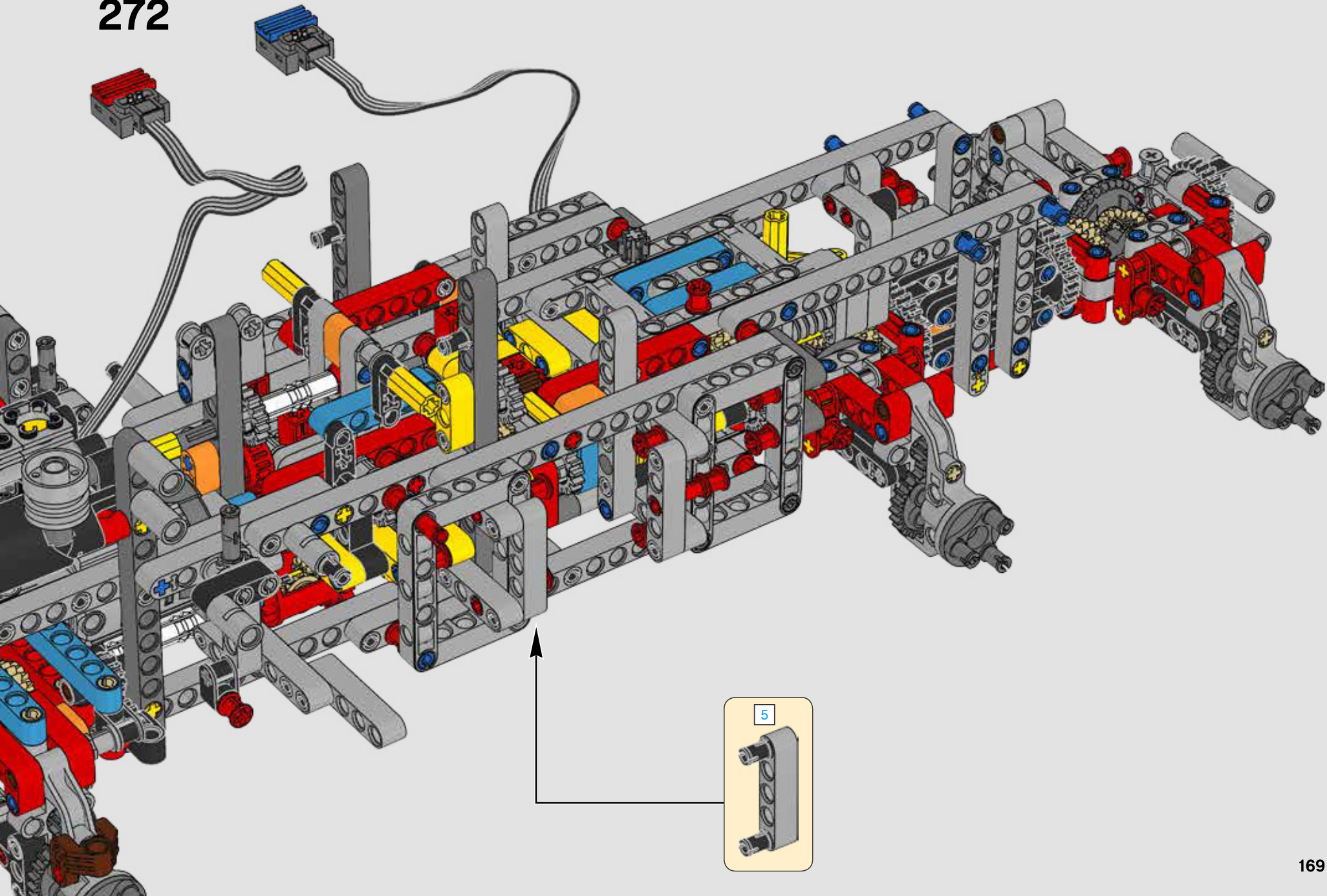



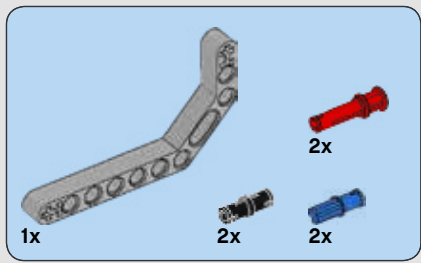

273

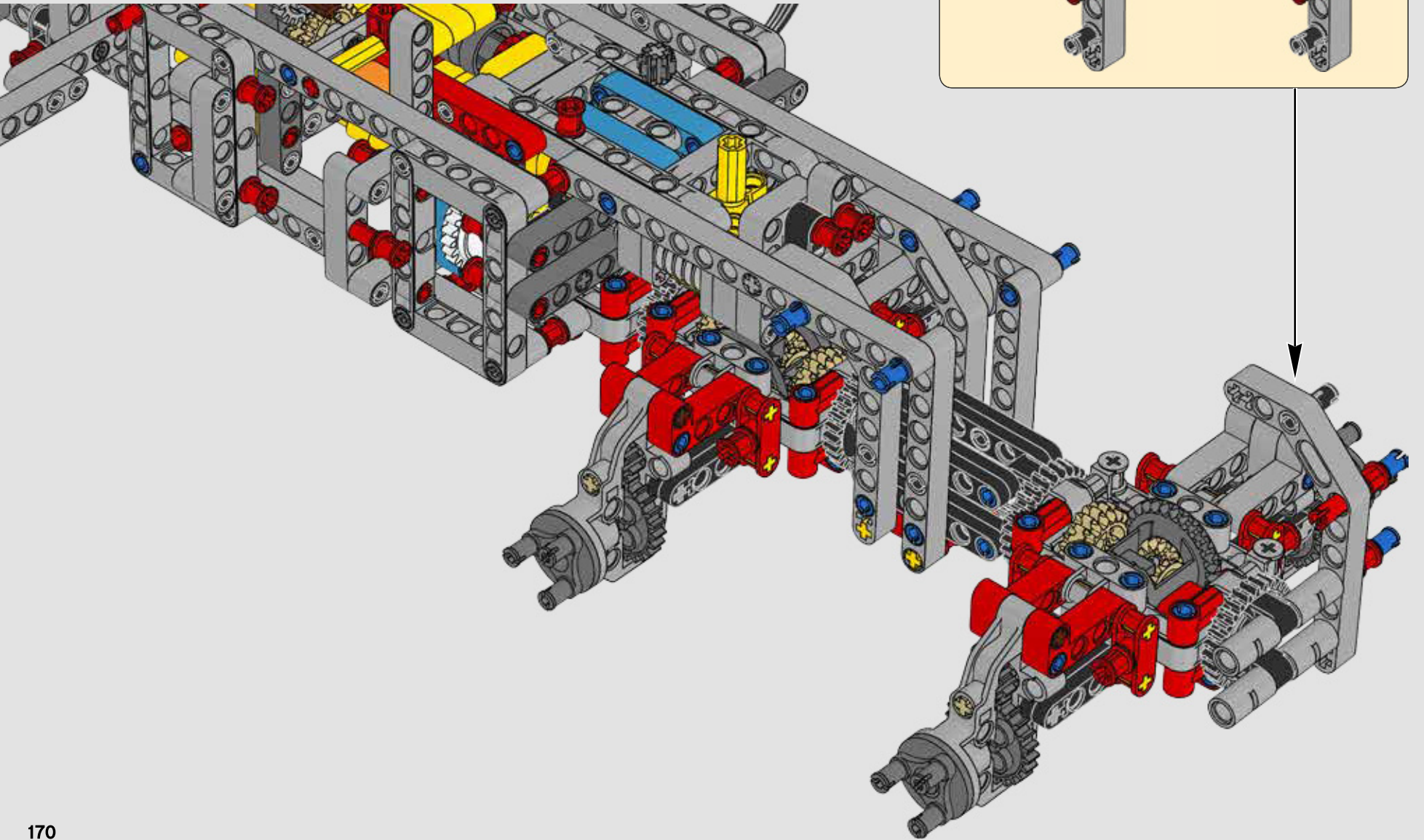
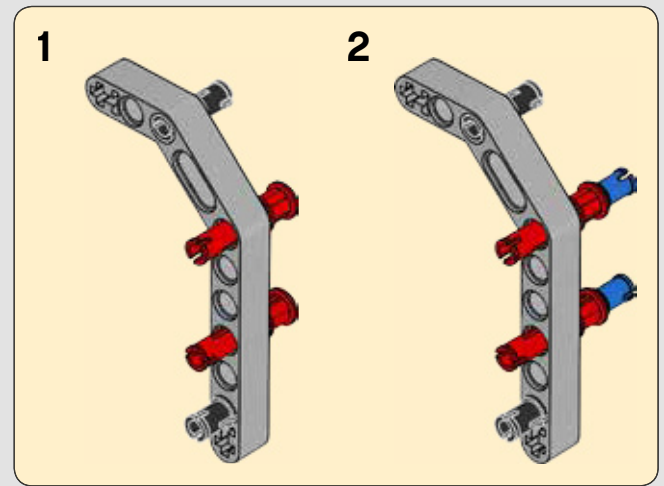
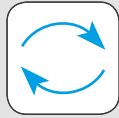

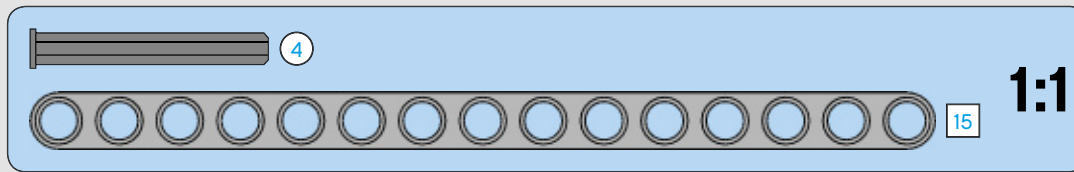
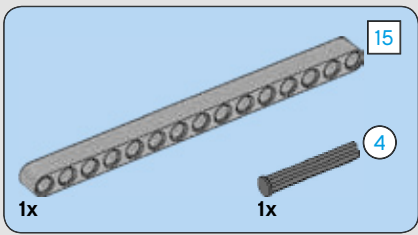

**274**

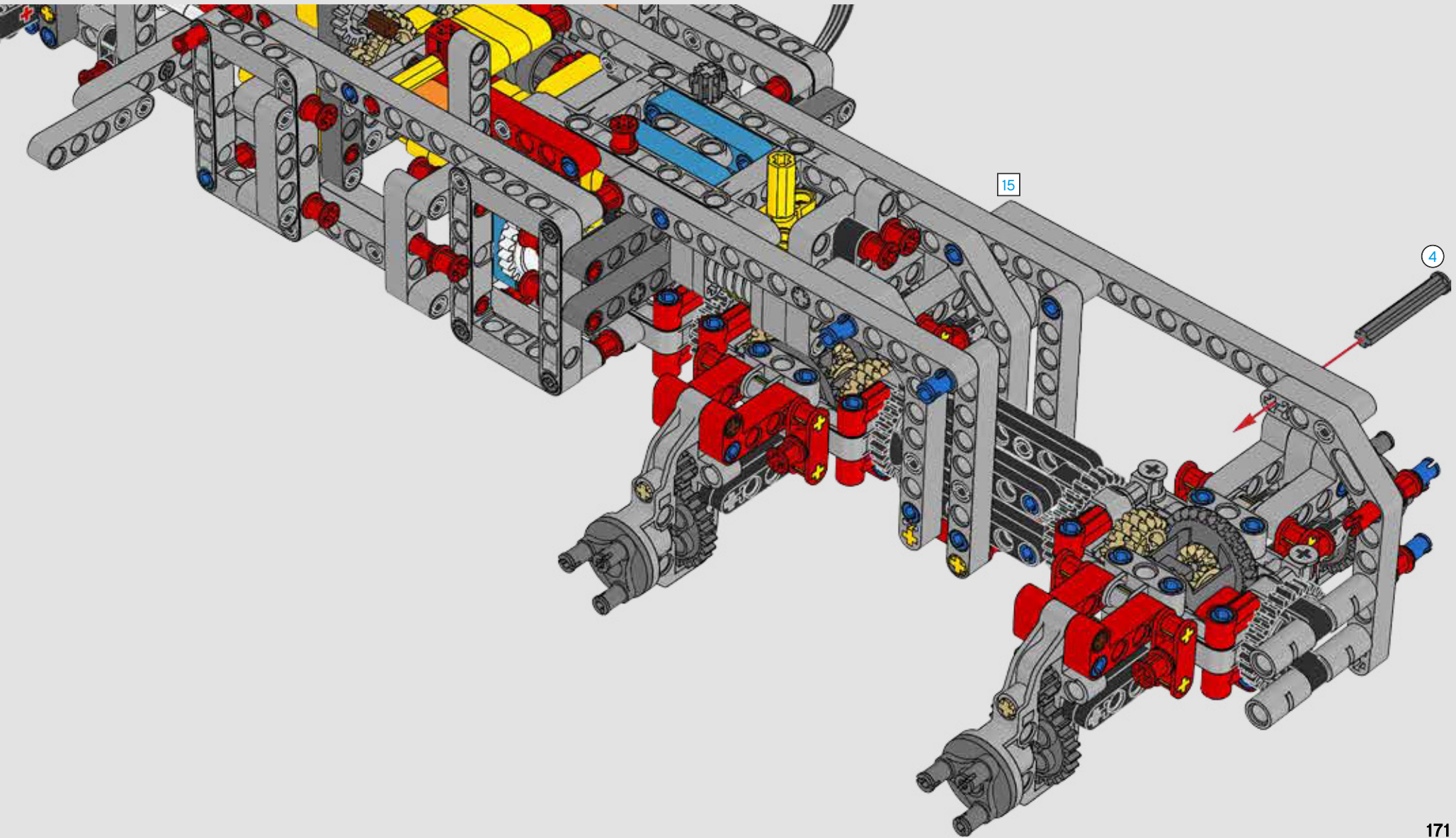



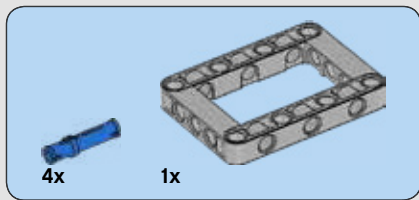

275

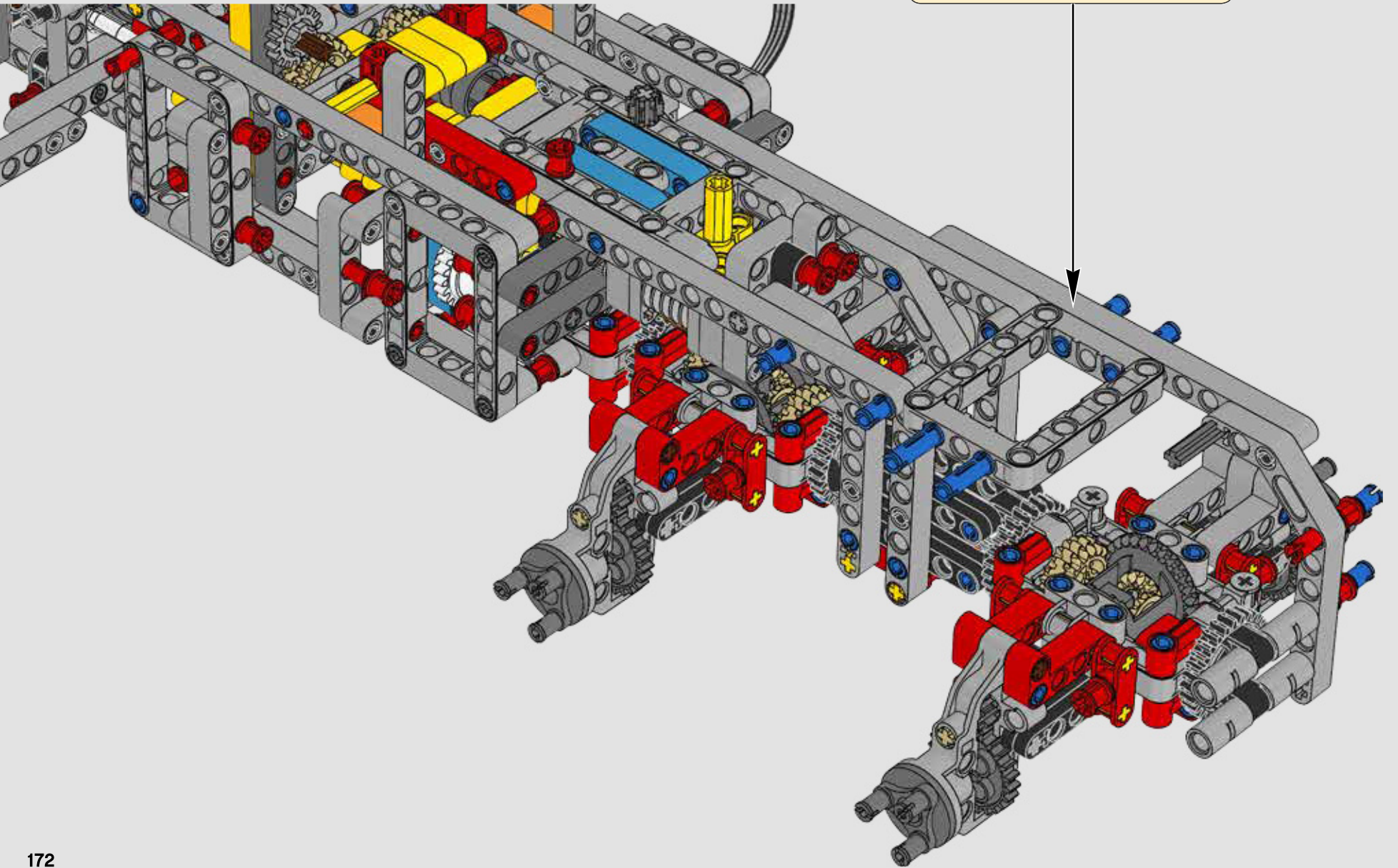
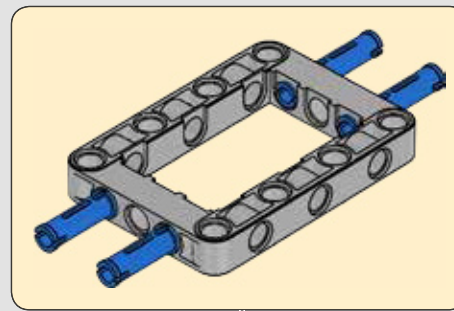



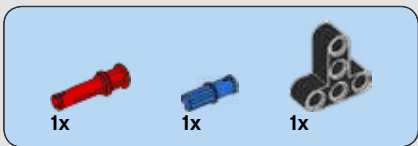

276

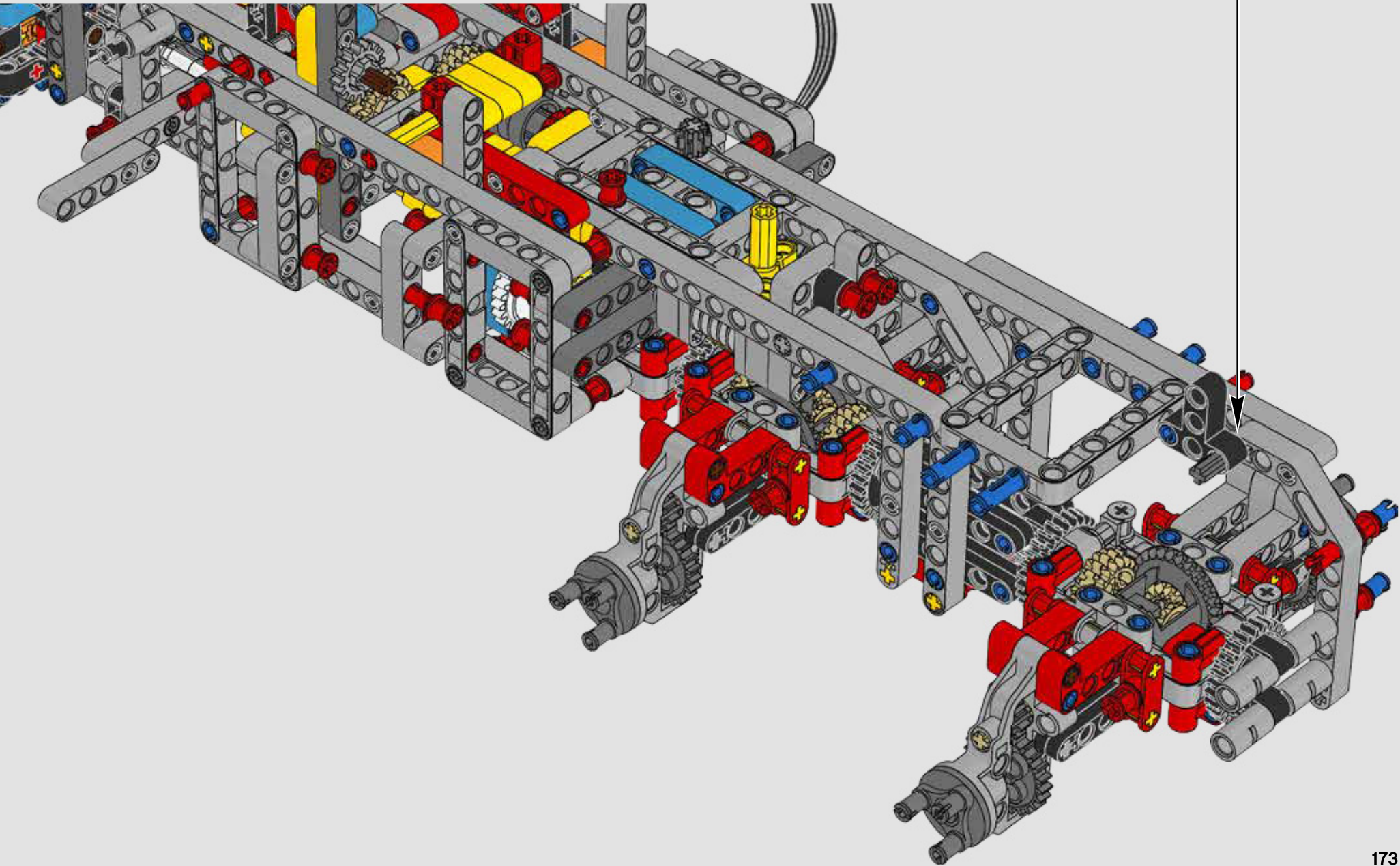
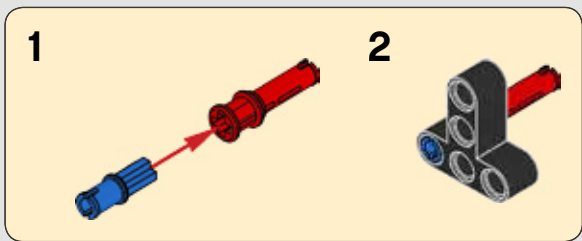



1x

277

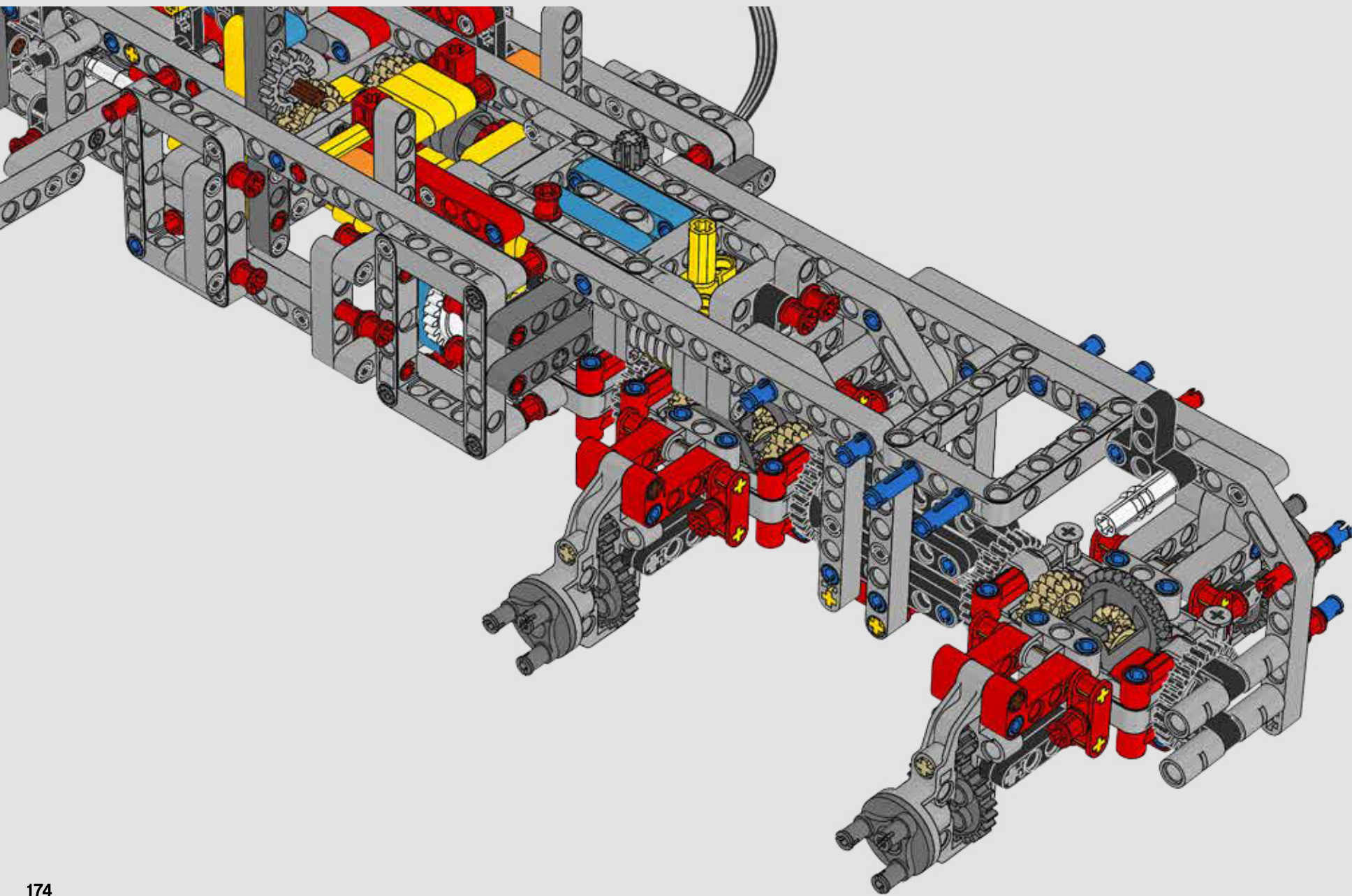



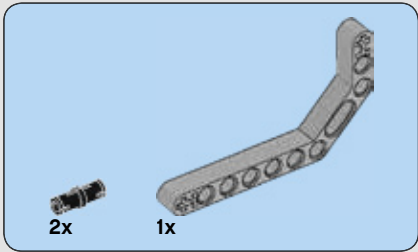
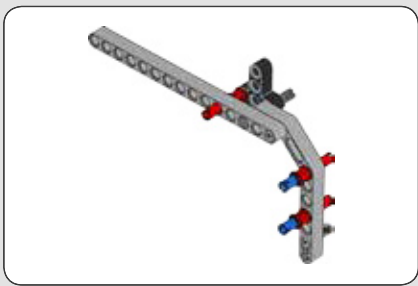

278

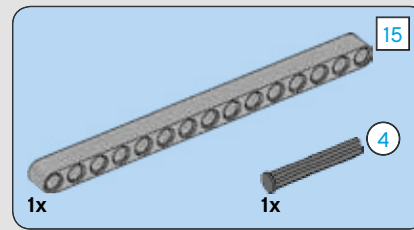
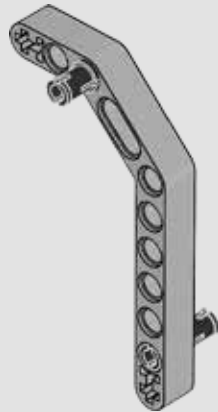

279

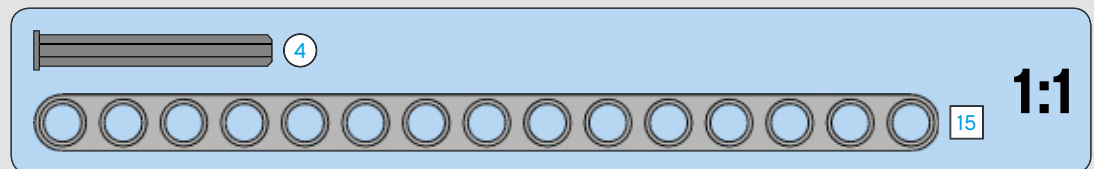
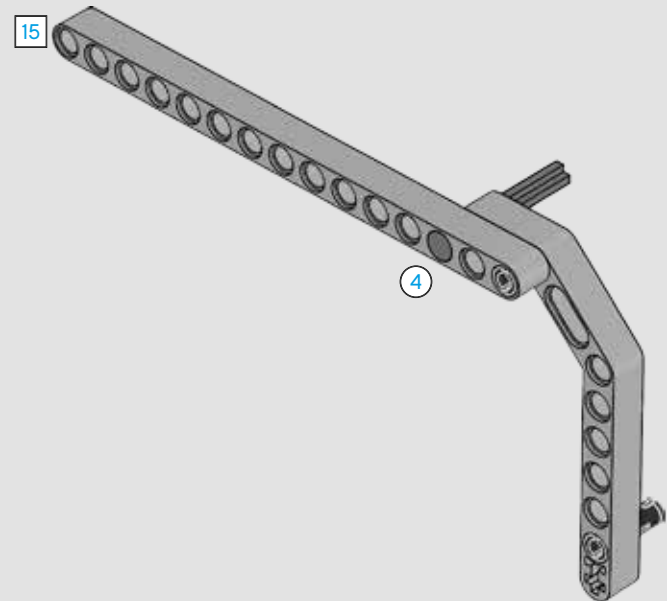





280

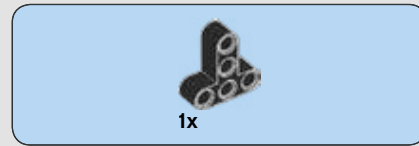
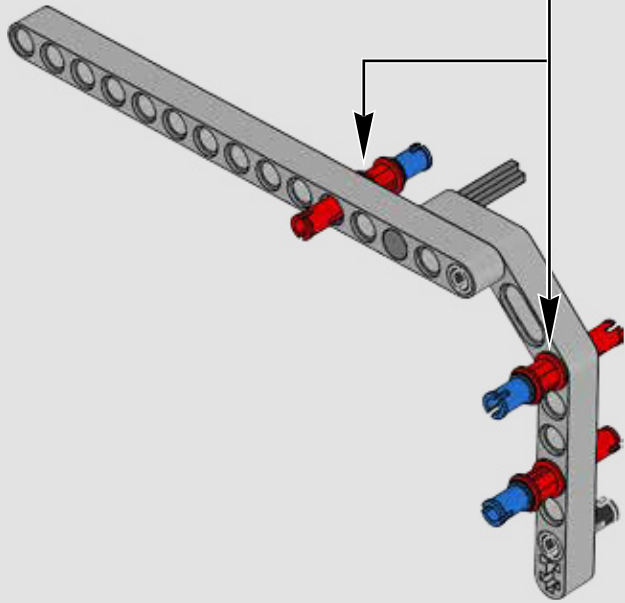
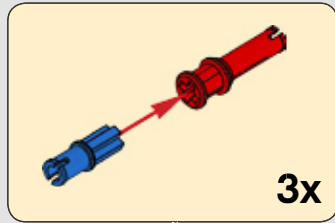

281

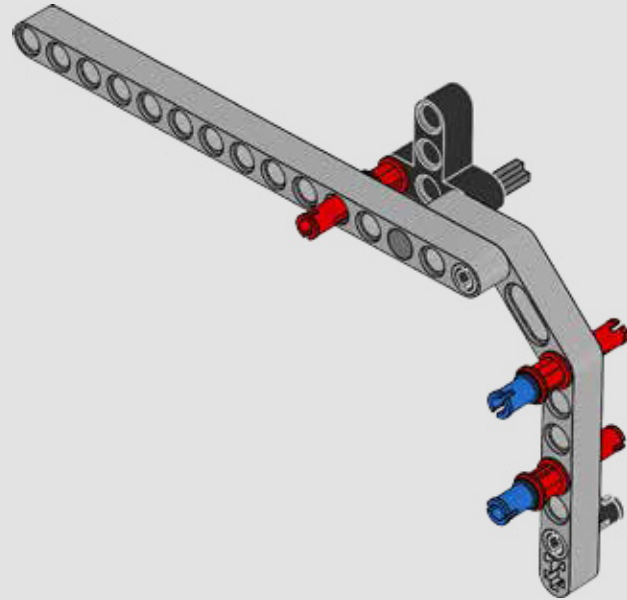

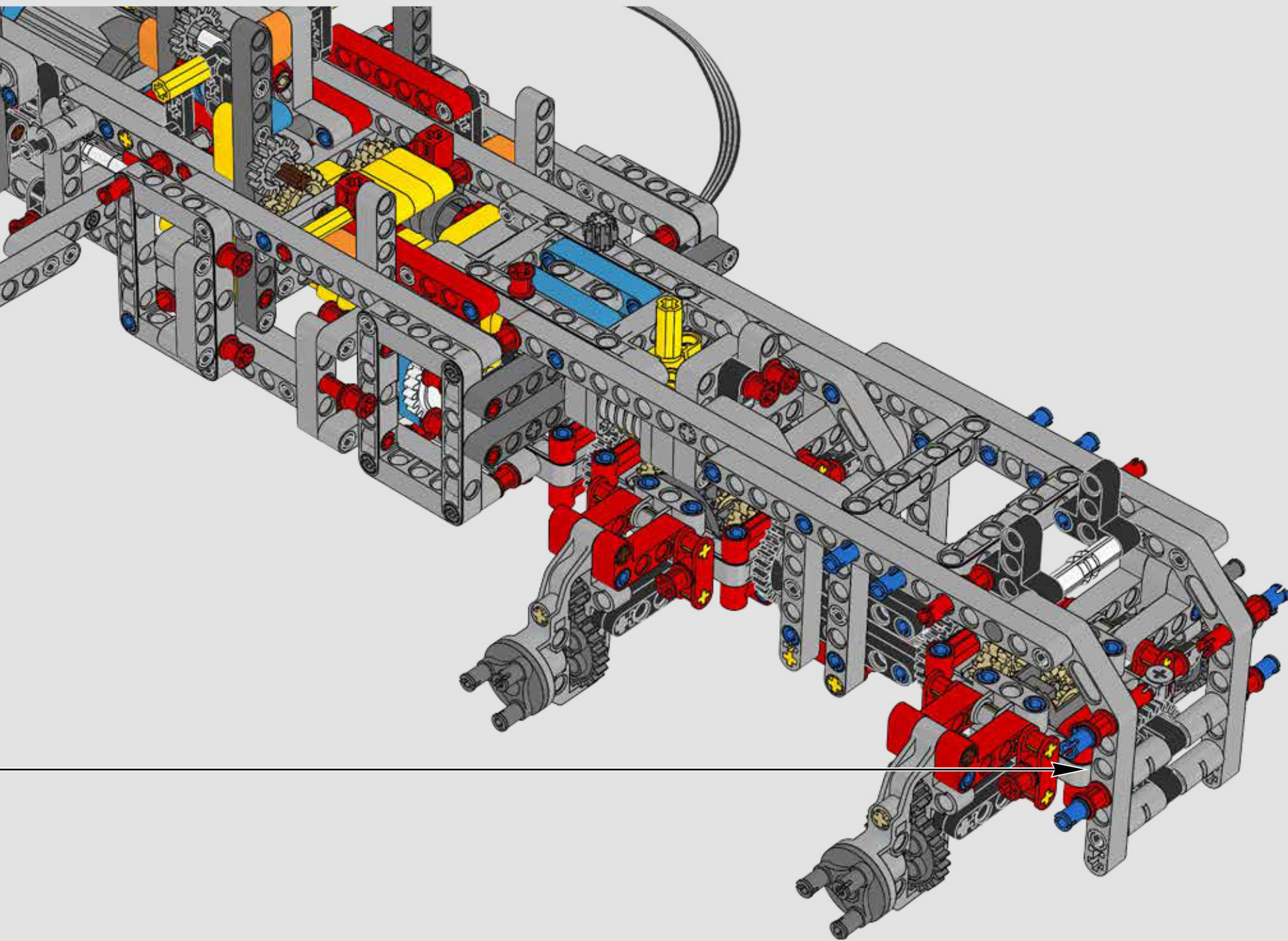



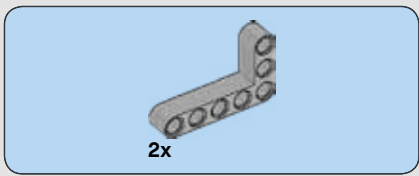

283

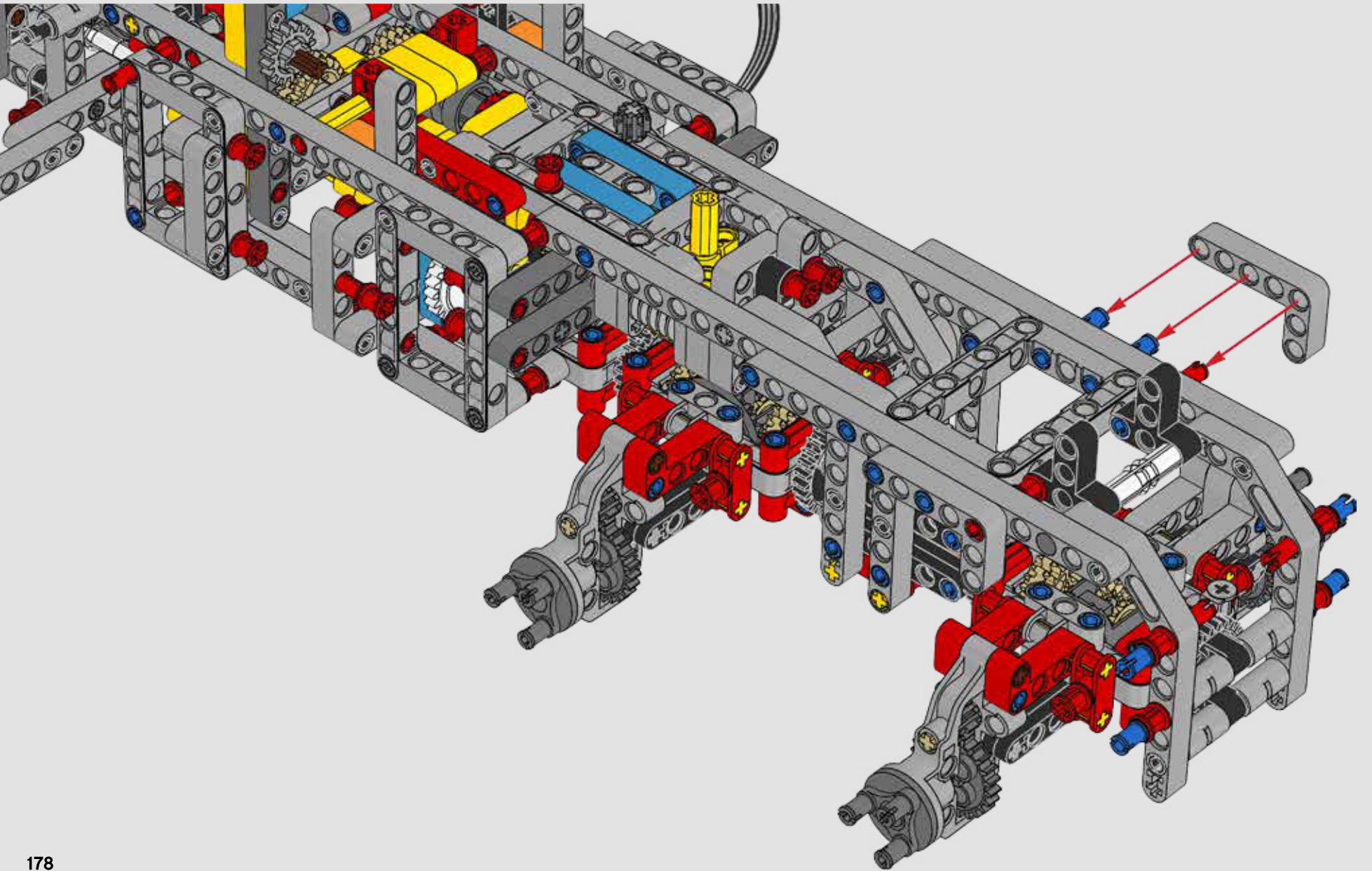





284

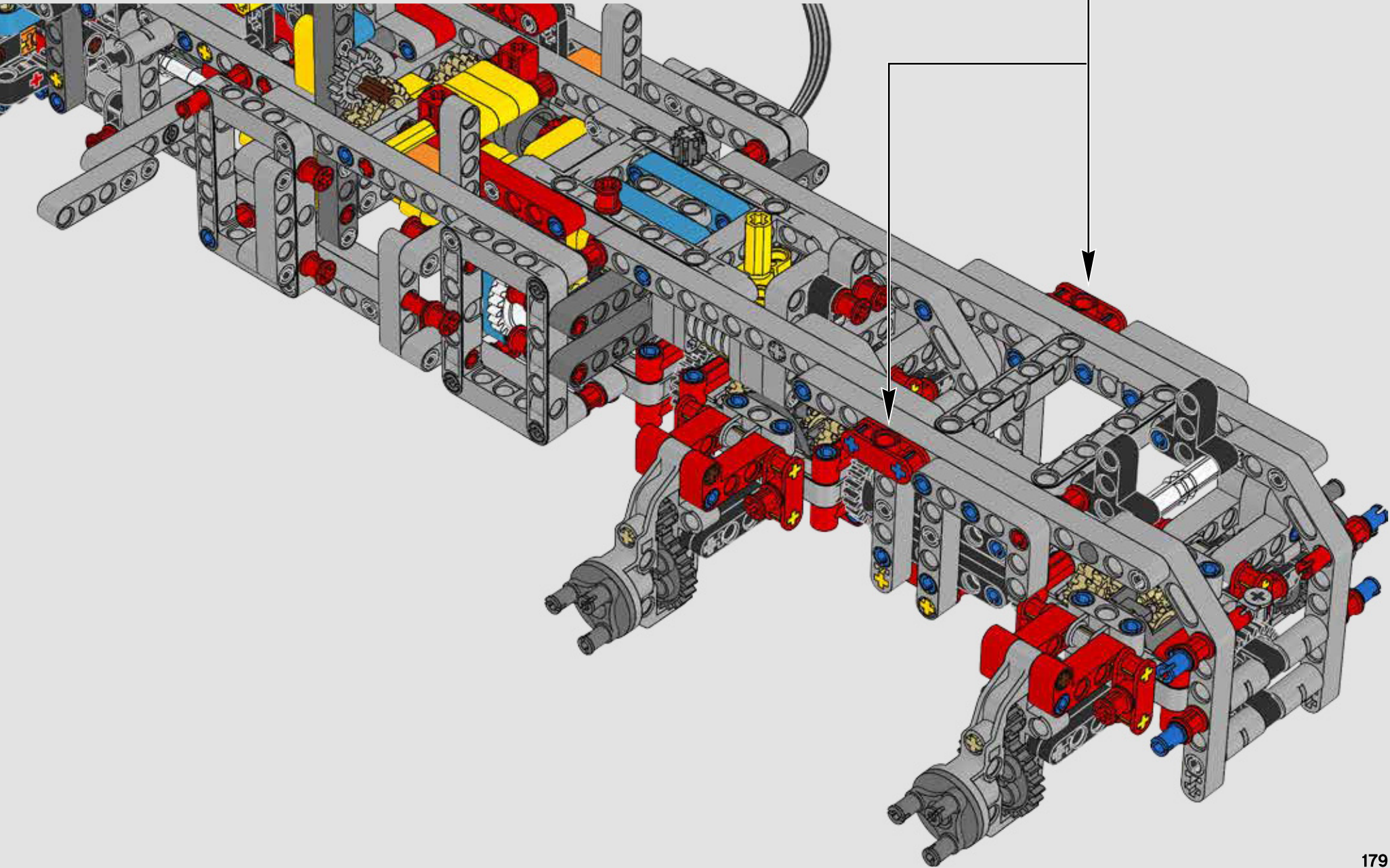

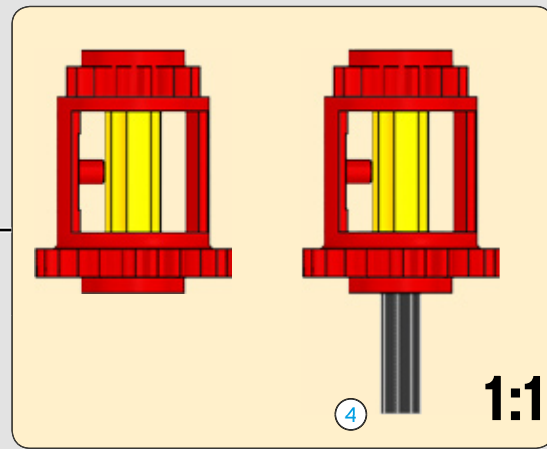
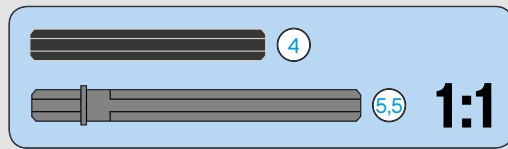
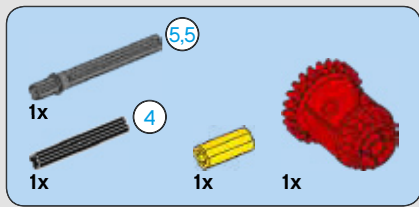

285

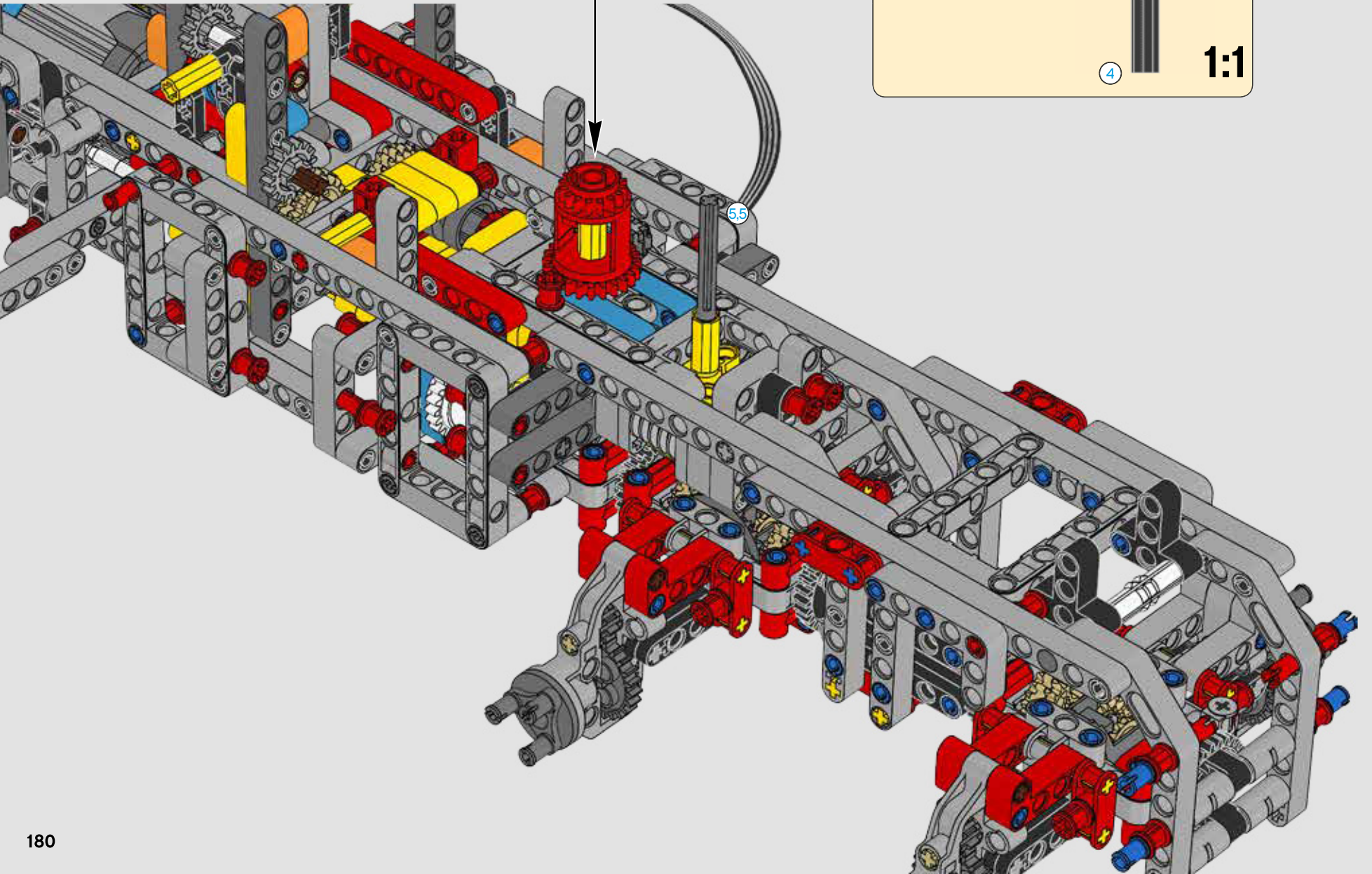



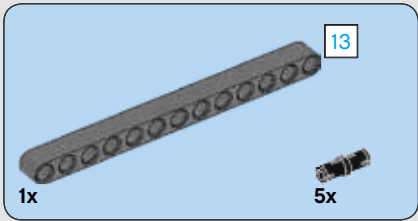
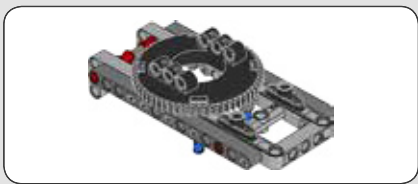

286

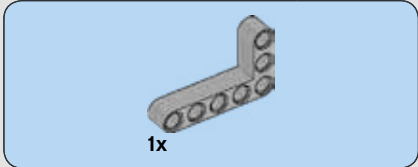
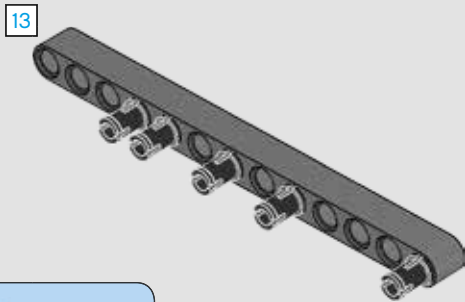

287

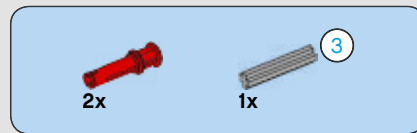
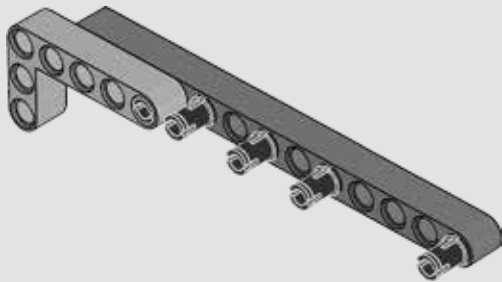

288

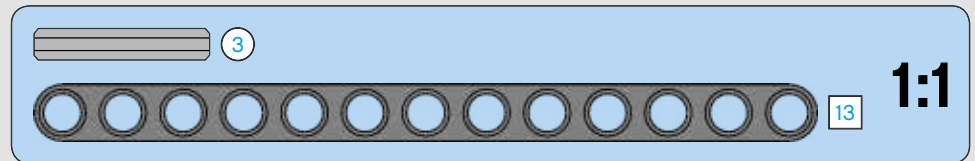
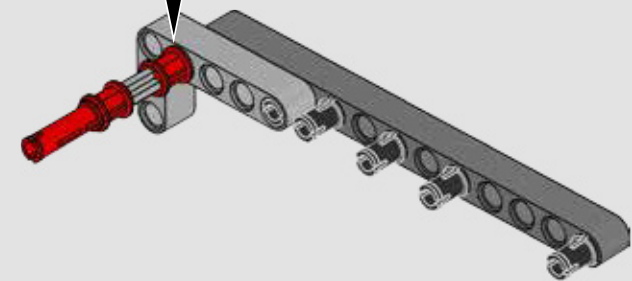
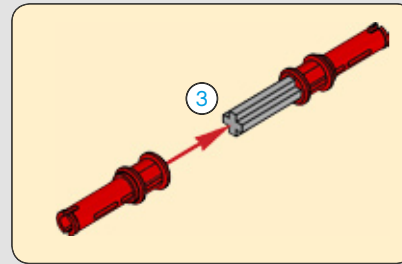



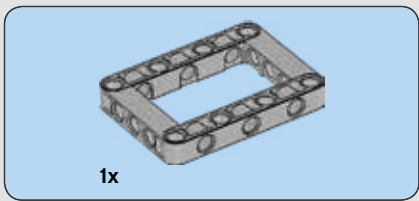

1x

289

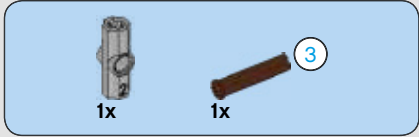
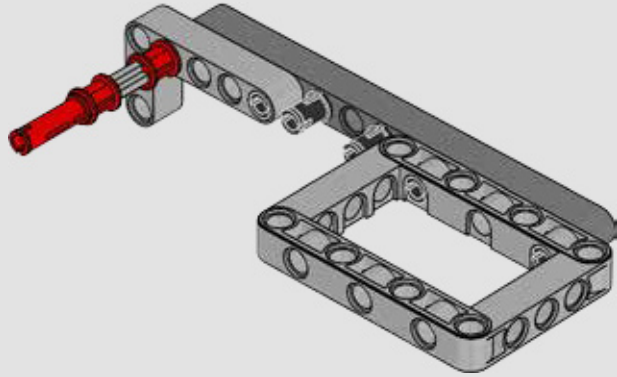

1x

1x

3

290

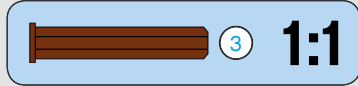

3

1:1

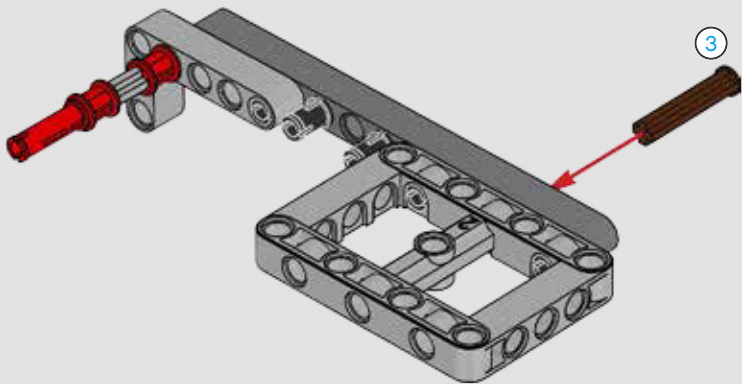

3

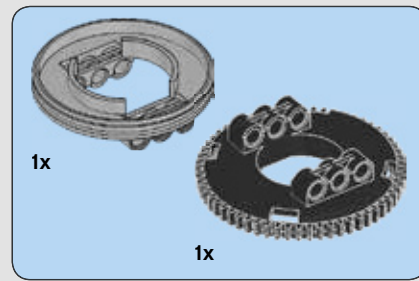

1x

1x

291

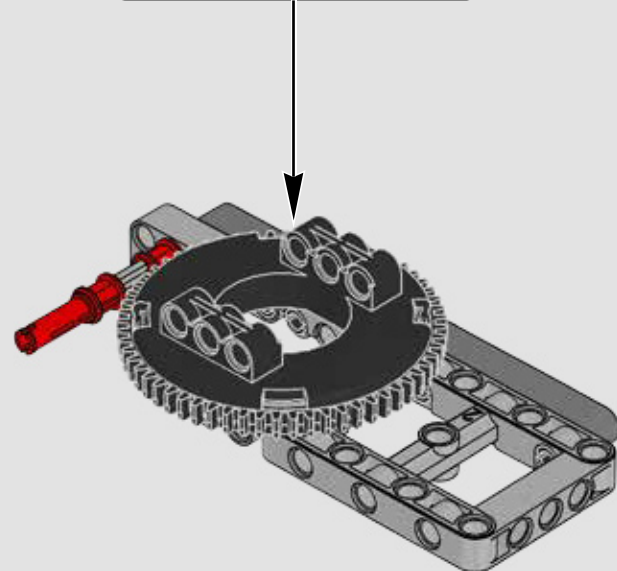
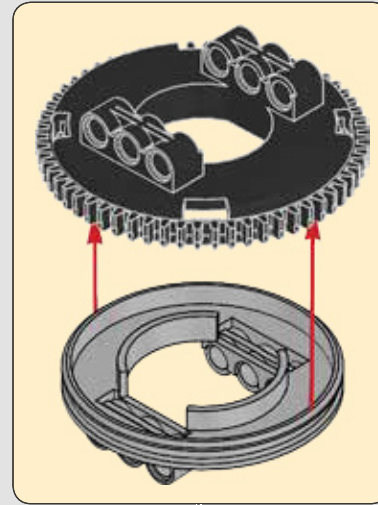

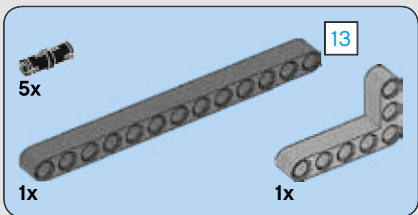

292

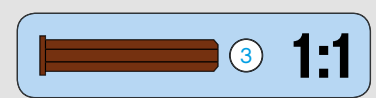
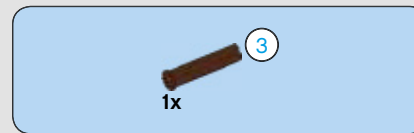
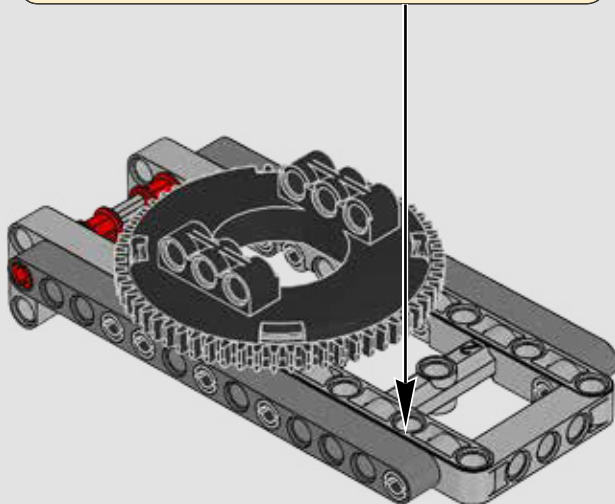
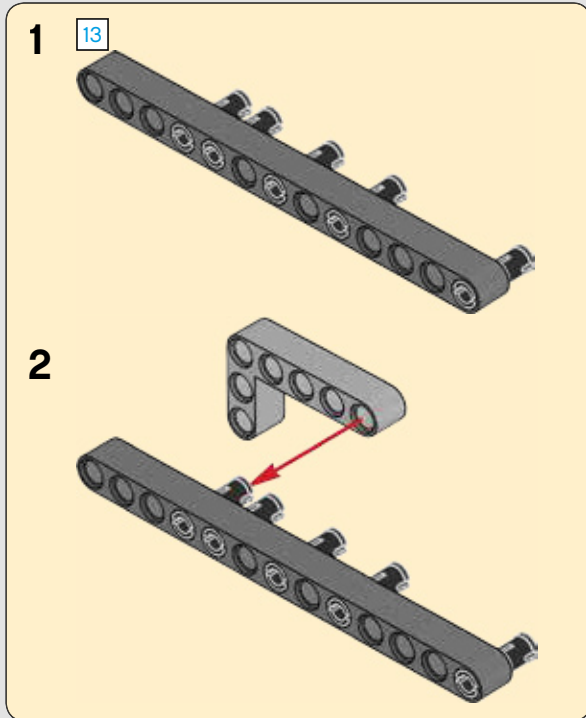

293

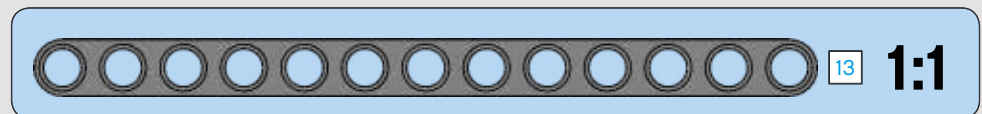
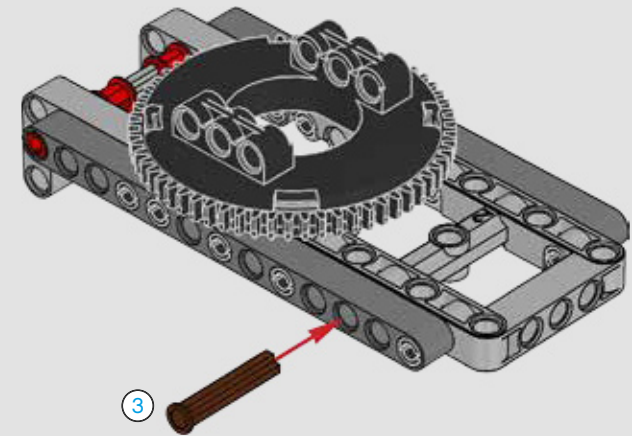



2x

# 294

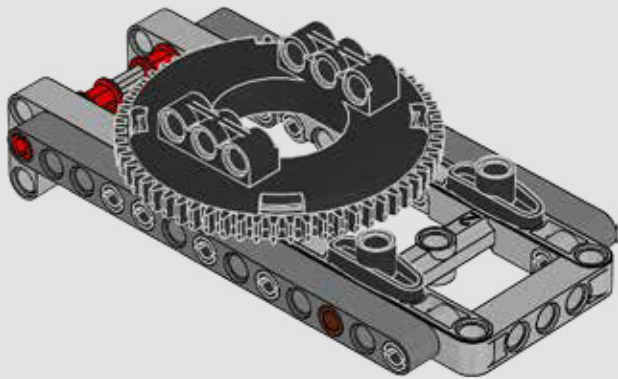

2x



2x

# 295

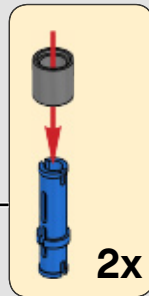

2x

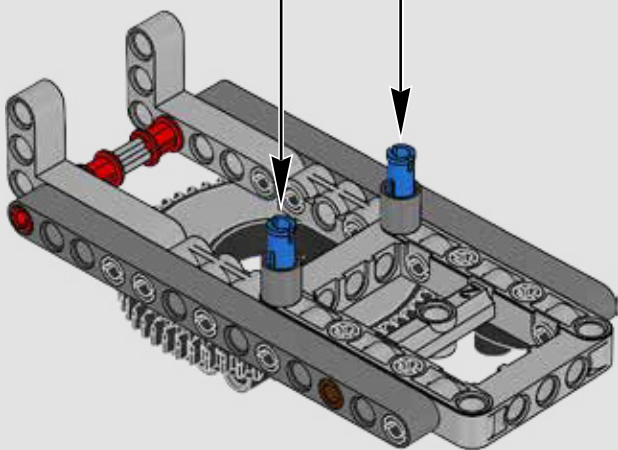

# 296

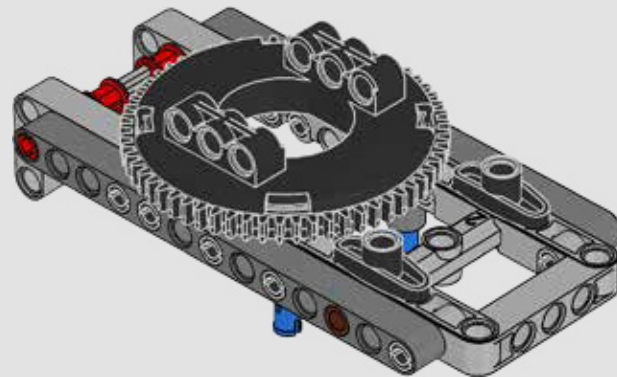
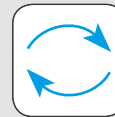



297

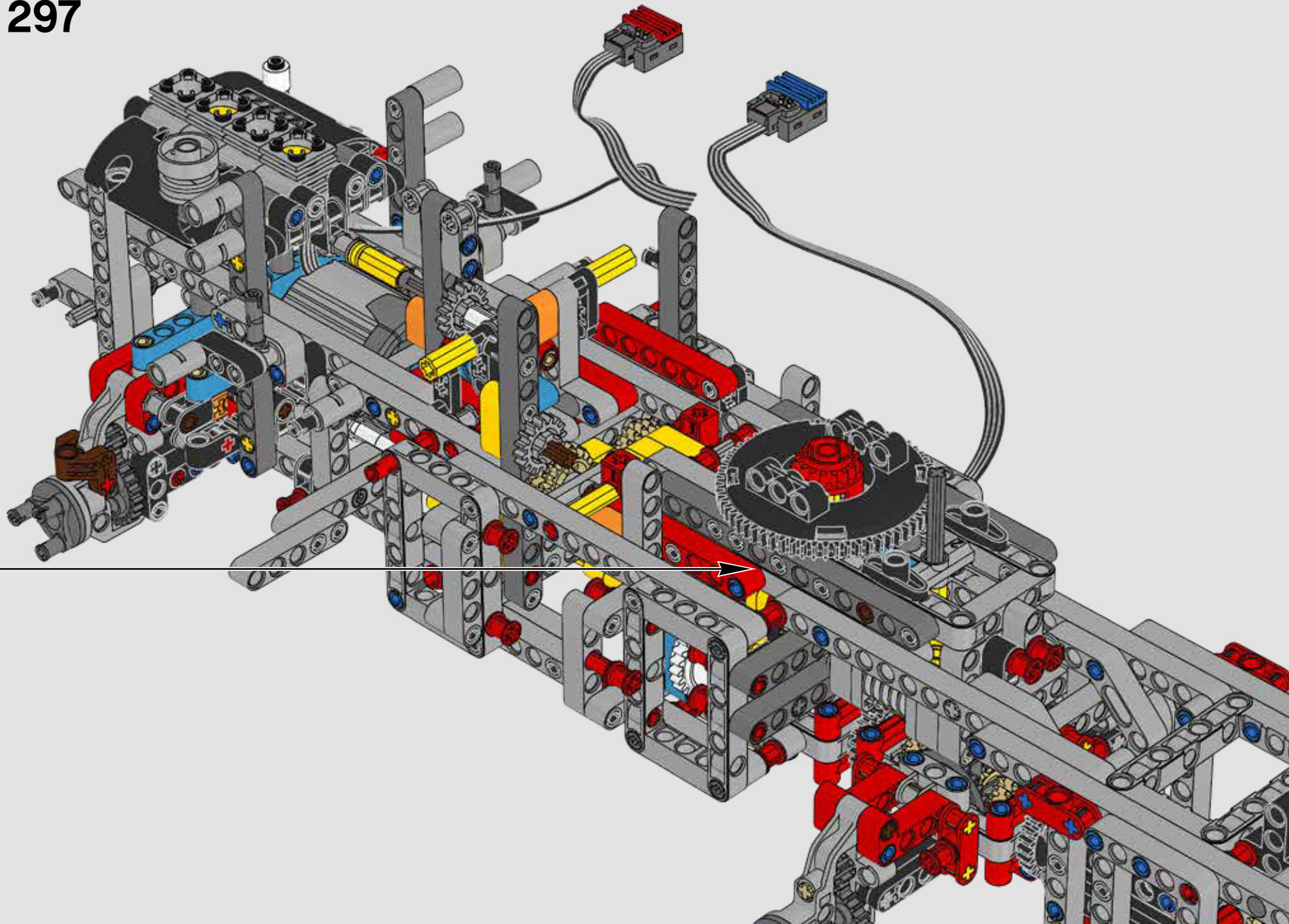





1x

298

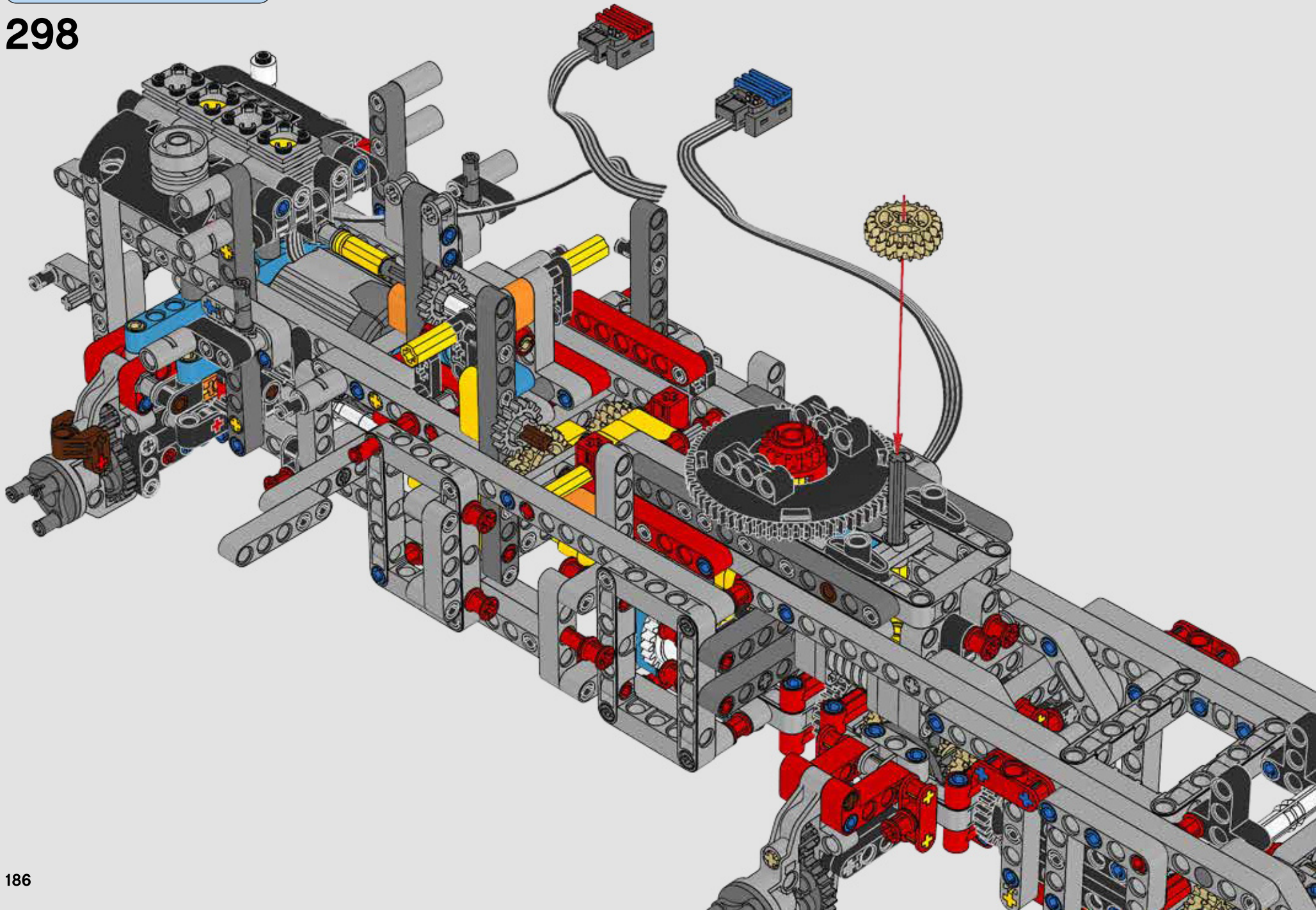



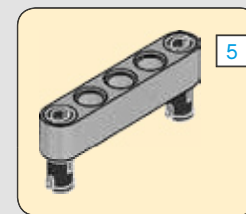
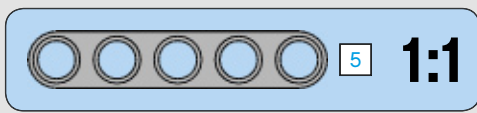
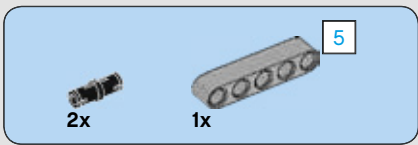

299

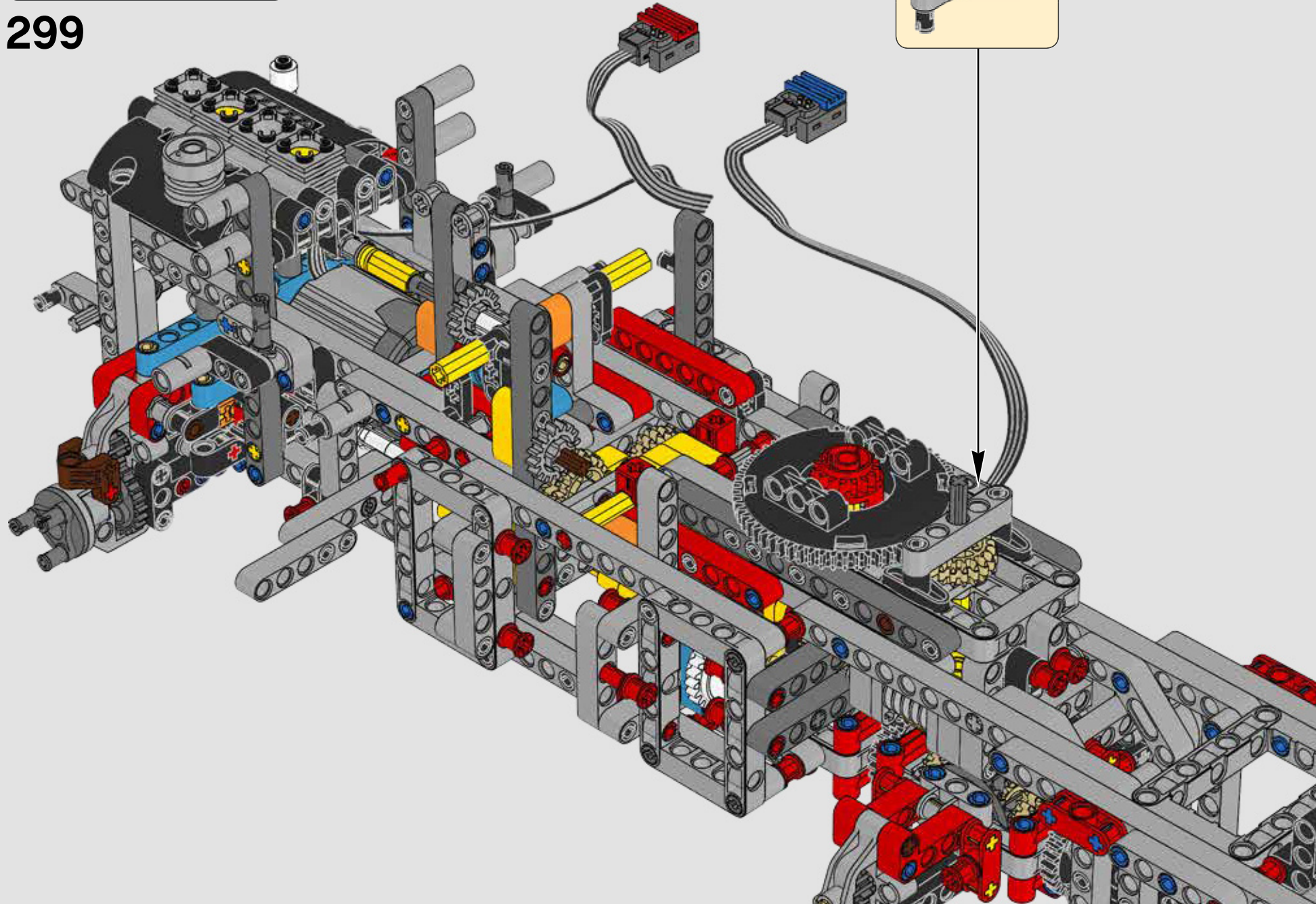



1x  3x 

300

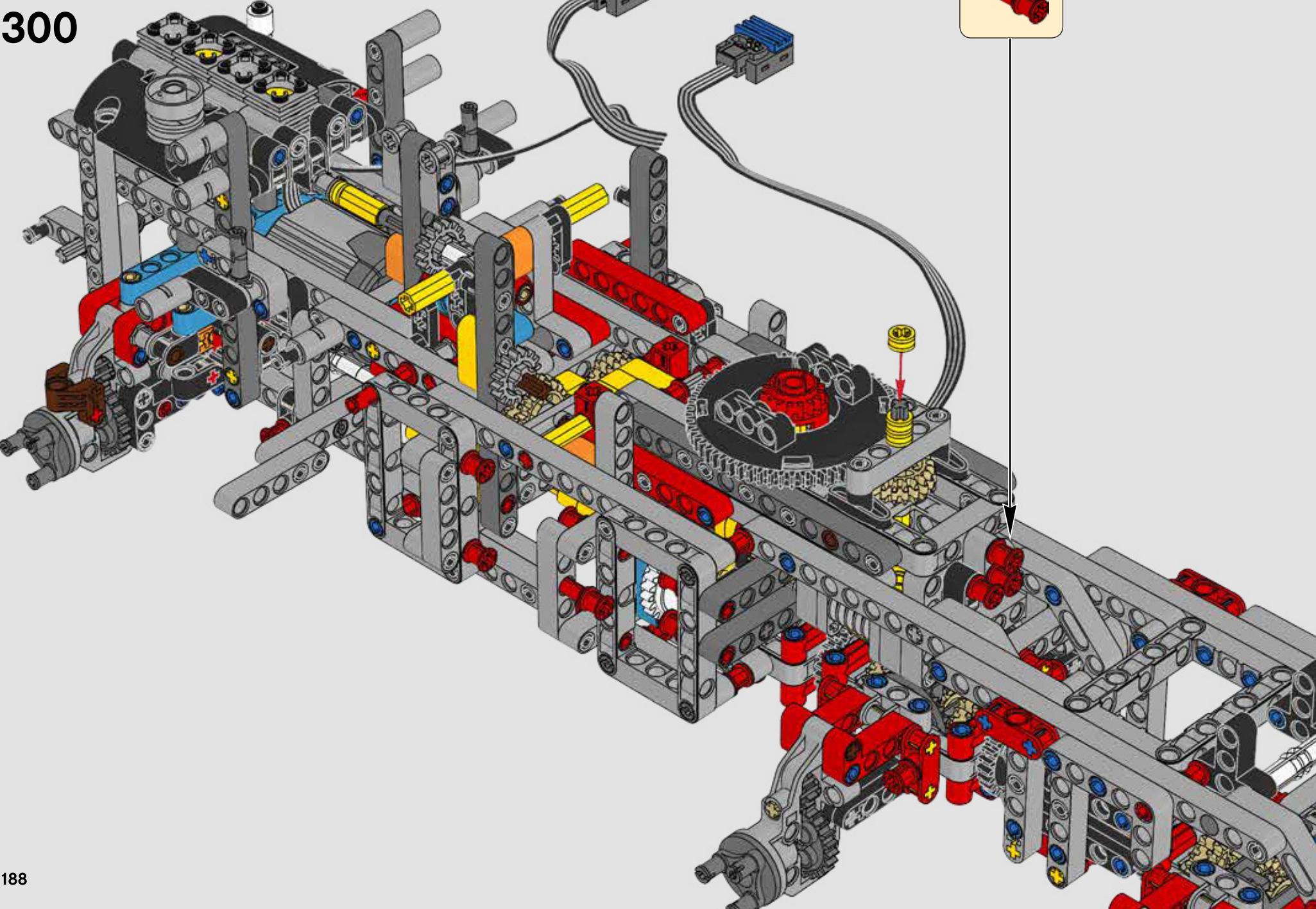



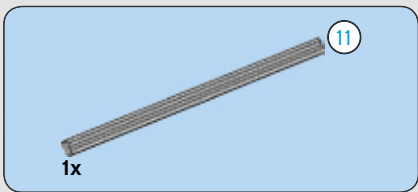

301

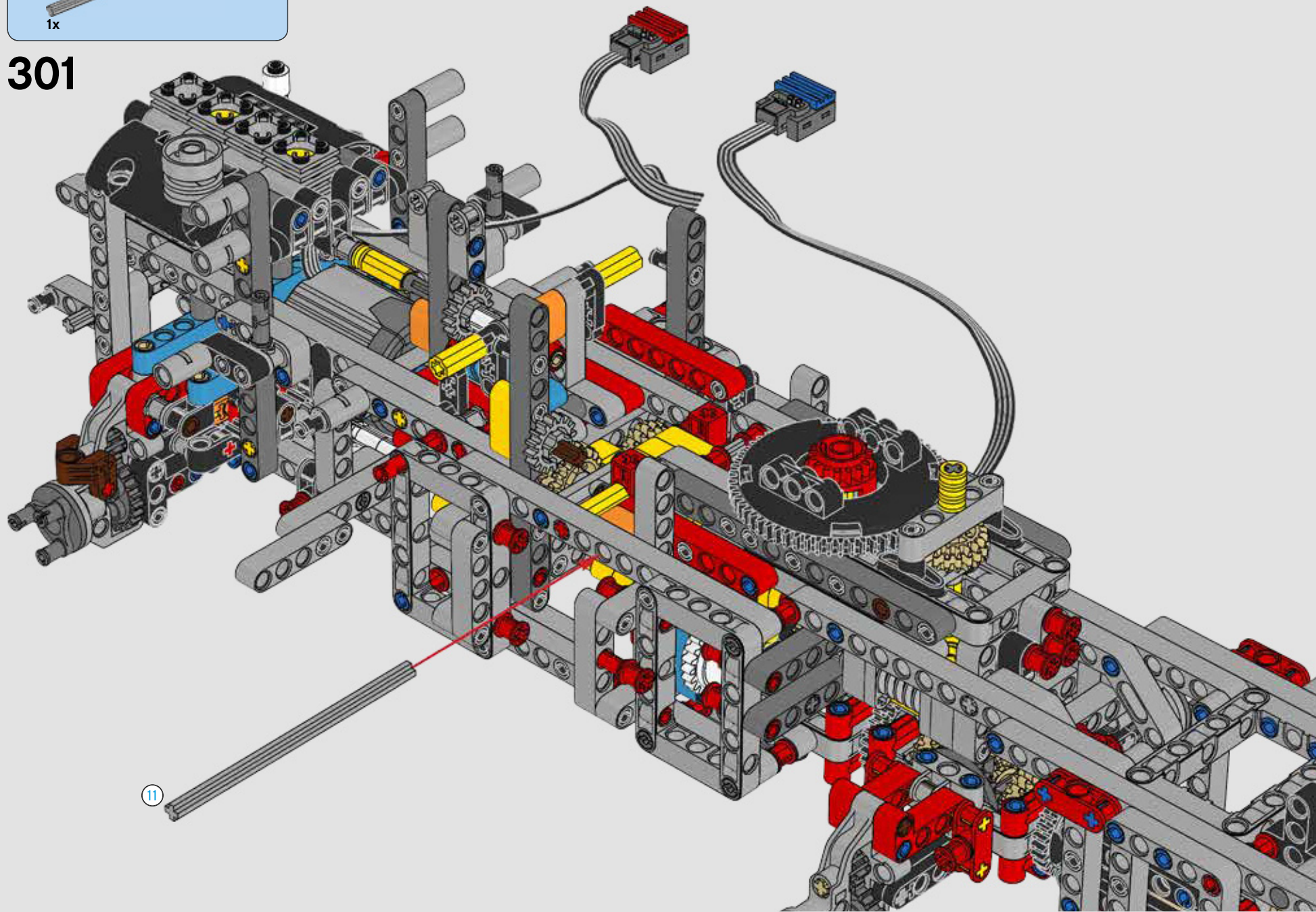



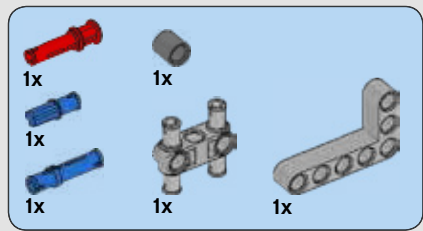

302

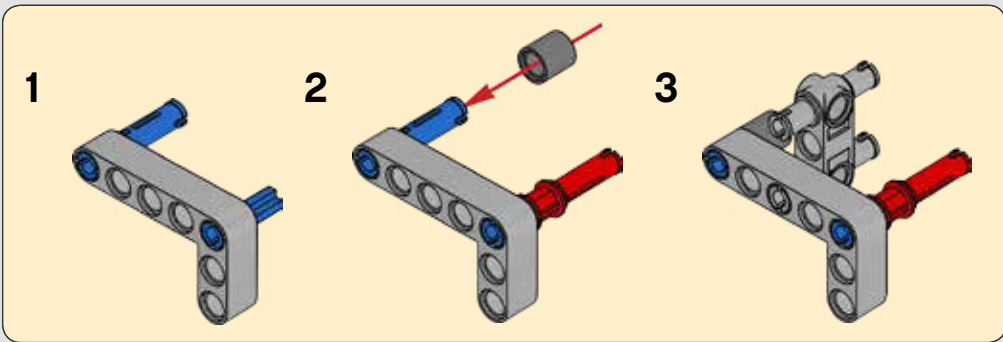
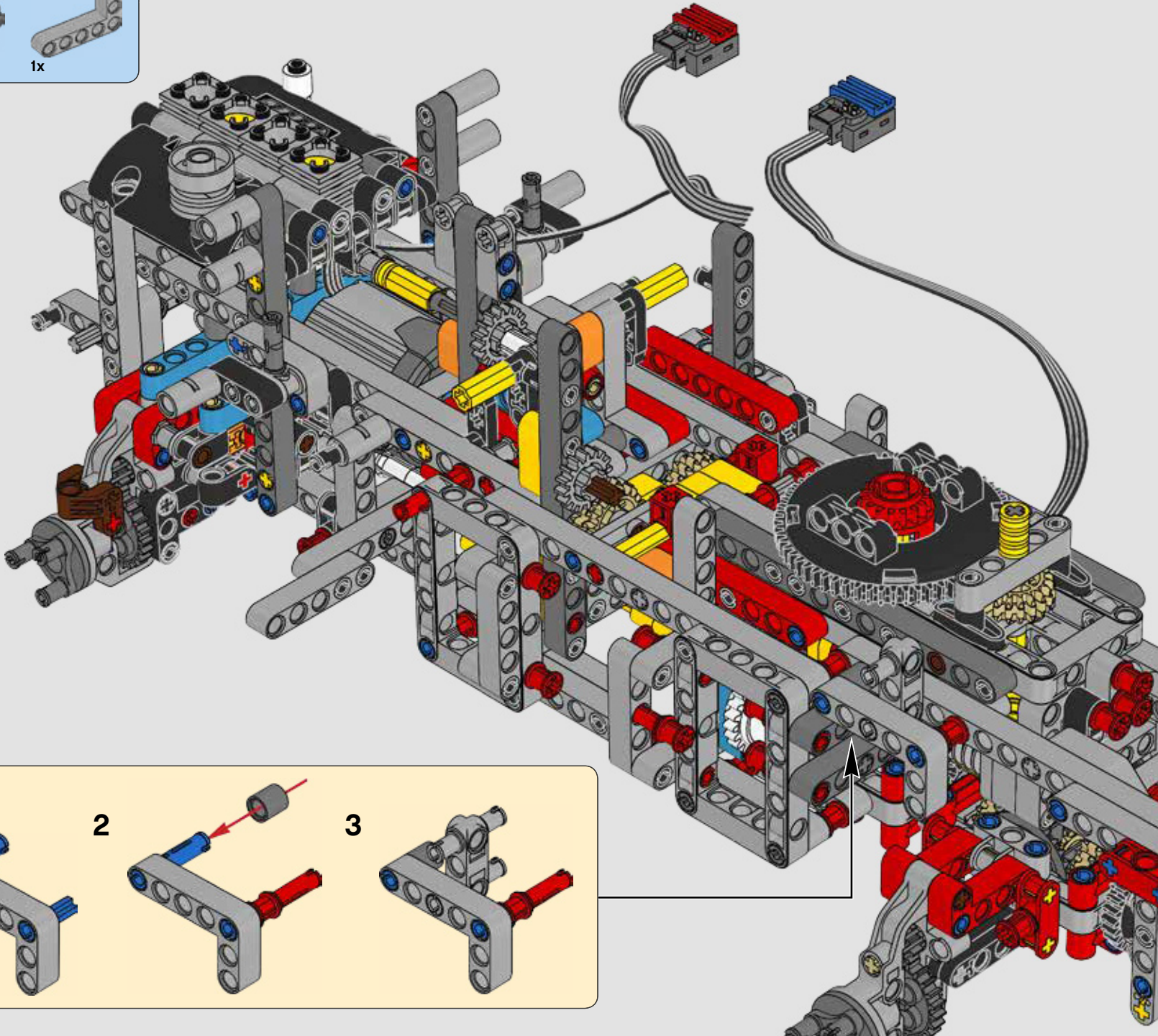



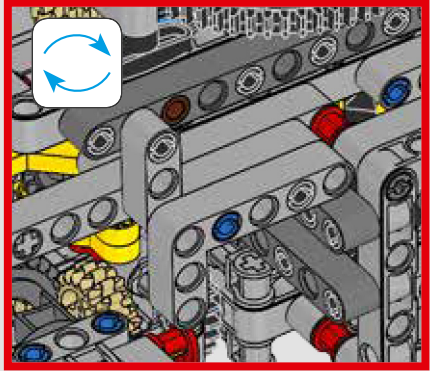
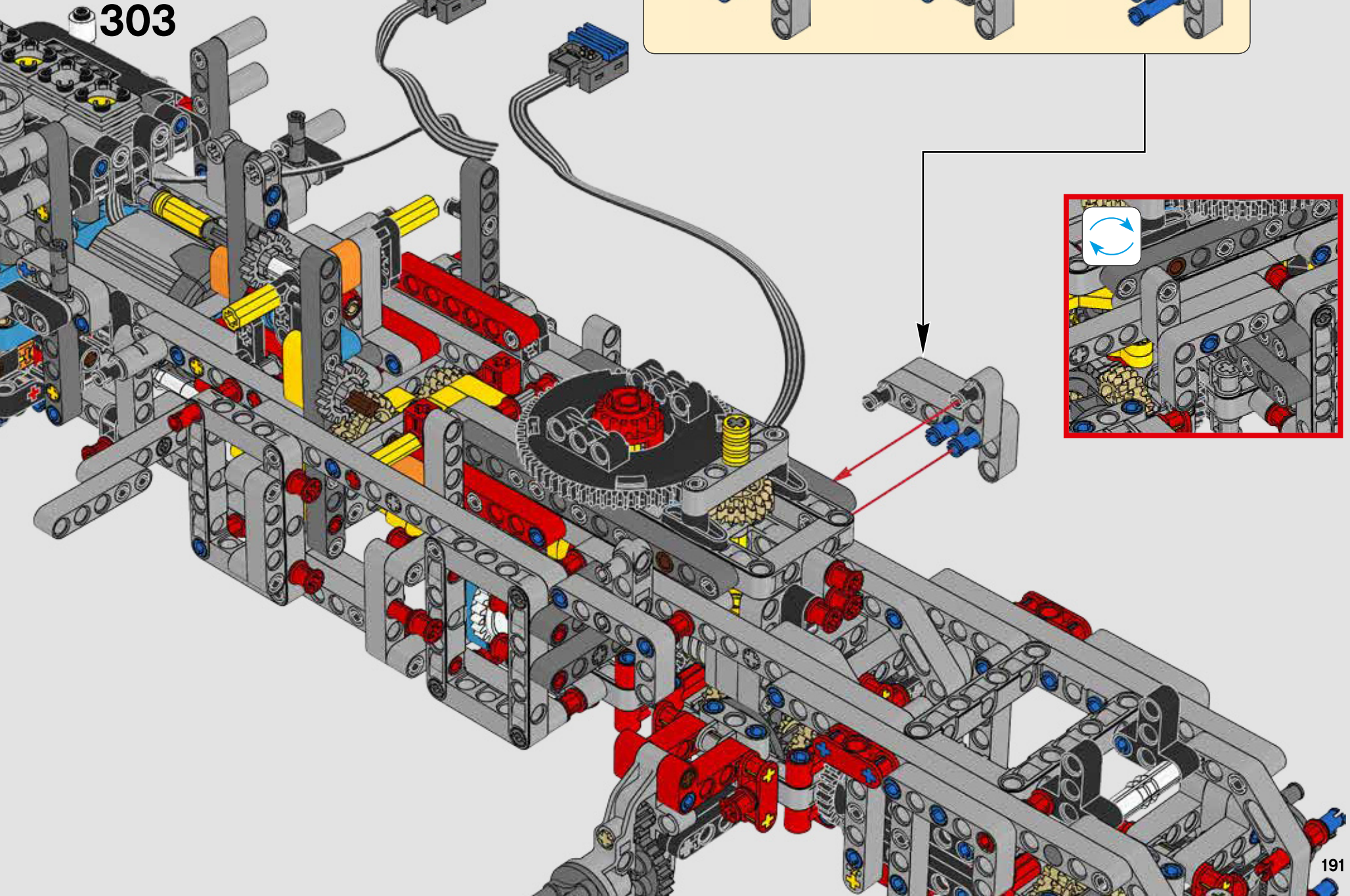
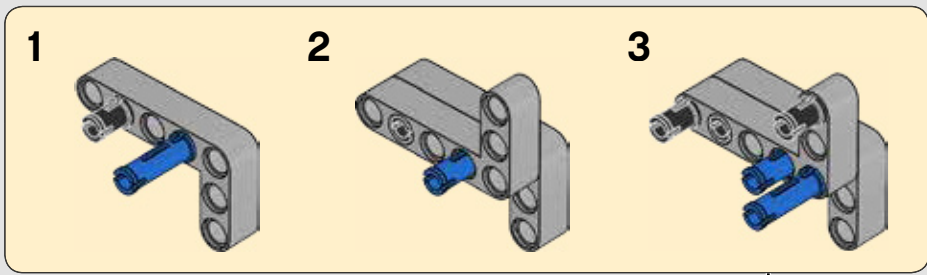
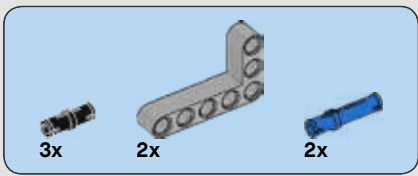

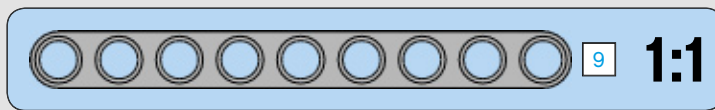
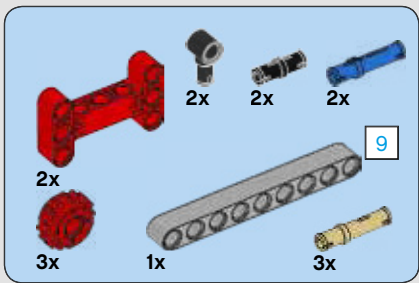

# 304

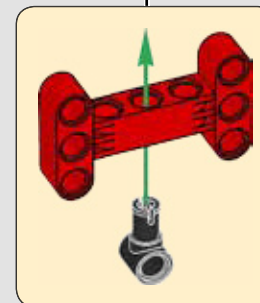
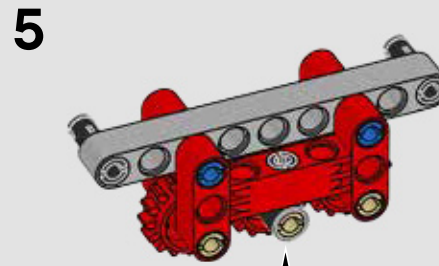
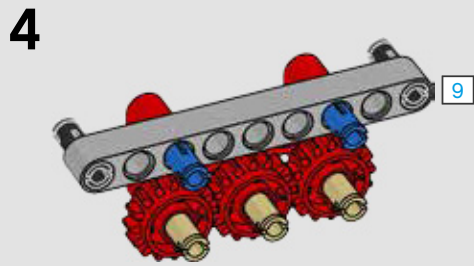
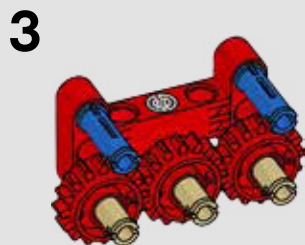
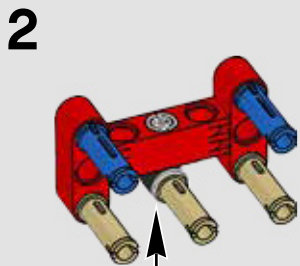
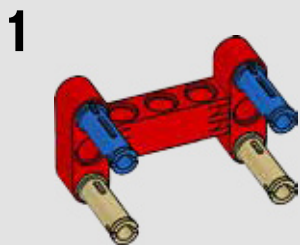



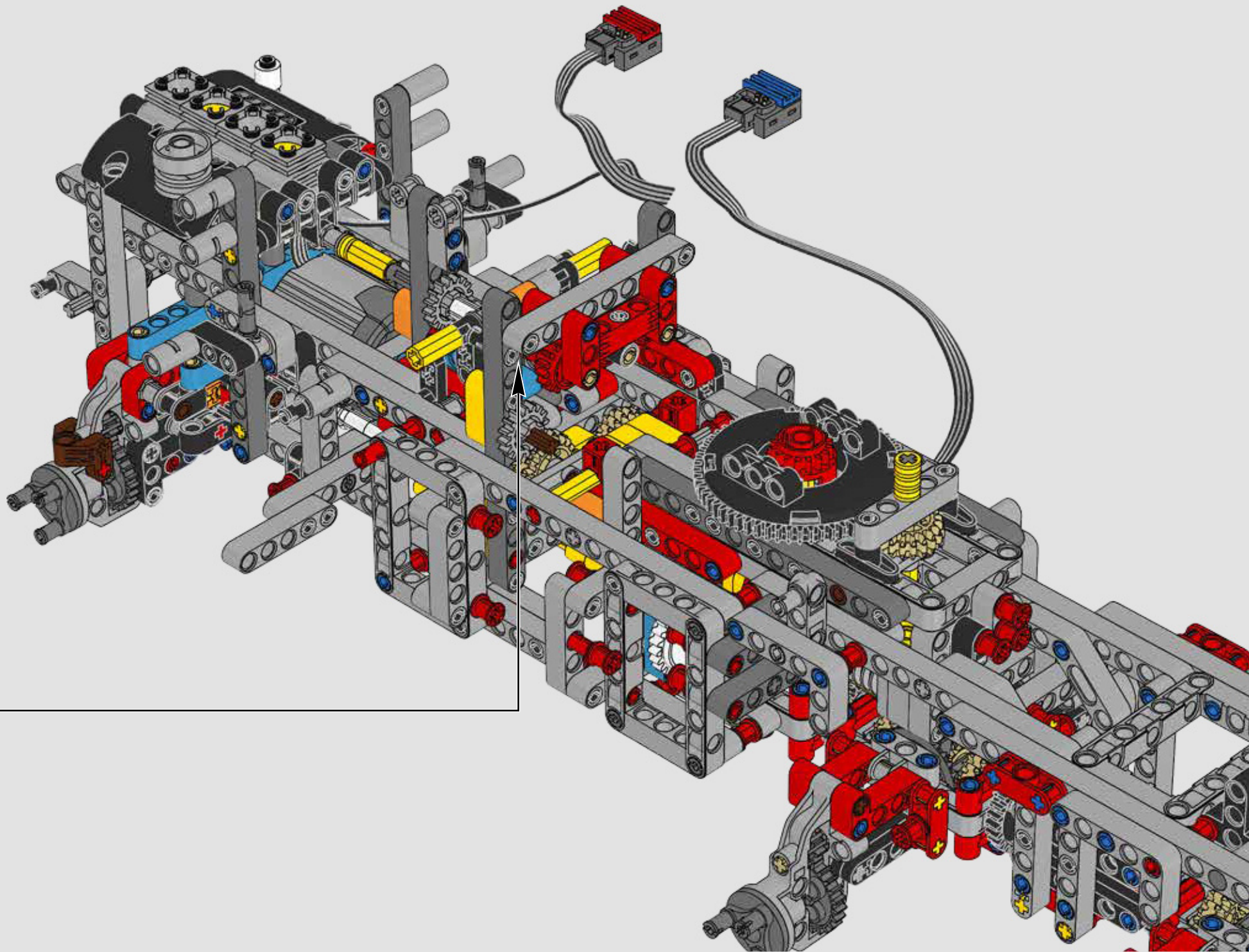





305

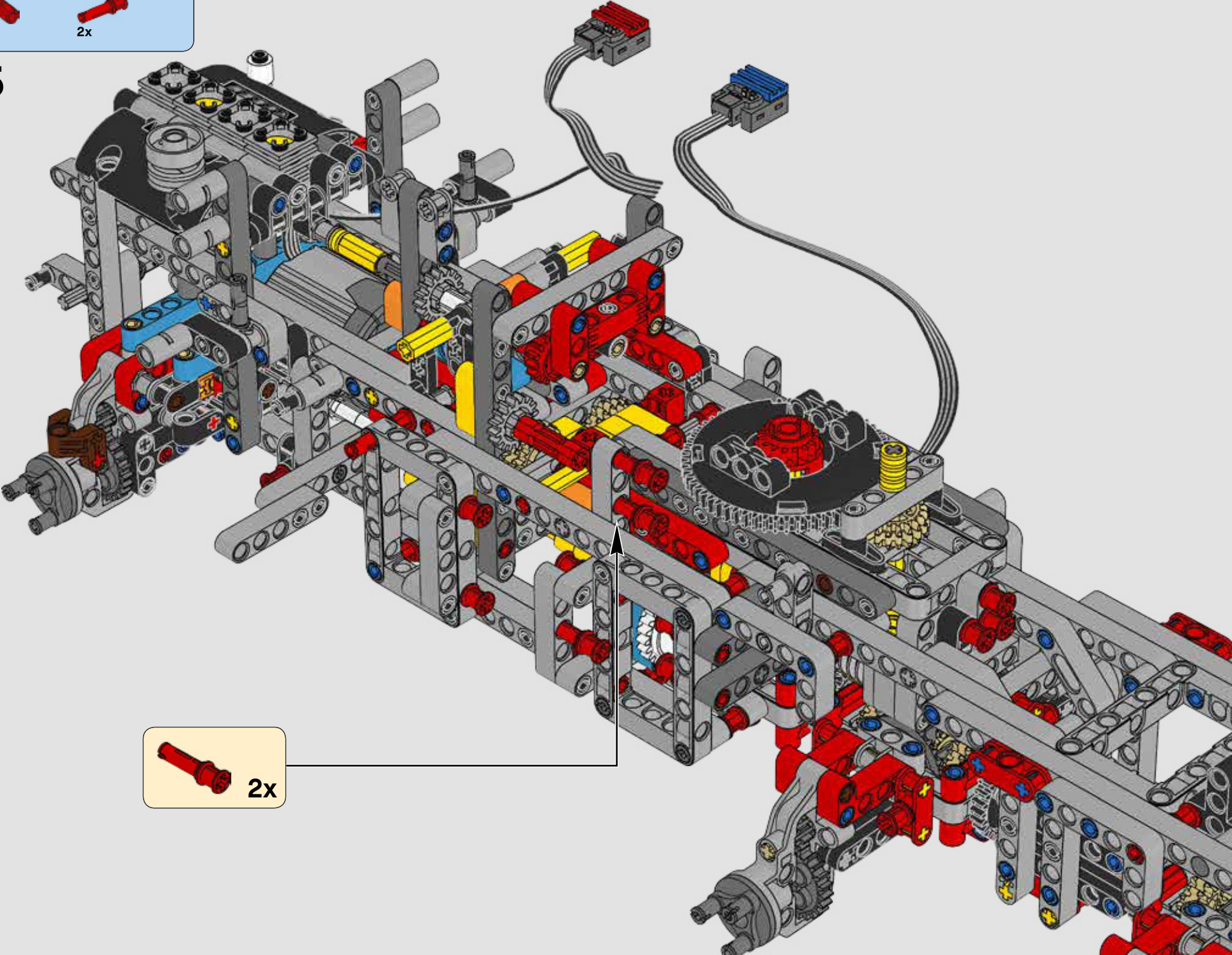

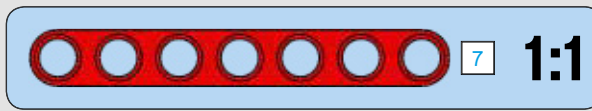
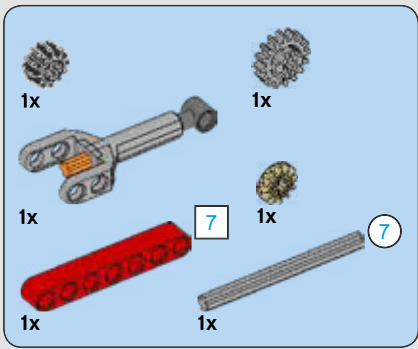

**306**

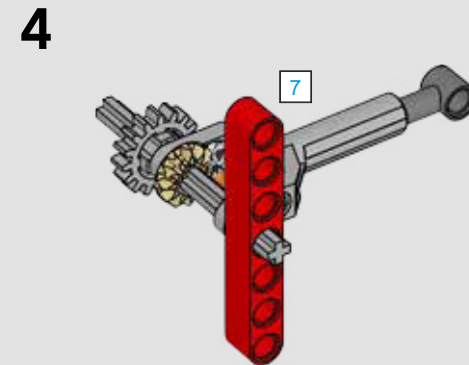
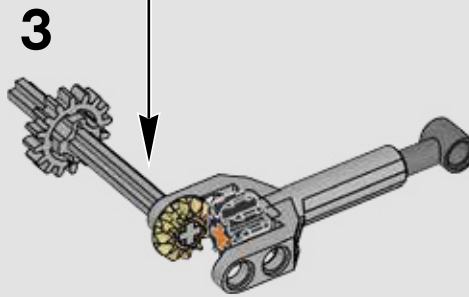
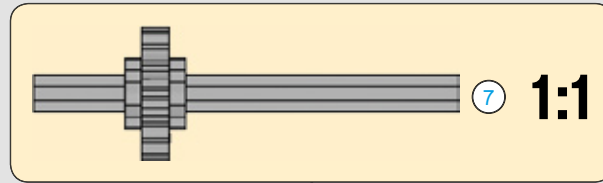
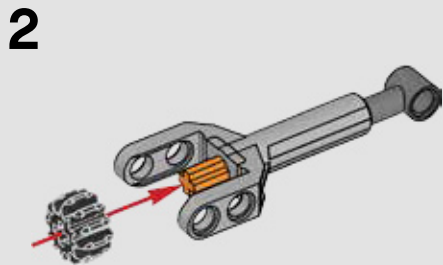
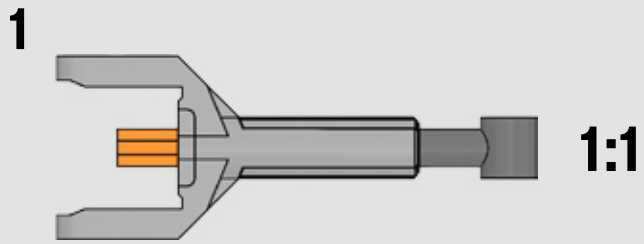



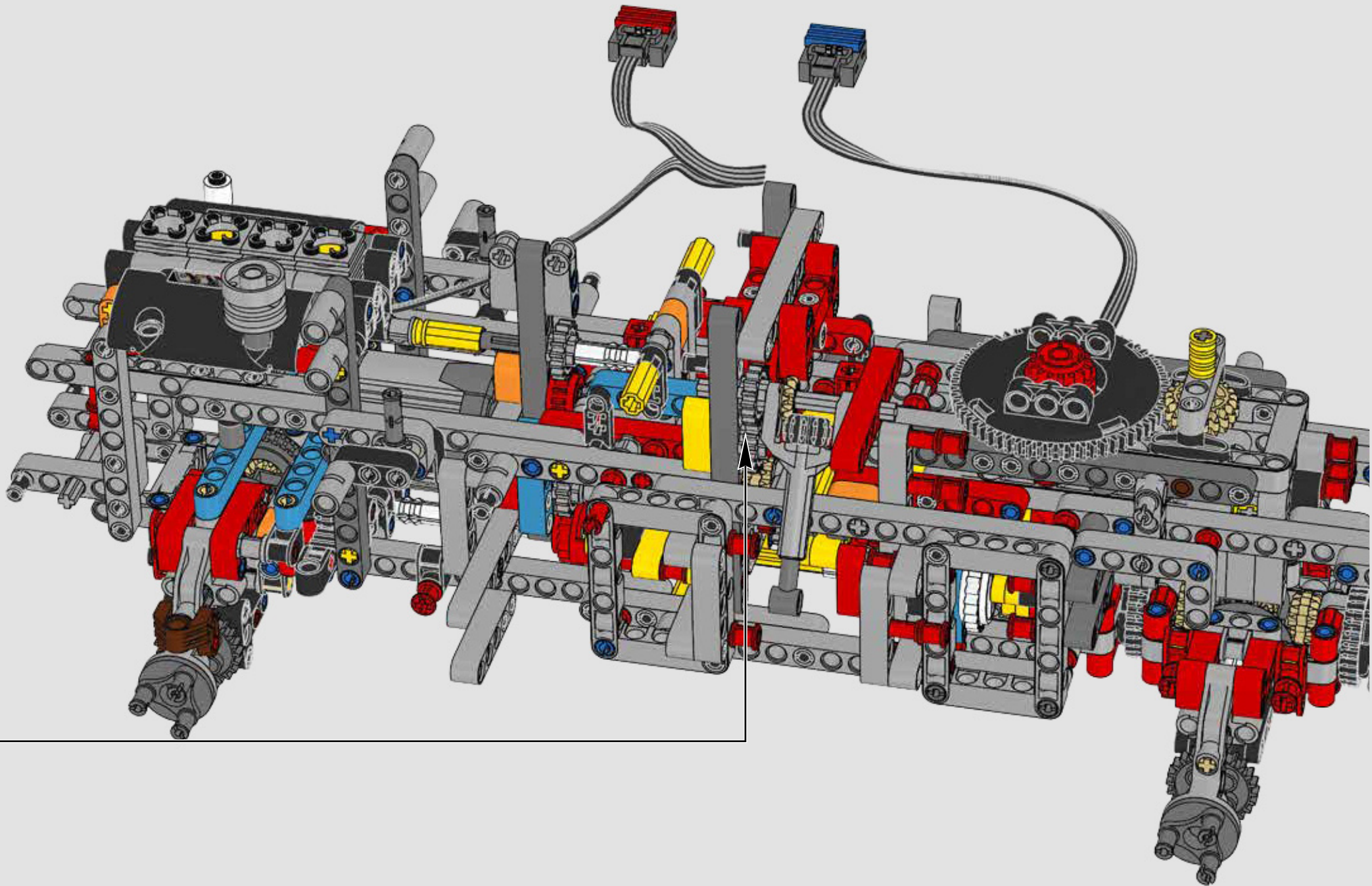



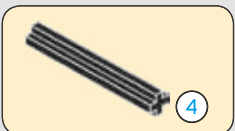
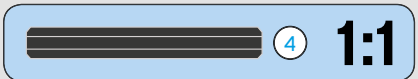
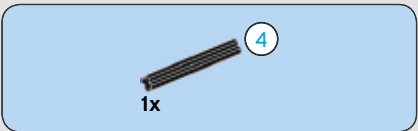

307

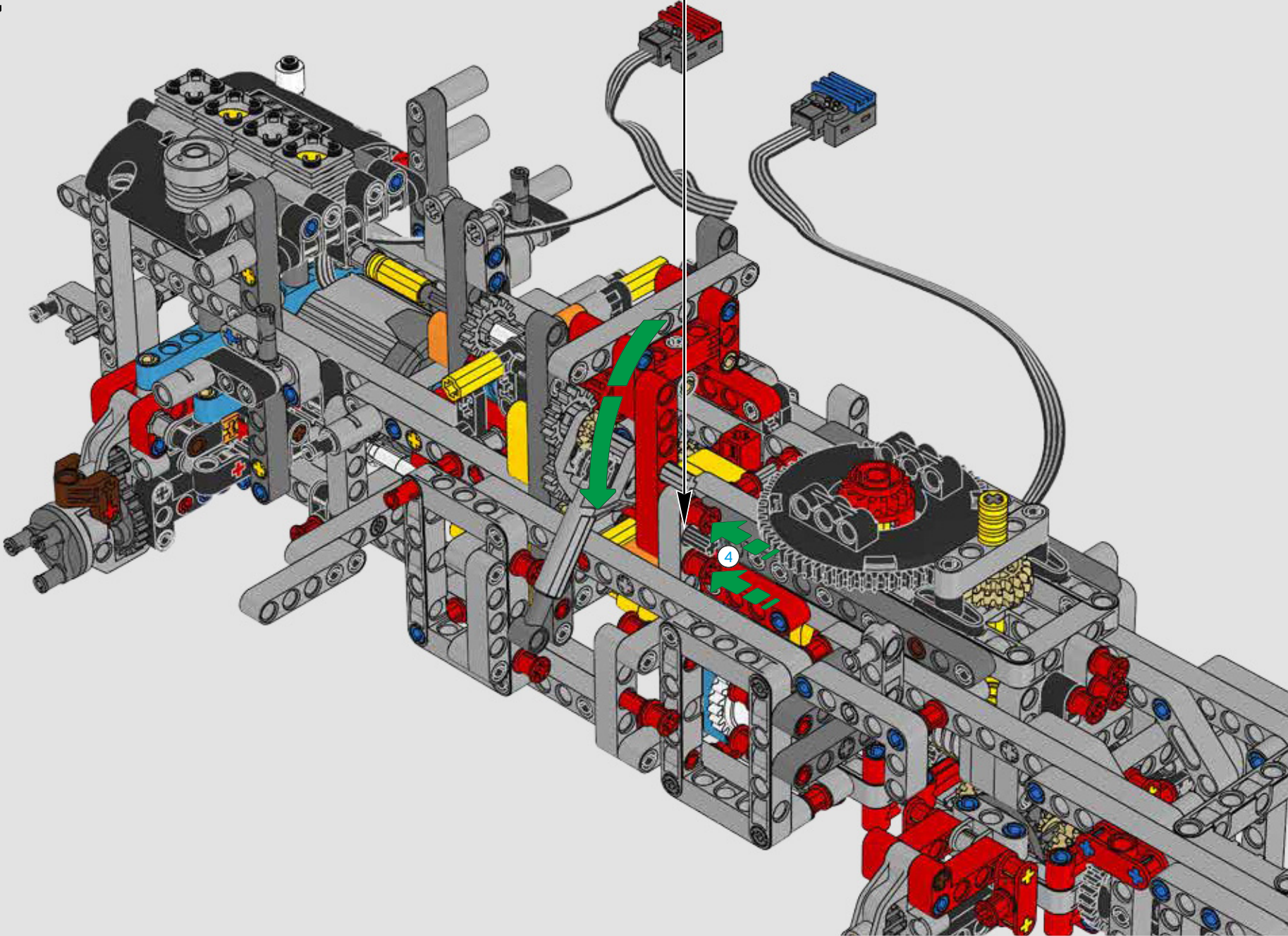



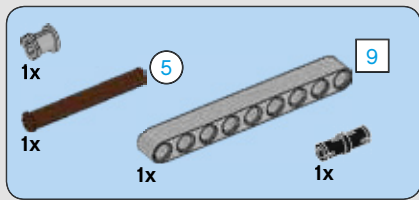

308

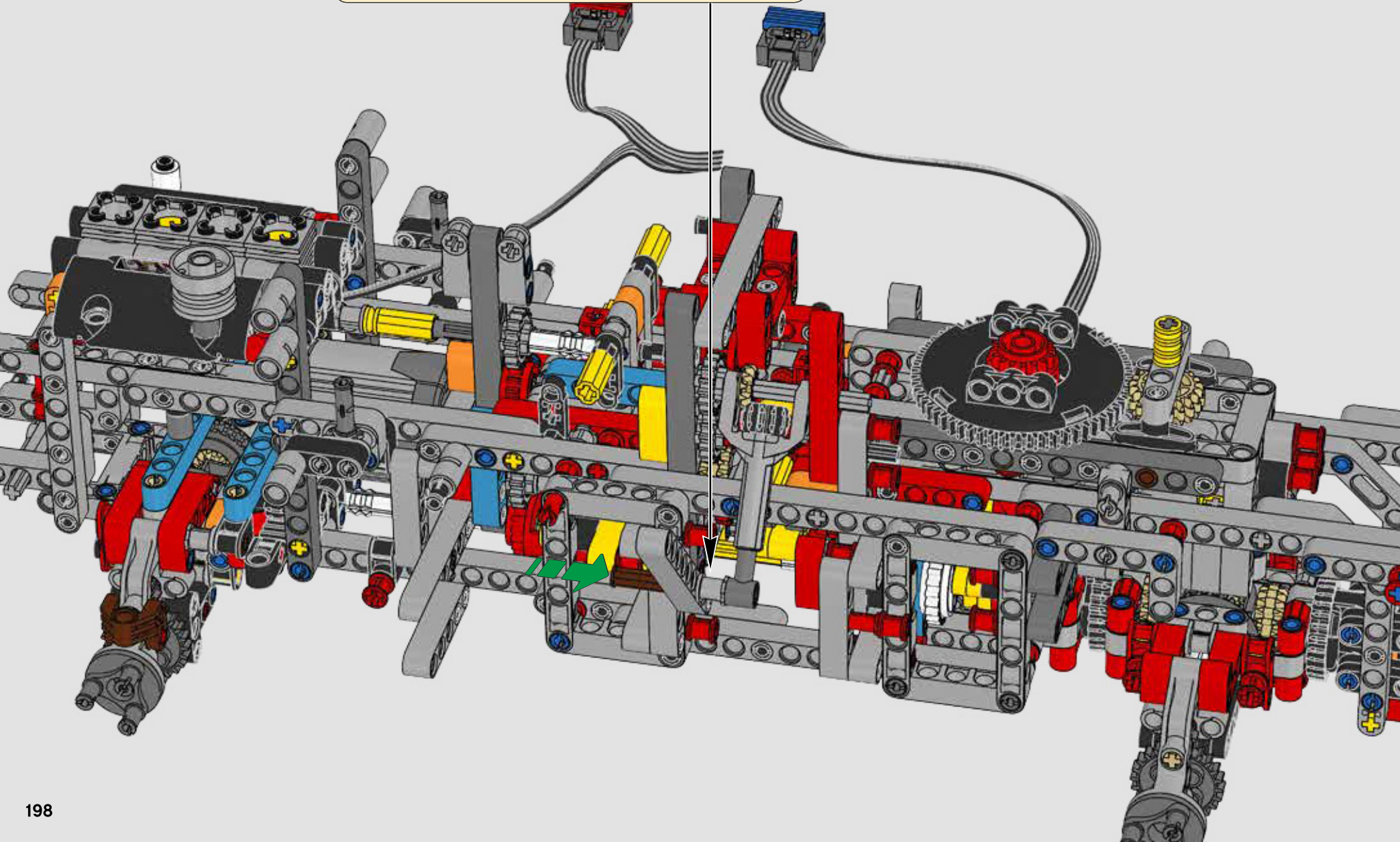
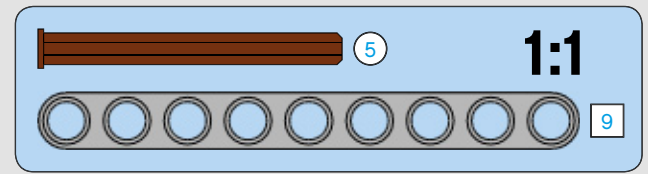
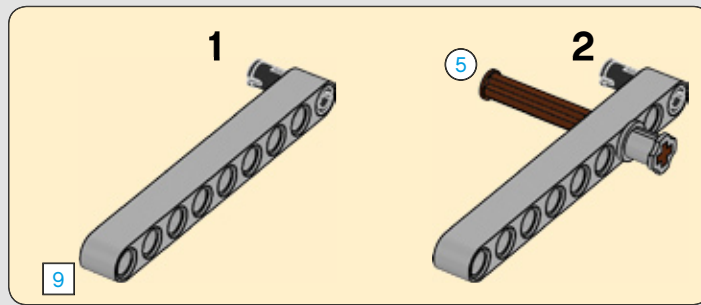





1x

# 309

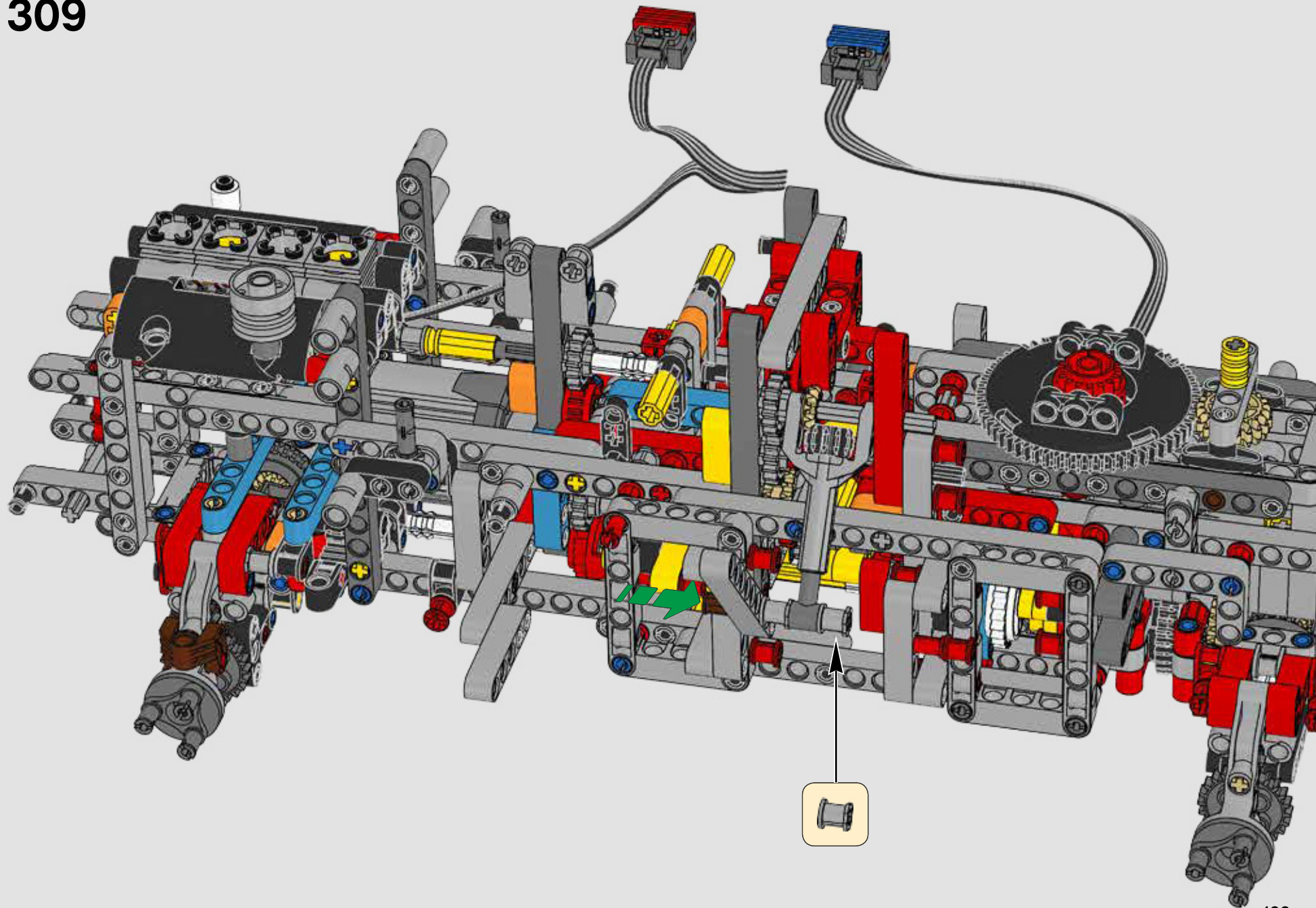



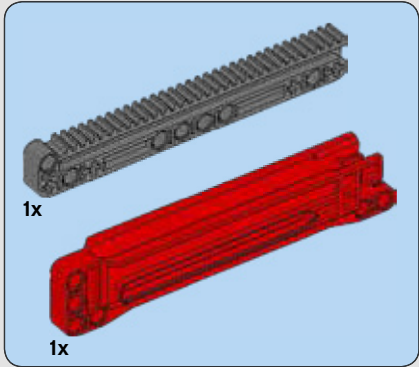

310

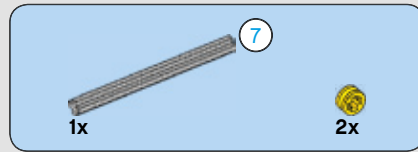
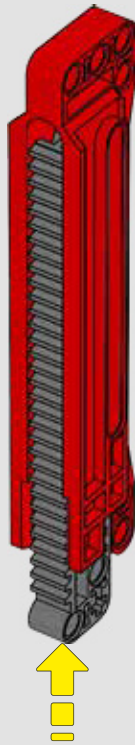

311

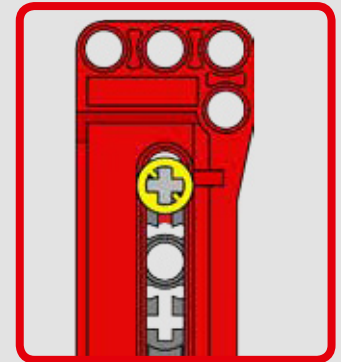
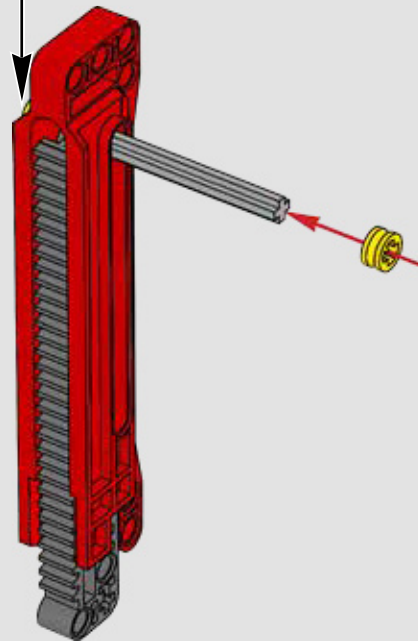
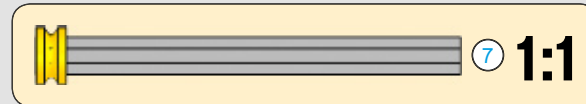

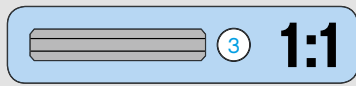
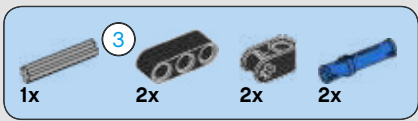

312

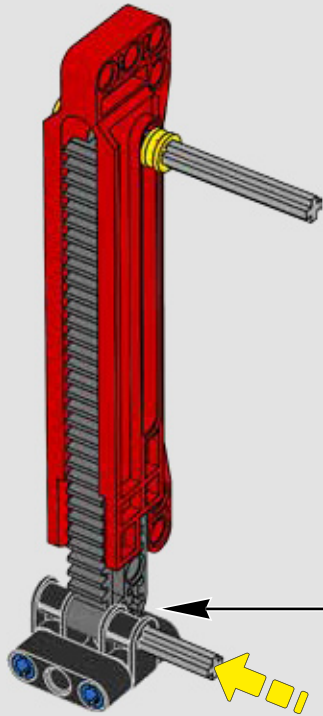
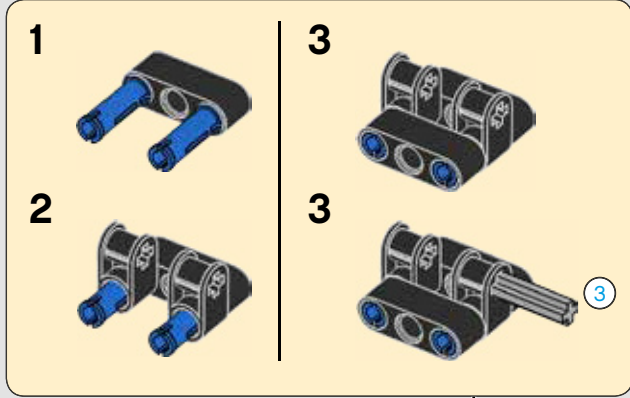

313

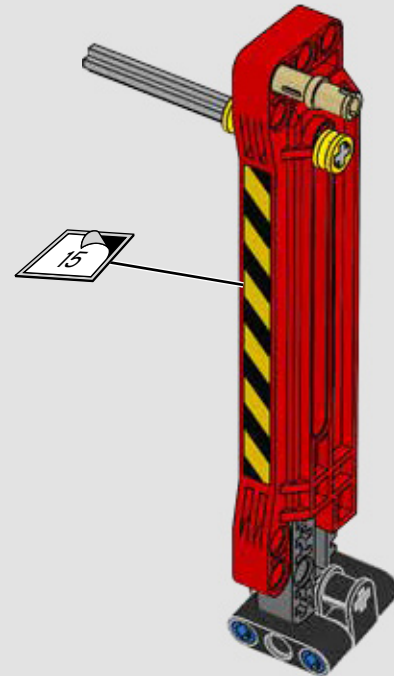
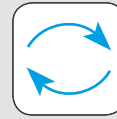



1x

314

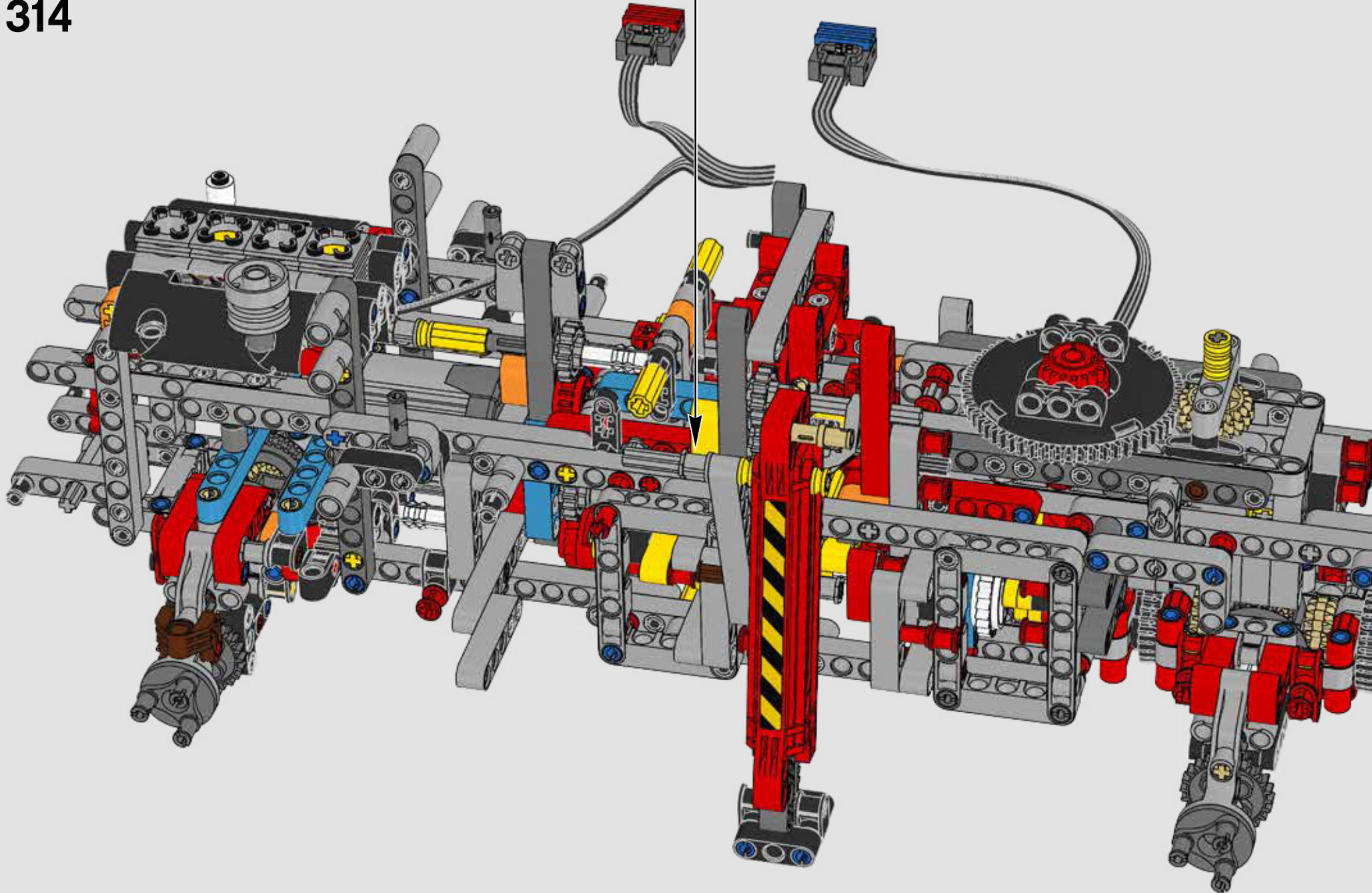
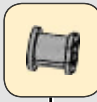



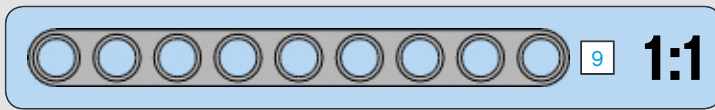
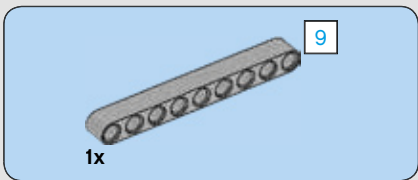

315

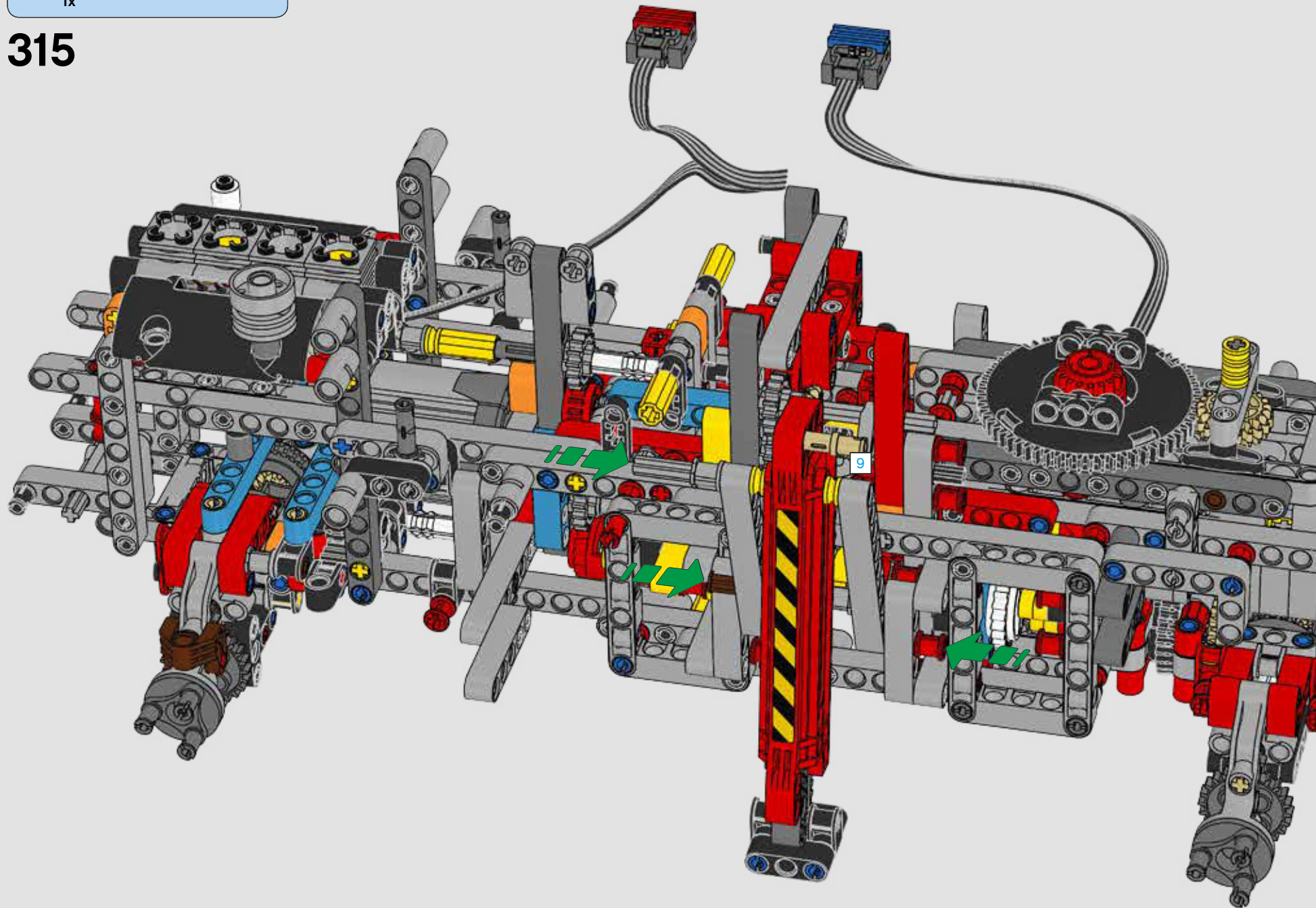



1x

316

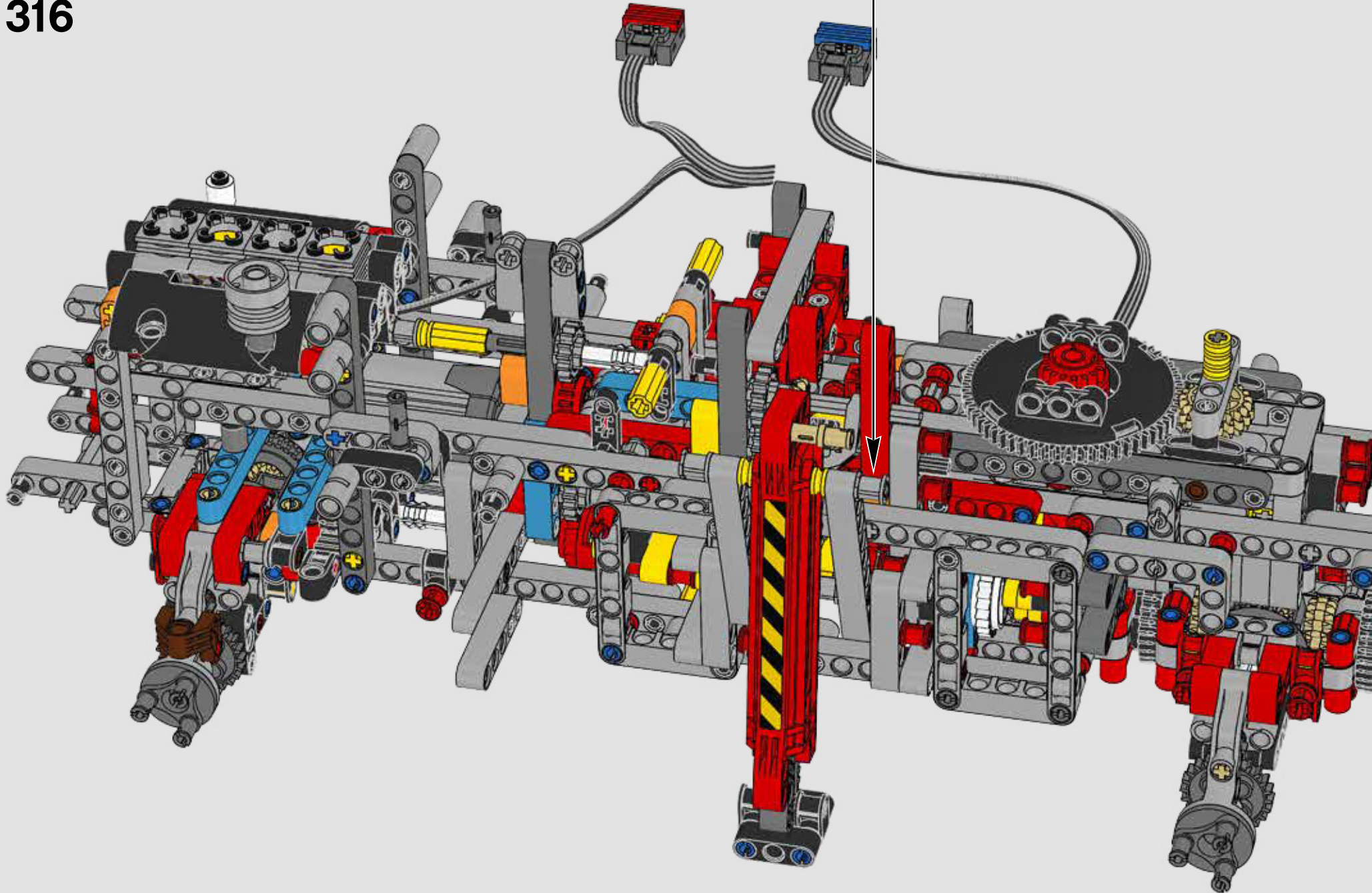
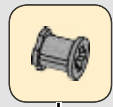





317

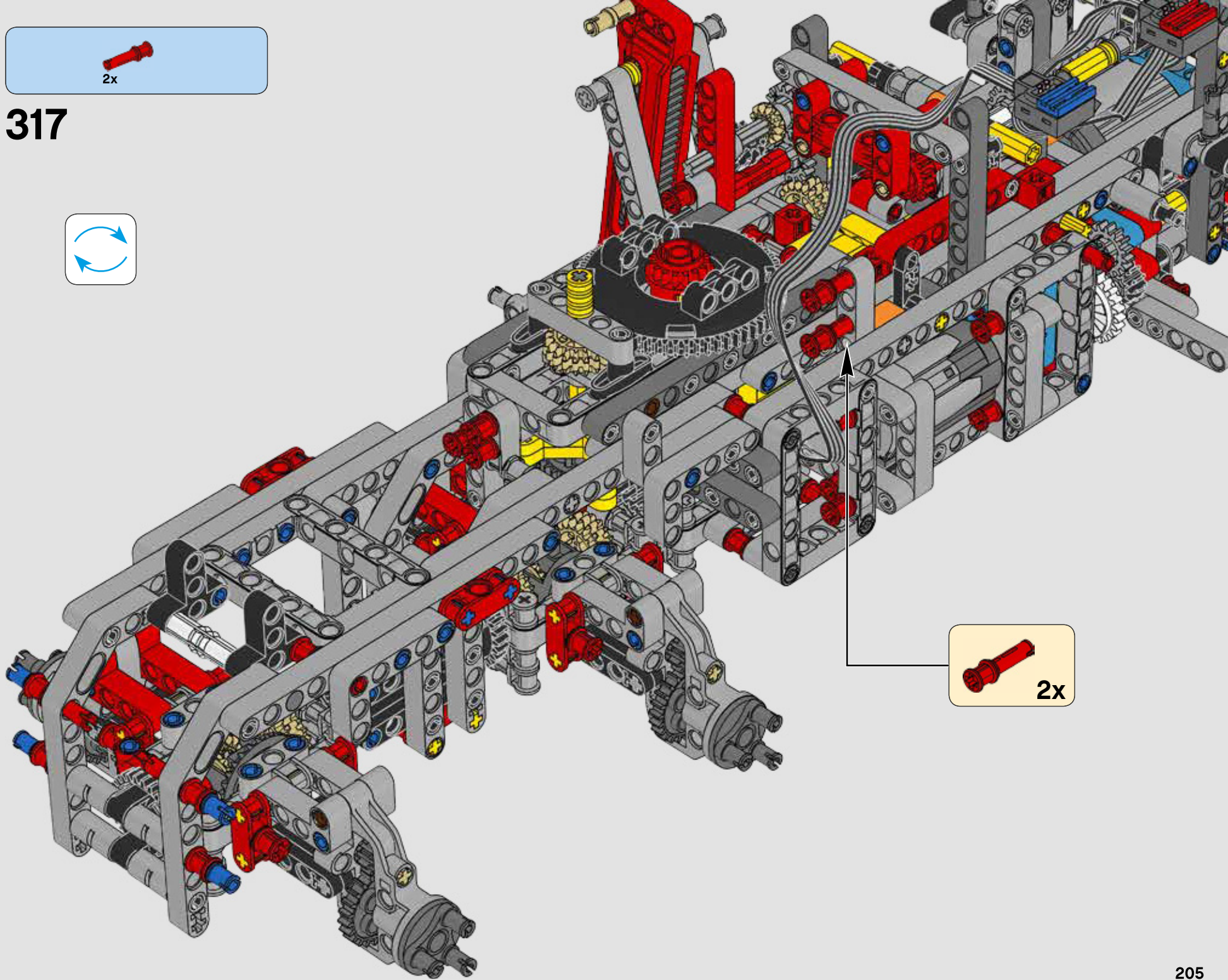



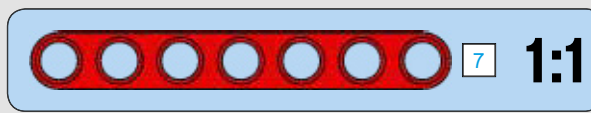
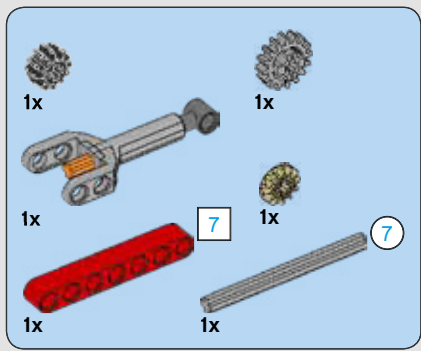

318

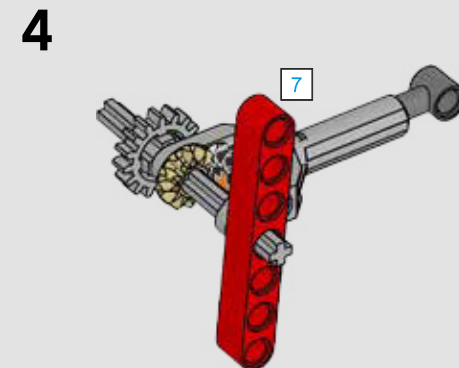
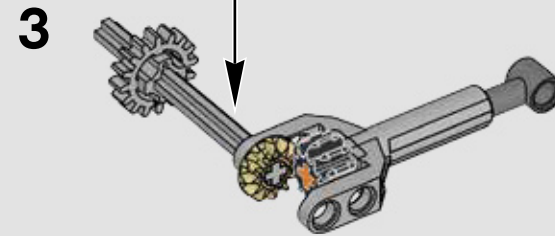
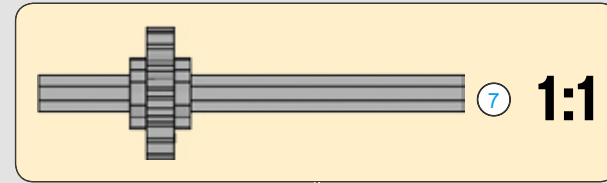
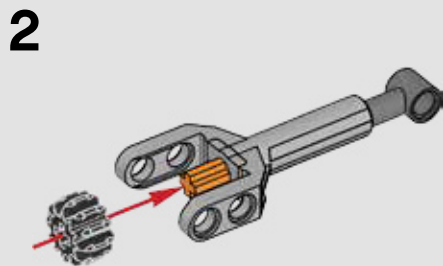
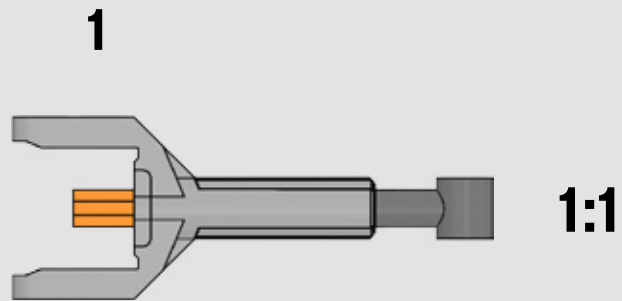

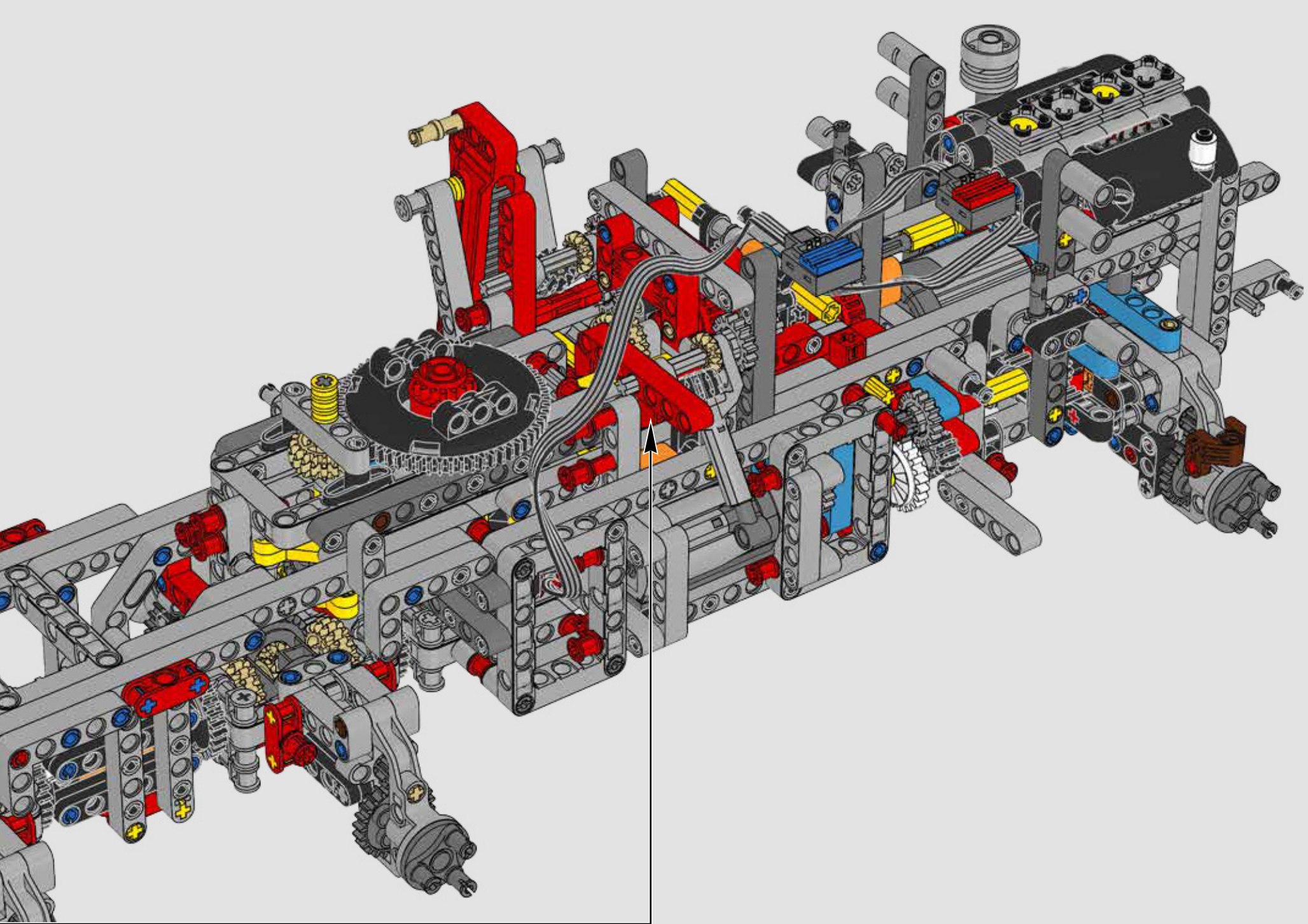



319

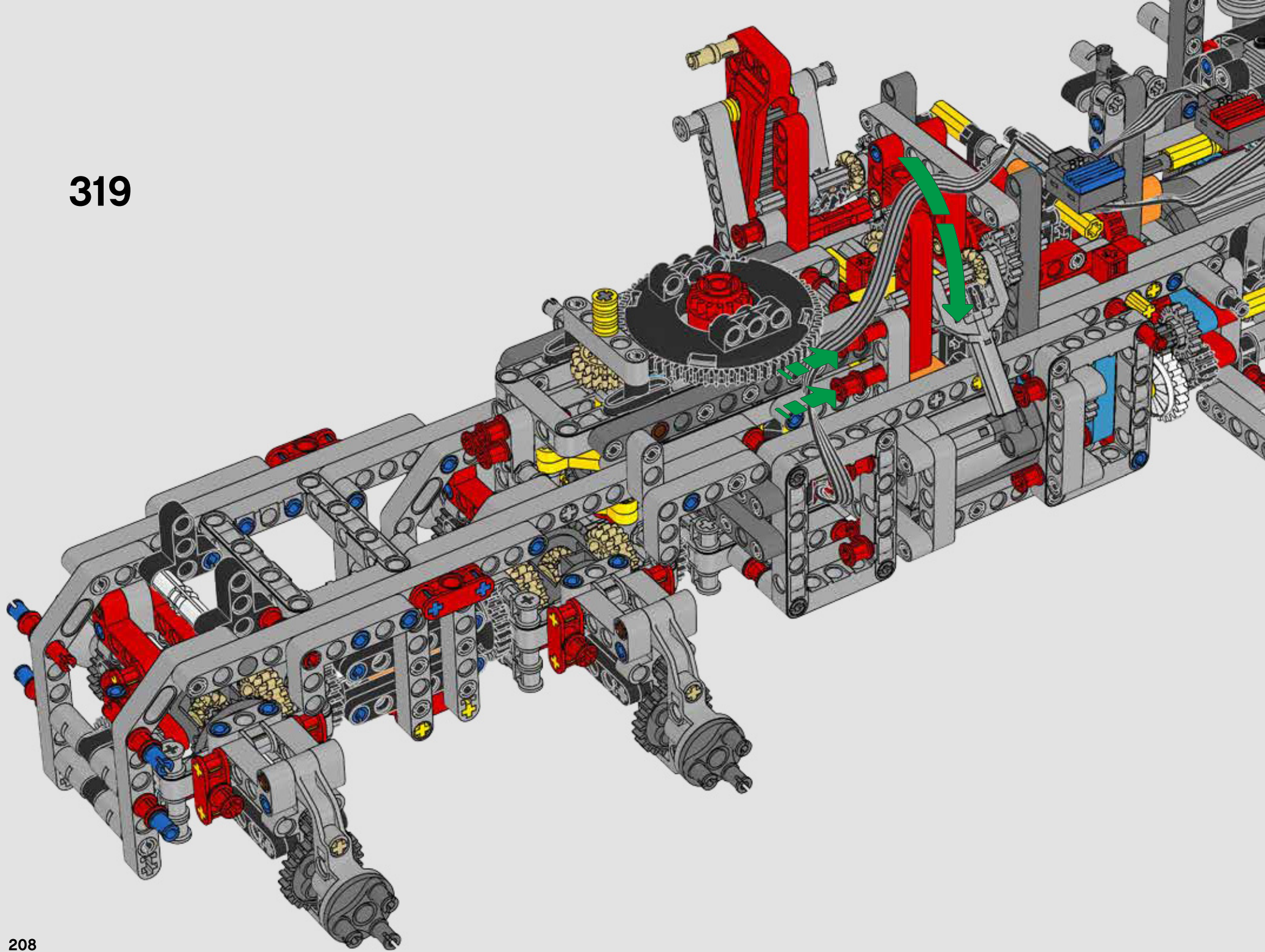



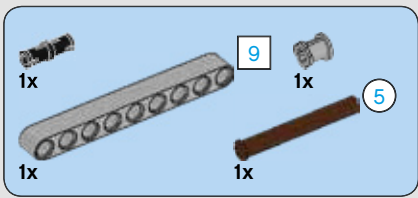

320

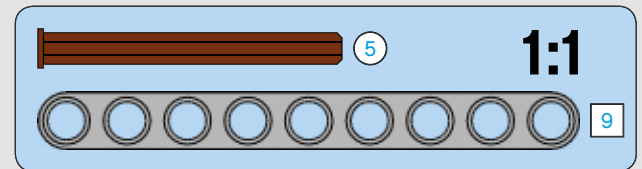
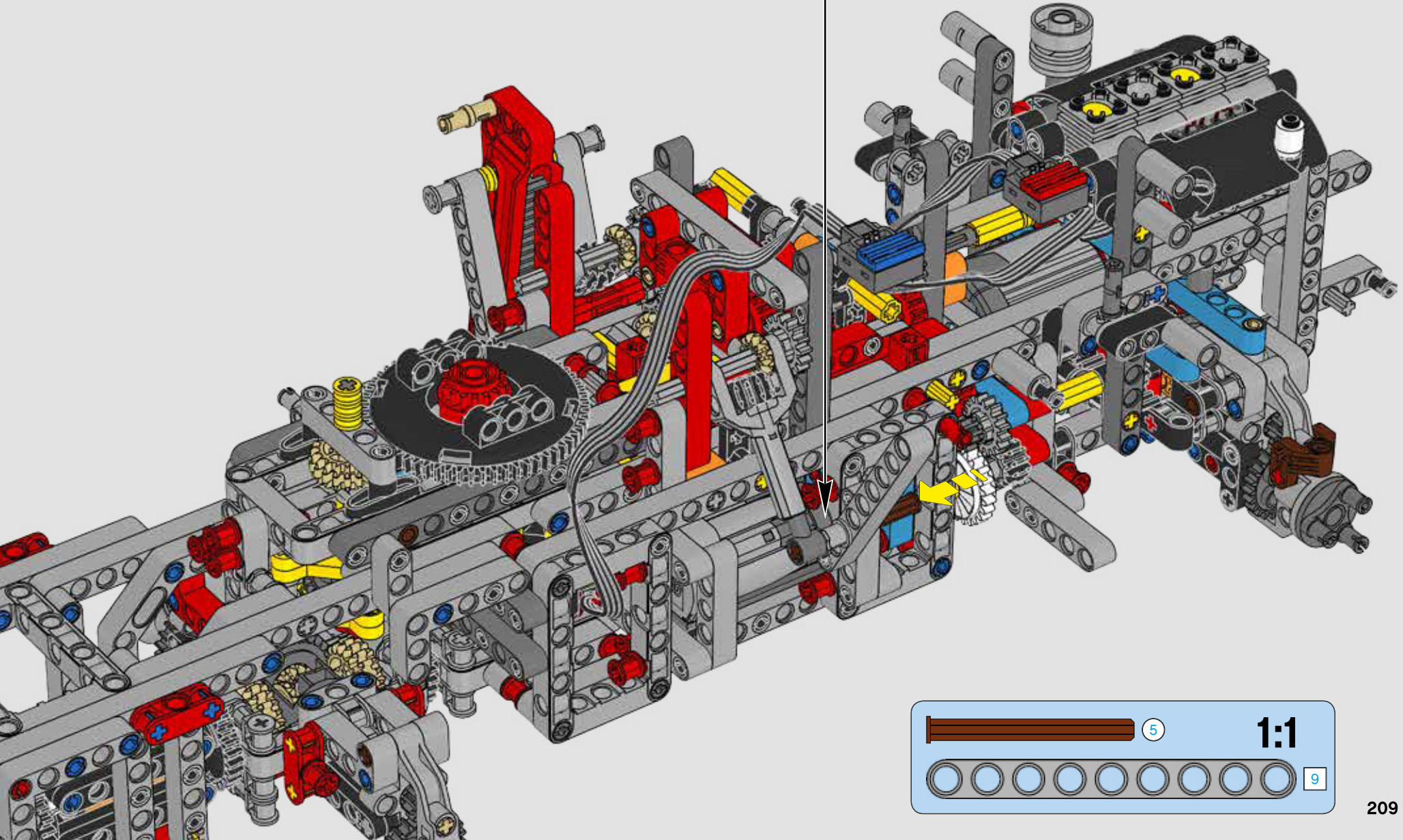
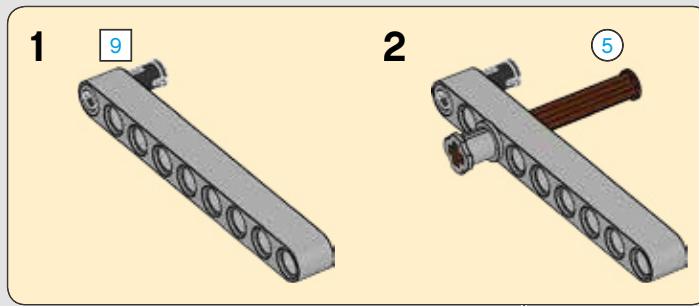



1x

321

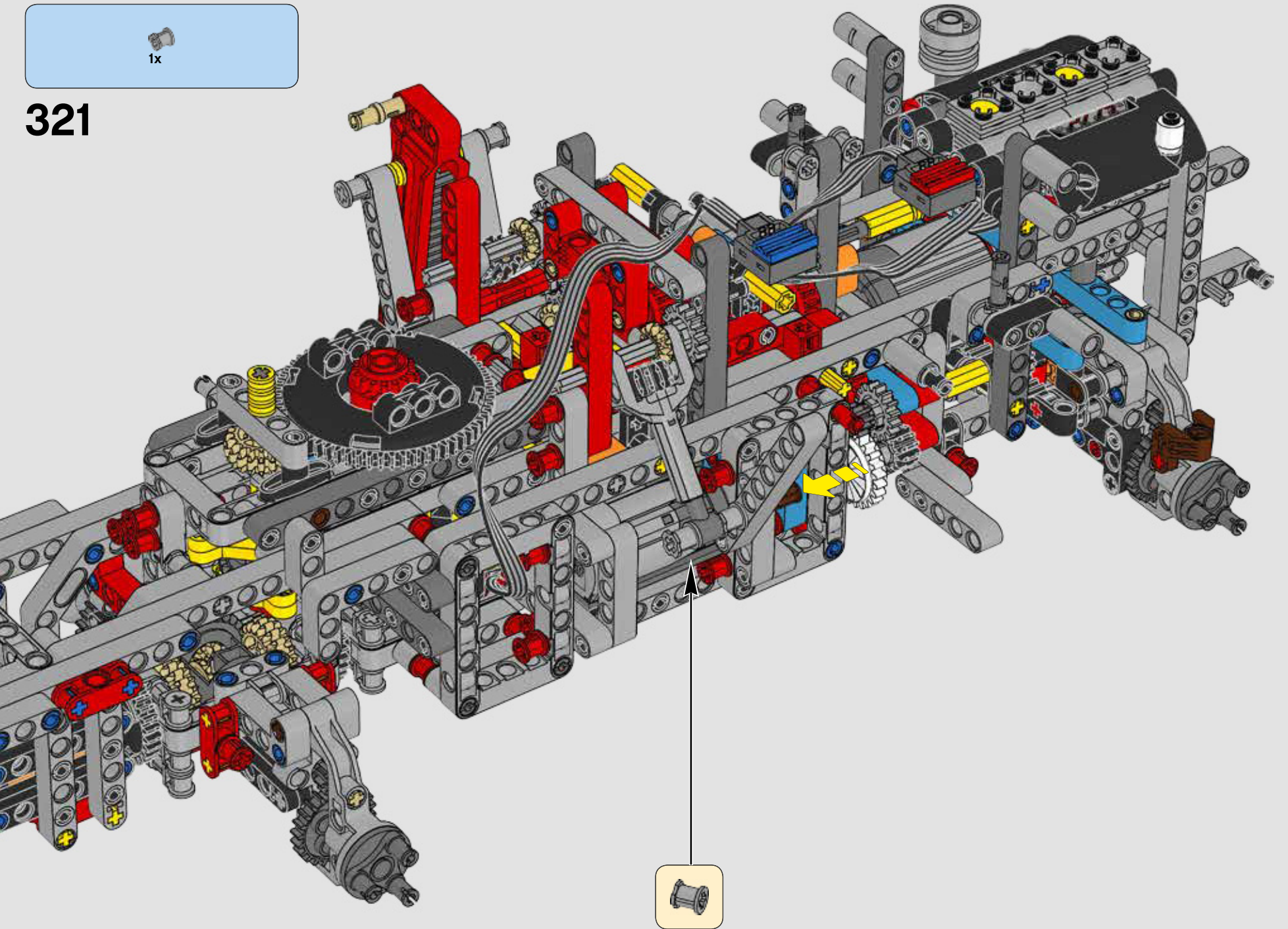

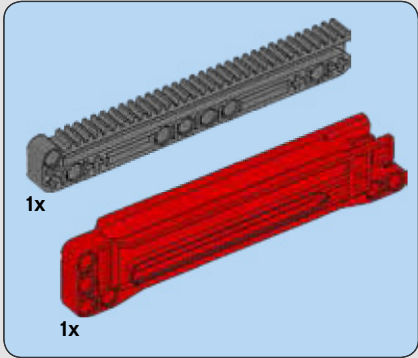

322

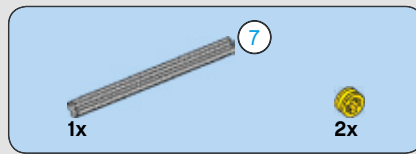

323

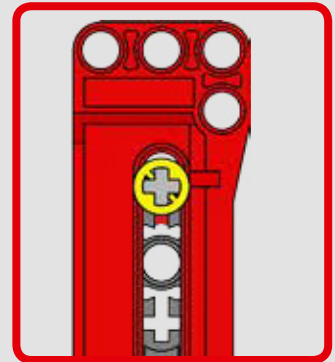
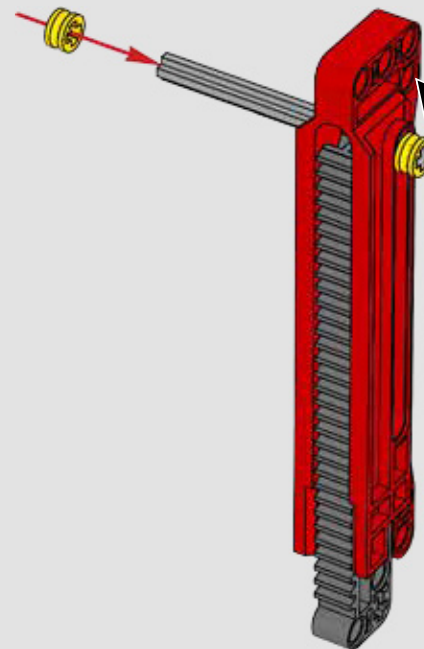
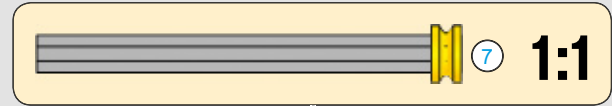



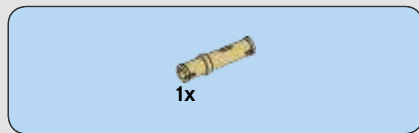
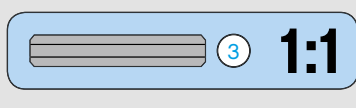

324

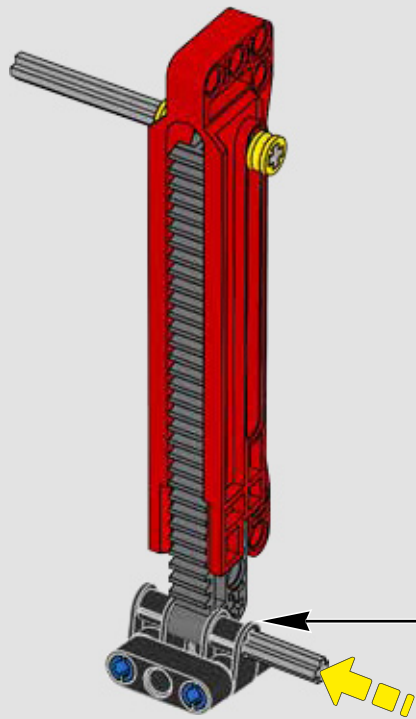
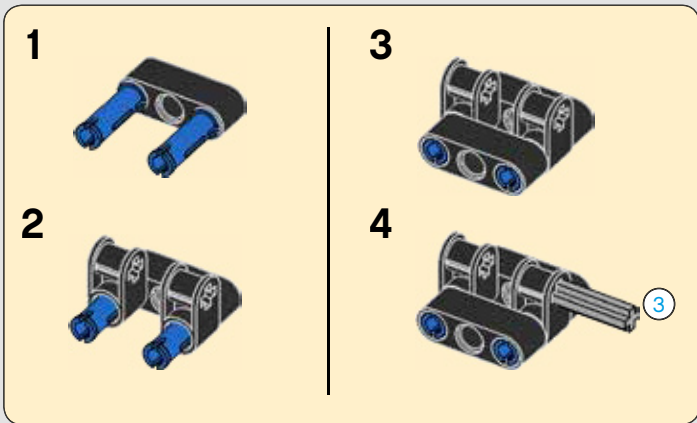

325

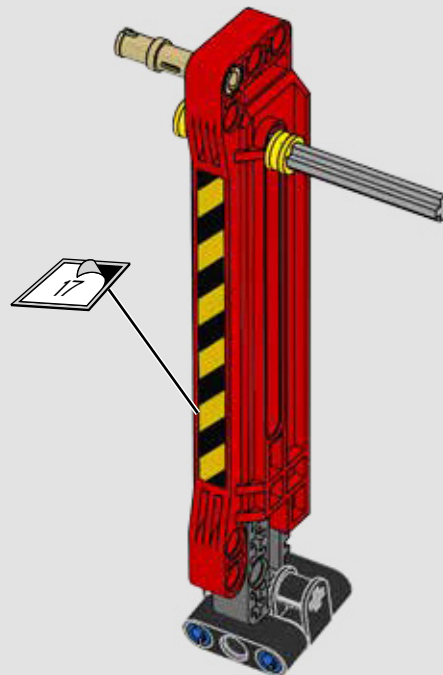
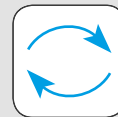

326

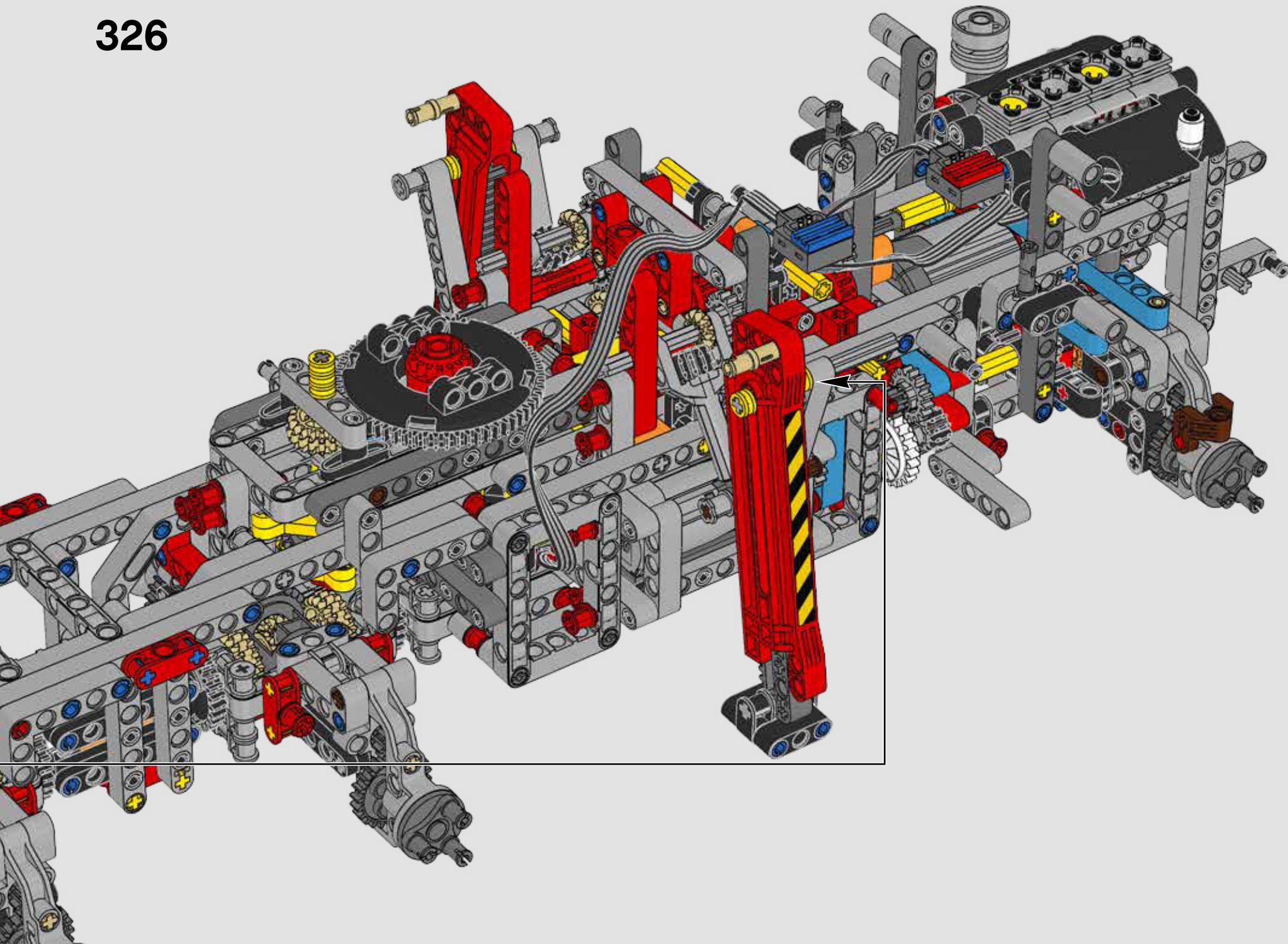



1x

327

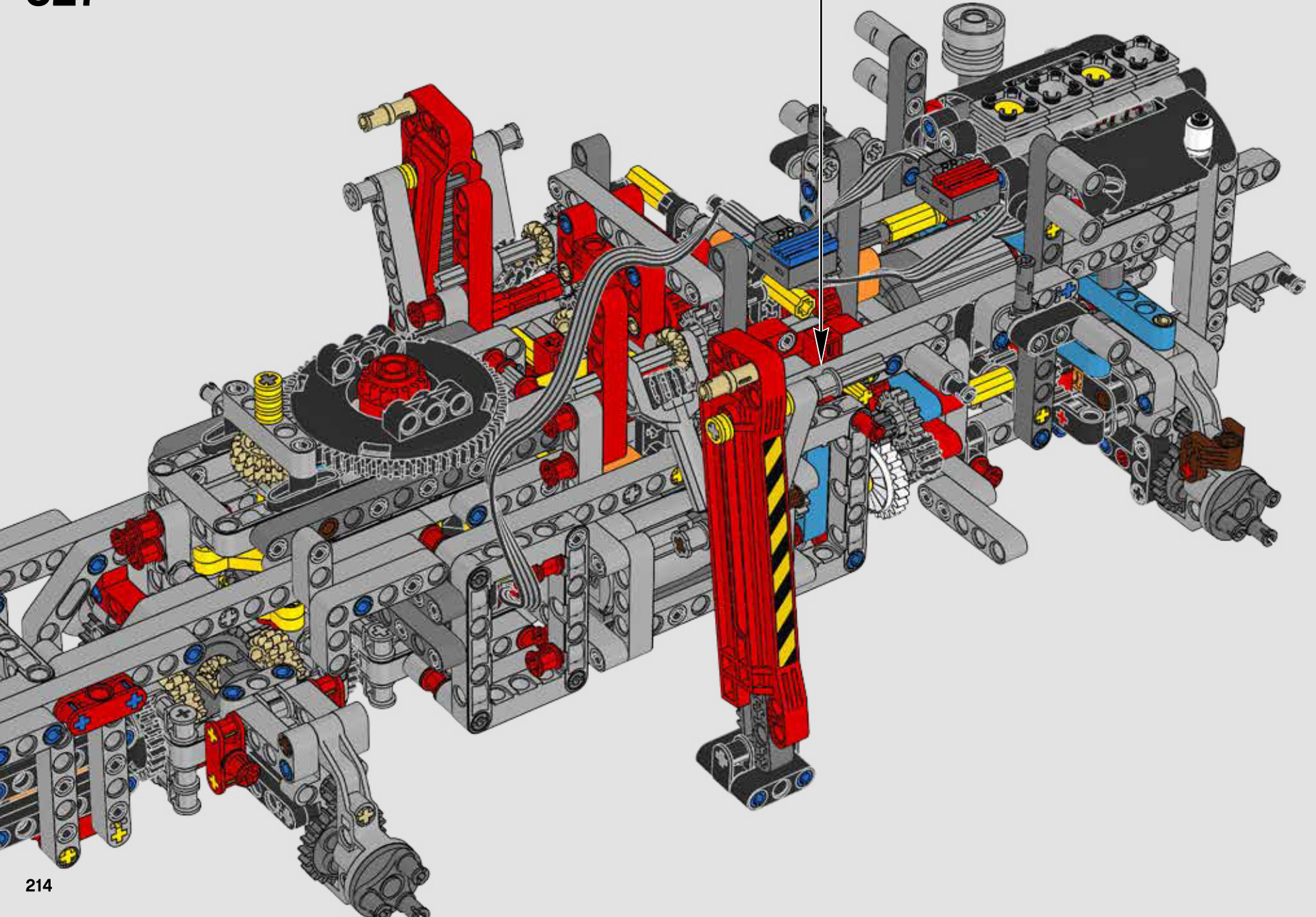
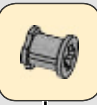



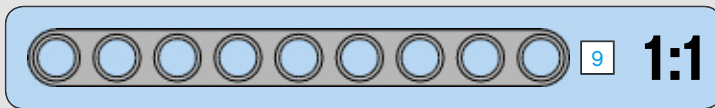
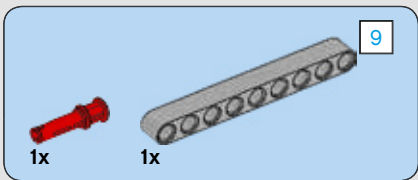

328

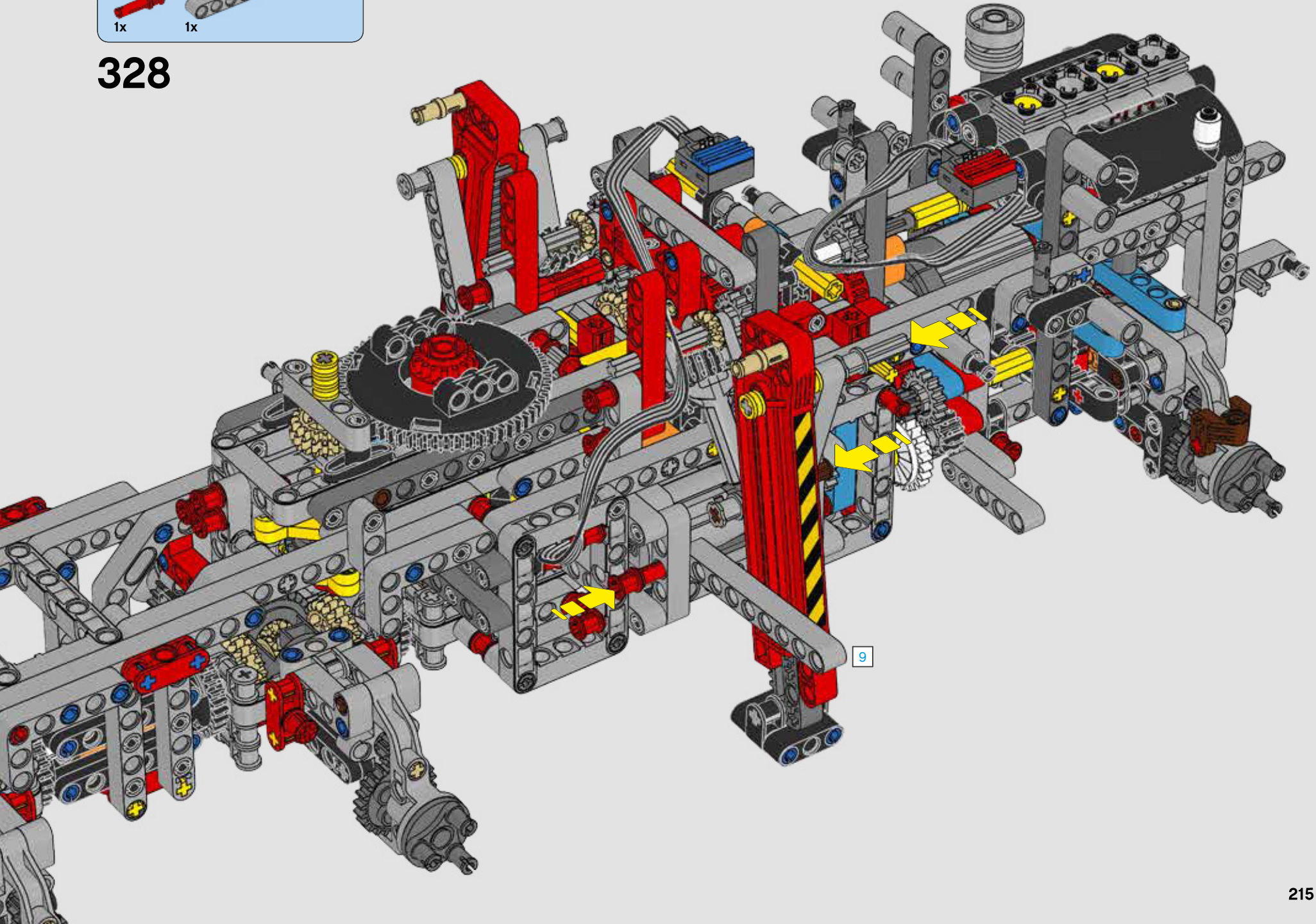





1x

329

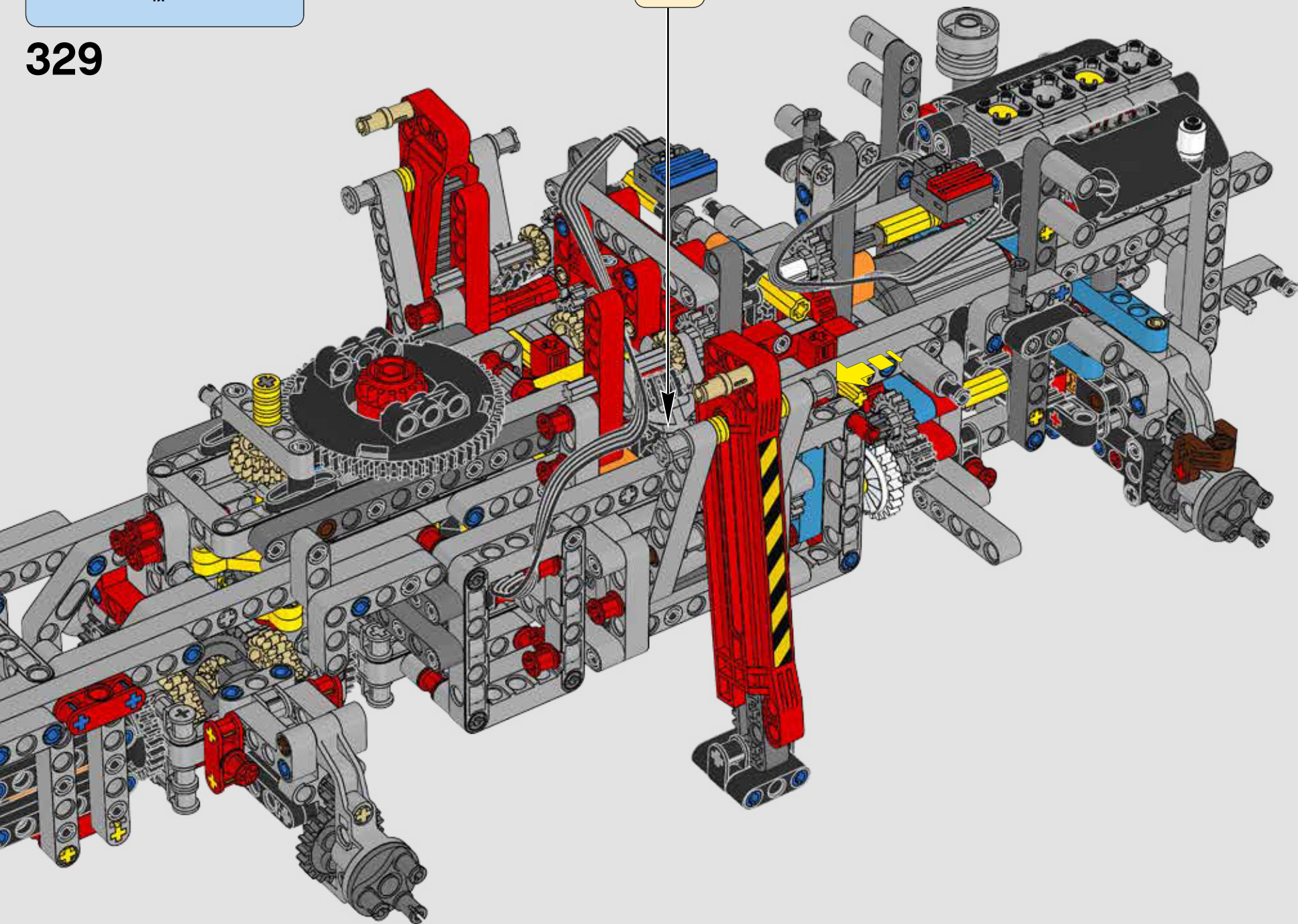

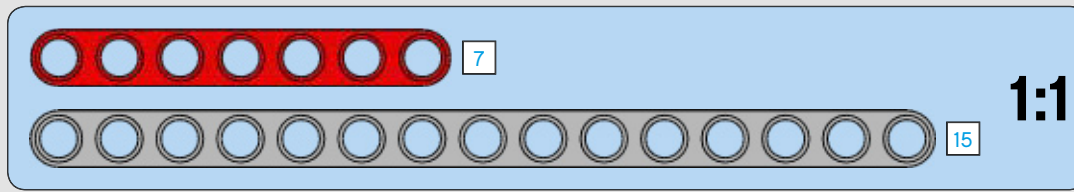
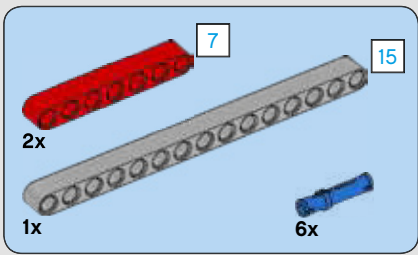

# 330

1

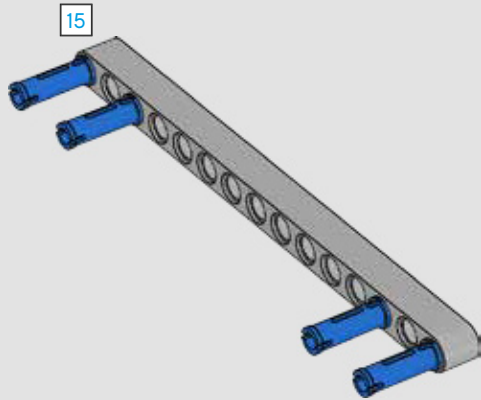

2

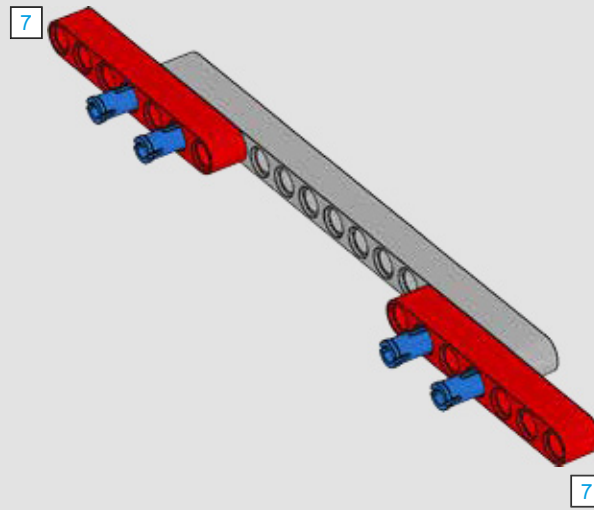

3

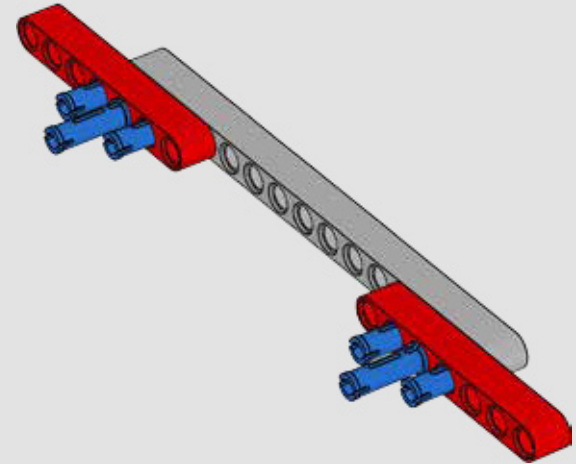



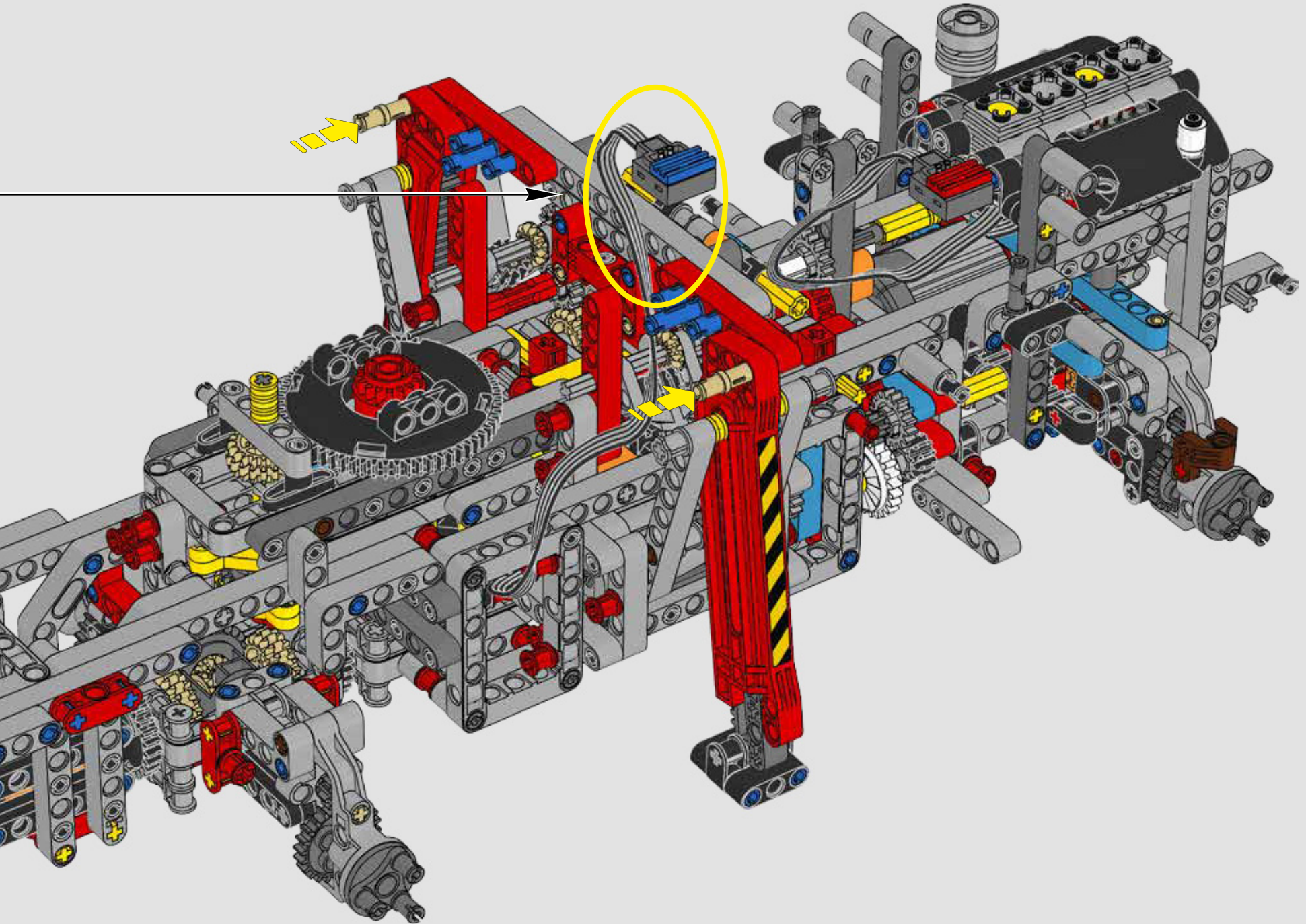



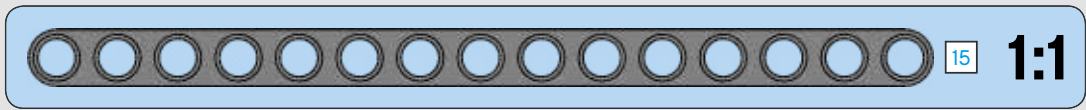
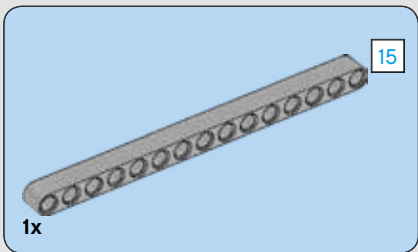

332

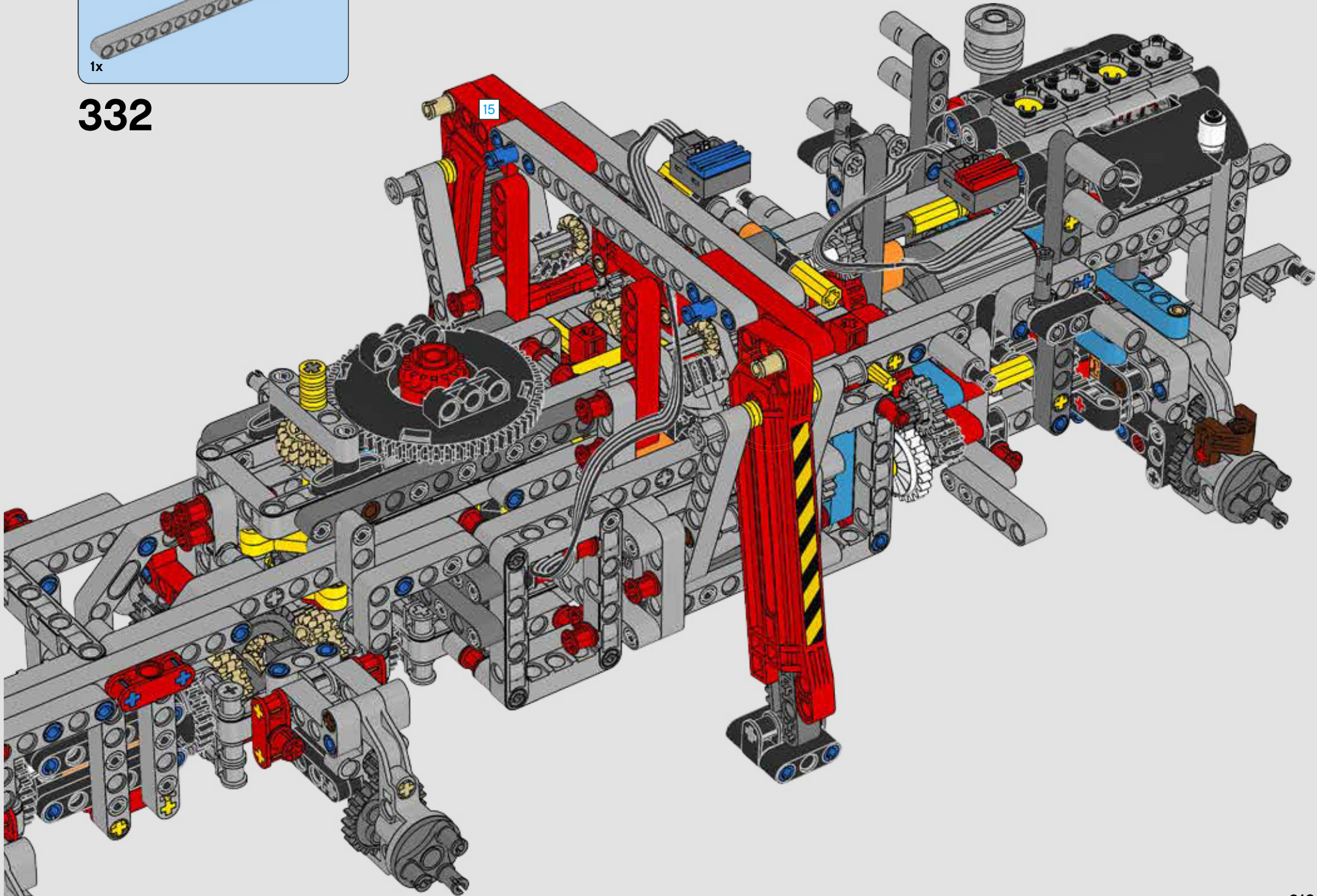



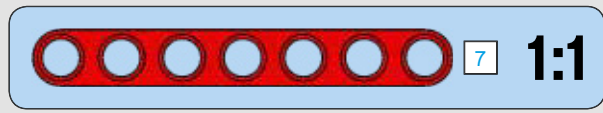
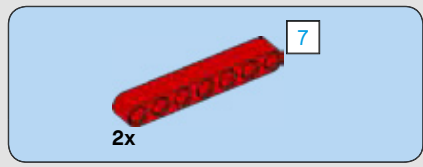

333

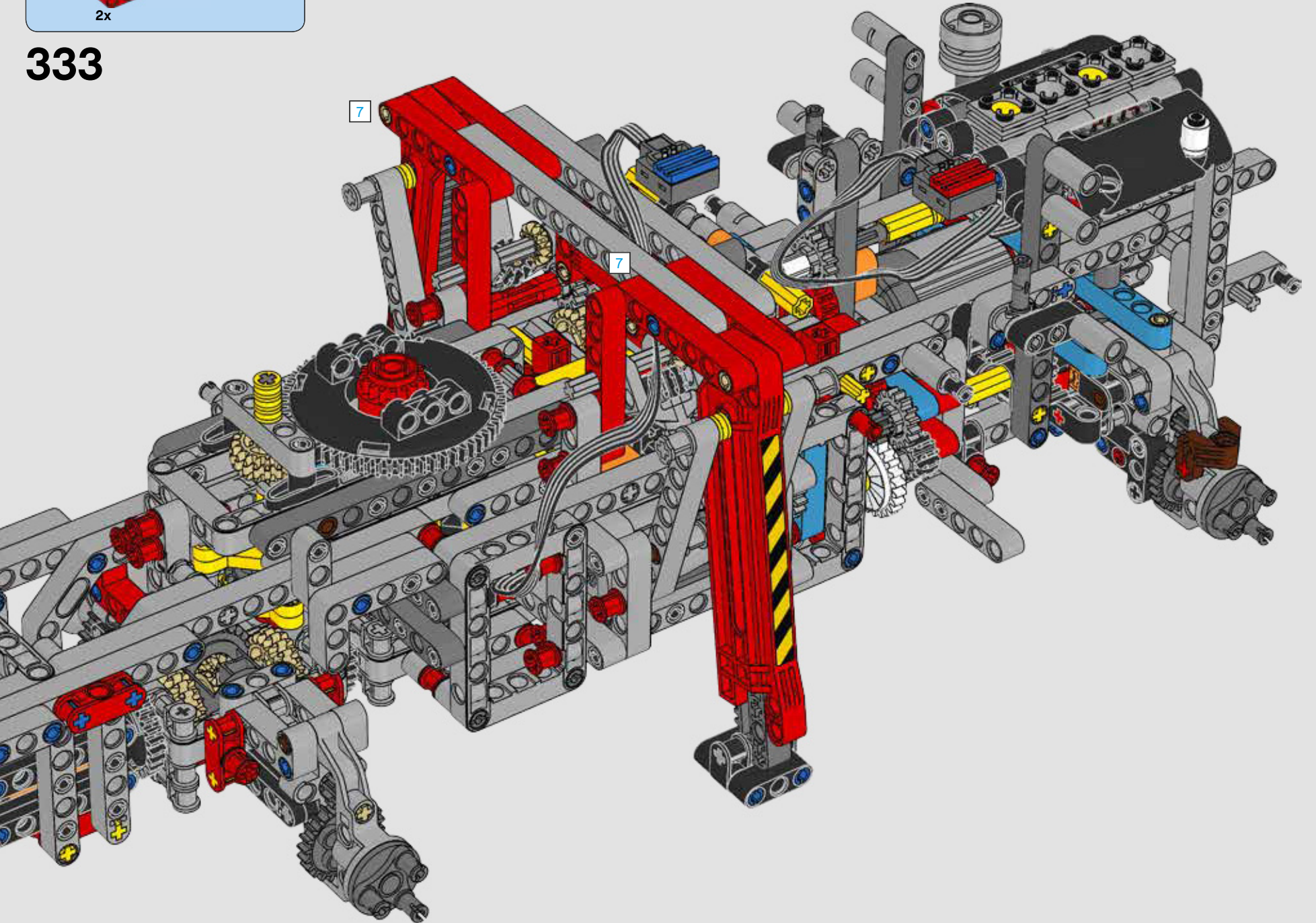





334

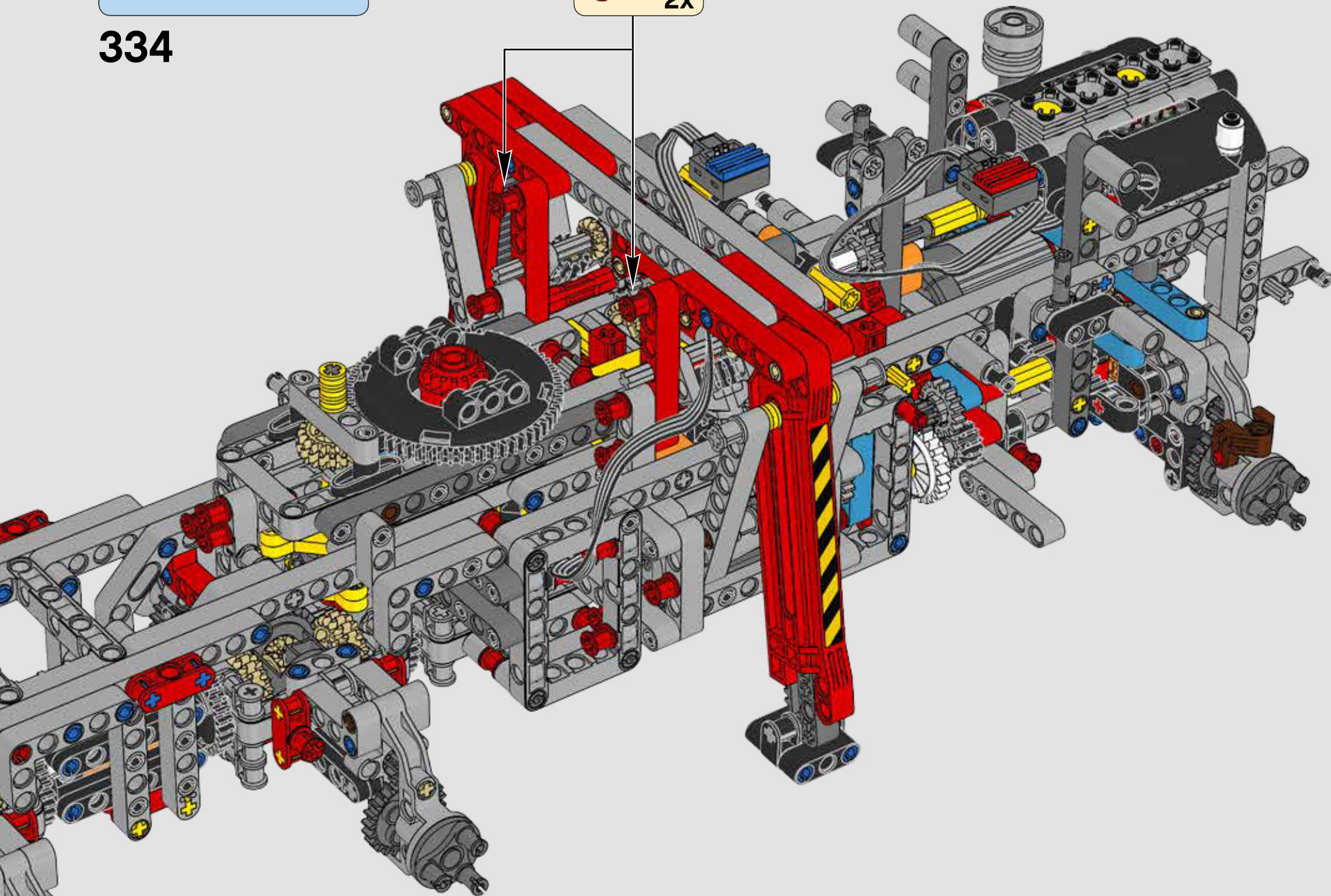





335

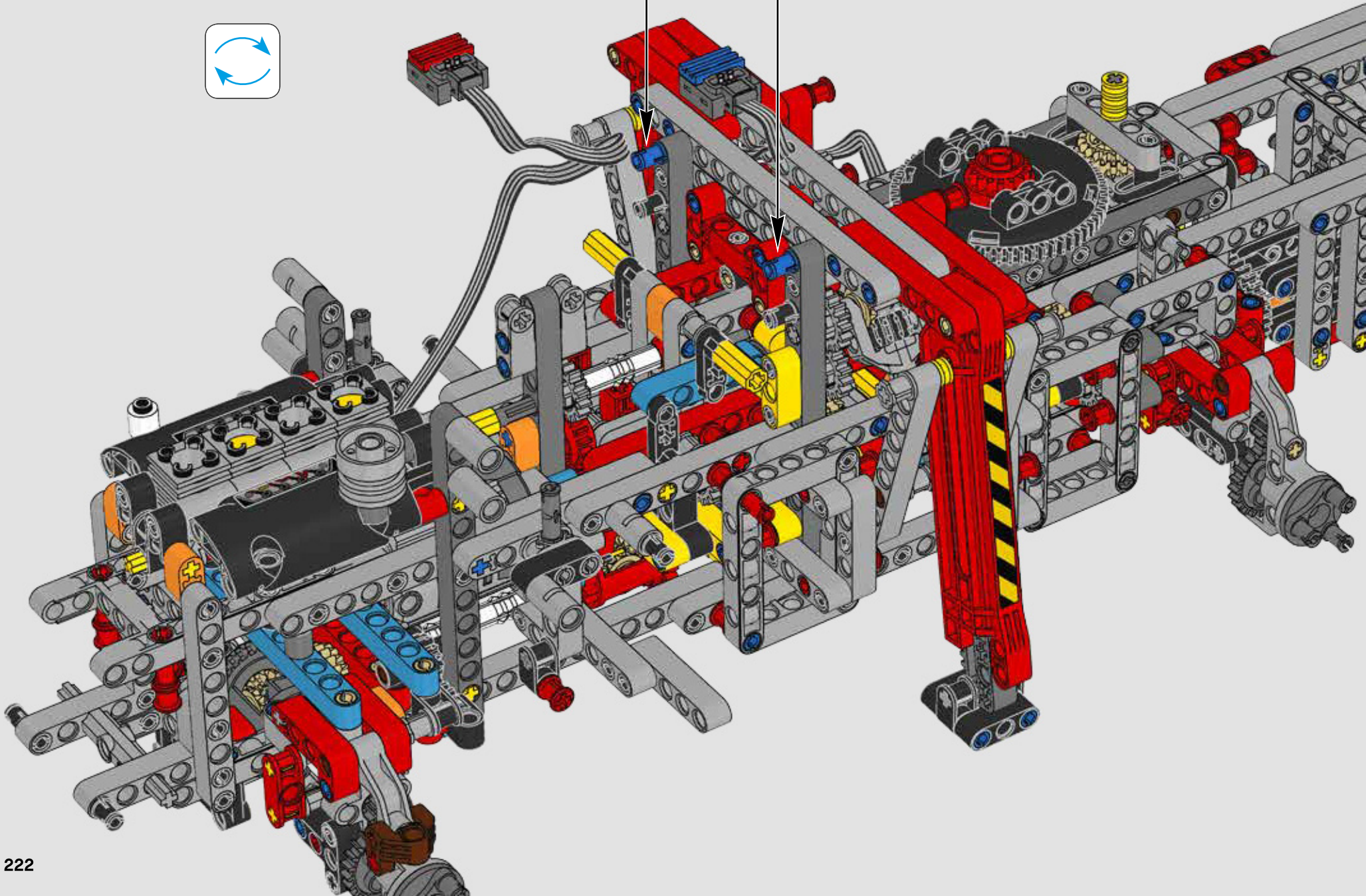



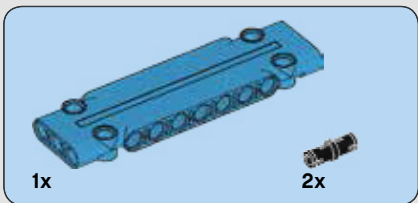

**336**

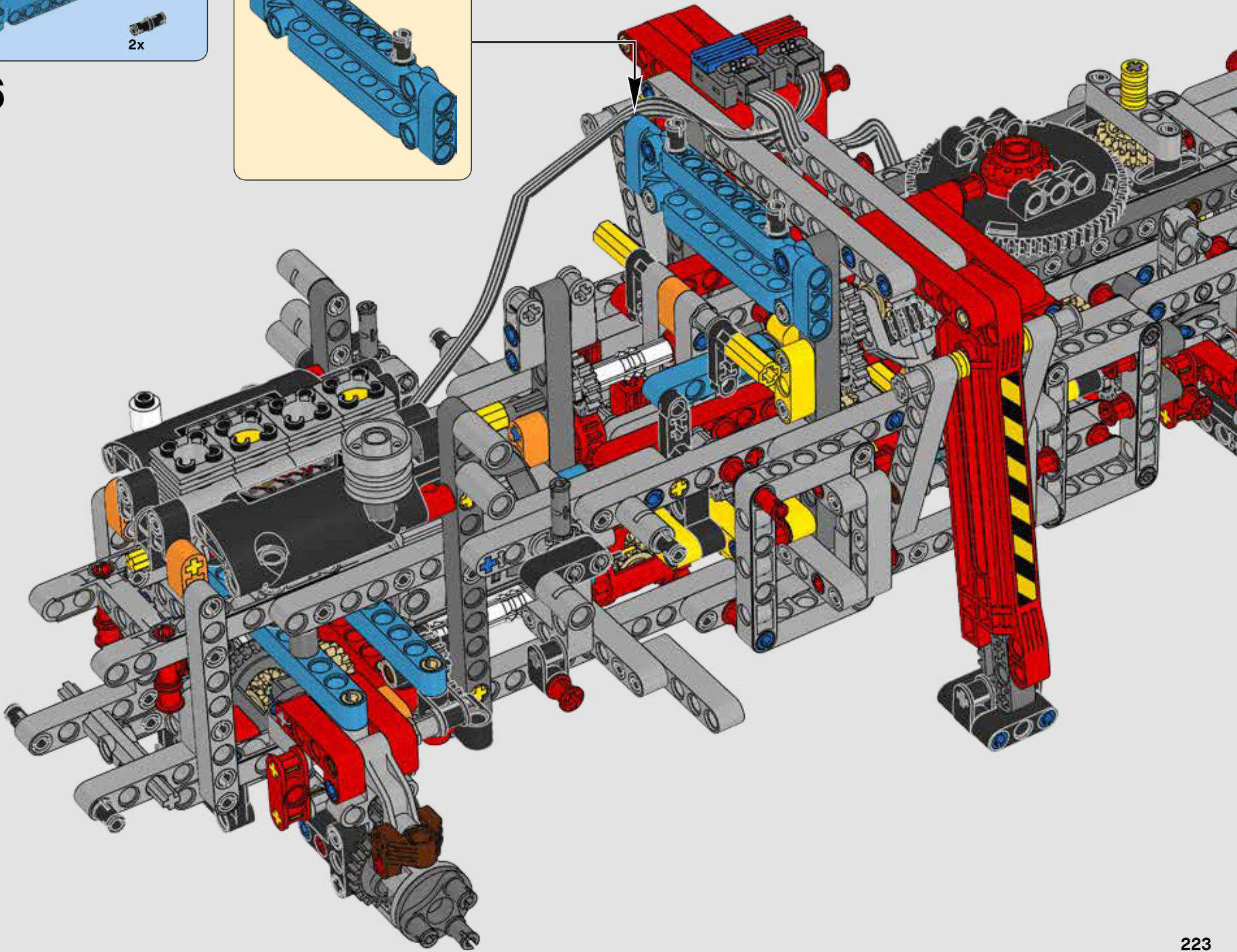
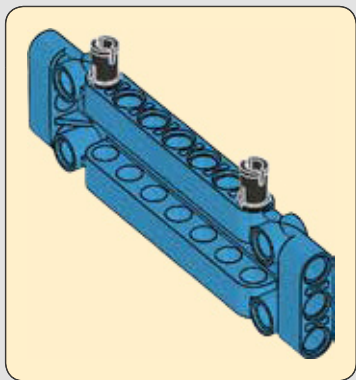



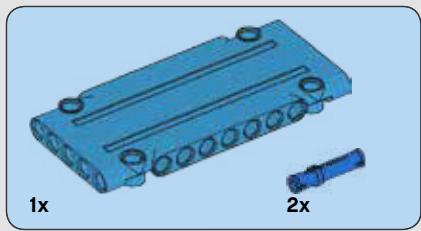

337

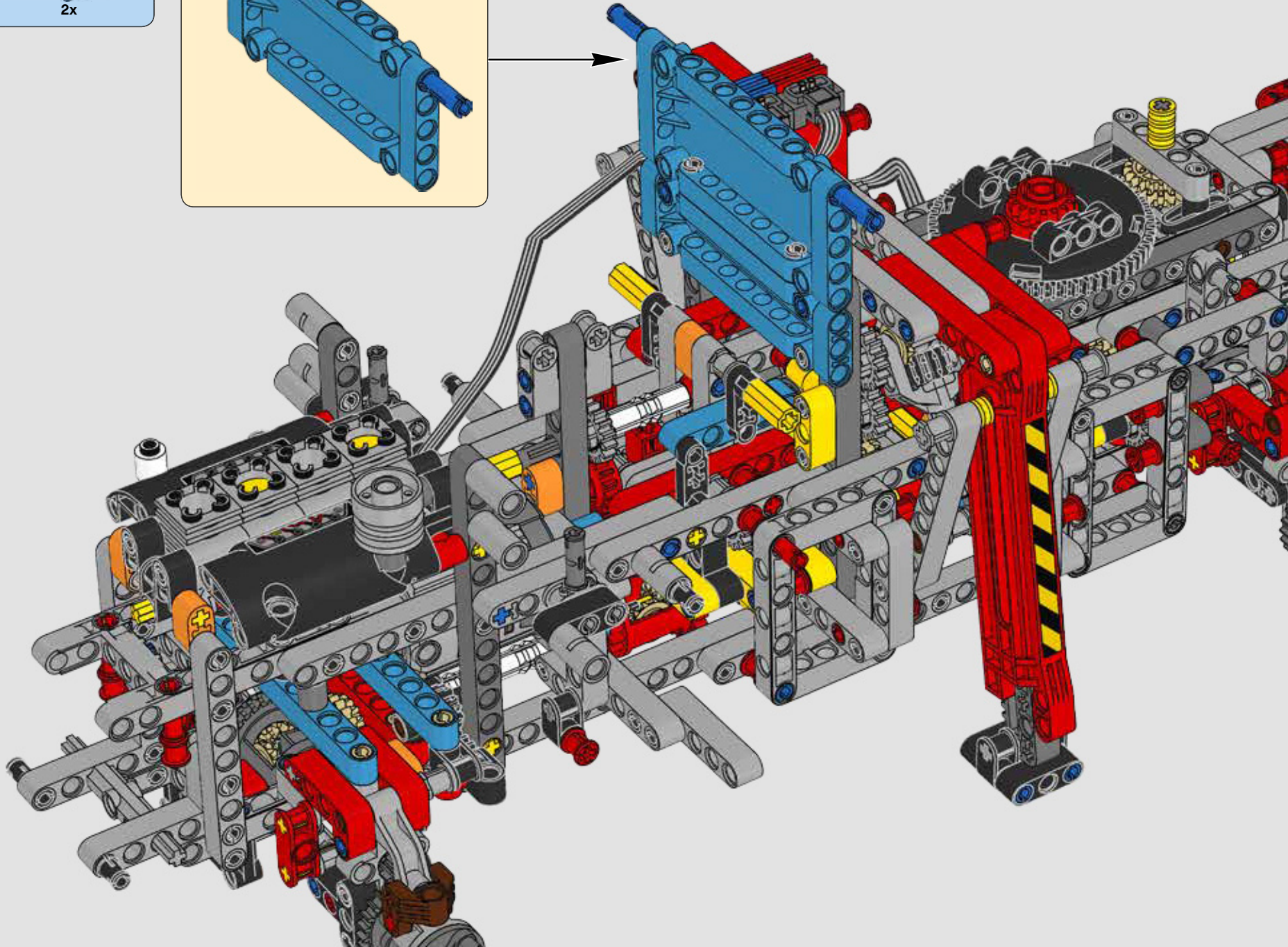
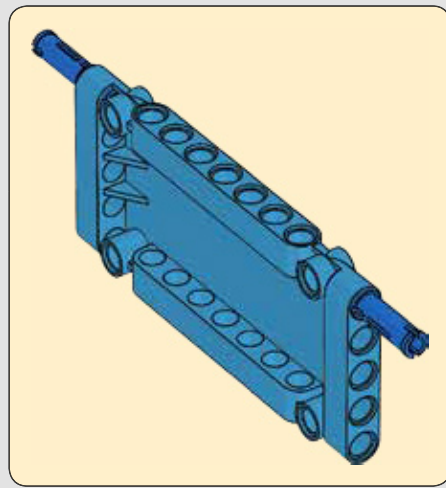



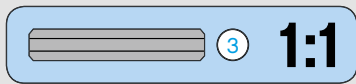
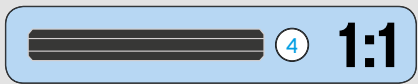
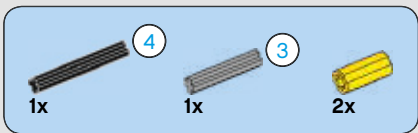

338

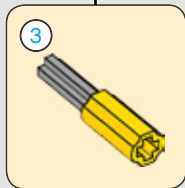
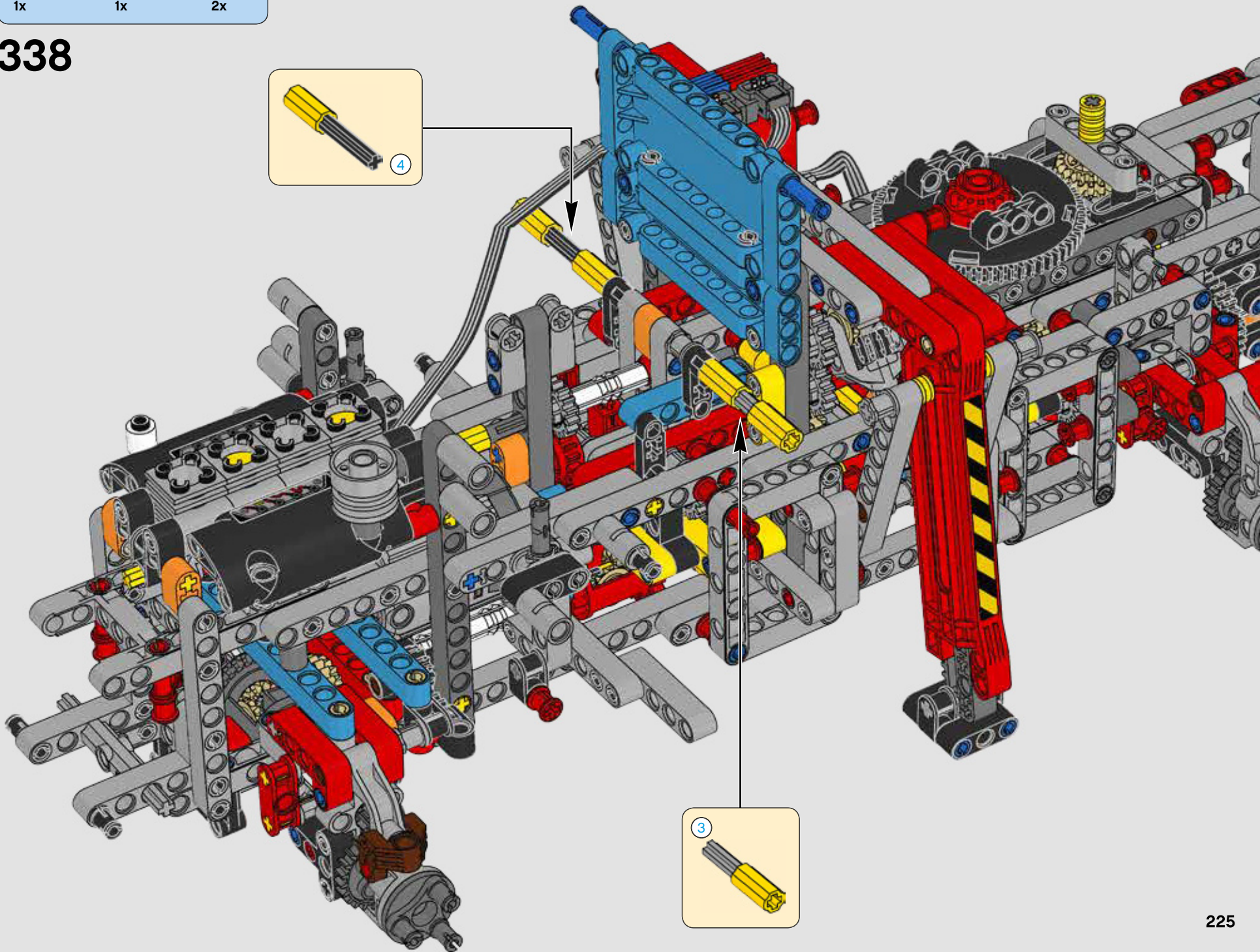
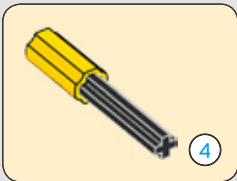

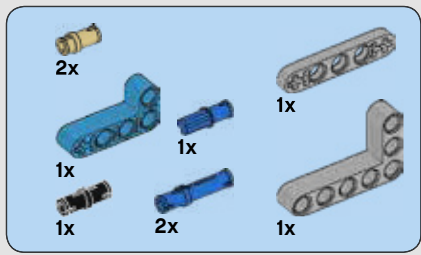

339

1

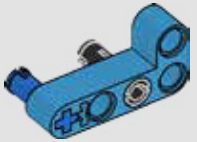

2

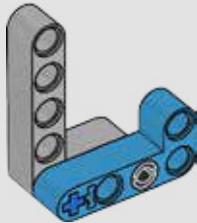

3

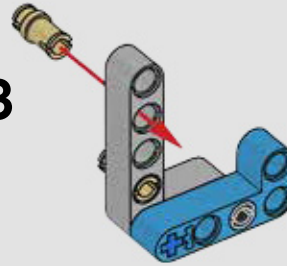

4

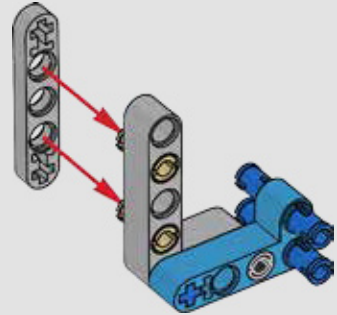



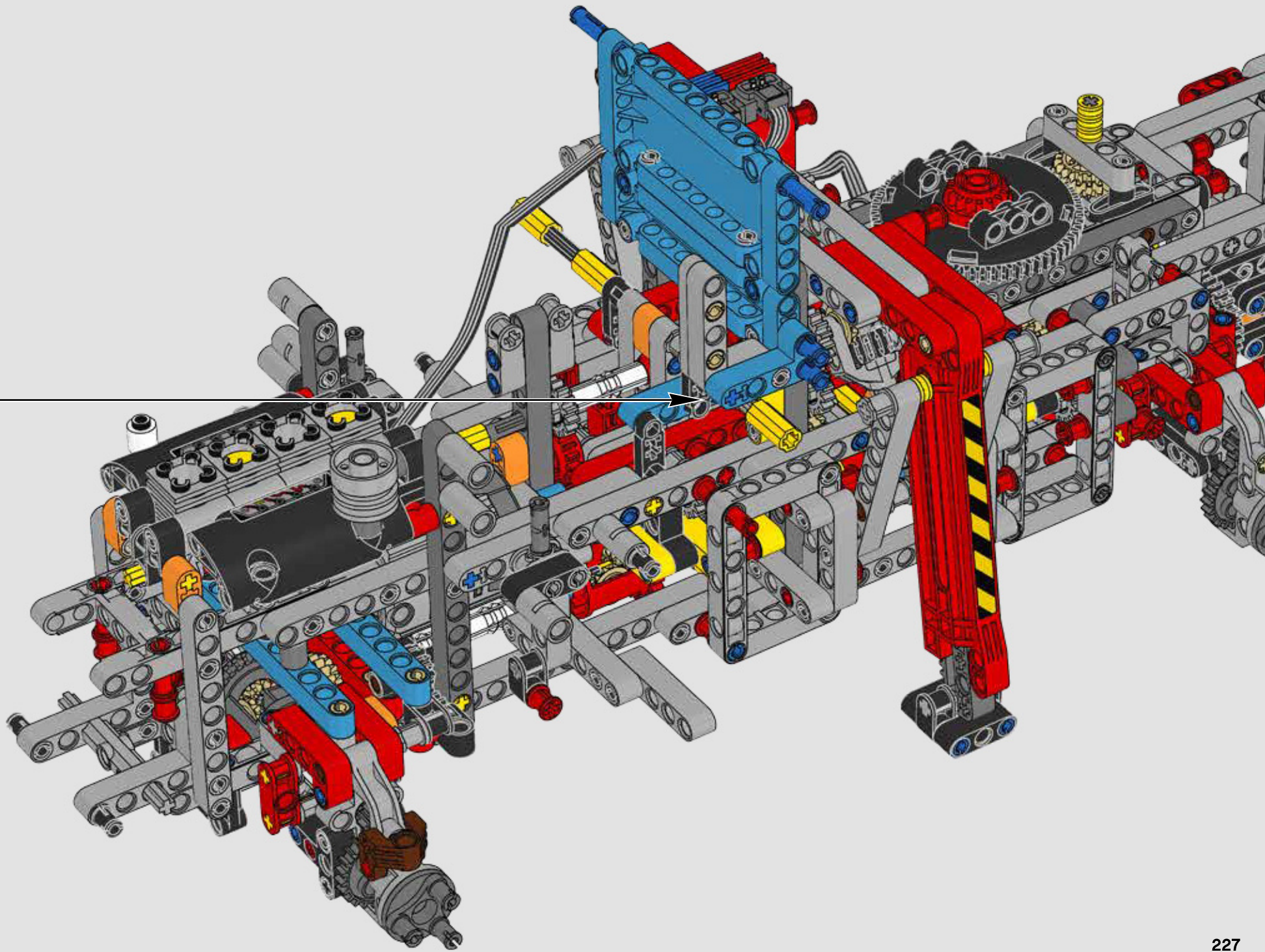

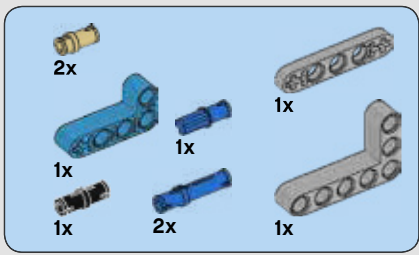

# 340

1

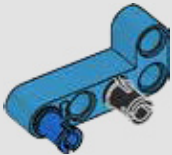

2

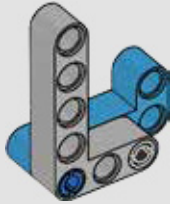

3

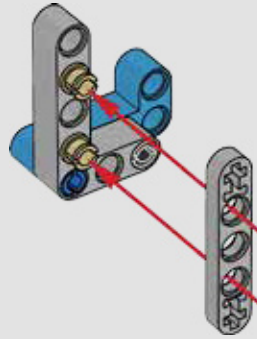

4

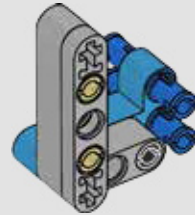



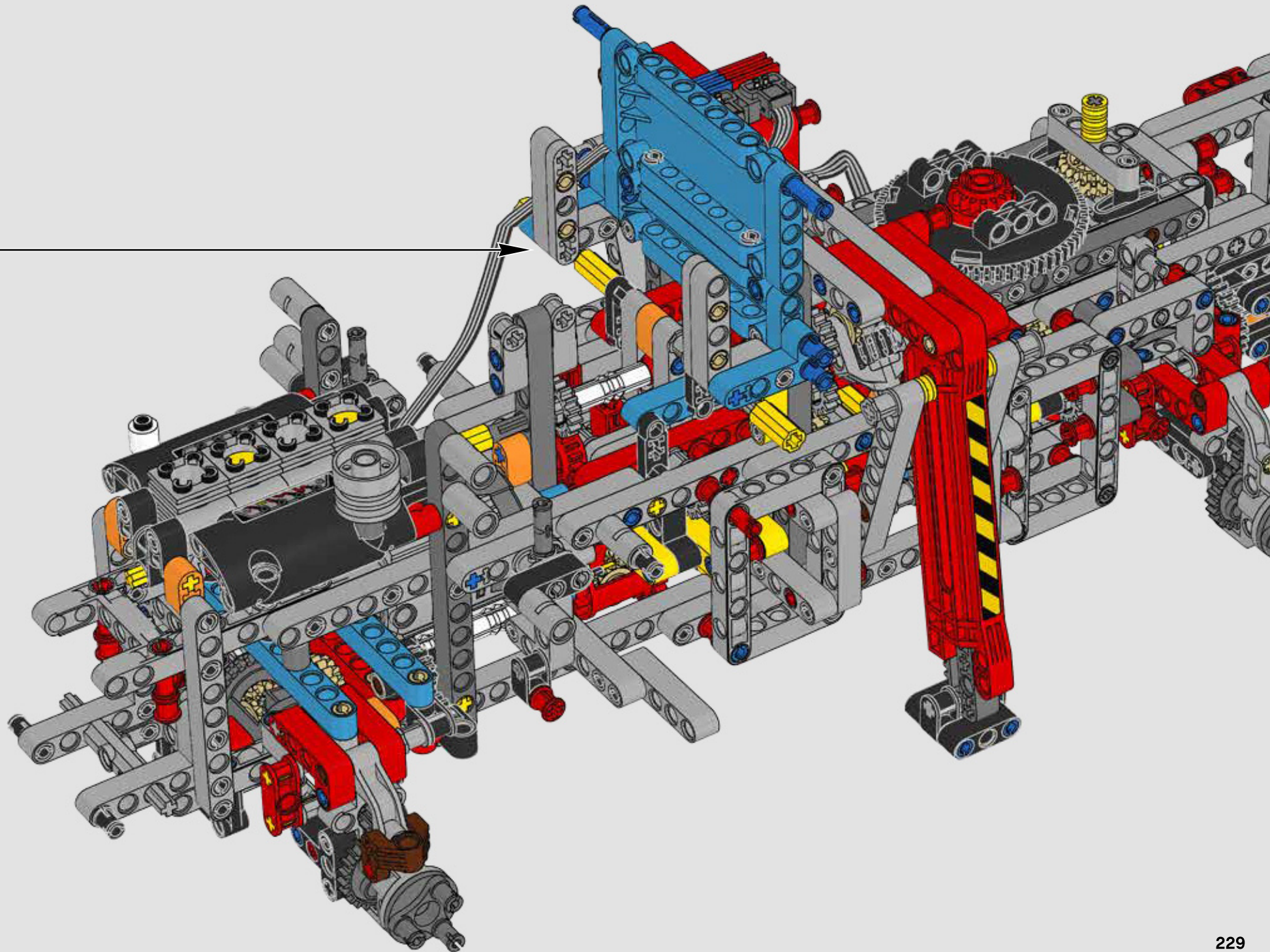

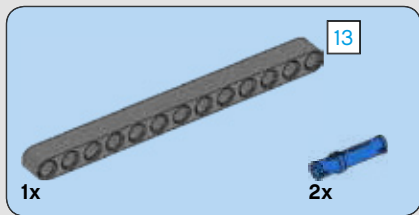

341

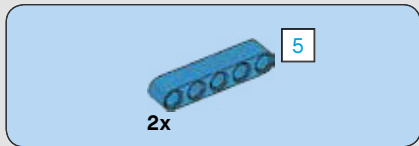
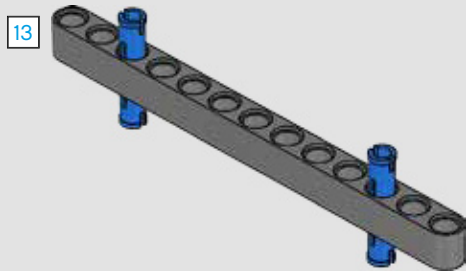

342

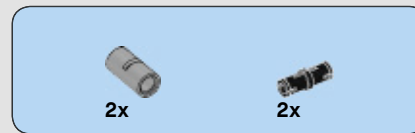
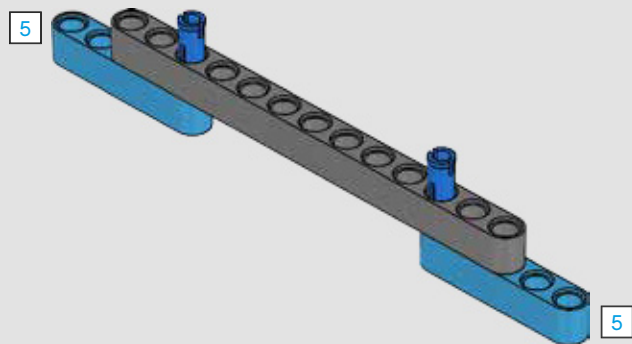

343

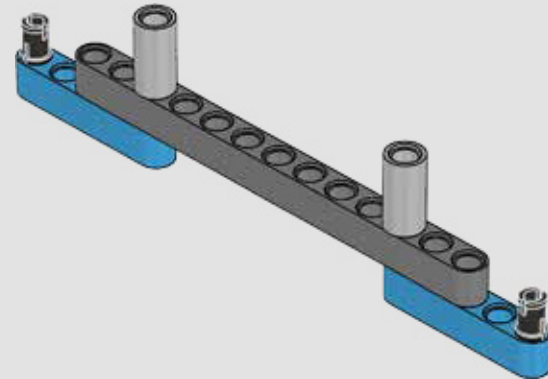

344

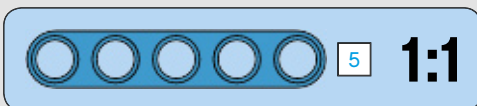
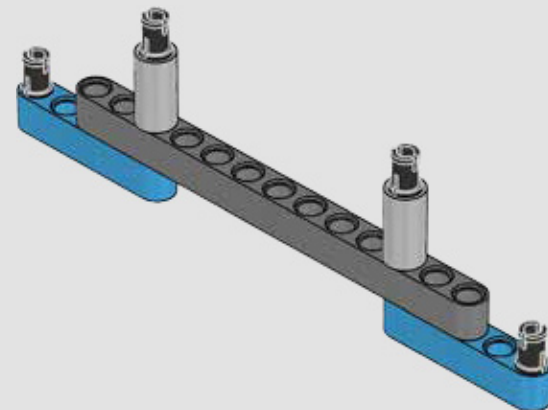



345

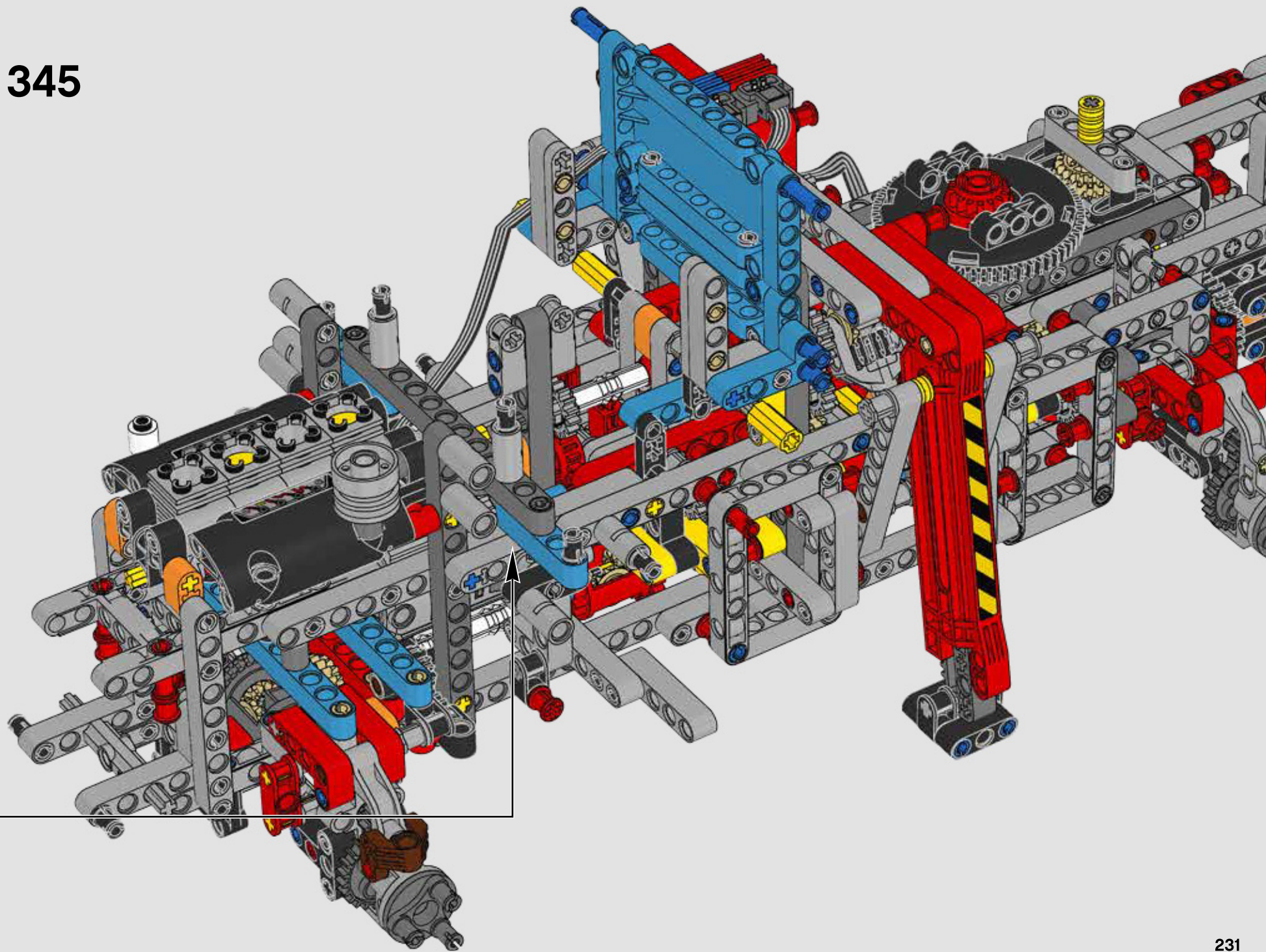



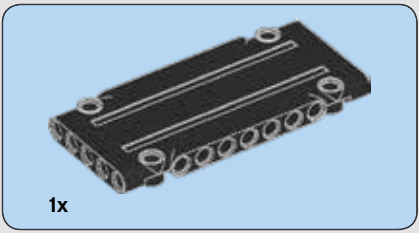

1x

346

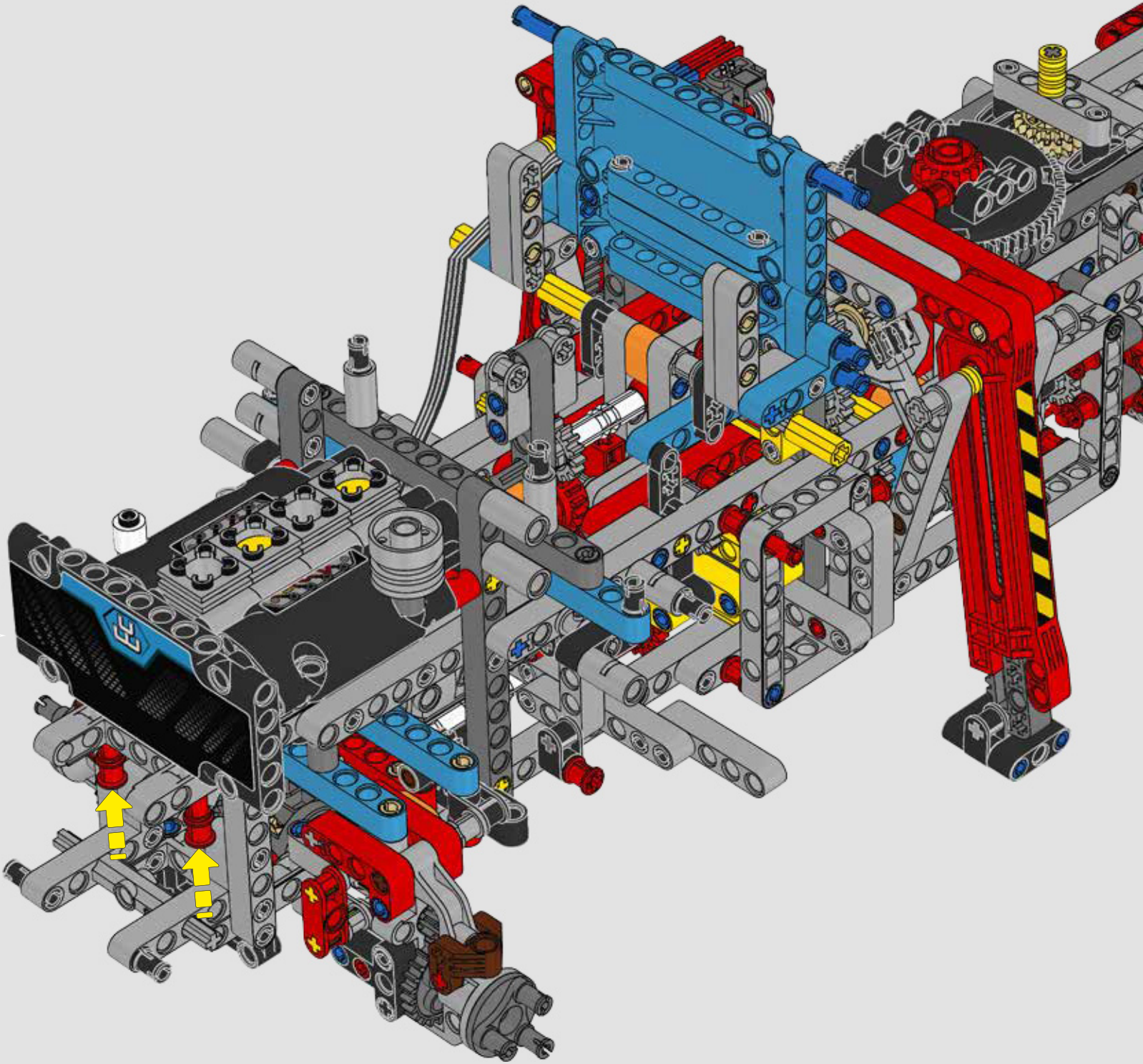
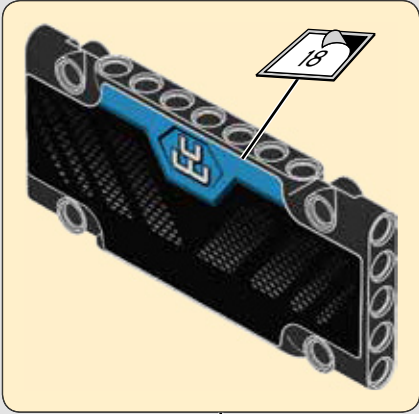



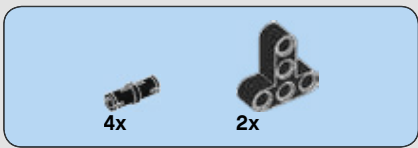

347

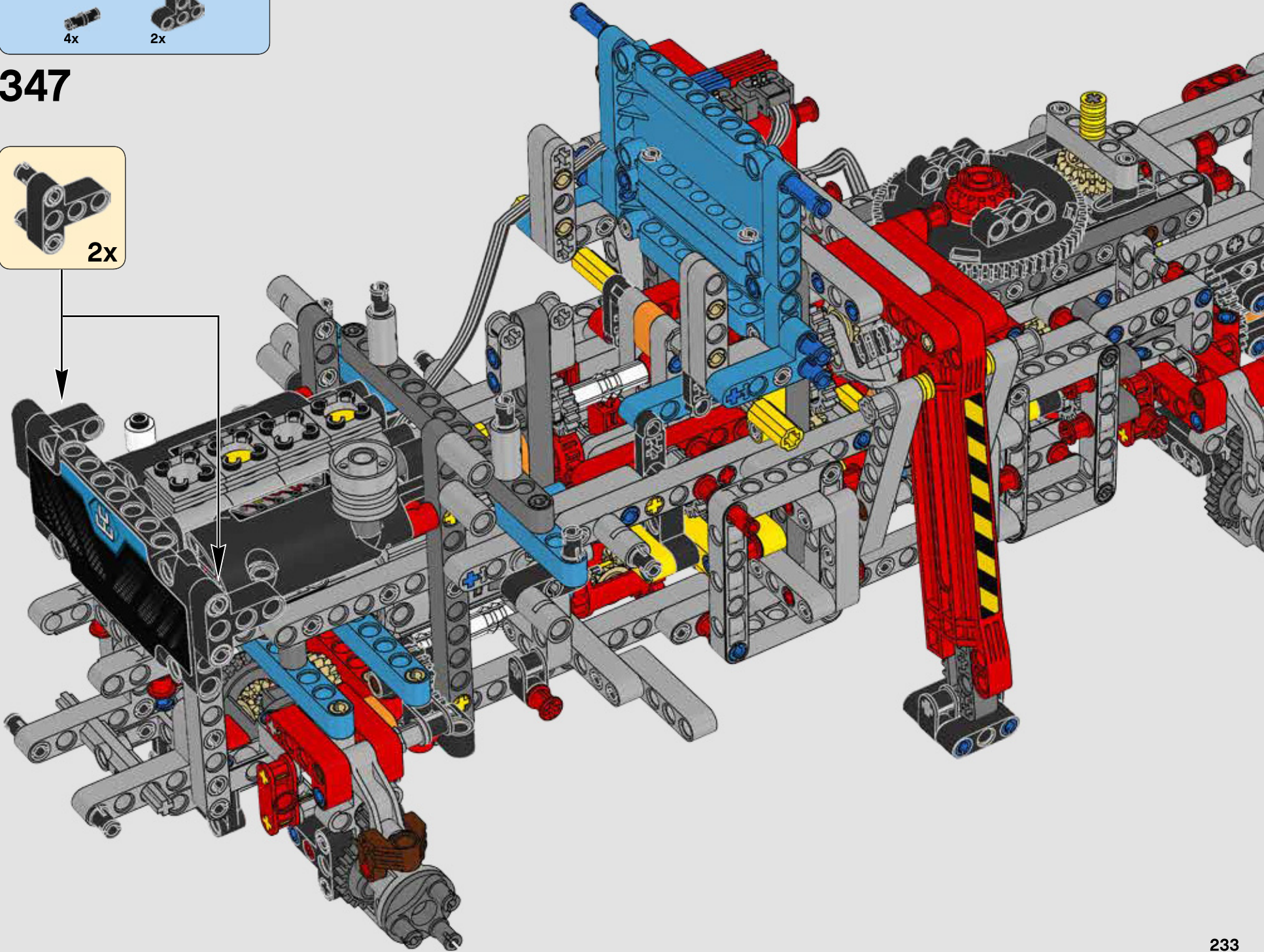
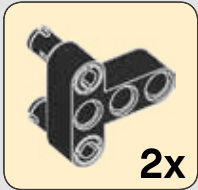

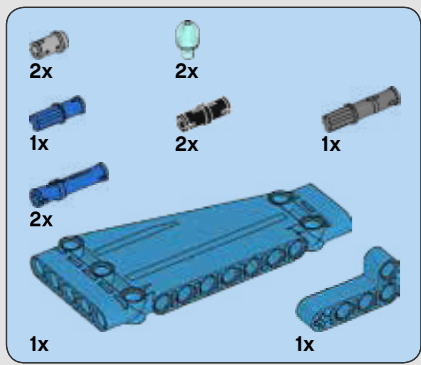

348

1

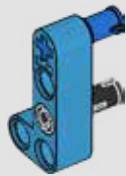

2

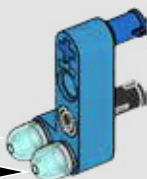
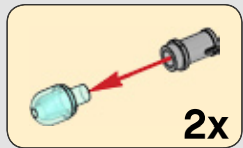

3

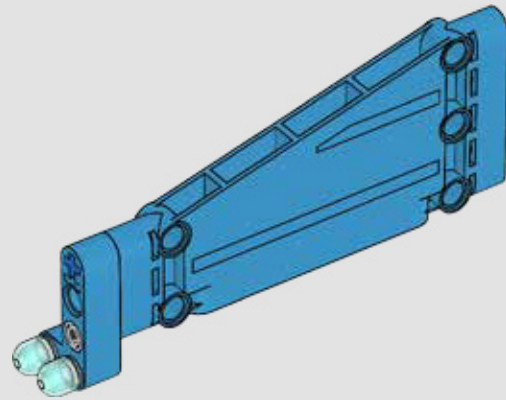

4

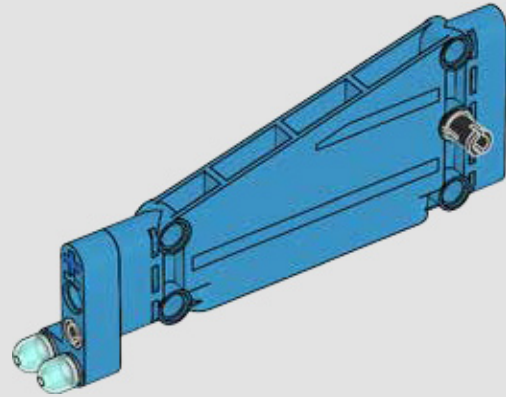

5

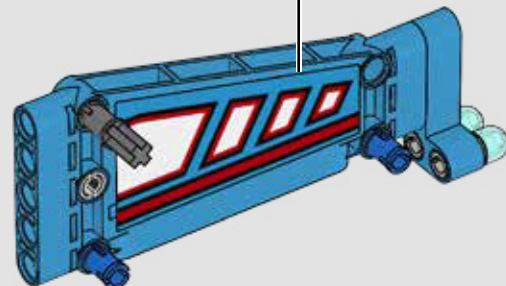
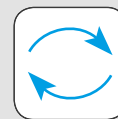



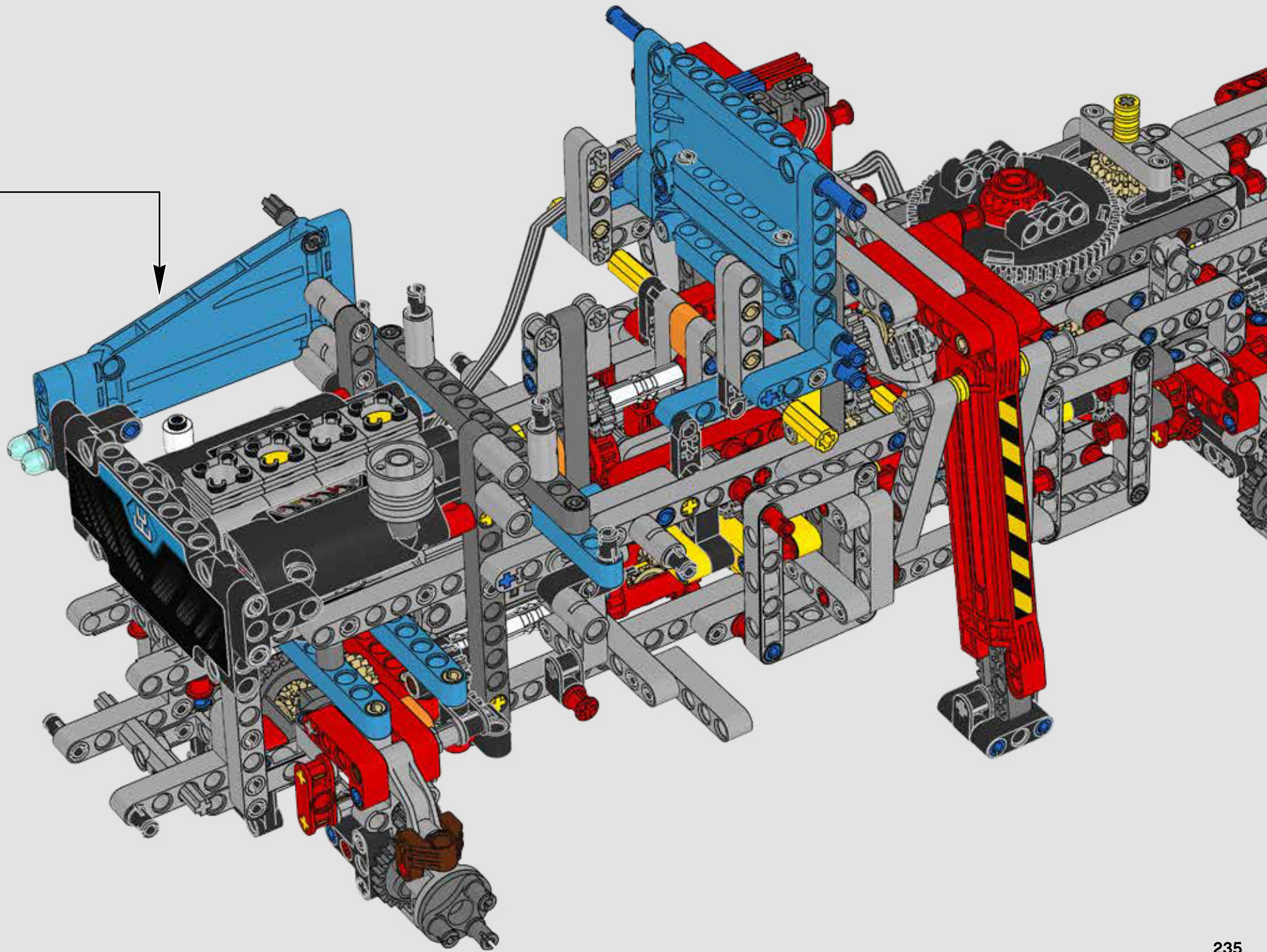

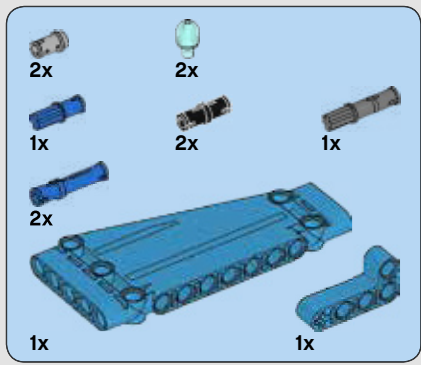

349

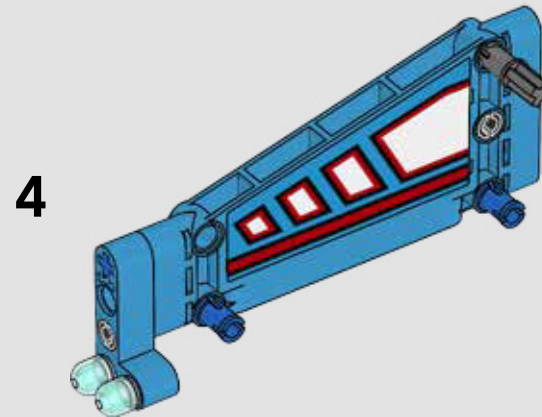
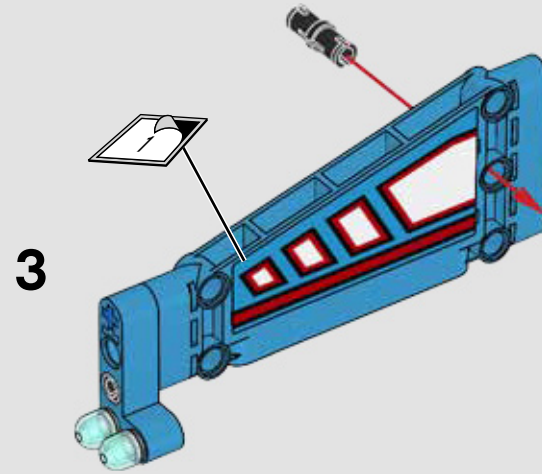
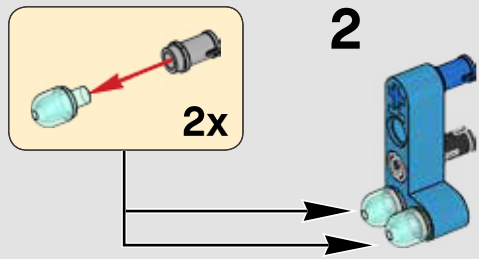
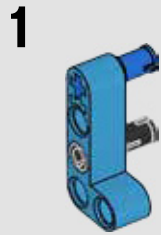



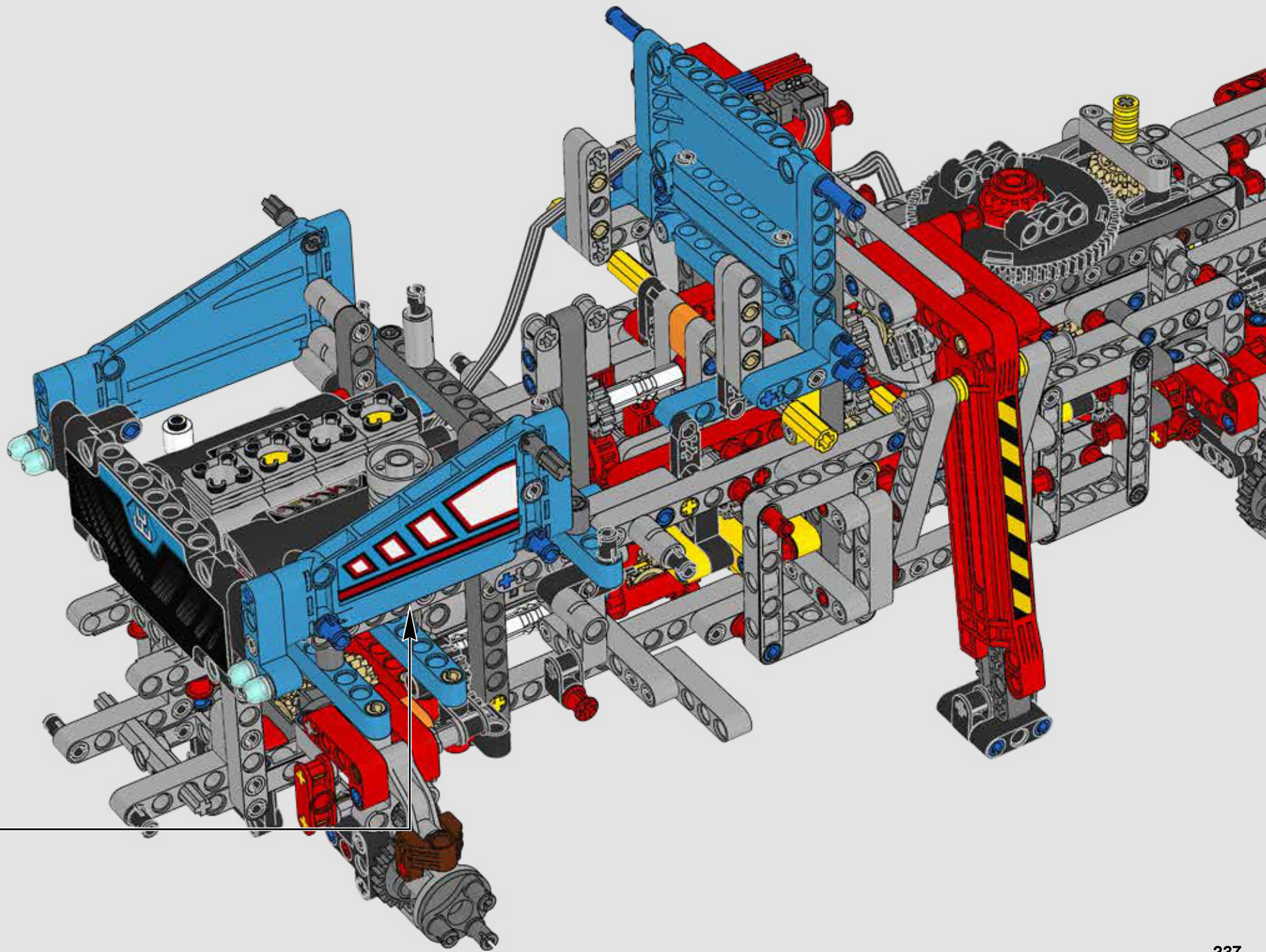



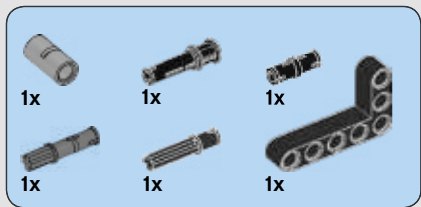

350

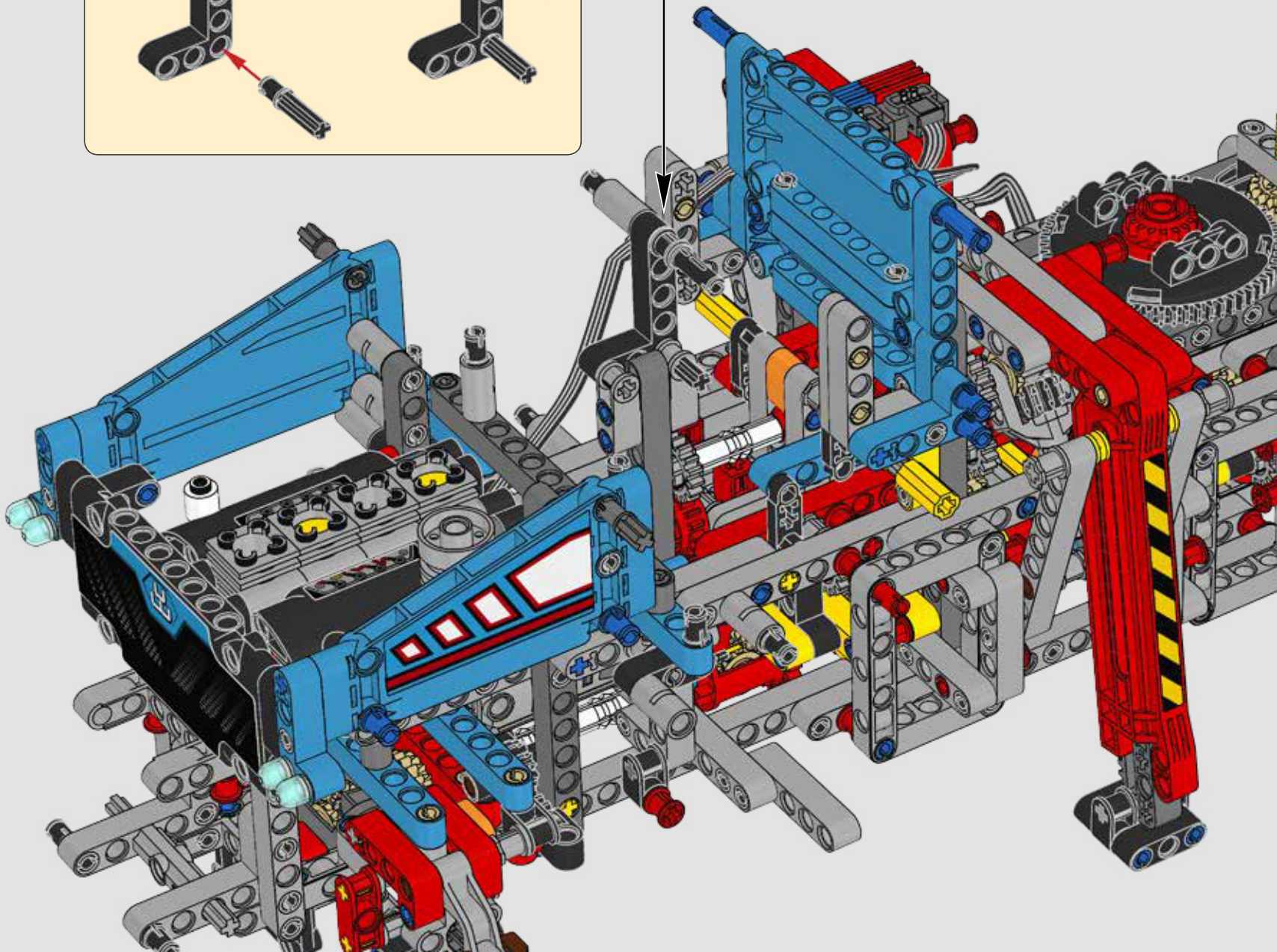
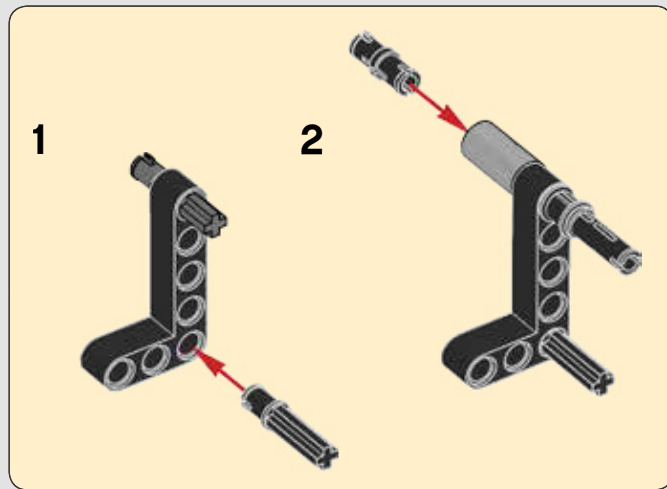



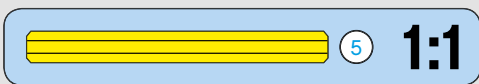
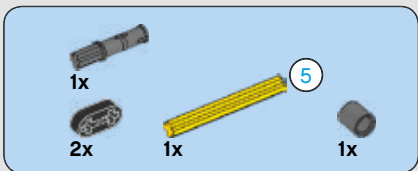

351

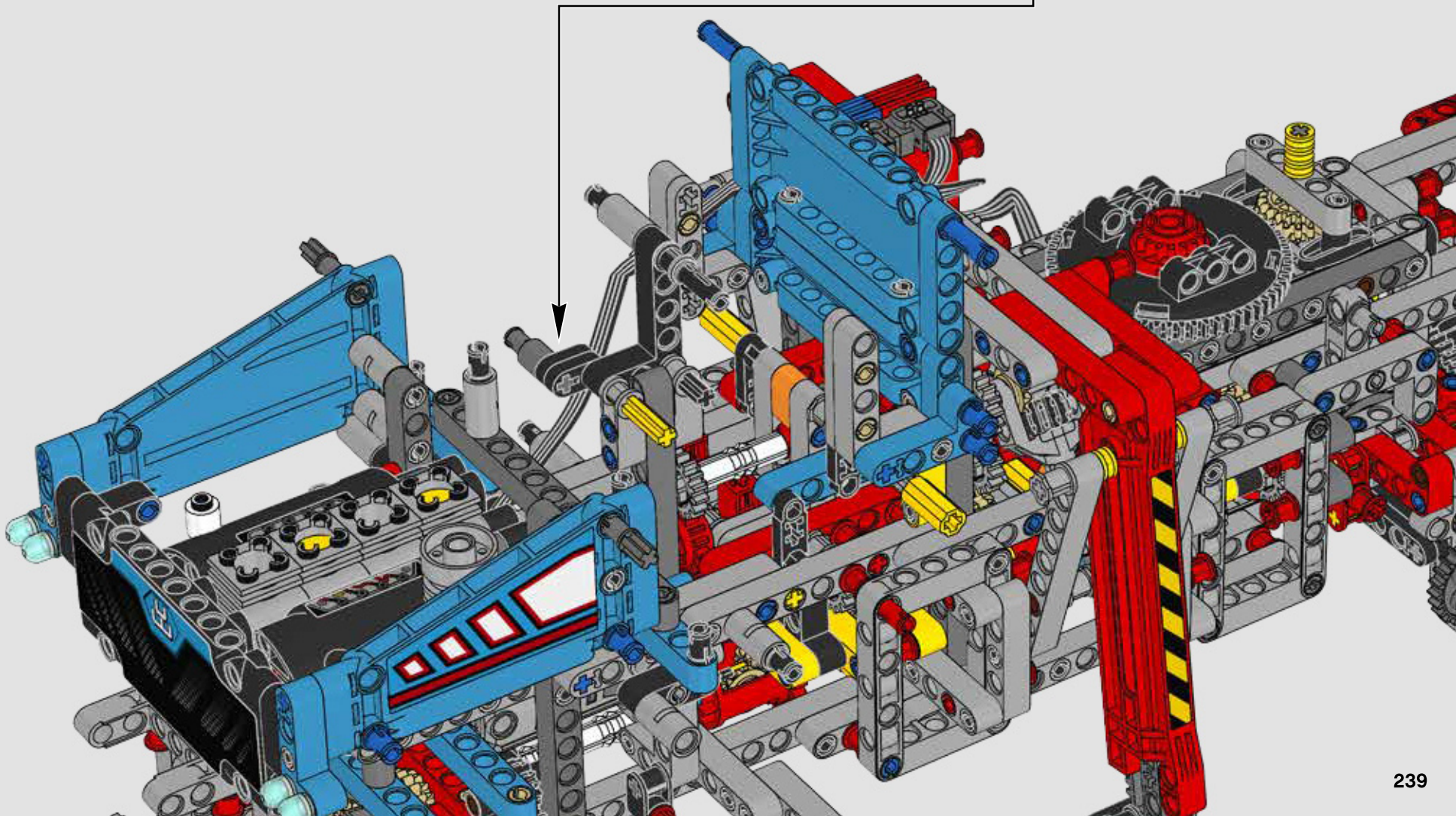
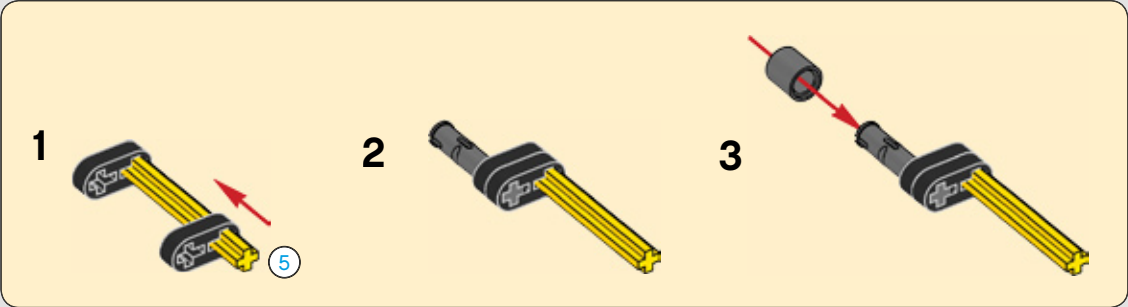



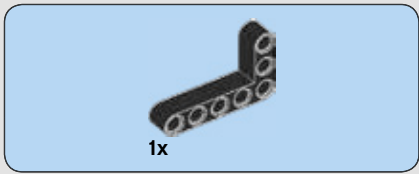

352

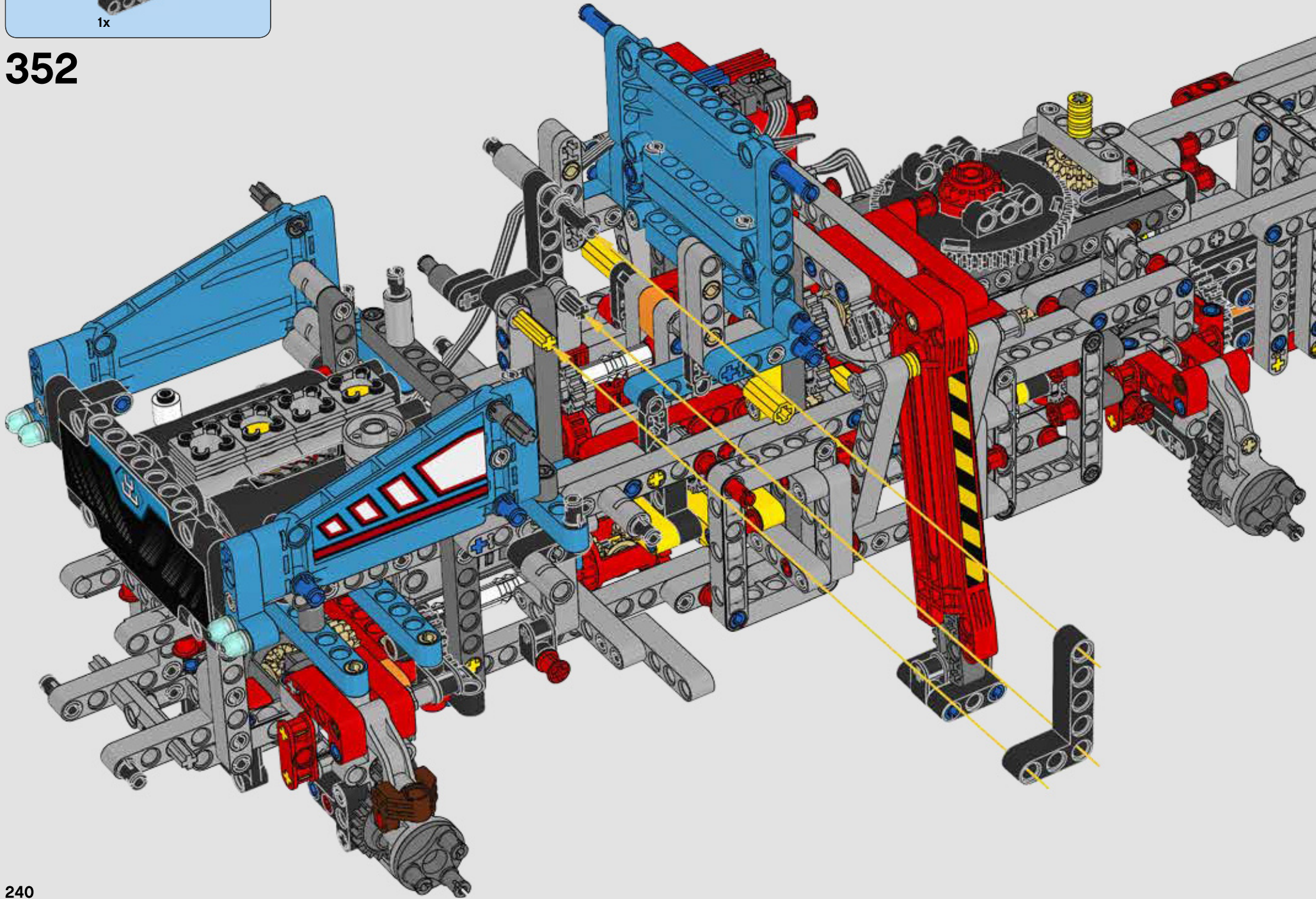





353

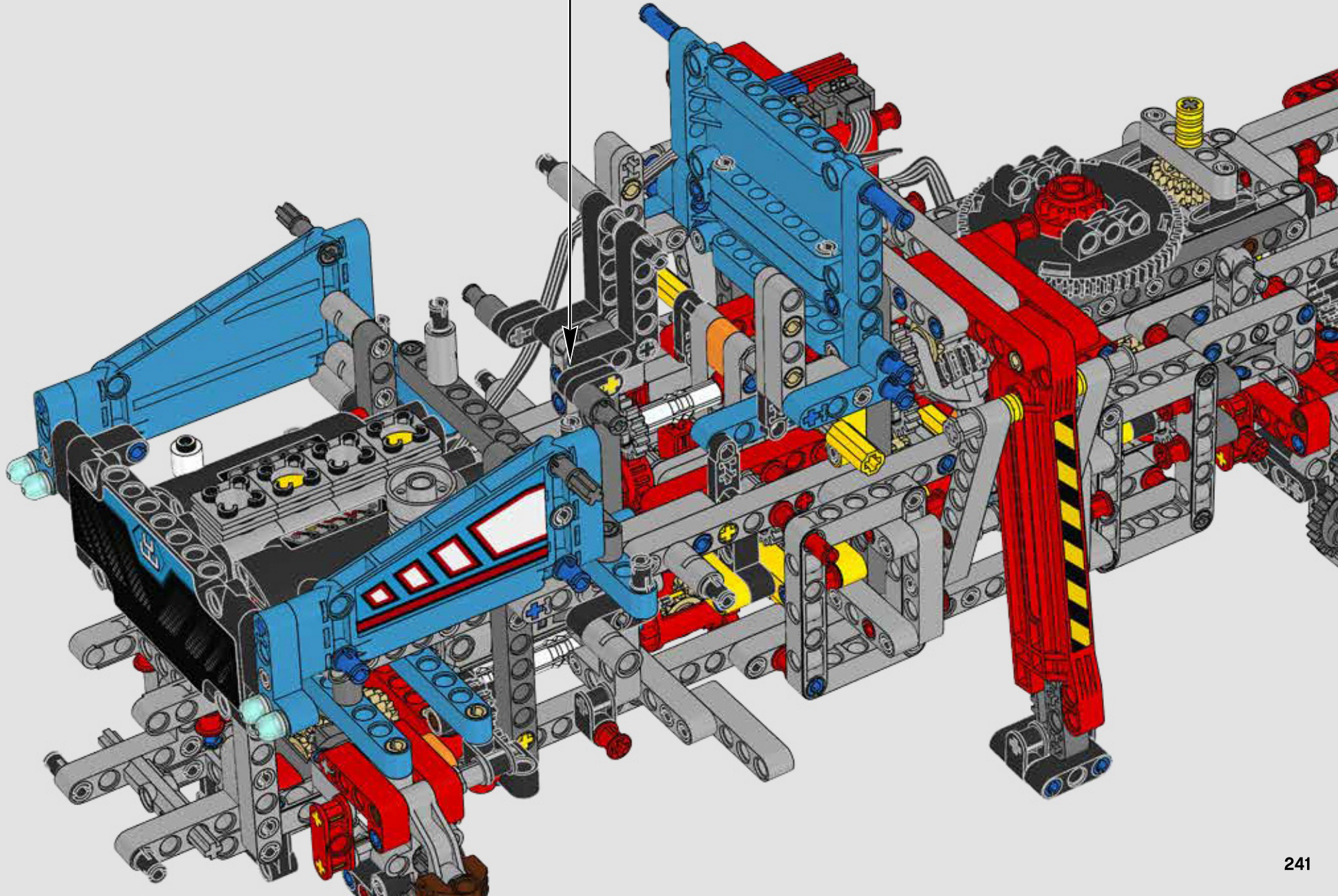
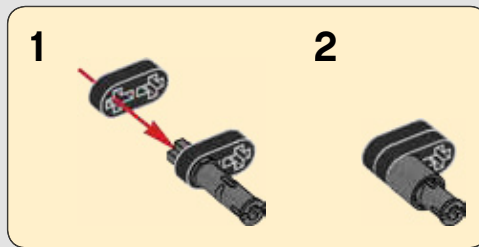



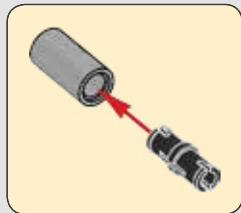
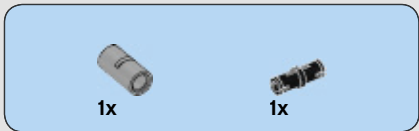

354

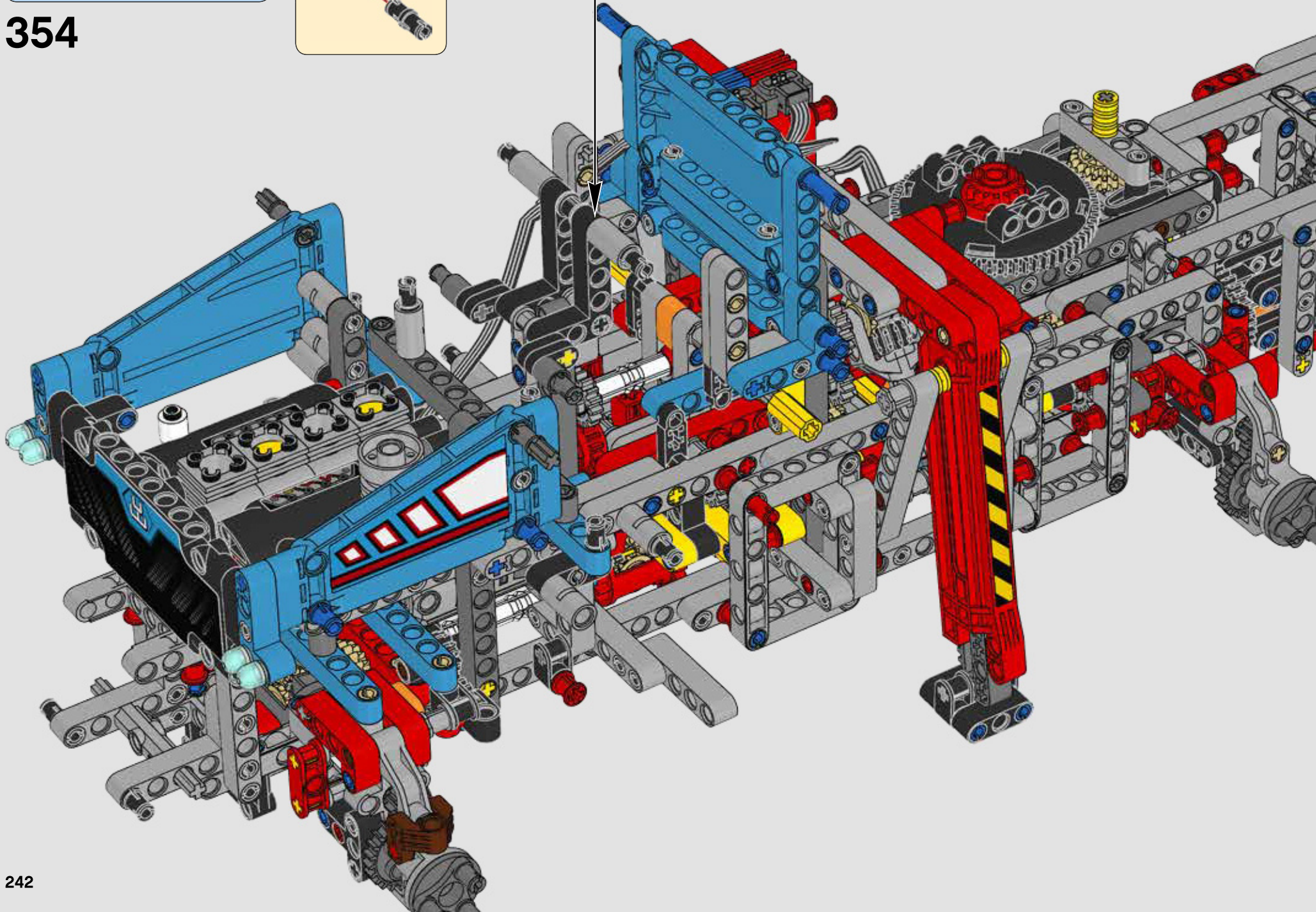





355

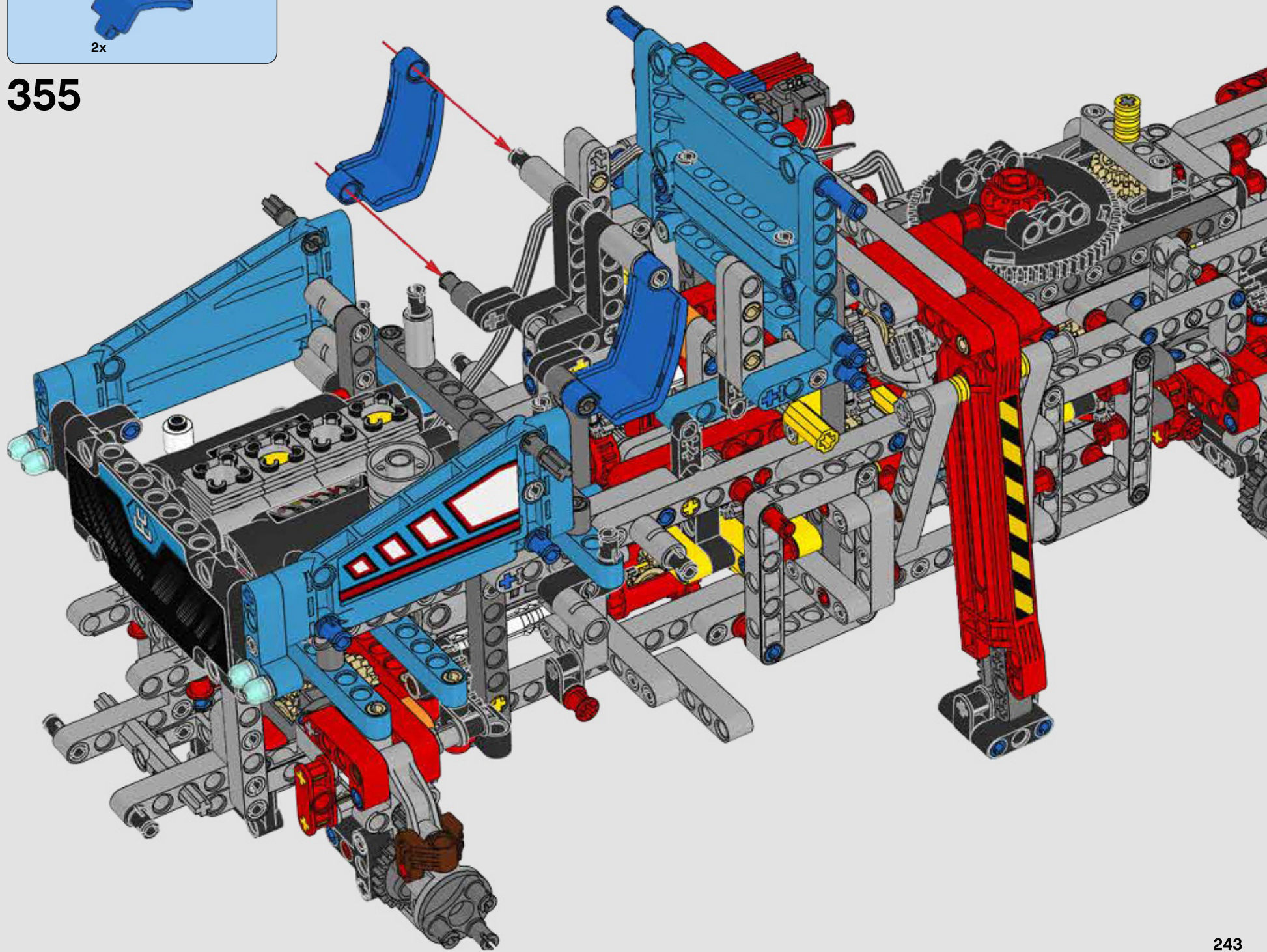



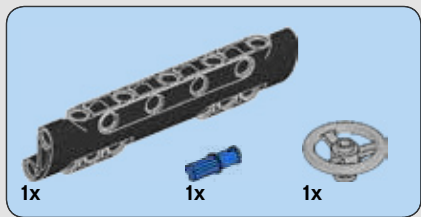

356

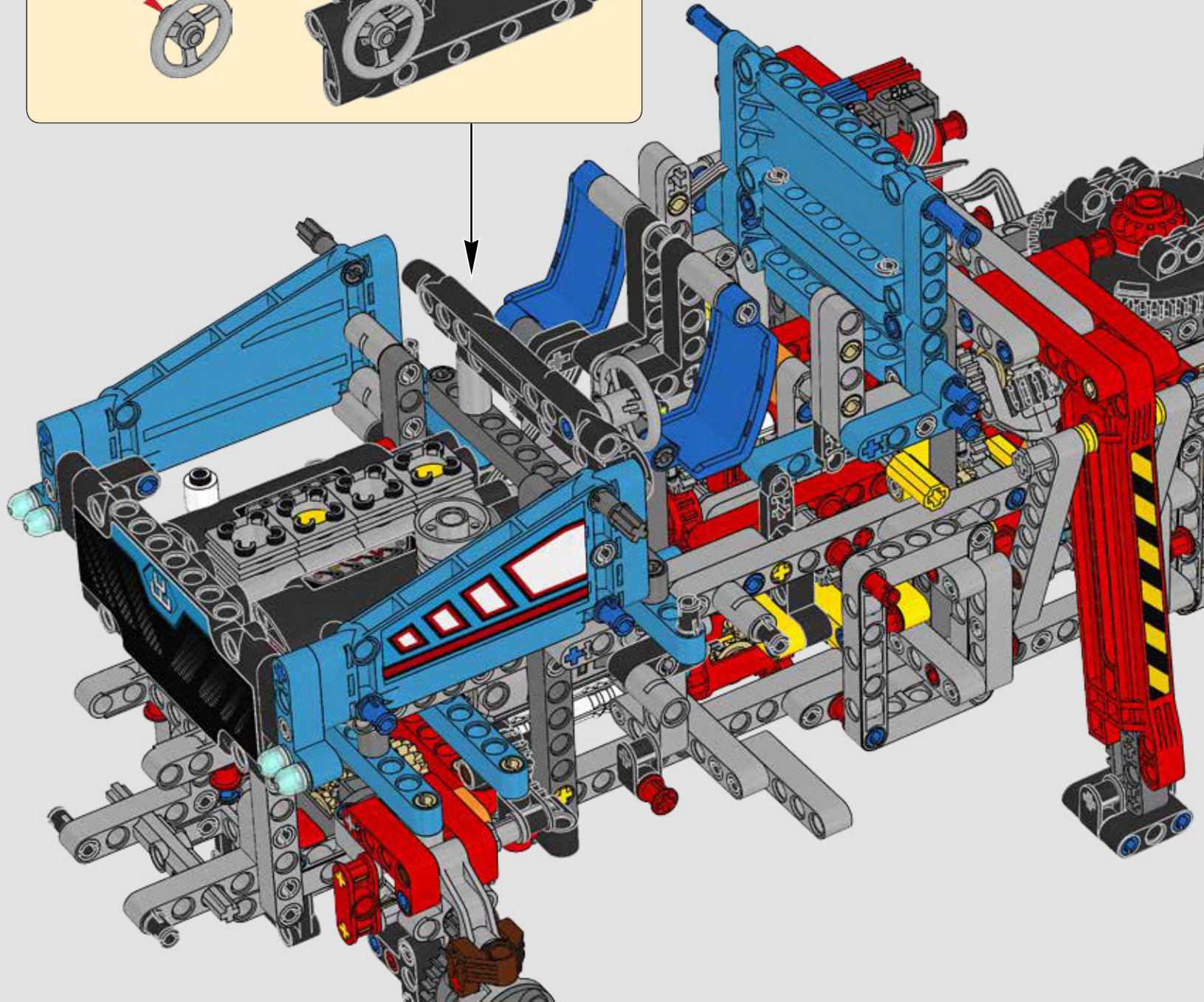
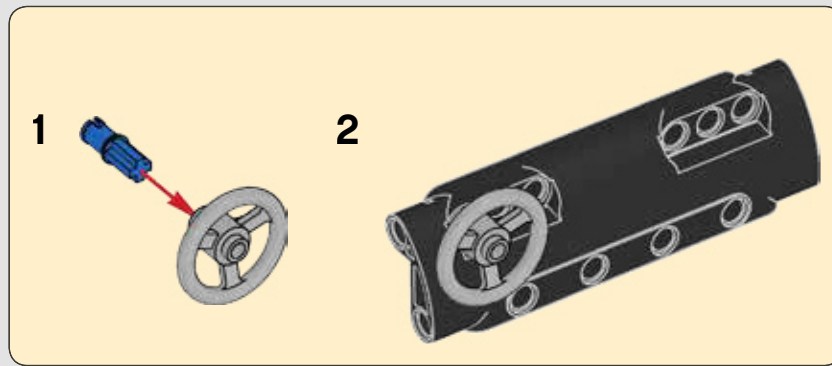



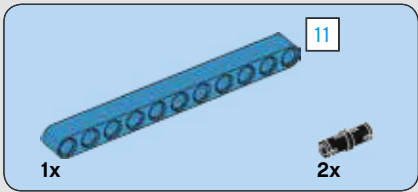
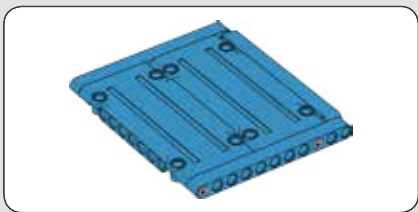

357

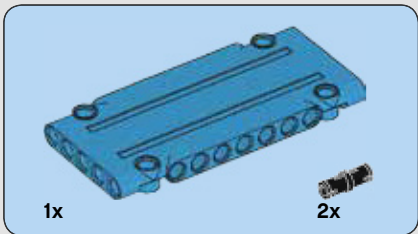
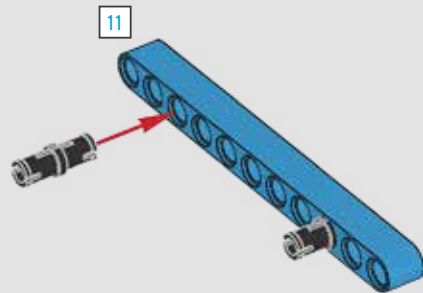

358

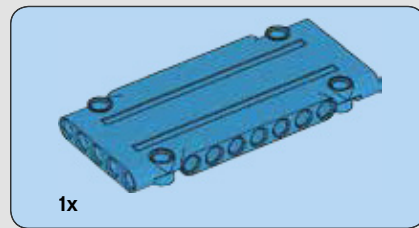
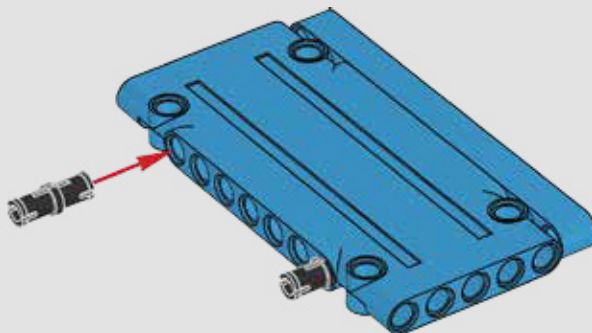

359

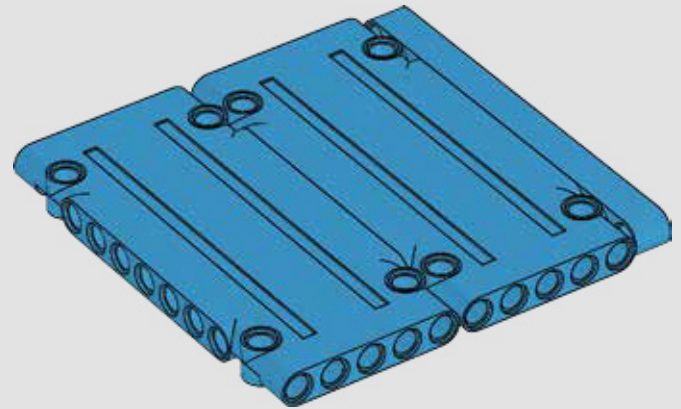

360

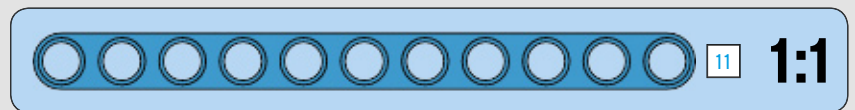
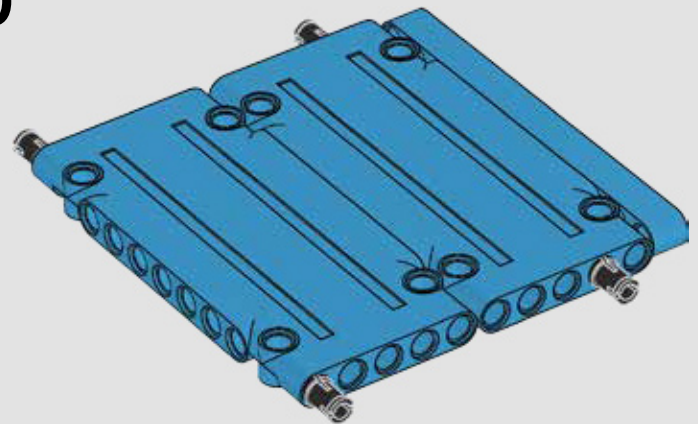

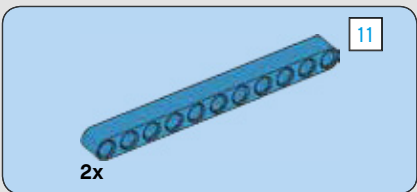

361

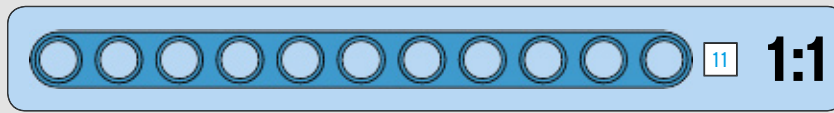
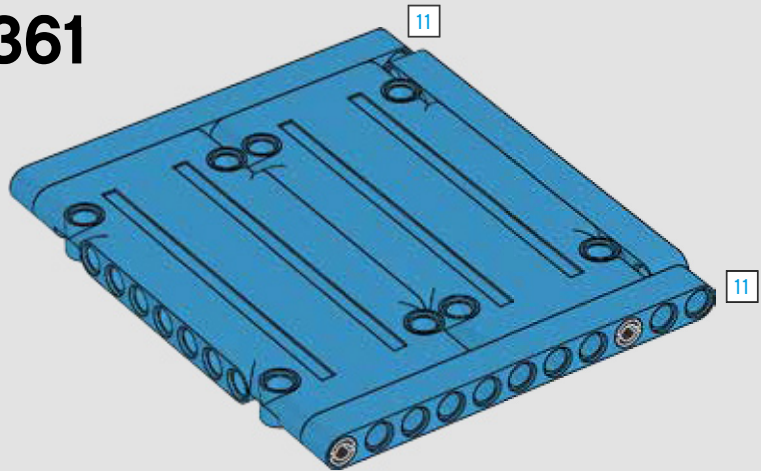

362

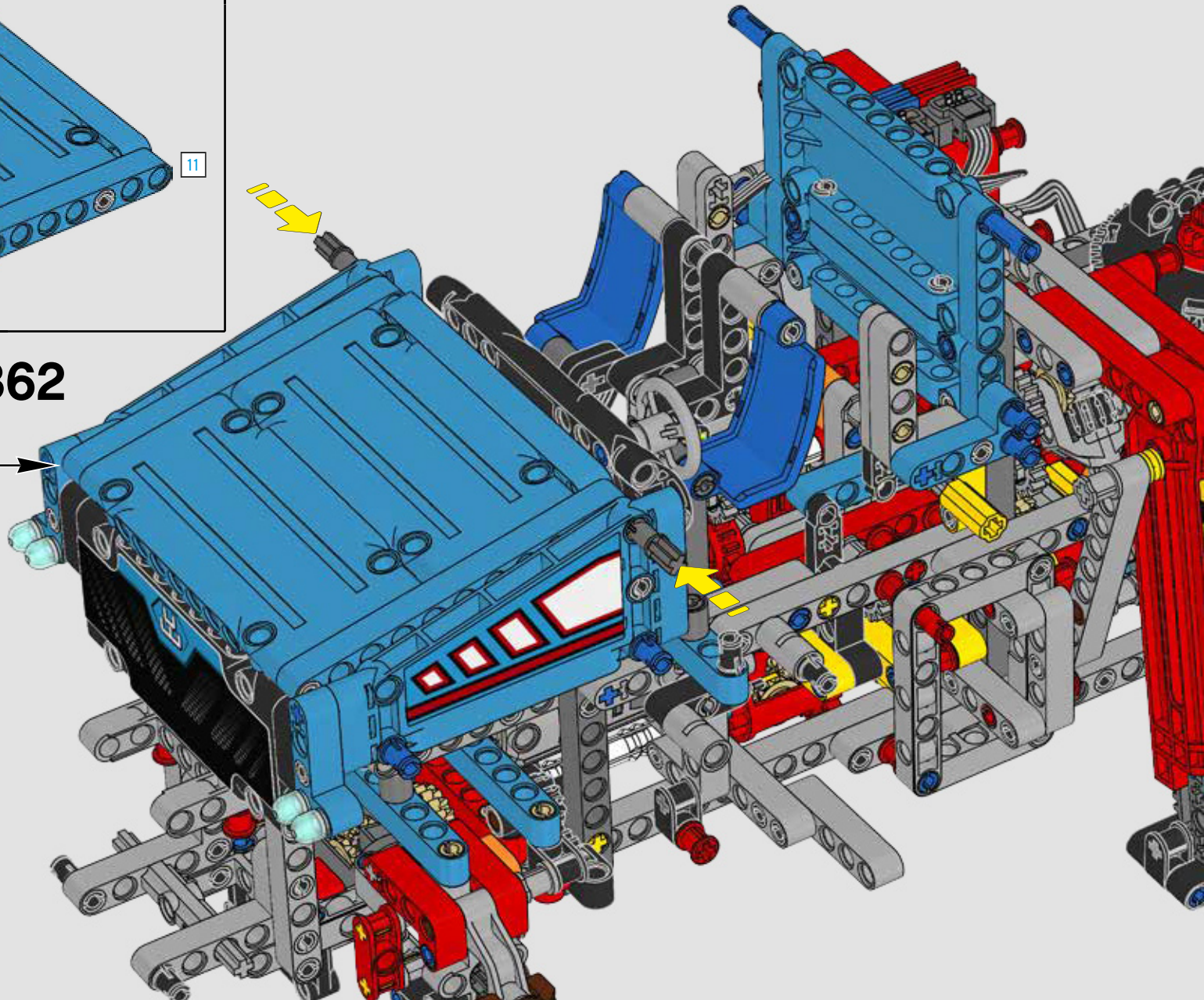



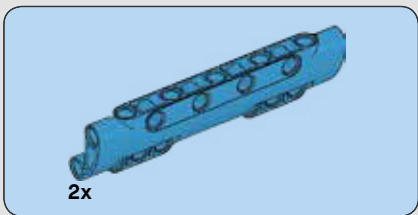

363

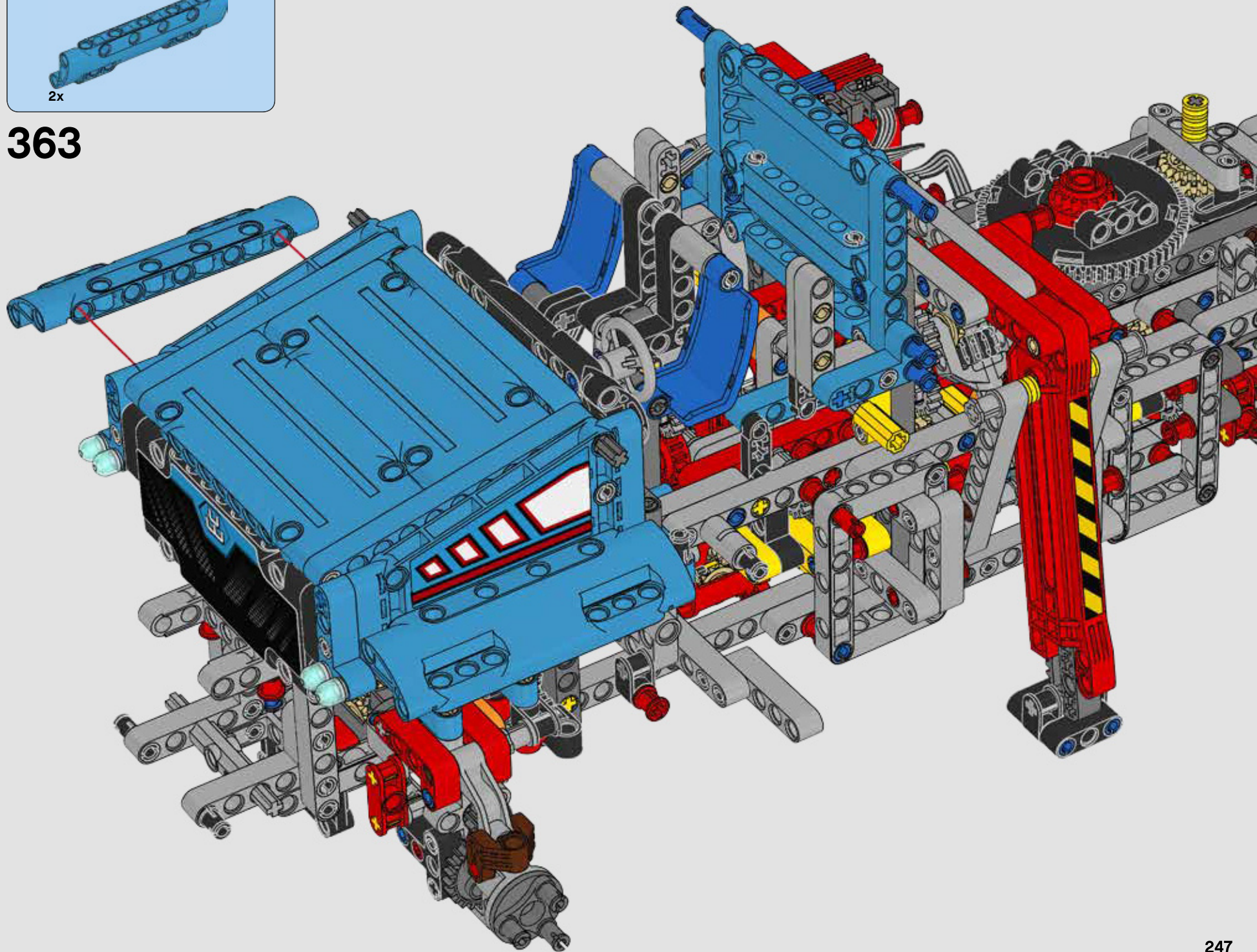

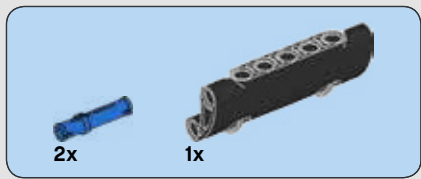

364

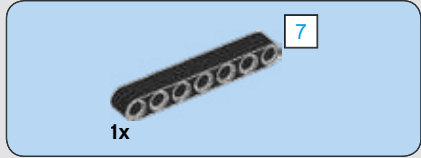
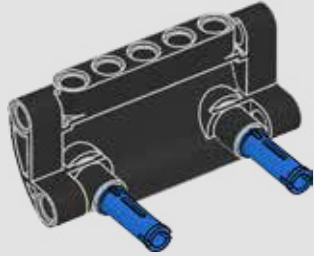

365

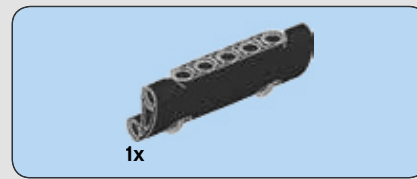
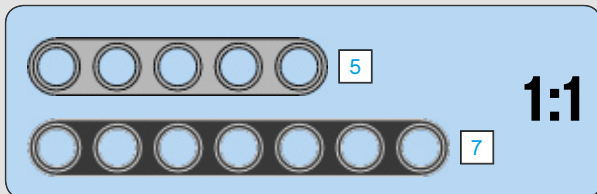
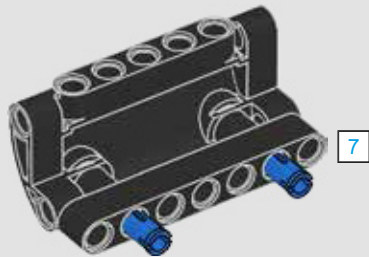

366

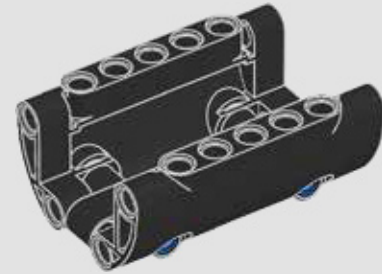

367

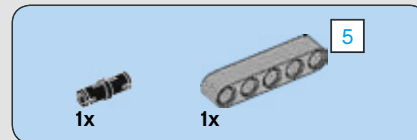
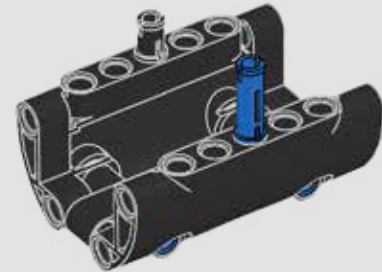

368

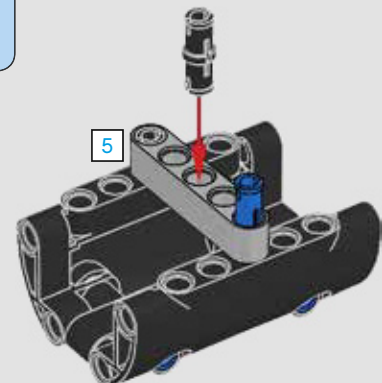



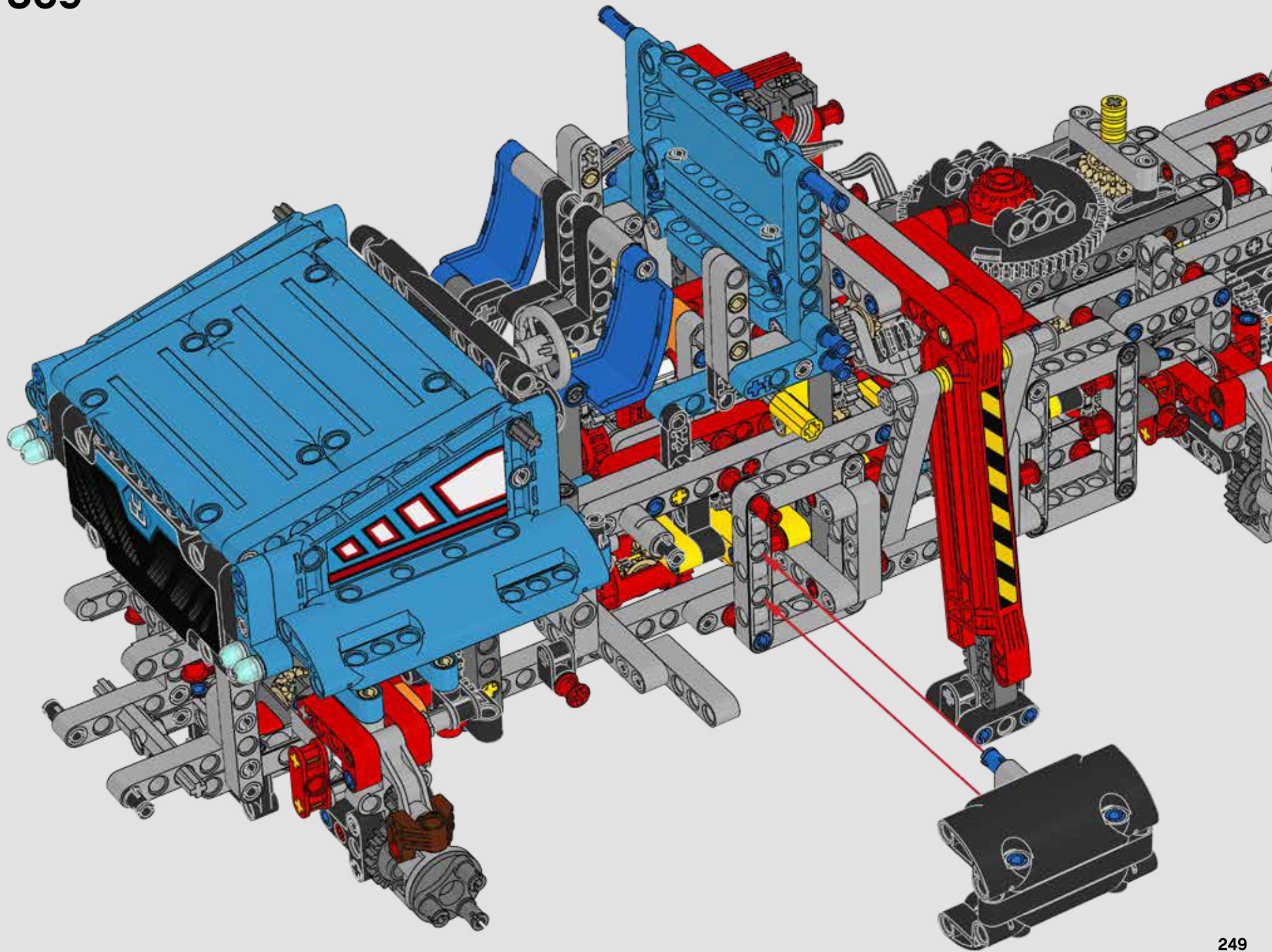



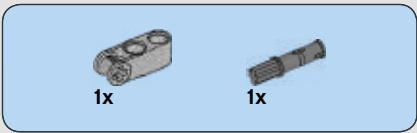

370

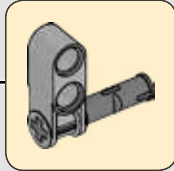
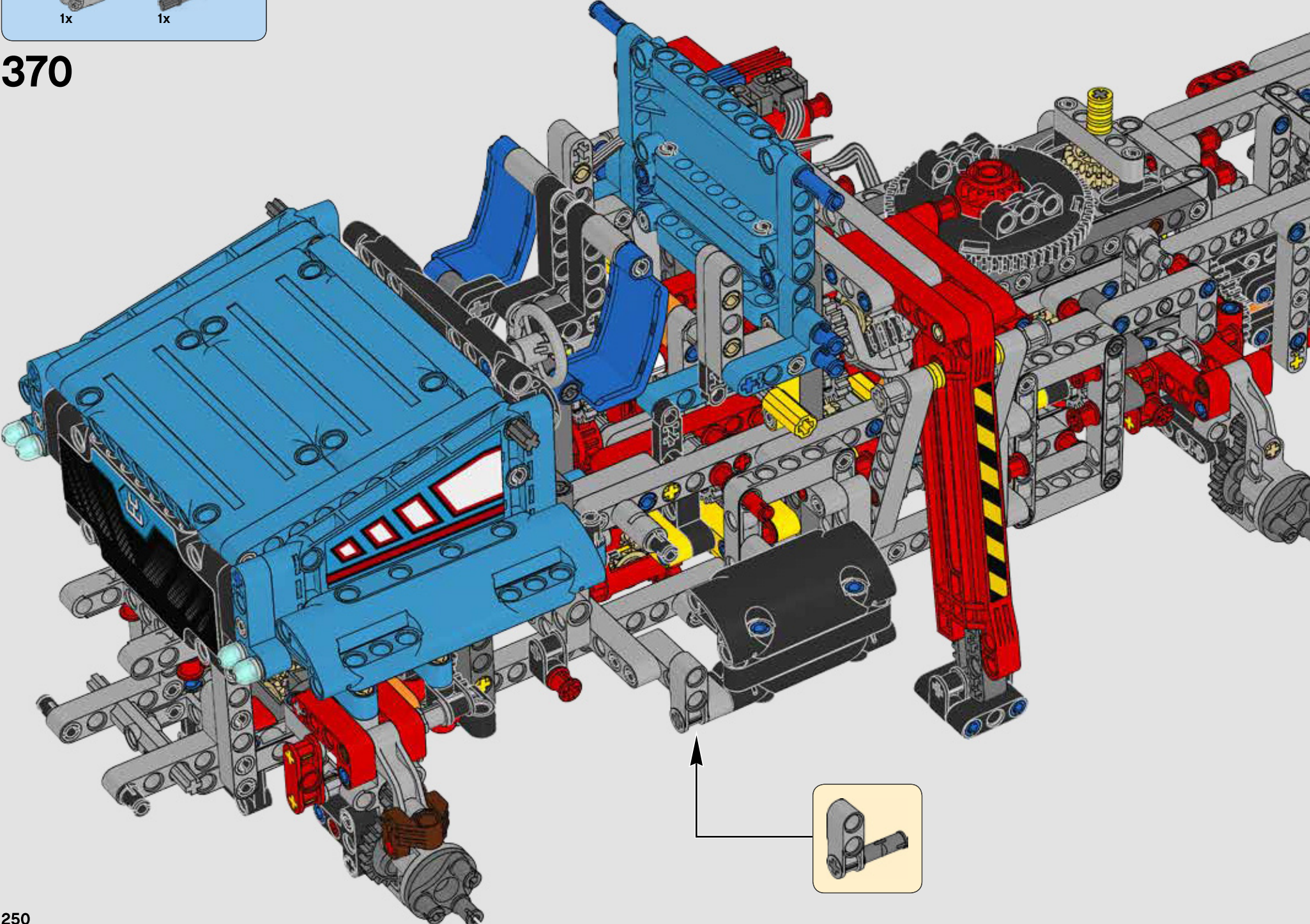



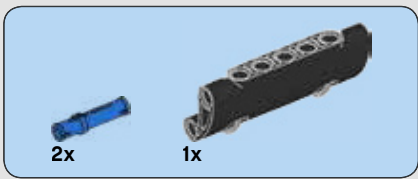

371

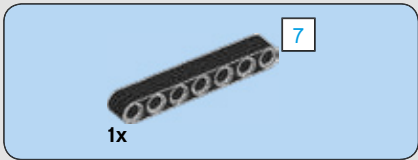
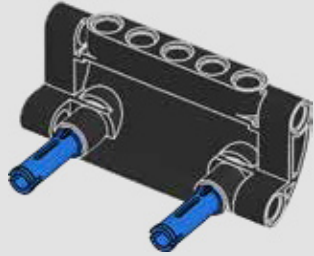

372

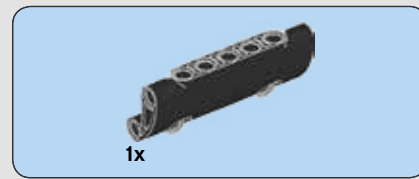
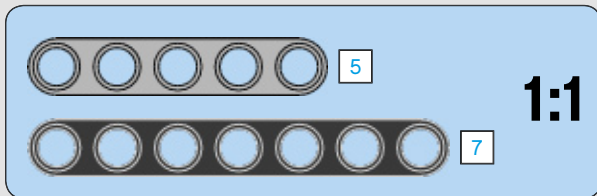
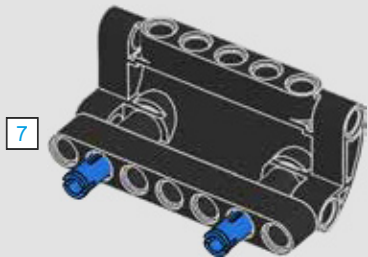

373

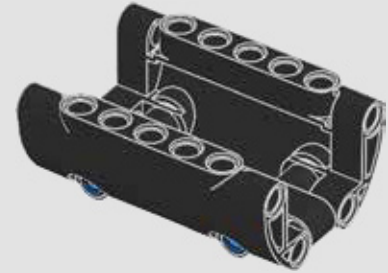

374

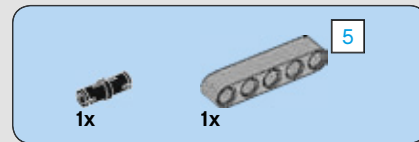
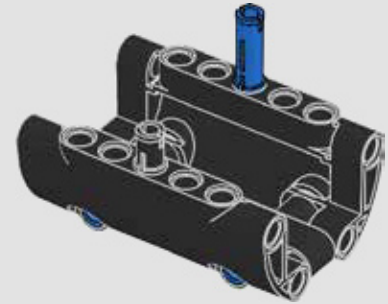

375

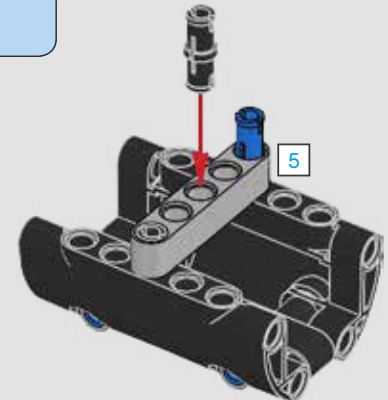

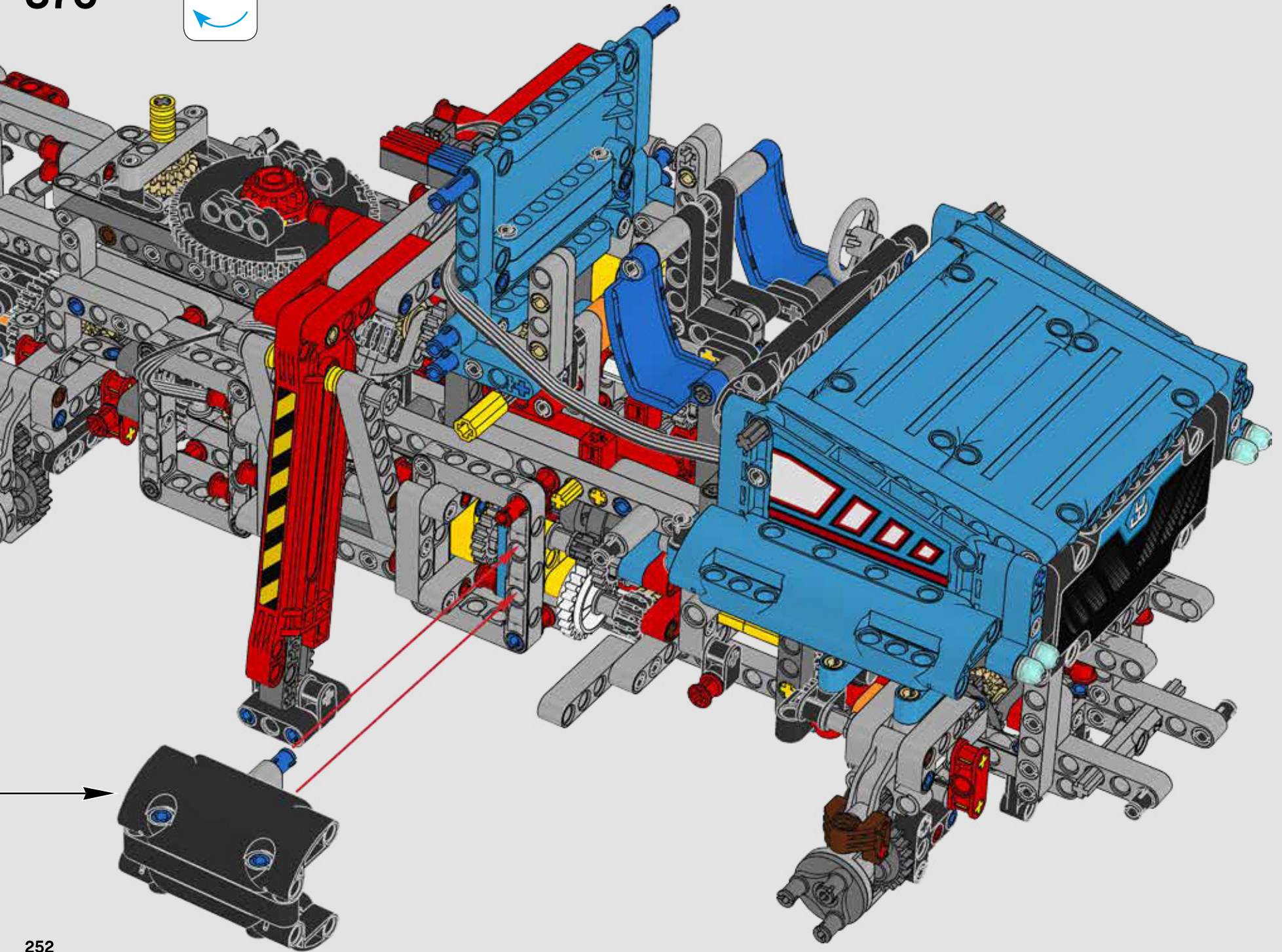



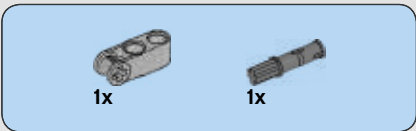

377

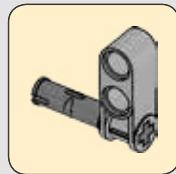
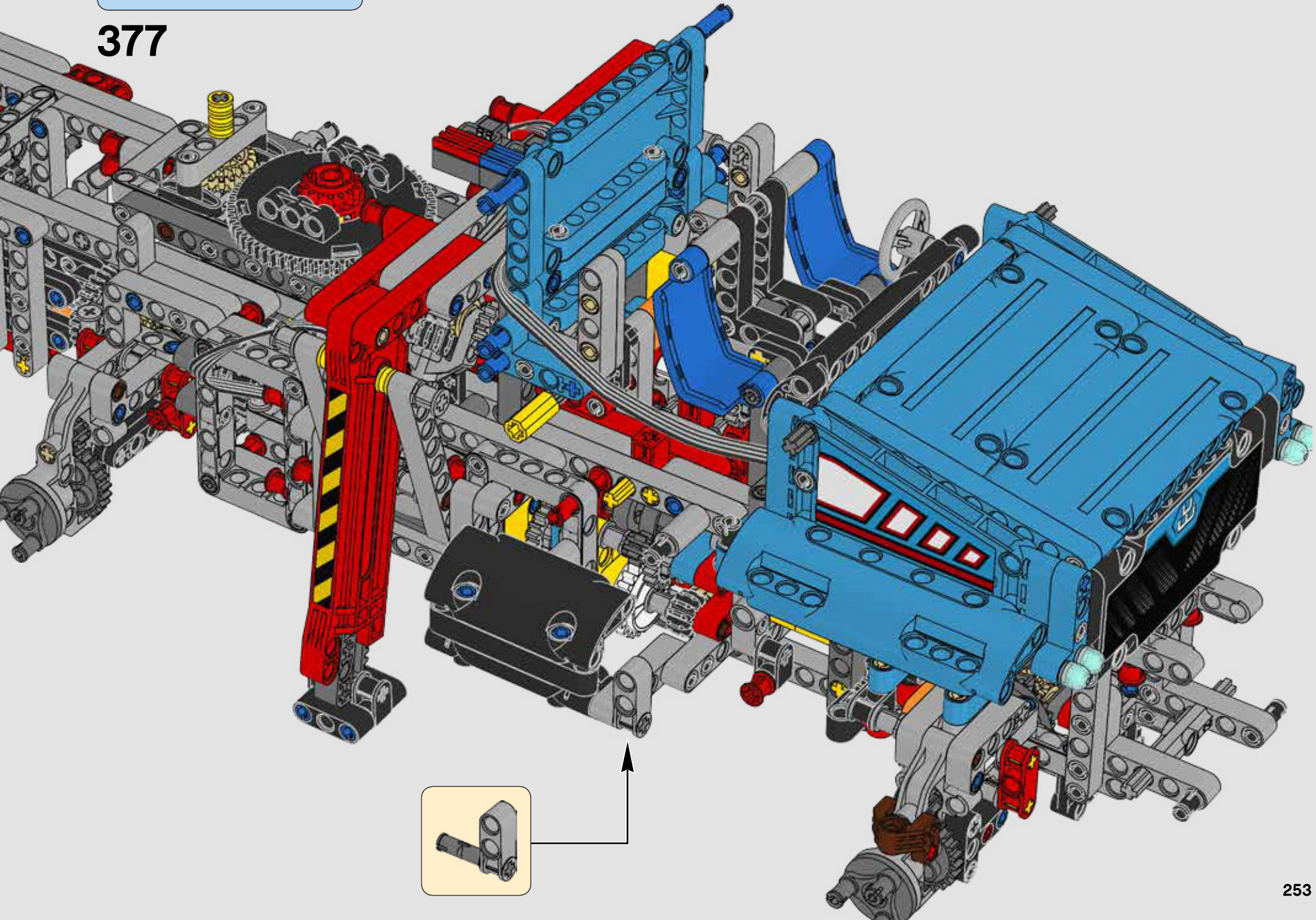

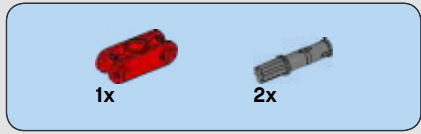
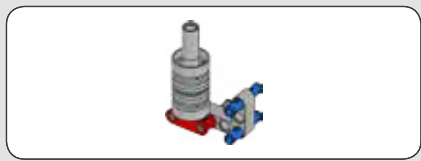

378

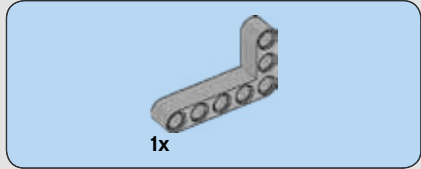
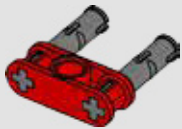

379

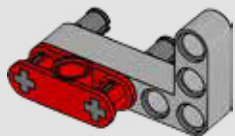

380

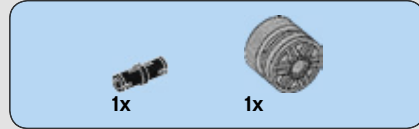
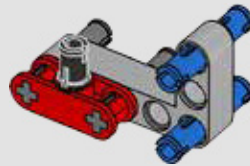

381

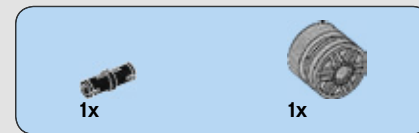
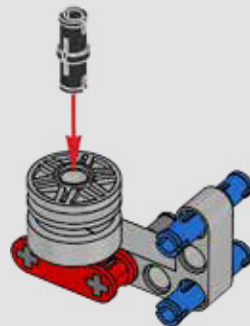

382

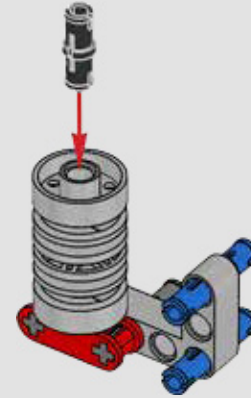

383

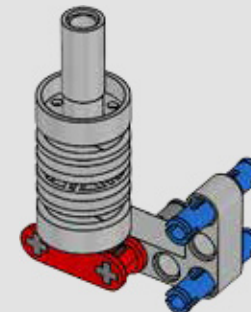



384

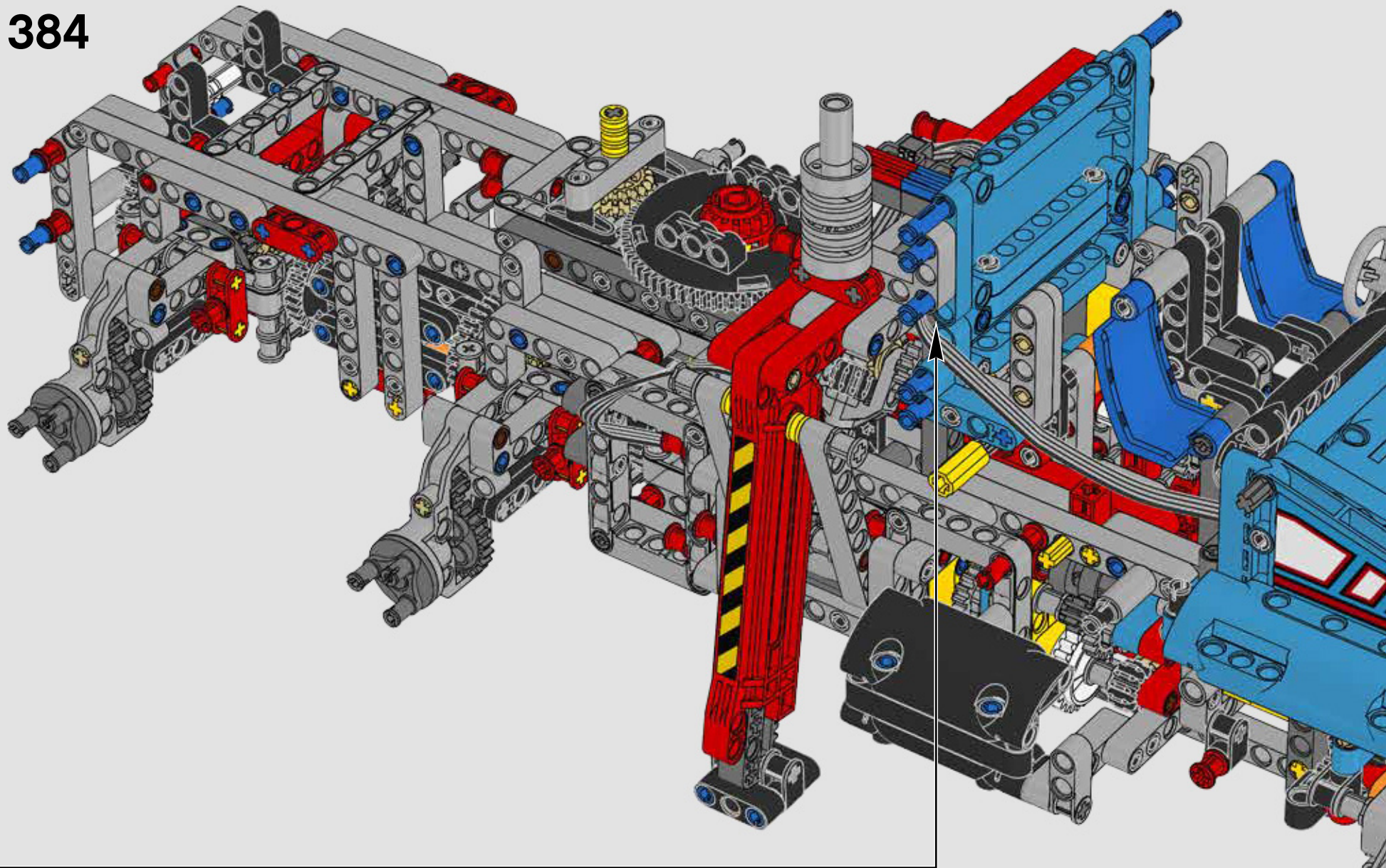

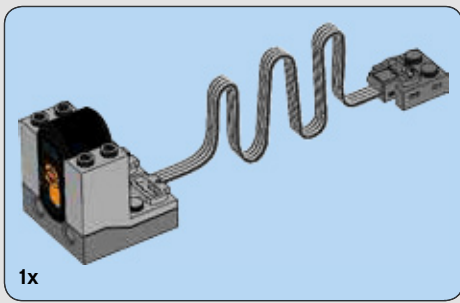

**385**

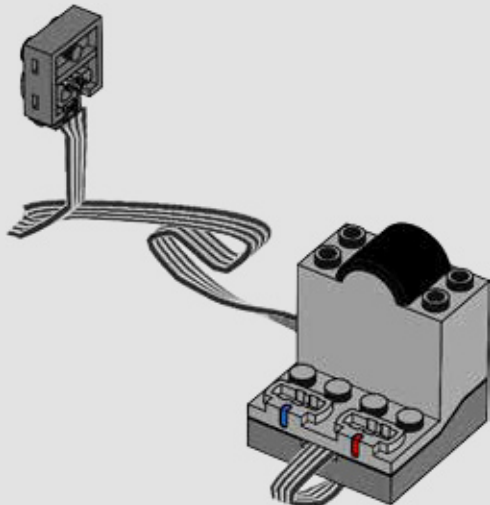
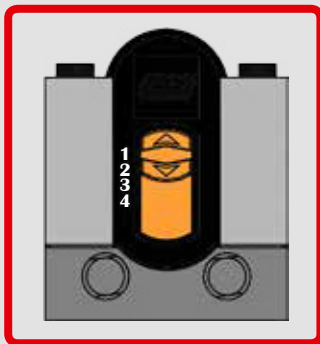

**386**

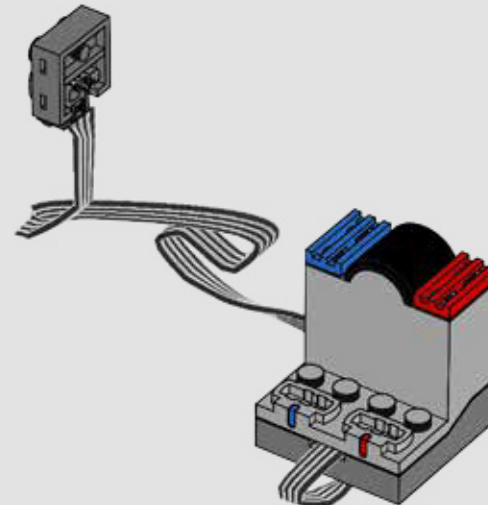



387

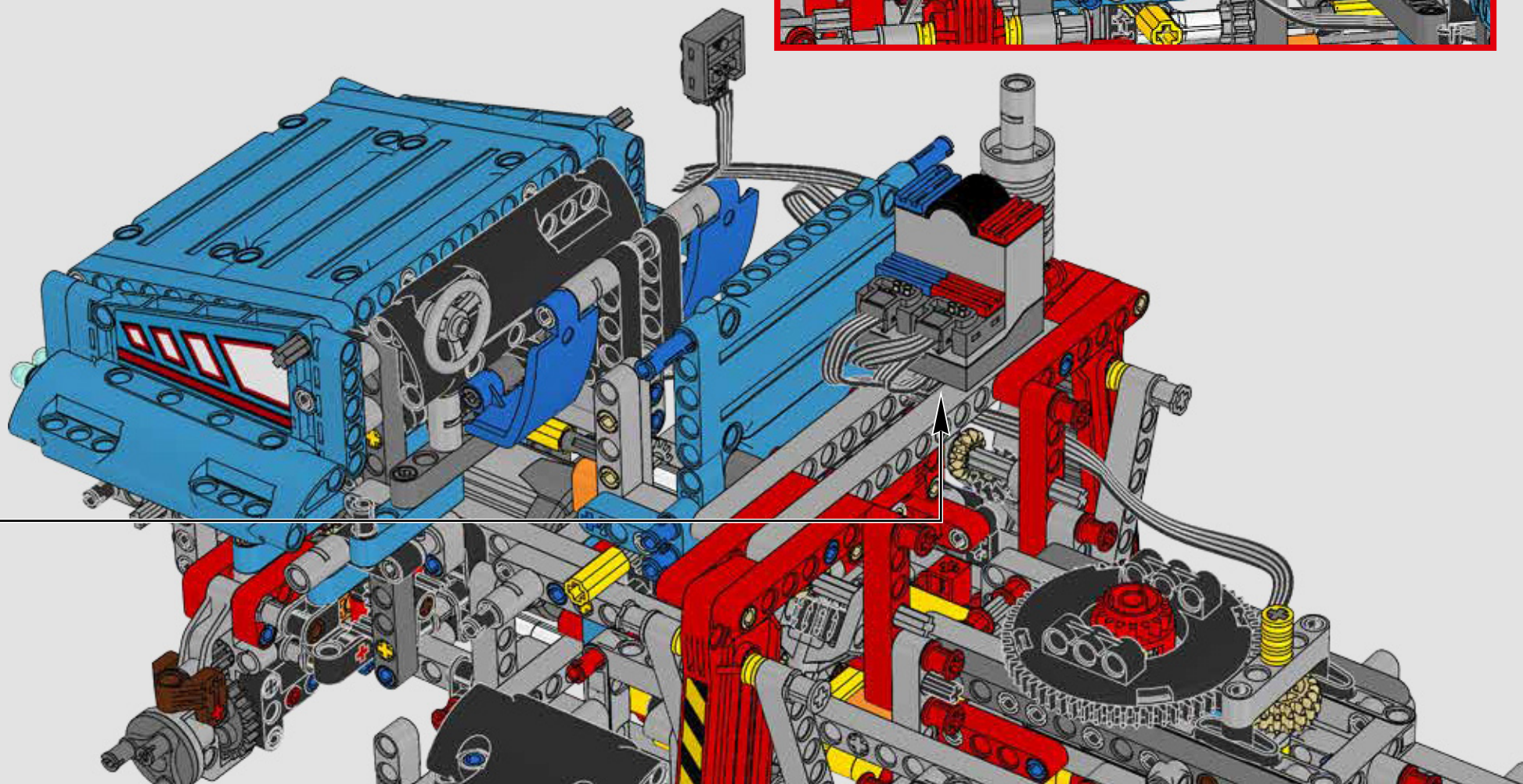
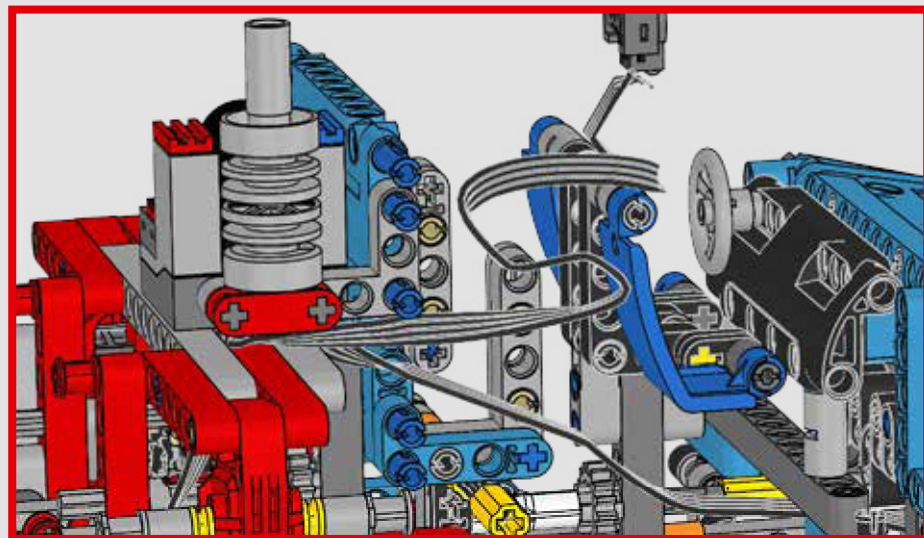

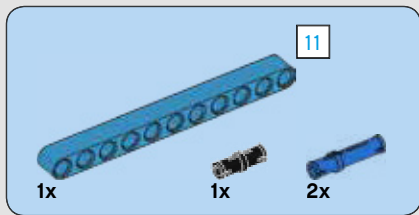

388

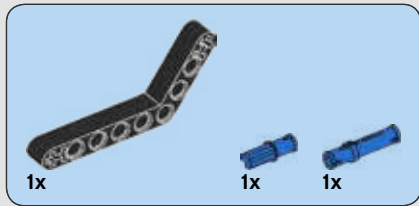
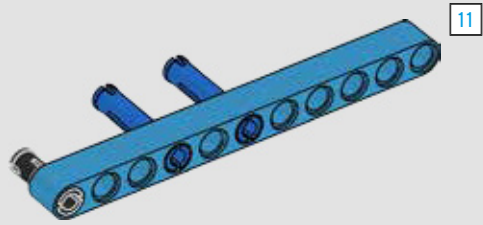

389

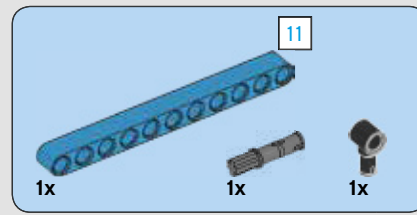
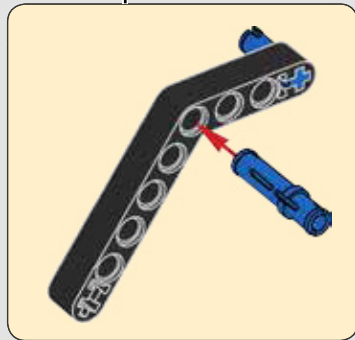
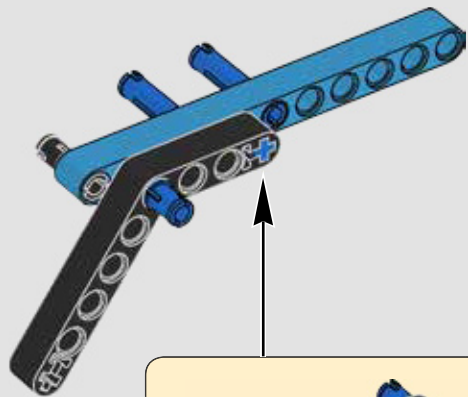

390

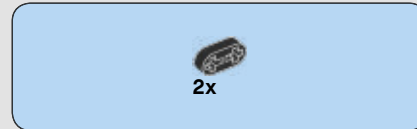
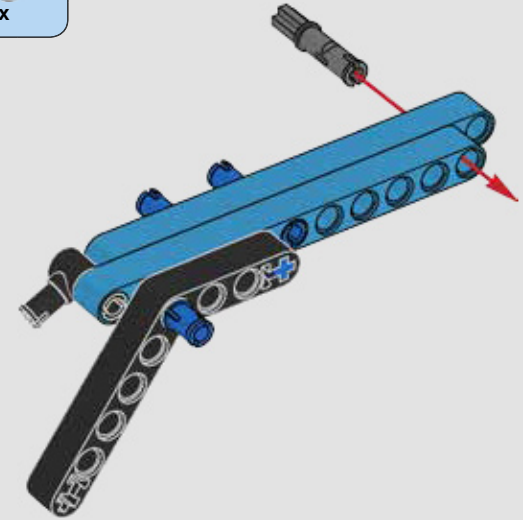

391

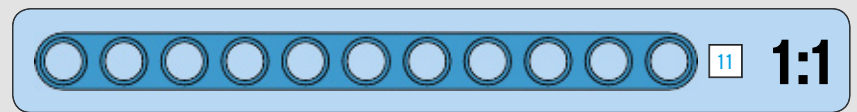
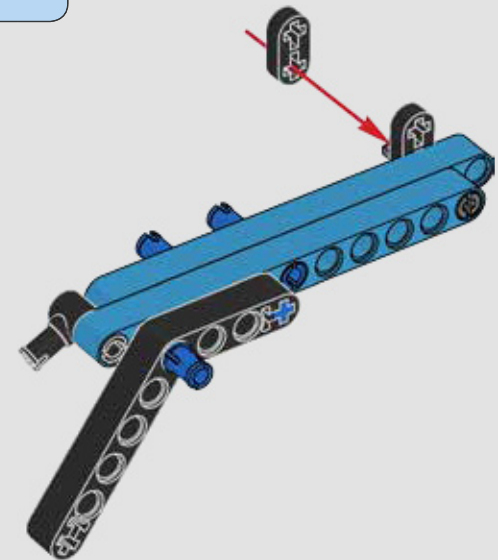



392

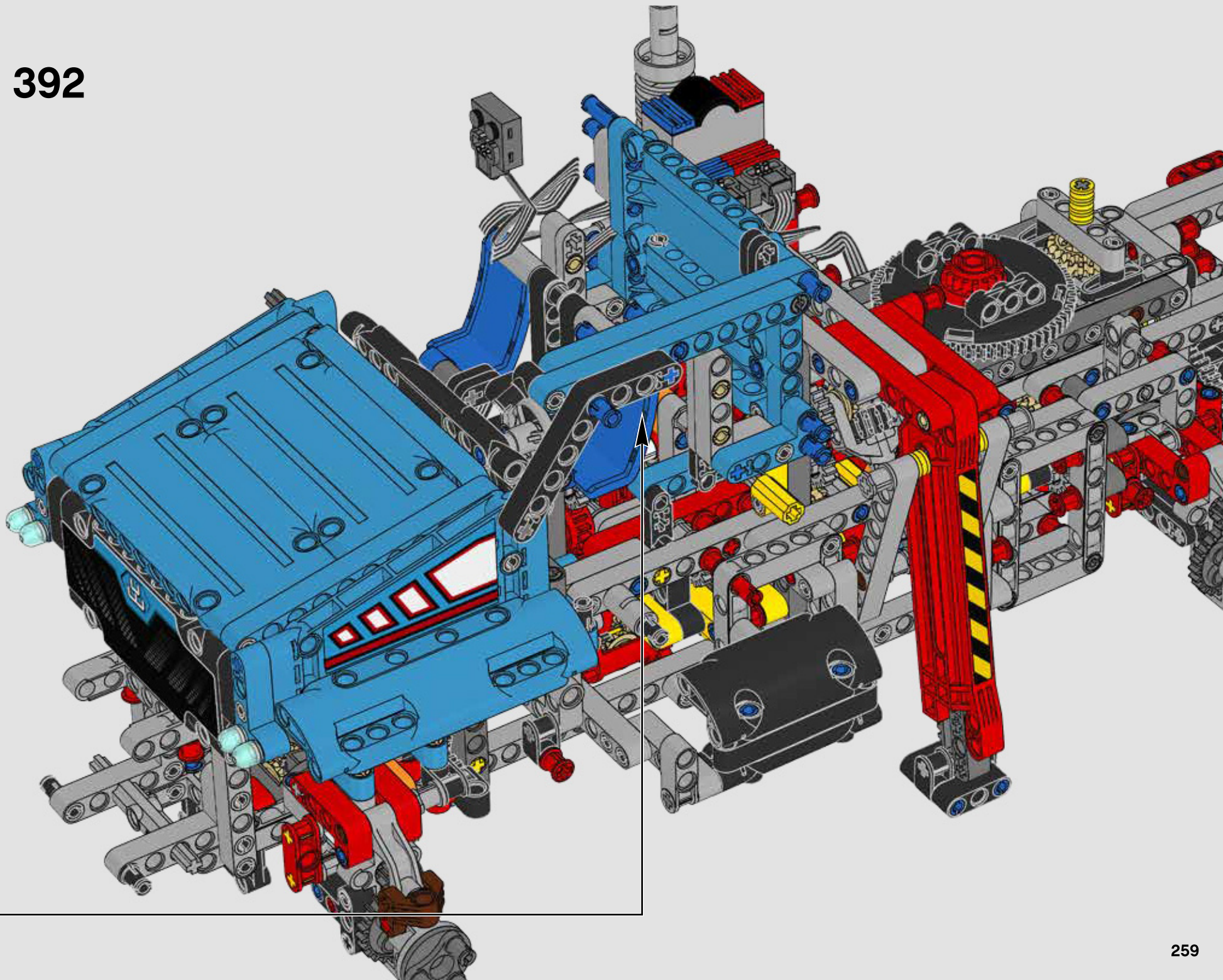



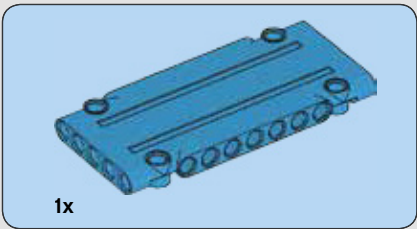

393

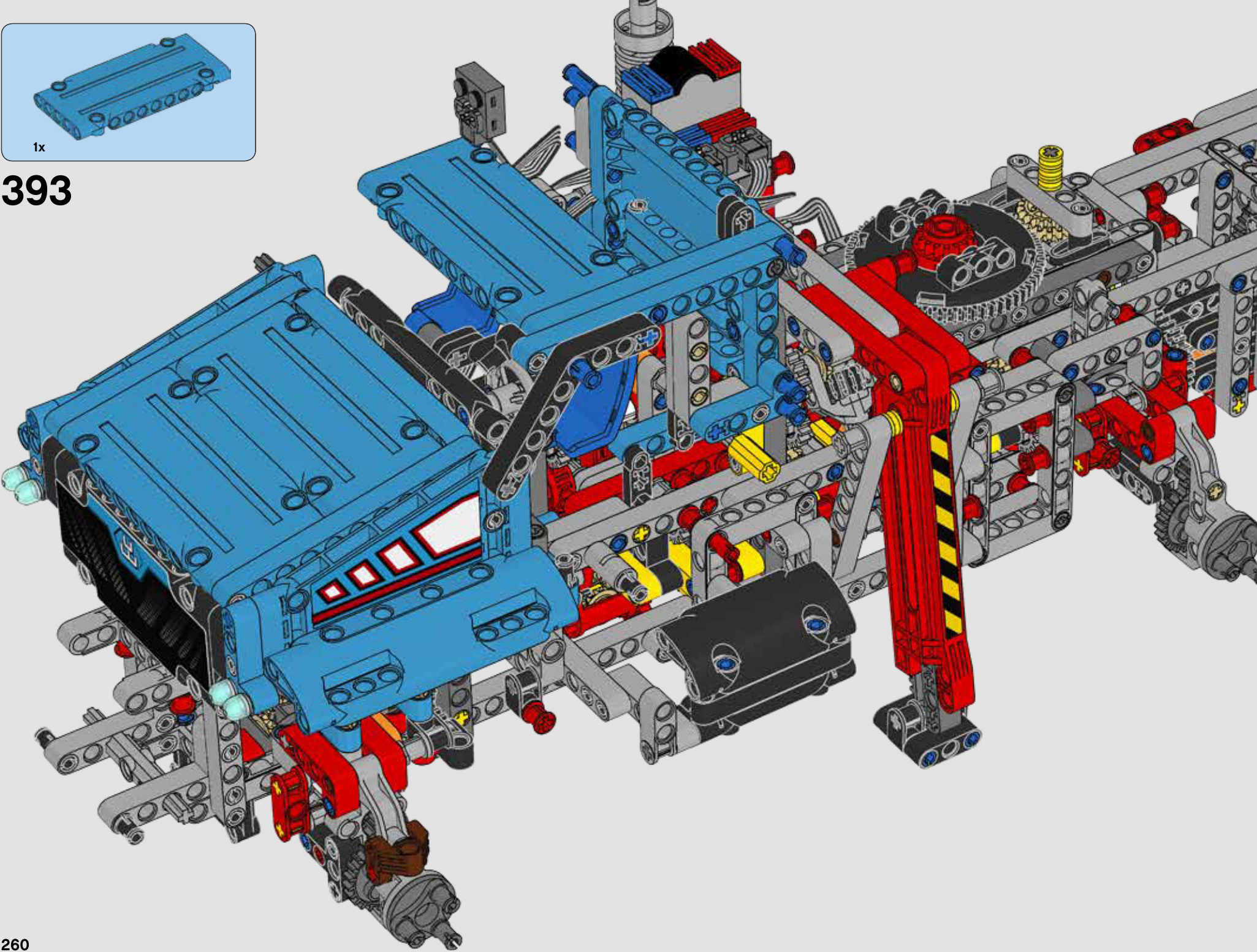



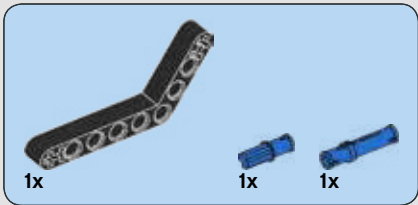

394

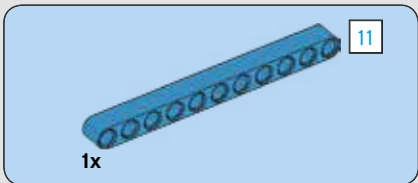

395

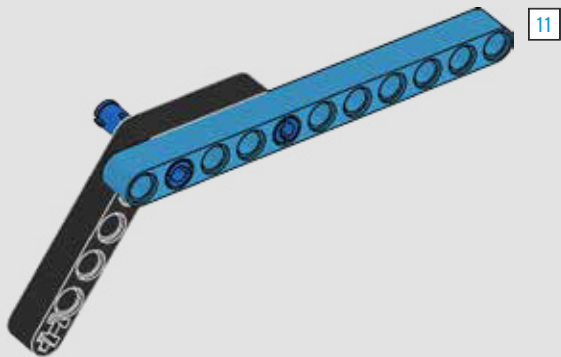

396

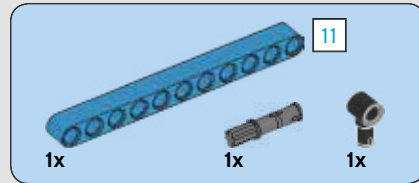
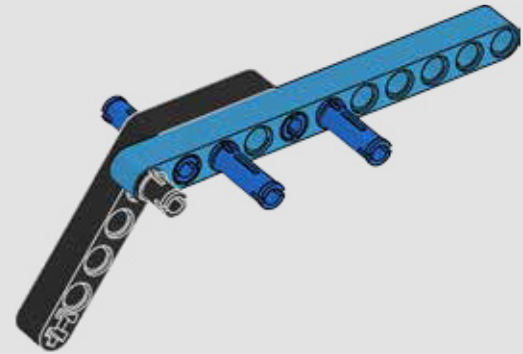

397

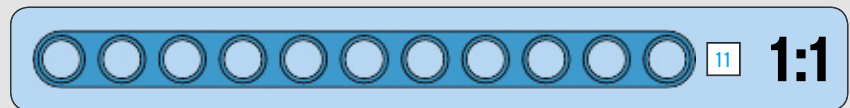
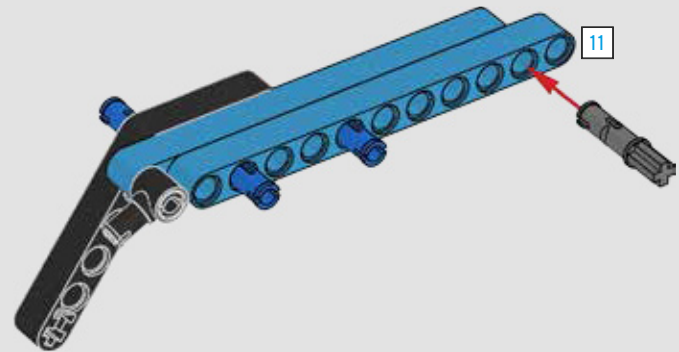

1:1

2x

398

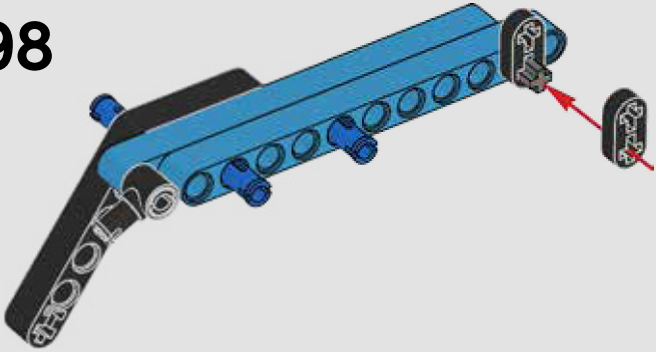

399

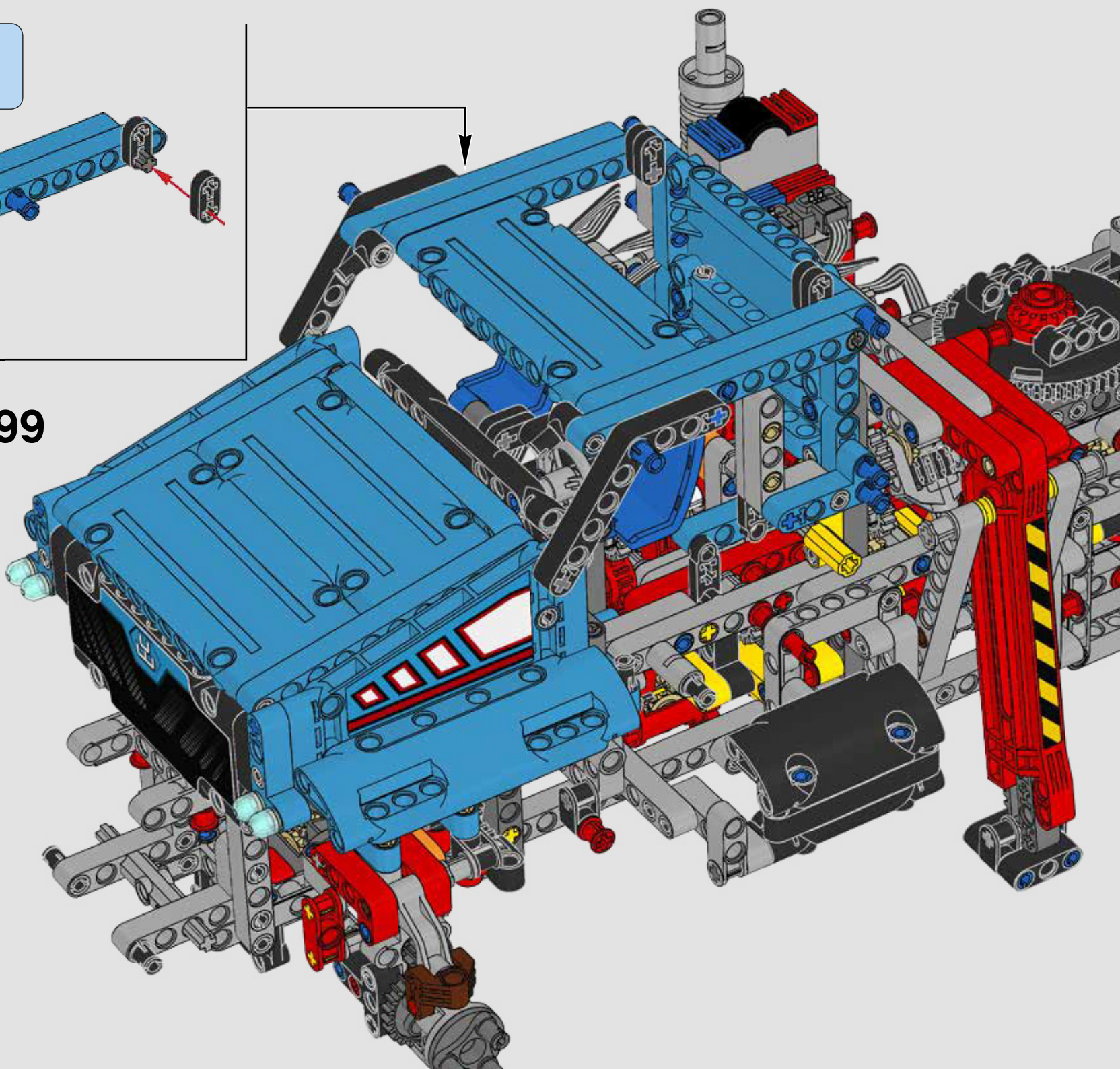



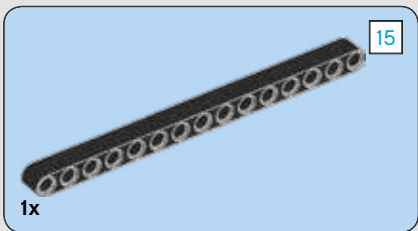

400

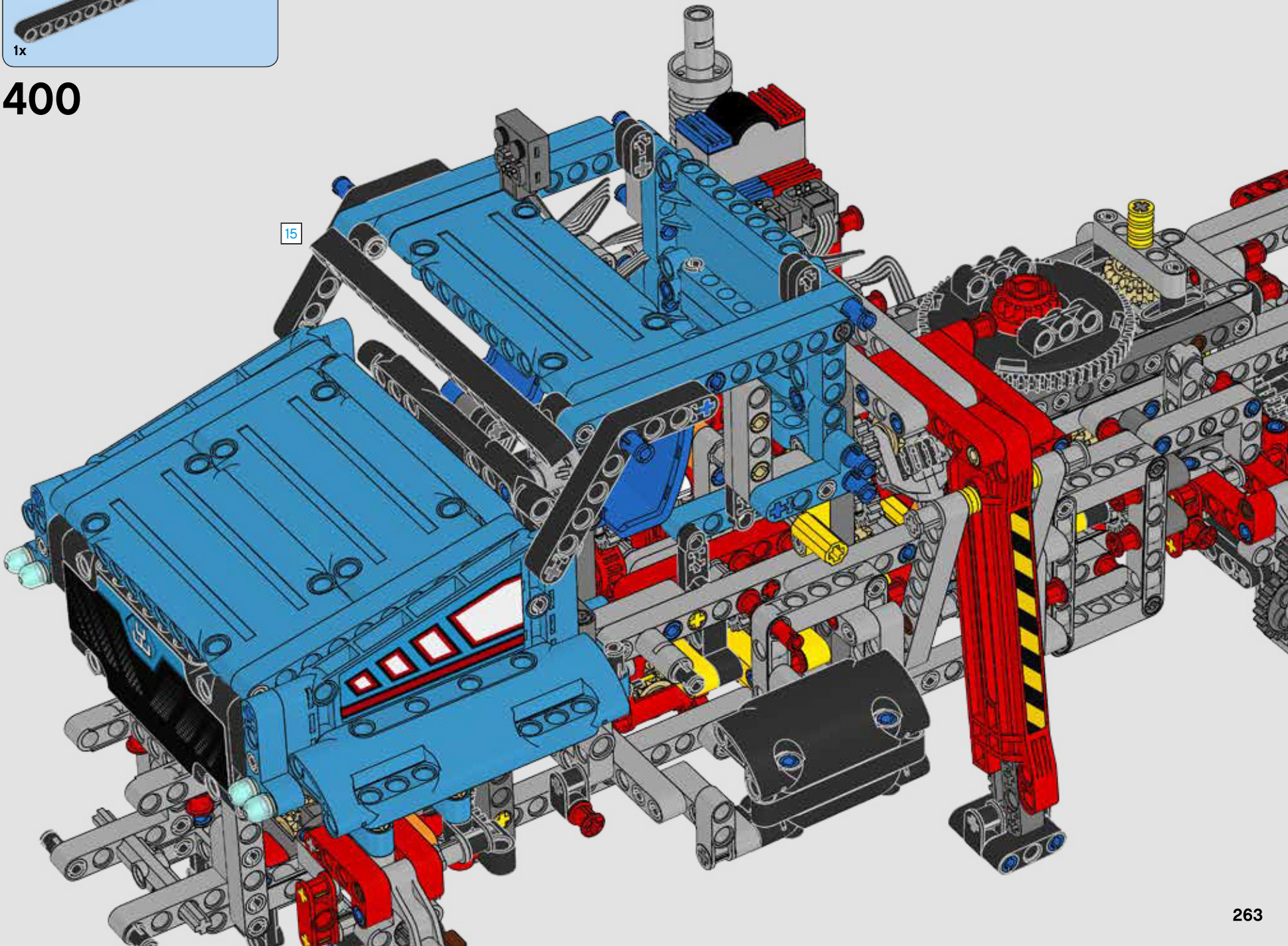
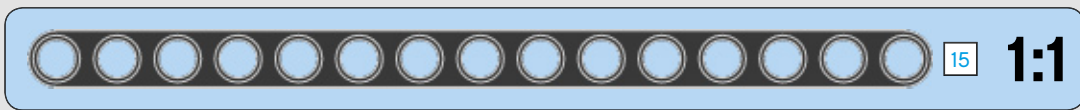



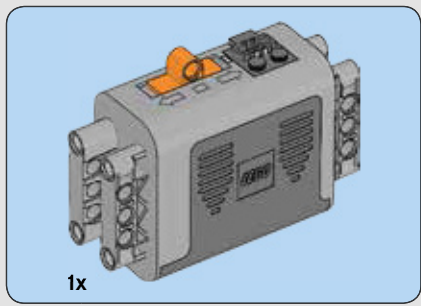

401

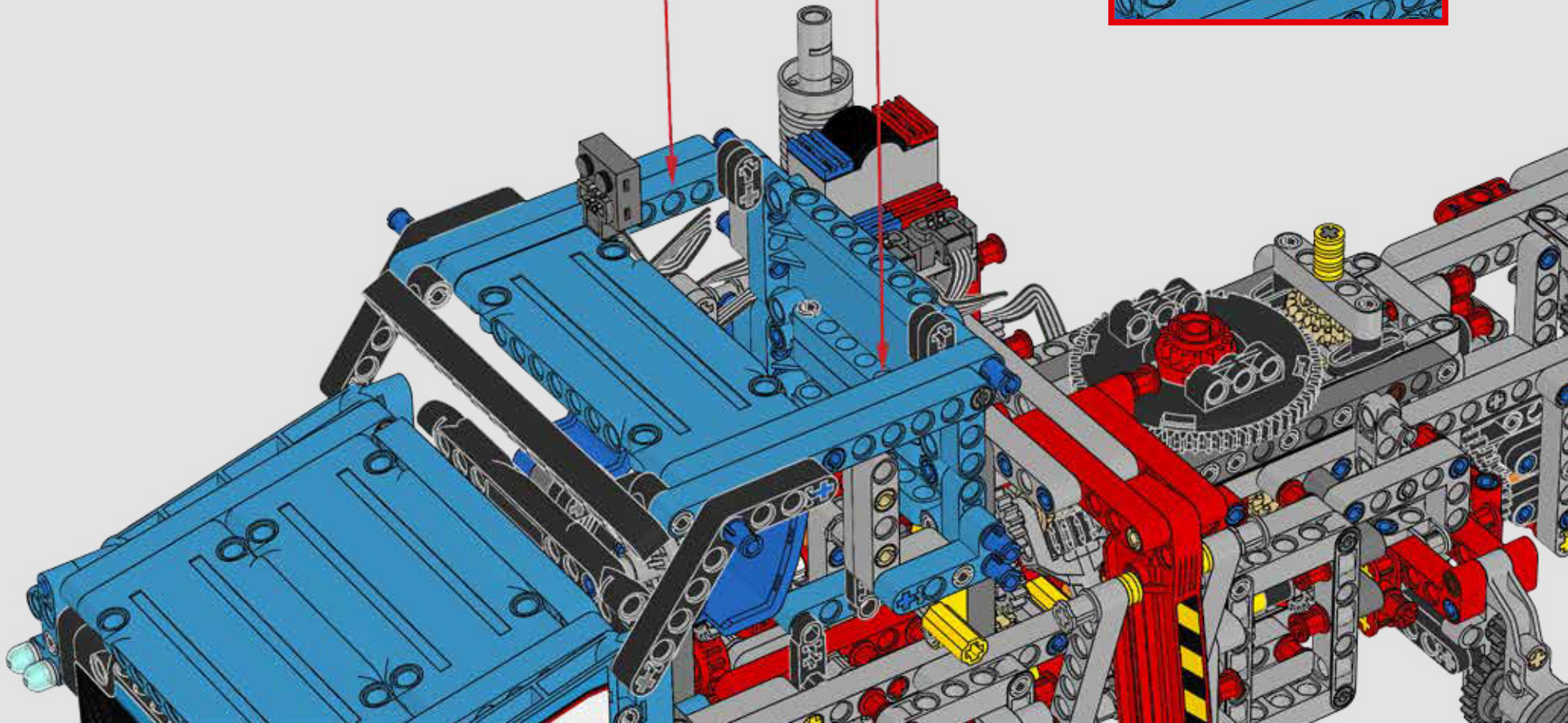
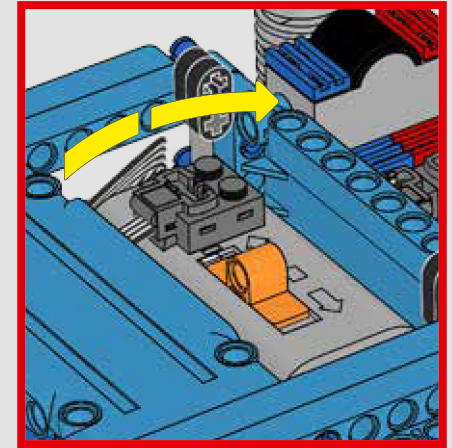
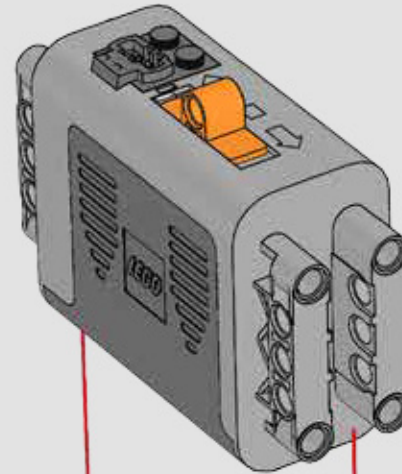



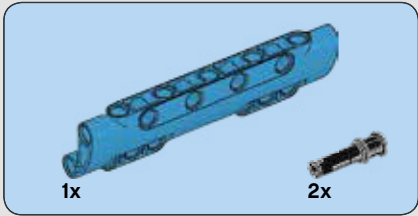
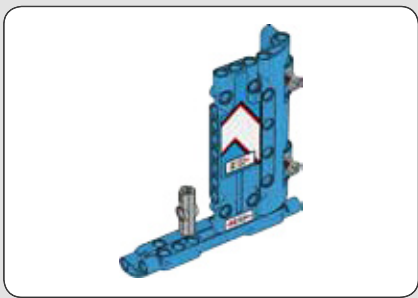

402

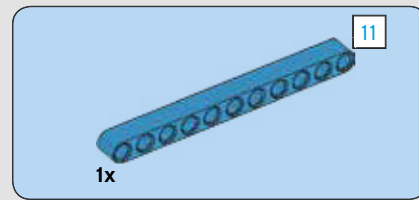
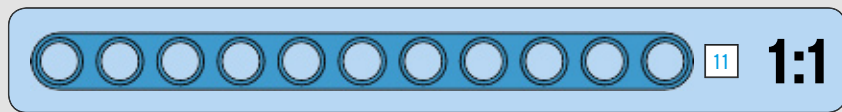

403

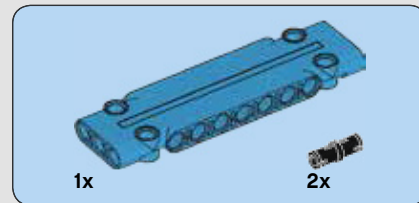
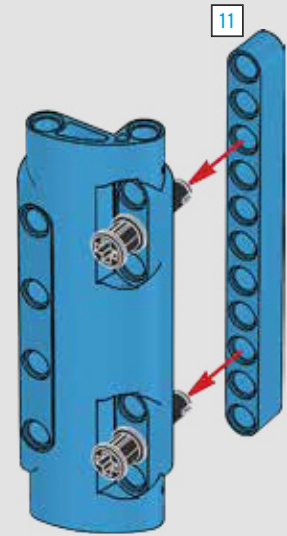

404

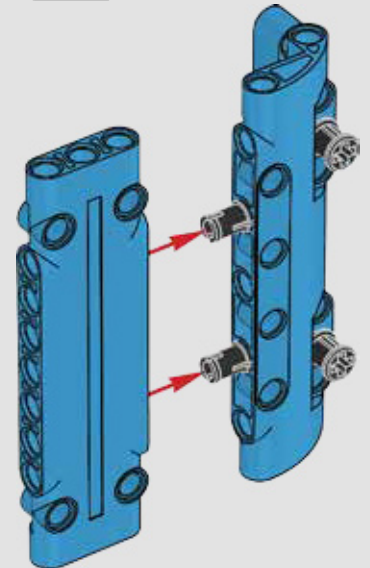
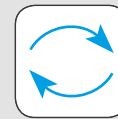

405

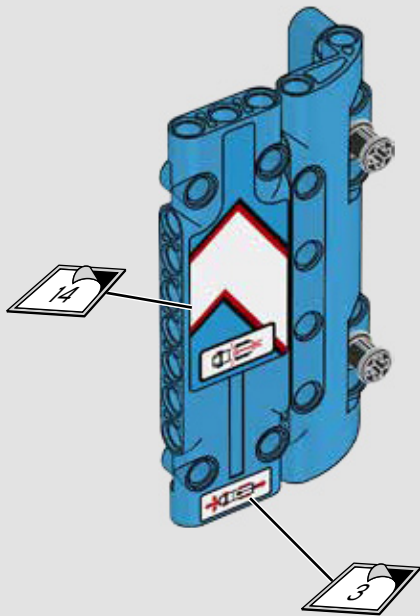

406

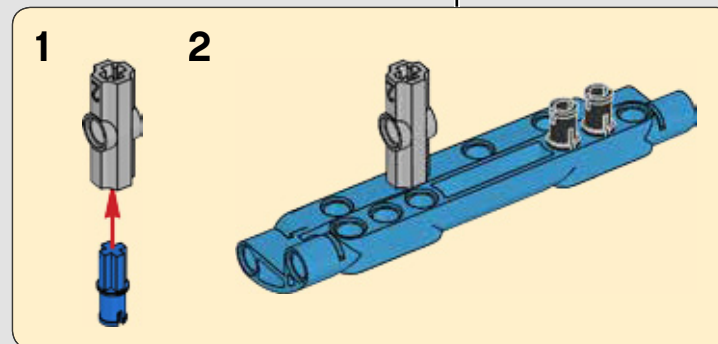
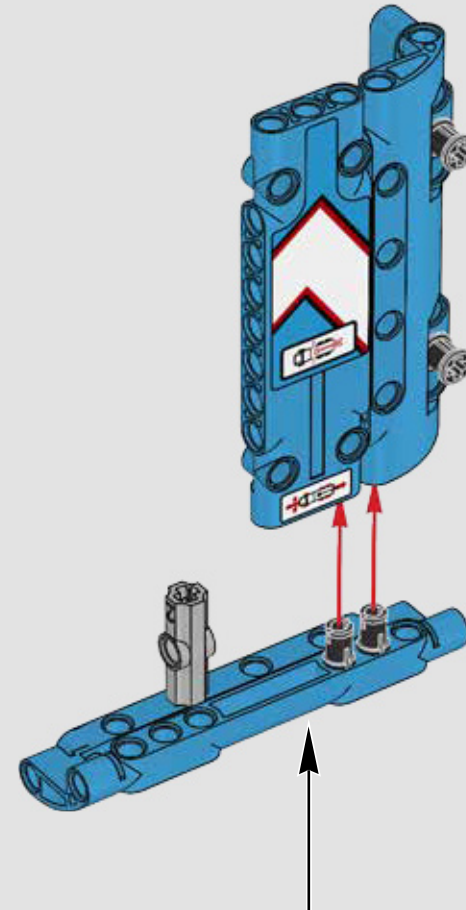
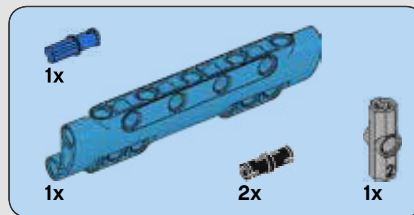



407

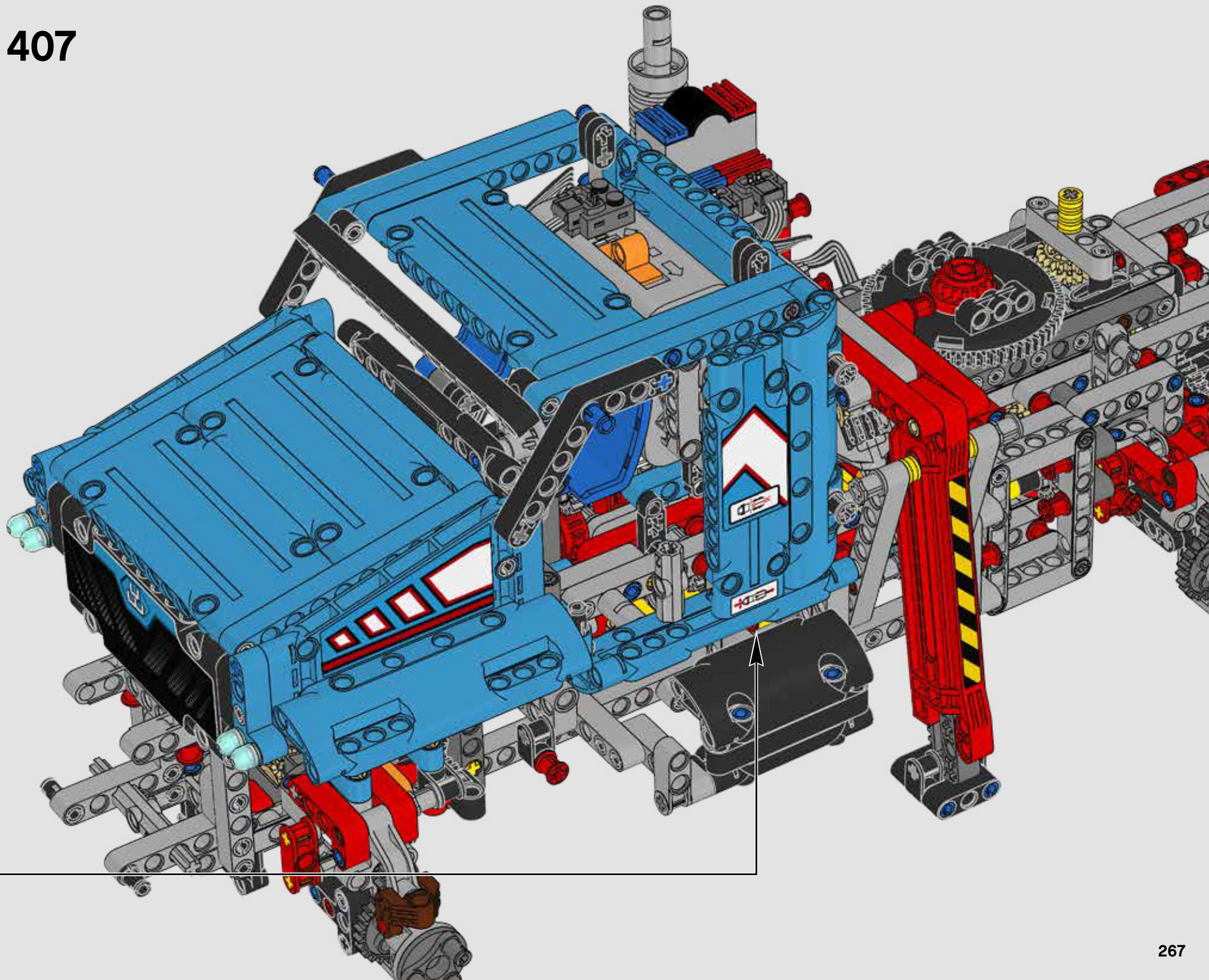



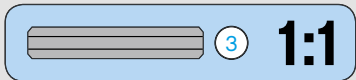
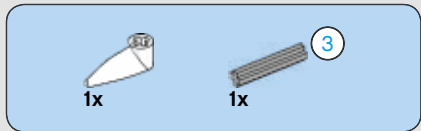

408

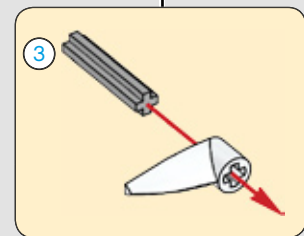
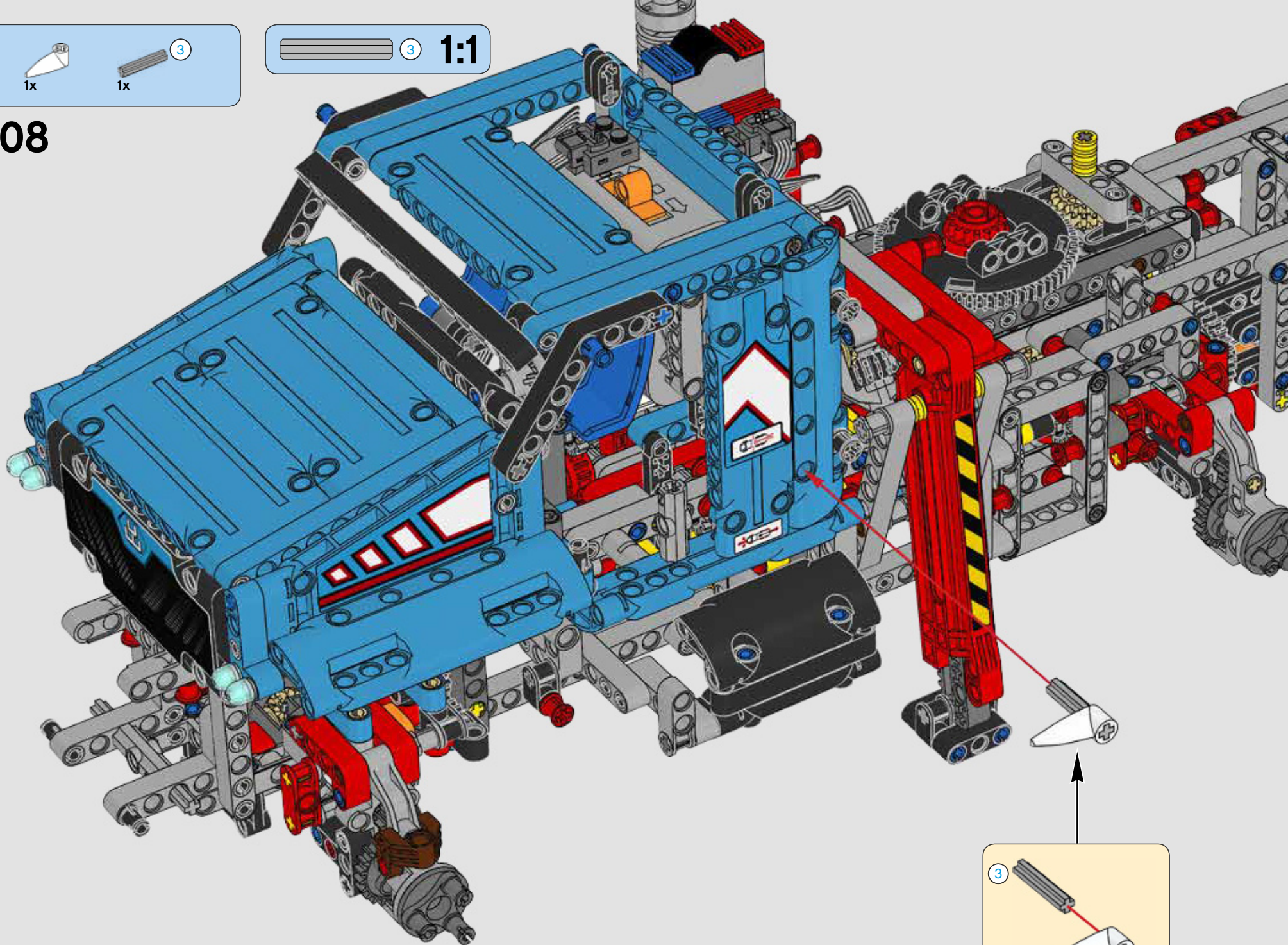



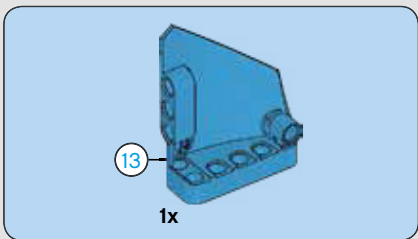

409

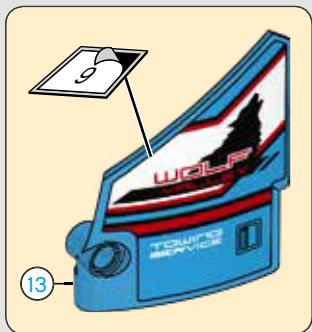
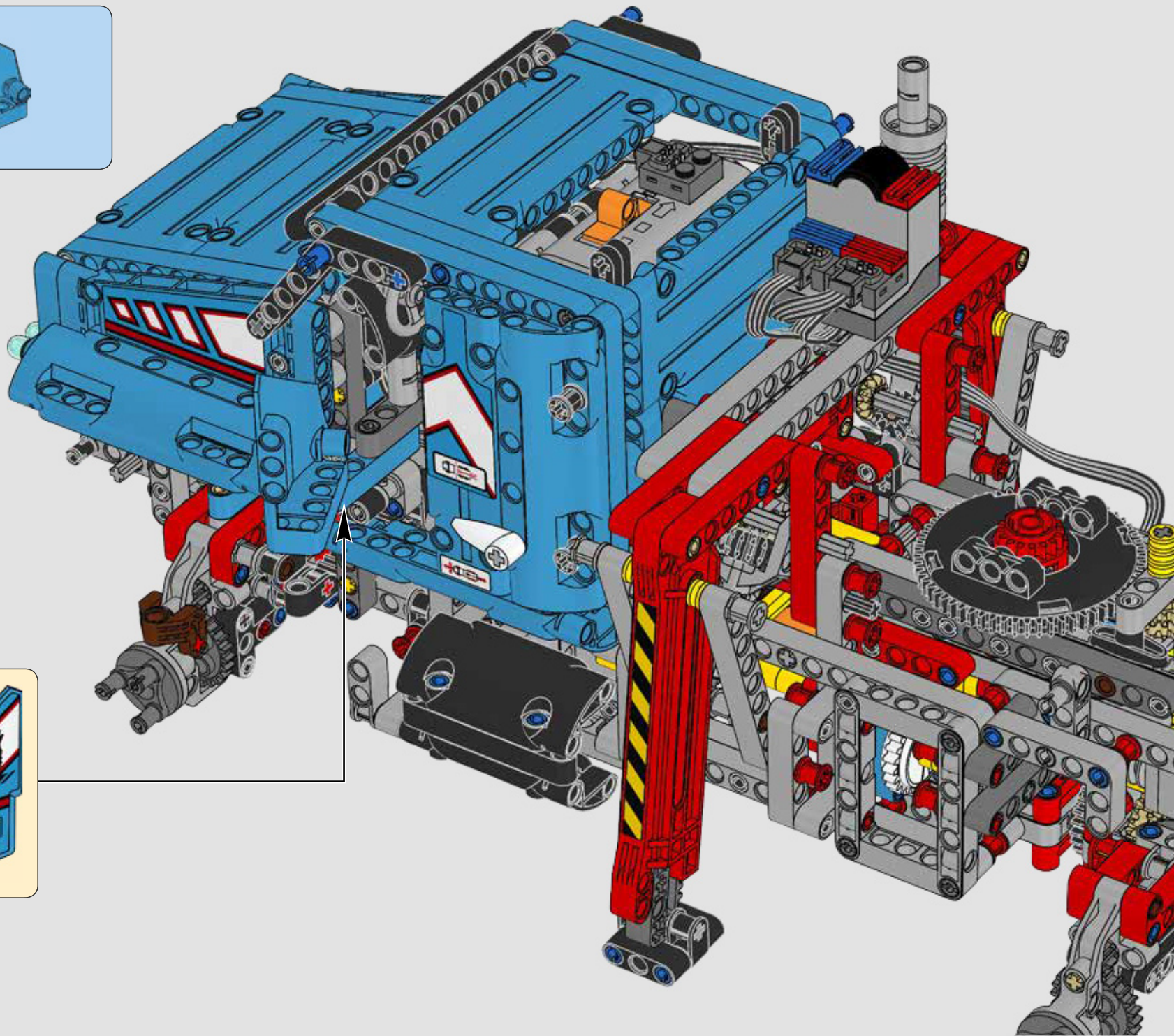

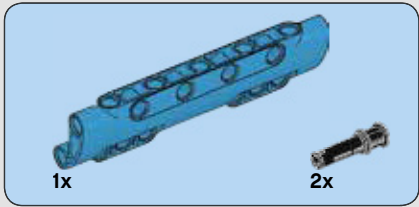
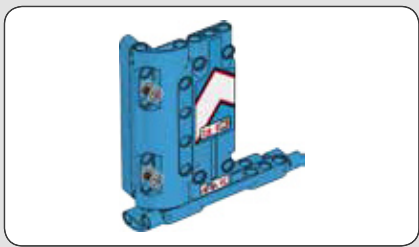

410

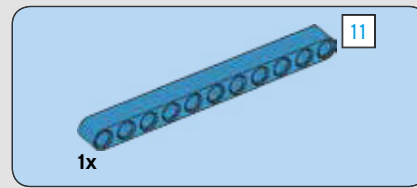

411

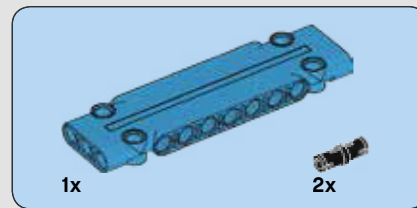
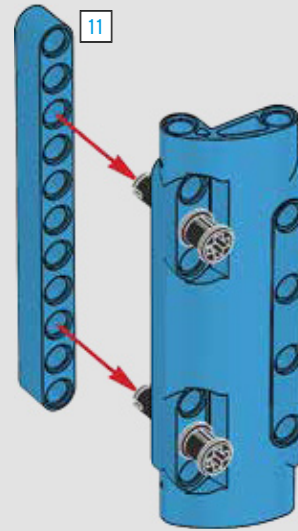

412

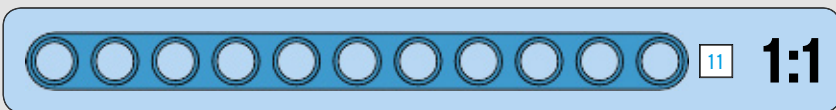
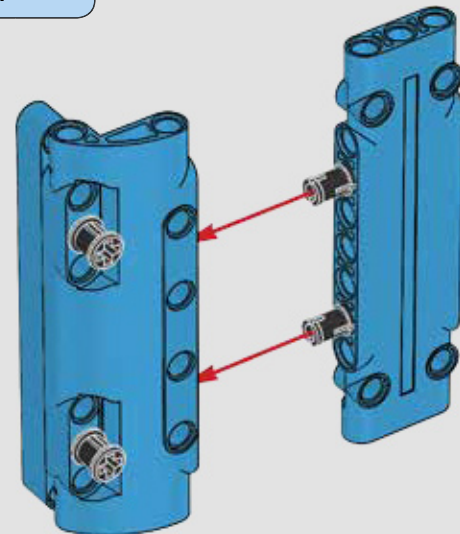



413

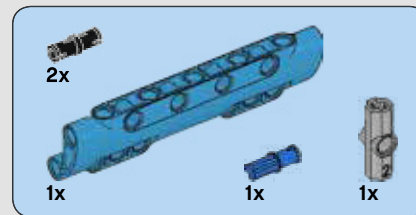
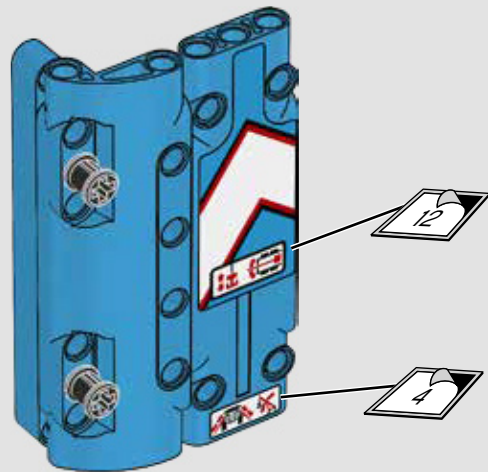

414

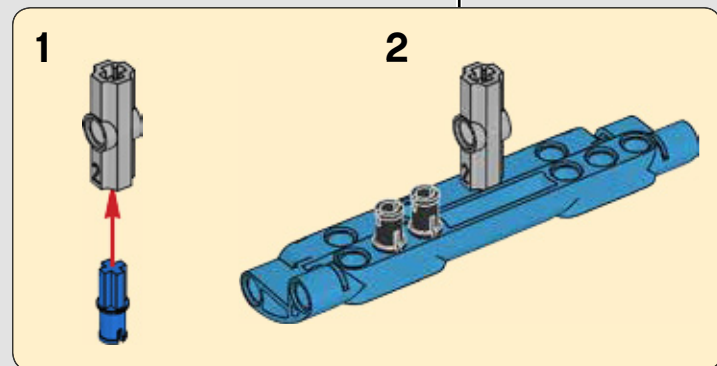
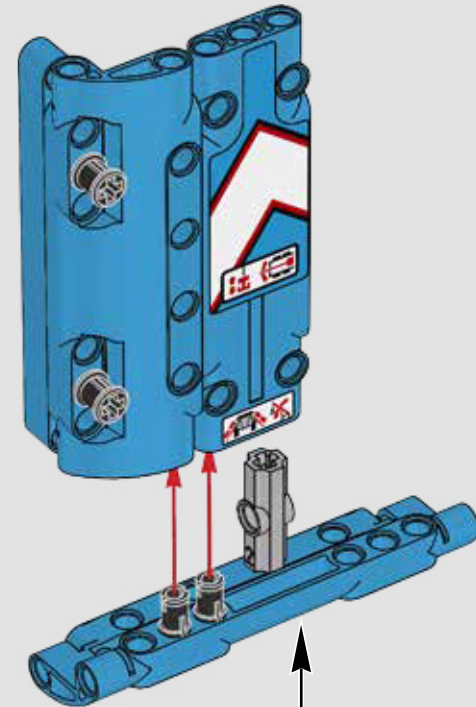

415

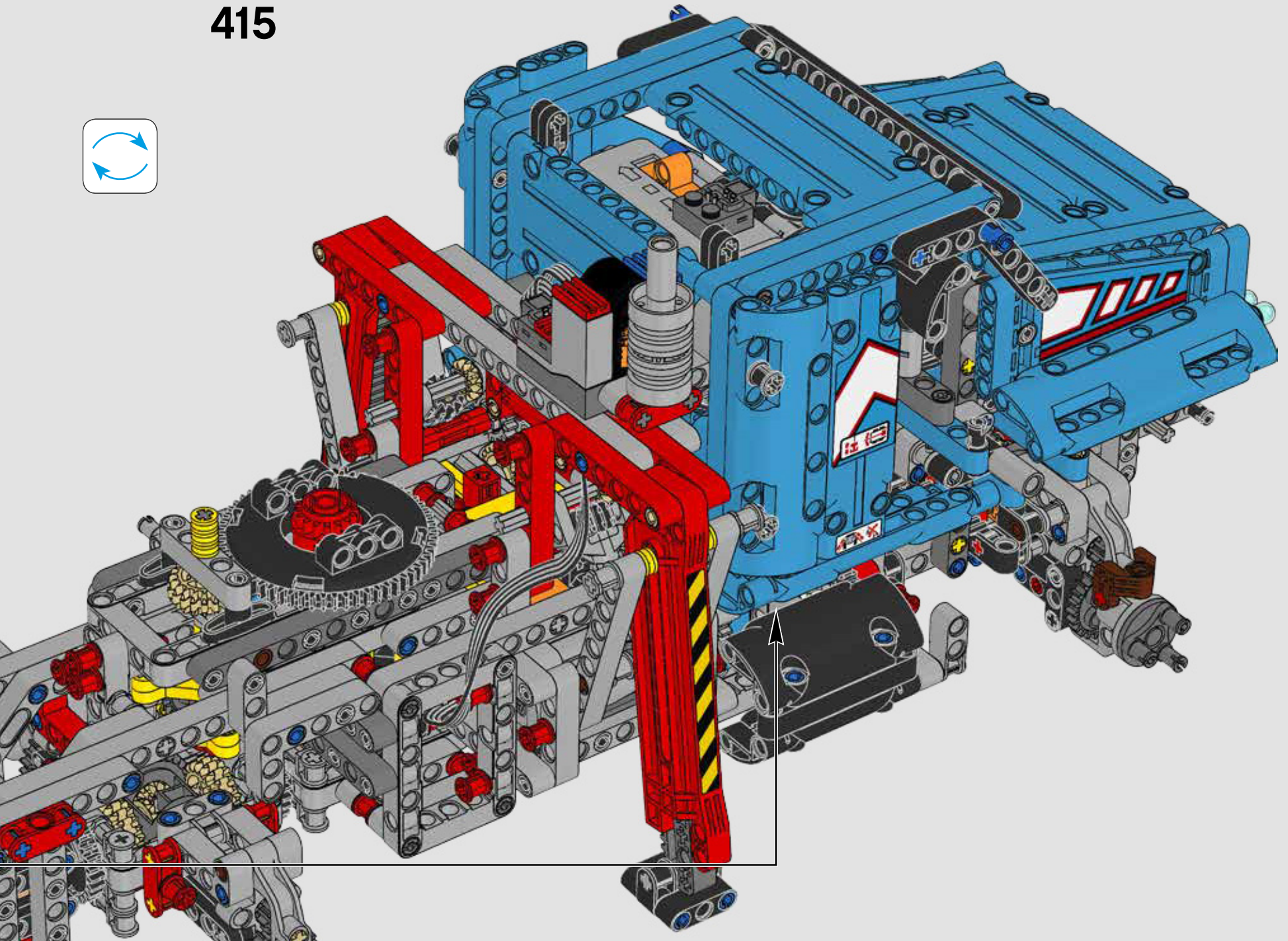



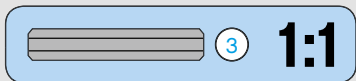
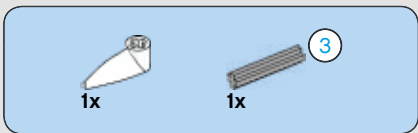

416

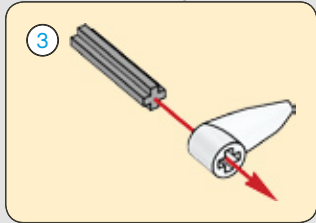
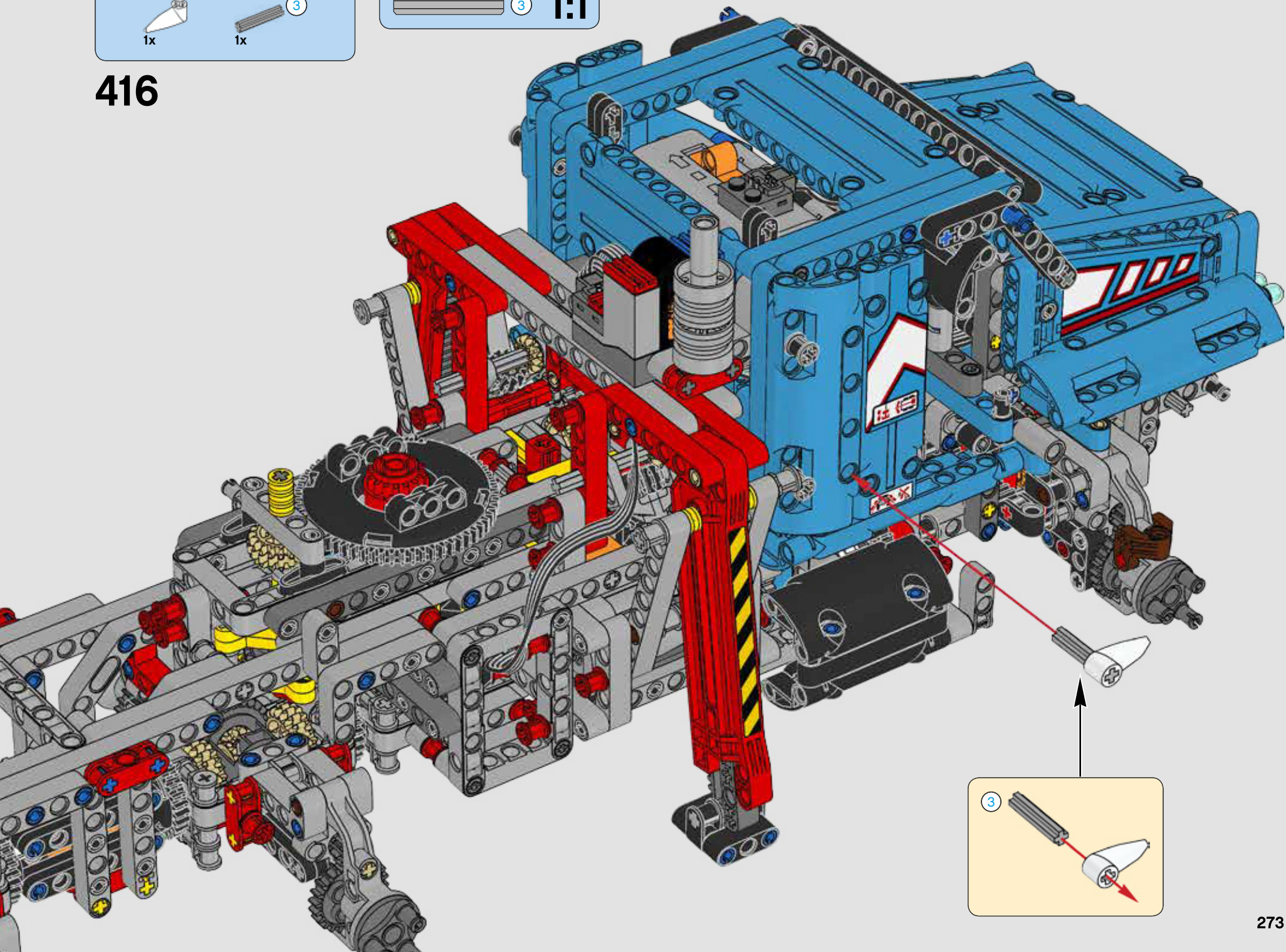



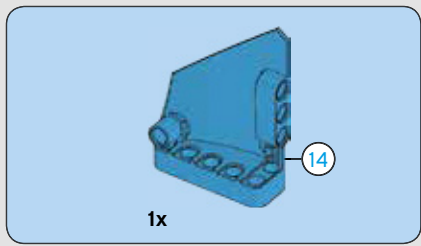

417

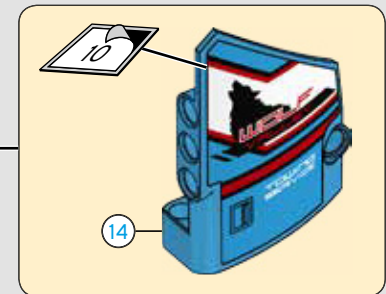
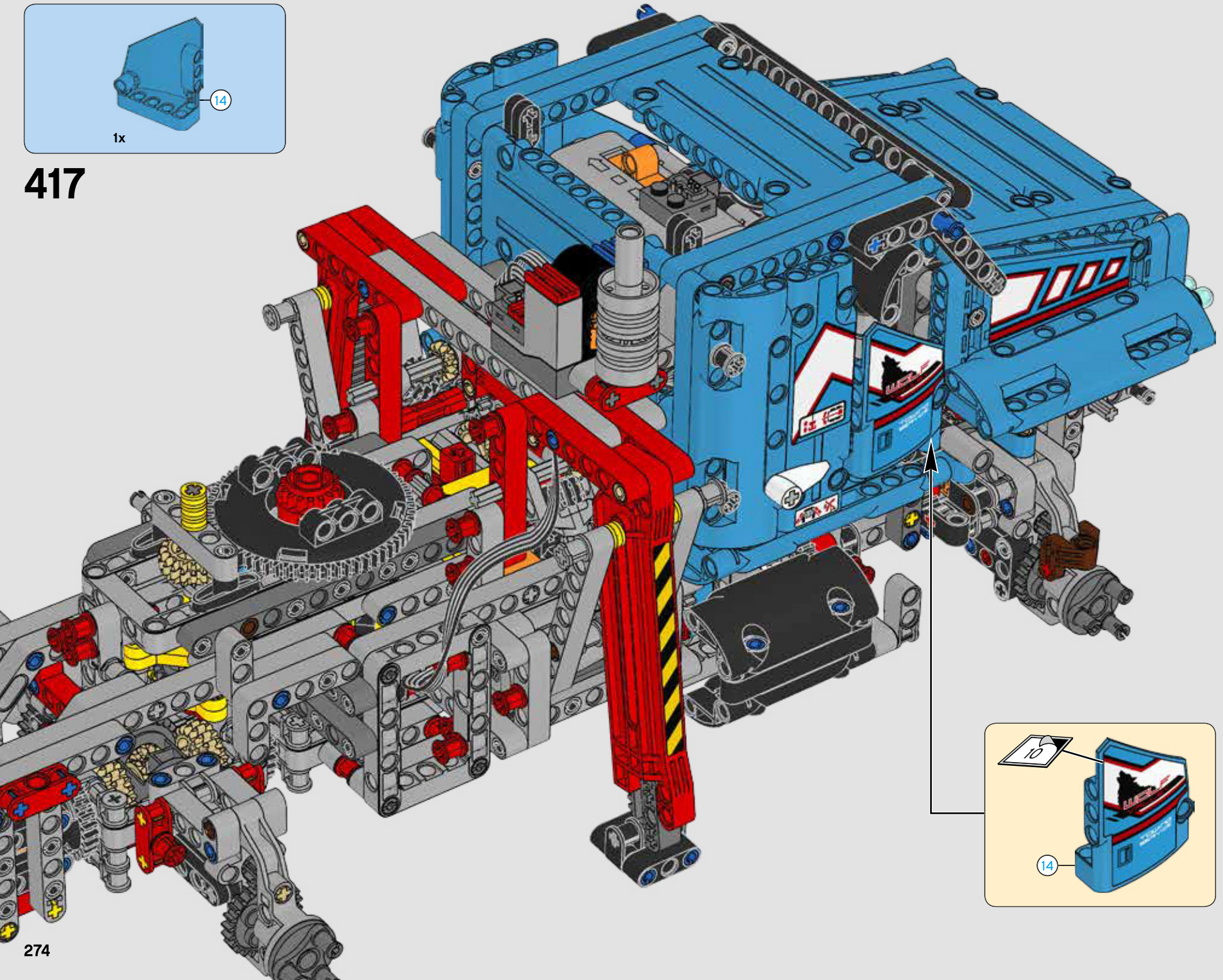



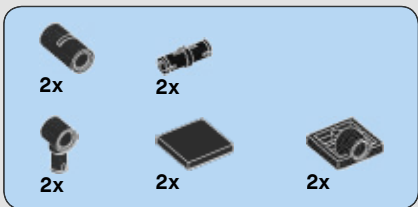

418

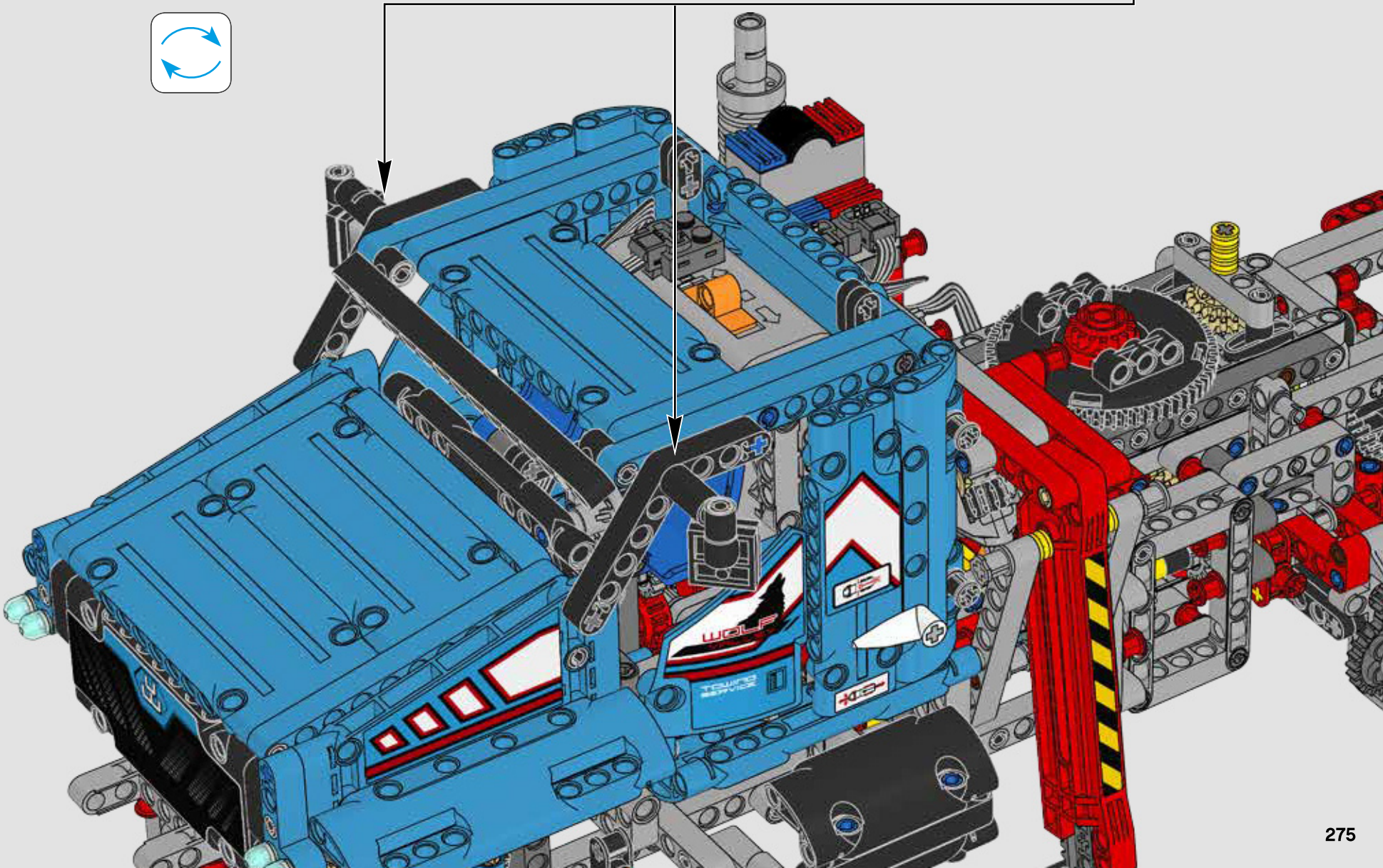
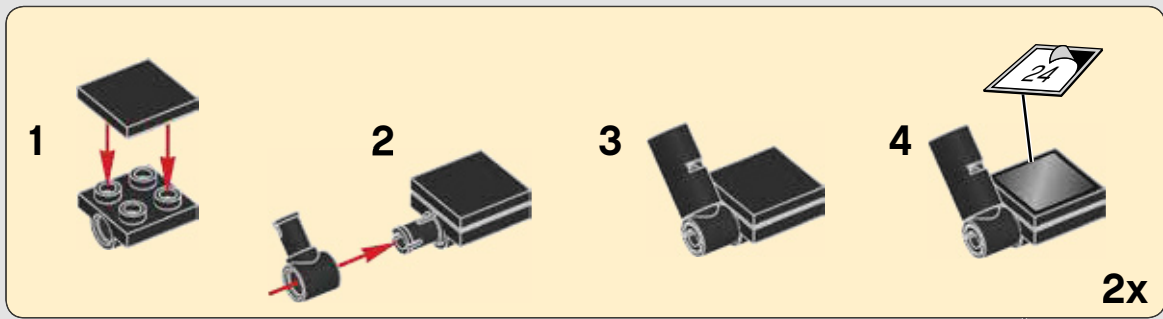



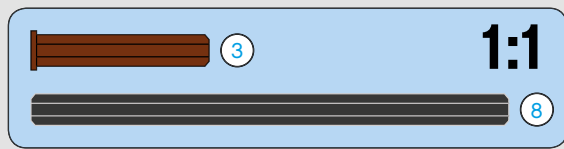
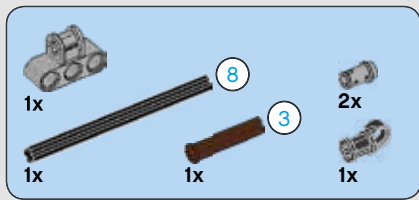

419

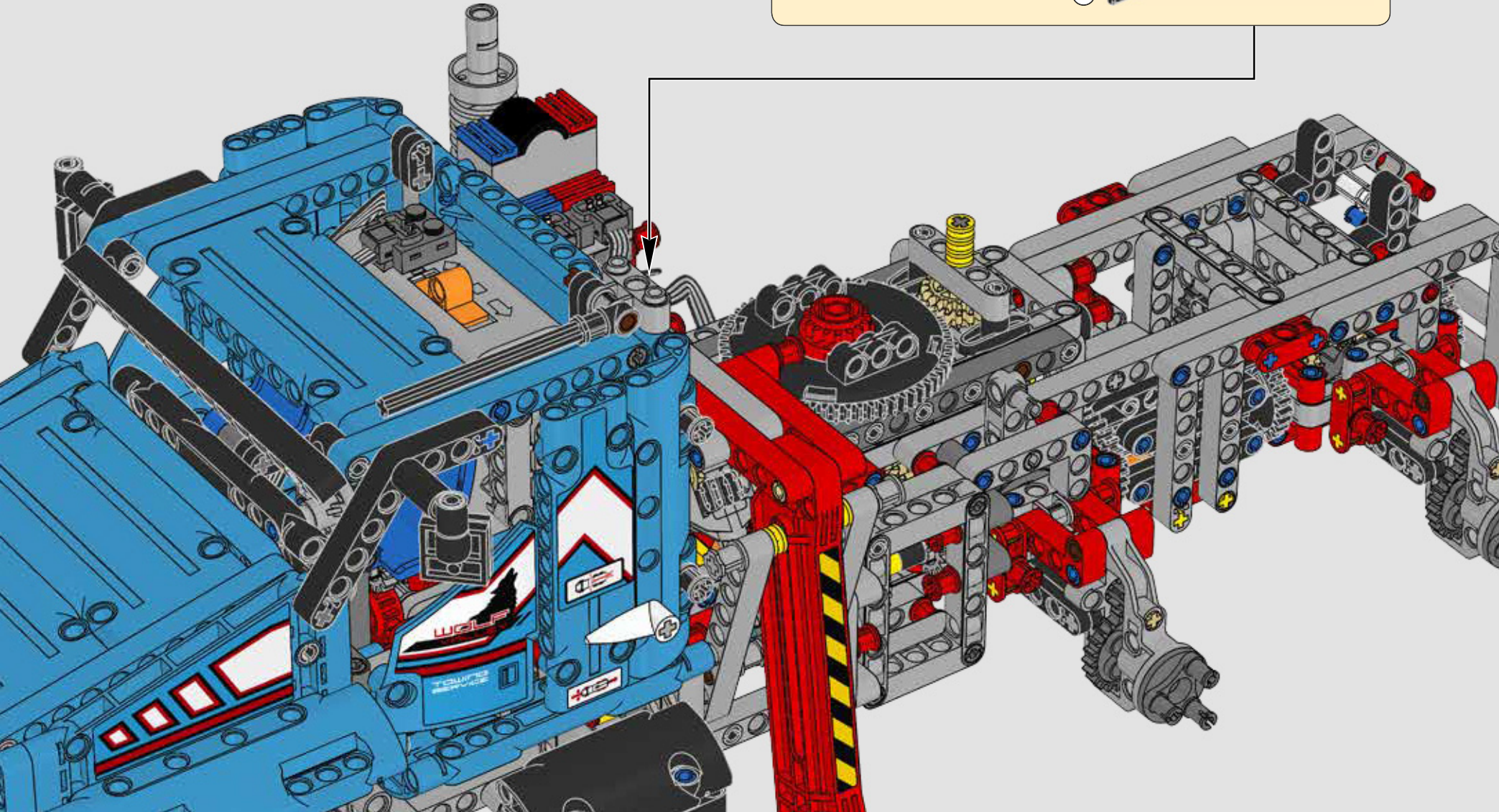
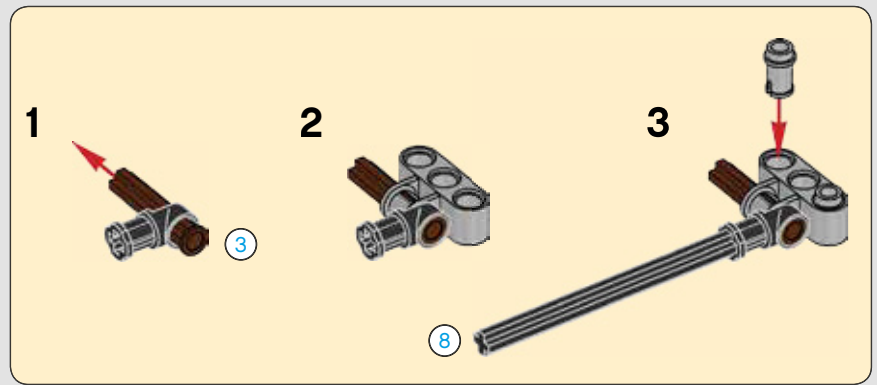



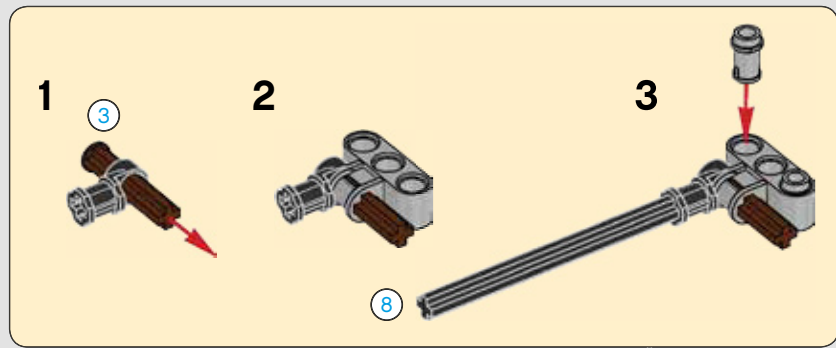
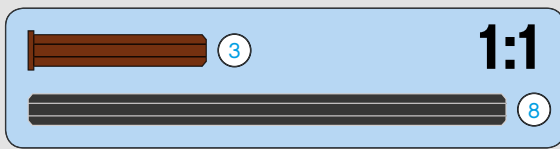
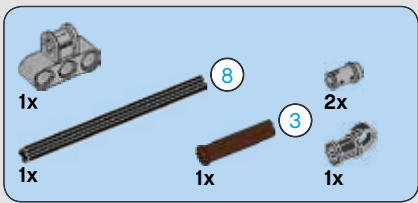

420

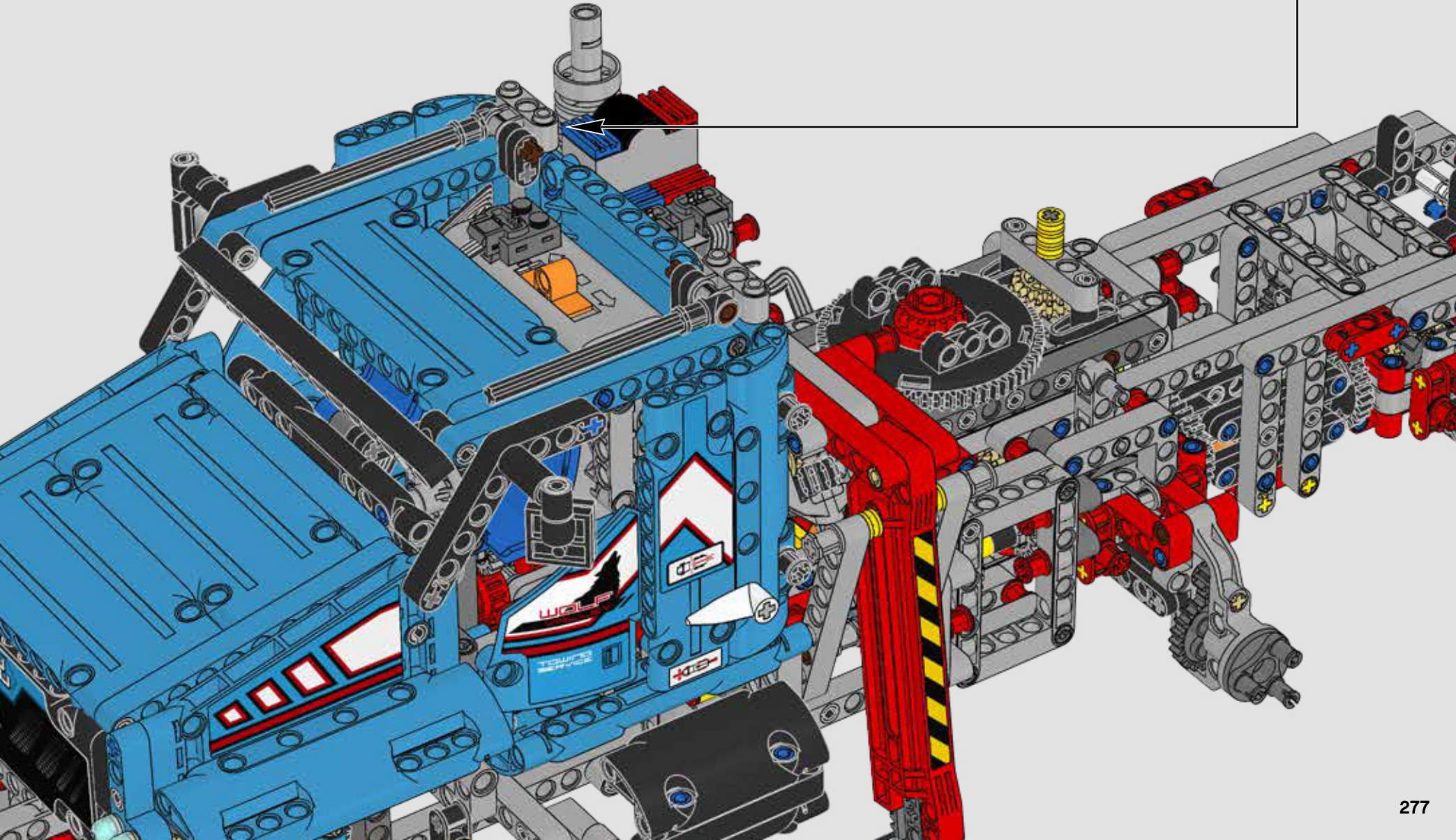



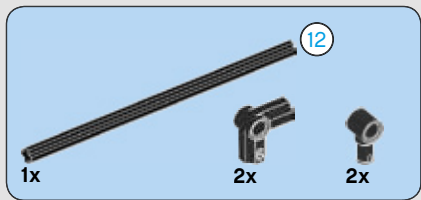

421

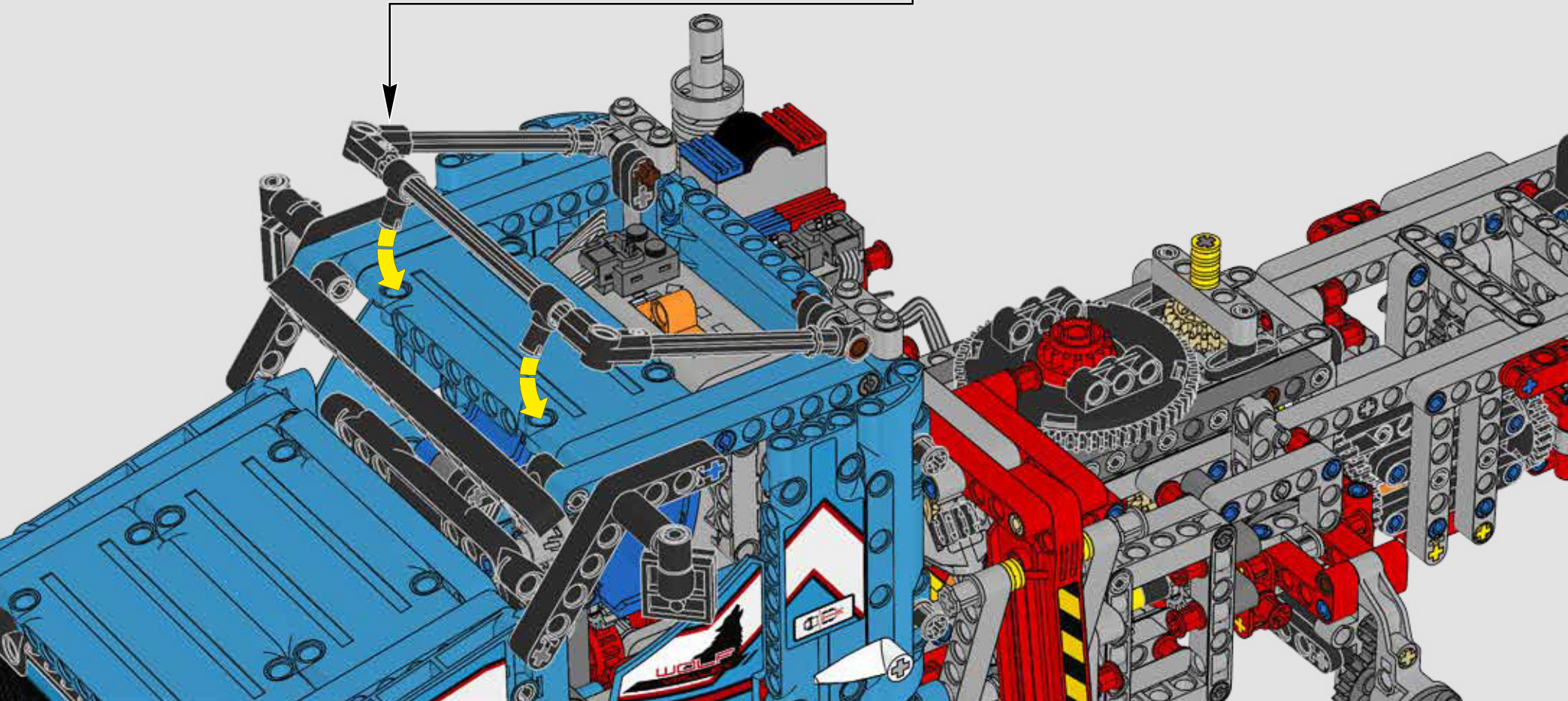
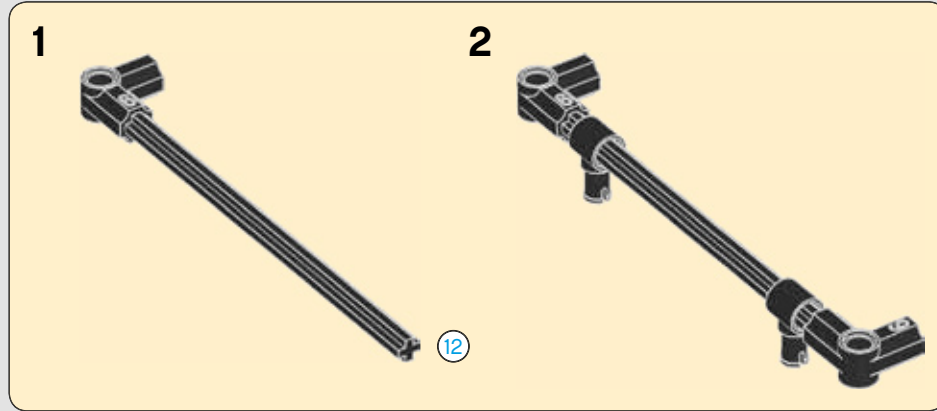
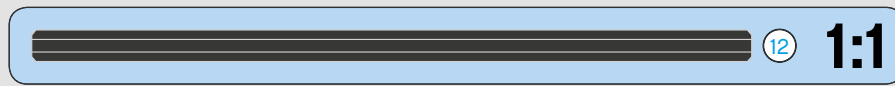





422

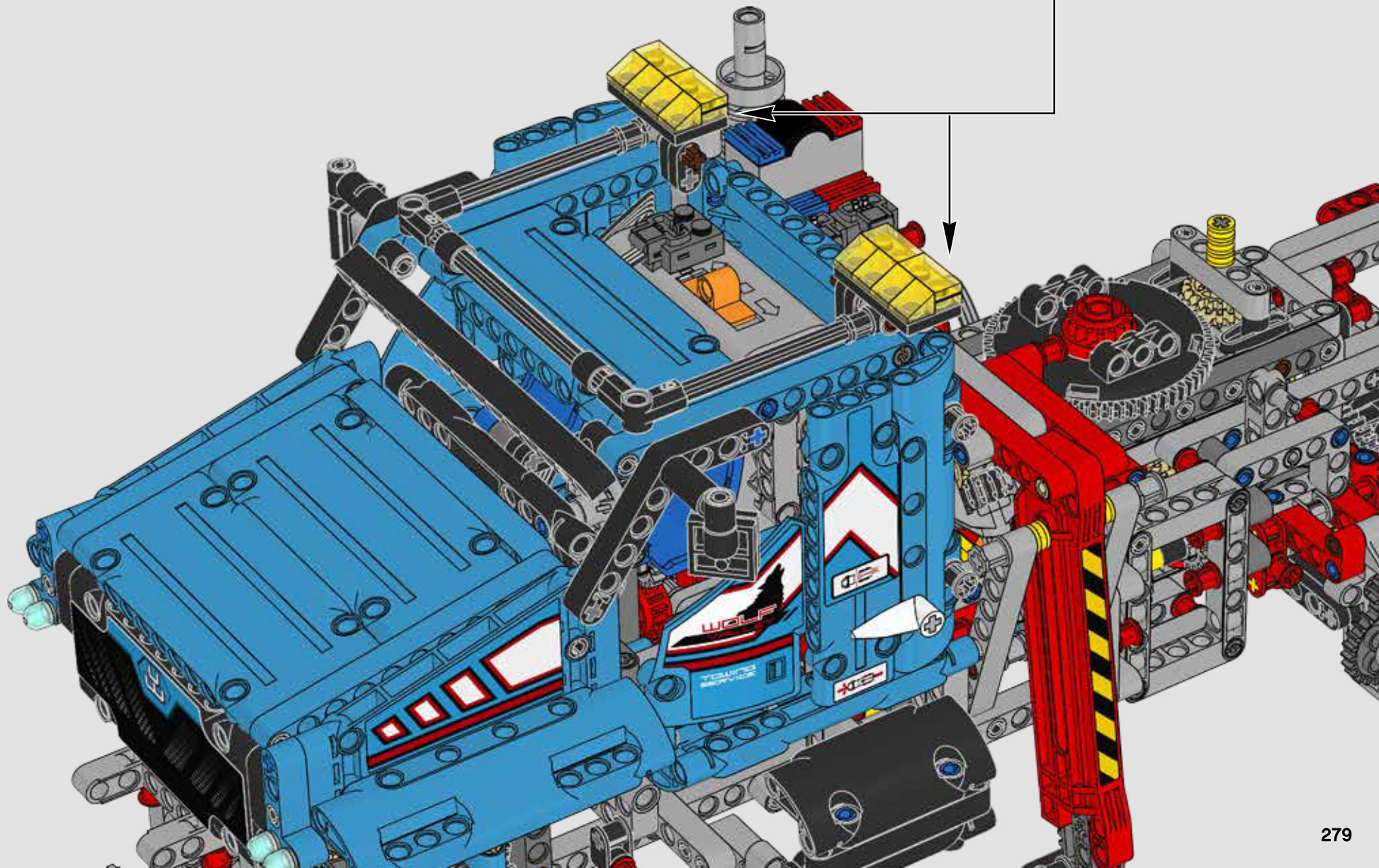



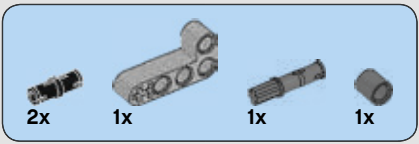

423

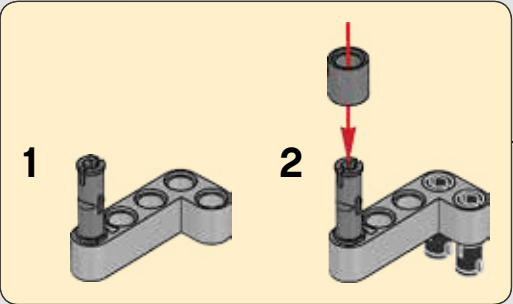
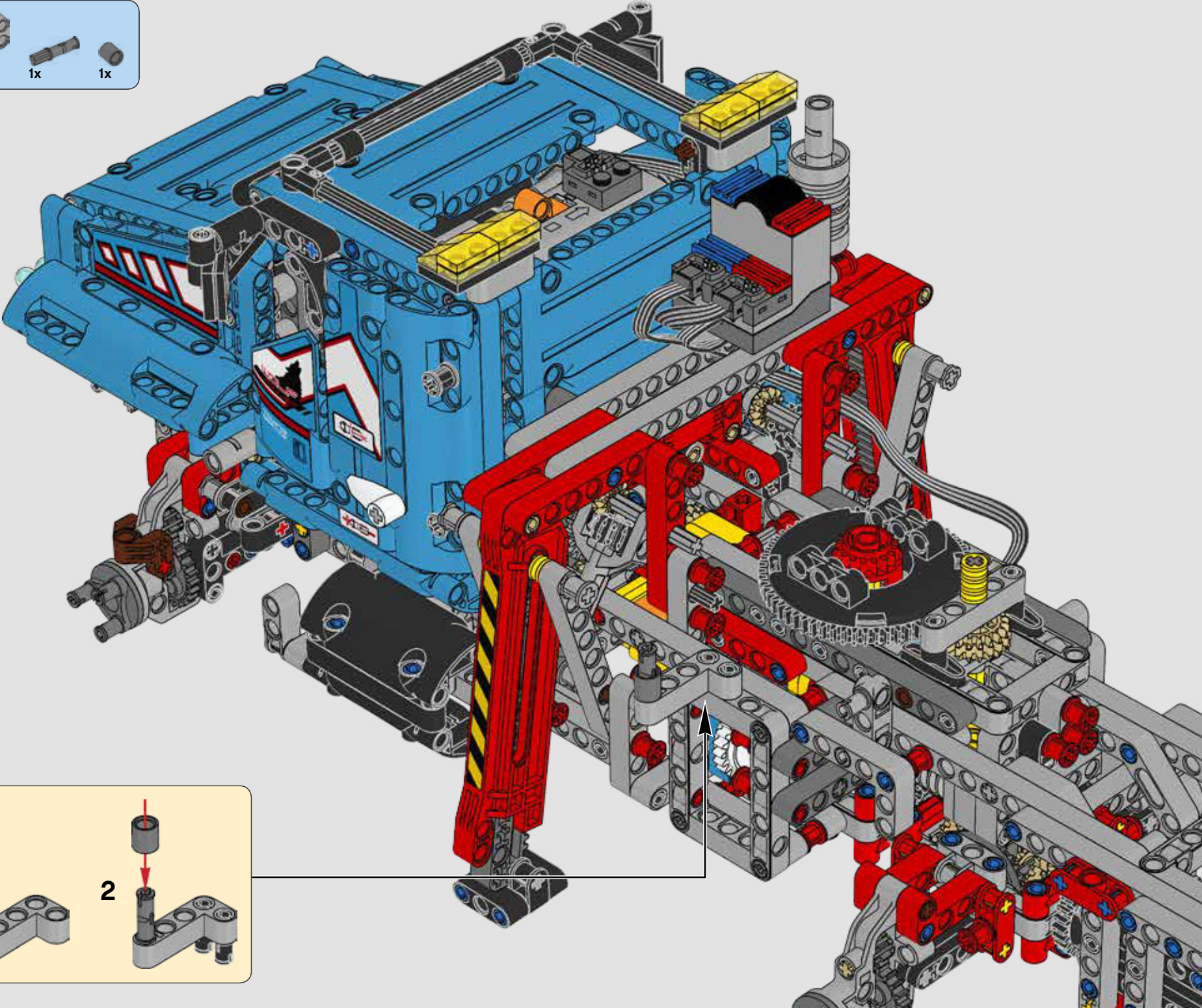



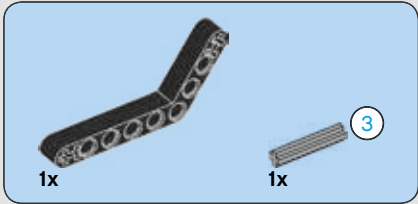
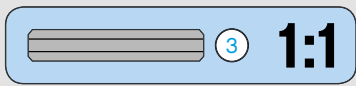

424

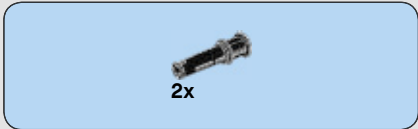
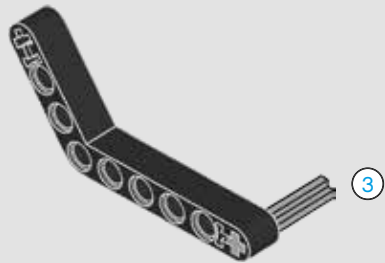

425

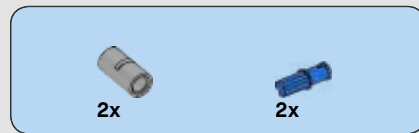
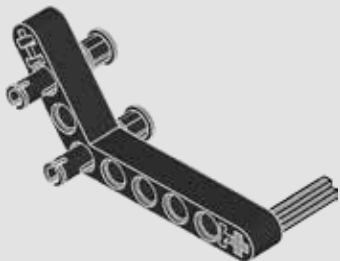

426

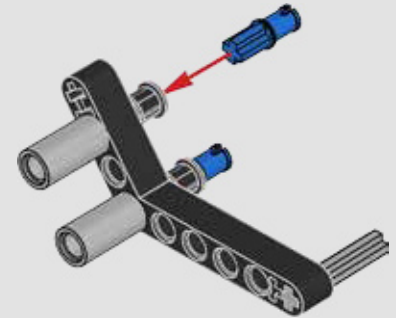

427

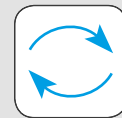
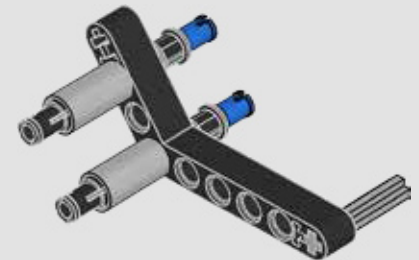

428

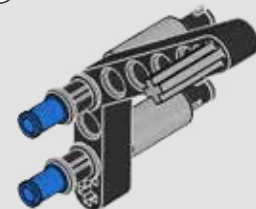

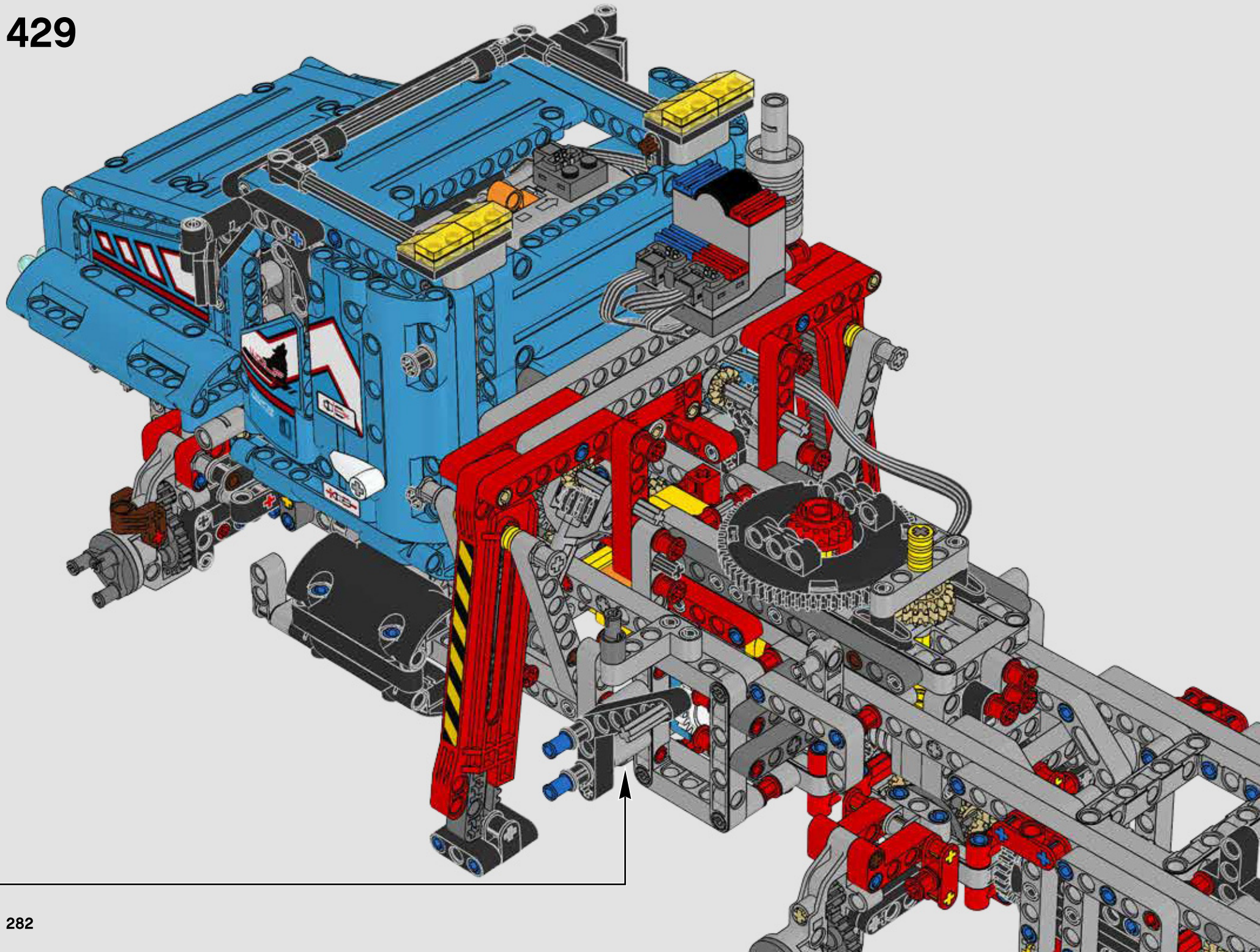



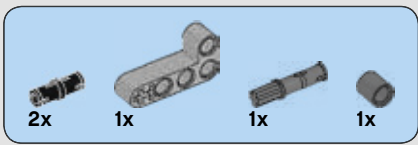

430

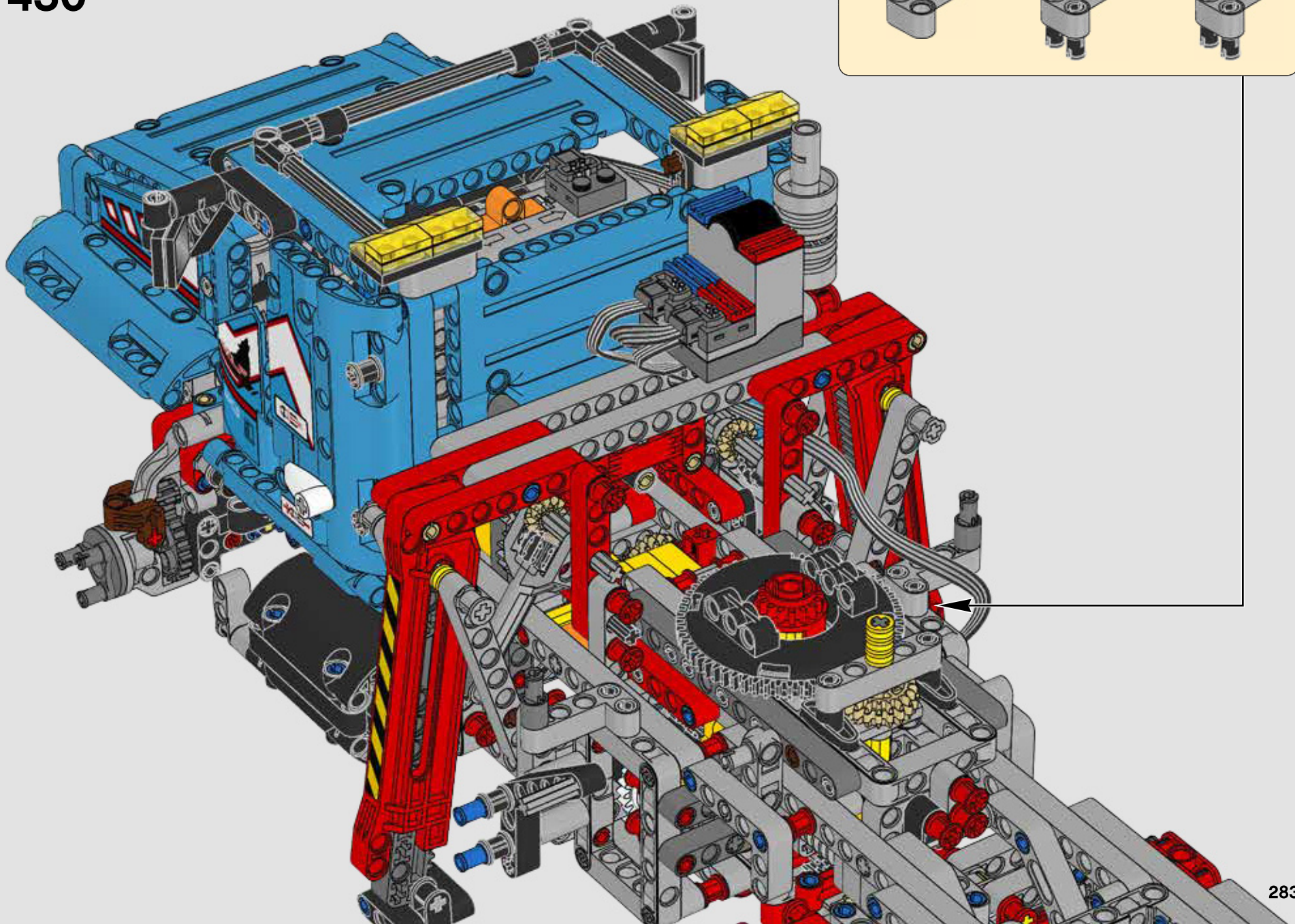
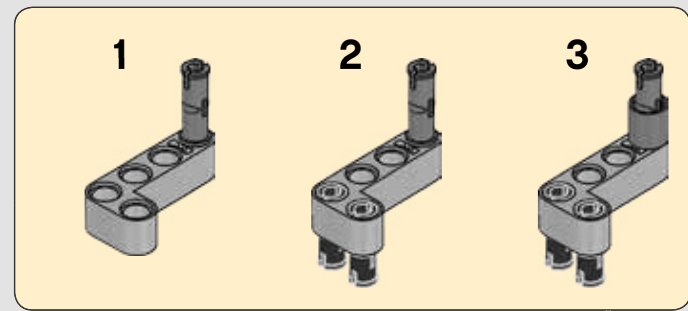

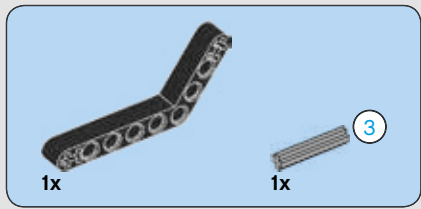

431



432

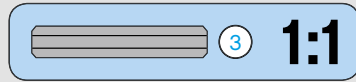

1:1

433

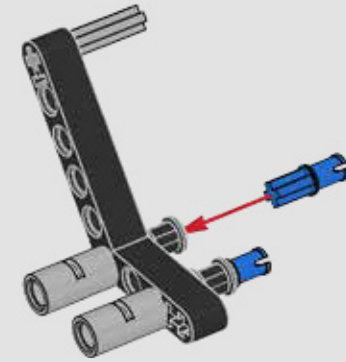

434

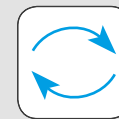
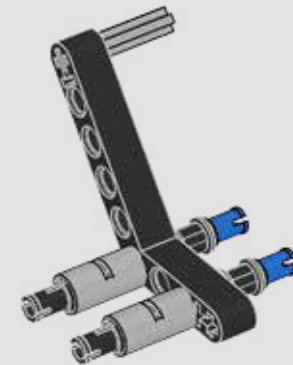

435

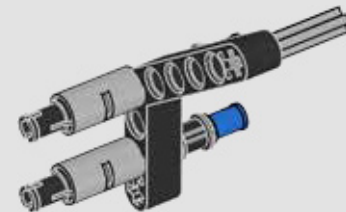



436

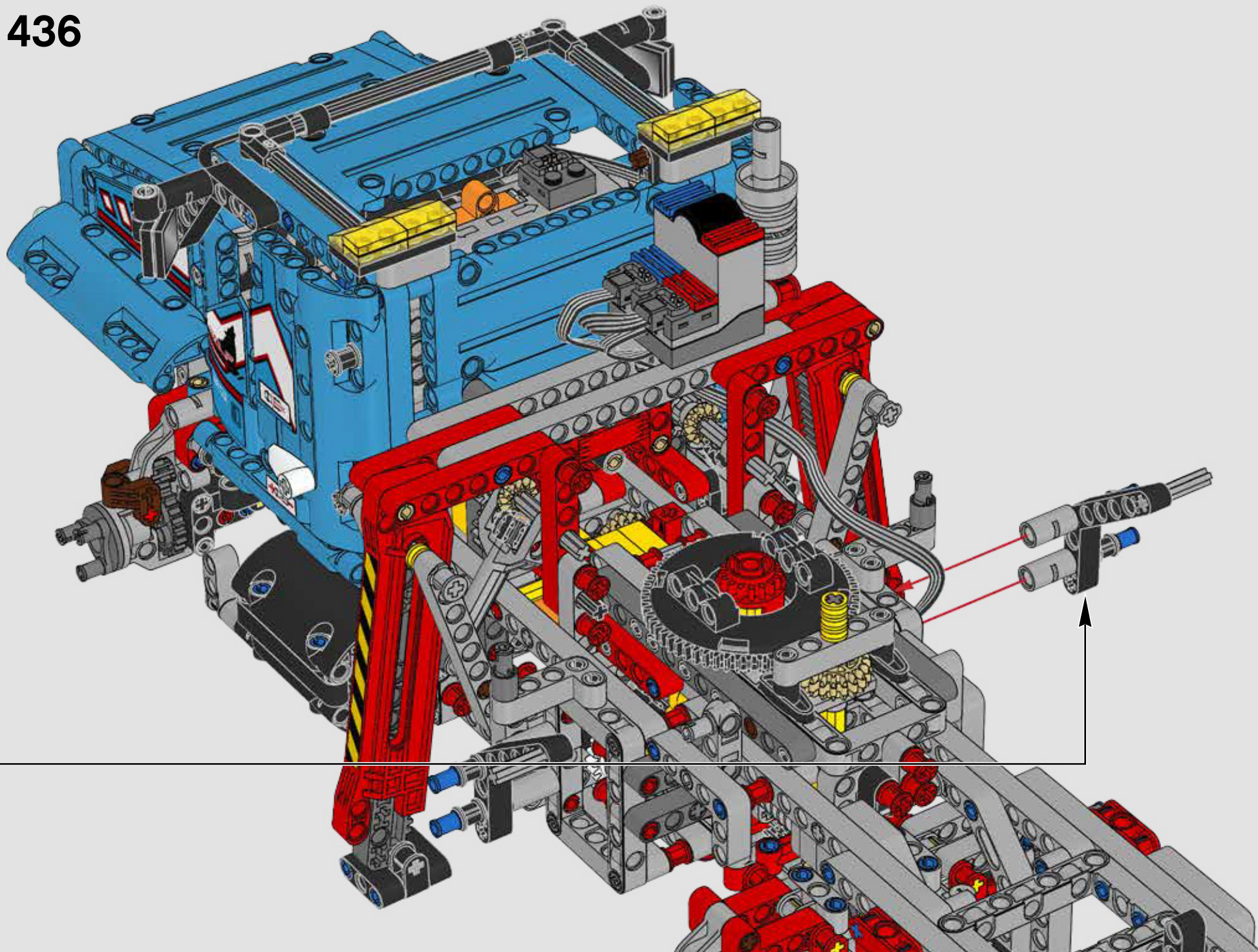

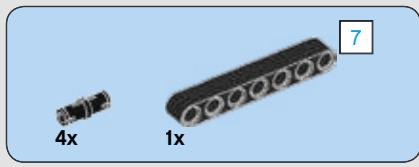

437

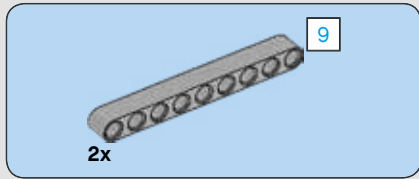

438

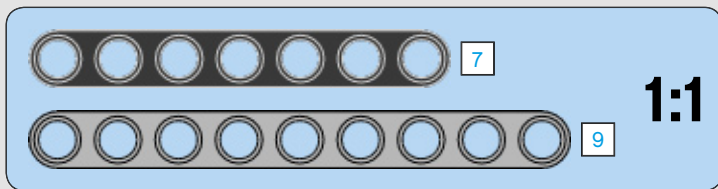
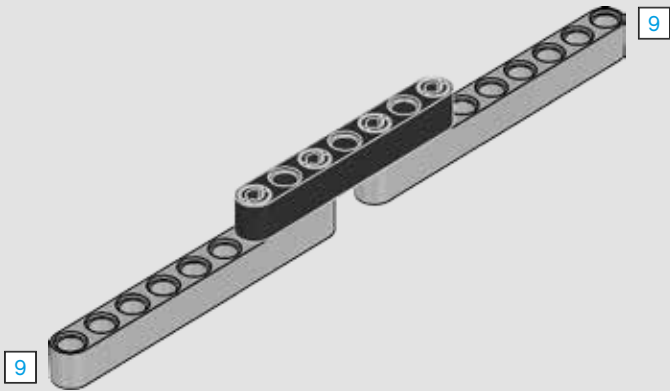

439

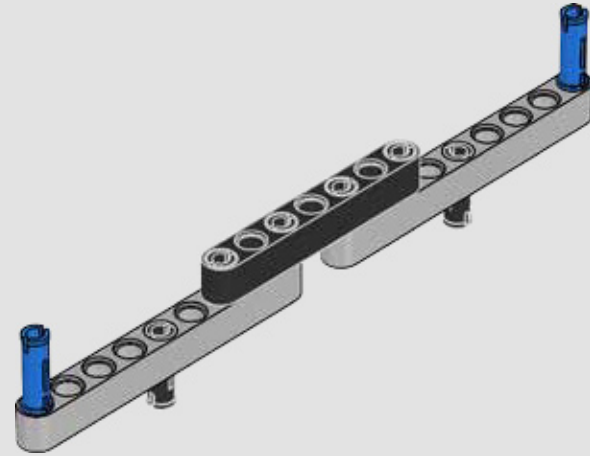

440

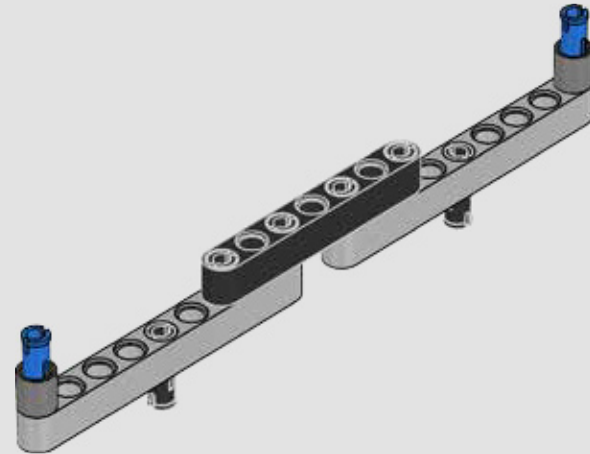



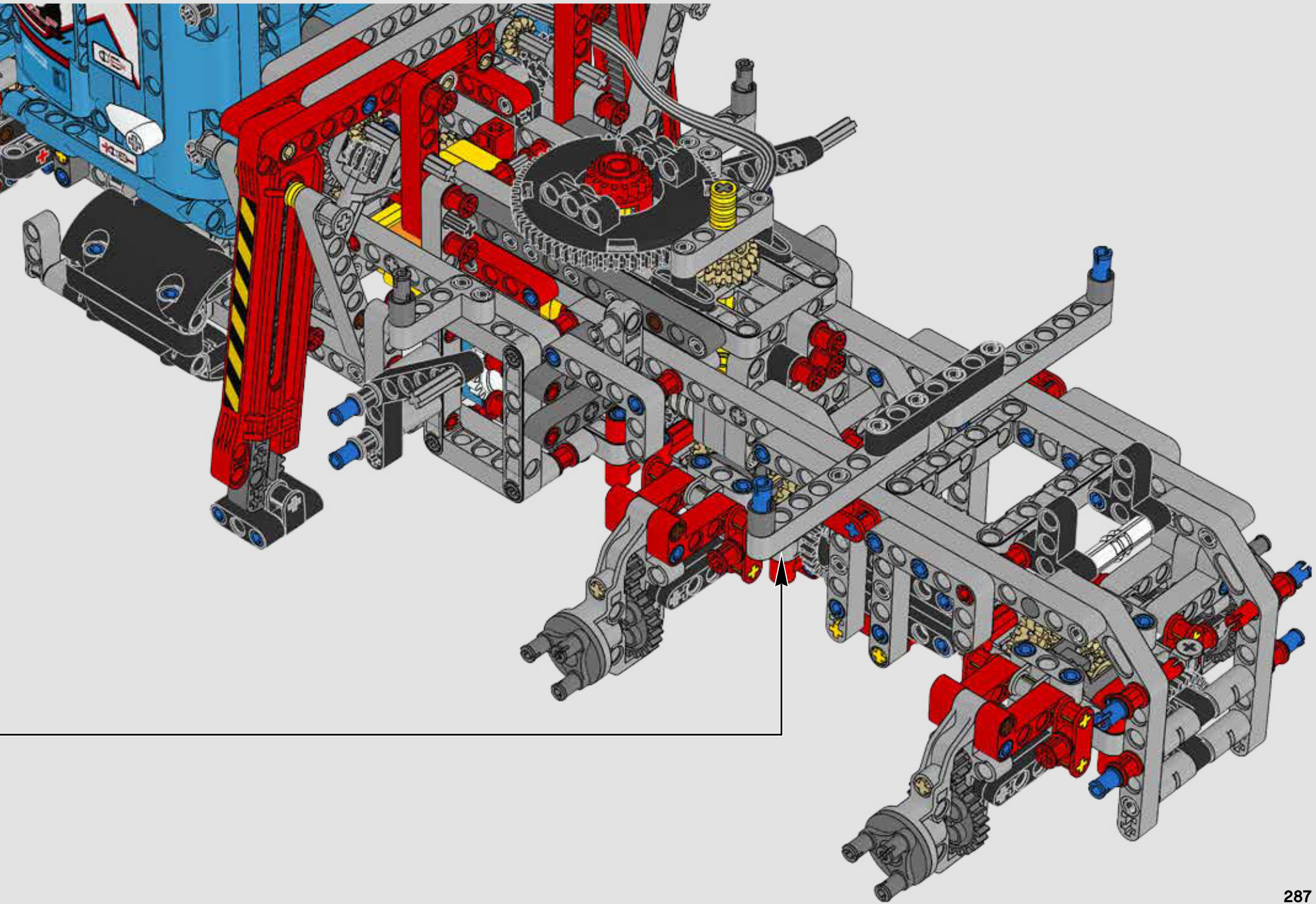



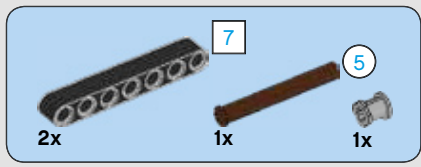

442

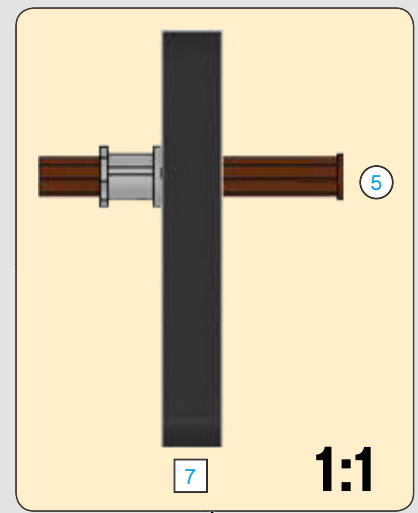
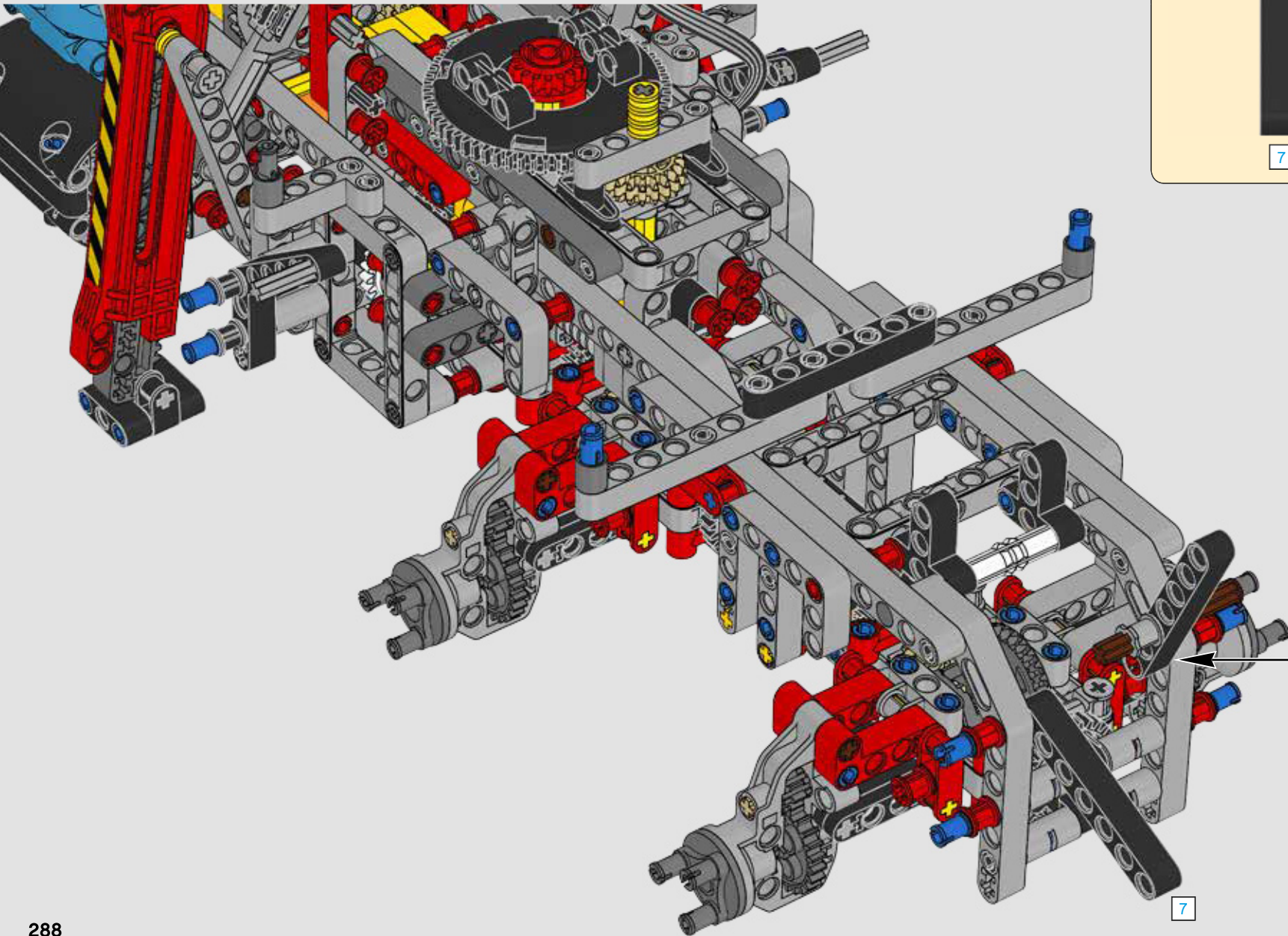



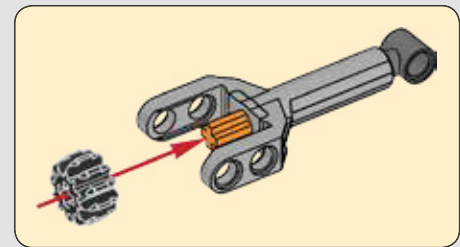
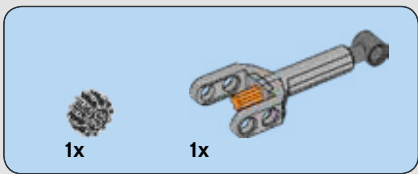

443

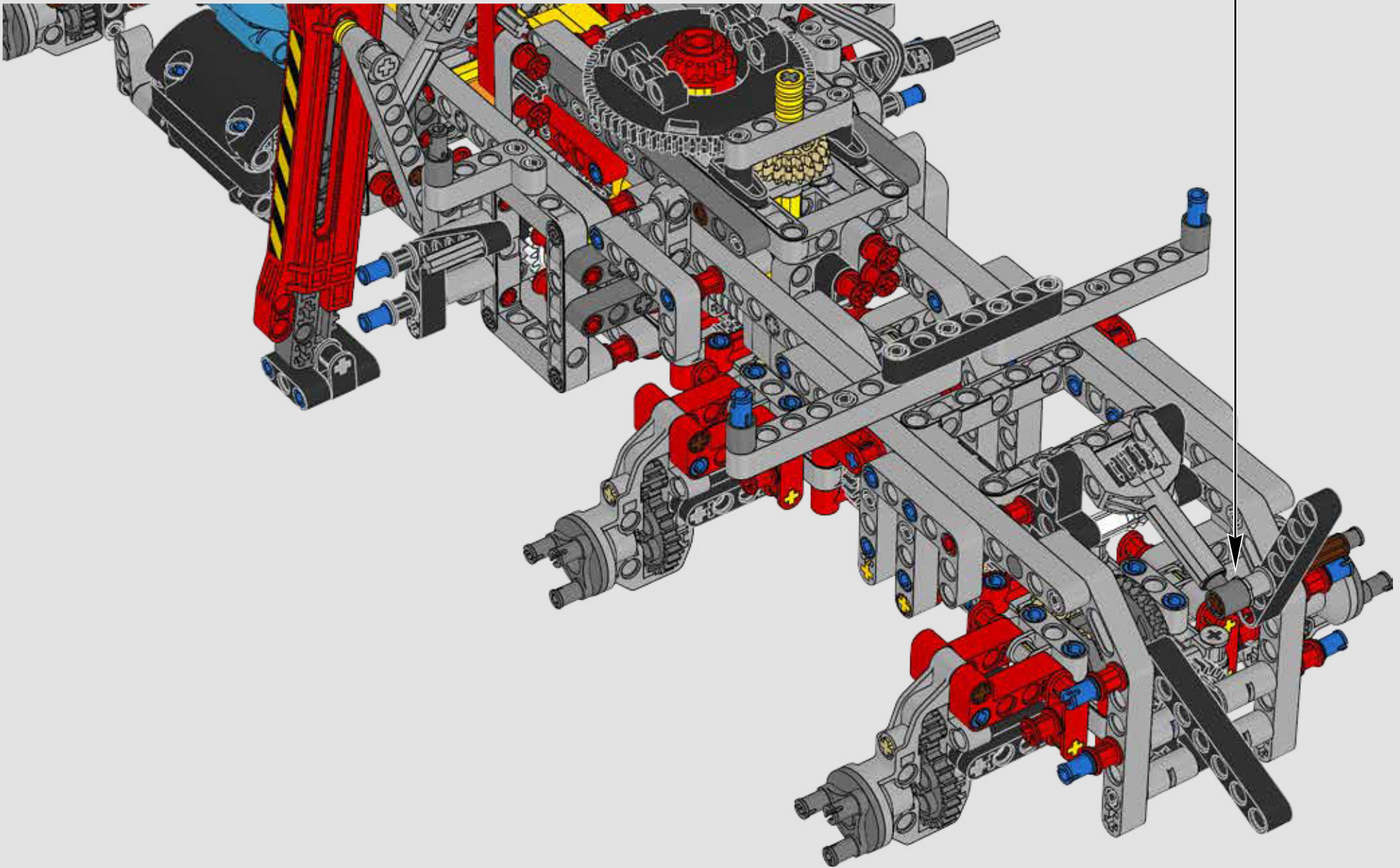

1x

444

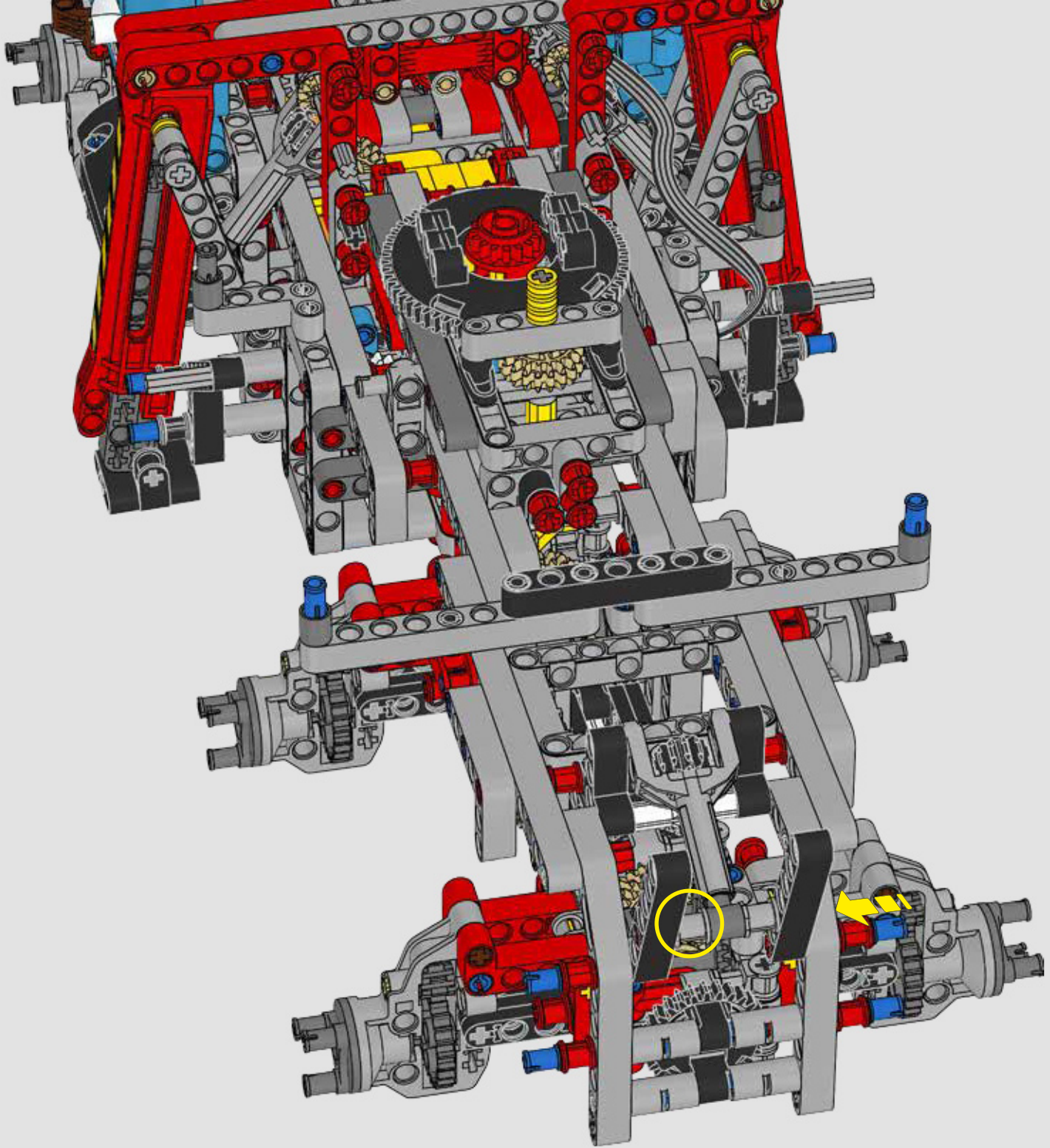



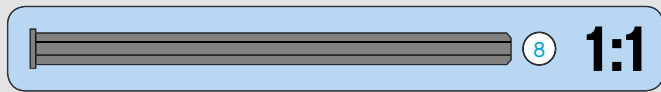
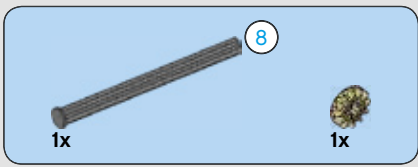

445

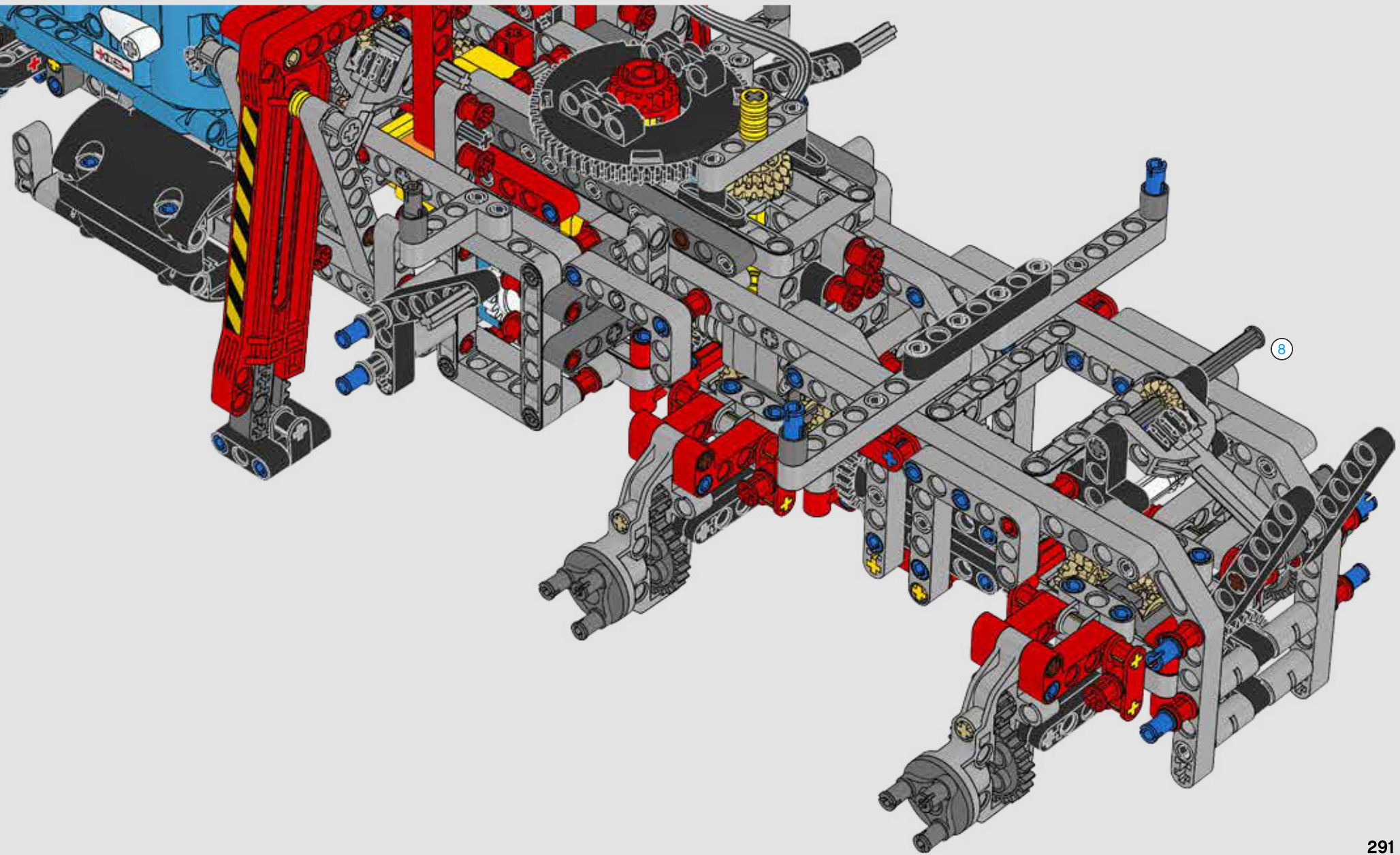



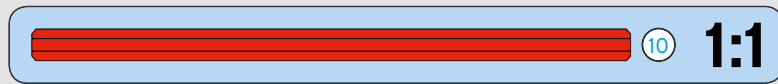
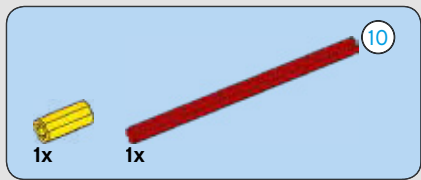

446

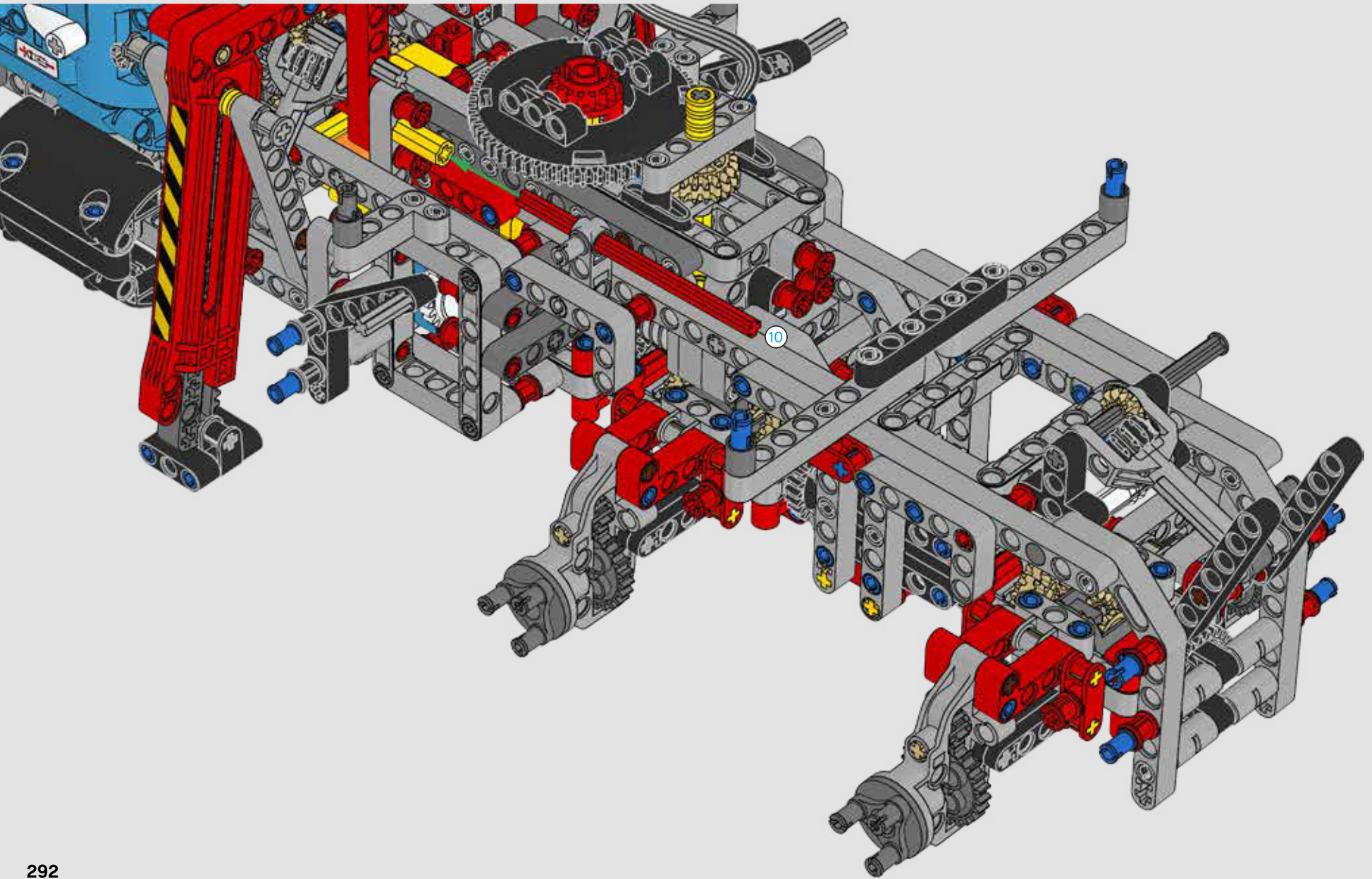



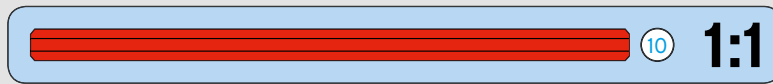
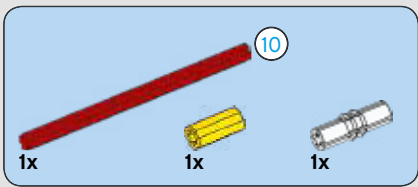

447

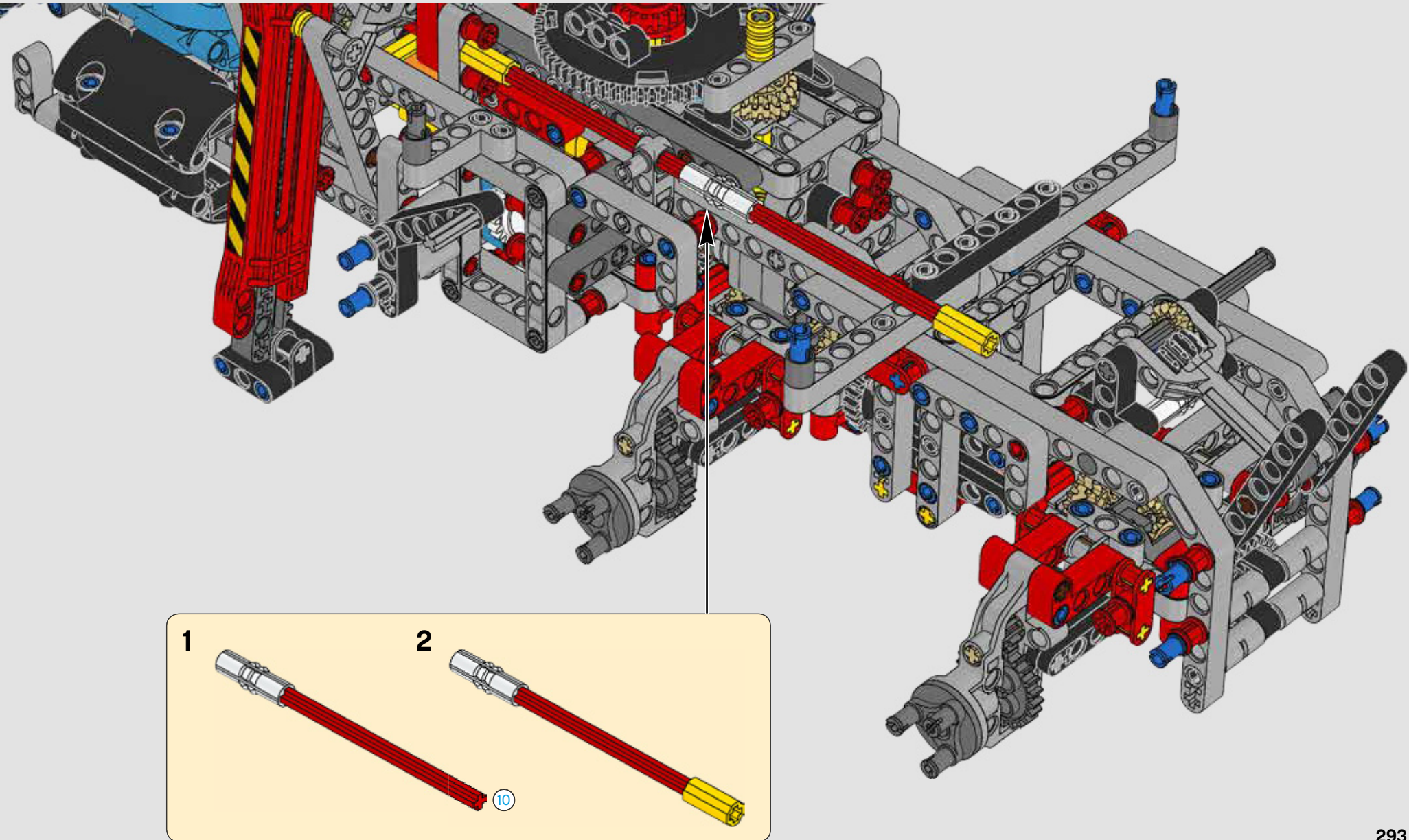

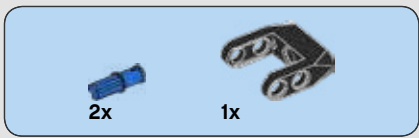

448

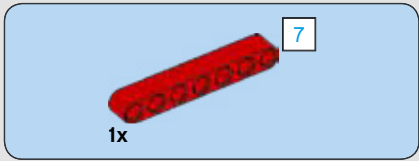
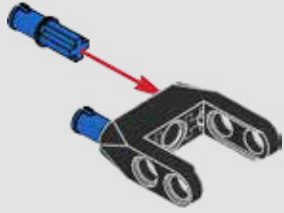

449

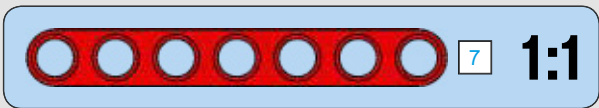
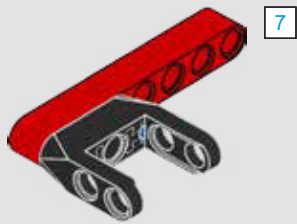

450

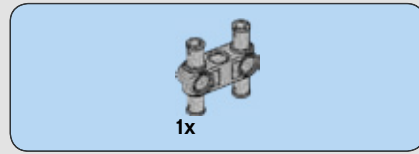
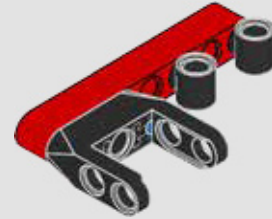

451

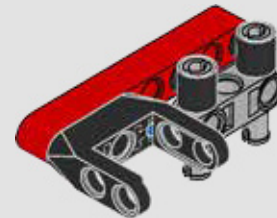



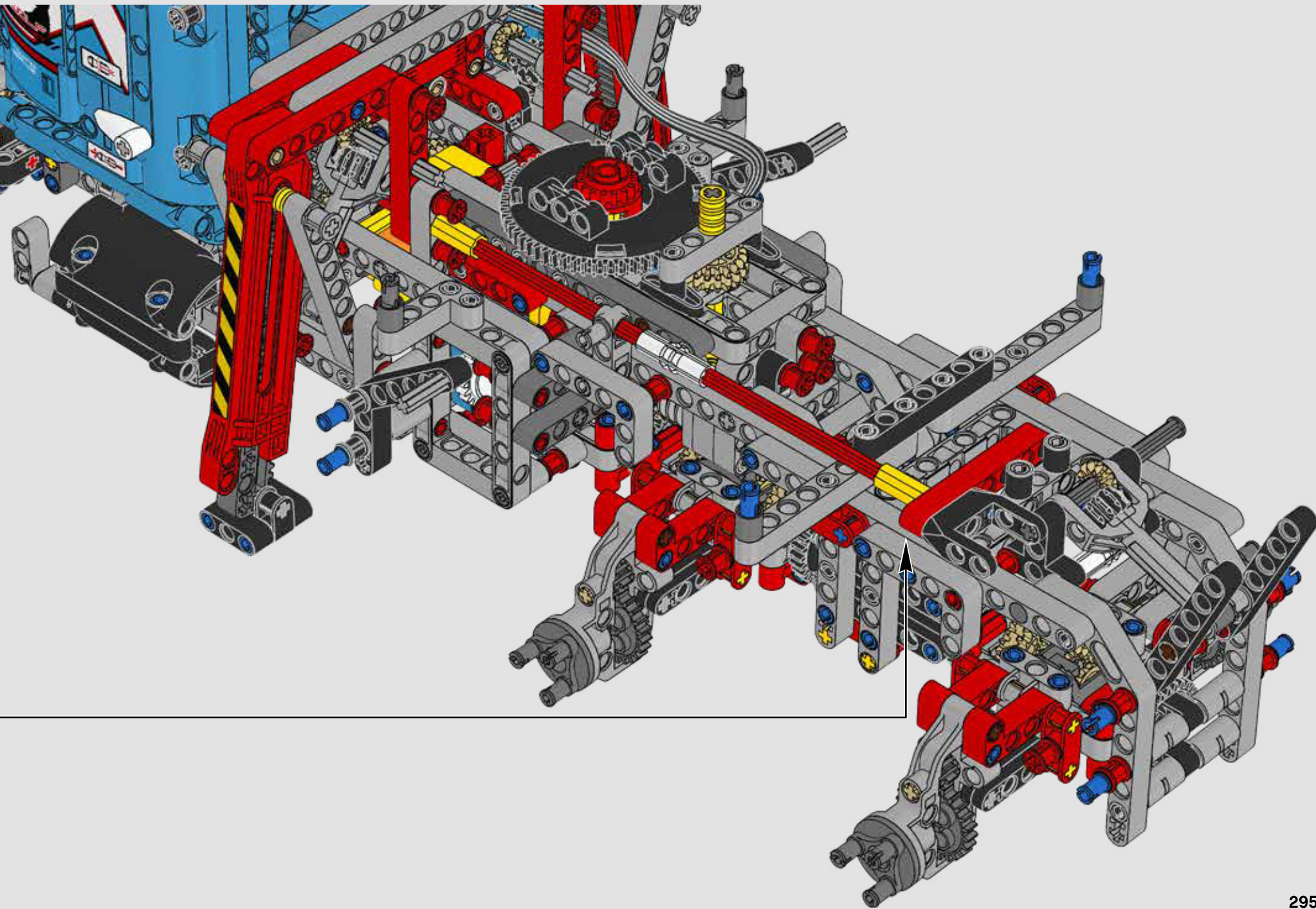



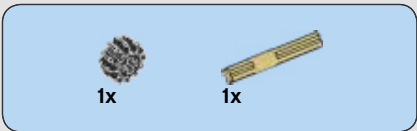

453

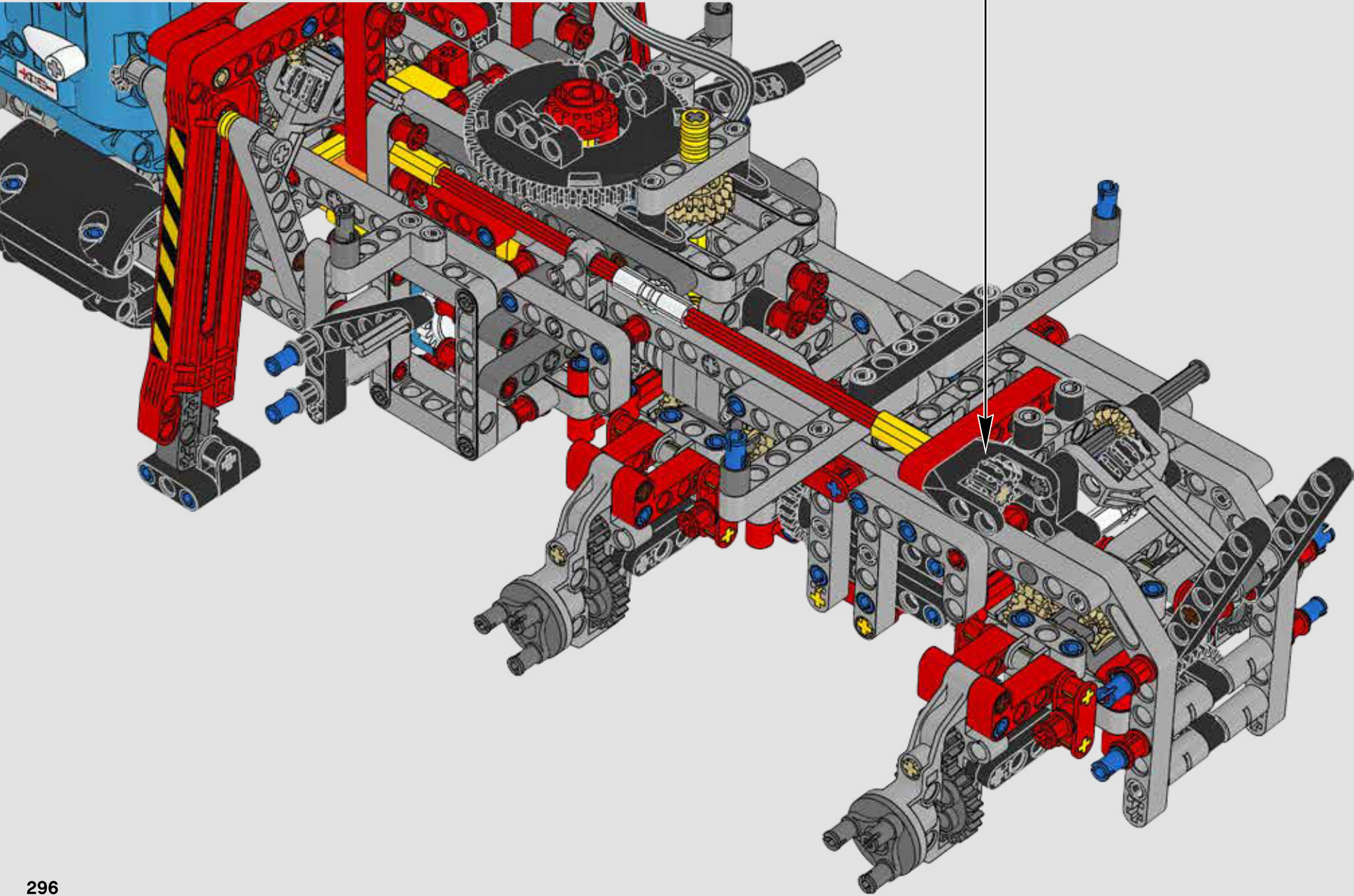



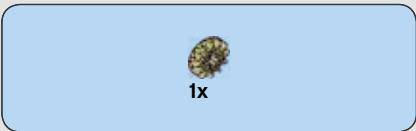

454

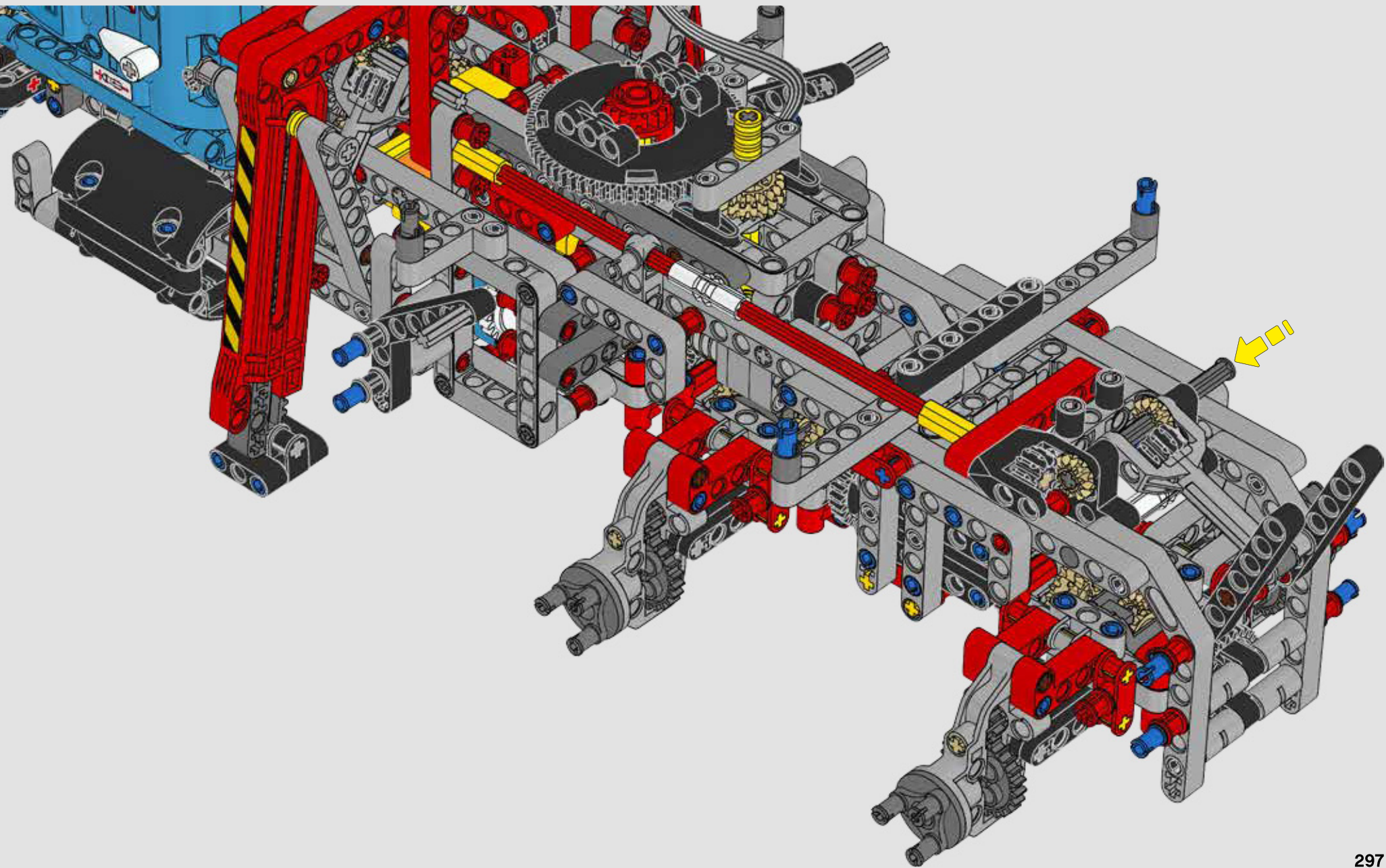

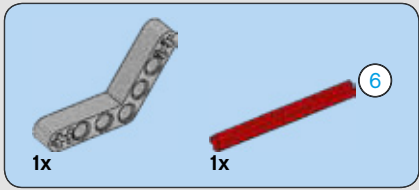
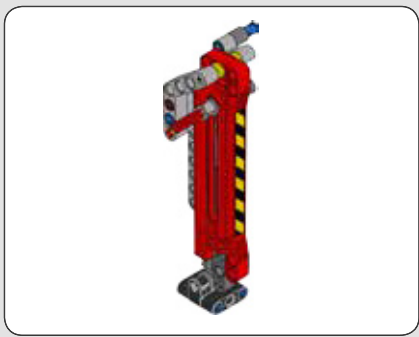

455

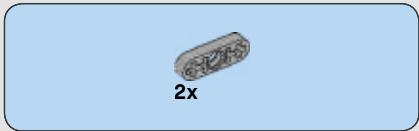
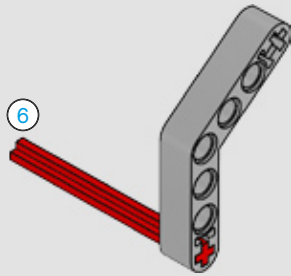

456

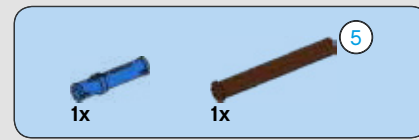
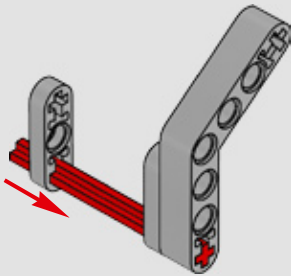

457

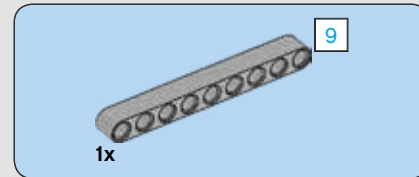
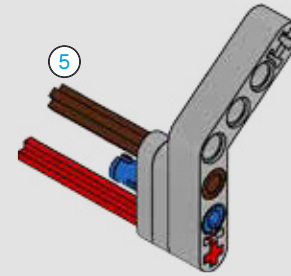

458

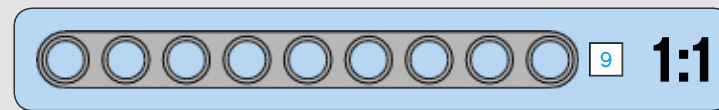
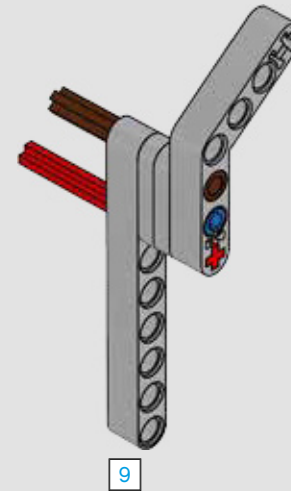



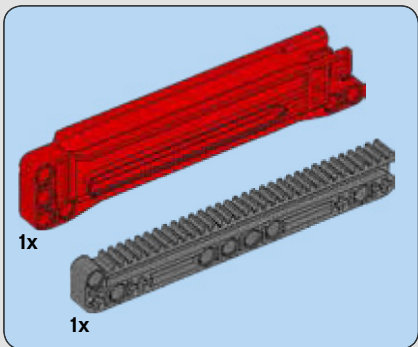

459

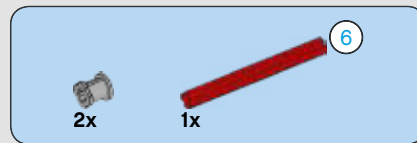
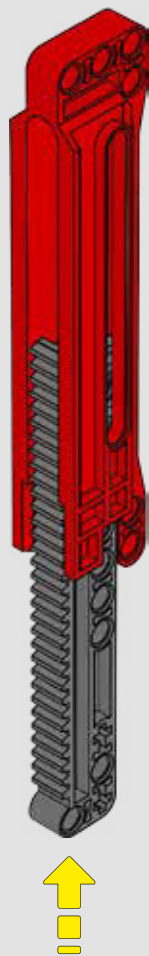

460

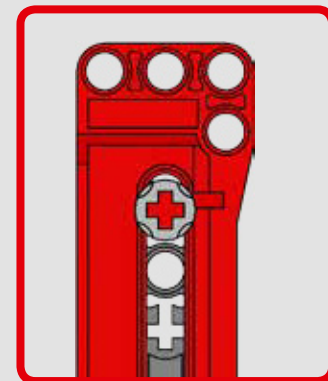
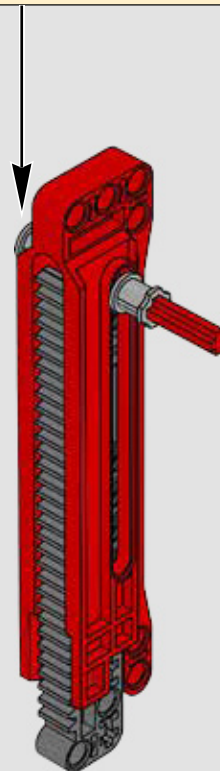
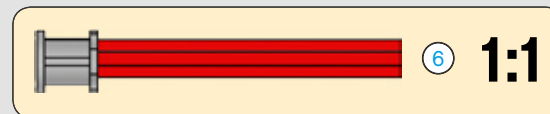

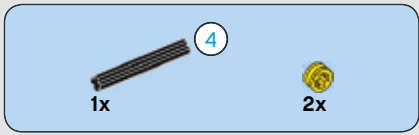

461

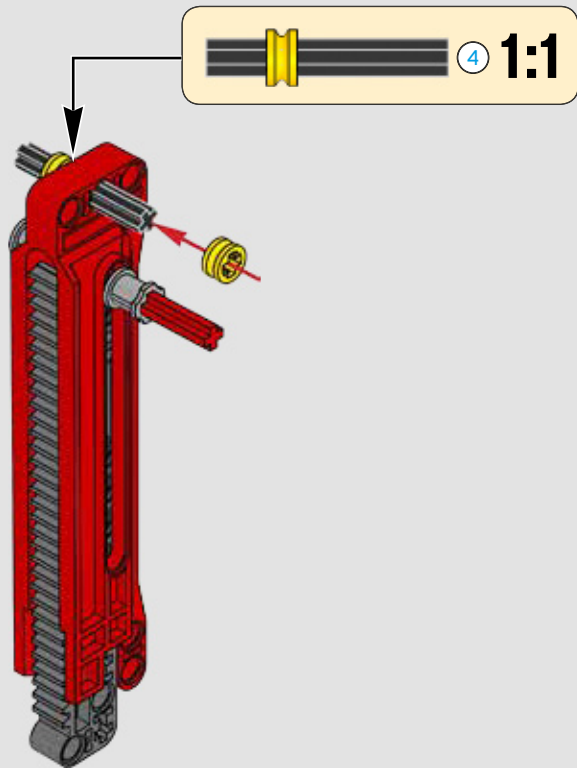

462

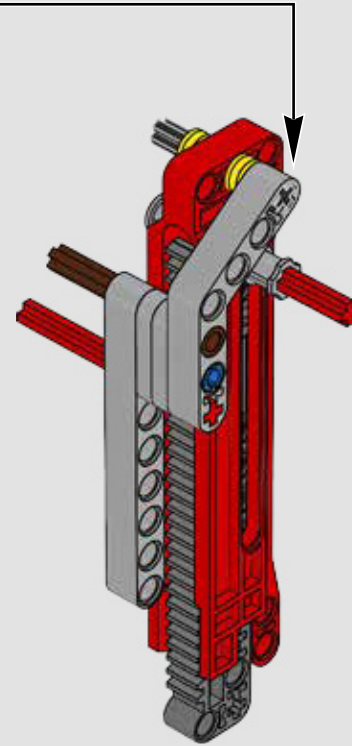



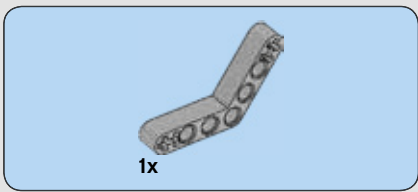

463

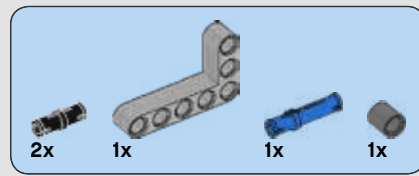
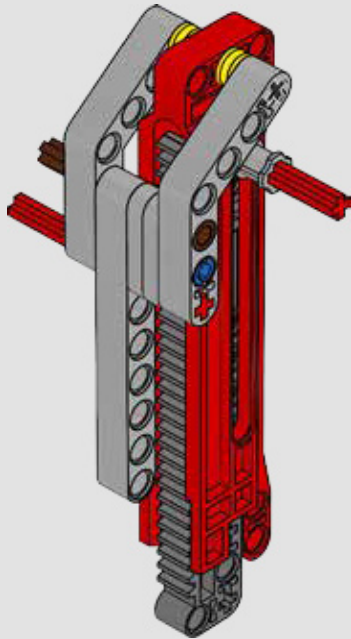

464

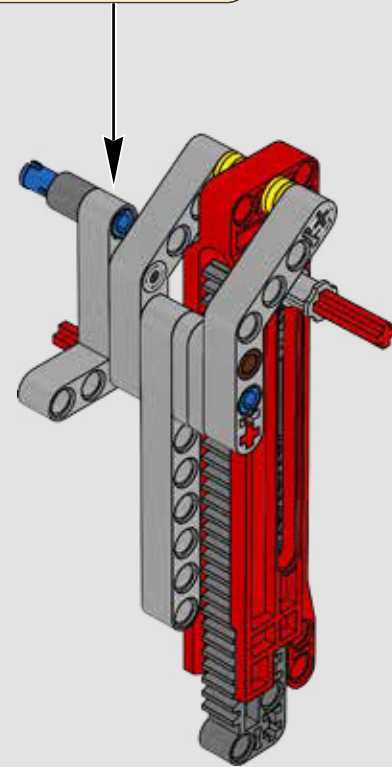
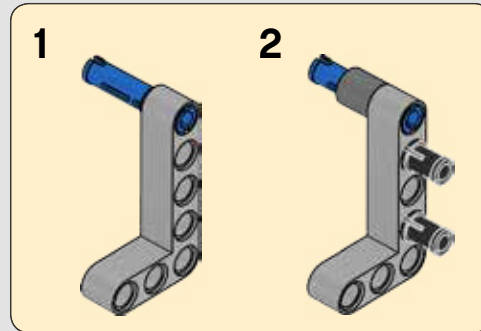

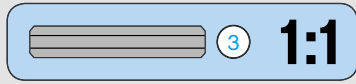
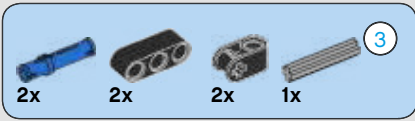

465

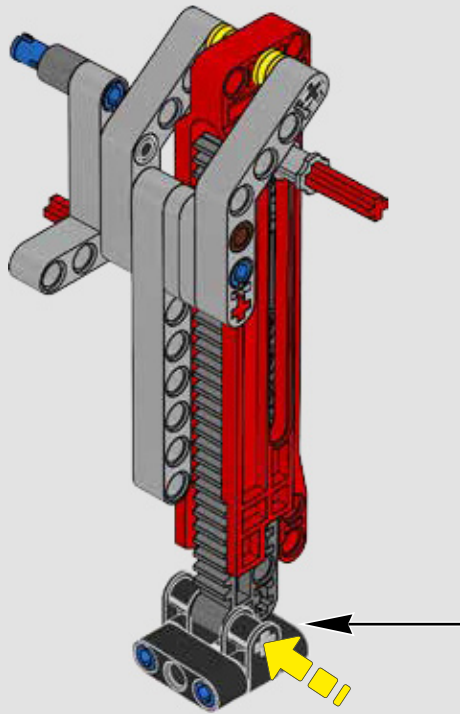
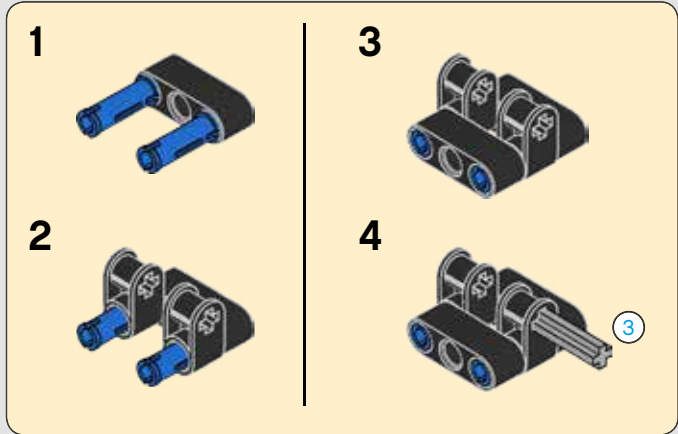

466

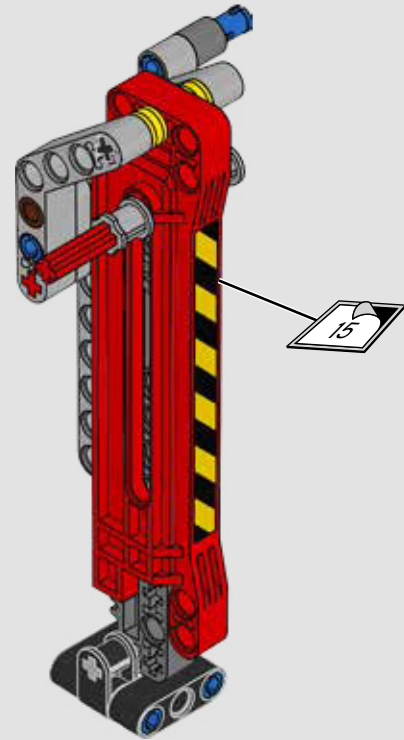
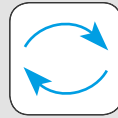



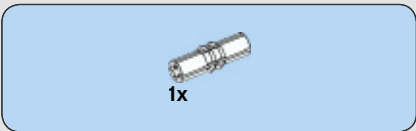

467

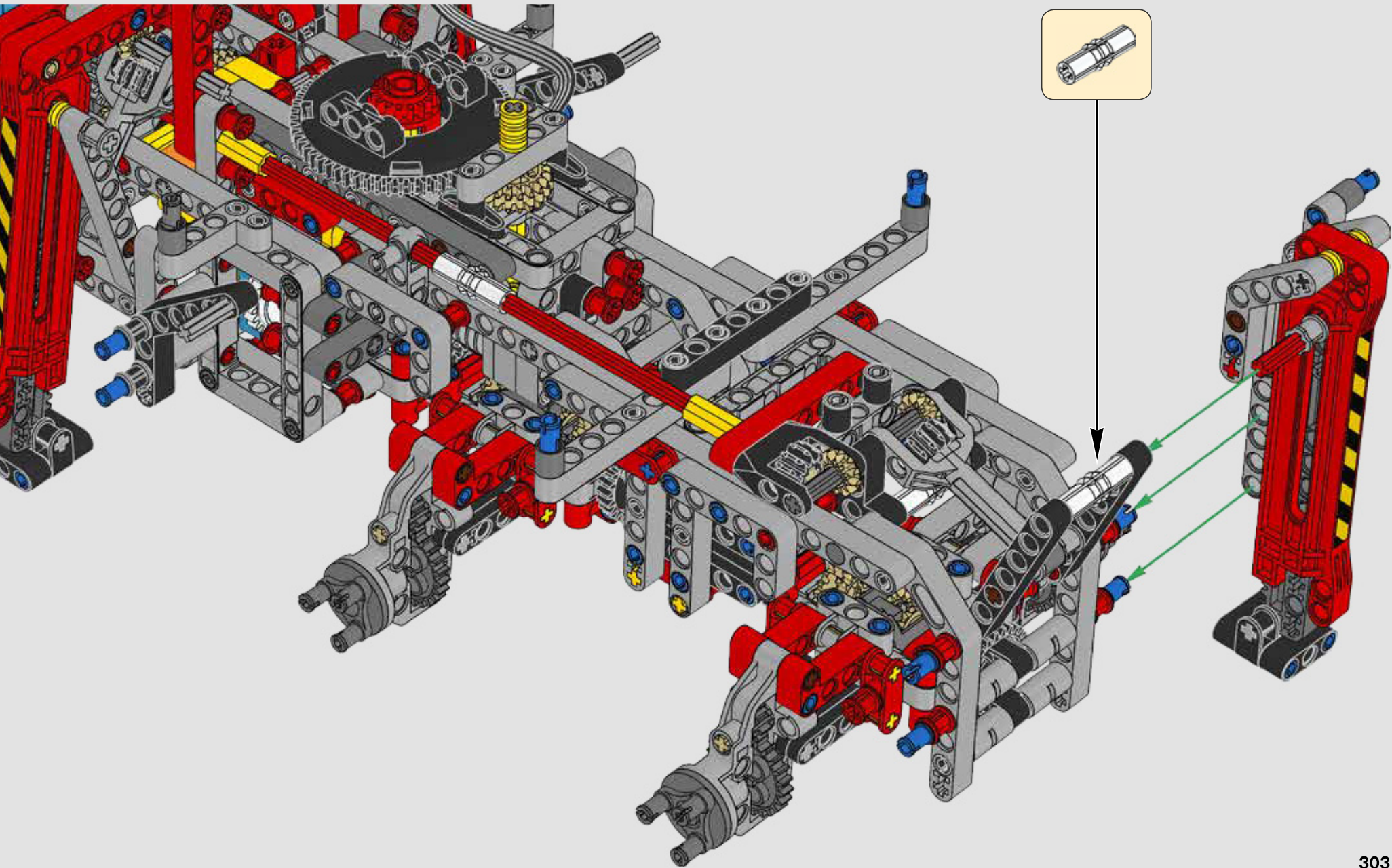

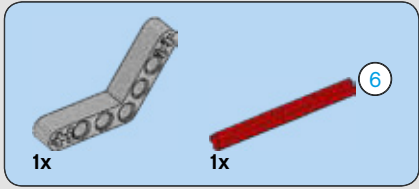
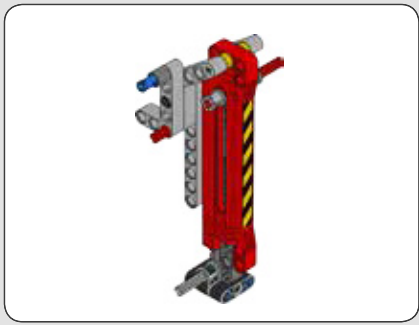

468

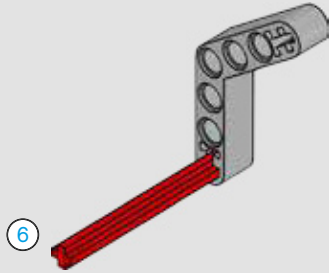

469

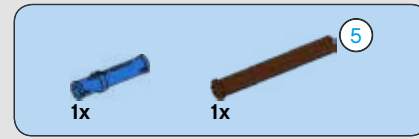
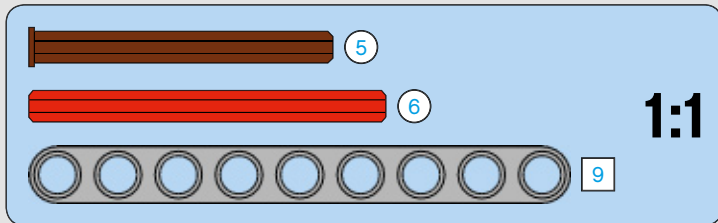
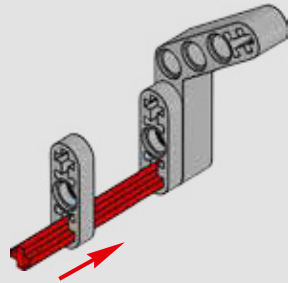

470

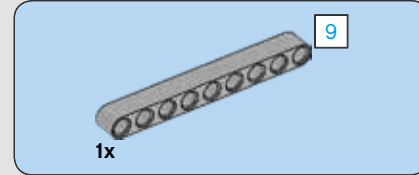
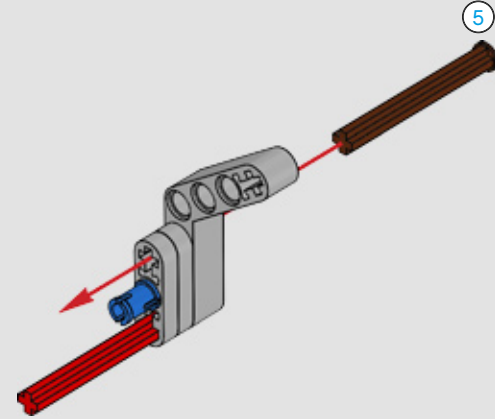

471

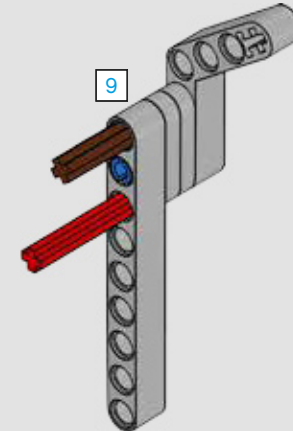



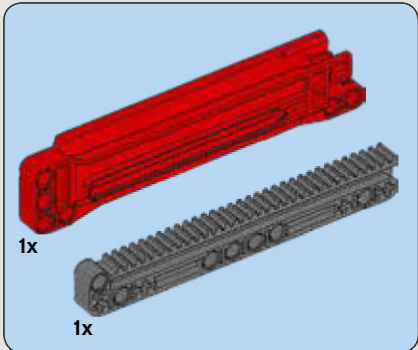
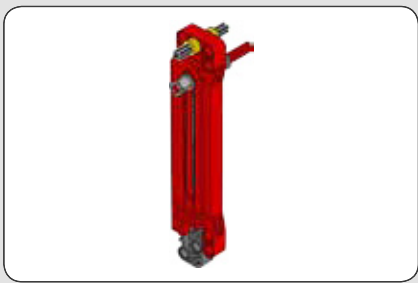

472

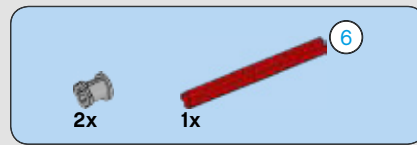

473

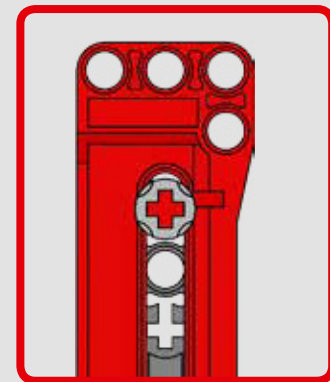
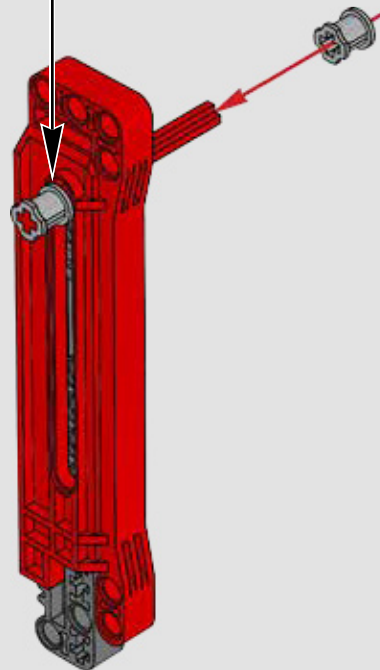
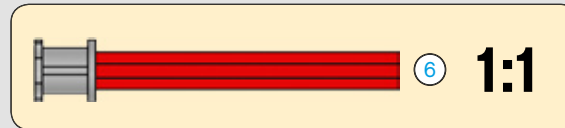

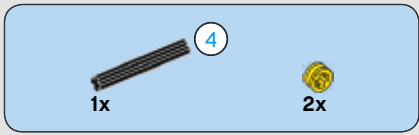

474

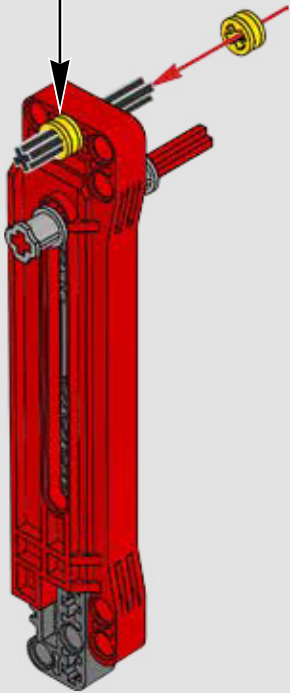
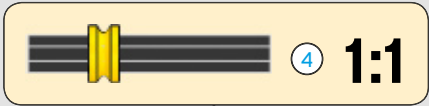

475

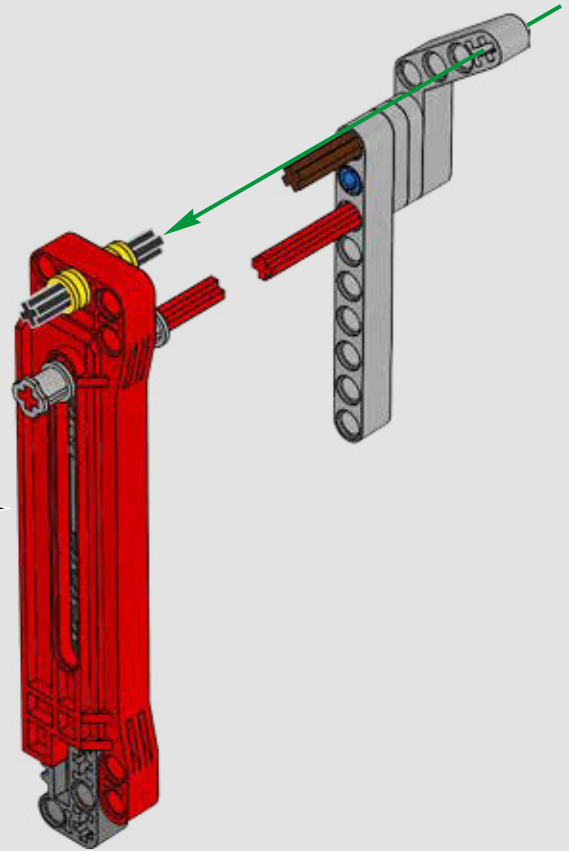



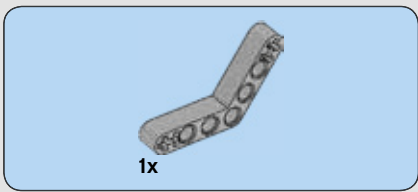

476

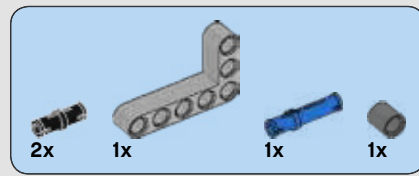
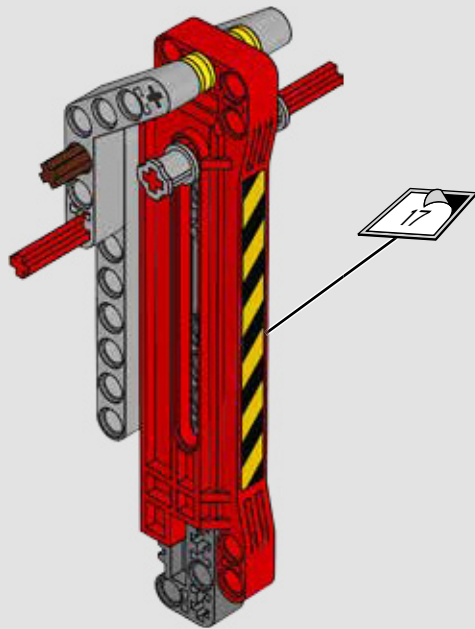

477

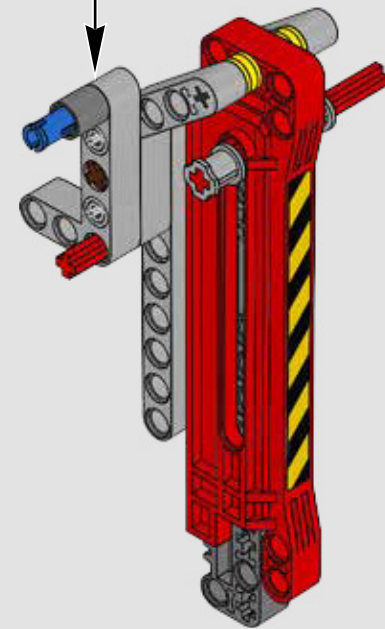
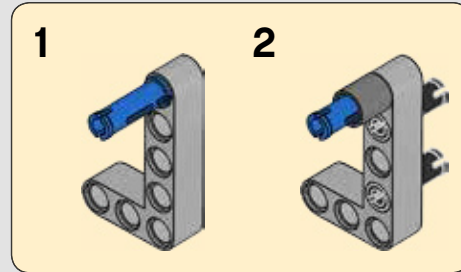

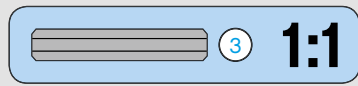
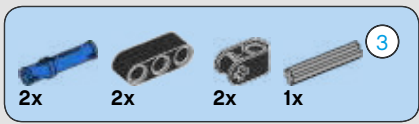

478

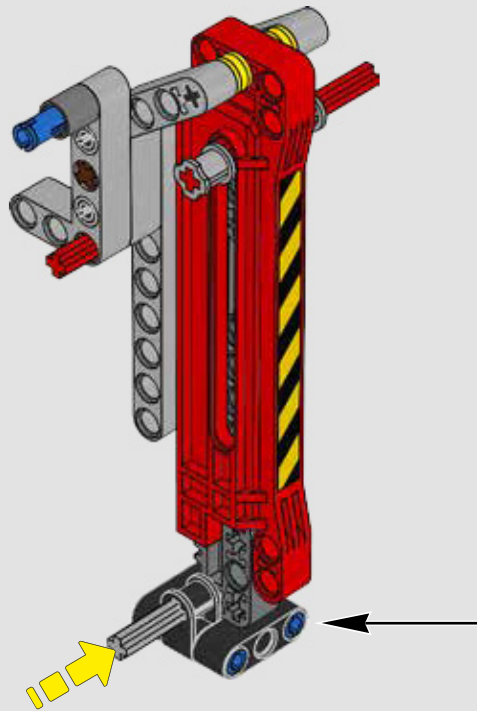



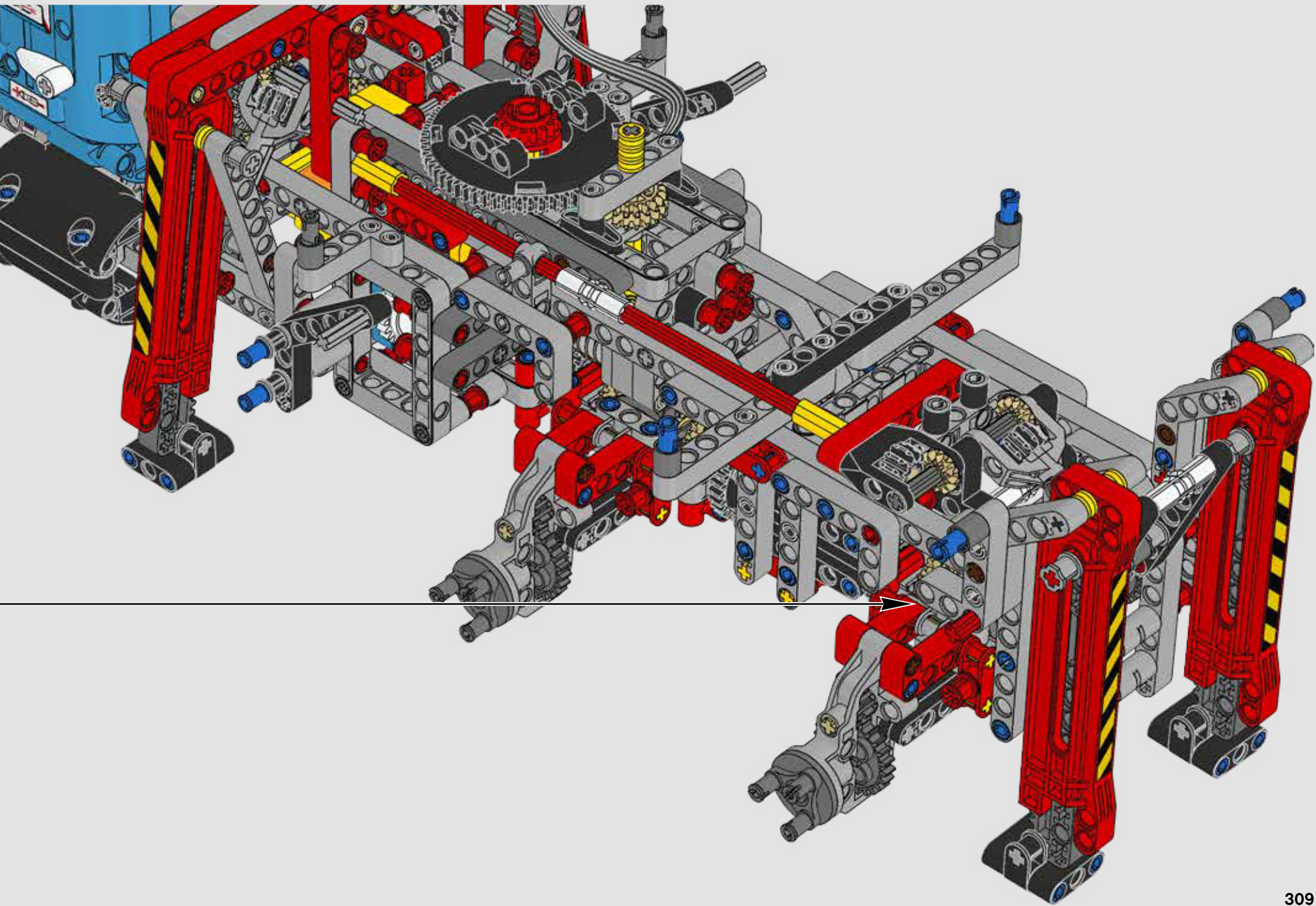

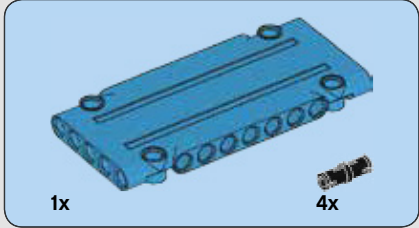
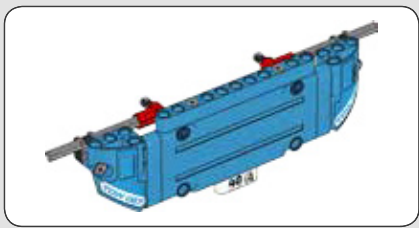

480

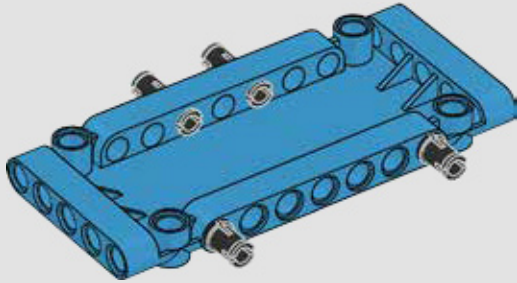

481

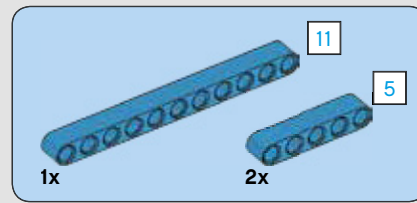
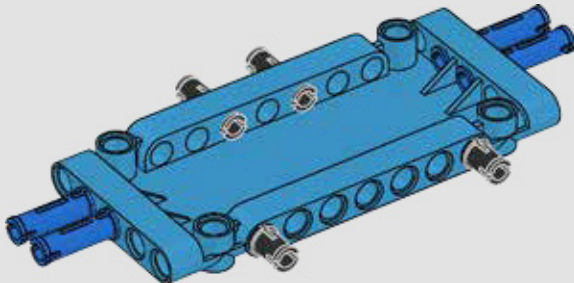

482

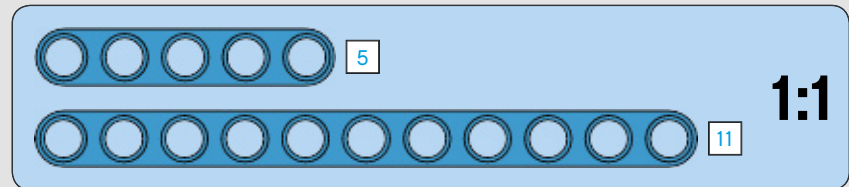
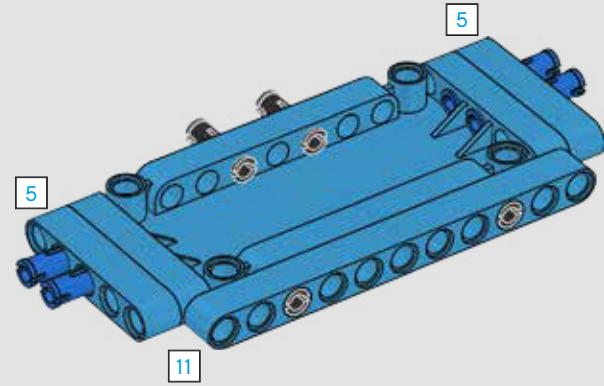



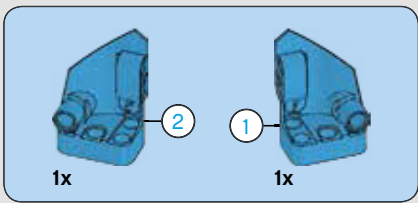

483

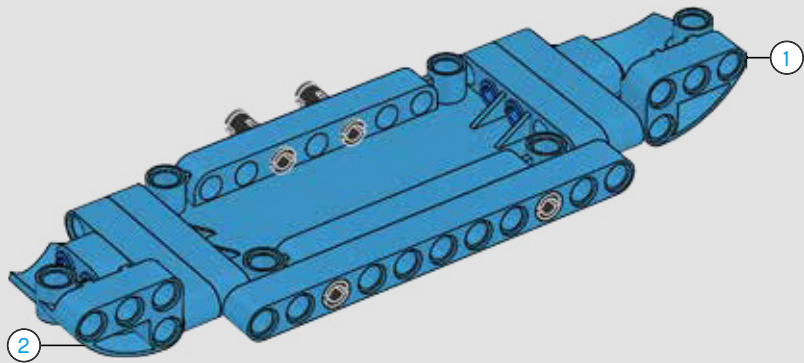

484

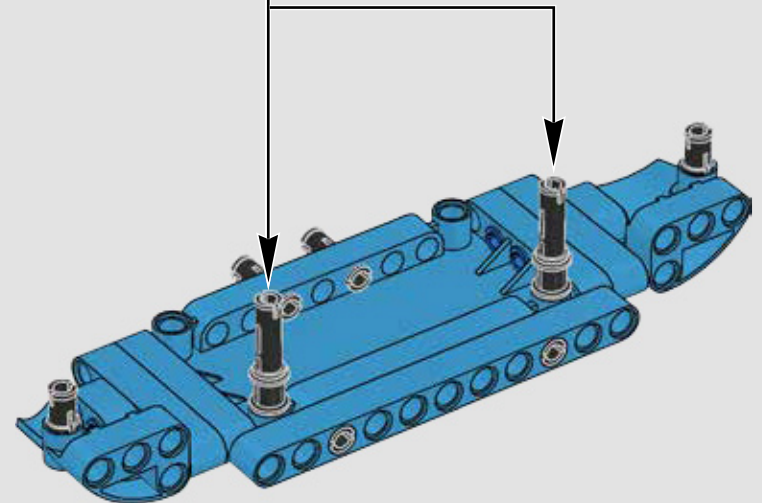
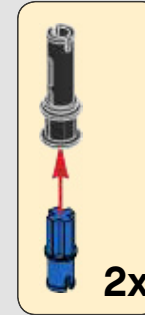

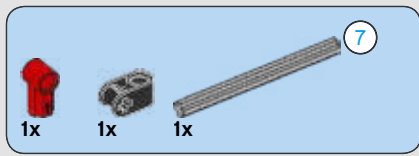

485

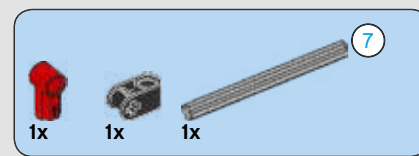
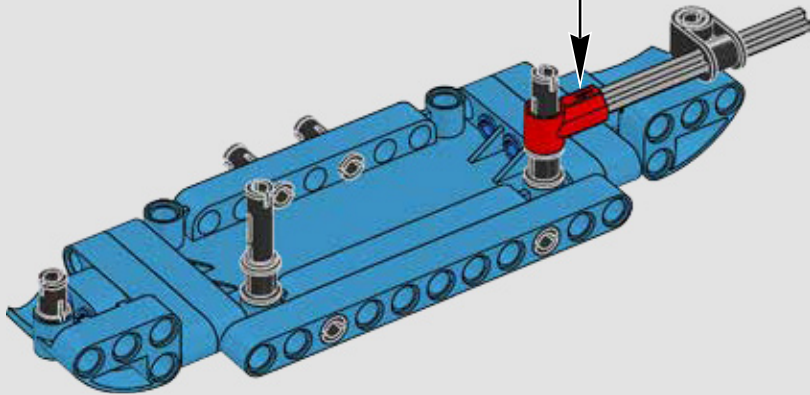
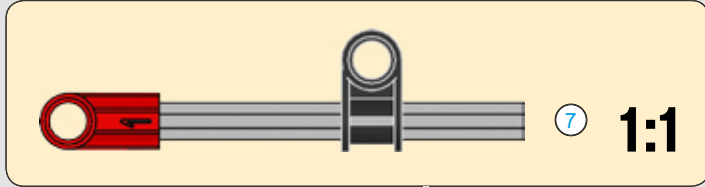

486

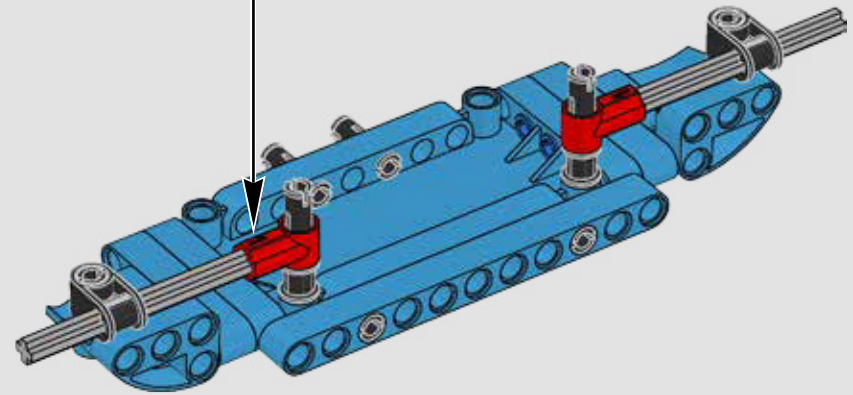
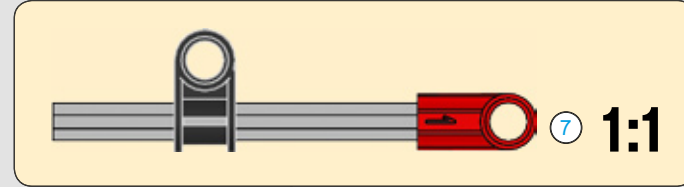



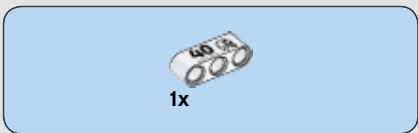

487

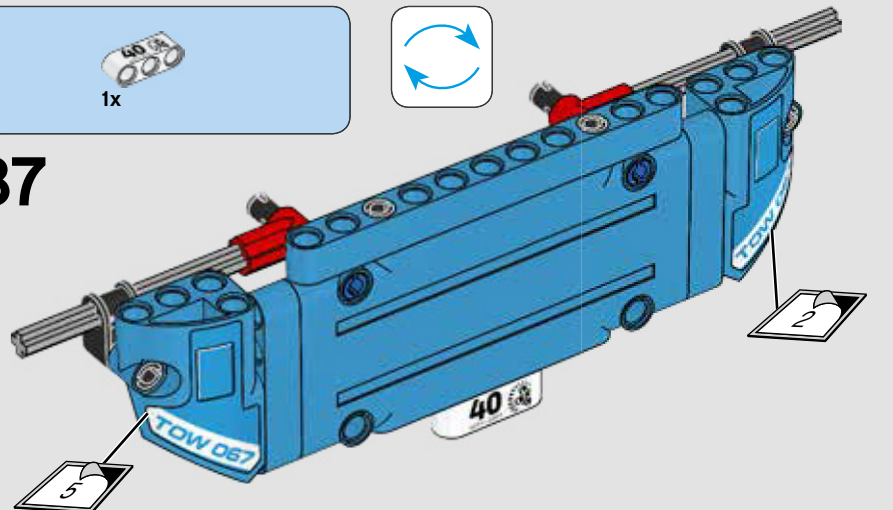

488

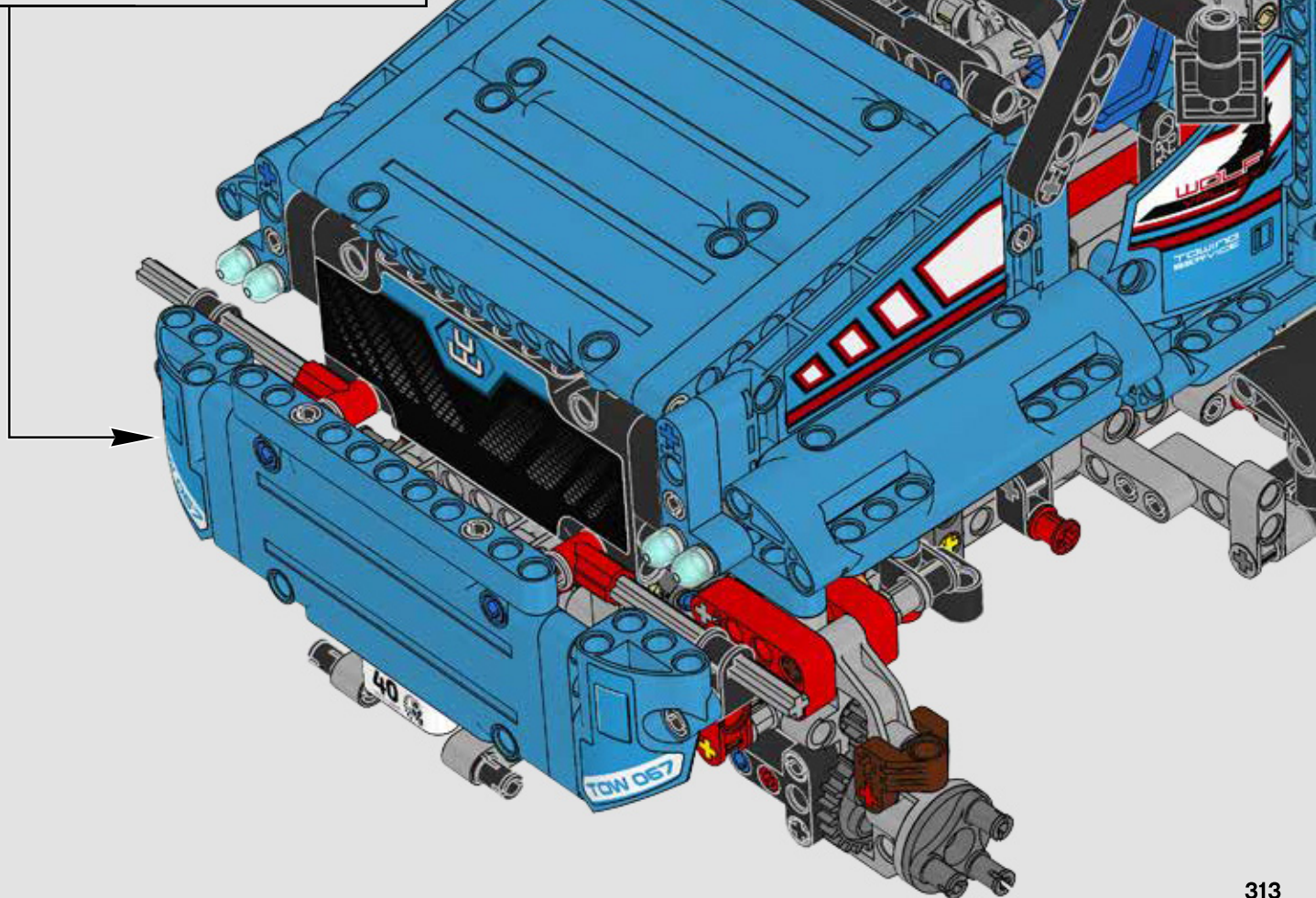
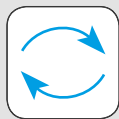



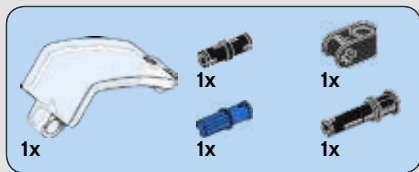

489

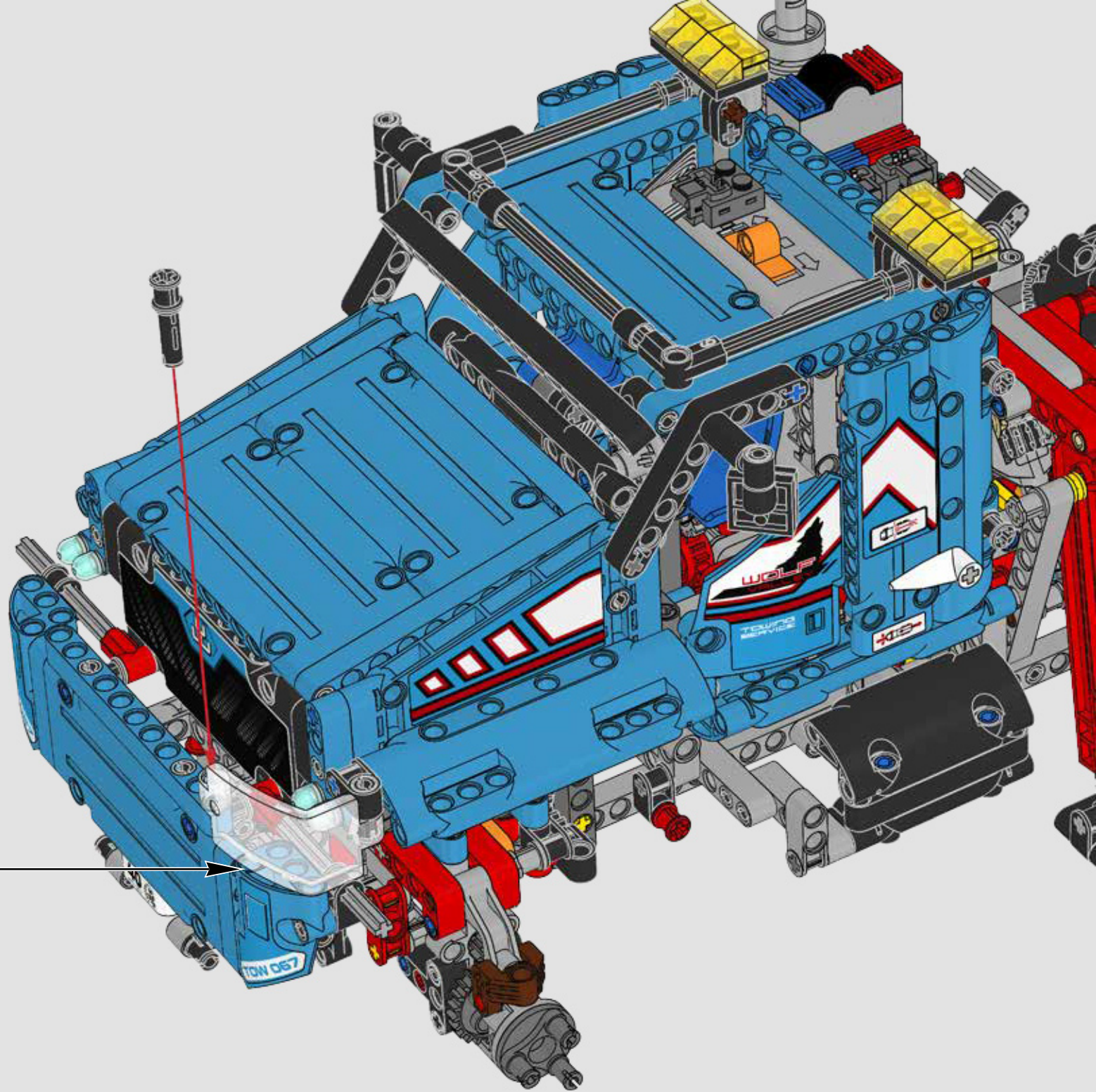
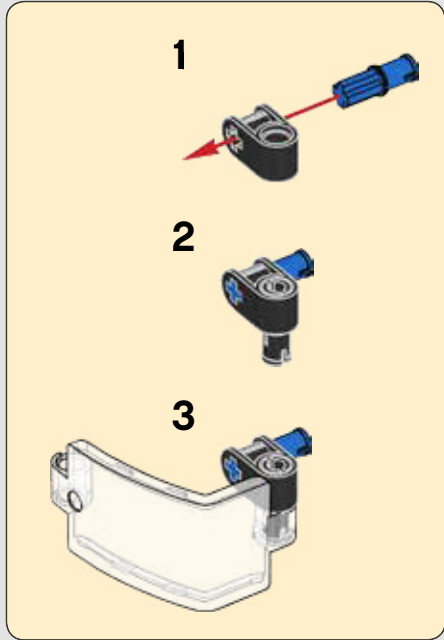



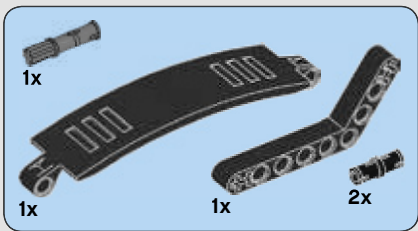

490

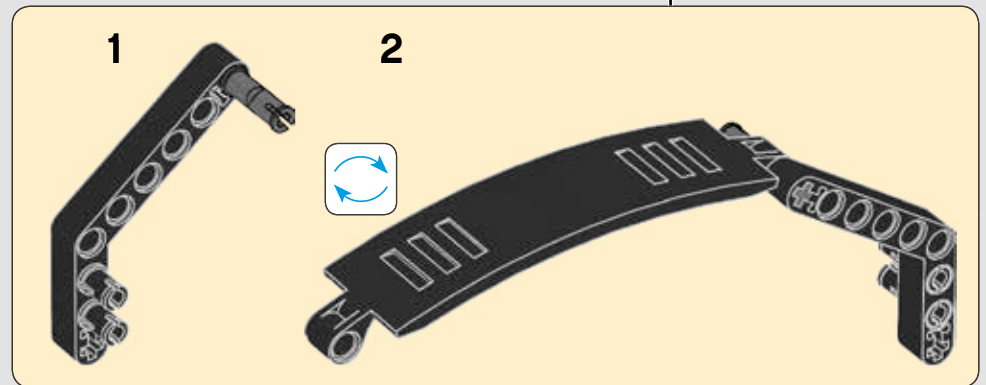
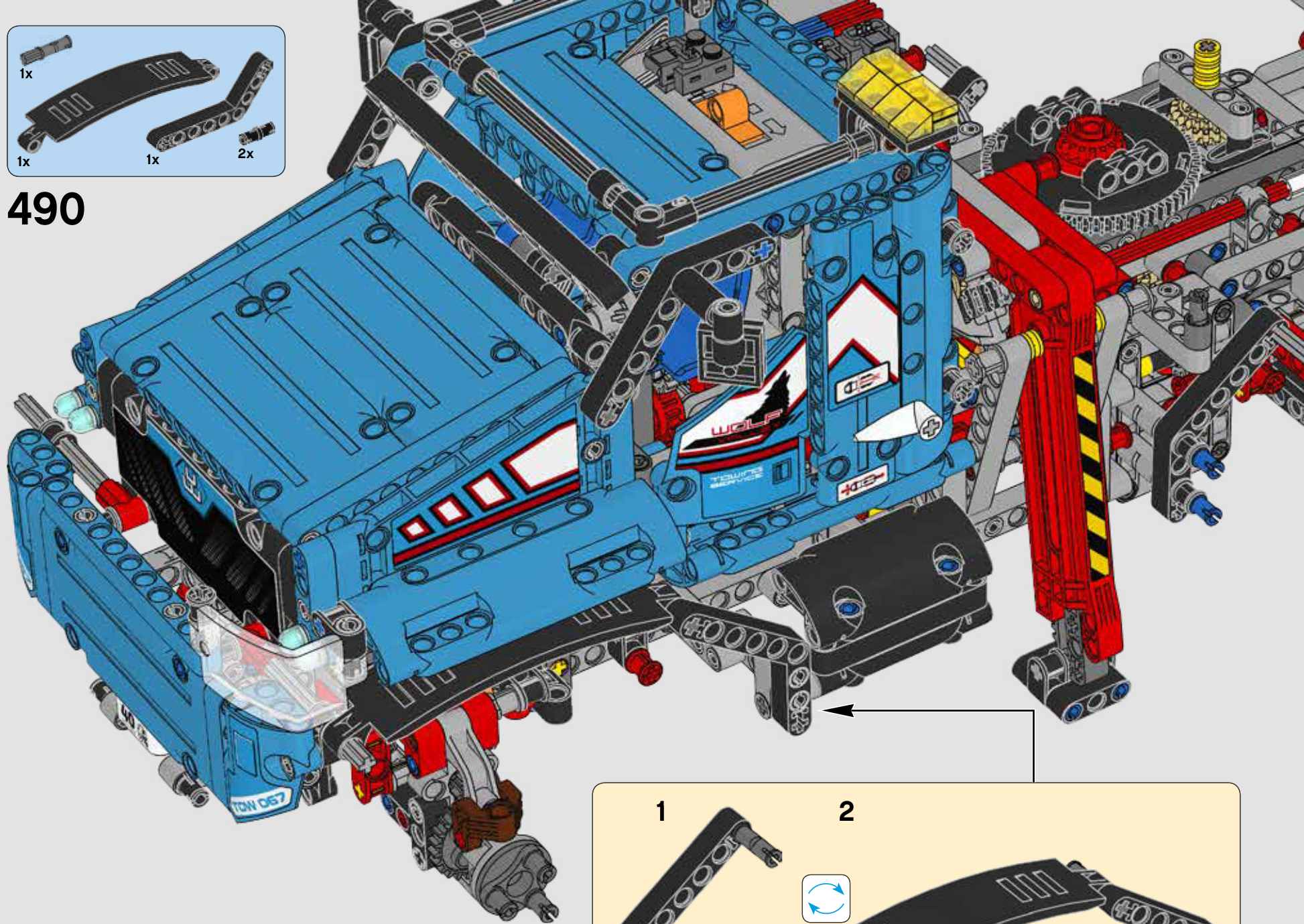



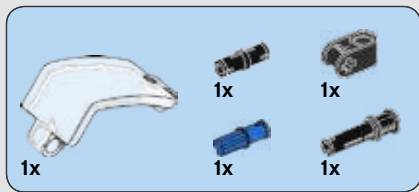

491

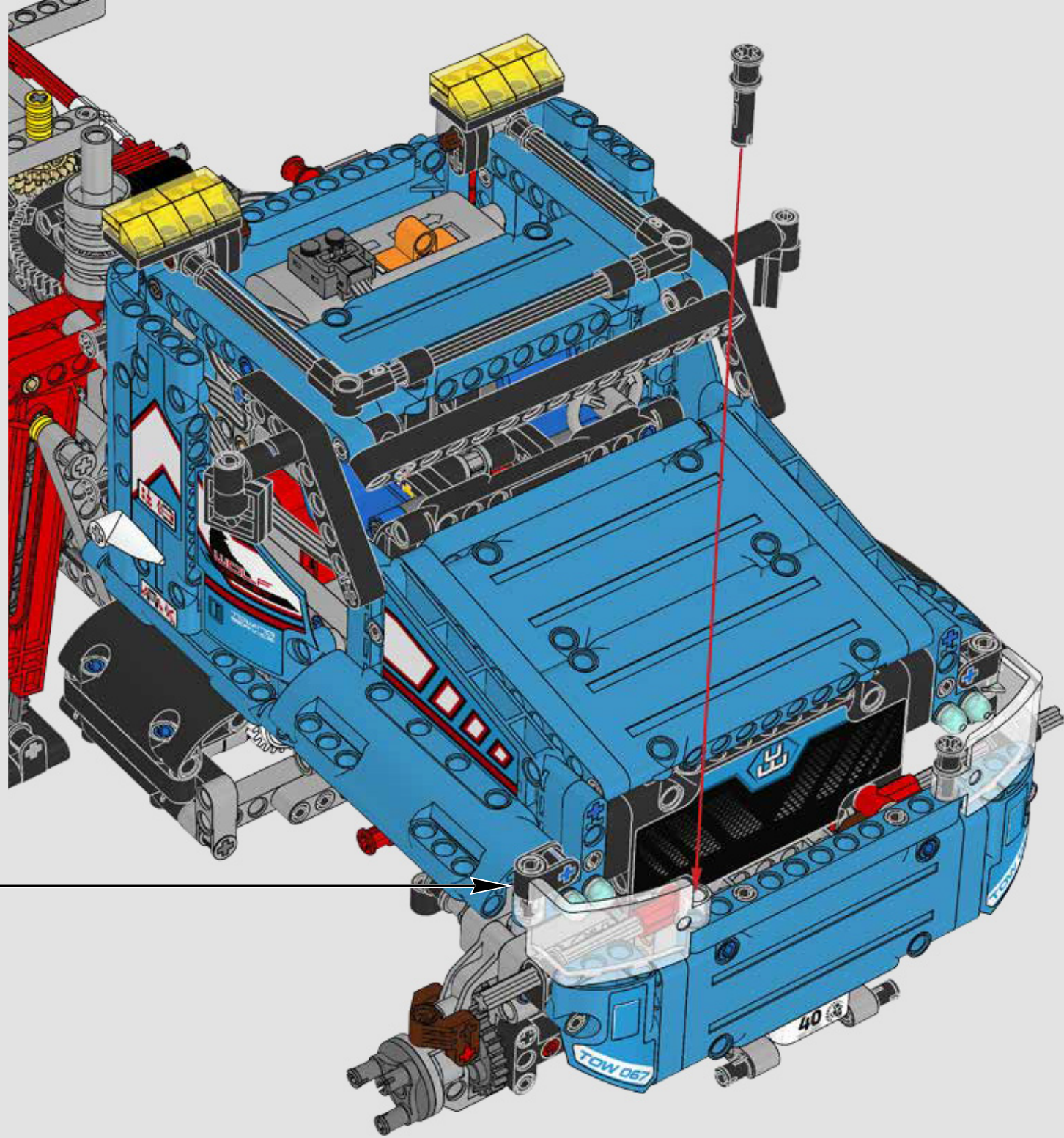
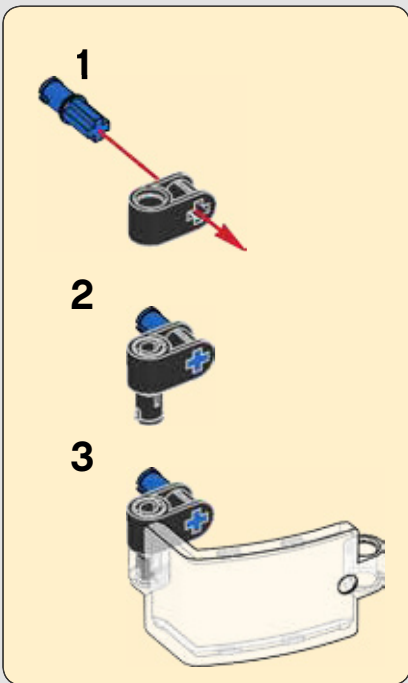
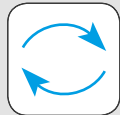



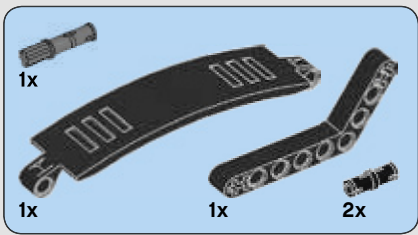

492

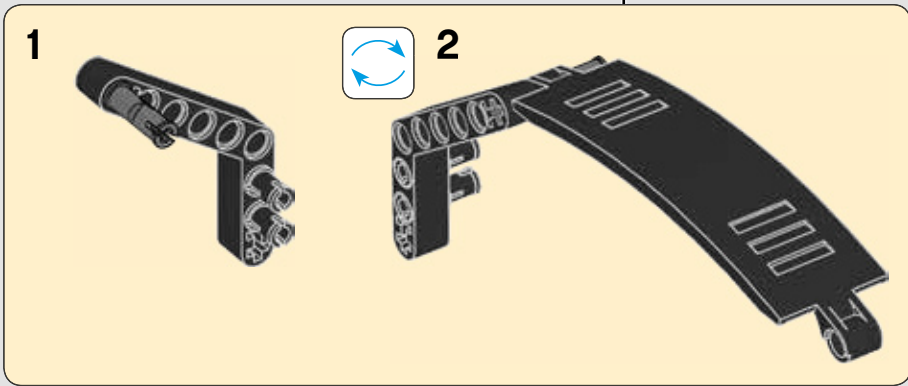
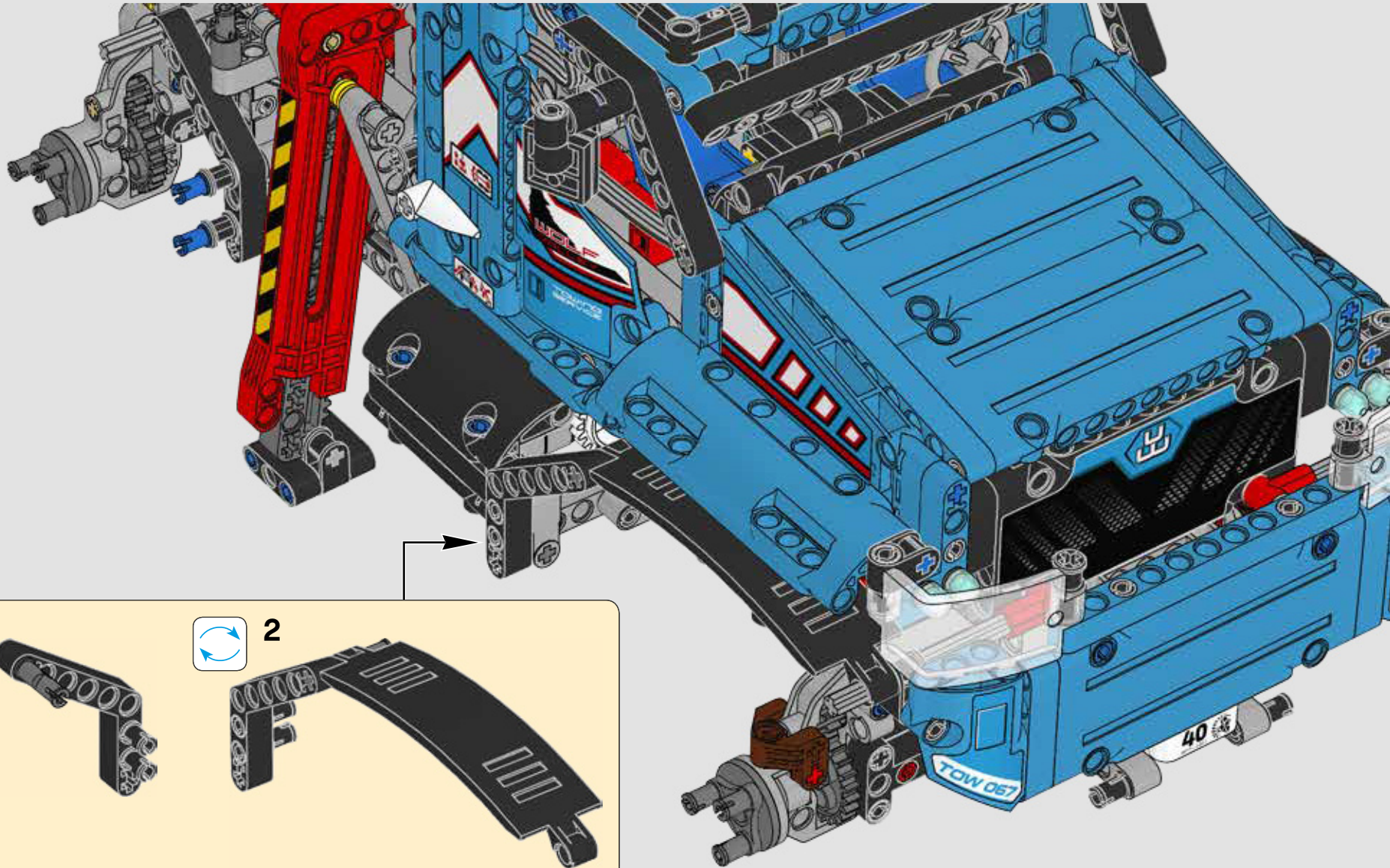



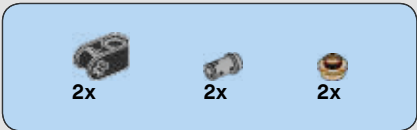

# 493

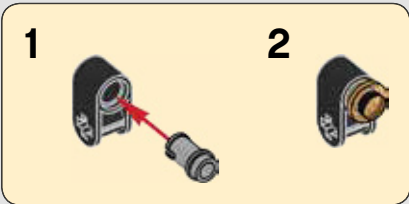

2

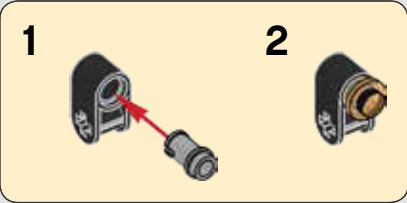
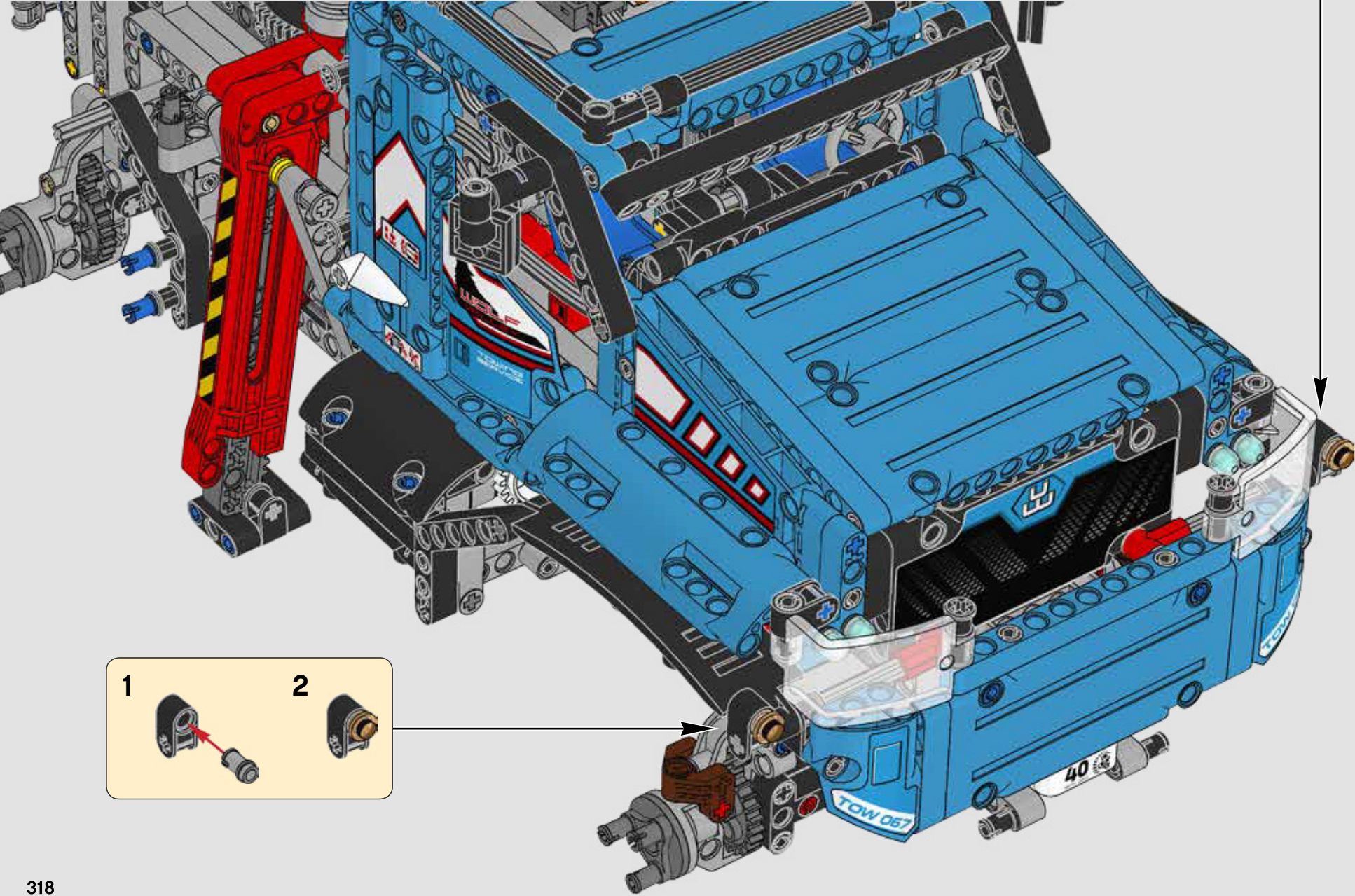



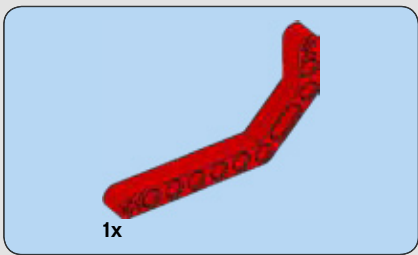

494

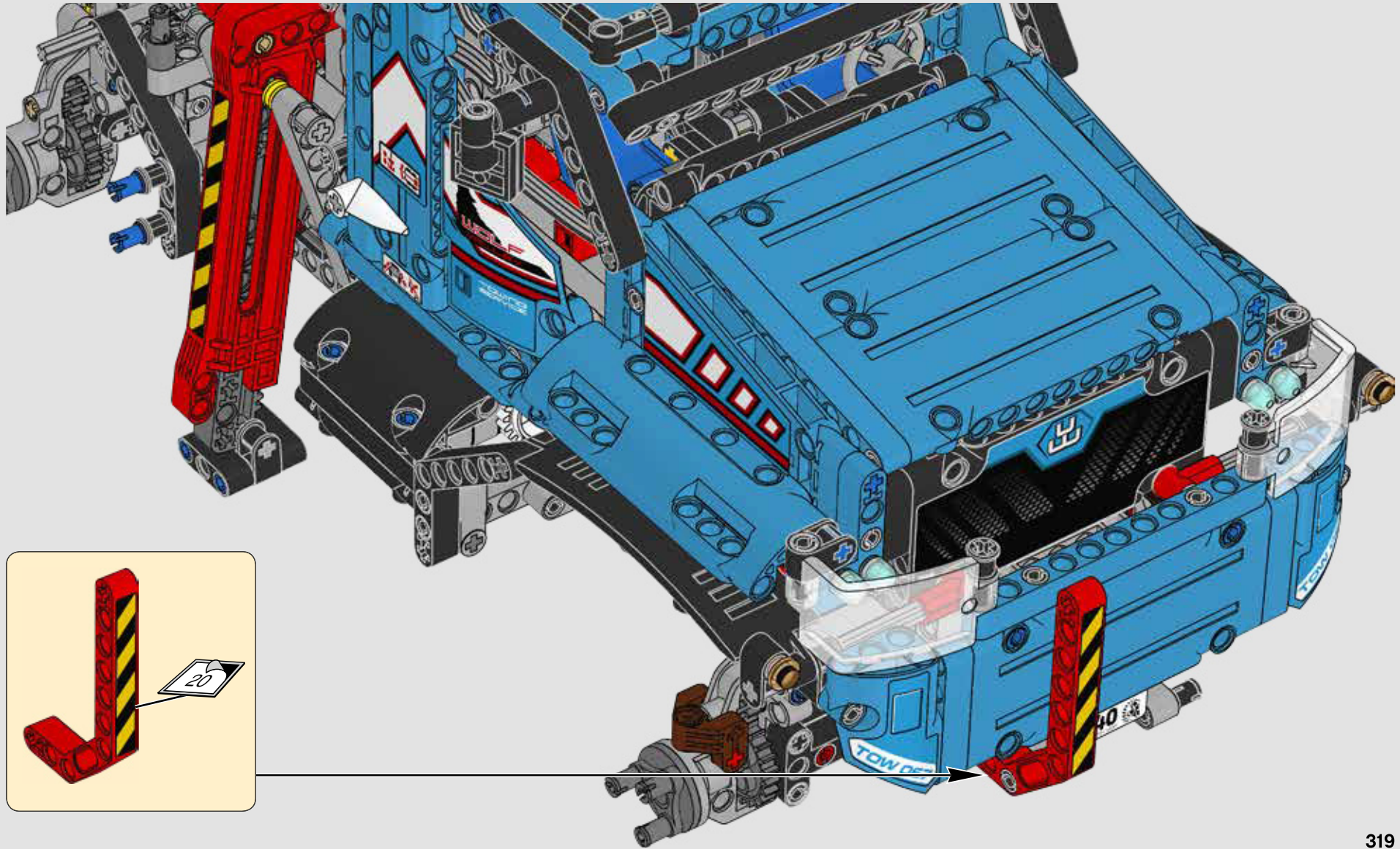



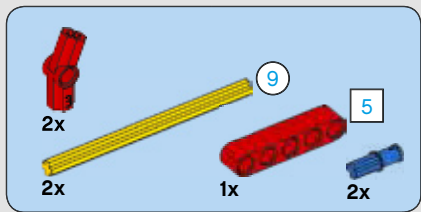

495

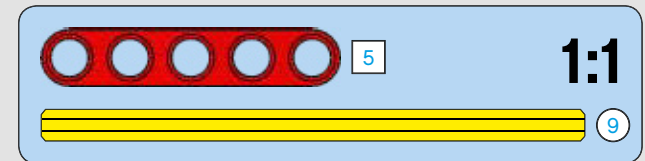
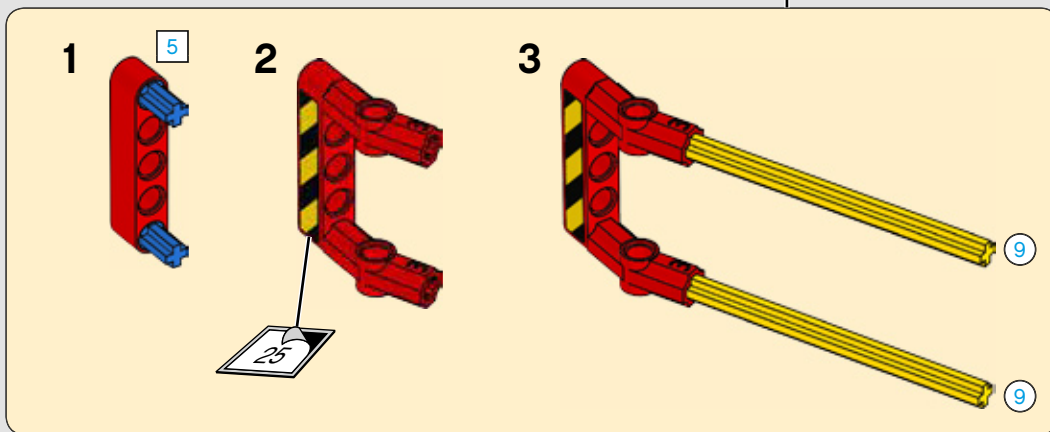
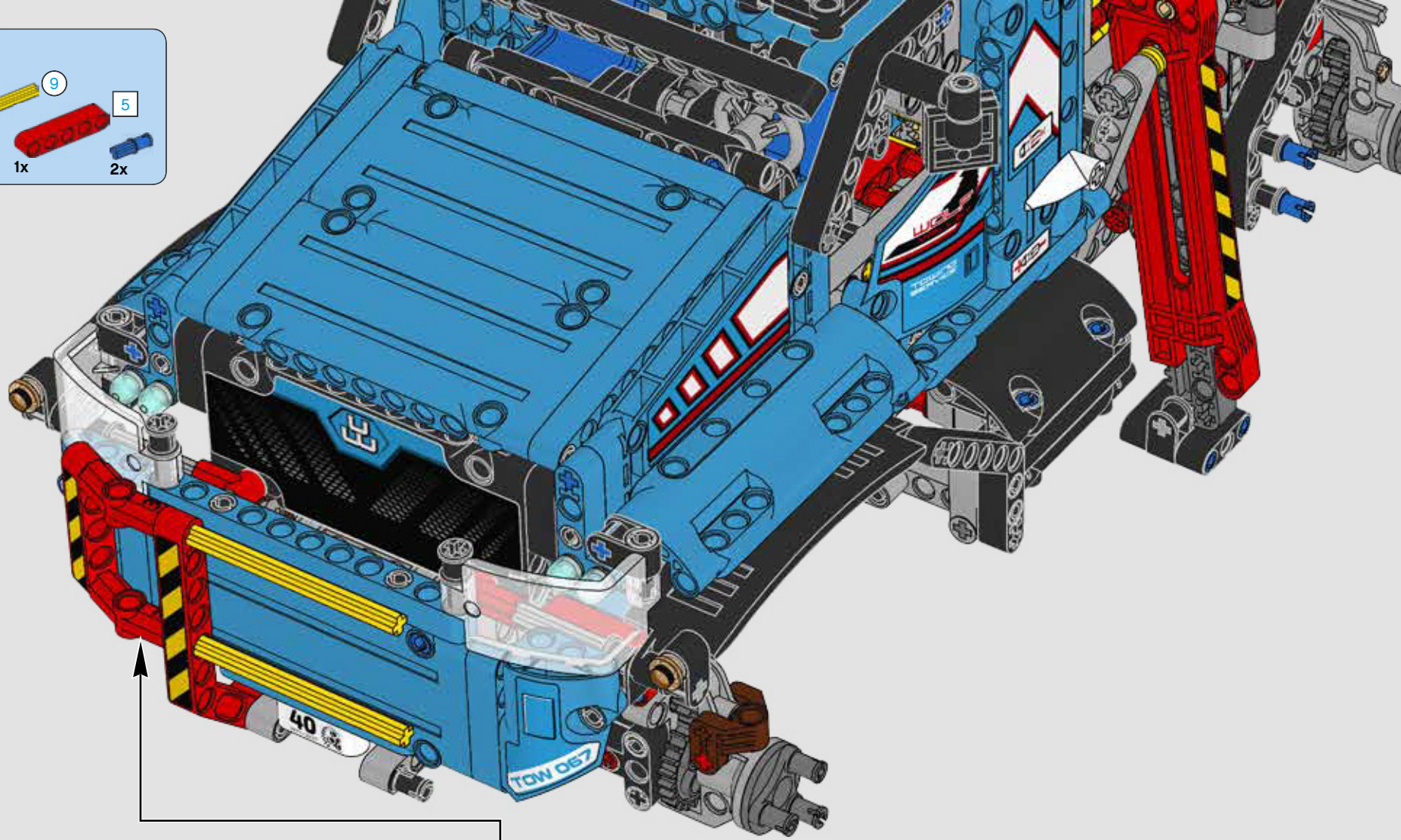





496

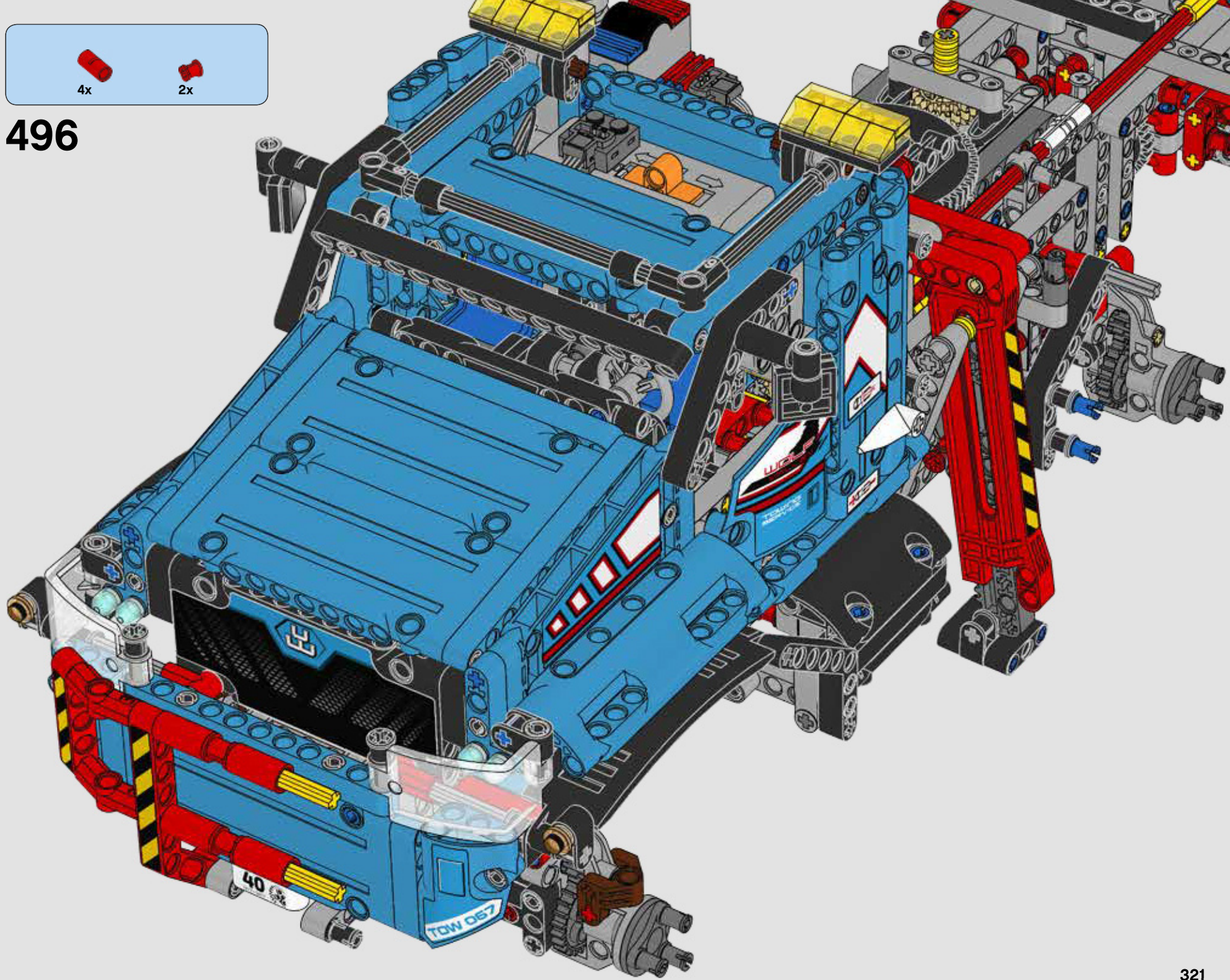



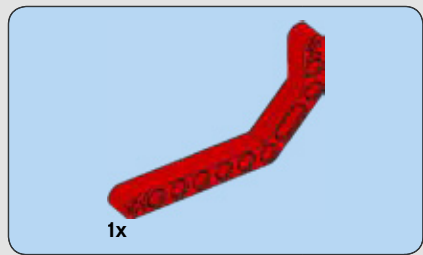

497

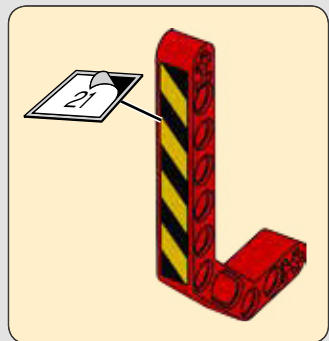
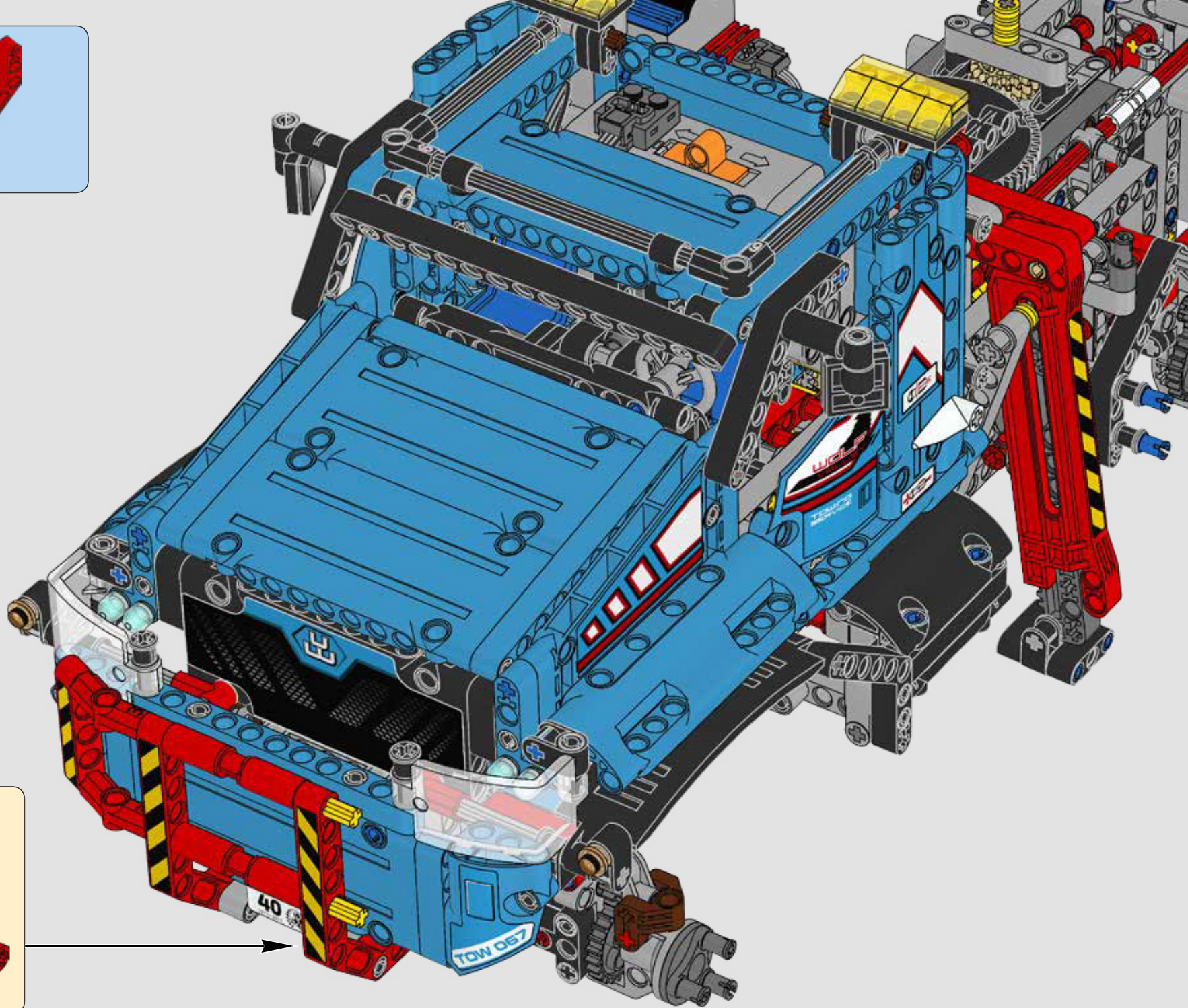



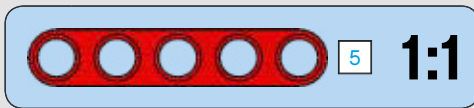
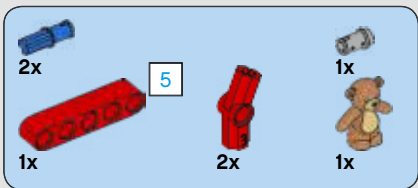

498

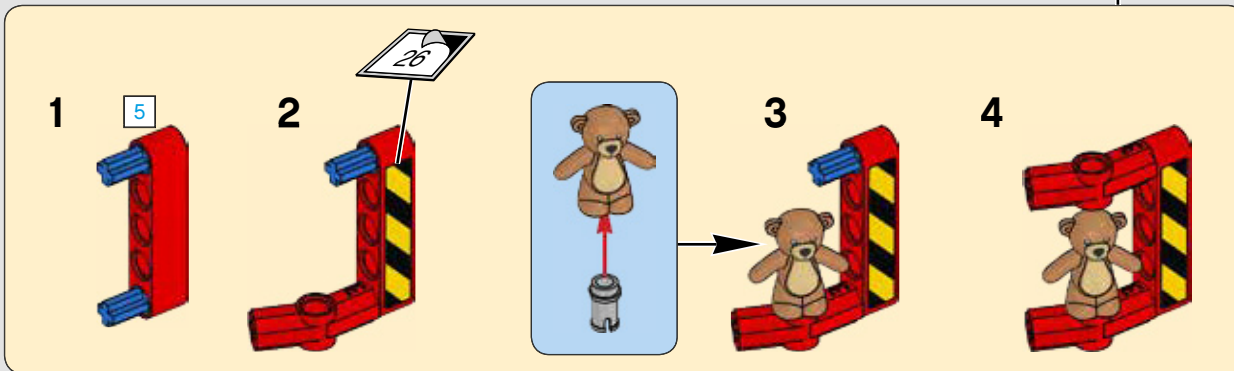
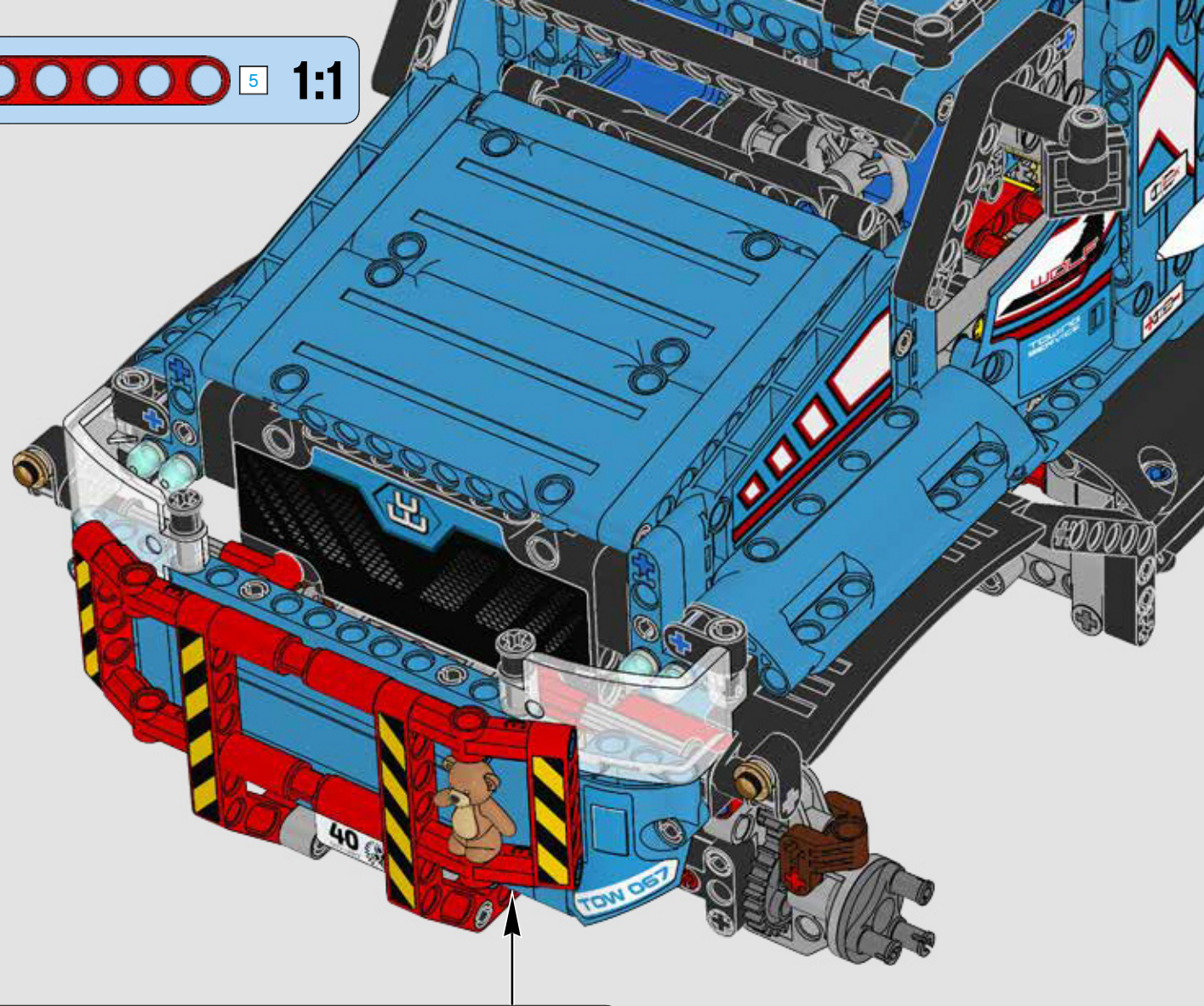



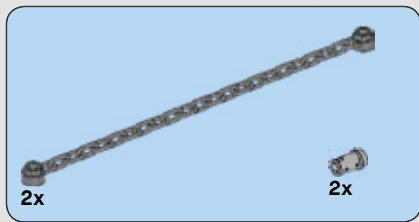

499

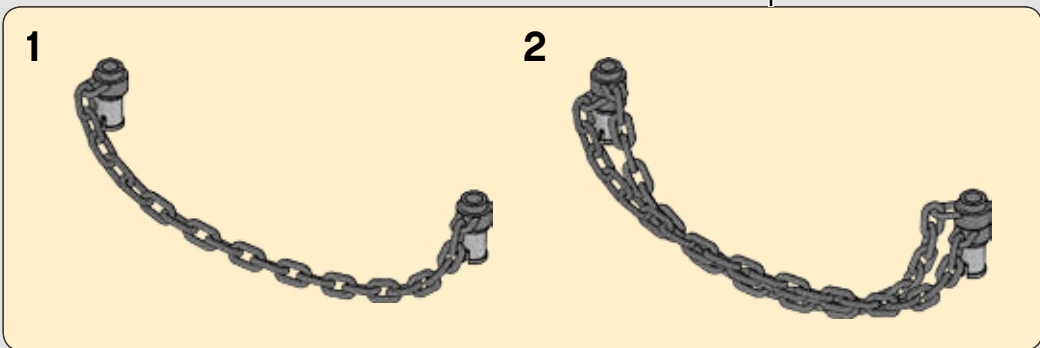
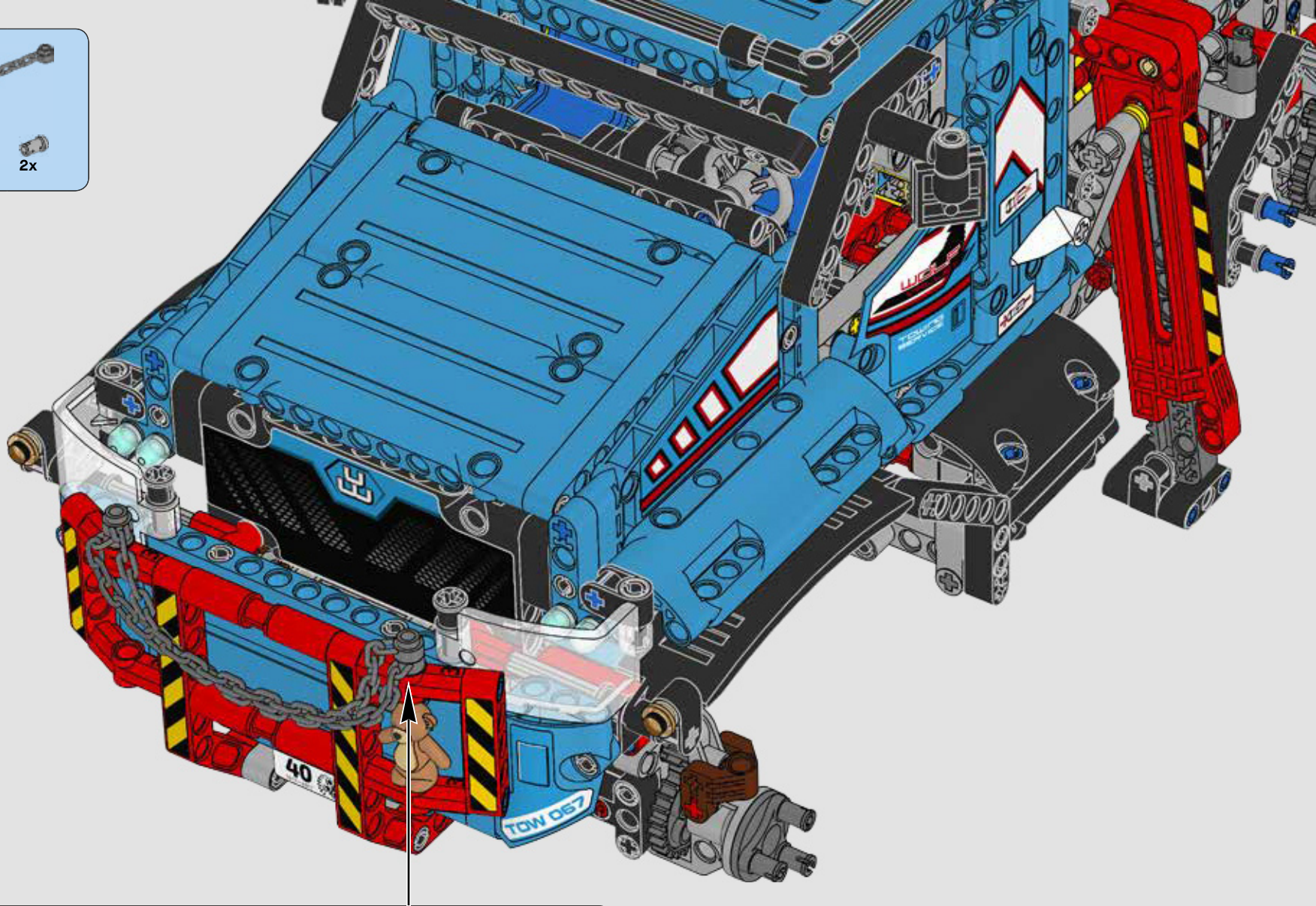



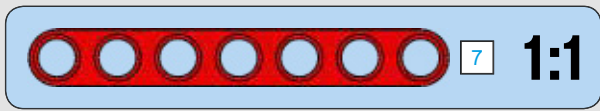
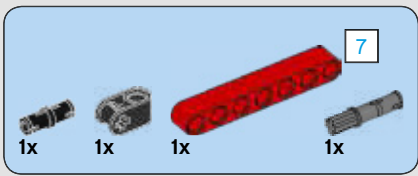

500

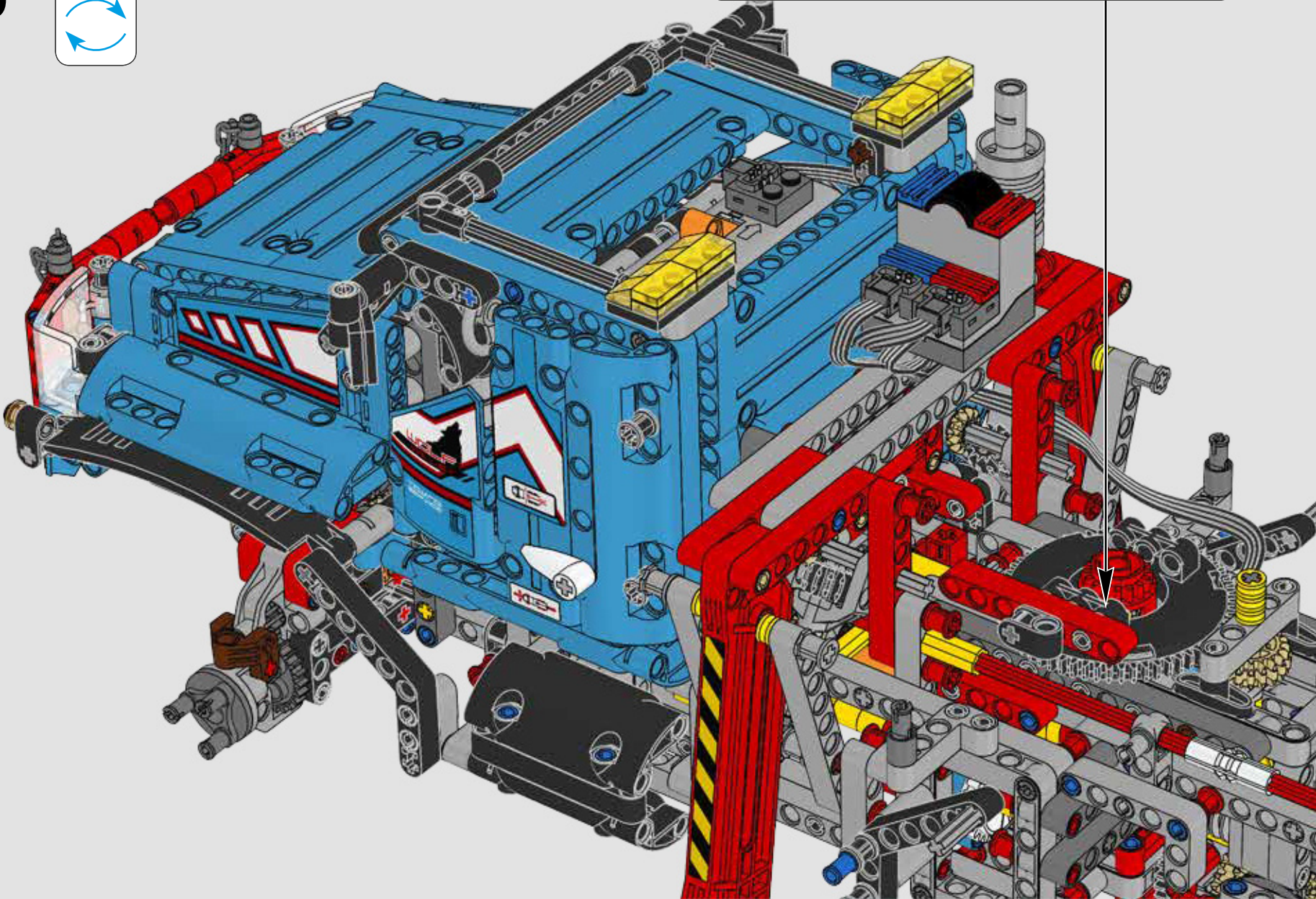
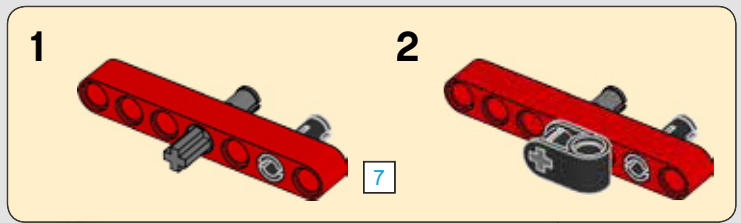

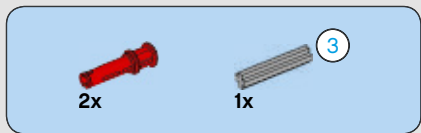

501

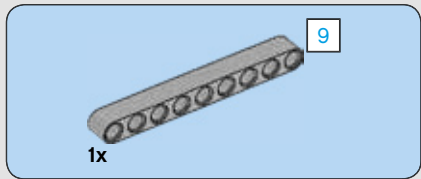
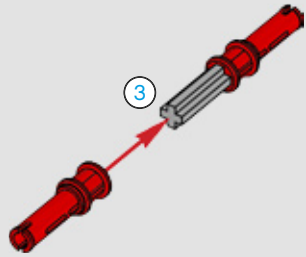

502

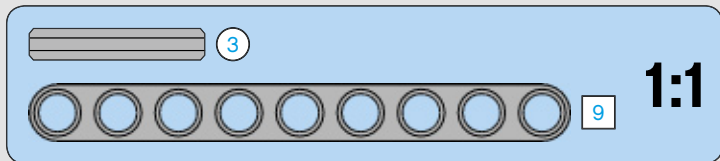
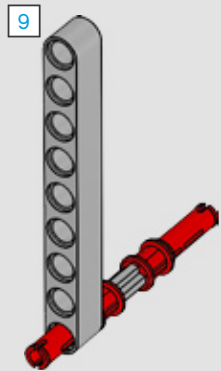

503

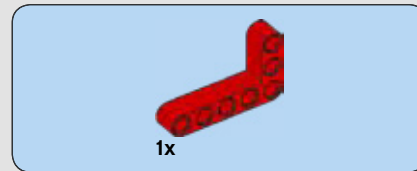
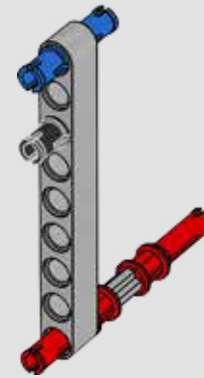

504

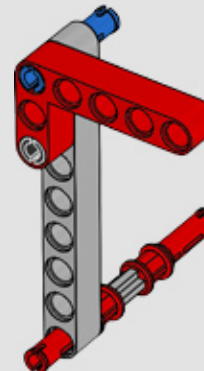



505

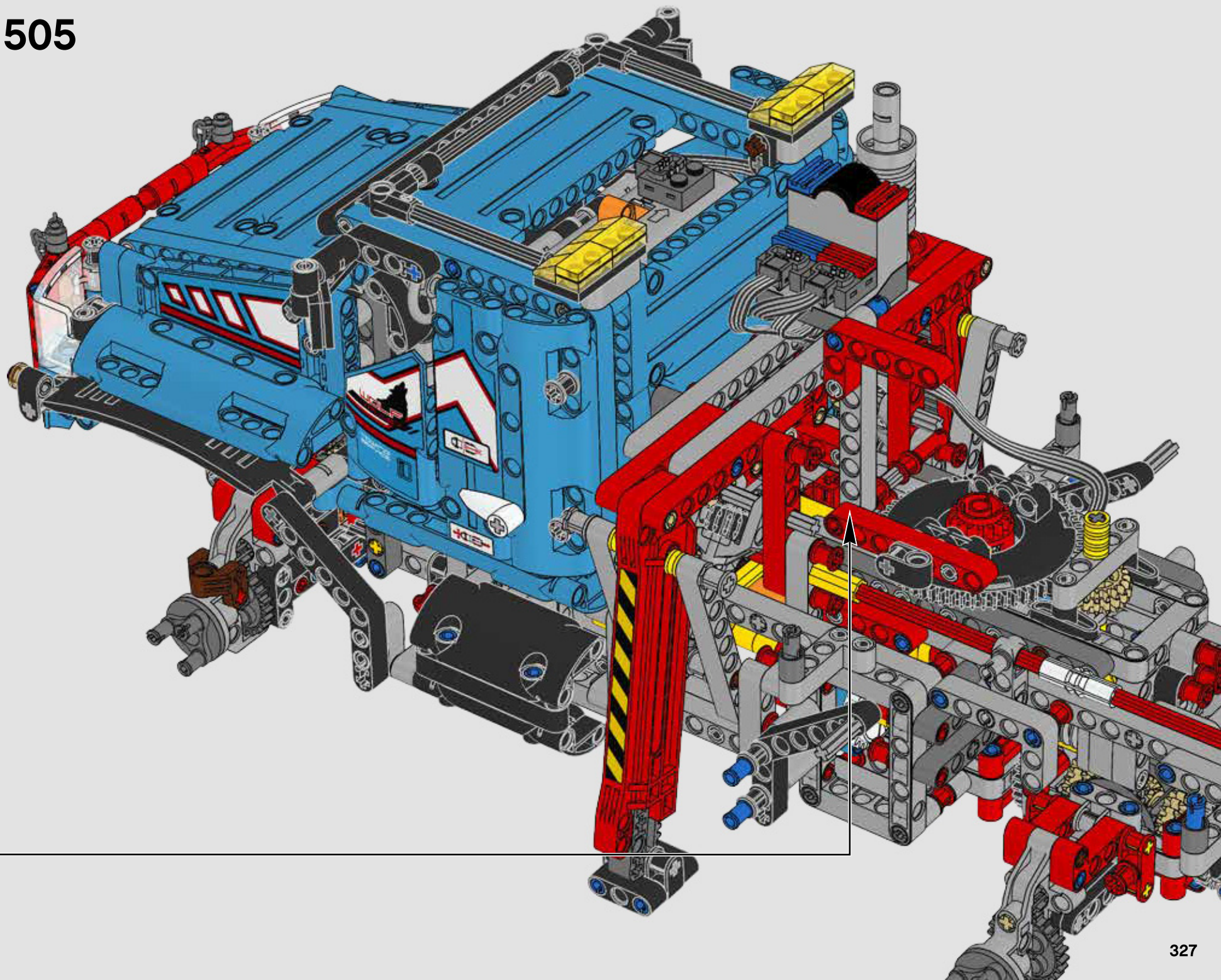

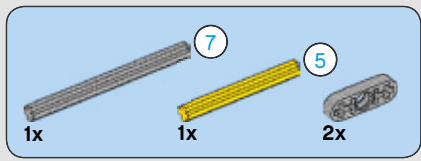

506

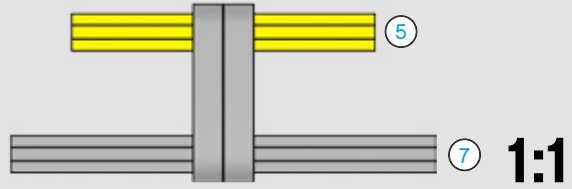

507

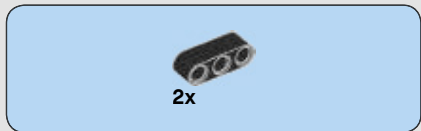
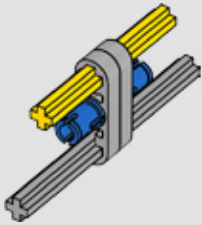

508

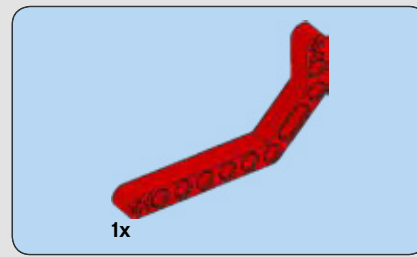
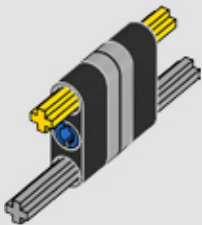

509

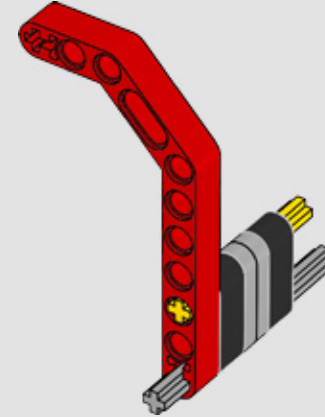

510

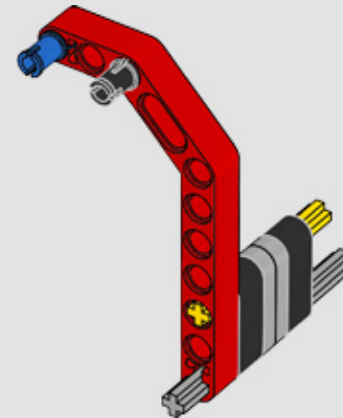



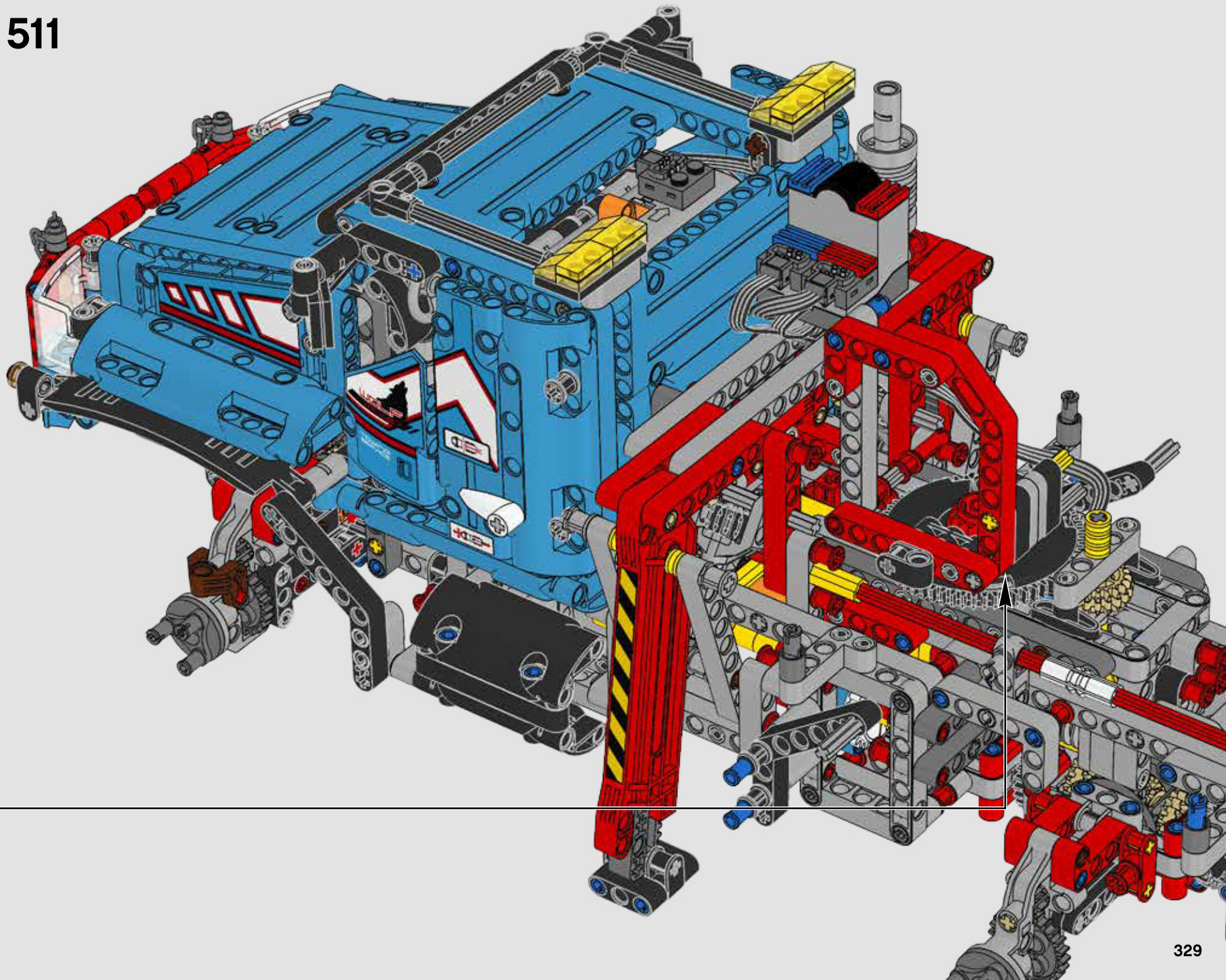

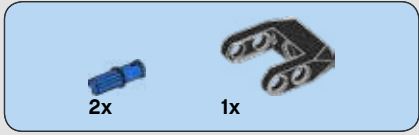
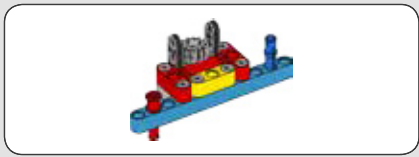

512

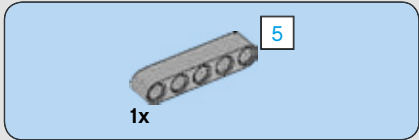
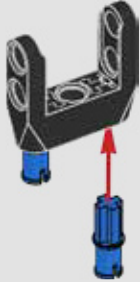

513

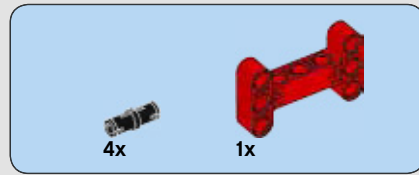
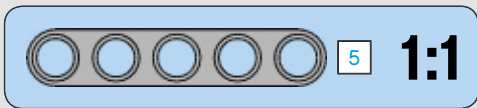
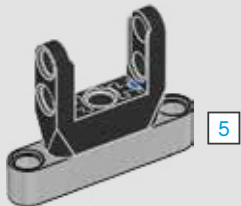

514

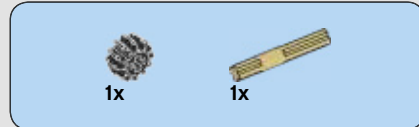
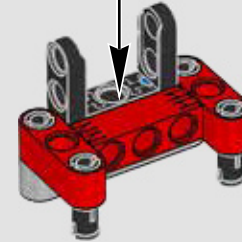
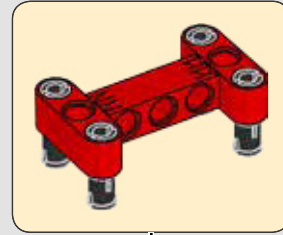

515

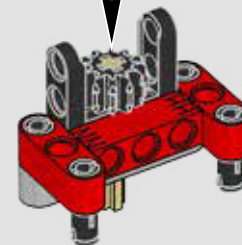
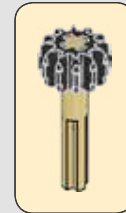



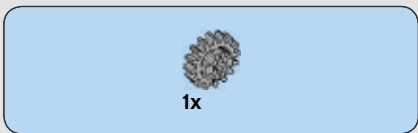

516

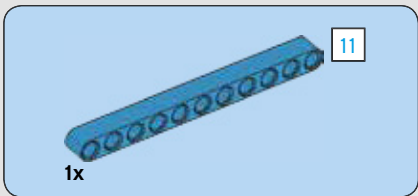
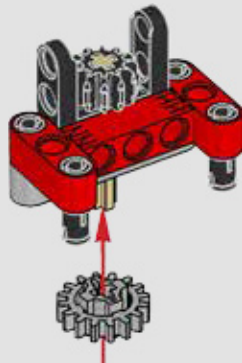

517

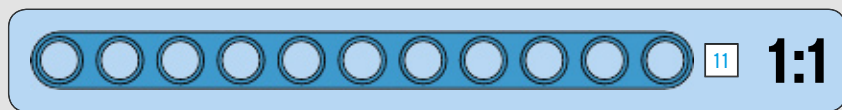
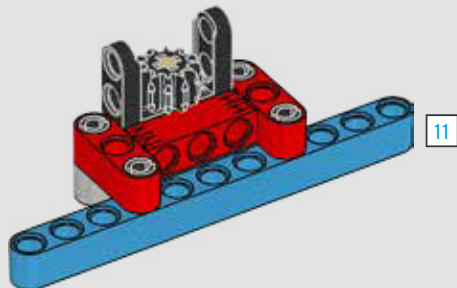

518

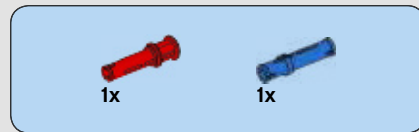
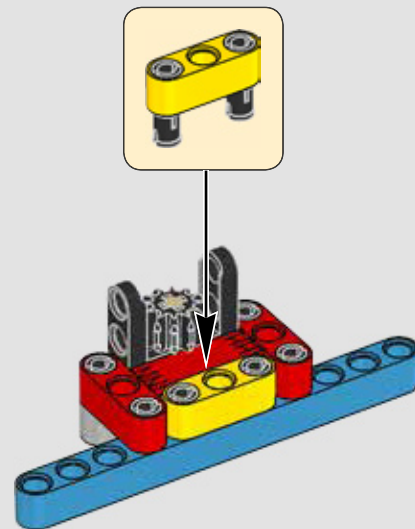

519

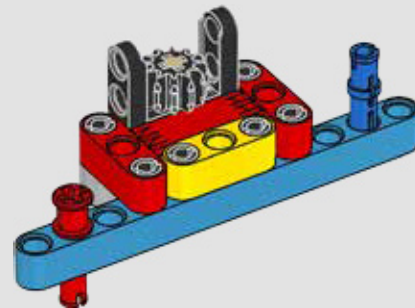

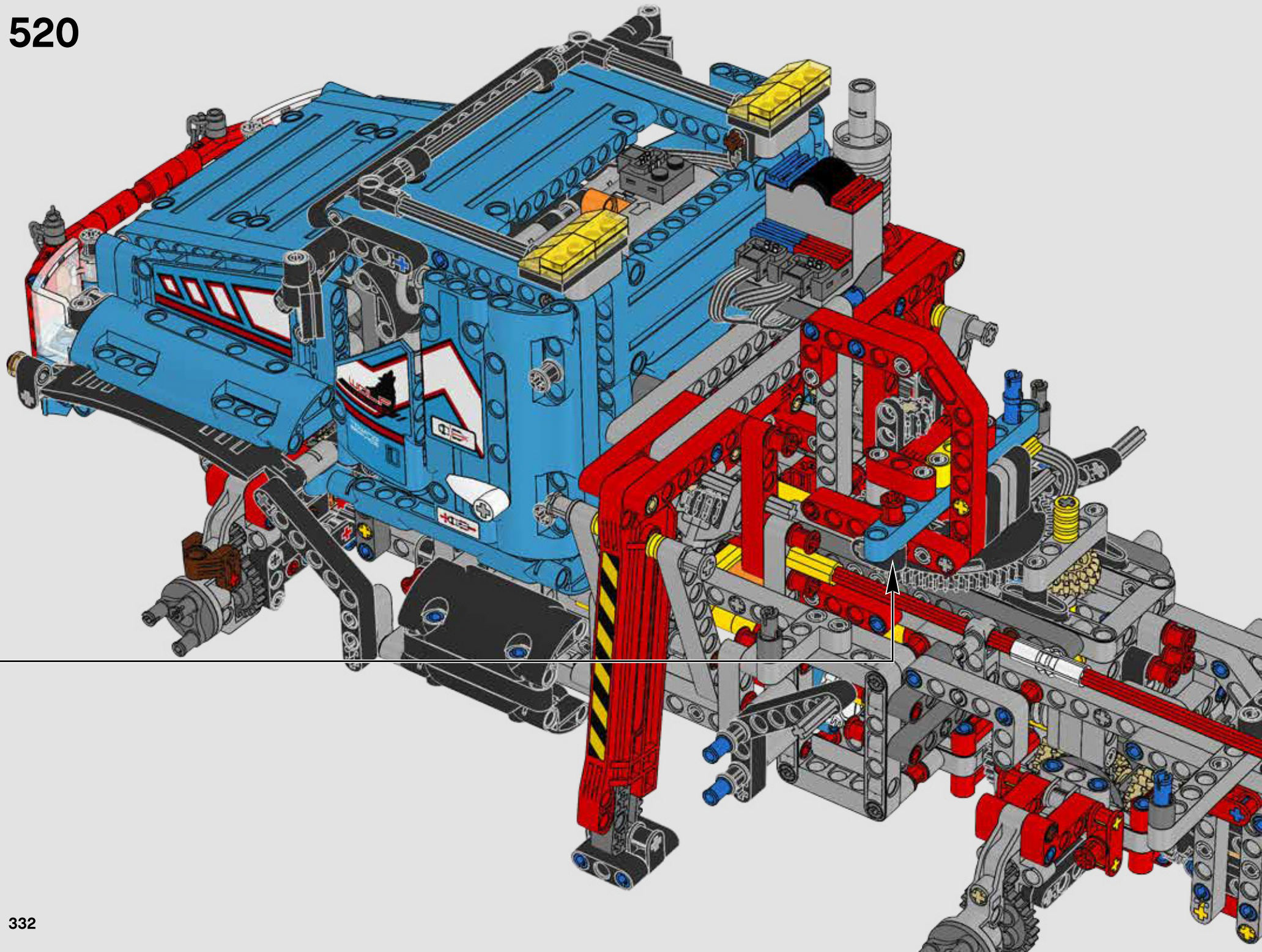



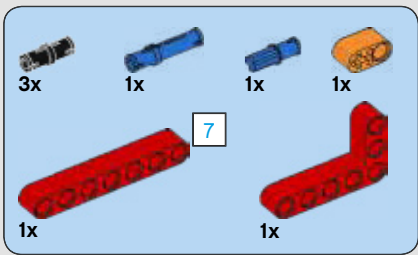

521

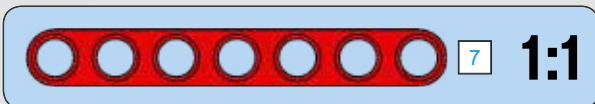
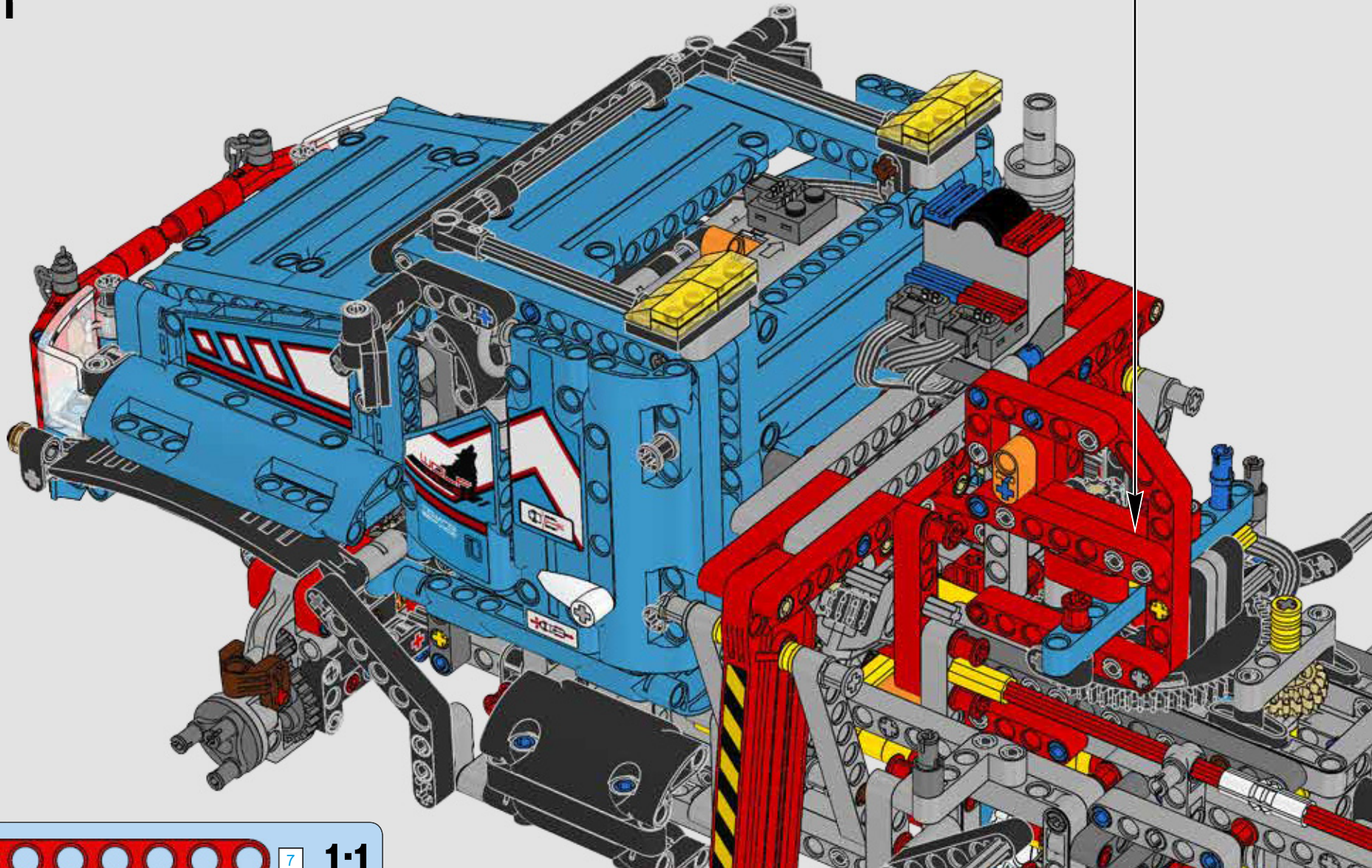
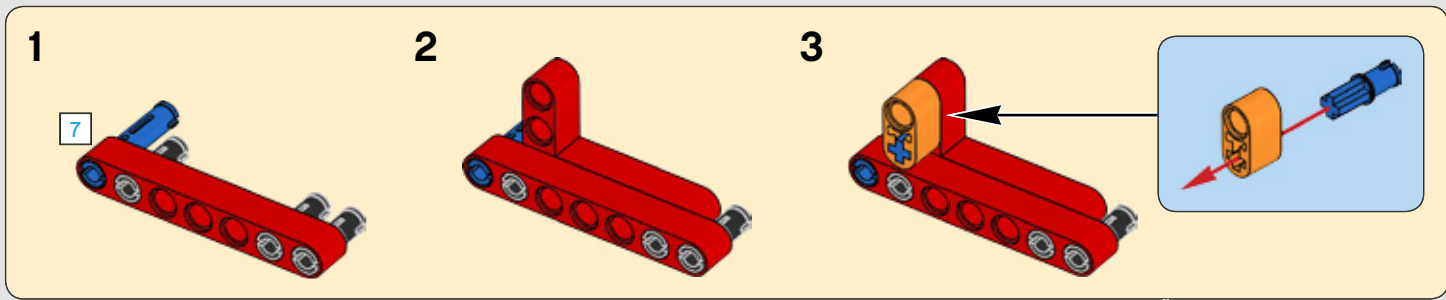



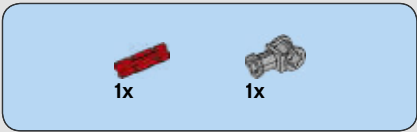

522

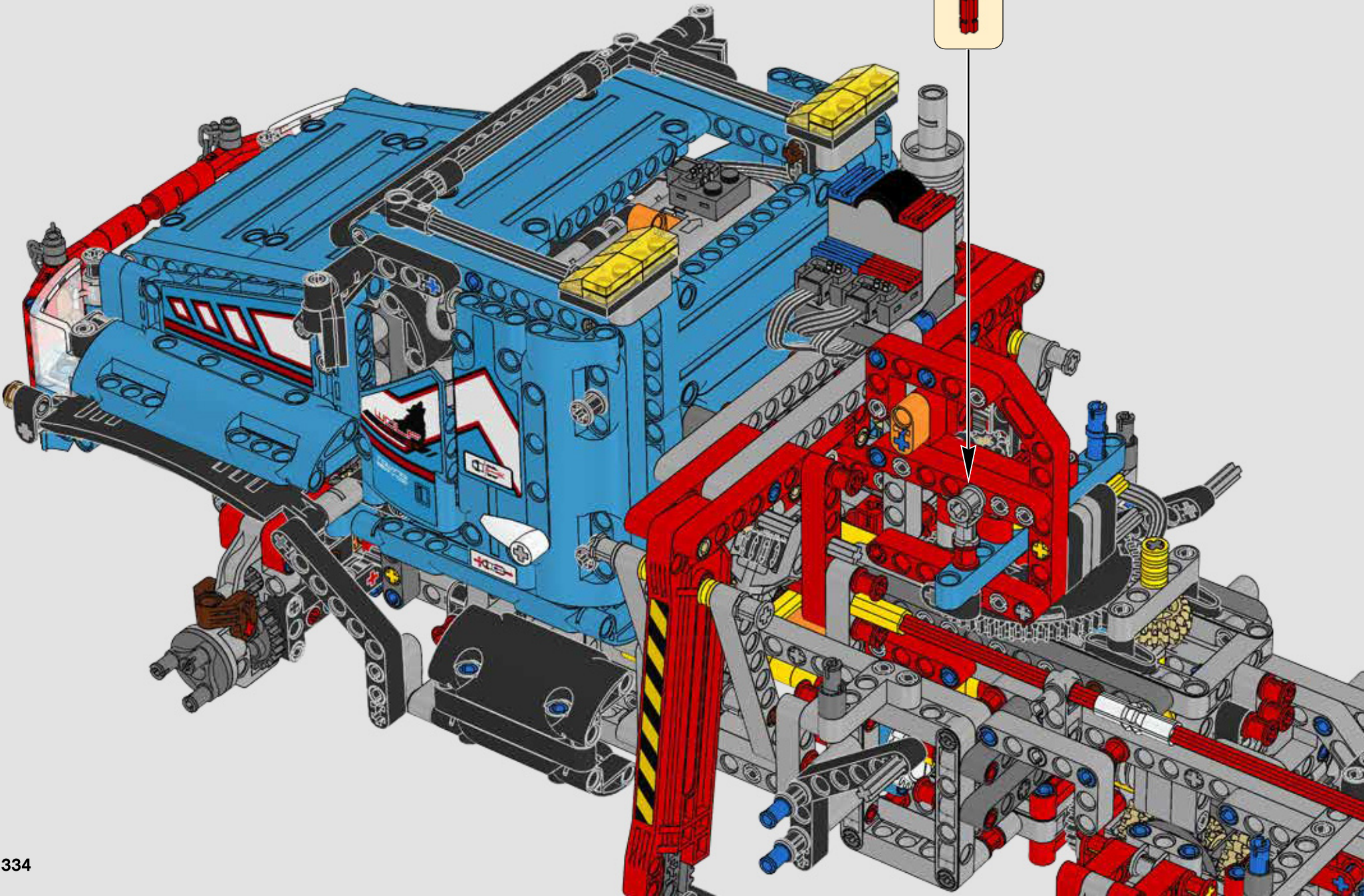
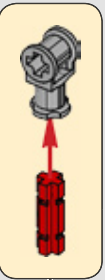



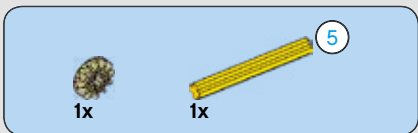

523

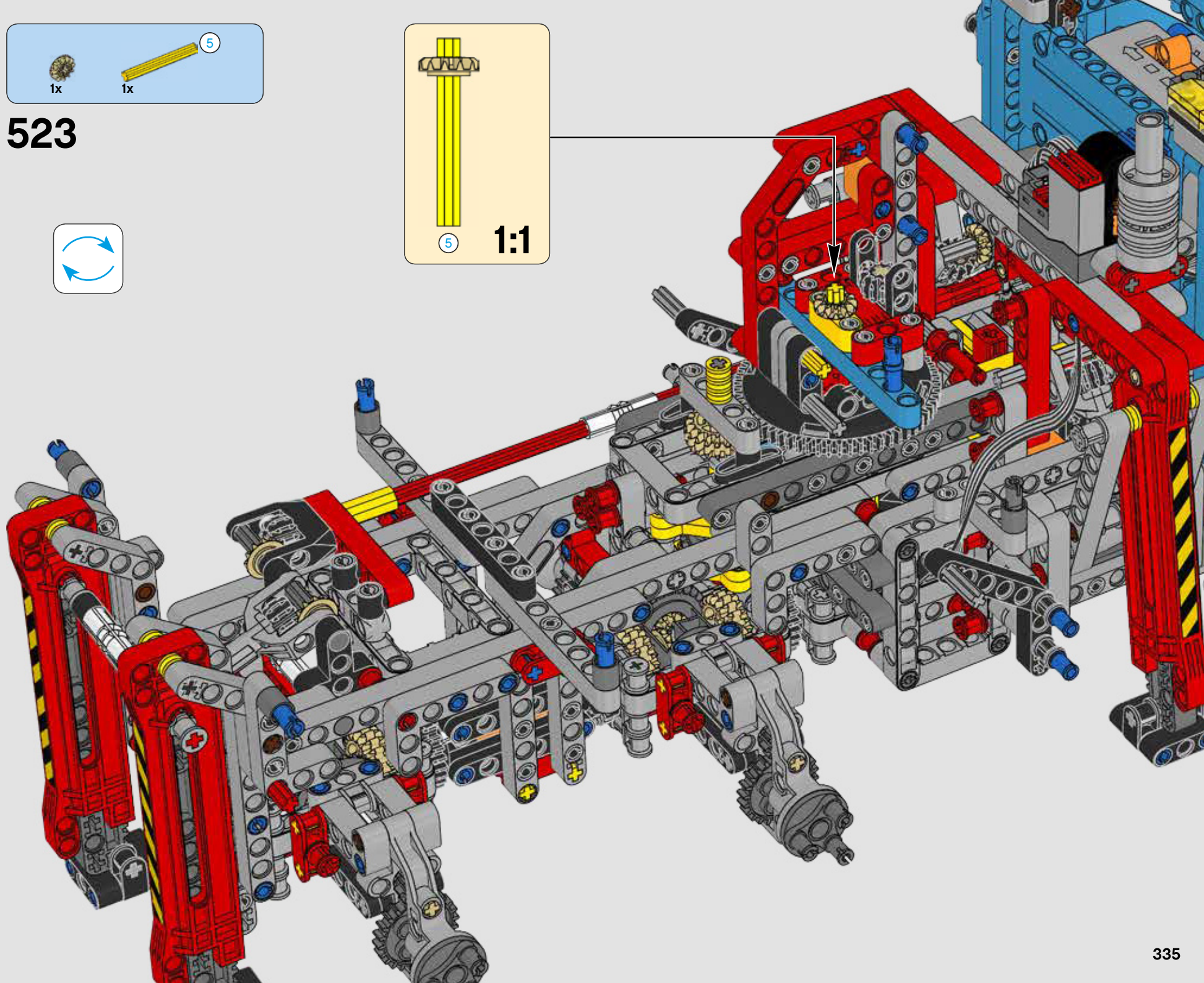
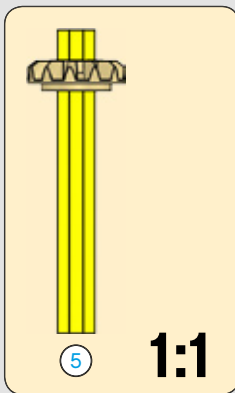
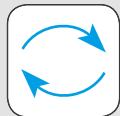



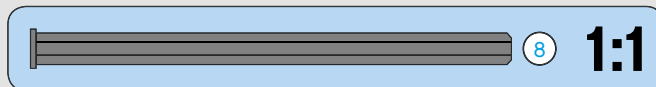
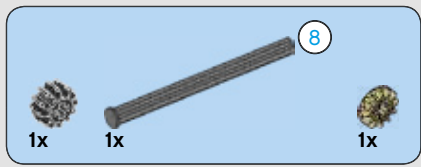

524

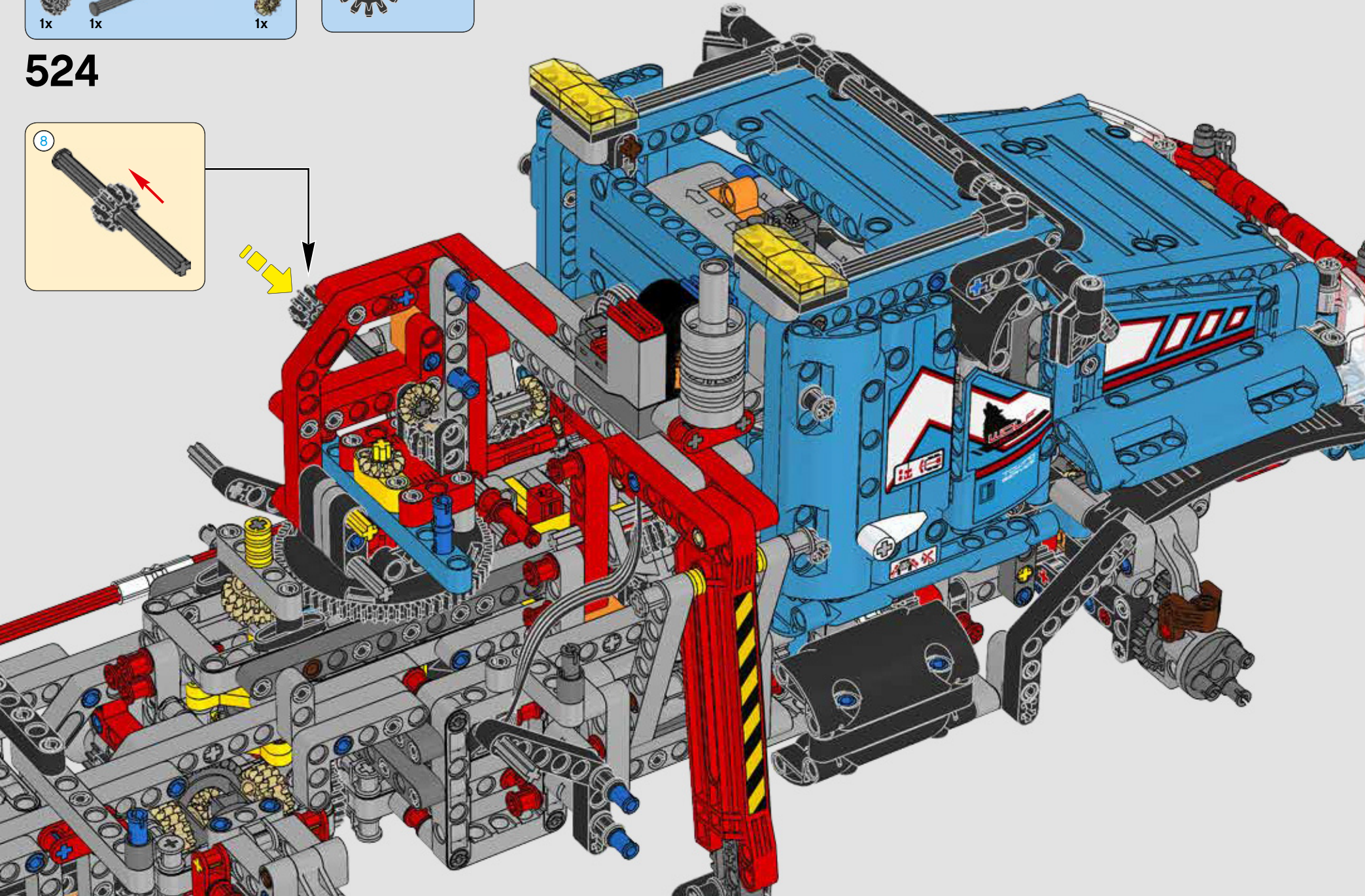
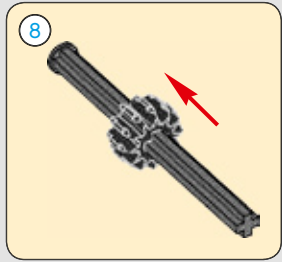



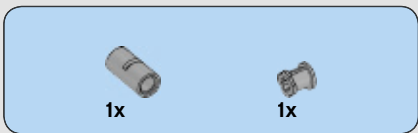

525

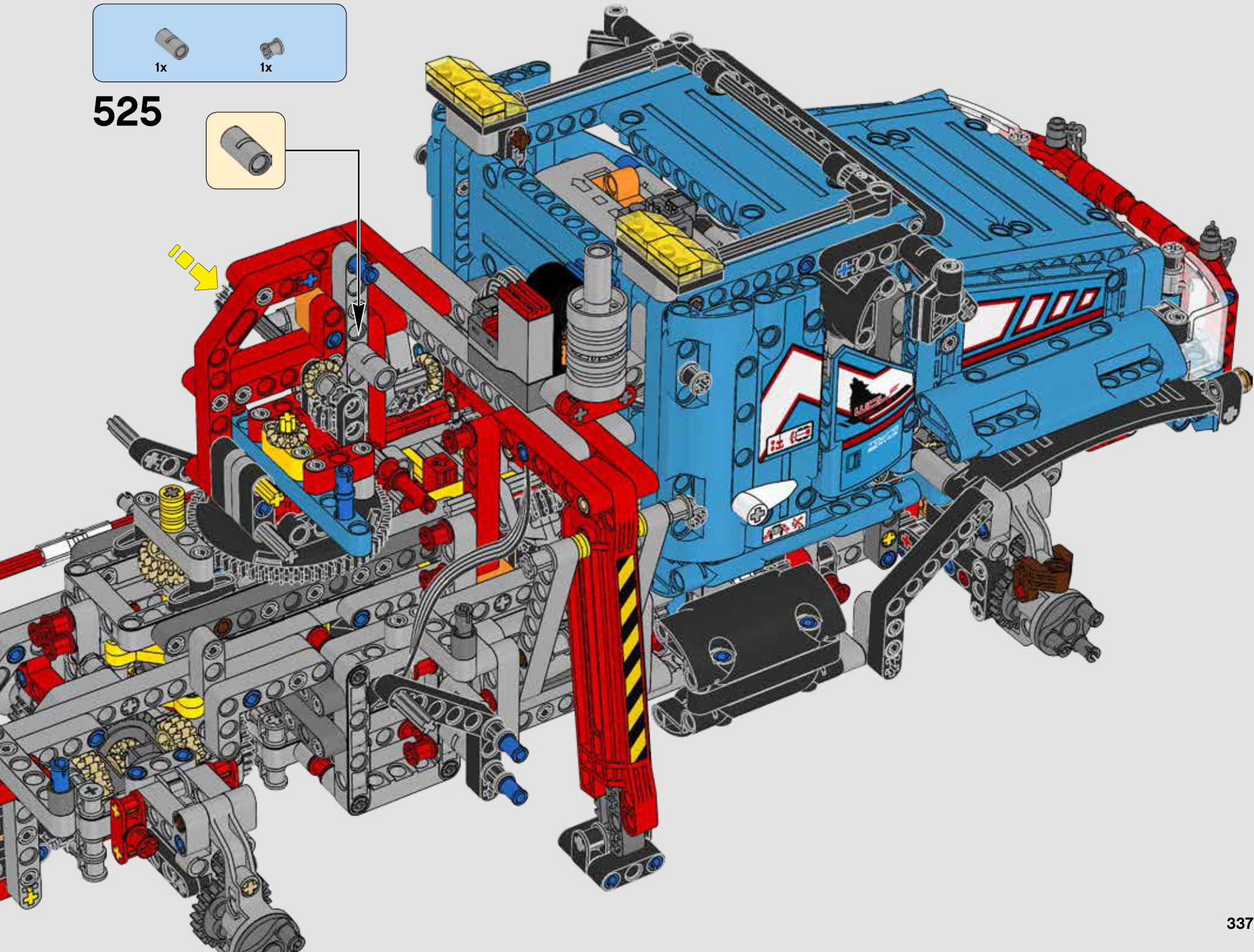

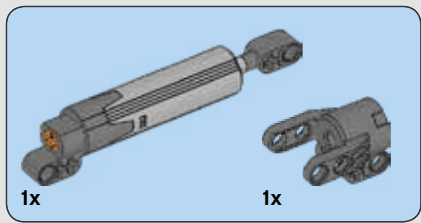

526

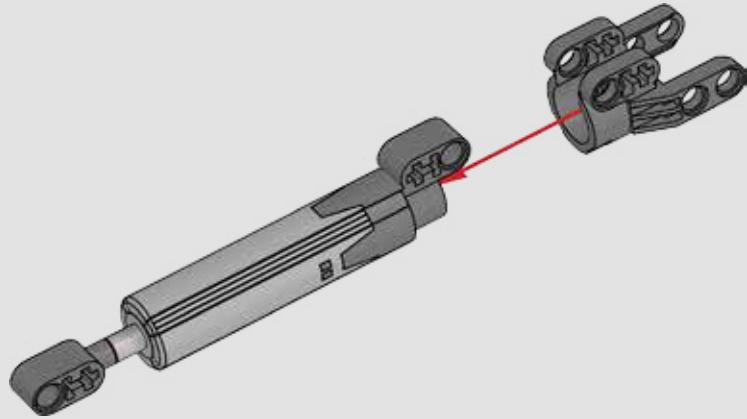

527

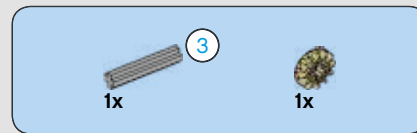
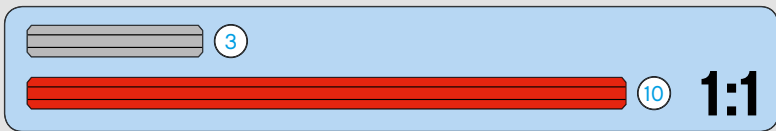
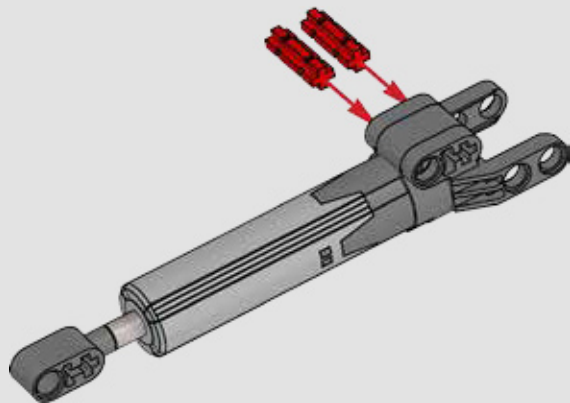

528

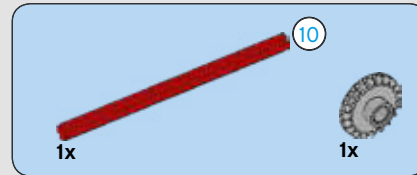
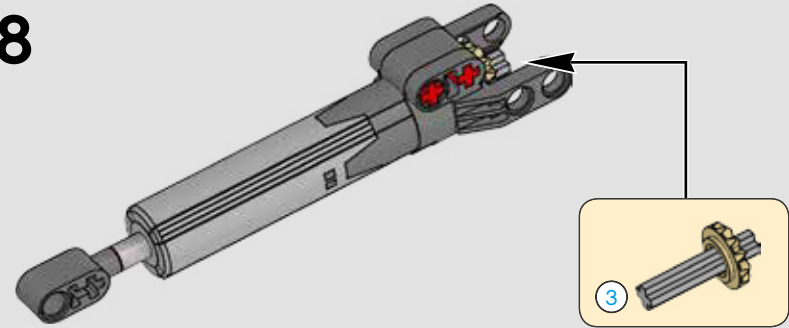

529

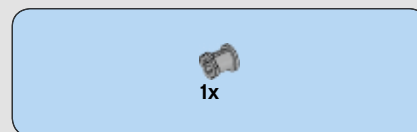
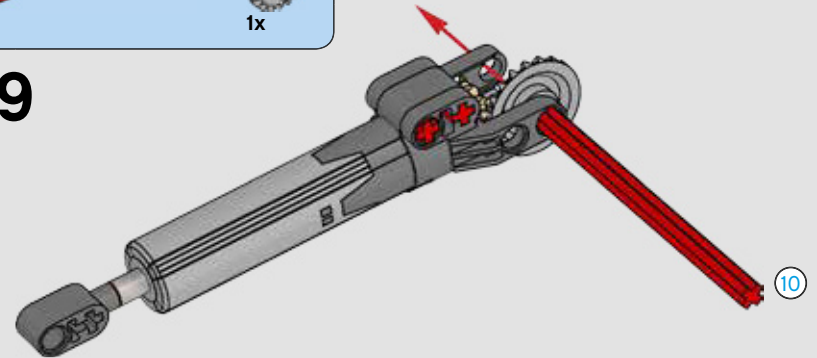

530

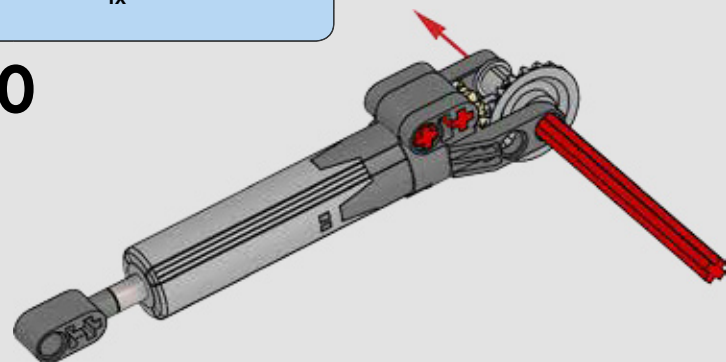



531

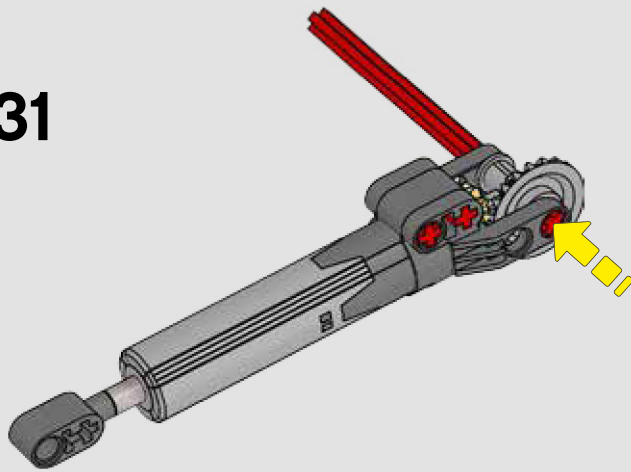

532

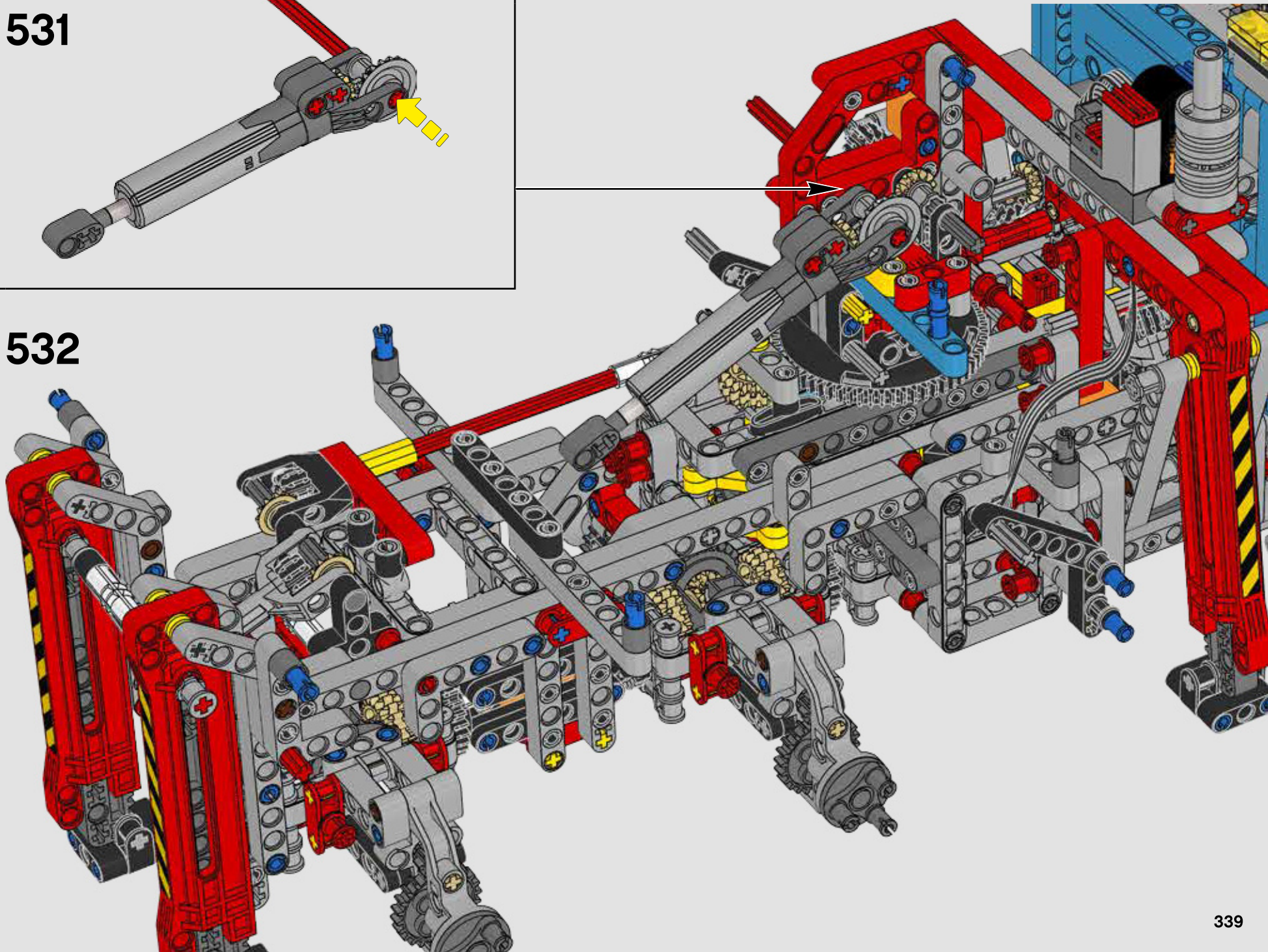



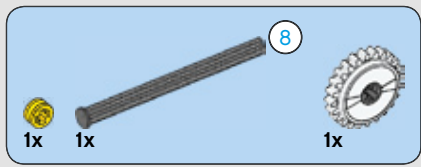

533

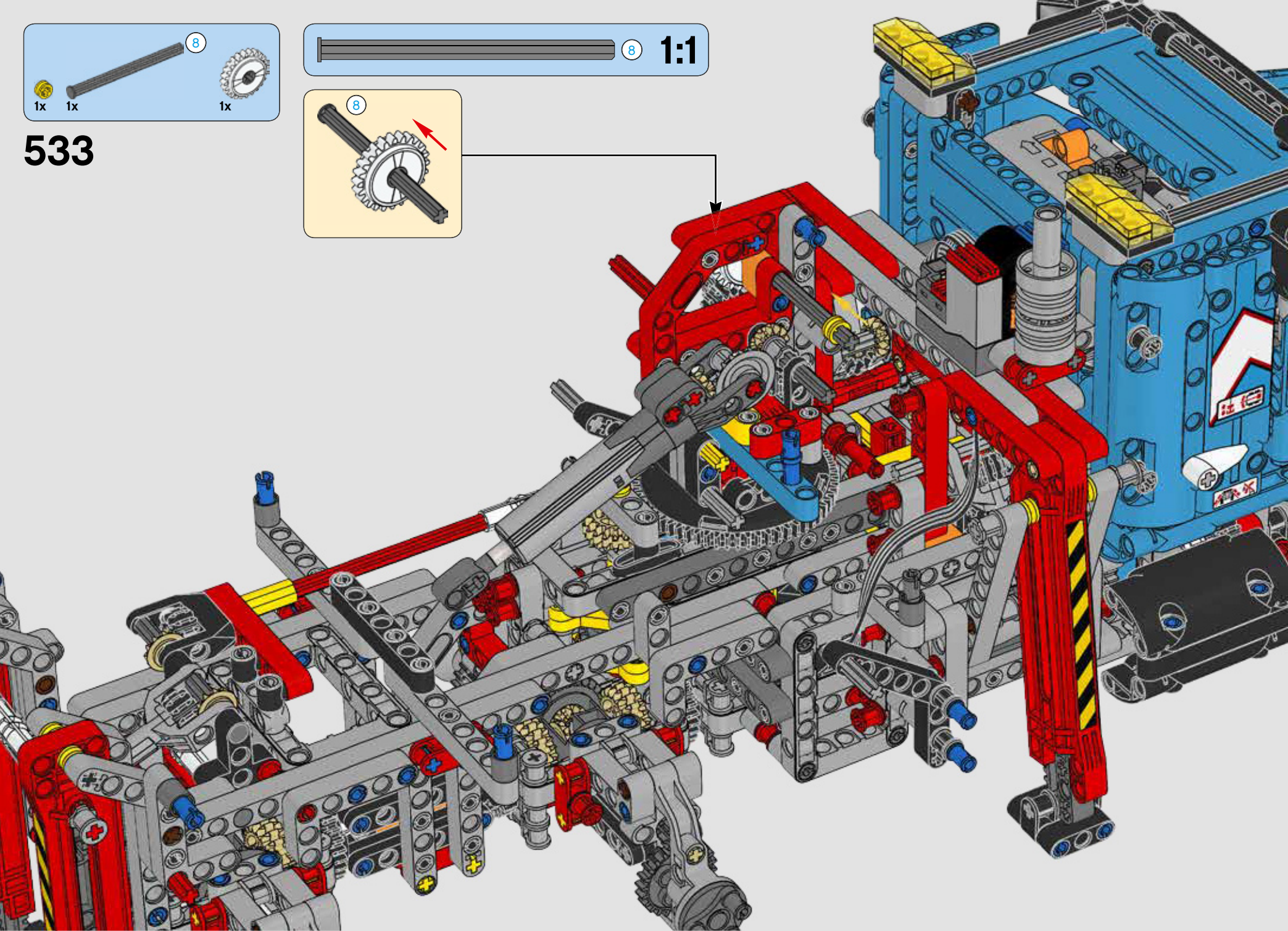
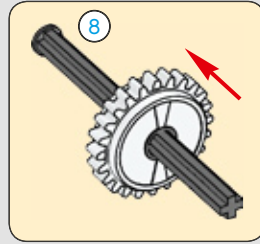
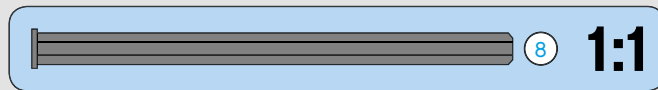



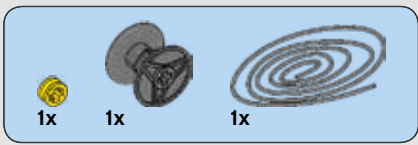

534

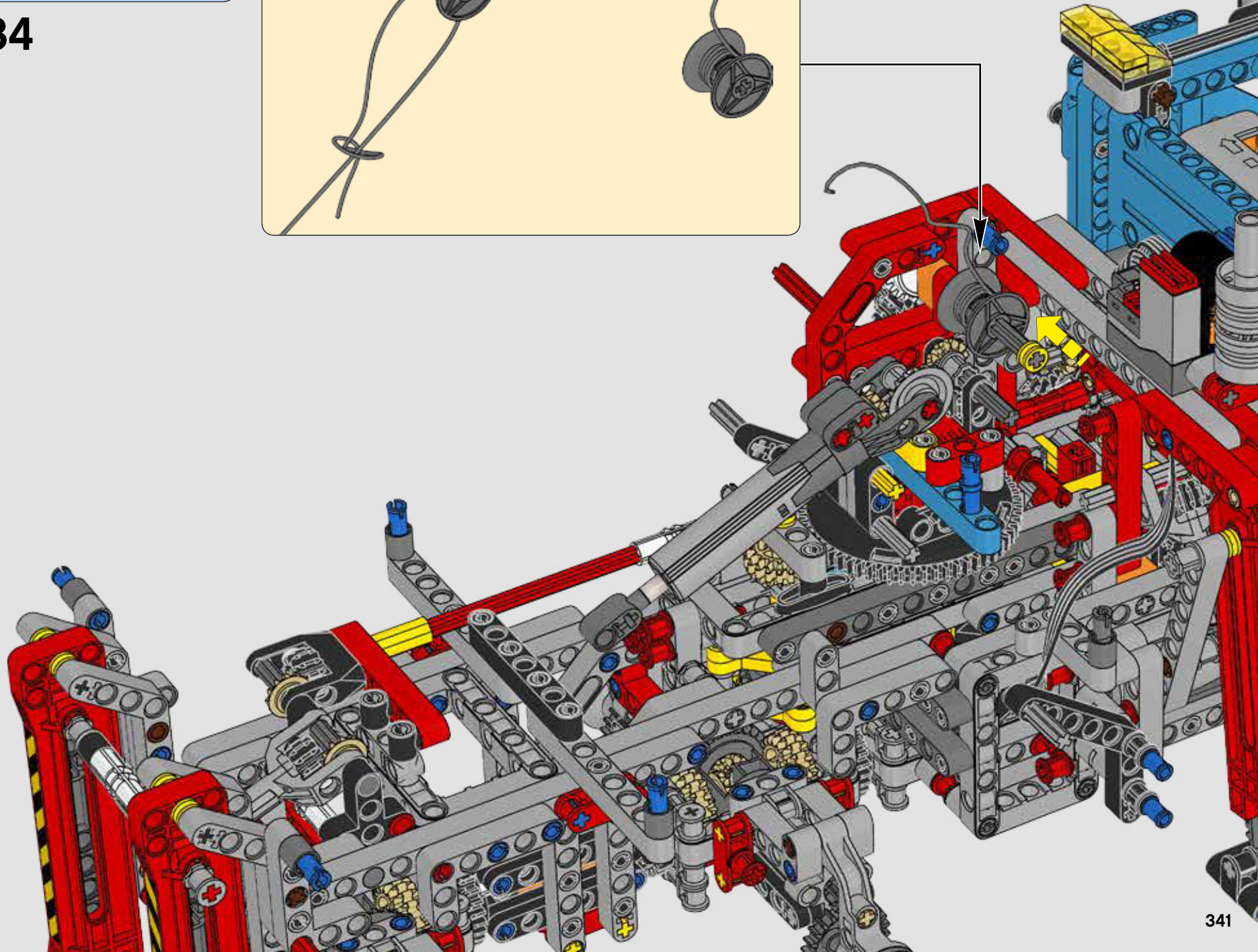
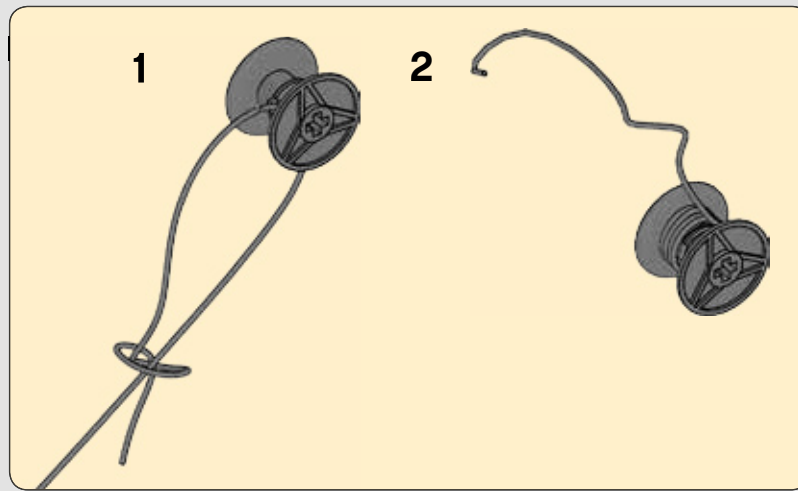

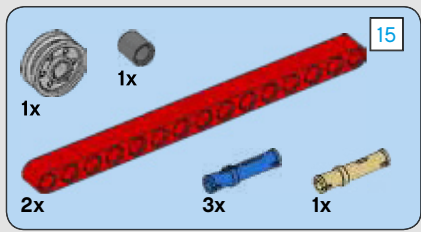

535

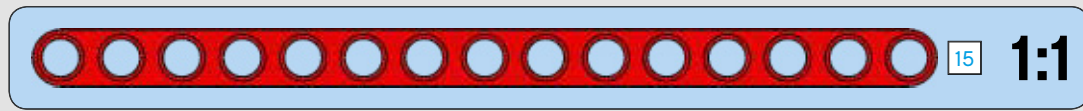

1

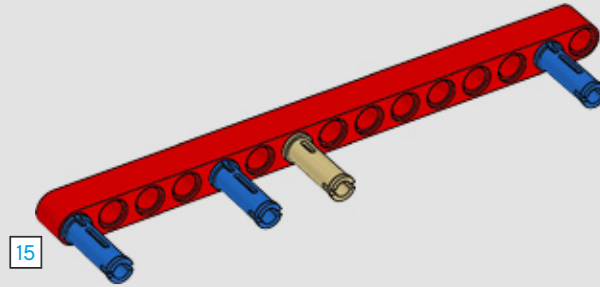

2

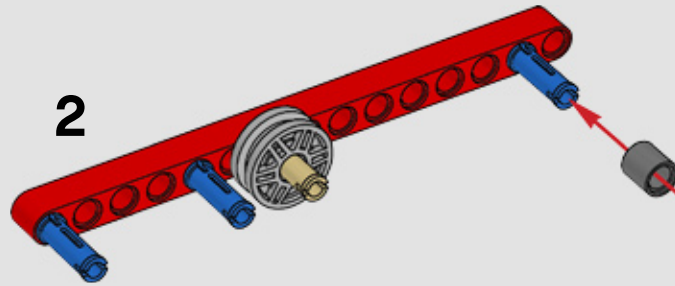

3

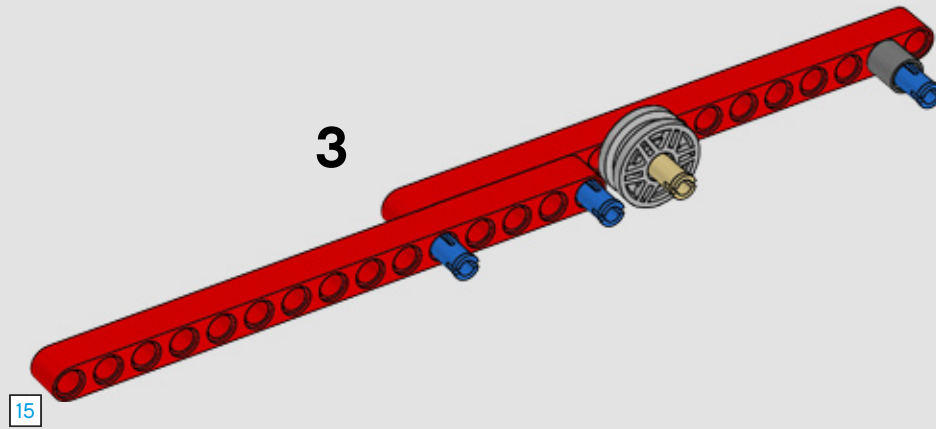



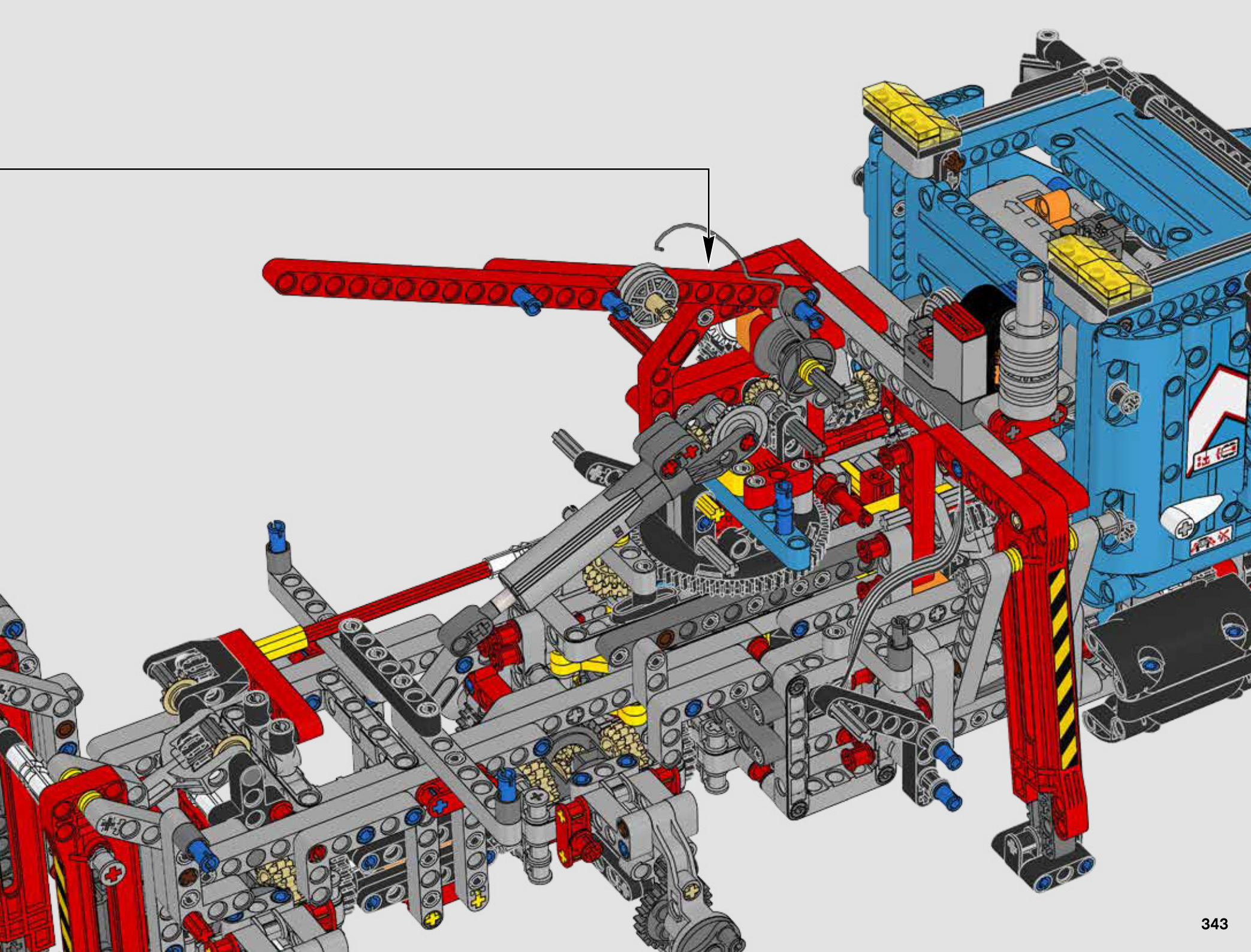



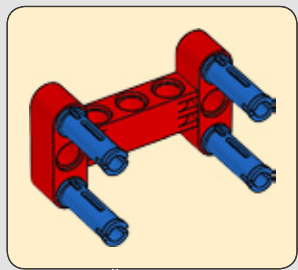
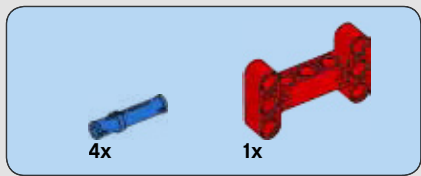

536

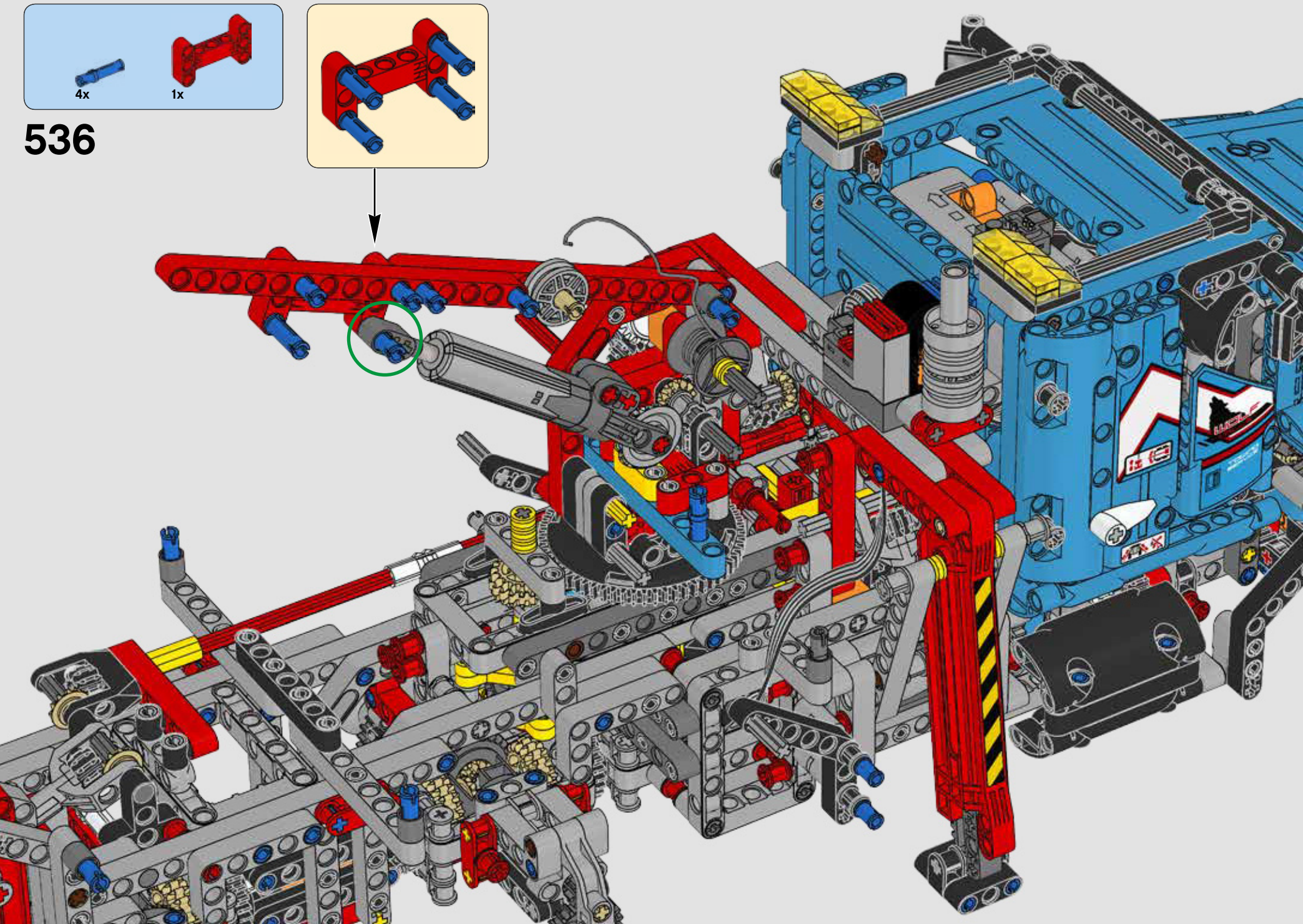



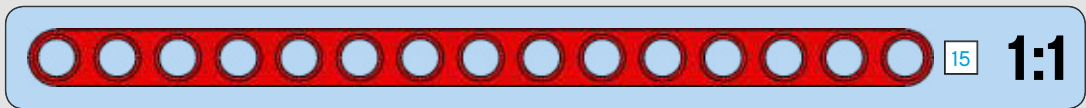
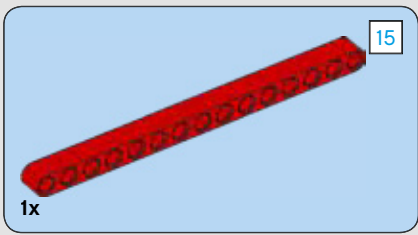

537

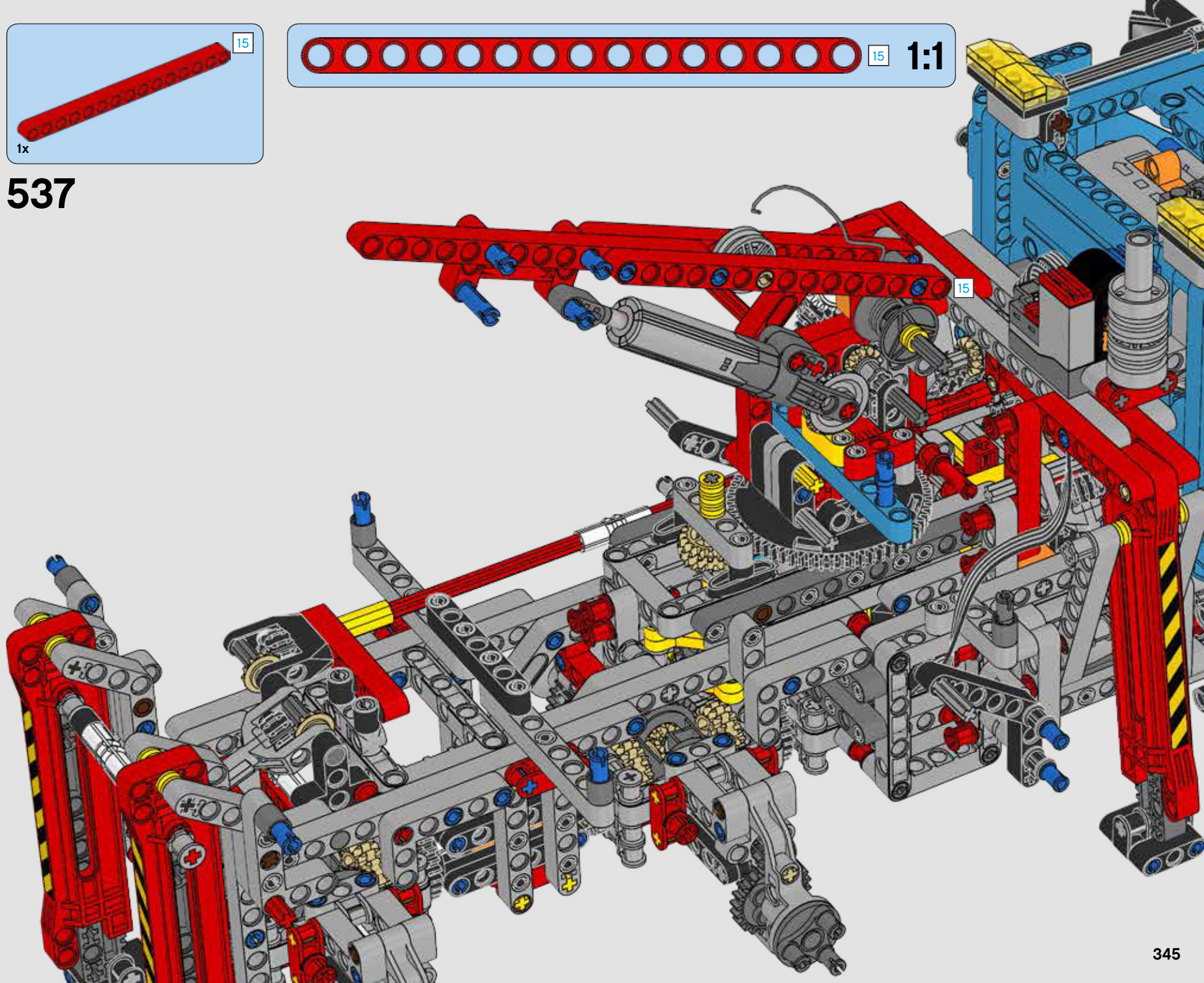



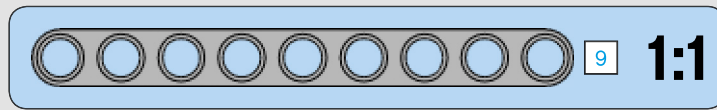
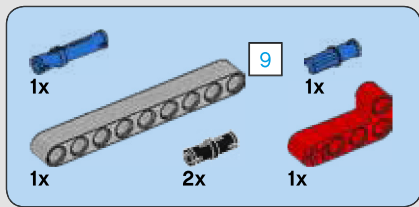

538

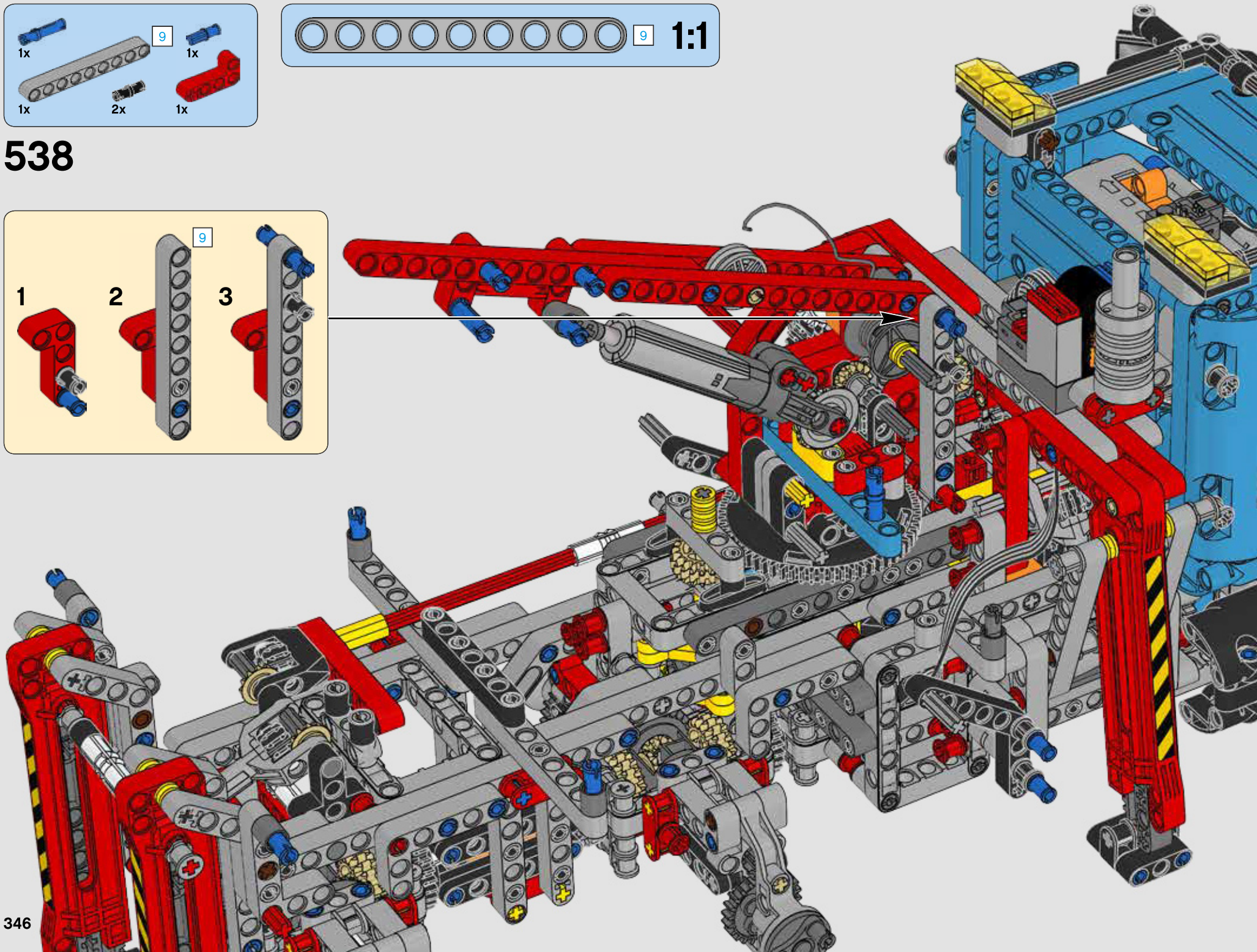
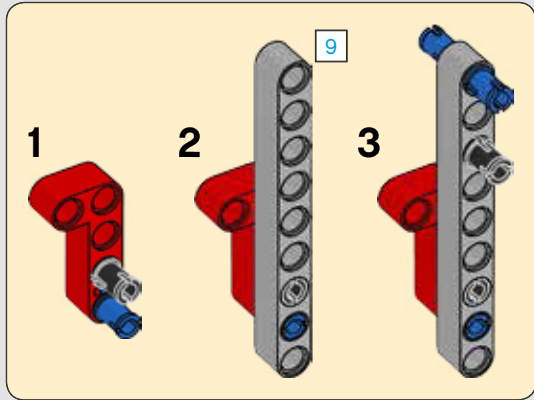



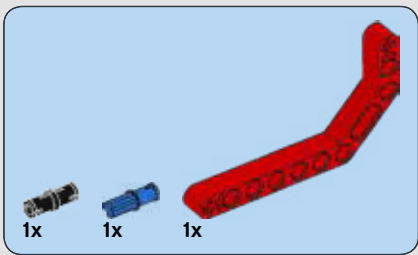

539

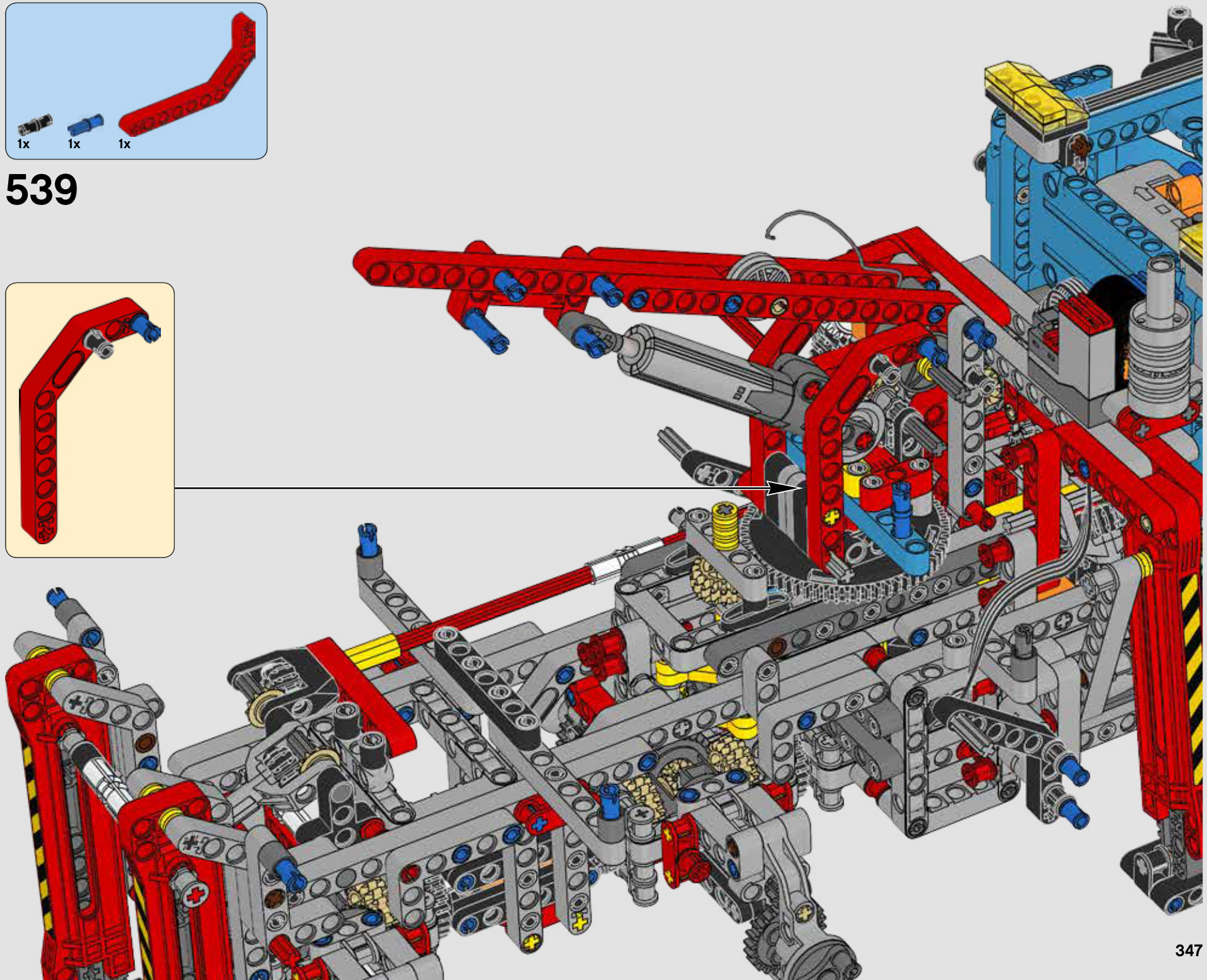
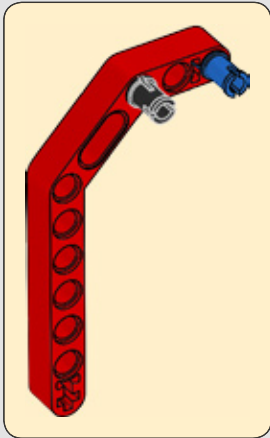



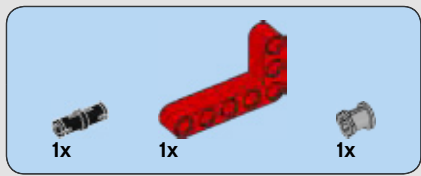

540

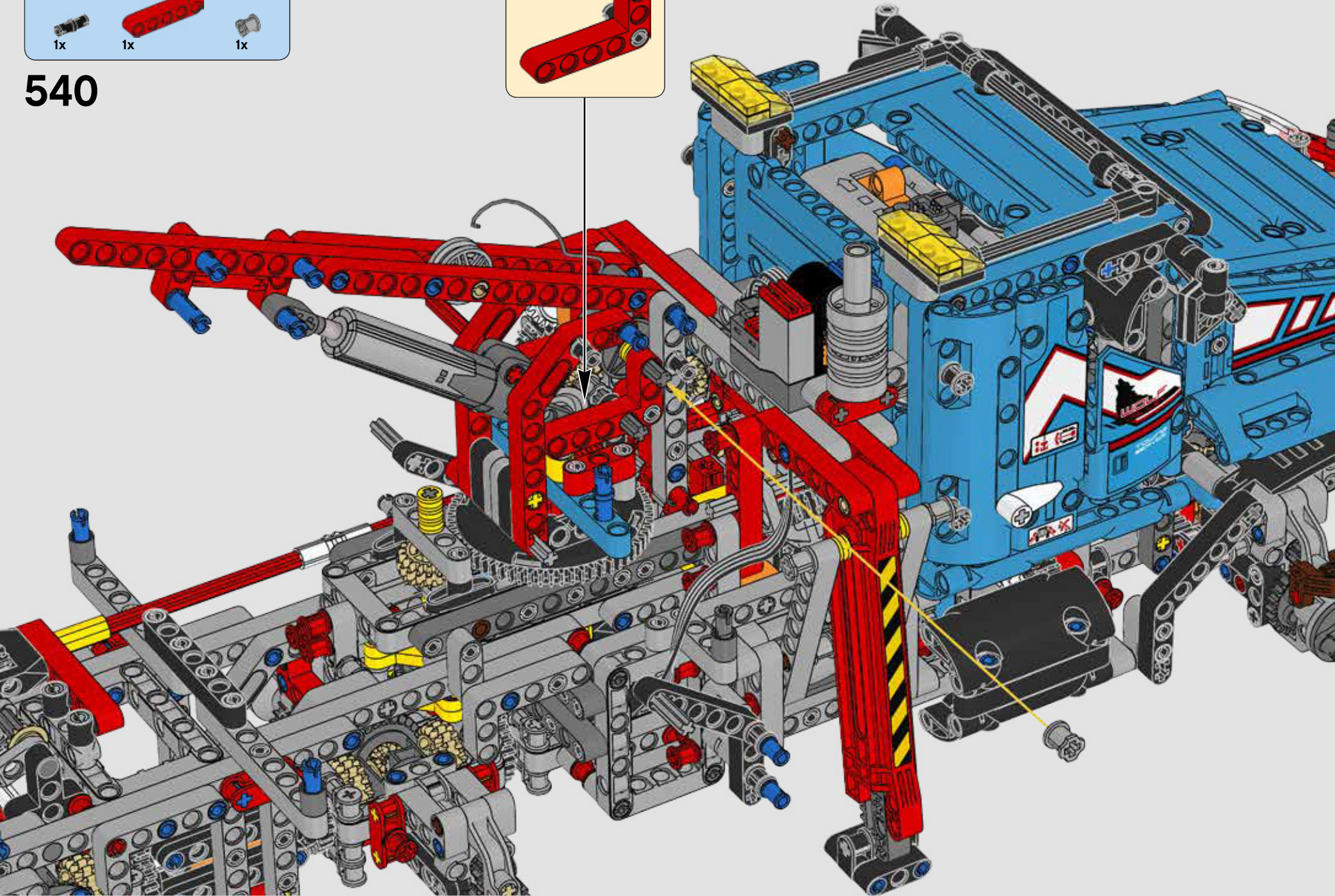
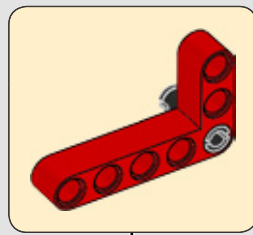



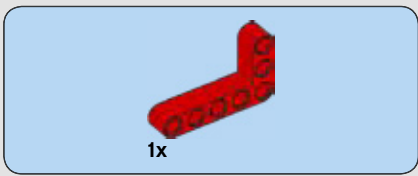

541

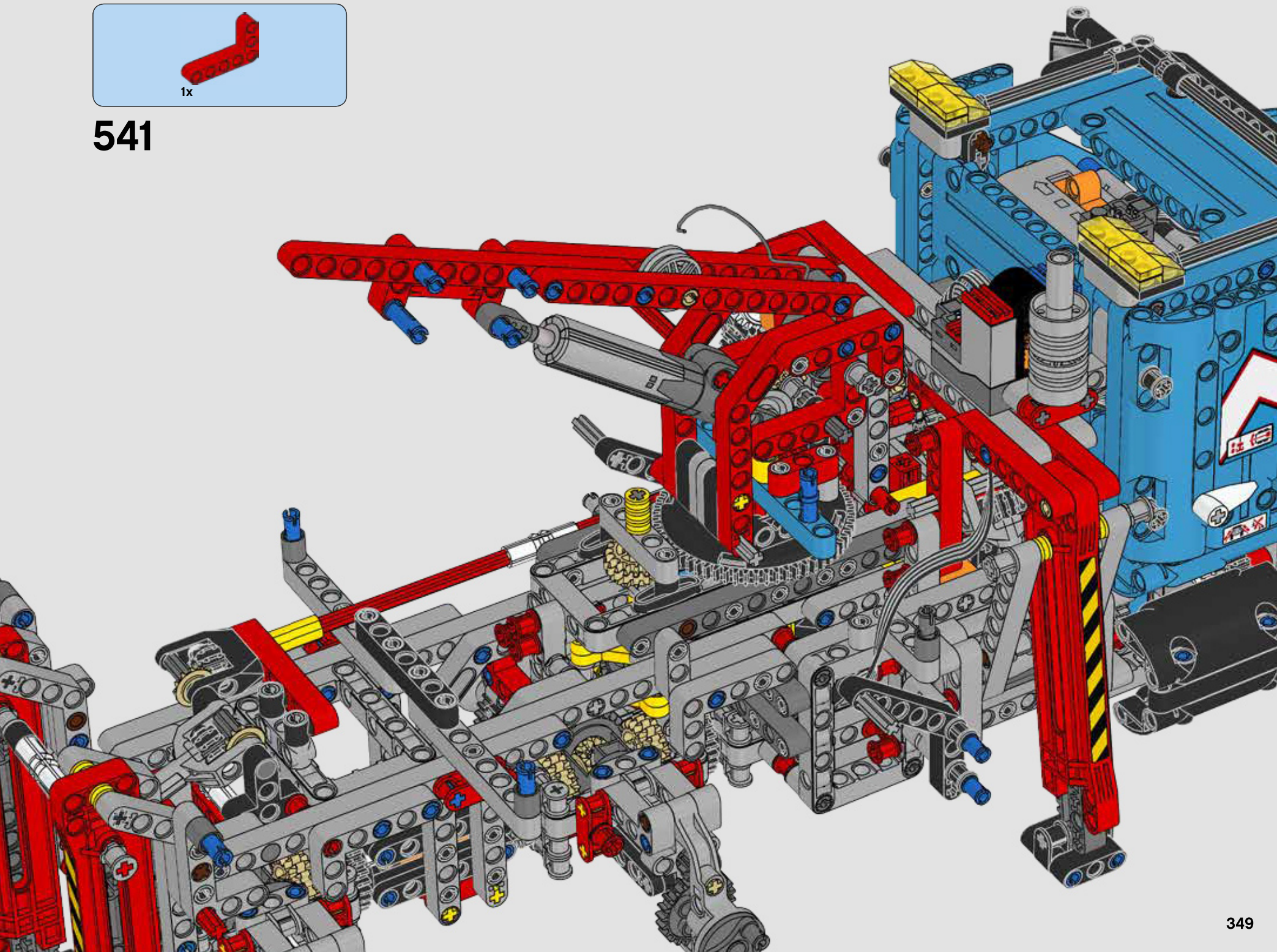



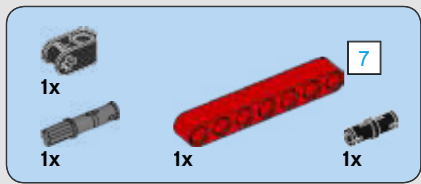

542

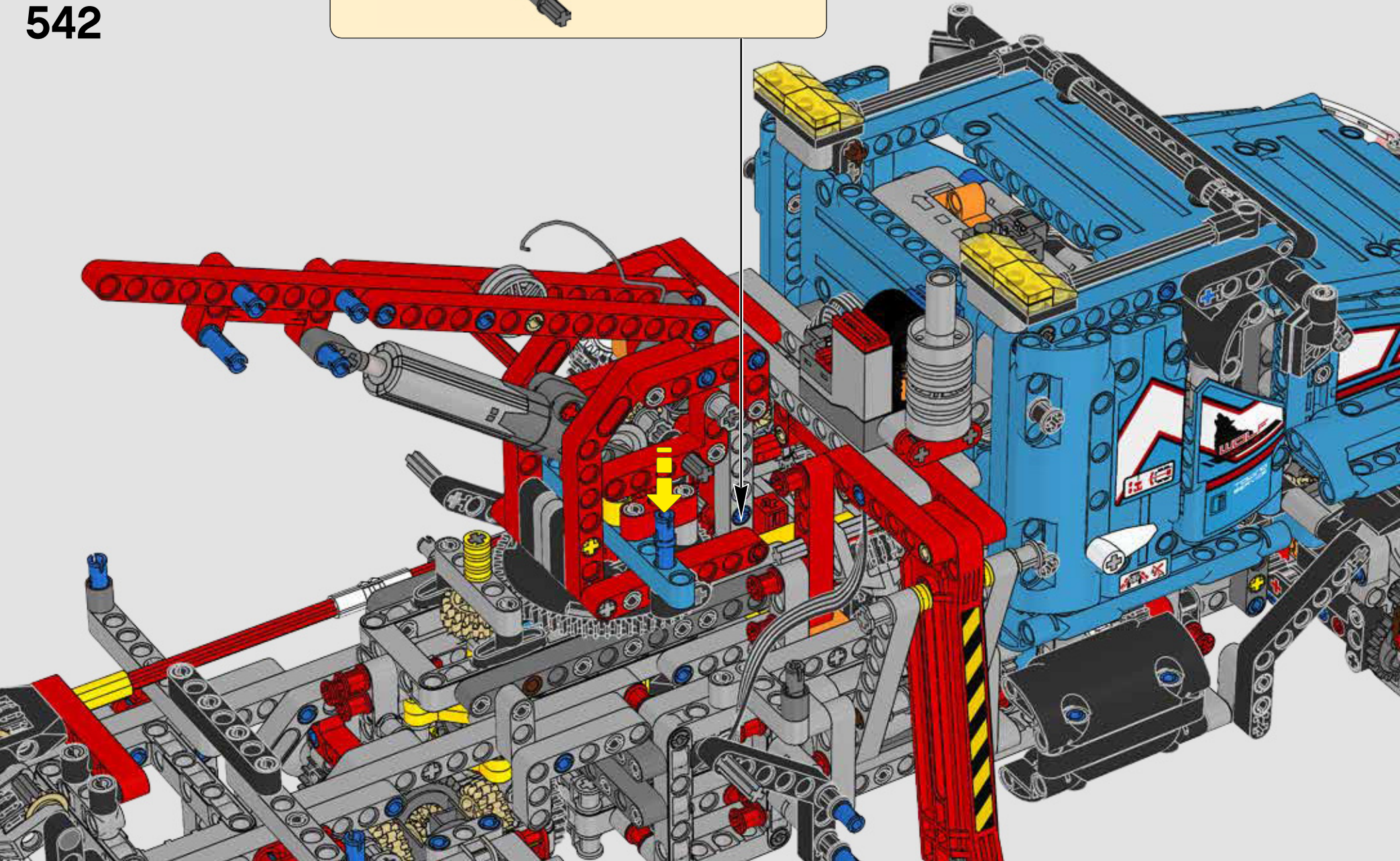
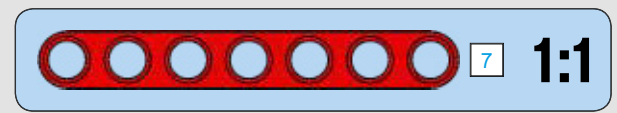
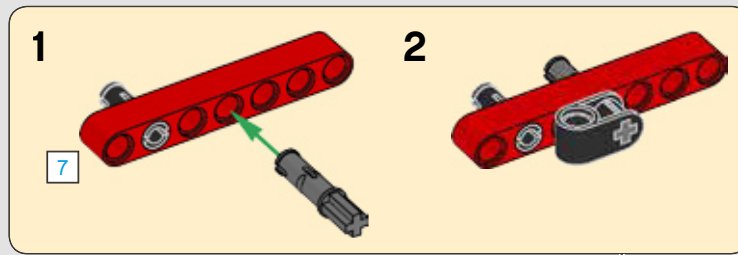



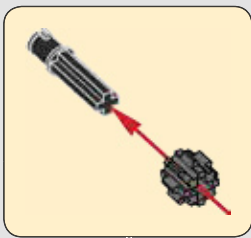
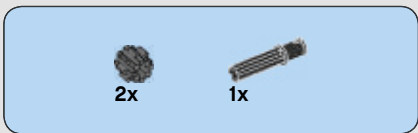

543

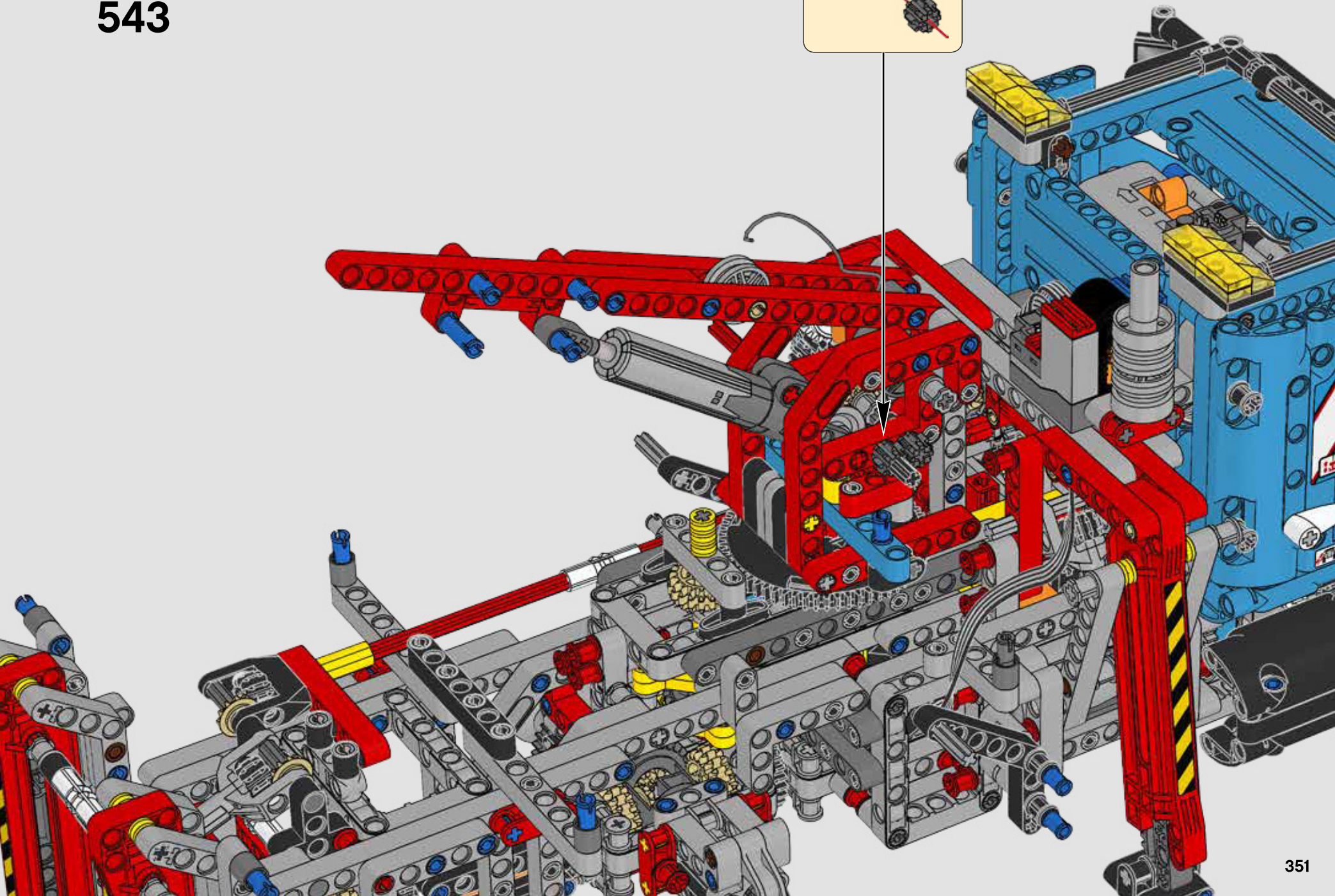



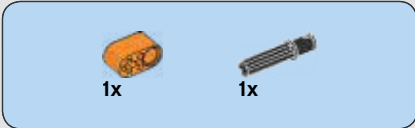

544

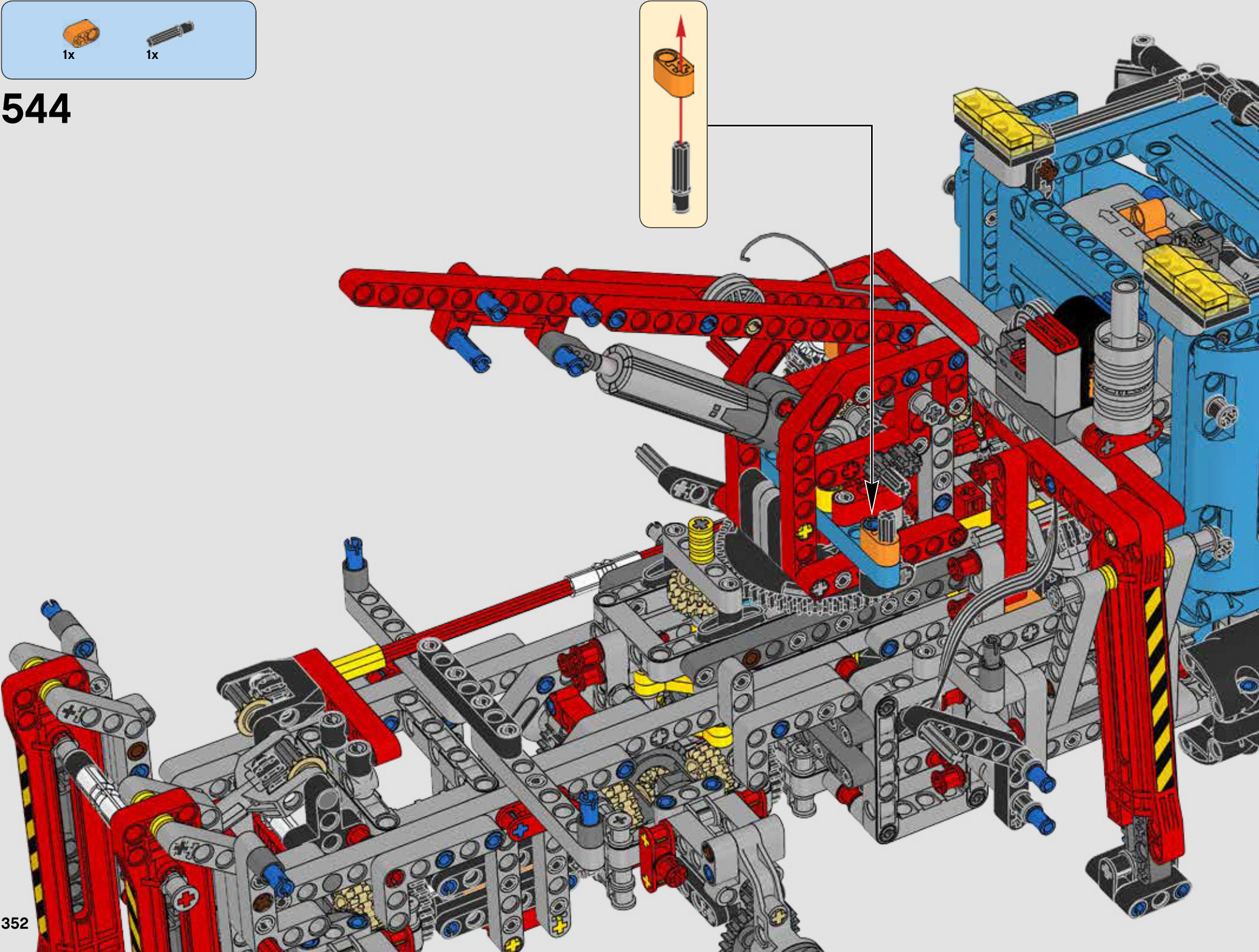



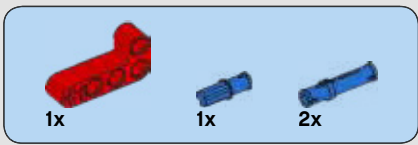

545

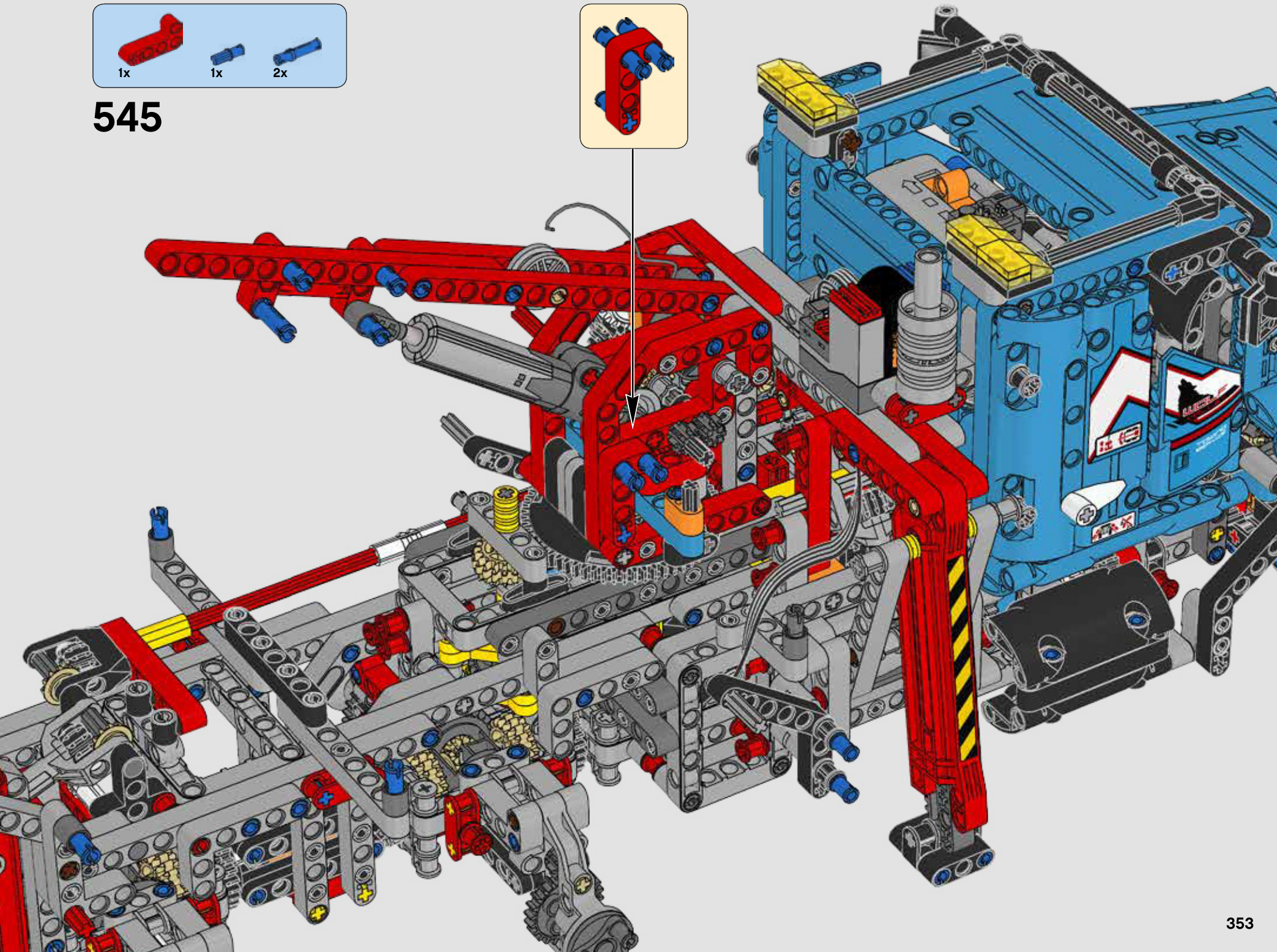
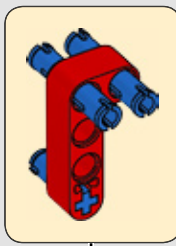





546

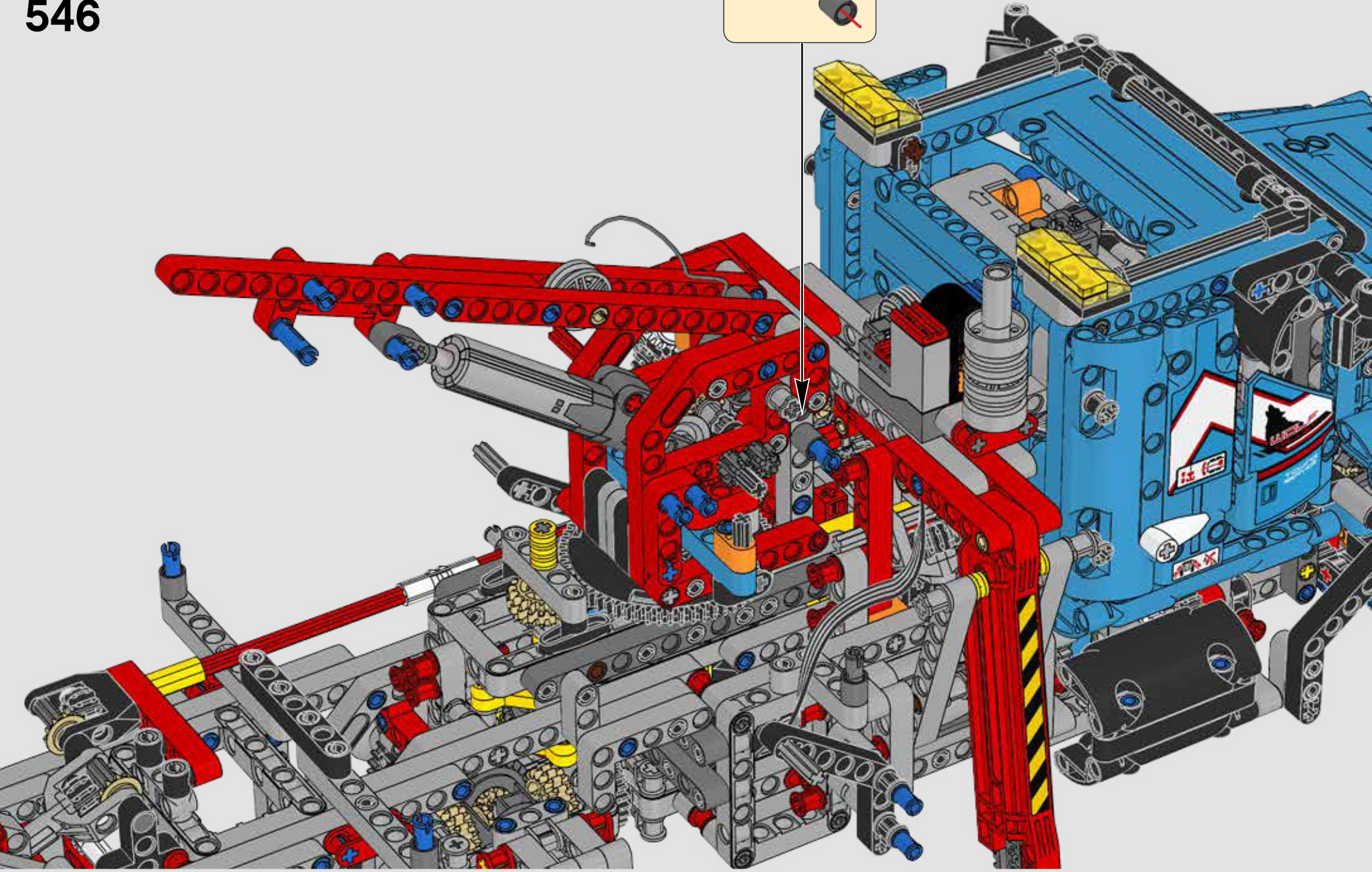
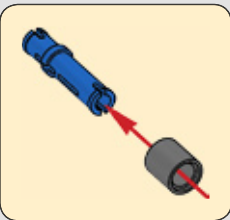



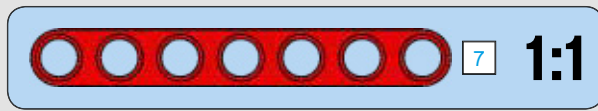
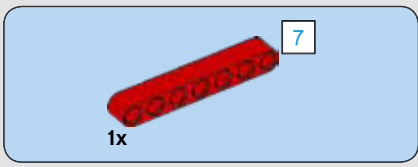

547

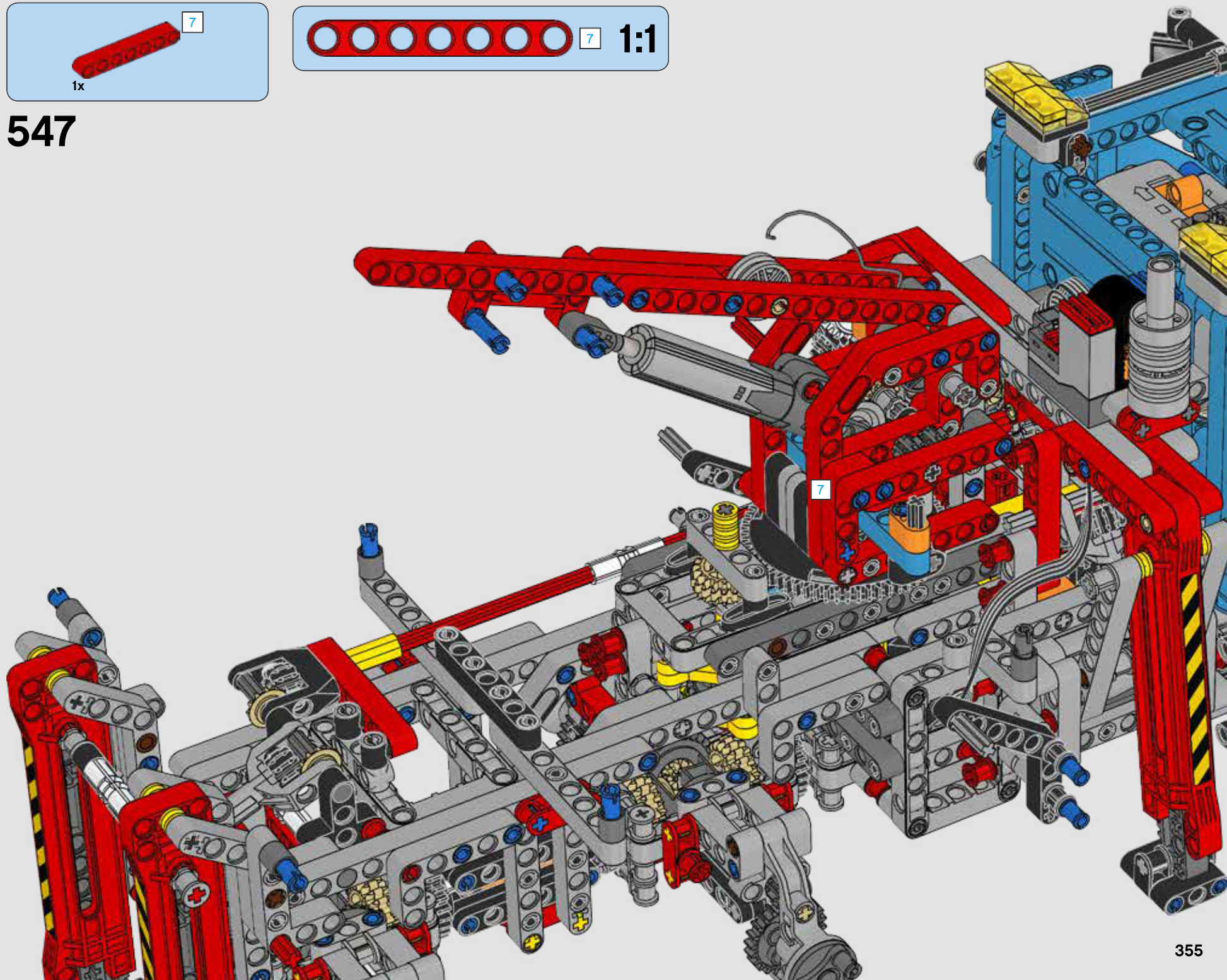





1x

548

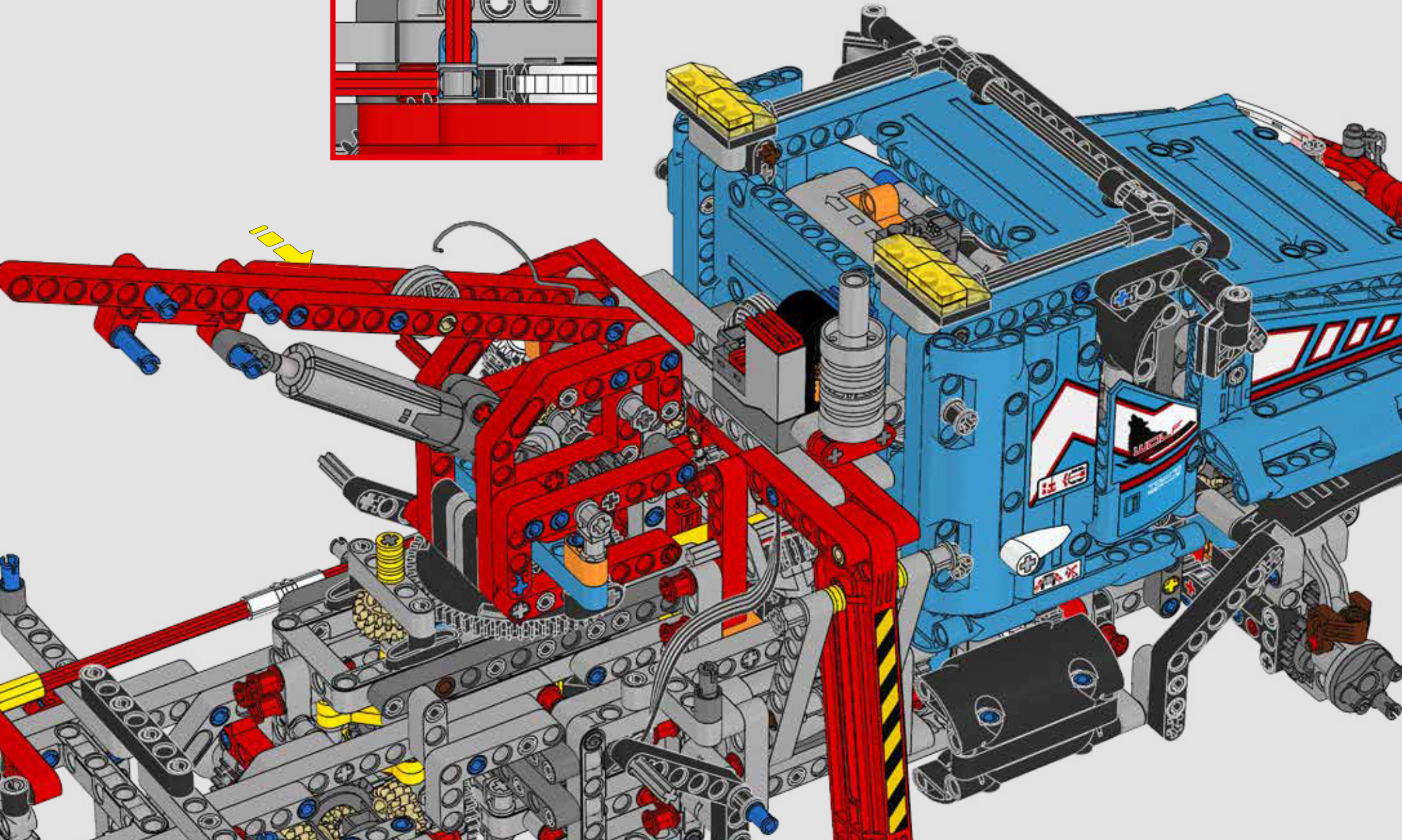
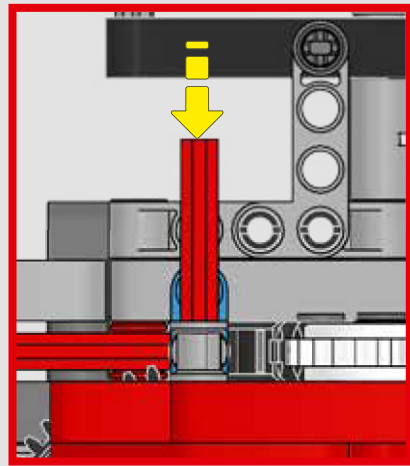



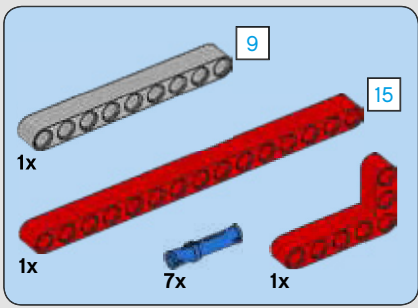

549

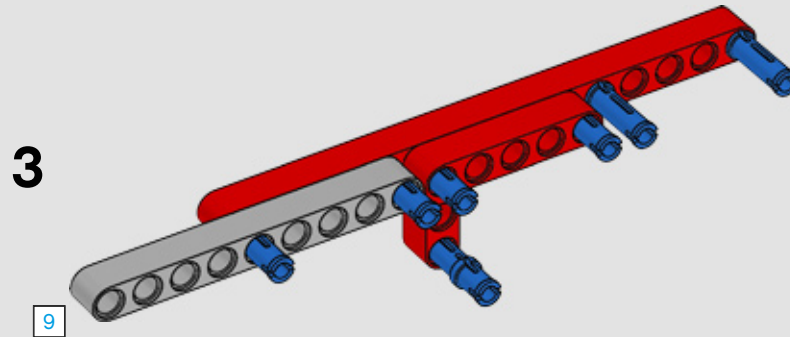
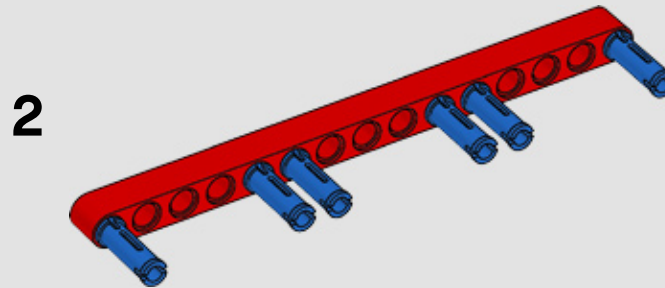
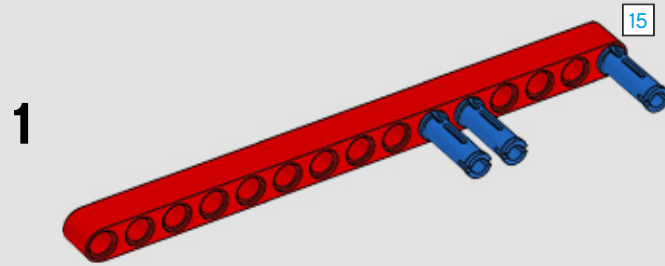
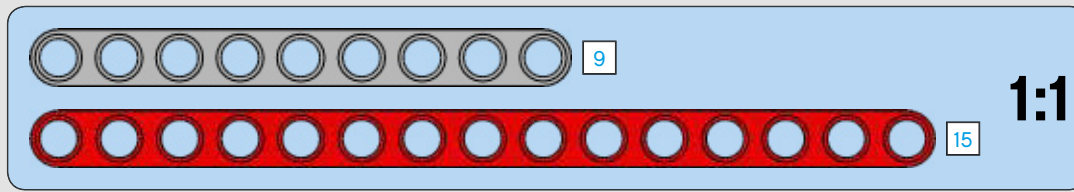

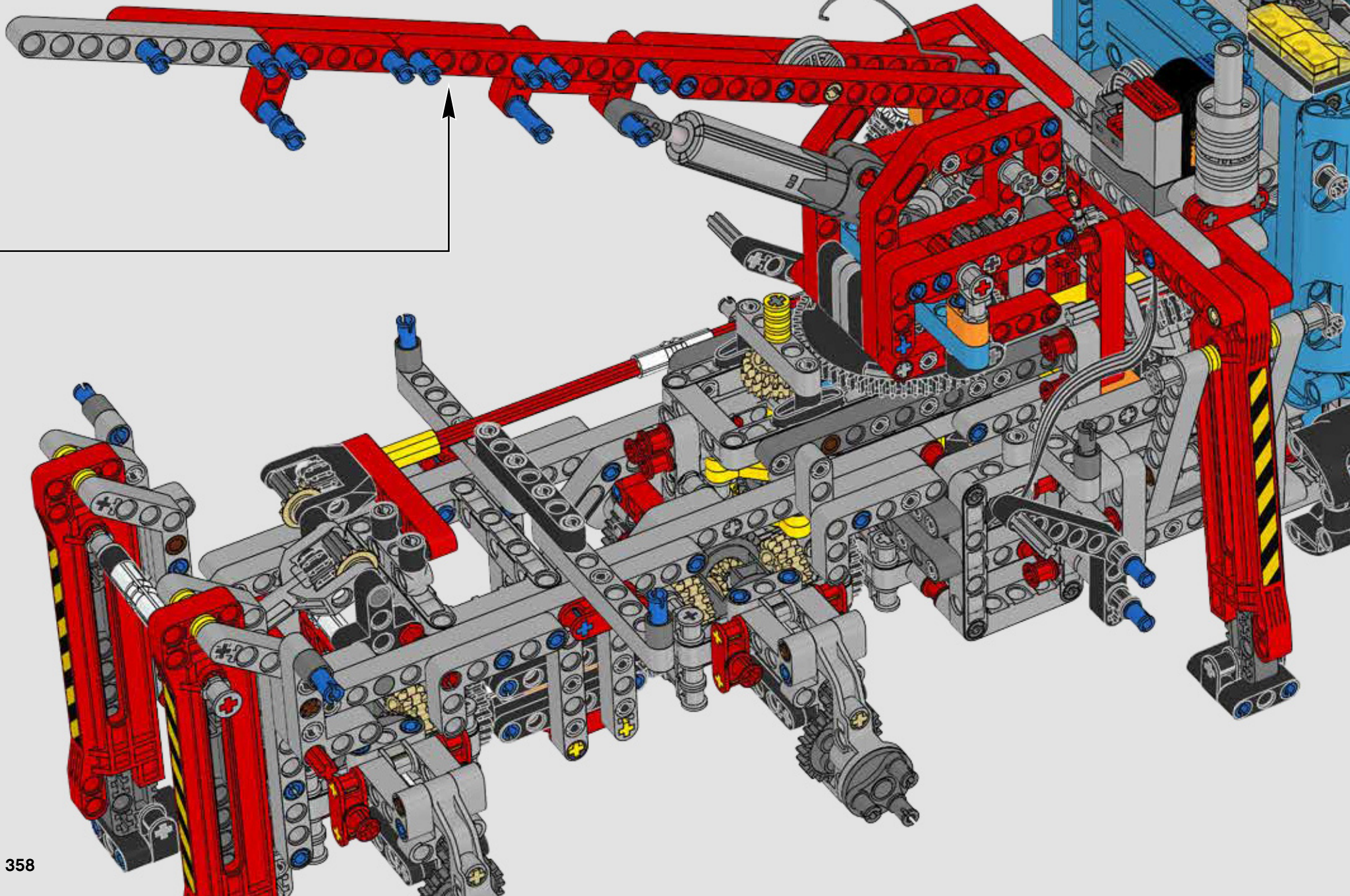



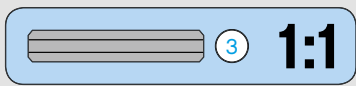
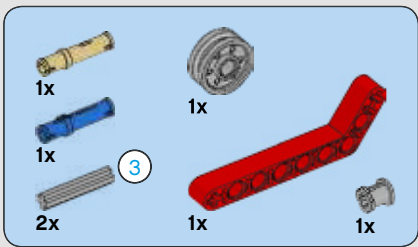

550

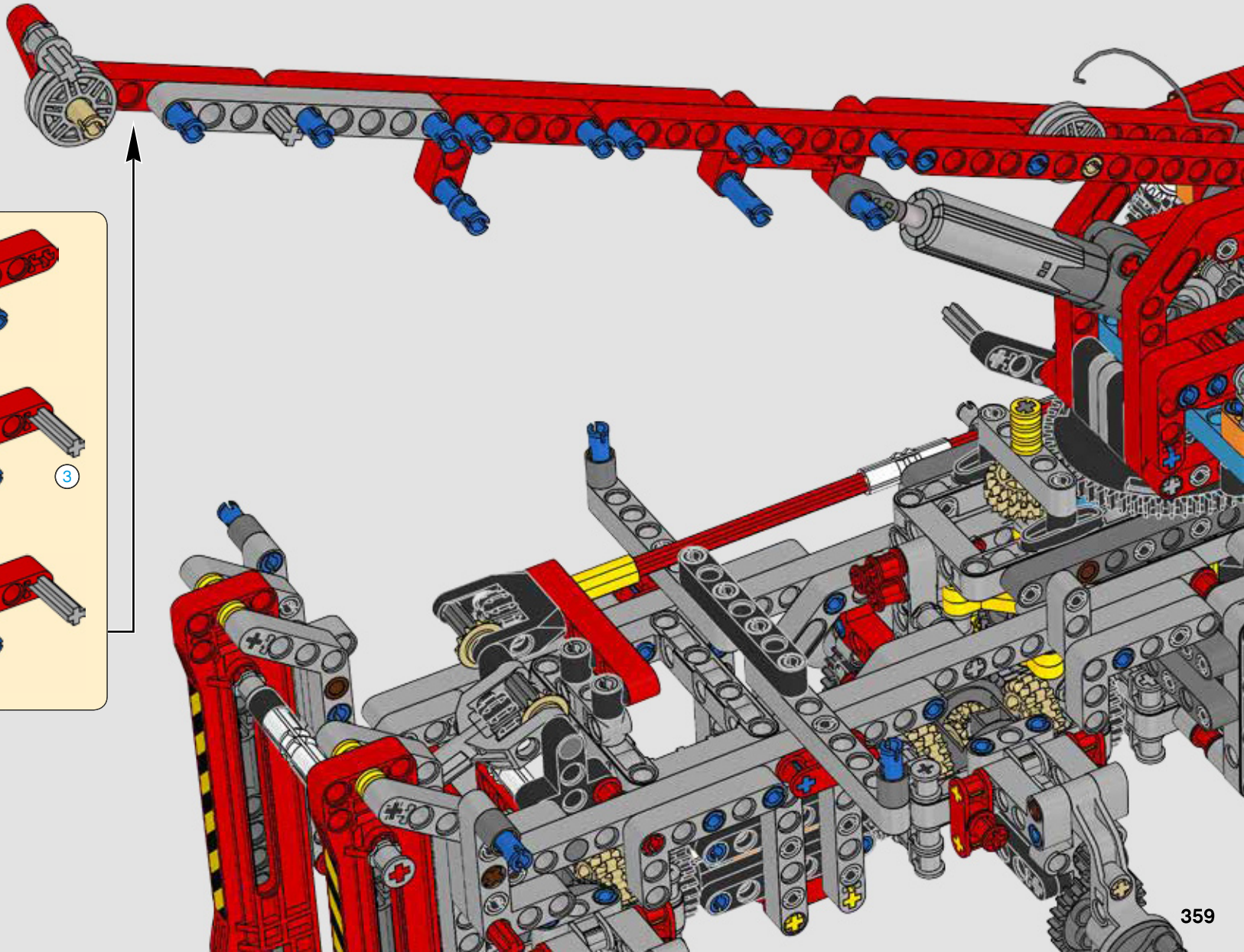
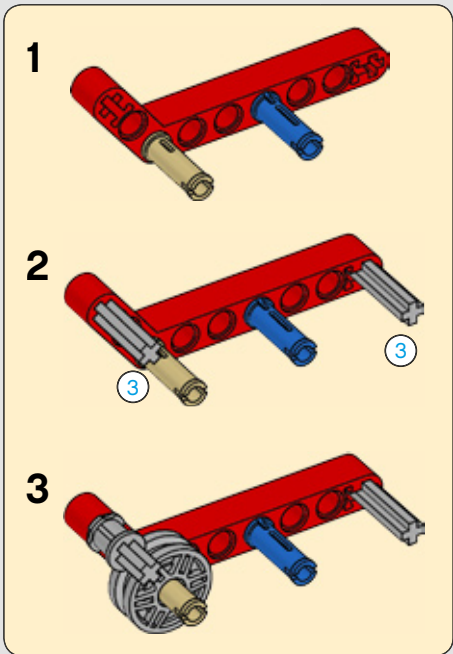



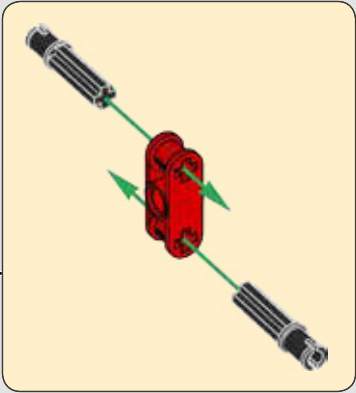

551

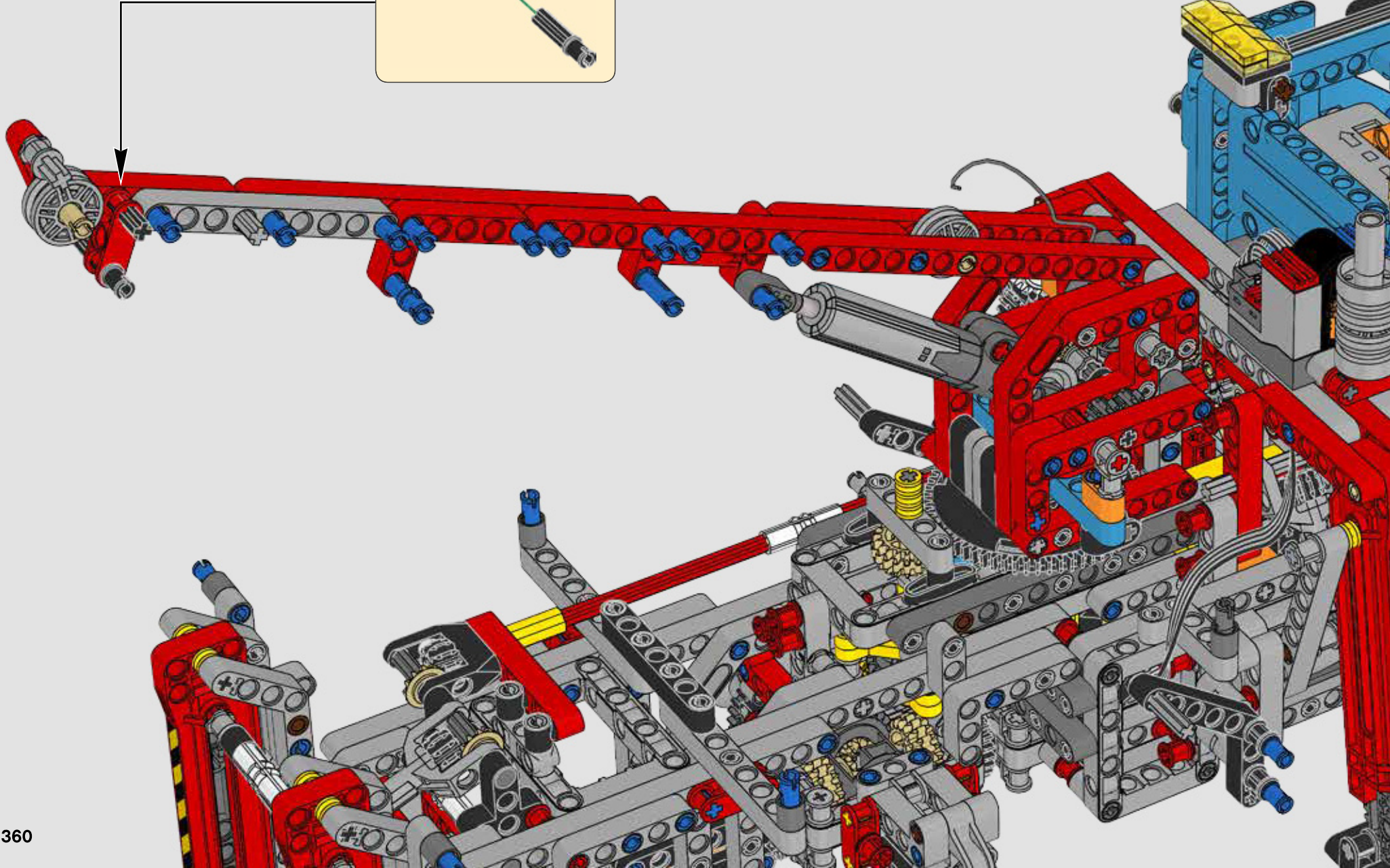



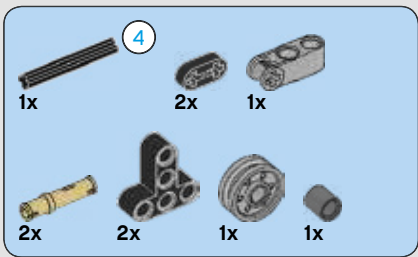

552

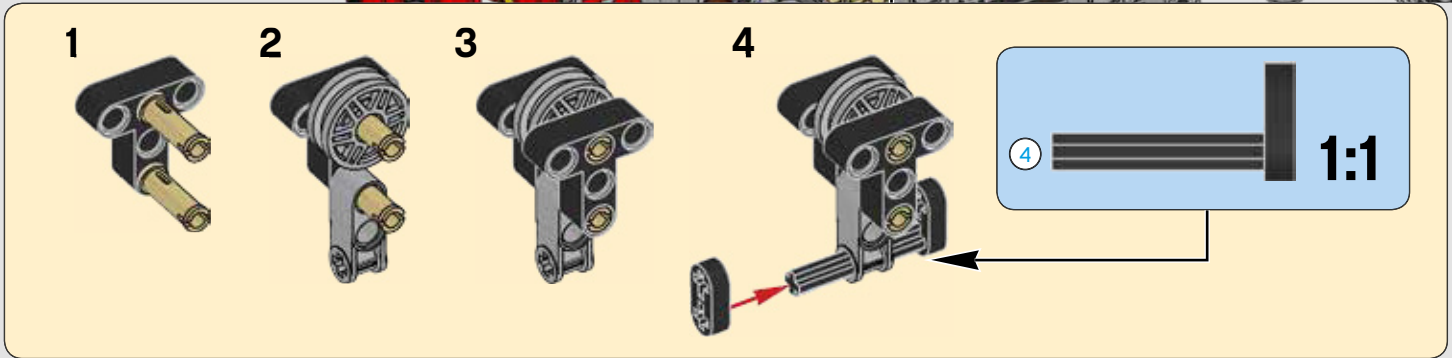
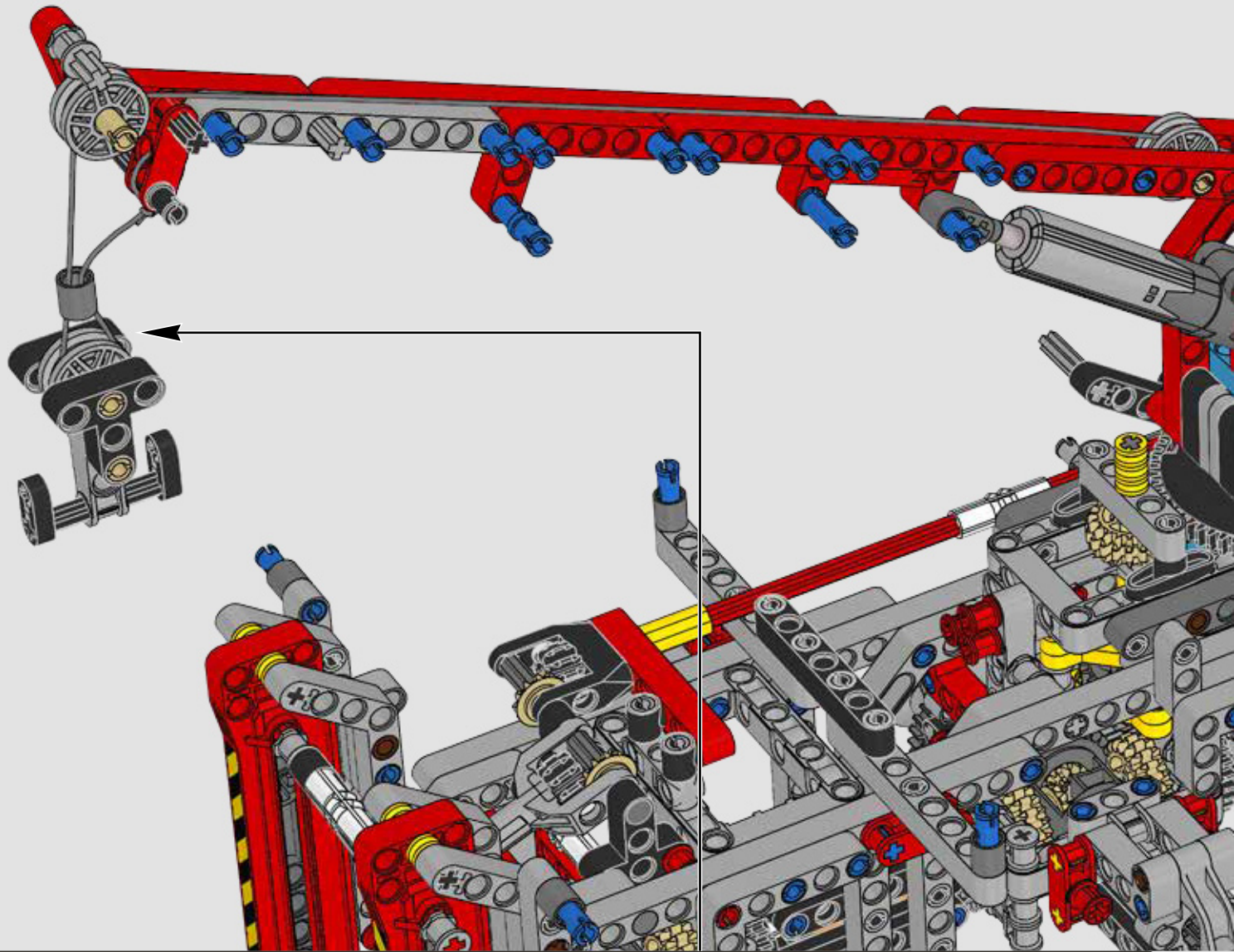
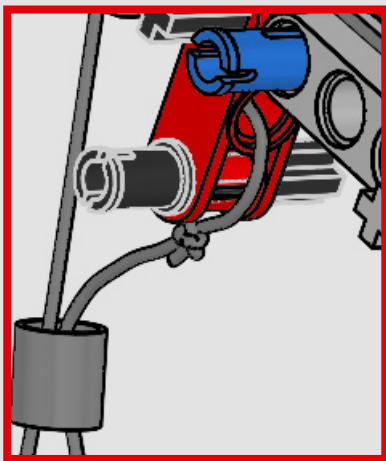
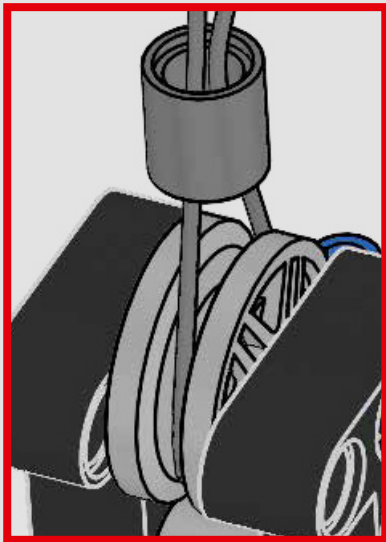



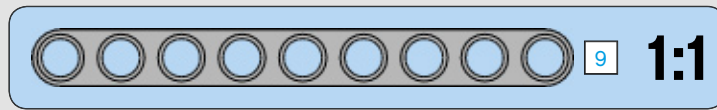
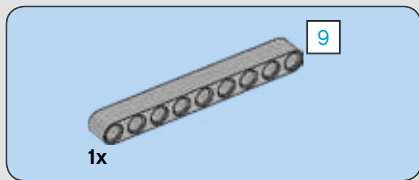

553

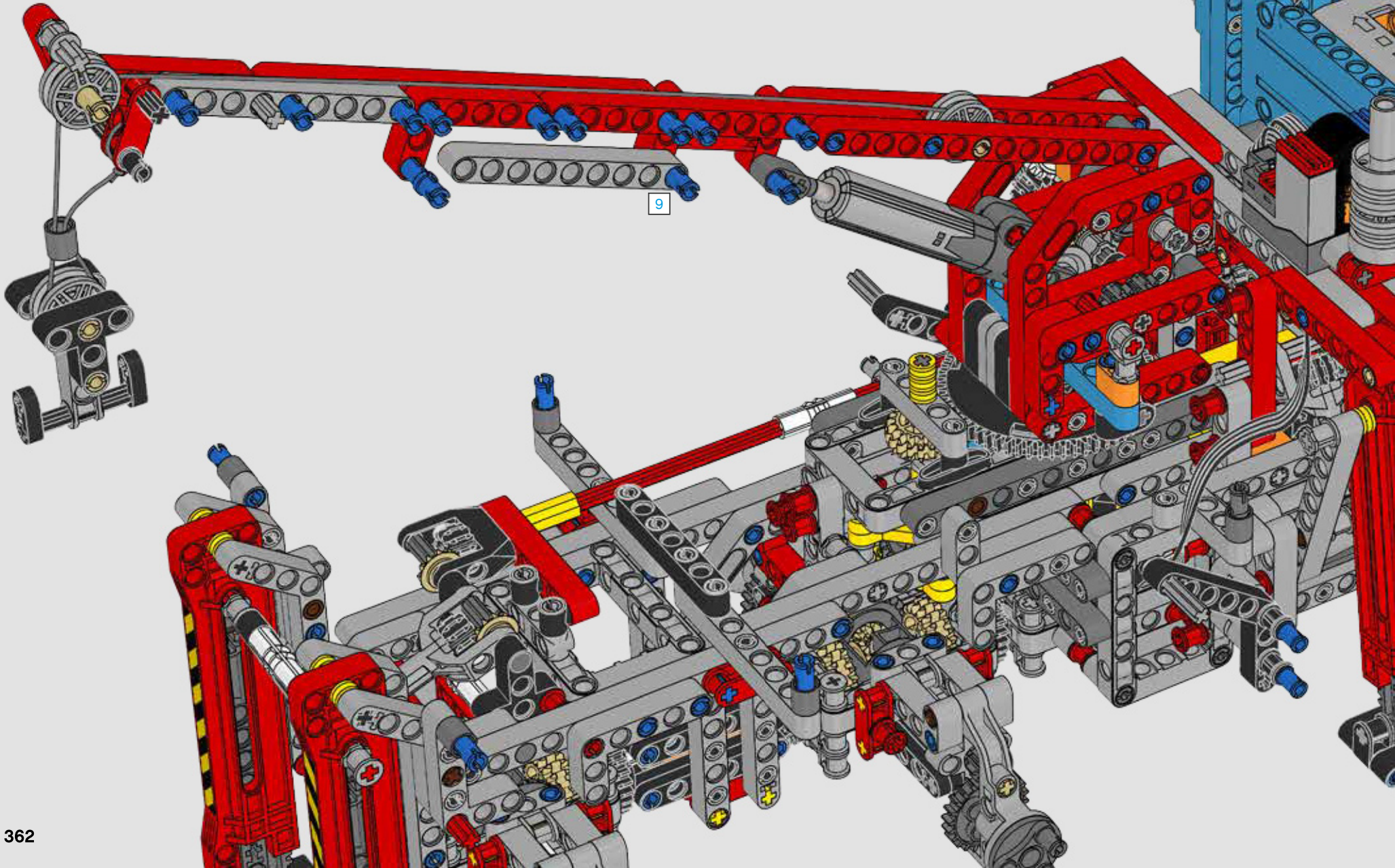



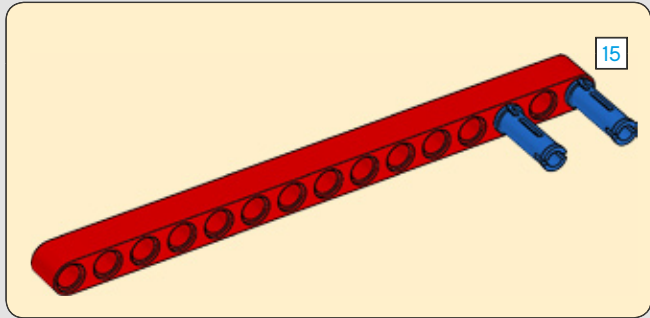
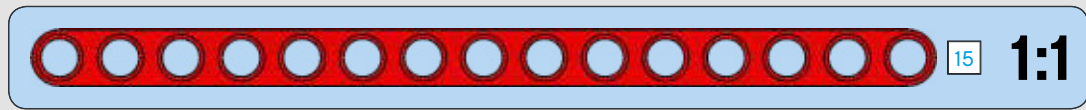
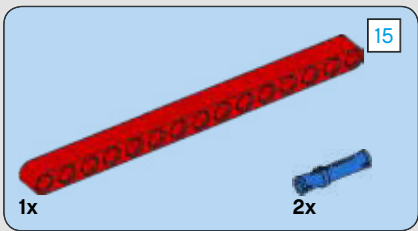

554

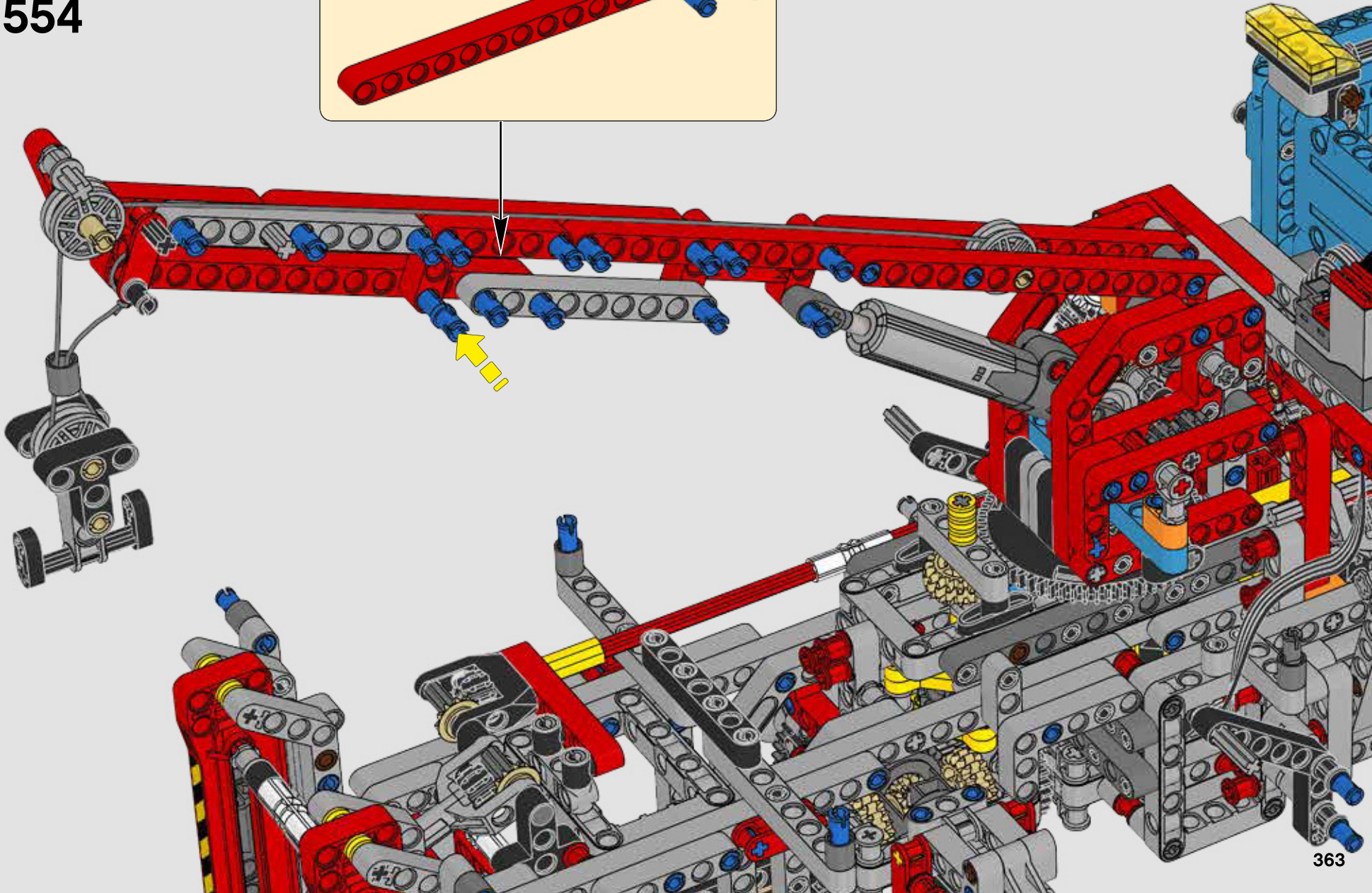



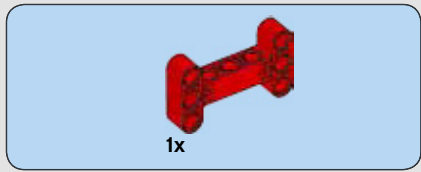

555

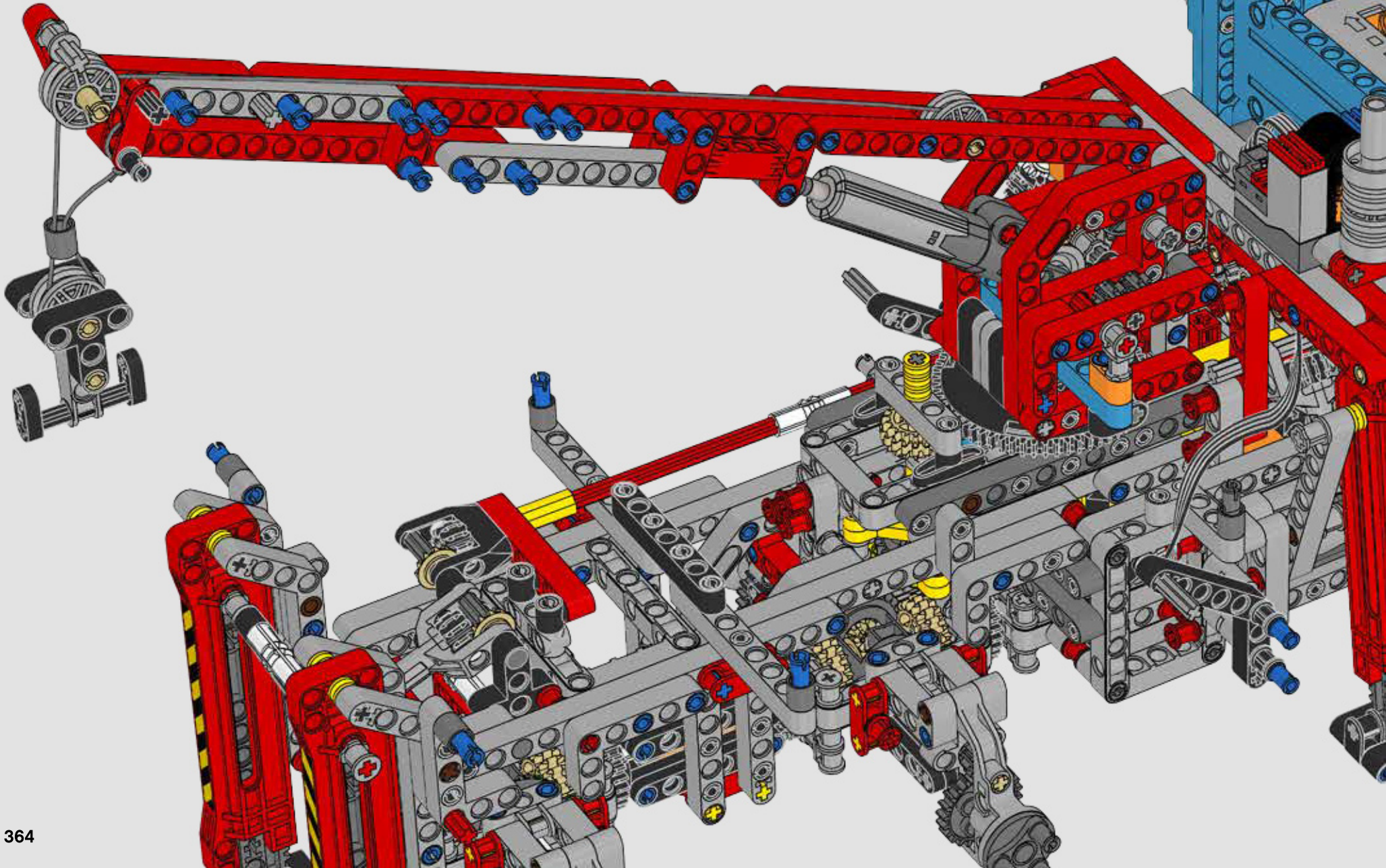



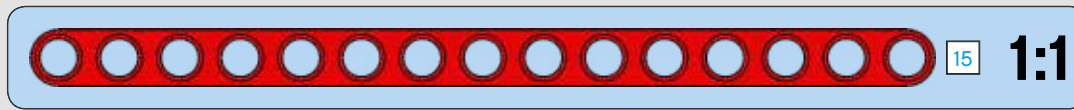
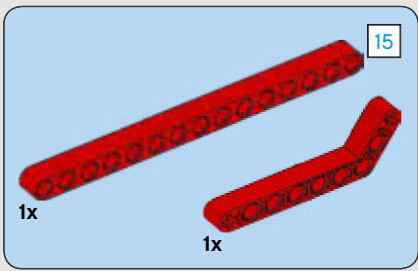

556

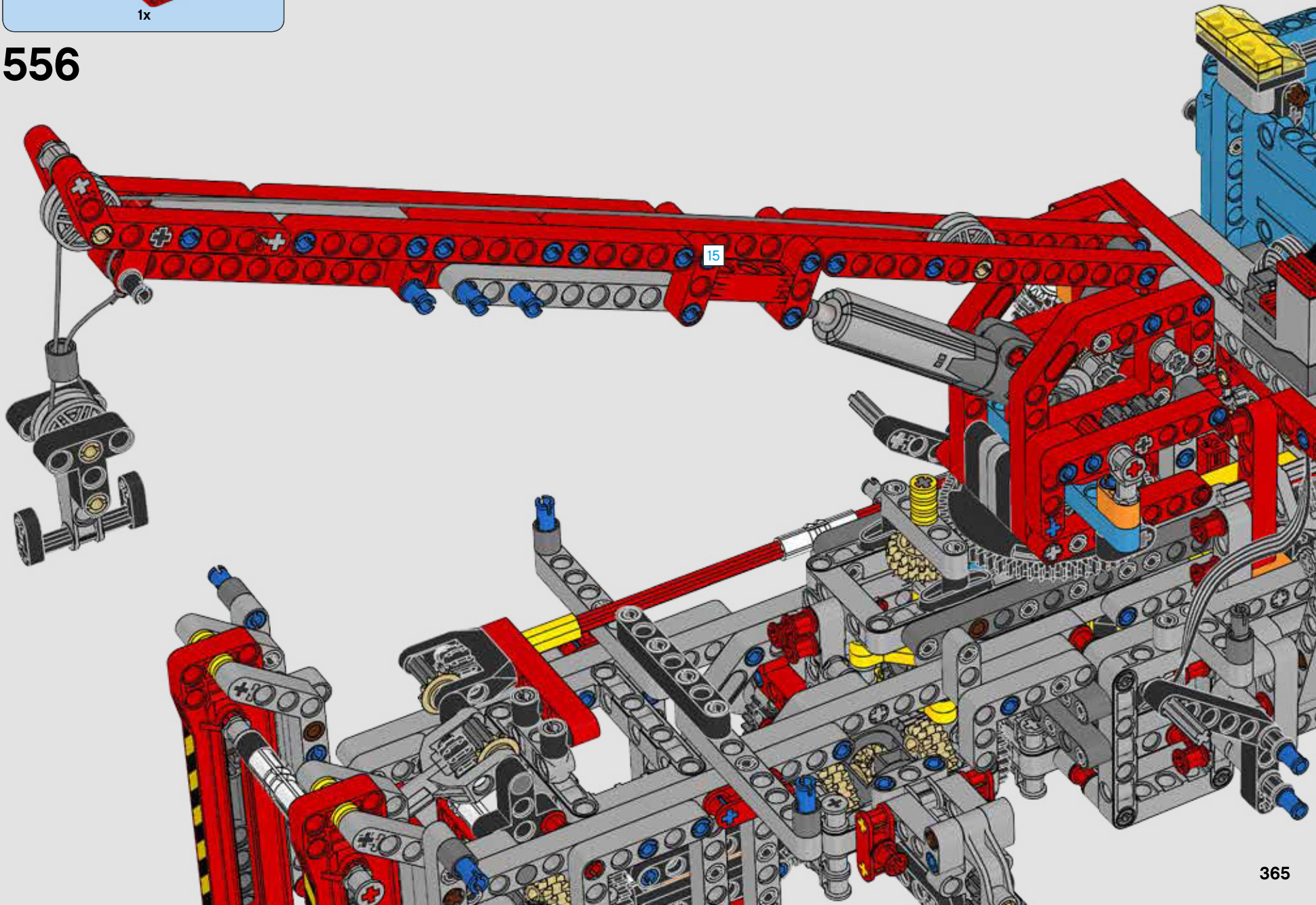



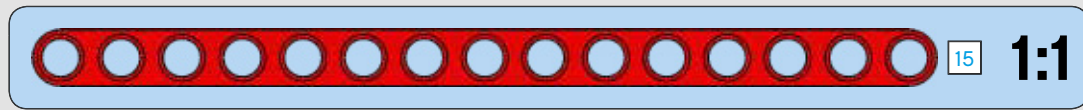
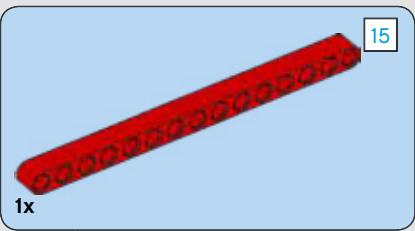

557

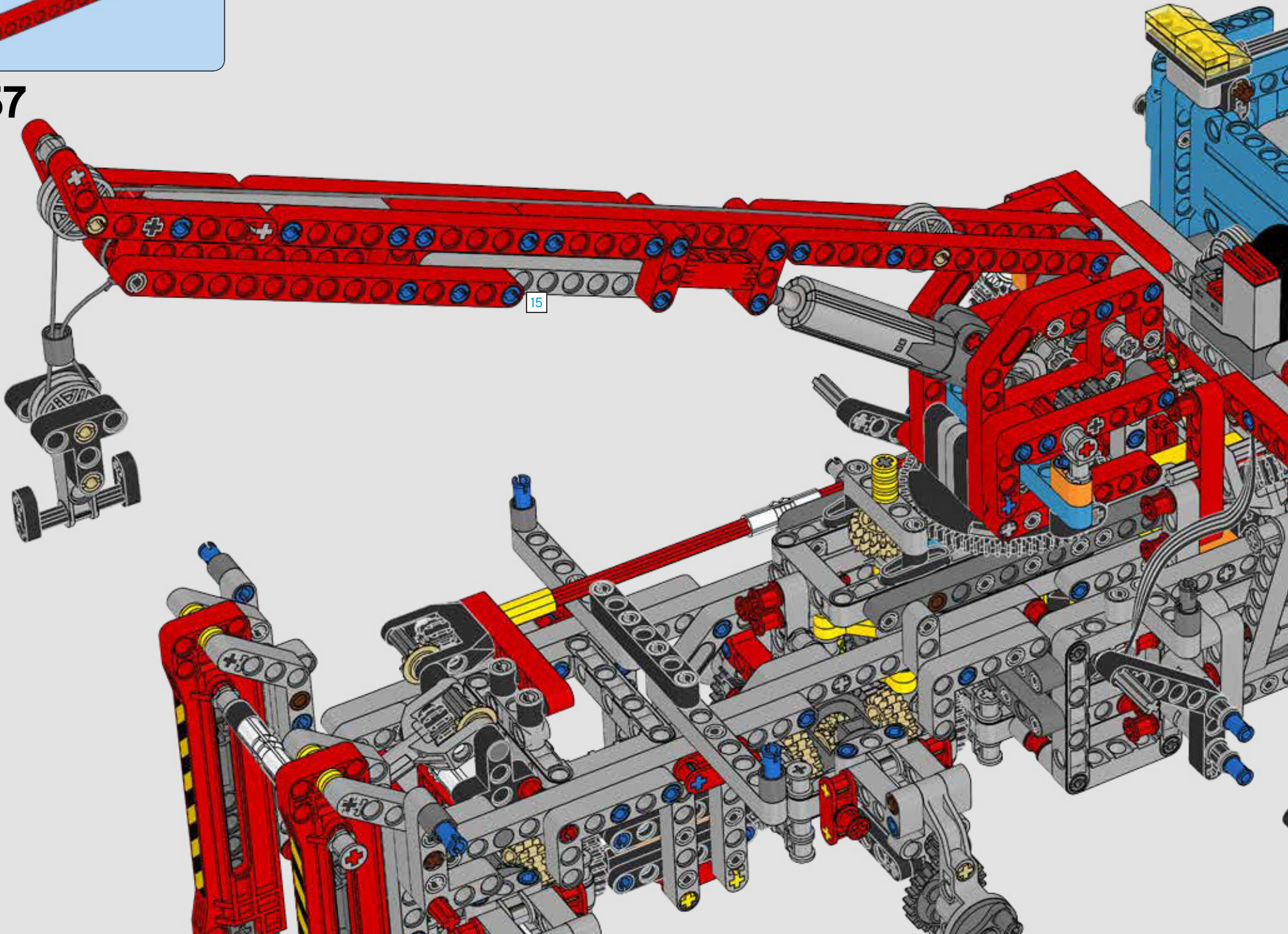



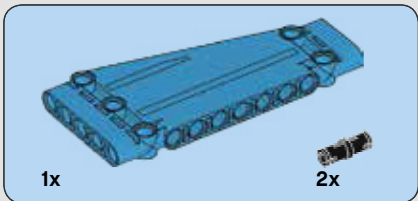
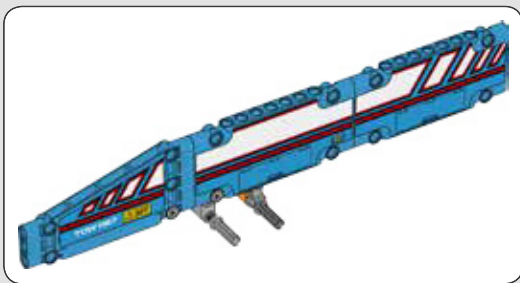

**558**

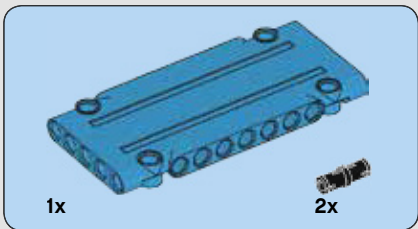
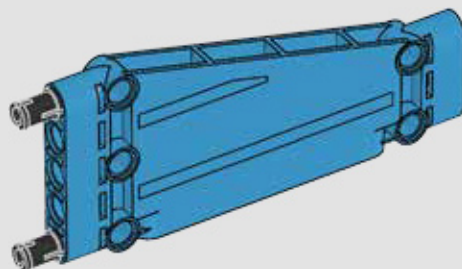

**559**

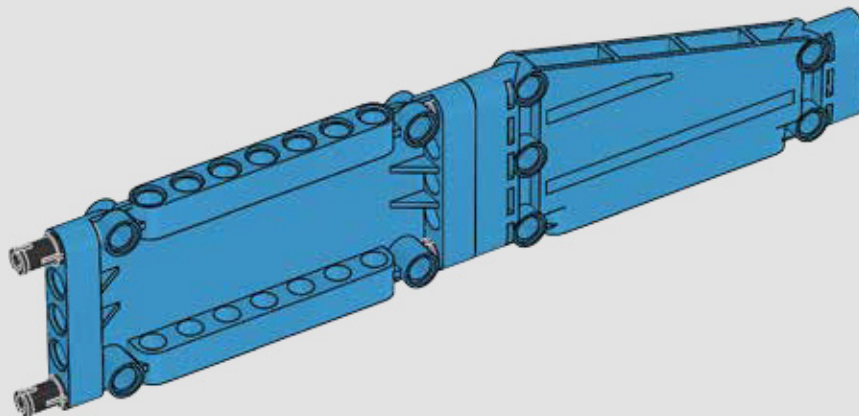

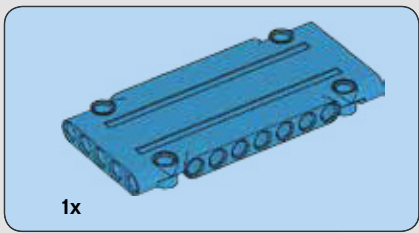

560

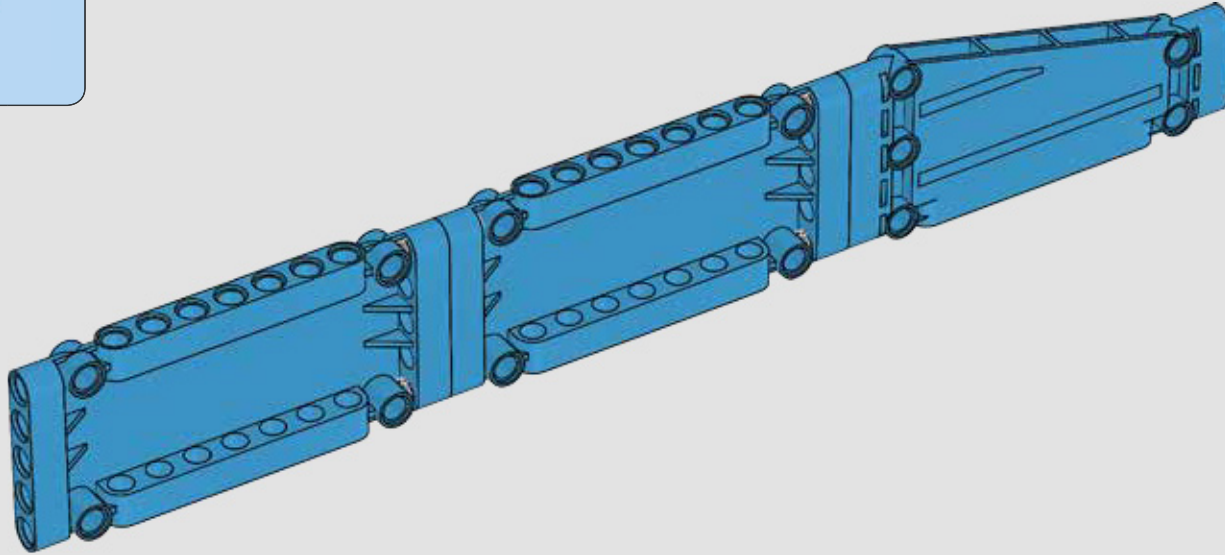

561

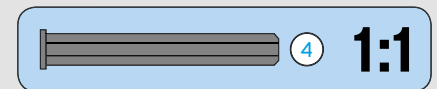
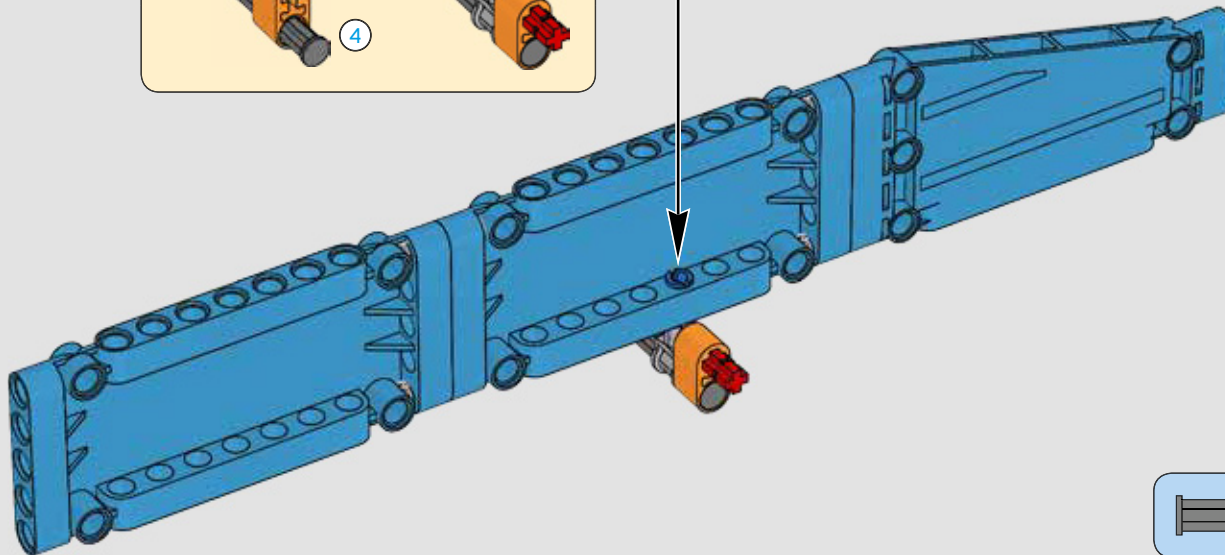
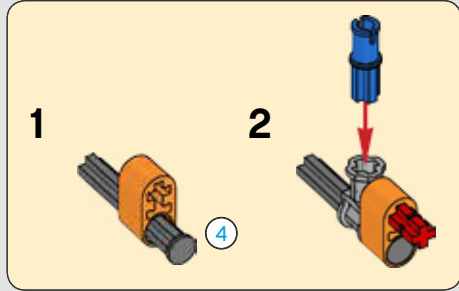



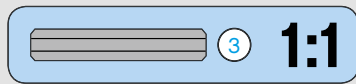
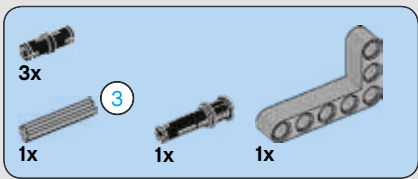

562

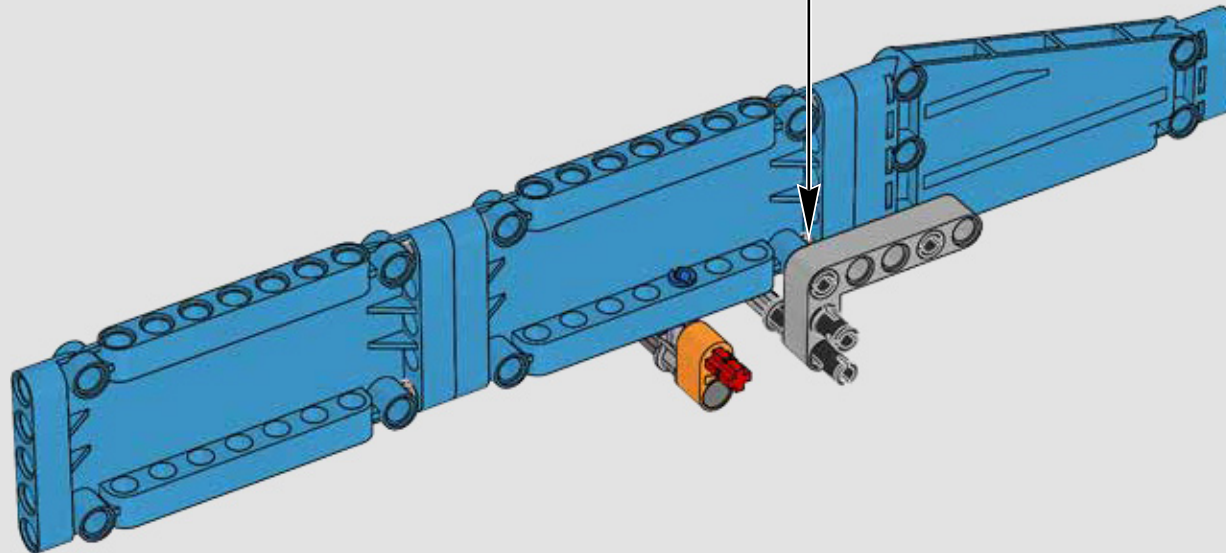
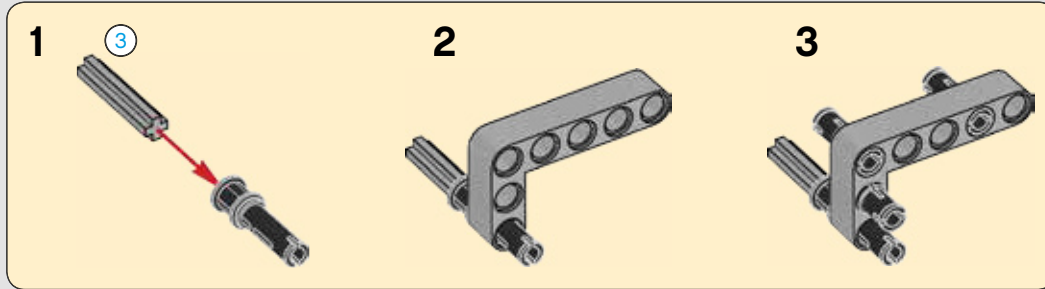

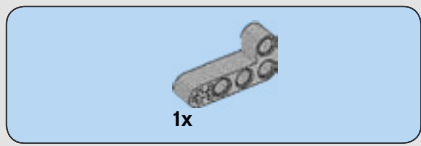

563

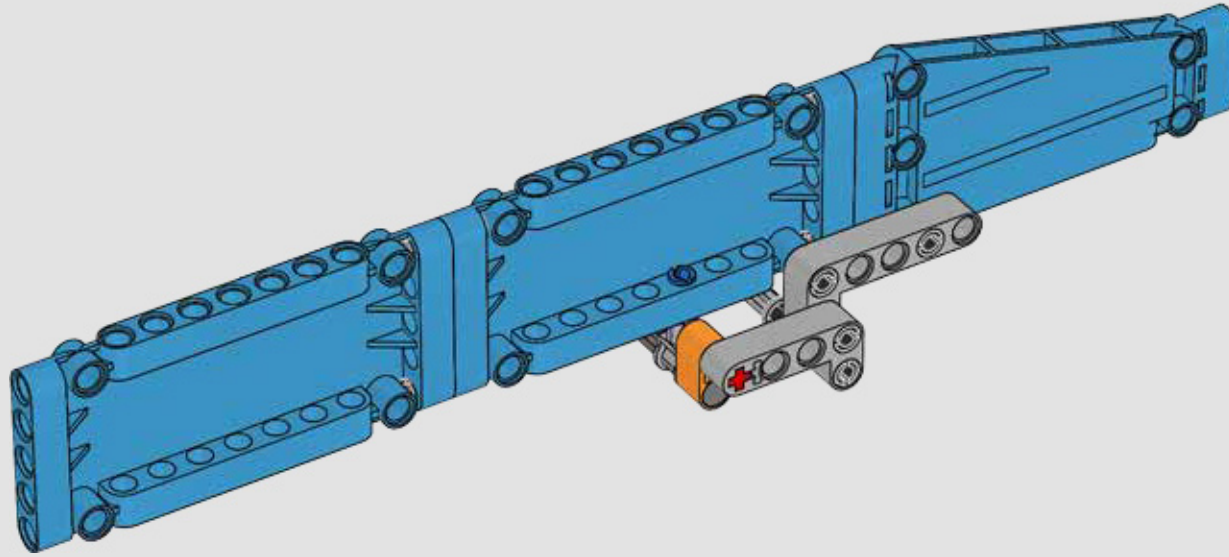

564

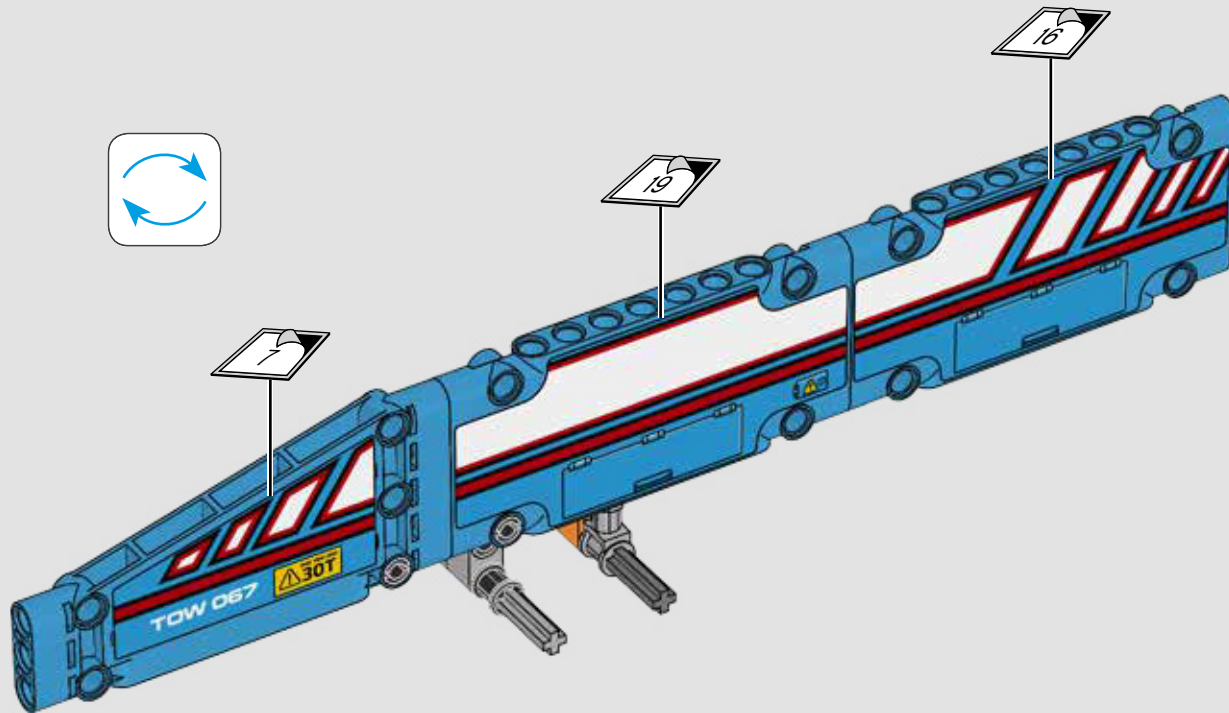
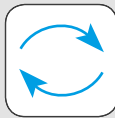



565

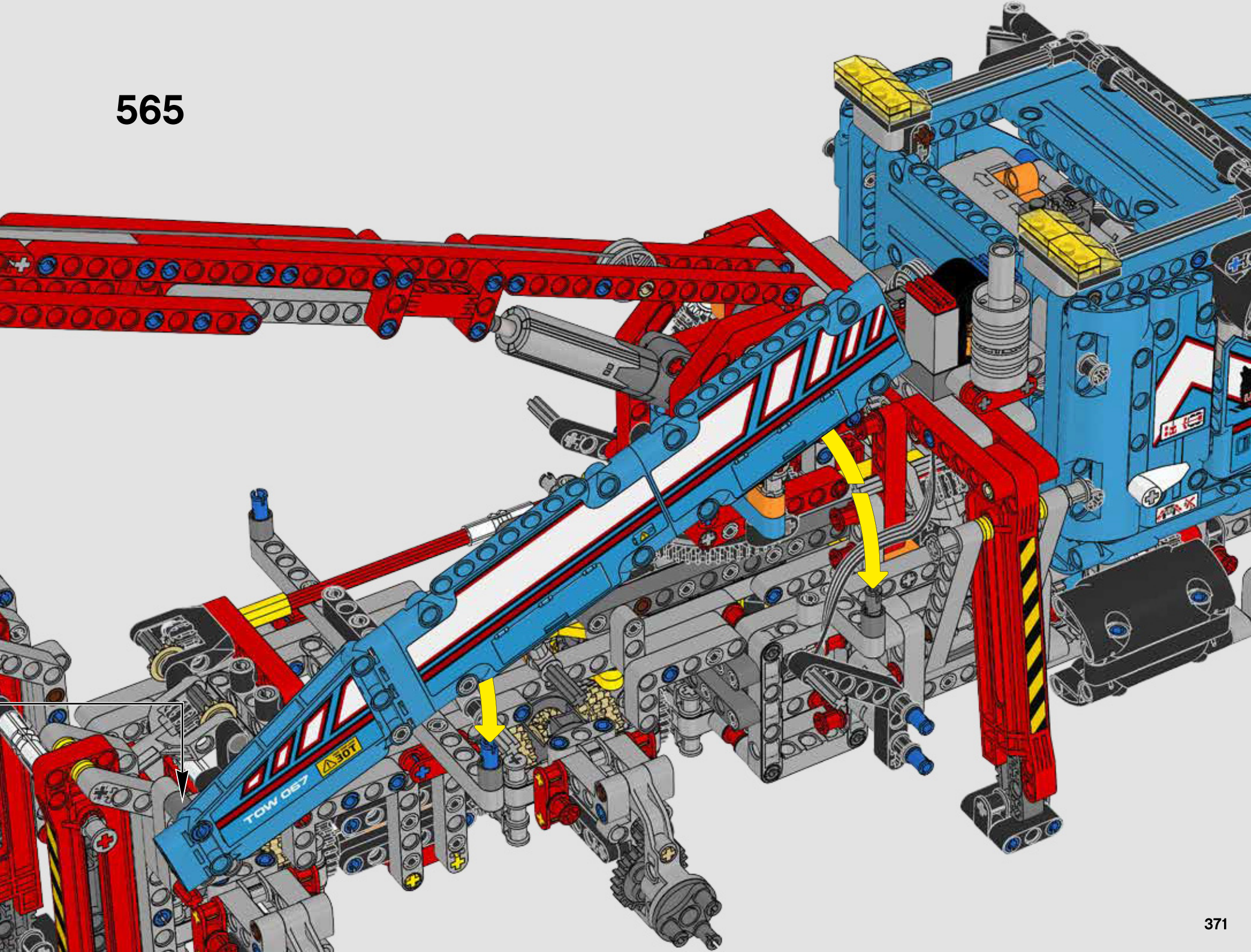

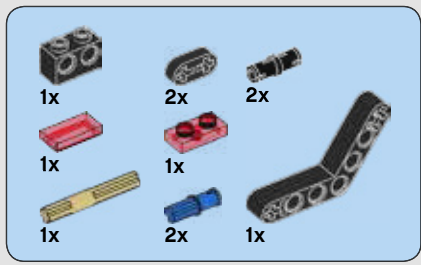

# 566

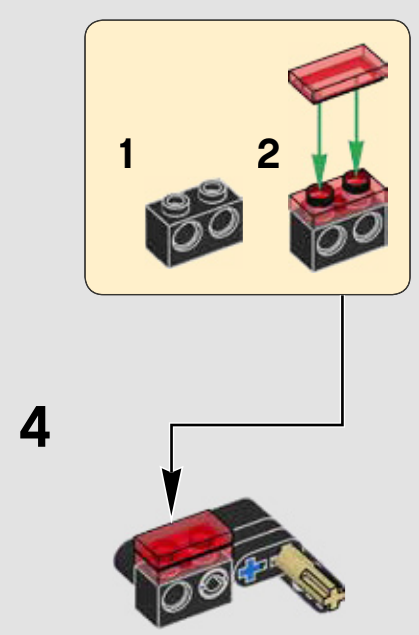
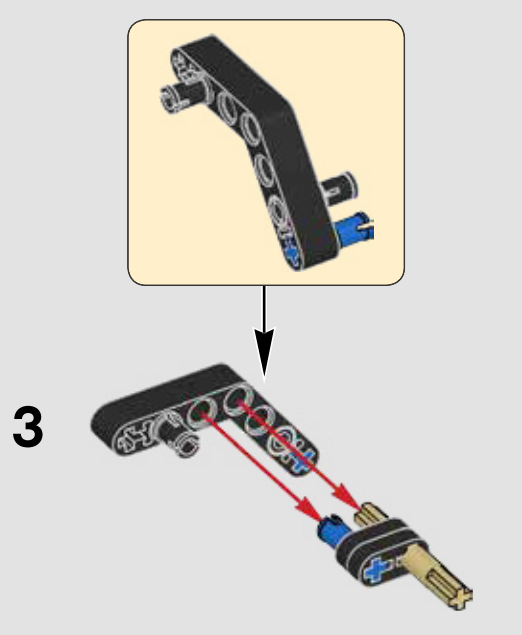
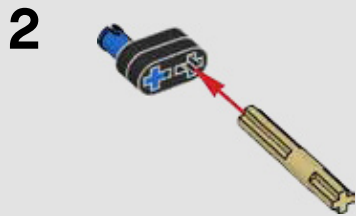
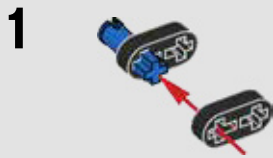



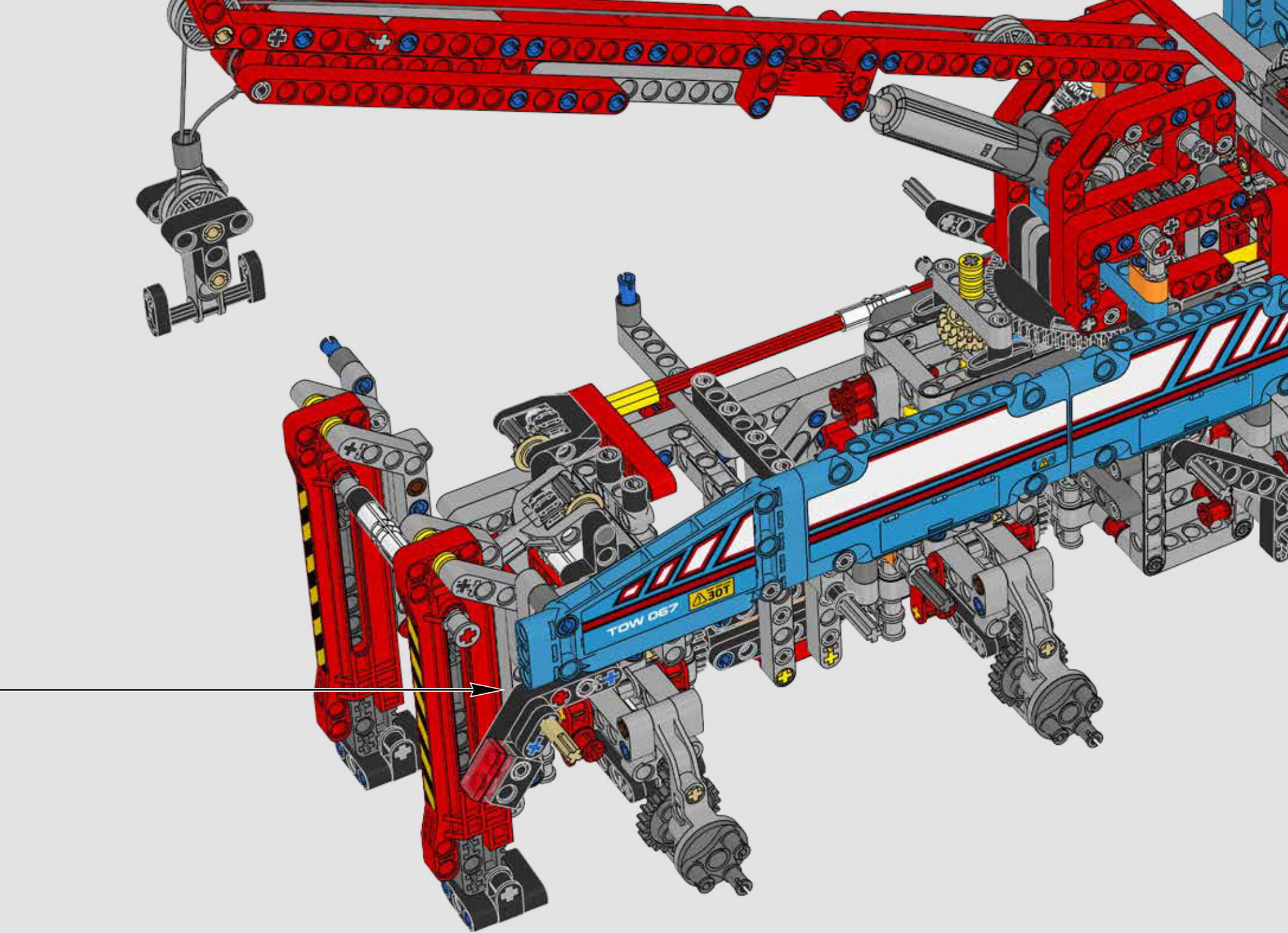



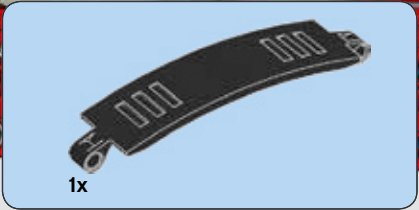

567

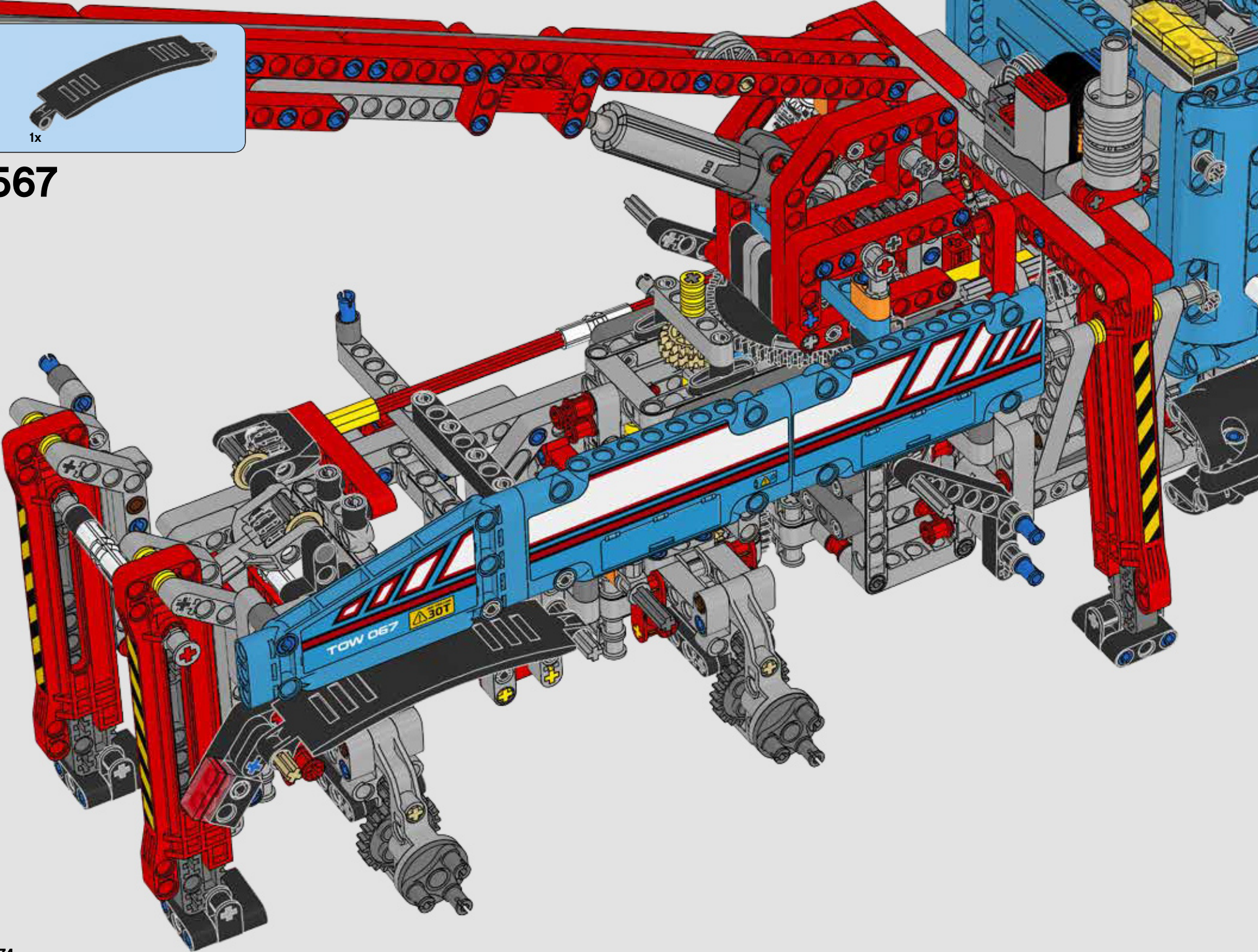



1x	1x	1x
1x	2x	1x

568



- 1
- 2
- 3

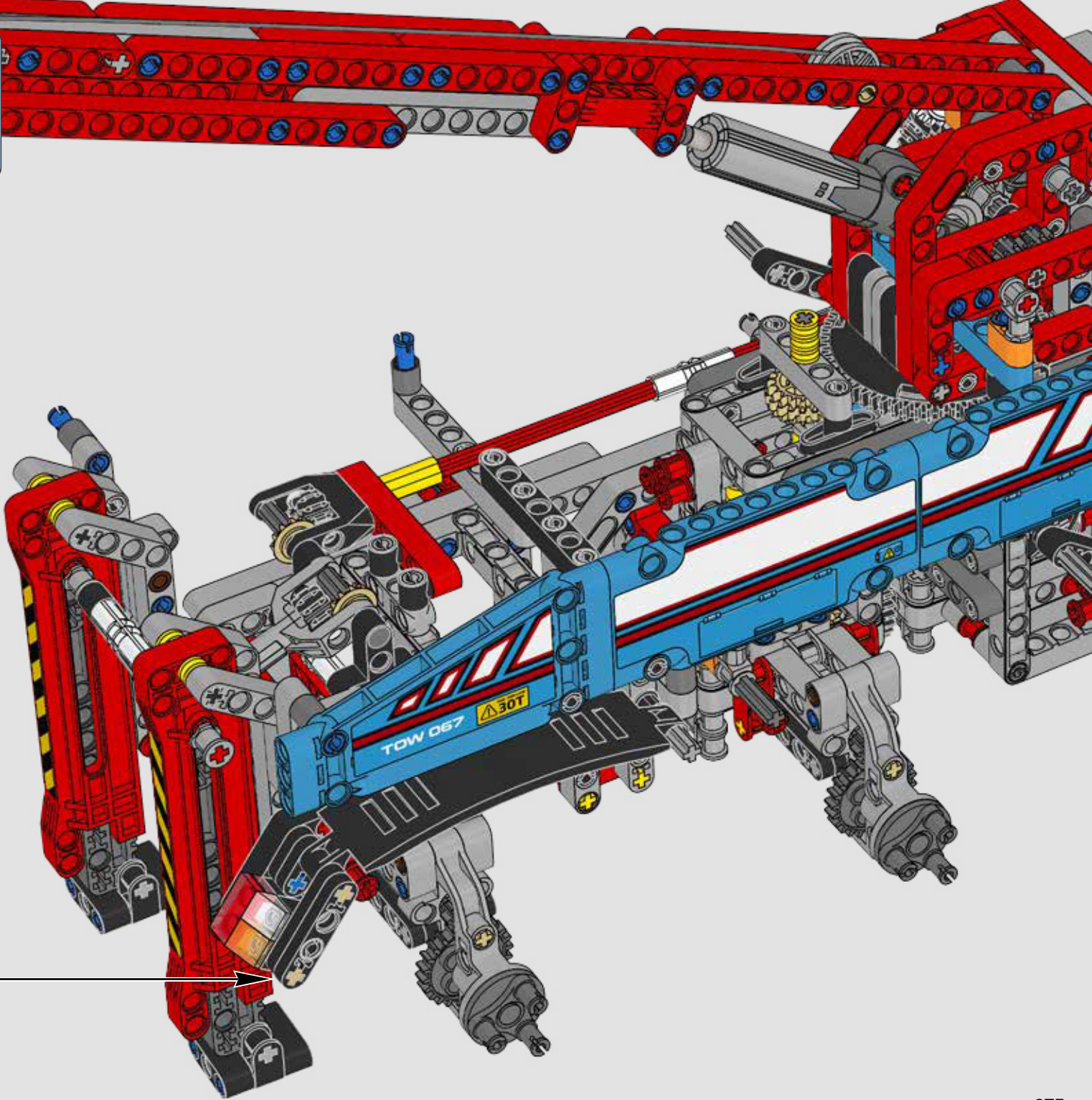



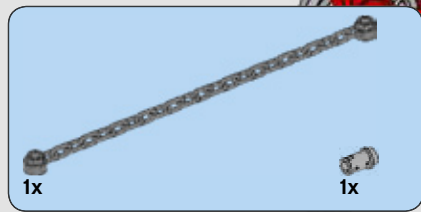

569

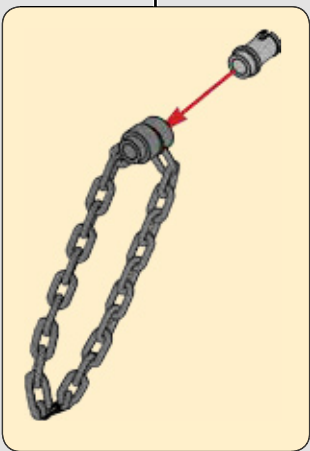
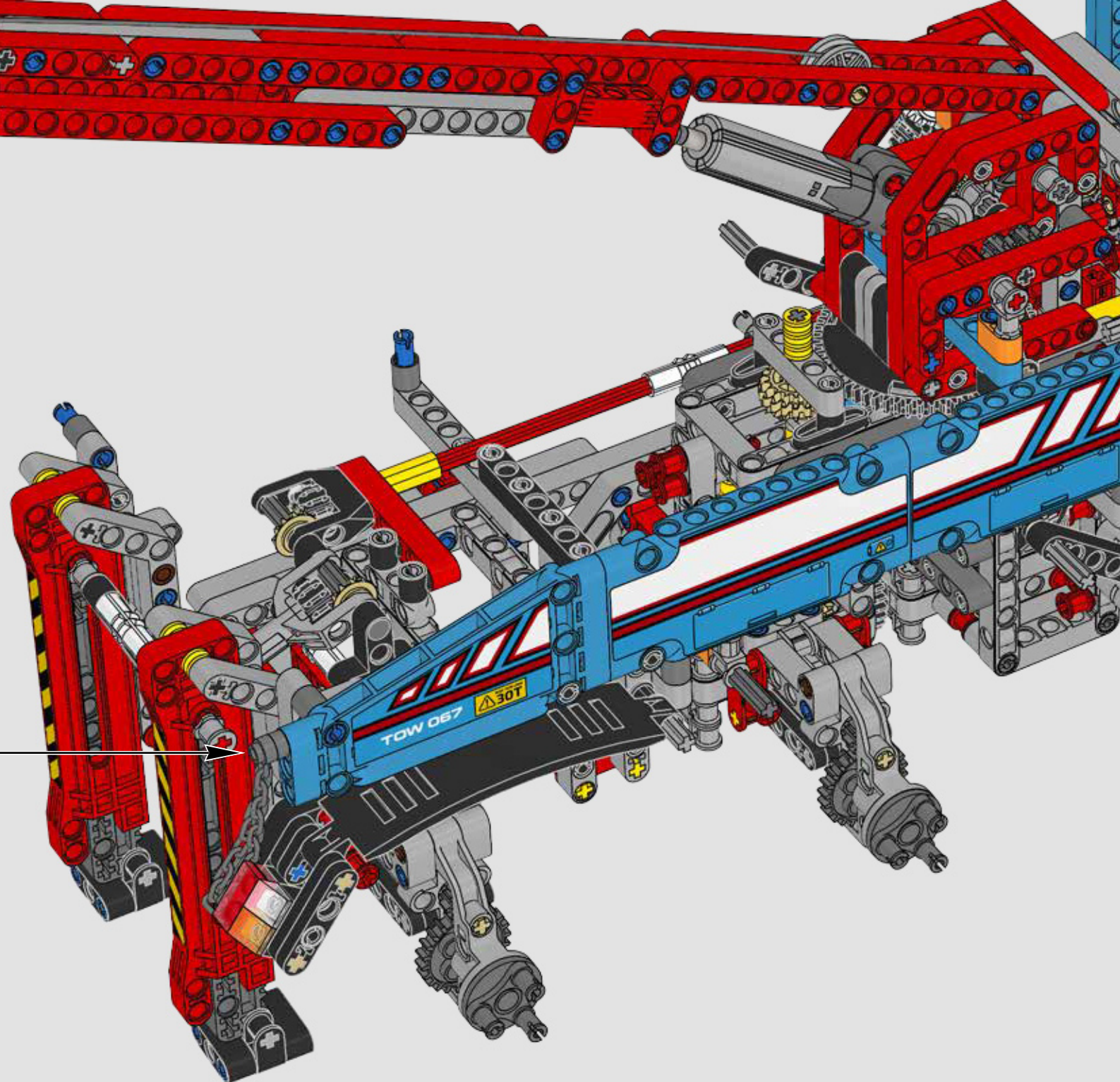



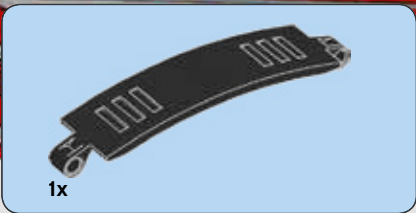

570

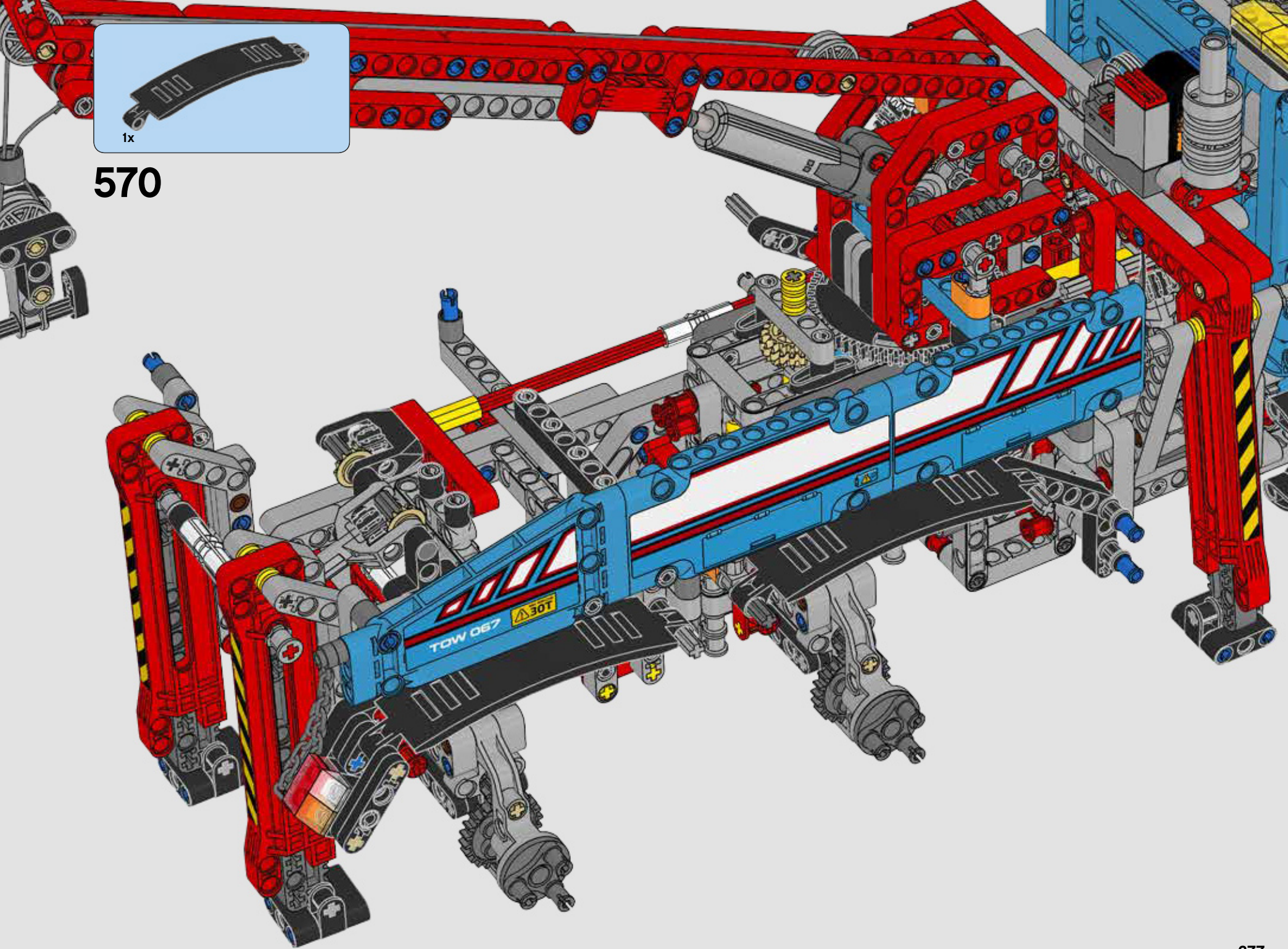





571

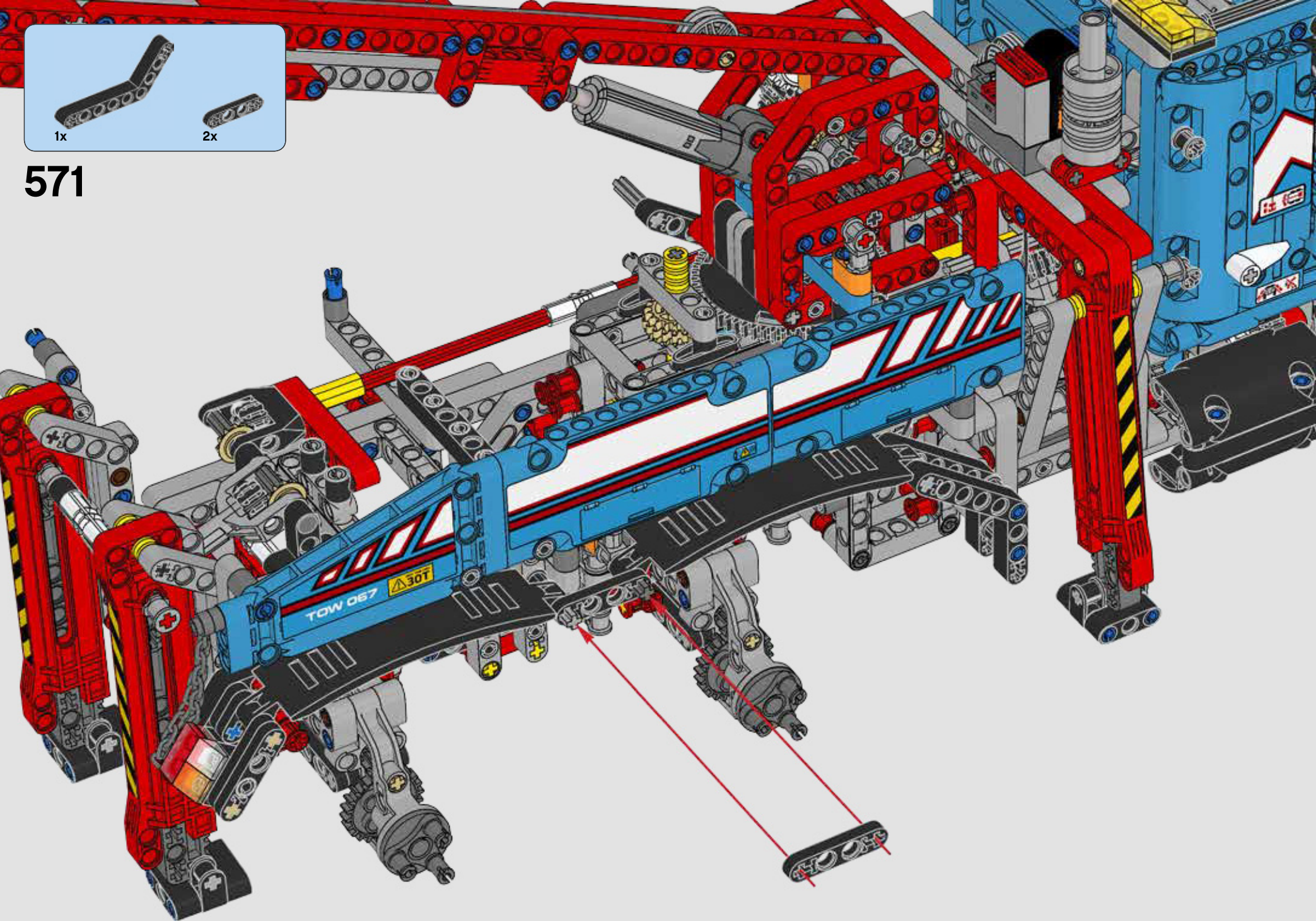



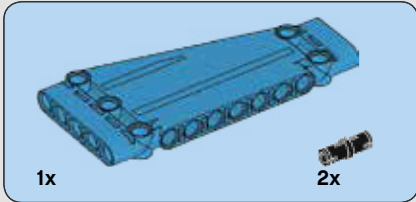
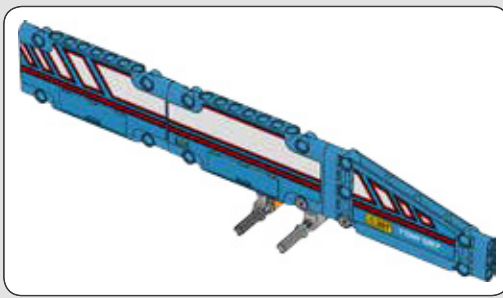

**572**

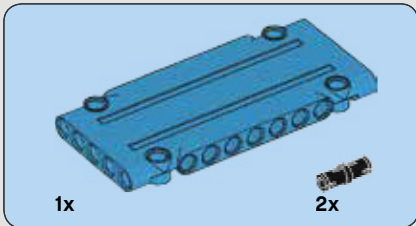

**573**

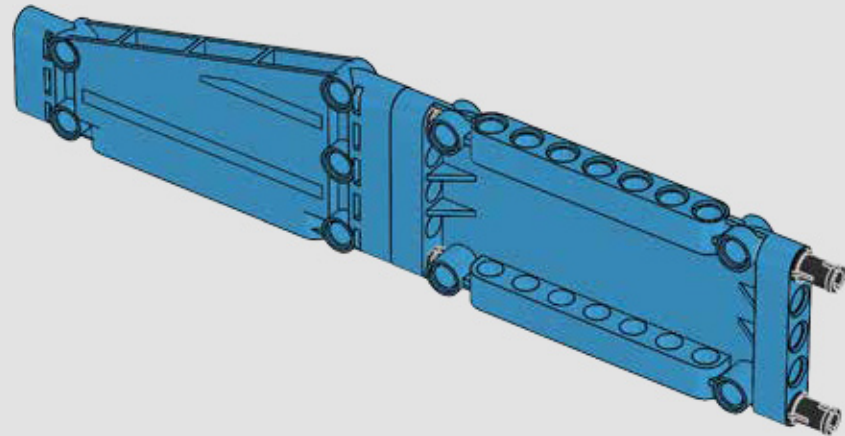
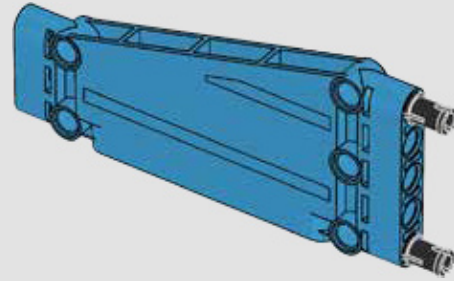

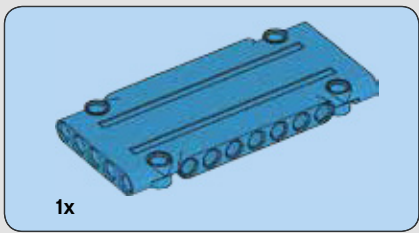

574

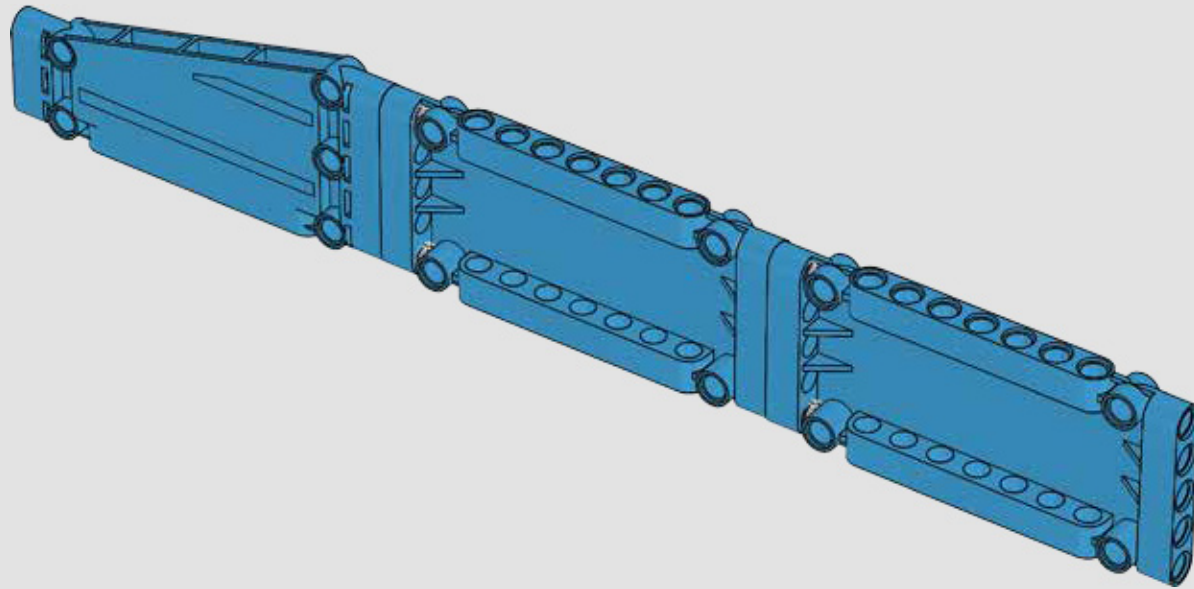

575

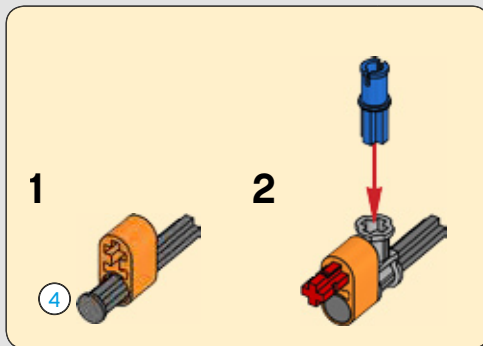
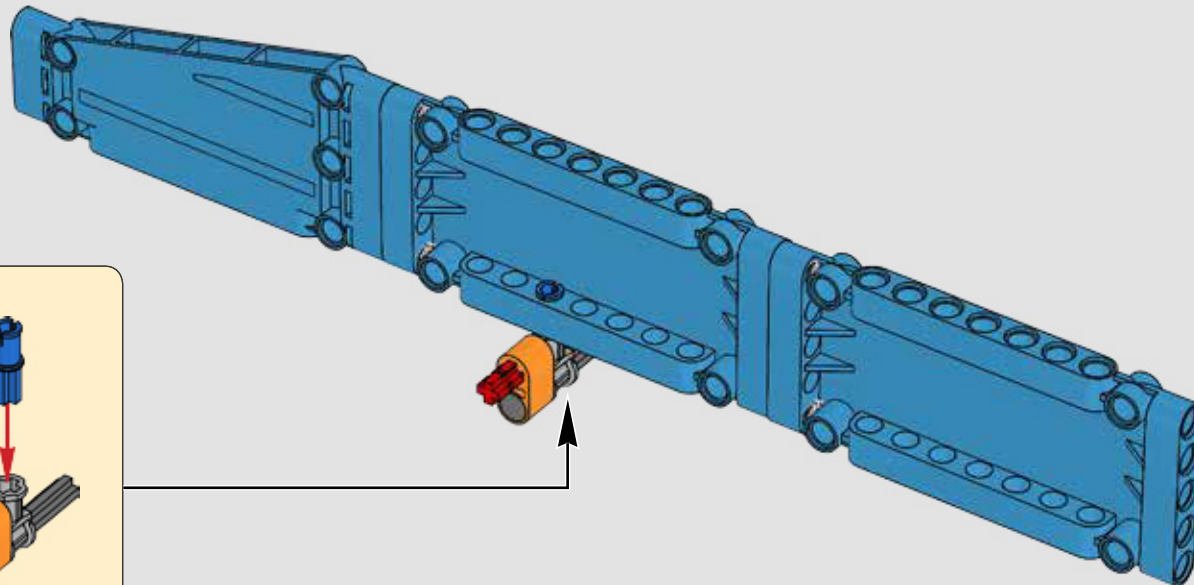
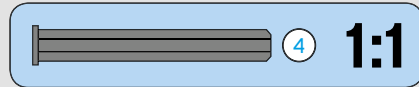



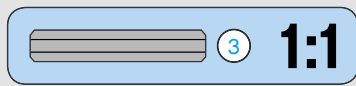
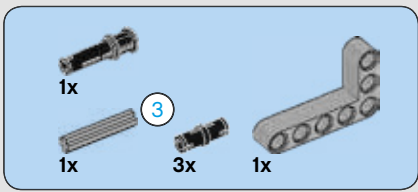

576

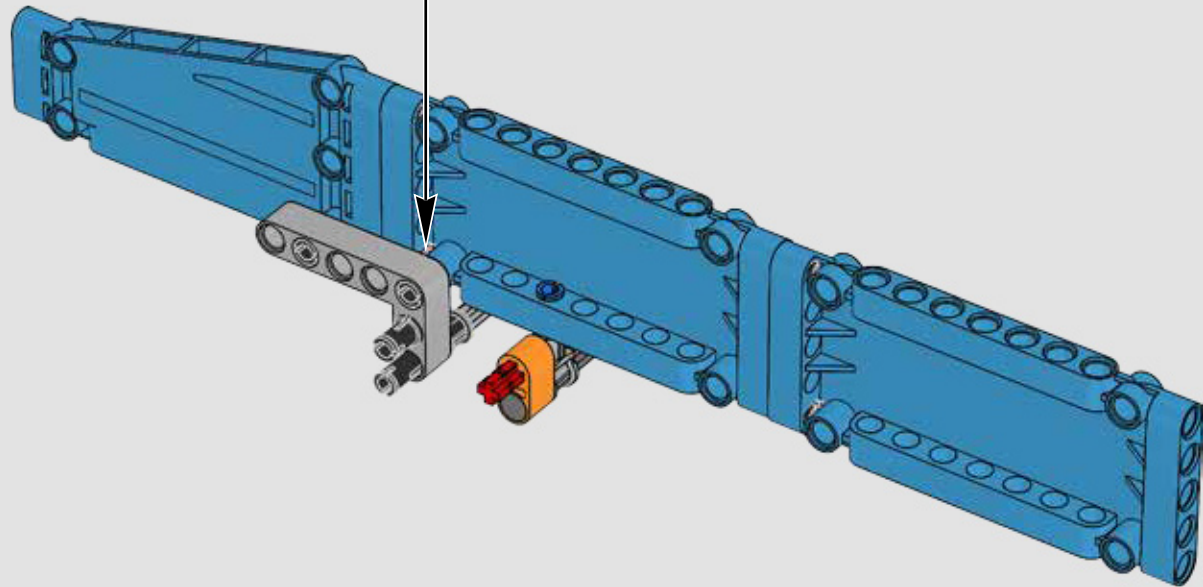
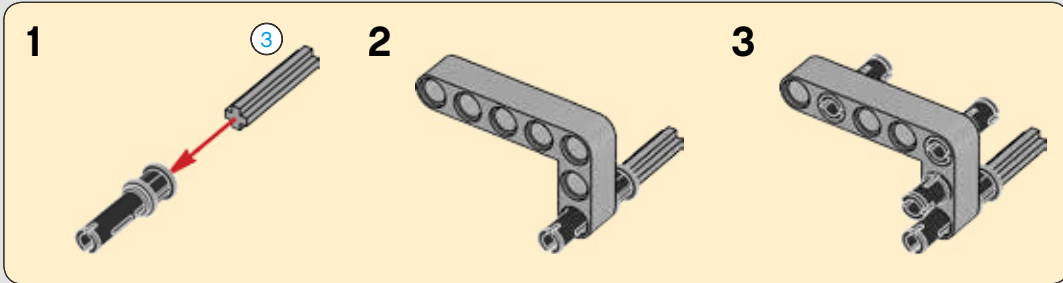

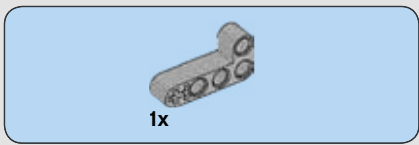

577

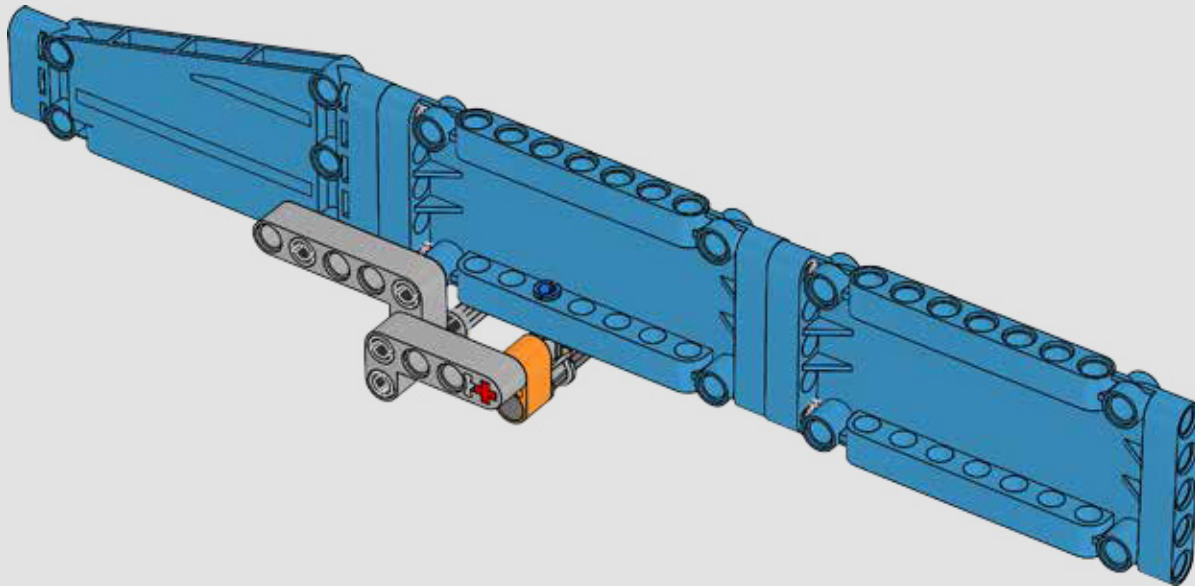

578

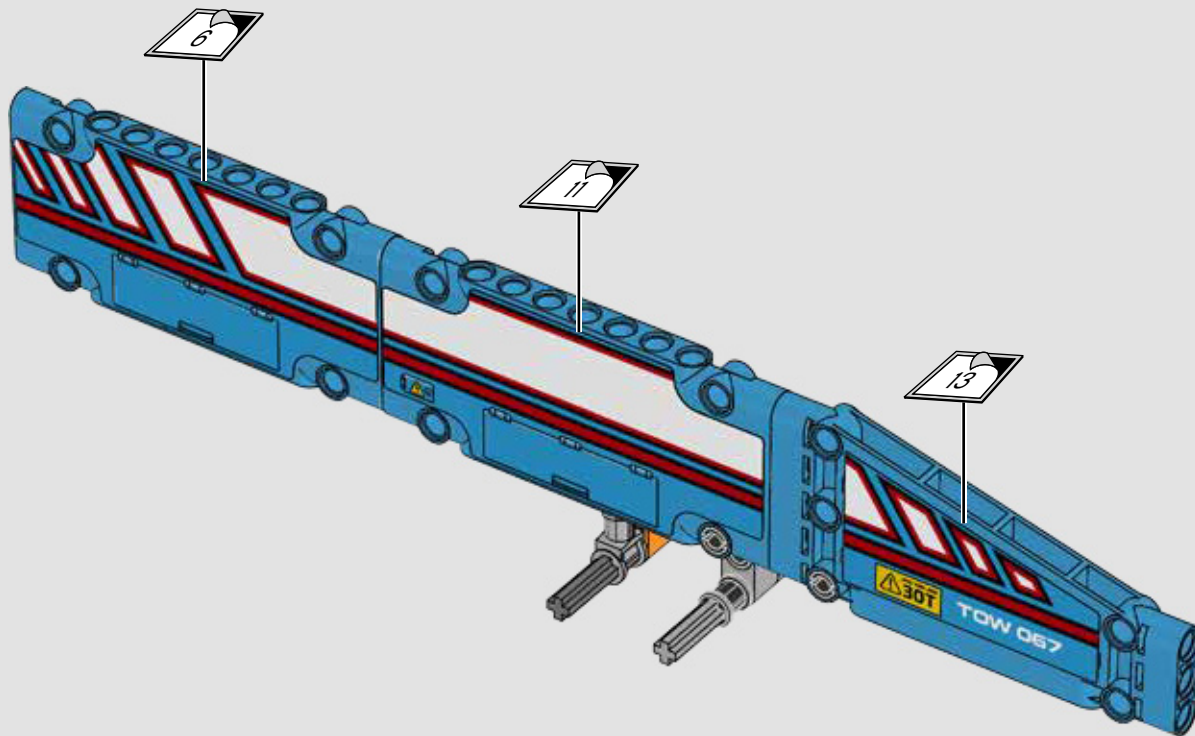



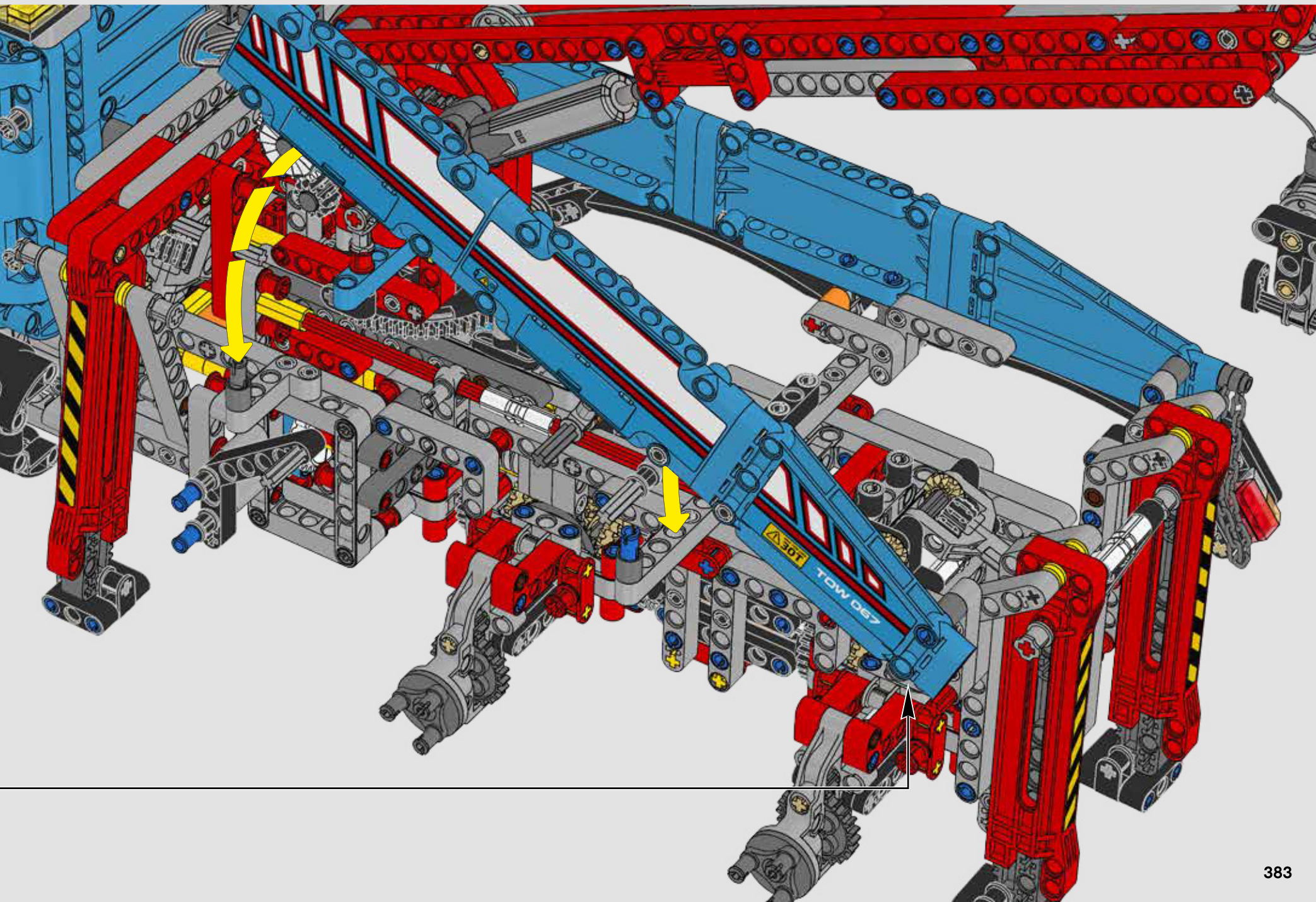

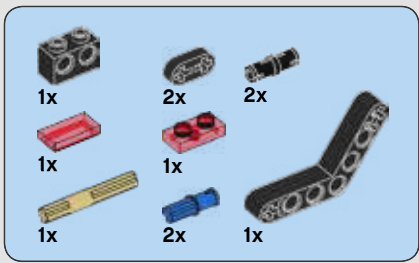

580

1

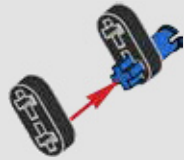

2

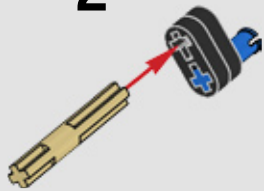

3

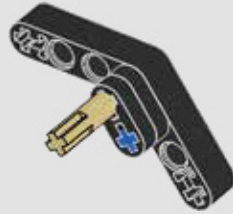

4

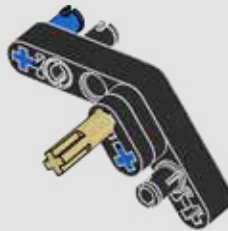

1



2



5

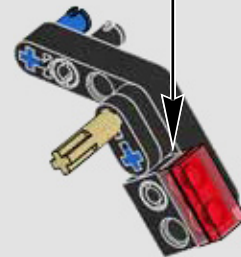



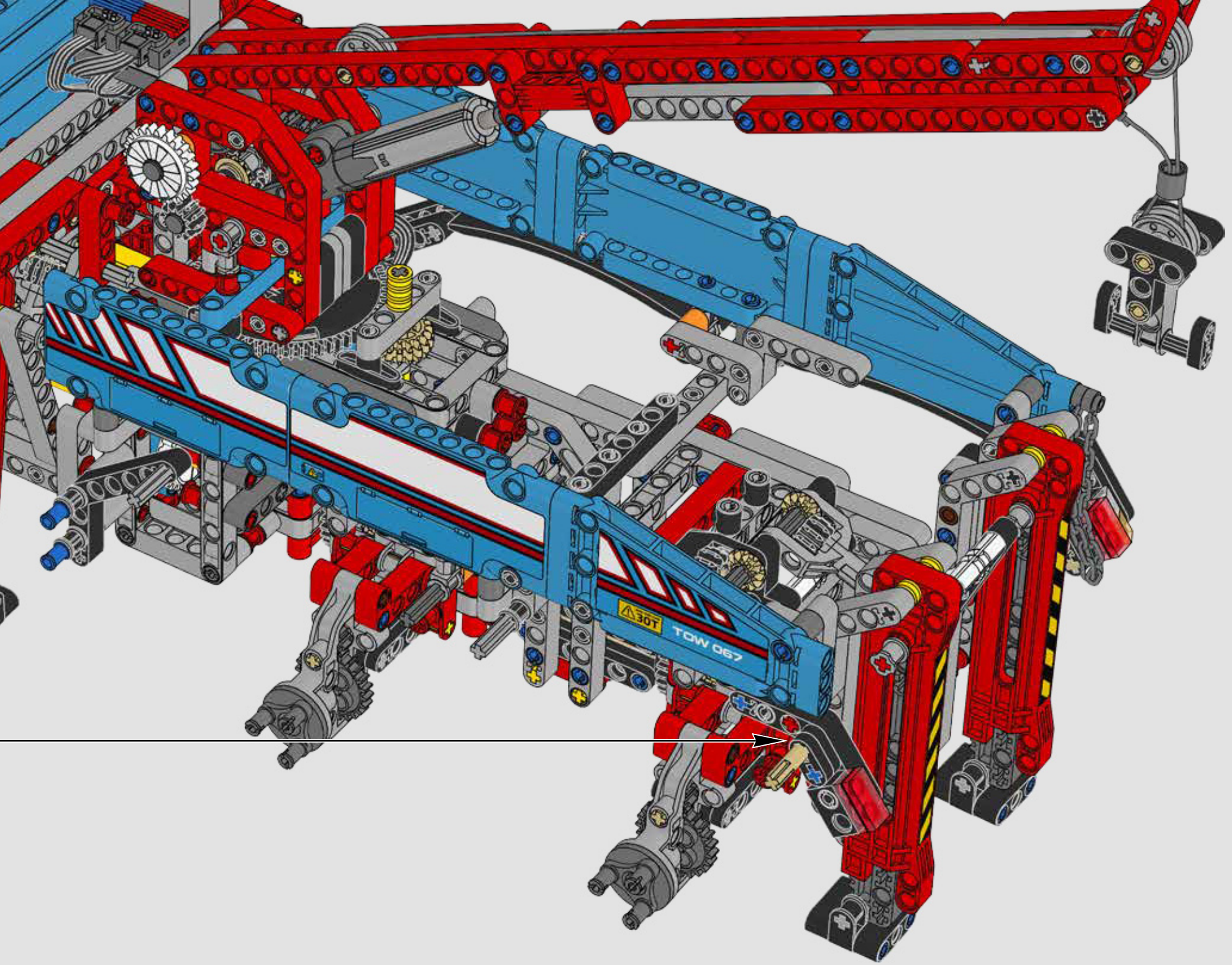



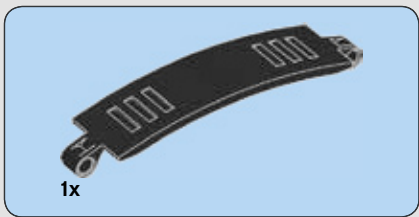

581

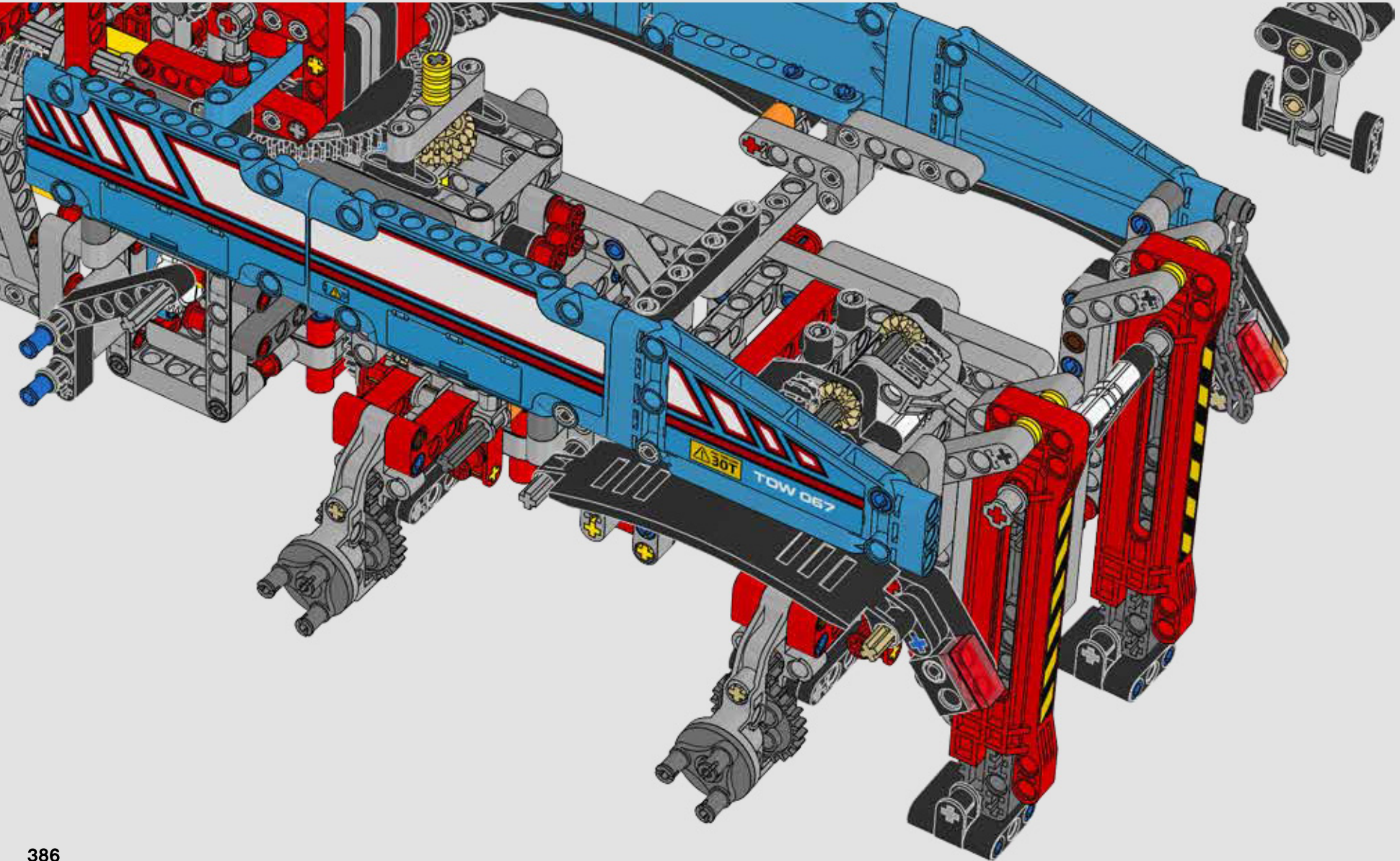



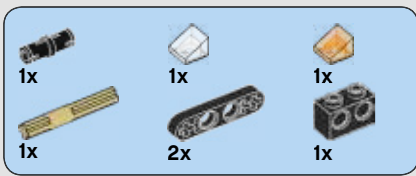

582

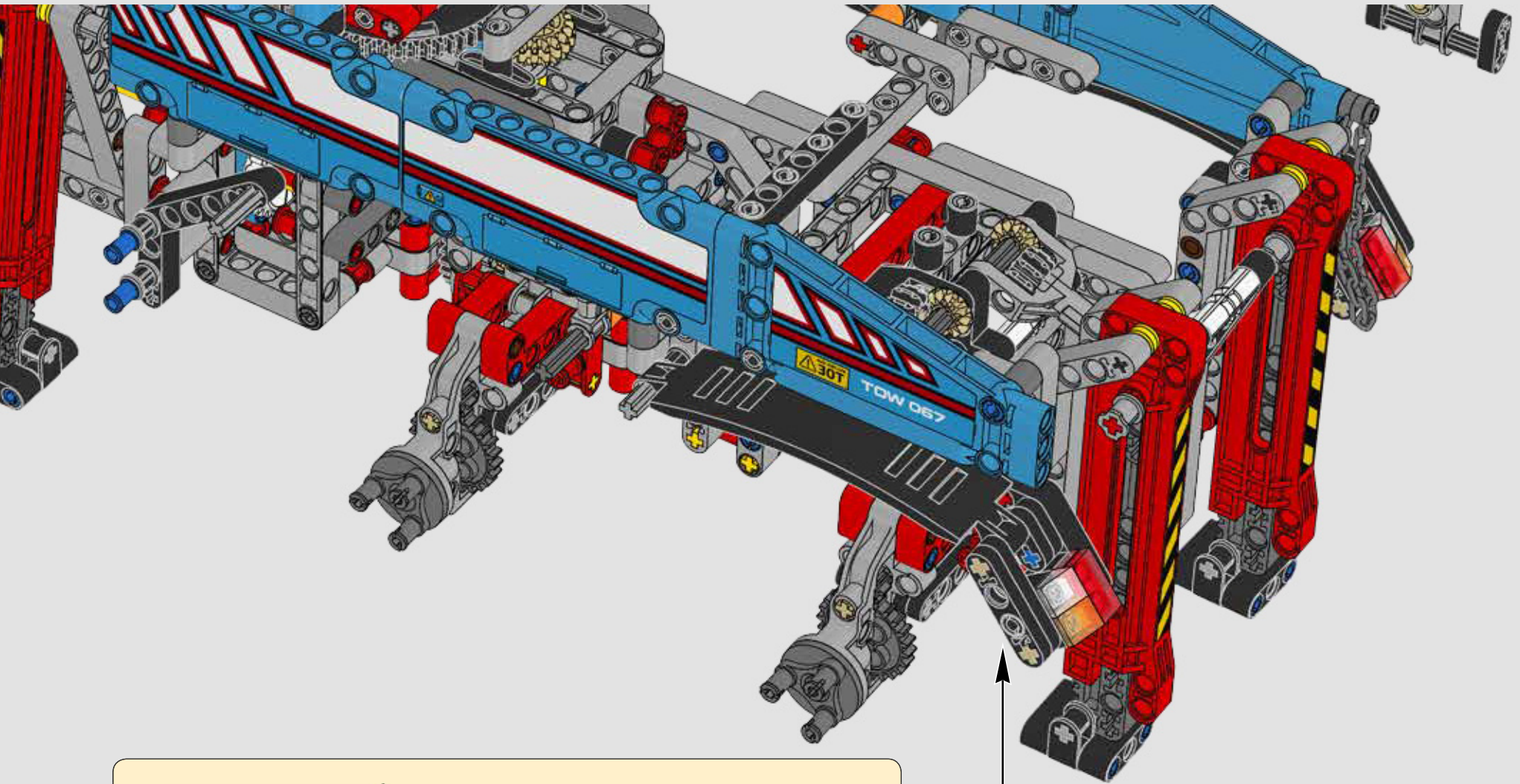



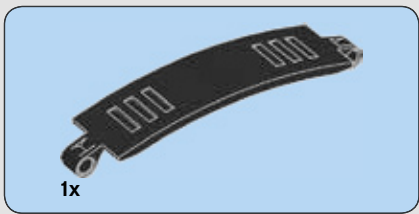

583

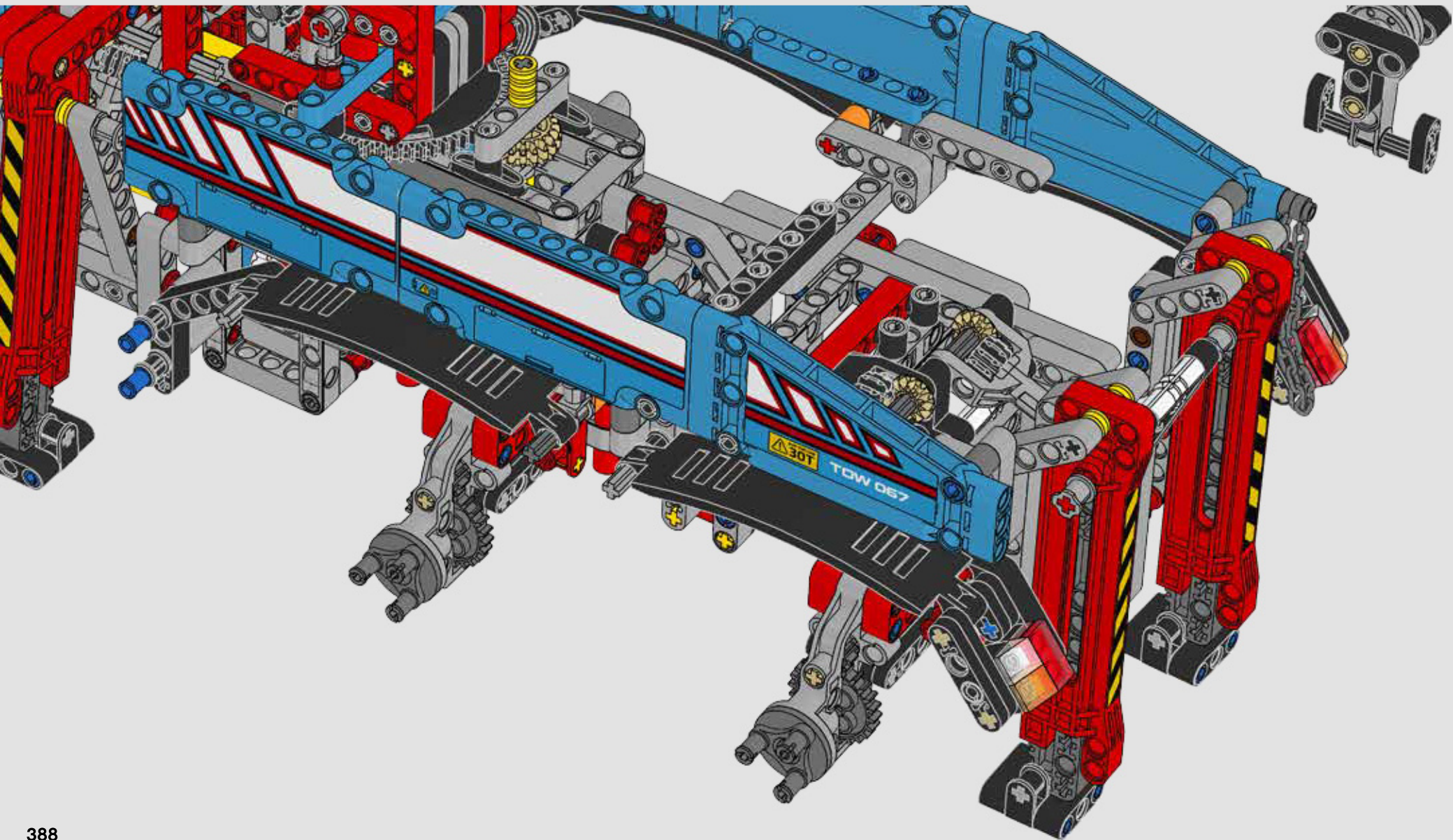



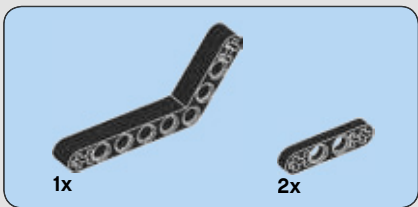

584

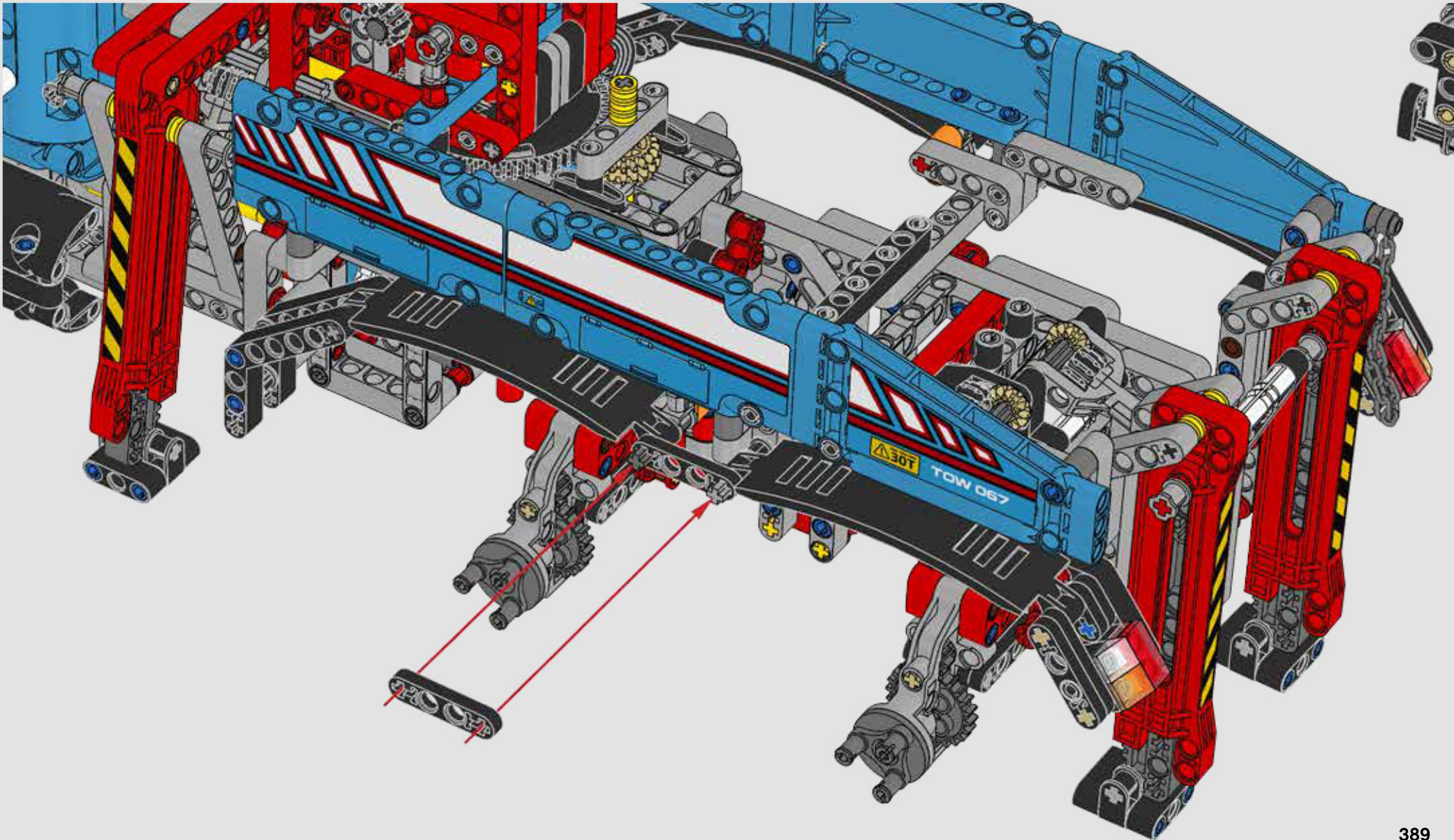



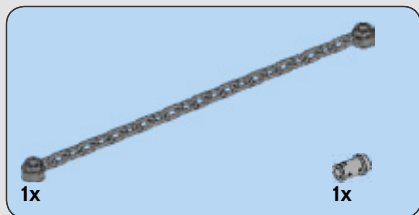

585

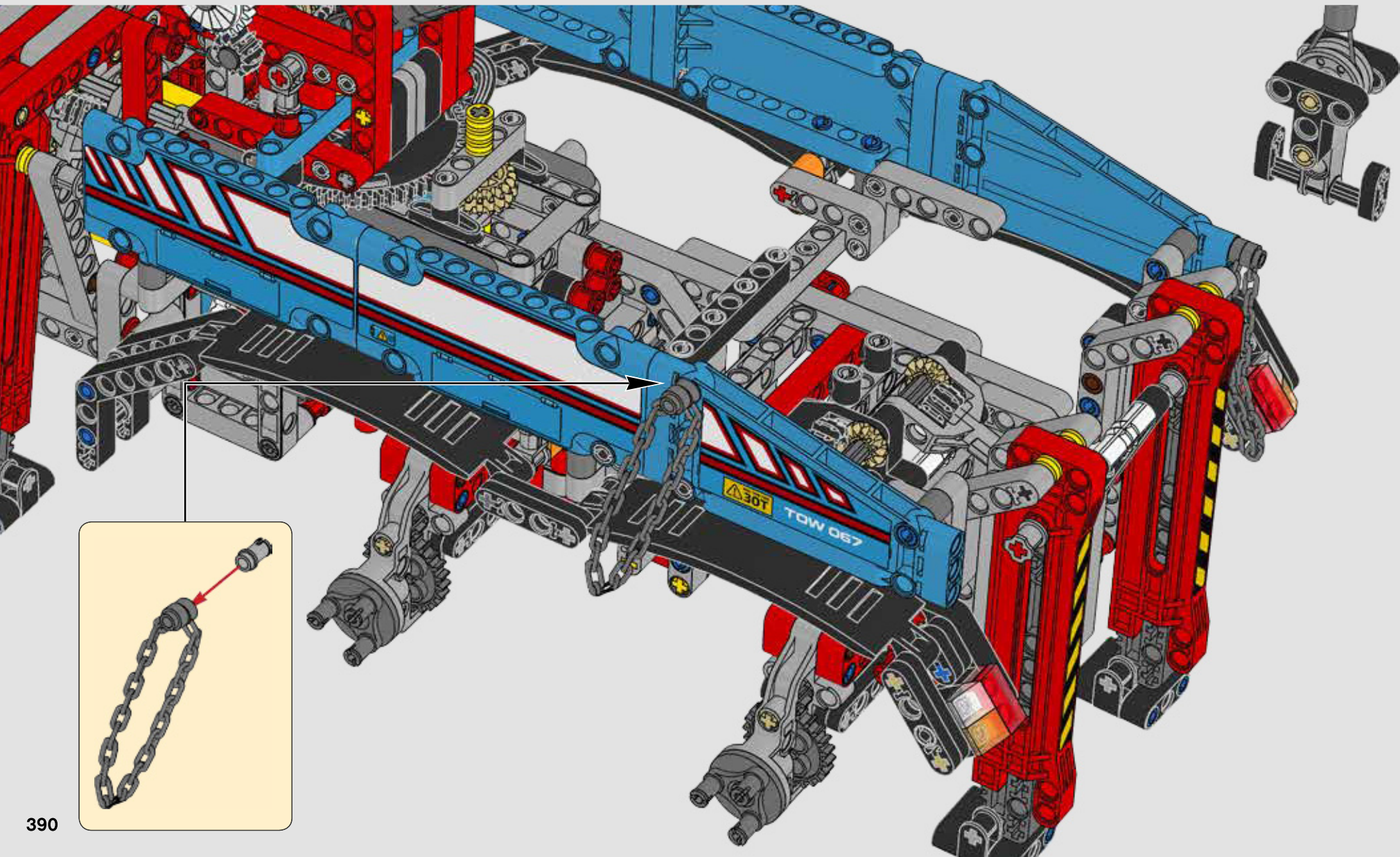



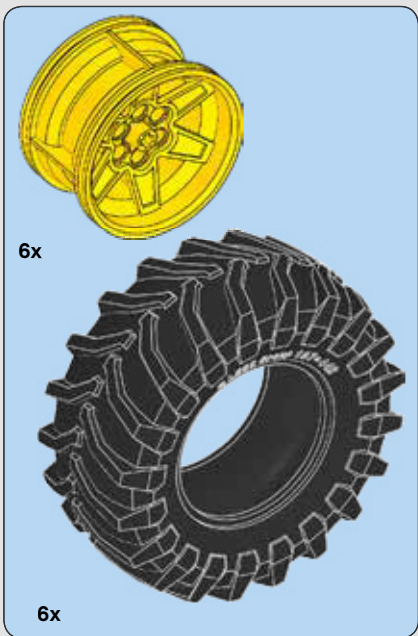

586

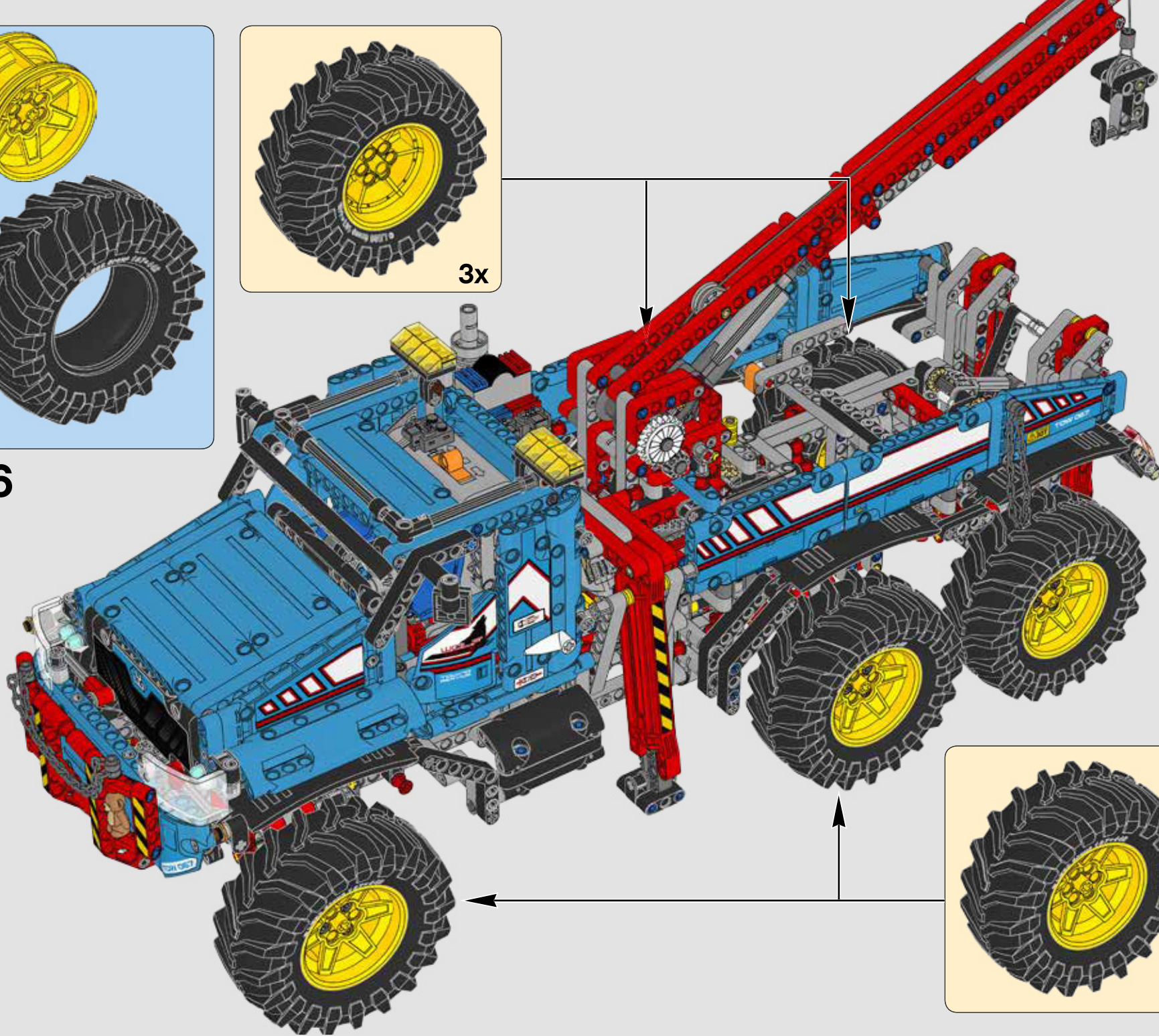
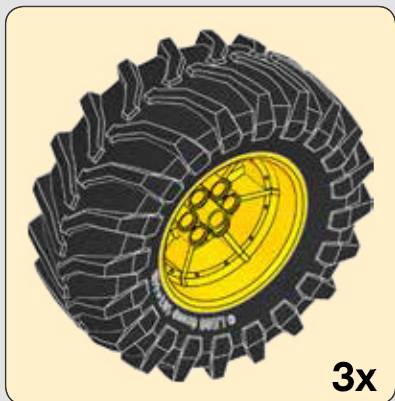



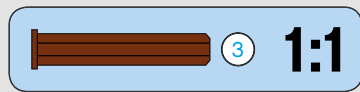
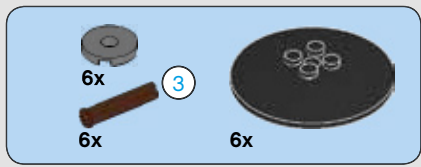

587

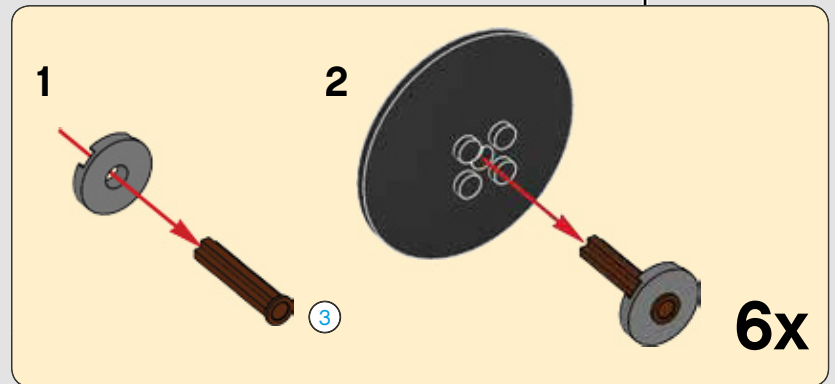
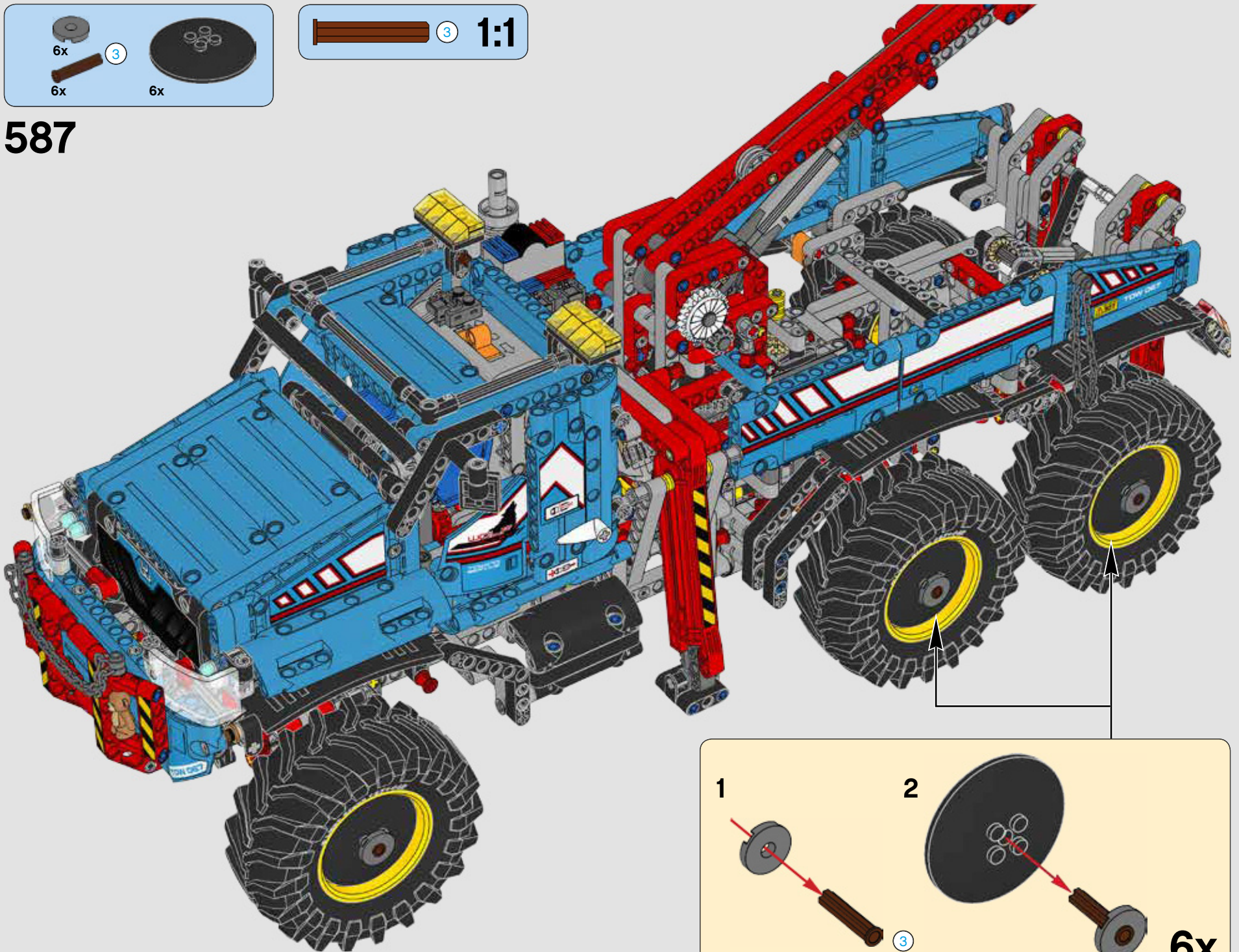



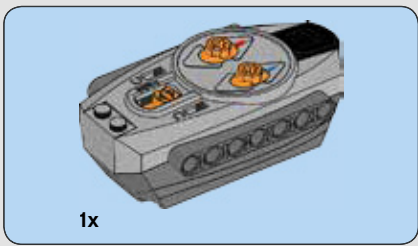

588

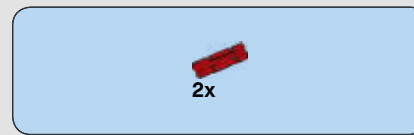
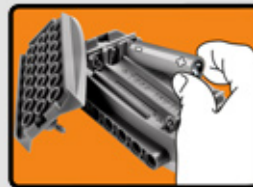
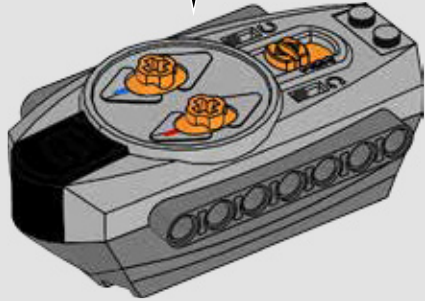
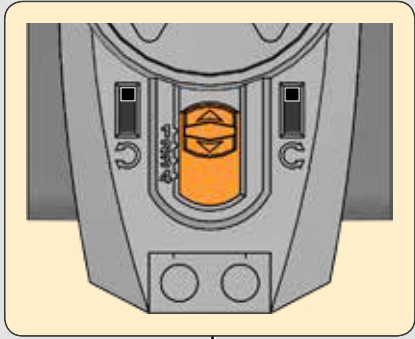

589

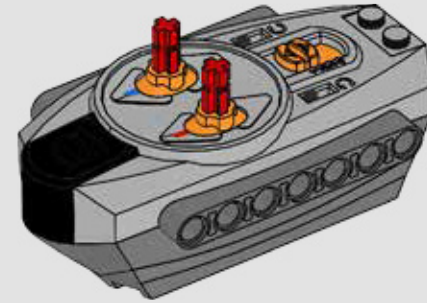

590

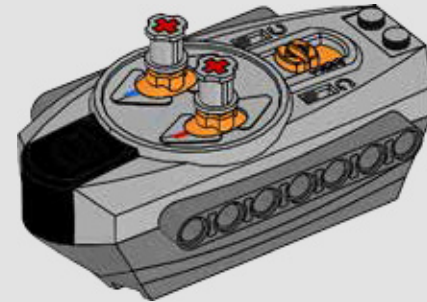

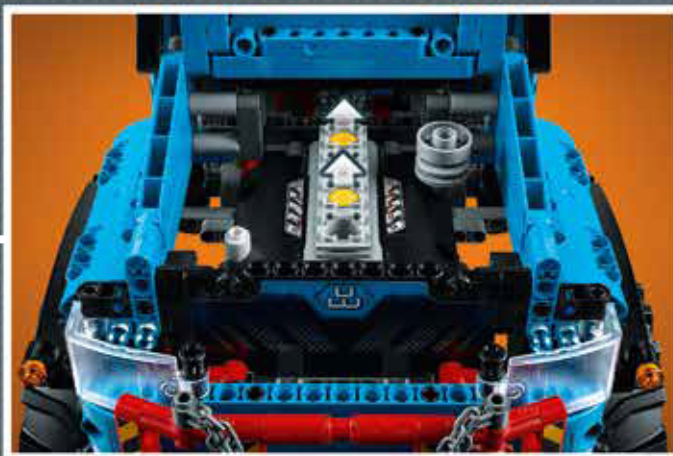







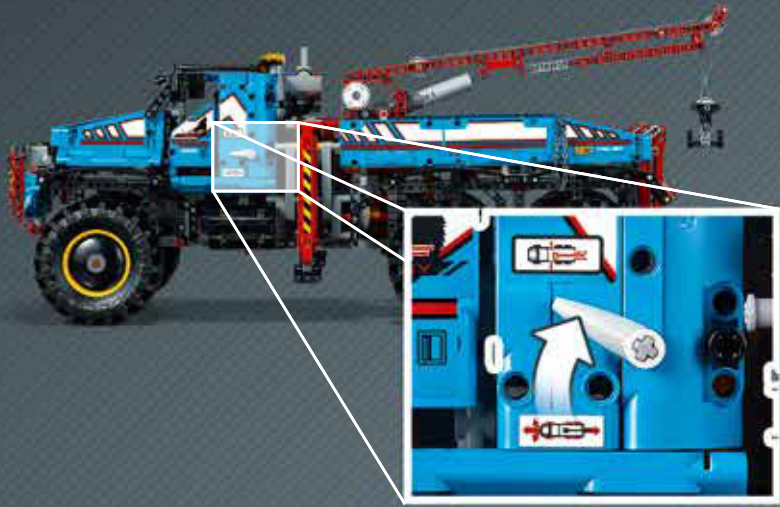



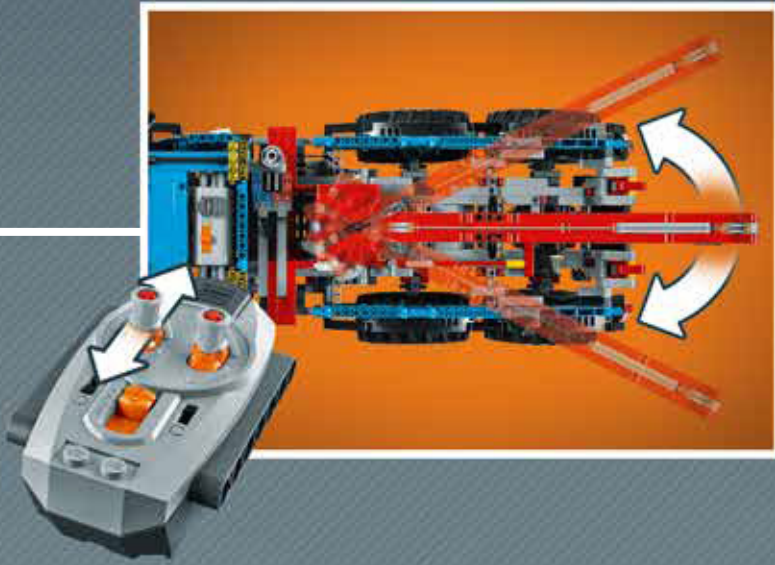





# TECHNIC



42066



42069



42063



**BMW Motorrad**

The BMW logo, the BMW word mark and model designation are trademarks of BMW and are used under license.





42068





# TECHNIC

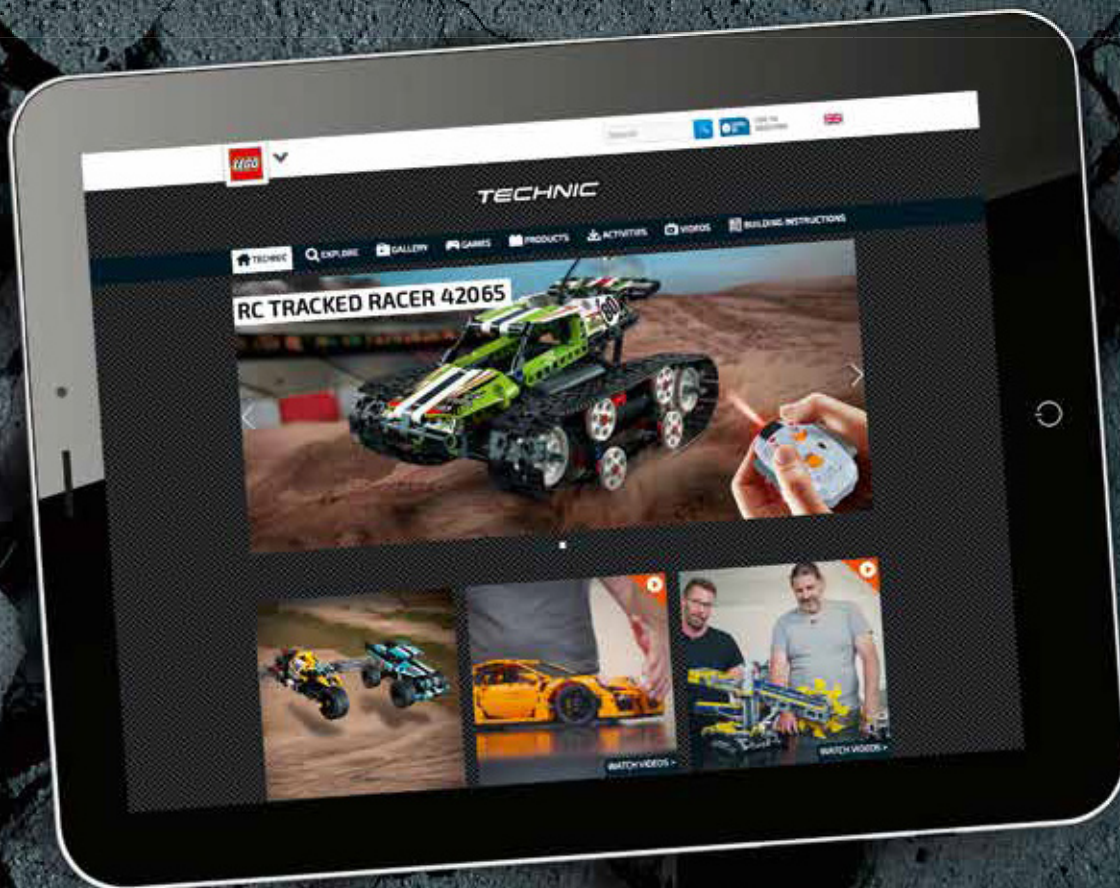

[LEGO.com/technic](https://www.lego.com/technic)





Share  
Partage  
Comparte  
分享

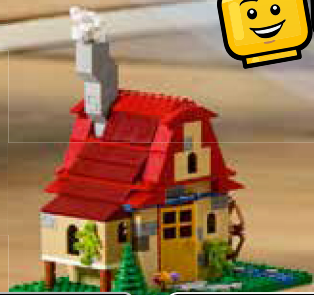
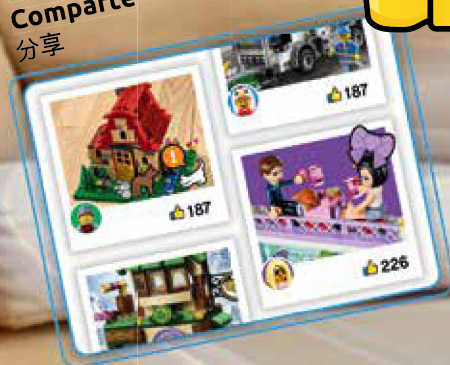

All your LEGO® fun in one app  
Tout l'amusement LEGO® dans une appli  
Toda la diversión LEGO® en una app  
乐高®乐趣尽在掌握

Minifigure yourself  
Transforme-toi  
en figurine  
Conviértete en una  
minifigura  
创建你的乐高小人仔



Create  
Crée  
Crea  
创建



Download on the  
App Store



GET IT ON  
Google play

Check availability of LEGO LIFE in your country  
now on [LEGO.com/life](http://LEGO.com/life)  
Ask parents' permission first.

Controlla la disponibilità di LEGO LIFE nel tuo  
paese su [LEGO.com/life](http://LEGO.com/life)  
Chiedere prima il permesso ai genitori.

Apple and the Apple logo are trademarks of Apple Inc.,  
registered in the U.S. and other countries. App Store is a service  
mark of Apple Inc. Google Play is a trademark of Google Inc.

Auf [LEGO.com/life](http://LEGO.com/life) erfährst du jetzt, ob LEGO LIFE in  
deinem Land verfügbar ist  
Bitte frage erst deine Eltern um Erlaubnis.

Consulta si LEGO LIFE está disponible en tu país  
en [LEGO.com/life](http://LEGO.com/life)  
Pide antes permiso a tus padres.

Ellenőrizd a LEGO LIFE elérhetőségét a lakóhelyeden,  
most a [LEGO.com/life](http://LEGO.com/life) honlapon!  
Először kérj engedélyt a szüleidtől!

Vérifie la disponibilité de LEGO LIFE dans ton pays sur  
[LEGO.com/life](http://LEGO.com/life)  
Demande d'abord l'autorisation d'un parent.

Verifica agora a disponibilidade de LEGO LIFE no  
teu país em [LEGO.com/life](http://LEGO.com/life)  
Pede primeiro permissão aos teus pais.

访问 [LEGO.com/life](http://LEGO.com/life) 网站, 查看乐高生活系列是否  
已在你所在国家上线。先请求家长的许可。

4x 6176754  
 21x 4142865  
 4x 6099696  
 6x 6167939  
 13x 6100930  
 2x 4185664  
 2x 241221  
 1x 6153686  
 68x 4140806  
 16x 4128598  
 5x 6173126  
 8x 4141270  
 2x 6188245  
 5x 4143154  
 2x 4142132

12x 4254606  
 3x 6168687  
 2x 4227155  
 6x 6185105  
 5x 6130002  
 20x 4495933  
 2x 6188299  
 4x 4268653  
 3x 6130005  
 7x 4542575  
 4x 6114965

2x 6121356  
 22x 6135494  
 10x 6159763  
 18x 4239601  
 4x 4112203  
 19x 4519010  
 2x 4119474  
 7x 4153707  
 6x 6010863  
 21x 6130008  
 8x 4144022  
 8x 6130010  
 3x 6115616  
 6x 6065490

2x 4660886  
 18x 4164133  
 43x 4173668  
 261x 4121715  
 4x 4107767  
 4x 3200026  
 4x 6055630  
 4x 4563044  
 2x 306826  
 3x 6061032  
 9x 6089119  
 15x 4140801  
 13x 4552347  
 12x 4142822  
 2x 6115616  
 2x 6173119  
 24x 4142236  
 14x 370526

4x 4652236  
 4x 4558692  
 2x 302026  
 2x 4142823  
 8x 4114634  
 2x 4128593  
 6x 6058341  
 5x 4495935  
 2x 370726  
 2x 370826  
 8x 4112282  
 1x 6109283

12x 6073231  
 13x 4177431  
 6x 6150082  
 1x 6031916  
 1x 4540906  
 6x 6162372  
 1x 4566243  
 1x 4542573  
 6x 6141782

2x 4244362  
 2x 6133686  
 2x 4189801  
 2x 4201019  
 4x 6081343  
 8x 4260942  
 4x 4194746  
 4x 4194535  
 14x 6057526  
 2x 4222960  
 2x 4244369

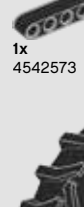
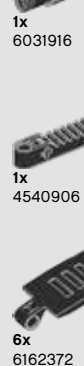
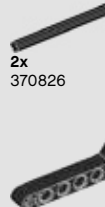
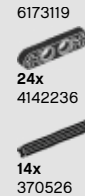
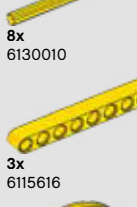
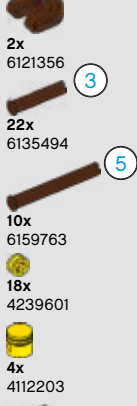
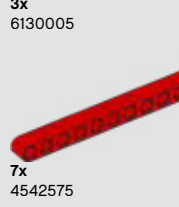



1x  
6185471

4x  
4234251

12x  
4211610

4x  
6029206

23x  
4211713

13x  
4211651

4x  
4211668

11x  
4211805

1x  
6109285

6x  
4610377

3x  
4612100

23x  
6102449

4x  
4234240

2x  
6178172

9x  
4539880

3x  
4540797

20x  
4542577

4x  
4516456

1x  
6153715

1x  
6074396

1x  
6073386

1x  
6194861

6x  
4610378

17x  
6083620

3x  
4525184

1x  
4528038

3x  
4508553

1x  
6187734

6x  
4499858

10x  
4522937

4x  
6114979

1x  
6171037

1x  
6151440

33x  
6015356

7x  
6133119

1x  
4239891

1x  
6055832

1x  
306201

2x  
4173941

3x  
6036892

17x  
6100932

1x  
6170737

66x  
4206482

2x  
241223

171x  
4514553

2x  
6133684

27x  
6100030

10x  
6012451

6x  
6055313

4x  
6100931

4x  
6163689

13x  
6163687

1x  
6163682

1x  
6163684

1x  
6163685

1x  
6163686

13x  
6163691

6x  
6163677

3x  
6176880

4x  
6163681

9x  
6163673

3x  
6044729

4x  
6000018

12x  
4211566

16x  
4211779

2x  
4211888

45x  
4211815

3x  
4299119

4x  
4652235

1x  
4580510

22x  
6173127

13x  
4538007

3x  
4225033

2x  
4525904

6x  
4211567

17x  
4211483

48x  
4211622

13x  
4640536

18x  
4211553

1x  
4558690

21x  
4565452

4x  
6013938

3x  
6013937

1x  
4666579

1x  
6031962

12x  
6084724

18x  
4514554

18x  
4666999



**Customer Service**  
**Kundenservice**  
**Service Consommateurs**  
**Servicio Al Consumidor**

**LEGO.com/service or dial**



**: 00800 5346 5555**  
**: 1-800-422-5346**

# WIN

GO TO [WWW.LEGO.COM/PRODUCTFEEDBACK](http://WWW.LEGO.COM/PRODUCTFEEDBACK) AND GIVE US YOUR SHORT **FEEDBACK** ABOUT THIS LEGO® SET FOR A CHANCE TO WIN A COOL LEGO PRIZE.

Terms & Conditions apply



## LEGO.com/productfeedback

### GEWINNE

Erzähle uns auf [www.LEGO.com/productfeedback](http://www.LEGO.com/productfeedback)

etwas über die Erfahrungen, die du mit diesem LEGO® Set gemacht hast, und sichere dir die Chance auf einen coolen LEGO Preis!

Es gelten die Teilnahmebedingungen

### GAGNE

Rends-toi sur [www.LEGO.com/productfeedback](http://www.LEGO.com/productfeedback)

et donne-nous quelques commentaires sur ce produit LEGO® pour avoir une chance de gagner un prix LEGO !

Voir Conditions Générales

### GANAN

Visita [www.LEGO.com/productfeedback](http://www.LEGO.com/productfeedback)

y envíanos tu opinión acerca de este set LEGO®. ¡Participarás en el sorteo de un premio LEGO!

Términos y Condiciones aplicables

### 获取奖品

登录 [www.LEGO.com/productfeedback](http://www.LEGO.com/productfeedback)

给出关于此乐高®套装的简短反馈，就有机会获得炫酷乐高奖品

《条款及条件》适用

### 경품 당첨 기회

[www.LEGO.com/productfeedback](http://www.LEGO.com/productfeedback)

페이지로 이동하여 이 레고® 세트에 대한 간략한 피드백을 보내 주시고 멋진 레고 경품을 탈 수 있는 기회도 잡으십시오

약관 적용

### ЗАПОЛНИ АНКЕТУ И ПОЛУЧИ ПРИЗ

Перейди по ссылке [www.LEGO.com/productfeedback](http://www.LEGO.com/productfeedback)

ответь всего на несколько вопросов об этом наборе LEGO®, и у тебя появится шанс выиграть замечательный приз от компании LEGO.

Применяются Условия и правила участия