

**LEGO**

**RACERS**

7968



1

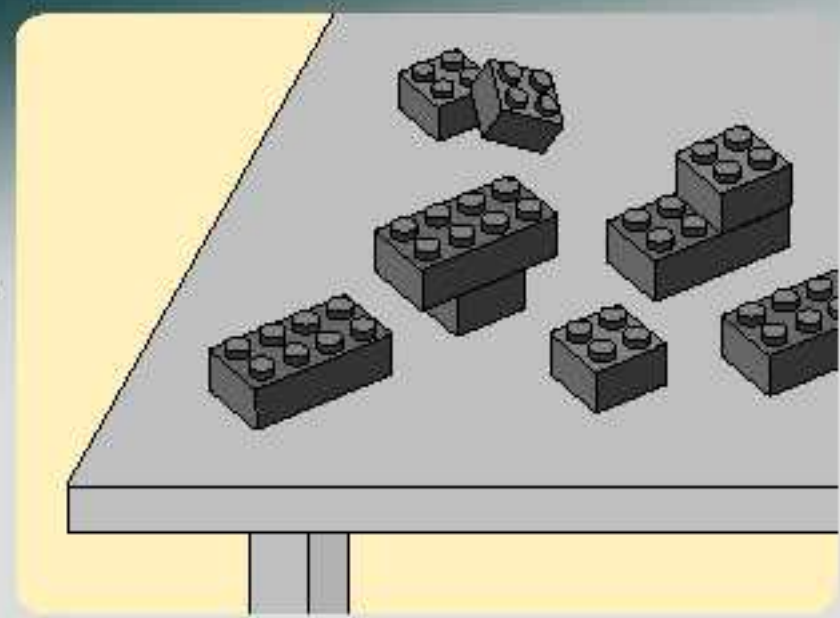

2

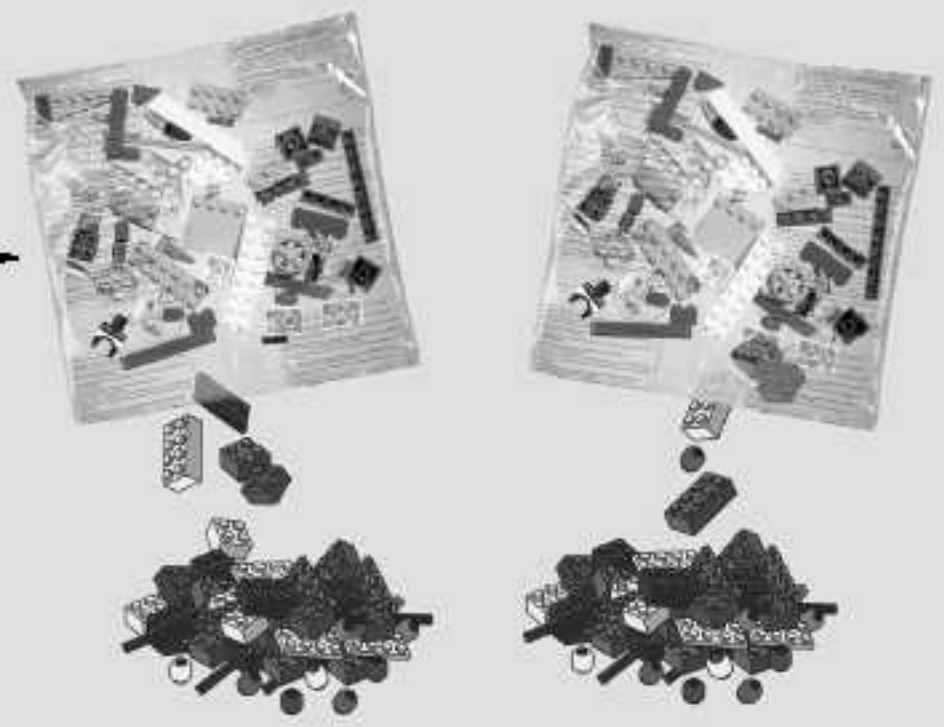

2

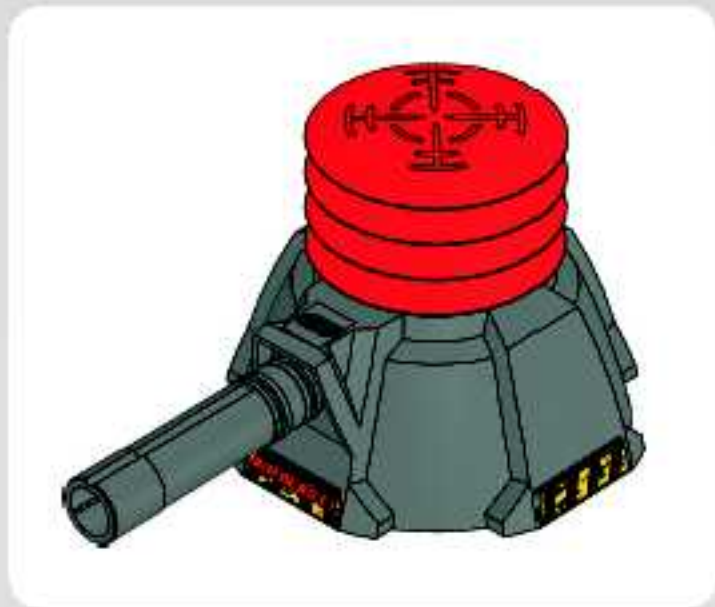

1

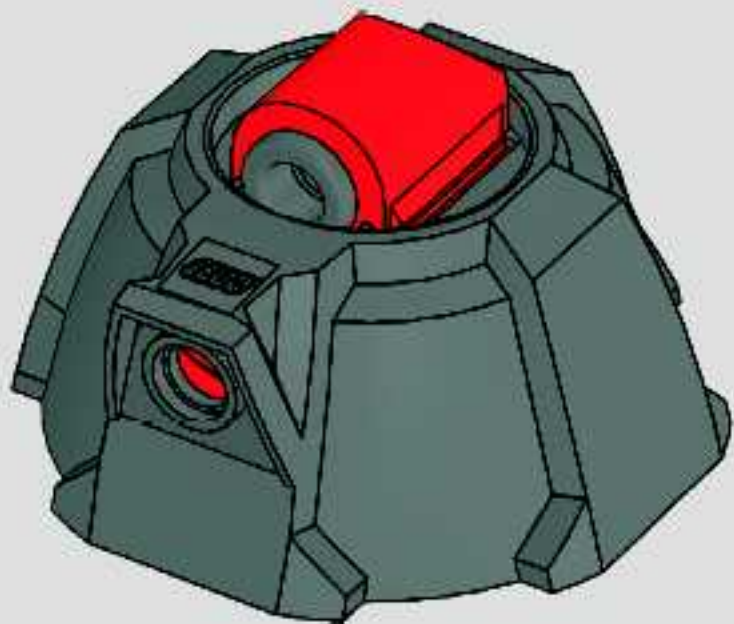

2

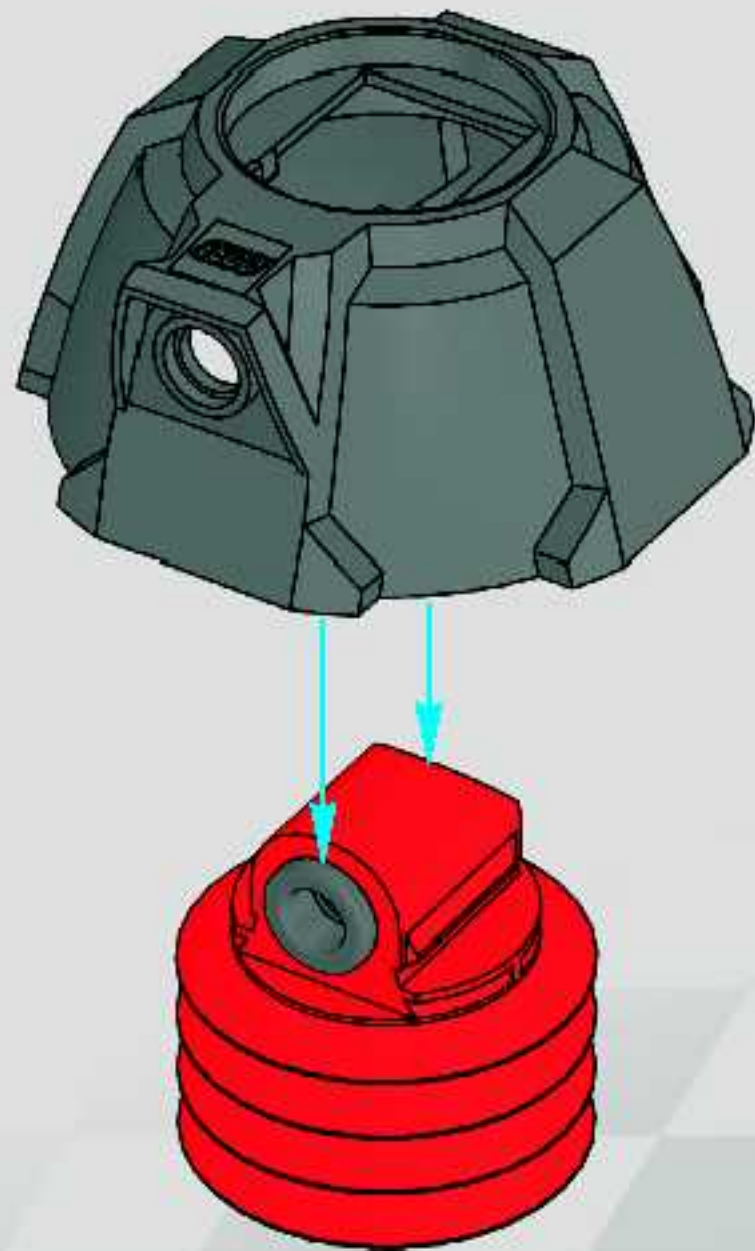

3

3



4

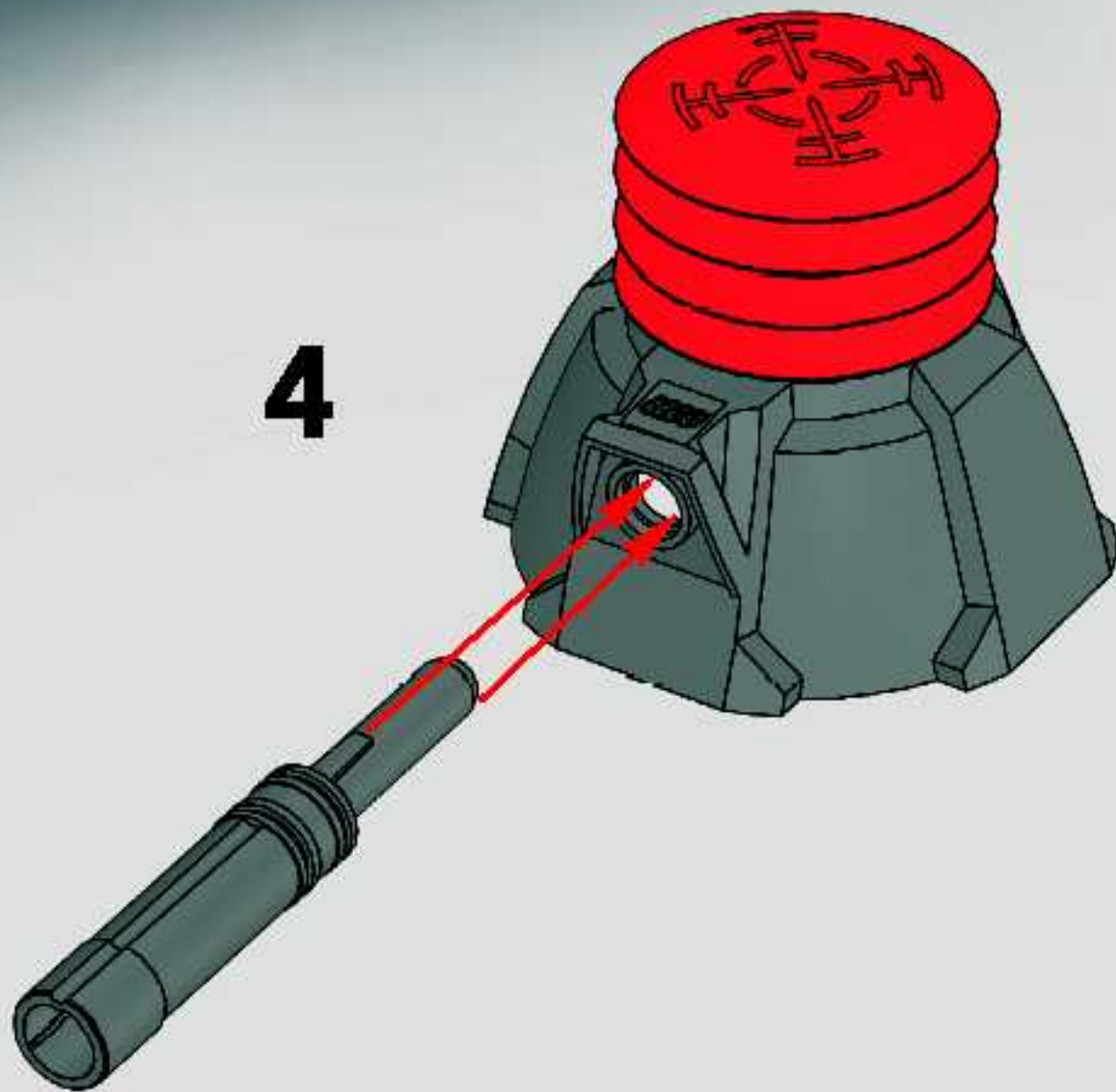

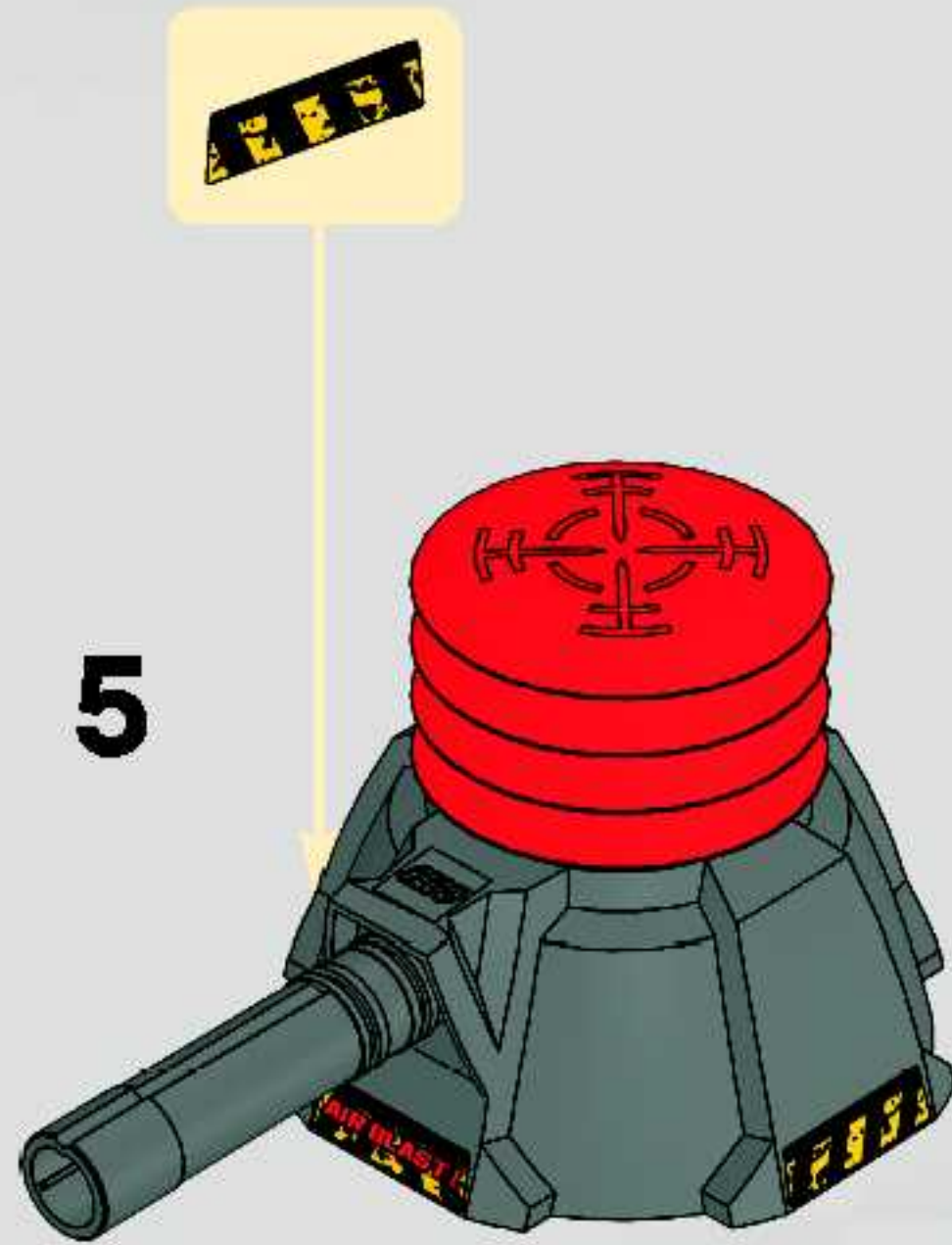



1

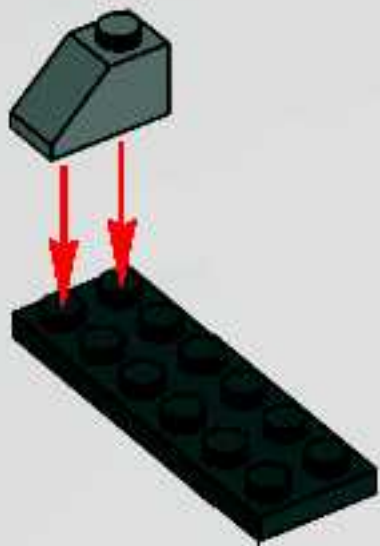

2

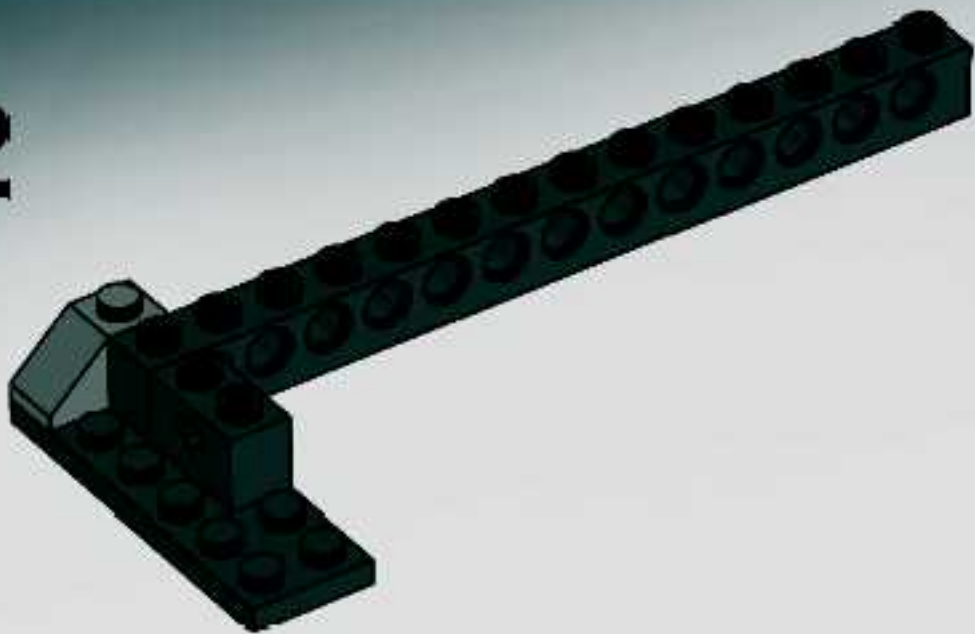

3

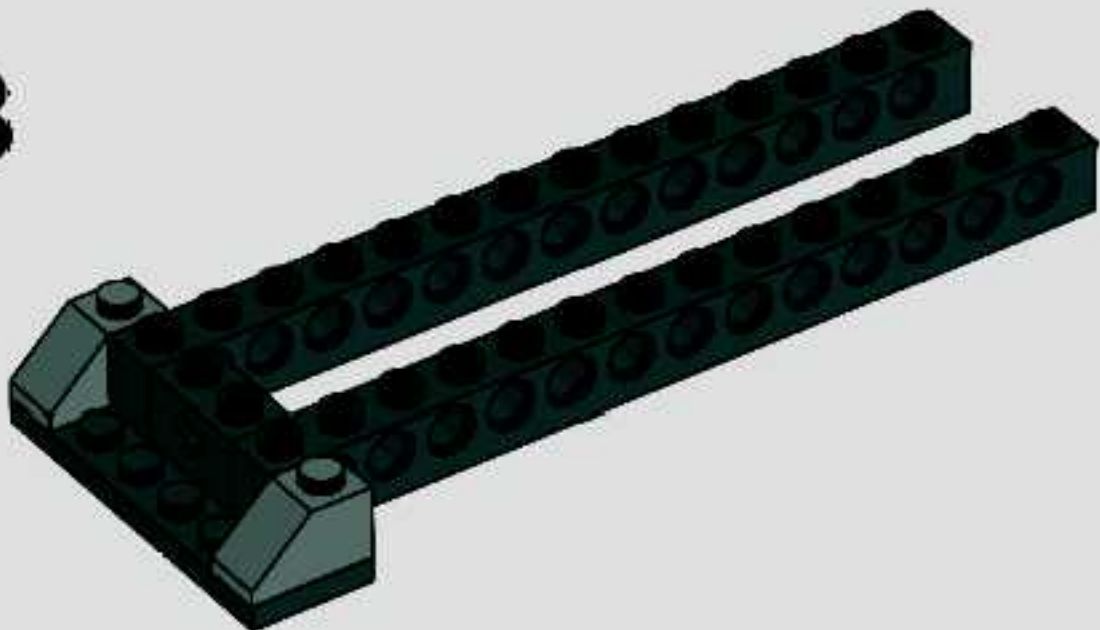

4

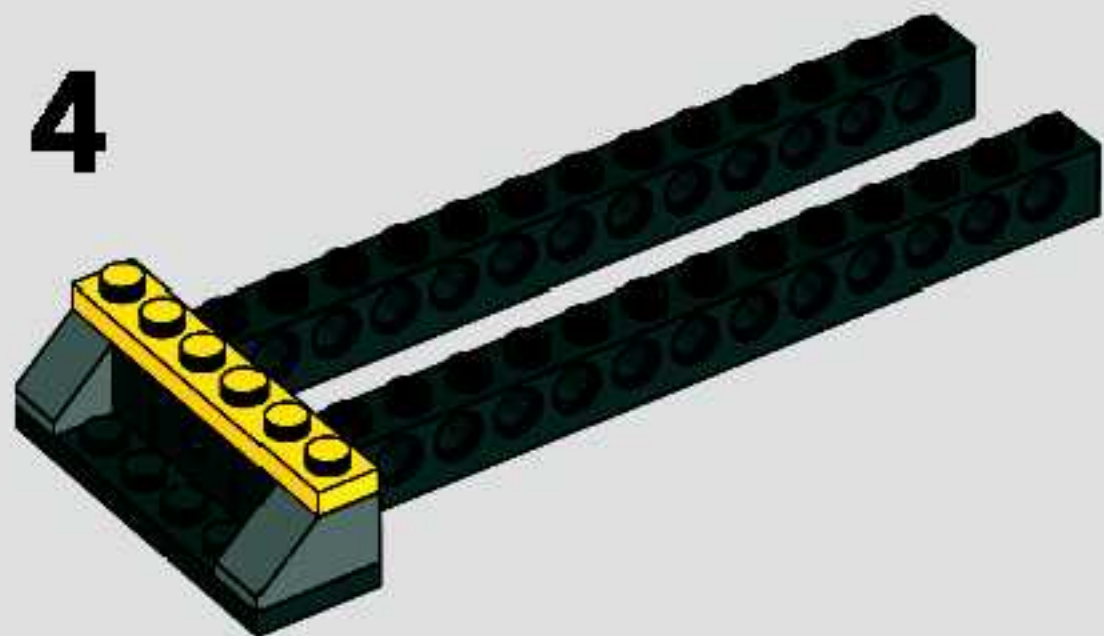

5

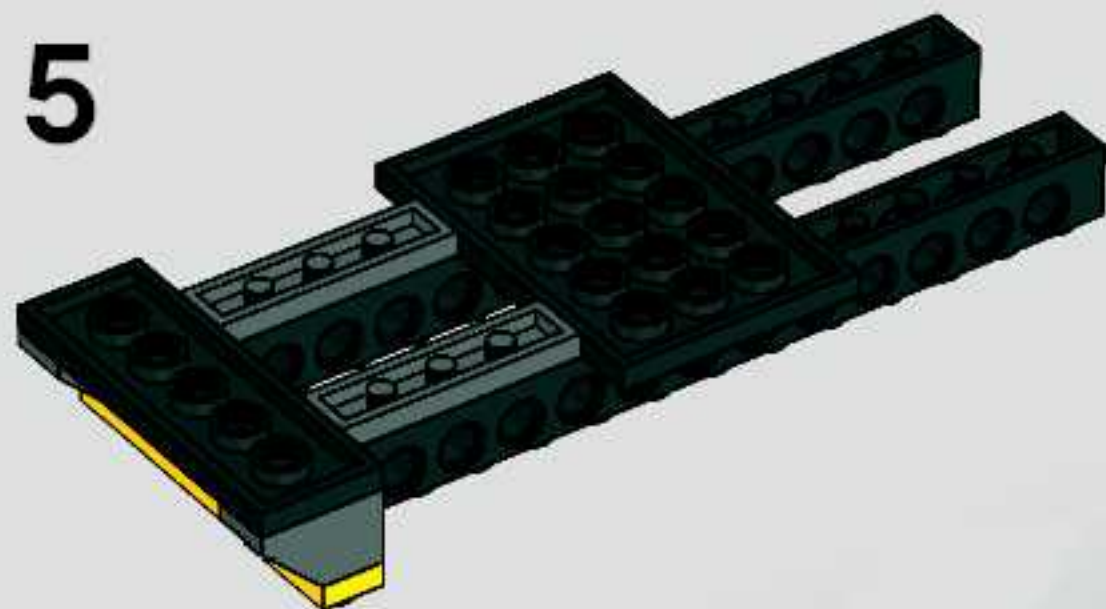

6

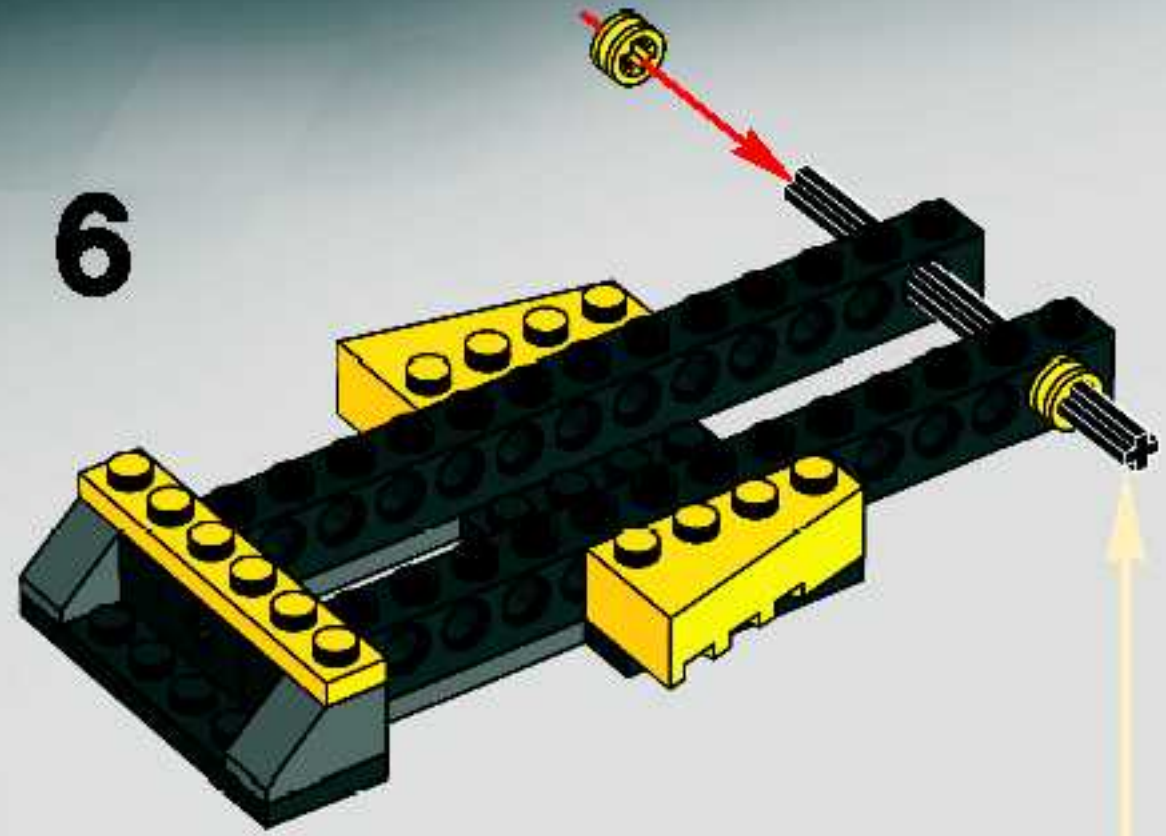



7

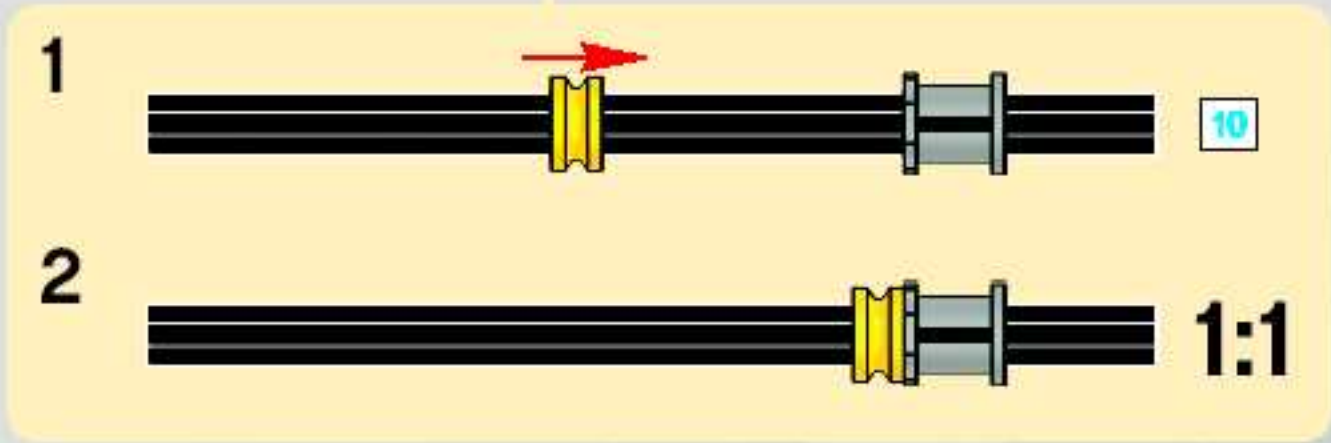
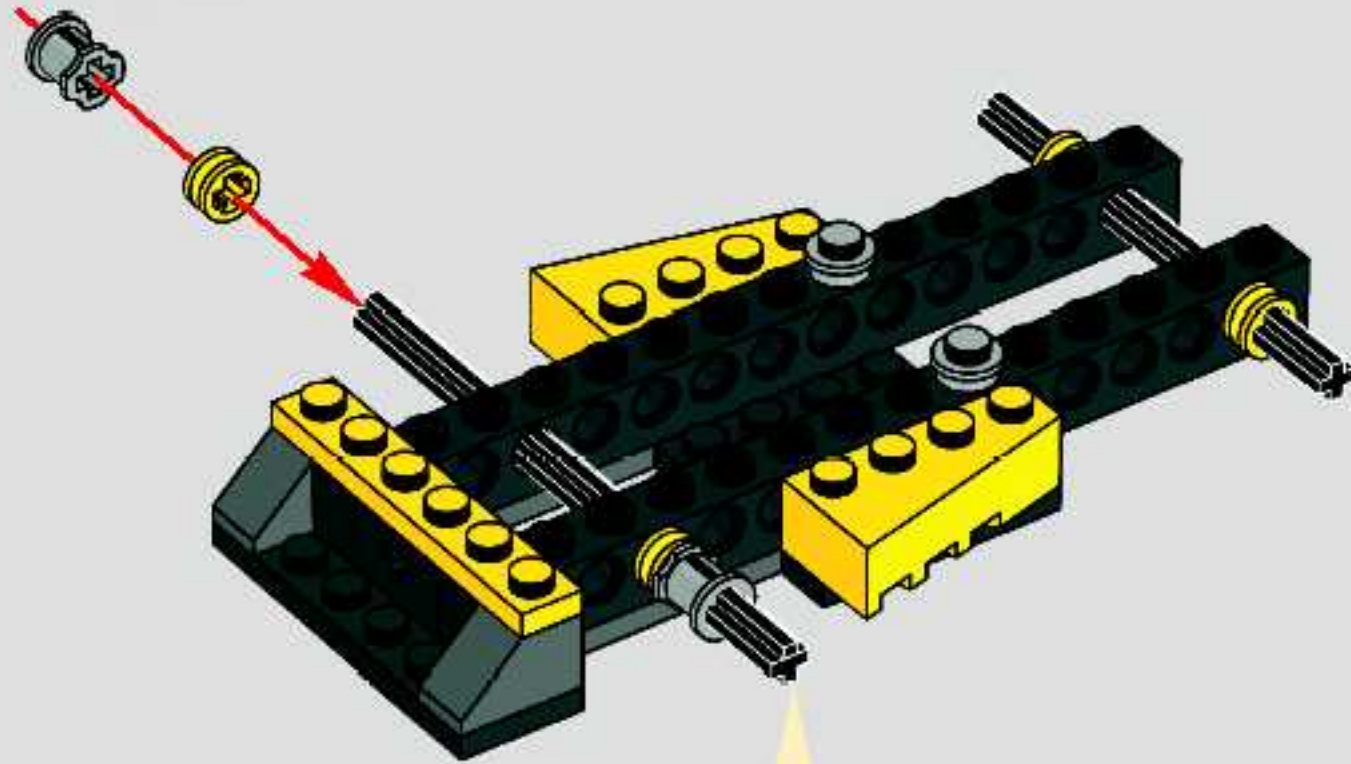

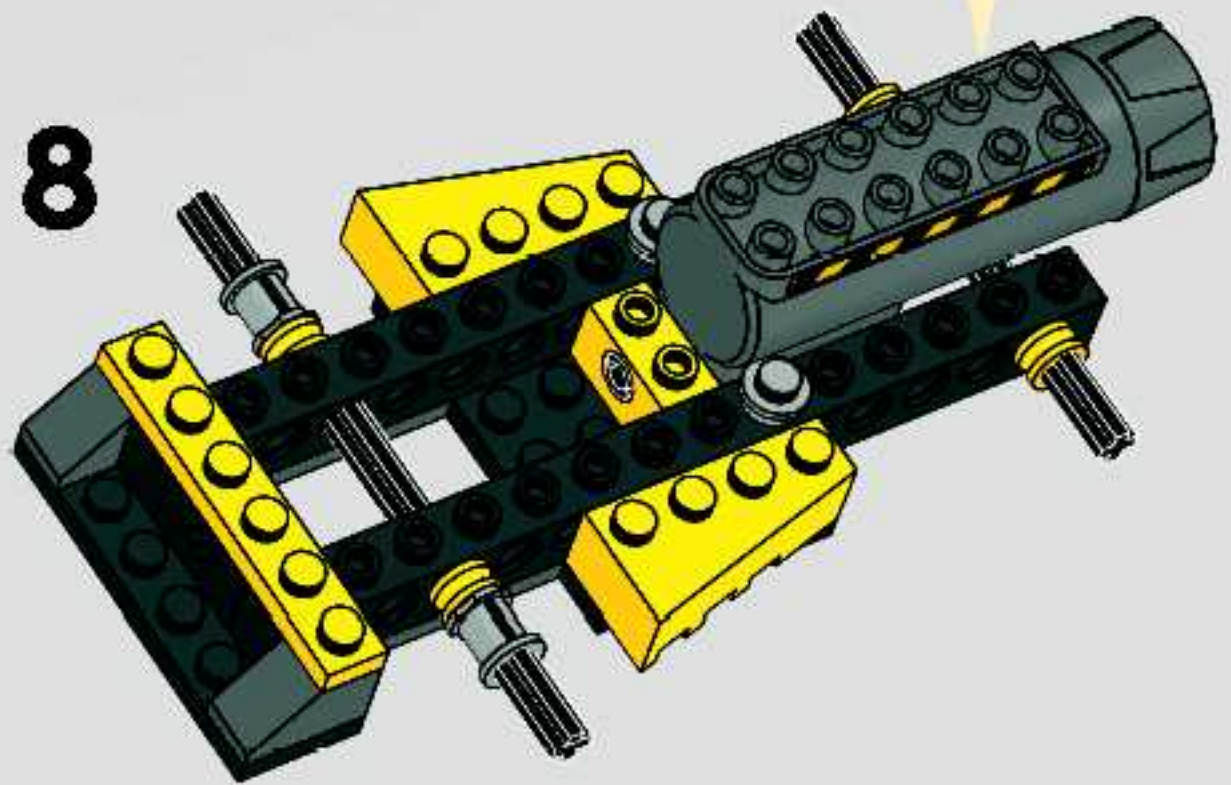
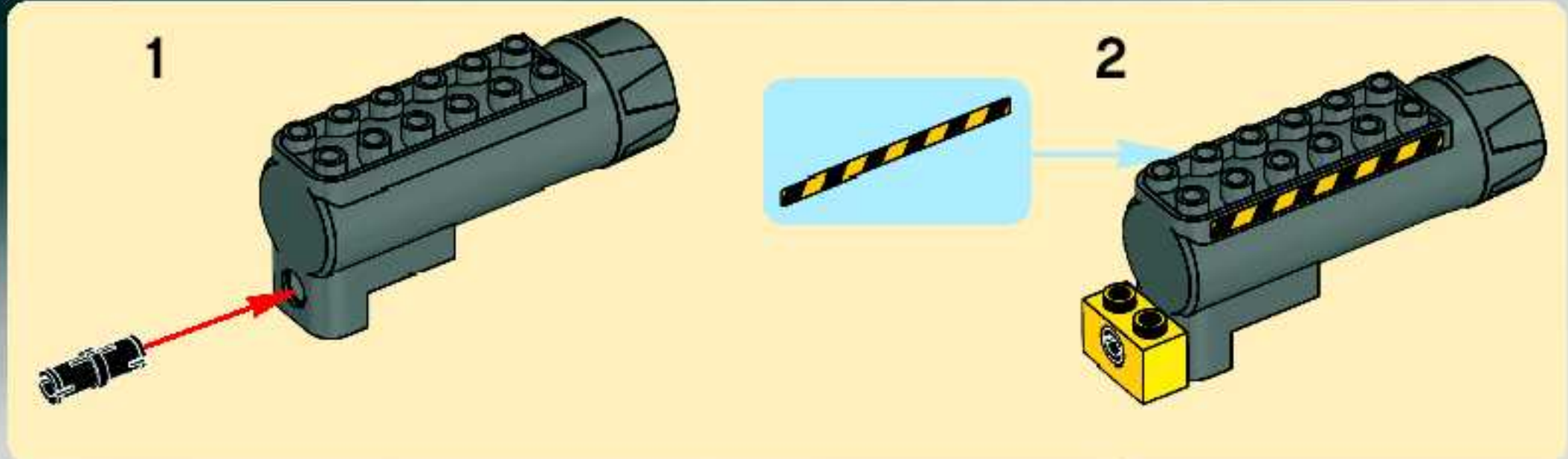

9

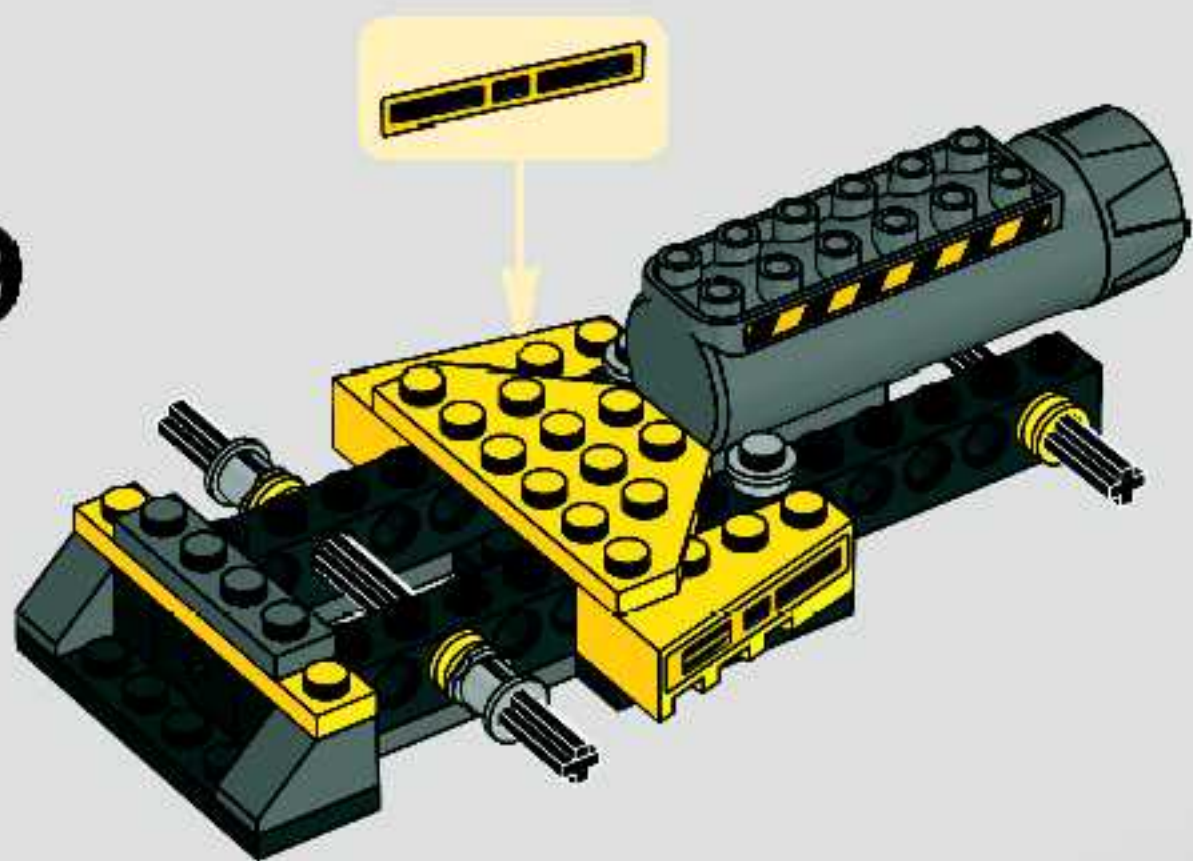

10

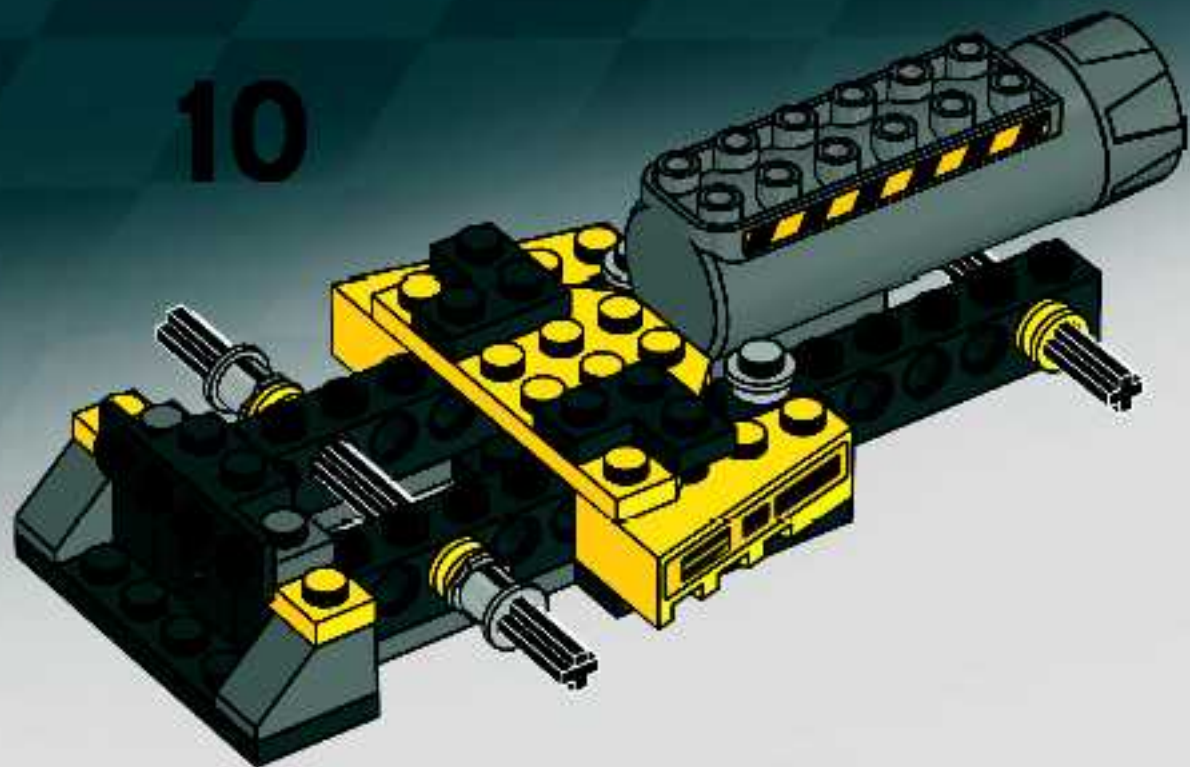

11

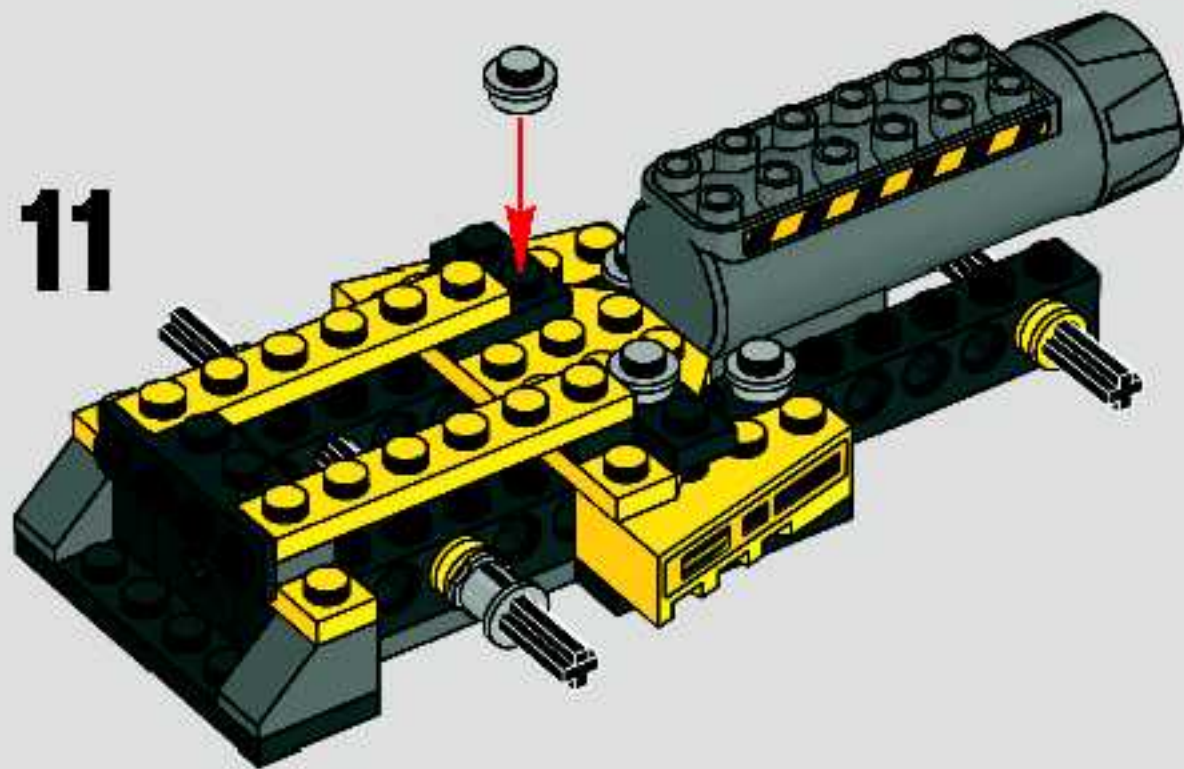

12

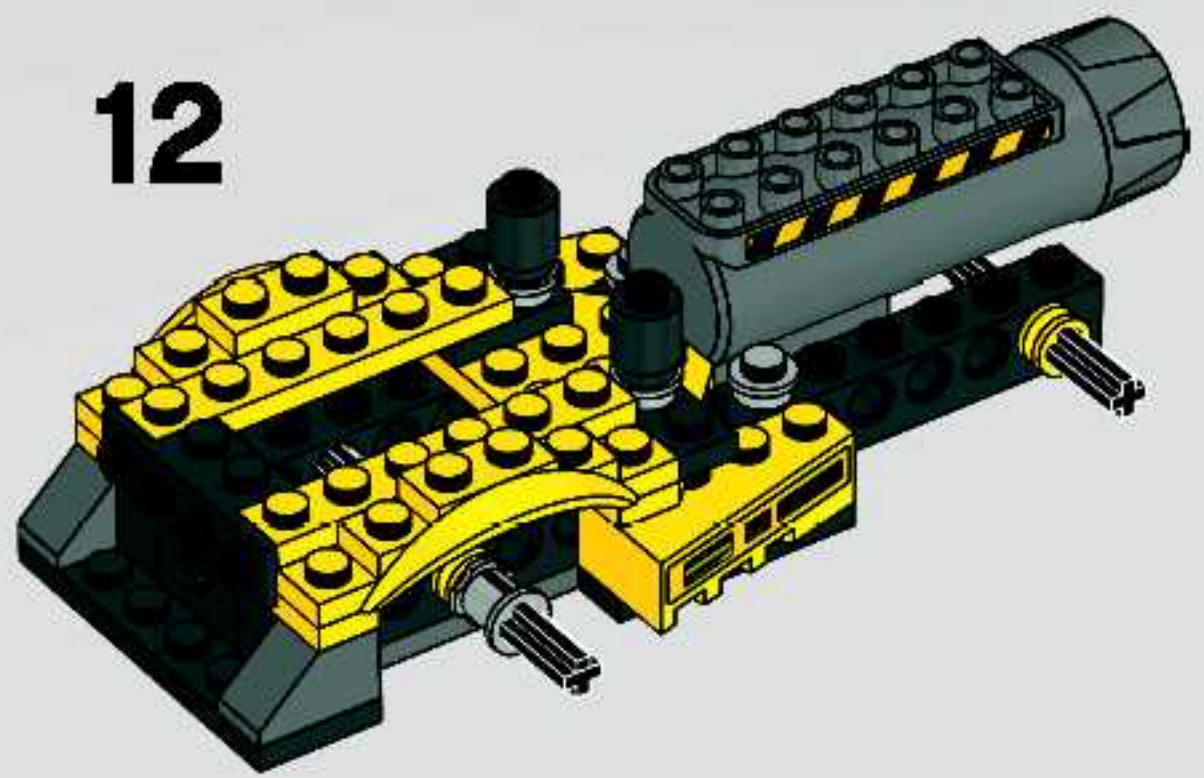

13

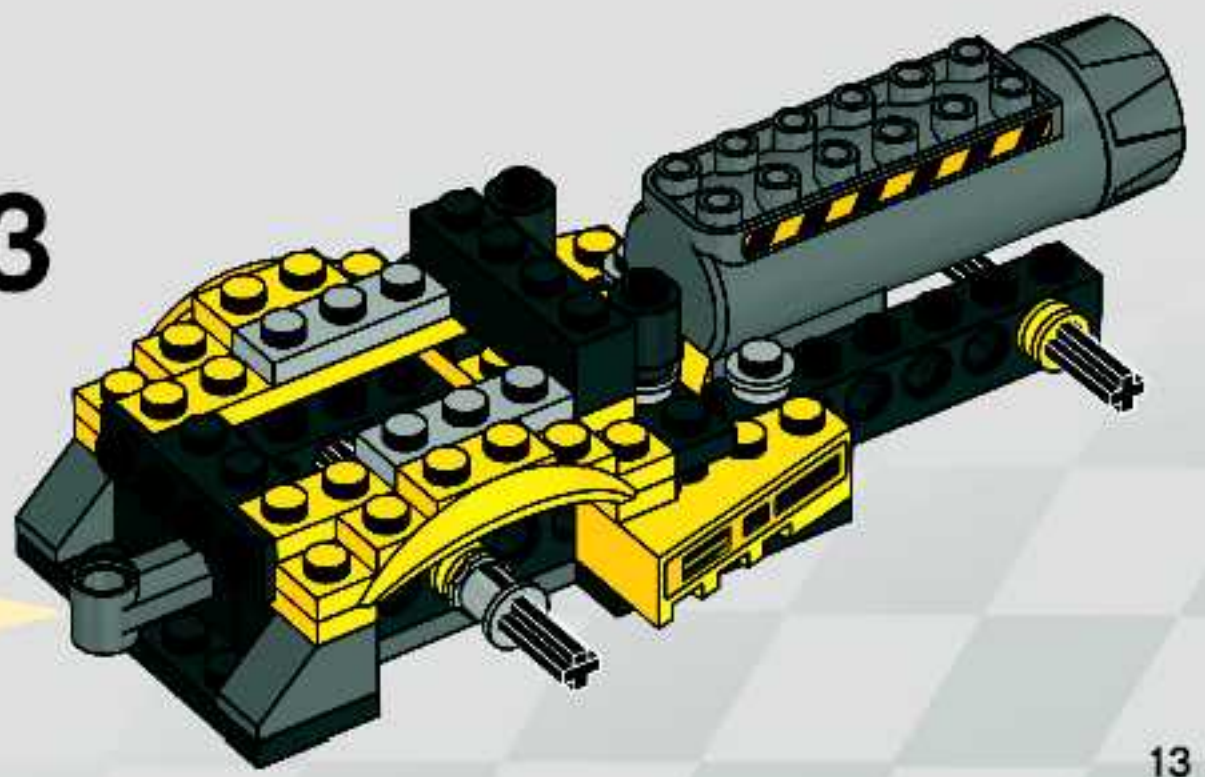
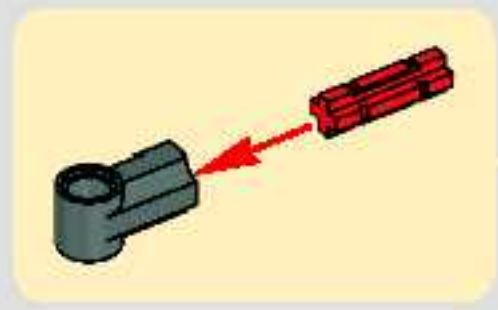

14

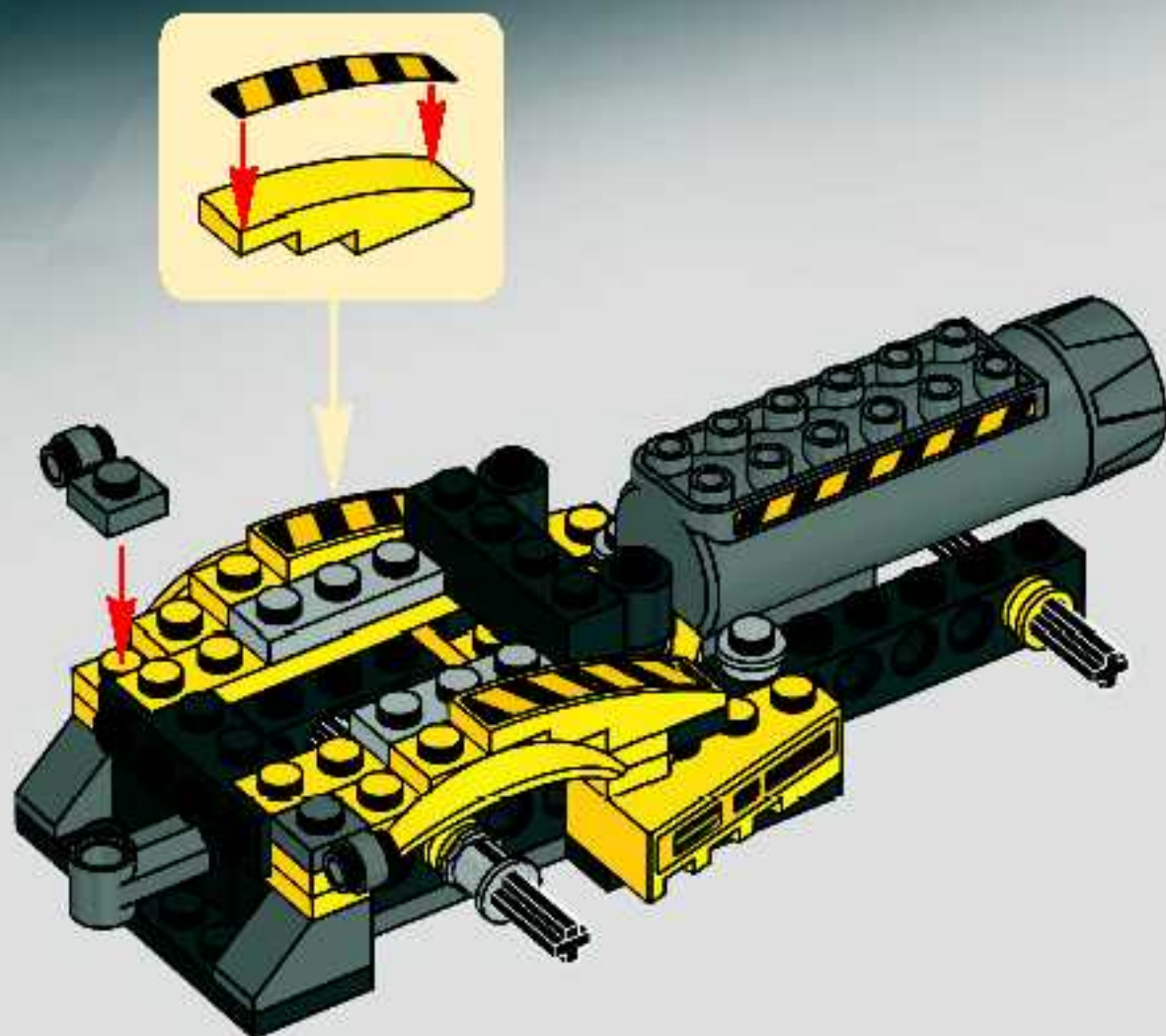

15

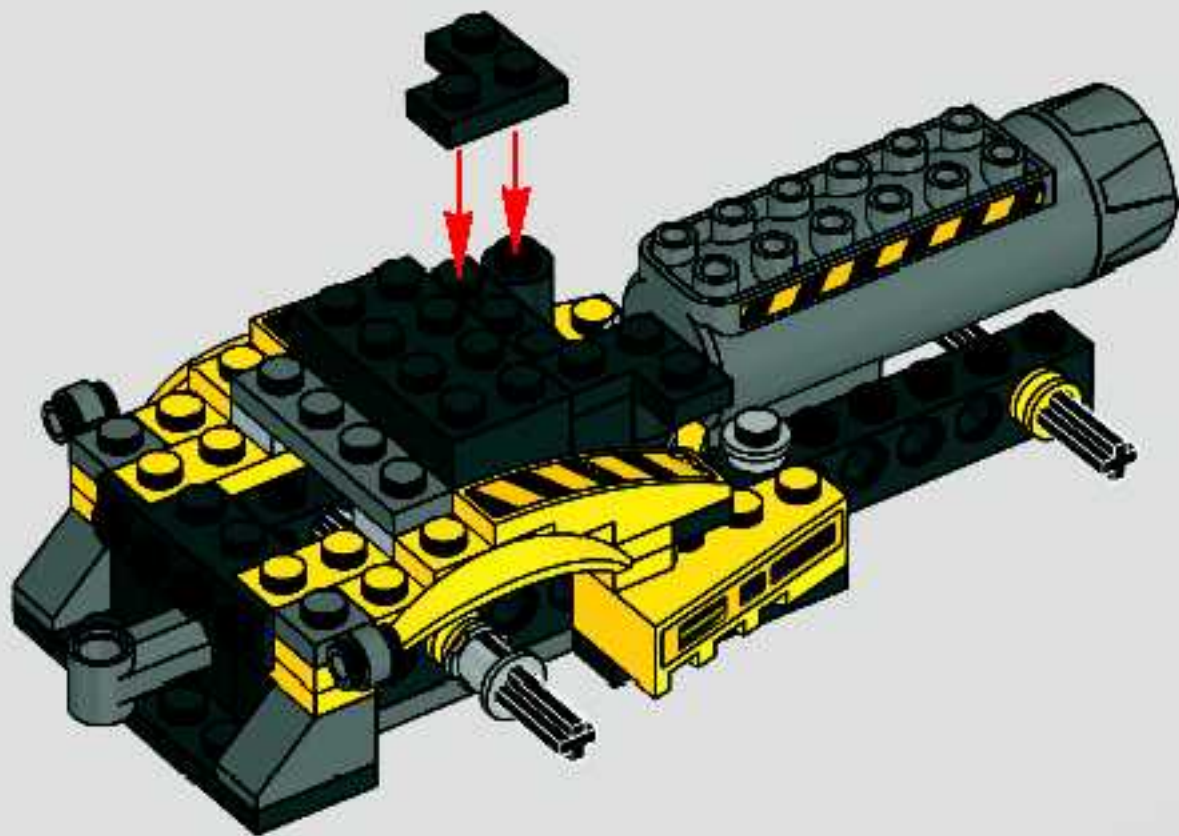

16

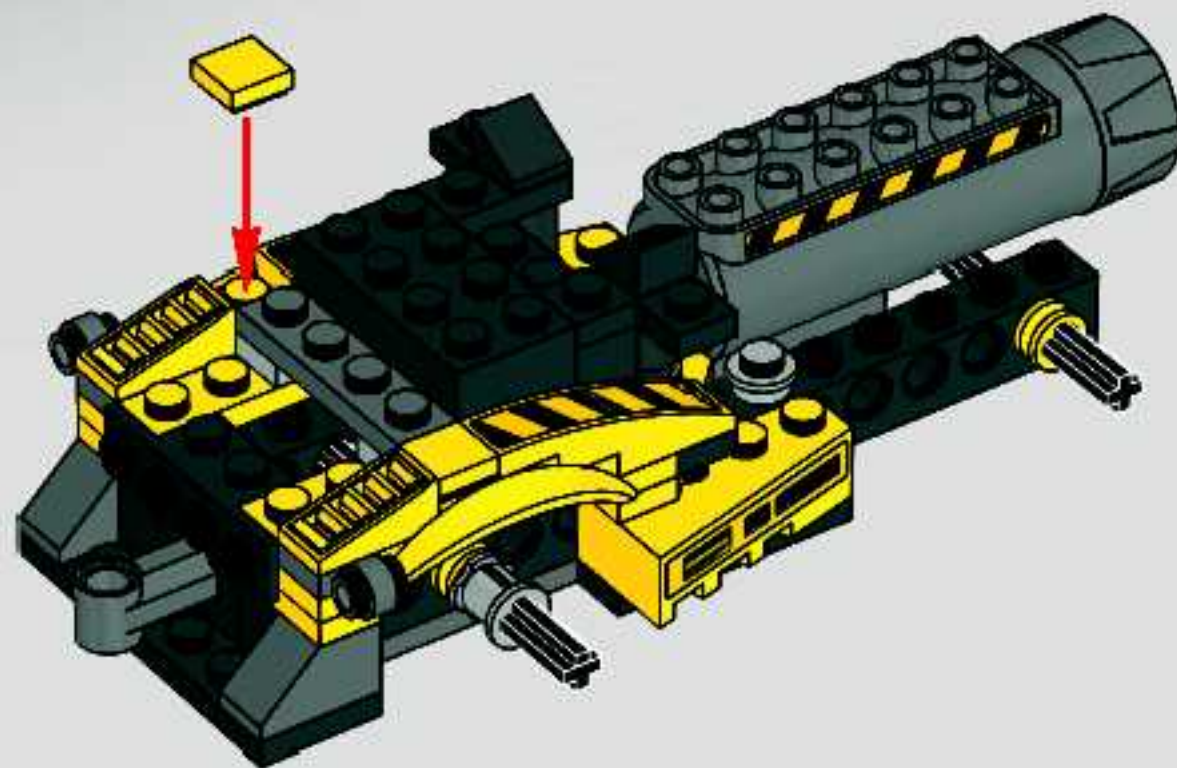



17

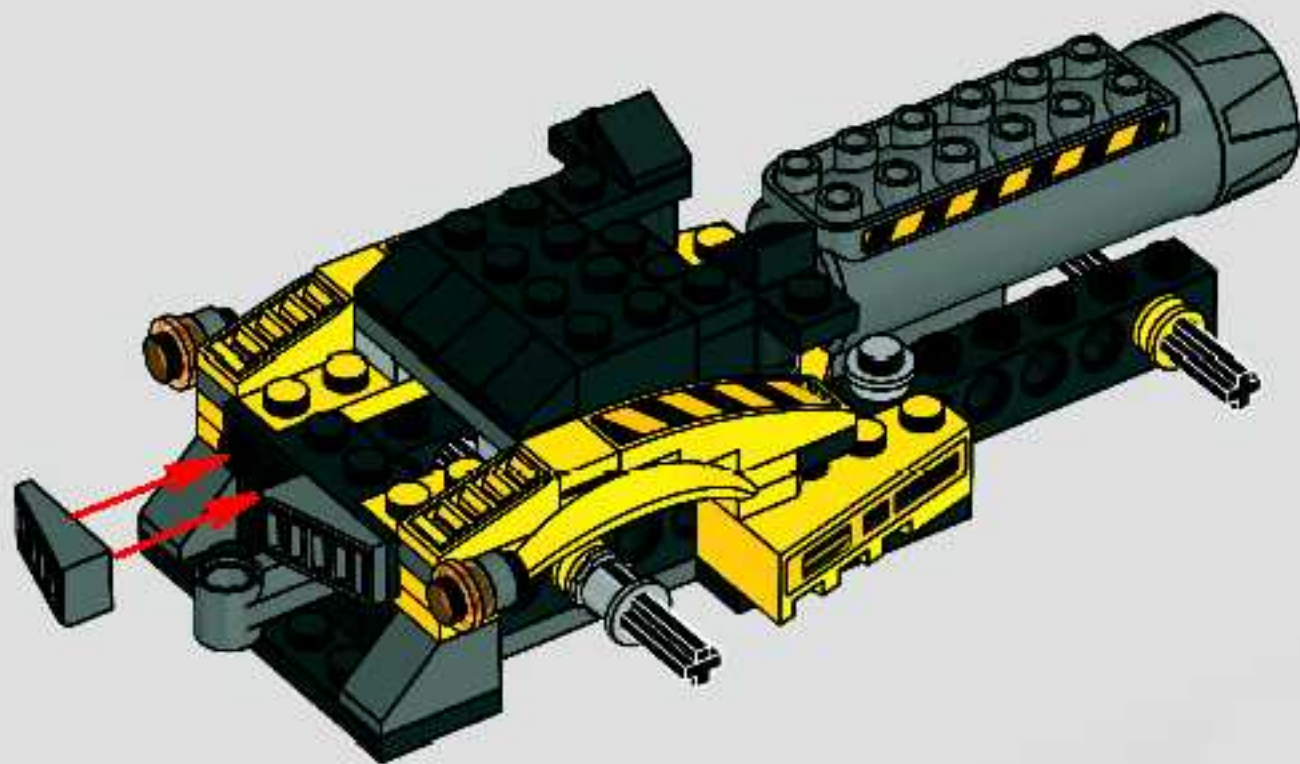

18

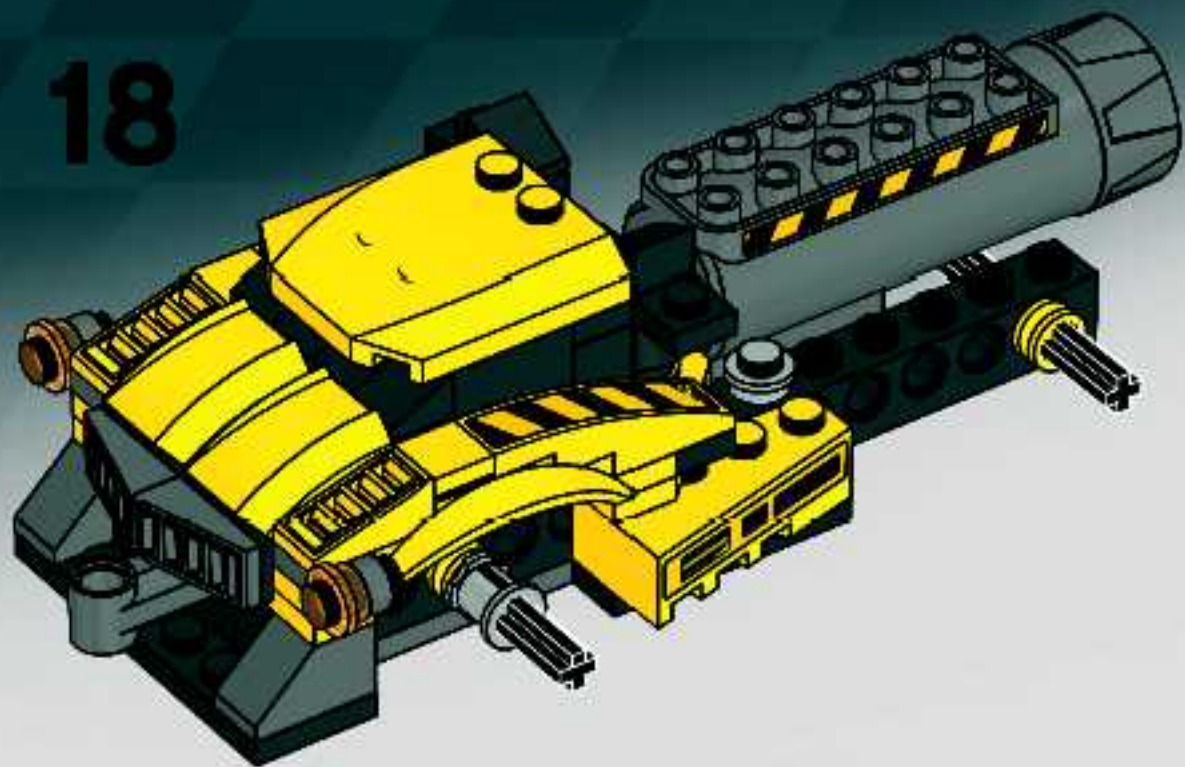

19

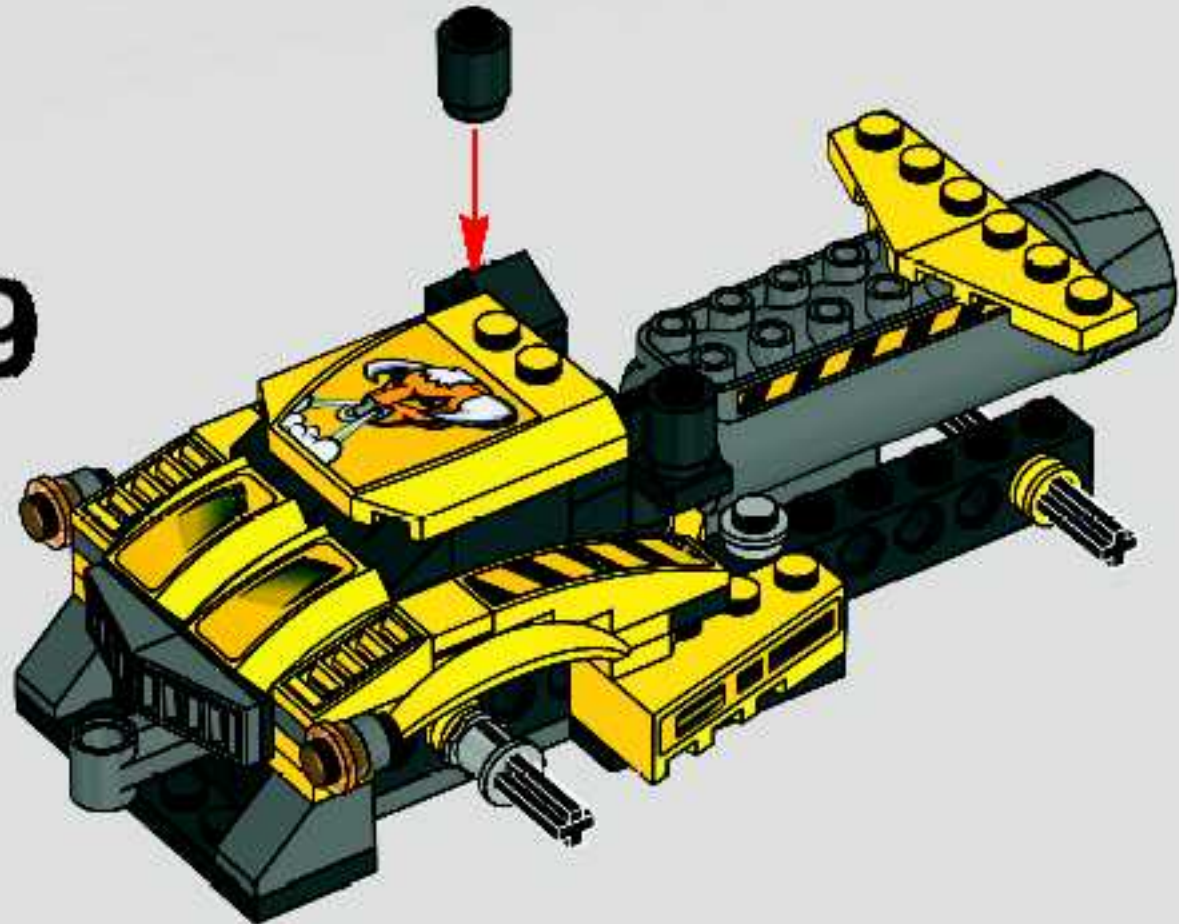

20

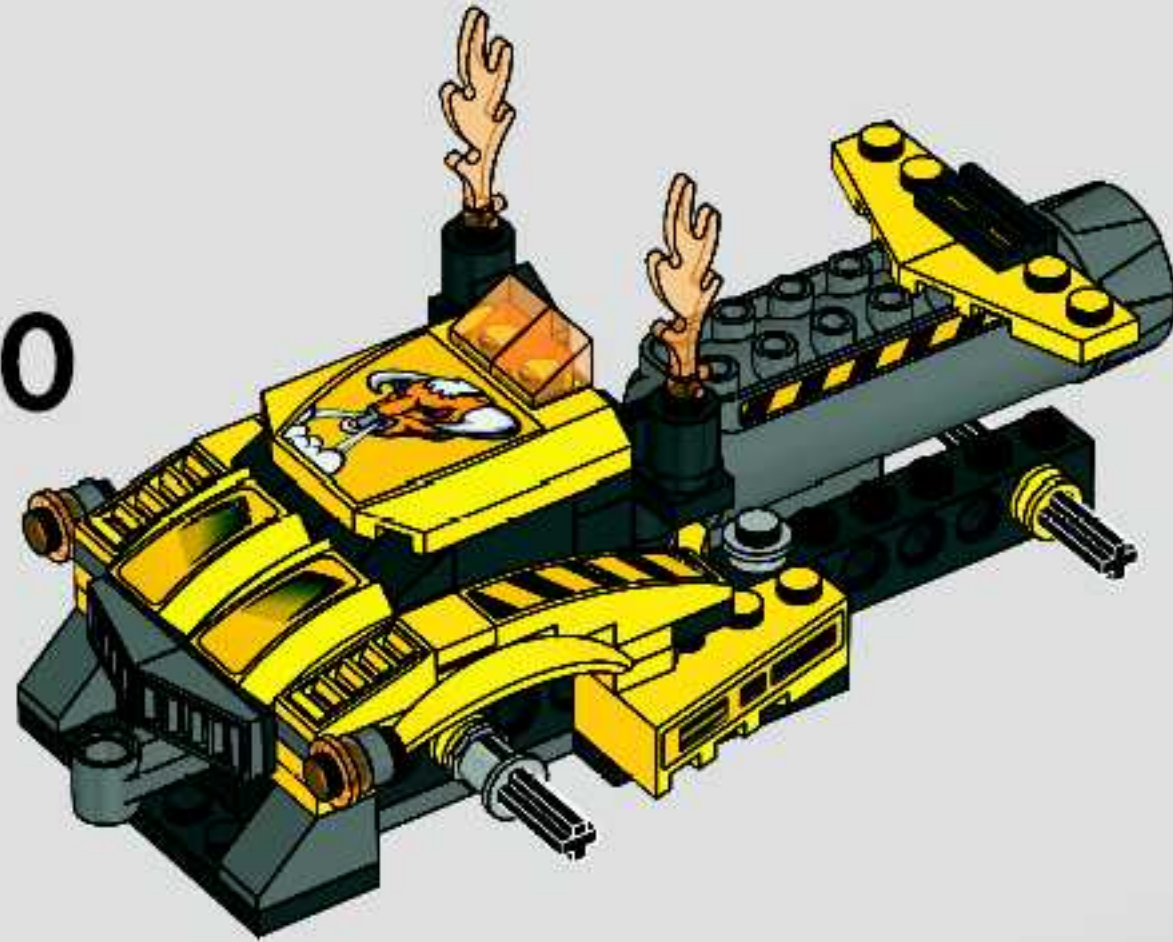

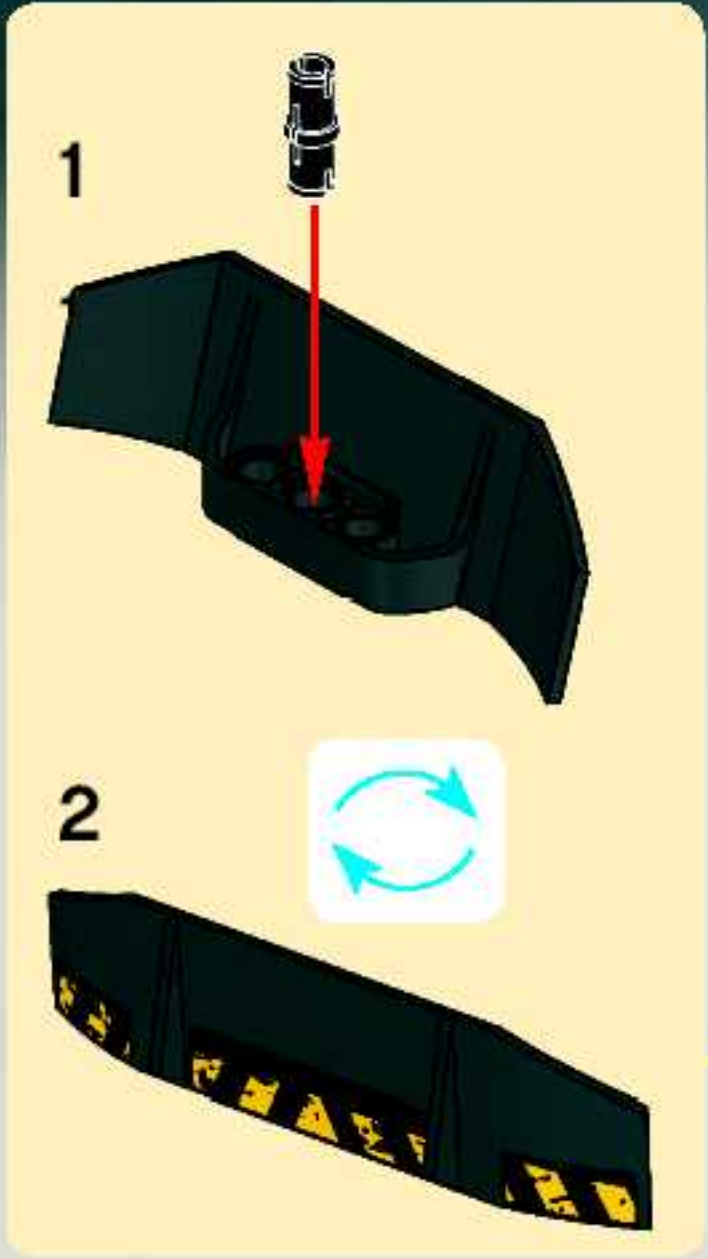

21



22



23

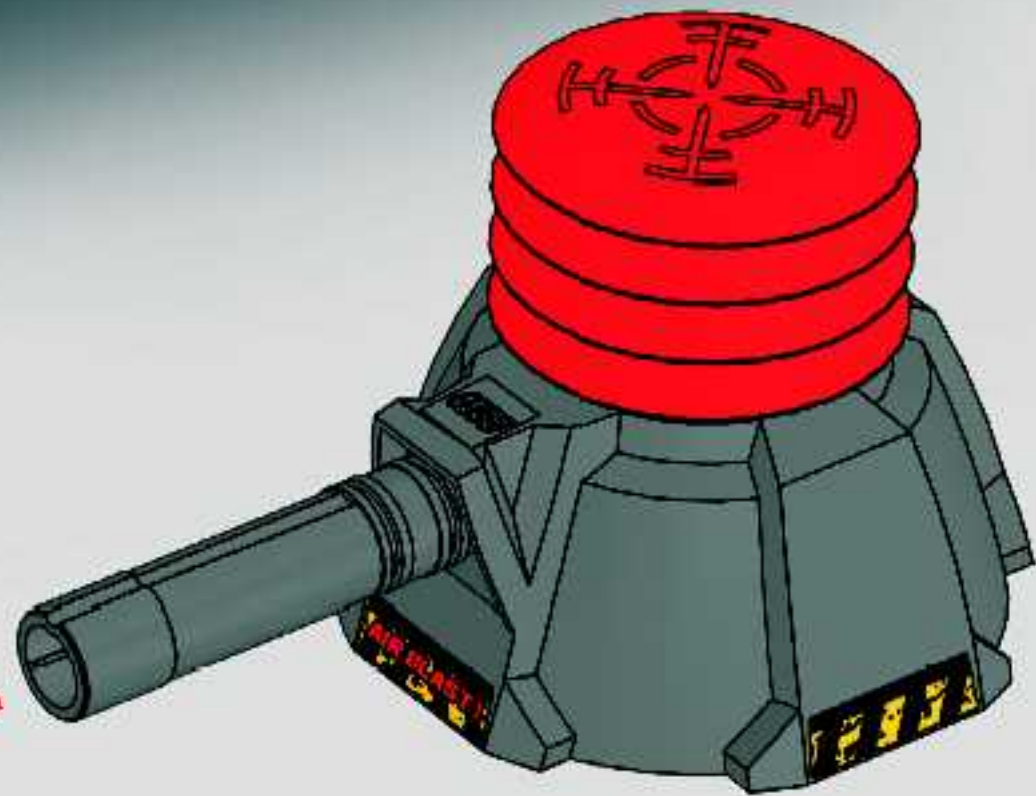



1x  
4568690



1x  
4142865



1x  
4160333



1x  
4160348



1x  
370024



2x  
4540384



2x  
4522035



2x  
307024



3x  
366624



1x  
4179094



1x  
4179095



1x  
241924



2x  
4144412



1x  
4193073



2x  
4523558



4x  
4239601



1x  
301026



1x  
300126



1x  
4233487



4x  
306226



2x  
4107558



6x  
4504382



4x  
242026



1x  
379526



1x  
303226



1x  
241226



1x  
4282746



4x  
4517737



4x  
4140670



1x  
4518336



2x  
4121715



1x  
370726



1x  
373726



2x  
4244369



2x  
4222960



2x  
4261397



2x  
4211429



4x  
4211525



2x  
4211622



1x  
4210658



2x  
4540386



2x  
4211135

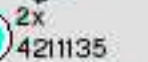

4x  
4211001



2x  
4210828



1x  
4563226



1x  
4568692

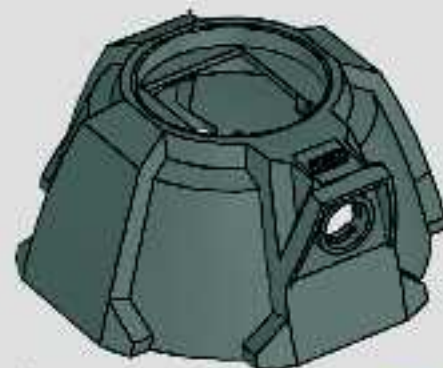

1x  
4563215



Customer Service

Kundenservice

Service Consommateurs

Servicio Al Consumidor

[www.lego.com/service](http://www.lego.com/service) or dial



: 00800 5346 5555

: 1-800-422-5346



# WIN!

Go to [www.nielsen.com/LEGO](http://www.nielsen.com/LEGO)  
to fill out a survey for a chance  
to win a cool LEGO® Product.

No purchase necessary.

Open to all residents where not prohibited.



## [www.nielsen.com/LEGO](http://www.nielsen.com/LEGO)

### GEWINNE!

Nimm an der Umfrage auf  
[www.nielsen.com/LEGO](http://www.nielsen.com/LEGO)  
teil und hab die Chance ein cooles  
LEGO® Produkt zu gewinnen!

Die Teilnahme am Gewinnspiel führt zu keinerlei  
Kaufverpflichtungen. Teilnahme in allen nicht  
ausgeschlossenen Ländern möglich.

### WIN!

Ga naar [www.nielsen.com/LEGO](http://www.nielsen.com/LEGO),  
vul een enquêteformulier in en  
maak kans op een  
cool LEGO® product.

Geen aankoopverplichting.

Iedereen mag deelnemen, uitgezonderd  
Ingezetenden

van landen waar een enquêteverbod geldt.

### GAGNE!

Visite [www.nielsen.com/LEGO](http://www.nielsen.com/LEGO)  
pour répondre à un questionnaire  
et avoir une chance de gagner  
un produit LEGO® très cool!

Aucune obligation d'achat.

OUvert à tous les résidents des pays  
autorisés.

### 当てよう!

[www.nielsen.com/LEGO](http://www.nielsen.com/LEGO)

にアクセスして、  
アンケートにご記入ください。  
当選者にはレゴ製品を  
差し上げます。

お買い上げの必要はありません。

禁止されていない限り、すべての年齢にご利用いただけます。