

BIONICLE®

CLICK



20012

 BrickMaster

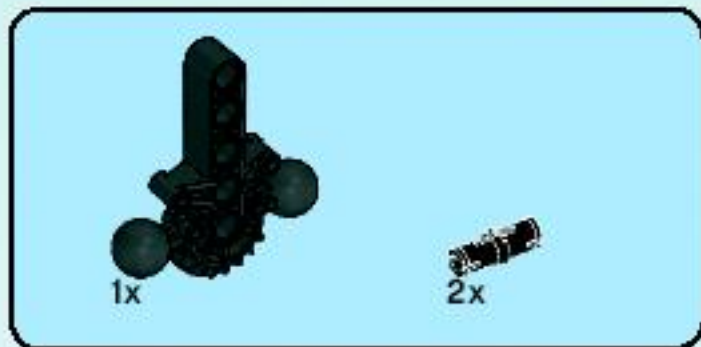

1

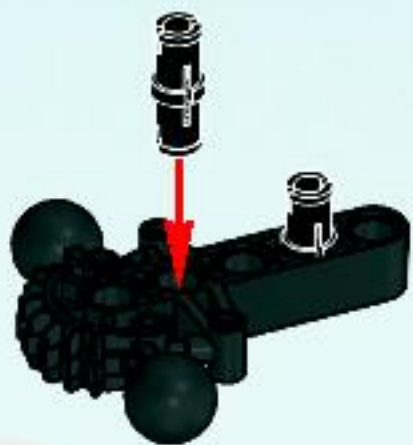

2

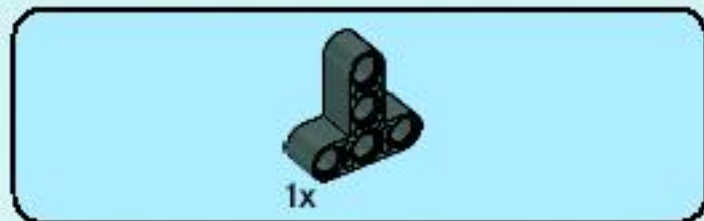

2

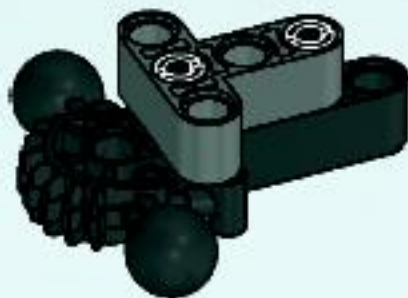



3

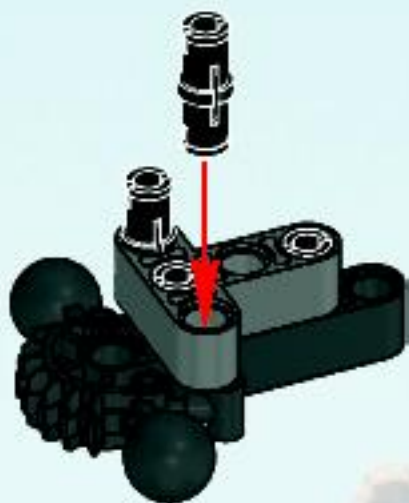

4



2x

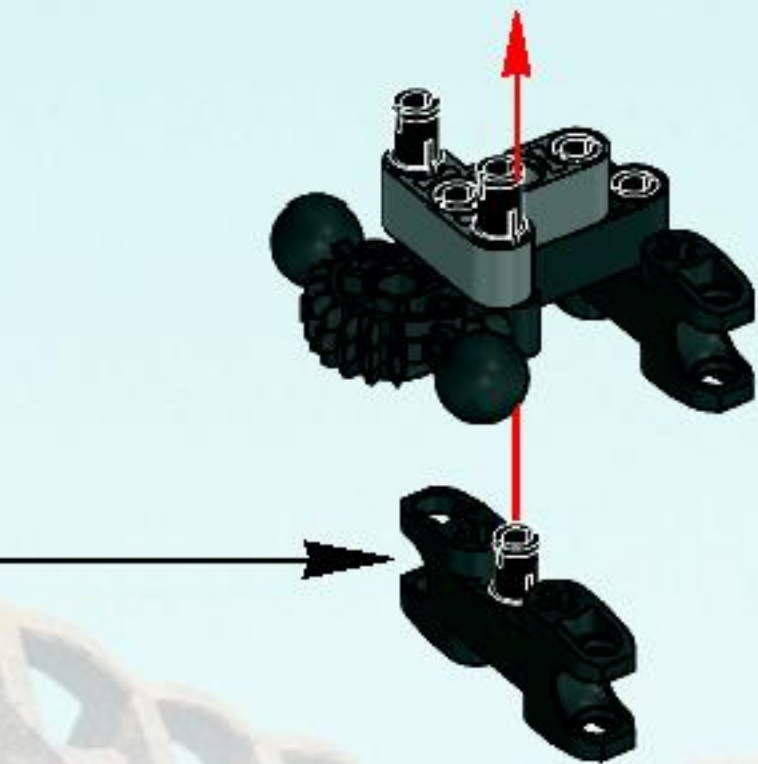

4

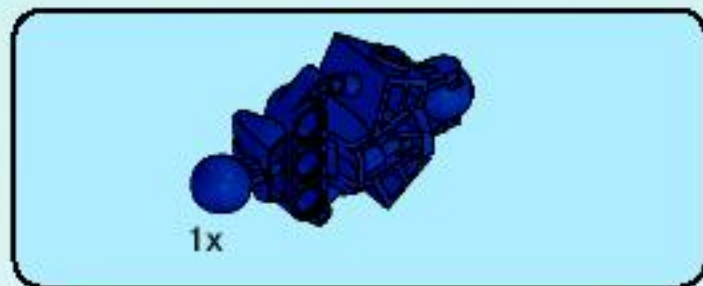

5

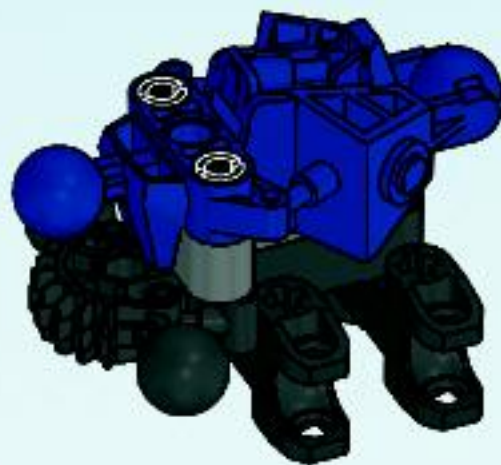



6

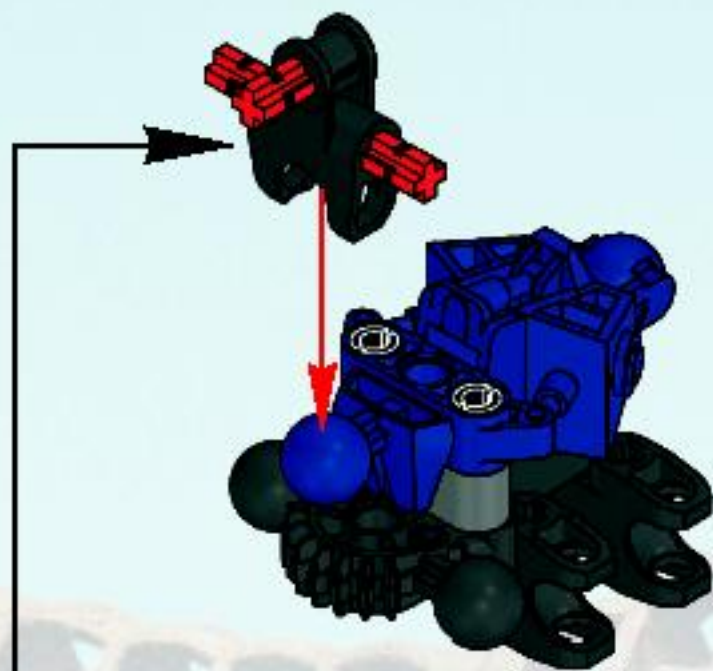
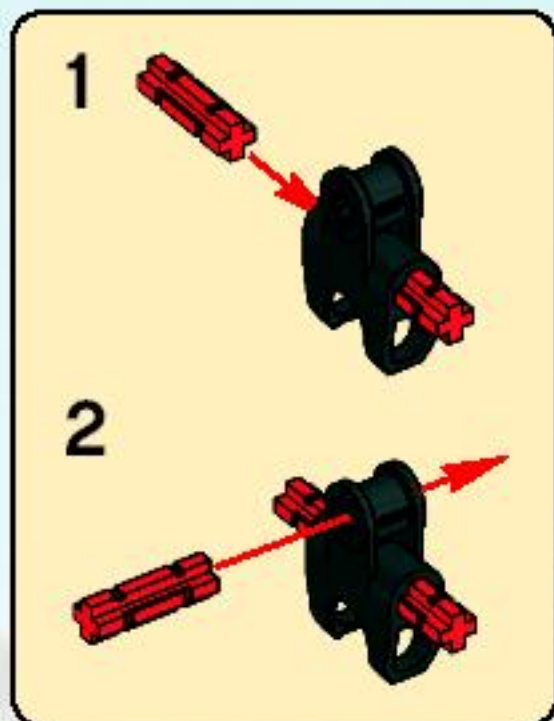

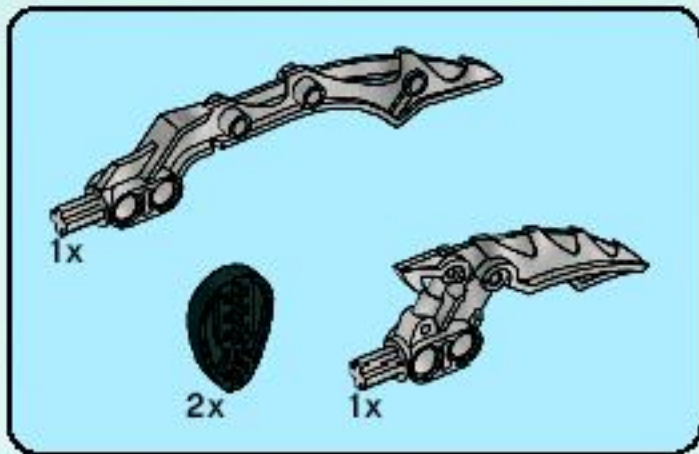

7

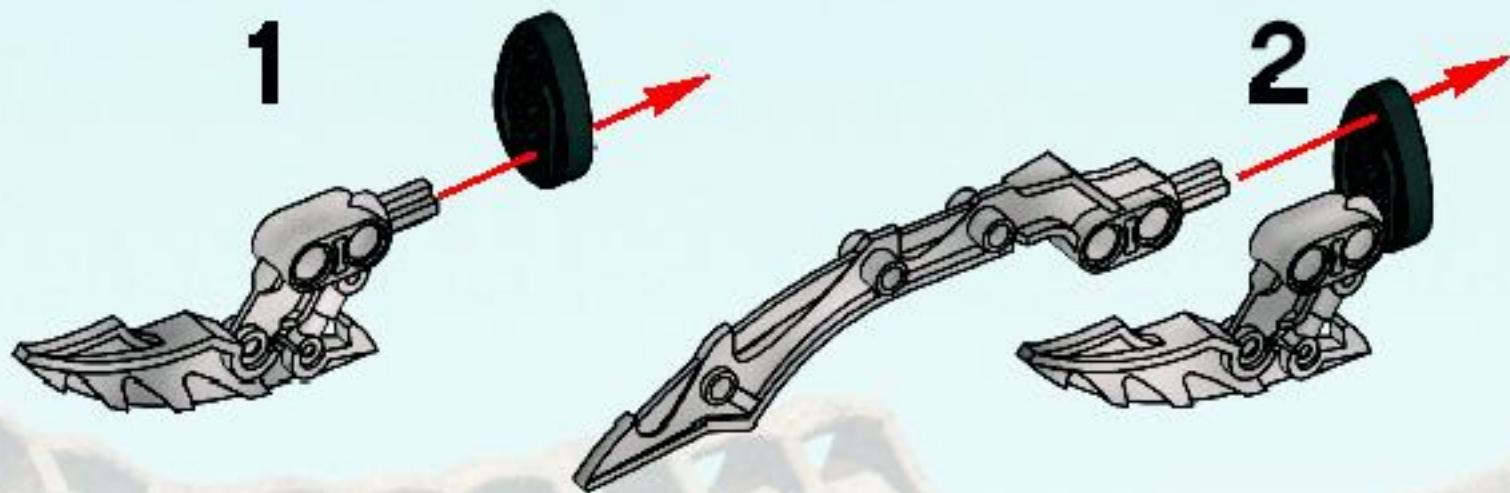

3

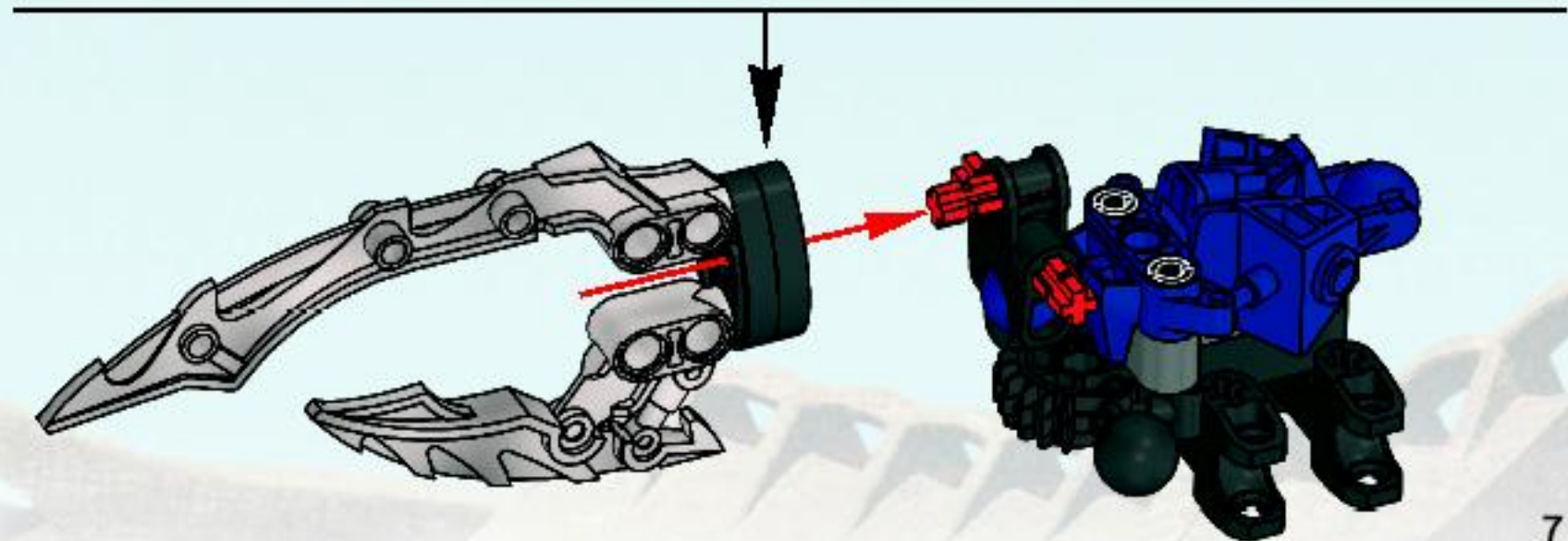
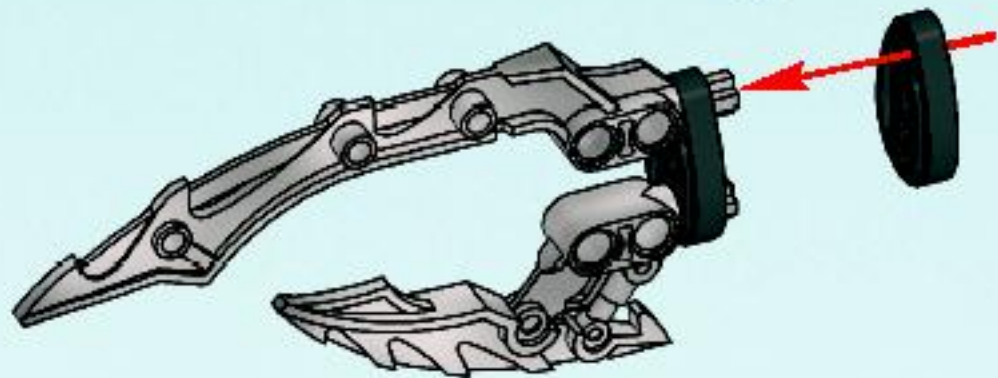

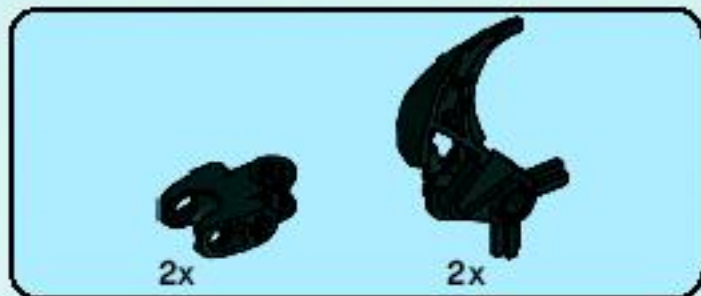

8

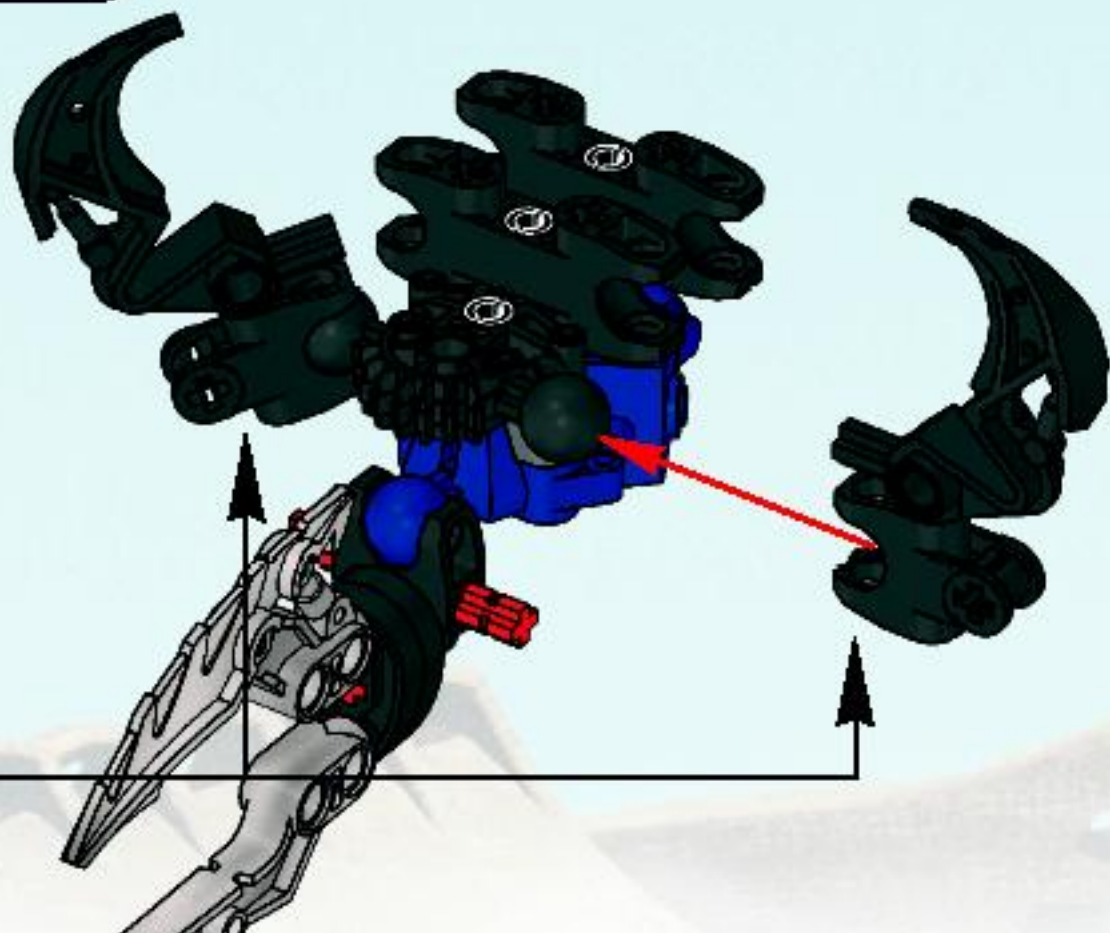

8

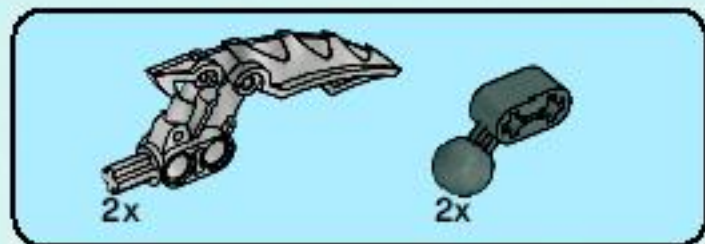

9

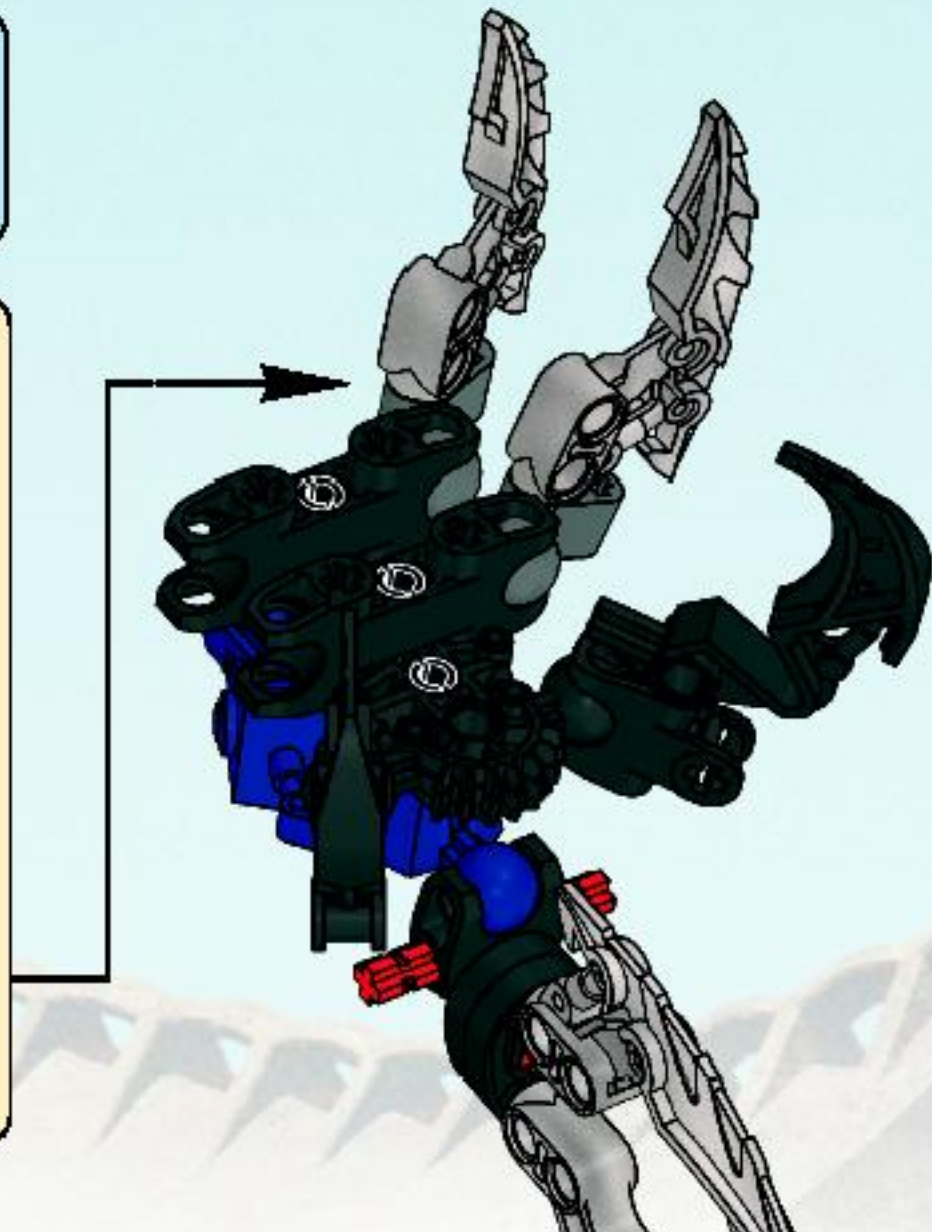
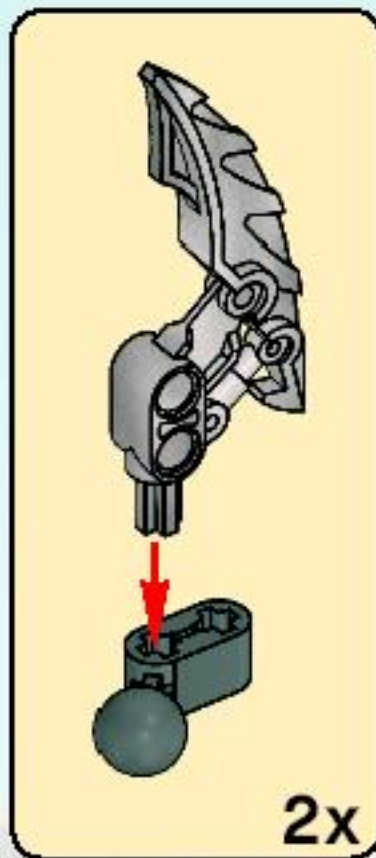

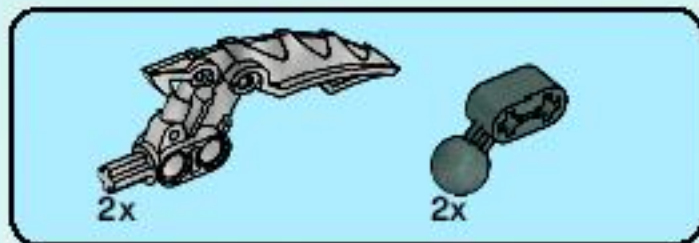

10

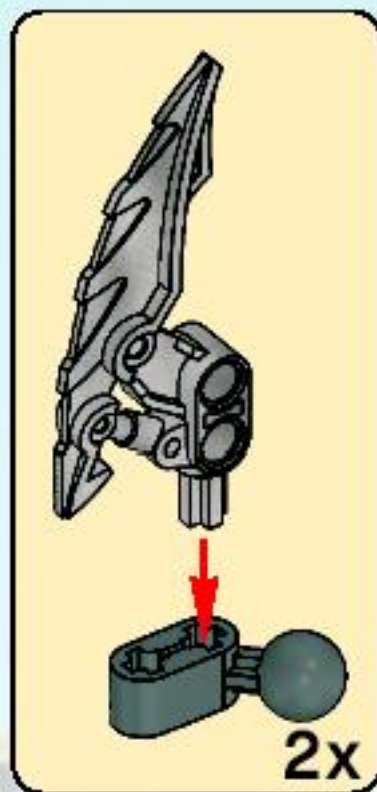

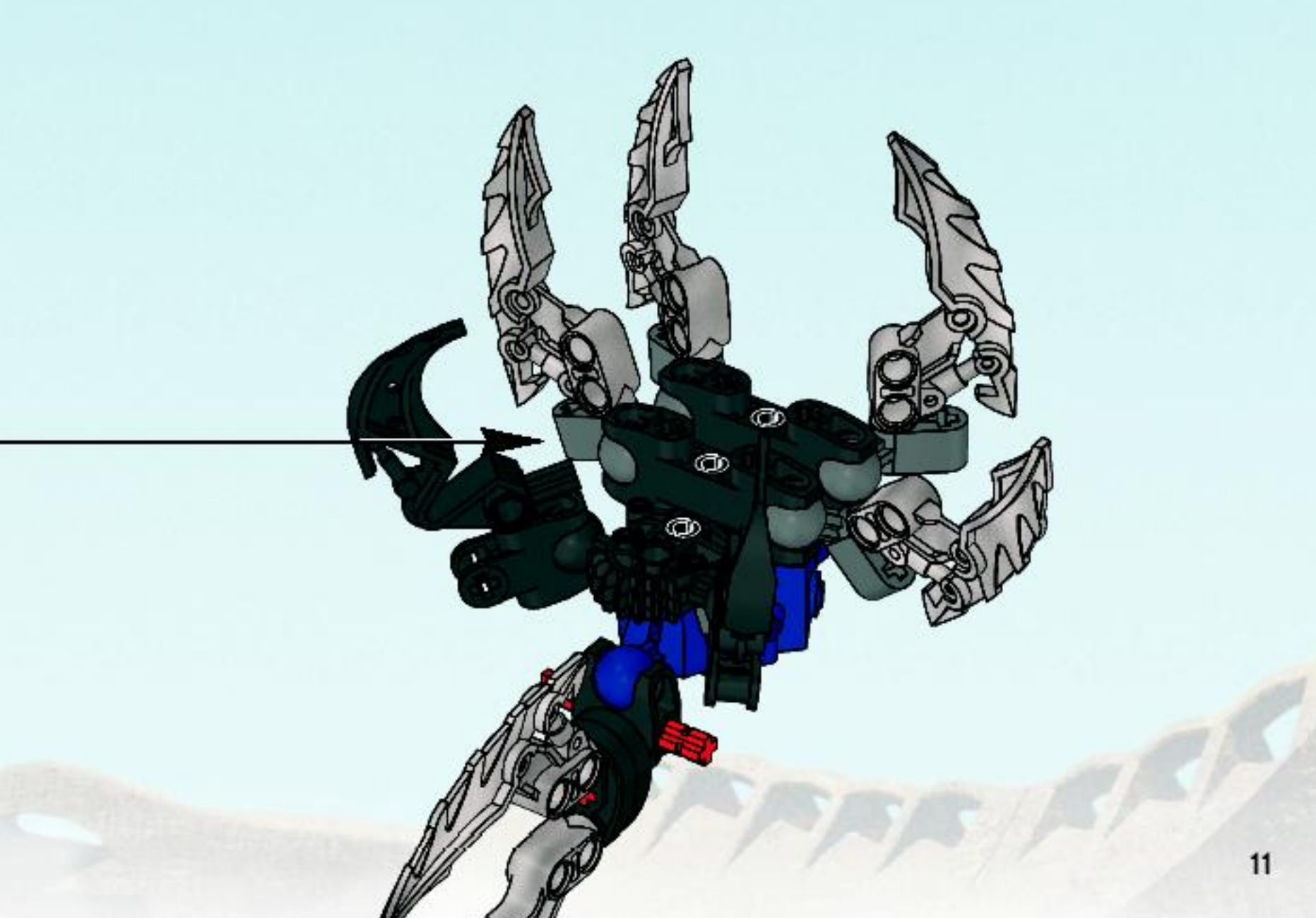

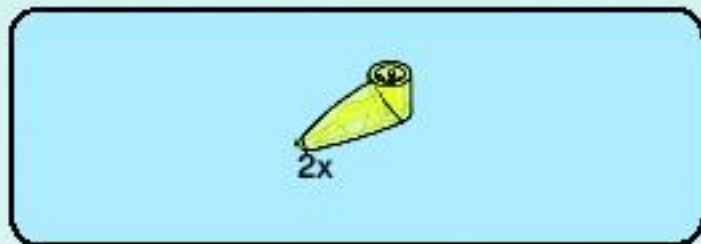

11

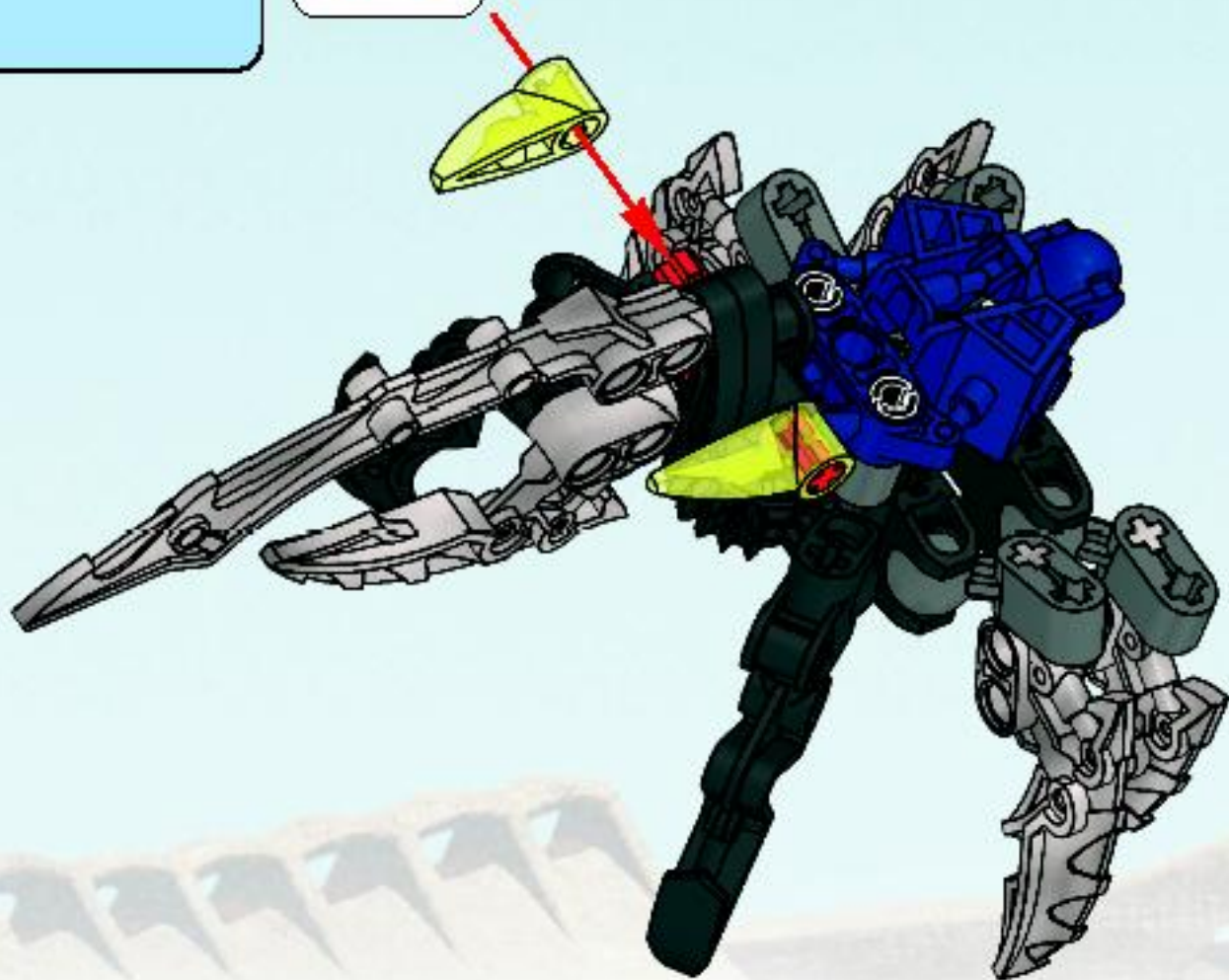



Customer Service

Kundenservice

Service Consommateurs

Servicio Al Consumidor

www.lego.com/service or dial





ALL-NEW MOVIE ON DVD

FALL 2009

BRANDNEUER FILM AUF DVD **HERBST 2009**
UN TOUT NOUVEAU FILM EN DVD **AUTOMNE 2009**
UNA PELÍCULA TOTALMENTE NUEVA
EN DVD **OTOÑO 2009**
UM FILME COMPLETAMENTE NOVO
EM DVD **OUTONO 2009**
EGY VADONATÚJ MOZIFILM DVD **SZ 2009**

UNIVERSAL

LEGO, BIONICLE, THE LEGEND REBORN, UNIVERSE, and the BIONICLE logo are trademarks of LEGO Group. © 2009 LEGO Group. All rights reserved. UNIVERSAL PICTURES and the UNIVERSAL logo are trademarks of Universal Studios. All rights reserved.



STRONIUS
8984



ACKAR
8985



VASTUS
8986

GLATORIAN LEGENDS



KIFIA
8987



GELLU
8988



MATA NUI
8989

www.BIONICLE.com



WIN LEGO® PRODUCTS

Fill out a survey and you might WIN a cool LEGO product
NO PURCHASE NECESSARY

Open to all residents where not prohibited

Go to www.nielsen.com/LEGO to fill out a survey for a chance to win a LEGO product.

WIN LEGO® PRODUCTEN

Vul een enquêteformulier in en maak kans op een cool LEGO® product!

Kopen niet nodig

Iedereen uit landen waar geen enquêteverbod geldt mag deelnemen.

Ga naar www.nielsen.com/LEGO, vul een enquêteformulier in en maak kans op een LEGO product.

GEWINNE LEGO® PRODUKTE

Nimm an der Umfrage teil und GEWINNE ein tolles LEGO® Produkt!
Die Teilnahme am Gewinnspiel führt zu keinerlei Kaufverpflichtungen.
Teilnahme in allen nicht ausgeschlossenen Ländern möglich.
Wir verlosen unter allen Teilnehmern der Umfrage auf www.nielsen.com/LEGO LEGO Produkte.

GAGNE DES PRODUITS LEGO®

Réponds à un questionnaire et tu pourrais GAGNER un produit LEGO® très cool !

Aucune obligation d'achat.

Ouvert à tous les résidents des pays autorisés.

Visite www.nielsen.com/LEGO pour répondre à un questionnaire et avoir une chance de gagner un produit LEGO.

レゴ®製品を「当てよう」

アンケートに記入して、カッコいいレゴ®製品を当てよう！

お買い上げの必要はありません。

禁止されていない限り、すべての皆様にご利用いただけます。

www.nielsen.com/LEGOにアクセスして、アンケートにご記入ください。当選者にはレゴ®製品を差し上げます。

